

# Forgotten Books

— [www.forgottenbooks.com](http://www.forgottenbooks.com) —

Copyright © 2016 FB &c Ltd.

All rights reserved. No part of this publication may be reproduced, distributed, or transmitted in any form or by any means, including photocopying, recording, or other electronic or mechanical methods, without the prior written permission of the publisher, except in the case of brief quotations embodied in critical reviews and certain other noncommercial uses permitted by copyright law.

N. B.—Take out carefully, leaving about quarter of an inch at the back. To do otherwise would, in some cases, release other leaves.

**MARTIN, H. NEWELL.**—The Human Body. An Account of its Structure and Activities, and the conditions of its healthy working, by H. Newell Martin, D. Sc., M. A., M. B., Professor of Biology in the Johns Hopkins University; Fellow of University College, London; late Fellow of Christ's College, Cambridge. New York: Henry Holt & Co., 1881. Large 12mo, pp. xvi. 606, Appendix 33. (American Science Series.)

**HUMAN BODY, THE.**—An Account of its Structure and Activities, and the conditions of its healthy working, by H. Newell Martin, D. Sc., M. A., M. B., Professor of Biology in the Johns Hopkins University; Fellow of University College, London; late Fellow of Christ's College, Cambridge. New York: Henry Holt & Co., 1881. Large 12mo, pp. xvi. 606, Appendix 33. (American Science Series.)

**ANATOMY.**—The Human Body. An Account of its Structure and Activities, and the conditions of its healthy working, by H. Newell Martin, D. Sc., M. A., M. B., Professor of Biology in the Johns Hopkins University; Fellow of University College, London; late Fellow of Christ's College, Cambridge. New York: Henry Holt & Co., 1881. Large 12mo, pp. xvi. 606, Appendix 33. (American Science Series.)

**PHYSIOLOGY.**—The Human Body. An Account of its Structure and Activities, and the conditions of its healthy working, by H. Newell Martin, D. Sc., M. A., M. B., Professor of Biology in the Johns Hopkins University; Fellow of University College, London; late Fellow of Christ's Col-





**THE**  
**AMERICAN SCIENCE SERIES**

FOR HIGH SCHOOLS AND COLLEGES.

---

The principal objects of this series are to supply the lack — in some subjects very great — of authoritative books whose principles are, so far as practicable, illustrated by familiar American facts, and also to supply the other lack that the advance of Science perennially creates, of text-books which at least do not contradict the latest generalizations.

The volumes are large 12mo.

The books arranged for are as follows. They systematically outline the field of Science, as the term is usually employed with reference to general education. Those marked \* had been published up to February 1, 1881.

***I. Physics.***

By ARTHUR W. WRIGHT, Professor in Yale College.

***II. Chemistry.***

By SAMUEL W. JOHNSON and WILLIAM G. MIXTER, Professors in Yale College.

***III. Astronomy.\****

By SIMON NEWCOMB, Supt. American Nautical Almanac, and EDWARD S. HOLDEN, Professor in the United States Naval Observatory. \$2.50.

***IV. Geology.***

By RAPHAEL PUMPELLY, late Professor in Harvard University.

***V. Botany.\****

By C. E. BESSEY, Professor in the Iowa Agricultural College and late Lecturer in the University of California. \$2.75.

***VI. Zoology.\****

By A. S. PACKARD, JR., Professor of Zoology and Geology in Brown University, Editor of the *American Naturalist*. \$3.

***VII. The Human Body.\****

By H. NEWELL MARTIN, Professor in the Johns Hopkins University. \$2.75. Copies without the Appendix on Reproduction will be sent when specially ordered.

***VIII. Psychology.***

By WILLIAM JAMES, Professor in Harvard University.

***IX. Political Economy.***

By FRANCIS A. WALKER, Professor in Yale College.

***X. Government.***

By EDWIN L. GODKIN, Editor of the *Nation*.

---

HENRY HOLT & CO., PUBLISHERS, NEW YORK.

AMERICAN SCIENCE SERIES

---

Laura Jacobs

# THE HUMAN BODY

AN ACCOUNT OF ITS STRUCTURE AND ACTIVITIES  
AND THE CONDITIONS OF ITS HEALTHY WORKING

LANE LIBRARY

H. NEWELL MARTIN, D.Sc., M.A., M.B.

*Professor of Biology in the Johns Hopkins University :*

*Fellow of University College, London ; Late*

*Fellow of Christ's College, Cambridge*



NEW YORK  
HENRY HOLT AND COMPANY

1881

7.

YVA. 37A. j 37A. j

Copyright, 1881,  
BY  
Henry Holt & Co.

---

J. CAMPBELL,  
PRINTER,  
18 Vandewater St., N. Y.

## PREFACE.

---

**In the following pages I have endeavored to give an account of the structure and activities of the Human Body, which, while intelligible to the general reader, shall be accurate, and sufficiently minute in details to meet the requirements of students who are not making Human Anatomy and Physiology subjects of special advanced study. Wherever it seemed to me really profitable, hygienic topics have also been discussed, though at first glance they may seem less fully treated of than in many School or College Text-books of Physiology. Whoever will take the trouble, however, to examine critically what passes for Hygiene in the majority of such cases, will I think find that, when correct, much of it is platitude or truism: since there is so much that is of importance and interest to be said it seems hardly worth while to occupy space with insisting on the commonplace or obvious.**

**It is hard to write a book, not designed for specialists, without running the risk of being accused of dogmatism, and some readers will, no doubt, be inclined to think that, in several instances, I have treated as established facts matters which are still open to discussion. General readers and students are, however, only bewildered by the production of an array of observations and arguments on each side of every question, and, in the majority of cases, the chief responsibility under which the author of a text-book lies is to select what seem to him the best supported views, and then to state them simply and concisely: how wise the choice of a side has been in each case can only be determined by the discoveries of the future.**

**Others will, I am inclined to think, raise the contrary**



WYANDOTT ILLINOIS

Copyright, 1911,  
BY  
HENRY HOLT & Co.



F 36  
M 38  
1881

## PREFACE.

In the following pages I have endeavored to give an account of the structure and activities of the Human Body, which, while intelligible to the general reader, shall be accurate, and sufficiently minute in details to meet the requirements of students who are not making Human Anatomy and Physiology subjects of special advanced study. Wherever it seemed to me really profitable, hygienic topics have also been discussed, though at first glance they may seem less fully treated of than in many School or College Text-books of Physiology. Whoever will take the trouble, however, to examine critically what passes for Hygiene in the majority of such cases, will I think find that, when correct, much of it is platitudinous or trite; since there is so much that is of importance and interest to be said it seems hardly worth while to occupy space with insisting on the commonplace or obvious.

It is hard to write a book, not designed for specialists, without running the risk of being accused of dogmatism, and some readers may be inclined to think that, in established facts matters. General readers and by the production of views on each side of every question, the chief responsibility of this book lies in to select and present views, and that it will be determined by the

objection, that too many disputed matters have been discussed: this was deliberately done as the result of an experience in teaching *Physiology* which now extends over more than ten years. It would have been comparatively easy to slip over things still uncertain and subjects as yet uninvestigated, and to represent our knowledge of the workings of the animal body as neatly rounded off at all its contours and complete in all its details—*totus, teres, et rotundus*. But by so doing no adequate idea of the present state of physiological science would have been conveyed; in many directions it is much farther travelled and more completely known than in others; and, as ever, exactly the most interesting points are those which lie on the boundary between what we know and what we hope to know. In gross Anatomy there are now but few points calling for a suspension of judgment; with respect to Microscopic Anatomy there are more; but a treatise on *Physiology* which would pass by, unmentioned, all things not known but sought, would convey an utterly unfaithful and untrue idea. *Physiology* has not finished its course; it is not cut and dried, and ready to be laid aside for reference like a specimen in an Herbarium, but is comparable rather to a living, growing plant, with some stout and useful branches well raised into the light, others but part grown, and many still represented by unfolded buds. To the teacher, moreover, no pupil is more discouraging than the one who thinks there is nothing to learn; and the boy who has “finished” Latin and “done” Geometry finds sometimes his counterpart in the lad who has “gone through” *Physiology*. For this unfortunate state of mind many Text-books are, I believe, much to blame: difficulties are too often ignored, or opening vistas of knowledge resolutely kept out of view: the forbidden regions may be, it is true, too rough for the young student to be guided through, or as yet pathless for the pioneers of thought; but the opportunity to arouse the receptive mental attitude apt to be produced by the recognition of the fact that much more still remains to be learnt—to excite the exercise of the reasoning faculties upon disputed matters—and, in some of the better minds, to arouse

the longing to assist in adding to knowledge, is an inestimable advantage, not to be lightly thrown aside through the desire to make an elegantly symmetrical book. While I trust, therefore, that this volume contains all the more important facts at present known about the working of our Bodies, I as earnestly hope that it makes plain that very much is yet to be discovered.

A work of the scope of the present volume is, of course, not the proper medium for the publication of novel facts; but, while the "Human Body," accordingly, professes to be merely a compilation, the introduction of constant references to authorities would have been out of place. I trust, however, that it will be found throughout imbued with the influence of my beloved master, Michael Foster; and on various hygienic topics I have to acknowledge a special indebtedness to the excellent series entitled *Health Primers*.

The majority of the anatomical illustrations are from Henle's *Anatomie des Menschen*, and a few from Arendt's *Schulatlas*, the publishers of each furnishing electrotypes. A considerable number, mainly histological, are from *Quain's Anatomy*, and a few figures are after Bernstein, Carpenter, Frey, Haeckel, Helmholtz, Huxley, McKendrick, and Wundt. About thirty, chiefly diagrammatic, were drawn specially for the work.

Quantities are throughout expressed first on the metric system, their approximate equivalents in American weights and measures being added in brackets.

H. NEWELL MARTIN.

BALTIMORE, October, 1880.



# CONTENTS.

---

## CHAPTER I.

### THE GENERAL STRUCTURE AND COMPOSITION OF THE HUMAN BODY.

	PAGE
Definitions. Tissues and organs. Histology. Zoological position of man. The vertebrate plan of structure. The mammalia. Chemical composition of the Body.....	1

## CHAPTER II.

### THE FUNDAMENTAL PHYSIOLOGICAL ACTIONS.

The properties of the living Body. Physiological properties. Cells. Cell growth. Cell division. Assimilation and reproduction. Contractility. Irritability. Conductivity. Spontaneity. Protoplasm. The fundamental physiological properties.....	15
--	----

## CHAPTER III.

### THE DIFFERENTIATION OF THE TISSUES, AND THE PHYSIOLOGICAL DIVISION OF EMPLOYMENTS.

Development. The physiological division of labor. Classification of the tissues. Undifferentiated tissues. Supporting tissues. Nutritive tissues. Storage tissues. Irritable tissues. Co-ordinating and automatic tissues. Motor tissues. Conductive tissues. Protective tissues. Reproductive tissues. Or-	
---	--

## CHAPTER IV.

## THE INTERNAL MEDIUM.

	PAGE
The external medium. The internal medium. The blood. The lymph. Histology of blood. Blood crystals. Histology of lymph.....	89

## CHAPTER V.

## THE CLOTTING OF THE BLOOD.

The coagulation of blood. Causes of coagulation. Whipped blood. The buffy coat. Uses of coagulation. The fibrin factors. Artificial clot. The fibrin ferment. Exciting causes of coagulation. Relation of blood-vessels to coagulation. Composition of the blood. Quantity of blood. Origin and fate of the blood corpuscles. Chemistry of lymph.....	50
---	----

## CHAPTER VI.

## THE SKELETON.

Exoskeleton and endoskeleton. The bony skeleton. Segmentation of the skeleton. Peculiarities of the human bony skeleton.....	62
--	----

## CHAPTER VII.

## THE STRUCTURE AND COMPOSITION OF BONE. JOINTS.

Gross structure of the bones. Microscopic structure of bone. Chemical composition of bone. Hygiene of the bony skeleton. Articulations. Joints. Hygiene of the joints.....	86
--	----

## CHAPTER VIII.

## CARTILAGE AND CONNECTIVE TISSUE.

Temporary and permanent cartilages. Varieties of cartilage. The connective tissues. Elastic cartilage and fibro-cartilage.	
--	--

	<b>PAGE</b>
Homologies of the supporting tissues. Hygiene of the developing skeleton. Adipose tissue.....	<b>100</b>

**CHAPTER IX.**

**THE STRUCTURE OF THE MOTOR ORGANS.**

Motion in animals and plants. Amœboid cells. Ciliated cells. The muscles. Histology of striped muscle. Unstriated muscles. Cardiac muscular tissue. The chemistry of muscular tissue. Beef-tea and Liebig's extract....	<b>118</b>
---	------------

**CHAPTER X.**

**THE PROPERTIES OF MUSCULAR TISSUE.**

Contractility. Irritability of muscle. A simple muscular contraction. Tetanus. Causes influencing the degree of muscular contraction. The measurement of muscular work. Muscular elasticity. Physiology of plain muscular tissue. Hygiene of the muscles. Exercise.....	<b>128</b>
---	------------

**CHAPTER XI.**

**MOTION AND LOCOMOTION.**

The special physiology of muscles. Levers in the Body. The erect posture. Walking. Running. Leaping.....	<b>143</b>
--	------------

**CHAPTER XII.**

**THE ANATOMY OF THE NERVOUS SYSTEM.**

Nerve-trunks. Plexuses. Nerve-centres. The cerebro-spinal centre and its membranes. The spinal cord. The spinal nerves. The brain. The cranial nerves. Ganglia and communications of the cranial nerves. The sympathetic system. The sporadic ganglia. The histology of nerve-fibres. The histology of nerve-cells. The structure of the spinal cord.....	<b>154</b>
---	------------



# **CONTENTS.**

## **CHAPTER XIII.**

### **THE GENERAL PHYSIOLOGY OF THE NERVOUS SYSTEM**

**PAGE**

The properties of nerve tissues. The functions of nerve-centres and nerve-trunks. Excitant and inhibitory nerves. The classification of nerve fibres. Intercentral nerve-fibres. The stimuli of nerves. General and special nerve stimuli. Specific nerve energies. All nerve-fibres are fundamentally alike. The nature of a nervous impulse. The rate of transmission of a nervous impulse. Functions of the spinal nerve-roots. The intercommunication of nerve-centres. . . . . 180

## **CHAPTER XIV.**

### **THE ANATOMY OF THE HEART AND BLOOD-VESSELS.**

General statement. Position of the heart. The membranes of the heart. The cavities of the heart. The heart as viewed from the outside. The interior of the heart. The valves of the heart. The arterial system. The capillaries. The veins. The pulmonary circulation. The course of the blood. The portal circulation. Arterial and venous blood. The structure of arteries, capillaries, and veins. . . . . 201

## **CHAPTER XV.**

### **THE WORKING OF THE HEART AND BLOOD-VESSELS.**

The beat of the heart. The cardiac impulse. Events in a cardiac period. Use of the papillary muscles. Sounds of the heart. Function of the auricles. The work done by the heart. The blood flow outside the heart. The circulation as seen with the microscope. Internal friction in the vessels. The conversion of an intermittent into a continuous flow. . . . . 219

## **CHAPTER XVI.**

### **ARTERIAL PRESSURE AND THE PULSE.**

Weber's schema. Arterial pressure. Modifications of arterial pressure, and how they may be produced. The pulse. The



**DIESE SEITE IST FÜR KOSTENLOSE MITGLIEDER GESPERRT**  
Beantragen Sie jetzt die volle Mitgliedschaft, um diese Seite zu betreten



**Seien Sie niemals ohne ein Buch!**

Die Vollmitgliedschaft von Forgotten Books bietet Ihnen einen universalen Zugang von unseren Apps und unserer Website, auf all Ihren Geräten: Tablet, Telefon, E-Reader, Laptop und Computer.

**Eine Bibliothek in Ihrer Tasche für € 8.99/monat**

**Fortfahren**

\*Es gelten Richtlinien zur fairen Nutzung.

	PAGE
fulfill. Alimentary principles. The composition of the more important foods. Cooking. Alcohol. The advantage of a mixed diet. ....	808

## CHAPTER XXI.

### THE ALIMENTARY CANAL AND ITS APPENDAGES.

General arrangement. The teeth. The tongue. The salivary glands. The fauces. The pharynx. The gullet. The stomach. The histology of the gastric glands. The small intestine. The large intestine. The liver. The pancreas....	808
---	-----

## CHAPTER XXII.

### THE LYMPHATIC SYSTEM AND THE DUCTLESS GLANDS.

Distribution and structure of lymph vessels. The thoracic duct. The serous cavities. The lymphatic glands. The movement of the lymph. The spleen. The thymus. The thyroid body. The supra-renal capsules. ....	829
--	-----

## CHAPTER XXIII.

### DIGESTION.

The object of digestion. Uses of saliva. Deglutition. The gastric juice. Gastric digestion. The chyle. The pancreatic secretion. The bile. The intestinal secretions. Intestinal digestion. Absorption from the intestines. The digestion of an ordinary meal. Dyspepsia. ....	834
--	-----

## CHAPTER XXIV.

### THE RESPIRATORY MECHANISM.

Definitions. Respiratory organs. The air-passages and lungs. The pleura. The respiratory movements. The structure of the thorax. The mechanism of inspiration. Expiration. Forced respiration. The respiratory sounds. The capacity of the lungs. Hygiene of respiration. The aspiration of the thorax. Influence of respiratory movements upon the flow of blood and lymph. ....	852
---	-----

CHAPTER XXV.

THE CHEMISTRY OF RESPIRATION.

PAGE

Nature of the problems. Changes produced in air by being once breathed. Ventilation. Changes undergone by blood in the lungs. The blood gases. Causes of color of arterial and venous blood. Laws governing the absorption of gases by liquids. The absorption of oxygen by the blood. Consequences of the way in which oxygen is held in the blood. The general oxygen interchanges of the blood. The carbon dioxide of the blood. Internal respiration..... 872 ✓

CHAPTER XXVI.

THE NERVOUS FACTORS OF THE RESPIRATORY MECHANISM.  
ASPHYXIA.

The respiratory centre. Is the respiratory centre reflex? The stimulus of the respiratory centre. The cause of the respiratory rhythm. The influence of the pneumogastric nerves upon the respiratory centre. The expiratory centre. Asphyxia. Carbon-monoxide hæmoglobin. Modified respiratory movements..... 890 ✓

CHAPTER XXVII.

THE KIDNEYS AND THE SKIN.

The general arrangement of the urinary organs. The structure of the kidneys. The renal secretion. The mechanism of the renal secretion. The function of the renal epithelium. The skin. Epidermis and cutis vera. Hairs. Nails. Glands of the skin. Relation of nerves to sweat secretion. Hygiene of the skin. Bathing..... 404 ✓

CHAPTER XXVIII.

NUTRITION.

The problems of animal nutrition. The seat of the oxidations of the Body. Tissue-building and energy-yielding foods. The source of the energy spent in muscular work. Luxus consumption. The antecedents of urea. Proteid starvation and

	PAGE
over-feeding. The storage tissues. Glycogen. Diabetes. The history of fats. Dietetics.....	433

## CHAPTER XXIX.

### THE PRODUCTION AND REGULATION OF THE HEAT OF THE BODY.

Cold- and warm-blooded animals. The temperature of the Body. The sources of animal heat. Energy lost by the Body in twenty-four hours. The superiority of the Body as a machine for executing mechanical work. The maintenance of an average temperature. Local temperatures. Thermic nerves. Clothing.....	440
---	-----

## CHAPTER XXX.

### SENSATION AND SENSE-ORGANS,

The subjective functions of the nervous system. Common sensation and organs of special sense. The peripheral reference of sensations. Differences between sensations. The essential structure of a sense organ. The cause of the modality of sensations. The psycho-physical law. Perceptions. Sensory illusions.....	461
---	-----

## CHAPTER XXXI.

### THE EYE AS AN OPTICAL INSTRUMENT.

The essential structure of an eye. The appendages of the eye. The lachrymal apparatus. The muscles of the eyeball. The anatomy of the eyeball. The structure of the retina. The refracting media of the eye. The properties of light. Accommodation. Short sight and long sight. Hygiene of sight. Optical defects of the eye.....	479
--	-----

## CHAPTER XXXII.

### THE EYE AS A SENSORY APPARATUS.

The excitation of the visual apparatus. Idio-retinal light. The parts of the retina on which light directly acts. The vision purple. Intensity of visual sensations. Duration of luminous sensations. The localizing power of the retina. Color vision.	
---	--

	PAGE
Color blindness. Fatigue of the retina and after-images. Contrasts. Hering's theory of vision. Visual perceptions. Single vision with two eyes.....	506

CHAPTER XXXIII.

THE EAR AND HEARING.

The external ear. The tympanum. The auditory ossicles. The internal ear. The organ of Corti. The loudness, pitch, and <i>timbre</i> of sounds. Sympathetic resonance. Functions of the tympanic membrane, of the auditory ossicles, of the cochlea, and of the vestibule. Auditory perceptions.....	535
---	-----

CHAPTER XXXIV.

TOUCH, THE TEMPERATURE SENSE, THE MUSCULAR SENSE, COMMON SENSATION, SMELL, AND TASTE.

Nerve-endings in the skin. The pressure sense. The localizing power of the skin. The temperature sense. Modality of skin sensations. The muscular sense. Pain. Hunger and thirst. Smell. Taste.....	556
---	-----

CHAPTER XXXV

THE FUNCTIONS OF THE BRAIN AND SPINAL CORD.

The special physiology of nerve-centres. The spinal cord as a centre. Reflex actions. The least-resistance hypothesis. The education of the spinal cord. The inhibition of reflexes. Psychological activities of the cord. The cord as a conductor of nervous impulses. Functions of the brain in general. Functions of medulla oblongata. Functions of cerebellum, pons Varolii, and mid-brain. Sensations of equilibrium and functions of semicircular canals. Functions of the fore-brain. Hygiene of the brain.....	573
---	-----

CHAPTER XXXVI.

VOICE AND SPEECH.

Anatomy of larynx. The vocal cords. Causes of the varying pitch of the voice. Range of the human voice. The production of vowels. Consonants.....	595
---	-----

**APPENDIX.****REPRODUCTION AND DEVELOPMENT.**

**Reproduction in general. Sexual and asexual reproduction. Male reproductive organs. Female reproductive organs. Puberty. Ovulation. Menstruation. Hygiene of menstruation. Impregnation. Pregnancy. The foetal appendages. The intra-uterine nutrition of the embryo. Parturition. Lactation. Feeding of infants. The stages of life. Death.**

# THE HUMAN BODY.

---

## CHAPTER I.

### THE GENERAL STRUCTURE AND COMPOSITION OF THE HUMAN BODY.

**Definitions.** The living human Body may be considered from either of two aspects. Its structure may be especially examined, and the forms, connections and mode of growth of its parts be studied, as also the resemblances or differences in such respects, which appear when it is compared with other animal bodies. Or the living Body may be more especially studied as an organism presenting definite properties and performing certain actions; and then its parts will be investigated with a view to discovering what duty, if any, each fulfills. The former group of studies constitutes the science of Anatomy, and in so far as it deals with the human Body alone, of *Human Anatomy*; while the latter, the science concerned with the uses—or in technical language the *functions*—of each part is known as *Physiology*. Closely connected with physiology is the science of *Hygiene*, which is concerned with the conditions which are favorable to the healthy action of the various parts of the Body; while the activities and structure of the diseased body form the subject-matters of the sciences of *Pathology* and *Pathological Anatomy*.

**Tissues and Organs. Histology.** Examined merely from the outside, our Bodies present a considerable complexity of structure. We easily recognize distinct parts as head, neck, trunk and limbs; and in these again smaller



constituent parts, as eyes, nose, ears, mouth; arm, forearm, hand; thigh, leg and foot. We can, with such an external examination, go even farther and recognize different materials as entering into the formation of the larger parts. Skin, hair, nails and teeth are obviously different substances; simple examination by pressure proves that internally there are harder and softer solid parts; while the blood that flows from a cut finger shows that liquid constituents also exist in the Body. The conception of complexity, which may be thus arrived at from external observation of the living, is greatly extended by dissection of the dead Body, which makes manifest that it consists of a great number of diverse parts or *organs*, which in turn are built up of a limited number of materials, the same material often entering into the composition of many different organs. These primary building materials are known as the *tissues*, and that branch of anatomy which deals with the characters of the tissues and their arrangement in various organs is known as *Histology*; or, since it is mainly carried on with the aid of the microscope, as *Microscopic Anatomy*. If, with the poet, we compare the Body to a house, we may go on to liken the tissues to the bricks, stone, mortar, wood, iron, glass and so on used in building; and then walls and floors, stairs and windows, formed by the combination of these, would answer to anatomical organs.

**Zoological Position of Man.** External examination of the human Body shows also that it presents certain resemblances to the bodies of many other animals: head and neck, trunk and limbs, and various minor parts entering into them, are not at all peculiar to it. Closer study and the investigation of internal structure demonstrates further that these resemblances are in many cases not superficial only, but that our Bodies may be regarded as built upon a plan common to them and the bodies of many other creatures: and it soon becomes further apparent that this resemblance is greater between the human Body and the bodies of ordinary four-footed beasts, than between it and the bodies of birds, reptiles or fishes. Hence, from



**DIESE SEITE IST FÜR KOSTENLOSE MITGLIEDER GESPERRT**

Beantragen Sie jetzt die volle Mitgliedschaft, um diese Seite zu betreten

# GESCHICHTE

Zehntausende von wichtigen historischen Quellen, viele bisher nicht erhältlich, stehen jetzt zum ersten Mal mit der Vollmitgliedschaft von Forgotten Books zur Verfügung.

Unbegrenzter Zugang  
\$8.99/monat

**Fortfahren**

\*Es gelten Richtlinien zur fairen Nutzung.



ones, insects, or oysters, but agrees in many points with the groups of fishes, amphibians, reptiles, and birds. These four are therefore placed with man and all other Mammals in one great division of the animal kingdom known as the *Vertebrata*. The main anatomical character of all vertebrate animals is the presence in the trunk of the body of two cavities, a dorsal and a ventral, separated by a solid partition, and in the adults of nearly all vertebrate animals a hard axis, the *vertebral column* (*backbone* or *spine*), develops in this partition and forms a central support for the rest of the body (Fig. 2, *s e*). The dorsal cavity is continued through the neck, when there is one, into the head, and there widens out. The bony axis is also continued through the neck and extends into the head in a modified form. The ventral cavity, on the other hand, is confined to the trunk. It contains the main organs connected with the blood-flow and is thus often called the *hæmal cavity*.

Upon the ventral side of the head is the *mouth opening* leading into a tube, the *alimentary canal*, *f*, which passes back through the neck and trunk and opens again on the outside at the posterior part of the latter. In its passage through the trunk region this canal lies in the ventral cavity.

**The Mammalia.** In many vertebrate animals the ventral cavity is not subdivided, but in the Mammalia it is; a membranous transverse partition, the *midriff* or *diaphragm* (Fig. 1, *z*), separating it into an anterior *chest* or *thoracic cavity*, and a posterior or *abdominal cavity*. The alimentary canal and whatever else passes from one of these cavities to the other must therefore perforate the diaphragm.

In the chest, besides part of the alimentary canal, lie important organs, the *heart*, *h*, and *lungs*, *lu*, the heart being on the ventral side of the alimentary canal. The abdominal cavity is mainly occupied by the alimentary canal and organs connected with it and concerned in the digestion of food, as the *stomach*, *ma*, the *liver*, *ls*, the *pancreas* and the *intestines*. Among the other more prominent organs in it are the *kidneys* and the *spleen*.

In the dorsal cavity lie soft white organs, the *brain* and

*spinal cord*, the former occupying its anterior enlargement in the head. Brain and spinal cord together form the *cerebro-spinal nervous centre*, but in addition to this there are found in the ventral cavity a number of small nerve cen-

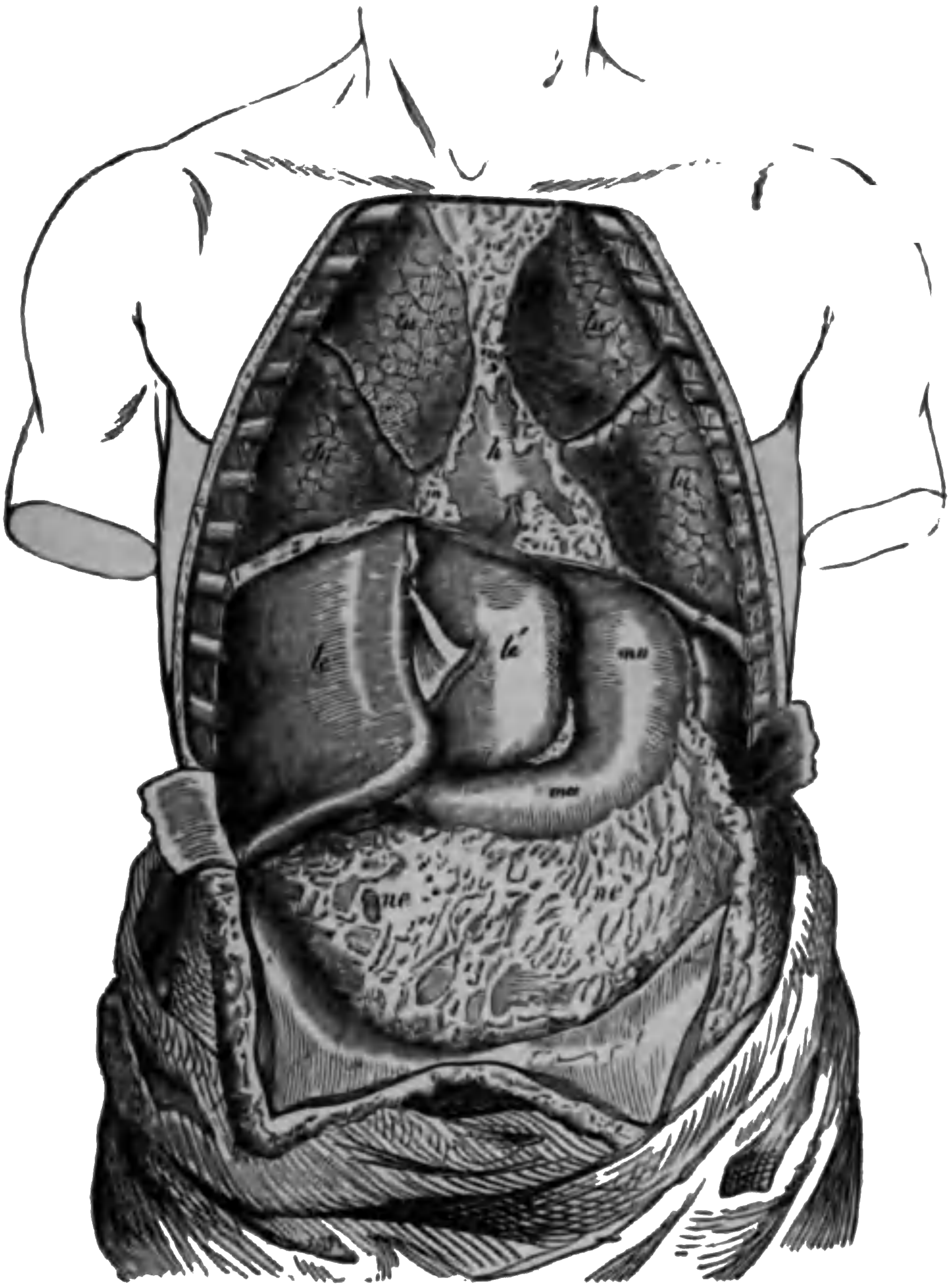

FIG. 1.—The Body opened from the front to show the contents of its ventral cavity.

tres united together by connecting cords, and with their offshoots forming the *sympathetic nervous system*.

The walls of the three main cavities are lined by smooth,

moist *serous membranes*. That lining the dorsal cavity is the *arachnoid*; that lining the chest the *pleura*; that

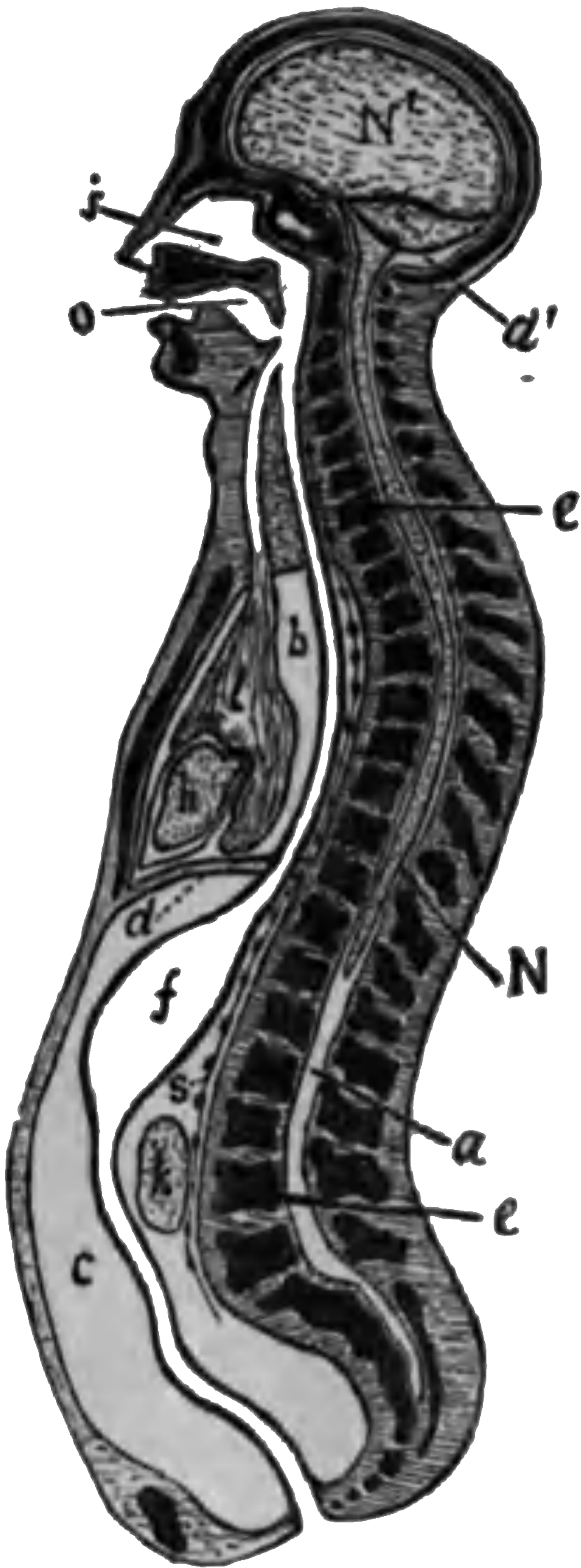

FIG. 2.—Diagrammatic longitudinal section of the body. *a*, the neural tube, with its upper enlargement in the skull cavity at *a'*; *N*, the spinal cord; *N'*, the brain; *ee*, vertebrae forming the solid partition between the dorsal and ventral cavities; *b*, the pleural, and *c*, the abdominal divisions of the ventral cavity, separated from one another by the diaphragm, *d*; *i*, the nasal, and *o*, the mouth chamber, opening behind into the pharynx, from which one tube leads to the lungs, *l*, and another to the stomach, *f*; *h*, the heart; *k*, a kidney; *s*, the sympathetic nervous chain. From the stomach, *f*, the intestinal tube leads through the abdominal cavity to the posterior opening of the alimentary canal.

lining the abdomen the *peritoneum*; the abdominal cavity is in consequence often called the *peritoneal cavity*. Externally the walls of these cavities are covered by the *skin*, which consists of two layers: an outer horny layer called the *epidermis*, which is constantly being shed on the surface and renewed from below; and a deeper layer, called the *dermis* and containing blood, which the epidermis does not. Between the skin and the lining serous membranes are *bones*, *muscles* (the lean of meat), and a great number of other structures which we shall have to consider hereafter. All cavities inside the body, as the alimentary canal and the air passages, which open directly or indirectly on the surface are lined by soft and moist prolongations of the skin known as *mucous membranes*. In these the same two layers are found as in the skin, but the superficial bloodless one is called *epithelium* and the deeper one the *corium*.

Diagrammatically we may represent the human Body in longitudinal section as in Fig. 2, where *aa'* is the dorsal or *neural cavity*, and *b* and *c*, respectively, the thoracic and abdominal subdivisions of the ventral cavity; *d* represents the diaphragm separating

them; *es* is the vertebral column with its modified prolongation into the head beneath the anterior enlargement of the dorsal cavity; *f* is the alimentary canal opening in front through the nose, *i*, and mouth, *o*; *h* is the heart, *l* a lung, *s* the sympathetic nervous system, and *k* a kidney.

A transverse section through the chest is represented diagrammatically in Fig. 3, where *x* is the neural canal containing the spinal cord. In the thoracic cavity are seen the heart, *h*, the lungs, *ll*, part of the alimentary canal, *a*, and the sympathetic nerve centres, *sy*; the dotted line on each side covering the inside of the chest wall and the outside of the lung represents the *pleura*.

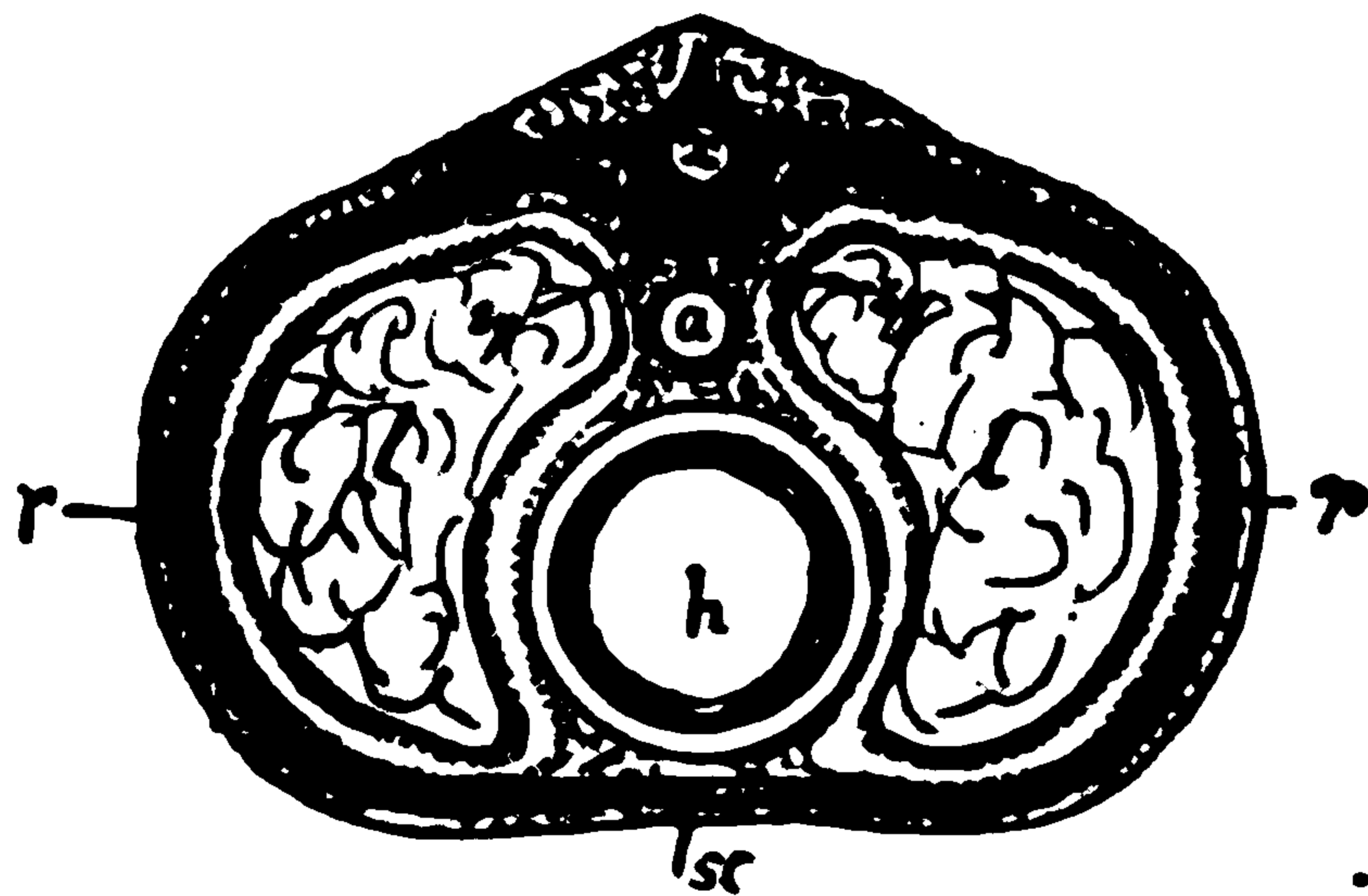

FIG. 3.—A diagrammatic section across the Body in the chest region. *x*, the dorsal tube, which contains the spinal cord; the black mass surrounding it is a vertebra; *a*, the gullet, a part of the alimentary canal; *h*, the heart; *sy*, sympathetic nervous system; *ll*, lungs; the dotted lines around them are the pleura; *rr*, ribs; *st*, the breastbone.

Sections through corresponding parts of any other Mammal would agree in all essential points with those represented in Figs. 2 and 3.

**The Limbs.** The limbs present no such arrangement of cavities on each side of a bony axis as is seen in the trunk. They have an axis formed at different parts of one or more bones (as seen at *U* and *R* in Fig. 4, which represents a cross-section of the forearm near the elbow joint), but around this are closely packed soft parts, chiefly muscles, and the whole is enveloped in skin. The only cavities in the limbs are branching tubes which are filled with liquids during life, either *blood* or a watery-looking fluid known as *lymph*. These tubes, the *blood* and *lymph vessels* respec-

tively, are not however characteristic of the limbs, for they are present in abundance in the dorsal and ventral cavities and in their walls.

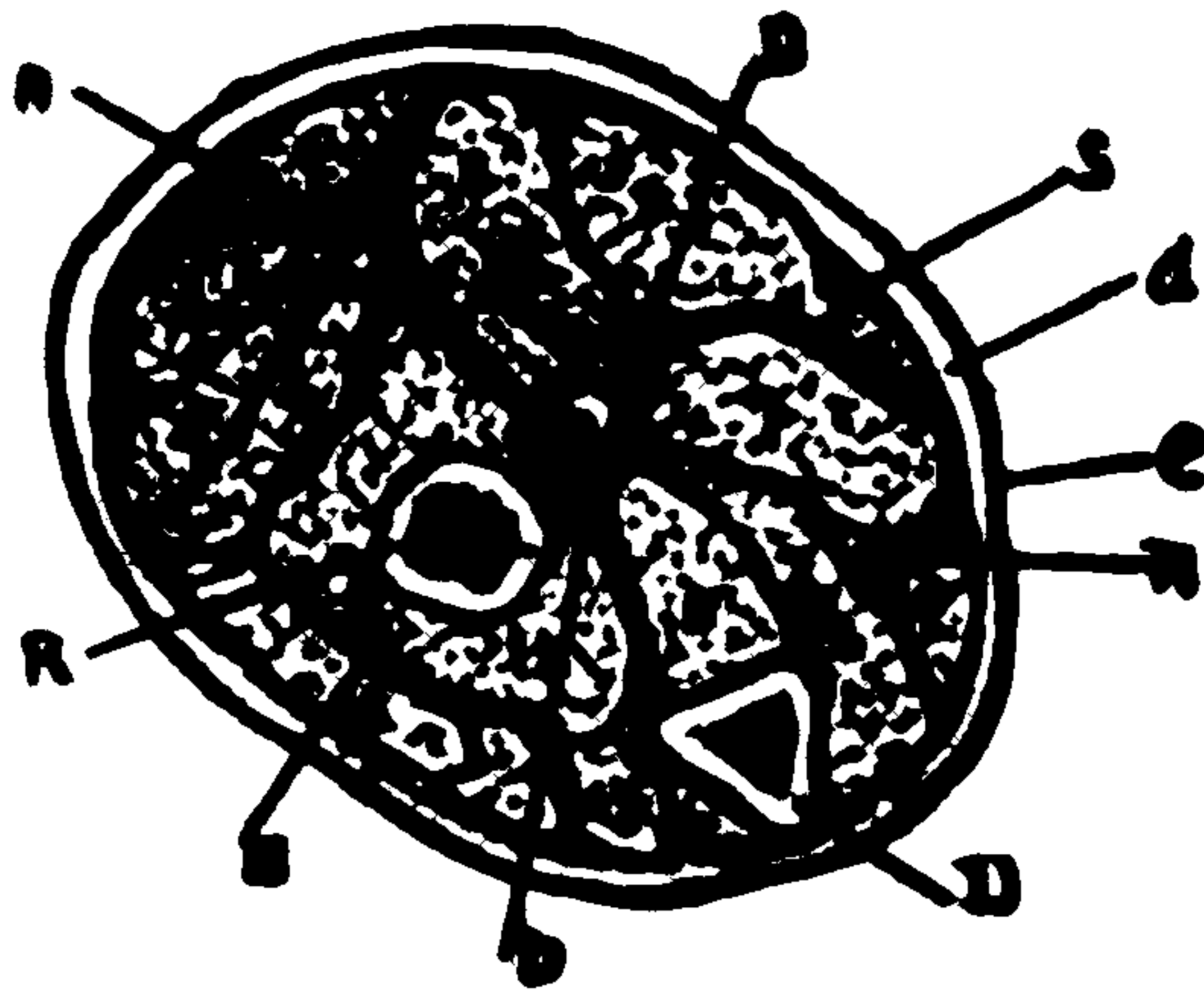

FIG. 4.—A section across the forearm a short distance below the elbow-joint, *R* and *U*, its two supporting bones, the radius and ulna; *e*, the epidermis, and *d* the dermis of the skin; the latter is continuous below with bands of connective tissue, *s*, which penetrate between and invest the muscles, which are indicated by numbers; *n*, *n*, nerves and vessels.

**Chemical Composition of the Body.** In addition to the study of the Body as composed of tissues and organs which are optically recognizable, we may consider it as composed of a number of different chemical substances. This branch of knowledge, which is still very incomplete, really presents two classes of problems. On the one hand we may limit ourselves to the examination of the chemical substances which exist in or may be derived from the dead Body, or, if such a thing were possible, from the living Body entirely at rest; such a study is essentially one of structure and may be called *Chemical Anatomy*. But as long as the Body is alive it is the seat of constant chemical transformations in its material, and these are inseparably connected with its functions, the great majority of which are in the long-run dependent upon chemical changes. From this point of view, then, the chemical study of the Body presents physiological problems, and it is usual to include all the known facts as to the chemical composition and metamorphoses of living matter under the name of *Physiological Chemistry*. For the present we may confine ourselves to the more important substances derived from or known to exist in the Body, leaving questions concerning the chemical changes taking place within it for consideration along with those functions which are performed in connection with them.

**Elements Composing the Body.** Of the elements known to chemists only sixteen have been found to take part in the formation of the human Body. These are carbon, hydrogen, nitrogen, oxygen, sulphur, phosphorus, chlorine, fluorine, silicon, sodium, potassium, lithium, calcium, magnesium, iron, and manganese. Copper and lead have sometimes been found in small quantities but are probably accidental and occasional.

**Uncombined Elements.** Only a very small number of the above elements exist in the body uncombined. *Oxygen* is found in small quantity dissolved in the blood; but even there most of it is in a state of loose chemical combination. It is also found in the cavities of the lungs and alimentary canal, being derived from the inspired air or swallowed with food and saliva; but while contained in these spaces it can hardly be said to form a part of the Body. *Nitrogen* also exists uncombined in the lungs and alimentary canal, and in small quantity in solution in the blood. Free *hydrogen* has also been found in the alimentary canal, being there evolved by the fermentation of certain foods.

**Chemical Compounds.** The number of these which may be obtained from the Body is very great; but with regard to very many of them we do not know that the form in which we extract them is really that in which the elements they contain were united while in the living Body; since the methods of chemical analysis are such as always break down the more complex forms of living matter and leave us only its *débris* for examination. We know in fact, tolerably accurately, what compounds enter the Body as food and what finally leave it as waste; but the intermediate conditions of the elements contained in these compounds during their sojourn inside the Body we know very little about; more especially their state of combination during that part of their stay when they do not exist dissolved in the bodily liquids, but form part of a solid living tissue.

For present purposes the chemical compounds existing in or derived from the Body may be classified as organic



and inorganic, and the former be subdivided into those which contain nitrogen and those which do not.

**Nitrogenous or Azotized Organic Compounds.** These fall into several main groups: *proteids*, *peptones*, *albuminoids*, *crystalline substances*, and *coloring matters*.

Proteids are by far the most characteristic substances obtained from the Body, since they are only known as existing in or derived from living things, either animals or plants. The type of this class of bodies may be found in the white of an egg, where it is stored up as food for the developing chick; from this typical form, which is called *egg albumin*, the proteids in general are often called *albuminous bodies*. Each of them contains carbon, hydrogen, oxygen, sulphur, and nitrogen united to form a very complex molecule, and although different members of the family differ from one another in minor points they all agree in their broad features and have a similar percentage composition. The latter in different examples appears to vary within the following limits, but it is almost impossible to get any one of them pure for analysis:

Carbon.....	52	to 54	per cent.
Hydrogen.....	7	to 7.5	"
Oxygen.....	21	to 24.0	"
Nitrogen.....	15	to 17.0	"
Sulphur.....	0.8	to 2.0	"

Proteids are recognized by the following characters: 1. Boiled, either in the solid state or in solution, with strong nitric acid they give a yellow liquid which becomes orange on neutralization with ammonia. This is the *xantho-proteic test*.

2. Boiled with a solution containing subnitrate and per-nitrate of mercury they give a pink precipitate, or, if in very small quantity, a pink-colored solution. This is known as *Millon's test*.

3. If a solution containing a proteid be acidulated with strong acetic acid and be boiled after the addition of an equal bulk of a saturated watery solution of sodium sulphate, the proteid will be precipitated.



**DIESE SEITE IST FÜR KOSTENLOSE MITGLIEDER GESPERRT**  
Beantragen Sie jetzt die volle Mitgliedschaft, um diese Seite zu betreten



**Seien Sie niemals ohne ein Buch!**

Die Vollmitgliedschaft von Forgotten Books bietet Ihnen einen universalen Zugang von unseren Apps und unserer Website, auf all Ihren Geräten: Tablet, Telefon, E-Reader, Laptop und Computer.

**Eine Bibliothek in Ihrer Tasche für €8.99/monat**

**Fortfahren**

\*Es gelten Richtlinien zur fairen Nutzung.

proteids, the nearest chemical allies of which they seem to be, they are only known in or derived from living beings. *Gelatin*, obtained from bones and ligaments by boiling, is a typical albuminoid; as is *chondrin*, which is obtained similarly from gristle. *Mucin*, which gives their glairy tenacious character to the secretions of the mouth and nose, is another albuminoid.

**Crystalline Nitrogenous Substances.** These are a heterogeneous group, the great majority of them being materials which have done their work in the Body and are about to be got rid of. Nitrogen enters the Body in foods for the most part in the chemically complex form of some proteid. In the vital processes these proteids are broken down into simpler substances; their carbon being partly combined with oxygen and passed out through the lungs as carbon dioxide; their hydrogen is similarly in large part combined with oxygen and passed out as water; while their nitrogen, with some carbon and hydrogen and oxygen, is usually passed out in the form of a crystalline compound, containing what chemists call an "ammonium residue."

Of these the most important is *urea* (Carbamide  $\left. \begin{array}{c} \text{CO} \\ \text{H}^2 \\ \text{H}^2 \end{array} \right\} \text{N}^2$ ),

which is eliminated through the kidneys. *Uric acid* is another nitrogenous waste product, and many others, such as *kreatin* and *kreatinin*, seem to be intermediate stages between the proteids which enter the body and the urea and uric acid which leave it.

In the bile or gall, two crystallizable nitrogen-containing bodies, *glycocholic* and *taurocholic acids*, are found combined with soda.

**Nitrogenous Coloring Matters.** These form an artificial group whose constitution and origin is ill known. Among the most important are the following:

*Hæmatin*, derived from the red corpuscles of the blood in which a residue of it is combined with a proteid residue to form *hæmoglobin*.

*Bilirubin* and *biliverdin*, which exist in the bile; the former predominating in the bile of man and of carnivo-

rous animals and giving it a reddish yellow color, while biliverdin predominates in the bile of Herbivora which is green.

**Non-Nitrogenous Organic Compounds.** These may be conveniently grouped as *hydrocarbons* or fatty bodies; *carbohydrates* or *amyloids*; and certain *non-azotized acids*.

**Fats.** The *fats* all contain carbon, hydrogen and oxygen, the oxygen being present in small proportion as compared with the hydrogen. Three fats occur in the body in large quantities, viz.: *palmitin* ( $C_{31}H_{62}O_2$ ), *stearin* ( $C_{37}H_{74}O_2$ ), and *olein* ( $C_{57}H_{110}O_2$ ). The two former when pure are solid at the temperature of the Body, but in it are mixed with olein (which is liquid) in such proportions as to be kept fluid. The total quantity of fats in the Body is subject to great variations, but its average quantity in a man weighing 75 kilograms (165 pounds) is about 2.75 kilograms (6 pounds).

Each of these fats when heated with a caustic alkali, in the presence of water, breaks up into a fatty acid (*stearic*, *palmitic*, or *oleic* as the case may be) and *glycerine*. The fatty acid unites with the alkali present to form a *soap*.

**Carbohydrates.** These also contain carbon, hydrogen and oxygen, but there is one atom of oxygen present for every two of hydrogen in the molecule of each of them. Chemically they are related to starch. The more important of them found in the Body are the following:

*Glycogen* ( $C_6H_{10}O_5$ ) found in large quantities in the liver, where it seems to be a reserve of material answering to the starch stored up by many plants. It exists in smaller quantities in the muscles.

*Glucose*, or *grape sugar* ( $C_6H_{12}O_6$ ), which exists in the liver in small quantities; also in the blood and lymph. It is largely derived from glycogen which is very readily converted into it.

*Inosit*, or *muscle sugar* ( $C_6H_{12}O_6 + 2H_2O$ ), found in muscles, liver, spleen, kidneys, etc.

important is *carbonic dioxide* ( $\text{CO}_2$ ), which is the form in which by far the greater part of the carbon taken into the Body ultimately leaves it. United with calcium it is found in the bones and teeth in large proportion.

*Formic, Acetic, and Butyric acids* also are found in the Body; stearic, palmitic, and oleic have been above mentioned as obtainable from fats. *Lactic acid* is found in the stomach and develops in milk when it turns sour. A body of the same percentage composition,  $\text{C}_3\text{H}_5\text{O}_2$  (*sarcocollactic acid*), is formed in muscles when they work or die.

*Glycero-phosphoric acid* ( $\text{C}_3\text{H}_5\text{PO}_4$ ) is obtained on the decomposition of *lecithin*, a complex nitrogenous fat found in nervous tissue.

**Inorganic Constituents.** Of the simpler substances entering into the structure of the body the following are the most important:

*Water*; in all the tissues in greater or less proportion and forming about two thirds of the weight of the whole Body. A man weighing 75 kilos (165 lbs.), if completely dried would therefore lose about 50 kilos (110 lbs.) from the evaporation of water. Of the constituents of the Body the enamel of the teeth contains least water (about two per cent) and the saliva most (about 99.5 per cent); between these extremes are all intermediate steps—bones containing about 22 per cent, muscles 75, blood 79.

*Common salt—Sodium chloride*—( $\text{NaCl}$ ); found in all the tissues and liquids, and in many cases playing an important part in keeping other substances in solution in water.

*Potassium chloride* ( $\text{KCl}$ ); in the blood, muscles, nerves, and most liquids.

*Calcium phosphate* ( $\text{Ca}_3\text{P}_2\text{O}_8$ ); in the bones and teeth in large quantity. In less proportion in all the other tissues.

Besides the above, ammonium chloride, sodium and potassium phosphates, magnesium phosphate, sodium sulphate, potassium sulphate and calcium fluoride have been obtained from the body.

Uncombined *Hydrochloric acid* ( $\text{HCl}$ ) is found in the stomach.

## CHAPTER II.

### THE FUNDAMENTAL PHYSIOLOGICAL ACTIONS.

**The Properties of the Living Body.** When we turn from the structure and composition of the living Body to consider its powers and properties we meet with the same variety and complexity, the most superficial examination being sufficient to show that its parts are endowed with very different faculties. Light falling on the eye arouses in us a sensation of sight but falling on the skin has no such effect; pinching the skin causes pain, but pinching a hair or a nail does not: when the ears are stopped, sounds arouse in us no sensation; we readily recognize, too, hard parts formed for support, joints to admit of movements, apertures to receive food and others to get rid of wastes. We thus perceive that different organs of our Bodies have very different endowments and serve for very distinct purposes; and here again the study of internal organs shows us that the varieties of quality observed on the exterior are but slight indications of differences of property which pervade the whole, being sometimes dependent on the specific characters of the tissues concerned and sometimes upon the manner in which these are combined to form various organs. Some tissues are solid, rigid and of constant shape, as those composing the bones and teeth; others, as the muscles, are soft and capable of changing their form; and still others are capable of working chemical changes by which such peculiar fluids as the bile or the saliva are produced. We find elsewhere a number of tissues combined to form a tube adapted to receive food and carry it through the Body for digestion, and again similar tissues

differently arranged to receive the air which we breathe-in, and expel after abstracting from it part of its oxygen and adding to it certain other things; and in the heart and blood-vessels we find almost the same tissues arranged to propel and carry the blood over the whole Body. The working of the Body offers clearly even a more complex subject of study than its structure.

**Physiological Properties.** In common with inanimate objects the Body possesses many merely physical properties, as weight, rigidity, elasticity, color, and so on; but in addition to these we find in it while alive many others which it ceases to manifest at death. Of these perhaps the power of executing spontaneous movements and of maintaining a high bodily temperature are the most marked. As long as the Body is alive it is warm and, since the surrounding air is nearly always cooler, must be losing heat all day long to neighboring objects; nevertheless we are at the end of the day as warm as at the beginning, the temperature of the Body in health not varying much from  $37.5^{\circ}$  C. ( $99^{\circ}$  F.), so that clearly our Bodies must be making heat somehow all the time. After death this production of heat ceases and the Body cools down to the temperature in its neighborhood; but so closely do we associate with it the idea of warmth that the sensation experienced in touching a corpse produces so powerful an impression as commonly to be described as icy cold. The other great characteristic of the living Body is its power of executing movements; so long as life lasts it is never at rest; even in the deepest slumber the regular breathing, the tap of the heart against the chest-wall, and the beat of the pulse tell us that we are watching sleep and not death. If to this we add the possession of consciousness by the living Body, whether aroused by forces immediately acting upon sense-organs or not, we might describe it as a heat-producing, moving, conscious organism.

The production of heat in the Body needs fuel of some kind as much as its production in a fire; and every time we move ourselves or external objects some of the Body is used up to supply the necessary working power, just

things, their great variety in the human Body depending upon special development and combination in different tissues and organs; and before attempting to study them in their most complex forms it is advantageous to examine them in their simplest and most generalized manifestations as exhibited by some of the lowest living things or by the simplest constituents of our own Bodies.

**Cells.** Among the anatomical elements which the histologist meets with as entering into the composition of the human Body are minute granular masses of a soft consistence, about 0.012 millimeter ( $\frac{1}{8000}$  of an inch) in diameter (Fig. 5, e). Imbedded in each lies a central portion, not granular and therefore different in appearance from the rest. These anatomical units are known as *cells*, the granular substance being the *cell body* and the imbedded clearer portion the *cell nucleus*. Inside the nucleus may often be distinguished a still smaller body—the *nucleolus*. Cells of this kind exist in abundance in the blood, where they are known as the *white blood corpuscles*, and each exhibits of itself



FIG. 5.—Forms of cells from the Body



certain properties which are distinctive of all living things as compared with inanimate objects.

**Cell Growth.** In the first place, each such cell can take up materials from its outside and build them up into its own peculiar substance; and this does not occur by the deposit of new layers of material like its own on the surface of the cell (as a crystal might increase in an evaporating solution of the same salt) but in an entirely different way. The cell takes up chemical elements, either free or combined in a manner different from that in which they exist in its own living substance, and works chemical changes in them by which they are made into part and parcel of itself. Moreover, the new material thus formed is not deposited, at any rate necessarily or always, on the surface of the old, but is laid down in the substance of the already existing cell among its constituent molecules. The new-formed molecules therefore contribute to the growth of the cell not by superficial *accretion*, but by interstitial deposit or *intussusception*.

**Cell Division.** The increase of size, which may be brought about in the above manner, is not indefinite, but is limited in two ways. Alongside of the formation and deposit of new material there occurs always in the living cell a breaking down and elimination of the old; and when this process equals the accumulation of new material, as it does in all the cells of the Body when they attain a certain size, *growth* of course ceases. In fact the work of the cell increases as its *mass*, and therefore as the cube of its diame-

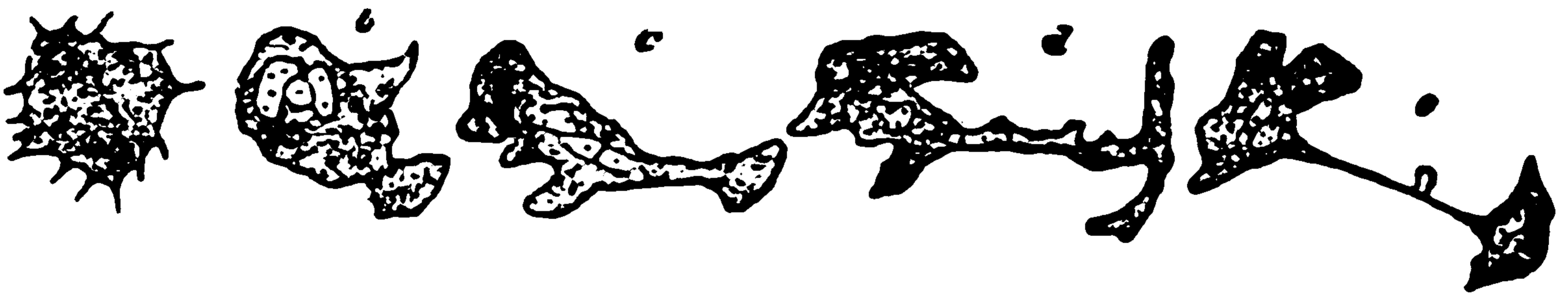

FIG. 6.—A white blood corpuscle dividing, as observed at successive intervals of a few seconds with the microscope.

ter; while the receptive powers, dependent primarily upon the superficial area, only increase as the square of the diameter. The breaking down in the cell increases when its



**DIESE SEITE IST FÜR KOSTENLOSE MITGLIEDER GESPERRT**  
Beantragen Sie jetzt die volle Mitgliedschaft, um diese Seite zu betreten

# GESCHICHTE

Zehntausende von wichtigen historischen Quellen, viele bisher nicht erhältlich, stehen jetzt zum ersten Mal mit der Vollmitgliedschaft von Forgotten Books zur Verfügung.

Unbegrenzter Zugang  
\$8.99/monat

**Fortfahren**

\*Es gelten Richtlinien zur fairen Nutzung.



pounds into simpler ones, sometimes called *disassimilation*, is as invariable in living beings as the building up of new **complex molecules** referred to above. It is associated with the assumption of uncombined oxygen from the exterior, which is then combined directly or indirectly with other elements in the cell, as for example carbon, giving rise to carbon dioxide, or hydrogen producing water. In this way the molecule in which the carbon and hydrogen previously existed is broken down, and at the same time energy is liberated, which in all cases seems to take in part the form of heat just as when coal is burnt in a fire, but may be used in part for other purposes such as producing movements. The carbon dioxide is usually got rid of by the same mechanism as that which serves to take up the oxygen, and these two processes constitute the function of *respiration* which occurs in all living things. Assimilation and disassimilation, going on side by side and being to a certain extent correlative, are often spoken of together as the process of *nutrition*, a term which therefore includes all the chemical transformations occurring in living matter.

**Contractility.** Nutrition and (with the above-mentioned partial exception) reproduction characterize all living creatures; and both faculties are possessed by the simple nucleated cells already referred to as found in our blood. But these cells possess also certain other properties which, although not so absolutely diagnostic, are yet very characteristic of living things.

Examined carefully with a microscope in a fresh-drawn drop of blood, they exhibit changes of form independent of any pressure which might distort them or otherwise mechanically alter their shape. These changes may sometimes show themselves as constrictions ultimately leading to the division of the cell; but more commonly (Fig. 12\*) they have no such result, the cell simply altering its form by drawing in its substance at one point and thrusting it out at another. The portion thus protruded may in turn be drawn in and a process be thrown out elsewhere; or the rest of the cell may collect around it, and a fresh protru-

---

\* P. 48.

sion be then made in the same side; and by repeating this manœuvre these cells may change their place and creep across the field of the microscope. Such changes of form from their close resemblance to those exhibited by the microscopic animal known as the *Amœba* (see Zoology) are called *amœboid*, and the faculty in the living cell upon which they depend is known in physiology as *contractility*. It must be borne in mind that physiological contractility in this sense is quite different from the so-called contractility of a stretched indian-rubber band, which merely tends to re-assume a form from which it has previously been forcibly removed.

**Irritability.** Another property exhibited by these blood-cells is known as *irritability*. An *Amœba* coming into contact with a solid particle calculated to serve it as food will throw around it processes of its substance, and gradually carry the foreign mass into its own body. The amount of energy expended by the animal under these circumstances is altogether disproportionate to the force of the external contact. It is not that the swallowed mass pushes in mechanically the surface of the *Amœba*, or burrows into it, but the mere touch arouses in the animal an activity quite disproportionate to the exciting force, and comparable to that set free by a spark falling into gunpowder or by a slight tap on a piece of gun-cotton. It is this disproportion between the excitant (known in Physiology as a *stimulus*) and the result, which is the essential characteristic of *irritability* when the term is used in a physiological connection. The granular cells of the blood can take foreign matters into themselves in exactly the same manner as an *Amœba* does; and in this and in other ways, as by contracting into rigid spheres under the influence of electrical shocks, they show that they also are endowed with irritability.

**Conductivity.** Further, when an *Amœba* or one of these blood-cells comes into contact with a foreign body and proceeds to draw it into its own substance, the activity excited is not merely displayed by the parts actually touched. Distant parts of the cell also co-operate, so that the influ-

ence of the stimulus is not local only, but in consequence of it a change is brought about in other parts, arousing them. This property of transmitting disturbances is known as *conductivity*.

Finally, the movements excited are not, as a rule, random. They are not irregular convulsions, but are adapted to attain a certain end, being so combined as to bring the external particle into the interior of the cell. This capacity of all the parts to work together in definite strength and sequence, to fulfil some purpose, is known as *co-ordination*.

**These Properties Characteristic but not Diagnostic.** These four faculties, irritability, conductivity, contractility, and co-ordination, are possessed in a high degree by our Bodies as a whole. If the inside of the nose be tickled with a feather, a sneeze will be produced. Here the feather-touch (*stimulus*) has called forth movements which are mechanically altogether disproportionate to the energy of the contact, so that the living body is clearly *irritable*. The movements, which are themselves a manifestation of *contractility*, are not exhibited at the point touched, but at more or less distant parts, among which those of abdomen, chest, and face are visible from the exterior; our Bodies therefore possess *physiological conductivity*. And finally these movements are not random, but combined so as to produce a violent current of air through the nose tending to remove the irritating object; and in this we have a manifestation of *co-ordination*. Speaking broadly, these properties are more manifest in animals than in plants, though they are by no means absolutely confined to the former. In the sensitive plant touching one leaflet will excite regular movements of the whole leaf, and many of the lower aquatic plants exhibit movements as active as those of animals. On the other hand, no one of these four faculties is absolutely distinctive of living things in the way that *growth by intussusception* and *reproduction* are. Irritability is but a name for unstable molecular equilibrium, and is as marked in nitroglycerine as in any living cells; in the telephone the influence of the voice is conducted as a

molecular change along a wire, and produces results at a distance; and many inanimate machines afford examples of the co-ordination of movements for the attainment of definite ends.

**Spontaneity.** There is, however, one character belonging to many of the movements exhibited by amœboid cells, in which they appear at first sight to differ fundamentally from the movements of inanimate objects. This character is their apparent *spontaneity* or *automaticity*. The cells frequently change their form independently of any recognizable external cause, while a dead mass at rest and unacted on from outside remains at rest. This difference is, however, only apparent and depends not upon any faculty of spontaneous action peculiar to the living cell, but upon its nutritive powers. It can be proved that any system of material particles in equilibrium and at rest will forever remain so if not acted upon by an external force. Such a system can carry on, under certain conditions, a series of changes when once a start has been given; but it cannot initiate them itself. Each living cell in the long-run is but a complex aggregate of molecules, composed in their turn of chemical elements, and if we suppose this whole set of atoms at rest in equilibrium at any moment, no change can be started in the cell from inside; in other words, it will possess no real spontaneity. When, however, we consider the irritability of amœboid cells, or, expressed in mechanical terms, the unstable equilibrium of their particles, it becomes obvious that a very slight external cause, such as may entirely elude our observation, may serve to set going in them a very marked series of changes, just as pulling the trigger will fire off a gun. Once the equilibrium of the cell has been disturbed, movements either of some of its constituent molecules or of its whole mass will continue until all the molecules have again settled down into a stable state. But in living cells the reattainment of this state is commonly indefinitely postponed by the reception of new particles, food in one form or another, from the exterior. The nearest approach to it is probably exhibited by the resting state into which some of the lower animals, as the wheel

animalcules, pass when dried slowly at a low temperature; the drying acting by checking the nutritive processes, which would otherwise have prevented the reattainment of molecular equilibrium. All signs of movement or other change disappear under these circumstances, but as soon as water again soaks into their substance and disturbs the existing condition, then the so-called "spontaneous" movements recommence. If, therefore, we use the term spontaneity to express a power in a resting system of particles of initiating changes in itself, it is possessed neither by living nor not-living things. But if we simply employ it to designate changes whose primary cause we do not recognize, and which cause was in many cases long antecedent to the changes which we see, then the term is unobjectionable and convenient, as it serves to express briefly a phenomenon presented by many living things and finding its highest manifestation in many human actions. It then, however, no longer designates a property peculiar to them. A steam-engine with its furnace lighted and water in its boiler may be set in motion by opening a valve, and the movements thus started will continue spontaneously, in the above sense, until the coals or water are used up. The difference between it and the living cell lies not in any spontaneity of the latter, but in its nutritive powers, which enable it to replace continually what answers to the coals and water of the engine.

**Protoplasm.** Finding all these properties possessed by a simple nucleated cell, we are naturally led to inquire upon what part of it do they depend? It is clear that if they are exhibited in the absence of any one it cannot be essential to their manifestation. Now a study of the lower forms of life shows us that these powers are independent of the cell nucleus, since we find them all exhibited by cells in which the nucleus is wanting. Moreover, in many cases not only the nucleus but all granules are absent, and yet we find the remaining mass nutritive, reproductive, irritable, contractile, conductive, co-ordinative, and automatic. We are thus driven to conclude that in the case of the granular blood-cells, these faculties are most probably endowments

of the transparent portions of the cell body, in which the granules lie imbedded. This, the really working part of the cell, is known as the cell *protoplasm*. The rôle of the nucleus and granules so often present is not yet well understood; possibly the granules in many cases represent incompletely assimilated food.

What the actual chemical constitution of protoplasm is we do not know, but it is one of great complexity. All methods of chemical analysis destroy it, and what we analyze is not protoplasm, which is always alive—which is a form of matter endowed with those properties which we call vital—but a mixture of the products of its decomposition when it ceases to live. Such a mixture is often called dead protoplasm, but the phrase is objectionable as implying a contradiction. Wherever there is protoplasm there is life, and wherever we meet with life we find protoplasm, so that it has been called the “physical basis of life.” The name protoplasm, too, is rather to be regarded as a general term for a number of closely allied substances agreeing with one another chemically in main points, as the proteids do, but differing in minor details, in consequence of which one cell differs slightly from another in faculty. On proximate analysis every mass of protoplasm is found to contain much water and a certain amount of mineral salts; the water being in part *constituent* or entering into the structure of the molecules of protoplasm, and in part probably deposited in layers between them. Of organic constituents protoplasm always yields one or more proteids, some fats, and some starchy or saccharine body. So that the original protoplasm is probably to be regarded as containing chemical “residues” of proteids, fats, and carbohydrates, combined with salts and water.

**The Fundamental Physiological Properties.** All living



## CHAPTER III.

### THE DIFFERENTIATION OF THE TISSUES AND THE PHYSIOLOGICAL DIVISION OF EMPLOYMENTS.

**Development.** Every human Body commences its individual existence as a single nucleated cell. This cell, known as the *ovum*, divides or *segments* and gives rise to

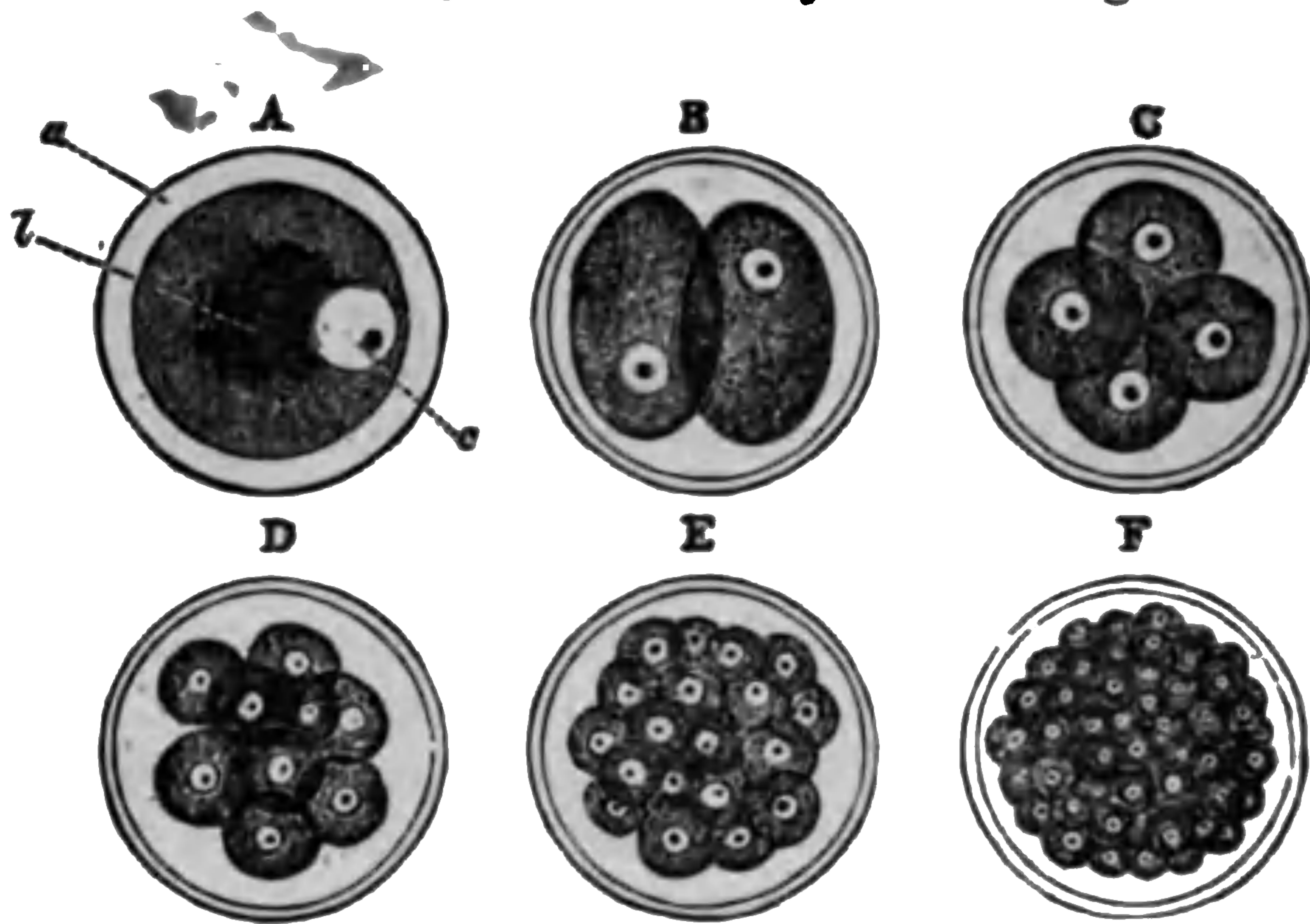

FIG. 8.—A, an ovum; B to E, successive stages in its segmentation until the morula, F, is produced. „

a mass consisting of a number of similar units and called the *mulberry mass* or the *morula*. At this period then, long before birth, there are no distinguishable tissues entering into the structure of the Body, nor are any organs recognizable.

For a short time the morula increases in size by the growth and division of its cells, but very soon new processes occur which ultimately give rise to the complex



**DIESE SEITE IST FÜR KOSTENLOSE MITGLIEDER GESPERRT**  
Beantragen Sie jetzt die volle Mitgliedschaft, um diese Seite zu betreten



**Seien Sie niemals ohne ein Buch!**

Die Vollmitgliedschaft von Forgotten Books bietet Ihnen einen universalen Zugang von unseren Apps und unserer Website, auf all Ihren Geräten: Tablet, Telefon, E-Reader, Laptop und Computer.

**Eine Bibliothek in Ihrer Tasche für € 8.99/monat**

**Fortfahren**

\*Es gelten Richtlinien zur fairen Nutzung.

any, provide his own shelter, and defend himself from wild beasts or his fellow-men. In the civilized country, on the other hand, we find agriculturists to raise food and cooks to prepare it, tailors to make clothes, and policemen and soldiers to provide protection. And just as we find that when distribution of employments in it is more minute the more advanced a nation is in civilization, so is an animal higher or lower in the scale according to the degree in which it exhibits a division of physiological duties between its different tissues.

From the subdivision of labor in advanced communities several important consequences arise. In the first place, each man devoting himself to one kind of work mainly and relying upon others for the supply of his other needs, every sort of work gets better done. The man who is constantly making boots becomes more expert than one whose attention is constantly distracted by other duties, and he will not only make more boots in a given time, but better ones; and so with the performance of all other kinds of work. In the second place, a necessity arises for a new sort of industry, in order to convey the produce of one individual in excess of the needs of himself and his family to those at a distance who may want it, and to convey back in return the excess of their produce which he needs. The carriage of food from the country to cities, and of city produce to country districts, and the occupation of shopkeeping, are instances of these new kinds of labor which arise in civilized communities. In addition there is developed a need for arrangements by which the work of individuals shall be regulated in proportion to the wants of the whole community, such as is in part effected by the agency of large employers of labor who regulate the activities of a number of individuals for the production of various articles in the different quantities required at different times.

Exactly similar phenomena result from the subdivision of labor in the human Body. By the distribution of employments between its different tissues, each one specially doing one work for the general community and relying on

the others for their aid in turn, each necessary work is better performed. And a need arises for a distributive mechanism by which the excess products, if any, of various tissues shall be carried to others which require them, and for a regulative mechanism by which the activities of the various tissues shall be rendered proportionate to the needs of the whole Body at different times and under different circumstances. Accordingly, as we may classify the inhabitants of the United States into lawyers, doctors, clergymen, merchants, farmers, and so on, we may

**Classify the Tissues**, by selecting the most distinctive properties of each of those entering into the construction of the adult Body and arranging them into physiological groups; those of each group being characterized by some one prominent employment. No such classification, however, can be more than approximately accurate, since the same tissue has often more than one well-marked physiological property. The following arrangement, however, is practically convenient.

**1. Undifferentiated Tissues.** These are composed of cells which have developed along no one special line, but retain very much the form and properties of the cells forming the very young Body before different tissues were recognizable in it. The lymph corpuscles and the colorless corpuscles of the blood belong to this class.

**2. Supporting Tissues.** Including *cartilage* (gristle), *bone*, and *connective tissue*. Of the latter there are several subsidiary varieties, the two more important being *white fibrous connective tissue*, composed mainly of colorless inextensible fibres, and *yellow fibrous tissue*, composed mainly of yellow elastic fibres. All the supporting tissues are used in the Body for mechanical purposes: the bones and cartilages form the hard framework by which softer tissues are supported and protected; and the connective tissues unite the various bones and cartilages, form investing membranes around different organs, and in the form of fine networks penetrate their substance and support their constituent cells. The functions of these tissues being for the most part to passively resist strain or pressure, none of

them has any very marked physiological property; they are not, for example, irritable or contractile, and their mass is chiefly made up of an intercellular substance which has been formed by the active living cells sparsely scattered through them, as for instance in cartilage, Fig. 42,\* where the cells are seen imbedded in cavities in a matrix which they have formed around them; and which matrix by its firmness and elasticity forms the functionally important part of the tissue.

**3. Nutritive Tissues.** This is a large group, the members of which fall into three main divisions, viz.:

*Assimilative tissues*, concerned in receiving and preparing food materials, and including—(a) *Secretory tissues*, composed of cells which make the digestive liquids poured into alimentary canal, and bringing about chemical or other changes in the food. (b) *Receptive tissues*, represented by cells which line parts of the alimentary canal and take up the digested food.

*Eliminative or excretory tissues*, represented by cells in the kidneys, skin, and elsewhere, whose main business it is to get rid of the waste products of the various parts of the Body.

*Respiratory tissues.* These are concerned in the gaseous interchanges between the Body and the surrounding air. They are constituted by the cells lining the lungs and by the colored corpuscles of the blood.

As regards the nutritive tissues it requires especially to be borne in mind that although such a classification as is here given is useful, as helping to show the method pursued in the domestic economy of the Body, it is only imperfect and largely artificial. Every cell of the Body is in itself assimilative, respiratory, and excretory, and the tissues in this class are only those concerned in the first and last interchanges of material between it and the external world. They provide or get rid of substances for the whole Body, leaving the feeding and breathing and excretion of its individual tissues to be ultimately looked after by themselves, just as even the mandarin described by Robinson Crusoe who found his dignity promoted by having

---

\* P. 101.

servants to put the food into his mouth, had finally to swallow and digest it for himself. Moreover, there is no logical distinction between a secretory and an excretory cell: each of them is characterized by the formation of certain substances which are poured out on a free surface on the exterior or interior of the Body. Many secretory cells too have no concern with the digestion of food, as for example those which form the tears and sweat.

**4. Storage Tissuee.** The Body does not live from hand to mouth: it has always in health a supply of food materials accumulated in it beyond its immediate needs. This lies in part in the individual cells themselves, just as in a prosperous community nearly every one will have some little pocket-money. But apart from this reserve there are certain cells, a sort of capitalists, which store up considerable quantities of material and constitute what we will call the *storage tissues*. These are especially represented by the liver-cells and fat-cells, which contain in health a reserve fund for the rest of the Body. Since both of these, together with secretory and excretory cells, are the seats of great chemical activity, they are all often called *metabolic tissues*.

**5. Irritable Tissues.** The maintenance, or at any rate the best prosperity, of a nation is not fully secured when a division of labor has taken place in food-supply and food-distribution employments. It is extremely desirable that means shall be provided by which it may receive information of external changes which may affect it as a whole, such as the policy of foreign countries; or which shall en-

whose business it is to ascertain and communicate to the whole, external changes which occur around it. Since the usefulness of these tissues depends upon the readiness with which slight causes excite them to activity, we may call them the *irritable tissues*.

6. **Co-ordinating and Automatic Tissues.** Such information as that collected by ministers in foreign parts or by meteorological observers, is usually sent direct to some central office from which it is redistributed; this mere redistribution is, however, in many cases but a small part of the work carried on in such offices. Let us suppose information to be obtained that an Indian chief is collecting his men for an attack on some point. The news is probably first transmitted to Washington, and it becomes the duty of the executive officers there to employ certain of the constituent units of the society in such definite work as is needed for its protection. Troops have to be sent to the place threatened; perhaps recruits enlisted; food and clothes, weapons and ammunition must be provided for the army; and so on. In other words, the work of the various classes composing the society has to be organized for the common good; the mere spreading the news of the danger would alone be of little avail. So in the Body: the information forwarded to certain centres from the irritable tissues is used in such a way as to arouse to orderly activity other tissues whose services are required; we find thus in these centres a group of *co-ordinating tissues*, represented by *nerve-cells* and possibly by certain other constituents of the nerve centres. Certain nerve-cells are also *automatic* in the physiological sense already pointed out. The highest manifestation of this latter faculty, shown objectively by muscular movements, is subjectively known as the "will," a state of consciousness; and other mental phenomena, as sensations and emotions, are also associated with the activity of nerve-cells lying in the brain. How it is that any one state of a material cell should give rise to a particular state of consciousness is a matter quite beyond our powers of conception; but not really more so than how it is that every portion of matter attracts every other por-

tion according to the law of inverse squares. In the living Body, as elsewhere in the universe, we can study phenomena and make out their relations of sequence or co-existence; but why one phenomenon is accompanied by another, why in fact any cause produces an effect, is a matter quite beyond our reach in every case; whether it be a sensation accompanying a molecular change in a nerve-cell, or the fall of a stone to the ground in obedience to the law of gravitation.

**7. Motor Tissues.** These have the contractility of the original protoplasmic masses highly developed. The more important are *ciliated cells* and *muscular tissue*. The former line certain surfaces of the body, and possess on their free surfaces fine threads which are in constant movement. One finds such cells, for example (Fig. 47\*) lining the inside of the windpipe, where their threads or *cilia* serve, by their motion, to sweep any fluid formed there towards the throat, where it can be coughed up and got rid of. Muscular tissue occurs in two main varieties. One kind is found in the muscles attached to the bones, and which are used in the ordinary voluntary movements of the body. It is composed of fibres which present cross-stripes when viewed under the microscope (Fig. 53†), and is hence known as *striped* or *striated muscular tissue*. The other kind of muscular tissue is found in the walls of the alimentary canal and some other hollow organs, and consists of elongated cells (Fig. 55‡) which present no cross striation. It is known as *plain* or *unstriated muscular tissue*.

The cells enumerated under the heading of "undifferentiated tissues" might also be included among the motor tissues, since they are capable of changing their form.

**8. The Conductive Tissues.** These are represented by the *nerve fibres*, slender threads formed by modification and fusion of cells, and having the conductivity of the amœboid cells of the morula highly developed; that is to say, they readily transmit molecular disturbances. When its equilibrium is upset at one end, a nerve-fibre will transmit to its other a molecular movement known as a

---

\* P. 115.

† P. 128.

‡ P. 124.



“*nervous impulse*,” and so can excite in turn parts distant from the original exciting force. Nerve-fibres place, on the one hand, the irritable tissues in connection with the automatic, co-ordinating, and sensory; and on the other put the three latter in communication with the muscular, secretory, and other tissues.

**9. Protective Tissues.** These consist of certain cells lining cavities inside the body and called *epithelial cells*, and cells covering the whole exterior of the Body and forming *epidermis*, *hairs*, and *nails*. The *enamel* which covers the teeth belongs also to this group.

The class of protective tissues is, however, even more artificial than that of the nutritive tissues, and cannot be defined by positive characters. Many epithelial cells are secretory, excretory, or receptive; and ciliated cells have already been included among the motor tissues, although from the fact that the movements of their cilia go on in separated cells and independently of recognizable external stimuli, they might well have been put among the automatic. The protective tissues may be best defined as including cells which line free surfaces, and whose functions are mainly mechanical or physical.

**10. The Reproductive Tissues.** These are concerned in the production of new individuals, and in the human Body are of two kinds, located in different sexes. The conjunction of the products of each sex is necessary for the origination of offspring, since the ovum, or female product which directly develops into the new human being, lies dormant until it has been *fertilized* or acted upon by the product of the male.

**The Combination of Tissues to Form Organs.** The various tissues above enumerated forming the building materials of the Body, anatomy is primarily concerned with their structure, and physiology with their properties. If this, however, were the whole matter, the problems of anatomy and physiology would be much simpler than they actually are. The knowledge about the living Body obtained by studying only the forms and functions



**DIESE SEITE IST FÜR KOSTENLOSE MITGLIEDER GESPERRT**

Beantragen Sie jetzt die volle Mitgliedschaft, um diese Seite zu betreten

# GESCHICHTE

Zehntausende von wichtigen historischen Quellen, viele bisher nicht erhältlich, stehen jetzt zum ersten Mal mit der Vollmitgliedschaft von Forgotten Books zur Verfügung.

Unbegrenzter Zugang  
\$8.99/monat

**Fortfahren**

\*Es gelten Richtlinien zur fairen Nutzung.



to take into account the arrangement of all these parts within it, and also its connections with other organs of the Body. The physiology of any muscle must take into account the actions of all these parts working together and not merely the functions of the muscular fibres themselves, and has also to make out under what conditions the muscle is excited to activity by changes in other organs, and what changes in these it brings about when it works.

**Physiological Mechanisms.** Even the study of organs added to that of the separate tissues does not exhaust the whole matter. In a factory we frequently find machines arranged so that two or more shall work together for the performance of some one work: a steam-engine and a loom may, for example, be connected and used together to weave carpets. Similarly in the Body several organs are often arranged to work together so as to attain some one end by their united actions. Such combinations are known as *physiological apparatuses*. The circulatory apparatus, for example, consists of various organs (each in turn composed of several tissues) known as heart, arteries, capillaries, and veins. The *heart* forms a force-pump by which the blood is kept flowing through the whole mechanism, and the rest, known together as the *blood-vessels*, distribute the blood to the various organs and regulate the supply according to their needs. Again, in the visual apparatus we find the co-operation of (*a*) a set of optical instruments which bring the light proceeding from external objects to a focus upon (*b*) the *retina*, which contains highly irritable parts; these, changed by the light, stimulate (*c*) the *optic nerve*, which is conductive and transmits a disturbance which arouses finally (*d*) sensory parts in the *brain*. In the production of ordinary sight sensations all these parts are concerned and work together as a visual apparatus. So, too, we find a *respiratory apparatus*, consisting primarily of two hollow organs, the *lungs*, which lie in the chest and communicate by the *windpipe* with the back of the throat, from which air enters them. But to complete the respiratory apparatus are many other organs, bones, muscles, nerves, and nerve-centres, which work together to renew

whole collection of bodily organs agreeing in structure with one another is often spoken of as a system; all the muscles, for example, are grouped together as the *muscular system*, and all the bones as the *osseous system*, and so on, without any reference to the different uses of different muscles or bones. The term system is, however, often used as equivalent to "apparatus:" one reads indifferently of the "circulatory system" or the "circulatory apparatus." It is better, however, to reserve the term system for a collection of organs classed together on account of similarity of structure; and "apparatus" for a collection of organs considered together on account of their co-operation to execute one function. The former term will then have an anatomical, the latter a physiological, significance.

**The Body as a Working Whole.** Finally it must all through be borne in mind that not even the most complex system or apparatus can be considered altogether alone as an independently living part. All are united to make one living Body, in which there is throughout a mutual interdependence, so that the whole forms one human being, in whom the circulatory, respiratory, digestive, sensory, and other apparatuses are constantly influencing one another, each modifying the activities of the rest. This interaction is mainly brought about through the conductive and co-ordinating tissues of the nervous system, which place all parts of the Body in communication. But in addition to this another bond of union is formed by the blood, which by the circulatory apparatus is carried from tissue to tissue and organ to organ, and so, bringing materials derived in one region to distant parts, enables each organ to influence all the rest for good or ill.

Besides the blood another liquid, called *lymph*, exists in the Body. It is contained in vessels distinct from those which carry the blood, but emptying into the blood-vessels at certain points. This liquid being also in constant movement forms another agency by which products are carried from part to part, and the welfare or ill-fare of one member enabled to influence all.

# CHAPTER IV.

## THE INTERNAL MEDIUM.

**The External Medium.** During the whole of life interchanges of material go on between every living being and the external world; by these exchanges material particles that one time constitute parts of inanimate objects come at another to form part of a living being; and later on these same atoms, after having been a part of a living cell, are passed out from the Body in the form of lifeless compounds. As the foods and wastes of various living things differ more or less, so are more or less different environments suited for their existence; and there is accordingly a relationship between the plants and animals living in any one place and the conditions of air, earth, and water prevailing there. Even such simple unicellular animals as the amœba live only in water or mud containing in solution certain gases and, in suspension, solid food particles; and they soon die if the water be changed either by essentially altering its gases or by taking out of it the solid food. So in yeast we find a unicellular plant which thrives and multiplies only in liquids of certain composition, and which in the absence of organic compounds of carbon in solution will not grow at all. Each of these simple living things, which corresponds to one only of the innumerable cells composing the full-grown human Body, thus requires for the manifestation of its vital properties the presence of a surrounding medium suited to itself: the yeast would die, or at the best lie dormant, in a liquid containing only the solid organic particles on which the amœba lives; and the amœba would die in such solutions as those in which yeast thrives best.

**The Internal Medium.** The same close relationship between the living being and its environment, and the same cyclical interchange between the two which we find in the amœba and the yeast-cell, occur also in even the most complex living beings. When, however, an animal comes to be composed of many cells, some of which are placed far away from the surface of its body and so from immediate contact with the environment, there arises a new need—a necessity for an internal medium or *plasma* which shall play the same part toward the individual cells as the surrounding air, water, and food to the whole animal. This internal medium kept in movement, and receiving at some regions of the bodily surfaces materials from the exterior, while losing other substances to the exterior at other surfaces, thus forms a sort of middleman between the individual tissues and the surrounding world, and stands in the same relationship to each of the cells of the Body as the water in which an amœba lives does to that animal or beer-wort does to a yeast-cell. We find accordingly the human Body pervaded by a liquid plasma, containing gases and food material in solution, and the presence of which is necessary for the maintenance of the life of the tissues. Any great change in this medium will affect injuriously few or many of the groups of cells in the Body, or may even cause their death; just as altering the media in which they live will kill an amœba or a yeast-cell.

**The Blood.** In the human Body the internal medium is primarily furnished by the *blood*, which, as every one knows, is a red liquid, very widely distributed over the frame, since it flows from any part when the skin is cut through. There are in fact very few portions of the Body into which the blood is not carried. One of the exceptions is the epidermis, or outer layer of the skin: if a cut be made through it only, leaving the deeper skin-layers intact, no blood will flow from the wound. Hairs and nails also contain no blood. In the interior of the Body the epithelial cells lining free surfaces, such as the inside of the alimentary canal, contain no blood, nor do the hard parts of the teeth, the cartilages, and the refracting media

of the eye (see Chap. XXXI.), but these interior parts are moistened with liquid of some kind, and unlike the epidermis are protected from rapid evaporation. All these bloodless parts together form a group of *non-vascular tissues*; they alone excepted, wounding any part of the Body will be followed by bleeding.

In many of the lower animals there is no need that the liquid representing their blood should be renewed very rapidly in different parts. Their cells live slowly, and so require but little food and produce but little waste. In a sea anemone, for example, there is no special arrangement to keep the blood moving; it is just pushed about from part to part by the general movements of the body of the animal. But in higher animals, especially those with an elevated temperature, such an arrangement, or rather absence of arrangement, as this would not suffice. In them the constituent cells live very fast, making much waste and using much food, and so alter the blood in their neighborhood very rapidly. Besides, we have seen that in complex animals certain cells are set apart to get food for the whole organism, and certain others to finally remove its wastes, and there must be a sure and rapid interchange of material between the feeding and excreting tissues and all the others. This can only be brought about by a rapid movement of the blood in a definite course, and this is accomplished by shutting it up in a closed set of tubes, and placing somewhere a pump, which constantly takes in blood from one end of the system of tubes and forces it out again into the other. Sent by this pump, the *heart*, through all parts of the Body and back to the heart again, the blood gets food from the receptive cells, takes it to the working cells, carries off the waste of these latter to the excreting cells; and so the round goes on.

**The Lymph.** The blood, however, lies everywhere in closed tubes formed by the vascular system, and does not come into direct contact with any cells of the Body except those which float in it and those which line the interior of the blood-vessels. At one part of its course, however, the vessels through which it passes have extremely thin



coats, and through the walls of these *capillaries* liquid transudes from the blood and bathes the various tissues. The transuded liquid is the *lymph*, and it is this which forms the immediate nutrient plasma of the tissues except the few which the blood moistens directly.

**Dialysis.** When two liquids containing different matters in solution are separated from one another by a moist animal membrane, an interchange of material will take

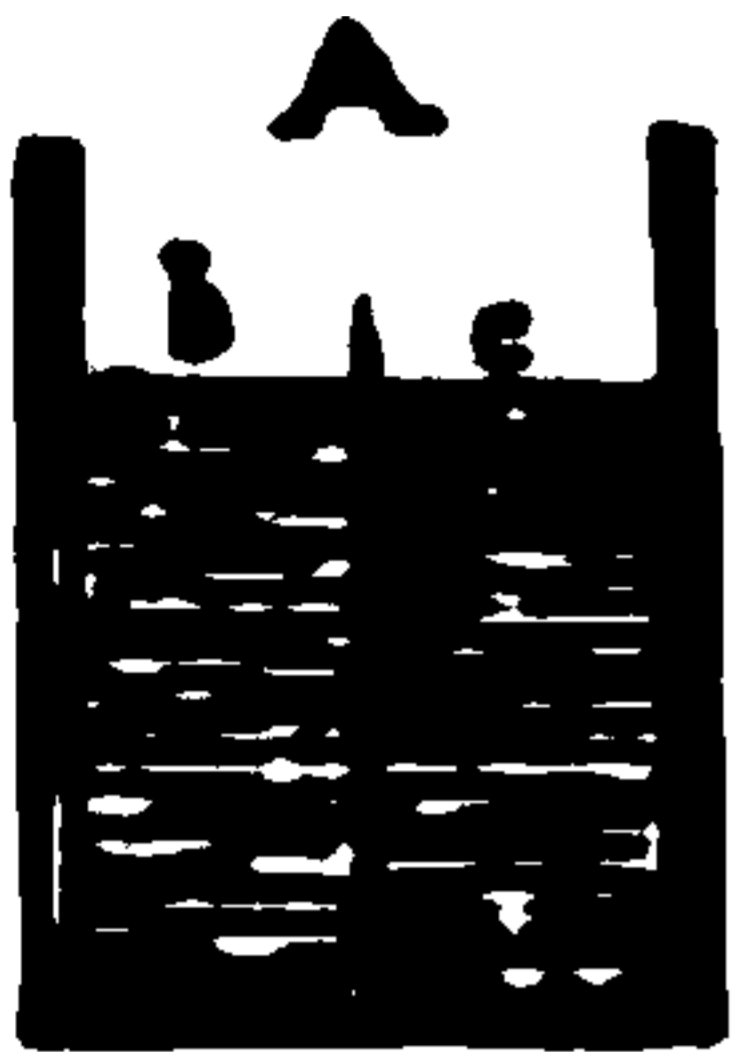

FIG 9.—A diagram of a dialysing apparatus, containing two liquids, *b* and *c*, separated by a moist animal membrane.

place under certain conditions. If *A* be a vessel (Fig. 9) completely divided vertically by such a membrane, and a solution of common salt in water be placed on the side *b*, and a solution of sugar in water on the side *c*, it will be found after a time that some salt has got into *c* and some sugar into *b*, although there are no visible pores in the partition. Such an interchange is said to be due to *dialysis* or *osmosis*, and if the process were

allowed to go on for some hours the same proportions of salt and sugar would be found in the solutions on each side of the dividing membrane.

**The Renewal of the Lymph.** Osmotic processes play a great part in the nutritive processes of the Body. The lymph present in any organ gives up things to the cells there and gets things from them; and so, although it may have originally been tolerably like the liquid part of the blood, it soon acquires a different chemical composition. Diffusion or dialysis then commences between the lymph outside and the blood inside the capillaries, and the latter gives up to the lymph new materials in place of those which it has lost and takes from it the waste products it has received from the tissues. When this blood thus altered by exchanges with the lymph gets again to the neighborhood of the receptive cells, having lost some food materials it is poorer in these than the richly supplied lymph around those cells, and takes up a supply by dialysis from it. When it reaches the excretory organs it has previously picked up a quantity of waste matters and loses these by dialysis to the lymph there present, which is specially poor in such matters,



**DIESE SEITE IST FÜR KOSTENLOSE MITGLIEDER GESPERRT**  
Beantragen Sie jetzt die volle Mitgliedschaft, um diese Seite zu betreten



**Seien Sie niemals ohne ein Buch!**

Die Vollmitgliedschaft von Forgotten Books bietet Ihnen einen universalen Zugang von unseren Apps und unserer Website, auf all Ihren Geräten: Tablet, Telefon, E-Reader, Laptop und Computer.

**Eine Bibliothek in Ihrer Tasche für €8.99/monat**

**Fortfahren**

\*Es gelten Richtlinien zur fairen Nutzung.

and which, besides containing a store of new food matters for the lymph, carries off the wastes which the various cells have poured into the latter, and thus is also a sort of sewage stream into which the wastes of the whole Body are primarily collected.

**Microscopic Characters of Blood.** If a finger be pricked, and the drop of blood flowing out be received on a glass slide, covered, protected from evaporation, and examined with a microscope magnifying about 400 diameters, it will be seen to consist of innumerable solid bodies floating in a liquid. The solid bodies are the *blood corpuscles*, and the liquid is the *blood plasma* or *liquor sanguinis*.

The corpuscles are not all alike. While currents still exist in the freshly spread drop of blood, the great majority of them are readily carried to and fro; but a certain number more commonly stick to the glass and remain in one place. The former are the *red*, the latter the *pale* or *colorless blood corpuscles*.

**Red Corpuscles. Form and Size.** The red corpuscles as they float about frequently seem to vary in form, but by a little attention it can be made out that this appearance is due to their turning round as they float, and so presenting different aspects to view; just as a silver dollar presents a different outline according as it is looked at from the front or edgewise or in three-quarter profile.

Sometimes the corpuscle (Fig. 10, *B*) appears circular; then it is seen in full face; sometimes linear (*C*), and slightly narrowed in the middle; sometimes oval, as the dollar when half-way between a full and a side view. These appearances show that each red corpuscle is a circular disk, slightly hollowed in the middle (or biconcave) and about four times as wide as it is thick. The average transverse diameter is 0.008 millimeter ( $\frac{1}{12500}$  inch).—*Color.* Seen singly each red corpuscle is of a pale yellow color; it is only when collected in masses that they appear red. The blood owes its red color to the great numbers of these bodies in it; if it be spread out in a very thin layer it, too, is yellow. The layer must, however, be very thin or the drop will still look red on account of the immense number

of these corpuscles present; in a cubic millimeter ( $\frac{1}{27}$  inch) of blood there are about five millions of them.—*Structure.* Seen from the front the central part of each red corpuscle in a certain focus of the microscope appears dimmer or darker than the rest (Fig. 10, *B*), except a narrow band near the outer rim. If the lens of the microscope be raised, however, this previously dimmer central part becomes brighter, and the previously brighter part obscure (*E*).

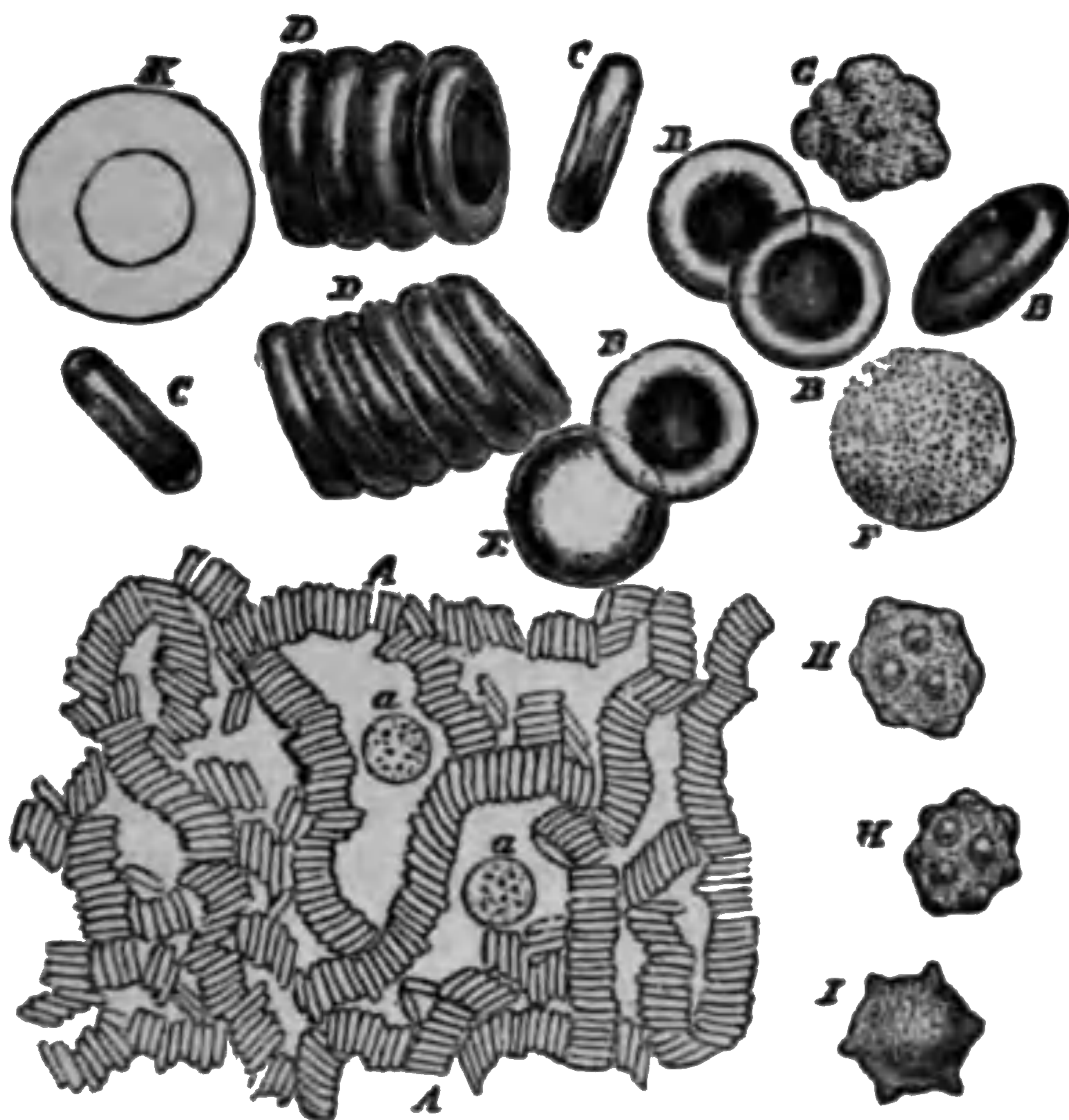

FIG. 10.—Blood corpuscles. *A*, magnified about 400 diameters. The red corpuscles have arranged themselves in rouleaux; *a, a*, colorless corpuscles; *B*, red corpuscles more magnified and seen in focus; *E*, a red corpuscle slightly out of focus. At the right-hand top corner is a red corpuscle seen in three-quarter face, and at *C* one seen edgewise. *F, G, H, I*, white corpuscles highly magnified.

This difference in appearance does not indicate the presence of a central part or *nucleus* different from the rest, but is an optical phenomenon due to the shape of the corpuscle, in consequence of which it acts like a little biconcave lens (see Physics). Rays of light passing through near the centre of the corpuscle are refracted differently from those passing through elsewhere; and when the microscope is so focused that the latter reach the eye, the former do not,

and *vice versa*; thus when the central parts look bright, those around them look obscure, and the contrary.

There is no satisfactory evidence that these corpuscles have any enveloping sac or cell-wall. All the methods used to bring one into view under the microscope are such as would coagulate the outer layers of the substance composing the corpuscle and so make an artificial envelope. So far as optical analysis goes, then, each corpuscle is homogeneous throughout. By other means we can, however, show that at least two materials enter into the structure of each red corpuscle. If the blood be diluted with several times its own bulk of water and be then examined with the microscope, it will be found that the red corpuscles are colorless and the plasma colored. The dilution has caused the coloring matter to pass out of the corpuscles and dissolve in the liquid. This coloring constituent of the corpuscle is *hæmoglobin*, and the colorless residue which it leaves behind and which swells up into a sphere in the diluted plasma is the *stroma*. In the living corpuscle the two are intimately mingled throughout it, and so long as this is the case the blood is opaque; but when the coloring matter dissolves in the plasma, then the blood becomes transparent, or, as it is called, *laky*. The difference may be very well seen by comparing a thin layer of fresh blood diluted with ten times its volume of ten-per-cent salt solution with a similar layer of blood diluted with ten volumes of water. The watery mixture is a dark transparent red; the other, in which the coloring matter still lies in the corpuscles, is a brighter opaque red.—*Consistency*. Each red corpuscle is a soft jelly-like mass which can be readily crushed out of shape. Unless the pressure be such as to rupture it, the corpuscle immediately reassumes its proper form when the external force is removed. The corpuscles are, then, highly elastic; they frequently can be seen much dragged out of shape inside the vessels when the circulation of the blood is watched in a living animal (Chap. XV.), but immediately springing back to their normal form when they get a chance.

**Blood-Crystals.** Hæmoglobin is, as above shown, readily

its ice-cold watery solution have one fourth of its volume of cold alcohol added to it and the mixture be put in a refrigerator for twenty-four hours, a part of the hæmoglobin will often crystallize out and sink to the bottom of the vessel, where it can be collected for examination. The hæmoglobin of the rat is less soluble than that of man, and therefore crystallizes out especially easily; but these hæmoglobin crystals, or, as they are often called, *blood-crystals*, can be obtained from human blood. In 100 parts of dry human red blood-

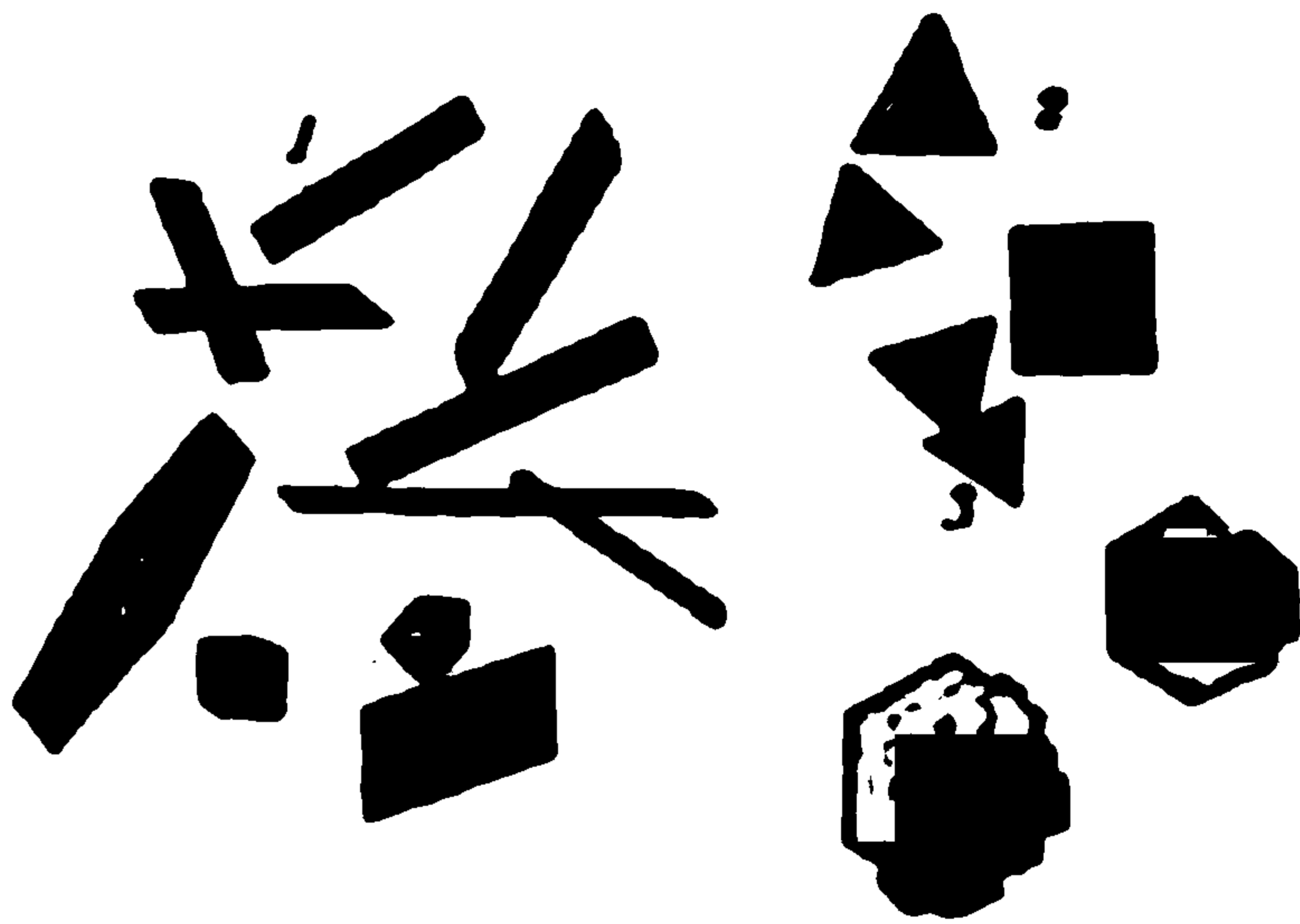

FIG. 11.—Blood - crystals, or hæmoglobin crystals.

corpuscles there are 90 of hæmoglobin. The hæmoglobin is the essential constituent of the red blood corpuscles, enabling them to pick up large quantities of oxygen in the lungs and carry it to all parts of the Body. (See Respiration.)

Hæmoglobin contains a considerable quantity of iron, much more than any other proximate constituent of the Body.

**The Colorless Blood Corpuscles (Fig. 10, *F*, *H*, *G*).** The *colorless, pale, or white corpuscles* of the blood are far less numerous than the red; in health there is on the average about one white to three hundred red, but the proportion may vary considerably. Each is finely granular and consists of a soft mass of protoplasm enveloped in no definite cell-wall, but containing a nucleus. The granules in the protoplasm commonly hide the nucleus in a fresh

corpuscle, but dilute acetic acid dissolves most of them and brings the nucleus into view. These pale corpuscles belong to the group of undifferentiated tissues and differ in no important recognizable character from the cells which make up the whole very young human Body, nor indeed from such an unicellular animal as an Amœba. Like the latter, they have the power of slowly changing their form spontaneously, and so have not the definiteness of outline which belongs to the red corpuscles. At one moment



FIG. 12.—A white blood corpuscle sketched at successive intervals of a few seconds to illustrate the changes of form due to its amoeboid movements.

(Fig. 12) a pale corpuscle will be seen as a spheroidal mass; a few seconds later processes will be seen radiating from this, and soon after these processes may be retracted and others thrust out; and so the corpuscle goes on changing its shape. These slow *amoeboid movements* are greatly promoted by keeping the specimen of blood at the temperature of the Body while under examination. By thrust-

ing out a process on one side, then drawing the rest of its body up to it, and then sending out a process again on the same side, the corpuscle can slowly change its place and creep across the field of the microscope. Inside the blood-vessels these corpuscles execute quite similar movements; and they sometimes here right through the capillary walls and, getting out into the lymph spaces, creep about among the other tissues. This *emigration* is especially frequent in inflamed parts, and the *pus* or "*matter*" which collects in abscesses is largely made up of white blood corpuscles which have in this way got out of the blood-vessels. The size of the white corpuscles is not so constant as that of the red; on the whole, however, they are larger, their average diameter being about 0.0127 millimeter ( $\frac{1}{7875}$  inch). The general properties of those corpuscles have already been described in Chap. II.

**Blood of Other Animals.** In all animals with blood the pale corpuscles are pretty much alike, but the red corpuscles, which with rare exceptions are found only in Verte-

**Histology of Lymph.** Pure lymph is a colorless watery-looking liquid; examined with a microscope it is seen to contain numerous pale corpuscles exactly like those of the blood, and no doubt largely consisting of pale blood corpuscles which have emigrated. It contains none of the red corpuscles. The lymph flowing from the intestines during digestion is, as already mentioned, not colorless but white and milky. It is known as *chyle* and will be considered with the process of digestion. During fasting the lymph from the intestines is colorless like that from other parts of the Body.



# CHAPTER V.

## THE CLOTTING OF BLOOD.

**The Coagulation of the Blood.** When blood is first drawn from the living Body it is perfectly liquid, flowing in any direction as readily as water. This condition is, however, only temporary ; in a few minutes the blood becomes viscid and sticky, and the viscosity becomes more and more marked until, after the lapse of five or six minutes, the whole mass sets into a jelly which adheres to the vessel containing it so that this may be inverted without any blood whatever being spilled. This stage is known as that of *gelatinization* and is also not permanent. In a few minutes the top of the jelly-like mass will be seen to be hollowed or “cupped” and in the concavity will be seen a small quantity of nearly colorless liquid, the *blood serum*. The jelly next shrinks so as to pull itself loose from the sides and bottom of the vessel containing it, and as it shrinks, squeezes out more and more serum. Ultimately we get a solid *clot*, colored red, and smaller in size than the vessel in which the blood coagulated but retaining its form, floating in a quantity of pale yellow *serum*. If, however, the blood be not allowed to coagulate in perfect rest, a certain number of red corpuscles will be rubbed out of the clot into the serum and the latter will be more or less reddish. The longer the clot is kept the more serum will be obtained: if the first quantity exuded be decanted off and the clot put aside and protected from evaporation, it will in a short time be found to have shrunk to a smaller size and to have pressed out more serum; and this goes on as long as it is kept, until putrefactive changes commence.



**DIESE SEITE IST FÜR KOSTENLOSE MITGLIEDER GESPERRT**

Beantragen Sie jetzt die volle Mitgliedschaft, um diese Seite zu betreten

# GESCHICHTE

Zehntausende von wichtigen historischen Quellen, viele bisher nicht erhältlich, stehen jetzt zum ersten Mal mit der Vollmitgliedschaft von Forgotten Books zur Verfügung.

Unbegrenzter Zugang  
\$8.99/monat

**Fortfahren**

\*Es gelten Richtlinien zur fairen Nutzung.



may be removed, and the pure fibrin thus obtained is perfectly white and in the form of highly elastic threads. It is insoluble in water and in dilute acids, but swells up to a transparent jelly in the latter. The "whipped" or "defibrinated blood" from which the fibrin has been in this way removed, looks just like ordinary blood, but has lost its power of coagulating spontaneously.

**The Buffy Coat.** That the red corpuscles are not an essential part of the clot, but are merely mechanically caught up in it, seems clear from the microscopic observation of the process of coagulation; and from the fact that perfectly formed fibrin can be obtained free from corpuscles by whipping the blood and washing the threads which adhere to the twigs. Under certain conditions, moreover, one gets a naturally formed clot containing no red corpuscles in one part of it. The corpuscles of human blood are a little heavier, bulk for bulk, than the plasma in which they float; hence, when the blood is drawn and left at rest they sink slowly in it; and if for any reason the clotting takes place more slowly or the corpuscles sink more rapidly than usual, a colorless top stratum of plasma, with no red corpuscles in it, will be left before gelatinization occurs and steps the further sinking of the corpuscles. The uppermost part of the clot formed under these circumstances is colorless or pale yellow, and is known as the *buffy coat*; it is especially apt to be formed in the blood drawn from febrile patients, and was therefore a point to which physicians paid much attention in the olden times when bloodletting was thought a panacea for all ills. In horse's blood the difference between the specific gravity of the corpuscles and that of the plasma is greater than in human blood, and horse's blood also coagulates more slowly, so that its clot has nearly always a buffy coat. The colorless buffy coat seen sometimes on the top of the clot must, however, not be confounded with another phenomenon. When a blood vessel is cut and the blood exposed to the air its top becomes bright red, and when immersed in the water it becomes colorless. The brightness of the top is due to the oxygen of the air,

which forms a bright red compound with the coloring matter of the red corpuscles. If the clot be turned upside down and left for a short time, the previously dark bottom layer, now exposed to the air, will become bright; and the previously bright top layer, now immersed in the serum, will become dark.

**Uses of Coagulation.** The clotting of the blood is so important a process that its cause has been frequently investigated; but as yet it is not perfectly understood. The living circulating blood in the healthy blood-vessels does not clot; it contains no solid fibrin, but this forms in it, sooner or later, when the blood gets by any means out of the vessels or if the lining of these is injured. In this way the mouths of the small vessels opened in a cut are clogged up, and the bleeding, which would otherwise go on indefinitely, is stopped. So, too, when a surgeon ties up an artery before dividing it, and the tight ligature crushes or tears its delicate inner surface, the blood clots where this is injured, and from there a coagulum is formed reaching up to the next highest branch of the vessel. This becomes more and more solid, and by the time the ligature is removed has formed a firm plug in the cut end of the artery, which greatly diminishes the risk of bleeding.

**The Fibrin Factors.** As regards the formation of fibrin the following points seem to be made out with tolerable certainty. Fresh-drawn blood contains or develops two substances, *fibrinoplastin* and *fibrinogen*, which by their interaction form fibrin, under the influence of a third body called the *fibrin ferment*; moreover, fibrin is only formed if a certain proportion of neutral mineral salts, such as are found dissolved in the blood plasma, is present.

Blood serum does not clot of itself at ordinary temperatures: it contains fibrinoplastin and fibrin ferment and the requisite quantity of salts, but not the fibrinogen; that which originally existed in the plasma having apparently been used up with the proper proportion of fibrinoplastin to form fibrin, leaving over an excess of fibrinoplastin in solution in the serum.

On the other hand, the liquids found in the cavities of

the Body which are lined by serous membranes, commonly contain fibrinogen and the salts but no fibrinoplastin, and therefore they do not coagulate spontaneously. But if a little blood serum be added to one of these liquids, coagulation takes place.

*a-  
v-* **Artificial Clot.** If serum be slightly diluted with water and kept ice-cold while a stream of carbon dioxide gas is passed through it for some hours, a white precipitate is thrown down which contains fibrinoplastin and the fibrin ferment. This precipitate after washing may be dissolved in cold water containing the merest trace of caustic potash. If the liquid moistening a serous cavity be treated in a similar way a precipitate is formed, containing fibrinogen instead of the fibrinoplastin, and but little of the ferment. If this precipitate be washed and dissolved and the solution be added to the solution of the blood-serum precipitate, no clot is formed; but if about one per cent of sodic carbonate or other neutral salt be added to the mixture, then it clots. This shows the necessity of the salts, which is perhaps better proved in another way. If serum be put in a dialyzer (see Physics) with distilled water on the other side of the membrane, all the salts will gradually pass out from the serum into the water: as the last portions of them pass out, the fibrinoplastin and ferment, which are "*colloids*" (that is, bodies which will not dialyze), are precipitated; they may be redissolved by the addition of a trace of caustic potash. Similarly the salts may be removed from the liquid obtained from a serous cavity, and the precipitated fibrinogen redissolved. If these solutions be now mixed no clot is formed; but if the salts which have been dialyzed out, or an equivalent portion of other neutral salts, be added to the mixture, it will clot.

*glot-* **The Fibrin Ferment.** The activity of the ferment is proved as follows: If serum be diluted with a large bulk of water and then carbon dioxide gas be passed through it, fibrinoplastin will be precipitated, with little or none of the ferment. If this fibrinoplastin be dissolved and added to the liquid from a serous cavity it will not cause it to clot, or only very slowly, according as no fibrin ferment or

but a little is present. But if some of the ferment be added, then the mixture coagulates rapidly. The ferment may be obtained by adding a large quantity of strong alcohol to some fresh blood serum. The alcohol precipitates albumen, fibrinoplastin, and the ferment. The precipitate is let stay under alcohol for some months, during which time the albumen and fibrinoplastin are altered so as to become insoluble in water. The alcohol is then decanted off and the residue treated with water which dissolves the ferment. This solution added to the above mixture containing fibrinoplastin, fibrinogen, and salts, will make it clot.

Of these four bodies which play a part in the coagulation of the blood, the fibrinoplastin and fibrinogen primarily determine the quantity of fibrin formed. The ferment seems to act on them in some way so as to make them interact, but it does not enter into the fibrin; it is not used up in the process, and the quantity of fibrin formed is thus independent of the quantity of the ferment present; but the more of it there is, the more quickly does the coagulation occur. The part the salts play is obscure: probably part of them are necessary constituents of the fibrin, since it leaves a large proportion of ash when burnt. But they seem to act in some other way when present in certain proportions, since too large a percentage of them stops coagulation as completely as their total absence. If fresh blood be mixed with an equal bulk of a saturated solution of magnesium sulphate (Epsom salts) or of common salt, it will not clot; but if this mixture be largely diluted with water, then clotting will take place.

**Exciting Causes of Coagulation.** The above facts show clearly enough that the coagulation of the blood is a physico-chemical process, but still leave unexplained why it does not occur in circulating blood inside healthy blood-vessels. It is, in fact, much easier to point out what are not the proximate reasons of the coagulation of drawn blood than what are.

Blood when removed from the Body and received in a vessel comes to rest, cools, and is exposed to the air, from

which it may receive or to which it may give off gaseous bodies. But it is easy to prove that none of these three things is the cause of coagulation. Stirring the drawn blood and so keeping it in movement does not prevent but hastens its coagulation; and blood carefully imprisoned in a living blood-vessel, and so kept at rest, will not clot for a long time: not until the inner coat of the vessel begins to change from the want of fresh blood. Secondly, keeping the blood at the temperature of the Body hastens coagulation, and cooling retards it; blood received into an ice-cold vessel and kept surrounded with ice will clot more slowly than blood drawn and left exposed to ordinary temperatures. Finally, if the blood be collected over mercury from a blood-vessel, without having been exposed to the air even for an instant, it will still clot perfectly well.

The formation of fibrin is then due to changes taking place in the blood itself when it is removed from the blood-vessels; clotting depends upon some rearrangement of the blood constituents. There is a good deal of reason to believe that what occurs is a breaking up of a number of the colorless corpuscles; that these then form fibrinoplastin and fibrin ferment, and, the fibrinogen and salts already existing in solution in the blood plasma, fibrin is formed. When fluids which contain no red corpuscles clot, as for instance vaccine lymph, the first threads of fibrin developed can be seen under the microscope to radiate from the pale corpuscles present.

**Relation of the Blood-Vessels to Coagulation.** As to the rôle of the vessels with respect to coagulation when the blood is flowing in them two views are held, between which the facts at present known do not permit a decisive judgment to be made. One theory is that the vessels actively prevent coagulation by constantly absorbing from the blood some substance, as for example the fibrin ferment, which may be supposed constantly to develop, and the presence of which is a necessary condition for the formation of fibrin. The other view is that the blood-vessels are passive and completely neutral. They simply do not excite those changes in the blood constituents which give rise to the

have affected the blood-vessels, the blood clots in them; but often very slowly, since the vessels only gradually alter. If the Body be left in one position after death, the clots formed in the heart have often a marked buffy coat, because the corpuscles have had a long time to sink in the plasma before coagulation occurred. In medico-legal cases it is thus sometimes possible to say what was the position of a corpse for some hours after death, although it has been subsequently moved. The lymph clots like the blood, but not so firmly; since it contains no red corpuscles, the clot formed is of course colorless.

**Composition of the Blood.** The average specific gravity of human blood is 1055. It has an alkaline reaction, which becomes less marked as coagulation occurs. About one half of its mass consists of moist corpuscles and the remainder of plasma. Exposed in a vacuum, 100 volumes of blood yield about 60 of gas consisting of a mixture of oxygen, carbon dioxide, and nitrogen.

**Chemistry of the Serum.** The blood plasma cannot well be examined as to its chemical constituents, since it clots under manipulation. The serum is, however, essentially blood plasma minus fibrin, and from an analysis of it we can draw conclusions as to the plasma. In 100 parts of serum there are about 90 parts of water, 8.5 of proteids, and 1.5 of fats, salts, and other less-known solid bodies. Of the proteids present the most abundant is *serum albumin*, which agrees with egg albumin in coagulating when heated: so that serum when boiled sets into an opaque white mass, just as the white of an egg does. Chemically, serum albumin differs from egg albumin in being coagulated by ether; and physiologically, in the fact that although present in such large quantities in the blood, it does not pass through



the kidneys, whereas egg albumin when injected into the blood-vessels of an animal is rapidly excreted by those organs. In health the fats are only present in the serum in small quantity except after a meal at which fatty substances have been eaten; serum obtained from the blood of an animal soon after such a meal is often milky in appearance from the fats present, instead of being perfectly colorless or pale yellow, and transparent as it is after fasting. The salts dissolved in the serum are mainly sodium chloride and carbonate; but small quantities of sodium, calcium, and magnesium phosphates are also present.

**Chemistry of the Red Corpuscles.** In these in the fresh moist state there are in 100 parts, 56 of water and 44 of solids. Of the solids about one per cent is salts, chiefly potassium phosphate and chloride. The remaining organic solids contain, in 100 parts, 90 of hæmoglobin and about 8 of other proteids; the residue consists of less well-known bodies.

**Chemistry of the White Corpuscles.** These yield besides much water, several proteids, some fat, glycogen (see Chap. XXVIII.), and salts; and smaller quantities of other bodies. The predominant salts, like those of the red corpuscles, are potassium phosphates.

**Variations in the Composition of the Blood.** *Hygienic Remarks.* The above statements refer only to the average composition of the healthy blood, and to its better known constituents. From what was said in the last chapter it is clear that the blood flowing from any organ will have lost or gained, or gained some things and lost others, when compared with the blood which entered it. But the losses and gains in particular parts of the Body are in such small amount as, with the exception of the blood gases, to elude analysis for the most part: and the blood from all parts being mixed up in the heart, they balance one another and produce a tolerably constant average. In health, however, the specific gravity of the blood may vary from 1045 to 1075; the red corpuscles also are present in greater proportion to the plasma after a meal than before it. Healthy sleep in proper amount also increase; the proportion of red



**DIESE SEITE IST FÜR KOSTENLOSE MITGLIEDER GESPERRT**  
Beantragen Sie jetzt die volle Mitgliedschaft, um diese Seite zu betreten



**Seien Sie niemals ohne ein Buch!**

Die Vollmitgliedschaft von Forgotten Books bietet Ihnen einen universalen Zugang von unseren Apps und unserer Website, auf all Ihren Geräten: Tablet, Telefon, E-Reader, Laptop und Computer.

**Eine Bibliothek in Ihrer Tasche für € 8.99/monat**

**Fortfahren**

\*Es gelten Richtlinien zur fairen Nutzung.

cesses of alteration or removal, and formation; their number is large, increased by taking food, even more than that of the red, so that their proportion to the red rises, from 1 to 1000 during fasting, to 1 to 250 or 300 after a meal. They no doubt multiply to a certain extent by division while circulating in the blood, but the majority come from the lymphatic glands and similar structures (see Chap. XXII.) found in many parts of the Body, which contain many cells like pale blood corpuscles, and often in process of division. From these organs the corpuscles enter the lymph-vessels and are carried on into the blood. From the capillary blood-vessels many again migrate, and it is probable that these emigrants take part frequently in the repair or regeneration of injured tissues. Being undifferentiated and specialized to no line of work they are ready to take up any that comes to hand, and may be compared to the young men in a community who have not yet selected an occupation and are on the lookout for an opening. On the other hand there seems little doubt that a great many white corpuscles give rise to red ones, and this is perhaps to be regarded as their special function. The corpuscles of nearly all invertebrate animals are colorless only, although the blood plasma of some contains hæmoglobin in solution. *Amphioxus*, the lowest undoubted vertebrate animal (see Zoology), also possesses only colorless corpuscles in its blood. But higher and more complex animals need more oxygen, and as blood plasma dissolves very little of that gas, they develop in addition the hæmoglobin-containing corpuscles which pick it up in the gills or lungs and carry it to all parts of the Body, leaving it where wanted (see Chap. XXV.). In cold-blooded vertebrates the red corpuscles are not nearly so many in proportion as in the warm-blooded, which use far more oxygen. The older view was that the mammalian red corpuscle represented the nucleus of one of the white, in which hæmoglobin had been formed and from about which the rest of the corpuscle had disappeared. This, however, does not seem to be the case; but the pale corpuscle develops or forms hæmoglobin in its cell protoplasm, and flattens and as-

sumes the form of a red corpuscle, while its nucleus disappears. Occasional transitional forms between the pale and the red corpuscle are seen in blood when examined with the microscope; and if blood be put fresh on a cold slide and examined in a cold room these transitional forms are more numerous, since at ordinary temperatures they very rapidly break down and fall to pieces when blood is drawn.

How long an individual red corpuscle lasts is not known, nor with certainty how or when it disappears. There is, however, some reason to believe that a great many are destroyed in the spleen (see Chap. XXII.).

**Chemistry of Lymph.** Lymph is a colorless fluid when pure, feebly alkaline, and with a specific gravity of about 1045. It may be described as blood minus its red corpuscles and considerably diluted, but of course in various parts of the Body it will contain minute quantities of substances derived from neighboring tissues. It contains a considerable quantity of carbon dioxide gas which it gives up in a vacuum, but no oxygen, since any of that gas which passes into it by diffusion from the blood is immediately picked up by the living tissues among which it flows.

# CHAPTER VI.

## THE SKELETON.

**Exoskeleton and Endoskeleton.** The skeleton of an animal includes all its hard protecting or supporting parts, and is met with in two main forms in the animal kingdom. First as an *exoskeleton* developed in connection with either the superficial or deeper layer of the skin, and represented by the shell of a clam, the scales of fishes, the horny plates of a turtle, the horny plates of an armadillo, and the feathers of birds. In man the exoskeleton is but slightly developed, but it is represented by the hairs, nails, and teeth; for although the latter lie within the month, the study of development shows that they are developed from an offshoot of the skin which grows in and lines the month long before birth. Hard parts formed from structures deeper than the skin constitute the *endoskeleton*, which in man is highly developed and consists of a great many *bones* and *cartilages* or *gristles*, the bones forming the mass of the hard framework of the Body, while the cartilages finish it off at various parts. This framework is what is commonly meant by the skeleton, and it primarily supports the softer parts and is also arranged so as to surround cavities in which delicate organs, as the brain, heart, or spinal cord, may lie with safety. The skeleton thus formed, however, is completed and supplemented by another made of the *connective tissue*, which not only, in the shape of tough bands or *ligaments*, ties the bones and cartilages together, but also in various forms pervades the whole Body as a sort of subsidiary skeleton running through all the soft organs, forming networks of fibres around their other constituents; so that it makes, as it were, a microscopic skeleton for the individual modified cells of which the Body is so largely composed.

and also forms partitions between the muscles, cases for such organs as the liver and kidneys, and sheaths around the blood-vessels. The bony and cartilaginous framework with its ligaments might be called the skeleton of the organs of the Body, and this finer supporting meshwork the skeleton of the tissues. Besides forming a support in the substance of various organs, the connective tissue is also often laid down as a sort of packing material in the crevices between them; and so widely is it distributed everywhere from the skin outside to the lining of the alimentary canal inside, that if some solvent could be employed which would corrode away all the rest and leave only this tissue, a very perfect model of the whole Body would be left; something like a "skeleton leaf," but far more minute in its tracery.

**The Bony Skeleton (Fig. 13).** If the hard framework of the Body were joined together like the joints and beams of a house, the whole mass would be rigid; its parts could not move with relation to one another, and we would be unable to raise a hand to the mouth or put one foot before another. To allow of mobility the bony skeleton is made of many separate pieces which are joined together, the points of union being called *articulations*, and at many places the bones entering into an articulation are movably hinged together, forming what are known as *joints*. The total number of bones in the Body is more than two hundred in the adult; and the number in children is still greater, for various bones which are distinct in the child (and remain distinct throughout life in many lower animals) grow together so as to form one bone in the full-grown man. The adult bony skeleton may be described as consisting of an *axial skeleton* found in the head, neck, and trunk; and an *appendicular skeleton*, consisting of the bones in the limbs and in the arches (*u* and *s*, Fig. 13) by which these are carried and attached to the trunk.

**Axial Skeleton.** The axial skeleton consists primarily of the *vertebral column* or *spine*, a side view of which is represented in Fig. 14. The upper part of this column is composed of twenty-four separate bones, each of which is a *vertebra*. At the posterior part of the trunk, beneath the

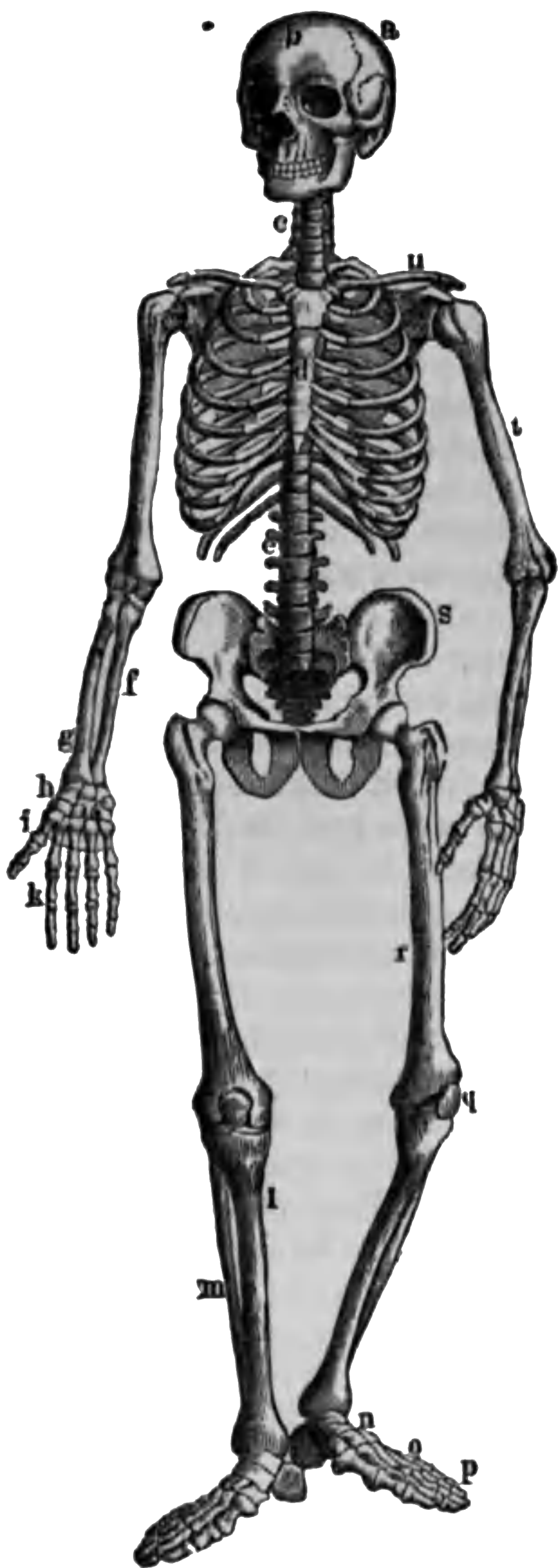

FIG. 13.—The bony and cartilaginous skeleton.

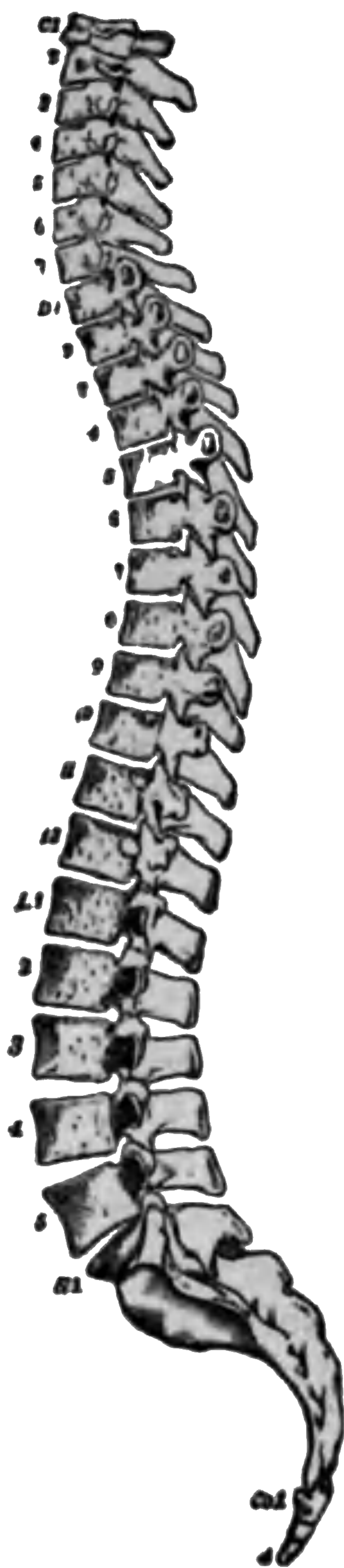

FIG. 14.—Side view of the spinal column.

movable vertebræ, comes the sacrum (*S* 1), made up of five vertebræ, which in the adult grow together to form one bone, and below the sacrum is the *coccyx* (*Co* 1-4), consisting of four very small tail vertebræ, which in advanced life also unite to form one bone.

On the top of the vertebral column is borne the *skull*, made up of two parts, viz., a great box above which incloses the brain and is called the *cranium*, and a large number of bones on the ventral side of this which form the skeleton of the face. Attached by ligaments to the under side of the cranium is the *hyoid bone*, to which the root of the tongue is fixed.

Of the twenty-four separate vertebræ of the adult the seven nearest the skull (Fig. 14. *C* 1-7) lie in the neck and are known as the *cervical vertebræ*. These are followed by twelve others which have *ribs* attached to them (see Fig. 13) and lie at the back of the chest; they are the *dorsal vertebræ* (*D* 1-12). The ribs (Fig. 25 \*) are slender curved bones attached by their dorsal ends, called their *heads*, to the dorsal vertebræ and running thence round the sides of the chest. In the ventral median line of the latter is the breast-bone or *sternum* (*d*, Fig 13). Each rib near its sternal end ceases to be bony and is composed of cartilage.

These parts—skull, hyoid bone, vertebral column, ribs, and sternum—constitute the axial skeleton, and we have now to consider its parts more in detail.

**The Dorsal Vertebræ.** If a single vertebra, say the eleventh from the skull, be examined carefully it will be found to consist of the following parts (Figs. 15 and 16):

First a bony mass, *C*, rounded on the sides and flattened on each end where it is turned towards the vertebræ above and below it. This stout bony cylinder is the “*body*” or *centrum* of the vertebra, and the series of vertebral bodies (Fig. 14) forms in the trunk that bony partition between the dorsal and ventral cavities of the body spoken of in Chapter I. To the dorsal side of the body is attached an arch—the *neural arch*, *A*, which with the back of the body incloses a space, *Fv*, the *neural ring*. In the tube formed

---

\* P. 78.



by the rings of the successive vertebræ lies the spinal cord. Projecting from the dorsal side of the neural arch is a long bony bar, *Ps*, the *spinous process*: and the projections of these processes from the various vertebræ can be felt through the skin all down the middle of the back. Hence the name of *spinal column* often given to the whole hæk-bone.

Six other processes arise from the arch of the vertebra: two project forwards, *i.e.* towards the head; these, *Pas*, are the *anterior articular processes* and have a smooth surface, covered with cartilage on their dorsal sides. A pair of sim-

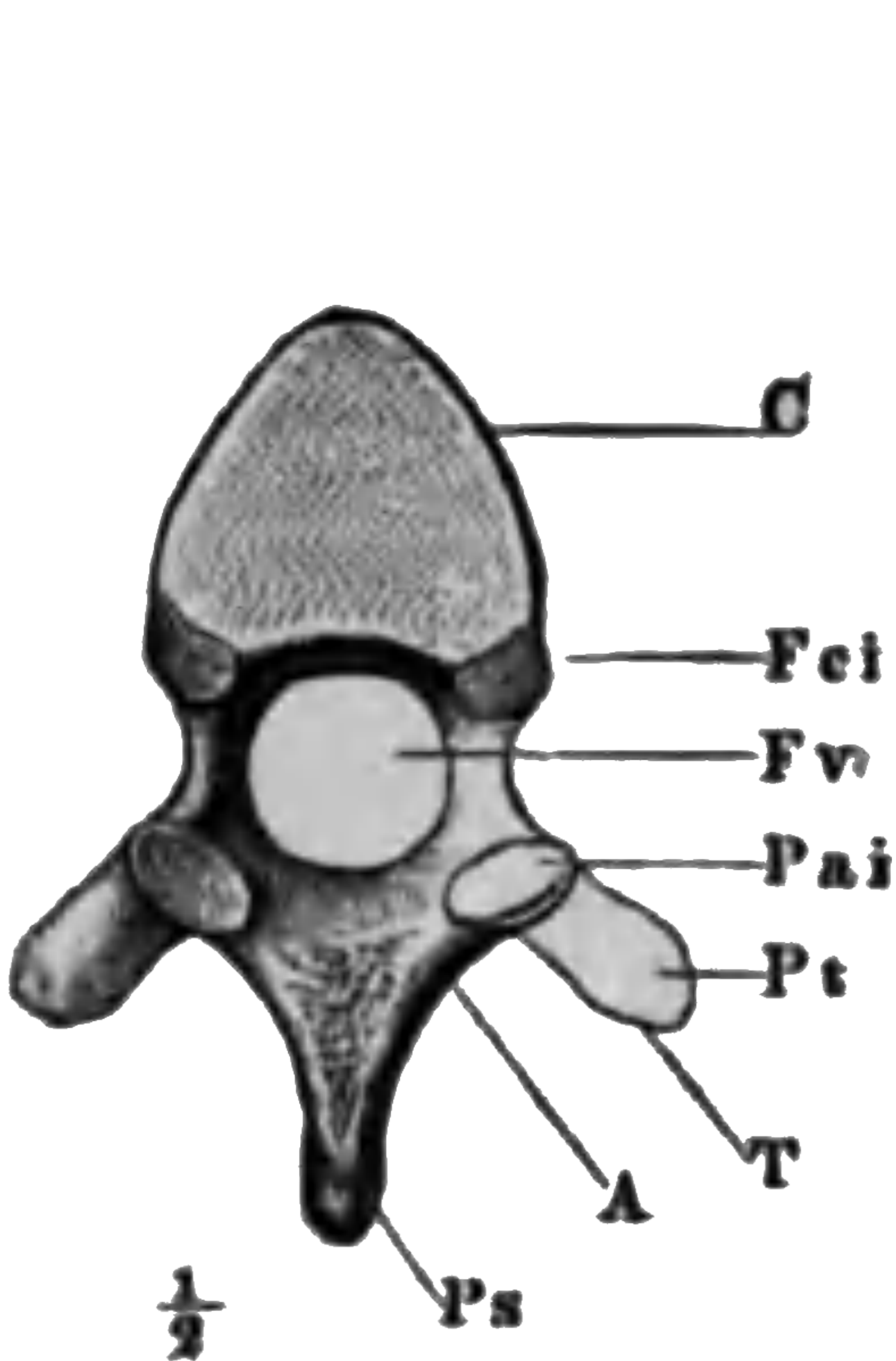

FIG. 15.

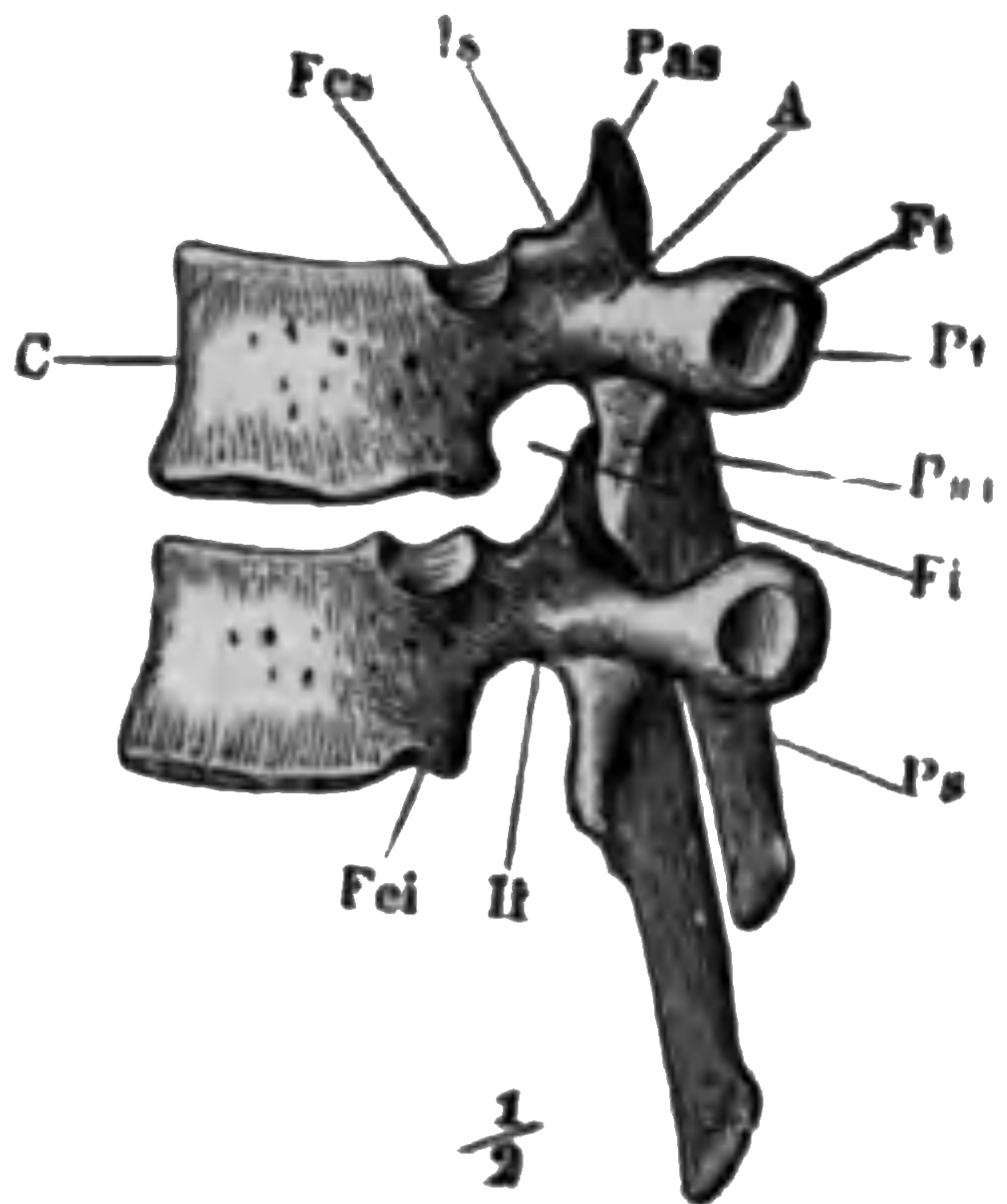

FIG. 16.

FIG. 15.—A dorsal vertebra seen from behind, *i.e.* the end turned from the head.

FIG. 16.—Two dorsal vertebræ viewed from the left side, and in their natural relative positions. *C*, the body; *A*, neural arch; *Fv*, the neural ring; *Ps*, spinous process; *Pas*, anterior articular process; *Pai*, posterior articular process; *Pt*, transverse process; *Ft*, facet for articulation with the tubercle of a rib; *Fcs*, *Fci*, articular surfaces on the centrum for articulation with a rib.

ilar *posterior articular processes*, *Pai*, runs back from the neural arch, and these have smooth surfaces on their ventral aspects. In the natural position of the vertebra, the smooth surfaces of its anterior articular processes fit upon the posterior articular processes of the vertebra next in front, forming a joint, and the two processes are united by ligaments. Similarly its posterior articular processes form joints (Fig. 16) with the anterior articular processes of the vertebræ next behind.



**DIESE SEITE IST FÜR KOSTENLOSE MITGLIEDER GESPERRT**  
Beantragen Sie jetzt die volle Mitgliedschaft, um diese Seite zu betreten

# GESCHICHTE

Zehntausende von wichtigen historischen Quellen, viele bisher nicht erhältlich, stehen jetzt zum ersten Mal mit der Vollmitgliedschaft von Forgotten Books zur Verfügung.

Unbegrenzter Zugang  
\$8.99/monat

**Fortfahren**

\*Es gelten Richtlinien zur fairen Nutzung.



the other, but having different portions of the complete segment much modified or rudimentary, or even altogether wanting in some regions. Parts which in this sort of way really correspond to one another though they differ in detail, which are so to speak different varieties of one thing, are said in anatomical language to be *homologous* to one another; and when they succeed one another in a row, as the trunk segments do, the *homology* is spoken of as *serial*.

**The Cervical Vertebrae.** In the cervical region of the vertebral column the bodies of the vertebrae are smaller than in the dorsal, but the arches are larger; the spinous processes are short and often bifid and the transverse processes appear perforated by a canal, the *vertebral foramen*.

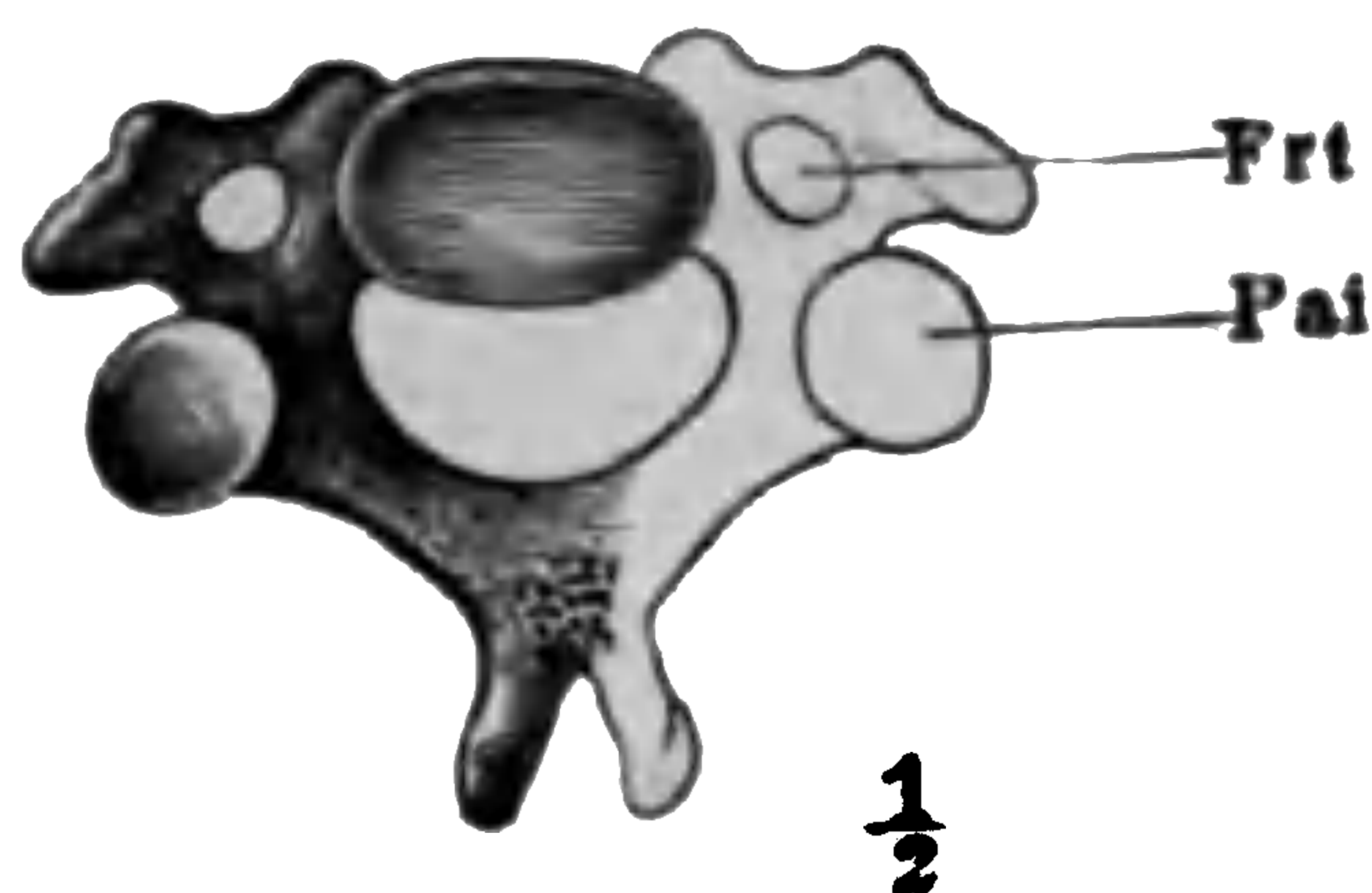

FIG. 18.—A cervical vertebra. *Frt.*, vertebral foramen; *Pai.*, anterior articular process.

The bony bar bounding this aperture on the ventral side, however, is in reality a very small rib which has grown into continuity with the body and true transverse process of the vertebra, although separate in very early life: the transverse process proper bounds the vertebral

foramen dorsally. In this latter during life runs an artery, which ultimately enters the skull cavity.

**The Atlas and Axis.** The first and second cervical vertebrae differ considerably from the rest. The first, or *atlas* (Fig. 19), which carries the head, has a very small body. *Aa*, and a large neural ring. This ring is subdivided by a cord, or the *transverse ligament*, *L*, into a dorsal moiety in which the spinal cord lies and a ventral into which the bony process *D* projects. This is the *odontoid process*, and arises from the front of the axis or second cervical vertebra (Fig. 20). Around this peg the atlas rotates when the head is turned from side to side, carrying the skull (which articulates with the large hollow surfaces *Fas*) with it.

The odontoid process really represents a large piece of the body of the atlas which in early life separates from its own vertebra and grows on the axis.

The Lumbar Vertebrae (Fig. 21) are the largest of all the movable vertebrae and have no ribs attached to them. Their spines are short and stout and lie in a more horizontal

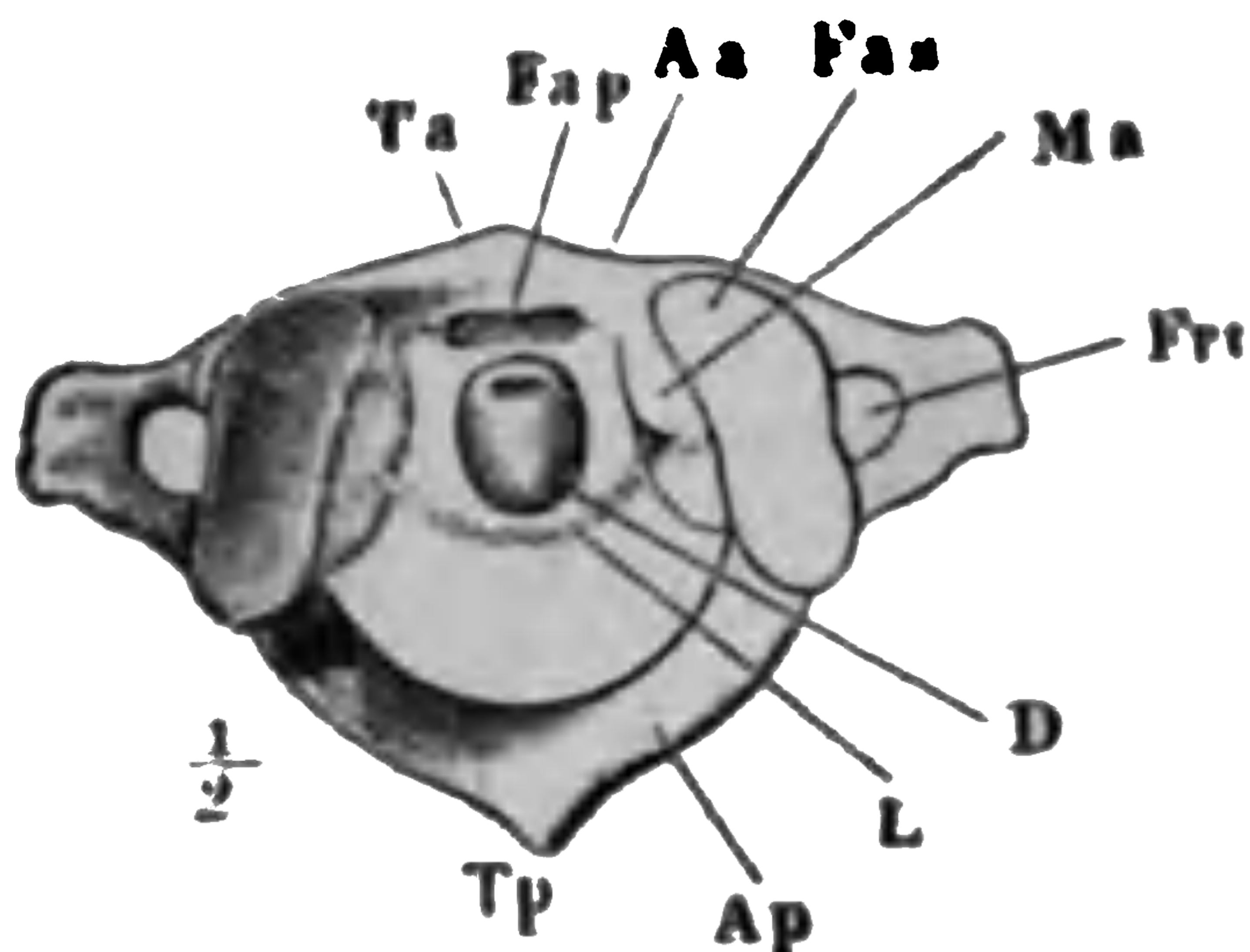

FIG. 19.

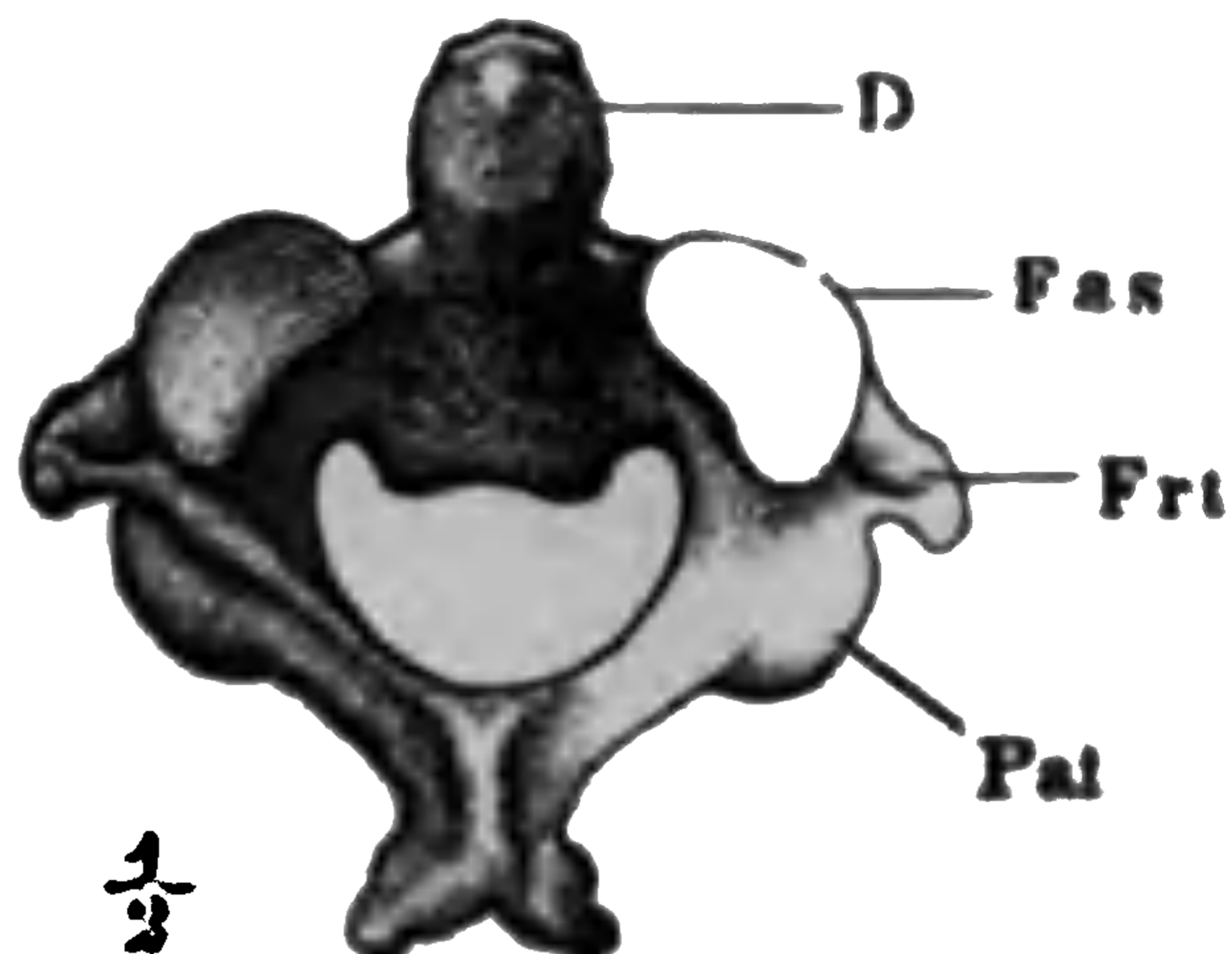

FIG. 20.

FIG. 19.—The atlas. FIG. 20.—The axis. *Aa*, body of atlas; *D*, odontoid process; *Fas*, facet on front of atlas with which the skull articulates; and in Fig. 20, anterior articular surface of axis; *L*, transverse ligament; *Fvt*, vertebral foramen.

plane than those of the vertebrae in front. The articular and transverse processes are also short and stout.

The Sacrum, which is represented along with the last lumbar vertebra in Fig. 22, consists in the adult of a single bone; but cross-ridges on its ventral surface indicate the

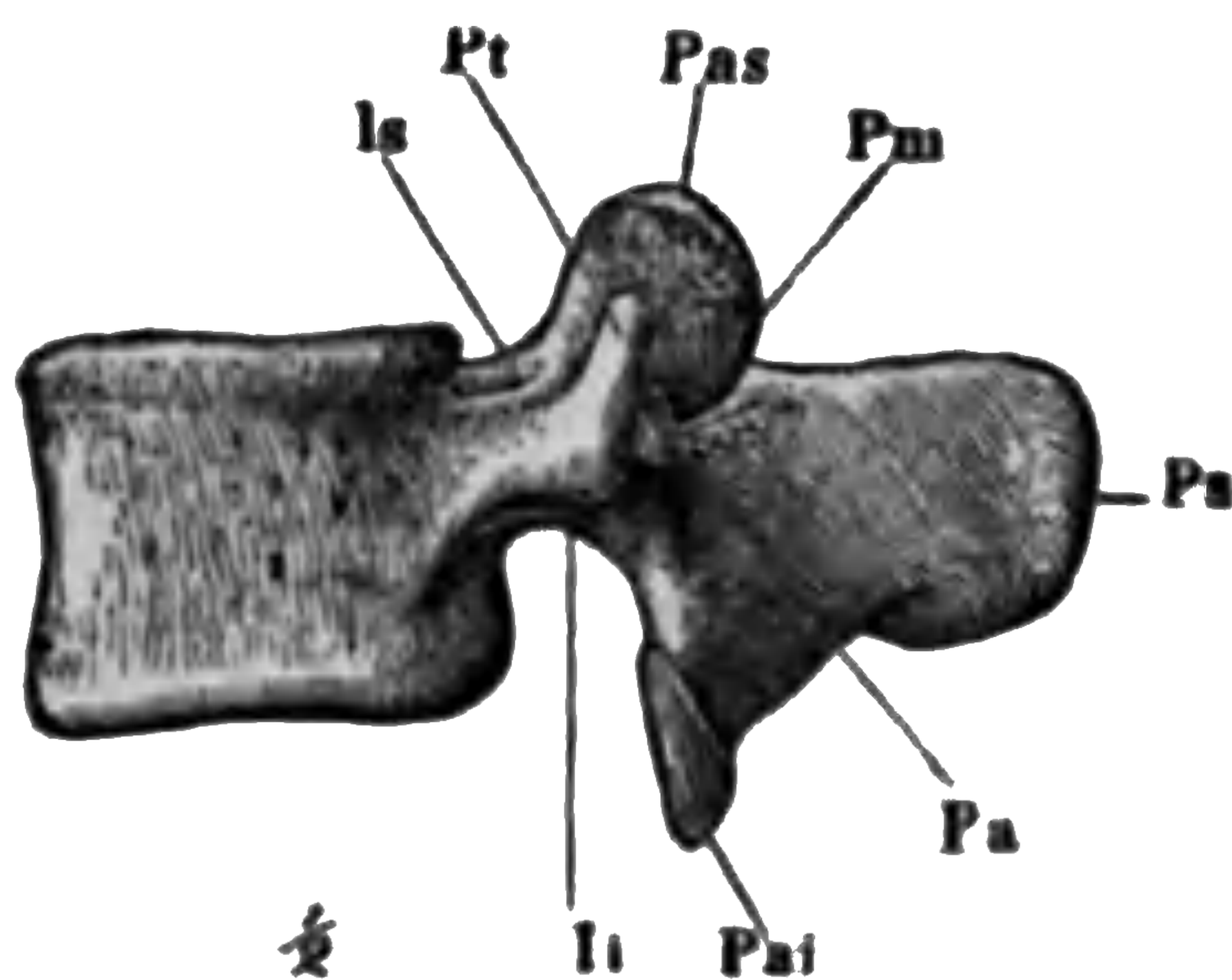

FIG. 21.—A lumbar vertebra seen from the left side. *Ps*, spinous process; *Pae*, anterior articular process; *Pai*, posterior articular process.

limits of the five separate vertebrae of which it is composed in childhood. It is somewhat triangular in form, its base being directed upwards and articulating with the under

surface of the body of the fifth lumbar vertebra. On its sides are large surfaces to which the arch bearing the lower

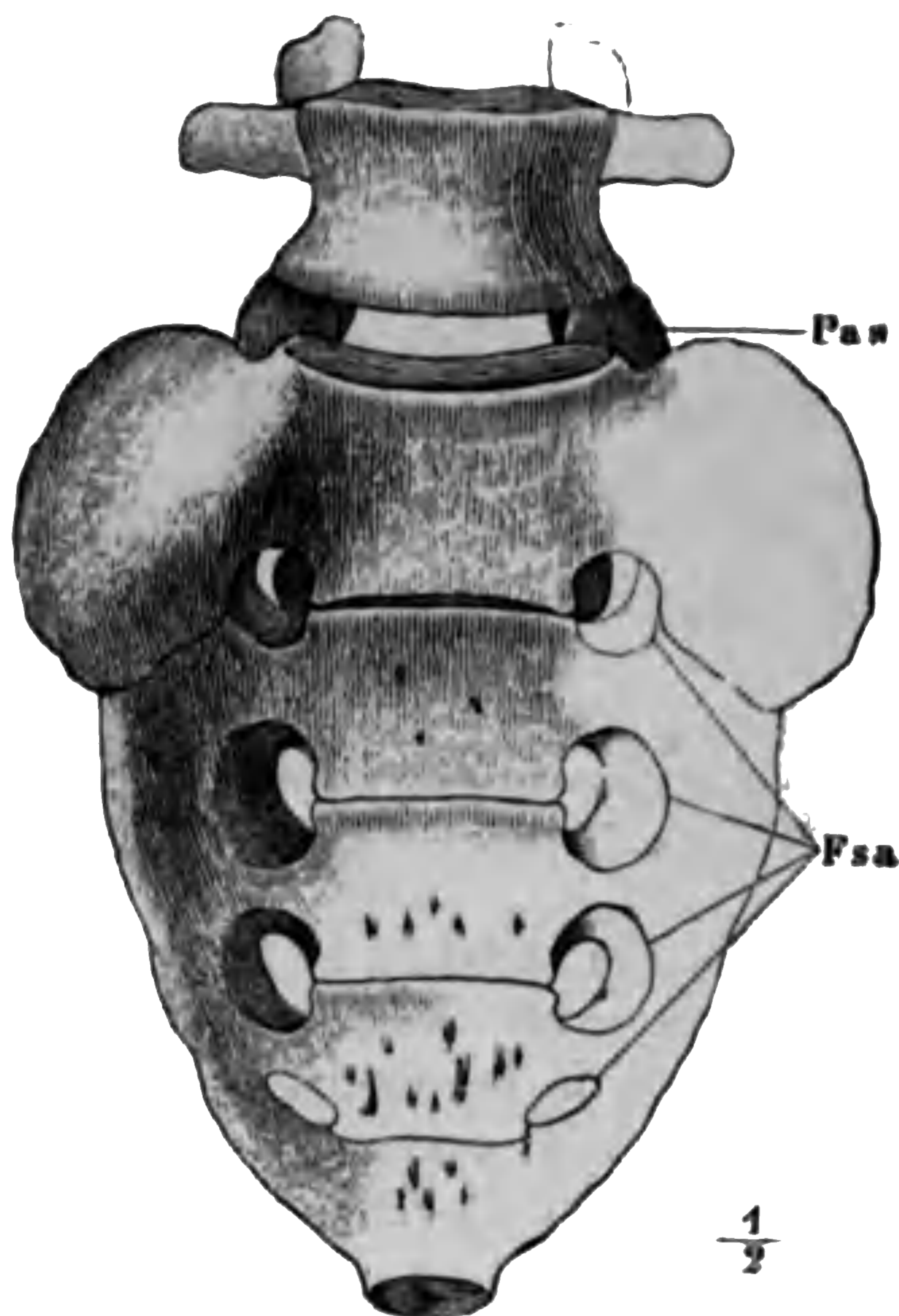

FIG. 22.—The last lumbar vertebra and the sacrum seen from the ventral side. *Fsa*, anterior sacral foramina.

limbs is attached (see Fig. 13). Its ventral surface is concave and smooth and presents four pairs of *anterior sacral foramina*, *Fsa*, which communicate with the neural canal. Its dorsal surface, convex and roughened, has four similar pairs of *posterior sacral foramina*.



FIG. 23.—The coccyx.

The *coccyx* (Fig. 23) calls for no special remark. The four bones which grow together, or *ankylose*, to form it represent only the bodies of vertebrae, and even that imperfectly. It is in reality a short tail, although not visible as such from the exterior.

**The Spinal Column as a Whole.** The vertebral column

is in a man of average height about twenty-eight inches long. Viewed from one side (Fig. 14) it presents four curvatures; one with the convexity forwards in the cervical region is followed, in the dorsal, by a curve with its concavity towards the chest. In the lumbar region the curve has again its convexity turned ventrally, while in the sacral and coccygeal regions the reverse is the case. These curvatures give the whole column a good deal of springiness such as would be absent were it a straight rod, and this is farther secured by the presence of compressible elastic pads, the *intervertebral disks*, made up of cartilage and connective tissue, which lie between the bodies of those vertebræ which are not ankylosed together, and fill up completely the empty spaces left between the bodies of the vertebræ in Fig. 14. By means of these pads, moreover, a certain amount of movement is allowed between each pair of vertebræ; and so the spinal column can be bent to considerable extent in any direction; while the movement between any two vertebræ is so limited that no sharp bend can take place at any one point, such as might tear or injure otherwise the spinal cord contained in the neural canal. The amount of movement permitted is greatest in the cervical region.

In the case of the movable vertebræ, where the arch joins the body on each side, it is somewhat narrowed; this narrowed stalk being known as the *pedicle* (*li*, Fig. 16), while the broader remaining portion of the arch is its *lamina*. Between the pedicles of two contiguous vertebræ there are in this way left apertures, the *intervertebral* holes which form a series on each side of the vertebral column, and one of which, *Fi*, is shown between the two dorsal vertebræ in Fig. 16. Through these foramina nerves run out from the spinal cord to various regions of the Body. The sacral foramina, anterior and posterior, are the representatives of these apertures, but modified in arrangement, on account of the fusion of the arches and bodies of the vertebræ between which they lie.

**Sternum.** The *sternum* or *breast-bone* (Fig. 24 and *d*, Fig. 13) is wider from side to side than dorso-ventrally. It

consists in the adult of three pieces, and seen from the ventral side has somewhat the form of a dagger. The piece *M* nearest the head is called the *handle* or *manubrium*, and presents anteriorly a notch, *Icl*, on each side, with which the collar-bone articulates (*u*, Fig. 13); on each side are two other notches, *Ic 1* and *Ic 2*, to which the sternal ends of the first and second ribs are attached. The middle piece, *C*, of the sternum is called the *body*; it completes

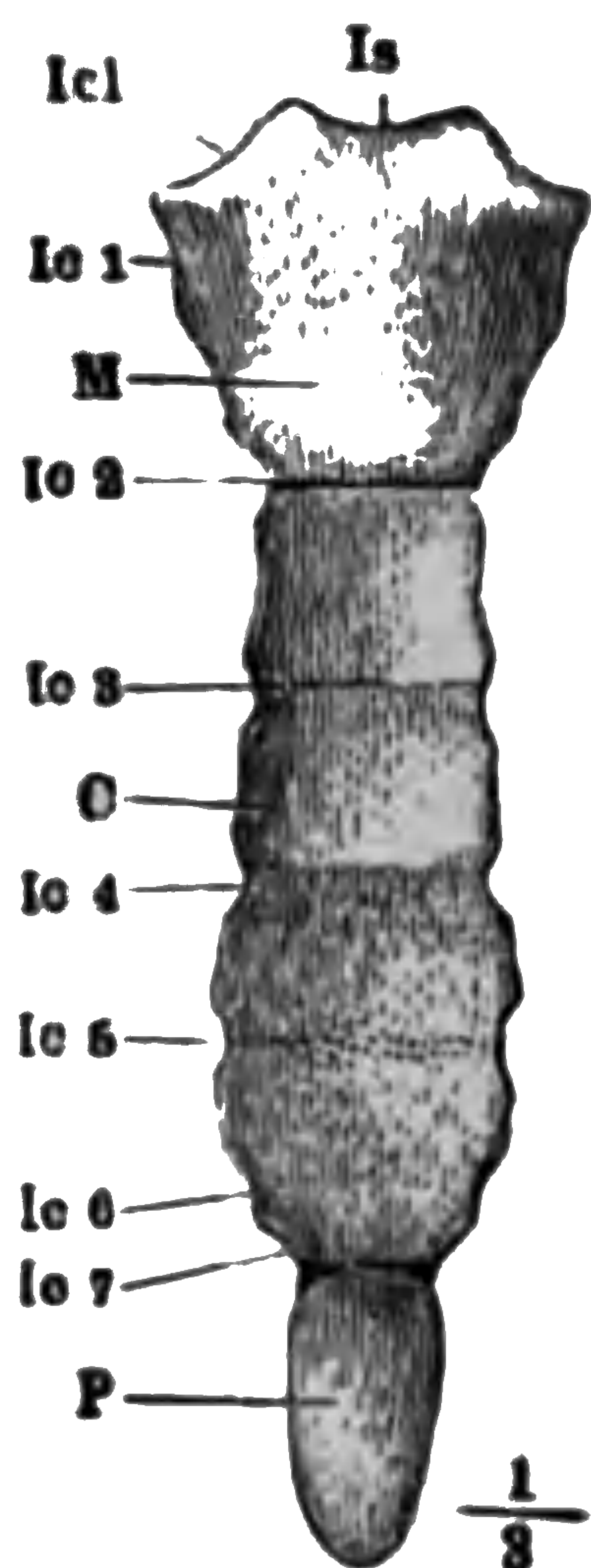

FIG. 24.—The sternum seen on its ventral aspect. *M*, manubrium; *C*, body; *P*, xiphoid process; *Icl*, notch for the collar-bone; *Ic*, 1-7, notches for the rib cartilages.

the notch for the second rib and has on its sides others, *Ic 3-7*, for the third, fourth, fifth, sixth, and seventh ribs. The last piece of the sternum, *P*, is called the *ensiform* or *xiphoid process*; it is composed of cartilage, and has no ribs attached to it.

**The Ribs** (Fig. 25). There are twelve pairs of ribs, each being a slender curved bone attached dorsally to the body and transverse process of a vertebra in the manner already mentioned, and continued ventrally by a *costal cartilage*. In the case of the anterior seven pairs, the costal cartilages are attached directly to the sides of the breast-bone; the next three cartilages are each attached to the cartilage of the preceding rib, while the cartilages of the tenth and twelfth ribs are quite unattached ventrally, so these are called the *free* or *floating ribs*. The convexity of each

curved rib is turned outwards so as to give roundness to the sides of the chest and increase its cavity, and each slopes downwards from its vertebral attachment, so that its sternal end is considerably lower than its dorsal.

**The Skull** (Fig. 26) consists of twenty-two bones in the adult, of which eight, forming the *cranium*, are arranged so as to inclose the brain-case and protect the auditory organ, while the remaining fourteen support

the face and surround the month, the nose, and the eye-sockets.

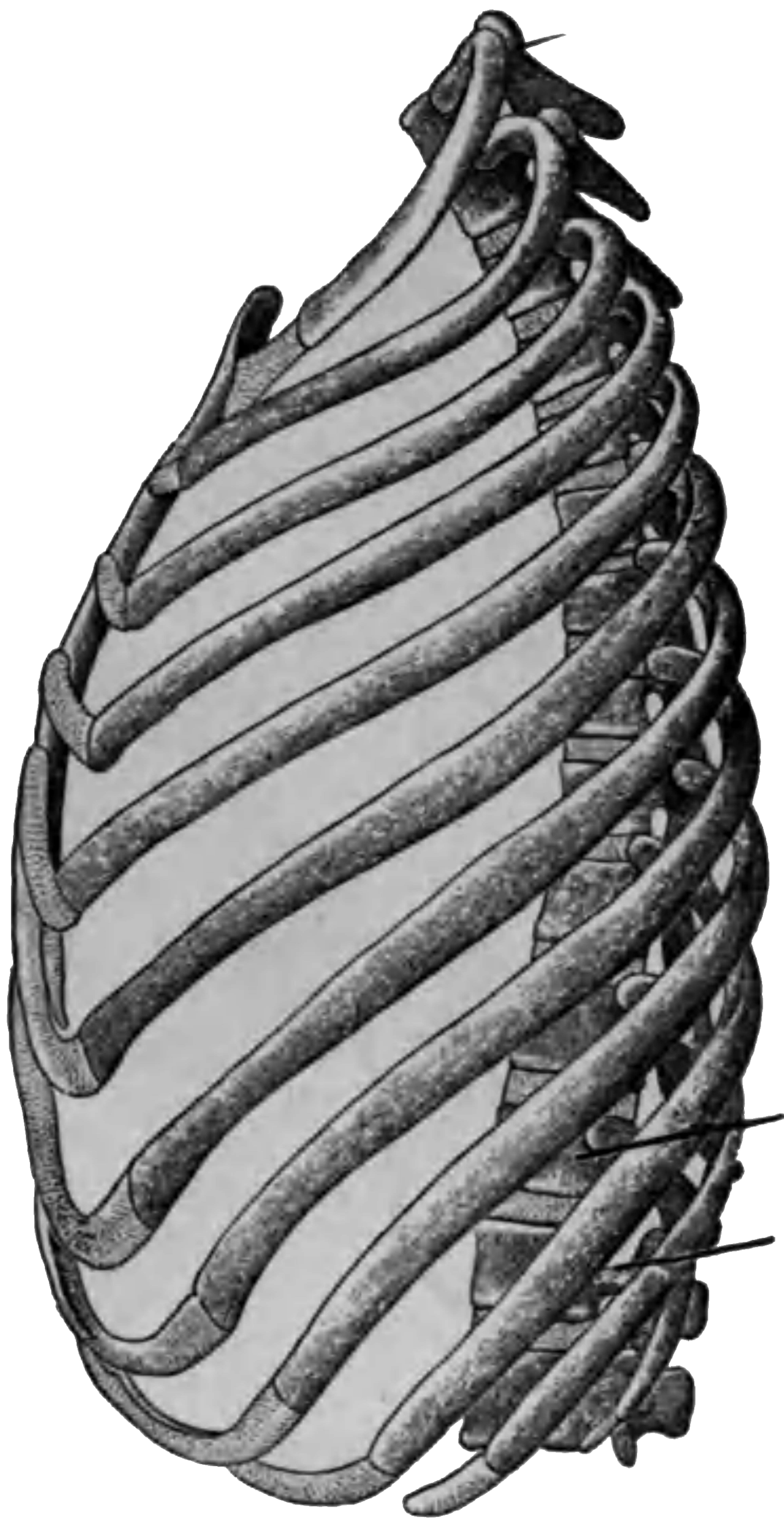

FIG. 25.—The ribs of the left side, with the dorsal and two lumbar vertebrae, the rib cartilages and the sternum.

**Cranium.** The cranium is a box with a thick floor and thinner walls and roof. Its floor or *base* represents in the head (as is depicted diagrammatically in Fig. 2) that par-



tition between the dorsal and ventral cavities which in the trunk is made up of the bodies of the vertebræ. In very early life it presents in the middle line a series of four hones, the *basi-occipital*, *basi-sphenoid*, *presphenoid*, and

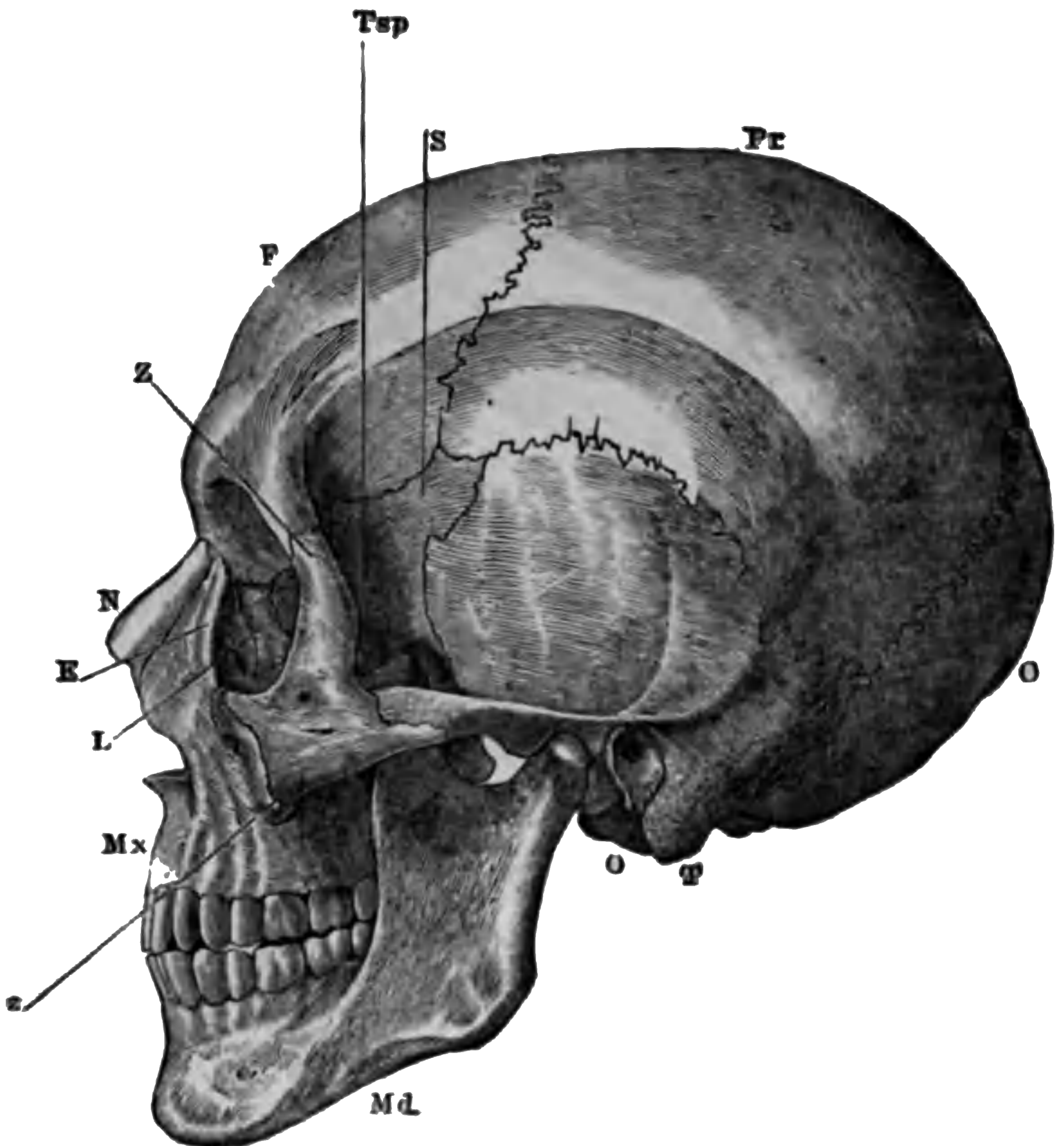

FIG. 26.—A side view of the skull. O, occipital bone; T, temporal; Pr, parietal; F, frontal; S, sphenoid; Z, malar; Mx, maxilla; N, nasal; E, ethmoid; L, lacrimal; Md, inferior maxilla.

*basi-ethmoid*, which answer pretty much to the bodies of four vertebræ, and have attached to them the thin hones which inclose the skull cavity (which may be likened to an enlarged neural canal) on the sides and top. In the



**DIESE SEITE IST FÜR KOSTENLOSE MITGLIEDER GESPERRT**  
Beantragen Sie jetzt die volle Mitgliedschaft, um diese Seite zu betreten



**Seien Sie niemals ohne ein Buch!**

Die Vollmitgliedschaft von Forgotten Books bietet Ihnen einen universalen Zugang von unseren Apps und unserer Website, auf all Ihren Geräten: Tablet, Telefon, E-Reader, Laptop und Computer.

**Eine Bibliothek in Ihrer Tasche für €8.99/monat**

**Fortfahren**

\*Es gelten Richtlinien zur fairen Nutzung.

small holes through which the nerves of smell pass. A little bit of it is seen on the inner side of the eye-socket at *E* in Fig. 26.

**Facial Skeleton.** The majority of the face bones are in pairs; two only being single and median. One of these is the lower jaw-bone or *inferior maxilla* (Fig. 26, *Md*); the other is the *vomer*, which forms part of the partition between the two nostrils.

The paired face-bones are: 1. The *maxillæ*, or upper jaw-bones (*Mx*, Fig. 26), one on each side, carrying the upper row of teeth and forming a great part of the *hard palate*, which separates the month from the nose. 2. The *palatine bones*, completing the skeleton of the hard palate, and behind which the nose communicates by the *posterior nares* (Fig. 27) with the throat cavity, so that air can pass in or out in breathing. 3. The *malar bones*, or cheek-bones, (*Z*, Fig. 26), lying beneath and on the outside of the orbit on each side. 4. The *nasal bones* (*N*, Fig. 26), roofing in the nose. 5. The *lacrimal bones* (*L*, Fig. 26), very small and thin and lying between the nose and orbit. 6. The *inferior turbinate bones* lie inside the nose, one in each nostril chamber.

**The Hyoid.** Besides the cranial and facial bones there is, as already pointed out, one other, the *hyoid* (Fig. 28), which really belongs to the skull, although it lies in the neck. It can be felt in front of the throat, just above "Adam's apple."

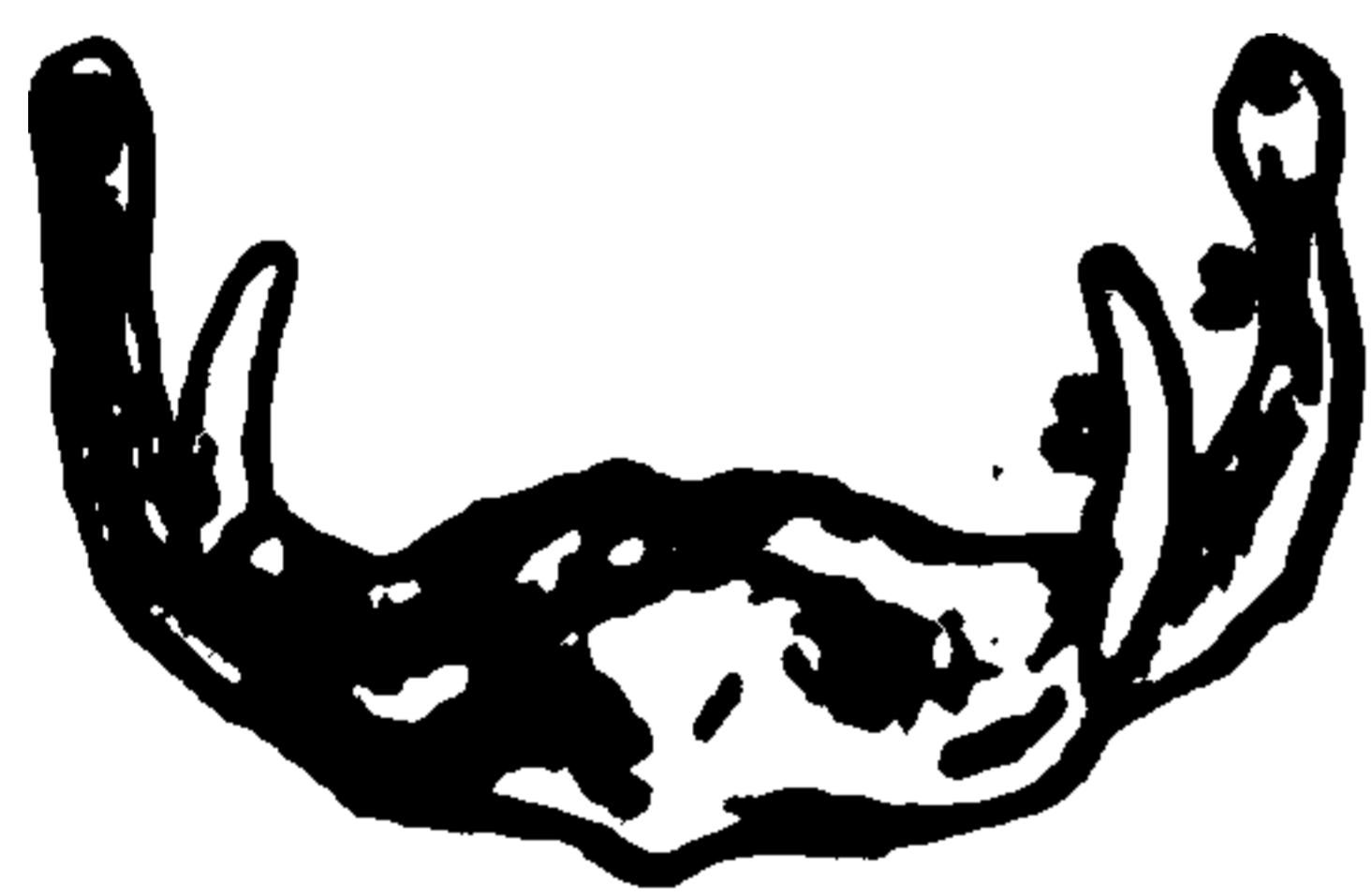

FIG. 28.—The hyoid bone. 1, body; 2, great cornua; 3, small cornua.

The hyoid bone is U-shaped, with its convexity turned ventrally, and consists of a *body* and two pairs of processes called *cornua*. The smaller cornua (Fig. 28, 3) are attached to the skull, close to *T* in Fig. 26, by long ligaments. These ligaments in many animals are represented by bones, so that the hyoid, with them, forms a bony arch attached to the base

of the skull much as the ribs are attached to the bodies of the vertebræ. In fishes, behind this *hyoidean arch* come several others which bear the gills; and in the very young Human Body these also are represented, though they almost

entirely disappear long before birth. The hyoid, then, with its cornua and ligaments answers pretty much to a gill-arch, or really to parts of two gill-arches, since the great and small cornua belong to originally separate arches present at an early stage of development. It is a remnant of a structure which has no longer any use in the Human Body; but in the young frog tadpole parts answering to it carry gills and have clefts between them which extend into the throat just as in fishes. The gills are lost afterwards and the clefts closed up when the frog gets its lungs and begins to breathe by them. In the embryonic human being these gill-clefts are also present and several more behind them, but the arches between them do not bear gills, and the clefts themselves are closed long before birth. As they have no use their presence is hard to account for; those who accept the doctrine of Evolution regard them as developmental reminiscences of an extremely remote ancestor in which they were of functional importance somewhat as in the tadpole; of course this does not mean that men were developed from tadpoles.

**The Appendicular Skeleton.** This consists of the *shoulder girdle* and the bones of the fore limbs, and the *pelvic girdle* and the bones of the posterior limbs. The two supporting girdles in their natural position with reference to the trunk skeleton are represented in Fig. 29.

**The Shoulder Girdle, or Pectoral Arch.** This is made up on each side of the *scapula* or *shoulder-blade*, and the *clavicle* or collar-bone.

The *scapula* (*S*, Fig. 29) is a flattish triangular bone which can readily be felt on the back of the thorax. It is not directly articulated to the axial skeleton, but lies imbedded in the muscles and other parts outside the ribs on each side of the vertebral column. From its dorsal side arises a crest to which the outer end of the collar-bone is fixed, and on its outer edge is a shallow cup into which the top of the arm-bone fits; this hollow is known as the *glenoid fossa*.

The *collar-bone* (*C*, Fig. 29) is cylindrical and attached

at its inner end to the sternum as shown in the figure, fitting into the notch represented at *Icl* in Fig. 24.

**The Fore Limb.** In the limb itself (Fig. 30) are thirty bones. The largest, *a*, lies in the upper arm, and is called

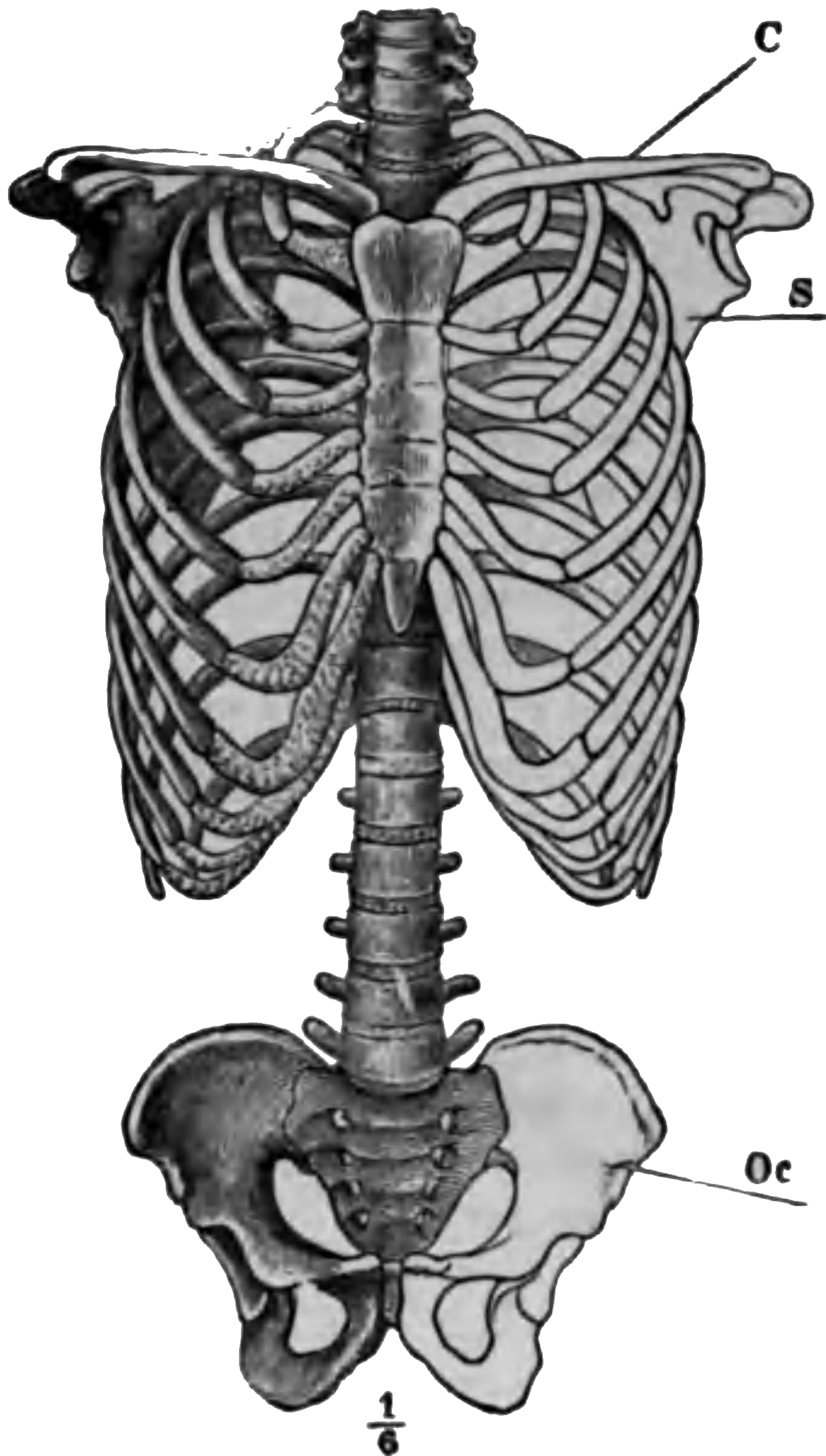

FIG. 29.—The skeleton of the trunk and the limb arches seen from the front. *C*, clavicle; *S*, scapula; *Oc*, innominate bone attached to the side of the sacrum dorsally and meeting its fellow at the *pubic symphysis* in the ventral median line.

the *humerus*. At the elbow the humerus is succeeded by two bones, the *radius* and *ulna*, *c* and *b*, which lie side by side, the radius being on the thumb side. At the distal ends of these bones come eight small ones, closely packed



**DIESE SEITE IST FÜR KOSTENLOSE MITGLIEDER GESPERRT**  
Beantragen Sie jetzt die volle Mitgliedschaft, um diese Seite zu betreten

# GESCHICHTE

Zehntausende von wichtigen historischen Quellen, viele bisher nicht erhältlich, stehen jetzt zum ersten Mal mit der Vollmitgliedschaft von Forgotten Books zur Verfügung.

Unbegrenzter Zugang  
\$8.99/monat

**Fortfahren**

\*Es gelten Richtlinien zur fairen Nutzung.



the great toe (or *hallux*) there are two phalanges, in each of the others three, arranged as in the fingers, but smaller.

**Comparison of the Anterior and Posterior Limbs.** It



FIG. 30.



FIG. 31.

FIG. 30.—The bones of the arm. *a*, humerus; *b*, ulna; *c*, radius; *d*, the carpus; *e*, the fifth metacarpal; *f*, the three phalanges of the fifth digit (little finger); *g*, the phalanges of the pollex (thumb).

FIG. 31.—Bones of the leg. *a*, femur; *b*, patella; *c*, tibia; *d*, fibula; *h*, calcaneum; *e*, remaining tarsal bones; *f*, metatarsal bones; *g*, phalanges.

is clear that the skeletons of the arm and leg correspond pretty closely to one another. Both are in fact quite alike in very early life, and their differences at birth depend upon

their diverging in different ways as they develop from their primitive simplicity; as both may be regarded as modifications of the same original structure, they are ho-

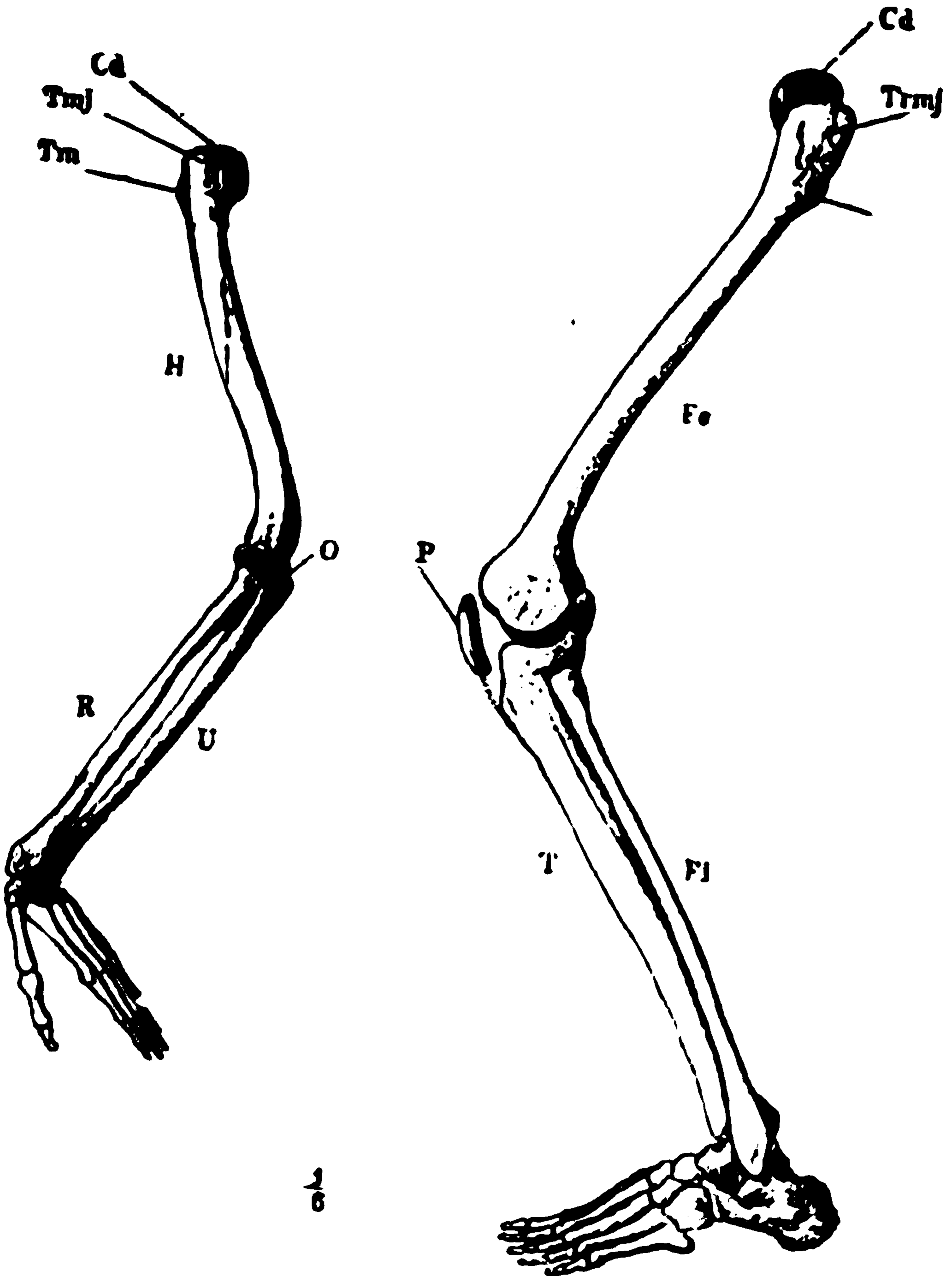

FIG. 22.—The skeleton of the arm and leg. *H*, the humerus; *Ca*, its articular head which fits into the glenoid fossa of the scapula; *U*, the ulna; *R*, the radius; *O*, the olecranon; *Fe*, the femur; *P*, the patella; *Fi*, the fibula; *T*, the tibia.

*mologous*. The pelvic girdle clearly corresponds generally to the pectoral arch, the tibia and fibula to the radius and



ulna; the five metatarsal bones to the five metacarpal, and the phalanges of the toes to those of the thumb and fingers. On the other hand, there is in the arm no separate bone at the elbow-joint corresponding to the patella at the knee. but the ulna bears above a bony process, the *olecranon* (*O*, Fig. 32), which at first is a separate bone and is the representative of the patella. There are in the carpus eight bones and in the tarsus but seven. The *astragalus* of the tarsus (*Ta*, Fig. 35) represents *two* bones which, however,

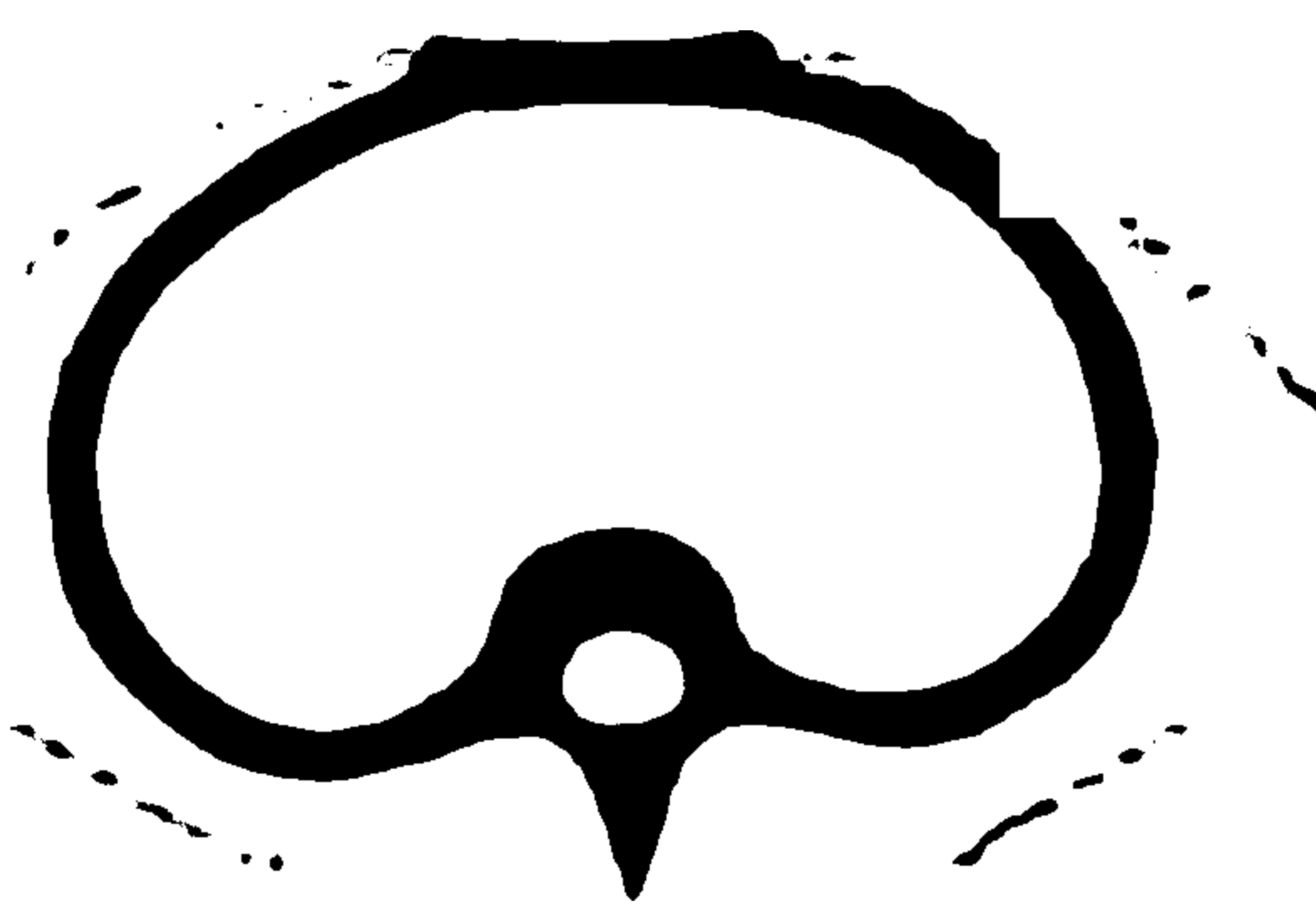

FIG. 33.—Diagram showing the relation of the pectoral arch to the axial skeleton.

have grown together. The elbow-joint bends forwards and the knee-joint backwards.

Comparing the limbs as a whole, greater differences come to light, differences which are mainly correlated with the different uses of the two limbs. The arms, serving as prehensile organs, have all their parts as movable as is consistent with the requisite strength, while the lower limbs, having to bear the whole weight of the Body,



FIG. 34.—Diagram showing the attachment of the pelvic arch to the axial skeleton.

require to have their parts much more firmly knit together. Accordingly we find the shoulder girdle, represented red in the diagram (Fig. 33), only directly attached to the axial skeleton by the union of the inner ends of the clavicles with the sternum, and capable of considerable independent movement, as seen, for instance, in "shrugging the shoulders." The pelvic arch, on the contrary, is firmly and immovably



**DIESE SEITE IST FÜR KOSTENLOSE MITGLIEDER GESPERRT**  
Beantragen Sie jetzt die volle Mitgliedschaft, um diese Seite zu betreten



**Seien Sie niemals ohne ein Buch!**

Die Vollmitgliedschaft von Forgotten Books bietet Ihnen einen universalen Zugang von unseren Apps und unserer Website, auf all Ihren Geräten: Tablet, Telefon, E-Reader, Laptop und Computer.

**Eine Bibliothek in Ihrer Tasche für € 8.99/monat**

**Fortfahren**

\*Es gelten Richtlinien zur fairen Nutzung.

mobile than they usually are, so that the foot can to a certain extent replace the hand; as has been illustrated in the case of persons born without hands who have learned to write and paint with their toes.

**Peculiarities of the Human Skeleton.** These are largely connected with the division of labor between the fore and hind limbs referred to above, which is carried farther in man than in any other creature. Even the highest apes frequently use their fore limbs in locomotion and their hind limbs in prehension, and we find accordingly that anatomically they present less differentiation of hand and foot. The other more important characteristics of the human skeleton are correlated for the most part with the maintenance of the erect posture, which is more complete and habitual in man than in the animals most closely allied to him anatomically. These peculiarities, however, only appear fully in the adult. In the infant the head is proportionately larger, the curves of the vertebral column are nearly absent, and the posterior limbs are relatively very short. In all these points the infant approaches more closely to the ape, and they all combine to give the centre of gravity of the Body a comparatively very high position and to render the maintenance of the erect posture difficult and insecure. The subsequent great relative length of the posterior limbs, which grow disproportionately fast in childhood as compared with the anterior, makes progression on them more rapid by giving a longer stride and at the same time makes it almost impossible to go on "all fours" except by crawling on the hands and knees. In other Primates this disproportion between the anterior and posterior limbs does not occur to nearly the same extent.

In man the skull is nearly balanced on the top of the vertebral column, the occipital condyles which articulate with the atlas being about its middle (Fig. 27\*), so that but little effort is needed to keep the head erect. In four-footed beasts, on the contrary, the skull is carried on the front end of the horizontal vertebral column and needs special ligaments to sustain it. For instance, in the ox and sheep there is a great elastic cord running from the cervical ver-

---

\* P. 75.

tebræ to the back of the skull and helping to hold up the head. Even in the highest apes the skull does not balance on the top of the spinal column; the face part is much heavier than the back, while in man the face parts are relatively smaller and the cranium larger, so that the two nearly equipoise. To keep the head erect and look things straight in the face, "like a man," is for the apes far more fatiguing, and so they cannot long maintain that position.

The human spinal column, gradually widening from the neck to the sacrum, is well fitted to sustain the weight of the head, upper limbs, etc., carried by it, and its curvatures, which are peculiarly human, give it considerable elasticity combined with strength. The pelvis, to the sides of which the lower limbs are attached, is proportionately very broad in man, so that the balance can be more readily maintained during lateral bending of the trunk. The arched instep and broad sole of the human foot are also very characteristic. The majority of four-footed beasts, as horses, walk on the tips of their toes and fingers, and those animals, as bears and apes, which like man place the tarsus also on the ground, or are *plantigrade* in technical language, have a much less marked arch there. The vaulted human tarsus, composed of a number of small bones, each of which can glide a little over its neighbors, but none of which can move much, is admirably calculated to break any jar which might be transmitted to the spinal column by the contact of the sole with the ground at each step. A well-arched instep is therefore justifiably considered a beauty; it makes progression easier, and by its springiness gives elasticity to the step. In London flat-footed candidates for appointment as policemen are rejected, as they cannot stand the fatigue of walking the daily "beat."

## CHAPTER VII.

### THE STRUCTURE AND COMPOSITION OF BONE. JOINTS.

**Gross Structure of the Bones.** The bones of the Body have all a similar structure and composition, but on account of differences in shape they are divided by anatomists into the following groups: (1) *Long bones*, more or less cylindrical in form, like the bones of the thigh and arm, leg and forearm, metacarpus, metatarsus, fingers and toes. (2) *Tabular bones*, in the form of expanded plates, like the bones on the roof and sides of the skull, and the shoulder-blades. (3) *Short bones*; rounded or angular in form and not much greater in one diameter than in another, like the bones of the tarsus and carpus. (4) *Irregular bones*, including all which do not get well into any of the preceding groups, and commonly lying in the middle line of the Body and divisible into two similar halves, as the vertebræ. Living bones have a bluish-white color and possess considerable elasticity, which is best seen in long slender bones such as the ribs.

To get a general idea of the structure of a bone, we may select the humerus. Externally in the fresh state it is covered by a dense white fibrous membrane very closely adherent to it and containing a good many small blood-vessels. This membrane is called the *periosteum*; on its under side new osseous tissue is formed while the bone is still growing, and all through life it is concerned in maintaining the nutrition of the bone, which dies if it is stripped off. The periosteum covers the whole surface of the bone except its ends in the elbow and shoulder joints; the surfaces there which come in contact with other bones and glide over them



**DIESE SEITE IST FÜR KOSTENLOSE MITGLIEDER GESPERRT**  
Beantragen Sie jetzt die volle Mitgliedschaft, um diese Seite zu betreten

# GESCHICHTE

Zehntausende von wichtigen historischen Quellen, viele bisher nicht erhältlich, stehen jetzt zum ersten Mal mit der Vollmitgliedschaft von Forgotten Books zur Verfügung.

Unbegrenzter Zugang  
\$8.99/monat

**Fortfahren**

\*Es gelten Richtlinien zur fairen Nutzung.



and rough patches on the shaft indicate places to which muscles of the arm were fixed.

**Internal Structure.** If the bone be divided longitudinally, it will be seen that its shaft is hollow, the space being known as the *medullary cavity*, and in the fresh bone filled with marrow. Fig. 37 represents a longitudinal section of the femur, which in this respect is quite similar to the humerus. The marrow cavity does not reach into the articular extremities, but there the bone has a loose spongy texture, except a thin layer on the surface. In the shaft, on the other hand, the outer compact layer is much the thickest, the spongy or *cancellated bone* forming only a thin stratum immediately around the medullary cavity. To the naked eye the cancellated bone appears made up of a trellis-work of thin bony plates which intersect in all directions and surround cavities rather larger than the head of an ordinary pin; the compact bone, on the contrary, appears to have no cavities in it until it is examined with a magnifying glass. In the spaces of the spongy portion lies, during life, a substance known as the *red marrow*, which is quite different from the yellow fatty marrow lying in the central cavity of the shaft.

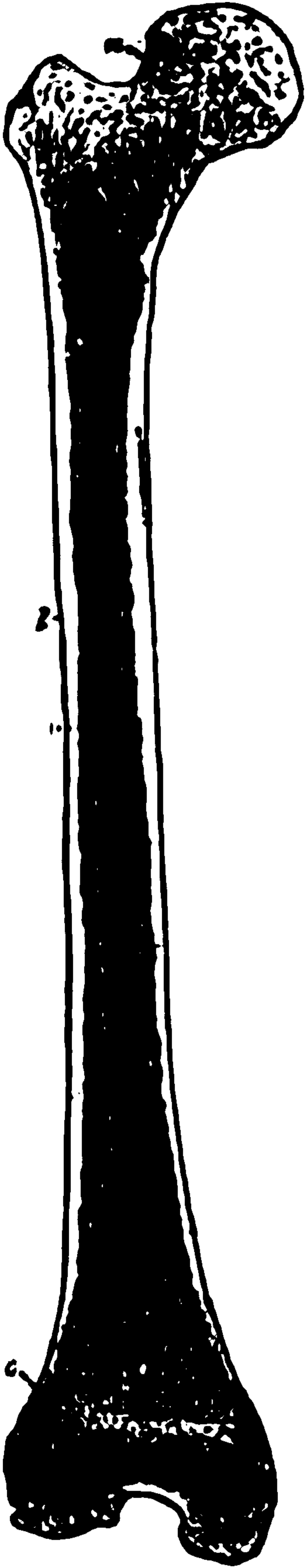

FIG. 37.—A longitudinal section of the femur. *d*, dense bone; *a*, cancellated bone; *b*, medullary cavity.

**Microscopic Structure of Bone.** The microscope shows that the compact bone contains cavities and only differs from the spongy portion in the fact that these are much smaller and the hard true bony plates surrounding them much more numerous in proportion than in the spongy

parts. If a thin transverse section of the shaft of the humerus be examined (Fig. 38) with a microscope magnifying

twenty diameters, it will be seen that numerous openings exist all over the compact parts of the section and gradually become larger as this passes into the cancellated part, next the medullary cavity. These openings are the cross-sections of tubes known as the *Haversian canals*, which ramify all through the bone, running mainly in the direc-



FIG. 38.—*A*, a transverse section of the ulna, natural size; showing the medullary cavity. *B*, the more deeply shaded part of *A* magnified twenty diameters.

tion of its long axis, but united by numerous cross or oblique branches as seen in the longitudinal section (Fig. 39). The outermost ones open on the surface of the bone beneath the periosteum, and in the living bone blood-vessels run from this through the Haversian canals and convey



materials for its growth and nourishment. The average diameter of the Haversian canals is 0.05 mm. ( $\frac{1}{20}$  of an inch).

Around each Haversian canal lies a set of plates, or *lamellæ*, of hard bony substance (see the transverse section Fig. 38), each canal with its lamellæ forming an *Haversian system*: and the whole bone is made up of a number of such systems, with the addition of a few lamellæ lying in the corners between them, and a certain number which run around the whole bone on its outer surface. In the spongy parts of the bone the Haversian canals are very large and the intervening lamellæ few in number.

Between the lamellæ lie small cavities, the *lacunæ*, each of which is lenticular in form, somewhat like the space which

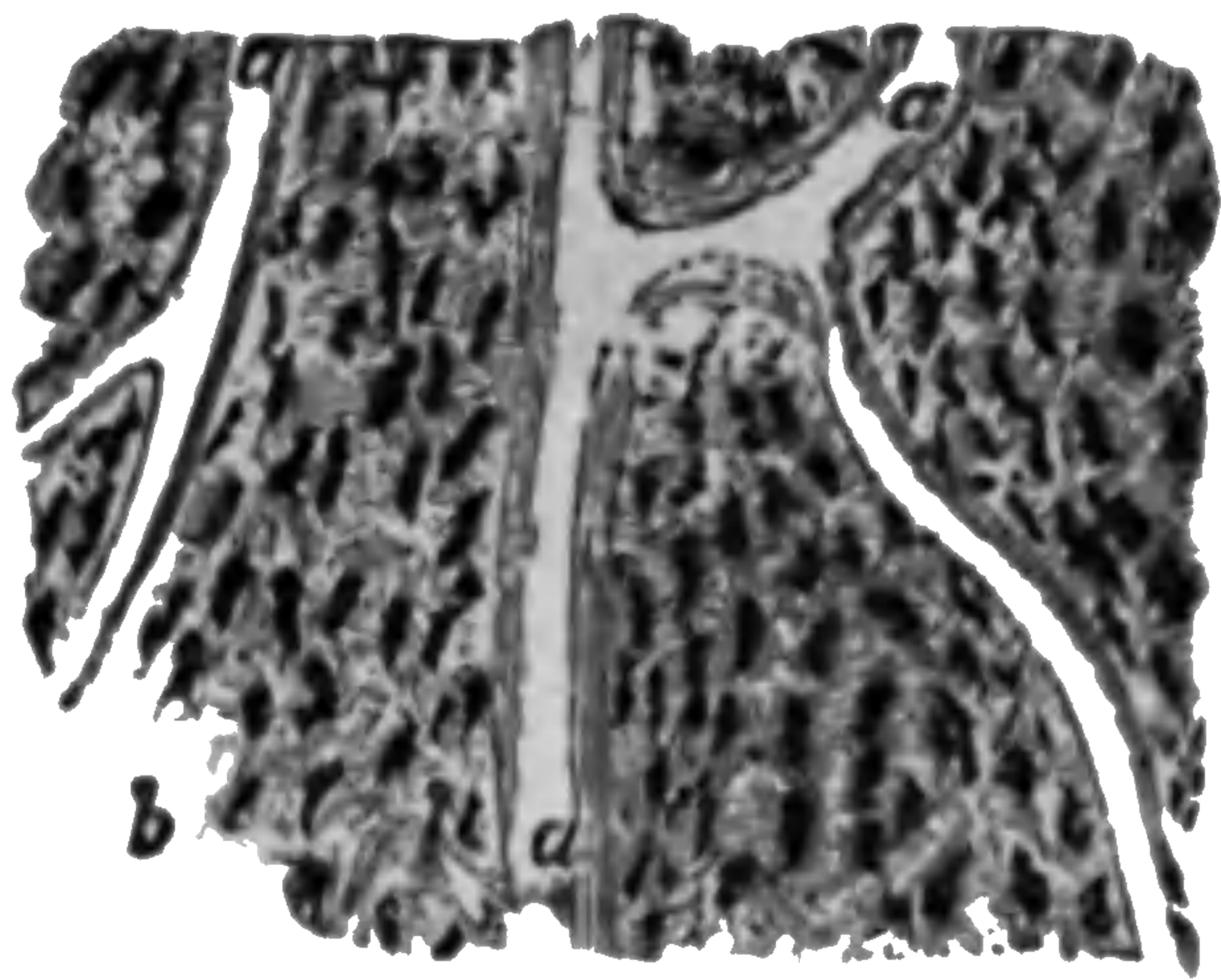

FIG. 39.—A thin longitudinal section of bone, magnified about 350 diameters. *aa*, Haversian canals.

would be inclosed by two watch-glasses joined by their edges. From the lacunæ many extremely fine branching canals, the *canaliculi*, radiate and penetrate the bony lamellæ in all directions. The innermost canaliculi of each system open into the central Haversian canal; and those of various lacunæ intercommu-

nicating, these fine tubes form a set of passages through which liquid which has transuded from the blood-vessels in the Haversian canals can ooze all through the bone. The lacunæ and canaliculi are well seen in Fig. 39.

In the living bone a granular nucleated cell lies in each lacuna. These cells, or *bone corpuscles*, are the remnants of those which built up the bone, the hard parts of the latter being really an intercellular substance or skeleton formed around and by these cells, much in the same way as a calcareous skeleton is formed around each Foraminifer (see Zoology) by the activity of its protoplasm. By the co-operation of all the bone corpuscles, and the union of their skeletons, the whole bone is built up.

In other bones we find the same general arrangement of



**DIESE SEITE IST FÜR KOSTENLOSE MITGLIEDER GESPERRT**  
Beantragen Sie jetzt die volle Mitgliedschaft, um diese Seite zu betreten



**Seien Sie niemals ohne ein Buch!**

Die Vollmitgliedschaft von Forgotten Books bietet Ihnen einen universalen Zugang von unseren Apps und unserer Website, auf all Ihren Geräten: Tablet, Telefon, E-Reader, Laptop und Computer.

**Eine Bibliothek in Ihrer Tasche für € 8.99/monat**

**Fortfahren**

\*Es gelten Richtlinien zur fairen Nutzung.

calcium phosphate, or *bone earth* ( $\text{Ca}_3, 2\text{PO}_4$ ); but there is also present a considerable proportion of calcium carbonate ( $\text{CaCO}_3$ ) and smaller quantities of other salts.

**Hygiene of the Bony Skeleton.** In early life the bones are less rigid, from the fact that the earthy matters then present in them bear a less proportion to the softer organic parts. Hence the bones of an aged person are more brittle and easily broken than those of a child. The bones of a young child are in fact tolerably flexible and will be distorted by any continued strain; therefore children should never be kept sitting for hours, in school or elsewhere, on a bench which is so high that the feet are not supported. If this be insisted upon (for no child will continue it voluntarily) the thigh-bones will almost certainly be bent over the edge of the seat by the weight of the legs and feet, and a permanent distortion may be produced. For the same reason it is important that a child be made to sit straight in writing, to avoid the risk of producing a lateral curvature of the spinal column. The facility with which the bones may be moulded by prolonged pressure in early life is well seen in the distortion of the feet of Chinese ladies, produced by keeping them in tight shoes; and in the extraordinary forms which some races of man produce in their skulls, by tying boards on the heads of the children.

Throughout the whole of life, moreover, the bones remain among the most easily modified parts of the Body; although judging from the fact that dead bones are the most permanent parts of fossil animals we might be inclined to think otherwise. The living bone, however, is constantly undergoing changes under the influence of the protoplasmic cells imbedded in it, and in the living Body is constantly being absorbed and reconstructed. The experience of physicians shows that any continued pressure, such as that of a tumor, will cause the absorption and disappearance of bone almost quicker than that of any other tissue; and the same is true of any other continued pressure. Moreover, during life the bones are eminently plastic; under abnormal pressures they are found to quickly assume abnormal shapes, being absorbed and disappearing

at points where the pressure is most powerful, and increasing at other points; tight lacing may in this way produce a permanent distortion of the ribs.

When a bone is fractured a surgeon should be called in as soon as possible, for once inflammation has been set up and the parts have become swollen it is much more difficult to place the broken ends of the bone together in their proper position than before this has occurred. Once the bones are replaced they must be held in position by splints or bandages, or the muscles attached to them will soon displace them again. With rest, in young and healthy persons complete union will commonly occur in three or four weeks; but in old persons the process of cure is slower and is apt to be imperfect.

**Articulations.** The bones of the skeleton are joined together in very various ways; sometimes so as to admit of no movement at all between them; in other cases so as to permit only a limited range or variety of movement; and elsewhere so as to allow of very free movement in many directions. All kinds of unions between bones are called *articulations*.

Of articulations permitting no movements, those which unite the majority of the cranial bones afford a good example. Except the lower jaw, and certain tiny bones inside the temporal bone belonging to the organ of hearing, all the skull-bones are immovably joined together. This union in the case of most occurs by means of toothed edges which fit into one another and form jagged lines of union known as *sutures*. Some of these can be well seen in Fig. 26\* between the frontal and parietal bones (*coronal suture*) and between the parietal and occipital bones (*lambdoidal suture*); while another lies along the middle line in the top of the crown between the two parietal bones, and is known as the *sagittal suture*. In new-born children where the sagittal meets the coronal and lambdoidal sutures there are large spaces not yet covered in by the neighboring bones, which subsequently extend over them. These openings are known as *fontanelles*. At them a pulsation can often be felt synchronous with each beat of the heart, which, driving more

---

\* P. 74.

blood into the brain, distends it and causes it to push out the skin where bone is absent. Another good example of an articulation admitting of no movement, is that between the rough surface on the sides of the sacrum and the innominate bone.

We find good examples of the second class of articulations—those admitting of a slight amount of movement—in the vertebral column. Between every pair of vertebræ from the second cervical to the sacrum is an elastic pad, the *intervertebral disk*, which adheres by its surfaces to the bodies of the vertebræ between which it lies, and only permits so much movement between them as can be brought about by its own compression or stretching. When the back-bone is curved to the right, for instance, each of the intervertebral disks is compressed on its right side and stretched a little on its left, and this combination of movements, each individually but slight, gives considerable flexibility to the spinal column as a whole.

**Joints.** Articulations permitting of movement by the gliding of one bone over another, are known as *joints* and all have the same fundamental structure, although the amount of movement permitted in different joints is very different.

**Hip-Joint.** We may take this as a good example of a true joint permitting a great amount and variety of movement. On the os innominatum is the cavity of the *acetabulum* (Fig. 40), which is lined inside by a thin layer of *articular cartilage* which has an extremely smooth surface. The bony cup is also deepened a little by a cartilaginous rim. The proximal end of the femur consists of a nearly spherical smooth *head*, borne on a somewhat narrower *neck*, and fitting into the acetabulum. This head also is covered with articular cartilage; and it rolls in the acetabulum like a ball in a socket. To keep the bones together and limit the amount of movement, *ligaments* pass from one to the other. These are composed of white fibrous connective tissue (Chap. VIII.) and are extremely pliable but quite inextensible and very strong and tough. One is the *capsular ligament*, which forms a sort of loose bag all round



**DIESE SEITE IST FÜR KOSTENLOSE MITGLIEDER GESPERRT**  
Beantragen Sie jetzt die volle Mitgliedschaft, um diese Seite zu betreten

# GESCHICHTE

Zehntausende von wichtigen historischen Quellen, viele bisher nicht erhältlich, stehen jetzt zum ersten Mal mit der Vollmitgliedschaft von Forgotten Books zur Verfügung.

Unbegrenzter Zugang  
\$8.99/monat

**Fortfahren**

\*Es gelten Richtlinien zur fairen Nutzung.



This contact is not maintained by the ligaments, which are too loose and serve only to check excessive movement, but by the numerous stout muscles which pass from the thigh to the trunk and bind the two firmly together. Moreover, the atmospheric pressure exerted on the surface of the Body and transmitted through the soft parts to the outside of the air-tight joint helps also to keep the parts in contact. If all the muscles and ligaments around the joint be cut away it is still found in the dead Body that the head of the femur will be kept in its socket by this pressure, and so firmly as to bear the weight of the whole limb without dislocation, just as the pressure of the air will enable a boy's "sucker" to lift a tolerably heavy stone.

**Ball-and-socket Joints.** Such a joint as that at the hip is called a ball-and-socket joint and allows of more free movement than any other. Through movements occurring in it the thigh can be *flexed*, or bent so that the knee approaches the chest; or *extended*, that is moved in the opposite direction. It can be *abducted*, so that the knee moves outwards; and *adducted*, or moved back towards the other knee again. The limb can also by movements at the hip-joint be *circumducted*, that is made to describe a cone of which the base is at the foot and the apex at the hip. Finally *rotation* can occur in the joint, so that with knee and foot joints held rigid the toes can be turned in or out, to a certain extent, by a rolling around of the femur in its socket.

At the junction of the humerus with the scapula is another ball-and-socket joint permitting all the above movements to even a greater extent. This greater range of motion at the shoulder-joint depends mainly on the shallowness of the glenoid cavity as compared with the acetabulum and upon the absence of any ligament answering to the round ligament of the hip-joint. Another ball-and-socket joint exists between the carpus and the metacarpal bone of the thumb; and others with the same variety, but a much less range, of movement between each of the remaining metacarpal bones and the proximal phalanx of the finger which articulates with it.

**Hinge-Joints.** Another form of synovial joint is known

articulation between the lower jaw and the base of the skull which allows us to open and close our mouths. The latter is, however, not a perfect hinge-joint, since it permits of a small amount of lateral movement such as occurs in chewing, and also of a gliding movement by which the lower jaw can be thrust forward so as to protrude the chin and bring the lower row of teeth outside the upper.

**Pivot-Joints.** In this form one bone rotates around another which remains stationary. We have a good example of it between the first and second cervical vertebræ. The first cervical vertebra or *atlas* (Fig. 19\*) has a very small body and a very large arch, and its neural canal is subdivided by a transverse ligament (*L*, Fig. 19) into a dorsal and a ventral portion; in the latter the spinal cord lies. The second vertebra or *axis* (Fig. 20) has arising from its body the stout bony peg, *D*, called the *odontoid process*. This projects into the ventral portion of the space surrounded by the atlas, and, kept in place there by the transverse ligament, forms a pivot around which the atlas, carrying the skull with it, rotates when we turn the head from side to side. The joints on each side between the atlas and the skull are hinge-joints and permit only the movements of nodding and raising the head. When the head is leaned over to one side, the cervical part of the spinal column is bent.

Another kind of pivot-joint is seen in the forearm. If the limb be held straight out, with the palm up and the elbow resting on the table, so that the shoulder-joint be kept steady while the hand is rotated until its back is turned upwards, it will be found that the radius has partly rolled round the ulna. When the palm is upwards and



the thumb outwards, the lower end of the radius can be felt on the outer side of the forearm just above the wrist, and if this be done while the hand is turned over, it will be easily discerned that during the movement this end of the radius, carrying the hand with it, travels around the lower end of the ulna so as to get to its inner side. The relative position of the bones when the palm is upwards is shown at A in Fig. 41, and when the palm is down at B. The former position is known as *supination*; the latter as *pronation*.

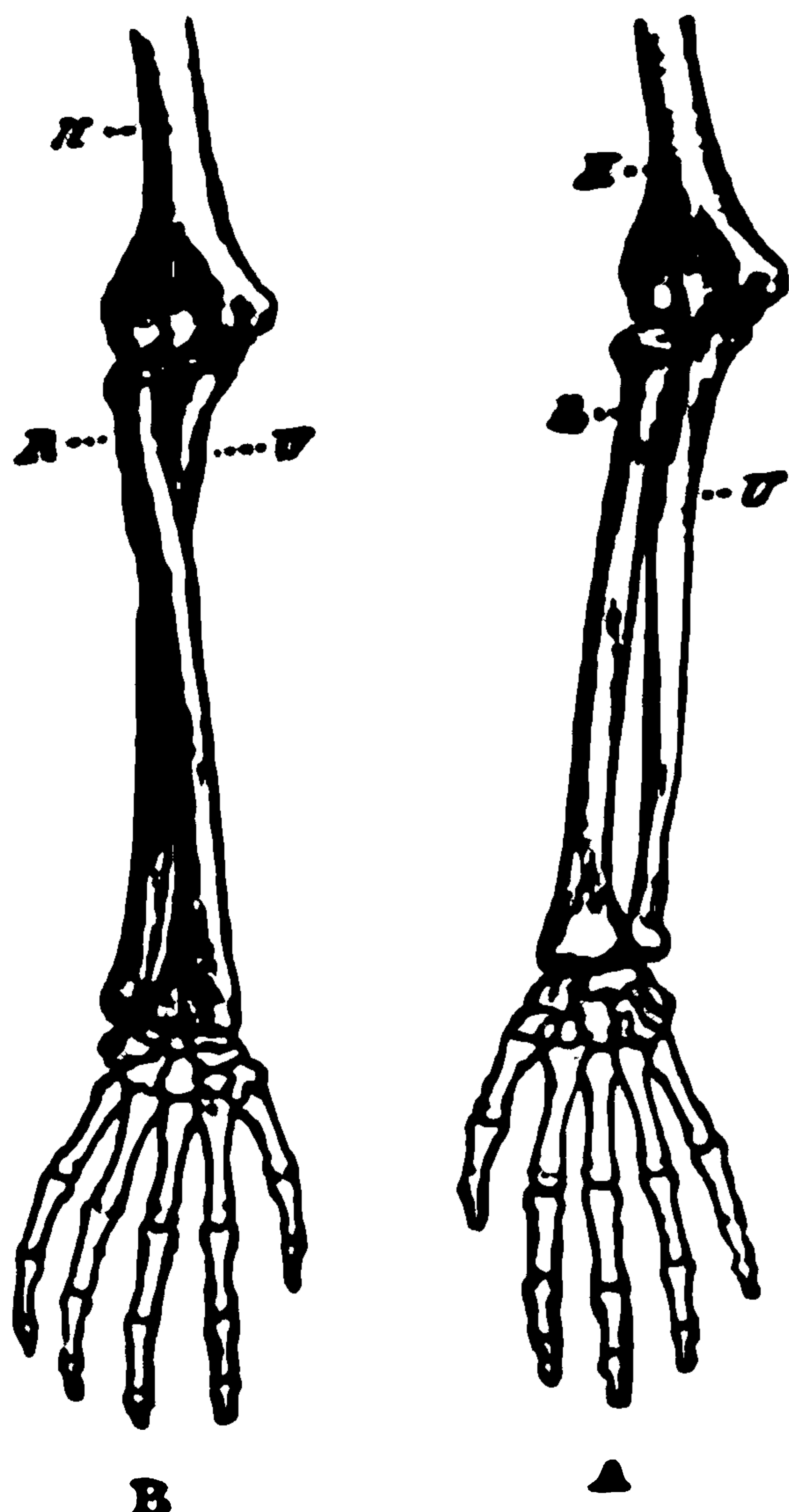

FIG. 41.—A, arm in supination; B, arm in pronation; H, humerus; R, radius; U, ulna.

The elbow end of the humerus (Fig. 36\*) bears a large articular surface: on the inner two thirds of this, *Tr*, the ulna fits, and the ridges and grooves of both bones interlocking form a hinge-joint, allowing only of bending or straightening the forearm on the arm. The radius fits on the rounded outer third, *Cpl*, and forms there a ball-and-socket joint at which the movement takes place when the hand is turned from the supine to the prone position; the ulna forming a fixed bar around which the lower end of the radius is moved.

**Gliding Joints.** These permit as a rule but little movement: examples are found be-

tween the closely packed bones of the tarsus (Fig. 35†) and carpus, which slide a little over one another when subjected to pressure.

**Hygiene of the Joints.** When a bone is displaced or *dislocated* the ligaments around the joint are more or less torn and other soft parts injured. This soon leads to inflammation and swelling which make not only the recognition of the injury but, after diagnosis, the replacement of the bone, or the *reduction of the dislocation*, difficult.

\* P. 87.

† P. 88.



**DIESE SEITE IST FÜR KOSTENLOSE MITGLIEDER GESPERRT**  
Beantragen Sie jetzt die volle Mitgliedschaft, um diese Seite zu betreten



**Seien Sie niemals ohne ein Buch!**

Die Vollmitgliedschaft von Forgotten Books bietet Ihnen einen universalen Zugang von unseren Apps und unserer Website, auf all Ihren Geräten: Tablet, Telefon, E-Reader, Laptop und Computer.

**Eine Bibliothek in Ihrer Tasche für € 8.99/monat**

**Fortfahren**

\*Es gelten Richtlinien zur fairen Nutzung.

# CHAPTER VIII.

## CARTILAGE AND CONNECTIVE TISSUE.

**Temporary and Permanent Cartilages.** In early life a great many parts of the supporting framework of the Body, which afterwards become bone, consist of cartilage. Such for example is the case with all the vertebræ, and with the bones of the limbs. In these cartilages subsequently the process known as *ossification* takes place, by which a great portion of the original cartilaginous model is removed and replaced by true osseous tissue. Often, however, some of the primitive cartilage is left throughout the whole of life at the ends of the bones in joints where it forms the articular cartilages; and in various other places still larger masses remain, such as the costal cartilages, those in the external ears forming their framework, others finishing the skeleton of the nose which is only incompletely bony, and many in internal parts of the Body, as the cartilage of "Adam's apple," which can be felt in the front of the neck, and a number of rings around the windpipe serving to keep it open. These persistent masses are known as the *permanent*, the others as the *temporary cartilages*. In old age many so-called permanent cartilages become *calcified*—that is, hardened and made unyielding by deposits of lime salts in them—without assuming the histological character of bone, and this calcification of the permanent cartilages is one chief cause of the want of pliability and suppleness of the frame in advanced life.

**Hyaline Cartilage.** In its purest form cartilage is flexible and elastic, of a pale bluish-white color when alive and seen in large masses, and cuts readily with a knife. In thin pieces it is quite transparent. Everywhere except in the

joints it is invested by a tough adherent membrane, the *perichondrium*, which resembles in structure and function the periosteum of the bones. When boiled for a long time in water such cartilages yield a solution of *chondrin*, which differs from gelatin in minor points but agrees with it in the fact that its hot watery solutions "set" or gelatinize on cooling. When a thin slice of hyaline cartilage is examined with a microscope it is found (Fig. 42) to consist of granular nucleated cells, often collected into groups of two, four, or more, scattered through a homogeneous or faintly granular ground substance or *matrix*. Essentially, cartilage resembles bone, being made up of protoplasmic cells and a proportionately large amount of non-protoplasmic intercel-



FIG. 42. - Hyaline cartilage. *c*, a cell with several nuclei, and about to divide; *b*, a cell which has divided into two; *a*, a group of four cells such as would result from a repetition of the division of *b*. The granules of the matrix are represented much too coarse and conspicuous.

lular substance, the cells being the more active living part and the matrix their product. Examples of this hyaline variety (so called from its glassy transparent appearance) are found in all the temporary cartilages, and in the costal and articular among the permanent.

They rarely contain blood-vessels except at those points where a temporary cartilage is being removed and replaced by bone; then blood-vessels run in from the perichondrium and form loops in the matrix, around which it is absorbed and bony tissue deposited. In consequence of the usual absence of blood-vessels the nutritive processes and ex-

might indeed be expected from the passive and mer 1 mechanical rôle which this tissue plays.

Hyaline cartilage is the type, or most characteristically developed form, of a tissue found with modifications elsewhere in the Body. One of its other modifications is the so-called *cellular cartilage*, which consists of the cells with hardly any matrix, only just enough to form a thin capsule around each. This form is that with which all the cartilages commence, the hyaline variety being built up by the increase of the cell capsules and their fusion to form the matrix. It persists throughout life in the thin cartilaginous plate of a mouse's external ear. Other varieties of cartilage are really mixtures of true cartilage and connective tissues, and will be considered after the latter.

**The Connective Tissues.** These complete the skeleton, marked out in its coarser features by the bones and cartilages, and constitute the final group of the supporting tissues. They occur in all forms from broad membranes and stout cords to the finest threads, forming networks around the other ultimate histological elements of various organs. In addition to subsidiary forms, three main varieties of this tissue are readily distinguishable, viz., *areolar*, *white fibrous*, and *yellow elastic*. Each consists of fibres and cells, the fibres being of two kinds, mixed in nearly equal proportions in the areolar variety, while one kind predominates in one and another in the second of the remaining chief forms.

**Areolar Connective Tissue.** This exists abundantly beneath the skin, where it forms a loose flocculent layer, somewhat like raw cotton in appearance but not so white. It is on account of its loose texture that the skin can everywhere be moved, more or less, to and fro over the subjacent parts to which it is united by this tissue. Areolar tissue consists of innumerable bands and cords interlacing in all directions, and can be greatly distended by blowing air in at any point, from whence it travels wid 1 through the intercommunicating meshes. In dropsy of the legs or feet the cavities of this tissue are distended with lymph. From beneath the skin the areolar tissue extends all through the



**DIESE SEITE IST FÜR KOSTENLOSE MITGLIEDER GESPERRT**  
Beantragen Sie jetzt die volle Mitgliedschaft, um diese Seite zu betreten

# GESCHICHTE

Zehntausende von wichtigen historischen Quellen, viele bisher nicht erhältlich, stehen jetzt zum ersten Mal mit der Vollmitgliedschaft von Forgotten Books zur Verfügung.

Unbegrenzter Zugang  
\$8.99/monat

**Fortfahren**

\*Es gelten Richtlinien zur fairen Nutzung.



yields gelatin when boiled in water. The substance in it, and in the bones, which is turned into gelatin by such treatment is known as *collagen*. Glue is impure gelatin obtained from tendons and ligaments, and calf's-foot jelly, so often recommended to invalids, is a purer form of the same substance obtained by boiling the feet of calves, which contain the tendons of many muscles passing from the leg to the foot.



FIG. 43.



FIG. 43a.

FIG. 43.—White fibrous connective tissue, highly magnified. The nucleated corpuscles, seen edgewise and appearing spindle-shaped, are seen here and there on the surface of the bundles of fibres.

FIG. 43a.—Yellow elastic tissue, magnified after its fibres have been torn apart.

**Elastic Tissue.** This is almost invariably mixed in some proportion in all specimens of white fibrous tissue, even the purest, such as the tendons of muscles; but in certain places it exists almost alone, as for example in the ligaments (*ligamenta subflava*) between the arches of the vertebrae, and in the coats of the larger arteries. In quadrupeds it forms the great ligament already referred to (p. 84), which helps to sustain the head. This tissue, in

naes, is of a dull yellow color and extremely extensible and elastic; when purest nearly as much so as a piece of india-rubber. Sometimes it appears under the microscope to be made up of delicate membranes, but most often it is in the form of fibres (Fig. 43a) which are coarser than those of white fibrous tissue and frequently branch and unite. It is unaffected by acetic acid and does not yield gelatin when boiled.

**Connective-Tissue Corpuscles.** The fibres of white fibrous tissue, wherever it is found, are united into bundles by a structureless ground material known as the *cement substance*, which also invests each bundle, or skein as we may call it, with a delicate coating. In this ground substance are numerous cavities, branched and flattened in



FIG. 44.—Connective-tissue corpuscles.

one diameter, and often intercommunicating by their branches. In these cavities lie nucleated masses of protoplasm (Fig. 44), frequently also branched, known as the *connective-tissue corpuscles*. These it is which build up the tissue, each cell in the course of development forming around it a quantity of intercellular substance, which subsequently becomes fibrillated in great part, the remainder forming the cement. The cells do not quite fill the cavities in which they lie, and these opening into others by their offsets there is formed a set of minute tubes ramifying through the connective tissues; and (since these in turn permeate nearly all the Body) pervading all the organs. In these cell cavities and their branches the lymph flows before it enters definite lymphatic vessels, and they are ac-



cordingly known as *lymph canaliculi*. In addition to the fixed branched connective-tissue corpuscles lying in the cavities of the ground-substance there are often found other cells, when living connective tissue is examined by the microscope. These cells much resemble white blood corpuscles, and probably are such which have bored through the walls of the finer blood-vessels. They creep about along the canaliculi by means of their faculty of amœboid movement, and are known as the "wandering cells." During inflammation at any point their number in that region is greatly increased.

**Subsidiary Varieties of Connective Tissue.** In various parts of the Body are connective-tissue structures which have not undergone the typical development, but have departed from it in one way or another. The cells having formed a non-fibrillated intercellular substance around them, development may go no farther and the mass remain permanently as the *jelly-like connective tissue*; or, as in the vitreous humor of the eye (Chap. XXXI.), the cells having formed the soft matrix, may disappear and leave the latter only. In other cases the intercellular substance disappears and the cells branching, and joining by the ends of their branches, form a network themselves, nucleated or not at the points answering to the centre of each originally separate cell. This *adenoid connective tissue* is found widely distributed in the Body especially in connection with the lymphatic system, and forming a supporting framework for the proper nervous elements in the brain and spinal cord. In other cases the cells almost alone constitute the tissue, becoming flattened, closely fitted at their edges, and united by a very small amount of cement substance. Membranes formed in this way lie beneath layers of epithelium in many places and are known as *basement membranes*, and the flattened cells which line joints and the serous cavities seem really to be closely apposed flattened connective-tissue corpuscles.

**Elastic Cartilage, and Fibro-Cartilage.** We may now return to cartilages and consider those forms which are made up of more or less true cartilage mixed with more or



**DIESE SEITE IST FÜR KOSTENLOSE MITGLIEDER GESPERRT**  
Beantragen Sie jetzt die volle Mitgliedschaft, um diese Seite zu betreten



**Seien Sie niemals ohne ein Buch!**

Die Vollmitgliedschaft von Forgotten Books bietet Ihnen einen universalen Zugang von unseren Apps und unserer Website, auf all Ihren Geräten: Tablet, Telefon, E-Reader, Laptop und Computer.

**Eine Bibliothek in Ihrer Tasche für € 8.99/monat**

**Fortfahren**

\*Es gelten Richtlinien zur fairen Nutzung.

with rare exceptions, form an inconspicuous part of it in its fully developed state, the chief mass of it consisting of intercellular substance. In hyaline cartilages this latter is not fibrillated; but these cartilages pass insensibly in various regions of the Body into elastic or fibro-cartilages, and these latter in turn into elastic or fibrous connective tissue. The lamellæ of bone, too, when peeled off a bone softened in acid and examined with a very high magnifying power, are seen to be pervaded by fine fibres. Structurally, therefore, one can draw no hard and fast line between these tissues. The same is true of their chemical composition; bone and white fibrous tissue contain a substance (collagen) which is converted into gelatin when boiled in water; and in old people many cartilages become hardened by the deposit in their matrix of the same lime salts which give its hardness to bone. Further, the developmental history of all of them is much alike. In very early life each is represented by cells only: these form an intermediate substance, and this subsequently may become fibrillated, or calcified, or both. Finally they all agree in manifesting in health no great physiological activity, their use in the Body depending upon the mechanical properties of their intercellular substance.

The close alliance of all three is further shown by the frequency with which they replace one another. All the bones and cartilages of the adult are at first represented only by collections of connective tissue. Before or after birth this is in some cases substituted by bone directly (as in the case of the collar-bone and the bones on the roof of the skull), while in other cases cartilage supplants the connective tissue, to be afterwards in many places replaced by bone, while elsewhere it remains throughout life.

Moreover in different adult animals we often find the same part bony in one, cartilaginous in a second, and composed of connective tissue in a third: so that these tissues not only represent one another at different stages in the life of the same animal but permanently throughout the whole life of different animals. Low in the animal scale

we find them all represented merely by cells with structureless intercellular substance: a little higher in the scale the latter becomes fibrillated and forms distinct connective tissue. In the highest *Mollusks* (see Zoology), as the cuttlefishes, this is partly replaced by cartilage, and the same is true of the lowest fishes; while in some other fishes and the remaining Vertebrates, we find more or less bone appearing in place of the original connective tissue or cartilage.

From the similarity of their modes of development and fundamental structure, the transitional forms which exist between them, and the frequency with which they replace one another, histologists class all three (bone, cartilage, and connective tissue) together as *homologous tissues* and regard them as differentiations of the same original structure.

**Hygienic Remarks.** Since in the new-born infant many parts which will ultimately become bone, consist only of cartilage, the young child requires food which shall contain a large proportion of the lime salts which are used in building up bone. Nature provides this in the milk, which is rich in such salts (see Chap. XX.), and no other food can thoroughly replace it. If the mother's health be such as to render it unwise for her to nurse her infant, the best substitute, apart from a wet-nurse, will be cow's milk diluted with one fourth its volume of water. Arrowroot, corn-flour, and other starchy foods will not do alone, since they are all deficient in the required salts, and many infants though given food abundant in quantity are really starved, since their food does not contain the substances requisite for their healthy development.

At birth even those bones of a child which are most ossified are often not continuous masses of osseous tissue. In the humerus for example the shaft of the bone is well ossified and so is each end, but between the shafts and each of the articular extremities there still remains a cartilaginous layer, and at those points the bone increases in length, new cartilage being formed and replaced by it. The bone

increases in thickness by new osseous tissue formed beneath the periosteum. The same thing is true of the bones of the leg. On account of the largely cartilaginous and imperfectly knit state of its bones, it is cruel to encourage a young child to walk beyond its strength, and may lead to "bow-legs" or other permanent distortions. Nevertheless here as elsewhere in the animal body, moderate exercise promotes the growth of the tissues concerned, and it is nearly as bad to wheel a child about forever in a baby-carriage as to force it to walk beyond its strength.

The best rule is to let a healthy child use its limbs when it feels inclined, but not by praise or blame to incite it to efforts which are beyond its age, and so sacrifice its healthy growth to the vanity of parent or nurse.

The final knitting together of the bony articular ends with the shaft of many bones takes place only comparatively late in life, and the age at which it occurs varies much in different bones. Generally speaking, a layer of cartilage remains between the shaft and the ends of the bone, until the latter has attained its full adult length. To take a few examples: the lower articular extremity of the humerus only becomes continuous with the shaft by bony tissue in the sixteenth or seventeenth year of life. The upper articular extremity only joins the shaft by bony continuity in the twentieth year. The upper end of the femur joins the shaft by bone from the seventeenth to the nineteenth year, and the lower end during the twentieth. In the tibia the upper extremity and the shaft unite in the twenty-first year, and the lower end and the shaft in the eighteenth or nineteenth: while in the fibula the upper end joins the shaft in the twenty-fourth year, and the lower end in the twenty-first. The separate vertebræ of the sacrum are only united to form one bone in the twenty-fifth year of life; and the ilium, ischium, and pubis unite to form the *os innominatum* about the same period. Up to about twenty-five then the skeleton is not firmly "knit," and is incapable, without risk of injury, of bearing strains which it might afterwards meet with impunity. To let



**DIESE SEITE IST FÜR KOSTENLOSE MITGLIEDER GESPERRT**

Beantragen Sie jetzt die volle Mitgliedschaft, um diese Seite zu betreten

# GESCHICHTE

Zehntausende von wichtigen historischen Quellen, viele bisher nicht erhältlich, stehen jetzt zum ersten Mal mit der Vollmitgliedschaft von Forgotten Books zur Verfügung.

Unbegrenzter Zugang  
\$8.99/monat

**Fortfahren**

\*Es gelten Richtlinien zur fairen Nutzung.



and sometimes a thin layer of protoplasm forms a lining to the cell-wall. The oily matter consists of a mixture of palmatin, olein and stearin, which are compounds of palmitic, stearic and oleic acids with glycerine, three molecules of the acid being combined with one of glycerine, with the elimination of water; as for example:

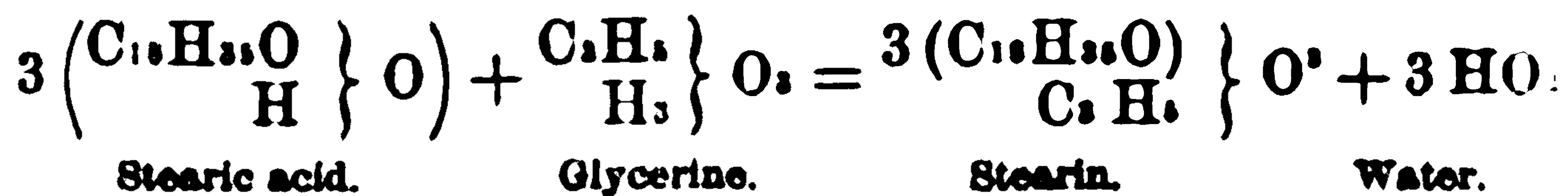

## CHAPTER IX.

### THE STRUCTURE OF THE MOTOR ORGANS.

**Motion in Animals and Plants.** If one were asked to point out the most distinctive property of living animals, the answer would probably be, their power of executing spontaneous movements. Animals as we commonly know them are rarely at rest, while trees and stones move only when acted upon by external forces, which are in most cases readily recognizable. Even at their quietest times some kind of motion is observable in the higher animals. In our own Bodies during the deepest sleep the breathing movements and the beat of the heart continue; their cessation is to an onlooker most obvious sign of death. Here however, as elsewhere in Biology, we find that precise boundaries do not exist; at any rate so far as animals and plants are concerned we cannot draw a hard and fast line between them with reference to the presence or absence of apparently spontaneous motility. Many a flower closes in the evening to expand again in the morning sun; and in many plants comparatively rapid and extensive movements can be called forth by a slight touch, which in itself is quite insufficient to produce mechanically that amount of motion in the mass. The Venus's flytrap (*Dionæa muscipula*) for example has fine hairs on its leaves, and when these are touched by an insect the leaf closes up so as to imprison the animal, which is subsequently digested and absorbed by the leaf. The higher plants it is true have not the power of *locomotion*, they cannot change their place as the higher animals can; but on the other hand some of the lower animals are permanently fixed to one spot; and among the lowest plants many are known which swim about actively through the water in



which they live. The lowest animals and plants are in fact those which have undergone least differentiation in their development, and which therefore resemble each other in possessing, in a more or less manifest degree, all the fundamental physiological properties of that simple mass of protoplasm which formed the starting point of each individual. With the physiological division of labor which takes place in the higher forms we find that, speaking broadly, plants especially develop nutritive tissues, while animals are characterized by the high development of tissues with motor and irritable properties; so that the preponderance of these latter is very marked when a complex animal, like a dog or a man, is compared with a complex plant, like a pine or a hickory. The higher animal possesses in addition to greatly developed nutritive tissues (which differ only in detail from those of the plant, and constitute what are therefore often called *organs of vegetative life*), well-developed spontaneous, irritable and contractile tissues, found mainly in the nervons and muscular systems, and forming what have been called the *organs of animal life*. Since these place the animal in close relationship with the surrounding universe, enabling slight external forces to excite it, and it in turn to act upon external objects, they are also often spoken of as *organs of relation*. In man they have a higher development on the whole than in any other animal, and give him his leading place in the animate world, and his power of so largly controlling and directing natural forces for his own good, while the plant can only passively strive to endure and make the best of what happens to it; it has little or no influence in controlling the happening.

**Amœboid Cells.** The simplest motor tissues in the adult Human Body are the amœboid cells (Fig. 12) already described, which may be regarded as the slightly modified descendants of the undifferentiated cells which at one time made up the whole Body. In the adult they are not attached to other parts, so that their changes of form only affect themselves and produce no movements in the rest of the Body. Hence with regard to the whole frame they



**DIESE SEITE IST FÜR KOSTENLOSE MITGLIEDER GESPERRT**  
Beantragen Sie jetzt die volle Mitgliedschaft, um diese Seite zu betreten



**Seien Sie niemals ohne ein Buch!**

Die Vollmitgliedschaft von Forgotten Books bietet Ihnen einen universalen Zugang von unseren Apps und unserer Website, auf all Ihren Geräten: Tablet, Telefon, E-Reader, Laptop und Computer.

**Eine Bibliothek in Ihrer Tasche für € 8.99/monat**

**Fortfahren**

\*Es gelten Richtlinien zur fairen Nutzung.

portion of the primitive protoplasmic mass, which forms the cilia. These, being supplied with food by the rest of the cell, are raised above the vulgar cares of life and have the opportunity to devote their whole attention to the performance of automatic movements; which are accordingly far more rapid and precise than those executed by the whole cell before any division of labor had occurred in it.

That the movements depend upon the structure and composition of the cells themselves, and not upon influences reaching them from the nervous or other tissues, is proved by the fact that they continue for a long time in isolated cells, removed and placed in a liquid, as blood serum, which does not alter their physical constitution. In cold-blooded animals, as turtles, whose constituent tissues frequently retain their individual vitality long after that bond of union has been destroyed which constitutes the life of the whole animal as distinct from the lives of its different tissues, the ciliated cells in the windpipe have been found still at work three weeks after the general death of the animal.

**The Muscles.** These are the main motor organs; their general appearance is well known to every one in the lean of butcher's meat. While amœboid cells can only move themselves, and (at least in the Human Body) ciliated cells the layer of liquid with which they may happen to be in contact, the majority of the muscles, being fixed to the skeleton, can, by alterations in their form, bring about changes in the form and position of nearly all parts of the Body. With the skeleton and joints, they constitute pre-eminently the organs of motion and locomotion, and are governed by the nervous system which regulates their activity. In fact skeleton, muscles, and nervous system are correlated parts: the degree of usefulness of any one of them largely depends upon the more or less complete development of the others. Man's highly endowed senses and his powers of reflection and reason would be of little use to him, were his muscles less fitted to carry out the dictates of his will or his joints less numerous or mobile. All the muscles are under the control of the nervous system, but all are not governed by it with the co-operation of will or

*skeletal muscles*, are also from their microscopic characters known as *striped muscles*, while the latter, or *visceral muscles*, are called *unstriped* or *plain muscles*. The skeletal muscles being generally more or less subject to the control of the will (as for example those moving the limbs) are frequently spoken of as *voluntary*, and the visceral muscles, which change their form independently of the will, as *involuntary*. The heart-muscle forms a sort of intermediate link ; it is not directly attached to the skeleton, but forms a hollow bag which drives on the blood contained in it and that quite involuntarily; but in its microscopic structure it resembles the skeletal voluntary muscles. The muscles of respiration might perhaps be cited as another intermediate group. They are striped skeletal muscles and, as we all know, are to a certain extent subject to the will; any one can draw a deep breath when he chooses. But in ordinary quiet breathing we are quite unconscious of their working, and even when attention is turned to them the power of control is limited; no one can voluntarily hold his breath long enough to suffocate himself. As we shall see hereafter, moreover, any one or all of the striped muscles of the Body may be thrown into activity independently of or even against the will, as, to cite no other instances, is seen in the "fidgets" of nervousness and the irrepressible trembling of extreme terror; so that the names voluntary and involuntary are not good ones. The functional differences between the two groups depend really more on the nervous connections of each, than upon any essential difference in

white cords which consist nearly entirely of white fibrous connective tissue. These terminal cords are called the *tendons* of the muscle and serve to attach it to parts of the bony or cartilaginous skeleton. In Fig. 48 is shown the *biceps muscle* of the arm, which lies in front of the *humerus*. Its fleshy belly, *Bb*, is seen to divide above and end there in two tendons, one of which, *Bl*, is fixed to the scapula, while the other joins the tendon of a neighboring muscle (the *coraco-brachial*) and is also fixed above to the shoulder-blade. Near the elbow-joint the muscle is continued into a single tendon, *B'*, which is fixed to the radius, but gives an offshoot, *B''*, to the connective-tissue membranes lying around the elbow-joint.

The belly of every muscle possesses the power of shortening forcibly under certain conditions. In so doing it pulls upon the tendons, which being composed of inextensible white fibrous tissue transmit the movement to the bony parts to which they are attached, just as a pull at one end of rope may be made to act upon distant objects to which the other end is tied. The tendons are merely passive cords and are sometimes very long, as for instance in the case of the muscles of the fingers, the bellies of many of which lie away in the forearm.

If the tendons at each end of a muscle were fixed to the same bone the muscle would clearly be able to produce no movement, unless by bending or breaking the bone; the probable result in such a case would be that the muscle would be torn by its own efforts. In the Body, however, the two ends of a muscle are always attached to two different pieces of the skeleton, between which more or less movement is permitted, and so when the muscle pulls it alters the relative positions of the parts to which its tendons are fixed. In the great majority of cases a true joint lies between the bones on which the muscle can pull, and when the latter *contracts* it produces movement at the joint. Many muscles even pass over two joints and can produce movement at either, as the biceps of the arm which, fixed at one end to the scapula and at the other to the radius, can move the bones at either the shoulder or



**DIESE SEITE IST FÜR KOSTENLOSE MITGLIEDER GESPERRT**

Beantragen Sie jetzt die volle Mitgliedschaft, um diese Seite zu betreten

# GESCHICHTE

Zehntausende von wichtigen historischen Quellen, viele bisher nicht erhältlich, stehen jetzt zum ersten Mal mit der Vollmitgliedschaft von Forgotten Books zur Verfügung.

Unbegrenzter Zugang  
\$8.99/monat

**Fortfahren**

\*Es gelten Richtlinien zur fairen Nutzung.



elbow joints. Where a muscle passes over an articulation it is nearly always reduced to a narrow tendon; otherwise the bulky bellies lying around the joints would make them extremely clumsy and limit their mobility.

**Origin and Insertion of Muscles.** Almost invariably that part of the skeleton to which one end of a muscle is fixed is more easily moved than the part on which it pulls by its other tendon. The less movable attachment of a muscle is called its *origin*, the more movable its *insertion*. Taking for example the *biceps* of the arm, we find that when the belly of the muscle contracts and pulls on its upper and lower tendons, it commonly moves only the forearm, bending the elbow-joint as shown in Fig. 49. The

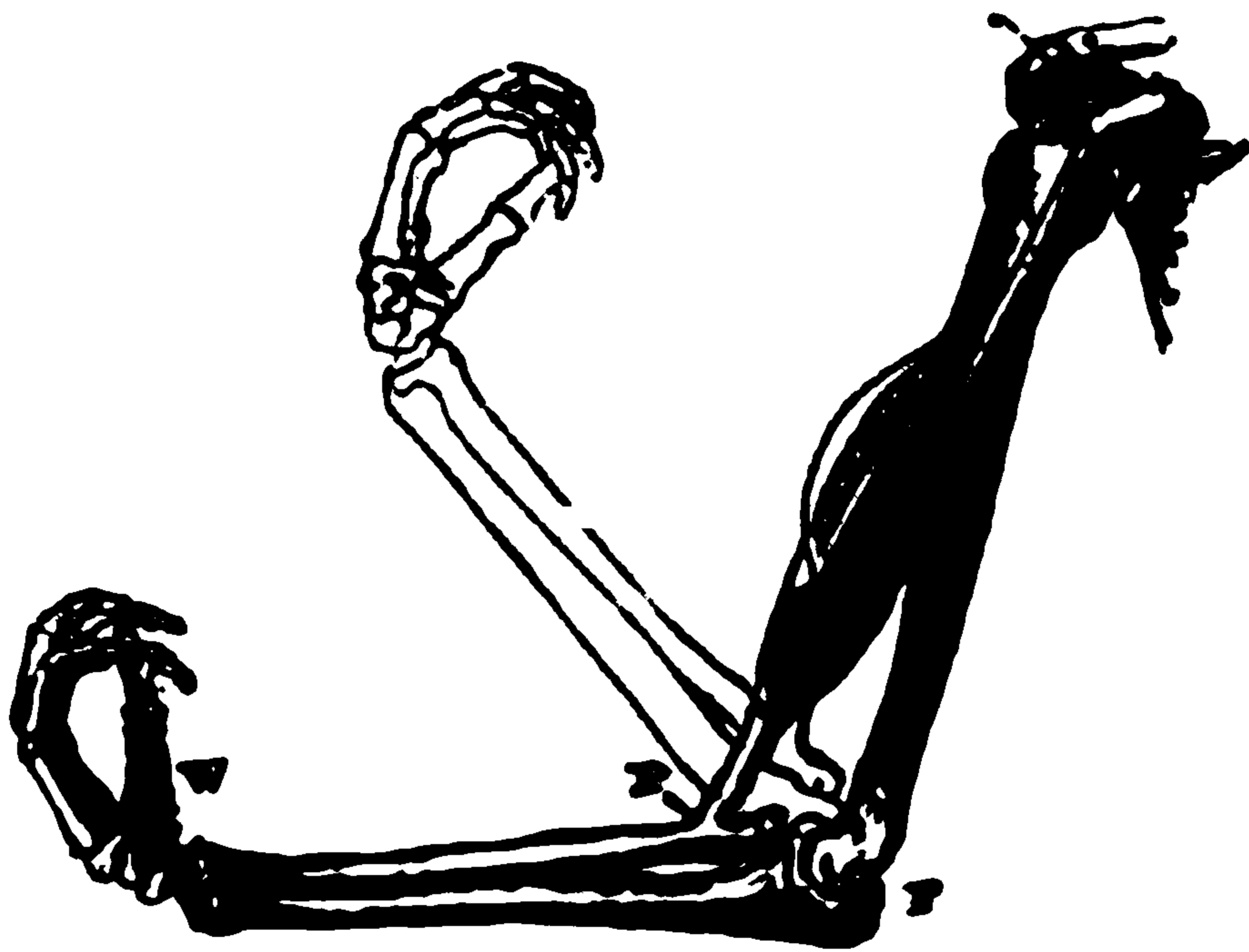

FIG. 49.—The biceps muscle and the arm-bones, to illustrate how, under ordinary circumstances, the elbow joint is flexed when the muscle contracts.

shoulder is so much more firm that it serves as a fixed point, and so that end is the origin of the muscle, and the forearm attachment, *P*, the insertion. It is clear, however, that this distinction in the mobility of the points of fixation of the muscle is only relative for, by changing the conditions, the insertion may become the stationary and origin the moved point; as for instance in going up a rope "hand over hand." In that case the radial end of the muscle is fixed and the shoulder is moved through space by its contraction.

**Different Forms of Muscles.** Many muscles of the Body have the simple typical form of a belly tapering to a

Fig. 50) are called *penniform* or feather-like; or a tendon runs obliquely down the middle of the muscle and has the fibres of the belly fixed obliquely on each side of it (c, Fig. 50), forming a *bipenniform muscle*: or even two tendons may run down the belly and so form a *tripenniform muscle*. In a few cases a tendon is found in the middle of the belly as well as at each end of it; such muscles are called *digastric*. A muscle of this form (Fig. 51) is found in connection with the lower jaw. It arises

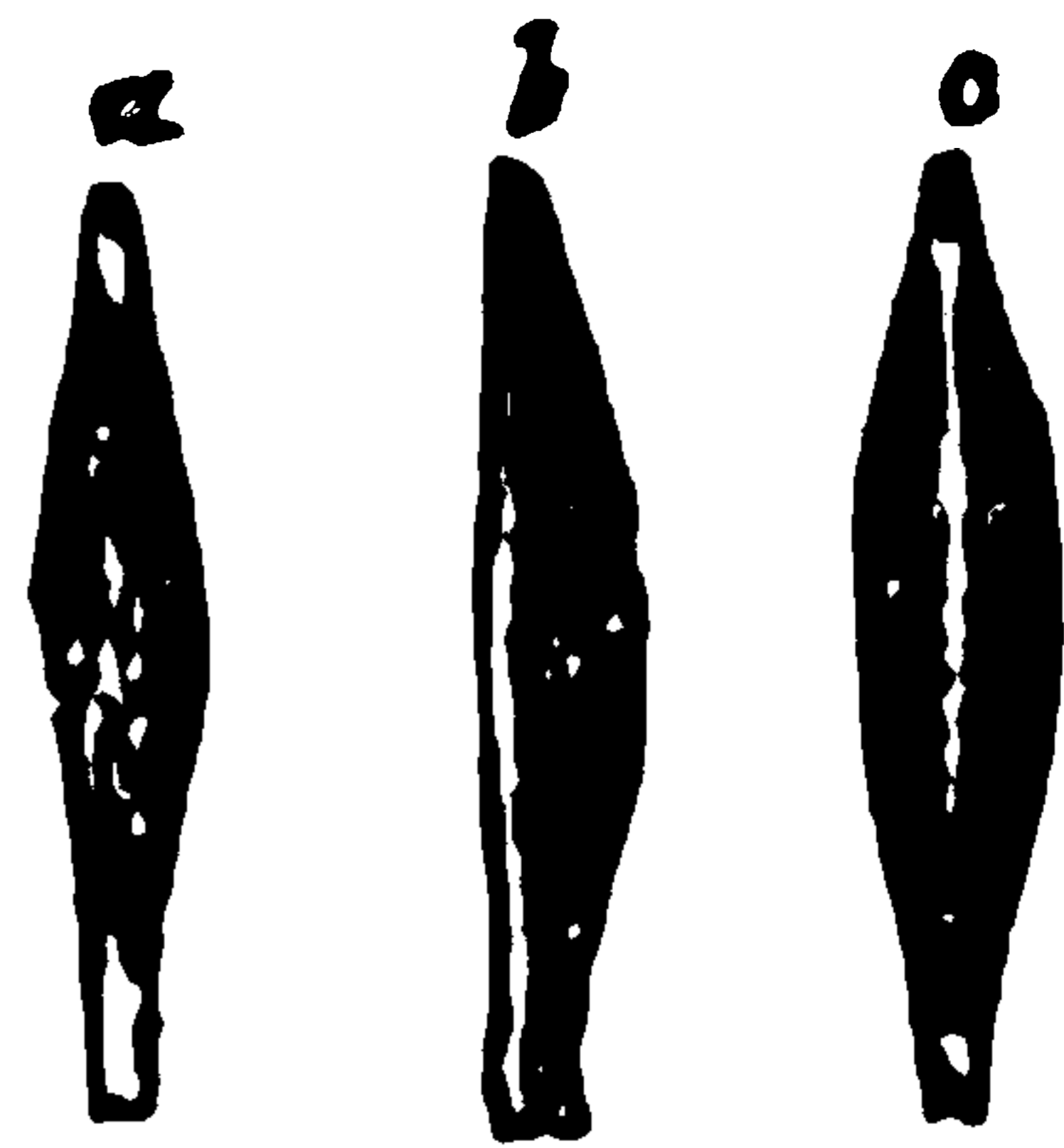

FIG. 50.—a, a simple typical muscle with a central belly and two terminal tendons; b, a penniform muscle (the tendon should not run uninterruptedly along its whole edge as represented in the figure); c, a bipenniform muscle.

by a tendon attached to the base of the skull; from there its first belly runs downwards and forwards to the neck by the side of the hyoid bone, where it ends in a tendon which passes through a loop serving as a pulley. This is



FIG. 51.—A digastric muscle.

succeeded by a second belly directed upwards towards the chin, where it ends in a tendon inserted into the lower jaw. Running along the front of the belly from the pelvis to the chest is a long muscle on each side of the middle line called the *rectus abdominis*: it is *polygastric*, consisting of four bellies separated by short tendons. Many muscles moreover are not rounded but form wide flat masses, as for example the muscle *Ss* seen on the ventral side of the shoulder-blade in Fig. 48.

**Gross Structure of a Muscle.** However the form of the skeletal muscles and the arrangement of their tendons may vary, the essential structure of all is the same. Each



consists of a proper *striped muscular tissue*, which is its essential part, but which is supported by connective tissue, nourished by blood-vessels and lymphatics, and has its activity governed by nerves; so that a great variety of things go to form the complete organ.

A loose sheath of areolar connective tissue, called the *perimysium*, envelops each muscle, and from this partitions run in and subdivide the belly into bundles or *fasciculi* which run from tendon to tendon, or for the whole length of the muscle when it has no tendons. The coarseness or fineness of butcher's meat depends upon the size of these primary fasciculi, which differs in different muscles of the same animal. These larger fasciculi are subdivided

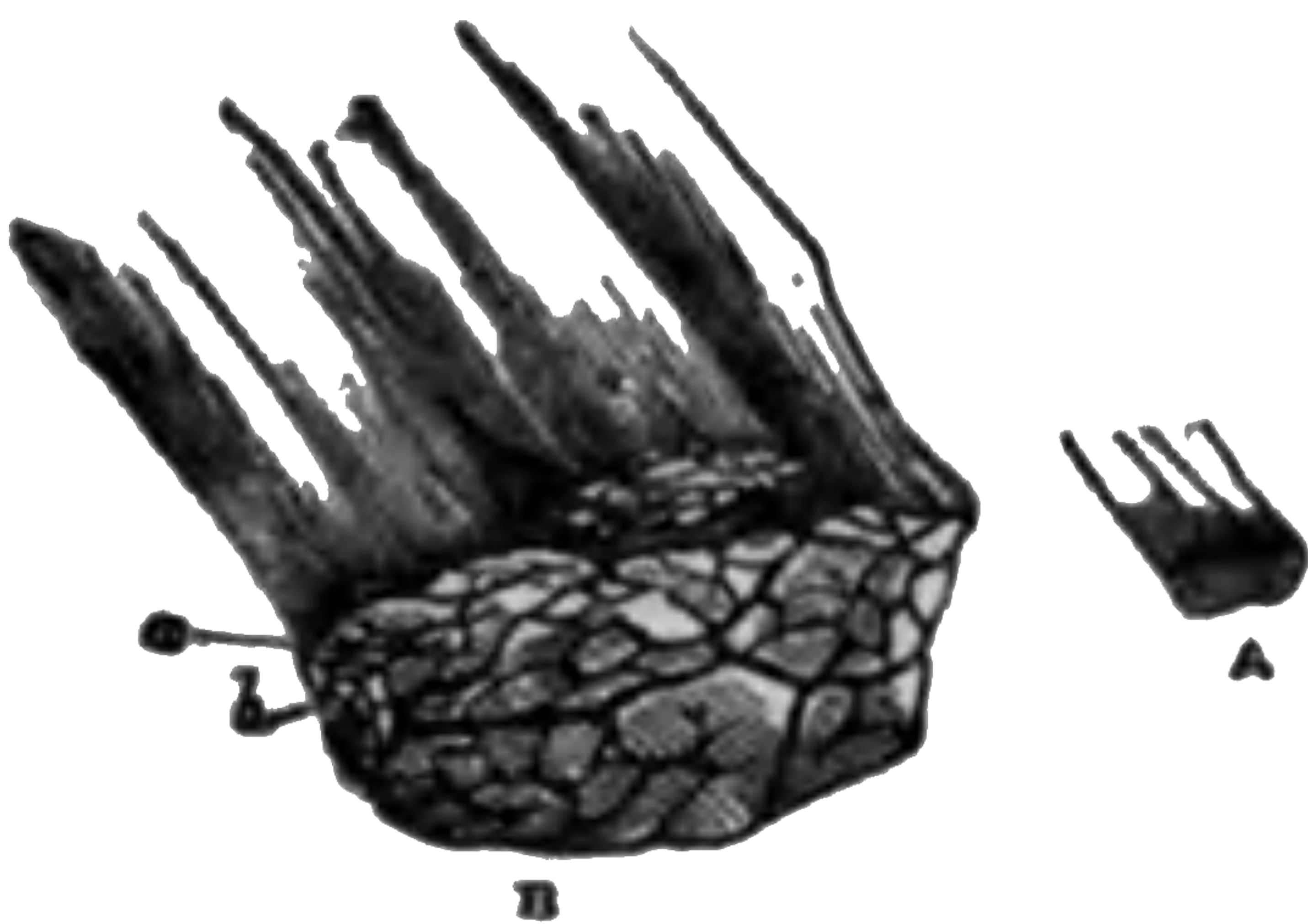

FIG. 52.—A small bit of muscle composed of three primary fasciculi. A, natural size; B, the same magnified, showing the secondary fasciculi of which the primary are composed.

by finer connective-tissue membranes into smaller ones (as shown in Fig. 52, which represents a few primary fasciculi of a muscle and the secondary fasciculi into which these are divided), each of which consists of a certain number of *muscular fibres* bound together by very fine connective tissue and envel-

oped in a close network of microscopic blood-vessels. Where a muscle tapers the fibres in the fasciculi become less numerous, and when a tendon is formed disappear altogether, leaving little but the connective tissue.

**Histology of Muscle.** For the present we need only concern ourselves with the muscular fibres. Each of these is from eight to thirty-five millimeters ( $\frac{1}{4}$  to  $1\frac{1}{4}$  inch) long, but only from 0.034 to 0.055 mm. ( $\frac{1}{7160}$  to  $\frac{1}{4100}$  inch) in diameter in its widest part, and tapering to a point at each end. Hence in long muscles with terminal tendons, no fibre runs the whole length of a fasciculus, which may be a foot or more long, but the fasciculus is made up of many successive fibres, the narrow end of each fitting in between the ends of those which follow it. In short or penniform



**DIESE SEITE IST FÜR KOSTENLOSE MITGLIEDER GESPERRT**  
Beantragen Sie jetzt die volle Mitgliedschaft, um diese Seite zu betreten



**Seien Sie niemals ohne ein Buch!**

Die Vollmitgliedschaft von Forgotten Books bietet Ihnen einen universalen Zugang von unseren Apps und unserer Website, auf all Ihren Geräten: Tablet, Telefon, E-Reader, Laptop und Computer.

**Eine Bibliothek in Ihrer Tasche für €8.99/monat**

**Fortfahren**

\*Es gelten Richtlinien zur fairen Nutzung.

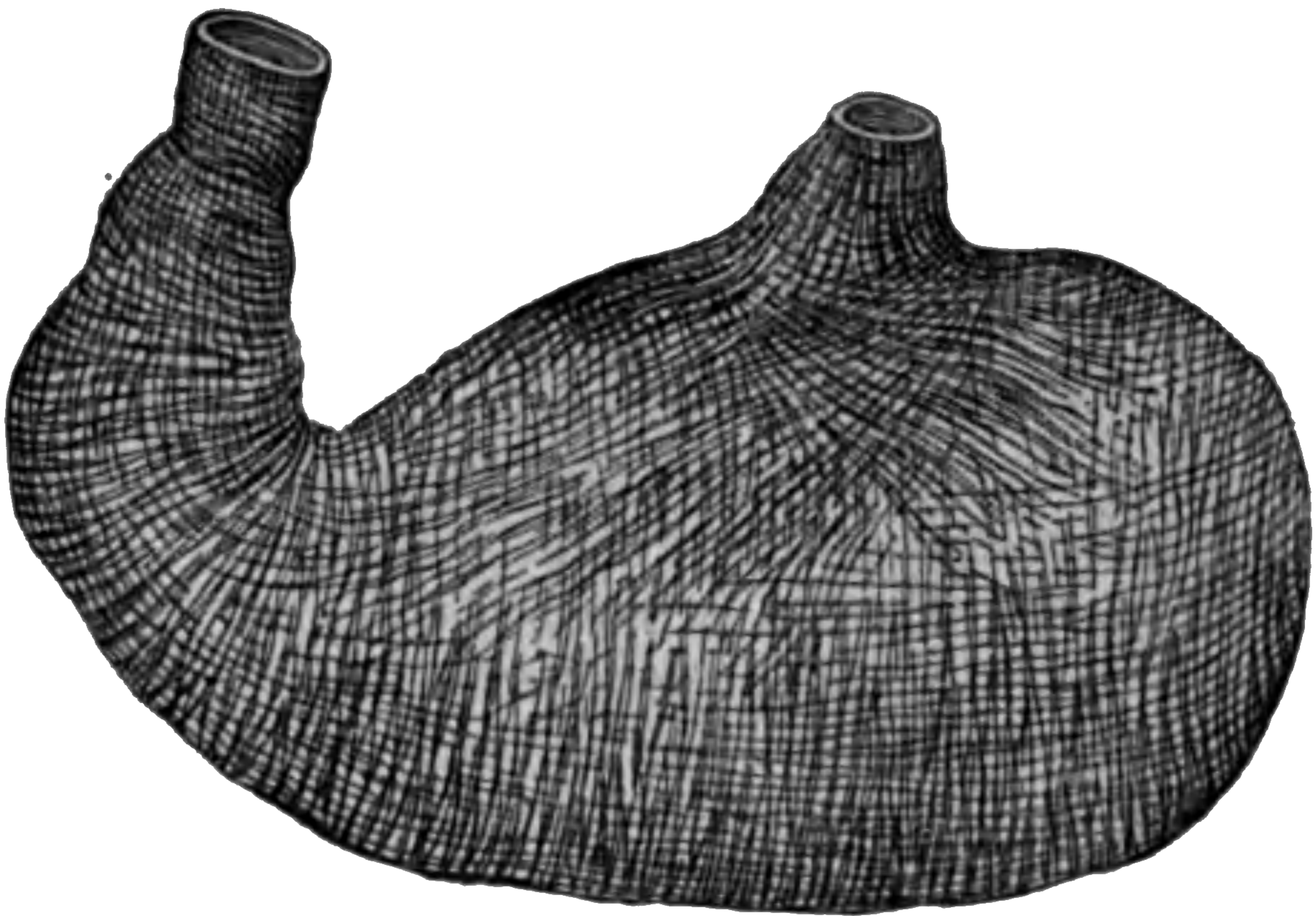

FIG. 54.—The muscular coat of the stomach.

have the power of shortening in the direction of their long axis, and so of diminishing the capacity of the cavities in the walls of which they lie.



FIG. 55.—Unstriated muscle-cells.

**Cardiac Muscular Tissue.** This consists of flattened branched cells which unite to form a network, in the interstices of which blood capillaries and nerve-fibres run. The cells present transverse striations, but not so distinct as those of the skeletal muscles, and are said to have no sarcolemma.

**The Chemistry of Muscular Tissue.** The chemical structure of the living muscular fibre is unknown, since all the methods of chemical analysis at present discovered decompose and kill it. It contains 75 per cent of water; and, among other inorganic constituents, phosphates and chlorides of potassium, sodium, and magnesium. When at rest a living muscle is feebly alkaline, but after hard work, or when dying, this reaction is reversed through the formation of sarcolactic acid ( $C_3H_5O_3$ ). Muscles contain small quantities of grape sugar and glycogen, and of organic

tive tissues, however, the main *post mortem* constituents of the muscular fibres are proteid substances, and it is probable that like protoplasm itself (p. 24) the essential contractile part of the tissue consists of a complex body containing proteid, carbohydrate and fatty residues; and that during muscular work this is broken up yielding proteids, carbon dioxide, sarcolactic acid, with probably other things; for this hypothetical substance, which has never yet been isolated, the name *inogen* has been proposed. The main proteid substance obtained from muscles is that known as *myosin*, which is prepared as follows. Perfectly fresh and still living muscles are cut out from a frog which has just been killed by destruction of its brain and spinal cord, a proceeding which entirely deprives the animal of consciousness and the power of using its muscles, but leaves these latter unaltered and alive for some time. The excised muscles are thrown into a vessel cooled below 0° C. by a freezing mixture and so are frozen hard before any great chemical change has had time to occur in them. The solidified muscles are then cut up into thin slices, the bits thrown on a cooled filter and let gradually warm up to the freezing point of water, with the addition of some ice-cold 0.5 per cent solution of common salt. Gradually a small quantity of a tenacious liquid filters through which is at first alkaline to test-paper but soon sets into a jelly and becomes acid. The coagulation and the acidity are due to the breaking up of the muscle substance into the myosin and other bodies referred to above. At first the jelly is transparent, but soon the myosin becomes opaque and shrinks just like blood fibrin, squeezing out a quantity of *muscle serum*, and remaining itself as the *muscle clot*. Myosin thus prepared is insoluble in water and in saturated solution of common salt, but soluble in five or ten per cent watery solutions of the latter substance. When boiled it is turned into coagulated proteid (p. 11) and becomes insoluble in dilute acids, in which the original myosin was soluble, being at the same time, however, converted into

another proteid, called *syntonin*, which was formerly considered to be the original proteid yielded by the muscles. Syntonin is insoluble in water but soluble in dilute acids and alkalies and its solutions are not coagulated by boiling.

**Beef Tea and Liebig's Extract.** From the above stated facts it is clear that when a muscle is boiled in water its myosin is coagulated and left behind in the meat: even if cooking be commenced by soaking in cold water, the myosin still remains as it is insoluble in cold water. Beef tea as ordinarily made, then, contains little but the flavoring matters and salts of the meat and some gelatin, the former making it deceptively taste as if it were a strong solution of the whole meat, whereas it contains but little of the most nutritious proteid portions, which in an insipid shrunken form are left when the liquid is strained off. Various proposals have been made with the object of avoiding this and getting a really nutritive beef tea; as for example chopping the raw meat fine and soaking it in strong brine for some hours to dissolve out the myosin; or extracting it with dilute acids which turn the myosin into syntonin and dissolve it, at the same time rendering it non-coagulable by heat when subsequently boiled. Such methods, however, make unpalatable compounds which invalids, as a rule, will not take. Beef tea is a slight stimulant but hardly a food and cannot be relied upon to keep up a patient's strength for any length of time. *Liebig's extract of meat* is essentially a very strong beef tea; containing much of the flavoring substances of the meat, nearly all its salts and the crystalline nitrogenous bodies, such as kreatin, which exist in muscle, but hardly any of its really nutritive parts. From its stimulating effects it is often useful to persons in feeble health, but other food should be given with it. It may also be used on account of its flavor to add to the "stock" of soup and for similar purposes; but the erroneousness of the common belief that it is a highly nutritious food cannot be too strongly insisted upon. Under the name of *liquid extracts of meat* other substances have been prepared



**DIESE SEITE IST FÜR KOSTENLOSE MITGLIEDER GESPERRT**

Beantragen Sie jetzt die volle Mitgliedschaft, um diese Seite zu betreten

# GESCHICHTE

Zehntausende von wichtigen historischen Quellen, viele bisher nicht erhältlich, stehen jetzt zum ersten Mal mit der Vollmitgliedschaft von Forgotten Books zur Verfügung.

Unbegrenzter Zugang  
\$8.99/monat

**Fortfahren**

\*Es gelten Richtlinien zur fairen Nutzung.



# CHAPTER X.

## THE PROPERTIES OF MUSCULAR TISSUE.

**Contractility.** The characteristic physiological property of muscular tissue, and that for which it is employed in the Body, is the faculty possessed by its fibres of shortening forcibly under certain circumstances. The direction in which this shortening occurs is always that of the long axis of the fibre, in both plain and striped muscles, and it is accompanied by an almost equivalent thickening in other diameters, so that when a muscle contracts it does not shrivel up or diminish its bulk in any appreciable way; it simply changes its form. When a muscle contracts it also becomes harder and more rigid, especially if it has to overcome any resistance. This and the change of form can be well felt by placing the fingers of one hand over the biceps muscle lying in front of the humerus of the other arm. When the muscle is contracted so as to bend the elbow it can be felt to swell out and harden as it shortens. Every schoolboy knows that when he appeals to another to "feel his muscle" he contracts the latter so as to make it thicker and apparently more massive as well as harder. In statues the prominences on the surface, indicating the muscles beneath the skin, are made very conspicuous when violent effort is represented, so as to indicate that they are in vigorous action. In a muscular fibre we find no longer the slow, irregular, and indefinite changes of form seen in the undifferentiated cells of early development; this is replaced by a precise, rapid, and definite change of form in one direction only. Muscular tissue represents a group of cells in the bodily community, which have taken up the one special duty of executing changes of form, and in proportion

fibres suffer themselves to be passively extended again by any force pulling upon them, and they so regain their resting shape; and since in the living Body other parts are nearly invariably put upon the stretch when any given muscle contracts, these by their elasticity serve to pull the latter back again to its primitive shape. No muscular fibre is known to have the power of actively expanding after it has contracted: in the active state it forcibly resists extension, but once the contraction is over it suffers itself readily to be pulled out to its resting form.

**Irritability.** With that modification of the primitive protoplasm of an amoeboid cell which gives rise to a muscular fibre, with its great contractility, there goes a loss of other properties. All trace of spontaneity seems to disappear; muscles are not automatic like native protoplasm or ciliated cells; they remain at rest unless directly excited from without. The amount of external change required to excite the living muscular fibre at any moment is, however, very small; in other words, it is highly *irritable*, a very little thing being sufficient to call forth a powerful contraction. In the living Human Body the exciting force, or *stimulus*, acting upon a muscle is almost invariably a *nervous impulse*, a molecular movement transmitted along the nerve-fibres attached to it, and upsetting the equilibrium of the muscle. It is through the nerves that the will acts upon the muscles, and accordingly injury to the nerve of a part, as the face or a limb, will cause paralysis of its muscles. They may still be there, intact and quite ready to work, but there are no means of sending commands to them, and so they remain permanently idle. Although "



nervous impulse is the natural physiological muscular stimulus it is not the only one known. If a muscle be exposed in a living animal and a slight but sudden tap be given to it, or a hot bar be suddenly brought near it, or an electric shock be sent through it, or a drop of glycerine or of solution of ammonia be placed on it, it will contract; so that in addition to the natural nervous stimulus, muscles are irritable under the influence of mechanical, thermal, electrical, and chemical stimuli. One condition of the efficacy of all of them is that they shall act with some suddenness; a very slowly increased pressure, even if ultimately very great, or a very slowly raised temperature, or a slowly increased electrical current passed through it, will not excite the muscle; although far less pressure, warmth, or electricity, more rapidly applied would stimulate it powerfully. It may perhaps still be objected that it is not proved that any of these stimuli excite the muscular fibres, and that in all these cases it is possible that the muscle is only excited through its nerves. For the various stimuli named above also excite nerves (see Chap. XIII), and when we apply them to the muscle we may really be acting first upon the fine nerve-endings there, and only indirectly and through the mediation of these upon the muscular fibres. That the muscular fibres have a proper irritability of their own, independently of their nerves, is, however, shown by the action of certain drugs—for example curari, a South American Indian arrow poison. When this substance is introduced into a wound, all the striped muscles are apparently poisoned, and the animal dies of suffocation because of the cessation of the breathing movements. But the poison does not really act on the muscles themselves: it kills the muscle nerves, but leaves the muscle intact; and it kills the very endings of the muscle-nerves right down in the muscle fibres themselves. Now after its administration we still find that the various non-physiological stimuli referred to above make the muscles contract just as powerfully as before the poisoning, so we must conclude that the muscles themselves are irritable in the absence of all nerve stimuli—or, what amounts to the same thing, when



**DIESE SEITE IST FÜR KOSTENLOSE MITGLIEDER GESPERRT**  
Beantragen Sie jetzt die volle Mitgliedschaft, um diese Seite zu betreten



**Seien Sie niemals ohne ein Buch!**

Die Vollmitgliedschaft von Forgotten Books bietet Ihnen einen universalen Zugang von unseren Apps und unserer Website, auf all Ihren Geräten: Tablet, Telefon, E-Reader, Laptop und Computer.

**Eine Bibliothek in Ihrer Tasche für € 8.99/monat**

**Fortfahren**

\*Es gelten Richtlinien zur fairen Nutzung.

from the moment of stimulation until the muscle regains its resting form is known as a "*simple muscular contraction*" or a "*twitch*." It occupies in the frog about one tenth of a second and is separable into three portions. First, there elapses a time, after the stimulation and before the commencement of the shortening, which is known as the "lost time" or the *period of latent excitement*. This lasts about one hundredth of a second, and represents the time during which molecular changes preparatory to the contraction are taking place in the muscle fibres. Then follows the shortening, at first slow, then rapid, then slower again up to a maximum, and occupying rather more than half of the remaining time; the elongation occupies the remainder of the time taken up in the contraction. In warm-blooded animals, the duration of a simple muscular contraction is even less than one tenth of a second and all its stages are quickened. In any given animal, cold increases the time taken in a muscular contraction and also impairs the contractile power, as we find in our own limbs when "numbed" with cold. Moderate warmth on the other hand (up to near the point at which heat-rigor is produced) diminishes the duration of the contraction; so that the molecular changes in a muscular fibre are clearly eminently susceptible to slight changes in its environment. The contractility of a muscle does not depend upon a vital force, entirely distinct from ordinary inanimate forces, but upon an arrangement of its material elements, which is only maintained under certain conditions and is eminently modifiable by the surroundings.

**Physiological Tetanus.** It is obvious that the ordinary movements of the Body are not brought about by such transient muscular contractions as those described in the last paragraph. Even a wink lasts longer than one tenth of a second. Our movements are, in fact, due to more prolonged contractions which may be described as consisting of several simple twitches fused together, and known as "*tetanic contractions*"; it might be better to call them "compound contractions," since the word tetanus has long been used by pathologists to signify a diseased state, such as occurs

in strychnine poisoning and hydrophobia, in which most of the muscles of the Body are thrown into prolonged and powerful involuntary contractions.

If, while a frog's muscle is still shortening under the influence of one electric shock, another stimulus be given it, it will contract again and the new contraction will be added on to that already existing, without any period of elongation occurring between them. While the muscle is still contracting under the influence of the second stimulus a third electric shock will make it contract more, and so on, until the muscle is shortened as much as is possible to it for that strength of stimulus. If now the stimuli be repeated at the proper intervals, each new one will not produce any further shortening, but, each acting on the muscle before the effect of the last has begun to pass off, the muscle will be kept in a state of permanent or "tetanic" contraction; and this can be maintained, by continuing the stimuli, until the organ begins to get exhausted or "fatigued" and it then commences to elongate in spite of the stimulation. When our muscles are stimulated in the Body, from the nerve-centres through the nerves, they receive from the latter about 20 stimuli in a second, and so are thrown into tetanic contractions. In other words, not even in the most rapid movements of the Body is a muscle made to execute a simple muscular contraction; it is always a longer or a shorter tetanus. When very quick movements are executed, as in performing rapid passages on the piano,

shorten to one third of its resting length, but in the Body the strongest effort of the will never produces a contraction of that extent. Apart from the rate of stimulation, the strength of the stimulus has some influence, a greater stimulus causing a greater contraction, but very soon a point is reached after which increasing the stimulus produces no increased contraction; the muscle has reached its limit. The amount of load carried by the muscle (or the resistance opposed to its shortening) has also an influence, and that in a very remarkable way. Suppose we have a frog's calf-muscle, carrying no weight, and find that with a stimulus of a certain strength it shortens two millimeters ( $\frac{1}{8}$  inch). Then if we hang one gram (15.5 grains) on it and give it the same stimulus, it will be found to contract more, say four or five millimeters, and so on, up to the point when it carries eight or ten grams. After that an increased weight will, with the same stimulus, cause a less contraction. So that up to a certain limit, resistance to the shortening of the muscle makes it more able to shorten: the mere greater extension of the muscle due to the greater resistance opposed to its shortening, puts it into a state in which it is able to contract more powerfully. Fatigue diminishes the working power of a muscle and rest restores it, especially if the circulation of the blood be going on in it at the same time. A frog's muscle cut out of the body will, however, be considerably restored by a period of rest, even although no blood flows through it.

**The Measure of Muscular Work.** The work done by a muscle in a given contraction, when it lifts a weight vertically against gravity, is measured by the weight moved, multiplied by the distance through which it is moved. In the above case when the muscle contracted carrying no load it did very little work, lifting only its own weight; when loaded with one gram and lifting it five millimeters it did five gram-millimeters of work, just as an engineer would say an engine had done so many kilogrammeters or foot-pounds. If loaded with ten grams and lifting it six millimeters it would do sixty gram-millimeters of work. Even after the weight becomes so great that it is lifted



**DIESE SEITE IST FÜR KOSTENLOSE MITGLIEDER GESPERRT**

Beantragen Sie jetzt die volle Mitgliedschaft, um diese Seite zu betreten

# GESCHICHTE

Zehntausende von wichtigen historischen Quellen, viele bisher nicht erhältlich, stehen jetzt zum ersten Mal mit der Vollmitgliedschaft von Forgotten Books zur Verfügung.

Unbegrenzter Zugang  
\$8.99/monat

**Fortfahren**

\*Es gelten Richtlinien zur fairen Nutzung.



fibres present in a section made across the long axes of the fasciculi, the greater the load that can be lifted or the other resistance that can be overcome. On the other hand, the extent through which a muscle can move a weight increases with the length of its fasciculi. A muscle a foot in length can contract more than a muscle six inches long, and so would move a bone through a greater distance, provided the resistance were not too great for its strength. But if the shorter muscle had double the thickness, then it could lift twice the weight that the longer muscle could. We find in the Body muscles constructed on both plans; some to have a great range of movement, others to overcome great resistance, besides numerous intermediate forms which cannot be called either long and slender or short and thick: many short muscles for example are not specially thick, but are short merely because the parts on which they act lie near together. It must be borne in mind, too, that many apparently long muscles are really short stout ones—those namely in which a tendon runs down the side or middle of the muscle, and has the fibres inserted obliquely into it. The muscle (*gastrocnemius*) in the calf of the leg for instance (Fig. 50, *b*) is really a short stout muscle, for its working length depends on the length of its fasciculi and these are short and oblique, while its true cross-section is that at right angles to the fasciculi and is very large. The force with which a muscle can shorten is very great. A frog's muscle of 1 square centimeter (0.39 inch) in section can just lift 2800 grams (98.5 ounces), and a human muscle of the same area more than twice as much.

**Muscular Elasticity.** A clear distinction must be made between elasticity and contractility. Elasticity is a physical property of matter in virtue of which various bodies tend to assume or retain a certain shape, and when removed from it forcibly, to return to it. When a spiral steel spring is stretched it will, if let go, "contract" in a certain sense in virtue of its elasticity, but such a contraction is clearly quite different from a muscular contraction. The spring will only contract as a result of previous distortion; it cannot originate a change of form, while the mus-

It does not merely tend to return to a natural shape from which it has been removed, but it assumes a quite new natural shape, so that physiological contractility is a different thing from mere physical elasticity; the essential difference being that the coiled spring or a stretched hand only gives back mechanical work which has already been spent on it, while the muscle originates work independently of any previous mechanical stretching. In addition to their contractility, however, muscles are highly elastic. If a fresh muscle be hung up and its length measured, and then a weight be hung upon it, it will stretch just like a piece of indian-rubber, and when the weight is removed, provided it has not been so great as to injure the muscle, the latter will return passively, without any stimulus or active contraction, to its original form. In the Body all the muscles are so attached that they are usually a little stretched beyond their natural resting length; so that when a limb is amputated the muscles divided in the stump shrink away considerably. By this stretched state of the resting elastic muscles two things are gained. In the first place when the muscle contracts it is already taut, there is no "slack" to be hauled in before it pulls on the parts attached to its tendons: and, secondly, as we have already seen the working power of a muscle is increased by the presence of some resistance to its contraction, and this is always provided for from the first, by having the origin and insertion of the muscle so far apart as to be pulling on it when it begins to shorten.

**Physiology of Plain Muscular Tissue.** What has hitherto been said applies especially to the skeletal muscles; but in the main it is true of the unstriped muscles. These also are irritable and contractile, but their changes of form are much more slow than those of the striated fibres. Upon stimulation, a longer period of latent excitement elapses before the contraction commences, and when finally this takes place it is extremely slow, very gradually attaining a maximum and then gradually dying away again.



There seems in fact to be some connection between that arrangement of the contractile substance which shows itself under the microscope as striation and the power of rapid contraction, since we find that the heart, which is not a skeletal or voluntary muscle but yet one that contracts rapidly, agrees with these in having its fibres striated.

**Hygiene of the Muscles.** The healthy working of the muscles needs of course a healthy state of the Body generally, so that they shall be supplied with proper materials for growth and repair and have their wastes rapidly and efficiently removed. In other words, good food and pure air are necessary for a vigorous muscular system, a fact which trainers recognize in insisting upon a strict dietary, and in supervising generally the mode of life of those who are to engage in athletic contests. The muscles should also not be exposed to any considerable continued pressure since this interferes with the flow of blood and lymph through them.

As far as the muscles themselves are directly concerned, exercise is the necessary condition of their best development. A muscle which is permanently unused degenerates and is absorbed, little finally being left but the connective tissue of the organ and a few muscle fibres filled with oil-drops. This is well seen in cases of paralysis dependent on injury to the nerves. In such cases the muscles at first may themselves be perfectly healthy, but lying unused for weeks they rapidly alter and, finally, when the nervous injury has been healed, the muscles may be found incapable of functional activity. The physician therefore is often careful to avoid this by exercising the paralyzed muscles daily by means of electrical shocks sent through the part. The same fact is illustrated by the feeble and wasted condition of the muscles of a limb which has been kept for some time in splints. After the latter have been removed it is only slowly, by judicious and persistent exercise, that the long idle muscles regain their former size and power. The great muscles of the "brawny arm" of the blacksmith or wrestler illustrate the reverse fact, the growth of the muscles by exercise. Exercise, however, must be judicious: re-



**DIESE SEITE IST FÜR KOSTENLOSE MITGLIEDER GESPERRT**  
Beantragen Sie jetzt die volle Mitgliedschaft, um diese Seite zu betreten



**Seien Sie niemals ohne ein Buch!**

Die Vollmitgliedschaft von Forgotten Books bietet Ihnen einen universalen Zugang von unseren Apps und unserer Website, auf all Ihren Geräten: Tablet, Telefon, E-Reader, Laptop und Computer.

**Eine Bibliothek in Ihrer Tasche für € 8.99/monat**

**Fortfahren**

\*Es gelten Richtlinien zur fairen Nutzung.

fact that gymnastic exercises are commonly carried on indoors is a great drawback to their value. When the weather permits, out-of-door exercise is far better than that carried on in even the best ventilated and lighted gymnasium. For those who are so fortunate as to possess a garden there is no better exercise, at suitable seasons, than an hour's daily digging in it; since this calls into play nearly all the muscles of the Body: while of games, the modern one of lawn tennis is perhaps the best from a hygienic view that has ever been introduced, since it not only demands great muscular agility in every part of the Body, but trains the hand to work with the eye in a way that walking, running, rowing and similar pursuits do not. For the same reasons baseball, cricket, and boxing are excellent.

**Exercise in Infancy and Childhood.** Young children have not only to strengthen their muscles by exercise but also to learn to use them. Watch an infant trying to convey something to its mouth, and you will see how little control it has over its muscles. On the other hand the healthy infant is never at rest when awake; it constantly throws its limbs around, grasps at all objects within its reach, coils itself about, and so gradually learns to exercise its powers. It is a good plan to leave every healthy child, more than a few months old, several times daily on a large bed or even on a rug or carpeted floor, with as little covering as is safe and that as loose as possible, and let it wriggle about as it pleases. In this way it will not only enjoy itself thoroughly, but gain strength and a knowledge of how to use its limbs. To keep a healthy child swathed all day in tight and heavy clothes is cruelty.

When a little later the infant commences to crawl, it is safe to permit it as much as it wishes; but unwise to tempt it when disinclined. The bones and muscles are still feeble and may be injured by too much work. The same is true of commencing walking.

From four or five to twelve years of age almost any form of exercise should be permitted, or even encouraged. At this time, however, the epiphyses of many bones are not firmly united to their shafts and so anything tending to

throw too great a strain on the joints should be avoided. After that up to commencing manhood or maidenhood any kind of outdoor exercise for healthy persons is good, and girls are all the better for being allowed to join in their brothers' sports. Half of the debility and general ill-health of so many of our women is dependent upon deficient exercise during childhood, and the day, which fortunately seems approaching, which will see dolls as unknown to, or as despised by, healthy girls as healthy boys, will see the beginning of a great improvement in the stamina of the female portion of our population.

**Exercise in Youth** should be regulated largely by sex; not that women are to be shnt up and made pale, delicate, and unfit to share the duties or participate fully in the pleasures of life; but the other calls on the strength of the adult woman render vigorous muscular work often unadvisable, especially under conditions where it is apt to be followed by a chill.

A healthy boy or young man may do nearly anything, but until twenty-two or twenty-three very prolonged effort is unadvisable. The frame is still not firmly knit or as capable of endurance as it will subsequently become.

Girls should be allowed to ride or play out-door games in moderation, and in any case should not be cribbed in tight stays or tight boots. A flannel dress and proper lawn-tennis shoes are as necessary for the healthy and safe enjoyment of an afternoon at that game by a girl as they are for her brother in the base-ball field. Rowing is excellent for girls if there be any one to teach them to do it properly, with the legs and back and not with the arms only, as women are so apt to row. Properly practiced it strengthens the back and improves the carriage.

sudden violent demand. On the other hand the man of thirty would more safely than the lad of nineteen or twenty undertake one of the long-distance walking matches which have lately been in vogue; the prolonged effort would be less dangerous to him, though a six days' match with its attendant loss of sleep cannot fail to be more or less dangerous to any one. Probably for one engaged in active business a walk of a couple of miles to it in the morning and back again in the afternoon is the best and most available exercise. The habit which Americans have everywhere acquired, of never walking when they can take a horse-car, is certainly detrimental to the general health; though the extremes of heat and cold to which we are subject often render it unavoidable.

For women during middle life the same rules apply: there should be some regular but not violent daily exercise.

**In Old Age** the needful amount of exercise is less, and it is still more important to avoid sudden or violent effort.

**Exercise for Invalids.** This should be regulated under medical advice. For feeble persons gymnastic exercises are especially valuable, since from their variety they permit of selection according to the condition of the individual; and their amount can be conveniently controlled.

**Training.** If any person attempts some unusual exercise he soon finds that he loses breath, gets perhaps a "stitch in the side," and feels his heart heating with unwonted violence. If he perseveres he will probably faint—or vomit, as is frequently seen in imperfectly trained men at the end of a hard boat-race. These phenomena are avoided by careful gradual preparation known as "training." The immediate cause of them lies in disturbances of the circulatory and respiratory organs, on which excessive work is thrown, and the further discussion of training must be postponed for the present.



**DIESE SEITE IST FÜR KOSTENLOSE MITGLIEDER GESPERRT**

Beantragen Sie jetzt die volle Mitgliedschaft, um diese Seite zu betreten

# GESCHICHTE

Zehntausende von wichtigen historischen Quellen, viele bisher nicht erhältlich, stehen jetzt zum ersten Mal mit der Vollmitgliedschaft von Forgotten Books zur Verfügung.

Unbegrenzter Zugang  
\$8.99/monat

**Fortfahren**

\*Es gelten Richtlinien zur fairen Nutzung.



directly; and similarly other muscles arising at the back of the orbit are directly fixed to the eyeball in front and serve to rotate it on the pad of fat on which it lies. Many facial muscles again have no direct attachment whatever to bones, as for example the muscle (*orbicularis oris*) which surrounds the mouth-opening and by its contraction narrows it and purses out the lips; or the *orbicularis palpebrarum* which similarly surrounds the eyes and when it contracts closes them.

**Lever in the Body.** When the muscles serve to move bones the latter are in nearly all cases to be regarded as levers whose fulcra lie at the joint where the movement takes place. Examples of all the three forms of levers recognized in mechanics are found in the Human Body.

**Lever of the First Order.** In this form (Fig. 56) the fulcrum or fixed point of support lies between the "weight"

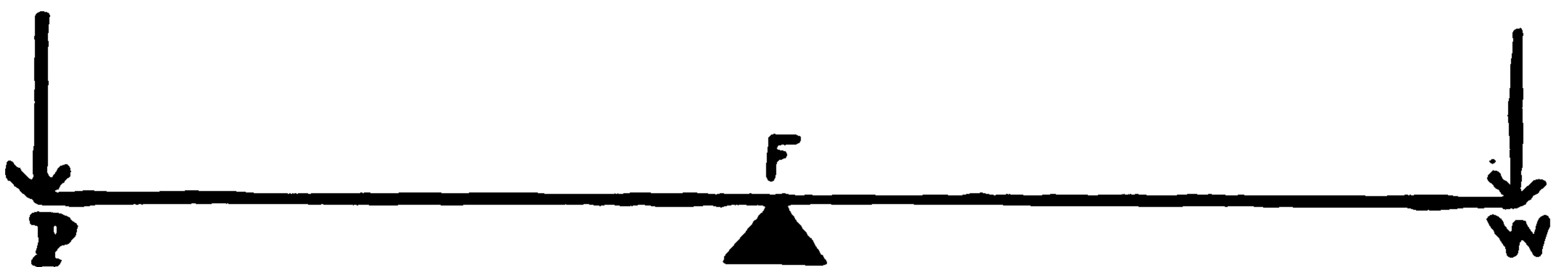

FIG. 56.—A lever of the first order. *F*, fulcrum; *P*, power; *W*, resistance or weight.

or resistance to be overcome, and the "power" or moving force, as shown in the diagram. The distance  $PF$ , from the power to the fulcrum, is called the "power-arm;" the distance  $FW$  is the weight-arm. When power-arm and weight-arm are equal, as is the case in the beam of an ordinary pair of scales, no mechanical advantage is gained, nor is there any loss or gain in the distance through which the weight is moved. For every inch through which  $P$  is depressed,  $W$  will be raised an equal distance. When the power-arm is longer than the other, then a smaller force at  $P$  will raise a larger weight at  $W$ , the gain being proportionate to the difference in the lengths of the arms. For example if  $PF$  is twice as long as  $FW$ , then half a kilogram applied at  $P$  will balance a whole kilogram at  $W$ , and

just more than half a kilogram would lift it; but for every centimeter through which  $P$  descended,  $W$  would only be lifted half a centimeter. On the other hand when the weight-arm in a lever is longer than the power-arm, there is loss in force but a gain in the distance through which the weight is moved.

Examples of the first form of lever are not numerous in the Human Body. One is afforded in the nodding movements of the head, the fulcrum being the articulations between the skull and the atlas. When the chin is elevated the power is applied to the skull, behind the fulcrum, by small muscles passing from the vertebral column to the occiput; the resistance is the excess in the weight of the part of the head in front of the fulcrum over that behind it, and is not great. To depress the chin as in nodding does not necessarily call for any muscular effort, as the head will fall forward of itself if the muscles keeping it erect cease to work, as those of us who have fallen asleep during a dull discourse on a hot day have learnt. If the chin however be depressed forcibly, as in the athletic feat of suspending one's self by the chin, the muscles passing from the chest to the skull in front of the atlanto-occipital articulation are called into play. Another example of the employment of the first form of lever in the Body is afforded by the curtsey with which a lady salutes another. In curtseying the trunk is bent forward at the hip-joints, which form the fulcrum; the weight is that of the trunk acting as if all concentrated at its centre of gravity, which lies a little above the sacrum and behind the hip-joints; and the power is afforded by muscles passing from the thighs to the front of the pelvis.

**Levers of the Second Order.** In this form the weight or resistance is between the power and the fulcrum. The power-arm  $PF$  is always longer than the weight-arm  $WF$ , and so a comparatively weak force can overcome a considerable resistance. But it is disadvantageous so far as regards rapidity and extent of movement, for it is obvious that when  $P$  is raised a certain distance  $W$  will be moved a less distance in the same time. As an example of the employ-



ment of such levers (Fig. 57) in the Body, we may take the act of standing on the toes. Here the foot represents the lever, the fulcrum is at the contact of its fore part with



FIG. 57.—A lever of the second order. *F*, fulcrum; *P*, power; *W*, weight. The arrows indicate the direction in which the forces act.

the ground; the weight is that of the Body acting down through the ankle-joints at *Ta*, Fig. 58; and the power is the great muscle of the calf acting by its tendon inserted into the heel-bone (*Ca*, Fig. 58). Another example is afforded by holding up the thigh when one foot is kept raised from the ground, as in hopping on the other. Here the fulcrum is at the hip-joint, the power is applied at the

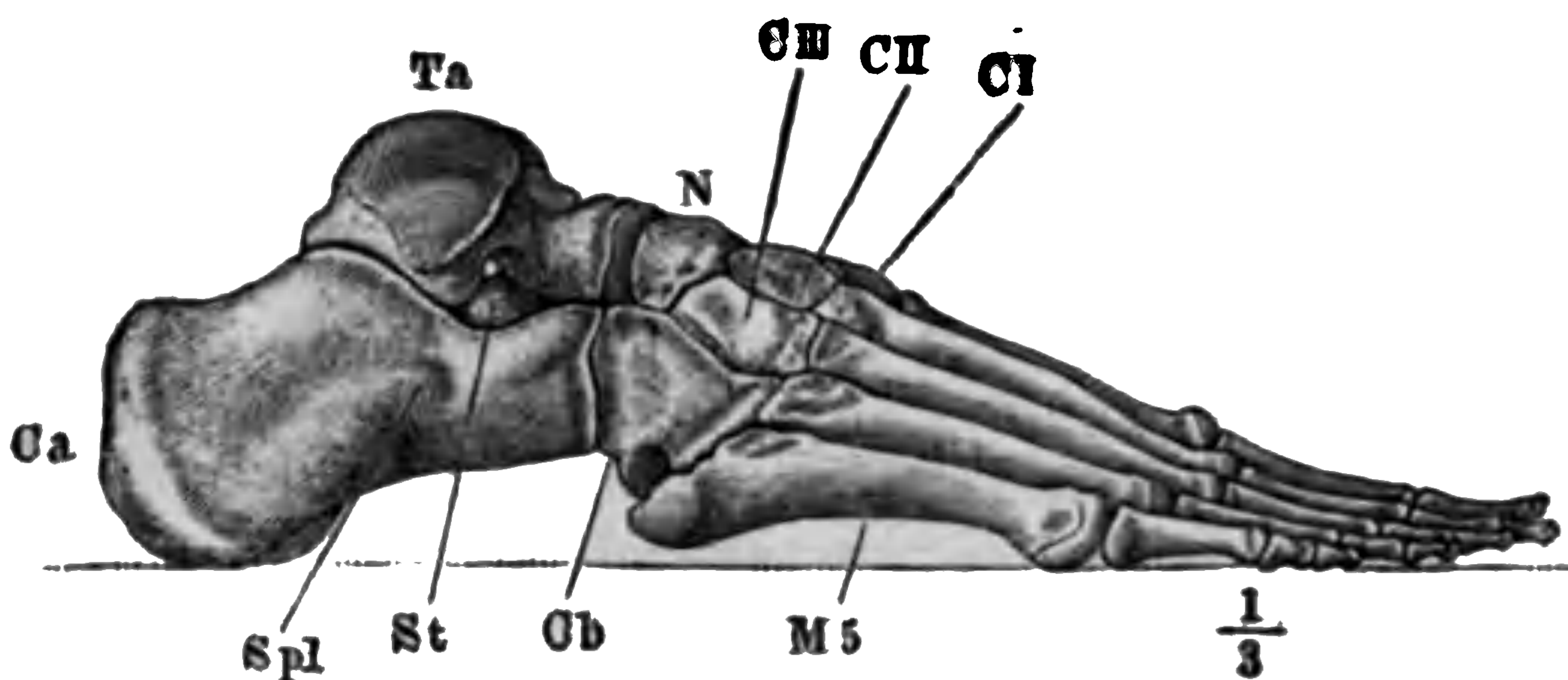

FIG. 58.—The skeleton of the foot from the outer side. *Ta*, surface with which the leg-bones articulate; *Ca*, the calcaneum into which the tendon (*tendo Achillis*) of the calf muscle is inserted; *M5*, the metatarsal bone of the fifth digit.

knee-cap by a great muscle (*rectus femoris*) inserted there and which arises from the pelvis; and the weight is that of the whole lower limb acting at its centre of gravity, which will lie somewhere in the thigh between the hip and



**DIESE SEITE IST FÜR KOSTENLOSE MITGLIEDER GESPERRT**  
Beantragen Sie jetzt die volle Mitgliedschaft, um diese Seite zu betreten



**Seien Sie niemals ohne ein Buch!**

Die Vollmitgliedschaft von Forgotten Books bietet Ihnen einen universalen Zugang von unseren Apps und unserer Website, auf all Ihren Geräten: Tablet, Telefon, E-Reader, Laptop und Computer.

**Eine Bibliothek in Ihrer Tasche für € 8.99/monat**

**Fortfahren**

\*Es gelten Richtlinien zur fairen Nutzung.

tion in which the muscles are commonly inserted into the bones, much of their force is lost so far as producing movement is concerned. Suppose the log of wood in the diagram (Fig. 60) to be raised by pulling on the rope in the direction *a*; it is clear at first that the rope will act at a great disadvantage; most of the pull transmitted by it will be exerted against the pivot on which the log hinges, and only a small fraction be available for elevating the latter. But the more the log is lifted, as for example into the position indicated by the dotted line, the more useful will be the direction of the pull, and the more of it will be spent on the log and the less lost unavailingly in merely increasing the pressure at the hinge. If we now consider the action of the biceps (Fig. 49) in flexing the elbow-joint, we see similarly that the straighter the joint is, the more of

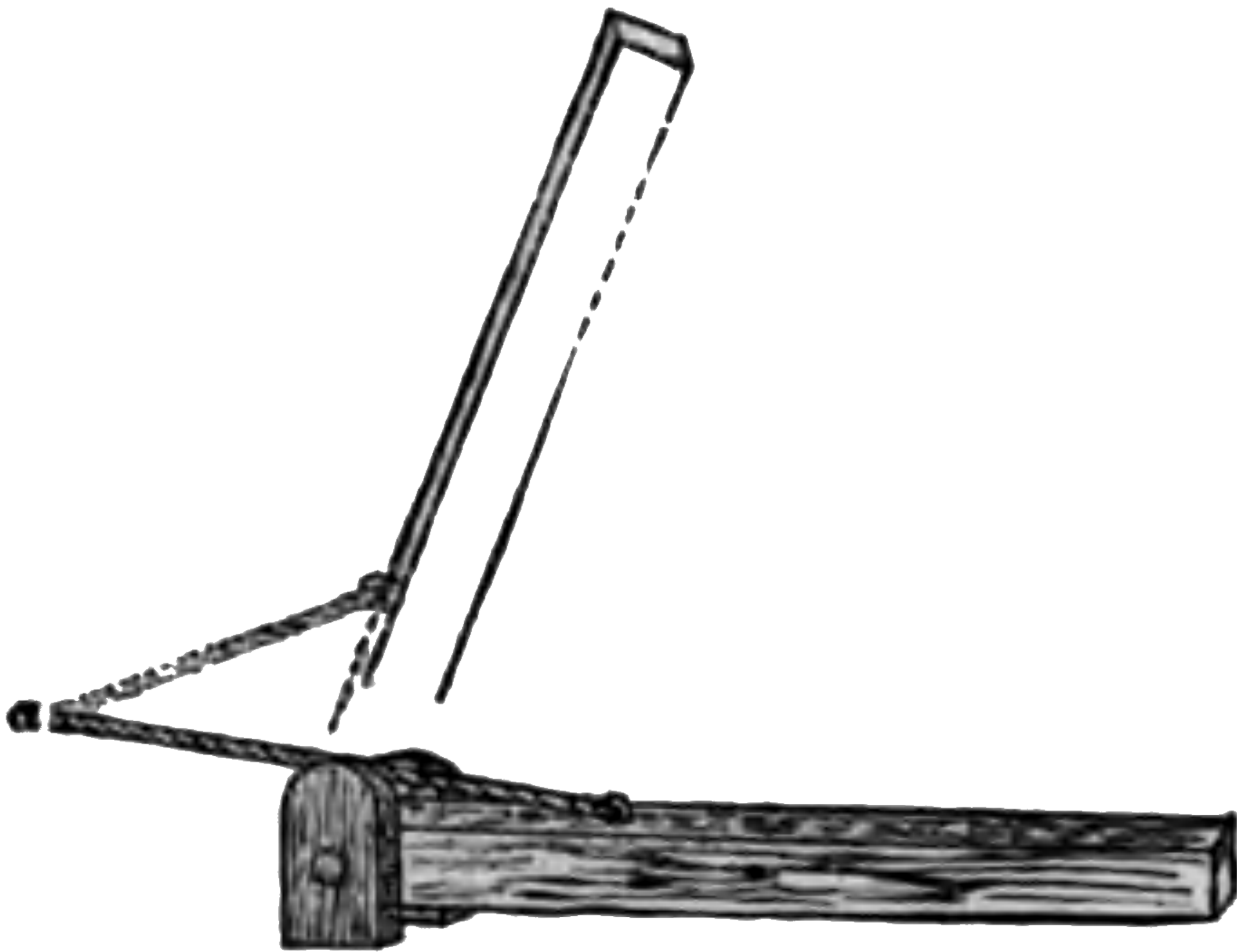

FIG. 60.—Diagram illustrating the disadvantage of an oblique pull.

the pull of the muscle is wasted. Beginning with the arm straight, it works at a great disadvantage, but as the forearm is raised the conditions become more and more favorable to the muscle. Those who have practiced the gymnastic feat of raising one's self by bending the elbows when hanging by the hands from a horizontal bar, know practically that if the elbow-joints are quite straight it is very hard to start; and that, on the other hand, if they are kept a little flexed at the beginning the effort needed is much

less; the reason being of course the more advantageous direction of traction by the biceps in the latter case.

Experiment proves that the power with which a muscle can contract is greatest at the commencement of its shortening, the very time at which, we have just seen, it works at most mechanical disadvantage; in proportion as its force becomes less the conditions become more favorable to it. There is however, it is clear, nearly always a considerable loss of power in the working of the skeletal muscles, strength being sacrificed for variety, ease, rapidity, extent, and elegance of movement.

**Postures.** The term posture is applied to those positions of equilibrium of the Body which can be maintained for some time, such as standing, sitting, or lying, compared with leaping, running, or falling. In all postures the condition of stability is that the vertical line drawn through the centre of gravity of the Body shall fall within the basis of support afforded by objects with which it is in contact; and the security of the posture is proportionate to the extent of this base, for the wider it is, the less is the risk of the perpendicular through the centre of gravity falling outside of it on slight displacement.

**The Erect Posture.** This is pre-eminently characteristic of man, his whole skeleton being modified with reference to it. Nevertheless the power of maintaining it is only slowly learnt in the first years after birth, and for a long while it is unsafe. And though finally we learn to stand erect without conscious attention, the maintenance of that posture always requires the co-operation of many muscles, co-ordinated by the nervous system. The influence of the latter is shown by the fall which follows a severe blow on the head, which may nevertheless have fractured no bone and injured no muscle: the "concussion" of the brain, as we say, "stuns" the man, and until its effects have passed off he cannot stand upright. In standing with the arms straight by the sides and the feet together the centre of gravity of the whole adult Body lies in the articulation between the sacrum and the last lumbar vertebra, and the perpendicular drawn from it will reach the

ground between the two feet, within the basis of support afforded by them. With the feet close together, however, the posture is not very stable, and in standing we commonly make it more so by slightly separating them so as to

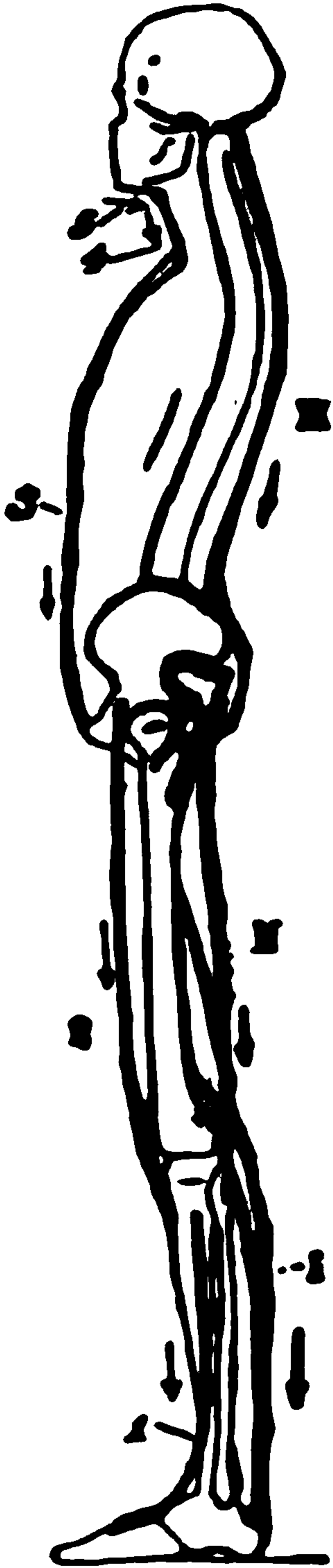

FIG. 61. — Diagram illustrating the muscles (drawn in thick black lines) which pass before and behind the joints and by their balanced activity keep the joints rigid and the Body erect.

increase the base. The more one foot is in front of the other the more swaying back and forward will be compatible with safety, and the greater the lateral distance separating them, the greater the lateral sway which is possible without falling. Consequently we see that a man about to make great movements with the upper part of his Body, as in fencing or boxing, or a soldier preparing for the bayonet exercise, always commences by thrusting one foot forwards obliquely, so as to increase his basis of support in both directions.

The ease with which we can stand is largely dependent upon the way in which the head is nearly balanced on the top of the vertebral column, so that but little muscular effort is needed to keep it upright. In the same way the trunk is almost balanced on the hip-joints: but not quite, its centre of gravity falling rather behind them; so that just as some muscular effort is needed to keep the head from falling forwards, some is needed to keep the trunk from toppling backwards at the hips. In a similar manner other muscles are called into play at other joints: as between the vertebral column and the pelvis, and at the knees and ankles; and thus a certain rigidity, due to muscular effort, extends all along the erect Body: which on account of the flexibility of its joints could not otherwise be balanced on its feet as a statue can. Beginning (Fig. 61) at the ankle-joint, we find it kept stiff in standing



**DIESE SEITE IST FÜR KOSTENLOSE MITGLIEDER GESPERRT**  
Beantragen Sie jetzt die volle Mitgliedschaft, um diese Seite zu betreten

# GESCHICHTE

Zehntausende von wichtigen historischen Quellen, viele bisher nicht erhältlich, stehen jetzt zum ersten Mal mit der Vollmitgliedschaft von Forgotten Books zur Verfügung.

Unbegrenzter Zugang  
\$8.99/monat

**Fortfahren**

\*Es gelten Richtlinien zur fairen Nutzung.



clearing the ground as the left did before. The Body is meanwhile supported on the left foot alone, but when the right completes its step the knee of that leg is straightened and the foot thus placed, heel first, on the ground. Meanwhile the left foot has been gradually leaving the ground, and its toes alone are at that moment upon it: from these a push is given, as before with the right foot, and the knee being bent so as to raise the foot, the left leg swings forwards at the hip-joint to make a fresh step.

During each step the whole Body sways up and down and also from side to side. It is highest at the moment when the advancing trunk is vertically over the foot supporting it, and then sinks until the moment when the advancing foot touches the ground, when it is lowest. From this moment it rises as it swings forward on this foot, until it is vertically over it, and then sinks again until the other touches the ground; and so on. At the same time, as its weight is alternately transferred from the right to the left foot and *vice versa*, there is a slight lateral sway, commonly more marked in women than in men, and which when excessive produces an ugly "waddling" gait.

The length of each step is primarily dependent on the length of the legs; but can be controlled within wide limits by special muscular effort. In easy walking, little muscular work is employed to carry the rear leg forwards after it has given its push. When its foot is raised from the ground it swings on like a pendulum; but in fast walking the muscles passing in front of the hip-joint, from the pelvis to the limb, by their contraction forcibly carry the leg forwards. The easiest step, that in which there is most economy of labor, is that in which the limb is let swing freely, and since a short pendulum swings faster than a longer, the natural step of short-legged people is quicker than that of long-legged ones.

In fast walking the advanced or supporting leg also aids in propulsion; the muscles passing in front of the ankle-joint contracting so as to pull the Body forwards over that foot and aid the push from the rear foot. Hence the fatigue and pain in front of the shin which is felt in

prolonged very fast walking. From the fact that each foot reaches the ground heel first, but leaves it toe last, the length of each stride is increased by the length of the foot.

**Running.** In this mode of progression there is a moment in each step when both feet are off the ground, the Body being unsupported in the air. The toes alone come in contact with the ground in each step, and the knee-joint is not straight when the foot reaches the ground. When the rear foot is to leave the support, the knee is suddenly straightened, and at the same time the ankle-joint is extended so as to push the toes forcibly on the ground and give the whole Body a powerful push forwards and upwards. Immediately after this the knee is greatly flexed and the foot raised from the ground, and this occurs before the toes of the forward foot reach the latter. The swinging leg in each step is violently pulled forwards and not suffered to swing naturally as in walking. By this the rapidity of the succession of steps is increased, and at the same time the stride is made greater by the sort of one-legged leap that occurs through the jerk given by the straightening of the knee of the rear leg just before it leaves the ground.

**Leaping.** In this mode of progression the Body is raised completely from the ground for a considerable period. In a powerful leap the ankles, knees, and hip-joints are all flexed as a preparatory measure, so that the Body assumes a crouching attitude. The heels, next, are raised from the ground and the Body balanced on the toes. The centre of gravity of the Body is then thrown forwards, and simultaneously the flexed joints are straightened, and by the resistance of the ground, the Body receives a propulsion forwards; much in the same way as a ball rebounds from a wall. The arms are at the same time swung forwards. In leaping back, the Body and arms are inclined in that direction; and in jumping vertically there is no leaning either way and the arms are kept by the sides.



## CHAPTER XII.

### ANATOMY OF THE NERVOUS SYSTEM.

**Nerve-Trunks.** In dissecting the Human Body numerous white cords are found which at first sight might be taken for tendons. That they are something else however soon becomes clear, since a great many of them have no connection with muscles at all, and those which have usually enter somewhere into the belly of the muscle, instead of being fixed to its ends as most tendons are. These cords are *nerve-trunks*: followed in one direction each (Fig. 62) will be found to break up into finer and finer branches, until the subdivisions become too small to be followed without the aid of a microscope. Traced the other way the trunk will in most cases be found to increase by the union of others with it, and ultimately to join a much larger mass of different structure, and from which other trunks also spring. This mass is a *nerve-centre*. That end of a nerve attached to the centre is naturally its *central*, and the other its *distal* or *peripheral end*. Nerve-centres, then, give origin to nerve-trunks; these latter radiate all over the Body, usually branching and becoming smaller and smaller as they proceed from the centre; they finally become very small, and how they ultimately end is not in all cases certain, but it is known that some have sense-organs at their terminations and others muscular fibres. The general arrangement of the larger nerve-trunks of the Body is shown in Fig. 62. Physically a nerve is not so tough or strong as a tendon of the same size; it may readily be split up into longitudinal strands, each of which consists of a number of microscopic threads, the *nerve-fibres*, bound together by connective tissue.



**DIESE SEITE IST FÜR KOSTENLOSE MITGLIEDER GESPERRT**  
Beantragen Sie jetzt die volle Mitgliedschaft, um diese Seite zu betreten



**Seien Sie niemals ohne ein Buch!**

Die Vollmitgliedschaft von Forgotten Books bietet Ihnen einen universalen Zugang von unseren Apps und unserer Website, auf all Ihren Geräten: Tablet, Telefon, E-Reader, Laptop und Computer.

**Eine Bibliothek in Ihrer Tasche für €8.99/monat**

**Fortfahren**

\*Es gelten Richtlinien zur fairen Nutzung.

**Plexuses.** Very frequently several neighboring nerve-trunks send off communicating branches to one another, each branch carrying fibres from one trunk to the other. Such networks are called *plexuses* (Fig. 65\*), and through the interchanges taking place in them it often happens that the distal branches of a nerve-trunk contain fibres which it does not possess as it leaves the centre to which it is connected.

**Nerve-Centres.** The great majority of the nerves take their origin from the *brain* and *spinal cord*, which together form the great *cerebro-spinal centre*. Some, however, commence in rounded or oval masses which vary in size from that of the kernel of an almond down to microscopic dimensions, and which are widely distributed in the Body. Each of these smaller scattered centres is called a *ganglion*, and the whole of them are arranged in three sets. A considerable number of the largest are united directly to one another by nerve-trunks, and also give off nerves to various organs, especially to the blood-vessels and the viscera in the thoracic and abdominal cavities. These ganglia and their branches form the *sympathetic nervous system*, as distinguished from the cerebro-spinal nervous system consisting of the brain and spinal cord and the nerves springing from them. Of the remaining ganglia some are connected with various cerebro-spinal trunks near their origin, while the rest, for the most part very small and connected with the peripheral branches of sympathetic or other nerves, are known as the *sporadic ganglia*.

**The Cerebro-Spinal Centre and its Membranes.** Lying in the skull is the *brain* and in the neural canal of the vertebral column the *spinal cord* or *spinal marrow*, the two being continuous through the *foramen magnum* of the occipital bone and forming the great cerebro-spinal nerve-centre. This centre is bilaterally symmetrical throughout except for slight differences on the surfaces of parts of the brain, which are often found in the higher races of mankind. Both brain and spinal cord are very soft and easily crushed; the connective tissue which pervades them being of the delicate retiform variety; accordingly both are placed in nearly

---

\* P. 162.

completely closed bony cavities and are also enveloped by membranes which give them consistency and support. These membranes are three in number. Externally is the *dura mater*, very tough and strong and composed of white fibrous and elastic connective tissues. In the cranium this *dura mater* adheres by its outer surface to the inside of the skull, serving as the periosteum of its bones; this is not the case in the vertebral column, where the *dura mater* forms a loose sheath around the spinal cord and is only attached here and there to the surrounding bones, which have a separate periosteum of their own. The innermost membrane of the cerebro-spinal centre, lying in immediate contact with the proper nervous parts, is the *pia mater*, also made up of white fibrous tissue interwoven with elastic fibres, but less closely than in the *dura mater*, so as to form a less dense and tough membrane. The *pia mater* contains many blood-vessels which break up in it into small branches before entering the nervous mass beneath. Covering the outside of the *pia mater* is a layer of flat closely fitting cells, a similar layer lines the inside of the *dura mater*, and these two layers are described as the third membrane of the cerebro-spinal centre, called the *arachnoid*. In the space between the two layers of the *arachnoid* is contained a small quantity of watery

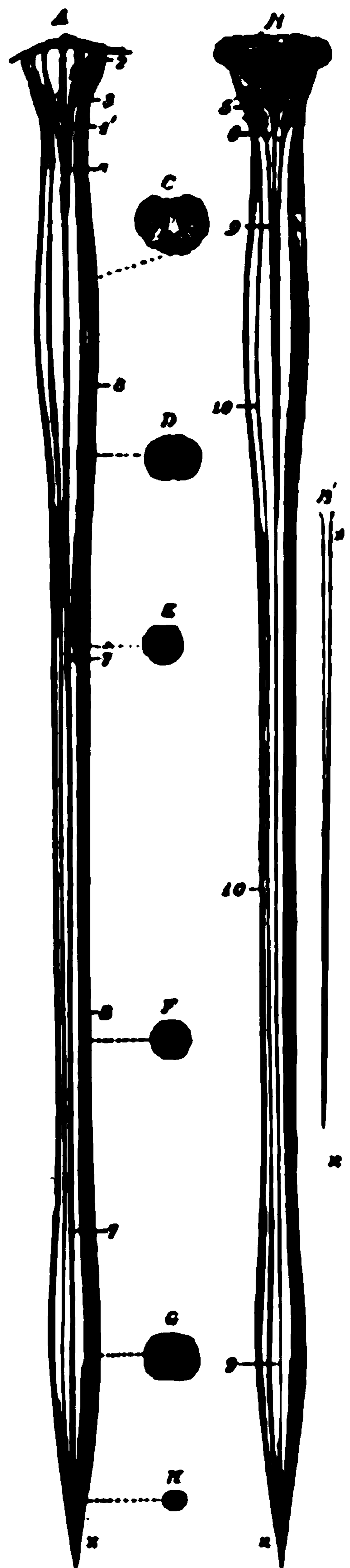

FIG. 63.—The spinal cord and medulla oblongata. A, from the ventral, and B, from the dorsal aspect; C to H, cross-sections at different levels.

*cerebro-spinal liquid*. Part of the surface of the brain is folded and the pia mater does not dip down and line the furrows between the folds but stretches across them: in the spaces thus left there is also contained some of the cerebro-spinal liquid.

The **Spinal Cord** (Fig. 63) is nearly cylindrical in form, being however a little wider from side to side than dorso-ventrally, and tapering off at its posterior end. Its average diameter is about 19 millimeters ( $\frac{3}{4}$  inch) and its length 0.43 meter (17 inches). It weighs 42.5 grams ( $1\frac{1}{2}$  ounces). There is no marked limit between the spinal cord and the brain, the one passing gradually into the other (Fig. 70\*), but the cord is arbitrarily said to commence opposite the outer margin of the foramen magnum: from there it extends to the articulation between the first and second lumbar vertebræ, where it narrows off to a slender filament, the *filum terminale* (cut off and represented separately at B' in Fig. 63), which runs back to the end of the neural canal behind the sacrum. In its course the cord presents two expansions, an upper, 10, the *cervical enlargement*, reaching from the third cervical to the first dorsal vertebræ, and a lower or *lumbar enlargement*, 9, opposite the last dorsal vertebra.

Running along the middle line on both the ventral and the dorsal aspects of the cord is a groove, and a cross-section shows that these grooves are the surface indications of fissures which extend deeply into the cord (C, Fig. 64) and nearly divide it into right and left halves.

The *anterior fissure* (1, Fig. 64) is wider and shallower than the *posterior*, 2. The transverse section, C, shows also that the substance of the cord is not alike throughout, but that its *white* superficial layers envelop a central *gray substance* arranged somewhat in the form of a capital H. Each half of the gray matter is crescent-shaped, and the crescents are turned back to back and united across the middle line by the *gray commissure*. The tips of each crescent are called its horns or *cornua*, and the ventral, or *anterior cornu*, on each side is thicker and larger than the posterior. In the cervical and lumbar enlargements the

---

\* P. 169.



**DIESE SEITE IST FÜR KOSTENLOSE MITGLIEDER GESPERRT**  
Beantragen Sie jetzt die volle Mitgliedschaft, um diese Seite zu betreten

# GESCHICHTE

Zehntausende von wichtigen historischen Quellen, viele bisher nicht erhältlich, stehen jetzt zum ersten Mal mit der Vollmitgliedschaft von Forgotten Books zur Verfügung.

Unbegrenzter Zugang  
\$8.99/monat

**Fortfahren**

\*Es gelten Richtlinien zur fairen Nutzung.



the anterior fissure; this forms the *anterior white commissure*. There is no posterior white commissure, the bottom of the posterior fissure being the only portion of the cord where the gray substance is uncovered by white. Running along the middle of the gray commissure, for the whole length of the cord, is a tiny channel, just visible to the unaided eye; it is known as the *central canal* (*canalis centralis*).

**The Spinal Nerves.** Thirty-one pairs of spinal nerve-trunks enter the neural canal of the vertebral column through the intervertebral foramina (p. 71). Each divides in the foramen into a dorsal and ventral portion known respectively as the *posterior* and *anterior roots* of the nerve (6 and 5, Fig. 64), and these again subdivide into finer branches which are attached to the sides of the cord, the posterior root at the point where the posterior and lateral white columns meet, and the anterior root at the junction of the lateral and anterior columns. At the lines on which the roots are attached there are superficial furrows on the surface of the cord. On each posterior root is a *spinal ganglion* (6', Fig. 64), placed just before it joins the anterior root to make up the common nerve-trunk. Immediately after its formation by the mixture of fibres from both roots, the trunk divides into a small *posterior primary* and a larger *anterior primary branch* (7' 7 D, Fig. 64). The former branches of the spinal nerves go for the most part to the skin and muscles on the back, while the anterior primary branches form a series of plexuses from which the nerves for the sides and ventral region of the neck and trunk, and for the limbs, arise.

The various spinal nerves are named from the portions of the vertebral column through the intervertebral foramina of which they pass out; and as a general rule each nerve is named from the vertebra in front of it. For example the nerve passing out between the fifth and sixth dorsal vertebrae is the "fifth dorsal" nerve, and that between the last dorsal and first lumbar vertebrae, the "twelfth dorsal." In the cervical region, however, this rule is not adhered to. The nerve passing out between the occipital bone and the

atlas is called the "first cervical" nerve, that between the atlas and axis the second, and so on; that between seventh cervical and first dorsal vertebræ being the "eighth cervical" nerve. The thirty-one pairs of spinal nerves are then thus distributed: 8 cervical, 12 dorsal, 5 lumbar, 5 sacral, and 1 coccygeal; the latter passing out between the sacrum and coccyx. Since the spinal cord ends opposite the upper lumbar vertebræ while the sacral and coccygeal nerves pass out from the neural canal much farther back, it is clear that the roots of those nerves, on their way to unite in the foramina of exit and form nerve-trunks, must run obliquely backwards in the spinal canal for a considerable distance. One finds in fact the neural canal in the lumbar and sacral regions, behind the point where the spinal cord has tapered off, occupied by a great bunch of nerve-roots forming the so-called "horse's tail" or *cauda equina*.

**Distribution of the Spinal Nerves.** It would be out of place here to go into detail as to the exact portions of the Body supplied by each spinal nerve, but the following general statements may be made. The anterior primary branches of the first four cervical nerves form on each side the *cervical plexus* (Fig. 65) from which branches are supplied to the muscles and integument of the neck: also to the outer ear and the back part of the scalp. The anterior primary branches of the remaining cervical nerves and the first dorsal form the *brachial plexus*, from which the upper limb is supplied. The roots of the trunks which form this plexus arise from the cervical enlargement of the spinal cord.

From the fourth and fifth cervical nerves on each side, small branches arise and unite to make the *phrenic nerve* (4, Fig. 65) which runs down through the chest and ends in the diaphragm.

The anterior primary branches of the dorsal nerves, except part of the first which enters the brachial plexus, form no plexus, but each runs along the posterior border of a rib and supplies branches to the chest-walls, and the lower ones to those of the abdomen also.

The anterior primary branches of the four anterior lumbar nerves are united by branches to form the *lumbar*



*plexus*. It supplies the lower part of the trunk, the buttocks, the front of the thigh, and medial side of the leg.

The *sacral plexus* is formed by the anterior primary branches of the fifth lumbar and the first four sacral nerves, which unite into one great cord and so form the

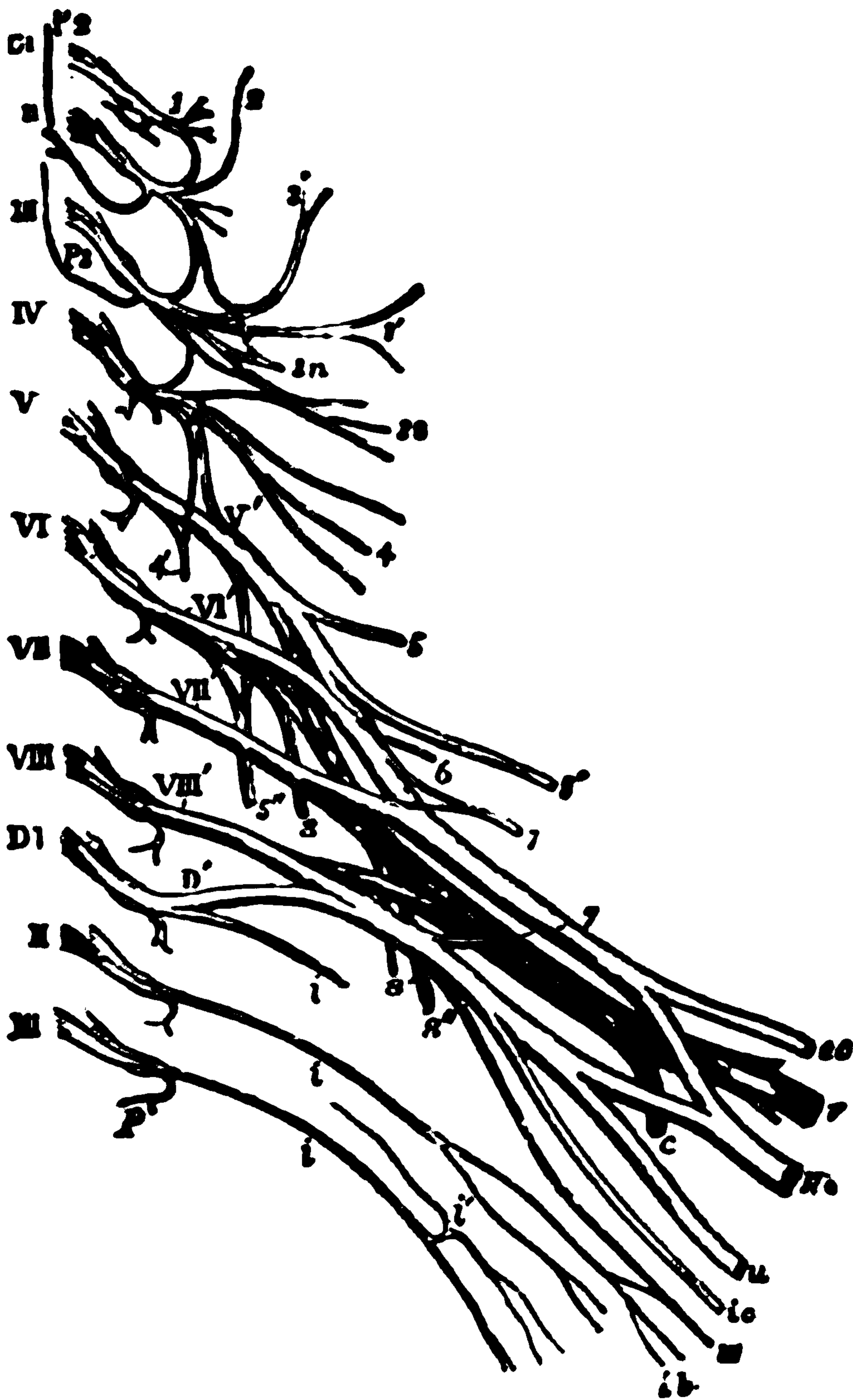

FIG. 65.—The cervical and brachial plexuses of one side of the Body.

*sciatic nerve*, which is the largest in the Body and, running down to the back of the thigh, ends in branches for the lower limb. The roots of the trunks which form the sacral plexus arise from the lumbar enlargement of the cord.



**DIESE SEITE IST FÜR KOSTENLOSE MITGLIEDER GESPERRT**  
Beantragen Sie jetzt die volle Mitgliedschaft, um diese Seite zu betreten



**Seien Sie niemals ohne ein Buch!**

Die Vollmitgliedschaft von Forgotten Books bietet Ihnen einen universalen Zugang von unseren Apps und unserer Website, auf all Ihren Geräten: Tablet, Telefon, E-Reader, Laptop und Computer.

**Eine Bibliothek in Ihrer Tasche für € 8.99/monat**

**Fortfahren**

\*Es gelten Richtlinien zur fairen Nutzung.

hemispherical eminences, the *corpora quadrigemina*. On its ventral side it exhibits two semicylindrical pillars (seen under the nerve *IV* in Fig. 70\* and known as the *crura cerebri*. The hind-brain consists of three main parts: on its dorsal side is the cerebellum, *B*, Fig. 66, consisting of a *right*, a *left*, and a *median lobe*; on the ventral side is the *pons Varolii*, *C*, Fig. 66, and behind the *medulla oblongata*, *D*, Fig. 66, which is continuous with the spinal cord.

In nature the main divisions of the brain are not separated so much as has been represented in the diagram for

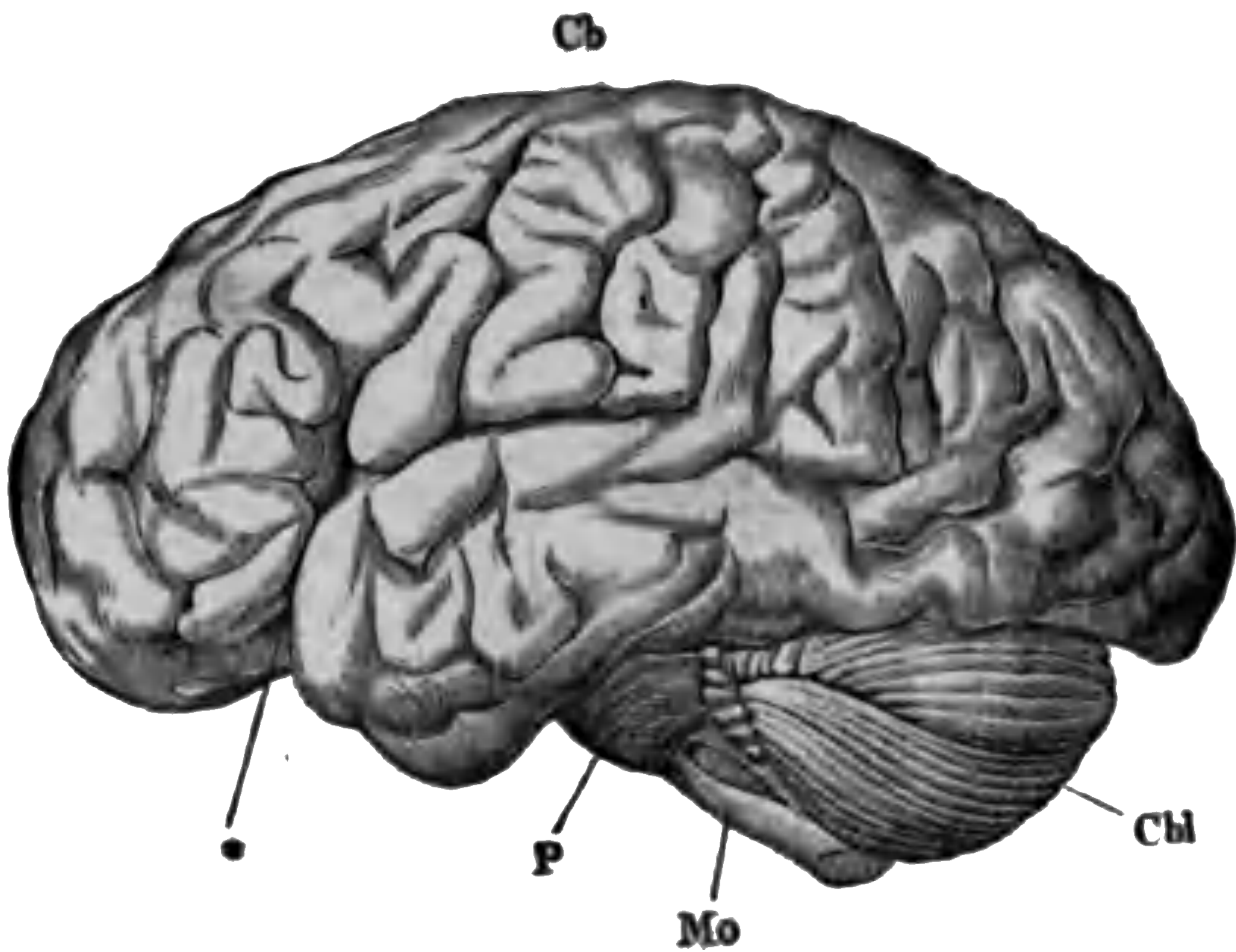

FIG. 67.—The brain from the left side. *Cb*, the cerebral hemispheres forming the main bulk of the fore-brain; *Cbl*, the cerebellum; *Mo*, the medulla oblongata; *P*, the pons Varolii; \*, the fissure of Sylvius.

the sake of clearness, but lie close together as represented in Fig. 67, only some folds of the membranes extending between them; and the mid-brain is entirely covered in on its dorsal aspect. Nearly everywhere the surface of the brain is folded, the folds, known as *gyri* or *convolutions*, being deeper and more numerous in the brain of man than in that of lower animals; and in the human species more marked in the higher than in the lower races.

The brain like the spinal cord consists of gray and white nervous matter but somewhat differently arranged, for while the brain, like the cord, contains gray matter in

\* P. 169.

its interior, a great part of its surface is also covered with it. By the external convolutions of the cerebellum and the cerebral hemispheres the surface over which this gray substance is spread is very much increased (see Fig. 68).

**The Ventricles of the Brain.** The minute central canal of the spinal cord is continued into the brain and expands there at several points into chambers known as the *ventricles*. Entering the medulla oblongata it approaches its upper surface and dilates into the *fourth ventricle*, which has a very thin roof, lapped over by the cerebellum. From the front of the fourth ventricle runs a narrow pas-

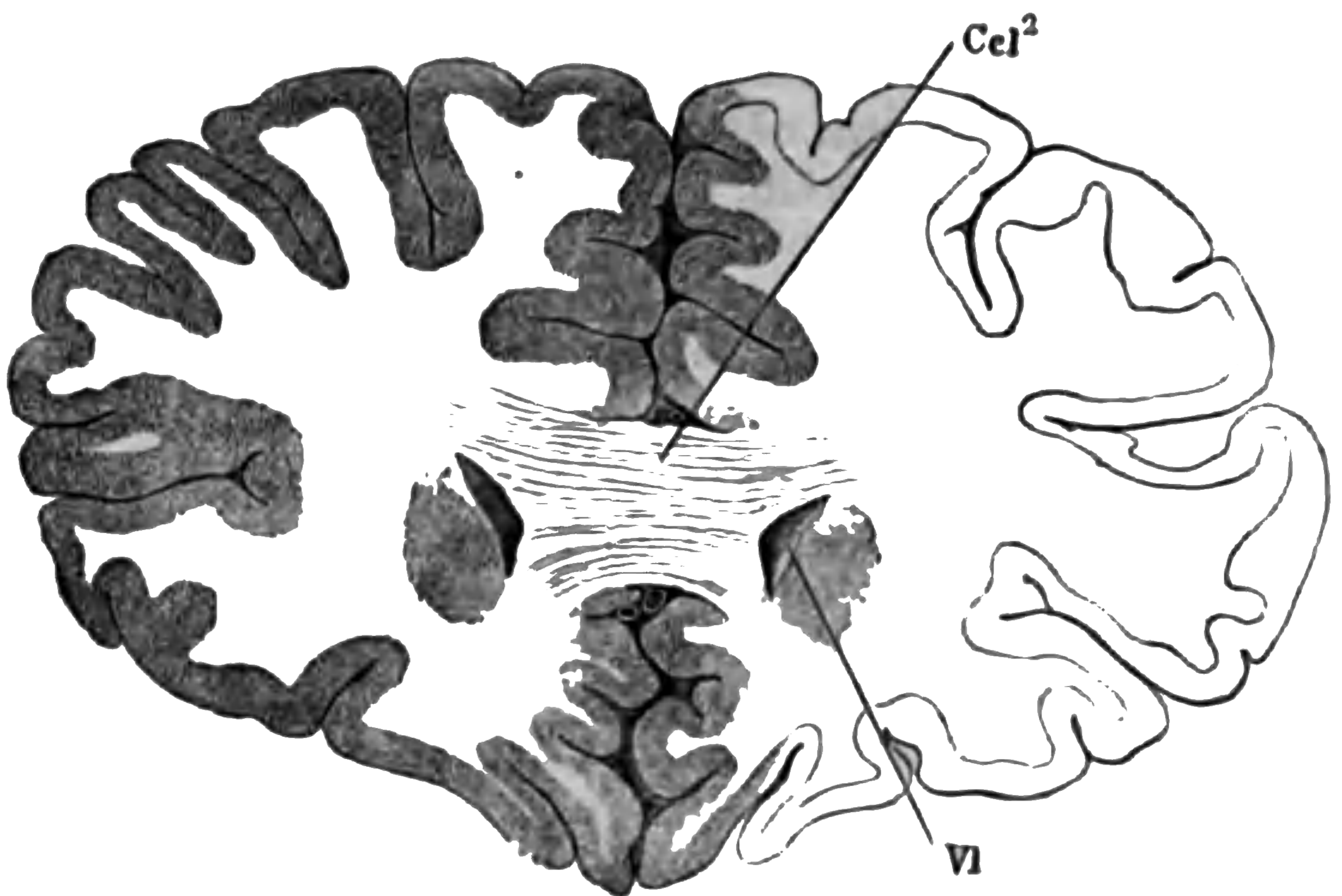

FIG. 69.—A vertical section across the cerebral hemispheres. *Ccl*<sup>2</sup>, the *corpus callosum*; *VI*, the anterior end of the right lateral ventricle: the gray mass on its exterior is the *corpus striatum*. On the left side the superficial gray matter covering the convolutions is shaded.

sage (*iter a tertio ad quartum ventriculum*) which enters another dilatation lying in the middle line near the under side of the fore-brain (just above the two small rounded masses seen between the nerves *II* and *III* in Fig. 70) and known as the *third ventricle*. From the third ventricle two apertures (the foramens of Monro) lead into the *first* and *second*, or *lateral ventricles*, one of which lies in each

of the cerebral hemispheres. The front ends of these two ventricles are seen in the vertical transverse section of the brain represented in Fig. 68.

The ventricles contain a small amount of *cerebro-spinal liquid* and are lined by epithelium which is ciliated in early life.

*Note.* A frequent cause of *apoplexy* is a hemorrhage into one of the lateral ventricles; the outpoured blood accumulating and pressing upon the cerebral hemispheres their functions are suppressed and unconsciousness produced. When a person is found in an apoplectic fit therefore the best thing to do is to leave him perfectly quiet until medical aid is obtained: for any movement may start afresh, bleeding into the ventricle which had been stopped by clots formed in the mouths of the torn blood-vessels.

**Sections of the Brain.** Having got a general idea of the parts composing the brain, the best way to complete a knowledge of its anatomy is to study sections taken in various directions. Two such are given in Figs. 68 and 69. Fig. 69 represents the right half of a vertical section of the brain, taken from before back in the middle line and viewed from the inner side. Above, the knife has passed between the two cerebral hemispheres, in the longitudinal fissure, without cutting either, and the convoluted inner surface of the right one is seen. The sickle-shaped mass lower down, *Ccl'* to *Ccl'* represents the cut surface of a connecting band of white nervous tissue called the *corpus callosum*, which runs across the middle line from one cerebral hemisphere to the other and puts them in communication. *Sl*, the *septum lucidum*, is a thin membrane which forms the inner wall of the lateral ventricle of the hemisphere. Between the two septa lucida on the sides (in the natural position of the parts) and the corpus callosum above is inclosed a narrow space known as the *fifth ventricle*. It is, however, quite different from the remaining cerebral ventricles, not being a continuation of the *canalis centralis* of the spinal cord. The space beneath the septum lucidum and the back part of the corpus callosum is the third ventricle, which, lying in the middle line, has been laid open in the



**DIESE SEITE IST FÜR KOSTENLOSE MITGLIEDER GESPERRT**  
Beantragen Sie jetzt die volle Mitgliedschaft, um diese Seite zu betreten

# GESCHICHTE

Zehntausende von wichtigen historischen Quellen, viele bisher nicht erhältlich, stehen jetzt zum ersten Mal mit der Vollmitgliedschaft von Forgotten Books zur Verfügung.

Unbegrenzter Zugang  
\$8.99/monat

**Fortfahren**

\*Es gelten Richtlinien zur fairen Nutzung.



the seat of the soul. Behind it come the *corpora quadrigemina*, *Lq*, and above the fourth ventricle the *cerebellum*, *Cbl*, showing the primary and secondary fissures on its surface which give its section a branched appearance known as the *arbor vitæ*. *Mo* is the *medulla oblongata*, and *P* the pons Varolii. The *canalis centralis* of the spinal cord is represented leading back from the fourth ventricle.

Fig. 68 represents a vertical transverse section of the brain taken through the fore part of the corpus callosum (*Ccl'*) and altogether in front of the third ventricle. It shows the foldings of the cerebrum and its superficial layer of gray substance; the anterior ends of the lateral ventricles, *Vl*, with a gray mass, the *corpus striatum* lying beneath and on the outer side of each. If the section had been taken a little farther back the *optic thalami* would have been found reaching the floor of each ventricle.

**The Base of the Brain and the Cranial Nerves.** Twelve pairs of nerves leave the skull by apertures in its base, and are known as the cranial nerves. Most of them spring from the under side of the brain, and so they are best studied in connection with the base of that organ, which is represented in Fig. 70. The *first pair*, or *olfactory nerves*, spring from the under sides of the olfactory lobes, *I*, and pass out through the roof of the nose. They are the nerves of smell. The *second pair*, or *optic nerves*, *II*, spring from the optic thalami and corpora quadrigemina and, under the name of the *optic tracts*, run down to the base of the brain where they appear passing around the *crura cerebri* as represented in the figure. In the middle line the two optic tracts unite to form the *optic commissure* (seen in section at *II'* in Fig. 69) from which an optic nerve proceeds to each eyeball. Behind the optic commissure is seen the conical stalk of the *pituitary body* or *hypophysis cerebri* (*H* in Fig. 69), and still further back a pair of hemispherical masses, about the size of split peas, known as the *corpora albicantia*.

All the remaining cranial nerves arise from the hind-brain. The third pair (*motores oculi*) arise from the front of the pons Varolii, and are distributed to most of the

muscles which move the eyeball and also to that which lifts the upper eyelid. The four-sided space bounded by the optic tracts and commissure in front and the third pair of nerves behind, and having on it the pituitary body

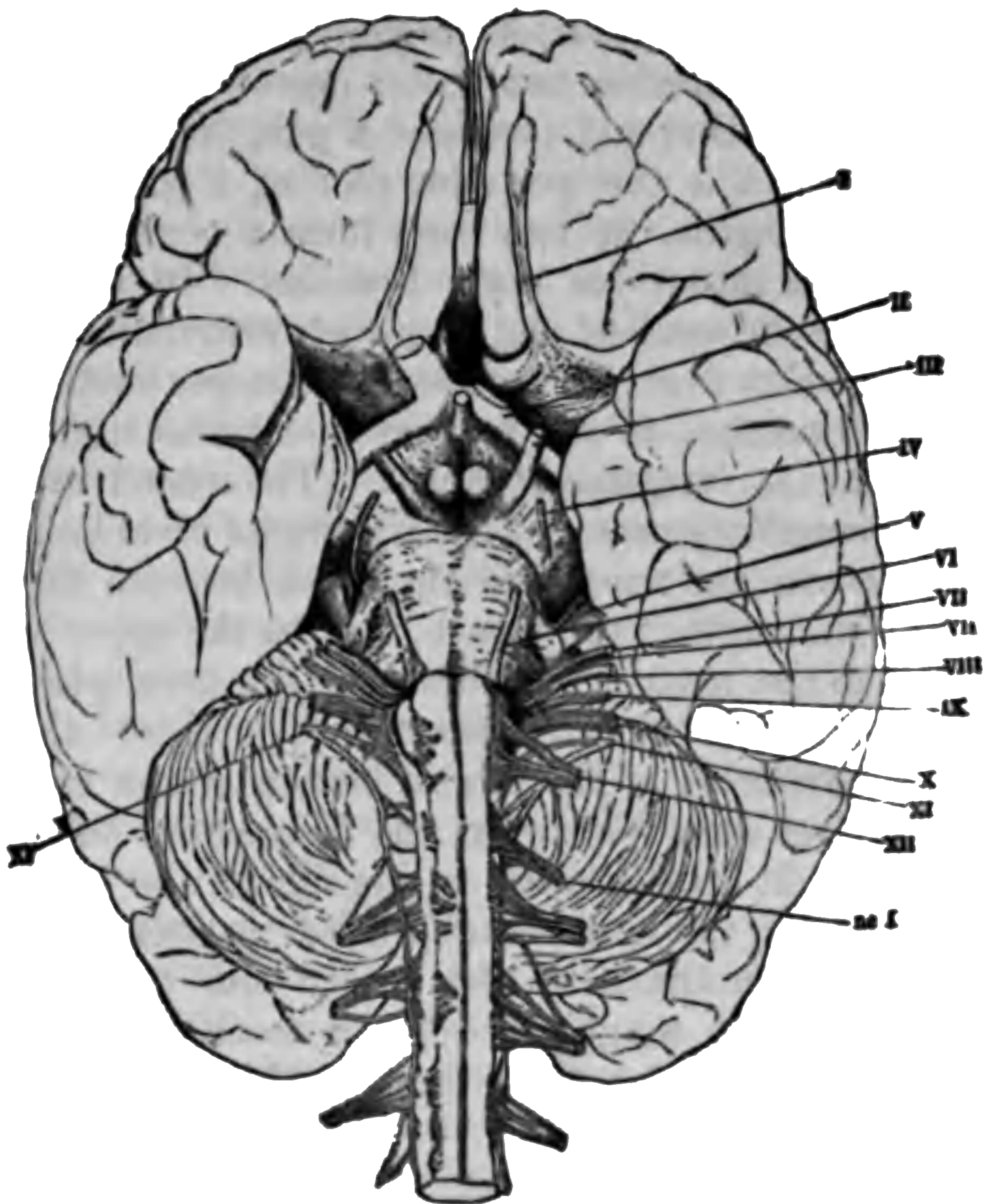

FIG. 70.—The base of the brain. The cerebral hemispheres are seen overlapping all the rest. *I*, olfactory lobes; *II*, optic tract passing to the optic commissure from which the optic nerves proceed; *III*, the third nerve or *motor oculi*; *IV*, the fourth nerve or *patheticus*; *V*, the fifth nerve or *trigeminalis*; *VI*, the sixth nerve or *abducens*; *VII*, the seventh or facial nerve or *portio dura*; *VIII*, the auditory nerve or *portio mollis*; *IX*, the ninth or glossopharyngeal; *X*, the tenth or pneumogastric or *vagus*; *XI*, the spinal accessory; *XII*, the hypoglossal; *nc I*, the first cervical spinal nerve.

and the corpora albicantia, lies beneath the third ventricle, so that a probe pushed in there would enter that cavity.

The fourth pair of nerves, *IV* (*pathetici*), arise from the front part of the roof of the fourth ventricle. From there,



each curls around a *crus cerebri* (the cylindrical mass seen beneath it in the figure, running from the pons Varolii to enter the under surface of the cerebral hemispheres) and appears on the base of the brain. Each goes to one muscle of the eyeball.

The fifth pair of nerves, *V* (*trigeminales*), resemble the spinal nerves in having two roots; one of these is much larger than the other and possesses a ganglion (the *Gasserian ganglion*) like the posterior root of a spinal nerve. Beyond the ganglion the two roots form a common trunk which divides into three main branches. Of these, the *ophthalmic* is the smallest and is mainly distributed to the muscles and skin over the forehead and upper eyelid; but also gives branches to the mucous membrane lining the nose, and to the integument over it. The second division (*superior maxillary nerve*) of the trigeminal gives branches to the skin over the temple, to the cheek between the eyebrow and the angle of the mouth, and to the upper teeth; as well as to the mucous membrane of the nose, pharynx, soft palate and roof of the mouth. The third division (*inferior maxillary*) is the largest branch of the trigeminal; it receives some fibres from the larger root and all of the smaller. It is distributed to the side of the head and the external ear, the lower lip and lower part of the face, the mucous membrane of the mouth and the anterior two thirds of the tongue, the lower teeth, the salivary glands, and the muscles which move the lower jaw in mastication.

The sixth pair of cranial nerves (*VI*, Fig. 70) or *abducentes* arise from the posterior margin of the pons Varolii, and each is distributed to one muscle of the eyeball.

The seventh pair (*facial nerves*), *VII*, appear also at the posterior margin of the pons. They are distributed to most of the muscles of the face and scalp.

The eighth pair (*auditory nerves*) arise close to the facial. They are the nerves of hearing and are distributed entirely to the internal ear.

The ninth pair (*glossopharyngeals*), *IX*, arising close to



**DIESE SEITE IST FÜR KOSTENLOSE MITGLIEDER GESPERRT**  
Beantragen Sie jetzt die volle Mitgliedschaft, um diese Seite zu betreten



**Seien Sie niemals ohne ein Buch!**

Die Vollmitgliedschaft von Forgotten Books bietet Ihnen einen universalen Zugang von unseren Apps und unserer Website, auf all Ihren Geräten: Tablet, Telefon, E-Reader, Laptop und Computer.

**Eine Bibliothek in Ihrer Tasche für € 8.99/monat**

**Fortfahren**

\*Es gelten Richtlinien zur fairen Nutzung.

nerves often receive branches from neighboring cranial or spinal nerves, so that very soon after it leaves the brain hardly any one remains free from fibres derived from other trunks except the olfactory, optic, and auditory nerves. This often makes it difficult to say from where the nerves of a special part have come; for example, the nerve-fibres going to the submaxillary salivary gland from the trigeminal leave the brain first in the facial and only afterwards enter the fifth; and many of the fibres going apparently from the pneumogastric to the heart come originally from the spinal accessory.

**The Sympathetic System.** The ganglia which form the main centres of the sympathetic nervous system lie in two rows (*s*, Fig. 2, and *sy*, Fig. 3), one on either side of the bodies of the vertebræ. Each ganglion is united by a nerve-trunk with the one in front of it, and so two great chains are formed reaching from the base of the skull to the coccyx. In the trunk region these chains lie in the ventral cavity, their relative position in which is indicated by the dots *sy* in the diagrammatic transverse section represented on p. 7 in Fig. 3. The ganglia on these chains are forty-nine in number, viz., twenty-four pairs, and a single one in front of the coccyx in which both chains terminate. They are named from the regions of the vertebral column near which they lie; there being three cervical, twelve dorsal, four lumbar, and five sacral pairs.

Each sympathetic ganglion is united by *communicating branches* with the neighboring spinal nerves, and near the skull with various cranial nerves also; while from the ganglia and their uniting cords arise numerous trunks, many of which, in the thoracic and abdominal cavities, form plexuses, from which in turn nerves are given off to the viscera. These plexuses frequently possess numerous small ganglia of their own; two of the most important are the *cardiac plexus* which lies on the dorsal side of the heart, and the *solar plexus* which lies in the abdominal cavity and supplies nerves to the stomach, liver, kidneys, and intestines. Many of the sympathetic nerves finally end in the walls of the blood-vessels of various organs. To the naked

eye they are commonly grayer in color than the cerebro-spinal nerves.

**The Sporadic Ganglia.** These, for the most part very minute, nerve-centres are found scattered in nearly all parts of the Body. They are especially abundant in the neighborhood of secretory tissues and about blood-vessels, while a very important set is found in the heart. Nerves unite them with the cerebro-spinal and sympathetic centres, and probably many of them belong properly to the sympathetic system.

**The Histology of Nerve-Fibres.** The microscope shows that in addition to connective tissue and other accessory parts, such as blood-vessels, the nervous organs contain tissues peculiar to themselves and known as *nerve-fibres* and *nerve-cells*. The cells are found in the centres only; while the fibres, of which there are two main varieties known as the *white* and the *gray*, are found in both trunks and centres; the white variety predominating in the cerebro-spinal nerves and in the white substance of the centres, and the gray in the sympathetic trunks and the gray portions of the central organs.

If an ordinary cerebro-spinal nerve-trunk be examined it will be found to be enveloped in a loose sheath of areolar connective tissue, which forms a packing for it and unites it to neighboring parts. From this sheath, or *perineurium*, bands of connective tissue penetrate the nerve and divide it up into a number of smaller cords or *funiculi*, much as a muscle is subdivided into fasciculi; each funiculus has a sheath of its own called the *neurilemma*, composed of several concentric layers of a delicate membrane, within which the true nerve-fibres lie. These, which would be nearly all of the white kind, consist of extremely delicate threads, about 0.0125 millm. ( $\frac{1}{8000}$  inch) in diameter, but frequently of a length which is in proportion very great. Each nerve-fibre in fact is continuous from a nerve-centre to the organ in which it ends, so that the fibres, *e.g.* which pass out through the sacral plexus and then run on through the sciatic nerve and its branches to the skin of the toes, are three to four feet long. If a perfectly fresh nerve-fibre

be examined with the microscope it presents the appearance of a perfectly homogeneous glassy thread; but soon it acquires a characteristic double contour (Fig. 71) from the coagulation of a portion of its substance. By proper treatment with reagents three layers may be brought into view. Outside is a fine transparent envelope (1, Fig. 72) called the *primitive sheath*; inside this is a fatty substance, 2,

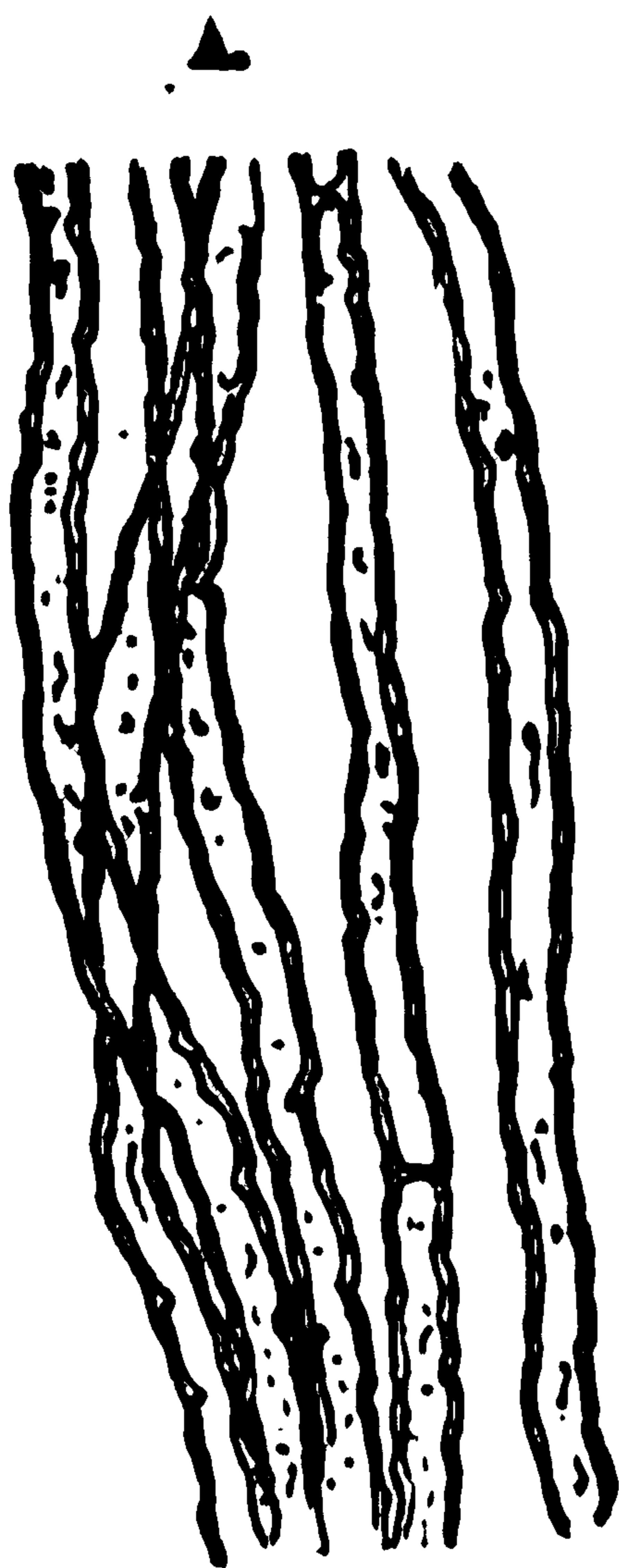

FIG. 71.



FIG. 72.

FIG. 71.—White nerve-fibres soon after removal from the Body and when they have acquired their double contour.

FIG. 72.—Diagram illustrating the structure of a white or medullated nerve-fibre. 1, 1, primitive sheath; 2, 2, medullary sheath; 3, axis cylinder.

forming the *medullary sheath* (the coagulation of which gives the fibre its double border), and in the centre is a core, the *axis cylinder*, 3, which is clearly the essential part of the fibre, since near its ending the primitive and medullary sheaths are frequently absent. At intervals of about one millimeter ( $\frac{1}{8}$  inch) along the fibre are found *nuclei*. These are indications of the primitive cells which by their elongation, fusion and other modifications have



**DIESE SEITE IST FÜR KOSTENLOSE MITGLIEDER GESPERRT**

Beantragen Sie jetzt die volle Mitgliedschaft, um diese Seite zu betreten

# GESCHICHTE

Zehntausende von wichtigen historischen Quellen, viele bisher nicht erhältlich, stehen jetzt zum ersten Mal mit der Vollmitgliedschaft von Forgotten Books zur Verfügung.

Unbegrenzter Zugang  
\$8.99/monat

**Fortfahren**

\*Es gelten Richtlinien zur fairen Nutzung.



jority of which subdivide and form fine nerve-fibres in the gray substance of the spinal cord. One process of the cell, however, *a*, does not branch, but is continued into the anterior root of a spinal nerve, acquiring a medullary and primitive sheath at *b*, and becoming thus the axis cylinder of a nerve-fibre. Other nerve-cells (as shown at 2 and 4) do not possess the peculiar axis-cylinder process; all their branches either join the branches of other cells or enter a fine net-

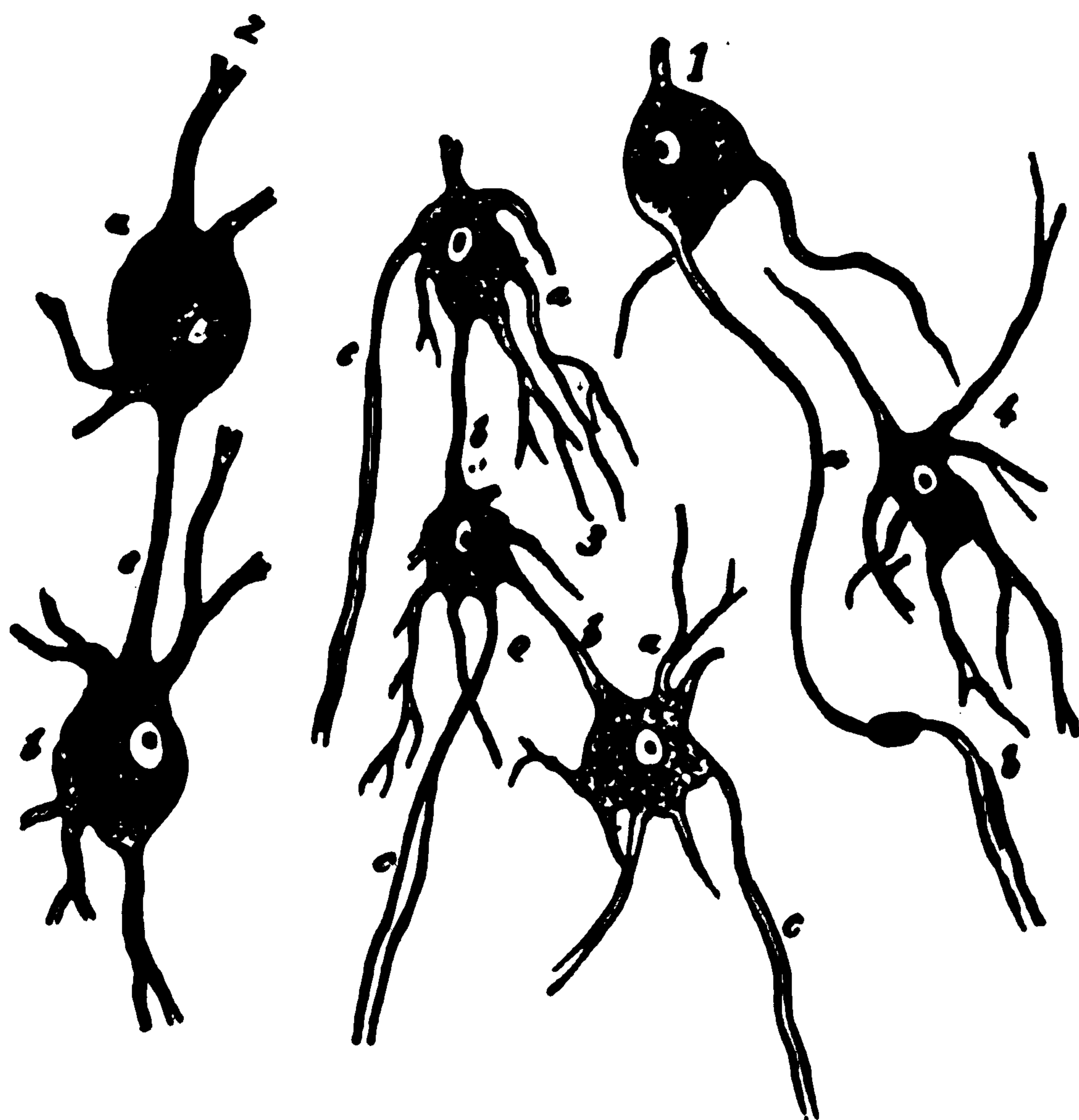

FIG. 73.—Different forms of nerve-cells. 1, a cell, one branch of which, *a*, becomes the axis cylinder of a nerve-fibre; 2, two cells united by a process, *c*; 3, diagram of three cells united by branches with one another, and each having an axis-cylinder process; 4, a multipolar cell without an axis-cylinder process.

work of gray nerve-fibrils. Most nerve-cells are larger than the majority of the other cells of the Body, their average diameter in the anterior horns of the gray substance of the cord being 0.1 millimeter ( $\frac{1}{16}$  inch). In the posterior horns they are smaller, and in the brain many minute nerve-cells are found in addition to these larger ones. In ganglia the cells as a rule are more reg-

ular in outline than those depicted in Fig. 73, and have fewer branches, most appearing indeed to have but two. Others have been described as possessing only one process connected with them, and some with none, but the existence of these is doubtful, since in separating the cells for microscopic examination the delicate processes may readily be broken off and so escape detection.

**The Structure of Nerve-Centres.** These consist of white and gray nerve-fibres, of nerve-cells, and of connective tissue and blood-vessels arranged in different ways in the different centres. *Ganglia* are collections of nerve-cells and nerve-fibres, some of the latter being connected with the cells, while others seem merely to pass through the ganglion on their way to other parts. The whole mass is enveloped and supported by other tissues. As an illustration of the structure of a more complex nerve-centre we may study the spinal cord.

**Histology of the Spinal Cord.** If a thin transverse section of the spinal cord be examined with a microscope it will be found to exhibit the following parts (Fig. 74). Enveloping the whole and adherent to the rest is the delicate layer of connective tissue forming the *pia mater*. This lines the anterior fissure, 1, and an offshoot from it fills up the posterior fissure, 2. Elsewhere fine bands of it run in and ramify through the cord, supporting the nervous elements; some of the coarser of these are represented at 6, 7, and elsewhere in the figure, but from these still finer processes arise, as represented at *d* and *e* in Fig. 75, and surround the individual nerve fibres and cells. This ultimate finest connective tissue supporting the nervous tissues directly, belongs to the retiform variety (p. 106), and is called the *neuroglia*. In the white columns, the cord (Fig. 75) will be seen to be mainly made up of medullated nerve-fibres which run longitudinally and therefore appear in the transverse section as circles, with a dot in the centre, which is the axis cylinder. At *b* in Fig. 75 these fibres are represented, the intermediate connective tissue being omitted, while at *c* this latter alone is represented in order to show more clearly its arrangement. At



the levels of the nerve-roots horizontal white fibres are found (9 and 10, Fig. 74, and *a*, Fig. 75) running into the gray matter, and others exist at the bottom of the anterior fissure, running from one side of the cord to the other. In the gray substance the same supporting network of connective tissue is found, but in it the majority of the nerve-fibres are non-medullated, and at certain points nerve-cells,

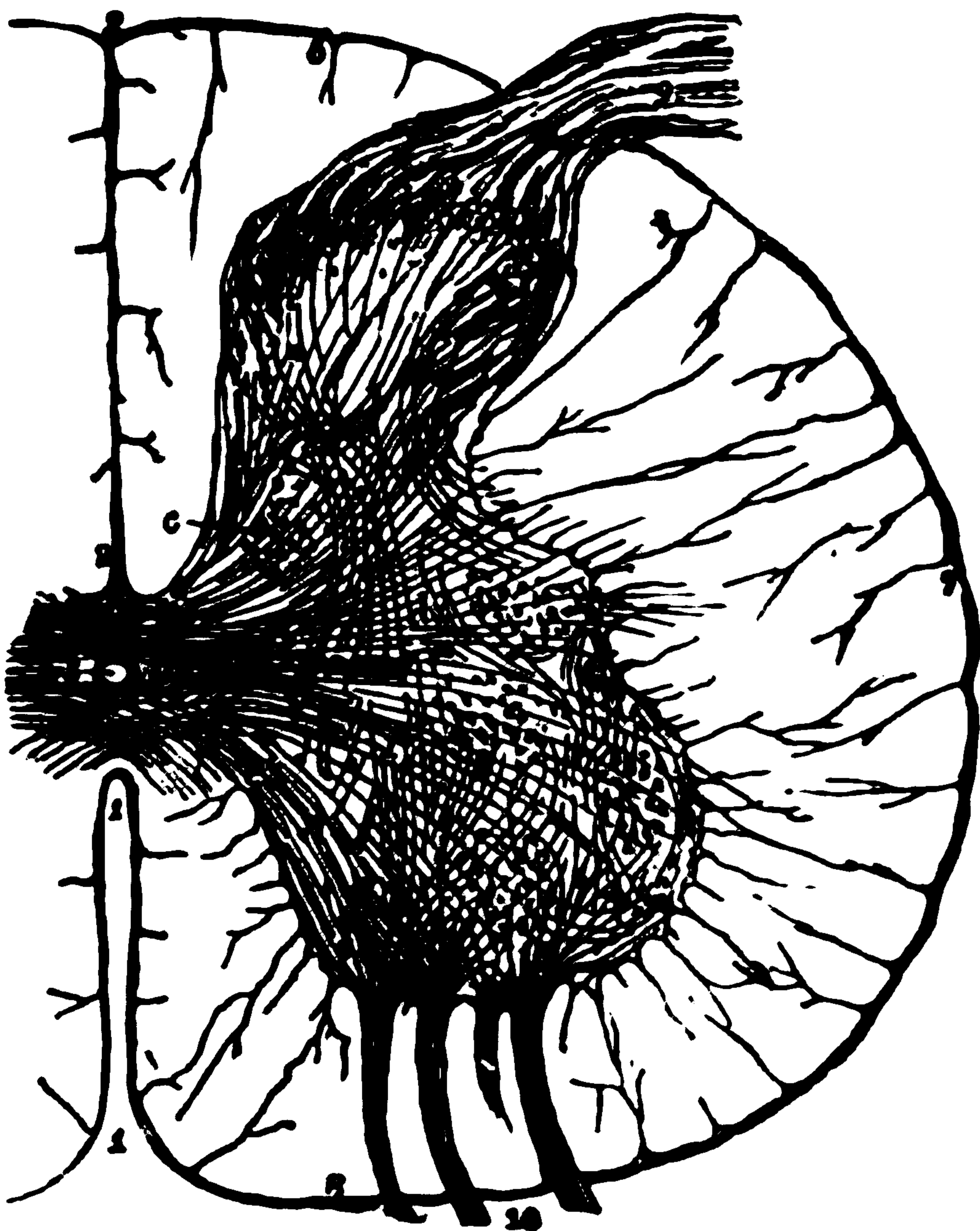

FIG. 74.—A thin transverse section of half of the spinal cord magnified about 10 diameters. 1, anterior fissure ; 2, posterior fissure ; 3, *canalis centralis* ; 4, *pia mater* enveloping the cord ; 5, 6, 7, bands of *pia mater* penetrating the cord and supporting its nerve elements ; 9, a posterior root ; 10, bundles of an anterior root ; *a*, *b*, *c*, *d*, *e*, groups of nerve-cells in the gray matter.

such as are totally absent in the white substance, are found. One collection of these nerve-cells is seen at *e* in Fig. 74, and others are represented at *a*, *d*, *f*, and elsewhere. The nerve-fibres in the gray matter are for the most part branches of these cells (see Fig. 73), and as they unite with one another they form a structurally continuous



**DIESE SEITE IST FÜR KOSTENLOSE MITGLIEDER GESPERRT**  
Beantragen Sie jetzt die volle Mitgliedschaft, um diese Seite zu betreten



**Seien Sie niemals ohne ein Buch!**

Die Vollmitgliedschaft von Forgotten Books bietet Ihnen einen universalen Zugang von unseren Apps und unserer Website, auf all Ihren Geräten: Tablet, Telefon, E-Reader, Laptop und Computer.

**Eine Bibliothek in Ihrer Tasche für €8.99/monat**

**Fortfahren**

\*Es gelten Richtlinien zur fairen Nutzung.

## CHAPTER XIII.

### THE GENERAL PHYSIOLOGY OF THE NERVOUS SYSTEM.

**The Properties of the Nervous System. *General Considerations.*** If the finger of any one unexpectedly touches a very hot object, pain is felt and the hand is suddenly snatched away; that is to say, sensation is aroused and certain muscles are caused to contract. If, however, the nerves passing from the arm to the spinal cord have been divided, or if they have been rendered incapable of activity by disease, no such results follow. Pain is not then felt on touching the hot body nor does any movement of the limb occur; even more, under such circumstances the strongest effort of the will of the individual will be unable to cause any movement of his hand. If, again, the nerves of the limb have uninjured connection with the spinal cord, but parts of the latter, higher up, between the brain and the point of junction of the nerves of the brachial plexus with the cord, are injured, then a sudden contact with the hot body will cause the arm to be snatched away, but no pain or other sensation due to the contact will be felt, nor can the will act upon the muscles of the arm. From the comparison of what happens in such cases (which have been observed over and over again upon wounded or diseased persons) with what occurs in the natural condition of things, several important conclusions may be arrived at:

1. *The feeling of pain does not reside in the burnt part itself; although that may be perfectly normal, no sensation will be aroused by any external force acting upon it, if the nervous cords uniting it with the centres be previously divided.*

2. *The hot body has originated some change which, pro-*

pagated along the nerve-trunks, has excited a condition of the nerve-centres which is accompanied by a sensation, in this particular case a painful one. This is clear from the fact that the loss of sensation immediately follows division of the nerves of the limb, but not the injury of any of its other parts; unless of such a character as to cut off the supply of blood, when of course the nerves soon die, with the rest. Even, however, some time after tying the vessels which carry blood to a limb one can observe in experiments upon the lower animals that sensibility is still retained if the nerves be not directly injured.

3. *When a nerve in the skin is excited by a burn or otherwise it does not directly call forth muscular contractions; for if so, touching the hot body would cause the limb to be moved even when the nerve is divided high up in the arm, and as a matter of observation and experiment we find that no such result follows if the nerve-fibres have been cut in any part of their course from the burnt part to the spinal marrow. It is therefore through the nerve-centres that the change transmitted from the excited part of the skin is reflected or sent back, to act upon the muscles.*

4. The last deduction makes it probable *that nerve-fibres must pass from the centre to muscles as well as from the skin to the centre.* This is confirmed by the fact that if the nerves of the limb be divided the will is unable to act upon its muscles, showing that these are excited to contract through the nerves. That the nerve-fibres concerned in arousing sensation and muscular contractions are different, is shown also by cases of disease in which the sensibility of the limb is lost while the power of voluntarily moving it remains, and by other cases in which the reverse is seen, objects touching the hand being felt while it cannot be moved by the will. We conclude then that certain nerve-fibres when stimulated convey something (*a nervous impulse*) to the centres, and that these when excited may radiate impulses through other nerve-fibres to distant parts, the centre serving as a connecting link between the fibres which carry impulses from without in, and those which convey them from within out.

5. Further we conclude that *the spinal cord can act as an intermediary between the fibres carrying in nervous impulses and those carrying them out, but that sensations cannot be aroused by impulses reaching the spinal cord only, nor has the Will its seat there ; volition and consciousness are dependent upon states of the brain.* This follows from the unconscious movements of the limb which follow stimulation of its skin after such injury to the spinal cord as prevents the transmission of nervous impulses farther on (showing that the cord is a *reflex centre*), and from the absence, in such cases, of sensation in the part whose nerves have been injured, and the loss of the power of voluntarily causing its muscles to contract.

6. Finally we conclude that *the spinal cord in addition to being a centre for reflex actions serves also to transmit onwards nervous impulses to the brain ; a fact which is confirmed by the histological observation that in addition to the nerve-cells, which are the characteristic constituents of nerve-centres, it contains the simply conductive nerve-fibres, many of which pass on to the brain.* In other words the spinal cord, besides containing fibres which enter it from, and pass from it to, peripheral parts contains many which unite it to other centres ; and connect the various centres in it, as those for the arms and legs, together. This is true not only of the spinal cord but of the brain (which contains many fibres uniting different centres in it), and probably of all nerve-centres.

**The Functions of Nerve-Centres and Nerve-Trunks.** From what has been stated in the previous paragraphs it is clear that we may distinctly separate the nerve-trunks from the nerve-centres. The fibres serve simply to convey impulses either from without to a centre or in the opposite direction, while the centres conduct and do much more. Some, as the spinal cord, are merely *reflex centres*, and have nothing to do with states of consciousness. A man with his spinal cord cut or diseased in the dorsal region will kick violently if the soles of his feet be tickled, but will feel nothing of the tickling, and if he did not see his legs *would not know that they were moving.* Reflex centres



**DIESE SEITE IST FÜR KOSTENLOSE MITGLIEDER GESPERRT**

Beantragen Sie jetzt die volle Mitgliedschaft, um diese Seite zu betreten

# GESCHICHTE

Zehntausende von wichtigen historischen Quellen, viele bisher nicht erhältlich, stehen jetzt zum ersten Mal mit der Vollmitgliedschaft von Forgotten Books zur Verfügung.

Unbegrenzter Zugang  
\$8.99/monat

**Fortfahren**

\*Es gelten Richtlinien zur fairen Nutzung.



impulses then by the many nerve-fibres connected with them. By such means a single nerve-fibre can act upon an extended region of the Body. In other cases it seems likely that a feeble nervous impulse reaching an irritable nerve-cell excites changes in this comparable to those produced in a muscle when it is stimulated; and the cell by its discharge sends on reinforced nerve impulses along its other branches.

**Excitant and Inhibitory Nerves.** The great majority of the nerve-fibres of the Body when they convey nervous impulses to a part arouse it to activity; they are *excitant fibres*. There is, however, in the Body another very important set which arrest the activity of parts and which are known as *inhibitory nerve-fibres*. Some of these check the action of central nervous organs, and others the work of peripheral parts. For instance taking a pinch of snuff will make most persons sneeze; it excites centrally acting fibres in the nose, these excite a centre in the brain, and this in turn sends out impulses by efferent fibres which cause various muscles to contract. But if the skin of the upper lip be pinched immediately after taking the snuff, in most cases the reflex act of sneezing, which the Will alone could not prevent, will not take place. The afferent impulses conveyed from the skin of the lip have "inhibited" what we may call the "sneezing centre;" and afford us therefore an example of inhibitory fibres checking a centre. On the other hand, the heart is a muscular organ which goes on beating steadily throughout life; but if the branches of the pneumogastric nerve going to it be excited, the beat of the heart will be stopped; it will cease to work and lie in a relaxed resting condition: in this we have an instance of an inhibitory nerve checking the activity of a peripheral organ.

**Classification of Nerve-Fibres.** Nearly all the nerve-fibres of the Body fall into one of two great groups corresponding to those which carry impulses to the centres and those which carry them out from the centres. The former are called *afferent* or *centripetal fibres* and the latter *efferent* or *centrifugal*. Since the impulses reaching the centres through the afferent fibres generally cause sen-

sations they are often called *sensory fibres*; and as many of those which carry out impulses from the centres excite movements, they are frequently called *motor fibres*; but these last names are bad, since even excluding inhibitory nerves, many afferent fibres are not sensory and many efferent are not motor.

We may distinguish as subdivisions of *afferent fibres*—the following groups. 1. *Sensory fibres proper*, the excitement of which is followed by a sensation when they are connected with their brain-centre, which sensation may or may not give rise to a voluntary movement. 2. *Reflex fibres*, the excitation of which may be attended with consciousness but gives rise to involuntary efferent impulses. Thus for example light falling on the eye causes not only a sensation but also a narrowing of the pupil, which is entirely independent of the control of the Will. No absolute line can, however, be drawn between these fibres and those of the last group: any sudden excitation, as an unexpected noise, will cause an involuntary movement, while the same sound if expected would cause a movement or not according as was *willed*. 3. *Excito-motor fibres*. The excitation of these when reaching a nerve-centre causes the stimulation of efferent fibres, but without the participation of consciousness. During fasting for instance bile accumulates in the gall-bladder and there remains until some semi-digested food passes from the stomach into the intestine. This is acid, and stimulates nerves in the mucous membrane lining the intestine, and these convey an impulse to a centre, which in consequence sends out impulses to the muscular coat of the gall-bladder causing it to contract and expel its contents into the intestine: but of all this we are entirely unconscious. 4. *Centro-inhibitory fibres*. Whether these exist as a distinct class is at present doubtful. It may be that they are only ordinary sensory or reflex fibres and that the inhibition is due only to the interference of two impulses reaching a central organ at the same time and impeding or hindering the full production of the normal result of either.

In *efferent nerve-fibres* physiologists also distinguish



several groups. 1. *Motor fibres*, which are distributed to the muscles and govern their contractions. 2. *Vaso-motor fibres*. These are not logically separable from other motor fibres; but they are distributed to the muscles of the blood-vessels and by governing the blood-supply of various parts, indirectly produce such secondary results as entirely overshadow their primary effect as merely producing muscular contractions. 3. *Secretory fibres*. These are distributed to the cells of the Body which form various liquids used in it, as the saliva and the gastric juice, and arouse them to activity. The salivary glands for instance may be made to form saliva by stimulating nerves going to them, and the same is true of the cells which form the sweat poured out upon the surface of the Body. 4. *Trophic nerve-fibres*. Under this head are included nerve-fibres which have been supposed to govern the nutrition of the various tissues, and so to control their healthy life. It is very doubtful, however, if any such nerve-fibres exist, most of the facts cited to prove their existence being otherwise explicable. For instance *shingles* is a disease characterized by an eruption on the skin along the line of certain nerves which run between the ribs; but it may be dependent upon disease of the vaso-motor nerves which control the blood-supply of the part. In other cases diseases ascribed to injury of trophic nerves have been shown to be due to injury of the sensory nerves of the part, which having lost its feeling, is exposed to injuries from which it would otherwise have been protected. On the other hand it may be said that secretory nerves are trophic nerves in the true sense of the word, since when excited they cause the secretory cells to live in a special way (p. 269) and produce substances which when unacted upon by their nerves they do not form. But if we call secretory nerves trophic we must include also under that name all other efferent nerves; the nutritive processes going on in a muscular fibre when at work are different from those in the same fibre when at rest, and the same is true of all other cells the activity of which is governed by nerve-fibres. 5. *Peripherally-acting inhibitory nerves*.



**DIESE SEITE IST FÜR KOSTENLOSE MITGLIEDER GESPERRT**  
Beantragen Sie jetzt die volle Mitgliedschaft, um diese Seite zu betreten



**Seien Sie niemals ohne ein Buch!**

Die Vollmitgliedschaft von Forgotten Books bietet Ihnen einen universalen Zugang von unseren Apps und unserer Website, auf all Ihren Geräten: Tablet, Telefon, E-Reader, Laptop und Computer.

**Eine Bibliothek in Ihrer Tasche für € 8.99/monat**

**Fortfahren**

\*Es gelten Richtlinien zur fairen Nutzung.

extent. If, for example, the sciatic of a frog be exposed in the thigh and divided, it will be found that electric shocks applied at the point of division to the outer half of the nerve stimulate the motor fibres in it, and cause the muscular fibres of the leg to contract: and similarly such shocks applied to the cut end of the central half irritate the afferent fibres in it, as shown by the signs of feeling exhibited by the animal. In ourselves, too, we often have the opportunity of observing that the sensory fibres can be stimulated in their course at some distance from their ends. A blow at the back of the elbow, at the point commonly known as the "funny bone" or the "crazy bone," compresses the ulnar nerve there against the subjacent bone, and starts nervous impulses which make themselves known by severe tingling pain referred to the little and ring fingers to which the nerve is distributed. This shows not only that the nerve-fibres can be irritated in their course as well as at their ends, but also that sensations do not directly tell us where a nerve-fibre has been excited. No matter where in its course the impulse has been started we unconsciously refer its origin to the peripheral end of the afferent nerve.

**General and Special Nerve Stimuli.** Certain external forces excite all nerve-fibres, and in any part of their course. These are known as *general nerve stimuli*; others act only on the end organs of nerve-fibres, and often only on one kind of end organ, and hence cannot be made to excite all nerves: these latter are commonly known as *special nerve stimuli*. In reality they are not properly nerve stimuli at all; but only things which so affect the irritable tissues attached to the ends of certain nerve-fibres as to make these tissues in turn excite the nerves. For example light itself will not stimulate any nerve, not even the optic: but in the eye it effects changes (apparently of a chemical nature) by which substances of the nature of general nerve stimuli are produced and these stimulate the optic nerve-fibres. The ends of the nerves in the skin are not accessible to light nor are the proper end organs on which the light acts there present, so light does not lead to the production of nervous impulses in them: but the optic nerve without

its peculiar end organs would be just as insensible to light as these are. Similarly the aërial vibrations which affect us as sounds, do not stimulate directly the fibres of the auditory nerve. They act on terminal organs in the ear, and these then stimulate the fibres of the nerve of hearing, just as they would any other nerve which happened to be connected with them.

**General Nerve Stimuli.** Those known are (1) *electric currents*: an electric shock passed through any part of any nerve-fibre, powerfully excites it. A steady current passing through a nerve does not stimulate it, but any sudden change in this, whether an increase or a decrease, does. A very gradual change in the amount of electricity passing through a nerve in a unit of time will not stimulate it. (2) *Mechanical stimuli*. Any sudden pressure or traction, as a blow or a pull, will stimulate a nerve-fibre. On the other hand steady pressure, or pressure very slowly increased from a minimum, will not excite the nerve. (3) *Thermal stimuli*. Any sudden heating or cooling of a nerve, as for instance bringing a hot wire close to it, will stimulate; slow changes of temperature will not. (4) *Chemical stimuli*. Many substances which alter the nerve-fibre chemically, stimulate before killing it; thus dipping the cut end of a nerve into strong solution of common salt will excite it, but very slow chemical change in a nerve fails to stimulate.

In the case of all these general stimuli it will be seen that as one condition of their efficacy they must act with considerable suddenness. On the other hand too transient influences have no effect. An electric shock sent for only 0.0015 of a second through a nerve does not stimulate it: apparently the inertia of the nerve molecules is too great to be overcome by so brief an action. So, also, too strong sulphuric acid and many other bodies kill nerves immediately, altering them so rapidly that they die without being stimulated.

**Special Nerve Stimuli.** These as already explained act only on particular nerves, not because one nerve is essentially different from another, but because their influence

is excited through special end organs which are peculiar to some nerves. These stimuli are—(1) Changes occurring in central organs, of whose nature we know next to nothing, but which excite the efferent nerve-fibres connected with them. The remaining special stimuli act on afferent fibres through the sense-organs. They are—(2) Light, which by the intervention of organs in the eye excites the optic nerve. (2) Sound, which by the intervention of organs in the ear excites the auditory nerve. (3) Heat, which through end organs in the skin is able, by very slight changes, to excite certain nerve-fibres: such slight changes of temperature being efficient as would be quite incapable of acting as general nerve stimuli without the proper end organs. (4) *Chemical agencies*. These when extremely feeble and incapable of acting as general stimuli, can act as special stimuli through special end organs in the mouth and nose (as in taste and smell) and probably in other parts of the alimentary tract, where very feeble acids and alkalies seem able to excite certain nerves, and reflexly through them excite movements or stir up the cells concerned in making the digestive liquids; for example the contraction of the gall-bladder already referred to. (5) Mechanical stimuli when so feeble as to be inefficient as general stimuli. Pressure on the skin of the forehead or the back of the hand, equal to .002 gram (.03 grain) can be felt through the end organs of the sensory fibres there, but would be quite incapable of acting as a general stimulus in the absence of these.

It will be noticed as regards the special stimuli of afferent nerves that many of them are merely less degrees of general stimuli; the end organs in skin, mouth, and nose are in fact excited by the same things as the nerve-fibres, but are far more irritable. In the case of the higher senses, seeing and hearing, however, the end organs seem to differ entirely in property from nerve-fibres, being excited by sonorous and luminous vibrations which, so far as we know, will in no degree of intensity directly excite nerve-fibres. To make an end organ for recognizing very slight pressures we may imagine all that would be needed



**DIESE SEITE IST FÜR KOSTENLOSE MITGLIEDER GESPERRT**

Beantragen Sie jetzt die volle Mitgliedschaft, um diese Seite zu betreten

# GESCHICHTE

Zehntausende von wichtigen historischen Quellen, viele bisher nicht erhältlich, stehen jetzt zum ersten Mal mit der Vollmitgliedschaft von Forgotten Books zur Verfügung.

Unbegrenzter Zugang  
\$8.99/monat

**Fortfahren**

\*Es gelten Richtlinien zur fairen Nutzung.



along the fibre. If the muscle were cut away from the end of the nerve we could still detect that a nervous impulse had traveled from the point of stimulation to that where the fibres were divided, by tracking the negative variation. Now if we examine the part of the nerve on the central side of the stimulated point we find that a negative variation (and hence we conclude a nervous impulse) travels that way too; it starts at the same moment as the efferent negative variation and travels in the same way, but the impulse of which it is a sign produces no more effect than the efferent impulse would after the muscle had been cut away; for it does not reach any muscular fibre, or sensory or reflex centre, which it can arouse to activity. (4) The following experiment is, however, more conclusive. If a rat's tail be amputated close to the body of the animal and be then transplanted to the back and sewn into the skin there by its narrow end, it will grow in this new position, with the broad end, which was previously attached and nearest the spinal cord, now free and farthest from it. The tail, in other words, will be upside down. After the wound has healed, the nerve-fibres in the tail, or some of them, attach themselves to the cut nerve-fibres in the wound of the back to which it was transplanted, and the tail again becomes sensitive if the end now free be pinched. Here one of two things must have occurred. Either the afferent nerve-fibres in the tail which naturally carried impulses from its tip up, now carry them in the opposite direction from the broad end to the tip, or the efferent nerve-fibres which carried motor impulses down the tail, now carry sensory impulses and transmit them to the sensory fibres in the back with which they have become continuous. If the first, which is the more probable hypothesis, be true, it is proved that afferent nerve-fibres can carry impulses in either direction: if the second be true it is still more clear that there is no special peculiarity in a sensory nervous impulse when compared with a motor.

Afferent and efferent nerve-fibres then differ in no observable property. All are alike in faculty and their different names simply imply that they have different ter-

minal organs. Just as all muscles are alike in general physiological properties, and differ in special function according to the parts on which they act, so are all nerve-fibres alike in general physiological properties, and differ in special function only because they are attached to special things. The special physiology of various nerves will hereafter be considered in connection with the working of various mechanisms in the Body. If it be true that the great subdivisions of afferent and efferent fibres have identical properties, it follows that this is *a fortiori* true of the minor subdivisions of each, and that auditory, gustatory, and optic nerve-fibres are all alike, and all identical with motor and vaso-motor and secretory nerve-fibres; and that the nervous impulse is in all cases the same thing, varying in intensity in different cases and in the rate at which others follow it in the same fibre, but the same in kind. To put the case more definitely: Light outside the eye exists as ethereal vibrations, sound outside the ear as vibrations of the air (commonly). Each kind of vibration acts on a particular end organ in eye or ear which is adapted to be acted upon by it, and in turn these end organs excite the optic and auditory nerve-fibres; these in consequence transmit impulses, which reaching different parts of the brain excite them; the excitement of one of these brain-centres is associated with sonorous and of the other with visual sensations. The nervous impulse in the two cases is quite alike, at least as to quality; though it may differ in quantity and rhythm, and the resulting difference in quality of the sensations cannot depend on it. The quality differences in these cases must be products of the central nervous system. If we had a set of copper wires we might by sending precisely similar electric currents through them produce very different results if different things were interposed in their course. In one case the current might be sent through water and decompose it, doing chemical work; in another through the coil of an electro-magnet and raise a weight; in a third through a thin platinum wire and develop light and heat, and so on; the result depending on the terminal organs, as we may call them,



of each wire. Or on the other hand we might generate the current in each wire differently, in one by a Daniell's cell, in a second by a thermo-electric machine, in a third by the rotation of a magnet inside a coil, but the currents in the wires would be essentially the same, as the nervous impulses are in a nerve-fibre. No matter how they have been started and, provided their amount is the same, whether they produce similar or dissimilar results, depends only on whether they are connected with similar or dissimilar end organs.

**The Nature of a Nervous Impulse.** Since between sense-organs and sensory centres, and these latter and the muscles, nervous impulses are the only means of communication, it is through them that we arrive at our opinions concerning the external universe and through them that we are able to act upon it; their ultimate nature is therefore a matter of great interest, but one about which we unfortunately know very little. We cannot well imagine it anything but a mode of motion of the molecules of the nerve-fibres, but beyond this hypothesis we cannot go far. In many points the phenomena presented by nerve-fibres as transmitters of disturbances are like the phenomena of wires as transmitters of electricity, and when the phenomena of current electricity were first observed there was a great tendency, explaining one unknown by another, to consider nervous impulses merely as electrical currents. The increase of our knowledge concerning both nerves and electric currents, however, has made such an hypothesis almost if not quite untenable. In the first place, nerve-fibres are extremely bad conductors of electricity, so bad that it is impossible to suppose them used in the Body for that purpose, and in the second place, merely physical continuity of a nerve-fibre, such as would not interfere with the passage of an electric current, will not suffice for the transmission of a nervous impulse. For instance if a damp string be tied around a nerve, or if it be cut and its two moist ends placed in contact, no nervous impulse will be transmitted across the constricted or divided point, although an electrical current would pass readily. An electrical



**DIESE SEITE IST FÜR KOSTENLOSE MITGLIEDER GESPERRT**  
Beantragen Sie jetzt die volle Mitgliedschaft, um diese Seite zu betreten



**Seien Sie niemals ohne ein Buch!**

Die Vollmitgliedschaft von Forgotten Books bietet Ihnen einen universalen Zugang von unseren Apps und unserer Website, auf all Ihren Geräten: Tablet, Telefon, E-Reader, Laptop und Computer.

**Eine Bibliothek in Ihrer Tasche für € 8.99/monat**

**Fortfahren**

\*Es gelten Richtlinien zur fairen Nutzung.

course and divided in a living animal, it will be found that irritating its peripheral stump causes muscular contractions, and pinching its central stump causes signs of sensation, showing that the trunk contained both motor and sensory fibres. If the trunk be followed away from the centre, as it breaks up into smaller and smaller branches, it will be found that these too are mixed until very near their endings, where the very finest terminal branches close to the end organs, whether muscular fibres, secretory cells, or sensory apparatuses, contain only afferent or efferent fibres. If the nerve-trunk be one that arises from the spinal cord and be examined progressively back to its origin, it will still be found mixed, up to the point where its fibres separate to enter either an anterior or a posterior nerve-root. Each of these latter however is *pure*, all the efferent fibres of the spinal nerves leaving the cord by the anterior roots, and all the afferent entering it by the posterior. This of course could not be told from examination of the dead nerves since the best microscope fails to distinguish an afferent from an efferent fibre, but is readily proved by experiments first performed by Sir Charles Bell. If an anterior root be cut and its outer end stimulated, the muscles of the parts to which the trunk which it helps to form is distributed, will be made to contract, and the skin will be made to sweat also if the root happen to be one that contains secretory fibres for the sweat-glands. On the other hand, if the central end of the root (that part of it attached to the cord) be stimulated no result will follow, showing that the root contains no sensory, reflex, or excito-motor fibres. With the posterior roots the reverse is the case: if one of them be divided and its outer end stimulated, no observed result follows, showing the absence of all efferent fibres; but stimulation of its central end will cause either signs of feeling, or reflex actions, or both. We might compare a spinal nerve-trunk to a rope made up of green and red threads with at one end all the green threads collected into one skein and the red into another, which would represent the roots. At its farther end we may suppose the rope divided into finer cords, each of these also containing

red and green threads down to the very finest branches consisting of only a few threads and those all of one kind either red or green, one representing efferent, the other afferent fibres.

**The Cranial Nerves.** Most of these are mixed also, but with one exception (the fifth pair, the small root of which is efferent and the large gangliated one afferent) they do not present distinct motor and sensory roots, like those of the spinal nerves. At their origin from the brain most of them are either purely afferent or efferent, and the mixed character which their trunks exhibit is due to cross-branches with neighboring nerves, in which afferent and efferent fibres are interchanged. The olfactory, optic, and auditory nerves remain, however, purely afferent in all their course, and others though not quite pure contain mainly efferent fibres (as the facial) or mainly afferent (as the glosso-pharyngeal).

**The Intercommunication of Nerve-Centres.** From the anatomical arrangement of the nervous system it is clear that it forms one continuous whole. No subdivision of it is isolated from the rest, but nerve-trunks proceeding from the centres in one direction bind them to various tissues and, proceeding in another, to other nerve-centres; which in turn are united with other tissues and other centres. Since the physiological character of a nerve-fibre is its conductivity—its power of propagating a disturbance when once its molecular equilibrium has been upset at any one point—it is obvious that through the nervous system any one part of the Body, supplied with nerves, may react on all other parts (with the exception of such as hairs and nails and cartilages, which are not known to possess nerves) and excite changes in them. Pre-eminently the nervous system forms a uniting anatomical and physiological bond through the agency of which unity and order are produced in the activities of different and distant parts. We may compare it to the Western Union Telegraph, the head office of which in New York would represent the brain and spinal cord; the more important central offices in other large cities, the sympathetic ganglia; and the minor offices in

country stations the sporadic ganglia; while the telegraph-wires, directly or indirectly uniting all, would correspond to the nerve-trunks. Just as information started along some outlying wire may be transmitted to a central office, and from it to others, and then, according to what happens to it in the centre, be stopped there, or spread in all directions, or in one or two only, so may a nervous disturbance reaching a centre by one nerve-trunk may excite changes in it or be radiated from it through other trunks more or less widely over the Body and arouse various activities in its other component tissues. In common life the very frequency of this uniting activity of the nervous system is such that we are apt to entirely overlook it. We do not wonder how the sight of pleasant food will make the mouth water and the hand reach out for it; it seems as we say "natural" and to need no explanation. But the eye itself can excite no desire, cause the secretion of no saliva, and the movement of no limb. The whole complex result depends on the fact that the eye is united by the optic nerve with the brain, and that again by other nerves with saliva-forming cells, and with muscular fibres of the arm; and through these a change excited by light falling into the eye is enabled to produce changes in far removed organs and excite desire, secretion and movement. In cases of disease this action exerted at a distance is more apt to excite our attention: vomiting is a very common symptom of certain brain diseases and most people know that a disordered stomach will produce a headache; while the pain consequent upon the hip-disease of children is usually felt not at the hip-joint but at the knee.



**DIESE SEITE IST FÜR KOSTENLOSE MITGLIEDER GESPERRT**

Beantragen Sie jetzt die volle Mitgliedschaft, um diese Seite zu betreten

# GESCHICHTE

Zehntausende von wichtigen historischen Quellen, viele bisher nicht erhältlich, stehen jetzt zum ersten Mal mit der Vollmitgliedschaft von Forgotten Books zur Verfügung.

Unbegrenzter Zugang  
\$8.99/monat

**Fortfahren**

\*Es gelten Richtlinien zur fairen Nutzung.



and these convey it again to the heart. At certain points in the course of the blood-paths valves are placed, which prevent a back-flow. This alternating reception of blood at one end by the heart and its ejection from the other g

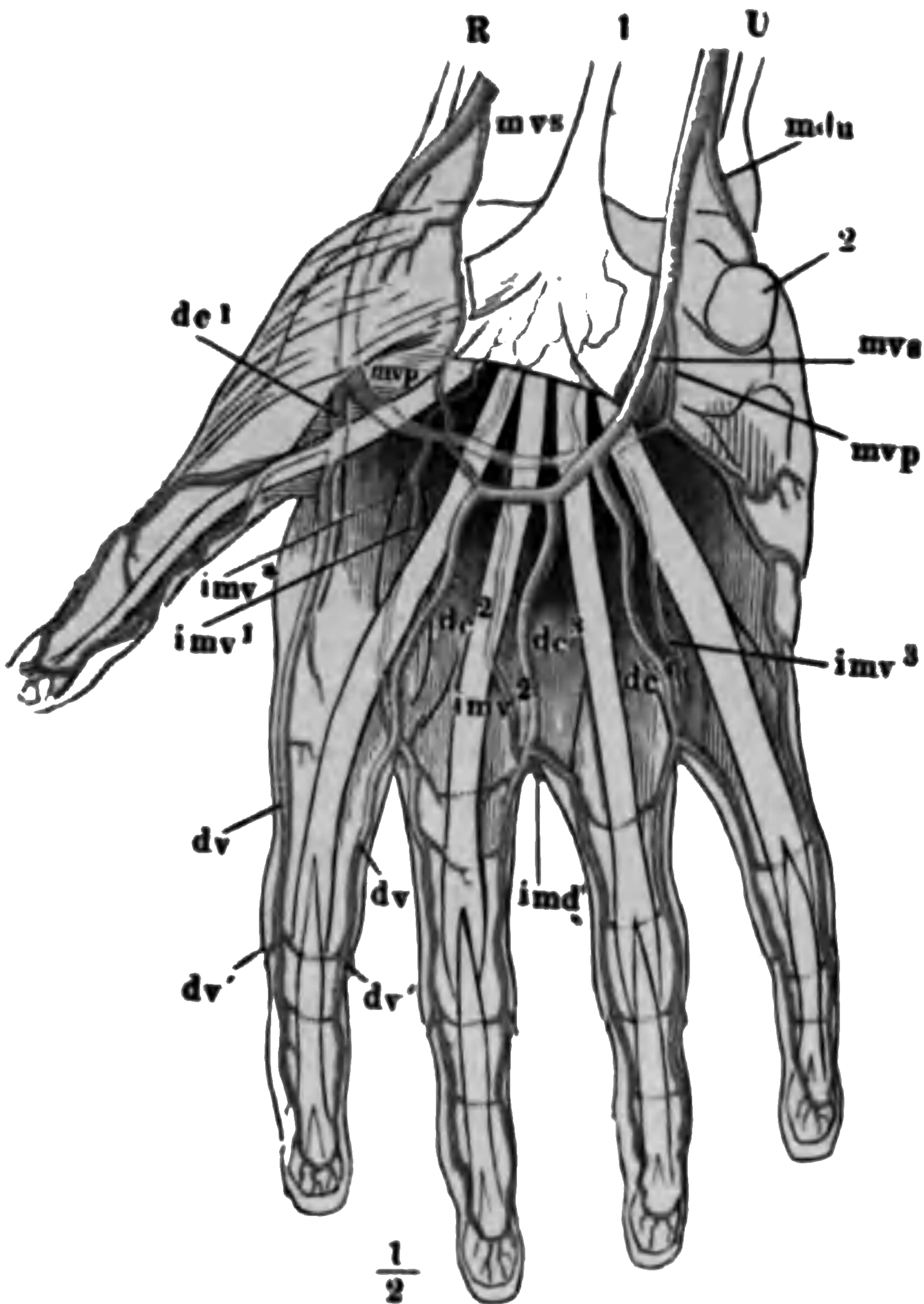

FIG. 77.—The arteries of the hand, showing the communications or anastomoses of different arteries and the fine terminal twigs given off from the large trunks; these twigs end in the capillaries which would only be visible if magnified. *R*, the radial artery on which the pulse is usually felt at the wrist; *U*, the ulnar artery.

on during life steadily about seventy times in a minute and so keep the liquid constantly in motion.

The vascular system is completely closed except at two points where the lymph-vessels open into the veins (p. 329) there some lymph is poured in and mixed directly with the blood. Accordingly everything which leaves the blood

and everything which enters it must do the same, except matters conveyed in by the lymph at the points above mentioned. This interchange through the walls of the vessels takes place only in the capillaries, which form a sort of irrigation system all through the Body. The heart, arteries, and veins are all mere arrangements for keeping the capillaries full and renewing the blood within them. It is in the capillaries alone that the blood does its physiological work.

**The Position of the Heart.** The heart (*h*, Fig. 1) lies in the chest immediately above the diaphragm and opposite the lower two thirds of the breast-bone. It is conical in form with its *base* or broader end turned upwards and projecting a little on the right of the sternum, while its narrow end or apex, turned downwards, projects to the left of that bone, where it may be felt beating between the cartilages of the fifth and sixth ribs. The position of the organ in the Body is therefore oblique with reference to its long axis. It does not, however, lie on the left side as is so commonly supposed but very nearly in the middle line, with the upper part inclined to the right, and the lower (which may be easier felt beating—hence the common belief) to the left.

**The Membranes of the Heart.** The heart does not lie bare in the chest but is surrounded by a loose bag composed of connective tissue and called the *pericardium*. This bag, like the heart, is conical but turned the other way, its broad part being lowest and attached to the upper surface of the diaphragm. Internally it is lined by a smooth *serous membrane* like that lining the abdominal cavity, and a similar layer (the *visceral layer* of the pericardium) covers the outside of the heart itself, adhering closely to it. Each of the serous layers is covered by a stratum of flat cells, and in the space between them is found a small quantity of liquid which moistens the contiguous surfaces, and diminishes the friction which would otherwise occur during the movements



*endocardium.* Between the endocardium and the visceral layer of the pericardium the bulk of the wall of the heart lies and is made up mainly of striped muscular tissue (differing somewhat from that of the skeletal muscles); but connective tissues, blood-vessels, nerve-cells, and nerve-fibres are also abundant in it.

*Note.* Sometimes the pericardium becomes inflamed, this affection being known as pericarditis. It is extremely apt to occur in acute rheumatism, and great care should be taken never, even for a moment, except under medical advice, to expose a patient to cold during that disease, since any chill is then especially apt to set up pericarditis. In the earlier stages of pericardiac inflammation the rubbing surfaces on the outside of the heart and the inside of the pericardium become roughened, and their friction produces a sound which can be recognized through the stethoscope. In later stages great quantities of liquid may accumulate in the pericardium so as to seriously impede the heart's beat.

#### The Cavities of the Heart.

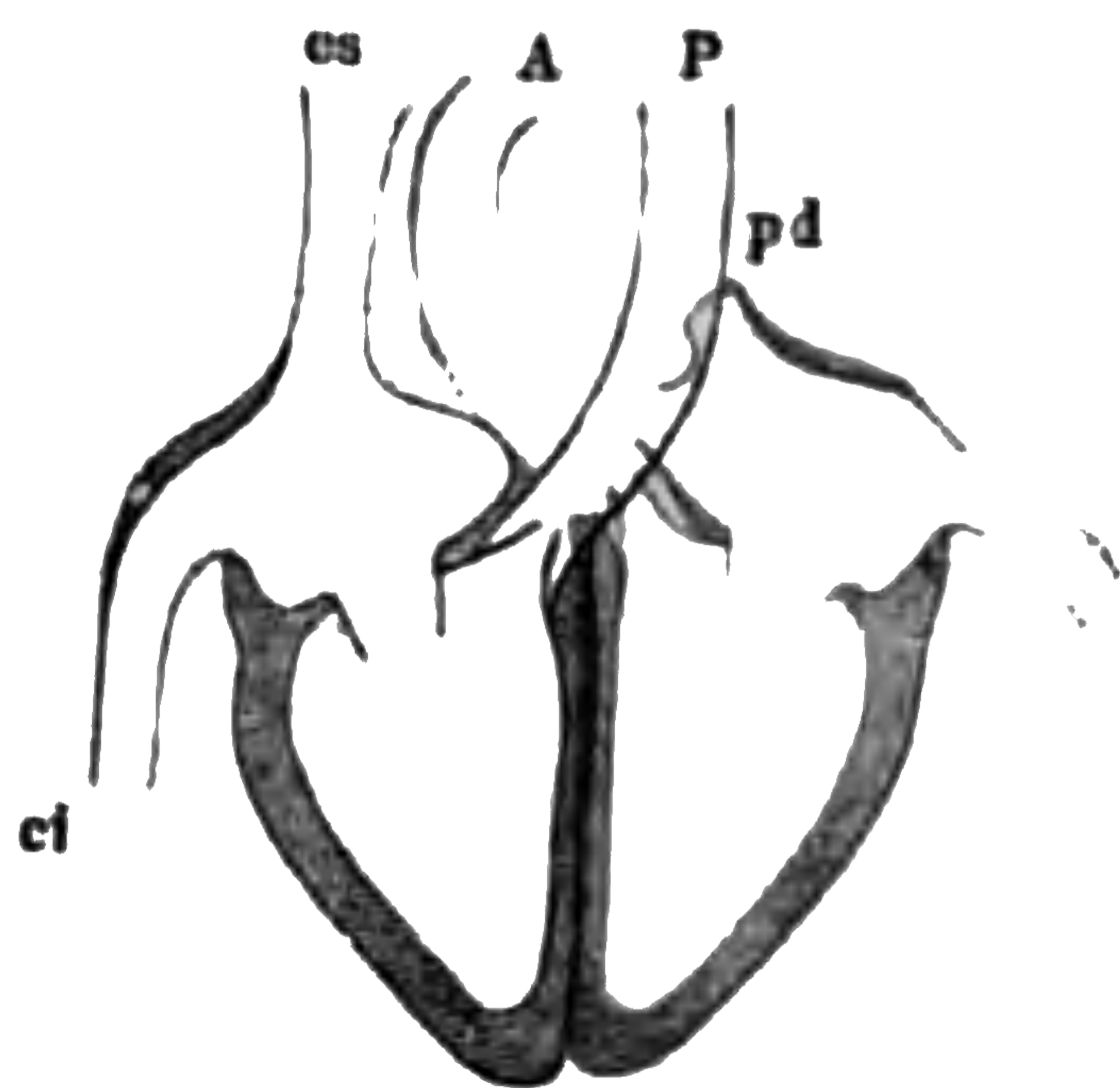

FIG. 78. — Diagram representing a section through the heart from base to apex.

On opening the heart (see diagram, Fig. 78) it is found to be subdivided by a longitudinal partition or *septum* into completely separated right and left halves, the partition running from about the middle of the base to a point a little on the right of the apex. Each of the chambers on the sides of the septum is again incompletly divided

transversely, into a thinner basal portion into which veins open, known as the *auricle*, and a thicker apical portion from which arteries arise, called the *ventricle*. The heart thus consists of a right auricle and ventricle and a



**DIESE SEITE IST FÜR KOSTENLOSE MITGLIEDER GESPERRT**  
Beantragen Sie jetzt die volle Mitgliedschaft, um diese Seite zu betreten



**Seien Sie niemals ohne ein Buch!**

Die Vollmitgliedschaft von Forgotten Books bietet Ihnen einen universalen Zugang von unseren Apps und unserer Website, auf all Ihren Geräten: Tablet, Telefon, E-Reader, Laptop und Computer.

**Eine Bibliothek in Ihrer Tasche für €8.99/monat**

**Fortfahren**

\*Es gelten Richtlinien zur fairen Nutzung.

by a deep groove from the ventricles, *Vd* and *Vs*. A more shallow furrow runs between the ventricles and indicates the position of the internal longitudinal septum. On the

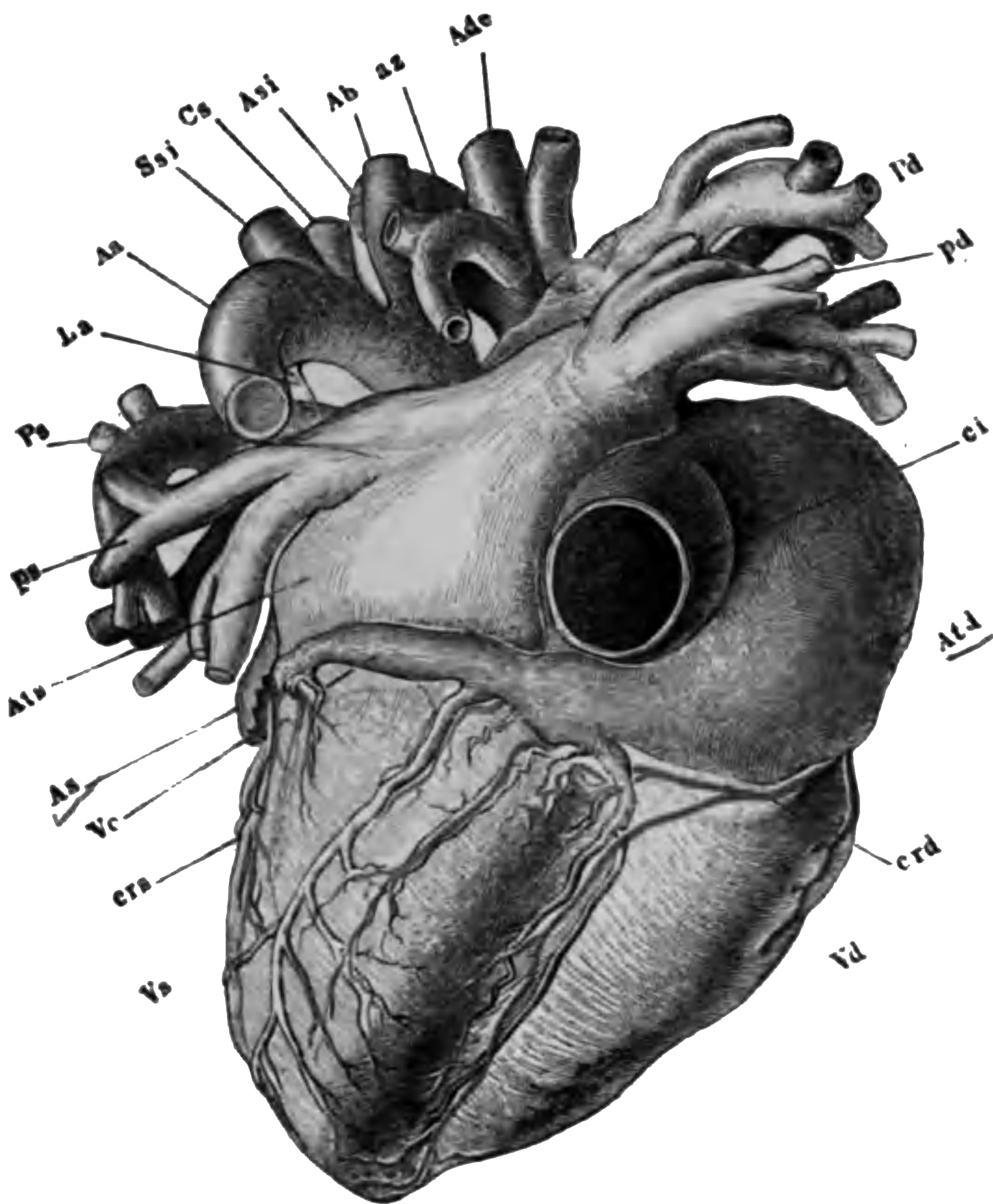

**FIG. 80.**—The heart viewed from its dorsal aspect. *Atd*, right auricle; *cf*, inferior vena cava; *az*, azygos vein; *Vc*, coronary vein. The remaining letters of reference have the same signification as in Fig. 79.

dorsal aspect of the heart (Fig. 80) similar points may be noted, and on one or other of the two figures the great vessels opening into the cavities of the heart may be seen. The *pulmonary artery*, *P*, arises from the right ventricle,

and very soon divides into the right and left pulmonary arteries, *Pd* and *Ps*, which break up into smaller branches and enter the corresponding lungs. Opening into the right auricle are two great veins (see also Fig. 78), *cs* and *ci*, known respectively as the *upper* and *lower venæ cavæ*, or "hollow" veins; so called by the older anatomists because they are frequently found empty after death. Into the back of the right auricle opens also another vein, *Vc*, called the *coronary vein* or *sinus*, which brings back blood that has circulated in the walls of the heart itself. Springing from the left ventricle, and appearing from beneath the pulmonary artery when the heart is looked at from the ventral side, is a great artery, the *aorta*, *Aa*. It forms an arch over the base of the heart and then runs down behind it at the back of the chest. From the convexity of the arch of the aorta several great branches are given off, *Ssi*, *Cs*, *Ab*; but before that, close to the heart, the aorta gives off two *coronary arteries*, branches of which are seen at *crd* and *crs* lying in the groove over the partition between the ventricles, and which carry to the substance of the organ that blood which comes back through the coronary sinus. Into the left auricle open two right and two left *pulmonary veins*, *ps* and *pd*, which are formed by the union of smaller veins proceeding from the lungs.

In the diagram Fig. 78 from which the branches of the great vessels near the heart have been omitted for the sake of clearness, the connection of the various vessels with the chambers of the heart can be better seen. Opening into the right auricle are the superior and inferior venæ cavæ (*cs* and *ci*) and proceeding from the right ventricle the *pulmonary artery*, *P*. Opening into the left auricle are the right and left pulmonary veins (*pd* and *ps*) and springing from the left ventricle the aorta, *A*.

**The Interior of the Heart.** The communication of each auricle with its ventricle is also represented diagrammatically in Fig. 78, and the valves which are present at those points and at the origin of the pulmonary artery and that of the aorta. Internally the auricles are for the most

part smooth, but from each a hollow pouch, the *auricular appendage*, projects over the base of the corresponding ventricle as seen at *Adx* and *As* in Figs. 79 and 80. These pouches have somewhat the shape of a dog's ear and have given their name to the whole auricle. Their interior is roughened by muscular elevations, covered by endocardium, known as the fleshy columns (*columnæ carneæ*). On the inside of the ventricles (Fig. 81) similar fleshy columns are very prominent.

**The Auriculo-Ventricular Valves.** These are known as *right* and *left*, or as the *tricuspid* and *mitral valves* respectively. The mitral valve (Fig. 81) consists of two flaps of the endocardium fixed by their bases to the margins of auriculo-ventricular aperture and with their edges hanging down into the ventricle when the heart is empty. These unattached edges are not however free, but have fixed to them a number of stout connective-tissue cords, the *cordæ tendineæ*, which are fixed below to muscular elevations, the *papillary muscles*, *Mpm* and *Mpl*, on the interior of the ventricle. The cords are long enough to let the valve flaps rise into a horizontal position and so close the opening between auricle and ventricle which lies between them, and passes up behind the opened aorta, *Sp*, represented in the figure. The *tricuspid valve* is like the mitral but with three flaps instead of two.

**Semilunar Valves.** These are six in number: three at the mouth of the aorta, Fig. 81, and three, quite like them, at the mouth of the pulmonary artery. Each is a strong crescentic pouch fixed by its more curved border, and with its free edge turned away from the heart. When the valves are in action these free edges meet across the vessel and prevent blood from flowing back into the ventricle. In the middle of the free border of each valve is a little cartilaginous nodule, the *corpus Arantii*, and on each side of this the edge of the valve is very thin and when it meets its neighbor doubles up against it and so secures the closure.

**The Arterial System.** All the arteries of the Body arise either directly or indirectly from the aorta or pulmonary artery and the great majority of them from the for-



**DIESE SEITE IST FÜR KOSTENLOSE MITGLIEDER GESPERRT**

Beantragen Sie jetzt die volle Mitgliedschaft, um diese Seite zu betreten

# GESCHICHTE

Zehntausende von wichtigen historischen Quellen, viele bisher nicht erhältlich, stehen jetzt zum ersten Mal mit der Vollmitgliedschaft von Forgotten Books zur Verfügung.

Unbegrenzter Zugang  
\$8.99/monat

**Fortfahren**

\*Es gelten Richtlinien zur fairen Nutzung.



opposite the last lumbar vertebra by dividing into the *right* and *left common iliac* arteries, which carry blood to the lower limbs. We have then to consider the branches of the arch of the aorta, and those of the *descending aorta*, which latter is for convenience described by anatomists as consisting of the *thoracic aorta*, extending from the end of the arch to the diaphragm, and the *abdominal aorta*, extending from the diaphragm to the final subdivision of the vessel.

**Branches of the Arch of the Aorta.** From this arise first the *coronary arteries* (*crd* and *crs*, Figs. 79 and 80) which spring close to the heart, just above two of the pouches of the semilunar valve, and carry blood into the substance of that organ. The remaining branches of the arch are three in number, and all arise from its convexity. The first is the *innominate artery* (*Ab*, Fig. 79), which is very short, immediately breaking up into the *right subclavian artery*, and the *right common carotid*. Then comes the *left common carotid*, *Cs*, and finally the *left subclavian*, *Ssi*.

Each *subclavian artery* runs out to the arm on its own side and after giving off a *vertebral artery* (which runs up the neck to the head in the vertebral canal of the transverse processes of the cervical vertebræ), crosses the arm-pit and takes there the name of the *axillary artery*. This continues down the arm as the *brachial artery*, which, giving off branches on its way, runs to the front of the arm, and just below the elbow-joint divides into the *radial* and *ulnar arteries*, the lower ends of which are seen at *R* and *U* in Fig. 77.\* These supply the forearm and end in the hand by uniting to form an arch, from which branches are given off to the fingers.

The *common carotid arteries* pass out of the chest into the neck, along which they ascend on the sides of the windpipe. Opposite the angle of the lower jaw each divides into an *internal* and *external carotid artery*, right or left as the case may be. The latter ends mainly in branches for the face, scalp, and salivary glands, one great subdivision of it with a tortuous course, the *temporal artery*, being often seen in thin persons on the side of the brow. The in-

---

\* P. 202.

ternal carotid artery enters the skull through an aperture in its base and supplies the brain, which it will be remembered also gets blood through the vertebral arteries.

**Branches of the Thoracic Aorta.** These are numerous but small. Some, the *intercostal arteries*, run out between the ribs and supply the chest-walls; others, the *bronchial arteries*, carry blood to the lungs for their nourishment, that carried to them by the pulmonary arteries being brought there for another purpose; and a few other small branches are given to other neighboring parts.

**Branches of the Abdominal Aorta.** These are both large and numerous, supplying not only the wall of the posterior part of the trunk, but the important organs in the abdominal cavity. The larger are—the *cæliac axis* which supplies stomach, spleen, liver, and pancreas; the *superior mesenteric artery* which supplies a great part of the intestine; the *renal arteries*, one for each kidney; and finally the *inferior mesenteric artery* which supplies the rest of the intestine. Besides these the abdominal aorta gives off very many smaller branches.

**Arteries of the Lower Limbs.** Each common iliac divides into an *internal* and *external iliac artery*. The former mainly ends in branches to parts lying in the pelvis, but the latter passes into the thighs and there takes the name of the *femoral artery*. At first this lies on the ventral aspect of the limb, but lower down passes back round the femur, and above the knee-joint, where it is called the *popliteal artery*, divides into the *anterior* and *posterior tibial arteries* which supply the leg and foot.

**The Capillaries.** As the arteries are followed from the heart their branches become smaller and smaller, and finally cannot be traced without the aid of a microscope. Ultimately they pass into the *capillaries*, the walls of which are simpler than those of the arteries, and which form very close networks in nearly all parts of the Body; their immense number compensating for their smaller size. The average diameter of a capillary vessel is .016 mm. ( $\frac{1}{625}$  inch) so that only two or three blood corpuscles can pass through it abreast, and in many parts they are so close



that a pin's point could not be inserted between two of them. It is while flowing in these delicate tubes that the blood does its nutritive work, the arteries being merely supply-tubes for the capillaries.

**The Veins.** The first veins arise from the capillary networks in various organs, and like the last arteries are very small. They soon increase in size by union and so form

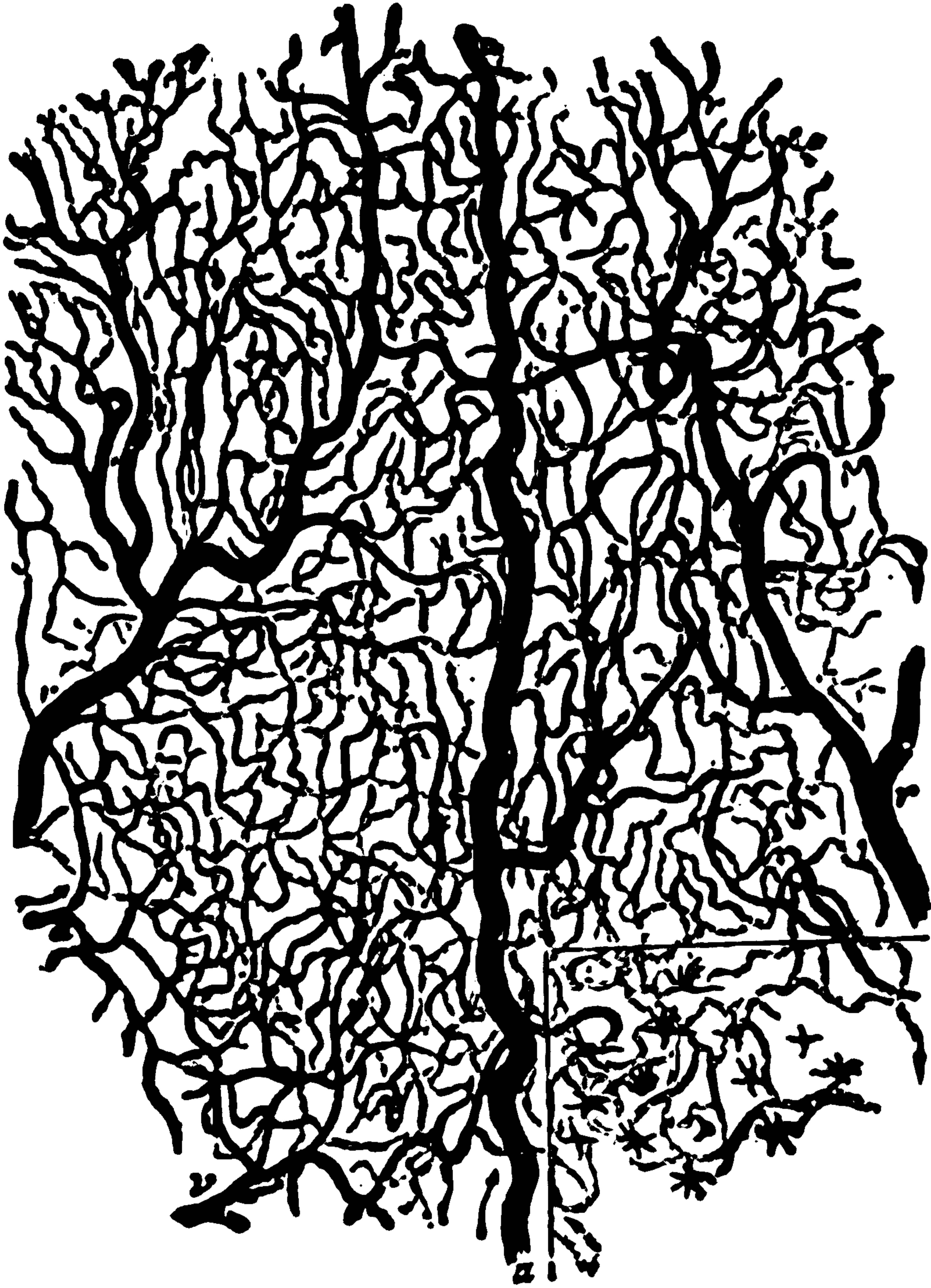

FIG. 82.—A small portion of the capillary network as seen in the frog's web when magnified about 35 diameters. *a*, a small artery feeding the capillaries; *v*, *v*, small veins carrying blood back from the latter.

larger and larger trunks. These in many places lie near or alongside the main artery of the part, but there are many more large veins just beneath the skin than there are large arteries. This is especially the case in the limbs, the main of which are superficial and can in many persons be



**DIESE SEITE IST FÜR KOSTENLOSE MITGLIEDER GESPERRT**  
Beantragen Sie jetzt die volle Mitgliedschaft, um diese Seite zu betreten



**Seien Sie niemals ohne ein Buch!**

Die Vollmitgliedschaft von Forgotten Books bietet Ihnen einen universalen Zugang von unseren Apps und unserer Website, auf all Ihren Geräten: Tablet, Telefon, E-Reader, Laptop und Computer.

**Eine Bibliothek in Ihrer Tasche für € 8.99/monat**

**Fortfahren**

\*Es gelten Richtlinien zur fairen Nutzung.

*median nerve*, 1, a branch of the brachial plexus which supplies several muscles of the forearm and hand, the skin over a great part of the palm, and the three inner fingers, is seen alongside the artery. The larger veins of the part are seen to form a more superficial network, joined here and there, as for instance at \*, by branches from deeper parts. Several small nerve-branches which supply the skin (2, 3, 4) are seen among these veins. It is from the vessel, *cep*, called the *cephalic vein*, just above the point where it crosses the median nerve, that surgeons usually bleed a patient.

A great part of the blood of the lower limb is brought back by the *long saphenous vein*, which can be seen running beneath the skin from the inner side of the ankle to the top of the thigh. All the blood which leaves the heart by the aorta, except that flowing through the coronary arteries, is finally collected into the *superior* and *inferior venæ cavæ* (*cs* and *ci*, Figs. 79 and 80), and poured into the right auricle. The *jugular veins* which run down the neck, carrying back the blood which went out along the carotid arteries, unite below with the arm-vein (*subclavian*) to form on each side an *innominate vein* (*Asi* and *Ade*, Fig. 79) and the innominates unite to form the superior cava. The coronary-artery blood after flowing through the capillaries of the heart itself, also returns to this auricle by the coronary veins.

**The Pulmonary Circulation.** Through this the blood gets back to the left side of the heart and so into the aorta again. The pulmonary artery, dividing into branches for each lung, ends in the capillaries of those organs. From these it is collected by the pulmonary veins which carry it back to the left auricle, whence it passes to the left ventricle to recommence its flow through the Body generally.

**The Course of the Blood.** From what has been said it is clear that the movement of the blood is a *circulation*. Starting from any one chamber of the heart it will in time return to it; but to do this it must pass through at least two sets of capillaries; one of these is connected with the aorta and the other with the pulmonary artery, and in its

circuit the blood returns to the heart twice. Leaving the left side it returns to the right, and leaving the right it returns to the left: and there is no road for it from one side of the heart to the other except through a capillary network. Moreover it always leaves from a ventricle through an artery, and returns to an auricle through a vein.

There is then really only one circulation; but it is not uncommon to speak of two, the flow from the left side of the heart to the right, through the Body generally, being called the *systemic circulation*, and from the right to the left, through the lungs, the *pulmonary circulation*. But since after completing either of these alone the blood is not again at the point from which it started, but is separated from it by the septum of the heart, neither is a "circulation" in the proper sense of the word.

**The Portal Circulation.** A certain portion of the blood which leaves the left ventricle of the heart through the aorta has to pass through three sets of capillaries before it can again return there. This is the portion which goes through the stomach, spleen, pancreas, and intestines. After traversing the capillaries of those organs it is collected into the *portal vein* which enters the liver, and breaking up in it into finer and finer branches like an artery, ends in the capillaries of that organ, forming the second set which this blood passes through on its course. From these it is collected by the *hepatic veins* which pour it into the inferior vena cava, which carrying it to the right auricle, it has still to pass through the pulmonary capillaries to get back to the left side of the heart. The portal vein is the only one in the Human Body which thus like an artery feeds a capillary network, and the flow from the stomach and intestines through the liver to the vena cava is often spoken of as the *portal circulation*.

**Diagram of the Circulation.** Since the two halves of the heart are actually completely separated from one another by an impervious partition, although placed in proximity in the Body, we may conveniently represent the course of the blood as in the accompanying diagram (Fig. 84) in which the right and left halves of the heart are rep-

resented at different points in the vascular system. Such an arrangement makes it clear that the heart is really two pumps working side by side, and each engaged in forcing the blood to the other. Starting from the left auricle, *la*,

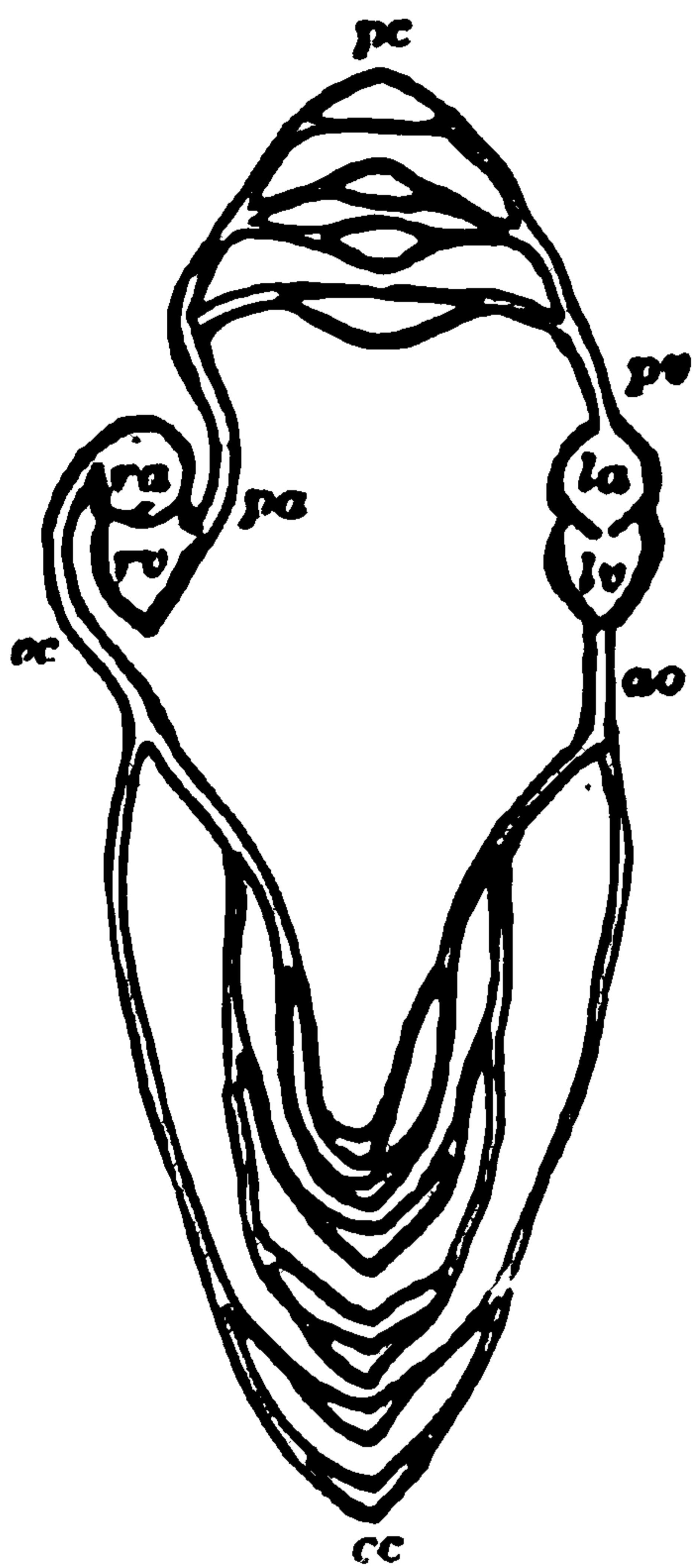

FIG. 84.—Diagram of the blood vascular system, showing that it forms a single closed circuit with two pumps in it, consisting of the right and left halves of the heart, which are represented separate in the diagram. *ra* and *rv*, right auricle and ventricle; *la* and *lv*, left auricle and ventricle; *ao*, aorta; *sc*, systemic capillaries; *vc*, venæ cavæ; *pa*, pulmonary artery; *pc*, pulmonary capillaries; *pv*, pulmonary veins.

and following the flow we trace it through the left ventricle and along the branches of the aorta into the systemic capillaries, *sc*; from thence it passes back through the systemic veins, *vc*. Reaching the right auricle, *ra*, it is sent into the right ventricle, *rv*, and thence through the pulmonary artery, *pa*, to the lung capillaries, *pc*, from which the pulmonary veins, *pv*, carry it to the left auricle, which drives it into the left ventricle, *lv*, and this again into the aorta.

**Arterial and Venous Blood.** The blood when flowing in the pulmonary capillaries gives up carbon dioxide to the air and receives oxygen from it; and since its coloring matter (hæmoglobin) forms a scarlet compound with oxygen, it flows to the left auricle in the pulmonary veins of a bright red color. This color it maintains until it reaches the systemic capillaries, but in these it loses much oxygen to the surrounding tissues and gains much carbon dioxide from them. But the blood coloring matter which has lost its oxygen has a dark purple-black color, and since this unoxidized or “reduced” hæmoglobin is now in excess, the blood returns to the heart by the venæ cavæ of a dark purple-red color. This color it keeps until it reaches the lungs, when the reduced hæmoglobin becomes again oxidized. The bright red blood, rich in oxygen and poor in carbon dioxide, is known as “arterial blood” and the dark



**DIESE SEITE IST FÜR KOSTENLOSE MITGLIEDER GESPERRT**

Beantragen Sie jetzt die volle Mitgliedschaft, um diese Seite zu betreten

# GESCHICHTE

Zehntausende von wichtigen historischen Quellen, viele bisher nicht erhältlich, stehen jetzt zum ersten Mal mit der Vollmitgliedschaft von Forgotten Books zur Verfügung.

Unbegrenzter Zugang  
\$8.99/monat

**Fortfahren**

\*Es gelten Richtlinien zur fairen Nutzung.



**Structure of the Veins.** In these the same three primary coats as in the arteries may be found: the inner and middle coats are less developed while the outer one remains thick, and is made up almost entirely of white fibrous tissue. Hence venous walls are much thinner than those of the corresponding arteries, and the veins collapse when empty while the stouter arteries remain open. But the tenacity and toughness of their outer coats give the veins great strength.

Except the pulmonary artery and the aorta, which possess the semilunar valves at their cardiac orifices, the arteries possess no valves. Many veins on the contrary have such, formed by semilunar pouches of the inner coat, attached by one margin and having that turned towards the heart free. These valves, sometimes single, oftener in pairs, and sometimes three at one level, permit blood to flow only towards the heart, for a current in that direction

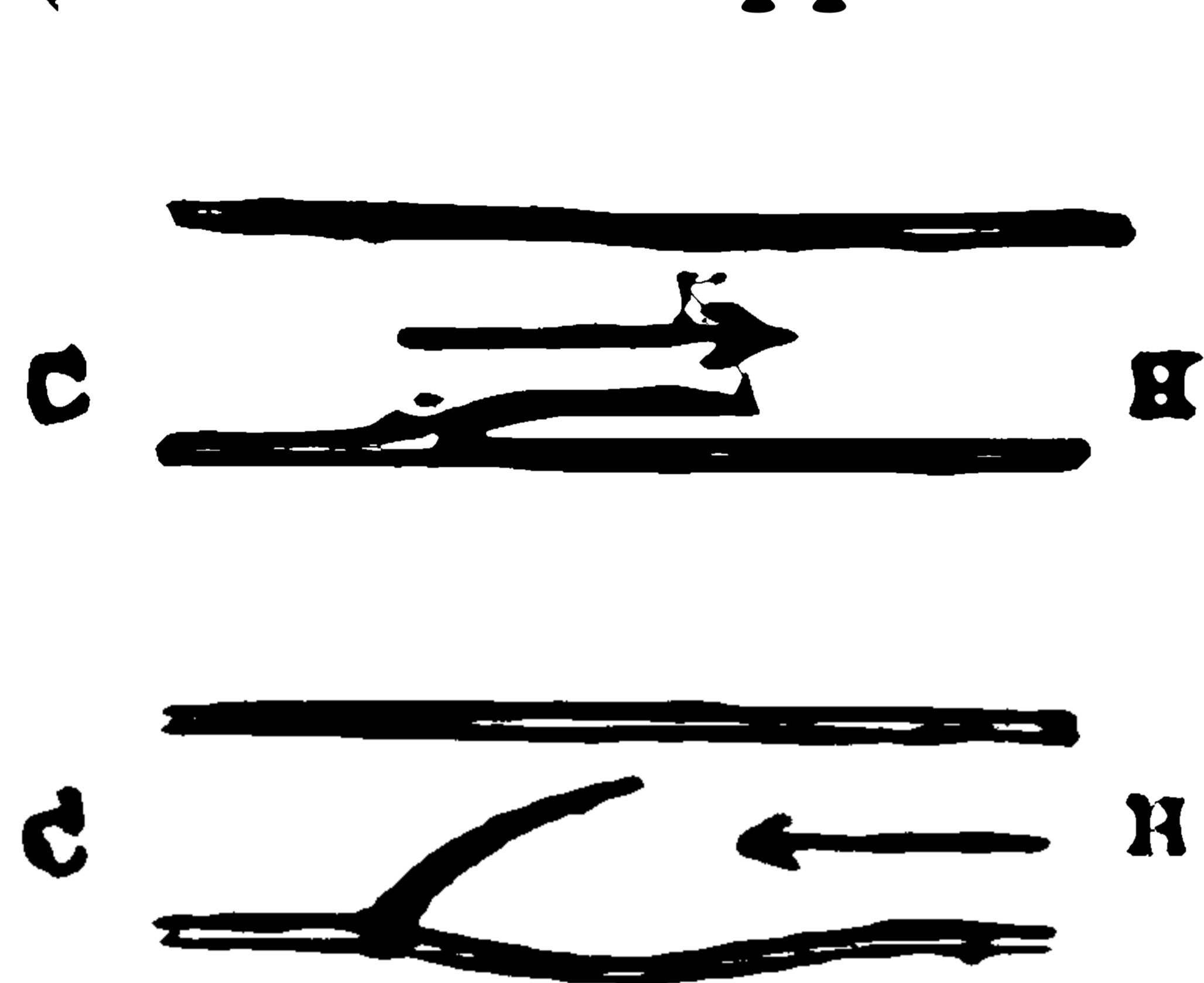

FIG. 85.—Diagram to illustrate the mode of action of the valves of the veins. C, the capillary, and H, the heart end of the vessel.

against the side of the vessel and meets with no obstruction from it.

Should any back-flow be attempted, however, the current closes up the valve and bars its own passage as indicated in the lower figure.

These valves are most numerous in superficial veins and those of muscular parts. They are absent in the venæ cavæ and the portal and pulmonary veins. Usually the

vein is a little dilated opposite a valve and hence in parts where the valves are numerous gets a knotted look. On compressing the forearm so as to stop the flow in its subcutaneous veins and cause their dilatation, the points at which valves are placed can be recognized by their swollen appearance. They are most frequently found where two veins communicate.

## CHAPTER XV.

### THE WORKING OF THE HEART AND BLOOD-VESSELS.

**The Beat of the Heart.** It is possible by methods known to physiologists to open the chest of a living narcotized animal, such as a rabbit, and see its heart at work, alternatingly contracting and diminishing the cavities within it and relaxing and expanding them. It is then observed that each beat commences at the mouths of the great veins; from there runs over the rest of the auricles, and then over the ventricles; the auricles commencing to dilate the moment the ventricles commence to contract. Having finished their contraction, the ventricles also commence to dilate and so for some time neither they nor the auricles are contracting, but the whole heart expanding. The contraction of any part of the heart is known as its *systole* and the relaxation as its *diastole*, and since the two sides of the heart work synchronously, the auricles together and the ventricles together, we may describe a whole "cardiac period" or "heart-beat" as made up successively of *auricular systole*, *ventricular systole*, and *pause*. This cycle is repeated about seventy times a minute; and if the whole time occupied by it be subdivided into 100 parts, about 9 of these will be occupied by the auricular systole, about 30 by the ventricular systole, and 61 by the pause: during more than half of life, therefore, the muscles of the heart are at rest. In the *pause* the heart if taken between the finger and thumb feels soft and flabby but during the systole it (especially in its ventricular portion) becomes hard and rigid.

**Change of Form of the Heart.** During its systole the



heart becomes shorter and rounder, mainly from a change in the shape of the ventricles. A cross-section of the heart at the base of these latter during diastole would be elliptical in outline, with its long diameter from right to left: during the systole it is more circular, the long axis of the ellipse becoming shortened while the dorso-ventral diameter remains little altered. At the same time the length of the ventricles is lessened, the apex of the heart approaching the base and becoming blunter and rounder.

**The Cardiac Impulse.** The human heart lies with its apex touching the chest-wall between the fifth and sixth ribs on the left side of the breast-bone. At every beat a sort of tap, known as the "cardiac impulse" or "apex beat," may be felt by the finger at that point. There is, however, no actual "tapping" since the heart's apex never leaves the chest-wall. During the diastole the soft ventricles yield to the chest-wall where they touch it, but during the systole they become hard and tense and push it out a little between the ribs, and so cause the apex beat. Since the heart becomes shorter during the ventricular systole it might be supposed that at that time the apex would move up a little in the chest. This however is not the case, the ascent of the apex towards the base of the ventricles being compensated for by a movement of the whole heart in the opposite direction. If water be pumped into an elastic tube, already tolerably full, this will be distended not only transversely but longitudinally. This is what happens in the aorta: when the left ventricle contracts and pumps blood forcibly into it, the elastic artery is elongated as well as widened, and this lengthening of that limb of its arch attached to the heart pushes the latter down towards the diaphragm, and compensates for the upward movement of the apex due to the shortening of the ventricles. Hence if the exposed living heart be watched it appears as if during the systole the base of the heart moved towards the tip, rather than the reverse.

**Events occurring within the Heart during a Cardiac Period.** Let us commence at the end of the ventricular systole. At this moment the semilunar valves at the orifices



**DIESE SEITE IST FÜR KOSTENLOSE MITGLIEDER GESPERRT**  
Beantragen Sie jetzt die volle Mitgliedschaft, um diese Seite zu betreten



**Seien Sie niemals ohne ein Buch!**

Die Vollmitgliedschaft von Forgotten Books bietet Ihnen einen universalen Zugang von unseren Apps und unserer Website, auf all Ihren Geräten: Tablet, Telefon, E-Reader, Laptop und Computer.

**Eine Bibliothek in Ihrer Tasche für €8.99/monat**

**Fortfahren**

\*Es gelten Richtlinien zur fairen Nutzung.

on each side of them; but of course they might be forced open without this by applying sufficient power to overcome the higher water pressure on one side. It is in this latter way that the semilunar valves are opened. The contracting ventricle tightens its grip on the blood inside it and becomes rigid to the touch. As it squeezes harder and harder, at last the pressure on the blood in it becomes greater than the pressure exerted on the other side of the valves by the blood in the arteries, the flaps are pushed open, and the blood begins to pass out: the ventricle continues its contraction until it has obliterated its cavity and completely emptied itself. Then it commences to relax and blood immediately to flow back into it from the highly stretched arteries. This back current, however, catches the pockets of the semilunar valves, drives them back and closes the valve so as to form an impassable barrier; and so the blood which has been forced out of either ventricle cannot flow directly back into it.

**Use of the Papillary Muscles.** In order that the contracting ventricles may not force blood back into the auricles it is essential that the flaps of the mitral and tricuspid valves be maintained horizontally across the openings which they close, and be not pushed back into the auricles. At the commencement of the ventricular systole this is provided for by the *cordæ tendinæ*, which are of such a length as to keep the edges of the flaps in apposition, a position which is farther secured by the fact that each set of *cordæ tendinæ* (Fig. 81\*) radiating from a point in the ventricle, is not attached around the edges of one flap but on the contiguous edges of two flaps, and so tends to pull them together. But as the contracting ventricles shorten, the *cordæ tendinæ*, if directly fixed to their interior, would be slackened and the valve-flaps pushed up into the auricle. The little papillary muscles prevent this. Shortening as the ventricular systole proceeds, they keep the *cordæ* taut and the valves closed.

**Sounds of the Heart.** If the ear be placed on the chest over the region of the heart during life, two distinguishable sounds will be heard during each cardiac cycle. They are known respectively as the first and second sounds of the

---

\* P. 209.

in a beating heart empty of blood, and in which there be no closure or tension of those valves. In various of heart disease these sounds are modified or cloaked additional "murmurs" which arise when the cardiac or are roughened or narrowed or dilated, or the valves i cient. By paying attention to the character of the sound then heard, the exact period in the cardiac cy which it occurs, and the region of the chest-wall at wh is heard most distinctly, the physician can often get in tant information as to its cause.

**Diagram of the Events of a Cardiac Cycle.** In following table the phenomena of the heart's heat are resented with reference to the changes of form who seen in an exposed working heart. Events in the vertical column occur simultaneously; on the same hori tal line, from left to right, successively.

	<b>Auricular Sys- tole.</b>	<b>Commence- ment of Ven- tricular Sys- tole.</b>	<b>Ventricular Systole.</b>	<b>Cessation of Ventricular Systole.</b>
<b>Auricles.....</b>	<b>Contracting and emptying.</b>	<b>Dilating and filling.</b>	<b>Dilating and filling.</b>	<b>Dilating and filling.</b>
<b>Ventricles.....</b>	<b>Dilating and filling.</b>	<b>Contracting.</b>	<b>Contracting and emptying.</b>	<b>Dilating.</b>
<b>Impulse.....</b>	.....	<b>Apex beat.</b>		
<b>Auriculo-ventric- ular valves.....</b>	<b>Closing.</b>	<b>Closed.</b>	<b>Closed.</b>	<b>Opening.</b>
<b>Semilunar valves.</b>	<b>Closed.</b>	<b>Closed.</b>	<b>Open.</b>	<b>Closing.</b>
<b>Sounds.....</b>	.....	<b>First sound.</b>	.....	<b>Second sound.</b>

**Function of the Auricles.** The ventricles have to do the work of pumping the blood through the blood-vessels. Accordingly their walls are far thicker and more muscular than those of the auricles; and the left ventricle, which has to force the blood over the Body generally, is stouter than the right, which has only to send blood around the comparatively short pulmonary circuit. The circulation of the blood is in fact maintained by the ventricles, and we have to inquire what is the use of the auricles. Not unfrequently the heart's action is described as if the auricles first filled with blood and then contracted and filled the ventricles; and then the latter contracted and drove the blood into the arteries. From the account given above, however, it will be seen that the events are not accurately so represented, but that during all the pause blood flows on through the auricles into the ventricles, which latter are already nearly full when the auricles contract; this contraction merely completing their filling and finishing the closure of the auriculo-ventricular valves. The real use of the auricles is to afford a reservoir into which the veins may empty while the comparatively long-lasting ventricular contraction is taking place: they also largely control the amount of work done by the heart.

If the heart consisted of the ventricles only, with valves at the points of entry and exit of the blood, the circulation could be maintained. During diastole the ventricle would fill from the veins, and during systole empty into the arteries. But in order to accomplish this, during the systole the valves at the point of entry must be closed, or the ventricle would empty itself into the veins as well as into the arteries; and this closure would necessitate a great loss of time which might be utilized for feeding the pump. This is avoided by the auricles, which are really reservoirs at the end of the venous system collecting blood when the ventricular pump is at work. When the ventricles relax, the blood entering the auricles flows on into them: but previously, during the  $\frac{1}{10}$  of the cardiac cycle occupied by the ventricular systole, the auricles have accumulated blood, and when they at last con-



**DIESE SEITE IST FÜR KOSTENLOSE MITGLIEDER GESPERRT**

Beantragen Sie jetzt die volle Mitgliedschaft, um diese Seite zu betreten

# GESCHICHTE

Zehntausende von wichtigen historischen Quellen, viele bisher nicht erhältlich, stehen jetzt zum ersten Mal mit der Vollmitgliedschaft von Forgotten Books zur Verfügung.

Unbegrenzter Zugang  
\$8.99/monat

**Fortfahren**

\*Es gelten Richtlinien zur fairen Nutzung.



millimeters (8 inches) high. The left ventricle therefore drives out, seventy times in a minute, 180 grams (6.3 ounces) of blood against this pressure. Since the specific gravity of mercury is 12.5 and that of blood may for practical purposes be taken as 1, the work of each stroke of the ventricle is equivalent to raising 180 grams (6.3 ounces) of blood  $200 \times 12.5 = 2500$  millim. (8.2 feet); or one gram 450 meters (one ounce 51.66 feet); or one kilogram 0.45 meters (one lb. 3.23 feet). Work is measured by the amount of energy needed to raise a definite weight a given distance against gravity at the earth's surface, the unit, called a *kilogrammeter*, being either that necessary to raise one kilogram one meter, or, called a *foot-pound*, that necessary to raise one pound one foot. Expressed thus the work of the left ventricle in one minute, when the heart's rate is seventy strokes in that time, is  $0.45 \times 70 = 31.50$  kilogrammeters ( $3.23 \times 70 = 226.1$  foot-pounds); in one hour it is  $31.50 \times 60 = 1890$  kilogrammeters ( $226.1 \times 60 = 13,566$  foot pounds); and in twenty-four hours  $1890 \times 24 = 45,360$  kilogrammeters (325,584 foot-pounds). The pressure in the pulmonary artery against which the right ventricle works is about  $\frac{1}{3}$  of that in the aorta; hence this ventricle in twenty-four hours will do one third as much work as the left, or 15,120 kilogrammeters (108,528 foot pounds) and adding this to the amount done by the left, we get as the total work of the ventricles in a day the immense amount of 60,480 kilogrammeters (434,112 foot-pounds). If a man weighing 75 kilograms (165 lbs.) climbed up a mountain 806 meters (2644 feet) high his skeletal muscles would probably be greatly fatigued at the end of the ascent, and yet in lifting his Body that height they would only have performed the amount of work that the ventricles of the heart do daily without fatigue.

**The Flow of the Blood Outside the Heart.** The blood leaves the heart intermittently and not in a regular stream, a quantity being forced out at each systole of the ventricles: before it reaches the capillaries, however, this rhythmic movement is transformed into a steady flow as may readily be seen by examining under the microscope thin trans-

parent parts of various animals, as the web of a frog's foot, a mouse's ear, or the tail of a small fish. In consequence of the steadiness with which the capillaries supply the veins the flow in these is also unaffected, directly, by each beat of the heart; if a vein be cut the blood wells out uniformly, while a cut artery spurts out not only with much more force, but in jets which are much more powerful at regular intervals corresponding with the systoles of the ventricles.

**The Circulation of the Blood as Seen in the Frog's Web.** There is no more fascinating or instructive phenomenon than the circulation of the blood as seen with the microscope in the thin membrane between the toes of a frog's hind limb. Upon focusing beneath the epidermis a network of minute arteries, veins and capillaries, with the blood flowing through them, comes into view (Fig. 82\*). The arteries, *a*, are readily recognized by the fact that the flow in them is fastest and from larger to smaller branches. The latter are seen ending in capillaries, which form networks, the channels of which are all nearly equal in size. While in the veins arising from the capillary the flow is from smaller to larger trunks, and slower than in the arteries but faster than in the capillaries.

The reason of the slower flow of the capillaries is that their united area is considerably greater than that of the arteries supplying them, so that the same quantity of blood flowing through them in a given time, has a wider channel to flow in and moves more slowly. The area of the veins is smaller than that of the capillaries but greater than that of the arteries, and hence the rate of movement in them is also intermediate. Almost always when an artery divides, the area of its branches is greater than that of the main trunk, and so the arterial current becomes slower and slower from the heart onwards. In the veins on the other hand, the area of a trunk formed by the union of two or more branches is less than that of the branches together, and the flow becomes quicker and quicker towards the heart. But even at the heart the united cross-sections of the veins entering the auricles is greater than that of



the arteries leaving the ventricles, so that, since as much blood returns to the heart in a given time as leaves it, the rate of the current in the pulmonary veins and the venæ cavæ is less than in the pulmonary artery and aorta. We may represent the vascular system as a double cone, widening from the ventricles to the capillaries and narrowing from the latter to the auricles. Just as water forced in at a narrow end of this would flow quickest there and slowest at the widest part, so the blood flows quickest in the aorta and slowest in the capillaries, which form together a much wider channel.

**The Axial Current and the Inert Layer.** If a small artery in the frog's web be closely examined it will be seen that the rate of flow is not the same in all parts of it. In the centre is a very rapid current carrying along all the red corpuscles and known as the *axial stream*, while near the wall of the vessel the flow is much slower, as indicated by the rate at which the pale blood corpuscles are carried along in it. This is a purely physical phenomenon. If any liquid be forcibly driven through a fine tube which it wets, water for instance through a glass tube, the outermost layer of the liquid will remain motionless in contact with the tube; the next layer of molecules will move faster, the next faster still; and so on until a very rapid current is found in the centre. If solid bodies, as powdered sealing-wax, be suspended in the water, these will all be carried on in the central faster current or *axial stream*, just as the red corpuscles are in the artery. The white corpuscles, on account of their power of executing independent amœboid movements and their consequent irregular form, get frequently pushed out of the axial current, so that many of them are found in the inert layer.

**Internal Friction.** It follows from the above-stated facts that there is no noticeable friction between the blood and the lining of the vessel through which it flows: since the outermost blood layer in contact with the wall of the vessel is almost motionless. But there is very great friction between the different concentric layers of the liquid, since each of them is moving at a different rate from those



**DIESE SEITE IST FÜR KOSTENLOSE MITGLIEDER GESPERRT**  
Beantragen Sie jetzt die volle Mitgliedschaft, um diese Seite zu betreten



**Seien Sie niemals ohne ein Buch!**

Die Vollmitgliedschaft von Forgotten Books bietet Ihnen einen universalen Zugang von unseren Apps und unserer Website, auf all Ihren Geräten: Tablet, Telefon, E-Reader, Laptop und Computer.

**Eine Bibliothek in Ihrer Tasche für € 8.99/monat**

**Fortfahren**

\*Es gelten Richtlinien zur fairen Nutzung.

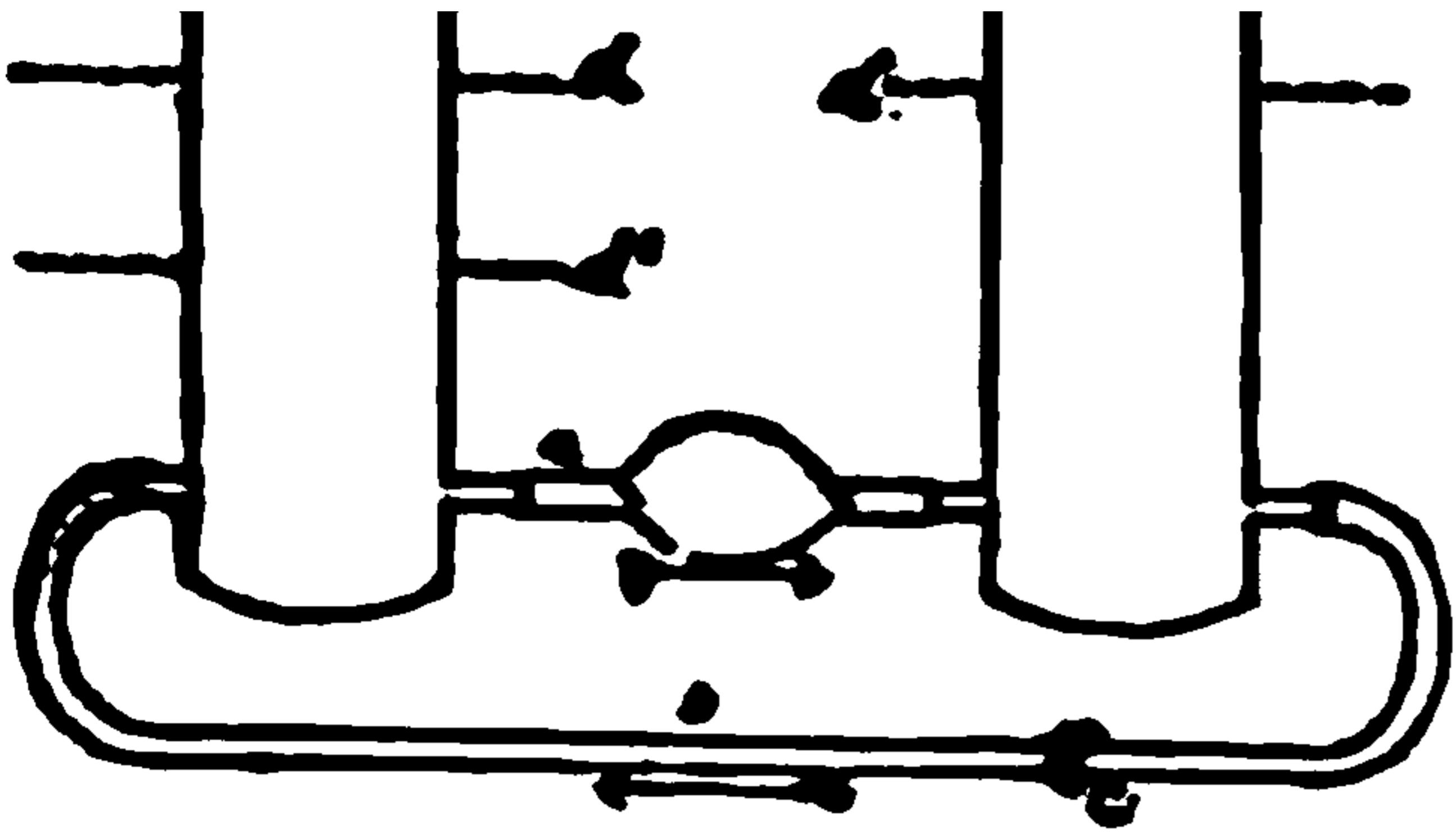

FIG. 88.

on which there is a pump provided with valves so that it can only drive liquid from *A* to *B*, and through *b*, which may be left wide open or narrowed by the clamp *c*, at will. If the apparatus be

left at rest the water will lie at the same level, *d*, in each vessel. If now we work the pump, at each stroke a certain amount of water will be conveyed from *A* to *B*, and as a result of the lowering of the level of liquid in *A* and its rise in *B*, there will be immediately a return flow from *B* to *A* through the tube *b*. *A*, in these circumstances, would represent the venous system, from which the heart constantly takes blood to pump it into *B*, representing the arterial system; and *b* would represent the capillary vessels through which the return flow takes place: but, so far, we should have as intermittent a flow through the capillaries, *b*, as through the heart-pump, *a*. Now imagine *b* to be narrowed at one point so as to oppose resistance to the back-flow, while the pump goes on working steadily. The result will be an accumulation of water in *B*, and a fall of its level in *A*. But the more the difference of level in the two vessels increases, the greater is the force tending to drive water back through *b* to *A*, and more will flow back, under

the greater difference of pressure, in a given time, until at last, when the water in *B* has reached a certain level,  $d'$ , and that in *A* has correspondingly fallen to  $d''$ , the current through *b* will carry back in one minute just so much water as the pump sends the other way, and this back-flow will be nearly constant; it will not depend directly upon the strokes of the pump but upon the head of water accumulated in *B*; which head of water will, it is true, be slightly increased at each stroke of the pump, but the increase will be very small compared with the whole driving force; and its influence will be inappreciable. We thus gain the idea that an incomplete impediment to the flow from the arteries to the veins (from *B* to *A* in the diagram), such as is afforded by internal friction in the capillaries, may bring about conditions which will lead to a steady flow through the latter vessels.

But in the arterial system there can be no accumulation of blood at a higher level than that in the veins, such as is supposed in the above apparatus: and we must next consider if the "head of water" can be replaced by some other form of driving force. It is in fact replaced by the elasticity of the large arteries. Suppose an elastic bag instead of the vessel *B* connected with the pump, "*a*." If there be no resistance to the back-flow the current through *b* will be discontinuous. But if resistance be interposed, then the elastic bag will become distended, since the pump sends in a given time more liquid into it than it passes back through *b*. But the more it becomes distended the more will the bag squeeze the liquid inside and the faster will it send that back to *A*, until at last its squeeze is so powerful that in a minute or any other unit of time it sends back into *A* as much as it receives. Thenceforth the back-flow through *b* will be practically constant, being immediately dependent upon the elastic reaction of the bag; and only indirectly upon the action of the pump which keeps it distended. Such a state of things represents very closely the phenomena occurring in the blood-vessels. The highly elastic large arteries are kept stretched with blood by the heart; and the reaction of their elastic walls,

steadily squeezing on the blood in them, forces it continuously through the small arteries and capillaries. The steady flow in the latter depends thus on two factors: first the elasticity of the large arteries; and secondly the resistance to their emptying, dependent upon internal friction in the small arteries and the capillaries, which calls into play the elasticity of the large vessels. Were the capillary resistance or the arterial elasticity absent the blood-flow in the capillaries would be rhythmic.



**DIESE SEITE IST FÜR KOSTENLOSE MITGLIEDER GESPERRT**

Beantragen Sie jetzt die volle Mitgliedschaft, um diese Seite zu betreten

# GESCHICHTE

Zehntausende von wichtigen historischen Quellen, viele bisher nicht erhältlich, stehen jetzt zum ersten Mal mit der Vollmitgliedschaft von Forgotten Books zur Verfügung.

Unbegrenzter Zugang  
\$8.99/monat

**Fortfahren**

\*Es gelten Richtlinien zur fairen Nutzung.



that its elastic walls are slightly stretched. These will in consequence press upon the liquid inside them and the amount of this pressure will be indicated by the gauges: so long as the pump is at rest it will be the same everywhere (and therefore equal in the gauges on *B* and *A*), since liquid in a set of horizontal tubes communicating freely, as these do at *D*, always distributes itself so that the pressure upon it is everywhere the same. Let the pump *c* now contract once, and then dilate: during the contraction it will empty itself into *B* and during the dilatation fill itself from *A*. Consequently the pressure in *B*, indicated by the gauge *x*, will rise and that in *A* will fall. But very rapidly the liquid will redistribute itself from *B* to *A* through *D*, until it again exists everywhere under the same

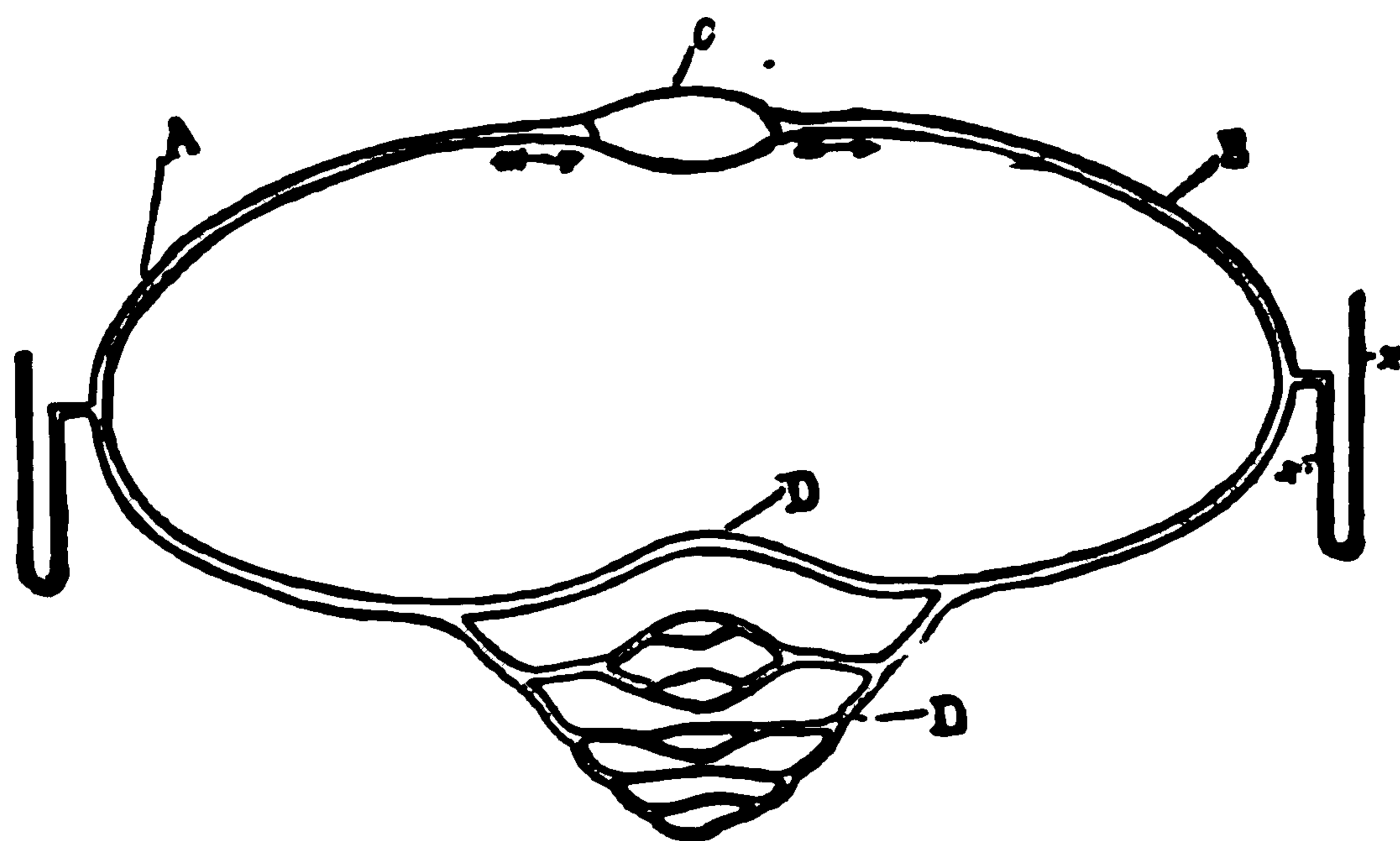

FIG. 87.—Diagram of Weber's Schema.

pressure. Every time the pump works there will occur a similar series of phenomena, and there will be a disturbance of equilibrium causing a wave to flow round the tubing; but there will be no steady maintenance of a pressure on the side *B* greater than that in *A*. Now let the upper tube *D* be closed so that the liquid to get from *B* to *A* must flow through the narrow lower tubes *D*, which oppose considerable resistance to its passage on account of their frequent branchings and the great internal friction in them; then if the pump works frequently enough there will be produced and maintained in *B* a pressure considerably higher than that in *A*, which may even become negative. If, for

example, the pump works 60 times a minute and at each stroke takes 180 cubic centimeters of liquid (6 ounces) from *A* and drives it into *B*, the quantity sent in at the first stroke will not (on account of the resistance to its flow offered by the small branched tubes), have all got back into *A* before the next stroke takes place, sending 180 more cubic centimeters (6 oz.) into *B*. Consequently at each stroke *B* will become more and more distended and *A* more and more emptied, and the gauge *x* will indicate a much higher pressure than that on *A*. As *B* is more stretched, however, it squeezes harder upon its contents, until at last a time comes when this squeeze is powerful enough to force through the small tubes just 180 cubic centimeters (6 oz.) in a second. Then further accumulation in *B* ceases. The pump sends into it 10,800 cubic centimeters (360 ounces) in a minute at one end and it squeezes out exactly that amount in the same time from its other end; and so long as the pump works steadily the pressure in *B* will not rise, nor that in *A* fall, any more. But under such circumstances the flow through the small tubes will be nearly constant since it depends upon the difference in pressure prevailing between *B* and *A*, and only indirectly upon the pump which serves simply to keep the pressure high in *B* and low in *A*. At each stroke of the pump it is true there will be a slight increase of pressure in *B* due to the fresh 180 cub. cent. (6 oz.) forced into it, but this increase will be but a small fraction of the total pressure and so have but an insignificant influence upon the rate of flow through the small connecting tubes.

**Arterial Pressure.** The condition of things just described represents very closely the phenomena presented in the blood-vascular system, in which the ventricles of the heart, with their auriculo-ventricular and semilunar valves, represent the pump, the smallest arteries and the capillaries the resistance at *D*, the large arteries the elastic tube *B*, and the veins the tube *A*. The ventricles constantly receiving blood through the auricles from the veins, send it into the arteries, which find a difficulty in emptying themselves through the capillaries, and so blood accumu-



lates in them until the elastic reaction of the stretched arteries is able to squeeze in a minute through the capillaries just so much blood as the left ventricle pumps into the aorta, and the right into the pulmonary artery, in the same time. Accordingly in a living animal a pressure-gauge connected with an artery shows a much higher pressure than one connected with a vein, and this persistent difference of pressure, only increased by a small fraction of the whole at each heart-beat, keeps up a steady flow from the arteries to the veins. The heart keeps the arteries stretched and the stretched arteries maintain the flow through the capillaries, and the constancy of the current in these depends on two factors: (1) the resistance experienced by the blood in its flow from the ventricles to the veins, and (2) the elasticity of the larger arteries which allows the blood to accumulate in them under a high pressure, in consequence of this resistance.

**The Arterial Pressure.** This cannot be directly measured with accuracy in man, but from measurements made on other animals it is calculated that in the human aorta its average is equal to that of a column of mercury 200 millimeters (8 inches) high. During the systole it rises about 5 millimeters ( $\frac{1}{4}$  inch) above this and during the pause falls the same amount below it. The pressure in the venæ cavæ on the other hand is often negative, the blood being, to use ordinary language, often "sucked" out of them into the heart, and it rarely rises above 5 millimeters ( $\frac{1}{4}$  inch) of mercury except under conditions (such as powerful muscular effort accompanied by holding the breath) which force blood on into the venæ cavæ and, by impeding the pulmonary circulation, interfere with the emptying of the right auricle. Hence to maintain the flow from the aorta to the vena cava we have an average difference of pressure equal to  $200 - 5 = 195$  millimeters ( $7\frac{1}{4}$  inches) of mercury, rising to  $205 - 5 = 200$  mm. (8 inches) during the cardiac systole and falling to  $195 - 5 = 190$  mm. ( $7\frac{1}{4}$  inches) during the pause; but the slight alterations, only about  $\frac{1}{8}$  of the whole difference of aortic and vena cava pressures which maintain the blood-flow, are too slight to cause appreciable



**DIESE SEITE IST FÜR KOSTENLOSE MITGLIEDER GESPERRT**  
Beantragen Sie jetzt die volle Mitgliedschaft, um diese Seite zu betreten



**Seien Sie niemals ohne ein Buch!**

Die Vollmitgliedschaft von Forgotten Books bietet Ihnen einen universalen Zugang von unseren Apps und unserer Website, auf all Ihren Geräten: Tablet, Telefon, E-Reader, Laptop und Computer.

**Eine Bibliothek in Ihrer Tasche für €8.99/monat**

**Fortfahren**

\*Es gelten Richtlinien zur fairen Nutzung.

cent. (480 oz.) instead of the former quantity. This will lead to an accumulation in *B*, since its squeeze is only sufficient, against the resistance opposed to it, to send out 10,800 cub. cent. (360 oz.) in a minute. *B* consequently will become more stretched and the pressure in it will rise. As this takes place, however, it will squeeze more powerfully on its contents until at last its distension is such that its elasticity is able to force out in a minute through the small tubes *D*, 14,400 cub. cent. (480 oz.). Thenceforth, so long as the pump beats with the same force and at the same rate and the peripheral resistance remains the same, the mean pressure in *B* will neither rise nor fall—*B* sending into *A* in a minute as much as *c* takes from it, and we would have a steady condition of things with a higher mean pressure in *B* than before.

On the other hand if the pump begins to work more slowly while the resistance remains the same, it is clear that the mean pressure in *B* will fall. If, for example, the pump works only forty times a minute and so sends in that time  $180 \times 40 = 7200$  cub. cent. (240 oz.) into *B*, which is so stretched that it is squeezing out 10,800 cub. cent. (360 oz.) in that time, it is clear that *B* will gradually empty itself and its walls become less stretched and the pressure in it fall. As this takes place, however, it will force less liquid in a minute through the small tubes, until at last a pressure is reached at which the squeeze of *B* only sends out 7200 cub. cent. (240 oz.) in a minute; and then the fall of pressure will cease and a steady one will be maintained, but lower than before.

Applying the same reasoning to the vascular system we see that (when the peripheral resistance remains unaltered), if the heart's force remains the same but its rate increases, arterial pressure will rise to a new level, while a slowing of the heart's beat will bring about a fall of pressure.

**Modifications of Arterial Pressure Dependent on Changes in the Force of the Heart's Beat.** Returning again to Fig. 87; suppose that while the rate of the pump remains the same, its power alters so that each time it sends 200 cub. cent. (6.6 oz.) instead of 180 (6 oz.) and so in

a minute 12,000 cub. cent. (396 oz.) instead of 10,800 (360 oz.)—the quantity which *B* is stretched enough to squeeze out in that time. Water will in consequence accumulate in *B* until it becomes stretched enough to squeeze out 12,000 cub. cent. (396 oz.) in a minute, and then a steady pressure at a new and higher level will be maintained. On the other hand if the pump, still beating sixty times a minute, works more feebly so as to send out only 160 cub. cent. (5.6 oz.) at each stroke, then *B*, squeezing out at first more than it receives in a given time, will gradually empty itself until it only presses hard enough upon its contents to force  $160 \times 60 = 9600$  cub. cent. (336 oz.) out in a minute.

Similarly, if while the resistance in the small arteries and capillaries remains the same and also the heart's rate, the power of the stroke of the latter alters, so that at each beat it sends more blood out than previously, then arterial pressure will rise; while if the heart beats more feebly it will fall.

**Modifications of Arterial Pressure by Changes in the Peripheral Resistance.** Let the pump *c* in Fig. 87 still work steadily sending 10,800 cub. cent. (360 oz.) per minute into *B* and the resistance increase, it is clear arterial pressure must rise. For *B* is only stretched enough to squeeze out in a minute the above quantity of liquid against the original resistance and cannot at first send out that quantity against the greater. Liquid will consequently accumulate in it until at last it becomes stretched enough to send out 10,800 cub. cent. (360 cubic oz.) in a minute through the small tubes, in spite of the greater resistance to be overcome. A new mean pressure at a higher level will then be established. If on the contrary the resistance diminishes while the pump's work remains the same, then *B* will at first squeeze out in a minute more than it receives, until finally its elastic pressure is reduced to the point at which its receipts and losses balance, and a new and lower mean pressure will be established in *B*.

So in the vascular system increase of the peripheral resistance by narrowing of the small arteries will increase ar-

terial pressure in all parts nearer the heart, while dilatation of the small arteries will have the contrary effect.

**Summary.** We find then that arterial pressure at any moment is dependent upon—(1) the rate of the heart's beat; (2) the quantity of blood forced into the arteries at each beat; (3) the calibre of the smaller vessels. All of these, and consequently the capillary circulation which depends upon arterial pressure, are under the control of the nervous system (see Chap. XVII.).

**The Pulse.** When the left ventricle contracts it forces a certain amount of blood into the aorta, which is already distended and on account of the resistance in front cannot empty itself so fast as the contracting ventricle fills it. As a consequence its elastic walls yield still more—it enlarges both transversely and longitudinally and if exposed in a living animal can be seen and felt to pulsate, swelling out at each systole of the heart, and shrinking and getting rid of the excess during the pause. A similar phenomenon can be observed in all the other large arteries, for just as the contracting ventricle fills the aorta faster than it empties (the whole period of the diastole of the heart being required for emptying the aorta of the blood sent in during the systole) so the increased tension in the aorta immediately after the cardiac contraction, drives on some of its contents into its branches, and fills these faster than they are emptying and so causes a dilatation of them also, which only gradually disappears as the aortic tension falls before the next systole. Hence after each beat of the heart there is a sensible dilatation of all the larger arteries, known as the *pulse*, which becomes less and less marked at points on the smaller branches farther from the heart, but which in health can readily be recognized on any artery large enough to be felt by the finger through the skin, etc. The radial artery near the wrist, for example, will always be felt tense by the finger, since it is kept overfilled by the heart in the way already described. But after each heart-beat it becomes more rigid and dilates a little, the increased distension and rigidity gradually disappearing as the artery passes on the excess of blood before the next heart-beat.



**DIESE SEITE IST FÜR KOSTENLOSE MITGLIEDER GESPERRT**

Beantragen Sie jetzt die volle Mitgliedschaft, um diese Seite zu betreten

# GESCHICHTE

Zehntausende von wichtigen historischen Quellen, viele bisher nicht erhältlich, stehen jetzt zum ersten Mal mit der Vollmitgliedschaft von Forgotten Books zur Verfügung.

Unbegrenzter Zugang  
\$8.99/monat

**Fortfahren**

\*Es gelten Richtlinien zur fairen Nutzung.



would be felt immediately after each stroke of the pump, although the liquid pumped in at the other end would have remained about its point of entry; it would cause the pulsation not by flowing along the tube itself, but by giving a push to the liquid already in it. If instead of absolutely closing the distal end of the tube one brought about a state of things more nearly resembling that found in the arteries by allowing it to empty itself against a resistance, say through a narrow opening, the phenomena observed would not be essentially altered; the increase of pressure would travel along the distended tube far faster than the liquid in it.

The pulse being dependent on the heart's systole, "feeling the pulse" of course primarily gives a convenient means of counting the rate of beat of that organ. To the skilled touch however it may tell a great deal more, as for example whether it is a readily compressible or "soft pulse" showing a low arterial pressure, or tense and rigid ("a hard pulse") indicative of high arterial pressure, and so on. In adults the normal pulse rate may vary from sixty-five to seventy-five. In the same individual it is faster when standing than when sitting, and when sitting than when lying down. Any exercise increases its rate temporarily and so does excitement; a sick person's pulse should not therefore be felt when he is nervous or excited (as the physician knows when he tries first to get his patient calm and confident), as it is then difficult to draw correct conclusions from it. In children the pulse is quicker than in adults, and in old age slower than in middle life.

**The Rate of the Blood-Flow.** As the vascular system becomes more capacious from the aorta to the capillaries the rate of flow in it becomes proportionately slower, and as the total area of the channels diminishes again from the capillaries to the venæ cavæ, so does the rate of flow quicken again, just as a river current slackens where it spreads out, and flows faster where it is confined to a narrower channel; a fact taken advantage of in the construction of Eads' jetties at the mouth of the Mississippi, the object of which is to make the water flow in a narrower channel and so with a

more rapid current. Actual measurements as to the rate of flow in the arteries cannot be made on man, but from experiments on lower animals it is calculated that in the human carotid the blood flows about 400 millimeters (16 inches) in a second. In the capillaries the current travels only from 0.5 to 0.75 mm. ( $\frac{1}{8}$  to  $\frac{3}{16}$  inch) in a second. The total time taken by a portion of blood in getting from the aorta through the carotid and its branches, and the capillaries, and then through veins to the right auricle, that is in going round the systemic circulation, is about 23 seconds—of which time about one second is spent in the capillaries; each portion of blood on its course from the last artery to the first vein passes through a length of capillary which on the average is 0.5 mm. ( $\frac{1}{8}$  inch). The rate of flow in the great veins is about 100 mm. (4 inches) in a second, but is subject to considerable variations dependent on the respiratory and other movements of the Body (see below).

**Secondary Causes of the Circulation.** While the heart's beat is the great driving force of the circulation, certain other things help more or less—viz. gravity, compression of the veins, and aspiration of the thorax. All of them are, however, quite subsidiary; experiment on the dead Body shows that the injection of whipped blood into the aorta under a less force than that exerted by the left ventricle during life, is more than sufficient to drive it round and back by the venæ cavæ. Not unfrequently the statement is made in books that, probably, the systemic capillaries have an attractive force for arterial blood and the pulmonary capillaries for venous blood, but there is not the slightest evidence of the correctness of such a supposition, nor any necessity for making it.

**The Influence of Gravity.** Under ordinary circumstances this may be neglected, since in parts of the Body below the level of the heart it will assist the flow in the



raised so as to make the back-flow in its veins easier; and sometimes when the heart is acting feebly it may be able to drive blood along arteries in which gravity helps, but not otherwise. Accordingly in a tendency to fainting it is best to lie down, and make it easier for the heart to send blood up to the brain, bloodlessness of which is the cause of the loss of consciousness in a fainting-fit. In fact so long as the breathing continues the aspiration of the thorax will keep up the venous flow (see below), while, in the circumstances supposed, a slight diminution in the resistance opposed to the arterial flow may be of importance. The head of a person who has fainted should accordingly never be raised until he has undoubtedly recovered, a fact rarely borne in mind by spectators who commonly rush at once to lift any one whom they see fall in the street or elsewhere.

**The Influence of Transient Compression of the Veins.** The valves of the veins being so disposed as to permit only a flow towards the heart, when external pressure empties a vein it assists the circulation. Continuous pressure, as by a tight garter, is of course bad since it checks all subsequent flow through the vessel, but intermittent pressure, such as exerted on many veins by muscles in the ordinary movements of the Body, acts as a pump to force on the blood in them.

The valves of the veins have another use in diminishing the pressure on the lower part of those vessels in many regions. If, for instance, there were no valves in the long saphenous vein (p. 214) of the leg the weight of the whole column of blood in it, which in the erect position would be about a meter (39 inches) high, would press on the lower part of the vessel. But each set of valves in it carries the weight of the column of blood between it and the next set of valves above, and relieves parts below, and so the weight of the column of blood is distributed and does not all bear on any one point.

**Aspiration of the Thorax.** Whenever a breath is drawn the pressure of the air on the vessels inside the chest is diminished, while that on the other vessels of the Body is unaffected. In consequence blood tends to flow into the chest.



**DIESE SEITE IST FÜR KOSTENLOSE MITGLIEDER GESPERRT**  
Beantragen Sie jetzt die volle Mitgliedschaft, um diese Seite zu betreten



**Seien Sie niemals ohne ein Buch!**

Die Vollmitgliedschaft von Forgotten Books bietet Ihnen einen universalen Zugang von unseren Apps und unserer Website, auf all Ihren Geräten: Tablet, Telefon, E-Reader, Laptop und Computer.

**Eine Bibliothek in Ihrer Tasche für € 8.99/monat**

**Fortfahren**

\*Es gelten Richtlinien zur fairen Nutzung.

1616, demonstrated that the movement of the blood was a continuous circulation as we now know it, and so laid the foundation of modern Physiology. In his time, however, the capillary vessels had not been discovered, so that although he was quite certain that the blood got somehow from the final branches of the aorta to the radicles of the venous system, he did not exactly know how.

The proofs of the course of the circulation are at present quite conclusive and may be summed up as follows. (1) Blood injected into an artery in the dead Body will return by a vein; but injected into a vein will not pass back by an artery. (2) The anatomical arrangement of the valves of the heart and of the veins shows that the blood can only flow *from* the heart, through the arteries and back *to* the heart by the veins. (3) A cut artery spurts from the end next the heart, a cut vein bleeds most from the end farthest from the heart. (4) A portion of a vein when emptied fills only from the end farthest from the heart. This experiment can be made on the veins on the back of the hand of any thin person, especially if the vessels be first gorged by holding the hand in a dependent position for a few seconds. Select then a vein which runs for an inch or so without branching, place one finger on its distal end and then empty it up to its next branch (where valves usually exist) by compressing it from below up. The vessel will then be found to remain empty as long as the finger is kept on its lower end, but will fill immediately when it is removed; which proves that the valves prevent any filling of the vein from its heart end backwards. (5) If a bandage be placed around the arm, so as to close the superficial veins but not tight enough to occlude the deeper-seated arteries, the veins on the distal side of the bandage will become gorged and those on its proximal side empty, showing again that the veins only receive blood from their ends turned towards the capillaries. (6) In the lower animals direct observation with the microscope shows the steady flow of blood from the arteries through the capillaries to the veins, but never in the opposite direction.

## CHAPTER XVII.

### THE REGULATION OF THE HEART AND BLOOD-VESSELS BY THE NERVOUS SYSTEM.

**The Need of Co-ordination.** For the safe and harmonious working of the circulatory apparatus it is obviously necessary that there be some mode of mutual interaction between the heart and the blood-vessels: if the heart beat and the arteries relaxed or contracted, each without any reference to the other, no orderly capillary flow could be maintained. To secure that, the work done by the heart and the resistance to the blood-flow offered in the vessels must at any given moment be correlated; so that the heart shall not by too powerful action over-distend or perhaps burst the small arteries, nor the latter contract too much and so, by increasing the peripheral resistance, raise the aortic pressure to a great height and increase unduly the work to be done by the left ventricle in forcing open the semilunar valves. Again, the total amount of blood in the Body is not sufficient to keep all its organs supplied with the amount needful for the full exercise of their activity at one time, and in the Body accordingly we never find all its parts hard at work at the same moment. If when one group of muscles was set at work and needed an extra blood-supply, this was attained merely by increasing the heart's activity and keeping up a faster blood-flow everywhere through the Body, there would be a clear waste of force, much as if the chandeliers in a house were so arranged that when a larger flame was wanted at one burner it could only be obtained by turning more gas on at all the rest at the same time; besides the big tap at the gas-meter regulating the general supply of the house, local taps at

each burner are required which regulate the gas-supply to each flame independently of the rest. A similar arrangement is found in the Body. Certain nerves control the calibre of the arteries supplying different organs and, when the latter are set at work, allow their arteries to dilate and so increase the amount of blood flowing through them while the general circulation elsewhere remains practically unaffected. The resting parts at any moment thus get just enough blood to maintain their healthy nutrition and the working parts get more; and as certain organs come to rest and others are set in activity, the arteries of the one narrow and of the other dilate; in this way the distribution of the blood in the Body is undergoing constant changes, parts which at one time contain much blood at another having but little. In addition, then, to nervous organs regulating the work of the heart and the arteries with reference to one another, we have to consider another set of vascular nerves which govern the local blood-supply of different regions of the Body.

**The Nerves of the Heart.** The heart gets nerves from three sources. (1) From nerve-cells buried in its own substance and known as its *intrinsic ganglia*. (2) From the tenth pair (pneumogastriacs) of cranial nerves. (3) From the sympathetic nervous system. The intrinsic ganglia keep the heart beating, and the other two sets of nerves control the rate and force of the heart.

**The Intrinsic Heart-Nerves.** The ganglia of the heart lie for the most part in the partition between the auricles and along the line of junction of the auricles and ventricles; a few are found also in the upper parts of the latter. From some of them arise nerve-fibres which go to the muscles of the heart, while others are connected with the endings of the extrinsic nerves reaching the organ; and probably all communicate by a network of nerve-fibres.

The heart is an automatic organ: its beat, like the movement of filaments of a ciliated cell, depends on its own structure and properties and not on anything outside itself. This is proved by the fact that the heart cut out of an animal which has just been decapitated, and entire re-



**DIESE SEITE IST FÜR KOSTENLOSE MITGLIEDER GESPERRT**

Beantragen Sie jetzt die volle Mitgliedschaft, um diese Seite zu betreten

# GESCHICHTE

Zehntausende von wichtigen historischen Quellen, viele bisher nicht erhältlich, stehen jetzt zum ersten Mal mit der Vollmitgliedschaft von Forgotten Books zur Verfügung.

Unbegrenzter Zugang  
\$8.99/monat

**Fortfahren**

\*Es gelten Richtlinien zur fairen Nutzung.



in the restricted physiological sense of the word. The primary cause of the heart's beat lying thus in itself, we have next to see how this beat is controlled from outside and coordinated with the condition of the rest of the Body at any given moment.

**Nerves Slowing the Heart's Beat.** Each pneumogastric trunk sends several branches to the heart. Certain of these contain fibres which when excited slow, or even altogether stop, the beat of the heart and are hence known as the *cardio-inhibitory fibres*.

If one pneumogastric trunk be divided as it runs down the neck and its peripheral, or lower, end be stimulated feebly the heart's beat becomes less frequent, while a more powerful stimulation will completely stop it for a few seconds, as if its muscles were suddenly paralyzed. If the experiment be performed upon a narcotized animal, the heart of which is at the same time exposed by opening the chest, it will be seen that during the stoppage the heart lies flabby and relaxed in diastole; the excitation of the nerve does not stop the heart's beat, as might perhaps be supposed, by keeping it in a state of permanent tetanic contraction, but it annuls its contractions and throws it into a state of rest; the nerve-fibres concerned are not excitant but inhibitory, stopping instead of calling forth the activity of the part on which they act. Whether their influence is exerted directly on the muscular fibres of the heart or upon its intrinsic ganglia, abolishing their automatic activity and so cutting off the stimuli which normally radiate from them to the muscles, is not certainly known, but the latter view is probably the correct one. In any case the full inhibitory power usually lasts only a short time; even if the pneumogastric stimulation be continued the heart will almost always after a few seconds recover from its influence and commence to beat again.

These cardio-inhibitory fibres originate in a collection of nerve-cells in the medulla oblongata known as the *cardio-inhibitory centre*. This centre is automatic and always in a state of slight excitation, feebly stimulating the fibres proceeding from it and slightly slowing the heart's beat.

This is shown by the fact that if both pneumogastric nerves be cut in the neck the heart at once begins to beat a little faster than before; the brake, so to speak, has been taken off it.

**The Influence upon Arterial Pressure of Inhibiting the Heart.** If the heart be entirely stopped arterial pressure will of course fall very rapidly, since the distended arterial system will go on emptying itself through the capillaries into the veins, without receiving any fresh supply at its cardiac end. So too if the heart be made to beat slower, but with the same force in each stroke, it follows from the facts pointed out in the last chapter (p. 238) that arterial pressure will fall to a new and lower level, at which the elastic arteries are only stretched enough to squeeze out in a minute as much as they receive. As a matter of fact, when the heart is made to beat slower by weak pneumogastric stimulation each beat is usually a little more powerful than before. However, this extra force is not sufficient to compensate entirely for the slower rate and so the general arterial pressure falls.

**Use of the Cardio-Inhibitory Mechanism.** Although the cardio-inhibitory centre is automatic and always in a state of slight activity it is also greatly under the control of afferent nerve-fibres reaching it and which can arouse it to a much greater degree, and so reflexly control the heart's beat. If a frog be rendered insensible and its abdominal cavity opened, it will be found that one or two smart taps on the intestine will cause the heart to stop in diastole. If, however, the pneumogastric nerves, or the spinal cord, or the anterior roots of the spinal nerves, or the communicating branches between the sympathetic nerves of the abdomen and the spinal nerves, be cut previously, then striking the intestine has no influence upon the heart; nor has it if the cardio-inhibitory centre in the medulla oblongata be previously destroyed. We thus get evidence that the mechanical stimulation of the intestinal nerves stops the heart reflexly through the pneumogastrics, the afferent impulses traveling from the sympathetic into the spinal nerves and passing then up the spinal cord to the cardio-inhibitory



centre, where they are reflected as efferent impulses down the pneumogastric trunks to the heart. In man and other mammals similar arrangements exist, the afferent fibres passing from the alimentary canal through the solar plexus (p. 172) which lies behind the stomach. It is by exciting them and so reflexly stopping the heart, that men are sometimes killed by a severe blow on the abdomen or even occasionally by a large draught of very cold water, the sudden cold acting as a thermal stimulus, through the walls of the stomach, on the nerve-fibres outside. A hot and very thirsty person requiring a big drink should therefore not take too cold water—or if he does, swallow it only a mouthful at a time.

The blood-vessels of the alimentary canal are very numerous and capacious and form one of the largest vascular tracts of the whole Body, and through the reflex mechanism above described we see how they may control the heart's heat. Probably if the heart is heating too frequently and keeping up too high a pressure in them, the sympathetic nerve-fibres in their coats are stimulated and then, reflexly, through the cardio-inhibitory centre slow the heart's heat and lower the general arterial pressure; and so we get one co-ordinating mechanism by which the heart and blood-vessels are made to work in unison.

Some other afferent nerves are also known to be in connection with the cardio-inhibitory centre. For instance, some persons are made to faint by a strong smell, the olfactory nerves exciting the cardio-inhibitory centre and stopping or greatly slowing the heart. Deaths from the administration of chloroform are also usually brought about in the same way, the vapor stimulating the sensory nerves of the air-passages which then excite powerfully the cardio-inhibitory centre and stop the heart.

**The Accelerator Nerves of the Heart.** These originate in the spinal cord, from which they pass by communicating branches to the lowest cervical and upper dorsal sympathetic ganglia and thence to the heart. When stimulated they cause the heart to beat quicker, but under what conditions they are employed in the physiological working of the Body is not known.



**DIESE SEITE IST FÜR KOSTENLOSE MITGLIEDER GESPERRT**  
Beantragen Sie jetzt die volle Mitgliedschaft, um diese Seite zu betreten



**Seien Sie niemals ohne ein Buch!**

Die Vollmitgliedschaft von Forgotten Books bietet Ihnen einen universalen Zugang von unseren Apps und unserer Website, auf all Ihren Geräten: Tablet, Telefon, E-Reader, Laptop und Computer.

**Eine Bibliothek in Ihrer Tasche für €8.99/monat**

**Fortfahren**

\*Es gelten Richtlinien zur fairen Nutzung.

keeping the arteries more constricted than they would be under the influence of their intrinsic nerves alone. Accordingly if they are cut, or paralyzed, in any region of the Body its arteries dilate and it becomes flushed with blood. Those of the external ear, for example, run in the cervical sympathetic, from the lower part of the neck where they leave the spinal cord, until they reach the arterial branches for the ear and run along the smaller twigs to it. If, therefore, the cervical sympathetic be divided on one side in an anæsthetized rabbit, the ear on that side becomes red and warm from the dilatation of its arteries and the extra amount of blood flowing through it. If, however, that end of the cut nerve still attached to the ear be excited electrically or otherwise, the ear arteries contract gradually until their passage is almost closed up, and the whole organ becomes cold and very pale. Although these vaso-constrictor fibres are thus shown to pass through the cervical sympathetic, other experiments show that they really originate in a group of nerve-cells in the medulla oblongata, and from there run down the spinal cord to the lower part of the neck, where they pass out in the anterior roots of some spinal nerves and reach the sympathetic system. The same is true of nearly all extrinsic vaso-constrictor nerve-fibres in the Body. Some few possibly arise from centres in the spinal cord, but the great majority come primarily from the medulla oblongata, and the collection of nerve-cells there from which they spring is known as the *vaso-motor centre*; a better name would be the *vaso-constrictor centre*.

**The Control of the Vaso-Motor Centre.** The vaso-motor centre is automatic; that is to say it maintains a certain amount of activity of its own, independently of any stimuli reaching it through afferent nerve-fibres. Nevertheless, like nearly all automatic nerve-centres, it is under reflex control, so that its activity may be increased or lessened by afferent impulses conveyed to it. Nearly every sensory nerve of the Body is in connection with it; any stimulus giving rise to pain, for example, excites it, and so constricting the arteries, increases the peripheral resistance to the blood-flow and raises arterial pressure. On

the other hand, certain fibres conveying impulses from the heart inhibit the centre and dilate the arteries, lower blood-pressure, and diminish the resistance to be overcome by the heart. These fibres run in branches of the pneumogastric, and are known as the *depressor fibres*, or in certain animals, for example the rabbit, where they are all collected into one branch, as the *depressor nerve*. If this nerve be divided and its cardiac end stimulated no effect is produced, but if its central end (that still connected with the rest of the pneumogastric trunk and through it with the medulla oblongata) be stimulated, arterial pressure gradually falls; this result being dependent upon a dilatation of the small arteries, and consequent diminution of the peripheral resistance, following an inhibition of the vaso-motor centre brought about by the depressor nerve. Through the depressor nerve the heart can therefore influence the calibre of the small arteries and, by lowering aortic pressure, diminish its own work if need be.

**Blushing.** The depressor nerves control a great part of the vaso-motor centre, and so can bring about dilatation of a large number of arteries—their influence is called into play when general arterial pressure is to be lowered, but is useless for controlling local blood-supply. This is managed by other afferent nerves, each of which inhibits a small part only of the vaso-motor centre, governing the arteries of a limited tract of the Body; the dilatation of these increases the amount of blood flowing through the particular region to which they are distributed, but does not affect the total resistance to the blood-flow sufficiently to influence noticeably the general pressure in the arterial system. In blushing, for example, under the influence of an emotion, that part of the vaso-motor centre which supplies constrictor nerves to the arteries of the skin of the neck and face, is inhibited by nerve-fibres proceeding from the cerebrum to the modulla oblongata, and the face and neck consequently become full of blood and flush up. Quite similar phenomena occur under other conditions in many parts of the Body, although when not visible on the surface we do not usually call them blushes. The mucous

membrane lining the empty stomach is pallid and its arteries contracted, but as soon as food enters the organ it becomes red and full of blood; the food stimulating afferent nerve-fibres there, which inhibit that part of the vaso-motor centre which governs the gastric arteries.

**Taking Cold.** This common disease is not unfrequently caused through undue reflex excitement of the vaso-motor centre. Cold acting upon the skin stimulates, through the afferent nerves, the region of the vaso-motor centre governing the skin arteries, and the latter become contracted, as shown by the pallor of the surface. This has a two-fold influence—in the first place, more blood is thrown into internal parts, and in the second, contraction of the arteries over so much of the Body considerably raises the general blood-pressure. Consequently the vessels of internal parts become overgorged or “congested,” a condition which readily passes into inflammation. Accordingly prolonged exposure to cold or wet is apt to be followed by catarrh or inflammation of more or less of the respiratory tract causing bronchitis, or of the intestines causing diarrhœa. In fact the common summer diarrhœa is far more often due to a chill of the surface, causing intestinal catarrh, than to the fruits eaten in that season which are so often blamed for it. The best preventive is to wear, when exposed to great changes of temperature, a woolen or at least a cotton garment over the trunk of the Body; linen is so good a conductor of heat that it permits any change in the external temperature to act almost at once upon the surface of the Body. After an unavoidable exposure to cold or wet the thing to be done is of course to maintain the cutaneous circulation; for this purpose movement should be persisted in, or a thick dry outer covering put on, until warm and dry clothing can be obtained.

For healthy persons a temporary exposure to cold, as a plunge in a bath, is good, since in them the sudden contraction of the cutaneous arteries soon passes off and is succeeded by a dilatation causing a warm healthy glow on the surface. If the bather remain too long in cold water, however, this reaction passes off and is succeeded by a more



**DIESE SEITE IST FÜR KOSTENLOSE MITGLIEDER GESPERRT**

Beantragen Sie jetzt die volle Mitgliedschaft, um diese Seite zu betreten

# GESCHICHTE

Zehntausende von wichtigen historischen Quellen, viele bisher nicht erhältlich, stehen jetzt zum ersten Mal mit der Vollmitgliedschaft von Forgotten Books zur Verfügung.

Unbegrenzter Zugang  
\$8.99/monat

**Fortfahren**

\*Es gelten Richtlinien zur fairen Nutzung.



the blood from the abdominal organs where it ought to be at that time. Young persons, whose organs have a superabundance of energy enabling them to work under unfavorable conditions, are less apt to suffer in such ways than their elders. One sees boys running actively about after eating, when older people feel a desire to sit quiet and ruminate—or even go to sleep.

## CHAPTER XVIII.

### THE SECRETORY TISSUES AND ORGANS.

**Definition.** In a strict sense of the terms every process in which substances are separated from the blood, whether they be altered or unaltered, is "secretory" and every product of such a separation is a "secretion;" in this sense secretions would be separable into three classes. (1) Liquids or gases transuding on free surfaces of the Body, whether external or internal; (2) the liquids (*lymph*) moistening the various tissues of the Body directly, filling the interstices between them and not contained in definitely limited cavities; (3) all the solid tissues of the Body since, after an early period of embryonic life, they are built up from materials derived from the blood. Secretions would thus come to include all constituents of the Body except the blood itself but, while it is well to bear in mind that the whole Body is in such a way derived from the blood, in practice the term *secretion* is given a narrower connotation, the solid tissues and the lymph being excluded; so that a secretion is a material (liquid or gaseous) derived from the blood and poured out on a free surface, whether that of the general exterior or that of an internal cavity. Such true secretions fall into two classes; one in which the product is of no further use in the Body and is merely separated for removal, as the urine; and one in which the product is intended to be used, for instance as a solvent in the digestion of food. The former group are sometimes distinguished as *excretions* and the latter as *secretions proper*, but there is no real difference between them, the organs and processes concerned being fundamentally alike in each case. A better division is into *transudata* and *secretions*, a transuda-



tion being a product which contains nothing which did not previously exist in the blood, and then in such quantity as might be derivable from it by merely physical processes; while a secretion in addition to transudation elements contains a *specific element*, due to the special physiological activity of the secretory organ; being either something which does not exist in the blood at all or something which, existing in the blood in small quantity, exists in the secretion in such a high proportion that it must have been actively picked up and conveyed there by the secretory tissues concerned. For instance, the gastric juice contains free hydrochloric acid which does not exist in the blood; and the urine contains so much urea that we must suppose its cells to have a peculiar power of removing that body from the liquids flowing near them. This subdivision is also justifiable on histological grounds; wherever there is a secreting surface it is covered with cells, but these where transudata are formed (as on the serous membranes) are mere flat scales, with little or no protoplasm remaining in them, while the cells which line a true secreting organ are cuboidal, spherical, or columnar, and still retain, with their high physiological activity, a good deal of their primitive protoplasm in a but slightly modified state.

**Organs of Secretion.** The simplest form in which a secreting organ occurs (*A*, Fig. 88) is that of a flat membrane provided with a layer of cells, *a*, on one side (that on which the secretion is poured out) and with a network of capillary blood-vessels, *c*, on the other. The dividing membrane, *b*, is known as the *basement membrane* and is usually made up of flat, closely fitting connective-tissue corpuscles; supporting it on its deep side is a layer of connective tissue, *d*, in which the blood-vessels and lymphatics are supported. Such simple forms of secreting surfaces are found on the serous membranes but are not common; in most cases an extended area is required to form the necessary amount of secretion, and if this were attained simply by spreading out plane surfaces, these from their number and extent would be hard to pack conveniently in the Body. Accordingly in most cases, the greater area is attained by folding the



**DIESE SEITE IST FÜR KOSTENLOSE MITGLIEDER GESPERRT**  
Beantragen Sie jetzt die volle Mitgliedschaft, um diese Seite zu betreten



**Seien Sie niemals ohne ein Buch!**

Die Vollmitgliedschaft von Forgotten Books bietet Ihnen einen universalen Zugang von unseren Apps und unserer Website, auf all Ihren Geräten: Tablet, Telefon, E-Reader, Laptop und Computer.

**Eine Bibliothek in Ihrer Tasche für €8.99/monat**

**Fortfahren**

\*Es gelten Richtlinien zur fairen Nutzung.

secreting surface in various ways so that a large surface can be packed in a small bulk, just as a Chinese lantern when shut up occupies much less space than when extended, although its actual surface remains of the same extent. In a few cases the folding takes the form of protrusions into the cavity of the secreting organ as indicated at *C*, Fig. 88, and found on some synovial membranes; but much more commonly the surface extension is attained in another way, the basement membrane, covered by its epithelium, being pitted in or involuted as at *B*. Such a secreting organ is known as a gland.

**Forms of Glands.** In some cases the surface involutions are uniform in diameter, or nearly so, throughout (*B*, Fig. 88). Such glands are known as *tubular*; examples are found in the lining coat of the stomach (Fig. 97\*); also in the skin (Fig. 120†), where they form the *sweat-glands*. In other cases the involution swells out at its deeper end and becomes more or less sacculated (*E*); such glands are *racemose* or *acinous*. The small glands which form the oily matter poured out on the hairs (Fig. 119‡) are of this type. In both kinds the lining cells near the deeper end are commonly different in character from the rest; and around that part of the gland the blood-vessels form a closer network. These deeper cells form the true secreting elements of the gland, and the passage, lined with different cells, leading from them to the surface, and serving merely to carry off the secretion, is known as the *gland duct*. When the duct is undivided the gland is *simple*; but when, as is more usual, it is branched and each branch has a true secreting part at its end, we get a compound gland, tubular (*G*) or racemose (*F*, *H*) as the case may be. In such cases the main duct, into which the rest open, is often of considerable length, so that the secretion is poured out at some distance from the main mass of the gland.

A fully formed gland, *H*, thus comes to be a complex structure, consisting primarily of a duct, *c*, ductules, *dd*, and secreting recesses, *ee*. The ducts and ductules are lined with epithelium which is merely protective and differs in character from the secreting epithelium which lines the

\* P. 319.

† P. 418.

‡ P. 416.

deepest parts. Surrounding each subdivision and hind- ing it to its neighbors is the *gland stroma* formed of con- nective tissue, a layer of which also commonly envelops the whole gland, as its *capsule*. Commonly on looking at the surface of a large gland it is seen to be separated by partitions of its stroma, coarser than the rest, into *lobes*, each of which answers to a main division of the primary duct; and the lobes are often similarly divided into smaller parts or *lobules*. In the connective tissue between the lobes and lobules blood-vessels penetrate, to end in fine capillary vessels around the terminal recesses. They never pene- trate the basement membrane. Lymphatics and nerves take a similar course; but there is reason to believe the nerve-fibres penetrate the basement membrane and be- come directly united with the secreting cells.

**The Physical Processes in Secretion.** From the struc- ture of a gland it is clear that all matter, derived from the blood and poured into its cavity, must pass not only through the walls of the capillary blood-vessels, but also, by filtra- tion or dialysis, through the basement membrane and the lining epithelium. By filtration is meant the passage of a fluid under pressure through the coarser mechanical pores of a membrane, as in the ordinary filtering processes of a chemical laboratory; and the higher the pressure on the liquid to be filtered the greater the amount which, other things being equal, will pass through in a given time. Since in the living Body the liquid pressure in the blood capillaries is nearly always higher than that outside them, filtration is apt to take place everywhere to a greater or less extent, and will be increased in amount in any region by circumstances raising blood-pressure there, and diminished by those lowering it. To a certain extent also the nature of the liquid filtered has an influence. True solutions, as those of salt in water, pass through unchanged; but solu- tions containing substances such as boiled starch or raw egg albumen, which swell up greatly in water rather than truly dissolve, are altered by filtration; the filtrate contain- ing less of the imperfectly dissolved body than the unfil- tered liquid. The higher the pressure the greater the pro-

portion of such substances which gets through; and if the pressure is slight the water or other solvent may alone pass, leaving all the rest behind on the filter. Under moderate pressure the blood may thus lose by filtration such bodies only as water and salines; while an increase of arterial pressure may lead to the passage of albumen and fibrinogen. Under healthy conditions, for example, the urine contains no albumen, but anything increasing the capillary pressure in the kidneys will cause it to appear. *Dialysis* or *osmosis* has already been considered (p. 42); by it substances pass through the intermolecular pores of a membrane independently of the pressure on either side, and for its occurrence two liquids of different chemical constitution are required, one on each side of the membrane. At least if diffusion takes place, as is probable, between two exactly similar solutions, the amount and character of the substances passing opposite ways in a given time are exactly equal, so that no change is produced by the dialysis; which practically amounts to the same thing as if none occurred. When a solution is placed on one side of a membrane allowing of dialysis and pure water on the other, it is found that for every molecule of the dissolved body that passes one way a definite amount of water, called the *endosmotic equivalent* of that body, passes in the opposite direction. Crystalline bodies as a rule (hæmoglobin is an exception) have a low endosmotic equivalent or are readily dialyzable; while *colloids* such as gum and proteids, have a very high one, so that to get, by dialysis, a small amount of albumen through a membrane, a practically infinite amount of water must pass the other way. Accordingly, if we find such bodies in a secretion we cannot suppose that they have been derived from the blood by osmosis.

**The Chemical Processes of Secretion.** As above pointed out certain secretions, called transudata, seem to be products of filtration and dialysis alone, containing only such substances as those which are found in the blood plasma, more or less altered in relative quantity by the ease or difficulty with which they severally passed through the layers met with on their way to the surface. But in many cases



**DIESE SEITE IST FÜR KOSTENLOSE MITGLIEDER GESPERRT**  
Beantragen Sie jetzt die volle Mitgliedschaft, um diese Seite zu betreten

# GESCHICHTE

Zehntausende von wichtigen historischen Quellen, viele bisher nicht erhältlich, stehen jetzt zum ersten Mal mit der Vollmitgliedschaft von Forgotten Books zur Verfügung.

Unbegrenzter Zugang  
\$8.99/monat

**Fortfahren**

\*Es gelten Richtlinien zur fairen Nutzung.



solution causes the rearrangement into carbon dioxide, alcohol, glycerine and succinic acid, of many atoms of carbon, hydrogen and oxygen which previously existed as sugar; and which during the metamorphosis were probably not passed through the living cell. How the latter acts we do not know with certainty, but most likely by picking certain atoms out of the sugar molecule, and leaving the rest to fall down into simpler compounds. On the other hand, we find cells forming and storing up in themselves large quantities of substances, which they afterwards liberate; starch, for instance, being formed and laid by in many fruit-cells, and afterwards rendered soluble and passed out to nourish the young plant.

Gland-cells might *a priori* give rise to the specific elements of secretions in either of these ways and we have to seek in which manner they work. Do they simply act as ferments (however that is) upon the surrounding medium; or do they form the special bodies which characterize their secretion, first within their own substance, and then liberate them, either disintegrating themselves or not at the same time? At present there is a large and an increasing mass of evidence in favor of the second view. There is, no doubt, some reason to believe that every living cell can act more or less as a ferment upon certain solutions should they come into contact with it. Not always, of course, as an alcoholic ferment, though even as regards that one fermentative power it seems very generally possessed by vegetable cells, and there is some evidence that alcohol is normally produced in small amount (and presumably by the fermentation of sugar) under the influence of certain of the living tissues of the Human Body. As regards distinctively secretory cells, however, the evidence is all the other way, and in many cases we can see the specific element collecting in the gland-cells before it is set free in the secretion. For example, in the oil-glands of the skin (Chap. XXVII.) we find the secreting cells, at first granular, nucleated and protoplasmic, gradually undergoing changes by which their protoplasm disappears and is replaced by oil-droplets, until finally the whole cell falls to bits and its

detritus forms the secretion; the cells being replaced by new ones constantly formed within the gland. In such cases the secretion is the ultimate product of the cell life; the result of degenerative changes of old age occurring in it.

In other cases, however, the liberation of the specific element is not attended with the destruction of the secreting cell; as an example we may take the pancreas, which is a large gland lying in the abdomen and forming a secretion used in digestion. Among others, this secretion possesses the power, under certain conditions, of dissolving proteids and converting them into dialyzable peptones (p. 11). This it owes to a specific element known as *trypsin*, the formation of which within the gland-cells can be traced with the microscope.

The pancreas, like the majority of the glands connected with the alimentary canal, has an intermittent activity; determined by the presence or absence of food in various parts of the digestive tract. If the organ be taken from a recently killed dog which has fasted thirty hours and, after proper preparation, be stained with carmine and examined microscopically, we get specimens of what we may call the "resting gland"—a gland which has not been secreting for some time. In these it will be seen that the cells lining the secreting recesses present two very distinct zones; an outer next the basement membrane which does not combine with the coloring matter and is granular, and an inner which is not granular but picks up the carmine. The granules we shall find to be indications of the presence of a trypsin-yielding substance, formed in the cells.

If another dog be kept fasting until he has a good appetite and be then allowed to eat as much meat as he will, he will commonly take so much that the stomach will only be emptied at the end of about twenty hours. This period may, so far as the pancreas is concerned, be divided into two. From the time the food enters the stomach and on for about ten hours, the gland secretes abundantly; after that the secretion dwindles, and by the end of the second ten hours has nearly ceased. We have, then, a time during which the pancreas is working hard, followed by a period



in which its activity is very little, but during which it is abundantly supplied with food materials. The pancreas taken from an animal at the end of the first period and prepared for microscopic examination will be found different from that taken from a dog killed at the end of the second digestion period, and also from the resting gland. Towards the end of the period of active work, the gland-cells are diminished in size and the proportions of the granular and non-granular zones are quite altered. The latter now occupies most of the cell, while the granular non-staining inner zone is greatly diminished. During the secretion there is, therefore, a growth of the non-granular and a destruction of the granular zone; and the latter process rather exceeding the former, the whole secreting cell is diminished in size. During the second digestive period, when secretion is languid, exactly a reverse process takes place. The cells increase in size so as to become larger than those of the resting gland; and this growth is almost entirely due to the granular zone which now occupies most of the cell.

These facts suggest that during secretion the granular part of the cells is used up: but that, simultaneously, the deeper non-granular zone, being formed from materials yielded by the blood, gradually gives rise to the granular. During active secretion the breaking down of the latter to yield the specific elements occurs faster than its regeneration; in a later period, however, when the secretion is ceasing, the whole cell grows and, especially, the granular zone is formed faster than it is disintegrated; hence the great increase of that part of the cell. If this be so, then we ought to find some relationship between the digestive activity of an infusion or extract of the gland and the size of the granular zones of the cells; and it has been shown that such exists; the quantity of trypsin which can be obtained from a pancreas being proportionate to the size of that portion of its cells.

The trypsin, however, does not exist in the cells ready formed, but only a body which yields it under certain circumstances, and called *zymogen*.

If a perfectly fresh pancreas be divided into halves and



**DIESE SEITE IST FÜR KOSTENLOSE MITGLIEDER GESPERRT**  
Beantragen Sie jetzt die volle Mitgliedschaft, um diese Seite zu betreten



**Seien Sie niemals ohne ein Buch!**

Die Vollmitgliedschaft von Forgotten Books bietet Ihnen einen universalen Zugang von unseren Apps und unserer Website, auf all Ihren Geräten: Tablet, Telefon, E-Reader, Laptop und Computer.

**Eine Bibliothek in Ihrer Tasche für € 8.99/monat**

**Fortfahren**

\*Es gelten Richtlinien zur fairen Nutzung.

the trypsin. To decide between the relative importance of these possible agencies we must pass to the consideration of other glands; since the question can only be decided by experiment upon the lower animals, and the position of the pancreas and the difficulty of getting at its nerves without such severe operations as upset the physiological condition of the animal, furnish obstacles to its study which have not yet been overcome.

In certain other glands, however, we find conclusive evidence of a direct action of nerve-fibres upon the secreting elements. If the sciatic nerve of a cat be stimulated electrically the balls of its feet will sweat. Under ordinary circumstances they become at the same time red and full of blood; but that this congestion is a factor of subsidiary importance as regards secretion is proved by the facts that stimulation of the nerve is still able to excite the gland-cells and cause sweating in a limb which has been amputated ten or fifteen minutes (and in which therefore no circulatory changes can occur) and also by the cold sweats, with a pallid skin, of phthisis and the death agony. It is, however, with reference to the submaxillary and parotid salivary glands that our information is most precise.

When the mouth is empty and the jaws at rest the salivary secretion is comparatively small: but a sapid substance placed on the tongue will cause a copious flow. The phenomenon is closely comparable to the production of a reflex muscular contraction. A stimulus acting upon an irritable tissue excites through it certain afferent nerve-fibres; these excite a nerve-centre, which in turn stimulates efferent fibres; going to a muscle in the one case, to a gland in the other. It will be useful to consider again for a moment what occurs in the case of the muscle, taking account only of the efferent fibres and the parts they act upon.

When a muscle in the Body is made to contract reflexly, through its nerve, two events occur in it. One is the shortening of the muscular fibres; the other is the dilatation of the muscular arteries; every muscular nerve contains two sets of fibres, one motor and one vaso-dilator, and normally both act together. In this case, however,

it is clear that the activities of both, though correlated, are essentially independent. The contraction is not due to the greater blood-flow for, not only can an excised muscle entirely deprived of blood, be made to contract by stimulating its nerves, but in an animal to which a small dose of curari—the arrow poison of certain South American Indians—has been given, stimulation of the nerve will cause the vascular dilatation but no muscular contraction: the curari paralyzing the motor fibres, but, unless in large doses, leaving the vaso-dilators intact. The muscular fibres themselves are quite unacted upon by the poison, as evinced by their ready contraction when directly stimulated by an electric shock.

Now let us return to the salivary glands and see how far the facts are comparable. The main nerve of the submaxillary gland is known as the *chorda tympani*. If it be divided in a narcotized dog, and a tube placed in the gland-duct, no saliva will be found to flow. But on stimulating the peripheral end of the nerve (that end still connected with the gland) an abundant secretion takes place. At the same time there is a great dilatation of the arteries of the organ, much more blood than before flowing through it in a given time: the *chorda* obviously then contains vaso-dilator fibres. Now in this case it might very well be that the process was different from that in a muscle. It is conceivable that the secretion may be but a filtration due to increased pressure in the gland capillaries, consequent on dilatation of the arteries supplying them. If a greater filtration into the lymph spaces of the gland took place, this liquid might then merely ooze on through the secreting cells into the commencing ducts and, as it passed through, dissolve out and carry on from the cells the specific organic elements of the secretion. Of these, in the submaxillary of the dog at least, mucin is the most important and abundant. That, however, the process is quite different, and that there are in the gland true secretory fibres in addition to the vaso-dilator, just as in the muscle there are true motor fibres, is proved by other experiments.

If the flow of liquid from the excited gland were merely

the outcome of a filtration dependent on increased blood-pressure in it, then it is clear that the pressure of the secretion in the duct could never rise above the pressure in the blood-vessels of the gland. Now it is found, not only that the gland can be made to secrete in a recently decapitated animal, in which of course there is no blood-pressure, but that, when the circulation is going on, the pressure of the secretion in the duct can rise far beyond that in the gland arteries. Obviously, then, the secretion is no question of mere filtration, since a liquid cannot filter against a higher pressure. Finally, the proof that the vascular dilatation is quite a subsidiary phenomenon has been completed by showing that we can produce all the increased blood-flow through the gland without getting any secretion—that just as in a muscle nerve we can, by curari, paralyze the motor fibres and leave the vaso-dilators intact, so we can by atropin, the active principle of deadly night-shade, get similar phenomena in the gland. In an atropized animal stimulation of the chorda produces vascular dilatation but not a drop of secretion. Bringing blood to the cells abundantly, will not make them drink; we must seek something more in the chorda than the vaso-dilator fibres—some proper secretory fibres; that the poison acts upon them and not upon the gland-cells, is shown, as in the muscle, by the fact that the cells still are capable of activity when stimulated otherwise than through the chorda tympani. For example, by stimulation of the sympathetic fibres going to the gland.

So far then we seem to have good evidence of a direct action of nerve-fibres upon the gland-cells. But even that is not the whole matter. It is extremely probable, if not certain, that there are two sets of secretory fibres in the gland-nerves: a set which so acts upon the cells as to make them pass on more abundantly the transudation elements of the secretion (the water and mineral salts), and another, quite different, which governs the chemical transformations of the cells so as to make them produce mucin from matters previously stored in them, in a comparable way to the production of trypsin from zymogen in the active pancreas.



**DIESE SEITE IST FÜR KOSTENLOSE MITGLIEDER GESPERRT**  
Beantragen Sie jetzt die volle Mitgliedschaft, um diese Seite zu betreten

# GESCHICHTE

Zehntausende von wichtigen historischen Quellen, viele bisher nicht erhältlich, stehen jetzt zum ersten Mal mit der Vollmitgliedschaft von Forgotten Books zur Verfügung.

Unbegrenzter Zugang  
\$8.99/monat

**Fortfahren**

\*Es gelten Richtlinien zur fairen Nutzung.



tion. The evidence is, perhaps, not quite conclusive, but experiments upon the parotid gland of the dog put the matter beyond a doubt.

The submaxillary gland receives fibres from the sympathetic system, as well as the *chorda tympani* from the cerebro-spinal. Excitation of the sympathetic fibres causes the gland to secrete, but the saliva poured out is different from that following chorda stimulation, which is in the dog abundant and comparatively poor in organic constituents, and accompanied by vascular dilatation: while the "sympathetic saliva," as it is called, is less abundant, very rich in mucin, and accompanied with constriction of the gland arteries. According to the above view we might suppose that the chorda contains many transudatory and few trophic fibres, and the sympathetic many trophic and few transudatory. It might, however, well be objected that the greater richness in organic bodies of the sympathetic saliva was really due to the small quantity of blood reaching the gland, when that nerve was stimulated. This might alter the nutritive phenomena of the cells and cause them to form mucin in unusual abundance, in which case the trophic influence of the nerve would be only indirect. Experiments on the parotid preclude this explanation. That gland like the submaxillary gets nerve-fibres from two sources: a cerebral and a sympathetic. The latter enter the gland along its artery, while the former, originating from the glosso-pharyngeal, run in a roundabout course to the gland. Stimulation of the cerebral fibres causes an abundant secretion, rich in water and salts, but with hardly any organic constituents. At the same time it produces dilatation of the gland arteries. Stimulation of the sympathetic causes contraction of the parotid gland arteries and no secretion at all. Nevertheless it causes great changes in the gland-cells. If it be first stimulated for a while and then the cerebral gland-nerve, the resulting secretion may be ten times as rich in organic bodies as that obtained without previous stimulation of the sympathetic; and a similar phenomenon is observed if the two nerves be stimulated simultaneously. So that the sympathetic nerve,

though unable of itself to cause a secretion, brings about great chemical changes in the gland-cells. It is a distinct trophic nerve. This conclusion is confirmed by histology. Sections of the gland after prolonged stimulation of the sympathetic show its cells to be quite altered in appearance, and in their tendency to combine with carmine, when compared either with those of the resting gland or of the gland which has been made to secrete by stimulating its glosso-pharyngeal branch alone.

We have still to meet the objection that the sympathetic fibres may be only indirectly trophic, governing the metabolism of the cells through the blood-vessels. If this be so, cutting off or diminishing the blood-supply of the gland, in any way, ought to have the same result as stimulation of its sympathetic fibres. Experiment shows that such is not the case and reduces us to a direct trophic influence of the nerve. When the arteries are closed and the cerebral gland-nerve stimulated, it is found that the percentage of organic constituents in the secretion is as low as usual; it remains almost exactly the same whether the arteries are open or closed or have been previously open or closed. We must conclude that the peculiar influence of the sympathetic does not depend upon its vaso-constrictor fibres.

These observations make it clear that the phenomena of secretion are dependent on very complex conditions, at least in the salivary glands and presumably in all others. Primarily dependent upon filtration and dialysis from the blood-vessels and the physiological character of the gland-cells, both of these factors are controlled by the nervous system, the secretory tissues being no more automatic than the muscular; and the facts also give us important evidence of power of the nervous system to influence cell nutrition directly.

**Summary.** By secretion is meant the separation of such substances from the blood as are poured out on free surfaces of the Body, whether external or internal. In its simplest form it is merely a physical process dependent on filtration and dialysis; for example, the elimination of carbon dioxide from the surfaces of the lungs, and the watery



liquid poured out on the surfaces of the serous membranes. Such secretions are known as *transudata* and their amount is only indirectly controlled by the nervous system, through the influence of the latter upon the circulation of the blood. The cells lining such surfaces are not secretory tissues in any true sense of the word, being merely flat, inactive, thin scales protecting the surfaces. In other cases the lining cells are thicker, and actively concerned in the process; they are then usually spread over the recesses of a much folded membrane, so that the whole is rolled up into a compact organ called a *gland*, the secretion of which may contain only *transudation elements* (as for example that of the lachrymal glands which form the tears) or may contain a *specific element*, formed in the gland by its cells, in addition to transudation elements. In either case the activity of the organ is directly influenced by the nervous system, usually in a reflex manner (*e.g.* the watering of the eyes when the eyeball is touched and the saliva poured into the mouth when food is tasted) but may also be otherwise excited, as for example the flow of tears under the influence of those changes of the central nervous system which are associated with sad emotions, or the watering of the mouth at the thought of dainty food. The nerves going to such glands, besides controlling their blood-vessels, act upon the gland-cells; one set governing the amount of transudation of water and salines which shall take place through them, and another (in the case of glands producing secretions with one or more specific elements) controlling the production of these, by starting new chemical processes in the cells by which a substance built up in them during rest is converted into the specific element, which is soluble in and carried off by the transudation elements. What the specific element of gland shall be, or whether its secretion contain any, is dependent on the nature of its special cells; how much transudation and how much specific element shall be secreted at any time is controlled by the nervous system; just as the contractility of a muscle depends on the endowments of muscular tissue, and whether it shall rest or contract—and if the latter how powerfully—upon *its nerve*.



**DIESE SEITE IST FÜR KOSTENLOSE MITGLIEDER GESPERRT**  
Beantragen Sie jetzt die volle Mitgliedschaft, um diese Seite zu betreten



**Seien Sie niemals ohne ein Buch!**

Die Vollmitgliedschaft von Forgotten Books bietet Ihnen einen universalen Zugang von unseren Apps und unserer Website, auf all Ihren Geräten: Tablet, Telefon, E-Reader, Laptop und Computer.

**Eine Bibliothek in Ihrer Tasche für € 8.99/monat**

**Fortfahren**

\*Es gelten Richtlinien zur fairen Nutzung.

TABLE SHOWING APPROXIMATELY THE AVERAGE DAILY LOSSES OF THE BODY THROUGH LUNGS, KIDNEYS, SKIN, AND ALIMENTARY CANAL.

	Grams.			Oxygen.		Carbon.		Hydrogen.		Nitrogen.	
	Grams.	Grains.		Grams.	Grains.	Grams.	Grains.	Grams.	Grains.	Grams.	Grains.
Carbon dioxide (CO <sub>2</sub> )...	916.5	14114.0	containing	666.5	10864.0	250.0	3850.0				
Water (H <sub>2</sub> O).....	8114.5	47963.0	"	2768.5	43635.0	....	....	846.0	5833.0		
Urea (CN <sub>2</sub> H <sub>4</sub> O).....	84.5	531.0	"	9.0	133.5	7.0	107.5	9.5	33.5	16.0	246.5
Salts—such as sodium chloride, etc.....	32.0	492.8									
Other substances.....	40.0	616.0	"	16.0	246.5	17.0	262.0	4.0	61.5	3.0	46.0
<b>Total.....</b>	<b>4137.5</b>	<b>68716.8</b>		<b>3460.0</b>	<b>58284.0</b>	<b>274.0</b>	<b>4219.5</b>	<b>852.5</b>	<b>5493.0</b>	<b>19.0</b>	<b>292.5</b>

The living Body thus loses daily in round numbers 4 kilograms of matter (8 lbs.) and, since it is unable to create new matter, this loss must be compensated for from the exterior or the tissues would soon dwindle away altogether; or at least until they were so impaired that life came to an end. After death the losses would be of a different kind, and their quantity much more dependent upon surrounding conditions; but except under very unusual circumstances the wasting away would still continue in the dead Body. Finally, the composition of the daily wastes of the living Body is tolerably constant; it does not simply lose a quantity of matter weighing so much, but a certain amount of definite kinds of matter, carbon, nitrogen, oxygen, and so on; and these same substances must be restored to it from outside, in order that life may be continued. To give one asking for bread a stone might, no doubt, if it were swallowed, compensate in weight for the matter he lost in twenty-four hours; but bread would be needed to keep him alive. In other words, the Body not only requires a supply of matter from outside, but a supply of certain definite kinds of matter.

**The Losses of the Body in Energy.** The daily expenditure of matter by the living Body is not the only one: as continuously it loses in some form or another *energy*, or the power of doing work; often as mechanical work expended in moving external objects, but even when at rest energy is constantly being lost to the Body in the form of heat, by radiation and conduction to surrounding objects, by the evaporation of water from the lungs and skin, and by removal in warm excretions. Unless the Body can make energy it must therefore receive a certain supply of it also from the exterior, or it would very soon cease to carry on any of its vital work; it would be unable to move and would cool down to the temperature of surrounding objects. The discoveries of this century having shown that energy is as indestructible and uncreatable (see Physics) as matter, we are led to look for the sources of the supply of it to the Body; and finding that the living Body daily receives it and dies when the supply is cut off, we no

longer suppose, with the older physiologists, that it works by means of a mysterious vital force existing in or created by it; but that getting energy from the outside it utilizes it for its purposes—for the performance of its nutritive and other living work—and then returns it to the exterior in what the physicists know as a degraded state; that is in a less utilizable condition. While energy like matter is indestructible it is, unlike matter, transmutable; iron is always iron and gold always gold; neither can by any means which we possess be converted into any other form of matter; and so the Body, needing carbon, hydrogen, oxygen, and nitrogen to build it and to cover its daily losses, must be supplied with those very substances. As regards energy this is not the case. While the total amount of it in the universe is constant, its form is constantly subject to change—and that one in which it enters the Body need not be that in which it exists while in it, nor that in which it leaves it. Daily losing heat and mechanical work the Body does not need, could not in fact much utilize energy, supplied to it in these forms; but it does need energy of some form and in amount equivalent to that which it loses.

**The Conservation of Energy.** The forms of energy known to us are not nearly so numerous as the kinds of matter. Still we all know several of them; such as light, heat, sound, electricity, and mechanical work; and most people nowadays know that some of these forms are interconvertible, so that directly or indirectly we can turn one into another. In such changes it is found that a definite amount of one kind always disappears to give rise to a certain quantity of the other; or, in other words, that so much of the first form is equivalent to so much of the second. In a steam-engine, heat is produced in the furnace; when the engine is at work all of this energy does not leave it as heat; some goes as mechanical work, and the more work the engine does the greater is the difference between the heat generated in the furnace and that leaving the machine. If, however, we used the work for rubbing two rough surfaces together we could get the heat back again, and if (which of course is impossible in practice)



**DIESE SEITE IST FÜR KOSTENLOSE MITGLIEDER GESPERRT**  
Beantragen Sie jetzt die volle Mitgliedschaft, um diese Seite zu betreten

# GESCHICHTE

Zehntausende von wichtigen historischen Quellen, viele bisher nicht erhältlich, stehen jetzt zum ersten Mal mit der Vollmitgliedschaft von Forgotten Books zur Verfügung.

Unbegrenzter Zugang  
\$8.99/monat

**Fortfahren**

\*Es gelten Richtlinien zur fairen Nutzung.



is the number of kilogrammeters or foot-pounds of work its unit quantity would perform, if converted into mechanical work and used to raise a weight. For example the unit quantity of heat is that necessary to raise one kilogram of water one degree centigrade in temperature; or sometimes, in books written in English, the quantity necessary to warm one pound of water one degree Fahrenheit. When therefore we say that the mechanical equivalent of heat is 423 kilogrammeters we mean that the quantity of heat which would raise one kilogram of water in temperature from  $4^{\circ}$  C. to  $5^{\circ}$  C. would, if all turned into mechanical work, be able to raise one kilogram 423 meters against the attraction of the earth; and conversely that this amount of mechanical work if turned into heat would warm a kilogram of water one degree centigrade. The mechanical equivalent of heat, taking the Fahrenheit thermometric scale and using feet and pounds as measures, is 772 foot-pounds.

**Potential and Kinetic Energy.** At times energy seems to be lost. Ordinarily we only observe it when it is doing work and producing some change in matter: but sometimes it is at rest, stored away and producing no changes that we recognize and thus seems to have been destroyed. Energy at work is known as *kinetic energy*; energy at rest, not producing changes in matter, is called *potential energy*. Suppose a stone pulled up by a string and left suspended in the air. We know a certain amount of energy was used to lift it; but while it hangs we have neither heat nor light nor mechanical work to represent it. Still the energy is not lost; we know we have only to cut the string and the weight will fall, and striking something give rise to heat. Or we may wind up a spring and keep it so by a catch. In winding it up a certain amount of energy in the form of mechanical work was used to alter the form of the spring. Until the catch is removed this energy remains stored away as potential energy: but we know it is not lost. Once the spring is let loose again it may drive a clock or a watch, and in so doing will perform again just so much work as was spent in coiling it; and when the watch has run down this energy will all have been turned

into other forms—mainly heat developed in the friction of the parts of the watch against one another: but partly also in producing movements of the air, a portion of which we can readily observe in the sound of its ticking. The law of the conservation of energy does not say, then, that either the total potential or the total kinetic energy in the universe is constant in amount: but that the sum of the two is invariable, while constantly undergoing changes from kinetic to potential and *vice versa*: and from one form of kinetic to another.

**The Energy of Chemical Affinity.** Between every two chemical atoms which are capable of entering into combination there exists a certain amount of potential energy; when they unite this energy is liberated, usually in the form of heat, and once they have combined a certain amount of kinetic energy must be spent to pull them apart again; this being exactly the amount which was liberated when they united. The more stable the compound formed the more kinetic energy appears during its formation, and the more must be spent to break it up again. One may imagine the separated atoms as two balls pushed together by springs, the strength of the spring being proportionate to the degree of their chemical affinity. Once they are let loose and permitted to strike together the potential energy previously represented by the compressed springs disappears, and in its place we have the kinetic energy, represented by the heat developed when the balls strike together. To pull them apart again, against the springs, to their original positions, just so much mechanical work must be spent as is the equivalent of that amount of heat which appeared when they struck; and thus kinetic energy will again become latent in breaking up the compound represented by the two in contact. The energy liberated in chemical combination is the most important source of that used in our machines: and also of that spent by the living Body.

**The Relation between the Matters Removed from the Body daily and the Energy Spent by it.** A working locomotive is, we know, constantly losing matter to the exterior in the form of ashes and gaseous products of com-



bustion, the latter being mainly carbon dioxide and water vapor. The engine also expends energy, not only in the form of heat radiated to the air, but as mechanical work in drawing the cars against the resistance offered by friction or sometimes, up an incline, by gravity. Now the engine-driver knows that there is a close relationship between the losses of matter and the expenditure of energy, so that he has to stoke his furnace more frequently and allow a greater draft of air through it in going up a gradient than when running on the level. The more work the engine does the more coals and air it needs to make up for its greater waste. If we seek the cause of this relationship between work and waste, the first answer naturally is that the engine is a machine the special object of which is to convert heat into mechanical work, and so the more work it has to do the more heat is required for conversion, and consequently the more coals must be burnt. This, however, opens the question of the source of the heat—of all that vast amount of kinetic energy which is liberated in the furnace; and to answer this we must consider in what forms matter and energy enter the furnace, since the energy liberated there must be carried in somehow from outside. For present purposes coals may be considered as consisting of carbon and hydrogen, both of which substances tend to forcibly combine with oxygen at high temperatures, forming in the one case carbon dioxide and in the other water. The oxygen necessary to form these compounds being supplied by the air entering the furnace, all the potential energy of chemical affinity which existed between the uncombined elements becomes kinetic, and is liberated as heat when the combination takes place. The energy utilized by the engine is therefore supplied to it in the form of potential energy, associated with the uncombined forms of matter which reach the furnace. Once the carbon and hydrogen have combined with oxygen they are no longer of any use as liberators of energy; and the compounds formed if retained in the furnace would only clog it and impede farther combustion; they are therefore got rid of as wastes through the smoke-stack. The engine,



**DIESE SEITE IST FÜR KOSTENLOSE MITGLIEDER GESPERRT**  
Beantragen Sie jetzt die volle Mitgliedschaft, um diese Seite zu betreten



**Seien Sie niemals ohne ein Buch!**

Die Vollmitgliedschaft von Forgotten Books bietet Ihnen einen universalen Zugang von unseren Apps und unserer Website, auf all Ihren Geräten: Tablet, Telefon, E-Reader, Laptop und Computer.

**Eine Bibliothek in Ihrer Tasche für € 8.99/monat**

**Fortfahren**

\*Es gelten Richtlinien zur fairen Nutzung.

and not upon any peculiarity in the energy utilized or in its source. The Body is, however, a far more economical machine than any steam-engine; of all the energy liberated in the latter only a small fraction, about one eighth, is usefully employed, while our Bodies can utilize for the performance of muscular work alone one fifth of the whole energy supplied to them; leaving out of account altogether the nutritive and other work carried on in them, and the heat lost from them.

**The Conditions of Oxidation in the Living Body.** Although the general principles upon which the Body and the steam-engine get their working power are the same, still in minor points very obvious differences are found between them. In the first place the coals of an engine are oxidized only at a very high temperature, one which would be instantly fatal to our Bodies which, although warm when compared with the bulk of inanimate objects, are very slow fires when compared with a furnace. Chemistry and physics, however, teach us that this difference is quite unimportant so far as concerns the amount of energy liberated. If magnesium wire be ignited in the air it will become white-hot, flame, and leave at the end of a few seconds only a certain amount of incombustible *rust* or *magnesia*, which consists of the metal combined with oxygen. The heat and light evolved in the process represent of course the energy which, in a potential form, was associated with the magnesium and oxygen before their combination. We can, however, oxidize the metal in a different way, attended with no evolution of light and no very perceptible rise of temperature. If, for instance, we leave it in the air it will become gradually turned into magnesia without having ever been hot to the touch or luminous to the eye. The process will, however, take days or weeks; and while in this slow oxidation just as much energy is liberated as in the former case it now all takes the form of heat; and instead of being liberated in a short time is spread over a much longer one, as the gradual chemical combination takes place. The slowly oxidizing magnesium is, therefore, at no moment noticeably hot since it loses its heat to surrounding

objects as fast as it is generated. The oxidations occurring in our Bodies are of this slow kind. An ounce of arrow-root oxidized in a fire, and in the Human Body, would liberate exactly as much energy in one case as the other, but the oxidation would take place in a few minutes and at a high temperature in the former, and slowly, at a lower temperature, in the latter. In the second place, the engine differs from the living Body in the fact that the oxidations in it all take place in a small area, the furnace, and so the temperature there becomes very high; while in our Bodies the oxidations take place all over, in each of the living cells; there is no one furnace or hearth where all the energy is liberated for the whole and transferred thence in one form or another to distant parts: and this is another reason why no one part of the Body attains a very high temperature.

**The Fuel of the Body.** This is clearly different from that of an ordinary engine: no one could live by eating coals. This difference again is subsidiary; a gas-engine requires different fuel from an ordinary locomotive; and the Body requires a somewhat different one from either. It needs as foods, substances which can, in the first place, be absorbed from the alimentary canal and carried to the various tissues; and, in the second, can there be oxidized at a low temperature or, perhaps more probably, can be converted by the living cells into compounds which can be so oxidized. With some trivial exceptions, all substances which fulfill these conditions are complex chemical compounds, and to understand their utilization in the Body we must extend a little the statements above made as to the liberation of energy in chemical combinations. The general law may be stated thus—*Energy is liberated whenever chemical union takes place: and whenever more stable compounds are formed from less stable ones, in which the constituent atoms were less firmly held together.* Of the liberation by simple combination we have already seen an instance in the oxidation of carbon in a furnace; but the union need not be an oxidation. Everyone knows how hot quicklime becomes when it is slaked; the water combining strongly with the lime, and energy being liberated in the form of

heat, during the process. Of the liberation of energy by the breaking down of a complex compound, in which the atoms are only feebly united, into simpler and stabler ones, we get an example in alcoholic fermentation. During that process grape sugar is broken down into more stable compounds, mainly carbon dioxide and alcohol, while oxygen is at the same time taken up. To pull apart the carbon, hydrogen and oxygen of the sugar molecule requires a certain expenditure of kinetic energy: but in the simultaneous formation of the new and stabler compounds a greater amount of energy is set free, and the difference appears as heat, so that the brewer has to cool his vats with ice. It is by processes like this latter, rather than by direct combinations, that most of the kinetic energy of the Body is obtained; the complex proteids and fats and starches and sugar taken as food being broken down (usually with concomitant oxidation) into simpler and more stable compounds.

**Oxidation by Successive Steps.** In the furnace of an engine the oxidation takes place completely at once. The carbon and hydrogen leaving it, if it is well managed, are each in the state of their most stable oxygen compound. But this need not be so: we might first oxidize the carbon so as to form carbon monoxide, CO, and get a certain amount of heat; and then oxidize the carbon monoxide farther so as to form carbon dioxide, CO<sub>2</sub>, and get more heat. If we add together the amounts of heat liberated in each stage, the sum will be exactly the quantity which would have been obtained if the carbon had been completely burnt to the state of carbon dioxide at first. Every one who has studied chemistry will think of many similar cases. As the process is important physiologically we may take another example; say the oxidation of alcohol. This may be burnt completely and directly, giving rise to carbon dioxide and water—

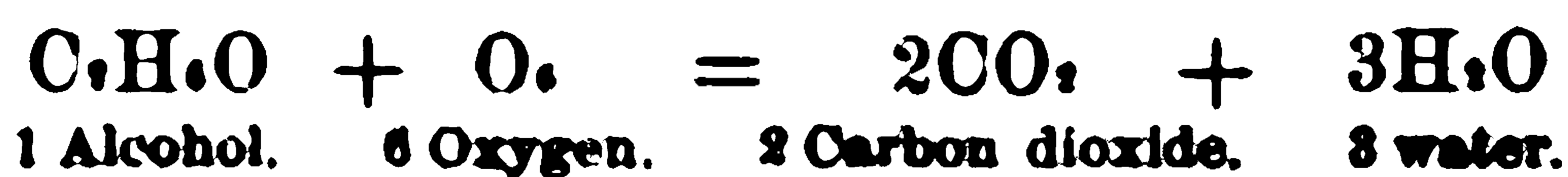

But instead of this we can oxidize the alcohol by stages,



**DIESE SEITE IST FÜR KOSTENLOSE MITGLIEDER GESPERRT**  
Beantragen Sie jetzt die volle Mitgliedschaft, um diese Seite zu betreten

# GESCHICHTE

Zehntausende von wichtigen historischen Quellen, viele bisher nicht erhältlich, stehen jetzt zum ersten Mal mit der Vollmitgliedschaft von Forgotten Books zur Verfügung.

Unbegrenzter Zugang  
\$8.99/monat

**Fortfahren**

\*Es gelten Richtlinien zur fairen Nutzung.



mations does not first take the form of heat; though some of it does. This, again, does not affect the general principle: the source of energy is essentially the same in both cases; it is merely the form which it takes that is different. In a galvanic cell energy is liberated during the union of zinc and sulphuric acid, and we may so arrange matters as to get this energy as heat; but on the other hand we may lead it off, as a so-called galvanic current, and use it to drive a magneto-electric machine before it has taken the form of heat at all. In fact, that heat may be used to do mechanical work we must reduce some of it to a lower temperature: an engine needs a condenser of some kind as well as a furnace; and, other things being equal, the cooler the condenser the greater the proportion of the whole heat liberated in the furnace which can be used to do work. Now in a muscle there is no condenser; its temperature is uniform throughout. So when it contracts and lifts a weight, the energy employed must be liberated in some other form than heat—some form which the muscular fibre can use without a condenser.

**Summary.** The living Body is continually losing matter and expending energy. So long as we regard it as working by virtue of some vital force, the power of generating which it has inherited, the waste is difficult to account for, since it is far more than we can imagine as due merely to wear and tear of the working parts. When, however, we consider the nature of the income of the Body, and of its expenditure, from a chemico-physical point of view, we get the clue to the puzzle. The Body does not waste because it works but works because it wastes. The working power is obtained by chemical changes occurring in it, associated with the liberation of energy which the living cells utilize; and the products of these chemical changes, being no longer available as sources of energy, are passed out. The chemical changes concerned are mainly the breaking down of complex and unstable chemical compounds into simpler and more stable ones, with concomitant oxidation. Accordingly the material losses of the

Bodies are highly or completely oxidized, tolerably simple chemical compounds; and its material income is mainly uncombined oxygen, and oxidizable substances, the former obtained through the lungs, the latter through the alimentary canal. In energy, its income is the potential energy of uncombined or feebly combined elements, which are capable of combining or forming more stable combinations; and its final expenditure, is kinetic energy almost entirely in the form of mechanical work and heat. Given oxygen, all oxidizable bodies will not serve to keep the Body alive and working, but only those which (1) are capable of absorption from the alimentary canal and (2) those which are oxidizable at the temperature of the Body under the influence of protoplasm. Just as carbon and oxygen will not unite in the furnace of an engine unless the "fire be lighted" by the application of a match but, when once started, the heat evolved at one point will serve to carry on the conditions of combination through the rest of the mass, so the oxidations of the Body only occur under special conditions; and these are transmitted from parent to offspring. Every new Human Being starts as a portion of protoplasm separated from a parent and affording the conditions for those chemical combinations which supply to living matter its working power: this serves, like the energy of the burning part of a fire, to start similar processes in other portions of matter. At present we know nothing in physiology answering to the match which lights a furnace; those manifestations of energy which we call life are handed down from generation to generation, as the sacred fire in the temple of Vesta from one watcher to another. Science may at some time teach us how to bring the chemical constituents of protoplasm into that combination in which they possess the faculty of starting oxidations under those conditions which characterize life; then we will have learnt how to strike the vital match. For the present we must be content to study the properties of that form of matter which possesses living faculties; since there is no satisfactory proof that it has ever been produced, within



our experience, apart from the influence of matter already living. How the vital spark first originated, how molecules of carbon, hydrogen, nitrogen and oxygen first united with water and salts to form protoplasm, we have no scientific data to ground a positive opinion upon, and such as we may have must rest upon other grounds.



**DIESE SEITE IST FÜR KOSTENLOSE MITGLIEDER GESPERRT**  
Beantragen Sie jetzt die volle Mitgliedschaft, um diese Seite zu betreten



**Seien Sie niemals ohne ein Buch!**

Die Vollmitgliedschaft von Forgotten Books bietet Ihnen einen universalen Zugang von unseren Apps und unserer Website, auf all Ihren Geräten: Tablet, Telefon, E-Reader, Laptop und Computer.

**Eine Bibliothek in Ihrer Tasche für € 8.99/monat**

**Fortfahren**

\*Es gelten Richtlinien zur fairen Nutzung.

state would serve as material for the constructive forces of the Body to work with. Experience, however, teaches us that this is not the case, but that the animal body requires, for the most part, highly complex compounds for the construction of new tissue elements. All the active tissues yield on analysis large quantities of proteids which, as pointed out in Chapter I., enter always into the structure of protoplasm. Now, so far as we know at present, the animal body is unable to build up proteids from simpler compounds of nitrogen, although when given one variety of them it can convert that one into others, and combine them with other things to form protoplasm. Hence proteids are an essential article of diet, in order to replace that portion of the living cells which is daily broken down and eliminated in the form of urea and other waste substances. Even albuminoids (p. 11), although so nearly allied to proteids, will not serve to replace them entirely in a diet; a man fed abundantly on gelatin, fats, and starches, would starve as certainly, though not so quickly, as if he got no nitrogenous food at all; his tissue waste would not be made good, and he would at last be no more able to utilize the energy-yielding materials supplied to him, than a worn-out steam-engine could employ the heat of a fire in its furnace. So, too, the animal is unable to take the carbon for the construction of its tissues, from such simple compounds as carbon dioxide. Its constructive power is limited to the utilization of the carbon contained in more complex and less stable compounds, such as proteids, fats, or sugars.

The main bulk of all useful foods must therefore be made up of complex substances, and of these a part must be proteids, since the Body can utilize nitrogen for tissue formation only when supplied with it in that form. The bodies thus taken in are sooner or later broken down into simpler and eliminated; some at once in order to yield energy, others only after having first been built up into part of a living cell. The partial exceptions afforded by such losses to the Body as milk for suckling the young, or the albuminous and fatty bodies stored for the same purpose in the egg of a bird, are only apparent; the chemi-

cal degradation is only postponed, taking place in the body of the offspring instead of that of the parent. In all cases animals are thus, essentially, proteid consumers or wasters, and breakers down of complex bodies; the carbon, hydrogen and nitrogen which they take as foods in the form of complex unstable bodies, ultimately leaving them in the simpler compounds, carbon dioxide, water, and urea; which are incapable of either yielding energy or building tissue for any other animal and so of serving it as food. The question immediately suggests itself, How, since animals are constantly breaking up these complex bodies and cannot again build them, is the supply kept up? For example, the supply of proteids, which cannot be made artificially by any process which we know, and yet are necessary foods for all animals, and daily destroyed by them.

**The Food of Plants.** As regards our own Bodies the question at the end of the last paragraph might perhaps be answered by saying that we get our proteids from the flesh of the other animals which we eat. But, then, we have to account for the possession of them by those animals; since they cannot make them from urea and carbon dioxide and water any more than we can. The animals eaten get them, in fact, from plants which are the great proteid formers of the world, so that the most carnivorous animal really depends for its most essential foods upon the vegetable kingdom; the fox that devours a hare in the long run lives on the proteids of the herbs that the hare had previously eaten. All animals are thus, in a certain sense, parasites; they only do half of their own nutritive work, just the final stages, leaving all the rest to the vegetable kingdom and using the products of its labor; and plants are able to meet this demand because they can live on the simple compounds of carbon, hydrogen, and nitrogen eliminated by animals, building up out of them new complex substances which animals can use as food. A green plant, supplied with ammonia salts, carbon dioxide, water, and some minerals, will grow and build up large quantities of proteids, fats, starches, and similar things; it will pull the stable compounds eliminated by animals to pieces, and build them up into com-

plex unstable bodies, capable of yielding energy when again broken down. However, to do such work, to break up stable combinations and make from them less stable, needs a supply of kinetic energy, which disappears in the process being stored away as potential energy in the new compound; and we may ask whence it is that the plant gets the supply of energy which it thus utilizes for chemical construction, since its simple and highly oxidized foods can yield it none. It has been proved that for this purpose the green plant uses the energy of sunlight: those of its cells which contain the substance called *chlorophyl* (leaf green) have the power of utilizing energy in the form of light for the performance of chemical work, just as a steam-engine can utilize heat for the performance of mechanical work. Exposed to light, and receiving carbon dioxide from the air, and water and ammonia (which is produced by the decomposition of urca) from the soil, the plant builds them up again, with the elimination of oxygen, into complex bodies like those which animals broke down, with fixation of oxygen. Some of the bodies thus formed it uses for its own growth and the formation of new protoplasm, just as an animal does; but in sunlight it forms more than it uses, and the excess stored up in its tissues is used by animals. In the long run, then, all the energy spent by our Bodies comes through millions of miles of space from the sun; but to seek the source of its supply there would take us far out of the domain of Physiology (see Astronomy).

**Non-Oxidizable Foods.** Besides our oxidizable foods, a large number of necessary food materials are not oxidizable, or at least are not oxidized in the Body. Typical instances are afforded by water and common salt. The use of these is in great part physical: the water, for instance, dissolves materials in the alimentary canal, and carries the solutions through the walls of the digestive tube into the blood and lymph vessels, so that they can be carried from part to part; and it permits interchanges to go on by diffusion. The salines also influence the solubility and chemical interchanges of other things present with them. Serum albumen, the chief proteid of the blood, for example,



**DIESE SEITE IST FÜR KOSTENLOSE MITGLIEDER GESPERRT**  
Beantragen Sie jetzt die volle Mitgliedschaft, um diese Seite zu betreten

# GESCHICHTE

Zehntausende von wichtigen historischen Quellen, viele bisher nicht erhältlich, stehen jetzt zum ersten Mal mit der Vollmitgliedschaft von Forgotten Books zur Verfügung.

Unbegrenzter Zugang  
\$8.99/monat

**Fortfahren**

\*Es gelten Richtlinien zur fairen Nutzung.



and for which effects they are taken. In other words, their influence as stimuli in exciting certain tissues to liberate energy, or as inhibitory agents checking the activity of parts, is more marked than their direct action as force generators. As examples, we may take condiments: mustard and pepper are not of much use as sources of energy, although they no doubt yield some; we take them for their stimulating effect on the mouth and other parts of the alimentary canal, by which they promote an increased flow of the digestive secretions or an increased appetite for food. Then, again, the active principle of tea and coffee, is taken for its stimulating effect on the nervous system, rather than for the amount of energy which is yielded by its own oxidation.

**Conditions which a Food must Fulfill.** (1) A food must contain the elements which it is to replace in the Body: but that alone is not sufficient. The elements leaving the Body being usually derived from the breaking down of complex substances in it, the food must contain them either in the form of such complex substances, or in forms which the Body can build up into them. Free nitrogen and hydrogen are no use as foods, since they are neither oxidizable under the conditions prevailing in the Body (and consequently cannot yield it energy), nor are they capable of construction by it into its tissues. (2) Food after it has been swallowed is still in a strict sense outside the Body; the alimentary canal is merely a tube running through it, and so long as food lies there it is not forming any part of the Body proper. Hence foods must be capable of absorption from the alimentary canal; either directly, or after they have been changed by the processes of digestion. Carbon, for example, is no use as a food, not merely because the Body could not build it up into its own tissues, but because it cannot be absorbed from the alimentary canal. (3) Neither the substance itself nor any of the products of its transformation in the Body must be injurious to the structure or activity of any organ. If so it is a *poison*, not a food.

**Alimentary Principles.** What in common language we

commonly call foods are, in nearly all cases, mixtures of several *foodstuffs*, with substances which are not foods at all. Bread, for example, contains water, salts, gluten (a proteid), some fats, much starch, and a little sugar; all true foodstuffs: but mixed with these is a quantity of *cellulose* (the chief chemical constituent of the walls which surround vegetable cells), and this is not a food since it is incapable of absorption from the alimentary canal. Chemical examination of all the common articles of diet shows that the actual number of important foodstuffs is but small: they are repeated in various proportions in the different things we eat, mixed with small quantities of different flavoring substances, and so give us a pleasing variety in our meals; but the essential substances are much the same in the fare of the workman and in the "delicacies of the season." These primary foodstuffs, which are found repeated in so many different foods, are known as "*alimentary principles*;" and the physiological value of any article of diet depends on them far more than on the traces of flavoring matters which cause certain things to be especially sought after and so raise their market value. The alimentary principles may be conveniently classified into proteids, albuminoids, hydrocarbons, carbohydrates, and inorganic bodies.

**Proteid Alimentary Principles.** Of the nitrogenous foodstuffs the most important are proteids: they form an essential part of all diets, and are obtained both from animals and plants. The most common and abundant are myosin and syntonin which exist in the lean of all meats; egg albumen; casein, found in milk and cheese; gluten and vegetable casein from various plants.

**Albuminoid Alimentary Principles.** These also contain nitrogen, but cannot replace the proteids entirely as foods; though a man can get on with less proteids when he has some albuminoids in addition. The most important is *gelatin*, which is yielded by the white fibrous tissue of animals when cooked. On the whole the albuminoids are not foods of high value, and the calf's-foot jelly and such compounds, often given to invalids, have not nearly the nutritive value they are commonly supposed to possess.



**Hydrocarbons (*Fats and Oils*).** The most important are stearin, palmatin, margarin and olein, which exist in various proportions in animal fats and vegetable oils; the more fluid containing most olein. Butter consists chiefly of a fat known as butyrin. All are neutral compounds of glycerine and fatty acids and, speaking generally, any such substance which is fusible at the temperature of the Body will serve as a food. The stearin of beef and mutton fats is not by itself fusible at the body temperature, but is mixed in those foods with so much olein as to be melted in the alimentary canal. Beeswax, on the other hand, is a fatty body which will not melt in the intestines and so passes on unabsorbed; although from its composition it would be useful as a food could it be digested. It is convenient to distinguish *fats* proper (the adipose tissue of animals consisting of fatty compounds inclosed in albuminous cell-walls) from *oils*, or fatty bodies which are not so surrounded.

**Carbohydrates.** These are mainly of vegetable origin. The most important are *starch*, found in nearly all vegetable foods; *dextrin*; *gums*; *grape sugar* (into which starch is converted during digestion); and *cane sugar*. *Sugar of milk* and *glycogen* are alimentary principles of this group, derived from animals. All of them, like the fats, consist of carbon, hydrogen and oxygen; but the percentage of oxygen in them is much higher, there being one atom of oxygen for every two of hydrogen in their molecule.

**Inorganic Foods.** Water; common salts; and the chlorides, phosphates, and sulphates of potassium, magnesium and calcium. More or less of these bodies, or the materials for their formation, exists in all ordinary articles of diet, so that we do not swallow them in a separate form. Phosphates, for example, exist in nearly all animal and vegetable foods; while other foods, as casein, contain phosphorus in combinations which in the Body yield it up to be oxidized to form phosphoric acid. The same is true of sulphates, which are partially swallowed as such in various articles of diet, and are partly formed in the Body by the oxidation of the sulphur of various proteids. Calcium salts are abundant in bread, and are also found in many drinking waters.



**DIESE SEITE IST FÜR KOSTENLOSE MITGLIEDER GESPERRT**  
Beantragen Sie jetzt die volle Mitgliedschaft, um diese Seite zu betreten



**Seien Sie niemals ohne ein Buch!**

Die Vollmitgliedschaft von Forgotten Books bietet Ihnen einen universalen Zugang von unseren Apps und unserer Website, auf all Ihren Geräten: Tablet, Telefon, E-Reader, Laptop und Computer.

**Eine Bibliothek in Ihrer Tasche für € 8.99/monat**

**Fortfahren**

\*Es gelten Richtlinien zur fairen Nutzung.

the flesh, by putting the raw meat at once into boiling water, which coagulates the surface albumin before it is exposed out, and the lungs in the rest. In any case the myosin, being insoluble in water, remains behind in the boiled meat. In boiling or roasting, all the solid parts of the flesh are preserved and certain agreeably flavored bodies are produced, as to the nature of which little is known.

**Eggs.** These contain a large amount of egg albumen and, in the yolk, another proteid, known as vitellin. Also fats, and a substance known as lecithin (p. 14), which is important as containing a considerable quantity of phosphorus.

**Milk.** This contains the proteid known as casein; several fats forming the butter; a carbohydrate, the milk sugar; and much water and salts, especially phosphates. Butter is mainly made of butyria, a compound of butyric acid and glycerin. In the milk it is disseminated in the form of minute globules which, for the most part, float up to the top when the milk is let stand and then form the cream. In this each fat droplet is surrounded by a pellicle of albuminous matter; by churning, these pellicles are broken up and the fat droplets run together to form the butter. Casein is insoluble in water, and in the milk it is dissolved by the alkaline salts present. When milk is kept its sugar ferments and gives rise to lactic acid, which neutralizes the alkali and precipitates the casein as curds. In cheese-making the casein is similarly precipitated by the addition of an acid and (the whey being pressed out) it constitutes the main bulk of the cheese.

**Vegetable Foods.** Of these wheat affords the best. In 1000 parts it contains 183 of proteids, 568 of starch, 46 of dextrin (a carbohydrate), 49 of grape sugar, 19 of fats, and 89 of cellulose, the remainder being water and salts. The proteid of wheat is mainly gluten, which when moistened with water forms a tenacious mass, and this it is to which wheatens bread owe its superiority. When the dough is made yeast is added to it, and produces a fermentation by which, among other things, carbon dioxide gas is produced. This gas, imprisoned in the tenacious dough,

and expanded during baking, forms cavities in it and causes it to "rise" and make "light bread," which is not only more pleasant to eat but more digestible than heavy. Other cereals may contain a larger percentage of starch but none have so much gluten as wheat; when bread is made from them the carbon dioxide gas escapes so readily from the less tenacious dough that it does not expand the mass properly. *Corn* contains in 1000 parts, 79 of proteids, 637 of starch, and from 50 to 87 of fats; much more than any other kind of grain. *Rice* is poor in proteids (56 parts in 1000) but very rich in starch (823 parts in 1000). *Peas* and *beans* are rich in proteids (from 220 to 260 parts in 1000), and contain about half their weight of starch. *Potatoes* are a poor food. They contain a great deal of water and cellulose, and only about 13 parts of proteids and 154 of starch in 1000. Other fresh vegetables, as carrots, turnips and cabbages, are valuable mainly for the salts they contain; their weight is mainly due to water, and they contain but little starch, proteids, or fats. Fruits, like most fresh vegetables, are mainly valuable for their saline constituents, the other foodstuffs in them being only present in small proportion. Some form of fresh vegetables is, however, a necessary article of diet; as shown by the scurvy which used to prevail among sailors before fresh vegetables or lime-juice were supplied to them.

**The Cooking of Vegetables.** This is of more importance even than the cooking of flesh, since in most the main alimentary principle is starch, and raw starch is difficult of digestion. In plants starch is nearly always stored up in the form of solid granules, which consist of alternating layers of *starch cellulose* and *starch granulose*. The digestive fluids turn the starch into grape sugar which is soluble and can be absorbed from the alimentary canal, while starch itself cannot. Now these fluids act very slowly and imperfectly on raw starch, and then only on the granulose; but when boiled, the starch granules swell up, and are more readily converted into grape sugar; and the starch cellulose is so altered that it too undergoes that change. When starch is roasted it is turned into a substance known as soluble starch which is readily dissolved in the alimentary canal.

There is therefore a scientific foundation for the common belief that the crust of a loaf is more digestible than the crumb, and toast than ordinary bread.

**Alcohol.** There are perhaps no common articles of diet concerning which more contradictory statements have been made than alcoholic drinks. This depends upon their peculiar position: according to quantity or circumstances alcohol may be a poison or a food; and as a food it may be regarded either as a force regulator or a force generator. There is no doubt that alcohol in certain doses may be properly called a food. If not more than two ounces (which would be contained in about four ounces of whiskey or two quarts of lager beer) are taken in the twenty-four hours, it is completely oxidized in the Body and excreted as water and carbon dioxide. In this oxidation energy is of course liberated and can be utilized. Commonly, however, alcohol is not taken for this purpose but, as a force regulator, for its influence on the nervous system or digestive organs, and it is in this capacity that it becomes dangerous. For not only may it be taken in quantities so great that it is not all oxidized in the Body but is passed through it as alcohol, or even that it acts as a narcotic poison instead of a stimulant, but when taken in what is called moderation there can be no doubt that the constant "whipping up" of the flagging organs, if continued, must be dangerous to their integrity. Hence the daily use of alcohol merely in such quantities as to produce slight exhilaration or to facilitate work is by no means safe; though in disease when the system wants rousing to make some special effort, the physician cannot dispense with it or some other similarly acting substance. In fact, as a force generator alcohol may be advantageously replaced by other foods in nearly all cases; and there is no evidence that it helps in the construction of the working tissues, though its excessive use often leads to an abnormal accumulation of fat. Its proper use is as a "whip," and one has no more right to use it to the healthy Body than the lash to overdrive a willing horse. The physician is the proper person to determine whether it is wanted under any given circumstances.



**DIESE SEITE IST FÜR KOSTENLOSE MITGLIEDER GESPERRT**  
Beantragen Sie jetzt die volle Mitgliedschaft, um diese Seite zu betreten

# GESCHICHTE

Zehntausende von wichtigen historischen Quellen, viele bisher nicht erhältlich, stehen jetzt zum ersten Mal mit der Vollmitgliedschaft von Forgotten Books zur Verfügung.

Unbegrenzter Zugang  
\$8.99/monat

**Fortfahren**

\*Es gelten Richtlinien zur fairen Nutzung.



substances. About 300 grams (4620 grains) of water (containing 33.3 grams (513 grains) of hydrogen are, however, formed in the Body by oxidation, and the hydrogen for this purpose must be supplied in the form of some oxidizable foodstuff, whether proteid, fat, or carbohydrate. The oxygen wanted is mainly received from the air through the lungs, but some is taken in the food.

Since proteid foods contain carbon, nitrogen and hydrogen, life may be kept up on them alone, with the necessary salts, water and oxygen; but such a form of feeding would be anything but economical. Ordinary proteids contain in 100 parts (p. 10) about 52 of carbon and 15 of nitrogen, so a man fed on them alone would get about  $3\frac{1}{2}$  parts of carbon for every 1 of nitrogen. His daily losses are not in this ratio, but about that of 274 grams (4220 grains) of carbon to 20 grams (308 grains) of nitrogen, or as 13.7 to 1; and so to get enough carbon from proteids far more than the necessary amount of nitrogen must be taken. Of dry proteids 527 grams (8116 grains) would yield the necessary carbon, but would contain 79 grams (1217 grains) of nitrogen; or four times more than is necessary to cover the daily losses of that element from the Body. Fed on a purely proteid diet a man would, therefore, have to digest a vast quantity to get enough carbon, and in eating and absorbing it, as well as in getting rid of the extra nitrogen which is useless to him, a great deal of unnecessary labor would be thrown upon the various organs of his Body. Similarly, if a man were to live on bread alone he would burden his organs with much useless work. For bread contains but little nitrogen in proportion to its carbon, and so, to get enough of the former, far more carbon than was utilized would have to be eaten, digested, and eliminated daily.

Accordingly, we find that mankind in general employ a mixed diet when they can get it, using richly proteid substances to supply the nitrogen needed, but deriving the carbon mainly from non-nitrogenous foods of the fatty or carbohydrate groups, and so avoiding excess of either. For instance, lean beef contains about  $\frac{1}{4}$  of its weight of dry

proteid, which contains 15 per cent of nitrogen. Consequently the 133 grams (2048 grains) of proteid, which would be found in 532 grams (1 lb. 3 oz.) of lean meat would supply all the nitrogen needed to compensate for a day's losses. But the proteid contains 52 per cent of carbon, so the amount of it in the above weight of fatless meat would be 69 grams (1062 grains) of carbon, leaving 205 grams (3157 grains) to be got either from fats or carbohydrates. The necessary amount would be contained in about 256 grams (3942 grains) of ordinary fats or 460 grams (7084 grains) of starch; hence either of these, with the above quantity of lean meat, would form a far better diet, both for the purse and the system, than the meat alone.

As already pointed out, nearly all common foods contain several *foodstuffs*. Ordinary butcher's meat, for example, contains nearly half its weight of fat; and bread, besides proteids, contains starch, fats, and sugar. In none of them, however, are the foodstuffs mixed in the physiologically best proportions, and the practice of employing several of them at each meal or different ones at different meals during the day, is thus not only agreeable to the palate but in a high degree advantageous to the Body. The strict vegetarians who do not employ even such substances as eggs, cheese, and milk, but confine themselves to a purely vegetable diet (such as is always poor in proteids), daily take far more carbon than they require, and are to be congratulated on their excellent digestions which are able to stand the strain. Those who use eggs, cheese, etc., can of course get on very well, since such substances are extremely rich in proteids, and supply the nitrogen needed without the necessity of swallowing the vast bulk of food which must be eaten in order to get it from plants directly.



# CHAPTER XXI.

## THE ALIMENTARY CANAL AND ITS APPENDAGES.

**General Arrangement.** The alimentary canal is essentially an involuted portion of the skin, specially set apart for absorption, and forming a tube which runs through the Body (Fig. 2); it communicates with the exterior at three points (the nose, the mouth, and the anal aperture), at which this modified skin, or *mucous membrane*, is continuous with the general outer integument. Supporting the lining absorptive membrane are other layers which strengthen the tube, and are also in part muscular and, by their contractions, serve to pass materials along it from one end to the other. In the walls of the canal are numerous blood and lymphatic vessels which carry off the matters absorbed from its cavity; and there also exist in connection with it numerous *glands*, whose function it is to pour into it various *secretions* which exert a solvent influence on such foodstuffs as would otherwise escape absorption. Some of these glands are minute and imbedded in the walls of the alimentary tube itself, but others (such as the salivary glands) are larger and lie away from the main channel, into which their products are carried by ducts of various lengths.

The alimentary tube is not uniform but presents several dilatations on its course; nor is it straight, since, being much longer than the Body, it is packed away by being coiled up in the abdominal cavity.

**Subdivisions of the Alimentary Canal.** The mouth opening leads into a chamber containing the teeth and tongue, the *mouth chamber* or *buccal cavity*. This is suc-



**DIESE SEITE IST FÜR KOSTENLOSE MITGLIEDER GESPERRT**  
Beantragen Sie jetzt die volle Mitgliedschaft, um diese Seite zu betreten



**Seien Sie niemals ohne ein Buch!**

Die Vollmitgliedschaft von Forgotten Books bietet Ihnen einen universalen Zugang von unseren Apps und unserer Website, auf all Ihren Geräten: Tablet, Telefon, E-Reader, Laptop und Computer.

**Eine Bibliothek in Ihrer Tasche für €8.99/monat**

**Fortfahren**

\*Es gelten Richtlinien zur fairen Nutzung.

two semicircles, formed by the borders of the upper and lower jaw-bones, which are covered by the *gums*, except at intervals along their edges where they contain sockets in which the teeth are implanted. During life two sets of teeth are developed; the first or *milk set* appears soon after birth and is shed during childhood, when the second or *permanent set* appears.

The teeth differ in minor points from one another, but in all three parts are distinguishable; one, seen in the mouth and called the *crown* of the tooth; a second, imbedded in the jaw-bone and called the *root* or *fang*; and between the two, embraced by the edge of the gum, is a narrowed portion, the *neck* or *cervix*. From differences in their forms and uses the teeth are divided into *incisors*, *canines*, *bicuspid*s, and *molars*, arranged in a definite order in each jaw. Beginning at the middle line we meet in each half of each jaw with, successively, two incisors, one canine, and two molars in the milk-set; making twenty altogether in the two jaws. The teeth of the permanent set are thirty-two in number, eight in each half of each jaw, viz.—beginning at the middle line—two incisors, one canine, two bicuspids, and three molars. The bicuspids, or premolars, of the permanent set replace the milk molars, while the permanent molars are new teeth added on as the jaw grows, and not substituting any of the milk teeth. The hindmost permanent molars are often called the *wisdom teeth*.

**Characters of Individual Teeth.** The *incisors* (Fig. 90) are adapted for cutting the food. Their crowns are chisel-shaped and have sharp horizontal cutting edges, which become worn away by use so that they are beveled off behind in the upper row, and in the opposite direction in the lower. Each has a single long fang. The *canines* (Fig. 91) are somewhat larger than the incisors. Their crowns are thick and somewhat conical, having a central point or *cuspid* on the cutting edge. In dogs, cats, and other *carnivora* the canines are very large and adapted for seizing and holding prey. The *bicuspid*s or *premolars* (Fig. 92) are rather shorter than the canines and their

crowns are somewhat cuboidal. Each has two cusps, an outer towards the cheek, and an inner on the side turned towards the interior of the mouth. The fang is compressed laterally, and has usually a groove partially subdividing it



FIG. 90.



FIG. 91.



FIG. 92.



FIG. 93.

FIG. 90.—An incisor tooth.

FIG. 91.—A canine or eye tooth.

FIG. 92.—A bicuspid tooth seen from its outer side; the inner cusp is, accordingly, not visible.

FIG. 93.—A molar tooth.

into two. At its tip the separation is often complete. The *molar teeth* or *grinders* (Fig. 93) have large crowns with broad surfaces, on which are four or five projecting tubercles, which roughen them and make them better adapted to crush the food. Each has usually several fangs. The *milk teeth* only differ in subsidiary points from those of the same names in the permanent set.

**The Structure of a Tooth.** If a tooth be broken open a cavity extending through both crown and fang will be found in it. This is filled during life with a soft vascular pulp, and hence is known as the “pulp cavity” (c, Fig. 94). The hard parts of the tooth disposed around the pulp cavity consist of three different tissues. Of these one immediately surrounds the cavity and makes up most of the bulk of the tooth; it is *dentine* (2, Fig. 94); covering the dentine on the crown is the *enamel* (1, Fig. 94) and, on the fang, the *cement* (3, Fig. 94).

The pulp cavity opens below by a narrow aperture at the tip of the fang, or at the tip of each if the tooth has more than one. The pulp consists mainly of connective tissue, but its surface next the dentine is covered by a layer of

columnar cells. Through the opening on the fang blood-vessels and nerves enter the pulp.

The dentine yields on chemical analysis the same mate-

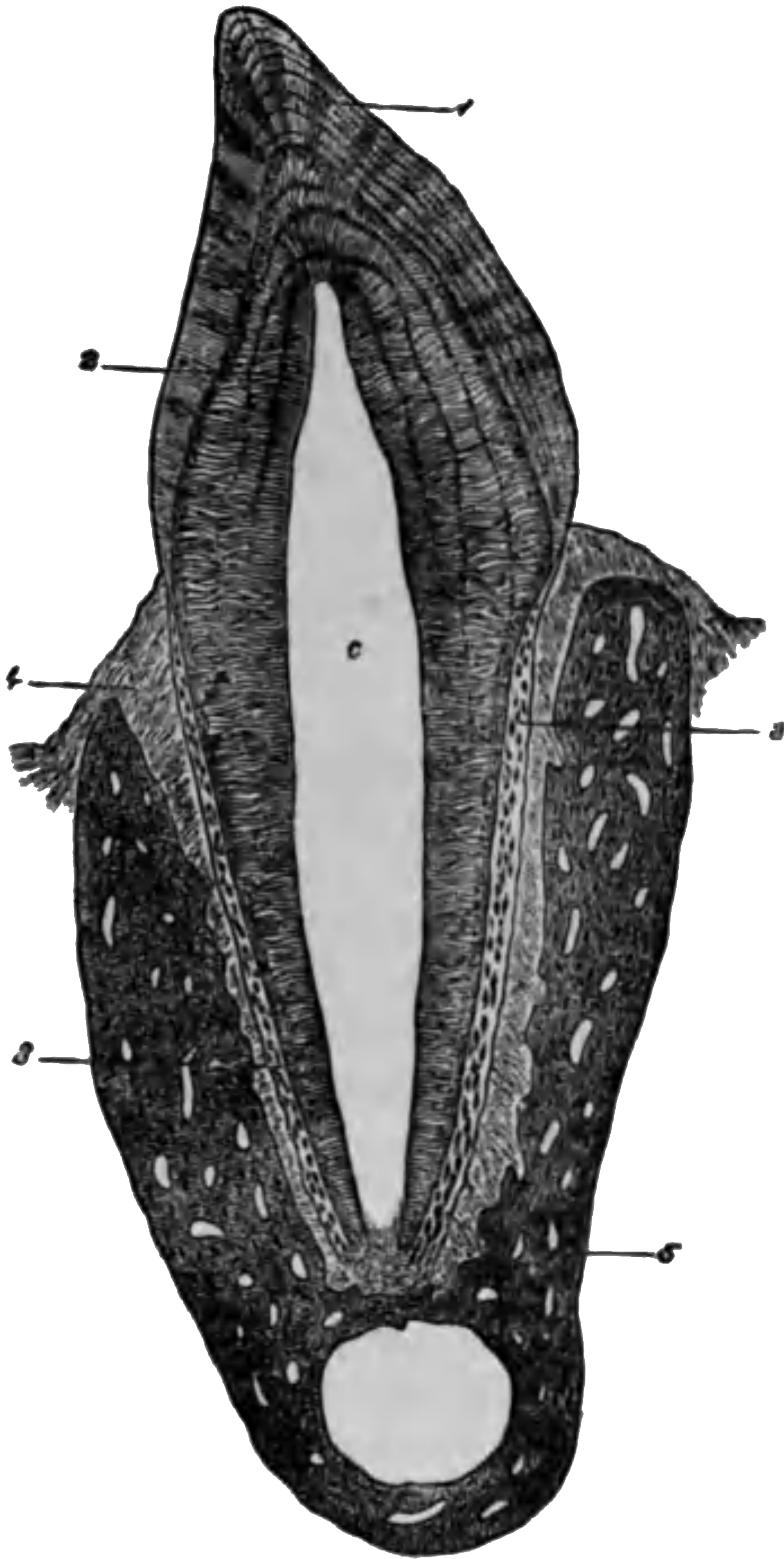

FIG. 24.—Section through a premolar tooth of the cat still imbedded in its socket. 1, enamel; 2, dentine; 3, cement; 4, the gum; 5, the bone of the lower jaw; c, the pulp cavity.

rials as bone but is somewhat harder, earthy matters constituting 72 per cent of it as against 66 per cent in bone. Under the microscope it is recognized by the fine *dentinal*



**DIESE SEITE IST FÜR KOSTENLOSE MITGLIEDER GESPERRT**  
Beantragen Sie jetzt die volle Mitgliedschaft, um diese Seite zu betreten

# GESCHICHTE

Zehntausende von wichtigen historischen Quellen, viele bisher nicht erhältlich, stehen jetzt zum ersten Mal mit der Vollmitgliedschaft von Forgotten Books zur Verfügung.

Unbegrenzter Zugang  
\$8.99/monat

**Fortfahren**

\*Es gelten Richtlinien zur fairen Nutzung.



the tongue. They are easily recognized on the living tongue by their bright red color. The *filiform papillæ*, most numerous and smallest, are scattered all over the dor-

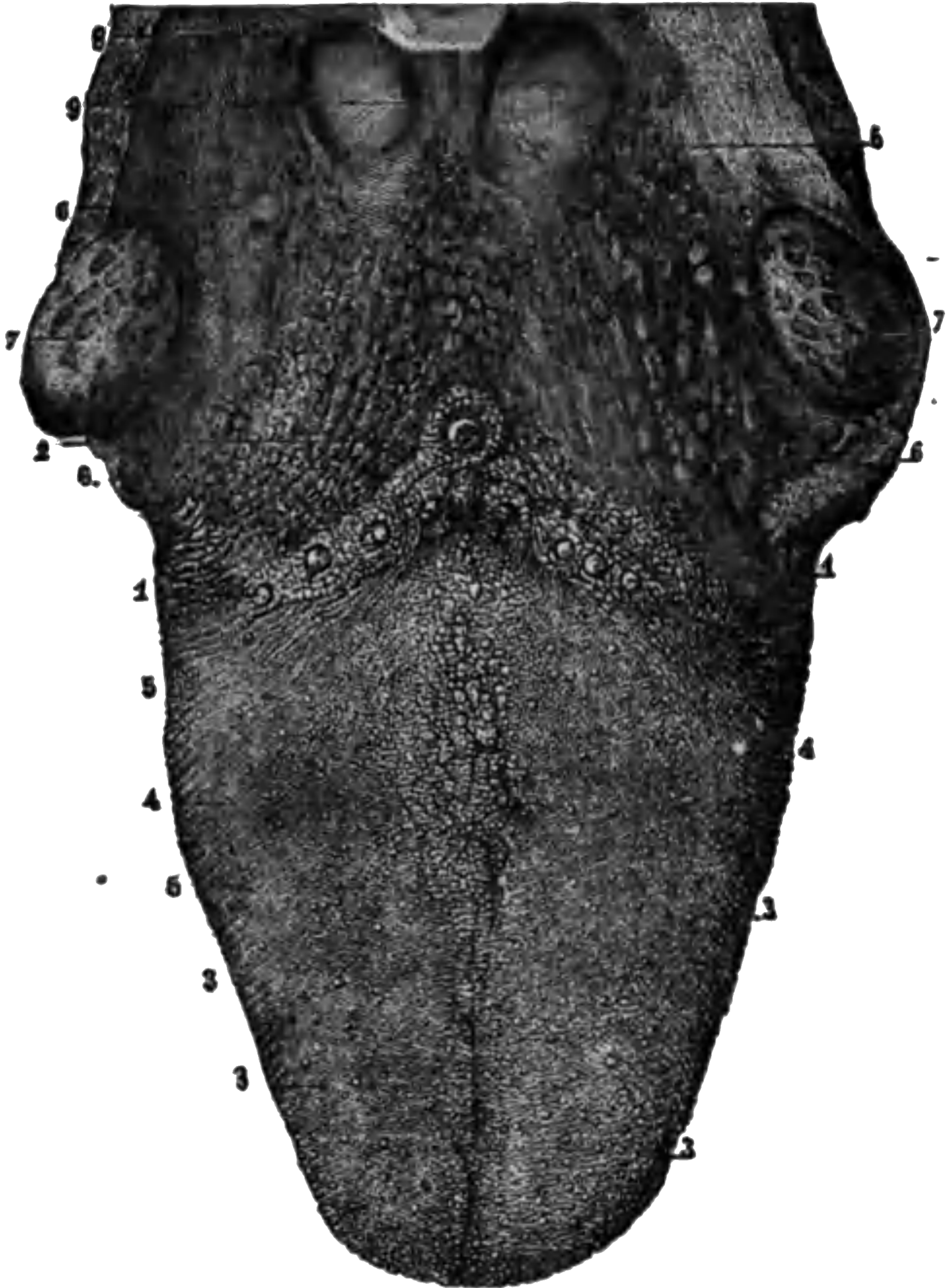

FIG. 35.—The upper surface of the tongue. 1, 2, circumvallate papillæ; 3, fungiform papillæ; 4, filiform papillæ; 5, mucous glands; 6, tonsils; 7, part of epiglottis.

sum of the tongue except near its base. Each is a conical eminence covered by a thick horny layer of epithelium. It is these papillæ which are so highly developed on the tongues of *Carnivora*, and serve them to scrape bones clean

of even such tough structures as ligaments. Tamed tigers have been known to draw blood by licking the hand of their master.

*Note.* In health the surface of the tongue is moist, covered by little "fur," and in childhood of a red color. In adult life the natural color of the tongue is less red, except around the edges and tip; a bright red glistening tongue being, then, usually a symptom of disease. When the digestive organs are deranged the tongue is commonly covered with a thick yellowish coat, composed of a little mucus, a few cells of epithelium shed from the surface, and numerous microscopic organisms known as bacteria; and there is frequently a "bad taste" in the mouth. The whole alimentary mucous membrane is in close physiological relationship; and anything disordering the stomach is likely to produce a "furred tongue."

**The Salivary Glands.** The saliva, which is poured into the mouth and which, mixed with the secretion of minute glands imbedded in its lining membrane, moistens it, is secreted by three pairs of glands, the *parotid*, the *submaxillary* and the *sublingual*. The parotid glands lie in front of the ear behind the ramus of the lower jaw; each sends its secretion into the mouth by a tube known as *Stenon's duct*, which crosses the cheek and opens opposite the second upper molar tooth. In the disease known as *mumps* the parotid glands are inflamed and enlarged. The submaxillary glands lie between the halves of the lower jaw-bone, near its angles, and their ducts open beneath the tongue near the middle line. The sublingual glands lie beneath the floor of the mouth, covered by its mucous membrane, between the back part of the tongue and the lower jaw-bone. Each has many ducts (8 to 20), some of which join the submaxillary duct, while the rest open separately in the floor of the mouth.

**The Fauces** is the name given to the aperture which can be seen at the back of the mouth (Fig. 89), leading from it into the pharynx below the soft palate. It is bounded above by the soft palate and uvula, below by the root of the tongue, and on the sides by muscular elevations, covered by



mucous membrane, which reach from the soft palate to the tongue. These elevations are the *pillars of the fauces*. Each bifurcates below, and in the hollow between its divisions lies a *tonsil* (7, Fig 95), a soft rounded body about the size of an almond, and containing numerous minute glands which form mucus.

*Note.* The tonsils not unfrequently become enlarged during a cold or sore throat, and then pressing on the Eustachian tube (Chap. XXXIII.), which leads from the pharynx to the middle ear, keep it closed and produce temporary deafness. Sometimes the enlargement is permanent and causes much annoyance. The tonsils can, however, be readily removed without danger, and this is the treatment usually adopted in such cases.

**The Pharynx or Throat Cavity** (Fig. 89). This portion of the alimentary canal may be described as a conical bag with its broad end turned upwards towards the base of the skull, and its narrow end downwards and passing into the gullet. Its front is imperfect, presenting apertures which lead into the nose, the mouth, and (through the larynx and windpipe) into the lungs. Except when food is being swallowed the soft palate hangs down between the mouth and pharynx; during deglutition it is raised into a horizontal position and separates an upper or *respiratory portion* of the pharynx from the rest. Through this upper part, therefore, air alone passes, entering it from the posterior ends of the two nostril chambers; while through the lower portion both food and air pass, one on its way to the gullet, *b*, Fig. 89, the other through the larynx, *d*, to the windpipe, *c*; when a morsel of food "goes the wrong way" it takes the latter course. Opening into the upper portion of the pharynx on each side is an Eustachian tube. *g*: so that the apertures leading out of it are seven in number; the two posterior nares, the two Eustachian tubes, the fauces, the opening of the larynx, and that of the gullet. At the root of the tongue, over the opening of the larynx, is a plate of cartilage, the *epiglottis*, *e*, which can be seen if the mouth is widely opened and the back of the tongue pressed down by some such thing as the handle of



**DIESE SEITE IST FÜR KOSTENLOSE MITGLIEDER GESPERRT**  
Beantragen Sie jetzt die volle Mitgliedschaft, um diese Seite zu betreten



**Seien Sie niemals ohne ein Buch!**

Die Vollmitgliedschaft von Forgotten Books bietet Ihnen einen universalen Zugang von unseren Apps und unserer Website, auf all Ihren Geräten: Tablet, Telefon, E-Reader, Laptop und Computer.

**Eine Bibliothek in Ihrer Tasche für € 8.99/monat**

**Fortfahren**

\*Es gelten Richtlinien zur fairen Nutzung.

apron. After middle life much fat frequently accumulates in the omentum, so that it is largely responsible for the "fair round belly with good capon lin'd." The protrusion *b* to the left side of the cardiac orifice, Fig. 96, is the *fundus* or *great cul de sac*. The size of the stomach varies greatly with the amount of food in it; just after a moderate meal it is about ten inches long, by five wide at its broadest part.

**Structure of the Stomach.** This organ has four coats, known successively from without in as the serous, the muscular, the submucous, and the mucous. The *serous coat* is formed by a reflexion of the peritoneum, a double fold of which slings the stomach; after separating to envelop it the two layers again unite and, hanging down beyond it, form the great omentum. The *muscular coat* (Fig. 54\*) consists of unstriated muscular tissue arranged in three layers: an outer, longitudinal, most developed about the curvatures; a circular, evenly spread over the whole organ, except around the pyloric orifice where it forms a thick ring; and an inner, oblique and very incomplete, radiating from the cardiac orifice. The *submucous coat* is made up of lax areolar tissue and binds loosely the mucous coat to the muscular. The *mucous coat* is a moist pink membrane which is inelastic, and large enough to line the stomach evenly when it is fully distended. Accordingly, when the organ is empty and shrunk, this coat is thrown into folds. During digestion the arteries supplying the stomach become dilated and, its capillaries being gorged, its mucous membrane is then much redder than when the organ is empty.

The blood-vessels of the stomach run to it between the folds of *peritoneum* which sling it. After giving off a few branches to the outer layers, most of the arteries break up into small branches in the submucous coat, from which twigs proceed to supply the close capillary network of the mucous membrane. The *pneumogastric nerves* (p. 171) end in the stomach, and it also gets branches from the sympathetic system.

**Histology of the Gastric Mucous Membrane.** Examination of the inner surface of the stomach with a hand

lens shows it to be covered with minute shallow pits. Into these open the mouths of minute tubes, the *gastric glands*, which are closely packed side by side in the mucous membrane; there being between them only a small amount of connective tissue, a close network of lymph-channels, and capillary blood-vessels. The whole surface of the mucous membrane is lined by a single layer of columnar epithelium cells (Fig. 97). These dip down and line the tubular glands, being in some (especially those about the pyloric end of the stomach) but little modified in appearance (*c*, Fig. 97). In others the epithelial cells become shorter and cuboidal, and have beneath them (*a* and *b*, Fig. 97) a second incomplete layer of much larger oval cells, *d*. The glands of this second kind are the most numerous, and have been called *peptic glands* from the idea that they alone formed *pepsin*, the essential digestive ingredient of the gastric juice; this is however by no means certain.

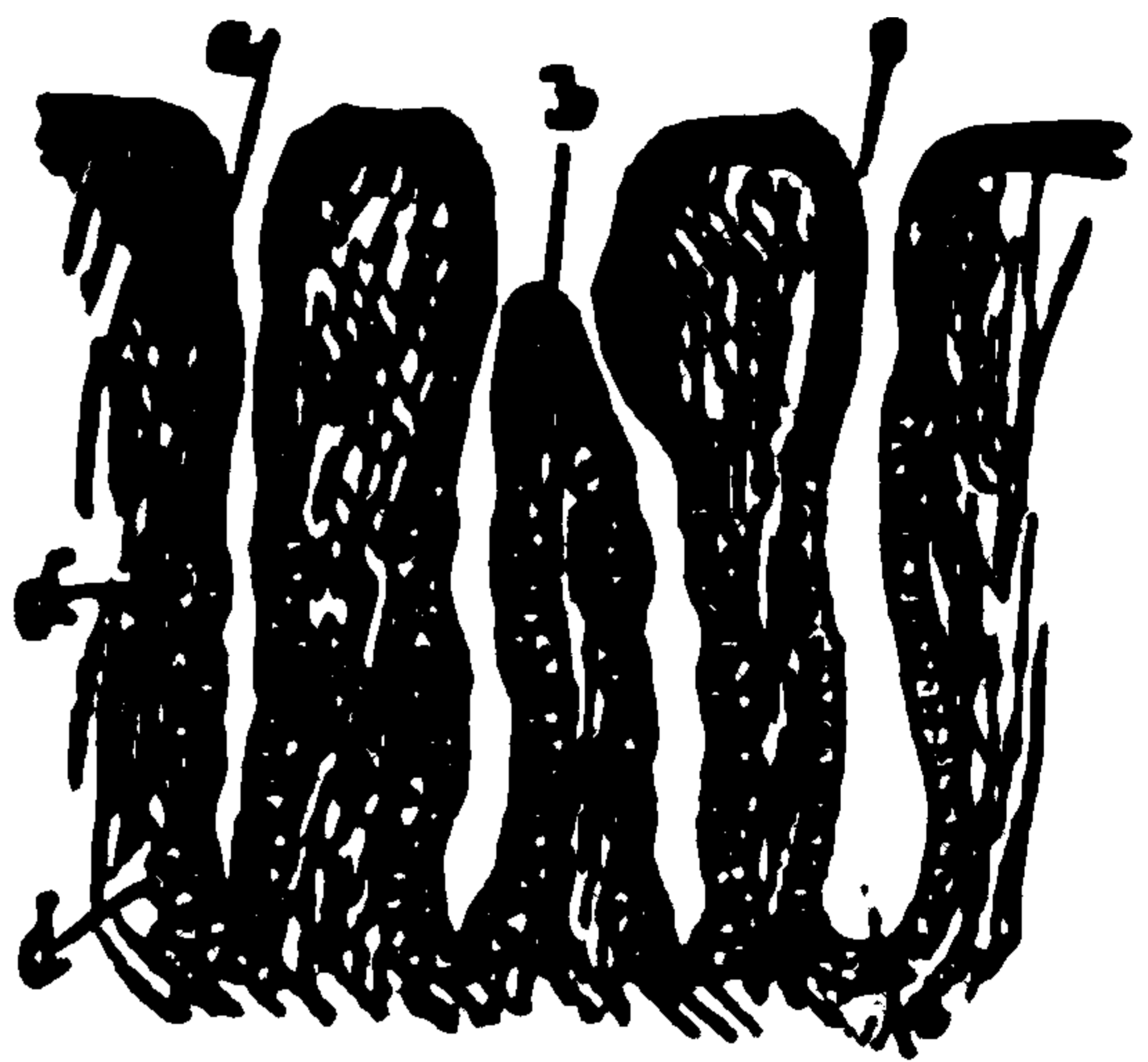

FIG. 97.—A thin section through the gastric mucous membrane, perpendicular to its surface, magnified about 35 diameters. *a*, a simple peptic gland; *b*, a compound peptic gland; *c*, a mucous gland; *d*, oval, chief, or so-called peptic cells.

The peptic glands frequently branch at their deeper ends.

**The Pylorus.** If the stomach be opened it is seen that the mucous membrane projects in a fold around the pyloric orifice and narrows it. This is due to a thick ring of the circular muscular layer there developed, and forming a *sphincter muscle* around the orifice, which in life, by its contraction, keeps the passage to the small intestines closed except when portions of food are to be passed on from the stomach to succeeding divisions of the alimentary canal.

*Note.* The cardiac end of the stomach lying immediately beneath the diaphragm, which has the heart on its upper side, over-distension of the stomach, due to indigestion or flatulence, may impede the action of the thoracic organs, and

cause feelings of oppression in the chest, or palpitation of the heart.

**The Small Intestine**, commencing at the pylorus, ends, after many windings, in the large. It is about six meters (twenty feet) long, and about five centimeters (two inches) wide at its gastric end, narrowing to about two thirds of that width at its lower portion. Externally there are no lines of subdivision on the small intestine, but anatomists arbitrarily describe it as consisting of three parts; the first twelve inches being the *duodenum*, the succeeding two fifths of the remainder the *jejunum*, and the rest the *ileum*.

Like the stomach, the small intestine possesses four coats: a serous, a muscular, a submucous, and a mucous. The *serous coat* is formed by a duplicature of the peritoneum, but presents nothing answering to the great omentum; this double fold, slinging the intestine as the small omentum slings the stomach, is called the *mesentery*. The *muscular coat* is composed of plain muscular tissue arranged in two strata, an outer longitudinal, and an inner transverse or circular. The *submucous coat* is like that of the stomach; consisting of loose areolar tissue, binding together the mucous and muscular coats, and forming a bed in which the blood and lymphatic vessels (which reach the intestine in the fold of the mesentery) break up into minute branches before entering the mucous membrane.

**The Mucous Coat of the Small Intestine.** This is pink, soft, and extremely vascular. It does not present temporary or effaceable folds like those of the stomach, but is throughout a great portion of its length, raised up into permanent transverse folds in the form of crescentic ridges, each of which runs transversely for a greater or less way round the tube (Fig. 98). These folds are the *valvule conniventes*. They are first found about two inches from the pylorus, and are most thickly set and largest in the upper half of the jejunum, in the lower half of which they become gradually less conspicuous; and they finally disappear altogether about the middle of the ileum. The folds serve greatly to increase the surface of the mucous membrane both for absorption and secretion, and they also de-



**DIESE SEITE IST FÜR KOSTENLOSE MITGLIEDER GESPERRT**  
Beantragen Sie jetzt die volle Mitgliedschaft, um diese Seite zu betreten

# GESCHICHTE

Zehntausende von wichtigen historischen Quellen, viele bisher nicht erhältlich, stehen jetzt zum ersten Mal mit der Vollmitgliedschaft von Forgotten Books zur Verfügung.

Unbegrenzter Zugang  
\$8.99/monat

**Fortfahren**

\*Es gelten Richtlinien zur fairen Nutzung.



outside the lacteals and beneath the muscular layer, is a close network of blood-vessels.

Opening on the surface of the small intestine, between the bases of the villi, are small glands, the *crypts of Lieberkühn*. Each is a simple unbranched tube lined by a layer of columnar cells similar to that which covers the villi and the surface of the mucous membrane between them. In

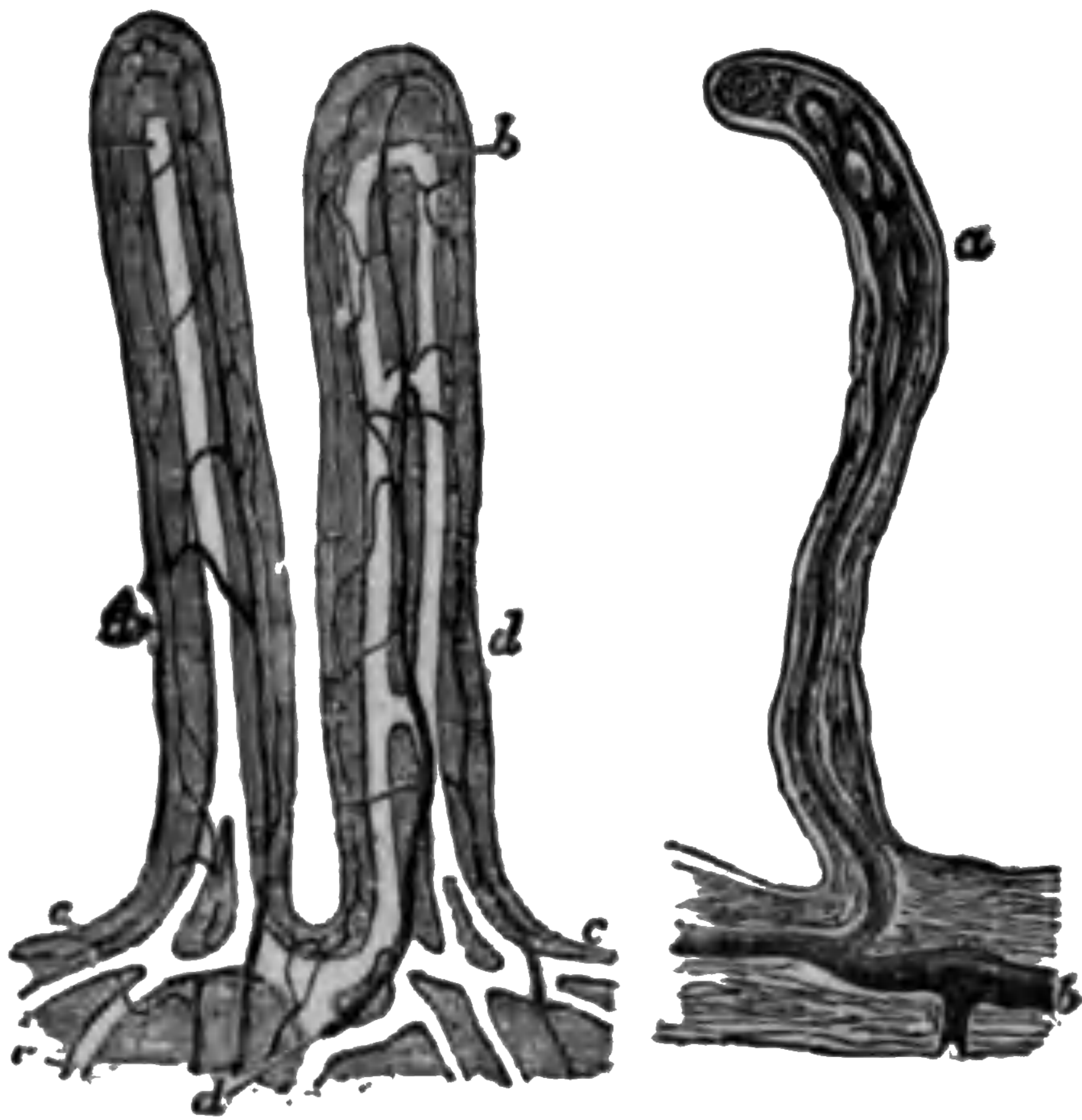

FIG. 99.—Villi of the small intestine; magnified about 80 diameters. In the left-hand figure the lacteals, *a*, *b*, *c*, are filled with white injection; *d*, blood-vessels. In the right-hand figure the lacteals alone are represented, filled with a dark injection. The epithelium covering the villi, and their muscular fibres, are omitted.

structure they greatly resemble the mucous glands of the stomach (*c*, Fig. 97). In the duodenum are found other minute glands, the *glands of Brunner*. They lie in the submucous coat and send their ducts through the mucous membrane to open on its inner side.

The **Large Intestine**, forming the final portion of the alimentary canal, is about 1.5 meters (5 feet) long, and varies in diameter from about 6 to 4 centimeters ( $2\frac{1}{2}$  to  $1\frac{1}{2}$  inches). Anatomists describe it as consisting of the *cæcum* with the *vermiform appendix*, the *colon*, and the *rectum*. The small intestine does not open into the commencement of the large but into its side, some distance from its closed

upper end, and the cæcum is that part of the large intestine which extends beyond the communication. From it projects the *vermiform appendix*, a narrow tube not thicker than a cedar pencil, and about 10 centimeters (4 inches) long. The colon commences on the right side of the abdominal cavity where the small intestine communicates with the large, runs up for some way on that side (*ascending colon*), then crosses the middle line (*transverse colon*) below the stomach, and turns down (*descending colon*) on the left side and there makes an S-shaped bend known as the *sigmoid flexure*; from this the *rectum*, the terminal straight portion of the intestine, proceeds to the anal opening, by which the alimentary canal communicates with the exterior. In structure the large intestine presents the same coats as the small. The external stratum of the muscular coat is not, however, developed uniformly around it, except on the rectum, but occurs in three bands separated by intervals in which it is wanting. These bands being shorter than the rest of the tube cause it to be puckered, or sacculated, between them. The mucous coat possesses no villi or *valvulae conniventes*, but is usually thrown into effaceable folds, like those of the stomach but smaller. It contains numerous closely set glands much like the crypts of Lieberkühn of the small intestine.

**The Ileo-Colic Valve.** Where the small intestine joins the large there is a valve, formed by two flaps of the mucous membrane sloping down into the colon, and so disposed as to allow matters to pass readily from the ileum into the large intestine but not the other way.

**The Liver.** Besides the secretions formed by the glands imbedded in its walls, the small intestine receives those of two other large glands, the *liver* and *pancreas*, which lie in the abdominal cavity. The ducts of both open by a common aperture into the duodenum about 10 centimeters (4 inches) from the pylorus.

The *liver* is the largest gland in the Body, weighing from 1400 to 1700 grams (50 to 64 ounces). It is situated in the upper part of the abdominal cavity (*la, la'*, Fig. 1), rather more on the right than on the left side and immediately below



the diaphragm, into the concavity of which its upper surface fits; it reaches across the middle line above the pyloric end of the stomach. It is of dark reddish-brown color, and of a soft friable texture. A deep fissure incomplet 1 divides the organ into *right* and *left lobes*, of which the right is much the larger; on its under surface (Fig. 100) shallower grooves mark off several minor lobes. Its upper surface is smooth and convex. The vessels carrying blood to the liver are the *portal vein*, *Vp*, and the *hepatic artery*; both enter it at a fissure (*the portal fissure*) on its under side, and there also a duct passes out from each half of the organ.

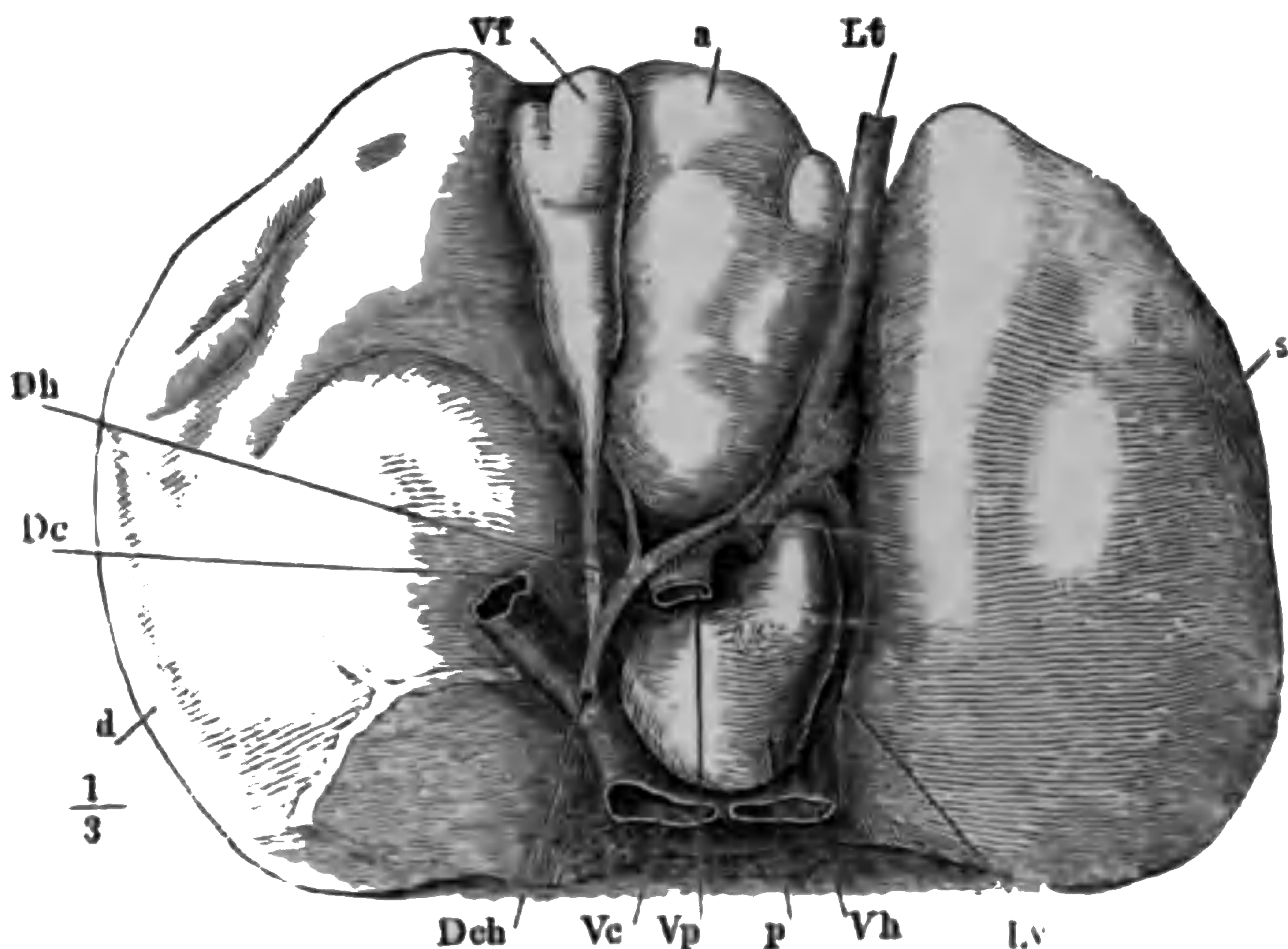

FIG. 100.—The under surface of the liver. *d*, right, and *s*, left lobe; *Vt*, hepatic vein; *Vp*, portal vein; *Vc*, vena cava inferior; *Dch*, common bile-duct; *Dc* cystic duct; *Dh*, hepatic duct; *Vf*, gall-bladder.

The ducts unite to form the *hepatic duct*, *Dh*, which meets at an acute angle, the *cystic duct*, *Dc*, proceeding from the gall-bladder, *Vf*, a pear-shaped sac in which the bile, or gall, formed by the liver, accumulates when food is not being digested in the intestine. The *common bile-duct*, *Dch*, formed by the union of the hepatic and cystic ducts, opens into the duodenum. The blood which enters the liver by the portal vein and hepatic artery passes out by the *hepatic veins*, *Vh*, which leave the posterior border of the organ



**DIESE SEITE IST FÜR KOSTENLOSE MITGLIEDER GESPERRT**  
Beantragen Sie jetzt die volle Mitgliedschaft, um diese Seite zu betreten



**Seien Sie niemals ohne ein Buch!**

Die Vollmitgliedschaft von Forgotten Books bietet Ihnen einen universalen Zugang von unseren Apps und unserer Website, auf all Ihren Geräten: Tablet, Telefon, E-Reader, Laptop und Computer.

**Eine Bibliothek in Ihrer Tasche für € 8.99/monat**

**Fortfahren**

\*Es gelten Richtlinien zur fairen Nutzung.

ries run. Covering the surface of the liver is a layer of the peritoneum, beneath which is a dense connective-tissue layer, forming the *capsule of Glisson*. At the portal fissure offsets from this capsule run in, and line canals, *the portal canals*, which are tunneled through the organs. These, becoming smaller and smaller as they branch, finally become indistinguishable close to the ultimate lobules. From their walls and from the external capsule, connective-tissue partitions radiate in all directions through the organ and support its other parts. In each portal canal lie three vessels—a branch of the portal vein, a branch of the hepatic

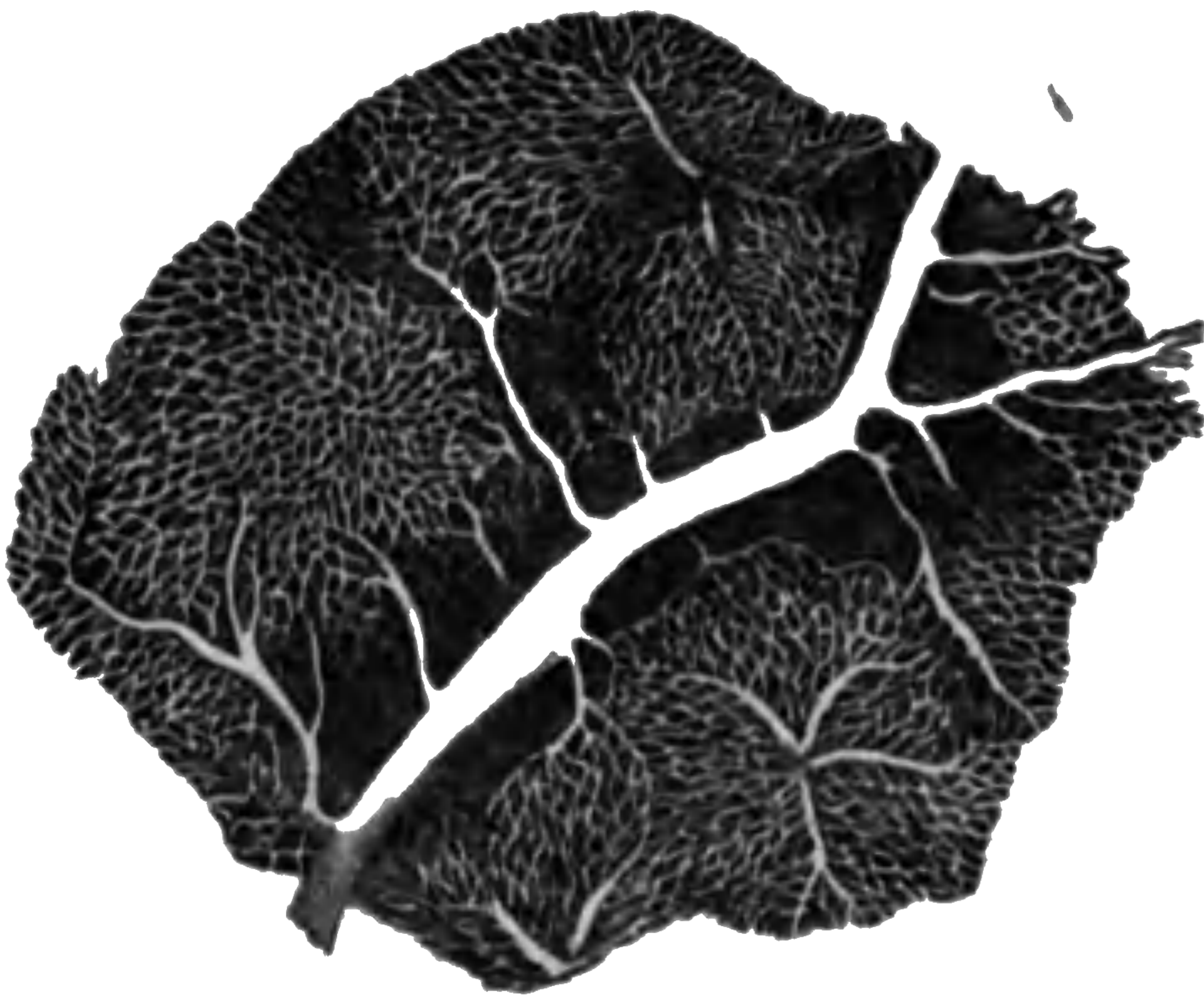

FIG. 103.—A small portion of the liver, injected, and magnified about twenty diameters. The blood-vessels are represented white; the large vessel is a sublobular vein, receiving the intralobular veins, which in turn are derived from the capillaries of the lobules.

artery, and a branch of the hepatic duct; the division of the portal vein being much the largest of the three. These vessels break up as the portal canals do, and all end in minute branches around the lobules. The blood carried in by the portal vein (which has already circulated through the capillaries of the stomach, spleen, intestines and pancreas) is thus conveyed to a fine vascular *interlobular plexus* around the liver lobules, from which it flows on through the capillaries (*lobular plexus*) of the lobules themselves. These (Fig. 101) unite in the centre of the lobule

to form a small *intra-lobular vein*, which carries the blood out and pours it into one of the branches of origin of the

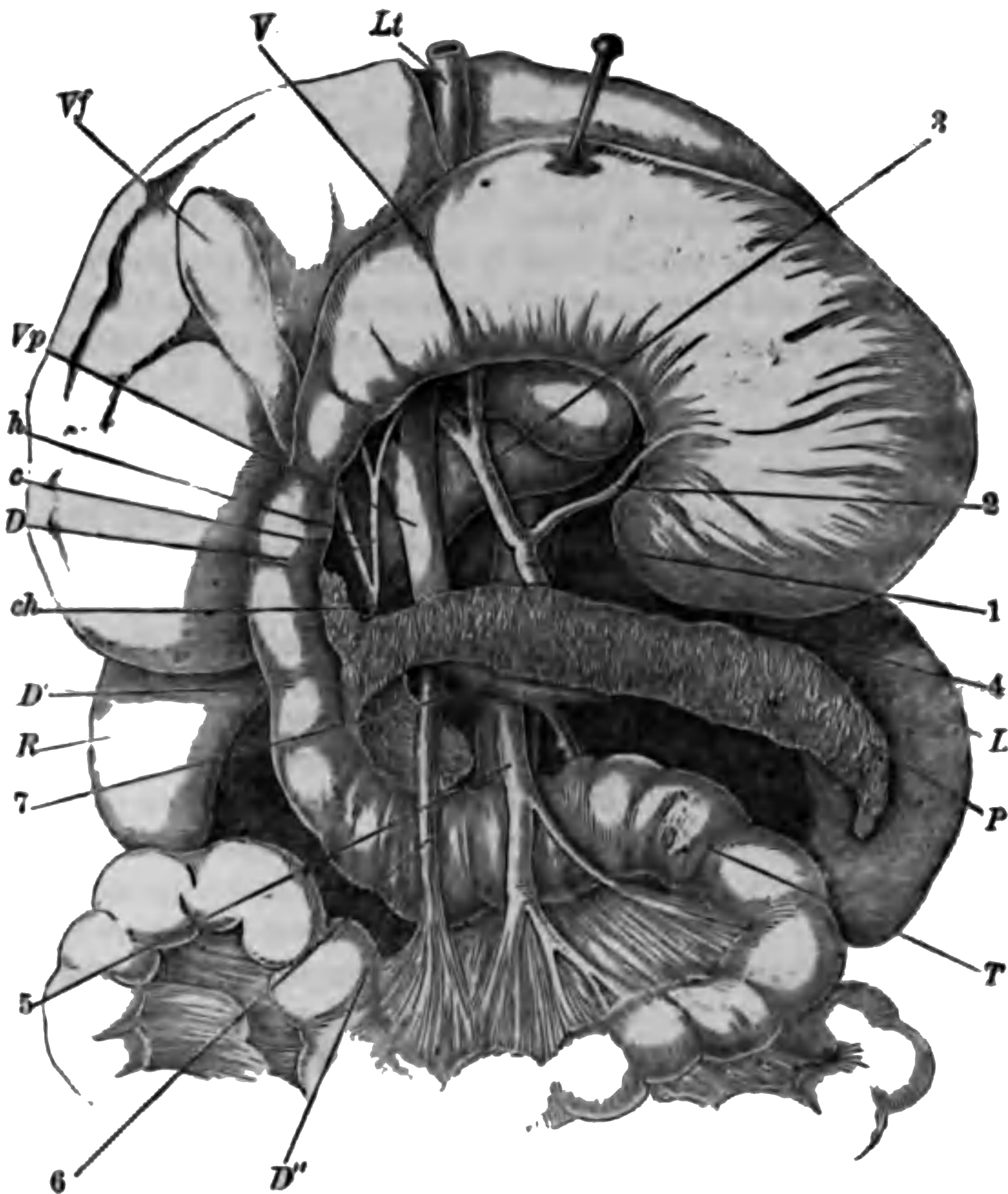

FIG. 103.—The stomach, pancreas, liver, and duodenum, with part of the rest of the small intestine and the mesentery; the stomach and liver have been turned up so as to expose the pancreas. V, stomach; D, D', D'', duodenum; L, spleen; P, pancreas; R, right kidney; T, jejunum; Vj, gall-bladder; h, hepatic duct; c, cystic duct; ch, common bile-duct; 1, aorta; 2, an artery (left coronary) of the stomach; 3, hepatic artery; 4, splenic artery; 5, superior mesenteric artery; 6, superior mesenteric vein; 7, splenic vein; Vp, portal vein.

hepatic vein, called the *sublobular vein*. Each of the latter has many lobules emptying blood into it, and if dissected out

with them (Fig. 102) would look something like a branch of a tree with apples attached to it by short stalks, represented by the intralobular veins. The blood is finally carried, as above pointed out, by the hepatic veins into the inferior vena cava. The hepatic artery, a branch of the cœliac axis (p. 211), ends mainly in Glisson's capsule and the walls of the blood-vessels and bile-ducts, but some of its blood reaches the lobular plexuses; it all finally leaves the liver by the hepatic veins.

The bile-ducts can be readily traced to the periphery of the lobules, and there probably communicate with a minute network of commencing bile-ducts ramifying in the lobule between the hepatic cells composing it.

**The Pancreas or Sweetbread.** This is an elongated soft organ of a pinkish yellow color, lying along the great curvature of the stomach. Its right end is larger, and is embraced by the duodenum (Fig. 103), which there makes a curve to the left. A duct traverses the gland and joins the common bile-duct close to its intestinal opening. The pancreas forms a watery-looking secretion which is of great importance in digestion.



**DIESE SEITE IST FÜR KOSTENLOSE MITGLIEDER GESPERRT**  
Beantragen Sie jetzt die volle Mitgliedschaft, um diese Seite zu betreten

# GESCHICHTE

Zehntausende von wichtigen historischen Quellen, viele bisher nicht erhältlich, stehen jetzt zum ersten Mal mit der Vollmitgliedschaft von Forgotten Books zur Verfügung.

Unbegrenzter Zugang  
\$8.99/monat

**Fortfahren**

\*Es gelten Richtlinien zur fairen Nutzung.



subclavian. The trunk on the right side is much smaller than the other and is known as the "*right lymphatic duct.*" It collects lymph from the right side of the thorax, from the right side of the head and neck, and the right arm. The lymph from all the rest of the Body is collected into the *thoracic duct.* It commences at the upper part of the abdominal cavity in a dilated reservoir (the *receptaculum chyli*), into which the lacteals from the intestines, and the lymphatics of the rest of the lower part of the Body, open. From thence the thoracic duct, receiving tributaries on its course, runs up the thorax alongside of the aorta and, passing on into the neck, ends on the left side at the point already indicated; receiving on its way the main stems from the left arm and the left side of the head and neck. The thoracic duct, thus, brings back much more lymph than the right lymphatic duct.

**The Serous Cavities.** These are great dependencies of the lymphatic system and may be regarded as large lacunæ. Each of them (peritoneal, pleural, arachnoidal and pericardiac) is lined by a definite epithelioid layer of close-fitting, hexagonal cells. At certain points, however, openings or *stomata* occur, surrounded by a ring of smaller cells, and leading into tubes which open into subjacent lymphatic vessels. The liquid moistening these cavities is, then, really lymph.

**The Lymphatic Glands.** These are roundish masses interposed, at various points, on the course of the lymph-vessels. They are especially numerous in the mesentery, groin, and neck. In the latter position they often inflame and give rise to abscesses, especially in scrofulous persons; and still more often enlarge, harden, and become more or less tender, so as to attract attention to them. In common parlance it is then frequently said that the person's "kernels have come down," or that he has "waxing kernels." Each lymphatic gland is enveloped in a connective-tissue capsule, and is pervaded by a connective-tissue framework. In the meshes of this lie numerous lymph corpuscles, which appear to multiply there by division. "Afferent" lymphatic vessels open into the periphery of the so-called gland, and ef-

ferent vessels arise in its centre. Hence, the lymph in its flow traverses the cellular gland substance, and in its course picks up extra corpuscles which it carries on to the blood. In the gland there is a close network of blood capillaries. It is clear that these organs are not glands at all, in the proper sense of the word. They are sometimes called *lymphatic ganglia*; but that suggests a false connection with nerve-centres.

**The Movement of the Lymph.** This is no doubt somewhat irregular in the commencing vessels, but, on the whole, sets on to the larger trunks and through them to the veins. In many animals (as the frog) at points where the lymphatics communicate with the veins, there are found regularly contractile "lymph-hearts" which beat with a rhythm independent of that of the blood-heart, and pump the lymph into a vein. In the Human Body, however, there are no such hearts, and the flow of the lymph is dependent on less definite arrangements. It seems to be maintained mainly by three things. (1) The pressure on the blood plasma in the capillaries is greater than that in the great veins of the neck; hence any plasma filtered through the capillary walls will be under a pressure which will tend to make it flow to the venous termination of the thoracic or the right lymphatic duct. (2) On account of the numerous valves in the lymphatic vessels (which all only allow the lymph to flow past them to larger vessels) any movement compressing a lymph-vessel will cause an onward flow of its contents. The influence thus exerted is very important. If a tube be put in a large lymph-vessel, say at the top of the leg of an animal, it will be seen that the lymph only flows out very slowly when the animal is quiet; but as soon as it moves its leg the flow is greatly accelerated. (3) During each inspiration the pressure on the thoracic duct is less than that in the lymphatics in parts of the Body outside the thorax (see Chap. XXIV.). Accordingly, at that time, lymph is pressed, or, in common phrase, is "sucked," into the thoracic duct. During the succeeding expiration the pressure on the thoracic duct becomes greater again, and some of its contents are pressed out; but on account of the valves



they can only go forwards, that is, towards the ending of the duct in the veins of the neck.

During digestion, moreover, the contraction of the villi will press on the lymph or chyle; and in certain parts of the Body gravity, of course, aids the flow, though it will impede it in others.

**The Spleen.** There are in the Body several organs of such considerable size, and of so great constancy in a large number of vertebrate animals, that they would *a priori* appear to be of considerable functional importance. What their use may be is still, however, unknown or uncertain. They are commonly spoken of collectively, along with the lymphatic ganglia, as the *ductless glands*; but they are not glands in the proper sense of the word. The *spleen* is the largest of them. It is a red organ situated at the left end of the stomach and about 170 grams (6 oz.) in weight. Its size is however very variable; it enlarges during digestion and shrinks again after it until the next meal. In malarial diseases it also becomes enlarged, frequently to a very great extent, and then constitutes the so-called "ague-cake." In structure, the spleen consists of a connective-tissue *capsule*, rich in elastic fibres, and giving off processes which ramify through the organ and form a framework for its *pulp*. The latter contains numerous blood corpuscles; and many bodies which seem to be red corpuscles in process of decay or destruction. Hence the spleen has been supposed to be a sort of graveyard for their bodies—a place where they are broken up and their materials utilized when they have run their life cycle. Others, however, consider that in the spleen new red blood corpuscles are produced from colorless; and others, again, that the main function of the organ is the formation of substances which are carried off to the stomach and pancreas, to be there finally elaborated into digestive ferments. The arteries of the spleen open directly into the pulp cavities, from which the veins arise. On their walls are rounded whitish nodules about the size of a millet-seed, and known as the



**DIESE SEITE IST FÜR KOSTENLOSE MITGLIEDER GESPERRT**  
Beantragen Sie jetzt die volle Mitgliedschaft, um diese Seite zu betreten



**Seien Sie niemals ohne ein Buch!**

Die Vollmitgliedschaft von Forgotten Books bietet Ihnen einen universalen Zugang von unseren Apps und unserer Website, auf all Ihren Geräten: Tablet, Telefon, E-Reader, Laptop und Computer.

**Eine Bibliothek in Ihrer Tasche für € 8.99/monat**

**Fortfahren**

\*Es gelten Richtlinien zur fairen Nutzung.

# CHAPTER XI.

## DIGESTION.

**The Object of Digestion.** Of the various foodstuffs swallowed, some are already in solution and ready to dialyze at once into the lymphatics and blood-vessels of the alimentary canal; others, such as a lump of sugar, though not dissolved when put into the mouth, are readily soluble in the liquids found in the alimentary canal, and need no further digestion. In the case of many most important foodstuffs, however, special chemical changes have to be wrought, either with the object of converting insoluble bodies into soluble, or non-dialyzable into dialyzable, or both. The different secretions poured into the alimentary tube act in various ways upon different foodstuffs, and at last get them into a state in which they can pass into the circulating medium and be carried to all parts of the Body.

**The Saliva.** The first solvent that the food meets with is the saliva, which, as found in the mouth, is a mixture of pure saliva, formed in parotid, submaxillary, and sublingual glands, with the mucus secreted by small glands of the oral mucous membrane. This *mixed saliva* is a colorless, cloudy, feebly alkaline liquid, "ropy" from the mucin present in it, and usually containing air-bubbles. Pure saliva, as obtained by putting a fine tube in the duct of one of the salivary glands, is less tenacious and contains no imprisoned air.

The uses of the saliva are for the most part physical and mechanical. It keeps the mouth moist and allows us to speak with comfort; most young orators know the distress occasioned by the suppression of the salivary secretion through nervousness, and the imperfect efficacy under such

circumstances of the traditional glass of water placed beside public speakers. The saliva, also, enables us to swallow dry food; such a thing as a cracker when chewed would give rise merely to a heap of dust, impossible to swallow, were not the mouth cavity kept moist. This fact used to be taken advantage of in the East Indian rice ordeal for the detection of criminals. The guilty person, believing firmly that he cannot swallow the parched rice given him and sure of detection, is apt to have his salivary glands paralyzed by fear, and so does actually become unable to swallow the rice; while in those with clear consciences the nervous system, acting normally, excites the usual reflex secretion, and the dry food causes no difficulty of deglutition. The saliva, also, dissolves such bodies as salt and sugar, when taken into the mouth in a solid form, and enables us to taste them; undissolved substances are not tasted, a fact which any one can verify for himself by wiping his tongue dry and placing a fragment of sugar upon it. No sweetness will be felt until a little moisture has exuded and dissolved part of the sugar.

In addition to such actions the saliva, however, exerts a chemical one on an important foodstuff. Starch (although it swells up greatly in hot water) is insoluble, and could not be absorbed from the alimentary canal. The saliva contains a specific element, *ptyalin*, which has the power of turning starch into the readily soluble and dialyzable grape sugar. In effecting this change the ptyalin is not altered; at least a very small amount of it can cause the conversion of a vast amount of starch, and it does not seem to have its activity impaired in the process, being still ready at the end of it to act upon more. The starch is made to combine with the elements of a molecule of water, and the ptyalin remains behind as it was—



Substances acting in this way, producing chemical changes without being themselves noticeably altered, are found in many of the digestive secretions, and are called

pharynx, any food which has once entered it must be swallowed: the isthmus of the fauces forms a sort of Rubicon; food that has passed it must continue its course to the stomach although the swallower learnt immediately that he was taking poison. The third stage of deglutition is that in which the food is passing along the gullet, and is comparatively slow. Even liquid substances do not fall or flow down this tube, but have their passage controlled by its muscular coats, which grip the successive portions swallowed and pass them on. Hence the possibility of performing the apparently wonderful feat of drinking a glass of water while standing upon the head, often exhibited by jugglers; people forgetting that one sees the same thing done every day by horses, and other animals, which drink with the pharyngeal end of the gullet lower than the stomach. The movements of the œsophagus are of the kind known as *vermicular* or *peristaltic*. Its circular fibres (p. 317) contract behind the morsel and narrow the passage there; and the constriction then travels along to the stomach, pushing the food in front of it. Simultaneously the longitudinal fibres, at the point where the food-mass is at any moment and immediately in front of that, contracting, shorten and widen the passage.

**The Gastric Juice.** The food having entered the stomach is exposed to the action of the gastric juice, which is a thin, colorless, or pale yellow liquid, of a strongly acid reaction. It contains as specific elements *free hydrochloric acid* (about .02 per cent), and an enzyme called *pepsin* which, in acid liquids, has the power of converting the ordinary non-dialyzable proteids which we eat, into the closely allied but dialyzable bodies called *peptones*. It also dissolves solid proteids, changing them too into peptones. Dilute acids will by themselves produce the same changes in the course of several days, but in the presence of pepsin and at the temperature of the Body the conversion is far more rapid. In neutral or alkaline media the pepsin is inactive; and cold checks its activity. Boiling destroys it. In addition to pepsin, gastric juice contains another enzyme which has the power of coagulating the casein of milk, as illustrated by the use of "rennet," prepared from the mu-



**DIESE SEITE IST FÜR KOSTENLOSE MITGLIEDER GESPERRT**  
Beantragen Sie jetzt die volle Mitgliedschaft, um diese Seite zu betreten

# GESCHICHTE

Zehntausende von wichtigen historischen Quellen, viele bisher nicht erhältlich, stehen jetzt zum ersten Mal mit der Vollmitgliedschaft von Forgotten Books zur Verfügung.

Unbegrenzter Zugang  
\$8.99/monat

**Fortfahren**

\*Es gelten Richtlinien zur fairen Nutzung.



in great part gradually dialyzed into the blood and lymphatic vessels of the gastric mucous membrane, and carried off, along with other dissolved dialyzable bodies, such as salts and sugar. After the food has remained in the stomach some time (one and a half to two hours) the chyme begins to be passed on into the intestine in successive portions. The pyloric sphincter relaxes at intervals, and the rest of the stomach, contracting at the same moment, injects a quantity of chyme into the duodenum; this is repeated frequently, the larger undigested fragments being at first unable to pass the orifice. At the end of about three or four hours after a meal the stomach is again quite emptied, the pyloric sphincter finally relaxing to a greater extent and allowing any larger indigestible masses, which the gastric juice cannot break down, to be squeezed into the intestine.

**The Chyle.** When the chyme passes into the duodenum it finds preparation made for it. The pancreas is in reflex connection with the stomach, and its nerves cause it to commence secreting so soon as food enters the latter; hence a quantity of its secretion is already accumulated in the intestine when food enters. The gall-bladder is distended with bile, secreted since the last meal; this passing down the hepatic duct has been turned back up the cystic duct (*Dc*, Fig. 100\*) on account of the closure of the common bile-duct. The acid chyme, stimulating nerve-endings in the duodenal mucous membrane, causes reflex contraction of the muscular coat of the gall-bladder, and a relaxation of the orifice of the common bile-duct; and so a gush of bile is poured out on the chyme. From this time on, both liver and pancreas continue secreting actively for some hours, and pour their products into the intestine. The glands of Brunner and the crypts of Lieberkühn are also set at work, but concerning their physiology we know very little. All of these secretions are alkaline, and they suffice very soon to more than neutralize the acidity of the gastric juice, and so to convert the acid *chyme* into alkaline *chyle*, which, after an ordinary meal, will contain a great variety of things: mucus derived from the alimen-

---

\* P. 324.

tary canal; ptyalin from the saliva; pepsin from the stomach; water, partly swallowed and partly derived from the salivary and other secretions; the peculiar constituents of the bile and pancreatic juice and of the intestinal secretions; some undigested proteids; unchanged starch; oils from the fats eaten; peptones formed in the stomach but not yet absorbed; possibly salines and sugar which have also escaped absorption in the stomach; and indigestible substances taken with the food.

The Pancreatic Secretion is clear, watery, alkaline, and much like saliva in appearance. The Germans call the pancreas the "abdominal salivary gland." In digestive properties, however, the pancreatic secretion is far more important than the saliva, acting not only on starch but, also, on proteids and fats. On starch it acts like the saliva, but more energetically. It produces changes in proteids similar to those effected in the stomach, but by the agency of a different ferment, *trypsin*; which differs from pepsin in acting only in an alkaline instead of an acid medium. On fats it has a double action. To a certain extent it breaks them up, with hydration, into free fatty acids and glycerine; for example—

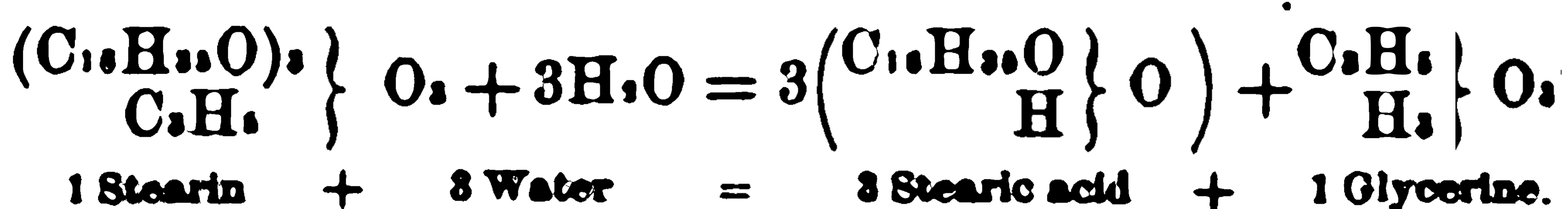

The fatty acid then combines with some of the alkali present to make a *soap*, which being soluble in water is capable of absorption. Glycerine, also, is soluble in water and dialyzable. The greater part of the fats are not, however, so broken up, but are simply mechanically separated into little droplets, which remain suspended in the chyle and give it a whitish color, just as the cream-drops are suspended in milk, or the olive-oil in mayonnaise sauce. This is effected by the help of a quantity of albumin which exists dissolved in the pancreatic secretion. In the stomach, the animal fats eaten have lost their cell-walls, and have become melted by the temperature to which they are exposed. Hence their oily part floats free in the chyme when it enters the



duodenum. If oil be shaken up with water, the two cannot be got to mix; immediately the shaking ceases the oil floats up to the top; but if some raw egg be added, a creamy mixture is readily formed, in which the oil remains for a long time evenly suspended in the watery menstruum. The reason of this is that each oil-droplet becomes surrounded by a delicate pellicle of albumen, and is thus prevented from fusing with its neighbors to make large drops, which would soon float to the top. Such a mixture is called an *emulsion*, and the albumin of the pancreatic secretion emulsifies the oils in the chyle, which becomes white (for the same reason as milk is that color) because the innumerable tiny oil-drops floating in it reflect all the light which falls on its surface.

The pancreatic secretion thus converts starch into grape sugar, dissolves proteids (if necessary) and converts them into peptones, emulsifies fats, and, to a certain extent, breaks them up into glycerine and fatty acids, which latter are saponified by the alkalies present.

**The Bile.** Human bile when quite fresh is a golden brown liquid; it becomes green when kept. As formed in the liver it contains hardly any mucin, but if it makes any stay in the gall-bladder it acquires a great deal from the lining membrane of that sac, and becomes very "ropy." It is alkaline in reaction and, besides coloring matters, mineral salts, and water, contains the sodium salts of two nitrogenized acids, *taurocholic* and *glychocholic*, the former predominating in human bile.

*Pettenkofer's Bile Test.* If a small fragment of cane sugar be added to some bile, and then a large quantity of strong sulphuric acid, a brilliant purple color is developed, by certain products of the decomposition of its acids; the physician can in this way, in disease, detect their presence in the urine or other secretions of the Body.

*Gmelin's Bile Test.* The bile-coloring matters, treated with yellow nitric acid, go through a series of oxidations, accompanied with changes of color from yellow-brown to green, then to blue, violet, purple, red, and dirty yellow, in succession.

Bile has no digestive action upon starch or proteids. It



**DIESE SEITE IST FÜR KOSTENLOSE MITGLIEDER GESPERRT**  
Beantragen Sie jetzt die volle Mitgliedschaft, um diese Seite zu betreten



**Seien Sie niemals ohne ein Buch!**

Die Vollmitgliedschaft von Forgotten Books bietet Ihnen einen universalen Zugang von unseren Apps und unserer Website, auf all Ihren Geräten: Tablet, Telefon, E-Reader, Laptop und Computer.

**Eine Bibliothek in Ihrer Tasche für € 8.99/monat**

**Fortfahren**

\*Es gelten Richtlinien zur fairen Nutzung.

bile probably has some influence in promoting the absorption of fats. If one end of a capillary glass tube, moistened with water, be dipped in oil, the latter will not ascend in it, or but a short way; but if the tube be moistened with bile, instead of water, the oil will ascend higher in it. So, too, oil passes through a plug of porous clay kept moist with bile, under a much lower pressure than through one wet with water. Hence bile, by soaking the epithelial cells lining the intestine, may facilitate the passage into the villi of oily substances. At any rate, experiment shows that if the bile be prevented from entering the intestine of a dog, the animal eats an enormous amount of food compared with that amount which it needed previously; and that of this food a great proportion of the fatty parts passes out of the alimentary canal unabsorbed. There is no doubt, therefore, that the bile somehow aids in the absorption of fats, but exactly how is uncertain. Its possible action in exciting the muscles of the villi to contract will be referred to presently. Bile precipitates from solution, not only pepsin, but any peptones contained in the chyme which enters the intestine from the stomach.

**The Intestinal Secretions or Succus Entericus.** This consists of the secretions of the glands of Brunner and the crypts of Lieberkühn. It is difficult to obtain pure; indeed the product of Brunner's glands has never been obtained unmixed. That of the crypts of Lieberkühn is watery and alkaline, and poured out more abundantly during digestion than at other times. It has no special action on starches, most proteids, or on fats; but is said to dissolve blood fibrin and convert it into peptone, and to change cane into grape sugar, a transformation the object of which is not very clear, since cane sugar is itself readily soluble and diffusible.

**Intestinal Digestion.** Having considered separately the actions of the secretions with which the food meets in the small intestine we may now consider their combined effect.

The neutralization of the chyme, followed by its conversion into alkaline chyle, will prevent any further action of the pepsin on proteids, but will allow the ptyalin of the

saliva (the activity of which was stopped by the acidity of the gastric juice) to recommence its action upon starch. Moreover, in the stomach there is produced, alongside of the true peptones, a body called parapeptone, which agrees very closely with syntonin (p. 126) in its properties, and this passes into the duodenum in the chyme. As soon as the bile meets the chyme it precipitates the parapeptone, and this carries down with it any peptones which, having escaped absorption in the stomach, may be present; it also precipitates the pepsin. In consequence, one commonly finds, during digestion, a sticky granular precipitate over the villi, and in the folds between the *valvulae conniventes* of the duodenum. This is soon redissolved by the pancreatic secretion, which also changes into peptones the proteids (usually a considerable proportion of those eaten at a meal) which have passed through the stomach unchanged, or in the form of parapeptones. The conversion of starch into grape sugar will go on rapidly under the influence of the pancreatic secretion. Fats will be split up and saponified to a certain extent, but a far larger proportion will be emulsified and give the chyle a whitish appearance. Cane sugar, which may have escaped absorption in the stomach, will be converted into grape sugar and absorbed, along with any salines which may, also, have hitherto escaped. Elastic tissue from animal substances eaten, cellulose from plants, and mucin from the secretions of the alimentary tract, will all remain unchanged.

**Absorption from the Small Intestine.** The chyme leaving the stomach is a semi-liquid mass which, being mixed in the duodenum with considerable quantities of pancreatic secretion and bile, is still further diluted. Thenceforth it gets the intestinal secretion added to it but, the absorption more than counterbalancing the addition of liquid, the food-mass becomes more and more solid as it approaches the ileo-colic valve. At the same time it becomes poorer in nutritive constituents, these being gradually removed from it in its progress; most dialyze through the epithelium into the subjacent blood and lymphatic vessels, and are carried off. Those passing into the blood capillaries are taken by

the portal vein to the liver; while those entering the lacteals are carried into the left jugular vein by the thoracic duct. As to which foodstuffs go one road and which the other, there is still much doubt; sugars probably go by the portal system, while the fats, mainly, if not entirely, go through the lacteals. How the fats are absorbed is not clear, since oils will not dialyze through membranes, such as that lining the intestine, moistened with watery liquids. Most of them, however, certainly get into the lacteals as oils and not as soluble soaps; for one finds these vessels, in a digesting animal, filled with a beautifully white milky chyle; while at other periods their contents are watery and colorless like the lymph elsewhere in the Body. The little fat-drops of the emulsion formed in the intestine, go through the epithelial cells and not between them, for during digestion one finds these cells loaded with oil-droplets. Now the free ends of these cells are striated and probably devoid of any definite cell-wall, and it is possible that the intestinal movements squeeze oil-drope into them, which the cell then passes on to its deeper end and, thence, out into the subjacent lymph-spaces, which communicate with the central lacteal of a villus. Possibly, too, these cells are amœboid and can thrust out processes from their free ends and actively pick up the oil-drope. In the villus there are all the anatomical arrangements for a mechanism which shall actively suck up substances into it. Each is more or less elastic, and, moreover, its capillary network when filled with blood will distend it. If therefore the muscular stratum (p. 321) contracts and compresses it, emptying its lacteals into the vessels lying deeper in the intestinal wall, the villus will actively expand again so soon as its muscles relax. In so doing it could not fill its lacteals from the deeper vessels, on account of the valves in the latter, and, accordingly, would tend to draw into itself materials from the intestines; much like a sponge re-expanding in water, after having been squeezed dry. The liquid thus sucked up may draw oil-drops with it, into the free ends of the cells and between them; and by repetitions of the process it is possible that considerable quantities of liquid, with suspended oil-drope,



**DIESE SEITE IST FÜR KOSTENLOSE MITGLIEDER GESPERRT**  
Beantragen Sie jetzt die volle Mitgliedschaft, um diese Seite zu betreten

# GESCHICHTE

Zehntausende von wichtigen historischen Quellen, viele bisher nicht erhältlich, stehen jetzt zum ersten Mal mit der Vollmitgliedschaft von Forgotten Books zur Verfügung.

Unbegrenzter Zugang  
\$8.99/monat

**Fortfahren**

\*Es gelten Richtlinien zur fairen Nutzung.



Table Showing the Alimentary Principles Eaten at an Ordinary Meal.

	Inorganic Foodstuffs.			Carbohydrates.			Fats.	Nitrogenous Organic Foodstuffs.		
	Water.	Salts soluble in Water.	Salts insoluble in Water.	Starch.	Sugars.	Indigestible Substances.		Proteids.	Albuminoids.	Indigestible Substances.
Bread contains . . .	Water.	Common salt and others.	Calcium phosphate, Calcium sulphate.	Starch.	Grape sugar.	Cellulose.	Small quantities of several.	Gluten, Vegetable casein.		
Butter contains . . .	Water.	Common salt and others.	.....	.....	.....	.....	Butyric and others.	Casein in small quantity.		
Cooked Beefsteak contains . . . . .	Water.	Potassium phosphate, Common salt and others.	.....	.....	Inosite, Grape sugar.	.....	Stearin, Palmitin, Margaric, Olein.	Myosin, Syntonin, others in less quantity.	Gelatin.	Elastic tissue.
Potatoes contain.	Water.	.....	.....	Starch.	.....	Cellulose.	A trace.	A very small quantity.		
Milk contains . . . . .	Water.	Common salt and others, especially phosphates.	Calcium phosphate, Iron phosphate.	.....	Milk sugar.	.....	Butyric and other fats.	Casein.		

From such a meal we may first separate the elastin, cellulose, and calcium sulphate, as indigestible and passed out of the Body in the same state and in the same quantity as they entered it. Then come the salines which need no special digestion, and, either taken in solution or dissolved in the saliva or gastric juice, are absorbed from the mouth, stomach and intestines without further change. Cane and grape sugars experience the same fate, except that any cane sugar reaching the intestines before absorption, is liable to be changed into grape sugar by the *succus entericus*. Calcium phosphate will be dissolved by the free acid in the stomach, yielding calcium chloride, which will be absorbed there or in the intestine. Starch will be partially converted into grape sugar during mastication and deglutition, and the sugar will be absorbed from the stomach. A great part of the starch will, however, be passed on into the intestine unchanged, since the action of the saliva is suspended in the stomach; and its conversion will be completed by the pancreatic secretion, and by the ptyalin of the saliva, which will recommence its activity when the chyle becomes alkaline. The various proteids will be partially dissolved in the stomach and converted into peptones, which will in part be absorbed there; the residue, with the undigested proteids, will be passed on to the intestines. There the bile will precipitate the peptones and parapeptones and, with the pancreatic secretion, render the chyme alkaline, and so stop the activity of the gastric pepsin. The pancreatic secretion will, however, redissolve the precipitated peptone, and the unchanged proteids and parapeptone, and turn the latter into peptones; these will be absorbed as they pass along the small intestine; a small quantity perhaps passing into the large intestine, to be taken up there. The fats will remain unchanged until they enter the small intestine, except that the proteid cell-walls of the fats of the beefsteak will be dissolved away. In the small intestine these bodies will be partially saponified, but most will be emulsified and taken up into the lacteals in that condition. Gelatin, from the white fibrous tissue of the beef-



steak, will undergo changes in the stomach and intestine and be dissolved and absorbed.

The substances leaving the alimentary canal after such a meal would be, primarily, the indigestible cellulose and elastin, together with some water. But there might be in addition some unabsorbed fats, starch, and salts. To this would be added, in the alimentary canal, mucin, some of the ferments of the digestive secretions, some slightly altered bile pigments, and other bodies excreted by the large intestine.

**Dyspepsia** is the common name of a number of diseased conditions attended with loss of appetite or troublesome digestion. Being usually unattended with acute pain, and if it kills at all doing so very slowly, it is pre-eminently suited for treatment by domestic quackery. In reality, however, the immediate cause of the symptoms, and the treatment called for, may vary widely; and its detection and the choice of the proper remedial agents often call for more than ordinary medical skill. A few of the more common forms of dyspepsia may be mentioned here, with their proximate causes, not in order to enable people to undertake the rash experiment of dosing themselves, but to show how wide a chance there is for any unskilled treatment to miss its end, and do more harm than good.

Appetite is primarily due to a condition of the mucous membrane of the stomach which, in health, comes on after a short fast, and stimulates its sensory nerves; and loss of appetite may be due to either of several causes. The stomach may be apathetic and lack its normal sensibility, so that the empty condition does not act, as it normally does, as a sufficient excitant. When food is taken it is a further stimulus and may be enough; in such cases "appetite comes with eating." A bitter before a meal is useful as an appetizer to patients of this sort. On the other hand, the stomach may be too sensitive, and a voracious appetite be felt before a meal, which is replaced by nausea, or even vomiting, as soon as a few mouthfuls have been swallowed; the extra stimulus of the food then over-stimulates the too irritable stomach, just as a draught of mustard and warm



**DIESE SEITE IST FÜR KOSTENLOSE MITGLIEDER GESPERRT**  
Beantragen Sie jetzt die volle Mitgliedschaft, um diese Seite zu betreten



**Seien Sie niemals ohne ein Buch!**

Die Vollmitgliedschaft von Forgotten Books bietet Ihnen einen universalen Zugang von unseren Apps und unserer Website, auf all Ihren Geräten: Tablet, Telefon, E-Reader, Laptop und Computer.

**Eine Bibliothek in Ihrer Tasche für €8.99/monat**

**Fortfahren**

\*Es gelten Richtlinien zur fairen Nutzung.

# CHAPTER XXIV.

## THE RESPIRATORY MECHANISM.

**Definitions.** The blood as it flows from the right ventricle of the heart, through the lungs, to the left auricle, loses carbon dioxide and gains oxygen. In the systemic circulation exactly the reverse changes take place, oxygen leaving the blood to supply the living tissues and carbon dioxide, generated in them, passing back into the blood capillaries. The oxygen loss and carbon dioxide gain are associated with a change in the color of the blood from bright scarlet to purple red, or from arterial to venous; and the opposite changes in the lungs restore to the dark blood its bright tint. The whole set of processes through which blood becomes venous in the systemic circulation and arterial in the pulmonary—in other words the processes concerned in the gaseous reception, distribution and elimination of the Body—constitute the function of *respiration*; so much of this as is concerned in the interchanges between the blood and air being known as *external respiration*; while the interchanges occurring in the systemic capillaries, and the processes in general by which oxygen is fixed and carbon dioxide formed by the living tissues, are known as *internal respiration*. When the term respiration is used alone, without any limiting adjective, the external respiration only, is commonly meant.

**Respiratory Organs.** The blood being kept poor in oxygen and rich in carbon dioxide by the action of the living tissues, a certain amount of gaseous interchange will nearly always take place when it comes into close proximity to the surrounding medium; whether this be the atmosphere itself or water containing air in solution. When an

animal is small there are often no special organs for its external respiration, its general surface being sufficient (especially in aquatic animals with a moist skin) to permit of all the gaseous exchange that is necessary. In the simplest creatures, indeed, there is even no blood, the cell or cells composing them taking up for themselves from their environment the oxygen which they need, and passing out into it their carbon dioxide waste; in other words, there is no differentiation of the external and internal respirations. When, however, an animal is larger many of its cells are so far from a free surface that they cannot transact this give-and-take with the surrounding medium directly, and the blood, or some liquid representing it in this respect, serves as a middleman between the living tissues and the external oxygen; and then one usually finds special *respiratory organs* developed, into which the blood is brought to replace its oxygen loss and get rid of its excess of carbon dioxide. In aquatic animals such organs take commonly the form of gills; these are protrusions of the body over which a constant current of water, containing oxygen in solution, is kept up; and in which blood capillaries form a close network immediately beneath the surface. In air-breathing animals a different arrangement is usually found. In some, as frogs, it is true, the skin is kept moist and serves as an important respiratory organ, large quantities of venous blood being sent to it for aëration. But for the occurrence of the necessary gaseous diffusion, the skin must be kept very moist, and this, in a terrestrial animal, necessitates a great amount of secretion by the cutaneous glands to compensate for evaporation; and accordingly in land animals the air is usually carried into the body by tubes with narrow external orifices, and so the drying up of the breathing surfaces is greatly diminished; just as water in a hottle with a narrow neck will disappear much more slowly than the same amount exposed in an open dish. In insects (as bees, butterflies, and beetles) the air is carried by tubes which split up into extremely fine branches and ramify all through the body, even down to the individual tissue elements, which thus carry on their gaseous exchanges

without the intervention of the blood. But in the great majority of air-breathing animals the arrangement is different; the air-tubes leading from the exterior of the body do not subdivide into branches which ramify all through it, but open into one or more large sacs to which the venous blood is brought, and in whose walls it flows through a close capillary network. Such respiratory sacs are called *lungs*, and it is a highly developed form of them which is employed in the Human Body.

**The Air-Passages and Lungs.** In our own Bodies some small amount of respiration is carried on in the alimentary

canal, the air swallowed with food or saliva undergoing gaseous exchanges with the blood in the gastric and intestinal mucous membranes. The amount of oxygen thus obtained by the blood is however very trivial, as

is that absorbed through the skin, covered as it is by its dry horny non-vascular epidermis. All the really essential gaseous interchanges between the Body and the atmosphere take place in the lungs, two large sacs (*lu*,

Fig. 1) lying in the thoracic cavity, one on each side of the heart. To these sacs the air is conveyed through a series of passages. Entering the pharynx through the nostrils or mouth, it passes out of this by the opening leading into the larynx, or

voice-box (*a*, Fig. 104), lying in the upper part of the neck (the communication of the two is seen in Fig. 89); from the larynx passes back the *trachea* or windpipe, *b*, which, after entering the chest cavity, divides into the *right* and *left bronchi*, *d*. Each bronchus divides up into smaller and smaller branches, called *bron-*

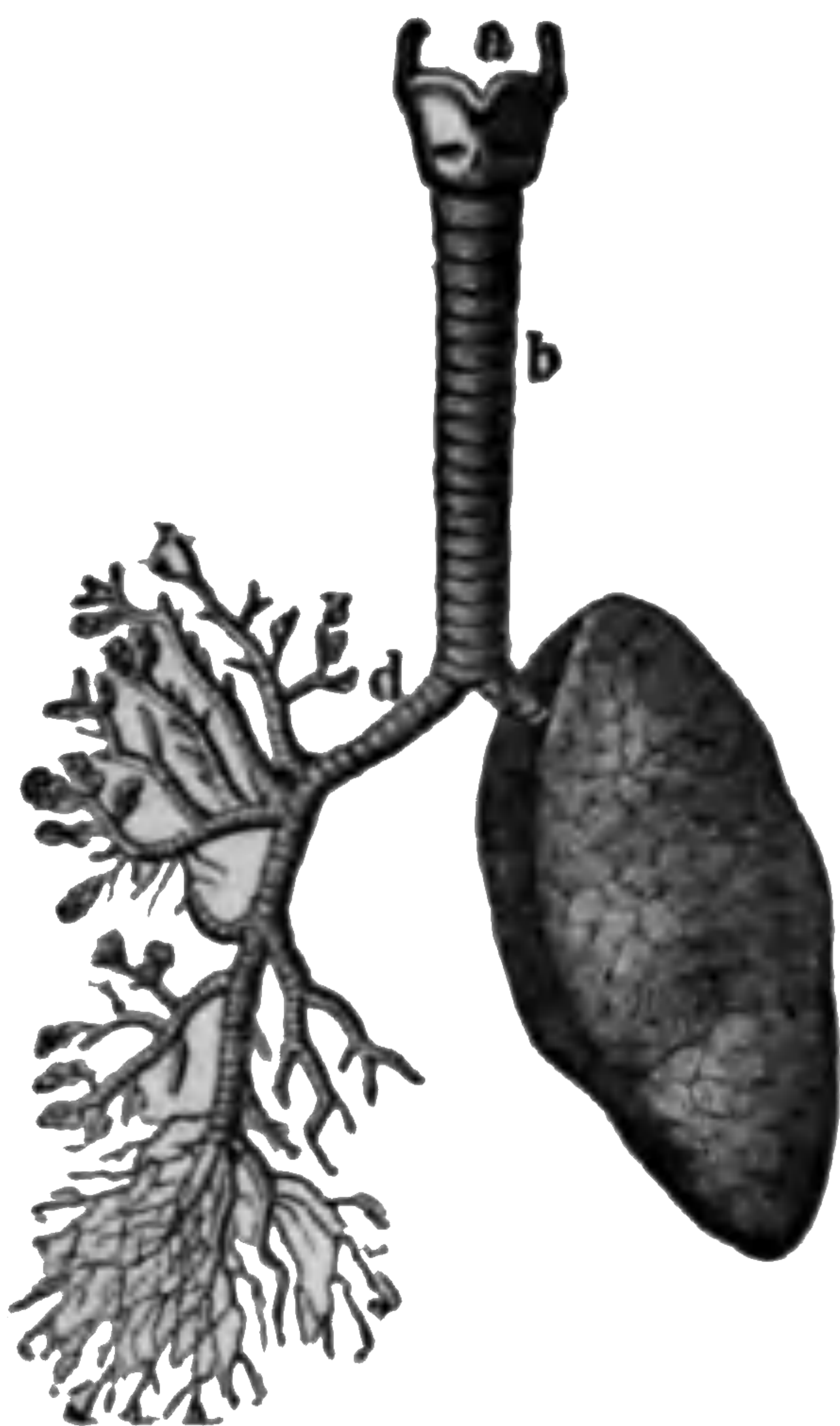

FIG. 104.—The lungs and air-passages seen from the front. On the left of the figure the pulmonary tissue has been dissected away to show the ramifications of the bronchial tubes. *a*, larynx; *b*, trachea; *d*, right bronchus. The left bronchus is seen entering the root of its lung.

chus divides up into smaller and smaller branches, called *bron-*



**DIESE SEITE IST FÜR KOSTENLOSE MITGLIEDER GESPERRT**  
Beantragen Sie jetzt die volle Mitgliedschaft, um diese Seite zu betreten

# GESCHICHTE

Zehntausende von wichtigen historischen Quellen, viele bisher nicht erhältlich, stehen jetzt zum ersten Mal mit der Vollmitgliedschaft von Forgotten Books zur Verfügung.

Unbegrenzter Zugang  
\$8.99/monat

**Fortfahren**

\*Es gelten Richtlinien zur fairen Nutzung.



ated, are much shorter than the columnar superficial cell layer of the larger tubes. The terminal alveoli (*a, a*, Fig. 106,) and the air-cells, *b*, which open into them, have walls composed mainly of elastic tissue and lined by a single



FIG. 106.—Two alveoli of the lung highly magnified. *b, b*, the air-cells, or hollow protrusions of the alveolus, opening into its central cavity; *c*, terminal branches of a bronchial tube.

layer of flat, non-ciliated epithelium, immediately beneath which is a very close network of capillary blood-vessels. The air entering by the bronchial tube is thus only separated from the blood by the thin capillary wall and the thin epithelium, both of which are moist, and well adapted to permit gaseous diffusion.

**The Pleura.** Each lung is covered, except at one point, by an elastic serous membrane which adheres tightly to it and is called the *pleura*; that point at which

the pleura is wanting is called the *root* of the lung and is on its inner side; it is there that its bronchus, blood-vessels and nerves enter it. At the root of the lung the pleura turns back and lines the inside of the chest cavity, as represented by the dotted line in the diagram Fig. 1. The part of the pleura attached to each lung is its *visceral*, and that attached to the chest-wall its *parietal layer*. Each pleura thus forms a closed sac surrounding a *pleural cavity*, in which, during health, there are found a few drops of lymph, keeping its surfaces moist. This lessens friction between the two layers during the movements of the chest-walls and the lungs; for although, to insure distinctness, the visceral and parietal layers of the pleura are represented in the diagram as not in contact, that is not the natural condition of things; the lungs are in life distended so that the visceral pleura rubs against the parietal, and the pleural cavity is practically obliterated. This is brought about by

the pressure of the atmosphere on the inside of the lungs, through the air-passages. The lungs are extremely elastic and distensible, and when the chest cavity is perforated each shrivels up just as an indian-rubber bladder does when its neck is opened; the reason being that then the air presses on the outside of each with as much force as it does on the inside. These two pressures neutralizing one another, there is nothing to overcome the tendency of the lungs to collapse. So long as the chest-walls are whole, however, the lungs remain distended. The pleural sac is air-tight and contains no air, and the pressure of the air around the Body is borne by the rigid walls of the chest and prevented from reaching the lungs; consequently no atmospheric pressure is exerted on their outsides. On their interior, however, the atmosphere presses with its full weight, equal (see Physics) to about 90 centigrams on a square centimeter (14.5 lbs. on the square inch), and this is far more than sufficient to distend the lungs so as to make them completely fill all the parts of the thoracic cavity not occupied by other organs. Suppose *A*, (Fig. 107) to be a bottle closed air-tight by a cork through which two tubes pass, one of which, *b*, leads into an elastic bag, *d*, and the other, *c*, provided with a stop-cock, opens freely below into the bottle. If the stop-cock, *c*, is open the air will enter the bottle and press there on the outside of the bag, as well as on its inside through *b*. The bag will therefore collapse, as the lungs do when the chest cavity is opened. But if some air be sucked out of *c* the pressure of that remaining in the bottle will diminish, while that inside the bag will be the same, and the bag will thus be blown up, because the atmospheric pressure on its interior will not be balanced by that on its exterior. At last, when all the air is sucked out of the bottle and the stop-cock on *c* closed, the bag, if sufficiently distensible, will be expanded until it completely fills the bottle and presses against its inside, and the state

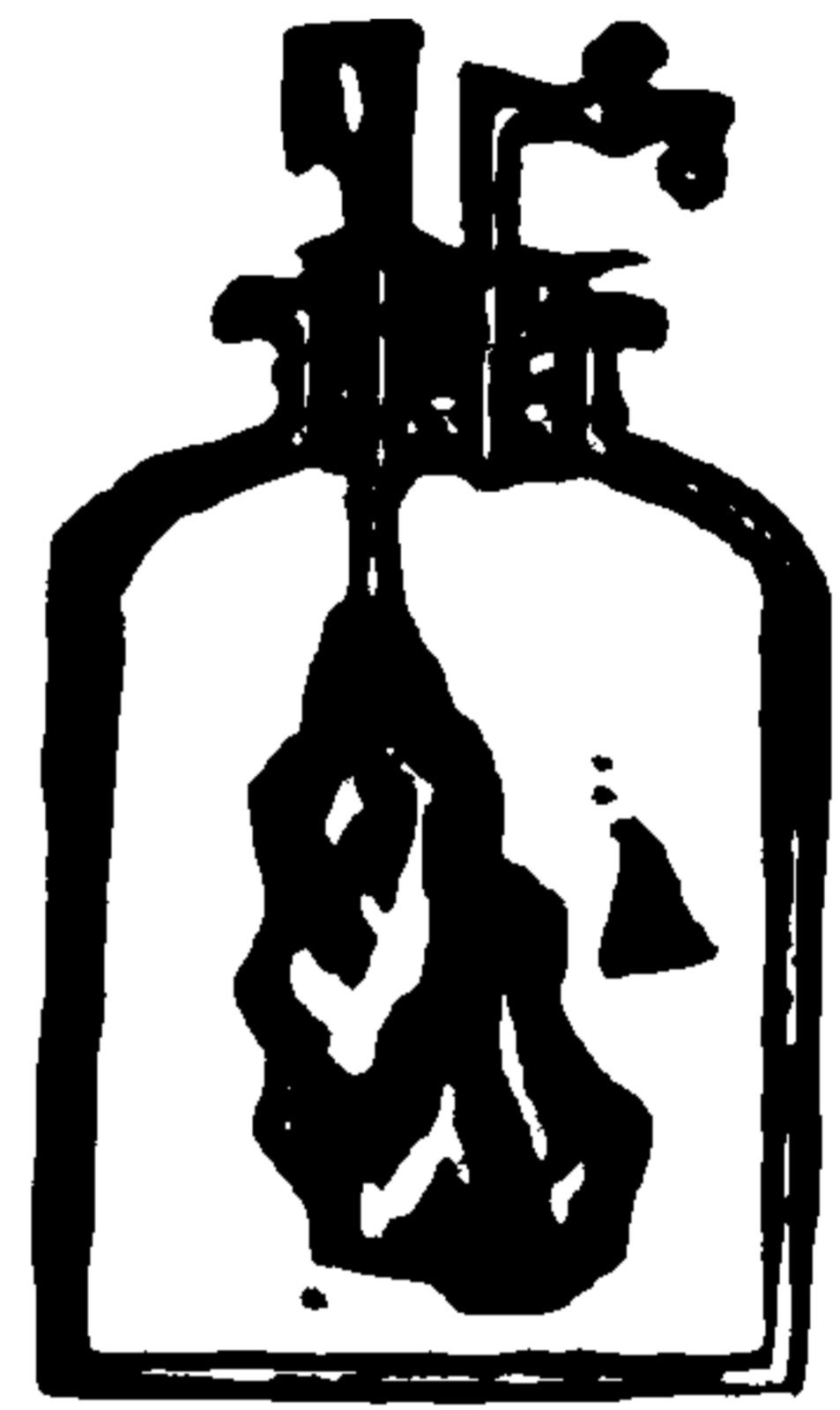

FIG. 107.—Diagram illustrating the pressure relationships of the lungs in the thorax.



of things will then answer to that naturally found in the chest. If the bottle were now increased in size without letting air into it, the bag would expand still more, so as to fill it, and in so doing would receive air from outside through *b*; and if the bottle then returned to its original size, its walls would press on the bag and cause it to shrink and expel some of its air through *b*. Exactly the same must of course happen, under similar circumstances, in the chest, the windpipe answering to the tube *b* through which air enters or leaves the elastic sac.

**The Respiratory Movements.** The air taken into the lungs soon becomes laden in them with carbon dioxide, and at the same time loses much of its oxygen; these interchanges taking place mainly in the deep recesses of the alveoli, far from the exterior, and only communicating with it through a long tract of narrow tubes. The alveolar air, thus become unfit to any longer convert venous blood into arterial, could only very slowly be renewed by gaseous diffusion with the outer air through the long air-passages—not nearly fast enough for the requirements of the Body, as any one readily experiences through the sensation of suffocation which follows holding the breath for a very short time. Consequently, added on to the breathing lungs is a *respiratory mechanism*, by which the air within them is periodically mixed with fresh air taken from the outside, and also the air in the alveoli is stirred up so as to bring fresh layers of it in contact with the walls of the air-cells. This mixing is brought about by the breathing movements, consisting of regularly alternating *inspirations*, during which the chest cavity is enlarged and fresh air enters the lungs, and *expirations*, in which the cavity is diminished and air expelled from the lungs. When the chest is enlarged the air the lungs contain immediately distends them so as to fill the larger space; in so doing it become rarefied and less dense than the external air; and since gases flow from points of greater to those of less pressure, some outside air at once flows in by the air-passages and enters the lungs. In expiration the reverse takes place. The chest cavity, diminishing, presses on the lungs and makes the air inside



**DIESE SEITE IST FÜR KOSTENLOSE MITGLIEDER GESPERRT**  
Beantragen Sie jetzt die volle Mitgliedschaft, um diese Seite zu betreten



**Seien Sie niemals ohne ein Buch!**

Die Vollmitgliedschaft von Forgotten Books bietet Ihnen einen universalen Zugang von unseren Apps und unserer Website, auf all Ihren Geräten: Tablet, Telefon, E-Reader, Laptop und Computer.

**Eine Bibliothek in Ihrer Tasche für €8.99/monat**

**Fortfahren**

\*Es gelten Richtlinien zur fairen Nutzung.

diaphragm is dome-shaped, its concavity being turned towards the abdomen. From the tendon on the crown of the dome striped muscular fibres radiate, downwards and outwards, to all sides; and are fixed by their inferior ends to the lower ribs, the breast-bone, and the vertebral column. In expiration the lower lateral portions of the diaphragm lie close against the chest-walls, no lung intervening between them. In inspiration the muscular fibres, shortening, flat-

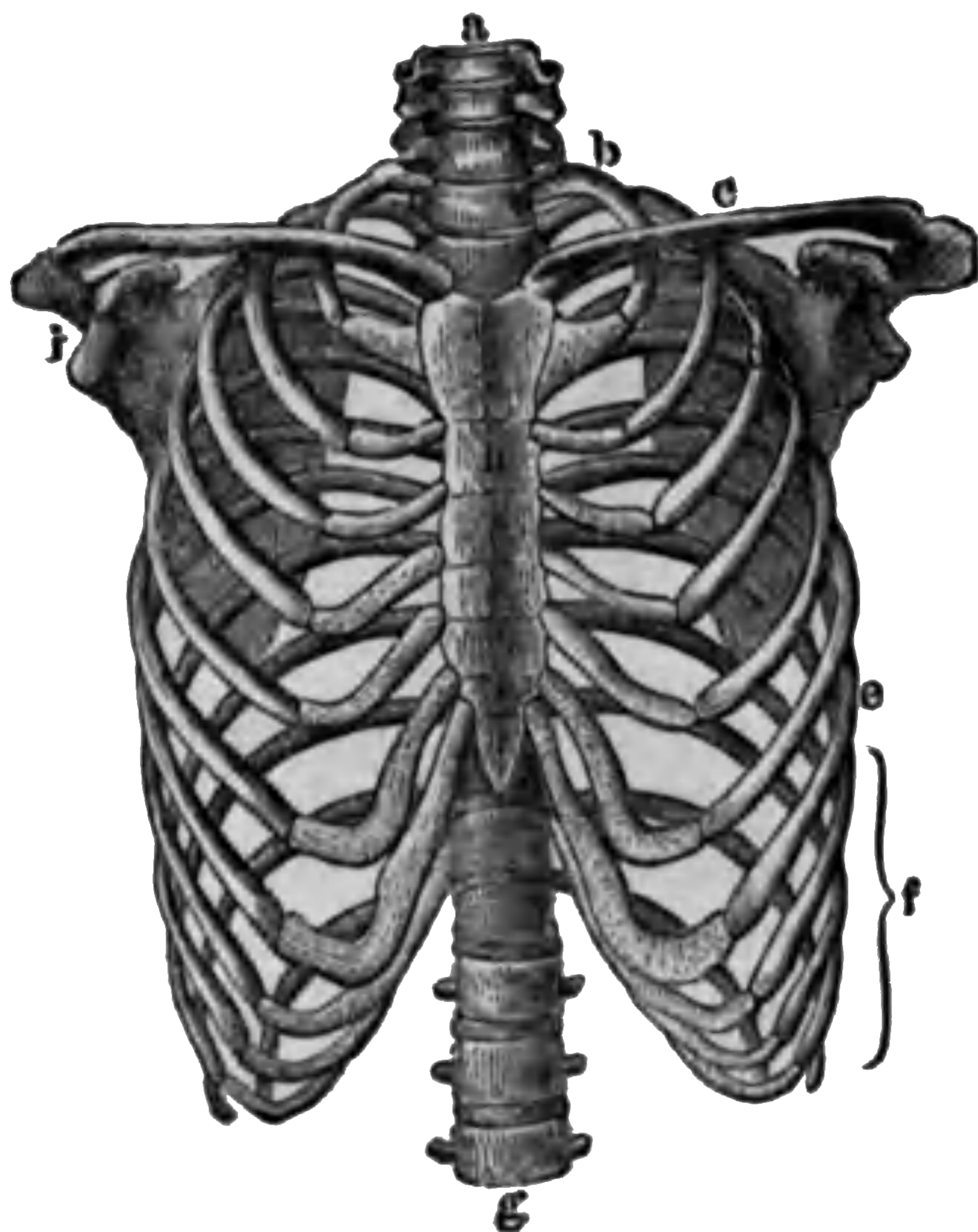

FIG. 109.—The skeleton of the thorax. *a, g*, vertebral column; *b*, first rib; *c*, clavicle; *d*, third rib; *i*, glenoid fossa.

ten the dome and so enlarge the thoracic cavity at the expense of the abdominal; and at the same time its lateral portions are pulled away from the chest-walls, leaving a space into which the lower ends of the lungs expand. The contraction of the diaphragm thus increases greatly the size of the thorax chamber by adding to its lowest and widest part.

**The Dorso-Ventral Enlargement of the Thorax.** The ribs on the whole slope downwards (*t*, Fig. 25) from the vertebral column to the breast-bone, the slope being most

marked in the lower ones. During inspiration the breast-bone and the sternal ends of the ribs attached to it are

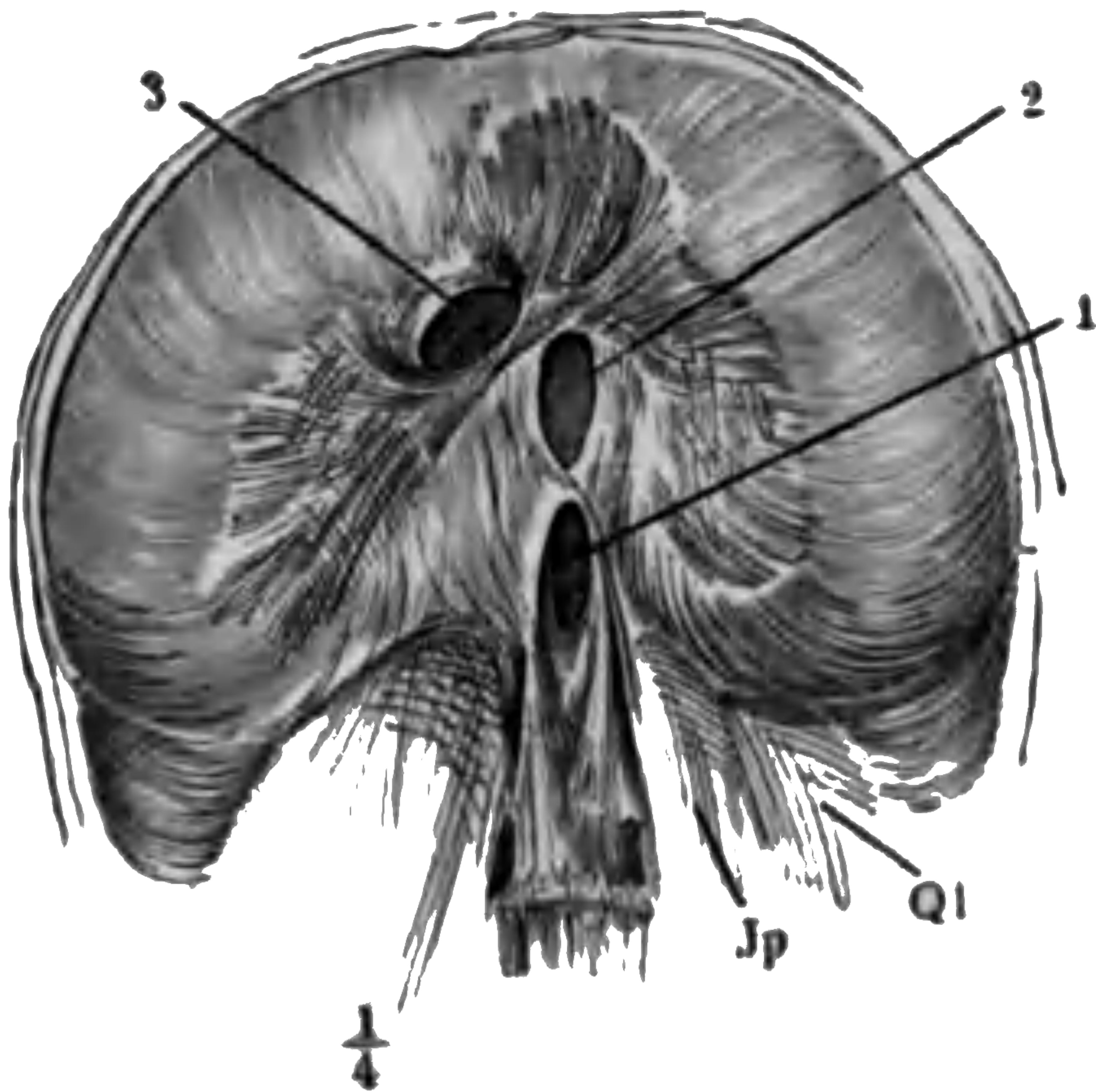

FIG. 110.—The diaphragm seen from below.

raised, and so the distance between the sternum and the vertebral column is increased. That this must be so will readily be seen by examining the diagram Fig. 111, where *ab* represents the vertebral column, *c* and *d* two ribs, and *st* the sternum. The continuous lines represent the natural position of the ribs at rest in expiration, and the dotted lines the position in inspiration. It is clear that when their lower ends are raised, so as to make the bars lie in a more horizontal plane, the sternum is pushed away from the spine, and so the chest cavity is increased dorso-ventrally. The inspiratory elevation of the ribs is mainly due to the action of the *scalene* and *external intercostal muscles*. The *scalene* muscles, three on each side, arise from the cervical vertebræ and are inserted into

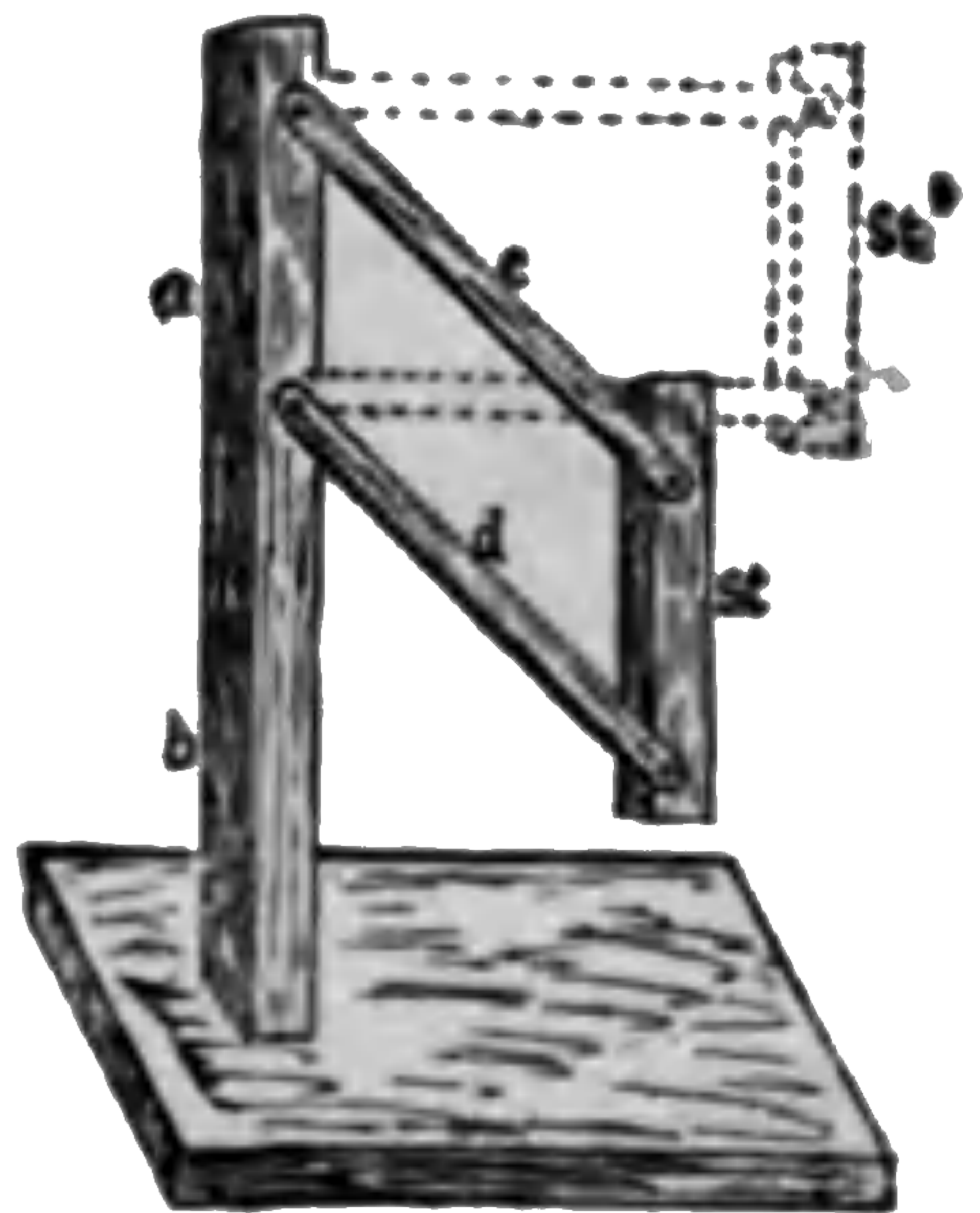

FIG. 111.—Diagram illustrating the dorso-ventral increase in the diameter of the thorax when the ribs are raised.

the upper ribs. The external intercostals (Fig. 112, *A*) lie between the ribs and extend from the vertebral column to the costal cartilages; their fibres slope downwards and forwards. During an inspiration the scalenes contract and fix the upper ribs firmly; then the external intercostals shorten and each raises the rib below it. The muscle, in fact, tends to pull together the pair of ribs between which it lies, but as the upper one of these is held tight by the

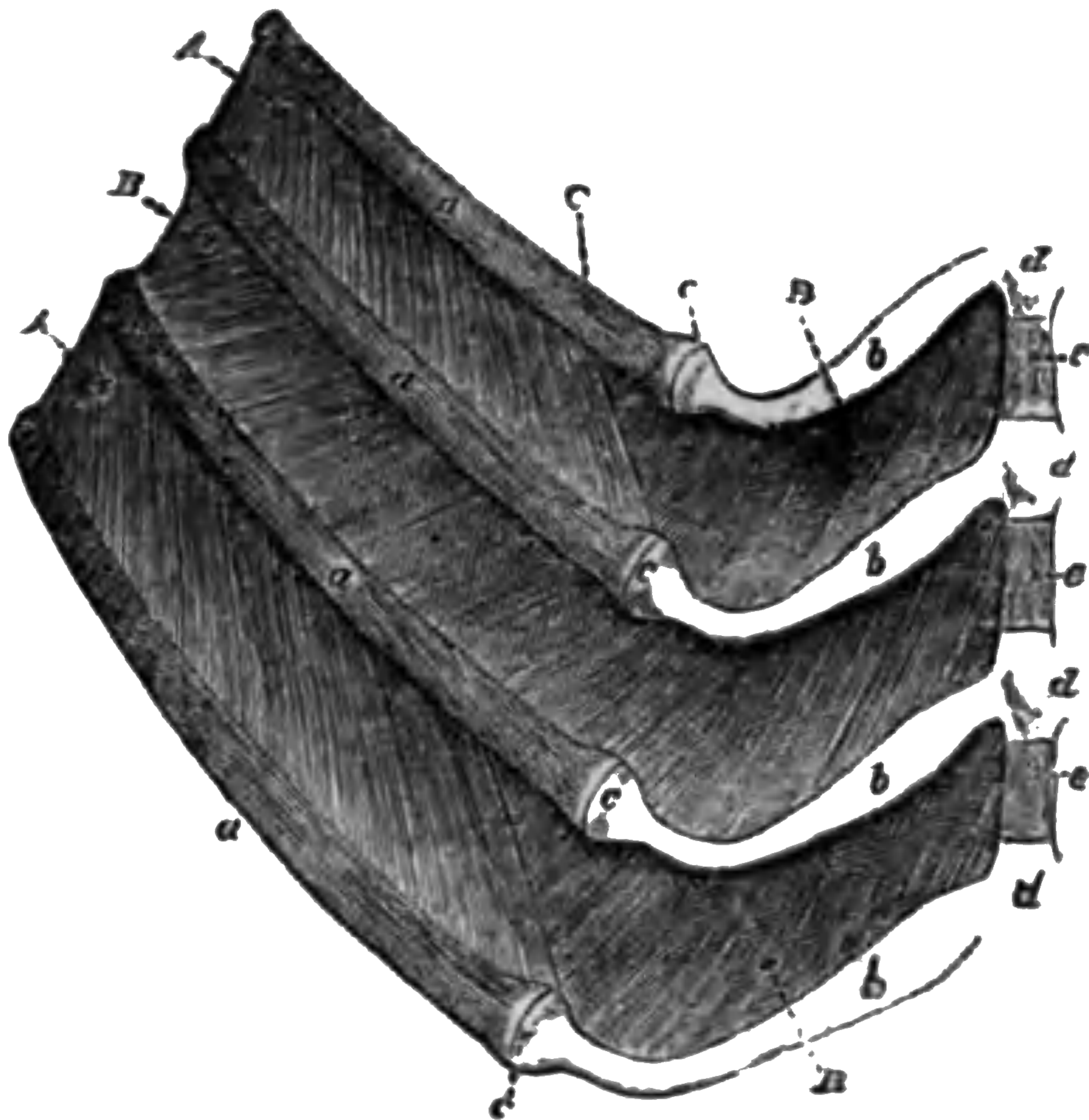

FIG. 112.—Portions of four ribs of a dog with the muscles between them. *a, a*, ventral ends of the ribs, joining at *c* the rib cartilages, *b, b*, which are fixed to cartilaginous portions, *d*, of the sternum. *A, A*, external intercostal muscle, ceasing between the rib cartilages, where the internal intercostal, *B, B*, is seen. Between the middle two ribs the external intercostal muscle has been dissected away, so as to display the internal which was covered by it.

scalenes and other muscles above, the result is that the lower rib is pulled up, and not the upper down. In this way the lower ribs are raised much more than the upper, for the whole external intercostal muscles on one side may be regarded as one great muscle with many bellies, each belly separated from the next by a tendon, represented by the rib. When the whole muscular sheet is fixed above and



**DIESE SEITE IST FÜR KOSTENLOSE MITGLIEDER GESPERRT**  
Beantragen Sie jetzt die volle Mitgliedschaft, um diese Seite zu betreten

# GESCHICHTE

Zehntausende von wichtigen historischen Quellen, viele bisher nicht erhältlich, stehen jetzt zum ersten Mal mit der Vollmitgliedschaft von Forgotten Books zur Verfügung.

Unbegrenzter Zugang  
\$8.99/monat

**Fortfahren**

\*Es gelten Richtlinien zur fairen Nutzung.



is needed. As soon as the muscles which have raised the ribs and sternum relax, these tend to return to their natural unconstrained position, and the rib cartilages, also, to untwist themselves and bring the ribs back to their position of rest; the elastic abdominal wall presses the contained viscera against the under side of the diaphragm, and pushes that up again as soon as its muscular fibres cease contracting. By these means the chest cavity is restored to its original capacity and the air sent out of the lungs, rather by the elasticity of the parts which were stretched in inspiration, than by any special expiratory muscles.

**Forced Respiration.** When a very deep breath is drawn or expelled, or when there is some impediment to the entry or exit of the air, a great many muscles take part in producing the respiratory movements, and expiration then becomes, in part, an actively muscular act. The main expiratory muscles are the *internal intercostals* which lie beneath the external between each pair of ribs (Fig. 112, *B*), and have an opposite direction, their fibres running upwards and forwards. In forced expiration the lower ribs are fixed or pulled down by muscles running in the abdominal wall from the pelvis to them and to the breast-bone. The internal intercostals then contracting, pull down the upper ribs and the sternum, and so diminish the thoracic cavity dorso-ventrally. At the same time, the contracted abdominal muscles press the walls of that cavity against the viscera within it, and pushing these up forcibly against the diaphragm make it very convex towards the chest, and so diminish the latter in its vertical diameter. In very violent expiration many other muscles may co-operate, tending to fix points on which those muscles which can directly diminish the thoracic cavity, pull. In violent inspiration, also, many extra muscles are called into play. The neck is held rigid to give the scalenes a firm attachment; the shoulder-joint is held fixed and muscles going from it to the chest-wall, and commonly serving to move the arm, are then used to elevate the ribs; the head is held firm on the vertebral column by the muscles going between the two, and then other muscles, which pass from the collar-bone and

sternum to the skull, are used to pull up the former. The muscles which are thus called into play in labored but not in quiet breathing are called *extraordinary muscles of respiration*.

**The Respiratory Sounds.** The entry and exit of air are accompanied by *respiratory sounds* or *murmurs*, which can be heard on applying the ear to the chest wall. The character of these sounds is different and characteristic over the trachea, the larger bronchial tubes, and portions of lung from which large bronchial tubes are absent. They are variously modified in pulmonary affections and hence the value of *auscultation* of the lungs in assisting the physician to form a diagnosis.

**The Capacity of the Lungs.** Since the chest cavity never even approximately collapses, the lungs are never completely emptied of air: the space they have to occupy is larger in inspiration than during expiration but is always considerable, so that after a forced expiration they still contain a large amount of air which can only be expelled from them by opening the pleural cavities; then they entirely collapse, just as the bag in Fig. 107 would if the bottle inclosing it were broken. The capacity of the chest, and therefore of the lungs, varies much in different individuals, but in a man of medium height there remains in the lungs after the most violent possible expiration, about 1640 cub. cent. (100 cub. inches) of air, called the *residual air*. After an ordinary expiration there will be in addition to this about as much more *supplemental air*; the residual and supplemental together forming the *stationary air*, which remains in the chest during quiet breathing. In an ordinary inspiration 500 cub. cent. (30 cub. inches) of tidal air are taken in, and about the same amount is expelled in natural expiration. By a forced inspiration about 1600 cub. cent. (98 cub. inches) of *complemental air* can be added to the tidal air. After a forced inspiration therefore the chest will contain  $1640 + 1640 + 500 + 1600 = 5380$  cubic centimeters (328 cubic inches) of air. The amount which can be taken in by the most violent possible inspiration after the strongest possible expiration, that is, the supplemental,



tidal and complementary air together, is known as the *vital capacity*. For a healthy man 1.7 meters (5 feet 8 inches) high it is about 3700 cub. cent. (225 cub. inches) and increases 60 cub. cent. for each additional centimeter of stature; or about 9 cubic inches for each inch of height.

**The Quantity of Air Breathed Daily.** Knowing the quantity of air taken in at each breath and expelled again (after more or less thorough mixture with the stationary air) we have only to know, in addition, the rate at which the breathing movements occur, to be able to calculate how much air passes through the lungs in twenty-four hours. The average number of respirations in a minute is found by counting on persons sitting quietly, and not knowing that their breathing rate is under observation, to be fifteen in a minute. In each of these half a liter (30 cubic inches) of air is concerned; therefore  $0.5 \times 15 \times 60 \times 24 = 10,800$  liters (374 cubic feet) is the quantity of air breathed under ordinary circumstances by each person in a day.

**Hygienic Remarks.** Since the diaphragm when it contracts pushes down the abdominal viscera beneath it, these have to make room for themselves by pushing out the soft front of the abdomen which, accordingly, protrudes when the diaphragm descends. Hence breathing by the diaphragm, being indicated on the exterior by movements of the abdomen, is often called "abdominal respiration," as distinguished from breathing by the ribs, called "costal" or "chest breathing." In both sexes the diaphragmatic breathing is the most important, but, as a rule, men and children use the ribs less than adult women. Since both abdomen and chest alternately expand and contract in healthy breathing anything which impedes their free movement is to be avoided; and the tight lacing which used to be thought elegant a few years back, and is still indulged in by some who think a distorted form beautiful, seriously impedes one of the most important functions of the Body, leading, if nothing worse, to shortness of breath and an incapacity for muscular exertion. In extreme cases of tight lacing some organs are often directly injured, weals of



**DIESE SEITE IST FÜR KOSTENLOSE MITGLIEDER GESPERRT**  
Beantragen Sie jetzt die volle Mitgliedschaft, um diese Seite zu betreten



**Seien Sie niemals ohne ein Buch!**

Die Vollmitgliedschaft von Forgotten Books bietet Ihnen einen universalen Zugang von unseren Apps und unserer Website, auf all Ihren Geräten: Tablet, Telefon, E-Reader, Laptop und Computer.

**Eine Bibliothek in Ihrer Tasche für € 8.99/monat**

**Fortfahren**

\*Es gelten Richtlinien zur fairen Nutzung.

**Influence of the Respiratory Movements upon the Circulation.** Suppose the chest in a condition of natural expiration and the external pressure on the blood in the blood-vessels within it, and in the heart, to have come, in the manner pointed out in the last paragraph, into equilibrium with the atmospheric pressure on the blood-vessels of the neck and abdomen. If an inspiration now occurs, the chest cavity being enlarged the pressure on all of its contents will be diminished. In consequence, air enters the lungs from the windpipe, and blood enters the venæ cavæ and the right auricle of the heart. Not only the lungs, then, but the right side of the heart, and the intra-thoracic portions of the systemic veins leading to it, are expanded during an inspiration; but the lungs being much the most distensible take far the greatest part in filling up the increased space. The left side of the heart is not much influenced as it is filled from the pulmonary veins; and the whole vessels of the lesser circulation lying within the chest, and being all affected in the same way at the same time, the blood-flow in them is not influenced by the aspiration of the thorax. Distension of the lungs seems, however, to diminish the capacity of their vessels, and so to a certain extent the flow is influenced; as the lungs expand blood is forced out of their vessels into the left auricle, and when they again contract their vessels fill up from the right ventricle. The pressure on the thoracic aorta being diminished in inspiration, blood tends to flow back into it from the abdominal portion of the vessel, but cannot enter the heart on account of the semilunar valves; and the back-flow does not in any case equal the onflow due to the beat of the heart; so the what happens in the aorta is but a slight slowing of the current. The general result of all this is that the circulation is considerably assisted. When the next expiration occurs, and the pressure in the thorax again rises, air and blood both tend to be expelled from the cavity. The aorta thus regains what it lost during inspiration; the pressure on it is increased and it empties itself faster into its abdominal portion. The semilunar valves having pre-

vented any regurgitation into the heart, there is neither gain nor loss so far as it is concerned. With the systemic intrathoracic veins, however, this is not the case; the extra blood entering them has already in great part gone on beyond the tricuspid valve, and cannot flow back during expiration; and the pressure in the auricle being constantly kept low by its emptying into the ventricle, the increased pressure on the venæ cavæ tends as much to send the blood on into the heart, as back into the extra-thoracic veins. Moreover, whatever blood tends to take the latter course cannot do it effectually since, although the venæ cavæ themselves contain no valves, the more distant veins which open into them do. Consequently, whatever extra blood has, to use the common phrase, been "sucked" into the intra-thoracic venæ cavæ in inspiration and has not been sent already on into the right ventricle before expiration occurs, is, on account of the venous valves, imprisoned in the cavæ under an increased pressure during expiration; and this tends to make it flow faster into the auricle during the diastole of the latter. How much the alternating respiratory movements assist the venous flow is shown by the dilation of the veins of the head and neck which occurs when a person is holding his breath; and the blackness for the face, from distension of the veins and stagnation of the capillary flow, which occurs during a prolonged fit of coughing, which is a series of expiratory efforts without any inspirations.

In still another way the aspiration of the thorax assists the heart. The heart and lungs are both extensible, though in different degrees, and each is stretched in the chest somewhat beyond its natural size; the one by the atmospheric pressure directly, the other by that pressure indirectly, exerted through the blood exposed to it in the extra-thoracic veins. Supposing, therefore, the heart suddenly to shrink it would leave more space in the chest to be filled by the lungs, and these, accordingly, at each cardiac systole expand a little to fill the extra room, just as they do when the space around them is otherwise enlarged during

an inspiration. The elasticity of the lungs, however, causes them to resist this distension and oppose the cardiac systole. The matter may be made clear by an arrangement like that in Fig. 113. *A* is an air-tight vessel with a tube, *e*, provided with a stop-cock, leading from it; *b* is a highly distensible elastic bag in free communication through *d*

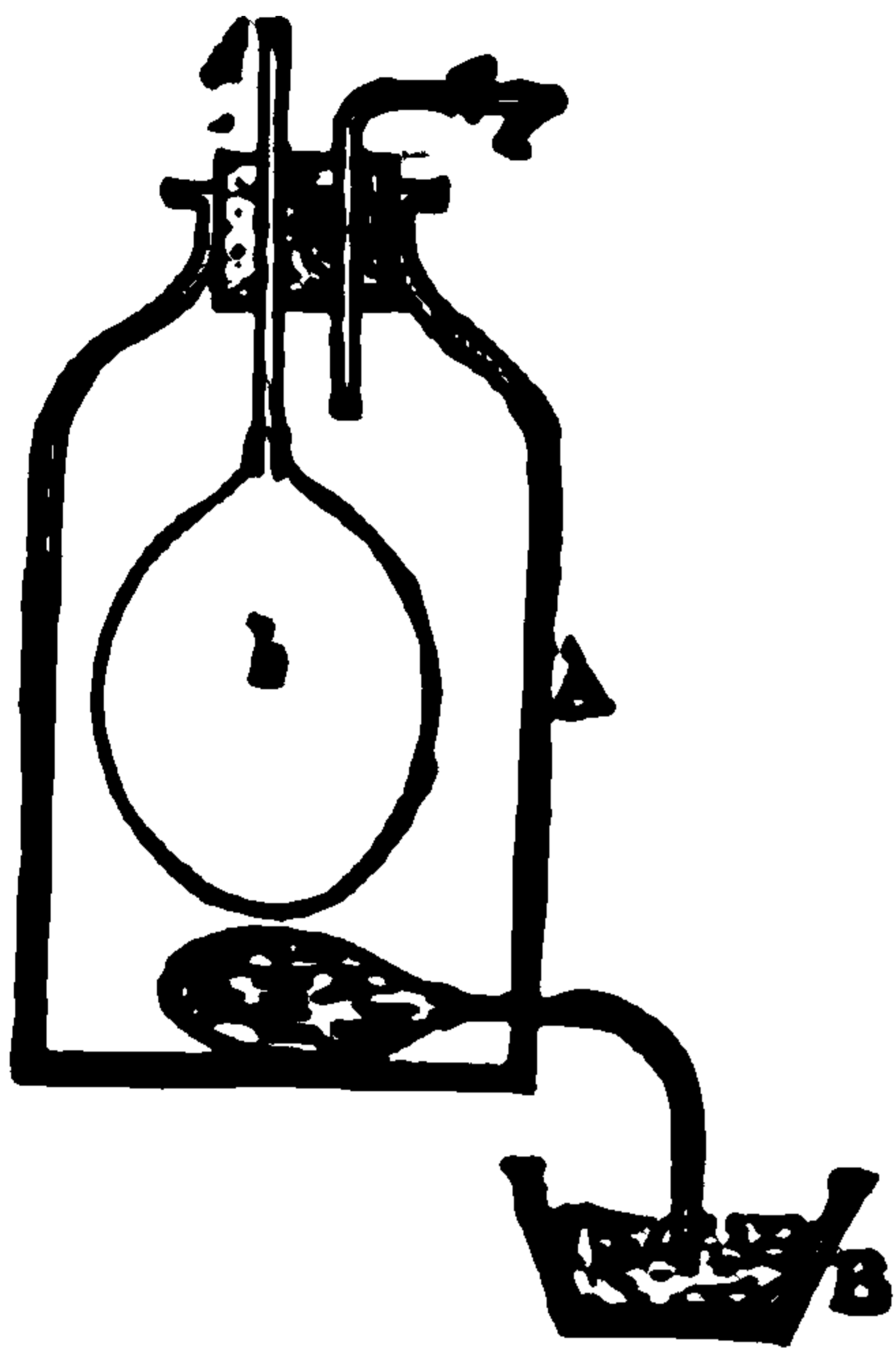

FIG. 113.—Diagram illustrating the influence of aspiration of the thorax on the circulation of the blood.

with the exterior; and *c*, representing the heart, is a less extensible sac, from which a tube leads and dips under water in the vessel *B*. If air be pumped out through *e* both bags will dilate, *b* filling with air, and *c* with water driven up by atmospheric pressure. Ultimately, if sufficiently extensible, they would fill the whole space, the thinner walled, *b*, occupying most of it. If then the stop-cock be closed, things will remain in equilibrium, each bag striving to collapse and so exerting a pull on the other, for if *b* shrinks *c* must expand and *vice versa*. If *c* suddenly shrink, as the

heart does in its systole, *b* will dilate; but as soon as the systole of *c* ceases, *b* will shrink again and pull *c* out to its previous size. In the same way, after the cardiac systole, when the heart-walls relax, the lungs pull them out again and dilate the organ. The contracting heart thus expends some of its work in overcoming the elasticity of the lungs, which opposes their expansion to fill the space left by the smaller heart; but during the diastole of the heart this work is utilized to pull out its walls again, and draw blood into it. Since the normal heart has muscular power, and to spare, for its systole, this arrangement, by which some of the work then spent is stored away to assist the diastole, which cannot be directly performed by cardiac muscles, is of service to it on the whole. It is a physiological though not a mechanical advantage; no work power is gained, but what there is, is better distributed.



**DIESE SEITE IST FÜR KOSTENLOSE MITGLIEDER GESPERRT**  
Beantragen Sie jetzt die volle Mitgliedschaft, um diese Seite zu betreten

# GESCHICHTE

Zehntausende von wichtigen historischen Quellen, viele bisher nicht erhältlich, stehen jetzt zum ersten Mal mit der Vollmitgliedschaft von Forgotten Books zur Verfügung.

Unbegrenzter Zugang  
\$8.99/monat

**Fortfahren**

\*Es gelten Richtlinien zur fairen Nutzung.



# CHAPTER XXV.

## THE CHEMISTRY OF RESPIRATION.

**Nature of the Problems.** The study of the respiratory process from a chemical standpoint has for its object to discover, first, what are, in kind and extent, the interchanges between the air in the lungs and the blood in pulmonary capillaries; and, in the second place, the nature and amount of the corresponding gaseous changes between the various living tissues and the blood in the systemic capillaries. These processes are the reverse of one another and in the long run balance, the blood losing as much carbon dioxide gas in the pulmonary circulation as it gains in the systemic, and gaining as much oxygen in the former as it loses in the latter. To thoroughly comprehend the matter it is, moreover, necessary to know the physical and chemical conditions of these gases in the lungs, in the blood, and in the tissues generally; for only so can we understand how it is that in different localities of the Body such exactly contrary processes occur. So far as the problems connected with the external respiration are concerned our knowledge is tolerably complete; but as regards the internal respiration, taking place all through the Body, much has yet to be learnt; for example, we know that a muscle at work gives more carbon dioxide to the blood than one at rest and takes more oxygen from it, but exactly how much of the one it gives and of the other it takes is only known approximately; as are also the conditions under which this greater interchange during the activity of the muscular tissue is effected: and concerning nearly all the other tissues we know even less than about muscle. In fact, as regards the Body as a whole, it is comparatively easy to

find how great its gaseous interchanges with the air are during work and rest, waking and sleeping, while fasting or digesting, and so on; but when it comes to be decided what organs are concerned in each case in producing the greater or less exchange, and how much of the whole is due to each of them, the question is one far more difficult to settle and still very far from completely answered.

**The Changes produced in Air by being once Breathed.** These are fourfold—changes in its temperature, in its moisture, in its chemical composition, and its volume.

The air taken into the lungs is nearly always cooler than that expired, which has a temperature of about  $36^{\circ}\text{C}$ . ( $97^{\circ}\text{F}$ ). The temperature of a room is usually about  $21^{\circ}\text{C}$ . ( $70^{\circ}\text{F}$ ). The warmer the inspired air the less, of course, the heat which is lost to the Body in the breathing process; its average amount is calculated as about equal to 3.5 calories in twenty-four hours; a calorie (see Physics) being as much heat as will raise the temperature of one kilogram (2.2 lbs) of water one degree centigrade ( $1.8^{\circ}\text{F}$ ).

The inspired air always contains more or less water vapor, but is rarely saturated; that is, rarely contains so much but it can take up more without showing it as mist; the warmer air is, the more water vapor it requires to saturate it. The expired air is nearly saturated for the temperature at which it leaves the Body, as is readily shown by the water deposited when it is slightly cooled, as when a mirror is breathed upon; or by the clouds seen issuing from the nostrils on a frosty day, these being due to the fact that the air, as soon as it is cooled, cannot hold all the water vapor which it took up when warmed in the Body. Air, therefore, when breathed once, gains water vapor and carries it off from the lungs; the actual amount being subject to variation with the temperature and saturation of the inspired air: the cooler and drier this is, the more water will it gain when breathed. On an average the amount thus carried off in twenty-four hours is about 255 grams (9 ounces). To evaporate this water in the lungs an amount of heat is required, which disappears for this purpose in the Body, to appear again outside it when the water vapor condenses (see Physics).



The amount of heat taken off in this way during the day is about 7.2 calories. The total daily loss of heat from the Body through the lungs is therefore 10.7 calories, 3.5 in warming the inspired air and 7.2 in evaporating water.

The most important changes brought about in the breathed air are those in its chemical composition. Pure air when completely dried consist in 100 parts of—

	By Volume.	By Weight.
Oxygen.....	20.8	23
Nitrogen.....	79.2	77

Ordinary atmospheric air contains in addition 4 volumes of carbon dioxide in 10,000, or 0.04 in 100, a quantity which, for practical purposes, may be neglected. When breathed once, such air gains rather more than 4 volumes in 100 of carbon dioxide, and loses rather more than 5 of oxygen. More accurately, 100 volumes of expired air when dried consist of—

Oxygen.....	15.4
Nitrogen .....	79.2
Carbon dioxide.....	4.8

The expired air also contains volatile organic substances in quantities too minute for chemical analysis, but readily detected by the nose upon coming into a close room in which a number of persons have been collected.

Since 10,800 liters (346 cubic feet) of air are breathed in twenty-four hours and lose 5.4 per cent of oxygen, the total quantity of this gas taken up in the lungs daily is  $10,800 \times 5.4 \div 100 = 583.2$  liters (20.4 cubic feet). One liter of oxygen measured at 0°C (32° F.) and under a pressure equal to one atmosphere, weighs 1.43 grams (see Chemistry), so the total weight of oxygen taken up by the lungs daily is  $583.2 \times 1.43 = 833.9$  grams. Or, using inches and grains as standards, 44.5 cubic inches of oxygen at the above temperature and pressure weigh almost exactly 16 grains, so the 20.4 cubic feet absorbed in the lungs daily weigh  $20.4 \times 1728 \div 44.5 \times 16 = 12,818$  grains.

The amount of carbon dioxide excreted from the lungs



**DIESE SEITE IST FÜR KOSTENLOSE MITGLIEDER GESPERRT**  
Beantragen Sie jetzt die volle Mitgliedschaft, um diese Seite zu betreten



**Seien Sie niemals ohne ein Buch!**

Die Vollmitgliedschaft von Forgotten Books bietet Ihnen einen universalen Zugang von unseren Apps und unserer Website, auf all Ihren Geräten: Tablet, Telefon, E-Reader, Laptop und Computer.

**Eine Bibliothek in Ihrer Tasche für €8.99/monat**

**Fortfahren**

\*Es gelten Richtlinien zur fairen Nutzung.

tiv | little of that gas. The headache and drowsiness which come on from sitting in a badly ventilated room, and the want of energy and general ill-health which result from permanently living in such, are dependent on a slow poisoning of the Body by the reabsorption of the things eliminated from the lungs in previous respirations. What these are is not accurately known; they doubtless belong to those volatile bodies mentioned above, as carried off in minute quantities in each breath; since observation shows that the air becomes injurious long before the amount of carbon dioxide in it is sufficient to do any harm. Breathing air containing one or two per cent of that gas produced by ordinary chemical methods does no particular injury, but breathing air containing one per cent of it produced by respiration is decidedly injurious, because of the other things sent out of the lungs at the same time. Carbon dioxide itself, at least in any such percentage as is commonly found in a room, is not poisonous, as used to be believed, but, since it is tolerably easily estimated in air, while the actually injurious substances evolved in breathing are not, the purity or foulness of the air in a room is usually determined by finding the percentage of carbon dioxide in it; but it must be borne in mind that to mean much this must have been produced by breathing; otherwise the amount of it present is no guide to the quantity of really important injurious substances present. Of course when a great deal of carbon dioxide is present the air is irrespirable: as for example sometimes at the bottom of wells or brewing-vats.

In one minute as we have seen (p. 366)  $.5 \times 15 = 7.5$  liters (0.254 cubic feet) of air are breathed and vitiated with carbon dioxide to the extent of rather more than four per cent; this, mixed with three times its volume of external air, would give thirty liters (a little over one cubic foot) vitiated to the extent of one per cent, and such air is no longer respirable for any length of time with safety. The result of breathing it for an evening is headache and general malaise; of breathing it for weeks or months a lowered tone of the whole Body—less power of work, physical or

the old air is a far more rapid flow, as the previous one.

Ventilation does not necessarily mean draughts of cold air, as is too often supposed. In warming by indirect radiation it may readily be secured by fixing, in addition to the registers from which the new warmed air reaches the room, corresponding openings at the opposite side, by which the old air may pass off to make room for the fresh. An open fire in a room will always keep up a current of air through it, and is one of the healthiest, though not the most economical, methods of warming an apartment.

Stoves in a room, unless constantly supplied with fresh air from without, dry its air to an unwholesome extent. If no appliance for providing this supply exists in a room, it can usually be got, without a draught, by fixing a board about four inches wide under the lower sash and shutting the window down on it. Fresh air then comes in by the opening between the two sashes and in a current directed upwards, which gradually diffuses itself over the room without being felt as a draught at any one point. In the method of heating by direct radiation, the apparatus employed provides of itself no means of drawing fresh air into a room, as the draught up the chimney of an open fireplace or of a stove does; and therefore special inlet and outlet openings are very necessary. Since few doors and windows,

fortunately, fit quite tight, fresh air gets even into closed rooms, in tolerable abundance for one or two inhabitants, if there be outlets for the air already in them.

**Changes undergone by the Blood in the Lungs.** These are the exact reverse of those exhibited by the breathed air.—what the air gains the blood loses, and *vice versa*. Consequently, the blood loses heat, and water, and carbon dioxide in the pulmonary capillaries; and gains oxygen. These gains and losses are accompanied by a change of color from the dark purple which the blood exhibits in the pulmonary artery, to the bright scarlet it possesses in the pulmonary veins.

The dependence of this color change upon the access of fresh air to the lungs while the blood is flowing through them, can be readily demonstrated. If a rabbit be rendered unconscious by chloroform, and its chest be opened, after a pair of bellows has been connected with its windpipe, it is seen that, so long as the bellows are worked to keep up artificial respiration, the blood in the right side of the heart (as seen through the thin auricle) and that in the pulmonary artery, is dark colored, while that in the pulmonary veins and the left auricle is bright red. Let, however, the artificial respiration be stopped for a few seconds and, consequently, the renewal of the air in the lungs (since an animal cannot breathe for itself when its chest is opened), and very soon the blood returns to the left auricle as dark as it left the right. In a very short time symptoms of suffocation show themselves and the animal dies, unless the bellows be again set at work.

**The Blood Gases.** If fresh blood be rapidly exposed to as complete a vacuum as can be obtained it gives off certain gases, known as the *gases of the blood*. These are the same in kind, but differ in proportion, in venous and arterial blood; there being more carbon dioxide and less oxygen obtainable from the venous blood going to the lungs by the pulmonary artery, than from the arterial blood coming back to the heart by the pulmonary veins. The gases given off by venous and arterial blood, measured under the normal pressure and at the normal temperature (see Physics),



**DIESE SEITE IST FÜR KOSTENLOSE MITGLIEDER GESPERRT**  
Beantragen Sie jetzt die volle Mitgliedschaft, um diese Seite zu betreten

# GESCHICHTE

Zehntausende von wichtigen historischen Quellen, viele bisher nicht erhältlich, stehen jetzt zum ersten Mal mit der Vollmitgliedschaft von Forgotten Books zur Verfügung.

Unbegrenzter Zugang  
\$8.99/monat

**Fortfahren**

\*Es gelten Richtlinien zur fairen Nutzung.



This suggests that the coloring matter or *hæmoglobin* of the red corpuscles combines with oxygen to form a scarlet compound, and when deprived of that gas has a darker and more purple color; and further experiments confirm this. Hæmoglobin combined with oxygen is known as *oxyhæmoglobin* and it is on its predominance that the color of arterial blood depends. Hæmoglobin uncombined with oxygen is *reduced hæmoglobin*; it predominates in venous blood, and is alone found in the blood of a suffocated mammal.

**The Laws Governing the Absorption of Gases by a Liquid.** In order to understand the condition of the gases in the blood liquid it is necessary to recall the general laws in accordance with which liquids absorb gases. They are as follows:—

1. A given volume of a liquid at a definite temperature if it absorbs any of a gas to which it is exposed, and yet does not combine chemically with it, takes up a definite volume of the gas. If the gas be compressed the liquid will still, at the same temperature, take up the same volume as before, but now it takes up a greater weight; and a weight exactly as much greater as the pressure is greater, since one volume of a gas under any pressure contains exactly twice as much of the gas by weight as the same volume under half the pressure, and so on. A liter or a quart of water, for example, exposed to the air will dissolve a certain amount of oxygen. If the air (and therefore the oxygen in it) be compressed to one fourth its bulk then the water will dissolve exactly the same volume of oxygen as before, but this volume of the compressed gas will contain exactly four times as much oxygen as did the same volume of the gas under the original pressure; and if now the pressure be again diminished the oxygen will be given off exactly in proportion as its pressure on the surface of the water decreases. Finally, when a complete vacuum is formed above the surface of the water it will be found that the latter has given off all its dissolved oxygen. This law, that the quantity of a gas dissolved by a liquid varies directly as the pressure of that gas on the surface of the liquid is known as Dalton's law (see Physics).

2. The amount of a gas dissolved by a liquid depends, not on the total pressure exerted by all the gases pressing on its surface, but on the fraction of the total pressure which is exerted by the particular gas in question. For example, the total atmospheric pressure is equal to that of a column of mercury 760 mm. (30 inches) high. But 100 volumes of air contain approximately 80 volumes of nitrogen and 20 of oxygen: therefore  $\frac{1}{5}$  of the total pressure is due to oxygen and  $\frac{4}{5}$  to nitrogen: and the amount of oxygen absorbed by water is just the same as if all the nitrogen were removed from the air and its total pressure therefore reduced to  $\frac{1}{5}$  of 760 mm. (30 inches) of mercury; that is to 152 mm. (6 inches) of mercury pressure. It is only the fraction of the total pressure exerted by the oxygen itself which affects the quantity absorbed by water at any given temperature. So, too, of all the atmospheric pressure  $\frac{4}{5}$  is due to nitrogen, and all the oxygen might be removed from the air without affecting the quantity of nitrogen which would be absorbed from it by a given volume of water. The atmospheric pressure would then be  $\frac{4}{5}$  of 760 mm. of mercury, or 608 mm. (24 inches), but it would all be due to nitrogen gas—and be exactly equal to the fraction of the total pressure due to that gas before the oxygen was removed from the air. When several gases are mixed together the fraction of the total pressure exerted by each one is known as the *partial pressure* of that gas; and it is this partial pressure which determines the amount of each individual gas dissolved by a liquid. If a liquid exposed to the air for some time had taken up all the oxygen and nitrogen it could at the partial pressures of those gases in the air, and were then put in an atmosphere in which the oxygen had all been replaced by nitrogen, it would now give off all its oxygen since, although the total gaseous pressure on it was the same, no part of it was any longer due to oxygen; and at the same time it would take up  $\frac{4}{5}$  more nitrogen, since the whole gaseous pressure on its surface was now due to that gas while before only  $\frac{4}{5}$  of the total was exerted by it. If, on the contrary, the liquid were exposed to pure hydrogen under a pressure of one atmos-



where it would give off all its previously dissolved oxygen and nitrogen, since none of the pressure on its surface would now be due to those gases; and would take up as much hydrogen as corresponded to a pressure of that gas equal to 760 mm. of mercury (30 inches).

3. A liquid may be such as to combine chemically with a gas. Then the amount of the gas absorbed is independent of the partial pressure of the gas on the surface of the liquid. The quantity absorbed will depend upon how much the liquid can combine with. Or, a liquid may partly be composed of things which simply dissolve a gas and partly of things which chemically combine with it. Then the amount of the gas taken up under a given partial pressure will depend on two things; a certain portion, that merely dissolved, will vary with the pressure of the gas in question; but another portion, that chemically combined, will remain the same under different pressures. The amount of this second portion depends only on the amount of the substance in the liquid which can chemically combine with it, and is totally independent of the partial pressure of the gas.

4. Bodies are known which chemically combine with certain gases when the partial pressure of these is considerable; but the compounds thus formed are broken up, and the gas liberated, when its partial pressure on the surface of the liquid falls below a certain limit.

5. A membrane, moistened by a liquid in which a gas is soluble, does not essentially alter the laws of absorption, by a liquid on one side of it, of a gas present on its other side, whether the absorption be due to mere solution or to chemical combinations or to both.

**The Absorption of Oxygen by the Blood.** Applying the physical and chemical facts stated in the preceding paragraph to the blood, we find that the blood contains (1) plasma, which simply dissolves oxygen, and (2) *hæmoglobin*, which combines with it under some partial pressures of that gas, but gives it up under lower.

Blood plasma or, what comes to the same thing, fresh serum, exposed to the air, takes up no more oxygen than so



**DIESE SEITE IST FÜR KOSTENLOSE MITGLIEDER GESPERRT**  
Beantragen Sie jetzt die volle Mitgliedschaft, um diese Seite zu betreten



**Seien Sie niemals ohne ein Buch!**

Die Vollmitgliedschaft von Forgotten Books bietet Ihnen einen universalen Zugang von unseren Apps und unserer Website, auf all Ihren Geräten: Tablet, Telefon, E-Reader, Laptop und Computer.

**Eine Bibliothek in Ihrer Tasche für €8.99/monat**

**Fortfahren**

\*Es gelten Richtlinien zur fairen Nutzung.

amount at ordinary temperatures, and still less at the temperature of the Body, were it not for its hæmoglobin. In the lungs even less would be taken up, since the air in the air-cells of those organs is poorer in oxygen than the external air; and consequently the partial pressure of that gas in it is lower. The tidal air taken in at each breath serves merely to renew directly the air in the big bronchi; the deeper one examined the pulmonary air the less oxygen and more carbon dioxide would be found, till, in the layers farthest from the exterior and only renewed by diffusion with the air of the large bronchi, it is estimated that the oxygen only exists in such quantity that its partial pressure is equal to 130 millimeters of mercury, instead of 152 as in ordinary air. In the second place, on account of the way in which hæmoglobin combines with oxygen, the quantity of that gas taken up by the blood is independent of such variations of its partial pressure in the atmosphere as we are subjected to in daily life. At the top of a high mountain, for example, the atmospheric pressure is greatly diminished, but still we can breathe freely and get all the oxygen we want. So long as the partial pressure of that gas remains above 25 millimeters (1 inch) of mercury, the amount of it taken up by the blood will depend on how much hæmoglobin there is in that liquid and not on how much oxygen there is in the air. So, too, breathing pure oxygen under a pressure of one atmosphere, or air compressed to  $\frac{1}{2}$  or  $\frac{1}{4}$  its bulk, does not increase the quantity of that gas taken up by the blood, apart from the very small extra quantity which would be dissolved by the plasma. All the widespread statements found as to the exhilaration and excitement caused by breathing pure oxygen are, as a matter of fact, erroneous, being founded on early experiments made with impure gas, and corrected by many competent observers since.

**The General Oxygen Interchanges in the Blood.** We may now try to depict what happens to the blood oxygen in a complete circulation. Suppose we have a quantity of arterial blood in the aorta. This, fresh from the lungs, will have its hæmoglobin almost fully combined with oxygen

and in the state of oxyhæmoglobin. In the blood plasma some more oxygen will be dissolved and so much as answers to a pressure of that gas equal to 130 mm. (5.2 inches) of mercury, which is the partial pressure of oxygen in the pulmonary air-cells. This *tension* of the gas in the plasma will be more than sufficient to keep the hæmoglobin from giving off its oxygen. Suppose the blood now enters the capillaries of a muscle. In the liquid moistening this organ the oxygen tension is almost *nil*, since the tissue elements are steadily taking the gas up from the lymph around them. Consequently, through the capillary walls, the plasma will give off oxygen until the tension of that gas in it falls below 25 millimeters of mercury. Immediately some of the oxyhæmoglobin is decomposed, and the oxygen liberated is dissolved in the plasma, and from there again passed on to the lymph outside; and so the tension in the plasma is once more lowered and more oxyhæmoglobin decomposed. This goes on so long as the blood is in the capillaries of the muscle, or at any rate so long as the muscular fibres keep on taking oxygen from the lymph bathing them; if they cease to do so of course the tension of that gas in the lymph will soon come to equal that in the plasma: the latter will therefore cease to yield oxygen to the former; and so maintain its tension (by the oxygen received from the last decomposed oxyhæmoglobin) at a point which will prevent the liberation of any more oxygen from such red corpuscles as have not yet given all theirs up. The blood will now go on as ordinary venous blood into the veins of the muscle and so back to the lungs. It will consist of (1) *plasma* with oxygen dissolved in it at a tension of about 25 millimeters (1 inch)\* of mercury. (2) A number of red corpuscles containing reduced hæmoglobin. (3) A number of red corpuscles containing oxyhæmoglobin. Or perhaps all of the red corpuscles will contain some reduced and some oxidized hæmoglobin. The relative proportion of reduced and unreduced hæmoglobin will depend on how active the muscle was; if it worked while the blood flowed through it it will have used up more oxygen, and the blood leaving it will consequently be more venous, than if it rested. This

venous blood, returning to the heart, is sent on to the pulmonary capillaries. Here, the partial pressure of oxygen in the air-cells being 130 mm. (5.2 inches) and that in the blood plasma much less, oxygen will be taken up by the latter, and the tension of that gas in the plasma tend to be raised above the limit at which hemoglobin combines with it. Hence, as fast as the plasma gets oxygen those red corpuscles which contain any reduced hemoglobin rob it, and so its oxygen tension is kept down below that in the air-cells until all the hemoglobin is satisfied. Then the oxygen tension of the plasma rises to that of the gas in the air-cells; no more oxygen is absorbed, and the blood returns to the left auricle of the heart in the same condition, so far as oxygen is concerned, as when we commenced to follow it.

**The Carbon Dioxide of the Blood.** The same general laws apply to this as to the blood oxygen. The gas is partly merely dissolved and partly in a loose chemical combination much like that of oxygen with hemoglobin, but the body with which it combines in this way exists in the plasma and not in the red corpuscles; what it may be is not certainly known. Besides this, some more carbon dioxide is stably combined and is only given off on the addition of a stronger acid. The partial pressure of carbon dioxide in the pulmonary air-cells is about 40mm. (1.6 inches) of mercury. Therefore the tension of that gas in the pulmonary capillaries must be more than this. On the other hand its tension in arterial blood must be less than that in the lymph around the tissues; otherwise it could not enter the blood in the systemic circulation, which it does, as proved by the fact that 100 vols. of venous blood give off 60 of this gas, and 100 vols. of arterial only 50.

The nitrogen contained in the blood is, so far as we know, quite unimportant.

**Internal Respiration.** As to the amount of oxygen used by each tissue and the quantity of carbon dioxide produced by it we know but little; the following points seem, however, tolerably certain:—

1. The amount of carbon dioxide produced in an organ



**DIESE SEITE IST FÜR KOSTENLOSE MITGLIEDER GESPERRT**  
Beantragen Sie jetzt die volle Mitgliedschaft, um diese Seite zu betreten

# GESCHICHTE

Zehntausende von wichtigen historischen Quellen, viele bisher nicht erhältlich, stehen jetzt zum ersten Mal mit der Vollmitgliedschaft von Forgotten Books zur Verfügung.

Unbegrenzter Zugang  
\$8.99/monat

**Fortfahren**

\*Es gelten Richtlinien zur fairen Nutzung.



and digested. The activity of the muscles and the digestive glands is dependent on processes which give rise to a large production of carbon dioxide and, during the night, when both are at rest, more oxygen is taken up than is contained in the carbon dioxide eliminated. If a man works and takes his meals at night, and sleeps in the day, the usual ratios of his gaseous exchanges with the exterior are entirely reversed.

4. The amount of work that a man's organs do, is not dependent on the amount of oxygen supplied to them, but the amount of oxygen used by him depends on how much he uses his organs. The quantity of oxygen supplied must of course always be, at least, that required to prevent suffocation; but an excess above this limit will not make the tissues work. Just as a man must have a certain amount of food to keep him alive, so he must have a certain amount of oxygen; but as extra food will not make his tissues or *him* (who is physiologically the sum of all his tissues) work, apart from some stimulus to exertion, so it is with oxygen. Highly arterialized blood, or an abnormal amount of blood, flowing through an organ will not arouse it to activity; the working organ, muscle (p. 257) or gland (p. 269), for example, usually gets more blood to supply its extra needs—just as a healthy man who works will have a better appetite than an idle one; but as taking more food by an idle man will not of itself make him more energetic, so neither will sending more arterial blood through an organ excite it to activity.

5. The preceding statement is confirmed by experiments which show that an animal uses no more oxygen in an hour when made to breathe that gas in a pure state, than when allowed to breathe ordinary air. In other words, the amount of oxygen an animal uses (provided it gets the minimum necessary for health) is dependent only on how much it uses its tissues. These (the rest in most cases subject to a certain amount of control from the nervous) determine their own activity, and this, in turn, how much oxygen shall be used in the systemic circulation and re-

stored in the pulmonary. In other words, the physiological work of an animal, which in turn is largely dependent upon how external forces act upon it, determines how much oxygen it uses daily; and not the supply of oxygen how much its tissue activity shall be, unless the supply sinks below the starvation limit.



## CHAPTER XXVI.

### THE NERVOUS FACTORS OF THE RESPIRATORY MECHANISM. ASPHYXIA.

**The Respiratory Centre.** The respiratory movements are to a certain extent under the control of the will; we can breathe faster or slower, shallower or more deeply, as we wish, and can also "hold the breath" for some time—but the voluntary control thus exerted is limited in extent; no one can commit suicide by holding his breath. In ordinary quiet breathing the movements are quite involuntary; they go on perfectly without the least attention on our part, and, not only in sleep, but during the unconsciousness of fainting or of an apoplectic fit. The natural breathing movements are therefore either reflex or automatic.

The muscles concerned in producing the changes in the chest which lead to the entry or exit of air are of the ordinary striped kind; and these, as we have seen, only contract in the Body under the influence of the nerves going to them; the nerves of the diaphragm are the two phrenic nerves (p. 161), one for each side of it; the external intercostal muscles are supplied by certain branches of the dorsal spinal nerves, called the intercostal nerves. If the phrenic nerves be cut the diaphragm ceases its contractions, and a similar paralysis of the external intercostals follows section of the intercostal nerves.

Since the inspiratory muscles only act when stimulated by nervous impulses reaching them, we have next to seek where these impulses originate; and experiment shows that it is in the *medulla oblongata*. All the brain of a cat or a rabbit in front of the medulla can be removed, and it will still go on breathing; and children are sometimes born with



**DIESE SEITE IST FÜR KOSTENLOSE MITGLIEDER GESPERRT**  
Beantragen Sie jetzt die volle Mitgliedschaft, um diese Seite zu betreten



**Seien Sie niemals ohne ein Buch!**

Die Vollmitgliedschaft von Forgotten Books bietet Ihnen einen universalen Zugang von unseren Apps und unserer Website, auf all Ihren Geräten: Tablet, Telefon, E-Reader, Laptop und Computer.

**Eine Bibliothek in Ihrer Tasche für € 8.99/monat**

**Fortfahren**

\*Es gelten Richtlinien zur fairen Nutzung.

largely under reflex control; a dash of cold water on the skin, the irritation of the nasal mucous membrane by snuff, or of the larynx by a foreign body, will each cause a modification in the respiratory movements—a long inspiration, a sneeze, or a cough. But, although thus susceptible to influences reaching it by afferent nerves, the respiratory centre seems essentially independent of such. In animals, as rabbits, (and in some men,) marked breathing movements take place in the nostrils, which dilate during inspiration; and when the spinal cord of a rabbit is cut to the medulla, thus cutting off all afferent nervous pulses to the respiratory centre except such as may reach it through cranial nerves, the respiratory movements in the nostrils still continue until death. The movements of the ribs and diaphragm of course cease, and so the animal dies very soon unless artificial respiration be maintained. Moreover, if after cutting the spinal cord as above described all afferent cranial nerves be divided, so as to cut off all respiratory centre from all possible afferent nervous pulses, the regular breathing movements of the nostrils continue. It is, therefore, obvious that the activity of the respiratory centre, however much it may be capable of modification through sensory nerves, is essentially independent of them; in other words the normal respiratory movements are not reflex.

**What it is that Excites the Respiratory Centre.** The thing that, above all others, influences the respiratory centre is the greater or less venosity of the blood flowing through it. If this blood be very rich in oxygen and comparatively poor in carbon dioxide the respiratory centre acts but feebly and the respirations are shallow. If, on the other hand, the blood be highly venous the respiratory movements are rapid than normal, and forced, the extraordinary muscular respiration being called into play; this state of very labored respiration, due to deficient aëration of the blood, is called *dyspnœa*. Normal quiet breathing is *eupnœa*. If the blood be highly aërated, as by keeping up forced artificial respiration for a time, all respiratory movements cease. Highly oxygenated blood does not excite the respi-

centre, and the animal therefore remains without breathing at all for some time; this condition is *apnoea*, though physicians by the word *apnoea* commonly mean merely extreme dyspnoea. If an animal be made apnoeic and the artificial respiration stopped, its blood, during the cessation of the respiratory movements, gradually losing oxygen and receiving carbon dioxide, passes into the state of ordinary blood and again stimulates the respiratory centre, and the breathing movements then recommence.

How it is that highly venous blood causes great excitation of the respiratory centre, and highly arterial cessation of its activity, is not certainly known; but we may make the following provisional hypothesis. The chemical changes occurring in the respiratory centre give rise to a substance or substances which stimulate its nerve-cells. When the blood is richly supplied with oxygen this substance is oxidized and removed as fast as it is formed, and so the centre is not excited. When the blood, on the other hand, is unusually poor in oxygen, this stimulating body accumulates and the respiratory discharges become more powerful. Under normal circumstances the blood oxygen is not kept quite up to the point of entirely removing this exciting substance, and the centre is stimulated so far as to produce the natural breathing movements but not the more forced ones of dyspnoea. That the stimulating cause, whatever it is, acts upon the respiratory centre and not upon the various organs of the Body and through their sensory nerves, in turn, upon the medulla, is proved not only by the facts above cited showing that the respiratory centre continues to act when all afferent nerves are cut off from it, but also by experiments which show that the circulation of venous blood through the body of an animal, while at the same time its respiratory centre is supplied with arterial blood, does not produce dyspnoea; while sending venous blood to the medulla and arterial to all the rest of the Body does cause dyspnoea.

**Why are the Respiratory Discharges Rhythmic?** Every complete respiratory act consists of an inspiration, an expiration and a pause; and then follows the inspiration of the

next act. In natural quiet breathing there is no essential difference between the expiration and the pause. The inspiration is the only active part (p. 353); the expiration and the pause are dependent on muscular inactivity and, therefore, on the cessation of the discharge of nervous impulses from the respiratory centre. But then, we may ask, if in accordance with the hypothesis made in the last paragraph, the respiratory centre is constantly being excited, why is it not always discharging? why does it only send out nervous impulses at intervals? This question, which is essentially the same as that why the heart beats rhythmically, belongs to the higher regions of Physiology and can only at present be hypothetically answered. Let us consider, for a moment, ordinary mechanical circumstances under which a steady supply is turned into an intermittent discharge. Suppose a tube closed water-tight below by a hinged plate, which is kept shut by a spring. If a steady stream of water is poured into the tube from above, the water will rise until its weight is able to overcome the pressure of the spring, and the plate will then be forced down and some water flow out. The spring will then press the plate up again, and the water accumulate until its weight again forces open the bottom of the tube, and there is another outrush; and so on. By opposing a certain resistance to the exit we could thus turn a steady inflow into a rhythmic outflow. Or, take the case of a tube with one end immersed in water and a steady stream of air sent into its other end. The air will emerge from the immersed end, not in a steady current, but in a series of bubbles. Its pressure in the tube must rise until it is able to overcome the cohesive force of the water, and then a bubble bursts forth; after this the air has again to get up the requisite pressure in the tube before another bubble is ejected; and so the continuous supply is transformed into an intermittent delivery. Physiologists suppose something of the same kind to occur in the respiratory centre. Its nerve-cells are always, under usual circumstances, being excited; but, to discharge a nervous impulse along the efferent respiratory nerves, they have to overcome a certain resistance. The nervous impulses have



**DIESE SEITE IST FÜR KOSTENLOSE MITGLIEDER GESPERRT**  
Beantragen Sie jetzt die volle Mitgliedschaft, um diese Seite zu betreten

# GESCHICHTE

Zehntausende von wichtigen historischen Quellen, viele bisher nicht erhältlich, stehen jetzt zum ersten Mal mit der Vollmitgliedschaft von Forgotten Books zur Verfügung.

Unbegrenzter Zugang  
\$8.99/monat

**Fortfahren**

\*Es gelten Richtlinien zur fairen Nutzung.



parts, and might therefore be suspected to have something to do with breathing. That they are not concerned in influencing the respiratory muscles directly is shown by the fact that all of these muscles (except certain small ones in the larynx) contract as usual in breathing after both pneumogastric nerves have been divided. Still, the section of both nerves has a considerable influence on the respiratory movements; they become *slower and deeper*. We may understand this by supposing that the resistance to the discharge of the respiratory centre is liable to variation. It may be increased, and then the discharges will be fewer and larger; or diminished, and then they will be more frequent but each one less powerful. If the spring, in the illustration used in the preceding paragraph, be made stronger, while the inflow of water to the tube remains the same, the outflows will be less frequent but each one greater; and *vice versa*. The effect of section of the pneumogastric trunk may, therefore, be explained if we suppose that, normally, it carries up, from its lung branches, nervous impulses which diminish the resistance to the discharges of the respiratory centre; when the nerves are cut these helping impulses are lost to the centre, and its impulses must gather more head before they break out, but will be greater when they do. This view is confirmed by the fact that stimulation of the central ends of the divided pneumogastrics, if weak, brings back the respirations to their normal rate and force; if stronger makes them more rapid and shallower; and when stronger still, abolishes the respiratory rhythm altogether, with the inspiratory muscles in a steady state of feeble con-

traction. That is to say, the resistance to the discharges of the centre being entirely taken away (which is equivalent to the total removal of the spring in our example), the centre sends out uninterrupted and non-rhythmic stimuli to the inspiratory muscles.

The pneumogastric nerve gives two branches to the larynx; known respectively as the *superior* and *inferior (recurrent) laryngeal* nerves; the action of these on the respiratory centre is opposite to that of the fibres from the lungs coming up in the main pneumogastric trunk. If the superior laryngeal branch be divided and its central end stimulated, the respirations become less frequent but each one more powerful; hence this nerve is supposed to increase the resistance to the discharges of the respiratory centre. The same, but to a less degree, is true of the inferior laryngeal branch.

**The Expiratory Centre.** Hitherto we have considered breathing as due to the rhythmically alternating activity and rest of an inspiratory centre—and such is the case in normal quiet breathing, in which the expirations are passive. But in dyspnoea expiration is a muscular act, and so there must be a section of the respiratory centre controlling the expiratory muscles. This part of the respiratory centre, however, is less irritable than the inspiratory part, and hence when the blood is in a normal state of aëration never gets stimulated up to the discharging point. In dyspnoea the stimulus becomes sufficient to cause it also to discharge, but only after the more irritable inspiratory centre; hence the expiration follows the inspiration. This alternation of activity is, moreover, promoted by the fact that the pneumogastric nerve-fibres coming up from the lungs are of two kinds. The predominant sort are those already referred to, which diminish the resistance to discharge of the inspiratory centre, and perhaps also increase the resistance to the expiratory discharge. This set is excited when the lungs diminish in bulk, as in expiration; and when the whole nerve is stimulated electrically they usually get the better of the other set, which carry up to the medulla impulses which increase the resistance to in-



spiratory discharges and diminish that to expiratory, and are stimulated when the lungs expand. Hence, every expansion of the lungs (inspiration) tends to promote an expiration, and every collapse of the lungs (expiration) tends to produce an inspiration; and so, through the pneumogastric nerves, the respiratory mechanism is largely self-regulating.

**Asphyxia.** Asphyxia is death from suffocation, or want of oxygen by the tissues. It may be brought about in various ways; as by strangulation, which prevents the entry of air into the lungs; or by exposure in an atmosphere containing no oxygen; or by putting an animal in a vacuum; or by making it breathe air containing a gas which has a stronger affinity for hæmoglobin than oxygen has, and which, therefore, turns the oxygen out of the red corpuscles and takes its place. The gases which do the latter are very interesting since they serve to prove conclusively that the Body can only live by the oxygen carried round by the hæmoglobin of the red corpuscles; that amount dissolved in the blood plasma being insufficient for its needs. Of such gases carbon monoxide is the most important and best studied; in the favorite French mode of committing suicide by stopping up all the ventilation holes of a room and burning charcoal in it, it is poisoning by carbon monoxide which causes death.

**The Relations of Carbon Monoxide to Hæmoglobin.** If aerated whipped blood, or a solution of oxyhæmoglobin, be exposed to a gaseous mixture containing carbon monoxide, the liquid will absorb the latter gas and give off oxygen. The amount of carbon monoxide taken up will (apart from a small amount dissolved in the plasma) be independent of the partial pressure of that gas in the gaseous mixture to which the blood is exposed; the quantity absorbed depends on the quantity of hæmoglobin in the liquid, and is replaced by an equal volume of oxygen liberated. This equivalence of volume, of itself, proves that the phenomenon is due to the chemical replacement of oxygen in some compound, by the carbon monoxide; for if the carbon monoxide were merely dissolved in the liquid in



**DIESE SEITE IST FÜR KOSTENLOSE MITGLIEDER GESPERRT**  
Beantragen Sie jetzt die volle Mitgliedschaft, um diese Seite zu betreten



**Seien Sie niemals ohne ein Buch!**

Die Vollmitgliedschaft von Forgotten Books bietet Ihnen einen universalen Zugang von unseren Apps und unserer Website, auf all Ihren Geräten: Tablet, Telefon, E-Reader, Laptop und Computer.

**Eine Bibliothek in Ihrer Tasche für € 8.99/monat**

**Fortfahren**

\*Es gelten Richtlinien zur fairen Nutzung.

of the inspiratory. Thus undue want of oxygen merely brings about an increased activity of the respiratory centre, and especially of its expiratory division which is excited in normal breathing. Then it stimulates convulsions (the *convulsive centre*) of the medulla oblongata and gives rise to violent and irregular muscular contractions. That the convulsions are due to excitation of nerves in the medulla (and not, as might be supposed, to stimulation of the muscles by the extremely venous blood) is proved by the facts (1) that they do not occur in the trunk of an animal when the spinal cord has been divided in the neck, and (2) that they occur if (the spinal cord remaining undivided) the parts of the brain in front of the medulla have been removed.

The violent excitation of the nerve-centres soon ceases, and all the more readily since their oxygen supply (which they like all other tissues need in order to maintain their activity) is cut off. The convulsions therefore gradually cease, and the animal becomes calm again, save for occasional acts of breathing when the oxygen want is so great as to cause efficient stimulation even of the respiratory centre: these final movements are convulsions and, becoming less and less frequent, at last

**Circulatory Changes in Asphyxia.** During death by suffocation characteristic changes occur in the working of the heart and blood-vessels. The heart at first beats quicker, but very soon, before the end of the dyspnoëic stage, more slowly, though, at first, more powerfully. This slowing is due to the fact that the unusual want of oxygen leads to stimulation of the cardio-inhibitory centre in the medulla (p. 250) and this, through the pneumogastric nerves, slows the heart's beat. Soon, however, the want of oxygen affects the heart itself and it begins to beat more feebly, and also more slowly, from exhaustion, until its final stoppage. During the second and third stages the heart and the venæ cavæ become greatly overfilled with blood, because the violent muscular contractions facilitate the flow of blood to the heart, while its beats become too feeble to send it out again. The overfilling is most marked on the right side of the heart which receives the venous blood from the Body generally.

During the first and second stages of asphyxia arterial pressure rises in a marked degree. This is due to excitation of the vaso-motor centre (p. 254) by the venous blood, and the consequent constriction of the muscular coats of the arteries and increase of the peripheral resistance. In the third stage the blood-pressure falls very rapidly, because the feebly acting heart then fails to keep the arteries

tense, even although their diminished calibre greatly ~~affairs~~ the rate at which they empty themselves into the capillaries.

Another medullary centre unduly excited during asphyxia is that from which proceed the nerve-fibres governing those muscular fibres of the eye which enlarge the pupil. During suffocation, therefore, the pupils become widely dilated. At the same time all reflex irritability is lost, and touching the eyeball causes no wink; the reflex centres all over the Body being rendered, through want of oxygen, incapable of activity. The same is true of the higher nerve-centres; unconsciousness comes on during the convulsive stage, which, horrible as it looks, is unattended with suffering.

**Modified Respiratory Movements.** *Sighing* is a deep long-drawn inspiration followed by a shorter but correspondingly large expiration. *Yawning* is similar, but the air is mainly taken in by the month instead of the nose, and the lower jaw is drawn down in a characteristic manner. *Hiccough* depends upon a sudden contraction of the diaphragm, while the aperture of the larynx closes; the entering air, drawn through the narrowing opening, causes the peculiar sound. *Coughing* consists of a full inspiration followed by a violent and rapid expiration, during the first part of which the laryngeal opening is kept closed; being afterwards suddenly opened, the air issues forth with a rush, tending to carry out with it anything lodged in the windpipe or larynx. *Sneezing* is much like coughing, except that, while in a cough the isthmus of the fauces is held open and the air mainly passes out through the month, in sneezing the fauces are closed and the blast is driven through the nostrils. It is commonly excited by irritation of the nasal mucous membrane, but in many persons a sudden bright light falling into the eye will produce a sneeze. *Laughing* consists of a series of short expirations following a single inspiration; the larynx is open all the time, and the vocal chords (Chap. XXXVI.) are set in vibration. *Crying* is, physiologically, much like laughing and, as we all know, one often passes into the other. The accompanying contrac-



**DIESE SEITE IST FÜR KOSTENLOSE MITGLIEDER GESPERRT**  
Beantragen Sie jetzt die volle Mitgliedschaft, um diese Seite zu betreten

# GESCHICHTE

Zehntausende von wichtigen historischen Quellen, viele bisher nicht erhältlich, stehen jetzt zum ersten Mal mit der Vollmitgliedschaft von Forgotten Books zur Verfügung.

Unbegrenzter Zugang  
\$8.99/monat

**Fortfahren**

\*Es gelten Richtlinien zur fairen Nutzung.



# CHAPTER XXVII.

## THE KIDNEYS AND SKIN.

**General Arrangement of the Urinary Organs.** These consist of (1) the *kidneys*, the glands which secrete the urine; (2) the *ureters* or ducts of the kidneys, which carry their secretion to (3) the *urinary bladder*, a reservoir in which it accumulates and from which it is expelled from time to time through (4) an exit tube, the *urethra*. The general arrangement of these parts, as seen from behind, is shown in the figure opposite. The kidneys, *R*, lie in the dorsal part of the lumbar region of the abdominal cavity, one on each side of the middle line. Each is a solid mass, with a convex outer and a concave inner border, and its upper end a little larger than the lower. From the abdominal aorta, *A*, a *renal artery*, *Ar*, enters the inner border of each kidney, to break up within it into finer branches, ultimately ending in capillaries. The blood is collected from these into the *renal veins*, *Vr*, one of which leaves each kidney and opens into the inferior vena cava, *Vc*. From the concave border of each kidney proceeds also the *ureter*, *U*, a slender tube from 28 to 34 cm. (11 to 13.5 inches) long, opening below into the bladder, *Vu*, on its dorsal aspect, and near its lower end. From the bladder proceeds the urethra, at *Ua*. The channel of each ureter passes very obliquely through the wall of the bladder to open into it; accordingly if the pressure inside the latter organ rises above that of the liquid in the ureter, the walls of the oblique passage are pressed together and

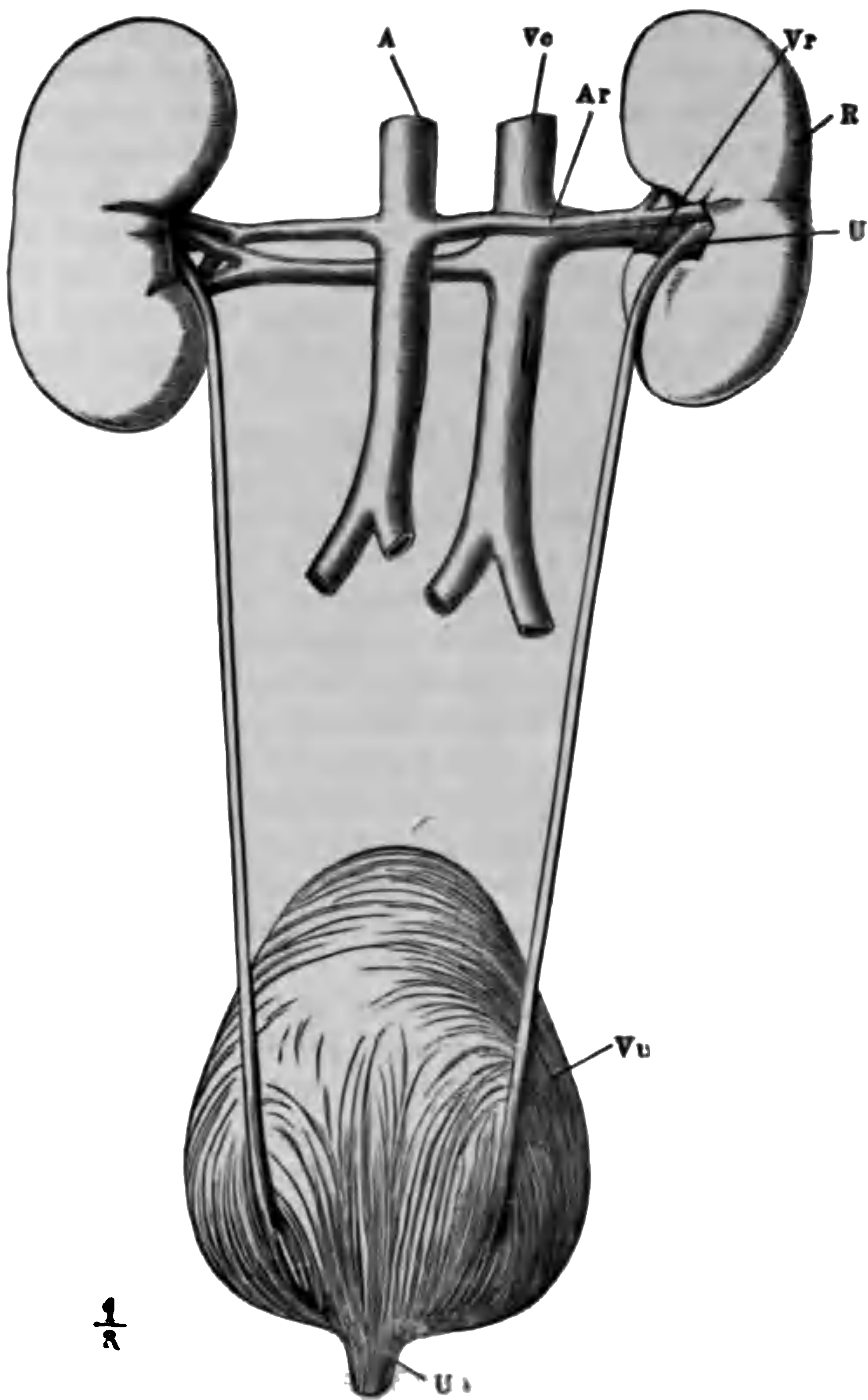

FIG. 114.—The renal organs, viewed from behind. *R*, right kidney; *A*, aorta; *Ar*, right renal artery; *Vc*, inferior vena cava; *Vr*, right renal vein; *U*, right ureter; *Vu*, bladder; *Ua*, commencement of urethra.



it is closed. Usually the bladder, which has a thick coat of unstriped muscular tissue lined by a mucous membrane, is relaxed, and the urine flows readily into it from the ureters. The commencement of the urethra being kept closed by elastic tissue around it (which can voluntarily be reinforced by muscles which compress the tube) the urine accumulates in the bladder. When this latter contracts and presses on its contents, the ureters are closed in the way above indicated, the elastic fibres closing the urethral exit from the bladder are overcome, and the liquid forced out.

**Naked Eye Structure of the Kidneys.** These organs have externally a red-brown color, which can be seen through the transparent *capsule* of peritoneum which envelops them. When a section is carried through a kidney from its outer to its inner border (Fig. 115) it is seen that a deep fissure, the *hilus*, leads into the latter. In the *hilus* the ureter widens out to form the *pelvis*, which breaks up again into a number of smaller divisions, the cups or *calices*. The cut surface of the kidney proper is seen to consist of two distinct parts; an outer or *cortical portion*, and an inner or *medullary*. The medullary portion is less red and more glistening to the eye, is finely striated in a radial direction, and does not consist of one continuous mass but of a number of conical portions, the *pyramids of Malpighi*, 2', each of which is separated from its neighbors by an inward prolongation,\* of the cortical substance. This, however, does not reach to the inner end of the pyramid, which projects, as the *papilla*, into a calyx of the ureter. At its outer end each pyramid separates into smaller portions, the *pyramids of Ferrein*, 2', separated by thin layers of cortex and gradually spreading everywhere into the latter. The cortical substance is redder and more granular looking and less shiny than the medullary, and forms everywhere the outer layer of the organ next its capsule, besides dipping in between the pyramids in the way described.

The renal artery divides in the hilus into branches (5) which run into the kidney between the pyramids, giving off a few twigs to the latter and ending finally in a much



**DIESE SEITE IST FÜR KOSTENLOSE MITGLIEDER GESPERRT**  
Beantragen Sie jetzt die volle Mitgliedschaft, um diese Seite zu betreten



**Seien Sie niemals ohne ein Buch!**

Die Vollmitgliedschaft von Forgotten Books bietet Ihnen einen universalen Zugang von unseren Apps und unserer Website, auf all Ihren Geräten: Tablet, Telefon, E-Reader, Laptop und Computer.

**Eine Bibliothek in Ihrer Tasche für € 8.99/monat**

**Fortfahren**

\*Es gelten Richtlinien zur fairen Nutzung.

side, into the cortex and there dilates and is twisted. It then narrows and doubles back again into the pyramid and runs as a straight tube towards the papilla, but before reaching it makes a loop, and turns back again as a straight tube to the base of the pyramid, where it once more enters the cortex, dilates and becomes contorted, and then ends in a spherical capsule, containing a tuft of small blood-vessels. Or, followed the other way, each tubule commences in the cortex with a globular dilatation, the *Malpighian capsule*. From this it continues as a convoluted tubule in the cortex; this passes into a pyramid, becomes straight, and runs on as the *descending limb* of a *loop of Henle*. Turning at the loop, it continues as its *ascending limb*, and this passes out again into the cortex and becomes the convoluted *junctional tubule*, which passes as a straight *collecting tubule* into the pyramid and there joins others to form an *excretory tubule* which opens on the papilla. Throughout its course the tubule is lined by a single layer of epithelium cells differing in character in its different sections. All the tubes are bound together by connective tissue and blood-vessels to form the gland.

**The Blood-Flow through the Kidney.** The final twigs of the renal artery in the cortex, giving off a few branches which end in a capillary network around the convoluted tubules, are continued as the *afferent vessels* of Malpighian capsules, the walls of which are doubled in before them (Fig. 116); there each breaks up into a little knot of capillary vessels called the *glomerulus*, from which ultimately an *efferent vessel* proceeds, and outside the capsule this breaks up into a close capillary network among the convoluted tubes. From the capillaries the blood is collected

into the renal vein. Most of the blood flowing through the kidney thus goes through two sets of capillaries; one in the capsules, and a second formed by the breaking up of the efferent vein of the latter. The capillary network in the pyramids is much less close than that in the cortex, which gives reason to suspect that most of the secretory work of the kidneys is done in the capsules and convoluted tubules. The pyramidal blood flows only through one set of capillaries, there being no glomeruli in the kidney medulla.

**The Renal Secretion.** The amount of this carried off from the Body in 24 hours is subject to considerable variation, being especially diminished by anything which promotes perspiration, and increased by conditions, as cold to the surface, which diminish the skin excretion. Its average daily quantity varies from 1200 to 1750 cub. cent. (40 to 60 fluid ounces). The urine is a clear amber-colored liquid, of a slightly acid reaction; its specific gravity is about 1040, being higher when the total quantity excreted is small than when it is greater, since the amount of solids dissolved in it remains nearly the same in health; the changes in its bulk being dependent mainly on changes in the amount of water separated from the blood by the kidneys.

Normal urine consists, in 1000 parts, of about 960 water and 40 solids. The latter are mainly crystalline nitrogenous bodies (*urea* and *uric acid*), but small quantities of pigments and of non-nitrogenous organic bodies are also present, and a considerable quantity of mineral salts. The following table gives approximately, in the first column, the

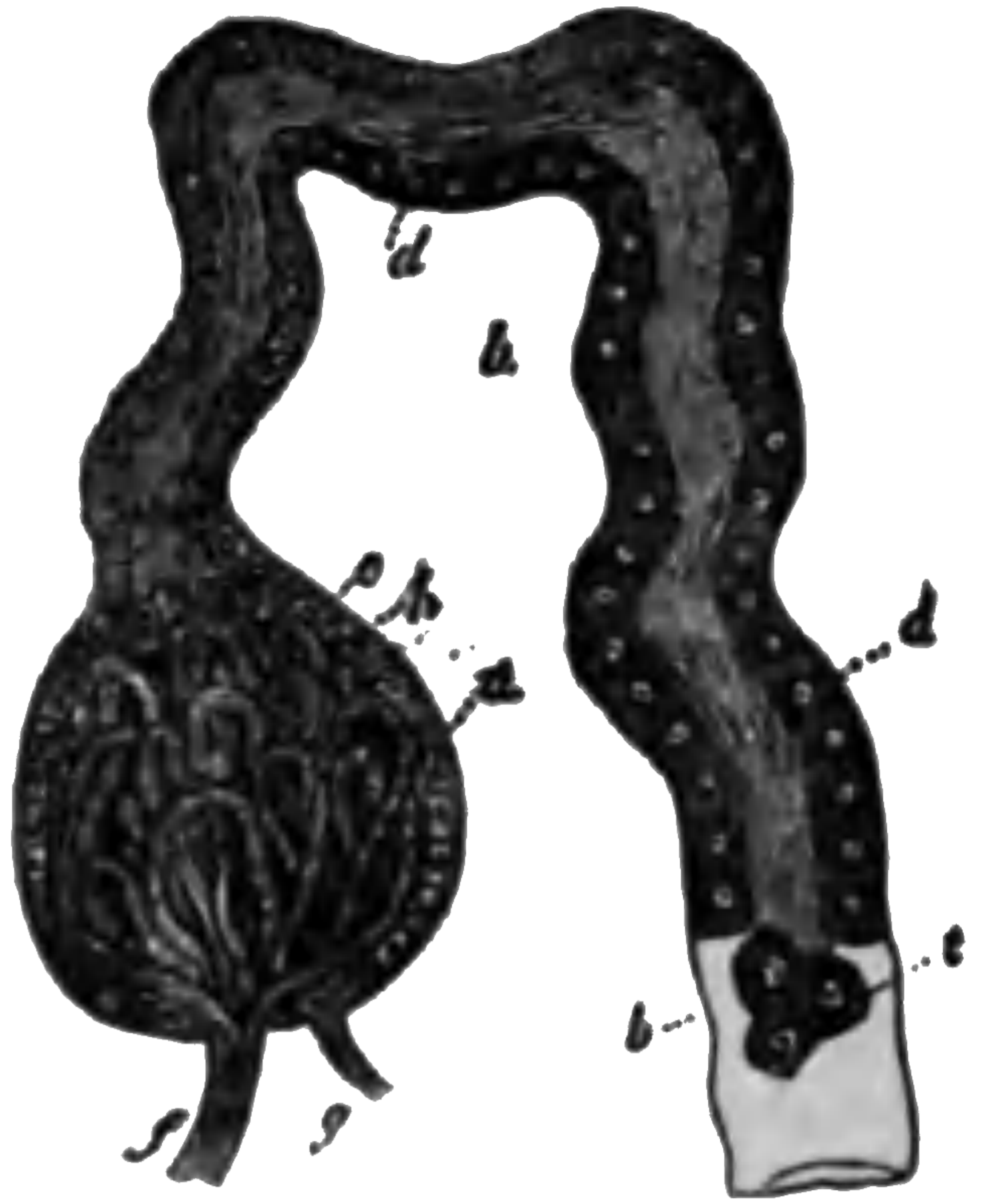

FIG. 116.—The termination of a uriniferous tubule, with its glomerulus. a, the glomerulus or Malpighian corpuscle; b, the convoluted ending of the tubule; d, its lining epithelium; f, the afferent blood-vessel of the glomerulus; g, the efferent vessel; c, h, the blood-vessels forming the tuft in the glomerulus.

average composition of the urine excreted in two hours expressed in grams; in the second column expressed in grains. The third column gives the portion of 1000 parts of urine.

Urine in 24 hours.	1000 grams.	23,250 grains.
Water.....	1428.00	22,134.00
Solids.....	72.00	1116.00
<b>The solids consists of—</b>		
Urea (CN <sub>2</sub> H <sub>4</sub> O).....	33.00	511.00
Uric acid (C <sub>5</sub> H <sub>4</sub> N <sub>4</sub> O <sub>6</sub> )....	0.50	7.75
Hippuric acid.....	0.40	6.20
Kreatinin.....	1.00	15.50
Pigments and fats.....	10.00	155.00
Sulphuric acid.....	2.00	31.00
Phosphoric acid.....	3.00	46.50
Chlorine.....	7.00	108.50
Ammonia.....	0.75	12.00
Potassium.....	2.50	38.75
Sodium.....	11.00	170.50
Calcium.....	0.25	3.80
Magnesium.....	0.20	3.00
	<b>71.60</b>	<b>1110.00</b>

The urine, however, even in health is subject to considerable variation in composition; not only as regards amount of water in it, but also in its solid constituents the latter are especially modified by the quantity and kind of the food taken.

100 volumes of urine contain in solution about 100 volumes of gas, consisting of about 13 of carbon dioxide and 87 of nitrogen, and mere traces of oxygen.

**Mechanism of the Renal Secretion.** The kidneys, the secreting organs, consist of two distinct parts; (1) the renal pelvis through which a filtration of water, probably with dissolved solids, takes place; and (2) an actively secretory apparatus, formed by all parts of the uriniferous tubules between their terminal capsules and the collecting tubes. Accordingly, we find in the urine bodies, as water and common salts which already exist in the blood and can be removed



**DIESE SEITE IST FÜR KOSTENLOSE MITGLIEDER GESPERRT**  
Beantragen Sie jetzt die volle Mitgliedschaft, um diese Seite zu betreten

# GESCHICHTE

Zehntausende von wichtigen historischen Quellen, viele bisher nicht erhältlich, stehen jetzt zum ersten Mal mit der Vollmitgliedschaft von Forgotten Books zur Verfügung.

Unbegrenzter Zugang  
\$8.99/monat

**Fortfahren**

\*Es gelten Richtlinien zur fairen Nutzung.



tinuous products of proteid degradation from which urea is made, are carried to the kidneys, and the final formation of urea occurs in these organs. The results of blood analysis are conflicting, but on the whole it seems proved that more urea exists in renal-artery blood than in renal-vein blood, which indicates that urea is not made in the kidneys. In death, too, from suppression of the renal reaction, urea is found to accumulate in the blood which would not be the case unless it were normally formed elsewhere and carried off by the kidneys. The whole urea question, which is one of great importance, will be more fully considered in Chapter XXVIII., in connection with the chemistry of nutrition in general.

The Skin, which covers the whole exterior of the Body, consists everywhere of two distinct layers; an outer, the *cuticle* or *epidermis*, and a deeper, the *dermis*, *cutis vera*, or *corium*. A blister is due to the accumulation of liquid between these two layers. The *hairs* and *nails* are excessively developed parts of the epidermis.

The Epidermis, Fig. 117, consists of cells, arranged in many layers, and united by a small amount of cementing substance. The deepest layer, *d*, is composed of elongated or columnar cells, set on with their long axis perpendicular to the corium beneath. To it succeed several strata of roundish cells, *b*, which in the outer layers become more and more flattened in a plane parallel to the surface. The outermost epidermic stratum is composed of many layers of extremely flattened cells from which the nuclei (conspicuous in the deeper layers) have disappeared. These superficial cells are dead and are constantly being shed from the surface of the Body, while their place is taken by new cells formed in the deeper layers, and pushed up to the surface and flattened in their progress. The change in the form of the cells as they travel outwards is accompanied by chemical changes, and they finally constitute a semi-transparent dry *horny stratum*, *a*, distinct from the deeper, more opaque and softer *Malpighian* or *mucous layer*, *c*, and *d*, of the epidermis. The cells of this latter are soluble in acetic acid; those of the horny stratum, not.

The rolls of material which are peeled off the skin in the "shampooing" of the Turkish bath, or by rubbing with a rough towel after an ordinary warm bath, are the dead outer scales of the horny stratum of the epidermis.

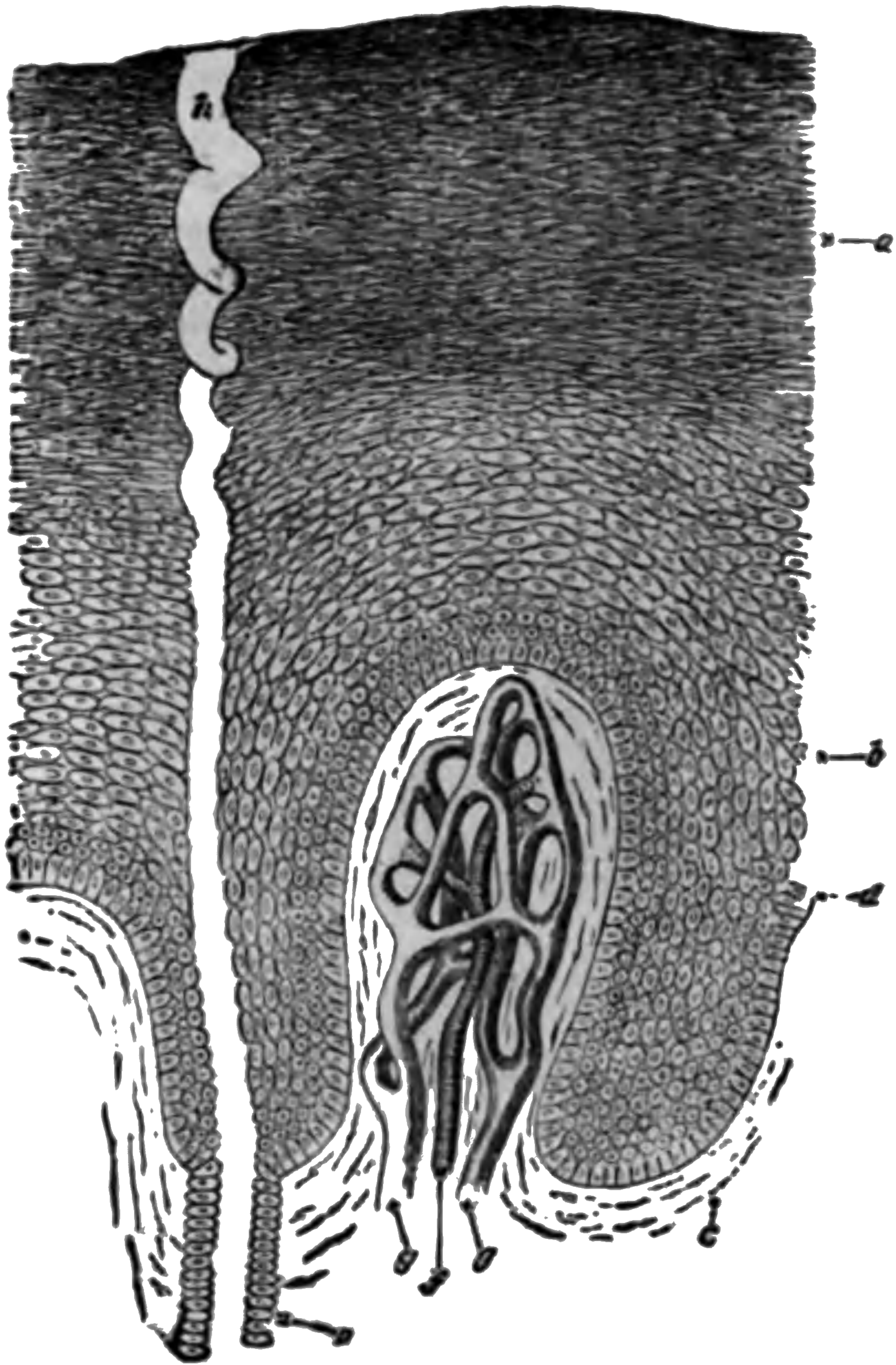

FIG. 117.—A section through the epidermis, somewhat diagrammatic, highly magnified. Below is seen a papilla of the dermis, with its artery, *f*, and veins, *gg*; *a*, the horny layer of the epidermis; *b*, the *rete mucosum* or Malpighian layer; *d*, the layer of columnar epidermic cells in immediate contact with the dermis; *h*, the duct of a sweat-gland.

In dark races the color of the skin depends mainly on minute *pigment granules* lying in the deeper cells of the Malpighian layer.



No blood-vessels or lymphatics enter the epidermis, which is entirely nourished by matters derived from the subjacent corium. Fine nerve-fibres run into it and end there among the cells, in various ways.

The Corium, Cutis Vera, or True Skin, Fig. 118, consists fundamentally of a close feltwork of elastic and white fibrous tissue, which, becoming wider meshed below, passes

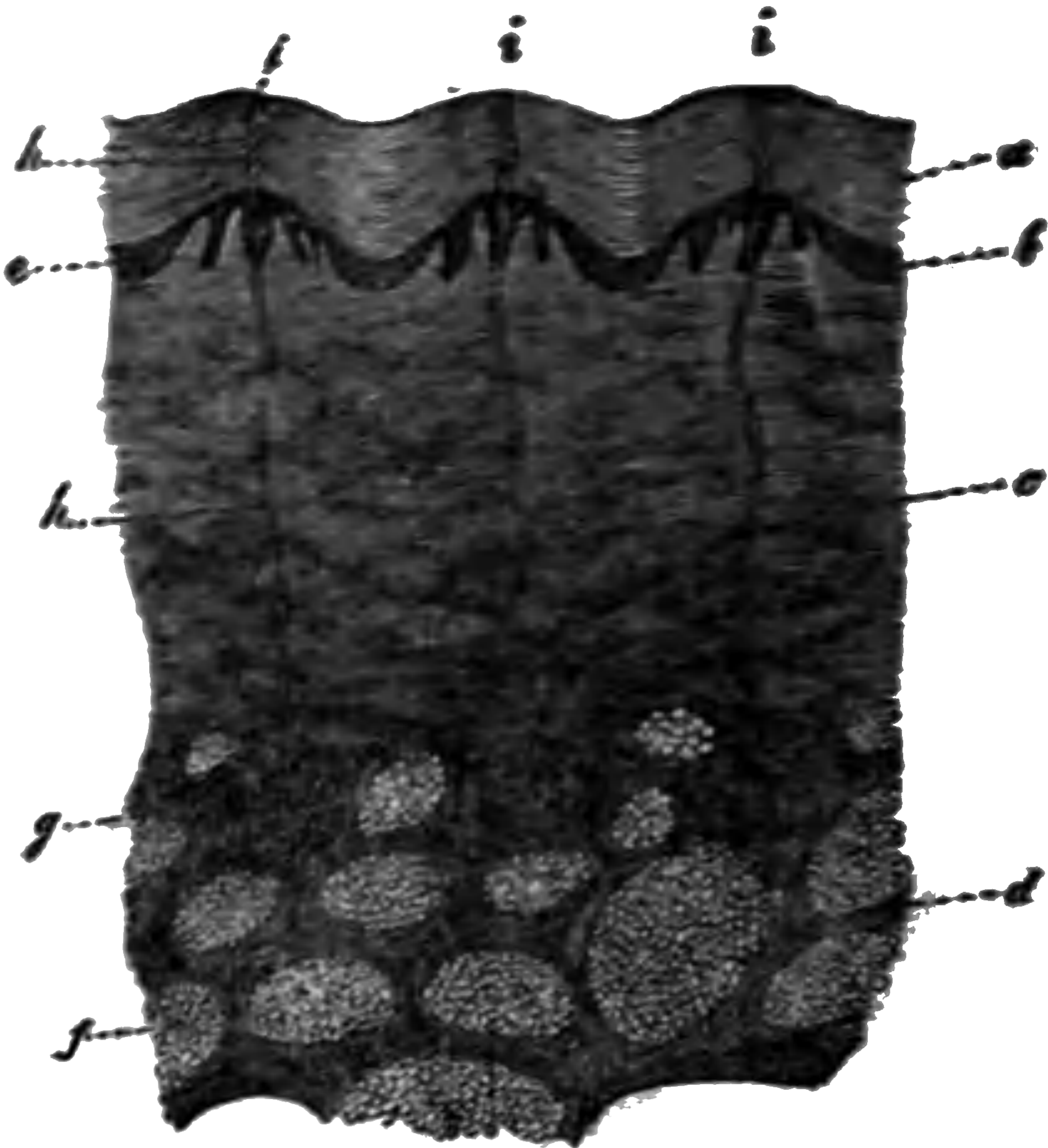

FIG. 118.—A section through the skin and subcutaneous areolar tissue. *a*, horny stratum, and *b*, Malpighian layer of the epidermis; *c*, dermis, passing below into, *d*, loose areolar tissue, with fat, *f*, in its meshes: above, dermic papillæ are seen, projecting into the epidermis which is moulded on them. *i*, opening of a sweat-gland; *h*, duct of ditto; *g*, the gland itself.

gradually into the *subcutaneous areolar tissue* (p. 102) which attaches the skin loosely to parts beneath. In tanning it is the *cutis vera* which is turned into leather, its white fibrous tissue forming an insoluble and tough compound with the tannin of the oak-bark employed. Wherever there are hairs, bundles of plain muscular tissue are found in the corium; it contains also a close capillary network



**DIESE SEITE IST FÜR KOSTENLOSE MITGLIEDER GESPERRT**  
Beantragen Sie jetzt die volle Mitgliedschaft, um diese Seite zu betreten



**Seien Sie niemals ohne ein Buch!**

Die Vollmitgliedschaft von Forgotten Books bietet Ihnen einen universalen Zugang von unseren Apps und unserer Website, auf all Ihren Geräten: Tablet, Telefon, E-Reader, Laptop und Computer.

**Eine Bibliothek in Ihrer Tasche für € 8.99/monat**

**Fortfahren**

\*Es gelten Richtlinien zur fairen Nutzung.

united to form fibres; and in the centre of the shaft there is found, in many hairs, a *medulla*, made up of more or less rounded cells. The color of hair is mainly dependent upon pigment granules lying between the fibres of the cortex. All hairs contain some air cavities, especially in the medulla. They are very abundant in white hairs and cause the whiteness by reflecting all the incident light, just as a liquid beaten into fine foam looks white because of the light reflected from the walls of all the little air cavities in it. In dark hairs the air cavities are few.

The hair follicle (Fig. 119) is a narrow pit of the dermis, projecting down into the subcutaneous areolar tissue, and lined by an involution of the epidermis. At the bottom of the

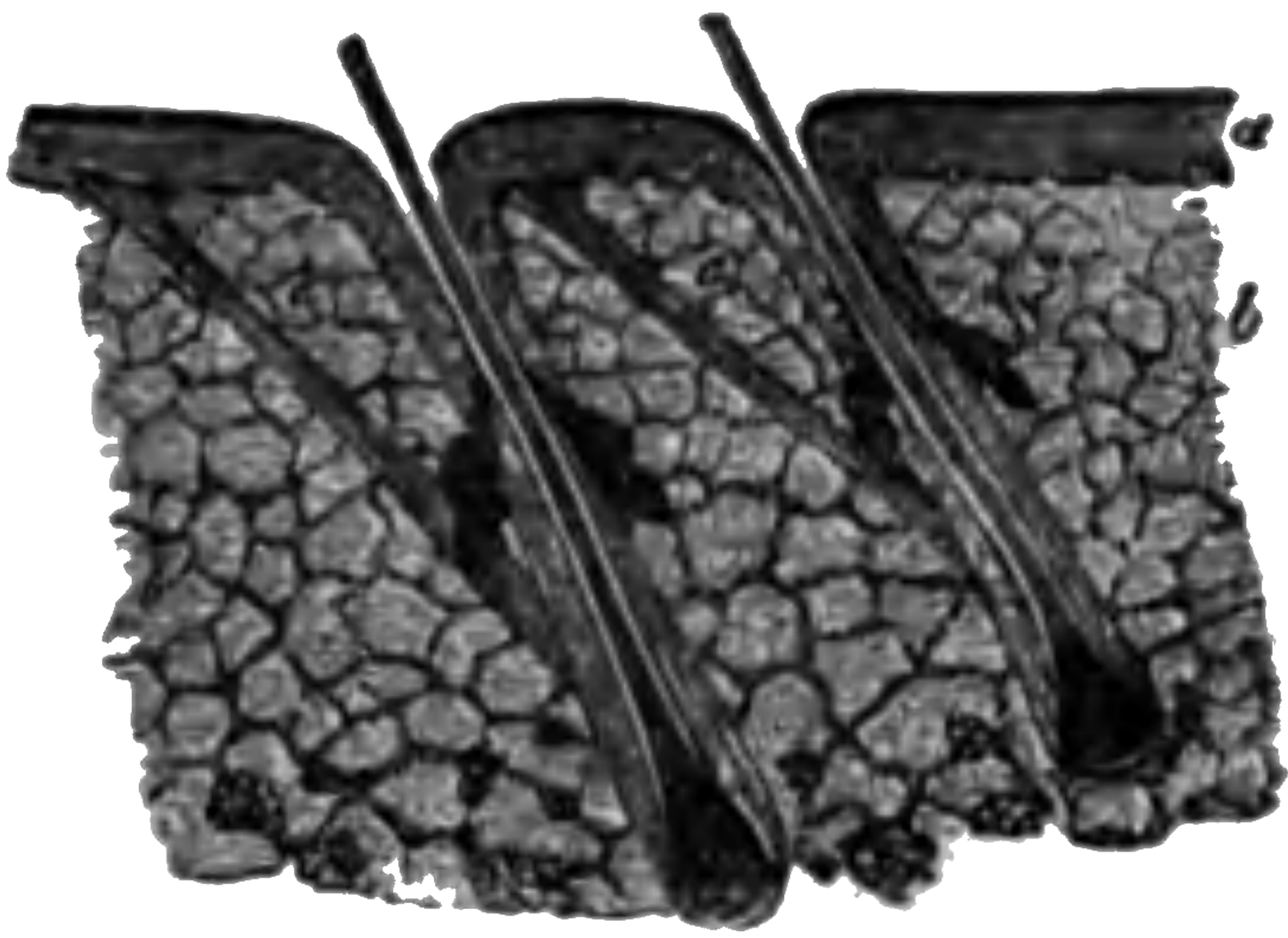

FIG. 119.—Parts of two hairs imbedded in their follicles. *a*, the skin, which is seen to dip down and line the follicle; *b*, the subcutaneous tissue; *c*, the muscles of the hair follicle, which by their contraction can erect the hair.

follicle is a papilla and the epidermis, turning up over this, becomes continuous with the hair. On the papilla epidermic cells multiply rapidly so long as the hair is growing, and the whole hair is there made up of roundish cells.

As these get pushed up by fresh ones formed beneath them, the outermost layer become flattened and form the hair cuticle; several succeeding layers elongate and form the cortex; while, in hairs with a medulla, the middle cells retain pretty much their original form and size. Pulled apart by the elongating cortical cells, these central ones then form the medulla with its air cavities. The innermost layer of the epidermis, lining the follicle, has its cells projecting, with overlapping edges turned downwards. Accordingly these interlock with the upward directed edges of the cells of the hair cuticle; consequently

the dermis to the side of the hair follicles. The latter are obliquely implanted in the skin so that the hairs lie down on the surface of the Body, and the muscles are so fixed that, when they shorten, they erect the hair and cause it to bristle, as may be seen in an angry cat, or sometimes in a greatly terrified man. Opening into each hair follicle are usually a couple of sebaceous glands (p. 418). Hairs are found on all regions of the skin except the palms of the hands and the soles of the feet; the back of the last phalanx of the fingers and toes, the upper eyelids, and one or two other regions.

**Nails.** Each nail is a part of the epidermis, with its horny stratum greatly developed. The back part of the nail fits behind into a furrow of the dermis and is called its *root*. The visible part consists of a *body*, fixed to the dermis beneath (which forms the *bed of the nail*), and of a *free edge*. Near the root is a little area whiter than the rest of the nail and called the *lunula*. The whiteness is due in part to the nail being really more opaque there and partly to the fact that its bed, which seen through the nail causes its pink color, is in this region less vascular.

The portion of the corium on which the nail is formed is called its *matrix*. Behind, this forms a furrow lodging the root, and it is by new cells added on there that the nail grows in length. The part of the matrix lying beneath the body of the nail, and called its *bed*, is highly vascular and raised up into papillæ which, except in the region of the *lunula*, are arranged in longitudinal rows, slightly diverging as they run towards the tip of the finger or toe. It is by new cells formed on its bed and added to its under surface that the nail grows in thickness, as it is pushed forward by the new growth in length at its root. The free end of a nail is therefore its thickest part. If a nail is "cast" in consequence of an injury, or torn off, a new one is produced, provided the matrix is left.

The Glands of the Skin are of two kinds, the *sudoriparous* or *sweat glands*, and the *sebaceous* or *oil glands*. The former belong to the tubular, the latter to the racemose type. The *sweat-glands*, Fig. 120, lie in the subcu-

taneous tissue, where they form little globular masses composed of a coiled tube. From the coil a duct (sometimes

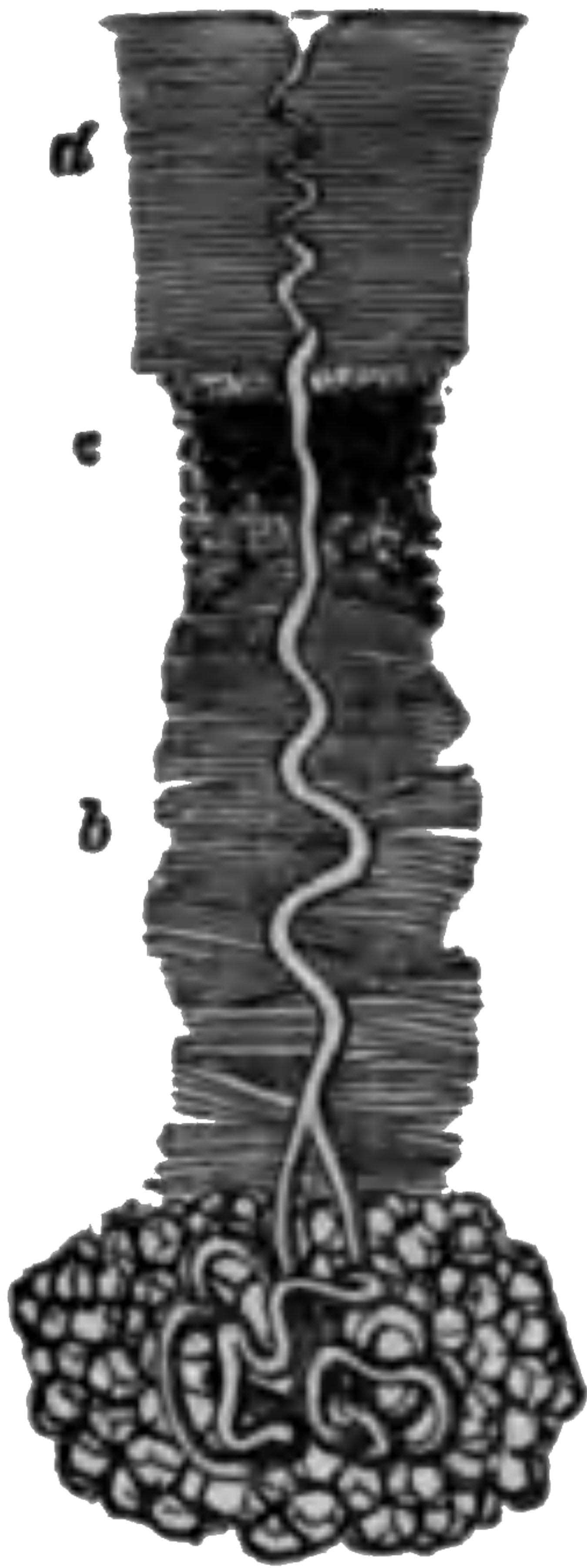

FIG. 120.—A sweat gland. *d*, horny layer of cuticle; *c*, Malpighian layer; *b*, dermis. The coils of the gland proper, imbedded in the subcutaneous fat, are seen below the dermis.

double) leads to the surface, being usually spirally coiled as it passes through the epidermis. The secreting part of the gland consists of a connective-tissue tube, continuous along the duct with the dermis; within this is a basement membrane and the final secretory lining consists of several layers of gland-cells. A close capillary network intertwines with the coils of the gland. Sweat-glands are found on all regions of the skin, but more closely set in some places, as the palms of the hands and the brow, than elsewhere. There are altogether about two and a half millions of them opening on the surface of the Body.

The *sebaceous glands* nearly always open into hair follicles, and are found wherever there are hairs. Each consists of a duct opening near the mouth of a hair follicle and branching at its other end: the final branches lead into globular secreting saccules, which, like the ducts, are lined with epithelium. In the saccules the substance of the cells becomes charged with oil-drops, the protoplasm disappearing; and finally the whole cell falls to pieces, its detritus constituting the secretion. New cells are, meanwhile, formed to take the place of those destroyed. Usually two glands are connected with each hair follicle, but there may be three or only one. A pair of sebaceous glands are represented on the sides of each of the hair follicles in Fig. 119.

**The Skin Secretions.** The skin besides forming a protective covering and serving as a sense-organ (Chap. XXXIV.) also plays an important part in regulating the temperature of the Body, and, as an excretory organ, in carrying off certain waste products from it.



**DIESE SEITE IST FÜR KOSTENLOSE MITGLIEDER GESPERRT**  
Beantragen Sie jetzt die volle Mitgliedschaft, um diese Seite zu betreten

# GESCHICHTE

Zehntausende von wichtigen historischen Quellen, viele bisher nicht erhältlich, stehen jetzt zum ersten Mal mit der Vollmitgliedschaft von Forgotten Books zur Verfügung.

Unbegrenzter Zugang  
\$8.99/monat

**Fortfahren**

\*Es gelten Richtlinien zur fairen Nutzung.



*sweat-centres* in the spinal cord, which may either be directly excited by blood of a higher temperature than usual flowing through them or, reflexly, by warmth acting on the exterior of the Body and stimulating the sensory nerves there. Both of these agencies commonly also excite the vaso-dilator nerves of the sweating part, and so the increased blood-supply goes along with the secretion; but the two phenomena are fundamentally independent.

**The Sebaceous Secretion.** This is oily, semifluid, and of a special odor. It contains about 50 per cent of fats (olein and palmatin). It lubricates the hairs and usually renders them glossy, even in persons who use none of the various compounds sold as "hair-oil." No doubt, too, it gets spread more or less over the skin and makes the cuticle less permeable by water. Water poured on a healthy skin does not wet it readily but runs off it, as "off a duck's back" though to a less marked degree.

**Hygiene of the Skin.** The sebaceous secretion, and the solid residue left by evaporating sweat, constantly form a solid film over the skin, which must tend to choke up the mouths of the sweat-glands (the so-called "pores" of the skin) and impede their activity. Hence the value to health of keeping the skin clean: a daily bath should be taken by every one. Women cannot well wash their hair daily as it takes so long to dry, but a man should immerse his head when he takes his bath. As a general rule, soap should only be used occasionally; it is quite unnecessary for cleanliness, except on exposed parts of the Body, if frequent bathing is a habit and the skin be well rubbed afterwards until dry. Soap nearly always contains an excess of alkali which in itself injures some skins, and, besides, is apt to combine chemically with the sebaceous secretion and carry it too freely away. Persons whose skin will not stand soap can find a good substitute, for washing the hands and face, in a little cornmeal. No doubt many folk go about in very good health with very little washing; contact with the clothes and other external objects keeps its excretions from accumulating on the skin to any very great extent. But apart from the duty of personal cleanliness imposed on

man as a social animal in daily intercourse with others, the mere fact that the healthy Body can manage to get along under unfavorable conditions is no reason for exposing it to them. A clogged skin throws more work on the lungs and kidneys than their fair share, and the evil consequences may be experienced any day when something else throws another extra strain on them.

Animals, a considerable portion of whose skin has been varnished, die within a few hours. This used to be thought due to poisoning by retained ingredients of the sweat. But the real cause of death seems to be an excessive radiation of heat from the surface of the body, which the vital oxidative processes cannot keep up with, so the bodily temperature falls until it reaches a fatal point, about 20° C. (68° F.) for rabbits. If the animal be packed in raw cotton or kept in an atmosphere at a temperature of 30° C. (86° F.) it will not die from the varnishing.

**Bathing.** The general subject of bathing may be considered here. One object of it is that above mentioned, to cleanse the skin; but it is also useful to strengthen and invigorate the whole frame. For strong healthy persons a cold bath is the best, except in extremely severe weather, when the temperature of the water should be raised to 15° C. (about 60° F.), at which it still feels quite cold to the surface. The first effect of a cold bath is to contract all the skin-vessels and make the surface pallid. This is soon followed by a reaction, in which the skin becomes red and congested, and a glow of warmth is felt in it. The proper time to come out is while this reaction lasts, and after emersion it should be promoted by a good rub. If the stay in the cold water be too prolonged the state of reaction passes off, the skin again becomes pallid, and the person probably feels cold, uncomfortable, and depressed all day. Then bathing is injurious instead of beneficial; it lowers instead of stimulating the activities of the Body. How long a stay in the cold water may be made with benefit, depends greatly on the individual; a vigorous man can bear it and set up a healthy reaction after much longer immersion than a feeble one; moreover, being used to cold bathing



renders a longer stay safe, and, of course, the temperature of the water has a great influence: water called "cold" may vary within very wide limits of temperature, as indicated by the thermometer; and the colder it is the shorter is the time which it is wise to remain in it. Persons who in the comparatively warm water of Narragansett during the summer months stay with benefit and pleasure in the sea, have to content themselves with a single plunge on parts of the coast where the water is colder. The nature of the water has some influence; the salts contained in sea-water stimulate the skin-nerve and promote the afterglow. Many persons who cannot stand a simple cold fresh-water bath take one with benefit when some salines are previously dissolved in the water. The best for this purpose are probably those sold in the shops under the name of "sea-salts."

It is perfectly safe to bathe when warm, provided the skin is not perspiring profusely, the notion commonly prevalent to the contrary notwithstanding. On the other hand, no one should enter a cold bath when feeling chilly, or in a depressed vital condition. It is not wise to take a bath immediately after a meal, since the afterglow tends to draw away too much blood from the digestive organs, which are then actively at work. The best time for a long bath is about three hours after breakfast; but for an ordinary daily dip, lasting but a short time, there is no better period than on rising and while still warm from bed.

The shower-bath abstracts less heat from the skin than an ordinary cold bath and, at the same time, gives it a greater stimulus: hence it has certain advantages.

Persons in feeble health may diminish the shock to the system by raising the temperature of the water they bathe in up to any point at which it still feels cool to the skin. Bathing in water which feels warm is not advisable: it tends generally to diminish the vital activity of the Body. Hence warm baths should only be taken occasionally and for special purposes.



**DIESE SEITE IST FÜR KOSTENLOSE MITGLIEDER GESPERRT**  
Beantragen Sie jetzt die volle Mitgliedschaft, um diese Seite zu betreten



**Seien Sie niemals ohne ein Buch!**

Die Vollmitgliedschaft von Forgotten Books bietet Ihnen einen universalen Zugang von unseren Apps und unserer Website, auf all Ihren Geräten: Tablet, Telefon, E-Reader, Laptop und Computer.

**Eine Bibliothek in Ihrer Tasche für €8.99/monat**

**Fortfahren**

\*Es gelten Richtlinien zur fairen Nutzung.

But if this were so the lungs ought to be the hottest parts of the Body, and the blood leaving them by the pulmonary veins much hotter than that brought to them by the pulmonary artery after it had been cooled by warming all the tissues; and neither of these things is true. A small amount of heat is liberated when hæmoglobin combines with oxygen in the pulmonary capillaries, but the affinities thus satisfied are so feeble that the energy liberated is trivial in amount when compared with that set free when this oxygen subsequently forms stabler compounds elsewhere. It is now, moreover, tolerably certain that hardly any of this latter class of oxidations occurs in the living circulating blood at all; its cells do, no doubt, use up some oxygen and set free some carbon dioxide; but not enough to be detected by ordinary methods of analysis. The percentage of oxygen liberated in a vacuum by two specimens of the blood of an animal, taken one from an artery near the heart, and the other from a distant one, are practically the same; showing that during the time occupied in flowing two or three feet through an artery the blood uses up no appreciable quantity of its own oxygen; while in the short time occupied in its brief capillary transit it loses so much oxygen as to become venous. The difference is explained by the fact that the blood gives off oxygen gas through the thin capillary walls to the surrounding tissues; and in them the oxidation takes place. As we have already seen, a freshly excised muscle deprived of blood can still be made to contract; and for some considerable time if it be the muscle of a cold-blooded animal. During its contraction it evolves large amounts of carbon dioxide, although the resting fresh muscle contains hardly any of that gas. Here we have direct evidence of oxidation taking place in a living tissue and in connection with its functional activity; and what is true of a muscle is probably true of all tissues; the oxidations which supply them with energy take place within the living cells themselves. The statement frequently made that the oxygen in the circulating blood exists as ozone, rests on no sufficient basis; decomposing hæmoglobin does seem to form ozone when exposed to the air, but fresh blood yields no sign of it.

Experiments made by adding various combustible substances, as sugar, to fresh blood, also fail to prove the occurrence of any oxidation of such bodies in that liquid.

**Tissue-Building and Energy-Yielding Foods.** The Human Body, like that of other animals, is, on the whole, chemically destructive; it takes in highly complex substances as food, and eliminates their elements in much simpler compounds, which can again be built up to their original condition by plants. Nevertheless the Body has certain constructive powers; it, at least, builds up protoplasm from proteids and other substances received from the exterior; and there is reason to believe it does a good deal more of the same kind of work, though never an amount equaling its chemical destructions. Given one single proteid in its food, say egg albumen, the Body can do very well; making serum albumen and fibrin factors out of it for the blood, myosin for the muscles, and so on: in such cases the original proteid must have been taken more or less to pieces, remodeled, and built up again by the living tissues; and it is extremely doubtful if anything different occurs in other cases, when the proteid eaten happens to be one found in the Body. In fact, during digestion the proteids are broken down somewhat, and turned into peptones; in this state they enter the blood and must again be built up into proteids, either there or in the solid tissues.

The constructive powers of the Body used to be rather too much ignored. Foods were divided into *assimilable* and *combustible*, the former serving directly to renew the organs or tissues as they were used up, or to supply materials for growth; these were mainly proteids and fats; no special chemical synthesis was thus supposed to take place, the living cells being nourished by the reception from outside of molecules similar to those they had lost. Fat-cells grew by picking up fatty molecules, like their contents, received from the food; and protoplasmic tissues by the reception of ready-made proteid molecules, needing no further manufacture in the cell. The combustible foods, on the other hand, were the carbohydrates and some fats: these, according to the hypothesis, were incapable of being made

into parts of a living tissue, and were simply burnt at once in order to maintain the bodily warmth. It having been proved, however, that more fat might accumulate in the body of an animal than was taken in its food, this excess was accounted for by supposing it was due to excess of combustible foods, converted into fats and stored away as oil-droplets in various cells; but not actually built up into true living adipose tissue. Liebig, somewhat similarly, classed all foods into *plastic*, concerned in making new tissues, and *respiratory*, directly oxidized before they ever constituted a tissue. The plastic foods were the proteids, but these also indirectly gave rise to the energy expended in muscular work, and to some heat: the proteid muscular fibre being broken first into a highly nitrogenous part (urea, or some body well on the road to become urea) and a non-nitrogenized richly hydrocarbonous part; and this latter was then oxidized and gave rise to heat. Several facts may be urged against this view—(1) Men in tropical climates live mainly on non-proteid foods, yet their chief needs are not heat production, but tissue formation and muscular work: according to Liebig's view their diet should be mainly nitrogenous. (2) Carnivorous animals live on a diet very rich in proteids, nevertheless develop plenty of animal heat, and that without doing the excessive muscular work which, on Liebig's theory, must first be gone through in order to break up the proteids, with the production of a non-azotized part which could then be oxidized for heat-production. (3) Great muscular work can be done on a diet poor in proteids; beasts of burden are for the most part herbivorous. (4) Further, we know exactly how much energy can be liberated by the oxidation of proteids to that stage which occurs in the Body; and it is perfectly possible to estimate pretty accurately the amount of urea and uric acid excreted in a given time; from their sum the amount of proteid oxidized and the amount of energy liberated in that oxidation can be calculated; if this be done it is found that, nearly always, the muscular work done during the same period represents far more energy expended than could be yielded by the proteids broken down.



**DIESE SEITE IST FÜR KOSTENLOSE MITGLIEDER GESPERRT**  
Beantragen Sie jetzt die volle Mitgliedschaft, um diese Seite zu betreten

# GESCHICHTE

Zehntausende von wichtigen historischen Quellen, viele bisher nicht erhältlich, stehen jetzt zum ersten Mal mit der Vollmitgliedschaft von Forgotten Books zur Verfügung.

Unbegrenzter Zugang  
\$8.99/monat

**Fortfahren**

\*Es gelten Richtlinien zur fairen Nutzung.



foot-pounds) of energy. If, therefore, we know how much urea a man excretes during a given time, and how much mechanical work he does during the same time, we can readily discover if the latter could possibly have been done by the energy set free by proteid decomposition. Let us take a special case. Fick and Wisleccnus, two German observers, climbed the Faulhorn mountain, which is 1956 meters (about 6415 feet) high. Fick weighed 66 kilograms and, therefore, in lifting his Body alone, did during the ascent 129,096 kilogrammeters (932,073 foot-pounds) of work. Wisleccnus, who weighed 76 kilograms, did similarly 148,656 kilogrammeters (1,073,296 foot-pounds) of work. But during the ascent, and for five hours afterwards, Fick secreted urine containing urea answering only to 37.17 grams of proteid, and Wisleccnus urea answering to 37 grams. Since each gram of proteid broken up in the Body liberates 1805.7 kilogrammeters (13,037 foot-pounds) of energy, the amount that Fick could possibly have obtained from such a source is  $1805.7 \times 37.17 = 67,117$  kilogrammeters (484,584 foot-pounds), and Wisleccnus  $1805.7 \times 37 = 66,810$  kilogrammeters. If to the muscular work done in actually raising their bodies, we add that done simultaneously by the heart and the respiratory muscles, and in such movements of the limbs as were not actually concerned in lifting their weight, we should have, at least, to double the above total muscular work done; and the amount of energy liberated meanwhile by proteid oxidation, becomes utterly inadequate for its execution. It is thus clear that muscular work is not wholly done at the expense of the oxidation of muscle proteid, and it is very probable that none is so done under ordinary circumstances, for the urea excretion during rest is about as great as that during work, if the diet remain the same; if the work is very violent, as in long-distance walking matches, the urea quantity is sometimes temporarily raised but this increase, which no doubt represents an abnormal wear and tear of muscle-fibre, is probably independent of the liberation of energy in the form in which a muscle can use it, more likely taking the form of heat; and is, moreover, compen-

sated for afterwards by a diminished urea excretion. Thus, hourly, before the ascent Fick and Wislecenus each excreted on the average about 4 grams (62 grains) of urea; during the ascent between 7 and 8 grams (108–124 grains); but during the subsequent 16 hours, when any urea formed in the work would certainly have reached the urine, only an average of about 3 grams (46.5 grains) per hour.

It may still be objected, however, that a good deal of the muscle work may be done by the energy of oxidized muscle proteid; that the amount of this oxidation occurring in a muscle during rest or ordinary work is pretty constant and simply takes different forms in the two cases, much as a steam-engine with its furnace in full blast will burn as much coal when working as when resting, but in the former case lose all the energy generated in the form of heat, and in the latter partly as mechanical work. Thus the want of increase in urea during muscular activity would be explained, while still a good deal of utilizable energy might come from proteid degradation. But if this were so, then the working Body should eliminate no more carbon dioxide than the resting; the amount of chemical changes in its muscles being by hypothesis the same, the carbon dioxide eliminated should not be increased. Experiment, however, shows that it is, and that to a very large extent, even when the work done is quite moderate and falls within the limits which could be performed by the normal proteid degradation of the Body. Quite easy work doubles the carbon dioxide excreted in twenty-four hours, and in a short period of very hard work it may rise to five times the amount eliminated during rest. Since the urea is not increased, or but very slightly increased, at the same time, this carbon dioxide cannot be due to increased proteid metamorphosis; and it therefore indicates that a muscle works by the oxidation of carbonaceous non-nitrogenous compounds. Since all the carbon compounds oxidized in the Body contain hydrogen this element is also no doubt oxidized during muscular work; but its estimation is difficult and has not been attempted, because the Body contains so much water ready formed that a large quantity is always ready for increased



evaporation from the lungs and skin, whenever the respirations are quickened, as they are by exercise. It, thus, is very difficult to say how much of the extra water eliminated from the Body during work is due merely to this cause and how much to increased hydrogen oxidation.

The conclusion we are led to is, then, that a muscle works by the oxidation mainly, if not entirely, of carbon and hydrogen; much as a steam-engine does: the proteid constituents of the muscle answer roughly to the metallic parts of the engine, to the machinery using the energy liberated by the oxidations, but in itself only suffering wear and tear bearing no direct proportion to the work done; as an engine may rust, so muscle proteid may and does oxidize, but not to supply the organ with energy for use. This conclusion, arrived at by a study of the excretions of the whole Body, is confirmed by the results obtained by the chemical study of a single muscle. A fresh frog's muscle (which agrees in all essential points with a man's) contains practically no carbon dioxide, yet, made to work in a vacuum, gives off that gas, and more the more it works. Some carbon dioxide is therefore formed in the working muscle. If the muscle, after contracting as long as it will, be thrown into death rigor it gives off more carbon dioxide; and if taken perfectly fresh and sent into *rigor mortis* without contracting it gives off carbon dioxide also, in amount exactly equal to the sum of that which it would have given off in two stages, if first worked and then sent into rigor. The muscle must, therefore, contain a certain store of a carbon-dioxide-yielding body, and the decomposition of this is associated with the occurrence both of muscular activity and death stiffening. Similar things are true of the acid simultaneously developed; the muscle when it works produces some sarcolactic acid, and when thrown into rigor mortis still more. No increase of urea or kreatin or any similar product of nitrogenous decomposition is found in a worked muscle when compared with a rested one, but the total carbohydrates are rather less in the former. These facts make it clear that muscular work is not done at the expense of



**DIESE SEITE IST FÜR KOSTENLOSE MITGLIEDER GESPERRT**  
Beantragen Sie jetzt die volle Mitgliedschaft, um diese Seite zu betreten



**Seien Sie niemals ohne ein Buch!**

Die Vollmitgliedschaft von Forgotten Books bietet Ihnen einen universalen Zugang von unseren Apps und unserer Website, auf all Ihren Geräten: Tablet, Telefon, E-Reader, Laptop und Computer.

**Eine Bibliothek in Ihrer Tasche für € 8.99/monat**

**Fortfahren**

\*Es gelten Richtlinien zur fairen Nutzung.

ing rest, and this breaking down may occur faster than the reconstruction. We are thus enabled, also, to understand how, during exercise, the carbon dioxide evolved from the lungs may contain more oxygen than that taken up at the same time; for it is largely oxygen previously stored during rest, that then appears in the carbon dioxide of the expired air.

**Are any Foods Respiratory in Liebig's Sense of the Term?** We find, then, that Liebig's classification of foods cannot be accepted in an absolute sense. There is no doubt that the substance broken down in muscular contraction is proper living muscular tissue; and if this (its proteid constituent being retained) be reconstructed from foods containing no nitrogen (whether carbohydrates or fats) then the term *plastic* or tissue-forming cannot be restricted to the proteids of the diet. We must rather conclude that any alimentary principle containing carbon may be used to replace the oxidized carbon, and any containing hydrogen to replace the oxidized hydrogen, of a tissue; and so even non-proteid foods may be plastic. A certain proportion of the foods digested may perhaps be oxidized to yield energy, before they ever form part of a tissue; and so correspond pretty much to Liebig's respiratory foods; but no hard and fast line can be drawn, making all proteid foods plastic and all oxidizable non-proteid foods respiratory.

**Luxus Consumption.** Not only, as above pointed out, may non-nitrogenous foods be plastic, but it is certain that if any foods are oxidized at once before being organized into a tissue, proteids are under certain circumstances; namely, when they are contained in excess in a diet. If an animal be starved it is found that its non-nitrogenous tissues go first; an insufficiently fed animal loses its fat first, and if it ultimately dies of starvation, is found to have lost 97 per cent of its adipose tissue and only about 30 per cent of its proteid-rich muscular tissue, and almost none of its brain and spinal cord; all of course reckoned by their dry weight. It is thus clear that the proteids of the tissues resist oxidation much better than fat does. But, on the other hand, if a well-fed animal be given a very rich proteid diet all the

nitrogen of its food reappears in its urine, and that when it is laying up fat; so that then we get a state of things in which proteids are broken up more easily than fats. This indicates that proteid in the Body may exist under two conditions; one, when it forms part of a living tissue and is protected to a great extent from oxidation, and another, in which it is oxidized with readiness and is presumably in a different condition from the first, and not yet built up into part of a living cell. The use of proteids for direct oxidation is known as *luxus consumption*; how far it occurs under ordinary circumstances will be considered presently. The main point now to be borne in mind is that while all organic non-nitrogenous foods cannot be called *respiratory*, neither can proteids under all circumstances be called *plastic*, in Liebig's sense.

**The Antecedents of Urea.** In the long run the progenitors of the urea excreted from the Body are the proteids taken in the food; but it remains still to be considered what intermediate steps these take before excretion in the urine; and whether urea itself is finally formed in the kidneys or merely separated by them from the blood.

In seeking antecedents of urea one naturally turns first to the muscles, which form by far the largest mass of proteid tissues in the Body. Analysis shows that they always contain kreatin, a body intermediate chemically between proteids and urea. The quantity of this in muscles is practically unaffected by work, and is from 0.2 to 0.4 per cent. Since it is readily soluble and dialyzable, and therefore fitted to pass rapidly out of the muscles into the blood stream, it is a fair conclusion that a good deal of it is formed in the muscles daily and carried off from them. Kreatin, too, exists in the brain, and probably there, and elsewhere in the nervous system, is produced by chemical degradation of protoplasm; the spleen also contains a good deal of kreatin, and so do many glands. This substance would therefore seem to be constantly produced in considerable quantities by the protoplasmic tissues generally; and since it belongs to a group of nitrogenous compounds which the Body is unable to utilize for reconstruction into proteids,

it must be carried off somehow. The urine, however, contains very little kreatin, or its immediate derivative, kreatinin, and what it does contain depends mainly on the feeding, since it varies with the diet and vanishes during starvation; so it is probable that this substance is converted into urea and excreted in that form. This conversion must occur elsewhere than in the muscles, which contain no urea; also, very little, if any, exists in the brain.

Where the kreatin is finally changed into urea is doubtful. It may be in the kidneys by the renal epithelium, or it may be elsewhere, and the urea produced be merely picked up from the blood and passed out by the kidney-cells; or both may occur; histologically the distinctly secretory epitheliums of the convoluted parts of the tubules and of Henle's loops, differ so much as to suggest an entirely different function for them.

On the whole, the evidence seems to show that urea is merely separated and not produced in the kidneys; *a priori* this is more probable, since in the degradation of kreatin to yield urea energy is liberated and this might very well be utilized in some organ; while if the process took place in the kidney tubules the force set free would be wasted. The blood always contains urea, and renal-artery blood apparently more than renal-vein blood, which shows that urea is removed from the blood in the kidneys. Moreover, if a mammal's kidneys be extirpated urea accumulates in its blood, which could not be the case if urea were normally only produced in the kidneys; and if urea be injected into a vein it is rapidly picked up and carried off in the urine, showing that the kidney-cells have a selective power with respect to it.

While the urea resulting from further changes in the kreatin formed in the tissues is a measure of the wear and tear of their protoplasm, part of the urea excreted has probably a different source; being due to the oxidation of proteids, as energy liberators or respiratory foods, before they have ever formed a tissue. When plenty of proteid food is taken the urea excretion is largely increased and ~~that~~ very rapidly, within a couple of hours for example,



**DIESE SEITE IST FÜR KOSTENLOSE MITGLIEDER GESPERRT**  
Beantragen Sie jetzt die volle Mitgliedschaft, um diese Seite zu betreten

# GESCHICHTE

Zehntausende von wichtigen historischen Quellen, viele bisher nicht erhältlich, stehen jetzt zum ersten Mal mit der Vollmitgliedschaft von Forgotten Books zur Verfügung.

Unbegrenzter Zugang  
\$8.99/monat

**Fortfahren**

\*Es gelten Richtlinien zur fairen Nutzung.



**Proteid Starvation and Overfeeding.** When an animal is fed on food deficient in proteids, or containing none of them at all, its urea excretion falls very rapidly during the first day or two, but then much more slowly until death: there is thus indicated a double source of urea, a part resulting from tissue wear and tear, and always present; and a part resulting from the breaking down of proteids not built up into tissue, and ceasing when the amount of this proteid in the Body (in the blood for example) falls below a certain limit as a result of the starvation. As the nitrogen-starved Body wastes, its bulk of proteid tissues is slowly reduced and the urea resulting from their degradation diminishes also. How well proteid built up into a tissue resists removal is shown by the facts already mentioned (p. 432) as to the relative losses of the proteid-rich and proteid-poor tissues in starvation.

On the other hand, if an animal be taken while starving and losing weight and have a small amount of flesh given it, it will continue to lose weight, and more urea than before will appear in the urine; increased proteid diet increases the proteid metamorphosis, and the animal still loses, though less rapidly than it did. A little more proteid still increases proteid metamorphosis in the body, and the urea elimination, and so on for some time; but each increment of proteid in the food increases the nitrogenous metamorphosis somewhat less than the last did, until, finally, a point is reached at which the nitrogen egesta and ingesta balance: in a dog this occurs when it gets daily  $\frac{1}{10}$  its weight of meat, and no other solid food. More food if then given is at first stored up and the animal increases in weight; but very soon the greater wear and tear of the larger mass of tissues shows itself as increased urea excretion; again the egesta and ingesta balance, and the animal comes to a new weight equilibrium at the higher level. More meat now causes a repetition of the phenomenon: at first increase of tissue, and nitrogen storage; and then a cessation of the gain in weight, and an excretion in twenty-four hours of all the nitrogen taken. And so on, until the animal refuses to eat any more.

These facts seem, very clearly, to show that proteids cannot be built up quickly into tissues. Meat given to the starving animal has its proteids, at first, used up mainly in *luxus consumption*—while a little is stored as tissue, though at first not enough to counterbalance the daily tissue waste. When a good deal more proteid is given than answers to the nitrogen excretion during starvation, the animal builds up as much into living tissues as it breaks down in the vital processes of these, the rest going in *luxus consumption*; it thus neither gains nor loses. More proteid does not all appear in the urine at once; some is used to build up new tissue, but only slowly; then, after some days, the increased metabolism of the increased flesh balances the excess of nitrogen in the diet, and equilibrium is again attained. But, all through, it seems clear that the tissue formation is slow and gradual; and so it becomes additionally probable that the increased urea excretion soon after a meal is not due to rapidly increased tissue formation and degradation, but to a more direct proteid oxidation.

**The Storage Tissues.** Every healthy cell of the Body contains at any moment some little excess of material laid by in itself, above what is required for its immediate necessities. The capacity of contracting, and the concomitant evolution of carbon dioxide, exhibited by an excised muscle in a vacuum, seem to show that even oxygen, of which warm-blooded animals have but a small reserve, may be stored up in the living tissues in such forms that they can utilize it, even when the air-pump fails to extract any from them. But in addition to the supplies for immediate spending, contained in all the cells, we find special food reserves in the Body, on which any of the tissues can call at need. These, especially the oxygen and proteid reserves, are found largely in the blood. Special oxygen storage is, however, rendered unnecessary by the fact that the Body can, except under very unusual circumstances, get more from the air at any time, so the quantity of this substance laid by is only small; hence death from asphyxia follows very rapidly when the air-passages are stopped, while, on account of the reserves laid up, death from other forms of starva-



tion is a much slower occurrence. Proteids, also, we have learnt from the study of muscle, are probably but little concerned in energy-production in the tissues. Speaking broadly, the work of the Body is carried on by the oxidation of carbon and hydrogen, and we find in the Body, in correspondence with this fact, two great storehouses of fatty and carbohydrate foods, which serve to supply the materials for the performance of work and the maintenance of the bodily temperature in the intervals between meals, and during longer periods of starvation. One such store, that of carbohydrate material, is found in the liver-cells; the other, or fatty reserve, is found in the adipose tissue. That such substances are true reserves, not for any special local purpose but for the use of the Body generally, is shown by the way they disappear in starvation; the liver reserve in a few days, and the fat somewhat later and more slowly, but very largely before any of the other tissues have been seriously affected. By using these accumulated matters the Body can work and keep warm during several days of more or less deficient feeding; and the fatter an animal is at the beginning of a starvation period the longer will it live; which would not be the case could not its fat be utilized by the working tissues. Hybernating animals prove the same thing; bears, before their winter sleep, are very fat, and at the end of it commonly very thin; while their muscular and nervous systems are not noticeably diminished in mass. During the whole winter, then, the energy needed to keep the heart and respiratory muscles at work, and to maintain the temperature of the body, must have been obtained from the oxidation of the fat reserve with which the animal started.

**Glycogen.** It may perhaps have struck the reader as curious that so large an organ as the liver should be set apart for the formation of so comparatively unimportant a digestive secretion as the bile; and were this the sole use of the liver the size of the organ would certainly be anomalous. The main function of the liver is, however, quite a different one, the formation and storage of a carbohydrate called *glycogen*, from the abundant food materials carried through it by the portal vein after a meal; in the times between



**DIESE SEITE IST FÜR KOSTENLOSE MITGLIEDER GESPERRT**  
Beantragen Sie jetzt die volle Mitgliedschaft, um diese Seite zu betreten



**Seien Sie niemals ohne ein Buch!**

Die Vollmitgliedschaft von Forgotten Books bietet Ihnen einen universalen Zugang von unseren Apps und unserer Website, auf all Ihren Geräten: Tablet, Telefon, E-Reader, Laptop und Computer.

**Eine Bibliothek in Ihrer Tasche für € 8.99/monat**

**Fortfahren**

\*Es gelten Richtlinien zur fairen Nutzung.

being constantly used up, and its maintenance in normal quantity depends on food.

**The Source and Destination of Liver Glycogen.** All foods are not equally efficacious in keeping up the stock of glycogen in the liver; fats by themselves are useless; proteids by themselves give a little; but by far the most is formed on a diet rich in starch and sugar; so it would seem that glycogen is mainly formed from carbohydrate materials absorbed from the alimentary canal and carried to the hepatic cells by the portal vein. These materials are mainly glucose, since the starch eaten is changed into that substance before absorption. This view of the matter is supported by several facts. (1) Grape sugar if it exist in the blood in above a certain small percentage passes out by the kidneys and appears in the urine, constituting the characteristic symptom of the disease called *diabetes*. In health, however, even after a meal very rich in carbohydrates, no sugar appears in the urine; so that the large quantity of it absorbed from the alimentary canal, within a brief time under such circumstances, must be stopped somewhere before it reaches the general blood current. (2) Glucose injected into one of the general veins of an animal, if in any quantity, soon appears in the urine; but the same amount injected into the portal vein, or one of its radicles, causes no diabetes, but an accumulation of glycogen in the liver. We may therefore conclude that the grape sugar absorbed from the alimentary canal is taken by the portal vein to the liver; there stayed and converted into glycogen; which is then more slowly passed on into the hepatic veins during the intervals between meals. Thus in spite of the intervals which elapse between meals the carbohydrate content of the blood is kept pretty constant; during digestion it is not suffered to rise very high, nor during ordinary periods of fasting to fall very much below the average.

In what form glycogen leaves the liver is not certain; it might be dissolved out and carried off as such, or previously turned again into glucose and sent on in that form; since the blood and the liver both seem to contain

ferments capable of changing glycogen into glucose the latter view is the more probable. Analyses of portal and hepatic bloods, made with the view of determining whether more sugar was carried out of the liver during fasting than into it, are conflicting. The main fact, however, remains that somehow this carbohydrate reserve in the liver is steadily carried off to be used elsewhere: and animal glycogen thus answers pretty much to vegetable starch, which, made in the green leaves, is dissolved and carried away by the sap currents to distant and not green parts (as the grains of corn or tubers of a potato, which cannot make starch for themselves) and in them is again laid down in the form of solid starch grains, which are subsequently dissolved and used for the growth of the germinating seed or potato. Reasons have already been given (p. 423) for believing that the carbohydrate leaving the liver is not oxidized in the blood, but first after it has passed out of that into a living tissue. Among these the muscles at least seem to get some, since a fresh muscle always contains glycogen, and even in normal amount when an animal is starved for some time; the muscle-fibres then, so to speak, calling on the balance with their hanker (the liver) so long as there is any. When a muscle contracts this glycogen disappears and some glucose appears, but not an amount equivalent to the glycogen used up; so that the working muscle would appear, probably for its repair after each contraction (see p. 431), to utilize this substance.

How it is that the glycogen, which is so rapidly converted into grape sugar by the liver ferment after death, escapes such rapid conversion during life has not been satisfactorily answered. Two possible reasons readily suggest themselves; the liver ferment may be only produced by dying hepatic cells; or the glycogen in the living cell may not exist free, but combined with other portions of the cell substance so as to be protected; while, after death, *post-mortem* changes may rapidly liberate it in a condition to be acted upon by the ferment.

**Diabetes.** The study of this disease throws some light upon the history of glycogen. Two distinct varieties of it

are known; one in which sugar appears in the urine only when the patient takes carbohydrate foods; the other in which it is still excreted when he takes no such foods, and must therefore form sugar in his Body from substances not at all chemically allied to it. The most probable source of the sugar in the latter case is proteids; since some glycogen is found in the livers of animals fed on proteids only, while fats alone give none of it. In some complex way the proteid molecule would appear to split up in the liver into a highly nitrogenized part (urea or an antecedent of urea) and a non-nitrogenized part, glycogen. On this view the more severe form of diabetes would be due to an increased activity of a normal proteid-decomposing function of the hepatic cells; and sometimes the urea and sugar in the urine of diabetics rise and fall together, thus seeming to indicate a community of origin. Diabetes dependent on carbohydrate food might be produced in several ways. The liver-cells might cease to stop the sugar and, letting it all pass on into the general circulation, suffer it to rise to such a percentage in the blood after a meal, that it attained the proportion in which the kidneys pass it out; or the tissues might cease to use their natural amount of sugar, and this, sent on steadily out of the liver, at last rise in the blood to the point of excretion. Or the liver might transform (into glucose) and pass on its glycogen faster than the other tissues used it, and so diabetes might arise; but this would only be temporary, lasting until the liver stock was used up by the rapid conversion. Artificially we can, in fact, produce diabetes in several of these ways; curari poisoning, for example, paralyzing the motor nerves, makes the skeletal muscles lie completely at rest, and so diminishes the glycogen consumption of the Body and produces diabetes. Carbon monoxide poisoning produces diabetes also, presumably by checking bodily oxidation. Finally, pricking a certain spot in the *medulla oblongata* causes a temporary diabetes. This may be due to the fact that the operation injures that part of the vaso-motor centre which controls the muscular coat of the hepatic artery; this artery, then dilating, carries so much blood through the liver that an excess of



**DIESE SEITE IST FÜR KOSTENLOSE MITGLIEDER GESPERRT**  
Beantragen Sie jetzt die volle Mitgliedschaft, um diese Seite zu betreten

# GESCHICHTE

Zehntausende von wichtigen historischen Quellen, viele bisher nicht erhältlich, stehen jetzt zum ersten Mal mit der Vollmitgliedschaft von Forgotten Books zur Verfügung.

Unbegrenzter Zugang  
\$8.99/monat

**Fortfahren**

\*Es gelten Richtlinien zur fairen Nutzung.



require some time, before it can be taken into the blood and carried off to other parts.

When adipose tissue is developing it is seen that undifferentiated cells in the connective tissues (especially areolar) show minute oil-drops in their protoplasma. These increase in size and, ultimately, fuse together and form one larger oil-droplet, while most of the original protoplasma disappears.

The oily matter would thus seem due to a chemical metamorphosis of the cell protoplasm, during which it gives rise to a non-azotized fatty residue which remains behind, and a highly nitrogenous part which is carried off. In many parts of the Body protoplasmic masses are subject to a similar but less complete metamorphosis; fatty degeneration of the heart, for example, is a more or less extensive replacement of the proper substance of its muscular fibres by fat-droplets; and the cream of milk and the oily matter of the sebaceous secretion are due to a similar fatty degeneration in gland-cells. Moreover, careful feeding experiments undoubtedly show that fat can come from proteids; when an animal is very richly supplied with these all the nitrogen taken in them reappears in its excretions, but all the carbon does not; it is in part stored in the Body: and, since such feeding produces but little glycogen, this carbon can only be stored as fat.

While there is, then, no doubt that some fat may have a proteid origin, it is not certain that all has such. During digestion a great deal of fat is ordinarily absorbed, in a chemically unchanged state, from the alimentary canal; it is merely emulsified and carried off in minute drops by the chyle to be poured into the blood: and this fat might be directly deposited, as such, in adipose tissue. There are, however, good reasons for supposing that all the fat in the Body is manufactured. The fat of a man, of a dog, and of a cat varies in the proportions of palmatin, stearin, margarin, and olein in it; and varies in just the same way if all be fed on the same kind of food, which could not be the case if the fat eaten were simply deposited unchanged. Moreover, if an animal be fed on a diet containing one kind of fat only,

say olein, but a very slightly increased percentage of that particular fatty substance is found in its adipose tissue, which goes to show that if fats come from fats eaten, these latter are first pulled to bits by the living cells and built up again into the forms normal to the animal; so that, even with fatty food, the fats stored up seem to be in most part manufactured in the Body.

In still another way it is proved that fats can be constructed in the Body. In animals fed for slaughter, the total fat stored up in them during the process is greatly in excess of that taken with their food during the same time. For example, a fattening pig may store up nearly five hundred parts of fat for every hundred in its food, and this fat must be made from proteids or carbohydrates. Whether it can come from the latter is still perhaps an open question; for, while all fattening foods are rich in starch or similar bodies, there are considerable chemical difficulties in supposing an origin of fats from such; and it is on the whole more probable that they simply act by sparing from use fats simultaneously formed or stored in the body, and which would have otherwise been called upon. They make glycogen, and this shelters the fats. Liebig, indeed, in a very celebrated discussion, maintained that fats were formed from carbohydrates. He showed that a cow gave out more butter in its milk than it received fats in its food; and Huber, the blind naturalist, showed that bees still made wax (a fatty body) for a time when fed on pure sugar; and indefinitely when fed on honey. Consequently, for a long time, an origin of fats from carbohydrates was supposed to be proved; but their possible origin from proteids (a possibility now shown to be a certainty) was neglected, and the validity of the above proofs of their carbohydrate origin is thus upset. The cow may have made its butter from proteids; the bees, fed on sugar, their wax for a time from proteids in their bodies already; and, indefinitely, when fed on honey, from the proteids in that substance. Moreover, animals (ducks) fed on abundant rice, which contains much carbohydrate but very little proteid or fat, remain lean; while if some fat be added they lay up fat.



Persons who fatten cattle for the butcher find that the foods useful for the purpose all contain proteids, carbohydrates, and fats, and that rapid fattening is only obtained with foods containing a good deal of fat; as oilcake, milk, or Indian corn. Taking all the facts into account we shall probably not be wrong in concluding that nearly all the bodily fat is manufactured either from fats or proteids; from fats easier than from anything else, but when much proteid is eaten some is made from it also. Carbohydrates alone do not fatten; the animal body cannot make its palmitin, etc., out of them. Nevertheless they are, indirectly, important fattening foods when given with others, since, being oxidized instead of it, they protect the fat formed.

**Dietetics.** That "one man's meat may be another man's poison" is a familiar saying, and one that, no doubt, expresses a certain amount of truth; but the difference probably depends on the varying digestive powers of individuals rather than on peculiarities in their laws of cell nutrition: all need pretty much the same amount of proteids, fats, and carbohydrates for each kilogram of body weight; but all cannot digest the same varieties of them equally well: while many foods have peculiar, almost poisonous, effects on some persons. A good many people are made ill by mutton, which the majority digest better than beef.

The proper diet, too, will necessarily vary, at least as to amount, with the work done; whether it should vary in kind with the nature of the work is not so certain. Provided a man gets enough proteids to balance those lost in the wear and tear of his tissues, it probably matters little whether he gets for oxidation and the liberation of energy either fats or carbohydrates, or even excess of proteids themselves; any one of the three will allow him to work either his brain or his muscles, and to maintain his temperature. Proteids, however, are wasteful foods for mere energy-yielding purposes: in the first place, they are more costly than the others; secondly, they are incompletely oxidized in the Body; and, thirdly, it is probably more laborious to the system to get rid of urea than of the carbon dioxide and water, which alone are yielded by



**DIESE SEITE IST FÜR KOSTENLOSE MITGLIEDER GESPERRT**  
Beantragen Sie jetzt die volle Mitgliedschaft, um diese Seite zu betreten



**Seien Sie niemals ohne ein Buch!**

Die Vollmitgliedschaft von Forgotten Books bietet Ihnen einen universalen Zugang von unseren Apps und unserer Website, auf all Ihren Geräten: Tablet, Telefon, E-Reader, Laptop und Computer.

**Eine Bibliothek in Ihrer Tasche für € 8.99/monat**

**Fortfahren**

\*Es gelten Richtlinien zur fairen Nutzung.

number of public institutions in which the health of many people is maintained as economically as possible. Such an examination made by Moleschott, gives us as its result a diet containing daily—

Proteids.....	90	grams	or	465	grains.
Fats.....	84	"	or	1,300	"
Amyloids.....	404	"	or	6,262	"
Salts.....	30	"	or	465	"
Water.....	2800	"	or	43,400	"

People in easy circumstances take as a rule more proteids and fats and less amyloids; and this selection, when a choice is possible, probably indicates that such a diet is the better one: the proteids in the above table seem especially deficient.

## CHAPTER XXIX.

### THE PRODUCTION AND REGULATION OF THE HEAT OF THE BODY.

**Cold- and Warm-Blooded Animals.** All animals, so long as they are alive, are the seat of chemical changes by which heat is liberated; hence all tend to be somewhat warmer than their ordinary surroundings, though the difference may not be noticeable unless the heat production is considerable. A frog or a fish is a little hotter than the air or water in which it lives, but not much; the little heat that it produces is lost, by radiation or conduction, almost at once. Hence such animals have no proper temperature of their own; on a warm day they are warm, on a cold day cold, and are accordingly known as *changeable-temperated* (*poikilo-thermous*) or, in ordinary language, "cold-blooded" animals. Man and other mammals, as well as birds, on the contrary, are the seat of very active chemical changes by which much heat is produced, and so maintain a tolerably uniform temperature of their own, much as a fire does whether it be burning in a warm or a cold room; the heat production at any given time balancing the loss a normal body temperature is maintained, and usually one considerably higher than that of the medium in which they live; such animals are therefore known as animals of constant temperature (*homo-thermous*), or more commonly "warm-blooded" animals. The latter name, however, does not properly express the facts; a lizard basking in the sun on a warm summer's day may be nearly as hot as a man usually is; but on the cold day the lizard becomes cold, while the average temperature of the healthy Human Body

is, within a degree, the same in winter or summer; within the arctic circle or on the equator.

Moderate warmth accelerates protoplasmic activity; compare a frog dormant in the winter with the same animal active in the warm months: what is true of the whole frog is true of each of its living cells. Its muscles contract more rapidly when warmed, and the white corpuscles of its blood when heated up to the temperature of the Human Body are seen (with the microscope) to exhibit much more active amoeboid movements than they do at the temperature of frog's blood. In summer a frog or other cold-blooded animal uses much more oxygen and evolves much more carbon dioxide than in winter, as shown not only by direct measurements of its gaseous exchanges, but by the fact that in winter a frog can live a long time after its lungs have been removed (being able to breathe sufficiently through its moist skin), while in warm weather it dies of asphyxia very soon after the same loss. The warmer weather puts its tissues in a more active state; and so the amount of work the animal does, and therefore the amount of oxygen it needs, depend to a great extent upon the temperature of the medium in which it is living. With the warm-blooded animal the reverse is the case. It always keeps up its temperature to that at which its tissues live best, and accordingly in cold weather uses more oxygen and sets free more carbon dioxide because it needs a more active internal combustion to compensate for its greater loss of heat to the exterior. In fact the living tissues of a man may be compared to hothouse plants, living in an artificially maintained temperature; but they differ from the plants in the fact that they themselves are the seat of the combustions by which the temperature is kept up. Since, within wide limits, the Human Body retains the same temperature no matter whether it be in cold or warm surroundings, it is clear that it must possess an accurate arrangement for heat regulation; either by controlling the production of heat in it, or the loss of heat from it, or both.

**The Temperature of the Body.** The parts of the Body are all either in contact with one another directly or, if



**DIESE SEITE IST FÜR KOSTENLOSE MITGLIEDER GESPERRT**  
Beantragen Sie jetzt die volle Mitgliedschaft, um diese Seite zu betreten

# GESCHICHTE

Zehntausende von wichtigen historischen Quellen, viele bisher nicht erhältlich, stehen jetzt zum ersten Mal mit der Vollmitgliedschaft von Forgotten Books zur Verfügung.

Unbegrenzter Zugang  
\$8.99/monat

**Fortfahren**

\*Es gelten Richtlinien zur fairen Nutzung.



every muscle in contracting has part of the mechanical energy expended by it turned into heat by friction against neighboring parts. Similarly the movements of cilia and of amœboid cells are for the most part converted in the Body into heat. The muscles and nerves are also the seats of manifestations of electricity, which, though small in amount, for the most part do not leave the Body in that form but are first converted into heat. A certain amount of heat is also carried into the Body with hot foods and drinks.

**The Energy Lost by the Body in Twenty-four Hours.** Practically speaking, the Body only loses energy in two forms; as heat and mechanical work: by applying conductors to different parts of its surface small amounts of electricity can be carried off, but the amount is quite trivial in comparison with the total daily energy expenditure. During complete rest, that is when no more work is done than that necessary for the maintenance of life, nearly all the loss takes the form of heat. The absolute amount of this will vary with the surrounding temperature and other conditions, but on an average a man loses, during a day of rest, 2700 calories; that is enough to raise 2700 kilograms (5940 lbs.) of water from 0° to 1° C. (from 32° to 33.8° F.); otherwise expressed, this amount of heat would boil 27 kilos (59.4 lbs.) of ice-cold water. This does not quite represent all the energy lost by the Body in that time: since a small proportion is lost as mechanical work in moving the clothes and air by the respiratory movements, and even by the beat of the heart, which at each systole pushes out the chest-wall a little and moves the things in contact with it. The working Body liberates and loses much more energy; part as mechanical work done on external objects, part as increased heat radiated or conducted from the surface, or carried off by the expired air in the quickened respirations. Every one knows that he becomes warmer when he takes exercise, and measurements made on men show that the heat produced and lost in a day of moderate work is about one third greater than that in a day of rest. The following table gives more accurate numbers—

Heat units (calories) produced.	Day of Rest.		Day of Work.		
	Rest 16 hrs.	Sleep 8 hrs.	Rest 8 hrs.	Work 8 hrs.	Sleep 8 hrs.
	2670.4	220	1225.2	2169.6	220.
	2790.4 ( 10,885 Fah.-lb. heat units )		3724.8 ( 14,525 Fah.-lb. heat units )		

The mechanical work done on the working day, represented in addition an expenditure of energy of 213,344 kilogrammeters, which is equal to 502 calories. Of the excess heat in the working day, part is directly produced by the increased chemical changes in the quicker working heart and respiratory muscles, and the other muscles set at work; while part is indirectly due to heat arising from increased friction in the blood-vessels as the blood is driven faster around them, and to friction of the various muscles used. The average cardiac work in twenty-four hours is about 60,000 kilogrammeters; that of the respiratory muscles about 14,000; and since nearly all of both is turned finally into heat within the Body, we have 74,000 kilogrammeters of energy answering to about 174 calories (6786 Fah.-lb. units) indirectly produced in the resting Body daily from these sources.

Of 100 parts of heat lost from the resting Body, about 73 are carried off in radiation or conduction from the skin. 14.5 are carried off in evaporation from the skin.

7.2 " " " " " " " lungs.

3.0 " " " expired air.

1.8 " " " in the excretions.

In a day of average work, of every 100 parts of energy lost in any form from the Body—

1-2 go as heat in the excreta.

3-4 in heating the expired air.

20-30 in evaporating water from the lungs and skin.

60-75 in heat radiated or conducted from the surfaces and in external mechanical work.

**The Superiority of the Body as a Working Machine.** During eight hours of work, we find (table at top of page) the Body loses 2169.6 calories of energy as heat; and can do



simultaneously work equivalent to 503 calories. So of all the energy lost from it in that time about  $\frac{1}{2}$  may take the form of mechanical work; this is a very large proportion of the total energy expended, being a much higher percentage than that given by ordinary machines. The best steam-engines can utilize as mechanical work only about  $\frac{1}{3}$  of the total energy liberated in them and lost from them in a given time; the remainder is transmitted directly as heat to the exterior, and is lost to the engine for all useful purposes.

**The Maintenance of an Average Temperature.** This is necessary for the continuance of the life of a warm-blooded animal; should the temperature rise above certain limits chemical changes, incompatible with life, occur in the tissues; for example at about  $49^{\circ}$  C. ( $120^{\circ}$  F.) the muscles begin to become rigid. On the other hand death ensues if the Body be cooled down to about  $19^{\circ}$  C. ( $66^{\circ}$  F.). Hence the need for means of getting rid of excess heat, and of protection from excessive cooling. Either end may be gained in two ways; by altering the rate at which heat, is lost or that at which it is produced. As regards heat-loss, by far the most important regulating organ is the skin: under ordinary circumstances nearly 90 per cent of the total heat given off from the Body in 24 hours goes by the skin (73 by radiation and conduction, 14.5 by evaporation; see above table). This loss may be controlled—

1. By *clothing*; we naturally wear more in cold and less in warm weather; the effect of clothes being, of course, not to warm the Body but to diminish the rate at which the heat formed in it is lost.

2. Increased temperature of the surrounding medium increases the activity of the heart and lungs. A hastened circulation by itself does not as already pointed out (p. 202) increase the general tissue activity of the Body, or the oxidations occurring in it, and, so, apart from the harder working heart itself, does not influence the amount of heat liberated in the Body during a given time: but the more rapid blood-flow through the skin carries more of that fluid through this cool surface and increases the loss of heat in that way. The



**DIESE SEITE IST FÜR KOSTENLOSE MITGLIEDER GESPERRT**  
Beantragen Sie jetzt die volle Mitgliedschaft, um diese Seite zu betreten



**Seien Sie niemals ohne ein Buch!**

Die Vollmitgliedschaft von Forgotten Books bietet Ihnen einen universalen Zugang von unseren Apps und unserer Website, auf all Ihren Geräten: Tablet, Telefon, E-Reader, Laptop und Computer.

**Eine Bibliothek in Ihrer Tasche für € 8.99/monat**

**Fortfahren**

\*Es gelten Richtlinien zur fairen Nutzung.

3. Cold tends to produce involuntary muscular movements, and so increased heat production; as chattering of the teeth and shivering.

4. Cold applied to the skin increases the bodily chemical metamorphoses and so heat production. At least the temperature in the armpit rises at first on entering a cold bath, though the heat carried off from the surface soon overbalances its increased production. The phenomenon may, however, be explained in another way, the rise being attributed to a sudden diminution of loss from more exposed parts of the skin, dependent on contraction of the cutaneous arteries. In some cases, however, the temporary rise is accompanied by an increased excretion of carbon dioxide, which would indicate that the surface cooling does really increase the oxidations of the Body.

5. Certain drugs, as salicylic acid, and perhaps quinine, diminish the heat production of the Body. Their mode of action is still obscure.

On the whole, however, the direct heat-regulating mechanisms of the Human Body itself are not very efficient, especially as protections against excessive cooling. Man needs to supplement them by the use of clothing, fuel, and exercise.

**Local Temperatures.** Although, by the means above described, a wonderfully uniform bodily temperature is maintained, and by the circulating blood all parts are kept at nearly the same warmth, variations in both respects do occur. The arrangements for equalization are not by any means fully efficient. External parts, as the skin, the lungs (which are really external in the sense of being in contact with the air), the mouth, and the nose chambers, are always cooler than internal; and even all parts of the skin have not the same temperature, such hollows as the armpit being warmer than more exposed regions. On the other hand, a secreting gland or a working muscle becomes warmer, for the time, than the rest of the Body, because more heat is liberated in it than is carried off by the blood flowing through. In such organs the venous blood leaving is warmer than the arterial coming to them; while the reverse is the

case with parts, like the skin, in which the blood is cooled. An organ colder than the blood is of course warmed by an increase in its circulation, as seen in the local rise of temperature in the skin of the face in blushing.

**Thermic Nerves.** All nerves, such as motor or secretory, which can throw working tissues into activity are in a certain sense thermic nerves: since they excite increased oxidation and heat production in the parts under their control. A true, purely thermic nerve would be one which increased the heat production in a tissue without otherwise throwing it into activity; and whether such exist is still undecided. Certain phenomena of disease, however, seem to render their existence probable. If we return for a moment to our former comparison of the working Body to a steam-engine, such nerves might be regarded as agencies increasing its rate of rusting without setting it at work. The oxidation of the iron would develop some heat, but by processes useless to the steam-engine, although such are, in moderation, essential to living cells; the vitality of these even when at rest, seems to necessitate a constant, if small, breaking down of its substance. In an amoeboid cell no doubt such processes occur quite independently of the nervous system; but in more differentiated tissues they may be controlled by it. Just as a muscle does not normally contract unless excited through its nerve, although a white blood corpuscle does, so may the natural nutritive processes of the muscle-fibre in its resting condition be dependent on the nerves going to it. If these be abnormally excited the muscle will break down its protoplasm faster than it constructs it, and consequently waste; at the same time the increased chemical degradation of its substance will elevate its temperature. Febrile conditions, in which many tissues waste, without any unusual manifesta-

division of the spinal cord in two ways tends to lower the temperature of parts below the injury: in the first place, the muscles are paralyzed and so a great source of heat is cut off; and in the second, the vaso-motor nerves traveling down from the medullary centre are cut, and hence the skin arteries behind the section dilate and carry more blood to the surface to be cooled. To explain the rise of temperature it has therefore been concluded that there are true thermic centres in the spinal cord, which centres, like others in that organ (Chap. XXXV.), are held in check or *inhibited* by brain-centres; when the controlling influence of the latter is removed the former may excite excessive oxidations in the tissues to which they are distributed, and so produce the rise of temperature. The proof, however, is not complete; for the raised temperature may, after all, be due merely to an excessive supply of blood, warmed elsewhere in the Body, to the dilated skin-vessels.

**Clothing.** To man, as social animal, endowed with moral feelings, clothing has certain uses in the interests of morality; but for such purposes the amount necessary is not great, as we find in many tribes living in warm climates. Except in tropical regions, however, clothing has in addition an important physiological use in regulating the bodily temperature. While the majority of other warm-blooded animals have coats of their own, formed of hairs or feathers, over most of man's Body his capillary coating is merely rudimentary and has lost all physiological importance; and so he has to protect himself by artificial garments, which his æsthetic sense has led him to utilize also for purposes of adornment. Here, however, we must confine ourselves to clothes from a physiological point of view. In civilized societies every one is required to cover most of his Body with something, and the question is what is the best covering; the answer will vary, of course, with the climatic conditions of the country dwelt in. In warm regions, clothing, in general terms, should allow free radiation or conduction of heat from the surface; in cold it should do the reverse; and in temperate climates, with varying temperatures, it should vary with the season. If the surface



**DIESE SEITE IST FÜR KOSTENLOSE MITGLIEDER GESPERRT**

Beantragen Sie jetzt die volle Mitgliedschaft, um diese Seite zu betreten

# GESCHICHTE

Zehntausende von wichtigen historischen Quellen, viele bisher nicht erhältlich, stehen jetzt zum ersten Mal mit der Vollmitgliedschaft von Forgotten Books zur Verfügung.

Unbegrenzter Zugang  
\$8.99/monat

**Fortfahren**

\*Es gelten Richtlinien zur fairen Nutzung.



of non-conducting material. Those whose skins are irritated by anything but linen should wear immediately outside the under-garments a jacket of silken or woolen material. In midwinter comparatively few people take cold, because all then wear thick and nonconducting clothing of some kind.

## CHAPTER XXX.

### SENSATION AND SENSE-ORGANS.

**The Subjective Functions of the Nervous System.** Changes in many parts of our Bodies are accompanied or followed by those states of consciousness which we call *sensations*. All such sensitive parts are in connection, direct or indirect, with the brain, by certain afferent nerve-fibres called *sensory*. Since all feeling is lost in any region of the Body when this connecting path is severed, it is clear that all sensations, whatever their primary exciting cause, are finally dependent on conditions of the central nervous system. Hitherto we have studied this as its activities are revealed through movements which it excites or prevents; we have seen it, directly or reflexly, cause muscles to contract, glands to secrete, or the pulsations of the heart to cease; we have viewed it *objectively*, as a motion-regulating apparatus. Now we have to turn to another side and consider it (or parts of it) as influencing the states of consciousness of its possessor: this study of the *subjective* activities of the nervous system is one of much greater difficulty.

It may be objected that considerations concerning states of feeling have no proper place in a treatise on Anatomy and Physiology; that, since we cannot form the beginning of a conception how a certain state of the nervous system causing the feeling redness, another the feeling blueness, and a third the emotion anger, all examination of mental phenomena should be excluded from the sciences dealing with the structure and properties of living things. But, although we cannot imagine how a nervous state (*neurosis*) gives rise to a conscious state (*psychosis*), we do know this, that distinct phenomena of consciousness never come under our



observation apart from a nervous system, and we are presumably, in some way, endowments of it; we are, therefore, justified in calling them properties of the nervous system; and their examination, especially with respect to what nerve-parts are concerned with different mental states, and what changes in the former are associated with given phenomena in the latter, forms properly a part of Physiology. Whether masses of protoplasm, before the differentiation of definite nerve-tissues, possess some ill-defined sort of consciousness, as they possess an indefinite contractility before they have been modified into muscular fibres, may for the present be left undecided: though those who accept the doctrine of evolution will be inclined to assent to the proposition.

While, however, the Physiologist has a right to be heard on questions relating to our mental faculties, it is nevertheless true that many laws of thought have been established, concerning which our present knowledge of the laws of the nervous system gives us no clue; the science of Psychology has thus a well-founded claim to an independent existence. But, in so far as its results are confined merely to the successions and connections of mental states, as established by observation, they are merely descriptions, and not explanations in a scientific sense: we know that so many mental phenomena have necessary material antecedents and concomitants in nervous changes, that we are justified in believing that all have such, and in continuing to seek for them. We do not know at all how an electric current sent round a bar of soft iron makes it magnetic; we only know that the one change is accompanied by the other; but we say we have explained the magnetism of a piece of iron if we have found an electric current circulating around it. Similarly, we do not know how a nervous change causes a mental state, but we have not explained the mental state until we have found the nervous state associated with it and how that nervous state was produced.

As yet it is only with respect to some of the simplest states of consciousness that we know much of the necessary physiological antecedents, and among these our sensations are the best investigated. As regards such mental pheno-



**DIESE SEITE IST FÜR KOSTENLOSE MITGLIEDER GESPERRT**  
Beantragen Sie jetzt die volle Mitgliedschaft, um diese Seite zu betreten



**Seien Sie niemals ohne ein Buch!**

Die Vollmitgliedschaft von Forgotten Books bietet Ihnen einen universalen Zugang von unseren Apps und unserer Website, auf all Ihren Geräten: Tablet, Telefon, E-Reader, Laptop und Computer.

**Eine Bibliothek in Ihrer Tasche für € 8.99/monat**

**Fortfahren**

\*Es gelten Richtlinien zur fairen Nutzung.

change causing a sensation of pain. Nevertheless in the one case we speak of the cold as being in the knife, and in the other of the pain as being in the finger.

Sensitive parts, such as the surface of the skin, through which we get, or believe we get, information about outer things, are of far more intellectual value to us than sensitive parts, such as the substantivus *firmis* into which the knife may cut, which give us only sensations referred to conditions of our bodies. The former are called *Sensory Organs proper*, or *Organs of Special Sense*; the latter are sensitive parts, or *Organs of Common Sensation*.

The Peripheral Reference of our Sensations. The fact that we refer certain sensations to external objects is only one case of a more general law, in accordance with which we do not ascribe our sensations, as regards their locality, to the brain, where the nervous system is concentrated by the sensation, but to a peripheral part. With respect to the brain, other parts of the body are external objects, as much as the rest of the material universe, yet the majority of our common sensations are felt at the places where the sensory nerves concerned are irritated, and not in the brain. Even if a nerve-trunk be stimulated in the middle of its course, we refer the resulting sensation to its outer endings. A blow on the inside of the elbow-joint, injuring the ulnar nerve, produces not only a local pain, but a sense of tingling ascribed to the fingers to which the ends of the fibres go. Persons with amputated limbs have feelings in their fingers and toes long after they have been lost, if the nerve-trunks in the stump be irritated. To explain such feelings must trench on the ground of Psychology, and as they cannot be fully discussed here; but they are commonly ascribed to the results of experience. The events of life have taught us that in the great majority of instances the sensory impulses which excite a given tactile sensation, for example, have acted upon the tip of a finger. The sensation goes when the finger is removed, and returns when it is replaced; and the eye confirms the contact of the external object with the finger-tip when we get the tactile sensation in question. We thus come firmly to associate a particular region of the

skin with a given sensation, and whenever afterwards the nerve-fibres coming from the finger are stimulated, no matter where, we ascribe the origin of the sensation to something acting on the finger-tip.

**The Differences between Sensations.** In both groups of sensations, those derived through organs of special sense and those due to organs of common sensation, we distinguish kinds which are absolutely distinct for our consciousness, and not comparable mentally. We can never get confused between a sight, a sound, and a touch, nor between pain, hunger, and nausea; nor can we compare them with one another; each is *sui generis*. The fundamental difference which thus separates one sensation from another is its *modality*. Sensations of the same modality may differ; but they shade imperceptibly into one another, and are comparable between themselves in two ways. First, as regards *quality*; while a high and a low pitched note are both auditory sensations, they are nevertheless different and yet intelligibly comparable; and so are blue and red objects. In the second place, sensations of the same modality are distinguishable and comparable as to amount or *intensity*: we readily recognize and compare a loud and a weak sound of the same pitch; a bright and feeble light of the same color; an acute and a slight pain of the same general character. Our sensations thus differ in the three aspects of *modality, quality within the same modality, and intensity*. Certain sensations also differ in what is known as the "*local sign*," a difference by which we tell a touch on one part of the skin from a similar touch on another; or an object exciting one part of the eye from an object like it, but in a different location in space and exciting another part of the visual surface.

As regards modality, we commonly distinguish five senses, those of sight, sound, touch, taste, and smell; it is doubtful whether temperature should not be added. The varieties of common sensation are also several; for example, pain, hunger, satiety, thirst, nausea, *malaise, bien-être* (feel-

brations; others (in the ear) become especially sensitive to sound vibrations; others to slight chemical changes (in mouth and nose), and others (in the skin) to variations in pressure or temperature.

All our sensations are thus modifications of ~~one common~~ primary sensibility, represented by that of the skin, or rather by the primitive representative of the skin in such an animal as the Hydra (see Zoology). The cutaneous sensations, being less differentiated, shade off more readily into the common sensibility of the other living tissues than do the activities of the highly differentiated cells in the eye and ear. We find, accordingly, that while a powerful pressure or a high temperature acting on the skin readily arouses a sensation of pain, that this is not the case with the more specialized visual and auditory organs. Their super-excitement may be disagreeable, but never passes into pain, in the ordinary sense of the word. Similarly the special skin sensations, touch and temperature, may sometimes be confounded, while a sound and a sight cannot be: the *acuity* of the less modified skin-senses is less complete. The study of comparative anatomy and development thus shows that the irritable parts of our sense-organs are but special differentiations of the primary external layer of cells covering the Body when it is very young. Some of these become ~~nerve~~



**DIESE SEITE IST FÜR KOSTENLOSE MITGLIEDER GESPERRT**  
Beantragen Sie jetzt die volle Mitgliedschaft, um diese Seite zu betreten

# GESCHICHTE

Zehntausende von wichtigen historischen Quellen, viele bisher nicht erhältlich, stehen jetzt zum ersten Mal mit der Vollmitgliedschaft von Forgotten Books zur Verfügung.

Unbegrenzter Zugang  
\$8.99/monat

**Fortfahren**

\*Es gelten Richtlinien zur fairen Nutzung.



(p. 190), so increase the sensitiveness of the parts containing them that degrees of change in the exciting forces, which would be totally unable to stimulate nerve-fibres themselves are appreciated. These terminal apparatuses are therefore as truly mechanisms enabling changes, which would not otherwise stimulate nerves, to excite them, as are the end organs in the eye or ear.

**The Cause of the Modality of our Sensations.** Seeing that the external forces usually exciting our different sensations differ, and that the sensations do also, we might at first be inclined to believe that the latter difference depended on the former: that brightness differed from loudness because light was different from sound. In other words, we are apt to think that each sensation derives its specific character from some property of its external physical antecedent, and that our sensations answer in some way to, and represent more or less accurately, properties of the forms of energy arousing them. It is, however, quite easy to show that we have no sufficient logical warrant for such a belief. Light falling into the eye causes a sensation of luminosity, a feeling belonging to the visual group or modality; and, since usually nothing else excites such feelings and light entering the healthy eye always does, we come to believe that the physical agent light is something like our sensation of luminosity. But, as we have already seen (p. 191), no matter how we stimulate the optic nerve we still get visual sensations; close the eyes and press with a finger-nail on one eyelid; a sensation of touch is aroused where the finger meets the skin; but the pressure on the eyeball distorts it and stimulates the optic nerve-fibres in it also, and the result is a luminous patch seen in front of the eye in such a position as a bright body must occupy in space to radiate light to that part of the expansion of the optic nerve. Finding, then, the same kind of sensation, a visual one, produced by the totally different causes, pressure and light, we are led to doubt if the differences of modality in our sensations depend upon the differences of the natural forces arousing them; and this doubt is strengthened when we find still other forces (p. 191)

giving rise to visual sensations. But then, since light and pressure, electricity and cutting, all cause visual sensations, we have no valid reason for supposing that light, more than either of the others, is really in any way like our sensation of light: or that sight-feeling differs from sound-feeling because objectively light differs from sound. The eye is an organ specially set apart to be excited by light, and accordingly so fixed as to have its nerve-fibres far more often excited by that form of force than by any other; but the fact that light sensations can be otherwise aroused shows plainly that their kind or character has nothing directly to do with any property of light. Just as by pinching or heating or galvanizing a motor nerve we can make the muscles attached to it contract, and the contraction has nothing in common with the excitant, so the visual sensation, as such, is independent of the stimulus arousing it and, of itself, tells us nothing concerning the kind of stimulus which has operated.

Differences in kind between external forces being thus eliminated as possible causes of the modalities of our sensations, we next naturally fall back upon differences in the sense-organs themselves. They do undoubtedly differ both in gross and microscopic structure, and the fact that pressure on the closed eye arouses a touch-feeling where the skin is compressed, and a sight-feeling where the optic nerve is, might well be due to the fact that a peripheral touch-organ was different from a peripheral sight-organ, and the same force might therefore produce totally different effects on them and so cause different kinds of feelings. However, here also closer examination shows that we must seek farther. Sensation is not produced in a sense-organ, but far away from it in the brain; the organ is merely an apparatus for generating nervous impulses. If the optic nerves be divided, no matter how perfect the eyeballs, no amount of light will arouse visual sensations; if the spinal cord be cut in the middle of the back no pressure on the feet will cause a tactile or other feeling; though the skin, and its nerves and the lower half of the spinal cord be all intact. In all cases we find that if the nerve-paths between a sense-organ



and the brain be severed no stimulation of the organ will call forth a sensation. The final production of this clearly depends, then, on something occurring in the brain, and so the kind of a sensation is presumably dependent upon brain events rather than on occurrences in sense-organs. Still it might be that something in the sense-organ caused one sensation to differ from another. Each organ might excite the brain in a different way and cause a different sensation, and so our sensations differ because our sense-organs did. Such a view is, however, negatived by observations which show that perfectly characteristic sensations can be felt in the absence of the sense-organs through which they are normally excited. Persons whose eyeballs have been removed by the surgeon, or completely destroyed by disease, have frequently afterwards definite and unmistakable visual sensations, quite as characteristic as those which they had while still possessing the visual end organs. The tactile sensations felt in amputated limbs, referred to above, afford another example of the same fact. The persons still *feel* things touching their legs or lying between their long-lost toes; and the sensations are distinctly *tactile* and not in any way less different from visual or auditory sensations than are the touch-feelings following stimulation of those parts of the skin which are still possessed. It is, then, clear that the modality of our sensations is to be sought deeper than in properties of the end organs of the nerves of each sense.

Properties of external forces and properties of peripheral nerve-organs being excluded as causes of differences in kind of sensation, we come next to the sensory nerve-fibres themselves. Is it because optic nerve-fibres are different from auditory nerve-fibres that luminous sensations are different from sonorous? This question must be answered in the negative, for we have already (p. 193) seen reason to believe that all nerve-fibres are alike in essential structure and that their properties are everywhere the same; that all they do is to transmit "nervous impulses" when excited, and that, no matter what the excitant, these impulses are molecular movements, always alike in kind, though they may differ in amount and in rate of succession. Since,



**DIESE SEITE IST FÜR KOSTENLOSE MITGLIEDER GESPERRT**  
Beantragen Sie jetzt die volle Mitgliedschaft, um diese Seite zu betreten



**Seien Sie niemals ohne ein Buch!**

Die Vollmitgliedschaft von Forgotten Books bietet Ihnen einen universalen Zugang von unseren Apps und unserer Website, auf all Ihren Geräten: Tablet, Telefon, E-Reader, Laptop und Computer.

**Eine Bibliothek in Ihrer Tasche für € 8.99/monat**

**Fortfahren**

\*Es gelten Richtlinien zur fairen Nutzung.

It is possible that the general statement in the last paragraph needs some limitation. While in senses of distinct modality, this character can be ascribed only to brain properties (so that we may be pretty sure that a man, the inner end of whose optic nerve was in physiological continuity with the outer end of his auditory, and the inner end of his auditory with the outer end of his optic, might hear a picture and see a symphony), yet, perhaps, differences in the rhythm or intensity of afferent nervous impulses may cause differences in modality in less differentiated senses. Thus contact with a cold soft object may be felt as heat, thought to be due to the approach of a warm body; and from such cases we must perhaps conclude that touch and temperature depend on excitations in different ways of one and the same brain-centre; impulses of a certain rhythm producing a sensation of heat, and those of another (determined by the different heat and touch end organs) causing a tactile sensation. If this be so, however, heat and touch would be but extreme varieties of one kind of sensation, and comparable to yellow and blue. Again, a heavy pressure, gradually increased, arouses sensations which pass imperceptibly from touch to pain, and the result may be due to the fact that regular and orderly afferent impulses, determined through tactile nerve-endings, excite the centre in one way; while irregular, disorderly, and violent, excited when the nerve-trunks beneath the skin are directly stimulated, may cause a different sensation; much as the same musical notes combined in one order cause pleasure but in another are disagreeable, causing a sort of pain, although the same brain-centres are stimulated in the two cases. The pain from a heavy weight may, however, be merely due to the fact that it excites the nerves very powerfully and gives rise to impulses which radiate farther in the brain than those causing touch sensations, and so excite new centres, the modality of which is a pain sensation.

However differences in nervous rhythm may account for minor differences in sensation, it remains clear that the characters of our sensations are creations of our own organ-

ism; they depend on properties of our Bodies and not on properties of external things, except in so far as these may or may not be adapted to arouse our different sensory apparatuses to activity. From the kind of the sensation we cannot, therefore, argue as to the nature of the excitant: we have no more warrant for supposing that light is like our sensation of light than that the knife that cuts us is like our sensation of pain. All that we know with certainty is states of our own consciousness, and although from these we form working hypotheses as to an external universe, yet, granting it, we have no means of acquiring any real knowledge as to the properties of things about us. What we want to know, however, for the practical purposes of life is, not what things *are*, but how to use them for our advantage, or to prevent them from acting to our disadvantage; and our senses enable us to do this sufficiently well.

**The Psycho-Physical Law.** Although our sensations are, in modality or kind, independent of the force exciting them, they are not so in degree or intensity, at least within certain limits. We cannot measure the amount of a sensation and express it in foot-pounds or calories, but we can get a sort of unit by determining how small a difference in sensation can be perceived. Supposing this smallest perceptible difference to be constant within the range of the same sense, (which is not proved,) it is found that it is produced by different amounts of stimuli, measured objectively, as forces; and that there exists in some cases a relation between the two which can be expressed in numbers. *The increase of stimulus necessary to produce the smallest perceptible change in a sensation is proportional to the strength of the stimulus already acting;* for example, the heavier a pressure already acting on the skin the more must it be increased or diminished in order that the increase or diminution may be felt. Expressed in another way the facts may be put thus: suppose three degrees of stimulation to hear to one another objectively the ratios 10, 100, 1000, then their subjective effects, or the amounts of sensation aroused by them, will be respectively as 1, 2, 3; in other words, *the sensation in-*

for luminosities so feeble as only to be seen at all with difficulty, or so bright as to be dazzling.

Besides their variations in intensity, dependent on variations in the strength of the stimulus, our sensations also vary with the irritability of the sensory apparatus itself; which is not constant from time to time or from person to person. In the above statements the condition of the sense-organ and its nervous connections is presumed to remain the same throughout.

**Perceptions.** In every sensation we have to carefully distinguish between the pure sensation and certain judgments founded upon it; we have to distinguish between what we really feel and what we think we feel; and very often firmly believe we do feel when we do not.

The most important of these judgments is that which leads us to ascribe certain sensations, those aroused through organs of special sense, to external objects—that our reference of our sensations which leads us to form ideas concerning the existence, form, position, and properties of external things. Such representations as these, founded on our senses, are called *perceptions*. Since these always imply some mental activity in addition to a mere feeling, their full discussion belongs to the domain of Psychology. Physiology, however, is concerned with them so far as it can determine the conditions of stimulation and nervousness under which a given mental representation concerning a sensation is made. It is quite certain that we can feel



**DIESE SEITE IST FÜR KOSTENLOSE MITGLIEDER GESPERRT**  
Beantragen Sie jetzt die volle Mitgliedschaft, um diese Seite zu betreten

# GESCHICHTE

Zehntausende von wichtigen historischen Quellen, viele bisher nicht erhältlich, stehen jetzt zum ersten Mal mit der Vollmitgliedschaft von Forgotten Books zur Verfügung.

Unbegrenzter Zugang  
\$8.99/monat

**Fortfahren**

\*Es gelten Richtlinien zur fairen Nutzung.



loose in its socket; and then we get two sensations on touching its free end with a foreign body.

This irresistible mental tendency to refer ~~certain~~ of our states of feeling to causes outside of our Bodies, and either in contact with them or separated from them by a certain space, is known as the phenomenon of the *extrinsic reference of our sensations*.

The discussion of its origin belongs properly to Psychology, and it will suffice here to point out that it seems largely to depend on the fact that the sensations extrinsically referred can be modified by movements of our Bodies. Hunger, thirst, and toothache all remain the same whether we turn to the right or left, or move away from the place we are standing in. But a sound is altered. We find that in a certain position of the head it is heard more by the right ear than the left; but on turning round the reverse is the case; and half way round the loudness in each ear is the same. Hence we are led, by mental laws outside of the physiological domain, to suspect that its cause is not in our Body, but outside of it; and depends not on a condition of the Body but on something else. And this is confirmed when going in one direction we find the sound increased, and in the other that it is diminished. This implies that we have a knowledge of our movements, and this we gain through the *muscular sense*. It constitutes the reactive side of our sensory life, associated with the changes we produce in external things; and is correlated and contrasted with the passive side, in which other things produce sensations by acting upon us.

As regards our common sensations we find something of the same kind. The more readily they can be modified by movement the more definitely do we localize them in space, though in this case within the Body instead of outside it. Hunger and nausea can be altered by pressure on the pit of the stomach; thirst by moistening the throat with water; the desire for oxygen (respiration-hunger) by movements of the chest; and so we more or less definitely ascribe these sensations to conditions of those parts of the Body. Other ~~general~~ sensations, as depression, anxiety, and so on, are not

modifiable by any particular movement, and so appear to us rather as mental states, pure and simple, than bodily sensations.

**Sensory Illusions.** "I must believe my own eyes" and "we can't always believe our senses" are two expressions frequently heard, and each expressing a truth. No doubt a sensation in itself is an absolute incontrovertible fact: if I feel redness or hotness I do feel it and that is an end of the matter: but if I go beyond the fact of my having a certain sensation and conclude from it as to properties of something else—if I form a *judgment* from my *sensation*—I may be totally wrong; and in so far be unable to believe my eyes or skin. Such judgments are almost inextricably woven up with many of our sensations, and so closely that we cannot readily separate the two; not even when we know that the judgment is erroneous.

For example, the moon when rising or setting, appears bigger than when high in the heavens—we seem to feel directly that it arouses more sensation, and yet we know certainly that it does not. With a body of a given brightness the amount of change produced in the end organs of the eye will depend on the size of the image formed in the eye, provided the same part of its sensory surface is acted upon. Now the size of this image depends on the distance of the object; it is smaller the farther off it is and bigger the nearer, and measurements show that the area of the sensitive surface affected by the image of the rising moon is no bigger than that affected by it when overhead. Why then do we, even after we know this, see it bigger? The reason is that when the moon is near the horizon we imagine, unconsciously and irresistibly, that it is farther off; even astronomers who know perfectly that it is not, cannot help forming this unconscious and erroneous judgment—and to them the moon appears in consequence larger when near the horizon, just as it does to less well-informed mortals. In fact we have a conception of the sky over which the moon travels, not as a half sphere but as somewhat flattened, and hence when the moon is at the horizon we unconsciously judge that it is farther off than when overhead. But any



most-regular in the ex-  
actly excited by blood  
flowing through them on  
exterior of the Body  
there. Both of these  
vase-dilator nerves of the  
blood-supply goes along  
plexus are from the

The Sebaceous Secret  
a special odor. It contains  
and palmaria). It helps  
them glossy, even in pe-  
components still as -  
spread more or less over  
permeable by water. It  
and wet it readily but  
though to a less extent

Epithelium of the Skin  
the solid residue left  
from a solid film over  
up the mouth of the  
the skin) and impedes  
health of keeping the  
skin by every one. It  
daily use takes on long  
its head when he takes  
should only be used on  
cleanliness, except on  
washing is a habit and  
will dry. Soap makes  
which is not a cure of  
time especially with  
the body soap. For  
can find a good substitute  
in a little ammonia.  
very good health with  
the skin and other  
from accumulating on  
the skin from the air



**DIESE SEITE IST FÜR KOSTENLOSE MITGLIEDER GESPERRT**  
Beantragen Sie jetzt die volle Mitgliedschaft, um diese Seite zu betreten



**Seien Sie niemals ohne ein Buch!**

Die Vollmitgliedschaft von Forgotten Books bietet Ihnen einen universalen Zugang von unseren Apps und unserer Website, auf all Ihren Geräten: Tablet, Telefon, E-Reader, Laptop und Computer.

**Eine Bibliothek in Ihrer Tasche für €8.99/monat**

**Fortfahren**

\*Es gelten Richtlinien zur fairen Nutzung.

body which excites the same extent of the sensitive surface of the eye at a great distance that another does at less, must be larger than the latter; and so we conclude that the moon at the horizon is larger than the moon in the zenith, and are ready to declare that we see it so.

So, again, a small bit of light gray paper on a white sheet looks gray: but placed on a large bright green surface it looks purple; and on a bright red surface looks blue-green. As the same bit of gray paper is shifted from one to the other we see it change its color: it arouses in us different feelings, or feelings which we interpret differently, although objectively the light reflected from it remains the same. Similarly a medium-sized man alongside of a very tall one appears short, but when walking with a very short one, tall.

Such erroneous perceptions as these are known as *sensory illusions*; and we ought to be constantly on guard against them.

## CHAPTER XXXI.

### THE EYE AS AN OPTICAL INSTRUMENT.

**The Essential Structure of an Eye.** Every visual organ consists primarily of a nervous expansion, provided with end organs by means of which light is enabled to excite nervous impulses, and exposed to the access of objective light; such an expansion is called a *retina*. By itself, however, a retina would give no visual sensations referable to distinctly limited external objects; it would enable its possessor to tell light from darkness, more light from less light, and (at least in its highly developed forms) light of one color from light of another color; but that would be all. Were our eyes mere 1 retinas we could only tell a printed page from a blank one by the fact that, being partly covered with black letters, (which reflect less light,) it would excite our visual organ less powerfully than the spotless white

**FIG. 122.**—Illustrating the use of a lens in giving definite retinal images, as in Fig. 121. *L*, a biconvex lens so placed that it brings the points *a* and *b* of the retina, rays of light diverging from respectively.

fibres would be stimulated and the result would be the recognition of two separate red objects. In the eye we find certain *refracting media* which lie in front of the retina and take the place of the lens *L* in Fig. 122. This portion of physiology which treats of the physical properties of these media, or in other words of the eye as an optical instrument, is known as the *dioptrics* of the eye.

**The Appendages of the Eye.** The eyeball consists of the retina and refracting media, together with supporting and nutritive structures and other



**DIESE SEITE IST FÜR KOSTENLOSE MITGLIEDER GESPERRT**  
Beantragen Sie jetzt die volle Mitgliedschaft, um diese Seite zu betreten

# GESCHICHTE

Zehntausende von wichtigen historischen Quellen, viele bisher nicht erhältlich, stehen jetzt zum ersten Mal mit der Vollmitgliedschaft von Forgotten Books zur Verfügung.

Unbegrenzter Zugang  
\$8.99/monat

**Fortfahren**

\*Es gelten Richtlinien zur fairen Nutzung.



ball but, near their inner ends, a red vertical fold of conjunctiva, the *semilunar fold* (*plica semilunaris*) intervenes. This is a remnant of the third eyelid, or *winking membrane*, found largely developed in many animals, as birds, in which it can be drawn all over the exposed part of the eyeball. Quite in the inner corner is a reddish elevation, the *caruncula lachrymalis*, caused by a collection of sebaceous glands imbedded in the semilunar fold. Opening along the edge of each eyelid are from twenty to thirty minute compound sebaceous glands, called the Meibomian follicles. Their secretion is sometimes abnormally abundant, and then appears as a yellowish matter along the edges of the eyelids, which often dries in the night and causes the lids to be glued together in the morning. The *eyelashes* are short curved hairs, arranged in one or two rows along each lid where the skin joins the conjunctiva.

The **Lachrymal Apparatus** consists of the tear-gland in each orbit, the ducts which carry its secretion to the upper eyelid, and the canals by which this, unless when excessive, is carried off from the front of the eye without running down over the face. The *lachrymal* or *tear gland*, about the size of an almond, lies in the upper and outer part of the orbit, near the front end. It is a compound racemose gland, from which twelve or fourteen ducts run and open in a row at the outer corner of the upper eyelid. The secretion there poured out is spread evenly over the exposed part of the eye by the movements of winking, and keeps it moist; finally it is drained off by two *lachrymal canals*, one of which opens by a small pore (*punctum lachrymalis*) on each lachrymal papilla. The aperture of the lower canal can be readily seen by examining the corresponding papilla in front of a looking-glass. The canals run inwards and open into the *lachrymal sac*, which lies just outside the nose, in a hollow where the lachrymal and superior maxillary bones (*L* and *Mx*, Fig. 26)\* meet. From the sac the *nasal duct* proceeds to open into the nose-chamber below the inferior turbinate bone (*q*, Fig. 89, p. 309).

Tears are constantly being secreted, but ordinarily in

---

\* Page 74

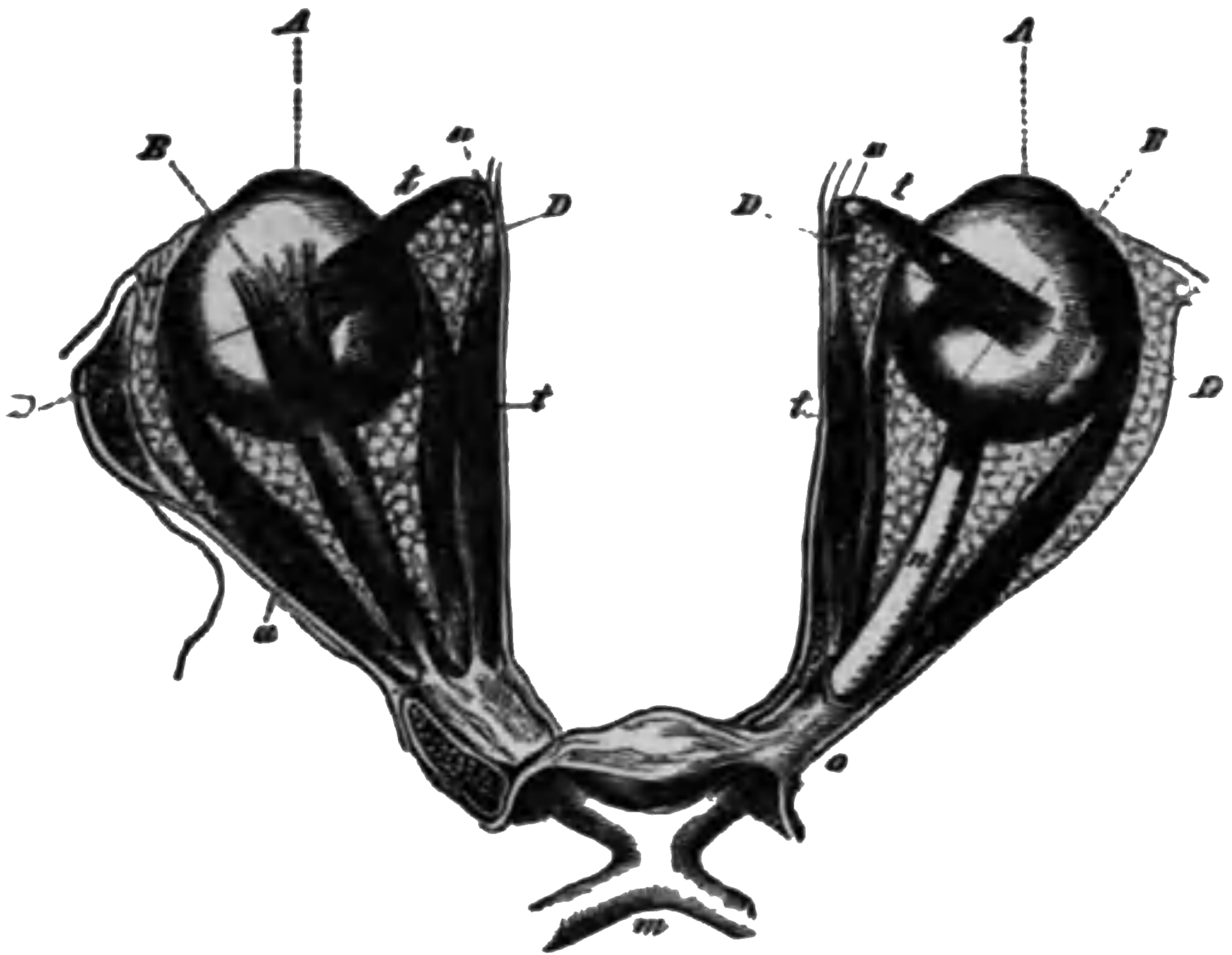

FIG. 122.—The eyeballs and their muscles as seen when the roof of the orbit has been removed and the fat in the cavity has been partly cleared away. On the right side the superior rectus muscle has been cut away. *a*, external rectus; *s*, superior rectus; *i*, internal rectus; *t*, superior oblique.

**The Muscles of the Eye** (Fig. 123). The eyeball is spheroidal in form and attached behind to the optic nerve, *n*, somewhat as a cherry might be to a thick stalk. On its outside are inserted the tendons of six muscles, four *straight* and two *oblique*. The straight muscles lie, one (*superior rectus*), *s*, above, one (*inferior rectus*) below, one (*external rectus*), *a*, outside, and one (*internal rectus*), *i*, inside the eyeball. Each arises behind from the bony margin of the foramen through which the optic nerve enters the orbit. In the figure,



which represents the orbits opened from above, the superior rectus of the right side has been removed. The *superior oblique* or *pulley (trochlear) muscle*, *t*, arises behind near the straight muscles and forms anteriorly a tendon, *u*, which passes through a fibro-cartilaginous ring, or pulley, placed at the notch in the frontal bone, where it bounds superiorly the front end of the orbit. The tendon then turns back and is inserted into the eyeball, between the upper and outer recti muscles. The ~~inferior oblique~~ *muscle* does not arise, like the rest, at the back of the orbit, but near its front at the inner side, close to the lachrymal sac. It passes thence outwards and backwards beneath the eyeball to be inserted into its outer and posterior part.

The inner, upper, and lower straight muscles, the inferior oblique, and the elevator of the upper lid are supplied by branches of the third cranial nerve (see p. 168). The sixth cranial nerve goes to the outer rectus; and the fourth to the superior oblique.

The eye may be moved from side to side; up or down; obliquely, that is neither truly vertically nor horizontally, but partly both; or, finally, it may be rotated on its antero-posterior axis. The oblique movements are always accompanied by a slight amount of rotation. When the glance is turned to the left, the left external rectus and the right internal contract, and *vice versa*; when up, both superior recti; when down, both the inferior. The superior oblique muscle acting alone will roll the front of the eye downwards and outwards with a certain amount of rotation; the inferior oblique does the reverse. In oblique movements two of the recti are concerned, an upper or lower with an inner or outer; at the same time one of the oblique also always contracts. Movements of rotation rarely, if ever, occur alone.

The natural combined movements of the eyes by which both are directed simultaneously towards the same point depends on the accurate adjustment of all its nervo-muscular apparatus. When the co-ordination is deficient the person is said to *squint*. A left *external squint* would be caused by paralysis of the inner rectus of that eye, for then,



**DIESE SEITE IST FÜR KOSTENLOSE MITGLIEDER GESPERRT**  
Beantragen Sie jetzt die volle Mitgliedschaft, um diese Seite zu betreten



**Seien Sie niemals ohne ein Buch!**

Die Vollmitgliedschaft von Forgotten Books bietet Ihnen einen universalen Zugang von unseren Apps und unserer Website, auf all Ihren Geräten: Tablet, Telefon, E-Reader, Laptop und Computer.

**Eine Bibliothek in Ihrer Tasche für € 8.99/monat**

**Fortfahren**

\*Es gelten Richtlinien zur fairen Nutzung.

measures about 22.5 millimeters ( $\frac{9}{16}$  inch), and from side to side about 25 millimeters (1 inch). Except when looking at near objects, the antero-posterior axes of the eyeballs are nearly parallel, but the optic nerves diverge considerably (Fig. 123); each joins its eyeball, not at the centre, but about 2.5 mm. ( $\frac{1}{8}$  inch) on the nasal side of the posterior end of its antero-posterior axis. In general terms the eyeball may be described as consisting of three *coats* and three *refracting media*.

The outer coat, 1 and 3, Fig. 124, consists of the *sclerotic* and the *cornea*, the latter being transparent and situated in front; the former is opaque and white and covers the back and sides of the globe and part of the front, where it is seen between the eyelids as the *white* of the eye. Both are tough and strong, being composed of dense connective tissue. The white of the eye and the cornea are also covered over by a thin layer of the conjunctiva, 4 and 5. Behind the proper connective-tissue layer, 3, of the cornea is a thin structureless membrane, 6, lined inside by a single layer of epithelial cells; it is called the *membrane of Descemet*, or *posterior elastic layer*.

The second coat consists of the *choroid*, 9, 10, the *ciliary processes*, 11, 13, and the *iris*, 14. The *choroid* consists mainly of blood-vessels supported by loose connective tissue containing numerous corpuscles, which in its inner layers are richly filled with dark brown or black pigment granules. Towards the front of the eyeball, where it begins to diminish in diameter, the choroid is thrown into plaits, the *ciliary processes*, 11, 12, 13. Beyond these it continues as the *iris*, which forms the colored part of the eye which is seen through the cornea; and in the centre of it this a circular aperture, the *pupil*: so the second coat does not, like the outer one, completely envelop the ball. In the iris are two sets of plain muscular fibres; a circular around the margin of the pupil and narrowing it when they contract; the other set radiate from the inner to the outer margin of the iris and by their contraction dilate the pupil. The pigment in the iris is yellow, or of lighter or darker brown, according to the color of the eye, and more or less

abundant according as the eye is black, brown, or gray. In blue eyes the pigment is confined to the deeper layers and modified in tint by light absorption in the anterior colorless strata through which the light passes.

The third coat of the eye, *the retina*, 15, is its essential portion, being the part in which the light produces those changes that give rise to impulses in the optic nerve. It is a still less complete envelope than the second tunic, extending forwards only as far as the commencement of the ciliary processes, at least in its typical form. It is extremely soft and delicate and, when fresh, transparent. Usually when an eye is opened it looks colorless; but by taking proper precautions the natural purple color of some of its outer layers can be seen. Its most external layer, moreover, is composed of black pigment cells. On its inner surface two parts, different from the rest, can be seen in a fresh eye. One is the point of entry of the optic nerve, 16, the fibres of which, penetrating the sclerotic and choroid, spread out in the retina. At this place the retina is whiter than elsewhere and presents an elevation, the *optic mound*. The other peculiar region is the *yellow spot* (*macula lutea*), 18, which lies nearly at the posterior end of the axis of the eyeball and therefore outside the optic mound; in its centre the retina is thinner than elsewhere and so a pit (*fovea centralis*), 18, is formed. This appears black, the thinned retina there allowing the choroid to be seen through it more clearly than elsewhere. In Fig. 125 is represented the left retina as seen from the front, the elliptical darker patch about the centre being the yellow spot, and the white circle on one side, the optic mound. The vessels of the retina arise from an artery (17, Fig. 124) which runs in with the optic nerve and from which branches diverge as shown in Fig. 125.

**The Microscopic Structure of the Retina.** A simplified stratum, continuous with the proper retina, and formed of a layer of nucleated columnar cells is continued over the ciliary processes; elsewhere the membrane has a very complex structure and a section taken, except at the yellow spot or the optic mound, shows ten layers, partly sensory

apparatuses and nerve-tissues, and partly accessory structures.

Beginning (Fig. 126) on the inner side we find, first, the *internal limiting membrane*, 1, a thin structureless layer. Next comes the *nerve-fibre layer*, 2, formed by radiating fibres of the optic nerve; third, the *nerve-cell layer*, 3;

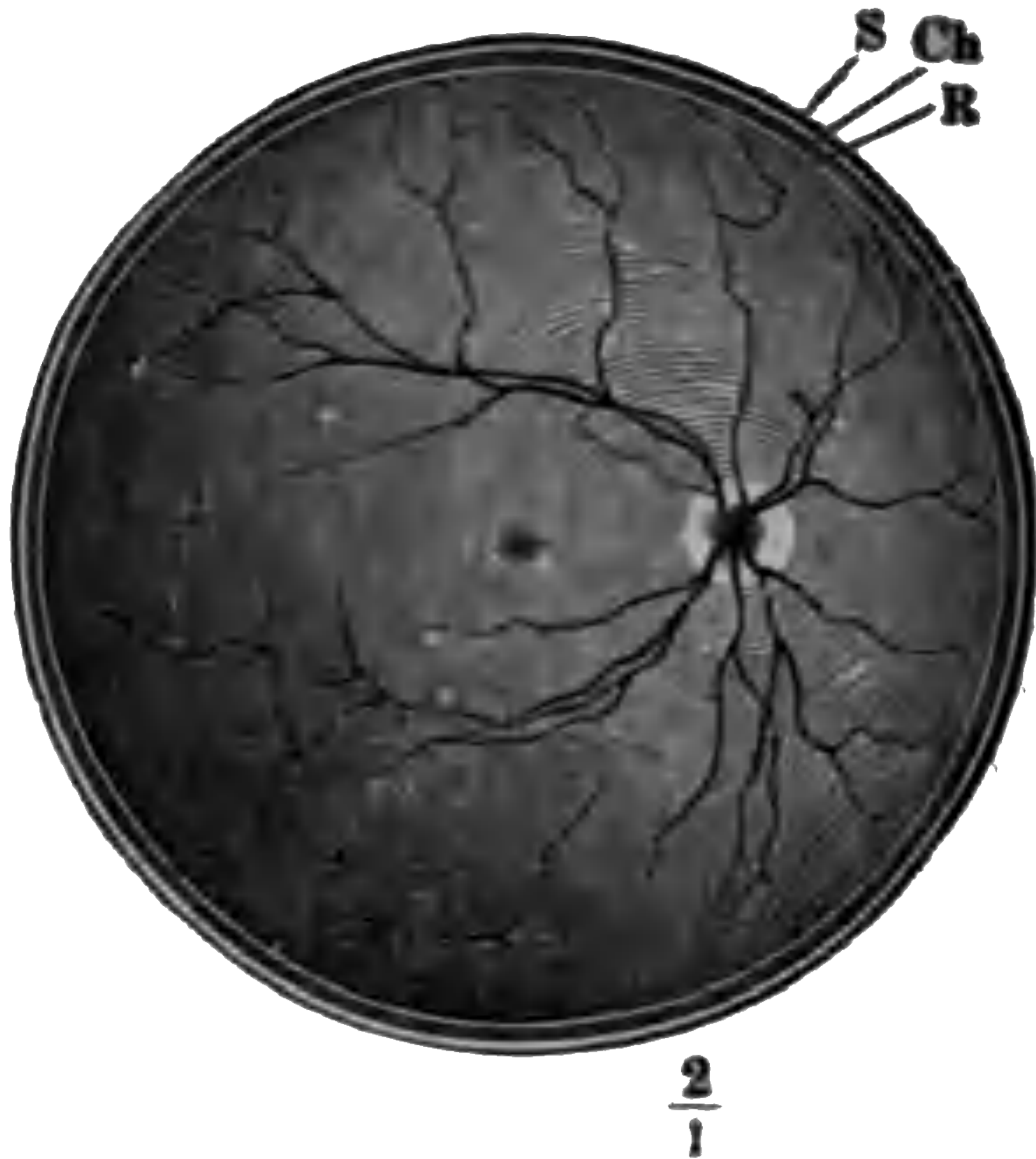

FIG. 125.—The left retina as it would be seen if the front part of the eyeball with the lens and vitreous humor were removed.

fourth, the *inner molecular layer*, 4, consisting partly of very fine nerve-fibrils, and largely of connective tissue; fifth, the *inner granular layer*, 5, composed of nucleated cells, with a small amount of protoplasm at each end, and a nucleolus. These *granules*, or at any rate the majority of them, have an *inner process* running to the inner molecular layer and an outer running to, 6, the *outer molecular layer*, which is thinner than the inner. Then comes, seventh, the *rod and cone fibre layer*, 7, or outer granular layer; composed of thick and thin fibres on each of which is a conspicuous nucleus with a nucleolus. Next is the thin *external limiting membrane*, 8, perforated by apertures through which the *rods and cones*, 9, of the ninth layer join the fibres of the seventh. Outside of all, next the choroid, is the *pigmentary layer*, 10. In addition, cer-



**DIESE SEITE IST FÜR KOSTENLOSE MITGLIEDER GESPERRT**  
Beantragen Sie jetzt die volle Mitgliedschaft, um diese Seite zu betreten

# GESCHICHTE

Zehntausende von wichtigen historischen Quellen, viele bisher nicht erhältlich, stehen jetzt zum ersten Mal mit der Vollmitgliedschaft von Forgotten Books zur Verfügung.

Unbegrenzter Zugang  
\$8.99/monat

**Fortfahren**

\*Es gelten Richtlinien zur fairen Nutzung.



and their branches, are undoubtedly accessory.

Each rod and cone consists of an *outer* and an *inner segment*. The outer segments of both tend to split up transversely into disks and are very similar, except that those of the rods are longer than those of the cones and do not taper as the latter do. The inner segments of the cones are swollen, while those of the rods are narrow and nearly cylindrical. Over most of the retina the rods are longer and much more numerous than the cones, but near the ciliary processes they cease before the cones do, and in the yellow spot elongated cones alone are found. In this region the whole retina is much modified; at its margin all the layers are thickened but especially the nerve-cell layer, which is here six or seven thick, while elsewhere the cells are found in but one or two strata. All the fibres also are oblique, reaching in to become continuous with the cones of the central pit, which are long, slender and very closely packed. In the fovea itself all the layers, except that of the cones, thin away, and so the depression is produced. The fovea is the seat of most acute vision; when we look at an object we always turn our eyes so that the light proceeding from it shall be focussed on this spot. Where the optic nerve enters, all the layers but the nerve-fibre layer, which is very thick, and the internal limiting membrane, are absent.

The blood-vessels of the retina lie in the nerve-fibre and nerve-cell layers.

**The Refracting Media of the Eye** are, in succession from before back, the *cornea*, the *aqueous humor*, the *crystalline lens*, and the *vitreous humor*.

The *aqueous humor* fills the space between the front of the lens, 28, and the back of the cornea. This space is in-

30, and a posterior, 31 (Fig. 124). Chemically, the aqueous humor consists of water holding in solution a small amount of solid matters, mainly common salt.

The *crystalline lens* (23, 26, 27) is colorless, transparent, and biconvex, with its anterior surface less curved than the posterior. It is surrounded by a capsule, and the inner edge of the iris lies in contact with it in front. In consistence it is soft, but its central layers are rather more dense than the outer.

The *vitreous humor* is a soft jelly, enveloped in a thin capsule, the *hyaloid membrane*. In front, this membrane splits into two layers, one of which, 22, passes on to be fixed to the lens a little in front of its edge. This layer is known as the *suspensory ligament of the lens*; its line of attachment around that organ is not straight but sinuous as represented by the curved line between 28 and 26 in Fig. 124. The space between the two layers into which the hyaloid splits is the *canal of Petit*. The vitreous humor consists mainly of water and contains some salts, a little albumin, and some mucin. It is divided up, by delicate membranes, into compartments in which its more liquid portions are imprisoned.

**The Ciliary Muscle.** Running around the eyeball where the cornea joins the sclerotic is a little vein called the *canal of Schlemm*; it is seen in section at 8 in Fig. 124. Lying on the inner side of this canal, just where the iris and the ciliary processes meet, there is some plain muscular tissue, imbedded mainly in the middle coat of the eyeball and forming the *ciliary muscle*, which consists of a *radial* and a *circular* portion. The radial part is much the larger, and arises in front from the inner surface of the sclerotic; the fibres pass back, spreading out as they go, and are inserted into the front of the choroid opposite the ciliary processes. The circular part of the muscle lies around the outer rim of the iris. The contraction of the ciliary muscle tends to pull forward (radial fibres) and press inward (circular fibres) the front part of the choroid, to which the back part of the suspensory ligament of the lens is closely attached. In this way the tension exerted on the lens by its ligament is diminished.



waves traveling in one plane only, as those on the surface of the water. Starting from a luminous point light would travel in all directions along the radii of a sphere of which the point is the centre; the light propagated along one such radius is called a *ray*, and in each ray the ethereal particles swing from side to side in a plane perpendicular to the direction of the ray. Taking a particle on any ray it would swing aside a certain distance from it, then back to it again, and across for a certain distance on the other side; and then back to its original position on the line of the ray. Such a movement is an *oscillation*, and takes a certain time; in lights of certain kinds the *periods of oscillation* are all the same, no matter how great the extent or *amplitude* of the oscillation; just as a given pendulum will always complete its swing in the same time no matter whether its swings be great or small. Light composed of rays in which the periods of oscillation are all equal is called *monochromatic* or *simple light*, while light made of a mixture of oscillations of different periods is called *mixed* or *compound light*.

If monochromatic light is steadily emitted from a point, then, at certain distances along a ray, we come to particles in the same *phase* of oscillation, say at their greatest distance from their position of rest; just as in the concentric waves seen on the water after throwing in a stone we would



**DIESE SEITE IST FÜR KOSTENLOSE MITGLIEDER GESPERRT**  
Beantragen Sie jetzt die volle Mitgliedschaft, um diese Seite zu betreten



**Seien Sie niemals ohne ein Buch!**

Die Vollmitgliedschaft von Forgotten Books bietet Ihnen einen universalen Zugang von unseren Apps und unserer Website, auf all Ihren Geräten: Tablet, Telefon, E-Reader, Laptop und Computer.

**Eine Bibliothek in Ihrer Tasche für € 8.99/monat**

**Fortfahren**

\*Es gelten Richtlinien zur fairen Nutzung.

incidence to that of the angle of refraction is always the same for the same two media with light of the same wavelength. When the first medium is air the ratio of the sine of the angle of refraction to that of the angle of incidence is called the refractive index of the second medium. The greater this refractive index the more is the refracted ray deviated from its original course. Rays which fall perpendicularly on the surface of separation of two media pass on without refraction.

The shorter the oscillation periods of light-rays the more they are deviated by refraction. Hence mixed light when

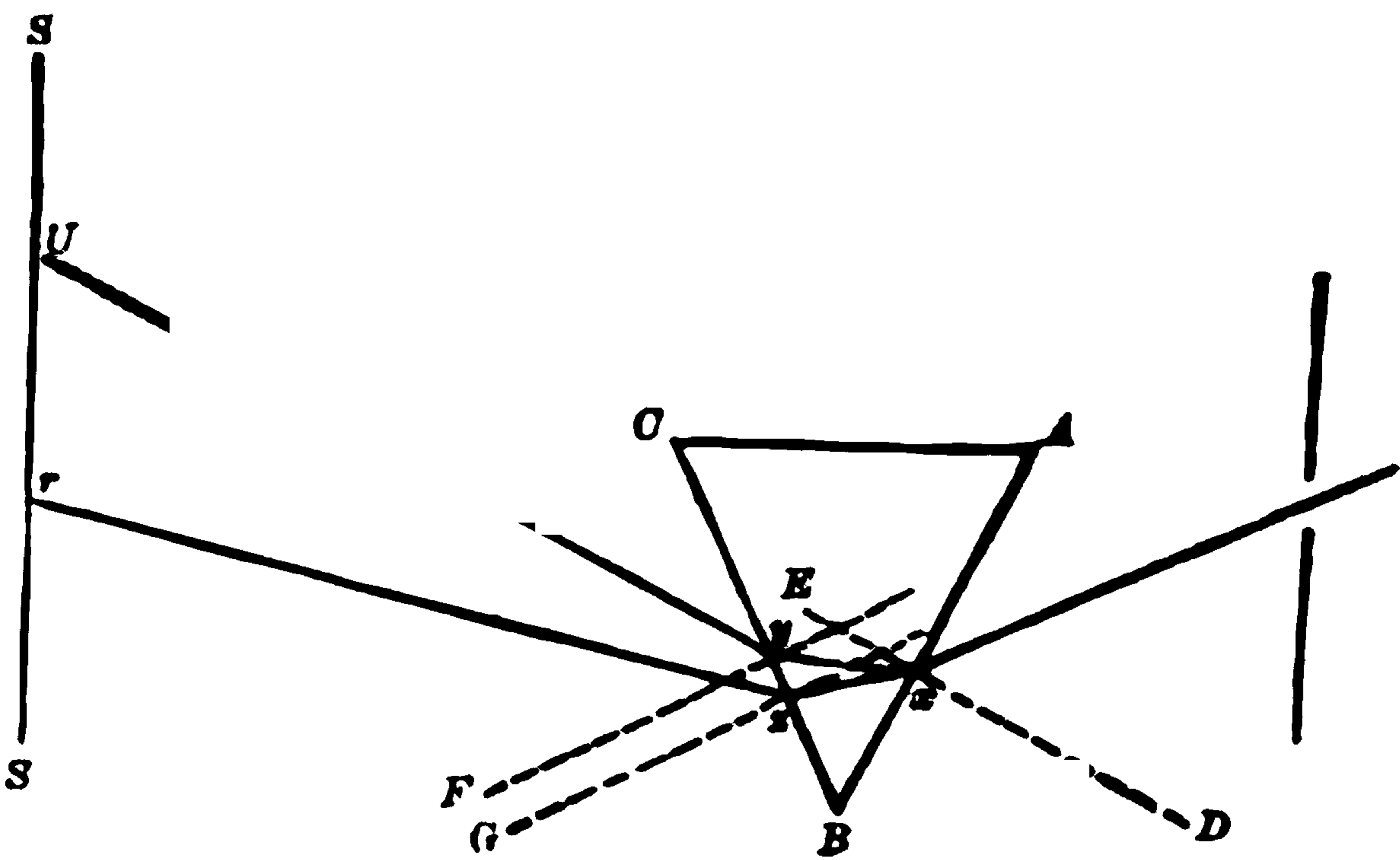

FIG. 128.—Diagram illustrating the dispersion of mixed light by a prism.

sent through a prism is spread out, and decomposed into its simple constituents. For let  $ax$  (Fig. 128) be a ray of mixed light composed of a set of short and a set of long ethereal waves. When it falls on the surface  $AB$  of the prism, that portion which enters will be refracted towards the normal  $ED$ , but the short waves more than the longer. Hence the former will take the direction  $xy$ , and the latter the direction  $xz$ . On emerging from the prism both rays will again be refracted, but now from the normals  $Fy$  and  $Gz$ , since the light is passing from a denser to a rarer medium. But again the ray  $xy$ , made up of shorter waves, would be most deviated, as in the direction  $yv$ , and

the long waves less, in the direction  $x r$ . If a screen were put at  $S S$ , we would receive on it at separate points,  $v$  and  $r$ , the two simple lights which were mixed together in the compound incident ray  $a x$ . Such a separation of light-rays is called *dispersion*.

Ordinary white light, such as that of the sun, is composed of ethereal vibrations of all possible lengths. Hence when such light is sent through a prism it gives a continuous band of light-rays, known as the *solar spectrum*, reaching from the least refracted to the most refracted and shortest. The exceptions to this statement due to Fraunhofer's lines (see Physics) are unessential for our present purpose. All of the simple lights into which the compound solar light is thus separated do not, however, excite in us visual sensations when they fall into the eye, but only certain middle ones. If solar light were used with the prism, Fig. 125, certain least refracted rays between  $r$  and  $S$  would not be seen, nor the most refracted between  $v$  and  $S$ ; while between  $v$  and  $r$  would stretch a luminous band exciting in us the series of colors red (due to the least refracted visible rays), successively through orange, yellow, green, bright blue, and indigo, to violet, which latter is the sensation aroused by the most refrangible visible rays. The still shorter waves beyond the violet, are known mainly by their chemical effects and make up what are called the *actinic rays*; the longer invisible waves, beyond the red, exert a powerful heating influence and compose the *thermal* or *dark heat* rays. The eye, as an organ for making known to us the existence of ethereal vibrations, has, therefore, only a limited range.



verging lens there is such a point behind it at which the rays from a given point in front of it meet: the point of meeting is called the *conjugate focus* of the point from which the rays start. If instead of a luminous point a luminous object be placed in front of the lens an image of the object will be formed at a certain distance behind it, for all rays proceeding from one point of the object will meet in the conjugate focus of that point behind. The image is inverted, as can be readily seen from Fig. 129. All rays

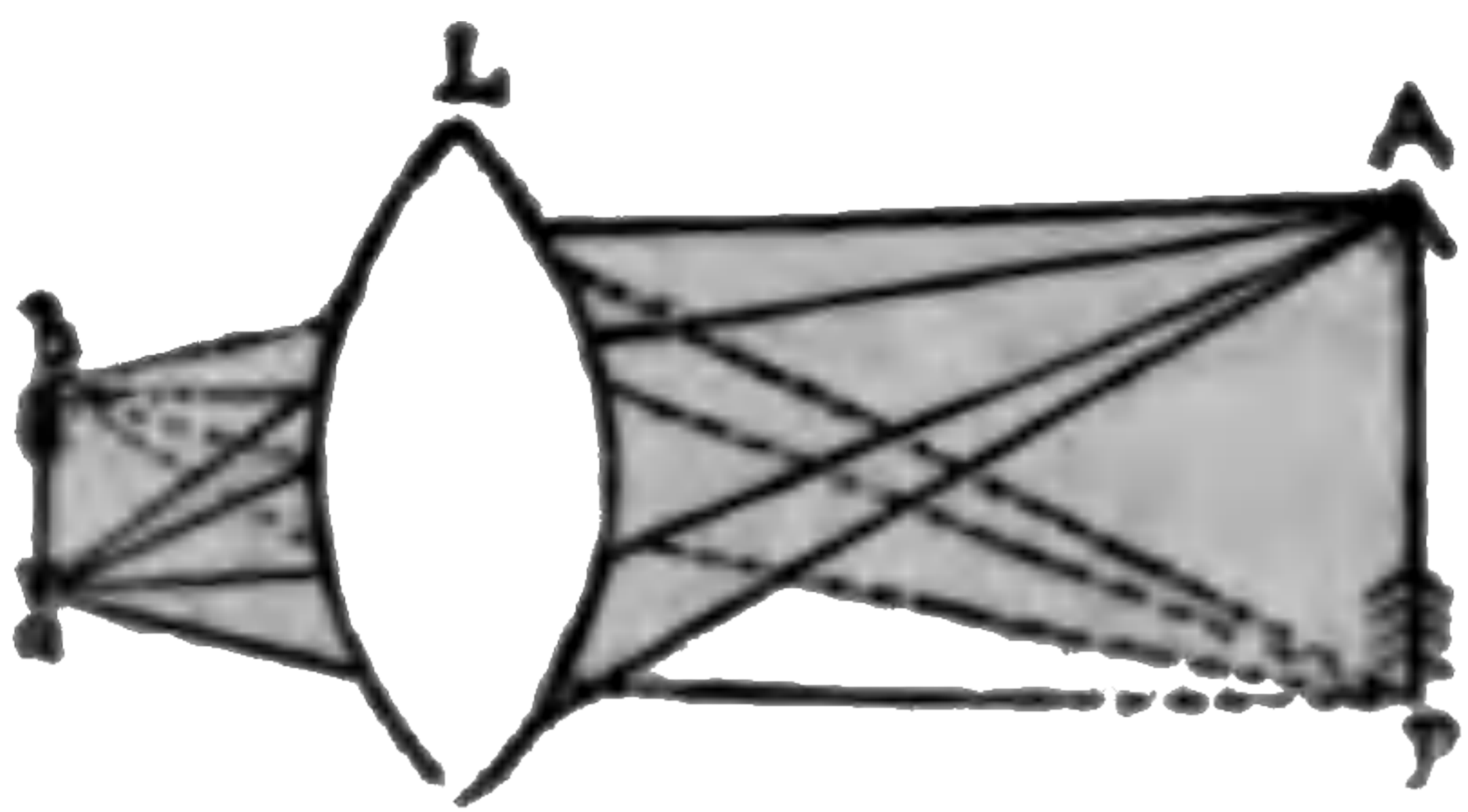

FIG. 129.—Diagram illustrating the formation of an image by a converging lens.

from the point *A* of the object meet at the point *a* of the image; those from *B* at *b*, and those from intermediate points at intermediate positions. If the single lens were replaced by several combined so as to form an *optical system* the

general result would be the same, provided the system were thicker in the centre than at its periphery.

The *Camera Obscura*, as used by photographers, is an instrument which serves to illustrate the formation of images by converging systems of lenses. It consists of a box blackened inside and having on its front face a tube containing the lenses; the posterior wall is made of ground glass. If the front of the instrument be directed on exterior objects, inverted and diminished images of them will be formed on the ground glass; those images are only well defined, at any one time, which are at such a distance in front of the instrument that the conjugate foci of points on them fall exactly on the glass behind the lens: objects nearer or farther off give confused and indistinct images; but by altering the distance between the lenses and the ground glass, in common language "focusing the instrument," either can be made distinct. For near objects the lenses must be farther from the surface on which the image is to be received, and for distant nearer. The reason of this may readily be seen from Fig. 130. If the system of lenses brings the parallel rays *a c* and *b d*, proceeding from an infinitely distant object, to a focus at *x*,



**DIESE SEITE IST FÜR KOSTENLOSE MITGLIEDER GESPERRT**  
Beantragen Sie jetzt die volle Mitgliedschaft, um diese Seite zu betreten

# GESCHICHTE

Zehntausende von wichtigen historischen Quellen, viele bisher nicht erhältlich, stehen jetzt zum ersten Mal mit der Vollmitgliedschaft von Forgotten Books zur Verfügung.

Unbegrenzter Zugang  
\$8.99/monat

**Fortfahren**

\*Es gelten Richtlinien zur fairen Nutzung.



without any effort; all rays emanating from a point of the object meet again in one point on the retina.

**Accommodation.** Points on near objects send into the eye diverging rays: these therefore would not come to a focus on the retina but behind it, and would not be seen distinctly, did not some change occur in the eye; since we can see them quite plainly if we choose (unless they be very near indeed), there must exist some means by which the eye is adapted or *accommodated* for looking at objects at different distances. That some change does occur one can, also, readily prove

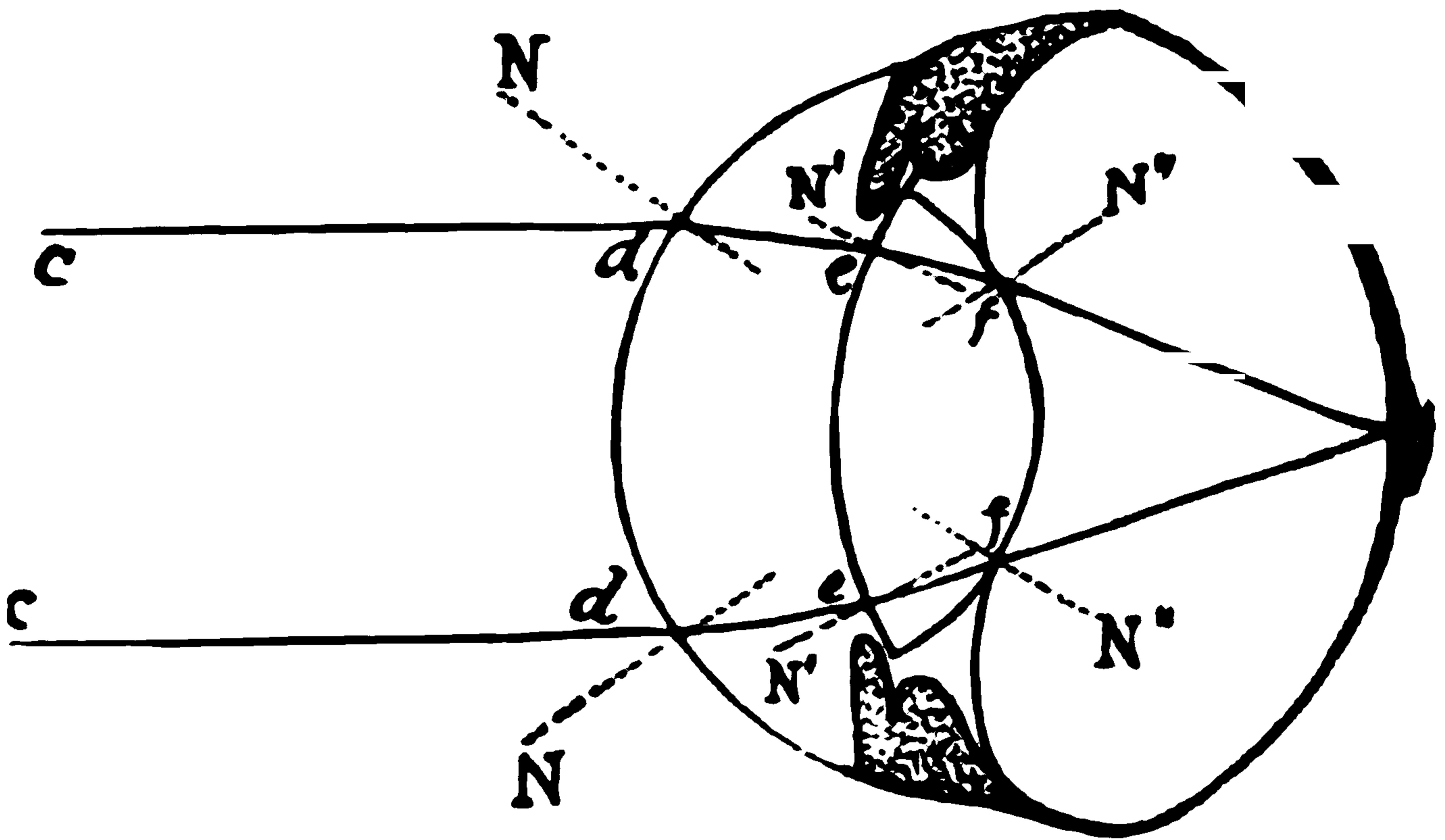

FIG. 181.—Diagram illustrating the surfaces at which light is refracted in the eye.

by observing that we cannot see distinctly, at the same moment, both near and distant objects. For example standing at a window, behind a lace curtain, we can if we choose look at the threads of the lace or the houses across the street; but when we look at the one we only see the other indistinctly; and if, after looking at the more distant object, we look at the nearer we experience a distinct sense of effort. It is clear, then, that something in the eye is different in the two cases. The resting eye, suited for distinctly seeing distant objects, might conceivably be accommodated for near vision in several ways. The refracting

indices of its media might be increased; that of course does not happen; the physical properties of the media are the same in both cases: or the distance of the retina from the refracting surfaces might be increased, for example by compression of the eyeball by the muscles around it; however, experiment shows that changes of accommodation can be brought about in the fresh excised eyes of animals, in which no such compression is possible; we are thus reduced to the third explanation, that the refracting surfaces, or some of them, become more curved, and so bring more diverging rays sooner to a focus; since a lens of smaller curvature is more converging than one of greater curvature composed of the same material. Observation shows that this is what actually happens: the corneal surface remains unchanged when a near object is looked at after a distant one, but the anterior surface of the lens becomes considerably more convex and the posterior slightly so. As already pointed out when light meets the separating surface of two media some is reflected and some refracted (p. 493). If, therefore, a person be taken into a dark room and a candle held on one side of his eye, while he looks at a distant object an observer can see three images of its flame in his pupil, due to that part of the light reflected from the surfaces between the media. One (*a*, Fig. 132) is erect and bright, reflected from the convex mirror formed by the cornea; the next, *b*, is dimmer and also erect; it comes from the front of the lens. The third, *c*, is dim and *inverted*, being reflected from the concave mirror (see Physics) formed by the back of the lens. If now the observed eye looks at a near object in the same line as the distant point previously looked at, it is seen that the image due to corneal reflection remains unchanged; that due to light from the front of the lens becomes smaller and brighter, indicating (see Physics) a greater convexity of the reflecting surface; the image from the back of the lens also becomes very slightly smaller, indicating a feebly increased curvature.

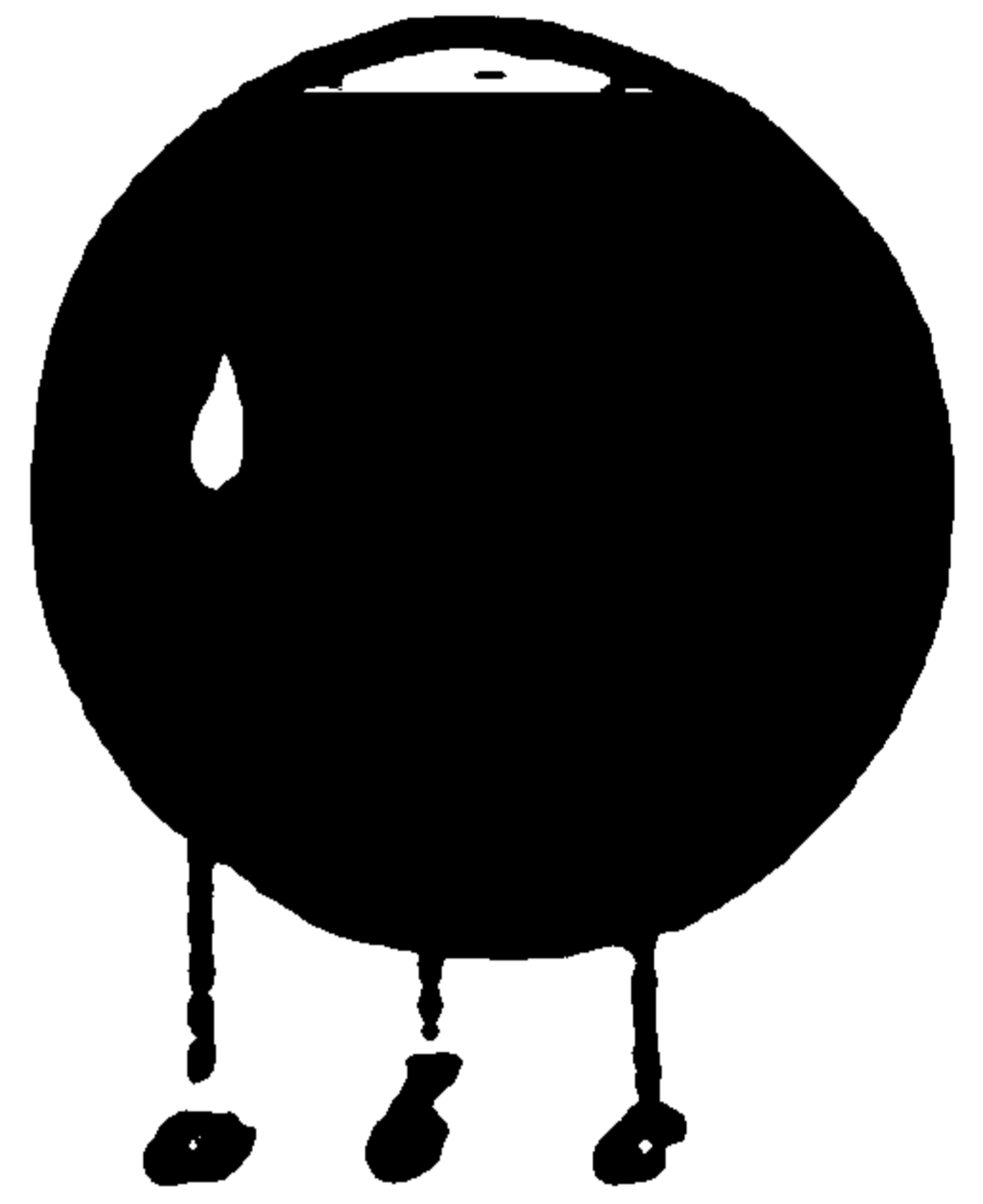

FIG. 132. — The images of a candle-flame as seen reflected from the refracting media of the eye.



Accommodation is brought about ~~mainly by the ciliary~~ muscle. In the resting eye it is relaxed and the suspensory ligament of the lens is taut, and, pulling on its edge, drags it out laterally a little and flattens its surfaces, especially the anterior, since the ligament is attached a little in front of the edge. To see a nearer object the ciliary muscle is contracted, and according to the degree of its contraction slackens the suspensory ligament (p. 491), and then the elastic lens, relieved from the lateral drag, bulges out a little in the centre.

**Short Sight and Long Sight.** In the eye the range of accommodation is very great, allowing the rays from points

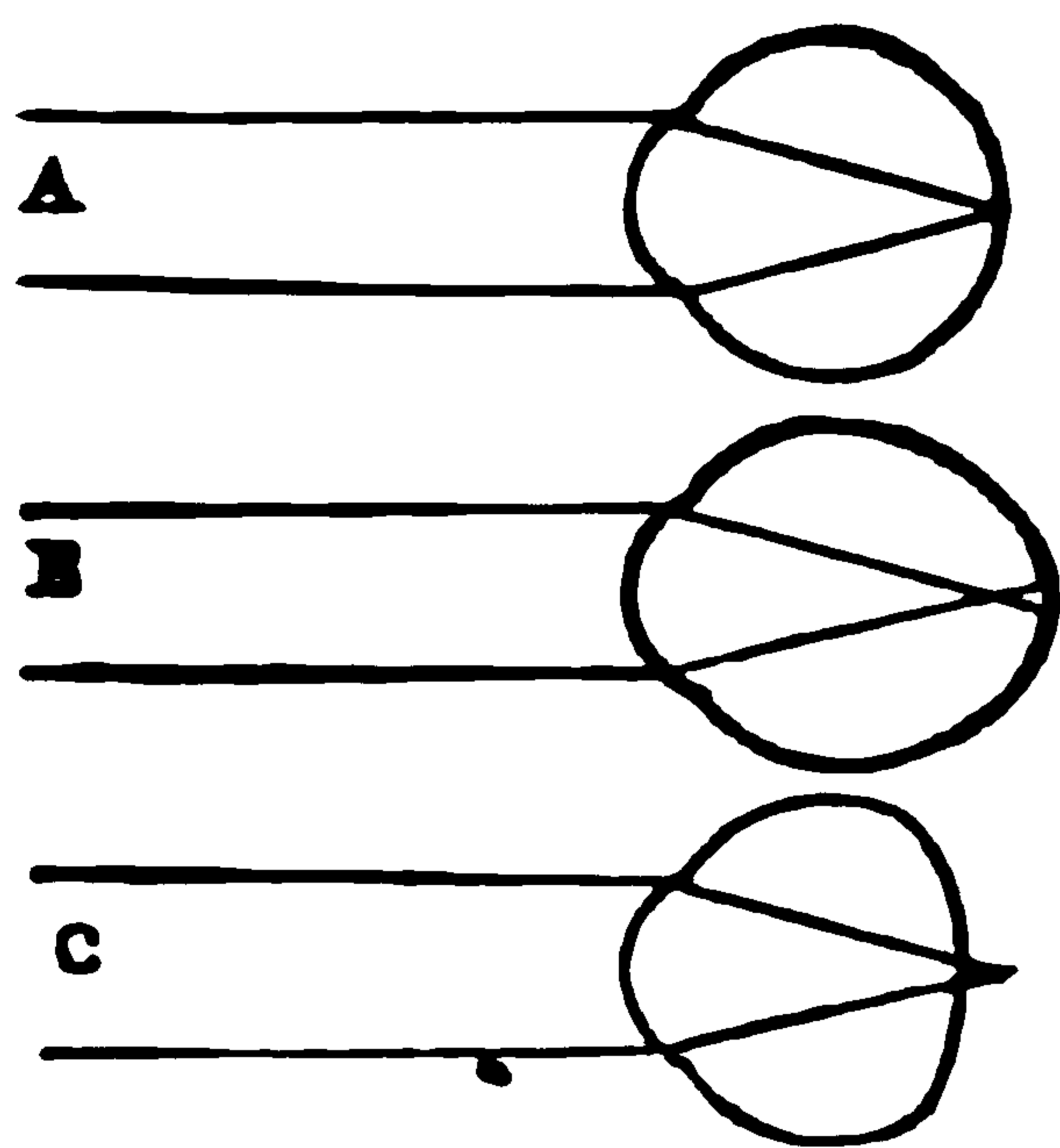

FIG. 189. — Diagram illustrating the path of parallel rays after entering an emmetropic (A), a myopic (B), and a hypermetropic (C) eye.

infinitely distant up to those from points about eight inches in front of the eye to be brought to a focus on the retina. In the normal eye parallel rays meet on the retina when the ciliary muscle is completely relaxed (A, Fig. 133). Such eyes are *emmetropic*. In other eyes the eyeball is too long from before back; in the resting state parallel rays meet in front of the retina (B). Persons with such

eyes, therefore, cannot see distant objects distinctly without the aid of diverging (concave) spectacles; they are *short-sighted* or *myopic*. Or the eyeball may be too short from before back; then, in the resting state, parallel rays are brought to a focus behind the retina (C). To see even infinitely distant objects, such persons must therefore use their accommodating apparatus to increase the converging power of the lens; and when objects are near they cannot, with the greatest effort, bring the divergent rays proceeding from them to a focus soon enough. To get distinct retinal images of near objects they therefore need converging (convex) spectacles. Such eyes are called *hypermetropic*, or in common language *long-sighted*.



**DIESE SEITE IST FÜR KOSTENLOSE MITGLIEDER GESPERRT**  
Beantragen Sie jetzt die volle Mitgliedschaft, um diese Seite zu betreten



**Seien Sie niemals ohne ein Buch!**

Die Vollmitgliedschaft von Forgotten Books bietet Ihnen einen universalen Zugang von unseren Apps und unserer Website, auf all Ihren Geräten: Tablet, Telefon, E-Reader, Laptop und Computer.

**Eine Bibliothek in Ihrer Tasche für € 8.99/monat**

**Fortfahren**

\*Es gelten Richtlinien zur fairen Nutzung.

matters in the demeanor or expression of those with whom they converse, which, being noticed by those of quicker sight, might induce feelings of distrust or annoyance."

In old age the eyeball tends to become flattened; hence emmetropic eyes become hypermetropic and old persons are usually "long-sighted" and need convex glasses. Such a flattening of the eyeball is of course a relief to the myopic eye; and so short-sighted persons can frequently, when old, still read without glasses. But this is poor compensation for the mistiness with which everything around them, except very near objects, has been seen throughout their previous life.

In all forms of deficient accommodation too strong glasses will injure the eyes irreparably, increasing the defects they are intended to relieve. Skilled advice should therefore be invariably obtained in their selection, except perhaps in the long-sightedness of old age when the sufferer may tolerably safely select for himself any glasses that allow him to read easily a book about 30 centimeters (12 inches) from the eye. As age advances stronger lenses must of course be obtained.

**Optical Defects of the Eye.** The eye, though it answers admirably as a physiological instrument, is by no means perfect optically; not nearly so good, for example, as a good microscope objective. The main defects in it are due to—

1. *Chromatic Aberration.* As already pointed out the rays at the violet end of the solar spectrum are more refrangible than those at the red end. Hence they are brought to a focus sooner. The light emanating from a point on a white object does not, therefore, all meet in one point on the retina; but the violet rays come to a focus first, then the indigo, and so on to the red, farthest back of all. If the eye is accommodated so as to bring to a focus on the retina parallel red rays, then violet rays from the same source will meet half a millimeter in front of it, and crossing and diverging there make a little violet *circle of diffusion* around the red point on the retina. In optical instru-

mente this defect is remedied by combining together lenses made of different kinds of glass; such compound lenses are called *achromatic*.

The general result of chromatic aberration, as may be seen in a bad opera-glass, is to cause colored borders to appear around the edges of the images of objects. In the eye we usually do not notice such borders unless we especially look for them; but if, while a white surface is looked at, the edge of an opaque body be brought in front of the eye so as to cover half the pupil, colorations will be seen at its margin. If accommodation is inexact they appear also when the boundary between a white and a black surface is observed. The phenomena due to chromatic aberration are much more easily seen if light containing only red and violet rays be used instead of white light containing all the rays of intermediate refrangibility. Ordinary blue glass only lets through these two kinds of rays. If a bit of it be placed over a very small hole in an opaque shutter and the sunlight be suffered to enter through the hole, it will be found that with one accommodation (that for the red rays) a red point is seen with a violet border, and with another (that at which violet rays are brought to a focus on the retina) a violet point is seen with a red aureole.

2. *Spherical Aberration*. It is not quite correct to state that ordinary lenses bring to a focus in one point behind them rays proceeding from a point in front, even when these are all of the same refrangibility. Convex lenses whose surfaces are segments of spheres, as are those of the eye, bring to a focus sooner the rays which pass through their marginal than those through their central parts. If the rays proceeding from a point and traversing the lateral part of a lens be brought to a focus at any point, then those passing through the centre of the lens will not meet until a little beyond that point. If the retina receive the image formed by the peripheral rays the others will form around this a small luminous circle of light—such as would be formed by sections of the cones of converging rays in Fig. 122, taken a little in front of  $r r$ . This defect is found in all

same extent in its vertical and horizontal diameters. Suppose the vertical meridian to be the most curved; then the rays proceeding from points along a vertical line will be brought to a focus sooner than those from points on a horizontal line. If the eye is accommodated to see distinctly the vertical line, it will see indistinctly the horizontal and *vice versa*. Few people therefore see equally clearly at once two lines crossing one another at right angles. The phenomenon is most obvious, however, when a series of concentric circles (Fig. 134) is looked at: then when the lines appear

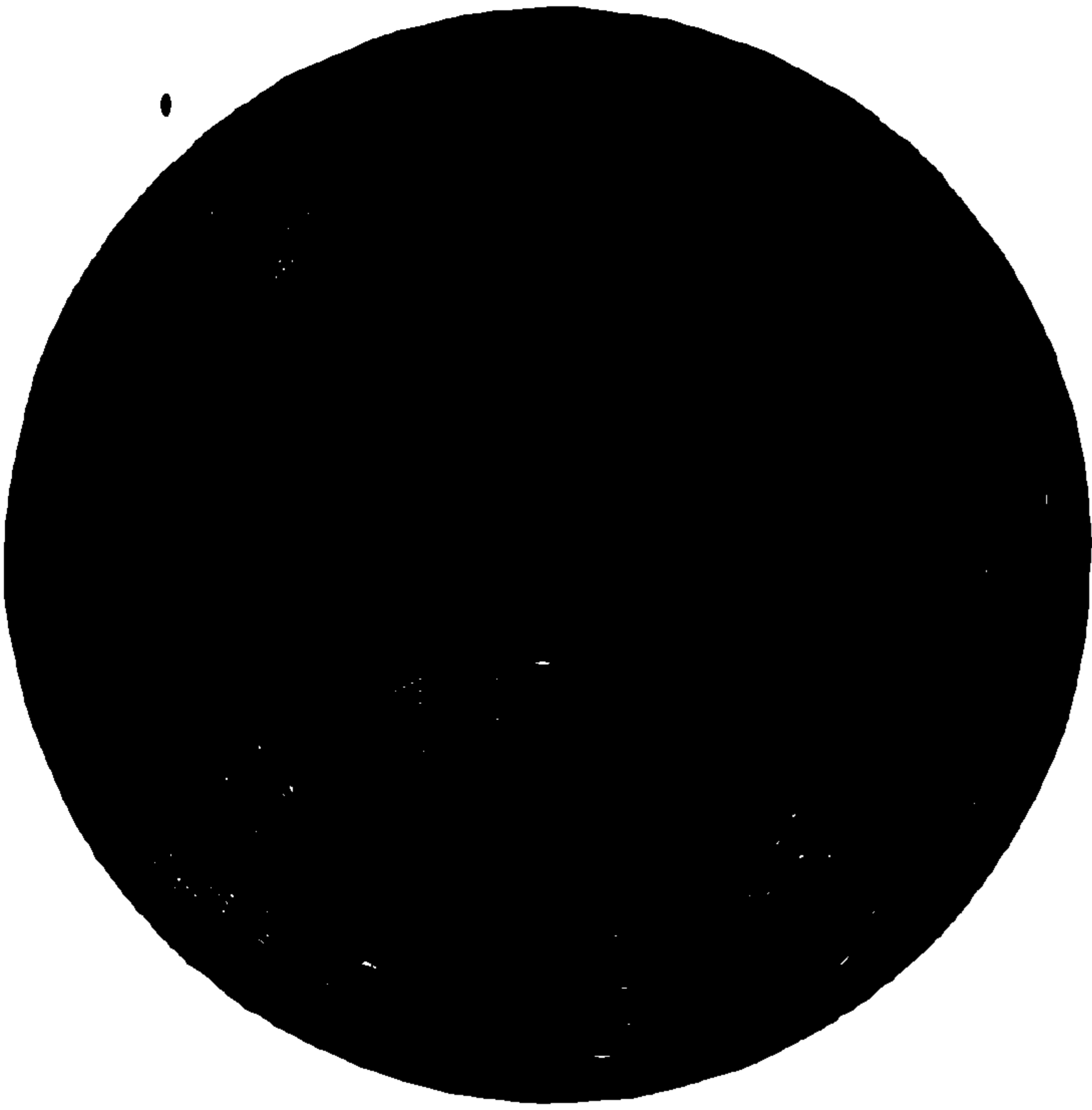

FIG. 134.

sharp along some sectors, they are dim along the rest. When this defect, known as *astigmatism*, is marked it causes serious troubles of vision and requires peculiarly shaped glasses to counteract it.

#### 4. *Opaque Bodies in the Refracting Media.*

In diseased eyes the lens may be opaque (*cataract*) and need removal; or opacities from ulcers or wounds may exist on the cornea. But even in the best eye there are apt to be small opaque bodies in the vitreous humor causing *muscae volitantes*; that is, the appearance of



**DIESE SEITE IST FÜR KOSTENLOSE MITGLIEDER GESPERRT**  
Beantragen Sie jetzt die volle Mitgliedschaft, um diese Seite zu betreten

# GESCHICHTE

Zehntausende von wichtigen historischen Quellen, viele bisher nicht erhältlich, stehen jetzt zum ersten Mal mit der Vollmitgliedschaft von Forgotten Books zur Verfügung.

Unbegrenzter Zugang  
\$8.99/monat

**Fortfahren**

\*Es gelten Richtlinien zur fairen Nutzung.



## CHAPTER XXXII.

### THE EYE AS A SENSORY APPARATUS.

**The Excitation of the Visual Apparatus.** The excitable visual apparatus for each eye consists of the retina, the optic nerve, and the brain-centres connected with the latter; however stimulated, if intact, it causes visual sensations. In the great majority of cases its excitant is objective light, and so we refer all stimulations of it to that cause, unless we have special reason to know the contrary. As already pointed out (p. 468) pressure on the eyeball causes a luminous sensation (phosphene), which suggests itself to us as dependent on a luminous body situated in space where such an object must be in order to excite the same part of the retina. Since all rays of light penetrating the eye, except in the line of its long axis, cross that axis, if we press the outer side of the eyeball we get a visual sensation referred to a luminous body on the nasal side; if we press below we see the luminous patch above, and so on.

Of course different rays entering the eye take different paths through it, but on general optical principles, which cannot here be detailed, we may trace all oblique rays through the organ by assuming that they meet and leave the optic axis at what are known as the *nodal points* of the system; these ( $k k'$ , Fig. 135) lie near together in the lens. If we want to find where rays of light from  $A$  will meet the retina (the eye being properly accommodated for seeing an object at that distance) we draw a line from  $A$  to  $k$  (the first nodal point) and then another, parallel to the first, from  $k'$  (the second nodal point) to the retina. The nodal points of the eye lie so near together that for practical purposes we may treat them as one ( $k$ , Fig. 136),

placed near the back of the lens. By manifold experience we have learnt that a luminous body (*A* Fig. 136) which we see, always lies on the prolongation of the line joining the excited part of the retina, *a*, and the nodal point, *k*. Hence

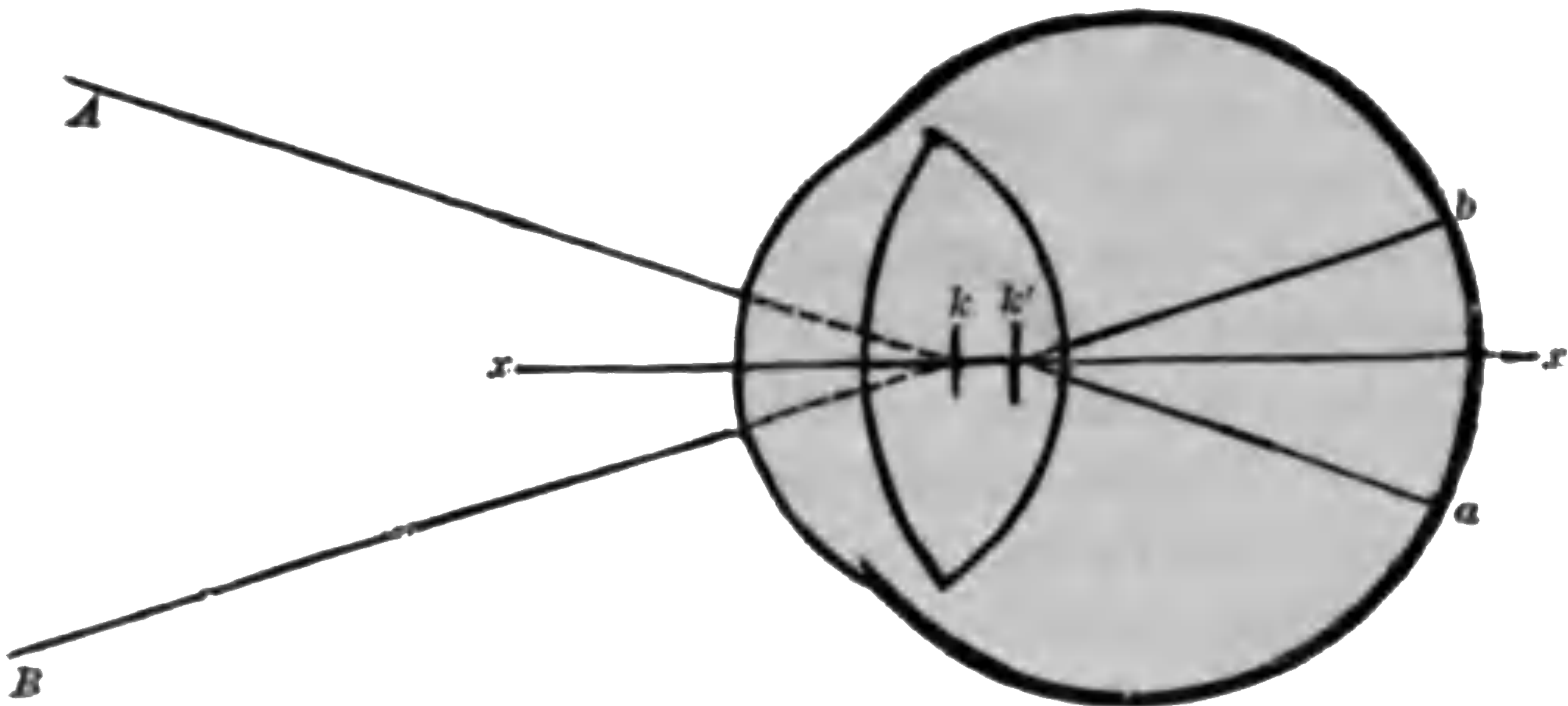

FIG. 135.—Diagram illustrating the points at which incident rays to the eye meet the retina. *x x*, optic axis; *k*, first nodal point; *k'*, second nodal point; *b*, point where the image of *B* would be formed, were the eye properly accommodated for it; *a*, the retinal point where the image of *A* would be formed.

any excitation of that part of the retina makes us think of a luminous body somewhere on the line *a A*, and, similarly, any excitation of *b*, of a body on the line *b B* or its prolongation. It is only other conflicting experiences, as that

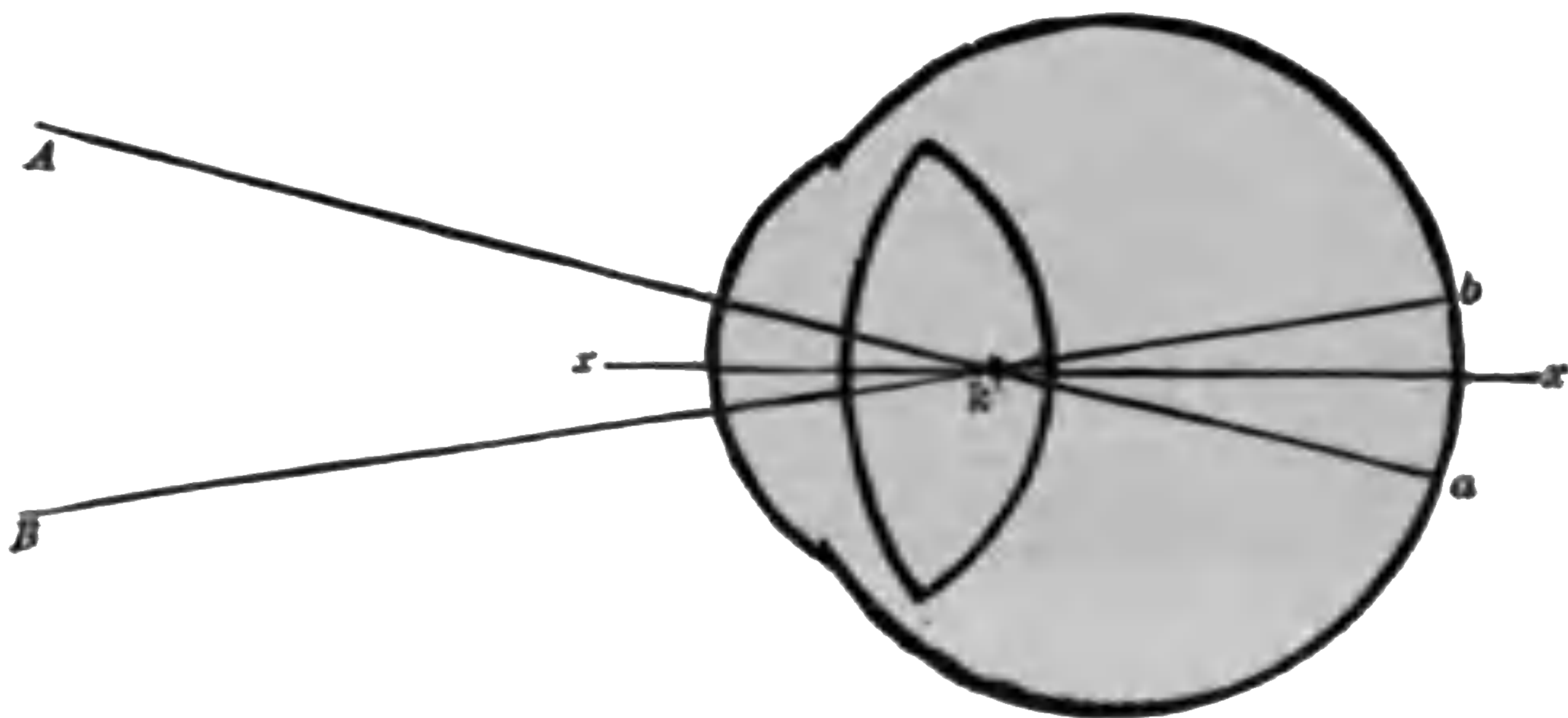

FIG. 136.—Diagrammatic section through the eyeball. *x x*, optic axis; *k*, nodal point.

with the eyes closed external bodies do not excite visual sensations, and the constant connection of the pressure felt on the eyelid with the visual sensation, that enable us when we press the eyeball to conclude that, in spite of what



we seem to see, the luminous sensation is not due to objective light from outside the eye.

**The Idio-Retinal Light.** The eyelids are not by any means perfectly opaque; in ordinary daylight they still allow a considerable quantity of light to penetrate the eye, as any one may observe by passing his hand in front of the closed eyes. But even in a dark room with the eyes completely covered up so that no objective light can enter them, there is still experienced a small amount of visual sensation due to internal causes. The field of vision is not absolutely dark but slightly luminous, with brighter fleeting patches traversing it. These are especially noticeable, for example, in trying to see and grope one's way with the eyes open up a perfectly dark staircase. Then the luminous patches attract special attention because they are apt to be taken for the signs of objective realities; they become very manifest when any sudden jar of the Body, due for example to knocking against something, occurs; and have no doubt given rise to many ghost stories. These visual sensations felt in the absence of all external stimulation of the eyes, may for convenience be spoken of as due to the *idio-retinal light*.

**The Excitation of the Visual Apparatus by Light.** Light only excites the retina when it reaches its nerve end



**DIESE SEITE IST FÜR KOSTENLOSE MITGLIEDER GESPERRT**  
Beantragen Sie jetzt die volle Mitgliedschaft, um diese Seite zu betreten



**Seien Sie niemals ohne ein Buch!**

Die Vollmitgliedschaft von Forgotten Books bietet Ihnen einen universalen Zugang von unseren Apps und unserer Website, auf all Ihren Geräten: Tablet, Telefon, E-Reader, Laptop und Computer.

**Eine Bibliothek in Ihrer Tasche für €8.99/monat**

**Fortfahren**

\*Es gelten Richtlinien zur fairen Nutzung.

dark branching lines which are the shadows of the retinal vessels. Now in order that these shadows may be seen the parts on which the light acts must be behind them, and therefore in the outer layers of the retina since the vessels lie (p. 490) in its inner strata.

If the light is kept steady the vascular shadows soon disappear; in order to continue to see them the candle must be kept moving. The explanation of this fact may readily be made clear by fixing the eyes for ten or fifteen seconds on the dot of an "i" somewhere about the middle of this page: at first the distinction between the slightly luminous black letters and the highly luminous white page is very obvious; in other words, the different sensations arising from the strongly and the feeble excited areas of the retina. But if the glance do not be allowed to wander, very soon the letters become indistinct and at last disappear altogether; the whole page looks uniformly grayish. The reason of this is that the powerful stimulation of the retina by the light reflected from the white part of the page soon fatigues the part of the visual apparatus it acts upon; and as this fatigue progresses the stimulus produces less and less effect. The parts of the retina, on the other hand, which receive light only from the black letters are very little stimulated and retain their original excitability so that, at last, the feebler excitation acting upon these more irritable parts produces as much sensation as the stronger stimulus acting upon the fatigued parts; and the letters become indistinguishable. To see them continuously we must keep shifting the eyes so that the same parts of the visual apparatus are alternately fatigued and rested, and the general irritability of the whole is kept about the same. So, in Purkinje's experiment, if the position of the shadows remain the same, the shaded part of the retina soon becomes more irritable than the more excited unshaded parts, and its relative increase of irritability makes up for the less light falling on it, so that the shadows cease to be perceived. It is for this same reason that we do not see the vessels under ordinary circumstances. When light, as usual, enters the eye from front through the pupil the

shadows always protect the same parts of the retina, and these parts are thus kept sufficiently more excitable than the rest to make up for the less light reaching them through the vessels. To see the latter we must throw the light into the eye in an unusual direction, not through the pupil but laterally through the sclerotic. If  $v$ , Fig. 139, be the section of a retinal vessel, ordinarily its shadow will fall at some point on the line prolonged through it from the centre of the pupil. If a candle be held opposite  $b$  it illuminates that part of the sclerotic and from there light radiates and illumines the eye. The sensation we refer to light entering the eye in the usual manner through the pupil, and accordingly see the surface

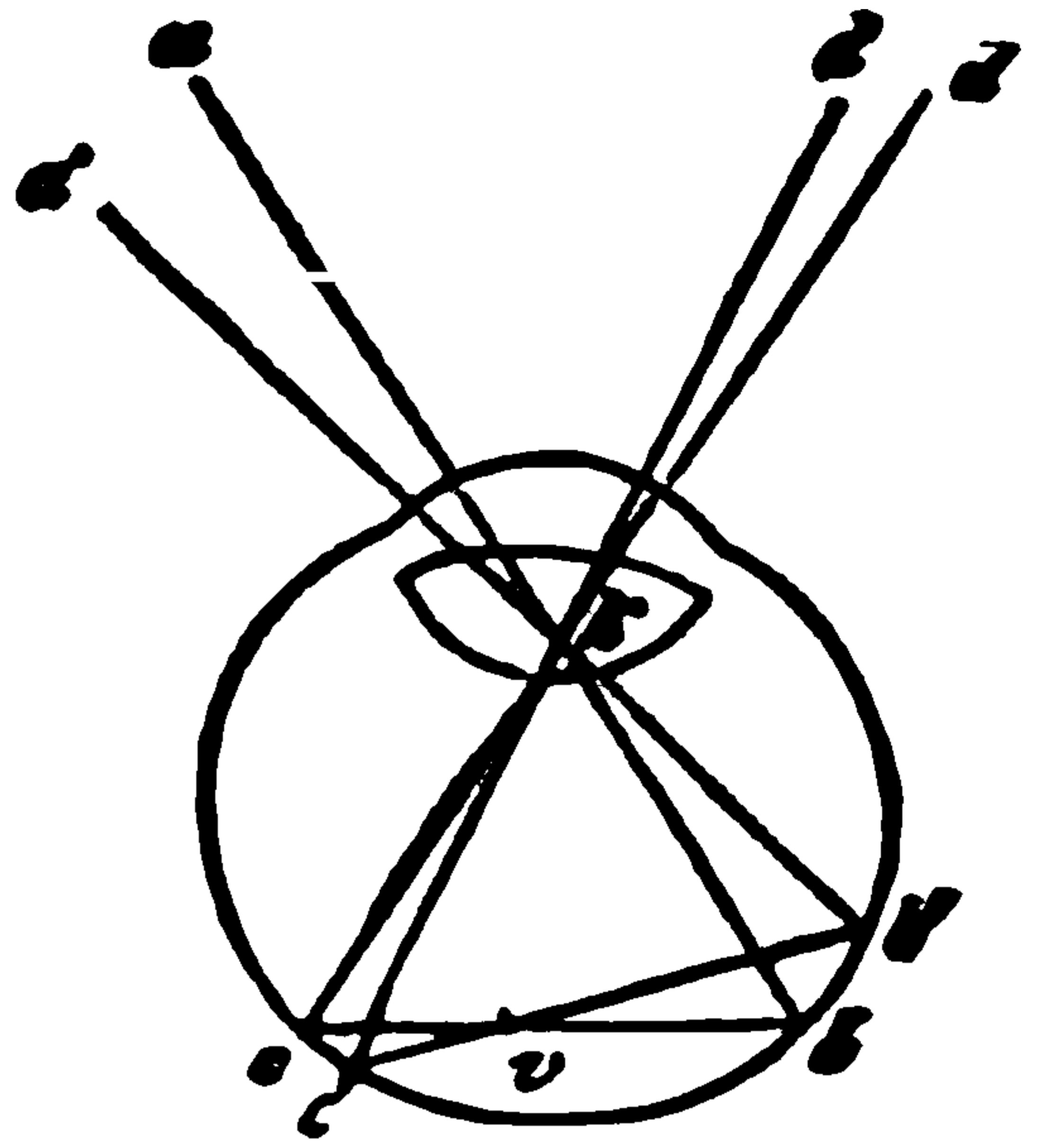

FIG. 139.

we look at as if it were illuminated. The shadow of  $v$  is now cast on an unusual spot  $c$ , and we see it as if at the point  $d$  on the wall, on the prolongation of the line joining the nodal point,  $k$ , of the eye with  $c$ . If the candle be moved so as to illuminate the point  $b'$  of the sclerotic, the shadow of  $v$  will be cast on  $c'$  and will accordingly seem on the wall to move from  $d$  to  $d'$ . It is clear that if we know how far  $b$  is from  $b'$ , how far the wall is from the eye, and how far the nodal point is from the retina (15 mm. or 0.6 inch), and measure the distance on the wall from  $d$  to  $d'$ , we can calculate how far  $c$  is from  $c'$ : and then how far the vessel throwing the shadow must be in front of the retinal parts perceiving it. In this way it is found that the part seeing the shadow, that is the layer on which light acts, is just about as far behind the retinal vessels as the main vascular trunks of the retina are in front of the rod and cone layer. It is, therefore, in that layer that the light initiates those changes which give rise to nervous impulses; which is further made obvious by the fact that the seat of most acute vision is the *fovea centralis*, where this layer and the cone-fibres diverging from it alone are found (p. 490).

When we want to see anything distinctly we always turn our eyes so that its image shall fall on the centre of the yellow spot.

**The Vision Purple.** How light acts in the retina so as to produce nerve stimuli is still uncertain. Recent observations show that it produces chemical changes in the rod and cone layer, and seemed at first to indicate that its action was to produce substances which were chemical excitants of nerve-fibres; but although there can be little doubt that these chemical changes play some important part in vision, what their rôle may be is at present quite obscure. If a perfectly fresh retina be excised rapidly, its outer layers will be found of a rich purple color. In daylight this rapidly bleaches, but in the dark persists even when putrefaction has set in. In pure yellow light it also remains unbleached a long time, but in other lights disappears at different rates. If a rabbit's eye be fixed immovably and exposed so that an image of a window is focused on the same part of its retina for some time, and then the eye be rapidly excised in the dark and placed in solution of potash alum, a colorless image of the window is found on the retina, surrounded by the visual purple of the rest which is, through the alum, fixed or rendered incapable of change by light. Photographs, or *optograms*, are thus obtained which differ from the photographer's in that he uses light to produce chemical changes which give rise to colored bodies, while here the reverse is the case. If the eye be not rapidly excised and put in the alum after its exposure, the optogram will disappear; the vision purple being rapidly regenerated at the bleached part. This reproduction of it is due mainly to the cells of the pigmentary layer of the retina. Portions of frogs' retinas raised from this bleach more rapidly than those left in contact with it, but become soon purple again if let fall back upon the pigment-cells. It thus seemed as if we had got a clue to the physiological action of light in the eye: but experiments show that animals (frogs) exposed for a long time to a bright light may have their retinas completely bleached and still see well; they can still unerringly catch flies that come



**DIESE SEITE IST FÜR KOSTENLOSE MITGLIEDER GESPERRT**  
Beantragen Sie jetzt die volle Mitgliedschaft, um diese Seite zu betreten

# GESCHICHTE

Zehntausende von wichtigen historischen Quellen, viele bisher nicht erhältlich, stehen jetzt zum ersten Mal mit der Vollmitgliedschaft von Forgotten Books zur Verfügung.

Unbegrenzter Zugang  
\$8.99/monat

**Fortfahren**

\*Es gelten Richtlinien zur fairen Nutzung.



$a$ , then that emitted by two candles will be  $2a$ ; and so on. If the amount of sensation excited by the single candle be  $A$ , then that due to two candles will not be  $2A$ , and that by three will be far less than  $3A$ . If a white surface,  $P$ , Fig. 140, be illuminated by a candle at  $c$  and another else-

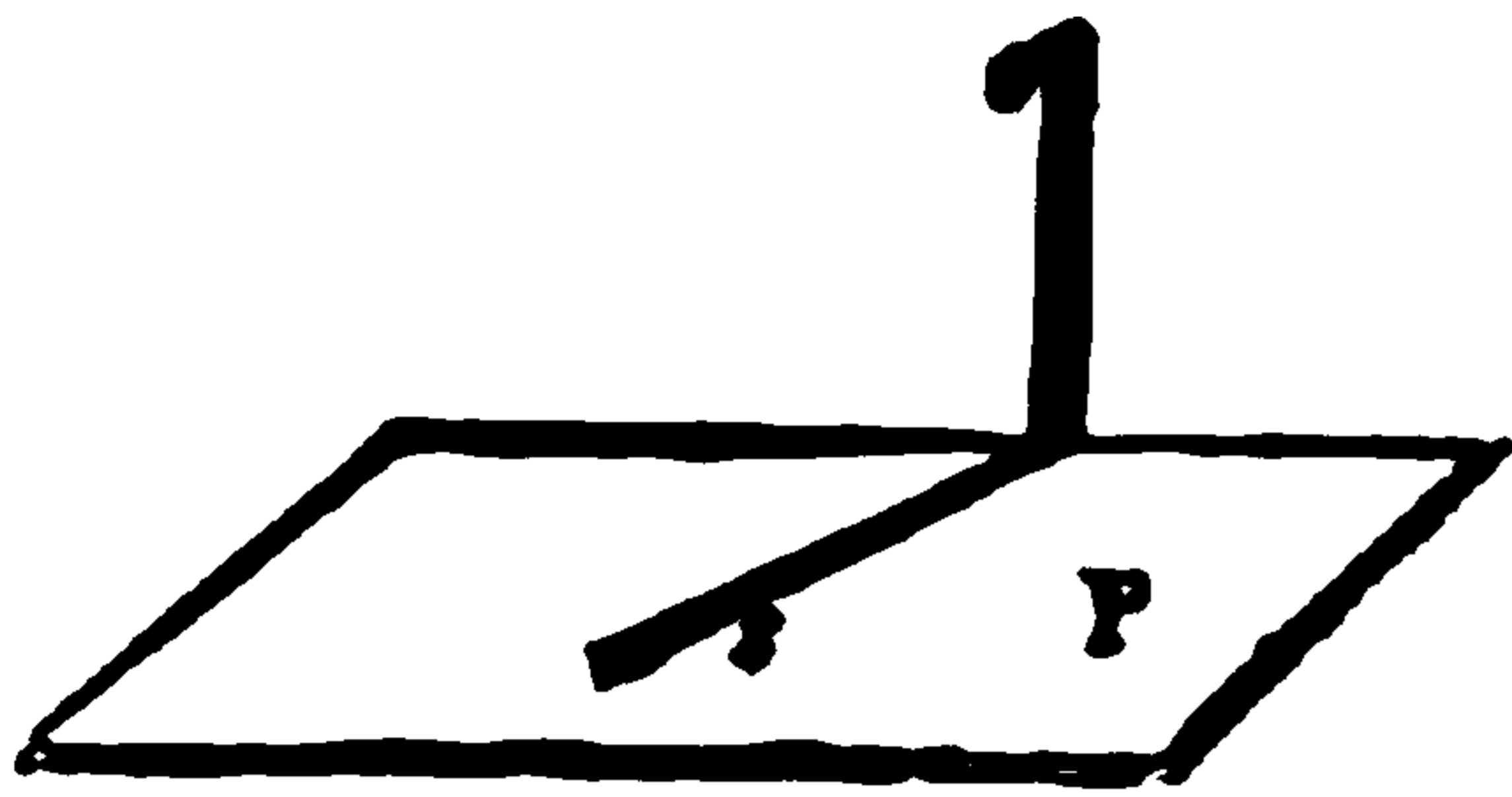

FIG. 140.

where, and a rod,  $o$ , be placed so as to intercept the light from  $c$ , we see clearly a shadow, since our eyes recognize the difference in luminosity of this part of the paper, reflecting light from one candle only,

from that of the rest which is illuminated by two: that is we tell the sensation due to the stimulus  $a$  from that due to the stimulus  $2a$ . If now a bright lamp be brought in and placed alongside, and its light be physically equal to that of 10 candles, we cease to perceive the shadow  $s$ . That is the sensation aroused by objective light =  $12a$  (due to the lamp and two candles) cannot be told from that due to light =  $11a$ ; although the difference of objective light is still  $1a$  as before. Most persons must have observed illustrations of this. Sitting in a room with three lights not unfrequently some object so intercepts the light from two as to cast on the wall two shadows which partly overlap. Where the shadows overlap the wall gets light only from the third candle; around that, where each shadow is separate, it is illuminated by this and one other candle; and the wall in the neighborhood of the shadows by all three. Objectively, therefore, the difference between the deep shadow and half shadow is that between the light of one candle and that of two. The difference between the half shadows and the wall around is that between the light of two and three candles. But as a matter of sensa-

shadow seems much greater than that between the half shadow and the rest of the wall; in other words the difference,  $a$ , between  $a$  and  $2a$ , is a more efficient stimulus than the same difference,  $a$ , between  $2a$  and  $3a$ . When the total stimulus increases the same absolute difference is less felt or may be entirely unperceived. An example of this which every one will recognize is afforded by the invisibility of the stars in daytime.

On the other hand, as the total stimulus increases or decreases the same fractional difference of the whole is perceived with the same ease; *i.e.* excites the same amount of sensation. In reading a book by lamplight we perceive clearly the difference between the amount of light reflected from the black letters and the white page. If we call the total lamplight reflected by the blank parts  $10a$  and that by the letters  $2a$ , we may say we perceive with a certain distinctness a luminous difference equal to one fifth of the whole. If we now take the book into the daylight the total light reflected from both the letters and the unprinted part of the page increases, but in the same proportion. Say the one now is  $50a$  and the other  $10a$ ; although the absolute difference between the two is now  $40a$  instead of  $8a$  we do not see the letters any more plainly than before. The smallest difference in luminous intensity which we can perceive is about  $\frac{1}{10}$  of the whole, for all the range of lights we use in carrying on our ordinary occupations. For strong lights the smallest perceptible fraction is considerably greater; finally we reach a limit where no increase in brightness is felt. For weak illumination the sensation is more nearly proportioned to the total differences of the objective light. Thus in a dark room an object reflecting all the little light that reaches it appears almost twice as bright as one reflecting only half; which in a stronger light it would not do. Bright objects in general obscurely thus appear unnaturally bright when compared with things about them, and indeed often look self-luminous. A cat's eyes, for example, are said to "shine in the dark;" and painters to produce moonlight effects always make the bright parts of a picture relatively brighter, when compared



of a moonlight landscape.

**The Duration of Luminous Sensations.** This is greater than that of the stimulus, a fact taken advantage of in making fireworks: an ascending rocket produces the sensation of a trail of light extending far behind the position of the bright part of the rocket itself at the moment, because the sensation aroused by it in a lower part of its course still persists. So, shooting stars appear to have luminous tails behind them. By rotating rapidly before the eye a disk with alternate white and black sectors we get for each point of the retina on which a part of its image falls, alternating stimulation (due to the passage of white sector) and rest, when a black sector is passing. If the rotation be rapid enough the sensation aroused is that of a uniform gray, such as would be produced if the white and black were mixed and spread evenly over the disk. In each revolution the eye gets as much light as if that were the case, and is unable to distinguish that this light is made up of separate portions reaching it at intervals: the stimulation due to each lasts until the next begins and so all are fused together. If one turns out suddenly the gas in a room containing no other light, the image of the flame persists a short time after the flame itself is extinguished.

**The Localizing Power of the Retina.** As already pointed out a necessary condition of seeing definite objects, as distinguished from the power of recognizing differences of light and darkness, is that all light entering the eye from one point of an object shall be focused on one point of the retina. This, however, would not be of any use had we not the faculty of distinguishing the stimulation of one part of the retina from that of another part. This power the visual apparatus possesses in a very high degree; while with the skin we cannot distinguish from one, two points touching it less than 1 mm. ( $\frac{1}{8}$  inch) apart, with our eyes we can distinguish two points whose retinal images



**DIESE SEITE IST FÜR KOSTENLOSE MITGLIEDER GESPERRT**  
Beantragen Sie jetzt die volle Mitgliedschaft, um diese Seite zu betreten



**Seien Sie niemals ohne ein Buch!**

Die Vollmitgliedschaft von Forgotten Books bietet Ihnen einen universalen Zugang von unseren Apps und unserer Website, auf all Ihren Geräten: Tablet, Telefon, E-Reader, Laptop und Computer.

**Eine Bibliothek in Ihrer Tasche für €8.99/monat**

**Fortfahren**

\*Es gelten Richtlinien zur fairen Nutzung.

to white: or beginning with green through darker and darker shades of it to black or through lighter and lighter to white: or beginning with red we can by imperceptible steps pass to orange, from that to yellow and so on to the end of the solar spectrum: and from the violet, through purple and carmine, we may get back again to red. Black and white appear to be fundamental color sensations mixed up with all the rest: we never imagine a color but as light or dark, that is as more or less near white or black; and it is found that as the light thrown on any given colored surface weakens, the shade becomes deeper until it passes into black; and if the illumination is increased, the color becomes "lighter" until it passes into white. Of all the colors of the spectrum yellow most easily passes into white with strong illumination. Black and white, with the grays which are mixtures of the two, thus seem to stand apart from all the rest as the fundamental visual sensations, and the others alone are in common parlance named "colors." It has even been suggested that the power of differentiating them in sensation has only lately been acquired by man, and a certain amount of evidence has been adduced from passages in the Iliad to prove that the Greeks in Homer's time confused together colors that are very different to most modern eyes; at any rate there seems to be no doubt that the color sense can be greatly improved by practice; women whose mode of dress causes them to pay more attention to the matter, have, as a general rule, a more acute color sense than men.

Leaving aside black, white, gray, and the various browns (which are only dark tints of other colors), we may enumerate our color sensations as red, orange, yellow, green, blue, violet and purple; between each there are, however, numerous transition shades, as yellow-green, blue-green, etc., so that the number which shall have definite names given to them is to a large extent arbitrary. Of the above, all but purple are found in the spectrum given when sunlight is separated by a prism into its rays of different refrangibility; rays of a certain wave-length or period of oscillation cause in us the feeling red; others yellow, and so on; for convenience

we may speak of these as red, yellow, blue, etc., rays; all together, in about equal proportions, they arouse the sensation of white. A remarkable fact is that most color feelings can be aroused in several ways. White, for example, not only by the above general mixture, but red and blue-green rays, or orange and blue, or yellow and violet, taken together in pairs, cause the sensation of white: such colors are called *complementary* to one another. The mixture may be made in several ways; as, for example, by causing the red and blue-green parts of the spectrum to overlap, or by painting red and blue-green sectors on a disk and rotating it rapidly; they cannot be made, however, by mixing pigments, since what happens in such cases is a very complex phenomenon. Painters, for example, are accustomed to produce green by mixing blue and yellow paints, and some may be inclined to ridicule the statement that yellow and blue when mixed give white. When, however, we mix the pigments we do not combine the sensations of the same name, which is the matter in hand. Blue paint is blue because it absorbs all the rays of the sunlight except the blue and some of the green; yellow is yellow because it absorbs all but the yellow and some of the green, and when blue and yellow are mixed the blue absorbs all the distinctive part of the yellow and the yellow does the same for the blue; and so only the green is left over to reflect light to the eye, and the mixture has that color. Grass-green has no complementary color in the solar spectrum; but with purple, which is made by mixing red and blue, it gives white. Several other colors taken three together, give also the sensation of white. If then we call the light-rays which arouse in us the sensation red, *a*, those giving us the sensation orange *b*, yellow *c*, and so on, we find that we get the sensation white with *a*, *b*, *c*, *d*, *e*, *f* and *g* all together; or with *b* and *e*, or with *c* and *f*, or with *a*, *d*, and *e*; our sensation *white* has no determinate relation to ethereal oscillations of a given period, and the same is true for several other colors; yellow feeling, for example, may be excited by ethereal vibrations of one given wave-length

modes of excitation of exactly the same nerve-fibres; a fibre which when excited alone gives us the sensation red will always give us that feeling when so excited. The simplest method of explaining our color sensations would therefore be to assume that for each there exists in the retina a set of nerve-fibres with appropriate terminal organs, each excitable by its own proper stimulus. But we can distinguish so innumerable and so finely graded colors, that, on such a supposition, there must be an almost infinite number of different end organs in the retina, and it is more reasonable to suppose that there are a limited number of primary color sensations, and that the rest are due to combinations of these. That a compound color sensation may be very different from its components when these are regarded apart, is clearly shown by the sensation white aroused either by what we may call red and blue-green, or green and purple, stimuli acting together; or of yellow due to grass-green and red. To account for our various color sensations we may, therefore, assume a much smaller number of primary sensations than the total number of color sensations we experience; all can in fact be explained by assuming any three primary color sensations which together give white, and regarding all the rest as due to mixtures of these in various proportions; there may be more than three, but three will account for all the phenomena, black being a sensation experienced when all visual stimuli are absent. This is known as *Young's theory of color vision*, and is that at present most commonly accepted. The selection of the three primary sensations is somewhat arbitrary, but they are usually regarded as red, green, and violet. It is



**DIESE SEITE IST FÜR KOSTENLOSE MITGLIEDER GESPERRT**  
Beantragen Sie jetzt die volle Mitgliedschaft, um diese Seite zu betreten

# GESCHICHTE

Zehntausende von wichtigen historischen Quellen, viele bisher nicht erhältlich, stehen jetzt zum ersten Mal mit der Vollmitgliedschaft von Forgotten Books zur Verfügung.

Unbegrenzter Zugang  
\$8.99/monat

**Fortfahren**

\*Es gelten Richtlinien zur fairen Nutzung.



a decision as to color blindness cannot be safely arrived at by simply showing a color and asking its name. The best plan is to take a heap of worsted of all tints, select one, say a red, and tell the man to put alongside it all those of the same color, whether of a lighter or a darker shade; if red blind he will select not only the reds but the greens, especially the paler tinte. About one man in eight is red blind. The defect is much rarer in women.

**Fatigue of the Retina.** The nervous visual apparatus is easily fatigued. Usually we do not observe this because its restoration is also rapid, and in ordinary life our eyes, when open, are never at rest; we move them to and fro, so that parts of the retina receive light alternately from brighter and darker objects and are alternately excited and rested. How constant and habitual the movement of the eyes is can be readily observed by trying to fix for a short time a small spot without deviating the glance; to do so for even a few seconds is impossible without practice. If any small object is steadily "fixed" for twenty or thirty seconds it will be found that the whole field of vision becomes grayish and obscure, because the parts of the retina receiving most light get fatigued, and arouse no more sensation than those less fatigued and stimulated by light from less illuminated objects. Or look steadily at a black object, say a blot on a white page, for twenty seconds, and then turn the eye on a white wall; the latter will seem dark gray, with a white patch on it; an effect due to the greater excitability of the retinal parts previously rested by the black, when compared with the sensation aroused elsewhere by light from the white wall acting on the previously stimulated parts of the visual surface. All persons will recall many instances of such phenomena, which are especially noticeable soon after rising in the morning. Similar things may be noticed with colors; after looking at a red patch the eye turned on a white wall sees a blue-green patch; the elements causing red sensations having been fatigued, the white mixed light from the wall now excites on that region of the retina only the other primary color sensations. The blending of colors so as to

nomena due to this cause are known as these of *successive contrast*. Even in the case of perfect fixation, however, something of the same kind is seen; black looks blacker near white, and green greener near red when the eye has not moved in the least from one to the other. A small piece of light gray paper put on a sheet of red, which latter is then covered accurately with a sheet of semi-transparent tissue-paper, assumes the complementary color of the red, i.e. looks bluish green; and gray on a green sheet under similar circumstances looks pink. Such phenomena are known as those of *simultaneous contrast*, and are explained on psychological grounds by those who accept Young's theory of color vision. Just as a medium-sized man looks short beside a tall one, so, it is said, a black surface looks blacker near a white one, or a gray (slightly luminous white) surface, which feebly excites red, green, and violet sensations, looks deficient in red (and so bluish green) near a deeper red surface. There are, however, certain phenomena of simultaneous contrast which cannot be satisfactorily so explained, and these have led to other theories of color vision, the most important of which is that described in the next paragraph.

**Hering's Theory of Vision.** Contrasts can be seen with



the eyes closed and covered. If we look a short time at a bright object and then rapidly exclude light from the eye, we see for a moment a *positive after-image* of the object, e.g. a window with its frame and panes after a glance at it and then closing the eyes. In these positive after-images the bright and dark parts of the object which was looked at retain their original relationship; they depend on the persistence of retinal excitement after the cessation of the stimulus and usually soon disappear. If an object be looked at steadily for some time, say twenty seconds, and the eyes be then closed a *negative after-image* is seen. In this the lights and shades of the object looked at are reversed. Frequently a positive after-image becomes negative before disappearing. The negative images are explained commonly by fatigue; when the eye is closed some light still enters through the lids and excites less those parts of the retina previously exhausted by prolonged looking at the brighter parts of the field of vision; or, when all light is rigorously excluded, the proper stimulation of the visual apparatus itself, causing the *idio-retinal light*, affects less the exhausted portions, and so a negative image is produced. If we fix steadily for thirty seconds a point between two white squares about 4 mm. ( $\frac{1}{4}$  inch) apart on a large black sheet, and then close and cover our eyes, we get a negative after-image in which are seen two dark squares on a brighter surface; this surface is brighter close around the negative after-image of each square, and brightest of all between them. This luminous boundary is called the *corona*, and is explained usually as an effect of simultaneous contrast; the dark after-image of the square it is said makes us mentally err in judgment and think the clear surface close to it brighter than elsewhere; and it is brightest between the two dark squares, just as a middle-sized man between two tall ones looks shorter than if alongside one only. If, however, the after-image be watched it will often be noticed not only that the light band between the squares is intensely white, much more so than the normal idio-retinal light, but, as the image fades away, often the two dark after-images of the squares disappear entirely with all of the corona, except that part between them which is



**DIESE SEITE IST FÜR KOSTENLOSE MITGLIEDER GESPERRT**  
Beantragen Sie jetzt die volle Mitgliedschaft, um diese Seite zu betreten



**Seien Sie niemals ohne ein Buch!**

Die Vollmitgliedschaft von Forgotten Books bietet Ihnen einen universalen Zugang von unseren Apps und unserer Website, auf all Ihren Geräten: Tablet, Telefon, E-Reader, Laptop und Computer.

**Eine Bibliothek in Ihrer Tasche für €8.99/monat**

**Fortfahren**

\*Es gelten Richtlinien zur fairen Nutzung.

suggest two of the above, and may be described as mixtures of them; but they themselves stand out as fundamental color sensations. Moreover, it follows from the above, that more than two simple colored sensations are never combined in a compound color sensation.

Since red always excludes green, and yellow blue, we may call them anti-colors (the complementary colors of Young's theory), and are led to suspect that in the visual organ there must occur, in the production of each, processes which prevent the simultaneous production of the other, since there is no *a priori* reason in the nature of things why we should not see red and green simultaneously, as well as red and yellow. Along with our color sensations there is always some colorless from the black-white series; which we recognize in speaking of lighter and darker shades of the same color.

Hering assumes, then, in the retina or some part of the nervous visual apparatus, three substances answering to the black-white, red-green, and yellow-blue sensational series, the construction of each substance being attended with one sensation of its pair, and its destruction with the other. Thus, when construction of the black-white substance exceeds destruction, we get a blackish-gray sensation; when the processes are equal the neutral gray; when destruction exceeds construction a light-gray, and so on. In the other color series similar things would occur; when construction of red-green substance exceeded destruction in any point of the retina we would get, say, a red feeling; if so, then excess of destruction would give green sensation. The intensity of any given simple sensation would depend on the ratio of the difference between the construction and destruction of the corresponding substance, to the sum of all the constructions and destructions of visual substances going on in that part of the visual apparatus. A little thought will show that this can hardly be reconciled with the results expressed in Fechner's law. The intensity of a mixed color sensation would be the sum of the intensities of its factors, and its tint and shade dependent on the relative proportion of these factors. When the construction

and destruction of the red-green substance are equal no color sensation is aroused by it; and we get gray, due to those simultaneously occurring changes in the black-white substance which are always present, but were previously more or less cloaked by the results of the changes in the red-green substance. Red and green in certain proportions cause then a white or gray sensation, not because they supplement one another, as on Young's theory, but because they mutually cancel; and so for other complementary colors.

Moreover, according to Hering, destruction of a visual substance going on in one region of the retina promotes construction and accumulation of that substance elsewhere, but especially in the neighborhood of the excited spot. Hence, when a white square on a black ground is looked at, destruction of the black-white substance overbalances construction in the place on which the image of the square falls, but around this construction occurs in a high degree. When the eyes are shut, this latter retinal region, with its great accumulation of decomposable material, is highly irritable and, under the internal stimuli causing the idio-retinal light, breaks down comparatively fast, causing the corona, which may be intensely luminous; for with the closed eye the total constructive and destructive processes in the visual apparatus are small, and so the excess of destruction in the coronal region bears a large ratio to the sum of the whole processes. The student must apply this theory for himself to the other phenomena of contrasts and negative images, as also to the gradual disappearance of differences between light and dark objects when looked at for a time with steady fixation; the general key being the principle that anything leading to the accumulation of a visual substance increases its decompositions under stimulation, and *vice versa*. The main value of Hering's theory is that it attempts to account physiologically for phenomena previously indefinitely explained psychologically by such terms as "errors of judgment," which really leave the whole matter where it was, since if (as we must believe) mind is a function of brain, the errors of judgment have

still to be accounted for on physiological grounds, as due to conditions of the nervous system.

**Visual Perceptions.** The sensations which light excites in us we interpret as indications of the existence, form, and position of external objects. The conceptions which we arrive at in this way are known as *visual perceptions*. The full treatment of perceptions belongs to the domain of Psychology, but Physiology is concerned with the conditions under which they are produced.

**The Visual Perception of Distance.** With one eye our perception of distance is very imperfect, as illustrated by the common trick of holding a ring suspended by a string a short way in front of a person's face, and telling him to shut one eye and pass a rod through the ring. If a penholder be held erect before one eye, while the other is closed, and an attempt be made to touch it with a finger moved across towards it, an error will nearly always be made. (If the finger be moved straight out towards the pen it will be touched because with one eye we can estimate direction accurately and have only to go on moving the finger in the proper direction till it meets the object.) In such cases, however, we get some clue from the amount of effort needed to "accommodate" the eye to see the object distinctly. When we use both eyes our perception of distance is much better; when we look at an object with two eyes the visual axes are converged on it, and the nearer the object the greater the convergence. We have a pretty accurate knowledge of the degree of muscular effort required to converge the eyes on all tolerably near points. When objects are farther off, their apparent size, and the modifications their retinal images experience by aërial perspective, come in to help. The relative distance of objects is easiest determined by moving the eyes; all stationary objects then appear displaced in the opposite direction (as for example when we look out of the window of a railway car) and those nearest most rapidly; from the different apparent rates of movement we can tell which are farther and nearer. We inseparably and unconsciously bind up perceptions of distance with the sensations aroused by objects looked at, that



**DIESE SEITE IST FÜR KOSTENLOSE MITGLIEDER GESPERRT**  
Beantragen Sie jetzt die volle Mitgliedschaft, um diese Seite zu betreten

# GESCHICHTE

Zehntausende von wichtigen historischen Quellen, viele bisher nicht erhältlich, stehen jetzt zum ersten Mal mit der Vollmitgliedschaft von Forgotten Books zur Verfügung.

Unbegrenzter Zugang  
\$8.99/monat

**Fortfahren**

\*Es gelten Richtlinien zur fairen Nutzung.



flat object with both eyes we get a similar retinal image in each. Under ordinary circumstances we see, however, not two objects but one. In the habitual use of the eyes we move them so that the images of the object looked at fall on the two yellow spots. A point to the left of this forms its image on the inner (right) side of the left eye and the outer (right) side of the right. An object vertically above that looked at would form an image straight below the yellow spot of each eye; an object to the left and above, its image to the inner side and below in the left eye and to the outer side and below in the right eye; and so on. We have learnt that similar simultaneous excitations of these *corresponding points* mean single objects, and so interpret our sensations. This at least is the theory of the experiential or *empirical* school of psychologists, though others believe we have a sort of intuition on the subject. When the eyes do not work together, as in the muscular incoördination of one stage of intoxication, then they are not turned so that images of the same objects fall on corresponding retinal points, and the person sees double. When a squint comes on, as from paralysis of the external rectus of one eye, the sufferer at first sees double for the same reason.

If a given object is looked at lines drawn from it through the nodal points reach the fovea centralis in each eye. Lines so drawn at the same time from a more distant object diverge less and meet each retina on the inner side of its fovea; but as above pointed out the corresponding points for each retinal region on the inside of the left eye, are on the outside of the right, and *vice versa*. Hence the more distant object is seen double. So, also, is a nearer object, because the more diverging lines drawn from it through the nodal points lie outside of the fovea in each eye. Most people go through life unobservant of this fact; we only pay attention to what we are looking at, and nearly always this makes its images on the two foveæ. That the fact is as above stated may, however, be readily observed. Hold one finger a short way from the face and the other a little farther off; *looking at one*, observe the other without moving

the eyes; it will be seen double. For any given position of the eyes there is a surface in space, all objects on which produce images on corresponding points of the two retinas: this surface is called the *horopter* for that position of the eyes: all objects in it are seen single; all others in the visual field, double.

**The Perception of Solidity.** When a solid object is looked at the two retinal images are different. If a truncated pyramid be held in front of one eye its image will be that represented at *P*, Fig. 142. If, however, it be held midway between the eyes, and looked at with both, then the left-eye image will be that in the middle of the figure, and the right-eye image that to the right. The small surface, *b d c a*, in one answers to the large surface, *b' d' c' a'*, in the other. This may be readily observed by

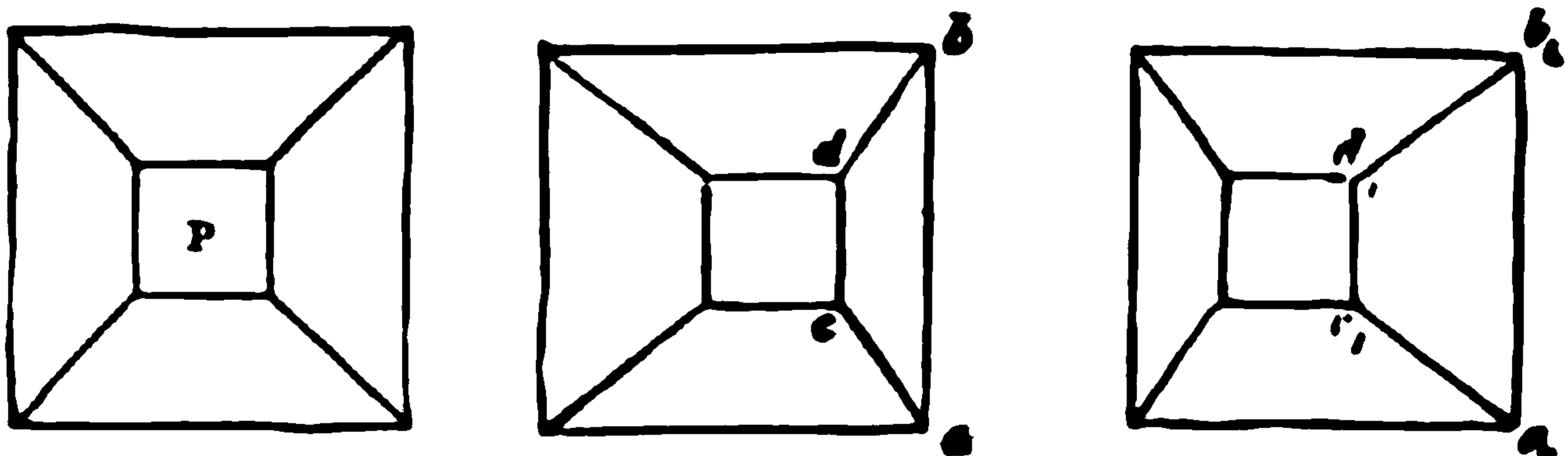

FIG. 142

holding a small cube in front of the face and alternately looking at it with each eye. In such cases, then, the retinal images do not correspond, and yet we combine them so as to see one *solid* object. This is known as *stereoscopic vision*, and the illusion of the common stereoscope depends on it. Two photographs are taken of the same object from two different points of view, one as it appears when seen by the left, and the other when looked at with the right eye. These are then mounted for the stereoscope so that each is seen by its proper eye, and the scene or object is seen in distinct relief, as if, instead of flat pictures, solid objects were looked at. Of course in many stereoscopic views the distribution of light and shade, etc., assist, but these are quite unessential, as may be readily observed by enlarging the middle and right outline drawings of Fig.



142 to the ordinary size of a stereoscopic slide, and placing them in the instrument. A solid pyramid standing out into space will be distinctly perceived; if the pictures be reversed the pyramid appears hollow. The pictures must not be too different, or their combination to give the idea of a single solid body will not take place. Many persons, indeed, fail entirely to get the illusion with ordinary stereoscopic slides. The phenomena of stereoscopic vision militate strongly against the view that there are any pre-arranged corresponding points in the two retinas.

**The Perception of Shine.** When we look at a rippled lake in the moonlight, we get the perception of a "shiny" or brilliant surface. The moonlight is reflected from the waves to the eyes in a number of bright points: these are not exactly the same for both eyes, since the lines of light-reflection from the surface of the water to each are different. The perception of brilliancy seems largely to depend on this slight non-agreement of the light and dark points on the two retinas. A rapid change of luminous points, to and fro between neighboring points on one retina, seems also to produce it.



**DIESE SEITE IST FÜR KOSTENLOSE MITGLIEDER GESPERRT**  
Beantragen Sie jetzt die volle Mitgliedschaft, um diese Seite zu betreten



**Seien Sie niemals ohne ein Buch!**

Die Vollmitgliedschaft von Forgotten Books bietet Ihnen einen universalen Zugang von unseren Apps und unserer Website, auf all Ihren Geräten: Tablet, Telefon, E-Reader, Laptop und Computer.

**Eine Bibliothek in Ihrer Tasche für €8.99/monat**

**Fortfahren**

\*Es gelten Richtlinien zur fairen Nutzung.

pharynx (*g*, Fig. 89)\*, and the mucous membrane of the pharynx is continued up the tube to line the tympanum; between this inside, and the skin of the external auditory meatus outside, is the proper tympanic membrane composed of connective tissue. The inner wall of the tympanum is bony except for two small apertures, the oval and round foramina, which lead into the labyrinth. During life the round aperture is closed by the lining mucous membrane, and the oval in another way, to be described presently. The *tympanic membrane*, *c c*, stretched like a drum-head across the outer side of the tympanum, forms a shallow funnel with its concavity outwards. (If a sheet of indian-rubber be stretched over a ring and pulled down in the centre, its form will be very like that of the membrane in question. It is pressed by the external air on its exterior, and by air entering the tympanic cavity through the Eustachian tube on its inner side. If the tympanum were closed these pressures would not be always equal when barometric pressure varied, and the membrane would be bulged in or out according as the external or internal pressure on it were the greater. On the other hand, were the Eustachian tube always open the sounds of our own voices would be extremely loud and disconcerting, so it is usually closed; but every time we swallow it is opened, and thus the air-pressure in the cavity is kept equal to that in the external auditory meatus. By holding the nose, keeping the mouth shut, and forcibly expiring, air may be forced under pressure into the tympanum, and will be held in part imprisoned there until the next act of swallowing. On making a balloon ascent or going rapidly down a deep mine, the sudden and great change of aërial pressure outside frequently causes painful tension of the drum membrane, which may be greatly alleviated by frequent swallowing.)

**The Auditory Ossicles.** Three small bones lie in the tympanum forming a chain (Fig. 144) from the drum membrane to the oval foramen. The external bone is the *malleus* or *hammer*; the middle one, the *incus* or *anvil*; and the internal, the *stapes* or *stirrup*. The malleus, *M*, has

\* Page 309.

an upper enlargement or *head*, which carries on its inner side an articular surface for the incus; below the head is a constriction, the *neck*, and below this two processes complete the bone; one, the *long* or *slender process*, is imbedded in a ligament which reaches from it to the front wall of the tympanum; the other process, the *handle*, reaches down between the mucous membrane lining the inside of the drum membrane and the

membrane proper, and is firmly attached to the latter near its centre and keeps the membrane dragged in there so as to give it its peculiar concave form, as seen from the outside. The incus has a body and two processes and is much like a molar tooth with two fangs. On its body is an articular hollow to receive the head of the malleus; its short process (*Jb*) is attached by ligament to the back wall of the tym-

panum; the long process (*Jl*) is directed inwards to the stapes; on the tip of this process is a little knob, which represents a bone (*os orbiculare*), distinct in early life. The stapes (*S*) is extremely like a stirrup, and its base (the foot-piece of the stirrup) fits into the oval foramen, to the margin of which its edge is united by a fibrous membrane, allowing of a little play in and out.

From the posterior side of the neck of the malleus a ligament passes to the back wall of the tympanum: this, with the ligament imbedding the slender process and fixed to the front wall of the tympanum, forms an antero-posterior *axial ligament*, on which the malleus can slightly rotate, so that the handle can be pushed in and the head out and *vices versa*. If a pin be driven through Fig. 144 just below the neck of the malleus and perpendicular to the

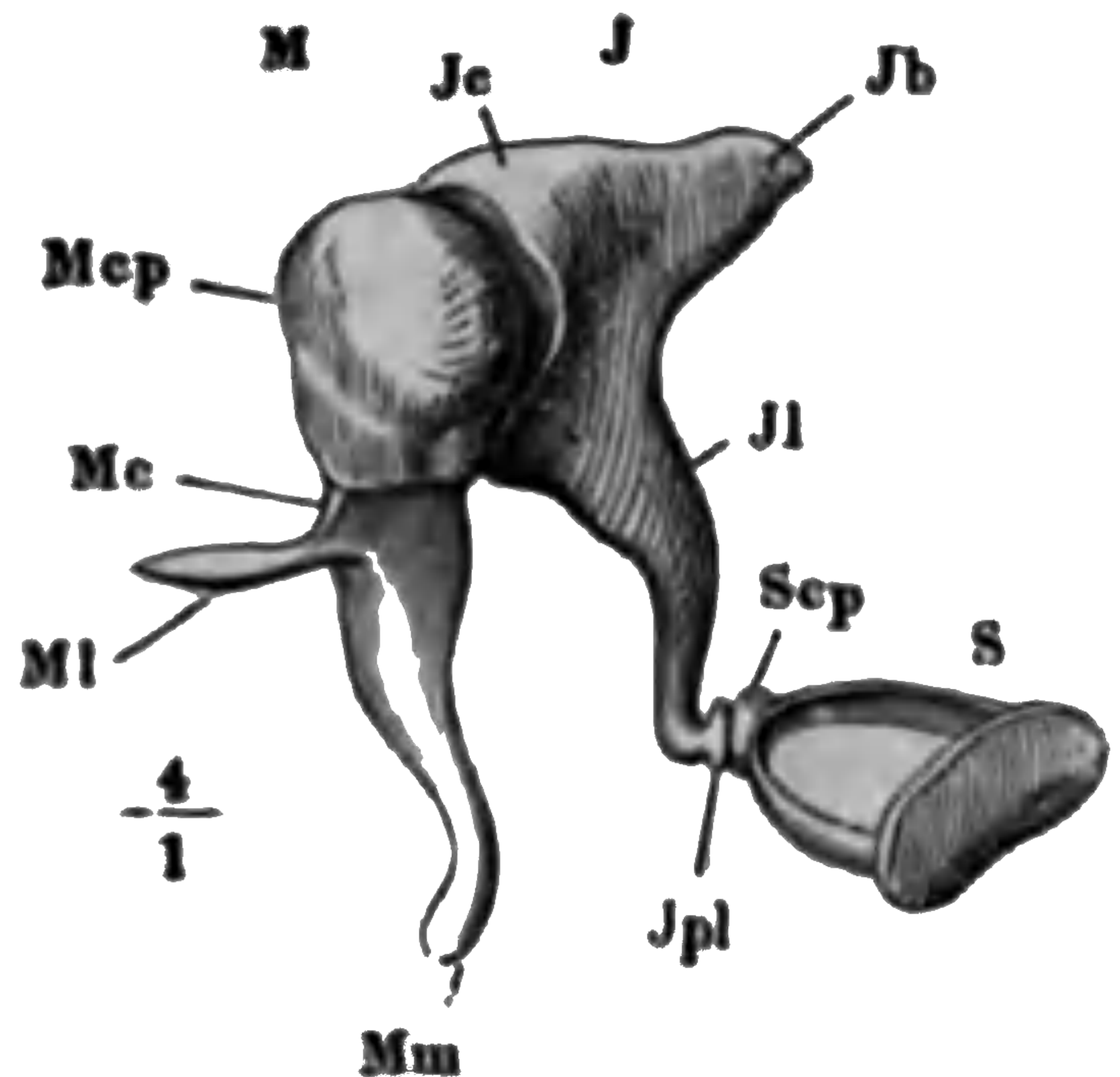

FIG. 144.—The auditory ossicles of the right ear, seen from the front. *M*, malleus; *J*, incus; *S*, stapes: *Mcp*, head of the malleus; *Mc*, neck of ditto; *Ml*, long process; *Mm*, handle; *Jc*, body, *Jb*, short, and *Jl*, long process, of incus; *Jpl*, *os orbiculare*; *Sep*, head of stapes.

paper it will very fairly represent this axis of rotation. Connected with the malleus is a tiny muscle, called the *tensor tympani*; it is inserted in the handle of the bone below the axis of rotation, and when it contracts pulls the handle in and tightens the drum membrane. Another muscle (the *stapedius*) is inserted into the outer end of the stapes, and when it contracts fixes the bone so as to limit its range of moment in and out of the fenestra ovalis.

**The Internal Ear.** The labyrinth consists primarily of chambers and tubes hollowed out in the temporal bone and inclosed by it on all sides, except for the oval and round

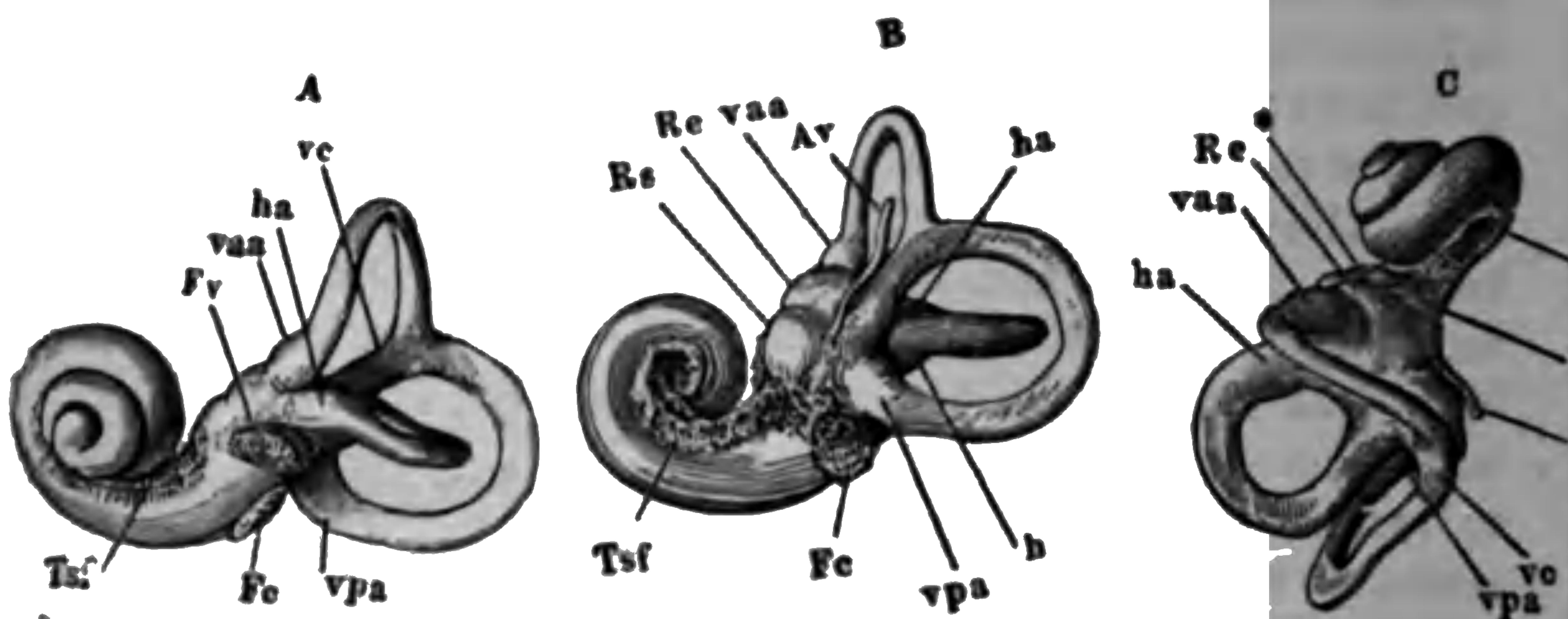

FIG. 145.—Casts of the bony labyrinth. *A*, left labyrinth seen from the outer side; *B*, right labyrinth from the inner side; *C*, left labyrinth from above; *Fc*, round foramen; *Fv*, oval foramen; *h*, horizontal semicircular canal; *ha*, its ampulla; *vaa*, ampulla of anterior vertical semicircular canal; *vpa*, ampulla of posterior vertical semicircular canal; *vc*, conjoined portion of the two vertical canals.

foramens on its exterior, and certain apertures on its inner side by which blood-vessels and branches of the auditory nerve enter; during life all these are closed water-tight in one way or another. Lying in the *bony labyrinth* thus constituted, are membranous parts, of the same general form but smaller, so that between the two a space is left; this is filled with a watery fluid, called the *perilymph*; and the *membranous internal ear* is filled by a similar liquid, the *endolymph*.

**The Bony Labyrinth.** The bony labyrinth is described in three portions, the *vestibule*, the *semicircular canals*, and the *cochlea*; casts of its interior are represented from



**DIESE SEITE IST FÜR KOSTENLOSE MITGLIEDER GESPERRT**  
Beantragen Sie jetzt die volle Mitgliedschaft, um diese Seite zu betreten

# GESCHICHTE

Zehntausende von wichtigen historischen Quellen, viele bisher nicht erhältlich, stehen jetzt zum ersten Mal mit der Vollmitgliedschaft von Forgotten Books zur Verfügung.

Unbegrenzter Zugang  
\$8.99/monat

**Fortfahren**

\*Es gelten Richtlinien zur fairen Nutzung.



wound two and a half times (from left to right in the right ear and *vice versa*) around a central bony axis, the *modiolus*. From the axis a shelf, the *lamina spiralis*, projects and partially subdivides the tube, extending farthest across in its lower coils. Attached to the outer end of this bony plate is the membranous cochlea (*scala media*), a tube triangular in cross-section and attached by its base to the outer side of the bony cochlear spiral. The spiral lamina and the membranous cochlea thus subdivide the cavity of the bony tube (Fig. 147) into an upper portion, the *scala vestibuli*, *SV*, and a lower, the *scala tympani*, *ST*. Between these lie the lamina spiralis (*lso*) and the mem-

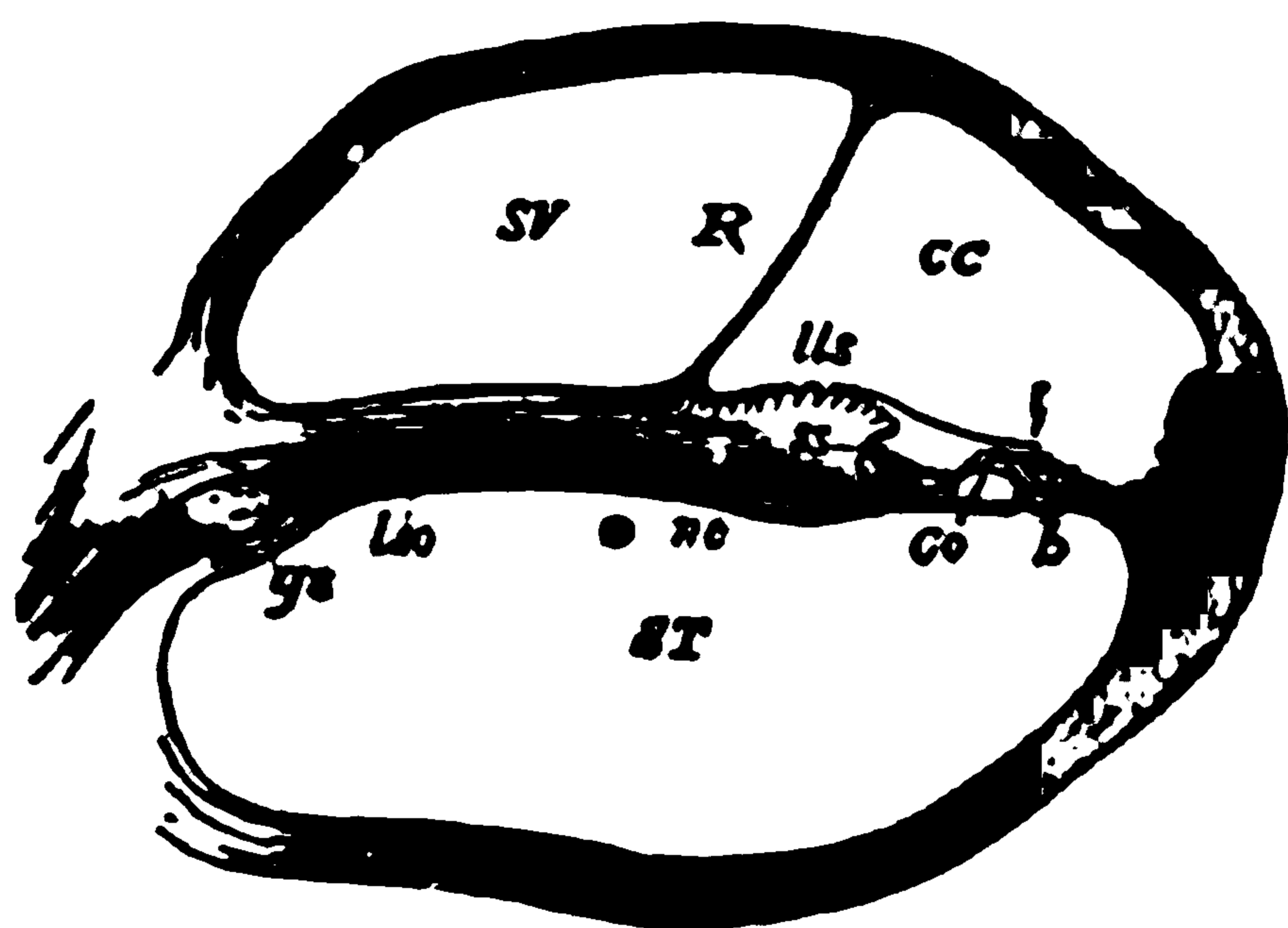

FIG. 147.—Section of one coil of the cochlea, magnified. *SV*, *scala vestibuli*; *R*, membrane of Reissner; *CC*, membranous cochlea (*scala media*); *lls*, *limbus laminae spiralis*; *t*, tectorial membrane; *ST*, *scala tympani*; *lso*, spiral lamina; *Co*, rods of Corti; *b*, basilar membrane.

branous cochlea (*CC*), the latter being bounded above by the membrane of Reissner (*R*) and below by the basilar membrane (*b*). The inner edge of the lamina spiralis is thickened and covered with connective tissue which is hollowed out so as to form a spiral groove (the *sulcus spiralis*, *ss*) along the whole length of the membranous cochlea. The latter does not extend to the tip of the bony cochlea; above its apex the *scala vestibuli* and *scala tympani* communicate; both are filled with perilymph, and the former communicates below with the perilymph cavity of the vestibule, while the *scala tympani* abuts below on the round foramen, which, as has already been pointed out, is closed by a membrane. The membranous cochlea contains cer-

tain solid structures seated on the basilar membrane and forming the *organ of Corti*; the rest of its cavity is filled with endolymph, which communicates with that in the sacculus.

**The Organ of Corti.** This contains the end organs of the cochlear nerves. Lining the sulcus spiralis are cuboidal cells; on the inner edge of the basilar membrane they become columnar, and these are succeeded by a row which bear on their upper ends a set of short stiff hairs, and constitute the *inner hair-cells*, which are fixed below by a narrow apex to the basilar membrane; nerve-fibres enter them. To the inner hair-cells succeed the *rods of Corti*

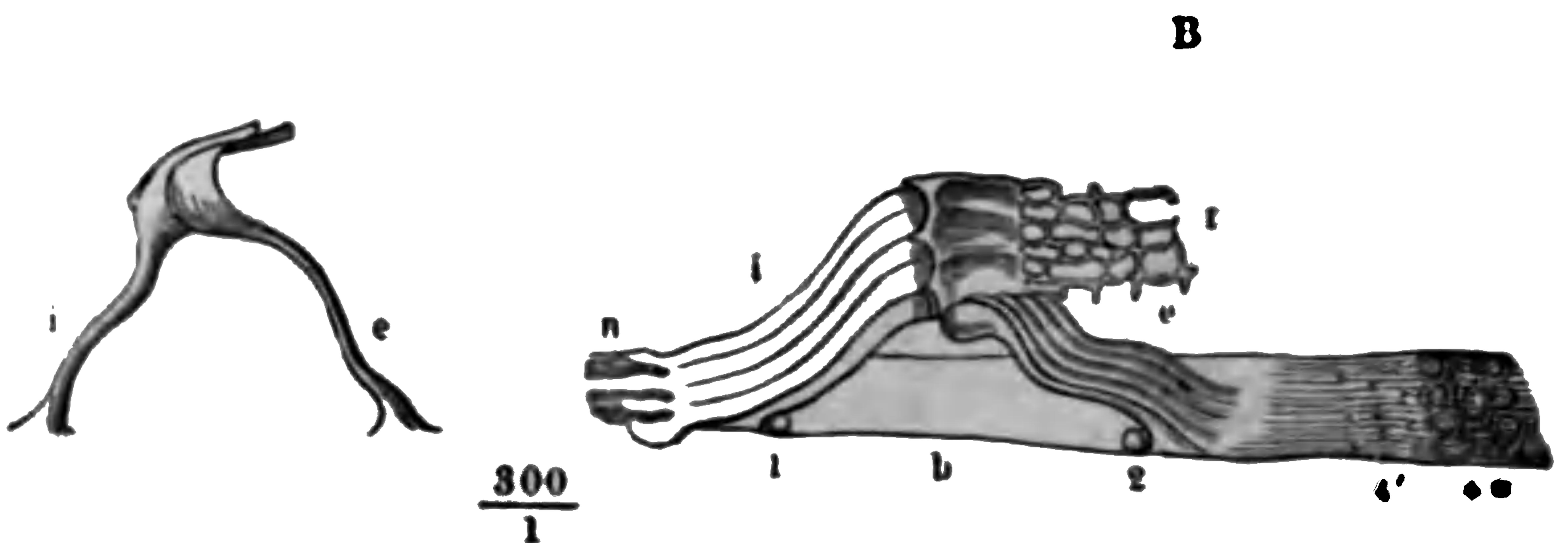

FIG. 148.—The rods of Corti. *A*, a pair of rods separated from the rest; *B*, a bit of the basilar membrane with several rods on it, showing how they cover in the tunnel of Corti; *i*, inner, and *e*, outer rods; *b*, basilar membrane; *r*, reticular membrane.

(*Co*, Fig. 147), which are represented highly magnified in Fig. 148. These rods are stiff and arranged side by side in two rows, leaned against one another by their upper ends so as to cover in a tunnel; they are known respectively as the *inner* and *outer rods*, the former being nearer the *lamina spiralis*. Each rod has a somewhat dilated base, firmly fixed to the basilar membrane; an expanded head where it meets its fellow (the inner rod presenting there a concavity into which the rounded head of the outer fits); and a slender shaft uniting the two, slightly curved like an italic *S*. The inner rods are more slender and more numerous than the outer, their numbers being about 6000 and 4500 respectively. Attached to the external sides of the heads of the outer rods is the *reticular membrane* (*r*,



Fig. 148), which is stiff and perforated by holes. External to the outer rods come four rows of *outer hair-cells*, con-

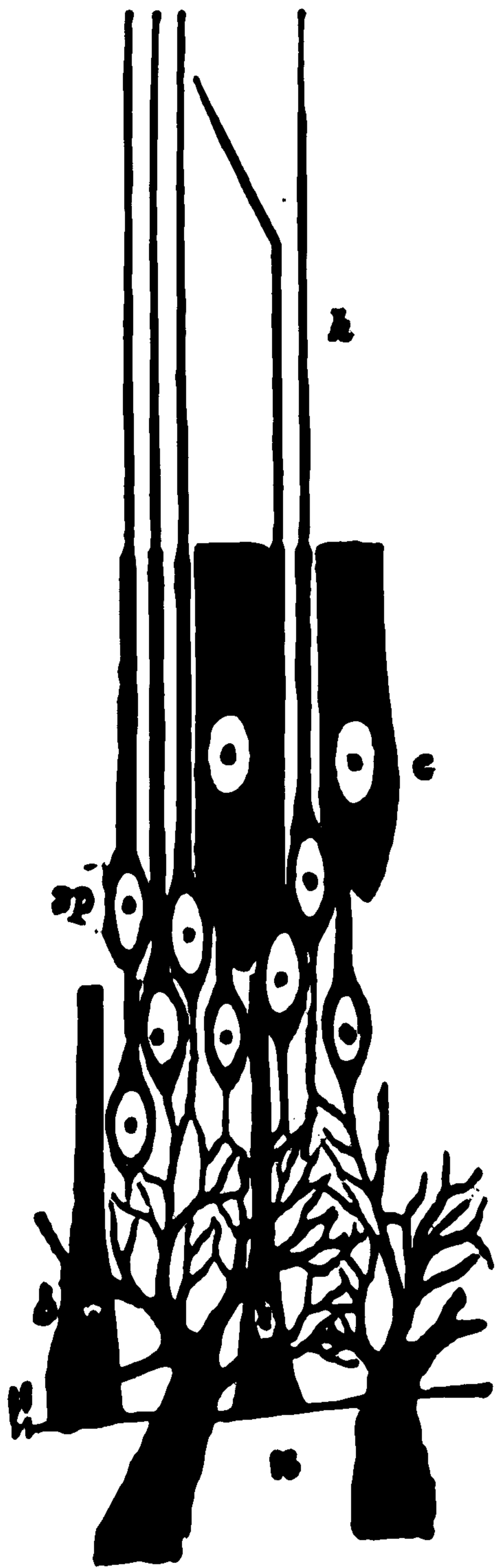

FIG. 149.—The epithelium at the point where the nerves enter an ampulla. *n*, nerves; *c*, superficial columnar epithelium; *sp*, hair-cells; *h*, hairs; *b*, basal cells.

nected like the inner row with nerve-fibres; their bristles project into the holes of the reticular membrane. Beyond the outer hair-cells is ordinary columnar epithelium, which passes gradually into cuboidal cells lining most of the membranous cochlea. The upper lip of the sulcus spiralis is uncovered by epithelium, and is known as the *limbus laminae spiralis*; from it projects the *lectorial membrane* (*t*, Fig. 147) which extends over the rods of Corti and the hair-cells.

**Nerve-Endings in the Semicircular Canals and the Vestibule.** Nerves reach the ampulla of each semicircular canal, and, perforating its wall, enter the epithelium lining it which is there several layers thick (Fig. 149). Some of the cells (*sp*) are fusiform and have large nuclei; a slender *external process* runs from each to the cavity of the ampulla and is then continued as slender stiff hair (*h*), which projects into the endolymph. The deeper ends of these cells have been described as joining the terminal branches of nerve-fibres, so that they must be regarded

as *end organs*. In the *utricle* and *sacculæ* are somewhat similar structures; but collected among the hairs are minute calcareous particles, the *ear-stones* or *otoliths*.

**The Loudness, Pitch, and Timbre of Sounds.** Sounds, as sensations, fall into two groups—*notes* and *noises*. Physi-



**DIESE SEITE IST FÜR KOSTENLOSE MITGLIEDER GESPERRT**  
Beantragen Sie jetzt die volle Mitgliedschaft, um diese Seite zu betreten



**Seien Sie niemals ohne ein Buch!**

Die Vollmitgliedschaft von Forgotten Books bietet Ihnen einen universalen Zugang von unseren Apps und unserer Website, auf all Ihren Geräten: Tablet, Telefon, E-Reader, Laptop und Computer.

**Eine Bibliothek in Ihrer Tasche für € 8.99/monat**

**Fortfahren**

\*Es gelten Richtlinien zur fairen Nutzung.

vibrational rate about 40 per second are not well heard, and a little below this become inaudible. The highest note used in orchestras is the  $d'$  of the fifth accented octave, produced by the piccolo flute, due to 4752 vibrations in a second; and the lowest-pitched is the  $E,$  of the contra octave, produced by the double bass. Modern grand pianos and organs go down to  $C,$  in the contra octave (33 vibrations per second) or even  $A,$  ( $27\frac{1}{2}$ ), but the musical quality of such notes is imperfect; they produce rather a "buzz" than a true tone sensation, and are only used along with notes of higher octaves to which they give a character of greater depth.

**Pendular Vibrations.** Since the loudness of a tone depends on the vibrational amplitude of its physical antecedent, and its pitch on the vibrational rate, we have still to seek the cause of *timbre*; the quality by which we recognize the human voice, the violin, the piano, and the flute, even when all sound the same note and of the same loudness. The only quality of periodic vibrations left to account for this, is what we may call *wave-form*. Think of the movement of a pendulum; starting slowly from its highest point, it sweeps faster and faster to its lowest, and then slower and slower to its highest point on the opposite side; and then repeats the movements in the reverse direction. Graphically we may represent such vibrations by the outer continuous curved line in Fig. 150. Suppose the lower end of the pendulum to bear a writing point which marked on a sheet of paper traveling down uniformly behind it, and at such a rate as to travel the distance 0-1 in two seconds. If the pendulum were at rest the straight vertical line would be drawn. But if the pendulum were swinging we would get a curved line, compounded of the vertical movement of the paper and the to-and-fro movement of the pendulum, writing sometimes on one side of the line 0-1-2 and sometimes on the other. Starting at a moment when the pendulum crosses the middle, 0, we would get described the curve 0  $a'$   $a'$ , at first separating fast from the vertical line, then slower, then returning, at first

gradually then faster, until it met the vertical again, at the end of 1" and commenced an exactly similar excursion on its other side, at the end of which it would be back at 1, and in just the same position, and ready to repeat exactly the swing, with which we commenced. A pendulum thus executes similar movements in equal periods of time, or its vibrations are *periodic*. A full swing on each side of the position of rest constitutes a complete vibration, so the vibrational period of a second's pendulum is two seconds: at the end of that time it is precisely where it was two seconds before, and moving in the same direction and at the same rate. It is clear that by examining such a curve we could tell exactly how the pendulum moved, and also in what period if we knew the rate at which the paper on which its point wrote was moving. The vertical line 0-1-2 is called the *abscissa*; perpendiculars drawn from it and meeting the curve are *ordinates*: equal lengths on the abscissa represent equal times; where an ordinate from a given point of the abscissa meets the curve, there the writing point was at that moment; where successive ordinates increase or decrease rapidly the pendulum moved fast from or towards its position of rest, and *vice versa*. Similarly, any other periodic movement may be perfectly represented by curves; and since the form of the curve tells us all about the movement, it is common to speak of the "form of a vibration," meaning the form of the curve which indicates its characters. Periodic vibrations like those in Fig. 150, where the ordinates at first grow fast, then more slowly, then diminish slowly and then faster, and represented by a symmetrical curve on one side the abscissa, which is repeated

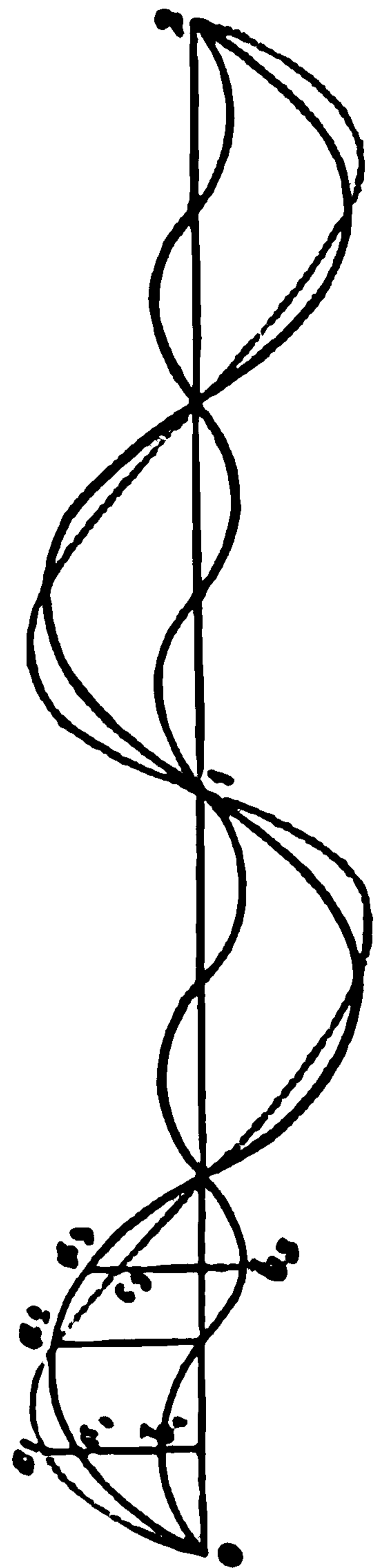

FIG. 150.

exactly on the other side of the abscissa, are known as pendular vibrations.

**The Composition of Vibrations.** The vibrations of a second's pendulum set the air-particles in contact with it in similar movement, but the aërial waves succeed one another too slowly to produce in us the sensation of a musical note. If for the pendulum we substitute a tuning-fork (the prongs of which move in a like way), and the fork vibrates 132 times per 1'', then 132 aërial waves will fall on the tympanic membrane in that time, and we will hear the note *c* of the unaccented octave. If the larger continuous curve in Fig. 150 represent the aërial vibrations in this case, the distance 0 to 1 on the abscissa will represent  $\frac{1}{132}$  of a second. Let, simultaneously, the air be set in movement by a fork of the next higher octave, *c'*, making 264 vibrations per 1''; under the influence of this second fork alone, the aërial particles would move as represented by the smaller continuous curved line, the waves being half as long and cutting the abscissa twice as often. But when both forks act together the aërial movement will be the algebraic sum of the movements due to each fork; when both drive the air one way they will reinforce one another, and *vice versa*; the result will be the movement represented by the dotted line, which is still periodic, repeating itself at equal intervals of time, but no longer *pendular*, since it is not alike on the ascending and descending limbs of the curves. We thus get at the fact that non-pendular vibrations may be produced by the fusion of pendular, or, in technical phrase, by their *composition*.

Suppose several musical instruments, as those of an orchestra, to be sounded together. Each produces its own effect on the air-particles, whose movements, being the algebraical sum of those due to all, must at any given instant be very complex; yet the ear can pick out at will and follow the tones of any one instrument. From the complex aërial movement it can select that fraction of it which one vibrating body produces. The air in the external auditory meatus at any given moment can only be in one state of rarefaction or condensation and at one rate



**DIESE SEITE IST FÜR KOSTENLOSE MITGLIEDER GESPERRT**  
Beantragen Sie jetzt die volle Mitgliedschaft, um diese Seite zu betreten

# GESCHICHTE

Zehntausende von wichtigen historischen Quellen, viele bisher nicht erhältlich, stehen jetzt zum ersten Mal mit der Vollmitgliedschaft von Forgotten Books zur Verfügung.

Unbegrenzter Zugang  
\$8.99/monat

**Fortfahren**

\*Es gelten Richtlinien zur fairen Nutzung.



tions *simple tones*; and we, consequently, recognize in music tones which are simple (such as those of tuning-forks) and those which are compound; these latter are non-pendular in form.

We find, then, that the form of aërial vibrations determines in our sensations the occurrence or non-occurrence of upper partial tones. It also, as we have seen, determines the quality or *timbre* of the tone, since vibrational amplitude and rate are otherwise accounted for in sensation by loudness and pitch.

It can be proved, by the employment of the higher mathematics, that every periodic non-pendular movement can be analyzed (as the dotted curve of Fig. 150 may be) into a given number of pendular vibrations, that is, every compound vibration into a set of simple ones; and that every periodic non-pendular vibration can be made by the combination of pendular. Moreover, any given compound vibration can be analyzed into but one set of simple ones; no other combination will produce it. Consequently a vibrational movement of the air in the external auditory passage, producing a compound musical tone sensation, can be exhibited always, but only in one way, as the sum of a number of simple vibrations, whose rates are multiples of that which determines the pitch of the tone.

Now when the trained ear listens to a tone with the object of detecting upper partials if present, it hears them only when the vibrations are non-pendular (*i.e.* when theoretically they ought to be present), and those it hears are exactly those demanded by theory. By the help of certain instruments their detection is made easy even to the untrained ear. But in ordinary circumstances we do not heed secondary partial tones; we hear a note of the pitch of the primary partial and of a certain timbre; and whenever the upper partials present are different, or of different relative intensities, the timbre of the note varies. Hence it becomes probable that, just as the ear can at will follow any instrument in an orchestra, analyzing the aërial movement so as to select and follow the fraction of the whole due to that one, so it can and does analyze compound

tones when proceeding from one instrument, and that the upper partials, not rising into consciousness as definite tones but present as subdued sensations, give its character to the whole tone and determine its timbre. It might be, however, that the composition of non-pendular vibrations from pendular was a mere mathematical fiction, having no real existence in nature; before we can accept the above explanation of timbre, we must see if there is any evidence that, as a matter of fact, non-pendular vibrations, not only may be, but are made up by the combination of pendular.

**Sympathetic Resonance.** Imagine slight taps to be given to a pendulum; if these be repeated at such intervals of time as to always help the swing and never to retard it, the pendulum will soon be set in powerful movement. If the taps are irregular, or when regular come at such intervals as sometimes to promote and sometimes retard the movement, no great swing will be produced; but if they always push the pendulum in the way it is going at that instant, they need not come every swing in order to set up a powerful vibration; once in two, three, or four swings will do. A stretched string, such as that of a piano, is in so far like a given pendulum that it tends to vibrate at one rate and no other; if aërial waves hit it at exactly the right times they soon set it in sufficiently powerful vibrations to cause it to emit an audible note. By using such strings we might hope to detect the separate pendular vibrations in any non-pendular aërial periodic movement if such really existed; certain strings would pick out the pendular component agreeing in rate with their own vibrational period and be soon set in powerful movement; while those not vibrating in the same period as any of the pendular components, would remain practically at rest, like the pendulum getting taps which sometimes helped and sometimes impeded its swing. If the dampers of a piano be raised and a note be sung to it, it will be found that several strings are set in vibration, such vibrations being called *sympathetic*. The human voice emits compound tones which can be mathematically analyzed into simple vibrations, and if the piano



strings set in movement by it be examined, they will be found to be exactly those which answer to these pendular vibrations and to no others. We thus get experimental grounds for believing that compound tones are really made up of a number of simple vibrations, and get an additional justification for the supposition that in the ear each note is analyzed into its pendular components; and that the difference of sensation which we call timbre is due to the effect of the secondary partial tones thus perceived. If so, the ear must have in it an apparatus adapted for *sympathetic resonance*.

It may be asked why, if the ear analyzes vibrations in this way, do we not commonly perceive it? How is it that what we ordinarily hear is the *timbre* of a given tone and not the separate upper partials which give it this character? The explanation is more psychological than physiological, and belongs to the same series as the reason why we do not ordinarily notice the blind spot in the eye, or the doubleness of objects out of the horopter, or the duplicity of stereoscopic images. We only use our senses in daily life when they can tell us something that may be useful to us, and we neglect so habitually all sensations which would be useless or confusing, that at last it needs special attention to observe them at all. The way in which tones are combined to give *timbre* to a note is a matter of no importance in the daily use of them, and so we fail entirely to observe the components and note only the resultant, until we make a careful and scientific examination of our sensations.

**The Functions of the Tympanic Membrane.** If a stretched membrane, such as a drum-head, be struck, it will be thrown into periodic vibration and emit for a time a note of a determined pitch. The smaller the membrane and the tighter it is stretched the higher the pitch of its note; every stretched membrane thus has a rate of its own at which it tends to vibrate, just as a piano or violin string has. When a note is sounded in the air near such a membrane, the alternating waves of aërial condensation and rarefaction will move it; and if the waves succeed at the vibrational rate of the membrane the latter will be set in powerful *sympathetic*



**DIESE SEITE IST FÜR KOSTENLOSE MITGLIEDER GESPERRT**  
Beantragen Sie jetzt die volle Mitgliedschaft, um diese Seite zu betreten



**Seien Sie niemals ohne ein Buch!**

Die Vollmitgliedschaft von Forgotten Books bietet Ihnen einen universalen Zugang von unseren Apps und unserer Website, auf all Ihren Geräten: Tablet, Telefon, E-Reader, Laptop und Computer.

**Eine Bibliothek in Ihrer Tasche für € 8.99/monat**

**Fortfahren**

\*Es gelten Richtlinien zur fairen Nutzung.

branous labyrinth to the endolymph. These liquids being chiefly water, and practically incompressible, the end of the stapes could not work in and out at the oval foramen, were the labyrinth elsewhere completely surrounded by bone: but the membrane covering the round foramen bulges out when the base of the stapes is pushed in, and *vice versa*; and so allows of waves being set up in the labyrinthic liquids. These correspond in period and form to those in the auditory meatus; their amplitude is determined by the extent of the vibrations of the drum-membrane.

The form of the tympanic membrane causes it to transmit to its centre, where the malleus is attached, vibrations of its lateral parts in diminished amplitude but increased power; so that the tympanic bones are pushed only a little way but with considerable force. Its area, too, is about twenty times as great as that of the oval foramen, so that force collected on the larger area is, by pushing the tympanic bones, all concentrated on the smaller. The ossicles also form a bent lever (Fig. 144) of which the fulcrum is at the axial ligament and the effective outer arm of this lever is about half as long again as the inner, and so the movements transmitted by the drum-membrane to the handle of the malleus are communicated with diminished range, but increased power, to the base of the stapes.

Ordinarily sound-waves reach the labyrinth in this way through the tympanum, but they may also be transmitted through the bones of the head in general; if the handle of a vibrating tuning-fork be placed on the vertex, for example. Such sounds seem to have their origin in the head itself. Similarly, when a vibrating body is held between the teeth, sound reaches the end organs of the auditory nerve through the skull-bones; and persons who are deaf from disease or injury of the tympanum can thus be made to hear, as with the *audiphone*. Of course if deafness be due to disease of the proper nervous auditory apparatus no device can make the person hear.

**Function of the Cochlea.** We have already seen reason to believe that in the ear there is an apparatus adapted for sympathetic resonance, by which we recognize different

musical tone-colors; the minute structure of the membranous cochlea is such as to lead us to look for it there. An old view was that the rods of Corti, which vary in length, were like so many piano-strings, each tending to vibrate at a given rate and picking out and responding to pendular aërial vibrations of its own period, and exciting a nerve which gave rise to a particular tone sensation. When the labyrinthine fluids were set in non-pendular vibrations, the rods of Corti were thought to analyze these into their pendular components, all rods of the vibrational rate of these being set in sympathetic movement, but that rod most whose period was that of the primary partial tone; this would determine the pitch of the note, and the less-marked sensations due to the others affected would give it its timbre. The rods, however, do not differ in size sufficiently to account for the range of notes which we hear, and they are absent in birds, which undoubtedly distinguish different musical notes; and the nerve-fibres of the cochlea are not connected with them but with the hair-cells.

On the whole it seems probable that the basilar membrane is to be looked upon as the primary arrangement for sympathetic resonance in the ear. It increases in breadth twelve times from the base of the cochlea to its tip (the less width of the lamina spiralis at the apex more than compensating for the less size of the bony tube there) and is stretched tight across, but loosely in the other direction. A membrane so stretched behaves as a set of separate strings placed side by side, somewhat as those of a harp but much closer together; and each string would vibrate at its own period without influencing much those on each side of it. Probably, then, each transverse band vibrates to simple tones of its own period, and excites the hair-cells which lie on it, and through them the nerve-fibres. Perhaps the rods of Corti, being stiff, and carrying the reticular membrane, rub that against the upper ends of the hair-cells which project into its apertures and so help in a subsidiary way, each pair of rods being especially moved when the band of basilar membrane carrying it is set in vibration. The tectorial membrane is probably a "damper;" it is soft and

inelastic, and suppresses the vibrations as soon as the moving force ceases.

**Function of the Vestibule and Semicircular Canals.** Many noises are merely spoiled music; they are due to tones so combined as not to give rise to periodic vibrations; these are probably heard by the cochlea. If a single violent air-wave ever cause a sound sensation (which is doubtful since any violent push of an elastic substance, such as the air, will cause it to make several rebounds before coming to rest) we perhaps hear it by the vestibule; the otoliths, there in contact with the auditory hairs, are imbedded in a tenacious gummy mass quite distinct from the proper endolymph, and are not adapted for executing regular vibrations, but they might yield to a single powerful impulse and transmit it to the hair-cells, and through them stimulate the nerves. There is reason to believe that the semicircular canals have nothing to do with hearing; their supposed function is described in Chapter XXXV.

**Auditory Perceptions.** Sounds, as a general rule, do not seem to us to originate within the auditory apparatus; we refer them to an external source, and to a certain extent can judge the *distance* and *direction* of this. As already mentioned, the extrinsic reference of sounds which reach the labyrinth through the general skull-bones instead of through the tympanic chain is imperfect or absent. The recognition of the distance of a sounding body is possible only when the sound is well known, and then not very accurately; from its faintness or loudness we may make in some cases a pretty good guess. Judgments as to the direction of a sound are also liable to be grossly wrong, as most persons have experienced. However, when a sound is heard louder by the left than the right ear we can recognize that its source is on the left; when equally with both ears, that it is straight in front or behind; and so on. The concha has perhaps something to do with enabling us to detect whether a sound originates before or behind the ear, since it collects, and turns with more intensity into the external auditory meatus, sound-waves coming from the front. By turning the head and noting the accompanying changes of sensation



**DIESE SEITE IST FÜR KOSTENLOSE MITGLIEDER GESPERRT**  
Beantragen Sie jetzt die volle Mitgliedschaft, um diese Seite zu betreten

# GESCHICHTE

Zehntausende von wichtigen historischen Quellen, viele bisher nicht erhältlich, stehen jetzt zum ersten Mal mit der Vollmitgliedschaft von Forgotten Books zur Verfügung.

Unbegrenzter Zugang  
\$8.99/monat

**Fortfahren**

\*Es gelten Richtlinien zur fairen Nutzung.



## CHAPTER XXXIV.

### TOUCH, THE TEMPERATURE SENSE, THE MUSCULAR SENSE, COMMON SENSATION, SMELL, AND TASTE.

**Nerve-Endings in the Skin.** Many of the afferent skin-nerves end in connection with hair-bulbs; the fine hairs over most of the cutaneous surface, projecting from the skin, transmit any movement impressed on them, with

increased force, to the nerve-fibres at their fixed ends. In many animals, as cats, large, specially tactile, hairs are developed on the face, and these have a very rich nerve-supply. Fine branches of axis cylinders have also been described as penetrating between epidermic cells and ending there without terminal organs. In or immediately beneath the skin several peculiar forms of nerve end organs have also been described; they are known as (1) *Touch-cells*; (2) *Pacinian corpuscles*; (3) *Tactile corpuscles*; (4) *End-bulbs*.

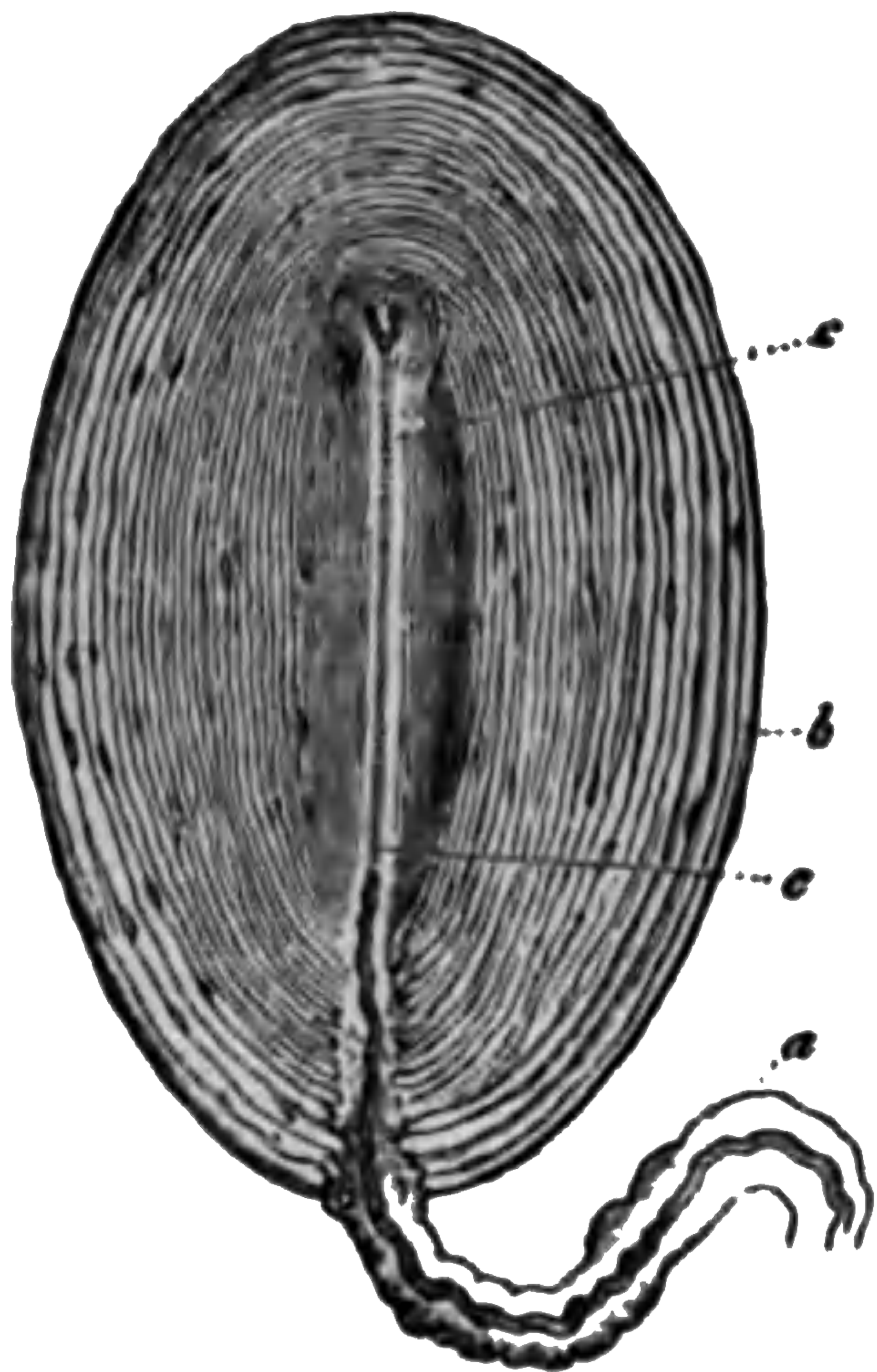

FIG. 151.—A Pacinian corpuscle, magnified.

The *Pacinian corpuscles* (Fig. 151) lie in the subcutaneous tissue of the hand and foot, and about the knee-joint; but also away from the skin on branches of the solar plexus (p. 172), so that it is doubtful if they are touch-organs.

They are oval, from 1.5 to 2.5 mm. ( $\frac{1}{16}$  to  $\frac{1}{8}$  inch) long, by about half that width, and have a whitish translucent appearance, with a more opaque centre. When magnified each is found to consist of a core, surrounded by many concentric capsules, *b*. A nerve-fibre, *a*, enters at one end, and its axis cylinder, *c*, runs along the core to the other, where it terminates in one or two little knobs, or a number of fine branches.

The *tactile corpuscles* lie in papillæ of the dermis, and are oval and about .08 mm. ( $\frac{1}{1000}$  inch) in length. They contain a soft core, enveloped by a connective-tissue cap-

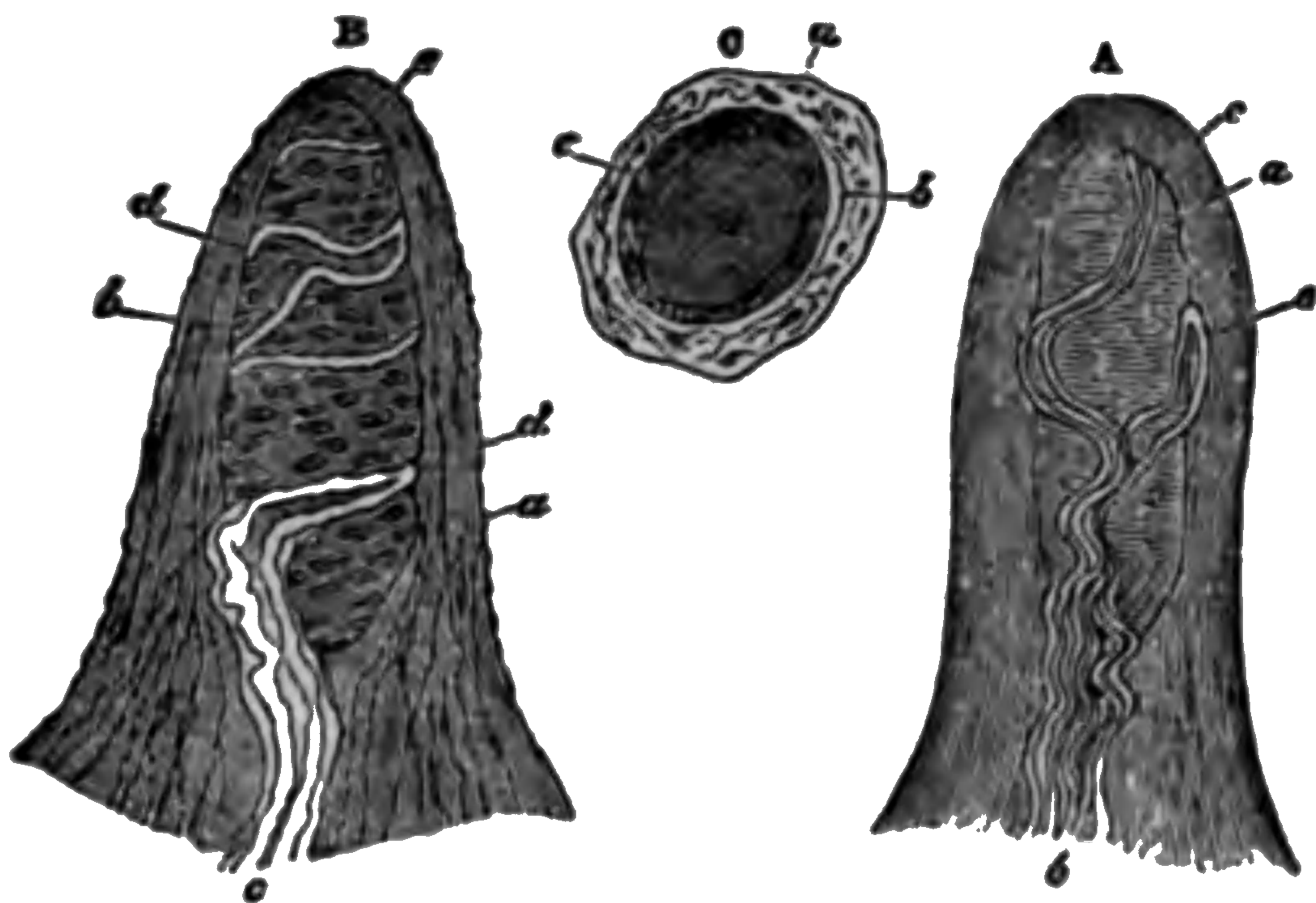

FIG. 152.—Dermic papillæ with tactile corpuscles. *A*, a corpuscle with four nerve-fibres; *a*, corpuscle; *b* and *c*, nerve-fibres. *B*, papilla made transparent with acetic acid to show tactile corpuscle within; *a*, proper tissue of the papilla; *b*, tactile corpuscle; *c*, entering nerve, *d*, *e*, nerve-fibres twining round the corpuscle. *C*, a papilla, containing a tactile corpuscle, seen in optical transverse section.

sule, and separated into several masses. Two, three, or more nerve-fibres go to each corpuscle and appear to end in plates lying between each of the segments of the core. Tactile corpuscles are numerous in the skin of the hand and foot, but are rare elsewhere. This limited distribution over the surface militated against the belief that they were tactile end organs; but it has lately been found that simpler bodies, the *touch-cells*, of the same essential structure but receiving only one nerve-fibre each, are distributed all over the skin; the more complex, and probably more irritable, form being found where the epidermis is especially thick.



The *end-bulbs* are spheroidal and about  $\frac{1}{100}$  inch in diameter. Each consists of a core, with a connective-tissue capsule, to which two or three nerve-fibres run; the axis cylinders penetrate the core. End-bulbs are found on one or two regions of the skin, as that on the red part of the lips, in the conjunctiva, and the mucous membrane covering the soft palate, and the tongue.

**Touch, or the Pressure Sense.** Through the skin we get several kinds of sensation; touch proper, heat and cold, and pain; and we can with more or less accuracy localize them on the surface of the Body. The interior of the month possesses also these sensibilities. Through touch proper we recognize pressure or traction exerted on the skin, and the force of the pressure; the softness or hardness, roughness or smoothness, of the body producing it; and the form of this, when not too large to be felt all over. In the latter case, as when we move the hand over an object to study its shape, muscular sensations are combined with proper tactile, and such a combination of the two sensations is frequent; moreover, we rarely touch anything without at the same time getting temperature sensations; so that pure tactile feelings are rare. From an evolution point of view, touch is probably the first distinctly differentiated sensation, and this primary position it still largely holds in our mental life; we mainly think of the things about us as objects which would give us certain tactile sensations if we were in contact with them. Though the eye tells us much quicker, and at a greater range, what are the shapes of objects and whether they are smooth, rough, and so on, our real conceptions of round and square and rough bodies are derived through touch, and we translate unconsciously the teachings of the eye into mental terms of the tactile sense. A person who saw but had no touch-sense would conceive solid objects very differently from the rest of mankind.

The delicacy of the tactile sense varies on different parts of the skin; it is greatest on the forehead, temples, and



**DIESE SEITE IST FÜR KOSTENLOSE MITGLIEDER GESPERRT**  
Beantragen Sie jetzt die volle Mitgliedschaft, um diese Seite zu betreten



**Seien Sie niemals ohne ein Buch!**

Die Vollmitgliedschaft von Forgotten Books bietet Ihnen einen universalen Zugang von unseren Apps und unserer Website, auf all Ihren Geräten: Tablet, Telefon, E-Reader, Laptop und Computer.

**Eine Bibliothek in Ihrer Tasche für € 8.99/monat**

**Fortfahren**

\*Es gelten Richtlinien zur fairen Nutzung.

guish them; some sub-sensation quality ~~not being, in reality~~ into prominence in consciousness ~~must be present, com-~~parable to the upper partials determining the ~~pitch of~~ a tone. The accuracy of the localizing power ~~varies widely~~ in different skin regions and is measured by observing the least distance which must separate two objects (as the blunted points of a pair of compasses) in order that they may be felt as two. The following table illustrates some of the differences observed—

Tongue-tip.....	1.1 mm.	(.04 inch)
Palm side of last phalanx of finger.....	2.2 mm.	(.08 inch)
Red part of lips.....	4.4 mm.	(.16 inch)
Tip of nose.....	6.6 mm.	(.24 inch)
Back of second phalanx of finger.....	11.0 mm.	(.44 inch)
Heel.....	22.0 mm.	(.88 inch)
Back of hand.....	30.8 mm.	(1.23 inches)
Forearm.....	39.6 mm.	(1.58 inches)
Sternum.....	44.0 mm.	(1.76 inches)
Back of neck.....	52.8 mm.	(2.11 inches)
Middle of back.....	66.0 mm.	(2.64 inches)

The localizing power is a little more acute across the long axis of a limb than in it; and is better when the pressure is only strong enough to just cause a distinct tactile sensation; than when it is more powerful; it is also very readily and rapidly improvable by practice.

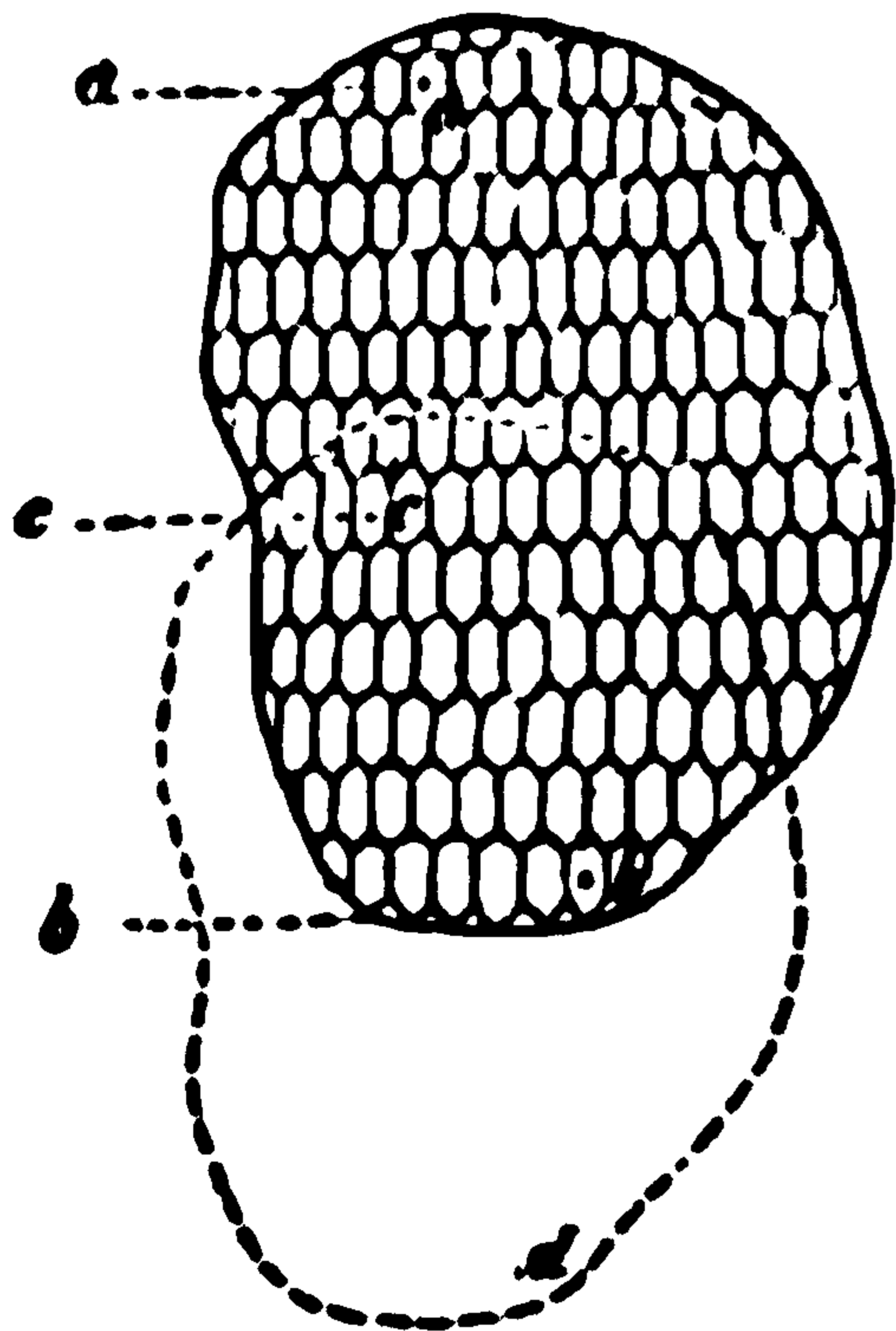

FIG. 152.

It might be thought that this localizing power depended directly on nerve distribution; that each touch-nerve had connection with a special brain-centre on the one hand (the excitation of which caused a sensation with a characteristic local sign), and at the other end was distributed over a certain skin area, and that the larger this area the farther apart might two

points be and still give rise to only one sensation. If this were so, however, the peripheral tactile areas (each being determined by the anatomical distribution of a nerve-fibre)

must have definite unchangeable limits, which experiment shows that they do not possess. Suppose the small areas in Fig. 153 to each represent a peripheral area of nerve distribution. If any two points in *c* were touched we would according to the theory get but a single sensation; but if, while the compass points remained the same distance apart, or were even approximated, one were placed in *c* and the other on a contiguous area, two fibres would be stimulated and we ought to get two sensations; but such is not the case; on the same skin region the points must be always the same distance apart, no matter how they be shifted, in order to give rise to two just distinguishable sensations.

It is probable that the nerve areas are much smaller than the tactile; and that several unstimulated must intervene between the excited, in order to produce sensations which shall be distinct. If we suppose twelve unexcited nerve areas must intervene, then, in Fig. 153, *a* and *b* will be just on the limits of a single tactile area; and no matter how the points are moved, so long as eleven, or fewer, unexcited areas come between, we would get a single tactile sensation; in this way we can explain the fact that tactile areas have no fixed boundaries in the skin, although the nerve distribution in any part must be constant. We also see why the back of a knife laid on the surface causes a continuous linear sensation, although it touches many distinct nerve areas; if we could discriminate the excitations of each of these from that of its immediate neighbors we would get the sensation of a series of points touching us, one for each nerve region excited; but in the absence of intervening unexcited nerve areas the sensations are fused together.

The ultimate differentiation of tactile areas takes place in the central organs, as will be more fully pointed out in the next chapter. Afferent nerve impulses reaching the spinal cord from a finger-tip enter the gray matter and tend to radiate some way in it; from the gray region through which they spread, impulses are sent on to perceptive tactile centres in the brain; if two skin-points are so close that their regions of irradiation in the cord overlap, then the two points touched cannot be discriminated in con-

sciousness, since the same brain regions are excited. The more powerful the stimulus the wider the irradiation in the cord, and hence the less accurate the discriminating power. The more often an impulse has traveled, the more does it tend to keep its own proper tract through the gray matter of the cord, and get on to its own proper brain-centre alone, hence the increase of tactile discrimination with practice, for we cannot suppose it to be due to a growth of more nerve-fibres down to the skin, and a rearrangement of the old, with smaller areas of anatomical distribution. As a general rule, more movable parts have smaller tactile areas; this probably depends on practice, since they are the parts which get the greatest number of different tactile stimulations.

**The Temperature Sense.** By this we mean our faculty of perceiving cold and warmth; and, with the help of these sensations, of perceiving temperature differences in external objects. Its organ is the whole skin, the mucous membrane of month and fauces, pharynx and gullet, and the entry of the nares. Direct heating or cooling of a sensory nerve may stimulate it and cause pain, but not a true temperature sensation; and the degree of heat and cold requisite is much greater than that necessary when a temperature-perceiving surface is acted upon; hence we must assume the presence of temperature end organs.

In a comfortable room we feel at no part of the Body either heat or cold, although different parts of its surface are at different temperatures; the fingers and nose being cooler than the trunk which is covered by clothes, and this, in turn, cooler than the interior of the month. The temperature which a given region of the temperature organ has (as measured by a thermometer) when it feels neither heat nor cold is its *temperature-sensation zero*, and is not associated with any one objective temperature; for not only, as we have just seen, does it vary in different parts of the organ, but also on the same part from time to time. Whenever a skin region has a temperature above its sensation zero we feel warmth and *vice versa*; the sensation is more marked the greater the difference, and the more



**DIESE SEITE IST FÜR KOSTENLOSE MITGLIEDER GESPERRT**  
Beantragen Sie jetzt die volle Mitgliedschaft, um diese Seite zu betreten

# GESCHICHTE

Zehntausende von wichtigen historischen Quellen, viele bisher nicht erhältlich, stehen jetzt zum ersten Mal mit der Vollmitgliedschaft von Forgotten Books zur Verfügung.

Unbegrenzter Zugang  
\$8.99/monat

**Fortfahren**

\*Es gelten Richtlinien zur fairen Nutzung.



sometimes pass into one another insensibly, and they are really extreme varieties of one kind of sensation comparable to yellow and blue in the visual series. A half dollar cooled to  $5^{\circ}\text{C}$ . ( $41^{\circ}\text{F}$ .) be placed on a person's brow, and then two (one on the other) warmed to  $37^{\circ}\text{C}$ . ( $98.5^{\circ}\text{F}$ .), he commonly thinks the weight in the two cases is equal; i.e. the temperature difference leads to error in his pressure perceptions, the cold body seeming heavier. But this does not prove an essential identity in the sensations; it is conceivable, *e.g.*, that the cold half dollar produces contraction of the cutaneous tissues, leading to compression of the tactile end organs, which is mistaken for a mental interpretation, for a heavier external object. When sensations are combined in other cases, as red and blue to produce green, or green and blue to produce cyan, or red and green to produce yellow, or partial tones to form a compound, we either cannot at all, or only with difficulty recognize the components; while in this case the person feels both the cold and pressure distinctly when the dollar is laid on him.

It has also been shown that in certain cases a person takes the contact of a piece of raw cotton with a small exposed area of his skin, for the approach of a warm object, and this has been taken to prove that touch and temperature feelings may gradate into one another. However, the feeble touch of the raw cotton might well be less felt than the increased temperature of the skin, due to diminished radiation when it was covered by this non-conducting substance, and the constancy with which, in the ordinary circumstances of life, we feel and discriminate clearly, on the same region, both temperature and touch sensations, is strongly against any transitional passage of one into the other.

In favor of the view that touch and temperature are sensations of distinct modality, with different end organs, afferent nerve-fibres, and brain-centres, are several well-known facts. The regions of most acute discrimination for each sensation are different; and cases of disease are recorded in which persons have been extremely sensitive to variations in temperature, while their tactile sensibility was unaltered.

and, conversely, cases in which the patient could feel that he had been touched but was unable to say whether with a hot or cold object.

**The Muscular Sense.** In connection with our muscles we have sensations of great importance, although they do not often become so obtrusive in consciousness as to arouse our attention until we look for them. Certain of these feelings (*muscle sensations proper*) are due to the excitation of sensory nerves ending within the muscles themselves: the others (*innervation sensations*) have probably a central origin and accompany the starting of volitional impulses from brain-cells; they are only felt in connection with the voluntary skeletal muscles.

The proper muscle sensations only become marked on powerful or long-continued muscular effort (cramp, fatigue), but a lower grade of them, not distinctly perceived, probably accompanies all muscular activity.

The innervation feelings are of far more consequence. They accompany the slightest movement of a skeletal muscle, and we derive from them means of determining with great accuracy the force and extent of the contraction willed. The belief that their origin is central mainly rests on the fact that we have sensations, not merely of executed but of intended movements. The actual nature of the movement performed is probably characterized by other contemporary sensations, as of the muscle sense proper, from pressure and folding of the skin, and so on.

The innervation feelings thus stand apart and opposed to all our others as primary factors in our mental life; they represent the reactive work of the organism with respect to its environment. Some distinguished physiologists, however, deny their existence, ascribing them all to a peripheral origin, either in sensory muscle-nerves, or in skin-nerves affected when a part of the Body is moved. As, however, we can determine more accurately the difference between two weights when we lift them than we can when they are merely laid on a hand supported by a table (see below), there are undoubtedly (apart from cramp and fatigue) true muscular sensations distinct from tactile; and



that these, or some of them, are central in origin seems proved by certain phenomena observed in disease. Persons suffering from paresis, i. e. muscular weakness not amounting to complete paralysis, make (until they have learned to interpret correctly their sensations under the influence of practice) entirely wrong judgments as to the nature and extent of their movements; they think they have contracted their muscles much more than is really the case. If the muscular sense depended on stimulation of sensory nerves in the muscles this error could not arise, for the intensity of the sensation would be determined by the amount of contraction which actually occurred. Under the circumstances, however, a stronger volition than previously is needed to cause a movement of given extent or power; and we can readily explain the mistakes if we suppose the sensation is of central origin, and determined in intensity by the will-power exerted.

We have already seen how closely muscular sensations are combined with visual in enabling us to form judgments as to the distance, size, and movements of objects. They are as closely combined in ordinary life with tactile sensations; in the dark, when an object is of such size and form that it cannot be felt all over by any one region of the skin, we deduce its shape and extent by combining the tactile feelings it gives rise to, with the muscular feelings accompanying the movements of the hands over it. Even when the eyes are used the sensations attained through them usually serve as short-cuts which we have learned by experience to interpret, as telling us what tactile and muscular feelings the object seen would give us if felt; and, in regard to distant points, although we have learnt to apply arbitrarily selected standards of measurement, it is probable that distance, in relation to perception, is primarily a judgment as to how much muscular effort would be needed to come into contact with the thing looked at.

When we wish to estimate accurately the weight of an object we always, when possible, lift it, and so combine muscular with tactile sensations. By this means we can form much better judgments. While with touch alone just percept-



**DIESE SEITE IST FÜR KOSTENLOSE MITGLIEDER GESPERRT**  
Beantragen Sie jetzt die volle Mitgliedschaft, um diese Seite zu betreten



**Seien Sie niemals ohne ein Buch!**

Die Vollmitgliedschaft von Forgotten Books bietet Ihnen einen universalen Zugang von unseren Apps und unserer Website, auf all Ihren Geräten: Tablet, Telefon, E-Reader, Laptop und Computer.

**Eine Bibliothek in Ihrer Tasche für €8.99/monat**

**Fortfahren**

\*Es gelten Richtlinien zur fairen Nutzung.

The matter cannot, however, be at present decided. The skin seems indubitably to contain many nerve-fibres which terminate in free axis cylinders without end-organs; and these may well be true pain-fibres, fitted to respond to stronger stimuli than those which excite the tactile and thermic end organs. Certain pathological and experimental phenomena tend also to prove that the brain-centres concerned in the production of tactile and painful sensations are different. Persons sometimes lose pain sensations and keep tactile; a gentle touch is felt as well as usual, but a powerful pinch causes no pain: in one stage of ether and chloroform narcosis the same thing is observed; the surgeon's hand and knife are felt where they touch the skin, but cutting deeper into the tissues produces no pain. In animals a similar state of things may be produced by dividing the gray matter of the cord, leaving the posterior white columns intact; while, if the latter be divided and the gray substance left uninjured, there is increased sensitiveness to pain, and probably touch proper is lost, though that is impossible to say with certainty. Such experiments make it pretty certain that when sensory afferent impulses reach the cord at any level and there enter its gray matter with the posterior root-fibres, they travel on in different tracks to conscious centres; the tactile coming soon out of the gray network and coursing on in a readily conducting white fibre, while the painful first travel on farther in the gray substance. It is still uncertain if both impulses reach the cord in the same fibres. The gray network conducts nerve impulses, but not easily; they tend soon to be blocked in it. A feeble (tactile) impulse reaching it by an afferent fibre might only spread a short way and then pass out into a single good conducting fibre in a white column, and proceed to the brain; while a stronger (painful) impulse would radiate farther in the gray matter, and perhaps break out of it by many fibres leading to the brain through the white columns, and so give rise to an inco-ordinate and ill localized sensation. That pains are badly localized, and worse the more intense they are, is a well-known fact, which would thus receive an explanation (see p. 579).

**Hunger and Thirst.** These sensations, which regulate the taking of food, are peripherally localized in consciousness, the former in the stomach and the latter in the throat, and local conditions no doubt play a part in their production; though general states of the Body are also concerned.

Hunger in its first stages is probably due to a condition of the gastric mucous membrane which comes on when the stomach has been empty some time, and may be temporarily stilled by filling the organ with indigestible substances. But soon the feeling comes back intensified and can only be allayed by the ingestion of nutritive substances; provided these are absorbed and reach the blood, their mode of entry is unessential; the hunger may be stayed by injections of food into the rectum as well as by putting it into the stomach.

Similarly, thirst may be temporarily relieved by moistening the throat without swallowing, but then soon returns; while it may be permanently relieved by water injections into the veins, without wetting the throat at all.

While both sensations thus depend in part on local peripheral conditions of afferent nerves (pneumogastric and glossopharyngeal), they may be also, and more powerfully, excited by poverty of the blood in foods and water; this probably directly stimulates the hunger and thirst brain-centres.

**Smell.** The olfactory organ consists of the upper portions of the two nasal cavities, over which the endings of the olfactory nerves are spread and where the mucous membrane has a brownish-yellow color. This region (*regio olfactoria*) covers the upper and lower turbinate bones (*o, p*, Fig. 89\*), which are expansions of the ethmoid (*p.* 75) on the outer wall of the nostril chamber, the opposite part of the partition between the nares, and the part of the roof of the nose (*n*, Fig. 89) separating it from the cranial cavity. The epithelium covering the mucous membrane contains two varieties of cells arranged in several layers (2, Fig. 154). Some cells are much like ordinary columnar epithelium but with long branched processes attached to their deeper ends; the others have a large

---

\* P. 200.

nucleus surrounded by a little protoplasm; a slender external process reaching to the surface; and a very fine deep one. The latter cells have been supposed to be the proper olfactory end organs, and to be connected with the fibres of the olfactory nerve, which enter the deeper strata of the epithelium and there divide; but it is doubtful whether both kinds of cells are not so connected.

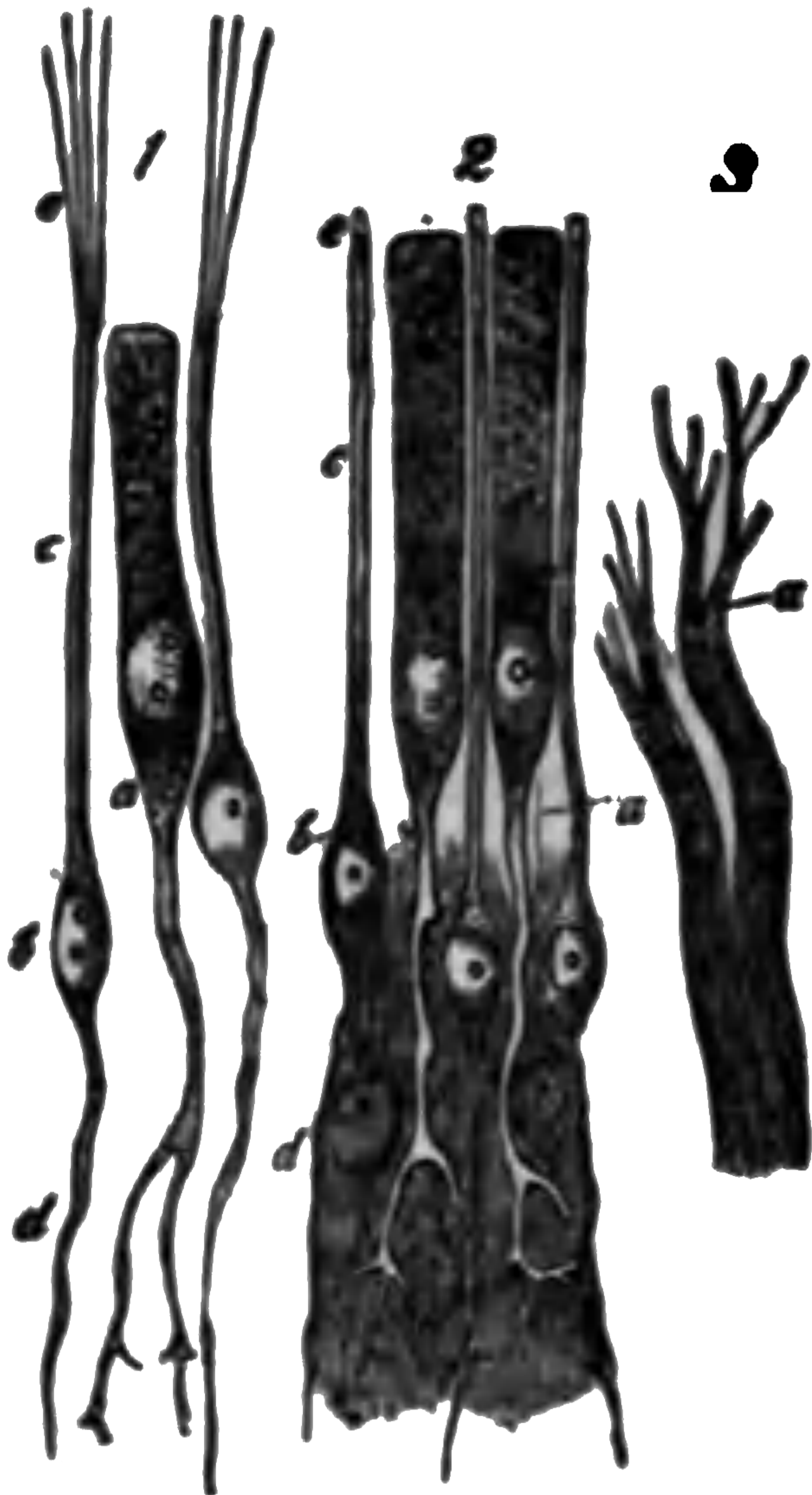

FIG. 154.—Cells from the olfactory epithelium. 1, from the frog; 2, from man: a, columnar cell, with its branched deep process; b, so-called olfactory cell; c, its narrow outer process; d, its slender central process. 3, gray nerve-fibres of the olfactory nerve, seen dividing into fine peripheral branches at a.

Odorous substances, the stimuli of the olfactory apparatus, are always gaseous and frequently act powerfully when present in very small amount. We cannot, however, classify them by the sensations they arouse, or arrange them in series; and smells are but minor sensory factors in our mental life. We commonly refer them to external objects since we find that the sensation is intensified by “sniffing” air powerfully into the nose, and ceases when the nostrils are closed. Their peripheral localization is, however, imperfect, for we confound many smells with tastes (see below); nor can we judge well of the direction of an odorous body through the olfactory sensations which it arouses.

The nose possesses also nerves of common sensation, which are stimulated by such substances as ammonia vapor.

**Taste.** The organ of taste is the mucous membrane on the dorsum of the tongue and possibly other parts of the boundary of the mouth cavity. The nerves concerned are the glossopharyngeals, distributed over the hind part of the



**DIESE SEITE IST FÜR KOSTENLOSE MITGLIEDER GESPERRT**  
Beantragen Sie jetzt die volle Mitgliedschaft, um diese Seite zu betreten

# GESCHICHTE

Zehntausende von wichtigen historischen Quellen, viele bisher nicht erhältlich, stehen jetzt zum ersten Mal mit der Vollmitgliedschaft von Forgotten Books zur Verfügung.

Unbegrenzter Zugang  
\$8.99/monat

**Fortfahren**

\*Es gelten Richtlinien zur fairen Nutzung.



except as aiding in the selection of food, and for that purpose they are not by any means safe guides at all times.

Many so-called tastes (flavors) are really smells; odoriferous particles of substances which are being eaten reach the olfactory region through the posterior nares and arouse sensations which, since they accompany the presence of objects in the mouth, we take for tastes. Such is the case, *e.g.*, with most spices; when the nasal chambers are blocked or inflamed by a cold in the head, or closed by compressing the nose, the so-called taste of spices is not perceived when they are eaten; all that is felt, when cinnamon, *e.g.*, is chewed under such circumstances is a certain pungency due to its stimulating nerves of common sensation in the tongue. This fact is sometimes taken advantage of in the practice of domestic medicine when a nauseous dose, as rhubarb, is to be given to a child. Tactile sensations play also a part in many so-called tastes.

Most persons taste bitters best with the back of the tongue and sweets towards the tip; but this is not constant. The curious interference of tastes which takes place when the acidity of a sour body is covered by adding a sweet one, which does not in any way chemically neutralize the acid (when sugar is put on a lemon for example), needs explanation.



## CHAPTER XXXV.

### THE FUNCTIONS OF THE BRAIN AND SPINAL CORD.

**The Special Physiology of Nerve-Centres.** We have already studied the general physiological properties of nerves and nerve-centres (Chap. XIII.) and found that while the former are mere transmitters of nervous impulses, the latter do much more. In some cases the centres are *automatic*; they originate nerve impulses, as illustrated by the beat of the heart under the influence of its ganglia. In other cases a feeble impulse reaching the centre gives rise to a great discharge of energy from it (as when an unexpected noise produces a violent start, due to many impulses sent out from the excited centre to numerous muscles), so that certain centres are *irritable*; they contain a store of energy-liberating material which only needs a slight disturbance to upset its equilibrium and produce many efferent impulses as the result of one afferent. Further, the impulses thus liberated are often *co-ordinated*. When mucus in the windpipe tickles the throat and excites afferent nerve impulses, these, reaching a centre, cause discharges along many efferent fibres, so combined in sequence and power as to produce, not a more aimless spasm, but a cough which clears the passage. In still other cases the excitation of centres, with or without at the same time some of the above phenomena, is associated with *sensations* or other *states of consciousness*. We have now to study which of these powers are manifested by different parts of the central cerebro-spinal nervous system, and under what circumstances and in what degree: what is known of the general functions of the sympathetic and sporadic ganglia has already been stated (p. 183).



**The Spinal Cord as a Centre.** The spinal cord, (except the slender sympathetic) ~~the~~ the only direct communication between the brain and most of ~~the~~ the nerves of the body was considered by the older physiologists as merely a nerve-trunk, into which the various spinal nerves collected on their way to the ~~encephalon~~ encephalon. It does not, however, contain the paths for the conduction of all the impulses which, originating in the cerebrum, give rise to voluntary movements of the trunk and limbs; also the centrally traveling impulses which give rise to actions ascribed to those parts; and it is also the path by which certain impulses giving rise to involuntary movements travel, for example, those which, originating in the respiratory centre, travel to the phrenic and intercostal nerves.

If, however, the cord were merely a collected and continued nerve-root it ought to increase considerably as it approached the skull, and this it does not do. A histological examination, too, shows that few, if any, of the entering fibres proceed directly to the brain; they pass to the central gray substance, containing nerve-cells and differing from anything in a true nerve-trunk. In the gray columns the fibres (anterior roots) end in cells of the anterior horn; others (posterior roots) in that fine network which permeates the whole gray substance (p. 179); the nerve-cell branches are also in continuity with this network. From the network fibres arise at different levels, and pass out into the white columns; some place two regions of gray matter in intimate connection, while others connect the cord to the brain. In order to understand physiologic reflex actions we must assume, first, that a nervous impulse entering the gray network at any point may, under certain conditions, travel all through it, and give rise to efferent impulses emerging at any level; and, on the other hand, that there are certain lines or paths of easiest propagation through different points in this network, which the impulses follow to under ordinary conditions.

**Reflex Actions.** When a frog is decapitated it li



**DIESE SEITE IST FÜR KOSTENLOSE MITGLIEDER GESPERRT**  
Beantragen Sie jetzt die volle Mitgliedschaft, um diese Seite zu betreten



**Seien Sie niemals ohne ein Buch!**

Die Vollmitgliedschaft von Forgotten Books bietet Ihnen einen universalen Zugang von unseren Apps und unserer Website, auf all Ihren Geräten: Tablet, Telefon, E-Reader, Laptop und Computer.

**Eine Bibliothek in Ihrer Tasche für €8.99/monat**

**Fortfahren**

\*Es gelten Richtlinien zur fairen Nutzung.

things applied to them; if, however, the skin of the feet be tickled the legs are thrown into vigorous movement. As a rule, however, orderly reflexes are less marked and less numerous in the higher animals; in them the organization is less machine-like, the spinal cord being more the servant of the larger brain, and less capable of working without directions. Such animals, when intact, can to a greater extent control the muscular responses which shall be made to stimuli under various conditions; they have less automatic protection in the ordinary risks of life, but a greater range of possible protection. The human spinal cord, controlled by the brain, can adapt the reactions of the Body, with great nicety, to a vast variety of conditions; the frog's cord by itself does this for a smaller number of possible emergencies without troubling at all such brain as the animal has, but is less completely under the control of the higher centres for adaptation to other conditions. The difference being, however, but one of degree and not of kind, it is best to approach the study of the reflex action of the human spinal cord through an examination of those exhibited by the frog.

**The Orderly Reflex Movements of a Decapitated Frog.** For the occurrence of these the following parts must be intact; (*a*) the end organs of sensory nerve-fibres; (*b*) afferent fibres from these to the cord; (*c*) efferent fibres from the cord to the muscles; (*d*) the part of the spinal cord between the afferent and efferent fibres; (*e*) the muscles concerned in the particular movement. If the animal be suspended vertically after the shock of the operation is over, it makes a few attempts to hold its hind legs in their usual flexed position; these soon cease, the legs hang down, and the creature comes to rest. If one flank be now gently scratched with the point of a pencil a reflex movement occurs, limited to the muscles of that region; they twitch, somewhat as a horse's neck when tickled by flies. If a pinch be given at the same spot, more muscles on the same side come into play; a harder pinch causes also the hind leg of that side to be raised to push away the offending object; more violent and prolonged irritation causes all the muscles

## **DISORDERLY REFLEX MOVEMENTS**

of the body to contract, and the animal is convulsed; then we see that a feeble stimulation causes a purpose-like response; stronger causes a wider range of efferent impulses from the cord and the contractile muscles, but still the movements are co-ordinated; while abnormally powerful stimulation of nerves throws all the motor fibres arising from the cord into activity, and calls forth inco-ordinate spasms. The orderly movements are very uniform for a given stimulation; if the anal region be pinched, both hind legs are raised to push away the forceps; if a tiny bit of paper moistened with dilute vinegar be put on the lower part of that leg is raised to wipe it off; if the middle of the back near the head, both feet are raised to the spot; if on one flank, the leg and foot of that side is used, and so on; in fact, by careful working, the movements can be mapped into many regions, the application of a certain water to each causing one particular movement due to the co-ordinated contractions of muscles in certain combinations, and never, under ordinary circumstances, any but that one movement. The above mentioned reflex movements may all be characterized as orderly, but all orderly reflexes are not so. For example, during the breeding season the male frog clasps the female with his fore limbs. If a male at this time be decapitated and left to recover from the shock, it is found that gently rubbing his sternal region with a certain water causes him to clasp it vigorously.

**Disorderly Reflexes or Reflex Convulsions** come on when an afferent nerve-trunk is stimulated at the tactile end organs in the skin; or when the nerve is very powerfully excited; or, with feeble stimuli, in diseased states (*pathological tetanus*), and under the influence of certain poisons, especially strychnine. In a warm-blooded animal be given a dose of the poison, a stimulus, such as normally would excite only orderly reflexes, will excite the whole cord, and discharges along all the efferent fibres so that convulsions result. It has been clearly proved that

cases, not the skin, or afferent or efferent nerves, or the muscles, but the spinal cord itself is affected by the (at least primarily), unless unnecessarily large doses have been given.

**The Least-Resistance Hypothesis.** In order to comprehend reflex acts we must assume a manifold union of sensory with efferent nerve-fibres; this is anatomically afforded by the minute plexus of the gray network, which is continuous through the whole cord and in which the fibres of the anterior and posterior nerve-roots, directly or indirectly end. The continuity of this network serves to explain general reflex convulsions, and the spread of an afferent impulse, or its results, through the whole cord, with the consequent emission of efferent impulses through many or all the anterior roots; but, on the other hand, it renders it difficult to understand limited and orderly reflexes, in which only a few efferent fibres are stimulated. To explain them we have to assume a great resistance to conduction in the gray network, so that a nerve impulse entering it is soon blocked and transmuted into some other form of energy; hence it only reaches efferent fibres originating near the point at which it enters, or fibres placed in specially easy communication with that. When the frog's flank is tickled, only muscles innervated from anterior roots on the same side of the body, and springing from the same level of the cord, are made to contract; when the stimulus is more powerful the stronger afferent impulse radiates farther, but mainly in directions determined by lines of conductivity in the cord; *e.g.*, to the origin of the efferent fibres which cause lifting of the hind leg to the irritated spot. These paths of easiest conduction, or of least resistance, in some cases lie in the gray matter itself, in others in *inter-central* or *commissural fibres* of the highly conductive medullated kind, which, passing out of the gray substance at one level, run in the white columns to it at another, where the efferent fibres of the muscles called into play originate. A still stronger afferent impulse radiates wider still, and, liberating energy from all the nerve-cells in the gray matter, produces a useless general convulsion. Under



**DIESE SEITE IST FÜR KOSTENLOSE MITGLIEDER GESPERRT**  
Beantragen Sie jetzt die volle Mitgliedschaft, um diese Seite zu betreten

# GESCHICHTE

Zehntausende von wichtigen historischen Quellen, viele bisher nicht erhältlich, stehen jetzt zum ersten Mal mit der Vollmitgliedschaft von Forgotten Books zur Verfügung.

Unbegrenzter Zugang  
\$8.99/monat

**Fortfahren**

\*Es gelten Richtlinien zur fairen Nutzung.



parts of the brain. Thence they travel down the white columns of the cord to its gray matter, ~~where~~ where they enter at different levels, each in the neighbourhood of a centre producing a given movement. If they there radiated and were not wide no definite movement could result, for all muscles supplied from the cord would be made to contract and not merely those necessary to bend the index finger for example. We must here again, therefore, assume a point of least resistance for the propagation of nerve impulses in a given fibre coming down from the brain, to the efferent fibres going to a certain muscle or group of muscles. The path between the two is almost certainly not direct; a co-ordinating spinal centre intervenes, and all that the brain has to do is to excite this centre, which then secures the proper muscular co-ordination. If the hand be laid on the table and its palm be rolled over, many muscles, including thousands of muscular fibres, have to contract in a definite order and sequence. Persons who have not studied anatomy and who are quite ignorant of the muscles to be used can perform the movement perfectly; and even a skilled anatomist and physiologist, if he knew them and their actions, could not by conscious effort combine them so well as the cord does without such direct interference. We have then to look on the cord as containing a host of co-ordinating centres for different muscles. These centres are put in nervous connection, on the one hand with certain regions of the skin, and, on the other, with regions of the brain, and may be excited from either; in the former case the movement is called reflex; in the latter it may be reflex, or may be accompanied by a feeling of "will" and is then called voluntary. The more accurately the required centre, and no other, is excited, the more definite and precise the movement.

**The Education of the Cord.** Much of what is called educating our touch or our muscles is really education of the spinal cord. A person who begins to play the piano finds at first much difficulty in moving his fingers independently; the nervous impulses from the brain to the centres radiate from the spinal centres of the muscle which is

desired to move, to others. But with practice the independent movements become easy. So, too, the localizing power of the skin can be greatly increased by exercise (p. 560) as one sees in blind persons, who often can distinguish two stimuli on parts of the skin which are so near together as to give only one sensation to other people. Such phenomena depend on the fact that the more often a nervous impulse has traveled along a given road in the gray matter, the easier does its path become, and the less does it tend to wander from it into others. We may compare the gray matter to a thicket; persons seeking to beat a road through from one point to another would keep the same general direction, determined by the larger obstacles in the way, but all would diverge more or less from the straight path on account of undergrowth, tree trunks, etc., and would meet with considerable difficulty in their progress. After some hundreds had passed, however, a tolerably beaten track would be marked out, along which travel was easy and all after-comers would take it. If instead of one entry and one exit we imagine thousands of each, and that the paths between certain have been often traveled, others less, and some hardly at all, we get a pretty good mental picture of what happens in the passage of nervous impulses through the gray matter of the cord; the clearing of the more trodden paths answering to the effects of use and practice. The human cord and that of the frog must not, however, be looked upon as pathless thickets at the commencement; each individual inherits certain paths of least resistance determined by the structure of the cord, which is the transmitted material result of the life experience of a long line of ancestry.

**The Inhibition of Reflexes.** Since it is possible, as by strychnine, to diminish the resistance in the gray matter, it is conceivably also possible to increase it, and diminish or prevent reflexes. Such is found to be actually the case. We can to a great extent control reflexes by the will; for example, the jerking of the muscles which tends to follow tickling; and it is found that after a frog's brain is removed it is much easier to get reflex actions out of the spinal cord. Certain drugs, as bromide of potassium, also diminish reflex excita-



bility. If a frog's brain be removed and the animal's be dipped into very dilute acid, it will be removed after few seconds; the time elapsing between the immersion and the lifting of the foot is known as the reflex time; a thing diminishing reflex excitability increases this, as stimulus (which has a cumulative effect on the centre) to act longer before it arouses the cord to the discharge point. If the sciatic nerve of the other leg be stimulated while the toe is in the acid the reflex time is increased the reflex may fail entirely to appear. This is one case a general law, that any powerful stimulation of one sensory nerve tends to inhibit orderly reflexes due to the citation of another. A common example is the well-known trick of pressing on the upper lip to prevent a sneeze. The whole question of reflex inhibition is at present obscure. It may be due to the excitation of special fibres which inhibit reflex centres, as pneumogastric fibres do cardio-motor; or to the fact that one nerve impulse in cord in some cases blocks or interferes with another partly to both.

**Psychical Activities of the Cord.** Since we can quite marked reflex movements in the lower part of Body of a man whose cord is divided and who can voluntarily move his lower limbs, and on questioning find that he feels nothing and is quite ignorant of movements unless he sees his legs, it is most probable that the spinal cord in all cases is devoid of centres of consciousness and volition: this is not certain, however; for there might well be a less division of physiological labor between the cord and brain of a frog, than between those of a man. Still we are entitled to good evidence before we admit that two things so similar as the human cord and the frog's possess different properties. Co-ordinated movements following a given stimulus, or cries emitted by an animal, will suffice to prove that it is conscious, since these we know occur entirely unconsciously in men, who alone can tell us their feelings. We must look for something that resembles actions only done by men consciously. In the frog it has been maintained that we have evidence of such. If a bi



**DIESE SEITE IST FÜR KOSTENLOSE MITGLIEDER GESPERRT**  
Beantragen Sie jetzt die volle Mitgliedschaft, um diese Seite zu betreten



**Seien Sie niemals ohne ein Buch!**

Die Vollmitgliedschaft von Forgotten Books bietet Ihnen einen universalen Zugang von unseren Apps und unserer Website, auf all Ihren Geräten: Tablet, Telefon, E-Reader, Laptop und Computer.

**Eine Bibliothek in Ihrer Tasche für € 8.99/monat**

**Fortfahren**

\*Es gelten Richtlinien zur fairen Nutzung.

most part cross soon after they enter the gray matter, and proceed onwards mainly on the side opposite to that of the nerve-root which conveyed them to the cord; while the afferent cross mainly in the medulla before they reach the cord; the crossing seems in neither case complete. Hemisection of the cord, therefore, causes marked, but not absolute, loss of voluntary movement in muscles of the same side supplied with nerves from a part of the cord below the level of the section; and a considerable, but not entire, loss of sensibility on the opposite side. Impulses so powerful as to lead to feelings of pain travel mainly in the gray matter (p. 300), and they also for the most part cross the middle line soon after their entry.

**The Functions of the Brain in General.** The brain, at least in man and the higher animals, is the seat of consciousness and intelligence; these disappear when its blood-supply is cut off, as in fainting; pressure on parts of it, as by a tumor or by an effusion of blood in apoplexy, has the same result; inflammation of it causes delirium; and when the cerebral hemispheres are unusually small idiocy is observed. The brain has, however, many other important functions; it is the seat of many reflex, automatic, and co-ordinating centres, which may act as entirely apart from consciousness as those of the spinal cord; experiment makes it probable that psychological faculties are dependent on the fore-brain, while the rest of the complex mass has other,

non-mental, duties. If the cerebral hemispheres be removed from a frog, the animal can still perform every movement as well as before; but it no longer performs any spontaneously; it must be aroused by an immediately acting stimulus, and its response to this is as invariable and predicable as that of a frog with its spinal cord only. The movements which can be educed are, however, far more complex; instead of mere kicks in various directions the animal can walk, leap, swim, get off its back on to its feet, and so on. Similar results are observable in pigeons whose fore-brain has been removed; mammals bear the operation badly, but some, as rats, survive it several hours and then exhibit like phenomena. The creatures can move, but do not unless directly stimulated; all their volitional spontaneity is lost, and, apparently, all perceptions also; they start at a loud noise, but do not run away as if they conceived danger; they follow a light with the eyes, but do not attempt to escape a hand stretched forth to catch them; they can and do swallow food placed in the mouth, but would die of starvation if left alone with plenty of it about them, the sight of edible things seeming to arouse no idea or conception. It may be doubted, perhaps, whether the animals have any true sensations; they start at sounds, avoid opaque objects in their road, and cry when pinched; but all these may be unconscious reflex acts: on the whole it seems more probable, however, that they have sensations but not perceptions; they feel redness and blueness, hardness and softness, and so on; but sensations, as already pointed out, tell in themselves nothing; they are but signs which have to be mentally interpreted as indications of external objects: it is this interpreting power which seems deficient in the animal deprived of its fore brain.

**Functions of the Medulla Oblongata.** This contains the paths of conduction between the parts of the brain in front of it and the spinal cord. It is also the seat of many important reflex and automatic centres, especially those governing the organs immediately concerned in the maintenance of life; as the respiratory, circulatory, and masticatory. It may therefore be called the "nerve cen-

tral organ of the nutritive processes." The physiological action of most of the medullary centres has already been described; the more important are—1. The respiratory centre (p. 390). 2. The cardio-inhibitory centre (p. 250); (there is also some reason to believe that the centre of the accelerator heart-fibres (p. 252) lies in the medulla). 3. The vaso-motor centre (p. 253). 4. The centre for the dilator muscle-fibres of the pupil (p. 486). 5. The centre for the muscles of chewing and swallowing (p. 337), which are commonly thrown into action reflexly, though they may be made to contract voluntarily. 6. The convulsive centre (p. 400). 7. The diabetic centre (p. 442). 8. The centre reflexly exciting activity in the salivary glands, when sensory nerves in the mouth are stimulated. 9. Certain centres for complex bodily movements; an animal with its medulla oblongata can execute much more complicated reflex acts than one with its spinal cord alone.

**Functions of the Cerebellum, Pons Varolii, and Mid-Brain.** These contain paths of conduction between the fore-brain and parts behind, and many important centres, especially those concerned with the maintenance of the equilibrium of the Body in various postures and modes of locomotion. If, as has been above suggested, an animal without its cerebral hemispheres has sensations which remain untranslated into terms of external things, these sensations must have their seats in these brain-regions.

The *crura cerebri* (p. 164) are essentially paths of conduction between the cerebral hemispheres and parts behind. Injury of one produces partial loss of sensibility and incomplete muscular paralysis on the opposite side of the Body. The anterior pair of eminences of the *corpora quadrigemina* are concerned with sight; stimuli reaching them through the optic nerve, there, probably, first cause visual sensations, which it is left to the fore-brain to interpret. If the latter is removed from an animal light brought in front of the eye still causes contraction of the pupil; direct irritation of the eminences in question has the same effect, and destruction of one of them causes blindness of the opposite eye. The functions of the posterior pair of eminences



**DIESE SEITE IST FÜR KOSTENLOSE MITGLIEDER GESPERRT**  
Beantragen Sie jetzt die volle Mitgliedschaft, um diese Seite zu betreten

# GESCHICHTE

Zehntausende von wichtigen historischen Quellen, viele bisher nicht erhältlich, stehen jetzt zum ersten Mal mit der Vollmitgliedschaft von Forgotten Books zur Verfügung.

Unbegrenzter Zugang  
\$8.99/monat

**Fortfahren**

\*Es gelten Richtlinien zur fairen Nutzung.



they served to distinguish the direction of sound-waves reaching the ear; but as the direction of oscillation of the tympanic ossicles is the same, no matter what that of the sound-waves entering the external auditory meatus, the latter hypothesis has no foundation. The cochlea abundantly accounts for the appreciation of notes, and such noises as are due to inharmonically combined tones; while the vestibule will suffice for other noises: and it is found that disease of the semicircular canals does not interfere with hearing, but it causes uncertainty in movements and feelings of giddiness.

Experiment shows that cutting a semicircular canal is followed by violent movements of the head in the plane of the canal divided; the animal staggers, also, if made to walk; and, if a pigeon and thrown into the air, cannot fly. All its muscles can contract as before, but they are no longer so co-ordinated as to enable the animal to maintain or regain a position of equilibrium. It is like a creature suffering from giddiness; and similar phenomena follow, in man, electrical stimulation of the regions of the skull in which the semicircular canals lie.

Such facts suggest that the semicircular canals are organs in which sensory afferent impulses, assisting in the preservation of bodily equilibrium, arise. The unconscious maintenance of the erect position depends on the excitation of many co-ordinating motor centres through tactile, muscular, visual, and aural sensations; all acting together in normal combination these enable us to stand without thought; but loss of any one, or its abnormal state, will throw the whole mechanism out of gear. Persons who have lost muscular or tactile sensibility stand and walk with difficulty; those who have *nystagmus* (jerking unconscious movements of the eyeballs which cause the visual field to seem to move in space) do the same and feel giddy; and, as we have just seen, similar phenomena follow injury of the semicircular canals.

How the nerves in the latter are stimulated is not certain; being filled with liquid the pressure of this on any ampulla will be increased when the head is bent so as to place that one below; and this may be the excitant; giving rise to

afferent impulses, which change the condition of the co-ordinating locomotor centres, with every position of the head. Or, movements of the endolymph in relation to the wall of the canal may be the stimulus, the current swaying the projecting hairs (Fig. 149).\* Place a few small bits of cork in a tumbler of water, and rotate the tumbler; at first the water does not move with it; then it begins to go in the same direction, but more slowly; and, finally, moves at the same angular velocity as the tumbler. Then stop the tumbler, and the water will go on rotating for some time. Now if the head be turned in a horizontal plane similar phenomena will occur in the endolymph of the horizontal canal; if it be bent sidewise in the vertical plane, in the anterior vertical canal; and if nodded, in the posterior vertical; the hairs moving with the canal would meet the more stationary water and be pushed and so, possibly, excite the nerves at the deep ends of the cells which bear them, and generate afferent impulses which will cause the general nerve-centres of bodily equilibration to be differently acted upon in each case. Under ordinary circumstances the results of these impulses do not become prominent in consciousness as sensations; but they sometimes may. If one spins round for a time, the endolymph takes up the movement of the canals, as the water in the tumbler does that of the glass; on stopping, the liquid still goes on moving and stimulates the hairs which are now stationary; and we feel giddy, from the ears telling us we are rotating and the eyes that we are not; hence difficulty in standing erect or walking straight. A common trick illustrates this very well; make a person place his forehead on the handle of an umbrella, the other end of which is on the floor, and then walk three or four times round it, rise, and try to go out of a door he will nearly always fail, being unable to combine his muscles properly on account of the conflicting afferent impulses. If a person, with eyes shut, be laid on a horizontal table which is turned, he can at first feel and tell the direction of the rotation; as it continues he loses the feeling, and when the movement stops feels as if he were being turned

---

\* Page 542.



in the opposite direction. All this becomes readily intelligible if we suppose feelings to be excited by relative movements of the endolymph and the canals inclosing it.

The so-called "auditory sacs" of many Mollusks (see Zoology) are probably organs for equilibration sensations and comparable to our semicircular canals.

**Functions of the Fore-Brain.** Beyond the broad fact that this part of the nervous system is essentially volitional and intellectual in function, we know very little. - It is clearly not the seat of the centres of muscular co-ordination; for, after its removal, an animal can still, if properly stimulated, execute perfectly all its usual movements. The true motor centres lie farther back; those for the less complicated combinations, as bending a limb, in the spinal cord, and those for more complex, as standing, walking, or breathing, in the mid- and hind-brains: and are not automatic. They may be excited to activity either, reflexly, by afferent impulses, traveling in from sensory regions and associated or not with consciousness; or, directly, by impulses, associated with those states of consciousness which we call volitions, passing back from the fore-brain. The fore-brain, also, frequently inhibits movements which, in its absence, would be caused by discharges, reflex in nature, of the lower centres; the will is as often employed in restraining as in exciting muscular contractions. For instance, after the cerebral hemispheres have been removed from a frog, stroking the animal gently on its back will, each time, cause it to croak; the skin stimulation originates afferent impulses which excite the "croaking centre" to discharge: but if the creature has its fore-brain it croaks or not as it pleases; it can then allow the co-ordinating mechanism to work freely under the stimulus, or check it: and it can also, independently of any immediate stimulus, excite voluntarily the same motor nerve-centre and croak if it chooses. We constantly meet with similar phenomena in ourselves; afferent impulses are all the time at work, tending to produce one action or another; and a great part of our mental activity consists in deciding which we shall prevent and which we shall permit. The restraint thus



**DIESE SEITE IST FÜR KOSTENLOSE MITGLIEDER GESPERRT**  
Beantragen Sie jetzt die volle Mitgliedschaft, um diese Seite zu betreten



**Seien Sie niemals ohne ein Buch!**

Die Vollmitgliedschaft von Forgotten Books bietet Ihnen einen universalen Zugang von unseren Apps und unserer Website, auf all Ihren Geräten: Tablet, Telefon, E-Reader, Laptop und Computer.

**Eine Bibliothek in Ihrer Tasche für € 8.99/monat**

**Fortfahren**

\*Es gelten Richtlinien zur fairen Nutzung.

doubtful. Stimulation of many regions of the brain is followed by no results; and that of others by movements the power of voluntarily executing which is not, even temporarily, lost when that brain-part is removed; these cerebral areas have been supposed to be concerned with mental faculties other than volition, the stimulation exciting sensations, perceptions, or emotions; but this is still very doubtful. Localized disease of regions of the human brain has, so far, given better results than physiological experiment on the lower animals. The power of using words to express ideas seems intimately connected with a small area on the fore part of the left cerebral hemisphere, and to be lost (producing the condition known as *aphasia*) when that part is diseased; and many cases have been recorded in which a wound of the skull has been followed exactly by loss of the power of voluntarily moving those muscle groups which (accepting the results of electrical stimulation in the lower animals) might be supposed to be normally excited, through the will, from the cerebral area injured. Absence of recovery unless the brain injury is cured seems, moreover, to be the rule in man; while as we have seen this is not the case in lower animals; this may, perhaps, indicate a more precise division of physiological labor in the human brain: which is *a priori* probable, considering its great superiority as a mental apparatus.

What the use of two cerebral hemispheres is, cannot at present be said. Injury of one produces its main effects, so far as sensation and motion are concerned, on the opposite side of the Body; but other faculties, as that of using speech, seem located on one side only; and in the brains of the higher human races the surface markings on the two sides are not perfectly symmetrical, which may indicate some difference in function. It has been suggested that in many cases we only learn to use one side of the brain, and that the other is in reserve in case of injury or disease; but the evidence is inconclusive: a good deal may, however, be said for the view that a good deal of brain in every one's skull is never used. It is there untaught but ready to be educated.

Movements which are commonly executed together tend to become so associated that it is difficult to perform one alone; many persons, *e.g.*, cannot close one eye and keep the other open. From frequent use, the paths of conduction between the co-ordinating centres for both groups of muscles have become so easy that a volitional impulse reaching one centre spreads to the other and excites both. This association of movements, dependent on the modification of brain structure by use, finds an interesting parallel in the psychological phenomenon known as *the association of ideas*; and all education is largely based on the fact that the more often brain regions have acted together the more readily, until finally almost indissolubly, do they so act. If we always train up the child to associate feelings of disgust with wrong actions and of approbation with right, when he is old he will find it very hard to do otherwise: such an organic nexus will have been established that the activity of the one set of centres will lead to an excitation of that which habit has always associated with it. The nerve-centres are throughout eminently plastic; every thought leaves its trace for good or ill; and the moral truism that the more often we yield to temptation—the more often an evil solicitation, sensory or otherwise, has resulted in a wrong act—the harder it is to resist it, has its parallel (and we can hardly doubt its physical antecedent) in the marking out of a path of easier conduction from perceptive to volitional centres in the brain. The knowledge that every weak yielding degrades our brain structure and leaves its trail in that organ through which man is the “paragon of animals,” while every resistance makes less close the bond between the thought and the act for all future time, ought surely to “give us pause:” on the other hand, every right action helps to establish a “path of least resistance,” and makes its subsequent performance easier.

The brain, like the muscles, is improved and strengthened by exercise and injured by overwork or idleness; and just as a man may specially develop one set of muscles and neglect the rest until they degenerate, so he may do with his brain; developing one set of intellectual faculties and

man, so absorbed in money-getting that he has no power of appreciating any but the lower sensual pleasures; the intellectual joys of art, science, and literature have no charm for him; he is a mere money-making machine, and he also, not unfrequently meets the scientific man who is not capable of sympathy with art or literature; and literary men are not capable of sympathy with science. A general education in early life, on a broad basis of languages, and the natural sciences, is a great advantage; such imperfect mental growth; one danger in early life is the tendency to put lads in a technical education before they have attained a general education. Another danger, no doubt, is the danger of making the training too broad; a man who knows one or two literatures fairly well, and who has some knowledge of the elements of mathematics and of one of the objects of the experimental sciences, is likely to have a better and more utilizable brain than he who has a smattering of a dozen languages and a confused idea of all things. The habits of mental slovenliness, the illogicality of thought, and the incapacity to know when a thing is really known and understood, which, one so often finds associated with such an education, are far worse than the narrowness of the mind to follow the opposite error, which is often met with in those with the power of accurate logical thought. The disadvantages of a general education are now, more easily than at any previous time, to be cultivated mental breadth by reading some excellent general reviews and magazines, and by exact popular expositions now available on almost all subjects, which are such a feature of our age. It is, out of working hours, with those whose special interests are different from our own is almost necessary to avoid such an asymmetrical development, which amounts to intellectual deformity.



**DIESE SEITE IST FÜR KOSTENLOSE MITGLIEDER GESPERRT**  
Beantragen Sie jetzt die volle Mitgliedschaft, um diese Seite zu betreten

# GESCHICHTE

Zehntausende von wichtigen historischen Quellen, viele bisher nicht erhältlich, stehen jetzt zum ersten Mal mit der Vollmitgliedschaft von Forgotten Books zur Verfügung.

Unbegrenzter Zugang  
\$8.99/monat

**Fortfahren**

\*Es gelten Richtlinien zur fairen Nutzung.



which may be compared to that of the sounding-board of a violin. By movements of throat, soft palate, tongue, cheeks, and lips the sounds emitted from the larynx are altered or supplemented in various ways, and converted into articulate language or *speech*.

The **Larynx** lies in front of the neck, beneath the hyoid bone and above the windpipe; in many persons it is prominent, causing the projection known as "Adam's apple." It consists of a framework of cartilages, partly joined by true synovial joints and partly bound together

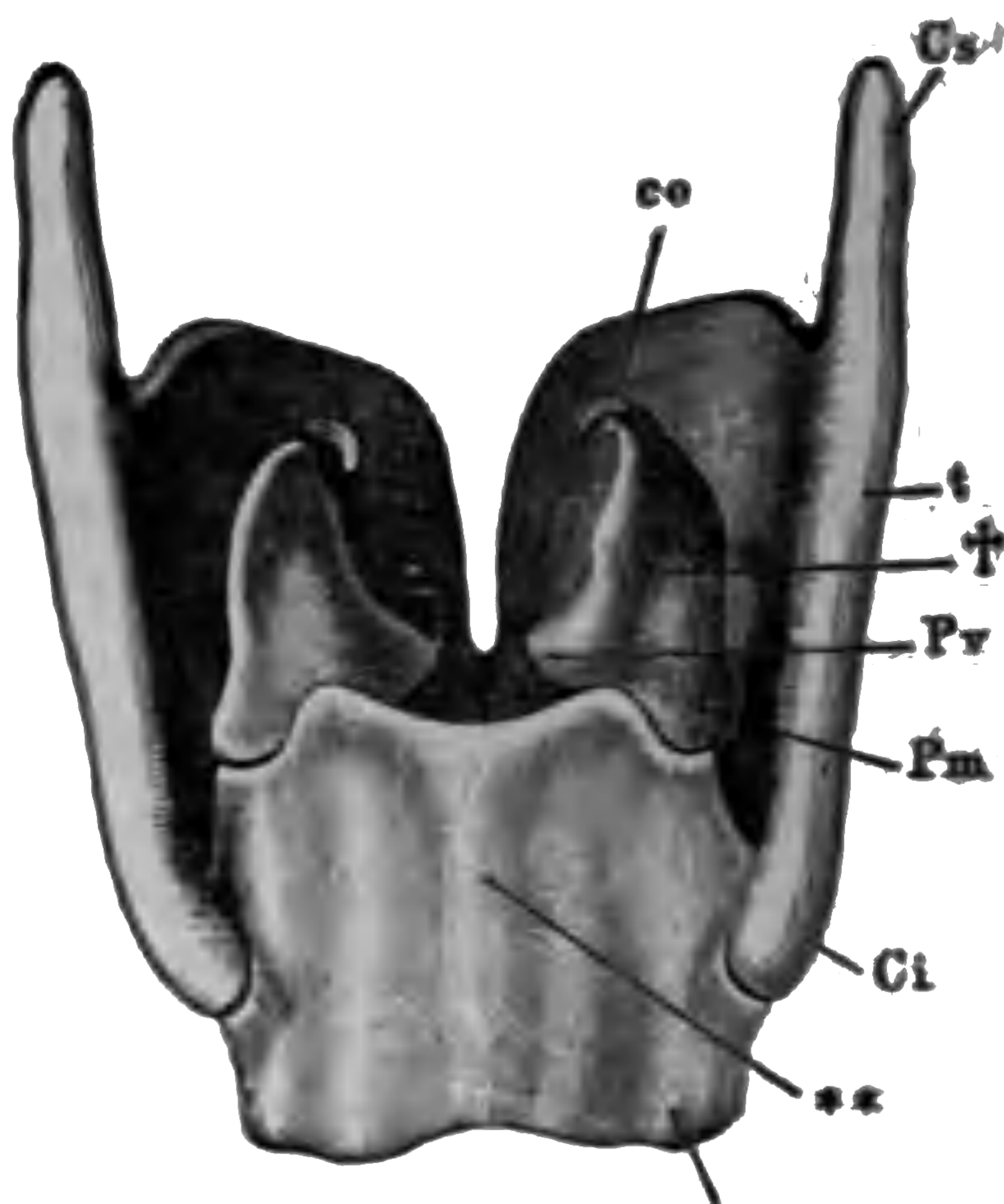

FIG. 156.—The more important cartilages of the larynx from behind. *t*, thyroid; *Cs*, its superior, and *Cl*, its inferior, horn of the right side; *co*, cricoid cartilage; †, arytenoid cartilage; *Pv*, the corner to which the posterior end of a vocal cord is attached; *Pm*, corner on which the muscles which approximate or separate the vocal cords are inserted; *co*, cartilage of Santorini.

by membranes; muscles are added which move the cartilages with reference to one another; and the whole is lined by a mucous membrane.

The cartilages of the larynx (Fig. 156) are nine in number; three single and median, and three pairs. The largest (*t*) is called the *thyroid*, and consists of two halves which meet at an angle in front, but separate behind so as to inclose a V-shaped space, in which most of the remaining cartilages lie. The *epiglottis* (not represented in the figure) is fixed to the top of the thyroid cartilage and overhangs the entry

from the pharynx to the larynx (*e*, Fig. 89);\* it may be seen, covered by mucous membrane, projecting at the base of the tongue, if the latter be pushed down while the mouth is held open in front of a glass; and is, similarly covered, represented, as seen from behind, at *a* in Fig. 157. The *cricoid*, the last of the unpaired cartilages, is the shape of a signet-ring; its broad part (*\*\*, Fig. 156*) is on the posterior side and lies at the lower part of the opening between the halves of the thyroid; in front and on the sides it is narrow, and a space, occupied by the *crico-thyroid membrane*, intervenes between its upper border and the lower edge of the thyroid cartilage. The angles of the latter are produced above and below into projecting *horns* (*Cs* and *Ci*, Fig. 156), and the lower horn on each side forms a joint with the cricoid. The thyroid can be rotated on an axis, passing through the joints on each side, and rolled down so that its lower front edge shall come nearer the cricoid cartilage, the membrane there intervening being folded. The *arytenoids* (*†, Fig. 156*) are the largest of the paired cartilages; they are seated on the upper edge of the posterior wide portion of the cricoid, and form true joints with it. Each is pyramidal with a triangular base, and has on its tip a small nodule (*co*, Fig. 156), the *cartilage of Santorini*. From the tip of each arytenoid cartilage *the aryteno-epiglottidean fold* of mucous membrane (*10, Fig. 157*) extends to the epiglottis; the cartilage of Santorini causes a projection (*8, Fig. 157*) in this; and a little farther on (*9*) is a similar eminence on each side, caused by the remaining pair of cartilages, known as the *cuneiform*, or cartilages of *Wrisberg*.

The **Vocal Cords** are bands of elastic tissue which reach from the inner angle (*Pv*, Fig. 156) of the base of each arytenoid cartilage to the angle on the inside of the thyroid where the sides of the *V* unite; they thus meet in front but are separated at their other ends. The cords are not, how-



projecting cushions formed by them on each side of this slit which are set in vibration during phonation. Above each vocal cord is a depression, the *ventricle of the larynx*, (*b'*, Fig. 157); this is bounded above by a somewhat promi-



FIG. 157.—The larynx viewed from its pharyngeal opening. The back wall of the pharynx has been divided and its edges (11) turned aside. 1, body of hyoid; 2, its small, and 3, its great, horns; 4, upper and lower horns of thyroid cartilage; 5, mucous membrane of front of pharynx, covering the back of the cricoid cartilage; 6, upper end of gullet; 7, windpipe, lying in front of the gullet; 8, eminence caused by cartilage of Santorini; 9, eminence caused by cartilage of Wrisberg; both lie in, 10, the *aryteno-epiglottidean fold* of mucous membrane, surrounding the opening (*aditus laryngis*) from pharynx to larynx. *a*, projecting tip of epiglottis; *c*, the glottis, the lines leading from the letter point to the free vibrating edges of the vocal cords. *b'*, the ventricles of the larynx: their upper edges, marking them off from the eminences *b*, are the false vocal cords.

nent edge, *the false vocal cord*. Over most of the interior of the larynx its mucous membrane is thick and covered by ciliated epithelium, and has many mucous glands imbedded in it. Over the vocal cords, however, it is represented only by a thin layer of flat non-ciliated cells, and



**DIESE SEITE IST FÜR KOSTENLOSE MITGLIEDER GESPERRT**  
Beantragen Sie jetzt die volle Mitgliedschaft, um diese Seite zu betreten



**Seien Sie niemals ohne ein Buch!**

Die Vollmitgliedschaft von Forgotten Books bietet Ihnen einen universalen Zugang von unseren Apps und unserer Website, auf all Ihren Geräten: Tablet, Telefon, E-Reader, Laptop und Computer.

**Eine Bibliothek in Ihrer Tasche für € 8.99/monat**

**Fortfahren**

\*Es gelten Richtlinien zur fairen Nutzung.

muscular process. The posterior crico-arytenoids, working alone, pull inwards and downwards the muscular process, and turn upwards and outwards the vocal processes, and rotate the posterior ends of the vocal cords. The crico-thyroid, working alone, pulls downwards and forwards the muscular process, and rotates inwards and upwards the vocal process, and narrows the glottis; it is the chief muscle in producing the approximation of the cords necessary

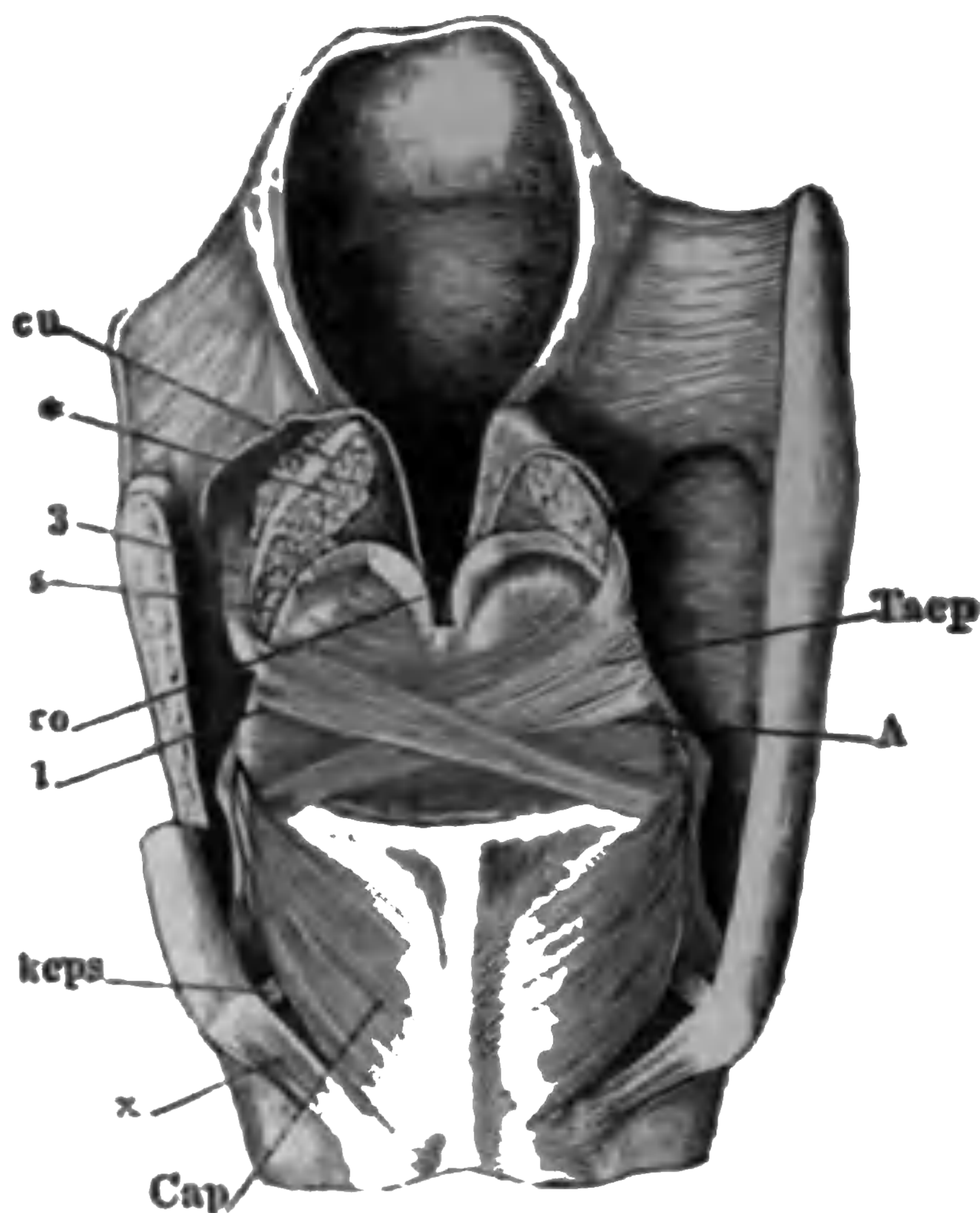

FIG. 158.—The larynx seen from behind and dissected so as to display its muscles. The mucous membrane of the front of the pharynx (b, has been dissected away, so as to display the laryngeal muscles better. Part of the left half of the thyroid cartilage has been cut away. co, cartilage of Santorini; cu, cartilage of Wrisberg.

the production of voice. When both pairs of muscles work together, however, each neutralizes the tendency of the other to rotate the arytenoid cartilage; the downward part of each is, thus, alone left, and this causes the arytenoid cartilages to slip downwards and outwards, off the eminence of the cricoid with which it articulates, as far as the loose ligament of the joint will allow. The arytenoid cartilages are thus moved apart and the glottis greatly widened.

food and drink rarely enter the larynx in swallowing, the edges of the folds of mucous membrane on its sides being so brought together as to effectually close the aperture between them.

Increased tension of the vocal cords is produced mainly by the *crico-thyroid muscles*, one of which lies on each side of the larynx, over the crico-thyroid membrane. Their action may be understood by help of the diagram, Fig. 159, in which *t* represents the thyroid cartilage, *c* the cricoid, *a* an arytenoid, and *vc* a vocal cord. The muscle in question passes obliquely backwards and upwards from near the front end of *c* (to the right in the diagram) to *t*, near the pivot (which represents the joint between the cricoid cartilage and the inferior horn of the thyroid).

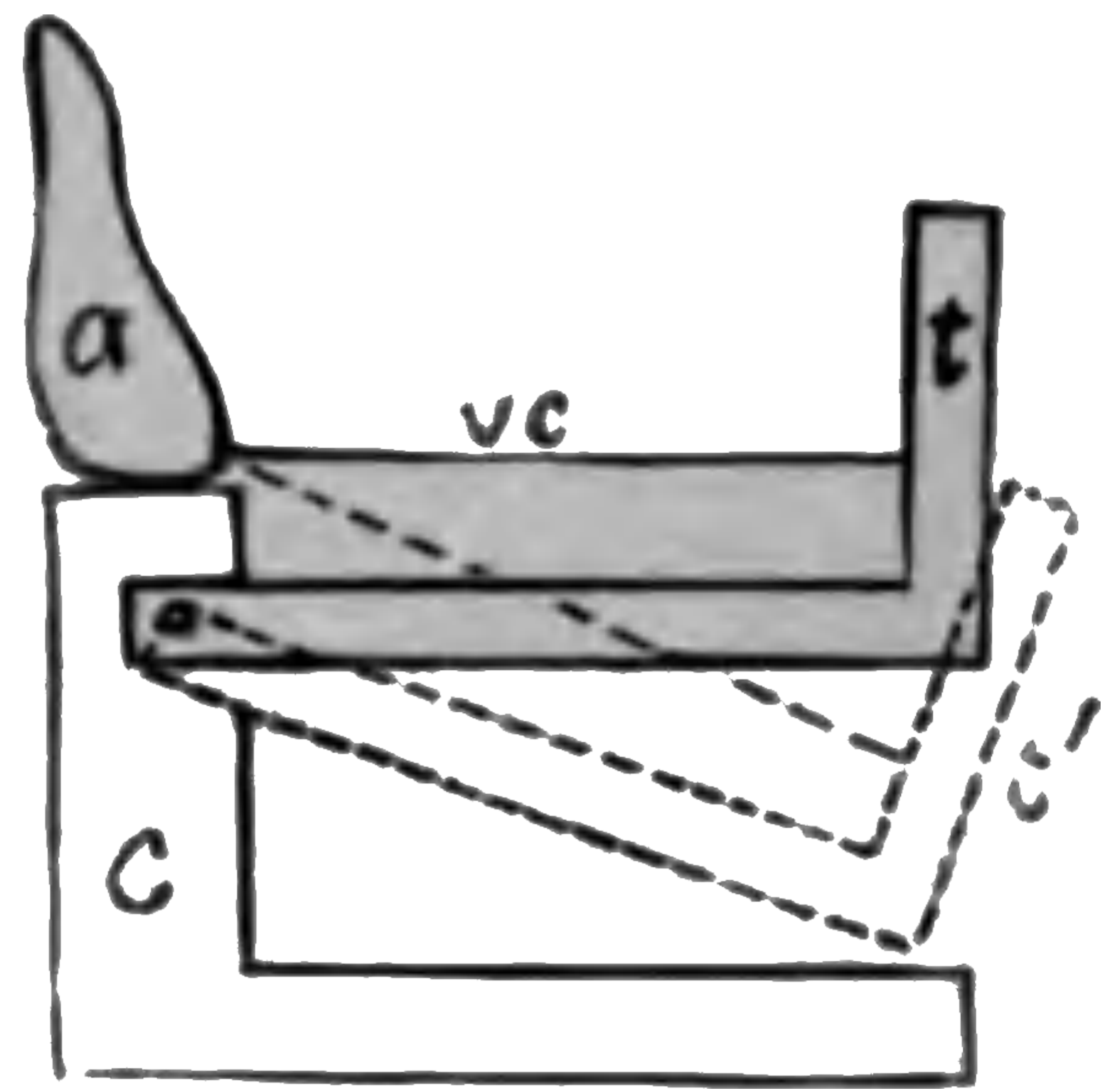

FIG. 159.

When the muscle contracts it pulls *t* down into the position indicated by the dotted lines and stretches the vocal cord, if the arytenoid cartilages be kept, by the muscles behind, from slipping forwards at the same time. The antagonist of the crico-thyroid is the

by which high notes are produced. Beginning at the bottom of his register, a singer can go on up the distance without a break; but, then, to reach higher notes, must pause, rearrange his larynx, and what happens is that, at first, the vocal process is turned in, so as to approximate but not to meet the length of each edge of the glottis then vibration is increased, while the pitch of the note is increased by increasing contraction of the crico-thyroid. At this point it attains its limit and a new method has to be adopted. More vocal processes are more rolled in, until they together produce a node (see Physics) at that point a shorter length of vocal cord which vibrates. The shorter string emits a higher note; so the crico-thyroid is again gradually tightened as the note is raised in pitch from the new starting-point. This is done easily and imperceptibly from one such arrangement of the larynx to another is a great art in singing. There is no reason to believe that a second node may, for higher notes, be produced at a more anterior point of the vocal cords.

The method of production of *falsetto notes* is that during their emission the free border of the vocal cords alone vibrates.

---



**DIESE SEITE IST FÜR KOSTENLOSE MITGLIEDER GESPERRT**  
Beantragen Sie jetzt die volle Mitgliedschaft, um diese Seite zu betreten

# GESCHICHTE

Zehntausende von wichtigen historischen Quellen, viele bisher nicht erhältlich, stehen jetzt zum ersten Mal mit der Vollmitgliedschaft von Forgotten Books zur Verfügung.

Unbegrenzter Zugang  
\$8.99/monat

**Fortfahren**

\*Es gelten Richtlinien zur fairen Nutzung.



~~space in the mouth being~~

u    ū

a    e    ī

The usual *ī* of English, as in *spire*, is not a true simple vowel but a diphthong, consisting of *â* (*pad*) followed by *ê* (*feet*); as may be observed by trying to sing a sustained note to the sound *ī*; it will then be seen that it begins as *â* and ends as *ê*. A simple vowel can be maintained pure as long as the breath holds out.

In uttering true vowel sounds the soft palate is raised so as to cut off the air in the nose, which, thus, does not take part in the sympathetic resonance. For some other sounds (the *semi-vowels* or *resonants*) the initial step is, as in the case of the true vowels, the production of a laryngeal tone; but the soft palate is not raised, and the mouth exit is more or less closed by the lips or the tongue; hence the blast partly issues through the nose, and the air there takes part in the vibrations and gives them a special is the case with *m*, *n*, and *ng*.

**Consonants** are sounds produced not mainly by the vocal cords, but by modifications of the expiratory blast on its way through the mouth. The current may be interrupted and the sound changed by the lips (*labials*); or, at or near the teeth, by the tip of the tongue (*dentals*); or, in the throat, by the root of the tongue and the soft palate (*gutturals*). Consonants are also characterized by the kind of movement which gives rise to them. In *explosives* an interruption to the passage of the air-current is suddenly interposed or removed (P, T, B, D, K, G). Other consonants are *continuous* (as F, S, R), and may be subdivided into—(1) *aspirates*, characterized by the sound produced by a rush of air through a narrow passage, as when the lips are approximated (F), or the teeth (S), or the tongue is brought near the palate (Sh), or its tip against the two rows of teeth, they not being quite in contact (Th). For L the tongue is put against the hard palate and the air escapes on its sides. For Ch (as in the proper Scotch pronunciation of *loch*) the passage between the back of the tongue and the soft palate is narrowed. To many of the above pure consonants answer others, in whose production true vocalization (*i.e.* a laryngeal tone) takes a part. F with some voice becomes V; S becomes Z, Th soft (*teeth*) becomes Th hard; and Ch becomes Gh. (2) *Resonants*; these have been referred to above. (3) *Vibratories* (the different forms of R), which are due to vibrations of parts bounding a constriction put in the course of the air-current. Ordinary R is due to vibrations of the tip of the tongue held near the hard palate; and guttural R to vibrations of the uvula and parts of the pharynx.

The consonants may physiologically be classified as in the following table (Foster).

<b>Explosives.</b>	<i>Labials</i> , without voice .....	P.
	“ with voice .....	B.
	<i>Dentals</i> , without voice .....	T.
	“ with voice .....	D.
	<i>Gutturals</i> , without voice .....	K.
	“ with voice .....	G (hard).



production, yet not so far as in quiet breath current then produces a friction sound but as it passes the glottis; and this is again in current strikes the wall of the pharynx. closure of the glottis, attended with no speech element, though we do not indicate letter, since it is always understood when with a vowel, and only rarely is used at all. The Greeks had a special sign for it, *h*, the *soft* another, *h'*, the *hard breathing*, answering *h* and indicating that the larynx was to be to give a friction sound, but not voice.

In whispering there is no true voice; there are true tones, and these are only produced by vibrations; whispering is a noise. To produce tolerably narrowed but the cords are not so produce a sharply defined edge on them, as past is then thrown into irregular vibrations as coincide in period with the air in throat are always present in sufficient number the vowels; and the consonants are produced in the same way. though the distinction between such *B*, *F* and *V*, remains imperfect.



**DIESE SEITE IST FÜR KOSTENLOSE MITGLIEDER GESPERRT**  
Beantragen Sie jetzt die volle Mitgliedschaft, um diese Seite zu betreten



**Seien Sie niemals ohne ein Buch!**

Die Vollmitgliedschaft von Forgotten Books bietet Ihnen einen universalen Zugang von unseren Apps und unserer Website, auf all Ihren Geräten: Tablet, Telefon, E-Reader, Laptop und Computer.

**Eine Bibliothek in Ihrer Tasche für €8.99/monat**

**Fortfahren**

\*Es gelten Richtlinien zur fairen Nutzung.

**Apoplexy, 166.**  
**Aqueduct of Sylvius, 187.**  
**Aqueous humor, 490.**  
**Arachnoid, 6, 157.**  
**Arbor vitæ, 168.**  
**Areolar tissue, 102.**  
**Areolar tissue, subcutaneous, 414.**  
**Arm, skeleton of, 78.**  
**Arterial blood, 216, 379.**  
**Arterial pressure, 235, 251.**  
**Arteries, distribution of, 208.**  
**Arteries, structure of, 217.**  
**Artery, axillary, 210; brachial, 210; bronchial, 211; carotid, 210; celiac, 210; coronary, 207, 210; iliac, 210; innominate, 210; intercostal, 211; radial, 210; subclavian, 210; ulnar, 210; vertebral, 210,**  
**Articular cartilage, 94.**  
**Articulations, 63, 93.**  
**Arytenoid cartilages, 597.**  
**Asphyxia, 398.**  
**Aspiration of thorax, 244, 287.**  
**Assimilation, 19.**  
**Assimilative tissues, 30.**  
**Associated movements, 593.**  
**Association of ideas, 598.**  
**Astigmatism, 503.**  
**Astragalus, 82.**  
**Atlanto-axial articulation, 97.**  
**Atlas vertebra, 68.**  
**Auditory nerve, 170.**  
**Auditory ossicles, 536.**  
**Auditory perceptions, 554.**  
**Auriculo-ventricular valves, 208.**  
**Automatic centres, 183.**  
**Automatic movements, 23.**  
**Automatic tissues, 32.**  
**Axis, visual, 518.**  
**Ball and socket joint**  
**Basement membrane**  
**Basilar membrane, 5**  
**Bathing, 421.**  
**Beans (as food), 303.**  
**Beat of heart, 219.**  
**Beef tea, 122.**  
**Biceps muscle of arm**  
**Bile, 342.**  
**Blackness, sensation**  
**Bladder, urinary, 406**  
**Blind spot, 506.**  
**Blood, 40; arterial 216, 379; composition of, 50; clotting of, 50; gases of 378; histology, 46; quantity of, 50.**  
**Bloodflow in capillaries, 408; in kidneys, 408; in rate of, 242.**  
**Blood-vessels, anatomy**  
**Blood-vessels, nerves**  
**Blood-vessels, structure**  
**Blushing, 255.**  
**Bone, composition and histology of, 88; growth of, 86.**  
**Bones of face, 64; of hand, 78; of hind-limb, 78; of thorax, 77; of vertebral arch, 77; of skull, 75.**  
**Brachial artery, 210.**  
**Brachial plexus, 161.**  
**Brain, anatomy of, 584; histology of, 584; metabolism of, 157.**  
**Bread, 302.**

- Breast-bone, 71.  
 Bronchial arteries, 211.  
 Bronchial tubes, 354.  
 Bronchus, 854.  
 Brunner's glands, 322.  
 Buccal cavity, 808.  
 Buffy coat on blood clot, 52.  
 Calcaneum, 79.  
 Camera obscura, 496.  
 Canals, semicircular, 539, 587.  
 Capacity of lungs, 865.  
 Capillaries, blood, 211, 217.  
 Capillaries, lymphatic, 329.  
 Capillary circulation, 237.  
 Capsule of Glisson, 826.  
 Carbohydrates, see amyloids.  
 Carbon dioxide, 14; in blood, 386; production of in muscle, 430.  
 Carbon monoxide hæmoglobin, 398.  
 Cardiac muscular tissue, 124.  
 Cardiac impulse, 220.  
 Cardiac nerves, 248.  
 Cardiac orifice of stomach, 817.  
 Cardiac plexus, 172.  
 Cardio-inhibitory nerves 250.  
 Carotid artery, 210.  
 Carpus, 79.  
 Casein, 11.  
 Cartilage, 100; articular, 94; elastic, 106; fibro-, 107; histology of, 101; inter-articular, 107.  
 Cartilages of larynx, 596.  
 Cataract, 504.  
 Catarrh, 256.  
 Cauda equina, 161.  
 Cells, 17; amœboid, 114; ciliated, 83, 115; division of, 18; differentiation of, 26; growth of, 18.  
 Cement, of tooth, 811.  
 Centre, cardio-inhibitory, 250; cerebro-spinal, 156; convulsive, 400; respiratory, 391.  
 Centre of gravity of body, 149.  
 Centres, nerve, general functions of, 182.  
 Cephalic vein, 214.  
 Cerebellum, 164, 586.  
 Cerebral hemispheres, 168.  
 Cerebral hemispheres, functions of, 590.  
 Cerebro-spinal centre, 5, 156.  
 Cerebro-spinal liquid, 158.  
 Cervical plexus, 161.  
 Cervical vertebræ, 68.  
 Characteristics of human skeleton, 84.  
 Chemical combinations, energy liberated in, 283.  
 Chemical composition of body, 8.  
 Chemical changes in breathed air, 373.  
 Chemistry, of bile, 342; of blood, 57; of bone, 91; of fats, 112; of gastric juice, 338; of lymph, 61; of muscle, 124, 429; of pancreatic secretion, 264; of respiration, 372; of secretion, 264; of teeth, 812; of urine, 410; of white fibrous tissue, 103; of working muscle, 427.  
 Chest. See Thorax.  
 Chondrin, 107.  
 Chorda tympani nerve, 271.  
 Choroid, 486.  
 Chromatic aberration, 503.  
 Chyle, 340.  
 Chyme, 339.  
 Ciliary muscle, 491.  
 Ciliary processes, 486.  
 Ciliated cells, 83, 115.  
 Circulation, 201, 214; during asphyxia, 401; influence of respiratory movements on, 368; influence of nerves on, 247; portal, 216, 325; renal, 408.  
 Circulatory organs, 201.

**Coccyx, 70.**  
**Cochlea, 559.**  
**Cochlea, functions of, 553.**  
**Cæcum, 322.**  
**Cœliac axis, 211.**  
**Cold-blooded animals, 449.**  
**Collagen, 104.**  
**Collar-bone, 77.**  
**Colon, 322.**  
**Color blindness, 523.**  
**Color mixing, 521.**  
**Color vision, 519.**  
**Combustible foods, 425.**  
**Commissures, cerebral, 167.**  
**Common bile duct, 324.**  
**Common sensation, 463, 567.**  
**Complemental air, 365.**  
**Complementary colors, 521.**  
**Concha, 535.**  
**Conduction in spinal cord, 578.**  
**583.**  
**Conductive tissues, 83.**  
**Conductivity, physiological, 21.**  
**Connective tissue, 62, 102, 106.**  
**Connective-tissue corpuscles, 105.**  
**Conservation of energy, 280.**  
**Consonants, 605.**  
**Contractile tissues, 83, 113.**  
**Contractility, 20, 128.**  
**Contrasts, visual, 525,**  
**Convulsive centre, 400.**  
**Cooking of meats, 301: of vege-**  
**tables, 303.**  
**Co-ordinating tissues, 82.**  
**Co-ordination, 22, 183.**  
**Cords, vocal, 567.**  
**Corium, 6, 418.**  
**Corresponding retina**  
**Corti, organ of, 541.**  
**Costal cartilages, 72.**  
**Costal respiration, 8.**  
**Cranial nerves, 168.**  
**Cranium, 78.**  
**Crazy bone, 153.**  
**Cream, 302.**  
**Cretinism, 333.**  
**Cricoid cartilage, 59.**  
**Crura cerebri, 164.**  
**Crying, 402.**  
**Crypts of Lieberküh**  
**Crystalline lens, 491.**  
**Curari poisoning, 130.**  
**Cutaneous organs, 41.**  
**Cutaneous secretions,**  
**Cutis vera, 418.**  
**Cystic duct, 324.**  
**Daltonism, 533.**  
**Death stiffening, 490.**  
**Defects (optical) of eye**  
**Deglutition, 336.**  
**Dentine, 311.**  
**Depressor nerve, 255.**  
**Derbyshire neck, 333.**  
**Dermis, 6, 418.**  
**Descemet, membrane**  
**Development, 26.**  
**Diabetes, 441.**  
**Dialysis, 42.**  
**Diaphragm, 4, 359.**  
**Dietetics, 446.**  
**Diet, mixed, advantage**  
**Differentiation of the**  
**Digestion, 334.**  
**Digestion of a typical**



**DIESE SEITE IST FÜR KOSTENLOSE MITGLIEDER GESPERRT**  
Beantragen Sie jetzt die volle Mitgliedschaft, um diese Seite zu betreten

# GESCHICHTE

Zehntausende von wichtigen historischen Quellen, viele bisher nicht erhältlich, stehen jetzt zum ersten Mal mit der Vollmitgliedschaft von Forgotten Books zur Verfügung.

Unbegrenzter Zugang  
\$8.99/monat

**Fortfahren**

\*Es gelten Richtlinien zur fairen Nutzung.



**Fuel of Body, 287.**  
**Fundamental physiological ac-**  
**tions, 15.**  
**Fungiform papilla, 312.**  
**Funny bone, 188.**  
**Fur on tongue, 315.**  
**Gall bladder, 334.**  
**Ganglia, 156, 177; of cranial**  
**nerve, 171; of heart, 248; of**  
**spinal nerve-roots, 160; spora-**  
**dic, 173.**  
**Ganglion, Gasserian, 170.**  
**Gases of blood, 378.**  
**Gasserian ganglion, 170.**  
**Gastric digestion, 339.**  
**Gastric juice, 338.**  
**Glands, 262; cutaneous, 417;**  
**ductless, 332; gastric, 319**  
**lachrymal, 482; lymphatic, 330;**  
**of Brunner, 332 of Lieberkühn;**  
**parotid, 274; salivary, 270, 315;**  
**submaxillary, 271.**  
**Glenoid fossa, 77.**  
**Gliding joints, 98.**  
**Glisson, capsule of, 326.**  
**Globe of eye, 485.**  
**Globulin, 11, 47.**  
**Glossopharyngeal nerve, 170.**  
**Glottis, 597.**  
**Glucose (grape sugar), 11.**  
**Gluten, 302.**

**Hand, ske**  
**Haversian**  
**Heart, 204**  
**of, 248.**  
**Heat prod**  
**in Body**  
**Heat lost**  
**Hect-bone**  
  
**tions of**  
**Hepatic ar**  
**Hepatic ce**  
**Hepatic di**  
**Hepatic ve**  
**Hering's t**  
**524.**  
**Hiccough,**  
**Hind limb**  
**Hinge-joint**  
**Hip-joint,**  
**Histology,**  
**111; of**  
**blood, 4**  
**diac mu**  
**101; of c**  
**of ear,**  
**104; of**  
**407; of**  
**355; of**  
**417; of**

- nerve-fibres, 173; of nose, 569;  
 of plain muscular tissue, 123;  
 of retina, 487; of skin, 412; of  
 small intestine, 320; of spinal  
 cord, 177; of stomach, 818; of  
 striped muscle, 122; of teeth,  
 811; of tactile organs, 556; of  
 tongue, 570; of white fibrous  
 tissue, 108.  
 Hollow veins, 207.  
 Homologies of supporting tissues  
 107.  
 Homology, 58; of limbs, 80.  
 Horopter, 588.  
 Humerus, 78, 86.  
 Humor, aqueous, 490; vitreous,  
 491.  
 Hunger, 569.  
 Hydrocarbons. *See* Fats.  
 Hydrogen, 9.  
 Hygiene, 1; of blood, 58; of  
 brain, 593; of clothing, 366,  
 458; of exercise, 138; of grow-  
 ing skeleton, 109; of joints, 98;  
 of muscles, 138; of respiration,  
 866, 875; of sight, 501; of  
 skeleton, 92; of skin, 420; of  
 supporting tissues, 109.  
 Hyoid bone, 76.  
 Hypermetropia, 500.  
 Hypoglossal nerve, 171.  
 Ideas, association of, 593.  
 Idio-retinal light, 508.  
 Ileum, 320.  
 Ileo-colic valve, 323.  
 Iliac artery, 210, 211.  
 Ilium, 79.  
 Illusions, sensory, 477.  
 Impulse, cardiac, 220.  
 Impulse, nervous, 196.  
 Incus, 587.  
 Indigestion, 350.  
 Inert layer, 228.  
 Inferior laryngeal nerve, 397.  
 Inferior maxillary nerve, 170.  
 Inferior mesenteric artery, 211.  
 Inferior vena cava, 207.  
 Inhibition of reflexes, 581.  
 Inhibitory nerves, 184.  
 Innervation sensations, 565.  
 Innominate artery, 210.  
 Innominate bone, 79.  
 Innominate vein, 214.  
 Inogen, 125.  
 Inorganic constituents of Body,  
 14.  
 Inosit, 18.  
 Inspiration, how effected, 359.  
 Intensity of sensations, 473.  
 Interarticular cartilage, 107.  
 Intercostal arteries, 211.  
 Intercostal muscles, 361.  
 Internal ear, 588.  
 Internal medium, 40.  
 Internal respiration, 352, 380.  
 Intervertebral disks, 71, 94.  
 Intervertebral foramina, 71.  
 Intestinal digestion, 340.  
 Intestines, 320.  
 Intra-thoracic pressure, 357.  
 Intrinsic heart-nerves, 248.  
 Iris, 491.  
 Irritability, 21.  
 Irritability, muscular, 129.  
 Irritable tissues, 81.  
 Ischium, 79.  
 Jaw-bones, 76.  
 Jejunum, 320.  
 Jelly-like connective tissue, 106.  
 Joints, 94.  
 Jugular vein, 214.  
 Kidneys, 403.  
 Kinetic energy, 282.  
 Knee-cap or knee-pan, 79.  
 Kreatin, 12, 434.  
 Labyrinth, 528.  
 Lachrymal apparatus, 482.  
 Lachrymal bone, 76.



**Law, the psycho-physical, 473.**  
**Leaping, 153.**  
**Least-resistance hypothesis, 573.**  
**Lecithin, 14.**  
**Leg, skeleton of, 79.**  
**Lens, crystalline, 491.**  
**Lenses, refraction of light by, 495.**  
**Levers in the Body, 144.**  
**Lieberkühn, crypts of, 323.**  
**Liebig's classification of foods, 426.**  
**Liebig's extract, 126.**  
**Ligament, suspensory, of lens, 491.**  
**Ligament, round, 95.**  
**Ligaments, 94.**  
**Light, dispersion of, 495.**  
**Light, properties of, 492.**  
**Light, refraction of, 493.**  
**Limbs, 7.**  
**Limbs, skeleton of, 77.**  
**Liquid extract of meat, 126.**  
**Liquor sanguinis, 44.**  
**Liver, 323.**  
**Local sign of sensations, 465.**  
**Local temperatures, 455.**  
**Localization of cerebral functions, 591.**  
**Localizing powers of retina, 516.**  
**Localizing power of skin, 559.**  
**Locomotion, 151.**  
**Long saphenous vein, 214.**  
**Long sight, 500.**  
**Losses of material from Body, 377.**  
**Losses of energy daily, 453.**  
**istry of, 61: h**  
**logy of, 49**  
**movement of,**  
**of, 42; vessel**  
**Lymphatic gland**  
**Lymphatic syst**  
**Malar bone, 76.**  
**Malleus, 336.**  
**Malpighian cor**  
**. 323.**  
**Malpighian lay**  
**412.**  
**Malpighian py**  
**406.**  
**Mammella, 4.**  
**Mandible, 70.**  
**Marrow of bone**  
**Marrow, spina**  
**177, 182, 574.**  
**Material daily**  
**377.**  
**Maxilla, 76.**  
**Meatus, externa**  
**Mechanisms, ph**  
**Medulla oblonga**  
**Media, refractin**  
**Medullary cavit**  
**Membrane, basi**  
**Descemet, 481**  
**tectorial, 542:**  
**Metabolic tissue**  
**Metacarpus, 79.**  
**Metatarsus, 79.**  
**Microscopic ana**  
**tology.**  
**Mid-brain, funct**  
**Midriff. See Di.**



**DIESE SEITE IST FÜR KOSTENLOSE MITGLIEDER GESPERRT**  
Beantragen Sie jetzt die volle Mitgliedschaft, um diese Seite zu betreten



**Seien Sie niemals ohne ein Buch!**

Die Vollmitgliedschaft von Forgotten Books bietet Ihnen einen universalen Zugang von unseren Apps und unserer Website, auf all Ihren Geräten: Tablet, Telefon, E-Reader, Laptop und Computer.

**Eine Bibliothek in Ihrer Tasche für € 8.99/monat**

**Fortfahren**

\*Es gelten Richtlinien zur fairen Nutzung.

**Over-tones (upper partial tones),**  
547.  
**Ovum, 26.**  
**Oxidation by stages, 288.**  
**Oxidations in the Body, 286, 423,**  
427.  
**Oxygen in the blood, 382.**  
**Oxygen consumed daily, 374.**  
**Oxyhæmoglobin, 379.**  
**Pacinian bodies, 556.**  
**Pain, 567.**  
**Palate, 309.**  
**Palate bones, 76.**  
**Pancreas, 267, 328.**  
**Pancreatic secretion, 341.**  
**Papillary muscles, 208, 221.**  
**Papillæ of tongue, 318.**  
**Parapeptone, 345.**  
**Parietal bone, 75.**  
**Parotid gland, 274, 315.**  
**Partial tones, 547.**  
**Patella, 79.**  
**Patheticus, 169.**  
**Pathology, 1.**  
**Pcus, 303.**  
**Pectoral arch, 77.**  
**Pelvic arch, 79.**  
**Pepsin, 338.**  
**Peptic glands, 319.**  
**Peptones, 11.**  
**Perceptions, 474; visual, 530;**  
auditory, 554.  
**Pericardium, 208.**

**66**

**Pharynx, 316**  
**Phrenic nerve**  
**Physiology, 1**  
219; of bra  
tive tissues,  
334; of ear  
of heart, 21  
of muscles,  
of nerve-ee  
nutrition, 4  
358; of skin  
569; of sp  
taste, 570;  
**Physiological**  
**Physiological**  
**Physiological**  
**Pia mater, 15**  
**Pineal gland,**  
**Pitch of notes**  
**Pitch of voice**  
**Pituitary body**  
**Pivot-joints, 9**  
**Plastic foods,**  
**Pleura, 6, 356**  
**Plexus, 156;**  
diac, 172;  
bar, 162; 1  
172.  
**Pneumogastri**  
**Pons Varolii,**  
**Popliteal arte**  
**Portal circula**

- Portal vein, 824.  
 Posterior tibial artery, 211.  
 Postures, 149.  
 Potatoes, 303.  
 Potential energy, 282.  
 Pressure, intra-thoracic, 857.  
 Pressure sense, 558.  
 Primates, 8.  
 Production of heat in Body, 449.  
 Pronation, 98.  
 Proofs of circulation, 205.  
 Protective tissues, 34.  
 Proteids, 10.  
 Proteids, oxidation of, 427.  
 Protoplasm, 24.  
 Psychological activities of cord, 582.  
 Psycho-physical law, 478.  
 Ptosis, 485.  
 Ptyalin, 335.  
 Pulmonary circulation, 214.  
 Pulmonary artery, 206.  
 Pulmonary veins, 207.  
 Pulse, 240.  
 Purkinje's experiment, 500.  
 Pus, 48.  
 Pylorus, 817, 819.  
 Pyramids of Malpighi, 406.  
 Qualities of sensation, 465.  
 Quantity of blood, 59.  
 Quantity of food needed daily,  
   305, 448.  
 Radial artery, 210.  
 Radio-ulnar articulation, 97.  
 Radius, 78.  
 Range of voice, 603.  
 Rate of blood flow, 242.  
 Receptaculum chyli, 330.  
 Receptive tissues, 30.  
 Rectum, 822.  
 Red blood corpuscles, 44, 59.  
 Reduced hæmoglobin, 870.  
 Reflex actions, 182, 574.  
 Reflex convulsions, 577.  
 Reflexes, acquired, 587.  
 Refracting media of eye, 490.  
 Refraction by lenses, 495.  
 Refraction of light, 493.  
 Refraction in the eye, 497.  
 Regulation of temperature, 454.  
 Renal artery, 211.  
 Renal organs, 402.  
 Renal secretion, 409.  
 Rennet, 388.  
 Reproduction, 19.  
 Reproductive tissues, 84.  
 Residual air, 365.  
 Resistance theory, 395.  
 Resonance, sympathetic, 540.  
 Respiration, 20, 352.  
 Respiration, chemistry of, 370.  
 Respiration, nerves of, 390.  
 Respiratory centre, 391.  
 Respiratory foods, 426.  
 Respiratory movements, 357.  
 Respiratory sounds, 365.  
 Reticular membrane, 541.  
 Retiform (adenoid) connective  
   tissue, 106.  
 Retina, 487.  
 Rhythmic movements, 393.  
 Ribs, 72.  
 Rib cartilage, 72.  
 Rice, 303.  
 Right lymphatic duct, 380.  
 Rigor mortis, 430.  
 Rods and cones, 488, 568.  
 Round foramen, 586.  
 Running, 153.  
 Sacculus, 539.  
 Sacral plexus, 162.  
 Sacral vertebræ, 69.  
 Saliva, uses of, 334.  
 Salivary glands, 315.  
 Salivary glands, nerves of, 270.  
 Salivin (ptyalin), 335.  
 Santorini, cartilages of, 697.  
 Sarcolactic acid, 14, 125.  
 Sarcolemma, 123.

- Scala of cochlea, 540  
 Scalene muscles, 361  
 Scapula, 77  
 Sciatic nerve, 162.  
 Sclerotic, 486.  
 Sebaceous glands, 418.  
 Secondary (acquired) reflexes, 587.  
 Secretion, 259.  
 Secretion, cutaneous, 417  
 Secretion, renal, 409.  
 Secretory tissues, 30, 265.  
 Secretory nerves, 271.  
 Sections of Body, 6, 7.  
 Segmentation of ovum, 26.  
 Segmentation of skeleton, 67.  
 Semicircular canals, 539, 587.  
 Semilunar valves, 208.  
 Sensations, 461. color, 519; common, 463, 567, intensity of, 645; of equilibrium, 587; of hunger, 567; of thirst, 567; peripheral reference of, 464, 476; qualities of, 465.  
 Sense-organs, 467.  
 Sense, muscular, 565; of hearing, 535; of pain, 567; of sight, 506; of smell, 569; of taste, 570; of temperature, 562; of touch, 558.  
 Sensory illusions, 477.  
 Serous canaliculi, 329.  
 Serous cavities, 330.  
 Serous membranes, 6.  
 Serum, 50, 57.  
 Serum albumin, 11, 57.  
 Shin bone, 79.  
 Shingles, 186.  
 Short sight, 500.  
 Shoulder blade, 77.  
 Shoulder girdle, 77.  
 Sighing, 402.  
 Sight, sense of, 506.  
 Sight, hygiene of, 501.  
 Sigmoid flexure, 323.  
 Size, perception of, 531  
 Skeleton, 62: appendic axial, 63, 67; of face skull, 76. peculiarities man, 84; of thorax, 8  
 Skin, 6, 412: glands of, hygiene of, 420; nerve in, 556.  
 Skull, 72.  
 Small intestine, 320.  
 Smell, 567.  
 Sneezing, 402.  
 Solar plexus, 172.  
 Solar spectrum, 495.  
 Solidity, visual perception of, 533.  
 Sounds, 542.  
 Sounds of the heart, 222.  
 Sounds, respiratory, 365.  
 Source of animal heat, 4  
 Source of fats, 441.  
 Source of glycogen, 440.  
 Source of muscular work  
 Source of urea, 433.  
 Sources of energy to Body  
 Special senses, 463.  
 Specific elements, 260.  
 Specific nerve energies, 1  
 Spectacles, 501.  
 Sphenoid bone, 75.  
 Spherical aberration, 503.  
 Spinal cord, 158; conductance, 578, 583; functions of, 1 histology of, 177; meridian of 157; psychical activity, 582.  
 Spinal accessory nerve, 1  
 Spinal marrow. *See* Spinal  
 Spinal nerves, 160.  
 Spinal nerve-roots, 160, 1  
 Spleen, 332.  
 Spontaneity, 23.  
 Sporadic ganglia, 173.



**DIESE SEITE IST FÜR KOSTENLOSE MITGLIEDER GESPERRT**  
Beantragen Sie jetzt die volle Mitgliedschaft, um diese Seite zu betreten

# GESCHICHTE

Zehntausende von wichtigen historischen Quellen, viele bisher nicht erhältlich, stehen jetzt zum ersten Mal mit der Vollmitgliedschaft von Forgotten Books zur Verfügung.

Unbegrenzter Zugang  
\$8.99/monat

**Fortfahren**

\*Es gelten Richtlinien zur fairen Nutzung.



tabolic, 81, 265; motor, 88, 122; muscular, 88, 128; nervous, 178; nutritive, 80; protective, 84; receptive, 80; reproductive, 84; respiratory, 30; retiform or adenoid, 106; secretory, 80, 265; storage, 31, 487 supporting, 29; undifferentiated, 29; white fibrous, 108.

**Tissue-forming foods, 425.**

**Toast, 304.**

**Tone, sensations of, 542.**

**Tone color (timbre), 550.**

**Tongue, 318.**

**Tonsil, 316.**

**Touch organs, 556.**

**Touch, sensations of, 558.**

**Trachea, 354.**

**Transudata, 259.**

**Trigeminal nerve, 170.**

**Trophic nerves, 278.**

**Trypsin, 267, 341.**

**Tunica adventitia, 217.**

**Turbinatè bones, 76.**

**Tympanic bones, 530, 551.**

**Tympanic membrane, 536, 550.**

**Ulna, 78.**

**Ulnar artery, 210.**

**Undifferentiated tissues, 29.**

**Upper maxilla, 76.**

**Urea, 12, 409, 488.**

**Ureter, 402.**

**Uric acid, 18.**

**Urinary organs, 402.**

**Vaso-motor ce**  
**Vaso-motor ne**  
**Vegetable food**  
**Vein, 212, 21**  
    coronary, 21  
    hollow, 207;  
    jugular, 214;  
    214; portal,  
    207.

**Vena cava, 208**  
**Venous blood,**  
**Ventilation, 371**  
**Ventral cavity,**  
**Ventricles of**  
    larynx, 508.  
**Vermicular (g**  
    ments, 229.  
**Vermiform app**  
**Vertebrae, 63; c**  
    geal, 70; do  
    69; sacral, 69  
**Vertebral arter**  
**Vertebral colu**  
**Vertebral foram**  
**Vertebrata, 8.**  
**Vestibule, 588.**  
**Vibrations, ana**  
    position of, 5  
    sonorous, 542  
**Villi of intestin**  
**Vision, color, 5**  
**Vision purple,**  
**Vision, stereosc**

- Visual axis, 518  
Visual contrasts, 525.  
Visual perceptions, 580.  
Visual sensations, 506, 519: duration of, 516; intensity of, 518.  
Vital capacity, 366.  
Vitreous humor, 491.  
Vocal cords, 597.  
Vocal cords, false, 598.  
Voice, 595.  
Vomer, 76.  
Vowels, 608.  
Walking, 151.  
Wandering cells, 106.  
Warm-blooded animals, 449.  
Water, constituent, 25.  
Water, percentage of, in Body, 14.
- Waxing kernels, 890.  
Weber's schema, 233.  
Weber's law, 478.  
Wheat, 802.  
Whipped blood, 51.  
White blood corpuscles, 17, 47, 59.  
White fibrous tissue, 108.  
Windpipe, 354.  
Wrisberg, cartilage of, 597.  
Wrist, 79.  
Xantho-proteic test, 10.  
Yawning, 402.  
Young's theory of color vision, 519.  
Zoological position of man, 2.  
Zymogen, 268.







**DIESE SEITE IST FÜR KOSTENLOSE MITGLIEDER GESPERRT**  
Beantragen Sie jetzt die volle Mitgliedschaft, um diese Seite zu betreten



**Seien Sie niemals ohne ein Buch!**

Die Vollmitgliedschaft von Forgotten Books bietet Ihnen einen universalen Zugang von unseren Apps und unserer Website, auf all Ihren Geräten: Tablet, Telefon, E-Reader, Laptop und Computer.

**Eine Bibliothek in Ihrer Tasche für € 8.99/monat**

**Fortfahren**

\*Es gelten Richtlinien zur fairen Nutzung.

ent work until, finally, a fully organized State is reached. Similarly, the body of one of the higher animals at an early stage of life, merely a collection of undifferentiated cells, each capable of multiplication by division, divides tolerably evenly all its original protoplasmic material, and with no specific individual endowment. The mass (Chap. III.) then slowly differentiates into various tissues, each with a predominant function; at the same time the majority of the cells retain their primitive powers of reproduction, though exact details are completely a problem not yet sufficiently studied. In Vertebrates it seems certain that the white blood cells multiply by division: and in some cases (in Tritons, for example,) a limb is reproduced after amputation, but exactly what cells take part in such restorations is uncertain; we do not know if the old cells left form new bones, old muscle-fibres, and so on; though it is probable that the undifferentiated tissues (which we have compared—p. 60—the look-out for an opening in life) build up the new parts. In Mammals no such restoration occurs; an animal may heal at the stump but does not grow a new limb. In healing processes the connective tissues play the same part as we might expect; their cellular elements become modified from their primitive state (p. 105) and

ply and develop. New blood capillaries, however, sprout out from the sides of old, and new epidermis seems only to be formed by the multiplication of epidermic cells; hence the practice, recently adopted by surgeons, of transplanting little bits of skin to points on the surface of an extensive burn or ulcer. In both blood capillaries and epidermis the departure from the primary undifferentiated cell is but slight; and, as regards the cuticle, one of the permanent physiological characters of the cells of the *rete mucosum* is their multiplication throughout the whole of life; that is a main physiological characteristic of the tissue: the same is very probably true of the protoplasmic cells forming the walls of the capillaries. Nerve-fibres are highly differentiated, yet nerves rapidly unite after division; this, however, occurs by modification of amœboid wandering cells (p. 106) which align themselves with them. In Mammals, muscular and glandular tissues seem never to be reproduced after removal.

We find, then, as we ascend in the animal scale a diminishing reproductive power in the tissues generally: with the increasing division of physiological labor, with the changes that fit pre-eminently for one work, there is a loss of other faculties, and this one among them. The more specialized a tissue the less the reproductive power of its elements, and the most differentiated tissues are either not reproduced at all after injury, or only by the specialization of amœboid cells, and not by a progenitive activity of survivors of the same kind as those destroyed. In none of the higher animals, therefore, do we find multiplication by simple division, or by budding: no one cell, and no group of cells used for the physiological maintenance of the individual, can build up a new complete living being; but the continuance of the race is specially provided for by setting apart certain cells which shall have this one property—cells whose duty is to the species and not to any one representative of it—an essentially altruistic element in the otherwise egoistic whole.

**Sexual Reproduction.** In some cases, especially among insects, the specialized reproductive cells can develop, each for itself, under suitable conditions, and give rise to new

other is the *sperm-cell* or spermatozoon. the two is known as *fertilization*. Animals producing both ova and spermatozoa are *hermaphrodites*; those producing only, *female*; and those spermatozoa only, *male*. Hermaphroditism is not found in Vertebrates, except in doubtful cases of monstrosity.

**Accessory Reproductive Organs.** The organ in which ova are produced is known as the *ovary*, and the organ in which spermatozoa are produced, as the *testis* or *testicle*; but in many of animals many additional accessory parts are developed. Thus, in Mammalia, the offspring is nourished for a considerable portion of its early life within the mother, in a special cavity, the *uterus* or *womb*, and for this purpose: the womb communicates with the exterior by a passage, the *vagina*, and two tubes, or *Fallopian tubes*, convey the eggs to it from the ovaries. In addition, *mammary glands* provide milk for the nourishment of the young in the first months of life. In the male mammal we find as accessory reproductive organs: the *vasa deferentia*, which convey off from the testes the seminal fluid, containing spermatozoa; *vesiculae seminales* (not present in all Mammalia), in which the seminal fluid is stored before expulsion; a *prostate gland*, which secretes a secretion added to the semen; and an erect *penis*, by which the fertilizing liquid is conveyed into the body of the female.

**The Male Reproductive Organs.** The testes are paired tubular glands, which lie in a pouch called the *scrotum*. This pouch is subdivided into two chambers, into right and left chambers, in each of which a testis lies. The chambers are lined inside by a serous membrane, the *tunica vaginalis*, and this doubles back (1



**DIESE SEITE IST FÜR KOSTENLOSE MITGLIEDER GESPERRT**  
Beantragen Sie jetzt die volle Mitgliedschaft, um diese Seite zu betreten

# GESCHICHTE

Zehntausende von wichtigen historischen Quellen, viele bisher nicht erhältlich, stehen jetzt zum ersten Mal mit der Vollmitgliedschaft von Forgotten Books zur Verfügung.

Unbegrenzter Zugang  
\$8.99/monat

**Fortfahren**

\*Es gelten Richtlinien zur fairen Nutzung.



these, when unrolled, are tubes from 15 to inches) in length; they taper somewhat from commencements at the vasa efferentia, where they ( $\frac{1}{16}$  inch) in diameter, to the other end where nate in the *epididymis* (e, e, Fig. 160). The larow mass, slightly longer than the testicle along the posterior side of that organ, near th of which (g) it passes into the *vas deferens*, epididymis be carefully unraveled it is found a tube about 6 meters (20 feet) in length, and diameter from 0.35 to 0.25 mm. ( $\frac{1}{16}$  to  $\frac{1}{16}$  inch

The *vas deferens* (h, Fig. 160) commences part of the epididymis as a slightly coiled tube, becomes straight and passes up beneath the sl the inner part of the groin, till it gets above th then, passing through the abdominal walls, tu backwards, and downwards, to the under side o bladder, where it joins the duct of the seminal about 0.6 meters (2 feet) in length and 2.5 m in diameter.

The *vesiculæ seminales*, two in number, are receptacles which lie, one on each side, beneath between it and the rectum. They are commo cm. (2 inches) long and a little more than a wide (or about 0.5 inch) at their broadest part rowed end of each enters the vas deferens on it the tube formed by the union being the *ejacu* which, after a course of about an inch, enters near the neck of the bladder.

The *prostate gland* is a dense body about t chestnut which surrounds the commencement thra; the ejaculatory ducts pass through it. made up of fibrous and unstriped muscular contains also a number of small secreting sac ~~ducts~~ open into the urethra.

The *male urethra* leads from the bladder to the end of the penis, where it terminates in an opening, *the meatus urinarius*. It is described by anatomists as made up of three portions, the prostatic, the membranous, and the spongy. The first is surrounded by the prostate gland and receives the ejaculatory ducts. On its posterior wall, close to the bladder, is an elevation containing erectile tissue (see below) and supposed to be dilated during sexual congress, so as to cut off the passage to the urinary receptacle. On this crest is an opening leading into a small recess, the *utricle*, which is of interest, since the study of Embryology shows it to be an undeveloped male uterus. The succeeding membranous portion of the urethra is about 1.8 cm. ( $\frac{3}{4}$  inch) long; the spongy portion lies in the penis.

The *penis* is composed mainly of *erectile tissue*, i.e. tissues so arranged as to inclose cavities which can be distended by blood. Covered outside by the skin, internally it is made up of three elongated cylindrical masses, two of which, the *corpora cavernosa*, lie on its anterior side; the third, the *corpus spongiosum*, surrounds the urethra and lies on the posterior side of the organ for most of its length; it, however, alone forms the terminal dilatation, or *glans*, of the penis. Each *corpus cavernosum* is closely united to its fellow in the middle line and extends from the pubic bones, to which it is attached behind, to the glans penis in front. It is enveloped in a dense connective-tissue capsule from which numerous bars, containing white fibrous, elastic, and unstriped muscular tissues, radiate and intersect in all directions, dividing its interior into many irregular chambers called *venous sinuses*. Into these arteries convey blood, which is carried off by veins springing from them.

The arteries of the penis are supplied with vaso-dilator nerves (p. 257), the *nervi erigentes*, from the sacral plexus (p. 162). Under certain conditions these are stimulated and, the arteries expanding, blood is poured into the venous sinuses faster than the veins drain it off; the latter are probably also at the same time compressed where they leave the penis by the contraction of certain muscles passing over them; the organ then becomes distended, rigid, and



and forms a fold, the *prepuce*, which double becoming soft, moist, red, and very vascular glans to the *meatus urinarius*, where it becomes with the mucous membrane of the urethra the projecting posterior rim of the glans, and many sebaceous glands.

**Histology of the Testis and its Secretion.** Seminiferous tubule consists of a basement membrane supporting an epithelium, which in early life forms lining to the tube; in the adult the cells multiply nearly fill the cavity. From these cells the sperm are formed. The seminal fluid is an albuminous

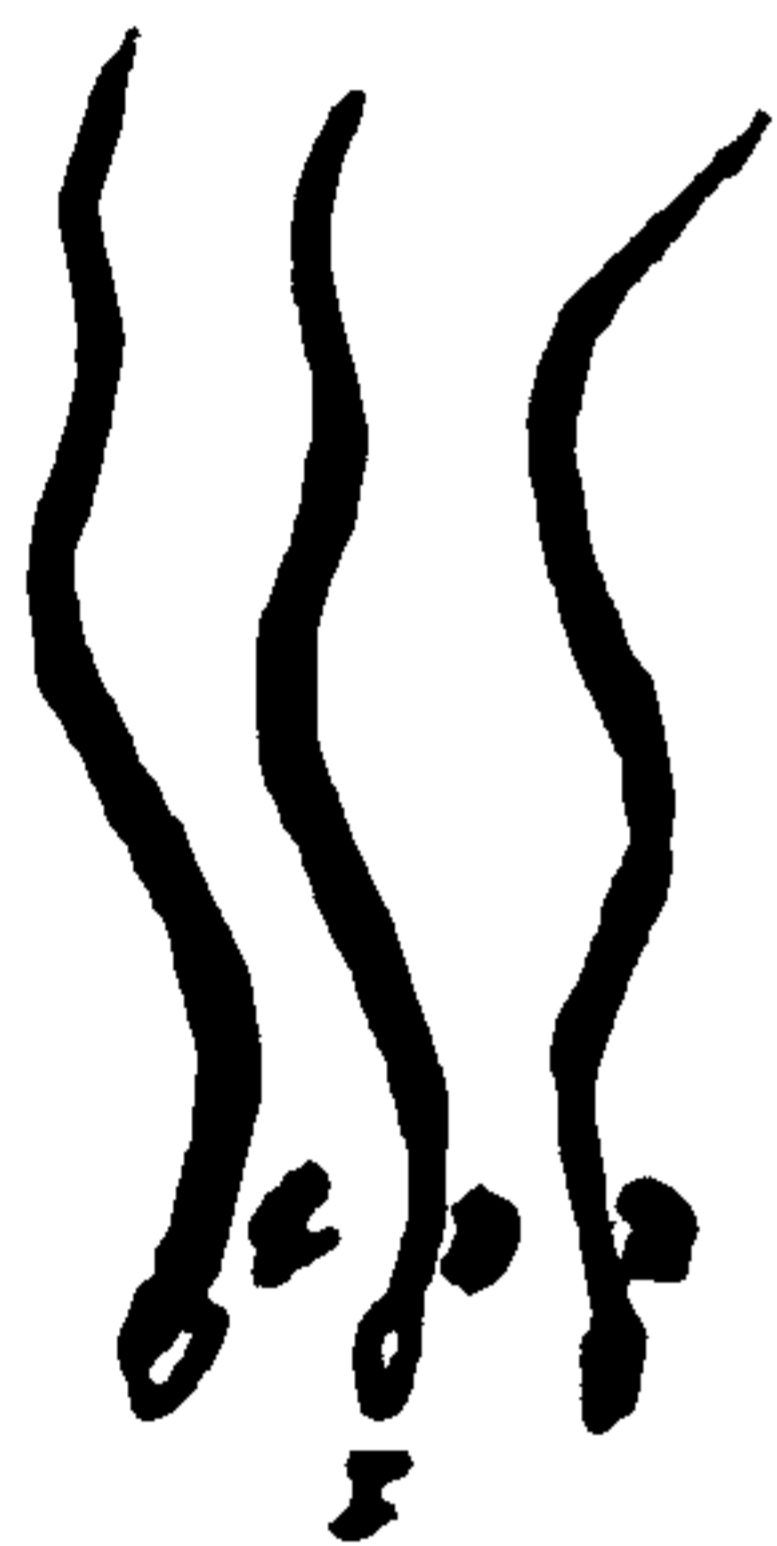

FIG. 161.—Spermatozoa. magnified 350 diameters. a, viewed from the side; b, seen from above.

containing granules and spermatozoa. Examined with the microscope the spermatozoa appear as rapidly moving minute objects, each consisting of a broad head and a slender vibratile tail or flagellum. They are about 0.04 mm. ( $\frac{1}{25}$  inch) in length.

The seminal fluid is not fully formed until it leaves the seminiferous tubules. It is completely developed spermatozoa are found in the vasa recta, and the contents of the vas deferens contain spermatozoa which have not yet finished

the production of a spermatozoon; probably, therefore, the fertilizing liquid is first fully elaborated in the vasa deferentia.

**The Reproductive Organs of the Female.**

The *ovary* (o, Fig. 162) is a dense oval mass about 3 inches in length, 2 cm. (0.75 inch) in width, and (0.5 inch) in thickness; it weighs from 4



**DIESE SEITE IST FÜR KOSTENLOSE MITGLIEDER GESPERRT**  
Beantragen Sie jetzt die volle Mitgliedschaft, um diese Seite zu betreten



**Seien Sie niemals ohne ein Buch!**

Die Vollmitgliedschaft von Forgotten Books bietet Ihnen einen universalen Zugang von unseren Apps und unserer Website, auf all Ihren Geräten: Tablet, Telefon, E-Reader, Laptop und Computer.

**Eine Bibliothek in Ihrer Tasche für €8.99/monat**

**Fortfahren**

\*Es gelten Richtlinien zur fairen Nutzung.

plan tubes, and narrows below to the *neck*, or *cervix uteri*, opposite *c* (Fig. 162), the communication between neck and body cavities being known as the *os internum*. Below this the neck dilates somewhat. The lowest part of the cervix reaches into the vagina and communicates with it by a transverse aperture, the *os uteri*. On account of the thickness of the uterine walls the cavity of the organ is very small

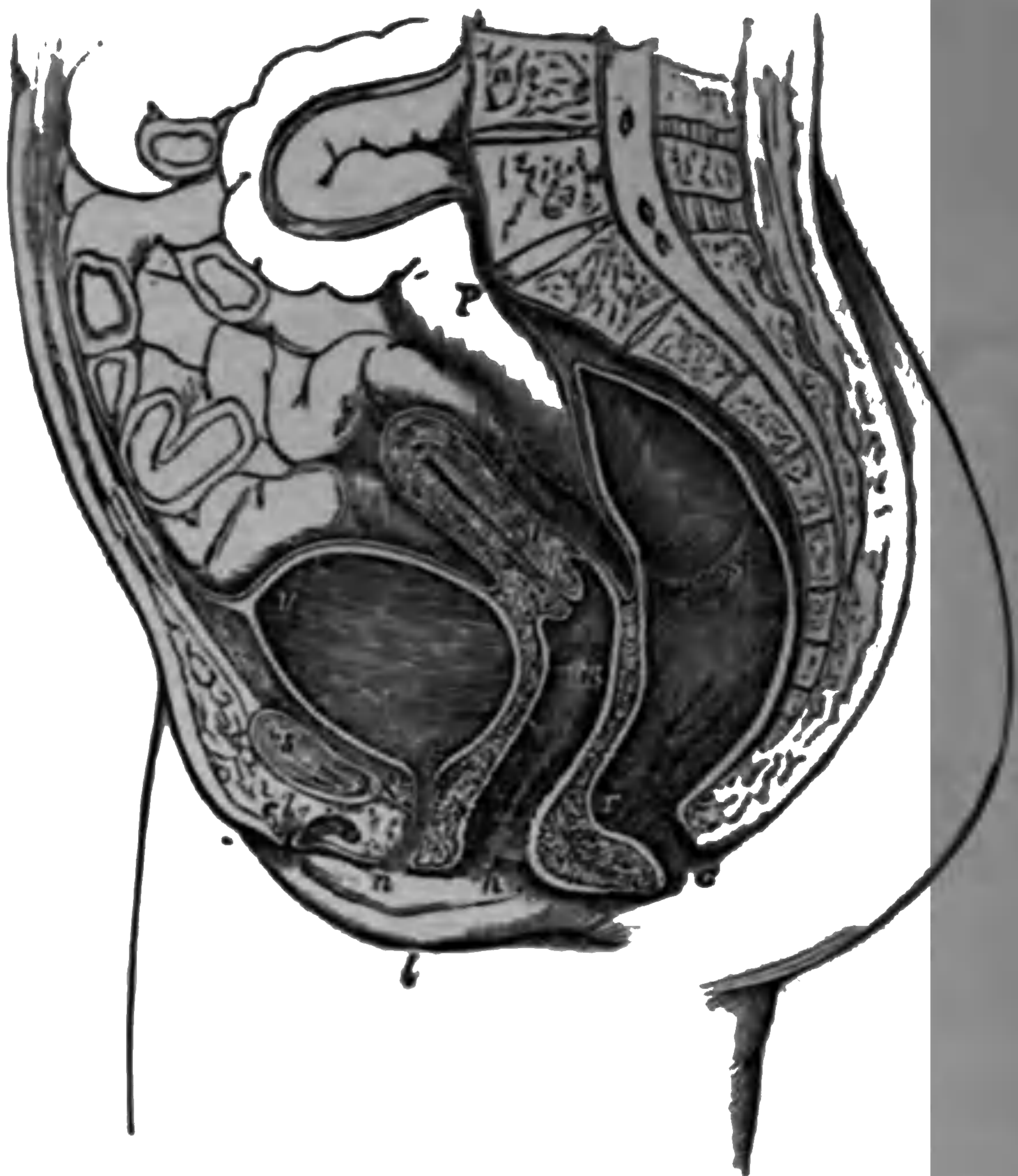

FIG. 163.—The viscera of the female pelvis as exposed by a dorso-ventral median section. *p*, upper end of sacrum; *s*, symphysis pubis; *u*, *u'*, urinary bladder; *v*, urethra; *u*, uterus; *va*, vagina; *r*, *r'*, rectum; *a*, anal opening; *l*, right labium major; *n*, right nympha; *h*, hymen; *cl*, divided clitoris.

in the unimpregnated state. During parturition the foetus develops in the body of the womb, which becomes greatly enlarged and rises high into the abdomen: the virgin womb lies entirely below the level of the bones of the pelvis.

The chief bulk of the uterus consists of plain muscular tissue; but it is lined internally by a ciliated mucous mem-

brane, and is covered externally by the peritoneum, bands of which project from each side of it as the *broad ligaments* (ll, Fig. 162). Opening on the internal mucous membrane are the mouths of closely set, simple or slightly branched, tubular glands.

The *vagina* is a distensible passage, extending from the uterus to the exterior; dorsally it rests on the rectum, and ventrally is in contact with the bladder and urethra. It is lined by mucous membrane, containing mucous glands, and outside this is made up of areolar, erectile, and unstriated muscular tissues. Around its lower end is a ring of striated muscular tissue, the *sphincter vaginæ*.

The *vulva* is a general term for all the portions of the female generative organs visible from the exterior. Over the front of the pelvis the skin is elevated by adipose tissue beneath it, and forms the *mons Veneris*. From this two folds of skin (l, Fig. 163), the *labia majora*, extend downwards and backwards on each side of a median cleft, beyond which they again unite. On separating the labia majora a shallow *genito-urinary sinus*, into which the urethra and vagina open, is exposed. At the upper portion of this sinus lies the *clitoris*, a small and very sensitive erectile organ, resembling a miniature penis in structure, except that it has no corpus spongiosum and is not traversed by the urethra. From the clitoris descend two folds of mucous membrane, the *nymphæ* or *labia interna*, between which is the *vestibule*, a recess containing, above, the opening of the short female urethra, and, below, the aperture of the vagina, which is in the virgin more or less closed by a thin duplicature of mucous membrane, the *hymen*.

**Microscopic Structure of the Ovary.** The main mass of the ovary consists of a close connective-tissue *stroma*, containing unstriated muscle, blood-vessels, and nerves: it is covered externally by a peculiar *germinal epithelium*, and contains imbedded in it many minute cavities, the *Graafian follicles*, in which *ova* lie. If a thin section of an ovary be examined with the microscope many hundreds of small Graafian follicles, each about 0.25 mm. ( $\frac{1}{16}$  inch) in diameter, will be found imbedded in it near the surface.

These are lined by cells, and each contains a single ovum. Deeper in, larger follicles (7, 8, 9, Fig. 164) are seen, their cavities being distended, during life, by liquid: in these the essential structure may be more readily made out. Each has an external fibrous coat constituted by a more dense layer of the ovarian stroma; within this come several layers of lining cells (9, *a*, Fig. 164) constituting the *membrana granulosa*. At one point, *b*, the cells of this layer are heaped up, forming the *discus proligerus*, which projects into the

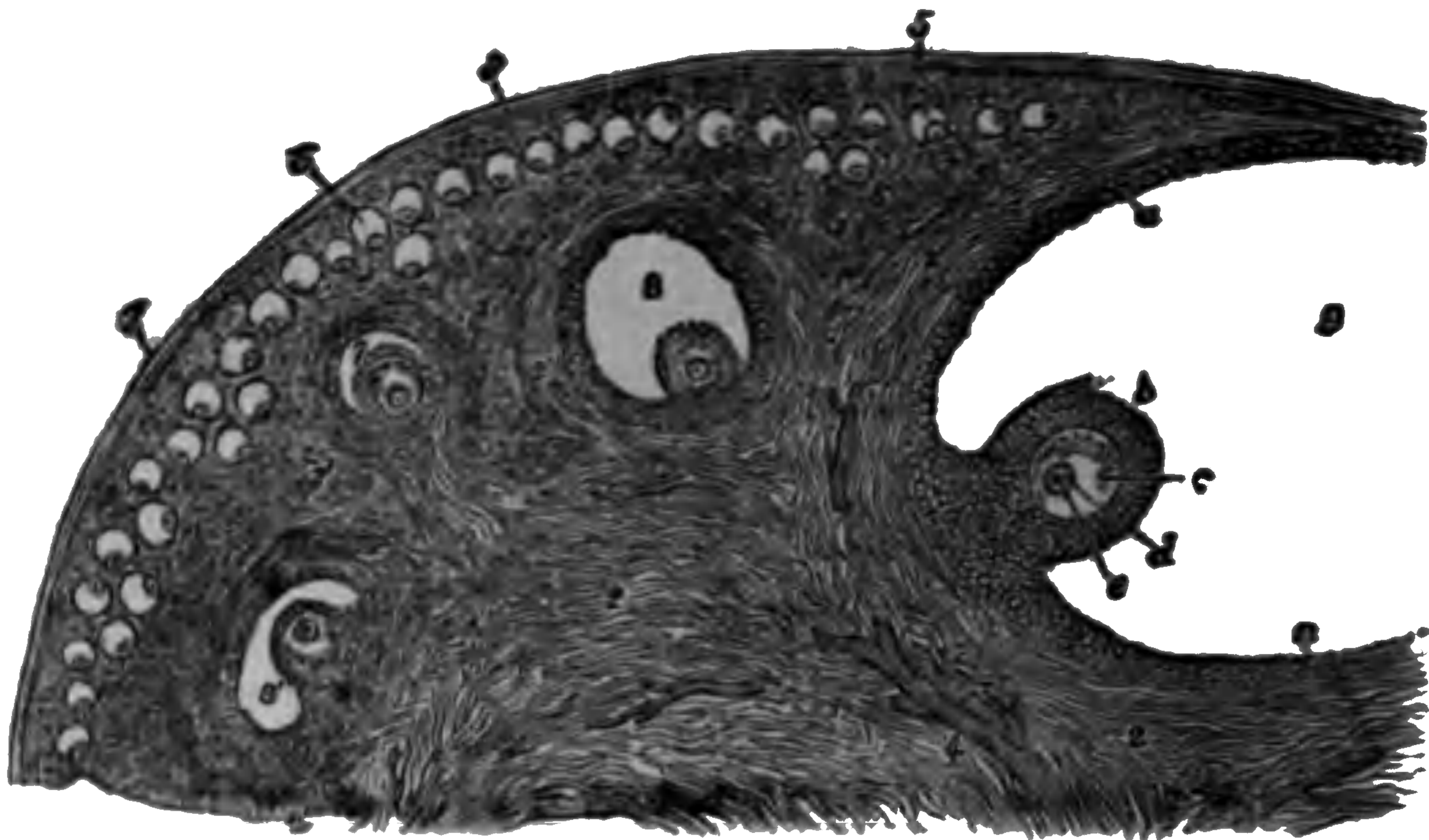

FIG. 164.—A section of a Mammalian ovary, considerably magnified. 1, outer capsule of ovary; 2, 3, 3', stroma; 4, blood-vessels; 5, rudimentary Graafian follicles; 6, 7, 8, follicles beginning to enlarge and mature, and receding from the surface; 9, a nearly ripe follicle which is again traveling towards the surface preparatory to discharging the ovum: *a*, membrana granulosa; *b*, discus proligerus; *c*, ovum, with, *d*, germinal vesicle and, *e*, germinal spot. The general cavity of the follicle (in which 9 is printed) is filled with liquid during life.

liquid filling the cavity of the follicle. In the discus proligerus the ovum, *c*, lies, having in it a nucleus or *germinal vesicle*, *d*, and a nucleolus or *germinal spot*, *e*. The ovum is about 0.2 mm. ( $\frac{1}{50}$  inch) in diameter; its structure is better represented at A, Fig. 8\*, where it is seen to consist of a thick outer coat or cell-wall, *a*, called the *vitelline membrane* or *zona pellucida*; within which is the granular cell protoplasm, called here the *vitellus* or *yolk*; and in that again the germinal vesicle and spot.



**DIESE SEITE IST FÜR KOSTENLOSE MITGLIEDER GESPERRT**  
Beantragen Sie jetzt die volle Mitgliedschaft, um diese Seite zu betreten

# GESCHICHTE

Zehntausende von wichtigen historischen Quellen, viele bisher nicht erhältlich, stehen jetzt zum ersten Mal mit der Vollmitgliedschaft von Forgotten Books zur Verfügung.

Unbegrenzter Zugang  
\$8.99/monat

**Fortfahren**

\*Es gelten Richtlinien zur fairen Nutzung.



The external generative organs increase in size, a clitoris and nymphæ become erectile. The uterine considerably, the ovaries enlarge, some Graafian ripen, and the events treated of in the succeeding paragraphs occur.

**Ovulation.** From puberty, during the whole bearing period of life, certain comparatively very Graafian follicles may nearly always be found either to the surface of the ovary or projecting on its exterior. These, by accumulation of liquid within them, have become distended to a diameter of about 4 mm. ( $\frac{1}{4}$  inch); finally the thinned wall of the follicle gives way and the ovum is discharged, surrounded by some cells of the discus proliferus. The emptied follicle becomes filled up with a reddish mass of cells, and constitutes the *corpus luteum*, which recedes again to the interior of the ovary and disappears in three or four weeks, unless pregnancy occurs; the *corpus luteum* increases for a time, and persists during the greater part of the gestation period.

**Menstruation.** Ovulation occurs during the sexum of a healthy woman at intervals of about four weeks, attended with important changes in other portions of the generative apparatus. The ovaries and Fallopian tubes become congested, and the fimbriæ of the latter are drawn out and come into contact with the ovary so as to receive the ova discharged. Whether the fimbriæ embrace the ova and catch the ovum, or merely touch it at various points and the ova are swept along them by their cilia, or whether the cavity of the oviduct, is not certain. Having entered the Fallopian tube the egg slowly passes on to the uterus, probably moved by the cilia lining the oviduct. In the womb, also, important changes occur at this time; the uterus comes swollen and gorged with blood, especially its internal mucous membrane and its glands. If the ovum is not fertilized it dies and is passed out. At the same time the superficial part of the uterine mucous membrane is softened.

broken down, and discharged along with more or less blood, constituting the *menses*, or monthly sickness, which commonly lasts from three to five days. During this time the vaginal secretion is also increased, and, mixed with the blood discharged, more or less alters its color, and usually destroys its coagulating power. Except during pregnancy and while suckling, menstruation occurs at the above intervals, from puberty up to about the forty-fifth year; the periods then become irregular, and finally the discharges cease; this is an indication that ovulation has come to an end, and the sexual life of the woman is completed. This time, the *climacteric* or "turn of life," is a critical one; various local disorders are apt to supervene, and even mental derangement.

**Hygiene of Menstruation.** During menstruation there is apt to be more or less general discomfort and nervous irritability; the woman is not quite herself, and those responsible for her happiness ought to watch and tend her with special solicitude, forbearance, and tenderness, and protect her from anxiety and agitation. Any strong emotion, especially of a disagreeable character, is apt to check the flow, and this is always liable to be followed by serious consequences. A sudden chill often has the same effect; hence a menstruating woman ought always to be warmly clad, and take more than usual care to avoid draughts or getting wet. At these periods, also, the uterus is enlarged and heavy, and being (as may be seen in Fig. 163) but slightly supported, and that near its lower end, it is especially apt to be displaced or distorted; it may tilt forwards or sideways (*versions of the uterus*), or be bent where the neck and body of the organ meet (*flexion*). Hence violent exercise at this time should be avoided, though there is no reason why a properly clad woman should not take her usual daily walk.

Painful menstruation (*dysmenorrhœa*) may be due to very many causes, but it is only within recent years that physicians have come to recognize how often it depends on uterine displacements, and in such cases how readily it may usually



after month until her health is undermined the trouble will get better of itself, which To submit to the necessary examination and to one of the other sex is, to a refined woman, to be a more severe trial than all the physical pain is no recent social movement more deserving encouragement and support than that whose aim is properly trained female medical attendance the diseases peculiar to their sex; such as menstrually, be found in most of our large cities. physicians, and perhaps few physicians, amount of relievable pain women endure in than run the risk of being forced to consult a doctor. If no skilled person of her own sex is a sufferer, if she do anything, is only too apt to be the nostrums advertised in such number for "female complaints," or to consult a half-educated lady of a "novel school" with a taking title. The result of this, or doing nothing, is often permanent invalidity and a life of uselessness, to those who might otherwise be happy wives and mothers.

The absence of the menstrual flow (*amenorrhoea*) is abnormal during pregnancy and while suckling; in some cases it never occurs throughout life, even in women capable of child-bearing. Usually, however, the appearance of the menses at the proper period is a symptom, and one which calls for prompt attention. In all such cases it cannot be too strongly insisted upon that the most dangerous thing to do is to attempt to induce the discharge, except under the direction of a physician. To excite the flow, in many cases, as for example in the case of the os uteri, or in general debility (when



**DIESE SEITE IST FÜR KOSTENLOSE MITGLIEDER GESPERRT**  
Beantragen Sie jetzt die volle Mitgliedschaft, um diese Seite zu betreten



**Seien Sie niemals ohne ein Buch!**

Die Vollmitgliedschaft von Forgotten Books bietet Ihnen einen universalen Zugang von unseren Apps und unserer Website, auf all Ihren Geräten: Tablet, Telefon, E-Reader, Laptop und Computer.

**Eine Bibliothek in Ihrer Tasche für €8.99/monat**

**Fortfahren**

\*Es gelten Richtlinien zur fairen Nutzung.

ova are occasionally discharged at other than the **monthly periods of ovulation**, especially under the influence of the erection and congestion of the part of the female genital tract during the sexual act. There is, therefore, a discharge of ova during a woman's life from puberty to old age, except during pregnancy or lactation, when it may not result in impregnation.

The exact parts taken by the male and female in the formation of the embryo are known with certainty; seeing that the ovum is much more than the spermatozoon it is not uncommon to speak of the ovum as a more stimulant or excitant, arousing developmental activity; but the definite characteristics inherited by children from the father show that the spermatozoon is much more than that; materials derived from the male are no doubt an essential constituent of the embryo which develops into the new human being.

**Pregnancy.** When the mulberry mass reaches the uterine cavity the mucous membrane lining the latter becomes thickened and forms a new, thick, very vascular lining known as the *decidua*. At one point on the inner surface of the decidua becomes attached, the decidua growing up as the pregnancy advances and the embryo grows, into the uterine cavity and pushes before it the decidua which has grown over it (the *decidua capsularis*). About the end of the third month this meeting of the decidua lining the opposite sides of the uterine cavity is complete and they grow together. That part of the decidua (*decidua basalis*) against which the morula is first attached su

dergoes a great development in connection with the formation of the placenta (see below). Meanwhile the whole uterus enlarges; its muscular coat especially thickens. At first the organ still lies within the pelvis, where there is but little room for it; it accordingly presses on the bladder and rectum (see Fig. 163) and the nerves in the neighborhood, frequently causing considerable discomfort or pain; and, reflexly, often exciting nausea or vomiting (the *morning sickness* of pregnancy). Later on, the pregnant womb escapes higher into the abdominal cavity, and although then larger, the soft abdominal walls more readily make room for it, and less discomfort is usually felt, though there may be shortness of breath and palpitation of the heart from interference with the diaphragmatic movements. All tight garments should at this time be especially avoided; the woman's breathing is already sufficiently impeded, and the pressure may also injure the developing child. Meanwhile, changes occur elsewhere in the Body. The breasts enlarge and hard masses of developing glandular tissue can be felt in them; and there may be mental symptoms: depression, anxiety, and an emotional nervous state.

During the whole period of gestation the woman is not merely supplying from her blood nutriment for the foetus, but also, through her lungs and kidneys, getting rid of its wastes; the result is a strain on her whole system which, it is true, she is constructed to bear and will carry well if in good health, but which is severely felt if she be feeble or suffering from disease. Many a wife who might have led a long and happy life is made an invalid or brought to premature death, through being kept in a chronic state of pregnancy. There is a general agreement that sexual continence is possible and a duty in unmarried men, but the husband rarely considers that he should put any bounds on himself beyond those indicated by his own passions; consideration for his wife's health rarely enters his head in this connection. The healthy married woman who endeavors to evade motherhood because she thinks she will thus preserve her personal appearance, or because she dislikes the trouble of a family, deserves but little sympathy; she is

trying to escape a duty voluntarily undertaken, and owe her husband, her country, and her race; but she weakness is undermined and whose life is made one discomfort for the sexual gratification of her husband for all aid, and it is wrong to keep silent on the subject. The professor of gynecology in a leading medical school gives it as his deliberate opinion that the majority of American women must at some periods of their lives choose between freedom from pregnancy or early death. He further says that he does not believe that healthy men are so organized that this matter can be regulated by them, but that the question depends on the tact and prudence of the wife. Men, however, as a rule, are not utterly selfish; they commonly err through ignorance or thoughtlessness, not knowing or realizing what a strain frequent pregnancy is on the strength of a delicate woman. A social custom, deep-rooted and ancient as the usual American and English one of married couples constantly occupying the same bed, not easily changed, yet it probably leads to much harm, especially in this country. Whatever the reason be, there is no doubt that the physical stamina of the average English woman is considerably greater than that of her American cousin, and she bears and brings up large families with greater safety. For a husband, who has reason to believe that child-bearing will injure his wife's health, to allow her to share her couch is a deliberate walking into temptation.

Apart from pregnancy, moreover, a woman's health is often injured by frequent sexual intercourse. A physician who has unusual opportunities of knowing states that he has reason to believe that not only is the act of sexual congress at best, from a physical point of view, a mere nuisance to the majority of women belonging to the more luxurious classes of society after they attain the age of twenty or twenty-three, but that a very considerable proportion suffer acute pain from it such as, if frequent, breaks down general health. A loving woman, finding her highest happiness in suffering for those dear to her, is very unlikely to let her husband know this, so long as she can bear it; but when the possibility is known it will not, perhaps, need m



**DIESE SEITE IST FÜR KOSTENLOSE MITGLIEDER GESPERRT**  
Beantragen Sie jetzt die volle Mitgliedschaft, um diese Seite zu betreten

# GESCHICHTE

Zehntausende von wichtigen historischen Quellen, viele bisher nicht erhältlich, stehen jetzt zum ersten Mal mit der Vollmitgliedschaft von Forgotten Books zur Verfügung.

Unbegrenzter Zugang  
\$8.99/monat

**Fortfahren**

\*Es gelten Richtlinien zur fairen Nutzung.



consists of three cell layers; an outer or *epiblast*, a middle or *mesoblast*, and an inner or *hypoblast*. From this simple sac, presenting no resemblance not merely to a human being but to a vertebrate animal, the fetus is built up by cell division and modification. The general history of intra-uterine development is much too long and too complex to enter upon here, but the formation of certain structures lost at or before birth, and associated with the protection and nourishment of the embryo, may be attempted: they are the *yolk sac*, the *amnion*, and the *allantois*. The developing blastoderm especially thickens in the neighborhood of the embryonal disk and there the outlines of the Body are first laid down. Along the thickening a groove appears, which



FIG. 165.—A, an early blastoderm with the first traces of the primitive groove; B, the same a little later; s, primitive groove; d, thickened region of the blastoderm which directly builds up the embryo.

marks out the future longitudinal axis and dorsal side of the body, (A, Fig. 166). This groove elongates, its edges rise (B), and finally arch over, meet, and fuse together above it. The tube thus closed in is the rudiment of the cerebro-spinal axis; from its lining epiblastic cells the brain and spinal cord are developed, and its cavity remains throughout life as the central canal of the spinal cord and as the cerebral ventricles, excluding the fifth (p. 165). Some way outside this dorsal tube the mesoblast splits into an outer leaf, adherent to the epiblast, and an inner adherent to the hypoblast; the conjoined meso-epiblastic layer is the *somatopleure*; the meso-hypoblastic the *splanchnopleure*. The proximal parts of the somatopleure (i.e., the regions nearest the central

axis) develop into the walls of chest and abdomen; farther out it turns up and arches over the back of the embryo, and its edges, there meeting, grow together and form a bag, the *amnion*, enveloping the fœtus. Into this a considerable quantity of liquid is secreted, in which the fœtus floats. At birth the contractions of the uterus, pressing on the amnion, drive part of it down like a wedge into the neck of the uterus, and through its liquid contents an equable pressure is exerted there, until the *os uteri* is tolerably dilated; the sac then normally ruptures and the "waters" escape. Sometimes, however, an infant is born still enveloped in the amnion, which is then popularly known as a *caul*. While the amnion is developing, a semi-cartilaginous rod forms along the axis of the Body beneath the floor of the dorsal tube; this is the *notochord*; when it appears the young being is marked out distinctly as a vertebrate animal, having a dorsal *neural tube* above an axial skeleton, and a ventral *hæmal tube* (p. 4), formed by the proximal regions of the somatopleure, beneath it. The ventral tube, however, is still widely open, the points where the amniotic folds turn back being far from meeting in the future middle line of the chest and abdomen.

The proximal portions of the splanchnopleure incurve to inclose the alimentary tube, which is at first straight and simple. Beyond the point where it bends in for this purpose the splanchnopleure again diverges, and incloses a small globular bag, the *yelk sac*, which is, thus, attached to the ventral side of the alimentary canal; it at first projects through the opening where the amniotic folds turn back, but has little importance in the mammalian embryo and is soon absorbed.

The *allantois* is primarily an outgrowth from the alimentary canal, containing blood-vessels. It passes out from the Body on the ventral side where the somatopleures have not yet met, and reaching the inside of the uterus, its distal end expands there to make the main part of the placenta (see below). Its narrow proximal portion forms the *umbilical cord*, around which the somatopleures, incurving to inclose the belly, meet at the *navel* some time before birth.



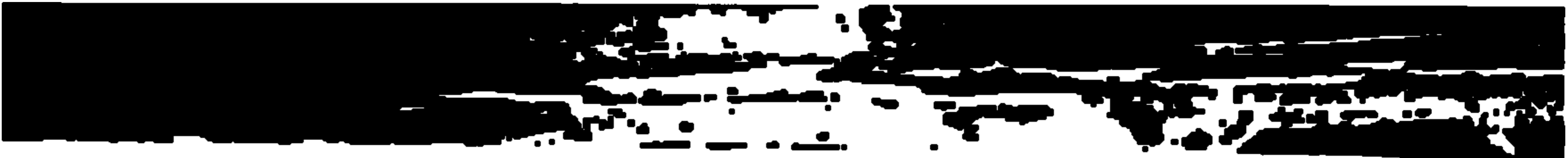

THE HUMAN BODY

**The Intra-Uterine Nutrition of the Embryo.** A large amount of material is absorbed by the embryo from the maternal blood. The placenta is a highly vascularized organ, the blood vessels of which are in direct communication with the maternal blood. The placenta is attached to the uterine wall by the umbilical cord, the blood vessels of which are in direct communication with the maternal blood. The placenta is a highly vascularized organ, the blood vessels of which are in direct communication with the maternal blood. The placenta is attached to the uterine wall by the umbilical cord, the blood vessels of which are in direct communication with the maternal blood. The placenta is a highly vascularized organ, the blood vessels of which are in direct communication with the maternal blood. The placenta is attached to the uterine wall by the umbilical cord, the blood vessels of which are in direct communication with the maternal blood.

**Parturition.** At the end of the 270 to 280 days of pregnancy the fetus is fully developed. The uterus contracts, and the fetus is pushed out of the vagina. The placenta is attached to the uterine wall by the umbilical cord, the blood vessels of which are in direct communication with the maternal blood. The placenta is a highly vascularized organ, the blood vessels of which are in direct communication with the maternal blood. The placenta is attached to the uterine wall by the umbilical cord, the blood vessels of which are in direct communication with the maternal blood. The placenta is a highly vascularized organ, the blood vessels of which are in direct communication with the maternal blood. The placenta is attached to the uterine wall by the umbilical cord, the blood vessels of which are in direct communication with the maternal blood.

The blood vessels of the placenta are in direct communication with the maternal blood. The placenta is a highly vascularized organ, the blood vessels of which are in direct communication with the maternal blood. The placenta is attached to the uterine wall by the umbilical cord, the blood vessels of which are in direct communication with the maternal blood. The placenta is a highly vascularized organ, the blood vessels of which are in direct communication with the maternal blood. The placenta is attached to the uterine wall by the umbilical cord, the blood vessels of which are in direct communication with the maternal blood.



**DIESE SEITE IST FÜR KOSTENLOSE MITGLIEDER GESPERRT**  
Beantragen Sie jetzt die volle Mitgliedschaft, um diese Seite zu betreten



**Seien Sie niemals ohne ein Buch!**

Die Vollmitgliedschaft von Forgotten Books bietet Ihnen einen universalen Zugang von unseren Apps und unserer Website, auf all Ihren Geräten: Tablet, Telefon, E-Reader, Laptop und Computer.

**Eine Bibliothek in Ihrer Tasche für € 8.99/monat**

**Fortfahren**

\*Es gelten Richtlinien zur fairen Nutzung.

**all, insanity:**

**Lactation.** ~~The~~ mammary glands at birth remain small, and alike in both sexes. At puberty they begin to enlarge in the female. In the developed form in that sex two rounded breasts, placed on the thorax. A little above each projects a small eminence, the areola, around this forms a colored circle, the areolæ are pink; they darken in time during the first pregnancy and never quite return to their original hue. The mammary glands are compound racemose type (p. 202).

Each consists of fifteen to twenty distinct lobes, made up of from each main lobe a separate *galactophore* by the union of smaller branches first towards the nipple, all converging into one. There each dilates and forms a small sinus in which the milk may temporarily collect. The ducts narrow again, and each opens by a small opening on the nipple. Imbedding the lobes of the gland is a quantity of adipose tissue which gives the whole breast its rounded form.

During maidenhood the glandular tissue is perfectly developed and dormant. Early in life it begins to increase in bulk, and the gland lobes project through the superjacent skin as small mounds. At maturity, however, their functional

established. The oil-globules of the milk are formed by a sort of fatty degeneration of the gland-cells, which finally fall to pieces; the cream is thus set free in the watery and albuminous secretion formed simultaneously, while newly developed gland-cells take the place of those destroyed. In the milk first secreted after accouchment (the *colostrum*) the cell destruction is incomplete, and many cells still float in the liquid, which has a yellowish color; this first milk acts as a purgative on the infant, and probably thus serves a useful purpose, as a certain amount of substances (biliary and other), excreted by its organs during development, are found in the intestines at birth.

Human milk is undoubtedly the best food for an infant in the early months of life; and to suckle her child is useful to the mother if she be a healthy woman. There is reason to believe that the processes of involution by which the large mass of muscular and other tissues developed in the uterine walls during pregnancy are broken down and absorbed. take place more safely to health if the natural milk secretion is encouraged. Many women refuse to suckle their children from a belief that so doing will injure their personal appearance, but skilled medical opinion is to the contrary effect; the natural course of events is the best for this purpose, unless lactation be too prolonged. Of course in many cases there are justifiable grounds for a mother's not undertaking this part of her duties; a physician is the proper person to decide.

In a healthy woman, not suckling her child, ovulation and menstruation recommence about six weeks after childbirth; a nursing mother usually does not menstruate for ten or twelve months; the infant should then be weaned.

When an infant cannot be suckled by its mother or a wet-nurse an important matter is to decide what is the best food to substitute. Good cow's milk contains rather more fats than that of a woman, and much more casein; the following table gives averages in 1000 parts of milk:

	Woman.	Cow.
Casein.....	28.0	54.0
Butter.....	83.5	48.0
Milk sugar.....	44.5	42.5
Inorganic matters.....	4.75	7.75

should, however, be employed from the much less than cane sugar, and infants refuse milk in which milk sugar is substituted. Cow's milk may be added to raise the per cent to the normal, but must be perfectly fresh and milk immediately before it is given to milk is standing for the cream to rise it a little sour; the amount of this sour milk cream is itself no harm when mixed with a milk; it carries with it, however, some of development causes the souring, and this develop and sour all the milk it is added to let stand. As the infant grows older less may gradually be given; after the seventh no addition of water is necessary.

In the first weeks after birth it is no use starchy foods, as arrowroot. The great starch passes through the bowels unchanged because the pancreas has not yet fully developed and not commenced to make its starch-converting enzyme (p. 341). Later on, starchy substances may be added to the diet with advantage, but it should be remembered that they cannot form the chief part of the infant's needs proteins for the formation of its tissues. Foods contain none of these. Many infants are starved by being fed almost entirely with sugar or arrowroot.



**DIESE SEITE IST FÜR KOSTENLOSE MITGLIEDER GESPERRT**  
Beantragen Sie jetzt die volle Mitgliedschaft, um diese Seite zu betreten

# GESCHICHTE

Zehntausende von wichtigen historischen Quellen, viele bisher nicht erhältlich, stehen jetzt zum ersten Mal mit der Vollmitgliedschaft von Forgotten Books zur Verfügung.

Unbegrenzter Zugang  
\$8.99/monat

**Fortfahren**

\*Es gelten Richtlinien zur fairen Nutzung.



in the arterial walls, which thus lose their elasticity; the refracting media of the eye become more or less opaque: the physiological irritability of the sense-organs in general diminishes; and fatty degeneration, diminishing their working power, occurs in many tissues. In the brain we find signs of less plasticity; the youth in whom few lines of least resistance have been firmly established is ready to accept novelties and form new associations of ideas; but the longer he lives, the more difficult does this become to him. A man past middle life may do good, or even his best work, but almost invariably in some line of thought which he has already accepted: it is extremely rare for an old man to take up a new study or change his views, philosophical, scientific, or other. Hence, as we live, we all tend to lag behind the rising generation.

**Death.** After the prime of life the tissues dwindle (or at least the most important ones) as they increased in childhood: it is conceivable that, without death, this process might occur until the Body was reduced to its original microscopic dimensions.

Before any great diminution takes place, however, a breakdown occurs somewhere, the enfeebled community of organs and tissues forming the man is unable to meet the contingencies of life, and death supervenes. "It is as natural to die as to be born," Bacon wrote long since: but though we all know it few realize the fact until the summons comes. To the popular imagination the prospect of dying is often associated with thoughts of extreme suffering: personifying life people picture a forcible and agonizing ridding of it, as an entity, from the bodily frame with which it is associated. As a matter of fact, death is probably rarely associated with any immediate suffering. The sensibilities are gradually dulled as the end approaches: the nervous tissues, with the rest, lose their functional capacity, and, before the heart ceases to beat, the individual has commonly lost consciousness.

The actual moment of death is hard to define: that of the Body generally, of the mass as a whole, may be taken to be the moment when the heart makes its last beat: arterial

pressure then falls irretrievably, the capillary circulation ceases, and the tissues, no longer nourished from the blood, gradually die, not all at one instant, but one after another, according as their individual respiratory or other needs are great or little.

While death is the natural end of life, it is not its aim—we should not live to die, but live prepared to die. Life has its duties and its legitimate pleasures, and we better play our part rather by attending to the fulfilment of the one and the enjoyment of the other, than by concentrating a morbid and paralyzing attention on the inevitable, with the too frequent result of producing indifference to the work which lies at hand for each. Our organs and faculties are not talents which we may justifiably leave unemployed; each is bound to do his best with them, and so to live that he may most utilize them. An active, vigorous, dutiful, unselfish life is a good preparation for death; when that time, at which we must pass from the realm controlled by physiological laws, approaches, when the hands tremble and the eyes grow dim, when “the grasshopper shall be a burden and desire shall fail,” then, surely, the consciousness of having “quitted us like men” in the employment of our faculties while they were ours to use, will be no mean consolation.



11

12



**DIESE SEITE IST FÜR KOSTENLOSE MITGLIEDER GESPERRT**  
Beantragen Sie jetzt die volle Mitgliedschaft, um diese Seite zu betreten



**Seien Sie niemals ohne ein Buch!**

Die Vollmitgliedschaft von Forgotten Books bietet Ihnen einen universalen Zugang von unseren Apps und unserer Website, auf all Ihren Geräten: Tablet, Telefon, E-Reader, Laptop und Computer.

**Eine Bibliothek in Ihrer Tasche für € 8.99/monat**

**Fortfahren**

\*Es gelten Richtlinien zur fairen Nutzung.

- Parthenogenesis, 4.  
Parturition, 24.  
Penis, 7.  
Placenta, 24.  
Pregnancy, 18.  
Prepuce, 8.  
Prostate gland, 6.  
Puberty, 18.  
Reproduction in general, 1.  
Reproductive organs, accessory,  
4; male, 4; female, 8.  
Rupture, 5.  
Seminal fluid, 8.  
Seminiferous tubules, 5.  
Sexual reproduction, 3.  
Somatopleure, 23.  
Spermatozoon, 4, 8.  
Sperm-cell, 4.  
Splanchnopleure, 23.



1 2 3 4



**DIESE SEITE IST FÜR KOSTENLOSE MITGLIEDER GESPERRT**

Beantragen Sie jetzt die volle Mitgliedschaft, um diese Seite zu betreten

# GESCHICHTE

Zehntausende von wichtigen historischen Quellen, viele bisher nicht erhältlich, stehen jetzt zum ersten Mal mit der Vollmitgliedschaft von Forgotten Books zur Verfügung.

Unbegrenzter Zugang  
\$8.99/monat

**Fortfahren**

\*Es gelten Richtlinien zur fairen Nutzung.













**DIESE SEITE IST FÜR KOSTENLOSE MITGLIEDER GESPERRT**  
Beantragen Sie jetzt die volle Mitgliedschaft, um diese Seite zu betreten



**Seien Sie niemals ohne ein Buch!**

Die Vollmitgliedschaft von Forgotten Books bietet Ihnen einen universalen Zugang von unseren Apps und unserer Website, auf all Ihren Geräten: Tablet, Telefon, E-Reader, Laptop und Computer.

**Eine Bibliothek in Ihrer Tasche für € 8.99/monat**

**Fortfahren**

\*Es gelten Richtlinien zur fairen Nutzung.





L. Landois'  
Lehrbuch  
der  
Physiologie des Menschen  
mit  
besonderer Berücksichtigung der praktischen Medizin

Vierzehnte Auflage.

Bearbeitet von

**Dr. R. Rosemann,**

o. ö. Professor der Physiologie und Direktor des physiologischen Instituts  
der Westfälischen Wilhelms-Universität zu Münster.

**Erster Band.**

*Mit 115 Abbildungen im Texte und 2 Tafeln.*

LANE LIBRARY

Urban & Schwarzenberg

Berlin

Wien

N., Friedrichstraße 105b

I., Maximilianstraße 4

1916.

Ka



**DIESE SEITE IST FÜR KOSTENLOSE MITGLIEDER GESPERRT**

Beantragen Sie jetzt die volle Mitgliedschaft, um diese Seite zu betreten

# GESCHICHTE

Zehntausende von wichtigen historischen Quellen, viele bisher nicht erhältlich, stehen jetzt zum ersten Mal mit der Vollmitgliedschaft von Forgotten Books zur Verfügung.

Unbegrenzter Zugang  
\$8.99/monat

**Fortfahren**

\*Es gelten Richtlinien zur fairen Nutzung.



## Tendenz und Bestimmung des Buches.

Bei der Bearbeitung des vorliegenden kurzgefaßten Lehrbuchs der Physiologie hat den Verfasser das Bestreben geleitet, für Ärzte dienende ein Buch zu liefern, welches in höherem Maße, als die meisten ähnlichen Werke der Fall ist, den Bedürfnissen des praktischen Arztes dienen soll.

In dieser Beziehung ist in allen Abschnitten an die Darstellung der normalen Vorgänge eine kurze Skizze der pathologischen Veränderungen angefügt. Dies hat den Zweck, den Blick des Lernenden von vornherein auf das Feld seiner späteren ärztlichen Wirkungen zu lenken und ihn aufmerksam zu machen, inwieweit der krankhafte Zustand eine Störung der normalen Vorgänge sei.

Andrerseits wird dadurch auch dem praktischen Arzt Gelegenheit geboten, das ihm in seiner Tätigkeit in der Regel schon bald ferner liegende theoretische Gebiet aufs neue mit Leichtigkeit zu rekapitulieren. Er kann hier mühelos von den krankhaften Erscheinungen, welche er behandelt, auf die normalen Vorgänge zurücksehen und durch die Erkenntnis dieser neuen Winke für die richtige Auffassung der Krankheitsbehandlung gewinnen.

Ganz besonders hat der Verfasser von diesem Gesichtspunkte alle jene Untersuchungsmethoden, welche auch von dem Praktiker zu großem Vorteile verwertet werden können, und die in den Büchern der Physiologie in der Regel nur sehr kurz dargestellt werden, eingehend behandelt. Es soll hier nur auf die Abschnitte hingewiesen werden: Untersuchung — graphische Untersuchung des normalen und krankhaft veränderten Herzstoßes — Herztöne und Geräusche — Pulslehre — Venenpuls — Transfusion — und abweichende Atmungsgeräusche — Ventilation — Untersuchung der Luft in Wohnräumen — Sputum — Abweichungen von den normalen Verdauungsprozessen — Diabetes

anung Fiebernder — Thermometrie und Calorimetric — Untersuchung des Trinkwassers — Fleisch und arate — übermäßiger Fett- und Fleischansatz und pfung — die Untersuchung des normalen Harnes timmung aller pathologischen Bestandteile sowie inkremente — Urämie, Ammoniämie, Harnsäuredys- rankhafte Störungen der Harnretention und Harn- — pathologische Abweichungen der Schweiß- und on — galvanische Durchleitung durch die Haut — Heilgymnastik — pathologische Abweichungen der unktionen — Laryngoskopie und Rhinoskopie — der Stimm- und Sprachbildung — physiologische der Anwendung der Elektrizität zu Heilzwecken — etten und elektrische Apparate. — Bei der Besprechung nen Nerven und der verschiedenen Nervencentra ist ne Skizze der pathologischen Erscheinungen an den- efügt. In bezug auf die Nervencentra ist besonders die Reflexe — die der Leitungen in den Centralorganen tmungscentrums, nebst Begründung der Hilfeleistung en — die Gruppe der Angioneurosen berücksichtigt. s Gewicht ist ferner gelegt auf die physiologische Topo- Großhirnoberfläche beim Menschen mit Rücksicht auf tersuchungen über die Lokalisation der Gehirnfunktionen. — g auf die Physiologie der Sinneswerkzeuge ist nach gleichem hren: die Refraktionsanomalien des Auges, die Brillen- pthalmoskopie, das Orthoskop, die Farbenblind- e praktische Bedeutung derselben, ferner die Unter- über die Funktionen der übrigen Sinnesorgane und imlichsten Störungen liefern hierfür Belege. Die Ent- eschichte hat namentlich überall den Hemmungsbildungen, ihmlichsten Formen der Mißbildungen, Rechnung getragen — nöglichst genauen Zeitbestimmung in der Entwicklung mensch- 3.

Darstellung war es das Bestreben des Verfassers, möglichst ersichtlich zu sein. Weitschweifige Diskussionen sind grund- ieden. Dabei ist im Äußeren überall die Anordnung so ge- schon durch den Druck das Wichtigere und das rein normal e hervortritt. Auch kann zunächst der Anfänger ohne Stö- ologisch-physiologischen Abschnitte übergeben; der Studierende schen Semestern wird jedoch mit Vorteil von den letzteren et der normalen Physiologie repetieren.

rfasser hat es ferner für geraten befunden, einem jeden Ab- Physiologie einen kurzen Abriß der geschichtlichen Ent-



wicklung der betreffenden Disziplin anzufügen, ebenso einen über die vergleichende Physiologie des Tierreiches. — die Histologie und mikroskopische Anatomie in jedem eingehender berücksichtigt, als dies in den meisten physiologischen Büchern der Fall zu sein pflegt.

Durch den hiermit entwickelten Grundplan in der Gestaltung glaube ich das Erscheinen des vorliegenden Werkes realisieren zu können.

Daß der entworfene Plan für die Darstellung kein Fehlgriff beweisen mir die vielfachen Besprechungen in den medizinischen Zeitschriften von Nord- und Süddeutschland, Österreich, der Schweiz, Ungarn, Frankreich, England, Italien, Skandinavien, Amerika, die das Wohlwollen und Anerkennung begrüßt haben.

Ganz besonders aber hat es den Verfasser gefreut, daß auch Reihen der Physiologen dem Buche Beifall gezollt worden ist. Um etwaige Bedenken derjenigen zu zerstreuen, welche vielleicht die Anlehnung der Physiologie an die praktischen Zweige der Medizin die wissenschaftliche Hoheit unserer für die gesamte medizinischen Disziplin gefährdet sehen könnten, gestatte ich mir ein Wort aus einem Briefe eines unserer geistreichsten und erfahrensten Lehrer hierher zu setzen.

*„Wenn jemand ein Handbuch veröffentlicht, wie dasjenige die erste Hälfte von Ihnen jetzt vorliegt, dann hat er den Dank der Lernenden, sondern auch des Lehrers und Forschers. Und Ehrgeiz darauf gerichtet ist, die drei bezeichneten Eigenschaften zu vereinigen, so sei Ihnen mein Dank aus vollem Herzen. Ihre pathologischen Ausführungen sind in ihrer gedrängten meisterhaft klar, daß ich mir von Ihrem Buche die heilsamste Wirkung und Rückwirkung auch auf klinischem Gebiete verspreche.*

*Rom, 10. April 1879. Ihr ergebener Kollege* *Jac. Moleschott*

Wenn diese Worte sich erfüllen sollten, würde ich den schönsten Lohn meines Strebens sehen. — Mir hat in meiner akademischen Lehrtätigkeit stets in erster Linie vorgeschwebt, daß mein Hauptzweck in der gründlichen Vorbildung physiologisch denkender Ärzte liegt. Und wenn man mir diesem meinen Ziele gegenüber das steigende Wort „wir bilden Physiologen“ entgegenhalten wollte, so würde mich dieses von meiner Richtung als Lehrer nicht entwegen, und nun einmal fest glaube, um mit dem Altmeister *Herophilus* zu reden: τὰ ὄντα εἶναι πρῶτα, εἰ καὶ μὴ ἔστι πρῶτα.

Der Verlagshandlung drängt es mich, meinen aufrichtigen Dank auszusprechen für die stets bereite Geneigtheit, allen Wünschen die schöne Ausstattung des Buches in ausgiebigster Weise zu entsprechen.



**DIESE SEITE IST FÜR KOSTENLOSE MITGLIEDER GESPERRT**  
Beantragen Sie jetzt die volle Mitgliedschaft, um diese Seite zu betreten



**Seien Sie niemals ohne ein Buch!**

Die Vollmitgliedschaft von Forgotten Books bietet Ihnen einen universalen Zugang von unseren Apps und unserer Website, auf all Ihren Geräten: Tablet, Telefon, E-Reader, Laptop und Computer.

**Eine Bibliothek in Ihrer Tasche für € 8.99/monat**

**Fortfahren**

\*Es gelten Richtlinien zur fairen Nutzung.

# Vorwort zur elften Auflage.

---

Als nach dem Tode *Landois'* die Verlagsbuchhandlung die Bearbeitung an mich richtete, die neue Auflage des *Landoisschen* Lehrbuches der Physiologie zu bearbeiten, war es für mich ebenso sehr eine Freude der Dankbarkeit gegen meinen von mir hochverehrten Lehrer, als die Freude an einer großen Aufgabe, die mich bestimmte, dieser Aufgabe Folge zu leisten. Hätte es sich darum gehandelt, etwa ein neues Lehrbuch der Physiologie zu verfassen, so hätte ich meine Kräfte und meine Zeit kaum für ausreichend angesehen, um eine derartige Aufgabe zu übernehmen. Für die Bearbeitung des *Landoisschen* Lehrbuches aber durfte ich mich zum mindesten aus dem Grunde für geeignet halten, weil *Landois* in langen Jahren, in denen ich sein Assistent war, häufig mit ihm über das Buch gesprochen und auch in der letzten Zeit mehrfach meine Vorschläge über etwa erwünschte Änderungen des Buches eingesehen und berücksichtigt hatte. So glaubte ich, daß es mir am ehesten gelingen würde, das Werk in dem Sinne seines Autors weiterzuführen.

Ich habe aber auch von Anfang an die Schwierigkeiten der übernommenen Aufgabe nicht unterschätzt; wie groß dieselben waren, habe ich ganz allerdings erst im Laufe der Bearbeitung erfahren. Die Arbeit, die ich aufgewandt habe, bin ich doch weit entfernt davon zu glauben, daß es mir gelungen sein könnte, dieser Schwierigkeit völlig Herr zu werden zur Zufriedenheit aller, denen das *Landoissche* Lehrbuch wertvoll geworden ist. Für jeden Rat nach dieser Richtung bin ich stets aufrichtig dankbar sein.

Die ganze Anlage des Buches ist selbstverständlich dieselbe, wie *Landois* sie getroffen hat; sie hat sich in den zahlreichen Auflagen und der weiten Verbreitung des Buches nicht nur in Deutschland, sondern auch im Auslande als richtig erwiesen. Es war der wohl berechtigten Forderung der Verlagsbuchhandlung, den Umfang des Buches, der in den letzten Jahren sehr zugenommen hatte, wieder etwas einzuschränken, daher, wo es nur angängig schien, Kürzungen vorgenommen, besonders aber die Abschnitte über Histologie und mikroskopische Anatomie etwas eingeschränkt. Dem entsprechend lautet auch der Titel des

er Physiologie des Menschen ohne den auf die Histologie  
che Anatomie bezüglichen Zusatz. Ich habe mich jedoch  
n können, die betreffenden Abschnitte etwa ganz fortzu-  
ird es manchem, der in dem Buche Auskunft sucht, er-  
renigstens die wichtigsten und für die Physiologie be-  
men Tatsachen aus der Histologie und mikroskopischen  
usammengefaßt zu finden.

des Buches habe ich einer gründlichen Durcharbeitung  
ihn mit dem heutigen Stande der Wissenschaft in Über-  
bringen. Von den *Landoisschen* Erben war der Verlags-  
liebenswürdigster Weise das Handexemplar *Landois'* zur  
lt worden, an welchem er bis kurz vor seinem Tode un-  
itet hatte. Ich habe seine Eintragungen nach Möglichkeit  
Obwohl der Gesamteindruck des Buches unverändert ge-  
doch der aufmerksame Leser die vielfachen Änderungen,  
n worden sind, bemerken; nur sehr wenige Seiten des  
z unverändert geblieben. Obwohl ich die Zeit, welche ur-  
ie Bearbeitung in Aussicht genommen war, erheblich über-  
var es mir doch nicht möglich, alle Abschnitte des Buches  
wie es mir wohl erwünscht gewesen wäre. So sind im  
Kapitel: Pathologisches, Vergleichendes, Historisches fast  
wesentliche Änderungen geblieben; ich mußte eine Bear-  
wie auch mancher anderer Abschnitte des Buches einer  
3 vorbehalten. Besondere Schwierigkeiten bereiteten mir  
el, in denen *Landois* auf Grund seiner eigenen Unter-  
speziellen Anschauungen zum Ausdruck gebracht hat. Ich  
für berechtigt, hier wesentliche Änderungen vorzunehmen,  
ig, daß *Landois* selbst, wenn es ihm noch beschieden ge-  
se Auflage seines Buches herauszugeben, diese Abschnitte  
rt gelassen hätte. Ich habe etwa abweichende Anschauungen  
t aufgenommen, so daß ich hoffe, daß der Leser auch  
ides Bild unserer heutigen Anschauungen gewinnen wird.  
ist das Literaturverzeichnis, welches ich dem Buche zuge-  
Fehlen jeglicher Literaturnachweise ist, wie mir von  
immer wieder versichert worden ist, vielfach als ein  
*loisschen* Lehrbuches empfunden worden; es war dadurch  
in dem Buche Auskunft suchte, die Möglichkeit sehr er-  
lfe der angeführten Autornamen die Originalarbeiten ein-  
vies sich jedoch nicht als möglich, für jeden im Text  
uch den entsprechenden Literaturnachweis zu geben; das  
nis hätte dann einen Umfang angenommen, der in  
is zu dem Nutzen desselben gestanden hätte. Ich habe  
uf beschränkt, besonders wichtige Literaturnachweise zu

geben, mit Hilfe deren eine weitere Orientierung leicht möglich ist, weit die Autoren schon im Texte zitiert sind, ist der Kürze wegen der Titel der Arbeit weggelassen worden, da aus der Erwähnung der Inhalt der betreffenden Abhandlung ersichtlich ist; ich habe auch mehrfach Arbeiten in das Literaturverzeichnis aufgenommen, im Texte nicht erwähnt wurden, aber gerade für die weitere Orientierung wertvoll erschienen; bei diesen ist dann auch der Titel (oft in kürzter Form) angegeben. Ich verhehle mir keineswegs, daß der Versuch eines Literaturverzeichnisses viele Mängel aufweist, ich um Nachsicht bitte; ich hoffe aber gleichwohl, daß das Verzeichnis auch in dieser noch wenig vollkommenen Form die Brauchbarkeit des Buches für viele erhöhen wird. — Das Inhaltsverzeichnis habe ich reichhaltiger gestaltet, damit es beim Nachschlagen möglichst leistet.

Zu großem Dank verpflichtet bin ich allen denen, welche mir Abzüge ihrer Arbeiten haben zugeben lassen; ich knüpfe daran mich auch weiterhin in gleich lebenswürdiger Weise unterstützen zu lassen. Besonderen Dank schulde ich den Herren *Ziemke* und *Müller* für die freundliche Überlassung der Spektraltafel. — Wenn die Fachgenossen eine etwaige weitere Auflage des Buches mir ihre Ratschläge zu lassen, mich auf Fehler oder Mängel aufmerksam machen würden, würde ich dafür aufrichtig dankbar sein; ich verspreche die so gegebene Prüfung und Berücksichtigung, soweit das nur immer möglich ist.

Die Verlagsbuchhandlung hat mir das weiteste Entgegenkommen erwiesen, allen meinen Wünschen und Vorschlägen freundlichste Berücksichtigung zuteil werden lassen und mich bei der Bearbeitung des Buches in vielfacher Weise unterstützt. Es ist mir eine große Freude, der Verlagsbuchhandlung auch an dieser Stelle dafür meinen Dank sagen zu können.

Möge die neue Auflage des Lehrbuches sich der vorangegangenen würdig erweisen, möge sie dem Buche die alten Freunde erhalten und neue gewinnen!

Münster i. W., im Mai 1905.

*R. Rosen*



**DIESE SEITE IST FÜR KOSTENLOSE MITGLIEDER GESPERRT**  
Beantragen Sie jetzt die volle Mitgliedschaft, um diese Seite zu betreten

# GESCHICHTE

Zehntausende von wichtigen historischen Quellen, viele bisher nicht erhältlich, stehen jetzt zum ersten Mal mit der Vollmitgliedschaft von Forgotten Books zur Verfügung.

Unbegrenzter Zugang  
\$8.99/monat

**Fortfahren**

\*Es gelten Richtlinien zur fairen Nutzung.



## Allgemeine Einleitung.

1. Begriff, Aufgabe und Stellung der Physiologie zu den verwandten Zweigen der Naturkunde . . . . .
2. Die Materie . . . . .
3. Kräfte. Arbeit. Lebendige Kraft. Energie . . . . .
4. Das Leben. Tier und Pflanze . . . . .

## Übersicht über die chemische Zusammensetzung des Organismus.

5. Die Eiweißkörper (Proteinstoffe) . . . . .
6. Die Fette . . . . .
7. Die Kohlehydrate . . . . .
8. Stoffwechselprodukte . . . . .
9. Anorganische Bestandteile . . . . .
- Literatur (§ 5—9) . . . . .

## Physiologie des Blutes.

10. Allgemeines über die Bedeutung des Blutes . . . . .
11. Physikalische Eigenschaften des Blutes . . . . .
12. Die Formelemente des Blutes . . . . .
13. Osmotischer Druck. Elektrolytische Dissoziation. Isotonie (Hyper- und Hypotonie). Permeabilität der Erythrocyten . . . . .
14. Auflösung der roten Blutkörperchen, Hämolyse . . . . .
15. Form, Größe und Zahl der Erythrocyten verschiedener Tiere . . . . .
16. Entstehung und Untergang der roten Blutkörperchen . . . . .
17. Die weißen Blutkörperchen (Leukocyten) und die Blutplättchen . . . . .
18. Pathologische Veränderungen der roten und weißen Blutkörperchen . . . . .
- Literatur (§ 10—18) . . . . .
19. Chemische Bestandteile der roten Blutkörperchen. Das Hämoglobin . . . . .
20. Sauerstoffverbindungen des Hämoglobins: Oxyhämoglobin und Methämoglobin. Spektroskopische Untersuchung . . . . .
21. Das Kohlenoxydhämoglobin und die CO-Vergiftung. Andere Hb-Verbindungen . . . . .
22. Zerlegung des Hämoglobins. Hämoglobinderivate . . . . .
23. Das Stroma der roten Blutkörperchen und die weißen Blutkörperchen . . . . .
- Literatur (§ 19—23) . . . . .
24. Das Blutplasma und der Faserstoff (das Fibrin) . . . . .
25. Allgemeine Erscheinungen bei der Gerinnung . . . . .
26. Wesen der Gerinnung . . . . .
27. Chemische Zusammensetzung des Blutplasmas und des Serums . . . . .
28. Bestimmung der einzelnen Bestandteile des Blutes . . . . .
29. Pathologische Veränderungen der Zusammensetzung des Blutplasmas und des Gesamtblutes . . . . .
- Literatur (§ 24—29) . . . . .

## Inhalt.

	Seite
ntes. Physikalische Vorbemerkungen . . . . .	89
Untersuchung der Blutgase . . . . .	90
nte . . . . .	92
Stickstoff im Blute . . . . .	94
. . . . .	96
rmehrung oder Verminderung der Blutmenge . . . . .	97
-35) . . . . .	98

## Physiologie des Kreislaufes.

ing und Einteilung . . . . .	99
misches. Anordnung der Muskelfasern . . . . .	100
Isolierung des Herzens . . . . .	103
des Herzens. Arbeit des Herzens . . . . .	106
en des Druckes im Herzen während seiner Tätigkeit . . . . .	112
as Kardiogramm . . . . .	114
erhältnisse der Herzbewegung . . . . .	118
. . . . .	120
ien Eigenschaften des Herzmuskels . . . . .	122
Herzbewegung . . . . .	127
r Herznerven auf die Herzbewegung . . . . .	131
influssung zwischen Herz und Lunge . . . . .	133
-47) . . . . .	135
rbemerkungen über die Strombewegung einer Flüssigkeit in einem . . . . .	138
chaften der Blutgefäße . . . . .	141
es Blutes im Gefäßsystem . . . . .	143
- Technik der Pulsuntersuchung . . . . .	145
las Sphygmogramm . . . . .	149
pulses . . . . .	151
schwindigkeit der Pulswelle . . . . .	152
Das Phlebogramm . . . . .	153
Plethysmographie . . . . .	154
isatorische Erscheinungen . . . . .	155
- Methoden der Messung des arteriellen Blutdruckes . . . . .	155
a den Arterien . . . . .	158
1 den Capillaren und Venen . . . . .	161
1 der Arteria pulmonalis . . . . .	162
keit des Blutstromes . . . . .	164
it . . . . .	168
g in den Venen . . . . .	169
g in den kleinsten Gefäßen . . . . .	169
sche in den Gefäßen . . . . .	171
des Blutes . . . . .	172
. . . . .	173
. . . . .	174
-69) . . . . .	176

## Physiologie der Atmung.

Einteilung . . . . .	178
. . . . .	178
Atembewegungen. Abdominaler Druck . . . . .	180
der gewechselten Atmungsgase . . . . .	182
ge. Größe der Lungenventilation . . . . .	183
ve (Pneumatogramm). Typus der Atembewegungen . . . . .	184
iskelwirkung bei der Inspiration und Expiration . . . . .	186
zelnem Atmungsmuskeln . . . . .	187



78. Maßverhältnisse und Ausdehnungsgröße des Thorax. Respiratorische Verhältnisse der Lungen . . . . .	
79. Pathologische Abweichungen von den normalen Schallverhältnissen am Brustkorbe . . . . .	
80. Die normalen Atmungsgeräusche . . . . .	
81. Pathologische Atmungsgeräusche . . . . .	
82. Mund- und Nasenatmung . . . . .	
83. Eigentümliche, abweichende Atembewegungen . . . . .	
84. Chemie der Atmung. Methoden der Untersuchung des respiratorischen Gaswechsels . . . . .	
85. Zusammensetzung und Eigenschaften der atmosphärischen Luft . . . . .	
86. Zusammensetzung der Ausatemungsluft . . . . .	
87. Der respiratorische Quotient . . . . .	
88. Größe des respiratorischen Gaswechsels . . . . .	
89. Der Vorgang der Sauerstoffaufnahme und der Kohlensäureausscheidung in der Atmung . . . . .	
90. Die Hautatmung (Perspiration) . . . . .	
91. Die innere oder Gewebsatmung . . . . .	
92. Atmung im abgesperrten Raume oder bei künstlich verändertem Gehalte der Atemungsluft an O und CO <sub>2</sub> . . . . .	
93. Atmen fremdartiger Gase . . . . .	
94. Normale Schleimbildung in den Luftwegen. Der Auswurf (Sputum) . . . . .	
95. Wirkungen der Veränderungen des Luftdruckes . . . . .	
96. Vergleichendes. Historisches . . . . .	
Literatur (§ 70—96) . . . . .	

## Physiologie der Verdauung.

97. Allgemeines über die Bedeutung der Verdauungsvorgänge . . . . .	
98. Die Mundhöhle und ihre Drüsen. Die Speicheldrüsen. Veränderung der Speicheldrüsen bei der Tätigkeit . . . . .	
99. Die Innervation der Speicheldrüsen . . . . .	
100. Eigenschaften und Zusammensetzung des Speichels . . . . .	
101. Physiologische Wirkungen des Speichels . . . . .	
102. Die Kaubewegung (Masticatio) . . . . .	
103. Bau und Entwicklung der Zähne . . . . .	
104. Schlingbewegung (Deglutatio) . . . . .	
105. Bewegungen des Magens. Das Erbrechen . . . . .	
106. Darmbewegungen. Innervation der Darmbewegungen . . . . .	
107. Entleerung des Kotes (Excretio faecum) . . . . .	
Literatur (§ 97—107) . . . . .	
108. Bau der Magenschleimhaut . . . . .	
109. Der Magensaft . . . . .	
110. Sekretion des Magensaftes . . . . .	
111. Vorgang der Magenverdauung und die Verdauungsprodukte . . . . .	
112. Bau des Pankreas. Absonderung des Pankreassaftes . . . . .	
113. Der Pankreassaft . . . . .	
114. Verdauende Wirkung des Pankreassaftes . . . . .	
Literatur (§ 108—114) . . . . .	
115. Bau der Leber . . . . .	
116. Chemische Bestandteile der Leberzellen . . . . .	
117. Die Zuckerharnruhr. Experimentelle Glykosurien . . . . .	
118. Bestandteile der Galle . . . . .	
119. Die Absonderung und Ausscheidung der Galle . . . . .	
120. Zurückaufnahme der Galle; Erscheinungen der Gelbsucht (Ikterus; Cholestasis) . . . . .	
121. Wirkung der Galle . . . . .	
122. Der Darmsaft . . . . .	
123. Die Gärungszersetzungen im Darne durch Mikroorganismen. Die Darmgärung . . . . .	
124. Vorgänge im Dickdarme. Bildung der Faeces . . . . .	
125. Krankhafte Abweichungen der Verdauungstätigkeiten . . . . .	
126. Vergleichendes . . . . .	
127. Historisches . . . . .	
Literatur (§ 115—127) . . . . .	



**DIESE SEITE IST FÜR KOSTENLOSE MITGLIEDER GESPERRT**  
Beantragen Sie jetzt die volle Mitgliedschaft, um diese Seite zu betreten



**Seien Sie niemals ohne ein Buch!**

Die Vollmitgliedschaft von Forgotten Books bietet Ihnen einen universalen Zugang von unseren Apps und unserer Website, auf all Ihren Geräten: Tablet, Telefon, E-Reader, Laptop und Computer.

**Eine Bibliothek in Ihrer Tasche für € 8.99/monat**

**Fortfahren**

\*Es gelten Richtlinien zur fairen Nutzung.

169.	Die anorganischen Bestandteile des Harns . . . . .
170.	Eiweiß im Harn (Albuminurie) . . . . .
171.	Blut und Blutfarbstoff im Harn (Hämaturie; — Hämoglobinurie) . .
172.	Gallenbestandteile im Harn (Cholurie) . . . . .
173.	Zucker im Harn . . . . .
174.	Sedimente im Harn . . . . .
175.	Die Harnkonkremente . . . . .
	Literatur (§ 158—175) . . . . .
176.	Der Vorgang der Bereitung und Absonderung des Harns . . . . .
177.	Einfluß der Nerven auf die Nierensekretion . . . . .
178.	Übergang verschiedener Stoffe in den Harn. — Urämie. — Giftigkeit
179.	Bau und Tätigkeit der Harnleiter . . . . .
180.	Bau der Harnblase und der Harnröhre . . . . .
181.	Ansammlung, Zurückhaltung und Entleerung des Harns. Innervation de
182.	Vergleichendes. — Historisches . . . . .
	Literatur (§ 176—182) . . . . .

### Tätigkeit der äußeren Haut.

183.	Bau der Haut . . . . .
184.	Nägel und Haare . . . . .
185.	Die Drüsen der Haut . . . . .
186.	Bedeutung der Haut als äußere Bedeckung . . . . .
187.	Die Hautatmung. — Die Hautsekretion. Der Hauttalg, der Schweiß . .
188.	Einflüsse auf die Schweißabsonderung. Nerveneinfluß . . . . .
189.	Pathologische Abweichungen der Schweiß- und Talgsekretion . . . . .
190.	Resorption der Haut. — Galvanische Durchleitung . . . . .
191.	Vergleichendes. — Historisches . . . . .
	Literatur (§ 183—191) . . . . .
192.	Innere Sekretion. — Die Blutgefäßdrüsen . . . . .
	Literatur (§ 192) . . . . .

### Physiologie der tierischen Wärme.

193.	Quelle der tierischen Wärme . . . . .
194.	Methoden der Temperaturmessung: Thermometrie . . . . .
195.	Methoden der Wärmemengen-Messung: Calorimetrie . . . . .
196.	Gleichwarme und wechselwarme Tiere . . . . .
197.	Temperatur-Topographie . . . . .
198.	Einflüsse auf die Temperatur der Einzelorgane . . . . .
199.	Schwankungen der mittleren Körpertemperatur . . . . .
200.	Regulierung der Wärme . . . . .
201.	Wärmebilanz . . . . .
202.	Größe der Wärmeproduktion . . . . .
203.	Einwirkung verschiedener Temperaturen auf den Körper . . . . .
204.	Künstliche Erhöhung der Körpertemperatur. Postmortale Temperatursteig
205.	Das Fieber . . . . .
206.	Künstliche Herabsetzung der Körpertemperatur . . . . .
207.	Historisches. — Vergleichendes . . . . .
	Literatur (§ 193—207) . . . . .

omie und Physiologie.  
ng.  
omie und Physiologie.  
lung.  
Anatomie, Physiologie  
dizin von Joh. Müller,  
is-Reymond.  
iologie.  
der Chemie und Phar-  
  
chimie et de physique.  
Physiologie.  
ygiene.  
iennes de Biologie.  
ournal of Physiology.  
linische Chirurgie.  
roskopische Anatomie.  
r Anzeiger.  
hrenheilkunde.  
physiologische Heil-  
  
experimentelle Patho-  
logie.  
erdauungskrankheiten.  
Centralblatt.  
der deutschen che-  
ft.  
inische Wochenschrift.  
Zeitschrift.  
ntralblatt.  
f. innere Medizin.  
: für klinische Me-  
t f. die medizinischen  
  
r Physiologie.  
is de l'académie des  
tes rendus de la so-  
es Archiv f. klinische  
ertation.  
medizinische Wochen-  
  
r Physiologie.  
er Medizin.  
ale de Paris.  
eiträge zur chemischen  
thologie.  
la Physiologie de  
imaux.  
le Physiologie et de  
  
experiment. Medicine.  
Monatsschrift für Ana-  
gie.  
Physiology.  
praktische Chemie.

L. A. = Abhandlungen der mathematisch-  
naturwissenschaftlichen Klasse der königl.  
sächsischen Gesellschaft der Wissenschaften  
zu Leipzig.  
L. B. = Berichte der mathematisch-natur-  
wissenschaftlichen Klasse der königl. säch-  
sischen Gesellschaft der Wissenschaften zu  
Leipzig.  
M. J. = Malys Jahresbericht über die Fort-  
schritte der Tier-Chemie.  
M. K. = Medizinische Klinik.  
M. m. W. = Münchener medizinische Wochen-  
schrift.  
M. U. = Moleschotts Untersuchungen zur Na-  
turlehre.  
N. F. = Neue Folge.  
P. A. = Pflügers Archiv für die gesamte Phy-  
siologie.  
P. R. S. = Proceedings of the Royal Society  
of London.  
P. S. = Philosophische Studien von Wundt.  
P. T. = Philosophical Transactions of the royal  
society of London.  
P. V. = Prager Vierteljahrsschrift.  
S. A. = Skandinavisches Archiv für Physiologie.  
S. B. A. = Sitzungsberichte der königl. preuß.  
Akademie der Wissenschaften zu Berlin.  
S. W. A. = Sitzungsberichte der k. Akademie  
zu Wien. Mathematisch-naturwissenschaft-  
liche Klasse.  
Th. M. = Therapeutische Monatshefte.  
V. A. = Virchows Archiv für pathologische  
Anatomie und Physiologie und klinische  
Medizin.  
V. 10. C. M. = Verhandlungen des 10. Con-  
gresses für innere Medizin.  
V. g. M. = Vierteljahrsschrift f. gerichtliche  
Medizin und öffentl. Sanitätswesen.  
W. B. = Sitzungsberichte der physikalisch-  
medizinischen Gesellschaft, Würzburg.  
W. K. = Wiener Klinik.  
W. k. W. = Wiener klinische Wochenschrift.  
W. m. P. = Wiener Medizinische Presse.  
W. V. = Verhandlungen der physikalisch-  
medizinischen Gesellschaft, Würzburg.  
Z. a. Ch. = Zeitschrift f. analytische Chemie.  
Z. a. P. = Zeitschrift für allgemeine Physiologie.  
Z. B. = Zeitschrift für Biologie.  
Z. e. P. u. T. = Zeitschrift für experimentelle  
Pathologie und Therapie.  
Z. k. M. = Zeitschrift für klinische Medizin.  
Z. O. = Zeitschrift für Ohrenheilkunde.  
Z. ph. Ch. = Zeitschrift für physiologische  
Chemie.  
Z. phk. Ch. = Zeitschrift für physikalische  
Chemie.  
Z. P. P. = Zeitschrift für Psychologie und  
Physiologie der Sinnesorgane.  
Z. r. M. = Zeitschrift für rationelle Medizin.

# 1. Begriff, Aufgabe und Stellung der Physiologie

zu den verwandten Zweigen der Naturkunde.

Die Physiologie ist die Wissenschaft von den Erscheinungen der Organismen, oder schlechtweg: die Lehre vom Leben. — Der Einteilung der Geschöpfe entsprechend unterscheidet man die Tierphysiologie, Pflanzenphysiologie und die Physiologie der niedersten Lebewesen, welche auf der Grenze von Tieren stehen, der sogenannten Protisten, und der mit ihnen auf gleichstehenden Elementarorganismen oder Zellen.

Aufgabe der Physiologie ist es, die Erscheinungen zu beobachten, festzustellen, ihre Gesetzmäßigkeit und Ursachen zu bestimmen und sie auf die allgemeinen Grundgesetze der Naturwissenschaftlich auf die der Physik und Chemie zurückzuführen.

Die Stellung der Physiologie zu den verwandten Zweigen der Naturkunde ergibt sich aus nachfolgendem Schema.

## Biologie,

die Wissenschaft von den organisierten Wesen, den Geschöpfen  
(Tiere, Pflanzen, Protisten und Elementarorganismen.)

### I. Morphologie:

Die Lehre von der Gestaltung der Geschöpfe.

Allgemeine Morphologie, Lehre von den geformten Grundbestandteilen der Geschöpfe (Histologie):	Spezielle Morphologie, Lehre von den Teilen und Organen der Geschöpfe (Organologie, Anatomie):
a) Histologie der Pflanzen,	a) Phytotomie,
b) Histologie der Tiere.	b) Zootomie.

### II. Physiologie:

Die Lehre von den Lebenerscheinungen der Geschöpfe.

Allgemeine Physiologie, Lehre von den Lebenserscheinungen im allgemeinen:	Spezielle Physiologie, Lehre von den Lebenserscheinungen im einzelnen:
a) der Pflanzen,	a) der Pflanzen,
b) der Tiere.	b) der Tiere.



**DIESE SEITE IST FÜR KOSTENLOSE MITGLIEDER GESPERRT**  
Beantragen Sie jetzt die volle Mitgliedschaft, um diese Seite zu betreten

# GESCHICHTE

Zehntausende von wichtigen historischen Quellen, viele bisher nicht erhältlich, stehen jetzt zum ersten Mal mit der Vollmitgliedschaft von Forgotten Books zur Verfügung.

Unbegrenzter Zugang  
\$8.99/monat

**Fortfahren**

\*Es gelten Richtlinien zur fairen Nutzung.



Denken wir uns den Teilungsprozeß an den Partikeln geführt, so gelangen wir endlich bis zu einer Grenze, über die weitere Spaltung weder durch mechanische noch auch durch sikalische Mittel ausgeführt werden kann. Wir dringen vor Molekülen. Ein Molekül ist demnach die geringste M. Körpers, welche im freien Zustande noch existieren k. ferner in der Einheit nicht mehr den Aggregatzustand z

Die Moleküle sind noch nicht die letzten Einheiten der K mehr besteht jedes Molekül aus einer Gruppe kleinster Einhe wir Atome nennen. Ein Atom für sich kann im freien Zu vorkommen, vielmehr vereinigen sich die Atome mit mater oder verschiedenen Atomen zu Atomkomplexen, die wir Molek haben. Den Atomen kommt unbedingte Unteilbarkeit zu, daher Benennung. Wir denken uns ferner die Atome von konstanter an sich fest. Vom chemischen Gesichtspunkte aus ist das . Elementes die geringste Menge desselben, welche in mische Verbindung einzutreten vermag. — So wie die Materie als ihre letzten Teilchen die ponderablen Atome i so setzt sich auch der Äther, die imponderable Materie, a kleinsten Teilchen, den Ätheratomen zusammen.

Innerhalb der ponderablen Materie sind nun die pondera mit den Ätheratomen in ganz bestimmten Verhältnissen zue geordnet. Die ponderablen Atome ziehen sich gegenseitig a derablen Atome ziehen gleichfalls die imponderablen Ätheratom die Ätheratome stoßen sich untereinander ab. So kommt es, ponderablen Materie um jedes ponderable Atom sich Ätherat lagern. Die ponderablen Atome streben vermöge ihrer gegen ziehungskraft zueinander hin, aber nur so weit, als die Abstoßu lagernden Ätheratome es zugibt. So können die ponderablen At ohne Zwischenräume sich zusammenlagern, sondern die ganze als locker gedacht werden, eben durch die zwischengelage atome, welche jedem unmittelbaren Kontakte der ponderablen A streben.

Von der gegenseitigen Anordnung der Moleküle hän, Aggregatzustand der Körper ab.

Die festen Körper haben ein eigenes nicht leicht ve Volumen und eigene Form, in weitem Maße unabhängig v gebung. In den festen Körpern sind die Moleküle in bestim leicht veränderlicher Lage zueinander angeordnet.

Die tropfbar flüssigen Körper haben ebenfalls ein eig leicht veränderliches Volumen, aber keine eigene Form, vielmehr von der Umgebung bestimmt. In den flüssigen Körper sich die Moleküle in einer steten Bewegung, ähnlich wie in ei wimmelnder Würmer oder Käfer die einzelnen Tiere unablässi, zueinander wechseln.

Die gasförmigen Körper haben weder ein eigenes noch eine eigene Form; sie füllen jeden ihnen dargebotene beliebiger Form gleichmäßig aus. In den gasförmigen Körper Bewegung der Moleküle so große Exkursionen angenommen, d einanderstieben, ähnlich wie der wimmelnde Haufen kleine einem aufgelösten Schwarme auseinanderfliegt.

in einer Ursache, welche den Vorgang bewirkt; diese Ursache ist die Kraft. Die Erscheinungen sind also der wahrnehmbare Ausdruck der auf die Materie wirkenden Kräfte. Die Kräfte selbst sind nicht wahrnehmbar, sie sind die Ursache der Erscheinungen.

Ein Körper beharrt, so lange keine Kraft auf ihn einwirkt, in dem augenblicklichen Bewegungszustand (Gesetz der Trägheit). Ein Körper ist in Ruhe, wenn er sich in Ruhe befindet (Geschwindigkeit = 0); seine Geschwindigkeit unverändert bei, wenn er sich in Bewegung befindet. Wirkt eine Kraft während einer gewissen Zeit auf einen Körper ein (auf den keine anderen Kräfte einwirken), so ändert sich der Bewegungszustand des Körpers: er bekommt eine gewisse Geschwindigkeit, wenn er sich vorher in Ruhe befand, oder er ändert seine Geschwindigkeit, wenn er sich bereits in Bewegung befand. Die Änderung der Geschwindigkeit pro Zeiteinheit nennt man die Beschleunigung; sie ist positiv, wenn die Geschwindigkeit des Körpers zugenommen hat (von 0 = Ruhe, oder von einer bestimmten Geschwindigkeit aus), negativ, wenn die Geschwindigkeit abgenommen hat. Das Maß der Kraft  $P$  ist das Produkt aus der Masse  $M$  und der Beschleunigung  $\varphi$ ; also  $P = M \cdot \varphi$ .

Im sogenannten Zentimeter-Gramm-Sekunden-Maßsystem (C. G. S.-Maßsystem) ist die Einheit der Länge das Zentimeter, die Einheit der Masse das Gramm, die Einheit der Zeit die Sekunde. Einheit der Kraft ist danach diejenige Kraft, welche auf ein Gramm während einer Sekunde die Beschleunigung  $1 \text{ cm}$  pro Sekunde erteilt. Diese Einheit der Kraft wird 1 Dyne genannt.

Die Schwerkraft an der Oberfläche der Erde erteilt einem Körper in einer Sekunde eine Beschleunigung  $g = 9,80 \text{ m}$ ; die auf einen Körper von der Masse  $M$  an der Oberfläche wirkende Kraft ist also  $= M \cdot g$ . Die Kraft, mit welcher ein Körper von der Erde angezogen wird, bezeichnet man als das Gewicht des Körpers, dasselbe ist also ebenfalls  $= M \cdot g$ . Im C. G. S.-Maßsystem ist die Kraft, mit der ein Körper von der Masse  $1 \text{ g}$  angezogen wird (Beschleunigung  $g = 9,80 \text{ m} = 980 \text{ cm}$ ) = 980 Dynen.

Ein frei fallender Körper erlangt unter dem Einfluß der Schwerkraft nach 1 Sekunde eine Geschwindigkeit  $g = 9,80 \text{ m}$ , nach  $t$  Sekunden die Geschwindigkeit  $v = t \cdot g$ , die Geschwindigkeit ist also proportional der verfloßenen Zeit. Die zurückgelegte Strecke,  $s$ , ist

$= \frac{g}{2} t^2$ , ist also proportional dem Quadrat der Zeit. Aus den beiden Gleichungen

$$\sqrt{2gs} \text{ und } s = \frac{v^2}{2g}.$$

Wenn eine Kraft ihren Angriffspunkt unter Überwindung eines Widerstandes in die Richtung einer ungesetzt gerichteten Kraft oder überhaupt eines Widerstandes längs eines bestimmten Weges verschoben hat, so hat sie Arbeit geleistet; die Größe der Arbeit wird bestimmt durch das Produkt aus der Länge des zurückgelegten Weges  $s$  und der Größe der Kraft  $P$ , also  $A = P \cdot s$ . Als Arbeitseinheit gilt die Arbeit, welche nötig ist, um  $1 \text{ kg}$  einen Meter hoch zu heben; diese Arbeitseinheit heißt Kilogramm-Meter.

Im C. G. S.-Maßsystem gilt als Arbeitseinheit diejenige Arbeit, welche zur Überwindung einer Kraft von 1 Dyne längs  $1 \text{ cm}$  nötig ist; diese Einheit heißt 1 Erg. Für größere Arbeit nimmt man als Einheit nicht die Dyne, sondern eine Kraft, welche  $1 \text{ kg}$  pro Sekunde eine Beschleunigung  $1 \text{ m}$  erteilt; sie ist  $= 100\,000 = 10^5$  Dynen; die Arbeit, welche zur Überwindung dieser Kraft längs  $1 \text{ m}$  nötig ist, heißt 1 Joule  $= 10^7$  Erg. 1 Kilogramm-Meter ist also  $= 10^7$  Erg.

Wirkt eine Kraft auf einen Körper ein, ohne dabei einen anderen Widerstand zu überwinden als den, welcher durch die Kraft selbst bewirkt wird, so wird keine Arbeit geleistet.



der Körper infolge seiner Trägheit einer Änderung seines Zustandes setzt, so erlangt der Körper unter der Einwirkung längs eines bestimmten Weges eine gewisse Geschwindigkeit. Kraft =  $P$ , die Masse des Körpers =  $M$ , die Beschleunigung ist nach Zurücklegung des Weges  $s$  die Geschwindigkeit des

$$v = \sqrt{2\varphi s}; \text{ mithin}$$

$$v^2 = 2\varphi s$$

$$Mv^2 = 2M\varphi s; \text{ und da } M\varphi = P, \text{ so folgt}$$

$$\frac{Mv^2}{2} = Ps.$$

Der Ausdruck  $\frac{Mv^2}{2}$  wird als „lebendige Kraft“ bez

Ausdruck  $Ps$  bezeichnete die Arbeit der Kraft  $P$  längs des W

Die Fähigkeit, Arbeit zu leisten, nennt man Energie. Ein Körpersystem kann Energie besitzen entweder infolge der Lage: Energie der Lage, potentielle Energie, Spannkräfte infolge seiner Bewegung, seiner lebendigen Kraft: Energie der Bewegung, kinetische Energie. Potentielle Energie enthält z. B. eine Last infolge ihrer Lage zum Mittelpunkt der Erde: stürzt sie von einer Höhe herunter, so vermag sie Arbeit zu leisten. Potentielle Energie enthält eine gespannte Feder: bei ihrer Entspannung vermag sie Arbeit zu leisten (daher der Name Spannkraft, der zuweilen für potentielle Energie überhaupt gebraucht wird). Kinetische Energie enthält jede in Bewegung befindliche Masse, so z. B. die von einer gewissen Höhe herabfallende Last, die mit einer bestimmten Geschwindigkeit unten ankommt. Das Spiel der von einer gewissen Höhe herabfallenden Last zeigt die Umwandlung von potentieller in kinetische Energie: die oben ruhende Last enthält potentielle Energie, der Betrag derselben ist gleich der Arbeit, die erforderlich war, die Last auf die Höhe zu heben, also  $= P \cdot s$ . Die mit einer gewissen Geschwindigkeit ankommende Last enthält kinetische Energie, der Betrag derselben ist gleich der lebendigen Kraft der Last, also gleich  $\frac{Mv^2}{2}$ . Nach der oben angegebenen Gleichung

sind die beiden Werte gleich: die potentielle Energie der oben ruhenden Last ist also ganz übergeführt in die kinetische Energie der unten mit derselben Geschwindigkeit ankommenden Last.

Ein Beispiel für die abwechselnde Umwandlung potentieller Energie in kinetische und umgekehrt liefert die Pendelbewegung. Die in dem höchsten Punkte der Schwingung sich befindende Pendellinse, welche hier für einen Moment in absoluter Ruhe werden kann, enthält (wie die gehobene Last des obigen Beispiels) potentielle Energie. In der nächsten Lage der Schwingung setzt sich diese in kinetische Energie um; wenn die Linse mit größter Geschwindigkeit durch die Vertikale geht, ist alle potentielle Energie umgewandelt. Steigt nunmehr das Pendel wieder in die Höhe, so wird die kinetische Energie wieder in potentielle umgewandelt. Ohne die Einwirkung der Widerstände (Luftwiderstand, Reibung) würde diese Umwandlung sich andauernd wiederholen.

Wenn sich in einem Systeme die einzelnen Teile der Schwingung der Gleichgewichtslage nähern, so nimmt in dem System die kinetische Energie auf Kosten der potentiellen zu; wenn sich die einzelnen Teile der Schwingung von der Gleichgewichtslage entfernen, so nimmt umgekehrt die potentielle Energie auf Kosten der kinetischen zu.

Die Umwandlung der einen Energieform in die andere erfolgt quantitativ nach bestimmten Verhältnissen vor sich; r



**DIESE SEITE IST FÜR KOSTENLOSE MITGLIEDER GESPERRT**  
Beantragen Sie jetzt die volle Mitgliedschaft, um diese Seite zu betreten



**Seien Sie niemals ohne ein Buch!**

Die Vollmitgliedschaft von Forgotten Books bietet Ihnen einen universalen Zugang von unseren Apps und unserer Website, auf all Ihren Geräten: Tablet, Telefon, E-Reader, Laptop und Computer.

**Eine Bibliothek in Ihrer Tasche für € 8.99/monat**

**Fortfahren**

\*Es gelten Richtlinien zur fairen Nutzung.

## 4. Das Leben. Tier und Pflanze.

Von den Vorgängen in der unbelebten Natur scheidet der erste Blick die Vorgänge in der belebten Natur prinzipiell ab, eine Reihe von Erscheinungen, wie Wachstum, Fortbewegung, Eigenbewegung, Empfindung usw., die wir an den belebten Wesen achten, kommen in der unbelebten Natur nicht vor. Diese Erscheinungen lassen sich alle wieder zurückführen auf eine Gesamtheit von Vorgängen, die für die lebenden Wesen charakteristisch sind und, solange sie währt, stets bei ihnen gefunden werden: die Vorgänge des Stoffwechsels. Die lebenden Wesen haben die Fähigkeit, den Stoff zu wechseln, ihn aus ihrer Umgebung aufzunehmen, zu Bestandteilen ihres Leibes zu verarbeiten und wieder nach außen abzugeben.

Die Bedeutung dieser Vorgänge für die lebenden Wesen ist zweifache. Einmal wird durch den Stoffwechsel den lebenden Wesen Stoff zugeführt, den sie zum Aufbau ihres Leibes bedürfen. Die ausgewachsenen Organismen geben dauernd im Laufe des Lebens Stoff ab, der zugrunde geht, die durch neue ersetzt werden müssen: das dazu benötigte Material muß immer wieder von neuem in der Nahrung zugeführt werden. Soweit dieses Material von anderen lebenden Wesen stammt (im Tier- oder Pflanzenreiche), muß es erst einer weitgehenden Verwitterung unterzogen werden, ehe es zur Aufnahme in den Körper des Lebewesens geeignet ist. Vielfältige Erfahrungen (§ 5, 130.3) beweisen es, daß die Stoffe, die die Zellen eines bestimmten Lebewesens zusammenbauen, vor allen andern die Eiweißstoffe durch einen besonderen Aufbau in großen Moleküls aus einfacheren Bausteinen charakterisiert sind, die einer bestimmten Art (vielleicht sogar jedem einzelnen Individuum?) eigen sind. Diese ihre Arteigentümlichkeit halten die lebenden Wesen während ihres ganzen Lebens mit großer Zähigkeit fest. Das in der Nahrung eingeführte artfremde Material muß daher zunächst durch Verdauungs- und Resorptionsorgane soweit zerlegt werden, bis der charakteristische Aufbau des Moleküls zerstört und ein indifferentes Material geschaffen ist, das nunmehr dem Körper dargeboten werden kann. In ihm baut der Organismus dann wieder das ihm zukommende Material auf seinen charakteristischen Arteigentümlichkeiten auf und verwandelt es zum Aufbau seiner Körperzellen.

Mit dem Stoffwechsel ist aber zweitens regelmäßig ein Energieumsatz verbunden, der den Lebewesen die für den Betrieb der Stoffvorgänge erforderliche Energie liefert. Dieser Energieumsatz ist bei allen lebenden Wesen, Tieren und Pflanzen im gleichen Sinne, nämlich in der Weise, daß potentielle chemische Energie in kinetische Energie umgewandelt wird. Die Unterhaltung der Lebensvorgänge dient und in verschiedener Weise nach außen abgegeben wird. Die Tiere nehmen in ihrer Nahrung Wasser und Salzen, deren Bedeutung ausschließlich stofflich ist, Eiweißkörper, Fette und Kohlehydrate auf, Stoffe, die infolge ihrer komplizierten chemischen Aufbaues reichliche chemische Spannung in sich enthalten. Im tierischen Stoffwechsel werden diese komplizierten Verbindungen in einfache gespalten, die unter Hilfe des eingeatmeten Sauerstoffs oxydiert; die Endprodukte des Stoffwechsels, die schließlich nach außen abgegeben werden, sind spannungsfreie Verbindungen, wie  $\text{CO}_2$ ,  $\text{H}_2\text{O}$ , oder doch ver-

me Verbindungen, wie z. B. Harnstoff. Die chemische Span-  
 genommenen Nahrungsstoffe wird also im Laufe des tierischen  
 s frei, sie wird umgesetzt in die kinetische Energie, die bei  
 in Lebensvorgängen zutage tritt, hauptsächlich in mechani-  
 gung und in Wärme. Aber auch in den Pflanzen ist ein völlig  
 Richtung verlaufender Energiewechsel vorhanden. Im pflanz-  
 ismus werden ebenfalls komplizierte chemische Verbindungen,  
 Kohlehydrate, aber auch Fette und Eiweißstoffe, abgebaut und  
 s Endprodukt wird  $\text{CO}_2$  produziert. Die freiwerdende chemische  
 it auch hier in derselben Weise wie im tierischen Körper dem  
 r Lebensvorgänge; eine Abgabe von kinetischer Energie in  
 Wärme ist vielfältig nachgewiesen. Allerdings wird bei einem  
 l der Pflanzen, nämlich bei allen grünen Pflanzen, dieser  
 isel verdeckt durch einen gleichzeitig vorhandenen, aber in  
 esetzter Richtung verlaufenden Energiewechsel. Die  
 nzen vermögen mit dem Chlorophyll ihrer Blätter kine-  
 ergie des Sonnenlichtes aufzunehmen; zugleich nehmen sie  
 unengesetzte, also spannkraftlose Verbindungen in sich  
 nsture, Wasser, einfache stickstoffhaltige Stoffe des Bodens.  
 endung der kinetischen Energie des Sonnenlichtes wird aus  
 achen Verbindungen der Sauerstoff abgespalten (Reduktion),  
 n Pflanzen ausgeatmet wird, und es werden die kompliziert  
 usetzten spannkraftreichen Kohlehydrate, Fette und Eiweißkörper  
 Synthese). Es findet hier also ein Energiewechsel in der  
 on kinetischer Energie zu potentieller chemischer Energie  
 ichte überwiegt quantitativ bei den grünen Pflanzen dieser  
 isel den gleichzeitig vorhandenen, entgegengesetzt gerichteten  
 her potentieller zu kinetischer Energie; im Dunkeln aber, wo  
 me von kinetischer Energie des Sonnenlichtes in Wegfall  
 l ebenso bei den chlorophyllosen Pflanzen, die überhaupt nicht  
 ne von Sonnenlicht-Energie befähigt sind, tritt dieser letztere  
 isel rein zutage. Die Umwandlung von potentieller  
 r Energie in kinetische Energie ist also eine allen  
 n gemeinsame Eigenschaft. Die hierfür erforderliche che-  
 ergie kompliziert zusammengesetzter Verbindungen muß den  
 chlorophyllosen Pflanzen als solche geliefert werden, die chloro-  
 n Pflanzen vermögen sie sich selbst unter Verwendung der  
 Energie des Sonnenlichtes zuzubereiten. Die Tiere und chloro-  
 Pflanzen sind daher auf die organische Substanz anderer Lebe-  
 . zuletzt auf die grünen Pflanzen angewiesen. In letzter In-  
 n alle lebenden Wesen vom Sonnenlichte.

energiewechsel von chemischer potentieller Energie zu kinetischer Energie erfolgt  
 r Umwandlung kompliziert zusammengesetzter chemischer Stoffe in einfache;  
 eine solche Umwandlung herbeizuführen, ist daher gleichfalls allen lebenden  
 i wie Pflanzen, gemeinsam. Diese Umwandlung kann entweder durch eine bloße  
 . B. des Traubenzuckers in Milchsäure,  $\text{C}_6\text{H}_{12}\text{O}_6 = 2 \text{C}_3\text{H}_4\text{O}_3$  oder durch  
 mit anschließender Oxydation erfolgen (z. B. der Milchsäure zu Kohlen-  
 stoff,  $\text{C}_3\text{H}_4\text{O}_3 + \text{O}_2 = 3 \text{CO}_2 + 3 \text{H}_2\text{O}$ ). Eine Gewinnung kinetischer Energie durch  
 kommt sicher im Laufe der Lebensvorgänge vielfach vor, die Oxydation der Spalt-  
 kann zeitlich und räumlich getrennt davon erfolgen; bemerkenswert aber ist  
 e Lebewesen während ihres ganzen Lebens auf Spaltungen allein ohne  
 zuweilen sind (Anoxybiose, vgl. § 92), so z. B. die in sauerstoffreicher Um-  
 von Fingergeldwürmern.

Die Gewinnung chemischer Energie aus der kinetischen Energie des Sonnenlichtes erfolgt im Organismus der grünen Pflanzen durch die chemischen Vorgänge der Photosynthese. Die Fähigkeit zu derartigen Vorgängen kommt aber keineswegs den grünen Pflanzen allein zu, sie findet sich ebenfalls bei allen Lebewesen, so auch bei den Tieren. Im Körper der höheren Tiere sind zahlreiche Umsetzungen bekannt, die mit der Reduktion (z. B. Entstehung von Fett aus Kohlehydraten, vgl. § 152. II) oder Synthese (z. B. des Harnstoffs aus Kohlensäure und Ammoniak, vgl. § 161, Bildung von Hippurinsäure, Glykokoll und Benzoesäure, vgl. § 165) einhergehen. Die hierfür erforderliche Energie wird allerdings der tierische Körper beziehen aus der chemischen Energie, die durch die Spaltung und Oxydation, eine Verwendung kinetischer Energie zum Zwecke der Reduktion und Synthese, wie bei den grünen Pflanzen, ist im Tierkörper nicht beobachtet. Es gibt aber auch im Organismus der grünen Pflanzen die nicht unter direkter Verwendung kinetischer Energie des Sonnenlichtes erfolgt, sondern unter Verbrauch chemischer Energie, die durch gleichzeitige Verbrennung etwa von Kohlehydraten gewonnen wird; indirekt stammt natürlich auch diese Energie schließlich aus dem Sonnenlichte.

Die Vorgänge des Energiewechsels in den lebenden Organismen vollziehen sich nach denselben quantitativen Verhältnissen wie in der unbelebten Natur: das Gesetz von der Erhaltung der Energie gilt in der belebten Natur ebenso wie in der unbelebten.

Es ist die Aufgabe der Physiologie, die Erscheinungen, welche in der belebten Natur wahrnehmen, auf die Kräfte der unbelebten Natur zurückzuführen und nach den für diese gefundenen Gesetzen zu erklären. Eine sogenannte „Lebenskraft“, welche nach einer früher verbreiteten Annahme in den belebten Wesen wirken und in die Äußerungen der Kräfte der unbelebten Natur in ungesetzmäßiger und daher unerkennbarer Weise eingreifen sollte, existiert nicht.

Wenn wir zur Zeit gleichwohl eine große Zahl von Erscheinungen nicht auf die uns bekannten Naturkräfte zurückzuführen können, so ist das einerseits dadurch bedingt, daß der sehr verwickelte Aufbau der kleinsten Teile der lebenden Wesen den Einblick in das Zustandekommen der Erscheinungen erschwert oder noch unmöglich macht, — andererseits dadurch, daß auch unsere Kenntnisse von den Kräften der unbelebten Natur und ihren Wirkungen noch beschränkt sind. Wir können mit Sicherheit annehmen, daß mit fortschreitender Erkenntnis der Kräfte der in der belebten und unbelebten Natur wirkenden Kräfte deutlicher sich ergeben wird, bis schließlich alle Erscheinungen an den lebenden Wesen wahrnehmen, ebenso als gesetzmäßige Äußerungen der Naturkräfte erkannt sind, wie die Vorgänge in der unbelebten Natur.

Von den sinnlich wahrnehmbaren Lebenserscheinungen sind zu trennen die psychischen (mit Bewußtsein verknüpften) Vorgänge, die nicht sinnlich wahrgenommen werden, sondern jedes Individuum in dem sie zukommen, wird sich derselben unmittelbar bewußt. Der Gegenstand der Naturwissenschaft nur die sinnlich wahrnehmbare materielle Welt ist, gehören die psychischen Vorgänge als solche nicht zum Gebiet der Naturwissenschaft. Das Wesen der psychischen Vorgänge, ihr Zustandekommen und ihre Beziehungen zur materiellen Welt sind nicht nur zur Zeit unbegreiflich, sondern werden es der Naturwissenschaft nach auch stets bleiben.



**DIESE SEITE IST FÜR KOSTENLOSE MITGLIEDER GESPERRT**  
Beantragen Sie jetzt die volle Mitgliedschaft, um diese Seite zu betreten

# GESCHICHTE

Zehntausende von wichtigen historischen Quellen, viele bisher nicht erhältlich, stehen jetzt zum ersten Mal mit der Vollmitgliedschaft von Forgotten Books zur Verfügung.

Unbegrenzter Zugang  
\$8.99/monat

**Fortfahren**

\*Es gelten Richtlinien zur fairen Nutzung.

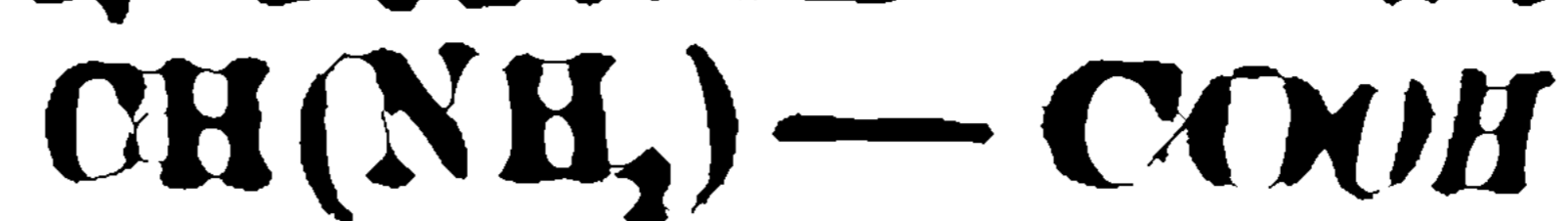

2.  $\alpha$ -Aminoglutarsäure, Glutaminsäure,

## II. Diaminosäuren.

1.  $\alpha$ -,  $\delta$ -Diaminovaleriansäure, Ornithin,

stets vereinigt mit dem Guanidinrest (Guanidin(HN))

als Guanidin- $\alpha$ -Aminovaleriansäure, Arginin,

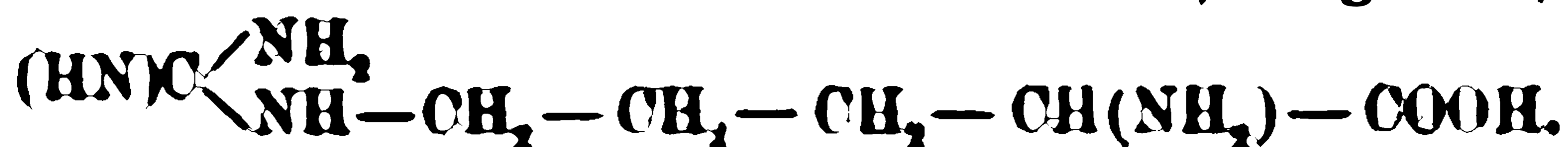
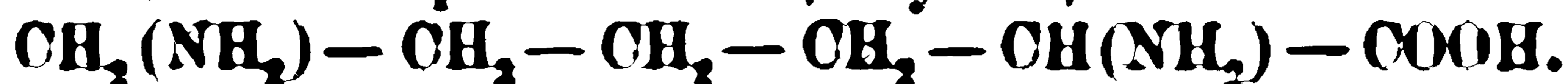
2.  $\alpha$ -,  $\epsilon$ -Diaminocaprinsäure, Lysin,

## III. Monoaminooxysäure:

$\alpha$ -Amino- $\beta$ -oxypropionsäure, Serin,  $\text{CH}_2(\text{OH}) - \text{CH}(\text{NH}_2) - \text{COOH}$

## IV. Schwefelhaltige Aminosäure:

Cystin, das Disulfid des Cysteins. Cystein ist  $\alpha$ -Aminopropionsäure,  $\text{CH}_2\text{.SH} - \text{CH}(\text{NH}_2) - \text{COOH}$ , Cystin hat die Substitution:

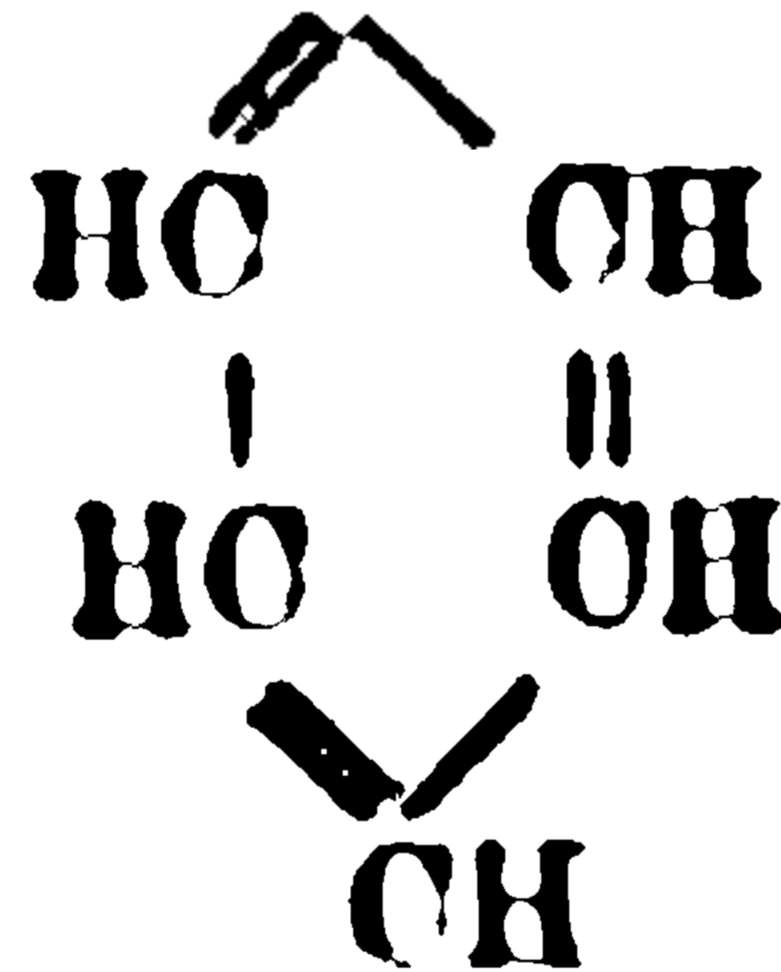
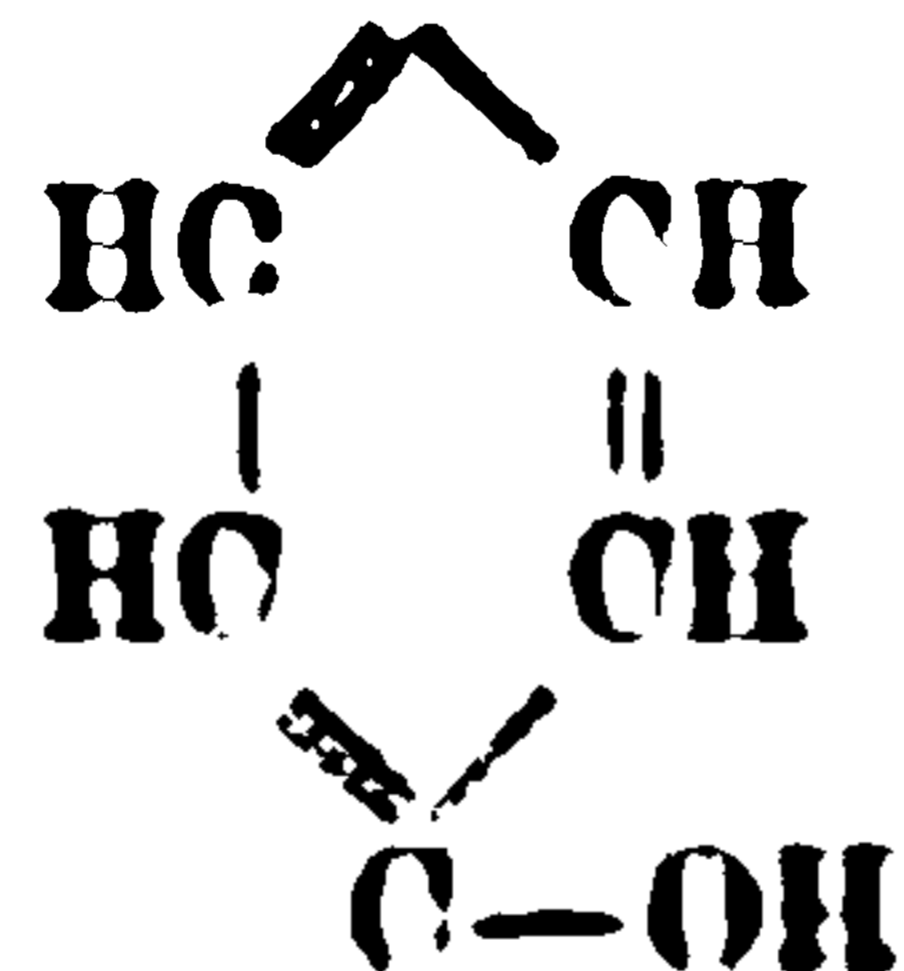

## C. Aromatische Kerne.

1. Phenyl- $\alpha$ -aminopropionsäure, Phenylalanin,2. *p*-Oxyphenyl- $\alpha$ -aminopropionsäure, Tyrosin,

## D. Heterocyclische Kerne.

## I. Pyrrol-Gruppe:

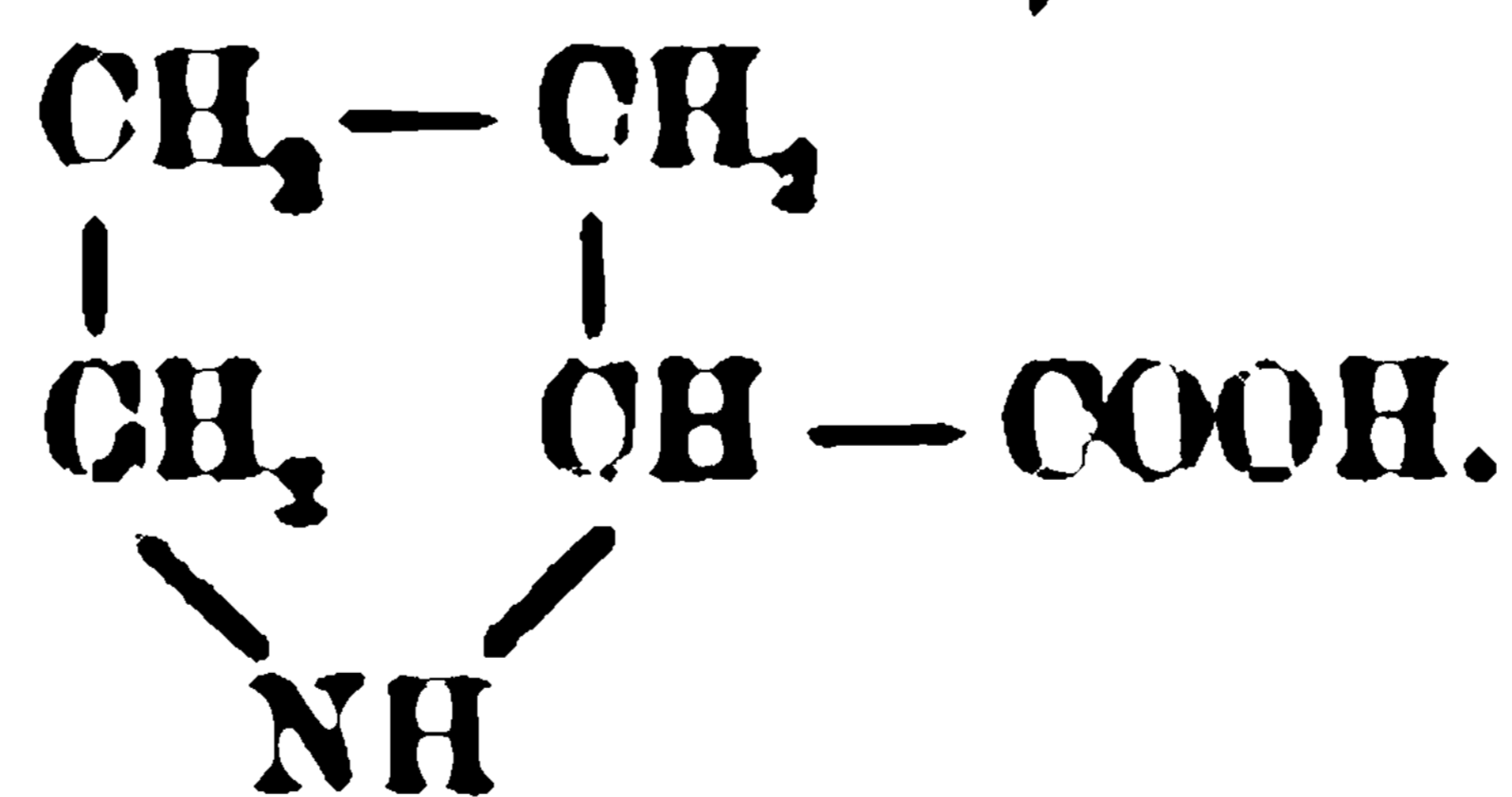
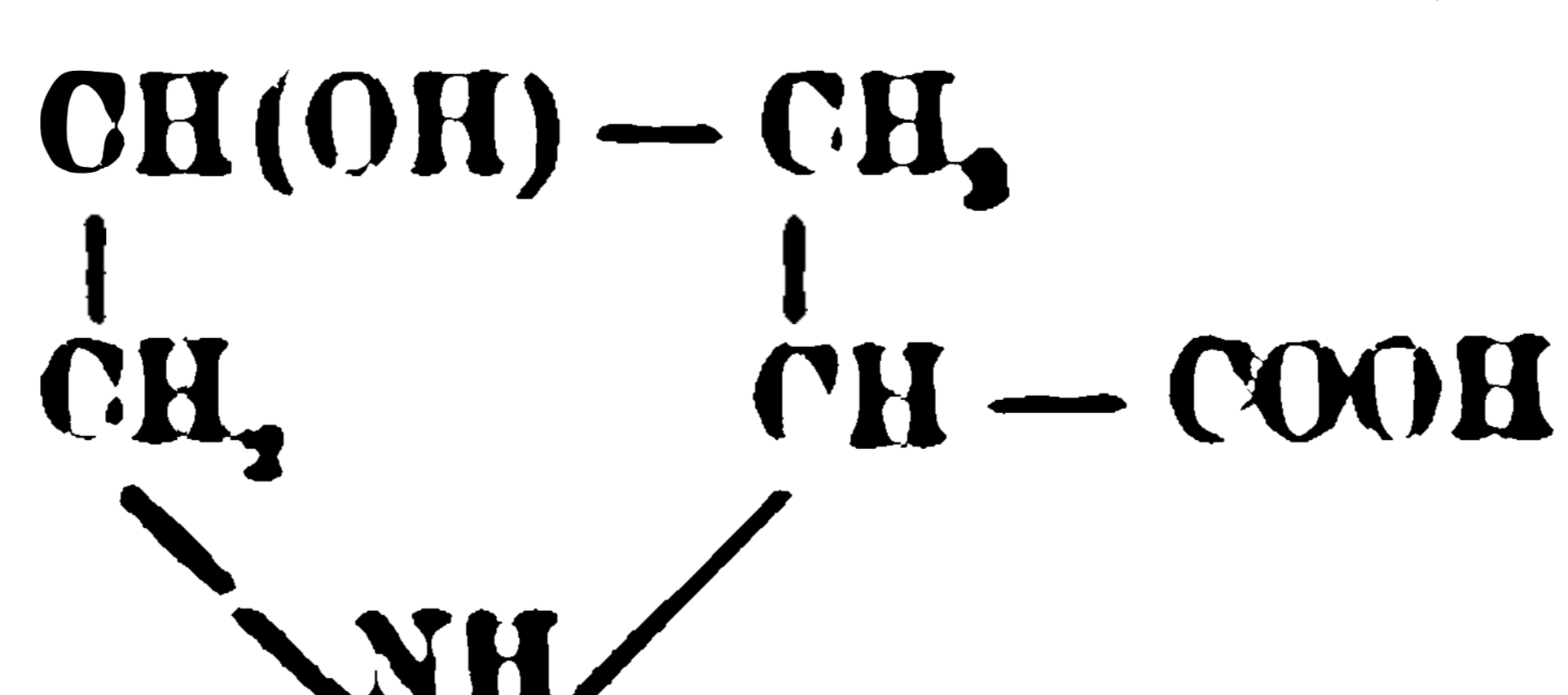
1.  $\alpha$ -Pyrrolidincarbonsäure, Prolin,2.  $\gamma$ -Oxy- $\alpha$ -Pyrrolidincarbonsäure, Oxy-Prolin,

## II. Indol-Gruppe.

Indol- $\alpha$ -aminopropionsäure, Tryptophan,

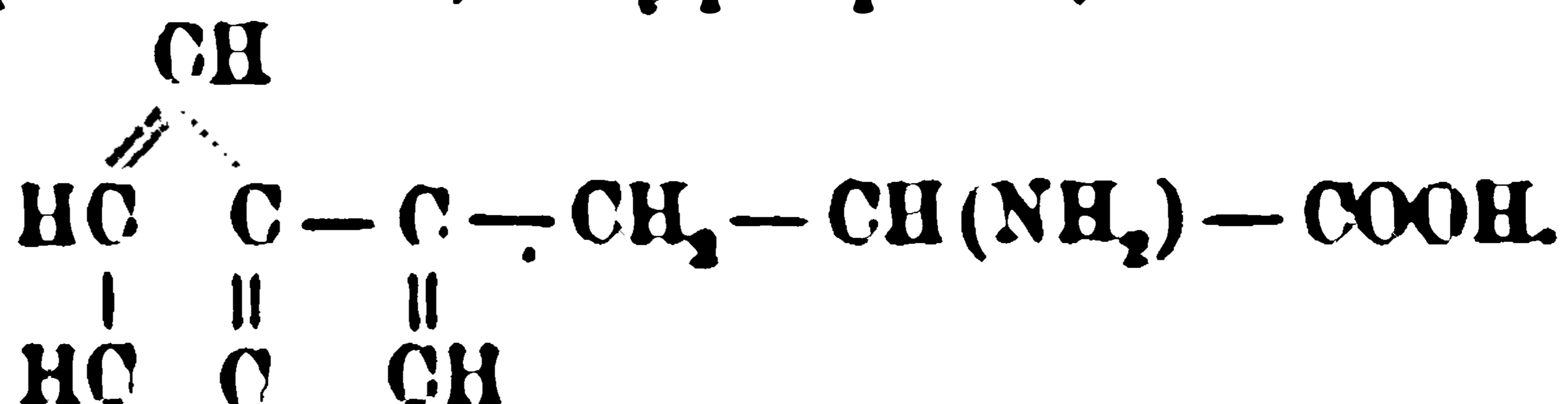

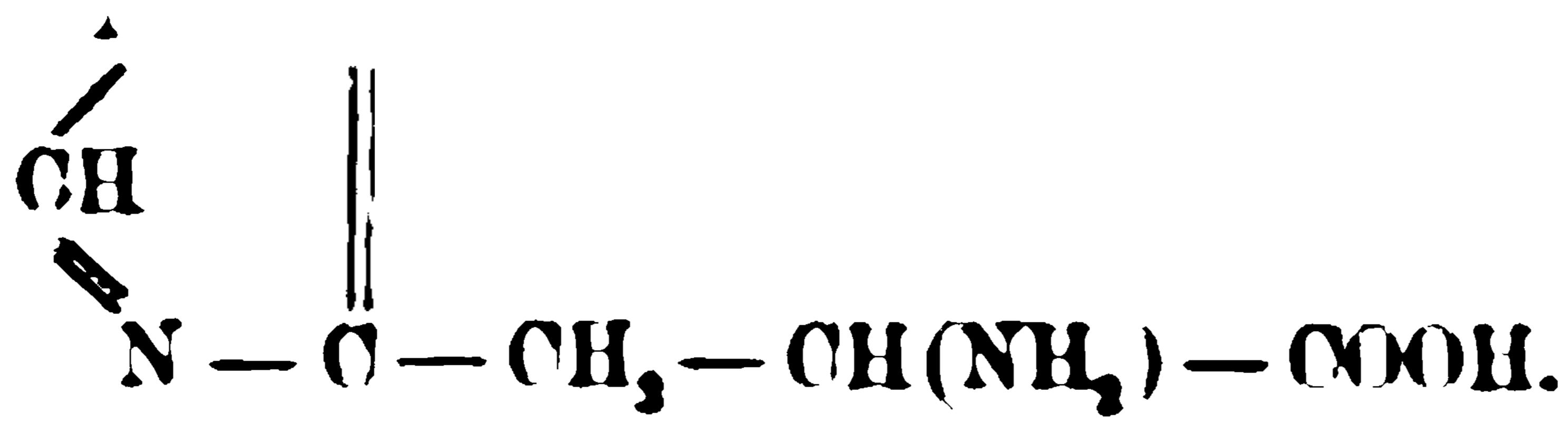

e Spaltprodukte des Eiweiß sind also durchweg Aminosäuren  
nahme des Glykokolls enthalten sämtliche Aminosäuren, die au  
entstehen, ein asymmetrisches C-Atom, sind also optisch aktiv

Verkettung der einzelnen Aminosäuren untereinander im Eiweiß  
erfolgt, ist nicht völlig bekannt; denkbar wären verschiede  
keiten, die vielleicht nebeneinander vorkommen. Nachgewiesen is  
nur eine Verkettung in der Art, daß die Aminogruppe der eine  
ture sich mit der Carboxylgruppe der anderen verbindet. So ent  
B. aus zwei Molekülen Glykokoll (Glycin) das Glycylglycin

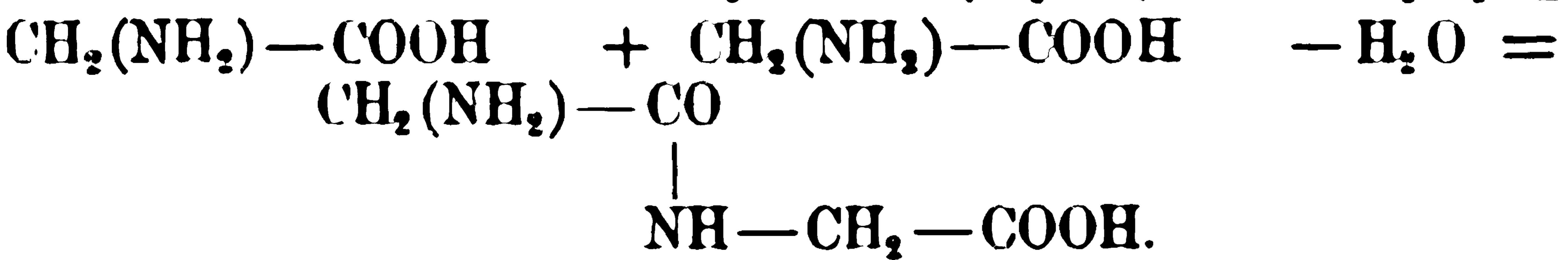

erartige Verbindungen, die sich aus zwei oder mehr Aminosäure  
ensetzen, bezeichnet *E. Fischer*<sup>3</sup> als Peptide und unterscheidet j  
r Zahl der Aminosäuren, die am Aufbau beteiligt sind: Di-, Tri  
, Penta-, Polypeptide. Das komplizierteste, bisher synthetisc  
ellte Polypeptid ist eine 18-gliedrige Kette, ein Oktadekapeptid  
nd aus 3 Molekülen Leucin und 15 Molekülen Glykokoll. Die Poly  
stehen bereits den Peptonen nahe. Die verschiedenen Eiweißkörper  
cheiden sich voneinander sowohl durch das Vorhandensein resp  
bestimmter Kerne, als auch durch Differenzen in den quantitative  
nissen der vorhandenen Kerne, sowie durch die verschiedene An  
der Kerne im Molekül. Selbst bei völlig gleichen quantitative  
nissen ist durch verschiedene Lagerung der einzelnen Kerne i  
des Eiweißes eine fast unendlich große Zahl von Isomerie  
. Vielfache Beobachtungen sprechen dafür, daß die chemisch von  
r nicht zu unterscheidenden Eiweißkörper verschiedener Tierarte  
ht sogar verschiedener Individuen?) derartige isomere Substanze  
en: jede Tierart ist danach durch einen ihr eigentümlichen Aufba  
eißmoleküls charakterisiert (Arteigentümlichkeit des Eiweiß)  
ie Eiweißkörper sind meist löslich in Wasser oder verdünnte  
ngen, dagegen unlöslich in Alkohol oder Äther. Die „gelösten  
örper befinden sich jedoch nicht in einer wahren Lösung, sonder  
sog. kolloiden Zustände: sie diffundieren (mit Ausnahm  
stone) schwer oder überhaupt nicht durch tierische Membranen  
sind entweder gar nicht oder nur schwer zum Krystallisieren  
gen; krystallisiert sind bisher dargestellt worden Hämoglobin, Eier  
rumalbumin, Vitellin, verschiedene pflanzliche Eiweißstoffe. Di  
örper drehen die Ebene des polarisierten Lichtes, und zwa  
ach links. (Rechtsdrehung zeigen Nucleoproteide, Nucleohiston  
obin [*Gamgee* u. *Croft Hill*].)

reaktionen der Eiweißkörper.

urbenreaktionen: — 1. Xanthoprotein-Reaktion. Mit Salpetersäure gekoch  
Eiweiß gelb, nach dem Übersättigen mit Ammoniak oder Natronlange orange. Di  
beruht auf der Anwesenheit aromatischer Kerne im Eiweißmolekül. — 2. *Millon*



sche Reaktion. Mit *Millons* Reagens (Mercurinitratlösung mit salpetriger Säure färbt sich Eiweiß rot. Die Reaktion beruht auf der Anwesenheit einer Oxypol-Gruppe (Tyrosin) im Eiweißmolekül. — 3. Biuret-Reaktion. Gelöstes Eiweiß gibt mit verdünnter Kupfersulfatlösung (tropfenweise zugesetzt, ein Überschuß verdeckt die violette bis rote Färbung. (Biuret, ein Derivat des Harnstoffes, gibt dieselbe Reaktion. — 4. *Adamkiewicz*sche Reaktion. Die Lösung möglichst trockenen, entfetteten Eiweißes in Eisessig wird durch konzentrierte Schwefelsäure violett gefärbt. (Die Wirkung des Eisessigs beruht nach *Hopkins* u. *Cole* nur auf dem Gehalt desselben an Glyoxylsäure, kann daher statt des Eisessigs auch verdünnte Glyoxylsäure verwenden.) Die Reaktion beruht auf der Anwesenheit des Tryptophans im Eiweißmolekül. — 5. *Liebermann*sche Reaktion. Lösungen von trockenem, entfetteten Eiweiß in konzentrierter Salzsäure färbt sich bei gewöhnlicher Temperatur nach einiger Zeit, beim Kochen schneller, violett. Die Reaktion beruht auf der gleichzeitigen Anwesenheit einer aromatischen Kohlenhydratgruppe im Eiweißmolekül. — 6. *Molisch*sche Reaktion. Zu einer Eiweißlösung einige Tropfen einer alkoholischen Lösung von  $\alpha$ -Naphthol und konzentrierte Schwefelsäure, so entsteht eine violette Färbung, bei Verwendung an Stelle des  $\alpha$ -Naphthols eine rote Färbung. Die Reaktion beruht auf der Anwesenheit einer Kohlenhydratgruppe im Eiweißmolekül. — 7. Schwefelblei-Reaktion. Eiweiß mit wenig Bleiacetat und überschüssiger Natronlauge entsteht Gelb-, Braun- oder Schwarzfärbung, eventuell ein schwarzer Niederschlag von Schwefelblei. Die Reaktion beruht auf der Anwesenheit der Cystingruppe im Eiweißmolekül, Abspaltung von Schwefelwasserstoff und Bildung von Schwefelblei.

**Fällungsreaktionen.** — Die Eiweißkörper befinden sich in ihren Lösungen in kolloiden Zustände (s. oben). Die kolloide Lösung eines Stoffes wird als Sol bezeichnet, wenn Wasser das Lösungsmittel, so spricht man von Hydrosol. Mannigfache Eiweißkörper können kolloide Körper aus dem Sol-Zustand ausfällen, der ausgefällte Körper wird als Gel, resp. Hydrogel bezeichnet. Die Umwandlung des Sol-Zustandes in den Gel-Zustand kann entweder irreversibel oder reversibel sein. Im ersteren Falle hat der Körper so weitgehende Veränderungen erlitten, daß er nicht wieder ohne weiteres in den Sol-Zustand übergeht. Bei den Eiweißkörpern nennt man diese irreversible Änderung ihres Zustandes bei den meisten Ausfällungen erleiden, Denaturierung; sie werden dabei in eine feste Modifikation übergeführt, koaguliert. Koaguliertes Eiweiß ist nach der Entfernung des Fällungsmittels nicht wieder unverändert löslich; es kann nur in Lösung gehen durch a) verdünnte Laugen, wodurch Alkalialbuminat entsteht, — b) verdünnte Säuren oder starke organische Säuren, wodurch Acidalbumin entsteht, — c) die Verdauung durch Pepsin, Albumosen und Peptone entstehen. — Das Aussalzen der Eiweißkörper durch Zugabe von Neutralsalzen (siehe unten 6.) ist dagegen eine reversible Zustandsänderung. Eiweißkörper werden dabei nicht koaguliert; nach Entfernung des Fällungsmittels sind sie unverändert löslich, wie zuvor. Die Methode des Aussalzens ist deswegen für die Untersuchung der Eiweißkörper von ganz besonderer Bedeutung.

**Eiweiß fällend wirken:** — 1. Erhitzen bei schwach saurer Reaktion. Die Koagulationstemperatur ist für die verschiedenen Eiweißkörper verschieden, für denselben Eiweißkörper aber auch abhängig von der Konzentration, dem Salzgehalt der Lösung. — 2. Starker Alkohol; bei längerer Einwirkung koaguliert Eiweiß in den koagulierten Zustand übergeführt. — 3. Konzentrierte Mineralsäuren, allem Salpetersäure, ebenso Metaphosphorsäure. — 4. Salze der Schwermetalle (Eisenchlorid, neutrales und basisches Bleiacetat, Kupfersulfat, Platinchlorid, Quecksilberchlorid in salzsaurer Lösung); die Schwermetalle bilden mit dem Eiweiß als Säure unlösliche Verbindungen. — 5. Die sogenannten Alkaloidreagentien: Essigsäure, Ferrocyankalium, Gerbsäure + Essigsäure, Pikrinsäure + Citronensäure, Tannin, Phosphorwolframsäure, Phosphormolybdänsäure, Jodquecksilber-Jodkalium + Salzsäure. — 6. Auflösung von Neutralsalzen (Sulfate des Ammoniums, Natriums, Zinks; Kochsalz) besonders bei saurer Reaktion (Aussalzen). Geschicklicher Zusatz ganz allmählich, so lassen sich auf diese Weise manche Eiweißkörper koagulieren und ausscheiden. Durch Aussalzen werden die Eiweißstoffe chemisch nicht verändert (nicht koaguliert), sie behalten insbesondere ihre Löslichkeit.

**Quantitative Bestimmung des Eiweiß.** Das Eiweiß wird durch Zugabe von Essigsäure bei schwach saurer Reaktion ausgefällt, auf einem gewogenen Filter gesammelt, getrocknet, gewogen, darauf verbrannt und das Gewicht der Asche in Abzug gebracht.

Enthält die zu untersuchende Flüssigkeit außer Eiweiß keine anderen N-baltigen Stoffe, so kann man nach *Kjeldahl* den N-Gehalt bestimmen (§ 162) und durch Multiplikation des N mit 6,25 ungefähr den Eiweißgehalt berechnen. (Eiweiß enthält im Mittel 16% N  $\times 6,25 =$  Eiweiß. Freilich ist der N-Gehalt verschiedener Eiweißstoffe verschieden.)



**DIESE SEITE IST FÜR KOSTENLOSE MITGLIEDER GESPERRT**  
Beantragen Sie jetzt die volle Mitgliedschaft, um diese Seite zu betreten



**Seien Sie niemals ohne ein Buch!**

Die Vollmitgliedschaft von Forgotten Books bietet Ihnen einen universalen Zugang von unseren Apps und unserer Website, auf all Ihren Geräten: Tablet, Telefon, E-Reader, Laptop und Computer.

**Eine Bibliothek in Ihrer Tasche für €8.99/monat**

**Fortfahren**

\*Es gelten Richtlinien zur fairen Nutzung.

werden, so in Verbindung mit Nuclein als Nucleohiston in der Thymusdrüse, in den Vogelerythrocyten und Leukocyten, als Globin (§ 22) verbunden mit Hämatin in den Erythrocyten, endlich im Sperma verschiedener Fische.

Die Protamine — sind sehr stickstoffreiche (25–30%), aber schwefelarm, stark basischer Natur; bei der Spaltung geben sie sehr reichlich Diaminosäuren (Arginin), aber wenig Monoaminosäuren. Kossel bezeichnet sie als die einfachsten Eiweißkörper. Sie kommen im Sperma vieler Fische in Verbindung mit Nucleinsäuren vor.

Vegetabilische Proteine. — Die Pflanzen enthalten, wenn gleich in geringerer Menge als die Tiere, Eiweißkörper verschiedener Art. Sie treten entweder in löslicher (gequollener) Form auf, namentlich in den Säften der lebenden Pflanzen, oder in unlöslicher Form. Man unterscheidet:

1. Pflanzenalbumine — sind in den Pflanzen weit verbreitet, aber schwer von den begleitenden Globulinen zu trennen. Näher untersucht sind Albumine aus Weizen, Roggen und Gerste, welche als Leukosin zusammengefaßt werden. Leukosin unterscheidet sich vom tierischen Albumin dadurch, daß es durch Säuren, Kochsalz und Magnesiumsulfat gefällt wird.

2. Pflanzenglobuline. — Ein Teil dieser Eiweißstoffe wurde früher als zencaseine bezeichnet, weil sie wie das Casein in schwachen Alkalien löslich sind, durch verdünnte Säuren und Lab gefällt werden. Hierzu gehören: Das Leguminose, das Glutencasein des Weizens (der in Alkohol unlösliche Teil der Kleberstoffe), das Conglutin der Lupinen. Für eine Gruppe aus verschiedenen Pflanzenglobulinen (Weizen, Mais, Gerste, Reis usw.) herstellbarer Globuline haben Chittenden und andere den Namen Edestin eingeführt, eine andere Gruppe (in Mais, Hafer, Bohnen) bezeichnet sie als Pflanzen-Myosine. Ein im Hafer vorkommendes Globulin wird als Haferglobulin bezeichnet.

Die meisten dieser Globuline lassen sich aus der kochsalzhaltigen Lösung in Form von Kristallen (Oktäeder, Sphäroide, hexagonale Platten) gewinnen.

3. In Alkohol lösliche Pflanzenproteine. — Diese Gruppe ist in den Pflanzen reichlich (im Gegensatz zum Tierreiche) weit verbreitet. Sie finden sich reichlich in den Kleberstoffen des Getreides, die als Kleberproteinstoffe zusammengefaßt werden. Im Weizen findet sich zunächst ein in Alkohol unlöslicher Eiweißstoff, das Glutencasein, welches zu den Globulinen gehört (s. unter 2), außerdem aber drei voneinander verschiedene in Alkohol lösliche Stoffe: das Glutenfibrin, das Gliadin und das Mucedin. In der Gerste kommt das Hordein vor.

## II. Proteide.

Die Proteide — sind Verbindungen von Proteinen mit anderen organischen oder anorganischen, meist kompliziert zusammengesetzten Körpern, die „prosthetische Gruppe“ bezeichnet; sie können durch Spaltung mit Wasser, Säuren oder Alkalien in ihre beiden Bestandteile zerlegt werden. Nach der Art der prosthetischen Gruppe unterscheidet man:

A. Chromo-Proteide — Verbindungen von Eiweiß mit Farbstoffen.

Das Hämoglobin (vgl. § 19, seine Verbindungen und Derivate § 20 bis 22) ist eine Verbindung von Hämatin mit Globin. Das Globin gehört zu den Globulinen (vgl. oben).

B. Glyko-Proteide — Verbindungen von Eiweiß mit Kohlenhydraten oder Kohlehydratderivaten; bei der Spaltung liefern sie Glucose (vgl. pag. 26). Kohlehydratgruppen sind aber auch in anderen Eiweißkörpern, echten Proteinen, gefunden worden; vielleicht gehören auch Kohlehydratgruppen überhaupt zu den Spaltprodukten des Eiweißes. Man würde also die Glykoproteide nur dieses Spaltprodukt in besonderer Menge enthalten.

1. Die Mucine — sind in Wasser unlöslich, verflüssigen sich aber in Wasser ziehend, schleimig. Mit wenig Alkali gehen sie neutrale, fadenziehende Salze ein. Sie gerinnen nicht beim Kochen, werden gefällt durch Säuren (verdünnte Essigsäure), durch Alkohol (der Alkoholniederschlag löst sich wieder in Wasser), nicht durch Essigsäure, Ferrocyankalium. Sie zeigen alle Farbenreaktionen der Eiweißkörper. Sie finden sich im Speichel, in der Galle, in den Schleimdrüsen und Sekreten der Schleimhäute, in

belschnur), in den Sehnen (im Tierreich besonders in den Schnecken und in der Lolothurien).

Die Mucocide — den Mucinen ähnlich, aber im physikalischen Verhalten und Funktionen abweichend; z. B. das Ovomucoid im Hühnereiweiß u. a. — Über Mucoid vgl. S. 17.

## Verbindungen von Eiweiß mit phosphorhaltigen Substanzen.

Die Nucleoproteide<sup>7</sup> — sind Verbindungen von Eiweiß (meist ein Protamin) und Nucleinen. Die Nucleine sind wiederum Verbindungen von Eiweiß mit Säuren. Die Nucleinsäuren endlich liefern bei der Spaltung Phosphor-Nucleinbasen nebst anderen Substanzen (s. u.).

Nucleoproteide bilden die Chromatinsubstanz der Zellkerne (daher der Name) und sind im Tier- und Pflanzenreich sehr verbreitet. Sie sind nur wenig löslich in Salzlösungen, haben sauren Charakter und vereinigen sich daher mit Alkalien zu leicht löslichen Verbindungen; durch Säuren werden sie gefällt. Durch Pepsin werden sie gespalten in Eiweiß, welches weiter zu Albumosen und Peptonen verdaut und Nuclein, welches sich abscheidet, da es gegen Pepsinsalzsäure eine große Widerstandsfähigkeit besitzt. Nucleoproteide sind hergestellt aus Thymusdrüse, Pankreas, Leber, Gehirn, Schilddrüse und anderen Organen, sowie aus Spermatozoenköpfen. Die Nucleine sind in Wasser und verdünnten Säuren unlöslich oder nur wenig löslich. Sie haben stärker sauren Charakter als die Nucleoproteide, höheren Phosphorgehalt und besitzen eine hohe (doch nicht absolute) Widerstandsfähigkeit gegen Pepsin; durch Trypsinverdauung werden sie gespalten. — Die Nucleinsäuren geben bei der Spaltung keine Eiweißreaktionen mehr, sie enthalten C, H, N, O und P, keinen S. Sie sind löslich in Wasser und Alkalien, werden durch Mineralsäuren aus ihren Lösungen bei der Spaltung liefern sie — 1. Phosphorsäure. — 2. Nuclein- oder Purinbasen (vgl. pag. 27), nämlich die beiden Aminopurine: Adenin und Guanin; durch Pepsinwirkung werden sie bei der Spaltung teilweise in die entsprechenden Oxypurine: Hypoxanthin und Xanthin umgewandelt, diese sind aber ursprünglich in der Nucleinsäure enthalten. — 3. Pyrimidinbasen (vgl. pag. 28), nämlich Thymin und Cytosin; durch Pepsin wird bei der Spaltung teilweise in Uracil übergeführt. — 4. Kohlehydrate, Dextrosen und (?) Pentosen. — Von der eigentlichen Nucleinsäure unterscheiden sich die Nucleoproteide durch verhältnismäßig einfache Zusammensetzung die aus Pankreas hergestellte Guanin-Nucleoproteide bei der Spaltung quantitativ in je 1 Molekül Guanin, Pentose und Phosphor. — und die im Fleischextrakt vorkommende Inosinsäure, welche analog zu Guanin-Nucleoproteiden besteht (1 Molekül Hypoxanthin, Pentose und Phosphorsäure).

Die Paranucleoproteide (Nucleoalbumine) — sind ebenfalls phosphorhaltige Eiweißkörper, unterscheiden sich aber von den Nucleoproteiden dadurch, daß sie bei der Spaltung neben Eiweiß und Phosphorsäure keine Nucleinbasen, Pyrimidinbasen oder Kohlehydrate liefern. Sie finden sich besonders als Bestandteile der Nahrung von Wachsen (Milch, Eidotter, s. u.), dagegen haben sie zu den Zellkernen gar keine Verbindung. Die Bezeichnung als Paranucleoproteide oder Nucleoalbumine ist also nicht gerechtfertigt, sie werden daher neuerdings auch einfach als Phosphorproteide bezeichnet. Sie sind Säuren, in Wasser fast unlöslich, geben aber mit Alkali lösliche Verbindungen, die bei neutraler Reaktion durch Kochen nicht gefällt werden, durch Zusatz von Alkalien aus diesen Verbindungen die Paranucleoproteide wieder frei gemacht und bei der Einwirkung von Pepsinsalzsäure werden sie gespalten in Eiweiß, welches gelöst wird, und in sich abscheidendes Parannuclein; doch wird dieses durch Pepsinwirkung schließlich auch völlig gelöst (vgl. § 111).

Das Casein (§ 142) — findet sich an Kalk gebunden in der Milch aller Säuger; durch Säurezusatz oder durch Lab gefällt; nicht jedoch durch Kochen.

Das Vitellin (§ 143) — findet sich im Eigelb; es ist durch Sättigung mit Kochsalz fällbar. Als „Dotterplättchen“ kommen krystallisierte Vitelline vor in den Eiern von Fische, Frösche, Schildkröten. In den Vogeleiern sind die Vitelline amorph.

Das Nucleoalbumin der Galle (§ 118. 3).

## III. Albuminoide.

Die Albuminoide — stehen den echten Eiweißkörpern hinsichtlich ihrer Zusammensetzung und Abstammung nahe, doch zeigen sie in ihrem physikalischen, chemischen und physiologischen Verhalten viele Abweichungen von ihnen. Sie sind unkrystallisierbar. Sie bestehen fast ausschließlich aus Monoaminosäuren im besonderen fehlen ihnen zum Teil

die aromatischen Gruppen, so daß sie bei der Spaltung kein geben. Einige von ihnen enthalten keinen Schwefel. Sie sind teils daulich, teils zwar verdaulich, allein ihre Verdauungsprodukte können Eiweiß gar nicht oder nur unvollkommen ersetzen, weil ihnen eben tige, für den Körper unentbehrliche Aminosäuren fehlen. Sie sind wesentlich in den Stütz- oder Schutzsubstanzen des Körpers; in Weise sie aus den Eiweißkörpern entstehen, ist unbekannt.

1. Keratine — bilden den Hauptbestandteil aller Horn- und Epidermoide. Sie sind unlöslich in Wasser, löslich in konzentrierter Schwefelsäure und kochenden Charakteristisch ist für sie der hohe S-Gehalt (2—5%). Sie widerstehen d und Pankreasverdauung sowie der Fäulnis. Bei der hydrolytischen Spaltung liefern Tyrosin und viel Cystin. — In den Nervenmarkscheiden findet sich das Neuro

2. Elastin — Grundstoff des elastischen Gewebes, am reichsten im Li In Wasser unlöslich, löslich in Kalilauge. Es gibt die Reaktionen des Eiweiß Zersetzungsprodukte. Von Magensaft und Pankreassaft wird es verdaut, aber schwerer :

3. Kollagen — ist der Hauptbestandteil der Bindegewebsfasern, der Sehnen Fascien, der organischen Grundsubstanz der Knochen und Knorpel. Mit Wasser geht es in Glutin oder Leim über, welcher beim Erkalten gelatiniert. In kalte ist Leim nicht löslich, sondern quillt nur darin auf; löslich in Alkalien. Die werden durch Säuren und im allgemeinen auch durch Metallsalze nicht gefällt. ist stark linksdrehend. Er wird durch Magensaft und Pankreassaft verdaut. Bei der liefert der Leim kein Tyrosin (er gibt daher auch keine Millonsche Reakti Tryptophan, kein Cystin.

4. Chondrin oder Knorpelleim — wird durch Kochen aus Knorpeln und gelatiniert beim Abkühlen. Es ist jedoch kein einheitlicher Körper, sondern Gemenge von Glutin und Chondromucoid (vgl. S. 16). Dieses liefert bei der Eiweiß, Kohlehydrat und Chondroitinschwefelsäure. Die Chondroitinsäure ist eine Äther-Schwefelsäure des Chondroitins  $C_{18}H_{27}NO_{14}$ ; dieses liefert bei seiner Spaltung Essigsäure und Chondrosin  $C_{12}H_{21}NO_{11}$ , und das letztere bei Glykuronsäure  $C_6H_{10}O_7$  und Glucosamin  $C_6H_{11}O_5(NH_2)$  (vgl. S. 26).

5. Fibroin und Sericin (Seidenleim) — sind die beiden Hauptbestandteile der Seidengespinnste der Insekten und Spinnen. — Dem Fibroin ähnlich ist das — die Substanz der Badeschwämme.

6. Das Amyloid — nur pathologisch vorkommend, in Form geschichteter (Corpora amylacea) im Gehirn und in der Prostata, als glänzende Infiltration in Milz, Nieren, Gefäßhäute, kenntlich an der Bläuung durch Jod und Schwefelsäure Rötung durch Jod.

Die Fermente (Enzyme)<sup>a</sup> — werden häufig als Eiweißstoffe den Eiweißstoffen nahestehende Körper angesehen, doch läßt sich ihre chemische Natur zur Zeit nichts Bestimmtes aussagen, da die Fermente aus ihren Lösungen wohl bis zu einem gewissen Grade isoliert werden können, aber nicht chemisch rein darstellen kann. Es ist gelungen, Präparate fermentativer Wirkung herzustellen, die keine Eiweißreaktionen Sicherlich besitzen die Fermente aber ein kompliziert aufgebautes sie enthalten alle N, die meisten auch S und P, in einigen ist C nachgewiesen worden.

Die Fermente bewirken durch ihre Gegenwart chemische Umsetzungen ohne selbst an dem chemischen Prozeß teilzunehmen, nach Beendigung der Reaktion erscheint das Ferment nicht in den Umsetzungsprodukten, sondern ist neben diesen unverändert vorhanden. Die Fermente werden als Katalysatoren aufgefaßt, d. h. ihre Wirkung besteht nach der Anschauung darin, daß sie chemische Prozesse, die auch von selbst ablaufen würden, mit außerordentlich geringer, unmeßbarer Geschwindigkeit ablaufen würden, so beschleunigen, daß sie in meßbarer Zeit ihr Ende erreichen. Die Wirkung der Fermente ist streng spezifisch, d. h. ein jedes Ferment wirkt immer nur auf bestimmte Vertreter einer bestimmten Körperklasse ein, und ist anderen Substanzen gegenüber durchaus wirkungslos.



**DIESE SEITE IST FÜR KOSTENLOSE MITGLIEDER GESPERRT**  
Beantragen Sie jetzt die volle Mitgliedschaft, um diese Seite zu betreten

# GESCHICHTE

Zehntausende von wichtigen historischen Quellen, viele bisher nicht erhältlich, stehen jetzt zum ersten Mal mit der Vollmitgliedschaft von Forgotten Books zur Verfügung.

Unbegrenzter Zugang  
\$8.99/monat

**Fortfahren**

\*Es gelten Richtlinien zur fairen Nutzung.



## 1. Kohlehydratspaltende Fermente.

a) Diastatische Fermente — welche die Polysaccharide (Stärke in Dextrin und Maltose umwandeln: das Ptyalin des Speichels (§ 101) und Maltase (§ 114. I), die Diastase der keimenden Getreidekörner. Außerdem kommen Fermente noch vor in: Darmsaft, Galle, Blut, Lymphe, Chylus, Leber, Harn,

b) Invertierende Fermente — welche die Disaccharide in Monosaccharide spalten: Saccharase (Invertin) spaltet Saccharose in Dextrose und Lävulose, Maltase spaltet Maltose in Dextrose, — Lactase spaltet Lactose in Dextrose und Glucose. Invertierende Fermente kommen vor allem in dem Darmsaft vor (§ 122, 1). Sie finden sich besonders reichlich in der Hefe.

c) Glykolytische Fermente — welche Dextrose zerstören; ihre Existenz ist noch zweifelhaft.

2. Fettspaltende Fermente — welche Fette in Glycerin und freie Fettsäuren spalten: die Lipase (Steapsin) des Pankreas- und Magensaftes (§ 114. III),

3. Eiweißspaltende Fermente — welche die Eiweißstoffe in Peptide und weiterhin in Aminosäuren spalten: das Pepsin des Magensaftes spaltet Eiweiß nur bis zu Pepton ab, das Trypsin des Pankreassaftes (§ 114. II) bis zu den Aminosäuren ab, das Erepsin des Darmsaftes (§ 122) greift die Peptide an, spaltet aber Albumosen und Peptide, sowie auch Casein bis zu Aminosäuren. Eiweißspaltende Fermente kommen auch in manchen Pflanzen vor (§ 122).

4. Nucleinsäurezersetzende Fermente — welche die Nucleinsäure in Nucleoside und die übrigen Bestandteile spaltet, die Adenase und Guanase, welche die Guanin- und Adenin-Base zu Hypoxanthin und Xanthin bewirkt, die Xanthinase, welche die Oxydation zu Xanthin und Harnsäure bewirkt, endlich das Uricase-Ferment, welches die Harnsäure weiter abbaut (§ 163). Diese Fermente sind in verschiedenen Organen nachgewiesen worden, so in Milz, Lunge, Leber, Darm, Niere.

5. Die Arginase — welche Arginin in Harnstoff und Ornithin zerlegt, die Urease — welche Harnstoff in Kohlensäure und Ammoniak spaltet (§ 163).

6. Gerinnungsfermente — welche lösliche Eiweißstoffe ausfällen: das Thrombin, welches das Fibrinogen in Fibrin umwandelt (§ 26), das Chymosin, welches das Casein der Milch ausfällt, im Magen- und Pankreassaft.

7. Oxydative Fermente — welche die Oxydation schwer oxydierbarer Substanzen bewirken, Oxydasen. Man unterscheidet:

a) direkte Oxydasen — welche den molekularen Sauerstoff zu Wasser aktivieren vermögen.

b) indirekte Oxydasen, Peroxydasen — welche nur in Gegenwart von Peroxyden wirksam sind, indem sie aus diesen aktiven Sauerstoff abspalten. Man bezeichnet man Stoffe, welche durch Aufnahme von Sauerstoff an Peroxyde übergeben und nun von den Peroxydasen gespalten werden können; diese sind selbst nicht fermentativer Natur. Die direkten Oxydasen sind aus Oxydase und Peroxydase zusammengesetzt.

c) Katalasen — welche nur aus Wasserstoffsuperoxyd aktiven Sauerstoff abspalten, aber keine anderen Peroxyde zerlegen, sie sind daher verschiedene Oxydasen. Katalase kommt im Blute, aber auch in allen tierischen und pflanzlichen Geweben vor (§ 32).

Die Fermente vermögen nicht nur kompliziert gebaute Körper abzubauen, sondern können auch in umgekehrter Richtung wirken, Synthesen ausführen (vgl. Fermentbildung § 111).

## 6. Die Fette.

Die Fette kommen vorzugsweise reichlich im Tierkörper wohl in allen Pflanzen vor, hauptsächlich in den Samen (Nüsse, Cocos, Mohn), seltener im Fruchtfleisch (Olive) oder in der Milch. Auf Papier bewirken sie charakteristische Fettflecken. Sie sind unlöslich in Wasser, löslich in Äther, Chloroform, Benzol, Aceton, Schwefelkohlenstoff, weniger leicht in Alkohol. In wässrigen Flüssigkeiten können sie durch Umrühren eine außerordentlich feine Verteilung in Form mikroskopischer Fettkügelchen erfahren, eine Emulsion bilden, und zwar entweder, wenn man sie mit schleimigen oder Eiweiß- oder Seifenlösungen schüttelt, oder

welche geringe Mengen freier Fettsäuren enthalten, mit *dün-*  
*ng* zusammenbringt, wobei sich Seifen bilden.

Die Fette sind Verbindungen eines Alkohols, des Glycerins, mit  
 1 Fettsäuren: die Glycerylester oder die Glyceride  
 nenn. Werden neutrale Fette mit Wasser überhitzt oder mit  
 Fermenten (Steapsin, Lipase s. S. 19) behandelt oder der Fäul-  
 nis anheimgegeben, so zerlegen sie sich unter Aufnahme von H<sub>2</sub>O in Glycerin  
 und freie Fettsäuren, von denen die letzteren, falls sie flüchtig sind,  
 den charakteristischen Geruch verbreiten. Mit kaustischen Alkalien behandelt  
 erleiden sie die gleiche Zersetzung: die Fettsäure bildet in diesem Falle  
 mit dem Alkali eine salzartige Verbindung (Seife); der Prozeß wird deswegen  
 als Verseifung bezeichnet.

Das Glycerin — ist ein dreiwertiger Alkohol  $C_3H_5$   $\begin{matrix} /OH \\ -OH \\ \backslash OH \end{matrix}$ . Es ist eine farb- und  
 süß schmeckende, sehr hygroskopische Flüssigkeit, in Wasser oder Alkohol  
 in jedem Verhältnis löslich, in Äther unlöslich.

Die Fettsäuren — welche in den Fetten vorkommen, gehören zwei verschiedene  
 Klassen an, nämlich:

**Gesättigte Fettsäuren von der Formel C<sub>n</sub>H<sub>2n</sub>O<sub>2</sub>.**

1. Weisensäure: CH<sub>3</sub>O<sub>2</sub>.  
 2. Essigsäure: C<sub>2</sub>H<sub>4</sub>O<sub>2</sub>.  
 3. Propionsäure: C<sub>3</sub>H<sub>6</sub>O<sub>2</sub>.  
 4. Buttersäure: C<sub>4</sub>H<sub>8</sub>O<sub>2</sub>.  
 5. Valeriansäure: C<sub>5</sub>H<sub>10</sub>O<sub>2</sub>.  
 6. Capronsäure: C<sub>6</sub>H<sub>12</sub>O<sub>2</sub>.  
 7. Heptylsäure: C<sub>7</sub>H<sub>14</sub>O<sub>2</sub>.  
 8. Octylsäure: C<sub>8</sub>H<sub>16</sub>O<sub>2</sub>.  
 9. Decylsäure: C<sub>10</sub>H<sub>20</sub>O<sub>2</sub>.

10. Myristinsäure: C<sub>14</sub>H<sub>28</sub>O<sub>2</sub>.  
 11. Palmitinsäure: C<sub>16</sub>H<sub>32</sub>O<sub>2</sub>.  
 12. Margarinsäure: C<sub>17</sub>H<sub>34</sub>O<sub>2</sub>.  
 13. Stearinsäure: C<sub>18</sub>H<sub>36</sub>O<sub>2</sub>.  
 14. Arachinsäure: C<sub>20</sub>H<sub>40</sub>O<sub>2</sub>.  
 15. Hyänasäure: C<sub>22</sub>H<sub>44</sub>O<sub>2</sub>.  
 16. Cerotinsäure: C<sub>26</sub>H<sub>52</sub>O<sub>2</sub>.  
 17. Melissinsäure: C<sub>30</sub>H<sub>60</sub>O<sub>2</sub>.

In diesen kommen im menschlichen und tierischen Fett hauptsächlich vor  
 die Myristin-, Palmitin-, Stearin-, Capryl-, Capron- und Buttersäure.

Die C-reicheren Fettsäuren sind konsistent und verflüchtigen sich nicht; die C-ärmeren  
 (siehe 8) sind ölig-flüssig und flüchtig, schmecken brennend sauer, riechen ranzig.  
 Ungesättigte Fettsäuren, und zwar Säuren der Acrylsäurereihe  
 von der Formel C<sub>n</sub>H<sub>2n-2</sub>O<sub>2</sub>. Von diesen kommt für den tierischen Organismus nur eine  
 vor, die Ölsäure C<sub>18</sub>H<sub>34</sub>O<sub>2</sub>.

Die Verbindungen des Glycerins mit der Palmitin-, Stearin- und Ölsäure heißen  
 Palmitin, Stearin und Olein.

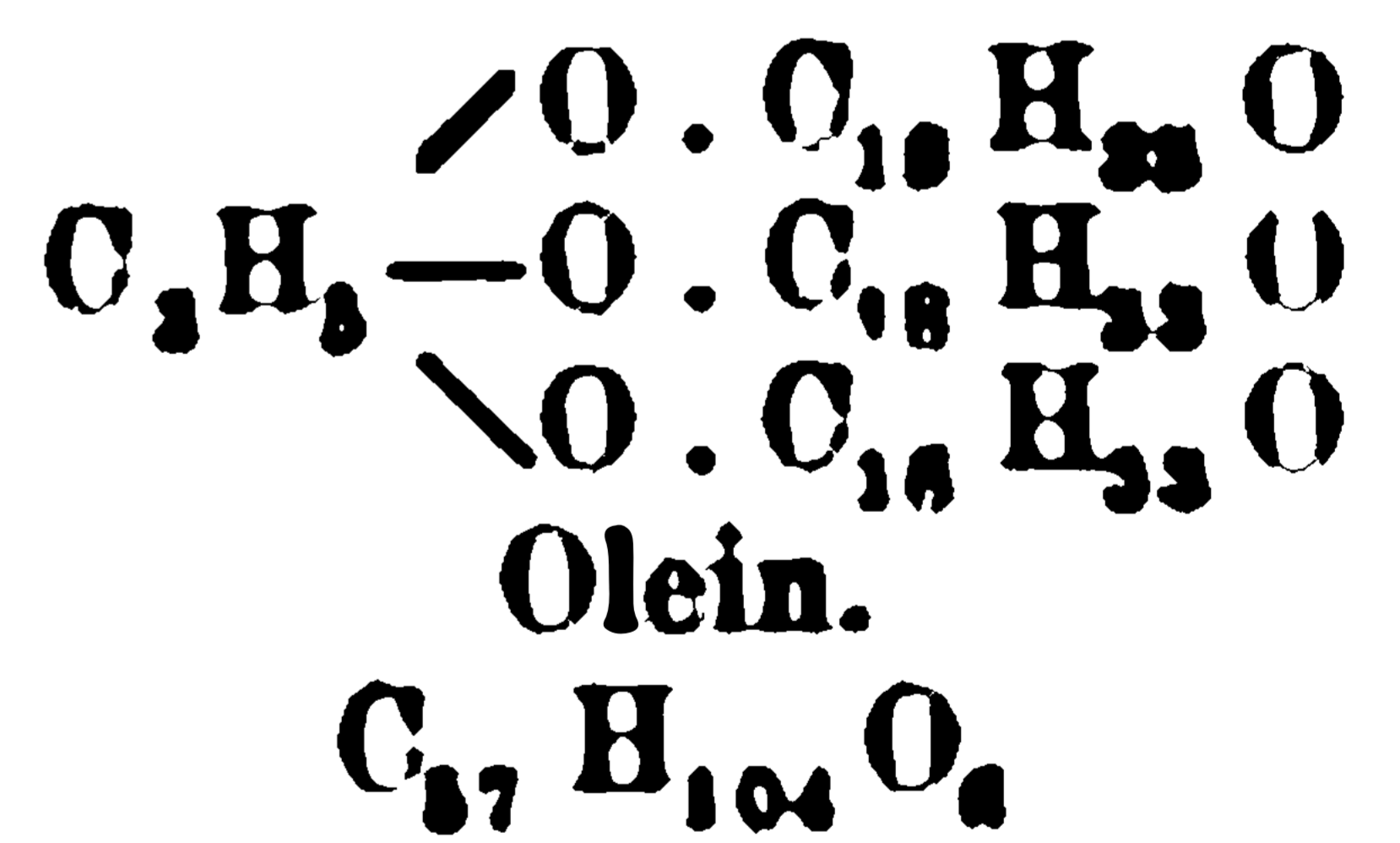
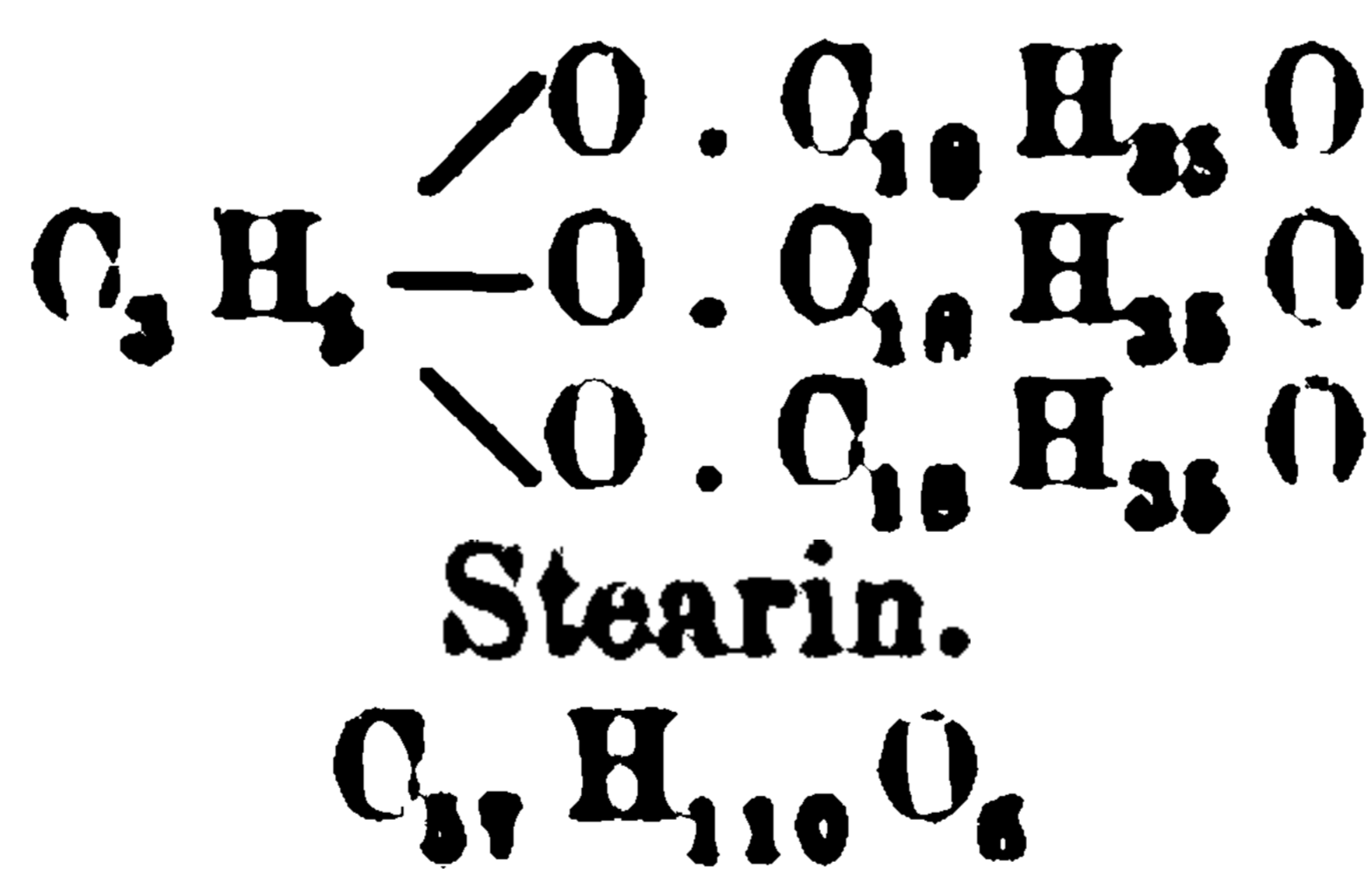
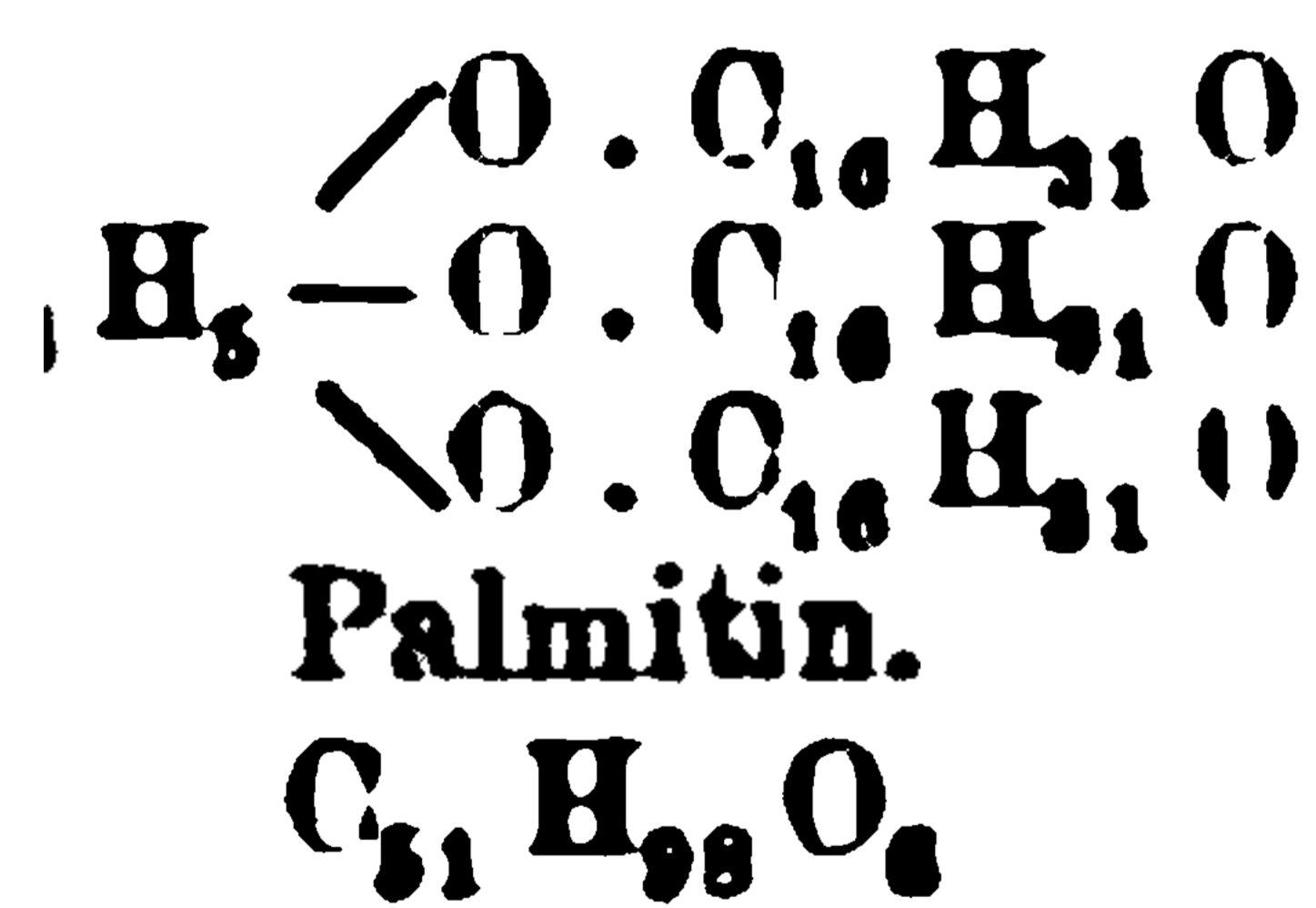

Der Schmelzpunkt des Palmitins ist 62°, der des Stearins 71,5°, das Olein erst  
 bei 78°. Die Fette sind Gemenge dieser drei Glyceride; je mehr Olein sie enthalten,  
 desto niedriger ist der Schmelzpunkt und umgekehrt. Das Fett Neugeborener  
 enthält mehr Palmitin und Stearin als das der Erwachsenen, welches mehr Olein be-  
 hält. Auch Fette, in denen die drei Alkoholgruppen des Glycerins mit verschie-  
 denen Fettsäuren verbunden sind; so können zwei und auch drei verschiedene Fettsäuren in  
 einmolekulare Fette vorkommen (Bömer<sup>10</sup>).

Die weitere Klasse von Fetten (auch Wachse genannt) enthält an Stelle des  
 Glycerins höhere aliphatische einwertige Alkohole. Dazu gehört das Walrat,  
 eine Verbindung des Cetylalkohols C<sub>16</sub>H<sub>34</sub>O mit der Palmitinsäure C<sub>16</sub>H<sub>32</sub>O<sub>2</sub>, — das  
 Carnaubawachs, eine Verbindung des Oktadecylalkohols C<sub>18</sub>H<sub>38</sub>O mit  
 der Stearinsäure C<sub>18</sub>H<sub>36</sub>O<sub>2</sub>.

Außerdem gibt es auch Fette, in denen an Stelle des Glycerins ein aromatischer  
 Alkohol auftritt, das Cholesterin (C<sub>27</sub>H<sub>46</sub>OH); sie finden sich



der Vernix caseosa, in allen keratinösen Substanzen (Haare, Federn, Hufe usw.) kommt auch im freien Zustand vor, im Blut, Dotter, Hirn, Galle. Es gibt eine von Körpern, die dem Cholesterin verwandt sind, sie werden als Sterine zusammengefaßt. Die Sterine des Pflanzenreichs (Phytosterine) sind von denen des Tierreichs verschieden.

Im Anschluß an die Fette sind als fettähnliche Körper (Lipoidkörper) dieser Bezeichnung werden alle in den Fettlösungsmitteln löslichen Stoffe zusammengefaßt, also auch das Cholesterin) aufzuführen:

Die Lecithine — sind esterartige Verbindungen der Glycerinphosphorsäure

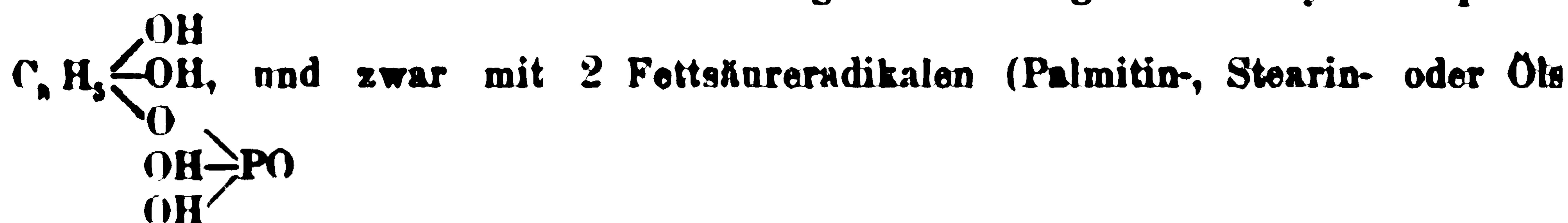

seits und dem Cholin (Trimethyloxäthylammoniumhydroxyd)

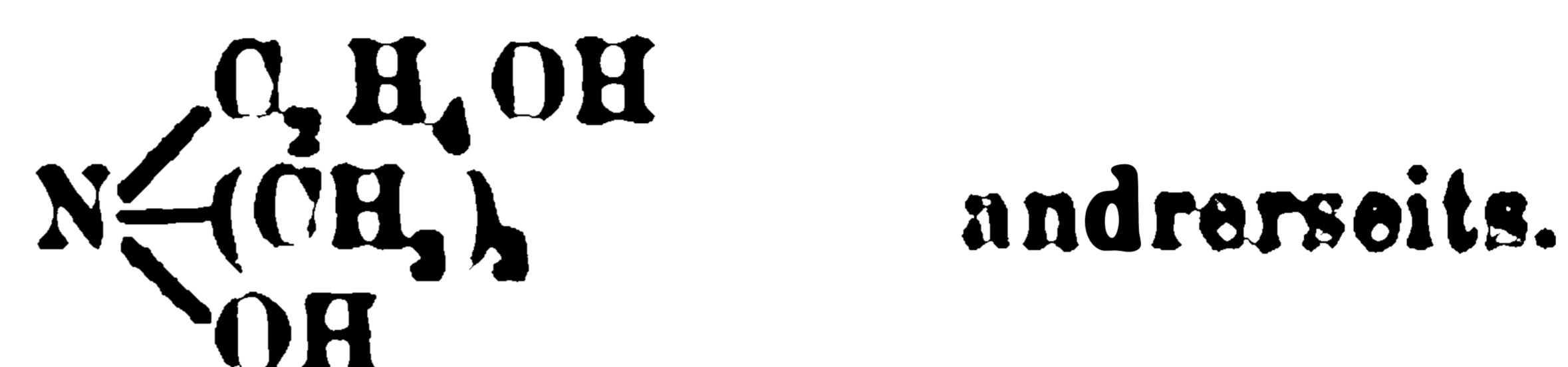

Die Konstitution des [Distearyl-] Lecithins ist daher:

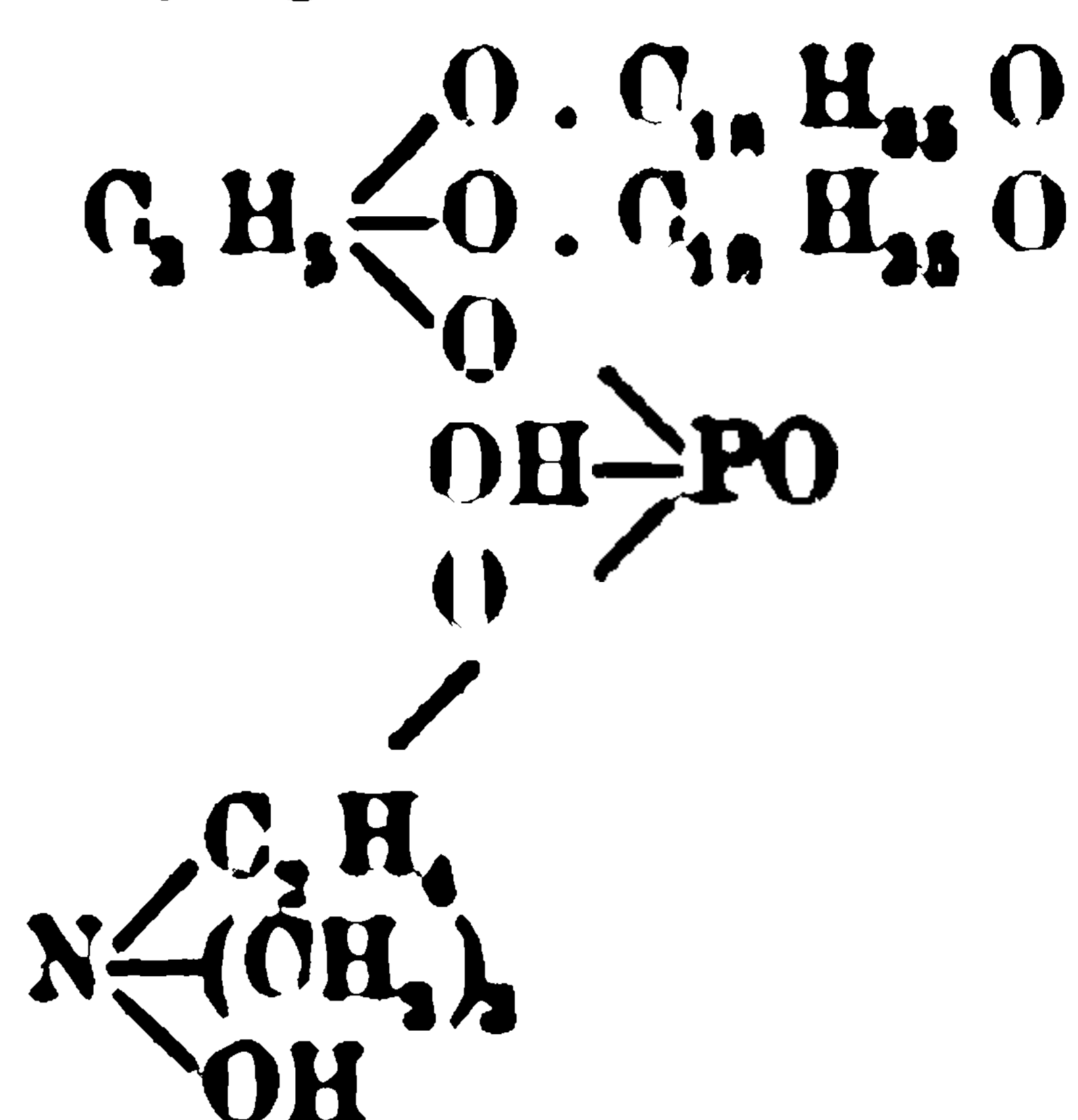

Die Lecithine sind unlöslich in Wasser, quellen darin aber in eigenartiger Weise (Myelinfiguren), sie sind löslich in Alkohol, Chloroform, Äther. Sie finden sich in tierischen und pflanzlichen Zellen, besonders reichlich in der Nervensubstanz, im Sperma. — Die Lecithine sind die am besten bekannten Glieder aus einer Gruppe fettähnlicher Verbindungen, die als Phosphatide zusammengefaßt sind charakterisiert durch den Gehalt an Phosphorsäure und stickstoffhaltigen Basen. Dazu gehören z. B. das Lecorin (vgl. § 27, III. § 116, 2), das Frotal, Cerebroside (§ 240, 2).

Quantitative Bestimmung des Fettes. — Die zu untersuchende Substanz vollständig getrocknet, fein pulverisiert und dann durch Äther im Extrahierapparat (Soxhlet) das Fett (allerdings auch die übrigen in Äther löslichen, fettähnlichen Stoffe) extrahiert; nach Verdampfen des Äthers wird das Fett gewogen.

## 7. Die Kohlehydrate.<sup>13</sup>

Die Kohlehydrate kommen besonders reichlich im Pflanzenreich vor, in geringeren Mengen auch im tierischen Körper vor. Sie haben die Eigenschaft, daß in ihrem Molekül neben C stets V und Sauerstoff in dem Verhältnis, wie im Molekül des Wassers zwei Atome H ein Atom O enthalten ist. Alle sind fest, ohne zu fließen, entweder süß schmeckend (Zuckerarten) oder doch leicht durch Säuren in Zucker umzuwandeln. Sie drehen das polarisierte Licht nach rechts oder nach links. Trocken erhitzt, riechen sie nach Stärke, färben sich mit Thymol und Schwefelsäure rot.

I. Die Monosaccharide (auch Hexosen genannt) — Formel  $\text{C}_6\text{H}_{12}\text{O}_6$  leiten sich durch Oxydation von sechswertigen Kohlenstoff ab. Die Oxydation kann dabei entweder an einer primären oder sekundären Alkoholgruppe erfolgen. Im ersteren Falle entsteht ein Aldehyd, der durch die Gruppe  $-\text{C} \begin{array}{l} \text{O} \\ \diagdown \\ \diagup \text{H} \end{array}$  charakterisiert ist, ein Aldehyd. Monosaccharide werden daher Aldosen genannt:



**DIESE SEITE IST FÜR KOSTENLOSE MITGLIEDER GESPERRT**  
Beantragen Sie jetzt die volle Mitgliedschaft, um diese Seite zu betreten



**Seien Sie niemals ohne ein Buch!**

Die Vollmitgliedschaft von Forgotten Books bietet Ihnen einen universalen Zugang von unseren Apps und unserer Website, auf all Ihren Geräten: Tablet, Telefon, E-Reader, Laptop und Computer.

**Eine Bibliothek in Ihrer Tasche für € 8.99/monat**

**Fortfahren**

\*Es gelten Richtlinien zur fairen Nutzung.

4. **Moore's & Hellers Probe:** — Die Flüssigkeit wird mit Kali- oder bis zur stark alkalischen Reaktion versetzt und gekocht: es entsteht gelbe, braunschwarze Verfärbung durch Bildung von Humussubstanzen; wird nach dem mit konz. Schwefelsäure angesäuert, so entsteht der Geruch nach gebranntem (Caramel) und Ameisensäure.

5. **Mollischs Proben:** —  $1\frac{1}{2}$  cm<sup>3</sup> der zu prüfenden Flüssigkeit versetzt man mit 2 Tropfen einer 17%igen alkoholischen  $\alpha$ -Naphthol- oder Thymollösung, gießt man 1–2 cm<sup>3</sup> konz. Schwefelsäure hinzu und schüttelt rasch. Bei Gegenwart von Zucker färbt sich das  $\alpha$ -Naphtholgemisch tief violett, die Thymolprobe tief rot (Reaktionen, S. 13).

6. **Phenylhydrazinprobe:** — Zu 7 cm<sup>3</sup> der Flüssigkeit setzt man im Erlenmeyerglas 2 Messerspitzen salzsauren Phenylhydrazins und 3 Messerspitzen essigsäuren Natriums bis zur Lösung (eventuell unter etwas Wasserzusatz) und setzt das Glas 1 Stunde in ein kochendes Wasserbad: bei Anwesenheit von Dextrose scheidet sich charakteristische mikroskopische Büschel feiner, langer, gelb gefärbter Nadeln von Phenylglykosid, welches in Wasser fast unlöslich ist, bei 204–205° schmilzt.

7. **Gärungsprobe:** — Man versetzt die zu untersuchende Flüssigkeit mit Hefe, füllt damit ein Reagenzglas vollständig, verschließt die Mündung mit dem Finger, hebt es so, daß die Luft hineingelangt, und stellt das Reagenzglas umgekehrt in eine mit Quecksilber beschickte Schale. (Zweckmäßig kann man auch statt dessen ein sogenanntes Gärungsröhrchen (Fig. 1) verwenden, bei dem die Mündung durch ein Stück Quecksilber zum Verschluss braucht.) In der Wärme (25–30°) erfolgt bald Zerlegung des Traubenzuckers durch die Hefe in Alkohol und Kohlensäure:

Fig. 1.



Graduiertes Erlenmeyersches Gärungsröhrchen.



die Kohlensäure sammelt sich im oberen Teile des Reagenzglases an. — Es ist nötig, zwei Kontrollproben anzustellen: 1. Hefe mit zuckerfreier Flüssigkeit, um auszuschließen, daß die Hefe selbst Zucker enthält; es darf keine CO<sub>2</sub>-Entwicklung eintreten. 2. Dieselbe Hefe mit zuckerhaltiger Flüssigkeit, um zu vergewissern, daß die Hefe auch gärkräftig ist.

Quantitative Bestimmung des Traubenzuckers.

I. Durch Titrierung mit Fehlingscher Lösung.

— (Die Methode beruht auf der Trommerschen Probe. Die Fehlingsche Lösung beim Aufbewahren sehr schnell verdirbt, wird sie jedesmal vor dem Gebrauch neu hergestellt, gleiche Volumina der beiden folgenden Flüssigkeiten miteinander mischt: I. 34,639 g reines, krystallisiertes Kupfersulfat (CuSO<sub>4</sub> + 5H<sub>2</sub>O) mit Wasser zu 500 cm<sup>3</sup> gelöst, II. 17,31 g krystallisiertes weinsaures Kali-Natron (Seignettesalz) in Wasser gelöst, dazu 100 cm<sup>3</sup> Natronlauge, die 50 g Natron enthalten, mit Wasser auf 500 cm<sup>3</sup> aufgefüllt. (Die Lösung verdirbt auch bald und muß daher häufig frisch hergestellt werden.) 20 cm<sup>3</sup> der Fehlingschen Lösung mit 80 cm<sup>3</sup> Wasser verdünnt, entsprechen 0,1 g Traubenzucker. (Das Reduktionsvermögen des Traubenzuckers ist jedoch je nach der Concentration der Zuckerlösung und der Verdünnung der Fehlingschen Lösung etwas verschieden<sup>14</sup>); man muß daher bei der Bestimmung genau nach der Vorschrift verfahren.)

Ausführung der Bestimmung in zuckerhaltigem Harn: 20 cm<sup>3</sup> der Fehlingschen Lösung, mit 80 cm<sup>3</sup> Wasser verdünnt, werden zum Kochen erhitzt. Aus dieser Lösung läßt man den Harn (der 5–10mal verdünnt worden ist) in kleinen Portionen zufließen und kocht jedesmal 2 Minuten lang. Man setzt so lange Harn zu, bis die blaue Flüssigkeit (nachdem sich der Niederschlag abgesetzt hat oder nachdem man sie schnell abfiltriert hat) vollständig verschwunden ist. Auf Grund dieser ersten Bestimmung führt man nun eine zweite aus, bei der man die gefundene Menge Harn auf einmal zufließen läßt, und stellt fest, ob nach 2 Minuten langem Kochen die Flüssigkeit noch blau ist. Ist dies der Fall, so nimmt man bei der nächsten Bestimmung noch mehr Harn zu, ist dagegen die Flüssigkeit schon völlig entfärbt, so nimmt man etwas weniger Harn zu. In dieser Weise fährt man fort, bis bei zwei Bestimmungen mit nur wenig veränderten Harnmengen die Flüssigkeit nach dem Kochen das eine Mal noch blau, das andere Mal dagegen entfärbt war. Die Mittelwerte zwischen den beiden gefundenen Werten in der Mi-

n entspricht dann genau 20 cm<sup>3</sup> Fehlingscher Lösung, enthält also 0,1 g per.

**Durch Polarisation.**<sup>16</sup> — Die Methode beruht auf der Eigenschaft des Traubenebene des polarisierten Lichtes nach rechts zu drehen. „Spezifisches Drehungsvermögen“ nennt man den Grad der Drehung, welchen 1 g einer optisch aktiven Substanz in 1 cm<sup>3</sup> Wasser gelöst, bei 1 dm dicker Schicht (Länge des Rohres des Polarisationsapparates) für gelbes Licht bewirkt; dieses ist für Dextrose = + 52,5°. Da die Drehung proportional ist der Menge der in der Flüssigkeit gelösten Substanz, so gibt der Beobachtung Auskunft über den Gehalt der Flüssigkeit an der optisch wirksamen Substanz. Bezeichnet  $\alpha$  die beobachtete Drehung,  $[\alpha]$  das spezifische Drehungsvermögen,  $l$  die Länge des Rohres,  $c$  die Anzahl der Gramme der optisch wirksamen Substanz in 1 cm<sup>3</sup>

so ist  $c = \frac{\alpha}{[\alpha] \cdot l}$ . Zur Ausführung der Bestimmung dienen: Der *Soleil-Ventzke*-Polarisationsapparat, das Polaristrobometer von *Wild* oder der Halbpolarisationsapparat von *Laurent, Lippich, Landolt*.

Die Galaktose — bildet zusammen mit Dextrose den Milchzucker (Lactose) und wird aus diesem bei der hydrolytischen Spaltung im Körper durch die Lactase. Sie entsteht ferner durch die Hydrolyse von Gummi und Schleimstoffen, auch als Zersetzungsprodukt des Glykosids Cerebrin (vgl. § 240, 2). — Die Galaktose ist der Aldehyd des D-Galactons, des Alkohols Dulcitol. Sie krystallisiert in Nadeln und Blättchen, dreht die Ebene des polarisierten Lichtes nach rechts (spezifische Drehung = + 83,88°). Ihr Phenyllosazon schmilzt bei 193°. Sie wirkt reduzierend, gibt die Reaktionen der Dextrose, ist gärungsfähig. Durch Oxidation liefert sie Schleimsäure.

Die Lävulose (Fructose, Fruchtzucker) — findet sich neben der Dextrose in Früchten und im Honig. Sie entsteht bei der Inversion des Inulins (s. pag. 25), oder der Dextrose bei der Inversion des Rohrzuckers, im Darmkanale durch das Invertin. Sie kommt sie (selten) im Harn vor, dabei zugleich im Blut (*Rosin u. Laband*<sup>16</sup>). In Fäulen fanden *Neuberg u. Strauss*<sup>17</sup> Lävulose im menschlichen Blutserum und in menschlichen Gewebsflüssigkeiten (Ascites, Pleuraflüssigkeit, wird von *Ofner*<sup>18</sup> beschrieben). Nach *Gürber u. Grünbaum*<sup>19</sup> kommt physiologisch Lävulose in beträchtlichen Mengen im Fruchtwasser von Rind, Schwein und Ziege vor, *Langstein u. Neuberg*<sup>20</sup> fanden sie im Urin neugeborener Kälber. — Die Lävulose ist eine Ketose. Sie krystallisiert nur in der Dextroform, dreht die Ebene des polarisierten Lichtes nach links (daher Lävulose); spezifisches Drehungsvermögen — 90,2 bis 93°. Sie bildet dasselbe Osazon wie die Dextrose, wirkt reduzierend; sie vergärt mit Hefe, aber schwerer als Dextrose.

Gibt es auch einfache Zucker mit weniger und mit mehr als 6 C-Atomen. Von diesen sind physiologisch nur noch in Betracht die Pentosen, C<sub>5</sub>H<sub>10</sub>O<sub>5</sub>. Dieselben sind in der Form der Anhydride, der Pentosane (C<sub>5</sub>H<sub>8</sub>O<sub>4</sub>)<sub>n</sub> (vgl. pag. 26), im Pflanzenreiche weit verbreitet. Im tierischen Körper sind sie als Spaltungsprodukte der Nucleoproteide und Nucleinsäuren (vgl. pag. 16) und pathologisch im Harn nachgewiesen. Von den Organen ist am reichsten an Pentose das Pankreas (2,48% des trockenen Organs) (*Grund*<sup>21</sup>). Die Pentosen geben dieselben Reduktionsproben wie der Traubenzucker und mit Phenylhydrazin charakteristische Verbindungen, — sie sind dagegen nicht mit Hefe vergärbar und liefern bei der Oxidation mit Salzsäure keine Lävulinsäure (wie die Hexosen), aber reichliche Mengen Oxalonsäure. Mit Salzsäure und Phloroglucin resp. Orcin geben sie charakteristische Farbenreaktionen.

Die Disaccharide — von der Formel C<sub>12</sub>H<sub>22</sub>O<sub>11</sub> sind Verbindungen von zwei Molekülen Monosaccharid unter Austritt von H<sub>2</sub>O:



Die Disaccharide werden durch Säuren sowie durch die invertierenden Fermente in ihre Bestandteile zerlegt. Sie sind nicht direkt vergärbar, sondern erst nach ihrer Spaltung in die Monosaccharide.

Die Maltose (Malzzucker) — = 1 Dextrose + 1 Dextrose — 1 H<sub>2</sub>O. Sie entsteht durch die Wirkung der diastatischen Fermente auf Stärke und Glykogen; durch Maltase wird sie leichter gespalten in Dextrose. Sie krystallisiert in feinen, zu Warzen vereinigte Kristalle, enthält 1 Molekül Krystallwasser, löslich in Alkohol, wird aus alkoholischer Lösung durch Fällung mit Salzsäure als Amorphes erhalten.

kalten in gelben Nadeln ab, schmilzt bei  $206^{\circ}$ . Maltose wirkt *reduzierend*  $\frac{2}{3}$  so stark wie Dextrose. Dextrose reduziert essigsaures Kupferoxyd (*Barfoeds* Reagens) Maltose nicht. — Als eine Modifikation der Maltose wird *die Isomalt* (vielleicht nur verunreinigte Maltose?); das Osazon derselben schmilzt schon

2. Die Lactose (Milchzucker) — = 1 Dextrose + 1 Galaktose — 1 H nur in der Milch vor (selten im Harn). Durch die Lactase wird sie in ihr zerlegt. Mit gewöhnlicher Bierhefe gärt sie nicht, dagegen wird sie durch Milchzuckerhefen zunächst gespalten und dann vergoren. Durch verschiedene sie in Milchsäure verwandelt. Lactose ist in Wasser und namentlich in Al löslich als Dextrose, schmeckt wenig süß; sie krystallisiert mit 1 Molekül sie dreht rechts, spez. Drehung =  $+52,5^{\circ}$ . Das Lactosazon ist in heißem V leicht löslich, scheidet sich beim Erkalten in gelben, zu kugeligen Aggrega Nadeln ab, schmilzt bei  $200^{\circ}$ . Lactose wirkt reduzierend, aber langsamer reduziert im Gegensatz zu Dextrose nicht *Barfoeds* Reagens (schwache Lös saurem Kupfer, der etwas Essigsäure zugesetzt ist).

3. Die Saccharose (Rohrzucker) — = 1 Dextrose + 1 Lävulose Zuckerrohr, in Zuckerrüben und einigen anderen Pflanzen verbreitet. Im I durch das Invertin in ihre beiden Komponenten gespalten. Durch Hefe ist aber nicht direkt: sie wird durch ein in der Hefe vorhandenes Invertin zun worauf die Gärung erfolgt. Die Saccharose krystallisiert in Prismen, sie i in Wasser, in absolutem Alkohol fast unlöslich. Sie dreht rechts, spez. Drehu Die bei der Spaltung der Saccharose in ihre beiden Komponenten entste dreht stärker nach links als die Dextrose nach rechts; durch die Spaltun Rechtsdrehung der Saccharose in Linksdrehung umgewandelt; daher die Invertierung, Invertin, Invertzucker (das bei der Spaltung entstehende Gemis und Lävulose). Die Saccharose bildet mit Phenylhydrazin kein Osazon, si reduzierend.

III. Die Polysaccharide — von der Formel  $(C_6H_{10}O_5)_n$  bindungen zahlreicher Moleküle Monosaccharid unter Austritt Die Größe des Faktors  $n$  ist noch unbekannt, jedenfalls Molekulargröße sehr hoch. Es sind amorphe Körper, ihre Lös dieren nicht oder nur sehr schwer. Durch Kochen mit verdün oder durch die Einwirkung von Fermenten werden sie hydr in die entsprechenden Zucker umgewandelt.

1. Das Glykogen — (Eigenschaften, qualitativer Nachweis, quantitat vgl. § 116), in geringen Mengen in fast allen Organen des Körpers vorkom in Leber und Muskeln. Es dreht die Ebene des polarisierten Lichtes nach rec Drehung  $[\alpha]_D = +196,57^{\circ}$  (*Gatin-Gruzevska*<sup>23</sup>). Es wirkt nicht reduzierend

2. Die Stärke (*Amylum*) — teils in den „mehligem“ Teilen viele organisierten, innerhalb der Pflanzenzellen sich bildenden, geschichteten Körn exzentrischem Kerne bestehend, teils, und zwar seltener, ungeformt in den Pflanz Der Durchmesser der Stärkekörnchen wechselt bei verschiedenen Pflanzen a z. B. bei der Kartoffel  $0,14—0,18\text{ mm}$ , im Runkelrübensamen nur  $0,004\text{ mm}$  Wasser von  $50—80^{\circ}$  quellen die Stärkekörner zu einer gelatinösen Masse, kleister. Mit Jod färbt sich Stärke blau, beim Erhitzen verschwindet die Farb Erkalten wieder. Sie reduziert nicht. Man hat in der Stärke zwei Bestandteil die Amylose, welche die Jodreaktion gibt, aber keinen Kleister liefert, u pektin, welches beim Kochen Kleister liefert, aber keine Jodreaktion gibt, mit verdünnten Säuren wird die Stärke in Dextrose umgewandelt, durch Fermente in Erythroextrin, Achrooextrin, Maltose (und nur wenig Dextro

3. Die Dextrine — sind Körper, welche zwischen Glykogen und S und Maltose andererseits stehen; sie werden bei der Einwirkung verdünnt der diastatischen Fermente auf Stärke oder Glykogen als Zwischenprodukt g in Wasser stark klebend löslich, durch Alkohol fällbar, drehen die Ebene c Lichtes nach rechts (daher Dextrin), spez. Drehung ungefähr  $+195^{\circ}$ . Von blau gefärbt (*Amylodextrin*), rot gefärbt (*Erythroextrin*) oder l gefärbt (*Achrooextrin*). Sie gären nicht. *Amylodextrin* reduziert *Fehl* nicht, wohl aber wirken Erythro- und Achrooextrine reduzierend.

4. Das Inulin — findet sich in der Wurzel der Cichorie, des Löwenz; in den Knollen der Georginen (*Dahlia variabilis*). Bei der Spaltung durch es Lävulose; es steht zu dieser in derselben Beziehung wie die Stärk Als Zwischenprodukt entsteht Lävulin (dem Dextrin entsprechend). Spez des Inulins =  $-36—37^{\circ}$ . durch Jod wird es nicht gefärbt.



**DIESE SEITE IST FÜR KOSTENLOSE MITGLIEDER GESPERRT**  
Beantragen Sie jetzt die volle Mitgliedschaft, um diese Seite zu betreten

# GESCHICHTE

Zehntausende von wichtigen historischen Quellen, viele bisher nicht erhältlich, stehen jetzt zum ersten Mal mit der Vollmitgliedschaft von Forgotten Books zur Verfügung.

Unbegrenzter Zugang  
\$8.99/monat

**Fortfahren**

\*Es gelten Richtlinien zur fairen Nutzung.



4. Oxalsäure,  $\text{COOH} - \text{COOH}$  — kommt als oxalsaurer Kalk im Harn

5. Bernsteinsäure,  $\text{COOH} - \text{CH}_2 - \text{CH}_2 - \text{COOH}$  — findet sich in der Flüssigkeit der Echinococcken, in geringen Mengen ist sie in manchen Flüssigkeiten gefunden. Sie entsteht als Nebenprodukt bei der Alkoholgärung

6. Citronensäure,  $\text{C}_6\text{H}_8\text{O}_7$  — in der Milch.

7. Cholsäure (Cholalsäure),  $\text{C}_{24}\text{H}_{40}\text{O}_5$  — in der Galle (vgl. § 11)

II. N-haltige.

1. Harnstoff,  $\text{CO}(\text{NH}_2)_2$  — das Diamid der Kohlensäure  $\text{CO}(\text{OH})_2$ , der Hauptbestandteil des Harns und das hauptsächlichste Endprodukt des Eiweiß (vgl. § 161).

2. Guanidin und seine Derivate.

Guanidin,  $\text{NH} = \text{C}(\text{NH}_2)_2$  — ist Imidoharnstoff. Mit dem Ornithin (valeriansäure) verbunden, bildet es das Arginin, ein Spaltungsprodukt (pag. 11). Vom Guanidin leiten sich ab

Kreatin, Methylguanidinessigsäure,  $\text{C}_4\text{H}_9\text{N}_3\text{O}_3$  — oder

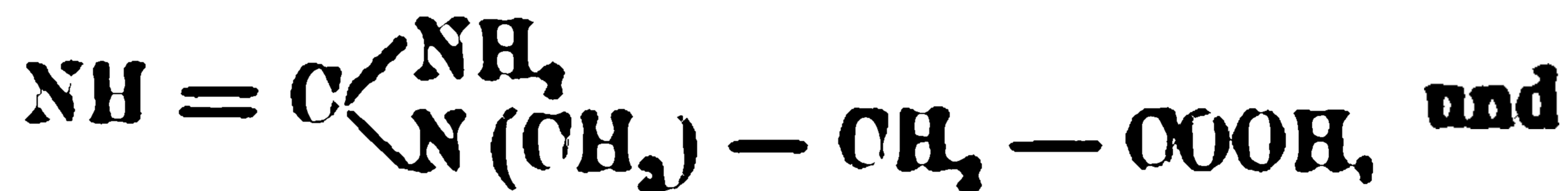

Kreatinin,  $\text{C}_4\text{H}_7\text{N}_3\text{O}$  — das Anhydrid des Kreatins:  $\text{NH} = \text{C} \begin{matrix} \swarrow \text{NH} \\ \searrow \text{N} \end{matrix}$

Kreatin findet sich hauptsächlich in den Muskeln (vgl. § 211), ferner Kreatinin im Harn (vgl. § 165).

3. Die Purinkörper (Alloxurkörper<sup>25</sup>) — sind eine Gruppe von sich alle von einem Kern, dem Purin,  $\text{C}_5\text{H}_4\text{N}_4$ , ableiten.

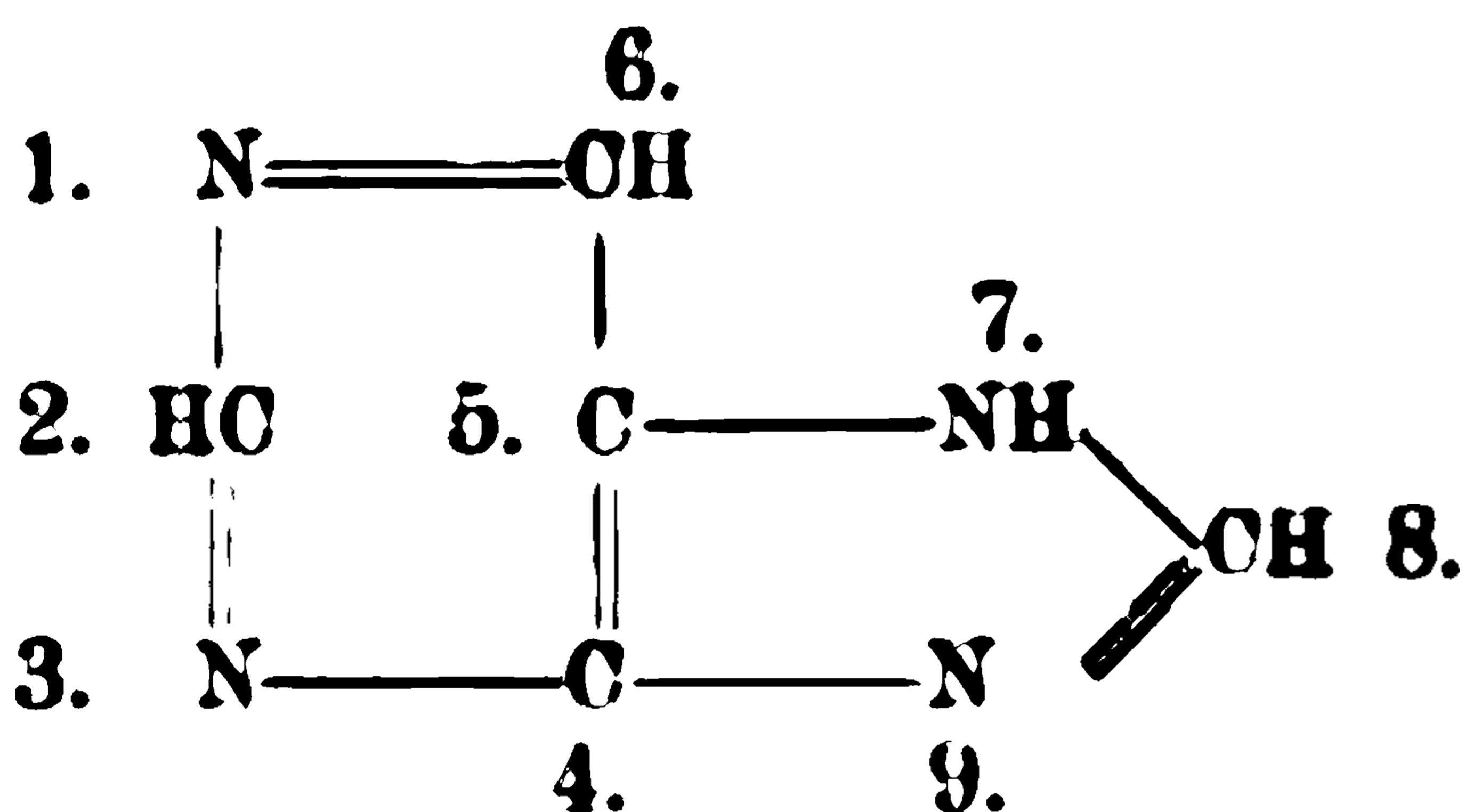

Die Zahlen 1.—9. geben die an, in welcher man die Atome des Kerns zu numerieren pflegt, um die Substitution der verschiedenen vorleitenden Verbindungen leicht bezeichnen zu können.

Der Purinkern ist zusammengesetzt aus dem Pyrimidinkern (s. 4) und dem Imidazolring (s. S. 12).

A. Die Harnsäure,  $\text{C}_5\text{H}_4\text{N}_4\text{O}_3$  — ist 2. 6. 8. Trioxypurin:

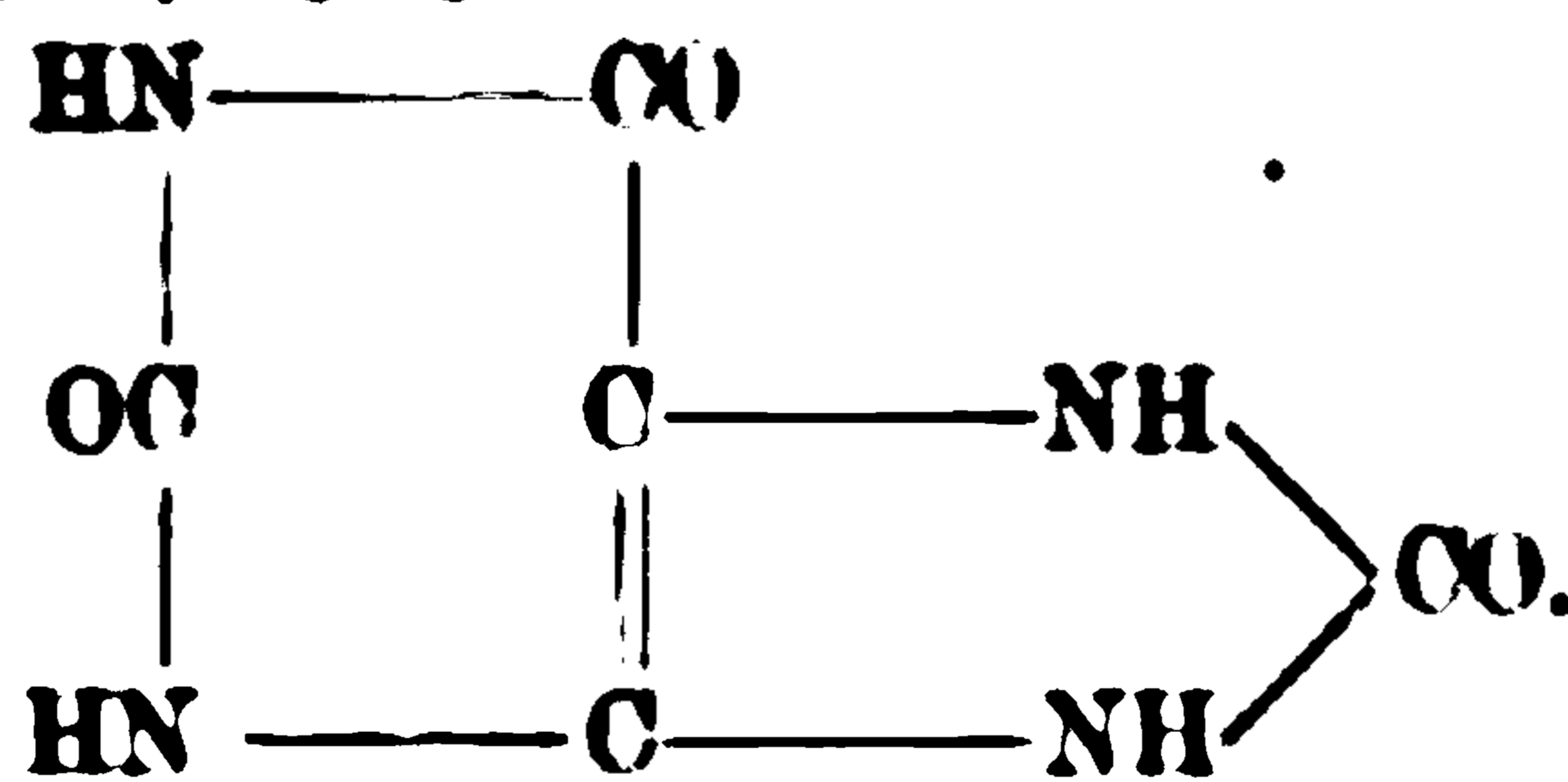

Die Harnsäure kommt im Harn vor (über Eigenschaften usw. vgl. § 165) in sehr geringen Mengen im Blute.

Durch Oxydation der Harnsäure mit übermangansaurem Kali entsteht

$\text{C}_4\text{H}_5\text{N}_5\text{O}_3$ ,  $\text{CO} \begin{matrix} \swarrow \text{NH}-\text{CH}-\text{NH} \\ | \\ \text{NH}-\text{CO} \end{matrix} \text{NH}_2 \text{CO}$  — es kommt in der Allantoisflüssigkeit mancher Tiere (§ 165), in geringen Mengen auch im normalen menschlichen Harn vor.

B. Die Purinbasen (Nuclein- oder Xanthin- oder Alloxurba

a) Adenin,  $\text{C}_5\text{H}_5\text{N}_5$ ; 6. Aminopurin.

b) Guanin,  $\text{C}_5\text{H}_5\text{N}_5\text{O}$ ; 2. Amino- 6. Oxyurin.

c) Hypoxanthin,  $\text{C}_5\text{H}_4\text{N}_4\text{O}$ ; 6. Oxyurin.

d) Xanthin,  $\text{C}_5\text{H}_4\text{N}_4\text{O}_2$ ; 2. 6. Dioxypurin.

Die beiden Aminopurine: Adenin und Guanin sind Bestandteile der Nucleinsäuren (vgl. pag. 16); bei der Spaltung werden sie teilweise in die entsprechenden Purine: Hypoxanthin und Xanthin umgewandelt.

Thymin,  $\text{C}_5\text{H}_8\text{N}_2\text{O}_2$ ; 5. Methyl- 2. 6. Dioxypyrimidin.

Cytosin,  $\text{C}_4\text{H}_6\text{N}_3\text{O}$ ; 6. Amino- 2. Oxypyrimidin.

Uracil,  $\text{C}_4\text{H}_4\text{N}_2\text{O}_2$ ; 2. 6. Dioxypyrimidin.

Thymin und Cytosin sind Bestandteile der Nucleinsäuren; bei der Spaltung wird ein Teil in Uracil übergeführt, welches daher ebenfalls unter den Spaltprodukten der Nucleinsäuren gefunden wird (vgl. pag. 16).

Glykokoll oder Glycin (Aminoessigsäure),  $\text{CH}_2(\text{NH}_2)\text{---COOH}$ , die einfachste Aminosäure unter den Spaltungsprodukten des Eiweißes (pag. 10). Mit Cholalsäure verbindet es die Glykocholsäure der Galle (vgl. § 118) — mit Benzoesäure gepaart als Hippursäure im Harn vor (vgl. § 165).

Taurin (Aminoäthylsulfosäure),  $\text{CH}_2(\text{NH}_2)\text{---CH}_2\text{---SO}_2(\text{OH})$  kommt mit Benzoesäure gepaart als Taurocholsäure in der Galle vor (vgl. § 118).

## 9. B. Anorganische Bestandteile.<sup>24</sup>

Anorganische Bestandteile kommen neben den organischen regelmäßig in allen flüssig- oder gasförmigen Bestandteilen des Körpers vor. Nur ein sehr geringer Teil dieser anorganischen Substanzen ist zufällig in den Körper eingeführt und an dieser oder jener Stelle verbraucht, die Mehrzahl stellt einen für den Ablauf des Lebens notwendigen Bestandteil dar. Mit den Exkreten (Harn, Schweiß, Faeces) werden dauernd anorganische Stoffe aus dem Körper ausgeschieden; sie müssen durch die Nahrung ersetzt werden, absichtliche Verweigerung der Salze der Nahrung (Salzhunger, vgl. § 148) führt sehr bald zu schweren Krankheiten und schließlich zum Tode. Der Gehalt der Flüssigkeiten und Gewebe des Körpers an einzelnen anorganischen Bestandteilen schwankt in der Norm nur in sehr engen Grenzen. Man sucht man experimentell diese Verhältnisse zu ändern, so gelingt dies immer nur in sehr beschränktem Umfange und sehr bald werden durch regulatorische Einrichtungen die normalen Verhältnisse wieder hergestellt. Obwohl danach an der großen Bedeutung der anorganischen Bestandteile des Körpers für das Leben kein Zweifel bestehen kann, so ist doch über die einzelnen nur wenig Sicheres darüber bekannt. Eine große Rolle spielen die anorganischen Salze bei der Aufrechterhaltung des normalen osmotischen Drucks in den Körperflüssigkeiten und -Geweben (vgl. § 13). Aber auch auf das Mischungsverhältnis der anorganischen Bestandteile kommt es in hohem Maße an, wie besonders deutlich aus den Versuchen hervorgeht, daß bei der Durchströmung überlebender Organe (z. B. Herz, § 38; § 106) Salzlösungen von ganz bestimmter Zusammensetzung (*Lockesche, Ringersche, Ringersche Lösung*, vgl. § 38) verwandt werden müssen und auch nur ganz geringfügige Abweichungen in der Zusammensetzung der Lösung die Verwendbarkeit beeinträchtigen oder gänzlich unmöglich machen.

**Wasser:** Der mittlere Wassergehalt des ganzen Körpers beträgt nach *Bischoff*<sup>24</sup> im Durchschnitt 58,5%. Er ist am höchsten beim Foetus (97,5%), schon erheblich niedriger beim Neugeborenen (66,4%) und nimmt mit zunehmendem Wachstum ab. Bei Hungerzustand ist der Wassergehalt des Körpers niedriger als bei schlecht Ernährten, während das bei Überernährung angesetzte Fett sehr wasserarm ist. Am wasserreichsten sind nach den Bestimmungen von *Engels*<sup>26</sup> an Hunden: Lungen (78%), Blut, Darm, Nieren (76%), Muskel (73%), am wasserärmsten das Skelett (34%); das Zahnbein enthält nur 10%, der Zahnschmelz fast gar kein Wasser. Fast die Hälfte des im ganzen Körper vorhandenen Wassers befindet sich in den Muskeln.

**Gase:** Sauerstoff, physikalisch absorbiert und (hauptsächlich) chemisch gebunden (vgl. § 32); in den übrigen Körperflüssigkeiten nur in sehr geringen Mengen. Aus den Lungenräumen im Körper, die nicht dauernd mit der Außenluft in Verbindung stehen, wird Sauerstoff allmählich von den Wandungen absorbiert (vgl. Magengase § 109, Darmgase, Paukenhöhle § 322). — Stickstoff, physikalisch absorbiert in geringen Mengen (vgl. § 33, III, ebenso Argon) und den andern Körperflüssigkeiten. Am Stoffwechsel, in dem organisch gebundene N der Eiweißkörper eine große Rolle spielt, hat der gasförmige Stickstoff keinen Anteil (vgl. § 86. 6, 148). — Wasserstoff entsteht durch die Gärungs-



vorgänge im Darm und findet sich daher in den Darmgasen (§ 123), eventuell a  
Mugengasen, geht von hier in das Blut und die Ausatemluft über (§ 86. 7).

Ammoniak entsteht als intermediäres Produkt beim Stoffwechsel der Ei  
durch die Desaminierung der Aminosäuren (§ 161); der größte Teil wird in der  
CO<sub>2</sub> zu Harnstoff synthetisiert, nur ein kleiner Teil geht als Ammoniumsalz in  
(§ 169. B.). Bei der ammoniakalischen Harn gärung wird Ammoniak aus Harnst  
macht (§ 160).

Schwefelwasserstoff kommt als Produkt von Gärungen im Darm (§ 14  
Harn (§ 169. A. 3) vor. — [Kohlensäure ist das Endprodukt der Verbrennung  
nischen Körperbestandteile; sie findet sich in reichlichen Mengen physikalisch ab  
(hauptsächlich) chemisch gebunden im Blut (§ 33. II), aber auch in allen ander  
flüssigkeiten und -Gewebe].

III. Metalloide: Chlor kommt in Form von Chloralkalien hauptsächt  
Körperflüssigkeiten vor (Blut 0,30% Cl, Lymphe, Harn, Schweiß), als freie Salze  
—0,58% H Cl) im Magensaft (vgl. § 109), weniger oder gar nicht in den gef  
standteilen, so enthält nach *Urano*<sup>27</sup> die Muskelsubstanz selbst kein oder nur  
Einen besonders hohen Cl-Gehalt (0,258% und höher) hat die Haut (*Wahlgre  
berg*<sup>28</sup>). Der mittlere Cl-Gehalt des ganzen Körpers beträgt 0,112%, für den H  
*mann*<sup>29</sup>), 0,123% für den Menschen (*Magnus-Levy*<sup>31</sup>); beim Foetus ist der Cl-  
höher (0,25—0,27% beim menschlichen Foetus), er sinkt mit zunehmendem Kö  
wie der Wassergehalt (s. oben) (*Rosemann*<sup>30</sup>). Durch chlorarme Ernährung, s  
Hunger kann nur eine geringfügige Abnahme des Cl-Vorrats des Körpers he  
werden, da unter diesen Umständen sehr bald die Cl-Ausscheidung im Harn  
wird oder aufhört; stärkere Verringerung bis auf 80% des Normalwerts kann du  
fütterung (§ 109) und Entleerung des abgesonderten Magensaftes nach außen bewir  
Durch chlorreiche Ernährung kann der Cl-Gehalt des Körpers stark erhöht we  
findet nach Aussetzen der Cl-reichen Ernährung ein schneller Rückgang des  
statt (*Rosemann*<sup>30</sup>).

Brom findet sich in geringen Mengen (nach *Justus*<sup>32</sup> 0,01—0,05 in 100  
Organ, nach *Labat*<sup>33</sup> bedeutend weniger) in allen untersuchten tierischen und m  
Organen, am reichlichsten in Nebenniere, Schilddrüse, Nagehn, Leber. Bei Cl-Entz  
gleichzeitiger Einfuhr von Na Br kann ein Teil des Cl im Körper durch Br ers  
(*Nencki* u. *Schoumow-Simanowski*<sup>34</sup>, *Bönniger*<sup>35</sup>).

Jod wurde von *Baumann*<sup>36</sup> in der Schilddrüse gefunden in organischer B  
Jodothyrim (§ 192. I) (*Baumann* u. *Roos*<sup>37</sup>); aber auch in fast allen ande  
finden sich sehr geringe Mengen Jod (*Justus*<sup>32</sup>).

Fluor in Knochen und Zähnen in sehr geringen Mengen, 0,1—0,3%  
(*Gabriel*<sup>38</sup>, *Jodlbauer*<sup>39</sup>), aber auch spurweise in andern Organen (*Tammann*<sup>40</sup>,  
*Clausmann*<sup>41</sup>). Nach Zufuhr von Na Fl wird Fl im Körper zurückgehalten  
*Tappeiner*<sup>42</sup>).

Schwefel kommt im Körper fast nur in organischer Bindung vor, h  
in den Eiweißstoffen (Cystin, vgl. S. 11); am schwefelreichsten sind die H  
(*Düring*<sup>43</sup>), der Schwefelgehalt des Muskels beträgt 1,1% der Trockensubstanz (H  
In nicht eiweißartiger Form kommt Schwefel in der Galle vor (Taurocholsäure,  
Knorpel (Chondroitinschwefelsäure), als Rhodanverbindung im Speichel (§ 100),  
(§ 109), Harn (§ 169. A. 3). In anorganischer Form findet sich Schwefel in den  
Körperflüssigkeiten und -Gewebe so gut wie gar nicht; im Harn als Sulfat-  
schwefelsäure (§ 169. A. 3), bei Fleischfressern auch als unterschwellige Sä  
Schwefelsäure kommt im Speichel mehrerer Schnecken (*Dolium galea*, 3%!)  
*Schulz*<sup>44</sup>).

Phosphor ist vorhanden in organischer Bindung in den Nukleo- und  
proteiden (S. 16), im Lecithin und den anderen Phosphatiden (S. 21), in an  
Bindung als Calcium- und Magnesiumphosphat in den Knochen, als Alkaliphosph  
und den Körperflüssigkeiten. Im Harn erscheint die Phosphorsäure gebunden  
und Erdalkalien (§ 169. A. 2).

Arsen wurde als regelmäßiger Bestandteil in gewissen Organen von *Ga  
allen Organen von Bertrand*<sup>45</sup> nachgewiesen; diese Angaben sind allerdings vielfac  
(*Cerny*<sup>46</sup>, *Hödlmoser*<sup>47</sup>, *Ziemke*<sup>48</sup>, *Kunkel*<sup>49</sup>).

Bor fanden *Bertrand* und *Agulhon*<sup>50</sup> konstant in tierischen Organen  
und Eiern.



**DIESE SEITE IST FÜR KOSTENLOSE MITGLIEDER GESPERRT**  
Beantragen Sie jetzt die volle Mitgliedschaft, um diese Seite zu betreten



**Seien Sie niemals ohne ein Buch!**

Die Vollmitgliedschaft von Forgotten Books bietet Ihnen einen universalen Zugang von unseren Apps und unserer Website, auf all Ihren Geräten: Tablet, Telefon, E-Reader, Laptop und Computer.

**Eine Bibliothek in Ihrer Tasche für € 8.99/monat**

**Fortfahren**

\*Es gelten Richtlinien zur fairen Nutzung.

- 23. *E. Fischer*: Untersuchungen in der Puringruppe (1882—1906). B.  
 24. *A. Albu* u. *C. Neuberg*: Physiologie u. Pathologie des Mineralstoffwechsel  
 — 25. *E. Bischoff*: Z. r. M. (3) 20, 1863, 75. — 26. *W. Engels*: A. P. P.  
 — 27. *F. Urano*: Z. B. 50, 1908, 212. — 28. *V. Wahlgren*: A. P. P. 6  
 — 29. *J. H. Padtberg*: A. P. P. 63, 1910, 60. — 30. *R. Rosemann*: P.  
 177. 142, 1911, 208, 447 u. 459. — 31. *A. Magnus-Levy*: B. Z. 24  
 — 32. *J. Justus*: V. A. 176, 1904, 1. 190, 1907, 524. — 33. *A. Labat*:  
 255. — 34. *M. Nencki* u. *E. O. Schoumoic-Simanowsky*: A. P. P. 34, 1  
 35. *M. Bönniger*: Z. o. P. u. T. 4, 1907, 414. 7, 1909, 2. 14, 1913, 452. — 36  
 Z. ph. Ch. 21, 1895, 319. 22, 1896, 1. — 37. *E. Baumann* u. *E. Roos*: Z. ph.  
 481. 25, 1898, 1. — 38. *S. Gabriel*: Z. a. Ch. 31, 1892, 522. — 39. *Jodlb*  
 1901, 487. 44, 1903, 259. — 40. *G. Tammann*: Z. ph. Ch. 12, 1888, 322. —  
 u. *P. Clausmann*: C. r. 156, 1913, 1347 und 1425. 157, 1913, 94. 158  
*A. Gautier*: C. r. soc. biol. 76, 1914, 107. — 42. *J. Brandl* u. *H. Tappei*  
 1891, 518. — 43. *F. Düring*: Z. ph. Ch. 22, 1896, 281. — 44. *H. Schulz*:  
 555. 56, 1894, 203. — 45. *Fr. N. Schulz*: Z. a. P. 5, 1905, 206. — 46. *A.*  
 129, 1899, 929. 130, 1900, 284. 134, 1902, 1394. 135, 1902, 812, 833. C.  
 1902, 727. 55, 1903, 1242. Z. ph. Ch. 36, 1902, 391. — 47. *G. Bertrand*:  
 1434. 135, 1902, 809. — 48. *K. Cerný*: Z. ph. Ch. 34, 1901, 408. — 49.  
 Z. ph. Ch. 33, 1901, 329. — 50. *E. Ziemke*: V. g. M. (3), 23, 1902, 51. — 51.  
 Z. ph. Ch. 44, 1905, 511. — 52. *G. Bertrand* u. *H. Agulhon*: C. r. 155, 19  
 1913, 732 u. 2027. — 53. *H. Schulz*: P. A. 84, 1901, 67. 89, 1902, 112. 1  
 144, 1912, 346 u. 350. — 54. *E. Herrmann*: P. A. 109, 1905, 26.

# Physiologie des Blutes.

---

## 10. Allgemeines über die Bedeutung des Blutes.

Das Blut vermittelt die Beziehungen der einzelnen Organe des Körpers untereinander. In der Lunge und im Magendarmkanal (entweder direkt oder indirekt durch die Chylusgefäße) nimmt es die für die Lebens- und Gesundheit notwendigen Stoffe: Sauerstoff und Nahrungsstoffe auf und trägt sie zu den einzelnen Organen zu. Andererseits nimmt es in den Organen die Produkte des Stoffwechsels auf und führt sie den Ausscheidungsorganen zu: Lunge, Haut, Niere. Zum Teil sind die in den Organen entstandenen Produkte Endprodukte des Stoffwechsels, die weiteres zur Ausscheidung gelangen können, zum Teil bedürfen sie zuvor noch weiterer Veränderung; sie gelangen in letzterem Falle durch das Blut von dem einen Organ, in welchem sie gebildet worden sind, zunächst in ein anderes Organ, in welchem sie erst in das zur Ausscheidung geeignete Stoffwechselendprodukt umgewandelt werden. So wird B. in den Organen entstandene  $\text{CO}_2$  und  $\text{NH}_3$  vom Blute zunächst zur Leber geführt, hier in Harnstoff umgewandelt, dann mit dem Blute zur Niere geführt und hier ausgeschieden. — Endlich kommt es auch vor, daß in dem einen Organ gebildete Stoffe in einem anderen Organ zur Ausführung ihrer Funktionen auszuüben haben; auch hier wird die Übertragung durch das Blut bewerkstelligt.

Das Blut hat die bemerkenswerte Fähigkeit, trotz der vielen Einwirkungen, welche auf seine Zusammensetzung einwirken, sich hinsichtlich seiner wesentlichen Eigenschaften annähernd konstant zu erhalten. Jede beginnende Änderung in der normalen Zusammensetzung des Blutes bedingt eine erhöhte Tätigkeit der Ausscheidungsorgane, welche in kürzester Zeit wieder die normalen Verhältnisse zurückführen. Genügt zeitweilige Tätigkeit der Ausscheidungsorgane nicht, um erheblichere Änderungen des Blutes sofort auszugleichen, so tritt ein Austausch zwischen Blut und Gewebsflüssigkeit in Kraft; abnorme Bestandteile des Blutes können zeitweilig in die Gewebe abgeschoben, andererseits Flüssigkeit aus den Geweben in das Blut aufgenommen werden. Für die Konstanz der Blutzusammensetzung ist endlich sehr wichtig die große Geschwindigkeit, mit welcher das Blut im Körper bewegt wird: Stoffwechselprodukte, die im Laufe eines Tages in beträchtlichen Mengen im Körper gebildet werden, finden daher in einem gegebenen Augenblicke oft nur in sehr geringer, eben merkbarer Menge im Blute, da es bei dem schnellen Transport zu den Ausscheidungsorganen niemals zu einer Anhäufung derselben im Blute

Tätigkeit der Organe auch die Zusammensetzung des Blutes geändert sein; angeführten Gründen ist aber in den meisten Fällen auch hier die Änderung möglich. Erhebliche Änderungen der Eigenschaften des Blutes, Anhäufung kranklicher Stoffe usw. kommen erst bei schweren Störungen der normalen Beobachtung.

## 11. Physikalische Eigenschaften des Blut

1. Die Farbe — des Blutes wechselt von hellem Scharlachrot in den Arterien bis zum tiefsten Dunkelrot in den Venen (auch die Luft) macht es hellrot, O-Mangel dunkel. ( $\text{CO}_2$  wirkt auf die Farbe des Blutes ein.) — Das O-freie Blut ist dichroitisch, scheint bei auffallendem Lichte dunkelrot, bei durchfallendem Licht hellrot.

Die Farbe des Blutes rührt her von den in der farblosen Flüssigkeit schwimmenden roten Blutkörperchen, welche den Blutfarbstoff oder das Hämoglobin in sich enthalten. Der Farbstoff ist also nicht im Blute in Lösung vorhanden, sondern in Form kleiner Teilchen in der Flüssigkeit suspendiert; dies bewirkt, daß das Blut auch in dünnen Schichten (wenn man es z. B. auf ein Glas ausbreitet) undurchsichtig oder „deckfarbig“ ist. Durch verschiedenartige Einwirkungen (vgl. § 14), am einfachsten durch Zugabe von destilliertem Wasser zum Blut, kann man bewirken, daß der Farbstoff aus den Blutkörperchen austritt und in der Blutflüssigkeit gelöst ist; das Blut wird dann durchsichtig oder „lackfarbig“.

Nach *Koeppe*<sup>1</sup> ist das deckfarbige Aussehen des Blutes dadurch bedingt, daß die Wand der roten Blutkörperchen aus einem fettartigen Stoff besteht und die Blutkörperchen in der Flüssigkeit suspendiert, wegen der verschiedenen Lichtbrechung das Wasser undurchsichtig wird. Wird Blut in sehr schnell rotierenden Zentrifugen (über 5000 Umdrehungen pro Minute) zentrifugiert, so daß die Blutkörperchen ohne jeden Rest voneinander aneinander gepreßt werden, so erscheint die Blutkörperchensäule lackfarbig. Werden die roten Blutkörperchen wieder im Plasma verteilt, so erscheint das Blut wieder deckfarbig.

Werden die roten Blutkörperchen zum starken Einschrumpfen gebracht, z. B. durch Vermischung des Blutes mit konzentrierten Salzlösungen, so wird die Farbe scharlachrot, heller als jemals in den Arterien. Beim Vermischen mit Wasser wird die Farbe des Blutes dunkel.

2. Das spezifische Gewicht des Blutes — beträgt 1,055—1,060, bei Frauen 1,050—1,056. Das spezifische Gewicht der roten Blutkörperchen ist 1,080—1,089, das des Plasmas (und der weißen Blutkörperchen) 1,027—1,030; hieraus erklärt sich die Neigung der roten Blutkörperchen sich zu senken.

Methode der Bestimmung. — 1. Nach *Schmaltz*<sup>2</sup>. Ein Glasröhrchen (Pyknometer) von 1,5 mm innerem Durchmesser und 12 cm Länge mit verengter Spitze, der Inhalt gut zurückgehalten werden kann, wird erst leer, dann mit destilliertem Wasser, dann mit Blut gefüllt gewogen. Das Gewicht des Blutes dividiert durch das Gewicht des Wassers gibt das spez. Gewicht des Blutes. (Eine zweckmäßige Modifikation der Methode gehen *Loewy* u. *v. Schrötter*<sup>3</sup> an.) — 2. Nach *Hammerschlag*<sup>4</sup>. Das zu untersuchende Blut bringt man in eine Mischung von Benzol (spez. Gewicht 0,88) und Chloroform (spez. Gewicht 1,49), welche annähernd dasselbe spez. Gewicht hat. Je nachdem der Blutstropfen in der Mischung steigt oder fällt, fügt man Benzol oder Chloroform hinzu, bis der Blutstropfen in der Mischung schwebt.



**DIESE SEITE IST FÜR KOSTENLOSE MITGLIEDER GESPERRT**  
Beantragen Sie jetzt die volle Mitgliedschaft, um diese Seite zu betreten

# GESCHICHTE

Zehntausende von wichtigen historischen Quellen, viele bisher nicht erhältlich, stehen jetzt zum ersten Mal mit der Vollmitgliedschaft von Forgotten Books zur Verfügung.

Unbegrenzter Zugang  
\$8.99/monat

**Fortfahren**

\*Es gelten Richtlinien zur fairen Nutzung.



Die Reaktion des Blutes wurde bis vor kurzem allgemein gehalten auf Grund des Verhaltens gegenüber Lackman einen Tropfen Blut (noch besser einen Tropfen einer gleichen Teilen Blut und konzentrierter Natriumsulfatlösung) liebes fliederfarbenes Lackmuspapier und saugt sogleich der dessen Eigenfarbe die Erkennung der Reaktion verhindert, sofort, so hinterbleibt auf dem Lackmuspapier ein blauer Fleck ist aber selbst eine mittelstarke Säure, es treibt die Kohlensäureverbindungen aus und ist also zur Untersuchung der Reaktionen, die Carbonate enthalten, wie das Blut, ungeeignet. Um Blutserum mit kohlensäureempfindlichen Indikatoren, wie Phthalein, so erweist sich die Reaktion, in Übereinstimmung mit den oben erwähnten Untersuchungen, als genau neutral (J. H. Schultz<sup>18</sup>).

Das Blut hat die Fähigkeit, eine bestimmte Menge von Säure zu binden, ehe es anfängt, sauer zu reagieren, und zwar durch den Gehalt an Carbonaten (Mononatriumcarbonat) und Eiweiß, falls Säure zu binden vermag. Durch Titration mit einer Standardlösung von Natriumhydroxid (NaOH) wird die Größe dieses „Säurebindungsvermögens“ bestimmt, welchen Wert, ausgedrückt durch die Zahl von mg NaOH, die 1 cm<sup>3</sup> Blut äquivalent sind, bezeichnet man als (Titrations-)Alkalität des Blutes.

**Quantitative Bestimmung der Alkaleszenz des Blutes.** 1. Titration des lackfarbigen Blutes. Man titriert ein bestimmtes Volumen Blut mit  $\frac{1}{10}$  Normalweinsäure (1 cm<sup>3</sup> = 4 mg NaOH), bis blaues Lackmuspapier sich rötet. Um die Bestimmung der Blutmengen ausführen zu können, verfährt man nach *Landois-v. Jaksch*<sup>17</sup>. Man bereitet sich eine Anzahl von Weinsäurelösungen abnehmender Acidität: 1 : 0,9 cm<sup>3</sup>  $\frac{1}{10}$  Normalweinsäure + 0,1 cm<sup>3</sup> konz. Natriumsulfatlösung; 1 : 0,8 cm<sup>3</sup>  $\frac{1}{10}$  Normalweinsäure + 0,2 cm<sup>3</sup> konz. Natriumsulfatlösung und so weiter bis 1 : 0,1 cm<sup>3</sup>  $\frac{1}{10}$  Normalweinsäure + 0,9 cm<sup>3</sup> konz. Natriumsulfatlösung; ferner Lösung 18 : 0,1 Normalweinsäure + 0,1 cm<sup>3</sup> konz. Natriumsulfatlösung bis Lösung 18 : 0,1 Normalweinsäure + 0,9 cm<sup>3</sup> konz. Natriumsulfatlösung. Mit einer Capillarpipette misst man ein genau gemessenes Quantum Blut, z. B. 0,1 cm<sup>3</sup> und setzt es der Reihe nach mit den obigen Lösungen, mischt und prüft die Reaktion mit Lackmuspapier. Diejenige Weinsäurelösung, welche das Blut gerade neutralisiert, und berechnete Menge Natriumhydroxid (NaOH) gibt die Alkaleszenz des Blutes. — 100 cm<sup>3</sup> Menschenblut haben nach dieser Methode eine Alkaleszenz entsprechend 260—300 mg NaOH (v. *Jaksch*<sup>16</sup>).

2. Titration des lackfarbigen Blutes. — *Loewy*<sup>20</sup> empfiehlt, die Titration lackfarbig zu machen, so daß der Inhalt der roten Blutkörperchen der Titration deckfarbigen Blutes in unberechenbarer Weise an der Reaktion vornehmlich an der Reaktion teilnimmt; die Bestimmung ist dann von der Menge des Blutes abhängig und läßt sich schneller und sicherer ausführen. In ein 50 cm<sup>3</sup> faßendes Reagenzglas dessen Hals zwischen 49,5 und 50,5 in  $\frac{1}{10}$  cm<sup>3</sup> geteilt ist, gibt man 45 cm<sup>3</sup> von oxalsaurem Ammonium, welche die Gerinnung verhindert und die Blutkörperchen suspendiert und ca. 5 cm<sup>3</sup> Blut; die genaue Menge, die verwendet worden ist, liest man an der Teilung ab. Nach der Mischung titriert man mit  $\frac{1}{10}$  Normalweinsäure und Lackmuspapier. — *Loewy*<sup>20</sup> fand nach dieser Methode die Alkaleszenz des Menschenblutes = 447—508 mg NaOH; *Strauß*<sup>21</sup> dagegen nach derselben Methode = 300—350 mg NaOH.

Das Blut hält seine neutrale Reaktion im lebenden Organismus es scheint, unter allen Umständen aufrecht. Werden in den Blutkreislauf eingeführt oder entstehen solche im Stoffwechsel (unter pathologischen Verhältnissen oft in großer Menge, z. B. Acetessigsäure, Oxybuttersäure, Diabetes, vgl. § 168), so werden sie abneutralisiert, entweder durch die Ammoniakbildung, an NH<sub>3</sub>, welches aus dem Eiweißstoffwechsel stets zur Verfügung

Andrerseits werden in den Organismus eingeführte Alkalien durch die reichlich vorhandene Kohlensäure neutralisiert. Wenn also dieser regulatorischen Einrichtungen die Reaktion des Blutes (an aktuellen H- und OH-Ionen) stets annähernd unverändert bleibt, so sind dabei doch die Titrationsalkalescenz (das Vermögen, Säuren zu binden, durch Abgabe weiterer potentieller OH-Ionen) schwanken können, die saurebindenden Valenzen des Blutes bereits anderweitig zum Teil weniger in Anspruch genommen sind. Die Titrationsalkalescenz zeigt unter physiologischen Verhältnissen Schwankungen nach oben (bis um 75 mg Na OH für 100 cm<sup>3</sup> Blut; *Straus*<sup>21</sup>). Durch starke körperliche Tätigkeit wird sie infolge der Säurebildung im Muskelgewebe herabgesetzt (*Cohnstein*<sup>22</sup>). Kinder und Frauen haben eine geringere Alkalescenz als Männer, Wöchnerinnen eine geringere als Schwangere (*Jacob*<sup>23</sup>), die eine stärkere als Nüchterne (*Peiper*<sup>24</sup>). — Nach dem Austritt aus dem Blut nimmt die Titrationsalkalescenz bis zur vollendeten Gerinnung ab, und zwar um so schneller, je größer die Alkalescenz war. Sie beruht auf einer Säurebildung, an welcher die roten Blutkörperchen, die einer noch unerforschten Zersetzung beteiligt sind. Höhere Temperatur und Kalizusatz befördern diese Säurebildung (*N. Zuntz*<sup>25</sup>). Altes, aus Wasser aus trockenen Stellen aufgelöstes Blut reagiert meist sauer.

**Pathologisches.** Auch unter pathologischen Verhältnissen hat sich die Reaktion (der Gehalt an aktuellen H- und OH-Ionen) in den bisher untersuchten Fällen als normal erwiesen, so bei Diabetes (*Benedict*<sup>26</sup>), Nerven- und Geisteskrankheiten, Epileptischen Anfall (*J. H. Schultz*<sup>27</sup>). — Dagegen zeigt die Titrationsalkalescenz unter pathologischen Verhältnissen Schwankungen nach oben und unten. Im Coma diabetico eine sehr starke Erniedrigung der Alkalescenz (*Magnus-Levy*<sup>28</sup>). Gifte, welche die roten Blutkörperchen bewirken, vermindern gleichfalls die Alkalescenz (*Kraus*<sup>29</sup>).

Der Gefrierpunkt des Blutes — liegt bei — 0,56° C (*Kraus*<sup>29</sup>). Vgl. § 13.

Das Blut hat einen eigentümlichen Geruch, der bei Menschen und Tieren verschieden ist, soll auf der Gegenwart flüchtiger Fettsäuren beruhen. — Der salinische Geschmack des Blutes rührt her von den in der Blutflüssigkeit vorhandenen Salzen. Über die Viscosität des Blutes vgl. § 48, über den Refraktionskoeffizienten § 28.

## 12. Die Formelemente des Blutes.

Die roten Blutkörperchen oder Erythrocyten (Fig. 2 u. 2a) wurden beim Menschen 1673 von *Lecuwenhoek*, beim Frosche 1658 von *van Leeuwenhoek* entdeckt.

Menschliche rote Blutkörperchen sind münzenförmige Scheiben mit einer zentralen tellerförmigen Aushöhlung und abgerundetem Rande. Sie sind von gelblicher Farbe und einem Stich ins Grünliche. Sie besitzen bei Säugetieren keinen Kern; dieser verschwindet bei der Entwicklung der roten Blutkörperchen aus den kernhaltigen Erythroblasten (§ 11). Das Vorhandensein einer Hülle wurde früher fast allgemein bestritten, neuerdings wieder mehrfach behauptet (*Deetjen*<sup>30</sup>, *Weidenreich*<sup>31</sup>, *Albrecht*<sup>32</sup>, *Löhner*<sup>33</sup>, *Schilling*<sup>34</sup>). Sie bestehen — 1. aus einer Substanz, einem äußerst blassen, weichen Protoplasma: Erythrocytenmembran und — 2. aus dem roten Blutfarbstoff, dem Hämoglobin.



Das Hämoglobin kann in den roten Blutkörperchen nicht etwa in gelöster Form vorhanden sein: da die roten Blutkörperchen 32,05% Hämoglobin und 63,2% Wasser enthalten, würde eine 33,65%ige Hämoglobinlösung resultieren; eine solche kann nicht bestehen wegen der geringeren Löslichkeit des Hämoglobins (Kollett<sup>30</sup>).

Nach Weidenreich<sup>28</sup> soll die normale Form der roten Blutkörperchen die nicht die bikonkave Scheibe, sondern eine konvex-konkave Glockenform sein. Löhner<sup>31</sup>.

Der Durchmesser der roten Blutkörperchen des Menschen beträgt 7,5  $\mu$ , die Randdicke 2,5  $\mu$ , die dünne Mitte 1,8—2  $\mu$  (Fig. 2).

Fig. 2.

Fig. 2a.

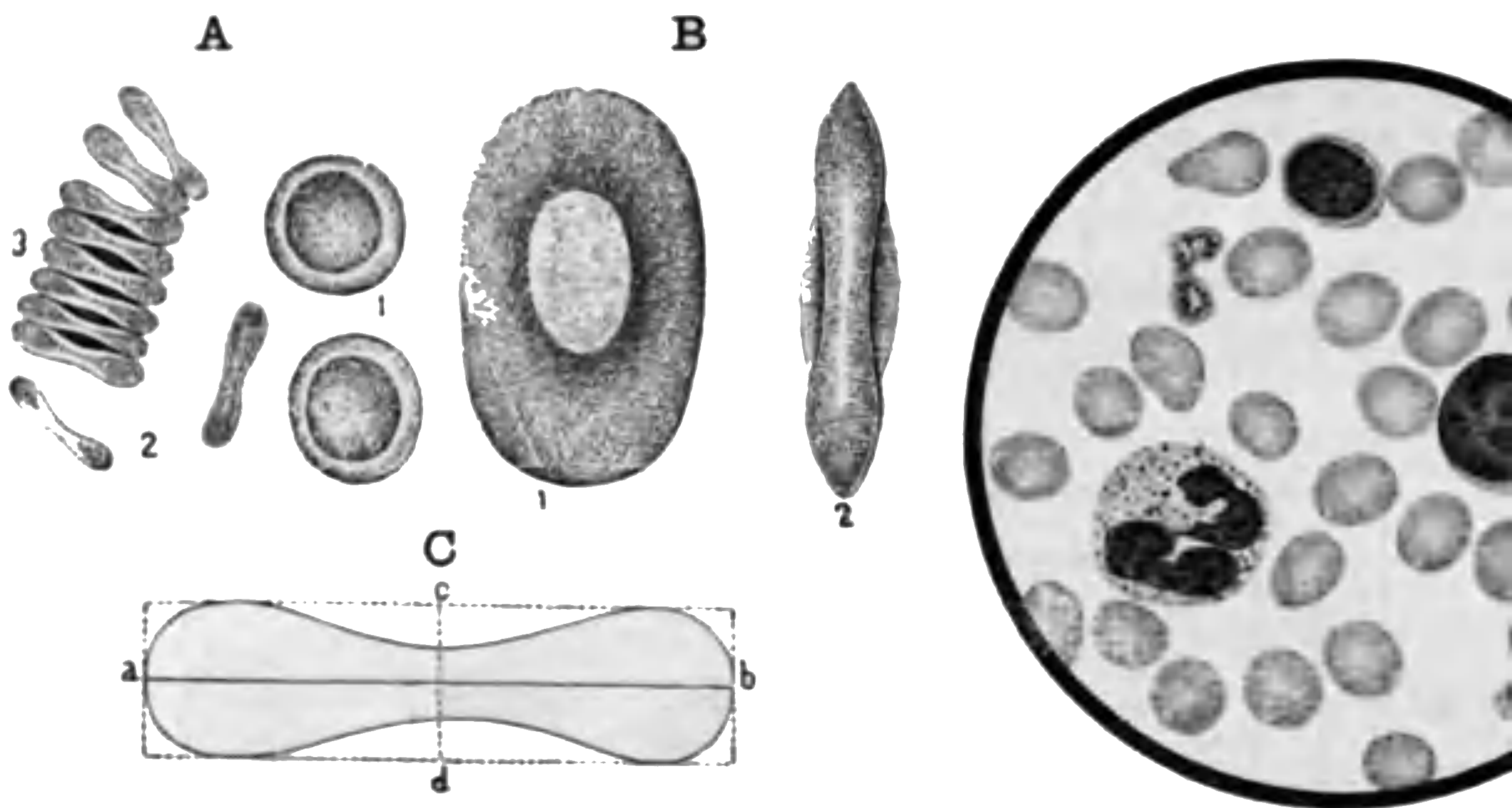

Fig. 2. A Rote Blutkörperchen vom Menschen: 1 von der Fläche, — 2 von der Kante aus gesehen; — 3 geldrollenartige Aneinanderlagerung der roten Blutkörperchen. — B Blutkörperchen vom Frosche: 1 von der Fläche, — 2 von der Kante aus gesehen. — C Querschnitt eines roten Blutkörperchens vom Menschen bei 5000facher linearer Vergrößerung. a b Durchmesser, c d größte (Rand-) Dicke. — Fig. 2a. Menschliches Blutpräparat: rote Blutkörperchen, dazwischen einige weiße.

Bei Gesunden schwankt der Durchmesser von 6—9  $\mu$ ; die Durchschnittsdicke = 7,2—7,8  $\mu$ . — Verkleinert werden die Körperchen durch Hunger, erhöhte Körpertemperatur,  $CO_2$ , Morphinum, — vergrößert durch O, Wasserigkeit des Blutes, Kälte, Chinin, Blausäure (Manassein<sup>32</sup>). [Pathologische Verhältnisse vgl. § 18.]

Das Volumen — eines Erythrocyten beträgt 0,000000072217  $mm^3$ , die Oberfläche 0,000128  $mm^2$ . Nimmt man die Gesamtblutmasse des Menschen zu 4400  $cm^3$  an, so enthält sämtliche darin enthaltene Blutkörperchen eine Oberfläche von 2816  $m^2$ , d. i. eine Quadratfläche von 80 Schritt in der Seite (Welcker<sup>33</sup>). — Das Volumen der roten Blutkörperchen im Verhältnis zum Plasma kann man bestimmen, indem man ein Blutpräparat (vermischt mit gleichen Teilen gerinnungshemmender konservierender Flüssigkeit: Kochsalz + 0,1% Natriumoxalat), oder unvermisches Blut in mit Öl überzogenen einem dünnen graduierten Glasaröhrchen (Hämatokrit) zentrifugiert (Hedin<sup>34</sup>). Hedin<sup>34</sup> fand das Volumen der Blutkörperchen bei Männern zu 42, bei Frauen zu 38. Bei anämischen Personen sind die Werte viel geringer. Mit sehr schnell rotierenden Zentrifugen (über 5000 Umdrehungen in der Minute) kann man frisches Blut ohne zu zentrifugieren, bevor Gerinnung eintritt; die Blutkörperchen werden dabei so gedrückt, daß auch der letzte Rest von Plasma zwischen ihnen entfernt wird. Die Blutkörperchen erscheinen lackfarbig, vgl. pag. 33); es wird dann also das absolute Volumen der roten Blutkörperchen gemessen (Koepppe<sup>35</sup>). Venöses Blut hat ein größeres Volumen an Erythrocyten als arterielles (Hamburger<sup>36</sup>).

Männer haben im Durchschnitt 5 Millionen, Frauen 4,5 Millionen rote Blutkörperchen in 1  $mm^3$ , in der gesamten Blutmasse (ca. 5 l) 25 Billionen. Die Zahl steht im umgekehrten Verhältnis zur Menge des Plasmas, woraus sich ergibt, daß je nach den Contractionszuständen



**DIESE SEITE IST FÜR KOSTENLOSE MITGLIEDER GESPERRT**  
Beantragen Sie jetzt die volle Mitgliedschaft, um diese Seite zu betreten



**Seien Sie niemals ohne ein Buch!**

Die Vollmitgliedschaft von Forgotten Books bietet Ihnen einen universalen Zugang von unseren Apps und unserer Website, auf all Ihren Geräten: Tablet, Telefon, E-Reader, Laptop und Computer.

**Eine Bibliothek in Ihrer Tasche für € 8.99/monat**

**Fortfahren**

\*Es gelten Richtlinien zur fairen Nutzung.

dünnung mit 100 resp. 200 erhält man die Zahl der Blutkörperchen in 1 mm<sup>3</sup> dünnem Blute. Eine sehr zweckmäßige Form der Zählkammer, welche die Fehlerkammern vermeidet, sowie andere Verbesserungen der Methode hat Bürker<sup>41</sup>

Zur Zählung der weißen Blutkörperchen verdünnt man das Blut und zwar mit einer  $\frac{1}{50}$ igen Essigsäuremischung, durch welche die roten Blutkörperchen aufgelöst werden. Zur Färbung der weißen Blutkörperchen setzt man der Flüssigkeit eine Spur Methylviolett hinzu.

Die roten Blutkörperchen zeichnen sich durch große Elastizität und Weichheit aus. Sie können infolgedessen (wenn deren Durchmesser kleiner ist als der eines roten Blutkörperchens) durch Formänderung passieren.

Blutkörperchen erhalten in entleertem und sogar defibriniertem Blute, wenn es wieder in den Kreislauf zurückgebracht wird, ihre Lebensfähigkeit ungeschwächt. Wird Blut aber bis gegen 40°C erwärmt, so ist die Lebensfähigkeit der Erythrocyten erloschen; solchen Blute lösen sich, wenn es in den Kreislauf zurückgebracht wird, schnell alle Blutkörperchen auf. — Kalt aufbewahrt kann Säuglingsblut 4—5 Tage lang sich funktionsfähig erhalten.

In frisch entleertem Blute legen sich häufig die Blutkörperchen rollenartig aneinander (Fig. 2, A. 3).

Fig. 5.

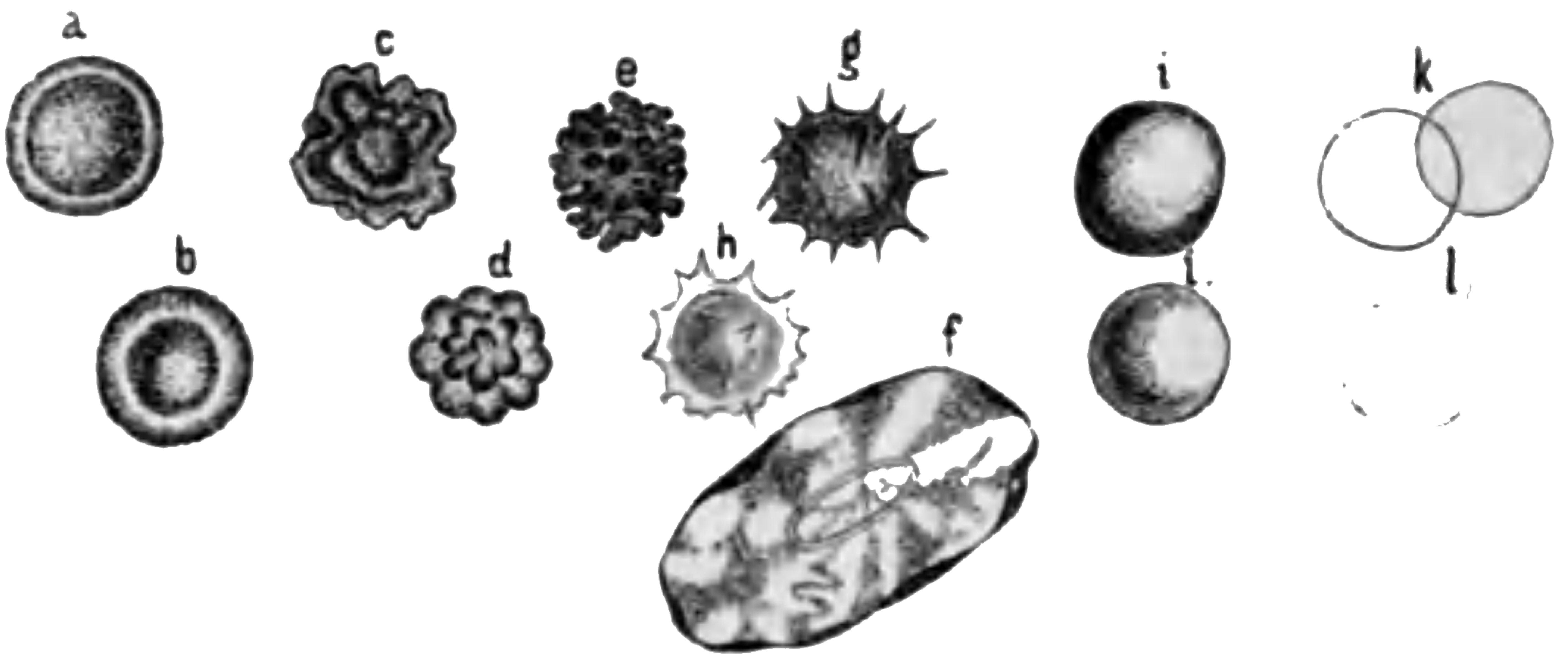

Rote Blutkörperchen in verschiedenen Formveränderungen und Auflösungsstadien: a b c d e f g h i j k abgeblaßte Kugeln; l Stroma; — f durch teilweise Wasserentziehung faltig geschrumpft. a b c d e f g h i j k l abgeblaßte Kugeln; l Stroma; — f durch teilweise Wasserentziehung faltig geschrumpft. Blutkörperchen vom Frosche.

Nach der Entleerung aus dem Körper bewirken schädigende Einflüsse, die auf die roten Blutkörperchen einwirken, besonders Flüssigkeiten, die von anderem osmotischen Druck wie das Blutplasma (§ 13), leicht Formveränderungen der Blutkörperchen. Manche Einwirkungen bringen eine Reihe von Formveränderungen schnell hintereinander hervor. Läßt man die Funken einer Leydener Flasche das Blut treffen, so werden alle Blutkörperchen „maulbeerförmig“, d. h. die Oberfläche wird unregelmäßig und mit größeren und kleineren rundlichen Höckern besetzt (Fig. 5 c d). Weiterhin werden die Blutkörperchen fast kugelig mit vielen ragenden Spitzen, „stechapfelförmig“ (g h). Alsdann nehmen die Blutkörperchen völlige „Kugelform“ an (i j). In dieser Gestalt erscheinen sie kleiner als die normalen, da sie ihre scheibenförmige Masse zu einer Kugel von kleinerem Durchmesser zusammenziehen. Endlich trennt sich der Blutfarbstoff von dem Stroma (k), die Blutflüssigkeit rötet sich,

ma nur als leichter Schatten erkennbar ist (1). Das Blut i  
lackfarbig geworden.

wärmt man auf einem heizbaren Objektische ein Blutpräpar  
n zwischen 56 und 60° die Blutkörperchen eigenartige Gestalt  
rungen. Sie werden teils kugelig, teils biskuitförmig auseinande  
mitunter durchlöchert, oder es schnüren sich größere und kleine  
n der Körpersubstanz vollständig ab und schwimmen in der u  
n Flüssigkeit (*Max Schultze*<sup>16</sup>). Bei Erwärmung auf 60—64° wä  
—20 Minuten lösen sich endlich die Erythrocyten völlig auf.  
ungen können die Blutkörperchen innerhalb der Gefäße dieselb  
rungen erfahren (vgl. § 18. 2).

r Konservierung der roten Blutkörperchen dienen: 1. *Pacinis Flüssigkeit*  
r. bichlorat. 2. *Natr. chlorat.* 4. *Glycerin.* 26. *Aq. destill.* 226. Vor der Anwendu  
en destillierten Wassers zu verdünnen.

*Hayems Flüssigkeit:* *Hydrargyr. bichlorat.* 0,5. *Natr. sulfuric.* 5. *Natr. chlorat.*  
. 200.

## Osmotischer Druck. Elektrolytische Dissoziation.

### e (Hyper- und Hypisotonie). Permeabilität der Erythrocyten

osmotischer Druck. Wenn in einem Gefäß eine Lösung irgend einer Subst  
rzuckerlösung) mit destilliertem Wasser vorsichtig überschichtet wird, so daß ke  
ng der beiden Flüssigkeiten stattfindet, so wandern die Teilchen der gelösten S  
(Rohrzucker-Moleküle) — der Wirkung der Schwere entgegen — allmählich in  
e Wasser empor, bis eine völlig gleichmäßige Vermischung eingetreten ist (Diffusio  
beiden Flüssigkeiten durch eine Membran voneinander getrennt, so hängt das weite  
von den Eigenschaften dieser Membran ab. Ist sie für das Lösungsmittel (Wass  
gelöste Substanz (Rohrzucker) völlig undurchgängig, so können die beiden Flüss  
türlich überhaupt in keine Beziehung zueinander treten. Ist die Membran für  
ittel und die gelöste Substanz in gleichem Maße durchgängig, so tritt natürli  
ein so, als ob keine Membran vorhanden wäre. Es kann nun aber drittens  
halbdurchlässig (*semipermeabel*) sein, d. h. durchlässig für das Lösun  
asser), aber undurchlässig für den gelösten Körper (Rohrzucker). (Derartige Me  
önnen künstlich hergestellt werden; sie kommen außerdem im Pflanzen- und Ti  
) In diesem Falle werden die Moleküle des gelösten Körpers ebenfalls das Bestre  
das destillierte Wasser einzudringen, aber auf ihrem Wege dahin werden sie du  
oran, die ja für sie undurchgängig ist, aufgehalten. Sie werden daher einen Dru  
Membran ausüben, und diesen Druck nennt man den osmotischen Druck.

efrierpunktserniedrigung. Der osmotische Druck einer Lösung kann dir  
werden in einer Weise, deren Beschreibung hier zu weit führen würde. Indir  
gemessen durch die Bestimmung der Gefrierpunktserniedrigung. Man v  
r Gefrierpunktserniedrigung die Differenz zwischen dem Gefrierpunkt der zu unt  
Lösung und dem Gefrierpunkt des destillierten Wassers und bezeichnet dies  
Δ. Die Gefrierpunktserniedrigung ist dem osmotischen Druck direkt proportio  
n aus derselben den osmotischen Druck berechnen. Häufig führt man diese U  
aber gar nicht aus, sondern gebraucht die Gefrierpunktserniedrigung selbst  
für die Größe des osmotischen Druckes.

e Bestimmung von Δ erfolgt mit dem *Beckmannschen Gefrierpunkts-*  
ngsapparat (Fig. 6). Derselbe besteht aus einem Kühlgefäß zur Aufnah  
ltmischung (Eis und Kochsalz), — einem in die Kältemischung eintauchend  
rohr, welches als Luftmantel dient und in welchem sich, rings von Luft umgeb  
gefrierrohr mit der zu untersuchenden Flüssigkeit befindet. In die Flüssigh  
n Rührer zum Umrühren und ein in  $\frac{1}{100}^{\circ}$  geteiltes *Beckmannsches Thermomet*  
beim Ablesen mittelst einer Lupe noch  $\frac{1}{1000}^{\circ}$  zu schätzen gestattet. (Das Therm  
gt an seinem oberen Ende ein Quecksilber-Reservoir; man kann mit Hilfe dessell  
thermometer selbst befindliche Quecksilbermenge verändern und so das Thermome

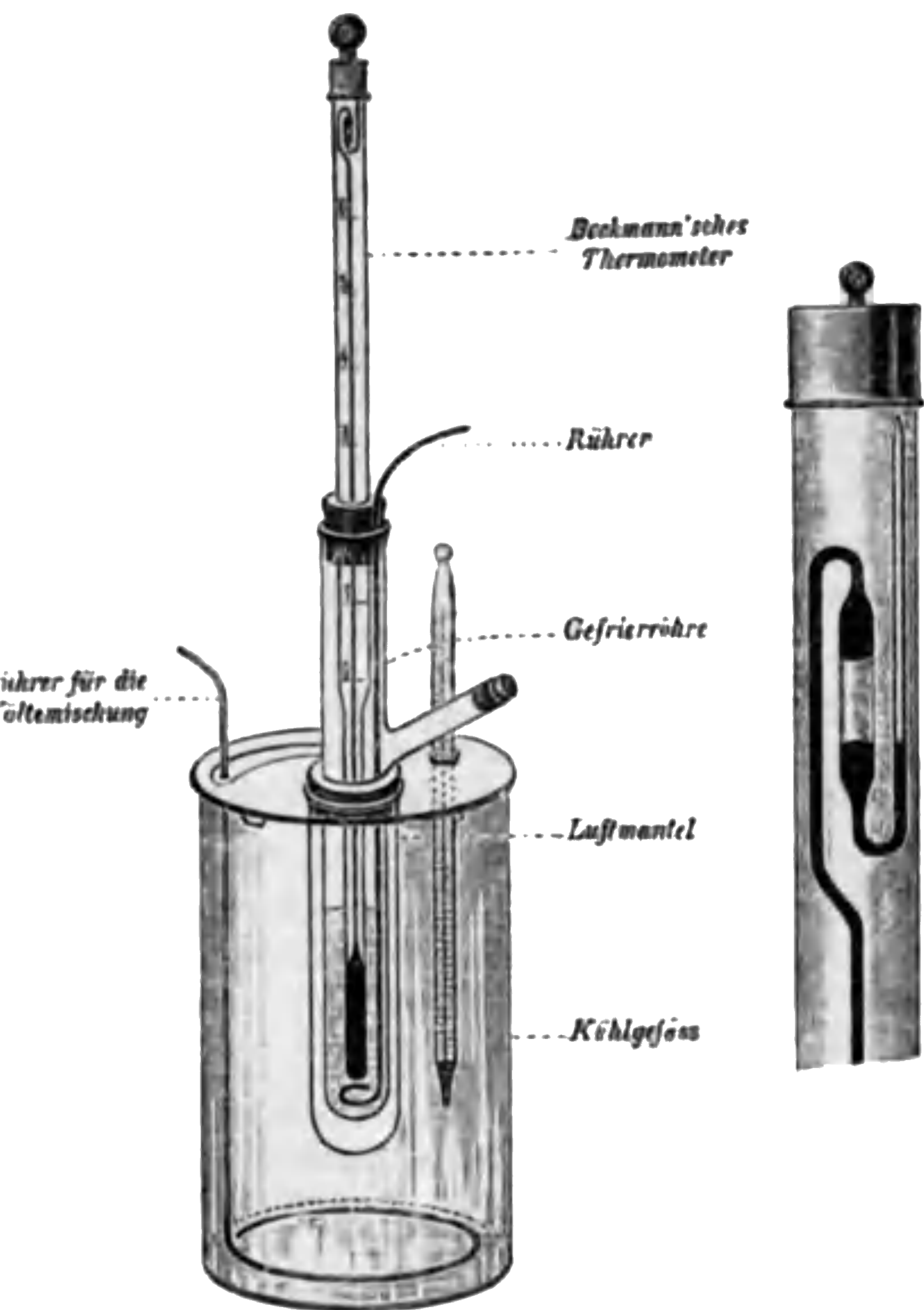

Apparat zur Gefrierpunktbestimmung nach Beckmann. Daneben das obere Ende des Thermometers im vergrößerten Maßstabe.

der abgelesenen und dem Gefrierdestillierten Wasser, dasmal wegen vor Verschiebungen besonders bestimmt ergibt die Gefriererniedrigung.

Zur Vermeidung von Fehlern bei der Messung sind eine Reihe von Vorkehrungen zu beobachten. Die Temperatur der Mischung soll nur wenig unter dem zu bestimmenden Gefrierpunkt liegen; die Unterkühlung darf nicht zu groß sein und muß bei jeder Messung möglichst gleich sein; vor der Ablesung des Thermometers muß das Thermometer durch Klopfen erschüttert werden. Ein solches Präzisionsapparat liefert eine sehr große Genauigkeit bei der Bestimmung. Ermöglicht von Nernst u. Raoult angegeben.

Van't Hoff hat 1887 das Gesetz der osmotischen Drücke aufgestellt, das dem Gay-Lussac'schen Gesetz gleiches Gesetz sein kann; ein gelöster Stoff hält sich in einer

Gas. Ein in einem bestimmten Raume Wasser gelöster Stoff übt denselben Druck aus, den er als Gasdruck ausüben würde, wenn er bei Abwesenheit des Wassers den gleichen Raum im gasförmigen Zustande erfüllte. Die Gasgesetze gelten auch für den osmotischen Druck. Wie nach dem Mariotteschen Gesetze bei konstanter Temperatur der Druck eines Gases der Dichtigkeit desselben proportional ist, so ist der osmotische Druck einer Lösung bei konstanter Temperatur der Konzentration desselben proportional, d. h. eine 2-, 3-, 4- usw. %ige Lösung eines Stoffes hat den doppelten, dreifachen, vierfachen usw. osmotischen Druck (und ebenso die doppelte, dreifache usw. Gefrierpunkterniedrigung) wie eine 1%ige Lösung desselben Stoffes. Gemäß dem Gay-Lussac'schen Gesetz der Gasdruck, wächst auch der osmotische Druck mit der Erhöhung der Temperatur um je  $1^\circ$  um  $\frac{1}{273}$  des Druckes bei  $0^\circ$ . Und schließlich nach der Avogadro'schen Regel der Gasdruck, so auch der osmotische Druck proportional der Natur der gelösten Substanz und allein bedingt von der Zahl der in der Lösung vorhandenen Moleküle. Löst man daher von verschiedenen Stoffen jedes ein Gramm, als dem Molekulargewicht entspricht, oder ein „Mol“ (z. B. 342 g Rohrzucker oder 17 g Harnstoff) in demselben Volumen Wasser auf, so haben diese Lösungen denselben osmotischen Druck (und denselben Gefrierpunkt). Äquimolekulare Lösungen verschiedener Stoffe haben denselben osmotischen Druck (und denselben Gefrierpunkt). Die Lösung eines Stoffes, welche in 1 Liter Wasser 1 Mol des Stoffes enthält, hat — unabhängig von der Natur des Stoffes (bei Elektrolyten ist allerdings die Dissoziation zu berücksichtigen) — denselben osmotischen Druck (und denselben Gefrierpunkt).



**DIESE SEITE IST FÜR KOSTENLOSE MITGLIEDER GESPERRT**  
Beantragen Sie jetzt die volle Mitgliedschaft, um diese Seite zu betreten

# GESCHICHTE

Zehntausende von wichtigen historischen Quellen, viele bisher nicht erhältlich, stehen jetzt zum ersten Mal mit der Vollmitgliedschaft von Forgotten Books zur Verfügung.

Unbegrenzter Zugang  
\$8.99/monat

**Fortfahren**

\*Es gelten Richtlinien zur fairen Nutzung.



Konzentration (Hypisotonie) quellen sie unter Wasseraufnahme. Änderungen des Volumens der roten Blutkörperchen in Salzlösungen verschiedener Konzentrationen können mit dem Hämatokriten (v) nachgewiesen werden. Hat die Quellung einen gewissen Grad erreicht, platzt die Membran, das Hämoglobin trennt sich vom Strömungssubstrat und lagert sich in der umgebenden Flüssigkeit ab: das Blut wird lackfarben.

Die roten Blutkörperchen sind aber keineswegs für alle Stoffe undurchlässig, sondern für eine Reihe von Stoffen vollständig durchlässig. Diese Stoffe sind in Abhängigkeit von der Permeabilität der roten Blutkörperchen. Diese Substanzen muß man unterscheiden in solche, welche für die roten Blutkörperchen giftig, und solche, welche nicht giftig sind. Zu den letzteren gehört z. B. der Harnstoff. Für diesen sind die roten Blutkörperchen völlig durchlässig; Harnstoff, dem man Blut hinzusetzt, verteilt sich gleichmäßig auf Blutkörperchen und Plasma. Daraus ergibt sich, daß der Harnstoff in seinen Lösungen überhaupt keinen osmotischen Druck auf die roten Blutkörperchen ausüben kann, ja seinem Eindringen keinen Widerstand entgegensetzen. In Salzlösungen jeder Konzentration verhalten sich daher die roten Blutkörperchen wie in destilliertem Wasser: sie lassen das Hb austreten, während man dagegen Harnstoff etwa zu einer Kochsalzlösung, welche die roten Blutkörperchen unverändert läßt, so bleiben dieselben nahezu unverändert: der Harnstoff ist also an sich nicht giftig. Ganz anders verhält sich eine Gruppe von Stoffen, als deren Typus das Arsenchlorid gelten kann. Für diese sind die roten Blutkörperchen durchlässig, zugleich aber wirken diese Stoffe auch direkt giftig auf die roten Blutkörperchen. Sie bewirken daher auch dann die Auflösung derselben, wenn man sie z. B. zu einer Kochsalzlösung hinzufügt, die an sich für die roten Blutkörperchen indifferent ist.

Es besteht schließlich aber auch eine Permeabilität der roten Blutkörperchen für gewisse Ionen. So sind die roten Blutkörperchen völlig undurchlässig für die elektropositiven K- und Na-Ionen, dagegen durchlässig für die elektronegativen Säure-Ionen  $\text{CO}_3$ ,  $\text{Cl}$ ,  $\text{NO}_3$ ,  $\text{SO}_4$  u. a. Es kann aber ein Eindringen von Ionen in die roten Blutkörperchen nur stattfinden, wenn zu gleicher Zeit ein Ausstrom gleichwertiger Ionen aus den roten Blutkörperchen erfolgt. So tritt z. B.  $\text{CO}_3$ -haltige rote Blutkörperchen in die Lösung eines Natriumcarbonats, so treten  $\text{CO}_3$ -Ionen aus den roten Blutkörperchen in die Salzlösung, zugleich aber Säure-Ionen der Salzlösung ( $\text{Cl}$ ,  $\text{NO}_3$ ,  $\text{SO}_4$ ) in die roten Blutkörperchen hinein. Dabei wird die Salzlösung (durch  $\text{Na}_2\text{CO}_3$ )

Die Permeabilität der Membran der roten Blutkörperchen für gewisse Stoffe undurchgängigkeit für andere Stoffe hängt nach *Ocerton*<sup>66</sup> von dem Gehalt der roten Blutkörperchen an Lipoiden (vgl. pag. 21) ab; in der Tat sind in dem Stroma der roten Blutkörperchen Sterin und Lecithin in verhältnismäßig großer Menge gefunden worden (§ 23). Die Membran, welche lipoid-löslich sind, vermögen die Membran zu durchdringen, für unlöslichen ist sie undurchgängig.

Der Gefrierpunkt des menschlichen Blutes liegt bei  $-0,56^\circ\text{C}$  und zeigt nur geringfügige Schwankungen [ $0,54$ — $0,58^\circ$ ] (*Strauss*). Unter den verschiedenartigsten Einflüssen hat das Blut die Fähigkeit, seine molekulare Konzentration (deren Ausdruck ja der Gefrierpunkt ist) unverändert zu erhalten. Transfundiert man einem Tiere Salz in das Gefäßsystem, so werden die fremdartigen Substanzen sehr rasch aus dem Blute in die Gewebe denoniert, respektive durch die Ni-

Kranken wird eine Steigerung der Gefrierpunktserniedrigung über  $0,6^{\circ}$  beobachteten Krankheiten ist dagegen die Gefrierpunktserniedrigung geringer als bei *rel<sup>66</sup>*, (*ohn<sup>67</sup>*, *Neudörffer<sup>68</sup>*).

## 4. Auflösung der roten Blutkörperchen, Hämolyse

Die Auflösung der roten Blutkörperchen, die Trennung von Hämoglobin und Stroma (Hämolyse) kann durch eine große Zahl sehr verschiedenartiger Einwirkungen herbeigeführt werden; das Hämoglobin löst sich dabei in der umgebenden Flüssigkeit und das vorher deckfarbene Blut wird lackfarbig. Gemeinsam scheint allen diesen Einwirkungen zu sein, daß sie, mechanisch oder chemisch, die roten Blutkörperchen zerstören und ihre Lebensfähigkeit aufheben.

Nach *Koeppe<sup>60</sup>* sind die roten Blutkörperchen von einer halbdurchlässigen Wand umgeben; diese Wand besteht aus fettähnlichen Substanzen (vgl. pag. 21) oder enthält solche: Zerstörung oder schonungsvolle Auflösung dieser halbdurchlässigen Wand macht das Blut lackfarbig. Auf dieser Weise wirken die folgenden Momente:

1. Wärme. Erwärmen des Blutes über  $65-68^{\circ}$  hat Auflösung der roten Blutkörperchen zur Folge (vgl. pag. 40), indem die fettähnliche Wand schmilzt.

2. Zusatz von destilliertem Wasser im Überschuß (vgl. pag. 3). Der beträchtliche Unterschied des osmotischen Druckes innerhalb und außerhalb der roten Blutkörperchen bringt diese zum Aufquellen und schließlich Platzen der halbdurchlässigen Wand.

Wird Blut mit viel destilliertem Wasser versetzt, so sind die Stromata unter dem Mikroskop ohne weiteres nicht sichtbar, sie können aber durch Zusatz von Methylenblau und sichtbar gemacht werden (*Koeppe<sup>60</sup>*).

Wiederholtes Gefrieren und Auftauen des Blutes wirkt ebenfalls hämolytisch. Beim Gefrieren friert reines Wasser aus; beim Auftauen der entstandenen Eiskristalle tritt also, wenn auch nur für kurze Zeit, reines Wasser auf die Blutkörperchen ein, infolge der Differenz des osmotischen Druckes zum Platzen.

Eine rein mechanische Zerstörung der Wand der roten Blutkörperchen kann durch Verreiben mit Seesand erreicht werden; bei nachträglicher Behandlung des Blutes mit osmotischen Flüssigkeiten findet Lösung des Hämoglobins statt (*Rywoosch<sup>61</sup>*).

3. Fettlösende Stoffe (Äther, Chloroform, Aceton, Alkohol) sind hämolytisch, indem sie die fetthaltige Wand der roten Blutkörperchen auflösen. Außer einer bestimmten Konzentration des hämolytischen Agens ist für die Wirkung eine bestimmte Temperatur notwendig.

Die Wirkung dieser ist das hämolytische Agens an sich unwirksam (*Koeppe<sup>60</sup>*). Umgekehrt können aber auch Stoffe, welche selbst in den Lipoiden der roten Blutkörperchen löslich sind, infolge dieser Löslichkeit in die Membran eindringen, sie schädigen und so Hämolyse herbeiführen.

1. Auf diese Weise bewirken Seifen, Fettsäuren, die ungesättigte Fettsäure (*Faust* u. *Tallqvist<sup>62</sup>*), aber auch die gesättigten, z. B. Palmitinsäure (*Shimazono<sup>63</sup>*), ferner Lipoide, wie das Lecithin, Hämolyse. Diese können auch durch ihre Einwirkung auf die Wand der roten Blutkörperchen



## Wirkung des Lecithins auf Kobragift, pag. 47).

In diese Gruppe gehört auch die hämolytische Wirkung der Gallsauren Salze sowie der sogenannten Saponinsubstanzen (*Kobert*<sup>66</sup>). der hämolytischen Substanzen dieser Gruppe wird durch Cholesterin geheilt (*Blohm*<sup>68</sup>).

4. Säuren und Basen wirken lösend auf rote Blutkörperchen. Wirksame dabei sind die H- resp. OH-Ionen (vgl. pag. 34). Die Voraussetzung der Wirkung ist notwendig eine genügende Konzentration der H- resp. OH-Ionen, eine bestimmte Temperatur und eine gewisse Zeit der Einwirkung. Nach *Koeppe*<sup>60</sup> handelt es sich bei der Wirkung der H-Ionen um eine katalytische Spaltung, bei der OH-Ionen um eine Verseifung der fettähnlichen Substanz der Wand der roten Blutkörperchen.

5. Durch elektrische Einwirkungen werden rote Blutkörperchen zerstört. Konstante Ströme, Induktionsströme, Wechselströme wirken vorwiegend durch elektrolytische Zersetzung (*Rolleit*<sup>66</sup>, *Hermann*<sup>67</sup>, *Cremer*<sup>68</sup>, *Drschewitzky*<sup>69</sup>) von Leydener Flaschen, Kondensatoren wirken dagegen durch eine nicht elektrische Einwirkung auf die roten Blutkörperchen (diese kann durch Zuckerslösungen verhindert werden, nicht jedoch durch Zusatz von Zuckerslösungen).

Eine große Gruppe hämolytisch wirkender Substanzen (Eiweißkörper im engeren Sinne) nimmt gegenüber den bisher erwähnten Substanzen eine besondere Stellung ein; sie ähneln in ihrem Verhalten durchaus den Giftprodukten gewisser Bakterien, den sogenannten Toxinen, sind ebenfalls äußerst labile Substanzen; sie veranlassen, in der Zelle eingeführt, die Bildung von Schutzstoffen, sogenannten Antitoxinen, ebenso wie die Toxine die Bildung von Antitoxinen auslösen, die ihre Wirkung aufheben; und ihre Wirkung ist spezifisch (s. pag. 46).

Die Bildung und Wirkung der Antitoxine erklärt sich nach der von Ehrlich aufgestellten Seitenkettentheorie, die auch für das Verständnis der Wirkungsweise von Antihämolytinen von grundlegender Bedeutung geworden ist, in folgender Weise: Nach *Ehrlich* hat man an dem lebenden Protoplasma zu unterscheiden den Zellkern, der das eigentliche vitale Zentrum darstellt, und zahlreiche, an der Zelle angeordnete Seitenketten oder Rezeptoren, die den einzelnen Funktionen der Zelle, allem auch der Ernährung derselben, dienen. Die Seitenketten oder Rezeptoren sind im Molekül des Protoplasmas, die infolge ihrer chemischen Konfiguration bestimmte Substanzen, z. B. Nahrungstoffe, aber auch Toxine chemisch verankert; sie verbinden sich dabei mit bestimmten Atomgruppen der Zelle, die als „haptophore Gruppen“ bezeichnet werden. Die Bindung zwischen einer haptophoren Gruppe eines Nahrungstoffes oder eines Toxins und den dazu passenden Rezeptoren der Zelle ist die Vorbedingung für die gegenseitige Einwirkung. Findet also ein Organismus eingeführt, dort keine für dasselbe passenden Rezeptoren, so kann er nicht giftig auf denselben zu wirken, der Organismus ist „immun“ für das Toxin (natürliche Immunität). Am Toxin hat man von der haptophoren Gruppe nur die Bindung an den Receptor der Zelle vermittelt, streng zu unterscheiden ist die haptophore Gruppe, welche nach erfolgter Bindung die eigentliche Giftwirkung ausübt, die haptophore Gruppe bezeichnet.

Wird ein Toxin in einen für dasselbe empfindlichen Organismus eingeführt, die nicht den Tod bedingt, so wird es also an die passenden Rezeptoren gebunden. Dadurch werden diese aber für ihre Aufgaben, z. B. Nahrungstoffaufnahme, außer Funktion gesetzt. Der Leistungskern bildet nun zum Ersatz derselben neue Rezeptoren. Diese Neubildung geht aber über den etwa gerade notwendigen Ersatz hinaus zu einer Überproduktion von Rezeptoren, die schließlich am Protoplasma nicht mehr verankert sind und in die Blutbahn abgestoßen werden. Diese frei in der Blutbahn befindlichen Rezeptoren sind die Antitoxine; sie vermögen die Toxine mittelst ihrer haptophoren Gruppen zu binden und dadurch vom Protoplasma abzuhalten (künstliche Immunität). Ist also, der, solange er als Receptor am Protoplasma sitzt, die Vorbedingung für die Wirkung des Toxins ist, stellt, wenn er sich frei in der Blutflüssigkeit befindet, die Ursache der Antitoxinwirkung dar.



**DIESE SEITE IST FÜR KOSTENLOSE MITGLIEDER GESPERRT**  
Beantragen Sie jetzt die volle Mitgliedschaft, um diese Seite zu betreten



**Seien Sie niemals ohne ein Buch!**

Die Vollmitgliedschaft von Forgotten Books bietet Ihnen einen universalen Zugang von unseren Apps und unserer Website, auf all Ihren Geräten: Tablet, Telefon, E-Reader, Laptop und Computer.

**Eine Bibliothek in Ihrer Tasche für €8.99/monat**

**Fortfahren**

\*Es gelten Richtlinien zur fairen Nutzung.

mit der entsprechenden haptophoren Gruppe des Blutkörperchens, diese Gruppe wird deswegen als cytophile Gruppe bezeichnet. Mittels der anderen Gruppe, der sogenannten komplementophilen Gruppe, bindet der Antikörper die entsprechende Gruppe des Komplements. Auch das Komplement besitzt zwei verschiedene Gruppen: eine haptophore, durch die es sich mit der komplementophilen Gruppe verbindet, und eine spezifische, die hämolytische Wirkung bedingt, die sogenannte zymotoxische (entsprechend der toxophoren Gruppe der Toxine).

Durch Vorbehandlung mit Blutkörperchen derselben Art können Antikörper erzeugt werden, welche die Blutkörperchen von anderen Angehörigen derselben Art zu lösen imstande sind, sogenannte Isolytine. Niemals dagegen gelingt es, Antikörper zu gewinnen, welche die eigenen Blutkörperchen des Tieres auflösen (Autolytine). *Maragliano*<sup>16</sup> soll bei zahlreichen Krankheiten das Serum die eigenen Blutkörperchen zugrunde richten.

Durch Immunisierung mit hämolytischem Serum kann ein Antikörper erzeugt werden, welcher die Wirkung der Hämolytine aufhebt.

Da das Hämolytin aus Amboceptor und Komplement besteht, die beiden Gruppen besitzen, zwei am Amboceptor und eine am Komplement, so sind bei der Wirkung drei verschiedene Antikörper denkbar: zwei, welche die eine haptophore Gruppe des Amboceptors binden: Antiamboceptoren, und ein Antikörper, welcher die haptophore Gruppe des Komplements bindet: Antikomplement.

Den Hämolytinen nahe stehen die Agglutinine, welche Agglutination von Blutkörperchen bewirken (es gibt auch Agglutinine, welche im gleichen Sinne wirken). Man versteht unter Agglutination eine Verklumpung der Zellen zu einem Haufen, die mikroskopisch erkannt werden kann, aber auch das makroskopisch verändert: größere Senkungsgeschwindigkeit der zusammengeballten Blutkörperchen durch Papierfilter. Solche Agglutinine sind gewisse giftige Substanzen pflanzlichen Ursprungs, Phytalbumosen (*Kobert*<sup>17</sup>): Ricin aus den Samen von Ricinus communis, Abrin aus den Samen von Abrus precatorius u. a. Auch im normalen Serum vorhanden oder können durch Immunisierung in dem Serum erzeugt werden. Diese Agglutinine des Serums ertragen ein Erhitzen auf 60°, sie finden sich daher noch in hämolytischem Serum.

Hämolytisch wirken auch gewisse tierische Gifte, so von Bienen, Spinnen, Kröten und Schlangen. Vom Schlangengift wiesen *Kobert*, daß es ebenso wie die Hämolytine des Blutserums die Wirkung auf die Blutkörperchen durch ein Zusammenwirken zweier Bestandteile herbeiführt: das Schlangengift selbst ist dabei der Amboceptor, das Komplement wirkt das Lecithin (*Kyes*<sup>18</sup>). Der Amboceptor des Schlangengiftes, z. B. des Kobragiftes, vereinigt sich dabei mit dem Lecithin zu einer neuen Verbindung, dem Kobralecithid, welches sich in seinen Löslichkeitsverhältnisse sowohl von dem ursprünglichen Kobragift als von dem Lecithin unterscheidet; das Kobralecithid kann reaktiv auf Lecithin wirken. — Die Hämolyse durch Kobragift und Lecithin wird durch Stearin stark gehemmt.

Die Stoffwechselprodukte zahlreicher Bakterien wirken hämolytisch. Tetanusbacillen, Cholera vibriionen, Typhusbacillen, Colibacillen, Staphylococci. In dem normalen Serum mancher Tiere sind Antikörper dieser Hämolytine vorhanden. Durch Immunisierung von Tieren mit Hämolytinen können sie künstlich erzeugt werden. Ein Antikörper entspricht einem bestimmten Hämolytin auch stets ein bestimmter Antikörper, dessen Wirkung des entsprechenden Hämolytins aufhebt, nicht aber die anderer Hämolytine. So schützt z. B. das durch künstliche Immunisierung von Kaninchen mit Staphylococci (Staphylolysin der Staphylococci) erhaltene Antistaphylolysin Kaninchenblutkörperchen gegen die Wirkung des Staphylolytins, aber nicht gegen die des Tetanolysins (Tetanusbacillen).

Die roten Blutkörperchen besitzen gegenüber hämolytischen Mitteln einen bestimmten Grad von Widerstandsfähigkeit. Diese Widerstandsfähigkeit ist verschieden bei verschiedenen Arten, aber auch ab von der Art des angewendeten hämolytischen Mittels. Die Widerstandsfähigkeit der Blutart ist z. B. um so weniger resistent gegen Saponin, je

## Die Erythrocyten der Tiere.

einen verschiedenen Resistenzgrad gegen hydrolytische Mo-  
sche Einflüsse, Saponin); zwischen den am meisten resist  
sich erst in 0,3% NaCl-Lösung auflösen, und den am wen  
ten, welche schon von einer 0,6%igen NaCl-Lösung auf  
, gibt es alle möglichen Übergangsstufen (*Lang*<sup>60</sup>). Gegen Sa  
ngere Blutkörperchen resistenter als ältere (*Handovsky*<sup>61</sup>),  
mbryonale Blutkörperchen den meisten hämolytischen Einfl  
ber resistenter als die des erwachsenen Tieres (*Rywoosch*<sup>70</sup>).

Bei Ikterus, Infektion, Magencarcinom ist die Resistenz der roten  
en gegen hypotonische NaCl-Lösungen erhöht (*Lang*<sup>60</sup>), die Resistenz  
bleibt dabei jedoch unverändert (*Port*<sup>62</sup>). Bei perniziöser Anämie schei  
deten roten Blutkörperchen eine besonders geringe Widerstandsfähigkeit geg  
h wirkenden Schädlichkeiten zu besitzen.

Das Hämoglobin vermag seine Aufgaben im Körper nur so lange zu erfüllen,  
roten Blutkörperchen gebunden ist. Kommt es zu einer Auflösung von roten  
en und Übertritt von Hämoglobin ins Plasma (Hämoglobinämie), so wi  
bin ausgeschieden: zunächst nimmt die Leber das Hämoglobin auf und verw  
ellenfarbstoffe; genügt das nicht, um das freie Hämoglobin aus dem Kreisla  
u, so scheiden es die Nieren aus: Hämoglobinurie. Bei der paroxys  
lobinurie kommt es aus noch nicht näher bekannten Ursachen anfallsweg  
g von roten Blutkörperchen und Hb-Ausscheidung im Harn.

## 15. Form, Größe und Zahl der Erythrocyten verschiedener Tiere.

Die Säugetiere — haben kreisrunde Blutkörperchen ohne Ker  
nsch, nur von verschiedener Größe. Eine Ausnahme machen K  
Alpaka und deren Verwandte; diese haben länglich-elliptische  
chen ohne Kern. Die Vögel, Reptilien, Amphibien und F  
länglich-elliptische Blutkörperchen mit Kern; eine Ausnahme  
schen machen die Cyclostomen, welche kreisrunde Blutkörper  
mit Kern haben.

Farbstoff in der Blutflüssigkeit gelöst sein (der Regenwurm, die Larve der Mücke z. B. haben rotes hämoglobinhaltiges Plasma und farblose Zellen) gebunden vorkommen. Es sind eine Reihe verschiedenartiger Farbstoffe im Blute gefunden worden. Das Hämoglobin kommt weit verbreitet vor bei den niederen Crustaceen. Andere respiratorische Farbstoffe sind: das Chlorocruorin (rot) der Echinodermen, das Chlorocruorin (grün) und Hämerytin (blau) der Würmer, das Hämocyanin (blau) der Mollusken und Crustaceen. Es ist ein kupferhaltiger, O<sub>2</sub>-bindender Farbstoff, es ist von Henze<sup>84</sup> krystallisiert worden. Er vermag nur  $\frac{1}{4}$  so viel Sauerstoff wie Hämoglobin zu binden. O<sub>2</sub>-haltige Blut ist blau, das venöse farblos (vgl. Kobert<sup>85</sup>, Winterstein<sup>86</sup>). Die Blutkörperchen des Blutes der Ascidien fand Henze<sup>87</sup> ein Chromogen, das O<sub>2</sub> hält; dieses Chromogen nimmt jedoch keinen Sauerstoff auf. Die Blutkörperchen enthalten außerdem 3% freie Schwefelsäure. — Im Blute einiger Mollusken sollen auch respiratorische, sauerstoffbindende Körper ohne besondere Farbe, sogenannte Achroglobine, vorkommen.

## 16. Entstehung und Untergang der roten Blutkörperchen.

### Entstehung der roten Blutkörperchen.

**Embryonale Entwicklung.** Im Embryo entstehen die ersten roten Blutkörperchen in den sogenannten Blutinseln des Gefäßhofes. Die zu den Stränge angelegten Blutgefäße erhalten durch Eindringen von Flüssigkeit im Innern, in welchen von der Wand her Haufen locker miteinander verbundene Zellen hineinragen. Diese Zellen, die zunächst noch einen Kern enthalten, sind die fertigen Erythrocyten, wandeln sich in rote Blutkörperchen um, wenn Sauerstoff in ihnen auftritt, lösen sich von den Zellhaufen ab und gelangen so in das Innere der Gefäße; sie vermehren sich weiterhin durch Teilung.

Im weiteren Verlaufe der embryonalen Entwicklung wird die Bildung der roten Blutkörperchen in bestimmten Organen lokalisiert; als solche kommen die Leber, später die Milz, die Lymphdrüsen, endlich das rote Knochenmark in Betracht. Im letzten zwei Dritteln der Embryonalentwicklung (beim Rind und Schaf) ist das Knochenmark (neben der weniger wichtigen Milz) das hauptsächlichste Blutbildungsorgan. Nach Eintritt des Knochenmarks in die Reihe der Blutbildungsorgane geht die Leber für die Blutbildung zurück (Jost<sup>88</sup>).

Aus den stets zuerst kernhaltigen roten Blutkörperchen des Embryo entstehen erst im späteren Verlaufe des Embryonallebens die charakteristisch kernlosen. Beim menschlichen Embryo sind in der 4. Woche nur kernhaltige rote Blutkörperchen vorhanden; im 3. Monat beträgt ihre Zahl nur noch gegen  $\frac{1}{4}$ — $\frac{1}{2}$  allmählich abnehmend, am Ende des Fötallebens trifft man normalerweise im strömenden Blute keine kernhaltigen roten Blutkörperchen mehr an; sie finden sich nun nur noch in den blutbildenden Organen.

Im extrauterinen Leben werden die roten Blutkörperchen in besonderen blutbildenden Organen gebildet, und zwar ist bei den schwänzten Amphibien und Fischen die Milz, bei allen übrigen das rote Knochenmark der Bildungsherd (Bizzozero<sup>89</sup> 1866). Hier entstehen die roten Blutkörperchen aus kernhaltigen „Erythroblasten“; der Kern wird bei der Entwicklung der roten Blutkörperchen von den Autoren (Kölliker<sup>90</sup>, Neumann<sup>91</sup>, Knoll<sup>92</sup>) im hämoglobinhaltigen Plasma aufgelöst, nach anderen (Rindfleisch<sup>93</sup>) tritt der Kern aus der Zelle aus. — Die Erythroblasten selbst entstehen wahrscheinlich auf zweierlei Weise: einerseits durch Zellteilung aus schon hämoglobinhaltigen Zellen, andererseits aus farblosen Mutterzellen, welche sich in hämoglobinhaltige umwandeln.

Bei der Geburt enthalten alle Knochen rotes Mark, im Verlaufe des Lebens wird dieses jedoch allmählich durch gelbes Fettmark ersetzt, so daß beim Erwachsenen in den platten und kurzen Knochen des Schädels und des Rumpfes rotes Mark findet, die langen Röhrenknochen der Extremitäten enthalten entweder es enthalten nur die oberen Teile des Femur und Humerus rotes Mark. In den Knochenmarken können sich durch Regenerationsprozesse des Blutes das Fett in rotes verwandeln, und zwar von jenen oberen Enden an abwärts.



**DIESE SEITE IST FÜR KOSTENLOSE MITGLIEDER GESPERRT**  
Beantragen Sie jetzt die volle Mitgliedschaft, um diese Seite zu betreten

# GESCHICHTE

Zehntausende von wichtigen historischen Quellen, viele bisher nicht erhältlich, stehen jetzt zum ersten Mal mit der Vollmitgliedschaft von Forgotten Books zur Verfügung.

Unbegrenzter Zugang  
\$8.99/monat

**Fortfahren**

\*Es gelten Richtlinien zur fairen Nutzung.



Die Leukocyten können nach ihrer Form, nach der Art ihres Protoplasmas, welches bei den einen homogen ist, bei den anderen Körnchen (Granulationen) enthält, und nach dem Verhalten gegen Farbstoffe in verschiedene Arten (Fig. 8) eingeteilt werden. Ein Teil der Körnchen färbt sich nur mit sauren Farbstoffen: oxyphile, ein anderer Teil nur mit basischen: basophile, ein dritter Teil nur mit neutralen: neutrophile Granulation. Danach unterscheidet Ehrlich<sup>106</sup> im normalen Blute:

1. Die Lymphocyten: kleine, an Größe den Erythrocyten gleichen, mit großem, rundem, sich mit allen basischen Farbstoffen färbendem und dünner homogener Protoplasmarinde ohne Granulationen im normalen Blute etwa 22—25% der farblosen Zellen. (Fig. 8, a, b.)

2. Die großen mononucleären Leukocyten: zwei- bis dreifach so groß wie die Erythrocyten, mit großem, ovalem, meist exzentrisch gelagertem, schwach gefärbtem Kern und homogener protoplasmatischer Rindenschicht ohne Granulation. (Fig. 8, c, d.)

Fig. 7.

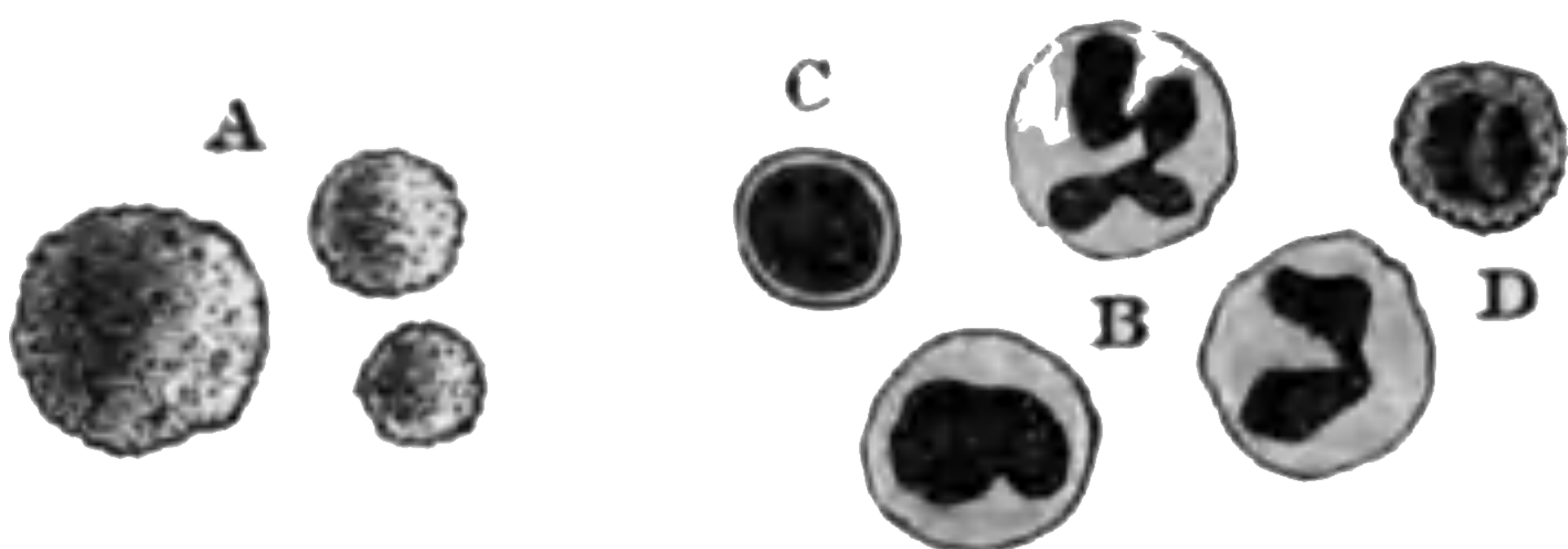

Leukocyten des Blutes oder weiße Blutkörperchen: A frisch ohne Zusatz; — B dieselben nach Wasserzusatz mit scharfer Kernbegrenzung und hervortretenden Kernen; — C mit großem Kern und wenig Protoplasma aus adenoidem Gewebe; — D Kern und Körnchen zugleich sichtbar.

Fig. 8.

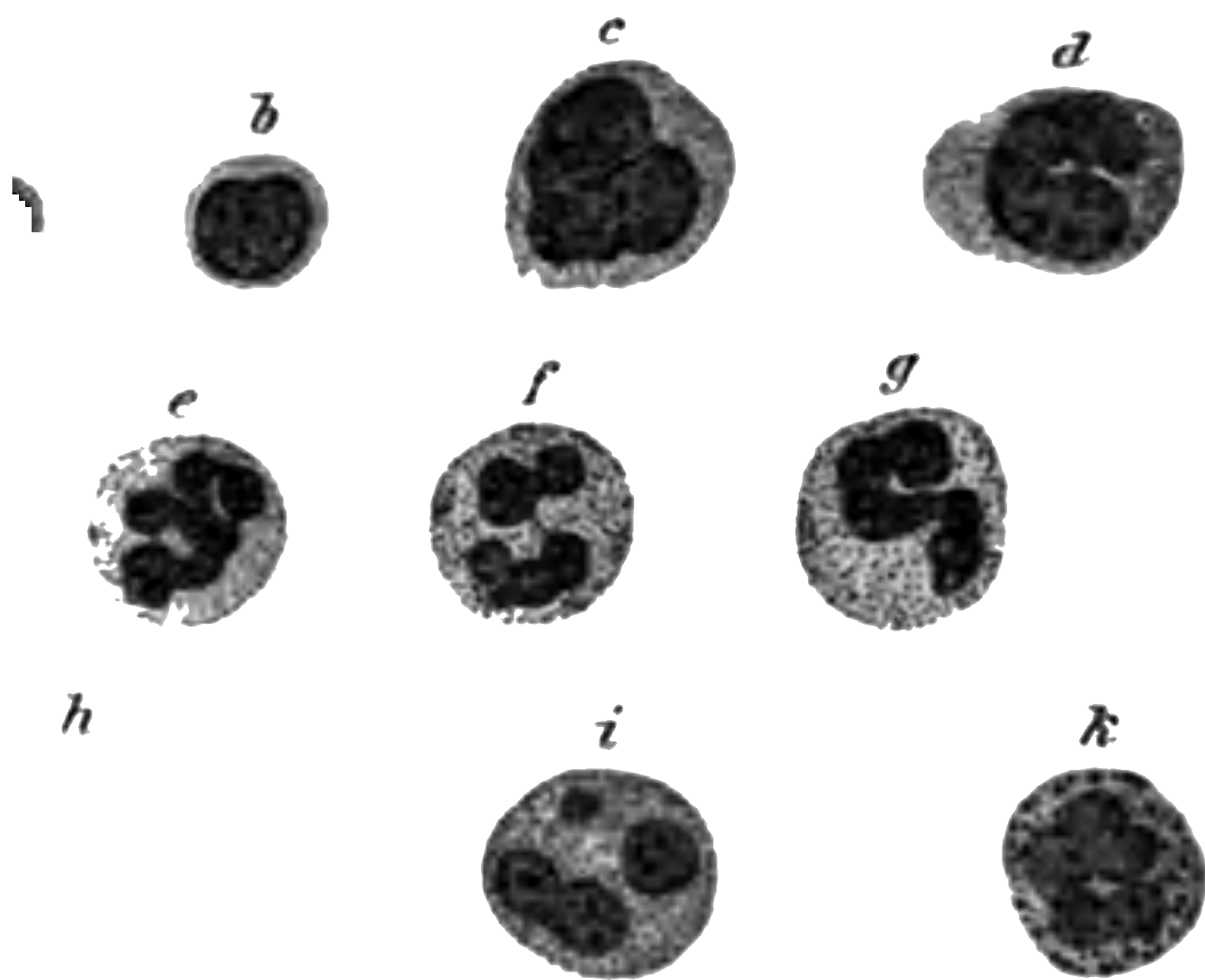

Leukocyten des Blutes: a, b Lymphocyten; — c großer mononucleärer Leukocyt; — d Übergangsform; — e, f, g polymorphonucleäre neutrophile Leukocyten; — h, i eosinophile Leukocyten; — k Mastzelle, basophil.

3. Die Überformen: den vorigen ähnlich, aber mit zwerchsackförmig gebuchtetem Kern; das Protoplasma tritt eine neutrophile Granulation auf. Gruppe 2 und 3 zusammen etwa 50% sämtlicher Leukocyten (Fig. 8, d.)

4. Die polymorphonucleären neutrophilen Leukocyten: etwas kleiner als die Gruppe 2 und 3 mit polymorphem, gelapptem Kern, vielgestaltig gewundenem oder in 3—4 durch Chromatinfäden miteinander verbundene Teile, die sich weichend dem Kern an der Basis des Protoplasmas mit basischen Farbstoffen intensiv färbend. Das Protoplasma besitzt dichte, sehr feine neutrophile Granulation. Im normalen Blute etwa 70 bis 72% aller Leukocyten. (Fig. 8, e, f, g.)

5. Die eosinophilen Zellen gleichen den vorigen, enthalten grobe, kugelige, in den sauren Farbstoffen intensiv färbbare Granulationen. Etwa 2—4% der farblosen Zellen. (Fig. 8, h, i.)

6. Die Mastzellen enthalten eine intensiv basophile Granulation. (Fig. 8, k.)

n pathologische Erscheinungen treten diese Formen nicht nur in veränderter Form, sondern es erscheinen auch noch andere Formen, die normalerweise im Blute überkommen.

Nach Ehrlich sind die großen mononucleären Leukocyten (2) und die Übergangsformen (3) Vorstufen der polynucleären neutrophilen Leukocyten (4); es besteht eine Stufenreihe (5) zwischen den ungranulierten Lymphocyten (1) und den granulierten Leukocyten (6) mit Einschluß von 2 und 3; 5 und 6), diese beiden Zellformen stehen in keiner Beziehung zu einander. Nach einer anderen Anschauung (vgl. Weigert) entwickeln sich dagegen die granulierten Zellen aus den nicht granulierten.

Die neutrophilen Leukocyten (nicht die Lymphocyten) des Menschen und der höheren Tiere, in geringerem Maße auch des Hundes (nicht der anderen Tiere) enthalten ein proteolytisches Ferment; Blutplasma und Blutserum haben einen hemmenden Einfluß auf die Fermentwirkung.

Das Blut bei myelogener Leukämie zeigt (bei 50°) starke Fermentwirkung (infolge Vermehrung der Leukocyten), das Blut bei lymphatischer Leukämie (Vermehrung der Lymphocyten) keine (Müller u. Jochmann<sup>107</sup>). Auch ein diastatisches Ferment in Leukocyten nachgewiesen worden (Haberlandt<sup>108</sup>, Mancini<sup>109</sup>), jedoch keine Lipase (Lipowski<sup>110</sup>). Die Lymphocyten enthalten dagegen ein fettspaltendes Ferment (Lipase).

Die Leukocyten vermehren sich durch Teilung. Sie entstehen in den Lymphdrüsen und dem adenoiden Gewebe überhaupt, in dem Knochenmark, und zwar nach Ehrlich<sup>106</sup> die Lymphocyten in dem lymphatischen Apparat, die granulierten Leukocyten im Knochenmark.

Die Leukocyten zeigen (besonders bei der Beobachtung auf dem Objektisch) Amöbenbewegungen (von Wharton Jones 1846 beschrieben, von Davaine 1847 beobachtet).

Die Leukocyten zeigen (besonders bei der Beobachtung auf dem Objektisch) Amöbenbewegungen (von Wharton Jones 1846 beschrieben, von Davaine 1847 beobachtet), welche sie den Bewegungen der Amöben gleichen, weshalb sie den Bewegungen der Amöben entsprechen „amöboide“ genannt. Das Protozoenverhalten ist dabei in abwechselnder Amöbenbewegung und Reformation des Kerns; von der Oberseite werden Fortsätze ausgesendet und wiegezogen (Fig. 9) (s. die Pseudopodien der Amöben).

Fig. 9.



Leukocyten vom Menschen in amöboider Bewegung begriffen.

Die Beweglichkeit kommt nicht nur, wie man früher angenommen hat, den Leukocyten, sondern allen weißen Blutkörperchen, auch den Lymphocyten (Lilljeström<sup>112</sup>, Deetjen<sup>113</sup>).

Die Erscheinung kann bei 40° stundenlang beobachtet werden, in der feuchten Kammer lang Bewegungen gesehen worden. Jolly<sup>114</sup> will in dem Blute von Batrachien, welches im Eisschranke aufbewahrt wurde, sogar nach 10 Monaten (!) noch amöboide Bewegungen der Leukocyten beobachtet haben. Bei 47° tritt „Wärmestarre“ und Tod ein. Die höchste Temperatur für die Möglichkeit der amöboiden Bewegung liegt bei 40°. Die Bewegung notwendig. Unter dem Einfluß von Induktionsschlägen werden die Leukocyten plötzlich durch Einziehung aller Fortsätze rund (wie gereizte Amöben). Wenn der Schlag nicht zu stark, so beginnen sie nach einiger Zeit wieder ihre Bewegungen. Anhaltende Schläge töten sie, lassen sie ferner aufquellen und völlig zergliedert, vernichtet die Beweglichkeit der Leukocyten.

Die Bewegung der Leukocyten hat zweierlei Erscheinungen zur Folge. Die Wanderungen der Zellen, indem sie sich mittelst



Ausstreckens und Einziehens der klebrigen Fortsätze fortziehen; Weise vermögen sie sogar durch die Wand intakter Gefäße zu wandern“ (vgl. § 65). — 2. Die Aufnahme kleiner Körnchen (Pigmente, Fremdkörperchen), die zuerst der Oberfläche ankleben, ins Innere gezogen, eventuell später wieder ausgestoßen werden (entsprechend der Nahrungsaufnahme der Amöben).

Die Bewegungen der Leukocyten können sogar nach einer bestimmten Richtung erfolgen, indem die Leukocyten (wie manche niedere Organismen) von gewissen Stoffen angezogen, von anderen abgestoßen werden: Chemotaxis oder Chemotropismus. Namentlich üben die Stoffwechselprodukte pathogener und nichtpathogener Organismen eine starke anziehende Wirkung auf die Leukocyten aus. Wenn z. B. Kolonien von *Staphylococcus* (Eiterbakterien) an einer Stelle des Körpers sind, so locken deren Stoffwechselprodukte die Leukocyten aus den benachbarten Gefäßen an, es entsteht entzündliche Reaktion und Eiterung.

Die Fähigkeit der Leukocyten, kleine Körnchen in sich aufzunehmen, ist besonders bedeutend bei Rückbildungsprozessen, indem die einzuschmelzenden Teile von ihnen aufgenommen, also gewissermaßen „gefressen“ werden. Metschnikoff hat die so tätigen Zellen daher „Freßzellen“ (Phagocyten). So wirken sie beim Schmelzen des Knorpels und Knochens als Chondro- und Osteoklasten. Ähnliche Zellen findet man im Schwanz der Batrachier, welche beim Schwund während der Metamorphose Teilchen der Gewebe, z. B. Fibrillentrümmer, in sich aufnehmen (vgl. auch Resorption des Milchgebisses, § 103). Ebenso fand man auch in das Blut eingekeimte Mikroorganismen von Leukocyten aufgenommen; diese stellen daher ein Abwehrmittel des Körpers gegen die Infektion mit Mikroorganismen dar. Die Aufnahme von Mikroorganismen durch die Leukocyten wird begünstigt durch gewisse im Plasma vorhandene Stoffe, die als Opsonine bezeichnet werden. — Über die Beeinflussung der Phagozytose (beobachtet an der Aufnahme von Kohlepartikelchen in die Zellen) durch verschiedene Einflüsse vgl. *Hamburger*<sup>117</sup>. Besonders bemerkenswert ist, daß die Hinzufügung von  $\text{CaCl}_2$ -Mengen das phagocytäre Vermögen erheblich steigert.

Die Zahl der Leukocyten (Technik pag. 39) beträgt 5000 in  $1 \text{ mm}^3$ , schwankt also in weiten Grenzen. Nach *Al. Schminow* unmittelbar nach der Entleerung des Blutes ein großer Teil der Leukocyten zugrunde gehen, so daß sie also in dem noch kreisenden Blute zahlreicher als in dem entleerten wären; diese Angabe wird allerdings von den meisten Untersuchern bestritten (*M. Loewit*<sup>118</sup>).

Eine Vermehrung der Leukocyten über die physiologische Maximalzahl vorgehender Art wird als Leukocytose bezeichnet; unter normalen Verhältnissen tritt sich dabei stets um eine Vermehrung der polynukleären neutrophilen Leukocyten derartige physiologische Leukocytose kommt vor während der Verdauung (*Gulland* u. *Paton*<sup>119</sup>, *Brasch*<sup>120</sup>); nach körperlichen Anstrengungen (*Schiff* u. *Zuntz*<sup>121</sup>); nach der Massage (*Ekgren*<sup>122</sup>); ferner in geringem Grade in den letzten Monaten der Schwangerschaft, während der Geburt stark zunehmend und im Wochenbett wieder zurückgehend (*Hahl*<sup>123</sup>, *Zangemeister* u. *Wagner*<sup>124</sup>); beim Neugeborenen nach Aufnahme einer großen Anzahl von Stoffen in den Organismus, z. B. Chinin, Terpentinöl, Albumose, Nucleinsäure, Milz-, Thymus-, Knochenmarksextrakt, Bakterienstoffwechselprodukte derselben u. a. (Über pathologische Leukocytose vgl. § 18.) In einer bestimmten Provinz des Gefäßsystems kann die Zahl der Leukocyten wechseln. So ist regelmäßig die Zahl derselben in den peripheren Gefäßen größer als in den zentralen (*Goldscheider* u. *Jakob*<sup>125</sup>). Lokale Erwärmung vermindert, Abkühlung in den Gefäßen des betreffenden Körperteiles die Leukocyten (*Winternitz*<sup>126</sup> u. *Winternitz*<sup>127</sup>), in den durch die Kälte kontrahierten Blutgefäßen angehalten werden.

Eine Verminderung der Zahl der Leukocyten unter die physiologische Norm wird als Hypoleukocytose oder Leukopenie bezeichnet. Durch die Einwirkung von Röntgenstrahlen kann eine hochgradige Abnahme der Leukocytenzahl bewirkt werden, das Blut ganz leukocytenfrei gemacht werden (*Heinecke*<sup>128</sup>, *Helber* u. *Linser*<sup>129</sup> u. *Sick*<sup>130</sup>); das Zustandekommen dieser Wirkung ist noch nicht völlig aufgeklärt, wie die Röntgenstrahlen wirken. Injektionen von Obolin (beim Kaninchen) (*Lichtenberg*<sup>130</sup>). Nach Injektion von artfremdem Serum tritt eine rapide Abnahme der Leukocyten ein, nicht nach Injektion von artgleichem Serum (*Hamburger* u. v. *Alten*<sup>131</sup>). Auf dieses Stadium der Leukopenie folgt immer eine Leukocytose (*Grisshammer*<sup>132</sup>).



**DIESE SEITE IST FÜR KOSTENLOSE MITGLIEDER GESPERRT**  
Beantragen Sie jetzt die volle Mitgliedschaft, um diese Seite zu betreten



**Seien Sie niemals ohne ein Buch!**

Die Vollmitgliedschaft von Forgotten Books bietet Ihnen einen universalen Zugang von unseren Apps und unserer Website, auf all Ihren Geräten: Tablet, Telefon, E-Reader, Laptop und Computer.

**Eine Bibliothek in Ihrer Tasche für €8.99/monat**

**Fortfahren**

\*Es gelten Richtlinien zur fairen Nutzung.

Zellen, bestehen aus Kern und Protoplasma und sind amöboider fähig. Für die Zellnatur der Blutplättchen spricht die Tatsache stark atmen (vgl. S. 94) und ein polypeptid-spaltendes Ferment (*Abderhalden* u. *Deetjen*<sup>144</sup>). Nach anderen entstehen sie als produkte aus den weißen oder roten Blutkörperchen (*Arnold*<sup>145</sup>, *Preisich* u. *Heim*<sup>147</sup>, *Schilling*<sup>148</sup>).

Die Blutplättchen stehen in naher Beziehung zur Blutg (vgl. pag. 78), diese ist an den typischen Zerfall der Blutplättchen knüpft. Nach *Bürker*<sup>146</sup> ist die schließlich gebildete Fibrinmenge von der Menge der zerfallenen Blutplättchen; alle Momente, die die Blutgerinnung beeinflussen, wirken in entsprechendem Sinne auf den Zerfall der Blutplättchen. Die entstehenden Fibrinfäden setzen sich an noch erhaltene Blutplättchen und zusammengeklebte Haufen derselben (Fig. 10, 6 u. 8), zwischen dem Zugrundegehen der Plättchen und dem Entstehen des Fibrinnetzes besteht ein deutlicher Parallelismus (

IV. Außerdem kommen im Blute regelmäßig Formelemente kleinster Art vor, wie Staub oder Hämokonien (*H. F. Müller*<sup>149</sup>). Es handelt sich dabei zum Teil um produkte von Blutkörperchen und Blutplättchen, zum Teil um feinst verteilte Stoffe (*mann*<sup>151</sup>, *Neisser* u. *Braeuning*<sup>152</sup>).

## 18. Pathologische Veränderungen der roten und weißen Blutkörperchen.

I. Rote Blutkörperchen. — 1. Die Zahl der roten Blutkörperchen wird durch Blutverluste vermindert, sowohl absolut, als auch in der Volumeneinheit, da die Flüssigkeit durch Eintritt von Wasser aus den Geweben schnell gedeckt wird und dann durch erhöhte Neubildung das normale Verhalten wiederhergestellt wird. Eine länger dauernde Verminderung der Zahl der roten Blutkörperchen resp. des Hämoglobins, wird als Anämie bezeichnet. Sie kann es sich entweder um eine Beeinträchtigung der Blutbildung oder um eine erhöhte normale Einschmelzung der roten Blutkörperchen oder endlich um eine Zerstörung derselben handeln; bisweilen mögen auch mehrere dieser Momente wirken. Bei der Chlorose (Bleichsucht) ist das Wesentlichste eine Beeinträchtigung der Blutbildung; es findet sich dabei eine mehr oder weniger starke Verminderung des Hämoglobins, die Zahl der roten Blutkörperchen kann dabei normal sein, sie aber ebenfalls vermindert. Im Gefolge anderer Krankheiten treten häufig sekundäre Anämien auf, so nach schweren Infektionen (Syphilis, Malaria etc.), Vergiftungen (Blei), bei malignen Tumoren, nach häufig wiederholten Blutverlusten und nach vielen anderen schweren Erkrankungen. Bei der sogenannten perniciösen Anämie, die schließlich zum Tode führt, ist die Zahl der roten Blutkörperchen sehr stark vermindert, sogar unter 1 Million: aus noch unbekanntem Grunde tritt eine starke Zerstörung der roten Blutkörperchen statt (Rückbildungsform der Anämie), dabei ist die Neubildung von roten Blutkörperchen im Knochenmark erheblich gesteigert (Ausbreitung des roten Knochenmarks auf die ganze Länge der Knochen (vgl. pag. 49), Auftreten kernhaltiger roter Blutkörperchen im Blute). Die Neubildung genügt offenbar nicht, um die Wirkung der die Blutkörperchen zerstörenden Momente aufzuheben.

Eine Vermehrung der Zahl der roten Blutkörperchen in der Volumeneinheit tritt bei Krankheiten, bei denen das Blut durch Wasserverluste wasserärmer wird, wie bei manchen Herzfehlern, nach Durchfällen, nach reichlichem Schwitzen. Eine besondere Form, bei der die Zahl der roten Blutkörperchen dauernd auf 7–8 Millionen vermehrt ist (daneben Milztumor und Cyanose), ist erst in neuerer Zeit unter *Polycythaemia rubra* oder *Erythrocytosis* beschrieben worden und ist noch völlig unklar (*Senator*<sup>153</sup>, *Hirschfeld*<sup>154</sup>).

2. Färbbarkeit, Größe und Form. — Die normalen roten Blutkörperchen (Erythrocyten) färben sich mit sauren Farbstoffen (z. B. Eosin), sie werden als orthochrom bezeichnet. In anämischem Blute kommen rote Blutkörperchen vor, die sich mit basischen Farbstoffen Affinität haben, sie werden als polychromatisch bezeichnet. Nach der Größe unterscheidet man Mikrocyten (Durchmesser unter 6  $\mu$ )

Durchmesser über  $9$  bis  $15 \mu$ ); beide Arten kommen bei Anämien zur Beobachtung. Erythroblasten besonders bei perniziöser Anämie. Kernhaltige rote Blutkörperchen werden als Erythroblasten bezeichnet; ihr Auftreten im anämischen Blute kann ein günstiges Zeichen für die beginnende Regeneration darstellen. Erythroblasten von der Größe eines normalen roten Blutkörperchens werden als Normoblasten, solche von erheblich größerem Durchmesser als Erythroblasten bezeichnet. Auch bei den kernhaltigen Formen findet sich Orthochromasie. — Erythrocyten von ganz unregelmäßiger Form (Birnen-, Handförmige) werden als Poikilocyten bezeichnet, sie finden sich bei schwereren Anämieformen der roten Blutkörperchen beobachtet man auch nach bedeutenden Verletzungen; die Körperchen erscheinen erheblich kleiner; vielleicht haben sich unter der Verbrennungshitze Tröpfchen von den Körperchen losgelöst, ähnlich wie man dies in mikroskopischen Präparate unter Einwirkung der Hitze (pag. 40) beobachtet. Zerfall der roten Blutkörperchen in viele derartige Tröpfchen ist bei verschiedenen Erkrankungen, namentlich bei typhösen Sumpfflebern, beobachtet worden. Aus den Bruchstücken gehen dem Hämatocrit dunkle Pigmentpartikeln hervor, die zunächst im Blute schwimmen (pag. 50). Die Leukocyten nehmen einen Teil dieser Partikeln in sich auf (pag. 50). In verschiedenen Geweben deponiert, namentlich in der Milz, im Gehirn und Knochenmark.

**Parasiten.** — Bei der Malaria entwickeln sich Parasiten, die zur Ordnung der Protozoen gehören, innerhalb der roten Blutkörperchen (*Laveran* 1880); sie werden durch den Stich von Mücken (*Anopheles*) übertragen. — Bei Rückfallfieber (Typhus) findet sich eine Spirochaete (*Obermeier* 1873) im Blute. — Trypanosomen sind Blutparasiten, die in zahlreichen Arten bei Tieren und Menschen im Blutplasma beobachtet worden sind; sie sind zum Teil unschädlich, zum Teil verursachen sie schwere Krankheiten. Zu diesen Erkrankungen gehören die Tssetsekrankheit der Rinder und die Schlafkrankheit.

Die weißen Blutkörperchen — sind bei den meisten Infektionskrankheiten vermehrt, so z. B. bei Pneumonie, Erysipel, Diphtherie usw. Eine Ausnahme machen die typhösen Typhus abdominalis und die Masern, bei denen die Zahl der Leukocyten vermindert ist. — Wenn bei Perityphlitis die Zahl der Leukocyten steigt bis  $30000$ , so ist dies ein Zeichen dafür, daß Absceßbildung eingetreten und chirurgische Eingriffe angezeigt ist (*Curschmann*<sup>155</sup>, *Federmann*<sup>156</sup>); ebenso findet sich eine Vermehrung der Leukocyten bei Eiterungen der inneren weiblichen Geschlechtsorgane (*Danzon*<sup>157</sup>). — Bei der pathologischen Leukocytose handelt es sich häufig um eine vorübergehende Vermehrung der polynucleären neutrophilen Leukocyten, doch kommt auch zuweilen eine Vermehrung der Lymphocyten vor. Bei Asthma bronchiale, manchen Hautkrankheiten sowie bei Trichinosis sind die eosinophilen Leukocyten vermehrt, bei Infektionskrankheiten dagegen (mit Ausnahme des Scharlach) können sie auf der Höhe der Krankheit verschwinden, um nachher wieder aufzutreten, ihr Wiedererscheinen kann dann als ein günstiges prognostisches Symptom aufgefaßt werden.

Bei der Leukämie findet sich eine exzessive Vermehrung der Leukocyten ( $300000$ ), das Verhältnis der roten zu den weißen Körperchen kann dabei  $2:1$  werden, die Erythrocyten sind vermindert. Bei der lymphatischen Leukämie finden sich im Blute neben den Erythrocyten fast nur Lymphocyten, die granulierten Leukocyten sind stark vermindert. Bei der myelogenen Leukämie finden sich neben den roten Blutkörperchen polynucleären neutrophilen, eosinophilen und basophilen Leukocyten zahlreiche weiße Blutzellen, unreife Zellen, welche normalerweise im Knochenmarke gebildet werden, jetzt aber in die Blutbahn gelangen.

Die Mykogenreaktion innerhalb der Leukocyten (*Czerny*<sup>158</sup>) findet sich bei schweren Infektionskrankheiten und Leukämie (*Hofbauer*<sup>159</sup>), sowie nach Einspritzung von Kulturen und Toxinen (*Kaminer*<sup>160</sup>).

#### Literatur (§ 10—18):

1. *H. Koeppe*: P. A. 107, 1905, 183. — 2. *R. Schmaltz*: D. A. k. M. 47, 1891, 1891, Nr. 16. — 3. *Loewy u. v. Schrötter*: Z. e. P. u. T. 1, 1905. — 4. *Hamm*: O. k. M. 12, 1891, 837. Z. k. M. 20, 1892, 444. — 5. *L. Zuntz*: P. A. 66, 1891, 189. — 6. *Schneider*: In. Diss. Dorpat 1891. — 7. *Peiper*: O. k. M. 12, 1891, 217. — 8. *Warwitz*: Klin. Pathol. d. Blutes. 3. Aufl. Leipzig 1906, pag. 85. — 9. *P. Fraenkel*: P. A. 98, 1903, 601. — 10. *G. Farkas*: P. A. 98, 1903, 551 u. 577. — 11. *R. Höpfer*: Chemie d. Zelle u. Gewebe. 3. Aufl. Leipzig 1911. P. A. 81, 1900, 522. 99, 1901, 100.

- 1912, 247. S. A. 27, 1912, 13. — 15. *L. Michaelis* u. *W. Davidoff*: B. Z. — 16. *F. Rolly*: Deutsche Zeitschr. f. Nervenheilk. 47, 48, 1914, 617. — *thal*: Z. a. P. 1, 1902, 56. 4, 1904, 1. — 18. *J. H. Schultz*: Über d. Velesenz d. Blutes u. d. weißen u. roten Blutkörperchen bei Nerven- und Diss. Göttingen 1906. — 19. *v. Jaksch*: Z. k. M. 18, 1887, 350. — 20. *A. L* 1894, 462. — 21. *H. Strauß*: Z. k. M. 30, 1896, 327. — 22. *W. Cohn* 1892, 332. — 23. *Jacob*: Alkalimetr. Untersuchungen d. Blutes b. Gesunden Diss. Greifswald 1888. — 24. *E. Peiper*: V. A. 116, 1889, 343. — 25. *Zu* 1868. C. m. W. 1867, Nr. 51, pag. 801. — 26. *H. Benedict*: P. A. 115, 27. *A. Magnus-Levy*: A. P. P. 42, 1899, 197. — 28. *F. Kraus*: A. P. P. 28 29. *v. Kórányi*: Z. k. M. 33, 1897. — 30. *H. Deetjen*: V. A. 165, 1901, *Weidenreich*: A. m. A. 61, 1903, 459. Ergebnisse d. Anatomie u. Entwicklun 1904, 1. An. An. 27, 1905, 583. P. A. 132, 1910, 143. — 32. *H. Koeppe*: 33. 107, 1905, 86. — 33. *Albrecht*: Sitz.-Ber. München. morphol. phys. Ge — 34. *L. Löhner*: A. m. A. 71, 1908, 129. — 35. *V. Schilling*: Folia H 1912, 95. — 36. *A. Rollett*: P. A. 82, 1900, 255. — 37. *L. Löhner*: P. A. — 38. *W. Manassein*: Über die Dimensionen der roten Blutkörperchen unter Einflüssen. Tübingen 1872. — 39. *H. Welcker*: Z. r. M. (3), 20, 1863, 25 *Hedin*: S. A. 2, 1891, 134 u. 360. P. A. 60, 1895, 360. — 41. *H. Koeppe*: P. A. 62, 1896, 574. 107, 1905, 187. — 42. *H. J. Hamburger*: Osmot. Druck in d. med. Wiss. Wiesbaden 1902. Z. B. 35, 1897, 252. — 43. *W. Zang Meissl*: M. m. W. 1903, Nr. 16. — 44. *J. Cohnstein* u. *N. Zuntz*: P. A. 34 45. *O. Hess*: D. A. k. M. 79, 1904, 128. — 46. *W. Erb jun.*: D. A. k. M. 8 47. *K. Bürker*: R. Tigerstedts Handbuch d. physiol. Methodik. Leipzig 2, 5, W. 1905, 912. 1912, 14. P. A. 105, 1904, 480. 107, 1905, 426. 118, 1907, 337. 153, 1913, 128. — 48. *M. Schultze*: A. m. A. 1, 1865, 26. — 4 fassende Darstellung: *H. J. Hamburger*: Osmot. Druck u. Ionenlehre in Wiesbaden 1902—04. *R. Höber*: Physikalische Chemie der Zelle und der Leipzig 1911. *A. v. Kórányi* u. *P. F. Richter*: Physikalische Chemie u. 1907. — 50. *H. J. Hamburger*: Z. B. 26, 1890, 414. 28, 1891, 405. 30, 1897, 252. V. A. 140, 503. 141, 1895, 230. A. P. 1886, 476. 1887, 31. 1 Suppl., 153, 157. 1894, 419. 1897, 144. 1898, 1, 31, 317. 1899, Suppl., 6, 1890, 319. — 51. *H. Koeppe*: Physikal. Chemie in d. Med. Wien 1900. 492. 67, 1897, 189. D. m. W. 1895, 545. Z. phk. Ch. 17, 1895, 552. A. P. 504. 1900, 308. — 52. *S. G. Hedin*: S. A. 2, 1891, 134, 360. 5, 1895, 20 A. 60, 1895, 360. 68, 1897, 229. 70, 1898, 525. — 53. *G. Gryus*: P. A. 54. *Overton*: Vierteljahrsschr. d. naturforsch. Gesellsch. zu Zürich. 40, 189 88. — 55. *H. Strauss*: D. m. W. 1902, Nr. 37, 38. — 56. *H. Kümmell* 901, 952, 982. — 57. *Cohn*: Mitteilung. aus den Grenzgebiet. d. Med. u. Ch 27. — 58. *Neudörffer*: Mitteilung. aus den Grenzgebiet. d. Med. u. Chirurg — 59. Zusammenfassende Darstellung: *H. Sachs*: Die Hämolyse u f. d. Immunitätslehre. Wiesbaden 1902 (S. A. aus Labarsch-Ostertags Er Anatom. 7.) Die Hämolyse u. die cytotoxischen Sera. Wiesbaden 1907. (S. Ostertag 11.) *K. Landsteiner*: Hämolyse in C. Oppenheimers Handbuch Jena 1910. II, 1, 444. — 60. *H. Koeppe*: P. A. 90, 1903, 33. 103, 1904, 86. — 61. *D. Rycroch*: C. P. 19, 1905, 388. — 62. *E. St. Faust* u. *T. 1* P. P. 57, 1907, 367. — 63. *J. Shimazono*: A. P. P. 65, 1912, 361. — 64. z. Kenntn. d. Saponinsubstanzen. Stuttgart 1904. — 65. *G. Johnson-Blohm*: Z. 59. — 66. *A. Rollett*: S. W. A. 46, 2. Abt., 1862, 65. 47, 2. Abt., 1863, aus d. Instit. f. Physiol. u. Histol. in Graz. Leipzig 1870, 1. P. A. 82, 1900, *Hermann*: P. A. 91, 1902, 164. — 68. *M. Cremer*: Z. B. 46, 1905, 10 *Drschewitzky*: A. P. P. 54, 1905, 62. — 70. *Ehrlich*: Über die Ehrlichs theorie vgl. *L. Aschoff*: Z. a. P. 1, 1902, Heft 3. Auch als S. A. Jena 1 *Landois*: C. m. W. 1874, Nr. 27. Die Transfusion d. Blutes. Leipzig 18 72. *Bordet*: Annales de l'Institut Pasteur 12, 1898. — 73. *L. Camus* u. *E. 1* sur l'action physiologique des Ichthyotoxines. Paris 1912. — 74. *H. Sa* 494. — 75. *Friedberger* u. *Dorner*: Zentralbl. f. Bakteriolog. 38, 1905, Heft *gliano*: V. C. M. 1892, 152. Z. k. M. 21, 1892, 415. A. i. B. 19, 1893, 55. Landwirtsch. Versuchsstat. 79—80, 1913. — 78. *P. Kyes*: B. k. W. 1902, 956, 982. B. Z. 4, 1907, 99. — 79. *D. Rycroch*: P. A. 116, 1907, 229. C. 28, 1914, 57. — 80. *Lang*: Z. k. M. 47, 1902, 153. — 81. *H. Handorsky*: A 412. — 82. *F. Port*: A. P. P. 69, 1912, 307. — 83. Zusammenfassend *O. v. Fürth*: Vergleich. chem. Physiol. der niederen Tiere. Jena 1903. Ab



**DIESE SEITE IST FÜR KOSTENLOSE MITGLIEDER GESPERRT**  
Beantragen Sie jetzt die volle Mitgliedschaft, um diese Seite zu betreten

# GESCHICHTE

Zehntausende von wichtigen historischen Quellen, viele bisher nicht erhältlich, stehen jetzt zum ersten Mal mit der Vollmitgliedschaft von Forgotten Books zur Verfügung.

Unbegrenzter Zugang  
\$8.99/monat

**Fortfahren**

\*Es gelten Richtlinien zur fairen Nutzung.



1.



3.



5.



**Hämoglobinkristalle nach Friboes<sup>9</sup>: 1. und 2. Krystalle aus frischem Menschenblut vom Blut einer menschlichen Leiche. — 4. Krystalle aus menschlichem Milzvenenblut aus menschlichem Nabelschnurblut. — 6. Krystalle aus Eichhörnchenblut**

eide (vgl. pag. 15). Seine procentische Zusammensetzung  
Blut vom Schweine (und Rind eingeklammert) nach *Hüfner*<sup>2</sup>  
66) — H 7,38 (7,25) — N 17,43 (17,70) — S 0,479 (0,447) — F  
0) — O 19,602 (19,543). — Es kommen auf 1 Atom Eisen  
vefel beim Pferde (*Hüfner*<sup>2</sup>, *Zinoffsky*<sup>3</sup>), 3 beim Hunde (*J*  
r den Fe-Gehalt des menschlichen Hb vgl. S. 62. Für das Mo  
licht des (Rinder-) Hämoglobins ergeben sich nach versch  
hoden Werte von 16 321 bis 16 721 (*Hüfner* u. *Gansser*<sup>6</sup>).  
ch in Wasser, beim Erhitzen koaguliert es unter Zersetzung. Das  
in gehört zu denjenigen Eiweißstoffen, welche krystallisieren (k  
allen Vertebratenklassen, bei denen man die Krystalle darstellen  
stallisiert es im rhombischen Systeme, zumeist in rhombischen  
Prismen, beim Meerschweinchen in rhombischen Tetraedern  
. *Lang*<sup>6</sup>). Das Eichhörnchen weicht ab, indem dessen K  
agonale Tafeln darstellen; nach *Uhlik*<sup>7</sup> kann das Hämoglo  
rdeblut außer in den bekannten rhombischen Krystallen a  
agonalen holodrischen Krystallen, und zwar in sechsseitigen  
lten werden. Die Krystalle scheiden sich bei sämtlichen  
klassen aus beim langsamen Verdunsten des lackfarb  
hten Blutes, jedoch mit verschiedener Leichtigkeit.

Es kommt auch vor, daß das Hb im Innern eines Blutkörperchens kry  
denreich<sup>8</sup>).

Die Hämoglobine der verschiedenen Tiere sind chemisch verschiedene Körp  
wahrscheinlich der färbende Bestandteil des Hämoglobins, das Hämatin, überall  
tanz, die Verschiedenheit der Hämoglobine ist vielmehr bedingt durch die Artver  
des eiweißartigen Bestandteils, des Globins. Die Krystallisation gelingt um so  
schwerer löslich das betreffende Hämoglobin ist. Am wenigsten löslich ist das  
schweinchen und Ratte, etwas leichter löslich das von Pferd, Hund, Katze, am l  
b das von Kaninchen, Schwein, Rind, Mensch (*Bärker*<sup>1</sup>).

### Darstellung der Hämoglobinkrystalle<sup>9</sup>.

1. Nach *Rollet*<sup>10</sup>. — Defibriniertes Blut, durch Gefrieren und Auftauen l  
cht, gießt man in eine flache Schale, deren Boden nur 1 1/2 mm hoch dami  
und läßt ganz langsam am kühlen Orte abdunsten, wobei die Krystalle sich ab

2. Nach *Hoppe-Seyler*<sup>11</sup>. — Defibriniertes Blut wird mit 10 Volumina ein  
Glaubersalzlösung (1 Vol. konz. Lösung auf 9 Vol. Wasser) vermischt und  
sen, resp. abzentrifugiert. Der dicke Blutkörperchen-Bodensatz wird mit etwa  
nen Glaskolben gespült und so lange mit gleichem Volumen Ather geschüttelt  
körperchen sich auflösen. Der Ather wird abgehoben, die Lackfarbe kalt filtri  
1/4 Volumen kalten (0°) Alkohols versetzt; bei — 5° C läßt man einige Tag  
nun reichlich gebildeten Krystalle können auf dem Filter gesammelt und  
papier abgepreßt werden. Durch ganz allmähliches Einwirken des Alkohols  
lösung (durch Eintreten desselben in einen Dialysator) erzielte *Landois* Krys  
ten Millimetern Länge. — *Ofringe*<sup>12</sup> vermeidet bei der Herstellung der Hb-  
Einwirkung chemischer Substanzen, durch welche das Hb verändert werden  
n er die abzentrifugierten roten Blutkörperchen mit Infusorienerde mischt und  
mechanischen Presse auspreßt; die so erhaltene hoch konzentrierte Hb-Lösung w  
Abkühlung oder noch weitere Konzentrierung zum Krystallisieren gebracht.

3. *Gscheidlen*<sup>13</sup> erzielte die größten Krystalle von mehreren Zentimeter  
rch, daß er defibriniertes Blut, welches 24 Stunden an der Luft gestanden  
e Glasröhre einschmolz und mehrere Tage bei 37° C aufbewahrte. Nun  
Glasplatte ausgebreitet, läßt das Blut die Krystalle anschießen.

Das vom Blutegel gesaugte Blut besteht, wenn man es nach etwa 14 Tagen  
n des Egels herausdrückt, aus zahllosen Hämoglobinkrystallen (*Budge*<sup>14</sup>). In der  
szeeke (*Ixodes ricinus*) gesaugten Blut entsteht unter Auflösung der Blutkörperchen  
des Hb und Eindickung ein Krystallbrei von sauerstofffreien Hb-Krystallen (*Grü*

Die Hb-Krystalle sind doppelbrechend und pleochroitisc  
ig n bei der Betrachtung im polarisierten Lichte bei versch



Orientierung hellere und dunklere Färbungen. Sie enthalten Krystallwasser und werden daher bei Abgabe desselben unter Verfall zertrümmert. Sie lösen sich in Wasser (aber bei verschiedenen verschieden leicht), leichter in dünnen Alkalien. Unlöslich ist Hämoglobin in Alkohol, Äther, Chloroform, Fetten. Hämoglobin dreht das polar nach rechts (*Gamgee u. Croft Hill*<sup>16</sup>).

Durch den Krystallisationsprozeß scheint das Hb selbst eine innere Veränderung zu erfahren. Vor der Krystallisation diffundiert es nicht als echte Kolloidsubstanz, sondern es zersetzt es stürmisch  $H_2O_2$ . Aus den Krystallen hingegen wieder aufgelöst, wird es durch  $H_2O_2$  nicht zersetzt und wird unter dessen Einwirkung selbst entfärbt. Hämoglobin in freiem Zustande sich in verschiedener Hinsicht anders verhalten als in unversehrten Blutkörperchen, so glaubte *Hoppe-Seyler*<sup>16</sup>, daß das  $O_2$ -Hb und Hb innerhalb der Erythrocyten mit Lecithin verbunden sei als Arterin re. Nach *H. Kobert*<sup>9</sup> kann Arterin und Phlobin auch krystallisiert erhalten werden. Diese Krystalle streng von den Hämoglobinkrystallen. *Bohr*<sup>17</sup> bezeichnet den veränderten Blutfarbstoff der roten Blutkörperchen als Hämochrom, zum Unterschied von dem aus ihm dargestellten Hämoglobin.

### Quantitative Bestimmung des Hämoglobins.<sup>1</sup>

1. Die genauesten Resultate gibt die von *Vierordt*<sup>18</sup> und *Häfner*<sup>19</sup> entwickelte spektrophotometrische Methode. Tritt Licht einer bestimmten Spektralfarbe durch die Lösung eines Farbstoffes hindurch, so ist die durch die Absorption bewirkte Abnahme der Lichtintensität, ausgedrückt in Bruchteilen der ursprünglichen Lichtintensität, für eine bestimmte Schichtdicke und Konzentration der absorbierenden Schicht immer gleich groß, unabhängig davon ob das durchfallende Licht stark oder schwach ist. Als Extinktionskoeffizient bezeichnet man den Wert der Schichtdicke, welche das Licht durchstrahlen muß, um ein Zehntel seiner ursprünglichen Intensität abgeschwächt zu werden. Dieser Extinktionskoeffizient einer gefärbten Flüssigkeit für einen bestimmten Spektralbereich ist direkt proportional der Konzentration der Flüssigkeit, das Verhältnis zwischen Extinktionskoeffizient und Konzentration ist also konstant. Das Absorptionsverhältnis eines Farbstoffes für einen bestimmten Spektralbereich kann man mithin aus dem beobachteten Extinktionskoeffizienten einer Lösung desselben berechnen. (Wegen der Details der Methode siehe die Originalarbeiten von *Vierordt*<sup>18</sup>, *Häfner*<sup>19</sup>, *v. Noorden*<sup>20</sup>, *Otto*<sup>21</sup>, *Albrecht*<sup>22</sup>.)

2. Zu klinischen Zwecken dienen die colorimetrischen Methoden. *Seyler*<sup>23</sup> wird die zu untersuchende Flüssigkeit mit einer reinen Hämoglobinlösung bekanntem Gehalt verglichen und so lange mit Wasser verdünnt, bis sie die gleiche Farbe hat wie die Vergleichsflüssigkeit; aus dem Grade der Verdünnung ergibt sich der Gehalt an Hämoglobin. Zweckmäßig werden die beiden zu vergleichenden Flüssigkeiten mit CO gesättigt (vgl. das von *J. Plesch*<sup>24</sup> angegebene Chromophotometerkeilhämoglobinometer).

Das Hämometer nach *Fleischl*<sup>25</sup>-*Miescher*<sup>26</sup> (Fig. 12) besteht aus einem auf einem Objektisch aufzustellenden, in zwei Hälften geteilten Cylinder. Die eine Hälfte ist mit Wasser gefüllt, die andere mit einer Verdünnung des zu untersuchenden Blutes. Durch eine Mischpipette, ähnlich wie bei der Blutkörperchenzählung, hergestellt wird die zu untersuchende rote gefärbte Lösung vergleicht man die Farbe eines unter dem reinen Wasser. Die andere Hälfte durch eine Schraube vorbeigeführten roten Rubinglaskeiles und die zu untersuchende rote Farben gleich einzustellen. Die Beleuchtung des Blutwassers und der Vergleichsflüssigkeit geschieht von unten durch Lampenlicht. Der Glaskeil trägt die Zahlen, welche den Hämoglobingehalt in Prozenten des normalen Gehaltes angeben, das untersuchte Blut enthält 80% des normalen Hb-Gehaltes (*Veillon*<sup>27</sup>, *Fr.*

Bei dem von *Grützner*<sup>28</sup> angegebenen Hämometer befindet sich die zu untersuchende Flüssigkeit in einem Glaskeil. Mittels eines horizontalen Schlitzes tragenden Schiebers aus Glas wird diejenige Stelle des Keiles aufgesucht, welche die gleiche Farbe zeigt wie die Vergleichsflüssigkeit (Pikrocarmin-Leimplatte oder besser rotes Glas).

Das *Gowersche*<sup>29</sup> Hämoglobinometer besteht aus zwei gleich kalibrierten Röhren, von denen das eine eine Pikrocarminlösung enthält, deren Farbe gegen eine 1%ige Lösung normalen Blutes entspricht. In dem anderen Röhren wird eine bestimmte Menge Blut so lange verdünnt, bis seine Farbe der der Vergleichsflüssigkeit gleich ist. Eine Modifikation dieses Apparates dient zum Vergleich der zu untersuchenden Lösung, welche salzsaures Hämatin enthält; das zu untersuchende Blut



**DIESE SEITE IST FÜR KOSTENLOSE MITGLIEDER GESPERRT**  
Beantragen Sie jetzt die volle Mitgliedschaft, um diese Seite zu betreten



**Seien Sie niemals ohne ein Buch!**

Die Vollmitgliedschaft von Forgotten Books bietet Ihnen einen universalen Zugang von unseren Apps und unserer Website, auf all Ihren Geräten: Tablet, Telefon, E-Reader, Laptop und Computer.

**Eine Bibliothek in Ihrer Tasche für € 8.99/monat**

**Fortfahren**

\*Es gelten Richtlinien zur fairen Nutzung.

In feuchten Erythrocyten fand *Hoppe-Seyler*<sup>41</sup> 40,4% Hb, in beträgt es 95,5% aller organischen Bestandteile (in den kern Erythrocyten weniger).

Im Hunger ist das Hämoglobin widerstandsfähiger als die übrigen festen teile des Blutes (*Hermann u. Groll*<sup>42</sup>). — Über das Verhalten des Hämoglobins untl logischen Verhältnissen vgl. pag. 55 (Chlorose).

## 20. Sauerstoffverbindungen des Hämoglobins: Oxyhämoglobin und Methämoglobin. Spektroskopische Untersuchu

Der Spektralapparat (Fig. 13) besteht aus — 1. dem Kollimator-Rohr *A* an dem einen Ende den verstellbaren Spalt *S* trägt, am anderen Ende die Samm Der Spalt befindet sich im Brennpunkt der Linse; die von einem Punkte des Sp

Fig. 13.

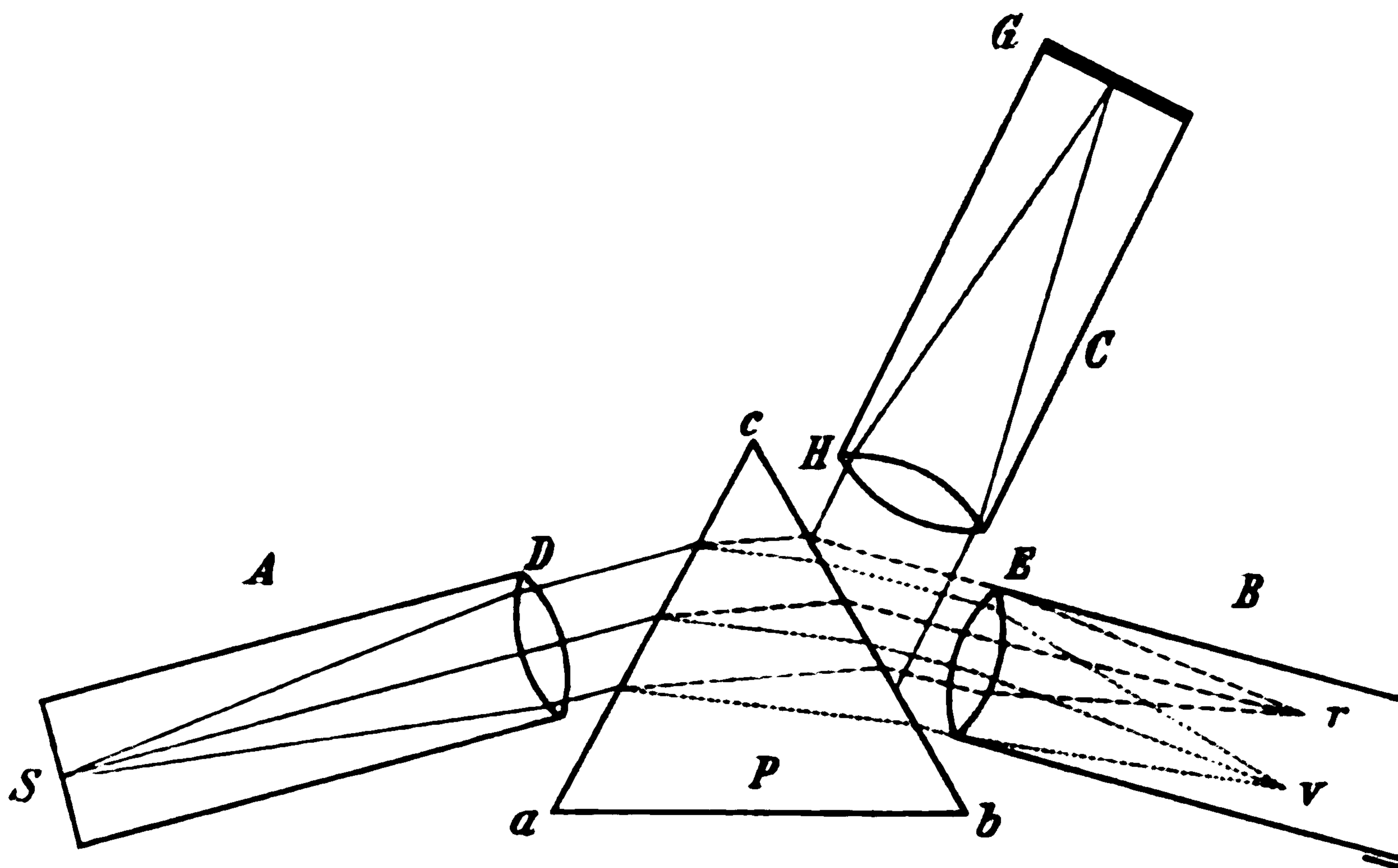

Schema des Spektralapparates.

gehenden Lichtstrahlen werden also durch die Linse parallel gemacht und treten 2. das Prisma *P* ein, durch welches die Strahlen gebrochen und in Strahlen vers Wellenlänge, entsprechend den Spektralfarben, zerlegt werden. Diese gelangen in Fernrohr *B*. Die Linse *E* dieses Fernrohrs vereinigt alle Strahlen gleicher Welle einem Punkte, alle roten Strahlen in *r*, alle violetten in *v*. So entsteht in *r* ein des Spaltes *S*, in *v* ein violettes, dazwischen befinden sich die Spaltbilder der zw und Violett liegenden Spektralfarben. Die Gesamtheit dieser Spaltbilder ist das *r—r*; es wird durch die Lupe *F* betrachtet. — 4. Das Rohr *C* enthält an dem e die Skala *G*, an dem anderen die Sammellinse *H*. Die von einem Punkte der E gehenden Lichtstrahlen werden durch *H* parallel gegen die Fläche *b c* des Prismas von dieser in das Fernrohr *B* reflektiert und durch die Linse *E* im Brennpunkte So entsteht an derselben Stelle wie das Spektrum *r—v* ein Bild der Skala *G*, we dem Beobachter zugleich mit dem Spektrum gesehen wird.

Beleuchtet man den Spalt *S* mit monochromatischem Licht (z. B. Natriumfla entsteht an Stelle der kontinuierlich nebeneinander liegenden Spaltbilder *r—r* de Lichtes nur ein Spaltbild in der Farbe des monochromatischen Lichtes, z. B. Natriumlinie.

Bringt man vor den mit weißem Licht beleuchteten Spalt *S* eine Farbs (z. B. Hämoglobinlösung), so läßt diese nur einen Teil der Strahlen des weißen Lich

## Das Sauerstoff-Hämoglobin.

eten, andere werden absorbiert. Der Abschnitt des Spektrums, dessen Strahlen and, erscheint daher dem Beobachter als dunkle Absorptionslinie.

Wird der Spalt *S* mit Sonnenlicht beleuchtet, so zeigt das Spektrum eine Reihe von dunklen Linien (*Fraunhofersche* Linien) in genau bestimmter Lage innerhalb der Farben, nach denen man sich im Spektrum zu orientieren pflegt. Sie werden bezeichnet durch *B C D* etc., *a b c* etc. (s. Fig. 14—17).

Außer durch Brechung des Lichtes in einem Prisma (Prismaspektrum) kann man auch durch Beugung des Lichtes mittelst eines sog. Gitters (bestehend aus zahlreichen, parallelen und gleichweit voneinander entfernten, in eine Glasplatte eingegrabenen Linien) ein Spektrum erhalten (Gitterspektrum). In den Gitterspektren ist die Ablenkung des Lichtes der Wellenlänge direkt proportional, in den Prismenspektren dagegen nimmt die Ablenkung nach dem violetten Ende hin stark zu. Im Gitterspektrum ist die Ausdehnung des Spektralbezirks von 400—500  $\mu\mu$  Wellenlänge dieselbe, wie im Gitterspektrum von 500—600  $\mu\mu$ , im Prismenspektrum ist der erste Bezirk bedeutend länger als der zweite. Es sind daher Prismen- und Gitterspektren nicht ohne weiteres miteinander vergleichbar. Die Spektren in Fig. 16 sind Prismenspektren, die in Fig. 17 sind Photographen von Gitterspektren.

Eine große Bedeutung hat die photographische Registrierung der Spektralersehnisse. Man unterscheidet zwei Methoden: Spektrophotographie (*Rost, Franz u. Heise*<sup>46</sup>). Durch die photogra-

Fig. 14.

Fig. 15.

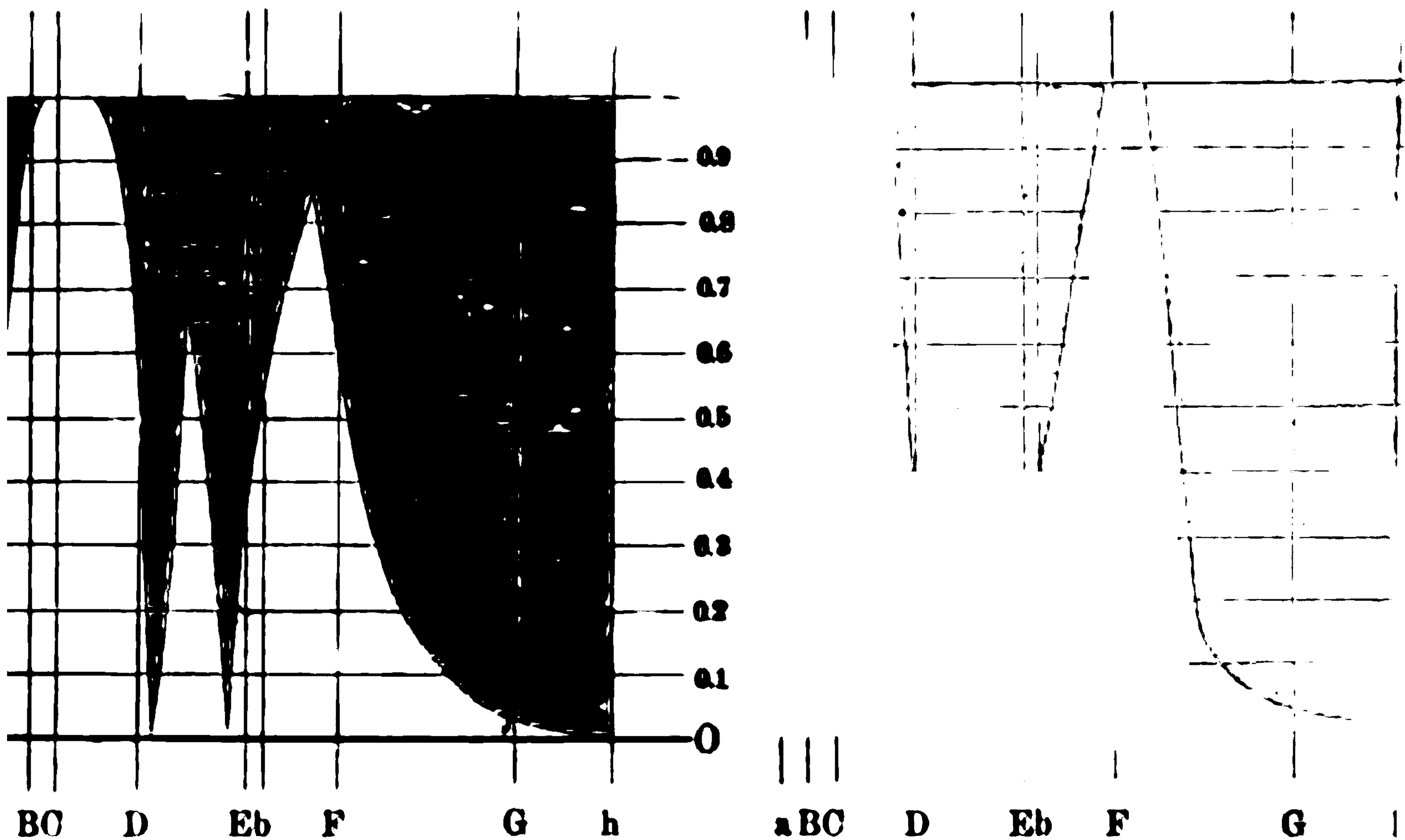

Die Absorptionsspektren des  $O_2$ -Hb (Fig. 14) und des gasfreien Hb (Fig. 15) bei steigender Konzentration. Die Dicke der untersuchten Flüssigkeitsschicht = 1 cm. Die Buchstaben unten bedeuten die *Fraunhoferschen* Linien; die Zahlen zur Seite geben den Prozentgehalt der Lösungen an (nach *Rollef*<sup>47</sup>).

aufnahme gelingt es, auch die im unsichtbaren, ultravioletten Teile des Spektrums gelegenen Absorptionsstreifen zu beobachten, die gerade bei sehr starker Verdünnung in ultravioletten Lösungen auftreten, wenn die im sichtbaren Teile des Spektrums gelegenen Absorptionsstreifen bereits verschwunden sind (vgl. pag. 65).

1. Das Sauerstoff-Hämoglobin oder Oxy-Hämoglobin = Oxyhämoglobin entsteht sehr leicht, wenn Hämoglobin oder Blut mit Sauerstoff oder Sauerstoffgas in Berührung kommt; schüttelt man Blut oder eine Hämoglobinlösung mit Luft, so wird fast alles vorhandene Hämoglobin in Oxyhämoglobin verwandelt. Das  $O_2$ -Hb ist eine chemische Verbindung: 1 Molekül Hämoglobin bindet 1 Molekül Sauerstoff =  $O_2$ ; 1 g Hämoglobin bindet 0,34  $cm^3$  Sauerstoff (*Hüfner*<sup>48</sup>). Doch ist der Sauerstoff im  $O_2$ -Hb nicht fest gebunden; das  $O_2$ -Hb ist eine sog. dissoziabile chemische Verbindung (vgl. § 30). Der Sauerstoff wird daher schon durch solche

11  
 $\lambda = 589$   
 $\lambda = 556$

---

---

2. *Stäube*  
 $\lambda = 596$

---

---

1.

die Buchstaben  $B-A$  angeben der Absorptionsstreifen jedesmal  
Haben & Schwach



**DIESE SEITE IST FÜR KOSTENLOSE MITGLIEDER GESPERRT**

Beantragen Sie jetzt die volle Mitgliedschaft, um diese Seite zu betreten

# GESCHICHTE

Zehntausende von wichtigen historischen Quellen, viele bisher nicht erhältlich, stehen jetzt zum ersten Mal mit der Vollmitgliedschaft von Forgotten Books zur Verfügung.

Unbegrenzter Zugang  
\$8.99/monat

**Fortfahren**

\*Es gelten Richtlinien zur fairen Nutzung.



Wellenlängenskala

Blutlösung 1:70

1:100

1:150

1:200

1:300

1:500

1:800

1:1000

1:1500

1:2000

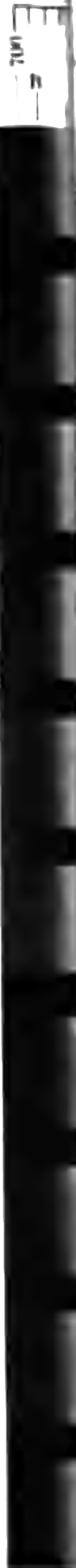

Wellenlängenskala.

in CO<sub>2</sub>-freiem Wasser.

in CO<sub>2</sub>-haltigem Wasser.

in alkalischer Lösung, Lösung 1:80.

Lösung 1:100.

etrocknet und konzentrierter Schwefelsäure verdünnt. 1, weiter verdünnt und mit Pyridin alkalisch gemacht.

Ferrocyanid zu normalem Blut

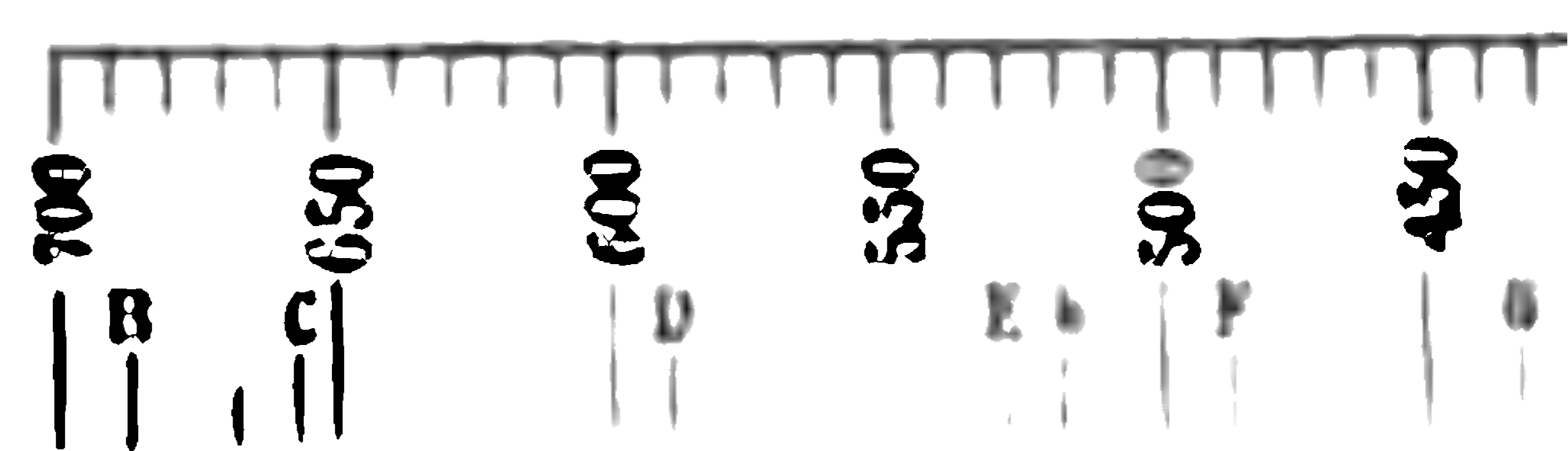

VI. Hämochromogen (durch Behandeln normalem Blut mit Natronlauge von Schwefelammonium berg)

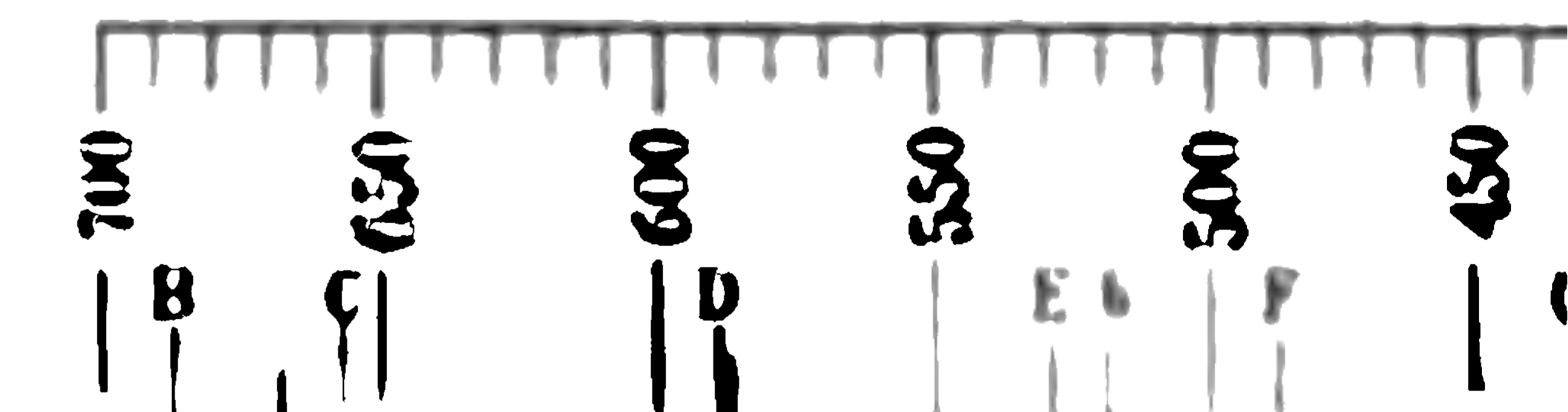

VII. Hämatoporphyrin

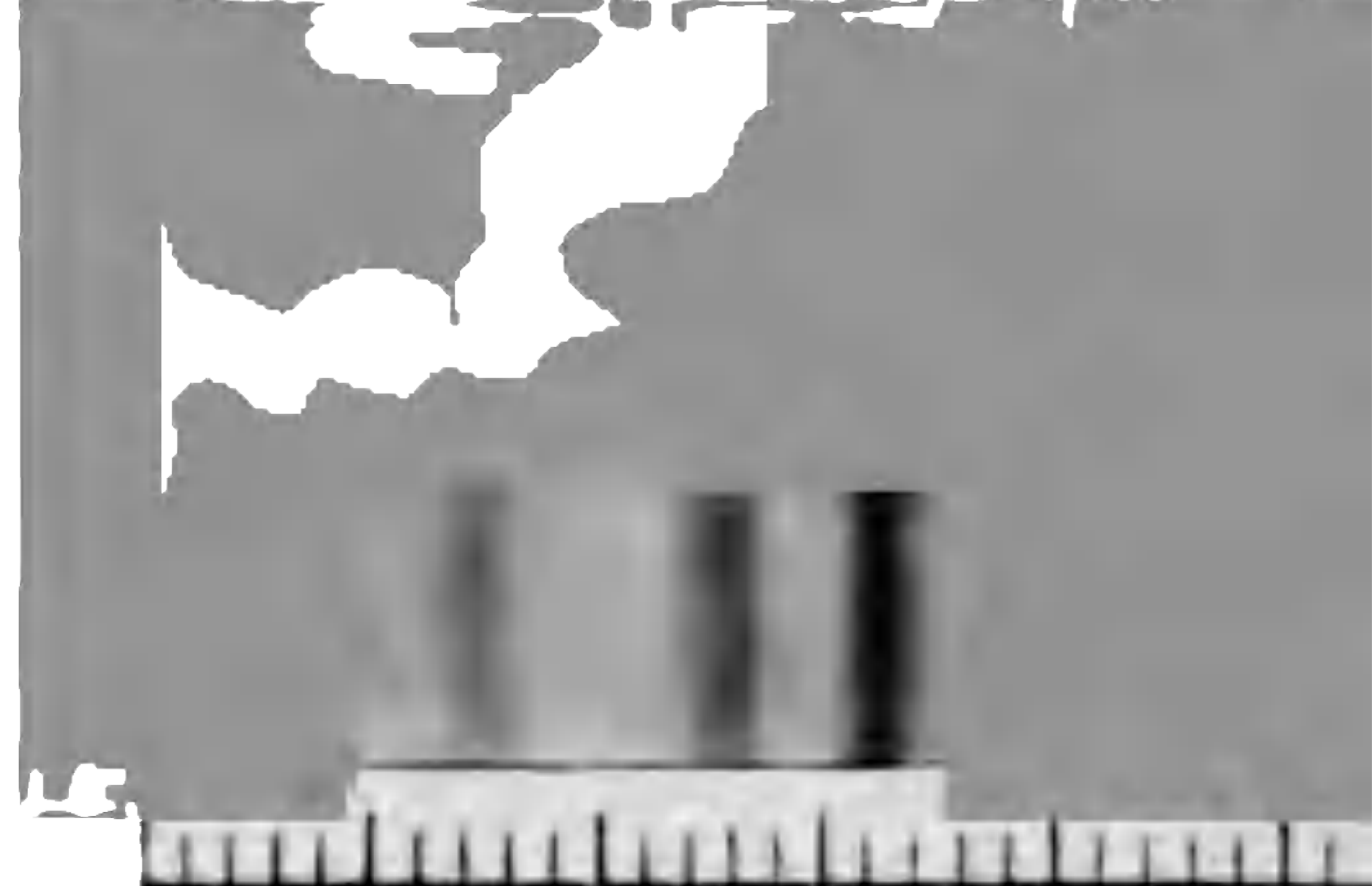





und Erhitzen bis zum Siedepunkt (§ 30). Chemisch kann den Sauerstoff entzogen werden durch reduzierende Substanzen, z. B. Ammonium oder *Stokessches*<sup>45</sup> Reagens (Lösung von weinsäureoxydulammon; stets frisch zu bereiten durch Auflösung von Eisensulfat in Wasser, Zusatz von Weinsäure und darauf von Ammonium zur alkalischen Reaktion): es entsteht reduziertes (gasfreies) Hämoglobin. Schütteln mit Luft bedingt sofort wieder Bildung von O<sub>2</sub>-Hb.

Lösungen des O<sub>2</sub>-Hb sind scharlachrot, Lösungen des reduzierten Hb violettrot und dichroitisch, d. h. bei auffallendem Licht bei durchfallendem grün (vgl. S. 33). Bei der spektroskopischen Untersuchung zeigen konzentriertere Blutlösungen Absorption des ganzen Teils des Spektrums; bei fortschreitender Verdünnung der Lösung dann die charakteristischen Absorptionsbänder auf (vgl. Fig. 16. I.). zeigt in etwa 1 bis 1/2% Blutlösung zwei Absorptionsstreifen, Violett und Grün (*Hoppe-Seyler*<sup>46</sup> 1862) (Fig. 16. I., 17. I.); reduziert man an Stelle der beiden Streifen des O<sub>2</sub>-Hb einen breiten verdünnten Absorptionsstreifen (*Stokes*<sup>45</sup> 1864) (Fig. 16. 2., 17. II).

Bei zunehmender Verdünnung der Blutlösung werden die beiden Absorptionsbänder des O<sub>2</sub>-Hb immer schwächer und verschwinden schließlich ganz. Dafür tritt Violett ein durch die Spektrophotographie nachweisbarer, ebenfalls für O<sub>2</sub>-reduzierter Streifen auf (*Soret*<sup>47</sup>, *Grube*<sup>48</sup>, *Kobert*<sup>49</sup>); durch diesen Streifen konnte in der Verdünnung 1:3000 nachgewiesen werden (Fig. 17. I.) (*Rost, Fraunhofer*<sup>50</sup>).

Wenn die Reduktion des O<sub>2</sub>-Hb zu reduziertem Hb durch Schwefelammonium genommen wird, so tritt außer dem charakteristischen Streifen des reduzierten Hb ein Streifen im Orange auf; er rührt von einer Bildung von Sulfhämoglobin her.

Setzt man zu Blut zuerst einige Tropfen einer 40% Formaldehydlösung und dann Schwefelammonium, so erhält man einen sehr scharfen und dunklen Streifen von Violett (*Tollens*<sup>51</sup>).

O<sub>2</sub>-Hb findet sich im kreisenden Blute innerhalb der roten Blutkörperchen; es kann durch die spektroskopische Untersuchung des Ohres oder der dünnen Hautschichten zwischen zwei aneinander angelegten Fingern nachgewiesen werden. Werden Tiere durch Ersticken so wird aller Sauerstoff des Blutes an die Körpergewebe abgegeben, so daß nur reduziertes Hämoglobin in den Gefäßen angetroffen wird.

Umschnürt man die Basis zweier Finger bis zur Circulationsunterbrechung, so man bei der spektroskopischen Untersuchung der roten Hautsäume, mit welcher man berühren, daß das O<sub>2</sub>-Hb alsbald in reduziertes Hb übergeht (*Vierordt*<sup>52</sup>). Die Kälte verzögert diese Reduktion; im Jugendalter, während der Muskeltätigkeit und drückter Atmung, meist auch im Fieber ist sie beschleunigt (*Dennig*<sup>53</sup>). Auch das Herz wirkt reduzierend auf O<sub>2</sub>-Hb (*Handler*<sup>54</sup>).

2. Das Hämoglobin bildet mit Sauerstoff noch eine zweite krystallisierbare Verbindung, das Methämoglobin, Met-Hb (*Seyler*<sup>55</sup>); es enthält ebenso viel Sauerstoff wie das O<sub>2</sub>-Hb, aber ist in einer artiger Anlagerung (*Hüfner* u. *Otto*<sup>57</sup>, *Hüfner* u. *Külz*<sup>58</sup>). Dem Sauerstoff im Met-Hb ist fest gebunden; das Met-Hb kann daher keinen Sauerstoff abgeben. Hierin liegt die Gefahr der Methämoglobinämie für den Körper begründet. Die Umwandlung des O<sub>2</sub>-Hb in Met-Hb vollzieht sich außerhalb des Körpers allmählich von selbst, bei längerem Verlassen des Blutes, bei längerem Erwärmen oder langsamem Erhitzen. Sie kann durch eine große Zahl chemischer Substanzen befördert werden, besonders schnell wirkt Ferricyankalium.

Nicht allein lackfarbiges Blut, sondern auch das Hb der intakten Erythrocyten kann in Met-Hb umgewandelt werden, z. B. durch chlorsaures Kalium, Antiforb



**DIESE SEITE IST FÜR KOSTENLOSE MITGLIEDER GESPERRT**  
Beantragen Sie jetzt die volle Mitgliedschaft, um diese Seite zu betreten



**Seien Sie niemals ohne ein Buch!**

Die Vollmitgliedschaft von Forgotten Books bietet Ihnen einen universalen Zugang von unseren Apps und unserer Website, auf all Ihren Geräten: Tablet, Telefon, E-Reader, Laptop und Computer.

**Eine Bibliothek in Ihrer Tasche für € 8.99/monat**

**Fortfahren**

\*Es gelten Richtlinien zur fairen Nutzung.

Wegen seiner größeren Beständigkeit widersteht das CO-Hb lange Zeit der Zersetzung, es kann daher auch noch in exhumierten Leichen nachgewiesen werden.

**Die Kohlenoxydvergiftung.** — CO entsteht bei unvollständiger Verbrennung von Kohlenstoff z. B. durch vorzeitiges Schließen der Ofenklappen, stark blakende Lampen; Leuchtgas kommen 12—28% CO vor. Doch ist die Leuchtgasvergiftung nicht völlig identisch mit der CO-Vergiftung (*Ferchland* u. *Vahlen*<sup>13</sup>).

Da das CO eine 140mal größere Affinität zum Hb besitzt als der O (Hämoglobin), so wird durch Atmung CO-haltiger Luft mehr und mehr der O aus dem Blute verdrängt und es kann natürlich das Leben nur solange bestehen, als noch hinreichend O im Blute enthalten ist, um die für das Leben notwendigen Oxydationsprozesse zu unterhalten. CO tötet den Menschen, wenn es auf einmal geatmet wird. Es genügen aber bereits kleine Mengen CO ( $\frac{1}{4000}$  bis  $\frac{1}{10000}$ ) in der Luft, um in kurzer Zeit verhältnismäßig große Mengen CO-Hb zu bilden (*Gréhant*<sup>14</sup>). Der Tod tritt ein, noch ehe aller O aus dem Blute verdrängt ist (im ungünstigsten Falle bleibt noch  $\frac{1}{6}$  des O im Blute zurück) (*Gréhant*<sup>14</sup>). Die Erscheinungen, die bei der CO-Vergiftung auftreten, sind zuerst lebhafter Kopfweh, große Unruhe, Aufregung, verstärkte Herz- und Atmungstätigkeit, Salivation, Zuckungen und Krämpfe, später treten Unbesinnlichkeit, Mattigkeit, Schläfrigkeit, Icterus ein, Verlust des Bewußtseins, mühsame röchelnde Atmung, schließlich völliges Verlöschen der Empfindung, Aufhören der Atmung und des Herzschlages und Tod. Die Temperatur zeigt im Anfange Erhöhung bis gegen einige Zehntel Grad, dann folgt Abnahme um 1° C und darüber. Die Pulsschläge zeigen anfangs gesteigerte Energie, später Puls sehr klein und frequent. Die Alkaleszenz und der Kohlensäuregehalt des Blutes wird vermindert, die Milchsäure vermehrt (beim Kaninchen, *Araki*<sup>15</sup>, *Saiki* u. *Wakabayashi*<sup>16</sup>). Mitunter tritt (bei Hunden nur nach reichlicher Eiweißfütterung, *Straub*<sup>17</sup>) Zuckerkoma auf. Nach überstandener Intoxikation soll die Harnstoffausscheidung zunehmen (*Gréhant*<sup>14</sup>). — In der Leiche ist auffällig die große Überfüllung der Organe mit flüssigem, dunkelrotem Blute und die Erweiterung der Gefäße. Alle Muskeln und Eingeweide haben eine rote Färbung; die Totenflecke sind hellrot. — Die noch lebenden Vergifteten müssen sofort an die frische Luft. Noch wirksamer sind O-Inhalationen. Da durch Anheftung (Durchleiten) des CO-Hb mit anderen Gasen (namentlich auch mit O) das CO wieder vom Hb getrennt werden kann (unter Neubildung von O<sub>2</sub>-Hb (*Zuntz*<sup>18</sup>, *Podolinski*<sup>19</sup>)), so gelangt auch im Körper durch die Atmung schon nach wenigen Stunden das CO zur Ausscheidung; eine Verbrennung des CO zu CO<sub>2</sub>, kommt ebenfalls vor (*Haldane*<sup>20</sup>). Hochgradige Intoxikation erfordert die Transfusion.

4. Das Stickoxyd-Hämoglobin entsteht, wenn NO mit dem Hb in Verbindung gebracht wird (*L. Hermann*<sup>21</sup>).

Da dieses Gas in Berührung mit O sich sofort zu Stickstoffdioxyd (Untersalzen) umwandelt, welches auf Hämoglobin zersetzend einwirkt, so muß bei der Herstellung des NO-Hb zuerst aller O aus dem Blut und den Apparaten (etwa durch Durchleiten) entfernt werden. Im Körper kann es sich aus diesem Grunde nicht bilden. Das NO-Hb ist eine noch festere chemische Verbindung als das CO-Hb; es ist mehr bläulich und gibt im Spektrum zwei Absorptionsstreifen, ziemlich ähnlich denen der beiden Gasverbindungen, aber weniger intensiv. Reduzierende Mittel löschen diese Streifen.

Die drei Verbindungen des Hb mit O<sub>2</sub>, CO und NO kristallisieren wie das gasfreie Hb, sie sind isomorph, ihre Lösungen sind nicht chroitisch. Alle drei Gase verbinden sich in molekularem Verhältnis zum Hb und sind im Vakuum austreibbar.

5. Auch Cyanwasserstoff CNH bildet Verbindungen mit Hb (*Kobert*<sup>22</sup>, vgl. pag. 15).

6. Über Verbindungen von Schwefelwasserstoff mit Hämoglobin (S-Hämoglobin) vgl. *Harnack*<sup>23</sup>, *Kobert*<sup>24</sup>, *Clarke* u. *Hurtley*<sup>25</sup>.

## 22. Zerlegung des Hämoglobins. Hämoglobinderivate

Das Hämoglobin ist ein zusammengesetzter Eiweißkörper, ein Chromoproteid (vgl. pag. 15); es besteht aus einem Eiweißkörper, dem Globin (94,09% des Hb) und einem Farbstoff (4,47% des Hb), dem Häm, die beiden sind Stoffe unbekannter Natur, *Lawrow*<sup>26</sup>): dem Hämatin (bei Zerlegung von O<sub>2</sub>-haltigem Hb) resp. Hämochromogen (bei Zerlegung von CO-Hb). Das Hämochromogen geht durch Oxydation in Hämatin, und



## Hämoglobinderivat. Das Stroma der roten Blutkörperchen.

ehen Hämatoporphyrins ähnelt dem des neutralen Met-Hb res  
ren Hämatins in alkoholischer oder ätherischer Lösung (Fig. 16. 9  
VII.) (vgl. *A. Schulz*<sup>100</sup>). Das Spektrum des Hämatoporphyrin  
rer und alkalischer Lösung ist zum forensischen Nachweis des  
Blutspuren sehr geeignet (*Kratter*<sup>110</sup>, *Ziemke*<sup>111</sup>). Hämatopor  
nmt normalerweise im Harn in Spuren vor, in größeren Meng  
wissen Vergiftungen (z. B. Sulfonalvergiftung).

Durch Reduktion des Hämatoporphyrins erhielten *Nencki* und seine Mitarb  
n völlig sauerstofffreien Körper, das Hämopyrrol; dieses ist ein methyl-äthyl



Nach *Fischer u. Hahn*<sup>112</sup> enthält das Molekül des Hämins vier Pyrrolkerne

Aus dem Chlorophyll der grünen Blätter gewannen *Schunck u. Marchlewski*  
Hämatoporphyrin sehr ähnliches Pigment, das Phylloporphyrin; durch Reduktion  
aus diesem Hämopyrrol (*Nencki u. Marchlewski*<sup>113</sup>). Danach sind mithin das  
in und das Chlorophyll chemisch verwandte Substanzen. Das Chlorophyll ent  
le des Eisens des Hämoglobins Magnesium (vgl. *Willstätter u. Stoll*<sup>116</sup>).

Durch Oxydation des Hämatins erhielt *Küster*<sup>100</sup> zwei Säuren: Hämatins

Der Blutfarbstoff ist chemisch nahe verwandt mit dem Gallen- und  
bstoff. Der Gallenfarbstoff Bilirubin  $\text{C}_{23}\text{H}_{36}\text{N}_4\text{O}_6$  ist isomer mit dem Hämatop  
 $\text{H}_{36}\text{N}_4\text{O}_6$ ; sowohl Bilirubin als Biliverdin geben bei der Oxydation dieselben H  
en wie Hämatin (*Küster*<sup>100</sup>). — Wenn Blut außerhalb des Kreislaufes stagni  
Zersetzung anheimfällt, z. B. in apoplektischen Blutergüssen, in geronnenen  
pfen usw., so entsteht aus dem Hämoglobin ein fuchsroter Farbstoff, das Häma  
 $\text{H}_{36}\text{N}_4\text{O}_6$ . Es ist eisenfrei, krystallisiert in klinorhombischen Prismen, ist lö  
oroform und warmen Alkalien. Wahrscheinlich ist es identisch mit dem Gal  
e Bilirubin. Nach umfangreicher Auflösung von Blut in den Gefäßen (z.  
nsfusion fremdartigen Blutes) sah man Hämatoidinkrystalle im Urin. Auch im H  
rus und im Sputum sind Hämatoidinkrystalle gefunden worden.

Urobilin, einer der Farbstoffe des Harns, läßt sich durch Reduktion des H  
alkalischer Lösung mit Zinn und Salzsäure (*Nencki u. Sieber*<sup>114</sup>) oder durch Ein  
 $\text{H}_2\text{O}_2$  auf saures Hämatin (*Mac Munn*<sup>115</sup>) gewinnen; Hämopyrrol geht an d  
selbst in Urobilin über; subcutane Injektion von Hämopyrrol beim Kaninchen  
scheidung von Urobilin (*Nencki u. Zaleski*<sup>112</sup>). — Urobilin findet sich mitu  
len, Ex- und Transudaten, — ebenso bildet es sich in steril bei Körpertem  
bewahrtem Blute (*Ajello*<sup>110</sup>).

Das Chorioidealpiment und das Haarpigment stammt nicht aus de  
stoffe (*E. Spiegler*<sup>120</sup>).

## 3. Das Stroma der roten Blutkörperchen und die we Blutkörperchen.

A. Das Stroma der roten Blutkörperchen enthält:

I. Eiweißkörper. — Nach *Pascucci*<sup>121</sup> bestehen die trockener  
ta rund zu  $\frac{2}{3}$  aus Eiweißstoffen. Der hauptsächlichste Eiweißst  
ch *Halliburton*<sup>122</sup> ein Nucleoproteid.

In den Kernen der kernhaltigen roten Blutkörperchen der Vögel findet sich  
ammengesetzt aus Nucleinsäure und Histon (*Ackermann*<sup>123</sup>).

II. Fette. — Neutralfett kommt in den roten Blutkörperchen  
; dagegen Cholesterin (nach *Manasse*<sup>124</sup>, *Hepner*<sup>125</sup>, *Wacker u. H*  
im freien Zustande, nach *Cytronberg*<sup>127</sup> dagegen bis zur Hälfte  
über als Cholesterinester) und Lecithin (vgl. *Beumer u. Bürg*



**DIESE SEITE IST FÜR KOSTENLOSE MITGLIEDER GESPERRT**  
Beantragen Sie jetzt die volle Mitgliedschaft, um diese Seite zu betreten

# GESCHICHTE

Zehntausende von wichtigen historischen Quellen, viele bisher nicht erhältlich, stehen jetzt zum ersten Mal mit der Vollmitgliedschaft von Forgotten Books zur Verfügung.

Unbegrenzter Zugang  
\$8.99/monat

**Fortfahren**

\*Es gelten Richtlinien zur fairen Nutzung.



ph. Ch. 16, 1892, 505. — 24. *J. Plesch*: Z. k. M. 63, 1907, 472. M. m. W. 57, 1909, 126. — 25. *v. Fleischl*: Wien. Med. Jahrb. 1885, 425. — 26. *J. G. Gadow*: Gesammelte Abhandlungen 1897, S. 334 u. 356. — 27. *E. Veillon*: A. P. P. 39, 1901, 126. — 28. *Fr. Müller*: A. P. 1901, 443. — 29. *P. v. Grützner*: M. m. W. 1905, 157. — 30. *Gowers*: Transact. of the clinical society of London. 12, 1879, 64. — 31. *H. H. H. H. H.*: Lehrbuch d. klin. Untersuchungsmethoden. 5. Aufl. Leipzig u. Wien 1909, 126. — 32. *K. Bürker*: P. A. 142, 1911, 273. — 33. *Tallquist*: Z. k. M. 40, 1900, 137. — 34. *G. Gaertner*: M. m. W. 1901, Nr. 50. — 35. *E. E. Butterfield*: M. m. W. 1909, 173. — 36. *A. Jolles*: P. A. 65, 1897, 579. B. k. W. 1899, 965. M. m. W. 1903, 503. vgl. *Schwenkenbecher*: D. A. k. M. 75, 1903, 503. — 37. *J. Haldane*: J. o. P. 26, 1901, 503. — 38. *Leichtenstern*: Untersuchungen über den Sauerstoffgehalt des Blutes. 1878. — 39. *R. Stierlin*: D. A. k. M. 45, 1889, 75. — 40. *H. H. H. H.*: P. A. 73, 1898, 299. — 41. *F. Hoppe-Seyler*: Med.-chem. Untersuchungen. Z. ph. Ch. 15, 1891, 179. — 42. *L. Hermann u. S. Groll*: P. A. 43, 1888, 126. — 43. *E. Kost, Fr. Franz u. R. Heise*: Arbeiten aus d. Kais. Gesundheitsamt. 32, 1901, 126. — 44. *G. Häfner*: A. P. 1894, 130. — 45. *G. G. Stokes*: Phil. Magazine. 28, 1864, 357. — 46. *Hoppe-Seyler*: V. A. 23, 1862, 446. 29, 1864, 223. — 47. *A. Rollett*: Hermanns Handbuch d. Physik. 1, 1880, pag. 48 u. 57. — 48. *E. Ziemke u. Fr. Müller*: A. P. 1901, Suppl., 126. — 49. *J. L. Soret*: Archiv. d. sciences physiques et naturelles de Genève. 61, 1878, 324. — 50. *Grabe*: Diss. Dorpat 1892. — 51. *R. Kobert*: P. A. 82, 1900, 603. — 52. *B. Tollens*: B. d. ch. G. 34, 1901, 1426. — 53. *K. Vierordt*: Z. B. 14, 1878, 422. — 54. *A. Dennig*: Z. B. 19, 1883, 483. — 55. *S. Handler*: Z. ph. Ch. 2, 1879, 150. — 56. *F. Hoppe-Seyler*: Z. ph. Ch. 2, 1879, 150. — 57. *G. Häfner u. J. Otto*: Z. ph. Ch. 7, 1883, 65. — 58. *G. Häfner u. R. Kälz*: Z. ph. Ch. 7, 1883, 65. — 59. *A. Dennig*: D. A. k. M. 65, 1900, 524. — 60. *A. Bornstein u. F. Müller*: A. P. 1901, 126. — 61. *R. Kobert*: P. A. 82, 1900, 603. — 62. *W. Sachs*: Die Kohlenoxydverbindung. — 63. *F. Hoppe-Seyler*: V. A. 11, 1857, 288. 29, 223 u. 597. — 64. *Cl. Bernard*: Leçons sur les effets des poisons toxiques et médicamenteuses. Paris 1857, 157. Leçons sur les propriétés de l'organisme. Paris 1859. 1, 365. — 65. *Hoppe-Seyler*: V. A. 13, 1858, 126. — 66. *E. Salkowski*: Z. ph. Ch. 12, 1888, 227. — 67. *Katayama*: V. A. 114, 1888, 126. — 68. *Rubner*: A. H. 10, 1890, 397. — 69. *Kunkel u. Welzel*: W. V. N. F. 22, 1888, Nr. 1. — 70. *S. Kostin*: P. A. 83, 1901, 572. — 71. *K. Bürker*: s. Nr. 1. — 72. *Ferchland u. E. Vahlen*: A. P. P. 48, 1902, 106. — 73. *J. Haldane*: J. o. P. 25, 430. — 74. *N. Gréhan*: G. m. 1878, Nr. 36. C. r. 114, 1892, 309. C. r. 1895, 251 u. 344. — 75. *H. Dreser*: A. P. P. 29, 1892, 119. — 76. *T. Araki*: Z. ph. Ch. 34, 1901, 96. — 77. *T. Saiki u. G. Wakayama*: Z. ph. Ch. 34, 1901, 96. — 78. *W. P. P.* 38, 1897, 139. — 79. *Fränkel*: V. A. 67, 273. — 80. *F. C. Donders*: V. A. 2, 20. — 81. *N. Zuntz*: P. A. 5, 1872, 584. — 82. *S. Podolinski*: P. A. 6, 1872, 584. — 83. *J. Haldane*: J. o. P. 25, 1900, 225. — 84. *L. Hermann*: A. A. P. 1865, 126. — 85. *R. Kobert*: P. A. 82, 1900, 603. — 86. *R. v. Zeynek*: Z. ph. Ch. 33, 1901, 126. — 87. *E. Harnack*: Z. ph. Ch. 26, 1898, 558. — 88. *T. W. Clarke u. W. H. Hurlley*: Z. ph. Ch. 34, 1901, 96. — 89. Zusammenfassende Darstellung: *Fr. N. Schulz*: E. P. I, 126. — 90. *D. Lacroux*: Z. ph. Ch. 26, 1898, 343. — 91. *Fr. N. Schulz*: Z. ph. Ch. 26, 1898, 343. — 92. *A. Kossel*: Z. ph. Ch. 49, 1906, 314. — 93. *W. Dilling*: Atlas der Hämochromogene u. der Absorptionsbänder der Hämochromogene. Stuttgart 1910. — 94. *Z. Doering*: V. A. 148, 1897, 234. — 95. *A. de Dominicis*: B. k. W. 1909, 1656. — 96. *K. Bürker*: s. Nr. 1, S. 150. M. m. W. 1909, 126. — 97. *G. W. Käster*: A. P. 1904, Suppl., 387. — 98. *F. Pregl*: Z. ph. Ch. 44, 1905, 126. — 99. *M. Nencki u. N. Sieber*: A. P. P. 18, 1884, 401. B. d. ch. G. 17, 1884, 2267. 126. — 100. *W. Käster*: B. d. ch. G. 29, 1896, 821. 30, 1897, 105. 32, 1899, 1268 u. 2948. Z. ph. Ch. 26, 1899, 314. 28, 1899, 1 u. 34. 29, 1900, 185. 44, 1905, 391. A. Ch. Ph. 315, 1901, 174. 345, 1906, 1. — 101. *R. Willstätt*: Z. ph. Ch. 87, 1913, 423. — 102. *L. Teichmann*: Z. r. M. N. F. 3, 1857, 141. — 103. *H. U. Kobert*: Das Wirbeltierblut in mikrokrytallographischer Darstellung. Stuttgart 1901, pag. 54, 56, 57. — 104. *Lewin u. Rosenstein*: V. A. 142, 1897, 126. — 105. *L. Wachholz*: V. g. M. 3. Folge, 21, 1901, 227. — 106. *H. U. Kobert*: v. g. M. 3. Folge, 21, 1901, 227. — 107. *C. Strzyzowski*: Pharmac. Post 30, 1897, 2. Ref. in C. C. 1897, 126. — 108. *J. Zaleski*: Z. ph. Ch. 37, 1902, 54. — 109. *A. Schulz*: A. P. 1904, Suppl., 126. — 110. *J. Kratter*: V. g. M. 3. Folge, 4, 1892, 62. — 111. *E. Ziemke*: V. g. M. 1, 231. — 112. *M. Nencki u. J. Zaleski*: B. d. ch. G. 34, 1901, 997. *L. Marchlewski*: B. d. ch. G. 42, 1909, 4693. — 113. *E. Schunck u. Marchlewski*: B. d. ch. G. 46, 1914, 2308. — 114. *E. Schunck u. Marchlewski*: Z. ph. Ch. 284, 1895, 81. 290, 1896, 306. — 115. *M. Nencki u. L. Marchlewski*: B.

34, 1901, 1687. — 116. *R. Willstätter* u. *A. Stoll*: Untersuchungen über Chlorophyllen und Ergebnisse. Berlin 1913. — 117. *M. Nencki* u. *N. Sieber*: Monatshefte für Chemie u. Physik. A. P. P. 24, 1888, 430. — 118. *C. A. Mac Munn*: P. R. S. 31, 1880, 119. *Ajello*: Ref. in C. i. M. 15, 1904, 502. — 120. *E. Spiegler*: H. B. 4, 1904, 4253. — 121. *O. Pascucci*: H. B. 6, 1905, 543. — 122. *W. D. Halliburton*: 1895, 306. — 123. *D. Ackermann*: Z. ph. Ch. 43, 1904, 299. — 124. *P. Manasse*: 14, 1890, 437. — 125. *E. Hepner*: P. A. 73, 1898, 595. — 126. *L. Wacker* u. *A. P. P.* 74, 1913, 416. — 127. *S. Cytronberg*: B. Z. 45, 1912, 281. — 128. *u. M. Bürger*: A. P. P. 71, 1913, 311. — 129. *H. Lyttkens* u. *J. Sandgren*: B. 382. 31, 1911, 153. 36, 1911, 261. — 130. *J. Bang*: B. Z. 38, 1912, 166. — 131. *u. L. Michaelis*: B. Z. 16, 1909, 60. — 132. *P. Rona* u. *D. Takahashi*: B. Z. 30, 1911, 1. — 133. *R. Lépine* u. *Boulud*: B. Z. 32, 1911, 287. — 134. *E. Frank* u. *A. Brückner*: Z. ph. Ch. 76, 1911, 226. — 135. *A. Hollinger*: B. Z. 17, 1909, 1. — 136. *L. Wacker* u. *P. Rona*: B. Z. 18, 1909, 375 u. 514. 37, 1911, 47. — 137. *E. Masing*: P. A. 227. — 138. *S. Kozawa*: C. P. 27, 1913, 793. B. Z. 60, 1914, 231. — 139. *B. P. A.* 63, 1896, 192. — 140. *T. Iriawata*: Z. ph. Ch. 17, 1893, 340. — 141. *u. B. Z.* 26, 1910, 140. — 142. *L. Lilienfeld*: Z. ph. Ch. 18, 1894, 473. — 143. *D. m. W.* 20, 1894, 146 u. 310. — 144. *Salomon*: D. m. W. 1877, Nr. 8 u. 35.

## 24. Das Blutplasma und der Faserstoff (das Fibrin)

Die unveränderte Flüssigkeit des Blutes heißt „Plasma“. Sowie das Blut aus den Gefäßen scheidet sich jedoch meist schon bald nach dem Austritt des Blutes in den Gefäßen eine faserige Substanz ab, der „Faserstoff“. Nach dieser Ausscheidung heißt die nun übrig gebliebene, spontan nicht mehr gerinnbare Flüssigkeit „Serum“. Das Plasma ist beim Menschen und bei anderen Tieren gelblich, beim Pferde zitronengelb, bei anderen Tieren, z. B. Kaninchen, fast farblos.

**Darstellung des Plasmas.** Um das Plasma darzustellen ist es notwendig, die Gerinnung zu verhüten; dies gelingt entweder durch Abkühlen oder durch Zusatz gewisser Salze.

**A. Kälteplasma.** — Man läßt das aus der Ader strömende Blut (namentlich des Pferdes, welches sich wegen der langsamen Gerinnung und der schnellen Senkung der Blutkörperchen hierzu besonders eignet) in kaltem Wasser in engen, in Kältemischung stehenden Meßcylinder fließen. In dem abbleibenden Blute senken sich innerhalb einiger Stunden die Erythrocyten und das Plasma bildet oben eine, mit der (abgekühlten) Pipette abpipettierbare klare Flüssigkeit. Wird diese schließlich noch (auf eiskaltem Wasser) durch ein Filter filtriert, so ist das Plasma auch von den Leukocyten befreit. Wenn man das Plasma gerinnen läßt, gerinnt das Plasma und geht dabei in eine zitternde Gallerte über. Wenn man es mit einem Stabe, so erhält man den Faserstoff als faserige Masse isoliert.

**B. Salzplasma.** — Wird das aus der Ader strömende Blut in einen Meßcylinder unter Umrühren mit  $\frac{1}{7}$  Vol. konzentrierter Lösung von Natriumsulfat oder mit 25%iger Magnesiumsulfat-Lösung (1 auf 4 Volumina Blut) vermischt, so senken sich (am kühlen Wasser) die Erythrocyten ab, während das klar obenstehende „Salzplasma“ abpipettiert werden kann. Wird dem Salzplasma der Salzgehalt durch Dialyse entzogen, tritt Gerinnung ein; dasselbe bewirkt schon eine Verdünnung mit Wasser. — Verhindert man die Gerinnung durch Zusatz von oxalsauren Salzen oder Fluoriden (vgl. § 25, II. c), so erhält man Oxalat-, resp. Fluoridplasma.

Über das quantitative Verhältnis von Blutkörperchen und Plasma, dem Volumen und dem Gewicht nach vgl. pag. 37 u. 84.

Der Faserstoff ist diejenige Substanz, welche sowohl in dem leerten Blute als auch in dem Plasma (ebenso in der Lymphe und im Chylus) durch ihre Ausscheidung aus der Flüssigkeit die C



rvorrath. Läßt man aus der Ader aufgefangenes Blut ruhig stehen, so bildet sich der Faserstoff aus zahllosen, mikroskopisch zarten (Fig. 1) doppelbrechenden Fäden, welche die Blutkörperchen wie in einem Netze zusammenhalten und mit ihnen eine gallertig feste Masse darstellen, die man „Blutkuchen“ (*Placenta sanguinis*) nennt. Anfänglich ist die Masse sehr weich, nach 12 bis 15 Stunden ziehen sich die Faserstoffäden enger und enger um die Körperchen zusammen; es entsteht eine feste, mit dem Messer zerschneidbare, gallertig zitternde Substanz, welche die klare Flüssigkeit auspreßt, das Blutserum (*Serum sanguinis*). Der Rest des Blutplasmas (*Plasma minus Fibrin = Serum*). Der Blutkuchen behält die Gestalt des Gefäßes, in welchem das Blut aufgefangen war.

Sinken sich die Blutkörperchen im Blute sehr schnell und verzögert sich der Eintritt in die Gerinnung, so ist die obere Schicht des Blutkuchens nur gelblich gefärbt wegen der Anwesenheit an eingeschlossnen Erythrocyten. Dies ist beim Pferdeblute die Regel, beim Menschenblute kommt es namentlich vor, wenn Entzündungen im Körper herrschen. Die *Crusta phlogistica* (Speckhaut). Die *Crusta* bildet sich auch noch unter anderen Umständen, und zwar ist die Ursache der Bildung nicht immer klar: bei größerem Wassergehalte der Blutkörperchen oder geringerem des Plasmas (wie in der Hydrämie und Chlorämie) durch sich erstere schneller senken; auch in der Schwangerschaft.

Wird frisch entleertes Blut mit einem Stabe geschlagen, so wickeln sich die auftretenden Faserstoffäden um den Stab herum, und es fällt ab das Fibrin als faserige, grau-gelblich-weiße Masse. Das übrige Blut kann nun nicht mehr gerinnen: defibriniertes Blut besteht aus Serum und Blutkörperchen.

Obschon das Fibrin voluminös erscheint, so beträgt es doch nur 0,8% der Blutmasse, merkwürdigerweise kann in zwei verschiedenen Proben desselben Blutes seine Menge erheblich schwanken. — Der Faserstoff ist unlöslich in Wasser oder Äther; Alkohol schrumpft ihn durch Entwässerung, Salzsäure läßt ihn glasig aufquellen (unter Veränderung in Acidalbumin). Er ist frisch zäh elastisch; getrocknet wird er hornartig erscheinend, spröde und pulverisierbar.

Frisches Fibrin vermag  $H_2O$ , lebhaft in  $H_2O$  und  $O$  zu zerlegen. Gekocht oder durch Alkohol aufbewahrt, verliert es dieses Vermögen.

Frisch löst Fibrin sich auf in 6—8%igen Lösungen von Natriumnitrat, Kaliumnitrat, Natriumsulfat, in dünnen Alkalien und Ammoniak; Hitze koaguliert diese Lösungen. Auch schwache Lösungen von Haloidsalzen ( $NaCl-NH_4Cl-KJ-NaJ-NaF-NH_4F$ ) lösen bei  $40^\circ$  das Fibrin, z. B. Kochsalzlösung von 0,7—2,0%. Auch Serum löst zuweilen gebildete Fibrin wieder auf: Fibrinolyse; am stärksten bei Phosphorvergiftung. Wahrscheinlich handelt es sich dabei um die Wirkung eines fibrinolytischen Fermentes.

## 25. Allgemeine Erscheinungen bei der Gerinnung.<sup>1</sup>

1. In unmittelbarer Berührung mit der lebendigen und unveränderten Gefäßwand gerinnt das Blut nicht (*Hewson*, 1772; *Macrae*, 1819). Daher konnte *Brücke*<sup>2</sup> auf  $0^\circ$  abgekühltes Blut in den stillstehenden Herzen getöteter Schildkröten 8 Tage ungeronnen erhalten. Lagert das Blut in einem lebenden Gefäße, so tritt in der zentralen Partie Gerinnung ein, weil hier kein Kontakt mit der lebenden Gefäßwand besteht. Läßt man Blut so aus einem Gefäße austreten, daß es nicht mit der unvorletzten Intima in Berührung kommt, nicht mit der Schnittfläche (wenn man die Intima aus dem Lumen des durchschnittenen Gefäßes herauszieht und nach außen umklappt), so gerinnt das Blut 6—7 Minuten später als das Blut aus einfach durchschnittenen Gefäßen (*Unger*<sup>3</sup>). Innerhalb toter Herzen oder Gefäße, oder innerhalb anderer Kanäle, z.



**DIESE SEITE IST FÜR KOSTENLOSE MITGLIEDER GESPERRT**  
Beantragen Sie jetzt die volle Mitgliedschaft, um diese Seite zu betreten



**Seien Sie niemals ohne ein Buch!**

Die Vollmitgliedschaft von Forgotten Books bietet Ihnen einen universalen Zugang von unseren Apps und unserer Website, auf all Ihren Geräten: Tablet, Telefon, E-Reader, Laptop und Computer.

**Eine Bibliothek in Ihrer Tasche für € 8.99/monat**

**Fortfahren**

\*Es gelten Richtlinien zur fairen Nutzung.

*Morawitz*<sup>16</sup>), wirkt gleichfalls gerinnungshemmend.

g) Das Blut der Vögelembryonen gerinnt vor dem 12.—14. Tage nicht, das Blut der Nierenvene — das der Lebervenen sehr wenig. — Blut (Hund), welches durch das Herz und die Lungen geleitet wird, gerinnt lange Zeit hindurch nicht (*Loehr*<sup>17</sup>). — Blut, welchem die Circulation durch Leber und Darm verschlossen ist, gerinnt sehr früh (*Loehr*<sup>17</sup>). — Fötalblut im Momente der Geburt gerinnt früh, aber langsam, sein Gerinnungsvermögen ist gering (*Krüger*<sup>18</sup>). — Das Menstrualblut zeigt geringere Neigung zur Gerinnung als demselben reichlicher alkalischer Schleim aus den Geschlechtsteilen beigemischt ist.

h) Bei der „Bluterkrankheit“ (Hämophilie) ist eine stark verminderte Thrombokinasität des Blutes vorhanden, so daß selbst kleine Wunden sehr lange bluten. Die Ursache ist das Fehlen der Thrombokinase (s. unten), das Protoplasma der geformten roten Blutkörperchen des Blutes, vielleicht sogar aller Zellen des Körpers hat das Vermögen eingebüßt, Thrombokinasen zu liefern (*Sakli*<sup>19</sup>, *Morawitz* u. *Lossen*<sup>20</sup>).

Auch bei Cholämie kommen bisweilen schwer stillbare Blutungen zur Beobachtung. Die Ursachen sind noch nicht aufgeklärt ist (vgl. *Morawitz* u. *Bierich*<sup>21</sup>).

### III. Beschleunigt wird die Gerinnung:

a) Durch Erwärmung (von 39—55°; vgl. IV).

b) Durch zahlreiche Stoffwechselprodukte: Harnsäure, Kreatinin, Aurin, Leucin, Tyrosin, Guanin, Xanthin, Hypoxanthin (nicht Harnsäure), die Gallensäuren, Lecithin, salzsaures Cholin, Protagon. — Intravenöse Injektionen von Gelatine sollen bewirken, daß das Blut nach dem Austritt aus den Gefäßen fast momentan gerinnt (*Dastre* u. *Floresco*<sup>22</sup>); von dieser Angabe wird diese Angabe bestritten oder auf den Kalkgehalt der Gelatine bezogen (*Camus* u. *Gley*<sup>23</sup>, *Sackur*<sup>24</sup>, *Zibell*<sup>25</sup>).

IV. Auf die Blutgerinnungszeit hat nach den Untersuchungen von *Bürker*<sup>26</sup> die Temperatur einen großen, aber durchaus regelmäßigen Einfluß. *Bürker*<sup>26</sup> fand die Blutgerinnungszeit bei 13,7° zu 18,5 Minuten, bei 17,9° zu 10, bei 24,2° zu 6,5, bei 28° zu 4, bei 34,7° zu 2,8, bei 39,8° zu 2,75 Minuten. In den ersten Nachmittagsstunden scheint ein Minimum der Gerinnungszeit vorhanden zu sein. Für verschiedene Injektionen ist bei gleicher Temperatur und gleicher Tageszeit die Gerinnungszeit eine ziemlich konstante Größe (*Bürker*<sup>26</sup>). Nach starken Blutverlusten wird die Gerinnungszeit abgekürzt, bei schneller Verblutung gerinnen die Blutmassen am schnellsten (*Arloing*<sup>27</sup>, *Arthur*<sup>28</sup>, *Milian*<sup>29</sup>). *Ner Velden*<sup>30</sup> erklärt sich die Erscheinung dadurch, daß nach Blutverluste Gewebsflüssigkeit in die Gefäße eintritt und reichlich Thrombokinase eintrifft und in sich einschwehmt.

Einen Apparat zur Bestimmung der Blutgerinnungszeit bei konstanter, je beliebiger Temperatur hat *Bürker*<sup>26</sup> angegeben.

## 26. Wesen der Gerinnung.

*Alexander Schmidt*<sup>31</sup> hat (1861) ermittelt, daß die Gerinnung ein fermentativer Vorgang ist: durch Einwirkung eines fermentativen Körpers, des „Fibrinferment“ oder „Thrombin“ (Thrombase) genannt, wird ein löslicher Eiweißkörper des Plasmas, das Fibrinogen, in einen unlöslichen Körper: das Fibrin, umgewandelt.

*A. Schmidt*<sup>31</sup> nahm ursprünglich an, daß außer dem Fibrinogen oder der fibrinogenen Substanz noch ein anderer Körper: die fibrinoplastische Substanz (*Serum*, vgl. pag. 80) bei der Gerinnung beteiligt sei; beide Körper faßte er zusammen unter der Bezeichnung: Fibringeneratoren. *Hammarsten*<sup>32</sup> (1875) wies aber nach, daß die Fibrinogen nur aus dem Fibrinogen unter der Einwirkung des Fibrinferments bildet.

Man hat angenommen, daß durch das Thrombin eine Spaltung des Fibrinogen stattfindet in das Fibrin und eine geringere Menge einer flüssigen

**Globulinsubstanz:** das Fibrinoglobulin (*Hammarsten*<sup>23</sup>, *Heubner*<sup>24</sup>); von anderer dieser Anschauung bestritten (*Huiskamp*<sup>25</sup>).

Das Fibrinogen — ist ein Globulin (vgl. pag. 14). Es ist verdünnten Alkalien löslich und wird aus dieser Lösung beim Durchleiten von CO<sub>2</sub> niedergeschlagen. Es ist ferner löslich in verdünnten Salzlösungen, z. B. in dünner (5—10%) Kochsalzlösung; durch Halbsättigung mit Kochsalz wird es zum größten Teil gefällt, vollständig bei Ganzsättigung mit Kochsalz. Seine Lösung in Kochsalz koaguliert beim Erwärmen auf 50°C. Die Zusammensetzung ist nach *Hammarsten*<sup>23</sup> C 52,93 H 6,9 N 16,0 O 22,26%, die spezifische Drehung  $\alpha [D] = -52,5^\circ$  (*Mittelbach*<sup>26</sup>).

**Darstellung des Fibrinogens.** Fibrinogen kommt außer in Blutplasma noch in den sogenannten lymphatischen Transsudaten (z. B. Hyalinfüssigkeit, ein Transsudat in der serösen Umhüllung des Hodens) vor. Es wird daraus (Salzplasma, Transsudate) durch Vermischen mit dem gleichen Volumen gesättigter Kochsalzlösung ausgefällt, und durch wiederholtes Auflösen in dünner Kochsalzlösung und Ausfällen mit gesättigter Kochsalzlösung gereinigt.

**Entstehung des Fibrinogens.** Das Fibrinogen ist bereits im Plasma des tierischen Blutes vorhanden; seine Menge nimmt (im Gegensatz zu älteren Vorstellungen, welche das Fibrinogen aus einem Zerfall der zelligen Elemente im entleerten Blut entstehen ließen) nach der Entleerung nicht zu. Woher das Fibrinogen des Blutplasmas entsteht ist nicht mit Sicherheit bekannt, vielleicht aus der Leber (*Whipple*<sup>27</sup>, *Goodpastor*<sup>28</sup>) oder dem lymphoiden Gewebe. Nach *P. Th. Müller*<sup>29</sup> ist das Knochenmark eine Ursprungsstelle des Fibrinogens; die Fibrinogen bildende Tätigkeit desselben wird durch die Fäulnisbakterieller Produkte beträchtlich gesteigert. (Vgl. *Morawitz* u. *Rehn*<sup>30</sup>.)

**Das Fibrinferment (Thrombin, Thrombase).** Darstellung. Nachdem die Gerinnung zum Abschluß gekommen ist, bleibt das Fibrin zurück, welches ja entsprechend seiner fermentativen Wirkung bei dem Verflüssigen nicht verbraucht wird, im Serum zurück, es kann aus diesem in verschiedener Weise hergestellt werden. Blutserum wird mit dem 20fachen Volumen starken Alkohols vermischt, der Niederschlag, welcher aus Eiweiß und Fibrinferment besteht, 2—4 Wochen unter dem Alkohol stehen gelassen. Nach dem Abgießen wird das Eiweiß koaguliert, in Wasser unlöslich. Man filtriert nach einiger Zeit, trocknet den Niederschlag über Schwefelsäure und extrahiert mit Wasser: das Ferment geht in Lösung, das koagulierte Eiweiß bleibt zurück.

Werden die Lösungen des Fibrinogens und des Fibrinferments zusammengemischt, so entsteht sofort Fibrinbildung. Am günstigsten erfolgt diese bei der Körpertemperatur: 0° verhindert die Gerinnung, die Hitze zerstört das Ferment. Die Menge des Fermentes ist gleichgültig, größere Mengen bedingen schnellere, aber nicht vermehrte Fibrinbildung. Zur Fibrinbildung ist ein gewisser Salzgehalt der Flüssigkeit erforderlich (1% Kochsalz), sonst tritt sie nur langsam und teilweise ein.

**Entstehung des Fibrinfermentes.** Im Plasma des circulierenden Blutes ist noch kein Fibrinferment vorhanden (oder nur geringe Mengen, die zur Auslösung der Gerinnung nicht ausreichende Mengen; auch sind in diesem Plasma gerinnungshemmende Stoffe vorhanden, welche die Wirkung des vorhandenen Fermentes aufheben). Dagegen enthält das Plasma des gerinnenden Blutes eine unwirksame Vorstufe des Fibrinfermentes, Prothrombin oder Thrombogen.

Vgl. über analoge Profermente: Propepsin (§ 110), Trypsinogen (§ 114).

Das wirksame Thrombin wird aus der unwirksamen Vorstufe Thrombogen, gebildet durch die Thrombokinasen (Aktivier





**DIESE SEITE IST FÜR KOSTENLOSE MITGLIEDER GESPERRT**  
Beantragen Sie jetzt die volle Mitgliedschaft, um diese Seite zu betreten

# GESCHICHTE

Zehntausende von wichtigen historischen Quellen, viele bisher nicht erhältlich, stehen jetzt zum ersten Mal mit der Vollmitgliedschaft von Forgotten Books zur Verfügung.

Unbegrenzter Zugang  
\$8.99/monat

**Fortfahren**

\*Es gelten Richtlinien zur fairen Nutzung.



## A. Die Globulinfraction enthält:

1. Das Serumglobulin (früher auch fibrinoplastische Substanz, Globulin, Serumcasein genannt) als wichtigsten Bestandteil. Es ist in wässrigen Lösungen von Neutralsalzen (10% NaCl) und in Alkalien, unlöslich in reinem Wasser. Aus seinen Lösungen wird es daher ausgefällt durch Fällung der Salze durch die Dialyse oder durch starke Verdünnung mit Wasser, sowie durch schwaches Ansäuern mit Essigsäure oder Erhitzen mit Kohlensäure. Es koaguliert bei 69—75°; spez. Drehung = +12,5° (Frédéricq<sup>68</sup>).

Wahrscheinlich ist das Serumglobulin kein einheitlicher Körper. Man kann nach Löslichkeit und Fällbarkeit wenigstens zwei Körper darin unterscheiden: das leicht fällbare Globulin (bei einem Gehalt von 28—36 Volumenprozent gesättigter Ammonsulfatlösung ausfallend) und das schwer fällbare Pseudoglobulin (bei 36—44 Volumenprozent gesättigter Ammonsulfatlösung ausfallend, Fuld u. Spiro<sup>69</sup>, Pick<sup>69</sup>). Doch ist die Abgrenzung zwischen beiden Fraktionen keine scharfe (Pick<sup>69</sup>). Eine noch weitergehende Trennung in verschiedene Globuline haben Freund u. Joachim<sup>61</sup> sowie Porges u. Spiro<sup>62</sup> an

2. Das Fibringlobulin kommt regelmäßig in geronnenen Fibrinlösungen nach stattgefundenener Fibrinbildung vor, daher auch im Serum. Es entsteht bei der Fibrinbildung, doch ist nicht näher bekannt, in welcher Weise (vgl. pag. 77). Es ist wie das Fibrinogen fällbar durch Säuren mit NaCl oder durch 28%ige Sättigung mit Ammoniumsulfat. Es koaguliert bei 64—66°.

3. Ein Nucleoproteid, nach Pikelharin<sup>63</sup> wahrscheinlich identisch mit dem Fibrinferment. Nur in sehr geringen Mengen im Serum vorhanden (im Pferdeblut 0,15—0,02%, Liebermeister<sup>64</sup>).

4. Glutelin (Faust<sup>65</sup>), dessen Natur noch zweifelhaft ist.

## B. Die Albuminfraction enthält als einzigen Bestandteil:

Das Serumalbumin. Es ist auch in völlig salzfreiem Wasser löslich und wird nicht gefällt durch Magnesiumsulfat, dagegen gefällt durch Säuren mit Ammoniumsulfat (s. o.). Es koaguliert in destilliertem Wasser bei etwa 50°, in salzhaltigen Lösungen aber erst bei bedeutend höherer Temperatur. Spez. Drehung = -61°. Es krystallisiert in hexagonalen Prismen mit einseitig aufsitzender Pyramide; die Krystalle sind optisch aktiv, koagulieren durch Hitze (Gürber<sup>66</sup>, Michel<sup>67</sup>).

Vielleicht ist auch das Serumalbumin kein einheitlicher Körper. Halliburton<sup>68</sup> teilt nach der Gerinnungstemperatur  $\alpha$ ,  $\beta$ ,  $\gamma$ -Serumalbumin, und Kauder<sup>69</sup> erhielt durch fraktionierte Fällung mit Ammoniumsulfat Fraktionen mit weit auseinander liegenden Gerinnungstemperaturen. Bei der Krystallisation bleibt regelmäßig ein nicht krystallisierender Anteil zurück, der vielleicht ein anderer Körper ist als das krystallisierende Serumalbumin.

Der Eiweißgehalt des Plasmas steigt fast in allen Fällen von Infektionen an. Der Fibrinogengehalt ist am stärksten vermehrt unter dem Einflusse der Pneumococcus- und Streptococcusinfektion (vgl. pag. 79). Das Verhältnis von Globulin zu Albumin (sog. „Eiweißquotient“) ist bei einzelnen Tierarten verschieden, beim Pferd und beim Hund die Menge des Globulins größer als die des Albumins, bei anderen Blutarten, eben beim Menschen überwiegt die Menge des Albumins über die des Globulins (Lewinski<sup>70</sup>). Der Eiweißquotient soll sich bei der Infektion zu Gunsten des Globulins ändern. Vgl. die Angaben verschiedener Untersucher in dieser Beziehung voneinander abgelesen bei Lewinski<sup>70</sup> u. Mayer<sup>71</sup>, P. Th. Müller<sup>72</sup>). Eine Vermehrung des Globulins im Verhältnis zum Albumin fand Erben<sup>73</sup> bei parenchymatöser Nephritis. Im Hunger nimmt die Menge des Globulins zu (Lewinski<sup>70</sup>). Beim Wiedersatz der Bluteiweißkörper nach starken

ziehungen überwiegt zunächst die Albuminfraktion, später erst erfolgt die Ver-  
Globuline (Morawitz<sup>12</sup>, Inagaki<sup>13</sup>).

Albumosen wurden im Blutserum von Embden u. Knoop<sup>14</sup>, Langstein<sup>15</sup>  
Horchardt<sup>11</sup> gefunden; diese Angabe wird jedoch von Abderhalden<sup>16</sup> und seinen  
bestritten. Nach Abderhalden enthält in der Norm das Blutplasma keine Stoffe,  
Biuretreaktion geben und nicht eiweißartiger Natur sind. Dagegen fand Abderha  
während der Verdauung Aminosäuren im Blute in sehr geringer Menge zu  
wahrscheinlich ist aber auch im Hunger das Blut nicht frei von Aminosäuren.

Zu den Eiweißkörpern gehören wahrscheinlich, obwohl ihr  
schen Natur nach nicht genau bekannt, gewisse Stoffe, welche  
körper oder Schutzstoffe des Blutes bezeichnet werden; sie  
zum Teil schon normalerweise in geringer Menge im Blute entha  
in größerer Menge treten sie jedoch erst auf, wenn dem Blute  
Körper oder Substanzen, die schädliche Wirkungen auf de  
ausüben können, in das Blut gelangen. Die Antikörper h  
schädliche Wirkung der fremdartigen Substanzen mehr oder wei  
sie stellen eine Schutzeinrichtung des Körpers dar. Stoffe, welche An  
bildung veranlassen, werden als Antigene bezeichnet; es kö  
verschiedenartige Körper sein, gefornite Elemente und gelöste St  
Nach der Wirkung der Antikörper kann man unterscheiden: B  
lysine, Hämolysine, Cytolysine; sie lösen Bakterien, Blutk  
oder Zellen einer anderen Art auf (vgl. § 14). — Agglutin  
bringen Bakterien, aber auch rote Blutkörperchen, Leukocyten  
„Verklebung“ (z. T. diagnostisch wichtig, Widalsche Typhusreal  
Antitoxine; sie entstehen unter der Einwirkung von Toxine  
wechselprodukten von Bakterien, aber auch durch manche tierische u  
liche Gifte), sie machen den Körper gegen ein bestimmtes Toxin in  
Präcipitine; sie bilden sich im Blute von Tieren, welche mit  
körperfremder Stoffe, z. B. Blut, Milch einer anderen Art vor  
sind; sie erregen in dem Stoff, mit welchem das Tier vorbehandelt  
Niederschläge. So liefert z. B. ein mit Menschenblut behandeltes E  
ein Serum, welches nur in Menschenblut Niederschläge gibt;  
Rinderblut vorbehandeltes Kaninchen ein Serum, welches nur in F  
Niederschläge gibt, usw. Man kann auf diese Weise Menschen-  
blut unterscheiden und die Blutart diagnostizieren (forensisch  
(Uhlenhuth<sup>19</sup>). — Abwehrfermente (Abderhalden<sup>20</sup>); sie treten  
auf, wenn dem Blute fremde gelöste Substanzen in das Blut

In der Norm werden sowohl vom Verdauungskanal aus, als auch von den  
Organe nur ganz bestimmte Substanzen in das Blut abgegeben, die „blutei  
„plasmaeigen“ sind. Die Bestandteile der Nahrung stammen von andern Tie  
aus dem Pflanzenreiche; sie sind „artfremd“, „körperfremd“; durch den V  
vorgang (Darmzellen, Leberzellen) werden sie erst ihrer fremden Arteigentümlich  
(§ 130. 3) und sodann als „körpereigenes“, „plasmaeigenes“ Material den  
geführt. Bringt man unter Umgebung des Verdauungskanals (parente  
Injektion unter die Haut oder in das Gefäßsystem solche blutfremde Substan  
Körper, so treten im Blutplasma Fermente auf, welche diese Substanzen  
vermögen; die fehlende Verdauung erfolgt sozusagen parenteral. So tritt nac  
von Rohrzucker Invertin im Blute auf (Weinland<sup>20a</sup>, Abderhalden<sup>20</sup>), nach In  
blutfremdem Eiweiß (Eiereiweiß, Blutserum einer anderen Art, Seidenpepton, K  
proteolytische Fermente. Aber auch aus den Organen des Körpers können unter  
Verhältnissen blutfremde (wenn auch arteigene) Substanzen in das Blut übe  
hier zum Auftreten proteolytischer Fermente Veranlassung geben. Abderhalden  
im Blutserum männlicher oder nicht schwangerer weiblicher Individuen ni  
mente vorkommen, die Placentagewebe abbauen; nach Eintritt einer Schwang  
gegen enthält das Blut vom 8. Tage nach der Befruchtung an während der ganz  
Schwangerschaft derartige Fermente. Durch den Nachweis von Fermenten im



nicht Placentagewebe).

*Hedin*<sup>81</sup> fand im Ochsen Serum ein schwaches proteolytisches Enzym (vielleicht von Leukocyten stammend, vgl. pag. 52).

II. Fette. — Neutrale Fette kommen in Form mikroskopischer Trümmchen, oft nur bei starker Vergrößerung eben sichtbarer oder nur durch das Ultramikroskop nachweisbarer Teilchen vor (*Leeuwenhoek*, 1673; vgl. pag. 10, IV). Die Menge wird sehr verschieden angegeben; *Engelhardt*<sup>82</sup> fand im normalen menschlichen Blute 0,186% (Ätherextrakt), *Bönninger*<sup>83</sup> dagegen 0,75—0,85% (Alkoholextrakt). Vermehrt ist der Fettgehalt bei reichlicher Fett- oder Milchnahrung bis zur milchigen Trübung des Serums (*Wasser* u. *Bräuning*<sup>84</sup>, *Lattes*<sup>85</sup>; *M. Bleibtreu*<sup>86</sup> fand bei gemästeten Gänsen 6% Fett im Blut), andererseits aber auch im Hungerzustande um 100% erhöht (*Fr. N. Schulz*<sup>87</sup>). Auch bei Schwangeren und Wöchnerinnen ist der Fettgehalt des Blutes erhöht. (Über Lipämie vgl. pag. 87.)  
— Lecithin, — Cholesterin, als Ölsäure-, Palmitinsäure- und Stearinsäure-Ester, 0,17% (*Hürthle*<sup>88</sup>), außerdem aber auch frei (*Hepner*<sup>89</sup>, *Fraser* u. *Gardner*<sup>91</sup>, *Wacker* u. *Hueck*<sup>92</sup>). Nach *Röhm*<sup>93</sup> wird freie Cholesterin durch ein besonderes Ferment, die Cholesterase, aus den Estern abgespalten. *Autenrieth* u. *Funk*<sup>94</sup> fanden 0,14—0,16% Gesamtcholesterin in normalem Menschenblut. — *Tanagl* u. *Weiser*<sup>95</sup> wiesen freies Cholesterin im Plasma nach.

Nach *Cohnstein* u. *Michaelis*<sup>96</sup> hat das Blut die Eigenschaft, in ihm enthaltenes oder durch die Nahrung zugesetztes Chylusfett bei Gegenwart von Sauerstoff in einen wasserlöslichen Emulsionskörper umzuwandeln („Lipolyse“). Nach *Hanriot*<sup>97</sup> kommt im Blut ein Ferment (Lipase), welches Neutralfett in Glycerin und Fettsäure zerlegt. Bei Zunahme des Fettgehaltes des Blutes (vermehrte Fettzufuhr, Hunger) steigt der Gehalt des Blutes an Lipase (*Abderhalden*<sup>98</sup>). Auch Fermente, die Cholesterinfettsäureester spalten, kommen im Blut vor (*J. H. Schultz*<sup>99</sup>). Welche Bedeutung diesen Fermenten zukommt, ist noch nicht klar.

III. Kohlehydrate. — Traubenzucker (*J. Bang*<sup>100</sup>) ist stets in geringen Mengen im Blute vorhanden (*Pickardt*<sup>101</sup>), und zwar nicht nur im Plasma, sondern auch in den roten Blutkörperchen (vgl. § 23. A. III). Nach *Liesmann* u. *Stern*<sup>102</sup> ist der normale Gehalt des Blutes 0,06%. Der Traubenzucker des Blutes stammt aus den Glykogenvorräten des Körpers, vor allen Dingen der Leber: die mit der Nahrung aufgenommenen Kohlehydrate gelangen nicht sofort in den allgemeinen Kreislauf, sondern werden in der Form von Glykogen in der Leber aufgestapelt. Von hier aus nach Maßgabe des Bedarfs wieder als Traubenzucker in das Blut abgegeben; eine sehr fein eingestellte Regulation (vgl. § 11) sorgt dafür, daß der Traubenzuckergehalt des Blutes stets innerhalb der normalen Grenzen bleibt. Wird der Gehalt des Blutes an Traubenzucker durch irgend eine Weise (z. B. durch Transfusion von Traubenzuckerlösung in eine Körpervene, durch den Zuckerstich oder Adrenalininjektion, § 11) zwar erhöht (pag. 87, Hyperglykämie), so wird der überschüssige Zucker durch die Nieren ausgeschieden (Glykosurie) und so der normale Gehalt des Blutes wieder hergestellt. Nach Aderlässen ist der Zuckergehalt des Blutes erhöht (*Rona* u. *Takahashi*<sup>103</sup>), auch von der Körpertemperatur wird er beeinflußt (*Senator*<sup>104</sup>, *Wacker* u. *Poly*<sup>105</sup>, *Freund* u. *Hand*<sup>106</sup>).

Es ist angenommen worden, daß nicht der gesamte Traubenzucker des Blutes in freier Form im Blute vorhanden ist, sondern daß ein Teil desselben an Lecithin in Form



**DIESE SEITE IST FÜR KOSTENLOSE MITGLIEDER GESPERRT**  
Beantragen Sie jetzt die volle Mitgliedschaft, um diese Seite zu betreten



**Seien Sie niemals ohne ein Buch!**

Die Vollmitgliedschaft von Forgotten Books bietet Ihnen einen universalen Zugang von unseren Apps und unserer Website, auf all Ihren Geräten: Tablet, Telefon, E-Reader, Laptop und Computer.

**Eine Bibliothek in Ihrer Tasche für € 8.99/monat**

**Fortfahren**

\*Es gelten Richtlinien zur fairen Nutzung.

Gesamteiweiß . . . . .	183,14	188,86	57,76	67,68
davon { Oxyhämoglobin . . . . .	149,60	129,70	—	—
{ andere Eiweißstoffe . . . . .	—	—	—	—
Fett . . . . .	1,70	2,31	3,59	3,473
Cholesterin . . . . .	1,58	2,265	1,28	0,654
Lecithin . . . . .	3,48	2,065	2,67	2,323
Wasseranzug . . . . .	4,14	3,93	4,03	2,18
Alkoholauszug . . . . .	2,20	1,59	1,59	1,63
Asche . . . . .	6,98	5,01	9,84	7,53
Trockenrückstand . . . . .	203,32	206,64	77,46	85,47
Wasser . . . . .	796,78	793,36	922,54	914,58

1000g Blut (Melanosarkom) = 321g Erythrocyten, 679g Plasma.

Über den Trockenrückstand-, Aschen- und Eiweißgehalt des Blutes der  
renen vgl. *Schiff*<sup>159</sup>. — Über die chemische Zusammensetzung des Blutes (un-  
ne) in Krankheiten vgl. *Dennstedt* u. *Rumpf*<sup>160</sup>.

Tierblut. Von den zahlreichen Analysen *Abderhaldens*<sup>161</sup> seien hier die  
tgeteilt:

Cholesterin . . . . .	1,238	0,298
Lecithin . . . . .	1,675	1,720
Fett . . . . .	0,926	1,300
Fettsäuren . . . . .	—	—
Phosphorsäure als Nucl. . . . .	0,0183	0,020
Natron . . . . .	4,312	4,434
Kali . . . . .	0,255	0,263
Eisenoxyd . . . . .	—	—
Kalk . . . . .	0,1194	0,1113
Magnesia . . . . .	0,0446	0,045
Chlor . . . . .	3,69	3,726
Phosphorsäure . . . . .	0,244	0,240
Anorganische Phosphorsäure . . . . .	0,0847	0,0715

	1000 g Blutkörperchen en	
	Rind	Pferd
Wasser . . . . .	591,858	613,15
Feste Stoffe . . . . .	408,141	386,84
Hämoglobin . . . . .	316,74	315,08
Eiweiß . . . . .	64,20	56,78
Zucker . . . . .	—	—
Cholesterin . . . . .	3,379	0,388
Lecithin . . . . .	3,748	3,973
Fett . . . . .	—	—
Fettsäuren . . . . .	—	—
Phosphorsäure als Nucl. . . . .	0,0546	0,095
Natron . . . . .	2,2322	—
Kali . . . . .	0,722	4,935
Eisenoxyd . . . . .	1,671	1,563
Kalk . . . . .	—	—
Magnesia . . . . .	0,0172	0,0809
Chlor . . . . .	1,8129	1,949
Phosphorsäure . . . . .	0,7348	1,901
Anorganische Phosphorsäure . . . . .	0,3502	1,458

Nach *H. J. Hamburger*<sup>143</sup> enthalten die roten Blutkörperchen Calcium. *Takahashi*<sup>163</sup> fanden in den roten Blutkörperchen von Hammel, Hund, Schweine 0,0025—0,0035% Ca O. Die Angaben, daß die roten Blutkörperchen kein Calcium sind darauf zurückzuführen, daß beim Waschen mit physiologischer Kochsalzlösung Calcium aus denselben entfernt wird.

## 28. Bestimmung der einzelnen Bestandteile des Blutes

### 1. Bestimmung des Wassers und der festen Bestandteile.

Eine gewogene oder gemessene Menge Serum oder defibriniertes Blut wird in Schälchen auf dem Wasserbade eingedampft, einige Tage im Vakuum über Schwefelsäure, dann im Trockenschrank bei 110—120° bis zum konstanten Gewicht getrocknet.

*Stintzing* u. *Gumprecht*<sup>144</sup> wiegen zu klinischen Zwecken in einem zugedeckten Glasschälchen einige Tropfen Blut, — dann trocknen sie 6 Stunden bei 65° C und wiegen den Rückstand.

### 2. Bestimmung des Gesamteiweißes.

*v. Jaksch*<sup>163</sup> bestimmt in 1 g Blut aus einem Schröpfkopf den N-Gehalt nach *Stintzing* und multipliziert die gefundene Zahl mit 6,25 (vgl. pag. 13). — Über eine mil-

methode zur Bestimmung des Gesamt-N und des Extraktiv-N in geringen Blutmenge u. Larsson<sup>166</sup>.

3. Die Brechkraft des Bluteserums hängt in erster Linie von dem Eiweißgehalt, resp. dem Wassergehalt ab. Die refraktometrische Blutuntersuchung läßt sich schon mit ganz geringen Mengen Blut ausführen und ist daher eine gute Methode zur Bestimmung des Eiweiß-, resp. Wassergehaltes des Bluteserums. Der Brechungscoefficient schwankt beim Gesunden zwischen 1,348 und 1,352 (*Strauss*<sup>167</sup>, *Reiss*<sup>168</sup>, *Ma*

#### 4. Bestimmung des Faserstoffes.

Ein abgemessenes Volumen Blut wird mit dem Stabe geschlagen; nach vollständiger Fibrinbildung wird aller Faserstoff auf einem Atlasfilter gesammelt und mit Wasser gewaschen, dann in einer Schale abermaliges Waschen mit Wasser, Alkohol und Äther. Dann bei 110° C im Trockenofen und Wägen. — *Kossler* u. *Pfeiffer*<sup>170</sup> bestimmen den Faserstoffgehalt im Serum und im Plasma (nach *Kjeldahl*): die Differenz ist auf den N-Gehalt des Faserstoffes zu beziehen. Die Fibrinmenge in 100 cm<sup>3</sup> Plasma enthält 39 mg N (30,8—45).

#### 5. Bestimmung des Fettes (Ätherextrakt).

Durch Extraktion des getrockneten Blutes mit Äther gelingt es nicht, die Fettmenge desselben zu gewinnen. Zur genauen Bestimmung ist es nötig, das Blut mit Salzsäure und Pepsin zu verdauen oder das Blut mit der 10fachen Menge 2%iger Salzsäure 2 Stunden lang zu kochen und aus der so gewonnenen Flüssigkeit mit Äther zu extrahieren (*Nerking*<sup>171</sup>, *Fr. N. Schulz*<sup>172</sup>).

Nach *Bönninger*<sup>173</sup> genügt es für klinische Zwecke, das Blut in dem 10- bis 15fachen Volumen 96%igen Alkohols aufzufangen, tüchtig zu zerreiben, abzufiltrieren, den Alkohol abzulassen und nochmals mit Alkohol zu extrahieren: man erhält so das Fett bis auf Spuren genau. Gegen diese Bestimmung Bedenken erhoben *Engelhardt*<sup>174</sup>.

#### 6. Bestimmung des Traubenzuckers.

Das Blut muß zunächst enteiweißt werden; hierfür sind zahlreiche Methoden angegeben worden, von denen hier die von *Rona* u. *Michaelis*<sup>175</sup>, *Oppler* u. *Rona*<sup>176</sup>, *Frank*<sup>177</sup> angeführt seien (vgl. die Originalarbeiten). Die eiweißfreie Flüssigkeit kann eventuell noch durch Eindampfen bei saurer Reaktion konzentriert werden; die Bestimmung des Traubenzuckers erfolgt schließlich durch Polarisation oder Titration.

#### 7. Bestimmung der anorganischen Stoffe.

Ein gewogenes oder gemessenes Quantum Blut oder Serum wird im Platintiegel eingedunstet und dann verascht. Die Bestimmung ist aber ungenau, da dabei aus dem Asche Eiweiß und Lecithin Schwefelsäure und Phosphorsäure entsteht und manche anorganische Stoffe verloren gehen.

## 29. Pathologische Veränderungen der Zusammensetzung des Blutplasmas und des Gesamtblutes.

1. Vermehrter Wassergehalt des Blutes resp. des Blutplasmas findet man häufig bei den Blutkrankheiten, z. B. den Anämien, bei perniziöser Anämie, bei Chlorose. Bei Herzkrankheiten und Nierenentzündungen kann der Wassergehalt des Blutes normal sein, beim Auftreten von Ödemen wird aber auch das Blut wasserreicher. Nicht immer geht der Wassergehalt des Blutes und des Bluteserums bei der perniziösen Anämie steigt der Wassergehalt des Serums in viel geringererem Maße als der des Gesamtblutes. — Über die Bestimmung des Wassergehaltes des Blutes vgl. die refraktometrische Blutuntersuchung und ihre Resultate in *Krankheiten des Blutes* von *Reiss*<sup>168</sup>.

Eine übermäßige Eindickung des Blutes durch Wasserverlust wird beim Cholera durch reichlichen, wässrigen Durchfällen, namentlich bei der Cholera, beobachtet. Auch bei typhöser, steuertartige, dickflüssige Blut in den Adern stockt. Auch reichliche Wasserabgabe durch die Haut bei Schwitzkuren, zumal bei gleichzeitigem Mangel an Getränk kann Vermehrung des Wassergehaltes des Blutes, wenn auch nur in mäßigen Graden, hervorrufen. Bei der von hochgradiger Lipämie bei Diabetes beobachtete *B. Fischer*<sup>178</sup> einen Wassergehalt des Blutes von nur 69,636%, im Serum von nur 69,287%.

2. Sind die Eiweißkörper des Blutes abnorm vermindert, so pflegt sich ein übermäßiger Wasserreichtum des Blutes einzutreten; dann sind auch die Eiweißkörper im Plasma vermindert. Eiweißverluste gehen die direkte Ursache ab: Albuminurie, anämische Veränderungen, umfangreiche nässende Hautflächen, hochgradige Milchverluste, eitrige Entzündungen (Ruhr). Aber auch häufige und umfangreiche Blutungen bringen, da der Wasserverlust zunächst vorwiegend durch Wasseraufnahme in die Gefäße gedeckt wird, im Anfang eine Verminderung der Eiweißkörper des Blutes hervor.



**DIESE SEITE IST FÜR KOSTENLOSE MITGLIEDER GESPERRT**  
Beantragen Sie jetzt die volle Mitgliedschaft, um diese Seite zu betreten

# GESCHICHTE

Zehntausende von wichtigen historischen Quellen, viele bisher nicht erhältlich, stehen jetzt zum ersten Mal mit der Vollmitgliedschaft von Forgotten Books zur Verfügung.

Unbegrenzter Zugang  
\$8.99/monat

**Fortfahren**

\*Es gelten Richtlinien zur fairen Nutzung.



- 60. *E. P. Pick*: H. B. 1, 1902, 351. — 61. *E. Freund* u. *J. Jouckin*: C. P. 297. Z. ph. Ch. 36, 1902, 407. — 62. *O. Porges* u. *K. Spiro*: H. B. 3, 1903, 277. — 63. *A. Pekkelharing*: C. P. 9, 1895, 102. — 64. *G. Liebermeister*: H. B. 8, 1906, 120. — 65. *E. S. Faust*: A. P. P. 41, 1898, 309. — 66. *Gürber*: Sitz.-Ber. d. Würzburger Ph. Ges. 1894, 143. — 67. *Michel*: W. V. 29, 1895, 117. — 68. *W. D. Halliburton*: P. 5, 1884, 152. 7, 1886, 319. — 69. *J. Lewinski*: P. A. 100, 1903, 611. — 70. *L. Langstein* u. *M. Mayer*: H. B. 5, 1904, 69. — 71. *Erben*: Z. k. M. 57, 1905, Heft 1. — 72. *P. Morawitz*: H. B. 7, 1906, 153. — 73. *C. Inagaki*: Z. B. 49, 1907, 77. — 74. *G. Embden* u. *F. Knoop*: H. B. 3, 1903, 120. — 75. *L. Langstein*: H. B. 3, 1903, 120. — 76. *Kraus*: Z. o. P. u. T. 3, 1906, 52. — 77. *L. Borchardt*: Z. ph. Ch. 57, 1907, 19. — 78. *E. Abderhalden* u. Mitarbeiter: Z. ph. Ch. 42, 1904, 155. 51, 1907, 286. 473. 88, 1913, 478. B. Z. 8, 1908, 368. Lehrb. d. physiol. Chemie, 3. Aufl., 1. Teil. Berlin 1914. S. 506 u. 540. *A. Costantino*: B. Z. 55, 1913, 411. — 79. *P. Uhlenhuth*: Zeidanz: Prakt. Anleitung z. Ausföhr. d. biolog. Eiweißdifferenzierungsverfahrens. Jena 1913. — 80. *E. Abderhalden*: Abwehrfermente d. tier. Organ. 3. Aufl. Berlin 1913. — 81. *E. Weinland*: Z. B. 47, 1906, 279. — 82. *S. G. Hedin*: J. o. P. 30, 1903, 185. — 83. *M. Engelhardt*: D. A. k. M. 70, 1901, 182. — 84. *Bönninger*: Z. k. M. 42, 1901, 65. — 85. *E. Neisser* u. *H. Brauning*: Z. o. P. u. T. 4, 1907, 747. — 86. *Lattes*: A. P. P. 132. — 87. *M. Bleibtreu*: P. A. 85, 1901, 345. — 88. *Fr. N. Schulz*: P. A. 299. — 89. *K. Härthle*: Z. ph. Ch. 21, 1896, 331. D. m. W. 1896, 507. — 90. *E. Hepner*: P. A. 73, 1898, 603. — 91. *E. Letsche*: Z. ph. Ch. 53, 1907, 110. — 92. *A. T. Fraser* u. *J. A. Gardner*: P. R. S. 81, B, 1909, 230. — 93. *L. Wacker* u. *W. Huebner*: P. 74, 1913, 416. — 94. *F. Röhmman*: B. k. W. 49, 1914, 1993. — 95. *W. Autenrieth* u. *F. Funk*: M. m. W. 1913, 23. — 96. *F. Tangl* u. *S. Weiser*: P. A. 115, 1906, 152. — 97. *W. Cohnstein* u. *H. Michaelis*: P. A. 65, 1897, 473. 60, 1898, 76. E. P. 3, 1, 1904, 1. — 98. *Hanriot*: C. r. soc. biol. 48, 1896, 925. C. r. 123, 1896, 753. 124, 1897, 778. — 99. *M. Michaelis* u. *P. Rona*: B. Z. 31, 1911, 345. 33, 1911, 413. 39, 1912, 21. *G. Jzur*: B. Z. 39, 1912, 390. — 100. *E. Abderhalden* u. *P. Rona*: Z. ph. Ch. 75, 1911, 30. *E. Abderhalden* u. *E. Lampé*: Z. ph. Ch. 78, 1912, 396. — 101. *J. H. Schultz*: B. Z. 42, 1912, 255. — 102. *Zusammenfassende Darstellung*: *J. Bang*: Der Blutzucker. Wiesbaden 1913. — 103. *M. Pickardt*: Z. ph. Ch. 17, 1893, 217. — 104. *E. Liefmann* u. *R. Stern*: B. Z. 1, 1906, 1. — 105. *P. Rona* u. *D. Takahashi*: B. Z. 30, 1910, 99. — 106. *Senator*: Z. k. M. 57, 1905, 253. — 107. *L. Wacker* u. *F. Poly*: D. A. k. M. 100, 1910, 567. — 108. *H. Freeman* u. *Marchand*: A. P. P. 73, 1913, 276. — 109. *E. Drechsel*: L. B. 38, 1886, 44. J. F. 33, 1886, 425. — 110. *D. Baldi*: A. P. 1887, Suppl., 100. — 111. *H. J. Bielow*: Z. B. 12, 1898, 209. — 112. *P. Mayer*: B. Z. 1, 1906, 81. 4, 1907, 545. — 113. *L. Aschmann*: Rosenfeld: C. P. 19, 1905, 449. B. Z. 3, 1907, 335. — 114. *E. Pflüger*: P. A. 217. — 115. *L. Michaelis* u. *P. Rona*: B. Z. 14, 1908, 476. — 116. *F. W. F. L. Siau*: J. o. P. 26, 1901, 282. — 117. *P. Mayer*: Z. ph. Ch. 32, 1901, 518. — 118. *R. Lépine* u. *Boulud*: C. r. 135, 1902, 139. 141, 1905, 453. J. d. P. 7, 1905, 775. — 119. *F. Rolly* u. *F. Oppermann*: B. Z. 48, 1913, 259 u. 268. — 120. *F. Röhmman*: B. d. ch. 892, 3654. 27, 1894, 3251. — 121. *M. Bial*: P. A. 52, 1892, 137. 53, 1893, 137. 893, 72. — 122. *C. Hamburger*: P. A. 60, 1895, 543. — 123. *Ch. Kusumoto*: B. Z. 908, 217. — 124. *Schlesinger*: D. m. W. 1908, 593. — 125. *J. Wohlgemuth*: B. Z. 1909, 381 u. 423. — 126. *K. Moeckel* u. *F. Rost*: Z. ph. Ch. 67, 1910, 433. — 127. *L. Haberlandt*: P. A. 132, 1910, 175. — 128. *R. Lépine*: C. r. 110, 1890, 742. D. m. W. 1890, 57. — 129. *G. Embden* u. Mitarbeiter: B. Z. 45, 1912, 1. — 130. *C. Fr. W. Kruck*: Sitz.-Ber. d. Jenaischen Ges. f. Med. u. Naturw. 1885, 52 (Suppl. z. Jenaischen Zeitschrift für Naturwiss. 19, 1886). — 131. *O. Hammarsten*: M. J. 8, 1879, 129. — 132. *Gallera*: B. Z. 43, 1905, 389. — 133. *A. A. Hymans* u. *d. Bergh* u. *J. Snapper*: D. A. k. M. 91, 1907, 1. — 134. *H. Hohlweg* u. *H. Meyer*: H. B. 11, 1908, 381. — 135. *R. Philipp*: Z. ph. Ch. 913, 494. — 136. *B. Schöndorff*: P. A. 74, 1899, 307 u. 357. — 137. *F. Gudze*: Z. ph. Ch. 63, 1909, 455. — 138. *E. Steinitz*: D. m. W. 1914, 19. Z. ph. Ch. 90, 1914, 19. — 139. *Th. Brugsch* u. *L. Kristeller*: D. m. W. 1914, 746. — 140. *R. Bass* u. *Ch. Sadowski*: W. k. W. 25, 1912, 1863. *R. Bass*: A. P. P. 76, 1914, 40. — 141. *J. C. Beck*: Z. ph. Ch. 87, 1913, 21. — 142. *A. Bingel*: Z. ph. Ch. 57, 1908, 382. — 143. *Strawbridge*: Chron. Nierenentzündung in ihrer Einwirkung auf die Blutflüssigkeit. Berlin 1902. — 144. *H. Hohlweg*: D. A. k. M. 104, 1912, 216. — 145. *Salkowski*: V. A. 50, 174. — 146. *Neuberg*: Z. ph. Ch. 2, 1878, 65. — 147. *Neuberg* u. *Richter*: D. m. W. 1904, 499. — 148. *G. v. Bergmann* u. *L. Langstein*: H. B. 6, 1905, 27. — 149. *C. Neuberg* u. *H. Strawbridge*: D. m. W. 1906, 258. — 150. *G. Gaglio*: A. P. 1886, 400. — 151. *M. Berlinerblau*: A. P. P. 887, 333. — 152. *H. Fries*: B. Z. 35, 1911, 368. — 153. *Zweifel*: Arch. f. Gyn. 1906, 561. M. m. W. 1906, 297. — 154. *J. Donath*: B. k. W. 1907, 241. — 155. *Enghart*: Z. k. M. 60, 1906, 225. — 156. *A. Plehn*: D. A. k. M. 91, 1907, 1. — 157. *W. Horodynski*, *S. Salaskin* u. *J. Zaleski*: Z. ph. Ch. 35, 1902, 246. — 158. *O. Fol*

Z. ph. Ch. 37, 1902, 161. — 157. *F. Hofmeister*: E. P. 10, 1910, 431. — 158. *Seyler*: Med.-chem. Untersuch. 1869, 551. Z. ph. Ch. 15, 1891, 179. — 159. *Sel* f. Kinderheilk. 64, 1906, 409. — 160. *Dennstedt u. Rumpf*: Mitteil. aus d. Hamb krankenanstalten 8, 1900, 1. Z. k. M. 58, 1906, 84. — 161. *E. Abderhalden*: Z. 1898, 106. — 162. *H. J. Hamburger*: Z. phk. Ch. 69, 1909, 663. — 163. *D. Takahashi*: B. Z. 31, 1911, 336. — 164. *Stintzing u. Gumprecht*: D. A. k. M. 267. — 165. *v. Jaksch*: Z. k. M. 23, 1893, 201. — 166. *J. Bang u. K. O. Lar* 49, 1913, 19. 51, 1913, 193. — 167. *Strauss*: Die chronischen Nierenentzündu Einwirkung auf die Blutflüssigkeit. Berlin 1902. Therapie der Gegenwart. 1903 1905, Nr. 2, Vereinsbeilage. Z. k. M. 52, 1904. — 168. *E. Reiss*: H. B. 4, 1904, 1 51, 1904, 18. — 169. *Martius*: Diss. Berlin 1906. *A. Böhme*: D. A. k. M. 103, — 170. *Kossler u. Pfeiffer*: Z. k. M. 33, 1897, 225. — 171. *J. Verking*: P. A 172. — 172. *P. Rona u. L. Michaelis*: B. Z. 7, 1908, 329. 8, 1908, 356. 14, 19 173. *B. Oppler u. P. Rona*: B. Z. 13, 1908, 121. — 174. *K. Moeckel u. E. Frank* 65, 1910, 323. 69, 1910, 85. — 175. *B. Fischer*: V. A. 172, 1903, 30. 17 u. *Derlin*: Z. k. M. 51, 1904, 428. — 177. *Bürger u. Beumer*: Z. e. P. u. T. 11 178. *Klemperer u. Umber*: Z. k. M. 61, 1907, 145. 65, 1908, 340. — 179. Z. ph. Ch. 86, 1913, 469.

## 30. Die Gase des Blutes. Physikalische Vorbemerkungen.

Die Menge eines Gases kann gemessen werden nach dem Volumen (in Metern) oder nach dem Gewicht (in Grammen). Das Volumen, welches eine Gasmenge einnimmt, hängt ab von dem Druck und der Temperatur. Nach *Mariotteschen* Gesetz ist das Volumen eines Gases umgekehrt proportional dem dem 2fachen, 3fachen . . . nfachen Druck beträgt das Volumen also  $\frac{1}{2}$ ,  $\frac{1}{3}$ , . . . Nach dem *Gay-Lussarschen* Gesetze nimmt das Volumen eines Gases bei Erwärmung um  $1^\circ$  zu um  $\frac{1}{273}$  des Volumens bei  $0^\circ$ ; eine Gasmenge, welche bei  $0^\circ$  ein Volumen  $273 \text{ cm}^3$  hat, hat also bei  $1^\circ$  das Volumen 274, und bei  $10^\circ$  das Volumen 283. — Im folgenden wird die Menge eines Gases stets nach dem Volumen bei  $0^\circ$  und dem Druck angegeben werden.

Wird eine Flüssigkeit mit einem Gase in Berührung gebracht, so nimmt die Flüssigkeit einen Teil des Gases in sich auf. Dabei kann das Gas in zweifacher, streng scheidender Weise in der Flüssigkeit enthalten sein, nämlich einfach physikalisch sorbiert oder chemisch gebunden. Enthält die Flüssigkeit keine Substanzen, mit dem Gase chemische Verbindungen eingehen, so findet einfache physikalische Absorption statt; sind dagegen solche Substanzen vorhanden, so erfolgt außer der physikalischen Absorption des Gases in der Flüssigkeit auch noch die chemische Bindung des Gases an die dazu befähigten Substanzen.

Wird eine Flüssigkeit (die keine das Gas chemisch bindenden Substanzen enthält) mit einem Gase gesättigt, so ist die absorbierte Gasmenge direkt proportional dem Druck der Flüssigkeit und dem Druck des Gases. Als Absorptionskoeffizient bezeichnet man eine Zahl, welche angibt, wieviel Kubikzentimeter Gas  $1 \text{ cm}^3$  Flüssigkeit nimmt, wenn diese bei  $760 \text{ mm}$  Druck mit dem Gase gesättigt wird. Der Absorptionskoeffizient nimmt mit steigender Temperatur bei den verschiedenen Gasen in eigenartiger Weise ab; er muß für die verschiedenen Temperaturen empirisch bestimmt werden. Der Absorptionskoeffizient für die Absorption in destilliertem Wasser bei  $40^\circ \text{ C}$  beträgt für Sauerstoff 0,0231 (*Winkler*<sup>1)</sup>, Kohlensäure 0,530 (*Bohr*<sup>2)</sup>, Stickstoff 0,0118 (*Bohr u. Boel*<sup>3)</sup>. Enthält die wässrige Flüssigkeit feste Stoffe gelöst, so wird dadurch der Absorptionskoeffizient herabgesetzt; diese Erniedrigung beträgt für Blutplasma aber nur 2,5% des Wertes für reines Wasser.

Steht eine Flüssigkeit mit einem Gasgemisch in Berührung, so absorbiert sie die einzelnen Gase des Gemisches entsprechend ihrem Partialdruck. Gase üben an sich keinen Druck aus. In einem Gasgemisch kommt daher von dem Gesamtdruck auf jedes einzelne Gas soviel (Partialdruck des einzelnen Gases), als dem Volumenprozent entspricht. Enthält also z. B. Luft von Atmosphärendruck 21 Volumenprozent Sauerstoff und 79 Volumenprozent Stickstoff, so beträgt der Partialdruck des Sauerstoffs

$$\frac{21 \cdot 760}{100} = 159,6 \text{ mm} \text{ und der des Stickstoffes } \frac{79 \cdot 760}{100} = 600,4 \text{ mm. Ist die Luft v}$$

so ist vom Gesamtdruck zuerst der Druck des in der Luft enthaltenen Wasserdampfes abzug zu bringen.

Absorbierte Gase entweichen aus der Flüssigkeit: 1. Im Vakuum.



ur mit einem anderen Gase in Berührung, so ist der Partiardruck für das ab  
as natürlich wiederum gleich 0. 3. Beim Erhitzen der Flüssigkeit b  
edepunkte. Der Absorptionskoeffizient nimmt mit steigender Temperatur ab u  
im Sieden der Flüssigkeit gleich 0.

Enthält die Flüssigkeit Substanzen, welche das Gas chemisch zu binden ve  
wird natürlich außer derjenigen Gasmenge, welche von der Flüssigkeit physika  
rbiert wird, noch so viel mehr von dem Gase aufgenommen, als die in der Fl  
rhandenen Substanzen chemisch binden können. Die chemische Verbindung zwisc  
der Flüssigkeit enthaltenen Substanzen und dem Gase kann nun sein entwe  
ste oder eine dissoziabile. Eine feste Verbindung ist unabhängig vom Dru  
rd daher im Vakuum nicht zerlegt, sondern kann nur durch chemische Mittel gelöst  
a Gegensatz dazu bezeichnet man als dissoziabile Verbindungen solche chemis  
ndungen einer Substanz mit einem Gase, die abhängig sind vom Druck und d  
akuum zerfallen. Bei einem bestimmten Druck verbindet sich alle vorhandene  
it dem betreffenden Gas, sinkt der Druck, so bleibt nur noch ein Bruchteil der  
chemischer Bindung mit dem Gase, ein anderer Teil ist unverbunden, bei  
uken des Druckes wird der Bruchteil der Substanz, der noch Gas gebunden hat,  
einer und beim Drucke 0 ist nur noch unverbundene Substanz vorhanden.

Beispiel: Leitet man durch eine wässrige Natronlauge  $\text{CO}_2$ -haltige Luft,  
e Kohlensäure von der Flüssigkeit aufgenommen, und zwar wird 1. ein Teil der  
ure physikalisch absorbiert vom Wasser proportional dem Absorptionskoeff  
i der herrschenden Temperatur, der Menge des Wassers und dem Partiardruck der  
ure; 2. ein anderer Teil der Kohlensäure wird chemisch gebunden, nämlich  
ebunden als Natriumcarbonat; nach der Formel  $2\text{NaOH} + \text{CO}_2 = \text{Na}_2\text{CO}_3 + \text{H}_2\text{O}$   
Moleküle  $\text{NaOH}$  1 Molekül  $\text{CO}_2$ , diese Bindung ist ganz unabhängig vom Druck; b,  
abel gebunden als Natriumbicarbonat; nach der Formel  $\text{Na}_2\text{CO}_3 + \text{CO}_2 + \text{H}_2\text{O} = 2\text{NaHCO}_3$   
ese Verbindung ist abhängig vom Druck. Nach Bohr<sup>3</sup> waren in einer 0,15%igen  
n Natriumcarbonat bei  $37^\circ$  beim Durchleiten von  $\text{CO}_2$  als Bicarbonat vorhanden  
i einer  $\text{CO}_2$ -Spannung von 12,53 mm, nur noch 83% bei 1,0 mm, 66% bei 0,3 m  
i 0,1 mm.

Die physiologisch wichtigen Gase des Blutes ( $\text{O}$  und  $\text{CO}_2$ ) sin  
ößten Teil im Blute chemisch gebunden vorhanden, und zwar i  
ssoziabler Verbindungen.

## 31. Gewinnung und Untersuchung der Blutgase.

Die Austreibung der Gase aus dem Blute und die Aufsammlun  
hemischen Analyse geschieht mittelst der Pflügerschen Quecksilber-Luf  
g. 20).

Der Blutrezipient (A), eine 250 bis 300  $\text{cm}^3$  fassende Glaskugel, verj  
eu und unten in Rohre, welche durch Hähne a und b verschlossen werden können.  
; ein gewöhnlicher Sperrhahn, der Hahn a jedoch hat eine durch die Längsach  
ufende, bei x ausmündende Durchbohrung der Art, daß diese je nach der Stell  
eder in den Rezipienten führt (Stellung x a) oder nach abwärts durch das unte  
stet (Stellung x' a'). Dieser Rezipient wird zuerst (mittelst der Quecksilberluftpump  
ftleer gemacht und nun gewogen. Hiernauf bindet man das Ende x' in eine Arte  
ene eines Tieres und läßt nun bei der Stellung des unteren Hahnes x a Blut in  
pienten einströmen. Ist die nötige Menge hineingelassen, so gibt man dem untere  
eder die Stellung x' a' (säubert äußerlich alles sorgfältig) und wägt nun den Rezi  
n die Gewichtsmenge des eingelassenen Blutes zu bestimmen. — Der zweite  
oparates ist das Schaumgefäß (B), ebenfalls oben und unten in Röhren aus  
e mit Sperrhähnen c und d verschlossen werden können; es dient zum Auffan  
urch die stürmische Gasentwicklung aus dem Blute sich bildenden Schaums. Durch  
ht das Schaumgefäß nach unten mit dem Rezipienten in Verbindung, nach oben  
-Trockenapparat (G). Dieser ist eine U-förmige Röhre, unten mit einem Gl  
stzterer ist halb mit Schwefelsäure gefüllt, in den Schenkeln liegen Bimsstei  
it Schwefelsäure getränkt. Die Blutgase geben hier alle mitgeführten Wasser  
die Schwefelsäure ab, so daß sie völlig trocken durch Hahn f weitergeführt  
nnen. Es folgt das kurze Rohr D mit der kleinen Barometerprobe y, an welc  
n Grad der Luftleere ablesen kann. — Von D gelangen wir zur eigentlichen  
rrichtung. Diese besteht aus zwei großen, oben und unten in offene Röhren aus  
askugeln, deren untere Röhren Z und w durch einen Gummischlauch G verbund  
side Kugeln und der Schlauch sind mit Quecksilber bis zur halben Höhe der Ku  
füllt. Die Kugel E ist befestigt, die Kugel F kann durch eine Windevorrichtung



**DIESE SEITE IST FÜR KOSTENLOSE MITGLIEDER GESPERRT**  
Beantragen Sie jetzt die volle Mitgliedschaft, um diese Seite zu betreten



**Seien Sie niemals ohne ein Buch!**

Die Vollmitgliedschaft von Forgotten Books bietet Ihnen einen universalen Zugang von unseren Apps und unserer Website, auf all Ihren Geräten: Tablet, Telefon, E-Reader, Laptop und Computer.

**Eine Bibliothek in Ihrer Tasche für € 8.99/monat**

**Fortfahren**

\*Es gelten Richtlinien zur fairen Nutzung.

ngt die Gase in *J* über Quecksilber. Wiederholte Senkung und Hebung von *F* mit Hahnstellung bringt schließlich alle Gase in *J*. — Die Entgasung des Blutes wird wesentlich befördert durch Einsenken des Rezipienten *A* in einen Kessel mit 60° C Wasser (pag. 89).

Über ein einfaches Verfahren („Ferricyanidmethode“), ohne Blutgas zu analysieren, den Sauerstoffgehalt des Blutes quantitativ zu bestimmen, vgl. *Haldane*<sup>9</sup>, *F. Croft* u. *Morawitz*<sup>9</sup>.

*Mayow* (1670) sah zuerst Gase aus dem Blute im Vakuum hervorsteigen. *Ricestley* wies in diesen O, sowie *Davy* CO<sub>2</sub> nach. *Magnus* (1837) untersuchte die chemische Zusammensetzung der Blutgase. Die wichtigen neueren Untersuchungen sind wesentlich von *Lothar Meyer* (1857), der *C. Ludwigschen* und der *Pflügerschen* ausgeführt worden.

**Quantitative Bestimmung der Blutgase.** Die Blutgase bestehen aus O, CO<sub>2</sub> und N.

Die ausgepumpten Blutgase befinden sich in dem Eudiometer-Rohre (Fig. 1) in einem genau kalibrierten Glasrohre, in dessen oberer geschlossener Kuppe 2 Platinplättchen eingeschmolzen sind. Das Eudiometer ist unten durch Hg abgesperrt.

**1. Bestimmung der CO<sub>2</sub>.** — Man bringt von unten durch das Quecksilbergemenge hinein eine, an einen Platindraht gegossene Ätzkalikugel, die an der Spitze befeuchtet ist. Die CO<sub>2</sub> verbindet sich mit dem Ätzkali zu Kaliumcarbonat. Nach Verweilen wird die Kugel auf demselben Wege wieder herausgezogen. Die Verminderung des Volumens der Gase zeigt das Volumen der weggenommenen CO<sub>2</sub>.

**2. Bestimmung des O.**

a) Ähnlich wie zur Bestimmung der CO<sub>2</sub> führt man mittelst eines Platindrahtes eine Phosphorkugel, welche den O unter Bildung von Phosphorsäure aufnimmt, oder eine Koks- oder Papiermachékugel, getränkt mit einer Lösung von Pyrogallkalilauge, welche O begierig an sich reißt, in die Eudiometerröhre. Nach Entfernung der Kugel zeigt auch hier die Volumenverminderung der Gase die Menge des O an.

b) Am genauesten und schnellsten wird der O durch Verpuffen im Eudiometer bestimmt. Man führt in die Eudiometerröhre reichlich H<sub>2</sub> ein, dessen Volumen bestimmt wird. Hierauf läßt man einen elektrischen Funken zwischen den Drähten durch die Röhre schlagen; O und H<sub>2</sub> verbinden sich zu Wasser. Hierdurch erfolgt eine Volumenverkleinerung im Eudiometer, von welcher der dritte Teil auf den zur Bildung (H<sub>2</sub>, O) verbrauchten O entfällt.

**3. Bestimmung des N.** — Sind nach den obigen Methoden CO<sub>2</sub> und O entfernt, so ist der Rest N.

## 32. Sauerstoff im Blute.

**I. Sauerstoff** — ist im arteriellen (Hunde-) Blute im Mittel 20 Volumenprozent vorhanden (in 12 Versuchen fand *Pflüger*<sup>9</sup> 18,4 Volumenprozent). Durch sehr ausgiebige künstliche Respirationen (in der Apnoe) oder auch durch starkes Schütteln von Blut mit Luft kann das Blut vollständig mit Sauerstoff gesättigt werden; das venöse Blut ist in der Regel nicht völlig, aber doch beinahe mit Sauerstoff gesättigt (*Pflüger*<sup>10</sup>). Im venösen Blute sind im Mittel 8 Volumenprozent Sauerstoff vorhanden, also rund 12 Volumenprozent Sauerstoff im arteriellen, doch wechselt die Menge des O sehr nach den Geweben und den Kreislaufverhältnissen; in dem Blute ruhender Muskeln fand *Scz* 10 Volumenprozent; im Erstickungsblute sind nur noch Spuren vorhanden. In dem stärker geröteten Blute tätiger Drüsen (Speicheldrüsen, Nieren) trotz des erhöhten Sauerstoffverbrauches der Organe infolge der Vermehrung des Blutzufusses (Vasodilatation) noch mehr Sauerstoff vorhanden, als im wöhnlichen dunkleren Venenblute.

Der O kommt im Blute vor:

a) Physikalisch absorbiert, und zwar vom Plasma: nur ein minimaler Teil des gesamten Sauerstoffes. Wasser nimmt aus dem Blute 1,5 bis 2,0 Volumenprozent Sauerstoff auf.

enthält, welche die Absorption herabsetzen, würde der Maximalen physikalisch absorbierten Sauerstoff noch unter 0,5 Volumen liegen. Die Menge des absorbierten Sauerstoffes ist natürlich proportional dem Druck.

b) Chemisch gebunden ist fast sämtlicher O des Blutes (Loth. Meyer<sup>12</sup>, 1857), und zwar an das Hb der Erythrocyten (§ 20). Nach Hüfner<sup>13</sup> kann 1 g Hb 1,34 cm<sup>3</sup> Sauerstoff binden. Einem Hb-Gehalt von 14% würde das einem Sauerstoffgehalt des Blutes von  $14 \cdot 1,34 = 18,76$  Volumenprozent entsprechen.

Die Verbindung des Sauerstoffes mit dem Hämoglobin ist eine reversible Verbindung (vgl. pag. 90), also abhängig vom Druck: in der Luft zerfällt sie und gibt allen Sauerstoff ab. Die vom Hb gebundene Sauerstoffmenge steigt aber nicht proportional dem Druck (wie bei physikalischer Absorption) und erreicht schon bei der Spannung der Sauerstoff in der atmosphärischen Luft fast das Maximum. Die folgenden Angaben (nach Hüfner<sup>14</sup>) geben an, wieviel Prozente des Hb des Blutes bei verschiedenem Partialdruck des O als gasfreies Hämoglobin resp. als Oxyhämoglobin vorhanden sind (bei 13% Hb-Gehalt und 37,4° C):

Partialdruck des Sauerstoffes in mm Hg	Barometerstand in mm Hg	Prozente an		Partialdruck des Sauerstoffes in mm Hg	Barometerstand in mm Hg	Prozente an	
		Hämoglobin	Oxyhämoglobin			Hämoglobin	Oxyhämoglobin
5,0	23,8	63,9	36,1	70,0	334,0	11,5	88,5
10,0	47,7	47,6	52,4	75,0	357,8	10,8	89,2
15,0	71,6	37,7	62,3	80,0	381,7	10,2	89,8
20,0	95,4	31,2	68,8	85,0	405,5	9,7	90,3
25,0	119,3	26,7	73,3	90,0	429,4	9,2	90,8
30,0	143,1	23,3	76,7	95,0	453,2	8,7	91,3
35,0	167,0	20,6	79,4	100,0	477,1	8,3	91,7
40,0	190,8	18,5	81,5	110,0	524,8	7,6	92,4
45,0	214,7	16,8	83,2	120,0	572,5	7,0	93,0
50,0	238,5	15,4	84,6	130,0	620,2	6,5	93,5
55,0	262,4	14,3	85,7	140,0	667,9	6,1	93,9
60,0	286,2	13,2	86,8	150,0	715,6	5,7	94,3
65,0	310,1	12,3	87,7	160,0	763,3	5,4	94,6

Zu etwas anderen Werten kam Loewy<sup>15</sup>; er fand für die Sättigung des Blutes (die aus atmosphärischer Luft aufgenommene Menge = 100% gesetzt) bei verschiedenen Partialdrücken des Sauerstoffes die folgenden Zahlen:

Sauerstoffpartialdruck mm Hg	10	15	20	25	30	35	40	45
Sättigung	35,77	44,52	53,36	62,40	67,29	71,09	74,51	77,8

Danach würde bei niederen Werten des Sauerstoffpartialdruckes eine stärkere Dissoziation des O<sub>2</sub>-Hb stattfinden als nach den Hüfnerschen Angaben. betont Loewy das Vorhandensein individueller Unterschiede in der Dissoziation des O<sub>2</sub>-Hb des Menschenblutes.

Bei dem Sauerstoffgehalt der atmosphärischen Luft und dem Barometerstand wird also schon fast alles Hb in O<sub>2</sub>-Hb umgewandelt. Beim Atmen in reinem Sauerstoff kann daher nur wenig mehr O vom Hb aufgenommen werden als beim Atmen in gewöhnlicher Luft. — Anzeigt die Tabelle, daß erst bei sehr stark erniedrigtem Partialdruck

Sauerstoffes ein erheblicher Teil des Hb keinen O mehr bindet. Es erklärt es sich, daß Tiere, die in einem abgesperrten kleinen Raum aus demselben bis zur Erstickung fast allen O bis auf Spuren im Blut aufnehmen, daß auch in verdünnter Luft (hohe Ballonfahrten, Aufstiege auf hohen Bergen) der notwendige Sauerstoff aufgenommen werden kann. Erst bei sehr hohen Aufstiegen, bei denen infolge des stark erniedrigten Partialdruckes und Partialdrucks des Sauerstoffes die Dissoziation des Hb stärker wird, muß die Sauerstoffversorgung des Körpers Nothwendigkeit haben (vgl. § 92 u. 95).

Im Körper gelangt das Blut aus den Lungen, wo ein ziemlich hoher Partialdruck des Sauerstoffes herrscht (annähernd derselbe wie in der atmosphärischen Luft), mit dem Blutkreislauf in die Capillaren der Gewebe, wo der Partialdruck des Sauerstoffes (der fortgesetzt durch Oxydationen verbraucht wird) sehr niedrig, resp. = 0 ist; hier muß der Sauerstoff aus seiner Bindung an das Hb frei werden und kann an die Gewebe abgegeben werden (vgl. § 91, innere Atmung).

Schon unmittelbar nach der Entleerung des Blutes findet in ihm eine O-Zehrung statt. Nach längerem Verweilen außerhalb des Kreislaufes und bei niedriger Temperatur kann sogar der O ganz aus dem Blute schwinden. Der Sauerstoffverbrauch ist besonders hoch bei jungen Erythrocyten, sowie bei den kernhaltigen Erythrocyten (Morawitz<sup>14</sup>, Warburg<sup>17</sup>). Die Blutplättchen haben an der O-Zehrung einen besonders starken Anteil: ungeronnen erhaltenes Blut (z. B. durch Hirudinzusatz) zeigt eine stärkere O-Zehrung als defibriniertes (Onaka<sup>18</sup>, Loebner<sup>19</sup>).

Wegen der vielfachen energischen Oxydationen, welche im Körper vor sich gehen, ist die Frage aufgeworfen worden, ob nicht auch in der O des Blutes in Form des Ozons (O<sub>3</sub>) vorhanden wäre. Allein in dem Blute selbst, noch auch in den aus demselben evakuierten Gasen kein Ozon enthalten.

Das Blut gibt gewisse Reaktionen, welche auf das Vorhandensein oxydierender Fermente (Oxydasen vgl. S. 19) schließen lassen. Mischt man Blut (oder Blutlösungen, z. B. bluthaltigen Harn) mit Guajactinktur und Wasserstoffsuperoxyd oder verharztem Terpentinöl, welches stets Sauerstoff in Form eines organischen Peroxyds enthält, so tritt Blaufärbung ein. (Die in der Guajactinktur enthaltene Guajactin wird dabei oxydiert zu einer blau gefärbten Verbindung). Blut allein bläut die Guajactin nicht; es enthält daher keine direkten Oxydasen (oder nur in geringen Mengen Leukocyten (Ewald<sup>20</sup>); Eiter bläut Guajactin ohne weiteres). Dagegen bläut Blut Guajactin bei Gegenwart von H<sub>2</sub>O<sub>2</sub> (oder altem Terpentinöl, s. o.); diese Wirkung scheint auf ein Ferment (Peroxydase) zu beziehen, da sie durch Kochen nicht zerstört wird, wahrscheinlich spielt dabei der Eisengehalt eine Rolle (v. Czylharz u. v. d. Hoff<sup>21</sup>). Indem Blut Wasserstoffsuperoxyd zu zerlegen, es enthält eine Katalase, oxydiert werden kann und dann nur die Wirkung der Katalasen zeigt, nicht etwa die von direkten Oxydasen oder Peroxydasen (Senter<sup>22</sup>). Ebenso ist die Bläunung von Guajactin durch Wasserstoffsuperoxyd durch Blut von dem Vorhandensein der Katalase durch die Katalase nachweisbar (Liebermann<sup>23</sup>, Lesser<sup>24</sup>, Ewald<sup>20</sup>). — Katalase kommt in allen bisher untersuchten pflanzlichen und fast allen pflanzlichen Geweben vor (Battelli u. Stern<sup>25</sup>). Sie wird durch Pepsin verdaut, was für ihre Eiweißnatur spricht (Wacntig u. Steche<sup>26</sup>).

### 33. Kohlensäure und Stickstoff im Blute.

II. Kohlensäure — findet sich im venösen Blute durchschnittlich zu 50 Volumenprozent (Bohr u. Henriques<sup>27</sup> fanden beim Hunde bei drei Versuchen im Blute des rechten Herzens 48,5—51,5 Volumenprozent). Auch ist der CO<sub>2</sub>-Gehalt des venösen Blutes je nach dem Orte der Entnahme und den Kreislaufverhältnissen sehr schwankend, im Erstickungsblute



**DIESE SEITE IST FÜR KOSTENLOSE MITGLIEDER GESPERRT**  
Beantragen Sie jetzt die volle Mitgliedschaft, um diese Seite zu betreten

# GESCHICHTE

Zehntausende von wichtigen historischen Quellen, viele bisher nicht erhältlich, stehen jetzt zum ersten Mal mit der Vollmitgliedschaft von Forgotten Books zur Verfügung.

Unbegrenzter Zugang  
\$8.99/monat

**Fortfahren**

\*Es gelten Richtlinien zur fairen Nutzung.



Die Blutmenge des Erwachsenen beträgt  $\frac{1}{13}$  des Körpergewichts (Zischoff<sup>37</sup>), (nach Haldane u. Smith<sup>38</sup> [siehe unten] nur  $\frac{1}{20,5}$ ), eugeborenen  $\frac{1}{10}$  (Welcker<sup>39</sup>).

Nach Schücking<sup>40</sup> soll jedoch der Blutgehalt des sofort abgenabelten  $\frac{1}{16}$ , der des später abgenabelten sogar =  $\frac{1}{9}$  des Körpergewichtes betragen.

Zur Bestimmung der Blutmenge dient:

1. Methode von Welcker<sup>39</sup> (vgl. Fr. Müller<sup>41</sup>). — Man fängt aus einer Carotis mit eingebundener Kanüle das Blut in einer gemessenen Menge einer Lösung von Ammoniumoxalat auf, um die Gerinnung zu verhüten. Schon während des Entblutens an in eine Vene entsprechende Mengen einer 0,9% warmen Kochsalzlösung nach und nach in das Herz- und Atemtätigkeit möglichst lange zu erhalten, eventuell wird künstliche Atmung angeleitet. Steht das Herz still, so bindet man in die beiden Enden der durchschnittenen Carotis eine T-förmige Kanüle ein und läßt eine 0,9%ige Kochsalzlösung unter Druck von etwa 1 m Wasser einfließen, während man aus den durchschnittenen Cava inferior diese Spülflüssigkeit so lange sammelt, bis sie vollständig abläuft. Hierauf wird der gesamte Körper zerhackt und (mit Ausnahme des Magens und Darminhaltes, dessen Gewicht man vom Körpergewicht abzieht) mit Wasser ausgelaugt und nach 24 Stunden ausgepreßt. Dieses Wasser und die Kochsalzlösung werden vermischt und gemessen. Man bestimmt schließlich nach einer der angegebenen Methoden in dem Blut und den Extrakten den Hämoglobingehalt und berechnen hieraus die gesamte Blutmenge.

Man fand das Gewicht des Blutes von Mäusen =  $\frac{1}{12}$  —  $\frac{1}{13}$ , Meerschweinchen =  $\frac{1}{19,7}$  ( $\frac{1}{17}$  —  $\frac{1}{22}$ ), — von Kaninchen =  $\frac{1}{20,1}$  ( $\frac{1}{18}$  —  $\frac{1}{22}$ ), — von Hunden =  $\frac{1}{13}$  ( $\frac{1}{11}$  —  $\frac{1}{18}$ ), — von Katzen =  $\frac{1}{21,5}$ , Vögeln =  $\frac{1}{10}$  —  $\frac{1}{13}$ , — von Fröschen =  $\frac{1}{16}$  —  $\frac{1}{20}$ , — von Fischen =  $\frac{1}{14}$  —  $\frac{1}{19}$  des Körpergewichtes (ohne Magen- und Darminhalt).

2. Beim lebenden Tiere ließen Gréhant u. Quinquand<sup>42</sup> eine gemessene Menge Blut abzusaugen, entzogen dann ein Blutquantum und bestimmten darin den CO-Gehalt. Hieraus ergibt sich leicht die Blutmenge. Nach demselben Prinzip bestimmten Haldane u. Smith<sup>38</sup> die Blutmenge des Menschen; sie fanden dieselbe =  $\frac{1}{20,5}$  des Körpergewichtes. In gleicher Weise bestimmte nach derselben Methode die Blutmenge des Kaninchens (in Kubikzentimetern entzogen auf das Bruttogewicht) zu  $\frac{1}{20,8}$  beim männlichen Tier,  $\frac{1}{21,8}$  beim weiblichen.

Über Versuche der Bestimmung der Blutmenge nach anderen Methoden vgl. Schürer<sup>43</sup>, Abderhalden u. Schmid<sup>44</sup>.

Im Hungerzustande nimmt die Blutmenge ab, doch stimmen die Angaben der verschiedenen Forscher nicht darin überein, ob diese Abnahme proportional dem Körpergewicht erfolgt oder nicht. Fette Individuen sind relativ blutreicher. Nach Blutverlusten ersetzt sich leichter die Menge durch Wasser. Allmählich regenerieren sich die Blutkörperchen (vgl. § 35).

3. Die Bestimmung der Blutmenge einzelner Organe geschieht nach plötzlicher Abschnürung ihrer Adern intra vitam. Man zerhackt das zerkleinerte Organ das Blut aus und bestimmt den Blutgehalt durch Vergleichung mit einer zu verdünnenden Blutprobe (Ranke<sup>45</sup>). Die Bestimmung nach dem Tode im gefrorenen Zustande ist zu vermeiden.

J. Ranke<sup>45</sup> bestimmte so am lebenden ruhenden Kaninchen die Verteilung des Blutes; es fand sich von der gesamten Blutmasse — a) in den ruhenden Muskeln, — b) in der Leber, — c) in den Ausscheidungsorganen (Herz und große Aderstämme), — d) in allen übrigen Organen zusammen (in den Lungen sind 6,85% des Gesamtblutes, Menicoff<sup>46</sup>).

Den hervorragendsten Einfluß auf den Blutgehalt der Organe übt die Tätigkeit derselben; hier gilt der alte Satz „ubi irritatio, ibi affluens“. Beispiele liefern die Speicheldrüsen, der Magen, die Muskeln.





Literatur (§ 30—35).

selben Hb-Gehalt wie die zurückgebliebenen; es kommt aber auch die Bildung hämogerer Blutkörperchen vor. Die Leukocyten nehmen einige Stunden nach der Blutentziehung stärker ab, als die Erythrocyten; schon am folgenden Tage tritt aber eine starke Zunahme, meist über die ursprüngliche Zahl hinaus ein (*Otto*<sup>58</sup>, *Inagaki*<sup>59</sup>). — Nach großen Blutverlusten tritt eine Steigerung des Energieumsatzes, sowie eine Retention von N. im Blut. Ausdruck der Blutregeneration (*Fuchs*<sup>60</sup>, *Hári*<sup>61</sup>).

Literatur (§ 30—35).

1. *L. W. Winkler*: B. d. ch. G. 24, 1891, 3602. Z. phk. Ch. 9, 1892, 171. — 2. *Ch. Bohr*: *Wiedemanns Ann. d. Phys. u. Chem. N. F.* 68, 1899, 500. — 3. *Ch. Bohr* u. *J. Bock*: *Wiedemanns Ann. d. Phys. u. Chem. N. F.* 44, 1891, 318. — 4. *Ch. Bohr*: S. A. 17, 1905, 104. — 5. *Ch. Bohr*: *W. Nagels Handbuch der Physiologie*, Braunschweig 1909, 1, 69. — 6. *J. Bock*: J. o. P. 22, 1898, 298. 25, 1900, 295. — 7. *F. Müller*: P. A. 103, 1904, 541. — 8. *J. Barcroft*: E. P. 7, 1908, 771. *J. Barcroft* u. *P. Morawitz*: D. A. k. M. 98, 1908, 100. — 9. *E. Pflüger*: O. m. W. 1867, 724. — 10. *E. Pflüger*: P. A. 1, 1868, 70. — 11. *Szczeklik*: A. 45, 2. Abt., 1862, 171. — 12. *L. Meyer*: Z. r. M. N. F. 8, 1857, 256. — 13. *G. Häfner*: A. 1894, 180. 1903, 217. — 14. *G. Häfner*: A. P. 1901, Suppl., 187. — 15. *A. Loewenherz*: P. A. 1904, 231. — 16. *P. Morawitz*: A. P. P. 60, 1909, 298. — 17. *O. Warburg*: Z. phk. Ch. 71, 1909, 112. — 18. *M. Onaka*: Z. ph. Ch. 71, 1911, 193. — 19. *J. Loeber*: P. A. 1904, 281. — 20. *W. Ewald*: P. A. 116, 1907, 334. — 21. *E. r. Czyhlarz* u. *O. v. Frenkel*: P. A. 10, 1907, 358. — 22. *G. Senter*: Z. phk. Ch. 44, 1903, 257. 51, 1905, 673. — 23. *L. Liebermann*: P. A. 104, 1904, 207 u. 227. 108, 1905, 489. — 24. *E. J. Leitch*: P. A. 49, 1907, 571. — 25. *F. Battelli* u. *L. Stern*: E. P. 10, 1910, 531. — 26. *P. Waentgen*: Z. ph. Ch. 83, 1913, 315. — 27. *Bohr* u. *Henriques*: A. d. P. 1897, 23. — 28. *Ch. Bohr*: *Handbuch d. Physiologie v. W. Nagel*, Braunschweig 1905, 1, 83. — 29. *Pflüger*: *Die Kohlensäure des Blutes*, Bonn 1864. — 30. *Ch. Bohr*: *Handbuch der Physiologie v. W. Nagel*, Braunschweig 1905, 1, 107. — 31. *Ch. Bohr*: C. P. 4, 1890, 253. S. A. 3, 1898, 363. *Die Kohlenoxydintoxikation*, Kopenhagen 1895, pag. 55. — 32. *Ch. Bohr*, *Hasselbalch* u. *A. Krogh*: C. P. 17, 1904, 661. S. A. 16, 1904, 402. — 33. *A. Loewenherz*: *Gase des Körpers*, in *C. Oppenheimers Handbuch der Biochemie*, Jena 1911, IV, 1. — 34. *Ch. Bohr*: *Handbuch der Physiologie v. W. Nagel*, Braunschweig 1905, 1, 117. — 35. *G. A. Buckmaster* u. *J. A. Gardner*: J. o. P. 43, 1912, 401. — 36. *P. Regnard* u. *H. Boesing*: O. r. 124, 1897, 302. — 37. *Bischoff*: *Zeitschrift f. wiss. Zoolog.* 7, 1856, 357, 65. — 38. *J. Haldane* u. *J. L. Smith*: J. o. P. 25, 1900, 331. *N. Zuntz* u. *J. Pflüger*: Z. B. 11, 1908, 47. — 39. *H. Welcker*: Z. r. M. (3), 4, 1858, 145. P. V. 11. Jahrg., 4, 1858, 63. — 40. *A. Schücking*: B. k. W. 1879, 581. — 41. *Fr. Müller*: A. P. 1901, 45. — 42. *Gréhant* u. *E. Quinquaud*: C. r. 94, 1882, 1450. J. d. P. 18, 1882, 564. — 43. *C. G. Douglas*: P. 33, 1906, 493. — 44. *L. Nelson*: A. P. P. 60, 1909, 340. — 45. *J. Schürer*: A. P. 1911, 171. — 46. *E. Abderhalden* u. *J. Schmid*: Z. ph. Ch. 66, 1910, 120. — 47. *R. Virchow*: *Blutverteilung und der Tätigkeitswechsel d. Organe*. Leipzig 1871. — 48. *G. Menicucci*: A. 80, 1894, 439. — 49. *Worm-Müller*: L. B. 25, 1873, 573. *Transfusion und Pletora*. Christiania 1875. — 50. *Panum*: V. A. 29, 1864, 241. — 51. *L. Lesser*: L. B. 26, 1874, 1. — 52. *S. Tschiriac*: L. B. 26, 1874, 441. — 53. *J. Forster*: Z. B. 11, 1875, 496. — 54. *K. A. W. W. W.*: *Wiener med. Jahrb.* 1884, 61. — 55. *Feis*: V. A. (13), 8, 1895, 75. — 56. *Koch*: W. 1892, 904. — 57. *Zenoni*: V. A. 139, 1895. — 58. *J. G. Otto*: P. A. 36, 1904, 1. — 59. *C. Inagaki*: Z. B. 49, 1907, 77. — 60. *D. Fuchs*: P. A. 130, 1909, 156. — 61. *P. Hári*: P. A. 130, 1909, 177.



**DIESE SEITE IST FÜR KOSTENLOSE MITGLIEDER GESPERRT**  
Beantragen Sie jetzt die volle Mitgliedschaft, um diese Seite zu betreten



**Seien Sie niemals ohne ein Buch!**

Die Vollmitgliedschaft von Forgotten Books bietet Ihnen einen universalen Zugang von unseren Apps und unserer Website, auf all Ihren Geräten: Tablet, Telefon, E-Reader, Laptop und Computer.

**Eine Bibliothek in Ihrer Tasche für € 8.99/monat**

**Fortfahren**

\*Es gelten Richtlinien zur fairen Nutzung.



äußeren Fasern lassen sich von den einmündenden Venenstämmen die vordere und hintere Wand hin verfolgen. Die inneren Fasern besonders dort reichlich hervortretend, wo sie sich senkrecht an die Ringe ansetzen, doch sind sie namentlich in der vorderen Wand der Vorhöfe an einzelnen Stellen nicht kontinuierlich angeordnet.

An dem Septum der Vorhöfe ist besonders der ringförmige Muskel hervortretend, welcher die Fossa ovalis (die frühere embryonale Öffnung der Vorhöfe) umgibt. An den Einmündungsstellen der Venen finden sich Faserrzüge: am wenigsten ausgeprägt an der Vena cava inferior, stark und bis zum Septum aufwärts reichend an der Vena cava superior. An den Einmündungen der vier Lungenvenen erstrecken sich bei einigen Säugetieren quergestreifte Muskelfasern auf die Lungenvenen bis zum Hilus der Lungen mit inneren Ring- und äußeren Längsfasern, bei anderen (Vögeln) sogar bis in die Lungen hinein. Auch an der Einmündungsstelle der Vena pulmonalis und in der sie schließenden Valvula Thebesii finden sich Muskelfasern, zumal in der Vorwand. — Im Perimysium der Vorkammern finden sich viele elastische Fasern.

**2. Die Muskulatur der Kammern.** — Man trifft unter dem Perimysium zuerst eine äußere longitudinale Schicht, welche am rechten Herzen nur einzelne Bündel, am linken jedoch eine zusammenhängende Schicht darstellt, die faßt von etwa  $\frac{1}{8}$  der Gesamtdicke der Wandung. Eine zweite Schicht longitudinaler Fasern liegt auf der Innenfläche der Kammerwand, die sie namentlich an den Ostien, sowie innerhalb der senkrecht aufsteigenden Papillarmuskeln deutlich sind, während sie an den anderen Stellen durch die unregelmäßig verlaufenden Züge der Trabeculae carneae ersetzt ist. Zwischen diesen beiden Längsschichten liegt die mächtigste Schicht der transversal geordneten Züge, welche in einzelnen ringförmigen Bündeln zerlegbar ist. In der linken Kammer läßt sich diese Schicht in Gestalt eines geschlossenen Muskelringes herausheben, der besteht teilweise aus Fasern, die überhaupt nicht sehnig enden, sondern stets muskulös bleibend ringförmig in sich zurück verlaufen (*Kreislaufmuskulatur*). Die drei Schichten sind jedoch nicht völlig selbständig und vor sich abgeschlossen, vielmehr vermitteln schräg verlaufende Faserrzüge einen allmählichen Übergang zwischen den transversalen Blättern und den inneren und äußeren longitudinalen Zügen.

An der Spitze des linken Ventrikels biegen die äußeren längsverlaufenden Fasern, indem sie in den sogenannten Wirbel zusammentreten, nach innen. Innere der Muskelsubstanz ein- und aufwärts und gelangen in die Papillarmuskeln; doch sind keineswegs sämtliche in die Papillarmuskeln einsteigende Züge von diesen vertikalen Muskelbündeln der äußeren Kammerwand abzuleiten; viele entstehen aus der Ventrikelwand selbständig. *Albrecht*<sup>3</sup> kann man in dem Spitzenteil des linken Ventrikels ein förmliches Muskelsystem nachweisen, welches einen überwiegenden Teil der gesamten Wanddicke dieses Abschnittes einnimmt, von der Herzspitze bis zur Kuppe der Papillarmuskeln reicht und zu diesen in engster Beziehung steht; die eigentlichen Papillarmuskeln und dieses Muskelsystem bilden danach eine anatomische Einheit, die Papillarmuskeln nichts als die freien Enden mit den Chordae als Sehnen in Verbindung mit den Enden dieses Systems.

**3. Das Reizleitungssystem.** — Die spezifischen Muskelfasern dieses Systems unterscheiden sich von der übrigen Herzmuskulatur anatomisch durch das Prävalieren des Sarkoplasmas und das Zurücktreten der Fibrillen, außerdem auch noch durch ihren Reichtum an Glykogen. Das System enthält außer diesen spezifischen Muskelfasern aber auch noch Nervenfasern und Ganglienzellen (*Engel*<sup>4</sup>, *Morison*<sup>5</sup>). Man

a) Das atrio-ventrikuläre System. — Die Muskulatur der Kammern ist von der der Vorhöfen durch bindegewebige Ringe, *anuli fibrosi*, getrennt. Diese Trennung ist aber keine vollständige, es verläuft ein Muskelbündel, das nach seinem Entdecker genannte *Hiss'sches atrioventrikulär-Bündel*, vom Vorhof zu den Ventrikeln. Nach Untersuchungen von *Tawara*<sup>7</sup> bildet dieses Bündel oberhalb des Septum atrioventriculare einen kompliziert gebauten Knoten, *Tawara'schen Atrioventrikulärknoten*, durchbricht das Septum und läuft in zwei benannten Schenkeln an der Kammercheidewand herab, durchsetzt die Ventrikelhöhlräume in Form von Trabekeln oder falschen Sehnenfasern, tritt endlich an den Papillarmuskeln und den peripheren Wandschichten der Kammermuskulatur in Gestalt der *Purkinjeschen Fäden* in Erscheinung. Dieses Verbindungssystem samt seinen Endausbreitungen zeigt bei Menschen und allen untersuchten Tieren eine gesetzmäßige, im großen ganzen übereinstimmende Anordnung. Das Bündel ist auf seinem ganzen Verlaufe von der übrigen Herzmuskulatur stets durch Bindegewebe getrennt, erst in seinen Endausbreitungen verschmilzt es mit der übrigen Kammermuskulatur.

Als *Purkinjesche Fäden* werden seit ihrer Beschreibung durch *Purkinje* (1845) Netze aus gallertartigen Fäden von eigenartiger histologischer Struktur (röhrenförmige Gebilde, die ganz von Sarkoplasma erfüllt, mit nur wenigen randständigen Längsfibrillen) bezeichnet. In der Innenfläche der Herzkammer besonders beim Schafe sind sie besonders zahlreich. Erst später wurden sie als die letzten Ausläufer der Schenkel des *Hiss'schen Bündels* erkannt.

b) Das sino-aurikuläre (sino-atriale) System. — Eine dem *Reptilien*-ähnlichen Knoten ganz analoge Bildung liegt nach *Keith* u. *Flack*<sup>8</sup> an der Grenze zwischen Vena cava sup. und rechtem Vorhof: *Keith-Flack'scher Sinusknoten*. Von dem Knoten verlaufen Verbindungsfasern zur Muskulatur des Vorhofs und der Vene.

Entwicklungsgeschichtlich sind die einzelnen Abschnitte des Herzens zunächst durch breite Übergänge der Muskulatur des einen Abschnittes in die des andern verbunden. Hier findet eine Reduktion dieser Verbindungen zu schmälere Brücken statt. Bei niederen Tieren geht noch die Muskulatur des Vorhofs im ganzen Umkreis der Vorhofskammergrenze über die Muskulatur der Kammer über, bei den höheren Wirbeltieren werden diese Verbindungen auf bestimmte isolierte Bündel beschränkt. — Bei den Amphibien und Reptilien tritt auch noch eine besondere Verbindung vom Ventrikel zum Bulbus aortae, der als *selbständiger Herzabschnitt* darstellt (*Kölbs*<sup>9</sup>, vgl. *Mangold*<sup>10</sup>).

Die Klappen des Herzens — die arteriellen (Semilunarklappen) und die venösen (Zipfelklappen: *Mitralis* und *Tricuspidalis*) bestehen aus lockeren Bindegewebe mit elastischen Fasern und werden vom Endokard gezogen. Die Zipfelklappen besitzen noch quergestreifte, radiär verlaufende Muskelfasern, die von der Muskulatur der Vorhöfe ausgehen. Nach *Albrecht*<sup>11</sup> ist diese Klappenmuskulatur absolut konstant und stellt eine ganz unmittelbare Fortsetzung der innersten longitudinalen wie der äußeren nach außen folgenden transversalen Schicht der Vorhofsmuskulatur dar. Nach ihrem Eintritt in die Klappe ordnen sich die Muskelfasern in einzelnen getrennten Bündeln, welche ihren Ansatz ausschließlich an den *chordae tendineae* finden, und zwar fast nur an denen, welche direkt am Verbindungsrande der Klappe inserieren und mit einem Teile an der inneren Fläche zur Ventrikelwand verlaufen.

Unterhalb der Semilunarklappen der Aorta und Pulmonalis befinden sich Muskelfasern, welche bei der Contraction des Ventrikels in Form



**DIESE SEITE IST FÜR KOSTENLOSE MITGLIEDER GESPERRT**  
Beantragen Sie jetzt die volle Mitgliedschaft, um diese Seite zu betreten

# GESCHICHTE

Zehntausende von wichtigen historischen Quellen, viele bisher nicht erhältlich, stehen jetzt zum ersten Mal mit der Vollmitgliedschaft von Forgotten Books zur Verfügung.

Unbegrenzter Zugang  
\$8.99/monat

**Fortfahren**

\*Es gelten Richtlinien zur fairen Nutzung.



mäßigen Schlägen bringen. Auch beim menschlichen Herzen möglich; *Kuliabko*<sup>24</sup> konnte ausgeschnittene Herzen von menschl. Leichen 20 Stunden nach dem Tode zum Pulsieren bringen; das arbeitete dabei ziemlich regelmäßig über eine Stunde lang.

Am ausgeschnittenen Herzen kann die Frage experimentell werden, von welchen Bedingungen die Fortdauer der normalen Tätigkeit abhängt.

A. Die Zusammensetzung der Nährflüssigkeit, die durch das Herz strömt.

1. Die Flüssigkeit muß isotonisch sein (vgl. § 13), um nicht den Herzmuskel direkt zu schädigen. Man verwendet daher im allgemeinen eine isotonische Kochsalzlösung (0,8—0,9%). Diese vermag jedoch für sich die Tätigkeit des Herzens nicht zu unterhalten: die Zahl der Herzschläge nimmt dabei fortwährend ab bis zum völligen Stillstand. Ein derartiges, durch Kochsalzlösung „erschöpft“ Herz kann jedoch durch eine geeignete Nährflüssigkeit wieder zum Schlagen gebracht werden.

2. Die Flüssigkeit muß außer Na Cl als notwendige anorganische Salze enthalten: Ca Cl<sub>2</sub> (*Langendorff* u. *Hueck*<sup>25</sup>), K Cl (vgl. unten), wahrscheinlich auch Na H CO<sub>3</sub>.

3. Dem Herzen muß Sauerstoff zugeführt werden, wenn es seine volle Leistungsfähigkeit bewahren soll (entweder durch die Fütterung oder durch Einschließung des Herzens in eine Sauerstoffatmosphäre unter hohem Druck; *Porter*<sup>26</sup>). Allerdings vermag kurze Zeit lang das blutlose Herz mit sehr geringen O-Mengen auszukommen, das des Kanarienvogels sogar ohne Sauerstoff.

4. Das Herz kann ohne Zufuhr organischer Nährstoffe leben, indem es von seiner eigenen Substanz zehrt (*Rohde*<sup>27</sup>). Doch genügt dies nicht auf die Dauer: es muß dann für Ersatz gesorgt werden. Dies ist hierfür z. B. Serumalbumin, Traubenzucker, Galaktose, aber nicht Cellulose sowie die Disaccharide: Rohrzucker, Maltose, Lactose (*Locke* u. *Rona*<sup>28</sup>). Das Herz verbraucht unter annähernd physiologischen Verhältnissen ungefähr 4 mg (*Knowlton* u. *Starling*<sup>29</sup>), 2,2—3,4 mg (*Feld*<sup>31</sup>) Traubenzucker pro Stunde und pro Gramm Herzmuskel.

5. Die Ernährungsflüssigkeit muß zugleich die bei der Herzarbeit gebildeten Stoffwechselprodukte, vor allem die CO<sub>2</sub> (*Saltet*<sup>32</sup>), entfernen.

Als geeignete Durchströmungsflüssigkeit für das Froschherz gab *Ringer*<sup>33</sup> an: 0,6% Na Cl, enthaltend 1 cm<sup>3</sup> 1% Na HCO<sub>3</sub>, 1 cm<sup>3</sup> 1% Ca Cl<sub>2</sub>, 0,75 cm<sup>3</sup> 1% K Cl. Die Notwendigkeit resp. Ersetzbarkeit der einzelnen Salze vgl. *Gross*<sup>34</sup>, *Boehm*<sup>35</sup>); eine Lösung von 0,65% Na Cl, 0,1% Na HCO<sub>3</sub>, 0,01% K Cl, 0,0065% Ca Cl<sub>2</sub>, Na<sub>2</sub> HPO<sub>4</sub>, 0,0008% Na H<sub>2</sub> PO<sub>4</sub>. Für das Säugetierherz empfahl *Locke*<sup>36</sup> eine Flüssigkeit von 0,9—1% Na Cl, 0,02—0,024% Ca Cl<sub>2</sub>, 0,02—0,042% K Cl, 0,01—0,03% Na HCO<sub>3</sub>. Mäßig ist noch ein Zusatz von 0,1% Glucose. *Neukirch* u. *Rona*<sup>37</sup> fanden am zweckmäßigsten die *Tyrodesche* Lösung: 0,8% Na Cl, 0,02% K Cl, 0,02% Ca Cl<sub>2</sub>, 0,01% Mg Cl<sub>2</sub>, Na H<sub>2</sub> PO<sub>4</sub>, 0,1% Na HCO<sub>3</sub>, 0,1% Glucose.

6. Zahlreiche chemische Substanzen wirken auf die Frequenz und Stärke der Herzbewegungen ein, wenn sie entweder direkt auf das ruhende Herz aufgetragen oder beim durchbluteten Herzen der Durchströmungsflüssigkeit zugesetzt werden; die Art der Wirkung (direkte Wirkung auf die Herzmuskulatur, indirekte durch Vermittlung der Nerven, Kombination beider Einflüsse) ist dabei nicht immer klar (*Hedbom*<sup>37</sup>, *Harnack*<sup>38</sup>).

Auffallend ist die giftige Wirkung der Kaliumsalze, die in sehr großen Mengen ein notwendiger Bestandteil der Ernährungsflüssigkeit sind (vgl. oben), a

den „elastischen Zug der Lungen“ (vgl. § 47), welcher, nachdem die aktive Zusammenziehung der Vorhöfe beendet ist, die nun erschlafften, zusammenliegenden, nachgiebigen Vorhofswände wieder aneinander zieht.

B. Die Vorhöfe contrahieren sich. Hierbei erfolgen schnell hintereinander: die Zusammenziehung der einmündenden Venen, der Herzwandungen der Vorhöfe. Die letzteren ziehen sich wellenförmig nach unten, nämlich gegen die venösen Ostien hin, zusammen.

Die Contraction der Vorhöfe hat ein leichtes Anstauen des Blutes in den Venenstämmen zur Folge, wie man es namentlich bei Kaninchen leicht erkennen kann, wenn nach Durchschneidung der Brustmuskeln der Zusammentritt der Venae communes und subclaviae freigelegt ist. Es findet kein eigentliches Zurückwerfen der Blutmasse statt, sondern nur eine teilweise stauende Unterbrechung des Einfließens in die Vorhöfe.

Fig. 22.

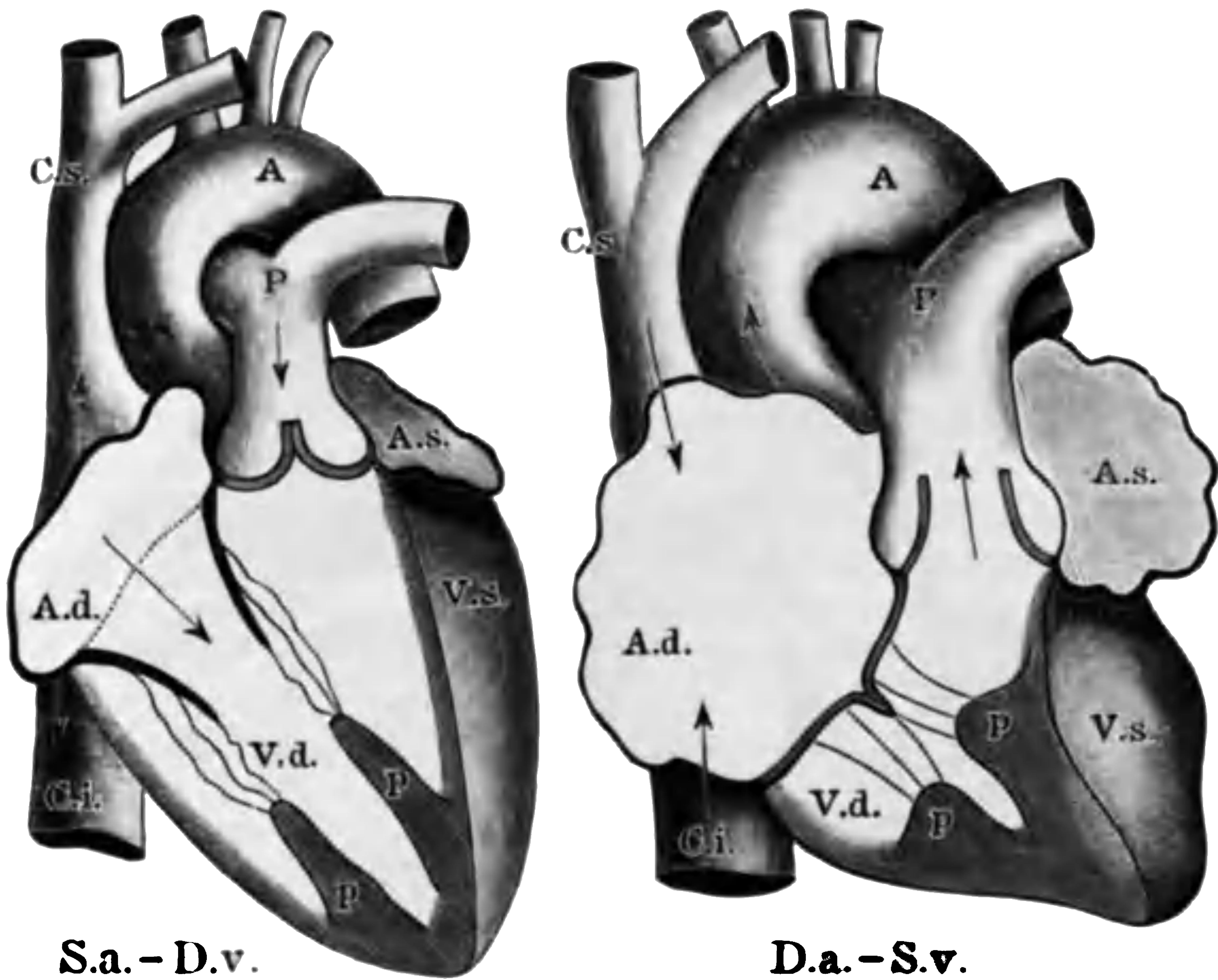

Schema der Systole atriorum, Diastole ventriculorum und der Diastole atriorum, Systole ventriculorum.

auf, weil die Einmündungsstellen der Venen sich verengern, weil ferner der Druck in der oberen Hohlvene und in den Lungenvenen der Rückstauung bald das Gegengewicht bildet und endlich weil in der weiteren Verzweigung der unteren, zum Teil auch der oberen Hohlvene und der Herzvenen Klappen die Rückstauung verhindern. In dem austauenden Venenblute bewirkt so die Herzbewegung eine regelmäßige, pulsatorische Erschütterung, die in abnormer Höhe zum Venenpuls (§ 55) führen kann.

Durch die Zusammenziehung der Vorhöfe wird das Blut in die erschlafften Ventrikel getrieben, wodurch diese beträchtlich erweitert werden; zum Teil wird diese Erweiterung der erschlafften Ventrikel durch den elastischen Zug der Lungen bewirkt. Man hat der Ventrikeln auch die Fähigkeit zusprechen wollen, sich aktiv zu erweitern und so das Blut anzusaugen<sup>63</sup>; eine derartige aktive Erweiterung findet jedoch tatsächlich nicht vor (von den Velden<sup>64</sup>, vgl. S. 114).

Während das Blut durch die Vorhöfe in die Kammern gedrückt wird, liegen die Zipfelklappen keineswegs etwa der Kammerwand



Es ist fraglich, ob Vorhof und Kammer genau alternierend daß im Momente des Beginnes der Kammerzusammenziehung die Vorkammer ob die Kammer bereits sich contrahiert, während noch die Vorkammer kurze bleibt, so daß also wenigstens für eine kurze Zeit das ganze Herz contrahiert.

C. Nun contrahieren sich die Ventrikel, während erschaffen.

Hierbei preßt sich das Blut gegen die Unterfläche der Atri klappen, welche sich, mit ihren nach unten umgebogenen Rändern förmig ineinander greifend, eng aneinander legen (*Sandborg Müller*<sup>56</sup>) (Fig. 23). Ein Rückwärtsschlagen in die Vorhofsh ist nicht möglich, da die Chordae tendineae ihre unteren Ränder festhalten. Für die Aneinanderlagerung der benachbar ränder wirkt der Umstand besonders günstig, daß von ein muskel die Sehnenfäden stets an die einander zugekehrten Ränder Klappen geben. Die geschlossenen Klappen sind der Fläche nach horizontal gestellt; daher bleibt in den Ventrikeln auch auf d Contraction stets ein Rest von Blut, das sogenannte „Residuum rück“ (*Sandborg u. Worm-Müller*<sup>56</sup>).

Die Semilunarklappen der großen Gefäße sind beim Systole der Ventrikel natürlich noch durch den hohen, in den Gefäßen herrschenden Druck geschlossen. Es ist daher der während des ersten Teils der Systole der Ventrikel sowohl gegen den Vorhof wie auch gegen die großen Gefäße abgesperrt; die Systole führt daher zunächst nicht zu einer Zusammenziehung der Kammer und Verkleinerung des Innenraumes, sondern nur zu einer Spannung der Kammerwand und einem Ansteigen des Druckes des Ventrikels: „Anspannungszeit“ oder „Verschlußzeit“. Augenblick, wo der Druck in der Kammer den in den großen Gefäßen übersteigt, öffnen sich die Semilunarklappen und das Blut strömt in die großen Gefäße: „Austreibungszeit“.

Während der Anspannungszeit kommt es zu keiner Änderung der Muskelfasern, sondern nur zu einer Zunahme der Spannung derselben, ein isometrischer Muskelakt; während der Austreibungszeit verkürzen sich die Muskelfasern bei (ungefähr) gleichbleibender Spannung, entsprechend dem isotonen Muskelakt (vgl. Muskelphysiologie, § 216 und 218).

Während das Blut in die großen Gefäße strömt, legen sich die Semilunarklappen keineswegs etwa an die Gefäßwand an (vgl. S. 103). Bei der Contraction der Ventrikel werden auch die Ostien der großen Gefäße verengt; dies geschieht besonders durch die Muskelwülste, welche sich unterhalb der Semilunarklappen hervorwölben (Fig. 24). Das Blut wird mithin durch einen engeren Spalt in die weite Öffnung der großen Gefäße gedrückt, dadurch entstehen oberhalb der Klappen (in dem Sinus Valsalvae) Wirbelbewegungen, welche die Klappen nach der Mitte des Gefäßes drängen, die Klappe „stellen“ (*Krogh*<sup>57</sup>).

Fig. 24.



Die geschlossenen Semilunarklappen der Pulmonalis vom Menschen (von unten).

D. Sowie die Systole der Kammer zu Ende erreicht hat und die Diastole beginnt, schließen die Semilunarklappen (Fig. 24). Da dieselben horizontal gestellt waren erfolgt der Schluß bei dem geringsten Überdruck.



**DIESE SEITE IST FÜR KOSTENLOSE MITGLIEDER GESPERRT**  
Beantragen Sie jetzt die volle Mitgliedschaft, um diese Seite zu betreten



**Seien Sie niemals ohne ein Buch!**

Die Vollmitgliedschaft von Forgotten Books bietet Ihnen einen universalen Zugang von unseren Apps und unserer Website, auf all Ihren Geräten: Tablet, Telefon, E-Reader, Laptop und Computer.

**Eine Bibliothek in Ihrer Tasche für € 8.99/monat**

**Fortfahren**

\*Es gelten Richtlinien zur fairen Nutzung.

steigende Linie, das sogenannte „Plateau“, schließlich wieder abfallenden Schenkel.

Eine Reihe von Autoren haben in ihren Druckkurven das Plateau vermißt, der Druck sofort wieder, nachdem er das Maximum erreicht hat. Die Differenz  $\Delta p$ , für die Druckregistrierung benutzte Methodik zurückzuführen (vgl. *Starling*<sup>67</sup>, *Porter*<sup>68</sup>, *Frank*<sup>69</sup>). Die neuesten, mit den besten Manometern angestellten Untersuchungen haben hierüber ebenfalls keine Entscheidung gebracht: *Piper*<sup>66</sup> zeigt Kurven kein Plateau, im Gegensatz zu ihm hält es *C. Tigerstedt*<sup>66</sup> nach seinen Untersuchungen für festgestellt, daß der wirkliche Druckablauf durch eine Kurve mit Plateau richtig wiedergegeben wird. Ob das Plateau absinkend, horizontal oder ansteigend verläuft, hängt nach *C. Tigerstedt* von dem Widerstand im arteriellen Gebiet ab.

Im besonderen lassen sich an der Kammerdruckkurve die folgenden Besonderheiten erkennen:

Vor dem steilen Anstieg des Druckes bemerkt man eine leichte Senkung der Kurve ( $v$  in Fig. 25 B u. C). Dieselbe fällt zeitlich zusammen mit der Vorhofscontraction ( $v$  in Fig. 25 A), entspricht also einer Senkung des Druckes durch das bei der Vorhofscontraction in den Vorhöfen abfließende Blut.

Zwischen der Vorhofscontraction und der eigentlichen Systole der Kammer bemerkt man eine in der Kammerdruckkurve zuweilen auftretende geringe Erhöhung des Druckes, die als „Intersystole“ bezeichnet. Die Deutung derselben ist nicht klar.

Es folgt der steile Anstieg des Druckes, der durch die Systole der Ventrikel bedingt wird; er geht sodann in das Plateau der Kurve über.

Fig. 26.

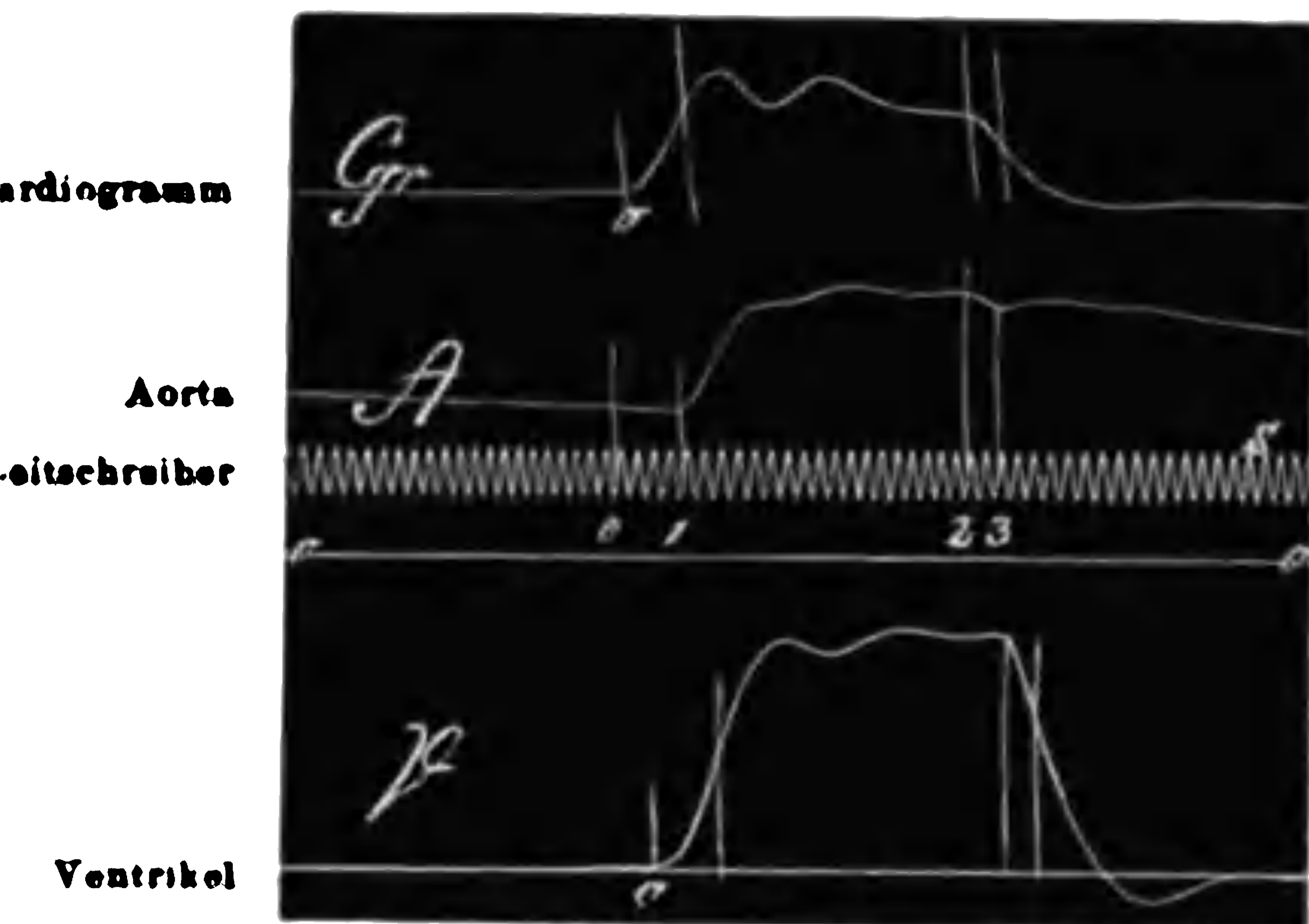

Gleichzeitiger Ablauf des Kardiogrammes, des Ventrikeldruckes und des Aortendruckes vom Hunde nach *K. Härtke*. Jede Zacke der Zeitkurve = 0,01 Sekunde.

Es folgt eine meßbare Zeit (von Marke 0 bis 1), bis der Druck in der Aorta zu steigen anfängt (Anspannungszeit, vgl. S. 109). In dieser Zeit (Marke 1) erfolgt die Öffnung der Semilunarklappen.

Am Plateau der Kammerdruckkurve zeigen sich fast immer kleine Wankungen, die sogenannten „systolischen Wellen“. Dieselben sind bei den älteren Untersuchungen sehr wahrscheinlich zum größten Teil bedingt durch Eigenschwingungen der registrierenden Weichen. Auch die neuesten Untersuchungen zeigen hier vereinzelte Wankungen; über ihre Erklärung s. *Piper*<sup>66</sup>, *C. Tigerstedt*<sup>66</sup>.

An irgend einer Stelle dieses venösen Abschnittes beginnt die Eröffnung der Semilunarklappen. Die Lage dieses Zeitpunktes läßt sich bestimmen durch Vergleich der gleichzeitigen Kurven des Druckes in der Aorta (Fig. 26). Der Druck in der Aorta steigt demselben Moment an, in welchem die Systole der Kammer beginnt (Zeitmarke 0), sondern erst nach einer gewissen Zeit (Zeitmarke 1), bis der Druck in der Aorta zu steigen anfängt (Anspannungszeit, vgl. S. 109). In dieser Zeit (Marke 1) erfolgt die Öffnung der Semilunarklappen.

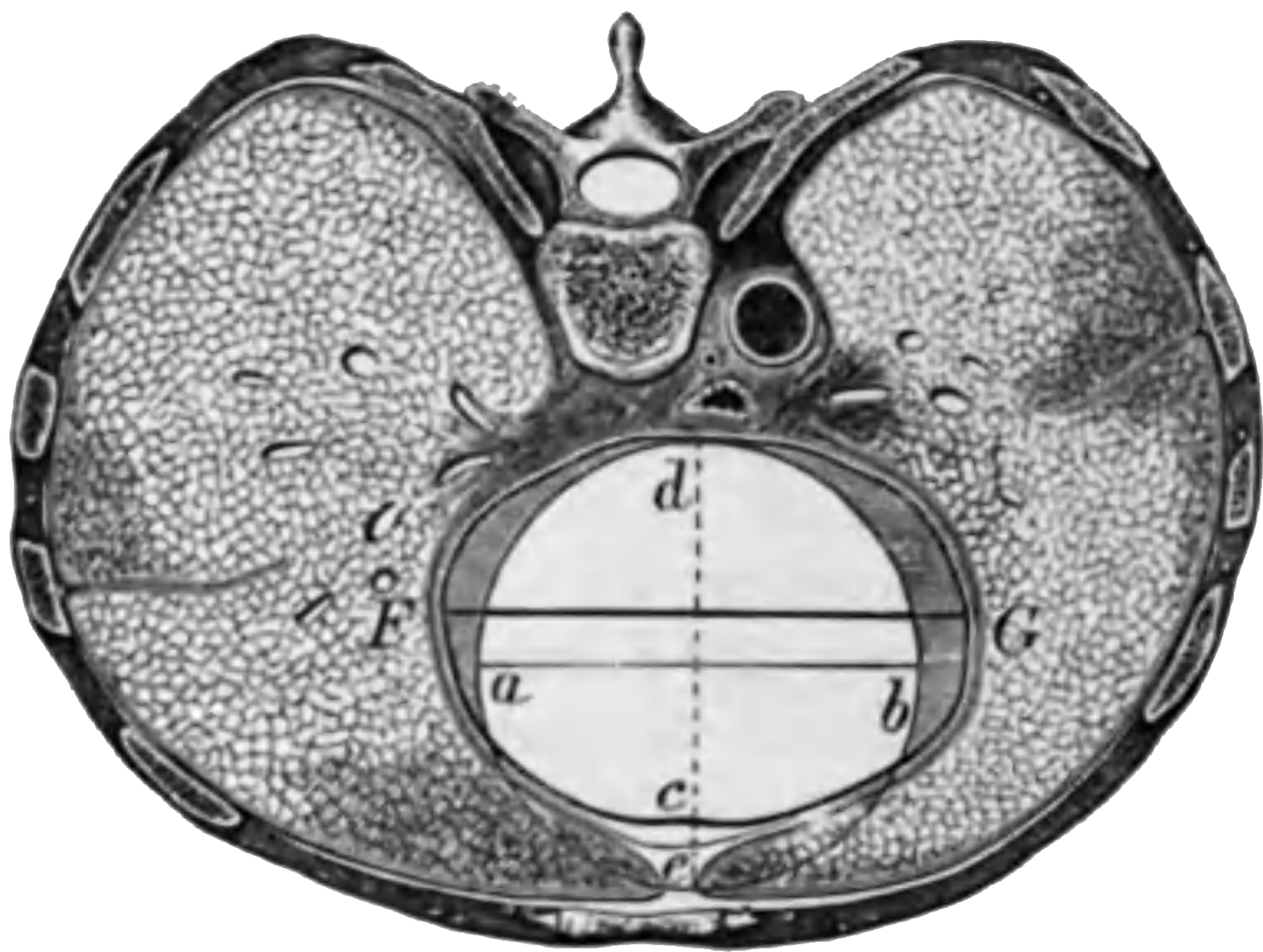

**I** Horizontalschnitt durch Herz und Lungen nebst den Thoraxwandungen zur Deutlichkeit der Formveränderung der Herzbasis bei der Contraction der Ventrikel. *FG* Querschnitt der Ventrikel in der Diastole, *c* der Ort der vorderen Ventrikelwand, *a b* Querschnitt der Ventrikel in der Systole mit *c*, dem Ort der vorderen Ventrikelwand während der Contraction.  
**II** Seitenansicht der Herzlage: *p* die Herzspitze in der Diastole; *p* dieselbe in der Systole.  
 (zum Teil nach *C. Ludwig u. Henke*).

mit der Achse senkrecht zur Basis. Hierdurch muß die Spitze unten und hinten nach vorn und oben (*p*) erhoben werden („*Cor sese erigere*“), und sie preßt sich so systolisch erhärtet in den costalraum hinein (Fig. 27. *II*). — Da somit der Herzstoß im wesentlichen von der Bewegung der Herzspitze herrührt, bezeichnet man ihn als „*spitzenstoß*“.

3. Die Herzventrikel erleiden bei der systolischen Contraction eine leichte spiralige Rollung um ihre Längsachse („*lateralis nationem*“, *W. Harvey*) in der Art, daß die Spitze von hinten nach vorn gebracht wird, wobei zugleich von dem linken Ventrikel ein größerer Streifen sich nach vorn wendet.

Die Rollung des Herzens um seine Längsachse leitete man früher ab von dem Verlauf der Faserzüge an der Vorderfläche des Herzens von oben und rechts nach unten und links. Begünstigt sollte die Drehung weiterhin dadurch werden, daß die gegenüberliegenden Stämme der Aorta und Pulmonalis bei ihrer Spannung ebenfalls eine Drehung des Herzens in demselben Sinne bewirkten.

der Herzstoß hierbei meist verstärkt. — Starke Erweiterung der Lunge (Empf das Zwerchfell niederdrückt, verschiebt ebenso den Herzstoß nach unten und kehrt hat das höhere Hinaufdrängen des Diaphragma (durch Lungenschrumpf Druck der Unterleibsorgane) die Verlagerung des Herzstoßes nach oben ( dritten Intercostalraum) und etwas nach links hin zur Folge. Verdickung des Herzens und Erweiterung der Höhlen (Hypertrophie und Dilatation) die den linken Ventrikel betrifft, denselben länger und breiter, und der vers ist über die Mammillarlinie hinaus nach links, selbst bis in die Axillarlinie 8. Intercostalraume fühlbar. Hypertrophie und Dilatation des rechten Ventri das Herz; der Herzstoß ist mehr nach rechts, ja selbst rechts vom Brustbe auch noch etwas über die linke Mammillarlinie hinaus fühlbar. — In den des Situs inversus, in welchen das Herz in der rechten Brustseite liegt, trifft auch den Herzstoß an der entsprechenden rechten Thoraxseite.

Der Herzstoß erscheint abnorm geschwächt bei hochgradiger Schw aktion. Auch eine Abdrängung des Herzens von der Brustwand durch A

Fig. 28.

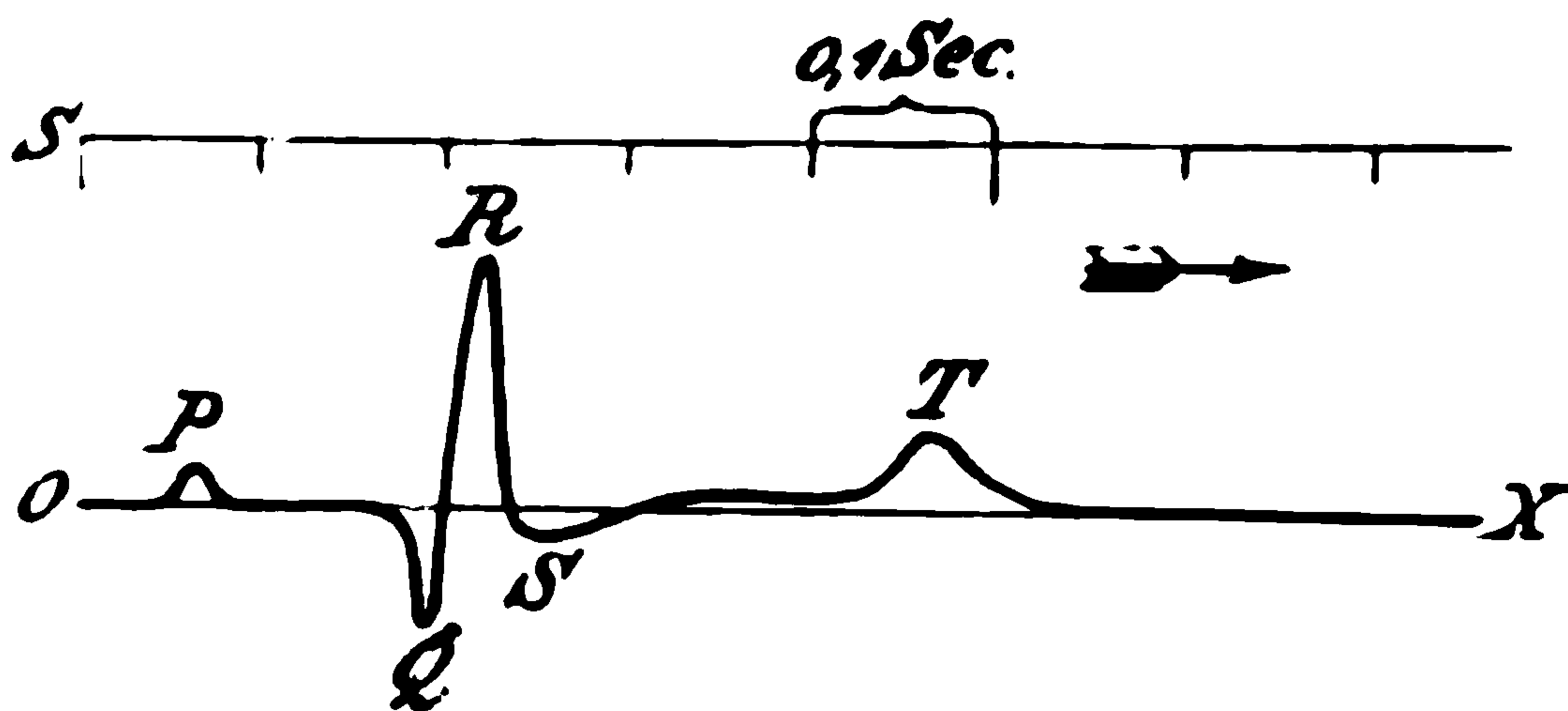

Fig. 29.

#### Elektrokardiogramme (nach Einthoven).

Flüssigkeiten oder Gasen im Herzbeutel, oder durch die sehr ausgedehnt oder durch eine linksseitige Füllung des Thoraxraumes schwächt den Herz ihn sogar völlig aus.

Eine Verstärkung des Herzstoßes wird beobachtet bei Hypertrophie sowie bei den verschiedensten Erregungen (psychische, entzündliche, fieberl welche das Herz treffen. Starke Hypertrophie des linken Ventrikels mach „bebend“, so daß ein Teil der linken Brustwand unter systolischer Ersch gehoben wird. In manchen Fällen findet man ihn deutlich oder sogar noch normal, und der Puls erscheint trotzdem nur klein. Es handelt sich hier u Ventrikelentleerung („frustrane Herzcontraction“) (Hochhaus u. Quinc

Ein herzsystolisches Einsinken an der vorderen Brustwand in und 4. linken Intercostalraum nicht selten unter normalen Verhältnissen, stärker Herzaktion, ferner auch bei exzentrischer Hypertrophie der Kamme Kammercontraction die Herzspitze etwas disloziert wird und die Ventrike verkleinern, so werden zur Ausfüllung des leergewordenen Raumes die nach teile der Intercostalräume einsinken. — Bei Verwachsung des Herzens mit und dem umgebenden Bindegewebe findet sich ebenfalls anstatt des Herzstoßes



**DIESE SEITE IST FÜR KOSTENLOSE MITGLIEDER GESPERRT**  
Beantragen Sie jetzt die volle Mitgliedschaft, um diese Seite zu betreten

# GESCHICHTE

Zehntausende von wichtigen historischen Quellen, viele bisher nicht erhältlich, stehen jetzt zum ersten Mal mit der Vollmitgliedschaft von Forgotten Books zur Verfügung.

Unbegrenzter Zugang  
\$8.99/monat

**Fortfahren**

\*Es gelten Richtlinien zur fairen Nutzung.



vom Anfangspunkt des aufsteigenden Schenkels bis zum Endplateaus (Marke 0—2 in Fig. 26).

Nach *Hürthle*<sup>76</sup> kann die Dauer der Systole auch an der Kurve des A. gemessen werden; die Strecke vom Beginn des Pulses bis zum Auftreten der dikrotischen Welle stellt ziemlich genau die Dauer der Kammerystole dar, obwohl sie sich mit dieser Phase der Herzrevolution deckt.

Beim Hund fand *Hürthle*<sup>76</sup> die Dauer der Kammerystole 0,20—0,22 Sekunden.

Beim Menschen ist man für die Bestimmung der Systole auf das Kardiogramm angewiesen. Bei manchen („typischen“) Kardiogrammen entspricht in der Tat der Beginn des ansteigenden Schenkels dem Anfang der Kammerzusammenziehung, der Beginn des steilen Schenkels dem Anfang der Diastole, aber es gibt auch Kardiogramme („atypische“), bei denen dies nicht der Fall ist, ohne es an der Kurve selbst entscheiden könnte. Man muß hierfür den Vergleich mit der Pulscurve heranziehen, bei der (s. o.) die Strecke vom Beginn des Pulses bis zum Auftreten der dikrotischen Welle der Dauer der Kammerystole gleich gesetzt werden kann. Auch die Markierung der Kammern für diese Zwecke hierfür in Betracht.

*Hürthle*<sup>76</sup> bestimmte die Dauer der Kammerystole beim Menschen zu 0,26 Sekunden. — *Landois*<sup>77</sup> berechnete die Dauer der Ventrikelsystole aus seinen Kardiogrammen zu 0,32—0,29 Sekunden; bei nur 60 Schlägen war der Wert 0,34 Sekunden; bei sehr hoher Frequenz bis 0,199 Sekunden.

Die Systolendauer stellt einen ziemlich konstanten Wert dar, wird dieselbe durch wechselnde Widerstände in der Aorta nicht beeinflusst, sie ist also (wenigstens innerhalb weiter Grenzen) unabhängig von der Arbeit, welche das Herz bei seiner Zusammenziehung leistet. Veränderungen in der Pulsfrequenz werden hauptsächlich hervorgebracht durch Veränderungen in der Dauer der Diastole, nicht der Systole.

*Landois* fand, daß bei enormer Hypertrophie und Dilatation des linken Ventrikels die Dauer der Ventrikelcontraction den normalen Wert nicht wesentlich übersteigt.

Die Zusammenziehung der Ventrikel zerfällt in zwei Abschnitte (vgl. S. 109): die „Anspannungszeit“ und die „Ausstreibungszeit“. Die Grenze zwischen beiden bildet der Moment der Öffnung der Semilunarklappen. Dieser Moment kann bei Tieren durch Vergleich der Druckkurve und der Aortadruckkurve bestimmt werden (Fig. 26, 1). In den Versuchen *Hürthles* am Hunde betrug die Anspannungszeit im Durchschnitt 0,02—0,04 Sekunden.

Am Menschen kann man die Anspannungszeit berechnen aus der Zeitdifferenz zwischen dem Beginn des Kardiogramms und dem Beginn der Pulscurve in einem dem Herzen naheliegenden Gefäß; dabei muß die Fortpflanzungsgeschwindigkeit der Pulswelle (vgl. § 10) in Rechnung gestellt werden. Auch bleibt zu bedenken, daß der Beginn des Kardiogramms nur in den typischen Kurven mit dem Beginne der Kammerystole zusammenfällt.

*Landois* berechnete die Anspannungszeit in folgender Weise: 1. Herzton bis zum Puls in der Axillaris verstreichen 0,137 Sekunden. Die Fortpflanzungsgeschwindigkeit der Pulswelle in der 30 cm langen Strecke von der Aortenwurzel bis zur Axillaris beträgt 0,052 Sekunden (berechnet aus der Geschwindigkeit in der 50 cm langen Bahn von der Axillaris bis Radialis = 0,087 Sekunden); es bleibt also für

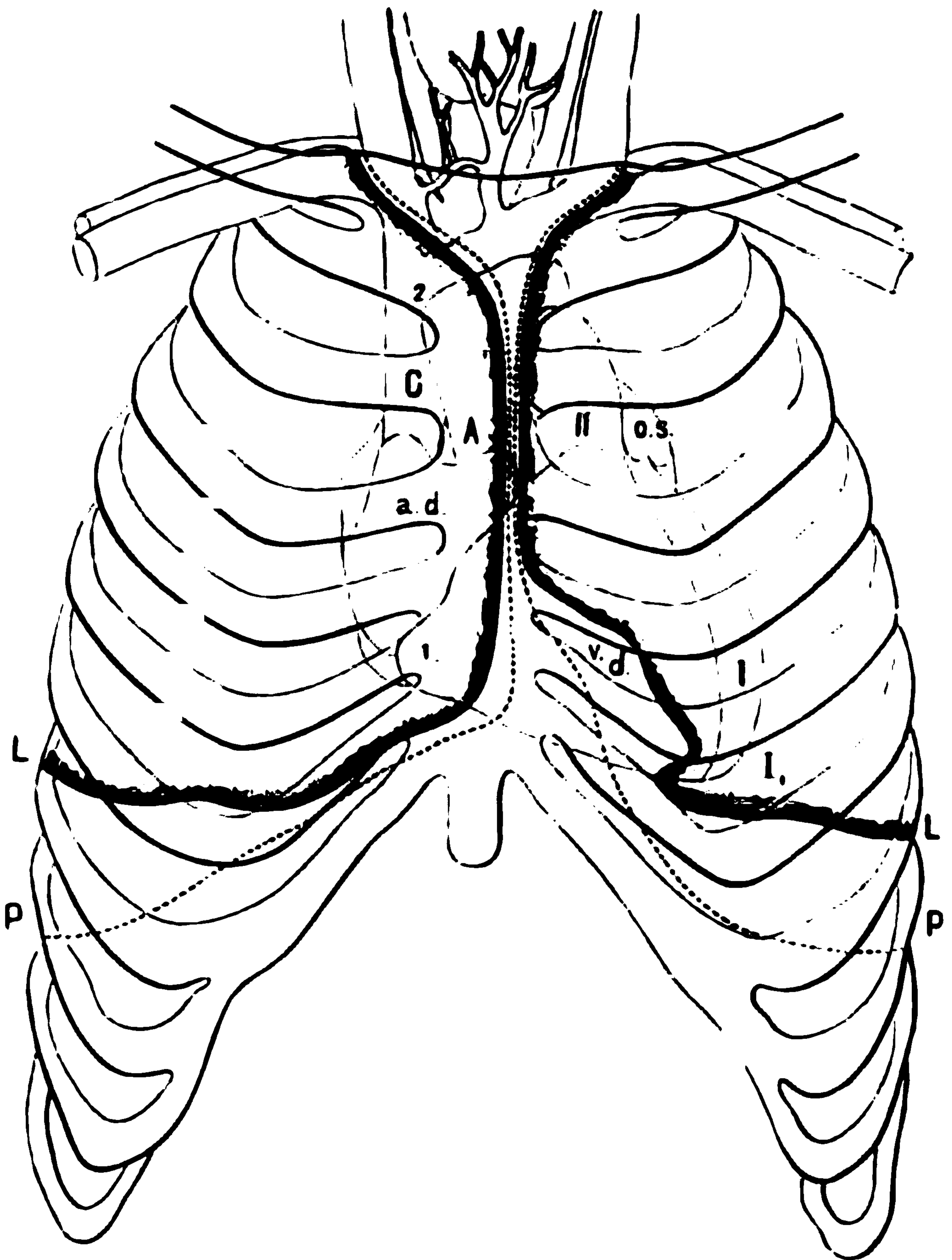

**Topographie des Brustkorbes und der Brusteingeweide.**

*a. d.* Atrium dextrum. — *o. s.* Auricula sinistra. — *v. d.* Ventriculus dexter. —  
*I* Ventriculus sinister mit *I<sub>1</sub>* der Herzspitze. — *A* Aorta. — *II* Arteria pulmonalis. —  
*C* Vena cava superior. — *LL* Begrenzung der Lungen. — *PP* Begrenzung der Pleura  
 parietalis (nach v. Luschka u. v. Dusch).

er Semilunarklappen selbst findet tonlos statt; erst einen Augen-  
 blick später, wenn dieselben stärker gespannt werden, erschallt der 2. |

Registrierung der Herztöne. Da man weiß, in welchem Moment  
 der Bewegung die Herztöne erschallen, so ist ihre objektive Registrierung von größ-  
 ter Wichtigkeit für die Deutung der Kurven der Herzbewegung. Für diesen Zweck sind zahlreiche  
 Methoden angegeben worden. Entweder werden die Herztöne auf ein Mikrophon übertragen  
 und schließt durch seine Schwingungen einen elektrischen Strom, wor-  
 durch ein Elektromagnet in Tätigkeit gesetzt (*Hürthle*<sup>99</sup>) oder ein Capillarelektrometer (*Ei-  
 nhorst*<sup>100</sup>) oder der Faden eines Saitengalvanometers (*Einthoven*<sup>101</sup>, *Kahn*<sup>102</sup>) be-  
 nutzt werden. Die Schwingungen der Herztöne werden auf eine Membran übertragen: ein



stillstehende oder auf das infolge der normalen Spontanreize pu Herz künstliche Reize, sog. Extrareize (meist Induktionsschl wendet und die Bewegungen registriert.

Die Untersuchungen können sowohl an dem freigelegten, in der normalen V belassenen, als auch am ausgeschnittenen und eventuell künstlich gespeisten Her führt werden. Um die Bewegungen der einzelnen Herzabschnitte zu registrieren, feine Häkchen durch die Herzwand und verbindet diese durch einen Faden Schreibhebel, der die Bewegungen in geeigneter Vergrößerung aufzeichnet (Susj methode, *Engelmann*<sup>106</sup>).

**Anatomie des Froschherzens.** — Das Froschherz, an dem viele der essierenden Untersuchungen ausgeführt worden sind, besteht aus einer Kammer Vorkammern. In den linken Vorhof mündet die Pulmonalvene. Die Hohlvenen (: eine untere) münden nicht direkt in den rechten Vorhof, sondern bilden zunäch genannten Hohlvenensinus, der durch ein Ostium mit dem rechten Vorhof ver Es schlägt zunächst der Hohlvenensinus, darauf die Vorhufe, dann die Kammer, Bulbus cordis, der letzte Herzabschnitt, der in das Anfangsstück des arteriellen Ge übergeht.

### 1. Reizbarkeit und 2. Contractilität.

Der Herzmuskel hat ebenso wie die übrige Muskulatur die F auf Reize zu reagieren, und zwar dadurch, daß er eine Cont ausführt. Die Reizbarkeit des Herzmuskels ist nicht etwa nur d zahlreichen, in ihm vorhandenen Nerven vermittelt (indirekte R.), sie ist eine direkte. Dies wird durch folgenden Versuch bewies bei einem Frosch die Herzspitze (die unteren zwei Drittel der Herz welche nur Nervenfasern, keine Ganglienzellen enthält, abgeklem müssen die von den Ganglienzellen getrennten Nervenfasern in c degenerieren. Die Herzspitze bleibt aber bei solchen Fröschen, die lang am Leben erhalten werden können, dauernd reizbar: auf B macht sie eine einmalige Contraction (*Bowditch*<sup>107</sup>, *Aubert*<sup>108</sup>, *Langen* — Ammoniak, Kalkwasser, sehr verdünnte Mineralsäuren, die auf m Nervenfasern nicht reizend wirken, wirken auf den Herzmuskel; triertes Glycerin, welches Nerven stark reizt, ist an der Herzs wirksam (*Langendorff*<sup>105</sup>).

Ein wesentlicher Unterschied im Verhalten des Herzmuskels über dem Extremitätenmuskel liegt darin, daß die Größe der Co nicht von der Größe des Reizes abhängt. Auf einen bestimm reagiert der Herzmuskel entweder überhaupt nicht, wenn nän Größe des Reizes unter der Schwelle der Wirksamkeit liegt (unterm Reiz) — oder, falls der Reiz überhaupt wirksam ist, sogleich maximalen Zuckung: Alles- oder Nichts-Gesetz; der m Reiz hat bereits maximale Wirkung (*Bowditch*<sup>107</sup>, *Kronecker* Herzmuskel verbraucht also auf einen überhaupt wirksamen Reiz l alle ihm augenblicklich zur Verfügung stehende Energie.

Aus diesem Verhalten des Herzmuskels erklären sich ein weiterer Eigentümlichkeiten desselben:

Auf jede Zusammenziehung des Herzens folgt eine Periode, in die Empfänglichkeit für weitere Reize (ebenso das Leitungsv *Engelmann*<sup>109</sup>) aufgehoben, resp. herabgesetzt ist: „refraktäre P (*Bowditch*<sup>107</sup>, *Kronecker*<sup>21</sup>, *Marey*<sup>110</sup>). Erst nach Ablauf dieser Zei Herz wieder für neue Reize erregbar. Da eben bei jeder Contra vorhandene Energie aufgebraucht wird, muß nach einer solchen gewisse Zeit verstreichen, bis die für eine neue Contraction no Energie sich wieder aufgespeichert hat.



**DIESE SEITE IST FÜR KOSTENLOSE MITGLIEDER GESPERRT**  
Beantragen Sie jetzt die volle Mitgliedschaft, um diese Seite zu betreten



**Seien Sie niemals ohne ein Buch!**

Die Vollmitgliedschaft von Forgotten Books bietet Ihnen einen universalen Zugang von unseren Apps und unserer Website, auf all Ihren Geräten: Tablet, Telefon, E-Reader, Laptop und Computer.

**Eine Bibliothek in Ihrer Tasche für € 8.99/monat**

**Fortfahren**

\*Es gelten Richtlinien zur fairen Nutzung.

Da das aus dem Körper ausgeschnittene Herz seine Tätigkeit unverändert fortsetzen kann (zumal bei gleichzeitiger Ernährung, vgl. S. 104), so kann es keinem Zweifel unterliegen, daß die Ursache der Herzbewegung im Herzen selbst gelegen ist und nicht etwa außerhalb desselben, im Centralnervensystem. Das Herz hat die Fähigkeit, die für die Auslösung seiner Contractionen nötigen Reize in sich selbst zu erzeugen. Automatie des Herzens. Es müssen ferner offenbar Einrichtungen im Herzen selbst vorhanden sein, welche bewirken, daß die Muskeln jedes einzelnen Herzabschnitts (Sinus, Vorkammer, Kammer, Bulbus) annähernd gleichzeitig zusammenziehen, daß dagegen die Contractionen der einzelnen Herzabschnitte in bestimmten zeitlichen Abständen aufeinander folgen, damit die normale Fortbewegung des Blutes durch die Herzkammern zustande kommen kann: Coordination der Herzbewegung.

Bei der quergestreiften Skelettmuskulatur sind sowohl die Einrichtungen für die Erzeugung als auch die Einrichtungen für die Coordination der Bewegungen in das Centralnervensystem verlegt; von hier aus fließen die für die Bewegung nötigen Reize in der gewöhnlichen Weise zu, um coordinierte Bewegungen auszulösen. Es erscheint am einfachsten, anzunehmen, daß auch beim Herzen die vorhandenen nervösen Elemente, Ganglienzellen und Nerven der Sitz der Reizerzeugung und der coordinatorischen Einrichtungen seien: Neurogene Theorie der Herzbewegung<sup>127</sup>. Zur Stütze dieser Anschauung wird die Tatsache angeführt, daß Teile des Herzmuskels, wenn sie eine spontane, nicht durch äußere Reize bedingte Tätigkeit zeigen, dann eine spontane, nicht durch äußere Reize bedingte Tätigkeit zeigen, wenn sie Ganglienzellen enthalten. Die abgeschnittene oder geklemmte Herzspitze des Frosches, die keine Ganglien mehr enthält, verharrt in dauernder Ruhe, bei Zuführung äußerer Reize dagegen contractiert sie sich (auf einen Stich hin eine Contraction, auf Dauerreize hin rhythmische Pulsationen). — Ebenso verhält sich die Kammer- und Vorhörspitze des Säugetierherzens, ebenso die isolierten, gangliensfreien Herzohren beim Salamander (Langendorff<sup>128</sup>). — Dagegen zeigt die in der Atrioventrikulargrenze verbleibende quetschte Herzkammer, die sicher Ganglienzellen enthält, beim Wagnis wie beim Frosch kräftige, anhaltende Pulsationen.

Nach der neurogenen Theorie sind im Herzen mehrere gangliöse Centra vorhanden, welche durch Leitungsbahnen miteinander in Verbindung stehen. Die einzelnen Centra sind einem dominierenden untergeordnet, von dem aus in bestimmter Ordnung die Reize zu den übrigen Centren zufließen; so kommt die Coordination der Herzbewegung zustande. Das dominierende Centrum liegt in den Vorhöfen, beim Frosch im Hohlvenensinus.

Im Gegensatz zu dieser Anschauung nimmt die myogene Theorie der Herzbewegung<sup>129</sup> an, daß die im Herzen gelegenen Ganglienzellen und Nervenfasern überhaupt nichts mit der Reizerzeugung und Reizleitung zu tun haben. Es sind vielmehr die Muskelzellen des Herzens, welche automatisch die motorischen Reize für die Herzschläge erzeugen, die Muskelzellen des Herzens selbst sind das excitomotorische Centralorgan.

Diese Anschauung stützt sich vor allen Dingen auf die Thatsache, daß das embryonale Herz verschiedener Wirbeltiere bereits vor dem Ausbruch der Ganglienzellen in demselben nachgewiesen

Ventrikel verbindet; erst nach Durchschneidung dieser letzten Brücke tritt der ein (*F. B. Hofmann*<sup>133</sup>). Auch an dem mit Atropin vergifteten Herzen, bei den Ligaturen des Vagus gelähmt sind, so daß Vagusreizung keine Herzbremmung mehr (vgl. S. 133), tritt nach der ersten *Stannius*schen Ligatur derselbe Erfolg ein (*L*

Eine noch genauere Lokalisierung der reizerzeugenden im Venensinus, resp. rechten Vorhof ermöglichte die Methode der begrenzten Erwärmung oder Abkühlung bestimmter Herzkörpertheile. *Gaskell*<sup>138</sup> und *Engelmann*<sup>139</sup> hatten bereits gezeigt, daß eine Änderung der Frequenz der Herzschläge, d. h. also eine Änderung im Tempo der Reizerzeugung nur dann eintritt, wenn Sinus und Vorhof oder die großen Herzvenen erwärmt werden; alleinige Erwärmung des Ventrikels dagegen erhöht nicht die Frequenz, sondern nur die Stärke der Zusammenziehung, bewirkt also nur Änderungen der Contractilität, nicht der Reizerzeugung. Die Methode ist dann durch *Adam*<sup>140</sup>, *Ganter* u. *Z. Brundenburg* u. *Hoffmann*<sup>142</sup> zu einer großen Vollkommenheit gelangt und auch auf das Warmblüterherz angewendet worden. Die Untersuchungen ergaben, daß beim Warmblüterherzen der wirksame Bezirk, durch Erwärmung oder Abkühlung die Frequenz der Herzschläge geändert werden kann, in der Wand des rechten Vorhofs zwischen den Mündungen der Hohlvenen liegt; er fällt zusammen mit dem Gebiete des *Flackschen* Sinusknotens (vgl. S. 102). An dieser Stelle entstehen in der Norm die Ursprungsreize für die Herzbewegung. In besonderen Verhältnissen (s. unten) auch andere Abschnitte des spez. Muskelgewebes des Herzens als Reizbildungscentra fungieren können. *Keith-Flacksche* Sinusknoten im Gegensatz zu diesen als primäres Reizbildungscentrum und die hier entstehenden Reize als topotopische Ursprungsreize (*Hering*<sup>143</sup>) bezeichnet. Die Reize entstehen in Form von Dauerreizen (wie aus dem Fehlen der kompensatorischen Pause an diesen Stellen hervorgeht, vgl. S. 126), diese Dauerreize wirken infolge der physiologischen Eigentümlichkeiten des Herzens in rhythmische Zusammenziehungen, sie werden gleichsam in Einzelreize

Welcher Art die Dauerreize am venösen Ende des Herzens sind, ist unklar, vielleicht handelt es sich um eine erregende Wirkung der in der Muskulatur ablaufenden Stoffwechselfvorgänge.

Außer dem *Keith-Flackschen* Sinusknoten kommt auch den anderen Abschnitten des spezifischen Muskelgewebes des Herzens die Fähigkeit der automatischen Reizerzeugung zu, wenn auch in geringerem Maße; die hier entstehenden Ursprungsreize werden im Gegensatz zu den an der norm. Reizbildungsstätte entstehenden nomotopen als heterotope bezeichnet. Solche Stellen sind: der *Tawarasche* Atrioventrikularknoten (vgl. S. 102): sekundäres Reizbildungscentrum, das *Hissche* Bündel: tertiäres Reizbildungscentrum. In der Norm kommt die Automotie dieser Teile nicht zur Geltung, da ihnen fortgesetzt vom Sinusknoten rhythmische Reize in schnellerer Folge zufließen, die die Frequenz der Pulsationen bestimmen. Wenn jedoch aus irgend einem Grunde die Reizbildungsstätte des Sinusknotens ausgeschaltet ist, dann kann die Automotie der untergeordneten Reizbildungsstätten wirksam und die Reize von hier aus zum Schlagen gebracht werden. Je nachdem die Reize in solchen Fällen vom *Tawaraschen* Knoten oder vom *Hisschen* Bündel ausgehen, d. h. von einer mehr im Vorhof oder mehr im Ventrikel gelegenen Stelle, können in der Schlagfolge des Vorhofs und Ventrikels charakteristische Änderungen eintreten: die Zeit zwischen Vorhof- und K-

bei den höheren nur Vorkammer und Kammer) erfolgt die motorischen Reizes schnell (der Zuckung eines quergestre vergleichbar). Das Reizleitungssystem hingegen, welches die Brücken zwischen jenen einzelnen Abteilungen bildet, leitet folge hiervon zieht jede einzelne Herzabteilung sich als ei gut wie gleichzeitig zusammen, wogegen die Systole einer abwärts gelegenen Herzabteilung erst nach einer merkliche führung des Blutes aus der einen in die andere Herzabteilung Zeit erfolgen kann. Auf diese Weise kommt die Coordina wegung der einzelnen Herzabschnitte zustande.

Beim Warmblüterherzen erfolgt die Übertragung des Re Vorkammern auf die Ventrikel durch das *Hissche* Bündel: achtete, daß nach Durchschneidung des Bündels Vorhof und ganz verschiedenem Tempo schlagen, *Hering*<sup>152</sup> zeigte, daß schneidung dieses Bündels jede funktionelle Verbindung von Kammer aufgehoben ist; Vorhöfe und Kammern schlagen voneinander (die Kammern seltener), beide automatisch kompensatorischen Pause am Ventrikel), weder von den Kammer noch umgekehrt geht eine spontane oder künstli Erregung über (vgl. *Cohn* u. *Trendelenburg*<sup>153</sup>, *Eppinger* u. *H*

**Pathologisches.** — Eine Leitungsunterbrechung im *Hissche* auch beim Menschen zu Dissoziation des Vorhof- und Kammerrhythmus: Krankheit (vgl. *His*<sup>154</sup>).

## 46. Die Wirkung der Herznerven auf die Herzb

**Anatomisches.**<sup>155</sup> — Den Plexus cardiacus bilden: — 1. Di des N. Vagus-Stammes; dazu Äste gleichen Namens aus dem Ram. exterr gens superior, des inferior, mitunter auch der Lungenäste vom Vagus, z als links. — 2. Die (an Zahl und Stärke nicht selten wechselnden) Rami c medius, inferior und imus aus den drei Halsganglien und dem ersten Br stellatum) des N. sympathicus [mitunter verläuft ein Zweig eine Stre Bahn des Ram. descendens hypoglossi]. Aus dem Geflechte geben hervor: die oberflächlichen Nerven (die letzteren in der Regel an der Teilung der dem Aortenbogen ein Ganglion enthaltend). Man unterscheidet:

a) den Plexus coronarius dexter et sinister, der die vas Nerven der Kranzgefäße durch den Vagusanteil, die dilatatorischen du thicus führt (*Maass*<sup>157</sup>, *Langendorff*<sup>158</sup>). Nach *Dogiel* u. *Archangelsky*<sup>159</sup> v die vasomotorischen Nerven durch den Sympathicus.

b) die in der Herzsubstanz und in den Furchen liegenden N reichlich mit Ganglienzellen versehen sind. Ein ganglienreicher Ne läuft im Herzen, dem Rande des Septum atriorum entsprechend, — ein Atrioventrikulargrenze. Wo beide sich treffen, tauschen sie Fasern aus. Die meist nahe dem Perikard. Bei Säugern liegen die beiden größeren Ganglie mündung der oberen Hohlvene, — bei Vögeln liegt der größte Nervenknote Kreuzungsstelle des Sulcus longitudinalis und transversalis. Von diesen m durchsetzten Ringen bohren sich nun in die Muskelwände der Vorkammer feinere Nebenästchen ein, welche auch ihrerseits wieder kleinere Ganglie

Beim Frosch<sup>160</sup> ist der Vagus der einzige Nerv, der zum Herzen laufen in seiner Bahn schon vom Anfang an auch sympathische Fas Rami cardiaci (vom rechten und linken Vagus) treten in die Wand des ein und bilden hier einen Plexus, dem zahlreiche Ganglienzellen eingelagert scher Haufen; eine kurze Anastomose verbindet hier die beiden Nerven.



**DIESE SEITE IST FÜR KOSTENLOSE MITGLIEDER GESPERRT**  
Beantragen Sie jetzt die volle Mitgliedschaft, um diese Seite zu betreten

# GESCHICHTE

Zehntausende von wichtigen historischen Quellen, viele bisher nicht erhältlich, stehen jetzt zum ersten Mal mit der Vollmitgliedschaft von Forgotten Books zur Verfügung.

Unbegrenzter Zugang  
\$8.99/monat

**Fortfahren**

\*Es gelten Richtlinien zur fairen Nutzung.



Wird der Thorax zunächst in die tiefste Inspirationsstellung, hierauf die Glottis geschlossen und nun durch Wirkung der Inspirationsmuskeln der Brustraum stark verkleinert, so können die Lungen so stark zusammengepreßt werden, daß sogar die Blutbewegung zeitweilig unterdrückt wird („*Valsalvas Versuch*“, 1740). Der Zug ist in dieser Stellung sehr beschränkt und hierzu wirkt nur unter hohem Drucke stehende Lungenluft pressend auf das Herz und die intrathorakalen Gefäße. Von außen kann kein Venenblut in den Thorax eintreten, es schwellen daher die sichtbaren Venen, das Blut des Herzes wird schnell in das linke Herz befördert und dieses entleert sich nach außen. Daher sind die Lungen blutarm und die Herzhöhlen blutreich. Also herrscht größeres Blutreichtum im großen Kreislaufe, geringeres im kleinen und im Herzen. Die Herztöne hören auf, die Pulse schwächen sich.

Wird umgekehrt in stärkster Expirationsstellung die Glottis geschlossen und nun mit aller Anstrengung der Brustkorb inspiratorisch erweitert, so wird das Herz gewaltsam dilatirt; denn außer dem Einströmen der Lungen wirkt noch die stark verdünnte Lungenluft auf die Herzhöhlen. In das rechte Herz ergießt sich reichlich Blut aus den Hohlvenen; in dem Maße ferner, wie der rechte Vorhof und die Kammer nach außen noch überwinden können, werden sich die Lungen der Lungen stark mit Blut füllen. Aus dem linken Herzen wird weniger Blut ausgetrieben, so daß sogar die Pulse stocken können. Es entsteht ein prall gefülltes, großes Herz und größeres Blutreichtum im großen Kreislaufes gegenüber dem großen („*Johannes Müllers Versuch*“).

Die Verkleinerung und Vergrößerung des Herzens beim *Valsalvaschen* u. *Johannes Müllerschen Versuch* können durch das Röntgenverfahren direkt beobachtet werden (Landois<sup>112</sup>).

Der Fig. 31 dargestellte Apparat zeigt schematisch den Einfluß der Inspirationsbewegung auf die Ausdehnung des Herzens und den Strom in den Blutbahnen, die zum und vom Herzen führen. Eine Glasflasche mit abgesprengtem Boden stellt den Thorax dar, an Stelle des Flaschenbodens ist *D*, eine elastische Gummimembran gebracht, welche das Zwerchfell repräsentiert. *PP* sind die Lungen, *L* die Luft im Thorax, *E* der Eingang (Glottis) durch einen Hahn beliebig geschlossen werden kann, *H* ist das Herz, *V* die Hohlvenen, *A* das Aortenrohr. Wird zuerst der Lufröhrenhahn geschlossen, dann wie bei I die Expirationsstellung mit Verkleinerung des Thoraxraumes herbeigeführt, so wird durch die Aufwärtspressung von *D*, so wird die Luft in *PP* verdichtet, zugleich aber wird das Herz *H* komprimiert; das venöse Ventil schließt sich, das arterielle wird geöffnet, die Flüssigkeit durch *A* ausgetrieben. Das eingesetzte Manometer *M* zeigt den Intrathorakaldruck an. — Wird gleichfalls bei geschlossenem Hahn *E* (in II) die Brust stark abwärts gezogen, so erweitern sich die Lungen *pp*, aber auch das Herz *H* und die Klappe öffnet sich, die arterielle schließt sich, es erfolgt also Einströmen von Blut in das Herz.

II. Einwirkung der Herzbewegungen auf die Lungen. Da das Innere des Thorax während der Systole einen kleineren Raum einnimmt als während der Diastole, so muß bei offener Glottis, wenn es sich verkleinert, Luft in den Thorax strömen, wenn es erschläft, seiner Vergrößerung entsprechend, Luft durch die geöffnete Glottis entweichen. Einen gleichen Einfluß muß der Füllungsgrad der großen intrathorakalen Blutstämme haben. Die hierdurch auch bei stillstehender Atmung bewirkte Bewegung der Lungen wird als „kardiopneumatische Bewegung“ bezeichnet; sie kann durch verschiedene Vorrichtungen demonstriert und sogar graphisch registriert werden (Landois<sup>112</sup>); die Deutung der dabei gewonnenen Kurve muß auf die Originalarbeiten verwiesen werden (Landois<sup>112</sup>, Haycraft u. Edie<sup>113</sup>, Harris<sup>114</sup>).

## Literatur (§ 36–47).

1. *L. Krehl*: L. A. 17, 1891, 341. — 2. *E. Albrecht*: Der Herzmuskel. Bedeutung für Physiologie, Pathologie und Klinik des Herzens. Berlin 1903. — 3. Zusammenfassende Darstellung: *J. Kälbs*: Das Reizleitungssystem im Herzen. 1904.

- u. C. Ludwig: L. B. 20, 1868, 89. — 95. L. Krehl: A. P. 1889, 253. — 96. W. B. 12. I. u. 21. III. 1895; 5. VI. 1896. V. A. 141, 1895, 1. M. m. W. 190  
 97. Wintrich: Sitz.-Ber. d. phys.-med. Sozietät z. Erlangen 7, 1875, 51. — 98. J. B. J. o. P. 11, 1890, 486. — 99. K. Hürthle: P. A. 60, 1895, 263. — 100. W. E. M. A. J. Geluk: P. A. 57, 1894, 617. — 101. W. Einthoven: P. A. 117, 190  
 102. R. H. Kahn: P. A. 133, 1910, 597. 140, 1911, 471. — 103. O. Weiß: An Psychol. 9, 1907, 483. (u. G. Joachim) P. A. 123, 1908, 341. Phonokardiogramm anat. u. physiol. Vorträge. Jena 1909. — 104. H. Gerhartz: Z. e. P. u. T. 5, P. A. 131, 1910, 509. Die Registrierung des Herzschalles. Berlin 1911. — 105. Zfassende Darstellung: O. Langendorff: E. P. I, 2, 1902, 263. IV, 190  
 106. Th. W. Engelmann: P. A. 52, 1892, 357. — 107. H. P. Bowditch: L. B. 23 J. o. P. 1, 1878, 104. — 108. H. Aubert: P. A. 24, 1881, 357. — 109. Th. W. P. A. 62, 1896, 543. — 110. Marey: C. r. 82, 1876, 408. 89, 1879, 203. Jou et de physiol. 1877, Nr. 1. Trav. d. laborst. 2, 1876, 63. — 111. Th. W. Engel 59, 1895, 309. — 112. O. Langendorff: A. P. 1885, 284. P. A. 61, 189  
 113. A. Walther: P. A. 78, 1899, 597. — 114. Rouget: A. d. P. 6, 188  
 115. O. Frank: Z. B. 38, 1899, 300. — 116. B. Danilewsky: P. A. 109, 190  
 117. O. Langendorff: A. P. 1884, Suppl., 1. P. A. 57, 1894, 409. 61, 189  
 118. Merunowicz: L. B. 27, 1875, 252. — 119. M. Löwit: P. A. 23, 1880, 313 399. — 120. O. Langendorff: P. A. 61, 1895, 333. — 121. W. Trendelenburg 1900, 268. — 122. W. Trendelenburg: A. P. 1903, 271. — 123. E. Kohde: 1906, 104. — 124. Fick: W. B. 1874, 13. Juni. — 125. Th. W. Engelmann 1875, 465. — 126. R. Marchand: P. A. 15, 1877, 511. 17, 1878, 137. — 127. P. A. 113, 1906, 111. Die Nerven des Herzens. Übersetzt von H. L. Heusner. A. Bethe: Allgemeine Anatomie und Physiologie des Nervensystems. Leipzig G. F. Nicolai: A. P. 1910, 1. H. Kronecker: C. P. 24, 1910, 388. — 128. dorff: P. A. 112, 1906, 522. — 129. Th. W. Engelmann: P. A. 56, 1894, 149. 65 Das Herz und seine Tätigkeit im Lichte neuerer Forschung. Festrede. Le Myogene Theorie und Innervation des Herzens. Die Deutsche Klinik. Berlin u. W. H. Gaskell: The contraction of cardiac muscle. Text-book of Physiology. E. A. Schäfer. 2, 1900, 169. — 130. W. His jun.: L. A. 18, 1891, 1. Arbe mediz. Klinik. Leipzig 1, 1893, 14. — 131. Th. W. Engelmann: P. A. 65, 189 132. L. Krehl u. E. Romberg: A. P. P. 30, 1892, 49. — 133. F. B. Hoffmann 1895, 139. 72, 1898, 409. 84, 1901, 130. — 134. A. J. Carlson: E. P. 8, 19 135. A. Bethe: A. P. 1909, 385. — 136. Stannius: Zwei Reihen physiolog Rostock 1851. A. A. P. 1852, 55. M. Löwit: P. A. 23, 1880, 313. — 137. T mann: A. P. 1903, 505. — 138. W. H. Gaskell: Philos. Transact. Roy. Soc. Part. 3, 993. — 139. Th. W. Engelmann: P. A. 65, 1897, 131. — 140. H. Ada 1905, 1749. P. A. 111, 1906, 607. — 141. G. Ganter u. A. Zahn: C. P. 25, P. A. 145, 1912, 335. C. P. 27, 1913, 211. A. Zahn: C. P. 26, 1912, 495. P. A 247. W. Koch: P. A. 151, 1913, 279. — 142. K. Brandenburg u. P. Hoffman 1911, 916. — 143. H. E. Hering: C. P. 19, 1905, 129. — 144. H. E. Hering 1910, 466. — 145. G. Ganter u. A. Zahn: P. A. 154, 1913, 492. — 146. C. J. u. H. Winterberg: P. A. 135, 1910, 559. 141, 1911, 343. 142, 1911, 461. — 147 berg: P. A. 117, 1907, 223. — 148. L. Haberlandt: Das Herztimmern. Sa physiol. Vorträge u. Aufsätze, 26. Heft. Jena 1914. — 149. S. Schmidt-Nielsen: A de Physiol. 4, 1907, 417. — 150. H. E. Hering: C. P. 21, 1907, 719. P. A. 126 — 151. W. His jun.: Wien. med. Blätter 1894, Nr. 44. C. P. 9, 1895, 469. D. 1899, 329. — 152. H. E. Hering: P. A. 108, 1905, 267. 111, 1906, 298. — 153. u. W. Trendelenburg: P. A. 131, 1910, 1. — 154. Eppinger u. Rothberger: 1910. — 155. His: Charité-Annalen. 32, 1909, 3. — 156. E. v. Cyon: Die Herzens. Übersetzt von H. L. Heusner. Berlin 1907. J. Dogiel u. K. Ar P. A. 113, 1906, 1. J. Dogiel: P. A. 142, 1911, 109. 155, 1914, 351. — 157 P. A. 74, 1899, 281. — 158. Langendorff: C. P. 21, 1907, 551. — 159. K. Archangelsky: P. A. 116, 1907, 482. — 160. F. B. Hofmann: A. A. 19 161. Th. W. Engelmann: P. A. 62, 1896, 555. A. P. 1900, 315. — 162. A. A. P. 1846, 483. Wagners Handwörterbuch der Physiologie. 3, 2, 18 163. Budge: A. A. P. 1846, 295. A. p. H. 5, 1846, 580. — 164. W. Cullis u. J. o. P. 46, 1913, 141. — 165. H. E. Hering: P. A. 115, 1906, 354. 141, 19 166. F. Marchand u. A. W. Meyer: P. A. 145, 1912, 401. — 167. Hofmann Jahrbücher der gesamten Medizin. 281, 1904, 113. — 168. H. E. Hering: P. 245 u. 253. — 169. Th. W. Engelmann: A. P. 1900, 315. — 170. L. J. P. A. 66, 1897, 328. — 171. H. Friedenthal: A. P. 1902, 135. — 172. Londo d. Naturforscher-Versamml. Hamburg 1876. — 173. J. B. Haycraft u. R. Edie 1891, 426. — 174. D. F. Harris: J. o. P. 32, 1905, 495.



er Öffnung ist sie — die Widerstandshöhe diejenige Kraft darstellt, die zur Überwindung der Widerstände nötig ist, so muß sie (und ebenso der Druck nach der Öffnung der Röhre zu konstant abnehmen. Der an einer bestimmten Röhre gemessene Druck ist somit das Maß für die Summe der Widerstände, die der Strom der Flüssigkeit auf seinem Wege von der untersuchten Stelle bis zur Ausflußöffnung noch zu überwinden hat.

Die Treibkraft nimmt daher im Verlauf der Röhre konstant ab, da derselben, die Widerstandshöhe, durch die Widerstände allmählich aufgebraucht (Wärme umgesetzt) wird; am Ende der Röhre bleibt von ihr nur noch die Geschwindigkeit übrig, welche die Ausströmungsgeschwindigkeit bewirkt.

Die Widerstände. Die Widerstände, welche sich einer strömenden Flüssigkeit entgegenstellen, hängen ab: — 1. Von der Kohäsion der Flüssigkeitsteile aneinander oder der Viscosität der Flüssigkeit (*Hürthle*<sup>1</sup>, *Hirsch u. Beck*<sup>2</sup>, *Trotter*<sup>3</sup>, *Bois-Reymond*, *Brodie u. Müller*<sup>4</sup>, *Münzer u. Bloch*<sup>5</sup>, *W. Müller*<sup>6</sup>, *De Vries*<sup>7</sup>). Während der Strömung befindet sich die äußerste, wandständige Schicht, welche die Röhrenwand benetzt, in völliger Ruhe. Alle übrigen Flüssigkeitsschichten, welche man sich vorstellen kann, als concentrisch ineinander geschobene Zylinderschichten, bewegen sich von der Achse der Röhre hin in fortschreitend größerer Bewegung, der Achsenfaden stellt den am schnellsten sich bewegenden Teil der Flüssigkeit dar. Bei diesem Vorwärtsschreiten der zylindrischen Flüssigkeitsschichten an ihren Begrenzungsflächen müssen die aneinanderliegenden Flüssigkeitsteilchen voneinander gerissen werden, wofür ein Teil der Treibkraft verbraucht wird. Die Größe der Widerstände ist wesentlich ab von der Kohäsionskraft der Flüssigkeitsteilchen; je inniger die Flüssigkeitsteilchen aneinander haften, desto größer werden die Widerstände. Umgekehrt ist es leicht verständlich, daß die Widerstände, welche das Kohäsionsvermögen in seiner Strömungsgeschwindigkeit läßt, größer sein müssen als bei Wasser oder Äther. Es bedarf des 4<sup>1/2</sup>-fachen D, um die gleiche Menge Wasser durch eine Röhre zu treiben.

Fig. 33.

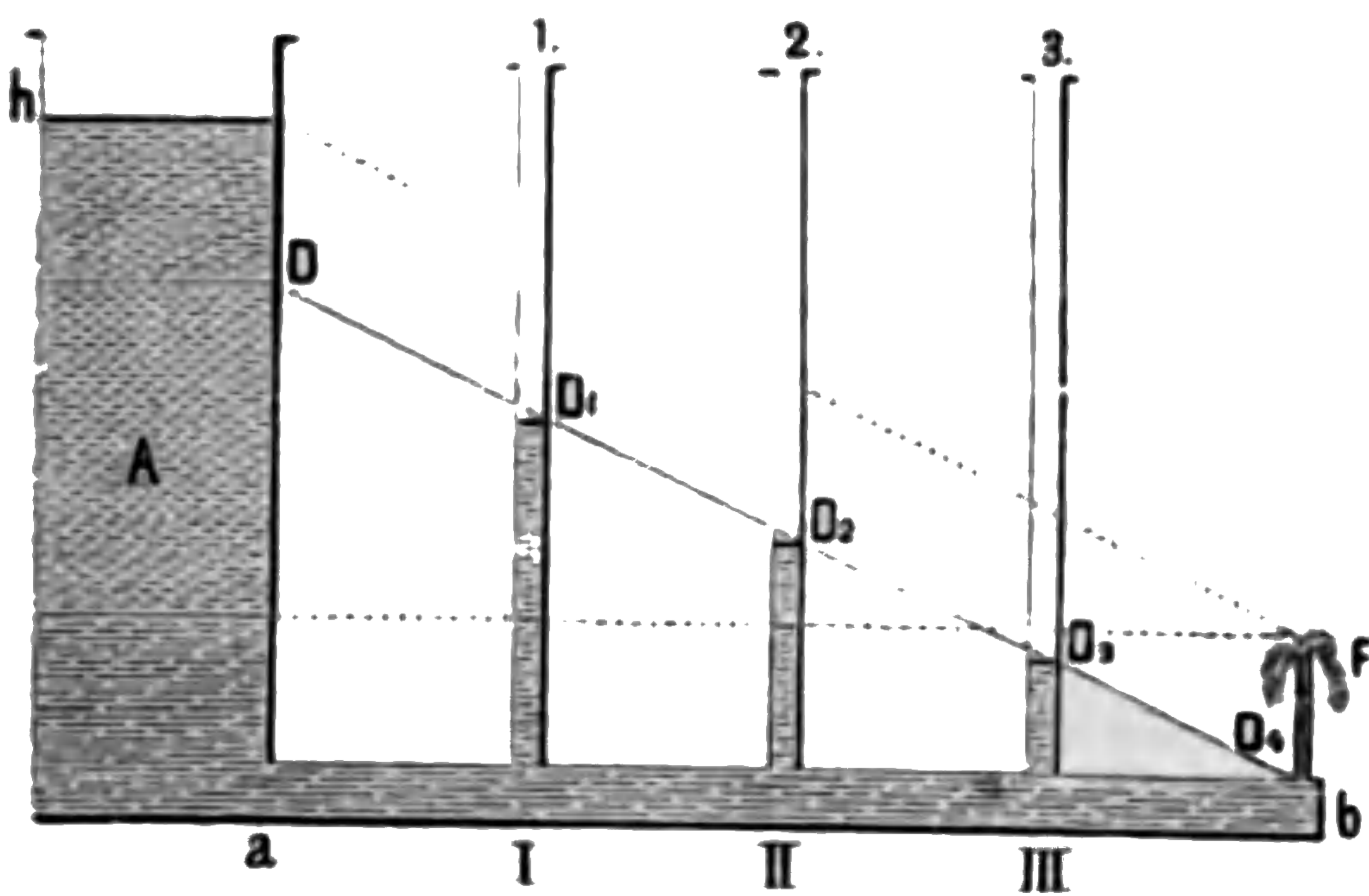

Ein Druckgefäß A mit dem Ausflußrohr a b und eingesetzten Druckmessern D<sub>1</sub> D<sub>2</sub> D<sub>3</sub>.

Erwärmung vermindert die Kohäsion der Teilchen und daher auch die Widerstände. Offenbar muß ferner je schneller die Strombewegung vor sich geht, desto mehr Flüssigkeitsteilchen in einer Zeiteinheit auseinandergerissen werden, desto größer auch die Summe der Widerstände werden. Da die wandständige, die Röhrenwand benetzende Flüssigkeit sich während der Strömung in absoluter Ruhe befindet, so hat hieraus, daß das Material der Röhrenwandung keinen Einfluß auf die Widerstände hat.

2. Von der Weite des Rohres. Bei gleicher Stromgeschwindigkeit ist die Summe der Widerstände abhängig von der Größe des Durchmessers des Rohres; je größer der Durchmesser ist, desto größer sind die Widerstände. Die Widerstände nehmen in abnehmenden Röhren schneller zu, als die Durchmesser der Röhre abnehmen.

Strömung einer Flüssigkeit in einem starren, ungleich weiten Röhren, welche in ihrem Verlaufe eine ungleiche Weite besitzen, ist die Geschwindigkeit des Stromes verschieden; sie ist innerhalb der weiten Stellen natürlich kleiner als innerhalb der engen größer. Im allgemeinen ist die Stromgeschwindigkeit innerhalb ungleich weiten Röhren umgekehrt proportional dem Durchschnitte des betreffenden Röhrenabschnittes.

Während in überall gleichweiten Röhren die Treibkraft der strömenden Flüssigkeit von Strecke zu Strecke gleichmäßig abnimmt, nimmt dieselbe innerhalb ungleich weiten Röhren nicht gleichmäßig ab. Denn da die Widerstände in engen Röhren größer sind als in weiten, so muß natürlich innerhalb der engen Stellen die Treibkraft stärker abnehmen als innerhalb der weiten.

Krümmungen und Schlingelungen der Gefäße bringen weiterhin Widerstände mit sich: infolge der Zentrifugalkraft pressen sich nämlich die Flüssigkeitsteilchen stärker an der konvexen Seite des Bogens und finden hier somit größeren Widerstand als an der konkaven Seite. Hierdurch wird die Strombewegung an der konkaven Seite erleichtert.

aneinanderliegenden Flüssigkeitsteilchen voneinander gerissen werden, wofür ein Teil der Treibkraft verbraucht wird. Die Größe der Widerstände ist wesentlich ab von der Kohäsionskraft der Flüssigkeitsteilchen; je inniger die Flüssigkeitsteilchen aneinander haften, desto größer werden die Widerstände. Umgekehrt ist es leicht verständlich, daß die Widerstände, welche das Kohäsionsvermögen in seiner Strömungsgeschwindigkeit läßt, größer sein müssen als bei Wasser oder Äther. Es bedarf des 4<sup>1/2</sup>-fachen D, um die gleiche Menge Wasser durch eine Röhre zu treiben.



**DIESE SEITE IST FÜR KOSTENLOSE MITGLIEDER GESPERRT**  
Beantragen Sie jetzt die volle Mitgliedschaft, um diese Seite zu betreten



**Seien Sie niemals ohne ein Buch!**

Die Vollmitgliedschaft von Forgotten Books bietet Ihnen einen universalen Zugang von unseren Apps und unserer Website, auf all Ihren Geräten: Tablet, Telefon, E-Reader, Laptop und Computer.

**Eine Bibliothek in Ihrer Tasche für € 8.99/monat**

**Fortfahren**

\*Es gelten Richtlinien zur fairen Nutzung.

Nach *Fuchs*<sup>11</sup> zeigen die Venen keine Erscheinung einer tonischen Erregung der Wandmuskeln; auf elektrische Reizung der Nerven zeigen nur die Arterien, nicht eine aktive Verengung.

Läßt man die Gefäße ausgeschnittener lebensfrischer Organe durchströmen, welchem gewisse Stoffe beigemischt sind, so wirken: erweiternd Amylnitrit, Cl Morphin, Chinin, Atropin (Harnstoff und Kochsalz auf die Nierengefäße), — v. Adrenalin, Digitalin, Veratrin.

Auch den Capillaren kommt Contractilität zu, und z. B. zeigt es sich nach den Untersuchungen von *Steinach* u. *Kahn* nicht, wie man früher angenommen hatte, nur um eine Verengung des Lumens infolge einer vergrößerten Turgescenz der Zellen der Capillaren, sondern um echte Contractilität. Diese hat ihren Sitz in den Endothelzellen, deren Körper parallel zur Längsachse des Gefäßes stehen, während feine Ausläufer aber senkrecht davon ausstrahlen und die Gefäßwand ringförmig umklammern. *Steinach* u. *Kahn*<sup>12</sup> konnten sowohl bei direkter elektrischer Reizung, als auch bei Reizung des Sympathicus die Capillaren der Nickhaut des Frosches zur Contraction bringen.

Die Elastizität der Gefäße ist gering, d. h. sie setzen den den äußeren Kräften wie Druck oder Zug einen nur geringen Widerstand entgegen, aber sie ist zugleich vollkommen, d. h. sie kehren nach Aufhören der äußeren Kräfte in ihre frühere Form wieder zurück (*Fuchs*<sup>12</sup>,

**Pathologisches.** Die Arteriosklerose bedingt starke Veränderungen der Permeabilität, Elastizität und Contractilität der Gefäßwand.

Eine große Kohäsionskraft — ist den Gefäßwänden innewohnend, vermöge deren sie selbst bei erheblicher Spannung im Innern einen großen Reißwiderstand zu leisten vermögen. Der Zerreißungswiderstand der Venen ist relativ noch größer als der gleichdicker Arterienwände. *Gréhant* u. *Quinquaud*<sup>13</sup> halten die normale Arteria carotis oder die eines Menschen einen Druck von 7—8 Atmosphären aus.

## 50. Die Bewegung des Blutes im Gefäßsystem

Das System der Blutgefäße ist nicht allein vollkommen mit Blut angefüllt, sondern es ist überfüllt. Das Volumen der gesamten Blutmasse ist nämlich größer als der Hohlraum des Gefäßsystems in leerem Zustande. Daraus folgt, daß die Blutmasse auf die Gefäßwände einen über den osmotischen Druck ausübenden Druck ausüben muß, welcher eine entsprechende Dehnung der elastischen und contractilen Gefäßwände bedingt. Dies gilt jedoch nur während des Lebens; nach dem Tode erfolgt eine Erschlaffung der Muskeln der Gefäßwände und ein Übertritt von Blutplasma in die Gewebe, so daß nun die Gefäße teilweise sogar leer angetroffen werden.

Denkt man sich die Blutmasse im ganzen Gefäßgebiet gleichmäßig verteilt unter überall gleich hohem Drucke, so würde sie sich in dieser Gleichgewichtslage befinden und in dieser verharren (wie das Blut nach dem Tode). Würde jedoch an einer Stelle des Röhrengebietes der Druck unter welchem das Blut steht, erhöht, so würde es von der Stelle des höheren Druckes dorthin ausweichen, wo der geringere Druck herrscht, es würde eine strömende Bewegung der Blutflüssigkeit entstehen. Diese derartige Druckdifferenz unterhält während des Lebens dauernd das Herz, indem es mit jeder Systole der Kammern eine gewisse Menge Blut in die Wurzeln der großen Arterien wirft, die unmittelbar zuvor d



und  $B$  dienen dazu, den Apparat auf der Umgebun  
 Die Metallschüsselchen  $S$  und  $S'$  gehen nach oben in  
 Gummischläuche  $K$  und  $K'$  mit entsprechend sinige  
 verbunden, die in umgekehrter Stellung, mit der Gum  
 befestigt sind. In der Mitte der Gummimembran ragt  
 an dem Schreibhebel  $Z$  auf  $Z'$  nahe an seiner Achse  
 Gummimembran, welche durch die pulsierende Stelle  $b$   
 der Metallschüsselchen und der Schläuche auf die o  
 oberen Schreibhebel übertragen.

Es sind eine große Zahl von Modifikationen de  
 (so von *r. Frey*<sup>26</sup>, *Jaquet*<sup>26</sup> u. a.). Eine besonders b  
 gebrauchte Form ist der *Dudgeonsche*<sup>27</sup> Sphygmogra  
 die Bewegung der Pelotte  $P$  (Fig. 39) nacheinander  
 schließlich auf die Schreibnadel  $s$  übertragen, die di  
 zeichnet; das Gegengewicht  $g$  hält die einzelnen Teile

Von einem idealen Sphygmographen n  
 wegung des Schreibhebels und somit die  
 wegung der pulsierenden Stelle absolut g

Fig. 38.

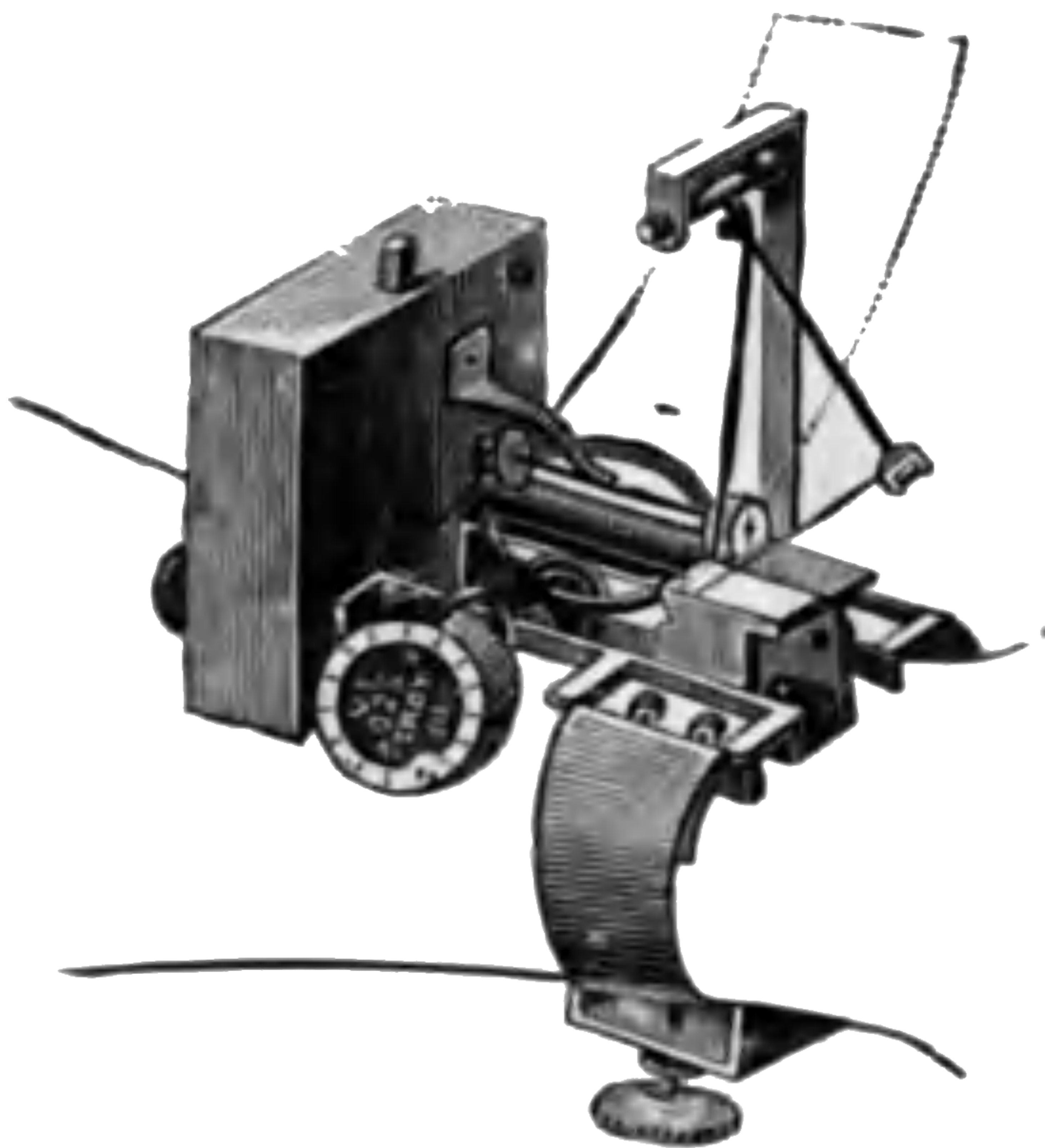

Dudgeons Sphygmograph.

Die Übertrag

derung erfüllen jedoch die meisten Instru  
 durch im Apparat liegende Fehler wird d  
 pulsierenden Stelle in stark entstellter I  
*Petter*<sup>28</sup> haben die für die Konstruktion de  
 kommenden Momente einer theoretischen und  
 unterzogen, auf die hier nur verwiesen v  
 Grund ihrer Untersuchungen einen neuen Sp  
 nach ihren Angaben alle Pulsformen, w  
 Menschen vorkommen, getreu aufzeic



**DIESE SEITE IST FÜR KOSTENLOSE MITGLIEDER GESPERRT**  
Beantragen Sie jetzt die volle Mitgliedschaft, um diese Seite zu betreten

# GESCHICHTE

Zehntausende von wichtigen historischen Quellen, viele bisher nicht erhältlich, stehen jetzt zum ersten Mal mit der Vollmitgliedschaft von Forgotten Books zur Verfügung.

Unbegrenzter Zugang  
\$8.99/monat

**Fortfahren**

\*Es gelten Richtlinien zur fairen Nutzung.



## 53. Qualitäten des Pulses.

1. Die Pulsfrequenz. Die Zahl der Pulsschläge in einer Minute heißt man unterscheidet danach den *Pulsus frequens et rarus*. Der normale erwachsene hat 71—72 Pulsschläge in einer Minute, das Weib gegen 80 Schläge. Doch die Pulsfrequenz von sehr vielen Momenten beeinflusst:

a) Das Lebensalter. Die Pulsfrequenz beträgt beim Neugeborenen im ersten Lebensjahre 120—130, sie sinkt dann mit zunehmendem Alter, beträgt ungefähr 90, vom 10.—15. Jahre 78 und bis zum 50. Jahre etwa 70, im Alter steigt sie wieder etwas an bis auf 80 und darüber. — v. *Lhota*<sup>23</sup> zeigte, daß bei Hunden die Abnahme der Pulsfrequenz vor allem durch das Auftreten und die Verstärkung des Vagustonus (§ 280) bedingt wird.

b) Die Körperlänge: unter sonst gleichen Verhältnissen nimmt die Pulsfrequenz mit zunehmender Körperlänge ab.

c) Sonstige Einflüsse: Der Puls ist im Stehen etwas frequenter als im Liegen (*Geigel*<sup>24</sup>). Muskeltätigkeit über das Zustandekommen dieses Einflusses vgl. § 74. 3, *Aulo*<sup>25</sup>, *Mansfeld*<sup>26</sup> Wirkung des arteriellen Blutdruckes, — Nahrungsaufnahme, erhöhte Temperatur, Schmerz, — Übelkeit, — psychische und geschlechtliche Erregungen beschleunigen den Puls. — Im Wochenbett, — im Hungerzustande ist die Pulsfrequenz herabgesetzt.

d) Im Laufe eines Tages zeigt sich eine Periodizität der Pulsfrequenz. Die Schwankungen folgen dem Verlaufe der Temperaturkurve.

**Pathologisches.** Unter krankhaften Verhältnissen ist die Pulsfrequenz verändert; im Fieber kann sie auf 120 und darüber steigen. Periodische Ansteigerter Pulsfrequenz (bis zu 250) werden als *Pyknokardie* (falsch ist die *Tachykardie*, da *ταχύς* = color ist, s. unten), abnorme Verlangsamung bis auf 10 als *Spanikardie* (falsch ist die Bezeichnung *Bradykardie*, da *βραδύς* = tardus net. In Fällen, in denen die Pulsfrequenz auf 24, 16, sogar 13 herabgesetzt war, war wohl das Allgemeinbefinden wenig gestört (*Frey*<sup>27</sup>, *Belski*<sup>28</sup>).

Pulsfrequenz einiger Tiere: — Elefant 28, — edler Hengst gegen 30 und Arbeitspferde etwas mehr), — Rind gegen 50, — Schaf, Schwein 75, — Katze 130, — Kaninchen 120—150, — Maus 520—675 (*Buchanan*<sup>29</sup>) in 1 Minute.

2. *Pulsus celer et tardus*. Von der Pulsfrequenz streng zu unterscheiden ist die Pulscelerität. Ein *Pulsus color* oder schnellender Puls ist ein solcher, der rasch entwickelt und wieder vergeht, rasch an- und absteigt; beim entgegenhalten, wenn die Dehnung des Arterienrohres durch die Pulswelle und das Zurückweichen langsam erfolgt, spricht man von *Pulsus tardus* oder gedehntem Puls. Keine Aktion, hohe Nachgiebigkeit der Arterienmembran, leichter Abfluß des Blutes, der pulsierenden Stelle am Herzen begünstigen die Entwicklung eines *Pulsus celer* gesprochen *celer* ist der Puls bei Aorteninsuffizienz.

3. Nach der Größe des Pulses, d. h. nach der Weite der Exkursion, die die Arterienwand bei jedem Pulsschlag macht, unterscheidet man den *Pulsus magnus* und *Pulsus parvus*. Ist die Größe verschiedener Pulse nicht unter sich gleich, wie normal, so spricht man von *Pulsus inaequalis*.

4. Unter Spannung oder Härte des Pulses (*Pulsus durus et mollis*) versteht man das Maß von Kraft, welches man aufwenden muß, um die Arterie vollständig zu komprimieren, so daß peripher von der komprimierten Arterie kein Puls mehr zu fühlen ist. Die Spannung des Pulses ist danach abhängig von dem maximalen, auf der Pulswelle in der Arterie vorhandenen Blutdruck. — Streng zu unterscheiden von der Härte des Pulses ist die Beschaffenheit der Arterienwand, die selbst hart (z. B. bei Atherosklerose) oder weich, elastisch (beim Gesunden) sein kann.

5. **Rhythmus des Pulses.** An dem normalen Pulse erkennt der tastende Untersucher keinen besonderen Rhythmus, sondern es folgt Schlag auf Schlag in anscheinend gleichmäßiger Weise, wenn auch geringe zeitliche Abweichungen der Pulse untereinander oft vorkommen (*Hebfisch*<sup>31</sup>, *Junowski*<sup>32</sup>). Zuweilen fällt in der normalen Reihe plötzlich ein aussetzender Puls. Rührt das Aussetzen von einer bloßen Schwäche der Systole her, heißt der Puls *P. intermittens*, — rührt es von einem Ausfall der Systole her, heißt man ihn *P. deficiens*. Mitunter erscheint in einer normalen Reihe ein Puls, der ausgespart ist, man schiebt ihn *P. intercurrentis*. Der regelmäßige Wechsel von einem hohen und einem niedrigen Pulse wird als *Pulsus alternans* bezeichnet. Beim *Pulsus bigeminus* folgen die Pulse paarweise auf, so daß der zweite Schlag dicht hinter dem ersten folgt.

## 55. Der Venenpuls. Das Phlebogramm.

**Methode.** — Man kann von den Bewegungen einer Vene mittelst empfindlicher Sphygmographen eine Kurve verzeichnen: die Venenpulskurve oder das Phlebogramm. Zur Deutung derselben ist die gleichzeitige Registrierung des Kardiogramms oder des Phlebogramms erforderlich. — *Volhard*<sup>55</sup> überträgt, um das zeitliche Verhältnis von Venen- und Carotispuls zu demonstrieren, die Pulsbewegungen mittelst zweier Glasstrichter, die auf die pulsierende Vene und die Carotis aufgesetzt werden, auf nebeneinanderstehende Wassermanometer mit gefärbter Flüssigkeit.

Unter normalen Verhältnissen erlischt im allgemeinen die pulsartige Bewegung im Capillargebiet; in den Venen findet nur noch ein gleichmäßiges Strömen des Blutes statt (S. 145). Häufig beobachtet man jedoch unter physiologischen Verhältnissen in der Vena jugularis communis eine Pulsation; sie erstreckt sich entweder nur auf den unteren Teil der Vene, den sogenannten Bulbus, oder auch höher hinauf auf den Stamm der Vene selbst. — Die Venenpulswelle pflanzt sich langsamer als die Arterienpulswelle, nämlich nur 1—3 m in 1 Sekunde (*Morrow*<sup>56</sup>).

Durch die Venenklappen oberhalb des Bulbus wird die Erscheinung des physiologischen Venenpulses nicht beeinflusst, da es sich dabei um eine negative Wellenbewegung handelt, die in der Richtung des Blutstromes verläuft (s. unten); beim pathologischen Venenpuls sind die Venenklappen oft insuffizient.

Bei dem physiologischen Venenpuls handelt es sich nicht etwa um eine vom Herzen in die Venen zurückgeworfene Welle, sondern der gleichmäßige Abfluß des Venenblutes wird durch die Herztätigkeit bald und bald behindert. Die normale Venenpulskurve zeigt drei Haupterhebungen. Die erste Erhebung, die mit der Systole des Vorhofes (der Diastole der Kammer) zusammenfällt, daher mit der Erhebung des Carotispulses synchronisiert, wird bewirkt durch die Beeinträchtigung, die der Abfluß des Venenblutes im Moment der Vorhofscontraction erfährt. Die zweite Erhebung der Venenpulskurve fällt annähernd mit der Erhebung des Carotispulses zusammen, es handelt sich dabei teilweise um eine von der Carotis übertragene Bewegung, zum Teil um eine Abflußbehinderung des Venenblutes zur Zeit der Ventrikelsystole und des Tricuspidalklappenschlusses. Die dritte Erhebung endlich fällt zusammen mit dem Maximum der Kammerdiastole; wie sie zustande kommt, ist unklar. Übergehen die Ansichten über die Deutung der Venenpulskurve noch auseinander (vgl. *Hering*<sup>55</sup>, *Wenckebach*<sup>56</sup>, *Frédéricq*<sup>57</sup>, *Rühl*<sup>58</sup>, *Edens*<sup>59</sup>).

**Pathologisches.** — Der pathologische Venenpuls findet sich bei Tricuspidalinsuffizienz; er fällt (im Gegensatz zum normalen) zeitlich mit der Ventrikelsystole zusammen. Er wird dadurch bewirkt, daß der rechte Ventrikel bei seiner Contraction Blut durch die nicht schlußfähige Klappe in den Vorhof und von da in die Venen wirft. Pflanzt sich die Pulsation in die untere Hohlvene und deren Äste fort, so entsteht der sogenannte Lebervenenpuls.

Zuweilen kommt es vor, daß der Puls in den Capillaren nicht erlischt, sondern durch das Capillargebiet bis in die Venen fortpflanzt, sogenannter penetrierender Puls; so z. B. wenn die Arterien stark erweitert sind (vgl. S. 145), oder wenn derselben stark ansteigt und schnell wieder abfällt, wie bei Insuffizienz der Aortenklappe. Unterscheidung der verschiedenen Arten des Venenpulses.



7) **Blutdruckes** bewirken: hydrostatisch wirkende Lageveränderungen oder Verengerungen anderer größerer Gefäßsprünge. — 5. Bewegung der Muskulatur der eingebrachten Extremitäten. — 6. Hohe (33—36° C) und niedere Temperaturen auf die Armhaut appliziert, vermehren das Volumen des Armes bei einer durch die thermischen Reize bewirkten Parese der Gefäße (Mosso<sup>61</sup>). — 7. Geistige Anstrengung vermindert das Volumen der Extremität (Mosso<sup>62</sup>), ebenso der Schlaf. — 8. Reizung der Nerven hat Abnahme, die der Vasodilatation Zunahme des Volumens.

## 57. Anderweitige pulsatorische Erscheinungen

1. Mundhöhlen- und Nasenhöhlenpuls; Trommelfellpuls. — Eine gefüllte Mund- und Nasenhöhle zeigen bei geschlossener Glottis dadurch, daß die Wände ihrer Weichteile pulsieren, ebenfalls in ihrer Luftmasse eine pulsatorische Bewegung, die mit Hilfe empfindlicher Registriervorrichtungen aufgeschrieben werden kann. In der Paukenhöhle kann auf dieselbe Weise eine Pulsation am intakten Trommelfelle beobachtet werden oder an Stellen, die etwa auffällig innerhalb der Öffnung eines krankhaft perforierten Trommelfells gesetzt haben.

2. Bei lebhafter Anstrengung erscheint häufig mit jedem Pulsschlag ein dunkeltes Gesichtsfeld eine pulsatorische Erhellung, — bei ruhiger Tätigkeit eine analoge Verdunklung. — Mit dem Augenspiegel erkennt man mitunter die Retinaarterien, die namentlich bei Insuffizienz der Aortaklappen bedeuten.

3. Der *Musculus orbicularis palpebrarum* zuckt unter ähnlichen Verhältnissen synchron mit dem Pulse; es rührt diese Zuckung, wie es scheint, durch den Pulsschlag ihn durch die sensiblen Nerven reflektorisch zu einer Contraction (Landois).

4. Sitzt man mit übereinander geschlagenen Beinen, so erkennt man an dem schwebenden Unterschenkel Pulsschlag und Rückstoßlevation.

5. Dem Gehirne wird durch die großen an der Basis verlaufenden Arterien pulsatorische Bewegung mitgeteilt.

6. Onychographie von Herz<sup>63</sup>. Setzt man einen empfindlichen Pulswellen in den kleinen Gefäßen der Fingerbeere contrahiert, so erlischt die Pulsation. Das Onychogramm erscheint als eine Kombination von Sphygmogramm und Plethysmogramm (Auerbach).

7. Eine pathologische Erscheinung sind die systolischen Pulsationen im Epigastrium, teils hervorgerufen vom Herzen bei Hypertrophie des linken Ventrikels bei Tiefstand des Zwerchfells, teils durch starkes Pulsieren der erweiterten Abdominalaorta oder der Art. coeliaca. — Abnorme Erweiterungen der Schlagadern lassen auch an anderen Stellen eine abnorme Pulsation (z. B. an der Trachea durch das Aneurysma der Aorta ascendens und transverse).

Hypertrophie und Dilatation des linken Ventrikels bewirkt eine Pulsation der dem Herzen zunächst liegenden Arterien; bei dem analogen Zustande der rechten Kammer pulsiert stärker die Pulmonalis im 2. linken Interkostalraum. Wenn bei gut ausgeglichener Aorteninsuffizienz kräftiger Kranker die Milz (geschwollen und fühlbar ist, so pulsiert sie ebenfalls (auch am Penis ist Pulsation beobachtet) bei Morbus Basedowii kann sie monatelang pulsieren.

## 58. Der Blutdruck. — Methoden der Messung des Blutdruckes.

A. Bei Tieren. — 1. *Stephan Hales*<sup>64</sup> band zuerst (1727) in die Seite eines Tieres eine lange Glasröhre ein und bestimmte den Blutdruck durch Messung der Höhe der Blutssäule, bis zu welcher das Blut in dieser Röhre senkrecht emporsteigt.



**DIESE SEITE IST FÜR KOSTENLOSE MITGLIEDER GESPERRT**  
Beantragen Sie jetzt die volle Mitgliedschaft, um diese Seite zu betreten



**Seien Sie niemals ohne ein Buch!**

Die Vollmitgliedschaft von Forgotten Books bietet Ihnen einen universalen Zugang von unseren Apps und unserer Website, auf all Ihren Geräten: Tablet, Telefon, E-Reader, Laptop und Computer.

**Eine Bibliothek in Ihrer Tasche für € 8.99/monat**

**Fortfahren**

\*Es gelten Richtlinien zur fairen Nutzung.

find bei normalen jüngeren Männern in der Ruhe (mit dem Apparat von maximalen Blutdruck zu 90—125, den minimalen zu 63—95 mm Hg. (Vgl. von v. Recklinghausen.)

Bei Kindern — nimmt mit dem Alter, der Größe und dem Blutdruck zu (*Tavastjerna*<sup>97</sup>, *Wolfensohn-Kriss*<sup>98</sup>).

Beim Neugeborenen noch vor Beginn der Atmung fand *Ribemont*<sup>99</sup> in einer Arteria umbilicalis = 64 mm Hg, *Seitz*<sup>100</sup> fand 73 mm Hg.

Nach *Volkmann*<sup>91</sup> beträgt in der Carotis der Druck beim Pferd 1 beim Hund 104—172 mm, bei der Ziege 118—135 mm, beim Kaninchen 90 88—171 mm, in der Kiemenarterie beim Hecht 35—84 mm Hg. *Fraen* mittleren Blutdruck beim Kaninchen zu 122, beim Hund zu 180 mm Hg; 150 mm Hg, die pulsatorische Schwankung variierend von 43—64 mm Hg. *Brenner*<sup>102</sup> als normalen Wert des Blutdrucks 218 mm Hg. Bei Vögeln ist bedeutend höher als bei den Säugetieren; er kann über 200 mm Hg betragen der Art. cruralis des Frosches ist der Minimaldruck 41, der Maximaldruck 60 *meister*<sup>93</sup>, *Fr. N. Schulz*<sup>94</sup>).

Im allgemeinen ist der Blutdruck bei größeren Tieren höher als weil bei jenen wegen der erheblicheren Länge der Blutbahnen größere Widerwinden sind. Sehr junge und sehr alte Tiere haben niedrigeren Druck auf der Höhe der Lebensfunktionen.

Der arterielle Druck bei Föten — ist niedriger als bei Neugeborenen Druck ist jedoch bedeutender. Bei einem nicht ausgetragenen Schaffötus 46 mm, beim fast reifen Schafe 84 mm. Man fand die fötale Druckdifferenz arteriellem und venösem Blute kaum halb so groß wie beim erwachsenen (v. *Zuntz*<sup>97</sup>).

Innerhalb der großen Arterienstämme nimmt der Blutdruck die Peripherie hin nur relativ wenig ab, weil die Widerstände in den großen Röhren nur unerheblich sind. Nach *E. Weber*<sup>98</sup> ist der Druck in der Carotis nur 3,5 mm Hg höher als in der Cruralis. Sobald die Schlagadern unter vielfacher Teilung eine erhebliche Verjüngung erleiden, nimmt in ihnen infolge der erheblichen Widerstände der Blutdruck stark ab.

Einflüsse auf die Höhe des Blutdruckes in den Arterien hängen ab: 1. von der Füllung der Arterien mit Blutmenge; 2. von der Herztätigkeit; 3. von den im Gefäßsystem vorhandenen Widerständen.

1. Einfluß der Gefäßfüllung. Man sollte erwarten, daß bei Vermehrung der Blutmasse durch Transfusion, auch nach reichlicher Nahrung der Blutdruck erhöht, bei Blutarmen, nach profusen Blutverlusten oder nach großen Ausgaben aus dem Blute (z. B. durch starke Schweiß, koptösen Durchfall) niedrig sei. Keineswegs ändert sich jedoch der Blutdruck mit der Verminderung des Blutes in geradem Verhältnis. Das Gefäßsystem besitzt vielmehr seiner Muskeln die Fähigkeit, sich dem größeren oder geringeren Blutvolumen ziemlich weit Grenzen anzupassen. Daher steigt bei mäßiger Blutvermehrung der Blutdruck zunächst noch nicht (*Worm-Müller*<sup>99</sup>) (§ 35, 1). Der Umstand, daß Flüssigkeit aus dem Blute in die Gewebe transsudiert, wirkt für das Sinken des Blutdruckes mit (*v. Regérzy*<sup>100</sup>). — Auch mäßige Aderlässe (beim Hund bis zu 6% des Körpergewichtes) haben noch keinen nennenswerten Abfall des Blutdruckes (§ 35, 2), nach kleinen Blutverlusten kann er sogar steigen (*Worm-Müller*<sup>99</sup>). Blutentziehungen bringen jedoch ein starkes Sinken des Blutdruckes hervor, so daß 6% des Körpergewichtes machen ihn = 0.

2. Einfluß der Herztätigkeit. Die Höhe des Blutdruckes hängt ab von der Frequenz und der Stärke der Herzschläge. Bei bestimmten Bedingungen zusammen die Größe der in der Zeiteinheit in das Gefäßsystem getriebenen Blutmenge und dadurch den Blutdruck.

Beim Menschen fand *r. Recklinghausen*<sup>79</sup> z. B. bei Messung am Oberarm folgende Werte für den maximalen, minimalen Pulsdruck und die Pulsdruckamplitude: 158 — 145, 88, 57 cm Wasser.

*Hürthle*<sup>71</sup> fand beim Kaninchen den pulsatorischen Druckzuwachs fast gleich dem Druckes während der Pulspause; *r. Born*<sup>110</sup> gleich  $\frac{1}{3}$  des maximalen Blutdruckes.

Der Ablauf der pulsatorischen Druckschwankung wird im allgemeinen von gewöhnlichen elastischen Manometern keineswegs getreu wiedergegeben, sondern mit manchen weniger großen Entstellungen. Über den wahren Verlauf der Druckschwankungen in der Aorta und in den peripheren Gefäßen vgl. *Frank*<sup>111</sup>.

2. Die respiratorischen Druckschwankungen. Der Druck in den Arterien erleidet durch die Atembewegungen regelmäßige Schwankungen und zwar in der Art, daß bei jeder stärkeren Inspiration der Druck sinkt, bei jeder Expiration steigt. Diese Schwankungen erklären sich am nächst rein mechanisch daraus, daß mit jeder Expiration das Blut in der Aorta den Druckzuwachs durch die komprimierte Luft im Thorax erfährt, bei jeder Inspiration dagegen die Druckabnahme durch die in der Aorta wirkende Verdünnung der Luft in den Lungen. Außerdem bewirkt die inspiratorische Thoraxerweiterung das Blut der Hohlvenen zu ziehen, die Expiration staut es an und wirkt so auch auf den Blutdruck. Die Schwankungen sind am ausgesprochensten in den dem Thorax näher liegenden Arterien (vgl. *Kronecker* u. *Heinricius*<sup>112</sup>).

Zum Teil aber rühren die respiratorischen Blutdruckschwankungen auch her von nervösen Einflüssen, nämlich von einer mit der rhythmischen Erregung des Atemcentrums parallel gehenden Erregungsschwankung des vasomotorischen Centrums, wodurch sich, jeder Arterie entsprechend, die Gefäße contrahieren und so den arteriellen Druck steigern („*Traube'sche Heringsche*<sup>114</sup> Druckschwankungen“). Diese Schwankungen treten besonders deutlich in die Erscheinung, wenn bei einem curarisierten, also nicht mehr selbständig atmenden und daher künstlich geatmeten Tiere die natürliche Atmung ausgesetzt oder ungenügend ausgeführt wird; durch die zunehmende Venosität des Blutes wird das vasomotorische Centrum gereizt, der Blutdruck steigt an, die Blutdruckkurve zeigt deutliche rhythmische Schwankungen.

Unter besonderen Versuchsbedingungen lassen sich noch verschiedene andere bedingte regelmäßige Schwankungen der Blutdruckkurve beobachten. So können durch Übertragung der Impulse vom Atemcentrum auf das Vaguscentrum Veränderungen der Frequenz und dadurch Änderungen des Blutdruckes verursacht werden (*Fredericq* u. *S. Mayer*<sup>116</sup> beobachtete Blutdruckschwankungen, bei denen zahlreiche Respirationen der Blutdruckwelle entsprechen; das Zustandekommen derselben ist noch nicht völlig klar). Endlich können Reflexe durch die Atembewegungen von den Lungen her Blutdruckschwankungen hervorrufen: pulmonale Reflexwellen (*Morawitz*<sup>117</sup>).

## 60. Der Blutdruck in den Capillaren und Venen.

Bestimmung des Blutdruckes in den Capillaren. — Legt man ein Glasplättchen von bekannter Größe auf die gefäßhaltige Unterlage und belastet es in passender Weise mit einem Gewicht, bis die Capillaren zuerst erblasen, so findet man annähernd den Druck, welchen der Blutdruck dieses Capillargebietes gerade überwindet. Man erhält den Druck (ausgedrückt in Zentimeter Wassersäule), wenn man die Zahl für das drückende Gewicht (Gewicht des Glasplättchens) durch die Zahl für die Druckfläche (angegeben in Quadratzentimetern) dividiert (*N. r. Kries*<sup>118</sup>, *Lombard*<sup>119</sup>). Für die Capillaren des Fingererhobener Hand beträgt der Druck 24 mm Hg, — der gesenkten Hand 62 mm, — am Zahnfleisch des Kaninchens 32 mm. — *r. Recklinghausen*<sup>120</sup> übt den Druck eines gelochten Gummibentels, der mit der Pumpe aufgeblasen werden kann und zwischen die zu untersuchende Haut und eine Glasplatte zu liegen kommt, einen zunehmenden

der Kugelapparat  $AB$  um seine Achse  $xy$  gedreht, so daß nun  $B$  an  $S$  kommt. So wiederholt sich die Erscheinung, und die Beobachtung kann oft lang werden. Aus der beobachteten Zeit, welche zur Füllung der einen Kugel durch strömende Blut notwendig ist, berechnet sich die auf die Zeiteinheit entfallende

3. C. Vierordts <sup>143</sup> Hämatochometer (1858) — mißt die Schnelligkeit des Stromes durch eine dem Fittelweinschen „Stromquadranten“ nachgebildete

Fig 47.

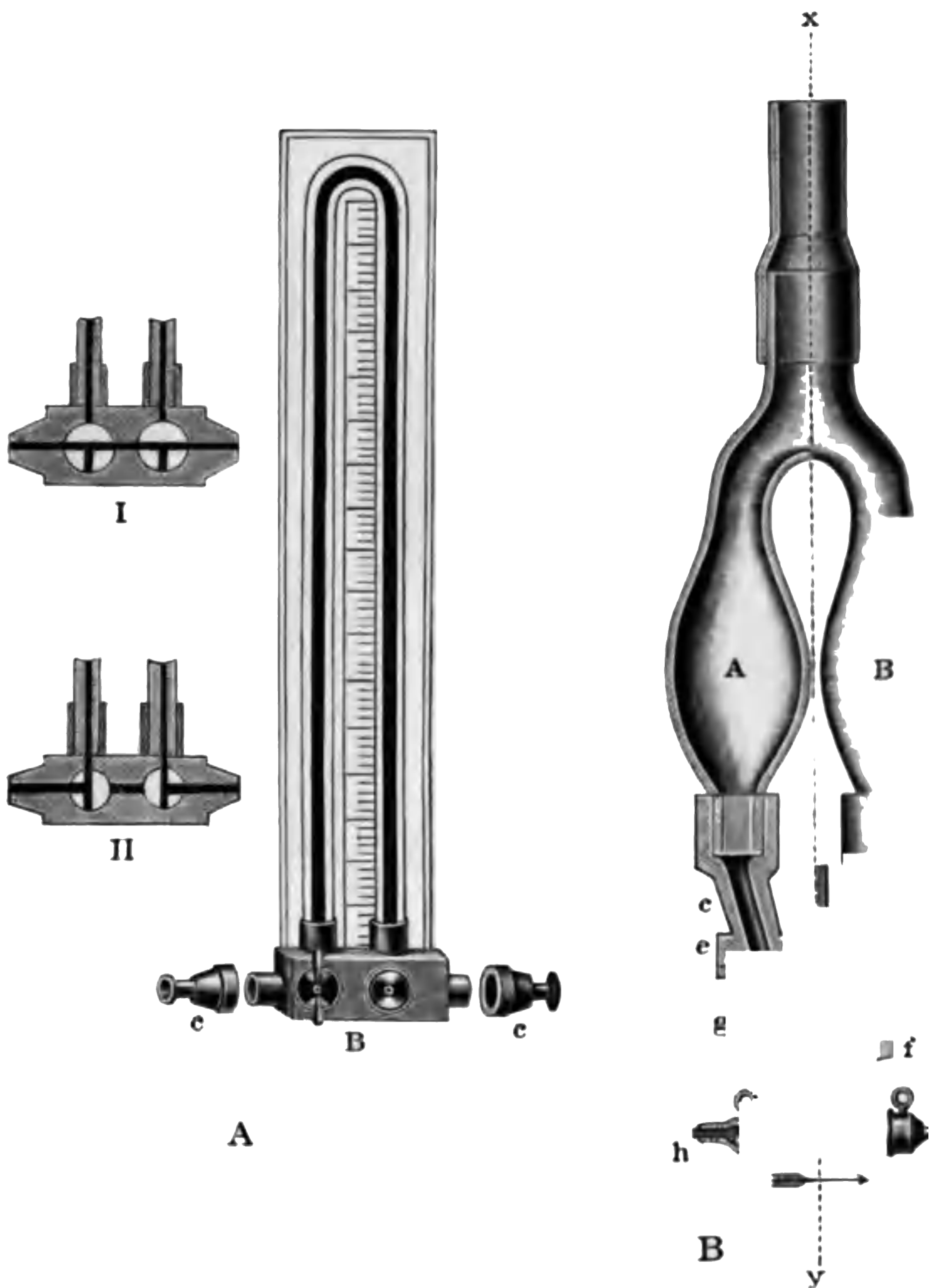

A Volkmanns Hämodromometer. — B Ludwigs Stromuhr.

in einer strömenden Flüssigkeit niederhängendes Pendel wird von dieser und zwar um so stärker, je größer die Stromgeschwindigkeit ist. — Der A) Metallkästchen (Fig. 48, I. A) mit planparallelen Glaswänden dar, welches auf beiden Seiten zum Ein- und Ausströmen des Blutes 2 Kanülen ( $e, a$ ) besitzt. Dem eintretenden Blutströme gegenüber ein Pendelchen ( $p$ ), dessen an



**DIESE SEITE IST FÜR KOSTENLOSE MITGLIEDER GESPERRT**  
Beantragen Sie jetzt die volle Mitgliedschaft, um diese Seite zu betreten

# GESCHICHTE

Zehntausende von wichtigen historischen Quellen, viele bisher nicht erhältlich, stehen jetzt zum ersten Mal mit der Vollmitgliedschaft von Forgotten Books zur Verfügung.

Unbegrenzter Zugang  
\$8.99/monat

**Fortfahren**

\*Es gelten Richtlinien zur fairen Nutzung.



kann daher nur Aufschluß geben über die kürzeste Zeit, in der ein Partikelchen den günstigsten Verhältnissen die ganze Kreislaufbahn durchheilen kann (vgl. r.). Auf die Zeit für den Umlauf der ganzen Blutmasse ermöglicht sie dagegen Rückschluß; diese ist unzweifelhaft größer.

Nach einer anderen Methode hat *Stewart*<sup>163</sup> gearbeitet. Bestimmt man galvanisch zunächst an einer uneröffneten Ader den elektrischen Widerstand und injiziert nun markierten Memento etwas Kochsalzlösung in die Blutbahn, so wird, wenn das Blut die zum Galvanometer abgeleitete Strecke passiert, der galvanische Widerstand sinken; dieser Moment wird gleichfalls markiert.

So fand *Stewart* für den kleinen Kreislauf etwa  $\frac{1}{3}$  der gesamten Kreislaufzeit (= 10,4 Sekunden; Kaninchen, Hund). Es betrug ferner die Kreislaufzeit der Lunge 8 Sekunden, der Leber 3,8 Sekunden; — venöse Blutheschaffenheit verlängert die Kreislaufzeit.

## 64. Die Blutbewegung in den Venen.

Die Blutbewegung in den Venen ist im allgemeinen eine gleichmäßige Strömung, sie erfährt aber infolge der besonderen Eigenschaften der Venen mannigfache Abweichungen. Folgende Momente sind hierbei in Betracht:

1. Die relative Schlaffheit, große Dehnbarkeit und leicht sammendrückbarkeit sogar der dicksten Stämme; — 2. die vielen und zugleich geräumigen Anastomosen unter benachbarten Stämmen in gleicher Gewebslage als auch von der Oberfläche zur Tiefe hin. Hier ist es möglich, daß bei partialer Kompression des Venengebietes noch zahlreiche, leicht dehbare Wege zum Ausweichen findet, so daß also einer wirklichen Stauung vorgebeugt wird; — 3. das Vorhandensein zahlreicher Klappen, welche dem Blutstrom nur die centripetale Bewegung gestatten. Diese fehlen in den kleinsten Venen, sie sind am zahlreichsten in den mittelgroßen. Hydrostatisch sind die Klappen dadurch von großer Bedeutung, daß sie lange Blutsäulen (z. B. bei aufrechter Stellung der Cruralvene) in Abschnitte zerlegen, so daß die ganze Säule nicht dem hydrostatischen Druck bis nach unten hin wirken lassen kann.

Sowie ein Druck auf die Vene ausgeübt wird, schließen sich zunächst unteren und öffnen sich die zunächst oberen Klappen und so dem Blute zum Herzen hin freie Bahn. Ein derartiger Druck wird regelmäßig auf die Venen bei Contractionen der benachbarten Muskeln durch die Verdickung der Muskeln ausgeübt und so der Blutstrom in den Venen befördert. Daß das Blut aus der geöffneten Vene stärker vorquillt, wenn die Muskeln bewegt werden, sieht man beim Anheben des Fußes.

Abweichende Anschauungen über die Blutbewegung in den Venen und die Wirkung der Venenklappen siehe bei *Ledderhose*<sup>164</sup>.

Bei der Streckung und Außenrollung des Oberschenkels erweitert und kollabiert die Schenkelvene in der Fossa iliaca unter negativem Druck, beim Biegen und Erheben fällt sie sich strotzend unter positivem Drucke. Durch diese pumpenartige Wirkung wird das Blut (mit Hilfe der Klappen) aufwärts geleitet. Etwas Ähnliches findet beim Gehen statt (*Brody*).

## 65. Die Blutbewegung in den kleinsten Gefäßen.

**Methode.** Die Strombewegung des Blutes innerhalb der kleinsten Gefäße kann an günstigen Objekten direkt mikroskopisch beobachtet werden. (*Malpighi* beobachtete (1661) den Kreislauf in den Lungengefäßen des Frosches.) Als Objekte sind für durchfallendes Licht: — der Schwanz von Froschlärven und jungen Fische, die Schwimmhaut, die Zunge, das Mesenterium oder die Lunge curarisierter Pröschchen geeignet.

weit in dem perivascularären Gewebe fortzuwandern (Fig. 50). Es ist zweifelhaft, ob Körperchen durch die etwa vorhandenen interendothelialen Stomata hindurch oder ob sie einfach zwischen den Endothelien durch die Kittsubstanz hindurch (§ 49. II). — *Hering*<sup>160</sup> beobachtete, daß sogar unter normalen Verhältnissen aus Gefäßen, welche von Lymphräumen umgeben sind, die Zellen in letztere eintreten, das Überwandern weißer, ja sogar einiger roter Blutkörperchen aus den kleinen in die Lymphgefäße für einen normalen Vorgang.

## 66. Töne und Geräusche in den Gefäßen.

1. Arterien. — In der Carotis (seltener in der Subclavia) hört man bei allen Gesunden zwei deutliche Töne, welche nach Dauer und Höhendifferenz den bei den Tönen entsprechen und durch Fortpflanzung des Schalles vom Herzen entstehen: „leitete Herztöne“. Durch die bei der Systole des Herzens entstehende starke Kontraktion der Gefäßwand kann aber auch in dem Gefäß selbst ein Ton, entsprechend dem Herztone, entstehen. Mitunter ist nur der zweite Herzton allein vernehmbar, wenn der Ort der Carotis näher gelegen ist.

Übt man auf eine beschränkte Stelle einer stärkeren Arterie, z. B. der A. cruralis, einen Druck aus, der so in seiner Stärke bemessen sein muß, daß nur noch eine kleine Öffnung des Lumens für den Durchlauf des Blutes übrig bleibt, so entstehen die sog. „Strömungsgeräusche“. Es dringt dann durch die verengte Stelle mit großer Schnelligkeit ein feiner Blutstrahl in die hinter der Kompressionsstelle belogene weitere Schlagader, der als „Preßstrahl“ die Flüssigkeitsteilchen in lebhaften Oszillationen und Wirbelbewegungen versetzt und hierdurch das Geräusch in der peripheren weiteren Röhrenpartie erzeugt. Analog verhält es sich an Knickungen, scharfen Biegungen und Schlingelungen der Schlagadern.

Ein Geräusch dieser Art ist auch das an der Subclavia beim Pulse mitzunehmende „Subclaviengeräusch“. Es entsteht durch Verwachsungen der beiden Pleuralblätter an den Lungenspitzen (namentlich bei Lungenkranke, Tuberkulösen), wodurch die A. subclavia durch Zerrung und Knickung eine lokale Verengung erfährt, die sich an der Verkleinerung oder am Fehlen der Pulswelle in der Radialis (Pulsus radialis) mitunter nachweisen läßt. — In gleicher Weise entstehen Geräusche — a) wenn in einem Arterienrohr an einer Stelle eine pathologische Erweiterung (Aneurysma) besteht, in welche hinein der Blutstrom von dem normalen engen Rohre aus sich ausbreitet — b) wenn seitens eines Organes auf eine Schlagader ein Druck ausgeübt wird, wie durch den stark vergrößerten Uterus in der Schwangerschaft oder durch einen Tumor erzeugten Tumor.

Nicht genauer hinsichtlich der Art ihrer Entstehung bekannt sind das zierliche Geräusch in den zahlreichen, stark gewundenen, erweiterten Arterienstämmen des Schwanzes (Uterus („Uterin- oder Placentengeräusch“), ferner das viel weniger deutliche Geräusch in beiden Arteriae umbilicales, „Nabelstranggeräusch“, das an den dünnwandigen Arterien der fast der Hälfte der Säuglinge hörbare „Gehirngeräusch“, sowie das Geräusch in den krankhaft vergrößerten Milz und das Schwirren in der Schilddrüse bei Morbus Basedowi.

2. Venen. Das Nonnengeräusch. — Oberhalb der Clavicula, in dem Zwischenraum zwischen den Ursprüngen der beiden Köpfe des Sternocleidomastoideus, und zwischen dem fünften und sechsten Rippenbogen rechts, vernimmt man bei anämischen und chlorotischen, zuweilen aber auch bei gesunden Menschen entweder ein kontinuierliches oder ein der Diastole des Herzens entsprechendes rhythmisches Geräusch von sausendem oder flüsterndem, selbst zischendem oder singendem Charakter, welches innerhalb des Bulbus der Vena jugularis communis entsteht und als Nonnengeräusch (Nonne = Brummkreisel) bezeichnet wird. Die Ursache des Nonnengeräusches liegt in dem wirbelnden Einströmen des Blutes in dem relativ engen Teile der Vena jugularis communis in den darunter liegenden, erweiterten Bulbus derselben. Hierdurch ist es verständlich, daß Druck begünstigend für das Entstehen des Geräusches wirkt, ebenso Seitenwendung des etwas erhobenen Kopfes. Auch die Beschleunigung des Blutstromes wird die Intensität des Geräusches gesteigert. Erklärt es sich, daß die Inspiration und die Diastole des Herzens (beides die blutstrom befördernde Momente) das Nonnengeräusch verstärken. Dasselbe gilt von der Wirkung der aufrechten Körperhaltung.



ferment verschieden. <sup>7</sup> is nat.ieren mit gutem K.ate Bl fundiert, das nicht defibriniert, sondern durch Zusatz von Blutege ungerinnbar gemacht worden war.

Infolge der zahlreichen Bedenken, die einer Transfusion entgegenstehen, hat man häufig mit gutem Erfolge statt dessen Transfusionen einer isotonischen (0,9%) Kochsalzlösung (vgl. *Erc*) ausgeführt. Diese können an sich zwar keine belebende Wirkung ausüben, sie können aber doch auf rein mechanischem Wege die Kreislaufverhältnisse bessern. Nach einem größeren Blutverluste vermag das verbleibende Rest des Blutes nicht mehr im Körper umherzutreiben, weil das Blutgefäßsystem zum Teil nicht gefüllt ist; wird jetzt durch eine Kochsalztransfusion die Menge der im Gefäßsystem vorhandenen Flüssigkeit wieder vermehrt, daß eine Blutbewegung durch die Herztätigkeit möglich wird, so reichen eventuell die noch vorhandenen roten Blutkörperchen aus, um das Leben zu unterhalten (*Goltz*<sup>1865</sup>, *Kronecker* u. *Sander*<sup>1866</sup>). In Fällen von gradigen Blutverlustes freilich, in denen die noch vorhandenen Blutkörperchen unzureichend sind, kann natürlich eine Kochsalz-Transfusion eine Blut-Transfusion nicht ersetzen (*Landois*<sup>1869</sup>).

## 68. Vergleichendes.

Wirbeltiere. — Das Herz der Fische (Fig. 51, I) sowie der Kieme Larven der Amphibien ist ein einfaches, venöses: es besteht aus Vorkammer und Kammer. Aus der Kammer fließt das Blut zu den Riemen, von diesen arterialisiert es sich zur Aorta, fließt in alle Körperteile und kehrt endlich durch die Körperöffnungen und Venen, die sich zu einem Venensinus vereinigen, wieder zum Vorhof zurück. Amphibien (Frosch, II) haben zwei Vorkammern und eine Kammer. Aus der Kammer entspringt nur ein Gefäß, welches die Arteriae pulmonales abgibt und als Aorta die Körperorgane versorgt. Die Venen des großen Kreislaufes vereinigen sich zu einem Sinus, der in den rechten Vorhof führt, die Venen des kleinen Kreislaufes münden in den linken Vorhof. Bei den Amphibien und teilweise bei den Fischen (Ganoiden, Platyfishen, Dipnoern) entspringt die Aorta aus einem selbständig pulsierenden Herzabschnitt, dem Conus cordis oder Conus arteriosus. Bei den Reptilien (III und IV) schreitet die Aorta des Herzens in eine rechte und links Hälfte weiter fort, indem auch die Kammer in zwei Abteilungen zerfällt. Die Scheidewand der Kammer bleibt aber bei den Schlangen, Schildkröten und Schildkröten durchbrochen; bei den Krokodilen ist sie vollständig, doch bleibt eine Kommunikation (Foramen Panizzae) zwischen linkem und rechtem Aortenbogen. — Alle Vögel und Säuger haben, wie der Mensch, zwei getrennte Vorkammern und zwei getrennte Kammern. — Das niederste aller Wirbeltiere, *Amphioxus*, besitzt ein dorsales und ventrales Gefäßsystem, welche durch zahlreiche Querschlingen verbunden sind. Einzelne Abschnitte dieses Gefäßapparates pulsieren, ein eigentliches Herz fehlt.

Wirbellose. — Bei den Tunicaten findet sich ein an der Ventralseite gelegenes Herz, die Blutgefäße führen in Lückensysteme der Leibeshöhle. Mollusken haben ein dorsal vom Darm gelegenes Herz, welches das von den Organen kommende arterielle Blut aufnimmt und in überwiegend geschlossene Blutbahnen nach den Organen hinleitet. Blutlacunen sind in den Verlauf der Gefäße aber eingeschaltet, wo wie bei den Cephalopoden Arterien und Venen durch Capillaren verbunden sind. — Bei den Arthropoden bildet ein an der Dorsalseite des Darmes verlaufendes Gefäß ein Längsschlauch, das sog. „Rückengefäß“, das Centralorgan der Circulation ist in mehrere Abschnitte (Kammern) geteilt, von denen jeder durch eine rechte Querspalte (venöse Ostien) das zum Herzen strömende Blut aufnimmt, durch eine linke Öffnung (Aorta) wird das Blut rhythmisch in die Zwischenräume der Körperorgane hineingestoßen. Geschlossene Gefäßbahnen fehlen. — Die Würmer haben zum Teil über ein eigenes Gefäßsystem, bei anderen ist ein solches vorhanden, am vollständigsten bei den Anneliden: ein dorsales und ventrales contractiles Gefäß, welche durch



**DIESE SEITE IST FÜR KOSTENLOSE MITGLIEDER GESPERRT**  
Beantragen Sie jetzt die volle Mitgliedschaft, um diese Seite zu betreten



**Seien Sie niemals ohne ein Buch!**

Die Vollmitgliedschaft von Forgotten Books bietet Ihnen einen universalen Zugang von unseren Apps und unserer Website, auf all Ihren Geräten: Tablet, Telefon, E-Reader, Laptop und Computer.

**Eine Bibliothek in Ihrer Tasche für € 8.99/monat**

**Fortfahren**

\*Es gelten Richtlinien zur fairen Nutzung.

- 54, 1904, 373. — 87. *A. Taraststjerna*: S. A. 21, 1909, 405. — 88. *Wolfens*: Arch. f. Kinderheilk. 53, 1910, 332. — 89. *Ribemont*: Archives de tocologie. 18  
90. *L. Seitz*: Volkmanns Samml. klin. Vorträge N. F. Nr. 320, 1901, 488. — 91. *J. mann*: Die Hämodynamik. Leipzig 1850, 177. — 92. *A. Fraenkel*: A. P. P. 40  
— 93. *K. Brenner*: In. Diss. Stuttgart 1912. — 94. *H. Stübel*: P. A. 135, 191  
95. *F. Hofmeister*: P. A. 44, 1889, 360. — 96. *Fr. N. Schulz*: P. A. 115, 190  
97. *J. Cohnstein* u. *N. Zuntz*: P. A. 34, 1884, 173. 42, 1888, 342. — 98. *E. W*  
20, 1906, 123. — 99. *Worm-Müller*: L. B. 25, 1873, 573. Transfusion un  
Kristiania 1875. — 100. *E. N. r. Regézy*: P. A. 37, 1885, 73. — 101. *Federn*  
1898, 833. — 102. *Grebner* u. *Grünbaum*: W. m. P. 1899, 2033. — 103.  
D. A. k. M. 74, 1902, 253. — 104. *O. Moritz*: D. A. k. M. 77, 1903, 339. — 10  
stein: Z. k. M. 50, 1903, 324. — 106. *Stursberg*: D. A. k. M. 90, 1907, 562. —  
mann: Medizin. Jahrbücher 1882, 200. — 108. *Kornfeld*: Wien. med. Blätter  
Nr. 30. — 109. *O. Müller*: D. A. k. M. 74, 1902, 316. — 110. *M. c. Born*: S. A  
127. — 111. *O. Frank*: Z. B. 46, 1905, 441. — 112. *G. Heinricus* u. *H. Kron*  
14, 1888, 411. — 113. *Traube*: Gesammelte Beitr. z. Pathol. u. Physiol. 1, 187  
114. *E. Hering*: S. W. A. 60, 2. Abt., 1869, 829. — 115. *Fredericq*: A. B. 3  
— 116. *S. Mayer*: S. W. A. 74, 3. Abt., 1876, 281. — 117. *P. Morawitz*:  
82. — 118. *N. r. Kries*: L. B. 27, 1875, 149. — 119. *W. P. Lombard*: C. P.  
157. A. J. P. 29, 1912, 335. — 120. *H. r. Recklinghausen*: A. P. P. 55, 190  
121. *A. Basler*: P. A. 147, 1912, 393. — 122. *C. S. Roy* u. *J. Graham Brown*:  
1880, 323. — 123. *H. r. Recklinghausen*: A. P. P. 55, 1906, 468. — 124. *I*  
*M. Reh*: Z. o. P. u. T. 10, 1912, 241. — 125. *Burton-Opitz*: A. J. P. 9, 190  
126. Zusammenfassende Darstellung: *R. Tigerstedt*: E. P. II, 2, 190  
127. *A. Boutner*: Z. r. M. N. F. 2, 1852, 97. — 128. *Ph. Knoll*: S. W. A. 97, A  
207. — 129. *Bodoud*: Arbeiten aus dem physiol. Laborat. d. Würzburger Hoc  
1876, 237. — 130. *Fr. Goltz* u. *J. Gaule*: P. A. 17, 1878, 100. — 131. *H.*  
*E. H. Starling*: J. o. P. 47, 1914, 286. — 132. *O. Funke* u. *J. Latschenberger*  
1877, 405. 17, 1878, 547. — 133. *Quincke* u. *Pfeiffer*: A. A. P. 1871, 90. —  
*Boeditch* u. *G. M. Garland*: J. o. P. 2, 1879, 91. — 135. *S. de Jager*: P. A.  
426. 27, 1882, 152. 33, 1884, 17. 36, 1885, 309. 39, 1886, 171. — 136. *A. J*  
*E. Müller*: Sitz.-Ber. d. Gesellsch. z. Beförderung d. Naturw. z. Marburg 1913,  
137. *M. Cloetta*: A. P. P. 63, 1910, 147. 66, 1911, 409. 70, 1912, 407. P. A.  
339. — 138. *Th. Openchowski*: P. A. 27, 1882, 233. Z. k. M. 16, 1889, 201  
139. *Lichtheim*: Die Störungen des Lungenkreislaufes und ihr Einfluß auf den  
Berlin 1876. — 140. Zusammenfassende Darstellung: *R. Tigerstedt*: E.  
481. — 141. *Hättenheim*: Diss. Halle 1846. — 142. *J. Dogiel*: L. B. 19,  
*Stolnikow*: A. P. 1886, 1. *K. Hürthle*: P. A. 97, 1903, 193. — 143. *C. Vicror*  
scheinungen und Gesetze der Stromgeschwindigkeiten des Blutes. Frankfurt a. M.  
144. *Chauveau*, *Bertolus* u. *Laroyenne*: Journ. de la physiol. 3, 1860, 695. — 1  
Recherches sur la vitesse du cours du sang dans les artères du cheval au moyen  
hémodynamographe. Paris 1867. — 146. *N. Cybulski*: P. A. 37, 1885, 382. *O. F*  
37, 1899, 1. — 147. *Fick*: Untersuch. aus d. physiol. Laborat. d. Züricher Hoc  
1869, 51. W. V. N. F. 20, 1886, 52. — 148. *J. r. Kries*: A. P. 1887, 254. Stud  
lehre. Freiburg 1892. Z. o. P. u. T. 9, 1911, 453. — 149. *O. Frank*: Z. B. 50,  
— 150. *E. Hering*: Zeitschr. f. Physiologie. 3, 1829, 85. 5, 1833, 58. A. p. H  
112. — 151. *L. Hermann*: P. A. 33, 1884, 169. — 152. *r. Kries*: Beiträge z. .  
Festschrift f. Ludwig. 1887, 101. — 153. *G. N. Stewart*: J. o. P. 15, 1894, 1  
— 154. *G. Ledderhose*: D. m. W. 1904, 1563. Mitteil. aus d. Grenzgebieten d. Mediz.  
15, 1905, 355. — 155. *W. Braune*: L. B. 22, 1870, 261. Beiträge z. Anatomie  
Festschrift f. C. Ludwig. 1, 1875, 1. — 156. *A. Schklarewsky*: P. A. 1, 1868,  
— 157. *J. Cohnheim*: V. A. 40, 1. 41, 1867, 220. — 158. *E. Hering*: S. W. A.  
1867, 691. — 159. *L. Landois*: Die Transfusion des Blutes. Leipzig 1875. Deutsc  
f. Chirurgie 9, 1878, 457. M. m. W. 1891, Nr. 50. Eulenburgs Real-Encyclopäd  
Wien u. Leipzig 1890, 20, 32, Artikel: „Transfusion“. *Panum*: V. A. 27, 1863,  
63, 1875, 1. 66, 1876, 26. *Ponjick*: V. A. 62, 1875, 273. — 160. *Loeb*, *Strickler*  
V. A. 201, 1910, 5. — 161. *G. Lefmann*: H. B. 11, 1908, 255. — 162. *V*  
B. k. W. 1910, 1407. — 163. *H. Freund*: D. A. k. M. 105, 1912, 44. — 164. *W*.  
Z. k. M. 48, 1903, Heft 3 u. 4. — 165. *Goltz*: V. A. 29, 1864, 394. — 166. *H.*  
u. *J. Sander*: B. k. W. 1879, 767. D. m. W. 1884, 507.

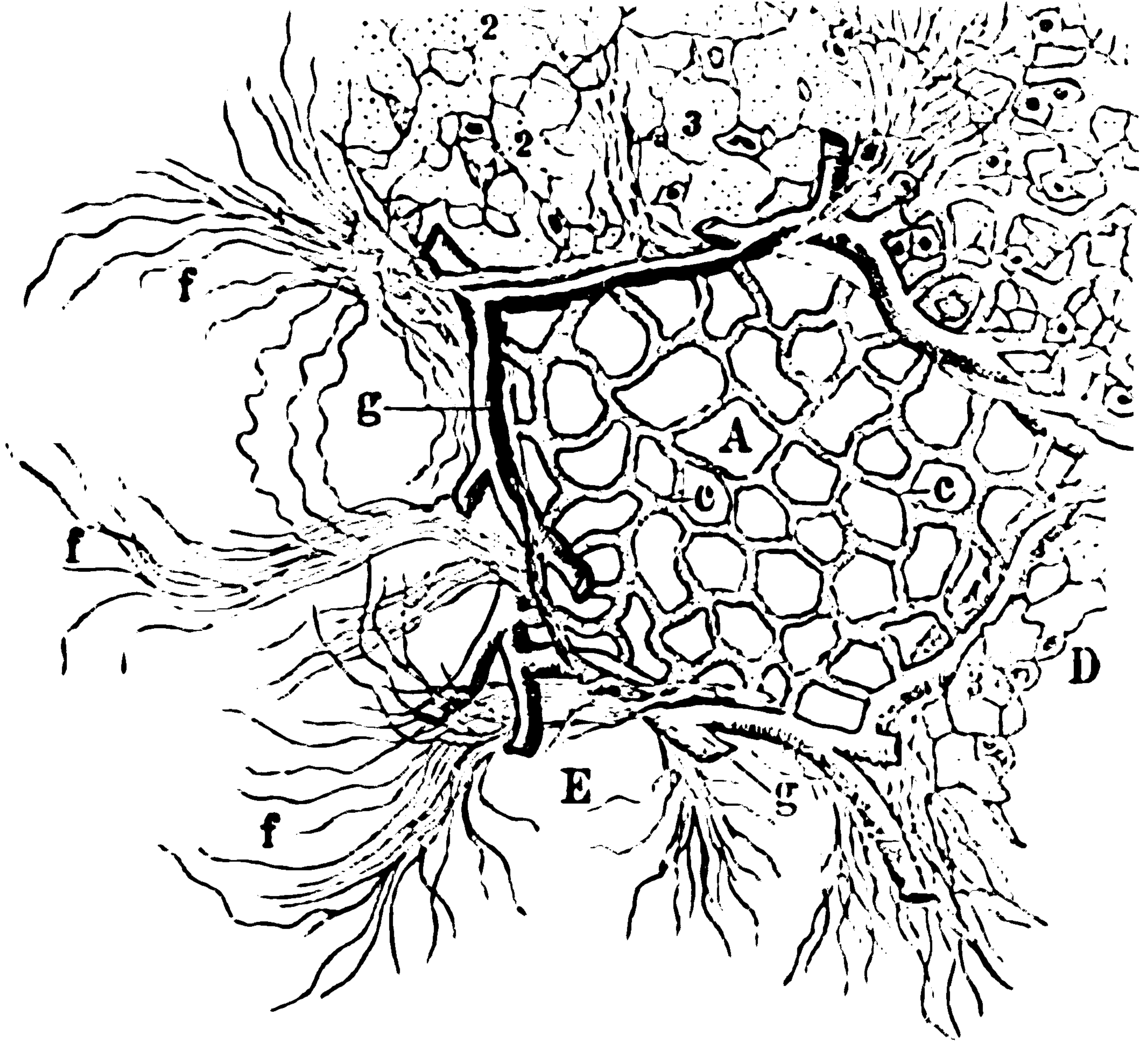

Flächenansicht mehrerer Lungenalveolen: A Alveole mit den Blutcapillaren (c), 1 aus größeren, die Alveole abgrenzenden Gefäßen (gg). — H Das Epithel einer Alveolarzelle, 2 kernlose Plättchen, 3 große, verschmolzene, kernlose Platten. — C Flächenepithelien und unter denselben liegenden Capillaren. — D Alveole, deren eine Lungenepithelien und Platten bekleidet ist. — E Alveole, deren Begrenzung alle elastischer Fasern (ff) dargestellt ist.

B. Das System der Bronchialgefäße (großer Kreislauf) — nahrungsmaterial für das Atmungsorgan. Zwischen den Verzweigungen bronchiales und pulmonalis bestehen vielfache Anastomosen (Zweige der Capillaren hervortretenden Gefäße gehen teils in die Anfänge der über (aus diesem Grunde haben alle erheblichen Stauungen im kleinen Blutlauf in dem Blutlauf der Bronchialschleimhaut, verbunden mit I zur Folge) — teils bilden sie besondere Venenbahnen, die als Venae bronchiales in den hinteren Mediastinalraum in die Stämme der Vv. azygos, intercostales ergießen.

Das interstitielle Gewebe der Lungen ist von einem Netzwerk von durchzogen; um die größeren Bronchien, die Lungenläppchen und die G sich ein gröberes, unregelmäßiges Lymphgefäßnetz (Miller<sup>2</sup>). Das Sa

zwischen Lungenoberfläche und Brustrauminnenfläche (Pneumothorax). Die betreffende Lunge ist hierdurch für die Atmungstätigkeit lahm. Ein doppelseitiger Pneumothorax zieht demnach den Tod nach sich.

An menschlichen Leichnamen kann man die Größe des elastischen Zuges in der Weise messen, daß man durch einen Intercostalraum ein Manometer bis in den Brustraum einfügt, — oder indem man das Manometer in die durchschnittene Luftröhre einfügt und nun doppelseitigen Pneumothorax macht. Nach letzterem Verfahren fand bei Expirationsstellung 6 mm, bei Inspirationsstellung bis 30 mm Hg. — A. fund. Aron<sup>16</sup> bei ruhiger Inspiration 4,64, bei ruhiger Expiration 3,02 mm Hg.

Werden mit der inspiratorischen Erweiterung des Brustkorbes gleich auch die Lungen ausgedehnt, so würde — falls für diese nächst die Glottis geschlossen wäre — eine Verdünnung innerhalb der Lungen stattfinden, da sich ja das Volumen dieser ein größeres ausdehnen müßte. Würde nun plötzlich die Glottis so würde die atmosphärische Luft so lange in die Lungen einströmen, bis die Lungenluft gleiche Dichtigkeit mit der Atmosphäre erlangt. Umgekehrt: werden mit dem Brustkorbe bei der Expiration die Lungen verkleinert, so würde — falls wir uns zunächst ebenso die Glottis geschlossen denken — die Lungenluft verdichtet, d. h. ein kleineres Volumen zusammengepreßt. Würde nun plötzlich die Glottis öffnet, so würde soviel Luft aus den Lungen entweichen, bis in der Außenluft gleicher Druck herrschte. Da beim gewöhnlichen Atmen die Glottis offen steht, so wird der Ausgleich des verminderten oder vermehrten Luftdruckes in der Lunge bei der In- und Expiration allmählich bewirkt. Aber auch so noch herrscht während der ruhigen Einatmung ein negativer, bei der Ausatmung ein geringer positiver Druck in der Lunge.

Setzt man bei Tieren ein Manometer mit einer seitlichen Trachealöffnung an, während die Atmung ungehindert bleibt, so zeigt sich bei jeder Einatmung ein negativer, bei jeder Ausatmung eine positive Druckschwankung. Für den Versuch hat Donders<sup>15</sup> den Versuch in der Weise modifiziert, daß er bei geschlossenem Mund ein U-förmiges Manometerrohr mit einem Nasenloch verband bei Offenhalten des Mundes nun ruhig in- und expirierte. Er fand, daß bei jeder ruhigen Inspiration ein negativer Druck von 1 mm anzeigte, bei jeder Expiration einen positiven von 2—3 mm. Aron<sup>16</sup> beobachtete bei Operierten mit Trachealfistel bei der Inspiration bis — 6,6 mm Hg, bei der Expiration + 0,7 bis + 6,3 mm Hg; (beim Sprechen die entsprechenden Schwankungen — 6 und + 7, beim Husten — 6 und + 46,1 mm). Mund- und die eine Nasenöffnung geschlossen sind, so daß das in der anderen Nasenöffnung befindliche Manometer allein mit dem Respirationskanale kommuniziert, und nun energisch in- und expirierte wird, so beträgt der größte Inspirationsdruck — 57 mm, der stärkste Expirationsdruck + 87 (82—100) mm (Donders<sup>16</sup>).

Trotz des höheren Expirationsdruckes darf nicht geschlossen werden, daß die Ausatemungsmuskeln kräftiger wirken als die Einatemungsmuskeln, denn es muß bei der Ausatmung eine Reihe von Widerständen überwunden werden, so daß nach Überwindung dieser nur noch ein geringer Kraftaufwand für die Aspiration des Hg übrig bleibt. Diese Widerstände sind: — 1. Der elastische Zug der Lungen; — 2. Das Emporheben des Brustkorbes; — 3. die elastische Torsion der Rippenknorpel — und 4. das Nachdrücken der Baucheingeweide und die elastische Dehnung der Bauchwandungen. Alle diese Widerstände wirken bei der Ausatmung unterstützend für die Expirationsmuskeln. Mithin kann es keinem Zweifel unterliegen, daß die gesamte Kraft aller Ausatemungsmuskeln größer ist als die aller Exspiratoren (vgl. Stigler<sup>17</sup>).

Der im Abdomen herrschende sogenannte „Abdominaldruck“ wird natürlich den Atmungsvorgang beeinflusst: doch gehen die Angaben darüber, in welcher Weise sich bei den einzelnen Phasen der Atmung ändert, noch sehr auseinander. Nach Stigler<sup>17</sup> ist das Verhalten des Abdominaldruckes davon abhängig, ob die Tätigkeit des Zwerchfells oder die der Bauchmuskulatur bei der Atmung überwiegt.

Wird bei forcierter Einatmung die Luft in der Luftröhre verdünnt, so vergrößert sich die Trachea nebst den Bronchi; umgekehrt ist das Verhalten bei forcierter Expiration (Nicaise<sup>18</sup>, vgl. Kahn<sup>19</sup>).



**DIESE SEITE IST FÜR KOSTENLOSE MITGLIEDER GESPERRT**  
Beantragen Sie jetzt die volle Mitgliedschaft, um diese Seite zu betreten

# GESCHICHTE

Zehntausende von wichtigen historischen Quellen, viele bisher nicht erhältlich, stehen jetzt zum ersten Mal mit der Vollmitgliedschaft von Forgotten Books zur Verfügung.

Unbegrenzter Zugang  
\$8.99/monat

**Fortfahren**

\*Es gelten Richtlinien zur fairen Nutzung.



I. Bei ruhiger Atmung

bewirkt die Verkleinerung des Thoraxraumes lediglich die Schwere des Brustkorbes, sowie die Elastizität der Lungen, der Rippenknorpel und der Bauchmuskeln.

II. Bei angestrenzter Atmung wirken:

1. Mm. intercostales interni (soweit sie zwischen den Rippen liegen) und Mm. infracostales (Nn. intercostales).
2. Die Bauchmuskeln (Nn. abdominis interni sive anteriores intercostalibus VIII.—XII.).
3. M. triangularis sterni (Nn. intercostales).
4. M. serratus posterior inferior (Rami exteriores nervorum deo).
5. M. quadratus lumborum (Rami musculares e plexu lumbi).

77. Wirkung der einzelnen Atmungsmuskeln.

A. Inspiration. — 1. Das Diaphragma — stellt eine gegen den Thorax gewölbte Doppelkuppel dar, in deren größerer, rechtsseitiger Konkavität die Leber, in deren kleinerer, linksseitiger die Milz und Magen liegen. In der Ruhe werden diese durch die Elastizität der Bauchdecken und den intraabdominalen Druck so gegen die innere Fläche des Zwerchfells angedrückt, daß dieses sich in die Thoraxhöhle hineinwölbt, wodurch der elastische Zug der Lungen beiträgt. Der Mittelteil des Zwerchfells (Centrum tendineum) ist oben größtenteils mit dem Herzbeutel verwachsen. Diese Stelle, auf welcher das Herz ruht und die von der unteren Hohlvene (Foramen quadrilaterum) durchbohrt wird, ist im ruhenden Zustande mehr gegen den Thoraxraum herab gedrückt als die seitlichen Teile des Mittelteiles (Fig. 56).

Fig. 56.

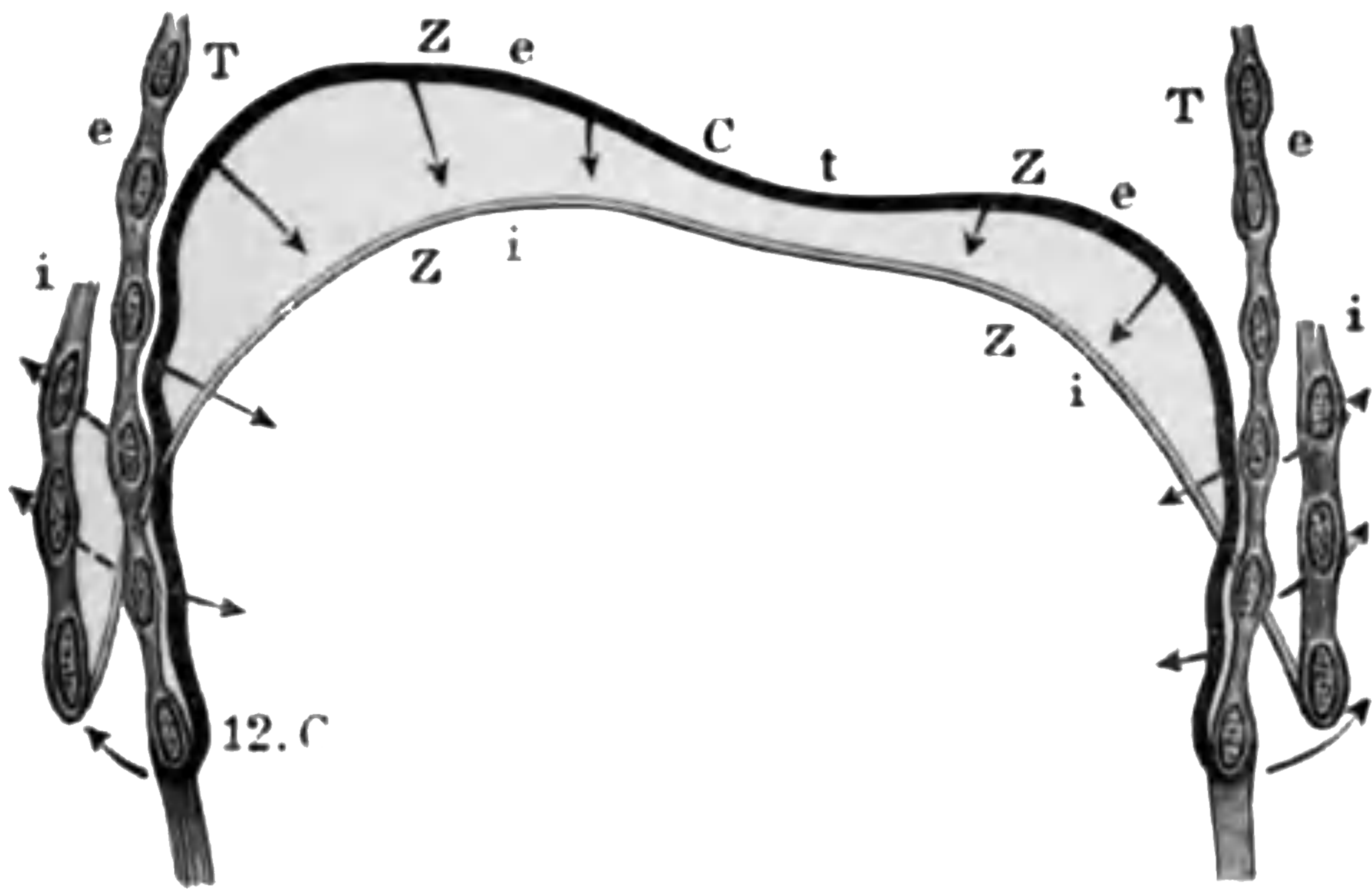

Frontalschnitt durch den Thorax an der Spitze der 12. Rippe (12. C) jederseits zur Demonstration der Gestalt des Zwerchfells in der Expiration (Ze-Ze) und in der Inspiration (Zi-Zi). — Te-Te Thoraxwand im Expirationsstadium, / / in der Inspiration. — Ct Centrum tendineum. Die Pfeile zeigen die inspiratorisch erfolgende Richtung der Bewegung an.

ruhenden Zustande mehr gegen den Thoraxraum herab gedrückt als die seitlichen Teile des Mittelteiles (Fig. 56).

Bei der Inspiration tritt eine Contraction ein, bei der beide Enden des Zwerchfells abgeflacht werden und der Brustraum unten hin erweitert wird. Hierbei gehen hauptsächlich die seitlichen muskulösen Teile aus dem gewölbten Zustande in einen mehr ebenen über, wobei sie gleich von der Thoraxwand, der sie in der Expiration unmittelbar anliegen, abgehoben werden.

Die Mitte des Centrum tendineum, wo das Herz ruht, nimmt bei ruhiger Atmung an der Bewegung keinen erheblichen Anteil, bei tiefster Inspiration senkt jedoch auch sie sich nachweislich.

Bei horizontaler Lage und guter Belichtung kann man, namentlich bei tiefer Inspiration, oft die Bewegung des Zwerchfells direkt sehen in Form einer wellenförmigen Ausdehnung, welche im 6. Intercostalraum beginnt und je nach der Tiefe der Inspiration in die Intercostalräume abwärts durchläuft (Litten<sup>27</sup>).

Das Zwerchfell kann außer der Erweiterung von oben nach unten den Thoraxraum noch im unteren Teile in transversaler Richtung ausdehnen: indem es nämlich auf die Eingeweide des Abdomens drückt, suchen diese seitlich auszuweichen und

Fig. 57, I (linke Seite der Figur) zeigt, daß bei Hebung der Stäbe sich die verkürzt: ( $ik < gh$ ; — Richtung der Intercostales externi), —  $lm$  sich jedoch vergrößert ( $lm < on$ ; — Richtung der Interni). — Fig. II zeigt, daß die durch  $gh$  angedeutete Intercartilaginei und die durch  $lk$  bezeichneten Intercostales externi sich bei Hebung der Rippen verkürzen. Bei Hebung der Rippen würde nämlich die Lage dieser Muskelzüge die kürzer gewordenen Diagonalen der punktierten Rhomben gegeben sein.

Der Streit über die Wirkung der Intercostalmuskeln ist uralt: — (130)–200 n. Chr.) hielt die Externi für Inspiratoren, die Interni für Expiratoren. *Hamberger* (1727) schloß sich (nach *Willis'* Vorgange) dieser Ansicht an, er hielt auch noch die Intercartilaginei als Inspiratoren. — *A. v. Haller* (*Hambergers* entschiedener Gegner) betrachtete Interni und Externi beide für Inspiratoren; — *Vesalius* (1540) betrachtete beide für Expiratoren an.

Nach *Landois* ist es eine wichtige Aufgabe der Externi und Intercartilaginei, die inspiratorische Dehnung der Intercostalräume und dem gleichzeitig verstärkten elastischen Zuge der Lungen entgegen zu wirken, Aufgabe der Interni, bei starker Expiration (z. B. Husten) der expiratorischen Dehnung Widerstand zu leisten. Ohne Muskelgegend würde auf die Dauer der ununterbrochene Zug und Druck die Intercostalsubstanz zerstören.

Bei ruhiger Atmung sind die *Mm. intercostales externi* und die Intercartilaginei allein als Rippenheber tätig.

Die *Mm. levatores costarum longi et breves*, die wohl auch als Rippenheber aufgeführt werden, können als solche überhaupt nicht in Betracht kommen: denn hinter der Drehungsachse der Rippen angreifen, könnten sie nur dazu dienen, die Rippen zu senken. Da sie jedoch ganz dicht an der Drehungsachse angreifen, könnten sie diesem Sinne nur eine sehr geringfügige Wirkung ausüben.

Bei angestrenzter Atmung kommen als Rippenheber die *Serratus anterior* und der *Serratus posterior superior* hinzu. Der *Serratus anterior magnus*, *Pectoralis major* und *minor* vermögen zur Hebung der Rippen nur dann mitzuwirken, wenn die Schultern unnachgiebig gehalten werden, teils durch festes Aufstützen der Arme, teils durch die *Mm. rhomboidales*, wie an Atemnot Leidende es instinktmäßig ausführen.

**3. Auf Brustbein, Schlüsselbein und Wirbelsäule wirkende Muskeln.** — Bei fixiertem Kopfe (durch die Nackenmuskeln) kann der *Sternocleidomastoideus* durch Emporziehen des *Manubrium sterni* und der *Extremitas sternalis* der *Clavicula* den Brustkorb wirksam nach oben hin durch Anheben erweitern, die *Scaleni* somit unterstützend. — In ähnlicher Weise, jedoch weniger erfolgreich, kann die Clavicularinsertion des *Trapezius* tätig sein. — Eine Streckung der Brustwirbelsäule muß eine Hebung der oberen Rippen und Erweiterung der Intercostalräume zur Folge haben. — Der *Trapezius*, die *Rhomboidei*, der *Levator scapulae* können schließlich dadurch unterstützend wirken, daß sie den Brustkorb vom Drucke der oberen Extremität entlasten.

4. Bei angestrenzter Atmung wird mit jeder Inspiration ein Schwere des Kehlkopfes und Erweiterung der Stimmritze beobachtet. Gleichzeitig wird der Gaumen stark emporgehoben, um dem durch die Stimmritze eintretenden Luftstrom einen möglichst freien Weg zu bereiten.

5. Im Gesichte prägt sich die forcierte Atmung zuerst durch die inspiratorische Erweiterung der Nasenlöcher aus (Pferd, Kaninchen). Bei Atemnot wird die Mundhöhle unter Senkung des Kiefers bei jeder Inspiration erweitert („Luftschnappen“).

**B. Expiration.** — Die ruhige Ausatmung verläuft ohne Muskelwirkung, zunächst lediglich bedingt durch die Schwere des Brustkorbes, welche ihn aus seiner erhobenen Stellung in die tiefere Expirationslage zurückdrückt. Sodann wirkt die Elastizität verschiedener Teile unterstützend mit. Die Erhebung der Rippenknorpel, welche mit einer leichten Drehung



der 6. Rippe, in der Axillarlinie bis zum oberen Rande der 7. Rippe; lin-  
 gesehen von der Lage des Herzens) die untere Lungengrenze vorn gleichwei  
 Fig. 58 zeigt die Linie  $a t b$  die untere Grenze der ruhenden Lungen  
 reichen beide Lungen bis zur 10. Rippe. Während einer möglichst tiefen  
 steigen die Lungen vorn über die 6. Rippe abwärts bis zur 7. nieder; h  
 11. Rippe, wobei sich das Zwerchfell von der Thoraxwand abhebt. Bei s  
 spiration rücken die unteren Lungenränder fast ebenso hoch empor, als sie  
 ration sinken. (In Fig. 58 zeigt  $m n$  die Grenze des rechten Lungenrandes be  
 ration,  $h l$  bei völliger Expiration.)

Besondere Beachtung verdient die Lage des linken Lungenrandes zur  
 Fig. 30 ist die fast dreieckige Stelle von der Mitte des Ansatzes der 4. l  
 6. Rippe links vom Sternum sichtbar, an welcher das Herz bei ruhendem Tho  
 wand direkt anliegt. In diesem Bereiche, welchem das Dreieck  $t t' t''$  in Fig.  
 zeigt die Perkussion die „Herzleere“, d. h. hier herrscht völlig leeren

Fig. 58.

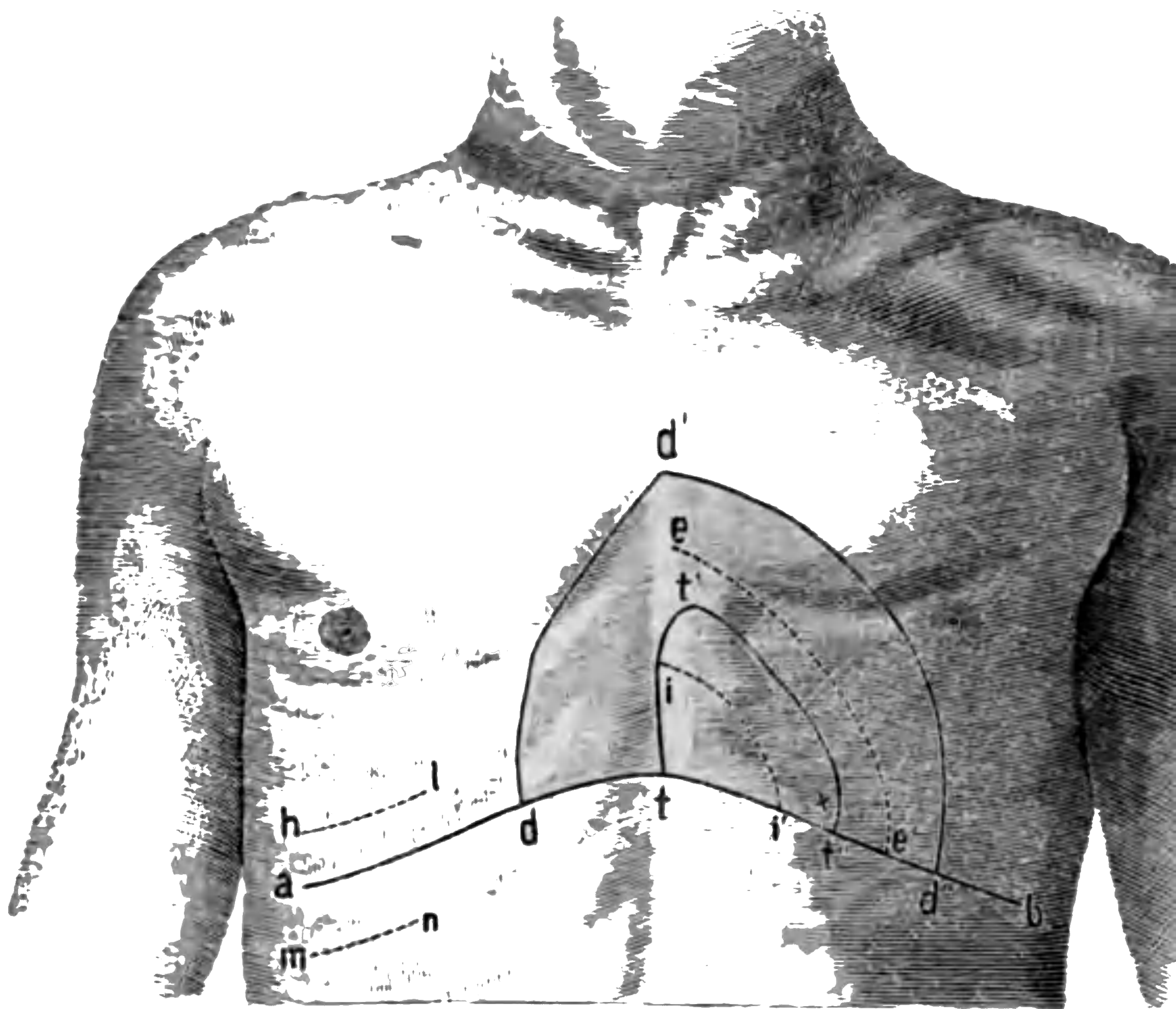

Topographie der Lungen- und Herzgrenzen bei der In- und Expiration nach v.

(„Schenkel-“)Schall. Im Bereiche des größten Dreieckes  $d d' d''$ , innerhalb  
 relativ dünne Lungenmassen das Herz von der Brustwand trennen (vgl. Fig. 30)  
 Perkussion „gedämpfter“ Schall zu hören. Erst nach außen davon ist „  
 „Lungenschall“. Bei tieferer Inspiration schiebt sich nun der innere Rand der  
 völlig über das Herz bis zur Insertion des Mediastinums (vgl. Fig. 30), wodurch  
 bis auf das kleine Dreieck  $t i i'$  eingeeengt wird. Umgekehrt weicht bei stärkster  
 der Lungenrand so weit zurück, daß die Herzleere den Raum  $t e e'$  umfaßt.

## 79. Pathologische Abweichungen

### von den normalen Schallverhältnissen am Brustk

Andeutungen über die Perkussion (auch des Unterleibes) lassen  
*Arctaeus* (81 n. Ohr.) zurückführen. Der eigentliche Erfinder ist jedoch  
 († 1809), dessen grundlegende Arbeit (1761) namentlich von *Piorry* und *Sk*  
 wurde; letzterer schuf die physikalische Theorie der Perkussion (1839).

Im Bereiche der Lungen wird der sonst voll — oder laut — erk  
 kussionschall gedämpft, wenn entweder die Lungen in geringerer oder



**DIESE SEITE IST FÜR KOSTENLOSE MITGLIEDER GESPERRT**  
Beantragen Sie jetzt die volle Mitgliedschaft, um diese Seite zu betreten



**Seien Sie niemals ohne ein Buch!**

Die Vollmitgliedschaft von Forgotten Books bietet Ihnen einen universalen Zugang von unseren Apps und unserer Website, auf all Ihren Geräten: Tablet, Telefon, E-Reader, Laptop und Computer.

**Eine Bibliothek in Ihrer Tasche für € 8.99/monat**

**Fortfahren**

\*Es gelten Richtlinien zur fairen Nutzung.

In- und Expirationen als senkrecht niederhängende Gaumensegel in schlotternde Bewegungen versetzt. Meist im Schlafe unwillkürlich; auch w

6. Gurgeln: — besteht in dem geräuschvollen, langsamen Hindurch Expirationsluft in Blasenform durch eine bei rückwärts geneigtem Kopf zwischen Zunge und weichem Gaumen gehaltene Flüssigkeitsmasse. Willkür

7. Weinen: — Durch Gemütsbewegungen hervorgerufene, kurze, tiefe, gezogene Expirationen bei verengter Glottis, erschlafften Gesichts- und Kiemen (unter der *M. zygomaticus minor* tätig), unter Tränensekretion, oft mit klagenden Lautäußerungen verbunden. Bei intensivem, längerem Weinen entstehen schließlich erfolgende unwillkürliche Zwerchfellcontractionen, welche durch ineinander schlagen der Stimmbänder das als — Schluchzen bekannte Inne erzeugen. Nur unwillkürlich. Das so häufige Schluchzen in der Agone ist durch eine Reizung der beim Absterben hochgradig erregbaren Nn. phrenischen Vorgänge bei der Contraction des Herzens zu erklären. — Stets gedehnte Atembewegung mit meist klagendem Laute, oft unwillkürlich durch Affekte erregt.

8. Lachen: — Kurze, schnell erfolgende Expirationsstöße durch die Töne gespannten, bald genäherten, bald von einander entfernten Stimmritzen unter charakteristischen, unartikulierten Lauten im Kehlkopfe mit Erztittern des Gaumens. Mund meist offen, das Antlitz durch Wirkung des *M. zygomaticus* und des *M. risorius*) mit charakteristischem Zuge. Meist unwillkürlich durch Ver schwache sensible Reize (Kitzeln) erregt und durch den Willen (durch Ver schluß und Atemanhalten), ferner auch durch schmerzhaft Reizung sensible auf Zunge oder Lippen), jedoch nur bis zu einem gewissen Grade (, unterdrückbar.

9. Gähnen: — Langgezogenes, tiefes, unter sukzessiver Aufbietung der Exspiratoren erfolgendes Einatmen bei weit geöffnetem Munde sowie offenem Glottis; Expiration kürzer, beide oft mit langgezogener, gedehnter, charakteristischer Äußerung, auch unter allgemeinem Strecken und Recken. Meistens unwillkürlich durch Schläfrigkeit oder Langeweile, doch auch willkürlich nachzunehmen.

## 84. Chemie der Atmung. Methoden der Untersuchung des respiratorischen Gaswechsels.<sup>63</sup>

Die Untersuchung des respiratorischen Gaswechsels erfolgt in verschiedenem nachdem man das Verhalten des Gaswechsels während eines längeren Zeitraumes (und mehr) oder während kürzerer Zeit (15 Minuten bis 1 Stunde) feststellen will. Im ersteren Falle muß natürlich die Versuchsperson oder das Versuchstier in einem geschlossenen Raume befinden (Respirationsapparat); die dort eintretenden Veränderungen in der Zusammensetzung der Luft dieses Raumes sucht man festzustellen. Hierbei wird außer der Lungenatmung auch die Perspiration durch die Haut festgestellt. Soll dagegen die Untersuchung des Gaswechsels auf kürzere Zeit beschränkt werden, so genügt es, die Versuchsperson oder das Versuchstier durch einen Respirometer atmen zu lassen; durch geeignete Ventile wird dafür gesorgt, daß die Ausatemungsluft durch zwei getrennte Rohrleitungen streicht und so untersucht werden kann.

I. Untersuchung des respiratorischen Gaswechsels in geschlossenen Zeiträumen. — Die Respirationsapparate. — 1) *Regnault* u. *Stokes* (Fig. 59) besteht aus einer Glocke (*R*), in welcher sich das Versuchstier befindet (Um dieselbe herum ist die Zylinderhülle (*g g*) gesetzt, die eventuell zu diesen Versuchen benützt werden kann, wozu bei *t* ein Thermometer angebracht ist). Die Glocke (*R*) führt zunächst das Rohr *c*, welches die (in Fig. 59, *O*) gemessenen Mengen des Sauerstoffes (welcher in Fig. 59  $CO_2$  die noch etwa beigemischte Kohlensäure anzeigt) zuleitet. Das Maßgefäß für den Sauerstoff (*O*) wird durch eine Chlorcalciumwanne (*CuCl<sub>2</sub>*) nach *R* und *B* aus führen die Röhren *d* und *e*, durch Kautschukröhren mit den kommutatoren (*KOH*, *koh*) verbunden, welche durch einen Wagebalken (*w*) abwärts und gehoben werden. Hierdurch aspirieren sie abwechselnd die Luft aus dem Respirometer, wobei die  $CO_2$  auf. Nach dem Versuche zeigt die Gewichtsdifferenz der Flaschen die Menge der ausgeatmeten  $CO_2$ . Die Mengen des verbrauchten Sauerstoffes werden durch die Gewichtsdifferenz der Flaschen bestimmt.

**II. Untersuchung des respiratorischen Zeiträumen.** *Speck*<sup>10</sup> ließ die Untersuchungsperson die Ein- und Ausatemluft voneinander trennen, atmet ein, die Ausatemluft wurde in einen anderen Raum gesammelt und schließlich analysiert. — Bei der von *Zuntz* wird in einer Gasuhr gemessen und während der ganzen Ausatemluft gesammelt und diese zum Schluß analysiert.

*Jaquet*<sup>12</sup> hat einen Respirationsapparat konstruiert in einem großen luftdicht schließenden Räume aufhält, in dem Zeiträume gemessen werden kann. Von der durch den Versuchsperson eingeatmeten Luft wird eine Probe entnommen, die ähnlich wie bei dem *Zuntz-Geppertschen* Verfahren, eingeatmet wird.

Fig. 60.

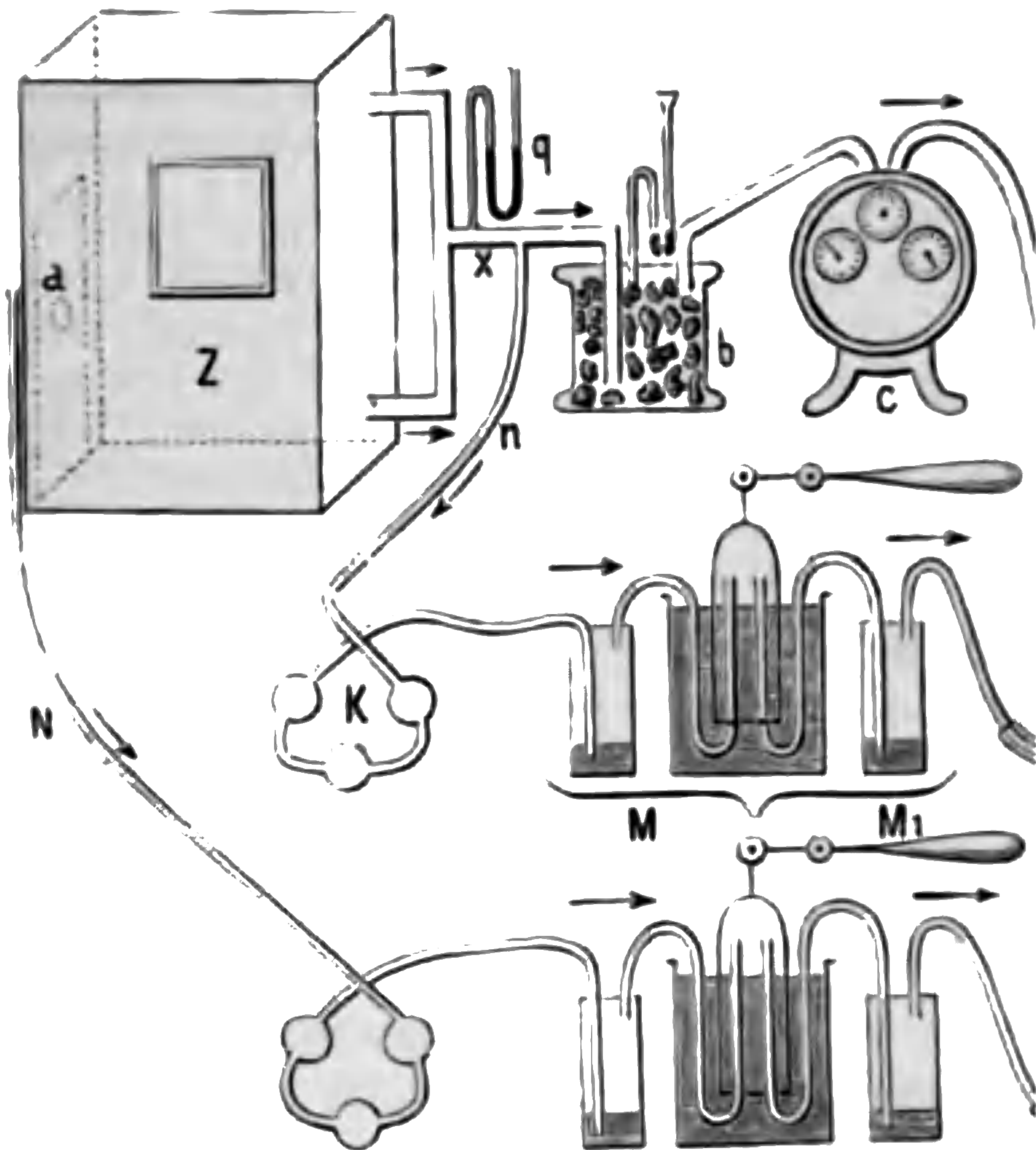

Schema des Respirationsapparates von v. P.

sammelt; im Laufe eines 24stündigen Versuches werden auch der Verlauf des Gaswechsels während der Versuche vereinigt somit die Vorzüge der Methoden I und II miteinander.

## 85. Zusammensetzung und Eigenschaften der atmosphärischen Luft

1. Die trockene atmosphärische Luft enthält:

Gasart	Volumenprozent
Sauerstoff	20,94
Stickstoff	78,40
Argon, Krypton, Neon	0,63

4. Die Ausatemungsluft ist bei ruhigem Atemholen mit Wasser gesättigt (*Galeotti*<sup>76</sup>, *Loewy* u. *Gerhartz*<sup>76</sup>). Infolgedessen wird bei selndem Wassergehalte der atmosphärischen Luft der verschieden große Mengen Wasser durch die Lungen entleeren. Bei Atemzügen sinkt der Prozentgehalt der Ausatemungsluft an Wasser. Die Temperatur der Umgebung hat einen Einfluß auf die Wasserabgabe: bei 15° C liegt ein Minimum, von hier abwärts steigt die Abgabe mäßig, aufwärts jedoch steigt sie rasch (*Rubner*<sup>77</sup>).

5. Die Ausatemungsluft hat eine ziemlich hohe Temperatur. *Loewy* u. *Gerhartz*<sup>76</sup> beträgt die Temperatur der Mundausatmung zwischen 32 und 35,25°, die der Nasenausatemungsluft ist niedriger, Mittel 32,2°. Die Werte schwanken mit der Atemtiefe und dem Volumen nur in sehr engen Grenzen.

6. Nach *Regnault* u. *Reiset* sollte N in sehr geringen Mengen in der Ausatemungsluft vom Körper abgegeben werden; dieser Befund ist von anderen Autoren bald bestätigt, bald bestritten worden. Nach den Untersuchungen von *Krogh*<sup>79</sup> u. *Oppenheimer*<sup>80</sup> kann es keinem Zweifel unterliegen, daß dieser Befund auf Versuchsfehler zurückzuführen ist. N wird vom Körper durch die Atmung nicht abgegeben.

Nach Versuchen von *Magnus*<sup>81</sup> wird von der lebenden Lunge weder Ammoniak resorbiert, noch aus dem Blute (in welches es injiziert worden war) in die Ausatemungsluft abgegeben. Nach *Höber*<sup>82</sup> findet jedoch eine Aufnahme von Ammoniak aus dem Blute in das Blut tatsächlich statt; daß eine Abgabe aus dem Blute in die Alveolen nicht stattfindet, wird nicht etwa durch eine Undurchgängigkeit der Alveolarwand für Ammoniak, sondern durch die außerordentlich große Absorbierbarkeit des Ammoniaks in Wasser bedingt.

7. Geringe Mengen Wasserstoff und Sumpfgas (CH<sub>4</sub>) — vom Darm aus resorbiert, werden in der Ausatemungsluft ausgeschieden.

*Tacke*<sup>83</sup> fand beim Kaninchen pro Stunde und Kilogramm Körpergewicht bis 3,9 cm<sup>3</sup> Wasserstoff und 1,214—4,24 cm<sup>3</sup> Sumpfgas. Beim Pferde bestimmten *Lehmann*<sup>84</sup> den Gehalt der Expirationsluft an Wasserstoff zu 0,013% und an Sumpfgas zu 0,038% im Mittel. Bei Wiederkäuern sind die in der Expirationsluft enthaltene Wasserstoff und Sumpfgas wesentlich höher; *Henneberg* u. *Pfeiffer*<sup>85</sup> fanden beim Rind, daß 7,3% des gesamten abgegebenen Kohlenstoffs als Sumpfgas ausgeschieden wird.

Die durch Kälte kondensierten Wasserdämpfe der Expirationsluft manchen Menschen wirken (subcutan) giftig (*Brown-Séguard* u. *d'Arsonval*<sup>86</sup>) durch die Bildung einer flüchtigen Basis (*R. Wurtz*<sup>87</sup>), oder von Ammoniak, welches sich als Zersetzungsprodukt in hohlen Zähnen oder in kranken Luftwegen bildet (*Formánek*<sup>88</sup>).

## 87. Der respiratorische Quotient.

Wenn der in der Atmung aufgenommene O einzig und allein für die Verbrennung verbraucht würde, um den C der Nahrungsstoffe zu CO<sub>2</sub> zu verbrennen, so müßte das Volumen der abgegebenen CO<sub>2</sub> gleich dem Volumen des aufgenommenen O sein (gleiche Volumina O und CO<sub>2</sub> enthalten gleiche Mengen O). Da aber mit dem aufgenommenen O auch noch andere Bestandteile der Nahrung verbrannt werden (H zu H<sub>2</sub>O, N zu H<sub>2</sub>N<sub>2</sub>S zu Schwefelsäure usw.), so wird unter gewöhnlichen Verhältnissen das Volumen der ausgeatmeten CO<sub>2</sub> kleiner sein müssen als das des aufgenommenen O, das Verhältnis  $\frac{CO_2}{O}$  oder „der respiratorische Quotient“ kleiner als 1. Wie groß der respiratorische Quotient im speziellen Falle ist, hängt in erster Linie von der Art der im Körper verbreiteten Nahrungsstoffe ab. Die Kohlehydrate z. B. enthalten im Molekül soviel O, als zur Verbrennung des H nötig ist, es wird mithin, wenn Kohlehydrate im Körper verbrennen würden, aller eingeatmete O



**DIESE SEITE IST FÜR KOSTENLOSE MITGLIEDER GESPERRT**  
Beantragen Sie jetzt die volle Mitgliedschaft, um diese Seite zu betreten

# GESCHICHTE

Zehntausende von wichtigen historischen Quellen, viele bisher nicht erhältlich, stehen jetzt zum ersten Mal mit der Vollmitgliedschaft von Forgotten Books zur Verfügung.

Unbegrenzter Zugang  
\$8.99/monat

**Fortfahren**

\*Es gelten Richtlinien zur fairen Nutzung.



**dynamische Wirkung** der Nahrungsstoffe. — Für die praktische Ernährungsverhältnisse des Menschen, bei denen in der gem. Kost das Eiweiß gegenüber den N-freien Nahrungsstoffen zurücktritt, hat jedoch dieser Einfluß der Nahrung auf die Zersetzungen von keiner großen Bedeutung, *Rubner*<sup>102</sup> veranschlagt den vollen Tageswe. Energieverbrauchs des Menschen bei mittlerer Kost nur um 7–8% als den Hungerverbrauch.

Die spezifisch-dynamische Wirkung der Nahrungsstoffe kann nach *Rubner* auf die Verdannungsarbeit im Sinne von *Zuntz*<sup>101</sup> zurückgeführt werden (vgl. *Hei*. *Rubner* nimmt zur Erklärung der Erscheinung an, daß bei der Zersetzung der Nahrungsstoffe im Körper Energie in zwei verschiedenen, für den Körper nicht gleichwertigen Formen auftritt, nämlich Wärme, welche als Kraftquelle für die Lebensvorgänge weiter benutzbar ist, und biologisch ansnutzbare Energie; der Betrag der biologisch verwertbaren Wärme ist besonders groß bei der Zersetzung der Eiweißkörper. Die spezifisch-dynamische Wirkung ist eben bedingt durch denjenigen Teil der Energie der Nahrung, der bei der Zersetzung sogleich als Wärme auftritt: bei abundanter Ernährung, bei aber bei hoher Umgebungstemperatur kann diese Wärme überhaupt nicht mehr zu den Zwecken des Körpers verwandt werden, sie wird auf dem Wege der physikalischen Wärmeregulation (s. unten) nach außen abgegeben, so daß die spezifisch-dynamische Wirkung unter diesen Umständen voll in Erscheinung tritt. Bei niedrigen und mittleren Temperaturen dagegen und bei einer den Bedarf gerade deckenden Nahrungszufuhr kann diese Wärme zur Aufrechterhaltung der Körpertemperatur verwandt werden, es wird dann eben nur ein entsprechender Teil bei anderen Zersetzungen eingespart (Compensationstheorie). Auf diese Weise tritt unter diesen Verhältnissen die spezifisch-dynamische Wirkung nicht oder überhaupt nicht in die Erscheinung; die Nahrungszufuhr verläuft dann ohne Einfluß auf die Zersetzungen.

3. Die Temperatur der Umgebung (vgl. § 200). — Zu unterscheiden ist das Verhalten der Kaltblüter und Warmblüter.

Die Kaltblüter (wechselwarme, poikilotherme Tiere) — lassen ihre Körpertemperatur der Umgebungstemperatur an; bei höherer Temperatur der Umgebung steigt ihre Eigentemperatur und damit zugleich der respiratorische Gaswechsel und umgekehrt (*H. Schulz*<sup>104</sup>).

Die Warmblüter (gleichwarme, homoiotherme Tiere) — halten bei weiten Schwankungen der Außentemperatur ihre Körpertemperatur konstant. Erst bei Einwirkung extremer Temperaturdifferenzen, unter pathologischen Bedingungen ändert sich die Eigentemperatur der Warmblüter; in diesem Falle verhalten sie sich wie Kaltblüter: bei Sinken der Körpertemperatur findet eine beträchtliche Verminderung der  $\text{CO}_2$ -Abgabe statt (*Pflüger*<sup>105</sup>, *Velten*<sup>106</sup>, *Erlor*<sup>107</sup>) — bei Steigerung der Körperwärme (auch im Fieber) eine Erhöhung der  $\text{CO}_2$ -Abgabe (*C. I. Sanders-Ezn*<sup>108</sup>). — Solange dagegen die Änderungen der Umgebungstemperatur keine ganz extremen sind, bleibt die Körpertemperatur der Warmblüter annähernd konstant. Dieses Resultat kann nun auf zweifache Weise erreicht werden:

1. durch physikalische Wärmeregulation. Dabei bleibt die Wärmeproduktion ganz unverändert, ein Einfluß der Umgebungstemperatur auf den Gaswechsel wird also ganz vermieden. Die Körpertemperatur wird vielmehr dadurch konstant erhalten, daß durch Änderungen der Umgebungstemperatur entsprechend die Bedingungen der Wärmeabgabe verändert werden, z. B. durch Veränderungen der Durchblutung der Hautgefäße, der Puls- und Atemfrequenz, der Körperhaltung, auch willkürlich durch Anlegen wärmerer oder dünnerer Kleidungsstücke. Die Wärmeabgabe wird auf diese Weise trotz den Veränderungen d

rie im späteren Kindesalter.

5. Das Geschlecht. — Bei gleichem Gewicht und gleicher Körperfläche haben Erwachsene beiderlei Geschlechtes denselben Grundumsatz (*Magnus-Levy* u. *Falk*<sup>90</sup>). In der Pubertätszeit fanden u. *Tigerstedt*<sup>98</sup> die  $\text{CO}_2$ -Ausscheidung der Knaben bei Zimmerruhe 31—56% höher als die der Mädchen (stärkere Bewegung der Knaben). *Magnus-Levy* u. *Falk*<sup>90</sup> fanden  $\text{O}_2$ -Verbrauch und  $\text{CO}_2$ -Ausscheidung bei Knaben nur um 6—7% höher als bei Mädchen. — Im Greisenalter nach den letzten Untersuchern der Sauerstoffverbrauch bei Männern größer als bei Frauen.

Durch die Menstruation wird die Intensität der Oxydationsvorgänge nicht einflußt (*L. Zuntz*<sup>110</sup>). Während der Gravidität ist der Sauerstoffverbrauch pro Kilogramm Gewicht der Mutter und des Kindes unverändert oder höchstens um 3—4% erhöht (*Hauschbaleh*<sup>120</sup>).

6. Schwankungen zur Tages- und Nachtzeit. — Während Schlafes ist der Gaswechsel natürlich geringer als im wachen Zustand wegen des Fehlens der Muskelbewegungen, der Nahrungsaufnahme. *Sondén* u. *Tigerstedt*<sup>98</sup> fanden im Mittel für das Verhältnis der  $\text{CO}_2$ -Ausscheidung während des Schlafes zu der während des wachen Zustandes den Wert 100:145. An sich hat der Schlaf keinen Einfluß auf den Umfang der Verbrennungsprozesse im Körper; der Umsatz während Schlafes ist ungefähr derselbe wie der Grundumsatz bei absoluter Müdigkeit. *Benedict* u. *Cathcart*<sup>121</sup> geben allerdings im Gegensatz hierauf an, daß nach ihren Versuchen die Verbrennungsvorgänge im festen Schlafe niedriger waren als im wachen Zustande bei vollkommenster Muskelruhe.

Im Laufe des Tages zeigt die  $\text{O}_2$ -Aufnahme und  $\text{CO}_2$ -Abgabe bei Hungernden und bei Ausschluß wechselnder Muskeltätigkeit) keine wesentlichen Schwankungen (*Rubner*<sup>114</sup>, *Magnus-Levy*<sup>99</sup>, *Johansson*<sup>122</sup>); bei Nahrungnahme von Nahrung bedingt natürlich jede Mahlzeit eine entsprechende Steigerung.

Im Winterschlaf (vgl. § 206), — in welchem die Körpertemperatur stark erniedrigt ist, die Nahrungsaufnahme und Muskeltätigkeit völlig unterbleibt, selbst die Muskelbewegungen ganz suspendiert oder doch außerordentlich verlangsamt sind, findet eine Herabsetzung des respiratorischen Gaswechsels statt. Am stärksten erniedrigt ist die  $\text{CO}_2$ -Ausscheidung: nach *Lembrey*<sup>123</sup> kann dieselbe bei *Myoxus* auf  $\frac{1}{100}$  der Menge sinken, wie im wachen Zustande ausgeschieden wird. Die  $\text{O}_2$ -Aufnahme wird ebenfalls, aber in geringerem Grade erniedrigt, so daß der respiratorische Quotient bis auf 0,23 sinken kann. Beim Erwachen aus dem Winterschlaf steigt der respiratorische Gaswechsel in kurzer Zeit bedeutend; der respiratorische Quotient wird auf 0,75 erhöht (vgl. *Nagai*<sup>124</sup>).

7. Der Aufenthalt im Hellen — sollte nach älteren Untersuchungen eine direkte Erhöhung des respiratorischen Gaswechsels zur Folge haben, gegenüber dem Gaswechsel bei Aufenthalt im Dunkeln; es dürfte sich dabei aber um eine indirekte Einwirkung durch Anregung zu Muskelbewegungen gehandelt haben. Wird der Einfluß wechselnder Muskeltätigkeit ausgeschaltet, so erhöht weder die Einwirkung des Lichtes auf die Atmung (*Speck*<sup>125</sup>), noch die Bestrahlung des ganzen Körpers mit Sonnenstrahlen (*Wolpert*<sup>126</sup>) den respiratorischen Gaswechsel.

8. Zahl und Tiefe der Atemzüge — haben auf den Verbrauch von  $\text{O}_2$  und die Bildung der  $\text{CO}_2$ , also auf die Verbrennung



fängt, die erste Hälfte (aus den größeren Luftkanälen stammende  $\text{CO}_2$  enthält (3,7 Vol.-Prozent, Vierordt<sup>128</sup>) als die zweite Hälfte (1,7 Prozent). Diese Ungleichheit des Gasgemenges in den verschiedenen Schichten des Atmungsorganes ruft selbstverständlich eine fortwährende Differenz zwischen den verschiedenen Schichten hervor, und ebenso endlich zwischen den Larynx- und Nasenhöhlen-Gasen und der äußeren atmosphärischen Luft und zwar wird die  $\text{CO}_2$  beständig aus der Tiefe der Lungenbläschen in die äußere Luft, hingegen der O der Luft in das Gasgemenge der Alveolen diffundieren. Unterstützt wird diese Diffusion bei den Atembewegungen durch das beständige Schütteln der Atmungsorgane durch die kardiopneumatische Bewegung; im Winterschlaf wird auf diese Weise einzig und allein der Gaswechsel innerhalb der Lunge erhalten werden (vgl. S. 135). Für gewöhnlich ist jedoch diese Diffusion für den Atmungsprozeß unzureichend; es kommt vielmehr durch die Atembewegung veranlaßte Luftwechsel hinzu: hierdurch wird die in den meisten nach den Ausführungsröhren liegenden Teile der Lunge befindliche atmosphärische Luft eingebracht, aus welcher und in welche die Diffusionsströmung von O und  $\text{CO}_2$  wegen der größeren Spannungsdifferenz der Gase um so lebhafter vor sich geht.

Von der eingeatmeten Luft dringt immer nur ein Teil in die Alveolen; ein Teil verbleibt in den Bronchien, der Trachea, der Nasenhöhle (sog. „schädlicher Raum“), ohne an dem Gasauswechsel teilzunehmen. Bei der Ausatmung mischt sich die Alveolenluft mit der atmosphärischen Luft des „schädlichen Raumes“ und wird so zur Ausatemluft. Aus der Größe des schädlichen Raumes ( $140 \text{ cm}^3$ , vgl. S. 135) und der Größe eines Atemzuges ( $500 \text{ cm}^3$ , vgl. S. 182) und der Zusammensetzung der atmosphärischen und der Ausatemluft kann man die Zusammensetzung der Alveolenluft berechnen; nach Bohr<sup>141</sup> enthält sie 14,6% O und 5,6%  $\text{CO}_2$ , entsprechend einer Partialspannung von 100 mm bzw. 40 mm Hg (Gesamtspannung nach Abzug der Tension des Wasserdampfes von 50 mm = 710 mm).

2. Gasaustausch zwischen der Alveolenluft und der Lungencapillaren. Über die Art des Vorganges, durch den in der Lunge der Sauerstoff aus der Alveolenluft in das Blut aufgenommen und die Kohlensäure aus dem Blute in die Alveolenluft abgegeben wird, gibt es sich zwei Anschauungen gegenüber. Nach der einen handelt es sich bei dem Vorgange um einen rein physikalischen Vorgang nach den Gesetzen der Diffusion, wonach jedes Gas von dem Orte höherer Spannung zum Orte niedrigerer Spannung wandert. Nach der anderen Anschauung übt die Lunge einen spezifischen Einfluß darauf aus, indem sie die Gase abgibt, daß sie gleichsam wie eine Drüse die Gase secerniert.

**Methode der Untersuchung.** Pflüger u. Wolffberg<sup>142</sup> haben in dieser Weise die Spannung der Gase im Blute der Lungencapillaren, resp. in der Alveolenluft bestimmt. Bei geöffneter Trachea wird einem Hunde ein Katheter (Lungenkatheter, Fig. 61 a) in den zum linken unteren Lungenlappen gehörenden Bronchialast eingeführt. Um denselben in dem letzteren zu dichten, wird um denselben eine von ihm durchbohrte Gummiblase (mittels kommunizierender Gummiröhre) aufgebläht, so daß nun aus dem zugehörigen Lungenterrain keine Luft neben dem Katheter vorbei entweichen kann. Der Katheter ist an seinem Ausflusse vorerst verschlossen. Der Hund atmet selbständig und möglichst ruhig. Schon nach 4 Minuten ist die Alveolenluft des abgesperrten Lungenbezirkes völlig mit den Blutgasen ausgetauscht, daher nunmehr aus dem Katheter (bei b) die Lungenluft ausgesogen und die Spannung von  $\text{CO}_2$  und O in ihr zugleich auf indirektem Wege durch die Diffusion dieser beiden Gase in dem Blute der Lungencapillaren an.



**DIESE SEITE IST FÜR KOSTENLOSE MITGLIEDER GESPERRT**  
Beantragen Sie jetzt die volle Mitgliedschaft, um diese Seite zu betreten



**Seien Sie niemals ohne ein Buch!**

Die Vollmitgliedschaft von Forgotten Books bietet Ihnen einen universalen Zugang von unseren Apps und unserer Website, auf all Ihren Geräten: Tablet, Telefon, E-Reader, Laptop und Computer.

**Eine Bibliothek in Ihrer Tasche für € 8.99/monat**

**Fortfahren**

\*Es gelten Richtlinien zur fairen Nutzung.

In vielen tierischen Organen und Geweben sind Fermente aufgefunden oxydierende Wirkungen ausüben: Oxydasen (vgl. S. 19, 94, *Battelli u. Ste* diese Oxydasen mit der physiologischen Verbrennung in den Geweben irger haben, ist außerordentlich zweifelhaft.

Im Blute — findet, wie in allen Geweben natürlich O-Verbrauch und CO<sub>2</sub>-Bildung statt. Dies beweist schon die Entleertes Blut allmählich O-ärmer und CO<sub>2</sub>-reicher wird (S der Umstand, daß im O-freien Blute Ersticker, und zwar Körperchen (*Afonassieff*<sup>166</sup>) immerhin, wenn auch nur geringe reduzierender Stoffe sich finden, die nach O-Zutritt sich oxydieren. Dings ist dieser Gaswechsel gegenüber dem in allen übrigen Geweben nur sehr gering. Daß auch die Gefäßwände, ihre Muskeln, O verzehren und CO<sub>2</sub> produzieren, ist selbst wenn auch dieser Prozeß nur so gering ist, daß das Blut auf arteriellen Bahn keine wahrnehmbare Farbenveränderung zeigt.

*Lavoisier* hatte den gesamten Gaswechsel, O-Verbrauch und CO<sub>2</sub>-Bildung, in die Lungen verlegt. Dies ist nach dem oben Gesagten natürlich haben aber auch die Lungen als lebendes Gewebe an sich einen gewissen Anteil. Nach *Bohr u. Henriques*<sup>167</sup>, *Pütter*<sup>168</sup> soll sogar ein Sauerstoffverbrauch und eine Kohlensäureproduktion die durchschnittlich etwa ein Drittel des gesamten Stoffwechsels ausmachen, doch wird die Beweiskraft ihrer Versuche stark bestritten (*Zuntz*<sup>170</sup>, *Evans u. Starling*<sup>171</sup>).

## 92. Atmung im abgesperrten Raume oder bei künstlich verändertem Gehalt der Atmung an O und CO<sub>2</sub>.

Die Atmung im abgesperrten Raume hat zur Folge: 1. eine allmähliche Verminderung des O, — 2. die gleichzeitige Vermehrung des CO<sub>2</sub> — und 3. eine Verminderung des Gasvolumens. Ist der O-Mangel mäßig groß, so verzehrt das Tier den O fast vollständig und das Blut wird fast O-frei und unter Erstickungskrämpfen erfolgt schließlich der Tod. Dieser ist also bedingt durch O-Mangel.

In größeren abgeschlossenen Räumen kommt es zu einer reichlichen CO<sub>2</sub>-Ansammlung als zu einer das Leben bedrohlichen Verminderung. Da die CO<sub>2</sub>-Ausscheidung aus dem Körper nur erfolgt, wenn die CO<sub>2</sub>-Spannung im Blute größer ist als in der Umgebung, so wird mit zunehmender CO<sub>2</sub>-Ansammlung in dem abgeschlossenen Raume alsbald CO<sub>2</sub>-Retention, ja schließlich CO<sub>2</sub>-Zurücktritt in den Blutgefäßen stattfinden. Dies erfolgt zu einer Zeit, in welcher der O zum Leben nicht mehr reicht. Es tritt daher hier der Tod direkt durch CO<sub>2</sub>-Vergiftung ein. Die Erscheinungen kurz dauernder Dyspnoe, der sich bei Abkühlung anschließen. So starben Kaninchen, nachdem die Luft im Teil der nachweisbar vorher von ihnen ausgeschiedenen CO<sub>2</sub> aufgenommen hatten (*W. Müller*<sup>172</sup>).

Erneuerung der Luft in Wohnräumen, Ventilation. In überfüllten Räumen steigt zunächst der CO<sub>2</sub>-Gehalt; *v. Pettenkofer*<sup>67</sup> fand den normalen (= 0,5‰) gesteigert im behaglichen Wohnzimmer auf 0,54—0,7‰, — in schlecht gelüfteten Krankenzimmern auf 2,4‰, — in stark gefüllten Hörsälen auf 3,2‰, — auf 4,9‰, — in Schulzimmern auf 7,2‰. Allerdings sind es nicht die

Steigert man den  $\text{CO}_2$ -Gehalt der einzuatmenden Luft, so die Atembewegungen zu, es tritt Dyspnoe ein. Eine Luft von 0,1 bezeichnet v. Pettenkofer als „schlechte Luft“, doch rührt das selben empfundene Unbehagen (z. B. in überfüllten Räumen) mehr ausgeatmeten widrigen Dünsten unbekannter Natur, als von der C her. Luft mit 1%  $\text{CO}_2$  erzeugt merkliches Unbehagen, bei 10% w Lehen ernstlich gefährdet, bei noch höherem  $\text{CO}_2$ -Gehalt (25%) t Tod unter Krämpfen ein (Albitzky<sup>183</sup>).

Bietet man Tieren ein der atmosphärischen Luft ähnliches Gasgemenge, in N durch H ersetzt ist, so atmen sie völlig wie normal; der H des Gemisches erleidennennenswerte Mengenveränderung. — Zunahme oder Abnahme des N in der Luft einfach eine größere oder kleinere Absorption desselben seitens der Körpersäfte (

### 93. Atmen fremdartiger Gase.

Kein Gas vermag ohne hinreichende O-Beimischung das Leben zu halten, es tritt vielmehr ohne O bei allen, auch an sich völlig unschädlichen, verschiedenen Gasen schnelle Erstickung (in 2—3 Minuten) ein.

I. Völlig indifferente Gase — sind N, H und  $\text{CH}_4$ .

II. Giftige Gase.

a) O-verdrängende: — 1) CO (siehe § 21). — 2) CNH (Blausäure) verbindet sich mit dem Hb, mit dem es eine stabilere Verbindung eingeht, und tötet äußere Blutkörperchen mit Blausäure beladen, verlieren die Fähigkeit, Wasserstoffsuperoxyd, Wasser und O zu zersetzen.

b) Narkotisierende: — 1)  $\text{CO}_2$ . Vgl. § 92. — 2)  $\text{N}_2\text{O}$  (Stickoxydulgas) eingeatmet (mit  $\frac{1}{2}$  Vol. O vermischt), bewirkt in  $1\frac{1}{2}$ —2 Minuten einen schnell vorübergehenden, besonders instigen Rauschzustand („Lustgas“), welchem eine vermehrte  $\text{CO}_2$ -Ausscheidung folgen soll. — 3) Ozonisierte reine Luft wirkt ähnlich: auch sie erzeugt angenehme Wirkung, dann Schläfrigkeit und rasch vorübergehenden Schlaf.

c) Reduzierende: — 1)  $\text{H}_2\text{S}$  (Schwefelwasserstoff) entzieht schnell den Erythrocyten allen O, hierdurch tritt schon schleuniger Tod ein, bevor noch das Gas eine Änderung des Hämoglobins unter Bildung von Sulphhämoglobin bewirken kann (S.

2)  $\text{PH}_3$  (Phosphorwasserstoff) wird im Blute zu phosphoriger Säure unoxidiert unter Zersetzung des Hb.

3)  $\text{AsH}_3$  (Arsenwasserstoff) und —  $\text{SbH}_3$  (Antimonwasserstoff) wirken dem Phosphorwasserstoff analog, lassen überdies das Hb aus dem Stroma austreten und Hb-reiche Ausscheidungen erfolgen.

4)  $\text{C}_2\text{N}_2$  (Cyan gas) wirkt O-entziehend und weiterhin das Blut zersetzend.

III. Irrespirable Gase — können überhaupt nicht geatmet werden, da beim Einströmen in den Kehlkopf reflektorischer Stimmritzenkrampf entsteht. Gewaltsam in die Lunge gebracht, bewirken sie lebhafteste Entzündungen und weiterhin Zerstörungen und Eiterbildung. Es sind Chlorwasserstoffsäure, — Fluorwasserstoffsäure, — schweflige Säure, — Unterschweflige Säure, — salpetrige Säure, — Ammoniak, — Chlor, — Fluor, — Jod, — Brom, — verdünntes Ozon, — reine  $\text{CO}_2$ .

### 94. Normale Schleimbildung in den Luftwegen.

#### Der Auswurf (Sputum).<sup>184</sup>

Die Schleimhaut des Respirationskanales ist von einer dünnen Schicht Schleim bedeckt. Diese verhindert mechanisch durch Abhaltung der wöhnlichen Reize der Luft und des Staubes eine weitere Schleimbildung. Letztere erfolgt nur insoweit, als die Verdunstung sie zum Ersatz notwendig macht. Im allgemeinen tritt mit vermehrter Blutdurchströmung der Trachealschleimhaut auch vermehrte Sekretion ein. Einseitige Entzündung durchschneidung bewirkt Rötung dieser Seite und stärkere Absonderung.

Beim Eintritt von Erkältung — (Eisbedeckung des Bauches) wird die Sekretion zuerst v. Zunahme der Absonderung tiefrot.

aus dem Körper entfernt werde, zugleich mit dem ausgeatmeten Wasser. Von *G* die wichtigsten Experimente über die Mechanik der Atmung her: er konstatiert die Lungen lediglich passiv den Bewegungen des Thorax folgen, daß das Zwerchfell der Atmungsmuskel sei, daß die Intercostales externi In-, die interni Exspiratoren durchschneidet die Intercostal-Nerven und -Muskeln und sah danach den Verlust eintreten. Nach stets höher hinaufreichenden Rückenmarksdurchschneidungen *G* und nach höher liegende Thoraxmuskeln gelähmt. — *Theophilus Philaretus* lehrte durch lautes Schreien, Singen, Reden den Kreislauf befördern könne. — *Oribasius* doppelseitigem Pneumothorax beide Lungen zusammensinken (360 n. Chr.). — *Avicenna* (1543) beschreibt bereits die künstliche Atmung zur Wiederbelebung und zur Aufrechterhaltung des Herzschlages. — *Malpighi* untersuchte 1661 den Bau der Lungen. Den Mechanismus der Atembewegungen erklärte zuerst am gründlichsten *Joh. Alf. Borelli* († 1679). *Reisner* entdeckte 1808 die Muskulatur in den Bronchien bis in ihre feineren Verzweigungen deren Contraction auf Reiz schon *Varnier* 1779 bekannt war.

Die chemischen Vorgänge — bei der Atmung ahnte schon *Mayow* 1669 *et vita iisdem particulis aëreis sustinetur.* Dennoch konnte genauere Einsicht gewonnen werden nach Entdeckung der einzelnen in Betracht kommenden Gase: *van Helmont* († 1644) entdeckte die  $\text{CO}_2$ , er fand, daß die Luft durch die Atmung verschlechtert, aber erst *Black* 1757 ermittelte die Ausscheidung der  $\text{CO}_2$  durch die Lungen — 1774 entdeckten *Priestley* und *Scheele* den O; *Lavoisier* fand 1775 den Sauerstoff und ermittelte zugleich die Zusammensetzung der atmosphärischen Luft. Derselbe fand dann auch die  $\text{CO}_2$ - und  $\text{H}_2\text{O}$ -Bildung bei der Atmung als das Resultat einer Verbrennung im Innern der Lungen dar. *J. Ingenhousz* entdeckte (1779) die Aufnahme der  $\text{CO}_2$  und Abgabe des O durch dieselben; daß dieser exhalirte O aus dem  $\text{CO}_2$  stamme, fand *Senneker* 1785. — *Vogel* und andere wiesen mit Bestimmtheit die O im venösen Blute, *Hoffmann* und andere O im arteriellen nach. *Lavoisier* machte 1789 die ersten Mitteilungen über die quantitative O-Aufnahme und  $\text{CO}_2$ -Abgabe bei der Atmung. — Völliger Einblick in den Gaswechsel bei der Atmung konnte erst gewonnen werden, nachdem durch *Magnus* (1837) die Gase des arteriellen und venösen Blutes gepumpt und analysiert wurden.

### Literatur (§ 70—96).

1. *H. N. Kohn*: M. m. W. 1893, Nr. 3. *D. Hansemann*: Sitz.-Ber. d. Preuss. Akad. d. Wiss. 1895, 999. Mathem. u. naturw. Mitteil. d. Preuss. Akad. d. Wiss. 9. Heft, 1899, 165. — 2. *Ch. Arby*: Der Bronchialbaum der Säugetiere und des Menschen. Leipzig 1880. — 3. *E. Zuckerkanndl*: S. W. A. 87, 3. Abt., 1883, 171. *W. S. Miller*: P. A. 1896, 110. — 4. *Klein*: The anatomy of the lymphatic system. London 1875. — 5. *W. Darazki*: A. A. 1881, 1. — 6. *A. Lohmann* u. *E. Müller*: Sitz.-Ber. d. Gesellsch. d. ges. Naturw. z. Marburg, 1912, Nr. 2. — 7. *W. E. Dixon* u. *T. G. Brodie*: P. A. 1903, 97. 30, 1904, 476. Transactions of the pathological society of London. — 8. *P. Trendelenburg*: C. P. 26, 1912, 1. A. P. P. 69, 1912, 79. — 9. *G. Bachr* u. *A. P. P.* 74, 1913, 41. — 10. *C. S. Roy* u. *G. Brown*: J. o. P. 6, 1885, S. XXI. — 11. *Titone*: P. A. 155, 1913, 77. — 12. *A. Biermer*: Über Bronchialasthma. Volksh. klin. Vortr. Leipzig 1870, Nr. 12. — 13. Zusammenfassende Darstellung von *Bois-Reymond*: E. P. I, 2, 1902, 377. — 14. *M. Cloetta*: P. A. 152, 1913, 15. — 15. *F. C. Donders*: Z. r. M. N. F. 3, 1853, 287. — 16. *Aron*: V. A. 126, 1891, 1892, 426. 160, 1900, 231. — 17. *R. Stigler*: P. A. 139, 1911, 234. — 18. *P. A.* 98, 1903, 163. — 19. *Nicaise*: C. r. 109, 1889, 573. — 20. *R. H. Kahn*: P. A. 398. — 21. *J. R. Ewald* u. *R. Kobert*: P. A. 31, 1883, 160. — 22. *J. Bernstein*: P. A. 1878, 617. — 23. *Hutchinson*: Medico-chirurgical transaction: of the Royal Society. London 1846, 137. — 24. *N. Girchant*: Journ. de l'anat. et physiol. 1, 1864, 523. C. P. 278. — 25. *M. Bernstein*: P. A. 50, 1891, 363. — 26. *A. Durig*: C. P. 17, 1882, 244. — 27. *E. Pflüger*: P. A. 29, 1882, 244. *Kochs*: Z. k. M. 7, 1884, 487. — 28. *Blatt* der 54. Naturforscherversamml. zu Salzburg 1881, 117. — 29. *F. Schenck*: P. A. 1894, 191. 58, 1894, 233. 59, 1895, 554. Vgl. *L. Hermann*: P. A. 43, 1888, 57, 1894, 387. 59, 1895, 165. 60, 1895, 249. — 30. *Vierordt*: Physiologie. Karlsruhe 1845. — 31. *W. Marcet*: J. o. P. 21, 1897, XXIII. — 32. *A. Loe*: P. A. 1894, 416. — 33. *r. Hoesslin*: M. m. W. 1902, 1952. — 34. *Gebhardt*: M. m. W. 1953. — 35. *C. W. Müller*: Diss. Göttingen 1868. — 36. *Arnold*: Über die Atmung des Menschen. 1855. — 37. *Hoopers Physicians Vademecum*. New edition by *C. G. Chait*: Diss. Zürich 1907. — 38. *Dohrn*: Zeitschr. f. Geburtsh. u. Gynäk. 25. — 39. *H. v. Recklinghausen*: P. A. 62, 1896, 451. — 40. *J. Geppert*: P. A. 42, 1888, 189. — 41. *J. E. Johansson*: S. A. 5, 1895, 20. — 42. *J. S. Priestley*: J. o. P. 32, 1905, 225. — 43. *H. E. Hering*: C. P. 8,



**DIESE SEITE IST FÜR KOSTENLOSE MITGLIEDER GESPERRT**  
Beantragen Sie jetzt die volle Mitgliedschaft, um diese Seite zu betreten

# GESCHICHTE

Zehntausende von wichtigen historischen Quellen, viele bisher nicht erhältlich, stehen jetzt zum ersten Mal mit der Vollmitgliedschaft von Forgotten Books zur Verfügung.

Unbegrenzter Zugang  
\$8.99/monat

**Fortfahren**

\*Es gelten Richtlinien zur fairen Nutzung.



Eigentümlichkeit desjenigen Eiweißes bewahren, aus dem sie hervorgeht (Rindseiweiß, Pferdeeiweiß, Pflanzeneiweiß usw.), sondern das Eiweiß abgebaut werden bis zu den einzelnen Aminosäuren, die alle eine Arteigentümlichkeit mehr besitzen. Diese erst werden resorbiert, aus ihnen als indifferenten Bausteinen setzt dann der betreffende Organismus wieder dasjenige Eiweiß zusammen, welches ihm zukommt. So ist durch den weitgehenden Abbau der Nahrungsstoffe im Darm eine Garantie geboten, daß die Arteigentümlichkeit erhalten wird. Dringen gleichartfremde Substanzen in den Körper ein, so schützt dieser sich durch weitere Maßnahmen: Bildung von Antikörpern (vgl. § 27) und Ausscheidung durch den Harn usw. — Ganz ebenso wie die Eiweiße unserer Nahrung wird auch die vegetabilische Stärke im Verdauungsorgan bis zu ihren indifferenten Bausteinen, den Dextrosemolekülen, abgebaut, aus denen dann nach der Resorption der tierische Körper die Stärke, das Glykogen, aufbaut. Auch für die Fette sind derartige Verhältnisse im Aufbau denkbar und wahrscheinlich.

Die Bearbeitung der Nahrungsbestandteile im Verdauungsorgan ist zunächst eine mechanische: Zerkleinerung durch den Kauakt. Es schließt sich dann die chemische Einwirkung der mit den Verdauungsorganen ausgeschiedenen Fermente an. Diese zerlegen im Wege der hydrolytischen Spaltung die Nahrungsstoffe in ihre einzelnen Bausteine, die zur Resorption geeignet sind. Dabei wirkt entsprechend der Natur der Fermente (S. 17) jedes einzelne Ferment immer nur auf eine ganz bestimmte Klasse von Nahrungsstoffen ein, deren chemischem Bau es angepaßt ist. In tieferen Abschnitten des Verdauungsapparates nehmen auch Mikroorganismen an der Aufspaltung der Nahrungsstoffe teil, doch ist ihre Wichtigkeit für den Menschen und den Fleischfresser von untergeordneter Bedeutung, von Wichtigkeit dagegen für den Pflanzenfresser.

## 98. Die Mundhöhle und ihre Drüsen. Die Speicheldrüsen. Veränderung der Drüsen bei der Tätigkeit.

Die Schleimhaut der Mundhöhle besteht aus fibrillärem Bindegewebe, in dem feinen elastischen Fasern vermischt, und trägt ein vielschichtiges Plattenepithel. — Von den ziemlich reichlichen Blutgefäßen liegen die gröberen in der Submucosa, während die feineren bis in die Papillen eindringen, in denen sie entweder Maschen oder einfache Schlingen bilden. — Von den Lymphgefäßen liegen die weite Maschen bildenden Stämme in der Submucosa, während die feineren, zu einem Netzwerke gefügten in der Mucosa selbst verlaufen. Zu dem Lymphapparate gehören die Balgfollikel oder Lymphfollikel. Auf dem Rücken der Zungenwurzel bilden sie eine fast zusammenhängende Schicht; sie liegen zu mehreren in rundlichen, die Schleimhaut etwas erhebenden Gruppen zusammen. In der Mitte einer jeden Gruppe liegt eine Vertiefung (Fig. 63), in deren Grund Schleimdrüsen ihre Ausmündung finden. Die kleinen Krater mit Schleimsekret ausfüllen. — Die Tonsillen lassen in demselben Bau erkennen; buchtenartige Vertiefungen, in deren Sinus kleine Schleimdrüsen einmünden, sind von Haufen (von 10—20) Lymphfollikeln umlagert. Festere Bindegewebslagen geben den Tonsillen eine Umbüllung. — Ziemlich zahlreiche markhaltige Nervenfasern, — welche von der Submucosa aus hervortreten, verteilen sich in der Schleimhaut und endigen zum Teil in einzelnen Papillen in Form der Krauseschen Endknäuel, reichlicher an den Lippen und am weichen Gaumen, spärlicher an den Wangen und dem Boden der Mundhöhle. Wahrscheinlich finden jedoch die Nerven auch noch ihre Ausmündung mittelst feinsten Terminalnoduli zwischen den Epithelzellen nach der Cohnheim-Haasschen Verbreitungsart.

Die Drüsen der Mundhöhle — liegen als kleine Drüsen zum Teil in der Zunge; dazu kommen

Speicheldrüsen — zeigen (ebenso wie das Pankreas) den zusammengesetzt-tubulösen Typus. Die Ausführungsgänge, aus elastischem Gewebe bestehend, führen Cylinderepithel. Der lebenden strukturlosen Membran des Acinus ist ein Gespinnstnetzwerk, anastomosierender Zellen eingefügt (Fig. 64 D). Der Acinus liegt zunächst spaltförmige Lymphräume an, in welchen erst die Blutcapillaren in netzartigen Maschen verlaufen. Lymphgefäße treten im Hilus aus der Drüse hervor.

Die Sekretionszellen — sind verschieden gebaut, je nach der Drüse schleimabsondernd (Sublingualis vom Menschen, Submandibularis vom Hund), oder eiweißsecernierend (Parotis vom Menschen) oder eine gemischte Drüse ist (Submaxillaris vom Menschen).

1. In den Acinis der Submaxillaris (Hund) und Sublingualis (Mensch) finden sich zweierlei Arten zelliger Elemente: — 1. die „glockenförmigen Schleimzellen“ (Fig. 64 B, c) (R. Heidenhain<sup>1</sup>), welche den Sekretionskanal begrenzen. Sie besitzen eine Membran, sind prall gefüllt und haben einen abgeplatteten, der Acinuswand zugekehrten Kern. Der Zellkörper ist reichlich imprägniert mit Mucin, das ihm ein glänzendes, stark lichtbrechendes Aussehen verleiht. Dieses Schleimgehaltes wegen färben sich die Zellen durch Karmin fast gar nicht, während der Kern den Farbstoff an sich zieht. Von der Zelle abgehender Fortsatz schmiegt sich gebogen an die inneren Acinuswand an; das eigentliche Protoplasma zieht als fadenförmiges Fortsatz vom Kern aus durch die Mucinschicht durch. — 2. Die andere Art der zelligen Elemente liegt zu einem oder mehreren in halbmondförmigen Komplexen an der Acinuswand unmittelbar an. Jeder Komplex besteht aus einer Anzahl dicht gelagerter, schwer löslicher, eckiger, stark eiweißhaltiger Zellen mit einem Kern; sie sind granuliert, dunkel gefärbt, durch Farbstoffe leicht imprägnierbar und zeigen zwischen den Zellen Sekretspalten.

2. Die Eiweiß absondernden Zellen (Mensch und Säugetiere) sind eine Art von Sekretionszellen, die im Protoplasma großenteils wenig durch Farbstoffe tingierbar sind. Sie sind zellenlose Zellen mit zackigem, stark lichtbrechendem, central gelegenen, stark lichtbrechenden Kern ohne Kernkörperchen. Die Zellen haben Sekretgänge zwischen sich (E. Müller<sup>2</sup>). Das Protoplasma findet sich in Gestalt von Körnern oder Granula vor. Das Lichtbrechungsvermögen in dem Protoplasma der Zellen (Langhans<sup>3</sup>).

Fig. 65.

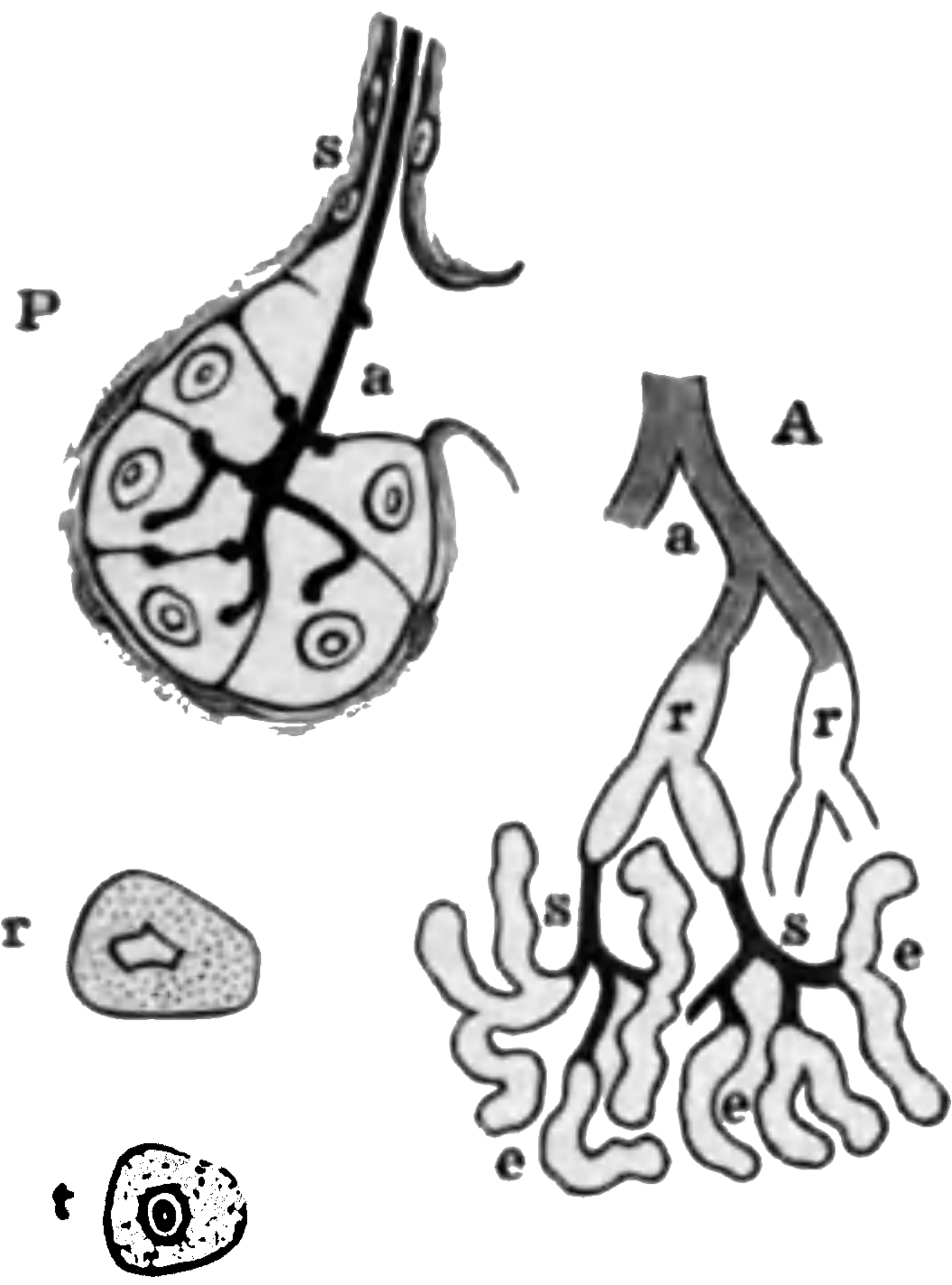

A Schema einer Speicheldrüse; a Ausführungsgang, r r Speichelröhren, s s Schaltstücke, e e Endstücke. — P Endstück der Parotis mit intercalierten (schwarzgefärbten) Sekretgängen, in den Ausführungsgang (a) des Schaltstückes (s) übergehend. — r Parotiszelle ausgerubt, t nach der Absonderung.

Die Zellen haben Sekretgänge zwischen sich (E. Müller<sup>2</sup>). Das Protoplasma findet sich in Gestalt von Körnern oder Granula vor. Das Lichtbrechungsvermögen in dem Protoplasma der Zellen (Langhans<sup>3</sup>).



sogar die pulsierende Bewegung der Arterien sich bis in die Drüse pflanzt (S. 145) (*Cl. Bernhard<sup>9</sup>*). Mehr als viermal so viel Sauerstoff in der Vene zurück, das überdies fast hellrot erscheint und ein Drittel größeren O-Gehalt zeigt als das Venenblut der ruhenden Drüse. Trotz dieses relativ hohen O-Gehaltes des Venenblutes absondernde Drüse doch absolut mehr O als die ruhende, einmal mehr, bei gleichzeitiger starker CO<sub>2</sub>-Bildung (*Barcroft*). Lymphbildung in der Drüse steigt parallel mit der Speicheldrüsenbildung (*Asher u. Barbèra<sup>11</sup>*).

Im N. facialis liegen zweierlei funktionell verschiedene Fasern: — 1. echte Sekretionsnerven, — 2. gefäßerweitende Vasodilatoren. Es ist nicht zulässig, die Erscheinung etwa als eine einfache Folge der lebhafteren Circulation (Siehe unten.)

II. Reizung des N. sympathicus bewirkt eine spärliche Absonderung eines sehr dickflüssigen, zähgallertigen, fadenzieherigen Sekrets (*Eckhard<sup>8</sup>*), in welchem die spezifischen Bestandteile reichlich sind, namentlich der Schleim; das spezifische Gewicht steigt bis 1010. Gleichzeitig verengern sich unter Abnahme des Blutstromes die Gefäße der Drüse, so daß das spärliche Blut dunkel durch die Venen abfließt.

Im N. sympathicus liegen ebenfalls zweierlei funktionell verschiedene Nervenfasern: — 1. echte Sekretionsnerven — und 2. verengende Nerven, Vasomotoren.

Mit steigender Stärke des Reizes nimmt die Absonderung und in ihr die Menge der organischen Bestandteile hängt außer von der Reizstärke auch von dem Ruhe- oder Erschöpfungszustande der Drüse ab (*Heidenhain*). Die Blutmischung und die Circulationsverhältnisse in der Drüse beeinflussen die Zusammensetzung des Speichels (*Langley u. Fletcher<sup>12</sup>, Asher u. Cutter<sup>14</sup>*).

Daß die Absonderung der Drüsen nicht als einfache Filtration, sondern Folge der veränderten Blutfülle angesehen werden darf, sondern ständige Leistung der secernierenden Zellen neben der Veränderung auftritt, geht aus folgenden Tatsachen hervor:

1. Die absondernde Tätigkeit der Drüse bei Reizung der Nerven hält lange an, nachdem alle Gefäße unterbunden sind (*Czermak<sup>13</sup>, Gianuzzi<sup>15</sup>*).

2. Atropin und Daturin vernichten die Tätigkeit der Sekretionszellen in der Chorda tympani, nicht jedoch die der gefäßerweiternden Zellen (*Heidenhain<sup>11</sup>*). — Durch Yohimbin kann der Blutdurchfluß durch die Drüse 10fache gesteigert werden, ohne daß Speichelsekretion eintritt. Der Sauerstoffverbrauch der Drüse bleibt dabei unverändert. Wird aber nachher die Chorda durchschnitten, tritt Speichelsekretion und damit eine Steigerung des Sauerstoffverbrauches 7fache ein (*Barcroft u. Müller<sup>10</sup>*).

3. Der Druck im Ausführungsgange der Speicheldrüsen (durch ein Manometer zu messen) kann fast die doppelte Höhe betragen als der Druck in den Gefäßen der Drüse (*C. Ludwig<sup>19</sup>*), im Ausführungsgange der Submaxillärdrüse 290 mm Hg. — [Mit Steigerung des Druckes im Ausführungsgange nimmt die Menge ab, ebenso auch die von der Drüse geleistete Arbeit (*Grünbaum<sup>20</sup>*).

4. Ähnlich wie Nerv und Muskel ermüden auch die Speicheldrüsen bei Einspritzung von Säuren oder Alkalien in den Ausführungsgang. Es beweist die sekretorische Gewebe unabhängig von der Circulation unter dem Einfluß des Reizes (*Gianuzzi<sup>16</sup>*).

Es muß somit gefolgert werden, daß ein direkter Einfluß des Reizes auf die Sekretionszellen der Drüsen vorhanden ist, unabhängig von der Vermittlung durch die Gefäße.

Während der Sekretion steigt die Temperatur der Submaxillärdrüse um 1,5° (*Ludwig u. Spiess<sup>21</sup>*), bei Reizung des Sympathikus (*Burton-Opitz<sup>22</sup>*), die Drüse sowie das aus der Vene abfließende Blut wärmer als das Arterienblut.



**DIESE SEITE IST FÜR KOSTENLOSE MITGLIEDER GESPERRT**  
Beantragen Sie jetzt die volle Mitgliedschaft, um diese Seite zu betreten



**Seien Sie niemals ohne ein Buch!**

Die Vollmitgliedschaft von Forgotten Books bietet Ihnen einen universalen Zugang von unseren Apps und unserer Website, auf all Ihren Geräten: Tablet, Telefon, E-Reader, Laptop und Computer.

**Eine Bibliothek in Ihrer Tasche für € 8.99/monat**

**Fortfahren**

\*Es gelten Richtlinien zur fairen Nutzung.

— 64,7 CO<sub>2</sub> (teils auspumpbare, teils durch Phosphorsäure austreibbare); Kütz<sup>60</sup> fand im Parotidenspeichel des Menschen bis 1,46 Vol.-Prozent O, — auspumpbare CO<sub>2</sub> und 62 gebundene CO<sub>2</sub>.

**Abnorme Speichelbestandteile.** — Vermehrten Harnstoff fand man (*Flischer*<sup>67</sup>), Harnsäure bei Urämie (*Boucheon*<sup>68</sup>), überhaupt stets, wenn die Blute vermehrt ist (*Stocker*<sup>69</sup>). Von verabreichten fremden Substanzen Speichel über: Quecksilber, Kalium, Jod- und Brommetalle, Blei, Morphin, Salz (*Ellenberger*<sup>70</sup>).

**Der Speichel der einzelnen Speicheldrüsen.** — Der Speichel der hält kein Mucin, ist daher nicht fadenziehend, leicht tropfend; alkalisch (γ von 1,003—1,006 spez. Gew. Der Speichel der Submaxillaris enthält Stärke ist daher etwas fadenziehend; der der Sublingualis ist sehr reich an Mucin stark klebrig. Der Speichel dieser beiden Drüsen reagiert stark alkalisch

## 101. Physiologische Wirkungen des Speichels

I. Der Speichel enthält als physiologisch wichtigsten Bestandteil Ptyalin, ein hydrolytisches Ferment, welches die Verdauung der Stärke einleitet. Es verwandelt die Polysaccharide unserer Nahrung von der Formel (C<sub>6</sub>H<sub>10</sub>O<sub>5</sub>)<sub>x</sub>, im wesentlichen Stärke, in Maltose, an infolge ihres großen Moleküls schwer löslich und daher nicht für die Ernährung geeignet sind, unter Wasseraufnahme in Körper von kleiner Molekülgröße die nunmehr leicht löslich sind. Als Zwischenprodukte entstehen zunächst Dextrine, Körper, die auch noch zu den Polysacchariden gehören, aber schon ein wesentlich kleineres Molekül als die Stärke. Das Endprodukt ist ein Disaccharid: Maltose C<sub>12</sub>H<sub>22</sub>O<sub>11</sub> (vgl.

Wenn man durch Kochen mit Wasser verkleisterte Speichel versetzt und bei Körpertemperatur stehen läßt, so kann man den Verlauf der Umwandlung im einzelnen verfolgen. Zuerst entsteht eine flüssige Lösung des Stärkekleisters das Amylodextrin: es reduziert die Fehlingsche Lösung nicht, färbt sich durch Jod blau (ist Hauptbestandteil des „löslichen Stärke“ oder Amydulin bezeichneten Präparates). Bei weiterem Übergeführt in Erythrodextrin, Fehlingsche Lösung schwach durch Jod sich rot färbend. Dieses wird in Achroodextrin übergeführt, Fehlingsche Lösung reduzierend, durch Jod un färbbar. Aus diesem schließlich Maltose (und Isomaltose?).

In keimenden Getreidekörnern kommt ein ähnlich wirkendes Ferment vor, die diastatische Ferment, sie verwandelt die in den Samen als Reservematerial aufgespeicherte Stärke in Maltose und macht sie so der keimenden Pflanze zugänglich (vgl. die Herstellung der Bier bei der Bierbereitung durch Keimenlassen von Gerste). Danach können alle Polysaccharide in Disaccharide umzuwandeln vermögen, diastatische Fermente.

Durch Kochen mit verdünnter Schwefel- oder Salzsäure wird die Stärke ebenfalls gespalten; doch macht die Zersetzung nicht nur die Bildung von Maltose Halt, sondern diese wird weiter gespalten und die ganze Stärke in Dextrose übergeführt. Im Gegensatz hierzu überführt das Ptyalin (und die diastatischen Fermente überhaupt) die überwiegenden Teile nur in Maltose übergeführt; daneben wird eine allerdings nur geringe Menge von Dextrose gebildet (*Külz* *Hamburger*<sup>72</sup>).

**Darstellung des Ptyalins.** — 1. Man erzeugt in dem Speichel durch Zugabe von Phosphorsäure und Kalkwasser einen voluminösen Niederschlag von Calciumphosphat, das Ptyalin mitniederreißt. Dieser Niederschlag wird auf dem Filter gesammelt und mit wenig Wasser das Ptyalin daraus aufgelöst. In diesem wässerigen Auszug

Das Kiefergelenk ist durch einen Zwischenknorpel (*Vidius* †) bei der energischen Wirkung der Kaumuskeln den gegenseitigen direkten Druckflächen abhält, — in zwei übereinander liegende Hohlräume geteilt. Die namentlich durch das äußere Band ansehnlich verstärkt, ist so geräumig, daß dem Heben und Senken des Unterkiefers zugleich noch eine Verschiebung des Kieferkopfes nach vorn auf das *Tuberculum articulare* zuläßt.

a) Die Erhebung des Kiefers — wird durch die Vereinigung der *Musculi temporales*, *masseteres* und *pterygoidei interni* bewirkt. War vorher der Unterkiefer stark gesenkt, so daß die Gelenkköpfe nach vorn auf die *Tubercula articularia* getreten waren, so gehen sie bei der Erhebung in die Gelenkhöhle zurück.

Bei Erhebung des möglichst hervorgestreckten Unterkiefers fällt die Wirkung der *Mm. temporales* aus, weil diese bei ihrer Hebewirkung den Kiefer zugleich nach hinten würden; — bei möglichst stark zurückgeschobenem Unterkiefer wirken die *Temporales*, weil die anderen Muskeln zugleich hervorziehend wirken würden. Bei seitlich verschoben gehaltenem Unterkiefer fällt die hebende Wirkung der *Temporales* aus.

b) Die Abwärtsbewegung des Unterkiefers — erfolgt so, als ob sein Gewicht, — unterstützt wird sie durch mäßige Contraction der äußeren Bänche der *Digastrici* und der *Mm. mylo-* und *geniohyoidei*. Die Muskeln wirken stärker bei weiterem und angestregtem Öffnen des Mundes. Die hierbei notwendige Fixierung des Zungenbeines bewirkt die *Omo-* und *Sternohyoidei* sowie die vereinigten wirkenden *Sternohyoidei* und *Thyreohyoidei*.

Da beim starken Niedergehen des Unterkiefers sich die Gelenkköpfe auf die *Tubercula articularia* begeben (*Ravius* 1719), so ist angenommen worden, daß in diesem Falle die *Mm. pterygoidei externi* dieses Verschieben aktiv begünstigen. — Bei starker Mundöffnung wird der Kopf hintenüber gebeugt, wobei (bei fixiertem Unterkiefer) die hinteren Bänche der *Digastrici* sowie die *Stylohyoidei* wirken. — (Bei manchen Tieren sind auf- und abwärts bewegliche Oberkiefer vorhanden, z. B. bei Krokodilen, Schlangen und Fischen.)

c) Verschiebung beider oder eines Gelenkkopfes nach vorn oder hinten. — 1. Das Hervorstrecken des Unterkiefers bewirkt die *Mm. pterygoidei externi*. Da hierbei der Gelenkkopf auf das *Tuberculum articulare* (also auch niederwärts) tritt, so müssen die Flächen der Zähne in dieser Stellung von einander weichen. — 2. Die zurückbewegung besorgen die *Mm. pterygoidei interni*. — 3. Es wird eine Gelenkkopf nach vorn gezogen und wieder zurück durch die *Mm. pterygoideus externus* und *internus* derselben Seite; hierbei bewirkt die Transversalbewegung des Unterkiefers statt. — Je mehr der Unterkiefer gesenkt ist, um so unergiebigere sind diese Bewegungen.

Bei der Kaubewegung, bei welcher sowohl die Hebung und Erhebung des Unterkiefers als auch die transversale „Mahlbewegung“ gleichzeitig stattfinden, werden die zu zerkleinernden Speisen von oben durch die Lippenmuskeln (*Orbicularis oris*) und die *Buccinatori* nach unten durch die Zunge unter die Kauflächen der Backen- und Unterkiefer geschoben. Das Muskelgefühl der Kaumuskeln sowie das Tastgefühl der Zähne, der Mundschleimhaut und der Lippen regulieren auf diesem Wege die aufzubietende Kraft der Kiefermuskeln: das Centrum für die Kaubewegung liegt in der *Medulla oblongata* (§ 278. 5). Unter gleichzeitiger Einspeichelung kleben die zerkleinerten Speiseteilchen zu einer Masse zusammen, welche dann auf dem Zungenrücken in einen länglichrunden „Bissen“ (*Bolus*) geformt wird.

**Das Cement** — (*Substantia ossea*) stellt eine dünne, die Wurzelknochenrinde dar (Fig. 68 a).

**Chemie der Hartgebilde des Zahnes.** — Die Zähne bestehen aus umgebender Substanz, durchdrungen von Calciumphosphatcarbonat (als Knochen). — 1. Das Dentin enthält: Organische Substanz 27,70, — Calciumcarbonat 72,06, — Magnesiumphosphat 0,75, neben Spuren von Eisen, Fluor (*Acby<sup>92</sup>, Hoppe-Seyler<sup>93</sup>*), Kali, Natron, Cl, (*Gabriel<sup>94</sup>*).

Fig. 67.

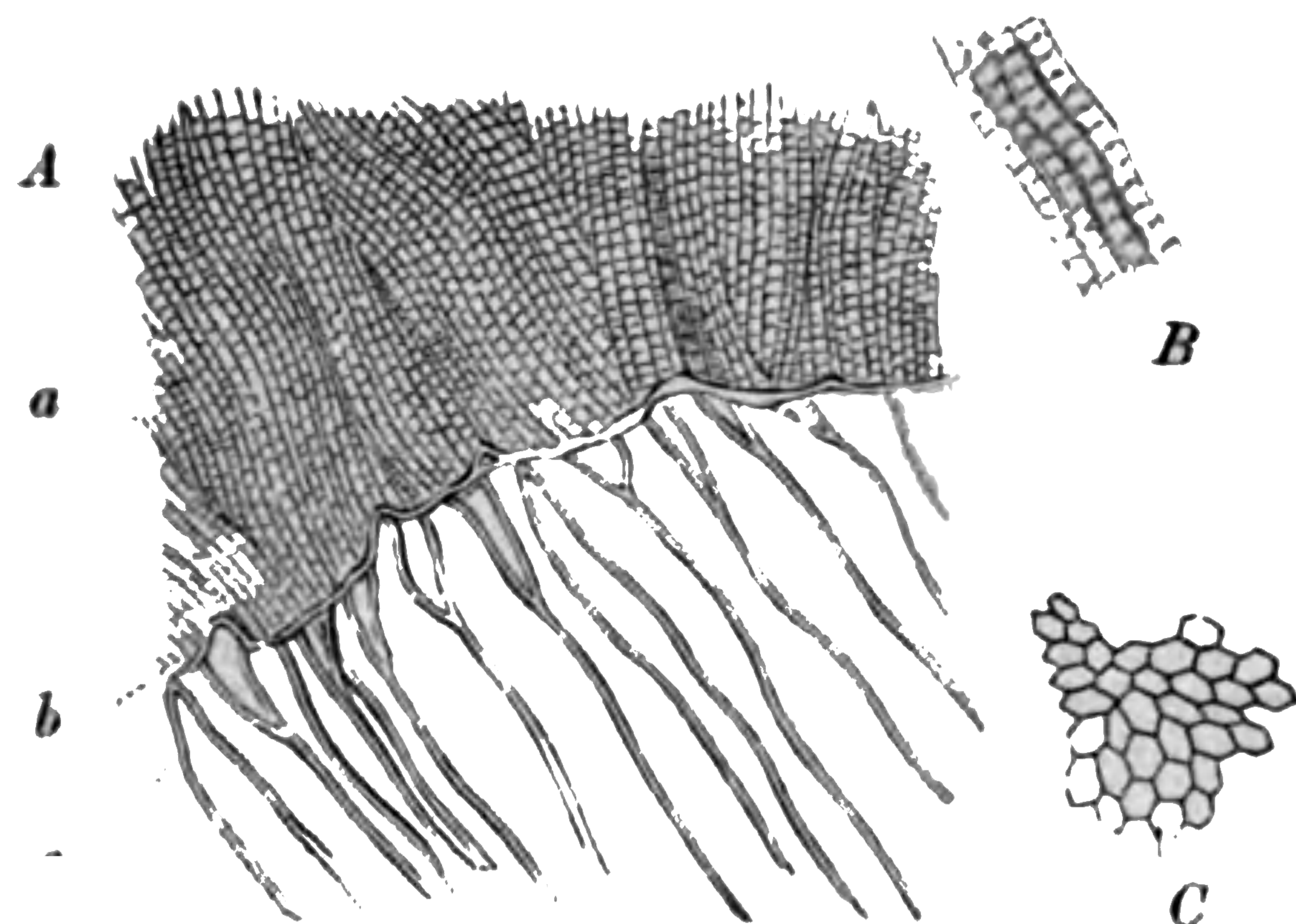

A Zahnschliff an der Grenze b zwischen Dentin und Schmelz, a Schmelz, c Dentinröhren. — B stark vergrößerte Schmelzprismen. — C dieselben im Querschliff.

2. Der sitzt als organische Substanz. An Bestandteilen (organische Substanz): — Calciumcarbonat 96,00, — Magnesiumphosphat 0,33—0,52%, unlöslichen Cl (*Acby<sup>92</sup>, Hoppe-Seyler<sup>93</sup>*), Kali, Natron, Cl.

3. Das Bindegewebe stimmt völlig mit Knochen-Substanz überein.

**Welches.** — Die Dentinschicht besteht aus einer unter weniger

capillarreichen Bindegewebe mit Bindegewebszellen und Leukocyten. Die oberste, dem Dentin anliegende Schicht der Zellen sind die Odontoblasten, die

Fig. 68.

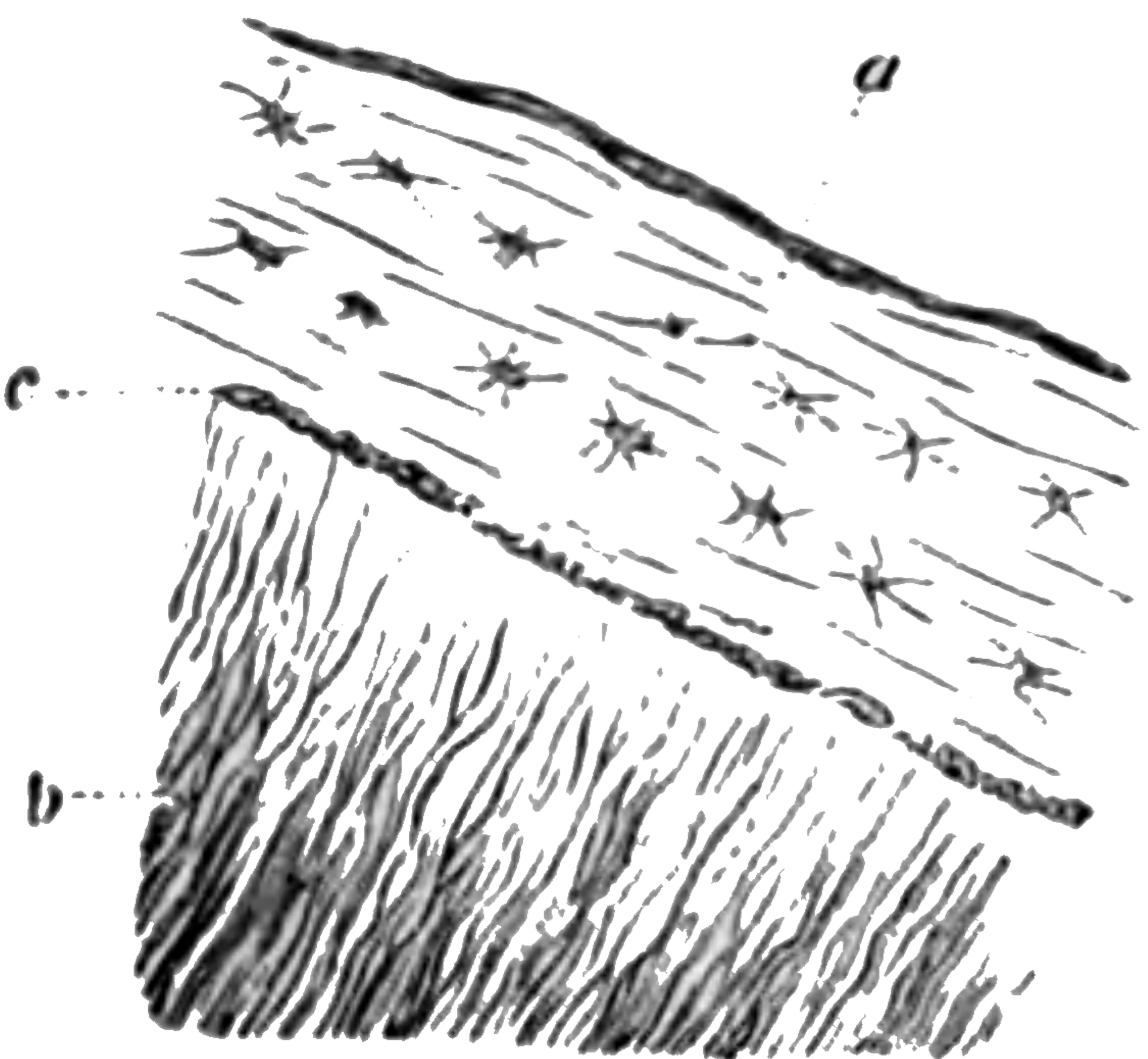

Querschliff der Wurzel: a Cement mit Knochenkörperchen, b Dentin mit Zahnkanälchen, c Grenze beider.

Zellen, von welchen die Bildung des Dentins ausgeht. Sie entsenden in die Pulpa lange Fortsätze, während ihr Körper, auf der Oberfläche der Pulpa durch andere Fortsätze eine Verbindung mit benachbarten Odontoblasten wirkt. Zahlreiche markhaltige, nach der Teilung marklos werdende Nerven liegen zwischen den Odontoblasten unter dem Zahnbein mit freien, knotig verdickten Spitzen. Weiter unten in den Zahnkanälchen, teils in der Bindegewebssubstanz. Die meisten scheinen unter pinselförmiger Ausstrahlung einer faserigen Plexus liegen. Die Arterien des Zahnes liegen unter den Nervenstämmchen; die Capillaren selbst bis in die Odontoblastenlage.

**Die Entwicklung der Zähne.** — Schon gegen den 40. Tag. Auf der Innenseite des Kieferrandes befindet sich eine

epithelialschicht gebildete, hervorragende Kante, „der Kieferwall“. Von dieser Kante senkt sich in den Kiefer hinein eine ebenfalls von Epithelien begrenzte „Zahnfurche“. Die Zahnfurche vertieft sich weiterhin in ihrer ganzen Ausdehnung zu einer Form, welche dem Querschnitte einer von unten eingebogenen



**DIESE SEITE IST FÜR KOSTENLOSE MITGLIEDER GESPERRT**  
Beantragen Sie jetzt die volle Mitgliedschaft, um diese Seite zu betreten

# GESCHICHTE

Zehntausende von wichtigen historischen Quellen, viele bisher nicht erhältlich, stehen jetzt zum ersten Mal mit der Vollmitgliedschaft von Forgotten Books zur Verfügung.

Unbegrenzter Zugang  
\$8.99/monat

**Fortfahren**

\*Es gelten Richtlinien zur fairen Nutzung.



jedoch nur für den Halssteil der Speiseröhre; im Brustteil ist die Speise Fremdkörper direkt reizbar, es wird hier eine peristaltische Bewegung, die Fremdkörper in den Magen befördert. Diese Reizbarkeit nimmt mit der Pharynx zu. Die Peristaltik setzt sich stets über die ganze Länge der Speiseröhre, sogar wenn dieselbe unterbunden ist, oder ein Teil derselben ausgeschnitten ist. Ebenso verläuft die Peristaltik bis abwärts, wenn man Hunde ein an einem Stück Fleisch bis zur halben Oesophaguslänge verschlucken läßt und es herauszieht (*C. Ludwig u. Wild*<sup>101</sup>).

Nach *Kronecker u. Meltzer*<sup>102</sup> ist die Dauer des Schlingens 0,3 Sek.; dann contrahieren sich die Schlundschürer, 0,9 Sek. später der Oesophagusabschnitt, sodann nach 1,8 Sek. der mittlere und dann nach 3 Sek. die Verengung der Kardia, nach dem Durchtritt der Massen, macht die Verengung die gesamte Bewegungsreihe. — Nach *Schreiber*<sup>103</sup> beginnt etwa 0,2 Sek. nach dem Mundschluckens (Mylohyoidens-Wirkung) zuerst eine Eröffnung des Oesophagus, dann die Pharynxschürer wirken. Daran schließt sich die peristaltische Bewegung der Muskulatur der Speiseröhre, welche bis zum Eintritt in den Brustkorb 3 bis zur Kardia 5—7 Sek. dauern kann (vgl. *Kraus*<sup>104</sup>).

## 105. Bewegungen des Magens<sup>105</sup>. Das Erbre

**Methode.** Zur Untersuchung der Magenbewegungen dient:

a) ein durch eine äußere Magentistel bei Tieren eingebrachter Gummiballon, den man an verschiedene Stellen des Innenraumes bringen kann; der Ballon ist mit einer Schreibvorrichtung durch Luftübertragung (§ 51. 2) verbunden (*Ducceschi*<sup>106</sup>).

b) Die Beobachtung des Austritts des Mageninhalts aus dem Mund durch eine Magentistel (*Hirsch*<sup>106</sup>, *v. Mering*<sup>107</sup>, *Moritz*<sup>108</sup>, *Otto*<sup>109</sup>, *Tobler*<sup>110</sup>).

c) Die Bestimmung des im Magen herrschenden Drucks und der Veränderungen desselben mittelst der Schlundsonde (*Moritz*<sup>111</sup>).

d) Die Durchleuchtung mit Röntgenstrahlen; dabei wird der Magen mit Speisen angefüllt, die mit dem für Röntgenstrahlen undurchlässigen Bismut versetzt sind (*Roux u. Balthazard*<sup>112</sup>, *Cannon*<sup>113</sup>).

Der herausgenommene, in einer feuchten Kammer liegende Magen zeigt die Bewegungen (*Hofmeister u. Schütz*<sup>114</sup>).

Am Magen verlaufen äußere longitudinale, innere ringförmige Fasern, innerst in diagonaler Richtung die *Fibrae obliquae*, jedoch mit vielfachen Kreuzungen ineinander. Am Pylorus bildet die Muskulatur einen ringförmigen Sphinkter (Sphincter pylori), dessen Fasern sich bis in die *Valvula pylori* hinein erstrecken. In der Kardia gruppieren sich Fasern zu einem „Kardiaschnürer“.

Bei den Bewegungen des Magens sind getrennt zu unterscheiden:  
1. Die Bewegungen der Kardia. — 2. Die Bewegungen der Magenwand. — 3. Die Bewegungen des Pylorus.

1. Die Bewegungen der Kardia. — Bei gefülltem Magen mit normalem Salzsäuregehalt des Mageninhalts (*Cannon*<sup>115</sup>) ist durch die in ihrer Wand gelegenen Muskeln (*Strecker*<sup>116</sup>) gegeben, daß der Mageninhalt selbst bei Drucksteigerung im Magen in den Oesophagus gelangt. Eröffnet wird die Kardia reflektorisch bei Reizung der unteren Oesophagusschleimhaut, wie sie durch den niedergleitenden Bissen ausgelöst wird; auf diese Weise eröffnet sich selbst der Weg zum Magen. Auf starke Reize hingegen schließt sich die Kardia; so werden kaltes oder kohlenensäurehaltige ätzende Flüssigkeiten vor der Kardia angehalten (*Kronecker u. Cannon* u. *Moser*<sup>96</sup>, *v. Mikulicz*<sup>116</sup>, *Kraus*<sup>104</sup>).

Bei schnell aufeinander folgenden kleinen Schlucken wird die Kardia erst im dritten bis vierten Schluck geöffnet (*Kronecker u. Meltzer*<sup>102</sup>).

Beim Verschlucken ätzender Flüssigkeiten findet sich die Verätzung gerade im unteren Teile des Oesophagus, weil die ätzende Flüssigkeit dort angehalten worden ist.

2. Die Bewegungen der Magenwand. — Der Fun

*Cannon*<sup>134</sup>) und mit Fett (*Best* u. *Cohnheim*<sup>135</sup>) bewirken Schließung des Pylorus; dagegen bewirkt Berührung der Duodenalschleimhaut mit alkalischen Flüssigkeiten, Salzlösungen Entleerung des Magens in den Darm. In ähnlicher Weise wird aber Schluß und Öffnung des Pylorus auch von der Magenschleimhaut aus reflektorisch beeinflusst. *Cannon*<sup>134</sup> bewirkt Berührung des Pylorusteils des Magens mit Speisebrei Erschlaffung des Pylorus.

Der Pylorusreflex hat zur Folge, daß die Entleerung des Magens in den Darm in einzelnen Schüben erfolgt. Ist der Antrumteil des Duodenums leer, eventuell sogar mit alkalischem Darmsaft gefüllt, so öffnet sich der Pylorus, sobald der saure Speisebrei die Schleimhaut des Pylorusteils des Magens berührt, ein Teil des Mageninhalts tritt in das Duodenum ein. Durch die Berührung der Darmschleimhaut mit dem sauren Mageninhalt wird aber sofort wieder Schluß des Pylorus bewirkt. Vergeht jetzt eine gewisse Zeit, bis der Inhalt des Duodenums neutral resp. weitergeführt ist: alsdann erfolgt wiederum Öffnung des Pylorus, Eintritt eines weiteren Teiles des Mageninhalts in den Darm.

Nach *Boldyreff*<sup>137</sup> soll unter bestimmten Bedingungen (bei fettreicher Nahrung) Einführung reichlicher Säuremengen in den Magen, während des Hungers) auch auftreten von Pankreas-, Darmsaft und Galle aus dem Duodenum in den Magen. Im Magen sollen dann unter dem Einfluß vor allem der Pankreasfermente die Verdauungsvorgänge sich vollziehen; besonders soll die Fettverdauung im Magen unter dem Einfluß zurückgetretenen Pankreassaftes erfolgen.

Innervation der Magenbewegungen. — Das Centrum der Magenbewegungen liegt im Magen selbst in Gestalt des autonomen Gangliennetzes des Plexus Auerbachii zwischen den beiden Schichten der Muscularis (vgl. S. 244). Die Kardial- und Pyloralmuskulatur haben automatische Ganglienzellen (*v. Openchowski*<sup>138</sup>). Diese automatische Innervation steht mit dem Centralnervensysteme in Verbindung durch die Vagi und den Sympathicus.

Nach *r. Openchowski*<sup>138</sup> liegt ein Centrum für die Contraction der Pyloralmuskulatur in den hinteren Vierhügeln, von wo aus die Bahnen meist durch die Vagi, welche die Splanchnici, abwärts laufen. Das Centrum für die Eröffnung der Kardialmuskulatur (und in Verbindung damit eins am Sulcus cruciatus der Esophagus des Hundes); die leitende Bahn geben die Vagi ab. Auch im oberen Rückenmark liegt ein öffnende Centra, von hier läuft die Bahn durch den Sympathicus (Plexus aorticus minor). Reflektorisch läßt sich eine Eröffnung der Kardialmuskulatur durch Reizung der sensiblen Eingeweidenerven (auch des Ischiadicus) bewirken.

Für den Magenkörper liegt ein Contractionscentrum in den Vierhügeln, von wo Bahnen durch die Vagi und das Rückenmark und von letzterem in den Sympathicus treten. Hemmende Centra enthält das obere Rückenmark; die Bahnen gehen durch die Vagi und Sympathici und Splanchnici.

Der Pylorus zeigt einen gewissen, jedoch wechselnden Tonus im Verhältnisse zum Sympathicus kann den Pylorus mehr öffnen, der Vagus ihn verschließen. Das Centrum für die Eröffnung der Kardialmuskulatur hemmt die Pylorusbewegung: Bahn durch das Rückenmark und die Splanchnici. Hemmende Pyloruscentra liegen in den Vierhügeln: Bahn durch das Rückenmark. Das Kardial-öffnende Hirnrindencentrum trahiert zugleich den Pylorus: Bahn durch die Vagi. Contractionscentra für die Pyloralmuskulatur liegen in den Vierhügeln: Bahn durch die Vagi (wenige Fasern durch das Rückenmark und den Sympathicus).

Der herausgenommene, in einer feuchten Kammer oder in Ringer liegende Magen zeigt noch die Peristaltik des Antrum pylori; dagegen nicht die Schließung des Pylorus (*Cohnheim*<sup>139</sup>). Durchschneidung der Vagi oberhalb des Antrum läßt den Tonus, die Bewegungen des Magens und Pylorus unverändert (*c. Mering*<sup>140</sup>), ebenso Ausrottung des Plexus coeliacus (nach zuerst auftretender Durchschneidung der beiden Vagi am Halse dagegen bewirkt sekretorische Störungen des Magens (*Katschkowsky*<sup>141</sup>)).



## 106. Darmbewegungen.<sup>151</sup> Innervation der Darm

**Methode.** — Zur Beobachtung der Darmbewegungen bei Tieren höhle zur Vermeidung des Luftzutrittes unter blutwarmer 0,9%iger Koell (van Braam-Houckgeest<sup>152</sup>), — oder man beobachtet durch die rasi Bauchdecken hindurch (Pal<sup>153</sup>). Katsch u. Borchers<sup>154</sup> ließen ein Zell Bauchdecken eines Kaninchens einheilen und beobachteten durch dies des Magens und Darms. — Cannon<sup>155</sup> untersuchte die Darmbewegun strahlen, der Darminhalt wurde durch Bismutum subnitricum für die B durchsichtig gemacht (vgl. S. 239). — Man kann auch den Darm aus d nehmen und in sauerstoffgesättigter Ringerscher Lösung von Körperw bewegungen beobachten (Magnus<sup>156</sup>).

Am Darm kommen zwei Arten von Bewegungen vor: Pendelbewegungen und die peristaltischen Bewegun

Die Pendelbewegungen oder Mischbewegung „segmentations“, Cannon<sup>155</sup>) bestehen in einem rhythmischen Herbewegen des Darminhalts in einer Darmschlinge ohne We desselben. Sie bewirken dadurch eine sehr innige Vermisch inhalts und bringen ihn immer aufs neue mit anderen Stell baut in Berührung.

Die Pendelbewegungen sind in ihrem Rhythmus und ihrer Geschw Temperatur abhängig; bei Körpertemperatur erfolgen 10—12 Pendel Minute, jede in einer Dauer von 5—6 Sekunden (Magnus<sup>156</sup>).

Die peristaltischen Bewegungen treten auf, (hauptsächlich mechanischer Art durch Berührung der Da doch sind auch mechanische, chemische, elektrische Reizun fläche des Darms wirksam) den Darm trifft. Es kommt da Reiz aus magenwärts gelegenen Teilen des Darms zu ein in den afterwärts gelegenen dagegen zu einer Erschlaffu (Starling<sup>157</sup>); auf diese Weise wird der Darminhalt versch nun von einer weiter unten gelegenen Stelle denselben auslösen.

Pendelbewegungen und Peristaltik kommen am Dt darm vor. Am Cöcum und obersten Teil des Kolons gese normalen Peristaltik noch eine Antiperistaltik, die den nicht weiter vorrücken läßt, sondern immer wieder zurückl Anfang des Dickdarms zu erneuter Durcharbeitung (Cannon<sup>1 gewissen Zeit wird dann die Antiperistaltik durch eine in tung verlaufende peristaltische Welle abgelöst, die den Inh befördert.</sup>

Die zwischen Dünn- und Dickdarm gelegene Valvula der die Dünndarmmündung ringförmig umgebende Sphin schließen unter normalen Verhältnissen den Dickdarm v vollständig ab (vgl. Hertz<sup>158</sup>), so daß einmal in das Kolon g nicht wieder in den Dünndarm zurückgelangen können. U Verhältnissen kann aber gleichwohl die Valvula Bauhini a werden (s. unten).

Der Sphincter ileo-colicus wird nach Elliott<sup>159</sup> vom Splanchnicus Durchschneidung des Splanchnicus oder Zerstörung des Rückenmarks wi lähmt, so daß Dünn- und Dickdarm mit einander kommunizieren; eine gung der Verdauung scheint dadurch nicht hervorgerufen zu werden.

Daß eine Antiperistaltik im ganzen Darne vorkommen kann, aus dem Auftreten des Koterbrechens bei Menschen mit Darmverschlü kotige Geruch der erbrochenen Massen kann jedoch auch berrühren vo Verweilen der Massen im Duodenum, von wo aus, wie das allbekannte z in den Magen z rü können. Versuche, in denen



**DIESE SEITE IST FÜR KOSTENLOSE MITGLIEDER GESPERRT**  
Beantragen Sie jetzt die volle Mitgliedschaft, um diese Seite zu betreten



**Seien Sie niemals ohne ein Buch!**

Die Vollmitgliedschaft von Forgotten Books bietet Ihnen einen universalen Zugang von unseren Apps und unserer Website, auf all Ihren Geräten: Tablet, Telefon, E-Reader, Laptop und Computer.

**Eine Bibliothek in Ihrer Tasche für €8.99/monat**

**Fortfahren**

\*Es gelten Richtlinien zur fairen Nutzung.

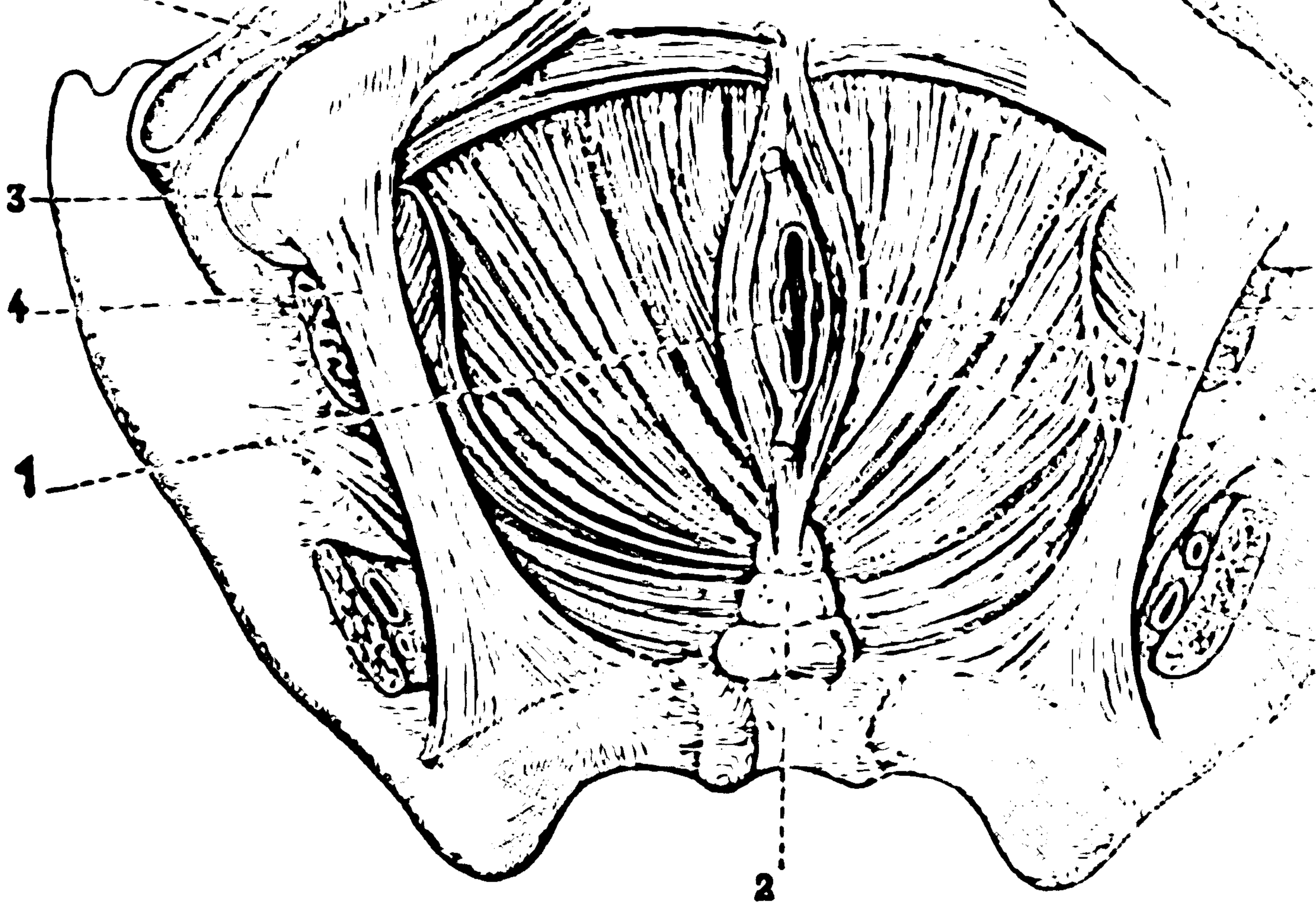

Der Darm und seine Muskeln.

1 Anus, — 2 Steißbein, — 3 Sitzhöcker, — 4 Lig. tuberoso-sacrum, — 5 Ischio-cavernosus, — *T* M. transversus perinei superficialis, — *F* Fascie des M. perinei profundus, — *J* M. ischio-cavernosus, — *O* M. obturator internus, — *S* M. sphincter internus, — *L* M. levator ani, — *P* M. piriformis

befinden sich in einer dauernden tonischen Contraction, vermehrt oder gehemmt werden kann. Ein nervöses Centrum, die Bewegungen dieser Muskeln liegt in ihnen selbst, d. Tonus derselben nach Zerstörung des Rückenmarks und pathischen Ganglien nach anfänglichem Verschwinden sich (Goltz u. Ewald<sup>181</sup>, v. Frankl-Hochwart u. Fröhlich<sup>182</sup>, Normalerweise stehen jedoch die beiden Sphincteren in übergeordneten Centren im Rückenmark und im Großhirn. Das Centrum im Rückenmark (*Budges Centrum*) ist durch zwei Bahnen des autonomen Systems (§ 270) verbunden (Hund, Katze, Kaninchen): Fasern, die, aus d

anlaßt, eine willkürliche Afterschließung, welche doch sonst zweifellos n wäre (vgl. *Merzbacher*<sup>185</sup>).

Sollen die Fäces willkürlich entleert werden, so muß v aus die Contraction der Sphincteren gehemmt werden. V Innervation dieses Hemmungsapparates verläuft die Kotsäu After, ohne reflektorisch den Schluß desselben zu bewirken.

Die die Defäkation einleitende stärkere Peristaltik kann l im gewissen Grade erregt werden teils durch Pressen, teils kürliche, kurze Bewegungen des Sphincter externus und des wodurch eine mechanische Anregung des Plexus myentericus unteren Dickdarms bewirkt wird, welche nun den Dickdarm 2 peristaltischer Bewegung veranlaßt. Die Ausstoßung der Kot befördert durch die willkürlich tätige „Bauchpresse“, zu spiratorischem Zwerchfellstand. Die Weichteile des Beckengru bei starkem Stuhl drang konisch abwärts gedrängt, wobei s die zugleich venös-blutreicher werdende Afterschleimhaut hervor den Levator ani (Fig. 70 und 71) wird willkürlich nunmet der Weichteile der Beckenhöhle gehoben und so der After im über die niedergehende Kotsäule emporgestreift. Dadurch v eine ausweitende Erschlaffung der Weichteile am Beckengru lich der Fascia pelvis verhindert.

#### Literatur (§ 97—107).

1. *R. Heidenhain* in L. Hermanns Handbuch der Physiologie. Leipzig
2. *E. Müller*: A. m. A. 45, 1895, 463. A. A. 1896, 305. Zeitschr. f. wiss. Zoo 624. — 3. *J. N. Langley*: J. o. P. 2, 1879, 261. — 4. Zusammenfassende
- A. Noll*: E. P. 4, 1905, 84. *R. Metzner* in W. Nagels Handbuch d. Physiologie. Bra 2, 899. — 5. *P. Stöhr*: Festschrift f. Kölliker 1887. A. m. A. 47, 1896, 447. - A. m. A. 45, 1895, 93. 49, 1897, 707. 59, 1902, 407. — 7. *C. Ludwig* u. C N. F. 1, 1851, 255 u. 285. — 8. *Eckhard*: Beitr. z. Anat. u. Physiol. Gießen. 207. Z. r. M. 29, 1867, 74. — 9. *Cl. Bernard*: C. r. 46, 1858, 159. 47, 1 G. m. 1858, 428. — 10. *J. Barcroft*: J. o. P. 25, 1900, 265 u. 479. 27, 19 1908, 731. — 11. *L. Asher* u. *A. G. Barbèra*: Z. B. 36, 1898, 154. — 12. P. A. 17, 1878, 1. — 13. *J. N. Langley* u. *H. M. Fletcher*: Phil. Transact. of London 180 B, 1889, 109. — 14. *L. Asher* u. *W. D. Cutter*: Z. B. 40, 15. *J. Czermak*: S. W. A. 39, 1860, 529. — 16. *G. Gianuzzi*: L. B. 17, 17. *R. Heidenhain*: P. A. 5, 1872, 309. — 18. *J. Barcroft* u. *F. Müller*: 259. — 19. *C. Ludwig*: Z. r. M. N. F. 1, 1851, 271. — 20. *O. F. F. Grünbe* 1898, 385. — 21. *C. Ludwig* u. *A. Spiess*: S. W. A. 25, 1857, 584. *Ludwig*: Nr. 28. — 22. *R. Burton-Opitz*: P. A. 97, 1903, 309. — 23. *Cl. Bernard*: et physiol. 1, 1864, 507. — 24. *J. N. Langley*: J. o. P. 6, 1885, 71. — A. J. P. 4, 1901, 483. — 26. *R. Heidenhain*: P. A. 17, 1878, 28. — 27. J. o. P. 9, 1888, 309. — 28. *G. Marinescu*: A. P. 1891, 357. — 29. *M* 1864, 336. — 30. *Th. Aschenbrandt*: P. A. 25, 1881, 101. — 31. *P. Grö* 1873, 522. — 32. *A. Beck*: C. P. 12, 1898, 33. — 33. *Eckhard* u. *Loeb*: ) u. Physiol. 5, 1869, 1. — 34. *F. R. Miller*: Quart. Journ. of Physiol. 6, 35. *J. Pawlow*: P. A. 16, 1878, 272. — 36. *J. P. Pawlow*: E. P. 3, 1, 1904, 357 u. 372. — 37. *Lépine*: G. m. 1875, 332. — 38. *Bary, Kerber*; s. W A. P. 1902, 264. — 39. *C. G. Mitscherlich*: Rusts Mag. f. d. ges. Heilk. 38, 18 d. Physik u. Chemie (Poggendorff) 27, 1833, 320. — 40. *J. P. Pawlow*: Die danungsdrüsen. Übersetzt von A. Walther. Wiesbaden 1898. — 41. *L. Popie* 1909, 443. — 42. *A. Scheunert* u. *A. Gottschalk*: C. P. 23, 1909, 249. In.-Diss. Zürich 1910. — 43. *E. r. Zebrowski*: P. A. 110, 1905, 105. — 44. *Br* Fisiol. 8, 1911. — 45. *C. Eckhard*: Z. r. M. (3), 29, 1867, 74. — 46. *Diem*

**Künstlichen Magensaft** — gewinnt man (*Eberle 1834*) durch Exzerrierten Magen Schleimhaut mit verdünnter Salzsäure, die von  $\frac{1}{2}$  Liter von 6 zu 6 Stunden stets aufs neue infundiert; [die späteren sogar wirksamer als der erste (*Klug<sup>60</sup>*)].

Die für die Pepsinwirkung notwendige Salzsäure kann auch durch organische und organische Säuren ersetzt werden, doch sind von diesen höhere erforderlich. Die Angaben der verschiedenen Untersucher über die von jeder erforderliche Konzentration stimmen jedoch nicht überein (*Hübner<sup>47</sup>, Hahn<sup>48</sup>, Larin<sup>49</sup>*).

*r. Wittich<sup>51</sup>* zeigte, daß man auch mittelst Glycerin aus der Magen Schleimhaut das Pepsin sehr rein extrahieren kann. Die gereinigte Schleimhaut wird in Alkohol gelegt, dann getrocknet, gepulvert und gebeutelt, hierauf eine Woche extrahiert. Der abfiltrierte Extrakt läßt durch Alkohol das Pepsin ausfallen, verdünnter Salzsäure gelöst den wirksamen Saft gibt.

Bei allen Extraktionsverfahren ist die Ausbeute an Pepsin am größten. Die Schleimhaut vor Fäulnis geschützt einige Zeit an der Luft gelegen, sich noch nachträglich in den Drüsenzellen Propepsin und Pepsin bilden (*Podwyssozki<sup>52</sup>*).

## 110. Sekretion des Magensaftes.

Während des Verlaufes der Verdauung gehen an den Hauptzellen und den Pylorusdrüsenzellen (Hund) charakteristische histologische Veränderungen vor sich (*Heidenhain<sup>1</sup>, Ebstein<sup>53</sup>*).

Die Hauptzellen — zeigen Körnchen, welche während der Absonderung verschwinden. Die Körnchen enthalten die pepsinbildende Substanz, welche umgewandelt wird. Auch die Größe der Hauptzellen schwankt während der Sekretion. In Ruhe nehmen die Zellen aus der Lymphe wieder Stoffe zur Körnchenbildung auf. Belegzellen scheinen bei der Absonderung erst geschwellt, dann kleiner zu werden. Die Belegzellen sind ferner dunkler, der Kern der Pylorusdrüsenzellen rückt mehr in die Nähe der Sekretgänge werden praller. — Die Belegzellen mancher Tiere tragen während der Absonderung einen nach dem Lumen der Drüse hin gerichteten Besatz kurzer Fortsätze („Bürstenbesatz“ *Torniers*).

Das Pepsin — wird in den Hauptzellen gebildet (*Ebstein<sup>53</sup>*). Sind diese geschwellt, so enthalten sie viel Pepsin; sind sie geschrumpft, so enthalten sie wenig. Die Pylorusdrüsenzellen enthalten weniger Pepsin als die Hauptzellen (*Ebstein u. Grützner<sup>54</sup>, Klug<sup>55</sup> u. a.*). Am Anfang des ersten Stadiums des Hungers wird das Pepsin angesammelt, am Ende der Verdauungstätigkeit (aber auch bei anhaltendem Hunger).

Kurz nach der Nahrungsaufnahme ist der Pepsingehalt des Magensaftes am höchsten, sinkt er, um später wieder zu steigen; ähnlich verhält sich das Labferment (*Hohmeier<sup>56</sup>*).

Innerhalb der Drüsenzellen ist noch kein Pepsin vorhanden, sondern eine Vorstufe oder das Zymogen desselben: die „pepsinogene Substanz“ oder das „Propepsin“ (*Ebstein u. Grützner<sup>54</sup>*), welche eben in den Hauptzellen entsteht (*Langley<sup>57</sup>*). Das Zymogen ist sich selbst unwirksam auf Eiweißkörper; wird es aber mit Säuren (mit Salzsäure) behandelt, so wird es in Pepsin umgewandelt: diese Umwandlung geht sehr schnell vor sich (*Langley u. Edkins<sup>58</sup>*). Das freie Wasser kann man aus einer Magenschleimhaut neben dem Pepsin zugleich die pepsinogene Substanz ausziehen. — Auch das Pepsin wird in den Hauptzellen.

Die Salzsäure — wird von den Belegzellen gebildet (*Ebstein<sup>53</sup>*). Sie findet sich auf der freien Fläche der Schleimhaut, es sind die Ausführungsgänge der Magendrüsenzellen. In der Tiefe der Drüsenzellen.



**DIESE SEITE IST FÜR KOSTENLOSE MITGLIEDER GESPERRT**  
Beantragen Sie jetzt die volle Mitgliedschaft, um diese Seite zu betreten

# GESCHICHTE

Zehntausende von wichtigen historischen Quellen, viele bisher nicht erhältlich, stehen jetzt zum ersten Mal mit der Vollmitgliedschaft von Forgotten Books zur Verfügung.

Unbegrenzter Zugang  
\$8.99/monat

**Fortfahren**

\*Es gelten Richtlinien zur fairen Nutzung.



euroker in, A y 10. Die rote e werden unter d  
des Magensaftes in ihre Bestandteile gespalten. So zerfällt das  
globin in Globin und Hämatin; ersteres wird peptonisiert,  
bleibt unverändert und erscheint teils in den Fäces, teils wird es re  
Die Glykoproteide (Mucin) werden in Eiweiß und Kohlehydrat  
Die Nucleoproteide zerfallen in Eiweiß und Nuclein, welch  
große Widerstandsfähigkeit gegen die Wirkung des Magensaftes  
Das Nuclein kann jedoch zum kleineren Teil noch weiter in Eiwei  
Nucleinsäure gespalten werden; eine weitere Zerlegung der Nucle  
findet jedoch im Magen nicht statt (vgl. S. 269) (*Umber*<sup>119</sup>, *Abd*  
u. *Schittenhelm*<sup>120</sup>).

Abweichend gestaltet sich die Einwirkung des Magensaftes  
Casein. Dieses wird im Magen zunächst in fester Form ausgefä  
bei es die Fettkügelchen der Milch mit einschließt). Die Ausfällun  
bereits bewirkt werden durch die freie Säure des Magensaftes.  
sein ist in der Milch nämlich als Kalksalz vorhanden; wird ihm c  
durch die Säure entzogen, so fällt das unlösliche Casein als solc

Es kommt aber im Magensaft noch ein besonderes Ferme  
das Labferment (*Chymosin*<sup>121</sup>), welches das Casein auch bei r  
oder alkalischer Reaktion ausfällt (*Hammarsten*<sup>122</sup> 1872). Dieser  
hat aber mit der Fällung des Caseins durch Säure nichts zu tun.  
das Labferment wird nämlich das Casein hydrolytisch gespalten  
paracasein und eine geringe Menge eines albumoseartigen Körper  
Molkeneiweiß (*Fuld*<sup>123</sup>). Beide Körper sind zunächst löslich; d  
casein bildet aber mit Kalk unlösliche Salze, welche nunmehr als  
ausfallen. Werden die Kalksalze vorher entfernt, so tritt die  
des Caseins in Paracasein und Molkeneiweiß durch das Lab ein,  
Paracasein bleibt in Lösung. Setzt man nachträglich Kalksalze  
hinzu, so erfolgt nunmehr die Bildung und Ausfällung des Käses.

Das Lab entsteht in den Hauptzellen der Magendrüsen durch Säurewirkung  
abbildenden Substanz. Letztere ist viel beträchtlicher in der Schleimhaut  
fertige Lab (*Lörcher*<sup>124</sup>, *Glössner*<sup>125</sup>). Ein Teil Labferment kann 800000 Teil  
fällen. Zusatz von etwas Chlorcalcium beschleunigt, von Wasser verzögert die  
*Hammarsten*<sup>122</sup>). Überschuß von Alkali schädigt die Labwirkung (*Johnson*<sup>126</sup>,  
*Klemperer*<sup>127</sup>, *Laqueur*<sup>128</sup>). — Das Labferment wird unterstützt am bes  
die Salzsäure, ihr folgen nach ihrer Wirkung geordnet: Milch-, Essig-, Schw  
Phosphorsäure (*Pfleiderer*<sup>49</sup>).

Zur Darstellung von Lab schüttelt *Hammarsten*<sup>122</sup> künstlichen Kalbs  
nach seiner Neutralisierung mit Magnesiumcarbonat. Im Filtrate ist nur Lab, we  
Ansäuren mit Essigsäure durch Einschütten von flüssiger Stearinsäure gefällt wi  
anhaftet. Letztere löst man in Äther, den man leicht trennen kann.

Die Labenzyme verschiedener Tierarten sind verschieden (*Hedin*<sup>130</sup>).

Zwischen Labferment und eiweißspaltendem Ferment besteht sowohl im  
*Grützner*<sup>131</sup>, *Winogradow*<sup>132</sup>, *Nencki* u. *Sieber*<sup>133</sup>) als auch im Pankreassaft  
Beziehung; die Mengen der beiden Fermente gehen vollständig parallel. Mancl  
haben daher angenommen, daß es sich überhaupt nicht um zwei verschiedene  
handle, sondern um einen einheitlichen Körper, der zugleich eiweißspaltende  
Wirkung habe; von andern wird dies bestritten (vgl. *Sawjalow*<sup>134</sup>, *Schmid*  
*Jacoby*<sup>135</sup>, *Geicin*<sup>136</sup>, *Sawitsch*<sup>137</sup>, *Hammarsten*<sup>138</sup>, *Burge*<sup>139</sup>, *Rakoczy*<sup>141</sup>, r

Nachdem das Casein im Magen ausgefällt ist, unterliegt  
dauernden Wirkung des Magensaftes. Dabei wird es gespalten  
welches peptonisiert wird, und Paranuclein. Das letztere ist  
löslich, wird aber schließlich auch gelöst unter Bildung einer pho  
organischen Säure, der Paranucleinsäure (*Salkowski*<sup>143</sup>,

Innenzone und ein Wachstum der gestrichelten Außenzone statt (Fig. 77, 2). Im

Fig. 77.



Veränderungen der Pankreaszellen in verschiedenen Stadien der Tätigkeit: — 1 im Hungerzustande, — 2 im ersten Stadium der Verdauung, — 3 im zweiten Stadium, — 4 bei der paralytischen Sekretion.

(10.—20. Stunde) geschwellten Drüsenzzone stark gewachsen Außenzone sehr vergrößert (Fig. 77, 3). Im nächsten vergrößert wieder (Fig. dem paralytisch werden, verkleinert Kreis ist die der geschrumpft fast völlig verloren (Fig. 77, 4) (Heid)

Zwischen den Drüsenschläuchen liegen eigentümliche Zellenkomplexe (*Langerhans Inseln*), welche mit keinem Ausführungsgang in Verbindung stehen; die Bedeutung ist noch nicht klar (vgl. S. 286).

**Absonderung des Pankreassaftes.** — Man kann beim Kaninchen einen Ruhezustand, in welchem die Drüse schlaff und blaßgelblich, einen Zustand der sekretorischen Tätigkeit, in welchem das Organ schwellt und blaßrot erscheint, unterscheiden. Bei der Absonderung halten sich die Gefäße ähnlich wie die der Speicheldrüsen nach Reizung: sie sind erweitert, das Venenblut ist hellrot: es ist daher scheinlich, daß hier eine ähnliche Innervation vorhanden ist (§ 1). Die Tätigkeit der Drüse ist in hohem Grade von der hinreichenden Blutversorgung abhängig, anämische Zustände schädigen die Absonderungsvorgänge (*Paulow*<sup>21</sup>, *Gottlieb*<sup>170</sup>). Bei der Tätigkeit der Drüse ist, wie bei den Speicheldrüsen, der Sauerstoffverbrauch und die Kohlenstoffabgabe vermehrt (*Barcroft* u. *Starling*<sup>171</sup>), die Lymphbildung (*Bainbridge*<sup>172</sup>).

Das Sekret steht beim Kaninchen unter einem Absonderungsdrucke von 17 mm Hg. — *Kühne* u. *Lea*<sup>173</sup> fanden, daß nicht alle Läppchen zu gleicher Zeit sekretorisch tätig waren. (Das Pankreas der Herbivoren secerniert ununterbrochen.)

Die Absonderung des Pankreassaftes findet nur nach Nahrungsaufnahme statt, und zwar wird dieselbe veranlaßt durch den Überschuß an saurem Mageninhalt in den Darm (*Dolinsky*<sup>174</sup>, *Paulow* u. *Klee*<sup>175</sup>). Bringt man im Versuche Säuren (30—50 cm<sup>3</sup>) in das Duodenum oder Jejunum, so beginnt nach etwa 2 Minuten eine lebhaftere Absonderung des Pankreas; dieselbe dauert etwa 10 Minuten und nimmt dann ab und hört nach etwa 10 Minuten ganz auf.

Über die Art und Weise, wie diese Anregung des Pankreas zur Tätigkeit zustande kommt, geben die Ansichten noch auseinander. *Bayliss* u. *Starling*<sup>176</sup> (1902) wird durch die Säuren ein in dem oberen Darmabschnitte gebildeter Stoff, das „Prosekretin“, nämlich in „Sekretin“ umgewandelt. Dieses wird durch die Gefäße dem Pankreas zugeführt und regt direkt die Drüsenzellen zur Absonderung an. Daß die nervösen Elemente dabei nicht beteiligt sind, geht auch daraus hervor, daß die Wirkung des Sekretins auch bei Narkose Vergiftung bestehen bleibt.

Das Sekretin läßt sich mittelst Säure (0,4% HCl, aber auch viele andere Säuren vgl. *Stepp*<sup>177</sup>) aus der Schleimhaut des oberen Dünndarms bei allen Klassen von Tieren extrahieren; bei intravenöser Injektion des Extraktes (1 cm<sup>3</sup>) beginnt sofort



# 113. Der Pankreassaft.

Zur Gewinnung des Pankreassaftes — band schon *Regner de* bei Hunden in den Ausführungsgang eine Kanüle mit einem Bläschen, in dem Saft sich sammelte. Andere leiteten das Röhrchen durch die Bauchdecken und machten so eine transitorische Kanülenfistel. Aus einer solchen fließt gleich nach der Operation so gut wie gar kein Sekret; das Pankreas scheint durch den Operationsreiz gesetzten Hemmung seine Arbeit fast ganz einzustellen. sucht man das Tier mit der Kanüle am Leben zu erhalten, so tritt nach 1—2 Tagen beständige, übermäßige Absonderung eines dünnflüssigen, schlecht wirksamen Sekrets, welches offenbar dem normalen Sekrete nicht entspricht. Noch ehe dieser Zustand wird das eingebundene Kanülenende entzündlich abgestoßen und die Fistel schließt sich wieder. — Eine wirklich dauernde Pankreasfistel erreichten *Paucow*<sup>191</sup> u. *H. H.* dadurch, daß sie das Stück des Duodenums, in welchem der Pankreasgang verläuft, schnitten und nach außen in die Bauchwunde einnähten. Ein so operiertes Tier bedarf sorgfältiger Pflege (die Bauchhaut wird leicht durch den ausfließenden Saft mit passender Ernährung (Milch und Brot, dazu 2—5 g Soda pro die) monatlang erhalten werden.

Die Menge des im Tage abgesonderten Pankreassaftes ist nicht genau bekannt, da bei den Tieren mit Pankreasfisteln unbekannt ist, wieviel des Saftes durch Nebenausführungsgänge in den Darm gelangen und so der Bestimmung entziehen können. Auch wechselt die Menge des abgesonderten Saftes mit der Nahrung (vgl. unten die Tabelle nach *Paucow*). *Glaessner*<sup>192</sup> hat an einem Patienten die Absonderung des Pankreassaftes beobachtet. In verschiedenen Zuständen wurden 15—18 cm<sup>3</sup>, nach einer Mahlzeit 30—40 cm<sup>3</sup> pro Stunde abgesondert. Die pro Tag secernierte Saftmenge schwankte zwischen 500 und 800 cm<sup>3</sup>.

Der zeitliche Verlauf der Pankreassekretion zeigt in der 2.—3. Stunde nach Nahrungsaufnahme ein Maximum; im einzelnen gestaltet sich der Verlauf je nach der geführten Nahrung verschieden (vgl. *Paucow*<sup>190</sup>, *Babkin*<sup>191</sup>, *Wohlgemuth*<sup>192</sup>).

Der normale Pankreassaft ist durchsichtig, farb- und geschmacklos, salzig von Geschmack und besitzt infolge des Gehalts an Natriumcarbonat ein erhebliches Säurebindungsvermögen, bei Säurezusatz wird er durch Abgabe von CO<sub>2</sub> auf. Von dieser starken Titrationskapazität ist zu unterscheiden die aktuelle Reaktion (vgl. § 11.3), die nach *Auerbach* u. *Pick*<sup>199</sup> sich nur sehr wenig vom Neutralpunkte entfernt, eine schwach alkalische Reaktion entfaltet.

*Paucow*<sup>190</sup> gibt folgende Tabelle über die Zusammensetzung des Pankreassaftes eines Hundes nach verschiedener Nahrung:

Menge und Art der Nahrung	Menge des Pankreassaftes	Dauer der Sekretion	Mittlere Sekretionsgeschwindigkeit in 6 Minuten	in Prozenten			
				Trockenrückstand	Asche	Organ. Substanz	N
600 cm <sup>3</sup> Milch	45,7	4 St. 30 Min.	0,85 cm <sup>3</sup>	5,268	0,869	4,399	0,68
250 g Brot	162,4	7 St. 35 Min.	1,75 cm <sup>3</sup>	3,223	0,925	2,298	0,39
100 g Fleisch	131,6	4 St. 12 Min.	2,61 cm <sup>3</sup>	2,465	0,907	1,558	(

Die Hauptmasse der organischen Bestandteile sind Eiweißkörper, ein Teil davon zu den Nucleoproteiden (*de Zilva*)<sup>200</sup>.

Für menschlichen Pankreassaft (2 Portionen wurden untersucht, die zweite Portion steht in Klammern) gibt *Glaessner*<sup>192</sup> folgende Zusammenfassung: 98,7292 (98,7516), Trockensubstanz 1,2708 (1,2494), Asche 0,5662



**DIESE SEITE IST FÜR KOSTENLOSE MITGLIEDER GESPERRT**  
Beantragen Sie jetzt die volle Mitgliedschaft, um diese Seite zu betreten



**Seien Sie niemals ohne ein Buch!**

Die Vollmitgliedschaft von Forgotten Books bietet Ihnen einen universalen Zugang von unseren Apps und unserer Website, auf all Ihren Geräten: Tablet, Telefon, E-Reader, Laptop und Computer.

**Eine Bibliothek in Ihrer Tasche für € 8.99/monat**

**Fortfahren**

\*Es gelten Richtlinien zur fairen Nutzung.

1. *R. Heidenhain*: A. m. A. 6, 1870, 368. L. Hermanns Handbuch 1883, 5, 1, 91. — 2. *Rollett*: C. m. W. 1870. Unters. aus d. Institut. f. Graz. 2, 1871. — 3. *K. W. Zimmermann*: A. m. A. 52, 1898, 552. — 19, 1893, 448. — 5. *O. Langendorff* u. *S. Laserstein*: P. A. 55, 1894, 5 A. m. A. 45, 1895, 463. A. A. 1896, 305. Zeitschr. f. wissensch. Zoologie
7. *M. Greenwood*: J. o. P. 5, 1885, 195. — 8. *G. Haane*: A. A. 1905, 1 Diss. Zürich-Dresden 1909. — 10. *J. Disse*: A. m. A. 78, 1912, 74. Neue Versuche und Beobachtungen über den Magensaft und die Physiologie. Deutsch von Luden. Leipzig 1834. — 12. *Bassow*: Bulletin de la soc. 16. — 13. *Blondlot*: Traité analytique de la digestion. Paris 1843. — *E. O. Schumowa-Simanowskaja*: O. P. 3, 1889, 113. A. P. 1895, 53. — u. *H. Roeder*: B. k. W. 1904, 1301. *Sommerfeld*: A. P. 1905, Suppl., 45 B. k. W. 1905, 60. D. m. W. 1906, 1325. V. 23. C. M. 1901, 481. — 1905, 56. — 18. *H. Kaznelson*: P. A. 118, 1907, 327. — 19. *H. Bogdanow*: 150. — 20. *R. Heidenhain*: P. A. 18, 1878, 169. 19, 1879, 148. L. der Physiologie. Leipzig 1883. 5, 1, 109. — 21. *J. P. Pawlow*: Die Verdauungsdrüsen. Deutsch von A. Walther. Wiesbaden 1898. E. P. I, 1, 1902, 246 Physiologische u. patholog. Chymologie. Leipzig 1913. — 22. *R. Rosemann*: 467. — 23. *O. Krummacher*: Z. B. 63, 1913, 275. 64, 1914, 554. — 24, 1895, 285. — 25. Zusammenfassende Darstellung: *Glaessner*: — 26. *E. O. Schoumow-Simanowsky*: A. P. P. 33, 1894, 336. — 27. Z. ph. Ch. 22, 1896, 233. 35, 1902, 8. — 28. *Lauder Brunton*: C. I. 29. *H. Friedenthal* u. *S. Miyamota*: C. P. 15, 1902, 785. 16, 1902, u. *N. Sieber*: Z. ph. Ch. 32, 1901, 291. — 31. *Ad. Mayer*: Z. B. 32. *Salkowski*: V. A. 70, 1877, 158. 81, 1880, 552. — 33. *A. Bickel*: 1383. — 34. *J. López-Suárez*: B. Z. 56, 1913, 167. — 35. *Frenn*: 238. — 36. *M. Pewsner*: B. k. W. 1907, 41, 77. — 37. *A. Bickel*: Klinik 1907, Nr. 48. D. A. k. M. 89, 1907, 34. C. Oppenheimers Handbuch 1910. III, 1, 53. — 38. *M. Nencki*: B. d. ch. G. 28, 1895, 1318. M. Z. ph. Ch. 32, 1901, 307. — 39. *N. P. Schierbeck*: S. A. 3, 1892. 40. *Planer*: S. W. A. 42, 1860, 307. — 41. *Leo*: Z. k. M. 41, 1900, 108 B. k. W. 1896, 385. — 43. *Zawadzki*: C. i. M. 15, 1894, Nr. 50. — 16, 1895, 68. — 45. *Dauber*: A. V. 3, 1897, 57 u. 177. — 46. *F. K. 43*: 65, 1897, 330. — 47. *Hübner*: F. M. 12, 1894, 163. — 48. *Hal*: 597. — 49. *R. Pfeleiderer*: P. A. 66, 1897, 605. Diss. Tübingen 1897. 1, 1905, 484. — 51. *v. Wittich*: P. A. 2, 1869, 193. 3, 1870, 339. — u. P. A. 39, 1886, 62. — 53. *Ebstein*: A. m. A. 6, 1870, 515. — 54. *W. Ebstein*: P. A. 6, 1872, 1. 8, 1874, 122 u. 617. 16, 1878, 105. *Grätzner*: Habilitation 1875. — 55. *F. Klug*: P. A. 92, 1902, 281. — 56. *Hohmeyer*: Diss. 57. *J. N. Langley*: J. o. P. 3, 1881, 269. — 58. *Langley* u. *Edkins*: J. 59. *E. Brücke*: S. W. A. 37, 1859, 153. — 60. *H. Schulz*: P. A. 61. *R. Rosemann*: P. A. 142, 1911, 208. — 62. *J. López-Suárez*: I — 63. *Bickel*: D. m. W. 1905, 1829. — 64. *W. r. Bechterew* u. *A*: 1902, 264. — 65. *Schüle*: A. V. 5, 1899, 165. Th. M. 13, 1899, 601. 16. Versamml. d. Gesellsch. f. Kinderheilk. 1899, 38. — 67. *O. Cohn*: Z. ph. Ch. 37, 1903, 467. — 68. *B. P. Babkin*: Die äußere Sekretion d. Berlin 1914, S. 125. — 69. *L. Popielski*: C. P. 16, 1902, 121. — 70. . 34, 1906, 133. *J. S. Edkins* u. *M. Tweedy*: J. o. P. 38, 1909, 263. P. A. 150, 1913, 390. — 72. *H. Lönnquist*: S. A. 18, 1906, 194. — 73 — 74. *S. Arrhenius*: Z. ph. Ch. 63, 1909, 323. — 75. *A. Herzen*: — 76. *R. Mark-Schnorf*: P. A. 85, 1901, 143. — 77. *Haan*: C. r. sc — 78. *C. Radzikowski*: P. A. 84, 1901, 513. — 79. *Spiro*: M. m 80. *Schütz*: Prag. med. Wochenschr. 10, 1885, 193. — 81. *W. Buc*: 1881, 537. — 82. *B. P. Babkin*: s. unter Nr. 68, S. 215. — 83. *Rieg*

33. 1894, 261. — 171. *J. Barcroft* u. *E. H. Starling*: *J. o. P.* 31, 172. *F. A. Bainbridge*: *J. o. P.* 32, 1904, 1. — 173. *Kähne* u. *Lea*: *Verh. Vereins zu Heidelberg*. N. F. 1, 1874, Heft 5. *Unters. aus d. physiol. Institut berg.* 2, 1878, 448. — 174. *Dolinski*: *Diss. St. Petersburg* 1894. — 175. *Ph. Klee*: *Z. ph. Ch.* 78, 1912, 464. — 176. *W. M. Bayliss* u. *E. H. Starling* 1902, 325. 29, 1903, 174. *C. P.* 15, 1902, 682. — 177. *W. Stepp*: *J. o. P.* — 178. *L. Popielski*: *C. P.* 10, 1896, 405. 16, 1902, 43 u. 505. 17, 1908, 801. *P. A.* 86, 1901, 215. 120, 1907, 451. 121, 1908, 239. 128, 1909, 179. *A. Hustin*: *Arch. intern. de physiol.* 12, 1914, 518. — 180. *L. Camus* 1902, 998. *C. r. soc. biol.* 54, 1902, 513. — 181. *O. v. Fürth* u. *C. Schick* 1908, 427. — 182. *E. Wertheimer*: *C. r. soc. biol.* 54, 1902, 472 u. 474. *Wertheimer* u. *Lepage*: *J. d. P. P.* 4, 1902, 1050 u. 1061. — 184. *A. Bylina*: *P.* 531. — 185. *B. P. Babkin* u. *W. W. Sawitsch*: *Z. ph. Ch.* 56, 1908, 32. *Bechterew* u. *Narbut*: *A. P.* 1902, 278. — 187. *B. P. Babkin*: s. unter *B. P. Babkin* u. *H. Ishikawa*: *P. A.* 147, 1912, 288. — 188. *A. J. Smirnov* 1912, 234. — 189. *J. Studzinski*: *Int. Beitr. z. Pathol. u. Therap. d. Ernähr.* 3, 1912, Heft 3. — 190. *Sawitsch*: *Centralbl. f. d. ges. Phys. u. Pathol. d. Stoff* Nr. 1. — 191. *N. O. Bernstein*: *L. B.* 21, 1869, 96. — 192. *L. Popielski*: 405. — 193. *Scaffidi*: *A. P.* 1907, 276. — 194. *M. Afanassiew* u. *J. Paul* 1878, 173. — 195. *K. Glaessner*: *Z. ph. Ch.* 40, 1904, 465. — 196. *J. Pawl* *Handbuch der Physiologie*. Braunschweig 1907. 2, 2, 732. — 197. *B. P. B* Nr. 68, S. 253. — 198. *J. Wohlgemuth*: *B. k. W.* 1907, 47. *B. Z.* 39, 199. *F. Auerbach* u. *H. Pick*: *Arbeit. aus d. kais. Gesundheitsamt* 43, 1913, 1913, 425. — 200. *L. A. E. de Zilva*: *J. o. P.* 31, 1904, 230. — 201. *Pir* 4, 1907, 484. — 202. *Bouchardat* u. *Sandras*: *C. r.* 20, 1845, 143, 1085. — *burger*: *P. A.* 60, 1895, 543. — 204. *F. Köhmann*: *B. d. ch. G.* 27, 1 205. *E. Weinland*: *Z. B.* 38, 1899, 607. — 206. *F. A. Bainbridge*: *J. o. P.* — 207. *R. H. A. Plimmer*: *J. o. P.* 34, 1906, 93. — 208. *J. Ibrahim* u. *L* *Z. ph. Ch.* 62, 1909, 287. — 209. *H. M. Vernon*: *J. o. P.* 27, 1901, 174. 156 u. 448. 29, 1903, 302. 47, 1914, 325. *C. P.* 27, 1913, 841. — 21 u. *M. Wachsmann*: *P. A.* 91, 1902, 195. — 211. *L. Corrisart*: *Sur une fonction du pancréas*. Paris 1857—58. *Z. r. M.* (3) 7, 1859, 119. — 212. *Kähne*: 130. *Verh. naturhistor. med. Ges. zu Heidelberg*, N. F. 1, 1874, 195. 3, 1886, aus d. physiol. Inst. Heidelberg 1, 1878. 222. — 213. *G. D. Bostock*: 1913, 471. — 214. *F. Kutscher*: *Z. ph. Ch.* 25, 1898, 195. 26, 1898, 110. *B. d. ch. G.* 33, 1900, 3457. 34, 1901, 504. — 215. *E. Fischer* u. *E. Abderhalden* 30, 1903, 81. — 216. *E. Fischer* u. *E. Abderhalden*: *Z. ph. Ch.* 46, 1905, 264. — 217. *E. Abderhalden* u. *Y. Teruuchi*: *Z. ph. Ch.* 49, 1906, 1. — *Herzberge*: *Z. ph. Ch.* 34, 1901, 119. — 219. *R. Baumstark* u. *O. Cohnh* 65, 1910, 477. — 220. *E. Abderhalden* u. *A. Schittenhelm*: *Z. ph. Ch.* 47, 221. *E. S. London* u. *A. Schittenhelm*: *Z. ph. Ch.* 70, 1910, 10. *E. S. London* u. *K. Wiener*: *Z. ph. Ch.* 77, 1912, 86. — 222. *F. Kutscher* u. *J. Seem* 34, 1902, 528. 35, 1902, 432. — 223. *E. S. London*: *Z. ph. Ch.* 47, 224. *E. Abderhalden*, *W. Klingemann* u. *T. Pappenhusen*: *Z. ph. Ch.* 71, 225. *Danilewsky*: *V. A.* 25, 1862, 279. — 226. *Dastre*: *C. r. soc. biol.* 4 A. d. P. (5) 8, 1896, 120. — 227. *W. M. Bayliss* u. *E. H. Starling*: *J. o. P.* 30, 1904, 61. 32, 1905, 129. — 228. *Landsteiner*: *Centralbl. f. Bakteriolog.* — 229. *E. P. Cathcart*: *J. o. P.* 31, 1904, 497. — 230. *S. G. Hedin*: *J.* 390. *Z. ph. Ch.* 50, 1907, 497. 52, 1907, 412. — 231. *Jochmann* u. *Kantor* 66, 1908, 153. — 232. *L. Brieger* u. *J. Trebing*: *B. k. W.* 1908, 1041. *Bamberg*: *B. k. W.* 1908, 1396. *v. Bergmann* u. *K. Meyer*: *B. k. W.* 19 233. *K. Meyer*: *B. Z.* 23, 1910, 68. *B. k. W.* 1910, 1890. — 234. *S. Cohl* 1910, 494. — 235. *H. Kümmerer*: *D. A. k. M.* 108, 1911, 341. — 236. *Fer* *Z. f. Hyg.* 18, 83. — 237. *Mays*: *Unters. physiol. Institut. Heidelberg* 3, 378. *Langley*: *J. o. P.* 3, 1882, 263. — 239. *E. Biernacki*: *Z. B.* 28, 1891, 49. *A. H.* 10, 1890, 1. 40, 1906, 155. — 241. *A. Palladin*: *P. A.* 134, 242. *Folhard*: *M. m. W.* 1907, 403. — 243. *O. Gross*: *A. P. P.* 58, 1908, 157. — *C. r. soc. biol.* 48, 1896, 77 u. 890. — 245. *C. Delezenne* u. *A. Frouin*: *C.* 1902, 691. — 246. *Chepoualnikoff*: *Thèse. St. Petersburg* 1899. *Paris* 19 *Delezenne*: *C. r. soc. biol.* 1901, 1161. 54, 1902, 281, 590, 893, 998. 1076. 248. *E. Hekma*: *A. P.* 1904, 343. — 249. *Mellanby* u. *Wolley*: *J. o. P.* 47, 1914, 339. — 250. *Delezenne*: *C. r. soc. biol.* 59, 1907, 476, 477, 523, 1070. 63, 1907, 274. — 251. *E. Zunz*: *Soc. roy. d. scienc. méd. et natur. de* 1907. *Bulletins* 64. *Annales* 16. — 252. *L. Lattes*: *V. A.* 211, 1913, 1. — *P. A.* 104, 1904, 433. 107, 1905, 599. — 254. *L. Kirchheim*: *A. P. P.* 7

sprechendes Arterienästchen begleitend) in Zweige der Pfortader einmündende Arterienzweige treten bis zur Oberfläche der Leber hervor, woselbst sie der Peritonealhülle ein weitmaschiges Netzwerk bilden. Die sich von hier Venenstämmchen gelangen gleichfalls zu Pfortaderästchen.

**3. Die Gallengänge.** — Die feinsten Gallengänge (Gallencapillaren) Centrum des Acinus her, und ebenso im ganzen Binnenbereiche desselben, (1—2  $\mu$  dicke), sehr regelmäßig anastomosierende, gerade verlaufende Röhren um jede Leberzelle eine polygonale Masche. Die Röhren liegen fast stets der Fläche zweier benachbarter Leberzellen (Fig. 78. II. a) als echte I oder Sekretspalten. Beim Anscinanderfallen der Zellen durch Maceration ver-

Fig. 78.

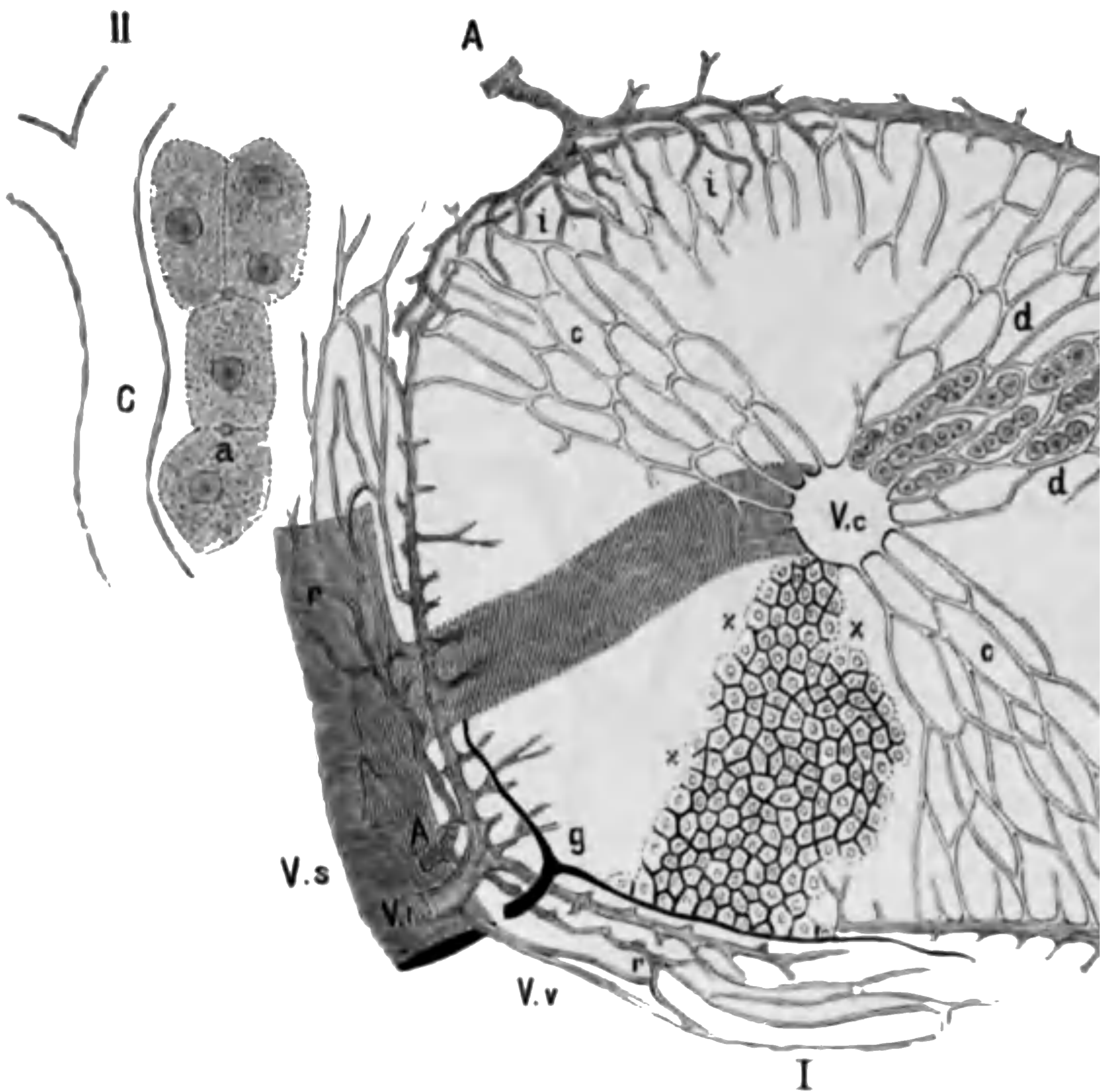

I Schema eines Leberläppchens. V. i V. i Venae interlobulares. — V. c Vena centralen zwischen beiden. — V. s Vena sublobularis. — V. v Vena vascularis. — A Leberarterie, bei r r an die Glissonsche Kapsel und die größeren Gefäße tretend und Venae vasculares bildend, — bei i i in die Capillaren der Venae interlobulares g Ästchen des Gallenganges, bei x x sich intercellular zwischen den Leberzellen v d d Lage der Leberzellen zwischen den Maschen der Blutcapillaren. — II Isolier bei c einer Blutcapillare anliegend, bei a einen feinen Gallengang bildend.

Zellen nur halbrinnenförmige Eindrücke. Da die Blutcapillaren auf den Kanten der Zellenreihen verlaufen, die Gallenröhren jedoch auf den Flächen der Zellen, so sind die Röhrensysteme stets durch dazwischenliegende Leberzellen getrennt (Fig. 78).

Innerhalb des peripheren Rindenteiles des Läppchens vergrößern sich die feinsten Röhren durch Anastomosen benachbarter und verlassen sodann den peripheren Teil nun an interlobulär (Fig. 78 g) sich mit den anstoßenden vereinigend, anastomosierende Gallengänge zu bilden, welche fortan in Begleitung der Leberarterie und der Vena portarum schließlich als Ductus hepaticus die Leber verlassen. — Die feineren interlobulären Gallengänge besitzen eine strukturlose



**DIESE SEITE IST FÜR KOSTENLOSE MITGLIEDER GESPERRT**  
Beantragen Sie jetzt die volle Mitgliedschaft, um diese Seite zu betreten

# GESCHICHTE

Zehntausende von wichtigen historischen Quellen, viele bisher nicht erhältlich, stehen jetzt zum ersten Mal mit der Vollmitgliedschaft von Forgotten Books zur Verfügung.

Unbegrenzter Zugang  
\$8.99/monat

**Fortfahren**

\*Es gelten Richtlinien zur fairen Nutzung.



werden, in der Leber abgelagert.)

## 117. Die Zuckerharnruhr.<sup>96</sup> Experimentelle Gl

Die Zuckerharnruhr (Diabetes mellitus) stellt eine Störung Verhältnissen des Kohlehydratstoffwechsels dar. Es kommt dabei zur Traubenzucker im Harn (oft in sehr großen Mengen; bis zu 1 kg und d gleichzeitiger starker Vermehrung der Harnmenge (bis zu 10 l und Die Kranken leiden infolge der erhöhten Diurese an beständigem Durst lustes eines wertvollen Nahrungstoffes (des Zuckers) an starkem Hunger. hydrate aus der Nahrung fortgelassen, so kann die Zuckerausscheidung aufhören, sogenannte „leichte Fälle“; in anderen Fällen bleibt sie aber at freier Kost bestehen, sogenannte „schwere Fälle“ (vgl. S. 281). Kon nicht zum Stillstand, so tritt starke Abmagerung und schneller Verfall gehalt des Blutes (vgl. S. 82) und der Säfte ist erhöht; er bedingt kationen (Furunkulose, Hautjucken, Gangrän, Linsentrübung, Dispositio Im Harn kommt es zur Ausscheidung von Aceton, Acetessigsäure,  $\beta$ - schweren Fällen wird zuweilen ein collapsusartiges Coma (Coma diabeticum) welchem der Tod erfolgen kann.

Experimentell kann man Zuckerausscheidung durch den Har Weise erzeugen; die Ausscheidung von Zucker durch den Harn kann ab weiteres mit dem Krankheitsbilde des menschlichen Diabetes identifiziert

1. Alimentäre Glykosurie. — Nach sehr reichlicher Zufuhr Nahrung tritt eine kurze Zeit anhaltende, geringfügige Zuckerausscheidung ein. Die Leber vermag offenbar den reichlich zuströmenden Zucker nicht in Glykogen abzulagern, ein Teil gelangt direkt ins Blut (auch unter Umstände durch Resorption in die Lymphgefäße, vgl. § 130. 2), erhöht den Blutzucker über die Norm und führt so zur Ausscheidung durch die Nieren.

Diejenige Menge eines Zuckers, die gerade genügt, um alimentäre Zuckerausscheidung zu verhindern, wird als „Assimilationsgrenze“ bezeichnet. Dieser Wert ist für verschiedene Tierarten, verschiedenen Individuen verschieden; so schwankt er nach den jeweiligen Umständen. Die Assimilationsgrenze für verschiedene Zuckerarten ist ebenfalls verschieden: am höchsten liegt sie für Sacchariden (Traubenzucker), am niedrigsten bei den Disacchariden, bei Disacchariden. Dies erklärt sich daraus, daß die Disaccharide erst in die Monosaccharide werden müssen, um von der Leber in Glykogen umgewandelt werden zu können. Sie werden bei reichlicher Zufuhr zum Teil ungespalten ins Blut, so können sie etwa noch im Blute gespalten werden, wie z. B. die Maltose, weder von der Leber noch von den anderen Organen verwertet werden und gelangen durch den Harn (vgl. S. 281).

2. Eingriffe, welche die Zuckerbildung in der Leber steigern. — Die normale Zuckerbildung in der Leber übermäßig gesteigert, so wird eine Erhöhung des Blutzuckergehaltes eintreten müssen, da den Organen mehr Zucker zugeführt wird, als sie verbrennen können, und damit Zuckerausscheidung durch den Harn.

Unter den Eingriffen, welche in dieser Weise wirken, ist an erster Stelle der Zuckerstich *Claude Bernards*; durch diesen wird das die Zuckerbildung anregende Centrum in der Medulla oblongata direkt gereizt (vgl. S. 282). Auch die Reizung gewisser Teile des Nervensystems, welche das Zuckercentrum mit den Organen verbinden, sowie reflektorisch die Reizung centripetaler Nervenbahnen, welche das Zuckercentrum in Verbindung stehen (vgl. S. 283). So erklärt sich die Ausscheidung von Zucker im Harn bei Ischias und anderen Nervenleiden. Eine Reihe von Eingriffen bewirken dadurch Zuckerausscheidung, daß sie das Zuckercentrum in d

In menschlicher Galle (ebenso beim Rinde) überwiegt die Glykocholsäure, Hundegalle enthält überhaupt nur Taurocholsäure, keine Glykocholsäure.

a) Die Glykocholsäure —  $C_{26}H_{43}NO_6$  zerfällt durch Kalilauge oder Barytwasser oder mit verdünnten Mineralsäuren unter Aufnahme von  $H_2O$  in Glykokoll, Aminoessigsäure  $CH_2COOH$  + Cholalsäure — (auch Cholsäure genannt)  $C_{24}H_{40}O_6$ .

b) die Taurocholsäure —  $C_{26}H_{45}NSO_7$  zerfällt bei Behandlung unter Aufnahme von  $H_2O$  in Taurin, Aminoäthylschwefelsäure  $CH_2(NH_2) - CH_2 - SO_2(OH)$  + Cholalsäure  $C_{24}H_{40}O_6$ .

**Darstellung der Gallensäuren.** — Galle wird auf  $\frac{1}{4}$  ihres Volumens zur Entfernung der Farbstoffe mit Tierkohle zu einem Brei verrieben und getrocknet. Die schwarze Masse wird mit absolutem Alkohol ausgezogen, los abfiltriert. Nachdem man einen Teil des Alkohols durch Abdampfen verjagt, im Ueberschuß hinzugesetzter Äther die gallensauren Salze anfangs bis später geben sie in eine Krystallmasse glänzender Nadeln über (*Platners lisierte Galle*, 1844). Die so gewonnenen Alkalisalze der Gallensäure lösen sich leicht in Wasser oder Alkohol löslich, unlöslich in Äther. Die Lösung der beiden Salze schlägt neutrales essigsaures Blei (Bleizucker) ein, die Glykocholsäure rein nieder (als glykocholsaures Blei): letzteres wird gesammelt, in heißem Alkohol gelöst, durch  $H_2S$  wird Schwefelblei niederschlagen, nach Entfernung des Niederschlages bewirkt Wasserzusatz das Ausfallen der Glykocholsäure. — Wird nach Anfüllung des glykocholsauren Bleies die Lösung mit basisch-essigsaurem Blei (Bleiessig) versetzt, so bildet sich ein Niederschlag von taurocholsaurem Blei (jedoch verunreinigt durch glykocholsaures Blei), aus diesem in analoger Behandlung die freie Säure gewonnen wird (*Strecker*<sup>110</sup>).

In der Rindsgalle und Menschengalle kommt noch die Glykocholeinsäure (aus Glykokoll und Choleinsäure bestehend) vor, in der Hundegalle und Rindsgalle die Taurocholeinsäure (aus Taurin und Choleinsäure bestehend), in der Schlangengalle die Hyoglykocholsäure, in der Gänsegalle die Chenotaurocholsäure, in der Menschengalle noch die Fellinsäure.

Die Cholalsäure —  $C_{24}H_{40}O_6$  ist rechtsdrehend, unlöslich in Wasser, löslich in Alkohol; in Äther ist sie schwer löslich und scheidet sich in Prismen ab. Ihre krystallinischen Alkalisalze sind leicht in Wasser löslich. Mit Jod gibt sie eine im auffallenden Licht durchfallenden blaue krystallinische Verbindung (*Mylius*<sup>114</sup>). Sie wird nur im Darmsaure vor (S. 292). Durch Kochen mit konzentrierter Salpetersäure oder trocken erhitzt auf  $200^\circ$  wird die Cholalsäure zum Anhydrid, dem Cholalinsäure, umgewandelt.

Das Glykokoll (auch Glycin genannt) ist eines der Eiweißbestandteile des Eiweiß (hauptsächlich des Leims) (vgl. S. 10); im Harn tritt es in Verbindung mit Benzoesäure als Hippursäure vor (§ 165).

Das Taurin leitet sich von dem schwefelhaltigen Spalt des Eiweiß, dem Cystin ab (vgl. S. 11). Das Cystin ist das Oxid des Cysteins, dieses geht in folgender Weise in Taurin über:

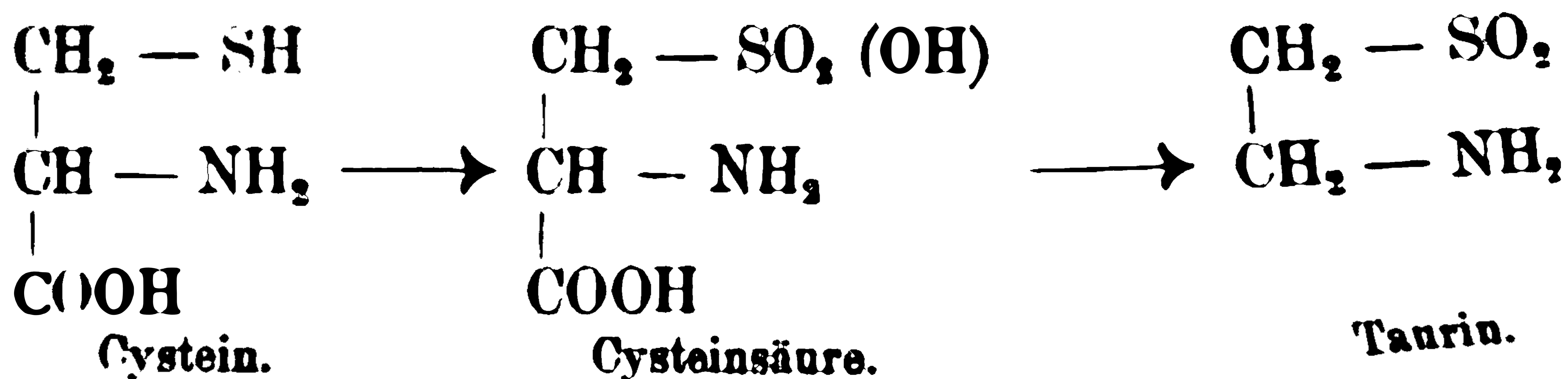

*Friedmann*<sup>116</sup> führte Cystein in Taurin über; *v. Bergmann*<sup>118</sup> zeigte den Übergang von Cystin in Taurin im tierischen Körper.

**Die Pettenkofersche Probe** (1844). — Die Gallensäure, Cholalsäure und ihre Anhydride geben gelöst oder zerteilt



von oben nach unten folgende Farbenringe: Grün (Bilive  
— Violett — Rot — Gelb. Die hierbei entstehenden Farbstoff-  
dationsprodukte der Gallenfarbstoffe.

Der bei der *Gmelinschen* Probe entstehende blaue Farbstoff wird  
der als letztes Oxydationsprodukt entstehende gelbe Farbstoff als Cholet  
In Gallensteinen sind außer dem Bilirubin und Biliverdin noch ein  
Gallenfarbstoffe gefunden worden.

Biliverdin soll in beträchtlicher Menge in der Placenta des Hundes v

Das Bilirubin geht durch Reduktion (bei Behandlung  
sehen Lösung mit Natriumamalgam) unter Aufnahme von  
Hydrobilirubin,  $C_{32}H_{40}N_4O_7$ , über (in Wasser nur wenig, le  
lösungen oder Alkalien, Alkohol, Äther, Chloroform löslich). Diese  
vollzieht sich regelmäßig im Dickdarm durch die Fäulnis  
bilirubin ist daher ein konstanter Farbstoff der Faeces, aus  
Ansäuerung mit Schwefelsäure durch absoluten Alkohol ausge  
kann. Wahrscheinlich ist es mit dem Harnfarbstoffe Urob  
oder nahe verwandt.

Außer den spezifischen Gallenbestandteilen: Gallensäuren und  
kommen in der Galle noch vor:

3. ein schleimähnliches Nucleoalbumin (*Pajkull*<sup>120</sup>), aber au  
(*Hammarsten*<sup>107</sup>, *Carazzani*<sup>127</sup>): sie machen die Galle fadenziehend. Sie s  
Schleimdrüsen der Gallenwege und der Gallenblase; durch Alkohol oder verd  
Essigsäure werden sie gefällt.

4. Cholesterin,  $C_{27}H_{46}O$  (vgl. pag. 20). Es bildet glashelle rh  
(Fig. 62, d), ist unlöslich in Wasser, löslich in heißem Alkohol, in Äther  
In der Galle wird es durch die gallensauren Salze in kolloidaler Lösung ei

Am einfachsten wird es aus sogenannten „weißen“ Galle  
gestellt (die nicht selten größtenteils aus fast reinem Cholesterin besteh  
sie zerreibt und mit Alkohol anskoht. Die bei Verdunstung des Alkohols si  
Krystalle färben sich mit Schwefelsäure (5 Vol. zu 1 Vol. Wasser) vom Ran  
violett, — mit Schwefelsäure und Jod violett, blau und grün.

5. Lecithin (vgl. S. 21), Fette, Seifen, Ätherschwefelsäuren, ge  
säuren, Spuren von Harnstoff.

6. Anorganische Bestandteile: Chlornatrium, Chlorkalium, Calc  
siumphosphat und wechselnde Mengen von Eisen, endlich etwas Mangan  
— Die frisch abgesonderte Galle enthält beim Hunde über 50, beim Kar  
Prozente  $CO_2$  (*Pflüger*<sup>128</sup>, *Charles*<sup>129</sup>), teils an Alkali gebundene, teils  
letzte wird innerhalb der Blase fast völlig resorbiert.

Analysen menschlicher Lebergallen (nach *Hammarsten*<sup>120</sup>,  
*c. Czychlarz*, *Fuchs* u. *r. Fürth*<sup>122</sup>).

Feste Stoffe . . . . .	25,200	35,260	
Wasser . . . . .	974,800	964,740	9
Mucin und Farbstoff . . . . .	5,290	4,290	
Gallensaure Alkalien . . . . .	9,310	18,240	
Taurocholat . . . . .	3,034	2,079	
Glykocholat . . . . .	6,276	16,161	
Fettsäuren aus Seifen . . . . .	1,230	1,360	
Cholesterin . . . . .	0,630	1,600	
Lecithin . . . . .	} 0,220	0,574	
Fett . . . . .		0,956	
Lösliche Salze . . . . .	8,070	6,760	
Unlösliche Salze . . . . .	0,250	0,490	

In die Galle gehen verschiedene Substanzen, welche  
sieren, über, so z. B.: die Metalle, die auch im Lebergewebe depos  
S. 285); Jod-, Brom-, Rhodankalium, chloresanres Kalium, Arsen, Te  
gespritzte Galle (auch die anderer Tiere), salicylsanres Natrium, Karbol  
Methylenblau, Rohr- und Traubenzucker, Äthyl-, Amylalkohol (dabei tri  
bares Eiweiß in der Galle auf) *Précast* u. *Binet*<sup>122</sup>, *Brauer*<sup>123</sup>). — N



**DIESE SEITE IST FÜR KOSTENLOSE MITGLIEDER GESPERRT**  
Beantragen Sie jetzt die volle Mitgliedschaft, um diese Seite zu betreten



**Seien Sie niemals ohne ein Buch!**

Die Vollmitgliedschaft von Forgotten Books bietet Ihnen einen universalen Zugang von unseren Apps und unserer Website, auf all Ihren Geräten: Tablet, Telefon, E-Reader, Laptop und Computer.

**Eine Bibliothek in Ihrer Tasche für € 8.99/monat**

**Fortfahren**

\*Es gelten Richtlinien zur fairen Nutzung.

den ersten Tagen wieder eingeschmolzen werden, die dadurch Farbstoffbildung kann dann ebenfalls Ikterus veranlassen.

Man nahm früher vielfach an, daß auch ohne die Leber Umstände direkt Blutfarbstoff in Gallenfarbstoff übergeben können. Im Gegensatz zu diesem sogenannten hämatogenen Ikterus, bei welchem in der Leber gebildete Galle ins Blut geht, Resorptionsikterus.

Die Cholämie ist von einer Reihe charakteristischer Erscheinungen begleitet.

1. Gallenfarbstoffe treten in die Gewebe des Körpers über. Die Sklera nimmt gelbe Färbung an: daher die Bezeichnung Gelbsucht, auch die Frucht.

2. Gallenfarbstoffe treten in den Urin über (nicht in Spuren). Ein hoher Gallenfarbstoffgehalt macht den Urin tief gelbbraun gelb; eingetauchte Papier- oder Leinenstreifen färben sich ebenfalls krystallinisch vor. Gallensäuren treten in dem Urin nur in Spuren auf.

3. Die Faeces werden lehmfarbig (weil das aus Gallenfarbstoff gebildete Hydrobilirubin fehlt), — sehr hart (weil der verdünnende Saft nicht zum Darm gelangt), — fettreich (weil die Fette ohne Galle im Darm nicht gelöst werden, so daß selbst bis 78% des genossenen Fettes in den Faeces erscheinen, vorwiegend Fettsäuren und Seifen in den Faeces, und sehr stinkend (weil unter normalen Verhältnissen die in den Faeces enthaltene Galle die faulige Zersetzung des Darminhaltes einschränken soll; dies ist jedoch sehr zweifelhaft). — Die Kotentleerung erfolgt trotz der Faeces, teils wegen Fehlens der peristaltischen Bewegungen im Darmlumen.

4. Der Herzschlag wird bis gegen 40 Schläge in 1 Minute erhöht her von den gallensauren Salzen, welche das Herz zuerst (vgl. S. 106). — Neben der Einwirkung auf das Herz zeigt sich auch eine Verlangsamung der Atmung und eine Abnahme der Temperatur.

5. Eine Einwirkung auf das Nervensystem, wahrscheinlich durch gallensaure Salze, vielleicht auch auf die Muskeln, zeigt sich in Form von Abspannung, Müdigkeit, Schwäche und Schlafsucht, endlich tiefer Schlaflosigkeit, Hautjucken, selbst Tobsucht und Krämpfen.

6. Bei hochgradigem Ikterus entsteht Gelbsehen (*Lucy'sche* Imprägnation der Netzhaut mit gelbem Gallenfarbstoff).

## 121. Wirkung der Galle.

A. Die wichtigste Wirkung, welche die Galle auf den Verdauungsapparat ausübt, ist ihr Einfluß auf die Verdauung und Resorption der Nahrung.

1. Die Galle wandelt (ebenso wie der Pankreassaft) die neutralen Fette in eine Emulsion um; indem hierbei das Fett stark vergrößert wird, wird die Einwirkung der löslichen Steapsins des Pankreassaftes auf die in Wasser unauflöselichen Fette wesentlich begünstigt.

2. Auf das emulsionierte Fett wirkt nunmehr der Pankreassaft (die Galle selbst hat keine fettspaltende Wirkung) ein. Er spaltet das Fett in Glycerin und Fettsäuren. Das Glycerin ist in Wasser auflöslich und ohne weiteres der Resorption fähig. Die Fettsäuren sind in Wasser unlöslich; sie werden nunmehr durch die Galle in einen emulsierten Zustand übergeführt (*Pflüger* <sup>164</sup>).

Nach *Moore* u. *Rockwood* <sup>165</sup> lösen 100 cm<sup>3</sup> frische alkalische Ölsäure. *Pflüger* <sup>164</sup> bestätigte diese Beobachtung, zeigte aber, daß ein Maximum der zugesetzten Ölsäure erst dann löst, wenn ihr eine gewisse Menge Soda zugesetzt wird: 100 cm<sup>3</sup> Galle lösen alsdann wenig Ölsäure. Im Gegensatz dazu löst Galle von Palmitinsäure und Stearinsäure praktisch so gut wie nichts. Wirkt aber Galle auf ein Gemisch von Ölsäure oder Stearinsäure mit Ölsäure bei Gegenwart der äquivalenten Menge Soda?

Bei Gallenstauungen und bei Behinderung des Abflusses der Galle im Darm liegt die Peristaltik sehr darnieder.

E. Beim Eintritt des stark sauer reagierenden Mageninhalts in das Duodenum werden die gallensauren Salze zerlegt, es entsteht ein Niederschlag von Gallensäuren und Eiweiß, der auch das Pepsin mit sich reißt. Auch durch das Abneutralisieren des sauren Mageninhalts wird eine weitere Wirkung des Pepsins im Darmlumen gehindert.

Wenn Galle in den Magen tritt, so wird dadurch in gleicher Weise die Verdauung beeinträchtigt werden; sobald aber wieder neuer Magensaft abgesondert wird die Verdauung fortgesetzt werden.

## 122. Der Darmsaft.

Der Darm des Menschen ist 7mal so lang wie die Körperlänge vom Mund zum After (der Darm der mehr Pflanzen essenden Asiaten ist um  $\frac{1}{5}$  länger). Die Kapazität des Darms ist bei Kindern relativ am größten. Der Männer Darm ist etwas länger als der der Weiber. — Der Darm der Herbivoren ist länger als der der Carnivoren. Bei Froschlurven stellte *Babák*<sup>112</sup> fest, daß Pflanzenfütterung eine Verlängerung des Verdauungskanales gegenüber Fleischfütterung hervorruft. Menschen können 2—4 m Darm reseziert werden, ohne daß dadurch eine Gefährdung des Patienten entsteht; allerdings ist die Darmtätigkeit, besonders die Resorption beeinträchtigt (*Schlatter*<sup>113</sup>, *Storp*<sup>114</sup>, *Arhansen*<sup>115</sup>). Hunde ertragen noch die Wegnahme von 1/3 des Dünndarms (*Erlanger* u. *Heulett*<sup>116</sup>).

Der Darmsaft (*Succus entericus*) ist die von den zahlreichen Drüsen der Darmschleimhaut abgesonderte Verdauungsflüssigkeit. Die größte Menge derselben liefern die *Lieberkühnschen* Drüsen; oben im Duodenum wird dazu das spärliche Sekret der *Brunnerschen* Drüsen eingebracht.

Die *Brunnerschen* Drüsen — finden sich beim Menschen nur vereinzelte in kontinuierlicher Schicht im Duodenum. Ihre Zellen stehen denen der *Lieberkühnschen* Drüsen nahe. Während des Hungerzustandes sind sie groß und hell, während der Verdauungstätigkeit klein und trüb (*Grützner*<sup>117</sup>); die Drüsen enthalten, ebensowenig wie die *Pylorusdrüsen* des Magens Granula (*Schwalbe*<sup>118</sup>, *Bogomoletz*<sup>119</sup>). Ihr Sekret enthält ein dem Pepsin analoges eiweißlösendes Ferment; bei alkalischer Reaktion ist es wirksamer (*Ponomarew*<sup>120</sup>, *Abderhalden* u. *Rona*<sup>121</sup>). Beim Pferd, Rind, Schwein konnte *Scheunert* u. *Grimmer*<sup>122</sup> keine proteolytische Wirksamkeit des Sekretes der *Brunnerschen* Drüsen nachweisen.

Die *Lieberkühnschen* Drüsen — sind einfach-schlauchförmige Drüsen dicht nebeneinander in der Darmschleimhaut, und zwar am reichlichsten in der Dünndarms (wegen des Fehlens der Zotten) vorkommen. Sie besitzen eine aus feinstem Bindegewebe Membrana propria und eine einschichtige Lage cylindrischer Drüsenzellen zwischen denen auch Becherzellen vorkommen, spärlich im dünnen, sehr reichlich im dicken Gedärme; die Dünndarmdrüsen liefern vorwiegend dünnes Sekret, die des Dickdarms aus ihren zahlreichen Bechern zähen Schleim (*Heidenhain* u. *Klose*<sup>123</sup>). — Die Hauptbestandteile des Darmsaftes sind die von den *Lieberkühnschen* Drüsen ist vom Duodenum an abwärts der Hauptbestandteil des Darmsaftes.

Der Darmsaft wird nach *Thiry's*<sup>124</sup> Methode (1864) in folgender Weise gewonnen. Aus einer hervorgezogenen Darmschlinge des Hundes wird ein handlanges Stück so getrennt, daß nur das Darmrohr, nicht das Mesenterium durchschnitten wird. Das eine Ende dieser Strecke wird zugebunden, das andere offen in die Bauchwunde eingenäht, nachdem vorher die Enden des Mesenteriums zwischen denen die Strecke angeschaltet war, durch Nähte sorgfältig wieder verbunden sind. *Vella*<sup>125</sup> (1881) läßt beide Enden des hufeisenförmig umzubiegenden Darmstückes auf der Bauchwand ausmünden. Auf diese Weise kann das Tier nach dieser Operation mit seinem nur wenig verkürzten Darmlumen weiterleben. Die nach oben mündende Darmfistel aber gibt einen durch kein anderes Verdauungsekret verunreinigten Darmsaft. — *London*<sup>126</sup> hat bei Hunden im Verlaufe des Darms mehrere Fisteln angelegt (*Polyfistel* Methode); nach Speisezufuhr fließt dann aus den oberen Fisteln ein Brei mit Magen-, Pankreassaft, Galle ab, während die unteren Fisteln Darmsaft

Die Zufuhr großer Fettmengen in der Nahrung bedingt nach P. saure Reaktion des Dünndarms, indem das Alkali des Pankreas-Darmsaftes bei der Verseifung der freien Fettsäuren verbraucht wird. Bei Pflanzenfressern reagiert nach Bidder u. Schmidt<sup>192</sup> die Dünnschleimhaut gegen Lackmus alkalisch, aber der Darminhalt sauer durch die Gärung der Kohlehydrate, vgl. S. 300). Gegen kohlensäureempfindliche Indikatoren, z. B. Phenolphthalein, reagiert nach I. der Dünndarmchymus bei Carni-, Herbi- und Omnivoren schwach sauer oder fast neutral. — Im Dickdarm ist meist saure Reaktion wegen sauren Gärung des Darminhaltes.

1. Wirkung auf die Kohlehydrate. — Der Darmsaft hat eine diastatische Wirkung, aber in geringerem Maße als Speichel und Pankreassaft (Hamburger<sup>197</sup>, Mendel<sup>198</sup>, Hamburger u. Hekma<sup>101</sup>, Nagano<sup>102</sup>). Die Wirkung des Darmsaftes auf die Polysaccharide kann daher gering sein. Dagegen enthält der Darmsaft sehr wirksame Fermente, die Disaccharide in Monosaccharide überführen, und zwar:

1. Maltase, welche Maltose in Dextrose überführt (Pautz u. Hamburger<sup>197</sup>, Mendel<sup>198</sup>, Nagano<sup>192</sup>). Dieses Ferment setzt also die diastatische Wirkung des Speichels und des Pankreassaftes, welche im

Fig. 81.

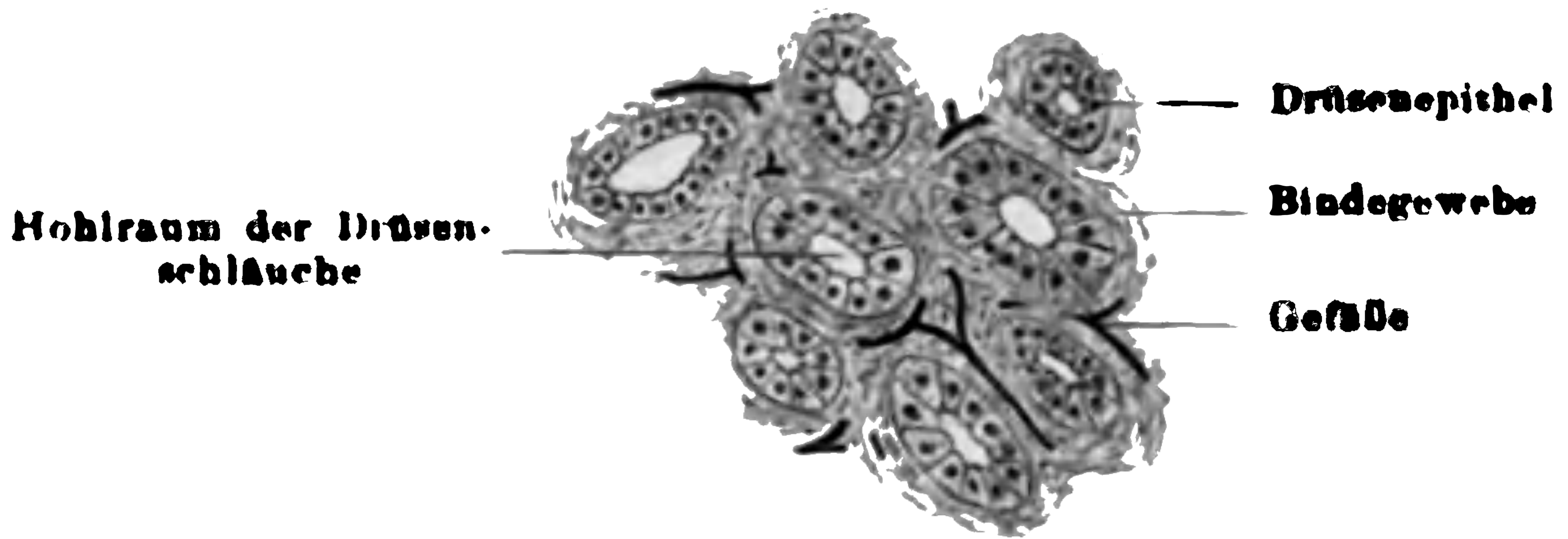

Querschnitt Lieberkühnchen Drüsen.

lichen nur Maltose bilden, fort. — Wird etwa unveränderte Maltose resorbiert, so kann sie noch durch die Maltase des Blutes (vgl. S. 83) in Dextrose und Lävulose gespalten werden.

2. Invertin, welches Rohrzucker in Dextrose und Lävulose spaltet (Miura<sup>200</sup>, Pautz u. Vogel<sup>199</sup>, Mendel<sup>198</sup>, Nagano<sup>192</sup>, Röhmann<sup>201</sup>). Das Invertin kommt nur im Dünndarm vor, nicht im Dickdarm.

3. Lactase, welche Milchzucker (Lactose) in Dextrose und Lävulose spaltet, kommt gewöhnlich nur bei Tieren vor, die in ihrer Muttermilch Milchzucker aufnehmen, und zwar im Dünndarm junger (saugender) Tiere und des Neugeborenen, ferner bei den Omnivoren, Schwein und Mensch, nicht beim erwachsenen Rind, Schaf, Kaninchen, Huhn, dagegen beim erwachsenen Pferd (Weinland<sup>202</sup>). Wurden Kaninchen vom Säuglingsalter an mehrere Monate lang fortgesetzt mit Milch gefüttert, so war auch bei dauernd Lactase bei ihnen vorhanden.

Im Foetus tritt das Invertin zuerst auf, am Anfang des 4. Monats, die Lactase dagegen erst im 7. bis 8. Monat (Ibrahim u. Kowalewsky<sup>203</sup>).

2. Eine Wirkung auf native Eiweißkörper besitzt der Darmsaft nicht. Dagegen wies Cohnheim<sup>204</sup> in Extrakten der Darmschleimhaut Kutscher u. Seemann<sup>205</sup>, Salaskin<sup>206</sup>, Hamburger u. Hekma<sup>101</sup> auch ein besonderes Ferment „Erepsin“ nach, welches, vom Trypsin verschieden, die echten Eiweißkörper nicht angreift, aber die V



**DIESE SEITE IST FÜR KOSTENLOSE MITGLIEDER GESPERRT**  
Beantragen Sie jetzt die volle Mitgliedschaft, um diese Seite zu betreten

# GESCHICHTE

Zehntausende von wichtigen historischen Quellen, viele bisher nicht erhältlich, stehen jetzt zum ersten Mal mit der Vollmitgliedschaft von Forgotten Books zur Verfügung.

Unbegrenzter Zugang  
\$8.99/monat

**Fortfahren**

\*Es gelten Richtlinien zur fairen Nutzung.



wasserreichere Faeces, die Menge aufgenom-  
 fluß. — Je schneller ferner die Peristaltik  
 sind die Faeces, weil nicht hinreichend Zeit  
 vorrückenden Ingestis Flüssigkeit zu resorbieren.

Die Reaktion — ist oft sauer, nach  
 Gärung der Kohlehydrate entstandenen Stoffen.  
 doch im unteren Darmabschnitte zur Bildung  
 so kann neutrale und selbst alkalische Reaktionen  
 sonderung von Schleim im Darm begünstigt werden.

Die Farbe — richtet sich nach der  
 änderten Gallenfarbstoffe.

Außerdem wirkt die Farbe der Nahrungsmittel  
 der Nahrung macht die Faeces fast braunschwarz durch  
 durch die Darmfäulnis zu Hämochromogen reduziert.  
 — grüne Vegetabilien braungrün durch Chlorophyll; -

Fig. 83.

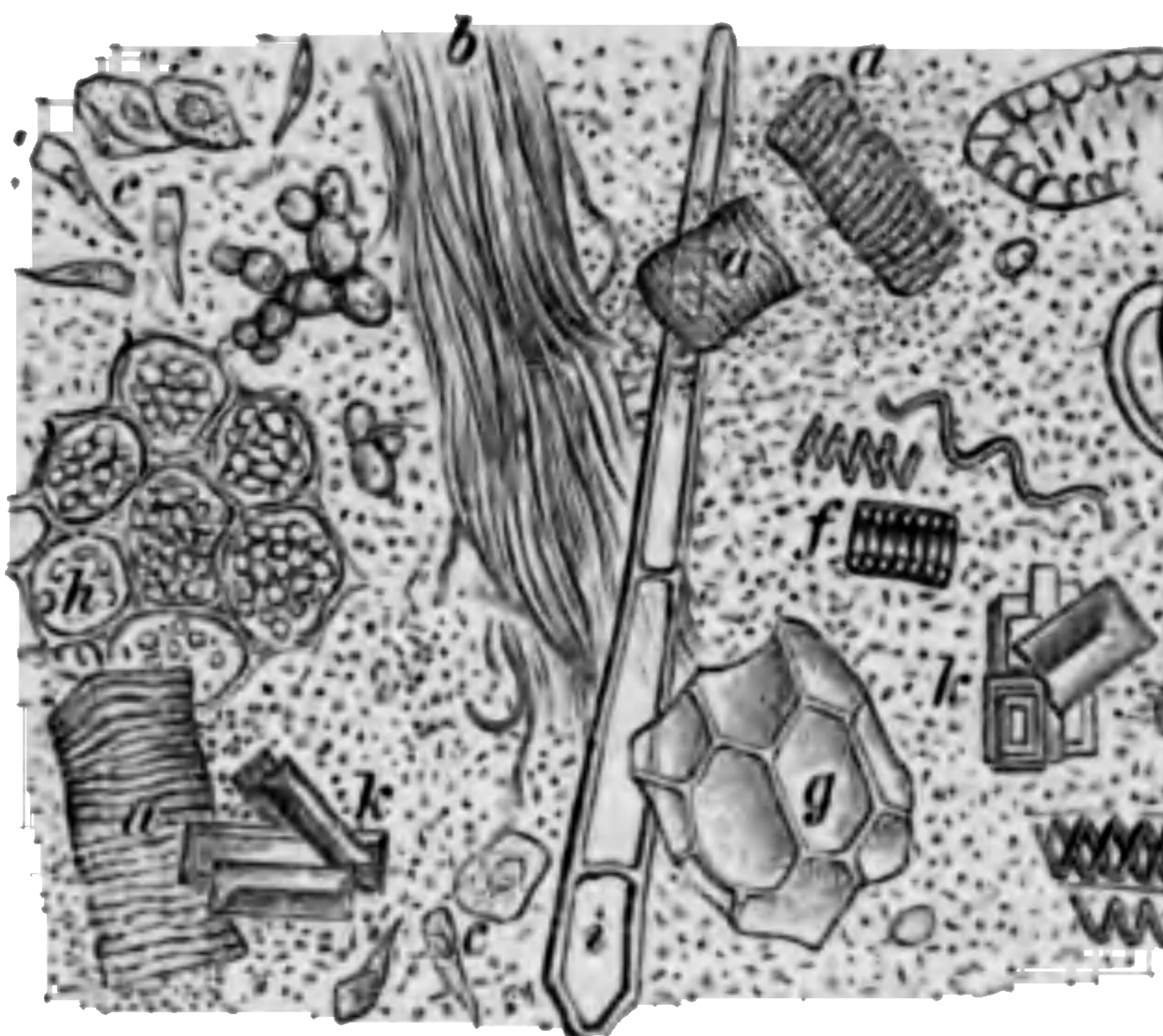

Faeces: a Muskelfasern, b Sehne, c Epithelien, d Leuko-  
 cyten, e Pflanzenzellen, dazwischen überall massenhafte Bakterien  
 Phoresaures Ammoniummag.

**Kalkgehalt;** — blaurote Pflanzensäfte blauschwarz;  
**Bildung von Schwefeleisen** (teilweise) schwarz.

Die Faeces enthalten (siehe Fig. 83):

1. Die unverdaulichen Rückstände der Gewebe-  
 mittel: Haare, Horngewebe; — Cellulose, Holzfasern,  
 Zellen, Gummi.

2. Bruchstücke sonst wohl verdaulicher Substanz.  
 Über großer Menge genossen waren oder durch Kauen  
 erfahren hatten: Fleischreste (bis 1%), Schinkenstücke,  
 Fetzen, Knorpelstückchen, Flocken von Fettgewebe, elastische  
 der Darmschleimhaut, — ferner Pflanzenzellen: Stärke  
 reifer Hülsenfrüchte, anzerriebene Kleberzellen des Ge-

3. Nach sehr reichem Milchgenuß, ebenso nach  
 Kote Kristallnadeln von fettsaurem Kalk, Kalkstein-  
 Klumpen von Casein und Fett auftreten. Reichere Faeces  
 schlechtere Verdauung und Ausnutzung des Fettes hin-  
 des Pankreassaftes).

4. Über den Übergang von Gallenbestandteilen  
 Purinbasen finden sich in den Faeces mehr als in  
 Harnsäure kommt fast regelmäßig im Meconium vor.  
 Körper der Faeces stammen zum kleinsten Teil aus  
 hauptsächlich aus abgestoßenen Darmepithelien und

50. *J. J. R. Macleod* u. *R. G. Pearce*: A. J. P. 25, 1910, 255. — 51. *E. J. L*  
52, 1913, 471. Z. B. 60, 1913, 371 u. 388. M. m. W. 1913, 341. — 52. *Arthur*  
C. r. soc. biol. 41, 1889, 674. A. d. P. 22, 1890, 168. — 53. *M. Kaufmann*  
1894, 656. — 54. *Doyon* u. *Dufour*: J. d. P. 3, 1901, 703. — 55. *Cl. Berni*  
cours du semestre d'hiver 1854—55), S. 289. — 56. *Eckhard*: Beiträge  
Physiol. 4, 1869, 11, 138. 8, 1879, 77. — 57. *Cl. Bernard*: Leçons sur  
1877, S. 380. — 58. *F. W. Dock*: P. A. 5, 1872, 571. — 59. *E. Cavazzani*  
1894, 181. — 60. *E. F. W. Pflüger*: oben unter 7., S. 393 u. 394. — 61. *R.*  
*E. Starkenstein*: P. A. 139, 1911, 181. — 62. *R. H. Kahn*: P. A. 140, 1911  
1912, 251, 396. 146, 1912, 578. — 63. *v. Noorden*: M. K. 7, 1911, 1. — 64  
*Gruzewska*: C. r. 142, 1906, 1165. — 65. *L. Pollak*: A. P. P. 61, 1909, 376  
*Starkenstein*: Z. e. P. u. T. 10, 1912, 78. — 67. *J. Bang*: Der Blutzucker.  
1913, S. 98. — 68. *J. Negrin y Lopez*: P. A. 145, 1912, 311. — 69. *P. Tri*  
u. *A. Fleischhauer*: Zeitschr. f. d. ges. exper. Med. 1, 1913, 369. — 70. *Cl. Berni*  
unter 55., S. 325. — 71. *Eckhard*: Beiträge z. Anatomie u. Physiol. 8, 18  
72. *Filehne*: C. m. W. 1878, 321. — 73. *E. Kälz*: P. A. 24, 1881, 109. —  
Journ. de l'anat. et de la physiol. 3, 1866, 354. — 75. *v. Mering* u. *Minkowski*  
mellitus nach Pankreasextirpation. Leipzig 1889. A. P. P. 26, 1889, 371.  
Untersuchungen über den Diabetes mellitus. Leipzig 1893. — 76. *W. Sandmeyer*  
1892, 86. — 77. Zusammenfassende Darstellung: *S. Rosenberg* in C. O.  
Handbuch der Biochemie. Jena 1910. 3, 1, 245. — 78. *V. Lombroso*: E. P. 9,  
79. *F. P. Knoultton* u. *E. H. Starling*: C. P. 26, 1912, 169. J. o. P. 45, 1912, 1  
85 B. 1912. 218. *S. W. Patterson* u. *E. H. Starling*: J. o. P. 47, 1914, 137  
*Cruickshank* u. *S. W. Patterson*: J. o. P. 47, 1914, 381. — 80. *E. Pflüger*: P. A  
265 u. 267. 119, 1907, 227. 122, 1908, 267. 123, 1908, 323. 124, 1908, 1 u  
1909, 125. *A. Herlitzka*: P. A. 123, 1908, 331. — 81. *O. Minkowski*: A. P. 1  
271. *R. Ehrmann*: P. A. 119, 1907, 295. 121, 1908, 237. *S. Rosenberg*: P. A.  
358. B. Z. 18, 1909, 95. *E. Tscherniachowski*: Z. B. 53, 1910, 1. — 82.  
P. A. 118, 1907, 271. — 83. *E. Leschke*: A. P. 1910, 401. — 84. *O. Minkows*  
1892, 90. — 85. *E. Hédon*: C. r. 115, 1892, 292. C. r. soc. biol. (4) 9, 1892. A  
Travaux de physiologie. Paris 1898. — 86. *Eppinger, Falta* u. *Rudinger*:  
1908, 1. — 87. *K. Drechsel*: J. p. Ch. N. F. 33, 1886, 425. L. B. 38, 1886  
33, 1896, 85. — 88. *J. Meinertz*: Z. ph. Ch. 46, 1905, 376. — 89. *M. Siegfried*  
Z. ph. Ch. 46, 1905, 492. — 90. *A. Baskoff*: Z. ph. Ch. 57, 1908, 395. 61, 19  
91. *J. Athanasiu*: P. A. 74, 1899, 511. — 92. *F. Kraus* u. *A. Sommer*: H.  
86. — 93. *G. Rosenfeld*: Z. k. M. 28, 1895. 36, 1898. E. P. 1, 1, 1902, 651.  
50. — 94. *Dastre* u. *Floresco*: A. d. P. (5) 10. Matières colorantes du foie et  
Paris 1899. — 95. *Naunyn*: Der Diabetes mellitus. 2. Aufl. Wien 1906. C.  
Die Zuckerkrankheit und ihre Behandlung. 6. Aufl. Berlin 1912. Handbuch  
Stoffwechsels. 2. Aufl. Berlin 1907. 2, 1. — 96. *W. Schulze*: A. m. A. 56, 19  
97. *Ssobelew*: V. A. 168, 1902, 91. — 98. *A. Weichselbaum*: S. W. A. 119, 3.  
73. — 99. *Herzheimer*: V. A. 183, 1906, 228. D. m. W. 1906, 829. — 100  
10. internat. med. Kongr. zu Berlin 1890. 2, Abt. 5., 97. *De Renzi* u. *Keule*: B.  
560. Vgl. *O. Minkowski*: B. k. W. 1892, 90. Untersuch. über d. Diabetes mellit. L  
8. 57. *E. F. W. Pflüger*: oben unter 7., S. 463. — 101. *v. Mering*: V. 5.  
V. 6. C. M. 1887. C. m. W. 1887, Nr. 53. Z. k. M. 14, 1888, 405. 16, 1889, 43.  
*Junkersdorf*: P. A. 131, 1910, 306. — 103. *A. Erlandsen*: B. Z. 23, 1910  
1910, 1. — 104. *E. Frank*: A. P. P. 72, 1913, 387. — 105. *L. Pollak*:  
1911, 415. — 106. *E. Hirsch* u. *H. Reinbach*: Z. ph. Ch. 87, 1913, 122. — 10  
*marsten*: E. P. 4, 1905, 1. — 108. *O. Jacobsen*: B. d. ch. G. 6, 1873, 1026. —  
B. k. W. 1900, 866, 891. — 110. *H. Strauss*: B. k. W. 1903, Nr. 12. — 111. *J.*  
P. A. 109, 1905, 307. — 112. *Platner*: A. Ch. Ph. 51, 1844, 105. — 113. *A.*  
A. Ch. Ph. 67, 1848, 1. 70, 1849, 149. — 114. *F. Mylius*: Z. ph. Ch. 11, 188  
1888, 262. B. d. ch. G. 19, 1886, 369, 2000. 20, 1887, 683, 1968. 28, 188  
115. *E. Friedmann*: H. B. 3, 1903, 1. — 116. *G. r. Bergmann*: H. B. 4, 190  
117. *J. Wohlgemuth*: Z. ph. Ch. 40, 1903, 81. — 118. *Pettenkofer*: A. Ch. Ph.  
90. — 119. *L. r. Udránszky*: Z. ph. Ch. 12, 1888, 355. 13, 1889, 248. — 120  
Z. ph. Ch. 45, 1905, 166. — 121. *O. Minkowski* u. *B. Naunyn*: A. P. P. 21, 1  
122. *G. Städeler*: A. Ch. Ph. 132, 1864, 323. — 123. *H. Stern*: A. P. P. 19.  
— 124. *Brugsch* u. *Yoshimoto*: Z. e. P. u. T. 8, 1911, 639. — 125. *J. B. I.*  
*H. Scofield*: C. P. 3, 1889, 222. Z. ph. Ch. 14, 1890, 173. — 126. *L. Pajkull*  
12, 1888, 196. — 127. *E. Cavazzani*: A. i. B. 57, 1913, 284. — 128. *E. Pflü*  
2, 1869, 173. — 129. *J. J. Charley*: P. A. 26, 1881, 201. — 130. *O. He*  
hrbuch d. physiol. Chemie. 8. Aufl. Wiesbaden 1914, S. 412. — 131. *J. Br*  
0, 1902, 491. — 132. *E. r. Czyhlarz*, *A. Fuchs* u. *O. r. Fürth*: B. Z. 49, 19



Z. k. M. 46, Heft 5 u. 6. 48, Heft 5 u. 6. —  
 des Menschen. Berlin 1901/02. *M. Schreuer*: K  
 Faeces, in C. Oppenheimers Handbuch der Biochemie  
 u. *G. Liebermeister*: D. A. k. M. 83, 1905, 413.  
 Z. ph. Ch. 21, 1895, 109. 22, 1896, 62. 23, 189  
 33. Arb. aus d. kais. Gesundheitsamte 1914. —  
 1908, 177. — 230. *Escherich*: Die Darmhal  
 231. *A. Macfadyen*, *M. Nencki* u. *N. Sieber*: A.  
 Z. B. 20, 1884, 52. 24, 1888, 105. — 233.  
 234. *W. Henneberg* u. *F. Stohmann*: Z. B. 21,  
 1901, 619. — 236. *H. Lohrlich*: Z. e. P. u. T.  
 237. *A. Scheunert* u. *E. Lötsch*: B. Z. 20, 190  
 1910, 395. Zeitschr. f. Kinderheilk. 1, 1911, 81. —  
*A. Ellinger*: E. P. 6, 1907, 29. — 240. *Bienst*  
 241. *A. Ellinger* u. *M. Gentzen*: H. B. 4, 1904,  
 242. *L. Udránszky* u. *E. Baumann*: Z. ph. Ch. 13,  
 Z. ph. Ch. 29, 1900, 334. B. d. ch. G. 31, 1898,  
 Z. ph. Ch. 4, 1880, 1. — 245. *Blauberg*: Diss  
 ph. Ch. 16, 1892, 460. — 247. *A. Albu*: B.  
 D. m. W. 1897, 509. — 248. *L. Hermann*: P.  
 P. A. 48, 1891, 74. — 250. *M. Berenstein*: F  
 29, 1892, 325. — 252. *W. v. Morawzewski*: Z.  
*Müller*, *Munk*, *Senator*, *Zuntz*: V. A. 131, :  
 Centralbl. f. d. ges. Physiol. u. Pathol. d. Stoffwe  
 Berlin 1906. — 256. *M. Krüger* u. *A. Schitten*  
 14. *A. Schittenhelm*: D. A. k. M. 81, 1904, 4  
 Heft 2. — 258. *Klein*: A. H. 59, 1906, Heft  
 79. — 260. *J. G. Rey*: A. P. P. 35, 1895, 295.  
 307. — 262. *R. Gottlieb*: Z. ph. Ch. 15, 1891,  
 A. P. P. 37, 1896, 159. — 264. *E. Abderhalde*  
 B. Z. 1, 1906, 153. — 266. *F. Jungklaus*: I  
 — 267. *W. Biedermann*: Die Aufnahme, Ve  
 H. Wintersteins Handbuch d. vergleich. Physiologi  
 A. P. 1906, 139. — 269. *N. Zuntz* u. *W. Ust*  
 B. Z. 4, 1907, 154.



**DIESE SEITE IST FÜR KOSTENLOSE MITGLIEDER GESPERRT**  
Beantragen Sie jetzt die volle Mitgliedschaft, um diese Seite zu betreten



**Seien Sie niemals ohne ein Buch!**

Die Vollmitgliedschaft von Forgotten Books bietet Ihnen einen universalen Zugang von unseren Apps und unserer Website, auf all Ihren Geräten: Tablet, Telefon, E-Reader, Laptop und Computer.

**Eine Bibliothek in Ihrer Tasche für €8.99/monat**

**Fortfahren**

\*Es gelten Richtlinien zur fairen Nutzung.

sollten dies die Albumosen und Peptone sein, die wegen ihrer Fähigkeit zum Durchtritt durch die Darmwand befähigt erschienen.

Nun sind aber während der Resorption einer eiweißreichen Albumosen oder Peptone niemals im Blute nachweisbar. Sie werden experimentell direkt in die Blutbahn, so wirken sie giftig auf den Blutdruck (junge Tiere können schon bei Gaben von 0,1—1 pro Kilogramm Tier zugrunde gehen), Herabsetzung oder Aufhebung der Gerinnung des Blutes (vgl. S. 75); zugleich werden sie durch die Niere ausgeschieden. Daraus folgt, daß bei der normalen Eiweißresorption Albumosen und Peptone nicht als solche in die Blutbahn gelangen können.

Die Angaben über den Nachweis von Albumosen im Blute werden vielfach bestritten; dagegen fand *Abderhalden*, daß während der Verdauung Albumosen im Blute in sehr geringer Menge vorhanden sind (vgl. S. 81).

Man hat früher angenommen, daß die Peptone allerdings resorbierbar sind, bevor sie in das Blut übertritt, indem sie eine Rückverwandlung in Eiweiß erfahren. *meister*<sup>64</sup>, *Heidenhain*<sup>65</sup>, *Glaessner*<sup>66</sup>, *Grossmann*<sup>67</sup>, *Pringle* u. *Cramer*<sup>68</sup>.

Es kann heutzutage kein Zweifel daran bestehen, daß die Albumosen und Peptone nicht die zur Resorption bestimmten Endprodukte der Verdauung des Eiweiß sind. Die Aufspaltung im Darmkanal schreitet über die Stufe der Peptone hinaus zu einfacheren Bausteinen fort. Die Trypsinverdauung der Eiweißkörper (vgl. § 114) führt nicht bei der Bildung von Peptonen Halt, sondern führt zur vollständigen Spaltung des Eiweiß in die Aminosäuren. In der Tat konnten *u. Seemann*<sup>69</sup> im Dünndarmchymus des Hundes Leucin, Lysin und Arginin nachweisen, dagegen keine nennenswerten Mengen von Albumosen und Peptonen; *London*<sup>70</sup> fand außerdem auch Tyrosin und Asparaginsäure, *Abderhalden*<sup>71</sup> noch weitere Aminosäuren. *Cohnheim*<sup>72</sup> im Darm entdeckte Erepsin (vgl. S. 297) spaltet nicht auf natives Eiweiß, sondern nur auf die Albumosen und Peptone und spaltet sie bis zu den einfachsten Spaltprodukten; nach ihm wird das Eiweiß im Darm durch die vereinigte Wirkung der Verdauungsfermente vollständig in die einfachsten Spaltprodukte zerlegt, die durch kochende Schwefelsäure.

Andererseits hat sich zeigen lassen, daß Tiere mit weit weniger Eiweiß ausreichend ernährt werden können. Es gelang, Fische durch Fütterung mit Verdauungsprodukten des Eiweiß, die keine Stickstoffreaktion mehr gaben (vgl. S. 269), im Stickstoffgleichgewicht zu halten (*Loewi*<sup>73</sup>, *Henriques* u. *Hansen*<sup>74</sup>, *Lüthje*<sup>75</sup>). Allerdings ist ein negativer Ausfall der Biuretreaktion noch kein Beweis dafür, daß das Eiweiß auch wirklich vollständig bis zu den einzelnen Aminosäuren abgebaut ist (*Abderhalden* u. *Prym*<sup>76</sup>). Aber auch mit Verdauungsprodukten, die nachweislich nur noch aus Aminosäuren bestanden, gelang es, Fische ausreichend zu ernähren, ja sogar Stickstoffansatz bei ihnen zu erzielen (*Abderhalden* u. Mitarbeiter<sup>77</sup>). Dasselbe ist beim Menschen bei Fütterung mit abgebautem Eiweiß vom Rectum her gelungen (*Abderhalden* u. *Schittenhelm*<sup>78</sup>). Man muß sich daher vorstellen, daß im menschlichen Darm unter gewöhnlichen Verhältnissen das Eiweiß ganz oder zum großen Teil bis zu den einfachsten Spaltprodukten, den Aminosäuren, abgebaut wird, daß also das Eiweiß in Form von Aminosäuren resorbiert wird.

5. Resorption anderer Stoffe. — Auch vie organische Stoffe kommen im Darmkanal zur Resorpti Alkohol schnell resorbiert, hauptsächlich durch die Bl aber auch durch die Chylusgefäße (*Dogiel*<sup>109</sup>).

Von Farbstoffen wird Alizarin, Alkanna, Indigokarmin zum Teil, wie Hämatin; Chlorophyll wird nicht resorbiert. Zahl eine schnelle Aufnahme (Blansäure nach wenigen Sekunden); ( im Chylus.

Resorption aus den Geweben heraus (nach parenchym Injektion). — Flüssigkeiten, welche man in die Parenchyme einspr Injektion. Hierbei beteiligen sich in erster Linie die Blutgefäße, d Lymphgefäße. In letztere treten hierbei, von den Spalt- und Saftlöcher selbst kleine Körperchen hinein, z. B. Zinnober- und Tuschkörnchen Haut, Blutkörperchen von Blutergüssen her, Fetttropfen vom Marke ana. Werden alle Lymphgefäße eines Teiles unterbunden, so finde gerade so schnell statt wie vorher; daher müssen die resorbierten F Blutgefäße aufgenommen worden sein. Der entgegengesetzte Versuch bindung aller Blutgefäße keine Resorption der Parenchymflüssigkeit gegen eine Mitbeteiligung der Lymphgefäße an der Aufsaugung, w and jede Lymphströmung aufhören muß (§ 134, 135). Die Aufsaug in die Gewebe, namentlich in das subcutane Zellgewebe, gabracl (-parenchymatöse und subcutane Injektion“) erfolgt meist schnell. als nach Verabreichung per os. Man bedient sich daher auch vielfä Injektionen von gelösten Arzneimitteln zu Heilzwecken. Außer d der Resorption bietet die subcutane Injektion vor der Verabreichung noch den Vorteil, daß manche Mittel, welche eingenommen werden, durch den Verdauungsprozeß so zersetzt werden, daß sie gar nicht nvo gelangen können.

### 131. Ernährende Klistiere. Subcutane E

Wenn bei Menschen die Aufnahme der Nahrung durch den M etwa bei Unwegsamkeit des Oesophagus, bei anhaltendem Erbrechen dem Vorgange von *Corn. Celsus* (3–5 n. Chr.) eine Ernährung v sucht. Freilich steht die Resorptionsfähigkeit des Dickdarms der des Da eine verdauende Tätigkeit des Dickdarms fast gar nicht stattf erster Linie gelöste, resorptionsfähige Substanzen verwenden. Man lä langes Trichterrohr langsam in den After einlaufen; der Empfänger i Masse möglichst lange zurückzuhalten. Größere Mengen als 300 cm<sup>3</sup> nal injiziert werden, da sie lebhaft Peristaltik bewirken und schn Leube<sup>110</sup>). Bei langs amem Einfließen gerät die Flüssigkeit mitunter

Leube empfiehlt für Nährklistiere: 1. Eiweißstoffe: Pepton der Eier, welche allerdings nur langsam resorbiert werden (3 Eier satz von 3 g Na Cl) (vgl. *Pfeiffer*<sup>111</sup>). Dagegen wird vollständig i Dickdarm aus gut resorbiert (*Schöpp*<sup>112</sup>, *Cohnheim*<sup>113</sup>). — 2. Ko er nicht mehr als 15–20 g auf 300 Flüssigkeit, da sonst der Dar rauss<sup>114</sup> tritt jedoch auch bei größeren Mengen Traubenzucker hä Stärke, welche im Rectum allmählich in Zucker verwandelt und res 100 Milch). — Dextrin wird von *Reach*<sup>115</sup> als besonders geeig

→ 3. Fette — werden nur in sehr geringer Menge resor it gehacktem Pankreas gemischt gegeben werden. Auch Fle scht zur Verwendung kommen. (60 Pankreassubstanz n diese Ernährung durch Klistiere bleibt jedoch stets ung nur die Resorption des vierten Teiles der zum nismenge (*Voit u. Bauer*<sup>43</sup>) und nur eines Dr in Calorienmenge (*Leube*<sup>110</sup>).

zuerst zur Ergänzung eine subcutane Er ich allein die Fette: 50–100 g lauwa am in ca. 1 Stunde aus einem mit e unt fließen. — Nach *Henderson* u

Bedingungen. Eine spezifische **biaber** nur bei Myxödem (gesetzt, und bei Morbus **chem** sie erhöht ist (*Magn* **Körpertemperatur** vgl. unte

Als Stoffwechsel **den** Diabetes (vgl. § 117 **führt** zu einer enorm hohen **Unbequemlichkeiten**, sondern **Ursache** der Fettsucht liegt **den** Bedarf; in manchen **Disposition** eine Rolle: **zu** Fettsucht (ebenso gewi **und** Bedarf kann verursac **Nahrungszufuhr**. — D **dem** die Quantität in Betr **Überschuß** über den Bed **Ansatz** von Fett. Allerdings **aufgenommen**, so z. B. **eiweiß-** oder fettreiche Nahr **wesentliche** Rolle zu, beson **an** Kohlehydraten in Betra **an** und für sich gering **sich** jahrelang Tag für Tag **führen** muß.

2. Durch einen **tätigkeit**: wenig Bewegung **Beziehung** des phlegmatisch **Vielleicht** spielt auch die E **eine** wesentliche Rolle. — **Lebensform**, teils wegen der **wirkt**. — c) Darniederl **der** Kastration, Fettsucht **ge** istige Tätigkeit: Fett

Die Behandlung d

a) die Nahrungs- **und** einseitige Beschränkung **möglichst** alle Fette und K **erzielte** schnelle Abnahme d **Folge**. Die Beschränkung d **stoffe** erstrecken und nicht **wird** am ehesten das Ziel e **Erhaltung** des Körpers **b) den** Verbrauch **geschwächtem** Herzen!) — **Bäder** — Trinkkuren usw.

Unter den niederen **Teile** (Regeneration) **Zerschneidung** des Süßwa **viduen** zur Folge; ja es v **ganzes** Wesen hervor (*Spe* **Ergänzungen**. Aus jedem **es** nur einen Teil des Ran **wärts** gerichteten Teile ei **ende**, aus dem oberen Teile **Enden** Köpfe. — Auch bei