



ebmpapst

engineering a better life

It pays off:
the AxiEco 200.

Reduces turbulence, quiet, efficient in applications requiring pressure.



The AxiEco 200 tames turbulence.

Where changes in flow are forced, turbulence is created. The AxiEco 200 reduces this and so gains in the following points:



Up to 9% more air performance compared to other fans of its size



Up to 7% more efficient, extremely compact and yet powerful up to 7,000 rpm



Up to 5 dB(A) quieter



Smart features for increased operational reliability and service life

At its best under pressure.



Specially designed for use in applications requiring pressure, the compact AxiEco 200 is particularly suitable for the challenges posed by data centers. Its secret: A unique impeller with no tip gap that reduces turbulence and swirling. Combining this with our S-Force motor and high-performance electronics

guarantees powerful performance and optimized noise behavior coupled with increased efficiency. Applications from the fields of communications, mobility, smart homes, industry, and indoor agriculture can also benefit from these features.

Outstanding design *that makes an impact.*

The AxiEco 200 boasts an innovative aerodynamic design. A significant feature is the new diagonally shaped impeller, which runs directly into the fan housing so that unwanted turbulence does not occur in the first place. The optimized inlet ring and guide blades

also ensure less turbulence and swirling. As a result, the AxiExo 200 is audibly quieter than other fans of its size. And especially where it counts: built into the application.

Optimized geometry

According to the latest aerodynamic findings, the AxiEco 200 is designed for use in applications requiring pressure. These include the inlet ring optimized for low-turbulence air inflow, its diagonally shaped impeller, and the flange with guide blades for low-turbulence air discharge.

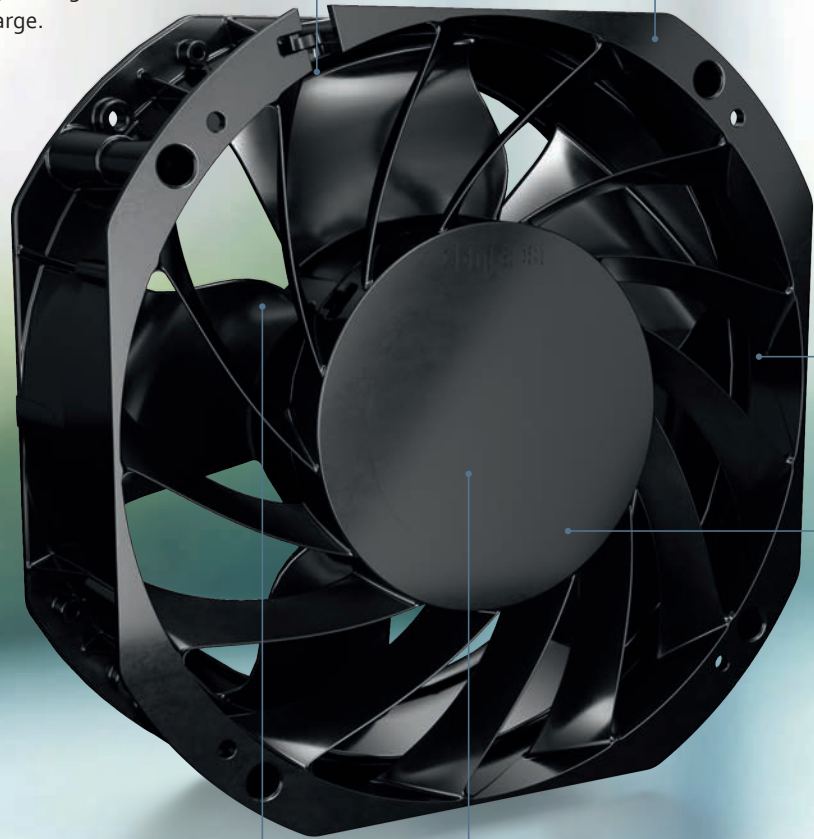

No tip gap

Impeller, integrated diffuser ring and hub form a compact unit in the AxiEco 200. There is no tip gap between the blades and housing, so there is no airflow over the blade tips. This increases efficiency while reducing noise.

Powerful S-Force motor

The 3-phase multi-pole DC GreenTech motor technology operates impressively smoothly, with low vibration and an enormous power output of up to 7,000 rpm. The motor is also very compact and dissipates heat brilliantly.

Robust housing

Made of aluminum, the housing can withstand adverse environmental conditions and, together with the reliable motor technology, guarantees a long service life in a temperature range of -20 to 60 °C.

Approvals

- + VDE
- + UL/CSA
- + CCC
- + CE
- + EAC

Interfaces

- + FanCheck for determining the remaining service life
- + Alarm signals
- + Temperature sensor
- + Analog control input (0...10 VDC)
- + Moisture protection (humidity up to 98%, no condensation)



Downtimes? Not with AxiEco 200!

IT equipment such as servers, routers, and in-row cooling applications must be 100% operational. For this reason, maintenance work is often carried out during operation.

If a single fan or a plug-in unit with several fans is taken out of service for this purpose, this can create a tricky situation: The remaining fans must provide adequate air flow. As a result of this and the back pressure of applications, air flows through the fan taken out of service and it is driven by an external source, as with a wind turbine.

The problem is that when driven by an external source, these speeds can amount to several thousand revolutions per minute and in the opposite direction of rotation.

AxiEco 200 manages a feat of strength: Thanks to its high-torque motor and state-of-the-art electronics, it still guarantees a proper start-up process, enabling efficient and fast system maintenance, including the replacement of fans while the system is running.

Turning your requirements into innovative and practical solutions is what drives us.

Powerful figures:
the AxiEco 200.



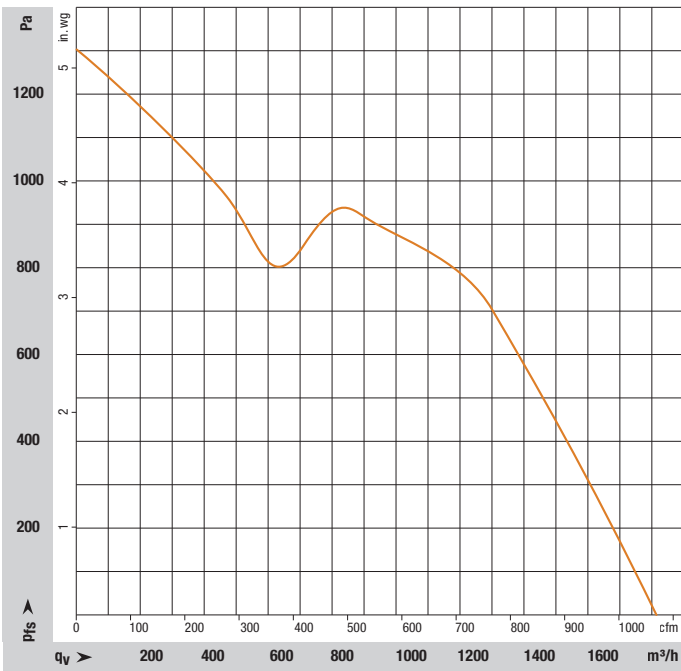
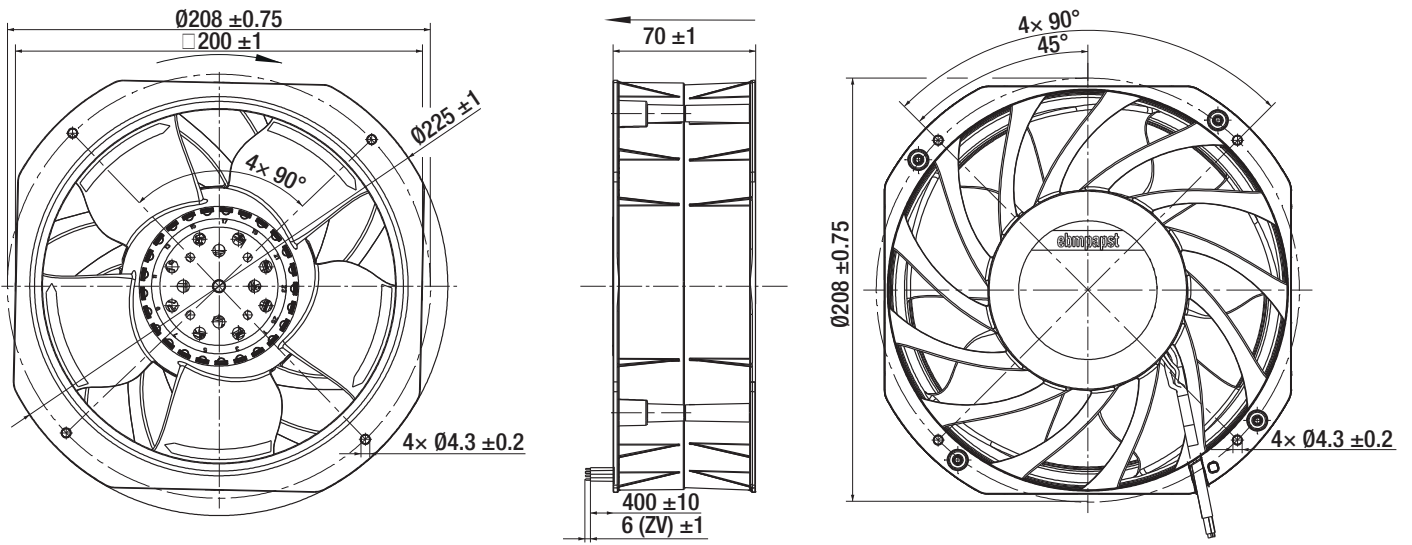

The combination of an aerodynamically optimized impeller and our GreenTech motor delivers huge performance values and greater efficiency.

Nominal data		Air flow	Air flow	Nominal voltage	Voltage range	Sound power	Sound pressure	Power consumption (free air)	Max. Power consumption	Nominal speed	Temperature range	Weight	Service life L10 _{40°C} per IPC 9591	Approvals
Type	Number	m ³ /h	cfm	V DC	V DC	Bel(A)	dB (A)	Watts	Watts	rpm	°C	g	Hours	
VWLH200CKLXS	8317081096	1,820	1,071	48	36...60	9.0	80.2	348	500	7,000	-20...+60	1,500	152,500	UL, CSA, VDE, CCC, CE



**What *Engineering*
a better life means
to us.**

Who we are.

With over 20,000 different products, ebm-papst offers the right solution for just about any challenge. As the logical next stage in the development of our highly-efficient GreenTech EC technology, we believe that industrial digitization offers the greatest future prospects for our customers. With GreenIntelligence, we already represent intelligently interconnected complete solutions that are unrivaled worldwide.

Because we are always committed to making each of our innovative hardware and software solutions more powerful, compact, efficient and sustainable than its predecessor, we have evolved over the years into the global technology leader for ventilation and drive technology.

What drives us.

But our consistent pursuit of efficiency and progress has even deeper roots. After all, there is something that excites us even more than our market position. It is the deep awareness that, with our solutions, like **AxiEco 200**, we are making the lives of many people around the globe more pleasant, safer and thus better. Therefore, the central driving force in all our thoughts and actions is Engineering a better life. It is the reason why it is worthwhile for us to get up every day and do our best.

More about this under ebmpapst.com/betterlife

What you get out of it.

- 1. Technological edge.**
With our EC technology and GreenIntelligence, we combine the highest energy efficiency with the advantages of IoT and digital networking.
- 2. Our sustainable approach.**
We take our responsibility seriously with energy-saving products, environmentally-friendly processes and through social engagement.
- 3. System expertise.**
As experts in advanced motor technology, electronics and aerodynamics, we provide perfect system solutions from a single source.
- 4. The ebm-papst spirit of invention.**
Over 800 engineers and technicians will develop a solution that precisely fits your needs.
- 5. Personal proximity to you.**
Thanks to numerous sales locations worldwide.
- 6. Our standard of quality.**
Our quality management is uncompromising, at every step and in every process.



ebmpapst

engineering a better life

Get in touch with us.

Let's find out how ebm-papst can help to make your company and your solutions even better.

If you have any questions, please contact:

Bernhard Thürmer

Tel.: +49 7724 81 1216

bernhard.thuermer@de.ebmpapst.com

www.ebmpapst.com

ebm-papst

St. Georgen GmbH & Co. KG

Hermann-Papst-Straße 1

78112 St. Georgen

Germany

Phone +49 7724 81-0

Fax +49 7724 81-1309

info2@de.ebmpapst.com