



Ready-To-Run Mini Conveyors

Installation, Maintenance & Parts Manual



DORNER MFG. CORP.
P.O. Box 20 • 975 Cottonwood Ave.
Hartland, WI 53029-0020 USA

INSIDE THE USA
TEL: 1-800-397-8664
FAX: 1-800-369-2440

OUTSIDE THE USA
TEL: 262-367-7600
FAX: 262-367-5827

For other service manuals visit our website at:
www.dorner.com/service_manuals.asp

Table of Contents

Introduction	3	Bearing Removal & Replacement.....	17
Warnings - General Safety	4	Removal.....	17
Product Description	5	Replacement.....	18
Specifications	5	Drive Pulley and Idler Pulley Installation	18
Models:	5	Drive Pulley Installation	18
Conveyor Assembly Model Number:	5	Idler Pulley Installation.....	19
Fixed Speed Control: 9 ft/min	5	Stand Height Adjustment	19
Fixed Speed Control: 15 ft/min	5	Height Adjustment for Fixed	
Fixed Speed Control: 21 ft/min	5	and Adjustable Height Stands	19
Fixed Speed Control: 35 ft/min	6	Required Tools	19
Variable Speed Control: 3 to 15 ft/min.....	6	Gearmotor Mounting Package Removal	20
Variable Speed Control: 6 to 35 ft/min.....	6	Timing Belt Tensioning.....	21
Variable Speed Control: 10 to 58 ft/min.....	6	Timing Belt Replacement.....	21
Adjustable Height Stand Models:	6	Drive or Driven Timing Pulley Replacement.....	21
Support Stand Cross Brace Models:.....	6	Gearmotor Replacement	22
Surface Mounting Bracket Models:	6	Notes	23
Conveyor Supports:	7	Service Parts.....	24
Maximum Distances:.....	7	2" (51 mm) Wide Conveyor	24
Specifications:	7	3" (76 mm) to 6" (152 mm) Wide Conveyor	26
Installation	8	8" (203 mm) to 12" (305 mm) Wide Conveyor	28
Required Tools.....	8	-04 3" (76 mm) Aluminum Side.....	30
Recommended Installation Sequence	8	-05 1.5" (38mm) Aluminum Side.....	31
Support Stand Mounting Brackets	8	-07 Low to Side Wiper	32
Surface Mount Brackets.....	9	-09 Low to High Side	33
Adjustable Cross Brace.....	10	-13 Adjustable Guiding	34
Required Tools	10	-14 Tool-Less Adjustable Guiding	35
Stand Attachment.....	10	Flared Side Guiding.....	36
Variable Speed Controller	11	Flat Belt Stand Mount Assembly	37
Variable Speed Controller		2" (51mm) to 6" (152mm)	
Mounting to Conveyor	11	Flat Belt Return Roller	38
Variable Speed Controller		8" (203mm) to 24" (610mm)	
Mounting to Stand Leg.....	12	Flat Belt Return Roller	38
Preventive Maintenance and Adjustment	13	Gearmotor Mounting Package.....	39
Required Tools.....	13	Conveyor Belt Part Number Configuration.....	40
Standard Tools.....	13	Notes	41
Special Tools	13	Return Policy.....	42
Checklist	13		
Lubrication	13		
Maintaining Conveyor Belt	13		
Troubleshooting	13		
Cleaning	13		
Conveyor Belt Replacement	13		
Conveyor Belt Replacement Sequence	13		
Belt Removal for Conveyor With			
Stands and Gearmotor Mounting Package	14		
Belt Installation for Conveyor with Stands			
and Gearmotor Mounting Package.....	14		
Conveyor Belt Tensioning	15		
Conveyors with 1.25" (32 mm) Diameter Pulleys.....	15		
Conveyor Belt Tracking.....	16		
V-Guided Belts.....	16		
Pulley Removal.....	16		
A - Idler Pulley Removal.....	16		
B - Drive Pulley Removal	17		

IMPORTANT

<i>Some illustrations may show guards removed. DO NOT operate equipment without guards.</i>

Upon receipt of shipment:

- Compare shipment with packing slip. Contact factory regarding discrepancies.
- Inspect packages for shipping damage. Contact carrier regarding damage.
- Accessories may be shipped loose. See accessory instructions for installation.

Dorner's Limited Warranty applies.

Dorner has convenient, pre-configured kits of Key Service Parts for all conveyor products. These time saving kits are easy to order, designed for fast installation, and guarantee you will have what you need when you need it. Key Parts and Kits are marked in the Service Parts section of this manual with the Performance Parts Kits logo .

Dorner 2200 series conveyors are covered by Patent Numbers 5,174,435, 6,298,981, 6,422,382 and corresponding patents and patent applications in other countries.

Dorner reserves the right to make changes at any time without notice or obligation.

Warnings - General Safety

⚠ WARNING

The safety alert symbol, black triangle with white exclamation, is used to alert you to potential personal injury hazards.

⚠ DANGER



Climbing, sitting, walking or riding on conveyor will cause severe injury. **KEEP OFF CONVEYORS.**

⚠ DANGER



DO NOT OPERATE CONVEYORS IN AN EXPLOSIVE ENVIRONMENT.

⚠ WARNING



Exposed moving parts can cause severe injury. **LOCK OUT POWER** before removing guards or performing maintenance.

⚠ WARNING



Gearmotors may be **HOT**. **DO NOT TOUCH** Gearmotors.

⚠ WARNING



Dorner cannot control the physical installation and application of conveyors. Taking protective measures is the responsibility of the user.

When conveyors are used in conjunction with other equipment or as part of a multiple conveyor system, **CHECK FOR POTENTIAL PINCH POINTS** and other mechanical hazards before system start-up.

⚠ WARNING



Loosening stand height or angle adjustment screws may cause conveyor sections to drop down, causing severe injury.

SUPPORT CONVEYOR SECTIONS PRIOR TO LOOSENING STAND HEIGHT OR ANGLE ADJUSTMENT SCREWS.

Product Description

Refer to Figure 1 for typical components.

1	Drive End
2	Gearmotor Mounting Package
3	Guiding & Accessories
4	Idler/Tension End
5	Conveyor
6	Mounting Brackets
7	Variable Speed Controller
8	Support Stand
9	Caster Wheels

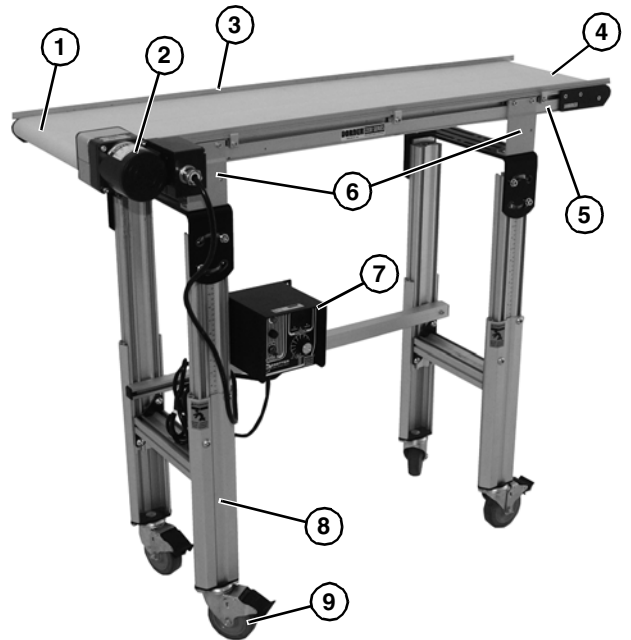

Figure 1

Specifications

Models:

Conveyor Assembly Model Number:

Fixed Speed Control: 9 ft/min

Length	1.75"	3"	4"	6"	8"	12"
3 foot	75009199	75009203	75009207	75009211	75009215	75009219
5 foot	75009223	75009227	75009231	75009235	75009239	75009243
8 foot	75009247	75009251	75009255	75009259	75009263	75009267

Fixed Speed Control: 15 ft/min

Length	1.75"	3"	4"	6"	8"	12"
3 foot	75009200	75009204	75009208	75009212	75009216	75009220
5 foot	75009224	75009228	75009232	75009236	75009240	75009244
8 foot	75009248	75009252	75009256	75009260	75009264	75009268

Fixed Speed Control: 21 ft/min

Length	1.75"	3"	4"	6"	8"	12"
3 foot	75009201	75009205	75009209	75009213	75009217	75009221
5 foot	75009225	75009229	75009233	75009237	75009241	75009245
8 foot	75009249	75009253	75009257	75009261	75009265	75009269

Specifications

Fixed Speed Control: 35 ft/min

Length	1.75"	3"	4"	6"	8"	12"
3 foot	75009202	75009206	75009210	75009214	75009218	75009222
5 foot	75009226	75009230	75009234	75009238	75009242	75009246
8 foot	75009250	75009254	75009258	75009262	75009266	75009270

Variable Speed Control: 3 to 15 ft/min

Length	1.75"	3"	4"	6"	8"	12"
3 foot	75009271	75009274	75009277	75009280	75009283	75009286
5 foot	75009289	75009292	75009295	75009298	75009301	75009304
8 foot	75009307	75009310	75009313	75009316	75009319	75009322

Variable Speed Control: 6 to 35 ft/min

Length	1.75"	3"	4"	6"	8"	12"
3 foot	75009272	75009275	75009278	75009281	75009284	75009287
5 foot	75009290	75009293	75009296	75009299	75009302	75009305
8 foot	75009308	75009311	75009314	75009317	75009320	75009323

Variable Speed Control: 10 to 58 ft/min

Length	1.75"	3"	4"	6"	8"	12"
3 foot	75009273	75009276	75009279	75009282	75009285	75009288
5 foot	75009291	75009294	75009297	75009300	75009303	75009306
8 foot	75009309	75009312	75009315	75009318	75009321	75009324

Adjustable Height Stand Models:

Height	
24 to 36 inches high	75009327
30 to 48 inches high	75009328

(Note: The stand bracket and conveyor add 5" to Top of Belt Height.)

Support Stand Cross Brace Models:

Height	
For 3' Long Conveyor	75009329
For 5' Long Conveyor	75009330
For 8' Long Conveyor	75009331

Surface Mounting Bracket Models:

Height	
2" to 3" Top of Belt Height	75009325
3" to 5" Top of Belt Height	75009326

Specifications

Conveyor Supports:

Maximum Distances:

- 1 = 18" (457 mm)
- 2 = 6 ft (1829 mm)
- 3 = 18" (457 mm)

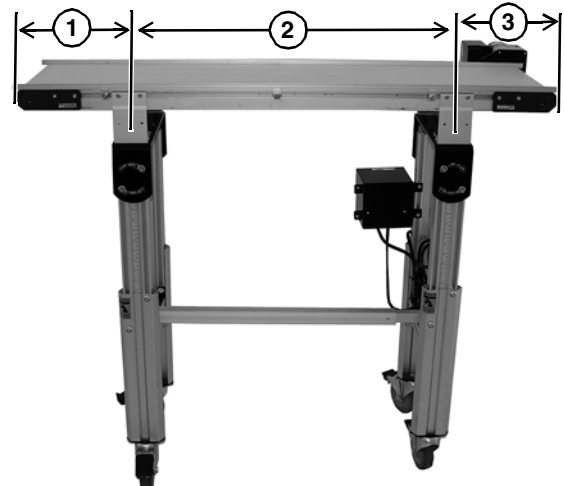

Figure 2

Specifications:

Table 1: Conveyor Speed / Maximum Load Capacity

Fixed Speed Gearmotors

Load Capacity (lbs)	Belt Width (in)					
	1.75	3	4	6	8	12
Speed (ft/min)						
9	30	35	42	60	70	80
15	30	35	42	60	70	80
21	30	35	42	57	52	43
35	30	35	34	29	24	14

Variable Speed Motors

Load Capacity (lbs)	Belt Width (in)					
	1.75	3	4	6	8	12
Speed (ft/min)						
3 to 15	30	35	42	60	70	80
6 to 35	30	35	42	52	47	37
10 to 58	30	35	27	22	17	8

NOTE

- Maximum conveyor loads based on:
- Non-accumulating product
 - Product moving towards gearmotor
 - Conveyor being mounted horizontal

Table 2: Gearmotor Specifications

Part Number	Output Hp	Input Volts	Input Phase	Input Hz	Amps FLA	Ratio	RPM	Torque in-lb
62M060PL411FN	0.03	115V	1	60	0.46	60	25	38
62M036PL411FN	0.03	115V	1	60	0.46	36	42	26
62M025PL411FN	0.03	115V	1	60	0.46	25	60	18
62M015PL411FN	0.03	115V	1	60	0.46	15	100	12
62M036PL423EN	0.03	230V	3	10 to 60	0.22	36	42	37
62M015PL423EN	0.03	230V	3	10 to 60	0.22	15	100	16.8
62M009PL423EN	0.03	230V	3	10 to 60	0.22	9	167	10.6

Table 3: Variable Speed Controller Specification

Part Number	Input Volts	Input Phase	Input Hz	Output Volts	Output Phase	Output Hz	Max Amps
22MV122BR	115V	1	60	230	3	10 to 60	2.4

Installation

NOTE

Conveyor **MUST** be mounted straight, flat and level within confines of conveyor. Use a level (**Figure 3, item 1**) for setup.



Figure 3

Installation Component List

- | | |
|---|--|
| 1 | Conveyor with Gearmotor Mounting Package |
| 2 | Variable Speed Controller (Optional) |
| 3 | Support Stand (Optional) |
| 4 | Support Stand Mounting Brackets (Optional) |
| 5 | Adjustable Stand Cross Bracket (Optional) |
| 6 | Surface Mount Brackets (Optional) |

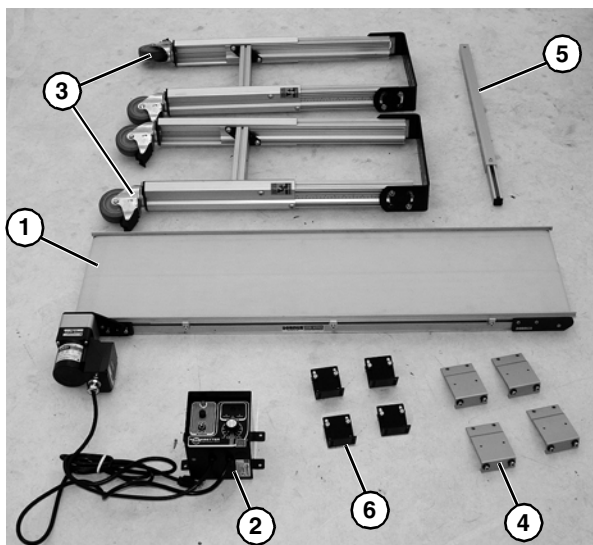

Figure 4

Required Tools

- Hex-key wrenches:
4 mm, 5 mm
- Level
- Torque wrench

Recommended Installation Sequence

- Attach mounting brackets to conveyor (see “Support Stand Mounting Brackets” on page 8 for stand mounting brackets and see “Surface Mount Brackets” on page 9 for surface mounting brackets).
- Attach conveyor to stands (see “Stand Attachment” on page 10).
- Install stand cross brace
- Install variable speed controller

Support Stand Mounting Brackets

1. Locate brackets. Exploded view shown in Figure 5.

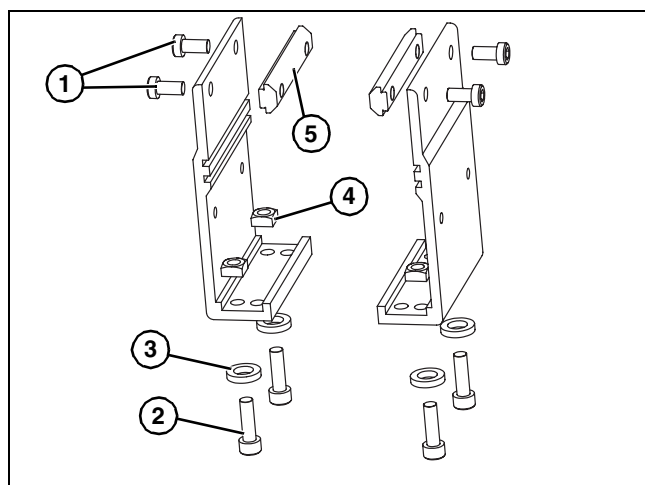

Figure 5

2. Remove screws (**Figure 5, item 1 & 2**), washers (**Figure 5, item 3**), nuts (**Figure 5, item 4**) and T-bars (**Figure 5, item 5**) from brackets.
3. Insert T-bars (**Figure 5, item 5**) into conveyor side slots (**Figure 6, item 1**). Fasten brackets (**Figure 6, item 2**) to conveyor with mounting screws (**Figure 6, item 3**).

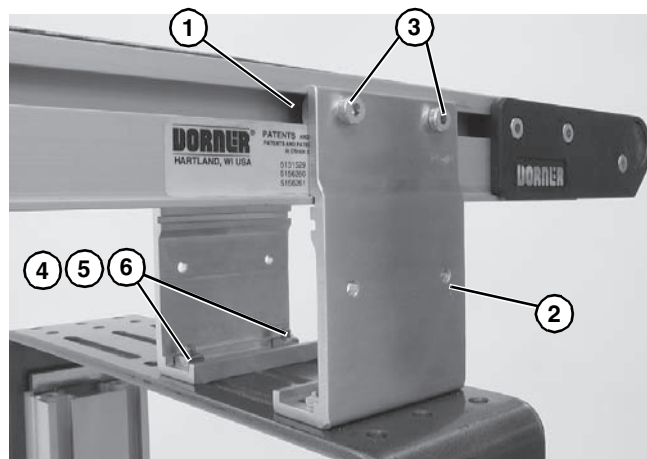

Figure 6

NOTE

Mounting brackets for flat belt conveyors shown.

4. Fasten brackets to support stand with mounting screws (**Figure 6, item 4**), washers (**Figure 6, item 5**) and nuts (**Figure 6, item 6**).
5. Tighten screws (**Figure 6, item 3 & 4**) to 60 in-lb (7 Nm).
6. See “Stand Height Adjustment” on page 19 for stand height adjustment.

Surface Mount Brackets

1. Locate brackets. Exploded view shown in Figure 8.

Illustration References

- | | |
|---|----------------------|
| 1 | Slotted Bracket (2x) |
| 2 | M6 T-Bar (2x) |
| 3 | Spacer Plate (2x) |
| 4 | M6 Screw (4x) |
| 5 | M6 Washer (4x) |

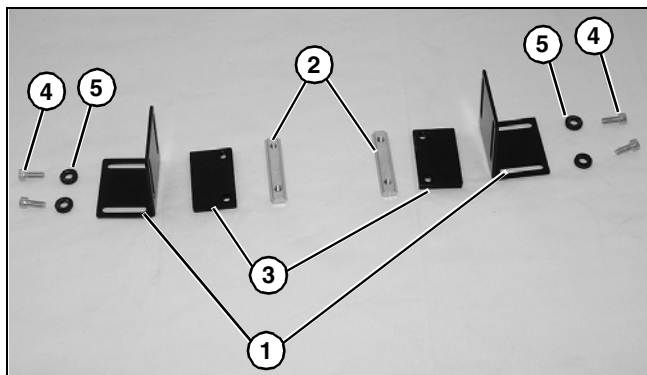

Figure 7

2. Install M6 T-bar (**Figure 8, item 1**) in T-slot (**Figure 8, item 2**).

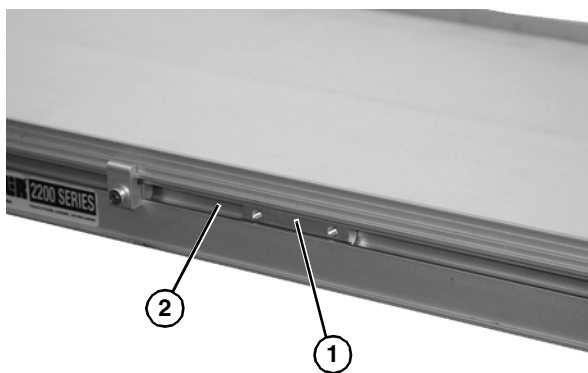

Figure 8

3. Set spacer (**Figure 9, item 1**) on conveyor lip (**Figure 9, item 2**).

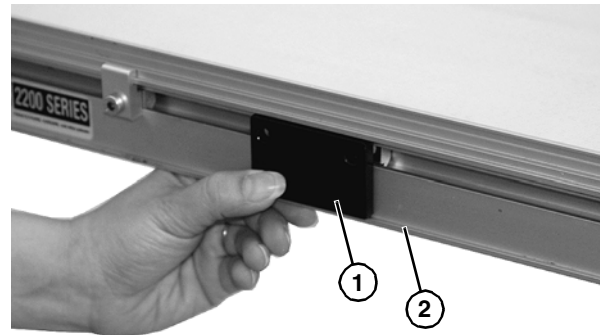

Figure 9

4. Mount slotted bracket (**Figure 10, item 1**) to conveyor frame with M6 screws (**Figure 10, item 2**).

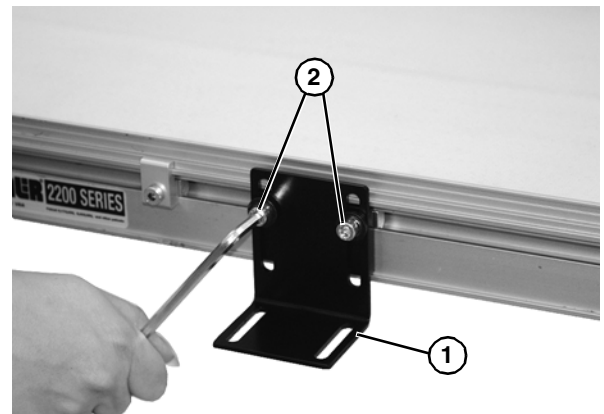



Figure 10

5. Adjust height as required. Tighten M6 screws to 80 in-lb (9 Nm).
6. Repeat for opposite side of conveyor.

Installation

Adjustable Cross Brace

⚠ WARNING

Exposed moving parts can cause severe injury. LOCK OUT POWER before removing guards or performing maintenance.

Required Tools

- 5 mm hex key wrench
- Torque wrench

Illustration References:

1	M6 T-Bar (2x)
2	Adjustable Bar
3	M6 x 40 mm Socket Head Screw (2x)

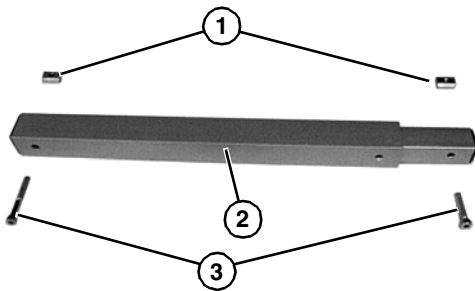

Figure 11

Stand Attachment

1. Loosen screw (Figure 12, item 1) of adjustable bar (Figure 12, item 2).

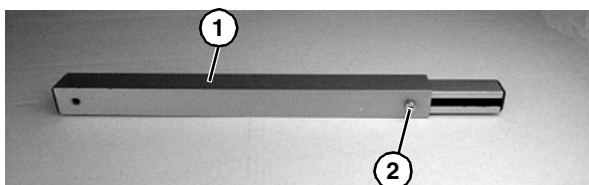

Figure 12

2. Install T-bar (Figure 13, item 1) in inner T-slot of stand leg (Figure 13, item 2).

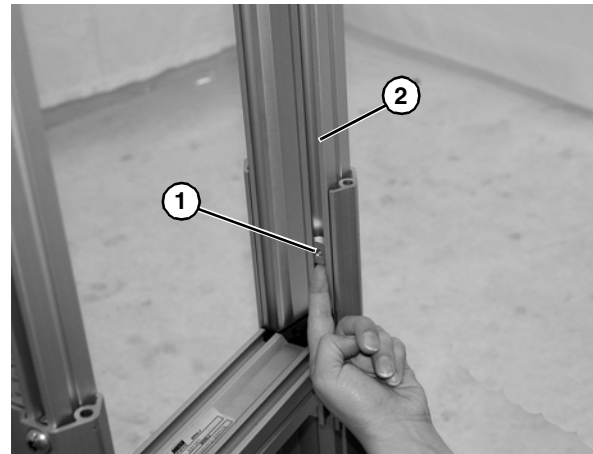

Figure 13

3. Loosely attach adjustable bar (Figure 14, item 1) or (Figure 15, item 1) to aluminum stand T-slot as required.
- Attach outer tube end with screw (Figure 14, item 2).

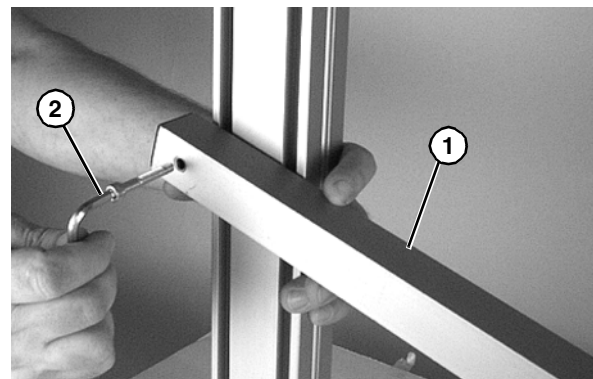

Figure 14

- Attach inner channel end with screw (Figure 15, item 2).

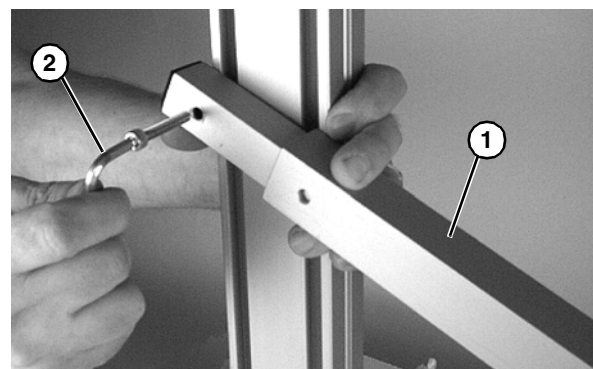



Figure 15

⚠ WARNING



Failure to secure three screws (Figure 16, item 1), may cause conveyor sections to drop down, causing severe injury. TIGHTEN SCREWS AFTER ADJUSTMENT.

4. Tighten three screws (Figure 16, item 1), to 80 in-lb (9 Nm).

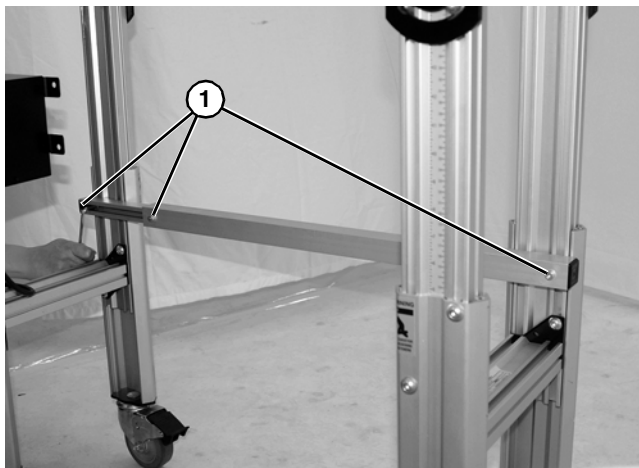

Figure 16

Variable Speed Controller

Variable Speed Controller Mounting to Conveyor



Typical Variable Speed Mounting on Conveyor

Figure 17

Illustration References:

Item	Part Number	Description
1	920406M	Socket Head Screw, M4-0.70 x 6 mm
2	202658	Mounting Clip (x2)
3	920612M	Socket Head Screw, M6-1.00 x 12 mm (x2)
4	639971M	T-Bar, Single Drop-In (x2)
5	827-101	Controller
	827-100	Reversing Controller

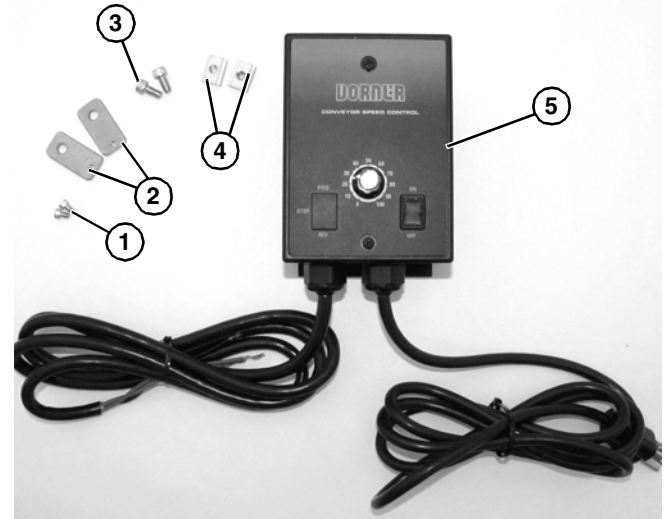

Shipping Package

Figure 18

⚠ WARNING



Exposed moving parts can cause severe injury. LOCK OUT POWER before removing guards or performing maintenance.

1. Assemble mounting clips (Figure 19, item 1) with screws (Figure 19, item 2) to the top of the controller.

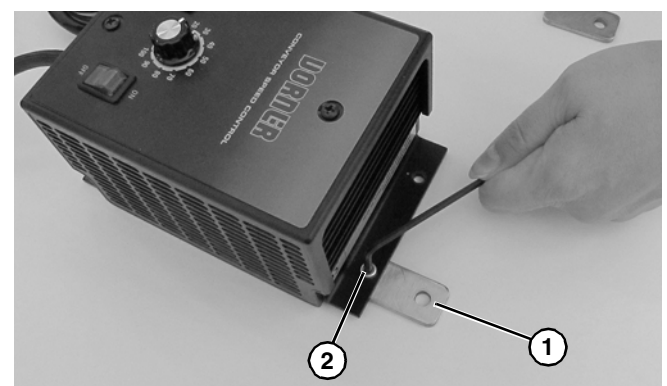

Figure 19

Installation

2. Install T-bars (**Figure 20, item 1**) into T-slots of conveyor.

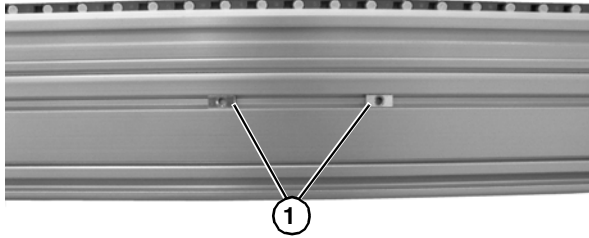

Figure 20

3. Attach controller to conveyor with two screws (**Figure 21, item 1**).

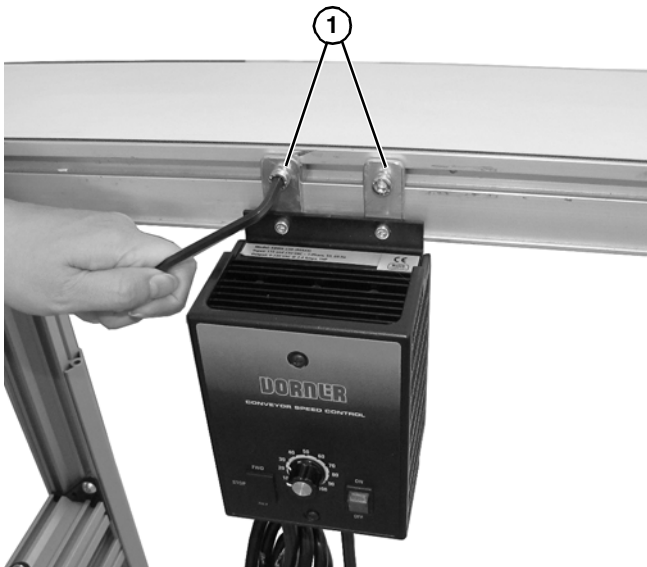

Figure 21

4. Slide controller to its desired mounting location along conveyor and tighten both screws.

Variable Speed Controller Mounting to Stand Leg

⚠ WARNING



Exposed moving parts can cause severe injury.
LOCK OUT POWER before removing guards or performing maintenance.

1. Assemble mounting clips (**Figure 22, item 1**) with screws (**Figure 22, item 2**) to the side of the controller.

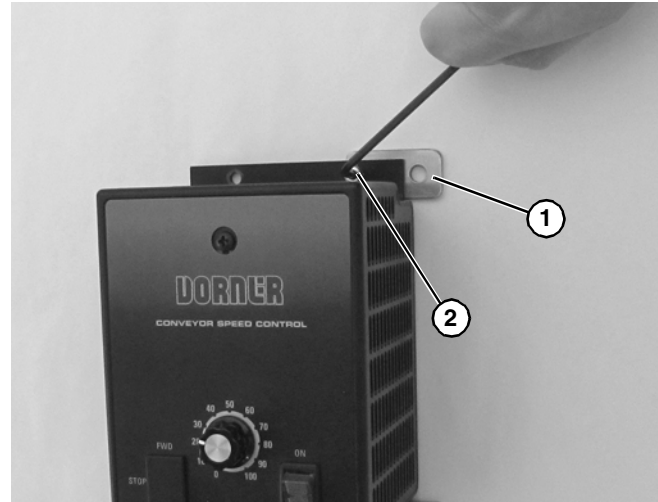

Figure 22

2. Install T-bars (**Figure 23, item 1**) into T-slots of stand leg.



Figure 23

3. Attach controller to stands with two screws (**Figure 23, item 2**).
4. Slide controller to its desired mounting location along conveyor and tighten both screws.

Preventive Maintenance and Adjustment

Required Tools

Standard Tools

- Hex-key wrenches:
2.5 mm, 4 mm, 5 mm
- Arbor press

Special Tools

- 807-1716 Bearing Puller Tool (or equivalent)
- 450292 Bearing Installation Tool (Pusher Sleeve)
- 450293 Bearing Installation Tool (Bearing Pusher)
- 456063 Bearing Removal Tool

Checklist

- Keep service parts on hand (see “Service Parts” section for recommendations)
- Keep supply of belt cleaner (part # 625619)
- Clean entire conveyor and knurled pulley while disassembled
- Replace worn or damaged parts

Lubrication

No lubrication is required. Replace bearings if worn.

Maintaining Conveyor Belt

Troubleshooting

Inspect conveyor belt for:

- Surface cuts or wear
- Stalling or slipping
- Damage to V-guide

Surface cuts and wear indicate:

- Sharp or heavy parts impacting belt
- Jammed parts
- Improperly installed bottom wipers (if installed)
- Accumulated dirt in wipers (if installed)
- Foreign material inside the conveyor
- Improperly positioned accessories
- Bolt-on guiding is pinching belt

Stalling or slipping indicates:

- Excessive load on belt
- Conveyor belt or drive timing belt are not properly tensioned
- Worn knurl or impacted dirt on drive pulley
- Intermittent jamming or drive train problems

Damage to V-guide indicates:

- Twisted or damaged conveyor frame
- Dirt impacted on pulleys
- Excessive or improper side loading

Cleaning

IMPORTANT

Do not use belt cleaners that contain alcohol, acetone, Methyl Ethyl Ketone (MEK) or other harsh chemicals.

Use Dorner Belt Cleaner (part # 625619). Mild soap and water may also be used. Do not soak the belt.

For /05 woven polyester and /06 black anti-static belts, use a bristled brush to improve cleaning.

Conveyor Belt Replacement

⚠ WARNING



Exposed moving parts can cause severe injury. LOCK OUT POWER before removing guards or performing maintenance.

Conveyor Belt Replacement Sequence

Remove old conveyor belt:

- Conveyor with Stands and Gearmotor Mounting Package
- Install new conveyor belt
- Tension conveyor belt

Preventive Maintenance and Adjustment

Belt Removal for Conveyor With Stands and Gearmotor Mounting Package

⚠ WARNING

Removing mounting brackets without support under gearmotor will cause conveyor to tip, causing severe injury. PROVIDE SUPPORT UNDERNEATH THE GEARMOTOR WHEN CHANGING THE BELT

1. Place temporary support stands (Figure 24, item 1) at both ends of the conveyor. Place an additional support stand (Figure 24, item 2) under the drive motor (Figure 24, item 3), if equipped. See WARNING.

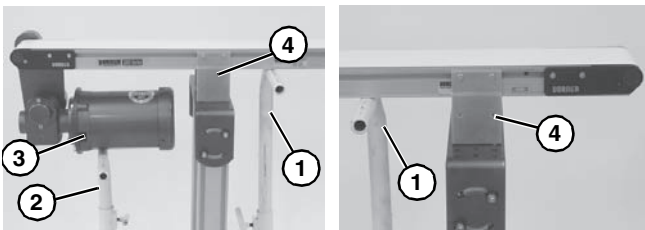

Figure 24

2. Remove mounting brackets (Figure 24, item 4) from one side of conveyor. (Reverse steps in “Support Stand Mounting Brackets” on page 8 or “Surface Mount Brackets” on page 9.) If equipped with heavy load drive package, remove brackets from side opposite drive (Figure 25, item 1).

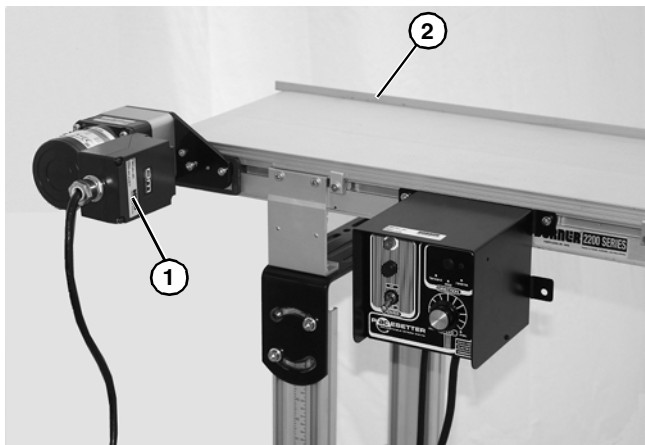



Figure 25

3. If equipped, remove return rollers, guiding (Figure 25, item 2) and accessories from side opposite drive (Figure 25, item 1).

4. On tension end of the conveyor, identified with a  label (Figure 26, item 1), push in head plate assembly (Figure 26, item 2): On both sides of conveyor, loosen and move cam tracking assemblies (Figure 26, item 3) (if equipped) away from head plates, then loosen fastening screws (Figure 26, item 4) and push head plate assembly inward.

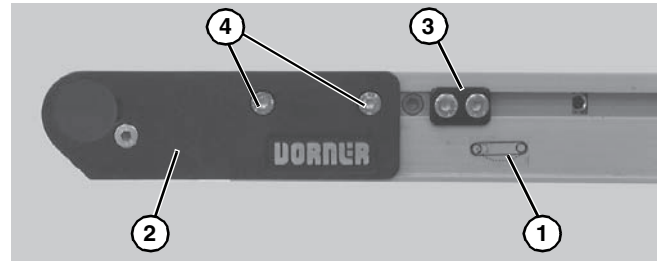



Figure 26

5. Remove belt (Figure 27, item 1) from conveyor.



Figure 27

Belt Installation for Conveyor with Stands and Gearmotor Mounting Package

⚠ WARNING

Removing mounting brackets without support under gearmotor will cause conveyor to tip, causing severe injury. PROVIDE SUPPORT UNDERNEATH THE GEARMOTOR WHEN CHANGING THE BELT

Preventive Maintenance and Adjustment

1. Ensure temporary support stands (Figure 24, item 1) are placed at both ends of the conveyor. Place an additional support stand under the drive motor (Figure 24, item 3), if equipped. See WARNING.
2. Orient belt so splice leading fingers (Figure 28, item 1) point in the direction of belt travel as identified by the conveyor directional label (Figure 28, item 2).

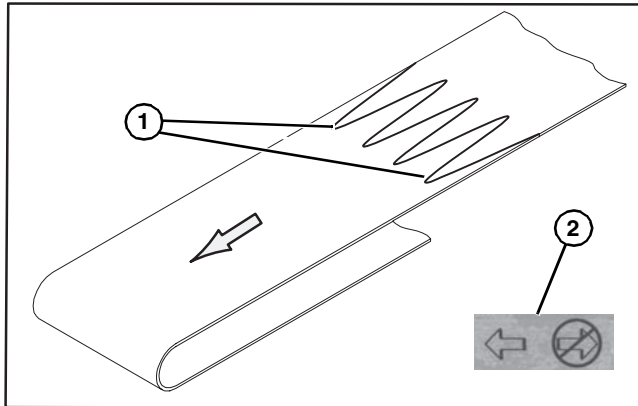

Figure 28

3. Install belt (Figure 29, item 1) on conveyor. Lift conveyor slightly to avoid pinching belt on temporary support stands.



Figure 29

4. Re-install conveyor mounting brackets. Refer to “Support Stand Mounting Brackets” on page 8 or “Surface Mount Brackets” on page 9.
5. Tension belt. Refer to “Conveyor Belt Tensioning” on page 15.
6. If equipped, re-install return rollers and guiding.

Conveyor Belt Tensioning

⚠ WARNING

Exposed moving parts can cause severe injury. LOCK OUT POWER before removing guards or performing maintenance.

Conveyors with 1.25" (32 mm) Diameter Pulleys

1. On tension end of the conveyor, identified with a label (Figure 30, item 1), adjust head plate assembly (Figure 30, item 2): On both sides of conveyor, loosen fastening screws (Figure 30, item 3) and rotate pinion gear (Figure 30, item 4) to adjust head plate assembly.

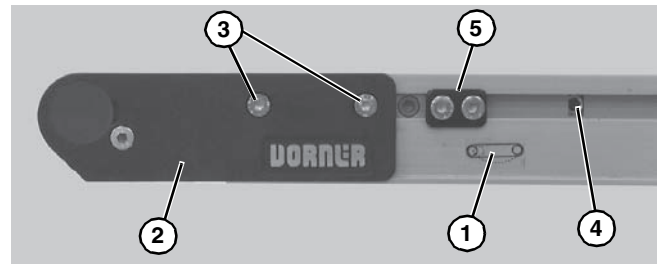

Figure 30

2. Adjust head plate assembly so end of conveyor frame aligns with or between the head plate tensioning marks (Figure 31, item 1 & 2). Replace belt if proper tensioning can not be obtained while aligning the end of the conveyor frame with or between the tensioning marks. See NOTE.

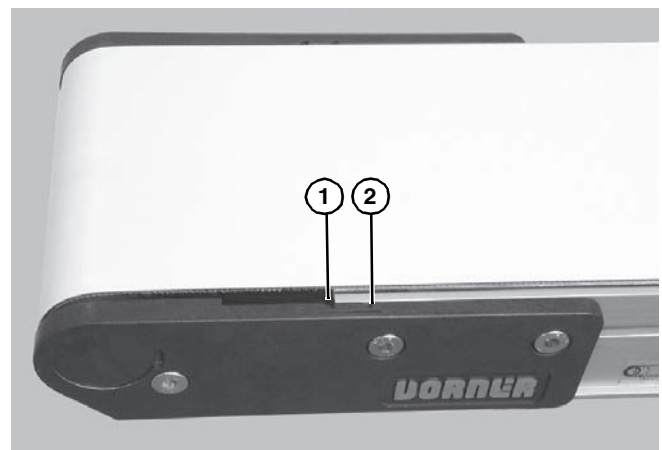

Figure 31

NOTE

On pinion gear, do not exceed a torque of 25 in-lb (2.8 Nm) for 2 – 12" (44 – 305 mm) wide conveyors and 50 in-lb (4.5 Nm) for an 18 – 24" (457 – 610 mm) wide conveyor. Over tensioning the conveyor belt could cause excessive pulley bearing load and early failure.

Preventive Maintenance and Adjustment

- After adjusting proper tensioning, tighten fastening screws (**Figure 32, item 1**) on both sides of conveyor to 60 in-lb (7 Nm).

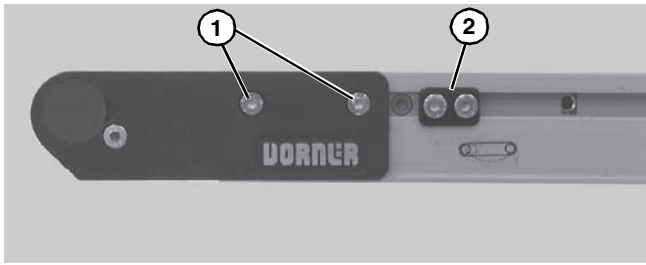

Figure 32

- If equipped with cam tracking assemblies (**Figure 32, item 2**), position against head plates and adjust belt tracking. Refer to “Conveyor Belt Tracking” on page 16.

Conveyor Belt Tracking

V-Guided Belts

V-guided belts do not require tracking adjustment.

Pulley Removal

⚠ WARNING
<p>Exposed moving parts can cause severe injury. LOCK OUT POWER before removing guards or performing maintenance.</p>

Leaving the conveyor belt in place, remove the desired pulley following the corresponding instructions below:

- A - Idler Pulley Removal
- B - Drive Pulley Removal

A - Idler Pulley Removal

- On one side of the conveyor, loosen two (2) head plate fastening screws (**Figure 33, item 1**) and remove them.

NOTE
<p><i>To prevent damage to the head plates and pulley, be sure to remove them slowly because they are not attached to pulley.</i></p>



Figure 33

- Remove the head plate (**Figure 34, item 1**) from the conveyor frame.

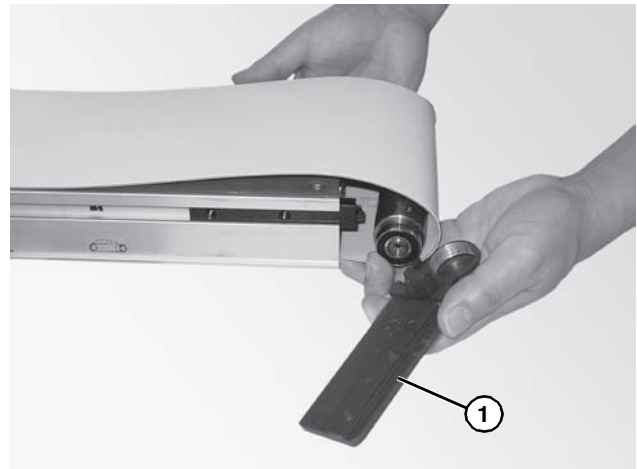

Figure 34

- Pulley will slide out of opposite head plate and drop into slack of belt (**Figure 35**).



Figure 35

- Slide spindle out of the belt loop.

Preventive Maintenance and Adjustment

B - Drive Pulley Removal

⚠ WARNING

Drive shaft keyway may be sharp. HANDLE WITH CARE.

1. Remove gearmotor mounting package. See “Gearmotor Mounting Package Removal” on page 20.
2. On one side of the conveyor, loosen two (2) head plate fastening screws (**Figure 36, item 1**) and remove.

NOTE
<i>To prevent damage to the head plates, be sure to remove them slowly because they are not attached to pulley.</i>

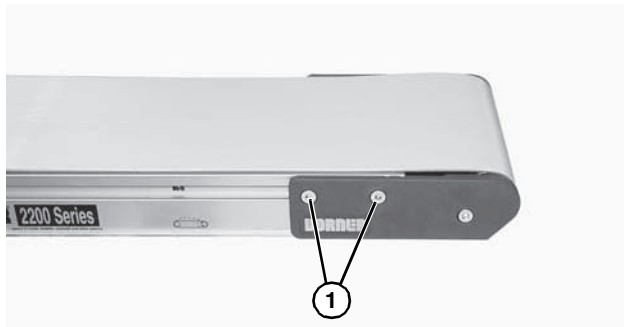

Figure 36

3. Remove the head plate (**Figure 37, item 1**) from the conveyor frame.

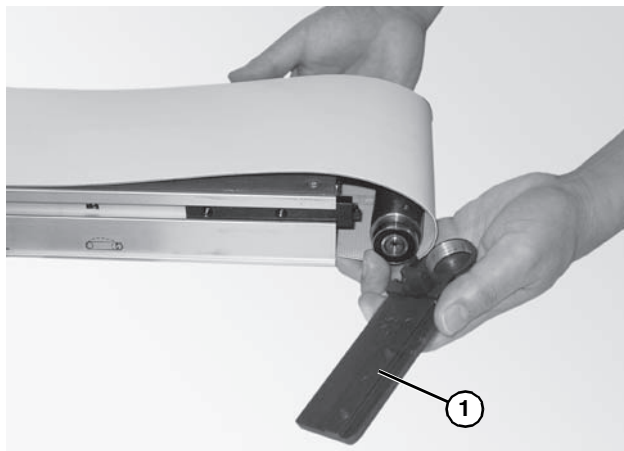

Figure 37

4. Drive pulley will slide out of opposite head and drop into slack of belt.
5. Slide the drive pulley out of the belt loop.

Bearing Removal & Replacement

Removal

IMPORTANT
<i>Do not use any removed bearings. Replace them.</i>

1. Place bearing removal tool part #456063 (**Figure 38, item 1**) below bearing (**Figure 38, item 2**) with lip (**Figure 38, item 3**) located in gap (**Figure 38, item 4**) between bearing and spindle hub (**Figure 38, item 5**) as shown.

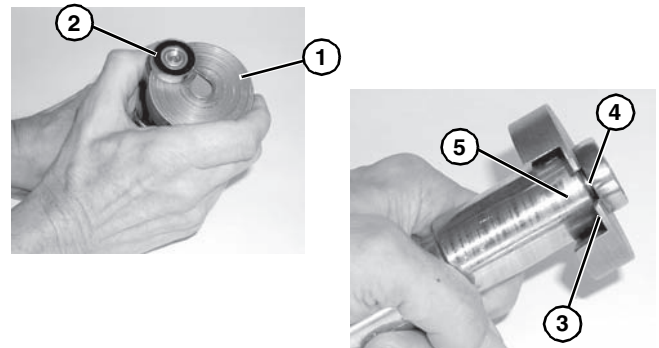

Figure 38

2. Using puller part #807-1716 (**Figure 39, item 1**), remove and discard bearing.

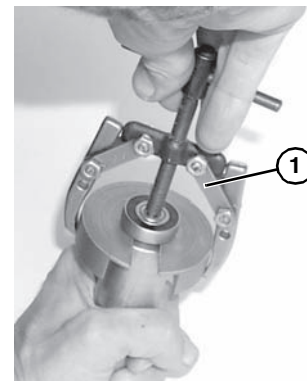

Figure 39

Preventive Maintenance and Adjustment

Replacement

1. Inspect the head plates bearing seating surface (**Figure 40, item 1**). If they are worn or damaged, replace. See “Service Parts” on page 24.

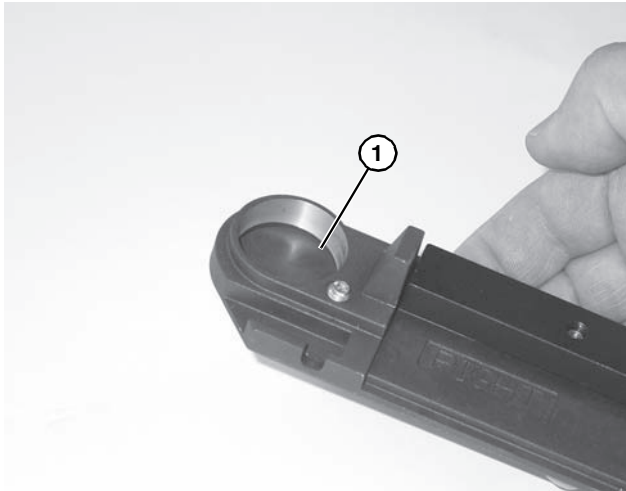

Figure 40

2. Inspect spindle (**Figure 41, item 1**). Replace if worn.
3. Slide bearing (**Figure 41, item 2**) onto spindle.

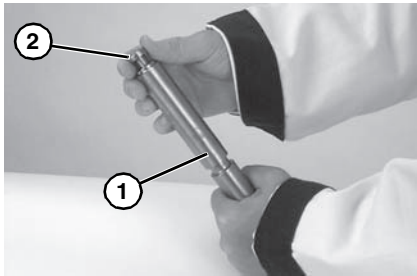

Figure 41

4. Slide sleeve (**Figure 42, item 1**) of tool over bearing.

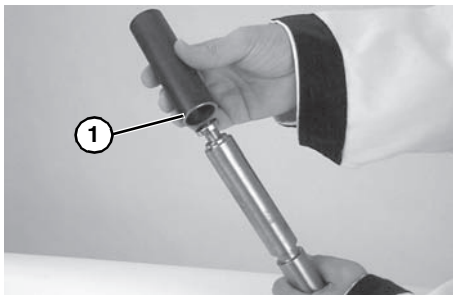

Figure 42

5. Place open end of pusher (**Figure 43, item 1**) into sleeve.

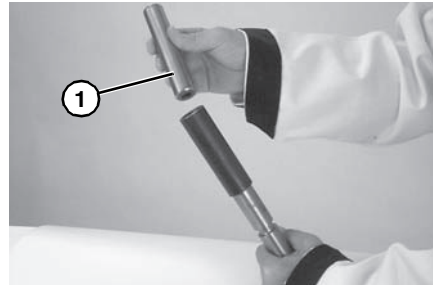

Figure 43

6. Using an arbor press or similar device, press bearing onto pulley shaft (**Figure 44**).

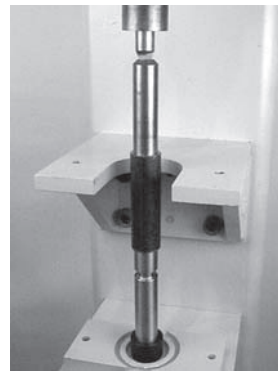

Figure 44

7. Repeat steps 1 through 5 for each bearing.

Drive Pulley and Idler Pulley Installation

Drive Pulley Installation

1. With opposite head plate installed, position the drive pulley through the loop of the belt, into the opposite head plate.
2. Place the head plate (**Figure 45, item 1**) and attach the head plate to the conveyor frame with the two (2) screws removed. Tighten screws 60 in-lb (7 Nm).

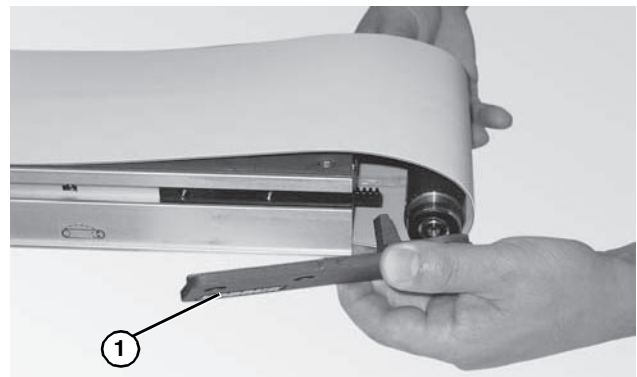

Figure 45

Preventive Maintenance and Adjustment

Idler Pulley Installation

1. With opposite head plate installed, position the idler pulley through the loop of the belt, into the opposite head plate.
2. Place the head plate (**Figure 46, item 1**) and attach the head plate to the conveyor frame with the two (2) screws removed and hand tighten.

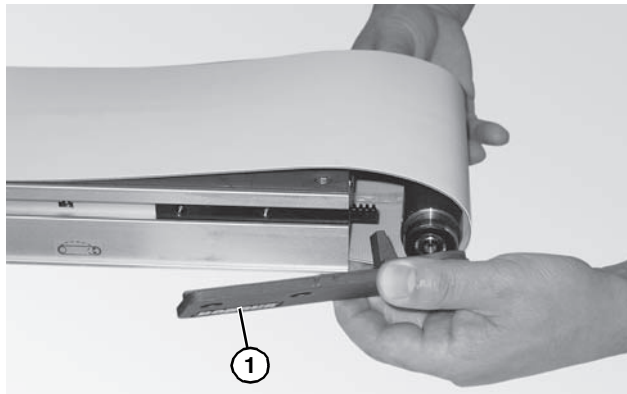

Figure 46

1. Using a support (**Figure 47, item 1**), raise conveyor and stand off the floor.

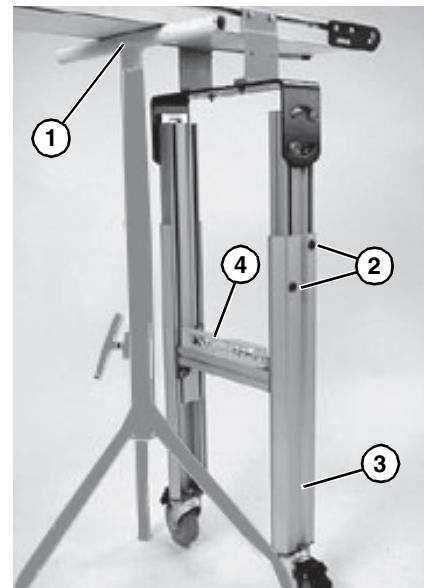

Figure 47

Stand Height Adjustment

Height Adjustment for Fixed and Adjustable Height Stands

Required Tools

- 6 mm Hex Key Wrench

⚠ WARNING
<p>Exposed moving parts can cause severe injury.</p> <p>LOCK OUT POWER before removing guards or performing maintenance.</p>

⚠ WARNING
<p>Loosening stand height or angle adjustment screws may cause conveyor sections to drop down, causing severe injury.</p> <p>SUPPORT CONVEYOR SECTIONS PRIOR TO LOOSENING STAND HEIGHT OR ANGLE ADJUSTMENT SCREWS.</p>

2. Loosen button screws (**Figure 47, item 2**).
3. Raise or lower stand leg (**Figure 47, item 3**) to the required height. Level stand from side to side using a level (**Figure 47, item 4**).

⚠ WARNING
<p>Failure to secure screws (Figure 47, item 2) may cause conveyor sections to drop down causing severe injury.</p> <p>TIGHTEN SCREWS (Figure 47, item 2) AFTER ADJUSTMENT.</p>

4. Tighten button screws (**Figure 47, item 2**) to 150 in-lb (17 N-m).
5. Repeat steps 2 through 4 on opposite stand leg.

Preventive Maintenance and Adjustment

Gearmotor Mounting Package Removal

⚠ WARNING



Exposed moving parts can cause severe injury.

LOCK OUT POWER before removing guards or performing maintenance.

1. Loosen two (2) screws (**Figure 48, item 1**).

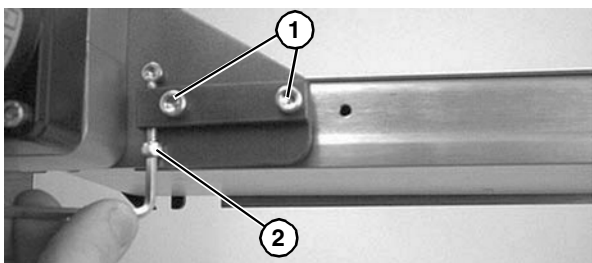

Figure 48

2. Loosen timing belt tensioner screw (**Figure 48, item 2**).
3. Remove four (4) screws (**Figure 49, item 1**). Remove gearmotor (**Figure 49, item 2**) and cover (**Figure 49, item 3**).

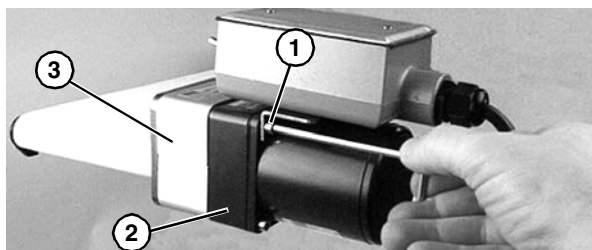

Figure 49

4. Remove timing belt (**Figure 50, item 1**).

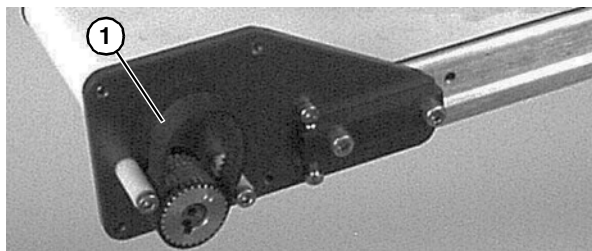

Figure 50

5. Loosen set screws (**Figure 51, item 1**) and remove driven pulley (**Figure 51, item 2**).

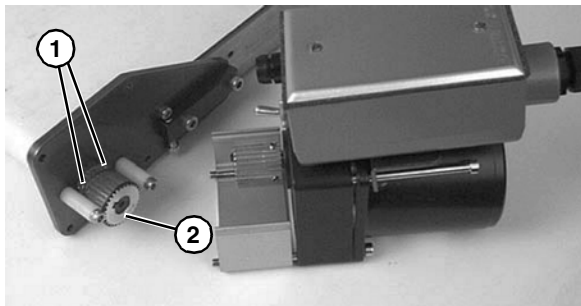



Figure 51

6. Replace drive or driven pulley. See “Drive or Driven Timing Pulley Replacement” on page 21. Tighten screws to 80 in-lb (9 Nm).
7. Complete steps 5-9 of “Timing Belt Replacement” on page 21. See “Drive or Driven Timing Pulley Replacement” on page 21.

Preventive Maintenance and Adjustment

Timing Belt Tensioning

⚠ WARNING

Exposed moving parts can cause severe injury. LOCK OUT POWER before removing guards or performing maintenance.

1. Loosen two (2) screws (Figure 52, item 1). Tighten timing belt tensioner screw (Figure 52, item 2) to 15 in-lb (1.7 Nm).

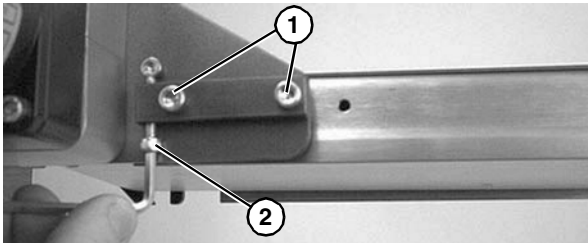



Figure 52

2. Tighten screws (Figure 52, item 1) to 80 in-lb (9 Nm).

Timing Belt Replacement

⚠ WARNING

Exposed moving parts can cause severe injury. LOCK OUT POWER before removing guards or performing maintenance.

1. Loosen two (2) screws (Figure 52, item 1).
2. Loosen timing belt tensioner screw (Figure 52, item 2).
3. Remove four (4) screws (Figure 53, item 1). Remove gearmotor (Figure 53, item 2) and top cover (Figure 53, item 3).

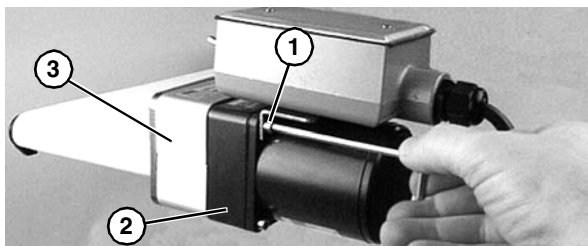

Figure 53

4. Remove old timing belt (Figure 54, item 1).

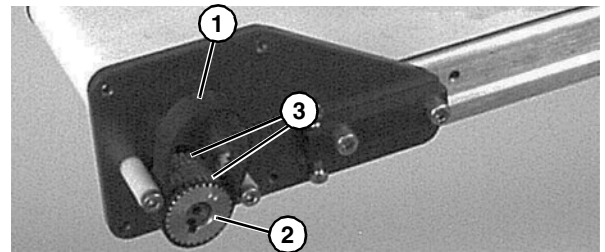

Figure 54

5. Place new timing belt (Figure 54, item 1) over driven pulley (Figure 54, item 2) and between belt flanges (Figure 54, item 3).
6. Insert gearmotor drive pulley into timing belt. Mount assembly with two (2) bottom screws (Figure 55, item 1). Tighten to 45 in-lb (5 Nm).

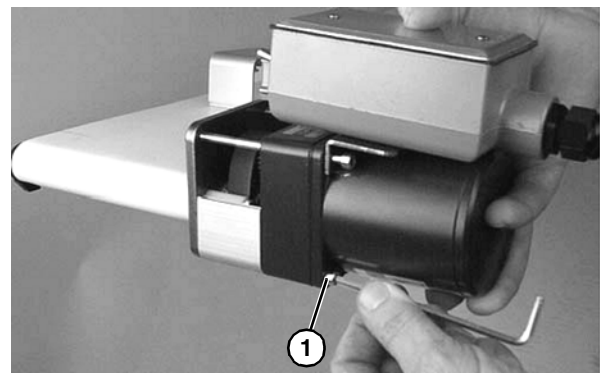



Figure 55

7. Insert top cover (Figure 53, item 3) into bottom cover. Mount assembly with two (2) top screws (Figure 53, item 1). Tighten to 45 in-lb (5 Nm).
8. Tighten timing belt tensioner screw (Figure 52, item 2) to 15 in-lb (1.7 Nm)
9. Tighten screws (Figure 52, item 1) to 80 in-lb (9 Nm).

Drive or Driven Timing Pulley Replacement

⚠ WARNING

Exposed moving parts can cause severe injury. LOCK OUT POWER before removing guards or performing maintenance.

1. Complete steps 1 through 4 of “Timing Belt Replacement” on page 21.

Preventive Maintenance and Adjustment

- Loosen set screws (**Figure 56, item 1**) and remove driven pulley (**Figure 56, item 2**) or drive pulley (**Figure 56, item 3**).

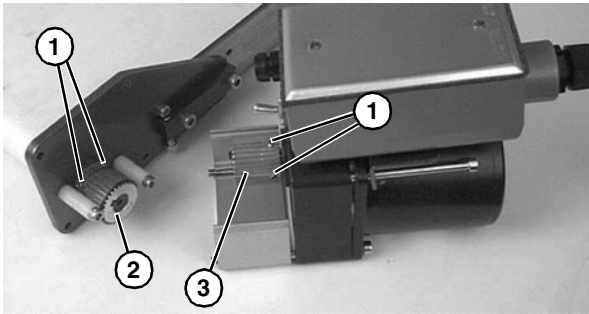

Figure 56

- Replace drive or driven pulley. Tighten set screws to 33 in-lb (3.7 Nm).
- Complete steps 5 through 9 of “Timing Belt Replacement” on page 21.

Gearmotor Replacement

⚠ WARNING
<p>Exposed moving parts can cause severe injury.</p> <p>LOCK OUT POWER before removing guards or performing maintenance.</p>
⚠ DANGER
<p>Hazardous voltage will cause severe injury or death.</p> <p>LOCKOUT POWER BEFORE before wiring.</p>

- For single phase motor, unplug power cord from outlet.

- For variable speed motor, unplug cord at disconnect (**Figure 57, item 1**).

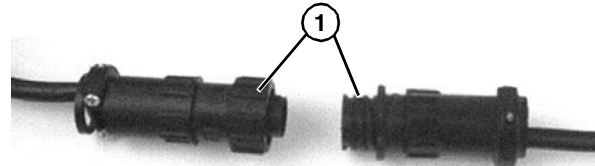

Figure 57

- Remove four (4) screws (**Figure 58, item 1**). Remove gearmotor (**Figure 58, item 2**) and top cover (**Figure 58, item 3**).

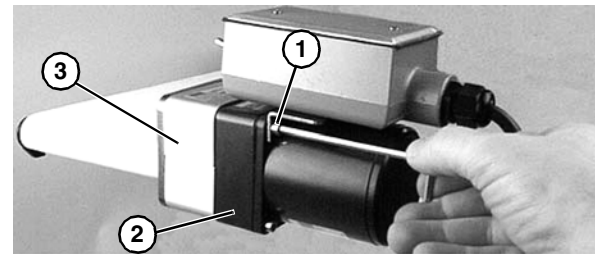

Figure 58

- Loosen set screws (**Figure 59, item 1**) and remove drive pulley (**Figure 59, item 2**).

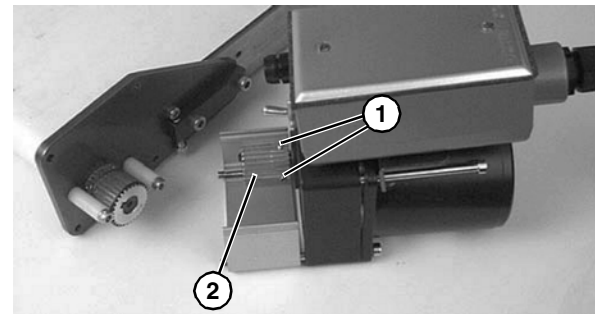



Figure 59

- Replace drive pulley (**Figure 59, item 2**) on new gearmotor and tighten set screws (**Figure 59, item 1**) to 33 in-lb (3.7 Nm).
- Complete steps 5 through 9 of “Timing Belt Replacement” on page 21.
- Replace wiring:
 - For a single phase motor, reverse step 1.
 - For variable speed motor, reverse step 2.

Service Parts

NOTE

For replacement parts other than those shown in this section, contact an authorized *Dorner Service Center* or the factory. Key Service Parts and Kits are identified by the Performance Parts Kits logo . Dorner recommends keeping these parts on hand.

2" (51 mm) Wide Conveyor

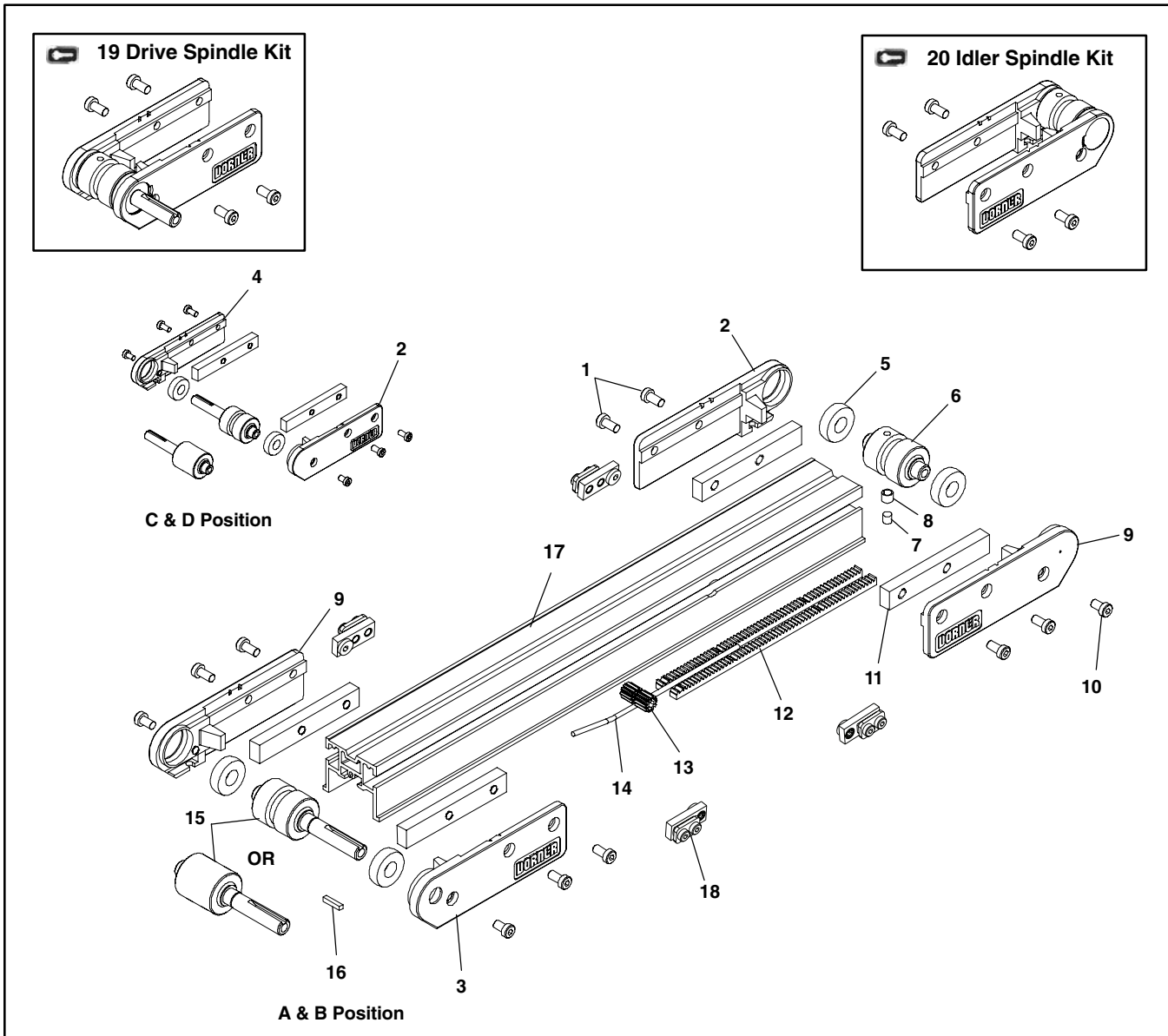

Item	Part Number	Description
1	920692M	Socket Head Screw, M6 x 12 mm
2	240425	Head Plate LH
3	240427	Head Plate LH Drive Side, Position A and B
4	240428	Head Plate RH Drive Side, Position C and D
5	22BK2	Bearing Kit (x2)
	22BK4	Bearing Kit (x4)
6	247302	Idler Spindle, 2" (51mm)
7	808-020	Magnet, 0.25" Dia. x 0.25" long Sleeve, 0.25"
8	450226SSP	Magnet Stainless Steel
9	240426	Head Plate, RH
10	920691M	Socket Head Screw, M6 x 10mm
11	240329	Tension Slide Bar
12	240420	Rack Gear, 14.5 Degree PA x 24 P
13	240423	Pinion, 2" (51 mm)
14	240422	Pinion Pin
15	456402	Drive Spindle, 2" (51 mm)
	247602	Nosebar Drive Spindle, Lagged 2" (51mm)
16	980422M	Square Key, 4 mm x 22 mm
17	240402-LLLLL	2" (51mm) Frame
18	240025	Cam Mounting Assembly
19	22A-02	Drive Spindle Kit, Position A and B - Grooved (Includes Items 1, 2, 3, 5, 9 and 15)
	22D-02	Drive Spindle Kit, Position C and D - Grooved (Includes Items 1, 2, 4, 5, 9 and 15)
20	22T-02	Idler Spindle Kit (Includes Items 1, 2 and 5 through 10)
LLLLL = part length in inches with 2 decimal places		
Example: Part Length = 55.08" LLLLL = 05508		

Service Parts

3" (76 mm) to 6" (152 mm) Wide Conveyor

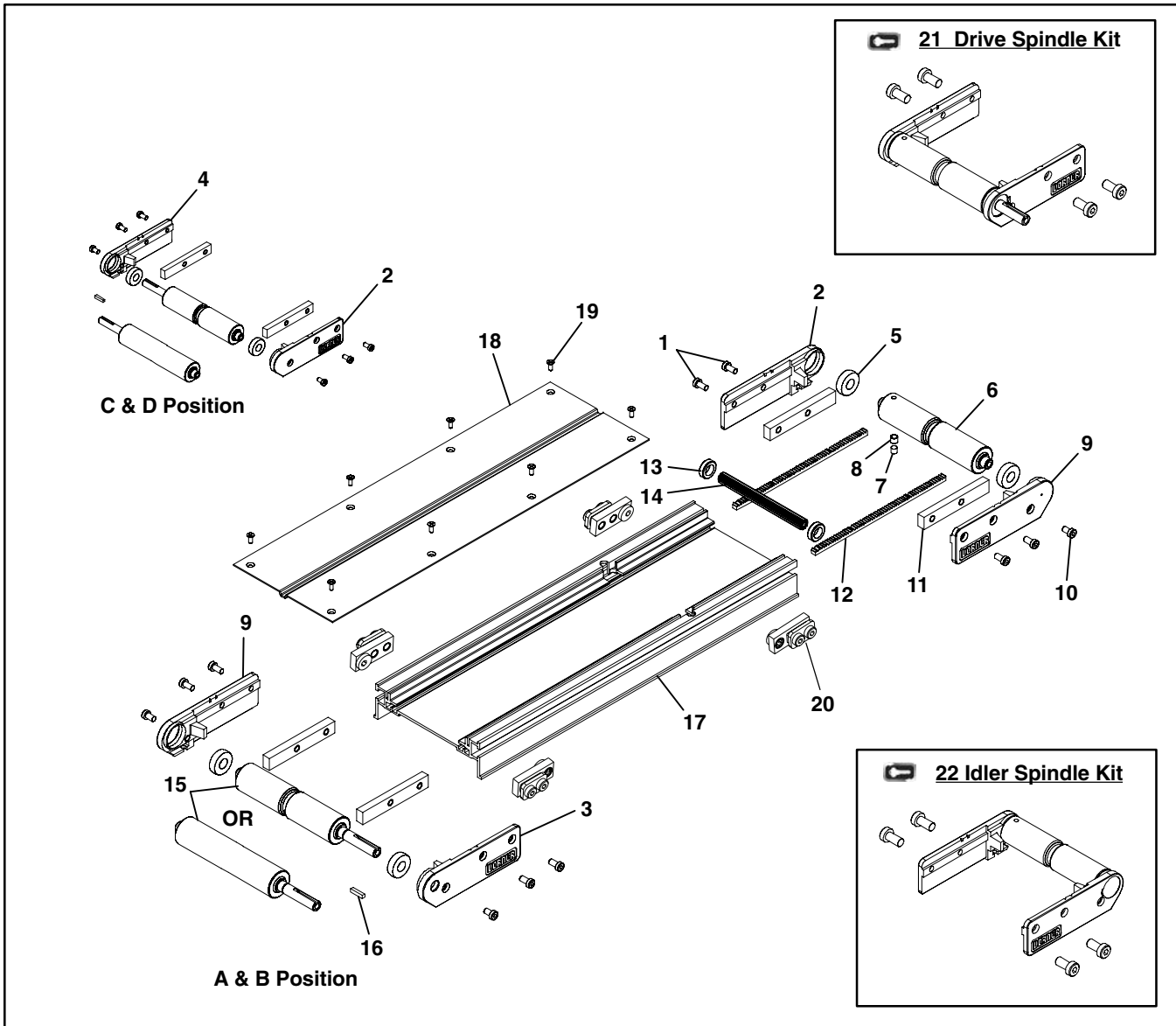

Item	Part Number	Description
1	920692M	Socket Head Screw, M6 x 12 mm
2	240425	Head Plate LH
3	240427	Head Plate LH Drive Side, Position A and B
4	240428	Head Plate RH Drive Side, Position C and D
5	22BK2	Bearing Kit (x2)
	22BK4	Bearing Kit (x4)
6	2473WW	Idler Spindle
7	808-020	Magnet, 0.25" Dia. x 0.25" long
8	450226SSP	Sleeve, 0.25" Magnet (Stainless Steel)
9	240426	Head Plate RH
10	920691M	Socket Head Screw, M6 x 10 mm
11	240329	Tension Slide Bar
12	240420	Rack Gear, 14.5 Degree PA x 24P
13	240421	Pinion Bushing
14	2030WWM	Pinion Gear
15	4564WW	Drive Spindle
	2476WW	Nosebar Drive Spindle, Lagged
16	980422MS	Square Key, 4 mm x 22 mm
17	2404WW-LLLLL	Conveyor Frame
18	2405WW-LLLLL	Conveyor Bed Plate
19	807-1105	Flat Head Torx Screw, M6 x 10 mm
20	240025	Cam Mounting Assembly
21	22A-WW	Drive Spindle Kit, Position A and B - Grooved (Includes Items 1,2, 3, 5, 9 and 15)
	22D-WW	Drive Spindle Kit, Position C and D - Grooved (Includes Items 1, 2, 4, 5, 9 and 15)
22	22T-WW	Idler Spindle Kit (Includes Items 1, 2 and 5 through 10)
WW = Conveyor width reference: 03, 04, 05, 06		
LLLLL = part length in inches with 2 decimal places		
Example: Part Length = 55.08" LLLLL = 05508		

Service Parts

8" (203 mm) to 12" (305 mm) Wide Conveyor

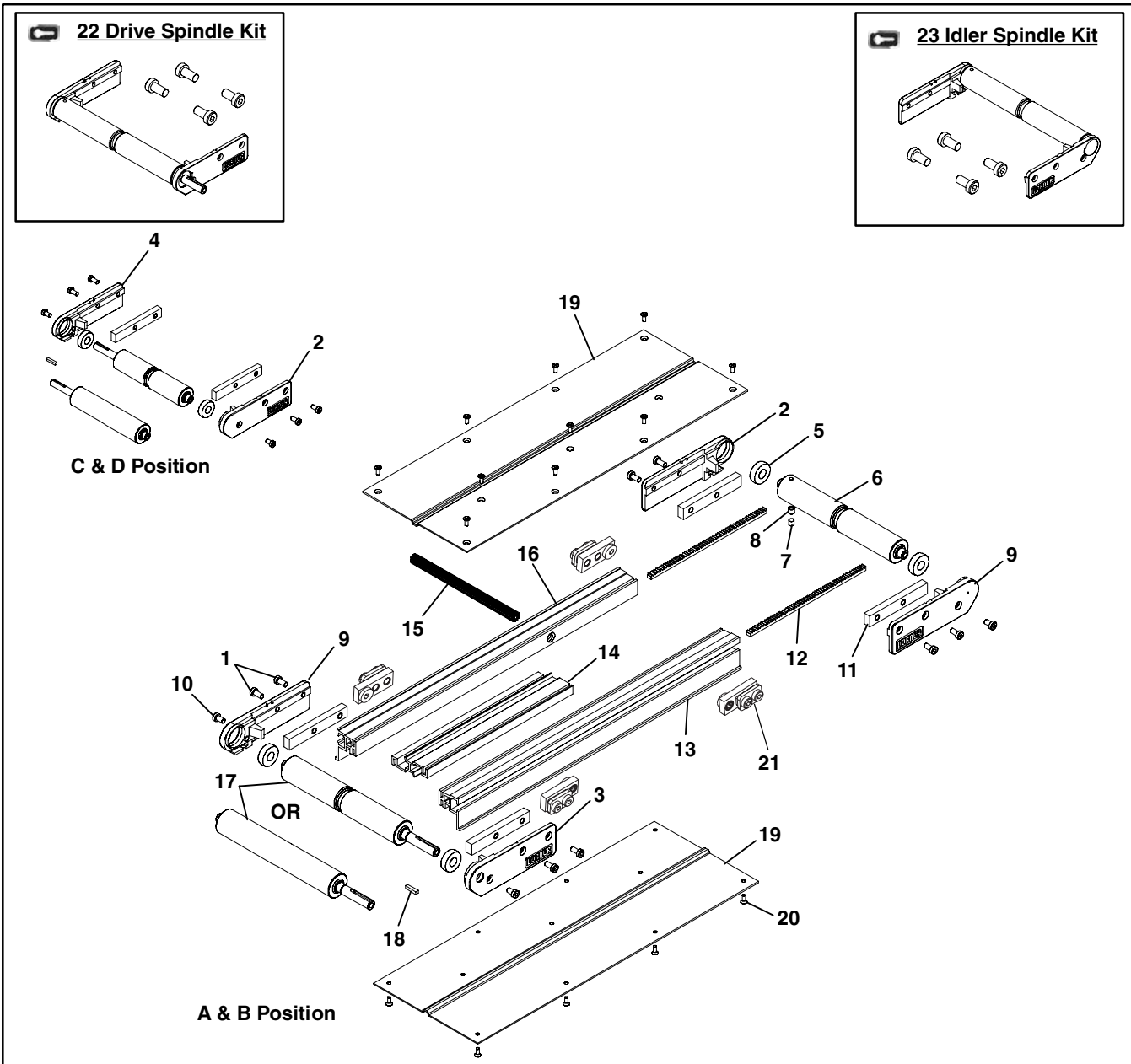

Item	Part Number	Description
1	920692M	Socket Head Screw, M6 x 12 mm
2	240425	Head Plate, LH
3	240427	Head Plate, LH Drive Side, Position A and B
4	240428	Head Plate RH Drive Side, Position C and D
5	22BK2	Bearing Kit (x2)
	22BK4	Bearing Kit (x4)
6	2473 WW	Idler Spindle
7	808-020	Magnet, 0.25" Dia. x 0.25" long
8	450226SSP	Sleeve, 0.25" Magnet Stainless Steel
9	240426	Head Plate RH
10	920691M	Socket Head Screw, M6 x 10 mm
11	240329	Tension Slide Bar
12	240420	Rack Gear, 14.5 Degree PA x 24P
13	240412- LLLLL	Side Rail, LH
14	240414- LLLLL	Center Rail
15	2030 WWM	Pinion Gear
16	240413- LLLLL	Side Rail, RH
17	4564 WW	Drive Spindle
	2476 WW	Nosebar Drive Spindle, Lagged
18	980422M	Square Key, 4 mm x 22 mm
19	2405 WW-LLLLL	Side Rail RH
20	807-1105	Flat Head Torx Screw, M6 x 10 mm
21	240025	Cam Mounting Assembly
22	22A- WW	Drive Spindle Kit, Position A and B - Grooved (Includes Items 1, 2, 3, 5, 9 and 17)
	22D- WW	Drive Spindle Kit, Position C and D - Grooved (Includes Items 1, 2, 4, 5, 9 and 17)
23	22T- WW	Idler Spindle Kit (Includes Items 1, 2 and 5 through 10)
WW = Conveyor width reference: 08, 10, 12		
LLLLL = part length in inches with 2 decimal places		
Example: Part Length = 55.08" LLLLL = 05508		

Service Parts

-04 3" (76 mm) Aluminum Side

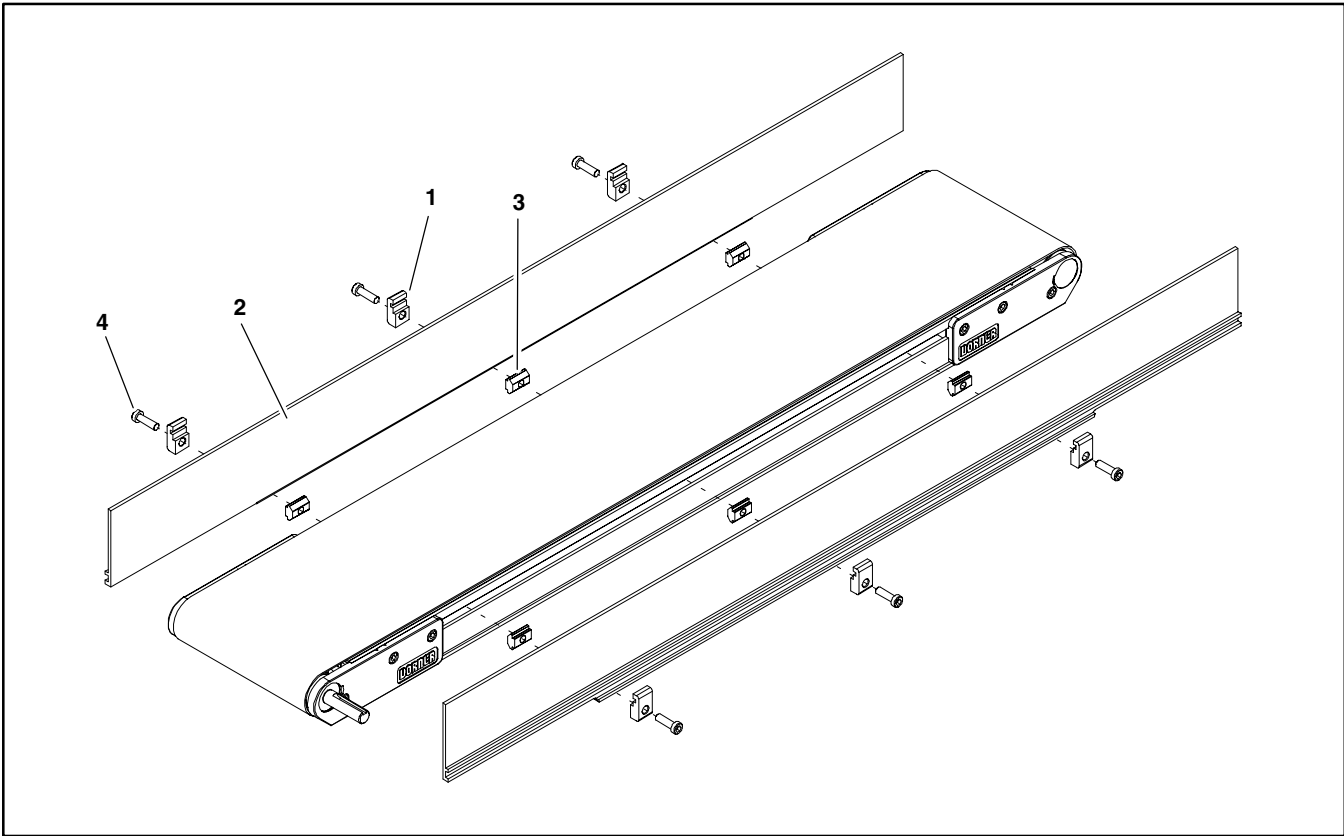

Item	Part Number	Description
1	200121	Guide Retaining Clip
2	See Chart Below	2200 Guide 3" (76mm) HS
3	639971MK10	Single Drop-in Tee Bar (x10)
4	920694M	Socket Head Screw M6 x 20mm

Item 2: 2200 Guide 3" (76mm) HS		
Length		End Guide
2' (610mm)	Left Hand	280403-02400
	Right Hand	280403-02400
3' (914mm)	Left Hand	280403-03600
	Right Hand	280403-03600
4' (1219mm)	Left Hand	280403-04800
	Right Hand	280403-04800
5' (1524mm)	Left Hand	280403-06000
	Right Hand	280403-06000
6' (1829mm)	Left Hand	280403-07200
	Right Hand	280403-07200
7' (2134mm)	Left Hand	280403-08400
	Right Hand	280403-08400
8' (2438mm)	Left Hand	280403-09600
	Right Hand	280403-09600

-05 1.5" (38mm) Aluminum Side

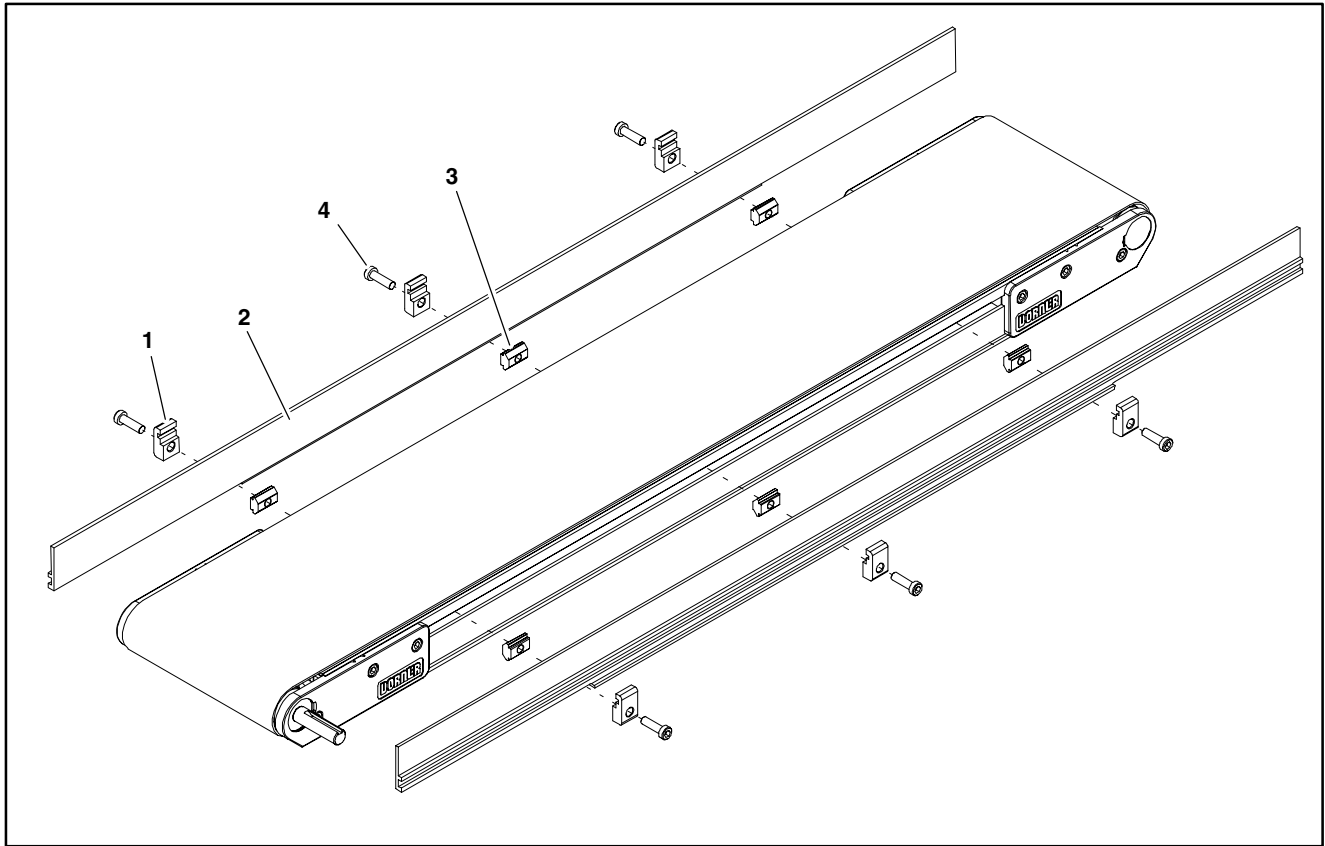

Item	Part Number	Description
1	200121	Guide Retaining Clip
2	See Chart Below	2200 Guide 3" (76mm) HS
3	639971MK10	Single Drop-in Tee Bar (x10)
4	920694M	Socket Head Screw M6 x 20mm

Item 2: 2200 Guide 0.5" (13mm) HS		
Length		End Guide
2' (610mm)	Left Hand	280503-02400
	Right Hand	280503-02400
3' (914mm)	Left Hand	280503-03600
	Right Hand	280503-03600
4' (1219mm)	Left Hand	280503-04800
	Right Hand	280503-04800
5' (1524mm)	Left Hand	280503-06000
	Right Hand	280503-06000
6' (1829mm)	Left Hand	280503-07200
	Right Hand	280503-07200
7' (2134mm)	Left Hand	280503-08400
	Right Hand	280503-08400
8' (2438mm)	Left Hand	280503-09600
	Right Hand	280503-09600

Service Parts

-07 Low to Side Wiper

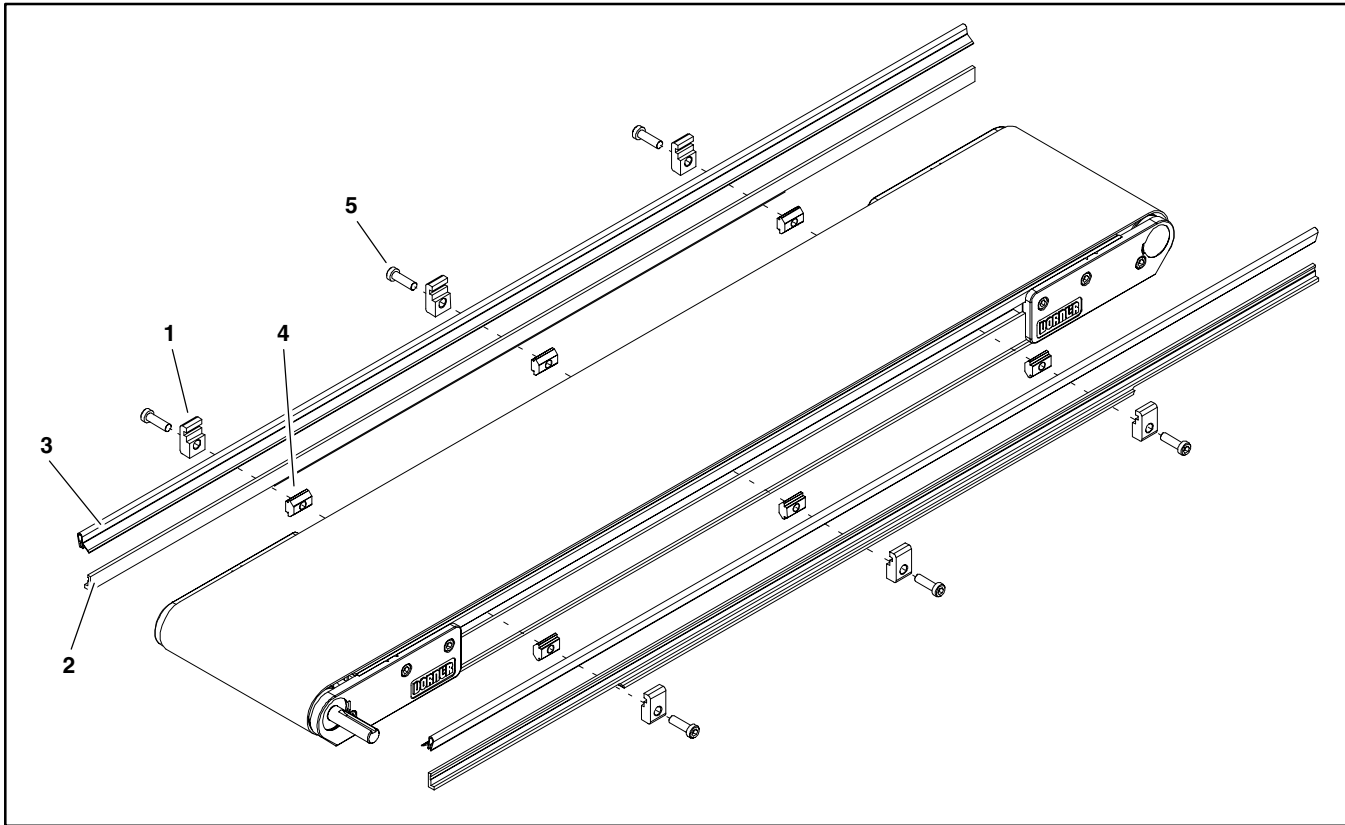

Item	Part Number	Description
1	200121	Guide Retaining Clip
2	See Chart Below	2200 Guide 3" (76mm) HS
3	41-00-24	Side Wiper Nylatron (per foot)
4	639971MK10	Single Drop-in Tee Bar (x10)
5	920694M	Socket Head Screw M6 x 20mm

Item 2: 2200 Guide 0.5" (13mm) HS		
Length		End Guide
2' (610mm)	Left Hand	280903-02400
	Right Hand	280903-02400
3' (914mm)	Left Hand	280903-03600
	Right Hand	280903-03600
4' (1219mm)	Left Hand	280903-04800
	Right Hand	280903-04800
5' (1524mm)	Left Hand	280903-06000
	Right Hand	280903-06000
6' (1829mm)	Left Hand	280903-07200
	Right Hand	280903-07200
7' (2134mm)	Left Hand	280903-08400
	Right Hand	280903-08400
8' (2438mm)	Left Hand	280903-09600
	Right Hand	280903-09600

-09 Low to High Side

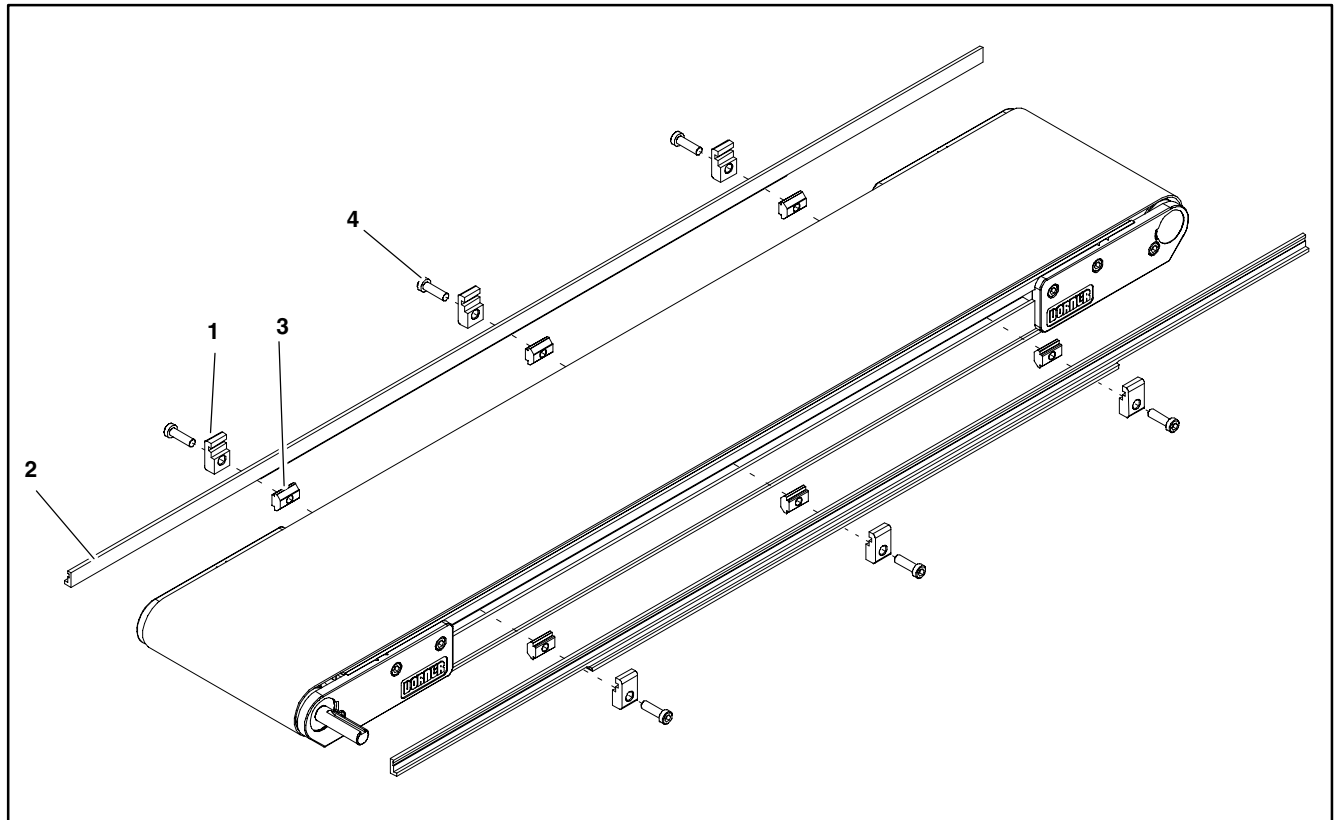

Item	Part Number	Description
1	200121	Guide Retaining Clip
2	See Chart Below	2200 Guide 3" (76mm) HS
3	639971MK10	Single Drop-in Tee Bar (x10)
4	920694M	Socket Head Screw M6 x 20mm

Item 2: 2200 Guide 0.5" (13mm) HS		
Length		End Guide
2' (610mm)	Left Hand	280903-02400
	Right Hand	280903-02400
3' (914mm)	Left Hand	280903-03600
	Right Hand	280903-03600
4' (1219mm)	Left Hand	280903-04800
	Right Hand	280903-04800
5' (1524mm)	Left Hand	280903-06000
	Right Hand	280903-06000
6' (1829mm)	Left Hand	280903-07200
	Right Hand	280903-07200
7' (2134mm)	Left Hand	280903-08400
	Right Hand	280903-08400
8' (2438mm)	Left Hand	280903-09600
	Right Hand	280903-09600

Service Parts

-13 Adjustable Guiding

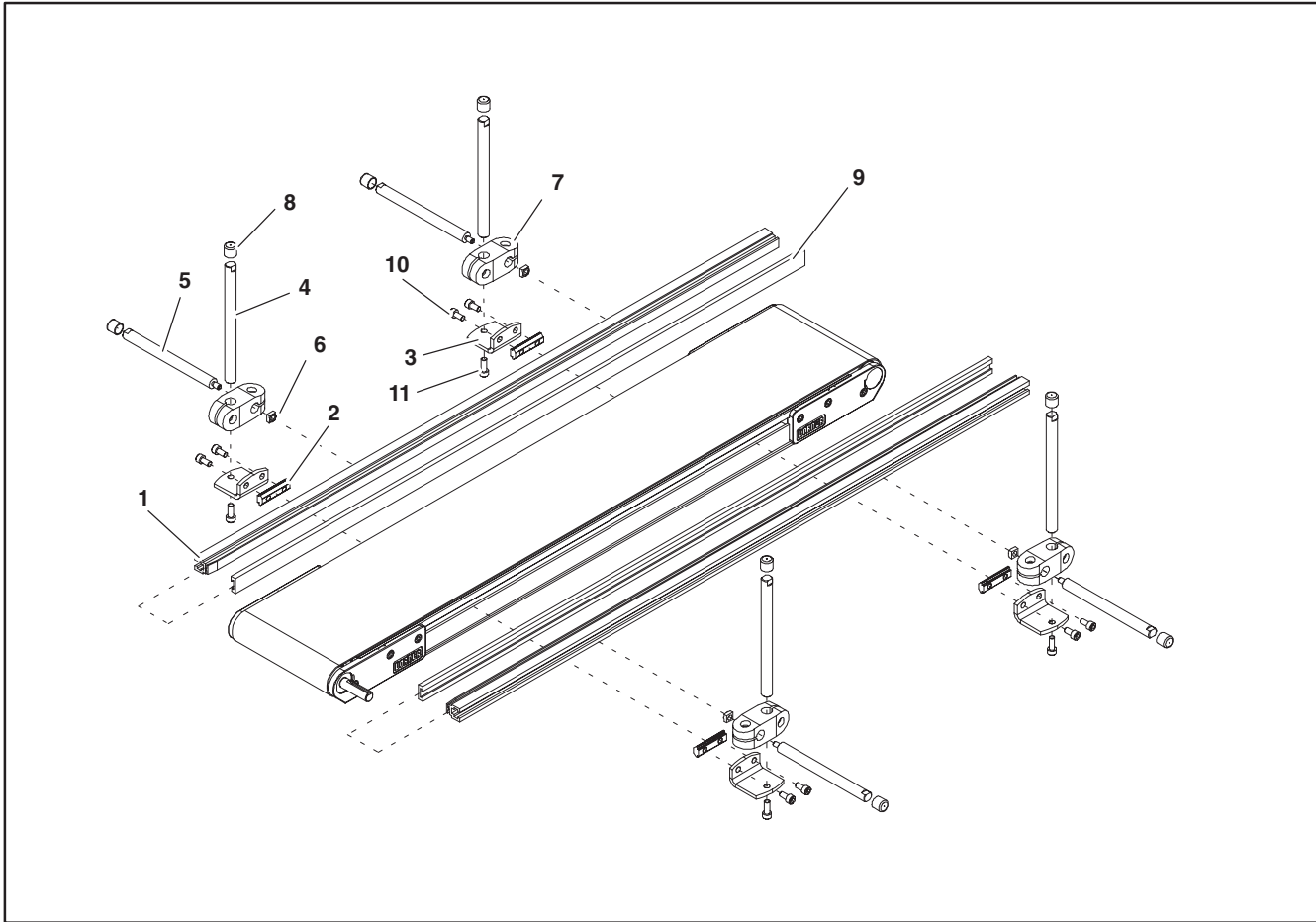

Item	Part Number	Description
1	202983	Aluminum Profile Guide 2' (610mm)
	202984	Aluminum Profile Guide 3' (914mm)
	202985	Aluminum Profile Guide 4' (1219mm)
	202986	Aluminum Profile Guide 5' (1524mm)
	202987	Aluminum Profile Guide 6' (1829mm)
	202988	Aluminum Profile Guide 7' (2134mm)
	202989	Aluminum Profile Guide 8' (2438mm)

Item	Part Number	Description
2	200830M	Drop-In Tee Bar
3	202004	Mounting Bracket
4	202027M	Guide Mounting Shaft Vertical
5	202028M	Guide Mounting Shaft Horizontal
6	674175MP	Square Nut
7	807-652	Cross Block
8	807-948	Vinyl Shaft Cap
9	614068P	Flat Extruded Guide (per foot)
10	920612M	Socket Head Screw M6 x 12mm
11	920616M	Socket Head Screw M6 x 16mm

-14 Tool-Less Adjustable Guiding

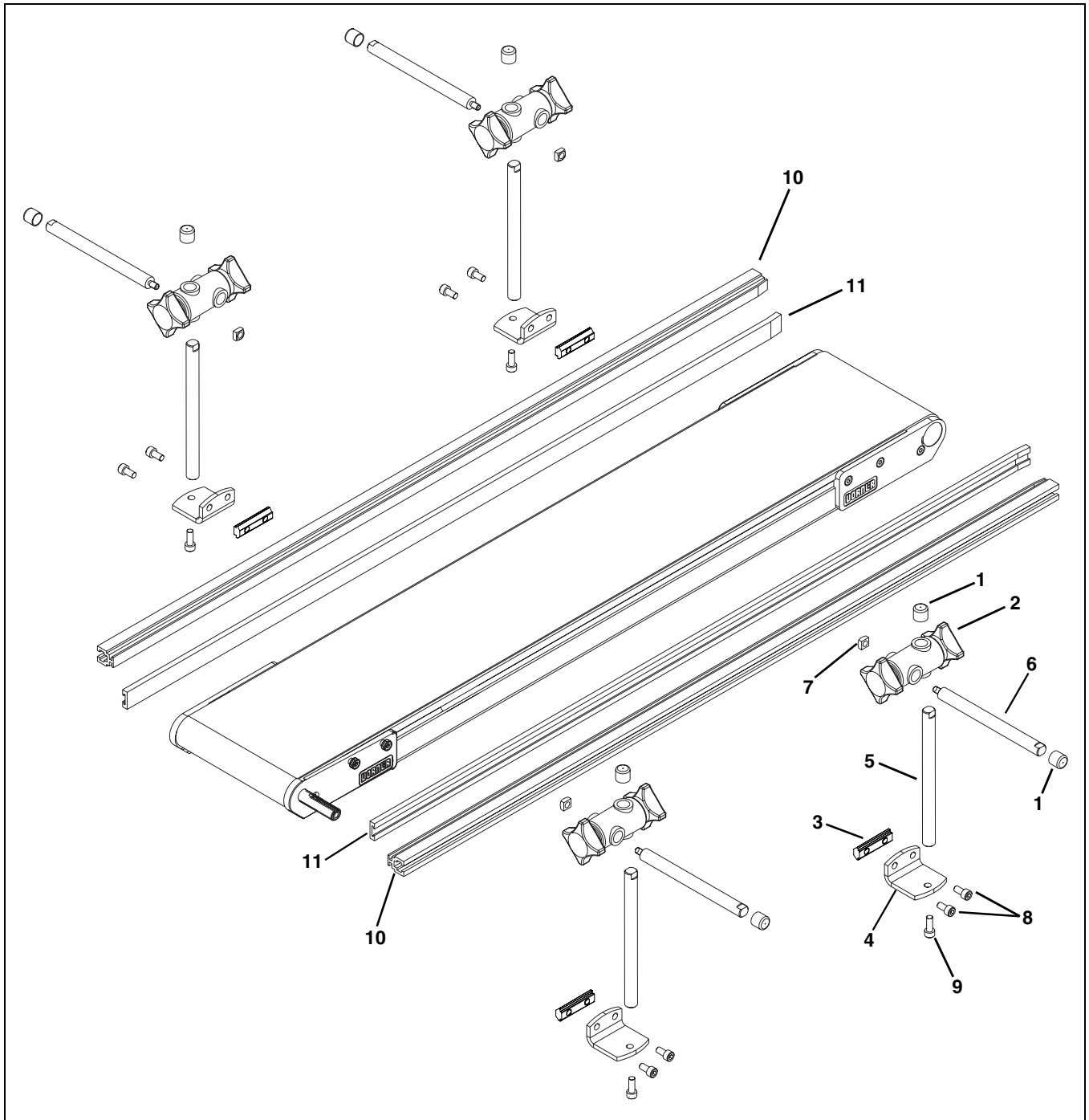

Item	Part Number	Description
1	807-948	Shaft Cap
2	807-1470	Cross Block
3	200830M	Drop-In Tee Bar
4	202004M	Mounting Bracket
5	202027M	Vertical Mounting Guide Shaft
6	202028M	Horizontal Mounting Guide Shaft

Item	Part Number	Description
7	674175MP	Square Nut, M6-1.00
8	920612M	Socket Head Screw, M6-1.00 x 12 mm
9	920616M	Socket Head Screw, M6-1.00 x 16 mm
10	460063-LLLLL	Aluminum Profile Guide
11	614068P-LLLLL	Extruded Guide

LLLLL = Length in inches with 2 decimal places.

Length Example: Length = 95.25" LLLLL = 09525

Service Parts

Flared Side Guiding

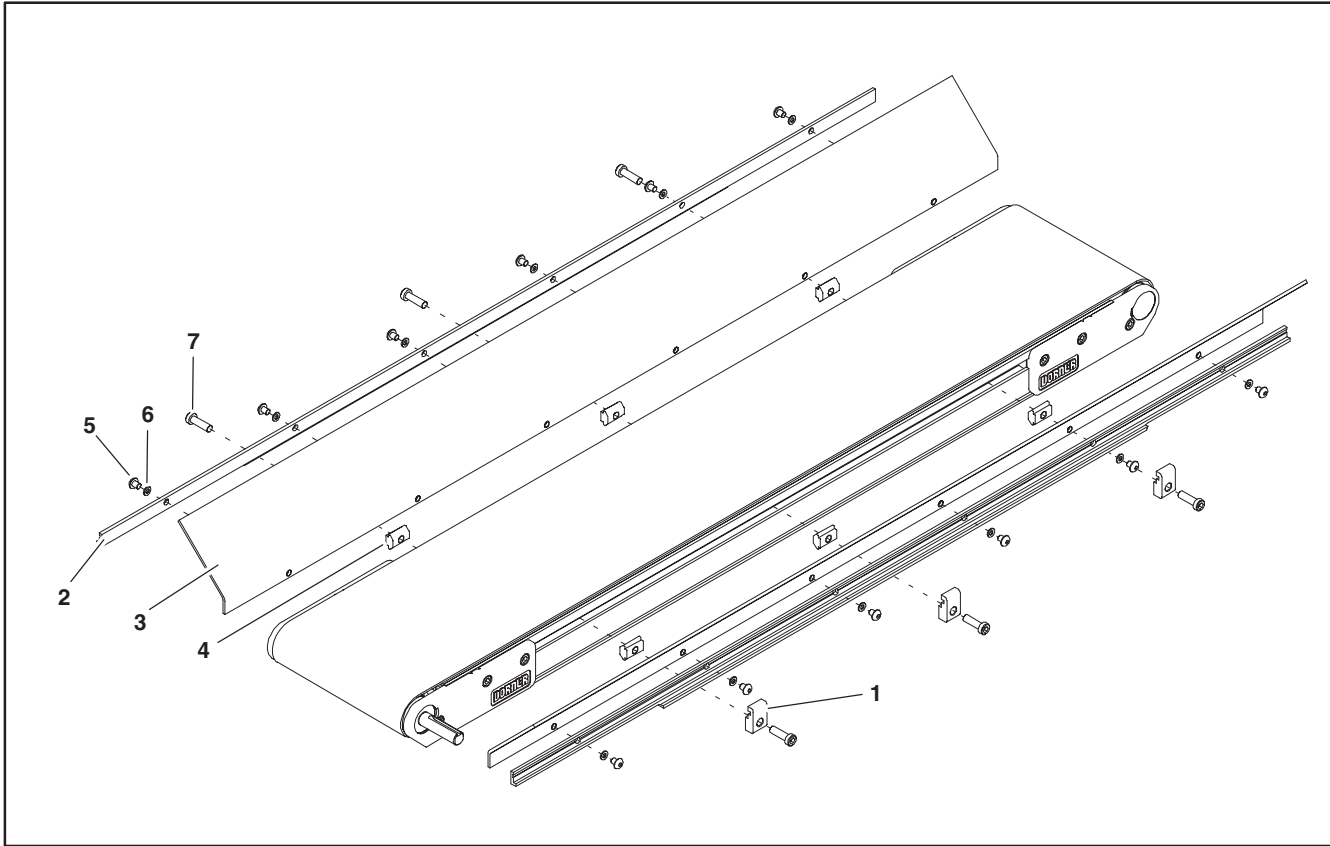

Item	Part Number	Description
1	200121	Guide Retaining Clip
2	202212	Side-Flare Mounting Guide 2' (610mm)
	202213	Side-Flare Mounting Guide 3' (914mm)
	202214	Side-Flare Mounting Guide 4' (1219mm)
	202215	Side-Flare Mounting Guide 5' (1524mm)
	202216	Side-Flare Mounting Guide 6' (1829mm)

Item	Part Number	Description
3	202522M	Flared Guide 45° 2' (610mm)
	202523M	Flared Guide 45° 3' (914mm)
	202523M	Flared Guide 45° 4' (1219mm)
	202523M	Flared Guide 45° 5' (1524mm)
	202523M	Flared Guide 45° 6' (1829mm)
4	639971M	Drop-In Tee Bar
5	910506M	Button Head Screw M5 x 6mm
6	911-512	Washer
7	920694M	Cap Low-Head Screw M6 x 20mm

Flat Belt Stand Mount Assembly

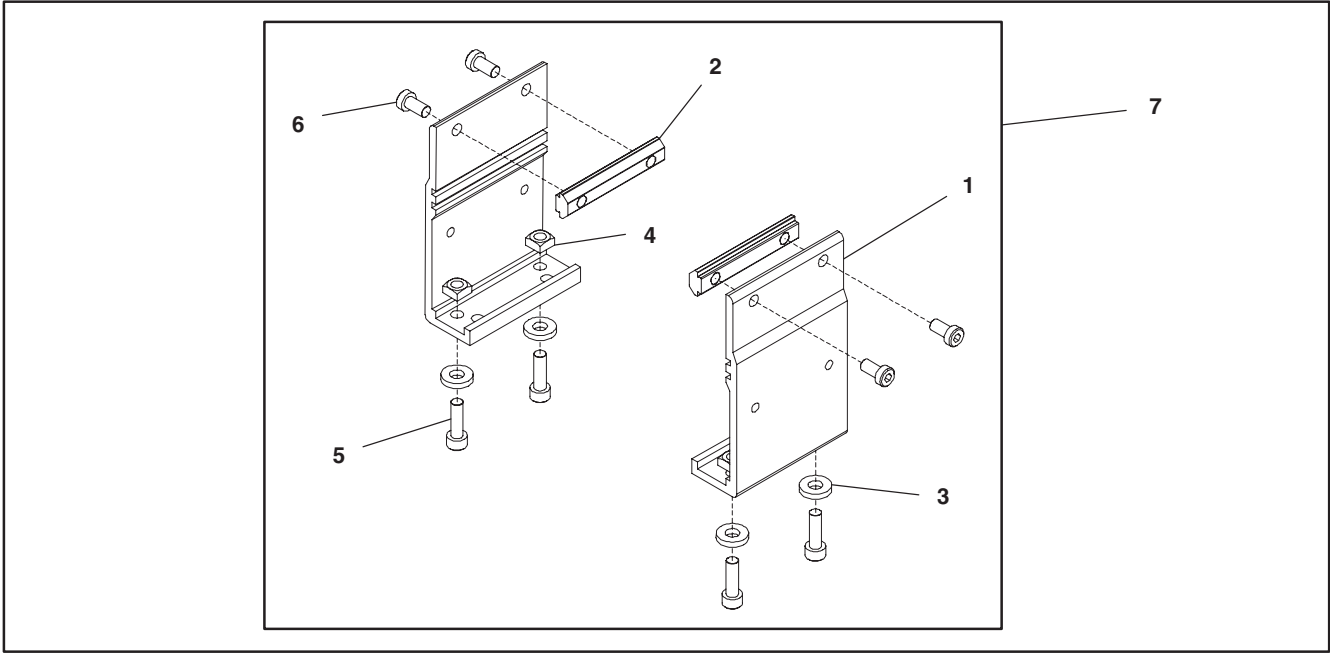

Item	Part Number	Description
1	240831	Stand Mount
2	300150MK14	Drop-In Tee Bar (x4)
3	605279P	Washer
4	807-920	Square Nut M6

Item	Part Number	Description
5	920620M	Socket Head Screw M6 x 20mm
6	920692M	Socket Low Head Screw M6x12mm
7	240839	Flat Belt Stand Mount Assembly

Service Parts

2" (51mm) to 6" (152mm) Flat Belt Return Roller

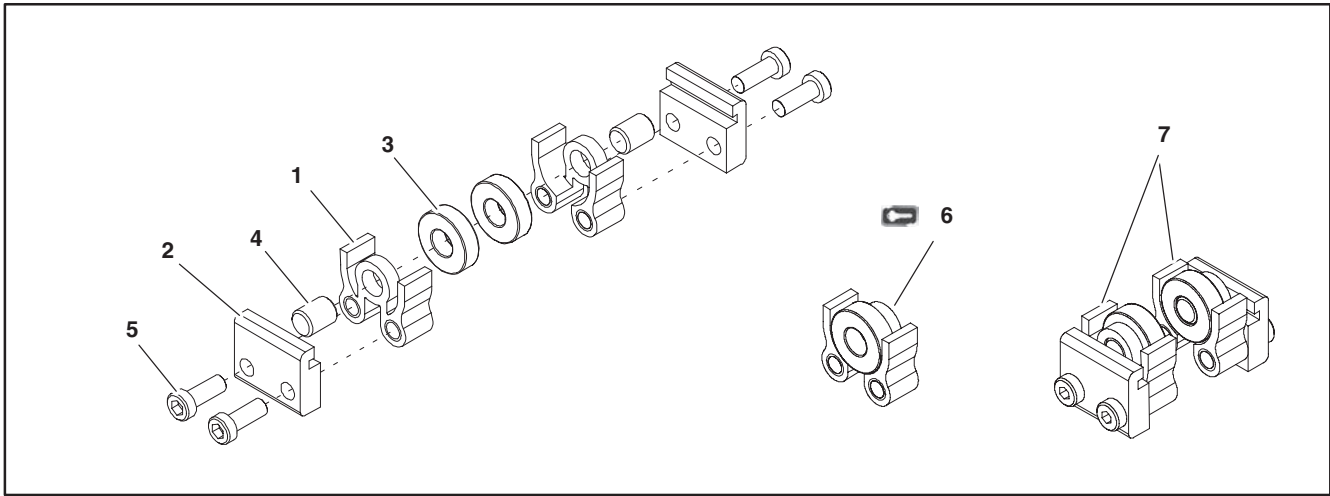

Item	Part Number	Description
1	240825	Return Roller Guard - Short
2	240827	Return Roller Clip
3	802-027	Bearing
4	913-100	Dowel Pin

Item	Part Number	Description
5	920693M	Socket Low Head Screw M6 x 16mm
6	240840	Roller Assembly (Includes Items 1, 3 and 4)
7	240830	2" (51mm) to 6" (152mm) Flat Belt Return Roller Assembly

8" (203mm) to 24" (610mm) Flat Belt Return Roller

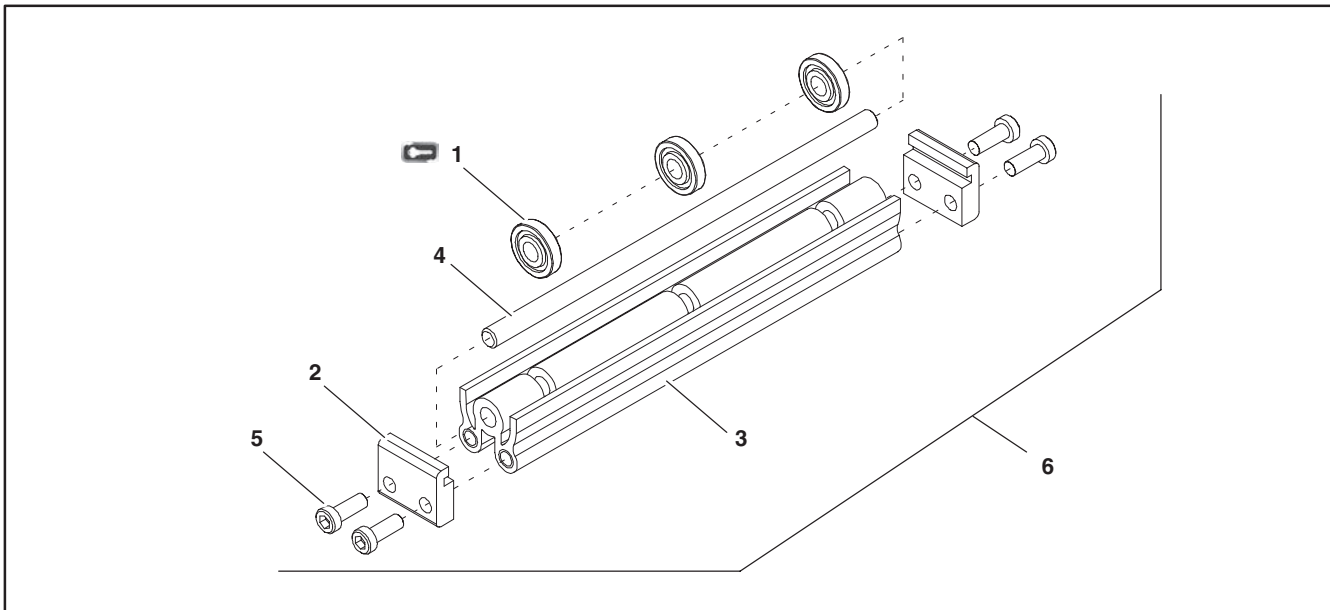

Item	Part Number	Description
1	240826	Return Roller
2	240827	Return Roller Clip
3	2409WW	Return Roller Guard
4	2410WW	Return Roller Rod
5	920693M	Socket Low Head Screw M6 x 16mm

Item	Part Number	Description
6	2408WW	8" (203mm) to 24" (610mm) Flat Belt Return Roller Assembly
WW.= Conveyor width ref.: 02, 03, 04, 05, 06, 08, 10, 12, 18, 21, 24		

Gearmotor Mounting Package

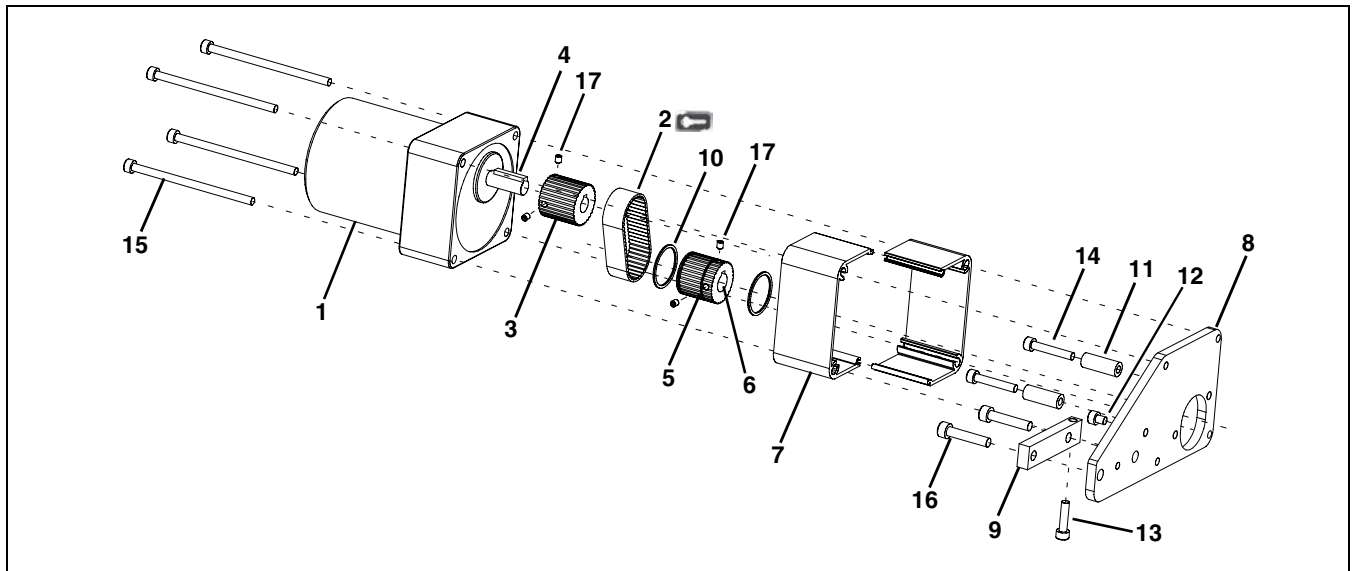

Item	Part No.	Part Description
1	62M060PL411FR	Gearmotor, 0.03 hp, 115 Volts, 25 RPM, 60 Hz, 1-Phase, 60:1
	62M036PL411FR	Gearmotor, 0.03 hp, 115 Volts, 42 RPM, 60 Hz, 1-Phase, 36:1
	62M025PL411FR	Gearmotor, 0.03 hp, 115 Volts, 60 RPM, 1-Phase, 25:1
	62M015PL411FR	Gearmotor, 0.03 hp, 115 Volts, 100 RPM, 139 RPM, 1-Phase, 15:1
	62M036PL423EN	Gearmotor, 0.03 hp, 230 Volts, 42 RPM, 10 - 60 Hz, 3-Phase, 36:1
	62M015PL423EN	Gearmotor, 0.03 hp, 230 Volts, 100 RPM, 10 - 60 Hz, 3-Phase, 15:1
	62M009PL423EN	Gearmotor, 0.03 hp, 230 Volts, 167 RPM, 10 - 60 Hz, 3-Phase, 9:1
2	814-088	Timing Belt, 3mm x 15mm (159mm long)
	814-089	Timing Belt, 3mm x 15mm (179mm long)
3	450078M	Drive Pulley, 1/2" Bore
	450076M	Drive Pulley, 10mm Bore
4	912-052	Key, 1/8" x 5/8", 1/2" Bore
	980422M	Key, 4mm x 22mm, 10mm Bore
5	450077M	Driven Pulley, 12 mm Bore
6	980422M	Driven Pulley Key, 4 mm x 22 mm

Item	Part No.	Part Description
7	450087	Guard, Half, Light Duty Side Drive
8	450046M	Plate, Side Drive LD
9	450088M	Tensioning Bar, Side Drive
10	807-954	Spiral Retaining Ring
11	807-973	Nylon Spacer
12	920506M	Socket Head Screw M5x6mm
13	920525M	Socket Head Screw M5x25mm
14	920530M	Socket Head Screw M5x30mm
15	920500M	Socket Head Screw M5x100mm
	920590M	Socket Head Screw M5x90mm
	920460M	Socket Head Screw M4x60mm
16	920635M	Socket Head Screw M6x25mm
17	970405M	Cup Set Screw M4x5mm

Service Parts

Conveyor Belt Part Number Configuration

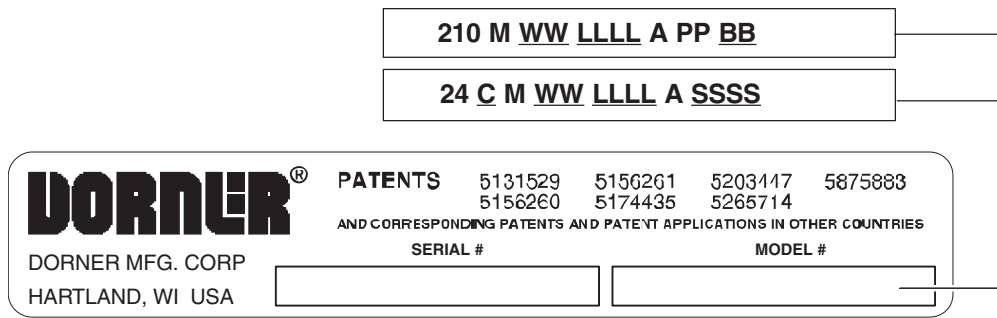

Figure 60

Flat Belt Part Number Configuration

Refer to Dorner patent plate (**Figure 60**). From the model number, determine conveyor width (“WW”), length (“LLLL”) and belt type (“BB”). Use data to configure belt part number as indicated below. *Add “V” for V-guided belts.

22 - WW LLLL / BB V *

22 - _____ / ____ V*

(Fill In)

Cleated Belt Part Number Configuration

Refer to Dorner patent plate (**Figure 60**). From the model number, determine conveyor type (“T”), width (“WW”), length (“LLLL”), cleat type (“C”) and cleat spacing (“SSSS”). Use data to configure belt part number as indicated below. *Add “V” for V-guided belts.

2T - WW LLLL C SSSS V *

2 - _____ / _____ V*

(Fill In)

Return Policy

Returns must have prior written factory authorization or they will not be accepted. Items that are returned to Dorner without authorization will not be credited nor returned to the original sender. When calling for authorization, please have the following information ready for the Dorner factory representative or your local distributor:

1. Name and address of customer.
2. Dorner part number(s) of item(s) being returned.
3. Reason for return.
4. Customer's original order number used when ordering the item(s).
5. Dorner or distributor invoice number (if available, part serial number).

A representative will discuss action to be taken on the returned items and provide a Returned Goods Authorization (RMA) number for reference. RMA will automatically close 30 days after being issued. To get credit, items must be new and undamaged. There will be a return charge on all items returned for credit, where Dorner was not at fault. It is the customer's responsibility to prevent damage during return shipping. Damaged or modified items will not be accepted. The customer is responsible for return freight.

Product Type									
Standard Products									Engineered to order parts
Product Line	Conveyors	Gearmotors & Mounting Packages	Support Stands	Accessories	Spare Parts (non-belt)	Spare Belts - Standard Flat Fabric	Spare Belts - Cleated & Specialty Fabric	Spare Belts - Plastic Chain	All equipment and parts
1100	30% return fee for all products except: 50% return fee for conveyors with modular belt, cleated belt or specialty belts						non-returnable		case-by-case
2200									
2200 Modular Belt									
2200 Precision Move									
2300									
2300 Modular Belt									
3200									
3200 LPZ									
3200 Precision Move									
4100									
5200									
5300									
6200									
Controls									
7200 / 7300	50% return fee for all products								
7350	non-returnable								
7360									
7400									
7600									

Returns will not be accepted after 60 days from original invoice date. The return charge covers inspection, cleaning, disassembly, disposal and reissuing of components to inventory. If a replacement is needed prior to evaluation of returned item, a purchase order must be issued. Credit (if any) is issued only after return and evaluation is complete.

Dorner has representatives throughout the world. Contact Dorner for the name of your local representative. Our Customer Service Team will gladly help with your questions on Dorner products.

For a copy of Dorner's Warranty, contact factory, distributor, service center or visit our website at www.dorner.com.

For replacement parts, contact an authorized Dorner Service Center or the factory.

 <p>Dorner Mfg. Corp. reserves the right to change or discontinue products without notice. All products and services are covered in accordance with our standard warranty. All rights reserved. © Dorner Mfg. Corp. 2013</p>	<p>DORNER MFG. CORP. 975 Cottonwood Ave., PO Box 20 Hartland, WI 53029-0020 USA TEL 1-800-397-8664 (USA) FAX 1-800-369-2440 (USA) Internet: www.dorner.com</p>	<p>Outside the USA: TEL 1-262-367-7600 FAX 1-262-367-5827</p>
---	--	---