

Isuzu Diesel Engines



4LE1

Generator: 33 HP @ 1800 RPM

Industrial Drive: 50 HP @ 2600 RPM

Standard features:

- U.S. EPA Tier 4 Interim
- Displacement: 2.2 L
- Naturally aspirated
- Peak torque: 106.0 LB/FT @ 1800 RPM
- Fuel consumption: .410 LB/HP-HR
- Flywheel housing: SAE 4 & 5 with additional unique hydraulic pump adaptor
- Electric & self-priming fuel lift pump
- 12V and 24V available
- Glow plug starting aid
- High angularity oil pan
- 250-hour service intervals
- 5-year / 5,000-hour warranty

The power behind it all.

ISUZU
DIESEL

Isuzu Diesel Engines

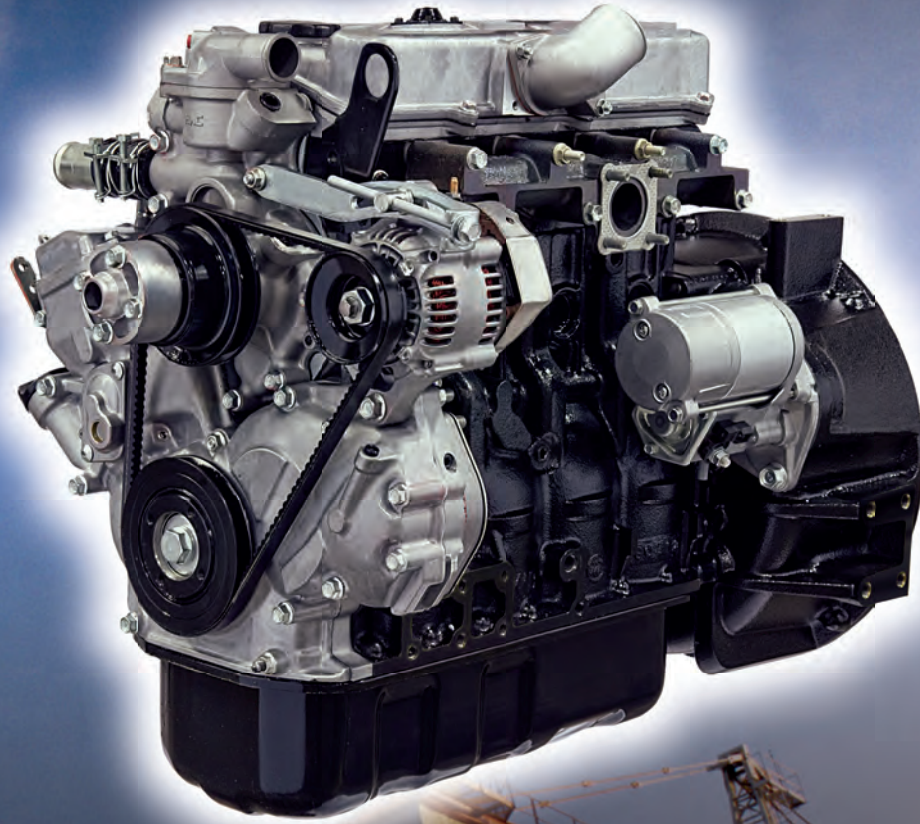

4LE1

Generator: 33 HP @ 1800 RPM

Industrial Drive: 50 HP @ 2600 RPM

Standard features:

- U.S. EPA Tier 4 Interim
- Displacement: 2.2 L
- Naturally aspirated
- Peak torque: 106.0 LB/FT @ 1800 RPM
- Fuel consumption: .410 LB/HP-HR
- Flywheel housing: SAE 4 & 5 with additional unique hydraulic pump adaptor
- Electric & self-priming fuel lift pump
- 12V and 24V available
- Glow plug starting aid
- High angularity oil pan
- 250-hour service intervals
- 5-year / 5,000-hour warranty

The power behind it all.

ISUZU
DIESEL

Isuzu Diesel Engines

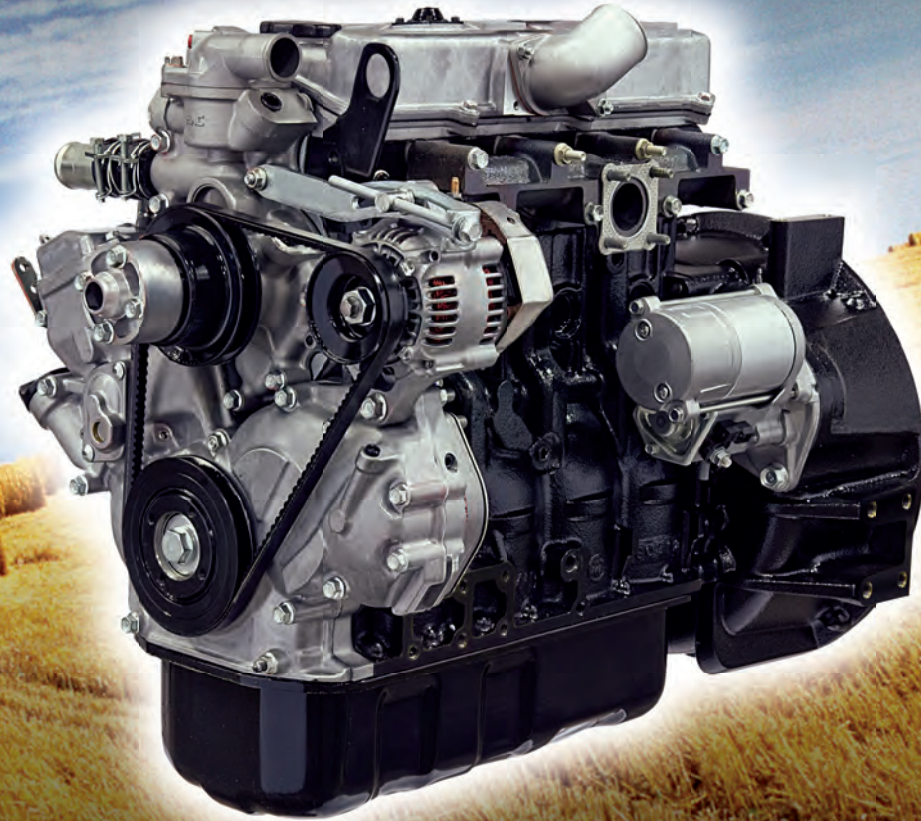

4LE1

Generator: 33 HP @ 1800 RPM

Industrial Drive: 50 HP @ 2600 RPM

Standard features:

- U.S. EPA Tier 4 Interim
- Displacement: 2.2 L
- Naturally aspirated
- Peak torque: 106.0 LB/FT @ 1800 RPM
- Fuel consumption: .410 LB/HP-HR
- Flywheel housing: SAE 4 & 5 with additional unique hydraulic pump adaptor
- Electric & self-priming fuel lift pump
- 12V and 24V available
- Glow plug starting aid
- High angularity oil pan
- 250-hour service intervals
- 5-year / 5,000-hour warranty

The power behind it all.

ISUZU
DIESEL

4LE1 Industrial Performance Curves:

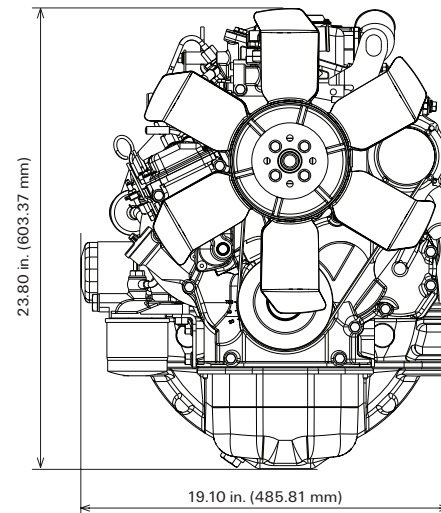
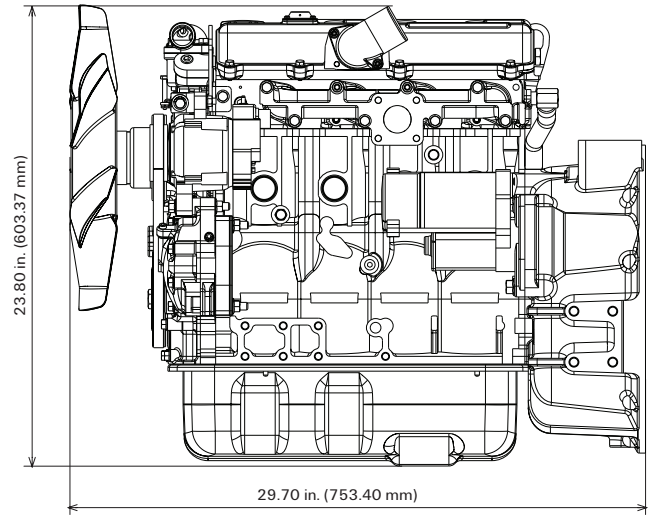
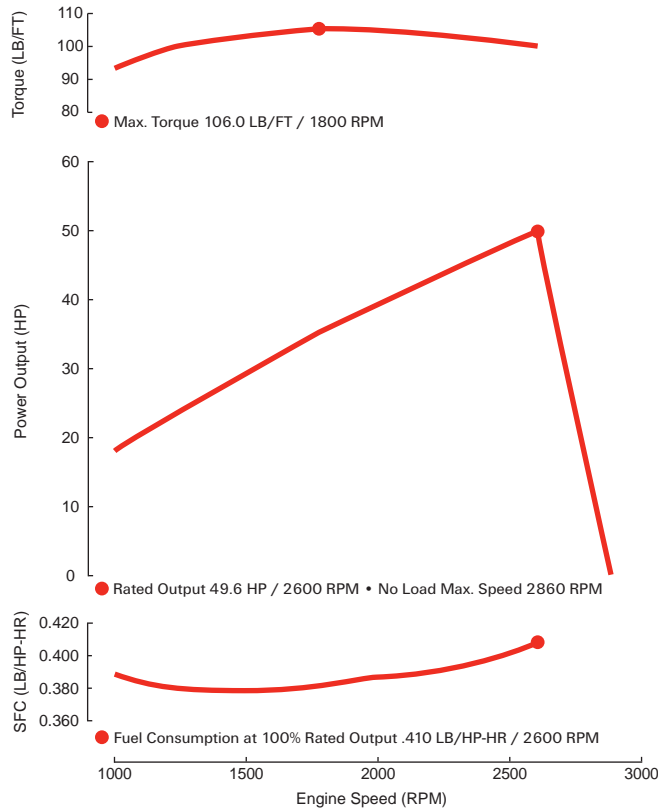

4LE1 Genset Performance Curves:

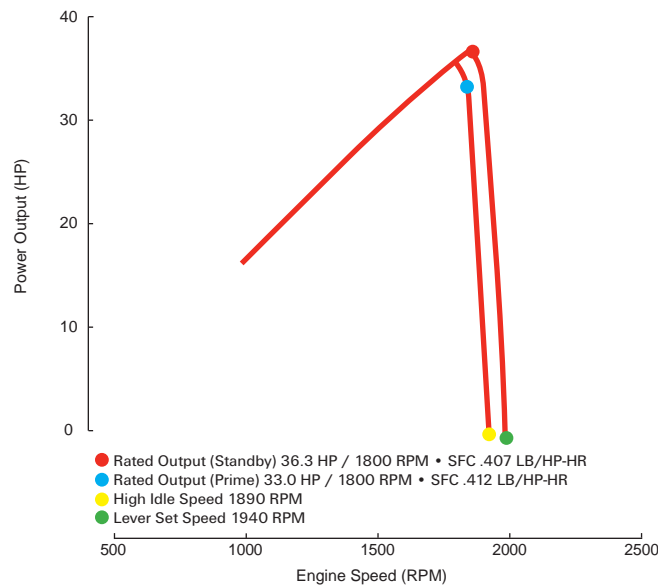

Available options:

- Cooling system
- Air cleaner
- Exhaust system
- Front and rear mounts
- Skid base
- Instrument panel & extension harness
- Custom power unit

Horsepower comparison:

Engine Model	Cylinders	Displacement (L)	HP Range
3CD1T	3	1.5	30-40
4LE1	4	2.2	30-50
4LE1T	4	2.2	40-60

For additional information, please contact your local distributor or visit www.isuzuengines.com

Isuzu Motors America, LLC

46401 Commerce Center Drive
 Plymouth, Michigan 48170
 Phone: 734.582.9470
 Fax: 734.455.7581

ILS-4LE1-E

www.isuzuengines.com