

CX-2

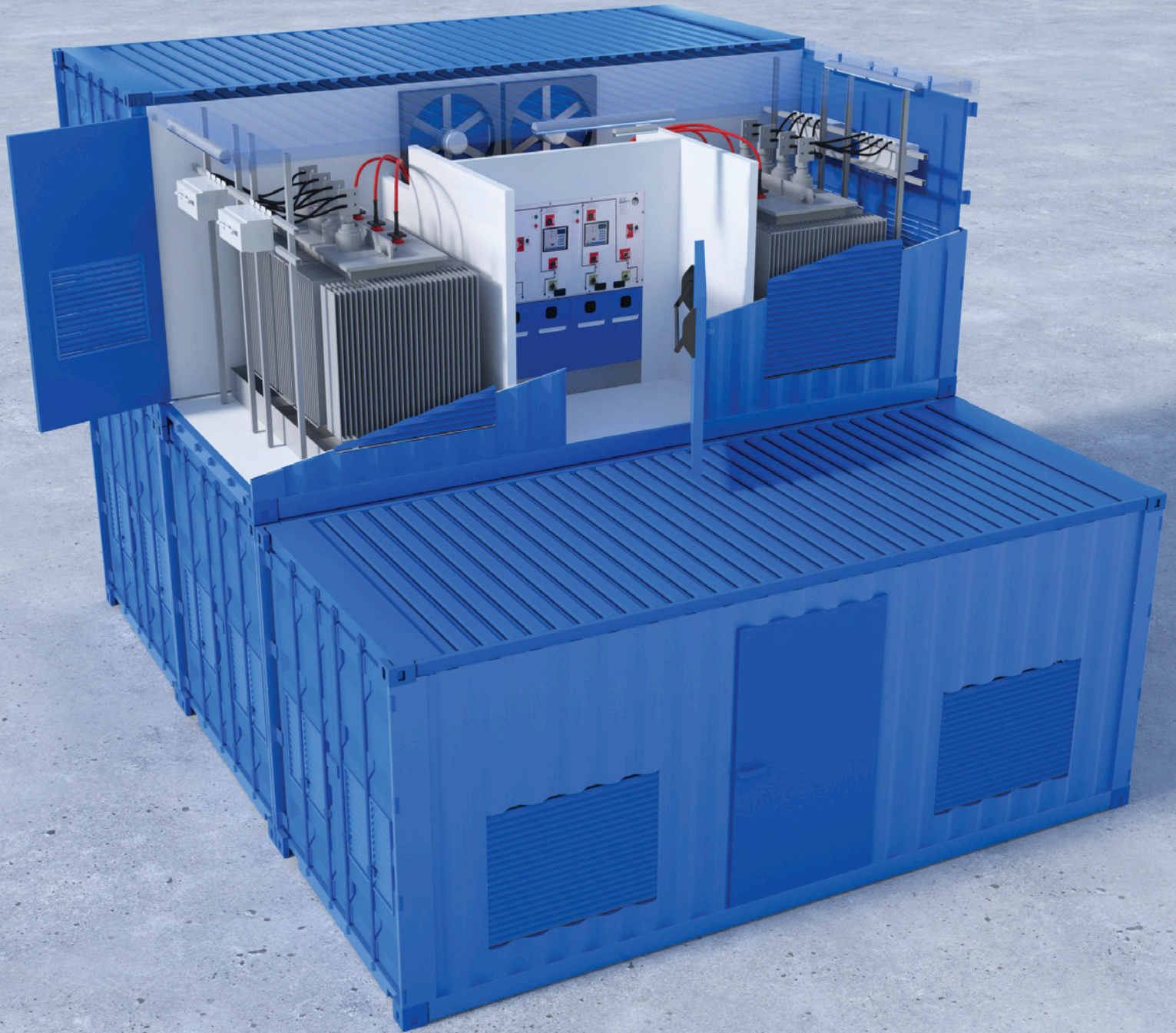

Containerised mobile substations.

Deba's CX-2 range provides versatile and mobile medium-voltage solutions. Be up and running with a turnkey Power Container, shipped worldwide with a custom configuration. **CX-2: All the power you need in a container solution.**



www.deba.biz



Quality & sustainability

Deba has been working with medium-voltage for over 35 years. **35 years of experience signals a deep passion for what we do.** It signals a passion for knowhow and an insight into every single detail of the medium-voltage grid. And dedication: to build better, more safely, more efficiently. We would love to introduce Deba's values.

Today, Deba is part of a **vertically integrated group**, as a direct result of our drive for quality and sustainability. And we were not about to make tradeoffs. Consequently, when it became more difficult to obtain parts that met our demanding quality standards, we started making them ourselves. And to ensure the end quality of our entire product, we even decided to make every switch and component in-house.

Meanwhile both activities have blossomed into fully independent subsidiaries. It shifted Deba's focus firmly back to its core business: the installation of medium-voltage switchgear. When it comes to Deba or our subsidiaries, each and every element is united by a singular vision: **a focus on quality, innovation, and service.**



Knowhow, experience & versatility

Today, Deba serves about half of all Belgian companies, institutions and governments working with medium-voltage.

Our focus is firmly on quality and on the environment. We also work with standards and modular product systems, which benefits both the price and the service we can provide.

Who is Deba?



Mobile switchgear solutions

One of our solutions is the **CX-2 range**: containerized mobile substations that offer a plug and play solution for mobile power plants and switching substations. The CX-2 includes medium-voltage switchgear cubicles, (a) power transformer(s), and low-voltage distribution boards. Your entire CX-2 container is fitted with all components, tested in our factory, and shipped worldwide. The CX-2 ranges sits in between our range of concrete solutions (**BX-2**) and galvanized steel solutions (**GS-2**), to complete a range of medium-voltage solutions that offer clients a quick and easy medium voltage experience. Deba has built hundreds of these solutions over the last 25 years

- 1 Weatherproof container, resistant to extreme conditions
- 2 SGC – SwitchGear Company cubicles: medium-voltage switchgear that's built to last
- 3 Solid transformers
- 4 Security measures and ventilation options

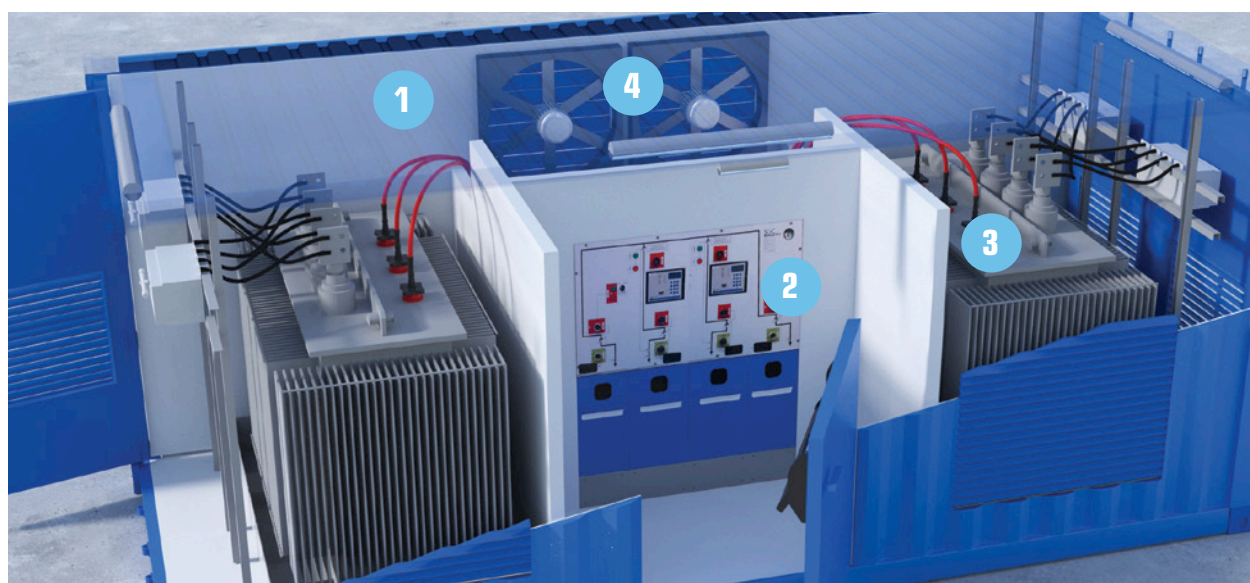

Standard Power Container: typical lay-out, other lay-outs by request.

How Deba's CX-2 answers your

Control & divide your medium-voltage network

Medium-voltage substations

Mobile substations are the ideal solution in all situations. New installations, or fast emergency power plants without the required construction time, are a perfect match for mobile substations. Mobile substations are prepared for operation at the factory. All possible internal connections within the container are installed, the equipment is fitted and tested. The remaining on-site connections are easy to install using the provided lateral and/or bottom cable entries. This minimizes the assembly and commissioning time.

Once the container is positioned and connected to the power and signal cables, **the installation is already operational within a few hours.**

By pre-assembling the components in our production plant, we can guarantee the highest quality and security. Containers are easily transported and quickly adapted to different applications and environments. Access to the switchgear is possible through lateral or floor hatches. Entrances can be protected from dirt, wind and water. All containers can be adapted and modified at your desire.

Lightning-fast Power Solutions

- Medium and low voltage transformer containers **up to 6,3MVA**
- Medium voltage cubicles manufactured and fitted by SGC - SwitchGear Company, **built to last**
- Voltages up to **36kV**
- Provided **with switch and security devices** on high and low voltage side
- Fitted complete **with over current & short circuit protection** on the MV breaker
- **ISO compliant** containers
- **Cast resin or oil-filled transformers**
- High or low ambient operation with **acclimatisation units installed**
- **Worldwide shipping**

Transport medium-voltage power

Power containers

To serve the international temporary power generation sector, Deba manufactures a range of containerised step-up/step-down transformers.

Our standard power containers contain everything required for operation, in order to get you up and running as quickly as possible:

Operational In No Time

- **Standardised blue sea container** (colour: RAL5015)
- Medium-voltage **switchgear**
- Medium-voltage **protection relays**
- One or multiple power **transformers**
- **Low-voltage breakers and a low-voltage utility panel**



Fast delivery, ready to use, tested, quick installation & easy commissioning

needs



Develop, design, or realize your own concept

Tailor-made solutions

Distribution substations meet the needs of medium voltage electrical distribution up to 36 kV.

Applications:

- **Electrical supply of an existent plant** in case of planned reconstruction
- **Replacing equipment during maintenance**
- **Temporary increase** in electricity requirements
- Turnkey delivery of substations with minimum construction times
- **Mobile power plants**
- **Temporary substation** for mining sites
- Ensure local industries have a reliable, **emergency supply** of electricity in case of a grid interruption

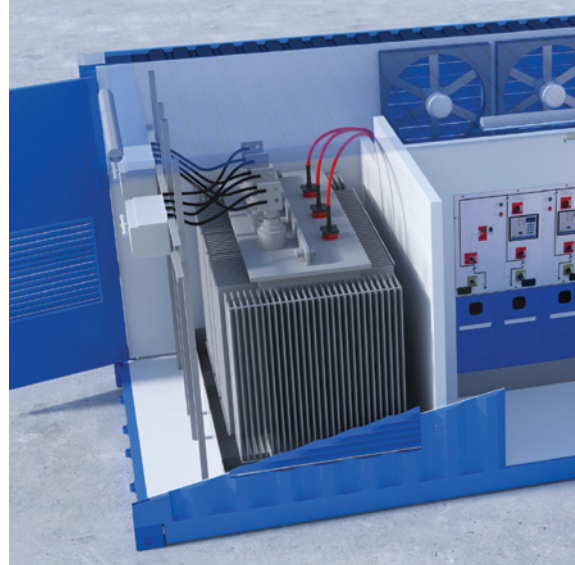

CX-2 Advantages

- Walk-in type medium-voltage switchgear operation room
- Easy to transport
- Approved for transport by sea
- Customized configurations for each application and environment
- Fully assembled and tested in the factory, ensuring a high quality
- Plug & play philosophy applied to a medium-voltage installation
- Shorter commissioning times
- Customized low-voltage and medium-voltage switchgear layout for each type of application
- Fully assembled and tested at Deba factory in Belgium

Interested in the CX-2 potential?

Contact our sales team now.

Call [+32 \(0\)9 371.75.51](tel:+32293717551),
mail to sales@deba.biz
or visit www.deba.biz



Available options and models

Wide range of cubicle types

DF-2

up to 12/24 kV



DI-2

36kV



DW-2

metal-clad



DR-6

RMU



Medium voltage switchgear by SGC

SGC - SwitchGear Company creates entirely custom-built medium-voltage switchgear. Because no two switchgear installations are the same. That is why Deba works with SGC to build a solution that fulfils your exact needs. We look beyond just the cubicles: we look at the entire picture. From the container, all the way down to the smallest component. SGC's switchgear and our container solutions are truly tailor-made.



- Rated voltage up to 36 kV.
- Standard switchgears (air insulated, or SF₆ gas insulated).

Transformers

- Cast resin or dry-type transformers.
- Installed in a separate transformer room, or protected against accidental touching.
- Suitable for step-up or step-down applications.
- Separated or container integrated oil sump under oil transformer.

Containers

We use standard size land or marine transportation containers.

- Joint-free processing of the concrete base unit in a single cast.
- Protection against impact and vandalism.
- Weatherproof.
- Unaffected by condensation.
- Watertight design.
- Exterior coated in RAL colours, matching your company colours or the surrounding landscape.
- Easy to transport using a standard container truck or towing trailer.

Finishing touch

All basic RAL colours are available (default colour RAL5015) and even special designs can be custom made. Your company colour and logo on a container? We make it happen.

Climatisation

Heating, cooling and/or ventilation systems are available in the container for sites with an extremely hot or low ambient temperature.

Standard external container dimensions

Container Size	10 ft.	20 ft.	40 ft.
Length	3,03 m	6,06 m	12,19 m
Width	2,44 m	2,44 m	2,44 m
Height (standard)	2,59 m	2,59 m	2,59 m
Height (high cube)	-	2,89 m	2,89 m



Worldwide shipping,
delivering power where needed.



Typical configurations CX-2

Power Container CX-2 CX222542

- 20ft ISO container
- 2 x 2,5MVA (ONAN)
- 400V/15kV
- 17,5kV - 800A - 20kA/1s HV cells
- 2 x incoming HV terminals on load breakers
- 2 x outgoing HV circuit breakers with protection relays
- 2 x outgoing LV terminals: 2500A/4p

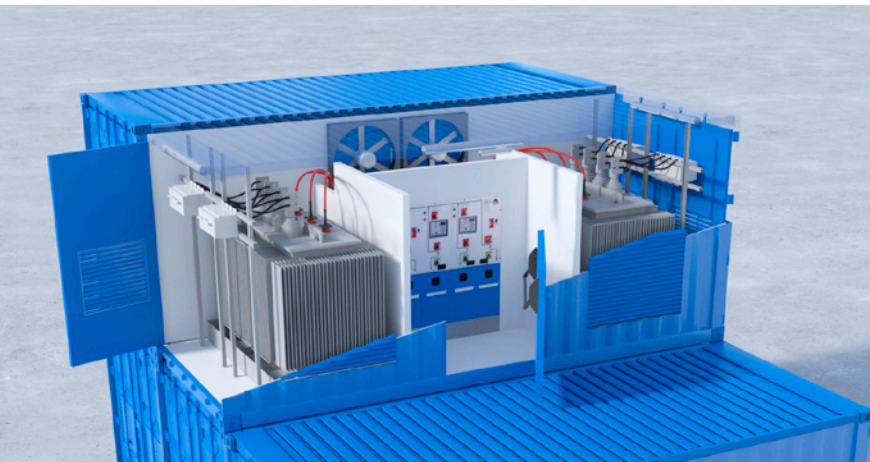
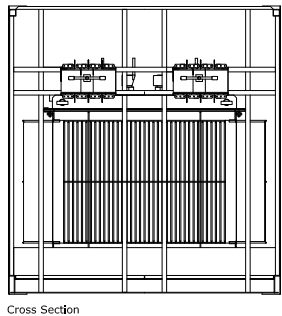
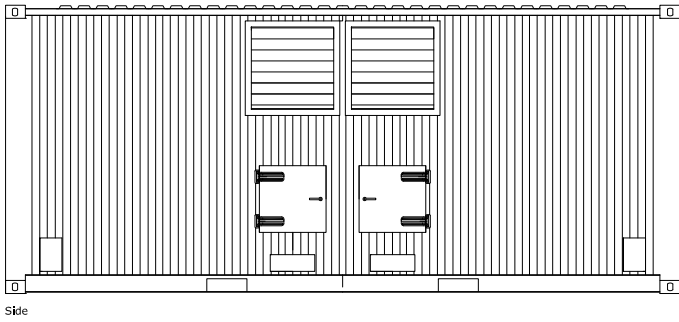
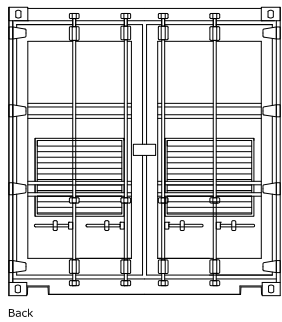
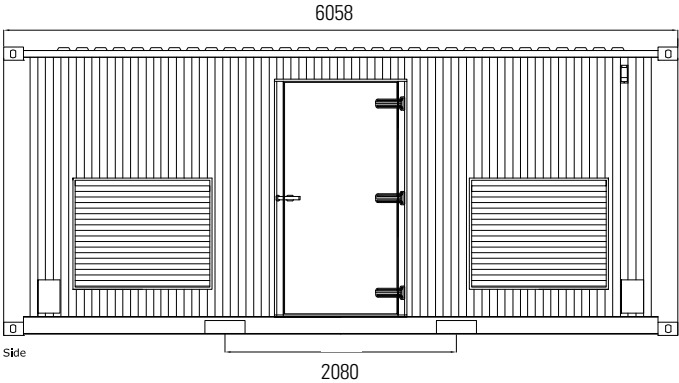
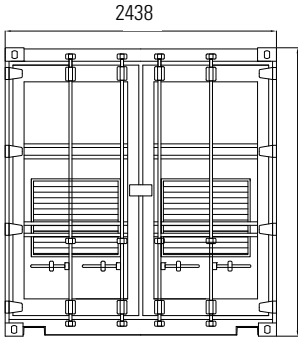
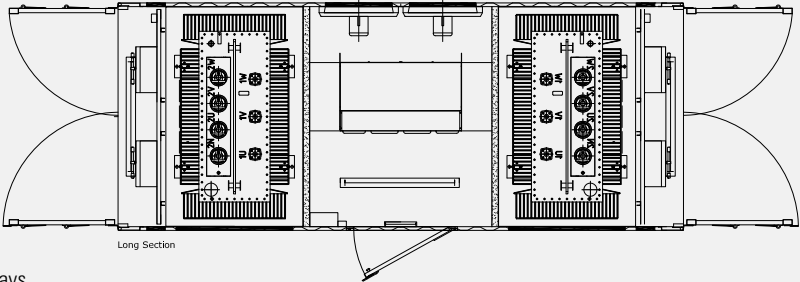

Medium voltage substation CX-2 CX200090

- 20ft ISO container
- 36kV - 630A - 16kA/1s modular HV cells
- 1 x incoming load switch
- 5 x outgoing circuit breakers
- 3 x outgoing load fuse switches
- 1 x outgoing load switch

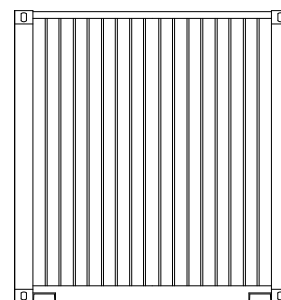
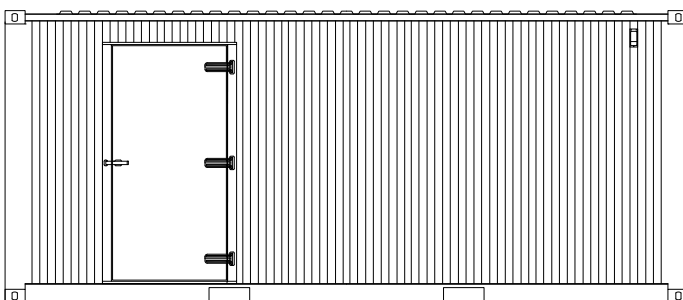
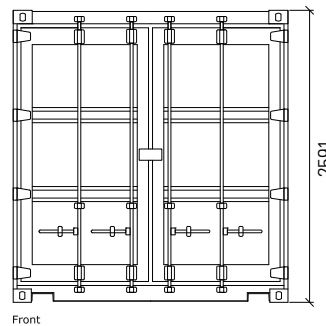
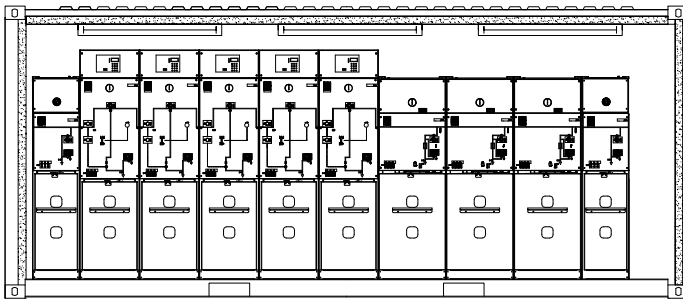
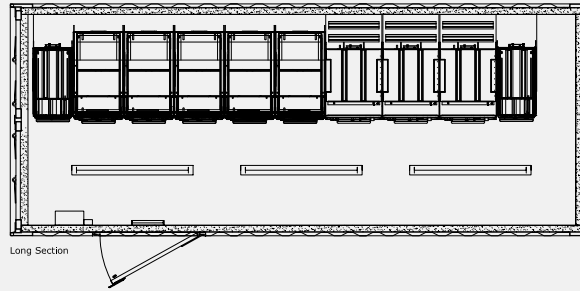

Interested in the CX-2 potential?

Contact our sales team now.

Call [+32 \(0\)9 371.75.51](tel:+322093717551),
mail to sales@deba.biz
or visit www.deba.biz

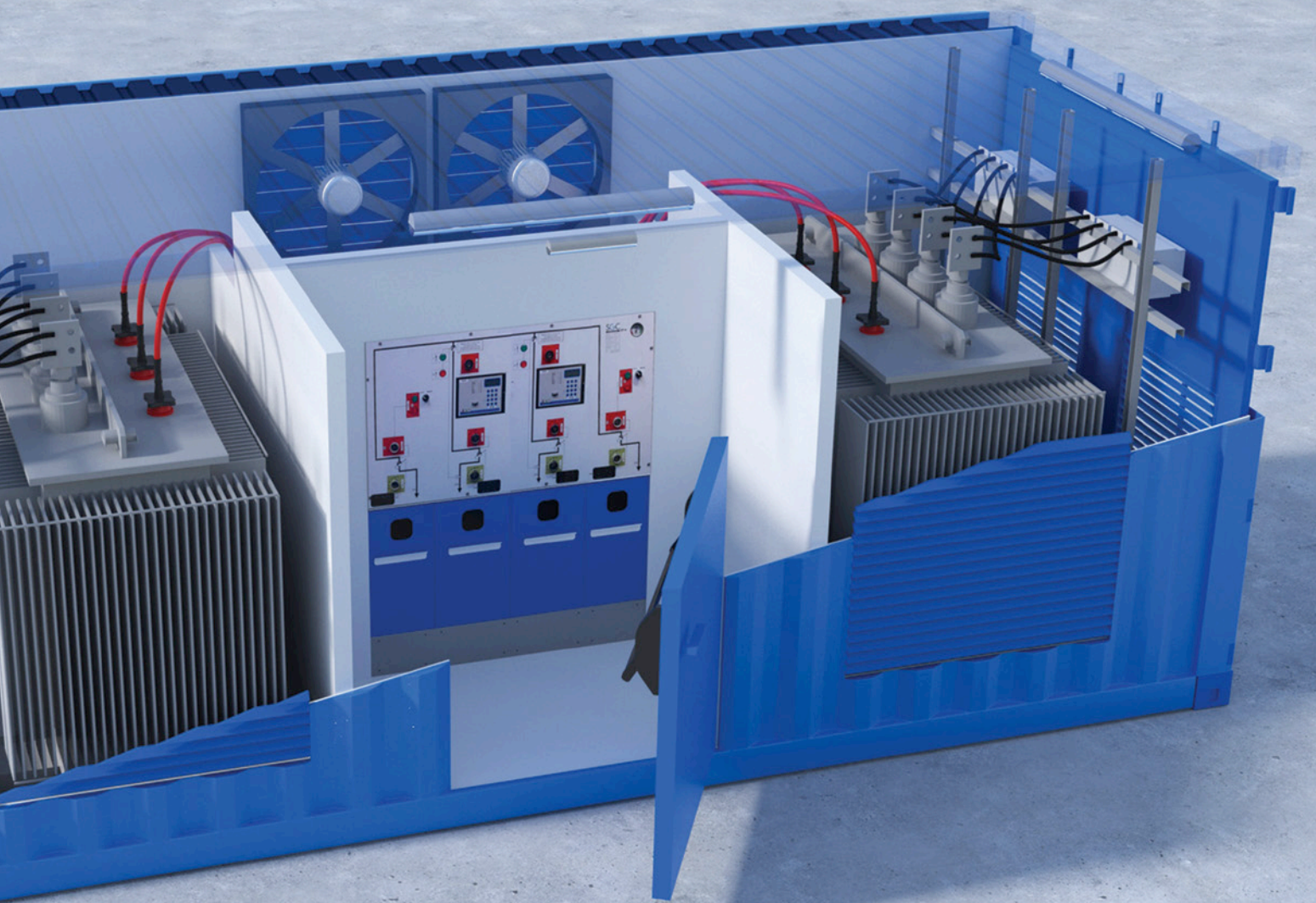

Other solutions by Deba...

BX-2

Concrete housing

- Fully customizable
- Wide array of possibilities: IT, sanitary units, etc.
- High-quality finish

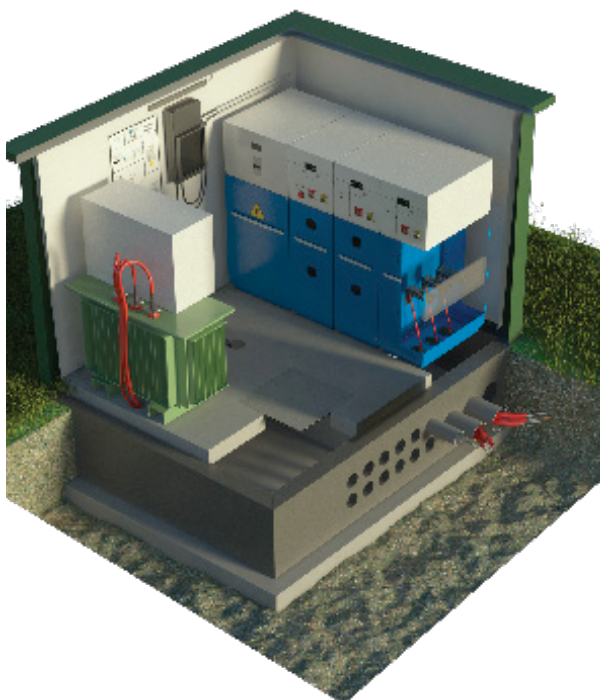

GS-2

Galvanized steel housing

- Lean design
- Tailor-made approach
- Superlative switchgear inside



Interested in the BX-2 or GS-2?

Contact our sales team now.

Call [+32 \(0\)9 371.75.51](tel:+322093717551),
mail to sales@deba.biz
or visit www.deba.biz



Deba, the specialist in medium-voltage.

Deba has been working with medium-voltage for over 35 years. **35 years of experience signals a deep passion for what we do.** It signals a passion for knowhow and an insight into every single detail of the medium-voltage grid. And dedication: to build better, more safely, more efficiently. We would love to introduce Deba's values.

Today, Deba is part of a **vertically integrated group**. As a direct result of our drive for quality and sustainability. And we were not about to make tradeoffs. Consequently, when it became more difficult to obtain parts that met our demanding quality standards, we started making them ourselves. And to ensure the end quality of our entire product, we even decided to make every switch and component in-house.

Meanwhile both activities have blossomed into fully independent subsidiaries. It shifted Deba's focus firmly back to its core business: the installation of medium-voltage switchgear. When it comes to Deba or our subsidiaries, each and every element is united by a singular vision: **a focus on quality, innovation, and service.**

Deba nv Headquarters

Moorstraat 24
B-9850 Nevele
Belgium

Tel: +32 (0)9/371.75.51
Fax: +32 (0)9/371.59.25
E-mail: info@deba.biz

Regional office Wallonia

Zone industrielle d'Achène
Rue du bois des mouches 8
B-5590 Ciney - Belgium

Tel: +32 (0)83/68.90.87
Fax: +32 (0)83/68.95.30
E-mail: wallonie@deba.biz

Regional office Limburg

Westlaan 268
B- 3550 Heusden-Zolder
Belgium

Tel: +32 (0)13/55.46.34
Fax: +32 (0)13/31.46.70
E-mail: limburg@deba.biz

www.deba.biz

