

NASA/SP-2000-6109/VOL1/REV1



International Space Station Evolution Data Book

Volume I. Baseline Design

Revision A

*Catherine A. Jorgensen, Editor
FDC/NYMA, Hampton, Virginia*

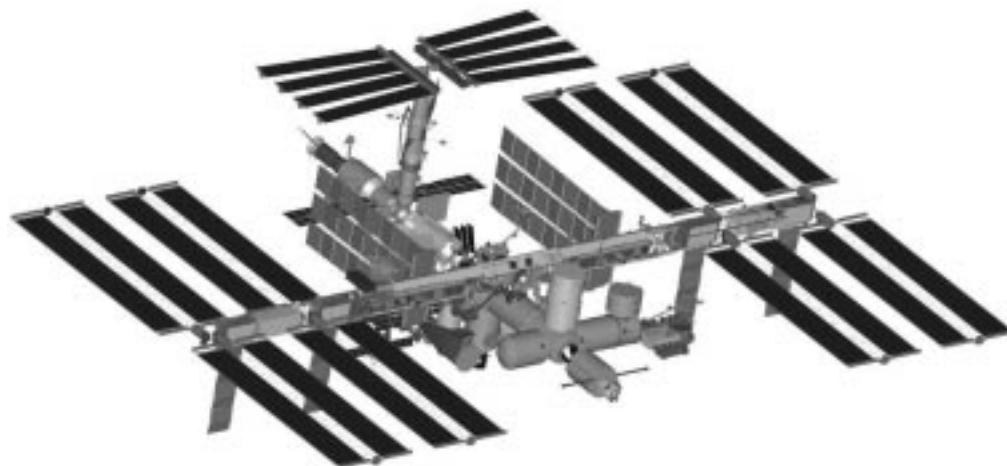

October 2000

The NASA STI Program Office . . . in Profile

Since its founding, NASA has been dedicated to the advancement of aeronautics and space science. The NASA Scientific and Technical Information (STI) Program Office plays a key part in helping NASA maintain this important role.

The NASA STI Program Office is operated by Langley Research Center, the lead center for NASA's scientific and technical information. The NASA STI Program Office provides access to the NASA STI Database, the largest collection of aeronautical and space science STI in the world. The Program Office is also NASA's institutional mechanism for disseminating the results of its research and development activities. These results are published by NASA in the NASA STI Report Series, which includes the following report types:

- **TECHNICAL PUBLICATION.** Reports of completed research or a major significant phase of research that present the results of NASA programs and include extensive data or theoretical analysis. Includes compilations of significant scientific and technical data and information deemed to be of continuing reference value. NASA counterpart of peer-reviewed formal professional papers, but having less stringent limitations on manuscript length and extent of graphic presentations.
- **TECHNICAL MEMORANDUM.** Scientific and technical findings that are preliminary or of specialized interest, e.g., quick release reports, working papers, and bibliographies that contain minimal annotation. Does not contain extensive analysis.
- **CONTRACTOR REPORT.** Scientific and technical findings by NASA-sponsored contractors and grantees.

- **CONFERENCE PUBLICATION.** Collected papers from scientific and technical conferences, symposia, seminars, or other meetings sponsored or co-sponsored by NASA.
- **SPECIAL PUBLICATION.** Scientific, technical, or historical information from NASA programs, projects, and missions, often concerned with subjects having substantial public interest.
- **TECHNICAL TRANSLATION.** English-language translations of foreign scientific and technical material pertinent to NASA's mission.

Specialized services that complement the STI Program Office's diverse offerings include creating custom thesauri, building customized databases, organizing and publishing research results . . . even providing videos.

For more information about the NASA STI Program Office, see the following:

- Access the NASA STI Program Home Page at <http://www.sti.nasa.gov>
- Email your question via the Internet to help@sti.nasa.gov
- Fax your question to the NASA STI Help Desk at (301) 621-0134
- Telephone the NASA STI Help Desk at (301) 621-0390
- Write to:
NASA STI Help Desk
NASA Center for AeroSpace Information
7121 Standard Drive
Hanover, MD 21076-1320

NASA/SP-2000-6109/VOL1/REV1



International Space Station Evolution Data Book

Volume I. Baseline Design

Revision A

Catherine A. Jorgensen, Editor
FDC/NYMA, Hampton, Virginia

National Aeronautics and
Space Administration

Langley Research Center
Hampton, Virginia 23681-2199

October 2000

Acknowledgments

The following personnel from the Spacecraft and Sensors Branch of the Aerospace Systems, Concepts and Analysis Competency, Langley Research Center, helped to compile and write various sections of this document:

Patrick A. Cosgrove: Electrical Power System, Thermal Control System, and Energy Enhancement
Jeffrey Antol: Structures and Mechanisms, Pressurized Payloads, Attached Payloads, and Free-Flyer Satellite Servicing
Frederick H. Stillwagen: Communications and Tracking and Advanced Communications Tower
Carlos M. Roithmayr: Guidance, Navigation, and Control and Tether for ISS Orbit Maintenance
John B. Hall, Jr.: Environmental Control and Life Support System
George G. Gano: Command and Data Handling
Gregory A. Hajos: Propulsion System and TransHab on ISS
Marianne Rudisill: Flight Crew Systems, Exploration DRM - Biotechnology
Melvin Ferebee: Exploration DRM
William Cirillo: Reusable Launch Vehicle DRM
Kathleen R. Gonzales (Langley Aerospace Research Summer Scholar): ISS Commercialization Activities

and from Boeing Engineering Services:

Rudy Saucillo: Reusable Launch Vehicle DRM

Special thanks are due to the Library and Media Services Branch of the Langley Research Center who published this document, with special acknowledgment to the NCI Technical Publications Support Group at Langley (Eloise Johnson and Mary Edwards who edited this document, Leanna Bullock who did the graphics, Martha Jones and Patricia Gottschall who typeset this document, and Cathy Everett who researched and formatted the references). Special thanks are also given to those members of the ISS Program Office at Lyndon B. Johnson Space Center and at other NASA centers who have provided information and assistance that was needed to compile and publish this document. This work was performed under contract NAS 1-96013 with Jeffrey Antol as Technical Monitor.

The use of trademarks or names of manufacturers in this report is for accurate reporting and does not constitute an official endorsement, either expressed or implied, of such products or manufacturers by the National Aeronautics and Space Administration.
--

Available from:

NASA Center for AeroSpace Information (CASI)
7121 Standard Drive
Hanover, MD 21076-1320
(301) 621-0390

National Technical Information Service (NTIS)
5285 Port Royal Road
Springfield, VA 22161-2171
(703) 605-6000

This report is also available in electronic form at URL <http://techreports.larc.nasa.gov/ltrs/>

Foreword

This document provides a focused and in-depth look at the opportunities and drivers for the enhancement and evolution of the International Space Station (ISS) during its assembly and until its assembly complete (AC) stage. These enhancements would expand and improve the current baseline capabilities of the ISS and help to facilitate the commercialization of the ISS by the private sector. The intended users of this document include the ISS organization, the research community, other NASA programs and activities, and the commercial sector interested in opportunities that the ISS offers.

The purpose of this document is threefold. First, it provides a broad integrated systems view of the current baseline design of the ISS systems and identifies potential growth and limitations of these systems. Second, it presents current and future options for the application of advanced technologies to these systems and discusses the impacts these enhancements may have on interrelated systems. Third, it provides this information in a consolidated format to research and commercial entities to help generate ideas and options for developing or implementing new technologies to expand the current capabilities of ISS and to assist them in determining potential beneficial uses of the ISS. The content of this document ventures beyond the current designs and capabilities of the ISS towards its future potential as a unique research platform and engineering test bed for advanced technology. It provides an initial source of information to help stimulate the government and private sectors to develop a technological partnership in support of the evolution and commercialization of the ISS.

The ISS Evolution Data Book is composed of two volumes. Volume I contains the baseline design descriptions with section 1 being an introduction to Volume I. Section 2 provides an overview of the major components of the ISS. Section 3 summarizes the ISS baseline configuration and provides a summary of the functions and potential limitations of major systems. Section 4 outlines the utilization and operation of the ISS and furnishes facility descriptions, resource time-lines and margins, and a logistics and visiting vehicle traffic model. Volume II contains information on future technologies, infrastructure enhancements, and future utilization options and opportunities. Section 1 is an introduction to Volume II. Section 2 identifies the advanced technologies being studied by the Preplanned Program Improvement (P³I) Working Group for use on ISS to enhance the operation of the station. Section 3 covers the commercialization of the ISS, and section 4 provides information on the enhancement technologies that go beyond the efforts of the P³I Working Group. Section 5 summarizes the analysis performed for several design reference missions (DRM's) that are being considered for post-AC utilization and enhancements. Section 6 provides utilization opportunities that may enhance the efforts of the human exploration and development of space (HEDS) missions.

The contents of this document were gathered by the Spacecraft and Sensors Branch, Aerospace Systems, Concepts and Analysis Competency, Langley Research Center (LaRC), National Aeronautics and Space Administration (NASA). This document will be updated as the current configuration of the ISS evolves into its AC state and beyond. Much of the baseline configuration description is derived from the International Space Station Familiarization Document, TD9702A, ISS FAM C 21109, NASA Johnson Space Center, July 1998.

Contents

Foreword	iii
Acronyms and Abbreviations	xi
1. Introduction	1-1
2. ISS Baseline Assembly Complete	2-1
2.1. ISS Program Organization	2-1
2.2. ISS Configuration Assembly Overview	2-3
2.3. Baseline Assembly Complete Description	2-5
2.3.1. Zarya	2-5
2.3.2. Node	2-6
2.3.3. Zvezda	2-6
2.3.4. Soyuz	2-6
2.3.5. Laboratory	2-6
2.3.6. MultiPurpose Logistics Module	2-6
2.3.7. Joint Airlock	2-6
2.3.8. Interim Control Module	2-7
2.3.9. Docking Compartment	2-7
2.3.10. Truss	2-7
2.3.11. Science Power Platform	2-7
2.3.12. Universal Docking Module	2-7
2.3.13. Japanese Experiment Module	2-7
2.3.14. Docking and Stowage Module	2-8
2.3.15. Cupola	2-8
2.3.16. Research Module	2-8
2.3.17. Columbus Module	2-8
2.3.18. Crew Return Vehicle	2-8
2.3.19. Centrifuge Accommodation Module	2-8
2.3.20. Habitation Module	2-8
2.3.21. Logistics Vehicles	2-9
3. System Descriptions	3-1
3.1. Electrical Power System	3-1
3.1.1. Introduction	3-1
3.1.2. Overview of EPS	3-1
3.1.3. Architecture and Components for EPS	3-1
3.1.3.1. Power System Requirements	3-1
3.1.3.2. USOS EPS Functional Design	3-2
3.1.3.3. Primary Power System	3-2
3.1.3.4. Secondary Power System	3-5
3.1.3.5. Support Systems	3-6
3.1.3.6. USOS EPS Systems Interfaces	3-6
3.1.3.7. Power Resource Allocation	3-7
3.1.4. EPS Growth for Evolution	3-9
3.1.5. Bibliography	3-10
3.2. Thermal Control System	3-11
3.2.1. Introduction	3-11
3.2.2. Overview of TCS	3-11
3.2.3. Architecture and Components for TCS	3-11

- 3.2.3.1. Passive Thermal Control System 3-11
- 3.2.3.2. Active Thermal Control System 3-12
- 3.2.3.3. Early External Thermal Control System 3-14
- 3.2.3.4. External Thermal Control System 3-14
- 3.2.3.5. Thermal Resource Margin 3-14
- 3.2.4. TCS Growth for Evolution 3-14
- 3.2.5. Bibliography 3-17
- 3.3. Communications and Tracking System 3-19
 - 3.3.1. Introduction 3-19
 - 3.3.2. Overview 3-19
 - 3.3.3. Architecture and Components for C&TS 3-20
 - 3.3.3.1. Internal Audio Subsystem 3-20
 - 3.3.3.2. S-Band Subsystem 3-22
 - 3.3.3.3. Ultrahigh Frequency Communications Subsystem 3-24
 - 3.3.3.4. Video Distribution Subsystem 3-25
 - 3.3.3.5. Ku-Band Subsystem 3-27
 - 3.3.4. Growth Options and Scars 3-29
 - 3.3.5. Bibliography 3-30
- 3.4. Guidance, Navigation, and Control System 3-31
 - 3.4.1. Introduction 3-31
 - 3.4.2. Overview of GN&C System 3-31
 - 3.4.3. Architecture and Components for GN&C System 3-31
 - 3.4.3.1. Guidance 3-31
 - 3.4.3.2. Navigation 3-31
 - 3.4.3.3. Control 3-32
 - 3.4.4. Growth Options and Scars 3-33
 - 3.4.5. Bibliography 3-33
- 3.5. Structures and Mechanisms 3-35
 - 3.5.1. Introduction 3-35
 - 3.5.2. Overview 3-35
 - 3.5.3. Architecture and Components for Structures and Mechanisms 3-35
 - 3.5.3.1. Structures 3-35
 - 3.5.3.2. Mechanisms 3-38
 - 3.5.4. Growth Options 3-38
 - 3.5.5. Bibliography 3-40
- 3.6. Environmental Control and Life Support System 3-43
 - 3.6.1. Introduction 3-43
 - 3.6.2. Overview of ECLSS 3-43
 - 3.6.3. Architecture and Major Components for ECLSS 3-43
 - 3.6.3.1. Architecture 3-43
 - 3.6.3.2. Major Components 3-43
 - 3.6.4. Growth Options and Scars 3-47
 - 3.6.4.1. Atmosphere Revitalization 3-47
 - 3.6.4.2. Water Recovery and Management 3-47
 - 3.6.5. Bibliography 3-49
- 3.7. Command and Data Handling System 3-51
 - 3.7.1. Introduction 3-51
 - 3.7.2. Overview of C&DH 3-51

3.7.3. Architecture and Components for C&DH	3-52
3.7.3.1. Overview	3-52
3.7.3.2. Hierarchical Structure	3-52
3.7.3.3. Hardware Components	3-55
3.7.3.4. Software Components	3-58
3.7.4. Growth Options	3-59
3.7.5. Bibliography	3-59
3.8. Propulsion System	3-61
3.8.1. Introduction	3-61
3.8.2. Overview of Propulsion System	3-61
3.8.3. Architecture and Components for Propulsion System	3-61
3.8.3.1. Russian Components	3-61
3.8.3.2. U.S. Components	3-64
3.8.4. Contingency Options	3-66
3.8.5. Growth Options	3-66
3.8.6. Bibliography	3-66
3.9. Robotics	3-67
3.9.1. Introduction	3-67
3.9.2. Overview	3-67
3.9.3. Architecture and Components for Robotics	3-68
3.9.3.1. Mobile Servicing System	3-68
3.9.3.2. European Robotic Arm	3-73
3.9.3.3. Japanese Experiment Module Remote Manipulator System	3-74
3.9.4. Growth Options and Scars	3-75
3.9.5. Bibliography	3-75
3.10. Flight Crew Systems	3-77
3.10.1. Introduction	3-77
3.10.2. Overview	3-77
3.10.3. Crew Systems Subsystems	3-78
3.10.3.1. Crew Support Facilities	3-78
3.10.3.2. Crew Support Equipment and Provisions	3-79
3.10.3.3. Crew Health Care System	3-81
3.10.4. References	3-85
4. Baseline Utilization and Operations Plans	4-1
4.1. Introduction	4-1
4.2. Pressurized Payload Accommodations	4-3
4.2.1. Rack Accommodations	4-3
4.2.1.1. International Standard Payload Rack	4-3
4.2.1.2. Expediting the Processing of Experiments to Space Station Rack	4-4
4.2.1.3. Active Rack Isolation System	4-8
4.2.2. Facility Descriptions	4-10
4.2.2.1. Gravitational Biology Facility	4-10
4.2.2.2. Centrifuge	4-12
4.2.2.3. Life Sciences Glove Box	4-13
4.2.2.4. Human Research Facility	4-13
4.2.2.5. Biotechnology Facility	4-15
4.2.2.6. Fluids and Combustion Facility	4-16
4.2.2.7. Materials Science Research Facility	4-18

- 4.2.2.8. Microgravity Science Glove Box 4-19
- 4.2.2.9. Window Observational Research Facility 4-21
- 4.2.2.10. X-Ray Crystallography Facility 4-22
- 4.2.3. Bibliography 4-25
- 4.3. Attached Payloads. 4-27
 - 4.3.1. Integrated Truss Structure. 4-27
 - 4.3.1.1. Payload Attachment System. 4-29
 - 4.3.1.2. Unpressurized Cargo Carrier Attachment System 4-29
 - 4.3.1.3. Capture Latch Assembly 4-29
 - 4.3.1.4. Umbilical Mechanism Assembly 4-30
 - 4.3.1.5. EXPRESS Pallet System 4-30
 - 4.3.2. Japanese Experiment Module Exposed Facility 4-32
 - 4.3.3. Bibliography 4-34
- 4.4. Resource Timelines and Margin Summary. 4-35
 - 4.4.1. Power Utilization 4-35
 - 4.4.2. Thermal Utilization. 4-35
 - 4.4.3. Volume Assessments 4-35
 - 4.4.3.1. Middeck Allocations During Assembly 4-36
 - 4.4.3.2. ISS Pressurized Storage Volume 4-36
 - 4.4.4. Crew Time 4-36
 - 4.4.4.1. Crew Duty Time. 4-36
 - 4.4.4.2. Operations. 4-39
 - 4.4.4.3. Generic Crew Time Activity Data 4-40
 - 4.4.4.4. Crew Time Required for Payload Survival 4-40
 - 4.4.5. Command and Data Handling 4-41
 - 4.4.6. Communications. 4-41
 - 4.4.6.1. S-Band Utilization 4-41
 - 4.4.6.2. Ku-Band Utilization 4-42
 - 4.4.6.3. Ku-Band Forward Link Capability. 4-42
 - 4.4.7. Bibliography 4-42
- 4.5. ISS Cargo Traffic 4-47
 - 4.5.1. Introduction. 4-47
 - 4.5.2. Hardware Descriptions for Bags, Trays, and Lockers 4-47
 - 4.5.2.1. Cargo Transfer Bags. 4-47
 - 4.5.2.2. Stowage Trays 4-47
 - 4.5.2.3. Cargo Bags 4-49
 - 4.5.2.4. Progress Spacecraft Containers 4-49
 - 4.5.2.5. Middeck Locker Stowage. 4-49
 - 4.5.3. Hardware Descriptions for Racks and Platforms 4-50
 - 4.5.3.1. Resupply Stowage Rack 4-50
 - 4.5.3.2. Resupply Stowage Platform. 4-50
 - 4.5.3.3. Zero-g Stowage Rack 4-52
 - 4.5.4. Transportation Systems 4-53
 - 4.5.4.1. Space Shuttle 4-53
 - 4.5.4.2. Automated Transfer Vehicle 4-57
 - 4.5.4.3. H-II Transfer Vehicle 4-59
 - 4.5.4.4. Soyuz TM 4-60
 - 4.5.4.5. Progress M and M1 Vehicles 4-61
 - 4.5.5. Cargo Return Assessments 4-62

4.5.6. Traffic Assessment	4-64
4.5.7. Bibliography	4-65
4.6. Operations and Planning	4-67
4.6.1. Introduction	4-67
4.6.2. Planning Time Frames and Products	4-67
4.6.2.1. ISS Planning Time Frames	4-67
4.6.2.2. Planning Process	4-67
4.6.2.3. Increment Planning Process Template	4-68
4.6.2.4. Strategic Planning	4-68
4.6.2.5. Tactical Planning	4-69
4.6.2.6. Preincrement Planning	4-70
4.6.2.7. Increment Execution	4-72
4.6.3. Planning and Analysis Tools	4-74
4.6.3.1. The Integrated Planning System	4-74
4.6.4. Inventory Management	4-75
4.7. Acceleration Measurement Services	4-77
4.7.1. Introduction	4-77
4.7.2. Second-Generation Space Acceleration Measurement System	4-77
4.7.2.1. Interim Control Unit Capabilities	4-79
4.7.2.2. Remote Triaxial Sensor Capabilities	4-79
4.7.2.3. Operations and Data Analysis	4-79
4.7.2.4. Customers	4-80
4.7.3. Microgravity Acceleration Measurement System	4-80
4.7.3.1. Science Objective	4-80
4.7.3.2. Hardware Description	4-80
4.7.3.3. Miniature Electrostatic Accelerometer	4-80
4.7.4.4. Crew Operations	4-82
4.7.5. Principal Investigator Microgravity Services	4-82
4.7.5.1. Preflight Services	4-82
4.7.5.2. Experiment Operations Services	4-82
4.7.5.3. Postexperiment Services and Feedback	4-84
4.7.6. Bibliography	4-84
Appendix—Assembly Sequence	A-1

Acronyms and Abbreviations

AAA	avionics air assembly
ABC	audio bus coupler
AC	assembly complete
AD	audio dosimeter
ACBSP	assembly complete baseband signal processor
Acc	accessory
ACESE	attitude control and energy storage experiment
ACRFG	assembly complete radio frequency group
ACRV	advanced crew return vehicle
ACS	assembly contingency subsystem
ACS	attitude control system
ACS	atmosphere control and supply
ACT	advanced communications tower
ACU	arm computer unit
ADAM	Able deployable articulated mast
AERCam	autonomous EVA robotic camera
AES	air evaporation system
AFDIR	automated fault detection, isolation, and recovery
AFR	anchor foot restraint
AFRL	Air Force Research Laboratory
AL	airlock
ALSP	advanced life support pack
AMP	ambulatory medical pack
AMS	alpha magnetic spectrometer
ANR	active noise reduction
AP	attached payload
APAS	androgynous peripheral attachment system
APDS	autonomous peripheral docking system
APFR	articulating portable foot restraint
APM	attached pressurized module
APS	automated payload switch
AR	atmosphere revitalization
ARCU	American to Russian converter unit
ARIS	active rack isolation system
ASCR	assured safe crew return
ASI	Italian Space Agency (Agenzia Spaziale Italiana)
ATCS	active thermal control system
ATM	asynchronous transmission mode
ATU	audio terminal unit
ATV	automated transfer vehicle
AUAI	assembly-contingency/UHF audio interface
avg	average
AVF	artificial vision function
AVU	artificial vision unit
AVU CCD	artificial vision unit cursor control device
AZ	azimuth

Revision A, October 2000

BCDU	battery charge–discharge unit
BCTA	bias calibration table assembly
BEE	basic end effector
BG	beta gimbal
BGA	beta gimbal assembly
BP/EGG	blood pressure/electrocardiogram
BSP	baseband signal processor
BTF	biotechnology facility
C&C	command and control
C&DH	command and data handling
C&T	communication and tracking
C&TS	communication and tracking system
C&W	caution and warning
CADU	channel access data unit
Cal	calibration
CAM	centrifuge accommodation module
CATO	Communication and Tracking Officer
CBA	common berthing adapter
CBM	common berthing mechanism
CCACS	Center for Commercial Applications of Combustion in Space
CCDB	configuration control database
CCDPI	command, control, and data prime item
CCPK	crew contaminant protection kit
CCTV	closed circuit television
CDM	Commercial Development Manager
CDRA	carbon dioxide removal assembly
CEB	combined electronics box
CETA	crew and equipment translation assembly
CEU	control electronics unit
c.g.	center of gravity
CH	collection hardware
CHeCS	crew health care system
CHIA	cargo-handling interface adapter
CHRS	centralized heat removal system
CID	circuit interrupt device
CIR	combustion integrated rack
CLA	capture latch assembly
CM	Columbus module
CMC	Center for Macromolecular Crystallography
CMG	control moment gyroscope
CMILP	consolidated maintenance inventory logistics planning
CMO	crew medical officer
CMRS	crew medical restraint system
CMS	carbon molecular sieve
CMS	countermeasures system
CNS	central nervous system
COF	Columbus Orbital Facility
comm	communication
cont	continued

COR	communications outage recorder
COUP	consolidated operations and utilization plan
CPPI	crystal preparation prime item
CPRP	Critical Path Road Map Project
CPS	consolidated planning system
CPU	central processing unit
CRPCM	Canadian remote power control module
CRV	crew return vehicle
CSA	Canadian Space Agency
CSA-CP	compound specific analyzer–combustion products
CSA-H	compound specific analyzer–hydrazine
CSC	Commercial Space Centers
CSVS	Canadian space vision system
CTB	cargo transfer bag
CTM	crew transportation module
CU	control unit
CVIU	common video interface unit
CWC	collapsible waste container
DA	Deutsche Aerospace
DAC	design analysis cycle
DAIU	docked audio interface unit
D&C	display and control
DC	docking compartment
dc	direct current
DCC	dry cargo carrier
DCPCG	dynamically controlled protein crystal growth
DCSU	direct-current switching unit
DDCU	direct-current-to-direct-current converter unit
DECAT	Dynamic Engineering Communications Analysis Testbed
DES	data encryption standard
dev	develop or development
DLR	German Space Agency (Deutschen Zentrum für Luft- und Raumfahrt)
DOD	depth of discharge
DO45	Flight Planning and Pointing Group
DPO	attitude control thruster
DPU	data processing unit
DRM	design reference mission
DSM	docking and stowage module
EACP	EMU audio control panel
EACP	EVA audio control panel
EAS	early ammonia servicer
EATCS	external active thermal control system
ECCS	expendable charcoal catalyst system
ECLS	environmental control and life support
ECLSS	environmental control and life support system
ECOMM	early communication
ECS	early communication subsystem

Revision A, October 2000

ECU	electronics control unit
EDO	extended duration orbiter
EDV	electronic depressurizing valve
EE	electronics enclosure
EEATCS	early external active thermal control system
EEL	emergency egress light
EETCS	early external thermal control system
EEU	equipment exchange unit
EF	exposed facility
EFA	engineering feasibility assessment
EFGF	electrical flight grapple fixture
EFPL	exposed facility payload
EFU	exposed facility unit
EHS	environmental health system
EIA	experiment integration agreement
EL	elevation
ELM	experiment logistics module
ELM-ES	experiment logistics module-exposed section
ELM-PS	experiment logistics module-pressurized section
ELS	environmental life support
EM	experiment module
EMMI	EVA man-machine interface
EMU	extravehicular mobility unit
EPCE	electrical power-consuming equipment
EPS	electrical power system
ERA	European robotic arm
ER&T	engineering research and technology
ES	exposed section
ESA	European Space Agency
ESP	external stowage platform
est	estimated
ETCS	external thermal control system
ETOV	Earth-to-orbit vehicle
ETSD	external tool stowage device
ETVCG	external television camera group
EUE	experiment unique equipment
EVA	extravehicular activity
EVAS	extravehicular attachment structure
EV-CPDS	extravehicular-charged particle directional spectrometer
EVR	extravehicular robotics
EVSU	external video switch unit
ExMU	EXPRESS memory unit
ExP	EXPRESS pallet
ExPA	EXPRESS pallet adapter
ExPCA	EXPRESS pallet control assembly
EXPRESS	expediting the processing of experiments to Space Station
ExPS	EXPRESS pallet system
ExSD	EXPRESS stowage drawer

FAR Federal Acquisitions Requirements

4BMS	four-bed molecular sieve
FCF	fluids and combustion facility
FCMS	fluid crystal management system
FCS	flight crew system
FDIR	fault detection, isolation, and recovery
FDPA	flight dynamics planning and analysis
FDS	fire detection and suppression
FESS	flywheel energy storage system
FF	free flyer
FGB	functional cargo block
FIR	fluids integrated rack
FLEX	control of flexible construction systems
flex	flexible
F-O	fiber-optic
FOV	field of view
FRCB	Flight Rule Control Board
FRCS	forward reaction control system
FSE	flight support equipment
<i>g</i>	gravity or gravitational unit
GASMAP	gas analysis system for metabolic analysis of physiology
GBF	gravitational biology facility
GCR	galactic cosmic radiation
GFE	government furnished equipment
GFI	ground fault interrupter
GLONASS	global navigation satellite system
GN&C	guidance, navigation, and control
govt	government
GPS	global positioning system
GR&C	generic groundrules, requirements, and constraints
GRC	NASA John H. Glenn Research Center at Lewis Field
GUI	graphical user interface
Hab	habitation module
HCMG3X	momentum H of CMG3 in <i>x</i> direction
HCMG3Y	momentum H of CMG3 in <i>y</i> direction
HCMG3Z	momentum H of CMG3 in <i>z</i> direction
HD	highly directable
HDPCG	high-density protein crystal growth
HDR	high data rate
HDTV	high-definition television
HEDS	Human Exploration and Development of Space
HGA	high gain antenna
HIRAP	high-resolution accelerometer package
HLV	heavy lift vehicle
HMC	hydrogen master clock
HMI	human machine interface
HMS	health maintenance system
HPGA	high pressure gas assembly

Revision A, October 2000

HRDL	high rate data link
HRF	human research facility
HRFM	high rate frame multiplexer
HRM	high rate modem
HTL	high-temperature loop
HTV	H-2 transfer vehicle
I	increment
I_{sp}	specific impulse
IAA	intravehicular antenna assembly
IAC	internal audio controller
IAS	internal audio subsystem
ICC	integrated cargo carrier
ICD	instrument control document
ICK	insert contaminant kit
ICM	interim control module
ICU	interim control unit
ID	identification
IDA	integrated diode assembly
IDD	interface definition document
IDRP	increment definitions requirements plan
IEA	integrated equipment assembly
IEPT	International Execution Planning Team
IF	intermediate frequency
I/F	interface
IFHX	interface heat exchanger
IFM	in-flight maintenance
IIDP	increment implementation data pack
IMARS	ISS mission operations directorate avionics reconfiguration system
IMAX	maximum image
IMCA	integrated motor controller assembly
IMMI	IVA man-machine interface
IMS	inventory management system
Int	international
INPE	National Institute for Space Research—Brazil (Instituto Nacional de Pesquisas Espaciais)
I/O	input/output
IOCU	input/output controller unit
IOP	integrated operations plan
IP	International Partners
IPACS	integrated power and attitude control systems
IPS	integrated planning system
IR	infrared
ISIS	international subrack interface standard
ISPR	international standard payload rack
ISS	International Space Station
ISSA	International Space Station assembly
ISSP	International Space Station Program
ITA	integrated truss assembly
ITCS	internal thermal control system

ITS	integrated truss structure
IVA	intravehicular activity
IV-CPDS	intravehicular-charged particle directional spectrometer
IVSU	internal video switch unit
JEM	Japanese experiment module
JEM RMS	JEM remote manipulator system
JEU	joint electronics unit
JOP	joint operations plan
JSC	NASA Lyndon B. Johnson Space Center
KhSC	Khrunichev Space Center
KSC	NASA John F. Kennedy Space Center
Ku-band	Ku-band subsystem
KuRS	Ku radar system
L	launch
Lab	laboratory module
LAN	local area network
LaRC	NASA Langley Research Center
LCA	loop crossover assembly
LCA	Lab cradle assembly
LDA	launch deploy assembly
LDCR	long-duration crew restraint
LDFR	long-duration foot restraint
LDM	logistics double module
LDR	low data rate
LDU	linear drive unit
LEE	latching end effector
LEO	low Earth orbit
LGA	low gain antenna
LOS	loss of signal
LRDL	low rate data link
LSG	life sciences glove box
LSS	life support system
LT	laptop
LTL	low-temperature loop
LTU	load transfer unit
LVLH	local-vertical–local-horizontal
MA	main arm
maint	maintenance
MAMS	microgravity acceleration measurement system
MAS	microbial air sampler
MATE	multiplexer/demultiplexer application test equipment
MBF	mission build facility
MBS	mobile remote servicer base system

Revision A, October 2000

MBSU	main bus switching unit
MCAS	MBS common attachment system
MCC	Mission Control Center
MCC—H	Mission Control Center—Houston
MCC—M	Mission Control Center—Moscow
MCHL	master component heat load
MCS	motion control system
MCU	MBS computer unit
MCV	Medical College of Virginia
MDL	middeck locker
MDM	multiplexer-demultiplexer
MEC	medical equipment computer
MECO	main engine cutoff
MELFI	minus eighty degree laboratory freezer for ISS
MEO	medium Earth orbit
MESA	miniature electrostatic accelerometer
MF	multifiltration
MFU	multifiltration unit
MHI	Mitsubishi Heavy Industries, Ltd.
MIM	multi-increment manifest
MIMO	multiple-input–multiple-output
min	minimum
MIP	mission integration plan
MITAC	Medical Informatics and Technology Application Center
MITP	multilateral increment training plan
MLE	middeck locker equivalent
MLI	multilayer insulation
MMCC	metal monolith catalytic converter
MMH	monomethyl hydrazine
MM/OD	micrometeoroid/orbital debris
MOD	mission operation directorate
MPLM	multipurpose logistics module
MPV	manual procedure viewer
MRD	Microgravity Research Division
MRDL	medium rate data link
MSC	mobile servicing center
MSD	mass storage device
MSFC	NASA George C. Marshall Space Flight Center
MSG	microgravity science glove box
MSL	materials science laboratory
MSRF	materials science research facility
MSRR	materials science research rack
MSS	mobile servicing system
MT	mobile transporter
MTCL	MT capture latch
MTL	moderate-temperate loop
MTSAS	module truss structures attachment system
N/A	not applicable
NASA	National Aeronautics and Space Administration

NASDA	National Space Development Agency of Japan
NC	nozzle closed
NGO	nongovernment organization
NIA	nitrogen interface assembly
NO	nozzle open
NPCC	nonpressurized cargo carrier
NRA	NASA Research Announcement
NRL	Naval Research Laboratory
NTA	nitrogen tank assembly
OARE	orbital acceleration research experiment
OCA	orbiter communications adapter
OCCS	onboard complex control system
ODF	operations data file
ODS	orbiter docking system
OE/V	OSTP editor/viewer
OFA	operations feasibility assessment
OFTS	orbital flight targeting system
OMS	orbital maneuvering system
OOCI	OSTP/ODF crew interface
OOS	on-orbit operations summary
OPS	operations
OPS LAN	onboard operations local area network
ORU	orbital replacement unit
OSE	on-orbit support equipment
OSTP	onboard short-term plan
OTCM	ORU tool changeout mechanism
OTD	ORU transfer device
OWI	Operational Work Instruction
P&S	pointing and support
P ³ I	Preplanned Program Improvement
PAA	phased array antenna
PAO	Public Affairs Office
PAS	payload attachment system
PBA	portable breathing apparatus
PBS	Public Broadcasting Service
PCAP	payload crew activity plan
PCBA	portable clinical blood analyzer
PCC	pressurized cargo carrier
PCG	protein crystal growth
PCS	portable computer system
PCU	plasma contactor unit
PD	payload developer
PDA	power distribution assembly
PDAC	procedures development and control
PDGF	power and data grapple fixture
PDR	preliminary design review
PEHB	payload Ethernet hub/bridge

Revision A, October 2000

PEHG	payload Ethernet hub gateway
PFC	pump and flow control
PFCS	pump and flow control subassembly
PFE	portable fire extinguisher
PFM	pulse frequency modulation
PG	Product Groups
PHP	passive hearing protection
PI	prime investigation
PIA	payload integration agreement
PIA	port inboard aft
PIF	port inboard forward
PIM	Payload Integration Manager
PIMS	principal investigator microgravity services
PIP	payload integration plan
PIU	payload interface unit
PL	payload
PLSS	personal life support system
PM	pressurized module
PM	propulsion module
PMA	pressurized mating adapter
PMAD	power management and distribution
POA	payload/ORU accommodation
POA	port outboard aft
POCB	Payload Operations Control Board
PODF	payload operations data file
POF	port outboard forward
POIC	payload operations integration center
POIF	payload operations and integration function
POP	payload operations plan
PP	planning period
PPA	pump package assembly
prelim	preliminary
PRLA	payload retention latch actuators
prox	proximity
PS	pressurized section
PSD	power spectral density
PTCS	passive thermal control system
PTU	pan-tilt unit
PU	panel unit
PUL	portable utility light
PV	photovoltaic
PVA	photovoltaic array
PVCU	photovoltaic control unit
PVM	photovoltaic module
PVR	photovoltaic radiator
PVT	pressure-volume-temperature
PVTCS	photovoltaic thermal control system
PWP	portable work platform
QD	quick disconnect

R/A	return air
R&D	research and development
RAIU	Russian audio interface unit
RAM	random access memory
RAM	radiation area monitor
RBI	remote bus isolator
RCS	reaction control system
R/D	receiver/demodulator
ref	reference
RF	radio frequency
R/F	refrigerator/freezer
RFP	request for proposal
RGA	rate gyro assembly
RHC	rotational hand controller
RHX	regenerative heat exchanger
RIC	rack interface controller
RIS	remote triaxial sensor
RLV	reusable launch vehicle
RLVCC	RLV Control Center
RM	research module
RMS	remote manipulator system
ROEU	remotely operable electrical umbilical
ROS	Russian Orbital Segment
RPC	remote power controller
RPCM	remote power controller module
RPDA	remote power distribution assembly
RPF	robotics planning facility
rpm	revolutions per minute
R-S	receive-send
RSA	Russian Aviation and Space Agency
RSC-E	Rocket Space Corporation-Energia
RSP	respiratory support pack
RSP	resupply stowage platform
RSR	resupply stowage rack
RSS	reusable space system
RSU	roller suspension unit
RTAS	Boeing/Rocketdyne truss attachment system
RTS	remote triaxial sensor
RUPSM	resource utilization planning and system models
RVCO	RVE closeout
RVE	rack volume equivalent
RWS	robotics workstation
SA	Spar Aerospace
SAFER	simplified aid for EVA rescue
SAGE	strategic aerosol and gas experiment
SAMS	space acceleration measurement system
SAM-II	second-generation space acceleration measurement system
SAREX	Shuttle amateur radio experiment
SARJ	solar alpha rotary joint

Revision A, October 2000

SAW	solar array wing
S-band	S-band subsystem
SCU	sync and control unit
SDFR	short-duration foot restraint
SE	sensor enclosure
SFA	small fine arm
SFCA	system flow control assembly
SGANT	antenna group
SIA	starboard inboard aft
SIF	starboard inboard forward
SIR	standard interface rack
SKD	orbit correction engine
SLP	Spacelab pallet
SM	service module
SMMOD	service module micrometeoroid and orbital debris shield
SOA	starboard outboard aft
SOC	state of charge
SODF	systems operations data file
SOF	starboard outboard forward
SPDA	secondary power distribution assembly
SPDG	Space Product Development Group
SPDM	special purpose dexterous manipulator
spec	specification
SPG	single point ground
SPP	science power platform
SPV	single-pressure vessel
SRMS	Shuttle remote manipulator system
SRTM	Shuttle radar topography mission
SS	Space Shuttle
SSAS	segment-to-segment attachment system
SSBRP	Space Station Biological Research Project
SSC	Station support computer
SSCB	Space Station Control Board
SSCS	space-to-space communication system
SSK	surface sampler kit
SSP	Space Shuttle Program
SSPCM	solid-state power control module
SSRMS	Space Station remote manipulator system
SSSR	space-to-Space-Station radio
SSU	sequential shunt unit
STP	short-term plan
STS	Space Transportation System
SVS	space vision system
S/W	software
T	takeoff or time
TBD	to be determined
TBS	to be supplied
TCCS	trace contaminate control subassembly
TCP/IP	transmission control protocol/internet protocol

TCS	thermal control system
TD	transfer device
TDRS	tracking and data relay satellite
TDRSS	tracking and data relay satellite system
TEA	torque equilibrium attitude
TEF	thermal electric freezer
TEPC	tissue equivalent proportional counter
TH	TransHab
THC	temperature and humidity control
THC	translational hand controller
TM	transport spacecraft, modified
TPA	tissue plasminogen activator
TRC	transmitter/receiver/controller
TRL	technology readiness level
TRRJ	thermal radiator rotary joint
TSC	Telescience Support Center
TSH	triaxial sensor heads
TUS	trailing umbilical system
TWMV	three-way mix valve
UAB CBSE	University of Alabama at Birmingham Center for Biological Sciences and Engineering
UCC	unpressurized cargo carrier
UCCAS	unpressurized cargo carrier attachment system
UCS	ultrahigh frequency communication system
UDM	universal docking module
UF	utilization flight
UHF	ultrahigh frequency
ULC	unpressurized logistics carrier
ULCAS	upper ULC attachment system
UMA	umbilical mechanism assembly
UOP	utility outlet panel
UP	urine processor
U.S.	United States
USAF	United States Air Force
USFS	U.S. Flywheel Systems, Inc.
USOS	U.S. on-orbit segment
UTA	utility transfer assembly
VASIMAR	variable specific impulse magnetoplasma rocket
VAX	virtual architecture extendable
VBSP	video baseband signal processor
VCD	vapor compression distillation
VCMS	video commanding and measuring system
VDS	video distribution system
verif	verification
VES	vacuum exhaust system
VOA	volatile organic analyzer
VRA	volatile removal assembly

Revision A, October 2000

VS	vacuum system
VSR	vacuum resource system
VSU	video switch unit
VTR	video tape recorder
WIF	worksite interfaces
WM	waste management
WMK	water microbiology kit
WORF	window observational research facility
WRM	water recovery and management
W/S	workstation
WSGS	White Sands Ground Station
WSS	workstation stanchions
WV	work volume
WWW	Worldwide Web
X,Y,Z	axes
XCF	X-ray crystallography facility
XDPI	X-ray diffraction prime item
XPNDR	standard TDRSS transponder
XPOP	X-axis perpendicular to orbit plane
ZEM	Z1 experiment module
ZOE	zone of exclusion
ZSR	zero-g stowage rack.
ϕ_x, θ_y, ψ_z	polar coordinates

1. Introduction

The International Space Station (ISS) will provide an Earth-orbiting facility that will accommodate engineering experiments as well as research in a microgravity environment for life and natural sciences. The ISS will distribute resource utilities and support permanent human habitation for conducting this research and experimentation in a safe and habitable environment. The objectives of the ISS program are to develop a world-class, international orbiting laboratory for conducting high-value scientific research for the benefit of humans on Earth; to provide access to the microgravity environment; to develop the ability to live and work in space for extended periods; and to provide a research test bed for developing advanced technology for human and robotic exploration of space.

The current design and development of the ISS has been achieved through the outstanding efforts of many talented engineers, designers, technicians, and support personnel who have dedicated their time and hard work to producing a state-of-the-art Space Station. Despite these efforts, the current design of the ISS has limitations that have resulted from cost and technology issues. Regardless, the ISS must evolve during its operational lifetime to respond to changing user needs and long-term national and international goals. As technologies develop and user needs change, the ISS will be modified to meet these demands. The design and development of these modifications should begin now to prevent a significant lapse in time between the baseline design and the realization of future opportunities.

For this effort to begin, an understanding of the baseline systems and current available opportunities for utilization needs to be achieved. Volume I of this document provides the consolidated overview of the ISS baseline systems. It also provides information on the current facilities available for pressurized and unpressurized payloads. Information on current plans for crew availability and utilization; resource timelines and margin summaries including power, thermal, and storage volumes; and an overview of the ISS cargo traffic and the vehicle traffic model is also included.

This information is general and does not provide the relevant information necessary for detailed design efforts. This document is meant to educate readers about the ISS and to stimulate the generation of ideas for the enhancement and utilization of the ISS either by or for the government, academia, and commercial industry. This document will be kept as up-to-date as possible. (The present document is Revision A.) Revisions to this document will be made as necessary to ensure that the most current information available is accessible to the users of this document. Much of the baseline configuration description is derived from the International Space Station Familiarization Document, TD9702A, ISS FAM C 21109, NASA Johnson Space Center, July 31, 1998.

The developers of this document welcome comments, questions, or concerns regarding the information contained herein. We are looking for input that will enhance sparse areas of the document with additional information, as well as suggestions for refining areas that may contain excessive information outside the scope of this document. Please direct any issues or suggestions regarding the ISS Evolution Data Book to

Jeff Antol
ISS Evolution Data Book Manager
M.S. 328
NASA Langley Research Center
Hampton, VA 23681-2199
Phone: (757) 864-5804
E-mail: j.antol@larc.nasa.gov

2. ISS Baseline Assembly Complete

2.1. ISS Program Organization

To accomplish the ISS objectives, the National Aeronautics and Space Administration (NASA) has joined with five other space agencies and their major contractors. (See fig. 2.1-1.) In addition to NASA, with the Boeing Company as the prime contractor, the ISS Program consists of the following:

- Russian Aviation and Space Agency (RSA)
- Canadian Space Agency (CSA)
- National Space Development Agency of Japan (NASDA)
- European Space Agency (ESA)
- National Institute for Space Research (INPE)—Brazil
- Italian Space Agency (ASI)

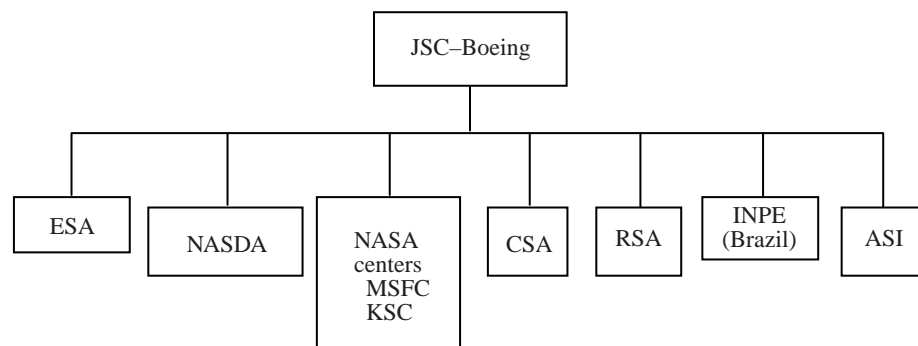

Figure 2.1-1. ISS program organization chart.

2.2. ISS Configuration Assembly Overview

At assembly complete (AC), the ISS will be approximately three to four times larger than the present Mir Space Station. In relative terms, the ISS will be the length of a football field (100 m). The ISS will have

- A pressurized volume of 1200 m³
- Mass of 419000 kg
- Maximum power output of 100 kW with a payload average power allocation of 30 kW
- A structure that measures 108.4 m (truss length) by 74 m (modules length)
- An orbital altitude of 370–460 km
- An orbital inclination of 51.6°
- A crew of seven at AC (three with 2R Soyuz)

Building the ISS requires more than 50 flights over a period of 4.5 to 5 yr. The Shuttle flies 31 of the flights, 24 of which are dedicated to ISS assembly tasks and are referred to as the “A flights” (e.g., flight 5A which is the fifth U.S. Shuttle assembly flight). Seven are utilization logistics flights dedicated to bringing up the Station logistics, science, and engineering experiments and are referred to as the “UF flights” (e.g., UF-2). Approximately 11 Soyuz flights will be required to provide crew rotation and crew escape capability. Prior to the delivery of the U.S. crew return vehicle (CRV) some of the Shuttle flights will also be used for crew rotation (bringing up a “new” crew and/or returning the “old” crew). Another 10 unmanned Russian assembly flights, required to bring up the Russian segment modules, will generally be launched on a Proton and referred to as the “R flights” (e.g., flight 1R). This number (50+) does not include all the resupply and logistics flights. Approximately 30 Russian Progress M1 flights are required by AC to provide logistics. The Progress spacecraft is used to provide the propulsion to support ISS reboosts. This is in addition to the use of the U.S. propulsion modules, which scavenges fuel from the shuttle and also supports the propulsive needs of the ISS.

2.3. Baseline Assembly Complete Description

The 50+ flights bring up and assemble the various modules and elements of the ISS. The following paragraphs address the modules and elements in the approximate order that they are assembled (per latest Assembly Sequence). Figure 2.3-1 illustrates the ISS at AC.

2.3.1. Zarya

Zarya (Russian for sunrise), known as the functional cargo block (FCB), is the first element and was launched in November 1998. Zarya was built by Khrunichev Space Center (KhSC) and launched and controlled by Mission Control Center—Moscow (MCC—M). It was funded, however, by NASA. Zarya is a self-contained vehicle capable of independent unmanned orbital operations. Zarya serves as the Station “building block” because it provides all the critical system functions until Zvezda, the service module (SM), is activated. After Zvezda is activated, Zarya is basically powered down and serves only as a backup and propellant storage tank for Zvezda. It also provides storage volume for the ISS. It continues to provide power to the U.S. elements through flight 15A.

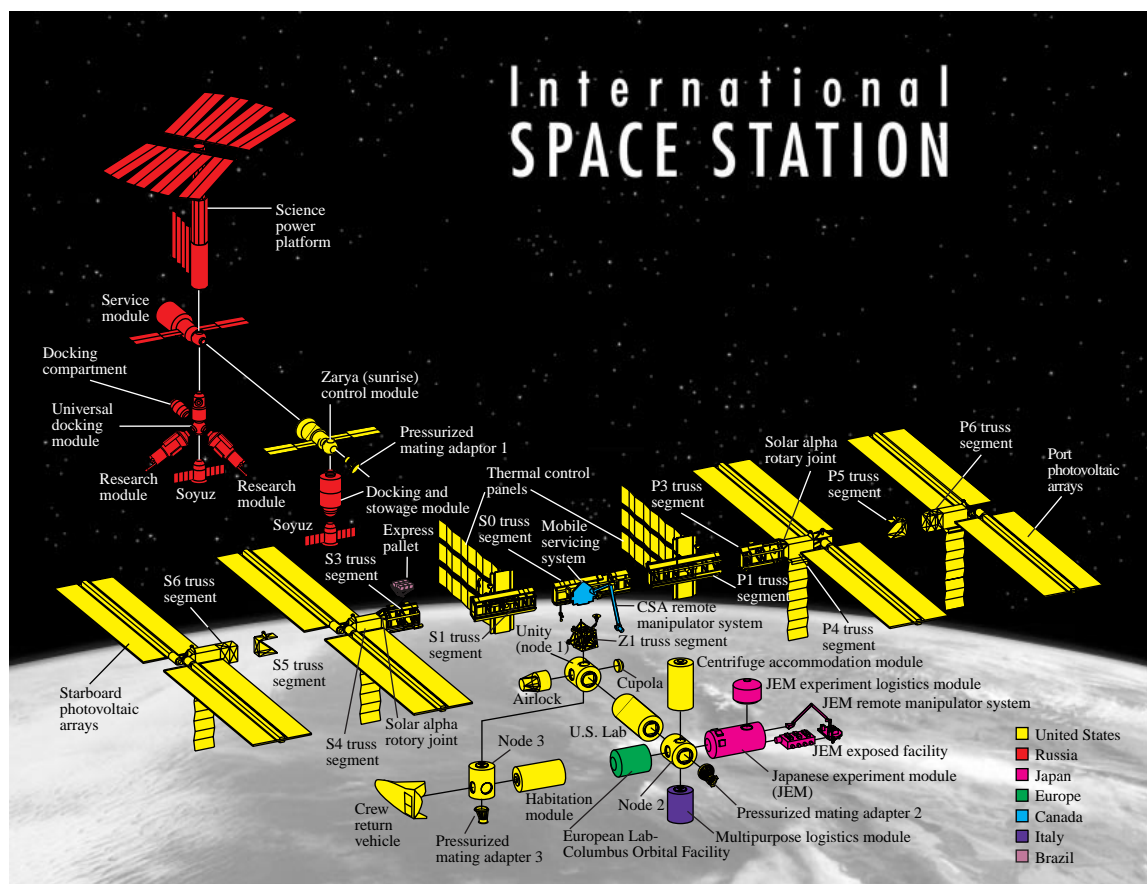

Fig. 2.3-1. International Space Station at assembly complete.

2.3.2. Node

The node is a U.S. element that provides six docking ports (four radial and two axial) for the attachment of other modules. It also provides external attachment points for the truss. There are three nodes. Node 1 provides internal storage and pressurized access between modules. Nodes 2 and 3 are longer to accommodate additional racks. The first node (Unity) was launched into orbit and connected with Zarya in December 1998.

2.3.3. Zvezda

Zvezda (Russian for star), also known as the Service Module, is similar in layout to the core module of the Russian Mir Space Station and provides the early Station living quarters, life support system, communication system, electrical power distribution, data processing system, flight control system, and propulsion system. Although many of these systems will be supplemented or replaced by later U.S. Station components, Zvezda always remains the structural and functional center of the Russian Orbital Segment (ROS). Living accommodations on Zvezda include personal sleeping quarters for the crew, toilet and hygiene facilities, galley with a refrigerator-freezer, and table for securing meals while eating. Spacewalks using Russian Orlan-M spacesuits can be performed from Zvezda by using the transfer compartment as an airlock.

2.3.4. Soyuz

Besides being an Earth-to-orbit vehicle (ETOV) used for crew rotations, Soyuz is the Russian element that provides the crew emergency return (“lifeboat”) capability, prior to the delivery of the U.S. CRV. After the U.S. CRV delivery, the Soyuz will continue to be used for rotation and emergency return of crewmembers, at least through AC. As such, a Soyuz is always docked to the Station whenever the Station crew is onboard. At least every 6 mo, the docked Soyuz is replaced with a “new” Soyuz.

2.3.5. Laboratory

The laboratory module (Lab) is a U.S. element that provides equipment for research and technology development. It also houses all the necessary systems to support a laboratory environment and control the U.S. segment.

2.3.6. MultiPurpose Logistics Module

Because the multipurpose logistics module (MPLM) is provided by ASI to NASA, through a bilateral agreement, it is considered a part of the U.S. on-orbit segment (USOS). Three MPLM’s will be in operation by AC, with the first being named Leonardo. It allows transfer of pressurized cargo and payloads. It is launched on the Shuttle and berthed to node 1, where supplies are off-loaded and finished experiments and return items are loaded. The MPLM is then reberthed in the Shuttle for return to Earth. The MPLM will be used numerous times during the lifetime of the Station.

2.3.7. Joint Airlock

The joint airlock is a U.S. element that provides Station-based extravehicular activity (EVA) capability with either a U.S. extravehicular mobility unit (EMU) or Russian Orlan EVA suits.

2.3.8. Interim Control Module

The interim control module (ICM) is a U.S. module built by the Naval Research Laboratory capable of providing the guidance, navigation, control, and propulsion functions for the ISS. (ICM is not shown in fig. 2.2-1.) Whether the ICM is used and what exact functions it provides are dependent on the timing and capabilities of the Zvezda. The ICM is planned to be a permanent feature of the ISS.

2.3.9. Docking Compartment

There are two Russian element docking compartments (DC's) to provide egress or ingress capability for Russian-based EVA's and additional docking ports.

2.3.10. Truss

The truss, built over numerous flights, is a U.S. element that provides the ISS "backbone" and attachment points for modules, payloads, and systems equipment. It also houses umbilicals, radiators, external payloads, and batteries. The truss is based on the *Freedom* preintegrated truss design. The truss segments are labeled by whether they are on the starboard (right) or port (left) side of the Station and its location. An example is the P6 truss located on the outermost port side. Two exceptions to this labeling scheme are truss S0, which is actually the center truss segment, and during early assembly, the P6 truss segment, with its photovoltaic array (PVA), is actually mounted on the Z1 truss on the Lab. The Z1 truss itself is an anomaly in that it is not part of the main truss but a truss segment needed under the ISS design until the main truss is built. The truss contains four sites for mounting payloads and two sites for mounting logistics carriers.

2.3.11. Science Power Platform

The science power platform (SPP) is a Russian element that is brought up by the Shuttle to provide additional power and roll axis attitude control capability.

2.3.12. Universal Docking Module

The universal docking module (UDM) is a Russian element that provides a five-port docking mode for additional Russian modules and vehicles. It performs the same function as the U.S. nodes and also has deployed arrays for power generation.

2.3.13. Japanese Experiment Module

The Japanese experiment module (JEM) is an element that provides laboratory facilities for Japanese material processing and life science research. It also contains an external platform, airlock, and robotic manipulator for in-space ("exposed") experiments and a separate logistics module to transport JEM experiments. Based upon a bilateral agreement between NASA and NASDA, NASA also has rights to use a percentage of the JEM.

2.3.14. Docking and Stowage Module

The docking and stowage module (DSM) is a Russian element that provides facilities for stowage and additional docking ports. Currently one DSM will be used. The DSM has deployed arrays for power generation.

2.3.15. Cupola

The cupola is a U.S. element that provides direct viewing for robotic operations and Shuttle payload bay viewing and is provided by ESA through a bilateral agreement.

2.3.16. Research Module

The research module (RM) is a Russian element that provides facilities for the Russian experiments and research. It is analogous to the U.S. Lab but will include externally mounted payloads. Two RM's will be used.

2.3.17. Columbus Module

The Columbus module (CM), also known as the Columbus attached pressurized module (APM) and the Columbus Orbital Facility (COF), is an ESA element that provides facilities for the ESA internal and external experiments and research. It is analogous to the U.S. Lab. Based upon a bilateral agreement between NASA and ESA, NASA also has rights to use a percentage of the CM. The CM has four sites on its end cone that can hold small external payloads.

2.3.18. Crew Return Vehicle

Similar to the Soyuz, the CRV provides the emergency crew return ("lifeboat") function. Although the exact design is still to be determined (TBD), it will be based on NASA's X-38. The X-38 will have a seven-person return capability, and therefore its presence is a requirement for going to a seven-person crew. The CRV will have a fully automated deorbit-landing mode, although the crew can manually override landing site selections.

2.3.19. Centrifuge Accommodation Module

The centrifuge accommodation module (CAM) is a U.S. element that provides centrifuge facilities for science and research and is provided by NASDA through a bilateral agreement. It also houses additional payload racks.

2.3.20. Habitation Module

The Hab is a U.S. element that provides six-person habitation facilities, such as personal hygiene (waste management, full body shower), crew health care, and galley facilities (wardroom with eating facilities, oven, drink dispenser, freezer-refrigerator).

2.3.21. Logistics Vehicles

Logistics flights are required throughout the life of the ISS and will be accomplished by using a variety of vehicles. The Shuttle will be used to bring water, pressurized and unpressurized cargo, and gases. When the MPLM is used, the Shuttle can bring nearly 9 metric tons of pressurized cargo to ISS. The Shuttle is also the only means for returning items intact from ISS. After the delivery of the propulsion module (PM), the Shuttle will also provide excess propellant from its tanks to the ISS.

Progress M vehicles with different payload capability are provided by RSA and used to accomplish three primary tasks: orbital reboost, attitude control fuel resupply, and pressurized cargo resupply. It will be launched on a Soyuz booster. Fuel that is not required for a reboost is transferred to the Zarya and Zvezda tanks to be used for propulsive attitude control. Pressurized cargo includes oxygen, nitrogen, food, clothing, personal articles, and water. The Progress is filled with trash as its stores are consumed, and when exhausted, undocks, deorbits, and reenters the atmosphere over the Pacific Ocean.

The automated transfer vehicle (ATV) is provided by ESA and is scheduled to be completed in 2003. It will be launched on an Ariane V launch vehicle and will dock to Zvezda. It is roughly three times as large as the Progress M1. It is used to deliver pressurized cargo and propellant to the ISS.

The H-2 Transfer Vehicle (HTV) is provided by NASDA and is scheduled to be completed in 2002. It will be launched on an H-2A launch vehicle and will be berthed by the Space Station remote manipulator system (SSRMS) to node 2 nadir. Its purpose is to carry pressurized and unpressurized cargo. The HTV can be configured to carry both pressurized and unpressurized payloads in a mixed configuration or to carry only pressurized cargo. It performs rendezvous and approaches the forward end of the Station where it is grappled by a robotic arm and berthed.

Section 4.5.4 of this document provides more detailed information on the logistics vehicles for the ISS.

3. System Descriptions

This section gives a basic functional and physical description of each of the primary systems onboard the ISS. Each description provides an overview of the components of the system, the architecture of the system, the assembly sequence milestones, and the growth potential of the system.

3.1. Electrical Power System

3.1.1. Introduction

The ISS electrical power system (EPS) provides power for all ISS functions such as command and control, communications, lighting, life support. Both the USOS and the ROS have the capability and responsibility for providing on-orbit power sources for their own segments as well as power sharing, as required, to support assembly and ISS operations for all International Partners (IP). The USOS and ROS EPS's are responsible for providing a safeguarded source of uninterrupted electrical power for ISS. To accomplish this task, the EPS must generate and store power, convert and distribute power to users, protect both the system and users from electrical hazards, and provide the means for controlling and monitoring system performance. These functions are performed by interrelated ISS hardware and software, which are discussed in section 3.1.4. Information from the documents listed in the bibliography (section 3.1.5) was used to compile this section.

3.1.2. Overview of EPS

The USOS EPS is a distributed power system; that is, power is produced in localized areas and then distributed to various modules. Five core functions are necessary to achieve the function of the EPS: generate primary power, store primary power, distribute primary power, convert primary power to secondary power, and distribute secondary power to users. In addition, three support functions must be accomplished: thermal control of EPS components, grounding of EPS components and ISS, and managing and controlling the EPS components. The assembly sequence for the primary elements of the EPS can be found in the appendix.

3.1.3. Architecture and Components for EPS

3.1.3.1. Power System Requirements

At AC, the EPS is required to supply user average and minimum continuous payload power of 30 and 26 kW, respectively. The requirements are based on an orbit of 220 nmi altitude, local-vertical–local-horizontal (LVLH) attitude, inclination of 51.6°, solar flux of 1371 W/m², albedo of 0.27, Earth infrared of 241 W/m², solar beta angle of ±52°. All other EPS requirements flow down from this 30-kW requirement (i.e., power quality requirements are specified at the equipment interfaces shown in fig. 3.1-1). During ISS buildup, the assembly “Stage” related user payload power allocations are goals. These allocations are described in section 3.1.3.7.

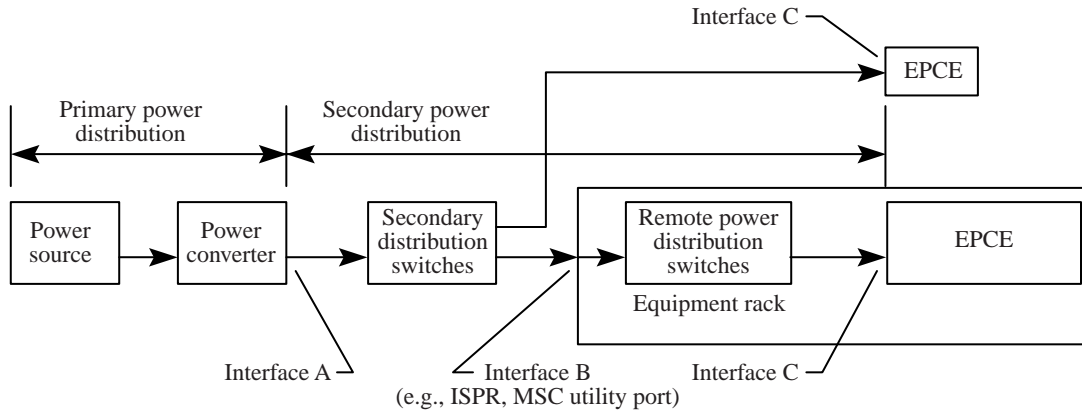

Figure 3.1-1. Power quality at equipment interfaces.

3.1.3.2. USOS EPS Functional Design

USOS EPS design incorporates photovoltaic modules (PVM's) that are dedicated to generating and storing power. Each of the four modules or "power plants" at AC provide two independent sources of primary power (approximately 23 kW of power at ≈ 160 V dc) called power channels. During both insolation and eclipse, each power channel provides a continuous supply of power for distribution throughout ISS. Primary power is converted to secondary power (≈ 124 V dc) in proximity to its users. The PVM's are independent power plants that add to the primary power production capability. The secondary power system, on the other hand, is a local power network that is integrated into the trusses, modules, and racks of the ISS.

The USOS EPS functions have been loosely grouped into three main subsystems: primary power system, secondary power system, and support systems. The entire power system, except for grounding and control, is illustrated in figure 3.1-2. The following sections briefly describe each of the three main subsystems, as well as their functions and components.

3.1.3.3. Primary Power System

The basic building block of the USOS EPS primary power system architecture is the power channel, which is a "group" of hardware components, beginning with a solar array, that is responsible for providing an independent primary power source. The primary power system can be seen in figure 3.1-3. The following components comprise a power channel:

- Solar array wing (SAW), including two photovoltaic (PV) blankets, the right and left blanket boxes, mast, and mast container
- Sequential shunt unit (SSU)
- Beta gimbal assembly (BGA)
- Electronics control unit (ECU)
- Direct-current switching unit (DCSU)

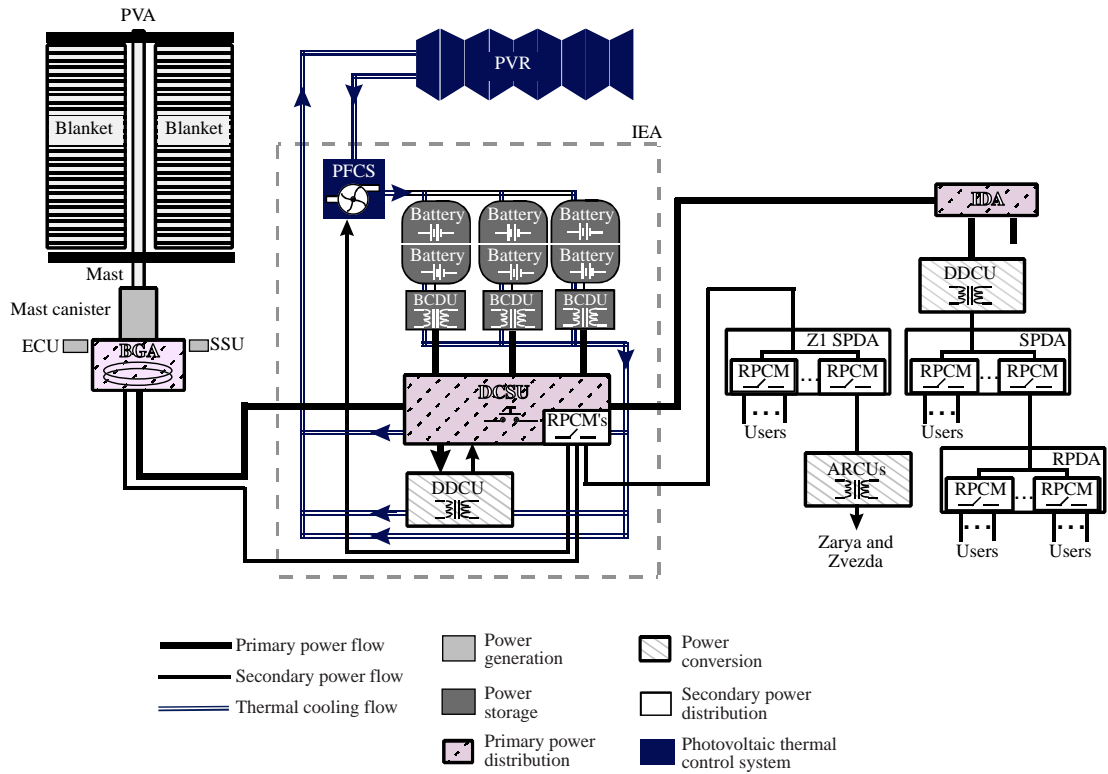

Figure 3.1-2. USOS EPS.

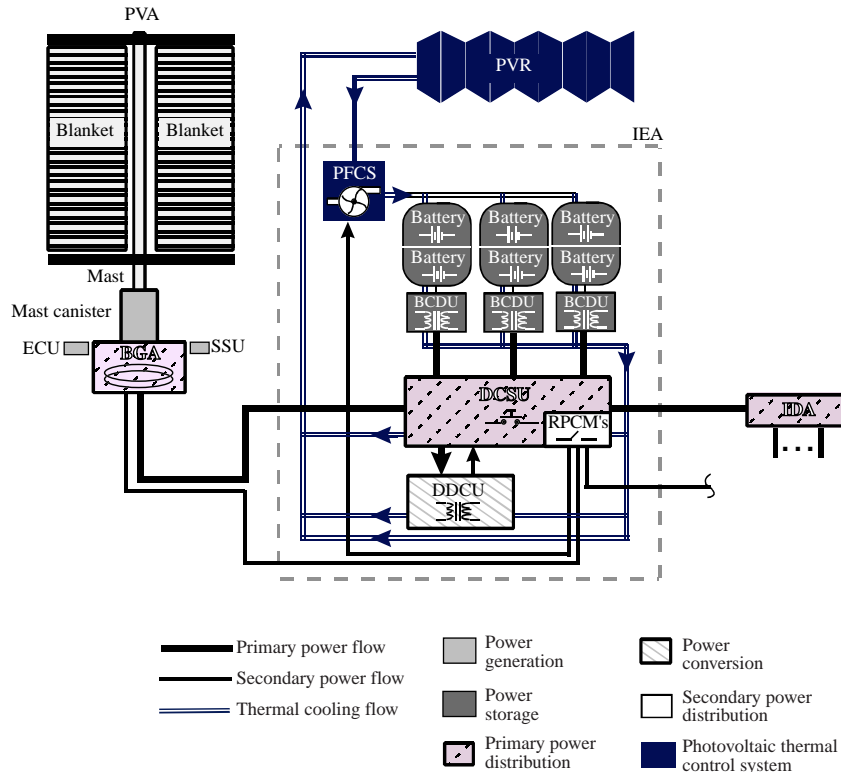

Figure 3.1-3. Primary power system.

- Three battery charge–discharge units (BCDU’s)
- Three battery assemblies (two–battery orbital replacement units (ORU’s) per assembly)

Though direct-current-to-direct-current converter units (DDCU’s) are generally associated with the secondary power system, each power channel also includes a DDCU to provide secondary power for integrated equipment assembly (IEA) components.

3.1.3.3.1. Primary Power Generation

Power generation onboard ISS includes conversion of solar energy to electrical energy, as well as the regulation of that electrical energy. The power generation function is accomplished by the PV blankets and structural support hardware (blanket boxes, mast, mast canister), BGA, ECU, and SSU. Regulation of the array output voltage is required because of the performance characteristics of PV cells; that is, output voltage is a function of the load placed on the cells, and this results in a varying power source. To accomplish this, the SSU receives power directly from the PV array and maintains output voltage within a specified range of 130 to 173V dc (normally 160 V dc that is referred to as “primary power voltage”). All EPS equipment or components that use primary power are designed to accept power within this wide voltage range. The rationale for regulating power within such a wide range is to account for

- Line losses resulting from transferring power across significant distances on ISS
- Flexibility in regulation to account for downstream hardware degradation and aging (i.e., solar cell aging results in a significant drop in peak output voltage)
- Output voltage of solar cells that vary significantly as a function of load

Thus, the SSU considers these factors, stabilizes the SAW output voltage based upon a voltage setpoint, and relies upon the secondary power system to provide consistent, tightly regulated ≈ 124 V dc secondary power to users for the life of the ISS.

3.1.3.3.2. Primary Power Storage

The power storage function is performed by batteries and BCDU’s. The actual storage devices are nickel hydrogen (NiH₂) battery assemblies, each having its own BCDU to control its state of charge (SOC). During insolation, array power is used to charge the batteries and run the station core and payloads; during eclipse, a portion of the stored battery power is discharged to supply the ISS. Stored power may also be used to supplement the power generation function during insolation, that is, to satisfy a temporary high power load on the EPS or to supply power if a failure occurs within the power generation function (including failure of the SAW orientation function). If the power generation function fails, the batteries can supply power for one complete orbit following a period of orbital eclipse with a reduced ISS power consumption rate.

3.1.3.3.3. Primary Power Distribution

Primary power distribution for a power channel is the function of the DCSU. Using a network of high power switches called remote bus isolators (RBI’s), the DCSU interconnects arrays and batteries to the primary power distribution bus. During insolation, the DCSU routes power from the arrays to the ISS, as well as to the BCDU’s for battery charging. During eclipse, the DCSU

routes battery power to the ISS to satisfy power demands. In addition to primary power distribution, the DCSU has the additional responsibility for routing secondary power to components on the PVM (e.g., the ECU and other support components). This secondary power is provided by the DDCU located on the IEA. The DDCU receives primary power from the DCSU, converts it into secondary power, and sends it back to remote power controller modules (RPCM's) for distribution. (See section 3.1.3.4.)

3.1.3.4. Secondary Power System

The secondary power system is illustrated in figure 3.1-4. The first step in the local power distribution is the conversion from primary power (≈ 160 V dc) to secondary power (≈ 124 V dc). Power conversion occurs in various areas throughout the ISS, within pressurized modules, on truss segments and on the IEA, that is, near wherever users require secondary power. After conversion, secondary power is distributed through a network of power distribution assemblies. The active components within these distribution boxes are remotely commanded switches that control and monitor the flow of power through the network to individual users, such as systems, payloads, crew equipment, EPS components.

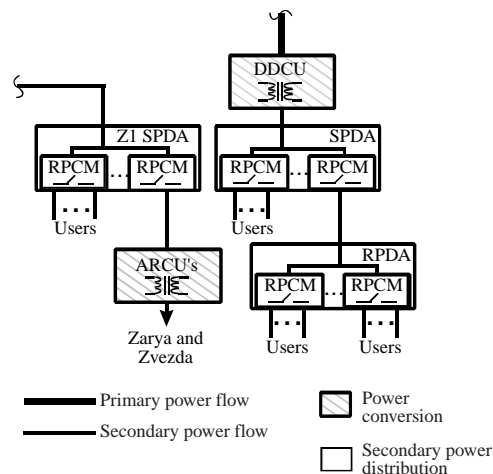

Figure 3.1-4. Secondary power system.

3.1.3.4.1. Secondary Power Conversion

The secondary power conversion function uses one type of ORU, the DDCU, which converts primary power into secondary power by using a transformer. Each DDCU has one primary power input and one secondary power output. As discussed earlier, the primary power voltage is typically ≈ 160 V dc but can vary over a wide range, whereas the output is specified to be ≈ 124 V dc, which is the prescribed voltage for all users of the secondary power system. If any other voltage level is required by user loads (e.g., payloads or crew equipment), then it is the responsibility of the user to perform the conversion from ≈ 124 V dc to the required voltage.

3.1.3.4.2. Secondary Power Distribution

The workhorse of the secondary power distribution system is the RPCM, an ORU, which contains solid-state or electromechanical relays, known as remote power controllers (RPC's). These

switches can be remotely commanded to control the flow of power through the distribution network and to the users. Secondary power originates in a DDCU and is then distributed through a network of ORU's called secondary power distribution assemblies (SPDA's) and remote power distribution assemblies (RPDA's). SPDA's and RPDA's are essentially housings that contain one or more RPCM's. The designation, either SPDA or RPDA, refers to the level of hierarchy within the distribution system. As a general rule, the hierarchy dictates that DDCU's feed power to SPDA's, which either provide power to one or more user loads or RPDA's. RPDA's, in turn, feed power to one or more user loads. Note that RPCM's have only one power input; thus, if power is lost at any level of the secondary power system, all downstream user loads will be without power. As mentioned previously, there is no redundancy in the secondary power system; rather, redundancy is a function of the user loads. For example, a critical user load may be able to select between two input power sources that use different power channels and thus different secondary power paths.

3.1.3.5. Support Systems

3.1.3.5.1. Thermal Control

USOS EPS PVM's are designed with their own photovoltaic thermal control system (PVTCS). This design is necessary because at AC, all PVM's are separated from the ISS by 360° rotating solar alpha rotary joints (SARJ's) which pass power and data, but not fluids. Thus, PVM's cannot interface with the ISS thermal control system (TCS). Each power channel has its own independent PVTCS consisting of one pump and flow control subassembly (PFCS) ORU and cold plates, coolant lines, and ammonia coolant which are integrated into the IEA. The PVTCS has redundancy with two PFC's and through a series of directional control valves. Each IEA also has a photovoltaic radiator (PVR), which rejects the heat generated by both channels of the PVM.

3.1.3.5.2. Grounding

The grounding function is incorporated in the single point ground (SPG) architecture that maintains all components on the ISS at a common potential. Another potential shock hazard exists when equipment such as personal computers are connected to utility outlet panels (UOP's). To eliminate this hazard, ground fault interrupters (GFI's) are installed on all utility outlet panels to detect short circuits and disconnect equipment from the power source.

3.1.3.5.3. Command and Control

Operating behind all these previously mentioned functions, four tiers of command and control units or applications work to monitor and control the operation of the USOS EPS. Command and control of the USOS EPS are provided by software applications and hardware which provide system monitoring and reconfiguration capabilities from both onboard and the ground. The onboard capability allows the crew to determine system status and provides any required reconfiguration for systems operations. Ground control and monitoring are required to support ISS EPS operations, analysis, and planning.

3.1.3.6. USOS EPS Systems Interfaces

3.1.3.6.1. Guidance, Navigation, and Control

To orient the arrays, the guidance, navigation, and control (GN&C) multiplexer-demultiplexer (MDM) broadcasts target angles for the BGA's. These data are routed to the photovoltaic control unit (PVCU), which commands the BGA to the proper orientation.

3.1.3.6.2. Command and Data Handling

Command and data handling (C&DH) provides all MDM's, data processors, and data buses required for the execution environment of the EPS software applications that provide the control and monitoring functions. Data communications include the transmission of commands, status, and data parameters required to monitor and control the EPS.

3.1.3.6.3. Thermal Control System

EPS components interface with the ISS TCS for thermal control. On the PVM's and the Z1 truss, the ISS TCS is not available. Consequently, PVM's use the PVTCS for active thermal control of IEA components, and DDCU's, SPDA's, and RPDA's located on the Z1 truss use heat pipes for passive cooling.

3.1.3.7. Power Resource Allocation

Program power reserve is the quantity of power held by the Program Office in addition to existing allocations to ensure a suitable risk level for the vehicle during the development stage and at AC. Program power reserve is the percentage of total USOS housekeeping power estimate that is held back from the total USOS generation. The channel balance allocation of 500 W for each power channel is provided as an overhead for the power system and the station software operating system. A graphical representation of the power resource contributions including the reserve policy is shown in figure 3.1-5. Table 3.1-1 shows the allocated power for user payloads for all the assembly stages; figure 3.1-6, the current estimates of power generation by the EPS. As stated previously, these values are goals at this time.

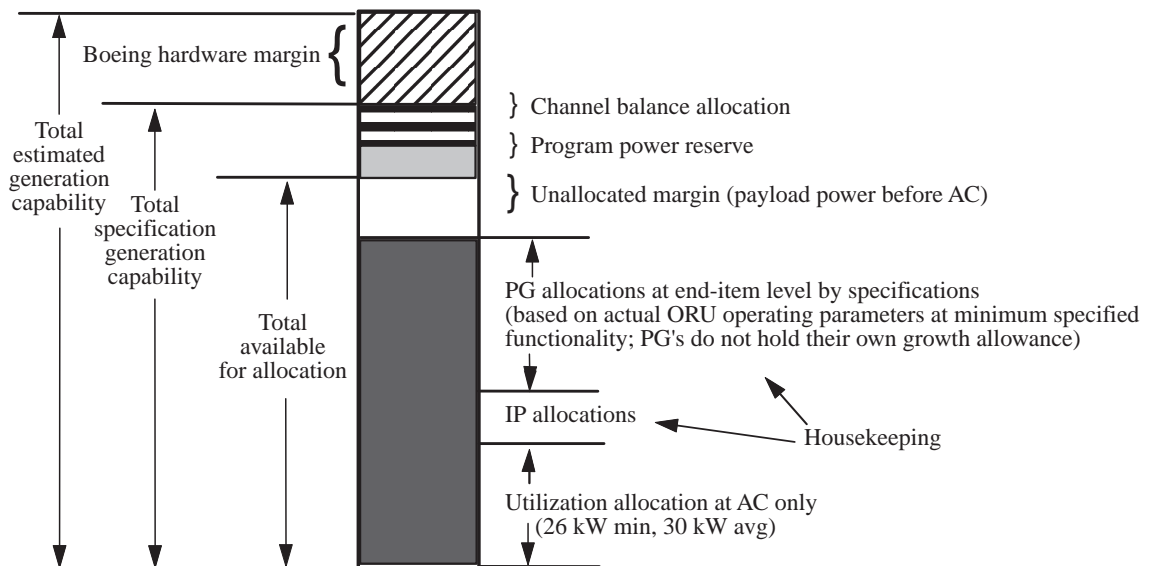

Figure 3.1-5. Power allocation distribution chart.

Table 3.1-1. Power for User Payloads

Stage	Available power, W, for —			
	Payload support	Payload minimum continuous power (a)	Payload average power (a)	Payload keep-alive power (a)
UF-1	1272	6210	10465	0
8A	1108	5408	9384	0
UF-2	1108	5408	9318	0
9A	996	4863	8602	0
9A.1	996	4863	8385	0
11A	1425	6955	10675	0
12A	1195	5835	6488	TBD
12A.1	2092	10216	16607	TBD
13A	2951	14408	27100	TBD
10A	4500	25498	31042	TBD
10A.1	4500	24438	29646	TBD
1J/A	4500	23855	28894	TBD
1J	4112	20075	24860	TBD
UF-3	4102	20027	24707	TBD
UF-4	4080	19922	24369	TBD
2J/A	3866	18875	23216	TBD
14A	4500	27597	32612	TBD
UF-5	4500	27553	32486	TBD
20A	4500	24206	28089	TBD
17A	4500	24206	27795	TBD
1E	4500	22028	25781	TBD
18A	4412	21540	24901	TBD
19A	4430	21630	24855	TBD
15A	4500	36732	48009	TBD
UF-6	4500	36732	47573	TBD
UF-7	4500	35827	46842	TBD
16A ^b	4500	33662	44063	TBD
16A (0,0,0) ^c	4500	33662	44063	TBD

^aPayload minimum continuous and average power are within the beta range from -52° to 52° and applicable at the payload locations; payload keep-alive power is applicable at all beta angles but is not additive to the 26/30 requirement.

^bThese first “16A” line item reflects TEA and is used to derive power available to payloads at 16A consistently with the other stages.

^c“16A (0,0,0)” reflects LVLH (0,0,0) to derive power available to payloads under allocation conditions.

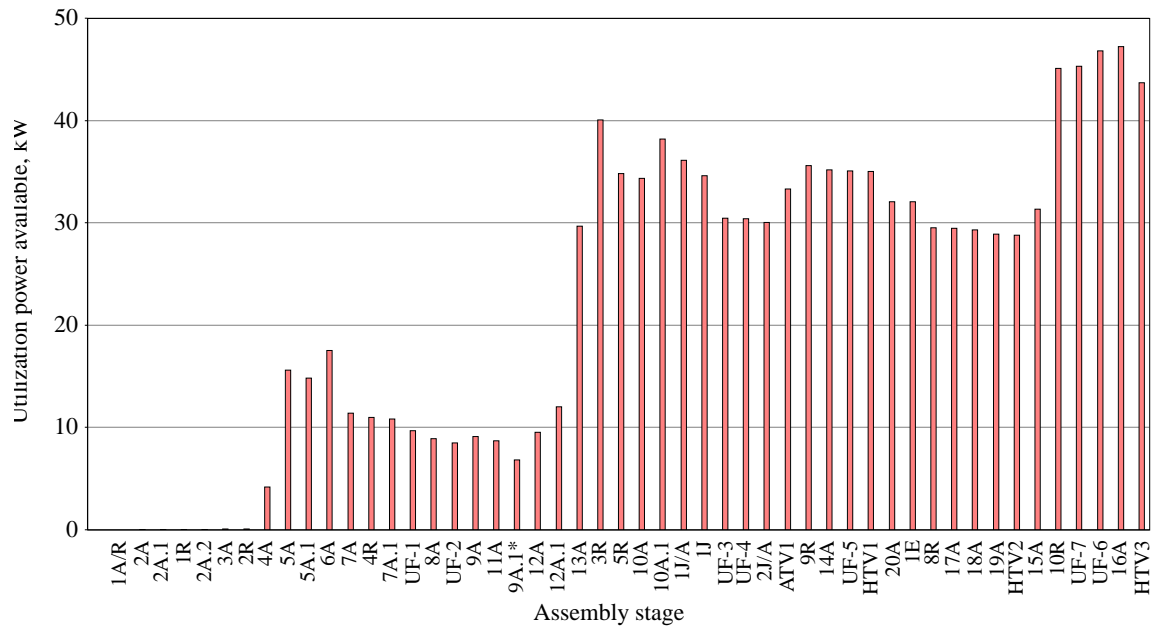

Figure 3.1-6. ISS utilization power available versus assembly stage.

3.1.4. EPS Growth for Evolution

The estimated power generation of the EPS exceeds the minimum continuous power requirement of 30 kW to the payloads. In fact, the current estimate of the average power available to the payloads is over 44 kW. With rigorous power management and assuming that the TCS can handle the additional thermal load, this value represents a significant operational increase in power for the users over the requirement. The realization of this power to the user will take place as the ISS operation plans optimize the system capability with time on orbit.

Most of the past growth options for the EPS have concentrated on the addition of power generating devices outboard of the baseline arrays. Typically, the power capability of the growth system has been of the same magnitude or greater than the baseline in order to make the cost to incorporate the changes economically attractive.

Of the five main functions that make up the EPS the “distribute primary power” function had the most significant loss in growth capability during the Space Station redesign efforts of the early 1990’s. The capability of the SARJ to transfer power from the outboard truss sections, where the arrays are, to inboard, where the payloads are, was significantly reduced. The growth roll rings, which conduct the primary power across the SARJ, were deleted.

The requirement for each SARJ is to transfer 60 kW of power at 160 V nominal dc primary power. This requirement translates into a total current capacity of 375 A. Because the primary voltage of the PV modules varies, and particularly decreases over time with array degradation, the transfer capability of the SARJ should be estimated at a lower voltage than the nominal 160 V. A typical voltage used for this estimate is 140 V, which at 375 A translates into 52.5 kW per SARJ or 105 kW total power transferred inboard. Although this voltage is considerably higher than the baseline nominal power of 75 kW, it actually represents only 20 kW (10 kW per side) over the latest estimated average power generation of 85.6 kW. One growth option is to add PV modules

Revision A, October 2000

outboard of SARJ to increase total power generated by 10 kW per side. However, once associated housekeeping power and losses are figured in, the cost associated with making such an addition would likely be prohibitive. In addition, system issues that relate to additional power generation such as additional thermal control capability will have to be evaluated and mitigated.

Another approach for power growth that has been incorporated by the Russians on MIR is localized power generation. In this option, power is generated very close to its consumer, and the power distribution, conversion, storage, and other associated functions are performed locally as well. This option has the advantage of not requiring power transfer across the SARJ, and conductor line length and associated power losses and mass requirements are reduced. Additionally, the thermal control system for the added power can be integrated into the design; thereby, the growth power has no impact on the baseline TCS.

One possible location for a power generation module is the Z1 integrated truss section. The Z1 is populated in the early phases of the assembly sequence with the P6 PV module, until flight 13A when P6 is transferred outboard the SARJ. When P6 is moved, hardware for early power conversion and distribution, as well as a passive thermal control system, remains on Z1. The nominal capability of the hardware on Z1 is 6.25 kW, which potentially would allow the addition of 6.25 kW power generation. Several system issues would require analysis to verify this approach. Most notably the viewing angles for the arrays to the Sun and the thermal radiators to deep space require evaluation because the Z1 area is a very densely populated area at AC.

Other locations for power module additions are worthy of consideration as well. Mounting single axis articulated PV modules, integrated with TCS radiators, on areas inboard of the SARJ should be investigated.

3.1.5. Bibliography

Anon.: Vehicle Integrated Performance and Resources (VIPeR)—Resource Margin Summary & Management Documents, International Space Station, NASA Johnson Space Center, July 20, 1999.

Anon.: International Space Station On-Orbit Assembly, Modeling, and Mass Properties Databook—Design Analysis Cycle #7, Revision D Assembly Sequence. JSC-26557, Rev. I, Vol. I, NASA Johnson Space Center, Sept. 1998.

Gietl, Eric: Electric Power Specifications and Standards—Volume 1: EPS Electrical Performance Specifications. International Space Station Alpha, SSP 30482, Vol. 1, Rev. B, NASA Johnson Space Center, Jan. 1996.

Orr, Kevin: Prime Item Development Specification for Integrated Truss Segment P3. Specification No. SP-M-235J, Cage Identification No. 18355 (Contract NAS15-10000, CDRL sequence No. VE07), Boeing Co., Dec. 22, 1998.

Marlatt, William P.; and Whalen, Kenneth J.: Power Architecture Description Document, International Space Station Alpha Program, D684-10094-01, Rev. F, (Contract NAS15-10000 (DR VE04), Boeing Co., Mar. 14, 1994.

3.2. Thermal Control System

3.2.1. Introduction

Throughout the life of the Space Station, experiments and equipment inside the modules are generating heat that must be removed. Outside the modules, experiments and equipment must be protected from the environment in low Earth orbit. The purpose of the TCS is to maintain Space Station equipment and payloads within their required temperature ranges. Information from the documents listed in the bibliography (section 3.2.5) was used to compile this section.

3.2.2. Overview of TCS

The TCS is required to collect, distribute, and dispose of up to 30 kW average (26 kW minimum continuous) waste heat from user payload heat sources at AC. This requirement is applicable during normal operational modes and with orbit solar beta angles between -75° and $+75^\circ$. All other TCS requirements flow down from this 30-kW requirement. The assembly sequence information for the primary elements of the TCS can be found in the appendix.

3.2.3. Architecture and Components for TCS

The ISS TCS is composed of passive and active thermal control systems as shown in figure 3.2-1.

3.2.3.1. Passive Thermal Control System

3.2.3.1.1. Purpose

The passive thermal control system (PTCS) is responsible for maintaining USOS structures and external equipment within an allowable temperature range. With no fluid interface, the PTCS isolates USOS elements from the external environment. PTCS components are designed for minimal maintenance and refurbishment.

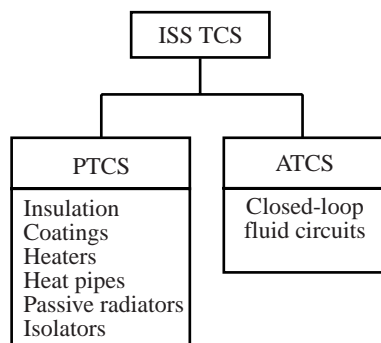

Figure 3.2-1. TCS architecture.

3.2.3.1.2. PTCS Components

The components used in the PTCS include but are not limited to insulation, surface coatings, heaters, and heat pipes. These components are used to maintain temperatures within acceptable ranges based on the local thermal environment and are discussed as follows:

Multilayer insulation: Multilayer insulation (MLI) is used to control heat transfer rates and minimize temperature gradients. The MLI consists of several layers of aluminized DuPont Kapton polyimide and beta cloth sandwiched together. MLI is used both inside and outside the modules, on truss segments, and on ORU's. It is also used as a safety device to prevent crew contact with extreme temperatures.

Surface coatings and paints: Since thermal requirements vary from location to location, surface finishes vary throughout the Space Station. Thermal coatings and paints must be compatible with the environment and must be resistant to atomic oxygen and radiation. Different types of finishes are used to provide various degrees of thermal control for equipment. By using coatings or paints with different emissivity or absorptivity characteristics, an ORU can either be "warmed" or "cooled" as required.

Heaters: Electrically powered heaters are used in locations where it is impossible or impractical to satisfy both high and low temperature requirements through the use of other PTCS or active thermal control system (ATCS) implementations. Numerous heaters are used throughout the USOS on ORU's and modules.

Heat pipes: Heat pipes provide a near-isothermal method for transporting heat over short distances and have no moving parts. A heat pipe operates by using the latent heat of vaporization of a working fluid (ISS applications use ammonia) to absorb heat at one end of a pipe and reject the heat into space at the other end. Heat pipes are used on the USOS to provide additional heat rejection for two DDCU's mounted on the Z1 truss segment and the two node 1 MDM's mounted on the pressurized mating adapter 1 (PMA 1).

3.2.3.2. Active Thermal Control System

An ATCS is required when the environment or the heat loads exceed the capabilities of the PTCS. As shown in figure 3.2-2, an ATCS uses a mechanically pumped fluid in closed-loop circuits to perform three functions: heat collection, heat transportation, and heat rejection.

3.2.3.2.1. Overview

USOS ATCS is composed of internal systems that collect heat from equipment within elements and an external system that rejects the heat to space. The internal thermal control system (ITCS) uses water because it is an efficient thermal transport fluid and is safe inside a habitable module. The early external thermal control system (EETCS) uses anhydrous ammonia because of its high thermal capacity and wide range of operating temperatures. The water and ammonia used in the ITCS and EETCS remain in a liquid state throughout the system.

All pressurized elements are outfitted with an ITCS. Some elements, such as node 1, only contain some heat collection devices and fluid lines, whereas other elements have complete thermal loops. The purpose of the Lab ITCS is to maintain equipment within an allowable temperature range by collecting, transporting, and rejecting waste heat.

3.2.3.2.2. ITCS Lab Components

The components that make up the ITCS can be categorized by function into three major groups: heat collection ORU's, heat transportation ORU's, and heat rejection ORU's. A schematic block diagram of the ITCS is shown in figure 3.2-3, and a description of the functional hardware is as follows:

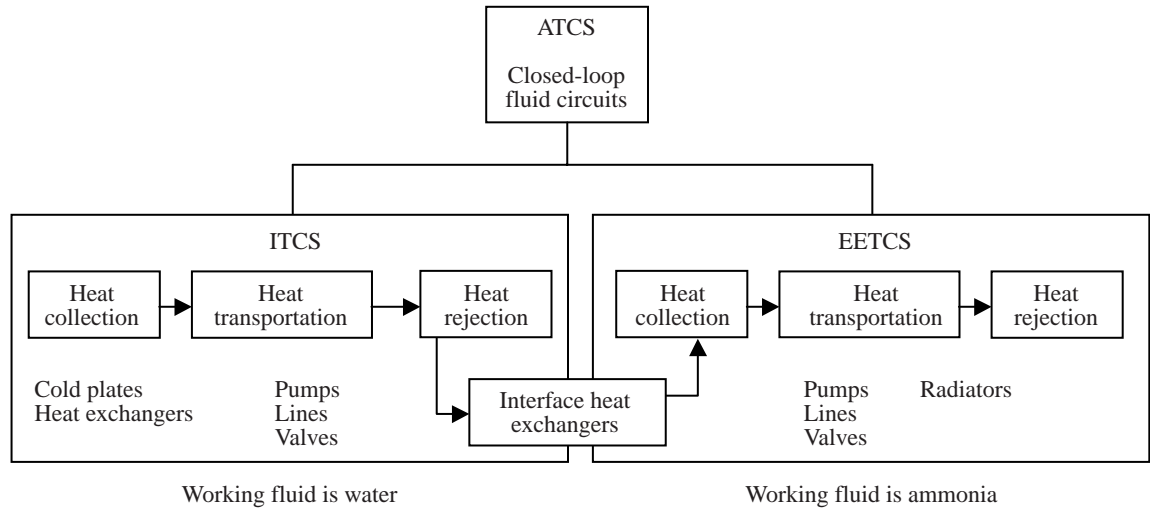

Figure 3.2-2. USOS ATCS architecture.

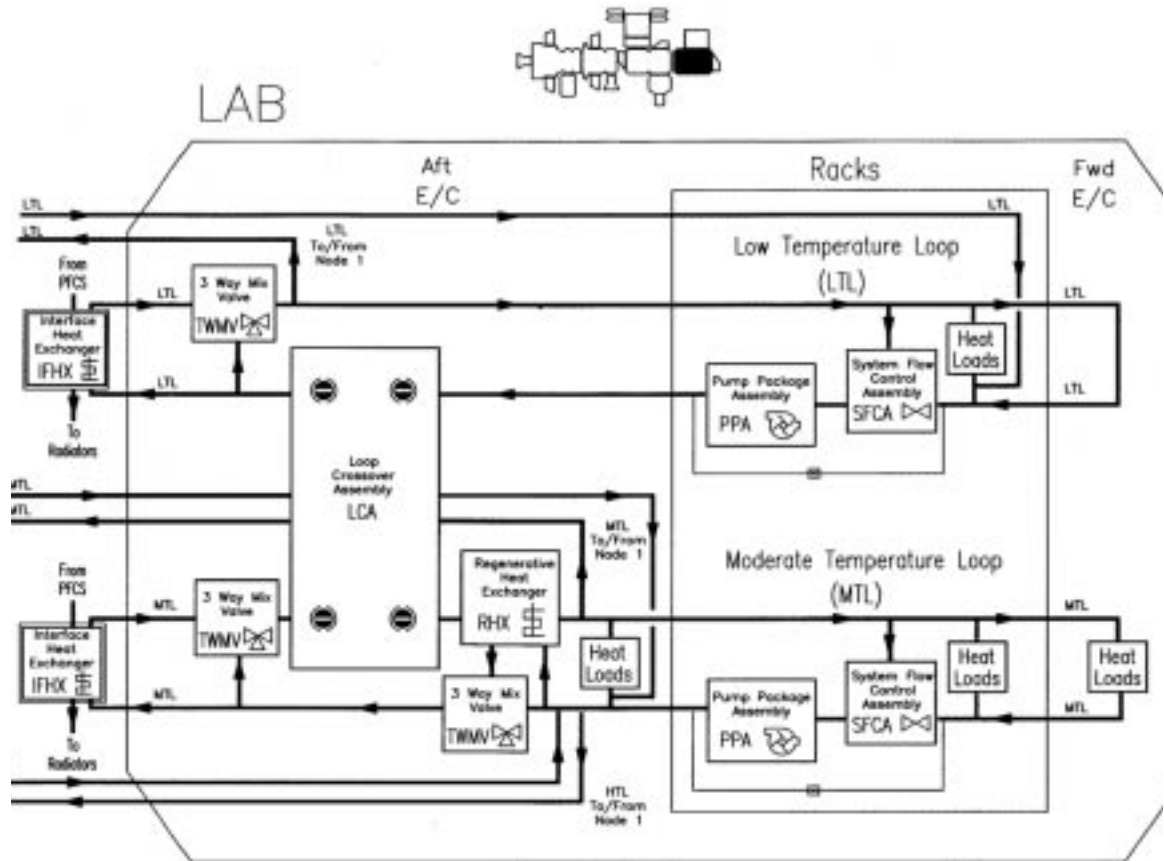

Figure 3.2-3. ITCS.

Heat collection units: The ITCS uses cold plates and heat exchangers to collect heat. Most heat collection devices are located in the racks and others are located in the end cones of the pressurized elements.

Heat transportation units: Heat transportation components include pumps, lines, accumulators, filters, quick disconnects (QD's), and valves. These components move and direct the flow of water around the loops.

Heat rejection units: The interface heat exchangers (IFHX's) are the heat-exchange interfaces between the two ITCS loops and the EETCS. The IFHX's are mounted on the aft end cone of the Lab external to the pressurized volume.

3.2.3.3. Early External Thermal Control System

Because the Lab becomes operational before the permanent external thermal control system (ETCS) is assembled, a temporary external cooling system is needed. External cooling from the Russian segment is not possible because no operational interfaces exist between the USOS and the ROS thermal systems. Instead EETCS acts as a temporary thermal system. The EETCS is needed until the components of the permanent ETCS are launched and activated. Once the permanent ETCS becomes operational, the EETCS is deactivated. After deactivation, portions of the EETCS are used as components on PVTCS loops. Figure 3.2-4 shows a schematic block diagram of the EETCS. Note the similarities in the functional hardware between the ITCS in figure 3.2-3 and the EETCS in figure 3.2-4.

3.2.3.4. External Thermal Control System

The ETCS replaces the EETCS and, once operational, continues the critical functions of collecting, transporting, and rejecting waste heat from USOS elements. Much like the EETCS, it is a mechanically pumped, single-phase subsystem that also uses ammonia as a coolant. However, the ETCS is designed to handle the heat loads for the entire USOS at AC. The major differences between the temporary EETCS and the permanent ETCS are summarized in table 3.2-1.

3.2.3.5. Thermal Resource Margin

The ISS TCS is a managed resource that is allocated to the payloads in a similar fashion as electrical power. Table 3.2-2 shows the thermal resource, in terms of the heat rejection available to payloads, that is estimated to be available at each assembly phase. Note that there is a slight variation in the rejection capability in later phases when the solar beta angle is higher than $\pm 52^\circ$, as view angles from the radiators to deep space will be affected.

3.2.4. TCS Growth for Evolution

The baseline TCS is limited in its growth potential by its distribution or transport system. In particular, the pumps, lines, and valves that circulate the working fluid between the thermal loads and the thermal radiators are limited by their flow rate. The "estimated radiator capability" is the same as the "specification radiator capability" and is 70 kW total. With housekeeping heat loads as well as reserve and payload support allowance totaling almost 44 kW, the estimated total heat rejection available to the payloads is approximately 26 kW.

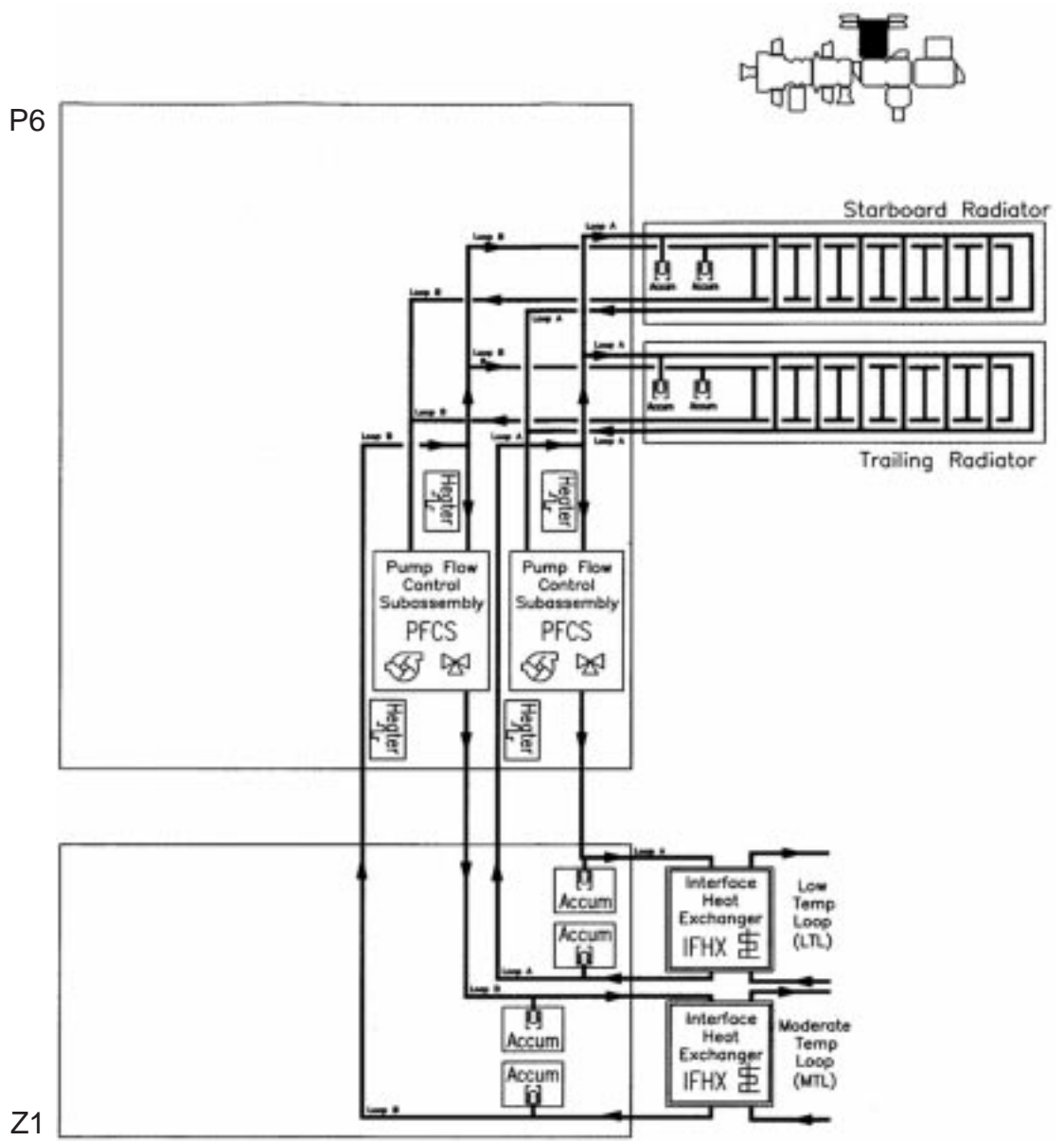

Figure 3.2-4. EETCS.

Therefore, there is no reported margin in TCS system capability beyond the specified requirement. Consequently, growth options should be focused in one or two areas. First, TCS growth capability could be achieved by reducing the loads that are managed by the baseline TCS. For example, heat loads that have an allocation on the external TCS could alternatively be managed by new body-mounted radiators equipped with heat pipes. Those radiators would be installed close to the thermal load on the preintegrated truss. Consequently, the TCS would be reconfigured to allow the internal heat loads (i.e., user payloads) to increase their demand on the ITCS in concert with the decreased demand on the ETCS truss loads. Second, increase the TCS capability beyond the baseline to accommodate growth thermal loads. To minimize the impacts on the baseline ISS, the growth strategy would be to incorporate a localized growth capability as described in section 3.1.4. Depending on the thermal capability increase required, the means for rejection could be passive or active. For small loads, the added thermal capability could be achieved through addition of passive body-mounted radiators with heat pipes, localized to the load as described previously. For higher loads in kilowatts, an integrated power and thermal module could be designed to meet the growth need.

Impacts to incorporate changes to the TCS system require significant analysis. Any modification that would create an interruption of current capability would affect most ISS systems for the duration of the outage. Work on plumbing in near-zero gravity presents an interesting problem of leakage, and the ETCS has ammonia as a working fluid, as discussed in section 3.2.3.2.1.

Table 3.2-1. Differences Between Early Capability and Assembly Complete for TCS

Temporary EETCS	Permanent ETCS
Heat collection: Two IFHX's—Lab	Heat collection: 10 IFHX's—Lab (2), Hab (2), and node 2 (6) Additional external equipment mounted on cold plates—MBSU (4) on S0 and DDCU (6) with 4 on S0 and 1 on S1 and P1
Heat transportation: Two loops operating at 771 kg/hr (1700 lb/hr) One PFCS (two pumps) in each loop	Heat transportation: Two loops operating at 3629 kg/hr (8000 lb/hr) One pump module (one pump) in each loop
Heat rejection: Two fixed radiators Each approximately 13 m (44 ft) long Both loops flow through both radiators Total heat rejection capability is 14 kW	Heat rejection: Six movable radiators Each approximately 23 m (75 ft) long One loop flows through each set of three radiators Total heat rejection capability is 75 kW

Table 3.2-2. Thermal Resource

Stage	Projected user capability (all β angles)				Projected user capability ($-52^\circ \leq \beta \leq 52^\circ$)			
	Radiator capability, MCHL value	Total house- keeping heat with reserve	Payload support allowance	Heat rejection available to payloads	Radiator capability, MCHL value	Total house- keeping heat with reserve	Payload support allowance	Heat rejection available to payloads
5A	16000	4304	2368	9278	16000	4304	2368	9278
6A	16000	5316	2162	8472	16000	5316	2162	8472
7A	15500	6611	1797	7042	15500	6611	1797	7042
8A	15000	6971	1622	6356	15000	6971	1622	6356
UF2	13200	6659	1320	5171	14500	6957	1523	5969
9A	11100	6671	890	3488	14000	6969	1419	5561
11A	9000	6644	469	1837	13500	5942	1323	5184
12A	23333	13388	1958	7673	23333	13388	1958	7673
13A	46666	13631	6540	25629	46666	13470	6573	25757
10A	46666	16672	6006	23536	46666	16511	6039	23665
1J/A	46666	17085	5922	23208	46666	16871	5966	23378
1J	70000	22135	9640	37774	70000	21921	9683	37944
UF4	70000	22510	9563	37475	70000	22297	9607	37645
2J/A	70000	22735	9518	37296	70000	22522	9561	37466
14A	70000	22806	9453	37044	70000	22593	9497	37214
20A	70000	26062	8792	34451	70000	25848	8835	34621
1E	70000	26406	8722	34177	70000	26193	8765	34347
17A	70000	26406	8722	34177	70000	26193	8765	34347
18A	70000	26491	8486	33252	70000	26278	8529	33422
19A	70000	27577	8265	32387	70000	27363	8308	32557
15A	70000	27577	8265	32387	70000	27363	8308	32557
UF7	70000	29106	8004	31363	70000	28893	8047	31533
16A	70000	37235	6570	25744	70000	37022	6613	25914

3.2.5. Bibliography

Anon.: Vehicle Integrated Performance and Resources (VIPeR)—Resource Margin Summary & Management Documents, International Space Station, NASA Johnson Space Center, July 20, 1999.

Nicholls, Marconi: Thermal Control Architecture Description Document—Volume 2: Subsystem Architecture Notebook, Rev. E, International Space Station Program, D684-10511-02E (Contract NAS15-10000), Boeing Co., July 1998.

3.3. Communications and Tracking System

3.3.1. Introduction

Communications is an integral component of the ISS. Without extensive communication with the ground, neither the safe, stable, reliable operation of the Station nor the dissemination of scientific research would be possible. The ISS communication and tracking system (C&TS) is designed to support the following functions:

- Two-way audio and video communication among crew members onboard the ISS, including EVA crew members
- Two-way audio, video, and file transfer communication with Flight Control Teams located in Mission Control Center—Houston (MCC—H) and payload scientists on the ground
- One-way communication of experiment data to the payload operations integration center (POIC)
- Control of the ISS by flight controllers through the reception of commands sent from MCC—H and remotely from the orbiter
- Transmission of system and payload telemetry from the ISS to MCC—H and the POIC

Information from the documents listed in the bibliography (section 3.3.5) was used to compile this section.

3.3.2. Overview

The C&TS is divided into six subsystems: the internal audio subsystem (IAS), the S-band subsystem (S-band), the ultrahigh frequency (UHF) subsystem (also known as the ultrahigh frequency communication system (UCS)), the video distribution subsystem (VDS), the Ku-band subsystem (Ku-band), and the early communication subsystem (ECS). Figure 3.3-1 shows the six subsystems and their interfaces with each other, with the C&DH system, and with other external entities necessary to achieve the communication and tracking (C&T) functions. The ECS is not part of this section because it is a temporary subsystem that will be dismantled early in the assembly sequence (port ECS on flight 5A.1 and starboard ECS on flight 6A) but may be retained on orbit as a conditional backup.

As illustrated in figure 3.3-1, all the USOS C&T subsystems work together to provide the communication services needed by the USOS to carry out the mission of the ISS. The S-band subsystem transmits voice, commands, telemetry, and files. The IAS distributes audio onboard the ISS and to external interfaces. The VDS distributes video onboard the ISS and to external interfaces, including the Ku-band for downlink. The UHF subsystem is used for EVA and proximity operations, whereas the Ku-band subsystem is used for payload data and video downlink and file two-way transfer.

NASA is developing a forward link capability for the Ku-band subsystem to transfer payload commands and data between the ground and the USOS and also to add two-way teleconferencing of video and associated voice between the USOS and the ground. This capability could be used to provide a backup to the S-band capability. The assembly sequence information for the primary elements of the C&TS can be found in the appendix.

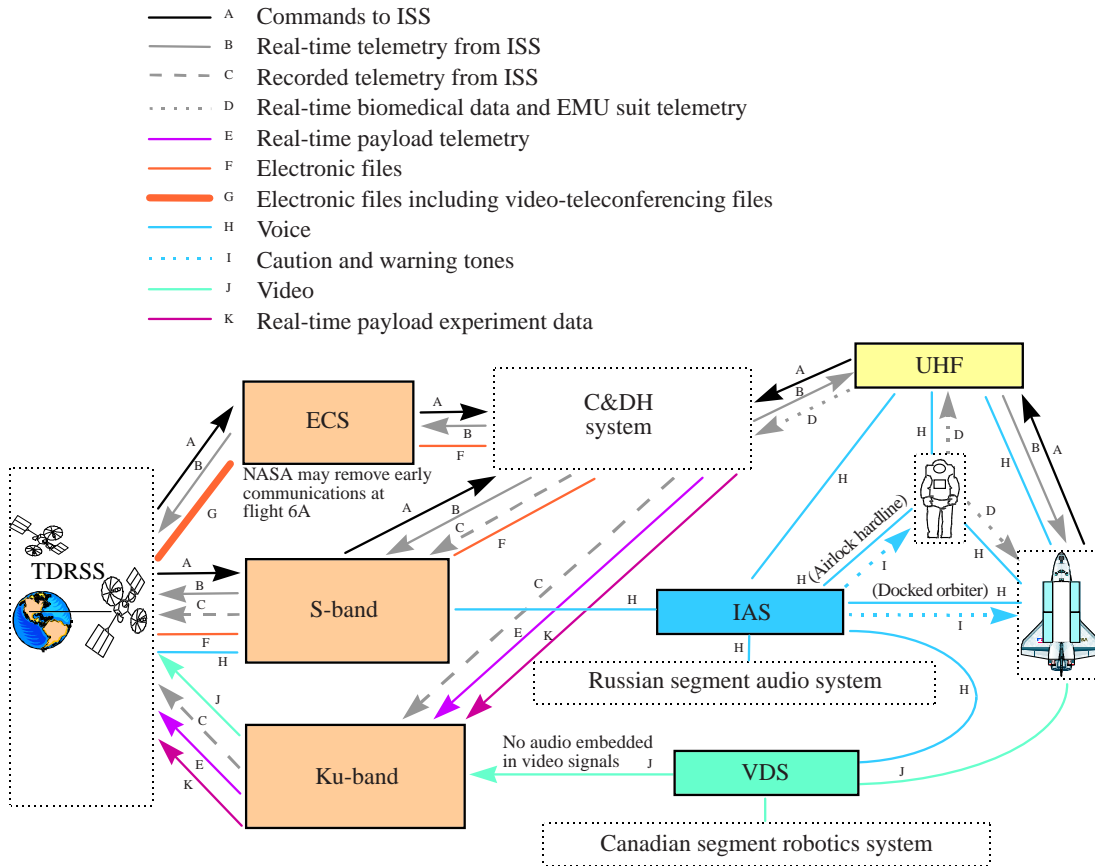

Figure 3.3-1. C&TS at flight 8A.

3.3.3. Architecture and Components for C&TS

The following descriptions are provided to detail information about each subsystem and its major components.

3.3.3.1. Internal Audio Subsystem

3.3.3.1.1. Overview

The purpose of the IAS is to distribute voice communications and caution and warning (C&W) tones onboard the ISS that includes distributing those signals to other subsystems for further distribution, both internally to the ISS modules and externally to the orbiter, ground, and EVA crews. Later, the IAS is the primary means of distributing audio between the USOS and other IP modules, such as the JEM and the APM.

Reliable electronic conversation among physically separated crew members is essential for their safety and the success of their flights or missions. The IAS acts as the intercom and telephone system for the pressurized elements in the U.S. segment to support this function. An interface with the SM allows for complete ISS communications to support multielement and multisegment operations.

The IAS link with the USOS UHF subsystem allows the crew members to communicate with an EMU-suited EVA crew (while in the joint airlock and during an EVA) and with an orbiter crew during approach and departure. Hardware interface connections allow direct voice and C&W communication with the Shuttle crew in a docked orbiter. Also, the IAS provides two-way air-to-ground voice by using the USOS S-band subsystem. Finally, the IAS connects with the USOS VDS video tape recorders (VTR's) to record and play back audio.

Perhaps the most important of all the IAS functions is its ability to inform the crew audibly of a C&W event. This capability is crucial to the safety of the crew and the condition of the ISS and its equipment.

3.3.3.1.2. IAS Operations and Components

Most of the signal routing and malfunction recovery for IAS are automated and, therefore, do not require crew or controller intervention. Flight controllers operate the subsystem occasionally to perform activation and checkout, troubleshooting, and some voice loop setup to offload the crew. The crew, however, performs most of the configuration for the IAS at an audio terminal unit (ATU); this includes making calls, joining conferences, and setting the volume, as needed. Establishing an air-to-ground conference requires commands to the IAS from a portable computer system (PCS) or the ground to configure the interface unit between the IAS and the S-band subsystem. The IAS consists of ORU's as follows:

Internal audio controller (IAC)

ATU

Audio bus coupler (ABC)

Three types of audio interface units:

Assembly-contingency/UHF audio interface (AUAI)

Docked audio interface unit (DAIU)

Russian audio interface unit (RAIU).

Figure 3.3-2 contains a simple schematic of this subsystem.

3.3.3.1.2.1. Internal audio controller. The IAC acts as the IAS switchboard for all calls made at the ATU's. It manages the IAS by automatically routing calls, C&W tones, and commands and status. Also, the two redundant IAC's are the only interface of the IAS to the C&C MDM via the 1553 bus. Losing both IAC's causes the loss of all U.S. segment audio capabilities.

3.3.3.1.2.2. Audio terminal unit. The ATU acts as the crew member's telephone. Its capabilities are similar to that of a typical office telephone. The crew can use the ATU to do the following tasks: listen in on five different conferences, talk on one of the conferences, call another location directly and exclusively (e.g., another ATU, the ground, the UHF subsystem), and initiate a page for a crew member. The ATU's also annunciate C&W tones.

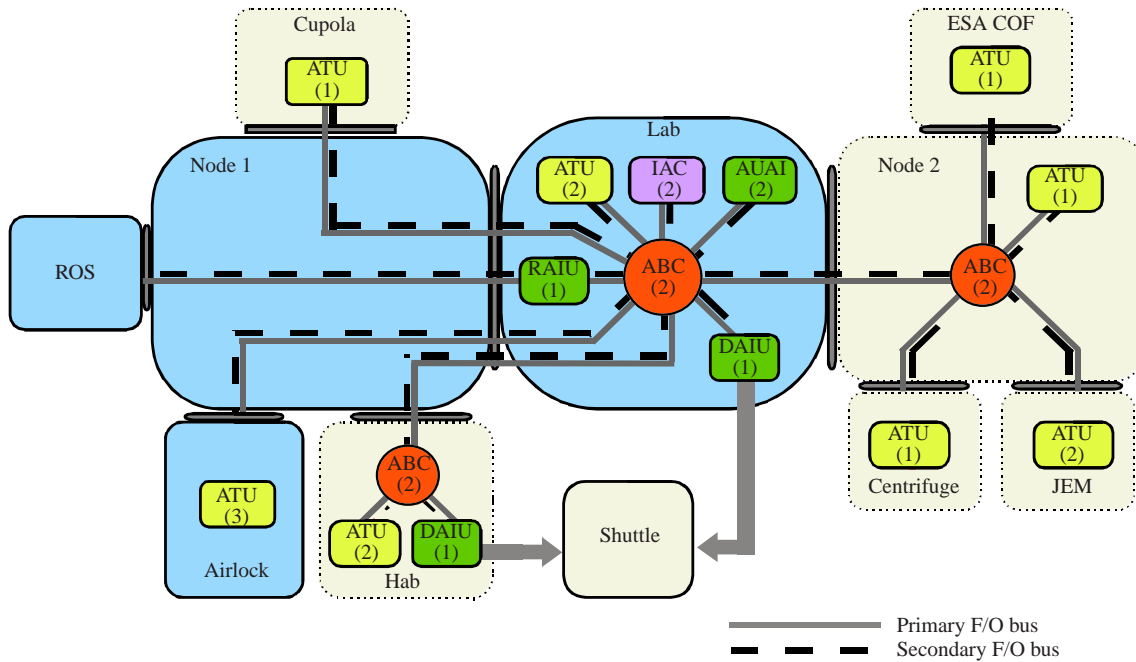

Figure 3.3-2. Internal audio subsystem (assembly at flight 8A).

3.3.3.1.2.3. Audio bus coupler (and bus network). The ABC provides the coupling of the different lines of the digital fiber-optic audio bus network. This bus network is the medium for the transport of the audio signal, including command and status signals, for all IAS ORU's.

There are two fully redundant fiber-optic digital audio buses. Each bus has its own ABC at each juncture (fig. 3.3-2); therefore, two redundant strings are present in the audio bus network.

3.3.3.1.2.4. Interface units. The IAS has many interface units that allow audio connectivity to other audio systems. The AUAI is the connection to both the EVA crew, via the UHF subsystem, and to the ground, via S-band. The DAIU is the interface between the USOS and a docked orbiter. The RAIU is the connection between the USOS and the ROS and is the interface to the VTR's. Both the DAIU and the RAIU must convert audio signals from digital (IAS) to analog (orbiter and ROS) and vice versa.

3.3.3.2. S-Band Subsystem

3.3.3.2.1. Overview

The S-band is the communication system that is used for primary command and control of the ISS, as well as for transferring ISS health and status data to the MCC—H. S-band utilizes the tracking and data relay satellite (TDRS) system for providing communications. Low and high data rate support is available (at different stages) between the ISS and MCC—H. The ROS communication system is used for backup command and control. However, MCC—M will command the ROS systems, coordinating with MCC—H concerning those commands that affect the USOS and the ISS as a whole.

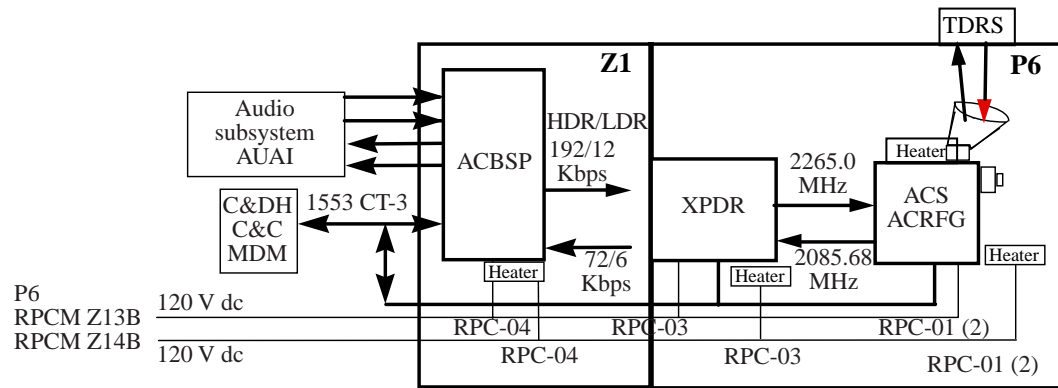

Figure 3.3-3. S-band subsystem.

3.3.3.2.2. S-Band Components and Operations

The S-band consists of two identical strings of three ORU's placed on different locations of the ISS (fig. 3.3-3), as well as an early communication (ECOMM) configuration that is temporary. The permanent ORU's are the assembly complete baseband signal processor (ACBSP), the standard TDRSS transponder (XPDR), and the assembly complete radio frequency (RF) group (ACRFG), including a gimbaled horn antenna and an omnidirectional antenna. S-band operates in a zero-fault-tolerant condition on truss segments Z1 and P6 until flight 9A, when a second complete S-band subsystem will be brought up to the Station on truss segment S1 and will become operational. At flight 1J/A, the Z1/P6 string is moved to its permanent location on truss segment P1.

3.3.3.2.2.1. Assembly complete baseband signal processor. For the return link, the ACBSP processes telemetry packets sent from the command and control (C&C) MDM over the 1553 bus and readies the data to be sent to the transponder. Data sent from MCC—H are received into the ACBSP after leaving the transponder receive section and are then decrypted prior to being sent over the 1553 serial bus to the C&C MDM. The S-band provides two independent channels of two-way voice communication between the crew and the ground. The ACBSP receives two channels of digital audio data from the AUAI unit of the IAS. The audio data are compressed in the ACBSP. Audio data are then segmented and encoded just as for telemetry data and files. For the forward audio link, the digital audio data are decoded, decrypted, and decompressed before being clocked into the AUAI of the IAS for distribution onboard. Two-way audio is available in high data rate (HDR) only.

3.3.3.2.2.2. Transponder. The transponder is the ORU that provides the RF connection through the ACRFG to the TDRS system for communication between the ISS and MCC—H. The transponder is responsible for generating an RF signal and modulating that signal corresponding to the digital data pattern received from the ACBSP. The transponder also receives the radio signal from the ACRFG, demodulates the signal, and recreates the digital data per the modulation pattern before transmitting these digital data to the ACBSP.

3.3.3.2.2.3. Assembly complete radio frequency group. For a return link, the ACRFG receives an RF signal from the transponder, amplifies it, and broadcasts the RF signal through the high gain antenna (HGA) or low gain antenna (LGA) to the TDRS, which in turn communicates with the MCC—H via the White Sands Ground Station (WSGS). On the forward link, the ACRFG antenna

(either HGA or LGA) receives a signal from the TDRS, converts this signal, and then sends the IF signal to the transponder for demodulation.

3.3.3.3. *Ultrahigh Frequency Communications Subsystem*

3.3.3.3.1. Overview

The ISS UCS is one of the subsystems of the space-to-space communication system (SSCS) and operates in the UHF range. The other parts of the SSCS are the orbiter EMU space-to-space UHF subsystems. The UCS, commonly referred to as “the UHF subsystem” or “UHF,” provides the SSCS link for the ISS.

The purpose of the ISS UHF subsystem is to provide for space-to-space communication in and around the ISS when hard-line communication is not possible. This space-to-space communication is between the ISS and the orbiter for voice, commands, and telemetry; EVA-suited crew members for voice, biomedical, and EMU data; and to accommodate future visiting vehicles for commands and telemetry. The UHF subsystem is designed to support up to five simultaneous users. It consists of a space-to-Space Station radio (SSSR), containing two transceivers, two sets of external double antennas, and internal antennas that are found in every USOS habitable module. (See fig. 3.3-4.)

The UHF subsystem supports not only traditional EVA functions of voice, EMU, and biomedical data transmission, it also supports the space-to-space transmission of commands and telemetry. This transmission is used during rendezvous and docking operations when the ISS must be configured remotely by the orbiter during proximity operations.

3.3.3.3.2. Space-to-Space Station Radio

The SSSR consists of one ORU containing two transceivers. Both transceivers are contained in one housing, but each is powered separately. Similar to RF systems, the SSSR transceivers (radios) consist of a 1553 module that receives and transmits commands and telemetry from and to the C&C MDM and an RF section designed to connect to sets of internal and external antennas.

3.3.3.3.3. UHF External Antennas

The UHF external antennas consist of two pairs of antennas mounted on the U.S. Lab module and truss of the ISS. The antennas are designed to receive signals up to 7 km away. For EVA activity, communication availability provided by these antennas is nearly 100 percent (with all four antennas functional). If the orbiter is present, the orbiter UHF subsystem can also communicate with the EVA crew.

3.3.3.3.4. UHF Internal Antennas

The UHF subsystem also supports the periods before and after EVA operations. Before the EVA crew members unplug from the EMU audio control panel (EACP) and open the airlock hatch to egress the ISS, the USOS EMU-suited crew members can communicate using the airlock antenna while still in the airlock. The internal antennas consist of an intravehicular antenna assembly (IAA) and the airlock antenna. The IAA is located throughout the U.S. pressurized modules and is used when an EVA is needed within the Station. The airlock antenna is used when the EVA

crew member first unplugs from the EVA audio control panel (EACP) and is ready to egress the Station through the airlock. Voice, biomedical, and EMU communication is thus uninterrupted.

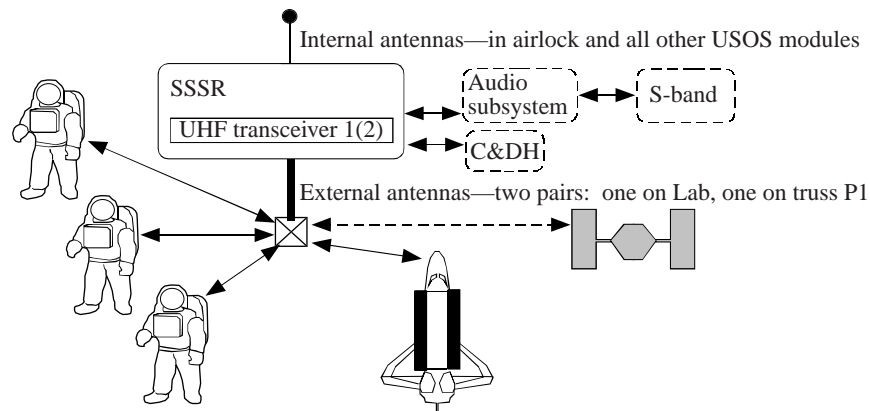

Figure 3.3-4. UHF subsystem.

3.3.3.4. Video Distribution Subsystem

3.3.3.4.1. Overview

The purpose of the VDS is to distribute video signals onboard the U.S. segment of the ISS. The VDS also interfaces with other IP video subsystems. The sources of this video are external cameras, internal cameras, recorders, and payload rack cameras. The possible destinations are internal monitors, recorders, payload rack recorders, a docked orbiter, and the ground through the Ku-band link with TDRSS. The video signals are distributed by fiber-optic (analog) video lines. The ISS routes video and audio separately. Video and audio are also sent to the ground via different paths. Audio and its associated video are resynchronized on the ground. As with the orbiter, sending any ISS video signals to the ground requires routing through the Ku-band.

3.3.3.4.2. Video Distribution System Operations and Components

The VDS uses the following components: robotics workstation (RWS), common video interface unit (CVIU), internal video switch unit (IVSU), external video switch unit (EVSU), sync and control unit (SCU), internal camera port, external camera port, robotics power and data grapple fixture (PDGF), external television camera group (ETVCG), VTR, video baseband signal processor (VBSP), and international standard payload racks (ISPR's). Figure 3.3-5 contains a simple schematic of the VDS at the completion of assembly flight 8A. Not all these components are part of the VDS. These components are interconnected rather than set up as "strings."

3.3.3.4.2.1. Common video interface unit. The CVIU is the interface between the fiber-optic video line and a component requiring a conventional copper connection. The CVIU also supplies electrical power to the component so that only one connection to the component is required. Multiple CVIU's can be used with each component that requires video signal conversion.

3.3.3.4.2.2. Internal video switch unit and external video switch unit. The video switch units (VSU's), both internal and external, perform the following functions: route video signals, distribute sync signals, and read external camera status from the incoming video signals and send the status to the C&C MDM.

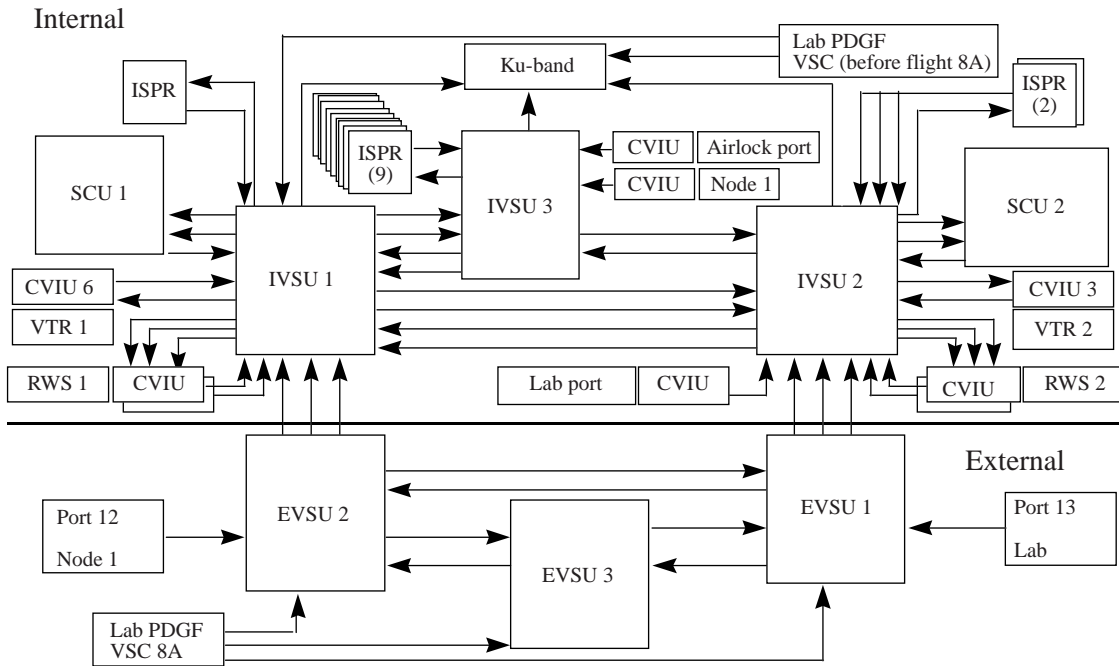

Figure 3.3-5. Video distribution subsystem.

3.3.3.4.2.3. Sync and control unit. The SCU performs the following functions: generates a “house” sync signal for the VDS, generates test patterns, provides the capability to “split-screen” two video images together into one image, provides the capability to perform “time-based correction” of a video signal from a VTR or camcorder, and routes the external camera commands from the C&C MDM to the external cameras. Two SCU’s are located in the Lab module.

3.3.3.4.2.4. Camera ports. The ISS has camera ports (part of the structures and mechanisms system), both internal and external, for connecting cameras to the ISS. The internal camera ports are for handheld commercial camcorders. The external camera ports (14 in all) are for the ETVCG’s.

3.3.3.4.2.5. Power data grapple fixture. The PDGF (part of the robotics system) provides the connection of the SSRMS with the ISS. The SSRMS can provide three video signals from cameras on the SSRMS elbow and wrist. The VDS routes these signals the same way that it routes video signals from the internal camcorders and the ETVCG’s.

3.3.3.4.2.6. External television camera group. The ETVCG contains the externally mounted camera, along with its associated hardware. This associated hardware includes a light source, mechanisms, and electronics for panning and tilting and a converter for converting the video signal to fiber-optic signal (similar to the function performed by the CVIU). At AC, there are four ETVCG’s, but they arrive at the ISS after assembly flight 8A. However, there will be at least 14 external camera ports with only the four ETVCG’s among them. If an external operation requires a camera view from a certain camera port, and no ETVCG is available at that port, then the ETVCG must be moved via EVA.

3.3.3.4.2.7. Video tape recorder. The VTR performs the same functions as those of a commercial VTR. It can record and play back video and audio (audio signals must go through the IAS). It can

be operated both from the VTR itself or remotely from an onboard PCS or the ground with a manual assist from the crew for putting in and taking out a tape.

3.3.3.4.2.8. Video baseband signal processor. The VBSP (part of the Ku-band) converts the video signal from the fiber-optic format to a digital format to be processed by the Ku-band for transmission to the ground. Section 3.3.3.5 discusses the VBSP in more detail.

3.3.3.4.2.9. International standard payload rack. The ISPR (part of the payloads system) provides a location for payloads on the ISS. Internal video ports are in each of the multiple ISPR's to support internal video operations. Each payload with video requirements must have its own TV camera or monitor to plug into the ISS-provided port. Video signal conversion from copper to fiber-optic cable (and vice versa) is the responsibility of the payload sponsor.

3.3.3.5. Ku-Band Subsystem

3.3.3.5.1. Overview

The purpose of the Ku-band subsystem is to provide a high data rate (HDR) return link for the U.S. segment of the ISS. This return link is for real-time payload data, video (real-time and recorded), and recorded ISS systems telemetry (recorded on the communications outage recorder). The ISS program has added a forward link capability to support the two-way transfer of files and video teleconferencing in support of the crew system's operations local area network (LAN). These capabilities are implemented during assembly flight 6A, and will provide a 3-Mbps forward link capability to interface with the onboard orbiter communications adapter (OCA) LAN for purposes of file transfers, "whiteboarding," and teleconferences, as well as data connections to payload racks. (See fig. 3.3-6.)

3.3.3.5.2. Operations and Components

Experiments and video activity generate enormous amounts of data to be sent to the ground. The capacity of the Ku-band, while large, is limited. Flight controllers in the POIC configure the Ku-band to accommodate the gigabits of payload data generated per hour. At certain times they must make decisions that reconcile the amount of data generated among many experiments, video, and recorded systems telemetry to the capacity of this subsystem.

The Ku-band is only single string. The Ku-band consists of the following ORU's: VBSP; high rate frame multiplexer (HRFM); high rate modem (HRM); and the antenna group (SGANT) ORU's, which are the transmitter/receiver/controller (TRC), and several antenna components. The VBSP, HRFM, and HRM are located in the Lab module. The antenna group is located on the Z1 truss. Figure 3.3-7 shows the route of the signal through the ORU's. Also, one interface to this subsystem not shown in figure 3.3-7 is the GN&C system. The GN&C system provides data required for a method of open-loop antenna pointing, in addition to providing initial pointing vector information for closed-loop, autotrack antenna pointing. Ku-band coverage to TDRSS for the ISS is approximately 70 percent per orbit, on average.

Several other enhancements being considered for this subsystem, after flight 8A, are as follows:

- Increase the downlink data rate from 50 Mbps to 150 Mbps by flight UF-5
- Add a communications outage recorder (COR) for recording payload data

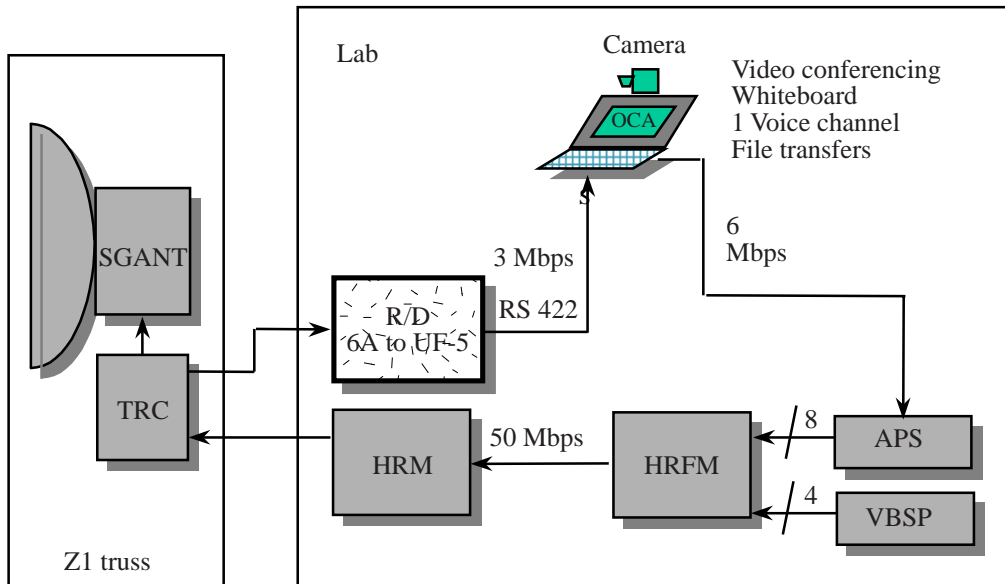

Figure 3.3-6. Ku-band forward link implementation approach.

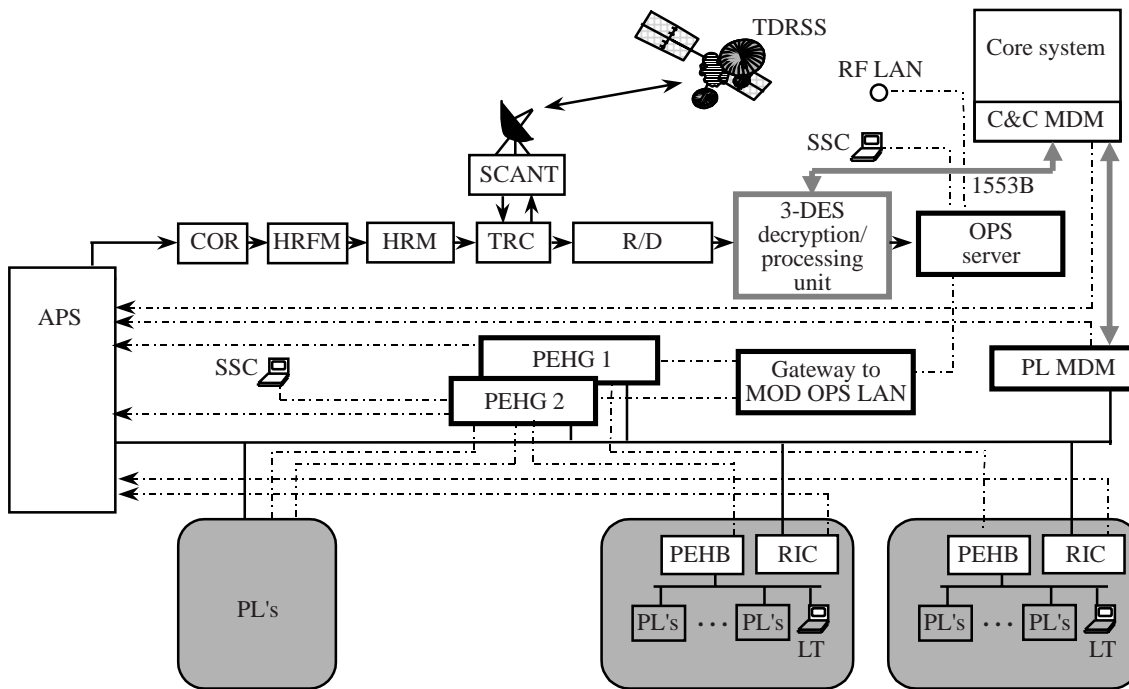

Figure 3.3-7. Ku-band subsystem (functional diagram of DPU within forward link access to PL and OPS LAN).

- The addition of two-way transfer of video with its associated audio by reestablishing the forward link capability to provide a two-way video and audio teleconferencing link with the crew operations network and a secondary interface with payload instruments.
- Add a permanent receiver/demultiplexer unit by flight UF-7 to increase the forward link rate to 3–9 Mbps. This may also include forward link commanding to both the C&C and payload (PL) MDM’s; thus encryption will be required in the format of 3 data encryption standards (DES’s).

3.3.3.5.2.1. Video baseband signal processor. The VBSP, shown with an interface with the VDS, converts the video signal from the fiber-optic format to a digital format to be processed by the Ku-band subsystem for transmission to the ground. The VDS selects and then sends up to four video signals to the VBSP for transmission. After processing the video signals, the VBSP sends the video data to the HRFM.

3.3.3.5.2.2. High rate frame multiplexer . The HRFM accepts up to four channels of data from the VBSP and eight channels of data from the automated payload switch (APS). The HRFM multiplexes, and receive-send (R-S) encodes these 12 together into a one-bit stream comprised of channel access data unit (CADU) formatted data. The HRFM then sends the resulting baseband signal to the HRM.

3.3.3.5.3. High Rate Modem

The HRM modulates an RF signal and converts that signal to an intermediate frequency (IF). It sends this modulated IF signal to the SGANT ORU's.

3.3.3.5.4. Antenna Group

The SGANT converts the IF signal, amplifies it, and broadcasts the signal to the TDRS through the Ku-band directional gimbaled antenna. The TRC of the SGANT assembly provides for automatic tracking; that is, the TDRS-received signal is used to point the antenna for broadcasting the return (downlink) signal. The TDRS transmits these data to the WSGS for further distribution to ground facilities.

3.3.4. Growth Options and Scars

Although many growth options and scars for ISS communications have been eliminated or delayed, some enhanced capability accommodations exist and are given as follows:

- The Ku-band subsystem now will accommodate a forward link of 3 Mbps with a future growth expected to reach 3–9 Mbps with the addition of the permanent receiver/demultiplexer
- Forward link commanding and file transfer capability to C&C MDM and a PL MDM. This requires use of the triple DES decryption capability
- Potential for higher than 150 Mbps return data rates exists with the use of advanced TDRSS but details still need to be worked about interfaces with current ISS Ku-band capabilities
- Potential upgrade to Ku-band technologies
- The VDS will accommodate the use of high-definition television (HDTV) at a later date and will most likely involve efficient forms of data compression
- New technology components will be tested as experiments on ISS and may provide an evolution of greater communications capability, along with links to telecommunications services

Revision A, October 2000

- The ACT design reference mission (DRM) in section 5.4 of Volume II of this document represents a proposal for enhancing the ISS communication capability (such as optical communications, phased array antennas)

3.3.5. Bibliography

Anon.: Space Station Program Video Baseband Signal Processor (VBSP) to U.S. Laboratory Standard Interface Control Document. International Space Station Program, Revision A. SSP 42141, NASA Johnson Space Center, Jan. 31, 1997.

Anon.: ESTL S-Band and Ku-Band Hardware and Software Verification Testing. International Space Station Program Change Directive. SSCN: 000819, NASA Johnson Space Center, Mar. 31, 1998.

Blackburn, R. J.: Development Specification Standard TDRSS Transponder. International Space Station Program Communications and Tracking Equipment. Doc. No. 10033011, Rev. J, Communications Systems, May 21, 1997.

Daniel, J. W.: Development Specification Video Baseband Signal Processor (VBSP). International Space Station Alpha Program Communications and Tracking Equipment. Doc. No. 10033040, Rev. D, Lockheed Martin Communications Systems, Nov. 20, 1996.

Daniel, J. W.: Development Specification High Rate Frame Multiplexer (HRFM). International Space Station Program Communications and Tracking Equipment. Doc. No. 10033034, Rev. P, Communications Systems, May 5, 1997.

Geraci, R.: Development Specification ACS RF Group (ACRFG). International Space Station Program Communications and Tracking Equipment. Doc. No. 10033702, Rev. J, Communications Systems, May 1997.

Larsen, David W.: International Space Station, United States On-Orbit Segment to Ground (Through Tracking and Data Relay Satellite System) Interface Control Document—International Space Station Alpha Program, Revision C. SSP 42018, Rev. C, NASA Johnson Space Center, Mar. 22, 1995.

Mackiw, G.: Development Specification SGS Transmitter-Receiver-Controller (SGTRC). International Space Station Program Communications and Tracking Equipment. Doc. No. 10033277, Rev. G, Communications Systems, May 27, 1997.

Neal, David D.: US Lab Architecture Control Document—Volume 5: Audio Subsystem Revision New. International Space Station Program, D683-14719-1-5, Boeing Co., Sept. 26, 1996.

Neal, David D.: US Lab Architecture Control Document—Volume 4: Internal Video Subsystem Revision New. International Space Station Program, D683-14719-1-4, Boeing Co., Nov. 27, 1996.

Scheiner, J.: Development Specification Video Switch (VSW). International Space Station Program Communications and Tracking Equipment. Doc. No. 10033705, Rev. D, Communications Systems, May 2, 1997.

3.4. Guidance, Navigation, and Control System

3.4.1. Introduction

The purpose of the ISS GN&C system is to control the Station's motion to be suitable for the intended uses of the facility. Information from the documents listed in the bibliography (section 3.4.5) was used to compile this section.

3.4.2. Overview of GN&C System

Navigation provides three functions: state determination, attitude determination, and pointing and support. In the first of these functions, the inertial position and velocity (referred to as the "state") of a point fixed in the core body of ISS is obtained. Loosely speaking, this answers the question, "Where am I?" The second function involves a quantitative description of the attitude of the core body of ISS relative to some other reference frame, answering the question, "How is the ISS oriented?" The third function, pointing and support, answers the question, "Where is everything else?" in order to move ISS appendages, such as solar arrays and antennas, so that they are properly oriented in relation to distant objects such as the Sun, communications satellites.

Guidance answers the question "What path does the ISS take to get from here to there?" In the case of the ISS, the current orbit is "here," and a desired set of orbital parameters is "there."

Control provides the means with which to travel the chosen path. Translational and angular motions of the ISS's core body must both be controlled.

The ISS GN&C system is made up of two components, one contributed by the U.S. and the other provided by the RSA. The assembly sequence information for the primary elements of the GN&C system can be found in the appendix.

3.4.3. Architecture and Components for GN&C System

3.4.3.1. Guidance

Guidance is generally performed by the ROS motion control system (MCS), although the U.S. GN&C system does provide a limited amount of guidance planning support.

3.4.3.2. Navigation

The U.S. GN&C system consists of software installed on the U.S. GN&C MDM's, as well as the ORU's.

3.4.3.2.1. State Determination

Onboard flight software estimates position and velocity by exercising propagation algorithms that receive periodic updates from one of the two global positioning system (GPS) receivers and processors, from the Russian MCS data from the global navigation satellite system (GLONASS), or from the ground uplinks. The ROS MCS exchanges data with the U.S. GN&C MDM's.

3.4.3.2.2. Attitude Determination

The orientation of the core body, relative to a terrestrial reference frame, is measured at a frequency of 0.1 Hz by interferometry of GPS signals. Four GPS antennas are placed on the core body at the corners of a rectangle measuring 3 by 1.5 m. GPS attitude determination “shall have an attitude performance error equal to or less than 0.44° axis (3σ).”

The angular velocity of the core body relative to an inertial reference frame is measured with two rate gyro assemblies (RGA's) consisting of three ring laser gyros each.

The ROS MCS provides an alternate source of measurements for attitude determination, and data are continuously exchanged with U.S. GN&C MDM's. Russian sensors include star trackers, Sun sensors, Earth horizon sensors, magnetometers, rate gyros, and GLONASS information.

3.4.3.2.3. Pointing and Support

Pointing and support (P&S) programmed into the system calculates the position vector from the ISS to the Sun, together with solar rise and set times, and provides this information to the external active thermal control system, where thermal radiator orientation is governed. Solar information is used by P&S to determine desired angular positions of U.S. solar array alpha and beta joints, used by the power manager controller application.

P&S calculates the position vector from the ISS to TDRSS, along with rise and set times, and supplies this information to the C&T system for pointing communications antennas.

The total mass and the distribution of mass (moments and products of inertia) of the Station is computed by P&S, accounting for payloads moved with the mobile servicing system (MSS), SSRMS, JEM remote manipulator system (JEM RMS), and the ROS remote manipulator system (RMS). Payload mass and mass center positions (rather than RMS joint angles) are reported to P&S. GPS time is provided to C&C MDM's to synchronize timing in all MDM's.

3.4.3.3. Control

3.4.3.3.1. Translational

Reboost is performed every 3 mo to offset the effects of aerodynamic drag and to raise the ISS's altitude. The primary method uses the Russian Progress main engine, with fuel from Progress propellant tanks. An alternate method uses Progress rendezvous and docking thrusters with fuel transferred from the Zvezda or the Zarya module. A third method uses the Zvezda main engines; however, this is avoided as much as possible since those engines have a limited burn lifetime. The Station's orbit may be changed from time to time to avoid orbital debris.

A U.S. PM is to be attached to pressurized mating adapter 2 on flight 10A.1. In the event that the Zvezda is not provided to the ISS, or there is an insufficient resupply of progress propellant, the U.S. PM can provide reboost, attitude control, CMG desaturation, and collision avoidance at 50 percent of vehicle life. The U.S. PM will be constructed such that it could contain two star trackers and two rate gyros. The hardware used for propulsion is described in section 3.8.

3.4.3.3.2. Attitude

The attitude of the core body is controlled initially by the Russian propulsion system and later by the U.S. attitude control system, which consists of two U.S. GN&C MDM's and four control moment gyroscopes (CMG's) on the Z1 truss.

The U.S. CMG's are double gimballed; each CMG has 3500 ft-lbf-sec of angular momentum and can produce 190 ft-lbf (257 N-m) of torque. The CMG momentum manager algorithm is designed to keep the CMG's from saturating by maintaining the core body at a torque equilibrium attitude (TEA), an orientation in which the angular acceleration of the core body in inertial space vanishes; that is, the resultant of gravitational torque, aerodynamic drag torque, gyroscopic torque, and other torques is zero. Because the TEA changes continuously, referring to the average TEA over an orbit is convenient.

ISS TEA's are of two types: the core body's attitude is nearly fixed either in an LVLH reference frame or an inertial reference frame. The latter type is required on configurations for flights 5A through 12A because the lack of one solar array joint prevents sufficient power generation at high solar beta angles, and is known as an X-axis (central principal axis of inertia) perpendicular to orbit plane (XPOP) TEA. (The XPOP reference frame is "quasi-inertial" because the orbit plane regresses slowly.) XPOP TEA's create difficulties in thermal control, and in the operation of communication and tracking antennas and GPS antennas.

Microgravity experiments require the CMG's to provide control, without reaction control system (RCS) jets firing for 180 days each year in increments of 30 continuous days or more. Although the requirement applies only to the unmated AC configuration in an LVLH flight orientation, it is possible (and highly desirable) to use the CMG's with configurations between flight 5A and AC. Russian RCS jets are used to desaturate the CMG's, hold attitude during reboost, and perform attitude maneuvers greater than 15°.

3.4.4. Growth Options and Scars

No significant provisions have been made for modifying the GN&C system. Additional CMG's could be placed at any available location; GN&C software may require slight modification to work with more than four CMG's.

If the flywheel energy storage system (FESS) (section 5.2 of Volume II of this document) culminates in the replacement of all batteries, 96 flywheels could be available to assist the CMG's. Torque could be produced in an open-loop fashion by the flywheels or extensive modifications to the CMG steering law software would allow the flywheels and CMG's to work together as an integrated set of momentum exchange devices.

3.4.5. Bibliography

Anon.: International Space Station GN&C Architecture Description Document, Vol. 4, Design Guidelines and Assumptions. Rev. B, D684-10506-04, Boeing Co., Mar. 31, 1997.

Anon.: Prime Item Development Specification for the International Space Station Space Integrated GPS/INS Navigation System (SIGI-ISS)—Appendix 90. DS34204000, Rev. C, Pt. 1, Cage Code 0BFA5, Honeywell Inc., July 29, 1998.

3.5. Structures and Mechanisms

3.5.1. Introduction

Every flight during ISS assembly involves the process of incorporating an additional structure, operating a mechanism, or both. Structures are vital ISS components because they protect the crew from the harsh environment of space. Mechanisms perform the critical role of holding structures together, allowing the orbiter to dock with the Station or providing temporary attachment for payloads. Information from the documents listed in the bibliography (section 3.5.6) was used to compile this section.

3.5.2. Overview

Two main types of structures on ISS are pressurized elements and truss assemblies. A pressurized element structurally contains the pressurized atmosphere, which provides the work and living area and protects the crew from the space environment. Examples of pressurized elements include the U.S. Lab, the APM, the JEM, and the Russian Zvezda. Pressurized elements can be broken down into two categories: primary and secondary structures.

The function of mechanisms is to structurally attach components, dock vehicles, or provide a temporary attachment. Most mechanisms are used once, such as those that attach components together. Some, such as those used to dock vehicles and provide temporary attachments, are used multiple times. Examples of mechanisms include the common berthing mechanism (CBM), Lab cradle assembly (LCA), segment-to-segment attachment system (SSAS), and the androgynous peripheral attachment system (APAS). The assembly sequence information for the primary structures and mechanisms elements can be found in the appendix.

3.5.3. Architecture and Components for Structures and Mechanisms

3.5.3.1. Structures

3.5.3.1.1. Pressurized Structures

A pressurized element structurally contains the pressurized atmosphere, which provides the work and living area and protects the crew from the space environment. Pressurized elements can be broken down into two categories: primary and secondary structures.

3.5.3.1.1.1. Primary structures. Primary structures are composed of a ring frame and a longeron-stiffened pressure shell. The ring frame resists loads and provides attachment points for the longerons and shell panels. The longerons are used to increase the stiffness and load-carrying capability of the shell panels, whereas the shell panels form the module walls. Integrated trunnions for Shuttle transport and windows are also considered primary structures. The integrated trunnions are used to hold the elements in the Shuttle bay for transportation to space (fig. 3.5-1).

3.5.3.1.1.2. Secondary structures. The secondary structures provide the function of crew and payload translation aids, equipment support, and debris shielding. Secondary structures exist both internal and external to the primary structures (fig. 3.5-2). Standoffs and racks are examples of internal secondary structures. Standoffs provide the attachment points for racks and a passageway

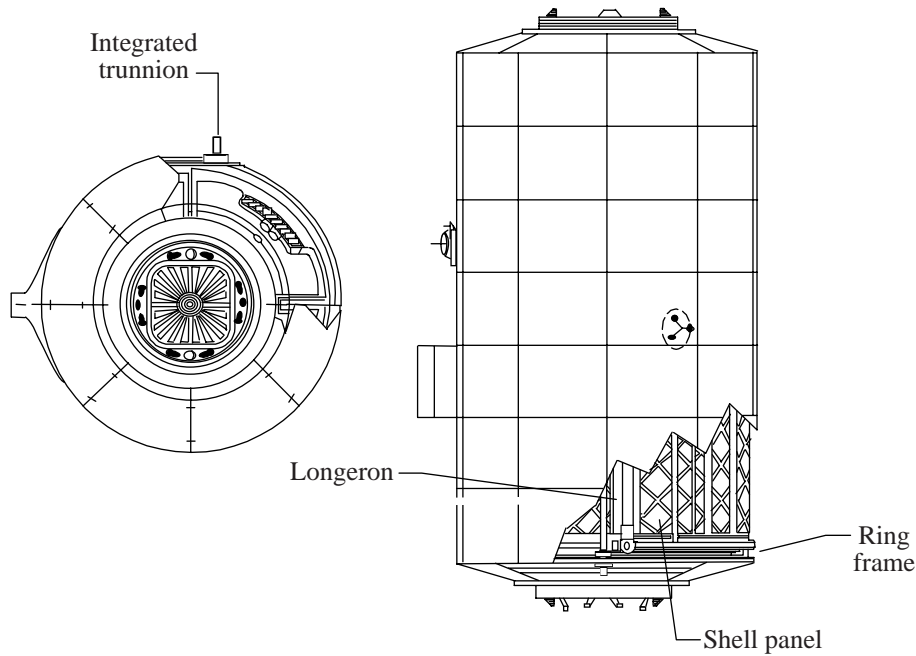

Figure 3.5-1. Primary structures.

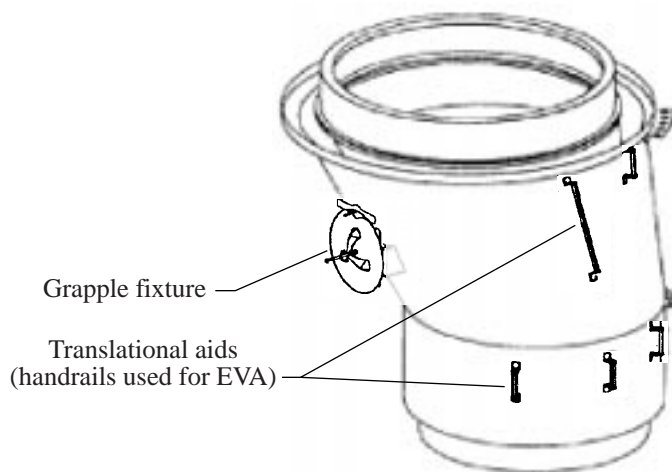

Figure 3.5-2. Secondary structure.

for electric and thermal lines. Racks provide the storage area for electrical equipment, sensors, and experiments. External secondary structures include crew translational aids, grapple fixtures, window shutters, and micrometeoroid/orbital debris (MM/OD) shielding. Translational aids are used by the EVA crew to move around a work site. The grapple fixtures are used by the robotic arms as attachment points. The MM/OD shields protect the crew modules, pressure vessels, and other critical components from orbital debris.

3.5.3.1.2. Truss Assemblies

The truss assemblies provide the structural backbone of the ISS and attachment points for exposed payloads. Truss assemblies also contain electrical and cooling utility lines, the mobile

transporter rails, and mechanical systems such as joints and mechanisms. The two types of truss assemblies are the integrated truss structure (ITS) (fig. 3.5-3) and the Russian SPP.

3.5.3.1.2.1. Integrated truss structure. The ITS is made up of 10 individual pieces. Each segment is made of aluminum. At full assembly, the truss reaches 100 m in length, approximately the length of a football field. The segments are labeled in accordance with their location; P stands for port and S stands for starboard. As illustrated in figure 3.5-3, the ITS is centered on the Station extending horizontally with the S0 segment attached to the U.S. Lab. The Z1 truss is located on the zenith side of node 1.

3.5.3.1.2.2. Science power platform. The SPP, located on the zenith side of the Zvezda transfer compartment and 8 m tall, is Russian built and contains radiators, solar arrays, and a small pressurized volume for hardware storage. It is also equipped with thrusters to aid the Zvezda with control moments along the roll axis.

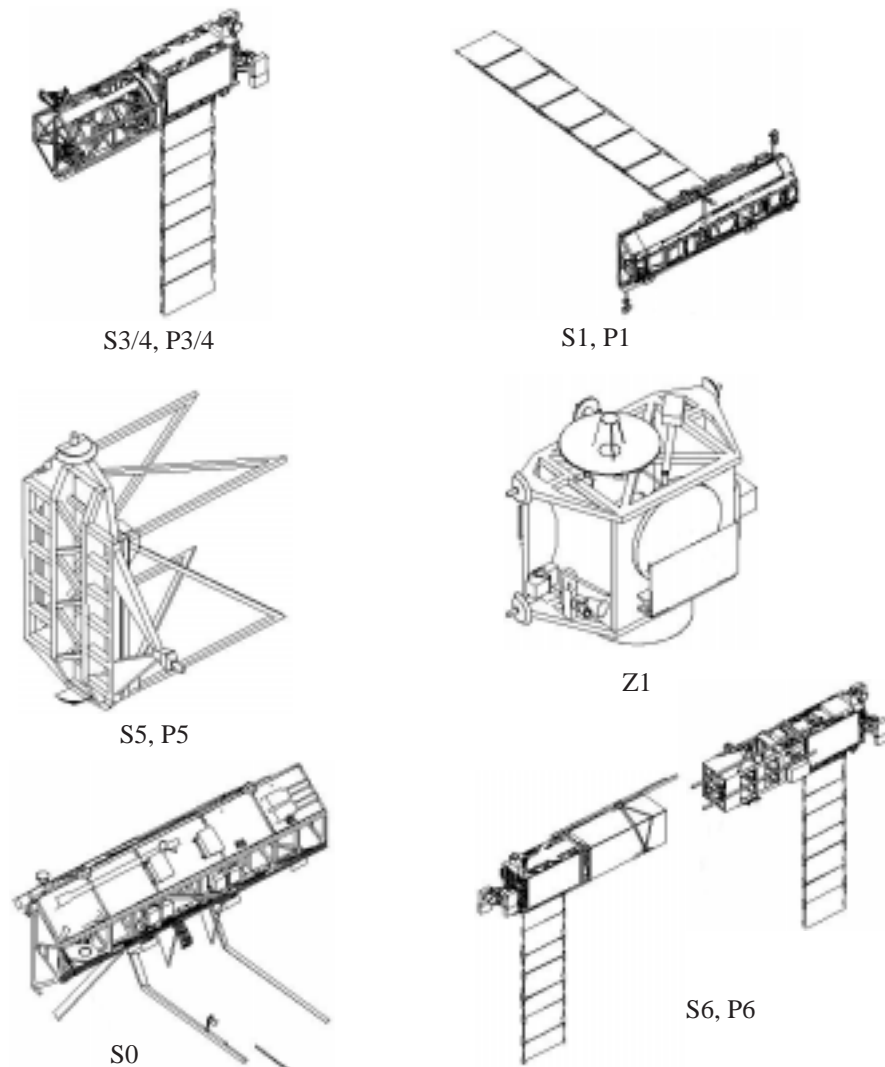

Figure 3.5-3. Integrated truss structure.

3.5.3.2. Mechanisms

The function of mechanisms is to structurally attach components, dock vehicles, or provide a temporary attachment. Most mechanisms are used once, such as those that attach components together; others, such as those used to dock vehicles and provide temporary attachment, get used multiple times. Examples of mechanisms include the CBM, the LCA, SSAS, and the APAS.

3.5.3.2.1. Common Berthing Mechanism

The function of the CBM is to mate one pressurized module to another pressurized module on the U.S.-developed side of the Station. The CBM has an active and a passive half (fig. 3.5-4). The active half contains a structural ring, capture latches, alignment guides, powered bolts, and controller panel assemblies. The passive half also has a structural ring, capture latch fittings, alignment guides, and nuts.

3.5.3.2.2. Lab Cradle Assembly

The LCA attaches the S0 truss during assembly, and by default the rest of the truss assembly, to the U.S. Lab. The LCA, shown in figure 3.5-5, has an active and a passive half. The active half contains a capture latch and alignment guides, whereas the passive half contains a capture bar and alignment bars. The LCA is attached to the ring frame and longerons of the U.S. Lab.

3.5.3.2.3. Segment-to-Segment Attachment System

The segments of the ITS are attached by using SSAS (fig. 3.5-6). The SSAS attaches various ITS segments, specifically S3/4, S1, S0, P1, and P3/4. The S5, S6, P5, and P6 segments are bolted to ITS by the EVA crew by using the Boeing/Rocketdyne truss attachment system (RTAS). The SSAS has an active and a passive half. The active half contains motorized bolts, coarse alignment pins, fine alignment cones, and a capture latch, and the passive half contains nuts, coarse and fine alignment cups, and a capture bar. The RTAS is similar to the SSAS except it does not have the motorized components. Instead, the capture latch and all the bolts are manually driven by the EVA crew.

3.5.3.2.4. Androgynous Peripheral Attach System

The APAS serves two functions on the station. One is to dock the orbiter and the other is to attach Zarya to PMA 1. An APAS is located on each of the three PMA's and on the Zarya forward side. The components of the APAS (fig. 3.5-7) are a structural ring, a movable ring, alignment guides, latches, hooks, dampers, and fixers. The APAS is a Russian design and is designed to mate with an exact copy of itself (hence the name androgynous). Each APAS can act as the passive half or the active half. The APAS is also used on the Shuttle/Mir flights and is referred to there as the "Androgynous Peripheral Docking System."

3.5.4. Growth Options

On the USOS, node 3 provides six attachment points that serve as docking ports for the Unity node, U.S. Hab module, U.S. CRV, a pressurized mating adapter, and two ports that remain open for future Station additions. These additions may include research laboratories from the IP, commercially developed research laboratories, or an additional habitation environment for the crew.

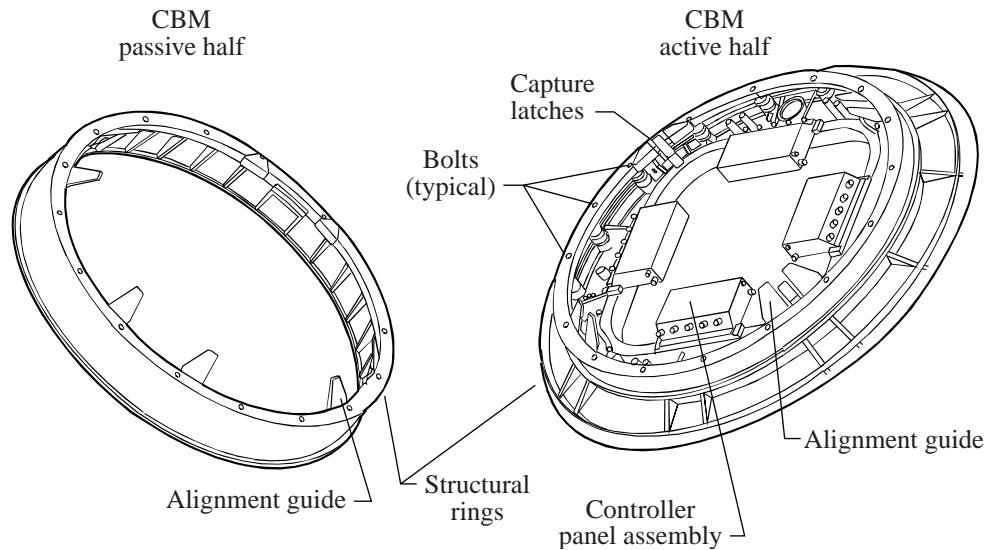

Figure 3.5-4. Common berthing mechanism.

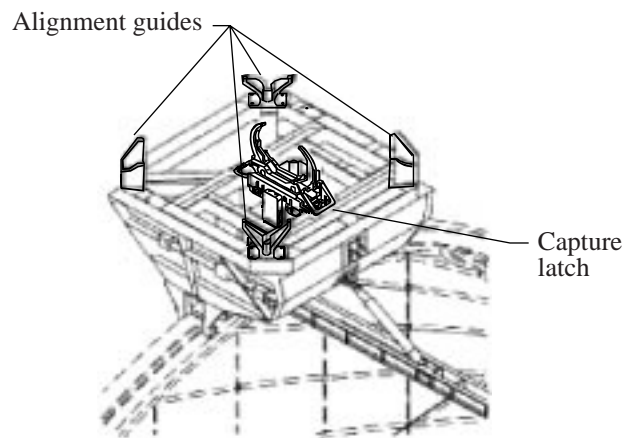

Figure 3.5-5. Lab cradle assembly.

An example application is found in section 5.5 in Volume II of this document. On the ROS, the UDM provides four docking locations that will be occupied by two Russian RM's and the docking compartment (DC 2). Two life support modules are planned for the fourth location; however, these are not included in the current assembly sequence.

Additional growth options also exist for unpressurized structures and mechanisms. The exterior of the APM module, on the end opposite the node 2 attachment point, may provide areas for small attached payloads, much like that of the JEM exposed facility (EF). Similar proposals have also been discussed for use on Russian modules. Additional attachment points on the truss (in addition to the P3 and S3 locations) for attached payloads may be studied in the future.

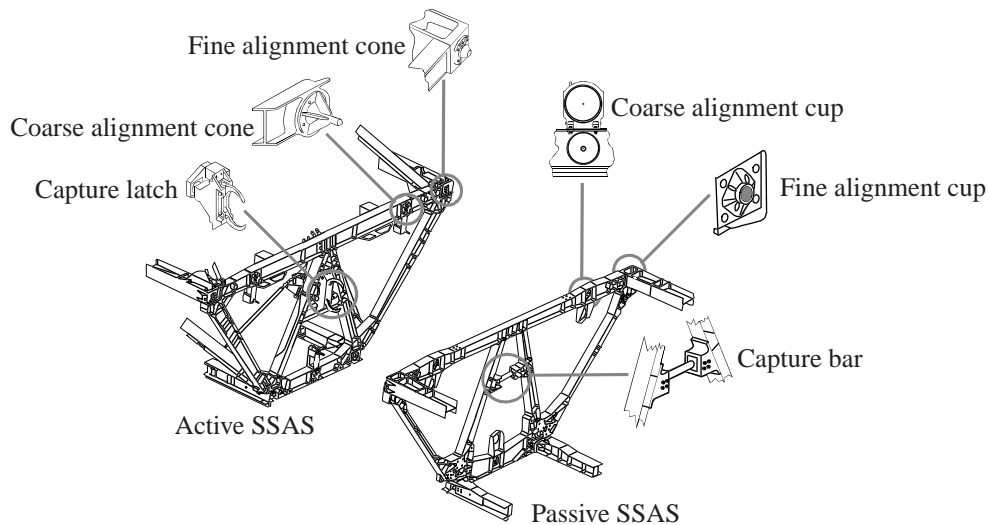

Figure 3.5-6. Segment-to-segment attachment system.

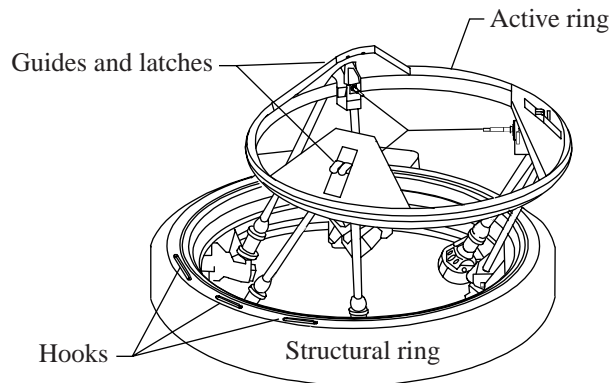

Figure 3.5-7. Androgynous peripheral attachment system.

3.5.5. Bibliography

Anon.: Configuration Item Specification for the Segment to Segment Attachment System CI NO. 222057A, 222057B, 222057C, 222057D, 222057E, 222057F, 222057G, 222057H, 222057J, 222057K, 222057L, 222057M, 222057N, 222057P. Specification No.: SP-M-598A, Cage Identification No.: 18355, McDonnell Douglas Aerospace, Jan. 16, 1998.

Jou, Reza: System Specification for the International Space Station—Type 1. Specification No. SSP 41000F, Cage Identification No. 2B945, Contract NAS15-10000, CDRL No. MG02, Boeing Co., July 4, 1997.

Rodriguez, Victoria: Common Berthing Mechanism to Pressurized Elements Interface Control Document—Part 1. International Space Station Program, SSP 41004, Pt. 1, Rev. G, NASA Johnson Space Center, June 1, 1999.

Rodriguez, Victoria: Common Berthing Mechanism to Pressurized Elements Interface Control Document—Part 2. International Space Station Program, SSP 41004, Pt. 2, Rev. G, NASA Johnson Space Center, Apr. 30, 1999.

Scott, John H.: Space Station Program Androgynous Peripheral Assembly System to Pressurized Mating Adapter Interface Control Document—Part 1 Core (APAS to PMA-2 & 3). International Space Station Program, SSP 42120, Rev. A, NASA Johnson Space Center, Oct. 30, 1998.

Scott, John: Space Station Program Androgynous Peripheral Assembly System to Pressurized Mating Adapter Interface Control Document—Part 1, Appendix A (APAS to PMA-1), International Space Station Program, SSP 42120, Pt. 1, Appendix A, Rev. A, NASA Johnson Space Center, Oct. 30, 1998.

Scott, John: Androgynous Peripheral Assembly System to Pressurized Mating Adapter Interface Control Document—Part 2, Core (APAS to PMA- 2 & 3). International Space Station Program, SSP 42120, Pt. 2, Core, Rev. A, NASA Johnson Space Center, Oct. 30, 1998.

Scott, John: Androgynous Peripheral Assembly System to Pressurized Mating Adapter Interface Control Document—Part 2, Appendix A (APAS to PMA-1). International Space Station Program, SSP 42120, Pt. 2, Appendix A, Rev. A, NASA Johnson Space Center, Oct. 30, 1998.

3.6. Environmental Control and Life Support System

3.6.1. Introduction

The environmental control and life support system (ECLSS) provides a habitat in which the crew can live and work in a safe and habitable environment. The design focus has been on evolving the ECLSS to utilize regenerative technologies to minimize the expenditures of ISS resources such as mass, volume, power, and consumables that must be resupplied by the Shuttle. The implementation of these technologies is planned for completion when the habitation module becomes an ISS element in 2004. The ECLSS is designed to sustain a seven-person crew in a habitable environment at an atmospheric pressure of 14.7 psia. When, however, the assembly is complete, there will be sufficient ECLSS capability to sustain a seven-person permanent crew. This capability will be provided by a combination of U.S. and Russian life support equipment as well as multiple on-orbit laboratories. The U.S. ECLSS is described in this section. Information from the documents listed in the bibliography (section 3.6.5) was used to compile this section.

3.6.2. Overview of ECLSS

The ECLSS provides six major functions as well as vacuum venting and maintenance for payload support. This section presents ECLSS by subsystems, starting with atmosphere control and supply (ACS), atmosphere revitalization (AR), temperature and humidity control (THC), fire detection and suppression (FDS), vacuum system (VS), and finally water recovery and management (WRM) and waste management (WM). These functions are shown in figure 3.6-1. The assembly sequence information for the primary elements of the ECLSS can be found in the appendix.

3.6.3. Architecture and Major Components for ECLSS

3.6.3.1. Architecture

The initial ECLSS equipment is included in node 1. This equipment consists primarily of ventilation and FDS components. The Lab will contain equipment to remove carbon dioxide, humidity, and detectable (sensorable) heat from the cabin atmosphere. Water supply and gases will be provided by the Russians to sustain the crew if the Lab is occupied before the airlock is launched. Gases will be onboard the airlock that will sustain the crew. Node 3 will remove carbon dioxide from the atmosphere as well as provide the capability to convert water to oxygen for crew consumption by the addition of the oxygen generation assembly. The potential to reduce the carbon dioxide to water will be maintained by scarring node 3 for the future addition of a Sabatier hydrogenation process. Node 3 will provide trace contaminant control capability and the capability to recover potable water from ISS liquid wastes. Facilities to collect and store crew metabolic wastes will be in node 3.

3.6.3.2. Major Components

Most ECLSS components are essentially state-of-the-art technologies or have direct heritage to flight-proven hardware. The valves, control devices, pressure monitoring units, fans, heat exchangers, and other such items in the ACS, THC, and FDS subsystems are not advanced technologies. The WM subsystem is derived from the Shuttle extended duration orbiter (EDO)

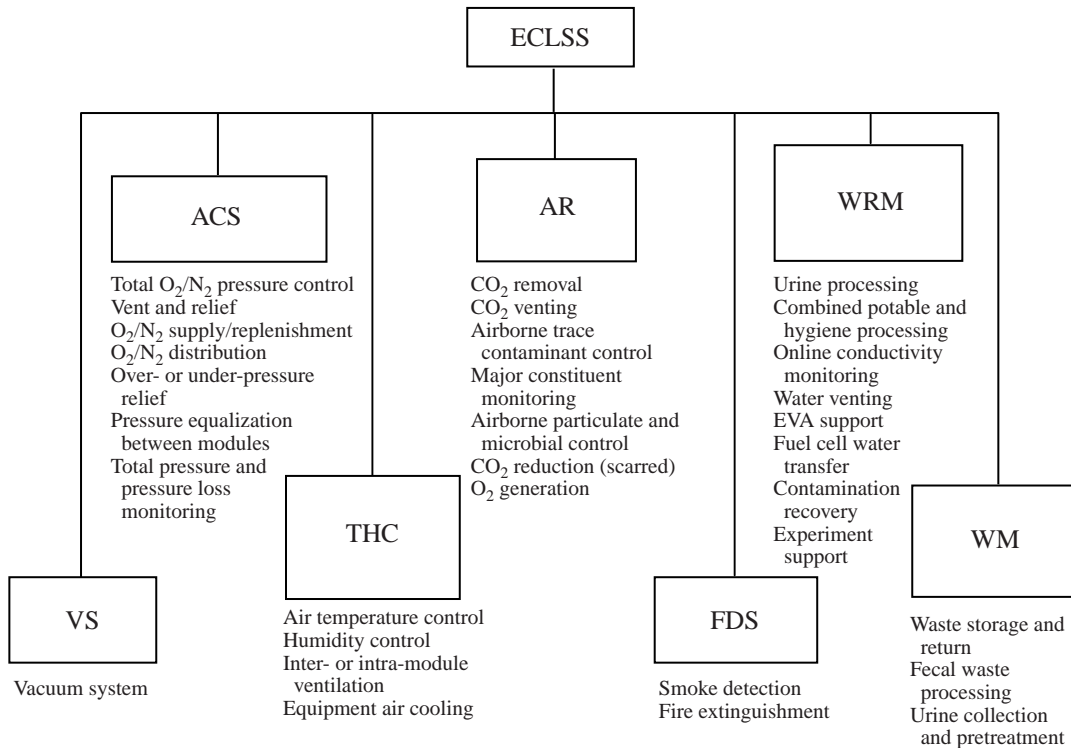

ECLSS also provides vacuum venting and maintenance for payload support.

Figure 3.6-1. ECLSS functional overview.

commode and urinal hardware that have successful flight histories. The AR and WRM include regenerative technologies that have the potential to significantly reduce ISS resources and Shuttle resupply consumables. These components are described in the sections that follow.

3.6.3.2.1. Atmosphere Control and Supply

The ACS subsystem provides oxygen/nitrogen pressure control, pressure vent and relief, oxygen/nitrogen storage and distribution, pressure equalization between modules, and total pressure control as well as pressure loss monitoring.

3.6.3.2.2. Atmosphere Revitalization Components

The AR subsystem controls the concentration of carbon dioxide (CO₂), trace contaminants, particulate material, and microorganisms in the cabin air. Major airborne constituents will also be monitored. The AR subsystem components for CO₂ removal and O₂ supply are shown in figures 3.6-2 and 3.6-3 before and after node 3 launch, respectively. Extensive testing of these components is proposed.

3.6.3.2.2.1. Before node 3. Oxygen and nitrogen gases are supplied by four high-pressure tanks, two each of oxygen and nitrogen, located on the exterior of the airlock. These gases are distributed throughout the ISS by a plumbed system installed in the ISS. The tanks are rechargeable or can be changed out for fully charged tanks. A four-bed molecular sieve (4BMS) collects carbon dioxide expired by the crew and vents the same to space.

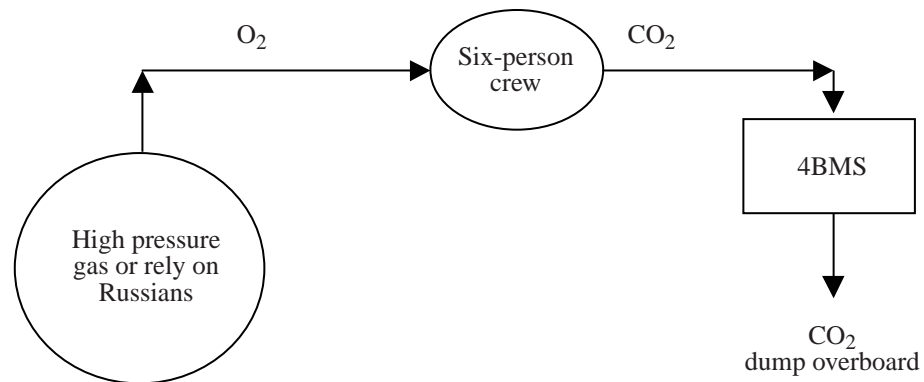
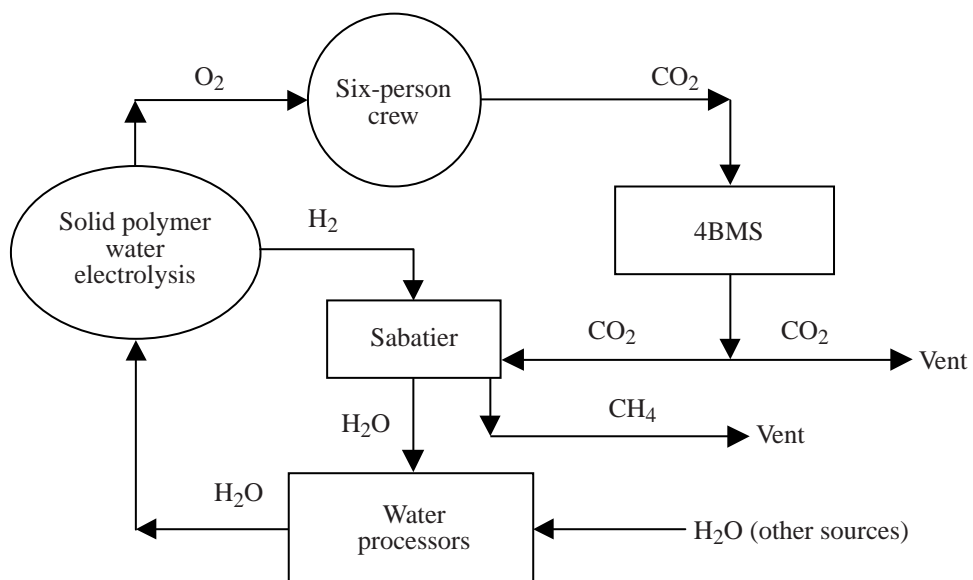
Figure 3.6-2. ISS CO₂ removal and O₂ supply before node 3.Figure 3.6-3. ISS CO₂ removal and O₂ supply after node 3.

3.6.3.2.2.2. After node 3. The potential to reclaim oxygen from crew-expired carbon dioxide will be provided. A 4BMS or a carbon molecular sieve (CMS) concentrates carbon dioxide for conversion to water by a Sabatier hydrogenation process. Node 3 will be scarred to accommodate this process at a future time. The Sabatier also produces methane, which is vented to space along with unconverted carbon dioxide. The Sabatier-produced water and makeup water from the WMS are converted to oxygen and hydrogen by a solid polymer electrolysis unit. The oxygen is returned to the cabin for crew consumption, whereas the hydrogen is supplied to the Sabatier to maintain the carbon dioxide conversion. Approximately 50 percent of the oxygen is reclaimed from the crew-expired carbon dioxide. Regenerative adsorbent catalyst technology or advanced catalyst technology will remove trace contaminants from the cabin atmosphere.

3.6.3.2.3. Temperature and Humidity Control

The THC subsystem provides cabin air temperature and humidity control and air ventilation in each pressurized element. Intermodule ventilation is provided between adjoining pressurized

elements to circulate air for the crew and to transport contaminants in the cabin air to the purification equipment. In addition, the THC provides equipment air cooling in each powered rack.

3.6.3.2.4. Fire Detection and Suppression

The FDS subsystem provides smoke detection sensors for station modules, fire extinguishers, and a system of alarms and automatic responses to a fire event. Figure 3.6-4 shows the USOS FDS subsystem and its interfaces.

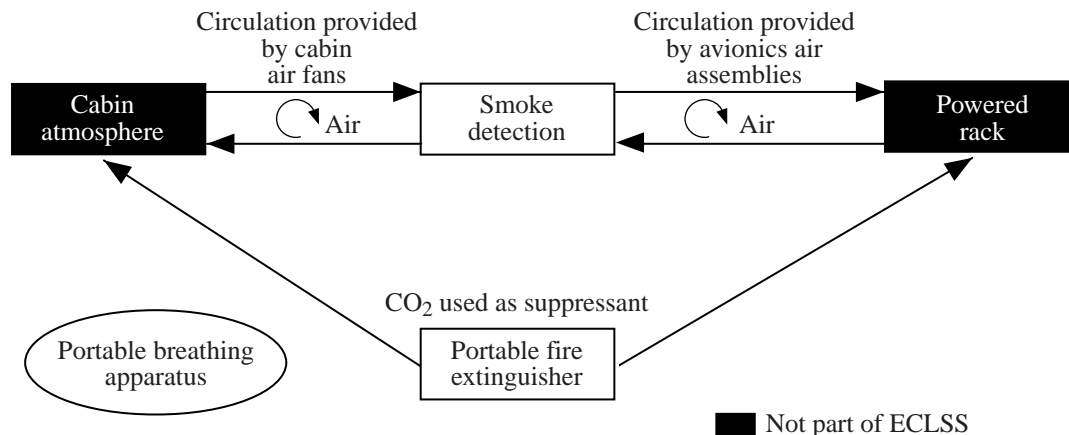

Figure 3.6-4. Fire detection and suppression subsystem.

3.6.3.2.5. Water Recovery and Management

The WRM subsystem recycles water to reduce the quantity of water that must be resupplied to the ISS and the quantity of waste water that must be removed from the ISS. This subsystem consists of processes to recover water from hygiene waste water, humidity condensate, Shuttle fuel cell water, extravehicular mobility unit waste water, urine flush water, and CO₂ reduction water. Water venting is included. The U.S. WRM components are shown in figure 3.6-5. Extensive testing of these components is proposed.

3.6.3.2.5.1. WRM components for node 3. The WRM system proposed by the Marshall Space Flight Center (MSFC) is shown in figure 3.6-5. Urine flush water will be processed in a vapor compression distillation unit. The distillate along with the waste waters shown in figure 3.6-5 will be processed in a multifiltration unit (MFU). The MFU is designed to be replaced every 40 days. The recovered water is treated in the volatile removal assembly (VRA) to reduce the total organic carbon in the recovered water to meet the ISS specification of less than 0.5 ppm. The VRA will operate at a pressure of 60 psia and a temperature of 250°F. The water will be treated with iodine in the microbial check valve for microorganism control and then checked for conductivity in the conductivity monitor. The recovered water will be stored in potable water tanks until required for ISS use. Total organic carbon, pH, and iodine were eliminated from the on-line monitor mainly because the crew health care system (CHeCS) will monitor water constituents off-line twice weekly from two storage tanks located in the Hab. These tanks will operate in a fill-use mode.

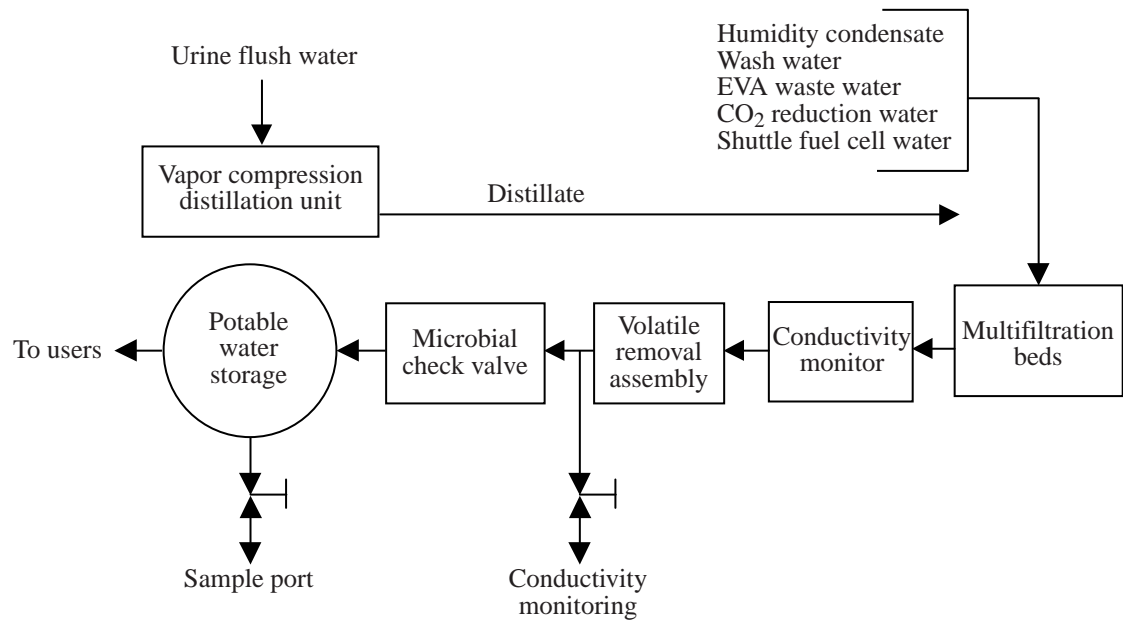

Figure 3.6-5. MSFC-proposed WRM system for node 3.

3.6.3.2.6. Waste Management

The WM subsystem provides the collection and storage of crew metabolic wastes. Prior to node 3 integration with the ISS, the waste management functions will be provided on the Shuttle or Russian segment when docked to the ISS. Commode facilities will be in node 3 to collect and store crew wastes. A urinal will be in node 3 to collect, pretreat, and store urine flush water.

3.6.4. Growth Options and Scars

Growth options and scars relative to the ECLSS are best focused on those technologies that have the potential to reduce ISS resources and resupply requirements. More efficient processes included in the AR and WRM subsystems provide this focus. (See table 3.6-2.)

3.6.4.1. Atmosphere Revitalization

The growth option technology shown in table 3.6-1 lists a carbon molecular sieve for cabin air CO₂ removal, mainly, because it uses less energy than the baseline 4BMS. Other technologies such as the electrochemical depolarized cell and the solid amine water desorbed unit should be considered for growth options. Also shown is a Sabatier reactor for reducing CO₂ to water for subsequent production of metabolic O₂ to sustain the crew. In addition, Sabatier + carbon formation and Bosch technologies should be considered for this function. Node 3 is scarred for the Sabatier reactor.

3.6.4.2. Water Recovery and Management

Both the baseline and growth option technologies listed for water recovery in table 3.6-1 are viable candidates for ISS growth application. These technologies require extensive testing with real waste water inputs to enhance the selection process. Also those components that are sensitive

Revision A, October 2000

to reduced gravity operation should be tested in the appropriate gravity environment. The utilization of the air evaporation system (AES) distillation technology will reduce makeup water to a minimum.

Table 3.6-1. ISS ECLSS Functional Buildup

Function	Designation	Airlock	Lab	Node 3
CO ₂ removal and dump	Baseline		4BMS	4BMS
	Growth option			Carbon molecular sieve
CO ₂ reduction	Baseline			Sabatier (scarred)
O ₂	Baseline before node 3	High pressure gas for early backup and EVA or rely on Russians		
	Baseline			Solid polymer water electrolysis
Trace contaminant control	Baseline		Expendable charcoal catalyst system (ECCS)	ECCS
	Growth option			Regenerable sorbent catalyst Advanced catalyst
Water supply	Baseline before node 3		Rely on Shuttle supply and Russians to process condensate and provide stored water	
Urine flush and other waste water recovery	Baseline			Vapor compression distillation (VCD) Multifiltration (MF)
	Growth option			Bioreactor, reverse osmosis and air evaporation or thermal integrated modular evaporative system
Feces and urine collection	Baseline			Shuttle EDO derived commode with oxygen/sulfuric acid urine pretreatment (solid pill) at the urinal

3.6.5. Bibliography

- Anon.: Environmental Control and Life Support System Architectural Control Document. Space Station Freedom Program Office, SSP 30262, Rev. D, NASA Space Station Freedom Program Office, July 1991.
- Hall, John B., Jr.; and Thomas, Carolyn C.: Alternate Environmental Control and Life Support Systems Technologies for Space Station Application. SAE Paper 941464, June 1994.
- Philistine, Cynthia: Environmental Control and Life Support (ECLS) Architecture Description Document—Volume 3: ECLS Subsystem Integration and Planning, Book 1: Verification Plan. International Space Station Program, D684-10508 (Contract NAS15-10000), Vol. 3, Book 1, Rev. B, Boeing Co., July 31, 1997.
- Reuter, James L.: International Space Station Environmental Control and Life Support System Status: 1998–1999. SAE Paper 1999-01-2147, July 1999.

3.7. Command and Data Handling System

3.7.1. Introduction

Over 100 different computers are on the ISS at AC primarily to collect data from onboard systems and payloads, process those data with various types of software, and distribute commands to the right equipment. The C&DH system has three primary functions. First, it provides the hardware and software computational resources to support ISS core systems command and control, to support science (payload) users of the ISS, and to provide services for the flight crew and ground operations. Second, it provides time reference within C&DH and to other systems. Third, it supports functionality for other system capabilities such as the C&W subsystem, the CHeCS, and all other major subsystems. Information from the documents listed in the bibliography (section 3.7.5) was used to compile this section.

3.7.2. Overview of C&DH

The C&DH system is comprised of cooperating systems from each IP including the U.S. C&DH system, the Russian onboard complex control system (OCCS), the Canadian computer system, the Japanese data management system, and the European data management system, as shown in figure 3.7-1. Intersystem cooperation is accomplished via multisegment data buses for communication of Station-level control information, crew interface computer inputs, C&W information dissemination throughout the Station, and overall system integration. The architecture for the U.S. elements consists of three tiers: Tier 1 is for overall Station control, tier 2 is for local system specific software, and tier 3 is for the local sensor/effector interface.

Five major points from figure 3.7-1 that form the basis of this system overview are as follows:

The U.S. C&DH system is unique because it provides “Station-level control” software to keep all parts of the Station vehicle operationally integrated

A variety of crew interface computers are located throughout the Station; crew interface computers have some common characteristics but also have some aspects unique to each IP system

All Station computer systems have C&W capabilities, which also have some common and some unique characteristics throughout the IP systems

All IP provide numerous processing computers and data buses located within their segment with two exceptions: first, two computers located in the Zarya used to process Zarya data and commands have hardware provided by the United States, but software within them is Russian developed and MCC—M is operationally responsible for them; second, several portions of the Canadian computer system, including the robotic workstation, are provided by the United States

Multisegment data buses exist between IP computer systems to ensure that Station-level control software, the crew interface computer inputs, the C&W information, and the IP processing computers and associated data buses are functioning as an integrated system throughout the Station. The assembly sequence information for the primary elements of the C&DH system can be found in the appendix.

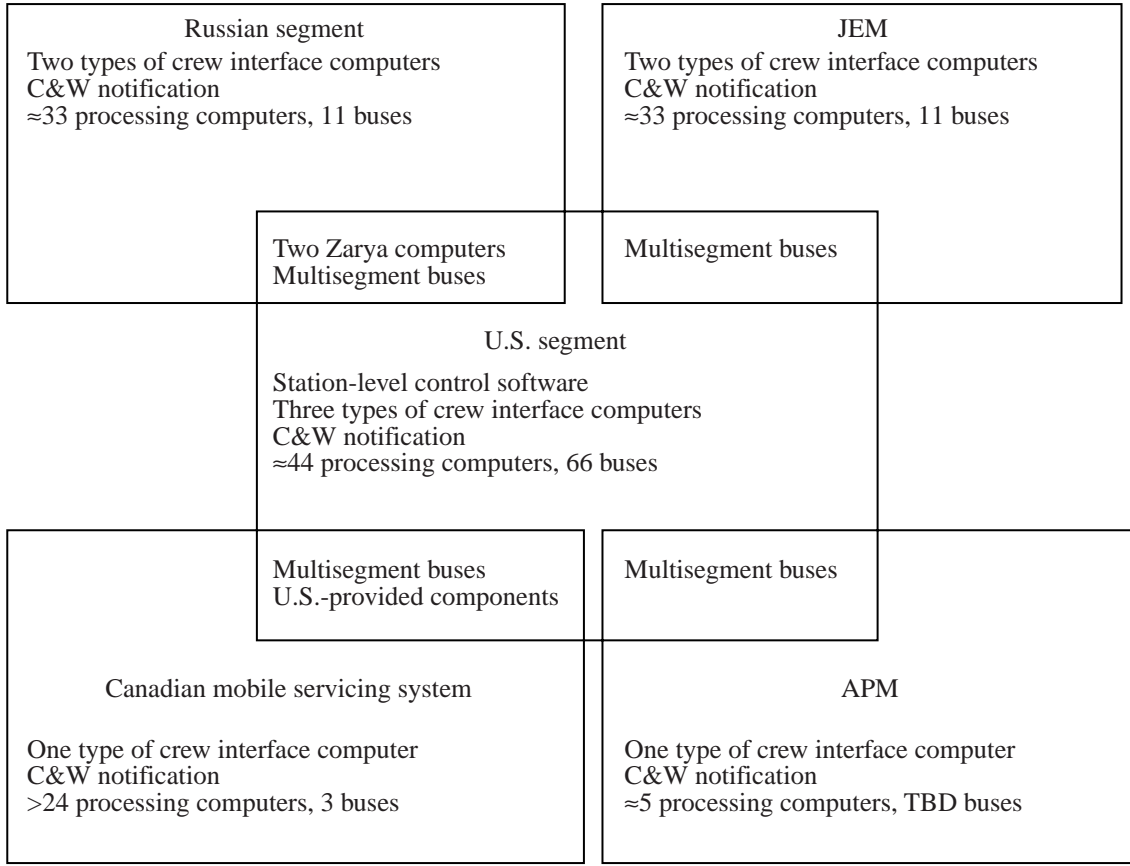

Crew interface computers exclude computers used for payload operations and dedicated hardware switch panels.
 Multisegment buses connect to various computer ports throughout the ISS to allow some crew interface computers to be used in multiple computer systems.
 Processing computers do not include keyboards or monitors.

Figure 3.7-1. Station computer systems at AC.

3.7.3. Architecture and Components for C&DH

3.7.3.1. Overview

The U.S. crew interface computers receive their telemetry data from and impart their commands to the U.S. C&DH computers. At flight 8A, the U.S. C&DH system consists of 25 processing computers interconnected by data buses that collect, process, and distribute data and commands. The computers consist only of the processing box; they have no associated keyboards or monitors. The C&DH computers exchange data and commands in a hierarchical structure referred to as “tiers.” In the U.S. C&DH system, the computers and associated data buses are grouped into three tiers called the control tier, the local tier, and the user tier.

3.7.3.2. Hierarchical Structure

3.7.3.2.1. Control Tier

All processing computers in the C&DH system, regardless of tier, perform multiplexing and demultiplexing of data. However, each tier typically has another unique purpose. The primary

purpose of the control tier, as the name implies, is to provide the interface for the crew and the controllers. They interface with the C&DH computers via the PCS and MCC's, respectively, through tier 1 only. Tier 1 provides two additional functions: it processes vehicle level software such as C&W and Station modes and it provides the interface to the IP computer systems and the orbiter.

3.7.3.2.1.1. Station-level control modes. To aid crews and controllers in configuring the systems and preventing undesirable results, the Station-level control software is divided into seven Station modes. Table 3.7-1 identifies the Station mode, characteristics, and example system configuration changes when making a transition into that mode.

Table 3.7-1. Station Modes

Station mode	Characteristics	Example system configuration changes
Standard	Supports all nominal housekeeping, internal maintenance, and nonmicrogravity payload operations Entered automatically by software from microgravity mode or manually by crew or ground Serves as gateway between microgravity, reboost, proximity operations, and external operations modes	Change IP segments to standard mode Power on and activate payload computer Shut down EVA operation support equipment Shut down ARIS Shut down MT
Microgravity ^a	Supports all microgravity payload operations Entered manually by crew or ground	Change IP segments to microgravity mode Shut down space-to-space subsystem radio Start up ARIS Configure GN&C to CMG attitude control mode
Reboost ^a	Supports ISS orbit reboost operations Entered manually by crew or ground	Change IP segments to reboost mode Configure GN&C to CMG/RCS
Proximity operations ^a	Supports all nominal rendezvous and departure operations for the Orbiter, Soyuz, Progress-M, and all other external vehicles Entered manually by crew, ground, or external vehicle	Change IP segments to proximity operations mode Configure space-to-space subsystem radio to orbiter mode Configure GN&C to CMG/RCS assist attitude control mode
External operations ^a	Supports all external assembly and maintenance operations involving EVA's and external robotics Entered manually by crew or ground	Change IP segments to external operations mode Configure space-to-space subsystem radio to EVA mode Configure GN&C to CMG/RCS assist attitude control mode
Survival	Supports long-term ISS operations in presence of major failure and lack of operator control Entered manually by crew, ground, or external vehicle automatically upon detection of complete failure of critical ISS functions	Change IP segments to survival mode Shut down user payload support equipment Shut down ARIS Shut down EVA operation support equipment

Table 3.7-1. Concluded

Station mode	Characteristics	Example system configuration changes
Assured safe crew return	Supports emergency separation and departure of Soyuz vehicles for unplanned crew return Entered manually by crew, ground, or external vehicle	Change IP segments to ASCR mode Shut down user payload support equipment Shut down ARIS Shut down EVA operation support equipment Command GN&C to attitude selected for Soyuz departure

^aMode also supports all housekeeping, internal maintenance, and nonmicrogravity payload operations that are comparable with the mode.

Station modes are very similar to major modes used on the Space Shuttle. The Station is only in one mode at a time; the mode reflects a major operational activity, and the Station must be commanded to change to another mode. All mode transitions can be manually commanded by the onboard crew or the ground. Transitions to proximity operations, survival, or assured safe crew return (ASCR) can also be commanded from an external vehicle. The Station-level control software can automatically change to only two modes: survival from any mode and standard from microgravity mode only. Notice that when a transition to a mode occurs, the software always automatically issues commands to the IP segments to make a transition to the required mode. This reflects the “multisegment” nature of this software. Also notice that the transition between modes, from microgravity to proximity operations for example, must always be through the standard mode except for survival and ASCR modes.

Figure 3.7-2 depicts a typical mission cycle of 50 days that includes a Shuttle arrival and departure. Notice that a standard mode is located between all other modes. The frequency of mode transitions could be as high as several in a couple of days (proximity operations) or as low as once per month (sustained microgravity). In general, mode transitions should take less than 10–15 min to complete. Mode transitions are always initiated before the new operation begins and always finish with a message to the operator when the transition is complete.

3.7.3.2.1.2. Time management. Time is received by the C&C processor from one of four sources: the GPS time (nominal), the Russian segment time reference, uplink from the ground, or the C&C reference clock. The source selection is under operator control. Each C&DH processor is synchronized to time from the controlling processor in the tier above. For example, tier 2 processors are synchronized to the active tier 1 processor, and tier 3 processors are synchronized to their controlling tier 2 processor. Time synchronization is kept to within 350 μsec of the reference for the system.

3.7.3.2.2. Local Tier

The primary purpose of the local tier or tier 2 is to execute system-specific application software. An example of this, tier 2 application software is the ECLSS software that monitors CO₂ levels in the Station atmosphere and controls airflow to the carbon dioxide removal assembly (CDRA).

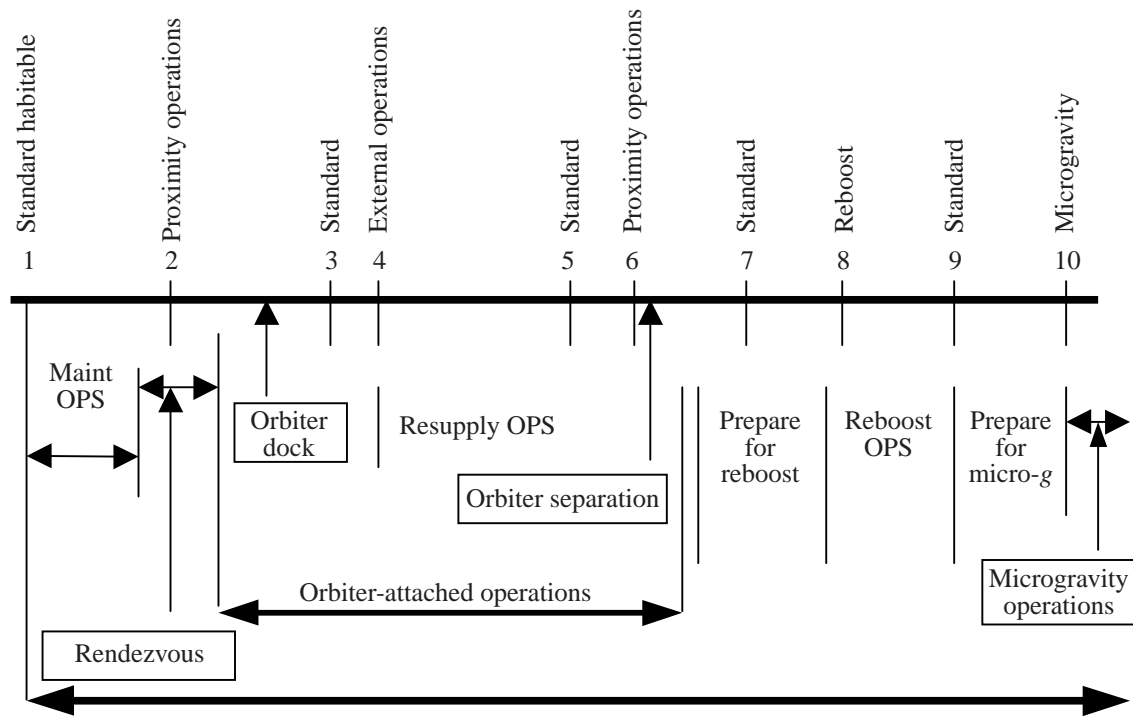

Figure 3.7-2. Station mode during typical mission cycle of 50 days.

3.7.3.2.3. User Tier

The main purpose of the user tier or tier 3 is to provide input/output processing to the thousands of sensors and effectors on the Station. Examples of sensors and effectors that tier 3 computers interface with include temperature sensors, pressure sensors, rack flow control assemblies, and remote power controllers. The tier 3 software converts the sensor analog data to digital data and monitors the condition of the attached hardware. Thus, tiers 1, 2, and 3 provide the crew-controller interface, execution of system application software, and sensor-effector interface, respectively.

3.7.3.3. Hardware Components

The three tiers are composed of various processing computers and buses. The four major types of U.S. hardware are the U.S. processing computers that control Station systems, MDM's, associated buses, and the payload network components.

3.7.3.3.1. Multiplexers and Demultiplexers

As discussed previously, these computers not only complete multiplexing and demultiplexing tasks, they also run application software and process information. Each MDM consists of a chassis containing a backplane with up to 16 slots and the cards needed for the unique tasks of the MDM. The main processing card, also referred to as the "input/output controller unit (IOCU)," can be enhanced to early IOCU by adding a math coprocessor or extra random access memory (RAM).

The MDM's can also contain mass storage device (MSD) cards and an associated hard drive. Other cards within MDM's include serial parallel digital 1553B (STD-1553B) cards to control bus communication, various input/output (I/O) cards that interface directly with sensors and effectors and power supply cards. The power for each MDM is provided by a two-card power supply.

3.7.3.3.2. 1553 Buses

The MDM's exchange data and commands between themselves via 1553B buses, which are named because they adhere to the bus protocol established in the Military Standard Number 1553B, Notice 2. The 1553B buses are also used on the ISS for communication between a C&DH MDM and "smart" components in other, non-C&DH systems. Smart components are those which have the ability to process their own information, such as firmware controllers.

3.7.3.3.3. Payload Network Components

The payload network components include payload MDM's (PL 1, PL 2), the payload 1553 buses, the APS, the payload Ethernet hub gateway (PEHG 1 and PEHG 2), and additional Ethernet and fiber-optic payload networks. The payload components provide the ability to switch between the payloads and different networks. This ability allows faster and more efficient data collection needed for payloads.

3.7.3.3.4. Crew Interface Computers

Since Station-level control software is part of the U.S. C&DH system, the crew can command a mode change only through the U.S. crew interface computer used to control the vehicle, called the PCS. However, seven different types of crew interface computers are on the Station at flight 8A (table 3.7-2).

3.7.3.3.5. Caution and Warning

The C&W subsystem alerts the crew and ground of conditions that (1) endanger the safety of the crew or Station, (2) threaten mission success, or (3) indicate out of tolerance conditions. Events that trigger the C&W subsystem are grouped into four classes that are common across all partner segments. These classes range from class 1, which is a life-threatening condition, to class 4, which is an advisory regarding system information. The tone and color associated with each class are also depicted. Only three emergencies are defined on Station: fire, loss of pressure, and toxic atmosphere.

The C&W panel consists of five push-button lights: one for each of the three emergencies, one for warning, and one for caution. Also a test button will ensure that the lights are still functioning. The emergency and warning buttons are red, and the caution button is yellow (fig. 3.7-3).

Table 3.7-2. Crew Interface Computers at Flight 8A

Type of crew interface computer	Purpose	Hardware and software	Location at flight 8A
Portable computer system	Execute Station mode changes Manage Station C&W Command and control U.S. systems	IBM ThinkPad 760XD laptop at flight 8A Data and power cables Various PC cards Six PCS's on station at flight 6A Two general purpose printers available in U.S. Lab Solaris UNIX operating system	PCS Ports: In Lab Two in Zvezda Two in Zarya Two in airlock Two in orbiter
Station support computer	View U.S. and multisegment electronic procedures Use inventory management system View and edit onboard short-term plan Provide standard office automation tools and other crew support software	IBM ThinkPad 760XD laptop at flight 8A Power cables Radio frequency (RF) PC cards One SSC on Station at flight 6A (seven "early" SSC's also available at flight 6A, but use earlier version of laptop, IBM 760ED) Windows 95 operating system Additional ThinkPad will serve as file server for RF local area network that allows SSC's to communicate to server	Minimum of three RF access points placed strategically throughout modules to maximize RF coverage Access points include power supply connections
Control post computer	C&C Russian systems using combination of software and hardware switches Manage Station C&W	One fixed console with inter-facing laptops	Zvezda
Russian laptop	C&C Russian systems Manage Station C&W	IBM ThinkPad 760ED Data and power cables Various PC cards One general purpose printer for Russian segment	Russian laptop ports: Four in Zvezda
Payload laptop and payload rack computers	Command and control payloads	TBD Many payload laptops run independently from computer systems; do not require port connectivity	PL ports: U.S. PL ports and one NASDA port in U.S. Lab TBD ports in Russian segment

Table 3.7-2. Concluded

Type of crew interface computer	Purpose	Hardware and software	Location at flight 8A
RWS computer	Command and control robotics Manage Station C&W	Two fixed robotic workstations include two hand controllers and dedicated processing computers PCS connects to robotic workstation or to various robotics ports	Robotics ports for use with PCS: Two in Lab
CHeCS laptop	Monitor crew health	IBM Thinkpad 760XD	Crew health ports: Six in Zvezda Three in Lab

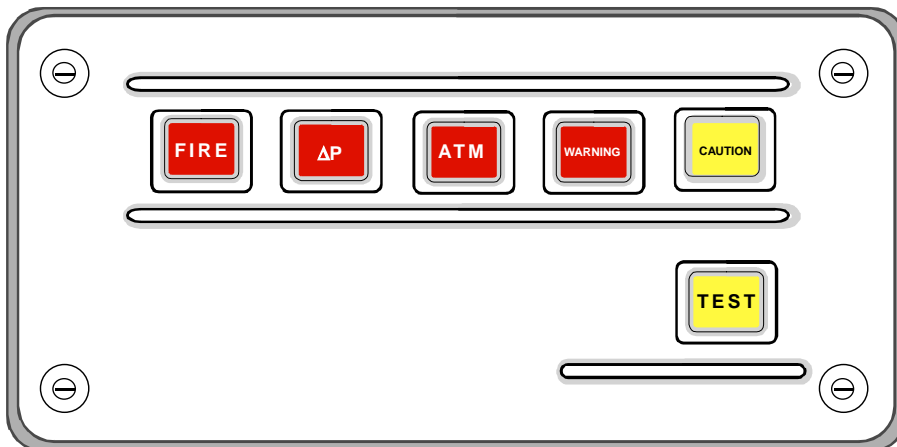

Figure 3.7-3. Caution and warning panel.

3.7.3.4. Software Components

At AC, the U.S. segment alone has over 300000 parameters compared with approximately 12000 parameters for a typical Shuttle flight. Extensive telemetry was designed into the ISS because of the long design life of the ISS and the need to complete maintenance on orbit as well as the desire to gather as much data as possible from the long duration environment. Managing this large volume of data requires extensive software capabilities. Four major software operations are performed by the C&DH software: telemetry; commands; time synchronization; and automated fault detection, isolation, and recovery (AFDIR).

3.7.3.4.1. Telemetry

The crew has access to any data in the C&C MDM providing that a display item is associated with it. After flight 5A, crew members may have more access and insight to data than MCC—H controllers. Unfortunately, currently no method exists for the C&C MDM to know whether the data it is holding are stagnant (not being updated by the lower tiered MDM due to a failure).

Additionally, it is important when trying to access telemetry on the PCS to know whether the PCS is connected to a tier 1 control bus or a tier 2 local bus.

3.7.3.4.2. Commands

To aid in troubleshooting across the highly distributed complex C&DH system, command response indications are provided to crew members via the PCS command display. The PCS that sent the command receives both negative command responses as well as all the positive command responses reflecting the successful progression of the command through the C&DH system. MCC—H only receives negative command information. Again, crew members may have greater insight than MCC—H because of bandwidth limitations.

3.7.3.4.3. Time Synchronization

Time management capabilities are available to crew members and controllers through C&DH displays. Bus communications need to be precisely timed and “synchronized” across C&DH. Precise timing of the computers is used to collect data at three different rates: 10, 1, and 0.1 Hz. Data are sent to the PCS displays at the fastest rate, 10 Hz. To ensure correct data are available to fill PCS displays, MDM time synchronization is critical.

3.7.3.4.4. Automated Fault Detection, Isolation, and Recovery

The C&DH software has two major types of automated fault detection, isolation, and recovery (FDIR) capabilities: one declares bus failures and the other declares MDM failures. Crew members or MCC—H can enable or disable either of these automated FDIR capabilities. Enabling and disabling FDIR software is used extensively during Station assembly operations.

3.7.4. Growth Options

There have been no significant provisions made for modifying the C&DH system. Because of the cabling needed to interface an MDM to the station equipment it is designed to control, it is likely impractical to add new MDM locations. However, the functionality of each MDM module could be enhanced through technology upgrades to the modules as they need to be replaced. An important consideration for any technology upgrades will be to maintain software compatibility between the existing and the new technology modules.

3.7.5. Bibliography

- Alibaruho, Macresia: Command & Data Handling Architecture Description Document—Volume 5: Operations Data Book. International Space Station Program, D684-10500-05 (Contract NAS15-10000 (DR VE05)), Boeing Co., July 25, 1997.
- Gough, Jefferson L.: Command & Data Handling Architecture Description Document—Volume 1: Requirements. International Space Station Program, D684-10500-01 (Contract NAS15-10000 (DR VE04)), Rev. C, Boeing Co., July 25, 1997.
- Schikner, Jeffrey S.: Command & Data Handling Architecture Description Document—Volume 2: Hardware Architecture. International Space Station Program. D684-10500-02 (Contract NAS15-10000 (DR VE04)), Boeing Co., Aug. 15, 1997.
- Vu, Robinson: Command & Data Handling Architecture Description Document—Volume 3: Software Architecture. International Space Station Program, D684-10500-03 (Contract NAS15-10000 (DR VE04)), Rev. C, Boeing Co., July 25, 1997.

3.8. Propulsion System

3.8.1. Introduction

The ISS propulsion system is used to make orbital and attitudinal adjustments to the Station. The system is contained in the Russian-built Zarya (formerly called FGB), Zvezda, and the U.S.-built PM. Information from the documents listed in the bibliography (section 3.8.6) was used to compile this section.

3.8.2. Overview of Propulsion System

ISS propulsion events are carried out with Zarya, Zvezda, and PM onboard propulsion systems. These are supplemented by the Shuttle, Progress M, and M1, or ATV when present. These propulsion events include orbital reboost, attitude control, and CMG desaturation.

3.8.3. Architecture and Components for Propulsion System

This section is divided into Russian and U.S. components. Each is then divided into the following subsections:

- Propulsion system operation

- Pressurization system

- Propellant tanks

- Main engine

- Control thrusters

The assembly sequence for the primary elements of the propulsion systems of the ISS can be found in the appendix.

3.8.3.1. *Russian Components*

The Zvezda propulsion system (fig. 3.8-1) consists of an integrated orbital maneuvering and reaction control system which incorporates a common propellant supply. The system is pressure fed with four positive expulsion bellows tanks. The fuel and oxidizer systems each have their own single fault tolerant pressurization subsystems and propellant feed subsystems. The attitude control system provides single fault tolerance control for yaw, pitch, roll, and small $-X$ -axis translation maneuvers by incorporating 32 thrusters arranged in 2 manifolds of 16 thrusters each.

3.8.3.1.1. Propulsion System Operation

The main engines on the Zvezda can be fired separately or together to perform the reboost operation. The attitude control thrusters on the Zvezda can operate on propellant fed from the Zvezda, resupply vehicle, or Zarya propellant tanks. The Zvezda main engines cannot operate by using propellant from Zarya. The Zvezda propellant tanks can also feed thrusters on the Progress

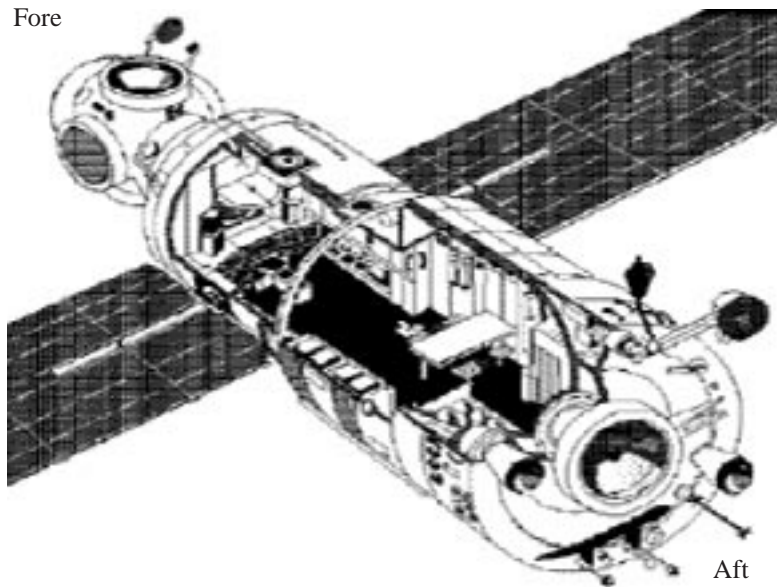

Figure 3.8-1. Interior and exterior views of Zvezda.

vehicle. Propellant from Zarya can flow through the Zvezda to support the firing of up to eight thrusters on the Progress M and M1. During operation, propellant is normally fed from one fuel and one oxidizer tank and one of the two nitrogen tank sets. The propulsion system will be inactive (passive mode) during docking with Zarya.

3.8.3.1.2. Pressurization System

The fuel and oxidizer systems each have their own single fault tolerant pressurization subsystems and propellant feed subsystems. The nitrogen stored in the pressurization subsystem of the Zvezda propulsion system is used for both propellant tank pressurization and control of the main engine pneumatic valves. Each pneumatic valve vents 0.0037 kg of nitrogen at each actuation. Storage pressure in the nitrogen tanks is 240 kgf/cm², and approximately 95 kg is loaded before launch. A maximum load of 205 + 5 kgf/cm² at 15°C was listed in the Zvezda specification document. The fuel and oxidizer tanks each have their own separate but interconnectable pressurization subsystems. Each propellant pressurization subsystem contains four 20-L (0.71-ft³) nitrogen tanks for a total of eight tanks for both subsystems. Each subsystem contains two interconnectable nitrogen supply manifolds (two tanks on each), two regulators, and pressurant cross-feed valves for redundancy. The system contains a nitrogen reserve of 36 kg.

Nitrogen from the supply manifolds is regulated to 21 kgf/cm² to maintain a constant propellant tank ullage pressure. A motor valve and a normally closed pyrotechnic valve in parallel are used to isolate the propellant tank ullage from the pressurant system until the system is activated. Once the system is activated, each propellant tank is supplied pressurant from its own regulator.

The system contains a block of three compressors to transfer nitrogen from the propellant tank ullages back into the nitrogen storage bottles to allow the propellant tanks to be resupplied from Zarya or the Progress vehicle without requiring pressurant resupply.

3.8.3.1.3. Propellant Tanks

The propulsion system is a pressure-fed system consisting of four 200-L tanks (two N₂O₄ oxidizer and two UDMH fuel) containing up to a maximum of 890 kg of total propellant at a mixture ratio of ≈ 1.82 . The Zvezda propellant tank is a positive expulsion tank with a bellows and a flexible diaphragm at the top. The bellows is formed from a single cylinder of stainless steel. The tank shell and flexible diaphragm are also made of stainless steel. Since the flexible ring-stabilized diaphragm is kept in the down oriented configuration, it cannot be filled to the 890-kg maximum load. In this position, only 860 kg of total propellant can be stored in the four-tank set. When the propulsion system is first activated, ≈ 80 kg of the 860 kg of stored propellant fills the lines and thruster manifolds; therefore, only 780 kg is considered “usable.” The entire tank set has only 8 kg of nonusable (residual) propellant from subsequent refills.

The propellant resupply system in the Progress vehicles will be used to refill the propellant tanks in both the Zvezda and Zarya propulsion systems. Propellant couplings are located in the docking adapters of the Progress vehicles, the Zvezda, Zarya, and the Russian UDM. All propellant resupply operations are controlled from the Zvezda. Tanks in the Zvezda can be resupplied with propellant while the Zvezda also performs attitude control. Also Zarya can be resupplied with propellant from a Progress vehicle through the Zvezda while the Zvezda also performs attitude control. In both cases, one of the two tanks for oxidizer or fuel can be connected to the propulsion system while the other tank is either refilled or bypassed to go to Zarya. The valves that separate the active propulsion system propellant lines and the propellant transfer lines are motor valves, which do not have any pressure back relief capability. The propellant storage system in the Zvezda can be refilled by using the propellant tanks in Zarya.

Tank propellant quantity gauging is primarily accomplished with an RF signal device. An antenna is located at the top of each propellant tank in the ullage section. The antenna in the tank broadcasts a wide range of radio frequencies (5 to 20 or 200 MHz) into the tank ullage volume. A sensor in the tank senses the resonant frequency at which the ullage/tank oscillates. Propellant quantity is gauged by comparing the resonant frequency of the ullage/tank when the tank is full and empty with the frequency of the measured resonant frequency. Because the life of the system is currently limited to 3 yr, the system is only operated before and after reboost to verify the quantity of propellant used. Pressure-volume-temperature (PVT) gauging is used as a backup to the RF gauging system.

3.8.3.1.4. Main Engine

The Zvezda main engines are regeneratively cooled engines that are canted at 15° to the X-axis and can gimbal $\pm 5^\circ$ in two axes. Each engine under nominal inlet pressures and temperatures provides 312 kgf thrust at a specific impulse of 294 sec. The engines are currently certified for a 500-kg propellant throughput and up to 75 starts. RSC plans on running life extension tests to certify the engine for a 25000-kg propellant throughput and up to 250 starts. A Sun cover is on each main engine to help maintain proper operating thermal conditions, and according to RSC an engine start inhibit occurs if the Sun cover is in the closed position.

3.8.3.1.5. Control Thrusters

The Zvezda has two manifolds of 16 thrusters each to perform yaw, pitch, roll, and small $-X$ translation maneuvers. Each thruster under nominal propellant inlet pressures and temperatures has a thrust of 13.3 kgf and a specific impulse I_{sp} of 251 sec for steady state and $I_{sp} = 180$ sec

during pulse operations. The thruster utilizes 25 percent oxidizer film cooling to maintain acceptable injector-chamber temperatures. The primary and backup thruster manifolds can be operated individually or at the same time. From 1 to all 16 thrusters on each manifold can be operated simultaneously. All thrusters have temperature sensors between the valve and thrust chamber; however, only one temperature sensor for each group of thrusters is monitored. Nominal thruster inlet pressure is 13 to 23 kgf/cm² with a maximum difference between fuel and oxidizer inlet conditions of pressure and temperature of 3 kgf/cm² and 10°C, respectively. The overall thruster propellant mixture ratio is 1.85 for nominal inlet conditions (15.5 kgf/cm² and 15°C). Thruster activation after command issuance is 0.012 to 0.04 sec (based on pressure sensor readings).

The six +T and six -T thrusters are canted 13° off the Y-axis (in the X-Y plane) and are used to perform pitch maneuvers. The six +P and six -P thrusters are canted 13° off the Z-axis (in the X-Z plane) and are used to perform yaw maneuvers. The K thrusters are canted 33° off the Y-axis and are coupled to produce roll maneuvers; +K1 and +K2 fired together produce positive roll and -K1 and -K2 fired together produce negative roll maneuvers.

All valves, including thruster injector valves, propellant lines, and tanks, are attached to the Zvezda TCS fluid heating-cooling loops. The FGB has electric heaters (2.6 W) on the 1.3-kgf and 40-kgf thrusters as backup to ensure that temperature does not drop below the lower limit of -5°C.

The Progress M and M1 each have an orbit correction engine (SKD) and attitude control thrusters (DPO). From a GN&C standpoint, the Progress M thrusters are not used for attitude control. The ISS X-axis location of the Progress M orbit correction engine is -42.57 m in the Space Station reference coordinate system.

3.8.3.2. U.S. Components

The PM (figs. 3.8-2 and 3.8-3), a Boeing Company reusable space system (RSS) design for a supplemental propulsion system, includes propellant tanks, reboost thrusters, RCS thrusters, avionics, and a crew transfer tunnel. It attaches to the ISS at PMA 2 and provides interface to the Shuttle. The PM uses many propulsion system elements from the Shuttle orbital maneuvering system/reaction control system (OMS/RCS). The PM is refillable on orbit from the Shuttle with modification to the Shuttle OMS system. At end of its service life, the PM can be returned to Earth in the Shuttle cargo bay.

3.8.3.2.1. Propulsion System Operation

The PM provides additional capability for ISS reboost and attitude control independent from the Russian propulsive components. The PM main engines are mounted facing the ram direction; therefore, the Station must perform a 180° yaw maneuver prior to reboosting with the PM.

3.8.3.2.2. Pressurization System

Four helium tanks provide pressurization for the propellant tanks. The PM does not include helium compressors. The pressurization system is used in blowdown mode; this means that the helium tanks must be resupplied by the orbiter with each resupply of propellant.

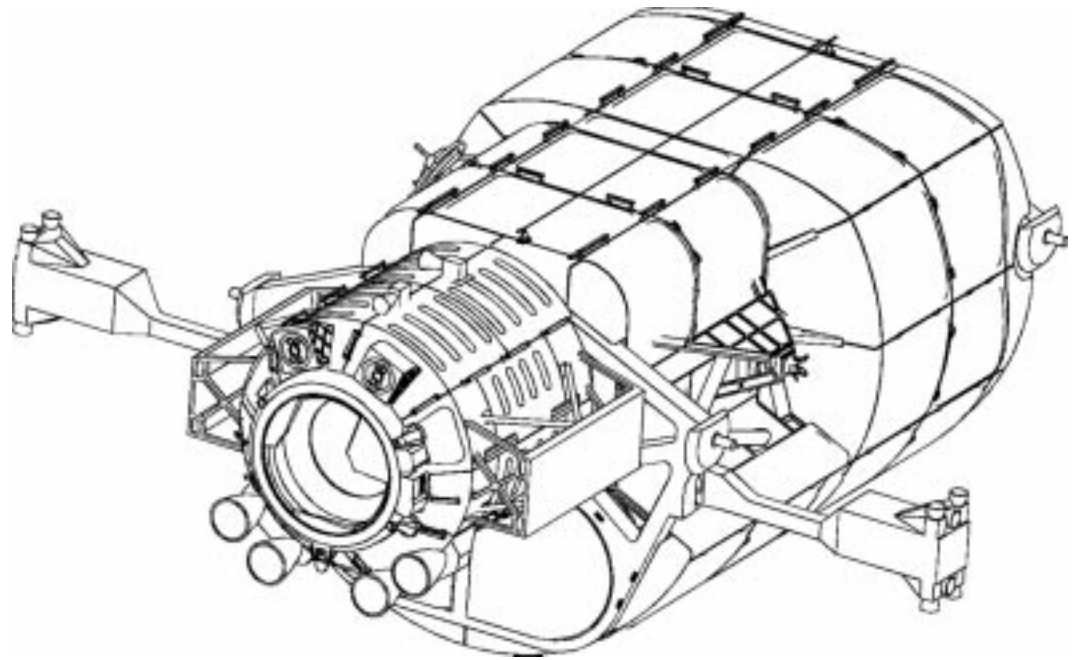

Figure 3.8-2. U.S. propulsion module.

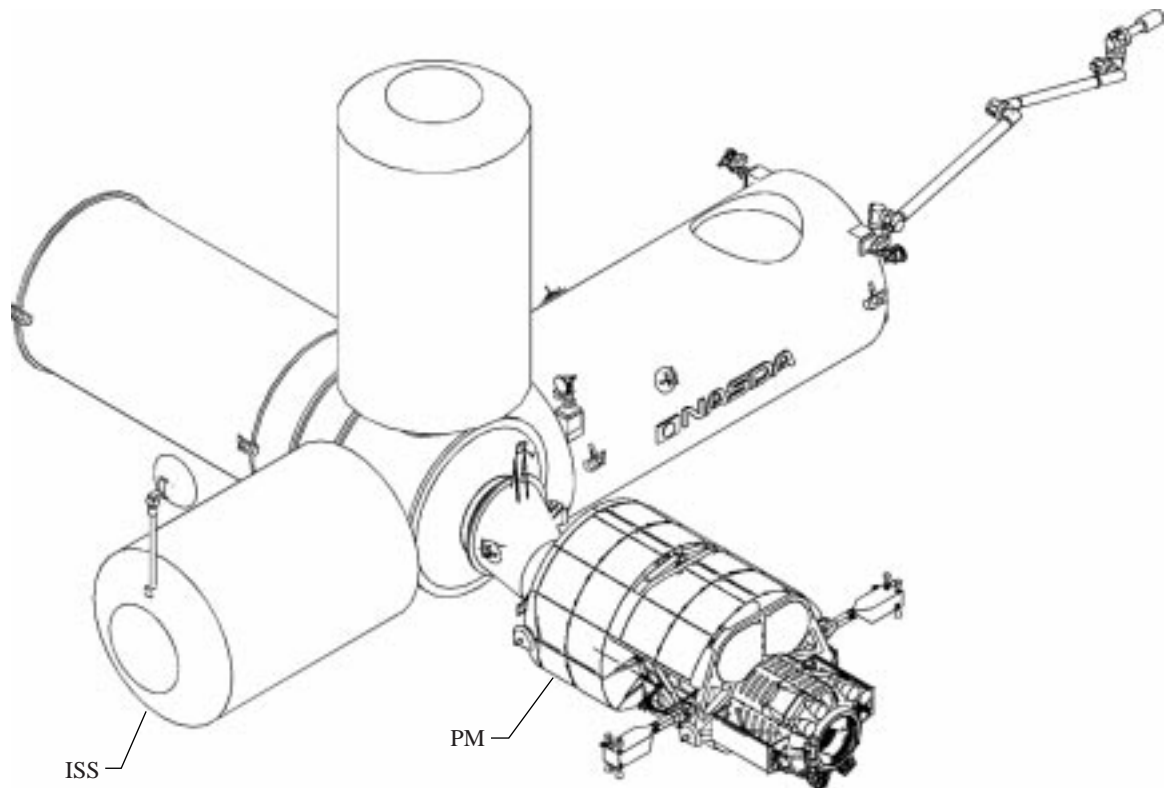

Figure 3.8-3. U.S. propulsion module in ISS configuration.

3.8.3.2.3. Propellant Tanks

The PM uses four Shuttle OMS tanks that contain up to 27000 lb of liquid N₂O₄ (nitrogen tetroxide) and monomethyl hydrazine (MMH), sufficient for 6 yr of ISS operation used in conjunction with the Zarya and Zvezda.

3.8.3.2.4. Main Engine

The PM uses four Kaiser Marquardt Model R-42 liquid bipropellant rocket engines for Station reboost. Each R-42 engine produces 200 lbf (890 N) thrust. Two of the engines are used for reboost and two are for redundancy. The R-42 engine has a specific impulse of 303 sec, with a maximum impulse of 4 500 000 lbf-sec.

3.8.3.2.5. Reaction Control System

The 12 attitude control thrusters on the PM are Kaiser Marquardt R-4D liquid bipropellant rocket engines with 100 lbf (445 N) of thrust. These thrusters are arranged in six pairs to provide for redundant operation. The R-4D engine is rated at a specific impulse up to 316 sec and maximum total impulse of 4 500 000 lbf-sec.

3.8.4. Contingency Options

The ICM is one proposal to provide the ISS with attitude control and reboost propulsion as a backup unit for the Russian-built Zarya or the Zvezda should either fail to launch or fail during its planned service life. The ICM is a modification of the Naval Research Laboratory (NRL) bus. The ICM is not refuelable on orbit. The ICM has photovoltaic panels to provide it with electric power.

3.8.5. Growth Options

Studies are proceeding to examine the use of new propulsion technologies. Electric propulsion, electromagnetic propulsion, and gravity manipulation are among the proposed technologies.

3.8.6. Bibliography

Anon.: Service Module Technical Data Book. Updated Jan. 22, 1998. <http://iss-www.jsc.nasa.gov/ss/issapt/rait/rsasm.html>. Accessed June 12, 2000.

Anon.: 110 lbf (490 Newton) Liquid Bipropellant Rocket Engine—Model Number R-4D. Kaiser Marquardt. <http://www.marquardt.com/R-4D.htm>. Accessed June 9, 2000.

Anon.: Zarya—Functional Cargo Block. NASA Facts IS-1999-01-ISSO14 JSC, Jan. 1999.

3.9. Robotics

3.9.1. Introduction

The robotics systems of the ISS are used in assembly and maintenance EVA support and payload handling. Three different robotics systems used on the ISS are

Mobile servicing system (MSS)

European robotic arm (ERA)

Japanese experiment module remote manipulator system (JEM RMS)

This section identifies the international agencies involved in the development of the robotics systems and then focuses on the function, capabilities, and operational aspects of each system. Information from the documents listed in the bibliography (section 3.9.5) was used to compile this section.

3.9.2. Overview

The CSA and NASA are working together in the development of the MSS, which has five subsystems. CSA is responsible for the SSRMS, the mobile remote servicer base system (MBS), and the special purpose dexterous manipulator (SPDM). The other two MSS subsystems, the MT and the RWS, are the responsibility of NASA. The second robotics system, ERA, is the joint responsibility of the ESA and the RSA. The third robotics system, JEM RMS, is the sole responsibility of the NASDA.

Figure 3.9-1 illustrates where the three different robotics systems are used. The MSS is used primarily on the U.S. segments and the truss; the ERA, on the Russian segments and the SPP; the JEM RMS, on the EF. The assembly sequence for the primary elements of the robotic systems of the ISS can be found in the appendix.

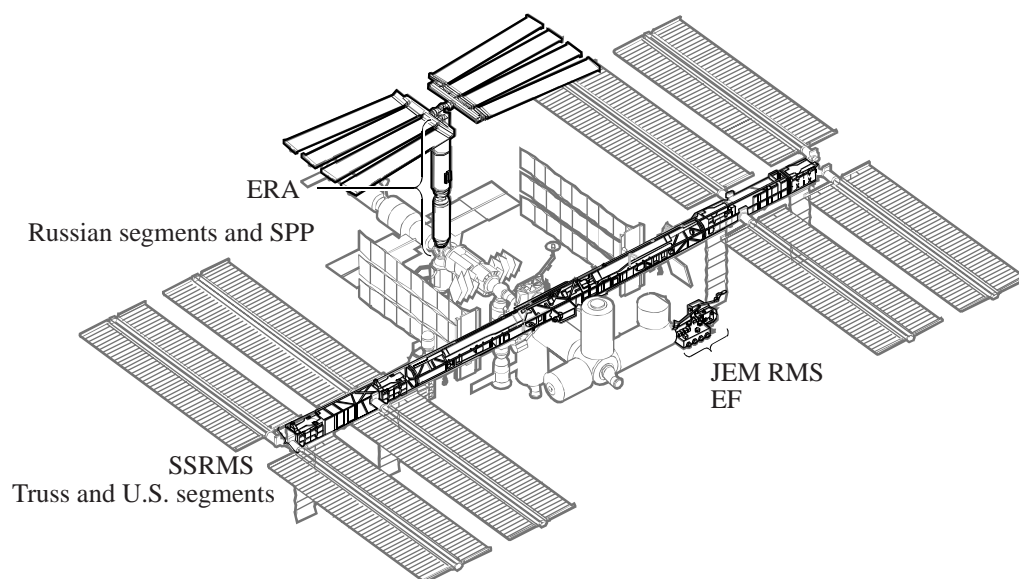

Figure 3.9-1. ISS locations for robotics systems.

3.9.3. Architecture and Components for Robotics

3.9.3.1. Mobile Servicing System

3.9.3.1.1. Introduction

The main functions of the MSS include assembly of ISS elements; large payloads; and ORU handling, maintenance, EVA support, and transportation. The MSS is controlled with the RWS from either the Lab or the cupola. Until the cupola arrives, there is no direct viewing; therefore, the MSS video system and the space vision system (SVS) provide the main visual inputs. The video system, combined with ISS C&T systems, provides video generation, control, distribution, and localized lighting throughout MSS elements. The SVS provides synthetic views of operations using cameras, targets, and graphical or digital real-time position and rate data. The MSS is presented in figure 3.9-2.

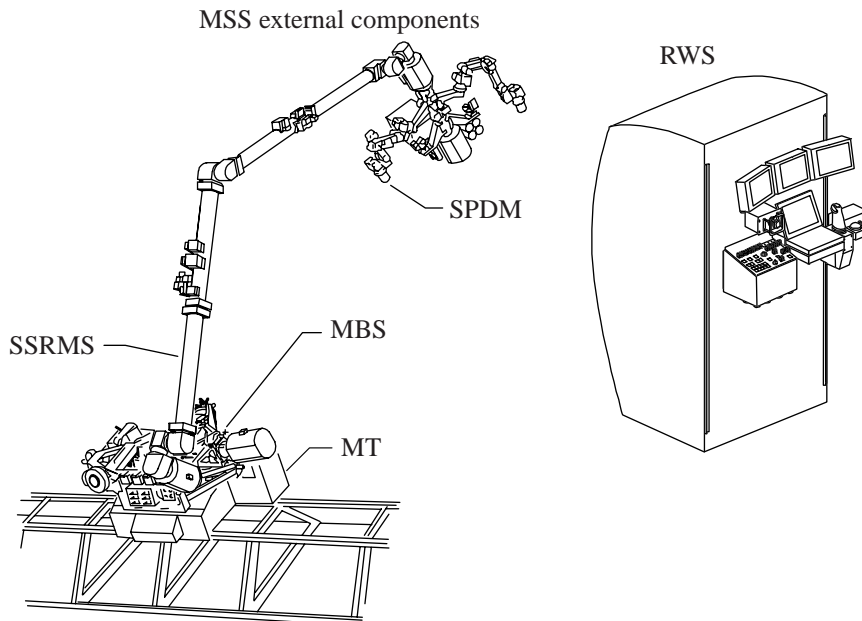

Figure 3.9-2. Mobile servicing system.

3.9.3.1.2. Space Station Remote Manipulator System

The SSRMS is used to handle large payloads and ORU's. Tasks include berthing and unberthing, maneuvering, and performing handoffs with other robotics systems. The SSRMS, illustrated in figure 3.9-3, is also able to position the SPDM at work sites, provide EVA support, and perform ISS external inspection. Other capabilities include free-flyer (FF) capture and Orbiter berthing (unplanned).

The SSRMS is a 56-ft (17-m) symmetric manipulator that supports electronic boxes and video cameras. It is composed of several ORU's, including two latching end effectors (LEE), two booms, and seven joints that can be rotated $\pm 270^\circ$. A LEE at each end of the SSRMS creates a "walking" capability between attachment points called PDGF's, which are located throughout the ISS. The SSRMS can operate from the truss, the Lab, Zarya, and the node modules. The PDGF provides power, data, and video connections to the arm and is the only interface from which the

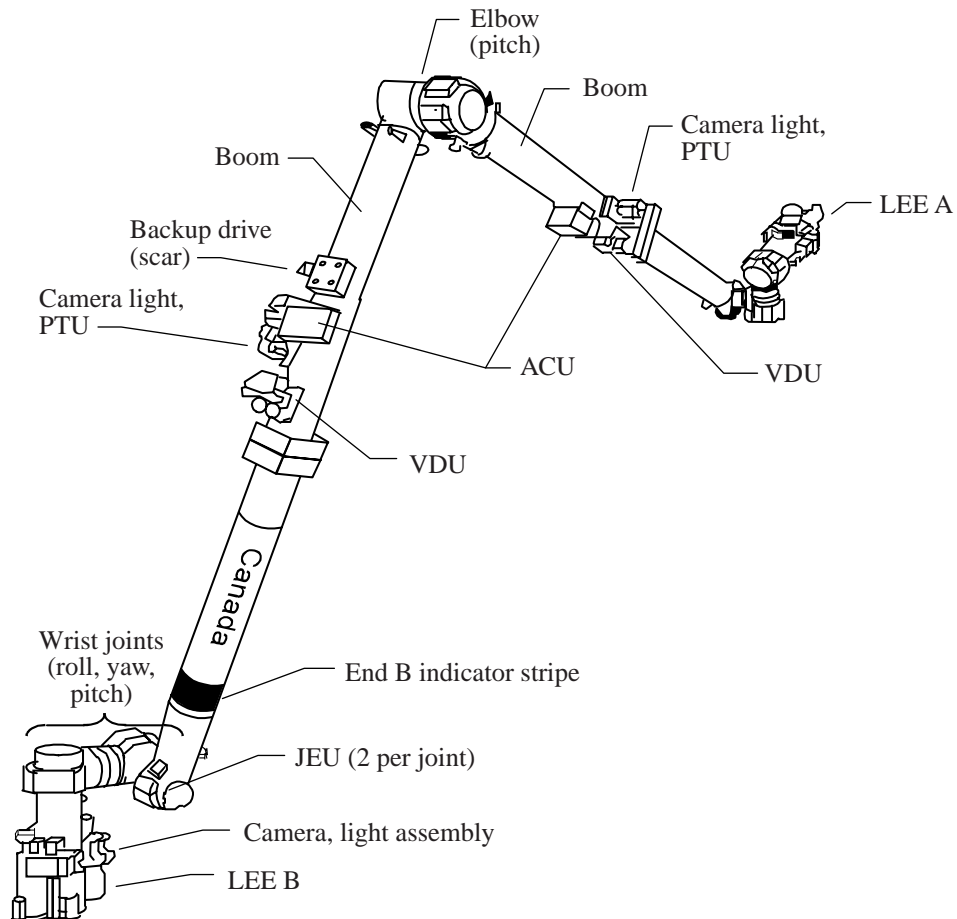

Figure 3.9-3. Space Station remote manipulator system.

arm can operate. The walking ability is the only mode of transportation for the SSRMS prior to the arrival of the MT and the MBS.

3.9.3.1.3. Artificial Vision Function

The artificial vision unit (AVU) is an element of the overall artificial vision function (AVF), also known as the Canadian space vision system (CSVS). The AVF is comprised of the AVU, SSRMS (including TV cameras and the pan tilt units (PTU's); RWS, ISS CDH (including camera control function); ISS C&T (including cameras and PTU's); and targets. The AVU provides the operational cues that allow remote manipulator system operators to successfully complete ISS assembly tasks. The AVF supports ISS crew control of the SSRMS and SPDM and could reduce both training and on-orbit operation timelines. The AVU will provide mission specialists and others with an accurate, computer-generated view of the payload and any important fixed reference points regardless of the position of the camera.

3.9.3.1.3.1. Mission. The mission of the AVU is to support intravehicular activity (IVA) operator control of the ISS MSS robotic devices (SSRMS and SPDM). The ISS missions will include Space Station assembly, external robotic operations, and maintenance of the on-orbit Space Station.

For station assembly tasks, a mating operation involves aligning the mating interface of an incoming station element with the mating interface of a fixed station element. The fixed element belongs to the partially assembled station. The incoming element is rigidly attached to the ISS via either the SSRMS or SPDM. The AVU determines the position and orientation of both the incoming and fixed elements, and provides accurate real-time positioning cues to the manipulator operator. These cues consist of precise relative position, attitude, and rate data provided in concise graphical and digital formats.

3.9.3.1.3.2. Operation. The AVU analyses and processes video imagery of objects from one or more external ISS cameras. These objects will typically be payloads (satellites and station structures) that are manipulated by the Shuttle and Station remote manipulators. Target arrays are located at known positions on the objects. With knowledge of the geometry of the target arrays on each object in a scene, the AVU can calculate the position, orientation, and rate of movement of each object relative to the viewing camera. Using knowledge of the viewing camera's position and orientation, the AVU can then derive the position and orientation of each object relative to any other point of resolution. The position, orientation, and rate information is presented to the RMS operator in both alphanumeric and graphical representations on a video display.

Once configured, the AVU processes video in real time to track an object as long as it remains within the camera's field of view (FOV). The AVU also has the capability to control Station cameras and PTU's to improve the video image and maintain the targets in the FOV. The human-machine-interface (HMI) for the AVU is provided by the RWS console.

3.9.3.1.4. Robotic Workstation

The RWS provides the operator interface to control and receive data from the SSRMS. The RWS has components either external or internal to the rack. The external components, illustrated in figure 3.9-4, are portable and include three video monitors, a translational hand controller (THC), a rotational hand controller (RHC), a display and control (D&C) panel, a PCS, and an artificial vision unit cursor control device (AVU CCD). Unlike the external components, which are moved between the Lab and the cupola, the internal components are fixed into the Lab racks. The internal components include an AVU and a control electronics unit (CEU) which houses the RWS software.

During operations, one workstation is active (prime), whereas the second is in monitor mode or powered down. The active RWS has primary control of MSS functions, whereas the backup only provides emergency stop, control and display of additional camera views, and feedback of function status. If the prime RWS fails, the second workstation can change monitor mode to active.

The RWS interfaces with the MSS local bus, the PDGF local bus, and the C&C bus (to C&C, MDM, and PCS). The workstation also provides various modes for operating the SSRMS and SPDM, including manual augmented mode via hand controller input, automatic trajectory mode via prestored and operator input, and single joint rate mode (joint-by-joint movement) via the THC and the joint select switch.

3.9.3.1.5. Mobile Transporter

The MT provides structural, power, data, and video links between the ISS and the MBS. It also provides transportation for the SSRMS, SPDM, payloads, and even EVA crew members

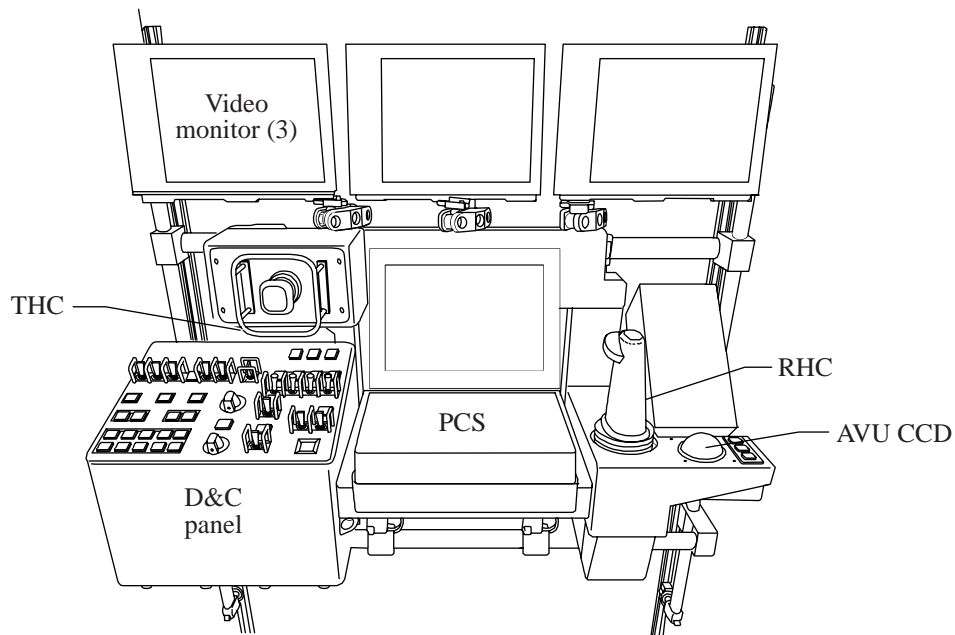

Figure 3.9-4. Robotic workstation external components.

when the MBS arrives. At its greatest velocity (1 in/sec), the maximum automated translation time is 50 min from one end of the truss to the other. When the MT is transporting large payloads across the Station, there can be an impact to the GN&C system because of the changing mass properties of the ISS. If the CMG's are unable to handle the change in momentum, jets may be fired to compensate for the change.

Each primary ORU on the MT, shown in figure 3.9-5, contributes to the function of the system as a whole. The trailing umbilical system (TUS) provides the power, communication, and video connections between the MT and the ITS. The umbilical mechanism assembly (UMA) provides the capability to transfer power at utility ports for stationary operation of the MBS, SSRMS, and SPDM. The UMA can be connected only when the MT is at one of the eight MT work sites along the truss. The RPCM provides power switching between appropriate MT power sources and loads. The linear drive unit (LDU) provides for the translation of the MT along the truss rails, whereas the roller suspension unit (RSU) constrains the MT to the truss. The load transfer unit (LTU) firmly fixes the MT to the truss at predetermined work sites.

Operator interface for the MT is through a PCS graphical user interface (GUI) that can be either at the RWS or connected to another PCS port. Since no switches are needed, total control from the ground is possible, although ground control capability is primarily for power up and system checkout.

3.9.3.1.6. Mobile Remote Servicer Base System

The MBS functions both as a work platform and as a base for the arm. Since the MBS is an interface between the SSRMS, SPDM, ORU's, payloads, EVA, and the MT, the MT cannot transport anything until the MBS arrives.

The MBS has several important components. The MBS computer unit (MCU) has various functions, including providing control and monitoring and performing failure management

functions for MBS equipment. A device called the payload/ORU accommodation (POA) acts as a spare LEE and provides power and a temporary storage location for payloads and ORU's. The MBS common attachment system (MCAS) also provides a temporary payload storage location that includes structural interfaces and power and data interfaces through the UMA on the MT. Another interface with the MT is provided by the MT capture latch (MTCL), which attaches the MBS onto the MT. There are four PDGF's to support attachment of the SSRMS and SPDM. Attachment points are also provided for EVA. The Canadian remote power control modules (CRPCM's) distribute and switch power to the MBS equipment and attached payloads. These CRPCM's are not interchangeable with other Station RPCM's. The MBS is seen in figure 3.9-6.

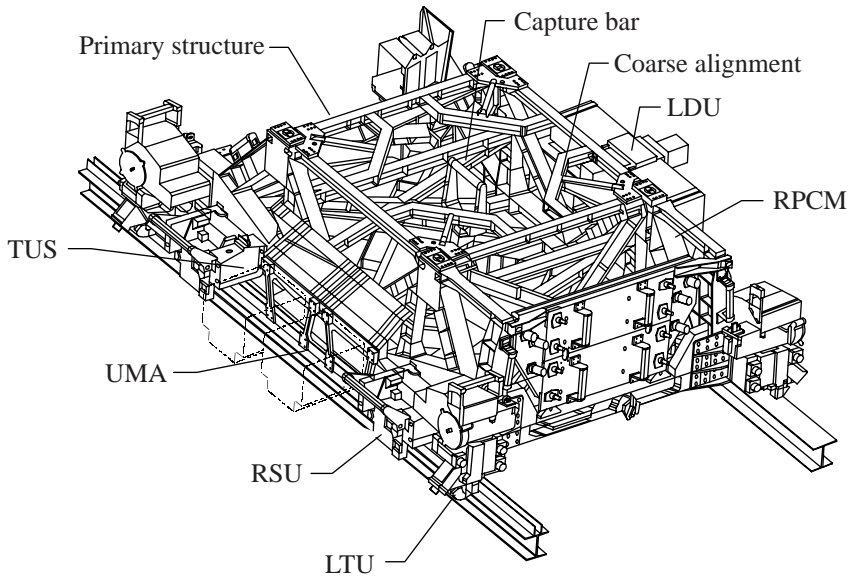

Figure 3.9-5. Mobile transporter.

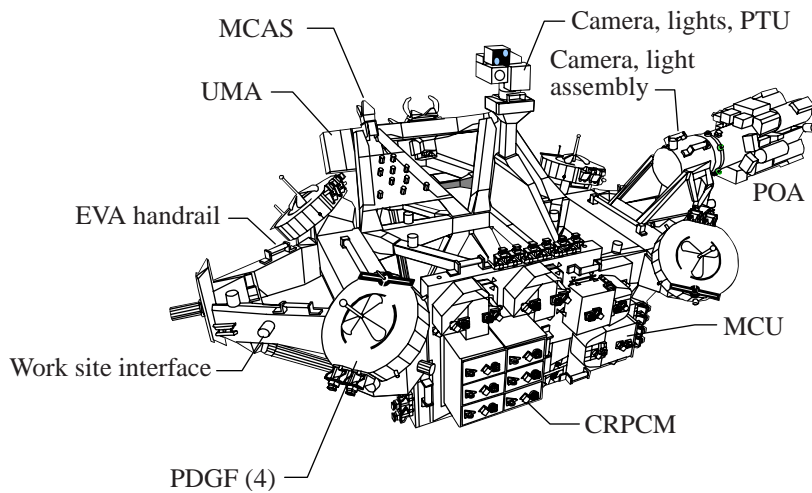

Figure 3.9-6. Mobile remote servicer base system.

3.9.3.1.7. Special Purpose Dexterous Manipulator

The SPDM, shown in figure 3.9-7, is the final component of the MSS to arrive at the ISS on flight UF-4 and is composed of two 11.5-ft (3.5-m) seven-joint arms attached to a central single-joint body structure. These joints help to create the dexterity of this system. Because of this manipulator's ability to execute dexterous operations, its primary function is to perform maintenance and payload servicing. The SPDM can remove and replace ORU's and ORU subcarriers as well as inspect and monitor payloads and ORU equipment. It can provide lighting and closed circuit television (CCTV) monitoring of work sites for EVA and IVA crews. SPDM can assist EVA by transporting and positioning equipment. Control of this manipulator is provided through the RWS with control modes and features common to the SSRMS. Only one SPDM arm may be used at a time; the other arm can be used for stabilization at a work site.

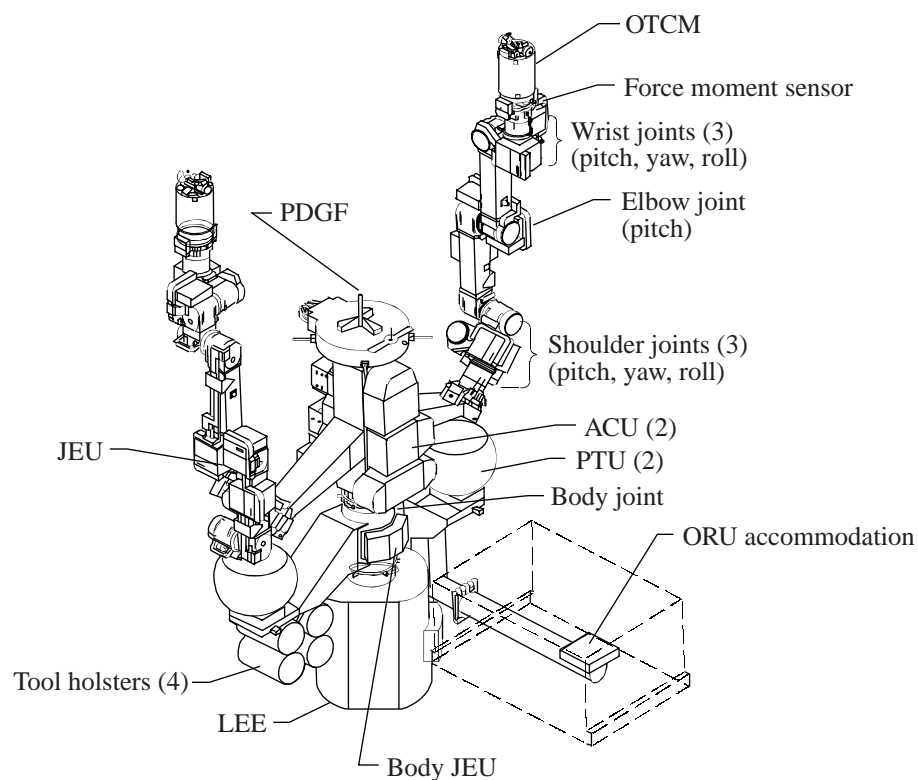

Figure 3.9-7. Special purpose dexterous manipulator.

3.9.3.2. European Robotic Arm

The ERA is the second robotics system to arrive on the Station. The ERA is being designed and built by ESA for the RSA to use on the Russian segments. The ERA, shown in figure 3.9-8, consists of two booms and seven joints that form a 36.7-ft (11.2-m) symmetric manipulator arm.

The ERA has similarities to the SSRMS that include the power, data, and video transfer capability by the end effectors and the ability for either end effector to act as a base point while the other does payload handling. The ERA basic end effector (BEE) is a latch and tool end effector that provides mechanical torque as well as electrical power to a payload. Furthermore, the ERA

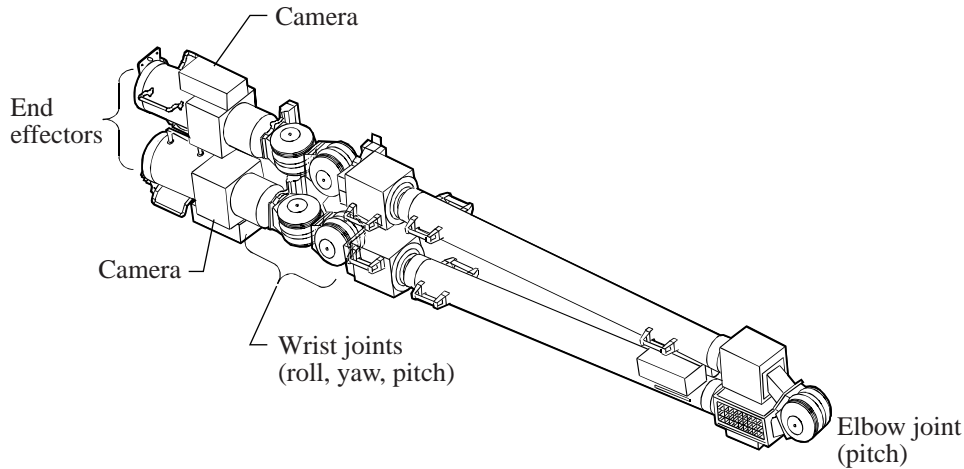

Figure 3.9-8. European robotic arm.

end effectors attach only to grapple fixtures specifically designed for them. These grapple fixtures or base points can only be used by ERA. They are located throughout the Russian structures and on certain payloads.

The primary functions of ERA are maintenance and support for EVA on the Russian segments, with some assembly tasks including the installation of the SPP solar arrays. ERA is also responsible for maintenance of SPP solar arrays, deployment of radiators, installation and replacement of ORU's, and inspection of external elements. Control during these operations is either through an EVA man-machine interface (EMMI), when the operator is EVA, or through an IVA man-machine interface (IMMI), when the operator is inside the Zvezda. Unlike the SSRMS, there are no hand controllers; thus, there is no manual augmented mode for ERA. Control is primarily through an autotrajectory mode, but single joint and single degree of freedom are available.

3.9.3.3. Japanese Experiment Module Remote Manipulator System

The two previously discussed robotics systems have a number of similarities. The JEM RMS also has some characteristics in common with the other two systems, but it has several unique attributes as well. Figure 3.9-9 shows the main arm (MA) and the small fine arm (SFA) of the JEM RMS working together over the EF.

The MA is a 32.5-ft (10-m) six-joint robotic arm with two main booms. At the end of one boom is a snare end effector (similar to the Shuttle remote manipulator system (SRMS)) and at the end of the other boom is a fixed base that keeps the arm from having the walking capability of the other two systems. Like the other two types of end effectors, this snare end effector attaches to grapple fixtures. The JEM RMS grapple fixture has a connection that provides power, data, and video from the JEM RMS to payloads and SFA.

The SFA is a 6-ft (2-m) dexterous manipulator, consisting of six joints, two booms, and an end effector mechanism or "tool." The SFA operates from and is relocated by the MA. Unlike the SPDMS, which can operate separated from the larger arm, the SFA must remain attached to operate.

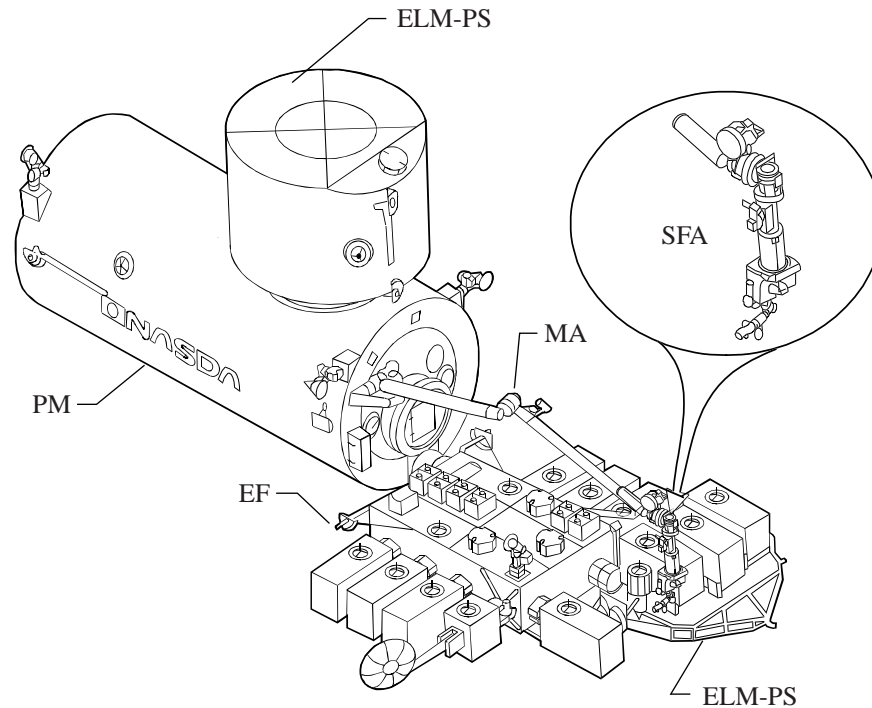

Figure 3.9-9. Japanese experiment module remote manipulator system.

The primary function of the JEM RMS MA is to handle the EF payloads, whereas the SFA supports more fine-tuned tasks that include interacting with ORU's and experiments on the EF. The JEM RMS console is located inside the JEM pressurized module (PM) and provides manual augmented, autotrajectory, and single joint modes, like the RWS. Control of the MA is primarily done by using the autotrajectory mode, whereas manual augmented mode (hand controllers) is mainly used for SFA.

3.9.4. Growth Options and Scars

There are several areas of growth potential in robotics that could be applied to the ISS robotics systems. Two of the primary areas that can be considered are enhanced manipulator capability and the increase in the number of robotic systems available to the ISS via free-flying robotics. The P³I Working Group is investigating several options for enhanced robotic capability onboard the ISS in these areas. The technology demonstrations/engineering research and technology (ER&T) payloads which are being pursued are the payload tutor (ASI), an internal robotic arm attached to a laboratory rack; FLEX payload, internal and external manipulator software and capability assessments; and Inspector, a free-flying observation platform for ISS external observations and EVA crew assistance.

3.9.5. Bibliography

Anon.: Robotic Workstation to Space Station Manned Base (SSMB)—Interface Control Document, Part 1. International Space Station Program, SSP 50098, Rev. A, Pt. 1, NASA Johnson Space Center, Dec. 1999.

Revision A, October 2000

Mobile Servicing System (MSS) to User (Generic): Interface Control Document—Part 1. International Space Station Program, SSP 42004, Rev. E, Pt. 1, NASA Johnson Space Center, May 22, 1997.

Stager, Michael A.: Mobile Servicing System to User (Generic) Interface Control Document— Part 2. International Space Station Program, SSP 42004, Rev. A, Pt. 2, NASA Johnson Space Center, May 22, 1997.

Stager, Michael A.: Space Station Manned Base to Mobile Servicing System Interface Control Document— Part 2. International Space Station Program. SSP 42003, Rev. A, Pt. 2, NASA Johnson Space Center, May 22, 1997.

3.10. Flight Crew Systems

3.10.1. Introduction

The ISS is designed to be occupied by astronaut crews for periods up to several months and the goal is to have the ISS permanently manned as early as possible. Eventually, the ISS will be permanently occupied with crews of astronauts from many nations who will be operating equipment, performing scientific research and technology development, supporting commercial investigations, and carrying out ISS housekeeping tasks. Therefore, the ISS was designed with astronauts in mind; that is, the ISS has facilities, systems, and supplies to support the resident crew while living and working on the Station. In addition, the ISS was also designed to be resupplied regularly with crew provisions and to support regular (i.e., approximately every 3 mo) rotation of astronaut crew members. Flight crew systems (FCS) refers to those systems supporting the astronaut crew while they are resident on the ISS.

3.10.2. Overview

FCS is a broad, distributed system that includes the facilities, subsystems, and supplies to maintain crew health and support crew performance over the duration of the mission. These include systems for (1) maintaining crew health and exercise countermeasures against the deconditioning effects of long-duration microgravity; (2) human factors, habitability, and crew accommodations; (3) routine and emergency provisions; (4) ISS housekeeping and maintenance; and (5) crew personal and task support equipment. The assembly sequence information for the primary elements of the FCS can be found in the appendix.

The following systems and subsystems are included in FCS and are described in this section:

- Crew support facilities

 - Galley/wardroom and food system

 - Crew quarters

 - Waste collection compartment and personal hygiene facility

- Crew support equipment and provisions

 - Restraints and mobility aids

 - Crew operational and personal provisions

 - Portable emergency provisions

 - On-orbit maintenance, tools, and diagnostic equipment

 - Housekeeping and trash management

 - Cargo transfer, stowage, and inventory management

Lighting

Decals and placards

- Crew health care system

Countermeasures system (CMS)

Environmental health system (EHS)

Health maintenance system (HMS)

During ISS buildup phase, crew systems facilities and equipment will be distributed throughout the Station. When the Hab is completed and attached, the crew systems facilities will be moved and integrated into the Hab. In addition, FCS equipment and supplies are often deliberately distributed throughout the ISS. Therefore, the location of FCS equipment is typically not stated in this section. The ECLSS is described in section 3.6.

3.10.3. Crew Systems Subsystems

3.10.3.1. Crew Support Facilities

3.10.3.1.1. Galley/Wardroom and Food System

The ISS food system is designed to meet the crew's basic nutritional/biomedical needs while also providing an opportunity for crew interaction and socialization. A galley and associated wardroom (initially located in the Zvezda) provides locations for food storage, equipment stowage (food warmers, trays, utensils, scissors, etc.), food preparation (microwave/convection oven), eating, and cleanup. A table provides crew and equipment restraints. The galley/wardroom also includes a potable water dispenser (with both hot and ambient water for beverage and food rehydration), trash compacting and storage, refrigerator/freezers, and electrical power.

The food system will operate under a "pantry-style" storage system with 50 percent of the food provided by NASA and 50 percent provided by the RSA. There are three categories of ISS food:

1. Daily menu foods provide the standard set of daily food for the entire crew
2. Missed resupply foods provide a 45-day food supply if a resupply flight is missed or during an emergency
3. EVA food and water are provided for 8 hr for use while working in the EMU

Because of the reduced water supply on the ISS relative to the Shuttle (i.e., power is provided by solar panels, not by fuel cells, thus reducing the amount of extra water available), the ISS food system differs somewhat from the comparable Shuttle food system. Several food types and beverages will be provided; the food types include frozen, refrigerated, thermostabilized, intermediate moisture, natural form, irradiated, shelf-stable, and, to a lesser degree, rehydratable forms. To the greatest degree possible, the food system includes "off-the-shelf" items packaged for use in

microgravity. These include such standard items as precooked meats; cereals; canned fruits and puddings; frozen vegetables; granola, nuts, and cookies; and tortillas.

Prior to launch, astronauts choose a 28-day flight menu from the standard ISS food list and the items are prepackaged in individual servings prior to shipment to the Station. Fresh foods (e.g., fruits, vegetables) will be provided to the degree possible and will be brought on Shuttle (within a MPLM having ambient, refrigerated, and frozen stowage) or Progress resupply flights on planned 90-day intervals. Missed resupply foods are described in section 3.10.3.2.3.

3.10.3.1.2. Crew Quarters

Crew quarters provide a private place for individual crew members to sleep (in sleep restraints), change clothes, stow their clothing and personal items (e.g., family pictures, tapes), and spend private time during off-duty hours. Presently, two crew quarters are provided in Zvezda; plans are to include additional private crew quarters within the Hab.

3.10.3.1.3. Waste Collection Compartment and Personal Hygiene Facility

A waste collection compartment, containing a commode/urinal, is provided in the Zvezda. (Waste handling is managed by the ECLSS.) Crew personal hygiene (cleansing, shaving, oral hygiene, etc.) is accommodated in an associated personal hygiene facility, and hygiene supplies, such as soap, washcloths, and toothbrushes, may be stowed here. At present, it has not been determined that the ISS requires a full body cleansing capability. Present plans are to accomplish body cleansing personal hygiene activities using the Shuttle's washcloth-type system.

3.10.3.2. Crew Support Equipment and Provisions

Much of the crew equipment is developed and managed by NASA organizations and is, therefore, considered Government-furnished equipment (GFE). The following information briefly describes the categories and items of crew equipment and provisions.

3.10.3.2.1. Restraints and Mobility Aids

Personnel restraints allow a crew member to be comfortably restrained and stabilized at work-sites while accommodating the neutral body posture and freedom of movement in microgravity. Equipment restraints allow crew members to restrain loose equipment at a worksite within the ISS interior. Mobility aids facilitate crew translation through the pressurized interior volume of the ISS.

Several types of personnel and equipment restraints are provided. Example restraints include bungees, tether straps, cable and crew restraints, brackets, clamps, equipment bags and anchors, cable ties, a PCS desk, long-duration foot restraints (LDFR's), short-duration foot restraints (SDFR's), anchor foot restraints (AFR's), torso restraints, long-duration crew restraints (LDCR's), and Velcro Industries VELCRO fastener.

Mobility aids are removable handrails that provide crew members (1) a stable and convenient grip point for crew translation through the IVA environment (e.g., on primary and secondary translation paths, around hatches), (2) attachment points for objects (e.g., tethers), (3) equipment mounting points, and (4) crew handholds for safely moving large objects (e.g., racks). Some

permanent (but removable) restraint and mobility aids are placed throughout the ISS interior at frequently used locations; other aids are portable and may be attached to points on secondary structures on racks (via seat tracks) and within modules, allowing repositioning as required by crew.

3.10.3.2.2. Crew Operational and Personal Provisions

Crew operational and personal equipment includes provisions for crew to carry out their daily routine work tasks and for their use during off-duty times. These provisions include clothing, cameras, work tools (e.g., calculators, pencils), recreational equipment (e.g., compact discs, books, tapes), individual personal hygiene supplies, personal (radiation) dosimeters, and individual personal items (e.g., family pictures, journal).

3.10.3.2.3. Portable Emergency Provisions

Portable emergency provisions are provided to sustain the crew during emergencies (e.g., fire, depressurization) or an evacuation or if there is a missed resupply flight. An emergency portable breathing apparatus (PBA) provides face protection, 15 min of 100 percent breathable oxygen, and communications for each crew member during emergency situations requiring supplemental oxygen. A PBA can also connect to the ISS oxygen system for crew use for periods longer than 15 min (e.g., while detoxifying an IVA location). Russian-provided portable breathing masks provide breathable oxygen for several hours.

Missed resupply provisions are additional crew provisions that are stowed in distributed locations around the ISS and are to be used in the event of a missed resupply flight or an emergency. These additional provisions provide (1) food and water and (2) waste and trash management, personal hygiene, and clothing supplies for the crew for 45 days beyond the nominal mission duration.

In addition to these emergency provisions, portable fire extinguishers (PFE's) are provided as part of the ECLSS FDS system.

3.10.3.2.4. On-Orbit Maintenance, Tools, and Diagnostic Equipment

A work area and tools, diagnostic, and maintenance test equipment aid the crew in diagnosing problems and maintaining and testing ISS equipment. A large supply of equipment is provided, including a power supply, a diagnostic caddy, a portable maintenance work area, driver/drill assembly, wire mount assemblies, Ethernet repair kit, and IVA hand tools (e.g., wrenches, sockets, ratchets, files, saws, screwdrivers, pliers, and hammers).

3.10.3.2.5. Housekeeping and Trash Management

Housekeeping and trash management provisions are used by crew for routine interior cleaning (e.g., cleaning filters) and wet and dry trash handling. The equipment includes a portable wet/dry vacuum cleaner with attachments, several types of wipes for general housekeeping and sanitizing equipment (e.g., utensils) and facilities, liquid cleaning supplies (e.g., detergent pouches, disinfecting agents), and portable trash bags and liners (for disposal in a Progress or other resupply vehicle).

3.10.3.2.6. Cargo Transfer, Stowage, and Inventory Management

Cargo delivery, transfer, stowage, and return are accomplished through the use of soft stowage containers, rack stowage, and hard-mounted stowage. Soft stowage containers hold cargo transfer bags in different sizes and other larger bags. A system is provided for orderly packaging, stowing, and shipping ISS equipment, supplies/consumables, trash, and hardware replacement units. The primary stowage unit is the stowage tray, which comes in single, double, and triple tray sizes to accommodate multiple items and stowage configurations. Trays fit into lockers, which then fit into stowage racks for shipping; these structures are designed to transfer launch and landing loads to the rack structure. On-orbit stowage is accomplished by using resupply stowage racks (RSR's), zero-g soft racks (ZSR's), and by replacing bags and items in prescribed stowage locations in the modules. Both soft packed and hard-mounted items are transported in the MPLM. These items are described in detail in section 4.5. There is additional stowage behind wall panels and in some modules behind hinged doors. Loose crew equipment items and supplies are managed through an automated inventory management system using unique bar code identifiers and a bar code reader.

3.10.3.2.7. Lighting

General lights, portable utility lights (PUL's), and emergency egress lights (EEL's) are provided. General lighting is located throughout the ISS in the modules as the primary illumination. PUL's are provided to allow crew to temporarily increase illumination at a task worksite when required. EEL's are provided in module end cones to illuminate the egress path to the escape vehicle.

3.10.3.2.8. Decals and Placards

Decals and placards are attached to equipment and structures throughout the ISS and provide object identification (including failed or expended items), operating instructions and procedures (e.g., on hatches), location coding information, and labeling for stowage and inventory control (e.g., contents). All information is in English, although additional labeling in a second language is permitted.

3.10.3.3. Crew Health Care System

The CHecs is the primary ISS system for maintaining the health, safety, and performance of the crew during ISS missions. Its subsystems manage the following three primary domains that may compromise crew health and well-being:

- Countermeasures system: Evaluates crew fitness, provides countermeasures against the potential damage of long durations in microgravity, and monitors crew during exercise countermeasures use
- Environmental health system: Monitors (1) the ISS air and water for contaminants, (2) radiation levels, (3) surface microbial contaminants, and (4) acoustic contaminants
- Health maintenance system: Provides medical care by (1) monitoring crew health, (2) providing support in the event of illness or injury, (3) managing preventive health care, and (4) managing the stabilization and transport of crew between vehicles during an emergency

- A CHeCS PCS serves as the medical equipment computer (MEC). The MEC stores and maintains crew medical records, medical references, and software for psychological support. The CHeCS hardware and systems will reside in the U.S. Lab until it is eventually integrated into the Hab.

3.10.3.3.1. Countermeasures System

The purpose of the CMS is to prevent crew cardiovascular and musculoskeletal deconditioning resulting from long-duration crew stays in the microgravity environment. The CMS provides equipment to monitor crew fitness and provides exercise equipment to aid the crew in maintaining muscle and bone mass/strength and cardiovascular fitness. The CMS exercise equipment includes a treadmill (with a vibration isolation system) located in Zvezda, a resistive exercise device which is mounted to the treadmill (to prevent atrophy of major muscle groups), and a cycle ergometer (with a vibration isolation system) for aerobic conditioning, located in the Lab (the ergometer is shared with the human research facility (HRF)). The heart rate monitor is worn by an individual crew member as a watch. A blood pressure/electrocardiogram (BP/ECG) monitor measures, records, and transmits blood pressure, heart rate, and ECG output. The CHeCS PCS provides data collection/storage and the capability for downlinking crew exercise and monitoring data.

3.10.3.3.2. Environmental Health System

The purpose of the EHS is to provide qualitative and quantitative (1) water quality, (2) microbiological (surface and air), (3) radiation, and (4) toxicology monitoring of both internal and external environments of the ISS. To serve this goal, the EHS contains the monitoring equipment and performs monitoring functions shown in table 3.10-1.

Table 3.10-1. Monitoring Functions

Category	Equipment	Analysis
Water quality	Total organic carbon analyzer	Concentration of carbon, pH, and conductivity of ISS potable water
	Water sampler and archiver	Collects and stores ISS water samples for analysis
Microbiology	Water microbiology kit	Detects and enumerates microorganisms in ISS water systems
	Surface sampler kit	Cultures microbial and fungal organisms from exposed surfaces within ISS
	Microbial air sampler	Determines levels of airborne microbial contaminants in ISS habitable modules (bacteria and fungi)
Radiation	Tissue equivalent proportional counter (TEPC)	Measures, stores, and downlinks accumulated radiation spectra
	Personal dosimeters	Dosimeters are worn continuously by each crew member and are analyzed on crew return to determine individual crew radiation exposure
	Radiation area monitors (RAM's)	Radiation monitors are attached to structures distributed throughout the ISS (4-6/module; 2-4/node); data are stored and analyzed post-flight to determine ISS radiation levels
	Intravehicular-charged particle directional spectrometer (IV-CPDS)	Measures the flux of trapped, secondary, and galactic cosmic radiation (GCR) within ISS and downlinks data to the ground for analysis
	Extravehicular-charged particle directional spectrometer (EV-CPDS)	Measures the flux of trapped, secondary, and GCR external to the ISS and downlinks data to the ground for analysis
Toxicology	Compound specific analyzer-combustion products (CSA-CP)	Detects, identifies, and quantifies concentrations of carbon monoxide, hydrogen cyanide, hydrogen chloride, and oxygen
	Volatile organic analyzer (VOA)	Determines and downlinks the concentration of several targeted compounds in the ISS internal atmosphere
	Compound-specific analyzer-hydrazine (CSA-H)	Used in the airlock to detect hydrazine presence and concentration contaminating the EMU after an EVA
Acoustics	Audio dosimeter (AD)	Monitors crew exposure to noise
	Sound level meter (SLM)	Measures octave bands across spectrum

Table 3.10-1. Concluded

Category	Equipment	Analysis
	Passive hearing protection (PHP)	Complements passive earplugs for passive hearing protection
	Active noise reduction (ANR) headset	Provides active cancelling of noise

3.10.3.3.3. Health Maintenance System

The purpose of the HMS is to provide preventive, diagnostic, and therapeutic care to crew members and to support patient transport, if required. The HMS has six components, which are shown in table 3.10-2.

Table 3.10-2. Health Maintenance System

Equipment	Function
Ambulatory medical pack (AMP)	Provides in-flight medical care (e.g., first aid, treatment for minor illness or injury) Includes oral, topical, and injectable medications and exam instruments, including a portable clinical blood analyzer (PCBA)
Crew contaminant protection kit (CCPK)	Protects the crew from toxic and nontoxic particulates and liquids Contains eyewash; eye, respiratory, and skin protection; and waste containment bags
Advanced life support pack (ALSP)	Provides advanced cardiac and basic trauma life support capabilities Contains airway, drug, emergency surgery, assessment, intravenous administration, and intravenous “packs” and related emergency medical supplies
Crew medical restraint system (CMRS)	Provides restraint and electrical isolation for an ill or injured crew member and for the crew medical officers (CMO’s) attending the patient
Defibrillator	Provides defibrillation and ECG and heart rate monitoring, analysis, and downlink
Respiratory support pack (RSP)	Provides resuscitation for a crew member with impaired pulmonary function Automatically ventilates an unconscious crew member, provides oxygen assistance to a conscious crew member, and allows the CMO to manually resuscitate a patient

3.10.4. References

- Anon.: International Space Station Catalogue of IVA Government Furnished Equipment Flight Crew Equipment. JSC 28533, NASA Johnson Space Center, May 2000.
- Anon.: International Space Station Flight Crew Integration Standard. Space Station Office, SSP 50005, Rev. B, (NASA-STD 3000/T), NASA Johnson Space Center, Nov. 1998.
- Anon.: International Space Station User's Guide, Release 2.0. International Space Station Program, updated April 27, 2000. <http://spaceflight.nasa.gov/station/reference/index.html> Accessed July 18, 2000.
- Anon.: Joint Crew Provisioning Catalog. International Space Station Program, SSP 50477, NASA Johnson Space Center, Feb. 2000.

4. Baseline Utilization and Operations Plans

4.1. Introduction

The mission of the Station is to conduct scientific experiments in an international Earth orbiting research facility in a microgravity environment. The ISS program operational mission objectives are as follows:

1. Perform significant long-duration space research in science, technology development, and commercial applications
2. Operate advanced human and autonomous space systems
3. Encourage international cooperation in science and technology
4. Support users, particularly industry users, in experimenting on new, commercially relevant products and processes
5. Conduct human scientific, commercial, and exploration activities

Hence, the ISS is made for human participation in its utilization for scientific, technological, and commercial research. The users of the ISS are private, public, academic, and international entities that will utilize the ISS for scientific experimentation, engineering research, technology development, or the development of commercial products. The classifications of scientific research that can be accommodated by the ISS are microgravity sciences, technology and engineering research, biological and life sciences, space science, observational sciences, and commercial research or applications. The ISS will be built for a minimum use of 10 yr.

The payloads for the conducting of the various research and development activities can be classified as either pressurized or unpressurized payloads. Pressurized payloads will reside and operate in the environmentally controlled pressurized modules of the ISS either as a stand-alone experiment or housed within a facility. Unpressurized payloads reside outside the ISS as attached payloads, and if necessary, they may have to provide some of their own environmental controls internal to their hardware. The ISS will provide all payloads with resources including electrical power, data communications, cooling, periods of microgravity, vacuum, celestial and Earth viewing, potable water, gases, and refrigerator storage.

Several ingredients of ISS operation will determine the success of the research and development activities. The primary ingredient will be the availability of the resources onboard. Available facilities to house the payloads or available space to attach payloads and their interfaces include crew time, power, thermal, and data communications.

The various pressurized payload facilities that will be available on the ISS and their functions and the attachment sites for external payloads as well as the attachment hardware are indentified. The allocation plans for several resource areas are also discussed as well as an overview of the ISS operations planning process and the acceleration measurement capabilities and services.

4.2. Pressurized Payload Accommodations

The pressurized payloads and research facilities onboard the ISS will be accommodated either by being housed in an ISPR, as part of a modified ISPR, or within their own pressurized module. The baseline configuration of the ISS pressurized modules includes the following manifest for the ISPR's:

- U.S. Lab will provide 24 ISPR locations; payload racks will occupy 13 ISPR locations
- Centrifuge accommodation module
- ESA APM will provide 10 ISPR locations: 5 for NASA, 5 for ESA
- JEM will accommodate 10 ISPR locations: 5 for NASA, 5 for NASDA
- Russian Modules —TBD

Information from the documents listed in the bibliography (section 4.2.3) was used to compile this section.

4.2.1. Rack Accommodations

4.2.1.1. International Standard Payload Rack

ISPR's are defined as racks which are interchangeable between the NASA, ESA, and NASDA laboratories, regardless of the provider or site of initial installation within the ISS. (See fig. 4.2-1.) NASA, ESA, and NASDA module rack locations designated for ISPR's will provide interfacing hardware and utilities that consist of the mechanical attachments, utility interface panel and utilities, and restraint and mobility hardware attachment. Crew interfaces for the smoke detector visual

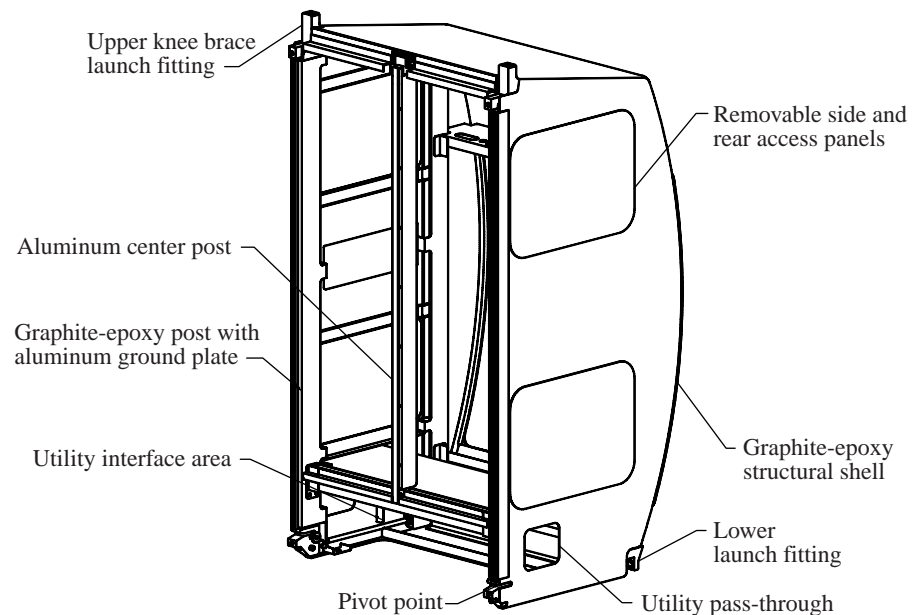

Figure 4.2-1. ISPR major components.

indicator, PFE insertion port, and maintenance power switch will be located on the ISPR front side.

Facility racks and expediting the processing of experiments to Space Station (EXPRESS) racks utilize the ISPR design as their baseline structure and are then modified to accommodate the type of activity that will occur in each type of rack. The U.S. facilities that will be housed in ISPR's include

- Centrifuge and life sciences glove box
- Gravitational biology facility
- Human research facility
- Biotechnology facility
- Fluids and combustion facility
- Material science research facility
- Microgravity science glove box
- Window observational research facility
- X-ray crystallography facility

4.2.1.2. Expediting the Processing of Experiments to Space Station Rack

The ISS provides the EXPRESS rack to the payloads that do not require the volume or mass capabilities of a full ISPR. These payloads have been deemed “subrack” payloads. A payload is a discrete set of equipment, software, specimens, and/or other items that are designated and treated as a collective whole in support of one or more experiments. Other payloads consisting of existing hardware that has previously flown in the orbiter, middeck, spacelab, or SPACEHAB, as well as new ISS payloads that have no requirements for the interfaces or resources of an entire ISPR location, are called EXPRESS rack payloads. The purpose of the EXPRESS rack is to provide accommodations to allow quick and simple integration for payloads of this type into the ISS.

The EXPRESS rack contains the required equipment to enable payloads to be integrated into an ISPR (fig. 4.2-2). This equipment includes structural support hardware, power conversion and distribution equipment, data and video equipment, nitrogen and vacuum exhaust distribution hardware, and thermal support equipment. An EXPRESS rack can be accommodated at any ISPR location on ISS. The EXPRESS rack can also be located in other IP laboratories, such as the APM or the JEM. It is the intent for the laboratories to be identical/transparent from the perspective of the EXPRESS rack payload. The EXPRESS rack typically will be installed in a 3-kW ISPR location.

4.2.1.2.1. Standard EXPRESS Rack Payload

Payloads that use the EXPRESS rack will be categorized for integration purposes as standard or nonstandard. This classification is based solely upon the quantity of interfaces and the resources/services required. This classification does not imply that a payload cannot be manifested in an EXPRESS rack; however, it does provide to the payload integrator a top level indication

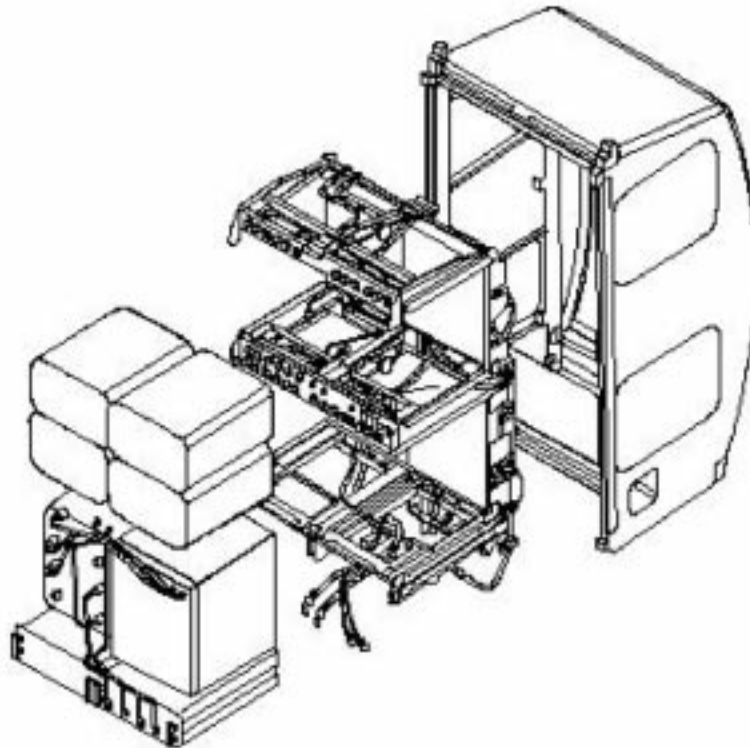

Figure 4.2-2. EXPRESS rack.

regarding the payload complexity and allows the integrator an opportunity to assess any impacts to the standard EXPRESS rack payload integration template. All payloads, regardless of their design complexity, are required to support all generic integration templates. Standard payloads will be located in the standard 8/2 EXPRESS rack configurations. The EXPRESS rack configuration accommodates eight MDL-class/style payloads in two areas of four lockers each and two 4-PU (panel unit) ISIS (international subrack interface standard) drawers. This layout is referred to as the “8/2 configuration.” The general arrangement for the 8/2 configuration is shown in figures 4.2-3 and 4.2-4. The 8/2 configuration can accommodate single or multiple middeck-type/style lockers.

If the payload is not stowed in a standard middeck locker (MDL) or in a 4-PU ISIS drawer, a standard EXPRESS rack payload can also occupy the equivalent volume of a single or double MDL or 4-PU ISIS drawer by providing its own unique support structure and attaching to the same points that an MDL or ISIS drawer would attach.

4.2.1.2.2. Nonstandard EXPRESS Rack Payload

Payloads with requirements exceeding standard EXPRESS rack allocations are nonstandard. This determination is dependent on the type of exceedance of the standard allocation or complexity of the unique interface. These payloads can be integrated into the EXPRESS rack. The non-standard payloads may be limited in manifesting possibilities or may necessitate alteration of the standard EXPRESS rack payload analytical and physical integration templates.

These interfaces and services are limited in quantity (i.e., water, vacuum exhaust, GN₂) in the standard EXPRESS rack configurations and may not be available on the earliest increment. These items may include, but are not limited to, requirements for

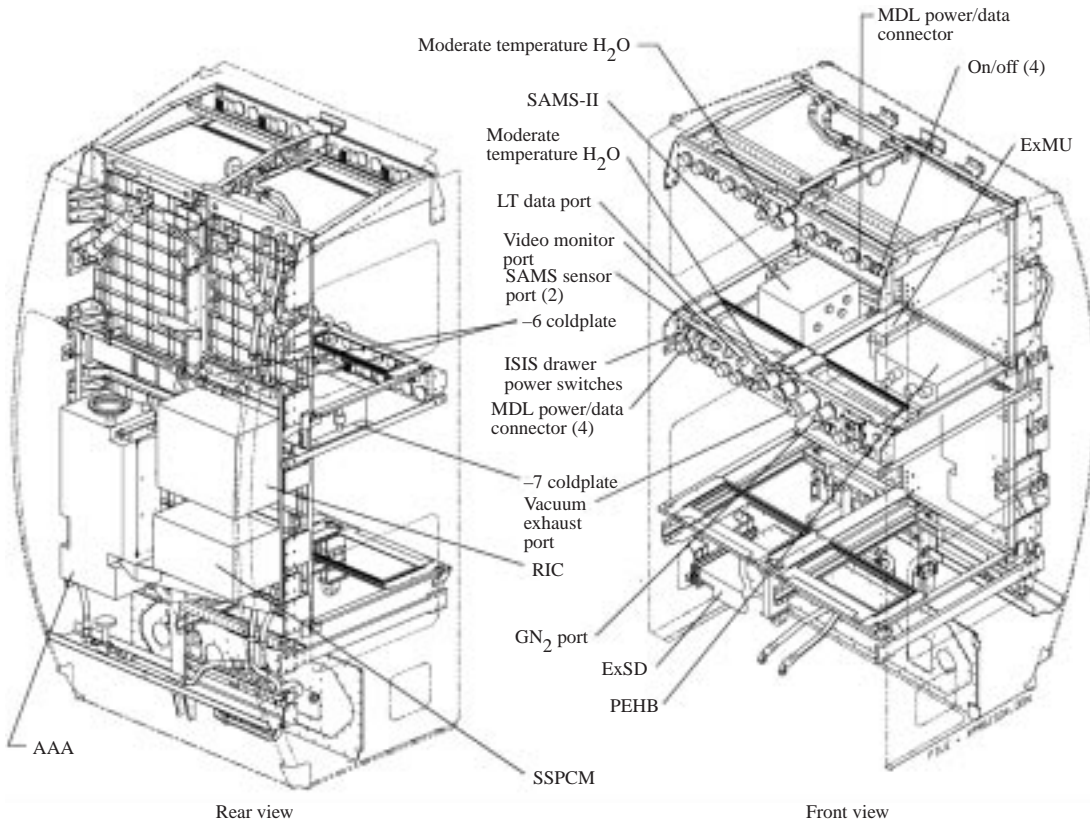

Figure 4.2-3. Isometric view of EXPRESS rack 8/2 configuration.

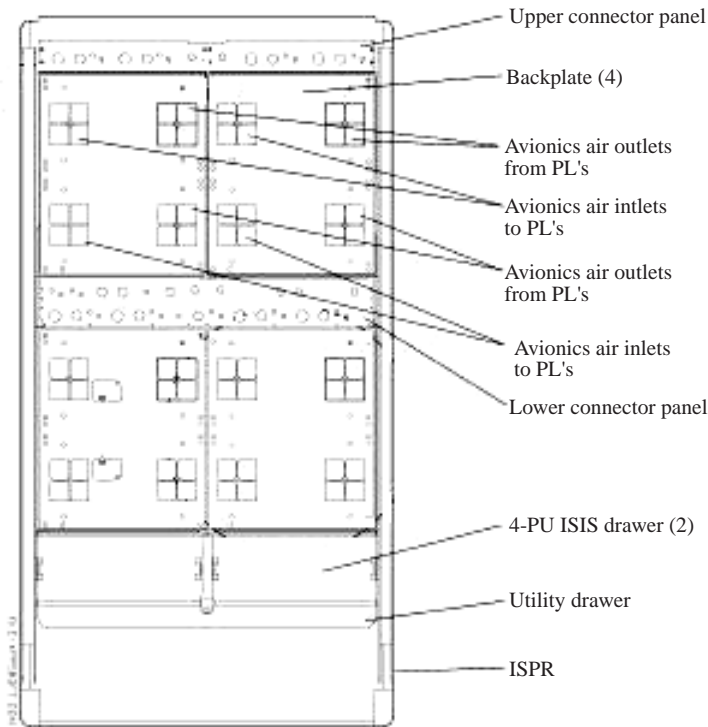

Figure 4.2-4. Structural provisions of EXPRESS rack 8/2 configuration.

- Specific payload location requests in the orbiter or ISS; these may not be available on the earliest increment
- Weight/volume/centers of gravity (c.g.)/frequency not meeting the requirements specified in the EXPRESS Rack Payload Interface Definition Document
- Specific environmental conditions (i.e., temperature, microgravity)
- Complexity of experiment-to-experiment interconnectivity
- Crew time resources exceeding TBD hr or accumulative, noncontiguous time on orbit during the increment
- Crew training time exceeding 12 hr total

There are services and/or special requests which may require the EXPRESS rack payload developer (PD) to identify interfaces/requirements or supply information/data at specific times to the ISS and/or the orbiter for use in further assessments, analyses, or development of data products. These include, but are not limited to, unique interfaces, middeck late installation, middeck early access, specific/unique microgravity environments, and crew training activities. Payloads that have nonstandard or unique interfaces must contact the payload integrator as soon as possible to discuss the request.

Requests for a specific location will be entertained, although on any flight the ISS reserves the right to assign locations to payloads mounted on an adapter plate and payloads stored within standard lockers or ISIS drawers.

The EXPRESS Rack Program will utilize the active rack isolation system (ARIS) for acceleration/*g*-distribution reduction for some of the 8/2 configurations of the EXPRESS racks. In addition, the 8/2 EXPRESS rack with ARIS has two connectors on the lower connector panel where second-generation space acceleration measurement system (SAMS-II) triaxial sensor heads (TSH) can be connected for the purpose of measuring the acceleration environment within the EXPRESS rack.

The 8/2 EXPRESS rack includes connector panels that provide interfaces to the services and resources offered by the EXPRESS rack facility. These include power, telemetry/commands, GN₂, vacuum exhaust. MDL payloads are bolted to the EXPRESS rack backplate which is attached to the rear posts of the ISPR. The EXPRESS rack accommodates standard MDL containers (i.e., Space Shuttle program-provided MDL's, SPACEHAB-provided lockers). The MDL payloads interface to the resources (power, commands/telemetry, water cooling, waste gas venting, and GN₂) via connections on the front face of the payload. Cooling is provided via passive radiation and heat exchange to the cabin environment (restricted) or forced air (avionics air) cooling via rear interfaces with the rack avionics air loop or water cooling. ISIS drawer payloads interface at the rear for power, data, and avionics air. A payload configurable and modifiable (i.e., blank) front panel is provided to allow for mounting interface connections through the front of the ISIS drawer.

The EXPRESS rack includes an avionics air assembly (AAA) to provide forced air cooling. This assembly has a limited capability that must be shared by all payloads within the rack. Use of cabin air cooling is restricted for EXPRESS rack payloads due to FDS concerns and restricted heat dissipation allocation for racks in the ISS. The EXPRESS rack interface to the moderate

temperature water loop and the forced air cooling are a common or shared resource and must be evaluated as an integrated subsystem to ensure that the heat loads are equally accommodated by the particular system. As stated, each system is capable of providing a specific, although not simultaneous, cooling capability. As the number of payloads operating at any one time increases, the temperatures available to payloads for cooling will approach the upper end of the specification.

A limited number of ISIS drawers are provided by the EXPRESS rack program. The ISIS drawers interface with the rack via a slide guide assembly. This hardware will be provided to the PD on an as-available basis, per the Experiment Interface Agreement, to facilitate preflight integration of payload hardware into the drawer.

4.2.1.3. Active Rack Isolation System

4.2.1.3.1. Requirements and Capabilities

For ARIS-equipped payload racks, the ARIS has the capability to (1) limit the vibratory accelerations, (2) measure the vibratory accelerations, and (3) distribute payload utilities. The capability of ARIS to limit vibratory accelerations depends on the state of the ARIS. In the active isolation state, the ARIS actively performs acceleration attenuation when commanded by the user payload. In its standby state, the ARIS is powered, initialized, and ready to perform active isolation. Normally, the ARIS is placed in either the active isolation or standby state when the Space Station is in microgravity mode. In its secured state, the ARIS is unpowered and manually locked down, usually when the Space Station is in a mode other than microgravity mode or the rack is unpowered.

4.2.1.3.2. ARIS Operation Concept

The ARIS will fly as a part of an integrated payload rack with the first unit manifested on flight 6A. The ARIS is planned to be installed at 12 ISPR locations within the U.S. Lab. ARIS rack installation provisions are installed at 12 U.S. Lab ISPR locations prior to flight 5A. ARIS racks are flown on MPLM. (First flight is 6A.)

ARIS is a closed-loop system that attenuates vibratory disturbances at selected user payload locations. Attenuation is achieved by imparting a reactive force between the payload rack and the module in response to sensed vibratory accelerations. Eight electromechanical actuators are used to move the rack in an attempt to cancel out the measured vibration/motion.

The system was designed to operate at frequencies below 1000 Hz, being most effective in the 20–200 Hz region. After installation and calibration of the rack, ARIS will be primarily controlled via ground commanding. The major components (ORU's) of the ARIS system are the controller, removable electronics units, accelerometers, actuator driver, the actuator assemblies, and the umbilical assemblies (fig. 4.2-5).

Crew participation will be required for ORU replacement, rack reconfiguration (maneuvering or access to adjacent racks), or other off-nominal activities. ARIS will be controlled via the payload-provided laptop (EXPRESS or facility laptop).

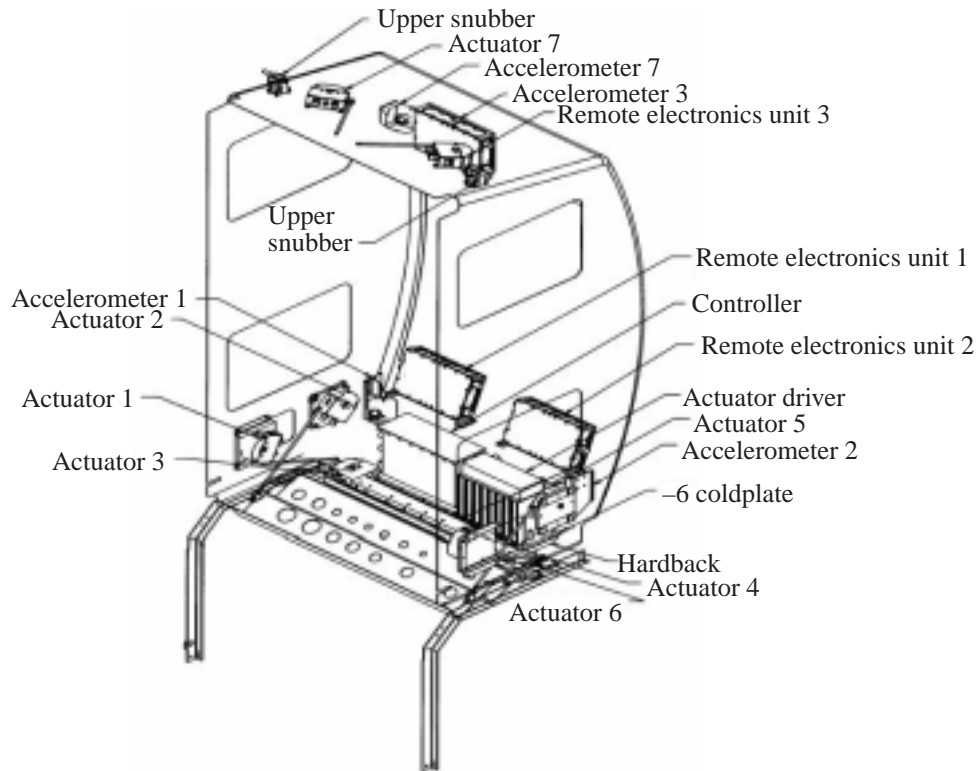

Figure 4.2-5. ARIS rack major components.

4.2.1.3.3. Limit Vibratory Accelerations

When in the active isolation state, the ARIS has the capability to attenuate vibratory accelerations between the U.S. Lab and the payload racks according to the minimum attenuation profile as specified in table 4.2-1. This profile applies to the 100-sec, root-mean-square, acceleration magnitude evaluated on a one-third-octave-band basis. When in the secured state, the ARIS is required to not magnify quasi-steady or vibratory accelerations (0.0 to 300 Hz) between the Lab and the payload rack other than those resulting from the integrated payload-rack-user-payload structural resonances.

Table 4.2-1. ARIS Minimum Acceleration Attenuation Capability

Attenuation, dB	Frequency, Hz
0	<0.00078
$13(\log(f) + 3.109)$	0.00078 to 0.00158
4	0.00158 to 0.00631
$-20(\log(f) + 2)$	0.00631 to 10
-60	10 to 300

4.2.1.3.4. Snubbers

The snubbers are “released” by the crew for microgravity-sensitive science operations (nominal procedure). The snubbers also provide 4-point restraint of the ISPR during payload servicing and rack maintenance. The snubbers are locked by the crew to secure the rack during

- Payload servicing
- Rack maintenance
- Orbital translation/reboost
- Debris avoidance maneuver
- Extended periods not requiring microgravity

4.2.2. Facility Descriptions

This section provides an overview of the facility racks that will be available to payload users for various scientific research and technology development activities.

4.2.2.1. Gravitational Biology Facility

The gravitational biology facility (GBF) (fig. 4.2-6) is part of the Space Station Biological Research Project (SSBRP), whose mission is to develop and validate in-flight, nonhuman specimen support capability for life sciences research on the ISS. The GBF consists of two holding racks that support the centrifuge habitats. This laboratory will provide the basic tools to conduct musculoskeletal, neurophysiology, developmental biology, and genetic research at the whole organism and cellular levels.

The holding racks (fig. 4.2-7) are modified ISPR's that will provide life support resources and electrical power to the habitats and other scientific equipment as well as data transfer links to computers on the ISS. These data links will allow data to be transferred from the ISS to the Ames Research Center which will then be relayed to scientists at their institutions and laboratories. Operators on the ground can also send commands to the laboratory equipment onboard the ISS. With this ability, researchers on the ground can monitor and control the environmental and experimental parameters inside the habitats. The habitats housed in the holding racks are maintained in the microgravity conditions present in the module rather than the artificial gravity conditions present on the centrifuge.

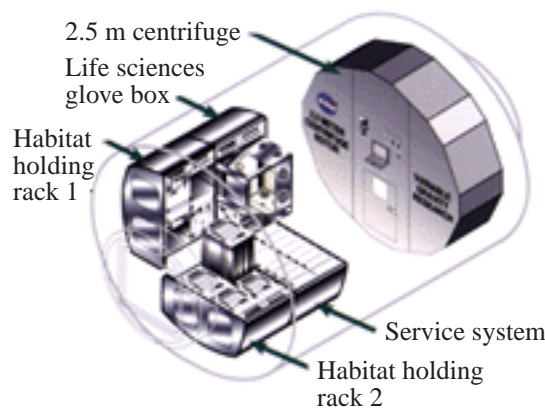

Figure 4.2-6. Centrifuge accommodation module with centrifuge facility and gravitational biology facility.



Figure 4.2-7. Holding racks.

The habitats (fig. 4.2-8) mount in both the centrifuge and the holding racks and will provide life support for a variety of organisms for research in cell, developmental, and plant biology. The habitats include a cell culture unit for cell and tissue cultures, a plant research unit for small plants, an egg incubator for studies in early development, an insect habitat for multigeneration and radiation studies, an aquatic habitat for small fresh water and marine organisms, and an advanced animal habitat for rats and mice. The habitats will provide food, water, light, air, humidity control, temperature control, and waste management for the organisms. In addition to environmental capabilities, the habitats will be able to collect and transmit engineering data. Habitats will attach to the life sciences glove box (LSG) in a manner that will prevent any exchange of biological material between the cabin and glove box or habitat.

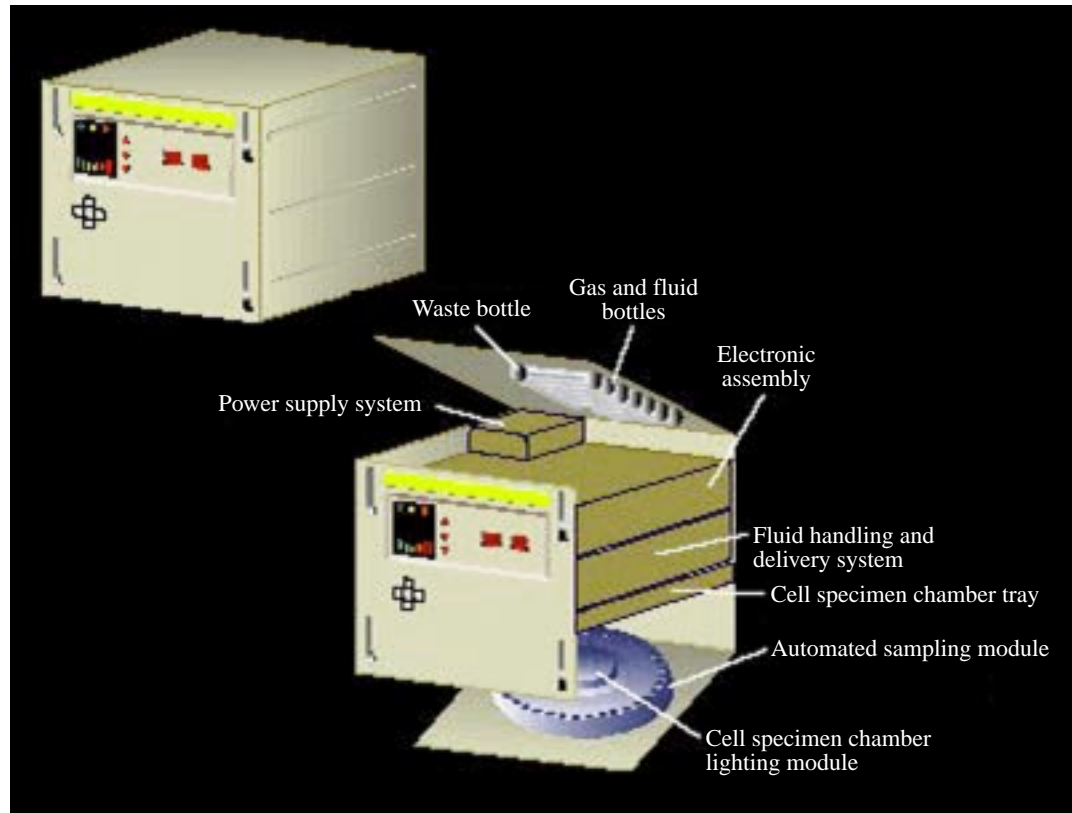

Figure 4.2-8. Habitats example.

4.2.2.2. Centrifuge

The centrifuge is a laboratory which produces artificial gravitational forces on biological specimens such as small animals and plants in the ISS. It is used to investigate precisely how microgravity affects biological specimens. The centrifuge (fig. 4.2-9) will be 2.5 m (\approx 8 ft) in diameter and accommodated within its own pressurized module, the CAM (fig. 4.2-6). As the centrifuge rotates, it will produce artificial gravitational forces upon attached habitats that house

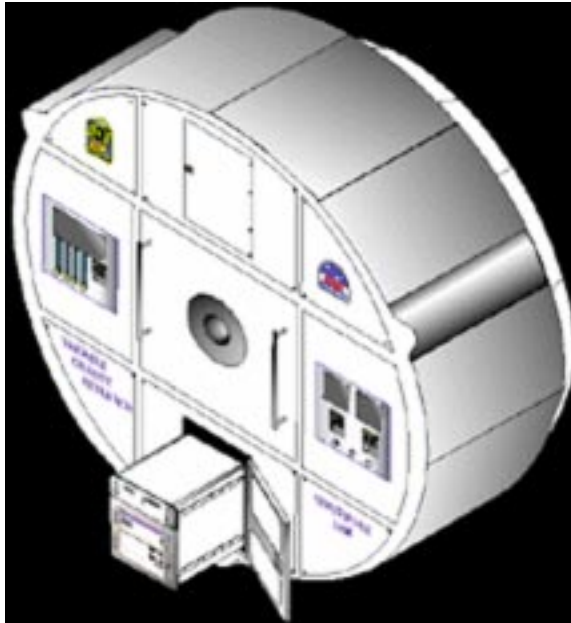

Figure 4.2-9. Centrifuge.

various biological specimens. It will be capable of producing controlled, artificial gravity levels ranging from 0.01g to 2.0g. To create a 1.0g field, the centrifuge rotates at 28 rpm. Comparison of living systems exposed to the reduced or intermittent gravity levels attainable with the centrifuge will help determine if artificial gravity is necessary during extended human missions into space.

The centrifuge will provide life support resources and electrical power to the habitats as well as data transfer links to computers on the ISS. The hub, or center, around which the centrifuge rotates is a complex electrical and mechanical system. It will provide structural support for the rotating part of the centrifuge and life support to the specimen habitats. Traveling through the hub are lines that carry liquids and electrical power as well as computer and video information.

Because the centrifuge is always spinning, the centrifuge must constantly remain balanced. Therefore, scientists and engineers have developed a system that continually moves weights distributed around the centrifuge to maintain balance. This system is called an active-balancing system. The active-balancing system compensates for changes in weight distribution on the centrifuge, prevents vibrational distribution on the centrifuge, and prevents vibrational disturbances to the ISS. This system will ensure that any vibrations caused by the centrifuge will not disturb other scientific payloads aboard the ISS.

4.2.2.3. Life Sciences Glove Box

The LSG (fig. 4.2-10) is a portion of SSBRP. The LSG provides a work volume for conducting experimental procedures on biological specimens, transferring specimens to and from the habitats, and maintenance of habitats. The LSG will be housed in an ISPR located in the CAM. The LSG provides the enclosed environment in which manipulations of the specimen chambers, specimens, materials, and science equipment will be conducted.

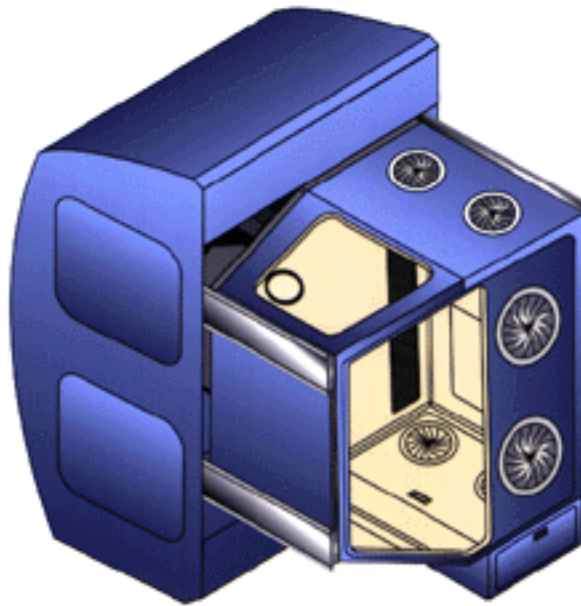

Figure 4.2-10. Life sciences glove box.

The LSG provides a sealed work area where crew members will perform experimental procedures. Two crew members will be able to use the glove box work space at the same time by means of gloves that extend into the work space. The enclosed volume of the glove box will be about 0.5 m^3 ($\approx 18 \text{ ft}^3$).

Specimens will be transported to and from the LSG work space via habitats or portions of habitats, depending upon habitat design. Small items, materials, and waste matter may be transported to and from the LSG work volume via a transfer system that operates independently of the habitat interface. Specimens, science equipment, tools, waste, samples, and other materials may be brought into and removed from the LSG work space during operational procedures. The LSG work volume will be stored inside the rack during launch, return, storage, and any nonoperating time. The LSG will have structural, thermal, electrical, video, and data interfaces with the ISS and with the habitats.

4.2.2.4. Human Research Facility

The human research facility (HRF) consists of a water-cooled EXPRESS rack that will house the major components of HRF and provide limited stowage. This equipment will be used to assess crew health, conduct research on how the human body responds and adapts to weightlessness, develop countermeasures, and conduct basic human research aimed at advancing knowledge in

areas relevant to human health. This facility supports the disciplines of cardiopulmonary physiology, environmental health, and human factors. The HRF rack provides complex capabilities typically found in ground laboratories for biomedical research, including a mass spectrometer, an ultrasound imaging system, and a computer workstation. Additional hardware items include an activity monitor, ambulatory data acquisition system, continuous blood pressure device, foot-ground interface, holter monitor, hand grip dynamometer/pinch force device, range-of-motion suit, sample collection kits, portable computer, lower body negative pressure device. Hardware from other projects will also be available to investigators conducting experiments with the HRF (e.g., ergometer, treadmill, portable clinical blood analyzer).

The HRF configuration consists of an HRF rack, standard interface rack (SIR) drawer mounted instruments, and stowed instruments that are deployed for use. The HRF rack accommodates up to 15 four-PU SIR drawers or a combination of SIR drawer sizes in four-PU increments (up to 16 PU in height) within a 32-PU (rack left half) and a 28-PU (rack right half) volume (fig. 4.2-11). Each four-PU SIR drawer location provides structural, C&DH, +28-V electrical, and air-to-liquid heat exchanger interfaces. The rack control panel provides C&DH, electrical, ISS fluid coolant loop, nitrogen, vacuum resource, and exhaust interfaces for HRF instrument use. All HRF thermal interfaces are connected to the ISS MTL.

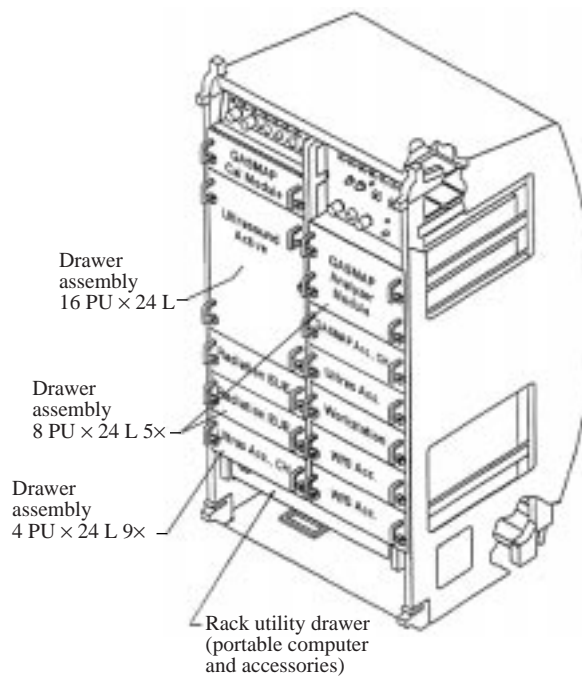

Figure 4.2-11. Human research facility.

The HRF rack interfaces to the following ISS core systems: structural, electrical, high rate data link (HRDL), medium rate data link (MRDL), low rate data link (LRDL), pulse frequency modulation (PFM) and differential video, MTL, vacuum exhaust system (VES), vacuum resource system (VRS), nitrogen gas, and FDS system. The crew may access HRF rack command and control functions through the HRF laptop.

The gas analysis system for metabolic analysis of physiology (GASMAP) instrument is used to monitor and analyze crew member breath streams to determine constituent gas concentrations.

The GASMAP receives analog input signals from the subject electrocardiograph to determine cardiovascular/cardiopulmonary parameters.

The ultrasound system is a medical instrument that utilizes ultrasound energy to perform medical imaging and to measure fluid flow rates in biological systems. This system generates and receives ultrasound signals by using hand-held probes to support cardiac, abdominal, vascular, muscle and tendon, transcranial, contrast, and veterinary applications.

The HRF workstation consists of a Pentium Pro class computer, mounted on a 4-PU SIR drawer, with deployable keyboard, deployable 16-in. diagonal LCD display, and accessory cables. The HRF workstation provides a platform for the installation and execution of HRF software to perform various tasks required in experiment operations. These tasks include command and control of HRF equipment, such as the HRF rack, experiment data acquisition and storage, storage of experiment procedure, and crew notes. The computer will be capable of virtual environment generation.

The HRF portable computer provides the crew interface to the HRF C&DH functions. This computer is a standard sized laptop mounted on an extendable arm on the front of the HRF rack. The portable computer is stowed in the HRF rack utility drawer.

HRF rack instrument accessory drawers are 4- and 8-PU flush-faced SIR drawers used to store HRF instrument equipment and experiment supplies when not in use. These drawers have no protrusions other than the standard handles provided with SIR drawers. The deployed envelope is that of a standard SIR drawer.

4.2.2.5. Biotechnology Facility

The biotechnology facility (BTF) (fig. 4.2-12) is designed for conducting low-gravity, long-duration protein crystallization, cell culture and tissue engineering, and fundamental biotechnology experiments. The BTF is a one-rack facility in which seven MDL-class/style experiment modules can be integrated and exchanged with each Space Shuttle visit. The BTF will support each experiment module with power conditioning and distribution, four different research grade gases, experiment computer control, and video signaling switching and processing. A centralized command and data management interface with the ISS and limited data and video storage will be provided.

Experiments must be powered continually from launch until landing, except for short transfer times between orbital vehicles. Biological samples are temperature sensitive and require a thermally controlled environment. Support systems that supply nutrients and oxygen are required to maintain cell viability. Longer duration experimental runs will produce larger protein crystals and cell cultures, which will potentially make analysis more accurate, easier, and more plentiful.

Late access to the Shuttle middeck and early postflight removal will be required for biotechnology samples. Samples will be loaded 14 to 24 hr prior to launch and removed 3 to 8 hr after landing. BTF precursor experiments will be flown by using an EXPRESS rack on flight UF-2; BTF will be launched on flight UF-7.

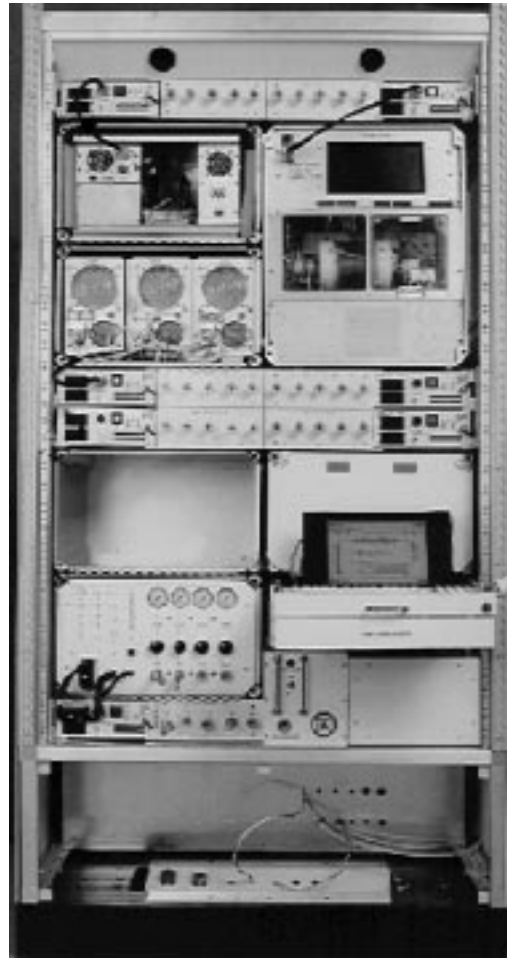

Figure 4.2-12. Biotechnology facility.

4.2.2.6. Fluids and Combustion Facility

The fluids and combustion facility (FCF) (fig. 4.2-13) is a modular, multiuser, microgravity science facility which will occupy three powered payload ISPR's plus the equivalent volume of one unpowered stowage rack. Together the three racks will provide the fundamental physical and functional infrastructure necessary to perform combustion science, fluid physics, and adjunct science onboard the ISS. The facility will be launched incrementally in three separate, integrated racks. The first rack, the combustion integrated rack (CIR), will be launched on flight UF-3 and will accommodate combustion science experiments. The second rack, the fluids integrated rack (FIR), will be launched on flight UF-5 and will accommodate fluids physics experiments. The FCF will be complete with the addition of the third rack, the core rack.

The FIR and the CIR both feature a modular design which offers flexible, on-orbit reconfiguration of the optical components to allow researchers the capability to conduct their experiments from the ground. The CIR provides common equipment including interchangeable diagnostics (e.g., high-resolution cameras, microscopic cameras, optics, lasers, illumination), combustion containment, gas mixing and distribution, electrical power, avionics, general thermal management, communications, data acquisition and storage, and vibration isolation (fig. 4.2-14). The researcher will provide the unique experiment equipment such as the experiment-mounting structure, unique

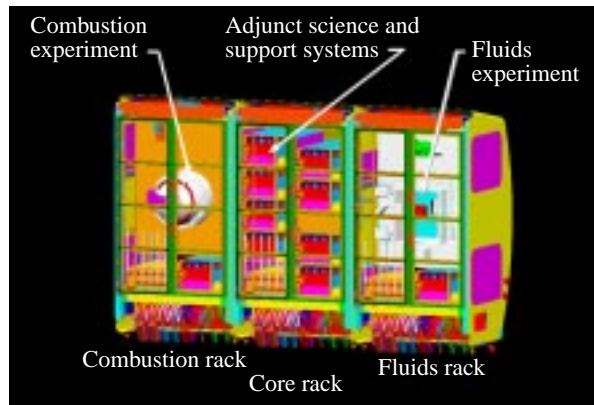

Figure 4.2-13. Fluids and combustion facility.



Figure 4.2-14. Combustion integrated rack.

diagnostics, gases. The types of combustion science to be accommodated by the CIR include laminar flames; reaction kinetics; droplet and spray combustion, fire, and fire suppressants; condensed phase organic fuel suppressants; condensed phase organic fuel consumption; turbulent combustion; soot and polycyclic aromatic hydrocarbons; materials synthesis; and detonations and explosions.

The FIR will provide equipment that includes high-resolution cameras, microscopic cameras, optics, fluid containment, lasers, illumination, electrical power, avionics, general thermal management, communications, data acquisition and storage, and vibration isolation (fig. 4.2-15). The fluids researcher will provide the unique experiment equipment such as fluid test cells, unique diagnostics, fluid mixers and insertion devices, high-precision test cell thermal conditioning. The types of fluid physics experiments to be accommodated in the FIR include capillary (isothermal); colloids; thermocapillary; fluid rheology, including polymers; electrohydrodynamics; multiphase flow; granular flow; granular media; critical fluids; and diffusive phenomena.

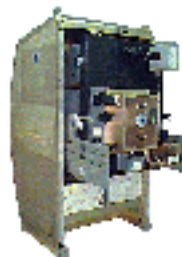

Figure 4.2-15. Fluids integrated rack.

The ARIS is integral to all three racks along with electrical power conservation and distribution, command and data management, image processing, and communication interfaces with the ISS.

4.2.2.7. Materials Science Research Facility

The materials science research facility (MSRF) (fig. 4.2-16) is a modular facility comprising three autonomous materials science research racks (MSRR) for research in the microgravity environment of the ISS. Each MSRR is a stand-alone autonomous ISPR and will have on-orbit replaceable experiment modules (EM) (furnace), module inserts, investigation unique apparatus, and/or multiuser generic processing apparatus and will support a wide variety of scientific investigations.

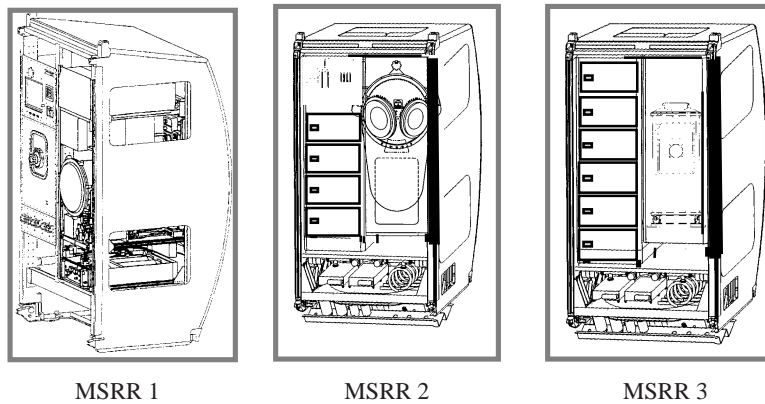

Figure 4.2-16. Materials science research facility.

ESA will provide the MSRF core rack, which will house five experiment modules (furnace inserts). NASA and ESA each will provide two inserts, and the German Space Agency (DLR) will provide a fifth. The NASA/ESA experiment module will be composed of all necessary experiment and unique support systems and will house the various replaceable module inserts. The core facility will contain the module inserts and include all items directly interfacing with the scientific sample. These items will include the furnace core; adiabatic zone; hot and cold zones; translation system; sample support structure; vacuum chamber; electrical equipment; and the supporting electrical, mechanical, vacuum, water, and gas supply lines. Each of the five inserts will be a furnace to process materials in different ways, such as directional solidification—melting and freezing a sample from one end to the other—or quenching a sample quickly to “freeze” its condition. The German insert will be a special furnace that uses a rotating magnetic field to control flows within the molten samples. The useful life of each rack is planned to be from a minimum of 5 up to 10 yr. The operational life of the experiment modules is planned for a minimum of 5 yr.

The MSRF will accommodate investigations in basic materials research and applications in the fields of solidification of metals and alloys, thermophysical properties, polymers, crystal growth studies of semiconductor materials, and research in ceramics and glasses. The first of the three MSRR’s (MSRR 1) (fig. 4.2-17) is scheduled to be launched in 2002 with the MSRR 2 and MSRR 3 following in a phased rack deployment through 2004.

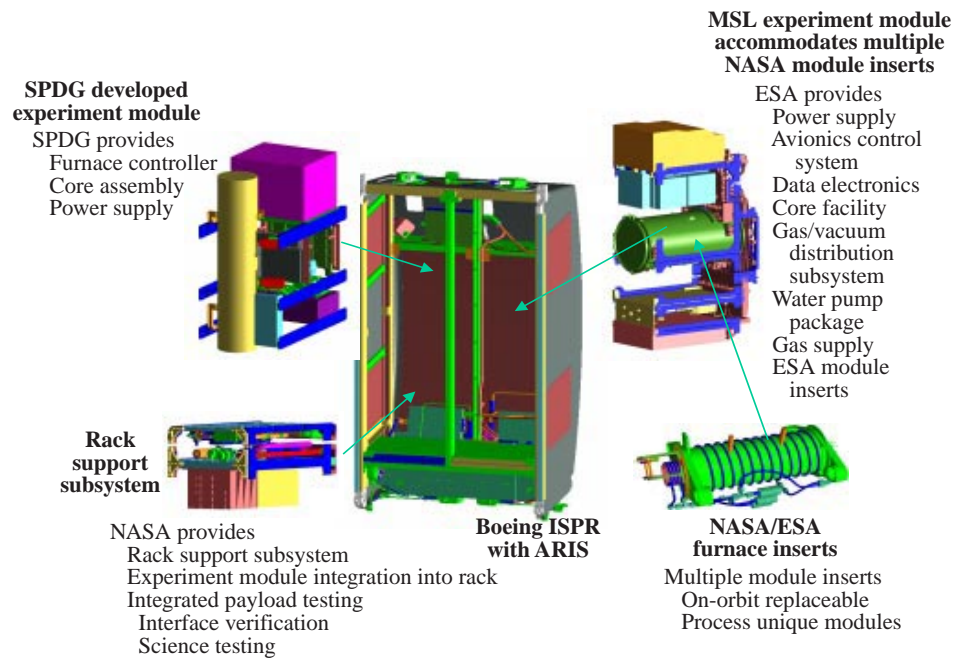

Figure 4.2-17. Materials science research rack 1.

4.2.2.8. Microgravity Science Glove Box

The microgravity science glove box (MSG) (fig. 4.2-18) is one of the early European-contributed items provided by ESA and, according to the baseline planning, will be accommodated in the U.S. Lab. The MSG is integrated into an ISPR, which is accommodated in the U.S. Lab and optionally in the APM. Investigations to be performed in the MSG are expected to include fluid physics, combustion science, material science, biotechnology (cell culturing and protein crystal growth), space processing, fundamental physics, and technology demonstrations. The principle of the glove box system is to provide double containment by a sealed compartment and a negative pressure. However, if the release of a fluid leads to catastrophic consequences, an additional level of containment, other than what the MSG can provide, will be provided by the experiment. The work volume (WV) operates at a minimum of 1.3 mbar below cabin air pressure to ensure that all potentially polluted air coming from, for example, an experiment goes through the filters even if there is a leak in the WV. Three independent filter banks, each with its dedicated fan, take care of this task.

The MSG core facility is an enclosure penetrated by gloves, which will allow the operator to safely perform microgravity experiments and equipment service tasks that require a safe cabinet and manipulation by hand. All these tasks will be performed in the core facility WV. An airlock (AL) is located under the WV. Basic lighting is provided by general operations, video, and cleanliness inspection of the WV and AL. The WV is a contained cabinet of 6.885 ft³, with clear visual access to its internal contents through a large front window. The core facility can be slid in and out of the rack to fixed positions to improve the ergonomic and functional performance.

Relevant functional requirements of the MSG include the following items:

- Approximate dimensions of the WV are

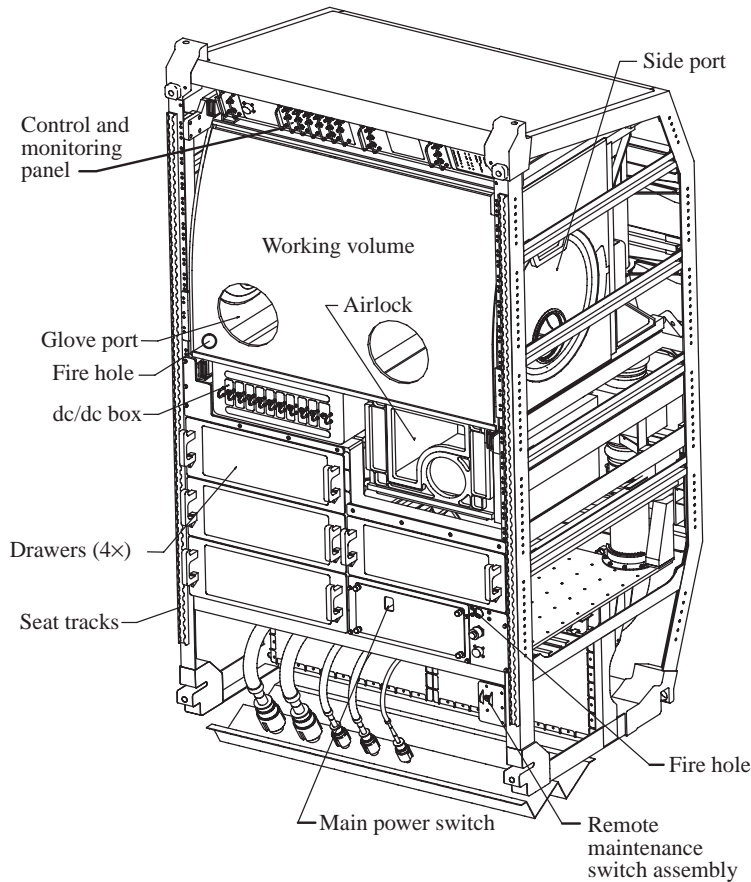

Figure 4.2-18. Microgravity science glove box.

Width: 35.67 in.

Depth (bottom): 19.69 in.

Depth (top): 15.16 in.

Height: 25.08 in.

- The WV is hermetically isolated from the cabin by means of seals and a negative pressure of ≥ 1.3 mbar provided in normal and in open mode, relative to cabin pressure
- The WV provides the capability to transfer an experiment or equipment article of up to 15.98 in. in diameter or 13.78 by 11.81 in. to the inside
- The MSG WV allows single containment quantity manipulation of up to 3.05 in³ (except where noted otherwise) in volume
- The MSG WV provides the capability to maintain a class 100000 environment
- The MSG WV provides a 99.97-percent efficient removal of all particulate matter of 0.3 μ or larger in aerodynamic diameter

4.2.2.9. Window Observational Research Facility

The window observational research facility (WORF), a facility that will enable the U.S. Lab nadir viewing research window to be utilized for Earth and space science research, is an ISPR-based structure equipped with structural support hardware, power conversion, and distribution equipment, data and video equipment, and thermal support equipment. The WORF will be accommodated at the LAB1D3 (U.S. Lab 1 deck third rack from forward end) ISPR location on ISS. The WORF will be transported to the ISS in the MPLM.

The WORF is illustrated isometrically in figure 4.2-19. Payloads are mounted on a WORF-provided mounting structure, and interface with WORF power, data, and cooling resources via connectors on the WORF front panels. Payload heat rejection is by passive radiation, forced air cooling via rear interfaces with the rack avionics air loop, air exchange with the cabin environment (restricted), or water cooling via front panel interfaces.

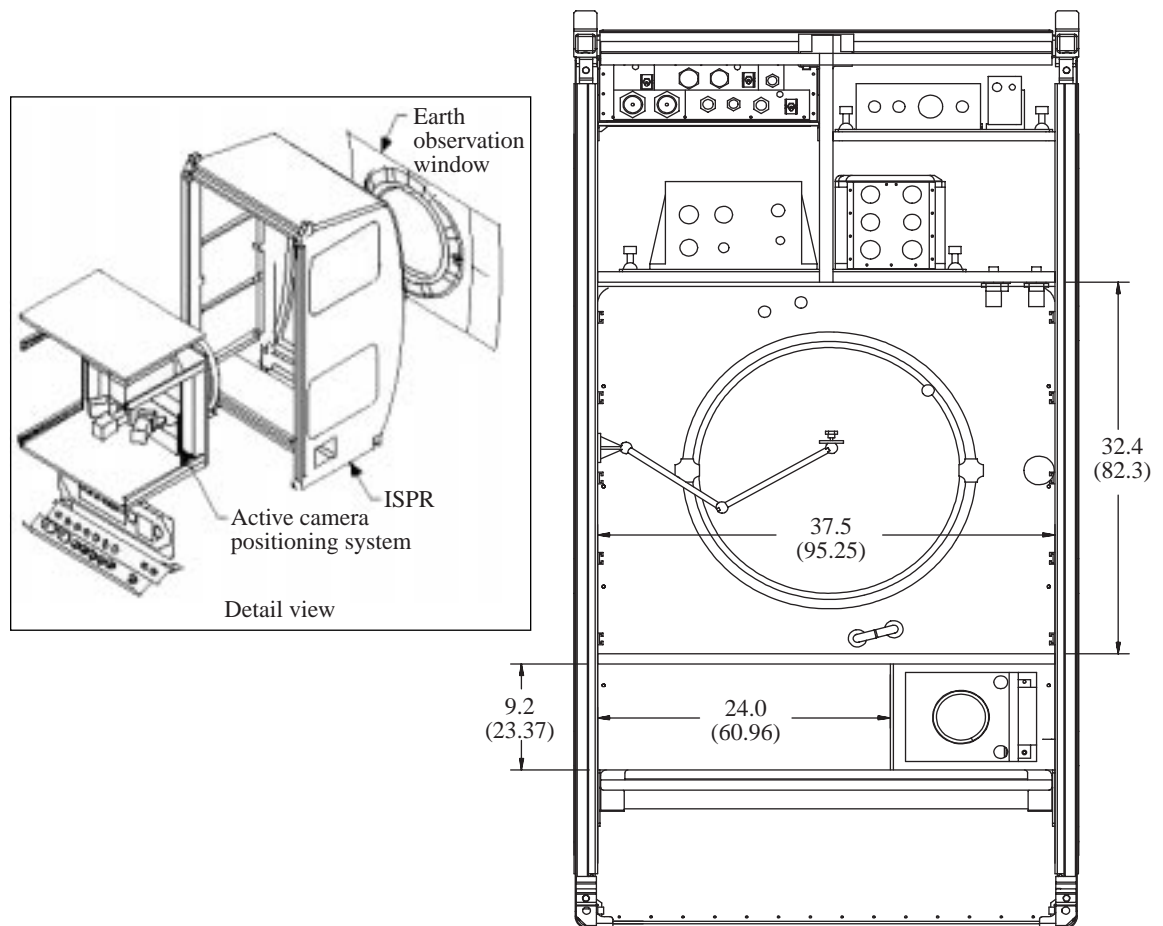

Figure 4.2-19. WORF rack. Dimensions are in inches (centimeters).

WORF will be launched with no payloads. WORF subrack payload hardware will typically be transported via Shuttle middeck or in standard stowage accommodations. The WORF will allow for crew-tended and autonomous payloads. The WORF will provide payloads with an equivalent volume of 0.8 m^3 and can support up to three payloads simultaneously, depending on the available

resources and the space available at the window. The WORF will also provide for access and equipment for crew-Earth observations, such as crew restraints and camera/camcorder brackets, and condensation prevention.

4.2.2.10. X-Ray Crystallography Facility

The X-ray crystallography facility (XCF) is a full protein-crystal analysis laboratory. It provides for crystal harvesting from sample growth chambers, crystal examination and selection for mounting and preservation, snap cryogenic freezing of mounted crystals if desired, X-ray diffraction of selected crystals, downlinking of acquired diffraction data to ground facilities, video observations of all XCF operations, and full telerobotic control of nearly all XCF operations by crystallographers on the ground. The XCF development has been sponsored by the NASA Space Products Development Office and performed by the University of Alabama at Birmingham Center for Biophysical Sciences and Engineering (UAB CBSE), formally known as the Center for Macromolecular Crystallography (CMC) and supporting contractors.

The XCF will have important advantages for protein crystallography onboard the ISS. First, a very large number of crystals will be grown in a protein crystal growth (PCG) facility on the ISS and the XCF can help scientists select the limited number of crystals which can be returned to the ground onboard the Shuttle. Nominally, a Shuttle will visit the ISS at 90-day intervals to transport equipment and payloads to and from the ISS. Since the nominal 90-day period between Shuttle visits to the ISS will be long compared with PCG times in space, the XCF could help implement multiple PCG cycles within one period by enabling scientists to analyze results of one cycle, change PCG conditions, and initiate the next cycle. In this context, the XCF can characterize crystal quality from one growth cycle to allow optimization of PCG conditions for the next.

The XCF will occupy a full ISPR as shown in figure 4.2-20. Protein crystals will be grown in an EXPRESS rack dedicated principally to PCG. At the end of a PCG cycle within any incubator, in response to directions from scientists on the ground, a crew member will remove selected crystal sample chambers from the incubator, transport them to the X-ray diffraction rack, and insert them into the crystal preparation prime item (CPPI). From that point, all operations within the XCF will be performed under telerobotic control by scientists on the ground.

4.2.2.10.1. XCF Major Elements

The XCF is composed of three major elements, the CPPI, X-ray diffraction prime item (XDPI), and command, control, and data prime item (CCDPI). Each major element is a subsystem of the XCF. Because each of these major elements also contains several subsystems, the term "prime item" was adopted to distinguish each major element.

4.2.2.10.2. Crystal Preparation Prime Item

The CPPI occupies about a quarter of the available volume in the rack. Figure 4.2-21 is a line drawing of the working volume of the CPPI. The CPPI is fully robotic, except for manual insertion and removal of cartridges containing the crystal growth chambers. When the cartridge containing crystal growth chambers has been inserted into the CPPI, a first sample chamber is selected from the ground, and the micromanipulator (a six-degree-of-freedom robotic arm) opens that chamber with a special wrench. The fluid and crystals from the pipette are transferred into one of the syringes located in the fluid crystal management system (FCJS). Once the transfer is complete, the selected syringe is returned to the tray. An empty mating syringe is placed opposite the filled

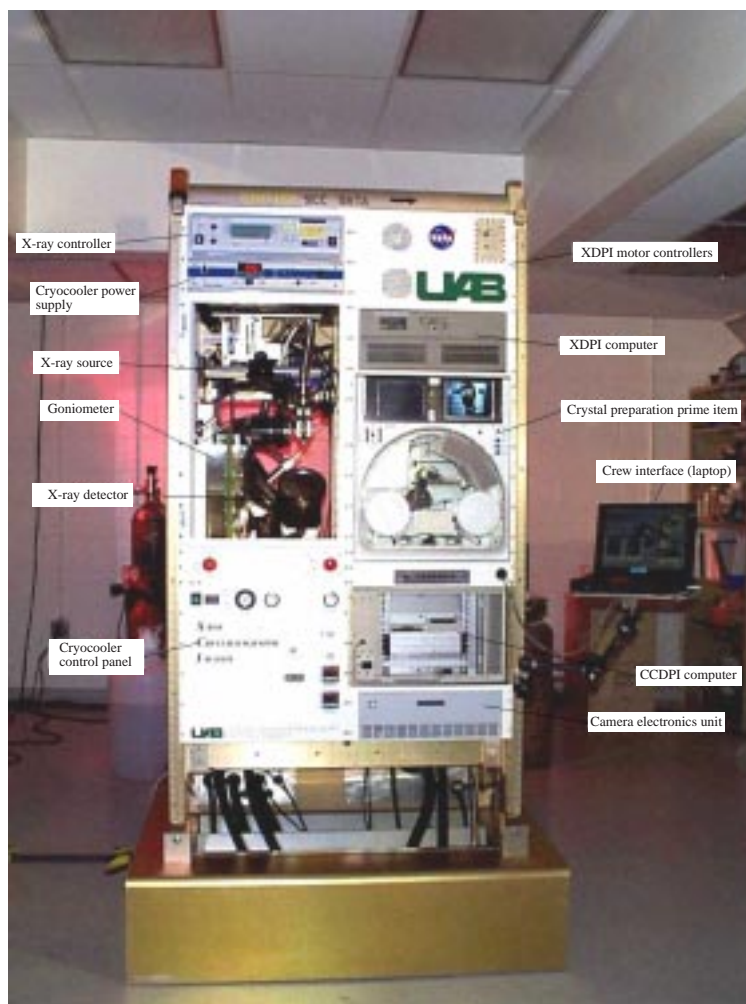

Figure 4.2-20. X-ray crystallography facility.

syringe in the tray. The two syringes are extended until their tips nearly touch, and a small amount of fluid is pushed from the filled syringe to form a fluid bridge between the two tips. Then the fluid is transferred back and forth between the two syringes while the bridge is viewed by the microscope camera to detect and examine crystals crossing the bridge. The crystals will be between 0.3 and 1 mm in size. A crystal is selected from the ground for mounting, and the micro-manipulator then inserts a small hair loop, approximately 0.3 to 1.0 mm in diameter and on the end of a stylus, into the fluid bridge, catches the crystal within the hair loop by surface tension, and extracts the mounted crystal from the fluid bridge.

4.2.2.10.3. X-Ray Diffraction Prime Item

The XDPI contains the X-ray source, goniometer, X-ray detector with associated electronics, and a cryocooled nitrogen source which maintains the crystal undergoing diffraction in a cryofrozen state. As shown in figure 4.2-20, the XDPI occupies less than half the space available in the rack. Figure 4.2-22 is a schematic of the XDPI.

As shown in figure 4.2-22, the slender X-ray beam (copper K-alpha X-rays) from the source traverses an evacuated tube and is focused on the target crystal held in the head of a three-circle

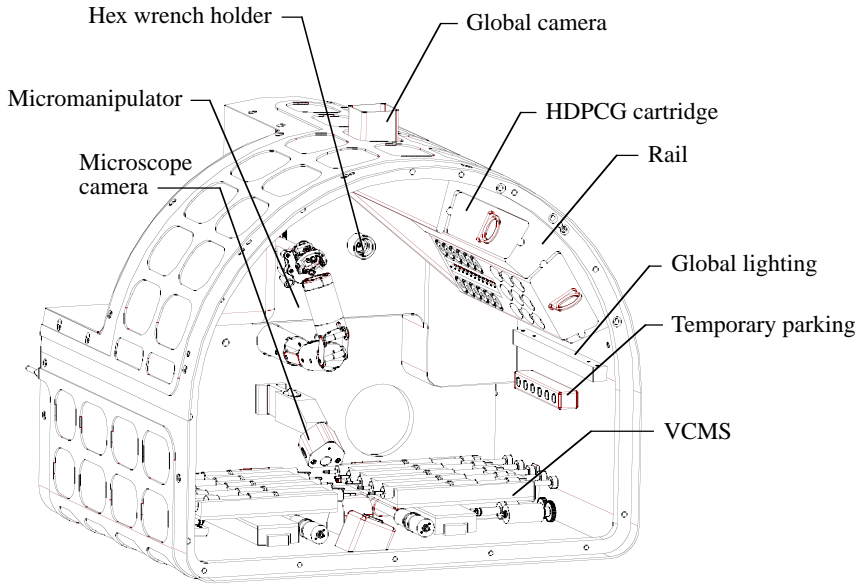

Figure 4.2-21. Crystal preparation prime item.

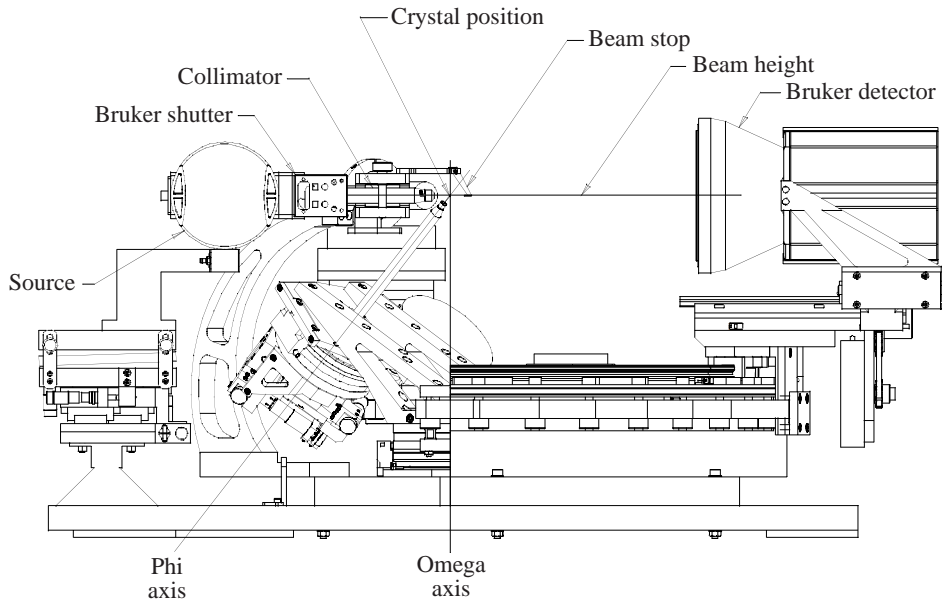

Figure 4.2-22. X-ray diffraction prime item.

goniometer. The X-ray source operates continuously during a diffraction event. The beam is switched on and off by the electrically actuated shutter. The goniometer is of unique design specifically for the rack application. Diffracted beams from the crystal enter the X-ray detector assembly. The detector captures images of the diffraction patterns produced by the target crystal.

4.2.2.10.4. Command, Control, and Data Prime Item

The CCDPI is a set of computer-controlled electronics which performs all command, control, data acquisition, data storage, and communications functions for operation of the XCF on orbit.

The CCDPI is being developed by UAB CBSE. A prototype has already been developed. In the ISS application, the CCPDI will provide command and control of the XCF by crystallographers on the ground and also by the ISS crew, if necessary.

4.2.3. Bibliography

- Alfonzo, Agustin J.: Life Sciences Glovebox (LSG) Hardware Interface Control Document. International Space Station Program, SSP 57214, NASA Johnson Space Center, Oct. 1998.
- Allen, James L.: Active Rack Isolation System (ARIS) User's Guide. International Space Station Program, SSP 57006, NASA Johnson Space Center, Mar. 29, 1999.
- Anon.: MICROGRAVITY—Fluids and Combustion Facility Catalog., <http://microgravity.nasa.gov/mf.html> Accessed June 23, 2000.
- Anon.: Combustion Element. Updated Oct. 6, 1998, <http://zeta.lerc.nasa.gov/fcfwww/fcf/combust.htm> Accessed July 11, 2000.
- Anon.: Fluids Element. Updated Oct. 6, 1998, <http://zeta.grc.nasa.gov/fcfwww/fcf/fluids.htm> Accessed July 11, 2000.
- Anon.: International Space Station Fluids and Combustion Facility. Updated Oct. 6, 1998, <http://zeta.grc.nasa.gov/fcfwww/index> Accessed July 11, 2000.
- Anon.: MICROGRAVITY—Microgravity Facilities. Updated Dec. 10, 1998, <http://microgravity.nasa.gov/mf.html> Accessed July 11, 2000.
- Anon.: Microgravity Science Glovebox (MSG) Payload Accommodation Handbook. Doc. No. MSG-RIBRE-RQ-0001, Rev. C, Daimler Chrysler Aerospace, Feb. 1, 1999.
- Anon.: Habitat Holding Racks—To House Specimens in the Microgravity Environment. Updated Aug. 23, 1999, http://spaceprojects.arc.nasa.gov/Space_Projects/SSBRP/index.html Accessed July 11, 2000.
- Anon.: Life Sciences Glovebox—A Fully Equipped Workstation/Glovebox. Updated Aug. 23, 1999, http://spaceprojects.arc.nasa.gov/Space_Projects/SSBRP/index.html Accessed July 11, 2000.
- Anon.: Multiple Habitats To Support a Variety of Organisms. Updated Aug. 23, 1999, http://spaceprojects.arc.nasa.gov/Space_Projects/SSBRP/index.html Accessed July 4, 1999.
- Anon.: 2.5 M Centrifuge—With a Selectable Rotation Rate to House Specimens at a Variety of Gravity Levels. Updated Aug. 23, 1999, http://spaceprojects.arc.nasa.gov/Space_Projects/SSBRP/index.html Accessed July 11, 2000.
- Arnold, Matt: International Standard Payload Rack (ISPR) Structural Integrator's Handbook. SSP 57007 Rev. A Draft (Contract NAS15-10000 (DR FP04)), Boeing Co., Oct. 6, 1999.
- Alfonzo, Agustin: Window Observational Research Facility (WORF) Block One Hardware Interface Control Document. International Space Station Program, SSP 57220, NASA Johnson Space Center, May 3, 1999.
- Corley, William L.: Microgravity Sciences Glovebox (MSG) Interface Control Document. International Space Station Program, SSP 57211, NASA Johnson Space Center, June 16, 1999.
- DeLucas, L. J.; Crysel, W. B.; Weise, L. D.; Smith, C. D.; and McDonald, W. T.: The International Space Station X-Ray Crystallography Facility. Presented at the 1999 Denver X-Ray Conference: Advances in X-Ray Analysis. (Steamboat Springs, CO) Aug. 2–6, 1999.
- D'Onofrio, Michael: Material Science Research Rack One Hardware Interface Control Document. International Space Station Program, SSP 57227, NASA Johnson Space Center, Mar. 15, 2000.

Revision A, October 2000

Geiger, Wade: EXpedite the PROcessing of Experiments to Space Station (EXPRESS) Rack One Interface Control Document. International Space Station Program, SSP 57201, NASA Johnson Space Center, Nov. 4, 1998.

Grimaldi, Rebecca; and McKay, Guy, eds.: EXpedite the PROcessing of Experiments to Space Station (EXPRESS) Rack. Updated: Mar. 27, 1997, <http://astro-2.msfc.nasa.gov/Shuttle/msl/science/express.html> Accessed June 23, 2000.

Grounds, Dennis J.; and Holler, Patricia A.: The Human Research Facility. Space Technology and Applications International Forum—1999, Mohamed S. El-Genk, ed., CP458, American Inst. Phys., 1999. Used With Permission of American Institute of Physics, c.1999.

Jenkins, Julia P.: International Standard Payload Rack to NASA/ESA/NASDA Modules Interface Control Document. International Space Station Program, SSP 41002, Rev. I, NASA Johnson Space Center, Mar. 31, 1999.

Jett, D.: International Space Station Payload Accommodations Handbook: EXpedite the PROcessing of Experiments to Space Station (EXPRESS) Rack Payloads. International Space Station Program, SSP 52000-PAH-ERP, NASA Johnson Space Center, Nov. 24, 1997.

Moore, Karen M; Long, Marianna M.; and DeLucas, Lawrence J.: Protein Crystal Growth in Microgravity: Status and Commercial Implications. Space Technology and Applications International Forum—1999. Mohamed S. El-Genk, ed., Am. Inst. Phys., 1999, pp. 217-224.

Orr, Kevin: Prime Item Development Specification for the Active Rack Isolation System. Specif. No. S684010158A, Cage ID No. 2B945 (Contract No. NAS15-10000), Boeing Co., Nov. 2, 1998.

Poates, Ines: Window Observational Research Facility (WORF). Updated June 24, 1999, <http://iss-www.jsc.nasa.gov/ss/issapt/payofc/0z1/faccharts.html> Accessed June 23, 2000.

4.3. Attached Payloads

An attached payload (AP) is defined as any scientific or technology experiment that attaches to the external unpressurized structure of the ISS. AP's can be a unique payload package with a single scientific or technical mission or a grouping of payloads integrated onto a larger carrier system. Several locations throughout the ISS can accommodate external AP's. These attached payload locations will provide capabilities primarily for Earth science and space science research, engineering research and technology, and commercial with other disciplines supported as well. The primary sites for attached payloads include

- ITS will provide 4 attached payload locations at the S3 location and 2 additional at the P3 location for logistics and maintenance
- JEM EF will accommodate 10 attached payload locations: 5 for NASA, 5 for NASDA
- Columbus Exposed Payload Facility will accommodate 4 EXPRESS pallet adapter (ExPA) sized payloads: 2 for NASA and 2 for ESA
- Russian segment—Russian Module 1, RM2, and Docking Compartment 2

ISS attached payloads planned by the United States include

- Alpha magnetic spectrometer
- Stratospheric aerosol and gas experiment III
- ESA 1
- ESA 2
- OSS 1
- Thermal management test bed
- ASI SAREX

Information from the documents listed in the bibliography (section 4.3.3) was used to compile this section.

4.3.1. Integrated Truss Structure

As a research platform in near-Earth orbit, the International Space Station (ISS) provides installation and operational support of science and technology experiments and their associated support equipment at four external attachment sites on the ITA S3 (starboard side) and two external attachment sites on the ITA P3 (port side). The four external payload attachment system (PAS) sites located on the ITS S3 have been designated as “primary attached payload sites.” The two external unpressurized cargo carrier attachment system (UCCAS) sites located on ITS P3 will serve as auxiliary attached payload sites on an as available basis. The physical interface between the ITA and unpressurized cargo carriers (UCC's) will occur at the two UCCAS sites located on ITS P3.

“Attached payload” is the generic term used to identify those scientific and technology experiments packaged for launch, ISS integration and operation in the unpressurized near-Earth orbit environment. For the purposes of this section, an AP shall be defined as an experiment and associated support equipment preintegrated on a carrier that interfaces directly to a PAS on ITS S3 or a UCCAS location on ITS P3.

“Unpressurized cargo carrier” (UCC) is the generic term used to identify ORU and logistics carriers (e.g., unpressurized logistics carrier) packaged for launch, ISS integration, and operation in the unpressurized near-Earth orbit environment. For the purposes of this document, a UCC shall be defined as an ORU and logistics carrier with associated support equipment that interfaces directly to UCCAS location on ITS P3.

The six external attachment site interfaces support the transfer of structural loads, power, and data. All six sites are configured to support multiple cycles of robotically assisted AP and UCC installation and removal. All six sites are configured for remotely actuated connection and disconnection of AP’s and UCC’s to and from ISS resources and services with an EVA releasable feature for contingency. The PAS and UCCAS sites differ in the level of drive motor redundancy in the active mechanical subsystems, and in location on the ITA. The sites will become operational at the conclusion of P3 and S3 assembly operations and remain operational for the life of the Station. The relative locations of the six external attachment sites are shown in figure 4.3-1.

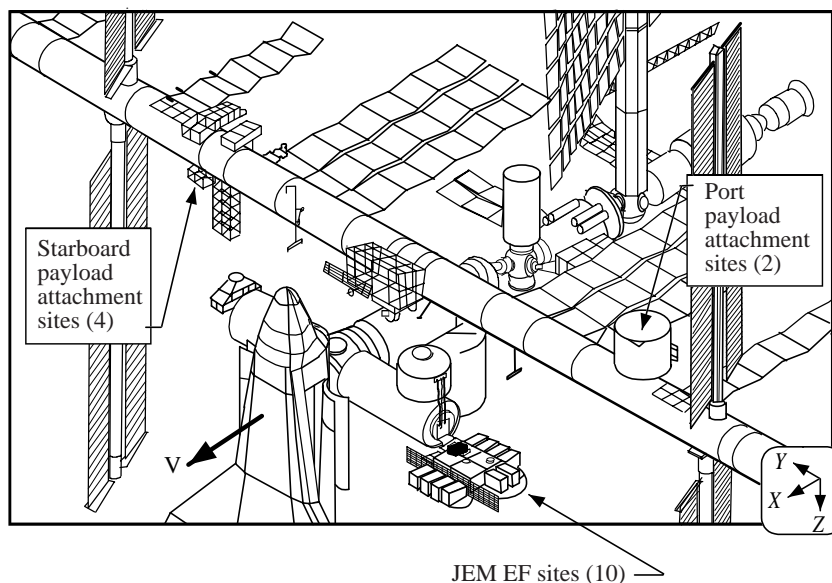

Figure 4.3-1. External integrated truss segment attachment sites.

ITS S3 supports the installation, removal, operation, and maintenance of external PA’s at the four PAS sites. The PAS sites will be launched integral to ITS S3 and deployed during ITS S3 assembly operations. While PAS deployment operations will be EVA based, all other AP operations will be performed by EVR.

ITS P3 supports the installation, removal, operation, and maintenance of unpressurized cargo carriers and AP at two UCCAS sites. The UCCAS sites will be launched integral to ITS P3 and

deployed during ITS P3 assembly operations. Although UCCAS deployment operations will be EVA based, all other UCC and AP operations will be performed by extravehicular robotics (EVR).

4.3.1.1. Payload Attachment System

The PAS is that portion of ITS S3 that has direct physical contact with the AP's and UCC's. The PAS design reflects the robotic nature of AP's and external logistics operations. The PAS is a zero fault tolerant subsystem. A PAS unit is detailed in figure 4.3-2.

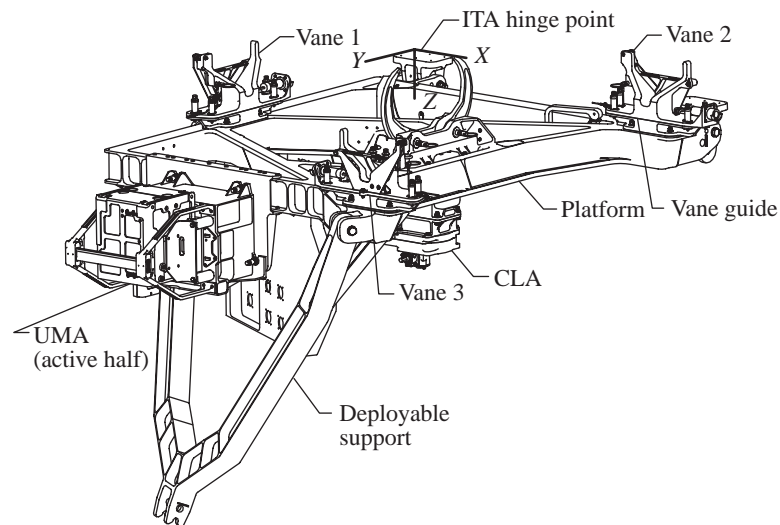

Figure 4.3-2. Payload attachment system.

4.3.1.2. Unpressurized Cargo Carrier Attachment System

The UCCAS is that portion of ITS P3 that has direct physical contact with the UCC's and AP's. The UCCAS design reflects the robotic nature of the AP's and external logistics operations. The UCCAS is similar to the PAS and can be represented by the same figures as the PAS because the interface to the payload is the same with the exception of payload addressing. The difference between the two attachment systems is that the UCCAS is designed as a single fault tolerant system through an additional integrated motor controller assembly (IMCA) on both its capture latch assembly (CLA) and active UMA.

4.3.1.3. Capture Latch Assembly

Each PAS and UCCAS includes one CLA. The CLA is a remotely actuated mechanism supporting capture, berthing, and structural integration of AP's and UCC's to the attachment system platform (a PAS or a UCCAS site). Each CLA is EVA removable and includes design provisions allowing for EVA manual override. The CLA consists of a pair of latch jaws which are driven open and closed by a standard dc IMCA. The PAS CLA has a single IMCA. The UCCAS CLA design includes two IMCA's to support UCC redundancy requirements. The CLA operates in conjunction with three guide vanes located on the attachment system platform. The guide vanes maintain proper alignment of the three guide pins on the PAS/UCCAS passive half as the AP or UCC is drawn into final position by the CLA. A CLA is shown in figure 4.3-3.

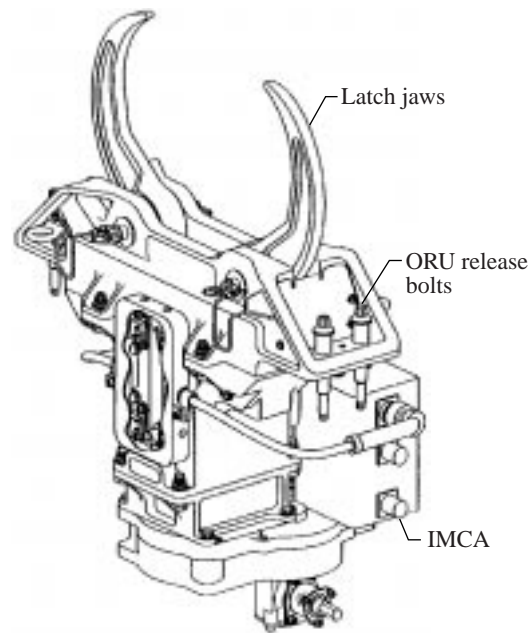

Figure 4.3-3. Capture latch assembly.

4.3.1.4. Umbilical Mechanism Assembly

Each PAS and UCCAS includes one UMA active half. The UMA is a remotely actuated mechanism supporting connection and disconnection of AP's and UCC's to ISS power and data systems. The PAS UMA has a single IMCA. The UCCAS UMA design includes two IMCA's to support UCC redundancy requirements.

The UMA active half will be integral to the PAS and UCCAS. The UMA passive halves will be provided by the AP's and UCC's interfacing directly to the PAS and UCCAS. Each UMA half provides copper wire for power, fiber-optic cable terminations for HRDL, and MIL-STD-1553B for address capability. Electrical and data connections are connected and disconnected during the mating/demating process with the AP and UCC UMA passive half. Each UMA is ORU removable and includes design provisions allowing for EVA manual override. The UMA active and passive halves are shown in figure 4.3-4.

4.3.1.5. EXPRESS Pallet System

The EXPRESS pallet system (ExPS) (fig. 4.3-5) is the ISS truss-attached payload facility which provides standard ISS accommodations for multiple external payloads mounted on the ExPA. It accommodates on-orbit installation, removal, and changeout of ExPA-mounted payloads, using ISS standard logistics and EVR capability in addition to planned and/or contingency crew EVA.

The ExPS is composed of three main functional elements: ExPA's, express pallet (ExP), and EXPRESS pallet control assembly (ExPCA) (fig. 4.3-6). The ExPA provides standard structural, mechanical, electrical, and communications interfaces for payloads. The ExPA will provide for a structural and mechanical interface with the ExP, with a capability for robotics or EVA manipulation, connection, and attachment of adapter-to-pallet related interfaces. The program baseline is

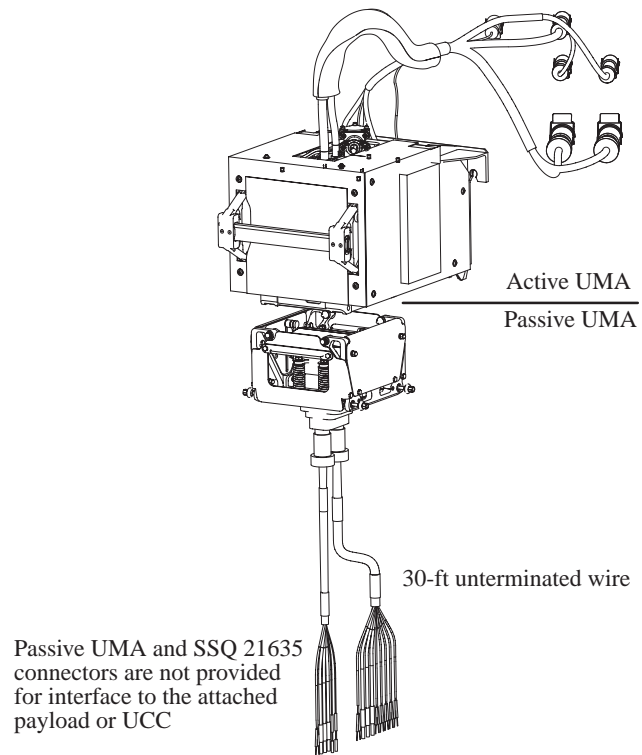

Figure 4.3-4. Umbilical mechanism assembly.

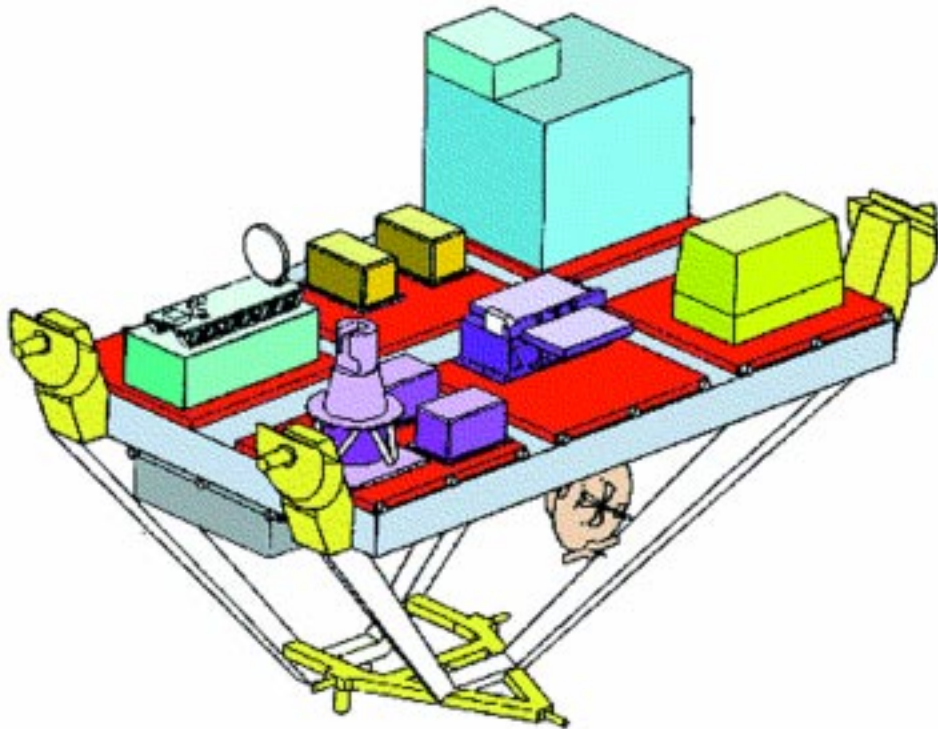

Figure 4.3-5. EXPRESS pallet system.

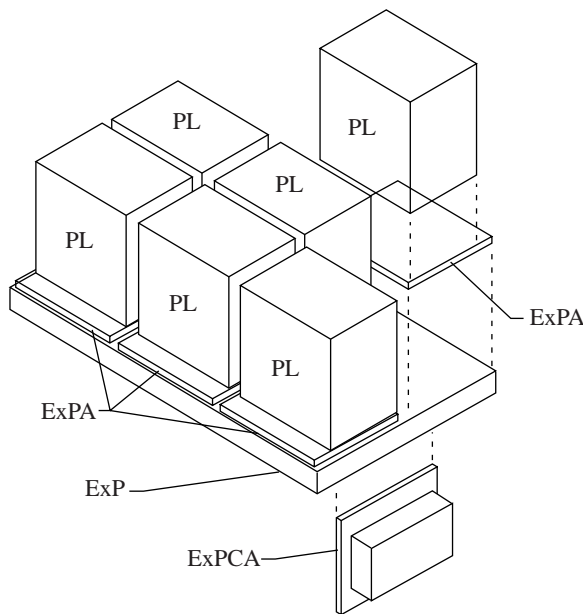

Figure 4.3-6. EXPRESS pallet physical diagram.

for EVR operations only, and contingency EVA occurs only upon failure or unavailability of EVR. The ExPA will utilize the ISS logistics systems and will provide to mounted payloads stay-alive power distributed by the ExPCA from a connection made between the ExP and the orbiter while in the orbiter cargo bay and while the ExPS is attached to the MSS enroute to its final destination on the ISS truss.

The ExP provides a structural platform for the integration of ExPA-mounted payloads. It will provide for a structural and mechanical interface with the ISS truss site (S3 or P3), with a capability for EVR or EVA manipulation, connection, and attachment of structural, electrical, and data interfaces.

The ExPCA provides data and command routing, status monitoring, and power control, distribution, and conversion. Up to six ExPA's will be directly serviced by this assembly. The ExPCA will be EVR and EVA compatible for manipulation, connection, and replacement.

4.3.2. Japanese Experiment Module Exposed Facility

The JEM is developed by NASDA and consists of a laboratory, logistics modules, robotic manipulator, and ground facilities for the purpose of supporting research and development experiments in a microgravity environment in an Earth orbit. The JEM supports permanent human habitation as a segment of the ISS. The JEM can support both internal and external user payloads and can transfer equipment and user payloads from the laboratory to the vacuum of space without the need of a pressure-suited crew member.

The JEM EF (fig. 4.3-7) is an unpressurized pallet structure exposed to the environments of space to support user payloads for the purpose of experimental research in areas such as communications, science, engineering, materials processing, and Earth observation. The EF will be attached to the JEM and will supply user payloads with structural support, thermal conditioning, power, video, and data services. The JEM RMS is the robotic system that will be used for the

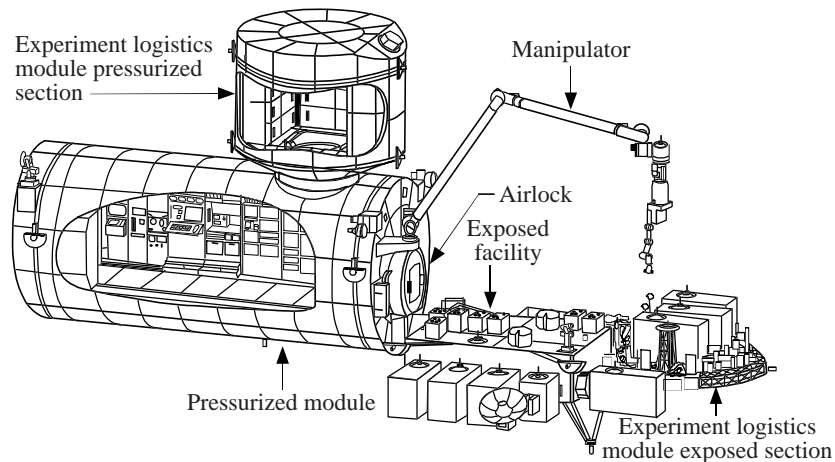

Figure 4.3-7. JEM exposed facility (shown attached to JEM).

transport and positioning of external user payloads on the JEM EF. The JEM RMS is comprised of both an internal and external section. The external section consists of a main arm and a fine arm for robotics manipulation. The internal section allows an IVA crew to operate the external robotics.

The EF payloads are divided into two categories: standard experiment payloads to 500 kg and large experiment payloads between 500 and 2500 kg. The EF will have the capability to support scientific observation, communications, and the other scientific experiments which require the exposed space environment and material processing experiments which should be conducted outside the PM for reasons of safety and interference.

To effectively perform various kinds of experiments, the EF will have common facilities to support the preparation of experiments, supply experimental environment (microgravity) and necessary resources, process the experiment results, et cetera. The EF will provide an adequate field of view for the zenith and nadir of payloads. Adequate space for payloads will be secured around the EF. The EF payloads will be served by the JEM RMS and EVA. In order to provide these services, the EF will possess the necessary mechanical attachments and adequate clearance. Adjacent EF payloads will be separated by 30 cm or more that is necessary to enable RMS operation. If failures of JEM EF payloads occur or resources are misused by payloads, JEM will have the capability to measure, monitor, and protect the data, electric power, and fluid interface by command of flight crew or ground operator to prevent degrading other payloads or operations.

The EF will have an equipment exchange unit (EEU) for payload attachment. The EEU is composed of an active exposed facility unit (EFU), which will have the capability to attach or detach the EF payloads positioned by the JEM RMS, and a passive payload interface unit (PIU). The EF will have 12 EFU's (10 EFU's for EF payload use, 1 for the experiment logistics module-exposed section (ELM-ES) use and 1 for the communication system).

The EF will be launched on flight 2J/A, a joint flight with a NASA payload. At this time, the basic JEM configuration will be completely assembled.

4.3.3. Bibliography

Anon.: JEM System Specification. NASDA-ESPC-840G (E), Mar. 1997.

Anon.: JEM Structure Exposed Facility. http://jem.tksc.nasda.go.jp/iss_jem/jem/bakuro_e.html Accessed June 22, 2000.

Anon.: Space Station Program Integrated Truss Segments P3 and S3 to Attached Payloads and Unpressurized Cargo Carriers (UCC) Standard Interface Control Document. International Space Station Program. SSP 42131, Rev. C (Draft 6), NASA Johnson Space Center, Feb. 9, 2000.

Ener, E. L.: Segment Specification for the Japanese Experiment Module. International Space Station Program, SSP 41165F (Advanced copy), NASA Johnson Space Center, Aug. 1, 1998.

Primm, Lowell E., Jr.: EXPRESS Pallet System Development Specification. International Space Station Program, SSP 52055, NASA Johnson Space Center, June 29, 1998.

4.4. Resource Timelines and Margin Summary

The proposed resources that are available on ISS and the associated margins are presented in tables and figures. This section summarizes the power capabilities, outlines the thermal capabilities over the assembly sequence, and presents the storage and rack volume allocations at AC. The on-orbit rack topology at AC, crew time, command and data handling, and communications resources and associated margins are also included. Information from the documents listed in the bibliography (section 4.4.7) was used to compile this section.

4.4.1. Power Utilization

The payload power in this section corresponds to the point in the beta range from -52° to 52° such that minimum power will be available to payloads. Table 4.4-1 (table 4.4-1 is at the end of this section on p. 4-43) summarizes the payload and payload support power available for each stage.

These numbers are preliminary and reflect orbital average power available from the main bus switching units (MBSU's). The channelization of this power available to the specific payload positions has not yet been performed and *may* result in slightly reduced margins. The margins shown (other than channelization aspects) for payload support and for payloads are available for U.S. and IP payloads under microgravity or standard habitable modes.

Post-AC analysis has not yet been performed, and as time goes on, the solar array performance will degrade. Even the values shown in this table may not be completely accurate because degradation due to on-orbit contamination over time has not been incorporated.

4.4.2. Thermal Utilization

Table 4.4-2 (table 4.4-2 is at the end of this section on p. 4-45) summarizes the payload and payload support margin capabilities of the ISS for each stage of the assembly sequence. Table 4.4-2 provides data both inside the beta range of -52° to $+52^\circ$ as specified in the ISS documentation and across the entire beta range for increased visibility to the payload community of the availability of active thermal heat rejection margins for the payload community. These margins are preliminary and reflect the analytically determined radiator performance estimates, rather than the specification-based minimum performance required. Stages 5A through 12A use the early external active thermal control system (EEATCS) radiators on the P6 element. Stages 12A through 1J/A use the external active thermal control system (EATCS) radiators on truss elements S1 and P1, but only one of three radiator ORU's per side has been activated for use during these stages. For stages 1J through AC, the full S1/P1 EATCS system of radiators is activated.

Post-AC analysis has not yet been performed, and as time goes on, the radiator performance will degrade. Even the values shown in table 4.4-2 may not be completely accurate because degradation due to on-orbit contamination over time has not been incorporated.

4.4.3. Volume Assessments

The ISS systems and USOS specifications include requirements for ISPR space and pressurized module storage volume for U.S.-provided items. The storage volume requirement is defined within the space needed for systems functions. Systems space is defined during the ISS program

design of rack layout and packaging of system rack equipment. ISPR space is determined by requirements developed by the user community.

4.4.3.1. Middeck Allocations During Assembly

Middeck stowage is unique as an ISS carrier resource in that it provides the best late and early ground access and immediate on-orbit access for operational needs. Power is also available to a number of middeck lockers. The number of middeck locker equivalents (MLE) allocated to ISS is determined by the Space Shuttle Program Office. A planning number for the total MLE's available to ISS for each flight before AC is shown in table 4.4-3. The MLE's listed in table 4.4-3 represent the total number of lockers available to ISS after core crew requirements and ISS flight requirements for crew size, days on-orbit, number of EVA's, EVA equipment, and crew rotation plans have been accounted for. The amount of middeck allocations available after AC is TBD.

4.4.3.2. ISS Pressurized Storage Volume

Storage volume is allocated to the pressurized modules for three functions at AC: flight crew support, logistics and maintenance, and user payloads activities. Storage volume is actively managed as an ISS resource. Storage volume is allocated in cubic feet.

Pressurized volume is required for stowage of thermally conditioned cargo and for stowage of other cargo in an ambient environment. Thermally conditioned cargo storage will be accommodated in a laboratory support equipment refrigerator/freezer contained in active racks that will be transported in the MPLM and used for storage of perishable samples, products, and materials on orbit. Ambient storage will be required for samples, products, and materials used for research and for prepositioned spares and ORU's required to maintain the user payloads. Thermally conditioned cargo storage in refrigerator/freezers on orbit will require active rack locations in pressurized modules. Ambient storage can be accommodated in the middeck, racks, and in soft storage containers.

The on-orbit ISS will accommodate no less than 2010.2 ft³ (56.92 m³) of user payloads in a pressurized volume as identified in table 4.4-4. Table 4.4-5 shows the volume allocations by numbers of rack spaces for each pressurized module for systems functions, storage, and user or payloads at AC. Table 4.4-6 (table 4.4-6 is at the end of this section on p. 4-46) shows the stowage volume allocations at AC. The proposed on-orbit rack topology, at AC, is displayed in figure 4.4-1.

4.4.4. Crew Time

This section provides the basic definitions used for crew time analysis during the multi-increment planning time frame.

4.4.4.1. Crew Duty Time

The available ISS crew duty time will be as follows:

- 8 hr per crew member available each duty day for scheduling crew activities
- 5 crew duty days each week

Table 4.4-3. ISS Middeck Volume Up/Down Allocation

Flight	Volume allocations, MLE, for—		
	Up	Down	Reserve
2A.2	53.3	53.3	3
3A	39.5	39.5	3
4A	43.2	43.2	3
5A	48.7	48.7	3
5A.1	48.8	48.8	3
6A	63.3	63.3	3
7A	53.3	53.3	3
7A.1	64.3	64.3	3
UF-1	74.3	64.3	3
8A	64.3	64.3	3
UF-2	74.3	74.3	3
9A	64.3	74.3	3
9A.1	74.3	64.3	3
11A	64.3	74.3	3
12A	74.3	64.3	3
12A.1	64.3	64.3	3
13A	74.3	74.3	3
10A	74.3	74.3	3
10.1	64.3	64.3	3
1JA	64.3	74.3	3
1J	74.3	64.3	3
UF-3	64.3	74.3	3
UF-4	74.3	64.3	3
2JA	74.3	74.3	3
14A	64.3	64.3	3
UF-5	64.3	64.3	3
20A	64.3	74.3	3
17A	74.3	64.3	3

Table 4.4-4. Internal User Payload Volume

Segment	Payload volume, ft ³	
	Powered	Passive
USOS	687.7	0
APM	529	0
JEM	529	0
ROS	0	0
Node 3	0	0
Rephased U.S. Hab	0	0
CRV	NA	NA
CAM	264.5	0
ISS total	2010.2	0

Table 4.4-5. ISS Pressurized Storage Volume Allocations for Racks

Rack utilization		U.S. Lab	U.S. Hab	Node 1	Node 2	Node 3	Airlock	CM	JEM	Zarya	CAM
Systems rack and integration	Boeing	10	3			^a 8 + 2 (RVE)	4				
	ASI				^b 8						
	KhSC										
	ESA							3			
	NASDA								16		
User integration		^c 13						10	12.5		^a 11.5
U.S. stowage integration ^d		1 (RVE)				3 (RVE)		^e 3	^e 2.5	^e 4.5	^a 4.5
Total		24	3	4	8	13	4	16	31	4.5	16

^aIntegration responsibility is TBD.

^b4 racks of DDCU's and 4 racks of crew quarters.

^cThirteen racks removed from Hab and placed in node 3 (8 rack positions, 5 RVE's in TBD).

^dAmbient rack stowage conversion: 1 rack = 36 ft³.

^eStowage volume for U.S.-provided items.

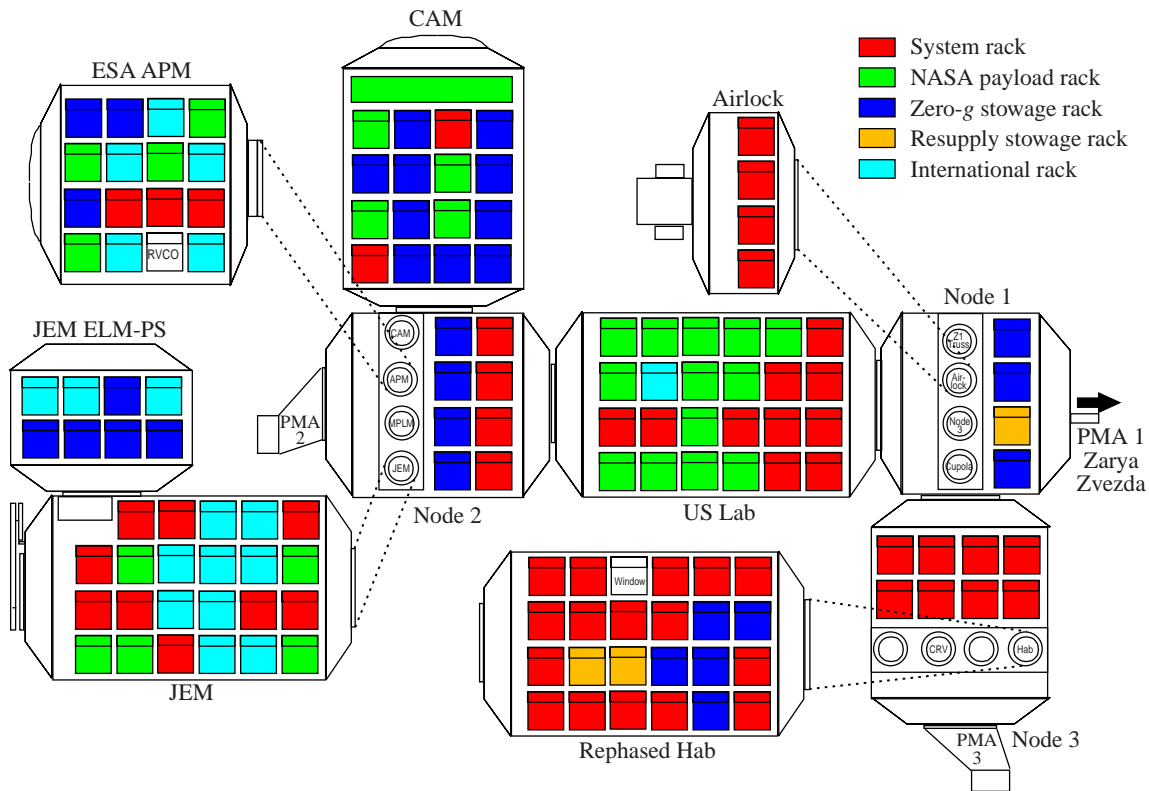

Figure 4.4-1. ISS rack on-orbit topology at assembly complete.

- 8 holidays provided for integrated crew per year regardless of nationality; these holidays provided to crew proportional to length of crew stay

Crew activities such as exercise, meals, sleep, personal time, and 30 min for ground coordination and planning will be performed outside the scheduled crew activities. ISS cleaning chores will be accomplished on nonduty days and, therefore, are not scheduled crew activities. Days on which an EVA is performed, crew activities may extend beyond the normal 8 hr per day available for scheduling crew activities. In this case, the crew will be compensated with time off during the week.

4.4.4.2. Operations

The independent operations period is defined as “the time when no orbiter is present and there is no overlap of rotating Soyuz TM vehicles.” Orbiter-based joint operations periods are defined as “the time that an orbiter is docked to the Station plus 1 day to include the rendezvous and docking day prior to actual docking.” Total crew time available during orbiter-based joint operations periods will be dependent upon flight specific objectives. Detailed mission planning and crew time availability will be performed beginning in tactical planning time frames considering requirements for both the Orbiter and Station. Soyuz TM based joint operations periods are defined as “the number of overlap days between the docking day of the arriving Soyuz TM spacecraft and the undocking day of the departing Soyuz TM spacecraft.” Soyuz-based joint operations periods are distinguished by the fact that additional crew members will be available to perform ISS activities. Nominal Soyuz flights rotate three crew members which increase the ISS crew size by three for the joint operations period that the arriving and departing crews will work together.

Nominally, utilization crew time is the time available to user payloads after ISS assembly, systems operations (not including payloads), and systems maintenance (not including payloads) tasks are completed. The exception is during joint operations periods when only the minimum requirements for payload survival and activation are considered utilization time. If crew time is required for payload survival or activation, these hours will be negotiated during the tactical time frame. Payload survival time is defined as “the minimum amount of time that operating Station payloads require to maintain current state and/or continue normal operations.” The nature of payload survival time is dependent upon individual payloads. Payload survival requirements are flight specific and are provided on a flight-by-flight basis during the tactical time frame. (See section 4.4.4.4.)

Transfer of payloads and associated utility connections are not considered utilization time. These requirements are considered flight specific operational objectives and the time to complete all transfers, including payloads, is recorded as systems time.

Orbiter-based joint operations periods have been identified as time-line critical due to the assembly, maintenance, transfer, and crew handover activities that must occur while the Orbiter is docked. When assembly is complete, assembly tasks will be replaced with ISS maintenance activities. To ensure that crew time is not overallocated during multi-increment planning, only a minimum of crew time can be committed for utilization during orbiter-based joint operations periods.

Payload activation time during orbiter based joint operations periods is also considered utilization time. Payload activation requirements are flight specific and are provided on a flight-by-flight basis during the tactical planning time frame.

The crew time available to utilization during Soyuz TM based joint operations period is calculated in nearly the same fashion as during the independent operations period. The only difference is that the crew time available is greater than during the independent operations period because of the number of additional crew members available.

4.4.4.3. Generic Crew Time Activity Data

The major categories of crew activities are assembly, operations, maintenance, and utilization. EVA's will be often required to support assembly and maintenance activities. Operations tasks include crew rotation, external vehicle docking, and undocking, ISS preparation for orbiter arrival, Soyuz TM and ISS module relocation, resupply vehicle unloading and loading, and routine operations.

To support the identification of the crew activities and crew time requirements, a series of operations scenarios were developed. These scenarios provide a convenient method of grouping a large number of crew operations activities and then distributing the amount of crew-hours that will be required to accomplish these activities.

Activities that occur only during joint operations periods are identified as such and are not included in crew time calculations for the independent operations period. Some tasks such as crew rotation contain activities that occur in both the joint operations period and independent operations period. For times such as this, the tasks that fall within either period are identified.

EMU-based and Orlan-M-based EVA's currently have different scenarios primarily because of the different operational procedures and hardware requirements for U.S. EMU's and the Russian Orlan-M suits. Nominal external EVA time (airlock egress to ingress) is 6 hr with a 1-hr allowance for extended external EVA time if required. During the assembly time frame, the U.S. segment estimate of 5 crew-hours per week is based on the general tasks identified at this time.

Post-AC, four crew members will be dedicated to the U.S. segment; three crew members, to the Russian segment. As more specific requirements are further understood during the early assembly sequence years, the time required for daily systems operations will be adjusted to reflect the latest systems requirements and ISS flight experience.

Daily systems operations include commonly repeated tasks not directly related to assembly, maintenance, logistics, joint vehicle, or utilization operations. They may include, but are not limited to, system tasks such as vehicle configuration, monitoring, or inspections that are performed routinely during ISS operations. Examples of additional tasks that are considered daily systems operation are audio system configuration, nonscheduled ground communication, periodic systems health checks, status report preparation, crew overhead associated with PCS, and daily trash collection.

4.4.4.4. Crew Time Required for Payload Survival

As stated in section 4.4.4.3, during orbiter-based joint operations periods a minimum amount of time will be available for payloads already on-orbit to perform minimal payload survival requirements. The requirements for payload survival are payload specific and will be specified

individually during the tactical planning time frame. The minimal payload survival crew time to use for multi-increment planning purposes is given in table 4.4-7.

Table 4.4-7. Payload Survival During Orbiter Joint Operations

Task	Crew-hours	Frequency
Minimal payload survival	4	Daily

4.4.5. Command and Data Handling

TBS

4.4.6. Communications

4.4.6.1. S-Band Utilization

The S-band will transport commands from the MCC—H and POIC to the ISS and will transport USOS system and critical payload telemetry from the ISS to MCC—H and POIC. Telemetry data can be real-time or recorded telemetry data. The S-band also will be used for two-way audio and file transfer between the ground and the ISS. The audio can be real-time or recorded. Selected Zarya and ROS system telemetry will also be transferred to the ground through the S-band. The S-band performance will vary by stage assembly sequence, with the early flights providing low data rates. (See table 4.4-8.)

The S-band will transmit and receive at a high data rate (HDR) of 192 kbps return link and 72 kbps forward link and a low data rate (LDR) of 12 kbps return and 6 kbps forward. There will be no audio transmission in LDR.

C&C forward link data will be subject to encryption at MCC—H. Currently, the C&C data link will be encrypted with the data encryption standard (DES) type, but eventually the plan will be to incorporate the triple-DES type encryption. The ISS S-band will receive and decrypt the data to verify and validate the commands sent.

Table 4.4-8. ISS S-Band Capability

[U.S. system only]

System/ORU functionality (U.S. capability only)	Assembly stage flight/location	Forward (F) and return (R) data rates, kbps
ECOMM	2A/node 1	Low: 6 (F) and 20.48 (R) High: 128 (F and R) for video
S-band string 1	3A and 4A/P6 (low) 5A/P6 (Full with audio)	Low: 6 (F) and 12 (R) Full: 72 (F) and 192 (R) with audio
S-band string 1	1JA/move to P1	Fully operational: 72 and 192 (R)
S-band string 2	9A/ S1	Fully operational: 72 and 192 (R)

4.4.6.2. Ku-Band Utilization

The ISS Ku-band will send 50 Mbps of serial data to the ground from up to 12 different channels. Subsystem “overhead” will be approximately 6.8 Mbps; therefore, about 43.2 Mbps of usable capacity will be available. Up to 4 of the 12 channels can contain video images (one image per channel); however, there will be a restriction because one video channel at full frame rate (high video quality) uses up almost the entire 43.2 Mbps. The video frame rate often must be decreased to allow the downlink of other data. Up to eight of the channels will be reserved for payload data. One of the payload data channels will be shared between transmitting recorded telemetry and payload data. Plans are to upgrade to 150 Mbps in the UF-5 timeframe.

4.4.6.3. Ku-Band Forward Link Capability

Enhancements being planned to the ISS Ku-band will provide a forward link capability to support video teleconferences and telescience. Currently, the Ku-band is employing an interim forward link receiver capable of supporting a 3-Mbps data rate, with routing to the OCA LAN computer (laptop) and a LAN. This capability is baselined for the flight 6A to UF-5 timeframe.

Plans are in work to provide a permanent Ku-band forward link capability after UF-5. This capability would coincide with an upgraded payload data network and could possibly handle forward link data rates between 3 and 9 Mbps. This upgrade would provide a permanent capability for telescience and science platforms where emerging technologies in data protocols (e.g., TCP/IP, asynchronous transmission mode (ATM), PCS) could be supported to bring ISS into the forefront of existing technologies on the ground. Additionally, the upgraded forward link may be implemented to provide a command path to the C&C MDM's, and ultimate connectivity to the payload MDM's. However, this command path would need to be protected by utilizing triple DES security data encryption, and the permanent receiver/demultiplexer would have to be upgraded or supplemented to handle triple DES decryption.

4.4.7. Bibliography

Amaral, James: System Specification for the International Space Station. SSP 41000N, Advance Copy, CAGE Identification No. 2B945, The Boeing Co., Sept. 15, 1999.

Anon.: Vehicle Integrated Performance and Resources (VIPeR)—Resource Margin Summary & Management Documents, International Space Station, July 20, 1999.

Crew Loading Report—Review Copy. International Space Station Program, SSP 50391, NASA Johnson Space Center, July 30, 1998.

Table 4.4-1 Payload Stage Power Status (Estimated)

[Stage power data are after successful assembly, activation, and checkout, return of orbiter, and reboost; payload activities can then begin in microgravity or standard habitable modes]

Assembly stage by flight	Power, W														
	Available			For ISSA housekeeping			Margin			PL support			Available for PL's (c)		
	Day (a)	Night (a)	Avg (b)	Day (a)	Night (a)	Avg (b)	Day	Night	Avg	Day	Night	Avg	Min cont	Avg	Keep alive
UF-1	21210	21217	25067	13729	13151	13330	7481	8066	11737	1272	6210	10465	0		
8A	20900	20800	24478	14384	13806	13986	6516	6994	10491	1108	5408	9384	0		
UF-2	20900	20781	24412	14384	13806	13986	6516	6975	10426	1108	5408	9318	0		
9A	20900	20735	24249	15041	14483	14651	5859	6253	9598	996	4863	8602	0		
9A.1	20900	20674	24032	15041	14483	14651	5859	6191	9381	996	4863	8385	0		
11A	20900	20720	24195	12520	11960	12096	8380	8760	12099	1425	6955	10675	0		
12A	19180	19180	19878	12107	12149	12195	7073	7031	7683	1195	5835	6488	TBD		
12A.1	35260	25370	32765	14757	13061	14066	20503	12309	18700	2092	10216	16607	TBD		
13A	50780	32700	45726	15958	15341	15675	34822	17359	30052	2951	14408	27100	TBD		
10A	50735	47050	52837	17746	17052	17295	32988	29998	35542	4500	25498	31042	TBD		
10A.1	50447	46992	52674	19111	18054	18528	31336	28938	34146	4500	24438	29646	TBD		
11/A	49987	46900	52413	19602	18545	19019	30384	28355	33394	4500	23855	28894	TBD		
1J	49296	46762	52021	23632	22575	23049	25664	24187	28972	4112	20075	24860	TBD		
UF-3	49008	46705	51858	23632	22575	23049	25376	24129	28809	4102	20027	24707	TBD		
UF-4	48376	46578	51498	23632	22575	23049	24743	24003	28450	4080	19922	24396	TBD		
2J/A	48088	46521	51335	24836	23779	24253	23252	22741	27082	3866	18875	24369	TBD		
14A	57840	55920	61572	24813	23823	24460	33027	32097	37112	4500	27597	32612	TBD		

Table 4.4-1. Concluded

Assembly stage by flight	Power, W												
	Available			For ISSA housekeeping			Margin			PL support	Available for PL's (c)		
	Day (a)	Night (a)	Avg (b)	Day (a)	Night (a)	Avg (b)	Day	Night	Avg		Min cont	Avg	Keep alive
UF-5	57840	55876	61446	24813	23823	24460	33027	32053	36986	4500	27553	32486	TBD
20A	57840	55692	60923	29134	26740	28334	28706	28951	32589	4500	24206	28089	TBD
17A	57840	55588	60629	29134	26741	28334	28706	28847	32295	4500	24206	27795	TBD
1E	57840	55645	60793	31312	28918	30512	26528	26727	30281	4500	22028	25781	TBD
18A	57840	55507	60401	31888	29495	31089	25952	26013	29312	4412	21540	24901	TBD
19A	57840	55460	60266	31780	29387	30980	26060	26073	29285	4430	21630	24855	TBD
15A	74900	72800	85191	33668	31114	32683	41232	41686	52509	4500	36732	48009	TBD
UF-6	74900	72800	84756	33668	31114	32683	41232	41686	52073	4500	36732	47573	TBD
UF-7	74900	72800	84930	34573	32020	33589	40327	40780	51342	4500	35827	46842	TBD
^d 16A	76430	76420	85846	38268	35714	37283	38162	40706	48563	4500	33662	44063	TBD
^e 16A (0,0,0)	76430	76420	85846	38268	35714	37283	38162	40706	48563	4500	33662	44063	TBD
Allocation										4500	26000	30000	6500
Margin.....										0	7662	14063	

^aDay and night power available and ISSA housekeeping correspond to point in beta range from -52° to 52° that minimum power is available to payloads.

^bAverage power available and for ISSA housekeeping are defined as average power within beta range from -52° to 52° using reference orbit parameters.

^cPayload minimum continuous and average power are within range from -52° to 52° and applicable at payload locations. Payload keep-alive power is applicable at all beta angles.

^dFirst line for 16A reflects TEA and is used to derive power available to payloads at 16A consistently with other stages; 16A (0,0,0) reflects LVLH (0,0,0) to derive power available to payloads under allocation conditions.

^eData for 16A (0,0,0) reflects TEA data because LVLH (0,0,0) power generation was not updated for DAC 8; margin differences between the two are historically minimal.

Table 4.4-2. Thermal Resource Margin Summary
[99 DAC 8]

Stage	Projected user capability for—									
	Entire range of β					$-52^\circ \leq \beta \leq +52^\circ$				
	Radiator (estimated)	ISS housekeeping with reserve	PL's and PL support	PL support allowance	Heat rejection available to PL's	Radiator (estimated)	ISS housekeeping with reserve	PL's and PL support	PL support allowance	Heat rejection available to PL's
5A	16000	4636	11364	2310	9054	16000	4636	11364	2310	9054
5A1	16000	5684	10316	2097	8219	16000	5684	10316	2097	8219
6A	16000	5807	10193	2072	8120	16000	5807	10193	2072	8120
7A	15643	6592	9051	1840	7211	15643	6592	9051	1840	7211
7A1	15286	6592	8694	1768	6927	15286	6592	8694	1768	6927
8A	15000	7304	7696	1565	6132	14929	7011	7917	1610	6308
UF2	13500	7304	6169	1260	4937	14571	7011	7560	1537	6023
9A	12000	7346	4654	946	3708	14214	7199	7016	1426	5589
9A1	10500	7346	3154	641	2513	13857	7199	6659	1354	5305
11A	9000	7402	1598	325	1273	13500	7597	5903	1200	4703
12A	9000	7435	1565	318	1247	13500	7630	5870	1193	4677
12A1	29300	11245	18055	3671	14384	29300	11245	18055	3671	14384
13A	29300	11283	18017	3663	14354	29300	11283	18017	3663	14354
10A	29300	14319	14981	3046	11935	29300	14319	14981	3046	11935
10A1	29300	14529	14771	3003	11768	29300	14529	14771	3003	11768
11A	29300	15162	14138	2874	11264	29300	15162	14138	2874	11264
11J	87900	19638	68262	8966	59296	87900	19638	68262	8966	59296
UF4	87900	19638	68262	8966	59296	87900	19638	68262	8966	59296
2JA	87900	19650	68250	8965	59285	87900	19650	68250	8965	59285
14A	87900	19817	68083	8954	59129	87900	19817	68083	8954	59129
20A	87900	24627	63273	8639	54634	87900	24627	63273	8639	54634
17A	87900	24877	63023	8623	54400	87900	24877	63023	8623	54400
1E	87900	27117	60783	8476	52307	87900	27117	60783	8476	52307
18A	87900	27722	60178	8437	51741	87900	27722	60178	8437	51741
19A	87900	28312	59588	8398	51190	87900	28312	59588	8398	51190
15A	87900	29086	58814	8348	50466	87900	29086	58814	8348	50466
UF7	87900	30362	57538	8264	49274	87900	30362	57538	8264	49274
16A	87900	34895	53005	7968	45037	87900	34895	53005	7968	45037

Table 4.4-6. ISS Pressurized Storage Volume Allocations at AC

(a) Design capability

	Design capacity, ft ³ , for—										
	Node 1	Node 2	Node 3	U.S. Lab	CAM	Rephased Hab	APM	JEM	Zarya	CRV	Total
Physical	146	146	109.5	36.5	330.5	255.5	109.5	91.25	237	TBD	1462

(b) Allocated capacity by specifications

Storage type	Allocated capacity, ft ³ , for—										
	Node 1	Node 2	Node 3	U.S. Lab	CAM	Rephased Hab	APM	JEM	Zarya	CRV	Total
Flight crew	78			36	72	72	18	36	78	TBD	390
Missed resupply	30								30		60
Crew health					20	38					58
Food storage						140					140
System spares	36						90	54			180
Payload					234				54		288
Additional storage		144	108		70	2					324
Total	144	144	108	36	396	252	108	90	162	TBD	1440

4.5. ISS Cargo Traffic

4.5.1. Introduction

Once the ISS assembly is complete around 2005, the assembly flights that had been fairly constant for the previous 5 yr will no longer be necessary. However, regular traffic to the ISS will still be required for crew rotation and cargo resupply and return. Several different types of vehicles have been chosen or developed for these tasks. This section provides descriptions of the different levels and types of cargo carriers, of the transportation vehicles and their characteristics, and the allowable mass and volume for resupply and return cargo. This section also presents the typical yearly traffic model and the current traffic plans for 9 yr following ISS AC. Information from the documents listed in the bibliography (section 4.5.7) was used to compile this section.

4.5.2. Hardware Descriptions for Bags, Trays, and Lockers

4.5.2.1. Cargo Transfer Bags

Cargo transfer bags (CTB's) are Du Pont Nomex fiber bags that contain removable, reconfigurable dividers. CTB's will be capable of providing stowage for cargo items on orbit in the ISS as well as in any of the following transportation vehicles: the Space Shuttle middeck, SPACEHAB module, MPLM, ATV, HTV, Progress, and Soyuz. (See section 4.5.4.) The CTB's are available in half, single, double, and triple sizes. Each configuration has a zipper closure and a removable mesh netting restraint system located inside the CTB. The sizes of each configuration are summarized in table 4.5-1.

Table 4.5-1. Cargo Transfer Bag
[H is height; W is width; L is length]

CTB	Approximate size		Maximum load, kg (lb)	Internal volume, m ³ (ft ³)
	External dimensions, H × W × L, in.	Internal dimensions, H × W × L, in.		
Half (1/2×)	9.250 × 16.750 × 9.750	8.625 × 16.125 × 9.125	13.62 (30)	0.024 (0.86)
Single (1×), with or without windows	9.750 × 16.750 × 19.750	9.125 × 16.125 × 19.125	27.24 (60)	0.050 (1.80)
Double (2×)	19.750 × 16.750 × 19.750	18.125 × 16.125 × 19.125	54.48 (120)	0.096 (3.39)
Triple (3×)	19.750 × 16.750 × 29.500	18.125 × 16.125 × 29.875	81.72 (180)	0.158 (5.59)

4.5.2.2. Stowage Trays

Stowage trays will be used for transportation and on-orbit stowage of pressurized cargo for the ISS. Stowage trays are designed to be modular and interchangeable to support a variety of cargo types. The two configurations of the stowage trays are shown in figure 4.5-1. Large stowage trays have a volume of 1.8 ft³ and weigh approximately 3.45 lb. The inside dimensions of the large stowage trays are 16.95 in. wide by 20.00 in. deep by 9.52 in. high. Small stowage trays have a volume of 0.85 ft³ and weigh approximately 2.45 lb. The inside dimensions of the small stowage trays are 16.95 in. wide by 20.00 in. deep by 4.57 in. high. The stowage trays are contained in

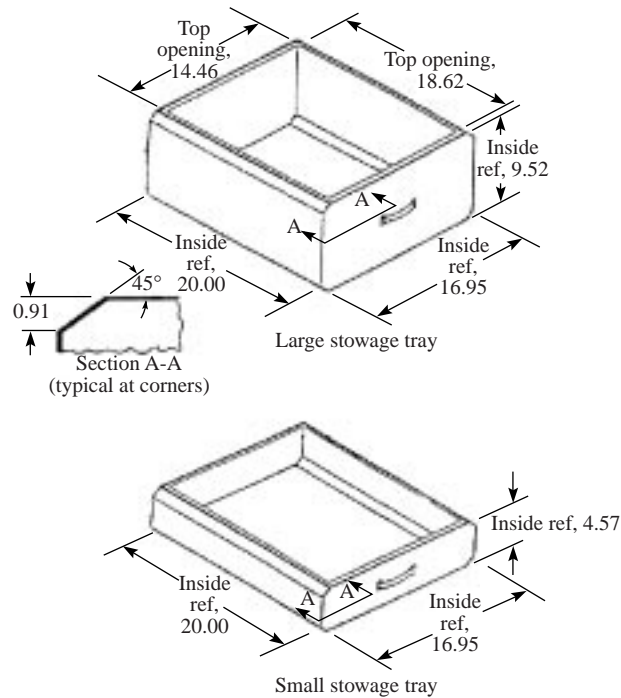

Figure 4.5-1. Small and large stowage trays. Dimensions are in inches.

compartment assemblies which will be installed in an RSR or system rack (section 4.5.3.1). Contents of the trays may be removed and stowed in the appropriate modules if the RSR is used only in the transportation phase. Restraints used to stow the cargo in the trays depend on the cargo item and unique requirements. Table 4.5-2 shows the current tray configuration for each of the RSR's.

Table 4.5-2. Resupply Stowage Rack Tray Configuration

[H is height; W is width; D is depth]

Size	Quantity	Volume, in ³	Dimensions, H × W × D, in.	Weight, cargo kg (lb)
S-10	2	0.98	5.2 × 16.5 × 8.75	6.76 (14.9)
S-17	3	2.52	5.2 × 16.5 × 15.7	13.80 (30.4)
S-30	1	1.50	5.2 × 16.5 × 28.7	11.62 (25.6)
S-34	1	1.70	5.2 × 16.5 × 32.7	23.70 (52.2)
D-10	2	2.00	10.5 × 16.5 × 8.75	35.73 (78.7)
D-17	1	1.72	10.5 × 16.5 × 15.7	20.66 (45.5)
D-30	2	6.11	10.5 × 16.5 × 28.7	42.09 (92.7)
D-34	1	3.46	10.5 × 16.5 × 32.7	63.51 (139.9)
T-17	1	2.60	15.7 × 16.5 × 15.7	23.47 (51.7)
T-30	1	4.64	15.7 × 16.5 × 28.7	47.76 (105.2)
T-34	2	10.52	15.7 × 16.5 × 32.7	72.05 (158.7)
Total	17	37.74		361.15 (795.5)

4.5.2.3. Cargo Bags

Soft good cargo bags will be specially developed to transport a wide variety of hard and soft internal cargo items to and from the ISS in the MPLM. The bags will be sized to accommodate standard ISS trays, loose hardware, and CTB's and will be two sizes. The characteristics of each size are given in table 4.5-3.

Table 4.5-3. Cargo Bag Characteristics

[W is width; D is depth; H is height]

Bag type	Maximum load, kg (lb)	Internal volume, m ³ (ft ³)	Approximate internal dimensions, W × D × H, in.	CTB equivalents
M01	136.2 (300)	0.368 (13)	34.25 × 20.5 × 31.78	6
M02	90.8 (200)	0.227 (8)	34.25 × 20.5 × 19.5	4

4.5.2.4. Progress Spacecraft Containers

Progress spacecraft containers are designed for stowing items weighing less than 10 kg (22 lb) for launch. Crew members will remove items from containers on orbit and place items into CTB's, other bags, or directly into the ISS.

4.5.2.5. Middeck Locker Stowage

Standard modular stowage locker accommodations will consist of stowing the payload hardware in vibration isolating foam inside a standard middeck stowage tray, which will be installed inside a standard modular stowage locker.

A standard modular stowage locker will provide approximately 2 ft³ of stowage volume (fig. 4.5-2) and will accommodate one single or two half CTB's. A modular locker will have a maximum design density of 30 lb/ft³ and a minimum of 10 lb/ft³. Baseline lockers will be designed such that the locker will be fully packed and there must be isolator material between the

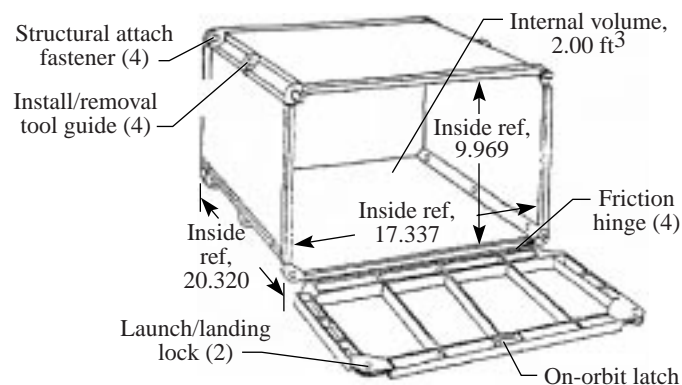

Figure 4.5-2. Standard middeck modular locker. Dimensions are in inches.

locker walls and the contents. The locker door will be flush with the bottom of the locker when opened 90° and can open 180° (straight down). The door will have friction hinges for zero-g operation and a magnetic latch for temporary closure of the door. The standard modular stowage locker will have provisions for either one large stowage tray or two small stowage trays.

4.5.3. Hardware Descriptions for Racks and Platforms

4.5.3.1. Resupply Stowage Rack

The RSR is a rack system for stowage of ISS pressurized loose cargo in the MPLM. The RSR will consist of various size locker assemblies. These locker assemblies, which will accommodate individual stowage trays, will be bolted into the rack structure. These individual lockers will have structural doors with latches. An RSR can accommodate 1.062 m³ (37.5 ft³) of stowage. Predicted cargo mass capacity is 297.8 kg (656 lb) based on a cargo density of 25 lb/ft³. Figure 4.5-3 shows the RSR with a typical stowage tray installation, and figure 4.5-4 depicts the typical RSR with typical compartment assembly installation.

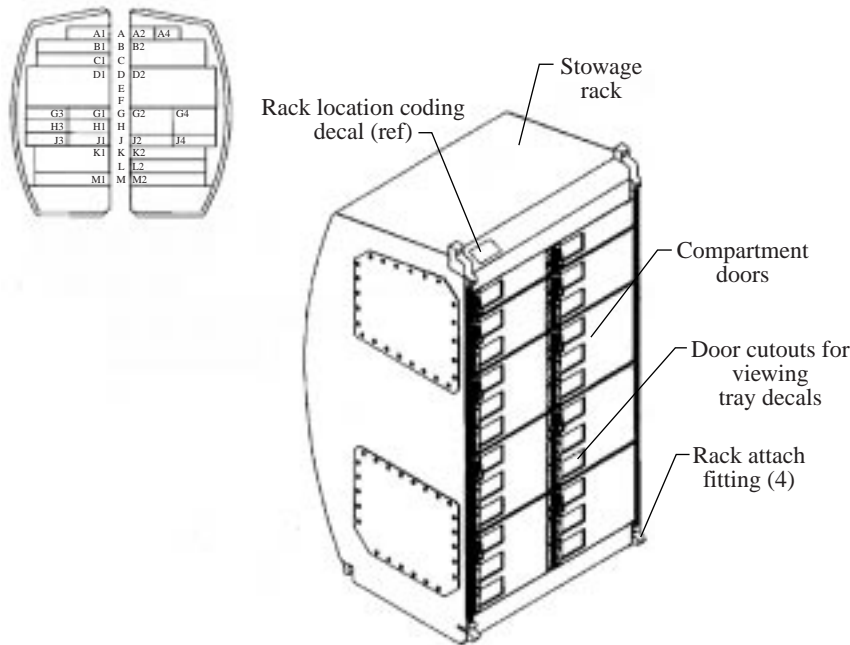

Figure 4.5-3. Resupply stowage rack with typical tray installation.

4.5.3.2. Resupply Stowage Platform

The resupply stowage platform (RSP) is a resupply and stowage carrier system for transporting ambient pressurized cargo to and from the ISS in the MPLM. The RSP is developed to transport a wide range of soft back CTB's, cargo bags, and mounted ORU's to and from orbit via the MPLM. The maximum cargo weight is 227 kg (500 lb) which includes the attachment hardware and bags. The maximum structure weight is 80.8 kg (178 lb). Figure 4.5-5 depicts the typical RSP carrier.

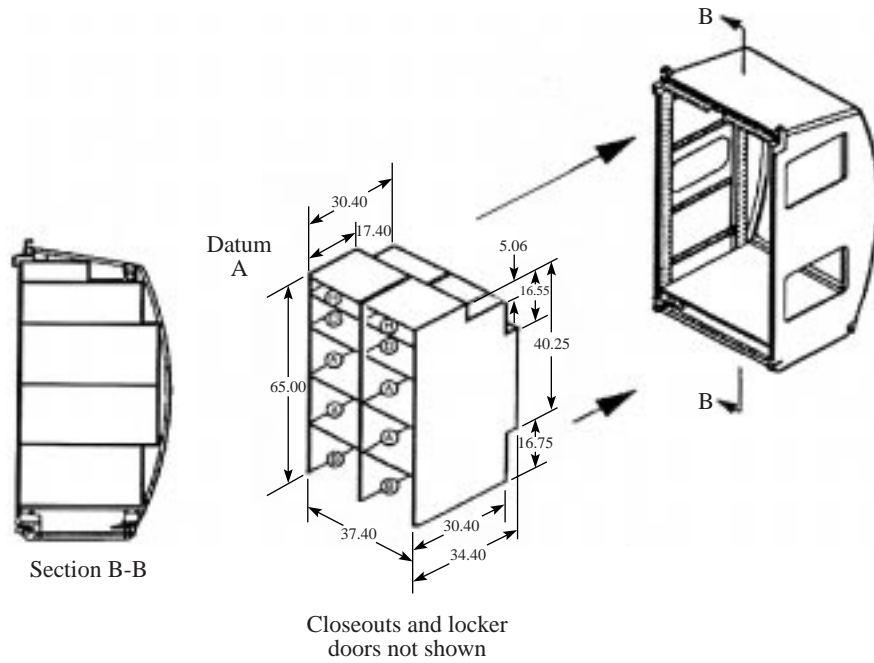

Figure 4.5-4. Resupply stowage rack with compartment assembly installation. Dimensions are in inches.

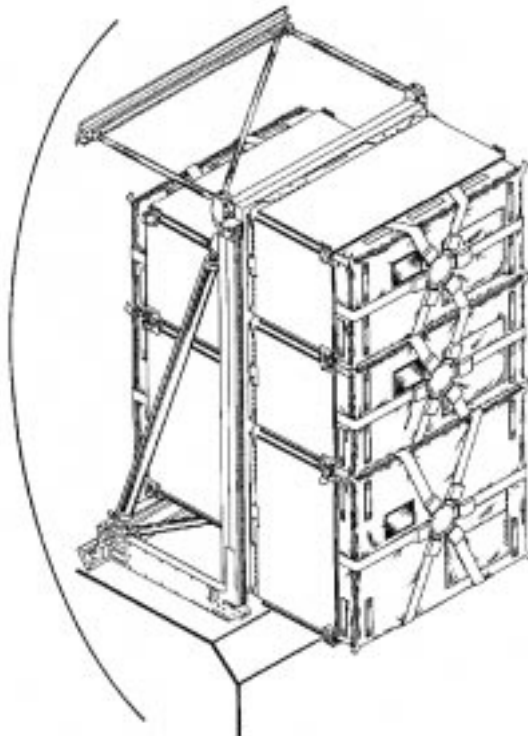

Figure 4.5-5. Resupply stowage platform 1.

4.5.3.3. Zero-g Stowage Rack

The zero-g stowage rack (ZSR) is a lightweight, on-orbit stowage restraint system. Although the zero-g stowage rack is not designed to transport cargo during launch and landing phases, it can support its own mass during launch and landing when installed into an ISS module. The ZSR is composed of two elements: a collapsible shell and fabric insert.

4.5.3.3.1. Shell

The collapsible shell will accommodate 1.21 m³ (42.8 ft³) of stowage with no mass constraints and weighs approximately 11.35 kg (25 lb). The shell envelope obtains its ISS rack shape by the deployment of two integral petallike panels. A 72- by 36.2-in., 2.54-kg (5.6-lb) shield is available to provide additional protection for items that might be adjacent to the ZSR envelope. The shield is made of Voltek Minicel L200FR foam material and is 0.5 in. thick.

4.5.3.3.2. Insert

Four types of RVE inserts are available for the shell. One RVE is equal to 1.02 m³ (36 ft³). These inserts can be configured to carry various sizes of containers, such as CTB's, M01 and M02 bags, trays, or other stowed items with or without containers (such as trash bags or large ORU's). An insert contaminant kit (ICK) can be used with the inserts to contain trash. The inserts weigh approximately 4.54 kg (10 lb) each. The characteristics of each type of insert are summarized in table 4.5-4.

Table 4.5-4. Zero-g Stowage Rack Inserts
[W is width; D is depth; H is height]

Description	Capacity	Divisions	Cargo accommodation
Type A	1 RVE	Four 0.125 RVE Two 0.25 RVE	10 single CTB's and 10 half CTB's (accommodates any size tray except 34-in. trays)
Type B ("broom closet")	1 RVE	One RVE with divider down center	12 single CTB's and 12 half CTB's (accommodates any size tray except 34-in. trays)
Type C (1/2 type B)	0.5 RVE	Six 0.083 RVE	6 single CTB's and 6 half CTB's (accommodates any size tray except 34-in. trays)
Type D	0.5 RVE	One 0.5 RVE	Large cargo items such as ORU's
Trash liner (ICK)	0.25 RVE		Collapsed food containers (14.9 (W) × 12.0 (D) × 1.0 (H) in.) Russian large and small trash bags Solid waste containers (12.9 (D) × 17.8 (H) in.) EDV's (12.9 (D) × 19.0 (H) in.) Used clothing

4.5.4. Transportation Systems

A transportation system is composed of a launch vehicle, a transfer vehicle, and one or more cargo carriers. The transportation systems currently expected to support ISS are given in table 4.5-5. Six primary types of cargo transportation vehicles will transport cargo to and from the ISS. These include the Space Shuttle Transportation System, Soyuz TM, Progress M and M1, ATV, HTV, and CRV. Table 4.5-6 gives each carrier and its capabilities for transport. The Space Shuttle and the Soyuz TM will provide transportation for crew rotations. The CRV will be transported to the ISS in the cargo bay of the Space Shuttle and will provide return capabilities for up to seven crew members or cargo. All resupply cargo delivered to the ISS will be classified as either recoverable or nonrecoverable and will be removed from the ISS. Recoverable cargo is removed from the ISS and returned to be refurbished for future use, evaluated (e.g., samples), or examined as part of sustaining engineering. Nonrecoverable cargo is designated to be destroyed when it is returned to Earth (e.g., Shuttle/ISS trash, destructive reentry).

Table 4.5-5. ISS Transportation Systems

[P is pressurized; U is unpressurized]







Transportation system	Launch vehicle	Transfer vehicle	Cargo carrier
STS–assembly flights	STS	Space Shuttle	Designated assembly carrier
STS–pressurized flights	STS	Space Shuttle	MPLM
STS–unpressurized	STS	Space Shuttle	2 ULC’s, SLP’s, Exp
STS–utilization	STS	Space Shuttle	MPLM, Exp ULC
Soyuz TM	Soyuz launcher	Soyuz TM	Soyuz TM
Progress M	Soyuz launcher	^a Progress	Progress M
Progress M1	Modified Soyuz launcher	^a Progress	Progress M1
ROS assembly Heavy lift (>19 MT)	Proton	Zarya, UDM, Zvezda	Zarya, UDM, Zvezda
Medium lift (≈7 MT)	Soyuz	Progress	DC, RM 1–2
ESA transportation vehicle	Ariane 5	ATV	ATV
Japanese transportation vehicle	HTV	HTV	HTV (12 racks P or 8 racks P and 3 PL’s or ORU’s U)
STS CRV	STS	Space Shuttle	TBD

^aProgress instrumentation compartment.

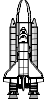
4.5.4.1. Space Shuttle

The Space Shuttle Transportation System will transport cargo and crew to and from the ISS. The Shuttle will carry up to seven U.S. or partner crew members per mission, three of which will be rotated into and out of the ISS on each Shuttle pressurized logistics flight. The Shuttle will also carry pressurized and unpressurized cargo to and from the ISS; several types of carriers can be fitted into the Space Shuttle to carry this cargo. Cargo can also be transported to the ISS in the mid-deck area of the Shuttle. The following descriptions outline the capacities and specification of each cargo carrier.

Table 4.5-6. ISS Transportation Vehicles

Vehicle	Payload (407 km; 51.6°), kg	Cargo type	Available date
Shuttle 	16 100	Crew rotation Pressurized Unpressurized Water, gas	Available
Soyuz TM 	480	Crew rotation Pressurized	Available
Progress M and M1 	2 350 (M) 2 230 (M1)	Pressurized Unpressurized Propellant Gas, water	Available
ATV 	7 500	Pressurized Propellant	2003
HTV 	6 000	Pressurized Unpressurized	2002
CRV 	TBD	Crew return	2006

4.5.4.1.1. Pressurized Space Shuttle Cargo Carriers

The pressurized cargo carriers are described in this section.

4.5.4.1.1.1. Multipurpose logistics module. The unpiloted, reusable logistics modules function as both a cargo carrier and an ISS module when they are flown. Mounted in the cargo bay of the Space Shuttle for launch and landing, these logistics modules will be berthed to the ISS using the Shuttle’s robotic arm after the Shuttle has docked. While berthed to the ISS, racks of equipment are unloaded from the module and then old racks and equipment may be reloaded to be brought back to Earth. The logistics module is then detached from the ISS and positioned back into the Shuttle’s cargo bay for the trip home. When in the cargo bay, the cargo module is independent of the Shuttle cabin, and no passageway exists for Shuttle crew members to travel from the Shuttle cabin to the module.

The MPLM cargo can be categorized as either “active” or “passive,” dependent on stowage items manifested. Active cargo requires the MPLM to be configured with refrigerator/freezer (R/F) racks as well as active power, thermal, and data support systems, whereas passive cargo does not require thermal conditioning from R/F racks.

The MPLM is designed to accommodate and transport a maximum combined total of 16 system racks, RSR’s, RSP’s, and ISPR’s. (See table 4.5-7.) Each rack location is designed to support a combined rack and cargo weight of 804 kg (1773 lb). The maximum cargo carrying capability of the MPLM for upmass and downmass is 9072 kg (20 000 lb).

Table 4.5-7. Cargo Types for MPLM Flight System

Cargo type	Cargo accommodation system	Payload	Comments
RSR	Trays	Consumables, hygiene equipment, experimental samples	Passive
RSP 1-SS/RSP 2	M01, M02, CTB, trays, hardmount	Crew rotation hardware	Passive
ISPR			Active (passive in MPLM)
R/F rack		Food and supplies	Active
MELFI rack	Dewars	Science samples	Active
System rack	Trays	Scientific equipment	Active (passive in MPLM)
ISPR	Trays		Active (passive in MPLM)
EXPRESS rack	Drawers, lockers	Experiments and small payloads	Active (passive in MPLM)

4.5.4.1.1.2. SPACEHAB. The SPACEHAB logistics double module (LDM) is a pressurized payload transportation system with a shirtsleeve environment that can transport approximately 4086 kg (9000 lb) of cargo (includes payload hardware and restraints) to the ISS. The LDM is designed to accommodate all types of cargo, both passive and active. Externally mounted payloads can also be accommodated on the flat roof of the LDM.

The LDM can be configured in many different setups using a variety of payload containers including double and single racks, single and double MLE plates and lockers, McDonnell Douglas Soft Stowage racks, McDonnell Douglas Soft Stowage bags (0.5 MLE, 1 MLE (front or top opening), 2 MLE, or 3 MLE), floor stowage plates, and rooftop plates. Figure 4.5-6 shows a typical configuration for the LDM.

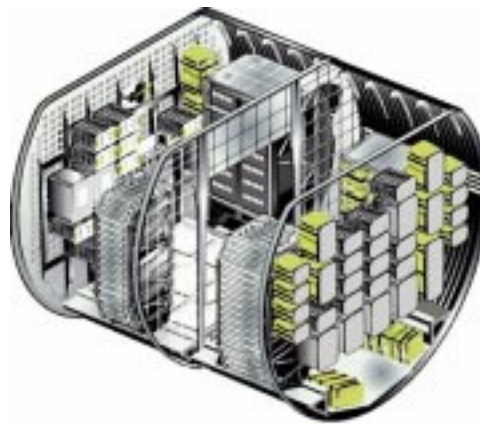

Figure 4.5-6. Typical configuration for LDM.

4.5.4.1.1.3. Middeck. The middeck portion of the orbiter is a payload transportation system that will provide the capability of transporting cargo to the ISS.

Middeck payload mounting provisions consist of locker accommodations or mounting panels provided by the Space Shuttle Program (SSP). Payloads heavier or of a larger size than those that can be accommodated by a standard stowage locker can be mounted via single adapter plates, double adapter plates, payload mounting panels, and vented payload mounting panels, which are discussed as follows:

Single adapter plates: Payloads may be attached directly to a single adapter plate by using a universal hole pattern for attachment. Payloads shall not protrude more than 20.312 in. along the X_{cm} -axis from the face of the adapter plate. A single adapter plate weighs 6.2 lb and is 0.750 in. thick.

Double adapter plates: Payloads heavier or larger than those that can be accommodated inside a standard stowage locker or attached to a single adapter plate or a payload mounting panel will be attached to a double adapter plate. If the double adapter plate is mounted to two single adapter plates or to two payload mounting panels, the payload will not protrude more than 10.437 or 19.687 in., respectively, along the X_{cm} -axis from the face of the double plate.

Payload mounting panels: Payloads may be attached directly to a payload mounting panel or directly to two payload mounting panels; thus, the need for a double adapter plate is eliminated. Payloads will not protrude more than 20.562 in. along the X_{cm} -axis from the face of the mounting panel. A single payload mounting panel weighs 3.5 lb with a thickness of 0.5 in.

Vented payload mounting panels: Ducted-air-cooled payloads will be mounted directly to vented payload mounting panels to accommodate orbiter-ducted air-cooling interfaces. Payloads will not protrude more than 21.062 in. (this includes the payload and vented payload mounting panel) along the X_{cm} -axis from the face of the wire tray.

Standard modular stowage locker accommodations consist of stowing the payload hardware in vibration isolating foam inside a standard middeck stowage tray, which is installed inside a standard modular stowage locker (as described in section 4.5.2.5). A standard middeck payload is defined as not exceeding 54 lb when stowed in a standard middeck modular locker. The maximum payload weight includes only the payload and not the weight of the locker shell, locker trays, or protective provisions, such as dividers, bungees, or vibration isolating foam.

4.5.4.1.2. Unpressurized Space Shuttle Cargo Carriers

The unpressurized cargo carriers are presented in this section.

4.5.4.1.2.1. Spacelab pallet. The spacelab pallet is a support structure designed for transport and stowage of external unpressurized cargo. The pallet cross section is U-shaped and provides hard points for mounting heavy experiments and a large panel surface area to accommodate light payload elements. A nonoutfitted Spacelab pallet is depicted in figure 4.5-7. Pallet segments are approximately 3 m in length and 4 m in width and can be flown independently or connected. As many as three pallets can be connected to form one pallet train supported by one set of attachment fittings. The Spacelab pallets are not designed to be removed from the Shuttle on orbit.

During ISS assembly, the pallets are manifested on numerous flights; currently, no power is assumed to be required for cargo on the pallets during the postassembly period. The Spacelab



Figure 4.5-7. Single nonoutfitted spacelab pallet.

pallets are comanifested with the MPLM on selected flights. There are 12 Spacelab pallets in three different configurations existing in the fleet. Table 4.5-8 describes the capabilities of the mini spacelab pallet, which is a half-pallet configuration, the single pallet as shown in figure 4.5-7, and the double spacelab pallet, which is a two-single pallet configuration.

Table 4.5-8. Spacelab Pallet Specifications

Characteristic	Mini pallet	Single pallet	Double pallet
Tare weight, kg	414	635	1270
Carrying capability, kg	3175	4128	5874

4.5.4.1.2.2. SPACEHAB integrated cargo carrier. The SPACEHAB integrated cargo carrier (ICC) is an unpressurized flatbed pallet and keel yoke assembly housed in the payload bay. It is 8 ft long, 15 ft wide, and 10 in. thick and has the capability to carry cargo on both faces of the pallet, on top and below. The ICC provides sufficient surface area in the cargo bay to carry approximately 3000 lb of cargo which would otherwise have to be carried in the cabin of the Shuttle. Figure 4.5-8 shows the ICC.

4.5.4.2. Automated Transfer Vehicle

The ESA ATV (fig. 4.5-9) is an unmanned servicing and logistics vehicle for the periodical resupply of the Russian segment of the ISS. It is a destructive reentry vehicle with no recoverable cargo capabilities. The cargo carrying capabilities for the ESA cargo vehicle are given in table 4.5-9 as per ESA. The ATV has a modular architecture that is made up of the ATV itself and an ICC which is different from the SPACEHAB ICC. The ATV ICC is equipped with a pressurized module for dry cargoes and an external bay for water and gas tanks, and it interfaces with the ISS. The ATV has a payload capability of 6.5 to 7.5 t and a download capability of 6.5 t. In the



Figure 4.5-8. SPACEHAB integrated cargo carrier.



Figure 4.5-9. Automated transfer vehicle.

Table 4.5-9. ATV Resupply and Return Capacities

Characteristic	Capacity
Maximum dry cargo upmass, kg	5500
Maximum usable pressurized volume, m ³	16.6
Packaging efficiency, kg/m ³	250–300
Maximum dry cargo return downmass, kg.	5500
Maximum return pressurized volume, m ³	20.6

same mission it carries both dry and liquid cargoes. Dry cargo of up to 5500 kg is located in the pressurized environment of the secondary structure of the ICC. The ICC accommodates all cargo except for the reboost propellant, which is carried in the ATV.

4.5.4.3. H-II Transfer Vehicle

The NASDA HTV (fig. 4.5-10) is an unmanned servicing and logistics vehicle designed to transport various cargo to and from the ISS. The HTV is a destructive reentry vehicle with no recoverable downmass capabilities. The cargo-carrying capabilities for the NASDA cargo vehicle are given in table 4.5-10. The HTV will fly either a 100-percent pressurized cargo or a mixture of pressurized and unpressurized cargo in the respective carrier. Figure 4.5-11 shows the mixed carrier, which can carry up to eight ISPR's in the pressurized section and up to three exposed facility payloads (EFPL's) for the JEM exposed pallet in the unpressurized section. The pressurized section has air-conditioning tubes and lights to realize the same environment for crew activities as other pressurized modules of the ISS. The HTV mission will not include any type of ISS orbit correction capability (propulsive attitude control or reboost).

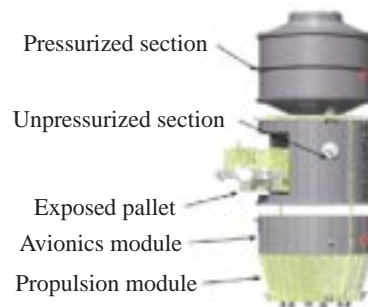

Figure 4.5-10. HTV components.

Table 4.5-10. HTV Payload Characteristics

Characteristic	Capacity	
	Pressurized	Mixed
Maximum pressurized cargo, kg	7000	6000
Maximum unpressurized cargo, kg	0	1500
Maximum usable pressurized volume:		
Internal, m ³	28	
Pressurized, m ³		20
Unpressurized, m ³		15
Packaging efficiency, kg/m ³	300	TBD
Maximum pressurized cargo downmass, kg	7000	6000
Maximum unpressurized cargo downmass, kg	0	1500
Maximum down volume:		
Internal, m ³	36	
Pressurized, m ³		24
Unpressurized, m ³		15

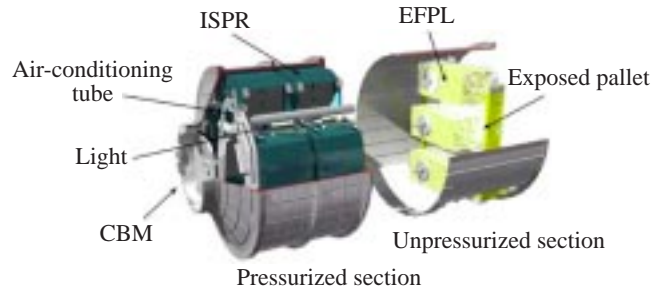

Figure 4.5-11. HTV logistics carrier.

4.5.4.4. Soyuz TM

The main function of the Soyuz TM (fig. 4.5-12) is crew transfer rather than cargo delivery. In addition, the Soyuz TM will be the crew return vehicle prior to the delivery of the CRV on flight 18A. During the assembly period, all ISS crew members, regardless of which delivery and return vehicle they are scheduled for, will be required to have a Soyuz seat liner and an RSA launch-entry suit with them. Even though the Soyuz is primarily a crew transfer vehicle it does provide a limited resupply capability. The Soyuz payload specifications are given in table 4.5-11. This assessment assumes availability of the Soyuz payload delivery or return capability for crew only.

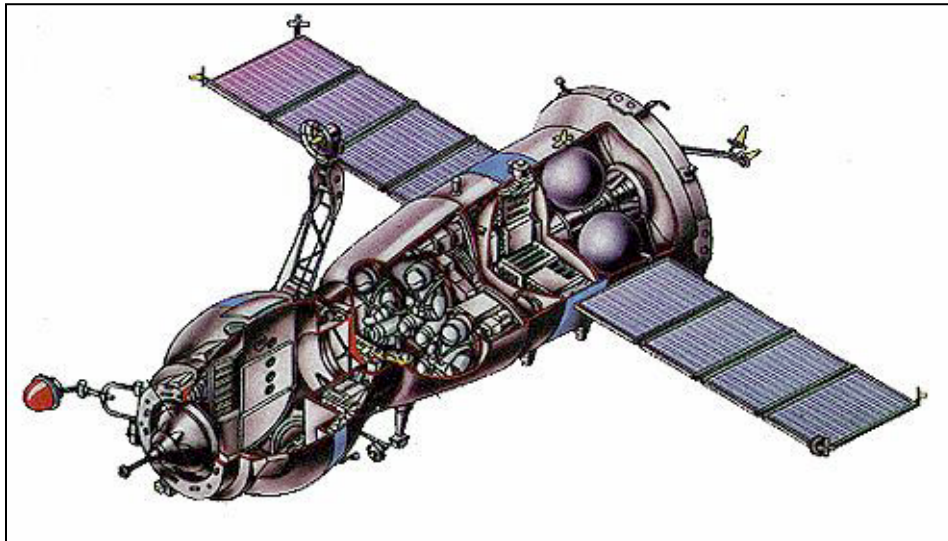

Figure 4.5-12. Soyuz TM.

Table 4.5-11. Soyuz TM Performance Specifications

Initial mass at 220 km, kg	7070
Maximum payload for—	
Three cosmonauts, kg	283
Delivered payload, kg	20–100
Returned payload, kg	20–60
Total pressurized volume, m ³	10.3
Passenger volume, m ³	6.5
Δ propellant/ Δ altitude (orbit transfer), kg/km	1.37
On-orbit lifetime for—	
Planning, days	180
Design, days	200
Seat liner (each), kg	~26–28
Personal gear (each), kg	23
Soyuz pressurized survival suit (each), kg	8–10

4.5.4.5. Progress M and M1 Vehicles

The Progress cargo vehicles (fig. 4.5-13) are unmanned servicing and logistics vehicles for the periodical resupply of the Russian segment of the ISS. They are destructive reentry vehicles with limited downmass capabilities. The cargo-carrying capabilities for Progress cargo vehicles are given in table 4.5-12.

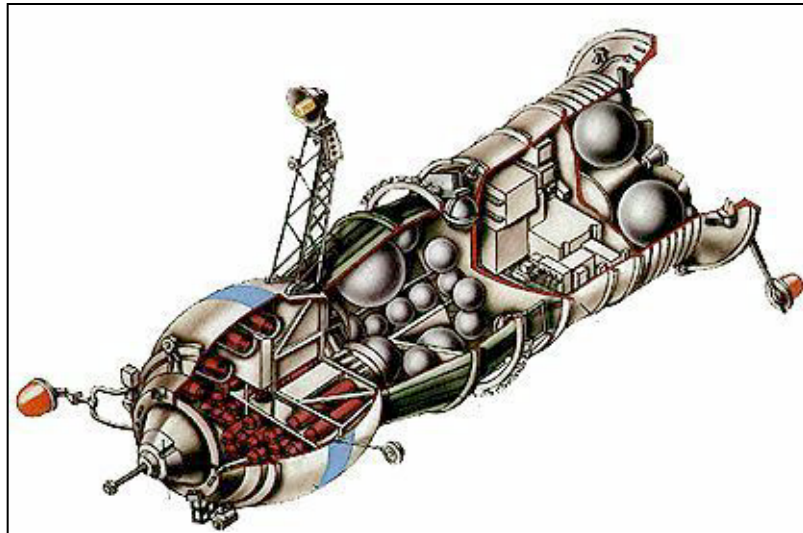

Figure 4.5-13. Progress M1.

Table 4.5-12. RSA Resupply Vehicle Carrier Specifications

Characteristic	Progress M	Progress M1 (improved Soyuz)	Progress M1 (modernized Soyuz)
Vehicle tare weight, kg	4740	5050	5050
Maximum payload, kg	2350	2500	3200
Maximum dry cargo, kg	1800	1800	1800
Maximum usable pressurized volume, m ³	6.6	6.6	6.6
Total downmass (destructive), kg	1600	1600	1600
Total maximum downvolume, m ³	6.6	6.6	6.6
Recoverable downmass, kg	0	0	0
Recoverable downvolume, m ³	0	0	0
Maximum on-orbit lifetime, days	180	180	180
Allowable docking port	Zvezda aft, UDM nadir, DSM nadir	Zvezda aft, UDM nadir, DSM nadir	Zvezda aft, UDM nadir, DSM nadir

4.5.5. Cargo Return Assessments

The following information is the cargo return assumptions utilized by the Boeing Company to develop the latest ISS traffic model. This information was developed by using key fleet resource resupply and return information provided by the ISS organization or the IP's. These assumptions are presented herein for information only.

- Pressurized utilization cargo

USOS (includes CSA, ESA, NASA, and NASDA)

95 percent NASA and CSA pressurized utilization cargo assumed recoverable

67 percent NASDA pressurized utilization cargo assumed recoverable

62 percent ESA pressurized utilization cargo assumed recoverable

Pressurized utilization cargo remains on orbit for minimum of 90 days

ROS

12 percent ROS utilization cargo assumed recoverable

- Unpressurized utilization

USOS

95 percent NASA and CSA unpressurized utilization cargo assumed recoverable

67 percent NASDA unpressurized utilization cargo assumed recoverable

Unpressurized utilization cargo remains on orbit for minimum of 90 days

ROS

TBD (Assume ROS does not deliver or have any unpressurized utilization requirement)

- Pressurized maintenance

USOS

97 percent NASA and CSA pressurized maintenance cargo assumed recoverable

19 percent NASDA pressurized maintenance cargo assumed recoverable

0 percent ESA pressurized maintenance cargo assumed recoverable

ROS

100 percent ROS maintenance cargo assumed nonrecoverable

- Unpressurized maintenance

USOS

65 percent NASA and CSA unpressurized maintenance cargo assumed recoverable

41 percent NASDA unpressurized maintenance cargo assumed recoverable

0 percent ESA unpressurized maintenance cargo assumed recoverable

ROS (assume ROS unpressurized logistics requirements included in pressurized logistics estimates)

TBD

- Crew supplies or life support system (LSS) cargo

USOS

32 percent USOS crew supply cargo assumed recoverable

20 percent frozen food waste assumed recoverable

ROS (LSS)

100 percent ROS LSS cargo assumed nonrecoverable

- CHeCS

USOS

78 percent CHeCS supply cargo assumed recoverable

- Water

USOS

Waste water available for removal when next USOS resupply flight undocks

ROS

4.5.6. Traffic Assessment

During the postAC period, an average annual flight rate of 4 Shuttle pressurized flights, 1 unpressurized Shuttle flight, 3.5 Progress M1 flights, 2 Soyuz TM flights, 0.8 ATV flight, and 1.5 HTV flights are planned. Figure 4.5-14 presents a pictorial representation of the planned typical yearly traffic model for the transportation vehicles.

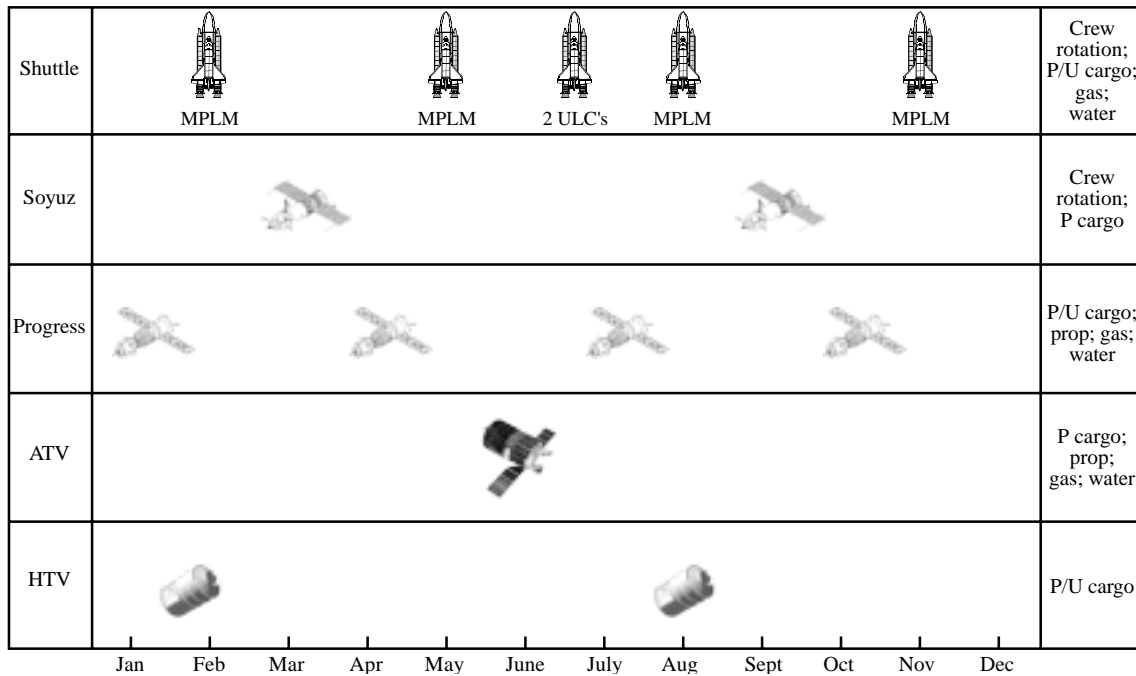

Figure 4.5-14. Typical yearly traffic model (based on 14 flights/year). P is pressurized; U is unpressurized; prop is propellant.

4.5.7. Bibliography

- Amborski, R. A.: SPACEHAB Experiment Interface Definition Document. MDC91W5023H, Boeing Co., Sept. 1999.
- Anon.: Leonardo Module: A “Moving Van” for the International Space Station. NASA Facts IS-1998-10-ISS021JSC, Nov. 1998.
- Anon.: H-II Transfer Vehicle (HTV). Updated July 26, 1999, http://yyy.tksc.nasda.go.jp/Home/Space_Trans/e/htv_e.html Accessed July 11, 2000.
- Anon.: The Automated Transfer Vehicle. European Space Agency, July 28, 1999.
- Arend, Jeff; Green, Jennifer; and Lemmons, Neil: ISS Traffic Model Overview. International Space Station, Boeing Co., July 28, 1999.
- Lemmons, N.; and Green, J.: International Space Station Program Subsystem Analyses and Analytical Models—Final: ISS Integrated Traffic Model Report (DAC 7). FINAL-D7.1.1-04 (Contract NAS15-10000), Boeing Co., Jan. 28, 1998.
- Orozco, Melissa L.: ISS Stowage Accommodations Handbook: Pressurized Volume. International Space Station Program—Preliminary Draft, SSP 50467, NASA Johnson Space Center, Mar. 1999.

4.6. Operations and Planning

4.6.1. Introduction

The ISS will operate on a continuous basis, with execution planning, logistics planning, and on-orbit operations occurring simultaneously for long periods of time. Additionally, the sheer size and unique constraints of the ISS compared with the Shuttle demand a somewhat different approach to both planning and operations.

The ISS planning process involves many interfaces and products. Utilizing the results of this planning process for operations as well as translating the results of current operations into future planning is a sophisticated process. This section introduces the overall process and several products and activities of each of the four phases of ISS planning that are important aspects of real-time ISS operations. How these activities are performed on orbit is also described.

4.6.2. Planning Time Frames and Products

4.6.2.1. ISS Planning Time Frames

Prior to discussing the ISS planning process, it is important to be familiar with the terms that are used to reference planning time frames. These terms are as follows:

- Increment (I): time frame from the launch of a vehicle rotating ISS crew members to the undocking of the return vehicle for that crew; length of an increment is approximately 3 to 6 mo; this term refers to all the increments occurring during the time frame, including the Shuttle, Russian, and other transportation vehicles; additionally a great deal of ISS planning is based upon the increment
- Expedition: same time frame as an increment but is used when referring to the ISS crew serving during that increment
- Planning period (PP): period on which much of ISS planning is based; spans approximately 1 calendar year, but is tied to the beginning and end of ISS increments, so usually does not begin on January 1

4.6.2.2. Planning Process

The planning process for the ISS is very complex. Many factors make planning for ISS more complex than previous programs, the most important of which are discussed. Both flight-specific planning and increment-specific planning must take place. For example, some products support individual Shuttle assembly flight requirements and others support the long-term increment requests.

A big challenge is international integration. The issues include language of operations and documentation and merging different cultural styles of planning as well as conforming to memorandums of understanding between international organizations. Just integrating programs is a significant challenge—not only merging IP programs with NASA programs, but also merging the NASA programs (Space Shuttle and Space Station). The Shuttle program is very stable and is

trying to shorten its planning templates. Shared products under these different styles and priorities for planning are sometimes difficult to schedule together.

Another area that is a particular challenge to ISS is resource management. Crew time, power, communication time, and bandwidth are just some of the resources that are limited for ISS and must be managed to achieve ISS objectives. Many of these resources, such as crew time, also fall under IP allocation agreements made at the program and government level. Planners from all the IP will work together to ensure that each partner is receiving an appropriate amount of resources over time.

Addressing these challenges is no small task, but the first step is to establish a template for the many product deliveries required to fly the ISS.

4.6.2.3. Increment Planning Process Template

The four main phases to planning are strategic planning, tactical planning, preincrement planning, and increment execution. The phases are not completely distinct because of the overlap in some products and early production. Each phase, along with major products produced, are illustrated in figure 4.6-1.

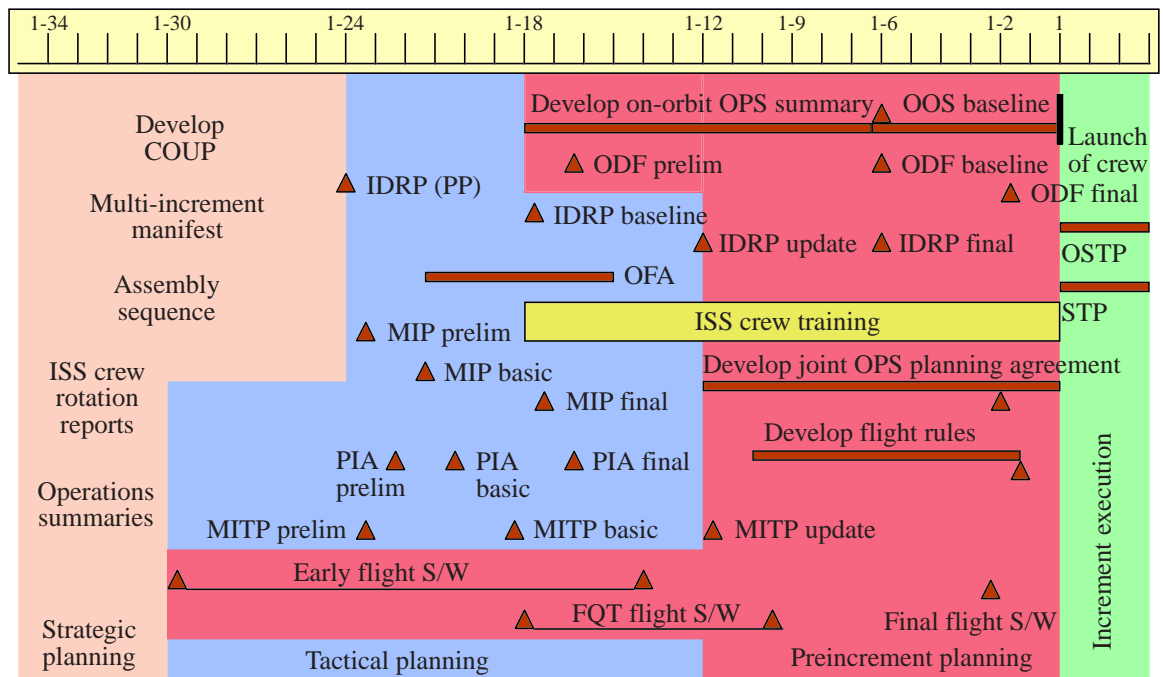

Figure 4.6-1. Process planning template.

4.6.2.4. Strategic Planning

Strategic planning is long-range planning and begins at about PP – 5 yr (5 yr before a planning period) and continues through I – 2 yr (2 yr before increment execution). Many products (documents) in this phase, such as the following, are scrolling plans that cover the next 5 yr and are updated regularly.

Generic ground rules, requirements, and constraints (GR&C): This document defines the generic ground rules and constraints used for program-level planning functions (i.e., planning for vehicle and cargo traffic, resource planning, crew rotation planning, crew loading, cargo integration, and ground processing), and the generic program-level operations requirements that must be met by the ISS execution-level organizations.

Consolidated operations and utilization plan (COUP): This document is a 5-yr plan for the ISS and defines the system operations and utilization activities planned for the ISS. For each planning period, it establishes the amount of resources and accommodations allocated and subscribed by the system and each IP for utilization and reflects the planned amounts of supporting services from other programs that are available and subscribed. The COUP also provides specific direction and guidance to tactical planning regarding COUP implementation. The COUP includes a high level manifest of major items planned for each planning period and is written by the ISS Program Office.

Multi-increment manifest (MIM): This document defines the traffic and crew rotation plans for the five planning periods contained in the COUP. MIM contains three major sections: the assembly sequence overview, flight schedule, and flight table. The flight schedule combines the high-level integrated traffic plan and crew rotation plan with other key planning information including flight-specific and deferred EVA's, docking port utilization plans, and planning period and increment boundary information. The flight table is a high-level summary which includes the number of crew members, altitude, number of days docked, and a high-level description of the cargo. It is controlled by the Space Station Control Board (SSCB) and is signed by all partners. The crew rotation takes into account the upmass capability of the planned vehicle, vehicle life, training currency for time critical and complex tasks, and the assembly sequence. The traffic model for ISS uses the assembly sequence, vehicle life, ISS altitude, logistics requirements, and microgravity requirements to plan the flow of vehicles to and from the ISS.

Assembly sequence: This is the schedule for building the ISS. It takes into account the system capabilities through the ISS building process, element availability dates, and partner agreements.

4.6.2.5. Tactical Planning

Tactical planning begins at about PP – 30 mo with development of the increment definitions requirements plan (IDRP). Delivery of the baseline PP IDRPs at PP – 16 mo initiates preincrement planning. Updates to the PP IDRPs are performed every 6 mo as needed through the end of the planning period. Tactical planning is a multilateral function which defines the resources, allocations, research objectives, priorities, and manifest for each increment. It also continues the integrated traffic planning started in the strategic time frame.

Increment definitions requirements plan: This document is produced for each planning period. The IDRPs serve as an internal program agreement on the requirements for the increments. Included in the IDRPs are resource allocations, requirements, mission priorities, and a manifest for each increment and flight in the planning period. The top-level IDRPs are published at PP – 24 mo, with the IDRPs baseline published at PP – 16 mo and then updated every 6 mo as required. All affected partners sign the document.

Resource and engineering feasibility assessments: During development of the baseline PP IDRP, after the system and utilization requirements have been integrated and compiled for each increment in the PP, two types of assessments are performed to determine the feasibility of satisfying these requirements: an engineering feasibility assessment (EFA) and an operations feasibility assessment (OFA). Now is the opportunity for the planning world to ensure that the priorities and objectives of the increments are possible to achieve.

Payload integration agreement (PIA): These documents lay out the agreements made between the ISS program and its payload customers. A PIA is produced for each major payload. The agreement includes requirements of each side and resource allocations, including crew time. This agreement will also have a payload data library to document the details concerning telemetry, training, et cetera much like Shuttle payload integration plan (PIP) annexes. These agreements are developed by the payload operations and integration function (POIF) at MSFC and approved by the Payload Operations Control Board (POCB).

Multilateral increment training plan (MITP): This document is written for each increment. It describes all the training required to support a single ISS increment including systems and payloads training. Sections cover ISS crew training, Shuttle crew training, and controller team training. The baseline version is published 1 mo prior to ISS increment-specific crew training.

Mission integration plan (MIP): This plan is a Shuttle-Program-Station-Program agreement. It is similar to a Shuttle PIP, but it covers all the cargo elements and Shuttle-supported activities for an entire ISS assembly or utilization flight. The Shuttle Program Office Payload Integration Manager (PIM) manages the document. The Station Launch Package Manager coordinates the ISS requirements to be included in the MIP, the overall ISS review, and the postflight report. This report documents the accomplishments of flight objectives. It does not include as extensive a set of annexes because many of the requirements documented in the PIP annexes are internal to MOD for the Station flights.

Postincrement evaluation report: This report documents the accomplishment of increment objectives, allocations, and requirements. It contains an overview of the increment, increment objectives and requirements, the degree to which the objectives and requirements were met, lessons learned from the increment, and recommendations.

4.6.2.6. Preincrement Planning

Preincrement planning begins at about I – 16 mo with delivery of the baseline PP IDRP and continues until launch. This phase is when actual flight and increment products are produced.

On-orbit operations summary (OOS): This summary is a high-level activity plan for an entire increment. High-level activities are planned for a specific day of the increment but are not scheduled for a specific time. No details about the activity are provided. The OOS establishes the basis from which distribution of ISS resources is made by providing expected resource availability and environmental conditions throughout an increment and by identifying constraints and critical events or time periods during an increment. The OOS is also the foundation for the development of the detailed short-term plan (STP). Work on the OOS begins at about PP – 16 mo with the preliminary OOS delivered at PP – 12 mo, basic OOS at PP – 6 mo, and final OOS at PP – 2 mo. Updates to the OOS will continue through to the end of the planning period to reflect operations as they actually occurred. The OOS is analogous to the expedition plan used on the Mir Space Station. There is no analogous Shuttle

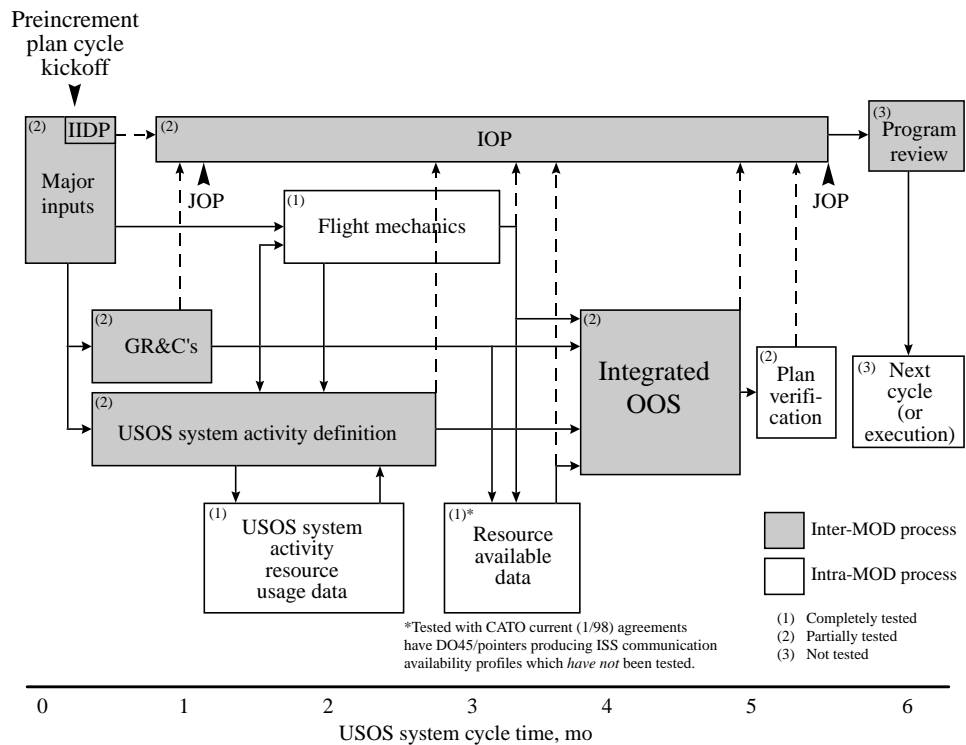

Figure 4.6-2. Overview of OOS cycle.

product due to the short duration of Shuttle missions. Refer to figure 4.6-2 for an overview of the OOS cycle.

Flight rules: These are the guidelines for real-time decision making and are monitored and approved by the Flight Rule Control Board (FRCB) chaired by the Flight Directors. There are generic, increment-specific, and flight-specific versions of the flight rules.

Execution planning ground rules and constraints: These are the guidelines used to create the OOS, STP, and other planning functions. As with flight rules, there are both generic GR&C's and increment specific GR&C's.

Operations data file (ODF): This file is the collection of procedures and reference material required to operate and maintain the ISS systems, payloads, and attached vehicles. The ODF includes both paper and electronic material, but the emphasis is on electronic data. The six major components to the ODF are

- Systems operations data file (SODF) which includes the NASA, CSA, and ASI system procedures as well as any multisegment procedures
- Payload operations data file (PODF) which includes U.S. and Italian payload procedures
- Canadian Space Agency (CSA) PODF which contains Canadian payload procedures
- Russian Space Agency operations data file (RSA ODF) which contains most of the systems and payload procedures for the ROS

- ESA also has an integrated ODF with both systems and payloads
- NASDA ODF is similar to the RSA and ESA ODF's in scope

Systems operations data file: The SODF is the repository of all the U.S. ISS onboard and ground systems procedures. Procedures contain the necessary technical information compiled in a standardized format that the crew and ground controllers need to perform their jobs. Procedure authors gather information from various sources before writing a procedure. Once written, the procedure is validated and verified to ensure its safety and effectiveness. The development of procedures takes place in three cycles: preliminary, basic, and final. The preliminary cycle is worked from L – 24 mo to L – 18 mo and involves the initial development of the procedure. Once written and reviewed the procedure moves to the basic cycle, where the majority of the validation occurs. The basic cycle covers the time period of L – 18 mo to L – 6 mo. During the basic cycle, the procedure is refined by incorporating any new information that has become available. At the end of the basic cycle, L – 6 mo, the procedures must be contained within the U.S. SODF. The final cycle is worked from L – 6 mo to L – 2 mo. This is the last chance to change a procedure. After the final cycle only critical change requests will be accepted. The U.S. SODF contains six different types of procedures:

- Activation and checkout are used for the activation or checkout of systems of components of systems
- Nominal is used to carry out the normal day-to-day functions
- Quick response is used in the event of a failure to quickly make safe the system within a very limited amount of time
- Malfunction is designed to cope with system or equipment failures that require a diagnostic process
- Corrective is designed to bypass or overcome a failure condition
- Reference includes nonexecutable ancillary information used to ensure the successful execution of a procedure

Integrated operations plan (IOP): This plan is really more of a tool to access and review many of the products discussed in this section. It provides on-line access via the Internet to operations products and schedules. The IOP is organized and developed by increment and includes access to the SODF, MITP, GR&C, and flight schedules. It is maintained by DO47, the Flight Planning and Tool Development Group. The preliminary IOP is frozen at I – 12 mo, the basic at I – 6 mo, and the final at I – 2 mo.

4.6.2.7. Increment Execution

This phase begins with the start of the increment. The planning products produced in this phase employ a “just-in-time” development philosophy to ensure the availability of up-to-date plans and to minimize the need for frequent replanning.

Short-term plan (STP): The STP is the detailed integrated schedule of activities to be performed during 1 wk of ISS operations. The STP includes all ISS activities, including U.S. and

IP systems and payload activities. In addition to crew activities, STP time lines also include automated onboard activities and ground controller activities, as well as ancillary data such as ISS attitude and communications coverage data. Activities in the STP include all the information necessary for execution, in addition to a reference to the procedure associated with each activity. The STP is somewhat analogous to a combination of the Shuttle flight plan and the SPACELAB payload crew activity plan (PCAP). The differences between the STP and the Shuttle products are that, while the flight plan and PCAP are paper products used for onboard execution, the STP is an electronic product used only for ground planning. However, the STP is used to derive the onboard short-term plan (OSTP) which is used for onboard execution. The STP is developed the week prior to its execution and is based on the OOS which was developed prior to the increment. An example of an STP is shown in figure 4.6-3. Development of the STP is performed by a team called the International Execution Planning Team (IEPT) which consists of planning personnel from the U.S. and the IP.

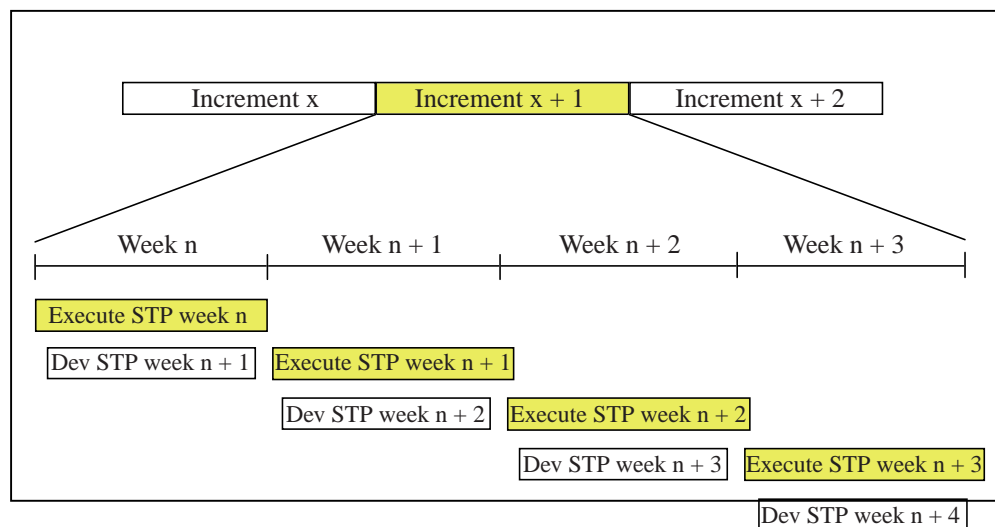

Figure 4.6-3. Weekly STP development.

Onboard short-term plan (OSTP): The OSTP is the integrated plan, which is viewed and executed onboard the ISS. Because it is derived directly from the STP, the OSTP contains all activities to be executed, including crew, ground, and automated activities for the U.S. and IP segments. The OSTP will contain approximately 3 days of activities. At any given time, the OSTP will contain yesterday's, today's, and tomorrow's activities, with uplink of new activities occurring daily. In addition to scheduled activities, the OSTP will also contain "jobjar" activities. These are activities which do not need to be performed at a specific time but may be performed at the crew's discretion. The OSTP is viewed using an onboard laptop computer with software called the OSTP/ODF crew interface (OOCI). In addition to the OSTP, OOCI software will also be used by the crew to view electronic procedures and other electronic documentation, and after flight 8A, it will allow the crew to view and interface with automated procedures. Ground controllers will be able to view and interface with the OSTP on MCC workstations using software called the OSTP editor/viewer (OE/V). OSTP and OOCI capabilities will be phased in during the assembly sequence. When all capabilities are available, the OSTP will provide a very powerful planning and execution tool for the crew and controllers. Some of the capabilities that will be available are linking to procedures directly from the OSTP, giving status of activities directly on the OSTP, filtering of activities, setting reminders

of upcoming activities, and making notes and annotations directly on the OSTP. Also, using OE/V software, ground controllers will be able to keep track of onboard activity status with constant voice communication with the crew. The relationship between the OOS, STP, and OSTP is summarized in figure 4.6-4.

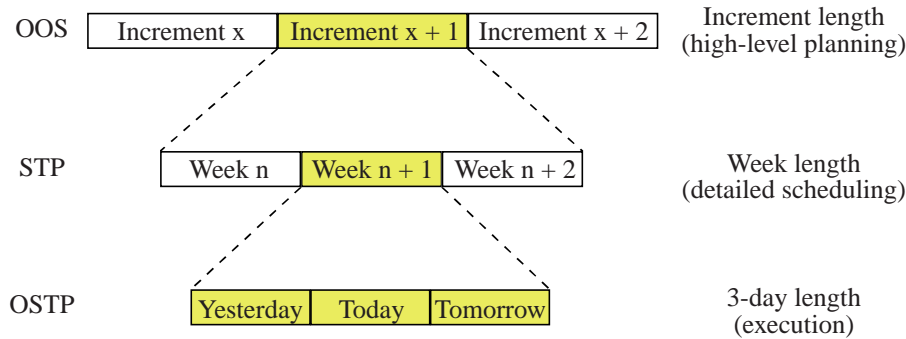

Figure 4.6-4. Relationship between OOS, STP, and OSTP.

4.6.3. Planning and Analysis Tools

Although many tools are available for planning and analysis of ISS operations, several tools and products in particular deserve special attention because of their widespread use and impact on operations.

4.6.3.1. The Integrated Planning System

To provide data on resources available, identify conflicts in resource allocation, and distribute ISS resources, the integrated planning system (IPS) was developed. The IPS is an integrated collection of computer applications used for planning and analysis of ISS operations. The primary users of IPS will be flight controllers and planners developing the OOS, STP, and OSTP. IPS consists of seven major applications:

- Consolidated planning system (CPS) is used for generation and analysis of both ground and on-orbit activity time lines and plans; CPS is used to assess the IDRP, generate the OOS, STP, and OSTP as well as performing real-time and near-real-time planning and replanning; CPS can schedule against multiple resources as well as handle complex conditions and constraints and is used for both ISS and Shuttle planning
- Consolidated maintenance inventory logistics planning (CMILP) tool is used by ground controllers and planners for onboard inventory tracking, developing ISS resupply and return requirements, and for real-time and near-real-time support of maintenance operations
- Flight dynamics planning and analysis (FDPA) tool is used by ground controllers and planners to provide high fidelity trajectory, attitude, propellant consumption, and communications coverage analysis
- Procedures development and control (PDAC) tool is used by ground controllers to develop and configuration manage operations procedures, develop onboard executable procedures via the time liner compiler interface, and distribute procedures electronically

- Resource utilization planning and system models (RUPSM) tool models the ISS EPS, TCS, and ECLSS and ground controllers using RUPSM can analyze and plan usage of ISS electrical, thermal, and life support resources to support time line development and monitor system performance in real and near real time
- Robotics planning facility (RPF) provides software tools to model robotics systems, including the SSRMS and is used as a robotics design, analysis, and training tool and provides real-time and near-real-time robotics operations support
- ISS mission operations directorate (MOD) avionics reconfiguration system (IMARS) is the central repository for ISS MOD reconfiguration products, provides the software tools required for processing reconfiguration data, produces mission build facility (MBF) utilization files from the standard in and command/telemetry products for the MCC and PCS from MBF standard output, provides flight software and data configuration management and serves as a central repository for command files, data load files, caution and warning limits, and standard input and standard output files.

4.6.4. Inventory Management

Due to the volume of articles onboard ISS, and the fact that ISS will be on orbit continuously for at least 15 yr, the need arises for a system of tracking the location and status of items that have been stored onboard. The inventory management system (IMS) fulfills that purpose.

The IMS, together with detailed logistics planning, provides a process used to ensure that the right items are in the right place at the right time. To perform this task, plans and processes are developed which ensure the continued support of the ISS core systems. Mission manifesting and transfer of items to KSC are also supported.

Logistics and inventory management starts years before a flight and determines who sends what items to the ISS, what vendors are used during the procurement process, and how items will be repaired. This information is extremely important because it is necessary to ensure that the right items are sent to, maintained on, and returned from the ISS at the right time. A current status and a forecast for the future availability of inventory is essential. It is necessary to know what is broken in order to fix it.

Inventory is affected by the manifest of each flight. The ISS uses the inventory storage file to determine exactly what is onboard. Inventory includes items pertaining to

- Crew support includes clothing, food, and personal items
- ISS support includes spares, repair parts, consumables, technical data and documentation, support equipment
- User support includes items required to support customer or user for payloads and their associated support items, consumables such as fluids and gases, returning experiment products, specimens, and disposal of waste materials

The inventory on the ISS is managed by the IMS, which is a software application that will reside onboard the station support computers (SSC's) so that updated inventory is available ISS wide. Updates to the inventory can be made via the keyboard, GUI, or bar code reader. IMS

provides capabilities for crew queries, displays, editing of locations, keeping track of quantities, changes in operational status, changing hazardous codes, keeping notes, et cetera. It also creates a change/update log to track inventory activities.

Two scheduled inventory audits are planned for the crew. The first will allow sufficient time for the necessary items to be manifested into the MPLM and the second will be done closer to launch for items to be manifested into the middeck lockers. The ground will track everything else. One thing to note is that food will not be tracked but will be in the database for volumetric purposes. There is a set resupply regardless of what has been consumed.

Resupply and return analysis is another part of inventory management. It evaluates the capability to supply logistics support resources for on-orbit systems. Weight and volume requirements of ORU spares, repair parts, support equipment, tools, et cetera have to be evaluated. Decisions must be made concerning everything from the number of crew members allowed on a flight to alternative logistics carriers that could be used. Unfortunately with all the constraints, science requirements may be impacted by system maintenance requirements. There may also be times when a payload item is moved to another flight or scheduled maintenance activities will have to be postponed because of changes in the manifest.

The manifest is an ever changing list of items that depends upon the IMS to ensure that crew members have what they need when they need it to sustain the ISS and themselves.

4.7. Acceleration Measurement Services

4.7.1. Introduction

The ISS will provide a research platform in space to conduct investigations that are not possible on Earth. The ISS provides a microgravity environment, which allows research in numerous disciplines to take place. To ensure validity of scientific research and technology studies, measuring the parameters of the environment is necessary. Like temperature is measured when conducting a thermal experiment, the acceleration variable needs to be measured while conducting microgravity experiments. Information from the documents listed in the bibliography (section 4.7.6) was used to compile this section.

The ISS microgravity acceleration environment consists of two regimes: the quasi-steady environment and the vibratory/transient environment. Therefore, the measurement of the microgravity acceleration environment is best accomplished by two accelerometer systems. In the U.S. Lab, the measurement of these two regimes is accomplished by the second-generation space acceleration measurement system (SAMS-II) and the microgravity acceleration measurement system (MAMS).

Each system detects vibrations present while the ISS is operating but at different frequency levels. Another aspect of the acceleration measurement service is the detailed analysis and interpretations of these data must be provided to the users of the microgravity environment for scientific research and eventually possible new technology and product development. The detailed analysis and interpretations of the accumulated acceleration data will be provided by the Principal Investigator Microgravity Services (PIMS) group. All these services are being provided through the Glenn Research Center.

4.7.2. Second-Generation Space Acceleration Measurement System

The SAMS-II design was based upon input from ISS researchers who defined their requirements for the acceleration measurement system that would support them. Input was also gathered from the Shuttle-based SAMS instruments, a precursor to SAMS-II. With this information, a generalized system was defined which will support the entire set of users and meet their initial measurement needs as well as those expected as the ISS becomes operational and research experience develops. The SAMS-II will measure the acceleration environment for multiple payloads conducting research in space throughout the lifetime of the ISS. It will accurately acquire these data within the resources available and constraints imposed by the ISS and provide this information to the ultimate user in various formats within a timely manner.

SAMS-II has developed a distributed architecture design that results in a measurement system that is expandable, upgradable, and deployable onboard the ISS. Multiple remote triaxial sensor (RTS) systems can be deployed near payloads requiring direct measurements of the acceleration environment. A controller, initially consisting of a Space-Station-derived laptop, ties the independent RTS systems together on-orbit and provides a single-point communication link to the SAMS-II ground operations equipment where data are received for distribution to users. (See fig. 4.7-1.)

The project relies on the infrastructure of the ISS similar to the manner in which a researcher relies on the capabilities of the laboratory to conduct scientific investigations. In this manner, duplication of resources is avoided when possible, and the needs of users are met while

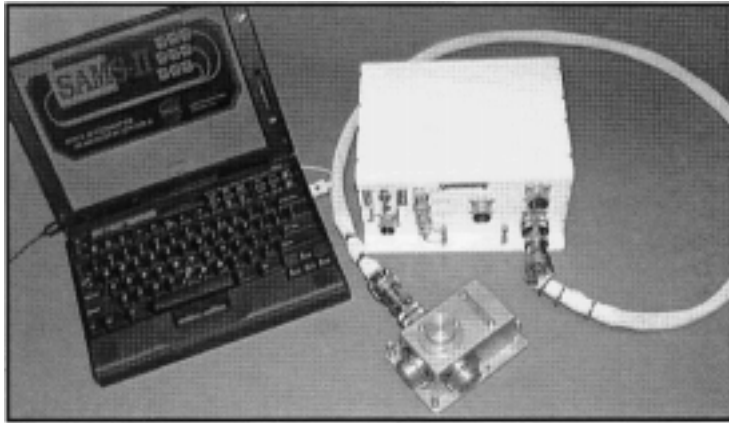

Figure 4.7-1. SAM-II.

minimizing the complexity and cost of developing the SAMS-II. The Space Station network will serve as the communication means to move data from source to receiver. A distributed deployment of sensors will serve multiple users but only when each user requires a sensor. Users will be able to modify acquisition parameters in a manner as if they “owned” the hardware by properly selecting the frequency range of the measurement; thereby, the burden on the network traffic load is minimized. Converting onboard data compensation into engineering units is implemented to provide a future capability of providing a direct feedback to payloads and crew of the current environment. A centralized controller system will provide a means to keep track of data acquired and the status of the health of each unit and allow for simplified enhancements to the systems by both modular software and hardware upgrades.

In an effort to initiate early research while the ISS is still under construction, it was realized that the early users would only be provided with a subset of the complete capabilities planned for ultimate use by future ISS researchers. The early deployment of an interim control unit (ICU) follows suit and will result in a two-phased capability to be executed, which will initially provide the limited number of initial users’ core measurement services. Ultimately, the ICU will be upgraded to a full-fledged control unit (CU). This second unit will allow onboard data analysis and direct feedback of information to payloads; thereby, onboard control of experimental parameters will be allowed, with the hope of optimizing the experiment time on the station. The CU deployment is timed to coincide with the initial operations of the facility class rack systems being developed. When these facilities are deployed, more measurements are expected to be required, and additional SAMS-II performance features will be desired.

Throughout this deployment of interim and final control capability, the core element of SAMS-II will be the RTS system. This system comprises sensor heads and a supporting electronics unit, which are installed in multiple locations throughout the ISS. Each system is capable of measuring from 0.01 Hz to and beyond 300 Hz. This wideband region is known as the vibratory or “g-jitter” regime. Amplitudes are expected from 1 μ g up to as high as 10 mg. The RTS heads are capable of measuring across this range and beyond, should there be a higher amplitude transient disturbance taking place. Multiple RTS systems are deployed at various locations throughout the ISS, specifically to support the ongoing microgravity research program experiments.

4.7.2.1. Interim Control Unit Capabilities

The ICU acts as a system traffic cop for numerous RTS systems that may be operating at any one time. The ICU provides a singular location in which the software required to operate an RTS is housed. Whenever an RTS is powered up, the ICU recognizes the RTS, instructs it across the ISS network to configure itself according to preprogrammed settings, and allows the RTS to initiate measurements for payload customers. Once the ICU receives the data from the RTS, it is checked for completeness, and combined with other sensor data and hardware performance data for subsequent downlink to the ground.

The ICU consists of an IBM ThinkPad laptop from the ISS pool of flight grade PCS. To communicate with the RTS systems, the ICU and its SAMS-II specific software operate across the Ethernet network known as the medium rate link in a two-way communication mode similar to that used to network computers together between offices. This laptop is integrated within an ISIS drawer with SAMS-II power and cooling subsystems. Although not expected to be needed for baseline operation, the ICU will have available sufficient hard disk capacity within the laptop to store up to 10 hr of data from five sensor heads running at their maximum frequency range. Such a backup approach is being made available in case downlink services are interrupted, but on-orbit research is able to continue while services are restored.

4.7.2.2. Remote Triaxial Sensor Capabilities

The SAMS-II RTS systems consist of two primary building block elements: the RTS sensor enclosure (SE) and the RTS electronic enclosure (EE). Each subsystem serves a distinct role in the measurement of microgravity acceleration onboard the ISS. The RTS SE is mounted as close as possible to the experiment being supported because it contains the digitizers that convert the analog signals at the source to minimize the influence of measurement noise. Integrated temperature transducers in the sensors also allow for temperature compensation of the data when the data are applied against temperature calibration curves. Precise alignment between the three sensors provides a triaxial measurement of the environment as well.

Each EE provides power and command signals to one or two SE units and receives the digital acceleration data. The EE can compensate the data for temperature and alignment effects and convert the data directly to engineering units. The EE also serves as the network interface to the control unit across the Ethernet on the ISS. Generally, the EE hardware is embedded within a science rack at the time of its initial launch, and an RTS cable is routed to a more accessible SE which is likely to be installed onto a particular science payload when the payload is brought up on orbit.

A custom designed RTS will be provided to support the low-temperature microgravity physics facility which will be conducting fundamental physics research outside the shirtsleeve laboratory of the ISS. This facility and the custom RTS will be located on the JEM EF.

RTS systems are in production and are being deployed to users as their system development schedule requires them.

4.7.2.3. Operations and Data Analysis

The operations of the SAMS-II hardware will be supported primarily through the Telescience Support Center (TSC) at GRC. However, mini-TSC's can be built at various facilities and

universities for real-time access to acceleration data and control of the RTS sensors by the principal investigators. Data analysis will be provided by the principal investigator.

4.7.2.4. Customers

The primary focus of the SAMS-II instrument is to support the microgravity science disciplines conducting research onboard the ISS. These disciplines include biotechnology, combustion, fluids science, fundamental physics, and materials science. Each discipline is developing a general-purpose facility to conduct modular research as well as initiating research using small, self-contained experiments which are housed in the EXPRESS racks available on orbit and within the microgravity science glove box system.

Secondary users may request acceleration measurement support on the ISS by contacting SAMS-II and developing a specific user agreement for services. Depending on the desire of the nonmicrogravity customer to collect data, a series of options may be made available. Options may range from sharing existing data, specifically deploying a single-use sensor, or development of a complete custom system for long-term use.

4.7.3. Microgravity Acceleration Measurement System

4.7.3.1. Science Objective

The objective of the MAMS is to measure and report vibratory and quasi-steady acceleration within the U.S. Lab on the ISS. Vibratory acceleration, produced by mechanical equipment and crew activity, has an oscillatory nature with a frequency greater than 1 Hz. Quasi-steady acceleration occurs at frequencies below 1 Hz and is caused by aerodynamic drag, gravity gradient and rotational velocity forces, spacecraft mass expulsion, and attitude control system actions.

Providing a microgravity environment is a major mission of the ISS. The MAMS instrument will be used to verify the microgravity environment, in addition to providing scientific data to individual microgravity experiments in combustion science, fluid physics, and materials research. MAMS acceleration data will also be used in the analysis of vehicle dynamics, attitude control system performance, docking loads, reboost performance, and atmospheric drag estimation.

4.7.3.2. Hardware Description

The MAMS consists of a low-frequency triaxial accelerometer; the miniature electrostatic accelerometer (MESA); a high-frequency accelerometer; the high-resolution accelerometer package (HIRAP); and associated computer, power, and signal processing subsystems contained within a double middeck locker enclosure. (See fig. 4.7-2.) MAMS will be launched preinstalled in EXPRESS rack 1 on ISS assembly flight 6A. Electrical power distribution to MAMS is controlled through a circuit breaker located on the front panel.

4.7.3.3. Miniature Electrostatic Accelerometer

GRC has considerable experience measuring quasi-steady acceleration data on orbiting spacecraft. A MESA sensor flew 11 times on *Columbia* as the heart of the orbital acceleration research experiment (OARE). The OARE provided a wealth of information about the low-frequency microgravity environment on *Columbia* in support of the Spacelab program. In addition, OARE

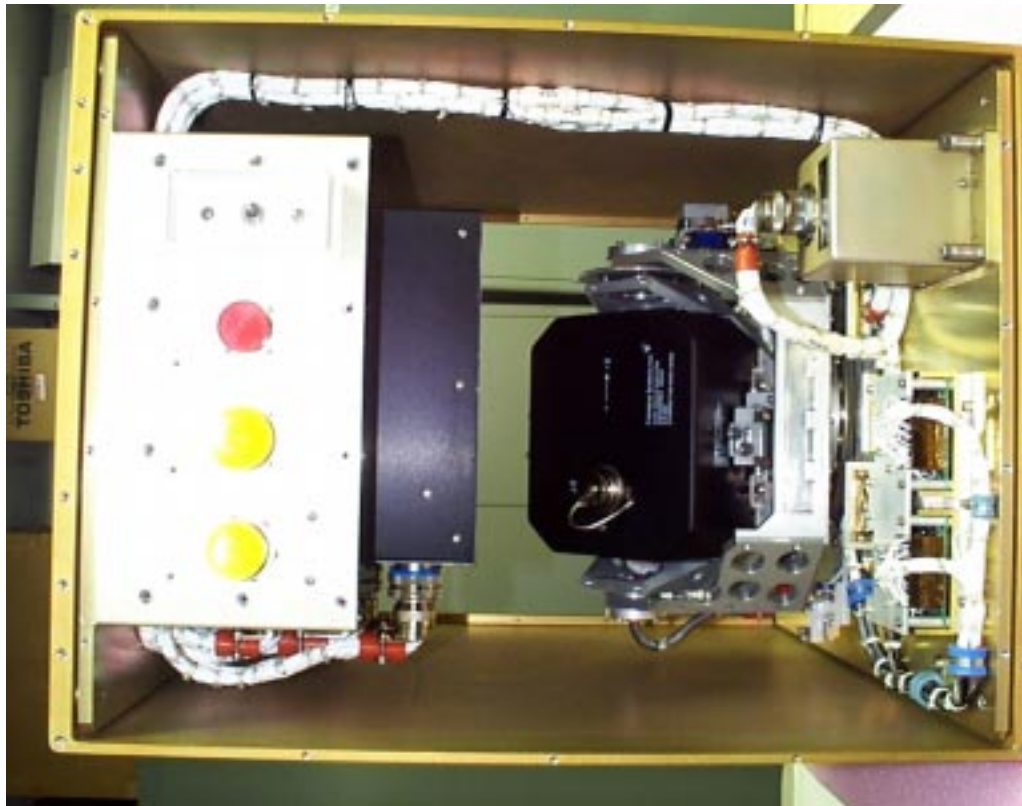

Figure 4.7-2. MAMS.

provided significant information about the density of the upper atmosphere during Space Shuttle reentry. The MESA sensor used in MAMS is a flight spare from the OARE program.

The MESA consists of a hollow cylindrical flanged proofmass, two *X*-axis forcing electrodes, an outer cylindrical proofmass carrier with *Y*- and *Z*-axis electrodes, and control electronics, all contained in a protective case. The sensor proofmass is constrained via electrostatic force feedback to remain centered between the cylindrical axis forcing electrodes and the radial axes carrier electrodes. The resulting “sensed” acceleration is proportional to the voltage required to generate the centering force.

The MESA is mounted on a bias calibration table assembly (BCTA). The BCTA is a dual-gimbal mechanism, which allows the MESA sensor to be calibrated on orbit. Calibration is used to remove electronic bias from acceleration data. Signal processing algorithms will be applied to the MESA bias calibration data to achieve absolute quasi-steady acceleration data with very high accuracy. Multiple calibrations taken over long operations periods will be used to further improve accuracy.

During early increments, MAMS will require a minimum operational period of 4 days (96 hr) to characterize the performance of the sensor and calculate sensor bias. During later increments, MAMS can be activated for time periods sufficient to satisfy payload or vehicle needs for acceleration data.

4.7.4.4. Crew Operations

The MAMS is designed to operate autonomously within the EXPRESS rack. MAMS will be commanded from the ground and requires no onboard crew interface. It is possible to obtain MAMS status data from the PCS via the EXPRESS rack interface controller. However, no current plans exist to provide MAMS laptop software applications.

4.7.5. Principal Investigator Microgravity Services

The Principal Investigator Microgravity Services Project, part of the Acceleration Measurement Program at GRS, provides the science community with usable acceleration information from data collected by various measurement instruments. Services have focused on responses to specific data requests from principal investigators and a generation of general acceleration environment summary reports for each microgravity mission supported by SAMS and the OARE.

The role of PIMS during the ISS era will evolve from supporting individual science missions on short-duration carriers such as the Shuttle and sounding rockets to an ongoing activity ranging from new user education, vehicle characterization for future user knowledge, and interpretation of events affecting the acceleration environment onboard the ISS. Reports still will be generated, but they will be status reports instead of completed mission reports. Examples of the analysis techniques that PIMS provides can be seen in table 4.7-1. Many lessons from the early involvement on the Mir space station with SAMS are being applied to the plans for acceleration measurement support of the ISS users.

The primary responsibility of the PIMS groups is to support Microgravity Research Division (MRD) Investigators in the area of acceleration data analysis and interpretation. Also, PIMS provides MRD with expertise in the area of microgravity experiment requirements, vibration isolation, and the implementation of requirements on different spacecraft.

4.7.5.1. Preflight Services

PIMS is able to contribute to experiment teams long before the launch of the science experiment during the planning stage of the system. PIMS works at educating microgravity principal investigators about the various environments of the reduced gravity experiment platform and about the accelerometer systems available to measure the environments of those platforms. For the ISS environment users, PIMS can provide invaluable information about the acceleration data during the experiment planning stages that can help with the actual design of the hardware and result in the collection of acceleration data best suited for correlation with measured science data.

4.7.5.2. Experiment Operations Services

In addition to providing the proper microgravity environment education during experiment planning, PIMS works with investigators to design acceleration data displays and analysis techniques best suited for understanding potential relationships between measured acceleration data and the science results. A number of plot options, displays, and analysis techniques are currently available to principal investigators.

PIMS ground support equipment located at the TSC at GRC will be capable of generating a standard suite of acceleration data displays, including the various time domain and frequency domain options described in table 4.7-1. These data displays will be updated in real time and will

Table 4.7-1. Acceleration Data Analysis Techniques

Display format	Frequency regime	Notes
Acceleration versus time	Transient, quasi-steady, vibratory	Precise accounting of measured data with respect to time; best temporal resolution
Interval min/max acceleration versus time	Vibratory, quasi-steady	Displays upper and lower bounds of peak-to-peak excursions of measured data Good display approximation for time histories on output devices with resolution insufficient to display all data in time frame of interest
Interval average acceleration versus time	Vibratory, quasi-steady	Provides measure of net acceleration of duration greater than or equal to interval parameter
Interval RMS acceleration versus time	Vibratory	Provides measure of peak amplitude
Trimmed mean filtered acceleration versus time	Quasi-steady	Removes infrequent, large amplitude outlier data
Quasi-steady mapped acceleration versus time	Quasi-steady	Uses rigid body assumption and vehicle rates and angles to compute acceleration at any point in vehicle
Quasi-steady three-dimensional histogram	Quasi-steady	Summarizes acceleration magnitude and direction for long period of time Indication of acceleration “center-of-time” via projections onto three orthogonal planes
Power spectral density (PSD) versus frequency	Vibratory	Displays distribution of power with respect to frequency
Spectrogram (PSD versus frequency versus time)	Vibratory	Displays power spectral density variations with time Identifies structure and boundaries in time and frequency
Cumulative RMS acceleration versus frequency	Vibratory	Quantifies RMS contribution at and below given frequency
Frequency band RMS acceleration versus time	Vibratory	Quantify RMS contribution over selected frequency band(s) as function of time
RMS acceleration versus one-third frequency bands	Vibratory	Quantify RMS contribution over proportional frequency bands Compare measured data to ISS vibratory requirements
Principal component spectral analysis	Vibratory	Summarizes magnitude and frequency excursions for key spectral contributors over long period of time Results typically have finer frequency resolution and high PSD magnitude resolution relative to spectrogram at the expense of poor temporal resolution

periodically update images available via the PIMS WWW page. The planned update rate is every 2 min. Future plans involve routing the measured ISS acceleration data directly to the operations facilities of the principal investigators.

4.7.5.3. Postexperiment Services and Feedback

To supplement the near-real-time displays, planned information resources will also be provided throughout the tenure of the systems on the ISS. General characterizations of the environment as it evolves will be made available on a regular basis so that investigators are aware of the overall environment in which their experiments were conducted. Accelerometer data archives and automated data analysis servers will allow investigators the ability to request customized data analysis support. Additionally, a catalog of characterized disturbance sources will be available in the future in the form of an ISS Microgravity Environment Description Handbook.

Because of the dynamic nature of the microgravity environment and its potential to influence sensitive experiments, the Principal Investigator Microgravity Services Project has initiated a plan through which the data from these instruments will be distributed to researchers in a timely and meaningful fashion. Beyond the obvious benefit of correlation between accelerations and the scientific phenomena being studied, such information is also useful for hardware developers who can gain qualitative and quantitative feedback about their facility acceleration output to the ISS. Furthermore, a general characterization of the ISS microgravity environment will be obtained that affords scientists and hardware developers the preflight ability to anticipate the acceleration environment available for experimentation. Similar to STS operations, a handbook of acceleration disturbance sources for the ISS will be developed and maintained to provide a concise visualization of the ISS disturbance database.

4.7.6. Bibliography

- DeLombard, R.; McPherson, K.; Hrovat, K.; Moskowitz, M.; Rogers, M. J. B.; and Reckart, T.: Microgravity Environment Description Handbook. NASA TM-107486, 1997.
- McPherson, Kevin M.; Francisco, David R.; and DeLombard, Richard: Principal Investigator Microgravity Services—PIMS. B-0904, NASA Glenn Research Center, Nov. 1999.
- Rogers, Melissa J. B.; Hrovat, Kenneth; McPherson, Kevin; Moskowitz, Milton E.; and Reckart, Timothy: Accelerometer Data Analysis and Presentation Techniques. NASA TM-113173, 1997.
- Sutliff, Thomas J.; Rogers, Melissa J. B.; and DeLombard, Richard: Space Acceleration Measurement System—II. B-0879-A, NASA Glenn Research Center, June 1999.
- Wagar, Bill: MAMS Familiarization Handout. NASA Glenn Research Center, July 1999.

Appendix

Assembly Sequence

This appendix presents the stage or flight descriptions (in table format) for the ISS assembly sequence from stage 2A.1 through stage 16A. The source of this information was the International Space Station On-Orbit Assembly, Modeling, and Mass Properties Data Book, JSC-26557 (LESC-31166), Revision J, August 1999, that used the Design Analysis Cycle (DAC) 8, Revision E, Assembly Sequence.

The designations after the flight or stage number are defined as follows:

- AR stage configuration with orbiter attached, after rendezvous
- AS free-flying configuration, after separation of Progress, Soyuz, or orbiter
- BS stage configuration with orbiter attached, before separation
- IN stage configuration with orbiter attached, intermediate (if more than one intermediate configuration, IN is followed by a number)
- M flight showing ISS geometry changes after Soyuz movement

Flight or stage	Mission or flight ID	Description
Prior to 2A.1		RSA Zarya and U.S. Unity node 1 delivered; Zarya components included core module with starboard and port solar PVA's; node 1 components included core module, four hatch covers, port and starboard ECOMM antennas, and PMA 1 for aft and PMA 2 for fore; PMA 1 components included APFR, two WSS's, MDM sunshade, and ORU OTD
2A.1	U.S. STS-96	Strela operation station delivered installed to PMA 2 EFGF; EVA node bags tethered to aft, starboard node 1 end cone, including logistic and outfitting to Zarya and node 1
Prior to 1R		Configuration status adjusted for fuel usage occurring after stage 2A.1 orbiter departure
1R		RSA Zvezda docks to Zarya aft interface; Zvezda components include core module with starboard and port solar PVA's and highly directable antenna; requires 10 days from launch for rendezvous, docking, and systems checkout; provides early ISS living quarters; is primary docking location for Progress-type resupply vehicles
1P	RSA 251	Propellant transferred from Zarya to Zvezda; first RSA Progress M1 docks to Zvezda aft interface with solar PVA's rotated -45° about X-axis
Prior to 2A.2 AR		Progress M1 1P propellant is consumed for stage 1R reboost

Revision A, October 2000

Flight or stage	Mission or flight ID	Description
2A.2 AR	U.S. STS-101	Configuration is in state immediately following orbiter docking and prior to all assembly operations; orbiter docks to PMA 2 on node 1 forward interface with tail zenith
2A.2 BS		Strela operation station moved from PMA 2 to Zarya EFGF and Strela cargo boom installed on Strela operation station; contents of Progress M1 1P unloaded to Zarya and Zvezda; propellant transferred to Zvezda; logistic and outfitting from orbiter transferred to Zarya, Zvezda, and node 1
2A.2		Configuration is in state immediately following orbiter departure, including postdeparture assembly operations
Prior to 2P		Progress M1 1P propellant consumed for stage 2A.2 reboost and propellant transferred from Zarya to Zvezda for consumption
2P	RSA 252	Progress M1 2P docked to Zarya nadir interface with solar PVA's rotated +45° about Z-axis
3A AR	U.S. STS-92	Configuration is in state immediately following orbiter docking and prior to all assembly operations; orbiter docked to PMA 2 on node 1 forward interface with tail zenith
3A IN		Stowed Z1 ITA berths to node 1 zenith interface; Z1 ITA includes Z1 truss segment, Ku-band antenna, CMG's, S-band antenna with BSP, and PCU assembly; during EVA 1, two DDCU's installed on Z1 ITA, thermal shrouds removed from Z1 ITA and RPDA, and additional thermal shrouds installed on Z1 ITA
3A BS		During EVA 2, PMA 3 installed on node 1 nadir interface and oriented for orbiter tail forward docking; during EVA 3, Ku-band antenna deployed, starboard and port EVAS tool boxes (ETSD's) and CID's installed on Z1 ITA; during EVA 4, Z1 ITA umbilical tray deployed and connected to node 1 and Z1 ITA keel moved; outfitting transferred to Zarya, Zvezda, and node 1 from orbiter and Progress M1 2P; Progress M1 2P cargo unloaded—now ISS has early science capability
3A		Configuration is in state immediately following orbiter departure including postdeparture assembly operations
2R (1S)	RSA 204	Progress M1 1P departs after propellant transfer to Zarya and Zvezda; first RSA Soyuz TM (designated 1S) docked to Zvezda aft interface with solar PVA's rotated -45° about X-axis; Soyuz TM 1S delivers first three-person ISS crew; Soyuz TM serves as CRV until delivery of CRV 1, an X-38 derived vehicle
2P AS		Progress M1 2P departs after transferring propellant to Zarya and receiving waste from Zarya
4A AR	U.S. STS-97	Configuration is in state immediately following orbiter docking and prior to all assembly operations; orbiter docked to PMA 3 on node 1 nadir interface with tail forward
4A IN1		Stowed P6 ITA removed from orbiter payload bay with SRMS; P6 ITA positioned with SRMS to overnight parking position called thermal hover position; Zvezda propellant consumed

Flight or stage	Mission or flight ID	Description
4A IN2		During joint EVA 1 and SRMS operation, P6 ITA berths to Z1 ITA zenith; P6 ITA includes P6 truss segment, P6 TCS radiator, 12 batteries (6 sets), PV spacer, spacer PFCS, spacer thermal blankets, S4 TCS radiator, S6 TCS radiator, P6 S-band transponder, BG assembly, POA solar PVA, and POF solar PVA; EVA 1 completed in next stage
4A BS		Forward P6 TCS radiator deploys to complete EVA 1; following EVA 1, P6 ITA POA and POF solar PVA deployed for power channels 4B and 2B, respectively; during EVA 2, P6 ITA MLI removed and S-band antenna activated after relocation from Z1 ITA to P6 ITA zenith; hardware transferred from orbiter payload bay to node 1 and Zarya; hardware transferred from node 1 to P6 ITA
4A		Configuration is in state immediately following orbiter departure including postdeparture assembly operations
Prior to 3P		Propellant transferred from Zarya to Zvezda for consumption during stage 4A reboost
3P	RSA 242	Progress M (M and M1 are different vehicles) 3P docks to Zarya nadir interface with solar PVA's rotated +45° about Z-axis
Prior to 5A AR		Progress M 3P departs
5A AR	U.S. STS-98	Configuration is in state immediately following orbiter docking and prior to all assembly operations; orbiter docked to PMA 3 on node 1 nadir interface with tail forward
5A IN1		PMA 2 relocated from node 1 to Z1 ITA forward interface; PMA 2 rotated from orientation on node 1 +105° about X-axis with origin at Z1 ITA and PMA 2 interface center
5A IN2		During EVA 1, U.S. Lab berths to node 1 forward interface and S6 TCS radiator on P6 aft deployed; following EVA 1, EMU transferred from orbiter to Zarya and outfitting from orbiter transferred to node 1, Lab, Zarya, and Zvezda; during EVA 2, Lab PDGF installed; during EVA 3, S4 TCS radiator on P6 starboard deployed and spare S-band antenna installed on Z1 ITA; EVA 3 completed in next stage
5A BS		Relocation of PMA 2 from Z1 ITA to Lab forward interface completes EVA 3; PMA 2 oriented from orbiter tail nadir docking
5A		Configuration is in state immediately following orbiter departure including postdeparture assembly operations
1S M		Soyuz TM 1S relocated to Zarya nadir interface with solar PVA's rotated +45° about Z-axis
4P	RSA 253	Progress M1 4P docks to Zvezda after interface with solar PVA's rotated -45° about X-axis
5A.1 AR	U.S. STS-102	Configuration is in state immediately following orbiter docking and prior to all assembly operations; orbiter docked to PMA 2 on Lab forward interface with tail nadir
5A.1 IN1		PMA 3 relocated to node 1 port interface and oriented for orbiter tail nadir docking; ESA Leonardo MPLM installed on node 1 nadir interface

Flight or stage	Mission or flight ID	Description
5A.1 IN2		Leonardo unloaded; during EVA 1, LCA and Lab PDGF rigid umbilical installed; LCA positioned on Lab zenith; during EVA 2, EAS and ammonia jumper kit installed on P6 ITA; Ku-band antenna gimbal locks removed and PFCS attached to ESP installed on Lab port aft trunnion; EMU transferred from orbiter to Zarya and outfitting from orbiter transferred to Lab, Zarya, Zvezda, and node 1
5A.1 BS		Leonardo removed from node 1 and placed in orbiter payload bay; Ku-band antenna and electric power equipment checkouts and activation completed; first ISS crew replaced by second during crew exchange between ISS and orbiter
5A.1		Configuration is in state immediately following orbiter departure including postdeparture assembly operations
5P	RSA 243	Progress M1 4P departs prior to arrival of Progress M 5P; Progress M 5P docks to Zvezda aft interface with solar PVA's rotated -45° about X-axis
6A AR	U.S. STS-100	Configuration is in state immediately following orbiter docking and prior to all assembly operations; orbiter docked to PMA 2 on Lab forward interface with tail nadir
6A IN1		During EVA 1, SLP, a type of ULC, with LDA installed on LCA; installation done via the MTSAS, active portion on LCA, and passive portion on LDA; UHF antenna removed from SLP and installed on Lab; SSRMS transferred off SLP to Lab PDGF remotely with "walk" technique; node 1 port ECOMM antenna removed and stored in node 1; MPLM installed on node 1 nadir interface
6A IN2		MPLM contents unloaded; outfitting from orbiter transferred to Lab, Zarya, Zvezda, and node 1; items transferred between orbiter middeck and modules
6A BS		During EVA 2, node 1 starboard ECOMM antenna removed and stored in node 1, and SLP moved to orbiter payload bay; during EVA 3, MPLM moved to orbiter payload bay
6A		Configuration is in state immediately following orbiter departure including postdeparture assembly operations—ISS now has micro-gravity capability
7A AR	U.S. STS-104	Configuration is in state immediately following orbiter docking and prior to all assembly operations; orbiter docked to PMA 2 on Lab forward interface with tail nadir
7A BS		During EVA 1, the AL berthed to node 1 starboard interface; AL allows ISS-based EVA's after orbiter departure; during EVA 2, two HPGA oxygen tanks attached to AL; during EVA 3, scheduled ISS maintenance completed; during EVA 4, two HPGA nitrogen tanks attached to AL; Zvezda gas supply system augmented by HPGA's; two ECOMM antennas and IMAX camera transferred from node 1 to orbiter; outfitting from orbiter transferred to Zarya
7A		Configuration is in state immediately following orbiter departure including postdeparture assembly operations; assembly operations completed after orbiter departure: during EVA 5, AL handrails and WIF's installed, UHF antenna cable attached, and checkouts completed—ISS is now at PHASE 2 COMPLETE and has initial science capability

Flight or stage	Mission or flight ID	Description
2S	RSA 205	Progress M 5P departs prior to arrival of Soyuz TM 2S; Soyuz TM 2S docked to Zvezda aft interface with solar PVA's rotated -45° about X-axis
2S M		Soyuz TM 1S departs prior to Soyuz TM 2S relocation; Soyuz TM 2S relocated to Zarya nadir interface with solar PVA's rotated $+45^\circ$ about Z-axis
4R	RSA TBD	RSA DC 1 with Strela cargo boom stowed inside docks to Zvezda nadir interface; DC 1 provides EVA AL capability on Russian segment of ISS
6P	RSA 254	Progress M1 6P docks to Zvezda aft interface with solar PVA's rotated -45° about X-axis
7A.1 AR	U.S. STS-105	Configuration is in state immediately following orbiter docking and prior to all assembly operations; orbiter docked to PMA 2 on Lab forward interface with tail nadir
7A.1 BS		OTD and APFR installed on P6 during EVA; outfitting from orbiter transferred to Lab, Zarya, Zvezda, and node 1; second ISS crew replaced by third during crew exchange between ISS and orbiter
7A.1		Configuration is in state immediately following orbiter departure including postdeparture assembly operations
7P	RSA 255	Progress M1 6P departs prior to arrival of Progress M1 7P; Progress M1 7P docks to Zvezda aft interface with solar PVA's rotated -45° about X-axis; during EVA, Strela cargo boom stowed inside DC 1 relocated to DC 1 starboard exterior attachment point and egress device (ladder) installed on DC 1
UF1 AR	U.S. STS-106	Configuration is in state immediately following orbiter docking and prior to all assembly operations; orbiter docked to PMA 2 on Lab forward interface with tail nadir
UF1 BS		Outfitting from orbiter transferred to Lab, Zvezda, and node 1
UF1		Configuration is in state immediately following orbiter departure including postdeparture assembly operations
3S	RSA 211	Soyuz TM 3S docked to DC 1 nadir interface with solar PVA's positioned in ISS Y-Z plane; Soyuz TM 2S departs after Soyuz TM 3S arrives
8P	RSA 256	Progress M1 7P departs prior to arrival of Progress M1 8P; Progress M1 8P docks to Zvezda aft interface with solar PVA's rotated -45° about X-axis
8A AR	U.S. STS-108	Configuration is in state immediately following orbiter docking and prior to all assembly operations; orbiter docked to PMA 2 on Lab forward interface with tail nadir

Revision A, October 2000

Flight or stage	Mission or flight ID	Description
8A BS		During joint EVA 1 and RMS operation, S0 ITA installed on LCA; installation done via MTSAS, active portion on LCA and passive portion on S0 ITA; S0 ITA includes S0 truss segment, EV-CPDS, four MBSU's, MT with umbilical spools, TUS, PWP, four GPS antennas, module-truss bars, CETA AL spur, utility trays, Lab umbilicals, Hab umbilicals, avionics, RPDA, four DDCU's, and thermal shrouds; during EVA 1, forward MTSAS struts and three Lab avionics trays and umbilicals installed; MDM units, ORU heaters, and EV-CPDS activated; during EVA 2, additional MTSAS struts installed, LCA capture latch opened, and TUS cable connected; during EVA 3, Z1 ITA CID installed and powered-up, TUS cable connected, CETA AL spur (connecting S0 and AL) installed, EV-CPDS and GPS antennas deployed (although EVA's 4, 5, and 6 occur after orbiter departure, some of these activities completed in this stage); third ISS crew replaced by fourth during crew exchange between ISS and orbiter
8A		Configuration is in state immediately following orbiter departure including postdeparture assembly operations; assembly operations completed after orbiter departure: S0 ITA SSAS capture latches opened; during EVA 4, handrails and MT energy absorbers installed, the keel beam stowed, and MT checkout completed; during EVA 5, umbilicals, handrails, and utility connections installed; during EVA 6, umbilicals and Lab and node 1 CETA lights installed and S0 launch restraint pins released and stowed
9P	RSA 257	Progress M1 8P departs prior to arrival of Progress M1 9P; Progress M1 9P docks to Zvezda aft interface with solar PVA's rotated -45° about X-axis
UF2 AR	U.S. STS-109	Configuration is in state immediately following orbiter docking and prior to all assembly operations; orbiter docked to PMA 2 on Lab forward interface with tail nadir
UF2 BS		During EVA 1, Zarya PDGF installed; during joint EVA 1 and SSRMS operation, MBS installed on MT; during EVA 2, MBS installation concluded; SSRMS transferred to MBS remotely with walk technique and parked in a "keep alive" position; during EVA 3, scheduled ISS maintenance completed; additional EVA task completed is installation of S0 MDM radiator; outfitting from orbiter transferred to Lab, Zvezda, and node 1
UF2		Configuration is in state immediately following orbiter departure including postdeparture assembly operations
10P	RSA 258	Progress M1 9P departs prior to arrival of Progress M1 10P; Progress M1 10P docks to Zvezda aft interface with solar PVA's rotated -45° about X-axis
4S	RSA 206	Soyuz TM 4S docks to Zarya nadir interface with solar PVA's rotated $+45^\circ$ about Z-axis; Soyuz TM 4S delivers fifth ISS crew and Soyuz TM 3S departs ISS with fourth ISS crew
9A AR	U.S. STS-111	Configuration is in state immediately following orbiter docking and prior to all assembly operations; orbiter docked to PMA 2 on Lab forward interface with tail nadir

Flight or stage	Mission or flight ID	Description
9A BS		During SSRMS operation, S1 ITA installed on starboard side of S0 ITA; S1 ITA includes S1 truss segment, CETA cart A, three TCS radiators with respective support, S-band antenna, S1 EVA camera, node 1 EVA camera, avionics, DDCU, TRRJ, launch locks, utility trays, ammonia tanks, nitrogen tank, pump module assembly, and thermal shrouds; during EVA 1, S1 and S0 ITA utilities connected, TRRJ and radiator beam launch locks released, ammonia tank quick disconnects and umbilicals connected, and S-band antenna deployed; during EVA 2, S1 ITA EVA camera installed and CETA cart A deployed to MT; APFR and tool stanchion transferred to CETA cart A and S1 ITA active TCS radiator beam launch locks released; during EVA 3, CETA cart A light and light stanchion installed, inboard and outboard keel pin/drag links removed and stowed, and OTD and ETSD installed on CETA cart A; other assembly operations completed are deployment but not activation of the middle S1 TCS radiator panel and installation of node 1 EVA camera; orbiter middeck items transferred to Zvezda and EMU from orbiter transferred to AL
9A		Configuration is in state immediately following orbiter departure including postdeparture assembly operations
11P	RSA 259	Progress M1 10P departs prior to arrival of Progress M1 11P; Progress M1 11P docks to Zvezda aft interface with solar PVA's rotated -45° about X-axis
11A AR	U.S. STS-112	Configuration is in state immediately following orbiter docking and prior to all assembly operations; orbiter docked to PMA 2 on Lab forward interface with tail nadir
11A BS		During SSRMS operation, P1 ITA installed on port side of S0 ITA; P1 ITA includes P1 truss segment, CETA cart B, three TCS radiators with respective support, UHF antenna, P1 upper and lower EVA cameras, avionics, DDCU, TRRJ, launch locks, utility trays, ammonia tanks, nitrogen tank, pump module assembly, and thermal shrouds; during EVA operations, P1 and S0 utilities connected, TRRJ launch locks released, ammonia tank quick disconnects and umbilicals connected, UHF antenna deployed, P1 upper and lower EVA cameras installed, CETA cart B deployed to MT, CETA cart B light and light stanchion installed, inboard and outboard keel pin links removed and stowed, and middle P1 TCS radiator panel deployed but not activated; outfitting and EMU from orbiter transferred to AL
11A		Configuration is in state immediately following orbiter departure including postdeparture assembly operations
12P	RSA 260	Progress M1 11P departs prior to arrival of Progress M1 12P; Progress M1 12P docks to Zvezda aft interface with solar PVA's rotated -45° about X-axis
13P	RSA 261	Progress M1 12P departs prior to arrival of Progress M1 13P; Progress M1 13P docks to Zvezda aft interface with solar PVA's rotated -45° about X-axis
9A.1 AR	U.S. STS-114	Configuration is in state immediately following orbiter docking and prior to all assembly operations; orbiter docked to PMA 2 on Lab forward interface with tail nadir

Revision A, October 2000

Flight or stage	Mission or flight ID	Description
9A.1 BS		During SSRMS operation, stowed SPP berths to Zvezda zenith interface; SPP includes core truss, B20 activator, radiator, four solar PVA's with respective beam supports, and ERA; orbiter middeck items transferred to Zvezda and EMU transferred from AL to orbiter
9A.1		Configuration is in state immediately following orbiter departure including postdeparture assembly operations; assembly operations completed after orbiter departure: during Russian EVA 11, folded SPP radiator rotated 90° and interfaces between SPP, Zvezda, and Zarya connected; during Russian EVA 12, SPP core truss extended and thermal shielding and cargo boom adapter installed; during Russian EVA 13, video pointing units, two universal WS items, and active base points installed; during Russian EVA 14, movable WS locks and exterior ERA panel installed, ERA deployed and tested, and ERA elbow cameras installed
5S	RSA 212	Soyuz TM 5S docks to DC 1 nadir interface with solar PVA's positioned in ISS Y-Z plane; Soyuz TM 5S delivers sixth ISS crew; Soyuz TM 4S departs with fifth ISS crew after Soyuz TM 5S arrives
12A AR	U.S. STS-115	Configuration is in state immediately following orbiter docking and prior to all assembly operations; orbiter docked to PMA 2 on Lab forward interface with tail nadir
12A BS		During EVA operation, SSRMS installs P3 and P4 ITA on port side of P1; P3 and P4 ITA includes P3 truss segment, P3 utility trays, P3 rotary bulkhead, P3 SARJ rotor, P3 SARJ stator, P3 SARJ UTA, P3 upper ULCAS, P3 lower ULCAS, P4 truss segment, P4 radiator, eight P4 batteries, P4 BG, P3 and P4 bars, PIA solar PVA, and PIF solar PVA; during EVA operations, P4 PIA and PIF PVA's (power channels 2A and 4A) and P4 radiator deployed and activated (P4 PVA's unable to Sun track can only supply power to P4 ITA); EMU transferred from AL to orbiter
12A		Configuration is in state immediately following orbiter departure including postdeparture assembly operations
14P	RSA 262	Progress M1 13P departs prior to arrival of Progress M1 14P; Progress M1 14P docks to Zvezda aft interface with solar PVA's rotated -45° about X-axis
Prior to 12A.1 AR		Assembly operations completed: during Russian EVA 15, B20 activator installed on SPP core truss, Regul antenna pointing unit installed on B20 activator, and contaminant monitoring system installed; during Russian EVA 16, both SPP solar PVA beam supports installed; during Russian EVA 17, SPP solar PVA 1 installed and deployed; during Russian EVA 18, SPP solar PVA 2 installed and deployed; during Russian EVA 19, SPP radiator deployed; during Russian EVA 20, SPP solar PVA 3 installed and deployed, and the komplast panel removed from Zarya (SPP solar PVA configuration is two on starboard side and one on port side)
12A.1 AR	U.S. STS-117	Configuration is in state immediately following orbiter docking and prior to all assembly operations; orbiter docked to PMA 2 on Lab forward interface with tail nadir

Flight or stage	Mission or flight ID	Description
12A.1 BS		During EVA operations, P5 truss segment installed on port side of P4 ITA, OSE stowed on P5 truss segment, PMA 3 relocated to node 1 nadir interface and oriented for orbiter tail starboard docking, port P6 ITA POA solar PVA (power channel 4B) retracted, S6 TCS radiator on P6 aft retracted, S4 TCS radiator on P6 starboard retracted, P3 SARJ activated to allow P4 solar PVA's to Sun track, S1 and P1 TCS radiators activated, and critical spares exchanged with on-orbit hardware; sixth ISS crew is replaced by seventh during crew exchange between ISS and orbiter
12A.1		Configuration is in state immediately following orbiter departure including postdeparture assembly operations
15P	RSA 263	Progress M1 14P departs prior to arrival of Progress M1 15P; Progress M1 15P docks to Zvezda aft interface with solar PVA's rotated -45° about X-axis
13A AR	U.S. STS-118	Configuration is in state immediately following orbiter docking and prior to all assembly operations; orbiter docked to PMA 2 on Lab forward interface with tail nadir
13A BS		During EVA, SSRMS installs S3 and S4 ITA on starboard side of S1; S3 and S4 ITA includes S3 truss segment, S3 utility trays, S3 rotary bulkhead, S3 SARJ rotor, S3 SARJ stator, S3 SARJ UTA, four S3 PAS's, S4 truss segment, eight S4 batteries, S4 BG, S3, and S4 bars, SIA solar PVA, and SIF solar PVA; during additional EVA operations, S4 TCS radiator on P6 starboard transferred to S4 ITA, starboard P6 ITA POF solar PVA (power channel 2B) retracted, and forward P6 TCS radiator retracted; orbiter middeck items transferred to Zvezda from Lab
13A		Configuration is in state immediately following orbiter departure including postdeparture assembly operations; assembly operations completed after orbiter departure: during EVA, S-band antenna with BSP and transponder transferred from P6 ITA to P1 ITA and P6 ITA transferred to port side of P5 ITA; P6 ITA POA and POF solar PVA's deployed for power channels 4B and 2B, respectively, and nadir P6 TCS radiator deployed
6S	RSA 213	Soyuz TM 6S docks to Zarya nadir interface with solar PVA's rotated $+45^\circ$ about Z-axis; Soyuz TM 5S departs after Soyuz TM 6S arrives; crew exchange schedules after 13A TBD
16P	RSA 264	During Russian EVA 21, Strela cargo boom on DC 1 transferred to SPP core truss and DC 1 utilities disconnected prior to arrival of Progress M1 16P; Progress M1 16P docks to DC 1 nadir interface with solar PVA's positioned in ISS Y-Z plane
16P AS		Progress M1 16P and DC 1 depart
3R		UDM docks to Zvezda nadir interface with solar PVA's rotated -45° about Z-axis; nonarticulating starboard and port UDM PVA's deployed
5R		DC 2 docks to UDM nadir interface then berths to UDM starboard interface
10A AR	U.S. STS-120	Configuration is in state immediately following orbiter docking and prior to all assembly operations; orbiter docked to PMA 2 on Lab forward interface with tail nadir

Flight or stage	Mission or flight ID	Description
10A BS		During EVA operations, an NTA (a component of HPGA) resupplied and Italian extended node 2 berths to node 1 port interface; orbiter middeck items transferred to Zvezda
10A		Configuration is in state immediately following orbiter departure including postdeparture assembly operations; assembly operations completed after orbiter departs: during EVA operations, node 2 transferred to Lab forward interface with PMA 2 on node 2 forward interface (PMA 2 oriented for orbiter tail nadir docking)
17P	RSA 265	Progress M1 15P departs prior to arrival of Progress M1 17P; Progress M1 17P docked to Zvezda aft interface with solar PVA's rotated -45° about X-axis; Progress M1 17P cargo items, docking cone, and KuRS millimeter antenna installed on UDM for RM 1 and Zarya, respectively
10A.1 AR	U.S. STS-121	Configuration is in state immediately following orbiter docking and prior to assembly operations; orbiter with PM berthed to ODS docked to PMA 2 on node 2 forward interface with tail nadir
10A.1 BS		PM provides U.S. propulsive attitude control and reboost capability; orbiter middeck items transferred to Zvezda
10A.1		Configuration is in state immediately following orbiter departure including postdeparture assembly operations; assembly operations completed after orbiter departs: during Russian EVA 24, Strela is moved from Zarya to UDM; during Russian EVA 25, SPP solar PVA 4 installed and deployed (SPP solar PVA configuration is two on each side—starboard and port); during Russian EVA 26, gas protective device installed, thermal shielding removed, and SPP B20 activator mechanism released; SPP solar PVA's now capable of Sun tracking; additional EVA's install SPP, Zvezda, and UDM interfaces
18P	RSA 266	Progress M1 17P departs prior to arrival of Progress M1 18P; Progress M1 18P docks to Zvezda aft interface with solar PVA's rotated -45° about X-axis
1J/A	U.S. STS-123	Configuration is in state immediately following orbiter departure including postdeparture assembly operations; ERA transferred from SPP core truss forward to aft, JEM ELM PS berthed to node 2 zenith interface, and ULC installed on SPP core truss; ULC includes two SPP solar PVA's with respective beam supports and Zvezda MM/OD conformal shields; EMU transferred from orbiter to AL and orbiter middeck items transferred to Zvezda
7S	RSA 214	Soyuz TM 7S docks to UDM nadir interface with solar PVA's rotated $+45^\circ$ about Z-axis; Soyuz TM 6S departs after Soyuz 7S arrives
19P	RSA 267	Progress M1 18P departs prior to arrival of Progress M1 19P; Progress M1 19P docks to Zvezda aft interface with solar PVA's rotated -45° about X-axis
Prior to 1J		Two SPP solar PVA's and respective beam supports from SPP ULC installed (SPP solar PVA configuration is three on each side—starboard and port)

Flight or stage	Mission or flight ID	Description
1J	U.S. STS-124	Configuration is in state immediately following orbiter departure including postdeparture assembly operations; Kibo JEM PM berths to node 2 port interface; JEM ELM PS transferred to JEM PM zenith interface; JEM RMS installed on port side of Kibo; JEM activated; EMU transferred to orbiter from AL and orbiter middeck items transferred to Zvezda
20P	RSA 268	Progress M1 19P departs prior to arrival of Progress M1 20P; Progress M1 20P docks to Zvezda aft interface with solar PVA's rotated -45° about X-axis
Prior to UF3		Zvezda MM/OD conformal shields installed; Zarya PVA's retracted; remaining S1 and P1 ITA TCS radiator panels deployed
UF3	U.S. STS-125	Configuration is in state immediately following orbiter departure including postdeparture assembly operations; the ExP A with SAGE III, HMC, and EMP payloads installed on lower, outboard S3 ITA PAS; EMU transferred from orbiter to AL and orbiter middeck items transferred to Zvezda
21P	RSA 269	Progress M1 20P departs prior to arrival of Progress M1 21P; Progress M1 21P docks to Zvezda aft interface with solar PVA's rotated -45° about X-axis
UF4	U.S. STS-127	Configuration is in state immediately following orbiter departure including postdeparture assembly operations; SPDM installed on MBS, ExP B installed on S3 ITA upper, outboard PAS; AMS installed on S3 ITA upper, inboard PAS; EMU transferred to orbiter from AL; orbiter middeck items transferred to Zvezda and Zarya; ammonia tanks replaced
22P	RSA 270	Progress M1 21P departs prior to arrival of Progress M1 22P; Progress M1 22P docks to Zvezda aft interface with solar PVA's rotated -45° about X-axis
8S	RSA 215	Soyuz TM 8S docks to Zarya nadir interface with solar PVA's rotated $+45^\circ$ about Z-axis; Soyuz TM 7S departs after Soyuz TM 8S arrives
2J/A	U.S. STS-128	Configuration is in state immediately following orbiter departure including postdeparture assembly operations; JEM EF with payloads attached to aft mounting on JEM PM to provide exposed experimental facilities for Japanese segment; JEM ELM ES with payloads attached to JEM EF core; JEM EF and JEM ELM ES activated; two battery sets added to both S4 and P4 ITA's; orbiter middeck items transferred to Zarya
Prior to ATV1		Soyuz TM 8S relocated to UDM nadir interface with solar PVA's rotated $+45^\circ$ about Z-axis
ATV1		Configuration is in state immediately following orbiter departure including postdeparture assembly operations; Progress M1 22P departs prior to arrival of ATV 1; ATV 1 docks to Zvezda aft interface for reboost operations and to resupply propulsion and dry cargo
9R	RSA TBD	Configuration is in state immediately following orbiter departure including postdeparture assembly operations; DSM docks to Zarya nadir interface with solar PVA's positioned in ISS Y-Z plane; nonarticulating starboard and port DSM PVA's deployed

Flight or stage	Mission or flight ID	Description
23P	RSA TBD	ATV 1 departs prior to arrival of Progress M1 23P; Progress M1 23P docks to Zvezda aft interface with solar PVA's rotated -45° about X-axis
14A	U.S. STS-130	Configuration is in state immediately following orbiter departure including postdeparture assembly operations; ULC with MT rail FSE installed on P3 ITA upper ULCAS (assume 6A ULC configuration with FSE); MT rails from ULC on P3 ITA installed on P4, P5, and P6 ITA's; SPP ULC from stage 1J/A removed and different ULC installed on SPP core truss; ULC includes two SPP solar PVA's with respective beam supports and Zvezda MM/OD debris wings; one SPP solar PVA with respective beam support and remaining SPP beam support removed from SPP ULC and installed (SPP solar PVA configuration is three on port side and four on starboard side); cupola berthed to node 1 port interface; orbiter middeck items are transferred to Zvezda, Zarya, and node 2
UF5	U.S. STS-131	Configuration is in state immediately following orbiter departure including postdeparture assembly operations; ExP C installed on S3 ITA lower, inboard PAS; orbiter middeck items transferred to Zarya; outfitting from orbiter transferred to Lab and JEM PM; MELFI replaced; final SPP solar PVA and Zvezda MM/OD debris wings removed from SPP ULC and installed (SPP solar PVA configuration is four on each side—starboard and port)
24P	RSA 272	Progress M1 23P departs prior to arrival of Progress M1 24P; Progress M1 24P docks to Zvezda aft interface with solar PVA's rotated -45° about X-axis
9S	RSA 216	Soyuz TM 9S docks to DSM nadir interface with solar PVA's rotated $+45^\circ$ about Z-axis; Soyuz TM 8S departs after Soyuz TM 9S arrives
25P	RSA 273	Progress M1 24P departs prior to arrival of Progress M1 25P; Progress M1 25P docks to Zvezda aft interface with solar PVA's rotated -45° about X-axis
HTV1		HTV 1 departs after 7 days berthed to node 2 nadir interface
20A	U.S. STS-133	Configuration is in state immediately following orbiter departure including postdeparture assembly operations; node 3 berthed to node 1 nadir interface after PMA 3 temporarily attached to node 2 nadir interface; PMA 3 relocated to node 3 nadir interface and oriented for orbiter tail forward docking; node 3 provides additional life support capability and berthing locations for future ISS elements; EMU transferred from orbiter to AL and orbiter middeck items transferred to Zvezda and Zarya
26P	RSA 274	Progress M1 25P departs prior to arrival of Progress M1 26P; Progress M1 26P docks to Zvezda aft interface with solar PVA's rotated -45° about X-axis
1E	U.S. STS-134	Configuration is in state immediately following orbiter departure including postdeparture assembly operations; ESA CM berths to node 2 starboard interface; orbiter middeck items transferred to Zvezda and Zarya
8R		RM 1 docks to UDM nadir interface and then berths to UDM port interface

Flight or stage	Mission or flight ID	Description
17A	U.S. STS-135	Configuration is in state immediately following orbiter departure including postdeparture assembly operations; orbiter middeck items transferred to Zvezda and Zarya; outfitting transferred from orbiter to node 3; EMU transferred from AL to orbiter
27P	RSA 275	Progress M1 26P departs prior to arrival of Progress M1 27P; Progress M1 27P docks to Zvezda aft interface with solar PVA's rotated -45° about X-axis; RM 1 external payloads installed
18A	U.S. STS-136	Configuration is in state immediately following orbiter departure including postdeparture assembly operations; CRV CBA berths to node 3 starboard interface just prior to CRV 1 berthing to CRV CBA; CRV 1 oriented tail forward; EMU transferred from orbiter to AL and orbiter middeck items transferred to Zvezda and Zarya
10S	RSA 217	Soyuz TM 10S docked to UDM nadir interface with solar PVA's rotated $+45^\circ$ about Z-axis; Soyuz TM 9S departs after Soyuz TM 10S arrives
28P	RSA 276	Progress M1 27P departs prior to arrival of Progress M1 28P; Progress M1 28P docks to Zvezda aft interface with solar PVA's rotated -45° about X-axis
19A	U.S. STS-137	Configuration is in state immediately following orbiter departure including postdeparture assembly operations; S5 truss segment installed on starboard side of S4 ITA; SPP ULC from stage 14A removed; three additional crew members delivered to ISS for a total of six (ISS now has six-person permanent presence capability); orbiter middeck items transferred to Zvezda and Zarya; outfitting from orbiter transferred to node 2—ISS is now U.S. ASSEMBLY COMPLETE
10S_M		Soyuz TM 10S relocated to DSM nadir interface with solar PVA's rotated $+45^\circ$ about Z-axis
HTV2		HTV 2 departs after 7 days berthed to node 2 nadir interface
15A	U.S. STS-138	Configuration is in state immediately following orbiter departure including postdeparture assembly operations; S6 ITA installed on starboard side of S5 ITA; S6 ITA includes S6 truss segment, PV spacer, eight batteries (four sets), BG assembly, S6 MT rails, S5 MT rails, S4 MT rails, SOA solar PVA, and SOF solar PVA; BG assembly, SOA and SOF solar PVA's for power channels 1B and 3B, and S6 TCS radiator relocated from P6 to S6 ITA deployed; S6 ITA power activated; S6, S5, and S4 MT rails installed on their respective truss segment; EMU transferred to orbiter from AL and orbiter middeck items transferred to Zvezda and Zarya
10R		RM 2 docks to UDM nadir interface and then berths to UDM forward interface
29P	RSA 277	Progress M1 28P departs prior to arrival of Progress M1 29P; Progress M1 29P docks to Zvezda aft interface with solar PVA's rotated -45° about X-axis; RM 2 external payloads installed
UF7	U.S. STS-139	Configuration is in state immediately following orbiter departure including postdeparture assembly operations; CAM berthed to node 2 zenith interface (CAM provides additional research facility); P3 ITA ULC from stage 14A removed; orbiter middeck items transferred to Zvezda and Zarya

Revision A, October 2000

Flight or stage	Mission or flight ID	Description
UF6	U.S. STS-140	Four S6 ITA batteries (two sets) installed; orbiter middeck items transferred to Zarya
30P	RSA 278	Progress M1 29P departs prior to arrival of Progress M1 30P; Progress M1 30P docks to Zvezda aft interface with solar PVA's rotated -45° about <i>X</i> -axis
11S	RSA 218	Soyuz TM 11S docks to UDM nadir interface with solar PVA's rotated $+45^\circ$ about <i>Z</i> -axis; Soyuz TM 10S departs after Soyuz TM 11S arrives
16A BS	U.S. STS-141	U.S. Hab berths to node 3 port interface and activated (Hab provides additional crew accommodations); one additional crew member delivered to ISS, for a total of seven; orbiter middeck items transferred to node 1, Zvezda, and AL
16A		Configuration is in state immediately following orbiter departure including postdeparture assembly operations—ISS is now at ASSEMBLY COMPLETE
31P	RSA 279	Progress M1 30P departs prior to arrival of Progress M1 31P; Progress M1 31P docks to Zvezda aft interface with solar PVA's rotated -45° about <i>X</i> -axis
HTV3		HTV 3 departs after 7 days berthed to node 2 nadir interface