



DIAMOND TOOLS & EQUIPMENT

NEW Products for 2016

THREE GENERATIONS BEYOND

ARIX™ Technology

ARIX Technology places diamond particles in three dimensional patterns to deliver optimum performance.



Advanced multi-layered diamond segments with precise distribution of diamond particles throughout the segment

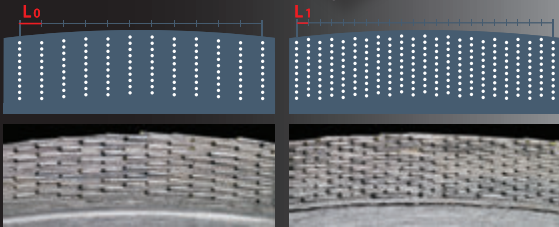
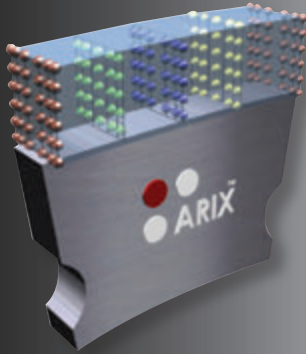

STEALTH-12



Dual Hydraulic Power Pack

Brute Core Bits



C-52 Threaded Core Bits

Industrial Floor Scrubber



Monster, Brute and Jet Stream Blade Series



TG18 -18 Inch Propane Grinder / Polisher

Discover the **DITEQ** Difference!



- 4-7** **Professional Diamond Blades**
High Horsepower Flat Saw Blades
- 8** **Green Concrete Diamond Blades / Equipment / Joint & Crack Repair**
G-TEQ Early Entry Saw / Diamond Blades
- 9** **Green Concrete Diamond Blades / Equipment / Joint & Crack Repair**
Diamond Blades / Skid Plates for Soff-Cut® Saws
- 10** **Green Concrete Diamond Blades / Equipment / Joint & Crack Repair**
Joint Widening Diamond Blades / Wire Brushes / Crack Repair
- 11** **Hydraulic Equipment / Blades**
Hydraulic Core Drill / Breakers / Power Packs
- 12** **Hydraulic Equipment / Blades**
Hydraulic Ring Saws / Diamond Blades
- 13** **Hydraulic Equipment / Blades**
Hydraulic Hand / HydraSaws / Diamond Blades
- 14-15** **Hydraulic Equipment / Blades**
Hydraulic Diamond Chain Saws / Diamond Chain
- 16** **Wall Saw / Diamond Blades / Diamond Wire**
Wall Saw Diamond Blades
- 17** **Wall Saw / Diamond Blades / Diamond Wire**
SHIBUYA Wall Saw / Diamond Blades / Diamond Wire
- 18-20** **Diamond Core Bits / Core Drill Machines**
Diamond Core Bits
- 21** **Diamond Core Bits / Core Drill Machines**
Core Bit Retipping Machines / Segments
- 22-26** **Diamond Core Bits / Core Drill Machines**
SHIBUYA Core Drill Machines
- 27-29** **Diamond Core Bits / Core Drill Machines**
Core Drill Accessories / Parts
- 30-31** **General Purpose Diamond Blades**
High Speed / Flat Saw / Masonry & General Purpose Diamond Blades
- 32-33** **General Purpose Diamond Blades**
High Speed / Masonry Diamond Blades / Masonry Saw
- 34-35** **Grinding Wheels / Scarifier Tools**
Diamond Cup Grinding Wheels
- 35** **Grinding Wheels / Scarifier Tools**
Carbide Cutters / Scarifier Tooling
- 36-37** **Vacuum Systems / Shrouds**
Industrial Vacuums
- 36** **Vacuum Systems / Shrouds**
Shrouds
- 38** **Floor Scrubbers**
Rideable Scrubbers / Walk Behind Scrubbers
- 39** **Floor Scrubbers**
Compact Scrubbers
- 39** **Slurry Control / Clean-up Supplies**
SlurrySep and Slurry Dry / Pressure Washers
- 39** **Slurry Control / Clean-up Supplies**
Concrete Destroyer / Sprayers
- 40-41** **Surface Prep Equipment and Tooling**
Grinders / Polishers
- 40-45** **Surface Prep Equipment and Tooling**
Diamond Tooling
- 46** **Surface Prep Equipment and Tooling**
Polishing Pads and Rings
- 47-48** **Surface Prep Equipment and Tooling**
Burnishers / Burnisher Pads
- 48** **Surface Prep Equipment and Tooling**
Cleaners / Hardeners / Densifier Chemicals
- 49** **Tuckpoint Blades / Abrasives**
Tuckpoint Blades / Abrasives
- 50-51** **Stone and Tile Fabrication Tooling**
Diamond Blades / Wire
- 52-53** **Stone and Tile Fabrication Tooling**
Core Bits / Router Bits / Profile Wheels
- 54** **Stone and Tile Fabrication Tooling**
Diamond Polishing Pads
- 55** **Terms and Conditions / Warranty**
Terms and Conditions / Warranty

Diamond Blade Operating Speeds		
Diameter	Recommended Operating Speed (RPM)*	Maximum Safe Speed (RPM)
4"	9,072	15,000
4-1/2"	8,063	13,300
5"	7,257	12,000
6"	6,048	10,185
7"	5,184	8,730
8"	4,536	7,640
9"	4,032	6,790
10"	3,629	6,110
12"	3,024	5,090
12" High Speed		6,300
14"	2,592	4,365
14" High Speed		5,460
16"	2,268	3,820
16" High Speed		4,725
18"	2,016	3,395
20"	1,814	3,055
22"	1,649	2,775
24"	1,512	2,545
26"	1,396	2,350
28"	1,296	2,180
30"	1,210	2,035
32"	1,134	1,910
36"	1,008	1,695
42"	864	1,455
48"	756	1,270
54"		1,130
60"		1,015

*Based on 9,500 SFPM (Surface Feet Per Minute)

Maximum Blade Cutting Depth			
Blade Diameter	Cutting Depth	Blade Diameter	Cutting Depth
Concrete Saw Blades		Masonry Saw Blades	
12"	3-5/8"	14"	5"
14"	4-5/8"	18"	7"
16"	5-5/8"	20"	8"
18"	6-5/8"	Power Hand Saw Blades	
20"	7-5/8"	6"	1-3/4"
24"	9-5/8"	7"	2-1/4"
26"	10-5/8"	8"	2-3/4"
30"	12-3/8"	9"	3-1/4"
36"	14-7/8"	10"	3-3/4"
42"	17-3/8"	Tile Saw Blades	
48"	19-7/8"	4"	1"
High Speed Saw Blades		4-1/2"	1-1/4"
12"	4"	5"	1-1/2"
14"	5"	7"	2-1/2"
16"	6"	8"	3"
Wall Saw Blades		10"	3-3/4"
18"	6-1/2"		
24"	9-1/2"		
30"	11-1/2"		
36"	14-1/2"		
42"	17-3/4"		
48"	20-3/4"		

ARIX™ Professional High Horsepower Flat Saw Diamond Blades

Cured Concrete

ARIX PROFESSIONAL CURED CONCRETE DIAMOND BLADE - NORMAL APPLICATION CHART

*Faster Speed
Softer Aggregate
Lower Horsepower* ← → *Harder Aggregate
Higher Horsepower*

AGGREGATE	C-43AX10	C-53AX10	C-53AX13	C-63AX13
SOFT	●	●		
MEDIUM SOFT	●	●	●	
MEDIUM HARD			●	●
HARD				●



C-43AX10

★★★★PRO IV D

Diameter & Width	Part No.	List
14" x .125" x 1"-DP	D10065	\$639
14" x .187" x 1"-DP	D18316	925
14" x .250" x 1"-DP	D18318	1,185
18" x .125" x 1"-DP	D10067	784
18" x .145" x 1"-DP	D18324	914
18" x .160" x 1"-DP	D18325	1,017
20" x .125" x 1"-DP	D18329	968
20" x .145" x 1"-DP	D10068	1,028
20" x .160" x 1"-DP	D18331	1,076
24" x .160" x 1"-DP	D18333	1,401
26" x .160" x 1"-DP	D18517	1,454
26" x .160" x 1"-DP with insert	D18526	1,613
30" x .160" x 1"-DP with insert	D18615	1,849

Insert for undercut protection



WET ONLY
10 mm / .393 in.
segment height



C-53AX10

★★★★★PRO V D

Diameter & Width	Part No.	List
14" x .125" x 1"-DP	D18275	\$687
14" x .250" x 1"-DP	D18281	1,238
16" x .125" x 1"-DP	D18283	805
16" x .145" x 1"-DP	D18284	1,011
16" x .160" x 1"-DP	D18520	1,022
18" x .125" x 1"-DP	D18519	914
18" x .145" x 1"-DP	D18287	1,022
18" x .160" x 1"-DP	D18288	1,130
18" x .187" x 1"-DP	D18290	1,293
20" x .125" x 1"-DP	D18292	1,022
20" x .145" x 1"-DP	D18293	1,076
20" x .160" x 1"-DP	D18294	1,185
20" x .187" x 1"-DP	D18386	1,401
24" x .145" x 1"-DP	D18295	1,401
24" x .160" x 1"-DP	D18296	1,454
24" x .187" x 1"-DP	D18298	1,617
26" x .160" x 1"-DP	D18300	1,563
26" x .160" x 1"-DP with insert	D18401	1,710
26" x .187" x 1"-DP	D18302	1,725
28" x .187" x 1"-DP	D18418	2,467
28" x .187" x 1"-DP with insert	D18724	2,617
30" x .160" x 1"-DP	D18303	1,833
30" x .160" x 1"-DP with insert	D18640	2,039
30" x .187" x 1"-DP	D18305	2,050
36" x .160" x 1"-DP	D18309	2,374
36" x .187" x 1"-DP	D18311	2,590
42" x .187" x 1"-DP with insert	D18710	3,672
48" x .187" x 1"-DP	D18725	4,213

Insert for undercut protection



WET ONLY
10 mm / .393 in.
segment height



C-53AX13

★★★★★PRO V D

Diameter & Width	Part No.	List
18" x .125" x 1"-DP	D18397	\$1,142
20" x .160" x 1"-DP	D18390	1,325
20" x .160" x 1"-DP with insert	D18711	1,401
26" x .160" x 1"-DP with insert	D18651	1,942
26" x .160" x 1"-DP	D18391	1,797
26" x .187" x 1"-DP with insert	D18393	2,050
28" x .187" x 1"-DP	D18737	2,200
28" x .187" x 1"-DP with insert	D18743	2,300
30" x .187" x 1"-DP	D18736	2,295
30" x .160" x 1"-DP with insert	D18713	2,158
30" x .187" x 1"-DP with insert	D18714	2,374
32" x .160" x 1"-DP with insert	D18715	2,482
36" x .160" x 1"-DP with insert	D18717	2,699
36" x .187" x 1"-DP with insert	D18718	2,915

Insert for undercut protection



WET ONLY
13 mm / .512 in.
segment height



C-63AX13

★★★★★PRO VI D *Great for Bridge Decks*

Diameter & Width	Part No.	List
14" x .125" x 1"-DP	D14830	\$1,076
14" x .145" x 1"-DP	D14843	1,185
14" x .160" x 1"-DP	D18500	1,293
18" x .125" x 1"-DP	D14854	1,293
18" x .145" x 1"-DP	D18511	1,401
18" x .160" x 1"-DP	D14860	1,563
20" x .125" x 1"-DP	D14868	1,454
20" x .145" x 1"-DP	D18512	1,563
20" x .160" x 1"-DP	D18513	1,617
20" x .187" x 1"-DP	D18701	1,887
24" x .160" x 1"-DP	D14888	2,050
24" x .160" x 1"-DP with insert	D14893	2,242
24" x .187" x 1"-DP	D14892	2,211
26" x .160" x 1"-DP	D14900	2,158
26" x .160" x 1"-DP with insert	D14901	2,244
26" x .187" x 1"-DP	D14902	2,320
30" x .160" x 1"-DP	D18226	2,428
30" x .160" x 1"-DP with insert	D18688	2,531
30" x .187" x 1"-DP	D18231	2,536
32" x .160" x 1"-DP	D18232	2,915
36" x .160" x 1"-DP	D18235	3,023
36" x .160" x 1"-DP with insert	D18694	3,131
36" x .187" x 1"-DP	D18237	3,564
42" x .187" x 1"-DP	D18035	4,223

Insert for undercut protection



WET ONLY
13 mm / .512 in.
segment height

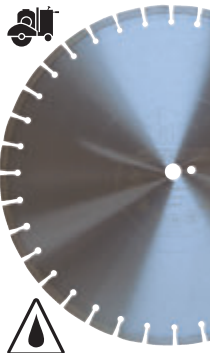

WET ONLY
13 mm / .512 in.
segment height

C-42N13 Traditional

★★★★ PRO IV High Performance
Fast Cut/Longest Life

Diameter & Width	Part No.	List
14" x .125" x 1"-DP	D13001	\$579
14" x .145" x 1"-DP	D13002	644
14" x .160" x 1"-DP	D13003	703
16" x .125" x 1"-DP	D13004	644
16" x .145" x 1"-DP	D13005	671
16" x .160" x 1"-DP	D13039	812
18" x .125" x 1"-DP	D13006	752
18" x .145" x 1"-DP	D13007	795
18" x .160" x 1"-DP	D13008	860
18" x .187" x 1"-DP	D13038	1,136
20" x .125" x 1"-DP	D13009	805
20" x .145" x 1"-DP	D13015	860
20" x .160" x 1"-DP	D13016	968
20" x .187" x 1"-DP	D13030	1,271
24" x .145" x 1"-DP	D13017	1,185
24" x .160" x 1"-DP	D13018	1,238

Diameter & Width	Part No.	List
24" x .160" x 1"-DP with insert	D13043	1,320
24" x .187" x 1"-DP	D13019	1,401
26" x .145" x 1"-DP	D13020	1,238
26" x .160" x 1"-DP	D13021	1,293
26" x .160" x 1"-DP with insert	D13029	1,401
26" x .187" x 1"-DP	D13022	1,422
30" x .160" x 1"-DP	D13023	1,509
30" x .160" x 1"-DP with insert	D13042	1,622
30" x .187" x 1"-DP	D13024	1,725
32" x .160" x 1"-DP	D13025	1,779
32" x .187" x 1"-DP	D13026	1,942
36" x .160" x 1"-DP*	D13027	2,103
36" x .187" x 1"-DP*	D13028	2,158
42" x .187" x 1"-DP*	D13036	3,071
48" x .187" x 1"-DP*	D13031	3,456

*Insert for undercut protection * wide notch blades*

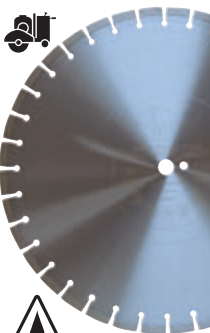

WET ONLY
13 mm / .512 in.
segment height

C-72N13 Traditional

★★★★★ PRO VII

Diameter & Width	Part No.	List
14" x .125" x 1"-DP	D14973	\$720
14" x .145" x 1"-DP	D14974	822
14" x .160" x 1"-DP	D14975	1,041
16" x .125" x 1"-DP	D14976	845
16" x .145" x 1"-DP	D14977	1,031
16" x .160" x 1"-DP	D14978	1,105
18" x .125" x 1"-DP	D14979	1,006
18" x .145" x 1"-DP	D14980	1,071
18" x .160" x 1"-DP	D14964	1,244
18" x .187" x 1"-DP	D14967	1,492
20" x .125" x 1"-DP	D14982	1,071
20" x .145" x 1"-DP	D14983	1,128
20" x .160" x 1"-DP	D14960	1,334
20" x .187" x 1"-DP	D14968	1,677
24" x .160" x 1"-DP	D14963	1,617
24" x .187" x 1"-DP	D14969	1,936
26" x .160" x 1"-DP	D14966	1,725
26" x .160" x 1"-DP with insert	D14985	1,808
26" x .187" x 1"-DP	D14965	1,925
30" x .160" x 1"-DP	D14959	2,055
30" x .160" x 1"-DP with insert	D14984	2,235
30" x .187" x 1"-DP	D14970	2,542
36" x .160" x 1"-DP	D14971	2,542
36" x .160" x 1"-DP with insert*	D14986	2,645
36" x .187" x 1"-DP*	D14972	3,050
42" x .187"	D15003	3,400
42" x .187" with insert*	D15008	3,510

** Wide notch blades Insert for undercut protection*

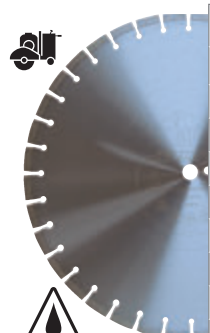

WET ONLY
13 mm / .512 in.
segment height

C-82N13 Traditional

★★★★★ PRO VIII

Diameter & Width	Part No.	List
14" x .125" x 1"-DP	D15063	\$773
14" x .145" x 1"-DP	D15058	884
14" x .145" x 1"-DP with insert	D15062	934
16" x .125" x 1"-DP	D15067	925
16" x .145" x 1"-DP	D15068	1,050
16" x .160" x 1"-DP	D15066	1,188
18" x .125" x 1"-DP	D15072	1,150
18" x .160" x 1"-DP	D15061	1,337
20" x .145" x 1"-DP with insert	D15071	1,240
20" x .160" x 1"-DP	D15051	1,434
24" x .160" x 1"-DP	D15052	1,738
26" x .160" x 1"-DP	D15054	1,854
26" x .160" x 1"-DP with insert	D15065	1,944
26" x .187" x 1"-DP with insert	D15055	2,177
30" x .160" x 1"-DP	D15053	2,403
30" x .160" x 1"-DP with insert	D15069	2,525
30" x .187" x 1"-DP with insert	D15056	2,840
36" x .160" x 1"-DP with insert*	D15070	3,095
36" x .187" x 1"-DP with insert*	D15057	3,386

** Wide notch blades Insert for undercut protection*

PROFESSIONAL CURED CONCRETE

DIAMOND BLADE - NORMAL APPLICATION CHART

Faster Speed ← → Harder Aggregate
Softer Aggregate Higher Horsepower
Lower Horsepower

AGGREGATE	C-42N13	C-72N13	C-82N13
SOFT	●		
MEDIUM SOFT	●	●	
MEDIUM HARD		●	●
HARD			●

Professional High Horsepower Flat Saw Diamond Blades

Hard Rock /
Electric

PROFESSIONAL CURED CONCRETE DIAMOND BLADE APPLICATION CHART - HARD ROCK

Faster Speed ← → Longer Life
Very Hard ← → Critically Hard

AGGREGATE	C-73AX13	C-74AX13	C-83N13	C-8313
VERY HARD	●	●	●	
CRITICALLY HARD		●	●	●



WET ONLY
13 mm / .512 in.
segment height

Diamond Blades for Hard Rock

Diameter & Width	C-73AX13	C-74AX13	C-83N13	C-8313	
	ARIX G3 PRO VII Part No.	ARIX G3 PRO VII Part No.	Traditional PRO VIII Part No.	D List	PRO VIII Part No. D List
14" x .125" x 1"-DP	D18902		D14113	\$1,095	
14" x .160" x 1"-DP	D18706		D14108	1,276	D14836 \$1,400
18" x .125" x 1"-DP			D14114	1,325	
20" x .160" x 1"-DP	D18903	D14895	D14106	1,942	D18015 2,185
22" x .160" x 1"-DP	D18909	D18910		2,100	
26" x .160" x 1"-DP	D18702		D14110	2,250	
30" x .160" x 1"-DP	D18703		D14111	2,788	
30" x .187" x 1"-DP WS	D18744				
36" x .160" x 1"-DP	D18705		D14112	3,395	

PROFESSIONAL ELECTRIC FLAT SAW DIAMOND BLADE APPLICATION CHART

Faster Speed
Harder Aggregate ← → Softer Aggregate

Horsepower	C-42AX10	C-51AX13	C-42N13	C-43AX10	C-53AX10
10	●				
15	●	●			
20	●	●	●	●	
30		●	●	●	
40		●	●	●	●
50					●

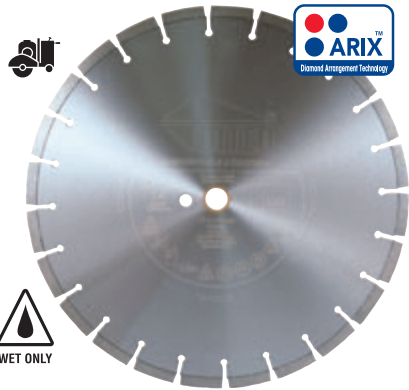

Diamond Blades Electric Flat Saws

Diameter & Width	C-42AX10		C-51AX13		C-42N13		C-43AX10		C-53AX10	
	ARIX PRO IV Part No.	D List	ARIX G3 PRO V Part No.	D List	Traditional PRO IV Part No.	D List	ARIX PRO IV Part No.	D List	ARIX PRO V Part	D List
14" x .125" x 1"-DP	D10073	\$481	D10111	\$536	D13001	\$579	D10065	\$639	D18275	\$687
16" x .125" x 1"-DP			D18425	690						
18" x .125" x 1"-DP	D11063	649	D18420	749	D13006	752	D10067	784	D18519	914
18" x .145" x 1"-DP			D18429	820	D13007	795	D18324	914	D18287	1,022
20" x .125" x 1"-DP	D10075	644	D10113	709	D13009	805	D18329	968	D18292	1,022
20" x .145" x 1"-DP	D10086	752			D13015	860	D10068	1,028	D18293	1,076
20" x .160" x 1"-DP					D13016	968	D18331	1,076	D18294	1,185
24" x .125" x 1"-DP	D10080	914	D18426	1,250			D18740	1,200		
24" x .145" x 1"-DP	D10102	1,076			D13017	1,185	D18332	1,293	D18295	1,401
24" x .160" x 1"-DP							D18333			1,401
26" x .145" x 1"-DP					D13020	1,238				
26" x .160" x 1"-DP					D13021	1,293	D18517	1,454	D18300	1,563
30" x .160" x 1"-DP					D13023	1,509	D18340	1,746	D18303	1,833

Asphalt Overlay Diamond Blades

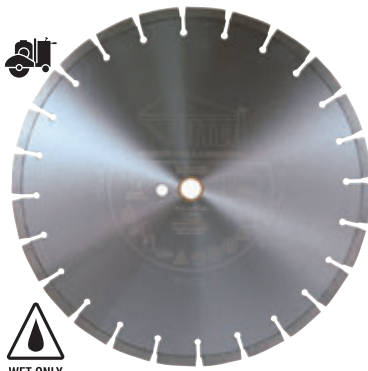

WET ONLY
13 mm / .512 in.
segment height

PROFESSIONAL ASPHALT OVERLAY DIAMOND BLADES			
	Faster Speed ←	→	More Life Slower Speed
AGGREGATE	C-63AX13	C-73AX13	C-84N13
SOFT		●	●
MEDIUM		●	●
HARD	●	●	●

Diameter & Width/Protection	C-63AX13 with Insert PRO VI		C-73AX13 with Wedge PRO VII G3		C-84N13 with Insert PRO VIII	
	Part No.	List	Part No.	List	Part No.	List
26" x .160" x 1"-DP	D14901	\$2,244	D18453	\$2,295		
26" x .187" x 1"-DP	D18686	2,428	D18452	2,495	D15073	\$2,177
30" x .160" x 1"-DP	D18688	2,531				
30" x .187" x 1"-DP	D18690	2,644				
36" x .160" x 1"-DP	D18694	3,131				
36" x .187" x 1"-DP	D18674	3,270				

*wide notch

PROFESSIONAL ASPHALT DIAMOND BLADES

AGGREGATE	Faster Speed Shorter Life		Slower Speed Longer Life		
	A46N	A46	A48	A55N	A56N
SOFT			●		●
MEDIUM	●	●	●	●	●
HARD	●	●		●	

Asphalt Diamond Blades



WET ONLY

A46N A46 A48 and A55N A56N Asphalt

Diameter & Width	★★★★ PRO IV		★★★★★ PRO V				
	A46N13 PRO IV	D List	A46 PRO IV	A48 PRO IV	A55N PRO V	A56N13 PRO V	D List
14" x .125" x 1"-DP	D26301	\$613	D26133	D28312	D27223	D27001	\$730
14" x .145" x 1"-DP			D26135	D28316	D27224	D27002	784
14" x .160" x 1"-DP				D28318	D27225	D27003	968
14" x .187" x 1"-DP			D26137	D28320	D27226	D27004	1,028
14" x .250" x 1"-DP			D29336		D27227	D27005	1,271
16" x .125" x 1"-DP			D26141	D28328	D27228	D27006	892
16" x .145" x 1"-DP			D28331	D28332	D27221	D27007	947
16" x .160" x 1"-DP					D27222		989
18" x .125" x 1"-DP	D26308	795	D26145	D28336	D27229	D27008	947
18" x .145" x 1"-DP			D26146	D28340	D27230	D27009	1,000
18" x .160" x 1"-DP			D26148	D28342	D27231	D27010	1,271
18" x .187" x 1"-DP			D26149	D28344	D27232	D27011	1,325
18" x .250" x 1"-DP					D27233	D27012	1,537
20" x .125" x 1"-DP			D26151	D28348	D27234	D27013	1,216
20" x .145" x 1"-DP			D28351	D28352	D27235	D27014	1,271
20" x .160" x 1"-DP			D26154	D28354	D27236	D27015	1,325
20" x .187" x 1"-DP					D27237	D27016	1,441
24" x .160" x 1"-DP			D26161	D28368	D27238	D27017	1,541
24" x .187" x 1"-DP				D28370	D27239	D27018	1,725
24" x .250" x 1"-DP					D27240	D27019	2,540
26" x .160" x 1"-DP	D26320	1,449	D26165	D28376	D27241	D27020	1,725
26" x .187" x 1"-DP			D26166	D28378	D27242	D27021	1,887
30" x .160" x 1"-DP	D26322	1,817	D26550		D27243	D27022	2,163
30" x .187" x 1"-DP	D26323	1,994		D29312	D27244	D27023	2,374
36" x .160" x 1"-DP					D27245	D27024	2,518
36" x .187" x 1"-DP				D28908	D27246	D27025	2,590
42" x .187" x 1"-DP			D29342				3,780

Green Concrete Diamond Blades / G-TEQ Early Entry Saws

Green Concrete Diamond Blades

PROFESSIONAL GREEN CONCRETE DIAMOND BLADES

AGGREGATE	C83N	A46	A55N	A56N	A59
SOFT					●
MEDIUM		●	●	●	
HARD	●		●		

C83N / A46 / A55N / A56N / A59 Green Concrete Blades

Diameter & Width	PROVIII		PROIV		PROV		D List	
	C83N	List	A46	A55N	A56N13	List		
14" X .125" X 1"-DP			D26133	D27223	D27001	\$730	D28748	\$784
14" x .145" x 1"-DP			D26135	D27224	D27002	784	D28750	892
14" x .160" x 1"-DP	D14836	\$1,952		D27225	D27003	968		
14" X .187" X 1"-DP			D26137	D27226	D27004	1,028		
16" X .125" X 1"-DP			D26141	D27228	D27006	892	D28756	968
16" X .145" X 1"-DP			D28331	D27221	D27007	947	D28800	1,022
18" X .125" X 1"-DP			D26145	D27229	D27008	947	D28760	1,055
18" X .145" X 1"-DP			D26146	D27230	D27009	1,000	D28620	1,108
18" x .160" x 1"-DP			D26148	D27231	D27010	1,271		1,293
18" x .187" x 1"-DP			D26149	D27232	D27011	1,325		

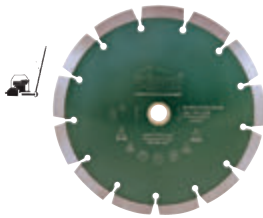
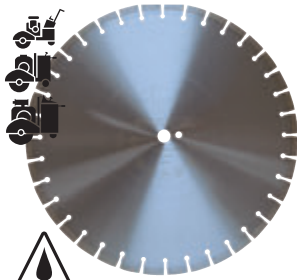

G33 Segmented Green Concrete Blade

Diameter & Width	Part No.	List	D
8" x .095" x 5/8"-7/8"	D12079	\$163	
10" x .095" x 5/8"	D12088	205	



12 mm / .472 in. segment height



GC-45AX 46AX Early Entry Blades

with 1" Arbors

★★★★ Pro IV

Diameter/Width	GC-45AX Orange	GC-46AX Yellow	D List
12" x .125" x 1" DP	D22650		\$466
14" x .125" x 1" DP	D22648	D22649	589

Refer to application chart on next page

G-TEQ Early Entry Saws

Model No.	G-TEQ 450	G-TEQ 200E
PUSH/SELF-PROPELLED	Push	Push
HORSEPOWER	4.5HP	2HP Electric
ENGINE/MOTOR	Subaru EX13	120V, 1 PH, 17 FLA
Max. Depth of Cut*	1.5 in.	1.5 in.
Weight	115 lb.	115 lb.
PART No.	F50001	F50002
LIST <i>E</i>	\$3,085	\$3,239

*With new blade - will be reduced as blade wears

Accessories	Part No.	List
Air Filter 4.5HP	100321	\$30.00
Flat trac wheel kit	100301	130.00
Dust Chute	100311	45.00
Outer Clamping Disc	100308	90.00
Outer Clamping Disc Bolt	100309	1.08



G-TEQ Green Concrete Connection Blades (Z-Arbor)

★★★ Super Premium

Diameter & Width	Hard Material ← → Soft Material				D List
	GC-31 Purple	GC-32 Green	GC-34 Red	GC-36 Yellow	
6.5" x .095" x 8.5mm	D22301	D22302	D22303	D22304	\$146

G-TEQ Deco Bevel Blades

★★★ Super Premium

Diameter/Width	Z-Arbor Part No.	D List
5" x 3/8" x 1/8" V	D22811	\$330
5" x 5/8" x 1/8" V	D22812	368
5" x 5/8" x 1/4" V	D22813	401
5" x 1/4" x 1/8" R	D22809	422
5" x 1/2" x 1/8" R	D22810	449



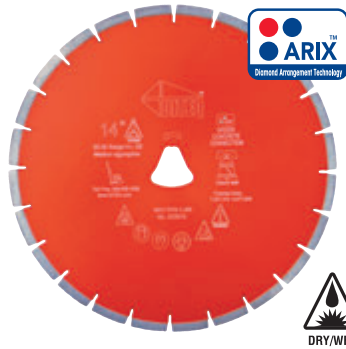

EARLY ENTRY BLADE APPLICATION CHART FOR GREEN CONCRETE

CONNECTION AND LIBERTY BELL ARBOR BLADES

Color Code	Clear	Purple	Green	Orange	Red	Yellow
For fast curing concrete / extreme hot weather	●					
Extremely hard aggregates, medium sharp sand		●				
Hard aggregates, sharp abrasive sand			●	●		
Medium aggregates, medium sharp sand			●	●	●	
Medium to hard aggregates, all types sand				●	●	
Medium soft aggregates, medium abrasive sand						●

ARIX Liberty Bell Arbor Green Concrete Blades

★★★★ PRO IV

Diameter & Width	Soff-Cut® Model	Hard Material ← Soft Material →					D List
		GC-40AX Clear	GC-41AX Purple	GC-42AX Green	GC-45AX Orange	GC-46AX Yellow	
6" x .095" x 10mm	150		D22681	D22682	D22683	D22684	\$153
8" X .095" x 10mm	2000/2500		D22685	D22686	D22687	D22688	249
10" x .095" x 10mm	2000/2500		D22631	D22632	D22633	D22634	314
10" x .187" x 10mm	2000/2500				D22651		550
10" x .250" x 10mm	2000/2500		D22638	D22639	D22617	D22618	644
12" x .125" x 10mm	4000/4200/5000	D22657	D22601	D22612	D22607	D22635	466
12" x .187" x 10mm	4000/4200/5000				D22652		740
12" x .220 x 10mm	4000/4200/5000				D22646		703
12" x .250" x 10mm	4000/4200/5000		D22602	D22613	D22608	D22640	790
13.5" x .125" x 10mm	4000/4200	D22645	D22627	D22628	D22629	D22636	552
13.5" x .187" x 10mm	4000/4200				D22644		812
13.5" x .250" x 10mm	4000/4200		D22641	D22642	D22619	D22620	882
14" x .125" x 10mm	5000		D22604	D22630	D22610	D22637	589
14" x .187 x 10mm	5000				D22653		820
14" x .250" x 10mm	5000		D22605	D22616	D22611	D22643	903

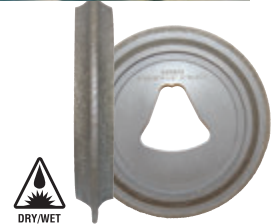

**Liberty Bell Arbor
Deco Bevel Blades**

★★★ Super Premium

Diameter/Width	Bell Arbor Soff-Cut Part No.	D List
5" x 3/8" x 1/8" V	D22801	\$330
5" x 5/8" x 1/8" V	D22802	368
5" x 5/8" x 1/4" V	D22803	401
5" x 3/4" x 3/8" V	D22804	487
5" x 1" x 1/2" V	D22805	497
5" x 1/4" x 1/8" R	D22806	422
5" x 1/2" x 1/8" R	D22807	449

Liberty Bell Arbor Green Concrete Blades

★★★ Super Premium



Diameter/Width	Hard Material ← Soft Material →				D List
	GC-31 Purple	GC-32 Green	GC-34 Red	GC-36 Yellow	
6" x .095" x 10mm	D22501	D22502	D22503	D22504	\$146
8" x .095" x 10mm	D22506	D22507	D22508	D22509	238

Skid Plates for Soff-Cut Saws



Description	Skid Plate Part No.	Soff-Cut® Model	P List
6"-8" x .095"	100608	150	\$40
9"-10" x .095"	100609	2000 / 2500	45
9"-10" x .187"	100728	2000 / 2500	45
9"-10" x .250"	100612	2000 Prowler / 2500	45
12"-13.5" x .125"	100610	4000 Prowler, 4200	50
12"-13.5" x .187"	100729	4000/4200	50
12"-13.5" x .250"	100613	4000 Prowler, 4200	50
12"-14" x .125"	100611	5000	55
12"-14" x .187"	100730	5000	55
12"-14" x .250"	100614	5000	55

Skid Plate Refurbishment Kits

Soff-Cut® Skid Plate

Cast-Away™ Refurbishment Kit

Description	Boot'Em™		Soff Cut® Model	P List
	Part No.	Part No.		
5"-5.5" x .095"	100220	100236	390	\$17.51
6"-8" x .095"	100221	100237	150/750 Prowler, 450	17.51
6"-8" x .225"	100226	100242	150/750 Prowler, 450	19.57
9"-10" x .095"	100222	100238	2000 Prowler, 2500	21.00
9"-10" x .250"	100227	100243	2000 Prowler, 2500	23.00
12"-13.5" x .125"	100223	100239	4000 Prowler, 4200	23.00
12"-14" x .125"	100224	100240	5000	24.00
12"-13.5" x .250"	100230	100246	4000 Prowler, 4200	25.00
12"-14" x .250"	100233	100249	5000	24.00

Soff-Cut® is a registered trademark of Soff-Cut® International, Inc. Boot'Em™ is a registered trademark of Swift Industries, Inc. Boot'Em™ patent no. 7,007,686. Cast Away™ is patent pending.

Joint Widening Diamond Blades / Wire Brushes / Crack Repair

JOINT WIDENING BLADES

AGGREGATE	C33	A38	A46N13	A46	A56N13
SOFT		•			•
MEDIUM	•			•	
HARD			•		



10 mm / .393 in.
segment height

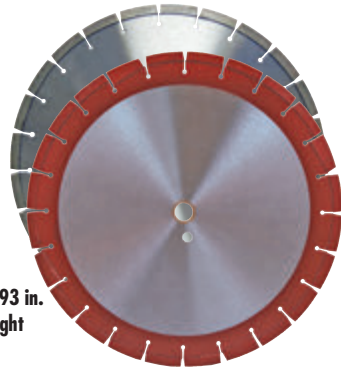

Widening Blades

Diameter & Width	Super Premium			PRO IV		PRO V		D
	C33	A38	List	A46N13	List	A46	A56N13	
14" X .187" X 1"-DP	D12087	D24066	\$536	D26304	\$863	D26137	D27004	\$1,028
14" X .250" X 1"-DP	D12062	D24063	695	D26305	1,067	D29336	D27005	1,271
14" X .375" X 1"-DP	D12063	D24064	812			D28325		1,942
14" X .500" X 1"-DP	D12085	D24065	1,136					
18" X .250" X 1"-DP				D26312	1,292		D27012	1,537

Blade Spacers

Diameter & Width	Part No.	List
8" x .03" thick x 1"-DP	110092	\$12.36
8" x .048" thick x 1"-DP	110107	10.00
8" x .07" thick x 1"-DP	110093	12.36
8" x .12" thick x 1"-DP	110094	13.39
8" x .18" thick x 1"-DP	110095	16.48
8" x .25" thick x 1"-DP	110096	19.57



Wire Brush

Diameter & Width	Part No.	List
12" x 3/8" x 1"-DP	100218	\$87

*Brushes priced individually. Sold 2 per box in whole box quantities only.
Low horsepower flat saws (5 to 20 hp) use only. 5/8" minimum blade clamping thickness.*



shown stacked together

Bevel Blades *** Super Premium

Diameter & Width	Part No.	List
12" x .375" x 1"-DP 45°	D22808*	\$968

*priced each



Carbide-Edge Routing Cutters / Crack Chasers

No. of Teeth	O.D.	I.D.	Thickness	Part No.	List
7	4.84"	1.00"	.36"	160805	\$73
7	4.84"	1.00"	.36"	161786*	99

* Full hub. More sizes available upon request!



CR C35 Beveled V-Crack Chaser

Diameter & Width	Part No.	List
4" x cont. type x 5/8"-11 thrd	D90001	\$211
4 x .375" x 5/8-11	D90008	157
4" x .375" x 7/8"-5/8"	D90002	146
5" x .375" x 7/8"-5/8"	D90003	184
7" x .375" x 7/8"-5/8"	D90004	298
8" x .375" x 1"	D90005	471

Accessories

Description	Part No.	List
Hardened spacer	161777	\$1.03
Pin 7/8" Dia x 4-1/4" L	161776	8.76

More sizes available upon request!

C-TEQ Crack Chasing Saw

POWER	22HP	22HP
Engine	Subaru	Subaru
RPM	5400	5400
Overall Width	30"	30"
Overall Length	53"	53"
Handle Height	42" to 51"	42" to 51"
Blade Depth	0 to 1-1/2"	0 to 1-1/2"
Weight	450 lb.	450 lb.
Blade Capacity	6"	6"
Blade Width	1/4"-3/4"	1/4"-3/4"
Model No.	C-TEQ 220	C-TEQ 220A
Part No.	F40003	F40007*
List Price	\$9,728	\$9,728

* Rubber wheels for use on asphalt

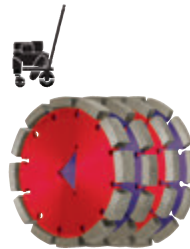

C-TEQ Saw Blades

Dia. & Width	C31		A34	D
	Concrete	Asphalt		
6" x .250"	D22401	D22402		\$190
6" x .375"	D22403	D22404		298
6" x .500"	D22405	D22406		379
6" x .750"	D22407	D22408		514

Z-Arbor for C-TEQ Crack Chasing Saw only.

Hydraulic Core Drill / Breakers / RGC Hydraulic Power Packs



Hydraulic Hand Core Drill Rigs

Motor	HHCD104	HHCD214
Max. RPM	1500 @ 5 gpm 2400 at 8 gpm	600 at 5 gpm 950 at 8 gpm
Bit Capacity	1-4"	2-14"
Bit Thread	1-1/4-7 UNC	1-1/4-7 UNC
Speed	Variable	Variable
Weight	17 lb.	17 lb.
Part No.	DR2026	DR2027
List E	\$2,825	\$2,825

Requires minimum of 5 gpm @ 1500-2500 psi. Includes hose whips

Hydraulic Breakers

Weight Class	20 lb	40 lb	70 lb	90 lb
Power	5 gpm@2300 psi	5 gpm@2300 psi	8 gpm@2300 psi	10 gpm@2300 psi
Tool Size	3/4" x 2"	1-1/4" x 6"	1-1/4" x 6"	1-1/4" x 6"
Tool Included	one 3/4 x 2" pointed (151856)	one 1 1/4 x 6" pointed	one 1-1/4 x 6" pointed	one 1-1/4 x 6" pointed
Weight	22 lb.	54 lb.	61 lb.	74 lb.
PART No.	H20001	H20003	H20007	H20012
List E	\$2,440	\$2,838	\$3,069	\$3,539

20 lb breaker requires size special bits - see above. Other breakers use standard size bits. Other breaker sizes available.

NEW



20 lb. Breaker Tools		P
Description	Part No.	List
3/4 x 2" w/ 2" Chisel	151854	\$85
3/4 x 1" w/ 1" Chisel	151855	42
3/4 x 2" w/ Pointed Tip	151856	48

Other tool sizes and types available.



Hydraulic Hoses	Part No.	List P
1/2" OD x 50 ft long	151859	\$560
1/2" OD x 25 ft long	151867	376

Flow Divider	Part No.	List E
Hydraulic Flow Divider*	140746	\$806

*Input - do not exceed 21 GPM, Output set at 5, 8 or 10 GPM depending on the orifice used - all 3 provided

Hydraulic Power Packs

Model No.	16 HP Gas	23 HP Gas	35 HP Gas	15 HP Electric
Engine/Motor	B & S Vanguard	B & S Vanguard	B & S Vanguard	480V 3PH, 60 Hz
Power	5 or 8 gpm@2000-2500 psi	0-12 gpm@1750/2000/2500 psi	Dual 0-12 gpm@2250	0-12 gpm@1750/2000/2500 psi
Weight	226 lb.	280 lb.	436 lb.	280 lb.
PART No.	P00008	P00001	P00015	P00002
List E	\$7,100	\$9,110	\$14,680	\$9,594

Other models available.

Hydraulic flow divider P/N 140746 \$806 (E) (Input - do not exceed 21 GPM, Output set at 5, 8 or 10 GPM depending on the orifice used - all 3 provided)

Professional Ring Saw / Diamond Blades

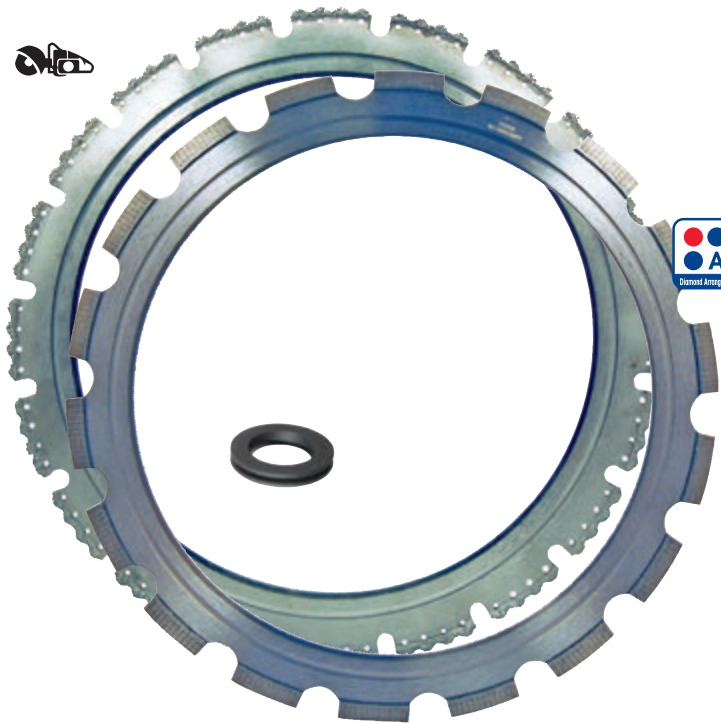

RING SAW DIAMOND BLADES

AGGREGATE	C-50AXS	C-50AX	C-51AX
SOFT			●
MEDIUM		●	●
HARD	●	●	

Ring Saw Blades

★★★★★ PRO V

Diameter & Width	ARIX		Vacuum Brazed Wet/Dry	D List
	C-50AX Wet Only	C-51AX Wet Only		
14" x .160" x 10mm	D10107	D10077		\$427
14" x .220" x 10mm	D10108			536
14" x .163" x 10mm			D10153*	454
*for ductile - cast iron				
Accessories	Part No.			List
Drive Wheel for 14"	D10052			\$22
<i>Drive Wheel included with each blade</i>				



Hydraulic Ring Saw

Model No.	HHRS
Blade Capacity	16"
Cutting Depth	11-3/4"
RPM	4100@8 gpm
Weight	24 lb.
PART No.	H00018
LIST E	\$4,920
<i>Includes guard, water attachment for wet sawing, hose whips w/flush face fittings, trigger lockout and a diamond ring blade. Requires 8-10 gpm@ 2300 psi</i>	

ARIX Ring Saw Blades for HHRS

★★★★★ PRO V

Diameter & Width	ARIX		D List
	C-50AXS	C-50AX	
16" x .160" x 10mm	D10163	D10159	\$795
16" x .235" x 10mm	D10164		900
P			
Accessories	Part No.		List
Drive Wheel for 16"	140689		\$35
<i>Drive Wheel included with each blade</i>			







C-50AX DP-DS Ring Saw Blades

★★★★★ PRO V

Diameter & Width	ARIX	D List
	C-50AX	
16" x .160" x 10mm	D10160	\$895
20" x .160" x 10mm	D10161	1,295

Hand Saw / Diamond Blades





HYDRAULIC HAND SAW DIAMOND BLADES

	 C42-AX	 C50-AXW	 G3 BRUTE C50AXT	 C51AX
AGGREGATE				
SOFT	●			
MEDIUM	●		●	●
HARD		●	●	●



C42-AX / C50-AXW / C51AX Hydraulic Hand Saw Blades

★★★★PROIV ★★★★★PROV

Diameter & Width	 C-42AX10	D	 C-50AXW	D	 G3 C-50AXT BRUTE	D	 C-51AX	D
	10mm PRO IV Part No.		List		13mm PRO V Part No.		List	
14" x .125" x 1" DP Flush	D10073	\$481	D10122	\$509	D11170	\$550	D10111	\$536
16" x .125" x 1" DP Flush	D10081	536	D10123	557	D11171	600	D10112	589
16" x .165" x 1" DP Flush	D10093	644						
18" x .125" x 1" DP Flush					D11172	650		
20" x .125" x 1" DP Flush	D10075	644	D10124	671			D10113	709
20-5/8" x .125" x 1" DP Flush					D11173	720		
24" x .125" x 1" DP Flush	D10080	914			D11174	1,025	D10114	1,006

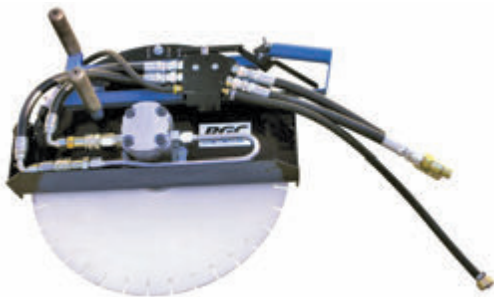

FS20 shown with upright handle kit



S16 Hydrasaw



FS20 Flushcut Hand Saw

	FS20 w/Std Handle	FS20 w/Std Handle & Upright Handle Kit	FS20 w/Upright Handle Kit
Model No.			
Blade Capacity	20"	20"	20"
Cutting Depth	8"	8"	8"
RPM	1830@8 gpm	1830@8 gpm	1830@8 gpm
Weight	57 lb.	98 lb.	83 lb.
PART No.	H00016	H00017	H00020
LIST E	\$2,764	\$4,031	\$2,862

Includes guard, water attachment for wet sawing, hose whips with flush face fittings and trigger lockout. Requires 5-8 gpm@ 2000-2500 psi.

Hydrasaws

	S14	S16	S20	S24
Model No.				
Blade Capacity	14"	16"	20"	24"
Cutting Depth	5-1/4"	6"	7-1/2"	9-1/2"
RPM	4100@8 gpm	2750@8 gpm	1830@8 gpm	1450@8 gpm
Auxiliary Handle	N/A	N/A	Included	Included
Weight	28 lb.	39 lb.	52 lb.	55 lb.
PART No.	H00019	H00013	H00014	H00015
LIST E	\$1,779	\$2,120	\$2,610	\$2,660

Includes guard, water attachment for wet sawing, hose whips w/flush face fittings and trigger lockout. Requires 5-8 gpm@ 2000-2500 psi

HydraSaw Accessories	Part No.	List E
Wall mount kit, 39"	140705	\$899
Wall mount kit, 84"	140706	1,003
Wall mount door guide kit	140707	1,139
Saw Cart Assy for S14/S16 only	140687	1,040

Hydraulic Chain Saw / Diamond Chain

NEW!

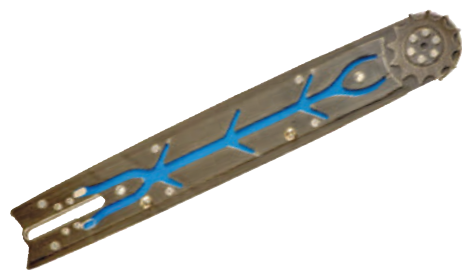

This separated bar shows the details of the guide bar manifold for water distribution. Precision machined ports on alternating sides of the bar ensure even distribution of water across the entire chain, not just one side.

STEALTH-12

- Efficiently cuts concrete, brick, decorative stone and utility pipe.
- Precise, square corners up to 25" deep
- Lightweight, ergonomic saw with optimal balance
- Standard features include an x-ring cover seal, a self-retained clamping plate and nuts, a reliable srench holder, a durable hand guard, and a replaceable rubber bumper pad.
- Compatible with the majority of bars, chains and sprockets on the market today.

STEALTH-12 Hydraulic Chain Saw

Bar Length	10"	15"	20"	25"
Weight (Powerhead)	22.9 lb.	22.9 lb.	22.9 lb.	22.9 lb.
Length/Width/Height	22/8/11 in.	22/8/11 in.	22/8/11 in.	22/8/11 in.
Power @ 2500 psi	17.5 HP	17.5 HP	17.5 HP	17.5 HP
Torque @ 2500 psi	170 in.-lb.	170 in.-lb.	170 in.-lb.	170 in.-lb.
Maximum Speed	6500 RPM	6500 RPM	6500 RPM	6500 RPM
Hydraulic Supply	12 GPM	12 GPM	12 GPM	12 GPM
Hydraulic Pressure (max)	2500 psi	2500 psi	2500 psi	2500 psi
Water Flow (min)	2.5 GPM	2.5 GPM	2.5 GPM	2.5 GPM
Water Pressure (min)	30 psi	30 psi	30 psi	30 psi
PART No.	H10013	H10014	H10015	H10016
LIST E	\$5,192	\$5,377	\$5,551	\$5,840

Includes bar and chain



STEALTH-12 Diamond Chain / Bars / Sprocket

Size	10"	15"	20"	25"
Chain Spec	H50S	H57S	H67S	H79S
Part No.	140650	140653	140664	140671
List Price A	\$1,295	\$1,495	\$1,695	\$2,095
Guide Bar				
Part No.	140732	140733	140734	140735
List Price P	\$166	\$219	\$273	\$423
Sprocket				
Part No.	140688	140688	140688	140688
List Price P	\$275	\$275	\$275	\$275

Chain Specs

- G** = Segment Every Other Link
 - H** = Segment Every Link
 - S** = Speed Bond
 - L** = Life Bond
- Other Chains/Bars/Sprockets/Transtorque Available



RGC Hydraulic Mini Chain Saw

Bar Length	13"	15"
Power	8 gpm@2000-2250 psi	8 gpm@2000-2250 psi
Trigger	Dual function*	Dual function*
PART No.	H10002	H10003
LIST E	\$2,812	\$3,037

*Includes bar and chain *starts and stops saw and water simultaneously*

Mini Chain Saw Accessories	13" Mini Chain Saw		15" Mini Chain Saw		
	H50S	List	H55S	List	
Sprocket	140685	\$150	140685	\$150	P
Guide Bar	140597	225	140598	237	P
Diamond Chain .375P	140446	1,060	140652	1,166	A

Hydraulic and Electric Chain Saws



Hydraulic Chain Saw - RGC C150/12 GPM* with .456P Chain			
Bar Length	15"	20"	30"
Power	12 gpm@2000-2500 psi	12 gpm@2000-2500 psi	12 gpm@2000-2500 psi
PART No.	H10007	H10008	H10009
LIST E	\$4,769	\$5,132	\$6,147

*Includes bar, chain and hose whips. *8GPM models available in 15" and 20"*

Hydraulic Chain Saw Accessories	15" Chain Saw		20" Chain Saw		30" Chain Saw		
Chain Spec	H62S	List Price	H72S	List Price	H90S	List Price	
	Part No.		Part No.		Part No.		
Sprocket	140738	\$242	140738	\$242	140738	\$242	P
Guide Bar	140729	246	140730	368	140731	826	P
Diamond Chain .456P	140742	1,610	140725	1,865	140727	2,331	A



Cardi Electric Chain Saw	
Model No.	CDS220
Bar Length	13"
Motor	220V, 16A, 60 Hz
Power	3.5 kW/3500W
Phase	Single
Weight	20 lb
PART No.	H10001
LIST E	\$3,895

Includes bar and chain

Electric Chain Saw Accessories			
	Part No.	List	
Sprocket	140679	\$40	P
Guide Bar, 13"	140678	160	P
Diamond Chain .375P (G58S)	140657	998	A

Other chains available.

880 / 890 .456P Hydraulic				
Size	10"	15"	20"	25"
Chain Spec	H50S	H57S	H67S	H79S
Part No.	140650	140653	140664	140671
List Price A	\$1,295	\$1,495	\$1,695	\$2,095
Guide Bar				
Part No.	140732	140733	140734	140735
List Price P	\$166	\$219	\$273	\$423

695 .465P Gas				
Size	12"	14"	16"	20"
Chain Spec	H50S	H53S	H57S	H67S
Part No.	140650	140622	140653	140664
List Price A	\$1,295	\$1,295	\$1,495	\$1,695
Guide Bar				
Part No.	140680	140626	140627	140682
List Price P	\$180	\$180	\$225	\$275

K950 / 960 / 970 .375P Gas			
Size	12"	14"	16"
Chain Spec	G58S	G64S	G70S
Part No.	140657	140662	140666
List Price A	\$998	\$1,095	\$1,204
Guide Bar			
Part No.	140617	140613	140563
List Price P	\$155	\$160	\$268

Sprockets	Part No.	List Price	
880	140736	\$208	P
890	140688	275	
890 Flush	140838	275	
695	140633	60	
K950 / 960	140593	30	

Chain Specs
G = Segment Every Other Link
H = Segment Every Link
S = Speed Bond
L = Life Bond
Other Chains/Bars/Sprockets/Transtorque Available

Professional Wall Saw Blades

PROFESSIONAL WALL SAW

DIAMOND BLADES

AGGREGATE	C-41AXW	C-41AX
SOFT		●
MEDIUM	●	●
HARD	●	



WET ONLY
10 mm / .393 in.
segment height

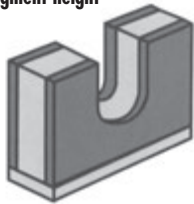

Additional arbor configurations including: GDM, Pentrunder, Braun, Multiquip, and Hilti available. Call for more information.

C-41AXW / C-41AX Wall Saw Blades

★★★★ PRO IV



C-41AXW



C-41AX

Diameter & Width	C-41AXW		List	C-41AX		D List
	Longyear 1" Arbor Part No.	Pent-GDM 1-3/8" Arbor Part No.		Longyear 1" Arbor Part No.	Pent-GDM 1-3/8" Arbor Part No.	
24" x .187"	D16551		\$1,195	D16501		\$1,395
24" x .220"	D16552		1,295	D16502	D16699	1,495
24" x .250"	D16553		1,495	D16503		1,695
26" x .187"	D16554	D16572	1,295	D16504		1,495
26" x .220"	D16555	D16573	1,395	D16505		1,595
26" x .250"	D16556		1,595	D16506		1,795
30" x .187"	D16557		1,495	D16507		1,695
30" x .220"	D16558		1,695	D16508		1,895
30" x .235"	D16590		1,795			1,995
30" x .250"	D16559		1,895	D16509	D16543	2,095
32" x .187"	D16560	D16574	1,695	D16510	D16542	1,995
32" x .220"	D16561	D16575	1,895	D16511	D16588	2,195
32" x .235"	D16591		1,995	D16703	D16705	2,295
32" x .250"	D16562		2,095	D16512	D16548	2,395
34" x .220"			2,095		D16675	2,395
34" x .250"			2,295		D16682	2,595
36" x .187"	D16563		1,995	D16513	D16706	2,295
36" x .220"	D16564		2,095	D16514	D16578	2,395
36" x .235"	D16592		2,195		D16707	2,495
36" x .250"	D16565		2,295	D16515	D16579	2,595
42" x .187"	D16566		2,995	D16516		3,295
42" x .220"	D16567	D16587	3,195	D16517	D16683	3,395
42" x .235"			3,395		D16709	3,495
42" x .250"	D16568		3,495	D16518		3,595
48" x .187"			4,095	D16519		4,095
48" x .220"		D16580	4,295	D16520	D16684	4,295
48" x .250"			4,495	D16521		4,695
54" x .187"	D16570		5,295	D16663		5,495
54" x .220"			5,595	D16659	D16692	5,795
54" x .250"			5,795	D16664		5,995
60" x .187"			7,295	D16571		7,895
60" x .220"			7,595	D16670	D16693	8,095

Professional Wall Saw/Blades / Curb Cut Blades / Diamond Wire

SHIBUYA Wall Saw

SS300R Plunge

Dimensions Saw	
Head & Chassis	743(H) x 350(W) x 463(H)
Motor	RS2521 2-Speed
Power Supply	115 Volts/1 PH
Spindle RPM (no load)	300/700
Rated Input	2.5 KW
Track	1-1.2m Track / 1-0.6m Track
Blade Capacity	30"
Blade Arbor Diameter	1-3/8 inch
Weight - Head & Chassis	80 lb
PART No.	WS0002
List E	\$15,995

Standard Wall Saw Kit includes: 27 amp electric motor RS2521 2 speed; 1-piece 23.6 in / 600mm Track; 1 piece 47.2 in / 1200mm Track; Auto Travel Control; 30" Blade Guard



10 mm / .393 in.
segment height

SHIBUYA Wall Saw Options

Description	Part No.	List	
Flange Assy True Flush Cut SS300R	152000	\$995	E
True 30" SS300R Guard Flush Cut	152001	1,995	P
Track - 23.6 in / 600mm	150405	995	P
Track - 47.2 in / 1200mm	150406	1,395	P

C-40 Blades for SHIBUYA Wall Saw

Diameter & Width	Part No.	List	D
24" x .160" x 1-3/8"	D16140	\$995	
26" x .160" x 1-3/8"	D16141	1,295	
30" x .160" x 1-3/8"	D16142	1,495	



C-42AX10 Curb Cut Blades

★★★★ PRO IV			D
Diameter & Width	Part No.	List	
20" x .250" x 1"	D16656	\$1,942	
22" x .220" x 1"	D16645	1,617	
24" x .250" x 1"	D16603	2,289	
26" x .187" x 1"	D16604	1,829	

Construction Diamond Wire

	C-32		C-41AX	D
	Part No.	List	Part No.	List
Meter	D91015	\$351	D91017	\$379

Prices per meter length.



Diamond Wire Crimps	Part No.	List	P
3/16" ID x 3/8" OD x 3/4" L	151157	\$1.08	
3/16" ID x 3/8" OD x 1-1/8" L	151304	4.33	

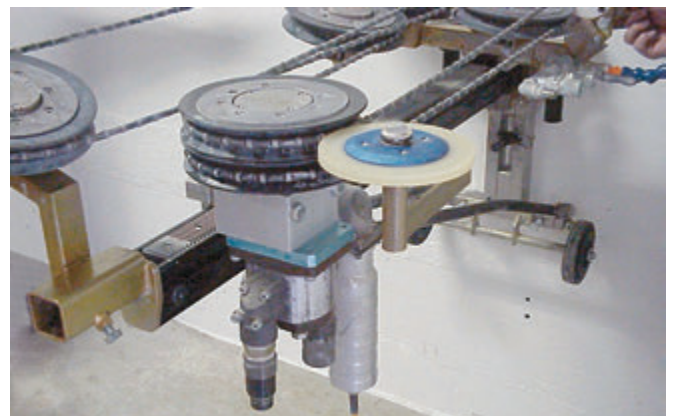

Wet Diamond Core Bits

WET DIAMOND CORE BITS

	C-50AXP								
AGGREGATE	C-41AX	C-42AX	BRUTE	C-62AX	C-53	C-52	C-51	C-43	C-32
SOFT	●		●		●	●		●	●
MEDIUM	●	●	●	●	●	●	●	●	●
HARD	●	●	●	●		●	●		●



12mm/.50" seg height

1-1/4" - 7 Thread



C-50AXP BRUTE ARIX G3 Core Bits

★★★★★ PRO V *Fast Speed with Good Life* **D**

Diameter	Part No.	List
2"	D34301	\$190
2-1/4"	D34302	215
2-1/2"	D34303	230
2-3/4"	D34304	250
3"	D34305	265
3-1/2"	D34306	320
4"	D34307	350
4-1/4"	D34308	385
4-1/2"	D34309	405
5"	D34310	435
5-1/2"	D34311	465
6"	D34312	560
8"	D34316	765
10"	D34318	950
12"	D34319	1,230
14" x .250"	D34320	1,380



1-1/4"-7 th for rig mounted and hand-held drills

C-42AX ARIX G3 Pro Wet/Dry Bit

★★★★ Pro IV **D**

Diameter	Part No.	List
2"	D31533	\$190
2-1/4"	D31544	200
2-1/2"	D31545	221
3"	D31546	233
3-1/2"	D31547	271
4"	D31548	324
4-1/2"	D31549	394
5"	D31550	433
6"	D31552	471
7"	D31554	640
8"	D31555	690

1-1/4"-7 Thread and 14" barrel



NEW!



1-1/4"-7 th for rig mounted and hand-held drills

C-41AX ARIX G3 Pro Wet Short Bit

★★★★ Pro IV **D**

Diameter	Part No.	List
2"	D30508	\$190
2-1/4"	D30509	200
2-1/2"	D30510	221
3"	D30511	233
3-1/2"	D30512	271
4"	D30513	324
4-1/2"	D30514	394
5"	D30515	433
6"	D30516	471
7"	D30517	640
8"	D30518	690
9"	D30519	750

1-1/4"-7 Thread and 9" usable length



1-1/4"-7 thread

C62AX WET Core Bit ARIX

★★★★★ PRO VI **D**

Diameter	Part No.	List
2"	D34101	\$228
2 1/4"	D34102	249
2 1/2"	D34103	260
2 3/4"	D34104	281
3"	D34105	298
3 1/2"	D34106	351
4"	D34107	406
4 1/4"	D34108	459
4 1/2"	D34109	514
5"	D34110	536
5 1/2"	D34111	595
6"	D34112	644
6 1/4"	D34113	730
6 1/2"	D34114	752
7"	D34115	805
8"	D34116	860
9"	D34117	1,022
10"	D34118	1,076
12"	D34119	1,401
14"	D34120	1,725

Other sizes available upon request

C51 / C52 Segmented / Double Pointed

★★★★★ PRO V



C51		C52	
Diameter	Part No.	List	Part No.
1"			D32321
1-1/8"			D32322
1-1/4"			D32323
1-3/8"			D32324
1-1/2"			D32325
1-5/8"			D32326
1-3/4"			D32327
1-7/8"			D32328
2"	D36101	\$175	D32201
2-1/4"	D36102	191	D32202
2 1/2"	D36103	201	D32203
2-3/4"	D36104	221	D32204
3"	D36105	232	D32205
3-1/4"	D36106	258	D32285
3 1/2"	D36107	283	D32207
4"	D36108	304	D32208
4-1/4"	D36109	361	D32209
4-1/4"x20"L			D33467
4 1/2"	D36110	386	D32210
5"	D36112	407	D32212
5 1/2"	D36113	438	D32213

C51		C52	
Diameter	Part No.	List	Part No.
6"	D36115	464	D32215
6-1/4"	D36116	510	D32216
6 1/2"	D36117	561	D32217
7"	D36118	613	D32218
7-1/2"			D32291
8"	D36119	664	D32219
8-1/2"			D32292
9"	D36120	798	D32220
10"	D36121	870	D32221
11"			D32230
12"	D36122	953	D32222
13"	D36132	1,391	D32240
14"	D36123	1,128	D32223
16"	D36124	1,586	D32232
18"	D36125	1,777	D32233
20"	D36126	2,060	D32234
24"	D36136	2,884	D32235
26"	D36163	4,400	D32231
30"			D32238
36"			D33417



1" - 1-3/4" are crown
 1" - 6" are laser welded
 6-1/4" > are brazed
 16" and above standard with spoke back
 Solid or welded backs and special barrel lengths are available upon request
 1" - 1-1/2" are 5/8"-11
 Remainder are 1-1/4"-7 thread

NEW



Double pointed segments

1" - 1-3/4" are crown
 1" - 6" are laser welded
 All cap sizes are 1-1/4"-7 thread

C-52 Threaded Core Bits ★★★★★ PRO V

Fast Speed with Good Life

Diameter	Threaded Crown		Threaded Cap		Threaded 12" Tubing	
	Part No.	List	Part No	List	Part No.	List
1"	D34861	\$95	C101034	\$50	T101013	\$35
1-1/8"	D34865	100	C101035	50	T101014	40
1-1/4"	D34862	110	C101036	50	T101015	40
1-1/2"	D34863	120	C101037	50	T101016	45
1-3/4"	D34866	135	C101038	55	T101017	50
2"	D34864	150	C101040	60	T101019	55
2-1/4"	D34867	160	C101041	65	T101020	60
2-1/2"	D34805	165	C101042	65	T101021	60
3"	D34806	195	C101043	70	T101022	70
3-1/2"	D34807	215	C101515	85	T101507	85
4"	D34808	255	C101045	95	T101024	110
4-1/4"	D34868	265	C101046	100	T101025	115
4-1/2"	D34869	275	C101047	100	T101023	120
5"	D34809	290	C101048	105	T101026	125
5-1/2"	D34870	325	C101050	110	T101027	135
6"	D34810	350	C101051	120	T101028	140

Wet / Dry Diamond Bits

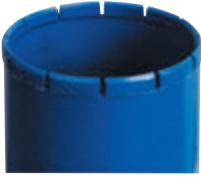

C43/C53 Segmented/Prestressed Concrete & Asphalt

Diameter	C43 ★★★★		C53 ★★★★★		D List
	PRO IV	List	PRO V	List	
2"	D32124	\$200	D33143	\$238	
2-1/4"	D32125	206			
2-1/2"	D32126	211			
3"	D32128	271	D33144	330	
3-1/2"	D32130	319			
4"	D32131	373	D33164	422	
4-1/4"	D32132	416	D33173	474	
4-1/2"	D32133	427			
5"	D32135	487			
5-1/2"	D32136	536			
6"	D32138	644			
6-1/4"	D32139	692			
6-1/2"	D32140	752			
7"	D32141	805			
8"	D32142	860			
10"	D32144	1,185			



WET ONLY
8 mm / .315 in.
segment height
1-1/4"-7 thread
Brazed



C34 ARIX Short Dry Bit

★★★ Super Premium

Diameter	Standard* 5/8"-11 thd		D List
	Part No.	List	
1"	D31536	\$140	
1-1/4"	D31543	135	
1-1/2"	D31521	146	
1-3/4"	D31522	163	
2"	D31523	190	
2-1/4"	D31524	200	
2-1/2"	D31525	221	
3"	D31526	233	
3-1/2"	D31527	271	
4"	D31528	324	
4-1/2"	D31529	394	
5"	D31530	433	
6"	D31531	471	



DRY/WET

.315" seg. height



*5/8"-11 thread
for hand held
drills

9" drilling depth

Laser Welded

Use your Hammer Drill to drill clean holes with these adapters and DITEQ's C34 ARIX Dry Bit!



Hammer Drill Adapters for Diamond Core Bits

Description	Part No.	P List
SDS Max to SDS Plus Chuck	151617	\$103
SDS Max to 5/8-11M Rotary adapter	151623	73
SDS Plus to 5/8-11 Rotary Adapter	151670	73

C32 Segmented/Pointed Brazed

Diameter	★★★ PRO III		D List
	Part No.	List	
3/8"	D32041	\$103	
1/2"	D32042	103	
5/8"	D32043	108	
3/4"	D32044	113	
7/8"	D32045	113	
1"	D32046	119	
1 1/8"	D32047	130	
1 1/4"	D32048	135	
1 3/8"	D32049	146	
1 1/2"	D32050	151	
1 5/8"	D32051	163	
1 3/4"	D32052	168	
1 7/8"	D32053	178	

3/8" - 1-3/4" are C32 crown
 1" - 1-1/2" are 5/8"-11 thread
 1-5/8" and up are 1-1/4"-7 thread





WET ONLY
Laser Welded



C25 Short Dry Bit

★★ Premium For Block Only

Diameter	★★ Premium For Block Only		D List
	Part No.	List	
1"	D31501	\$66	
1-1/4"	D31502	70	
1-1/2"	D31503	76	
1-3/4"	D31504	92	
2"	D31505	98	
2-1/4"	D31506	103	
2-1/2"	D31507	125	
3"	D31508	141	
3-1/2"	D31509	200	
4"	D31510	238	
4-1/2"	D31511	265	
5"	D31512	298	
6"	D31513	336	



5/8"-11 thread

1" and 1-1/4"

.275" segment hgt

1-1/4" and above

.315" segment hgt

9" drilling depth



Laser Welded

C32 Pointed Segments ★★ ★ Super Premium Segment Segment

Diameter	Part No.	Thickness	Length	Height	List
4 - 6.5"	D35014	.165"	.945"	.315"	\$16.48
7 - 9"	D35015	.187"	.945"	.315"	16.48
10 - 14"	D35019	.187"	.945"	.315"	18.54
10 - 16"	D35016	.210"	.945"	.315"	22.00
10 - 16"	D35017	.250"	.945"	.315"	27.00
18 - 36"	D35018	.250"	.945"	.315"	27.00

C62AX Segments ★★ ★ ★ ★ PRO VI

Diameter	Part No.	Thickness	Length	Height	List
2" - 2.5"	D35051	.145"	.945"	.393"	\$22
2.75" - 3.5"	D35052	.145"	.945"	.393"	22
4 - 6.5"	D35053	.160"	.945"	.393"	24
7 - 9"	D35054	.165"	.945"	.393"	25
10 - 14"	D35055	.187"	.945"	.393"	27
10 - 16"	D35056	.210"	.945"	.393"	33
14 - 36"	D35057	.250"	.945"	.393"	38

C42AX Segments ★★ ★ ★ PRO IV

Diameter	Part No.	Thickness	Length	Height	List
2"	D35082	.145"	.629"	.314"	\$16
2.5" - 3.5"	D35083	.150"	.945"	.314"	16
4 - 6"	D35084	.165"	.945"	.314"	19
7 - 9"	D35085	.165"	.945"	.314"	19
7 - 10"	D35086	.187"	.945"	.314"	21
10 - 14"	D35087	.187"	.945"	.314"	21
12 - 36"	D35088	.250"	.945"	.314"	31

C-50AX Segments ★★ ★ ★ ★ PRO V

Diameter	Part No.	Thickness	Length	Height	List
2" - 2.5"	D35091	.145"	.945"	.472"	\$17
2.75" - 3.5"	D35092	.145"	.945"	.472"	17
4 - 6.5"	D35093	.160"	.945"	.472"	20
7 - 9"	D35094	.160"	.945"	.472"	20
10 - 14"	D35095	.187"	.945"	.472"	23
10 - 14"	D35096	.220"	.945"	.472"	28
12 - 36"	D35097	.250"	.945"	.472"	34

C52 Double Pointed Segments ★★ ★ ★ ★ PRO V

Diameter	Part No.	Thickness	Length	Height	List
2" - 2.5"	D35032	.145"	.945"	.420"	\$16.48
2.75" - 3.5"	D35033	.145"	.945"	.420"	16.48
2.75" - 3.5"	D35042	.160"	.945"	.420"	19.57
2.75" - 3.5"	D35077	.187"	.945"	.420"	22.00
2" - 3.5"	D35079	.250"	.945"	.420"	33.00
4 - 6.5"	D35034	.165"	.945"	.420"	19.57
5" - 7"	D35078	.187"	.945"	.420"	22.00
7 - 9"	D35035	.165"	.945"	.420"	19.57
10 - 14"	D35036	.187"	.945"	.420"	22.00
10 - 16"	D35037	.210"	.945"	.420"	27.00
14 - 36"	D35038	.250"	.945"	.420"	33.00

Segments include solder.

Diatip™ Diamond Core Bit Retipping Machines

	CD 600	CD 7-28
Power	Economy	Manual
Amps/Volts		
Minimum Bit Diameter	2-1/8"	2-1/8"
Maximum Bit Diameter	28"	28"
Core Bit Maximum Length	22"	22"
Maximum Steel Thickness	.125"	.125"
Part No.	DR5003	DR5002
List Price E	Call for Pricing	

Diatip Machines are special order items



DITEQ carries a wide variety of hammer bits and flat chisels. Contact customer service or our website for details



Magnets

Description	Part No.	List E
Superstrong Flux Magnet - each magnet has four different side clearances: 0.02"/0.03"/0.04" and 0.05" (0.5mm/1.0mm & 1.25mm) (Standard for segments 2" - 16")	151167	\$91
US magnet, each magnet has four different side clearances: 0.06"/0.07"/0.08"/ and 0.09" (1.5mm/1.78/2.03mm/2.3mm (for larger segments)	151627	91



Carbide SDS Max Drill Bits

Part No.	Size/Description	Usable Length	List E
150905	1/2" x 13"	8"	\$67
150906	5/8" x 13"	8"	81
150907	7/8" x 13"	8"	94

Numerous bits available in a variety of specs for SDS Plus and SDS Max Hammer Drills. Many bits are available in bulk packs or individual display packages. Call for info.

SHIBUYA Professional Core Drill Machines - Hand Drills and TS-092

Hand Held Drills

	D-Handle Hand Held RH1531	Pistol-Grip Hand Held RH1532	RH1531 ABV Combo Drill RH1531
MOTOR			
AMPS/VOLTS	15/115	15/115	15/115
RPM (Under Load)	560/1400/2900	560/1400/2900	560/1400/2900
BIT CAPACITY	(Max. Handheld) 4"	(Max. Handheld) 4"	8" (Angle)
BIT CAPACITY			10" (Vertical)
COLUMN LENGTH			39.4"
WEIGHT w/o accessories	15 lb (6.8 kg)	15 lb (6.8 kg)	69 lb. w/pump
MODEL No.	RH1531	RH1532	RH1531ABV
PART No.	DR2003	DR2023	DR2024
List E	\$1,833	\$2,158	\$3,345

RH1531 220V models available

Hand Drill Accessories	Part No.	List	
Stand, Fixed base, column & carriage	150340	\$805	P
Stand, Angle base, column & carriage	150341	1,022	P
Stand, ABV combo includes stand/pump	151774*	1,695	E
Stand, combo angle base ABV-50	151838**	1,895	E
Dust/Slurry Ring (5")	151291	195	P
Dust/Slurry Ring (7")	151287	195	P
Adaptor kit/Squeeze clamp	150342	141	P
Adaptor kit/Fixed bolt on	150343***	60	P
Grease Tube - Hand Drill only	151082	45	P
Brass quick disconnect	150590	7.57	P

*Includes angle combo stand assy., squeeze mount, vac pump - fits any hand drill (no motor) Fits any hand drill (inc. 151773,150004,150342,150491,151770,150046,150045)
**Combo base assy less carriage and motor (incl 151773, 151770,15004 and 150491
***RH1531 D-Handle model only



Both the "D" handle and pistol grip hand drills come standard with molded plastic storage cases

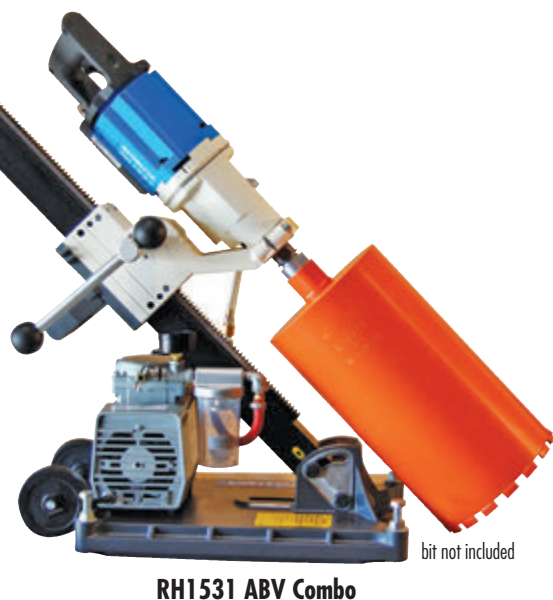

RH1531 ABV Combo



Use with 9" core travel bits

TS-092

	w/ CASE	w/ CASE
BASE STYLE	ANGLE ANCHOR	ANGLE ANCHOR
MOTOR	R1011	R1012
AMPS	10	10
RPM (no Load)	970	1750
BIT CAPACITY (Max.)	6"	4"
COLUMN LENGTH	22" (560mm)	22" (560mm)
WEIGHT w/o accessories	20 lb	20 lb
MODEL No.	TS-092ABKIT	TS-092ABKIT
PART No.	DR0017	DR0019
List E	\$1,725	\$1,725

220V models available

TS-092 Accessories	Part No.	List
Vacuum Pads — Extra Small	150159	\$195
Vacuum Pads — Small	150001	245
Vacuum Pump Assembly	150004	589

SHIBUYA Core Drills - TS-132/TS-162



bit not included



Molded plastic storage cases keeps accessories organized



bit not included



TS-132

BASE STYLE	TS-132 15 amps - 1 Speed				TS-132ABV 15 amps - 1 Speed
	Without Case		With Case		Angle Base Combo
	FIXED	ANGLE BASE	FIXED	ANGLE BASE	
MOTOR			R1511		R1511
AMPS/VOLTS			15/115		15/115
RPM (No Load)			850		850
BIT CAPACITY (Max.)			9"		10" Vertical/8" Angle
COLUMN LENGTH	31.5" (800mm)	39.4" (1000mm)	23.5" short*	23.5" short*	39.4" (1000mm)
WEIGHT w/o access.	28.7 lb (13 kg)	33.8 lb (15.3 kg)	33.5lb (15.2kg)	33.5lb (15.2kg)	64 lb (14 kg) w/pump
MODEL No.	TS132	TS132AB	TS132KIT	TS132ABKIT	TS-132ABV
PART No.	DR0001	DR0002	DR0011	DR0003	DR0037
List E	\$1,779	\$1,995	\$2,050	\$2,158	\$2,395

220V models available

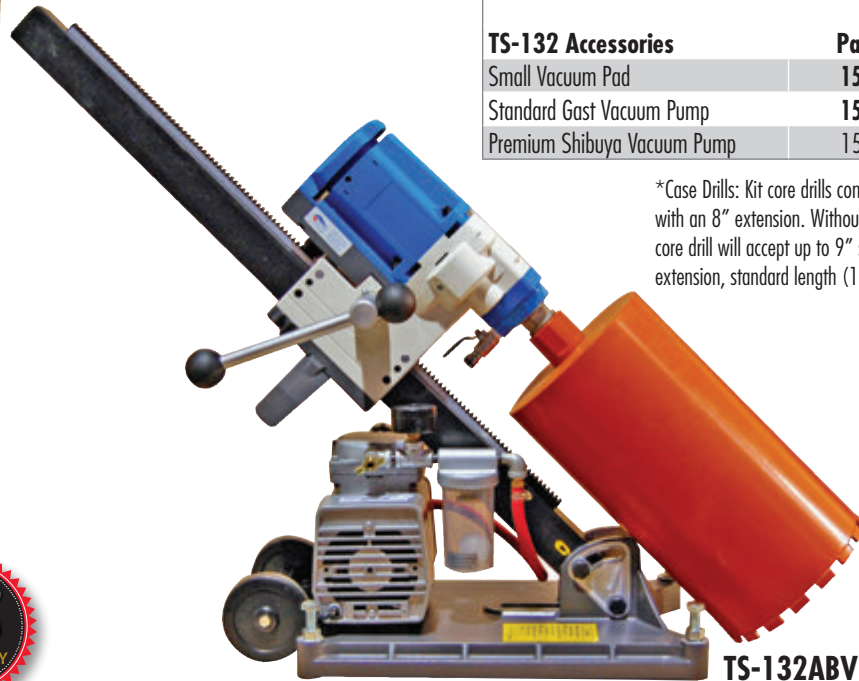

TS-132ABV
bit not included

TS-132 Accessories	Part No.	List E
Small Vacuum Pad	150001	\$245
Standard Gast Vacuum Pump	150004	589
Premium Shibuya Vacuum Pump	150005	1,295

*Case Drills: Kit core drills come with a 23.5" column with an 8" extension. Without the extension, the kit core drill will accept up to 9" short core bits. With the extension, standard length (14") core bits can be used.

TS-162

BASE STYLE	TS-162 15 amps - 2 Speed				TS-162ABV 15 amps - 2 Speed
	Without Case		With Case		ANGLE BASE COMBO
	FIXED	ANGLE BASE	FIXED	ANGLE BASE	
MOTOR			R1521		R1521
AMPS/VOLTS			15/115		15/115
RPM (No Load)			700/1000		700/1000
BIT CAPACITY (MAX)			9"		10" Vertical/8" Angle
COLUMN LENGTH	31.5" (800mm)	39.4" (1000mm)	23.5" short*	23.5" short*	39.4" (1000mm)
WEIGHT w/o access.	30.9 lb (14 kg)	36 lb (16.3 kg)	35.7 lb (16.2 kg)	35.7 lb (16.2kg)	66 lb.
MODEL No.	TS162	TS162AB	TS162KIT	TS162ABKIT	TS-162ABV
PART No.	DR0004	DR0005	DR0012	DR0006	DR0036
List E	\$1,942	\$2,158	\$2,320	\$2,428	\$2,595

220V models available

TS-162 Accessories	Part No.	List E
Small Vacuum Pad	150001	\$245
Standard Gast Vacuum Pump	150004	589
Premium Shibuya Vacuum Pump	150005	1,295

*Case Drills: Kit core drills come with a 23.5" column with an 8" extension. Without the extension, the kit core drill will accept up to 9" short core bits. With the extension, standard length (14") core bits can be used.

SHIBUYA Core Drills - TS-252 / Auto Feed System

TS-252	TS-252 20 amps - 2 speed		TS-252ABV 20 amps - 2 speed	
BASE STYLE	FIXED	FIXED	ANGLE BASE	ANGLE BASE COMBO
MOTOR			R1721	
AMPS/VOLTS			20/115	
RPM (No Load)			450/900	
BIT CAPACITY (Max.)	12"		12" Vertical/10" Angle	
COLUMN LENGTH	31.5" (800mm)	39.4" (1000mm)	39.4" (1000mm)	39.4" (1000mm)
WEIGHT w/o accessories	40.1 lb (18.2 kg)	43 lb (19.2 kg)	42.3 lb (19.2 kg)	73 lb. w/pump
MODEL No.	TS252	TS252	TS252AB	TS-252ABV
PART No.	DR0007	DR0008	DR0009	DR0034
List E	\$2,644	\$2,752	\$2,860	\$3,095
PART No. Less Pump*				DR0035*
List E				\$2,495

220V models available

TS-252 Accessories	Part No.	List	
Large Vacuum Pad - TS252	150002	\$375	E
Standard Gast Vacuum Pump	150004	589	E
Premium Shibuya Vacuum	150005	1,295	E
Optional Ceiling Jack	150160	55	P
Optional 51" 1 piece column	150609	536	P



bit not included

TS-252ABV
DR0034

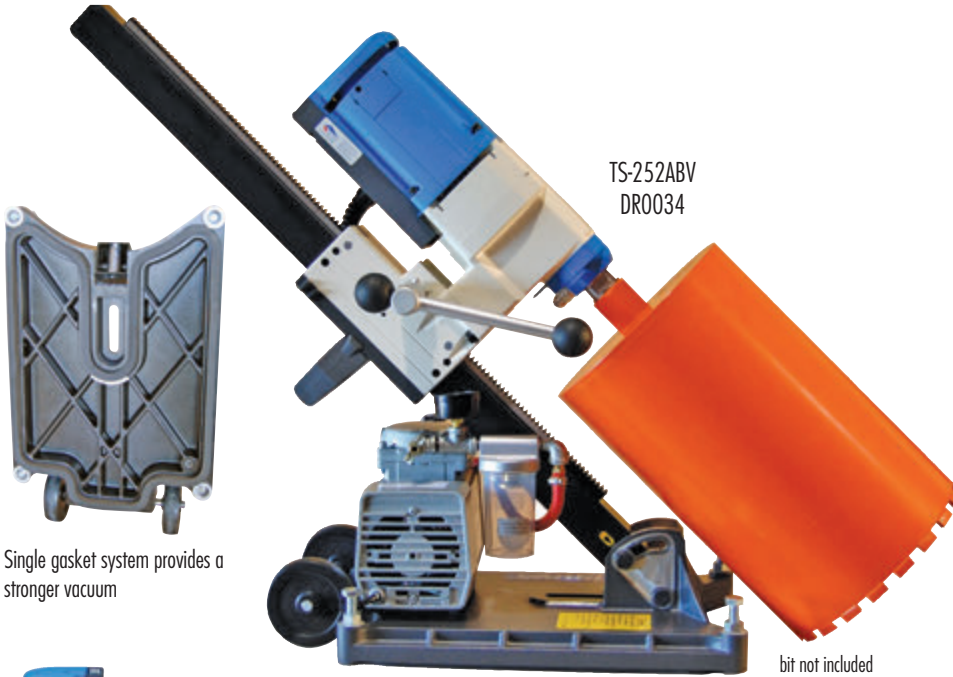

bit not included

Single gasket system provides a stronger vacuum

IMPROVED!

Auto Feed

	Part No.	List	
Auto-Feed - AFS-V 115V*	152021	\$3,295.00	E
Auto-Feed - AFS-V 220V*	152022	3,295.00	E
Remote Feed System - TS-503/603 115V	151290	7,133.00	E
Adapter Kit - TS-252	150320	90.00	P
Adapter Kit Left - TS-132/162	150321	78.00	P
Adapter Kit Right - TS-132/162	150322	78.00	P
Depth Stop Clamp	150477	73.00	P
Quick Pin Fed Handle	150142	18.54	P

* Does not include the stop clamp P/N 150477



Auto Feed shown on TS-252



top view

SHIBUYA Core Drills - TS-353 / TS-402 / TS-403



DR1047
Angle Base Combo

bit not included

TS-353	TS-353		TS-353ABV
	23 amps - 3 Speed		23 amps - 3 Speed
BASE STYLE	FIXED	FIXED w/swivel/ext kit	ANGLE BASE COMBO
MOTOR	R2031		R2031
AMPS/VOLTS	23 / 115		23 / 115
RPM - Standard	380/1000/1700		380/1000/1700
BIT CAPACITY	14"-16" (with spacer)		14" Vertical, 12" Angled
COLUMN LENGTH	39.4" (1000mm)		39.4" (1000mm)
WEIGHT	68.8 lb.	68.8 lb.	87 lb.
MODEL No.	TS353	TS353SW	TS-353ABV
PART No.	DR1017	DR1024	DR1047
List E	\$3,509	\$3,888	\$3,795

Only available in 115V



bit not included

TS-402	TS-402		TS-403		
	27 amps - 2 Speed		27 amps - 3 speed		
BASE STYLE	FIXED	FIXED	ANGLE	FIXED w/swivel/ext kit	ANGLE w/swivel/ext kit
MOTOR	R2221		R2231		
AMPS/VOLTS	27 / 115		27 / 115		
RPM - Standard	300/700		300/800/1400		
RPM - Optional			400/1200/2000		
BIT CAPACITY	14"-16" (with spacer)		14"-16" (with spacer)		
COLUMN LENGTH	39.4" (1000mm)		39.4" (1000mm)		
WEIGHT	68.8 lb.	68.8 lb.	69.9 lb.	68.8 lb.	69.9 lb.
MODEL No.	TS-402	TS403	TS403AB	TS403SW	TS403SW
PART No.	DR1001	DR1003	DR1004	DR1011	DR1012
List E	\$3,564	\$3,726	\$4,429	\$4,105	\$4,807

220V models available

TS-353 / TS-402/403 Accessories	Part No.	List P
Column Assy - TS353/TS-402/403 (59" one piece)	150766	\$644
Column Assy w/swivel/ext. kit - TS353/TS-402/403 (39"+19.5" two piece)	150770	995
Ceiling Jack - TS353/TS-402/403	150160	55
Angle Base - TS353/TS-402/403	150025	1,055
Extra Large Anchor Base	150998	968
Extra Large Vacuum Pad	150003	495
Premium Shibuya Vacuum Pump	150005	1,295

SHIBUYA Core Drills - TS-503 / TS-603 / Hydraulic Core Drills



bit not included

TS-503

	TS-503 27-amps - 3 Speed	TS-503 27-amps - 3 Speed
BASE STYLE	FIXED	ANGLE
MOTOR	R2231	R2231
AMPS/VOLTS	27/115	27/115
RPM	300/800/1400	300/800/1400
BIT CAPACITY	18"	18"
COLUMN LENGTH	43" (1100mm)	43" (1100mm)
COLUMN SIZE	2-7/8"	2-7/8"
WEIGHT w/o accessories	113 lb	113 lb
PART No.	DR1009	DR1041
List E	\$6,995	\$7,565

220V models available

TS-503 / TS-603 Accessories

	Part No.	List P
TS-503 / TS-603 Angle Anchor Base only	151632	\$1,509
TS-503 / TS-603 Angle Anchor Base with Column	151530	2,915
Extension kit, column - TS-503 / TS-603 (22.75")	150393	475
Brace Kit, column - TS-503/TS-603 (can use w/column ext.)	150394	519
Swivel Kit, column - TS-503/TS-603 (15")	150395	475



**Hand Held
Hydraulic Drills
on Page 11**

bit not included

Hydraulic Core Drill Rigs

Motor	OMS80	OMS160	OMS250	OMS400
Displacement	80cc	160cc	250cc	400cc
RPM	500 at 10 gpm	250 at 10 gpm	160 at 10 gpm	100 at 10 gpm
Max. Bit Cap.	8"	16"	24"	32"
Column Size	2-3/8"	2-7/8"	2-7/8"	2-7/8"
Column Length	39.4"	43"	43"	43"
Model No.	TS-420H	TS-540H	TS-660H	TS-680H
Part No.	DR1026	DR1027	DR1028	DR1029
List E	\$6,700	\$9,728	\$9,995	\$9,995

TS-603

HAWG TS-603

27amps - 3 speed

	FIXED ANCHOR
BASE STYLE — Large	FIXED ANCHOR
MOTOR	R2531
AMPS/VOLTS	27/115
RPM	150/300/600
Standard BIT CAPACITY	26"
COLUMN LENGTH	43" (1100mm)
COLUMN SIZE	2-7/8"
WEIGHT	138 lb
PART No.	DR1010
List E	\$8,995

220V models available



TS-603



bit not included

Hydraulic Motor Assemblies

MOTOR	Danfoss OMS80	Danfoss OMS160	Danfoss OMS250	Danfoss OMS400
Displacement	80cc	160cc	250cc	400cc
RPM'S	500 at 10 GPM	250 at 10 GPM	160 at 10 GPM	100 at 10 GPM
Bit Diameter	8"	16"	24"	32"
PART No.	151271	151272	151273	151274
List E	\$4,995	\$4,995	\$4,995	\$4,995

Assemblies include motor spindle, flow control, adapter plate and disconnect. Hydraulic motors only are also available.

Hydraulic Motor Accessories

	Part No.	List P
Adapter — 1-1/4" male — A - rod female	151276	\$168
Quick Release	150039	395
Flow Control Valve Manifold	151269	1,725
Pillow Block Assembly - A-rod Spindle	151270	2,374
Hydraulic Hose 30' x 5/8" set of 2	151277	920

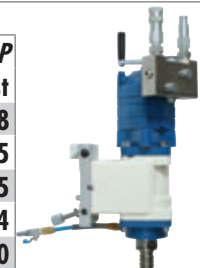

SHIBUYA Drill Motors / Slurry Rings / Generators / Pumps

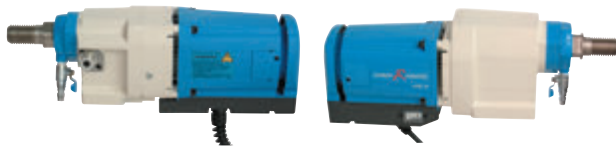

Motors			
Description	Part No.	List	E
R1721 115V 20A 450/900 RPM	150027	\$1,595	
R2031 115V 23A 380/1000/1700 RPM	151053	1,955	
R2221 115V 27A 300/700 RPM	150028	1,995	
R2231 115V 27A 300/800/1400 RPM	150029	1,995	
R2231 220V 13A 300/800/1400 RPM	150330	2,095	
R2531 220V 13A 150/300/600 RPM (HAWG)	150473	4,095	
R2531 110V 27A 150/300/600 (HAWG)	150336	3,995	

Motor Adapter Kits			
Description	Part No.	List	P
Adapter Plate Kit for most competitors 2-7/8" carriages for Shibuya motors	150311	\$175	
Adapter Kit - 2-7/8" rig x R17 motor (20A)	150869	175	

Wall Mount			
Description	Part No.	List	E
Wall Mount - 4"-8"	150323	\$595	

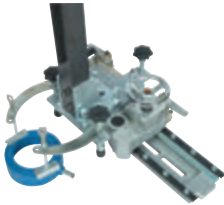

Stitch Drill Cradle			
Description	Part No.	List	E
Stitch Drill Cradle - TS402/403	150722	\$4,595	
Track - 23.6 in/600mm	150405	995	
Track - 47.2 in/1200mm	150406	1,395	



Drilling a line of holes using the stitch drill.



WCR Water Slurry Rings	5"	7"	P
	Part No.	Part No.	List
WCR Slurry Ring	151291	151287	\$195
Cover Plate Slurry Ring	151292	151288	48
Seal, Slurry Ring	151293	151289	6.49



Slurry Rings	Part No.	List	P
8" Slurry Ring	150012	\$146	
10" Slurry Ring	150013	168	
12" Slurry Ring	150014	211	
14" Slurry Ring	150015	319	



Slurry Ring Fixture*	Part No.	List	P
Fixture - TS252 (4"-10")**	150020	\$146	
Fixture - TS402/403 (14"-18")**	150023	319	

*Use with slurry rings above ** Bit size



BitBuddie	Part No.	List	E
1-3/8" dia. bits w/hose	160220	\$53	
1" to 4" dia. bits (round) w/hose	160979	53	
2-8" dia. bits (round)	161625	61	



Water Tanks	Part No.	List	E
Stainless Steel w/Pump	151990	\$295	
Steel w/Pump	151055	145	



Subaru Generators Multi-Duty Industrial Gensets			
Description	Part No.	List	E
Genset, RGX6500	150459	\$2,777	
Genset, RGX6500E*	150460	3,095	
RGX 7500	150461	3,511	
RGX 75000E*	150462	3,807	
Genset, RGV12100*	150463	5,787	

*w/o Battery Full line of Subaru generators is available. Call for details.



Water Pumps			
Description	Part No.	List	E
Subaru Pump, 1" Centrifugal PKV101	110011	\$497	
Subaru Pump, 2" Centrifugal PKX201	110012	637	
Subaru Pump, 2" Trash PKX201T	110017	1,383	
Subaru Pump, 2" High Pressure PKX201H	110021	1,082	
RGC 3" Hydraulic Trash Pump PT300	110109	2,000	

Core Drill Accessories / Bases / Column Options

Optional Columns*		Fits Models		
Column Length	Width	FB - Fixed Base	AB - Angle Base	Part No. List
31" / 800mm	1-5/8"	TS-092 AB	150573	\$381
31" / 800mm	2"	TS-162 FB	150353	280
31" / 800mm	2"	TS-252 FB	150412	356
51" / 1300mm	2"	TS132 FB	150609	536
51" / 1300mm	2"	TS-162 FB	150609	536
51" / 1300mm	2"	TS-252 FB	150609	536
59" / 1500mm	2-3/8"	TS-353 FB & AB	150766	644
39" + 19.5" Swivel Top	2-3/8"	TS-353 FB & AB	150770	995
59" / 1500mm	2-3/8"	TS-402 FB & AB	150766	644
39" + 19.5" Swivel Top	2-3/8"	TS-402 FB & AB	150770	995
59" / 1500mm	2-3/8"	TS-403 FB & AB	150766	644
39" + 19.5" Swivel Top	2-3/8"	TS-403 FB & AB	150770	995
78.5" / 2000mm	2-7/8"	TS-503 FB & AB	150975	1,995
22.75" / 580 mm Extension	2-7/8"	TS-503 FB & AB	150395	475
15" / 380mm Swivel top	2-7/8"	TS-503 FB & AB	150393	475
78.5" / 2000mm	2-7/8"	TS-603 FB & AB	150975	1,995
22.75" / 580 mm Extension	2-7/8"	TS-603 FB & AB	150395	475
15" / 380mm Swivel top	2-7/8"	TS-603 FB & AB	150393	475

* refer to model product charts for standard column specs

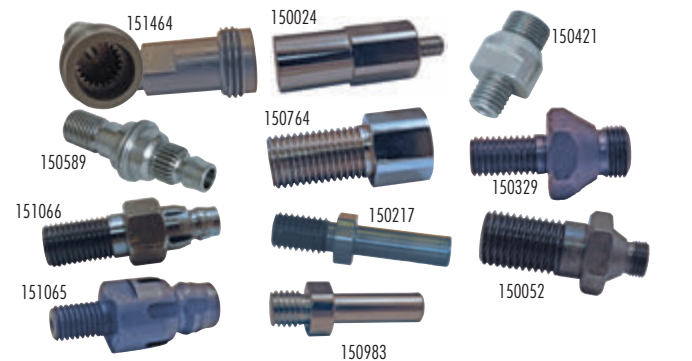

Vacuum Pads	Part No.	List
Step Vac Pad - RH1531/1532, TS-092/132/162	150874	\$195
Extra Small Vac Pad - R1531 TS092/132/162	150159	195
Small Std Vac Pad - R1531 TS132/162	150001	245
Large Standard Vac Pad - TS252	150002	375
Extra Large Std. Vac Pad TS402/403	150003	495
Small Twin / Pipe Pad	150036	695

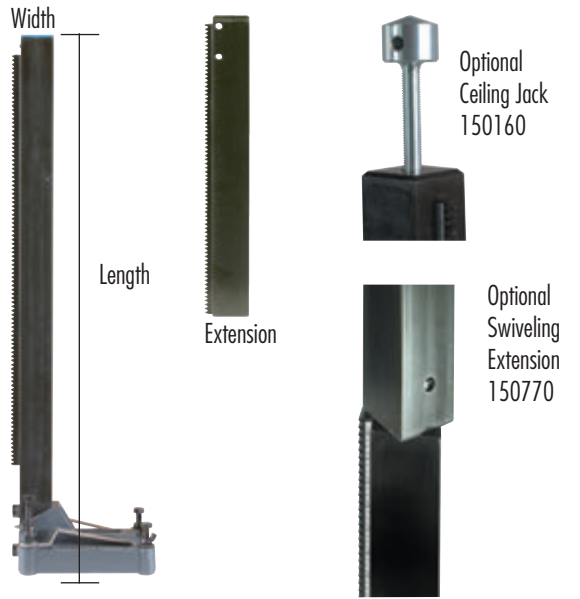
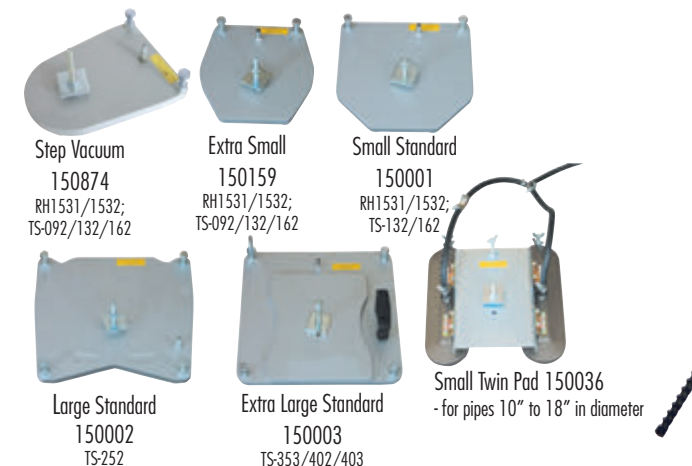

Threaded Adapters	Part No.	List
Hilti Adapter, DD-160-200-250-350 x 1-1/4" -7	151464	\$530
Hilti Adapter, (splines x 1-1/4"-7M)	150589	395
Hilti Adapter, DD100, DD130 (Slots x 1-1/4"-7M)	151066	65
Hilti Adapter, DD100, DD130 (Slots x 5/8")	151065	55
Adapter 1-1/4"-7F to 5/8"-11 M	150024	48
Adapter 5/8"-11 F to 1-1/4"-7 M	150764	48
3/8" shank, 5/8"-11M	150217	30
1/2" shank, 5/8"-11M	150983	27
1/2 Gas Thread x 5/8" 11 short	150421	30
1/2 Gas Thread x 5/8" 11 long	150329	30
1/2" Gas Thread x 1-1/4"-7 M	150052	85

Pro Fastnut and Washer	Part No.	List
Pro Fastnut - 1/2" - 13	150327	\$76
Heavy Square Washer - 1/2"	150615	5

Steel Drop-in Anchors	Part No.	List Each
1/2" - 13 Smart	151700	\$1.08
1/2"-13 knurled	151758	1.14
5/8" - 11 Smart	151701	3.24

Other sizes and types of anchors, setting tools and bits are available.

Carbide SDS Max Drill Bits	Part No.	Size/Description	Usable Length	List
150905	1/2" x 13"	8"	\$67	
150906	5/8" x 13"	8"	81	
150907	7/8" x 13"	8"	94	

Numerous bits available in a variety of specs for SDS Plus and SDS Max Hammer Drills. Many bits are available in bulk packs or individual display packages. Call for info.

SHIBUYA Core Drill Accessories / Parts

Vacuum Pumps	Part No.	List	P
Standard Gast Vacuum Pump	150004	\$589	E
Premium Shibuya Vacuum Pump w/tank	150005	1,295	E
Jar, vacuum pump	150539	26	P
Ball, vacuum pump	150540	13.39	P



Gaskets	Part No.	List	P
Gasket - X-small Pads / Small Twin Pad	150570	\$42	
Gasket - Small Pads	150215	47	
Gasket - Large Pads	150216	68	
Gasket - X-Large Pads	150409	76	
Gasket - Combo Pad	151802	35	

Water Seals/Swivels/Valves	Part No.	List	P
Water Seal - R10/R15/R17 motors (2 Req'd)	150070	\$13	
Water Seal - R20/R22/R25 motors (2 Req'd)	150083	13	
Water Swivel - R10 motors	150484	66	
Water Swivel - R15/R17 motors	150074	68	
Water Swivel - R20/R22/R25 motors	150085	76	
Water Valve w/nipple	150318	30	
Water Hose Valve w/nipple assy	150456	76	
Garden Hose Quick Disconnect - Brass	150590	8	

Switches and Circuit Protectors	Part No.	List	P
Switch/Circuit Protector - R10 motors 115V	150486	\$70	
Trigger Switch - RH-1532 115V hand drill	151805	80	
Trigger Switch - RH-1531 115V hand drill	151777	90	
Circuit Protector - RH-1531 115V hand drill	150447	36	
Rocker Switch - RH15 hand-held/rig mode change 115V	150450	28	
Switch/Circuit Protector - R15 Motors & RH15 rig mode	150120	75	
Switch/Circuit Protector - R17 motor 115V TS-252	150121	75	
Switch - R22/R25 motors 115V TS-402/403	150122	64	
Switch/Circuit Protector - R22/R25 motors 220V	150478	75	
Circuit Protector - R22/R25 motors 115V TS402/403	150124	75	
Switch/circuit protector - R20 115V TS-353	151100	75	

Carbon Brushes	Part No.	List	P
Carbon Brush - RH15/R15/R17/R20 motors 115V (2 Req'd)	151668	\$8	
Carbon Brush - R22/R25 motors 120V (2 Req'd)	151669	8	
Carbon Brush - R15/17/22 motors 220V (2 Req'd)	150416	8	
Carbon Brush - R10 motors 115V (2 Req'd)	150485	8	

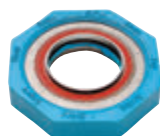

Diamond Bit Accessories	Part No.	List	P
Washer, Copper 1-1/4"-7 core bit	150653	\$17	
Washer, Plastic 1-1/4"-7 core bit	150654	6	
Slider	151769	138.00	

Carriages	Part No.	List	P
Pro 2-7/8" Roller Carriage Assy w/quick release motor mount - TS503 (18" bit)	150381	\$2,482	
Pro 2-7/8" Roller Carriage Assy w/quick release motor mount - TS603 (26" bit)	150382	2,595	



Quick Release Motor Mount	Part No.	List	P
Quick Release Motor Mount - TS402/403/503/603	150039	\$395	
Quick Release Motor Mount - R1721 / TS252	150310	395	



Extensions	Part No.	List	P
Ext., 5/8"-11 x 12" L	150509	\$50	
Ext., 5/8"-11 x 6" L	150547	45	
Ext., 1-1/4"-7 x 6" L	150161	70	
Ext., 1-1/4"-7 x 12" L	150043	85	
Ext., 1-1/4"-7 x 24" L	150890	140	
Ext., 1-1/4"-7 x 36" L	151664	325	



Spacers	Part No.	List	P
4" Spacer Kit- TS-402/403/503/603	150079	\$195	
1-1/4" Spacer Kit - TS402/403	150312	92	
1-1/4" Spacer Kit - TS252	150514	87	

Gear Clamps/Clutch	Part No.	List	P
Socket, Clutch - R motors	150051	81	
Gear Clamp - R17/R22/R25 motors	150054	81	
Gear Clamp - R15 motors	150055	81	
Gear Clamp - RH1531 hand drill	150506	24	



Crows Foot



Ratchet



Spoke Handle



Spindle Wrench

Tools/Miscellaneous	Part No.	List	P
Crows Foot - 36mm R17/R22/R25 motors	150049	190	
Crows Foot - 32mm R15 motors	150050	190	
4 Spoke Feed Handle - TS-252/353402/403/503/603	150758	211	
Ratchet - 19/21mm - TS402/403/503/603	150537	45	
Ratchet - 17/19mm - TS252	150877	45	
Wrench, Spindle, 36mm - R17/R22 motors	150513	15	
Wrench, Spindle, 32mm - R15/R15 motors	150535	15	

High Speed / Flat Saw / Masonry / General Purpose Diamond Blades

HIGH SPEED, FLAT SAW, MASONRY & GENERAL PURPOSE SEGMENTED BLADES

Material	C/A44 ARIX	C/A34GD Guardian	C/S- 33SC	C/A-33 Monster	C/S-32 BRUTE	C/A24	C-43 AX	C-33 AX	U23 XTRA	U22	U13 XTRA	JS-S Jet Stream	DXS XTRA	DXS
Hard Brick			●		●									
Granite			●		●									
Brick/Pavers			●		●		●	●	●	●	●	●	●	●
Cured Concrete	●	●	●	●	●	●	●	●	●	●	●	●	●	●
Concrete w/ Steel	●	●	●	●	●	●	●	●	●	●	●	●	●	●
Clay Tile		●	●	●	●	●	●	●	●	●	●	●	●	●
Block		●		●		●	●	●	●	●	●			
Asphalt	●	●		●										
Green Concrete	●	●		●										

PROFESSIONAL COMBO BLADES



C-44AX Combo *DITEQ's Do All Blades*
★★★★ PRO IV High Performance
with Undercut Protection
Concrete/Asphalt/Green Concrete
Fast Cut/Medium Life

Diameter & Width	Part No.	List Price
14" x .125" x 1"-20mm DP	D10082	\$471
16" x .125" x 1" DP	D10095	536
18" x .125" x 1 DP	D10084	589
20" x .145" x 1 DP	D10087	697

DRY/WET
 .393" seg height
 Laser Welded



C/A-33 MONSTER **NEW**
★★★ Super Premium **G3**
Concrete/Block/Green Concrete/Asphalt
Fast Cut/Medium Life

Diameter & Width	Part No.	List Price
12" x .125" x 1" -20mmDP	D11150	\$265
14" x .125" x 1"-20mm DP	D11151	295
16" x .125" x 1"-20mm DP	D11152	355
18" x .125" x 1"-DP	D11153	430
20" x .145" x 1"-DP	D11154	550

13mm / .512" seg. height



C/A-34GD Guardian Combo
★★★ Super Premium
Concrete/Block/Asphalt/Green Concrete
Fast Cut/Long Life

Diameter & Width	Part No.	List Price
12" x .125" x 1/20mm DP	D11030	\$363
12" x .125" x 20mm DP	D11050	363
14" x .125" x 1/20mm DP	D11031	406
14" x .125" x 20mm DP	D11051	406
16" x .125" x 1/20mm DP	D11032	487
16" x .125" x 20mm DP	D11052	487
18" x .125" x 1/20mm DP	D11033	589
20" x .145" x 1/20mm DP	D11034	752
24" x .145" x 1" DP*	D11080	995

*24" blade has solid core and is wet use only

DRY/WET
 .512" seg. height
 3 Segment Design



C/S-32 BRUTE **NEW**
★★★ Super Premium **G3**
Granite/Brick/Hard Concrete/Pavers
Fast Cut/Medium Life

Diameter & Width	Part No.	List Price
12" x .125" x 1" -20mmDP	D11160	\$245
14" x .125" x 1"-20mm DP	D11161	275
16" x .125" x 1"-20mm DP	D11162	335
18" x .125" x 1"-DP	D11163	395
20" x .145" x 1"-DP	D11164	505

13mm / .512" seg. height



C/S-33SC
★★★ Super Premium **Fast Cut/Longest Life**
Granite/Brick/Hard Concrete/Pavers
Fast Cut/Long Life

Diameter & Width	Part No.	List Price
12" x .125" x 20mm DP	D11069	\$363
12" x .125" x 1"-20mm DP	D11067	363
14" x .125" x 20mm DP	D11070	406
14" x .125" x 1"-20mm DP	D11068	406
16" x .125" x 1"-20mm DP	D11079	487

DRY/WET
 .591" seg height



C/A 24 Combo
★★ Premium
Concrete/Block
Medium Cut/Medium Life

Diameter & Width	Part No.	List Price
14" x .125" x 1"-20mm	D11042	\$249
14" x .125" x 20mm	D11059	249
16" x .125" x 1"-20mm	D10202	308
16" x .125" x 20mm	D11060	308

DRY/WET
 .591" seg height

High Speed/Flat Saw/Masonry/ General Purpose Diamond Blades

SUPER PREMIUM BLADES

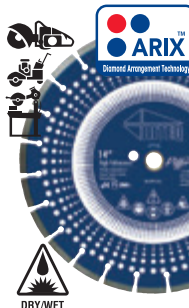

C-43AX
★★★★ PRO IV High Performance
Fast Cut/Long Life
 Cured Concrete/Brick/Block

Diameter & Width	Part No.	List
14" x .125" x 1" 20mm DP	D10053	\$444
16" x .125" x 1" 20mm DP	D10054	519
18" x .125" x 1" DP	D10055	536
20" x .145" x 1" DP	D10056	644

DRY/WET
 .393" seg. height
 Laser Welded

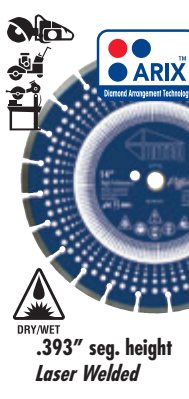

C-33AX
★★★ Super Premium
Fast Cut/Long Life
 Brick/Cured Concrete/Block

Diameter & Width	Part No.	List
12" x .125" x 1" 20mm DP	D11021	\$286
14" x .125" x 1" 20mm DP	D11022	319
14" x .125" x 20mm DP	D11027	319
16" x .125" x 1" 20mm DP	D11023	389
18" x .125" x 1" DP	D11024	427
20" x .145" x 1" DP	D11025	536
24" x .160" x 1" DP	D11028	805

DRY/WET
 .393" seg. height
 Laser Welded



U23 Xtra Segmented Blade
★★ Premium Gen. Purpose
Fast Cut/Long Life
 Brick/Cured Concrete/Block

Diameter & Width	Part No.	List
14" x .125" x 1"-20mm +DP	D70069	\$211

DRY/WET
 .512" seg. height
 Laser Welded



U-22 General Purpose
★★ Premium Fast
Fast Cut/Medium Life
 Cured Concrete /Brick/Block

Diameter & Width	Part No.	List
4" x .080" x 7/8"-5/8"	D70001	\$40
4.5" x .080" x 7/8"-5/8"	D70003	60
5" x .080" x 7/8"-5/8"	D70004	68
6" x .080" x DM-7/8"-5/8"	D70005	74
7" x .080" x DM-7/8"-5/8"	D70006	81
9" x .095" x 7/8"-5/8"	D70008	106
10" x .095" x DM-7/8"-5/8"	D70009	113
12" x .125" x 20mm DP	D70012	125
12" x .125" x 1"-20mm DP	D70013	125
14" x .125" x 20mm DP	D70016	141
14" x .125" x 1"-20mm +DP	D70017	141
16" x .125" x 1"-20mm +DP	D70085	168

DRY/WET
 Laser Welded
 .393 in.
 segment height



U13-Xtra General Purpose Segment
★ Economy Medium Cut/Long Life
 Cured Concrete/Brick/Block

Diameter & Width	Part No.	List
14" x .125" x 1"-20mm	D70080	184

DRY/WET
 .512" seg. height
 Laser Welded



JS-S Jet Stream
★ Economy Fast Cut/Long Life
 Brick/Concrete/Block

Diameter & Width	Part No.	List
12" x .125" x 1" -20mm DP	D96401	\$95
14" x .125" x 1"-20mm DP	D96402	100

DRY/WET
 12mm / .500"
 seg. height



DX Xtra-S
★ Economy Medium Cut/Long Life
 Brick/Concrete/Block

Diameter & Width	Part No.	List
12" x .125" x 1"-20mm	D96231	\$135
14" x .125" x 1"-20mm	D96230	146
16" x .125" x 1"-20mm	D96232	211

DRY/WET
 .591" seg. height

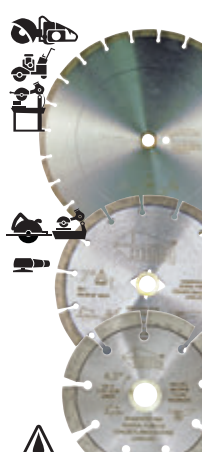

DX-S Universal Segmented Blade
★ Economy Medium Cut/Long Life
 Brick/Concrete/Block

Diameter & Width	Part No.	List
4" x .080" x 7/8"-5/8"	D96205	\$22
4.5" x .080" x 7/8"-5/8"	D96206	25
5" x .080" x 7/8"-5/8"	D96220	30
6" x .080" x 7/8"-5/8"	D96221	42
7" x .080" x DM-7/8"-5/8"	D96207	47
8" x .085" x DM-7/8"-5/8"	D96222	60
9" x .095" x 7/8"-5/8"	D96223	66
10" x .095" x DM-7/8"-5/8"	D96208	83
12" x .125" x 1" -20mm	D96214	98
14" x .125" x 1" -20mm	D96215	103

DRY/WET
 .393" seg. height

Shaft Adapter		P
Description	Part No.	List
20mm to 1 inch	161778	\$3.09

High Speed / Small Diameter General Purpose Turbo / Speciality Diamond Blades

ASPHALT, GREEN CONCRETE, BRICK, BLOCK SPECIALITY DIAMOND BLADES

Material	A36 ARIX	U/A26	U/A16	D23 Utility/ Rescue	D25
Hard Brick				●	
Brick				●	
Cured Concrete				●	
Concrete w/ Steel				●	
Stone				●	
Clay Tile				●	
Block/Pavers	●	●	●	●	
Green Concrete	●	●	●	●	
Asphalt	●	●	●	●	
Ductile Iron				●	●
Steel				●	
Glass				●	
Fiberglass				●	
Plastic				●	

SPECIALTY BLADES



D23 Construction Utility
★★ Premium
Fast Cut/Multi-Purpose

Diameter & Width	Part No.	List
4.5" x .125" x 7/8"-5/8"	D11102	\$92
5" x .125" x 7/8"-5/8"	D11103	103
7" x .125" x DM-7/8"-5/8"	D11104	157
12" x .125" x 1-20mm	D10061	308
14" x .125" x 1-20mm	D10057	319
16" x .125" x 1-20mm	D10100	536

DRY/WET
.200" seg. height



D25 Ductile Iron
★★ Premium

Diameter & Width	Part No.	List
14" x .125" x 1"-20mm	D44002	271
16" x .125" x 1"-20mm	D44005	379

DRY/WET
.200" seg. height
Laser Welded

SUPER PREMIUM BLADES

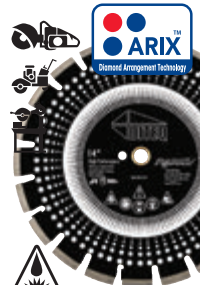

A36AX
★★★ Super Premium
Fast Cut/Long Life
Asphalt/Green Concrete/Lightweight Block

Diameter & Width	A36AX	List
14" x .125" x 1"-20mm DP	D24502	389
16" x .125" x 1"-20mm DP	D24503	427
18" x .135" x 1" DP	D24504	536

DRY/WET
.393" seg. height
Laser Welded

MASONRY SAW AND BLADES



Includes 14"
B32 Slanted U-Slot
Diamond Blade
D43037

PREMIUM BLADES



U-A26 Universal Segmented
★★ Premium
Fast Cut/Medium Life
Block/Green Concrete/Asphalt

Diameter & Width	Part No.	List
14" x .125" x 1"-20mm DP	D70073	\$228
16" x .125" x 1"-20mm DP	D70086	281

DRY/WET
.393" seg. height
Laser Welded

Chopper

HORSEPOWER	1-3/4
MOTOR	115V/60 Hz
BLADE GUARD	14"
RPM	3500
Arbor Size	1"
PART No.	M10008
List E	\$1,185

Accessories

Description	Part No.	List
Folding Stand	120090	\$305

ECONOMY BLADES



U-A16 Segmented Blade
★ General Purpose,
Medium Cut/Medium Life
Green Concrete/Asphalt/Block

Diameter & Width	Part No.	List
14" x .125" x 1"-20mm DP	D70088	\$151

DRY/WET
.472" seg. height

Masonry Saws / Masonry Diamond Blades

TURBO AND MASONRY BLADE APPLICATION CHART										
Material	B31/ B33 Silent Turbo	B35/ ARIX B38 Silent	B28	B32	ARIX B41	C33 Fire- star	B22 Fire- hawk	U23ST	U13ST	DX-T
	Refractory					●				
Hard Brick								●	●	●
Brick	●	●		●		●	●	●	●	●
Stone	●					●	●	●		
Clay Tile						●	●		●	
Block/Pavers	●	●	●	●		●	●			●



C33 Firestar		
★★★ Super Premium		
Diameter & Width	Part No.	List
4.5" x .070" x 7/8"-5/8"	D57116	\$48
5" x .080" x 7/8"-5/8" Flush	D57107	55
7" x .095" x DM-7/8"-5/8"	D57101	108
8" x .095" x DM-7/8"-5/8"	D57102	125
10" x .110" x DM-7/8"-5/8"	D57106	190
14" x .125" x 1"-20mm DP	D57104	351

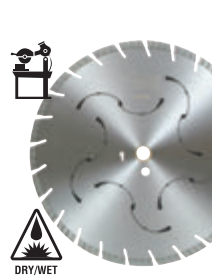

Silent Turbo			
★★★ Super Premium			
Diameter & Width	B31 Stone/ Brick	B33 Brick/ Block	D List
14" x .125" x 1" -20mm	D43034	D41023	\$395
20" x .145" x 1"	D44113	D44109	695

.393" segment height



B22 Firehawk III Multi-Purpose Turbo Blade		
★★ Premium Fast Cut		
Diameter & Width	Part No.	List
4" x .095" x 7/8 - 5/8" flush	D58013	\$38
4.5" x .095" x 7/8 - 5/8" flush	D58012	43
5" x .095" x 7/8 - 5/8" flush	D58011	48
6" x .095" x 7/8 - 5/8" flush	D58018	70
7" x .095" x 7/8 - 5/8" DM	D58014	92
10" x .110" x 7/8 - 5/8" DM	D58015	178
12" x .110" x 1" - 20mm DP	D58016	233
14" x .125" x 1" - 20mm DP	D58017	286



Silent Core			
★★★ Super Premium			
Diameter & Width	ARIX Brick/ Block	B38 Block	D List
20" x .135" x 1"	D44104	D44102	\$895



U23ST Segmented Turbo Blade		
★★ Premium General Purpose		
Diameter & Width	Part No.	List
14" x .125" x 1" -20mm +DP	D41004	\$265

Fast Cut/Longest Life Cured Concrete/Brick
.472" segment height

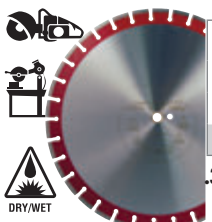

B28 Segmented		
★★ Premium		
Diameter & Width	Block Part No.	D List
20" x .145" x 1"	D43004	\$395

.393" segment height



U13ST Segmented Turbo Blade		
★ General Purpose		
Diameter & Width	Part No.	List
14" x .125" x 1" -20mm DP	D41030	\$125

Fastest Cut/Good Life - Brick
.472" seg. height



B32 Slanted U-Slot Segmented		
★★★ Super Premium		
Diameter & Width	Brick/Block Part No.	D List
14" x .125" x 1"	D43037	\$225

WET ONLY



B41 Segmented		
★★★★ PRO IV		
Diameter & Width	Refractory Part No.	D List
14" x .125" x 1"	D43021	\$445
20" x .125" x 1"	D43023	595

.393" segment height

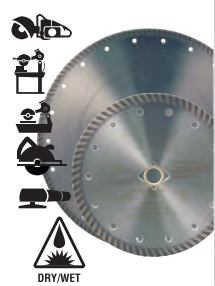

DX-T Wide Turbo Rim Blade		
★ Economy, Fast Cut		
Diameter & Width	Part No.	List
4" x .095" x 7/8" - 5/8"	D96209	\$21
4.5" x .095" x 7/8" - 5/8"	D96210	24
5" x .095" x 7/8" - 5/8"	D96224	30
7" x .095" x DM-7/8" - 5/8"	D96211	47
9" x .095" x 7/8" - 5/8"	D96225	78
10" x .110" x 7/8" - 5/8"	D96213	90

.275" seg. height

Grinding Wheels



CS14, CD14 Cup Grinding Wheel ★ Standard

Description	CS14 Single		CD14 Double	
	Row	List	Row	List
4" x 7/8"-5/8"	D80001	\$48	D80006	\$76
4" x 5/8"-11 thread	D80002	48	D80007	76
4.5" x 7/8"-5/8"	D80025	65	D80026	92
4.5" x 5/8"-11	D80029	65	D80030	92
5" x 7/8"-5/8"	D80003	92	D80008	108
5" x 5/8"-11 thread	D80023	92	D80024	108
7" x 7/8"-5/8"	D80004	103	D80009	146
7" x 5/8"-11 thread	D80005	103	D80010	146



Segmented Storm Cup Wheel CST24 ★★ Premium

Description	CST24		CST34	
	List	Part No.	List	Part No.
4" x 7/8"-5/8"			D81019	\$146
4" x 5/8"-11 thread	D81038	\$108	D81020	146
4.5" x 7/8"-5/8"			D81021	163
4.5" x 5/8"-11 thread	D81040	125	D81022	163
5" x 7/8"-5/8"			D81023	190
5" x 5/8"-11 thread			D81024	190
7" x 7/8"-5/8"	D81043	195	D81025	298
7" x 5/8"-11 thread	D81044	195	D81026	298



CS33, CD33 Cup Grinding Wheel ★★★ Super Premium

Description	CS33 Single		CD33 Double	
	Row	List	Row	List
4" x 7/8"-5/8"	D80011	\$87	D80016	\$141
4" x 5/8"-11 thread	D80012	87	D80017	141
4.5" x 7/8"-5/8"	D80027	103	D80028	163
4.5" x 5/8"-11	D80031	103	D80032	163
5" x 7/8"-5/8"	D80013	119	D80018	178
5" x 5/8"-11 thread	D80033	119	D80034	178
7" x 7/8"-5/8"	D80014	178	D80019	276
7" x 5/8"-11 thread	D80015	178	D80020	276



Arrowhead Cup Wheel ★★★ Super Premium

Description	Part No.	List
4" x 7/8"-5/8" + 5 Seg	D81065	\$98
4" x 5/8"-11 + 5 Seg	D81066	100
7" x 7/8"-5/8" + 10 Seg	D81071	168
7" x 5/8"-11 + 10 Seg	D81072	168

Additional sizes available upon request.



Segmented Turbo Cup Grinding Wheels CST13 ★ Standard CST23 ★★ Premium

Description	CST13	List	CST23	List
4" x 9-10 seg x 7/8"-5/8"	D81047	\$55	D81001	\$92
4" x 9-10 seg x 5/8"-11	D81035	55	D81002	92
4" x 18 seg x 5/8"-11	D81049	81	D81058	138
4.5" x 9-10 seg x 5/8"-11	D81051	60	D81028	98
5" x 12 seg x 5/8"-11			D81003	113
7" x 12 seg x 7/8"-5/8"	D81034	90	D81004	135
7" x 12 seg x 5/8"-11	D81036	98	D81005	135
7" x 24 seg x 7/8"-5/8"	D81055	157	D81008	216
7" x 24 seg x 5/8"-11	D81056	157	D81009	216



Vacuum Brazed Spike Discs

Diameter	35 Grit		80 Grit	
	Concrete	Metal	Part No.	List
4.5"	162020	162021		\$120
5" with air holes	162022	162023		140
7"	162024	162025		195

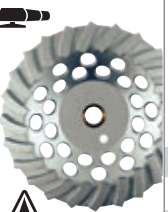

Segmented Turbo Cup Grinding Wheels w/ Drive pin hole CST13 ★ Standard

Diameter / Segment	Part No.	List
7" x 12 seg x 7/8"-5/8"	161594	\$100
7" x 24 seg x 7/8"-5/8"	161597	167

Includes drive pin hole for EDCO machines



PCDC-35 and PCDC-39 Cup Wheels

Description	No. of Chips		Part No.	
	Part No.	List	Part No.	List
PCDC-35 4" x 7/8" - 5/8"	5	D83201	\$199	
PCDC-35 4" x 5/8" - 11	9	D83203	149	
PCDC-35 5" x 5/8"-11	8	D83205	189	
PCDC-39 7" x 5/8" - 11 or 7/8"	12	D83204	299	

Brazed Diamond Grinding Wheels

Description	4.5"		7"	
	List	Part No.	List	Part No.
Position 0 (25 Grit)	161027	\$126	161021	\$221
Position 1 (30 Grit)	161028	108	161022	213
Position 2 (40 Grit)	161029	100	161023	191
Position 3 (50 Grit)	161030	100	161024	191
Position 4 (100 Grit)	161031	100	161025	191
Position 5 (200 Grit)	161032	100	161026	191



CTC32 Continuous Turbo Cup

★★★ Super Premium

	Fine 100/120	Medium 60/80	Coarse 30/40	D
Description	Part No.	Part No.	Part No.	List
4" x 5/8"-11 th	D82006	D82004	D82002	158
5" x 5/8"-11 th	D82018	D82016	D82014	169
6" x 5/8"-11 th	D82024		D82020	180
7" x 5/8"-11 th	D82030	D82028	D82026	300

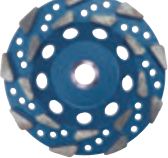

S-Segment Cup Wheel

CST24 ★★ Premium

Description	20 Grit	List	40 Grit	List	D
4" x 5/8"-11	D81075	\$108	D81079	\$88	
5" x 7/8"-5/8"	D81076	180			
7" x 7/8"-5/8"	D81077	211			
7" x 5/8"-11	D81078	216	D81080	175	



Turbo HD Grinding Wheels

★★★ Super Premium

Description	Part No.	List	D
4" x 7/8"-5/8" 7 + 7 Seg	D81032	\$119	
4" x 5/8"-11 7 + 7 Seg	D81045	119	
7" x 7/8"-5/8" 9 + 9 Seg	D81033	254	
7" x 5/8"-11 9 + 9 Seg	D81046	254	



NEW



Turbo Low Profile Grinding Wheels

★★★ Super Premium

Description	Part No.	List	D
6" x 3/4" - 16 segments	D81083	\$165	

Designed with a 3/4" arbor to fit on Hilti machines.



FTC32 Ceiling Grinding Plate

★★★ Super Premium

Description	Part No.	List	D
5" x 5/8"-11	160161	\$204	
6" x 5/8"-11	160162	263	



S22 Vacuum Brazed Grinding Wheels

★★ Premium

Description	Part No.	List	D
4" Coarse x 5/8"-11	D66039	\$148	



Adpter

Description	Part No.	List	P
5/8"-11F x 7/8" bore	130117	\$18.54	

Scarifier Drum Assemblies, Spacers and Cutters



Cutters for Scarifiers

Type	No. of Teeth	OD (in)	ID (in)	Thickness (in)	Part No.	List	A
Star, Steel	18	1.250	0.438	0.188	160347	\$2.16	
Star, Steel	18	2.000	0.500	0.188	160342	2.16	
Star, Steel	18	2.000	0.500	0.156	160343	2.16	
Star, Steel	18	2.000	0.750	0.156	160334	2.43	
TCT Flail	6	1.750	0.625	0.250	160203	14.06	
TCT Flail	8	2.250	0.750	0.250	160379	22.00	
TCT Flail	8	2.250	1.000	0.250	160380	22.00	
TCT Full Face Flail	8	2.250	0.625	0.250	160350	43.00	
TCT Full Face Flail	8	2.250	0.750	0.250	160351	43.00	

DITEQ carries a full line of carbide cutters. This is just a sampling of the most commonly used cutters. Call customer service for recommendation.

Scarifier Drum Assemblies

Description	Std.	Total No.	Part No.	List	A
Drum Assembly w/8 pt tungsten carbide cutters (complete)	160379	160919	160970	\$2,153	
	66 cutters/75 spacers				
Drum Assembly w/8 pt FF tungsten carbide cutters (complete)	160351	160919	160995	3,130	
	66 cutters/75 spacers				
Drum Assembly w/pointed steel cutters (complete)	160334	160918	160996	1,349	
	111 cutters/111 spacers				
Drum Assembly w/milling cutters (complete)	160358	160920	161116	1,982	
	24 cutters/33 spacers				

Scarifier Shafts and Spacers

Description	Part No.	List	P
1/2" diameter x 10-5/8" shaft	160182	\$9.73	
1/2", Thin Hardened Spacer	160918	.30	
1/2", Thick Hardened Spacer	160919	1.08	
1/2", Small-Thick Hardened Spacer	160920	.38	

Drums and shafts are available for many brands and models of scarifiers. Call customer service for information and pricing.

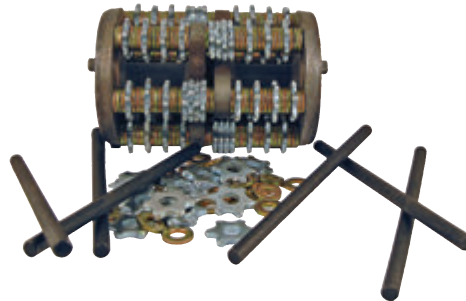

CPM8 Cutter Package

Description	Qty	Part No.
TCT Cutter - 6T-44 x 16 x 6	78	160203
Hardened Spacer, 1/2", small thick	215	160920
Shaft for Spacers, 1/2 x 8-9/16"	6	160988
CPM8 Cutter Package*		161434
List A		\$1,226

**Drum not included*

Vacuum Systems / Shrouds



WET/DRY Dustless Vacuum Systems		
	Std Vac	HEPA
Specifications		16 WD
Inches Water Lift		72
CFM		116
Volts		110
Watts		1324 peak
Amps		11.5
RPM's		23,000
Vac Only Part No.	162251	162252
List E	\$380	\$580

Dustless Vacuum Accessories		
	Part No.	List P
WD Filter package wet/dry lifetime	160089	\$46
WD Filter master pk (pkg. 5 Pri & Sec)	160090	209
HEPA Filter	160074	192
HEPA Filter cover	160233	35
Micro pre-filter bags (qty of 10 filter bags)	160072	104
Micro pre-filter bags (qty of 20 filter bags)	160076	202
Micro pre-filter bags (qty of 2 filter bags)	160123	26
6' Hose 1-1/4" Diameter	160092	26
25' x 2" Flexible hose w/coupler	160093	147
Splitter, Y- 2" x 2" x 2"	160105	16.48
"Y" hose stub (req'd with 160105)	160235	23
2" hose to 2" hose coupler	161107	8.65
2" Core Drill Shroud w/hose	160085	69
3" Core Drill Shroud w/hose	160086	87
Turbo Carpet Tool	160154	114



DRY Henry Cannister Vacuum	
Inches Water Lift	100
CFM	120
Soil Recovery	84%
Filtration	0.3 micron @ 99.97% EFF.
Std. Filter	TRITEX combination + HEPAFLO
Tank Capacity	2.5 gal.
Vacuum Motor	.9 hp/680 Watts/2 speed
Hose Length	8.5 ft
Weight	15 lb.
Part No.	162245
List E	\$490

Accessories		
	Part No.	List P
Vacuum Bags - Pkg of 10	162246	\$34

WET Dustless Slurry Continuous Duty Vacuums

VOLTS/Watts	120V/1,500
AMPS	13
Vacuum Pressure (H ₂ O")	90"
Air Movement (CFM)	115
Inlet (in.)	2"
Capacity (gal)	55
Effective Slurry pickup distance	100 ft
Hose Included	25 ft x 2" diameter
PART No. Complete	100553
List E	\$3,426
Motor Head and Hose	100554
List E	\$2,350

For wet use only.



Vacuum and motor unit shown mounted on 55 gallon metal drum (included)

Accessories/Components		
Description	Part No.	List P
Cart	100630	\$630
Vacuum Wand, slurry vac	100631	140
Motor only	100555	189
Motor brush set	100556	24
Filter, slurry vac	100558	35
Seal, slurry vac	100561	48



Description	Fits 4 - 5" Grinders		Fits 6-9" Grinders	
	Part No.	List E	Part No.	List E
DustBuddie	162437	\$64	162438	\$69
18" Hose		160091		21

Hose sold separately



Description	Fits 4 - 5" Grinders		Fits 6-9" Grinders	
	Part No.	List E	Part No.	List E
DustBuddie XP	162456	\$126	162457	\$138

Includes 18" Hose



Description	5"		7"	
	Part No.	Part No.	Part No.	List E
Dustie	160321	160322		\$38.00
Cover Plate	160224	160328		14.06
18" Hose		160091		21

Hose sold separately



Description	5"		7"	
	Part No.	List E	Part No.	List E
CutBuddie III	161781	\$163	161782	\$200

Includes 18" Hose



Description	Part No.	List E
1-3/8" dia. bits w/hose	160220	\$53
1" to 4" dia. bits (round) w/hose	160979	53
2-8" dia. bits (round)	161625	61



DRY DUST DROID For Extra Fine Dust

Specifications	
HEPA Rated	99.97%
Motor	dual 2 hp
Volts	120 or 240v /50-60 hz
Watts/AMPS	3120 / 13 (ea)
Vacuum Pressure (H ₂ O")	90 in.
Air Movement (CFM)	600
Inlet (in.)	3"
Capacity (gal)	30
Hose(included)	3" X 25'
PART No.	161682
List E	\$12,220

Droid 600 Accessories		
	Part No.	List P
Bags - pack of 100	161864	\$380
Bags - pack of 10	161865	40

Industrial Wet and Dry Vacuums



Shown with wand kit
Comes standard with 15 ft. of 2 inch Hiloflex hose

DRY Dual Motor Vacuum

Motor	Dual, 2 hp, 1600 Watts
Vacuum Pressure (H ₂ O")	110"
Air Movement (CFM)	180
Filtration at 99.55%	.5 micron
Sound Level	67 dB(A)
Weight	50 lb.
Capacity (gal)	12
PART No.	160799
List E	\$1,700

Accessories for Dual Motor Dry Vacuum		P
Description	Part No.	List
5 Pack Hepa-Flo Bags (large - 4B)	160814	\$110
10 Pack standard bags (large - 4B)	160839	52
Optional HEPA Assembly	160812	623
HEPA Replacement Element	160817	288
"Y" Connector	160815	99
Wand Kit	160801	200
Replacement Hose - 15 ft. Hiloflex	160813	188
29" Mounted Brush Attachment	160818	270



Shown with optional wand kit
Comes standard with 15 ft. of 2 inch Hiloflex hose

DRY Single Motor Fine Dust Vacuum

Motor	Single, 1.6 hp, 1200 Watts
Airflow	95 cfm
Inches Water Lift	100"
Capacity	5 gallons
Hose	15' two inch diameter Hiloflex
Sound Level	64 dB(A)
Weight	36 lb.
Standard Filtration	.3 micron @ 99.6% efficiency
Part No.	160800
List E	\$900

Accessories for Single Motor Dry Vacuum		P
Description	Part No.	List
5 Pack Hepa-Flo Bags (small 3B)	160816	\$100
10 Pack standard bags (small 3B)	161554	48
HEPA Assembly	160812	623
Wand Kit	160801	200
Replacement Hose - 15 ft. Hiloflex	160813	188



Shown with 29" mounted squeegee P/N 160802

Wet Slurry Clean-up Vacuum

Pickup Unit	29" mounted squeegee kit	w/Wand	w/Wand	29" mounted squeegee kit
Motor	Single 2 stage,	Single 2 stage	Single 2 stage	Single 2 stage
Power	1.6 hp, 1200 Watts	1.6 hp, 1200 Watts	1.6 hp, 1200 Watts	1.6 hp, 1200 Watts
Speed	Single	Single	Single	Single
Airflow	95 cfm	95 cfm	95 cfm	95 cfm
Inches Water Lift	110"	110"	110"	110"
Tank Capacity (gallons)	12	12	20	20
Power Cord	42' in length	42' in length	42' in length	42' in length
Sound Level	64 dB(A)	64 dB(A)	64 dB(A)	64 dB(A)
Weight	44 lb.	52 lb.	70 lb.	70 lb.
Tank & Head	Structural foam	Structural foam	Structural foam	Structural foam
Part No.	160802	160825	161552	160838
List E	\$860	\$820	\$1,060	\$1,090

Optional Accessories	Part No.	P
Squeegee Wand Kit w/10' Hose	160824	\$200
Filter, 14" nylon, primary	160829	110
Filter, 14" nylon, secondary	162088	90
Thin filter grid	162089	30



Motor Filter	Part No.	A
13" Pad, white	A70022	\$7.73

A 13" pad can be used as vapor barrier to eliminate moisture completely by preventing foam or stripper from reaching the vacuum motor.



Drum is not included. Shown for illustrative purpose only

WET/DRY Single and Dual Motor Drum Top System Vacuum for Dry or Wet Materials

	Single Motor	Dual Motor
Motor	1,200 Watts	2,1600 Watts
Airflow	95 cfm	160 cfm
Water Lift	90"	90"
Hose	10' 1-1/2" Diameter	10' 1-1/2" Diameter
Power Cord	42'	42'
Part No.	162211	162212
List E	\$1,500	1,900

Includes motor power head, drum adapter, wet float assembly, secondary dry filter, hose, wand, wet tool

High Reach Wand	Part No.	P
Wand Assy. High Reach Kit	162383	\$675
Wand Telescopic Extension	162384	90

DRY Triple Motor Fine Dust Vacuum

Motor	3, 1200 Watts, 1.6 Hp
Water Lift	100"
Airflow	250 cfm
Inches Water Lift	100"
Filtration	0.3 micron @99.6% eff
Capacity	12 gallons
Hose	15' two inch diameter Hiloflex
Sound Level	70 dB(A)
Weight	85 lb.
Tank Construction	Steel
Part No.	162258
List E	\$3,500



Hose	Part No.	P
Hose 3" dia x 10 ft.	162379	\$225
Hose 3" dia x 20 ft.	162380	460

Industrial Scrubbers

Rideable Industrial Scrubbers

NEW

	TWINTEC VARIO/TTV678	TWINTEC TTB 3226	TWINTEC TTB2120
Cleaning Path	26", 30", 34"	26"	20"
Pad or Brush Size	3 x 12"	2 x 13"	20"
Solution/Recovery Tank	32 gal.	32 gal.	21 gal.
Chemical Capacity	1 gal.	N/A	N/A
Chemical Mixture Rates	32:1, 64:1, 96:1, 128:1	N/A	N/A
Water Flow Rate	1.0 / 0.8 / 0.5 / 0.25 gpm	.25, 0.5, 0.8, 1.0 gpm	.25/0.5/0.8/1.0 gpm
Brush Pressure	160 lbs. max	120 lbs. max	52 lbs. max
Brush Speed	125-200 rpm	200 rpm	150 rpm
Brush Motor	3 x 24V, 400W	2 x 24V, 400W	1 x 24V, 600W
Traction Motor	600W	600W	400W
Working Speed	0.3 - 4.3 mph	0.3 - 4.3 mph	0.3 - 3.7 mph
Maximum Gradient	11°	9°	6°
Vacuum Motor Power	24V, 400W	24V, 400W	24V, 400W
Noise Level	67 dB(A)	69 / 67 dB(A)	65 dB(A)
Working Capacity (sq. ft./hr.)	64,045	49,192	30,000
Run Time	4 hrs.	3.5 hrs	2.5 hrs.
Batteries (gel)	6 x 12V, 100 Ahr.	4 x 12V, 100 Ahr	2 x 12V, 100 Ahr
Weight	1,100 lb.	920 lb.	450 lb.
Dimensions (LxWxH)	66" x 26" x 56"	66" x 26" x 56"	57" x 22" x 45"
Part No.	G00056*	G00097*	G00115
List E	\$20,000	\$16,900	\$10,700

G00056 includes 3 pad drivers, G00097 includes 2 pad drivers and G00115 includes one pad driver



TTV678 G00056



TTB 3226 G00097



TTB 2120 G00115

Scrubber Accessories	Fits Rider Model	Part No.	List	Fits Walk Behind Model	Part No.	List
Off aisle wand kit	All	161851	\$190	All	161851	\$190
Squeegee Blade Set, Small	G00056	161849	105	G00096/61	161850	125
Squeegee Blade Set, Large	G00056/97	161850	125			
Pad Driver - 12"	G00056	161845	179			
Pad Driver - 13"	G00097	162038	179	G00061/96	162037	209
Pad Driver - 17"	G00110/14	161436	188			
Pad Driver - 20"	G00115	162037	209			
Brush, Poly Scrub -12"	G00056	161846	140			
Brush, Poly Scrub -13"	G00097	162039	155			
Brush, Poly Scrub -17"	G00110/104	161437	189			
Brush, Poly Scrub-20"	G00115	161868	180	G00061/96	161868	180
Brush, Nylon Scrub-12"	G00056	161847	160			
Brush, Nylon Scrub-13"	G00097	162040	165		162040	165



TTB 1620 G00096



TTB 1120 G00061

Walk-Behind Industrial Scrubbers

	TTB1117	TT1117	TTB1620	TTB1120	TT1120
Cleaning Path	17"	17"	20"	20"	20"
Pad or Brush Size	17"	17"	20"	20"	20"
Solution/Recovery Tank	11 gal.	11 gal.	16 gal.	11 gal.	11 gal.
Water Flow Rate			.25-1 gpm		
Brush Pressure	72 lbs. max	105 lb.	90 lbs. max	75 lbs. max	105 lb.
Brush Speed	150 rpm	180 rpm	150 rpm	150 rpm	180 rpm
Brush Motor	400W	1000W	24V, 400W	24V, 400W	1000W
Vacuum Motor Power	24V, 400W	1200W	24V, 400W	24V, 400W	1200W
Noise Level	65 dB(A)	72 dB(A)	68 dB(A)	67 dB(A)	72 dB(A)
Working Capacity (sq. ft./hr.)	18,700	18,700	22,000	22,000	22,000
Run Time (hours)	2.5 - 3.5		3-3.5	3.5	
Batteries (gel)	2 x 100AH		2 x 100 Ah.	2 x 100 Ah.	
Electric Cord		65 ft.			65 ft.
Weight	268 lb.	140 lb.	393 lb.	277 lb.	150 lb.
Dimensions (LxWxH)	44"x17"x43"	44"x17"x43"	57"x22"x43"	44"x22"x43"	44"x21.65"x43"
Part No.	G00110	G00104	G00096**	G00061**	G00105
List E	\$5,799	\$4,200	\$7,000	\$6,200	\$4,500

All models include pad driver

Compact Scrubbers / Slurry Control / Cleaners

Compact Scrubbers

	TT516 Corded	TTB516 Battery
Cleaning Path	16"	16"
Pad Size	15"	15"
Brush Size	15"	15"
Solution/Recovery Tank	5 gal.	5 gal.
Brush Pressure	55 lbs.	55 lbs.
Brush Speed	150 RPM	200 RPM
Brush Motor	400W/.5 HP	400W
Vacuum Motor Power	400W/.5 HP	300W/.4 HP
Noise Level	67 dB(A)	66 dB(A)
Working Capacity	16,600 sf	17,600 sf
Power	115V electric	12V gel 18 Ah battery
Weight	85 lb.	115 lb.*
Dimensions (LxWxH)	33"x18"x44"	33"x18"x44"
Part No. w/poly scrub brush	G00114	G00107
List E	\$2,300	\$3,100
Part No. w/pad driver	G00095	G00094
List E	\$2,300	\$3,100

*including battery



Compact Scrubber	Part No.	P
Optional Accessories	Part No.	List
Spare Battery	162035	\$310
Brush, Nylon Scrub	162034	165
Brush, Poly Scrub	162033	155
Pad Driver	162032	179

Slurry Control

NEW



Pressure Washers

	K1622	K1122TST
Pump Type	Brass, Triplex Piston	Brass, Triplex Piston
Pump Pressure	1600 PSI	1400 PSI
Motor	1.5 HP, 13.0 Amps	1.5 HP, 13.0 Amps
Volume	1.6 gpm	2.1 gpm
Max. Temperature	140° F	140° F
Power Cord Length	35 ft.	23 ft.
Weight	40 lb.	70 lb.
Pressure Hose	30 ft.	50 ft.
Flow Rate	1.6 GPM	2.1 GPM
Hose Length	30 ft.	50 ft.
Voltage	120V	120V
Dimension (LxWxH)	38"x15"x15"	34"x14"x14"
	Gun w/Lance & Vario	Gun w/Lance & Vario
	Nozzle	Nozzle & Dirt Killer
Includes	Nozzle	Nozzle
Part No.	162493	162257
List E	\$1,038	\$1,722

CONCRETE DESTROYER	Standard Formula	Foaming Formula	A
Description	Part No.	Part No.	List
32-oz. spray bottle*	100316	100335	\$25 / \$35
1 gallon bottle**	100317	100336	50 / 58
5 gallon bucket	100318	100337	239 / 255
55 gallon drum	100319	100338	2,158 / 2,163

* Packaged 2 boxes of 6 32-oz bottles (12 total per case) ** Packaged 4 one gallon bottles per case
270 Gallon tote size is also available. Call for more information.



Pumps, Sprayer Pumps and Spigots	P	
Description	Part No.	List
Pump for 55 gallon drums	100328	\$100
Sprayer Pump, 3.5 gal.	151470	185
Spigot for 5 gallon bucket	100323	6.49

SlurrySep Flocc Agent

Description	SlurrySep	List	SlurrySep-PH	A
50-lb bag	100540	\$839	100541	\$1,164
4 gallon bucket*	100543	453	100544	613

SlurryDry Slurry Gel

Description	SlurryDry-QS	List	SlurryDry-LS	A
50-lb bag	100539	\$1,164	100562	\$1,130
4 gallon bucket*	100542	613	100563	595

QS - Quick Solidification

LS - Low Solids Slurries * 4 gallon buckets weigh approximately 25 lb.



See Page 48 for Cleaners, Degreasers and Densifiers

Surface Prep / TG8 and TG12 Grinder / Polisher / Tools



TG8 Grinder / Polisher			
Motor	2hp	5.5 Honda	5.5 Subaru
Phase	Single	Gas	Gas
Full Load AMPS @115V	18.4	GXV160	EA190
RPM - Disc	2800	2800	2800
Model	FGE 2L	FGG 5H	FGG5S
Weight	130 lbs	120 lbs	120 lbs
Part No. w/Grinding Plate	G00046	G00048	G00072
List E	\$3,239	\$3,564	\$3,264
Part No. w/TEQ-Lok Plate	G00057	G00058	G00073
List E	\$3,111	\$3,435	\$3,135

*Grinding disc is D91003 TEQ-Lok plate is 160222 - uses 4 TEQ-Lok tools.
Standard rotation is RH (right hand)*



Grinding disc
D91003



TEQ-Lok plate
160222

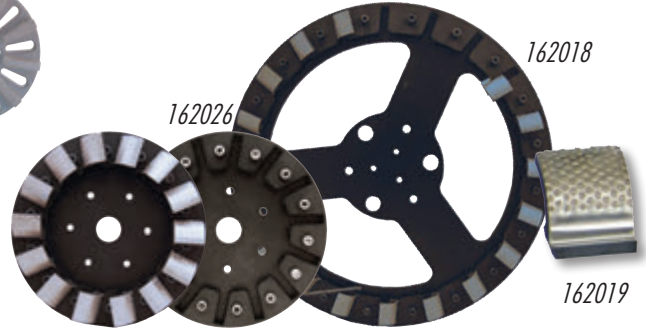

Standard TG8 Grinding Tools/Accessories					D
Diameter & Width	Seg	Grit	Part No.	List	
FGG34 8" x 3/4"* (std bond)	10	Coarse - 30/40	D91003	\$589	
FGP35 8" x 3/4"* (std bond)	10	Med - 60/80	D91005	589	
FGG36 8" x 3/4"* (hard bond)	10	Coarse - 30/40	D91009	589	
FGG34 8" x 3/4"* (std bond)	5	Coarse - 30/40	D91006	536	

**includes rubber isolator 161113*

Vacuum Brazed Grinding Plates and Modules			
Description	Part No.	List	
VB-Module 30L 35 Grit	162019	\$25	A
TG8 Plate with Hub for VB-Modules (holds 14 modules)	162026	395	P
TG18 Plate for VB-Modules (holds 20 modules)	162018	695	P

Plates and Modules sold separately



TG12 Grinder/Polisher				
Disc Size	12"	12"	12"	12"
Horsepower/RPM	3 HP / Variable 0 - 1000	3HP / 1000	5HP / 1000	11 HP Gas / 1000
Engine/Motor	220V 1 PH	220V, 1 PH	220V, 1 PH	Honda
Amps	8.4 A	16.8 A	23 A	N/A
Height	41"	41"	41"	41"
Length	32"	32"	32"	32"
Width	18"	18"	18"	18"
Weight	200 lb.	220 lb.	220 lb.	200 lb.
Part No.	G00054	G00117	G00051	G00055
List E	\$4,537	\$3,885.00	\$4,321	\$4,645

TEQ-Lok / Multi-Accessory plate is included - uses 3 or 6 TEQ-Lok tools.

TG18 and Stonekor Production Grinder/Polishers

TG18 Grinder / Polisher

Specifications	Grinder	Grinder	Grinder	Grinder / Polisher	Grinder	Grinder / Polisher
Disc Size	18"	18"	18"	18"	18"	18"
Horsepower / RPM	5 / 425	5 / 425	5 / 425	3 / 425	11 Gas / 1400	18 / 1400
Engine / Motor	220V / 1 PH	240V / 3 PH	480V / 3 PH	Variable/220 1 PH	Honda	Kawasaki Propane
Amps	23	14	6.6	8.4	N/A	N/A
Height	37"	37"	37"	37"	37"	37"
Length	56"	56"	56"	56"	56"	56"
Width	25"	25"	25"	25"	25"	25"
Weight	290 lb	295 lb	295 lb	295 lb	280 lb	360
Part No.	G00066	G00067	G00068	G00069	G00070	G00116
List Price E	\$4,641	\$4,965	\$4,965	\$4,857	\$4,965	\$8,465

TEQ-Lok / Multi-Accessory plate is included TG18 can use TEQ-Lok tools or cup wheels (either 4 or 8 TEQ-Lok tools or 3 or 6 cup wheels)



G00066



G00116

NEW



TG30 Production Grinder / Polisher

Disc Size	30"
Propane Engine	Robin
Horsepower	22
Drum Speed	1082 rpm
Head Speed	542 rpm
	counter clockwise
Production	800 - 900 sq ft per hr
Head Pressure	350 lb.
Grinding Width	30"
Vacuum Ports	1
Weight	700 lb
Part No.	G00118

List E \$16,915
Multi-accessory plate is included

NEW



G & P II Planetary Production Grinder/Polisher

Disc Size	30"
Engine	Subaru/Propane
Horsepower	22
RPM	3200
Production	800-1300 sf per hr
Height	55"
Length	80"
Width	38"
Weight	1,385 lb.
Part No.	G00063
List E	\$38,771



LX-30 Planetary Grinder / Polisher

Disc Size	30 in.
Engine	Subaru/Propane
Horsepower	22 hp
Engine Speed	3,200 rpm
Drum Speed	1,410 rpm
Head Speed	840 rpm
Production	800-900 sq ft per hr
Grinding Pressure	500 lbs.
Grinding Diameter	28 inches
Box Dimensions	L80"xW38"xH55"
Shipping Weight	950 lb.
Part No.	G00076
List E	\$29,000



Low Profile Edger Production Grinder/Polisher

Disc Size	19"
Engine	Kawasaki Propane
Horsepower	18 hp
Production per hour	450 - 500 sf
Head speed	640 rpm
Head Pressure	165 lbs.
Height	56"
Length	55"
Width	39.5"
Weight	615 lb.
Part No.	G00065
List E	\$19,172



TEQ-Lok Tools / Surface Prep Grinding Tools

TEQ-Lok Tools for All Machines Using TEQ-Lok System



TEQ-Lok System		
Description	Part No.	P List
8" TEQ-Lok Adapter Plate w/o segments	160222	\$197
12" TEQ-Lok Adapter Steel Plate w/o segments	160223	328
TEQ-Lok 2" velcro pad driver	161165	47
TEQ-Lok 3" velcro pad driver	160969	60
Replacement plastic ring for 2" pad driver	161621	18.54
Replacement velcro for 2" pad driver	161622	1.35
Placement plastic ring for 3" pad driver	161451	24
Replacement velcro for TEQ-Lok 3" pad driver	161452	2.16



PCD TEQ-Lok Segments		
Description	Part No.	D List
PCD - 1 whole round per seg - RH	161788	\$271
PCD - 1 whole round per seg - LH	161642	271
PCD - 2 whole round per seg RH	162482	298
PCD - 2 whole round per seg LH	162483	298
PCD Segment (PCDS - 2 chips per seg) - RH	D91101	226
PCD Segment (PCDS - 3 chips per seg) - RH	D91102	284
PCD 2 segments	162490	120
PCD 2 segments bar RH	162491	220
PCD 2 segments bar LH	162492	220



Adapter Description*		
Description	Part No.	P List
10" TEQ-Lok Plate w/o segments	161638	\$556

(*10" x 3/4" x 3/8"-24 threads) (Universal bolt pattern fits most single-head grinders)



TEQ-Lok 3" Arrow/PCD "Bearclaw" Grinding Tool			
Description	Part No. Right Hand	Part No. Left Hand	D List
Combination diamond and PCD	162284	162283	\$295



TEQ-Lok Single Round and Rectangular Segments			
Description	Bond	Part No.	D List
35/40 Grit Round	Medium	162410	\$50
35/40 Grit Rectangular	Medium	162411	50

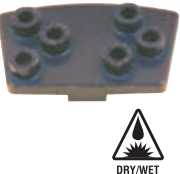

TEQ-Lok Diamond Segment Coating Stripper		
Description	Part No.	D List
Diamond Segment (30/40) Grit	D91107	\$131



TEQ-Lok Twin Full Rectangular Segments				
Description	Bond	Part No.	D List	
16/18 Grit	Hard	D91118	\$102	
16/18 Grit	Extra Hard	D91119	102	
20/25 Grit	Medium	D91103	102	
30/40 Grit	Medium	D91104	102	



Carbide Scraping Mounting Block and Chips			
Description	Part No.	List	
TEQ-Lok Carbide Mounting Block (RH)	161641	\$103.00	P
TEQ-Lok Carbide Mounting Block (LH)	161704	103.00	P
Low Profile Flathead Steel Mounting Screw	900138	1.63	P
Carbide Replacement Chip - 8 sided	160309	30.00	A



TEQ-Lok Twin Round Segments					
Description	Soft Bond	Medium Bond	Hard Bond	Extra Hard Bond	D List
16 Grit	D91110	D91108	D91117		\$102
30 Grit	D91111	D91109	D91112	D91120	102
60 Grit	D91115	D91105	D91113		102
120 Grit	D91116	D91106	D91114		102



TEQ-Lok 3" Metal "Pizza" Grinding Tools				
Grit	Soft Bond Part No.	Med Bond Part No.	Hard Bond Part No.	D List
6		162504		\$185
16/18	162476	162300	162477	185
30/40	162453	162301	162454	155
60/80	162478	162434	162479	155
120/150	162480	162435	162481	155
200	162484	162485	162486	155
400		162495		155



TEQ-Lok Arrowhead Segments				
Description	Soft Bond Part No.	Med Bond Part No.	Hard Bond Part No.	A List
16 Grit	161975	161978	161981	\$90
30 Grit	161976	161979	161982	90
60 Grit	161977	161980	161983	90



Metal Bond Diamond TEQ-Lok Mini Segments		
Description	Part No.	A List
16 Grit	161238	\$181
30 Grit	161162	159
50 Grit	161163	159
80 Grit	161164	159

Surface Prep Tools / Bolt-On Trapezoids



Grit	Hard Bond	Med Bond	Soft Bond	A List
	Soft Concrete	Medium Concrete	Hard Concrete	
30/40	160893	160314	160895	99
60/80	160896	160315	160898	85



Grit	Part No.	A List
18/20	161571	\$79
30/40	161572	59
60/80	161573	59
120/150	161574	59



Grit	Medium Bond	Hard Bond	A List
30	162306	162307	\$85

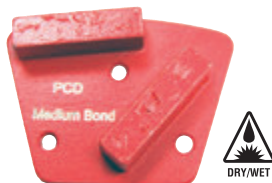

Description	Part No.	D List
Two Segment PCD Chip Med Bond	162075	\$120
Two Segment PCD Chip Soft Bond	162076	120

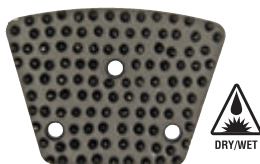

Grit	Part No.	A List
35	162098	\$75



Description	Part No.	D List
Two Segment with PCD Bar (RH)	162080	\$220
Two Segment with PCD Bar (LH)	162329	220

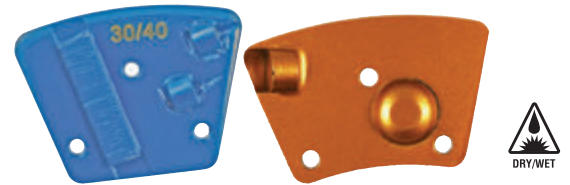

Description	Part No.	D List
PCD-2 with 30 Grit Dia Seg Wear Bar	161192	\$278
PCD-1 Whole w/Wear Button (Rt Hand)	161575	281
PCD-1 Whole w/Wear Button (Lt Hand)	161829	281



Grit	Single Segment			Double Segment			A List
	Soft Bond	List	Soft Bond	Med Bond	Med Hard Bond	Hard Bond	
16/20	161753	\$77	161756	161761	161766	161771	\$108
30/40	161754	52	161757	161762	161767	161772	82
60/80	161755	52	161758	161763	161768	161773	82

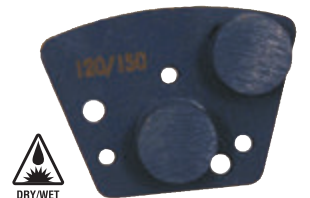

Grit	Soft Bond	Medium Bond	Med Hard Bond	Hard Bond	A List
120/150	161759	161764	161769	161774	\$82
250/300	161760	161765	161770	161775	82

Surface Prep Tools / Trapezoids



Single Round Dovetail Trapezoids					D
Grit	Soft Bond	Med Bond	Hard Bond	List	
18/20	161903	161908	161913	\$77	
25	161904	161909	161914	77	
35/40	161905	161910	161915	52	
60/80	161906	161911	161916	52	
120	161907	161912	161917	52	



Wing - Single Round Segment Trapezoids					D
Grit	Hard Bond Soft Concrete	Med Bond Medium Concrete	Soft Bond Hard Concrete	List	
18/20	161943	161938	161933	\$77	
25	161944	161939	161934	77	
33/40	161945	161940	161935	52	
60/80	161946	161941	161936	52	
120	161947	161942	161937	52	



Double Round Dovetail Trapezoids					D
Grit	Soft Bond	Med Bond	Hard Bond	List	
18/20	161918	161923	161928	108	
25	161919	161924	161929	108	
35/40	161920	161925	161930	82	
60/80	161921	161926	161931	82	
120	161922	161927	161932	82	



Wing - Double Round Segments Trapezoids					D
Grit	Hard Bond Soft Concrete	Med Bond Medium Concrete	Soft Bond Hard Concrete	List	
18/20	161958	161953	161948	\$108	
25	161959	161954	161949	108	
33/40	161960	161955	161950	82	
60/80	161961	161956	161951	82	
120	161962	161957	161952	82	



Single and Double Segmented Dovetail Trapezoids					D
Grit	Single Med Bond	List	Double Med Bond	List	
18/20	162428	\$77	161427	\$108	
30/40	162305	52	162304	82	



Wing - Single PCD with Wear Button			D
Description	Part No.	List	
Right Hand	162323	\$265	
Left Hand	162324	265	



Wing - Flat Tip PCD			D
Description	Part No.	List	
Right Hand	162321	\$295	
Left Hand	162322	295	

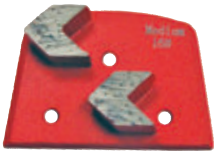

Arrowhead Dovetail Trapezoids						D
Grit	Extra Soft Bond	Soft Bond	Med Bond	Hard Bond	Extra Hard Bond	List
6	162340	162343	162346	162349	162352	\$105
16	162341	162344	162347	162350	162353	95
30	162342	162345	162348	162351	162354	90



NCE Qtr Round PCD w/ Wear Bar			D
Description	Part No.	List	
Right Hand	162408	\$220	
Left Hand	162409	220	



NCE Double Segmented				D
Grit	Hard Bond	Soft Bond	List	
18/20	162432	162430	\$90	
30	162433	162431	90	

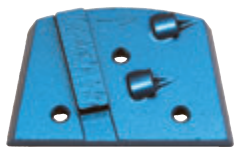

PCD Dovetail Trapezoid Grinding Segments					D
RH	LH	List	RH w/Wear Bar	LH w/Wear Bar	List
162001	162002	\$220	162003	162004	\$220

RH - Right Hand LH - Left Hand Wear bar is 30 grit diamond segment

Surface Prep Tools / Grinding Heads / Diamond Blocks

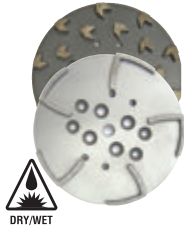

Standard 10" Diameter Floor Grinding Heads and Adapters		
Grinding Head Description	Part No.	List
FGG25 10" x 20 Segments Arrow	D91034	\$536
FGG-25 10" x 20 Segments	D91001	536
FGG-28 10" x 20 Segments-Asphalt	D91010	536
FGG15 10" Segments FG	D91002	351

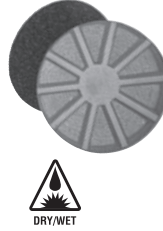

3" Metal Sintered Polishing Pads		
Grit	Part No.	List
30	161017	\$191
50	161018	191
70	161019	191
120	161020	191



Diamond and PCD Blocks				
Description	Soft Bond Part No.	Med Bond Part No.	Hard Bond Part No.	List
30/40 Grit	161462	161457*	161461	\$195
40/50 Grit	161463			195
50/60 Grit	161464			195
80/100 Grit	161465			195
PCD Block (4 chips)	161555			366
Diamond Plate only 30/40 Grit	161182			187
Wedge P	160178			1.03

*general purpose (other bonds available)

3" Arrow Diamond/PCD "Bearclaw" Grinding Tool			
Description	Right Hand Part No.	Left Hand Part No.	List
TFW mounting wedge	162297	162296	\$295
TEQ-Lok mounting wedge	162284	162283	295

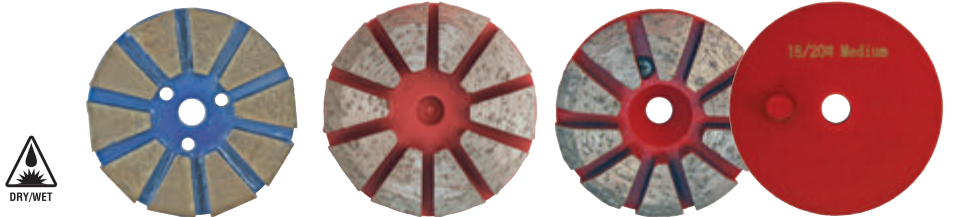

Grit	Velcro Backing or Bolt-On			TEQ-Lok Med Bond	TFW Med Bond	Velcro Back/Bolt-On/C-Sunk Med Bond	Magnetic/1 Pin Med Bond	List
	Soft Bond	Med. Bond	Hard Bond					
16/18	162065	161720	162070	162300	162298	161725	162302	\$185
30/40	162066	161721	162071	162301	162299	161726	162303	155
50/60/80	162067	161722	162072	162434	162414	161727		155
100/120/150	162068	161723	162073	162435	162415	161728		155
200	162069	161724	162074			161729		155

Diamond Plugs						
Grit	1" Taper Med Bond Medium Concrete		2" Taper Med Bond Medium Concrete		3" Segment on 2" Taper Med Bond Medium Concrete	
	Part No.	List	Part No.	List	Part No.	List
6	160852	\$73				
14/16	160855	73	161195	\$216	162398	\$175
30/40	160858	68	161197	204	162399	175
60/80	160861	58	161198	194	162366	175
120/150	160864	50	161199	194	162400	175
220/300	160867	50	161201	194		

More specs and bonds available.



Concrete Polishing Pads and Rings



Brazed Lippage Pads

2"		A 3"		A 4"		A 5"		A
Grit	Part No.	List	Part No.	List	Part No.	List	Part No.	List
24			160997	\$153	160989	\$181	160980	\$204
30	161603	\$78	160934	142	160990	153	160981	171
50	161604	76	160935	126	160991	153	160982	171
100	161605	76	160936	108	160992	142	160983	159
200	161606	76	160937	108	160993	142	160984	159
325			160938	108	160994	142	160985	159

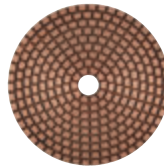

Super Premium Copper Pads

Grit	4" Part No.	List	5" Part No.	A List
30	161897	\$72	160915	\$96
50	161898	72	160916	96
100	161899	72	160917	96
200	161900	72	162006	96
400	161901	72		



Diamond Sanding Pads

4"		A 5"		A 7"		A
Grit	Part No.	List	Part No.	List	Part No.	List
50	161542	\$50	160633	\$77	161882	\$140
70	161543	50	160634	77	161883	140
120	161544	45	160635	65	161884	110
220	161545	45	160636	60	161885	95
400	161546	40	161880	52	161886	90
600	161547	40	161881	52	161887	90

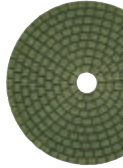

5" Resin Polishing Pads

Grit	Super Premium		Premium		A	
	WET/DRY	List	WET/DRY	List	WET Only	
50	160282	\$68	161654	\$52	161664	\$38
100/120	160283	68	161655	52	161665	38
200/220	160284	68	161657	52	161667	38
400	160285	68	161658	52	161668	38
800	160286	68	161660	52	161670	38
1500/1800	160288	68	161661	52	161671	38
3000/3500	160289	68	161662	52	161672	38
Buff			161663	52	161673	38



2" Concrete Polishing Velcro Backed Pads

Grit	Semi Metal		Resin		A
	Wet/Dry	List	DRY Only*	WET Only	List
30	161166	\$45	161169		\$35
50	161167	45	161170		35
100	161168	45	161171		35
200	161588	45	161172	161696	35
400	161590	45	161173	161697	35
800			161174	161698	35
1500			161175	161700	35
3000			161176	161701	35

*Life greatly reduced when used with water



"Ceramic" Pads and Rings

Description	5" Pad		7" Ring		A
	Very Hard Concrete	Very Hard Concrete	Very Hard Concrete	Very Hard Concrete	List
C1	161157	161150			\$96
C2	161158	161151			91
C3	161159	161152			91
C4	161160	161153			91



3" Concrete Resin Polishing Pads

Grit	Super Premium		Premium		A		
	Epoxy WET/DRY	Phenolic WET/DRY*	A Transitional List	A Polymer WET Only	List		
30	160906	161051	\$56	161643	\$45	130340	\$39
50	160907	161052	56	161644	45	130341	39
100	160908	161053	56	161645	45	130342	39
200	160909	161054	56	161647	45	130343	39
400	160910	161055	56	161648	45	130344	39
800	160912	161056	56	161650	45	130345	39
1500	160913	161057	56	161651	45	130346	39
3000	160914	161459	56	161652	45	130347	39
Buff				161653	45		

* for heavy, high contact pressure machines



7" Super Premium Wet/Dry Velcro-backed Resin Rings

Grit	Part No.	A List
30	161034	\$84
50	161035	84
120	161036	80
220	161037	80
400	161038	80
800	161039	80
1800	161040	80
3000	161041	80



5" Flex Metal Dots

Grit	Part No.	D List
30	162294	\$120
50	162295	120
100	162439	120
200	162440	120

3" Concrete Metal Resin Polishing Pads

Grit	Super Premium		Premium	
	Wet/Dry	List	Wet Only	List
30	161012	\$84	130370	\$52
50	161013	84	130371	52
100	161014	84	130372	52
200	161015	84	130373	52
400	161992	84	130374	52

TEQ-Swing / TEQ-Burnisher / Burnisher Pads



Shown with optional solution tank
Includes 50 ft. cord

17" TEQ-Swing Machine*	
Gears	Triple Planetary
Weight	107 lb.
Pad Width	17"
Motor Power	1.5HP AC
Disc RPM	175
Part No.	G00103
List E	\$1,365

*Includes pad driver



Includes 50 ft. cord

20" TEQ-Burnisher*	
Gears	Belt Drive
Weight	112 lbs
Width	20"
Motor Power	1.5 hp DC Rectified
Disc RPM	1500
Part No.	G00039
List E	\$1,845

*Includes pad driver

Optional Accessories	Part No.	List P
Maintenance Pad Driver	162270	\$160
17" Rigid Plate	161415	167
2 gallon solution tank kit	162247	215
Poly scrub brush	162223	125
Shampoo brush	162271	175

Accessories	Part No.	List P
Maintenance Pad Driver	162272	\$190
20" Rigid Plate	161414	178



G00044

Production Burnishers	Contractor	Professional	
		Dry (Dust Control)	DITEQ Professional Wet/Dry
Polishing Diameter	27 Inch	27 Inch	27 Inch
Engine	18 hp Kawasaki Propane	18 hp Kawasaki Propane	Subaru 22 hp Propane
Engine Speed	3,600 RPM	3,600 RPM	3,450 rpm
Drum Speed	1800 RPM	1800 RPM	800-1000 RPM
Production per hour	23,000 sf	33,000 sf	33,000 sf
Weight	350 lbs	350 lbs	350 lbs
Part No.	G00082	G00088	G00044
List E	\$5,093	\$6,400	\$8,297

Other models available.



VL Burnisher Pads												
VL M Series	13"	A	17"	A	20"	A	21"	A	24"	A	27"	A
Grit / Color	Part No.	List	Part No.	List	Part No.	List	Part No.	List	Part No.	List	Part No.	List
200 Blue	161837	\$99	161476	\$125	161483	\$146	161490	\$154	161556	\$189	161497	\$231
400 Red	161838	99	161477	125	161484	146	161491	154	161557	189	161498	231
800 White	161839	87	161478	111	161485	127	161492	136	161558	165	161499	203
1500 Yellow	161840	87	161479	111	161486	127	161493	136	161559	165	161500	203
3000 Green	161841	87	161480	111	161487	127	161494	136	161560	165	161501	203
8000 Orange	161842	87	161481	111	161488	127	161495	136	161561	165	161502	203
11000 Purple	161843	87	161482	111	161489	127	161496	136	161562	165	161503	203

Monroe Burnisher Pads												
M Series	13"	A	17"	A	20"	A	21"	A	24"	A	27"	A
Grit / No.	Part No.	List	Part No.	List	Part No.	List	Part No.	List	Part No.	List	Part No.	List
800 #1	161253	\$98	161256	\$163	161257	\$184	161258	\$195	161824	\$206	161259	\$271
1500 #2	161261	98	161264	163	161265	184	161266	195	161825	206	161267	271
3000 #3	161269	98	161272	163	161273	184	161274	195	161826	206	161275	271
R Series	13"	A	17"	A	20"	A	21"	A	24"	A	27"	A
Grit / Color	Part No.	List	Part No.	List	Part No.	List	Part No.	List	Part No.	List	Part No.	List
400 Orange	161293	\$146	161295	\$206	161296	\$254	161297	\$298	161298	\$314	161299	\$401
800 Silver	161301	146	161303	206	161304	254	161305	298	161306	314	161307	401
1800 Blue	161309	146	161311	206	161312	254	161313	298	161314	314	161315	401
3000 Red	161317	146	161319	206	161320	254	161321	298	161322	314	161323	401
Buff Black (Dry)	161325	146	161327	206	161328	254	161329	298	161330	314	161331	401

Hog Hair Cushion Pads		
Description	Part No.	List A
12" x 1" Round	161581	\$6.59
15" x 1" Round	162228	10.00
17" x 1" Round	161455	11.12
20" x 1" Round	161473	14.68
21" x 1" Round	161474	16.48
24" x 1" Round	161576	23.00
27" x 1" Round	161475	32.00



Floor Maintenance Pads for Polished Concrete			
Dimensions	Black		List A
	Stripper	White Polish	
15" x 1" Round	A70026	A70027	\$10.00
17" x 1" Round	A70003	A70004	11.12
20" x 1" Round	A70013	A70014	14.68
21" x 1" Round	A70015	A70016	16.48
24" x 1" Round	A70019	A70020	23.00
27" x 1" Round	A70017	A70018	32.00

Other pad sizes and colors are available. Call for info

Diamond Pads / Chemicals / Pump-up Sprayers and Accessories



DOTS/LUX D/L-Series - 17" Resin ^A		
Grit	17" Part No.	List
1500	161340	\$271
3000	161341	271



DOTS/Vacuum Brazed V-Series ^A		
Grit	17" Part No.	List
30	161613	\$697
50	161614	697
100	161615	697
200	161616	697



Monroe Dots* D - Series Semi-Metal						
	17"	A	20"	A	21"	A
Grit	Part No.	List	Part No.	List	Part No.	List
30	161363	\$293	161364	\$682	161365	\$700
50	161369	293	161370	682	161371	700
100	161375	293	161376	682	161377	700
200	161381	293	161382	682	161383	700
400	161387	293	161388	682	161389	700
D Series Resin						
	17"	A	20"	A	21"	A
Grit	Part No.	List	Part No.	List	Part No.	List
400	161393	\$271	161394	\$611	161395	\$630
800	161399	271	161400	611	161401	630
1800	161405	271	161406	611	161407	630
3000	161411	271	161412	611	161413	630

*Require cushion pad



Pads	Part No.	List ^P
Foam Floating pad, 3"	161016	12.36
Foam Floating pad, 5"	160632	24.00
Hog hair cushion pad-17" pad	161455	11.12
Hog hair cushion pad-20" pad	161473	14.68
Hog hair cushion pad-21" pad	161474	16.48

Microfiber Mop and Mop Head ^P		
Description	Part No.	List
Microfiber Mop	160806	\$89
Microfiber Mop Heads (pkg of 10)	160808	120

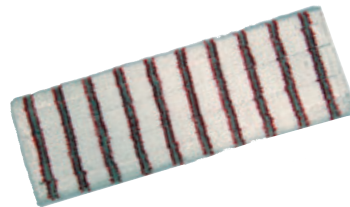

microfiber mop head



160945 & 160946
151470

Pump-up Sprayers for Decorative Concrete ^E		
Description	Part No.	List
Sprayer for Acetone Dyes, 3.5 gal	160945	\$261
Sprayer for Acid Stains, 2 gal.	160946	114
Sprayer for Cure-N-Seal, 3.5 gal.	151470	185



Daily Cleaner for Polished Concrete Floors Concentrated ^A		
Description	Part No.	List
1 gallon*	161233	\$35
5 gallon	161234	165

*Packaged 4 one gallon bottles per case



DI-HARD Concrete Hardener/Densifier				
	Sodium Formula		Lithium Formula	
Description	Part No.	List	Part No.	List ^A
1 gallon bottle*	160940	\$35	161529	\$50
5 gallon bucket	160941	142	161530	221
55 gallon drum	160942	1,413		

*Packaged 4 one gallon bottles per case
Covers approximately 300 sf per gallon



Heavy-Duty Concentrated Degreaser for Polished Concrete Floors ^A		
Description	Part No.	List
1 gallon*	161235	\$45
5 gallon	161236	210

*Packaged 4 one gallon bottles per case



DI-GARD Concrete Hardener/Sealer ^A		
Description	Part No.	List
1 gallon bottle*	160943	\$108
5 gallon bucket	160944	489

*Packaged 4 one gallon bottles per case
Covers approximately 1100 sf per gallon

Tuckpoint Diamond Blades / Abrasive Blades

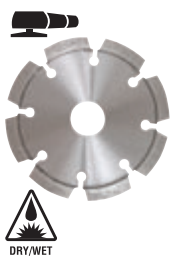

Segmented Tuckpoint/Rodding Blades

Diameter & Width	TP23		TP33	
	Premium	List	Super Premium	List
4"x.250"x7/8"-5/8"	D45001	\$38	D45002	\$70
4.5"x.250"x7/8"-5/8"	D45004	43	D45005	81
5"x.250"x7/8"-5/8"	D45007	55	D45008	92
7"x.250"xDM-7/8"-5/8"	D45010	98	D45011	151
4.5"x.375"x7/8"-5/8"	D45020	65		
5"x.375"x7/8"-5/8"	D45021	76		
7"x.375"xDM-7/8"-5/8"	D45022	103		



Abrasive Wheels are priced individually and sold in whole box quantities only. Other size and specs available.



High Speed Abrasive Blades

Dimensions	Grit	Application	Part No.	List
12"x1/8"x1"		Metal	A30001	\$10.45
14"x1/8"x1"		Metal	A30009	15.19
14"x1/8"x20mm		Metal	A30010	15.19
14"x1/8"x1"	AC24R	Ductile	A30013	16.74

10 per box Abrasive blades are priced individually and sold in whole box quantities only.



Double and Triple Segmented Tuckpoint Blades

Diameter & Width	TP23D Double		TP33D Double		TP33T Triple	
	Premium	List	Premium	List	Premium	List
4"x.250"x7/8"-5/8"	D45039	\$43				
4.5"x.250"x7/8"-5/8"	D45040	55	D45032	\$87		
5"x.250"x7/8"-5/8"	D45041	60	D45033	98		
7"x.250"xDM-7/8"-5/8"			D45034	163		
4.5"x.375"x7/8"-5/8"					D45036	\$113



Raised Hub Abrasive Wheels

Diameter & Width	Application	Pack Qty.	Part No.	List
4-1/2" x .045" x 7/8"	Metal/Stainless	25 per box	A00001	\$3.61



Chop Saw Abrasive Blades

Diameter & Width	Application	Part No.	List
14" x 3/32" x 1"	Metal	A20002	\$11.59

10 per box



Cup Grinding Wheels

Diameter & Width	Application	Grit	Part No.	List
4"x2"x5/8"-11 prong type	Concrete	C16R	A50002	\$36
5"x2"x5/8"-11 prong type	Concrete	C16R	A50003	37
6"x2"x5/8"-11 safety back	Concrete	C16R	A50004	42

10 per box



CR C35 Beveled V-Crack Chaser

Diameter & Width	Part No.	List
4" x cont. type x 5/8"-11 thrd	D90001	\$211
4 x .375" x 5/8-11	D90008	157
4" x .375" x 7/8"-5/8"	D90002	146
5" x .375" x 7/8"-5/8"	D90003	184
7" x .375" x 7/8"-5/8"	D90004	298
8" x .375" x 1" with DP	D90005	471



Cut/Off Abrasive Blades

Diameter & Width	Application	Type 1 Part No.	List
4-1/2" x 3/32" x 7/8"	Metal	A10003	\$4.12
7" x 3/32" x DM-5/8"	Metal	A10001	5.00

25 per box



TEQ-ZEK wheels are made of silicon carbide and are aggressive and long lasting.



Type 27

TEQ-ZEK Grinding Wheels

Description	Grit	Part No.	List
4.5" x 7/8"	16	160142	\$7.57
7" x 7/8"	16	160143	9.73

(priced each, packaged 5 per box) 8/10 and 24 grit also available 5/8"-11 Adapter and nut (P/N 161779) \$15.45 (P)



Stone Diamond Blades / Stone Diamond Wire



S52X ARIX Silent Core
20 mm / 25 mm Segment Height
Stone & Granite Blade
★★★★★ PRO V

	20mm	D	25mm	D
Diameter & Width	Part No.	List	Part No.	List
14" x .125" x 60-50mm	D61111	\$489	D61121	\$630
16" x .125" x 60-50mm	D61112	590	D61122	721
18" x .135" x 60-50mm	D61113	705	D61123	903
20" x .135" x 60-50mm	D61114	966	D61124	1,017



Stone Cutter
★★★★ Super Premium Fast Cut/Longest Life Stone

Diameter & Width	Part No.	List
12" x .125" x 20mm DP	D11069	\$363
12" x .125" x 1"-20mm DP	D11067	363
14" x .125" x 20mm DP	D11070	406
14" x .125" x 1"-20mm DP	D11068	406
16" x .125" x 1"-20mm DP	D11079	487



M22 Stone & Hard Material Blade
★★ Premium

Diameter & Width	Part No.	List
8" x .110" x DM-7/8"-5/8"	D60001	\$148
10" x .110" x 1" - 5/8"	D60028	187
12" x .125" x 1-20mm	D60009	221
14" x .125" x 1-20mm	D60010	255
14" x .125" x 60-50mm	D60039	268
20" x .135" x 1"	D60027	512
20" x .135" x 1"*	D60037	710

*Silent Core



DX-S Universal Segmented Blade
★ Economy, Fast Cut
Cured Concrete/Brick/Block

Diameter & Width	Part No.	List
4" x .080" x 7/8"-5/8"	D96205	\$22
4.5" x .080" x 7/8"-5/8"	D96206	25
5" x .080" x 7/8"-5/8"	D96220	30
6" x .080" x 7/8"-5/8"	D96221	42
7" x .080" x DM-7/8"-5/8"	D96207	47
8" x .085" x DM-7/8"-5/8"	D96222	60
9" x .095" x 7/8"-5/8"	D96223	66
10" x .095" x DM-7/8"-5/8"	D96208	83

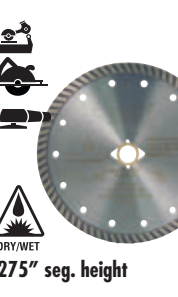

DX-T Wide Turbo Rim Blade
★ Economy, Fast Cut

Diameter & Width	Part No.	List
4" x .095" x 7/8"-5/8"	D96209	\$21
4.5" x .095" x 7/8"-5/8"	D96210	24
5" x .095" x 7/8"-5/8"	D96224	30
7" x .095" x DM-7/8"-5/8"	D96211	47
9" x .095" x 7/8"-5/8"	D96225	78
10" x .110" x 7/8"-5/8"	D96213	90

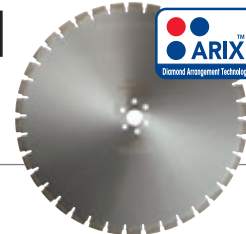

SV ARIX Thin Veneer Material Blade
★★★★ PRO IV

Retipping Services Available

Diameter & Width	Part No.	Part No.	Part No.	List
40" x .250" x 13mm x 3-1/4"	D61078	D61072		\$3,351
40" x .250" x 13mm x 3-1/4"			D61065	3,684



Thin Veneer Silent Turbo
★★★ Super Premium

Diameter & Width	Part No.	List
20" x .145" x 1" (B31ST)	D44113	\$693
20" x .135" x 1" (S42 U-Slot)	D44137	800



S32X Silent Core 15 mm Segment Height Stone & Granite Blade
For Saws less than 10 hp
★★★ Super Premium

Diameter & Width	Part No.	List
14" x .125" x 60-50mm	D61045	\$398
16" x .125" x 60-50mm	D61046	449



T42 Curly Que Blade
★★★★ PRO IV

Diameter & Width	Part No.	List
10" x .085" x 5/8"	D56006	\$135
14" x .095" x 1"	D56002	319

Other sizes available. Please call for pricing and availability.



Diamond Wire for Stone
Stone-Urethane

Diameter & Width	Part No.	List
WS40	D91033	\$300

Prices per meter length.

Diamond Wire Accessories

Part No.	List
Crimps (3/16" ID x 3/8" OD x 3/4" L)	151157 \$1.08

Stone Continuous / Segmented and Turbo Diamond Blade



T23 Laser Cut Spider Continuous Rim

★★ Premium

Diameter & Width	Part No.	Wet/Dry	List
4" x .060" x 5/8"	D50053		\$27
4.5" x .060" x 5/8"	D50054		43
Diameter & Width	Part No.	Wet Only	List
7" x .060" x 5/8"	D50040		\$60
8" x .060" x 5/8"	D50041		70
10" x .060" x 5/8"	D50042		103

T24 Continuous Rim

★★ Premium

Diameter & Width	Part No.	List
8" x .060" x 5/8"	D51009	\$65
10" x .080" x 5/8"	D51010	98
12" x .095" x 1"	D51011	146

TG-32 Glass Tile Blade

★★★ Super Premium

Diameter & Width	Part No.	List
7" x .060" x 5/8"	D50056	\$58
10" x .060" x 5/8"	D50043	101

DX-C Continuous Rim Blade

★ Economy, Fast Cut

Diameter & Width	Part No.	List
4" x .060" x 5/8"	D96201	\$19.57
4.5" x .060" x 7/8"-5/8"	D96202	24
5" x .060" x 7/8"-5/8"	D96219	34
7" x .060" x 5/8"	D96203	47
10" x .060" x 5/8"	D96204	83

Sharpening Stone

Description	Part No.	List
Sharpening Stone	130009	\$6.49

S21 Dish Turbo Convex Blade

★★ Premium

Diameter & Width	Part No.	List
5" x .110" x 7/8"-5/8"	D66031	\$132

S21 T-Segmented Blade

★★ Premium

Diameter & Width	Part No.	List
4.5" x .110" x 7/8"-5/8"	D62006	\$108
5" x .110" x 7/8"-5/8"	D62007	122

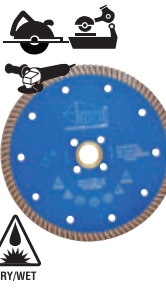
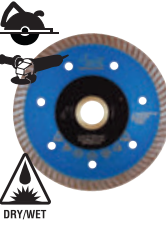

Blade Adapters

Description	Part No.	List
Flush Mount Adapter (Stainless)	130122	\$26.00
5/8" - 11F to 7/8" Arbor	130117	18.54

S32 Raised Hub Turbo Blade

★★★ Super Premium

Diameter & Width	Part No.	List
4" x .060" x 7/8"-5/8"	D50032	\$42
4.5" x .060" x 7/8"-5/8"	D50033	60
5" x .060" x 7/8"-5/8"	D50034	78

S31 Turbo Blade

★★★ Super Premium

Diameter & Width	Part No.	List
4" x .085" x 7/8"-5/8" flush	D53021	\$34
4.5" x .085" x 7/8"-5/8" flush	D53022	36
5" x .085" x 7/8"-5/8" flush	D53020	45
6" x .085" x 7/8"-5/8"	D53023	60
7" x .085" x DM-7/8"-5/8"	D53024	78

S42 Narrow Rim Turbo Blade

★★★★ PRO IV

Diameter & Width	Part No.	List
4" x .080" x 7/8"-5/8" flush	D53027	\$47
4.5" x .080" x 7/8"-5/8" flush	D53028	55
5" x .080" x 7/8"-5/8" flush	D53029	66
6" x .080" x 7/8"-5/8"	D53030	83
7" x .080" x DM-7/8"-5/8"	D53031	107

Stone Fire Rim Turbo Blade

★★★ Super Premium

Diameter & Width	Part No.	List
4.5" x .095" x 7/8"-5/8" flush	D58022	\$65
5" x .095" x 7/8"-5/8" flush	D58023	70
6" x .095" x 7/8"-5/8" flush	D58024	81
7" x .095" x DM7/8"-5/8" flush	D58025	92

M31V-S Vacuum Bond Blade

★★★ Super Premium

Diameter & Width	Part No.	List
4" x .095" x 7/8"-5/8"	D66011	\$47
4.5" x .095" x 7/8"-5/8"	D66012	66
5" x .095" x 7/8"-5/8"	D66013	69
7" x .095" x 7/8"-5/8"	D66015	90

Milling Wheel

★★★ Super Premium

Diameter & Width	Part No.	List
14" x 40L x 8T x 8W	D66332	\$1,963

Stone Fabrication Tools - Cutting / Drilling



S23 Thin Wall Crown Core Bits with 5/8" -11 Threads

★★ Premium

Diameter	Part No.	List	D
3/8"	D31001	\$90	
1/2"	D31002	93	
5/8"	D31003	94	
3/4"	D31004	98	
7/8"	D31005	101	
1"	D31006	110	
1-1/8"	D31007	113	
1-1/4"	D31008	134	
1-3/8"	D31009	139	
1-1/2"	D31010	143	
1-5/8"	D31011	145	
1-3/4"	D31012	148	
1-7/8"	D31013	156	
2"	D31014	173	



S43AX Core Bit

★★★★ PRO IV

Diameter	Part No.	List	D
1-1/4" x 5/8-11th	D66215	\$108	
1-3/8 x 5/8-11th	D66216	113	
1-1/2" x 5/8-11th	D66217	119	
1-3/4" x 5/8-11th	D66218	126	
2" x 5/8-11th	D66219	142	

3" drilling depth



(blue)

3" drilling depth



S33 Laser Welded Segmented Type Core Bits with 5/8" -11 Thread

★★★ Super Premium

Diameter	Crown Part No.	List	Segmented Part No.	List	D
1/2"	D66134	\$68			
5/8"	D66135	71			
3/4"	D66136	73			
7/8"	D66137	77			
1"	D66032	80			
1-1/8"			D66119	\$85	
1-1/4"			D66033	91	
1-3/8"			D66034	96	
1-1/2"			D66035	103	
1-3/4"			D66036	108	
2"			D66037	119	
2-1/2"			D66118	131	
3"			D66038	142	
4"			D66138	159	



(silver)
3" drilling depth



S33 Laser Welded Segmented with Side Protectors - 5/8" -11 Threads

★★★ Super Premium

Diameter	Part No.	List	D
1-1/8"	D66203	\$96	
1-1/4"	D66204	103	
1-3/8"	D66205	108	
1-1/2"	D66206	113	
1-3/4"	D66208	119	
2"	D66210	126	
2-1/2"	D66211	142	
3"	D66212	159	
4"	D66213	176	



BitBuddie

Description	Part No.	List	P
1-3/8" dia. bits with 18" Hose	160220	\$53	



2-3/4" drilling depth

S23V-C Vacuum Bond Core Bit

★★ Premium

Diameter	Part No.	List	D
1/4"	D66286	\$125	
3/8"	D66287	130	
1/2"	D66228	135	
5/8"	D66229	140	
7/8"	D66230	150	
1"	D66231	155	
1-1/8"	D66232	160	
1-1/4"	D66233	160	
1-1/2"	D66234	165	
1-3/8"	D66235	170	
2"	D66236	180	



Threaded Adapters	Part No.	List	P
3/8" shank, 5/8"-11M	150217	\$30	
1/2" shank, 5/8"-11M	150983	27	

Stone Fabrication Tools - Shaping



N25 NCB Non-Coring Bits		
★★ Premium		
Diameter	Part No.	List
1/4"	D30001	\$81
5/16"	D30004	87
3/8"	D30002	92
1/2"	D30003	125



CTC32 Continuous Turbo Cup				
★★★ Super Premium				
Description	Fine	Medium	Coarse	D List
	100/120	60/80	30/40	
4" x 5/8"-11 th	D82006	D82004	D82002	158
5" x 5/8"-11th	D82018	D82016	D82014	169
6" x 5/8"-11 th	D82024		D82020	180
7" x 5/8"-11 th	D82030	D82028	D82026	300



SRT31 Radial Arm Bits		
★★★ Super Premium		
Diameter	Part No.	List
20mm x 15 mm	D66131	\$96
Mandrel 4: x 1/2" Gas	D66130	149



S43AX Finger/Router Bits		
★★★★ Pro IV		
Diameter and Width	Part No.	List
3/4" x 40mm x 1/2" gas (male) - 5 seg	D66242	\$165
7/8" x 40mm x 1/2" gas (male) - 5 seg	D66243	187
1" x 40mm x 1/2" gas (male) - 6 seg	D66241	199
1" x 48mm x 1/2" gas (male) - 6 seg	D66244	210
1" x 40mm x 1/2" gas (male) - 6 seg	D66092*	220
1" x 48mm x 1/2" gas (male) 6 seg	D66093*	238

*has bottom "starter" segment



More sizes, positions and shapes available upon request!

RB43 Router/Profile Bits				
★★★★ PRO IV				
Diameter & Width	Pos.	Profile	Part No.	List
20mm Demi-Bull	1	B	D66176	\$392
25mm Demi Bull	1	B	D66277	482
30mm Demi-Bull	1	B	D66042	536
20mm Full-Bull	1	V	D66044	451
30mm Full-Bull	1	V	D66045	512
40mm Full-Bull	1	V	D66165	Call
60mm Full-Bull	1	V	D66057	Call
20mm Ogee	1	F	D66047	381
25mm Ogee	1	F	D66167	562
30mm Ogee	1	F	D66350	464
20mm Bevel	1	E	D66058	381
30mm Bevel	1	E	D66262	527
20mm Bullnose	1	A	D66297	392
30mm Bullnose	1	A	D66308	571
20mm DuPont	1	H	D66288	398
25mm DuPont	1	H	D66291	522
30mm DuPont	1	H	D66294	653
15mm Cove	1	L	D66340	357
20mm Cove-DuPont	1	O	D66337	416
25mm Cove DuPont	1	O	D66306	452
20mm Cove Ogee	1	Q	D66339	476
25mm Cove Ogee	1	Q	D66059	523
30mm Cove Ogee	1	Q	D66060	595
25mm Triple Demi	1	TB	D66311	522
40mm Talon Z	1	TZ	D66274	374



S43VT Vacuum Bond Finger Bit		
★★★★ Pro IV		
Diameter & Width	Part No.	List
15mm x 40 mm x 1/2" gas (male)	D66301	\$149
15mm x 48 mm x 1/2" gas (male)	D66302	167



S33 Finger/Router Bit		
★★★ Super Premium		
Diameter & Width	Part No.	List
1" x 48mm x 1/2" gas male	D66090	\$194
1" x 40mm x 5/8"-11 female	D66238	218



Diameter & Width	Granite		D List
	Marble Premium	Super Premium	
6" x 5/8", 1/2"R Dupont	D63002	D63005	\$157
6" x 5/8", 3/8"R Dupont		D63006	157
8" x 5/8", 1/2"R		D63013	228
8" x 5/8", 3/8"R	D63015	D63012	228



PSW 4" Profile Wheel		
★★★ Super Premium with 5/8-11 Adapter		
Description	Part No.	List
Profiler, Granite - 3/16R	D63009	\$289
Profiler, Granite - 3/8R	D63010	312
Profiler, Granite - 3/4R	D63011	336
1/4" Radius	130243	210
3/8" Radius	130244	245
1/2" Radius	130245	275
3/4" Radius	130246	345
Full Bull 40mm	130247	800
45 Degree x 10mm	130336	229
45 Degree x 5mm	130337	193
Full Bull 30mm	130339	309
Ogee 3/8" F	130248	309
Ogee 3/4" F	130249	450



S22 Vacuum Brazed Grinding Wheels		
★★ Premium		
Diameter	Part No.	List
4" Coarse x 5/8"-11	D66039	\$148

Stone Fabrication Tools - Polishing



Snail-Lok Polishing Pads				
	4" A		5" A	
Grit	Part No.	List	Part No.	List
50 Grit	130574	\$117	130566	\$129
100 Grit	130575	117	130567	129
200 Grit	130576	117	130568	129
500 Grit	130577	117	130569	129
1000 Grit	130578	117	130570	129
2000 Grit	130579	117	130571	129
3000 Grit	130580	117	130572	129
BUFF	130581	117	130573	129

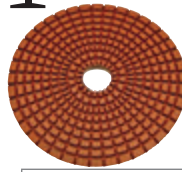

Wet Polishing Pads

Grit	★★ Premium		★★★ Super Premium			
	4" D	List	4" D	List	5" D	List
50	D64082	\$14.42	D64010	\$22	D64019	\$40
100	D64083	14.42	D64011	22	D64020	40
200	D64084	14.42	D64012	22	D64021	40
400	D64085	14.42	D64013	22	D64022	40
800	D64086	14.42	D64014	22	D64023	40
1500	D64087	14.42	D64015	22	D64024	40
3000	D64088	14.42	D64016	22	D64025	40
10000DF (Blk)	D64089	21.00	D64017	25	D64026	45
10000DF (Wht)	D64090	21.00	D64018	25	D64027	45
Complete Set per box	D64091	126.00	D64070	181	D64028	336



S33 Smooth Face Resin Filled Cup Wheels ★★★ Super Premium			D
Diameter & Width	Part No.	List	
4" x coarse x 5/8"-11	D66063	\$152	
4" x medium x 5/8"-11	D66065	152	
4" x fine x 5/8"-11	D66089	152	

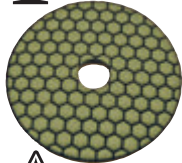

Dry Polishing Pads

★★★ Super Premium				
Size	Grit	Part No.	List	D
4"	50	D64040	\$29	
4"	100	D64041	29	
4"	200	D64042	29	
4"	400	D64043	29	
4"	800	D64044	29	
4"	1500	D64045	29	
4"	3000	D64046	29	
4"	10000DF (Blk)	D64047	29	
4"	10000DF (Wht)	D64048	29	
4"	Complete Set per box	D64071	250	

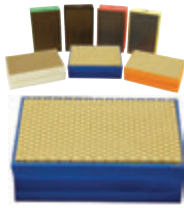

★★ Premium			D
Grit	Part No.	List	
50 Grit	130375	\$40	
100 Grit	130376	40	
200 Grit	130377	40	
400 Grit	130378	40	
800 Grit Resin	130380	28	
1500 Grit Resin	130381	28	
3000 Grit Resin	130382	28	



DITEQ's 3 Step Wet Polishing Pads

★★★ Super Premium			
Size	Description	Part No.	List
4"	Step 1	D64054	\$36
4"	Step 2	D64055	36
4"	Step 3	D64056	36

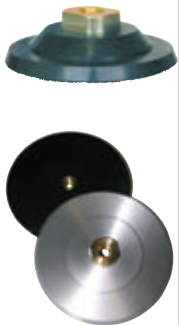

Backer Pads (5/8"-11 threaded)			P
Rubber	Part No.	List	
3" Standard Flex	130119	\$13.39	
4" Super Flex	130338	24.00	
4" Standard Flex	130120	10.30	
4" Rigid	130335	10.30	
4" Extreme Flex	130510	24.00	
5" Standard Flex	130121	36.00	
7" Standard Flex	130520	44.00	
Aluminum	Part No.	List	
3" Aluminum	130522	24.00	
4" Aluminum	130511	24.00	
5" Aluminum	130512	39.00	
7" Aluminum	130521	72.00	

To place orders:

Call 866-688-1032 or Fax: 877-220-4777

You will need the following items for Customer Service:

- Your purchase order number and/or name
- Company name and billing information
- Customer number
- Shipping address, if different from billing address
- Date needed
- Products desired and quantity

For detailed product information visit www.DITEQ.com.

Freight Policy

Equipment: Freight is paid (Ground Shipment) as one shipment to one location within the continental United States by the carrier of DITEQ's choice for three (3) pieces of equipment shipped of equal value.

Diamond tools and/or Abrasives (with the exception of Carbide Cutters and Chemicals): Freight is prepaid by the shipper and added to the invoice for orders less than \$400.00. Freight is paid (ground shipment) to one location within the continental United States by the carrier of DITEQ's choice for orders of \$400.00 or greater. Freight is prepaid by the shipper and added to the invoice on orders of carbide cutters only that are less than \$1,000.

Parts and Chemicals: Freight is prepaid by the shipper and added to the invoice.

Orders of \$3,000 or greater in Diamond tools: Freight is paid (ground shipment) to one location within continental United States by carrier of DITEQ's choice on the total order including all the additional items on the order.

Anything not meeting the exemptions above are Shipped FOB Factory.

We reserve the right to route all shipments via the carrier of DITEQ's choice.

Priority, Next Day or Two-day Service will be added to your invoice or billed collect.

Shipments requiring special handling or to a residence may incur additional charges.

Terms and Conditions

Minimum order: For all finished product orders of less than \$50, a \$10 minimum order charge will be added. (shipping and tax excluded.)

Sales tax will be charged where applicable unless a tax exemption certificate is provided.

Repairs: Carefully package all returned items for repair and send with the following information on a packing slip:

- Your company name, address and phone number
- Original Invoice (warranty only)
- List of items for repair
- Returned Goods Authorization (RGA) number obtained from Customer Service
- Explanation of repair(s) needed

Replacement/Refund: All returned catalog items are subject to a 15% restocking fee. Returned for replacement or refund items should be in original cartons and accompanied by a packing slip with the following information:

- Contact customer service for a Returned Goods Authorization (RGA). (Merchandise cannot be accepted without this authorization.)
- List of items returned and reason(s) for return(s)
- Copy of original invoice(s). Merchandise receipt must be dated no longer than 12 months from date shipped.
- Ship merchandise prepaid to:
DITEQ Corporation, 9876 Pflumm Road, Lenexa, KS 66215

We reserve the right to change and/or modify products and part numbers. Images within this catalog may not reflect the most current product line.

Prices are in U.S. dollars. Prices, color and specifications subject to change without notice.

© Copyright 2016 DITEQ Corporation. All rights reserved

LIMITED WARRANTY FOR NEW DITEQ EQUIPMENT

GENERAL PROVISIONS — The warranties described below are provided by DITEQ Corporation ("DITEQ") to the original purchasers of new DITEQ Equipment from DITEQ or authorized DITEQ dealers. Under these warranties, DITEQ will repair or replace, at its option, any covered part which is found to be defective in material or workmanship during the applicable warranty term. Warranty service must be performed by DITEQ or a dealer or service center authorized by DITEQ to sell and/or service the type of product involved, which will use only new or remanufactured parts or components furnished by DITEQ. Warranty service will be performed without charge to the purchaser for parts. The purchaser will be responsible, however for any service call and/or labor, transportation and/or freight of product to and from DITEQ, the dealer's or service center's place of business, for any premium charged for overtime labor requested by the purchaser, and for any service and/or maintenance not directly related to any defect covered under the warranties below.

WHAT IS WARRANTED — All parts of any new DITEQ Equipment are warranted for the number of months specified below. Component manufacturers offer separate warranties and warranty terms as stated below. Warranty statements required by law covering engine emission-related parts and components are found in the engine operating manual delivered with the machine. Each warranty term begins on the date of product delivery to the purchaser.

27" Propane Burnishers	24 Months	Nacecare Rideable Scrubbers	24 Months
Baldor Motors	12 Months	Nacecare Walk Behind Scrubbers	24 Months
Batteries, Gel	12 Months	Nacecare Dry/Wet Vacuums	24 Months
Cardi Electric Chainsaw	12 Months	Nacecare Upright Vacuums	12 Months
C-TEQ Saws	24 Months	Nacecare Pressure Washers	12 Months
Chopper Saws	12 Months	RGC Hydraulic Equipment	12 Months
Dustless™ Vacuums	36 Months	Scarifier Drums	3 Months
Dustless Industrial Vacuum Systems	12 Months	Shibuya Core Drills	24 Months
Eaton Transmissions	12 Months	Shibuya Wall Saw	24 Months
G & P II Grinder /Polishers	24 Months	Subaru Generators	36 Months
G-TEQ Saws	24 Months	Subaru Robin Engines	36 Months
Gast Vacuum Pumps	12 Months	Subaru water pumps	36 Months
Honda Engines	36 Months	TEQ-Burnishers (Electric)	12 Months
Leeson Motors	12 Months	TG8 Floor Grinder / Polishers	24 Months
Little Giant Pumps	12 Months	TG12 Floor Grinder /s	24 Months
LX-30 Grinder / Polishers	12 Months	TG18 Floor Grinders	24 Months
Stealth-12 Chainsaw	12 Months	TG30 Floor Grinder/Polisher	24 months
Nacecare Compact Scrubbers	12 Months	TEQ-Swing Machines	12 Months

WHAT IS NOT WARRANTED — DITEQ IS NOT RESPONSIBLE FOR THE FOLLOWING:

(1) Used products; (2) Any product that has been modified in ways not approved by DITEQ; (3) Depreciation or damage caused by normal wear, lack of reasonable and proper maintenance, failure to follow operating instructions, misuse, lack of proper protection during storage, transporting or accident; (4) Normal maintenance parts such as belts, bearings, filters, wheels, cutters, etc. and service.

SECURING WARRANTY SERVICE — To secure warranty service, the purchaser must (1) report the product defect to DITEQ, an authorized dealer or an authorized service center and request repair within the applicable warranty term, (2) present evidence of the warranty start date, and (3) make the product available to DITEQ, the dealer or service center within a reasonable period of time.

LIMITATIONS OF IMPLIED WARRANTIES AND OTHER REMEDIES — To the extent permitted by law, neither DITEQ nor any company affiliated with it makes any warranties, representations or promises as to the quality, performance or freedom from defect of the equipment covered by this warranty.

IMPLIED WARRANTIES OF MERCHANTABILITY AND FITNESS FOR A PARTICULAR PURPOSE, TO THE EXTENT APPLICABLE, SHALL BE LIMITED IN DURATION TO THE APPLICABLE PERIOD OF WARRANTY SET FORTH ON THIS PAGE. THE PURCHASER'S ONLY REMEDIES IN CONNECTION WITH THE BREACH OR PERFORMANCE OF ANY WARRANTY ON THE DITEQ EQUIPMENT ARE THOSE SET FORTH ON THIS PAGE. IN NO EVENT WILL THE DEALER, DITEQ OR ANY COMPANY AFFILIATED WITH DITEQ BE LIABLE FOR INCIDENTAL OR CONSEQUENTIAL DAMAGES. (Note: Some states do not allow limitations on how long an implied warranty lasts or the exclusion or limitation of incidental or consequential damages so the above limitations and exclusions may not apply to you.) This warranty gives you specific legal rights, and you may also have other rights which vary from state to state. **NO DEALER WARRANTY-THE SELLING DEALER MAKES NO WARRANTY OF ITS OWN AND THE DEALER HAS NO AUTHORITY TO MAKE ANY REPRESENTATION OR PROMISE ON BEHALF OF DITEQ, OR TO MODIFY THE TERMS OR LIMITATIONS OF THIS WARRANTY IN ANY WAY.**

If further information is desired, please contact DITEQ.



DITEQ CORPORATION
9876 PFLUMM ROAD • LENEXA, KS 66215
PHONE 866-688-1032 • FAX 877-220-4777 • www.DITEQ.COM