

Bang & Olufsen

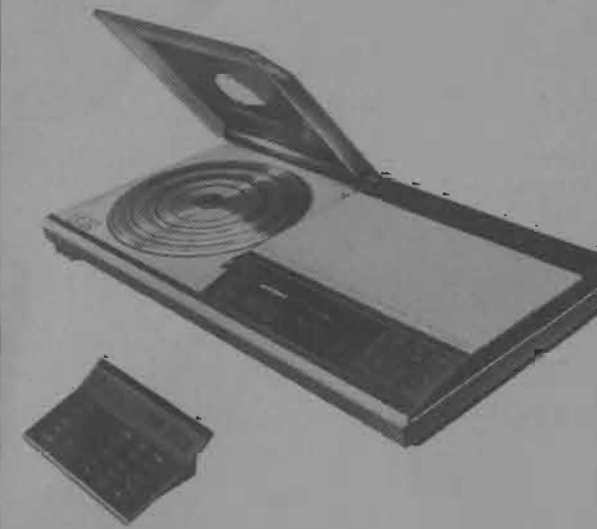

Beocenter 7700
Type 1811

BANG & OLUFSEN
DK - 7600 STRUER
DENMARK

TELEPHONE 07 - 85 11 22* - TELEX 66529
CABLE ADDRESS BANGOLUF

3538549

09-82

PRINTED IN DENMARK BY BOSTRUPHUSGOLDEN A/S, STRUER 8848



3 Power Supply and Output Ampl.	diagr. B	42 Microcomputer	diagr. C
4 Power Supply	diagr. B	43 Volume and Tone Control	diagr. B
11 Tape	diagr. E	44 Power Back Up and Mic. Ampl.	diagr. C-D
13 Mains Transformer	diagr. B	45 Remote	diagr. D
17 Phono	diagr. F	46 Socket Panel	diagr. A-B
18 Phono Keyboard	diagr. F	47 FM	diagr. A
22 FM Preset	diagr. A	48 Primary Keyboard	diagr. C
23 AM	diagr. A-B	49 Secondary Keyboard	diagr. C
24 Switch Section	diagr. A-B-E	51 Volume Keyboard	diagr. C
25 Record Level	diagr. B	52 Master Control Panel Keyboard	diagr. D
41 Display	diagr. C	53 Master Control Panel	diagr. D

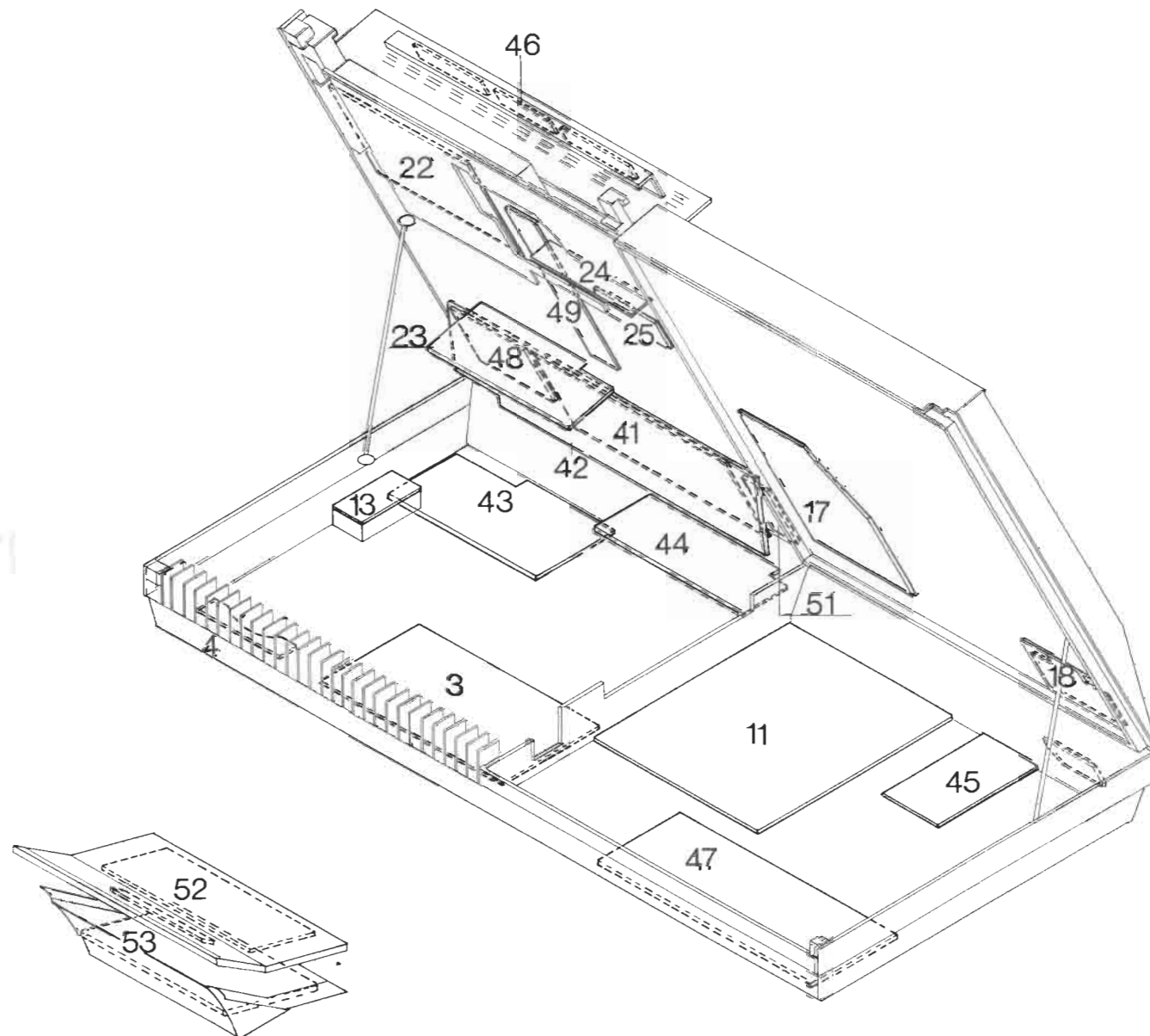

Beocenter 7700
Type 1811

DIAGRAM EXPLANATION

The individual diagram pages are marked with a letter, e.g. DIAGRAM A.

Type numbers of transistors and ICs (e.g. TR30/BC557B) have been indicated on the diagram in those cases where the type number is unambiguous for the position of the component in a circuitry. If the position number is followed by an asterisk (e.g. TR101*), the spare parts number **must be used** because this component has been especially selected.

Control Circuit

In certain control circuits the active mode has been indicated by means of a letter symbol (Cr = HIGH with CrO₂ tapes). If the symbol has a negation superscript bar the active mode is LOW (C[~]r = LOW with CrO₂ tapes).

The arrow indications on the microcomputer pins indicate whether the pins in question are an input or an output.

WIRING CONNECTIONS

The wiring connections on the diagram are assembled in »bundles«. The individual wires are coded to indicate to where they are leading.

INTERNAL CONNECTION ON ONE DIAGRAM PAGE



Internal connections on a diagram page are indicated by a number. The bend of the wire indicates in which direction the other end of the wire may be found.

CONNECTION TO ANOTHER DIAGRAM PAGE





Connections to another diagram page are indicated by a number, as well as by a letter indication of the diagram to which the connections lead.

GROUND SYMBOLS

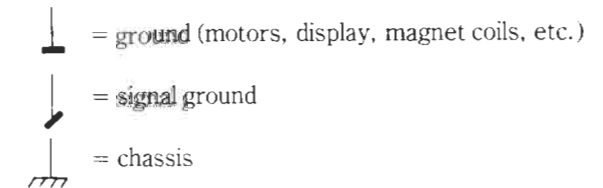
Three different ground symbols are used in the set.



TP0

In the power supply on PC3 is stated a ground test point TP0. In this and only in this test point , , and  are connected to each other. TP0 may therefore be used as reference for both DC measurements and signals measurements in the set. However, in connection with fault finding on the various modules the ground of the module in question should always be used as reference. TP0 is used as reference at measurements of DC voltages from the power supply (PC3-4).

CO-ORDINATE NUMBERS

The biggest PC boards are provided with co-ordinate systems. The components on these PC boards are provided with a co-ordinate number on the diagram (smaller printing type than the position numbers) indicating in which co-ordinate they are placed on the PC board. The co-ordinate numbers for the left channel of the output amplifier are stated in brackets in the diagram for right channel.

Measuring conditions and explanation of the pin designation on 42IC7 see page 1-14.

OPERATION SURVEY

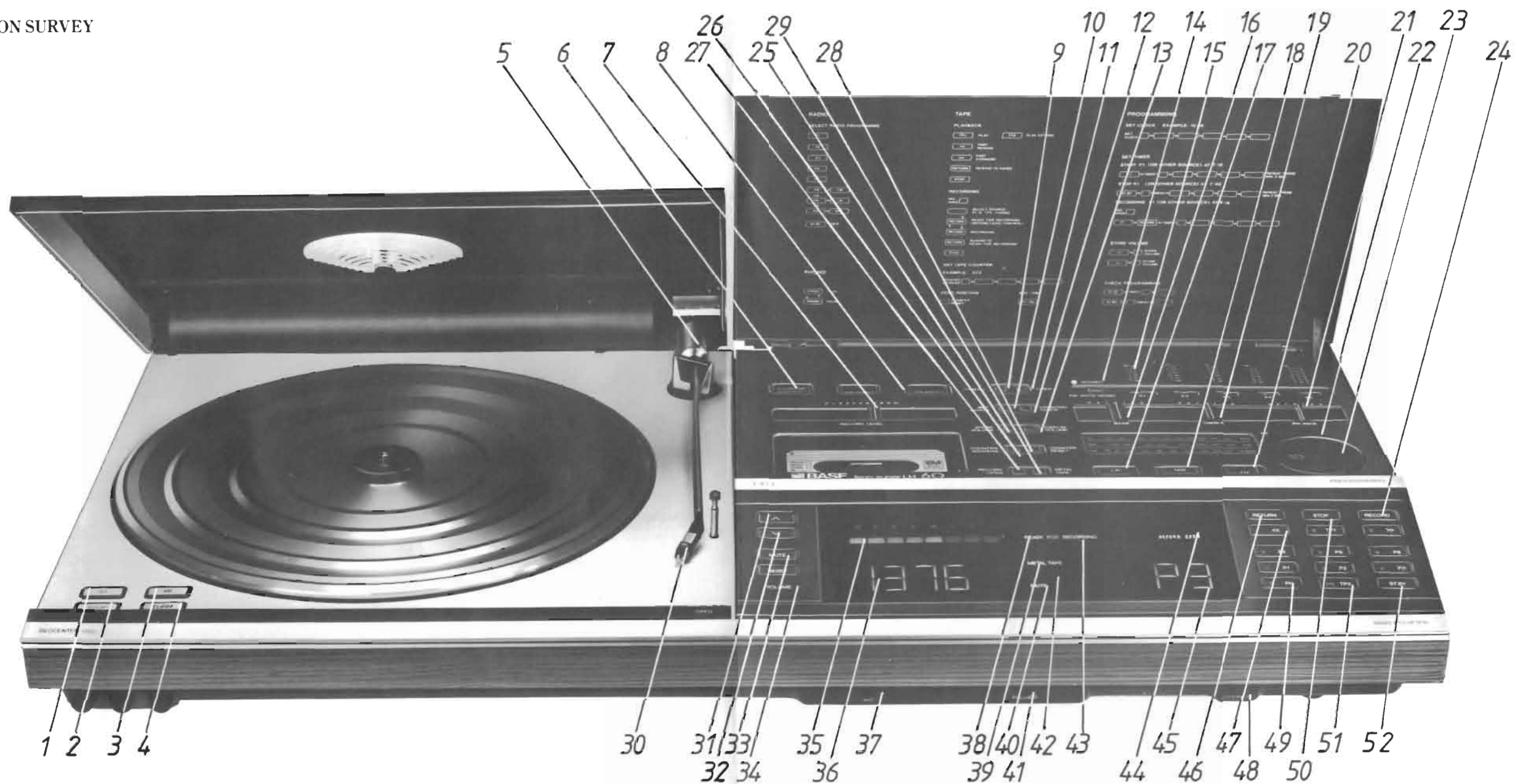

1. 33 – manual selection of 33 r.p.m.
2. STOP – manual stopping of Record Player.
3. 45 – manual selection of 45 r.p.m.
4. TURN – starting of turntable without moving of pickup arm.
5. Counter-balance weight.
6. Dolby NR switch.
7. SPEAKER 1 and 2 – loudspeaker switch.
8. RECORD LEVEL – recording volume.
9. TIMER 1 – starting of time programming.
10. SET CLOCK – start for pre-setting of clock.
11. TIMER 2 – starting of time programming.
12. COUNTER/CLOCK – switching tape counter or clock.
13. DISPLAY VOLUME – control of volume.
14. FM AUTO/MONO – switch for FM automatic and FM mono.
15. Pre-setting FM Program 1.
16. BASS – bass control.
17. LW – long wave Program 6.
18. MW – medium wave Program 6.

19. TREBLE – treble control.
20. FM – FM Program 6.
21. BALANCE – balancing LH and RH channels.
22. FM – balance light indicator.
23. Turning button Program 6.
24. RECORD – start of recording.
25. STORE VOLUME – programming of starting volume.
26. COUNTER ADDRESS – automatic cueing on tape.
27. RECORD OPEN – acceptance for recording.
28. COUNTER RESET – zeroing of counter.
29. METAL TAPE – recording on metal tape.
30. Pick-up unit.
31. A – stronger sound.
32. V – weaker sound.
33. MUTE – sound OFF/ON.
34. RESET – return to programmed sound volume.
35. Peak Program Meter – recording level indicator.

36. Digital Display for clock, tape counter and sound volume.
37. MIC – socket for microphone.
38. READY FOR – light indicator, ready for recording.
39. METAL TAPE – light indicator.
40. MUTE – light indicator.
41. PHONES – socket for headphones.
42. PROGRAMMED – light indicator for time programming.
43. RECORDING – recording in progress.
44. RECORD OPEN – light indicator.
45. P1 – program indicator.
46. RETURN – return to starting point of recording and playback.
47. P1 to P6, selection of program and time programming (see 9, 10, 11).
48. LOUDNESS – switch.
49. PH – starting of record player.
50. STOP – tape recorder.
51. TP2 – playback of extra tape recorder.
52. ST. BY – stand-by switch.

BLOCK DIAGRAM OF SIGNAL PROCESSING

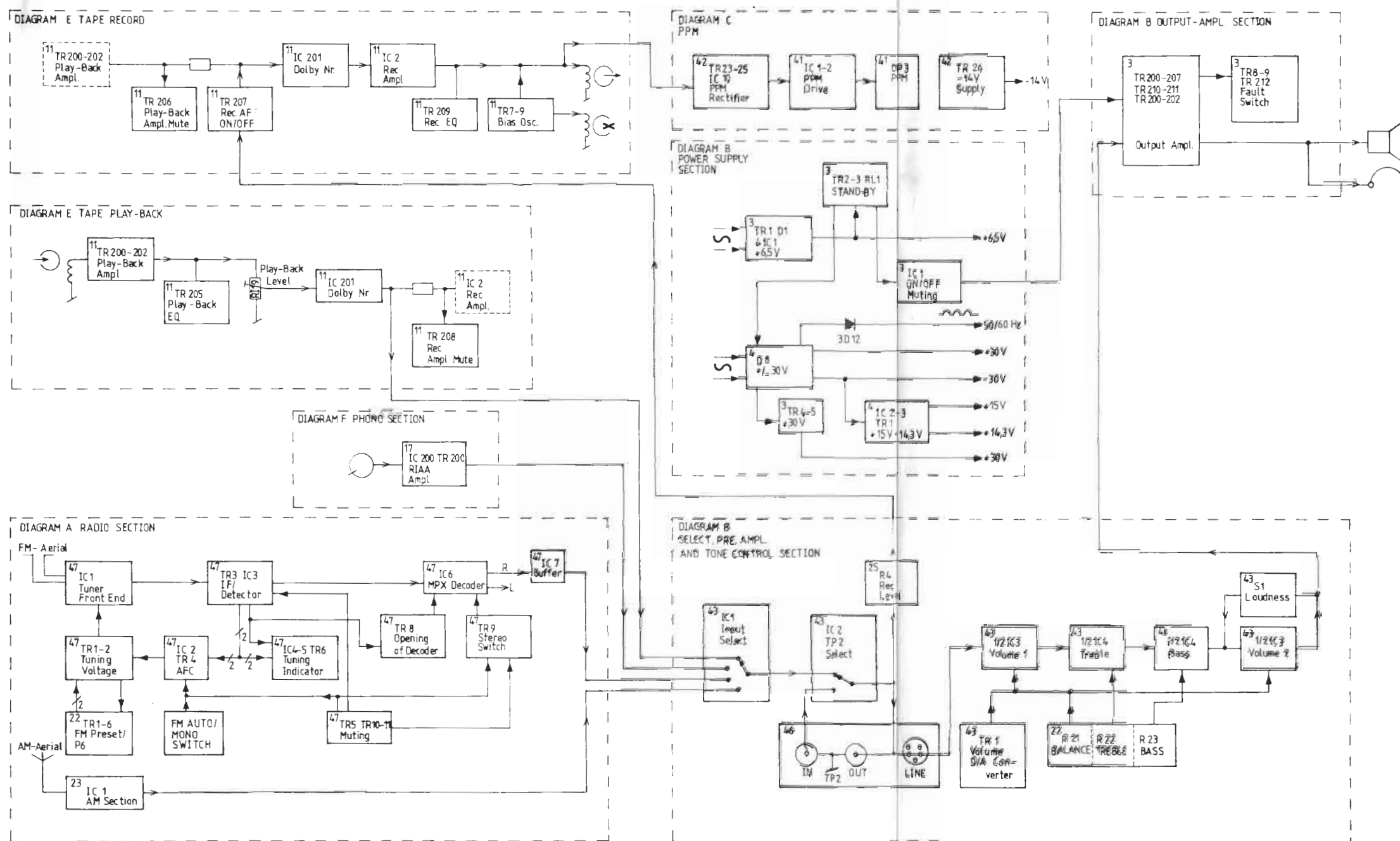

DIAGRAM A
22Module
FM Preset
23Module
AM Section
P6 Tuning
47Module
FM Section

DIAGRAM B
03Module
Power Supply
Muting
Stand By
Power Amplifier
04Module
Power Supply
22Module
Potentiometers
24Module
Loudspeaker Switches
25 Module
Record Level
43 Module
Input Select
Volume Control
Tone Control
44Module
Headphone Socket
46Module
Socket Panel

DIAGRAM E
11-12Module
Tape Recorder

DIAGRAM F
15-17-18Module
Phono Section

BLOCK DIAGRAM OF REMOTE SYSTEM DIAGRAM D

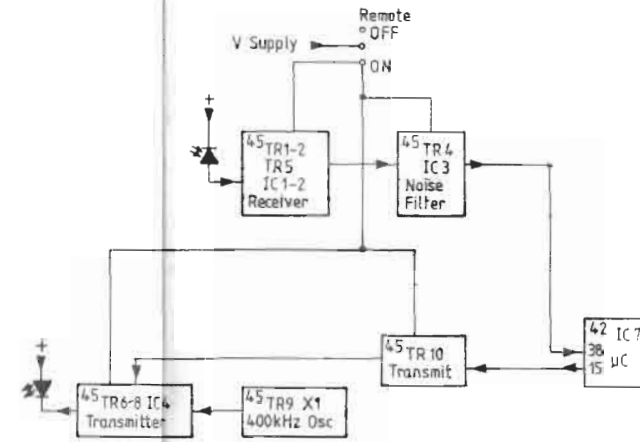
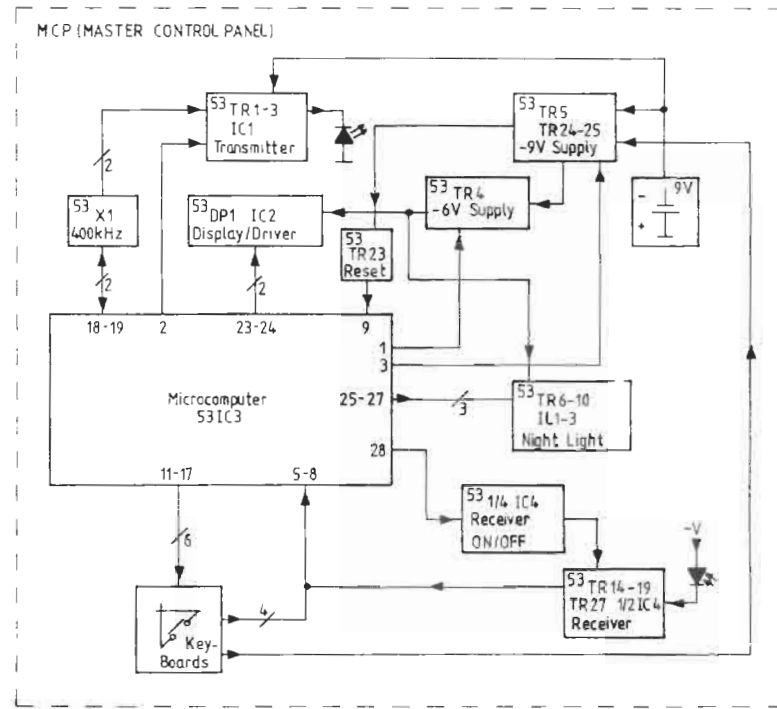

- DIAGRAM D**
- 44Module Mic. Amplifier
 - 45Module IR Receiver
 - IR Transmitter
 - 53Module (Master Control Panel) Microcomputer
 - IR Receiver
 - IR Transmitter
 - LCD Display
 - LCD Decoder/Driver
 - Power Supply
 - Reset
 - Night Light
 - 52Module Key-board

PIN CONFIGURATIONS OF MICROCOMPUTERS

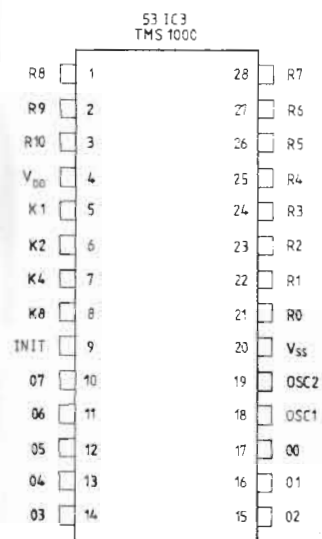

FUNCTION TABLES FOR DIAGRAM D

FUNCTION	START	53TP47
P1	1	0 1 0 1 0 0 0 0
P2	1	0 1 0 0 0 1 0 0
P3	1	0 1 0 0 0 0 1 0
P4	1	0 1 1 1 0 0 0 0
P5	1	0 1 1 1 0 1 0 0
P6	1	0 1 1 0 0 0 1 0
PH	1	0 0 1 1 0 0 0 0
TP1	1	0 0 1 0 1 0 0 0
TP2	1	0 1 0 1 0 1 0 0
←	1	1 0 0 0 1 0 0 0
→	1	1 0 0 0 0 1 0 0
STOP	1	0 0 0 1 0 1 0 0
RETURN	1	1 0 0 1 0 1 0 0
RECORD	1	1 0 0 0 0 0 1 0
A	1	1 0 1 0 0 0 1 0
V	1	1 0 1 0 1 0 0 0
RESET	1	1 0 1 1 0 1 0 0
MUTE	1	0 0 1 1 0 1 0 0
STATUS	1	0 1 1 1 0 1 0 0
STBY	1	0 0 1 0 0 1 0 0

ANSWER TO MCP	START	45TP40 DATA	STOP
PH	1	1 0 1	0 0 0 0 1 0 0 0
P1			0 0 0 0 1
P2			0 0 1 0
P3			0 0 1 1
P4			0 1 0 0
P5			0 1 0 1
P6			0 1 1 0
□			0 1 1 1
TP 1			1 0 0 0
TP 2			1 0 0 1
←			1 0 1 0
→			1 0 1 1
RECORD			1 1 0 0
RECORD PAUSE			1 1 0 1
MUTE			1 1 1 0
RECORD MUTE			1 1 1 1

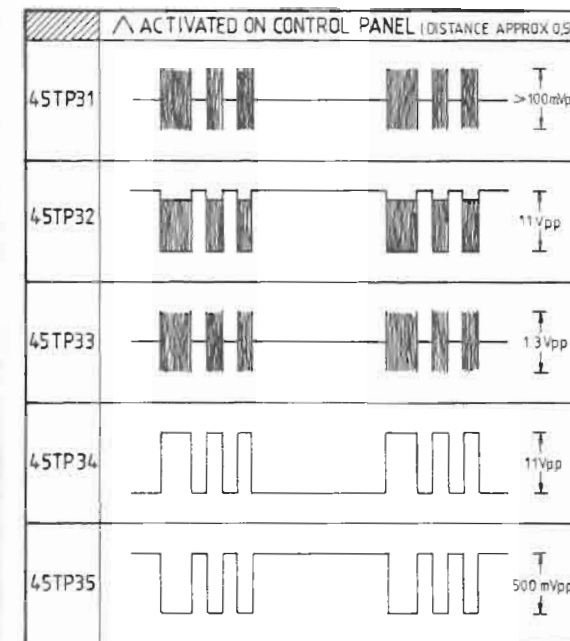

— PULSE — PAUSE —
— 50 mS —

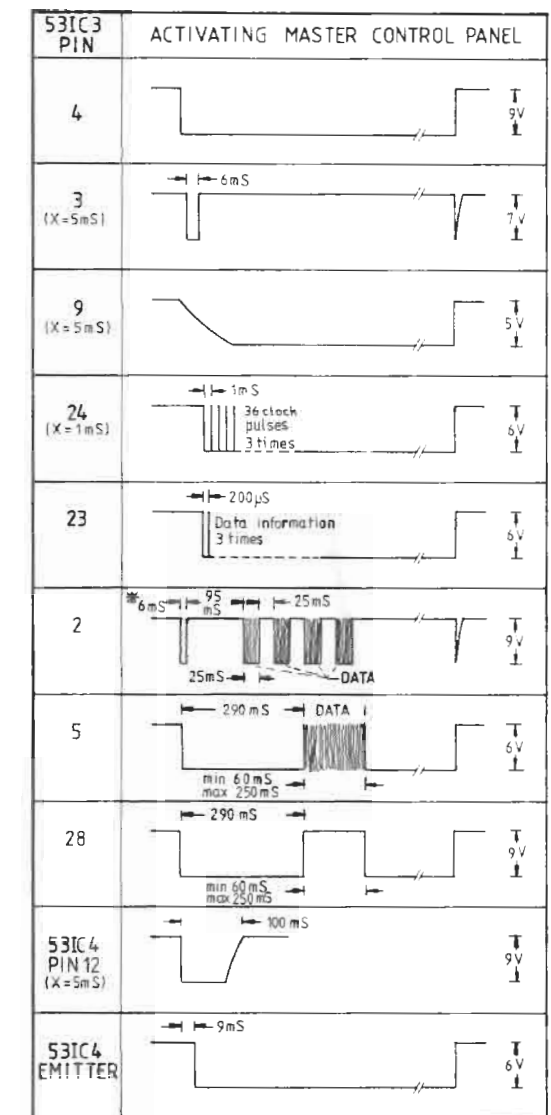

— 6 Sec —
*NOT V / ^

DIAGRAM A

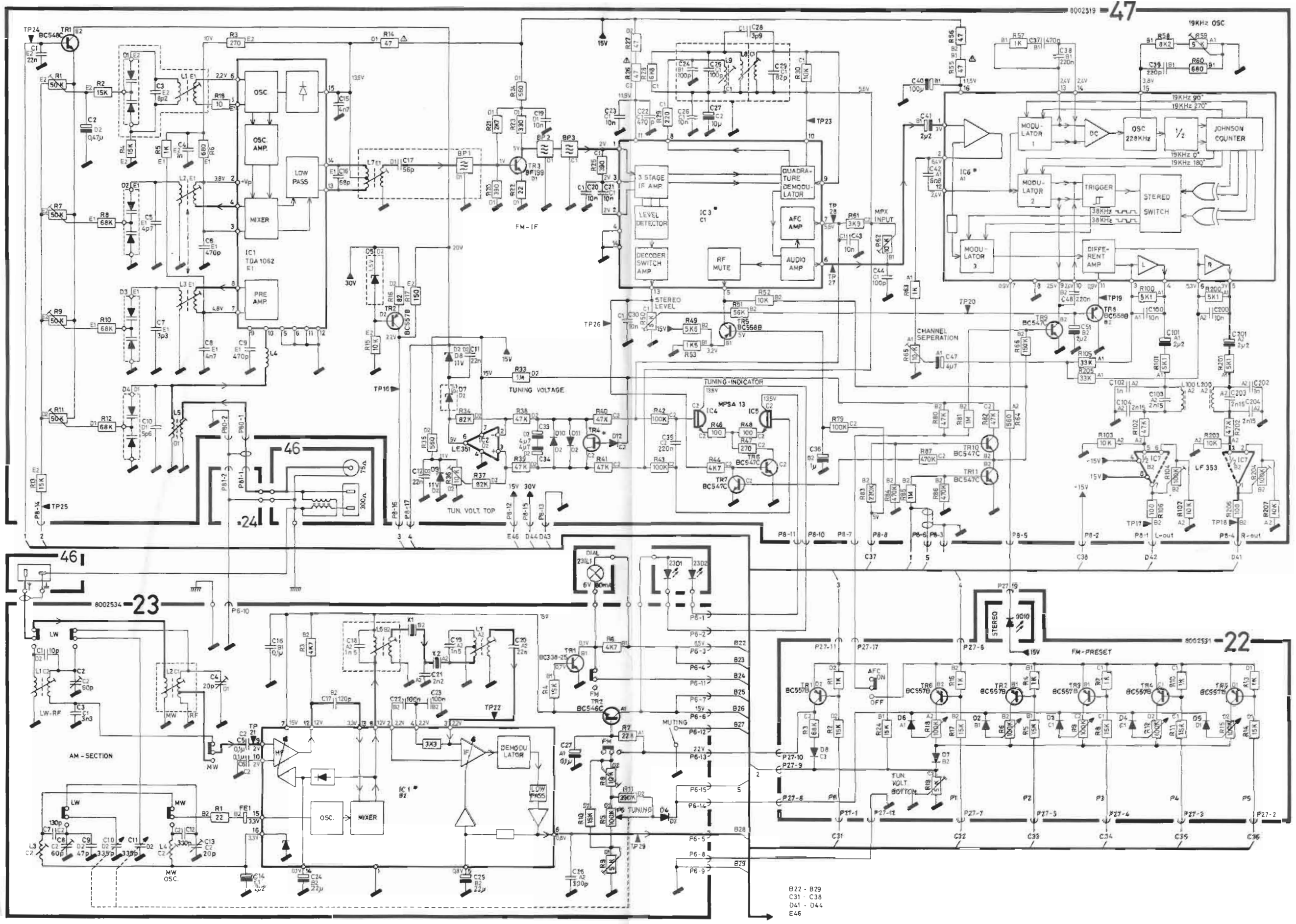

B22 - B29
 C31 - C38
 D41 - D44
 E46

DIAGRAM B

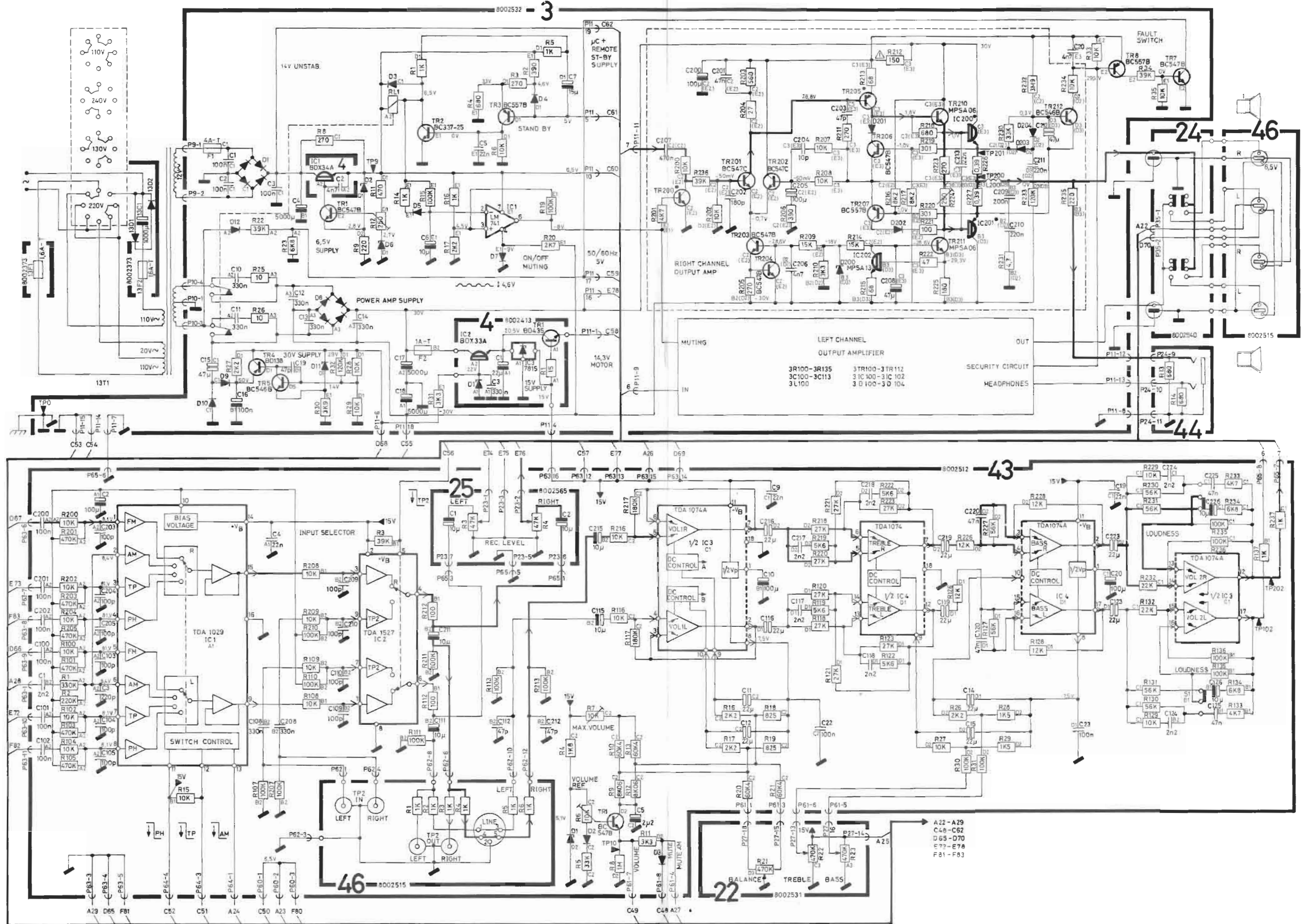

DIAGRAM C

PIN ASSIGNMENT #1P1	COMMON	ANODE	SEG A CATHODE	SEG B CATHODE	SEG C CATHODE	SEG D CATHODE	SEG E CATHODE	SEG F CATHODE	SEG G CATHODE	SEG H CATHODE
1	COMMON	ANODE	SEG A CATHODE	SEG B CATHODE	SEG C CATHODE	SEG D CATHODE	SEG E CATHODE	SEG F CATHODE	SEG G CATHODE	SEG H CATHODE
2	COMMON	ANODE	SEG A CATHODE	SEG B CATHODE	SEG C CATHODE	SEG D CATHODE	SEG E CATHODE	SEG F CATHODE	SEG G CATHODE	SEG H CATHODE
3	COMMON	ANODE	SEG A CATHODE	SEG B CATHODE	SEG C CATHODE	SEG D CATHODE	SEG E CATHODE	SEG F CATHODE	SEG G CATHODE	SEG H CATHODE
4	COMMON	ANODE	SEG A CATHODE	SEG B CATHODE	SEG C CATHODE	SEG D CATHODE	SEG E CATHODE	SEG F CATHODE	SEG G CATHODE	SEG H CATHODE
5	COMMON	ANODE	SEG A CATHODE	SEG B CATHODE	SEG C CATHODE	SEG D CATHODE	SEG E CATHODE	SEG F CATHODE	SEG G CATHODE	SEG H CATHODE
6	COMMON	ANODE	SEG A CATHODE	SEG B CATHODE	SEG C CATHODE	SEG D CATHODE	SEG E CATHODE	SEG F CATHODE	SEG G CATHODE	SEG H CATHODE
7	COMMON	ANODE	SEG A CATHODE	SEG B CATHODE	SEG C CATHODE	SEG D CATHODE	SEG E CATHODE	SEG F CATHODE	SEG G CATHODE	SEG H CATHODE
8	COMMON	ANODE	SEG A CATHODE	SEG B CATHODE	SEG C CATHODE	SEG D CATHODE	SEG E CATHODE	SEG F CATHODE	SEG G CATHODE	SEG H CATHODE
9	COMMON	ANODE	SEG A CATHODE	SEG B CATHODE	SEG C CATHODE	SEG D CATHODE	SEG E CATHODE	SEG F CATHODE	SEG G CATHODE	SEG H CATHODE
10	COMMON	ANODE	SEG A CATHODE	SEG B CATHODE	SEG C CATHODE	SEG D CATHODE	SEG E CATHODE	SEG F CATHODE	SEG G CATHODE	SEG H CATHODE
11	COMMON	ANODE	SEG A CATHODE	SEG B CATHODE	SEG C CATHODE	SEG D CATHODE	SEG E CATHODE	SEG F CATHODE	SEG G CATHODE	SEG H CATHODE
12	COMMON	ANODE	SEG A CATHODE	SEG B CATHODE	SEG C CATHODE	SEG D CATHODE	SEG E CATHODE	SEG F CATHODE	SEG G CATHODE	SEG H CATHODE
13	COMMON	ANODE	SEG A CATHODE	SEG B CATHODE	SEG C CATHODE	SEG D CATHODE	SEG E CATHODE	SEG F CATHODE	SEG G CATHODE	SEG H CATHODE
14	COMMON	ANODE	SEG A CATHODE	SEG B CATHODE	SEG C CATHODE	SEG D CATHODE	SEG E CATHODE	SEG F CATHODE	SEG G CATHODE	SEG H CATHODE
15	COMMON	ANODE	SEG A CATHODE	SEG B CATHODE	SEG C CATHODE	SEG D CATHODE	SEG E CATHODE	SEG F CATHODE	SEG G CATHODE	SEG H CATHODE
16	COMMON	ANODE	SEG A CATHODE	SEG B CATHODE	SEG C CATHODE	SEG D CATHODE	SEG E CATHODE	SEG F CATHODE	SEG G CATHODE	SEG H CATHODE
17	COMMON	ANODE	SEG A CATHODE	SEG B CATHODE	SEG C CATHODE	SEG D CATHODE	SEG E CATHODE	SEG F CATHODE	SEG G CATHODE	SEG H CATHODE
18	COMMON	ANODE	SEG A CATHODE	SEG B CATHODE	SEG C CATHODE	SEG D CATHODE	SEG E CATHODE	SEG F CATHODE	SEG G CATHODE	SEG H CATHODE

A31 - A38
B48 - B62
D85 - D90
E92 - E106
F108 - F111

Mechanically, capacitors with this symbol are designed as resistors

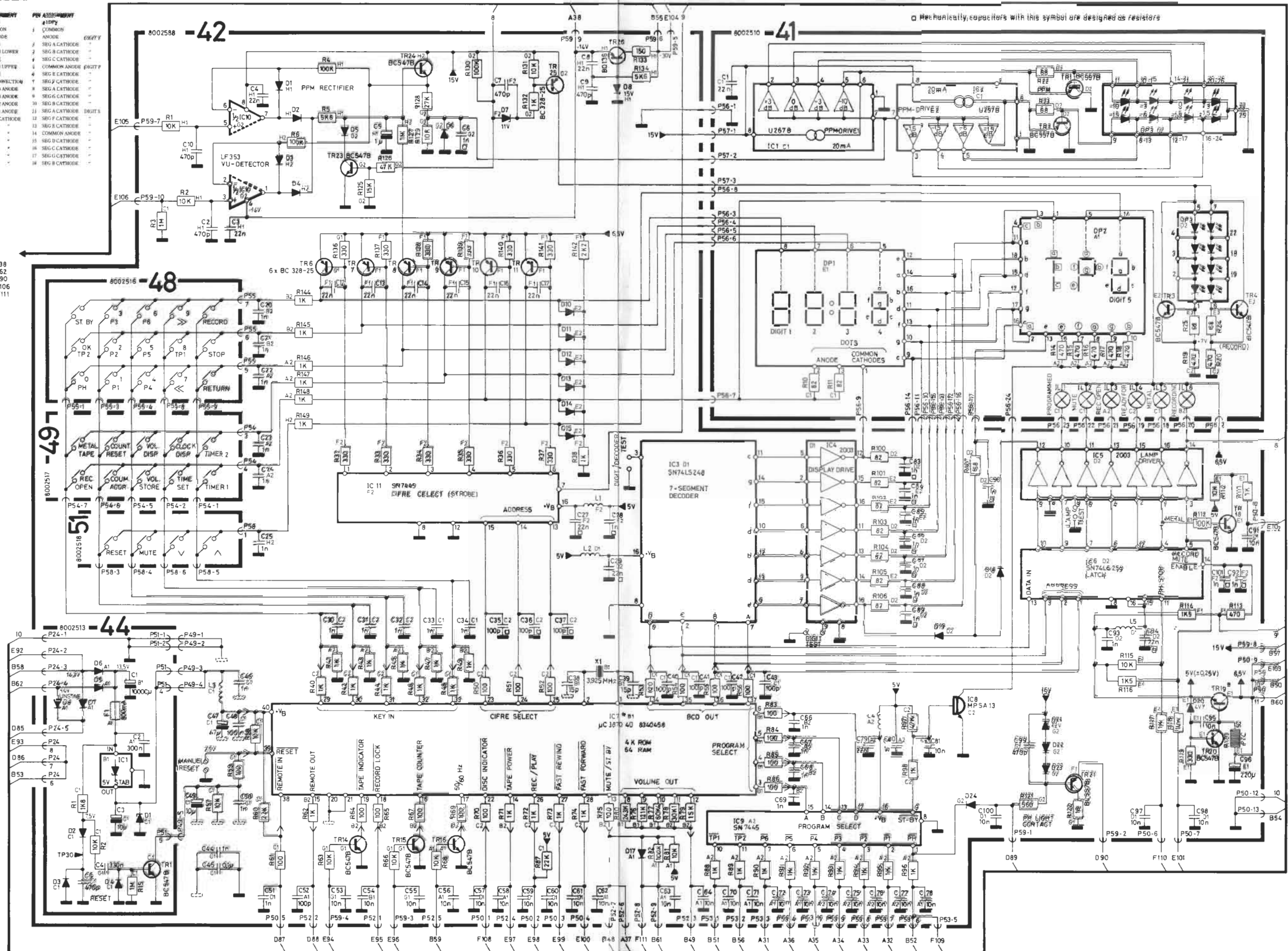

DIAGRAM D

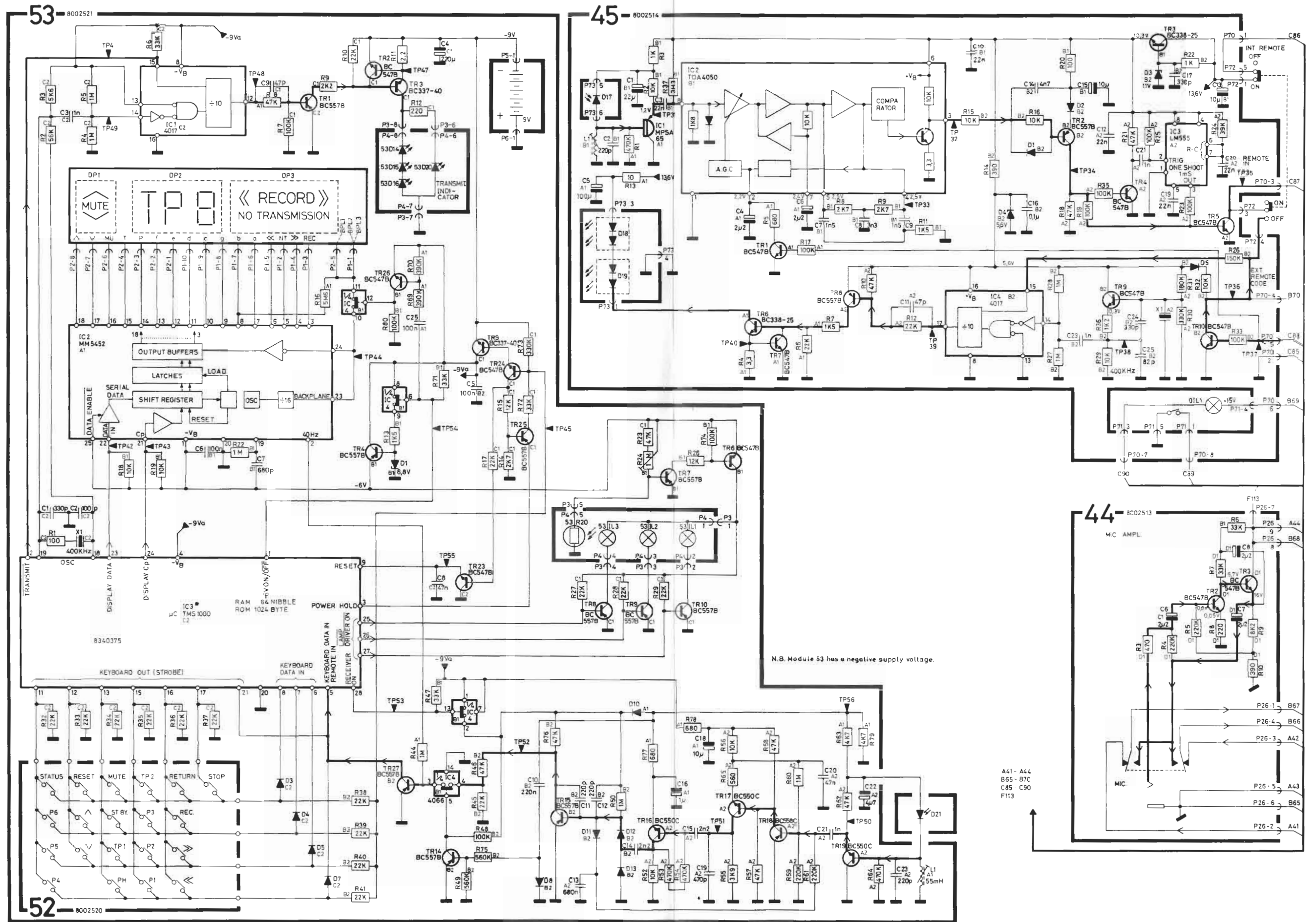
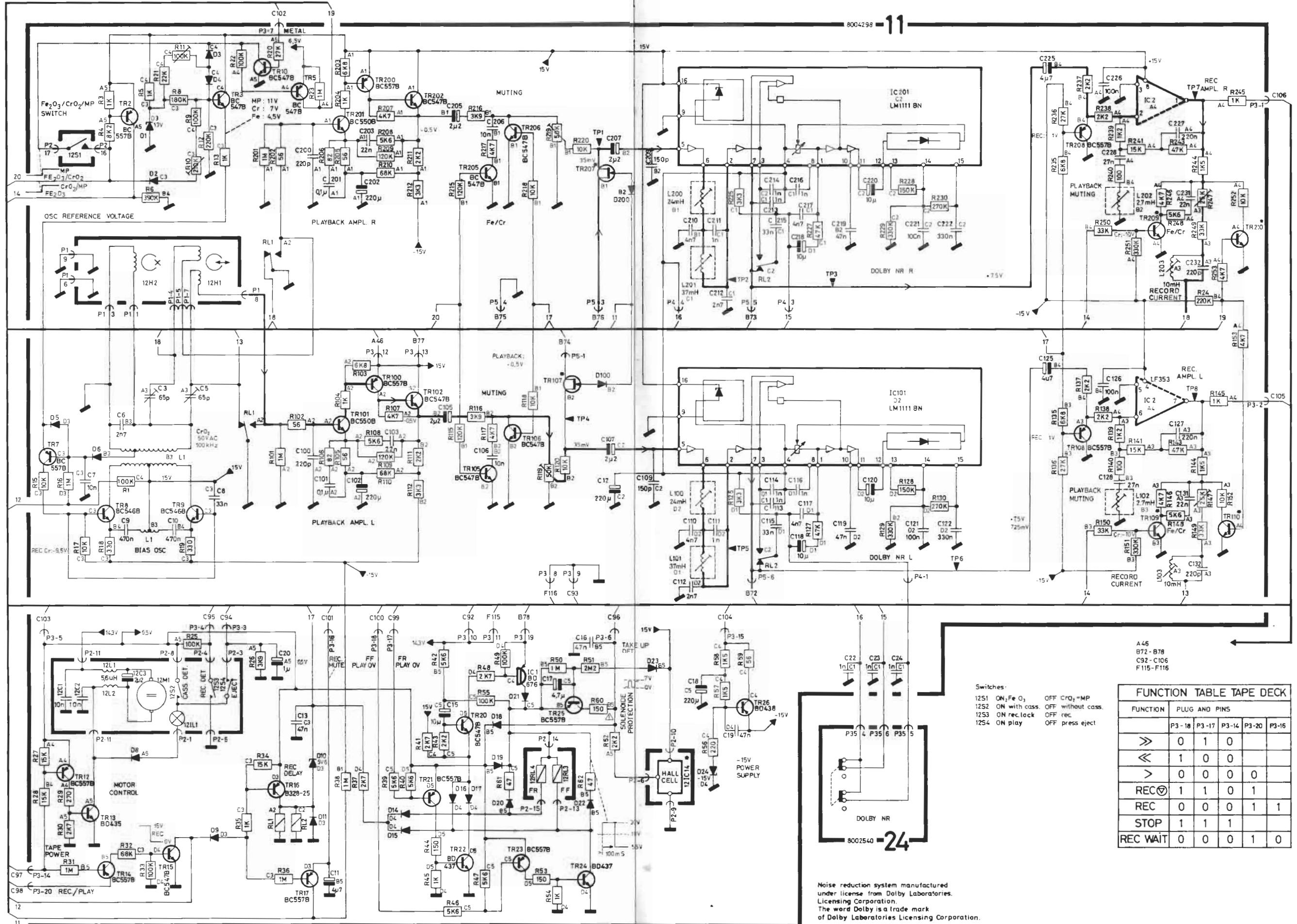
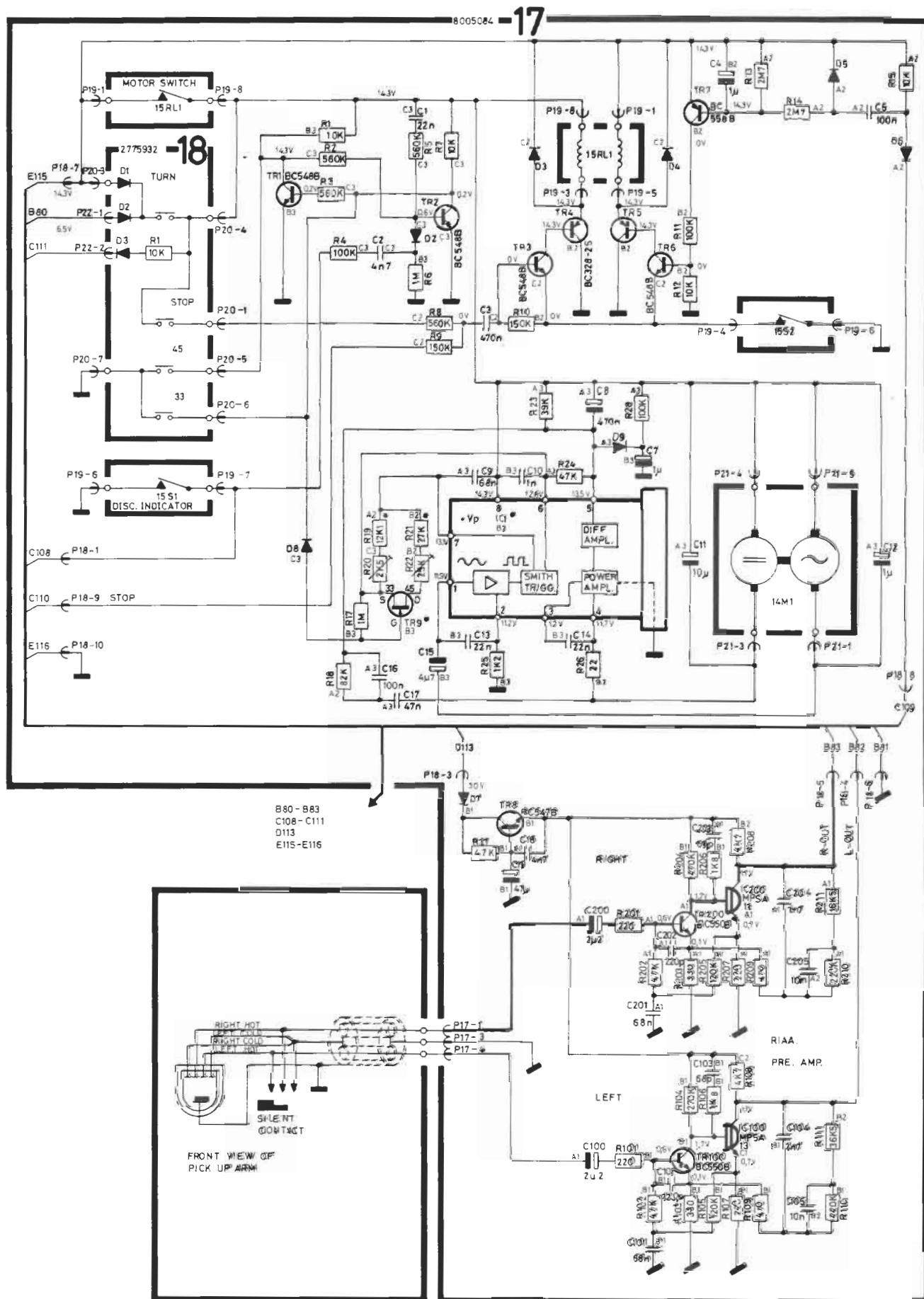
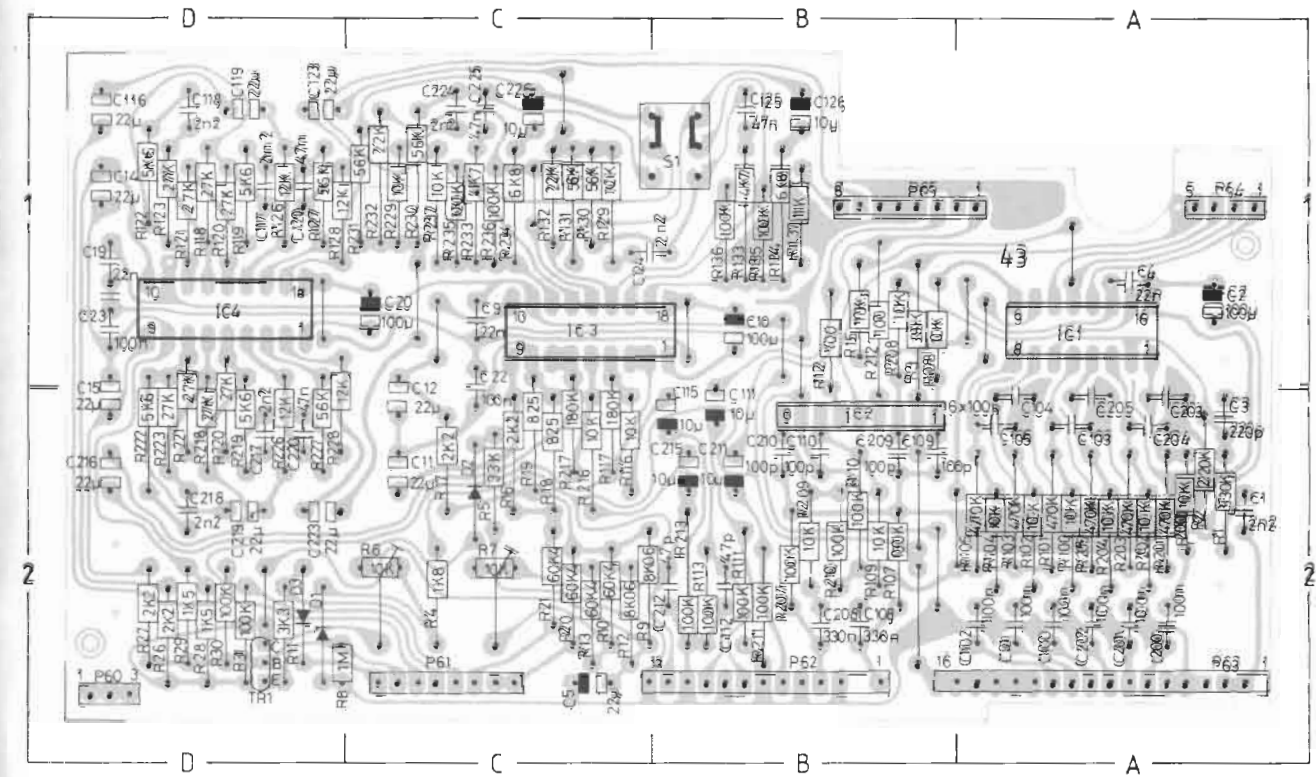

DIAGRAM E





PC drawings are seen from copperfoil side
Volume and Tone Control, 8002512, PC43



Master Control Panel, 8002521, PC53

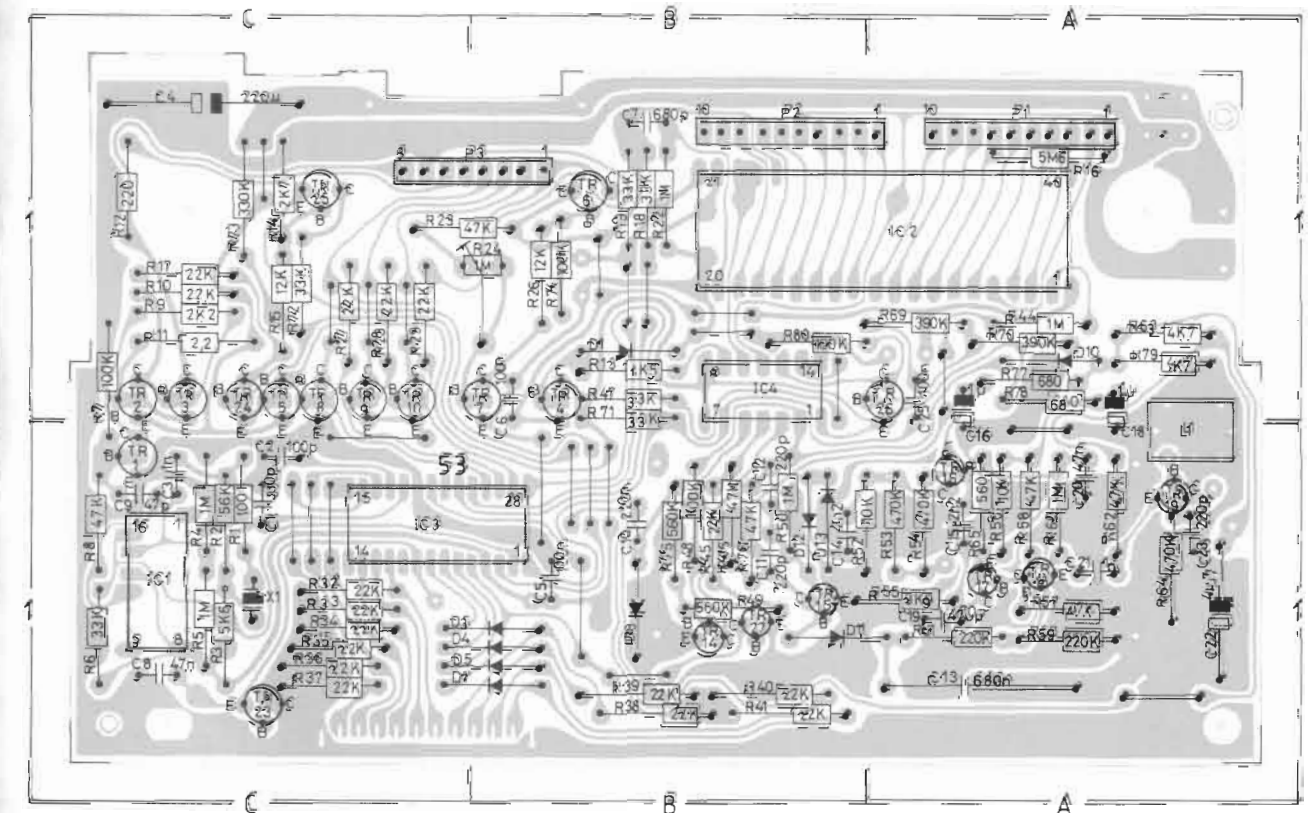

Microcomputer, 8002588, PC42

PC drawings are seen from copperfoil side

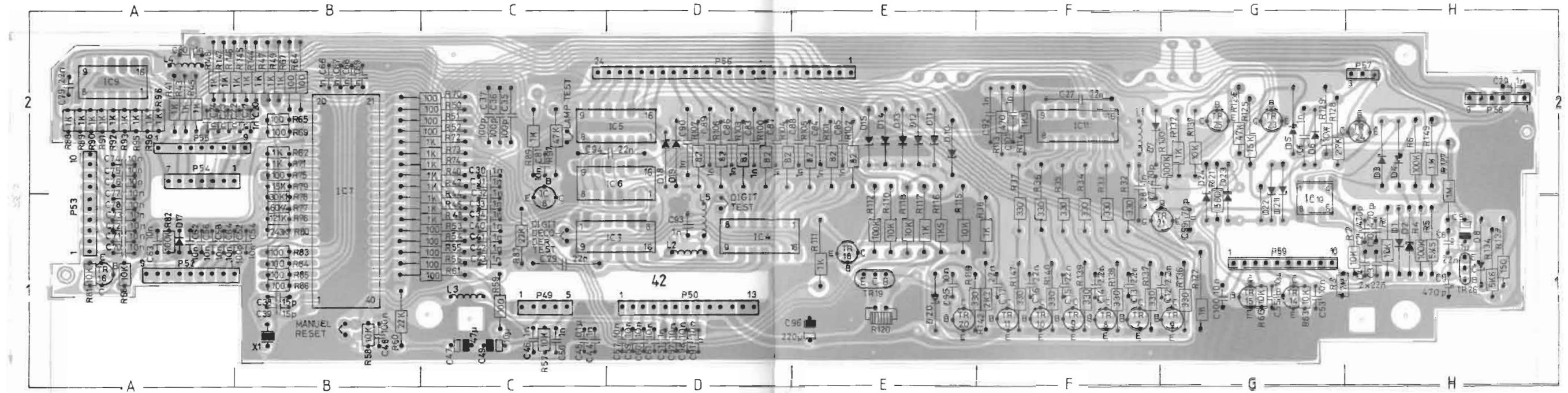

Remote, 8002514, PC45

Power Supply and Output Amplifier, 8002532, PC3

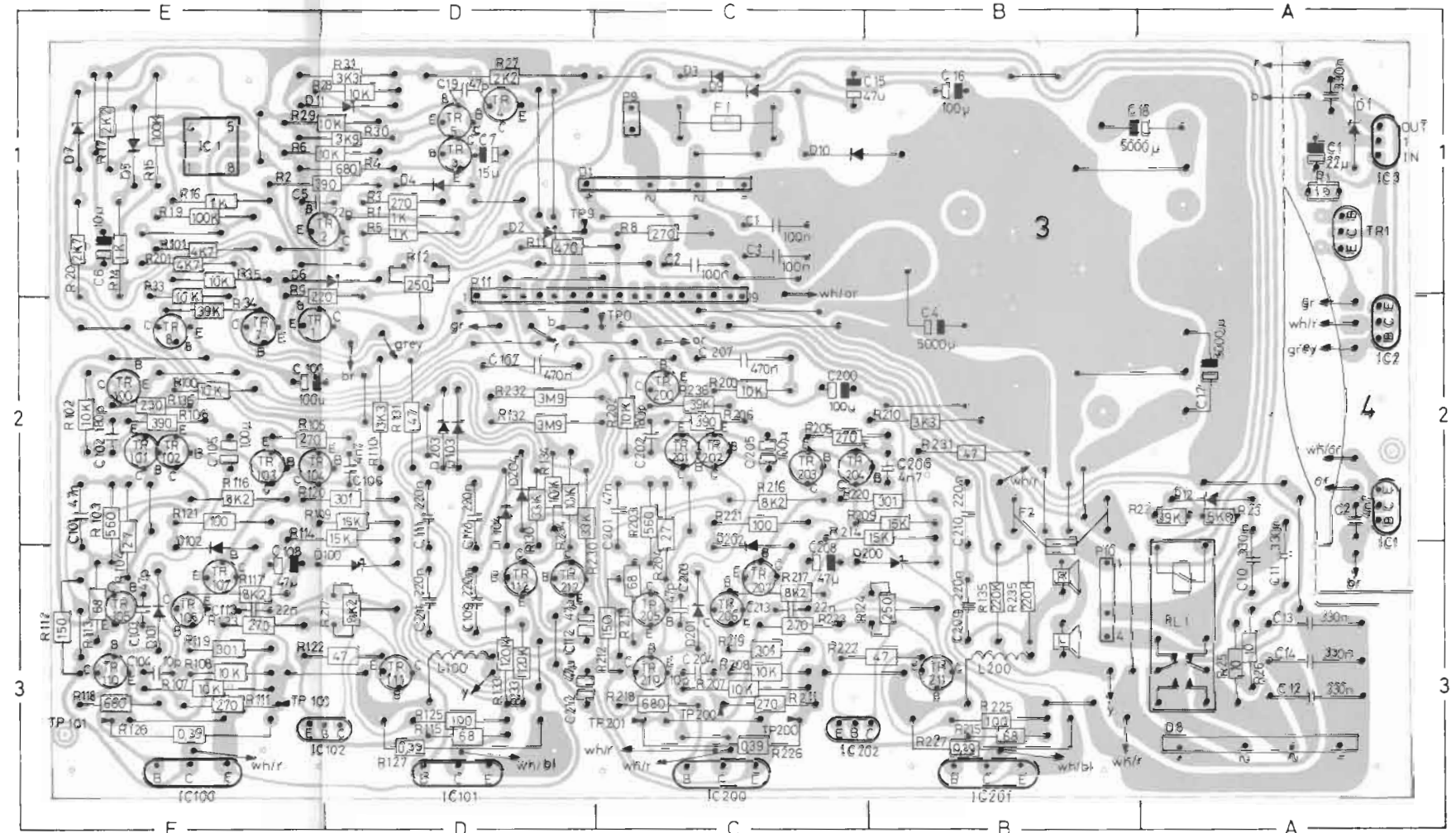
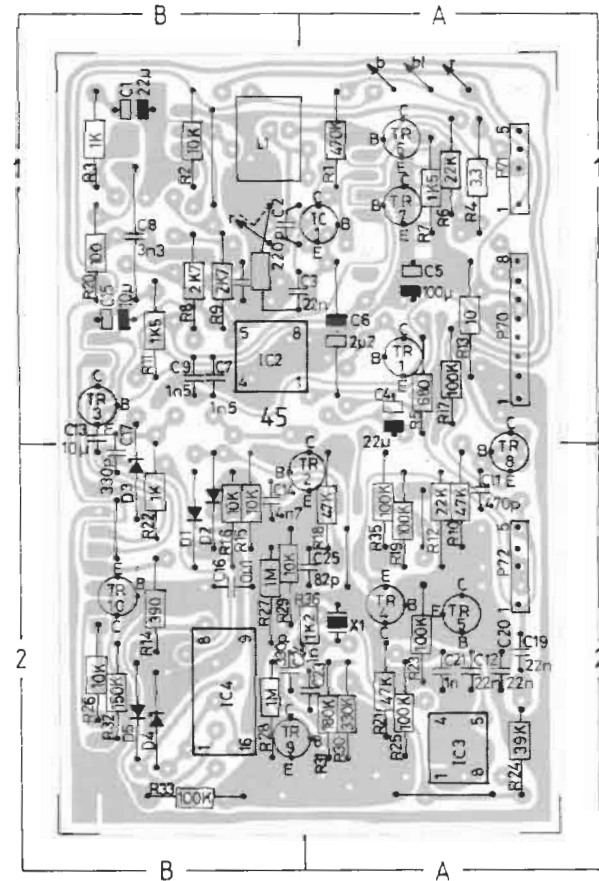

MEASURING CONDITIONS

All DC voltages are measured relative to ground with voltmeter (inner resistance 10 Mohms).
 DC voltages are stated in volts (V), ex.: 0.7 V.
 Oscillograms and AC voltages are measured relative to signal ground with oscilloscope or voltmeter with an input resistance of 1 Mohm.
 AC voltages are stated in millivolt (mV), ex.: 725 mV.
 Voltages on the FM, AM and remote section are measured without signal in position P6 – FM.
 Voltages on the turntable section are measured in position PH (33 r.p.m.).
 Voltages on the tape recorder section are measured in position TP, play back, (333 Hz, 250 pWb mm).
 Signal paths are shown for AM (position MW), FM, remote control, and for AF right channel.
 The tape recorder signal path in recording position is shown in right channel, and replay position is shown in left channel.
 Mechanical switches are shown in neutral position.

ADJUSTMENT OF NO-SIGNAL-CURRENT

Adjust no-signal-current with receiver cold and volume control turned down. **SPEAKERS MUST NOT BE CONNECTED.**
 With 3R224 (3R124) adjust to 10 mV DC measured across emitter resistor 3R226 (3R126) TP200/201 (TP100/TP101), or adjust to 25 mA in collector of 3IC200 (3IC100).

SYMBOL FOR SAFETY RESISTORS



When replacing components with this symbol the same type with the same values of ohm and watt must be used. The new component must be fitted in the same way as the replaced one.

Explanation of the Pin Designation on the Microcomputer 42IC7

Pin

3-6 PROGRAM SELECT
 8-12 VOLUME OUT
 13 MUTE/ST.BY
 14 TAPE POWER
 15 REMOTE OUT
 16 TAPE COUNTER
 17 50/60 Hz
 18 RECORD LOCK
 19 TAPE INDICATOR
 22 DISC INDICATOR
 23-25 CIFRE SELECT
 26 REC./PLAY
 27 FAST REWIND
 28 FAST FORWARD
 29-33 KEY IN
 34-37 BCD OUT
 38 REMOTE IN
 39 RESET

Selection of program.
 Digital counter sequence for volume matrix.
 LOW at MUTE and ST./BY.
 LOW when the tape recorder is ON.
 Feedback signals to Master Control Panel and Master Control Link.
 Counter pulses from the Hall element of the collector coil.
 Reference to the TIME functions.
 LOW if REC OPEN cannot be activated.
 LOW with a cassette in the cassette tray.
 Low with a record on the turntable.
 Binary changing code for multiplexing of the display polling and latch enable.
 Switching between Record and Playback functions.
 LOW at fast rewinding and normal forward.
 LOW at fast forward and normal forward.
 Reading-in of data from keyboards.
 Control of 7-segment decoder and latch.
 Input from Master Control Panel and Master Control Link.
 Goes LOW if mains voltage fails.

LIST OF MECHANICAL PARTS
(Bottom Chassis)

03Modul 8002532	PC, power ampl. + power supply		
1001	2039011	Screw AM3 x 25 black	1029
1002	2622306	Washer 3.2 black	1030
1003	2038081	Screw M3 x 8	1031
1004	2013201	Screw 2.9 x 6.5	1032
1005	3152006	Holder	1033
1006	3152260	Holder	1034
1007	3413831	Cabinet, self-adhesive, teak	1035
	3413833	Cabinet, self-adhesive, rosewood	1036
	3413834	Cabinet, self-adhesive, oak	1037
	3413835	Cabinet set, self-adhesive, white	1038
1008	2015090	Screw 3.5 x 6.3 black	1039
1009	2015089	Screw 3.5 x 9.5 black	1040
1010	2015094	Screw 3.5 x 6.5 black	1041
1011	2015089	Screw 3.5 x 9.5 black	1042
1012	2084004	Screw 4.0 x 6.5	1043
1013	2622022	Washer 4.3	1044
1014	2542542	Arm	1045
1015	2039033	Screw M3 x 20	1046
1016	3152259	Holder	1047
1017	2380016	Washer M4	1048
1018	2576050	Spacer	1049
1019	3152260	Holder	1050
1021	3152330	Holder	1051
1022	2039037	Screw AM3 x 16	1052
1023	2015096	Screw M3.5 x 38	1053
1024	3302305	Screen	1054
1025	2622022	Washer 4.3	10P51
1026	2938154	Bushing	10P80
1027	3172082	Insulating piece	
1028	2015088	Screw M3.5 x 16 black	
11Modul 8004298	PC, tape		
12P1	6275440	Set of wires with socket	3152214
12P2	6275441	Set of wires with socket	
13Modul 8013203	Mains transformer	1305	7400119
1301	6271101	Mains lead	13F1
1302	6275407	Set of wires	13F2
1303	8002373	Fuse holder	13P9
1304	7500002	Fuse holder	13P10
1305	7400119	Voltage switch	
13F1	6600022	Fuse 1.6 A - T/250	
13F2	6600022	Fuse 1.6 A - T/250	
13P9	6275421	Set of wires P9 & P10	
13P10	6275421	Set of wires P9 & P10	
14P71	6275490	Wire bundle	
19Modul 6275488	Mains wire bundle	19P26	7210364
19P3	7210369	Socket/housing 20/20 contacts	19P60
19P4	7210366	Socket/housing 1/4 contacts	19P61
19P5	7210367	Socket/housing 3/6 contacts	19P63
19P8	7210370	Socket/housing 15/17 contacts	19P64
19P11	7210359	Socket/housing 13/19 contacts	19P65
19P24	7210362	Socket/housing 2/11 contacts	19P70
19P26	7210364	Socket/housing 9/9 contacts	
19P60	7210363	Socket/housing 3/3 contacts	
19P61	7210371	Socket/housing 8/8 contacts	
19P63	7210360	Socket/housing 16/16 contacts	
19P64	7210372	Socket/housing 4/4 contacts	
19P65	7210361	Socket/housing 5/8 contacts	
19P70	7210371	Socket/housing 8/8 contacts	
7500170	Contact pin		
43Modul 8002512	PC, switch		
44Modul 8002513	PC, Power backup	4404	3164450
4401	2039015	Screw M3 x 6	4405
4403	2542589	Bracket	4406
4404	3164450	Cover	
4405	3358177	Heat sink	
4406	2819157	Spring	
45Modul 8002514	PC, remote	45P73	7210164
4501	6140883	Mounting plate	
45P73	7210164	Socket/housing 6/5 contacts	
46P62	7210197	Socket/housing 13/12 contacts	
47Modul 8002519	PC, FM		

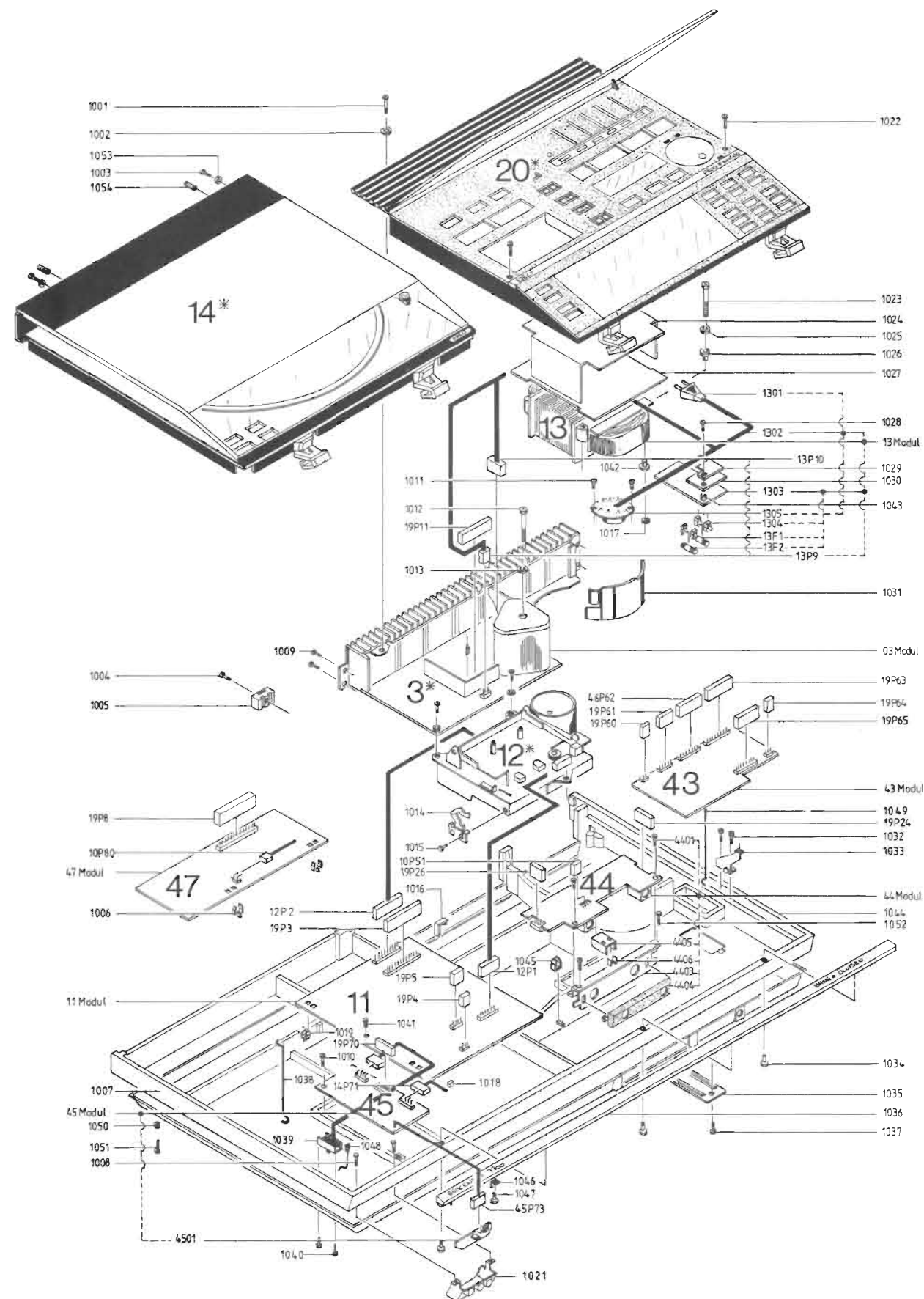

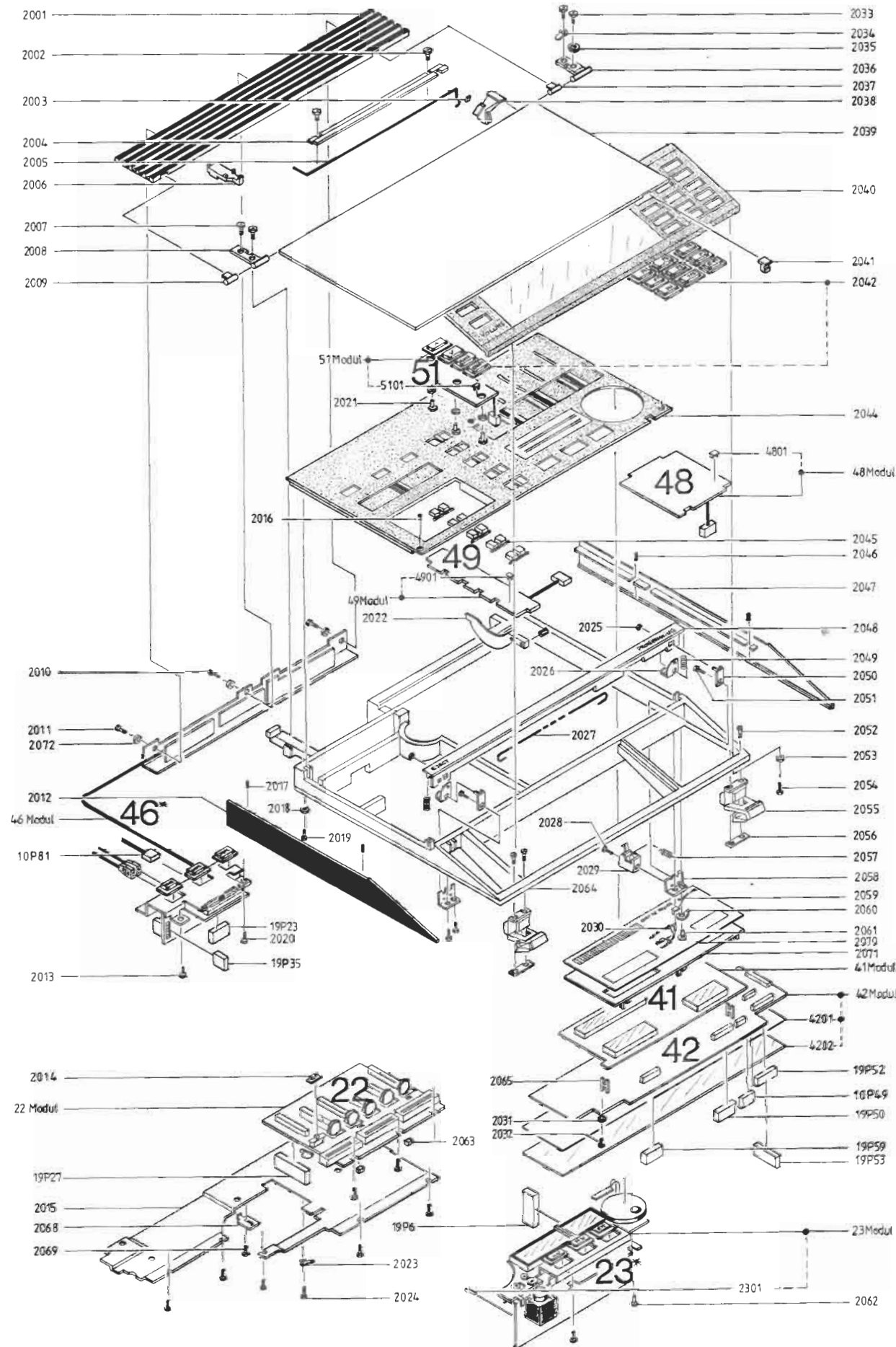

Top Chassis

10P49	6275485	Set of wires P51/49			
19P6	7210373	Socket/housing 12/15 contacts	19P52	7210375	Socket/housing 10/10 contacts
19P23	7210364	Socket/housing 9/9 contacts	19P53	7210365	Socket/housing 10/10 contacts
19P27	7210374	Socket/housing 17/19 contacts	19P39	7210375	Socket/housing 10/10 contacts
19P35	7210376	Socket/housing 3/6 contacts	7500170		Contact pin
19P50	7210377	Socket/housing 13/13 contacts			
2001	2568698	Moulding	2036	3030055	Hinge
2002	2015093	Screw 3.5 x 13 black	2037	3030041	Hinge
2003	3035027	Slider	2038	3011010	Friction plate
2004	3014048	Guide plate	2039	2568752	Lid
2005	2812083	Spring	2040	3168242	Panel
2006	3010015	Stop	2041	2034039	Lock
2007	2015066	Screw M3.5 x 16	2042	2775917	Set of buttons
2008	3030043	Hinge	2044	3168211	Panel
2009	3030041	Hinge	2045	2775815	Set of buttons
2010	2039033	Screw M3 x 6	2046	2070034	Threaded pin M3 x 5
2011	2013215	Screw M2.9 x 16	2047	2568764	Side piece
2012	2568542	Side piece	2048	2568768	Moulding
2013	2015089	Screw 3.5 x 9.5 black	2049	2810097	Spring
2014	2775350	Button	2050	2530389	Bracket
2015	3302301	Screen	2051	2039007	Screw AM3 x 3
2016	3010007	Stop	2052	2013107	Screw M2.9 x 9.5 black
2017	2070034	Threaded pin M3 x 5	2053	2622306	Washer 3.2 black
2018	2622306	Washer 3.2 black	2054	2013067	Screw M2.9 x 13 black
2019	2013089	Screw 2.9 x 7.9	2055	2030054	Hinge
2020	2015089	Screw 3.5 x 9.5 black	2056	2641092	Clamp
2021	2039043	Screw AM3 x 4	2057	2810008	Spring
2022	3011011	Arm	2058	2530356	Bracket
2023	7530090	Contact tag	2059	7500145	Contact piece
2024	2015091	Screw 3.5 x 9.5	2060	7530087	Solder tag
2025	2390001	Locking ring 2.3	2061	2013089	Screw 2.9 x 7.9
2026	2854070	Arm	2062	2015091	Screw 3.5 x 9.5 black
2027	2850095	Connection piece	2063	2576050	Spacer
2028	2039007	Screw AM3 x 3	2064	3114140	Chassis
2029	2530388	Bracket	2065	2930086	Spacer
2030	6250093	Socket with wire	2068	2816199	Spring
2031	2938081	Rubber bushing	2069	2039026	Screw AM3 x 4 black
2032	2015089	Screw 3.5 x 9.5 black	2070	3199062	Film
2033	2015066	Screw M3.5 x 16 black	2071	3131207	Frame
2034	7530087	Solder tag	2072	2625002	Washer 3.2
2035	2622304	Washer			
22Modul	8002531	PC, preset			
23Modul	8002534	PC, AM			
41Modul	8002510	PC, display			
42Modul	8002588	PC, microcomputer	4202	3302364	Screen
4261	3170207	Insulating piece			
46Modul	8002515	PC, speakers switch + socket panel			
48Modul	8002516	PC, primary operation	4801	7500148	Contact spring
49Modul	8002517	PC, secondary operation	4901	7500148	Contact spring
51Modul	8002518	PC, volume control	5101	7500148	Contact spring

Chassis, Record Player

1401	2726142	Turntable	1436	2514028	Hook
1402	2853097	Arm	*1 1437	2815012	Leaf spring
1403	2038948	Screw M3 x 16	1438	2070400	Threaded pin M2 x 3
1405	2034231	Screw AM2 x 4	1439	2722022	Pulley
1406	2046910	Screw	1440	8954870	Pick-up MMC4 (replacement)
1407	2036213	Screw AM2.6 x 8	1441	2732037	Drive belt
1408	2622271	Washer 2.7	1442	3458268	Top plate
1409	2938137	Rubber bushing	1443	2775866	Moulding
1410	2930074	Brass bushing	1444	2991023	Tap
1413	3152272	Holder	1445	2361060	Cylinder pin
1414	2039903	Screw AM3 x 5	1446	3956004	Connection rod
1415	7500145	Contact piece	1447	2361060	Cylinder pin
1417	6030453	Socket with wire	1448	3152333	Holder
1419	3180767	Washer	1449	2039903	Screw AM3 x 5
1420	2042034	Screw AM4 x 10	1450	2810086	Spring
1421	2640031	Clamp	1451	2039903	Screw AM3 x 5
1422	2938129	Bushing	1452	2510067	Wire holder
1423	2514028	Hook	1453	2039903	Screw AM3 x 5
*1 1424	2815012	Leaf spring	1454	3152063	Holder
1425	2640032	Clamp	1455	2622231	Mica sheet
1426	2938100	Bushing	1456	2013201	Screw 2.9 x 6.5
1427	2622228	Washer	1457	2992077	Tap
1428	2072101	Lifting screw	1458	2039903	Screw AM3 x 5
1429	2854076	Lifting arm	1459	2850118	Arm
1430	2622310	Washer	1460	2384010	Nut
1431	2013200	Screw	1461	3152332	Holder
1432	3030054	Hinge	1462	2850109	Arm
1433	2641092	Clamp	1463	3035027	Plastic foot
1434	2810091	Spring	1464	2622264	Cover washer
*2 1435	2815007	Leaf spring			
14M1	8400113	Motor	8275490	Wire bundle with plug for green light	
14P21	7210115	Socket/housing 5 contacts			
14S1	7400251	Switch			
15P17	6270207	Set of wires with socket	15P19	6273948	Set of wires with socket
17Modul	8005084	PC, phono			
18Modul	8005085	PC, operation	1801	7500148	Contact spring
18P20	7210128	Socket/housing 7/6 contacts			
19P18	7210365	Socket/housing 10/10 contacts	19P22	7210368	Socket/housing 2 contacts
				7500114	Contact pin
40Modul	2850002	Pick-up arm	4003	2576114	Adjustment bushing
4001	3342083	Counterweight	4004	2834045	Shaft
4002	2070035	Threaded pin M3 x 6			
55Modul	3164452	Dust cover	5507	2039046	Screw AM3x 12
5501	2070036	Pin M3 x 4	5509	2568673	Moulding
5502	3152329	Holder	5510	2038081	Screw AM3x 8
5503	2622013	Spring washer 3.2	5511	2934097	Bushing
	2624007	Tooth-lock washer 3.2	5512	2361061	Pin
5504	3011015	Friction plate	5514	3152331	Holder
5505	2812092	Spring	5515	2070036	Pin M3 x 4
5506	3011016	Friction plate			
55IL1	8230077	Bulb 12V			

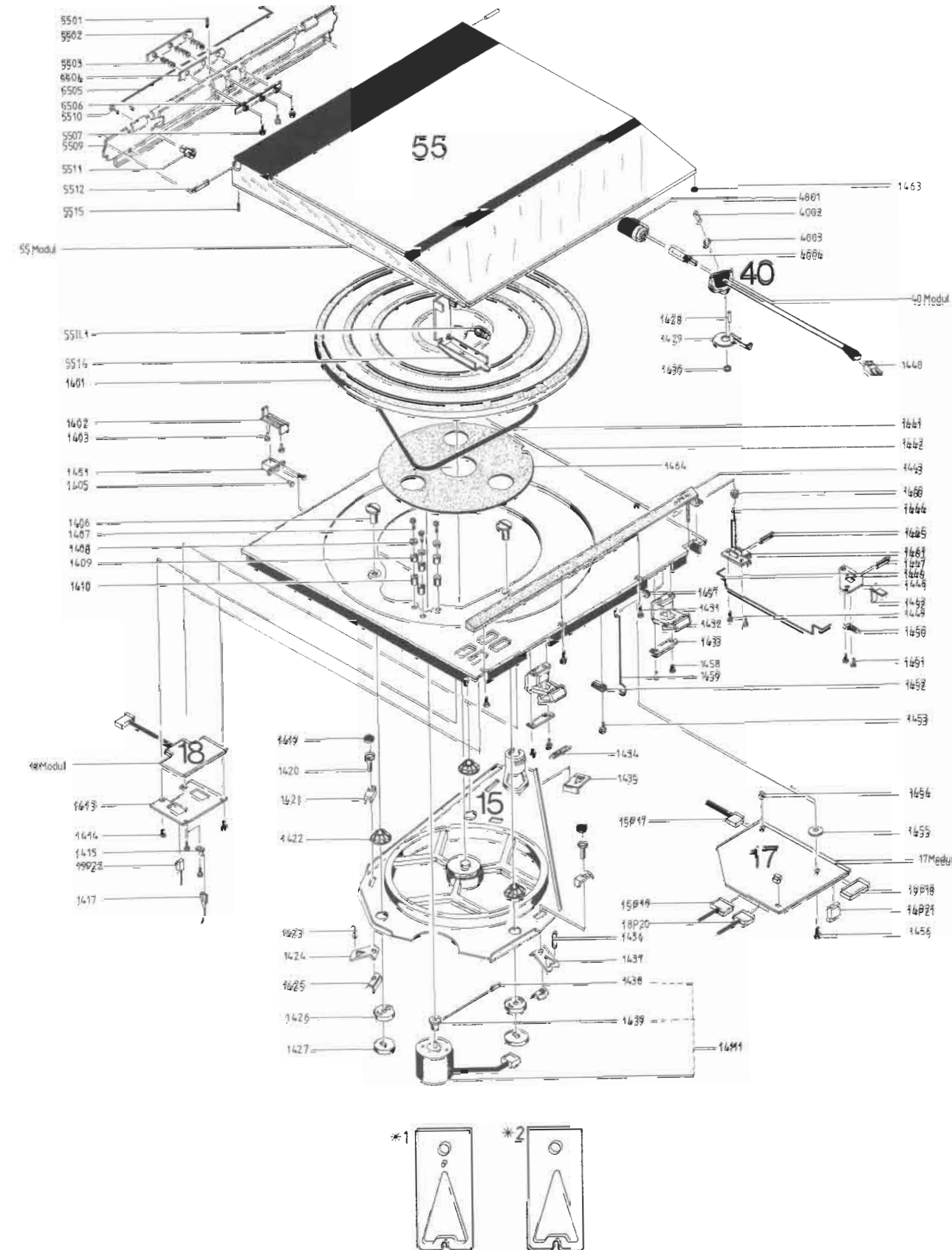

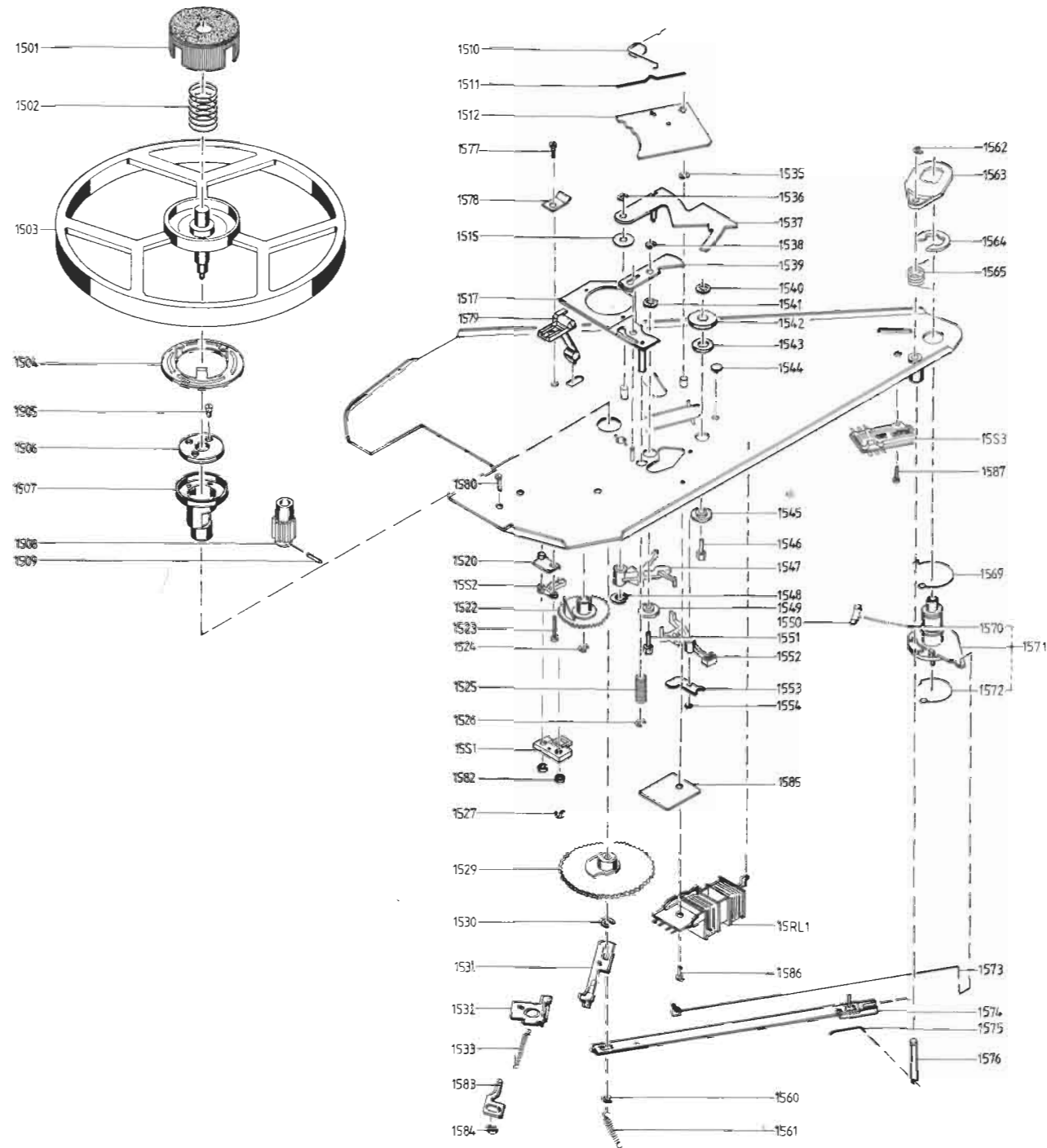

Record Player Deck

1501	3014039	Adaptor	1545	2803005	Washer
1502	2818059	Spring	1546	2992048	Tap
1503	2794075	Flywheel	1547	2853058	Arm
1504	3014040	Adaptor ring	1548	2390084	E-ring 5.5
1505	2038220	Screw AM3 x 12	1549	2803005	Washer
1506	2905075	Bearing ring	1550	2816162	Slider
1507	3150037	Bearing bushing	1551	2992076	Tap
1508	2700024	Gear-wheel	1552	2853059	Arm
1509	2361048	Locking pin	1553	3164387	Cover
1510	2819145	Spring	1554	2380011	Nut M3
1511	2819155	Spring	1560	2390002	E-ring 3.2
1512	3014041	Friction plate	1561	2810082	Spring
1515	2622285	Cover	1562	2390002	E-ring 3.2
1517	3014052	Adaptor plate	1563	2623034	Lifting plate
1520	2576129	Spacer	1564	2938141	Lock
1522	2700026	Gear wheel	1565	2812082	Spring
1523	2038229	Screw M3x18	1567	7459018	Silente contact
1524	2390002	E-ring 3.2	1569	2819106	Spring
1525	2818068	Spring	1570	2810095	Spring
1526	2390002	E-ring 3.2	1571	2938153	Bearing complete
1527	3152118	Lead holder	1572	2819107	Spring
1529	3017014	Camwheel	1573	2850105	Arm
1530	2390002	E-ring 3.2	1574	2850040	Arm
1531	2542511	Bracket	1575	2430326	Arm
1532	2542512	Bracket	1576	2850093	Bar
1533	2818069	Spring	1577	2039908	Screw M3 x 10
1535	2390002	E-ring 3.2	1578	2819160	Spring
1536	2390002	E-ring 3.2	1579	2853091	Arm
1537	3014031	Arm	1580	2039013	Screw M3 x 16
1538	2990001	E-ring 2.3	1582	2380011	Nut M3
1539	3014043	Stop	1583	3031068	Bracket
1540	2995030	Locking disc.	1584	2389061	Adjustment nut
1541	2995030	Locking disc.	1585	3170203	Insulation piece
1542	2938084	Washer	1586	2039908	Screw M3 x 10
1543	2622198	Washer	1587	2039908	Screw M3 x 10
1544	3035020	Plastic foot			

15RL1	8024060	Coil complete
	6273948	Set of wires for 15RL1
	7500135	Contact spring

15S1	3131205	Reed-contact	15S2	7402081	Micro-switch
------	---------	--------------	------	---------	--------------

Tape Deck, Top

12001	2036017	Screw M2.6 x 4	12062	2810104	Spring
12002	7530088	Solder tag	12063	2853062	Sensor
12003	2530382	Bracket	12064	2818062	Spring
12004	2036030	Screw 2.6 x 8	12065	2853061	Sensor
12005	2810110	Spring	12066	2036023	Screw 2.6 x 7
12006	2530377	Bracket	12067	2810113	Spring
12007	2036028	Screw 2.6 x 6	12068	2853068	Arm
12008	2542534	Bracket	12069	2932093	Bushing
12009	2810101	Spring	12070	2036021	Screw M2.6 x 3
12010	2917018	Ball 2.5	12071	2624045	Washer
12011	2917018	Ball 2.5	12072	2542538	Bracket
* 12012	3010017	Stop	12073	2036029	Screw 2.6 x 8
12013	2917018	Ball 2.5	12074	6140766	Mounting plate
12014	2530380	Bracket	12075	3151189	Lamp housing
12015	2036018	Screw M2.6 x 5	12076	2036022	Screw M2.6 x 5
* 12016	3010017	Stop	12077	2036022	Screw M2.6 x 5
12017	2034047	Screw M2 x 4 black	12078	2624045	Washer
12018	3151190	Holder	12079	2932089	Brass bushing
12019	3199058	Light conductor	12080	2036023	Screw M2.6 x 7
12020	3151188	Bracket	12081	2542506	Damping system
12021	3164380	Cover	12082	2036019	Screw M2.6 x 3 black
12022	2932092	Supply reel	12083	2624045	Screw
12023	2390078	E-ring 2.0	12084	2548172	Bracket
12024	2853063	Arm	12085	2810103	Spring
12025	2034048	Screw M2 x 5	12086	2034052	Screw M2 x 2 black
12026	2034049	Screw M2 x 4	12087	2622298	Washer
12027	2034050	Screw M2 x 7	12088	2816178	Leaf spring
12028	2034207	Screw M2 x 5	12089	2034047	Screw M2 x 4 black
12029	2622300	Washer	12091	2530379	Bracket
12030	2036029	Screw 2.6 x 8	12092	2034052	Screw M2 x 2 black
12031	2812087	Spring	12093	2810100	Spring and cord
12032	2622294	Washer	12094	2036017	Screw M2.6 x 4
12033	2812088	Spring	12095	7530088	Solder tag
12034	2036019	Screw M2.6 x 3 black	12096	2542536	Holder
12035	2816175	Leaf spring	12097	2932088	Cord pulley
12036	3151191	Wire holder	12100	2390056	E-ring 1.5
12037	2917018	Ball 2.5	12101	2722027	Fulley
12038	3112244	Chassis	12102	2072008	Threaded pin
12039	2034051	Screw 2 x 8	12103	2036021	Screw M2.6 x 3
12040	2810108	Spring	12104	2542535	Bracket
12041	2804039	Arm	12105	2036021	Screw M2.6 x 3
12042	2036028	Screw 2.6 x 6	12106	2542537	Bracket
12043	3164380	Cover	12107	2932090	Rubber bushing
12044	2932091	Take-up reel	12108	2932089	Brass bushing
12045	2036020	Screw M2.6 x 4	12109	2932090	Rubber bushing
12046	2810109	Spring	12110	2036023	Screw M2.6 x 7
12047	2390078	E-ring 2.0	12111	2036023	Screw M2.6 x 7
12048	2622297	Washer	12112	2530381	Bracket
12049	2804041	Thrust roller	12113	2624013	Washer
12050	2622297	Washer	12114	2039039	Screw M3 x 4
12051	2390078	E-ring 2.0	12115	2039039	Screw M3 x 4
12052	2853067	Arm	12116	2624013	Washer
12053	2622297	Washer	12117	2622245	Plastic washer
12054	7530089	Solder tag	12118	2034207	Screw M2 x 5
12055	2816176	Bracket	12119	2818067	Spring
12056	2036029	Screw 2.6 x 8	12120	2034051	Screw 2 x 8
12057	2816177	Leaf spring	12121	2932095	Bushing
12058	2036029	Screw 2.6 x 8	12122	2810128	Spring
12059	2917018	Ball 2.5	12123	2853090	Arm
12060	2816175	Leaf spring	12124	2013099	Screw 2.9 x 1.5
12061	2917018	Ball 2.5	12125	8004286	Noise filter
<hr/>					
12H1	8600054	Tape head	12H2	8600055	Erase head
<hr/>					
12IL1	8230060	Lamp			
<hr/>					
12M1	8400101	Motor			
<hr/>					
12S1	7410018	Switch	12S4	7410019	Switch
<hr/>					
12TR1	8320429	Transistor			

* Replacing stops 12012/12016 new stops are to be glued with IS 12 (code no. 3980033)

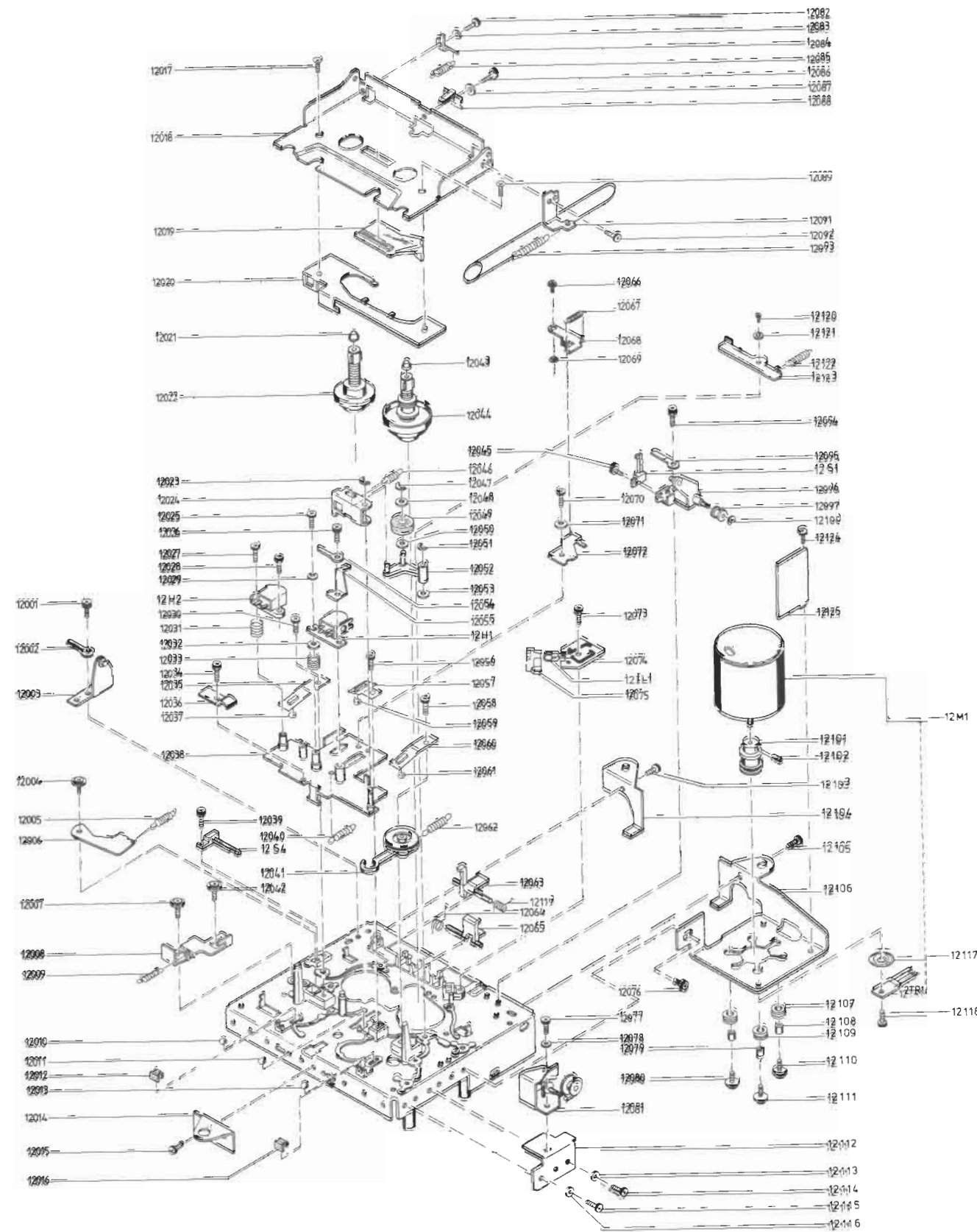

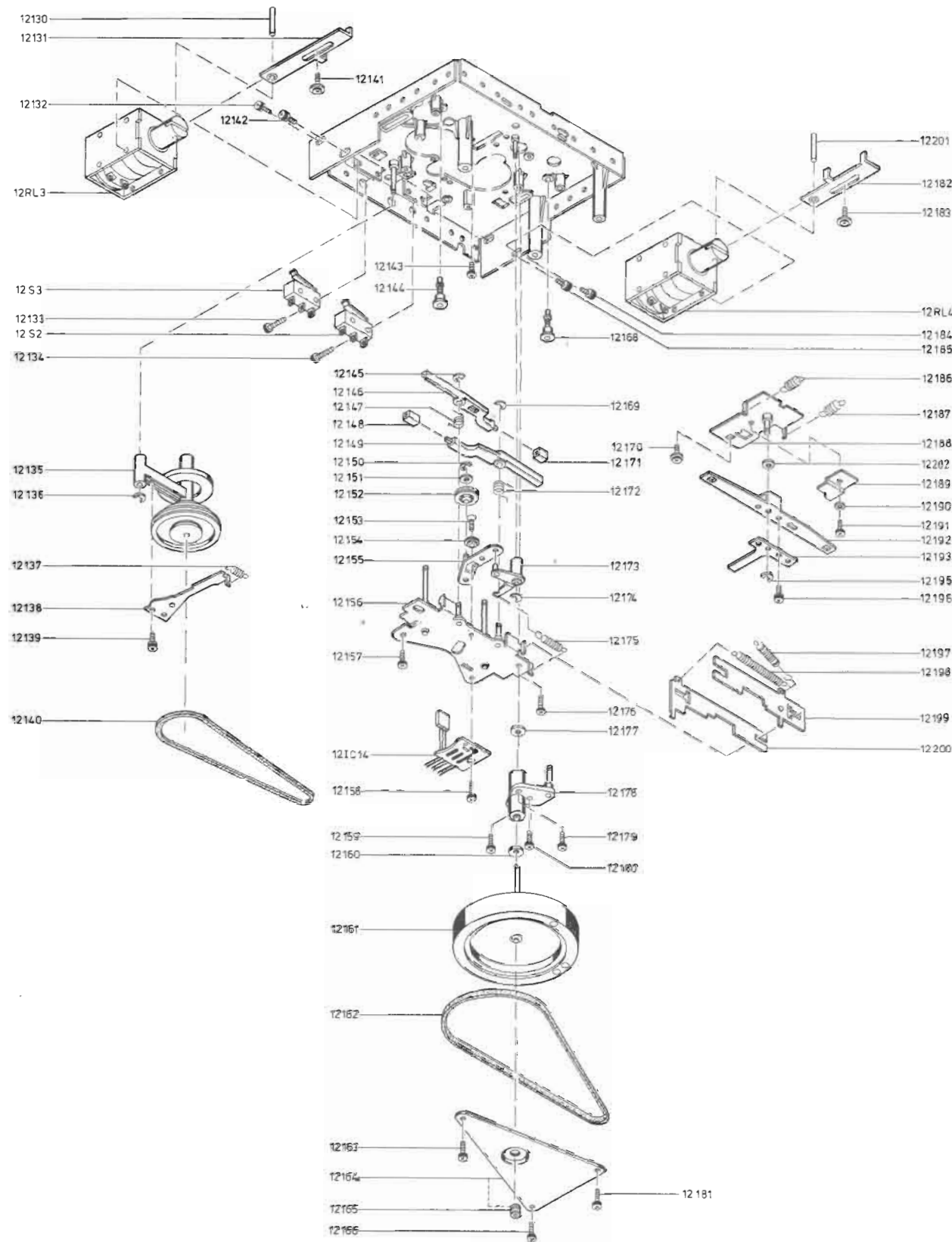

Tape Deck, Bottom

12130	2361055	Pin	12166	2036027	Screw 2.6 x 10
12131	2894046	Arm	12168	2994023	Guide pin
12132	2038063	Screw M3 x 5	12169	2850078	E-ring 2.0
12133	2036026	Screw M2.3 x 10	12170	2036025	Screw M2.6 x 6.5
12134	2036026	Screw M2.3 x 10	12171	2958191	Brake block
12135	2724059	Cluth	12172	2818066	Spring
12136	2390079	E-ring 2.5	12173	2854077	Arm
12137	2810099	Spring	12174	2390078	E-ring 2.0
12138	2530378	Bracket	12175	2810102	Spring
12139	2036010	Screw M2.6 x 8	12176	2036027	Screw 2.6 x 10
12140	2732047	Belt	12177	2622296	Plastic washer
12141	2036030	Screw 2.6 x 8	12178	3114148	Bearing
12142	2038063	Screw M3 x 5	12179	2036024	Screw M2.6 x 6
12143	2034051	Screw 2 x 8	12180	2036024	Screw M2.6 x 6
12144	2994023	Guide pin	12181	2036027	Screw 2.6 x 10
12145	2890078	E-ring 2.0	12182	2894047	Arm
12146	2853065	Arm	12183	2036030	Screw 2.6 x 8
12147	2818065	Spring	12184	2038063	Screw M3 x 5
12148	2938161	Brake block	12185	2038063	Screw M3 x 5
12149	2853064	Arm	12186	2810107	Spring
12150	2390056	E-ring 1.5	12187	2810107	Spring
12151	2622299	Washer	12188	3112248	Bracket
12152	2804040	Wheel	12189	2542539	Bracket
12153	2034053	Screw M2 x 4	12190	2624045	Washer
12154	2932087	Bushing	12191	2036021	Screw M2.6 x 3
12155	2851109	Arm	12192	2853066	Arm
12156	3112246	Chassis	12193	3014049	Arm
12157	2036027	Screw 2.6 x 10	12195	2390073	E-ring 2.5
12158	2036027	Screw 2.6 x 10	12196	2036022	Screw M2.6 x 5
12159	2036024	Screw M2.6 x 6	12197	2810105	Spring
12160	2622295	Plastic washer	12198	2810106	Spring
12161	2794081	Flywheel	12199	3014050	Bracket
12162	2732048	Belt	12200	3014051	Bracket
12163	2036027	Screw 2.6 x 10	12201	2361055	Pin
12164	3112247	Holder	12202	2622322	Washer
12165	2991021	Bearing			

12IC14 8004216 PC complete

12RL3 6840254 Solenoid

12RL4 6840254 Solenoid

12S2 7410020 Switch

12S3 7410020 Switch

AM Module, 8002534

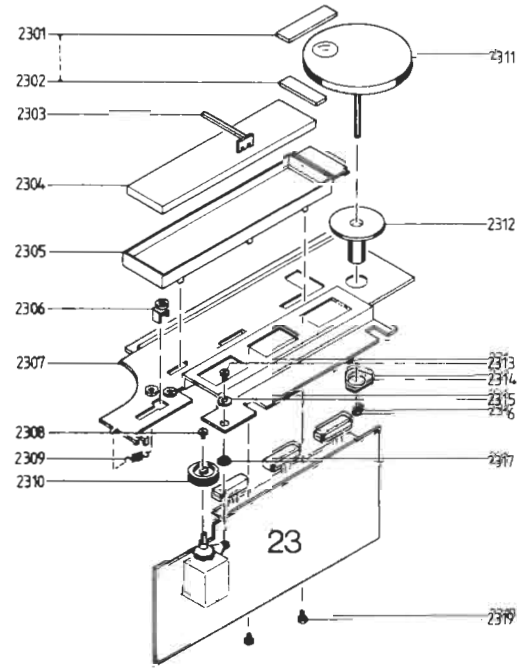

2301	3120253	Mounting plate	2311	2794083	Dial wheel
2302	3120253	Mounting plate	2312	2905066	Bearing
2303	3190078	Pointer	2313	2036016	Screw AM2.6 x 6
2304	3370124	Light conductor	2314	2395035	Screw
2305	3131170	Housing	2315	2622041	Fibre washer 3.2
2306	2542514	Cord pulley	2316	2390004	Cordlip CG3 x 0.6
2307	3124076	Bracket	2317	2938026	Bushing
2308	2036201	Screw AM2.6 x 3	2319	2039007	Screw AM3 x 3
2309	2810086	Spring		3955016	Dial cord
2310	2724056	Cord wheel			

PC, Power Amplifier and Power Supply, 8002532

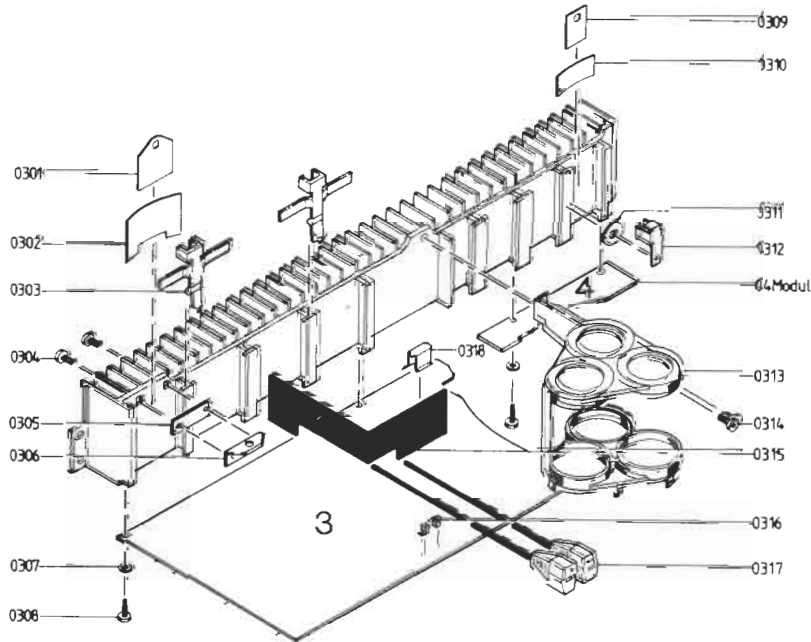

0301	3170169	Mica sheet	0310	2816179	Holder spring
0302	2816120	Holder spring	0311	2622231	Mica sheet
0303	3152257	Holder	0312	3152280	Holder
0304	2039015	Screw M3 x 16	0313	3152262	Holder
0305	3170152	Insulating piece	0314	2039015	Screw M3 x 6
0306	2542508	Bracket	0315	3358146	Heatsink
0307	2622052	Fibre washer 3.2	0316	7500002	Fuse holder
0308	2039028	Screw AM3 x 8 black	0317	6100054	Wire with socket
0309	2622248	Mica sheet	0318	2816169	Holder spring

04Modul 8002413 PC, power supply

Speaker Switch and Socket Panel, 8002515

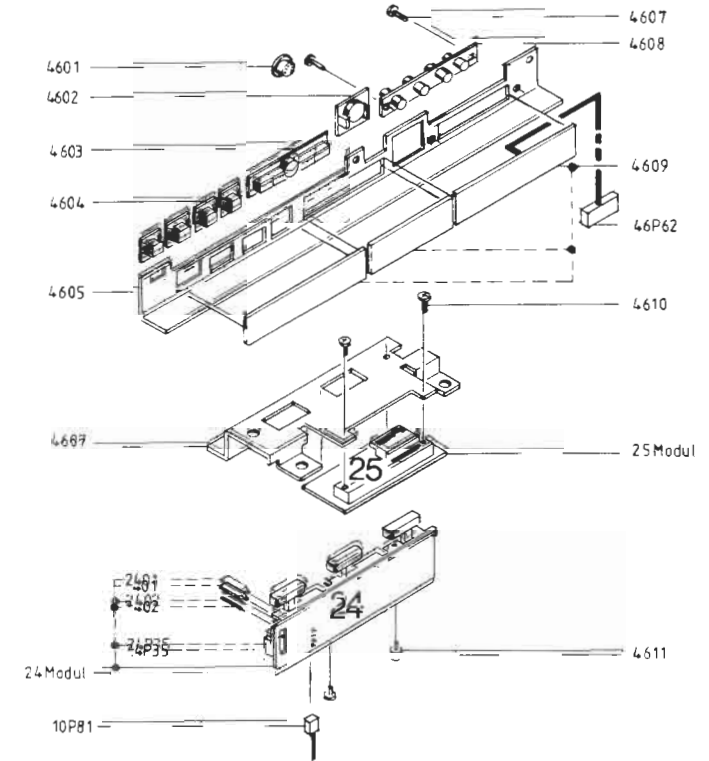

10P81 6274050 Set of wires P80/81

24Modul 8002540 PC, speaker switch
2401 7500101 Pin, flat
2402 7500100 Pin, round
24P35 7220308 Socket

25Modul 8002565 PC, level

4601 7220265 Short circuit socket
4602 7210269 Socket 7 contacts
4603 7210292 Socket panel AM/FM
4604 7210378 Socket 3 contacts
4605 2530423 Bracket
4606 3124075 Bracket
4607 2039026 Screw AM3 x 4
4608 7210399 Socket panel phono
4609 6140884 Mounting plate, Set
4610 2039007 Screw AM3 x 3
4611 2039007 Screw AM3 x 3

46P62 6275086 Wire bundle

Master Control Panel

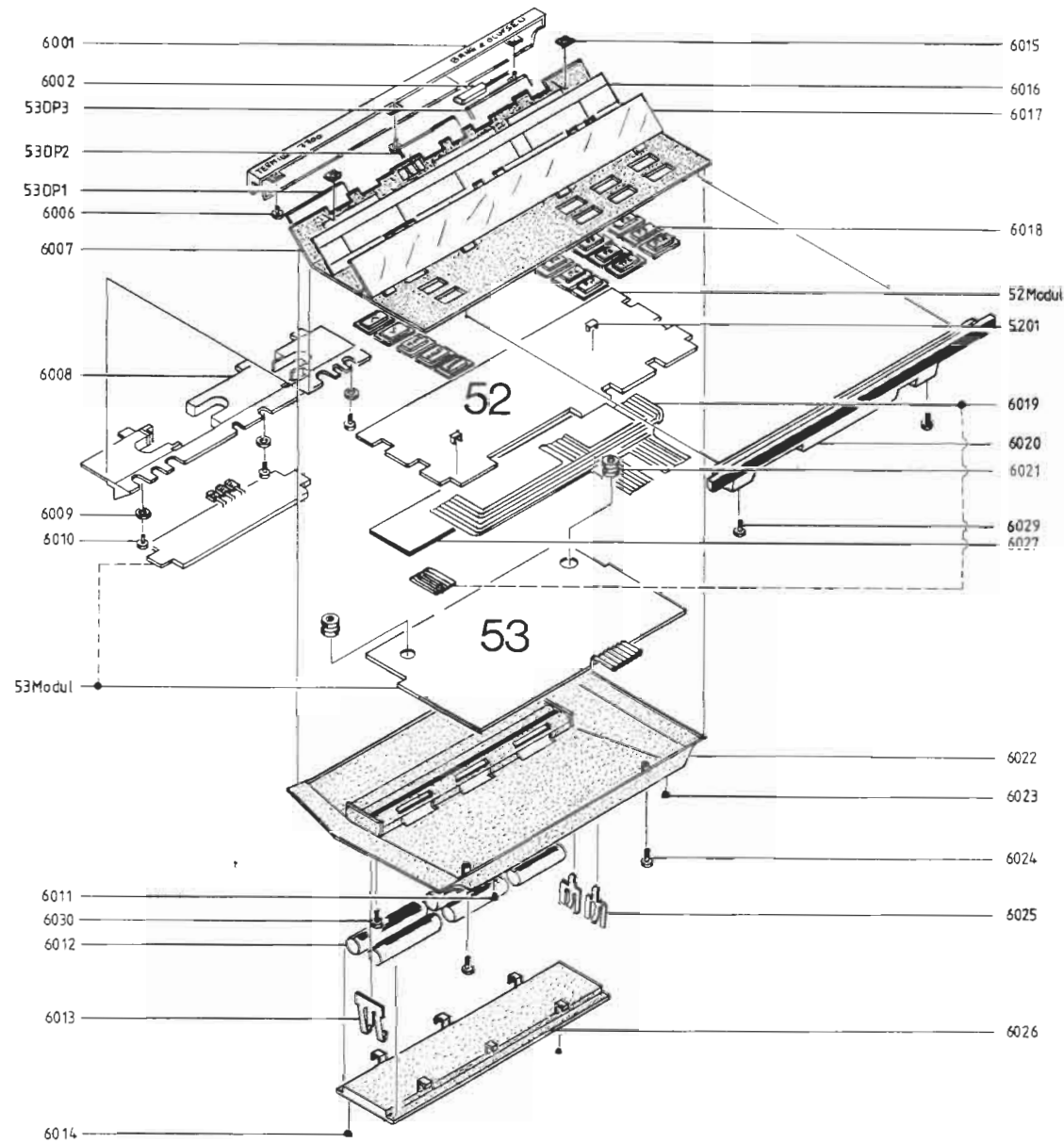

52Modul 8002520 PC, operation 5201 7500149 Connection spring

53Modul 8002521 PC, remote

53DP1	8330061	Display -MUTE-	53DP3	8330060	Display -RECORD-
	3152369	Holder - small		3152369	Holder - small
	3152368	Holder - big		3152368	Holder - big
53DP2	8330062	Display -TP8-		7500166	Contact rubber
	3152369	Holder - small			
	3152368	Holder - big			

6001	3322086	Window	6016	3199061	Film
6002	8330088	Receiver diode	6017	3322093	Window
6006	2039020	Screw AM3 x 5 black	6018	2775931	Set of buttons
6007	3168243	Panel	6019	6140897	PC, flexible
6008	3370140	Light conductor	6020	2563692	Moulding
	3947454	Black tape	6021	2938125	Rubber bushing
6009	2622022	Washer 4.3	6022	3454295	Bottom
6010	2013098	Screw 2.9 x 4.5 black	6023	3010007	Plastic foot
6011	3010007	Stop	6024	2039020	Screw AM3 x 5 black
6012	8700013	Battery	6025	2816189	Spring - connection
6013	2816188	Spring, short circuit	6026	3160027	Lid
6014	3010007	Plastic foot	6027	3170210	Insulating plate
6015	2380132	Square washer M3	6029	2013098	Screw 2.9 x 4.5 black

Parts not shown

3532155 Diagram
 3391647 Outer carton
 3397467 Foam packing, set
 3917040 Foam block for pick-up arm
 3917062 Foam for terminal
 3627006 Cleaning brush for pick-up

3984005 Lubricant Rocol Kilopoise 1016S for lid
 3950007 Plastic moulding for screen mains transformer
 6270097 AM aerial

Modulpacking

Modul no.	Designation		emb. no.
03	Power	8002532	3391577
11*	Tape	8004298	3391576
17	Phono	8005084	3391574
22	Preset FM	8002531	3391574
23	AM	8002534	3391571
24	HT and Dolby switch	8002540	3391575
41	Display	8002510	3391575
42*	µC	8002588	3391575
43	Switch	8002512	3391574
44	Power back-up	8002513	3391574
45*	Remote (center)	8002514	3391574
46	Connection panel (incl. 24-25)	8002515	3391575
47*	FM	8002519	3391575

* = Packed in bag, protecting against static electricity.

ELECTRICAL ADJUSTMENTS
ADJUSTMENTS RADIO
SECTION

The references apply to the RH channel (the references in parentheses apply to the LH channel).

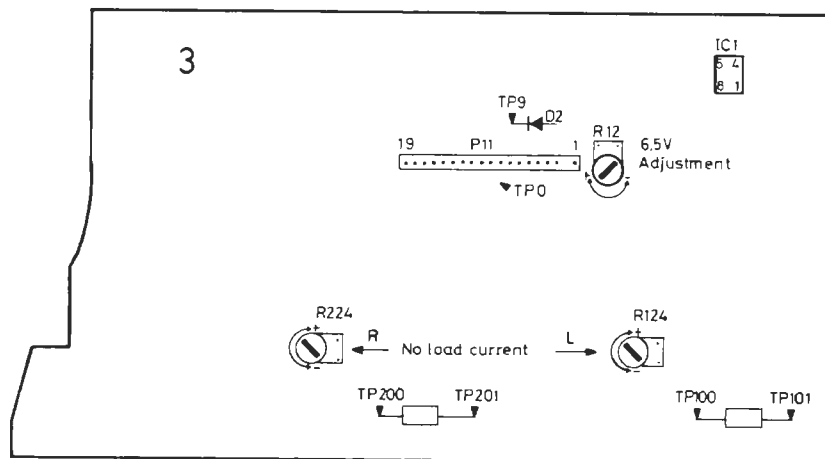

6.5 V Power Supply

Switch to ST-BY. Connect a DC voltmeter between 3TP0 and 3TP9. Adjust with 3R12 the voltage to 6.5 V ± 0.1 V.

No-Load Current

Set the receiver in P1-P5 mode. Adjust the no-load current while the receiver is in a cold state and the volume control is fully turned down. The loudspeakers must not be connected. Connect a DC millivoltmeter between 3TP200 and 3TP201 (3TP100 and 3TP101). Adjust with 3R224 (3R124) to 10 mV. The adjustment can also be made by inserting a milliammeter in series with the collector of 3IC200 (3IC100) and adjust 3R224 (3R124) to 25 mA.

Amplification (AF)

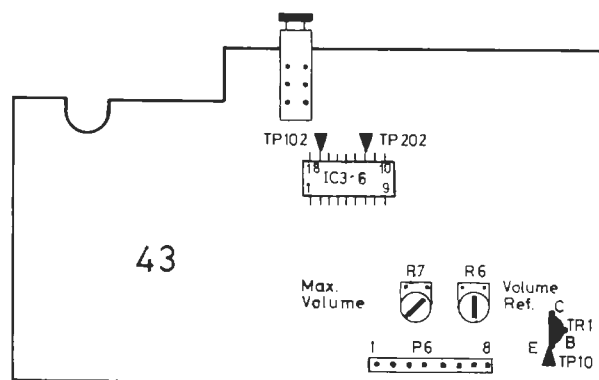

Switch to TP2. Connect a tone generator to Tape 2 and set to 1 kHz 150 mV EMF. Set volume control at max. Set bass, treble and balance control in neutral position. Connect DC voltmeter to 43TP10 (emitter of 43TR1). Adjust 43R6 until a reading of 4 V. Connect an AC voltmeter to TP202 (TP102). Set the balance control at equal voltage in TP200 and TP102. Adjust 43R7 until a reading of 2.85 V AC is obtained in TP202 (TP102).

Tuning Voltage

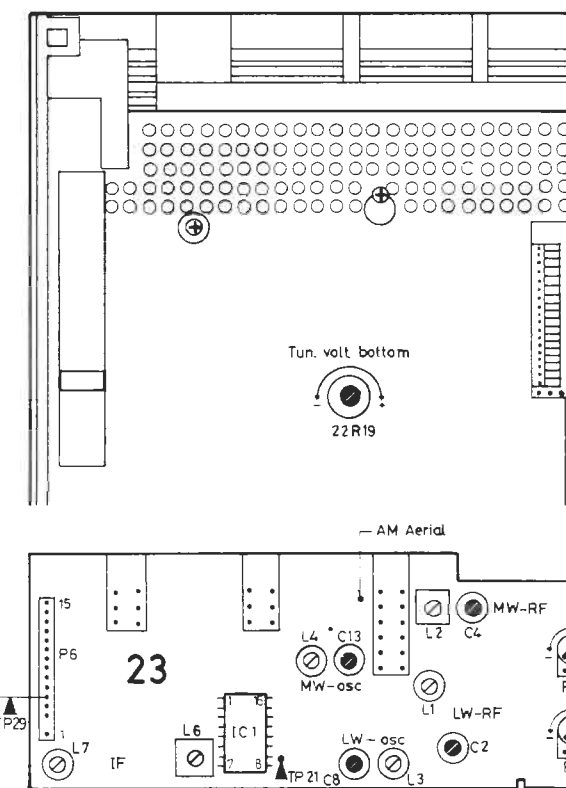

Set switch in MONO (AFC. OFF). Activate P6. Set dial pointer at 10.8 MHz. Connect DC voltmeter to 47TP16 (collector of 47TR2). Adjust 47R36 until a reading of 21.2 V is obtained. Connect DC voltmeter to 47TP24. Adjust 23R8 until a reading of 19.5 V is obtained. Set dial pointer of the first mentioned 8 in 88 MHz. Connect DC voltmeter to 47TP25. Adjust 22R19 until a reading of 3.0 V is obtained. Connect DC voltmeter to 47TP24. Adjust 23R9 until a reading of 3.6 V is obtained. The adjustment procedure is repeated at incorrect dial calibration.

Tuner and MF-section

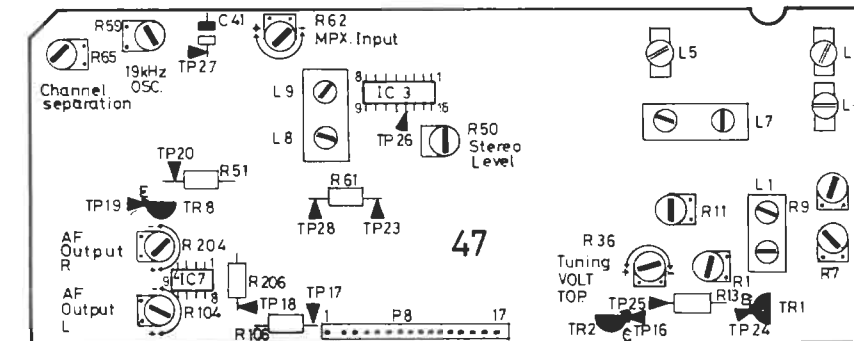

Set P6 at 87.5 MHz. Connect an sweep generator to the aerial input and set it at 87.5 MHz. Connect an oscilloscope to 47TP26 via an RC-probe no. 8802036. Adjust with 47L1, 47L2, 47L3, 47L5 and 47L7 till maximum and symmetrical MF curve. (Repeat the procedure, if necessary). The receiver and the sweep generator are now set at 108 MHz. Adjust with the potentiometers 47R1, 47R7, 47R9 and 47R11 until maximum and symmetrical MF curve.

Tuner/MF

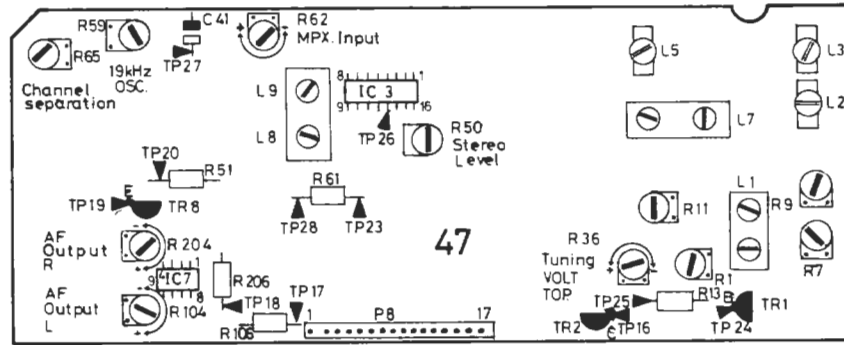

Detector

In order to be able to make a correct adjustment of the detector, such equipment as a distortion meter as described in point 1 must be used. If a distortion meter is not available, an approximated adjustment can be made as described in point 2.

1. Set the receiver at, e.g. 94 MHz.
Connect a combined signal generator/sweep generator to the aerial input and set it to 1 mV EMF, $\Delta \pm 75$ kHz.
Connect an oscilloscope to 47TP26.
Set the signal generator frequency to 94 MHz and to at least 2nd harmonic of the signal (see ill.).

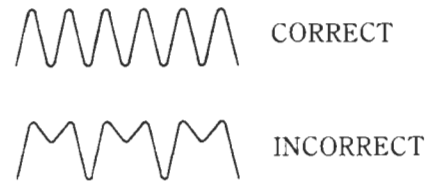

Connect a distortion meter to the loudspeaker output.
Connect a DC voltmeter between 47TP28 and 47TP23.
Adjust with 47L9 until minimum distortion is measured.
Then adjust with 47L8 until a reading of 0 V is obtained.
Repeat both adjustments until they are OK.

2. The adjustment is made by means of the »S-curve« but it will be uncertain whether the receiver complies with its distortion data.

Set the receiver to, e.g. 94 MHz.
Connect a combined signal generator/sweep generator to the aerial input and set it to 1 mV EMF, $\Delta \pm 75$ kHz.
Connect an oscilloscope to 47TP26.
Set the signal generator frequency to 94 MHz and to at least 2nd harmonic of the signal (see ill.).

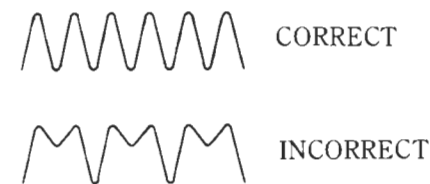

Set the generator at sweep.
Connect an oscilloscope to 47TP27 and a DC voltmeter between 47TP28 and 47TP23.
Adjust with 47L9 and 47L8 to maximum and symmetrical S-curve.
Then adjust with 47L8 until a reading of 0 V is obtained.
Check that a reading of 21.2 V is obtained at 47TP16 (collector of 47TR2).
If not, repeat the procedure dial adjustment.

FM-AF Output

Connect a signal generator to the aerial input and set to e.g. 94 MHz and to 1 mV EMF, $\Delta \pm 75$ kHz.
Set the receiver at the same frequency as signal generator and in MONO mode.
Connect AC voltmeter to 47TP27 and adjust 47R62 until a reading of 0.65 V is obtained.
Take AC voltmeter to 47TP17 (47TP18) and adjust 47R104 (47R204) until a reading 0.9 V is obtained.

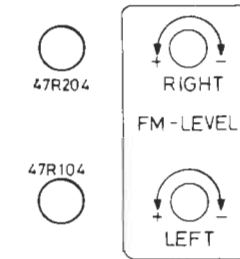

BOTTOM VIEW

* 47R204 (47R104) are adjustable to an output level according to the customer's wishes.

Opening of Stereo Decoder

Connect a signal generator to the aerial input and set it to e.g. 94 MHz and to 25 μ V EMF, $\Delta \pm 75$ kHz.
Set the receiver at the same frequency as the signal generator.
Connect a DC voltmeter to 47TP20.
Adjust with 47R50 until a reading of 0.6 V is obtained.
NOTE: Channel separation will then be 10 dB (± 2 dB).

Stereo Decoder

To be able to make this adjustment correctly a frequency counter or Bang & Olufsen's Voltmeter RV11 and Frequency Probe PF5 as described in point 1, are needed. If such instruments are not available, an approximated adjustment can be made as described in point 2.

1. Solder a 220 kohm resistor from 47TP20 (the base of 47TR8) to +15 V.
Tune the receiver to a mono station. (Switch in pos. FM auto).
Connect a frequency counter (or RV11/PF5) to 47TP19.
Adjust with 47R59 until a reading of 19 kHz ± 50 Hz is obtained.
After the adjustment, remove the soldered-on resistor.
2. Solder a 220 kohms resistor from 47TP20 (the base of 47TP8) to +15 V.
Tune the receiver to a stereo station.
Turn the potentiometer 47R59 anti-clockwise (as seen from the component side) until the stereo effect just ceases. Then turn 47R59 clockwise until the stereo effect just ceases. Now set 47R59 right between the two positions and an approximately correct adjustment has been achieved.
After the adjustment, remove the soldered-on resistor.

Channel Separation

Connect a stereo encoder to the aerial input.
Connect a wattmeter or an AC voltmeter to the loudspeaker output.
Adjust with the potentiometer 47R65 until the maximum signal is obtained in the non-modulated channel.
47L100 (47L200) must not be adjusted.

AM-IF

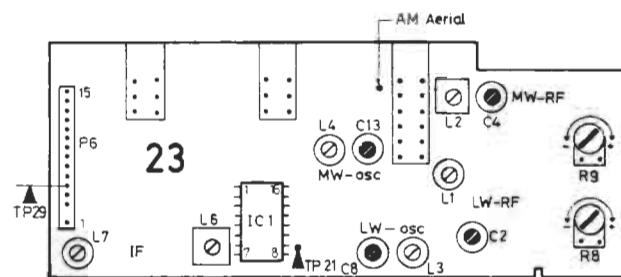

Set the receiver to, e.g. MW 575 kHz. The signal from the sweep generator is applied to 23TP21 through 0.1 μ F, the centre frequency 469.5 kHz Δ 10 kHz (468 kHz resonance will in the coupling used give a centre frequency of 469.5 kHz).

The RF voltage necessary is approx. 10 mV (due to the IF suppression in the IC).

However, it is recommendable to stop the oscillator by connecting the 0.1 μ F capacitor from pin 15 on 23IC1 to chassis, whereby the IF suppression is considerably reduced. The necessary RF level will now be 10-100 μ V.

It is recommendable to use a signal as weak as possible to avoid influence from the AGC.

Connect the oscilloscope to 23TP29 (pin 6 on 23IC1). Adjust 23L6 and 23L7 until maximum and symmetrical IF curves is obtained.

Remove the oscillator stop.

MW Oscillator and Aerial Circuits

Connect a signal generator to the aerial input via a dummy aerial, 575 kHz, modulation 30%-400 Hz or 1 kHz.

Connect a wattmeter or an AC voltmeter to the AF output.

Set the receiver to 575 kHz.

Trim the oscillator with 23L4 until the receiver is spot on the transmitter frequency. (Always use signals as weak as possible during the whole adjustment job, this will result in the most accurate adjustment).

Adjust with 23L2 to max. on the AF output.

Set signal generator and receiver to 1495 kHz.

Adjust the oscillator into position with 23C13.

Adjust the aerial circuit to max. with 23C4.

Repeat the adjustment until the dial setting is correct and the aerial circuit is in max.

Always end with 23C4.

LW Oscillator and Aerial Circuits

Set signal generator and receiver to 155 kHz.

Adjust the oscillator in position with 23L3.

Adjust the aerial circuit to max. with 23L1.

Adjust the signal generator and receiver to 285 kHz.

Adjust the oscillator in position with 23C8.

Adjust the aerial circuit to max. with 23C2.

Repeat the adjustment until the dial setting is correct and the aerial circuit is max.

Always end with 23C2.

Adjustment Remote Control

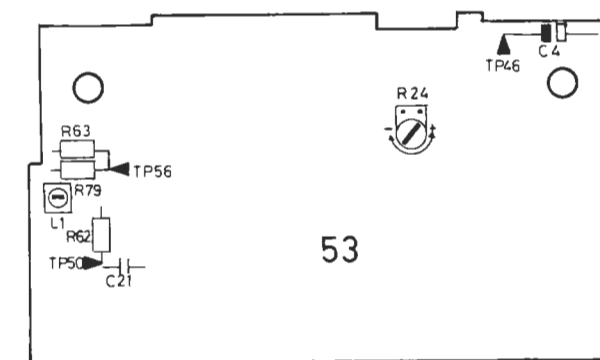

Adjust 53R24 LCD display according to the customer's requirements.

Adjustment of 53L1. Make a jumper from 53TP46 to function between 53R63 and 53R79.

Connect oscilloscope to 53TP50.

Activate »volume down« on the MASTER CONTROL PANEL.

Adjust 53L1 to max.

L.C.D. Night Light Remote Control Receiver in Master Control Panel

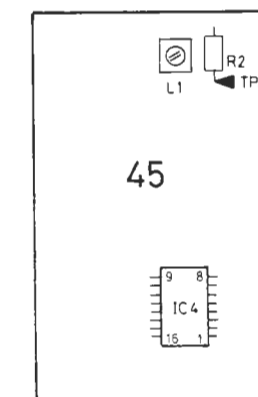

Remote Control Receiver in Beocenter

Adjustment of 45L1.

Connect oscilloscope to 45TP31.

Place the Master Control Panel indirectly against sensor.

Activate »volume down« on Master Control Panel.

Adjust 45L1 to max.

ELECTRICAL ADJUSTMENTS
TAPE RECORDER

Azimuth

References apply to right channel (Bracketed references apply to left channel).
Electrical adjustments to be made without DOLBY NR.

Demagnetise tape head and erase head.
Connect LF voltmeter to 11TP3 (11TP6).
Insert azimuth tape 6780036.

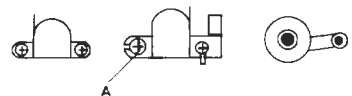

Adjust screw A for max. signal in both channels and for equal output for left and right channels (mean value 11TP3 (11TP6)).

Playback level

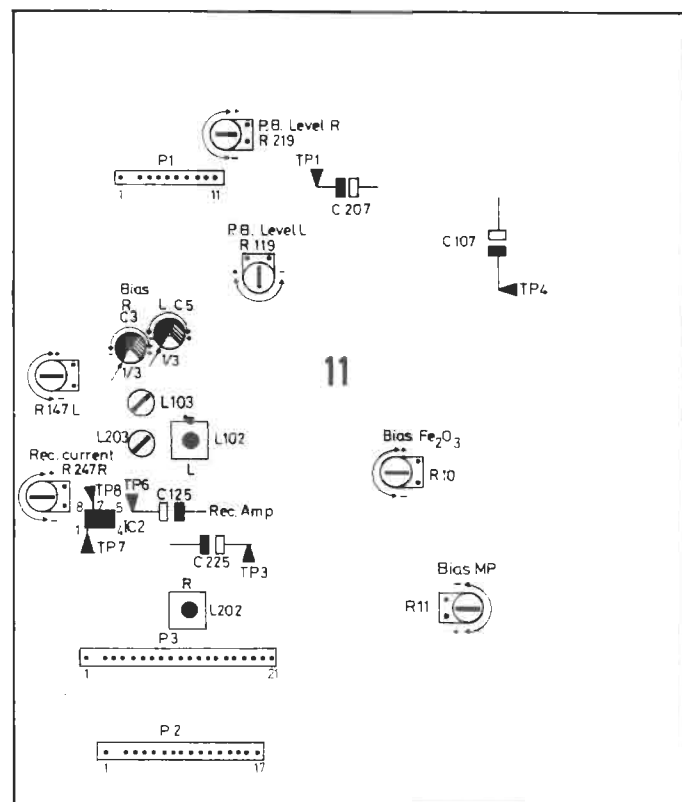

Insert Pegel tape 6780035 in cassette holder.
Connect LF voltmeter to 11TP3 (11TP6).
Adjust 11R219 (11R119) so that 725 millivolts is measured at 11TP3 (11TP6).

Speed

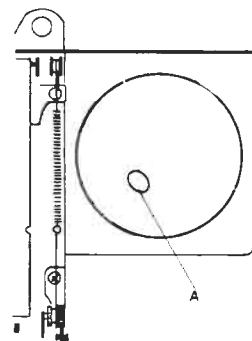

Insert wow tape 6780037 in cassette holder.
Connect wowmeter to 11TP3.
With potentiometer A in motor adjust for correct speed as read on the wowmeter's driftmeter.
Adjustment to be made in the middle of the tape.

Record Boost

Insert a CrO₂ tape.
Connect tone generator to tape input and set to deliver 333 Hz in the 1-Volt range.
Activate record pause.
Adjust record potentiometer so that 316 millivolts is measured at 11TP7 (11TP8).
Set tone generator to 10 kHz.
Adjust 11L202 (11L102) so that 1 volt is measured at 11TP7 (11TP8).

Bias filter

AF voltmeter is connected over tape head.
Activate Pause (without signal).
Adjust 11L203 (11L103) to maximum voltage, measured across the tapehead.

Bias and Record Current CrO₂

Insert CrO₂ tape 6780066.
Set 11R247 (11R147) to midscale and 11C3 (11C5) to one-third of full scale.

Record Current

Connect tone generator to tape input and set to deliver 333 Hz in the 1-volt range.
Activate record pause.
Adjust record potentiometer so that 200 millivolts is measured with AF voltmeter at 11TP3 (11TP6).
While recording and playing back, respectively, adjust 11R247 (11R147) so that 200 millivolts is measured at 11TP3 (11TP6) during both record and playback.

Bias

Set tone generator to deliver 333 Hz in 100-millivolt range.
Adjust record potentiometer so that approx. 25 millivolts is measured with AF voltmeter at 11TP3 (11TP6).
While recording and playing back 333 Hz and 15 kHz, respectively, adjust 11C3 (11C5) so that the level at 15 kHz is 1 dB higher than the level at 333 Hz (less bias gives treble boost; more bias gives treble cut).
Check record current.

Fe₂O₃ Bias

CrO₂ must be adjusted, and tone generator and potentiometer settings must be the same as for CrO₂ bias.
Insert Fe₂O₃ standard tape 6780067.
While recording and playing back 333 Hz and 15 kHz, respectively, adjust 11R10 for identical levels at 15 kHz as well as 333 Hz as measured with AF voltmeter in 11TP3.

MP Bias

CrO₂ bias must be adjusted, and tone generator and record potentiometer settings must be the same as for CrO₂ bias.
Insert MP test tape 6780059.
Activate METAL TP.
While recording and playing back 333 Hz and 15 kHz, respectively, adjust 11R11 for identical levels at 15 kHz as well as 333 Hz, measured with AF voltmeter in 11TP3.

Check of Bias

The bias adjustment can be checked by measuring the 3rd harmonic distortion of 333 Hz (K₃ distortion).
The measuring can be performed with distortion meter DM1 (Bang & Olufsen).
The K₃ measurement is to be made with DM1 connected to the tape input.
Record pause is activated.
The Record potentiometer is adjusted till 725 mV is measured in 11TP3 (11TP6).
The measurements are to be performed with the standard tape mentioned in the bias adjustments.
The K₃ must lie below:

CrO ₂	3%
------------------	----

MECHANICAL ADJUSTMENTS

Erase Head Height

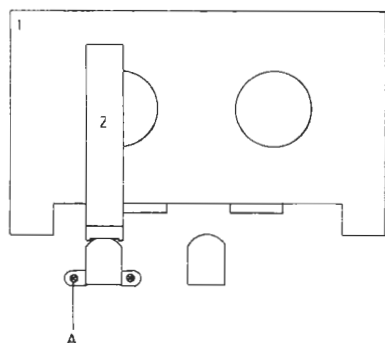

Erase head height is adjusted with adjustment tools 1 and 2 from adjustment tool kit 3624020.

Place adjustment tools in cassette holder as shown in sketch.

Carefully press tape head bridge in against tool 2.

With screw A adjust until tape guide goes in above tool 2.

Rewind

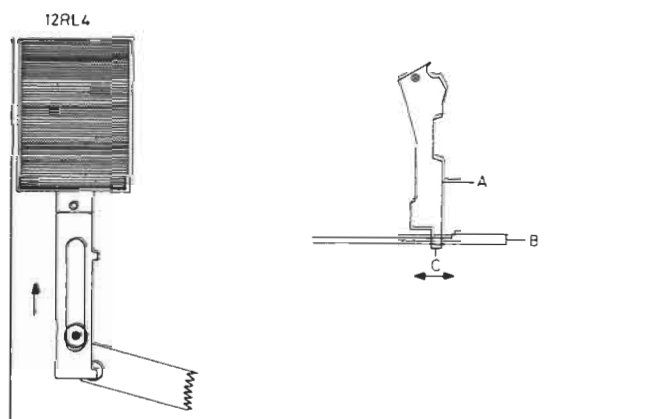

Press armature in magnet coil 12RL4 in as far as it will go. Clearance between arm A and arm B should then be 0.5 - 1 mm. Adjustment is performed by bending the arm A so that tag C moves in one of the directions of the arrow.

Thrust Roller Free Travel

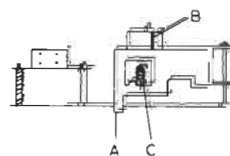

Press tape head bridge as far as it will go. Clearance between pin A on thrust roller arm and tape head bridge should then be approx. 0.5 mm. Adjustment is performed by bending pin A.

Thrust Roller Thrust

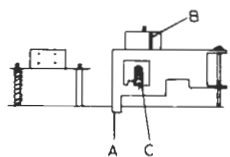

Activate play. With spring balance at point B pull thrust roller back. Carefully release thrust roller until it just touches the capstan shaft. Shift spring C to one of the two notches where the spring balance reading is closest to 300 p. Example: Spring in right-hand notch gives 280 p and spring in left-hand notch gives 330 p. Since ideal force is 300 p right-hand notch is correct adjustment.

Eject Switch

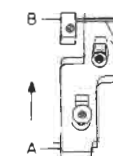

Carefully push arm A in direction of arrow. Eject switch B should then open from travel of from 0.5 mm to 2 mm and before the cassette drawer releases mechanically.

Cassette Detector Record Lock

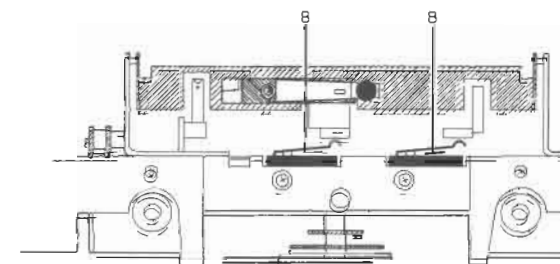

The two switches for cassette detector and record locking are bent back at the points »B« so that the switches change-over reliably when a cassette is inserted, and will change back again when the cassette is removed.

Assembler Moment

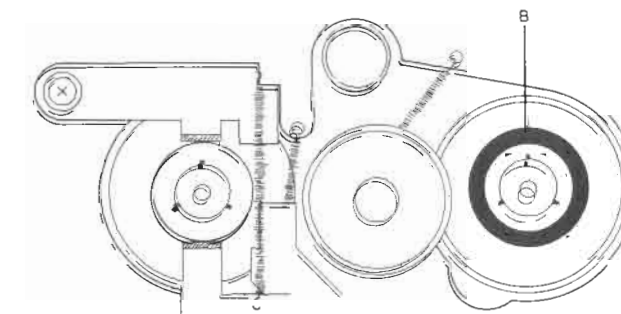

The assembler moment should be within 35/60 p/cm. Adjustment is made by pressing the ring »B« of the assembler coil all the way down and turn it.

Coil Moment

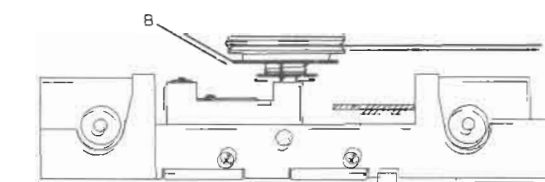

The coil moment is measured by winding forward until just before the auto stop is activated. The moment should be more than 1.00 p/cm. Wind forward until end stop. Brake to stop the motor pulley with a finger, activate forward winding, release the motor pulley slowly thus allowing the motor to start-up slowly. When the motor runs freely, read off moment. Adjustments are made by turning the disc »13«.

Lubrication

The need for lubrication is negligible, but the directions given below should be followed during overhauls and when replacing major mechanical components.

Bracket 12084: Against spring 12085. Arm 12024: Surfaces of contact against arm 12052. Balls 12037, 12059, 12061: Face slidings against leaf springs 12035, 12057, 12060, and chassis 12038. Shaft on holder 12096: Surface of contact against pulley 12097. Switch 12S4: Surface of contact against bracket 12008. Bracket 12008: Face sliding against screws 12007, 12042, and chassis 12038. Balls 12010, 12011, 12013: Face slidings against chassis 12038, and top chassis. Chassis 12038: Surface of contact against top chassis. Sensor 12065: Shaft both sides. Arms 12131, 12182: Face slidings against taps in top chassis. Pins 12130, 12201: Face slidings against top chassis. Arm 12173: Surface of contact against tap in top chassis. Bracket 12188: Face slidings against top chassis chassis 12038, against arms 12192, 12193. Arm 12192: Surfaces of contact against arms 12131, 12182. Arm 12193: Surfaces of contact against arm 12155, and angles 12199, 12200 Arm 12155: Surface of contact against arm 12173, and shaft for idler wheel 12152. Chassis 12156: Shafts for turntables 12022, 12044. Bracket 12199, 12200: All surfaces of contact.	3984022 Floil GB-TS-1
Bracket 12008: Face sliding at screw 12042. Arm 12155: Surface of contact at bushing 12154. Arm 12052: Surface of contact against chassis 12038.	3984216 Molykote (pasta G)
Bracket 12072: Surface of contact against arm 12041. Damping system 12081: All gear-wheels. Bearing 12165: Against flywheel 12161.	3984021 Eprohon Grease

ADJUSTMENTS
RECORD PLAYER
Speed

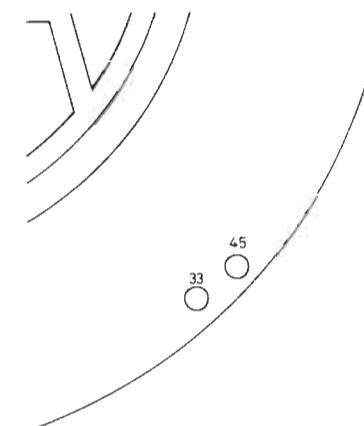

Remove the turntable so that the adjustment holes are accessible. 33 r.p.m./min. should be adjusted first. Adjust with 17R22. 45 r.p.m./min. is adjusted with 17R20.

Speed may be checked in two ways:

1. Stroboscope disc and lamp connected to the mains. This check gives an accuracy of approx. 2% because the 50 Hz mains frequency deviates approx. ± 1 Hz.
2. Stroboscope disc and stroboscope lamp's tolerance which normally is superior to that of the mains frequency.

Turntable height

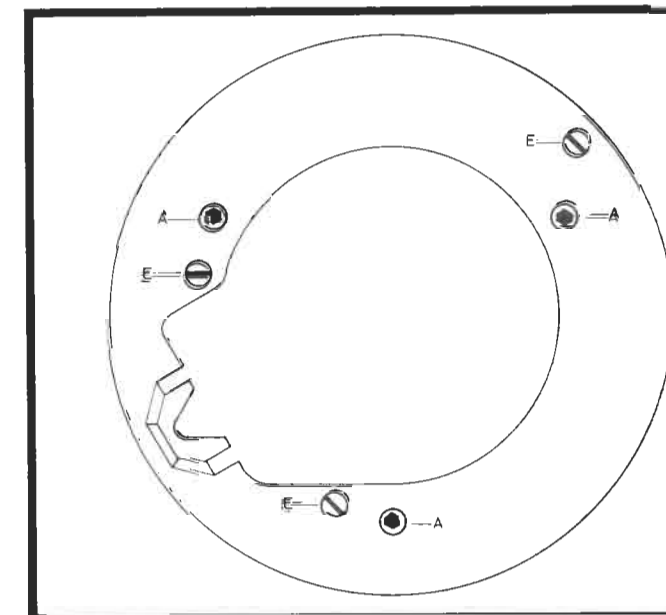

Place turntable and two LP records of normal weight on the chassis. The chassis should then clear all three transit bushings E (see points B). The turntable should likewise be parallel with the chassis deck, and when the two LP records are removed from the turntable, distances C and D should be approximately identical.

Adjustments are made with screws A.

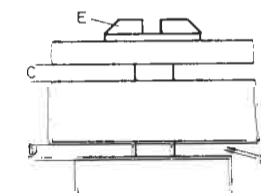

Pick-up height

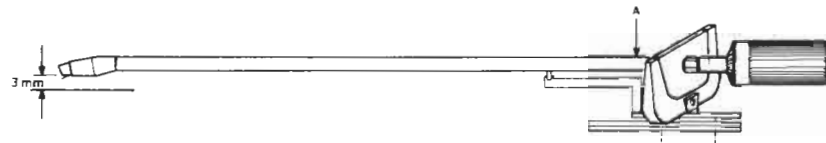

Put a record on the turntable.
Position the pick-up arm above a run-off groove.
Adjust screw A until the distance from the stylus to the record is 3 mm.
This adjustment must be made with a counterbalance weight mounted.

Pick-up arm balance

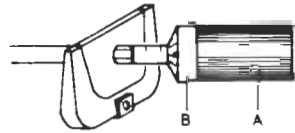

Turn the counter-balance weight until pick-up arm is in balance.
Hold the counter-balance weight in this position and zero the dial B.
The counter-balance weight A is turned clockwise until the dial B shows the stylus pressure required (for MMC 4 - 1.2 g).

Pick-up arm parallelism

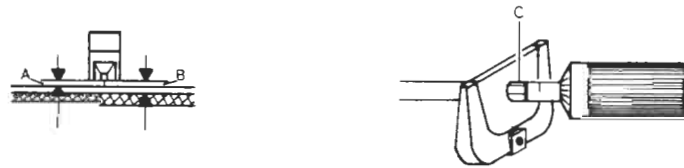

Loosen the screw C and turn the pick-up arm until the A and B clearances are equal and the straight section of the pick-up is parallel to the top side of the record.

Pick-up arm lowering

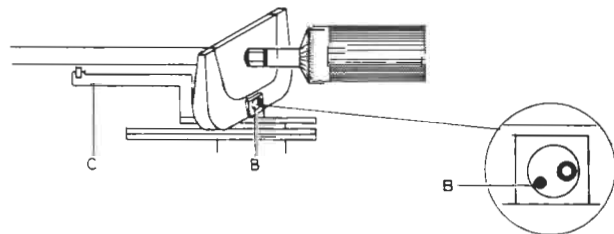

When playing a record the tap B is adjusted so that the pick-up arm positively clears the holder C.

Antiskating

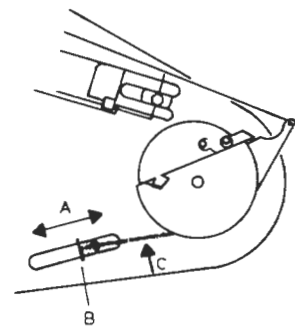

Put the test record 3621045 on the turntable.
Set stylus pressure to 1.2 grams with MMC 4.
Play cut 1.
Connect an oscilloscope to the RH and LH channels.
Push stud B in either direction of the arrow A until there is an equal distortion in both channels (for LH channel distortion, slacken spring C, tighten for RH channel distortion).

Automatic record-size mechanism

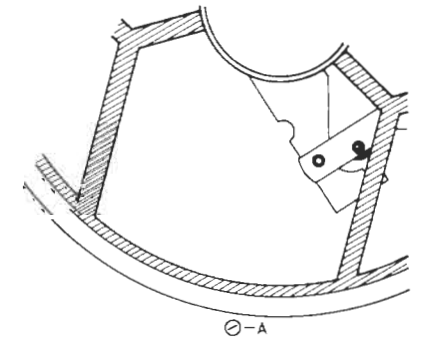

Take off turntable.
Place 60-gram weight on centre adaptor (60-gram and 20-gram weight kit 3624024).
Start turntable.
The centre adaptor should then be capable of lifting the weight, and the pick-up arm should travel in to 17-cm lowering.
Adjustment can be made with screw A. Turn screw A anticlockwise for greater lifting power and clockwise for less lifting power.
Place weights of 60 and 20 grams on the center adaptor.
Start turntable.
The centre adaptor should then be incapable of lifting the weights, and the pick up arm should travel in to 30-cm lowering.
Adjustment should likewise be made with screw A.

Pick-up arm lowering

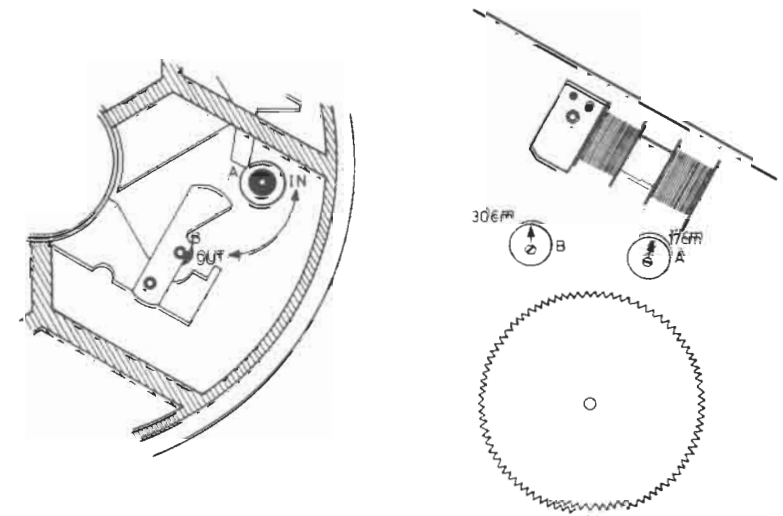

Pick-up arm lowering can be adjusted both from above and from below.
The adjustment described here is made from above.
Take 60-gram weight on centre adaptor.
Start turntable.
With eccentric A adjust until pick-up arm lowers inside the field marked 17 cm in the accompanying drawing.
Place 60- and 20-gram weights on the centre adaptor.
Start turntable.
With eccentric B adjust until the pick-up arm lowers inside the field marked 30 cm in the accompanying drawing.
When making the adjustment from below, a single record (17 cm) and an LP record (30 cm) may be used instead of weights.

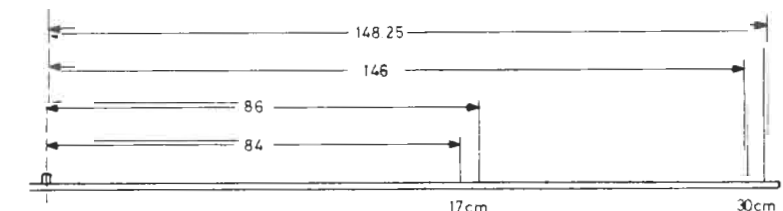

Motor switch (15RL1)

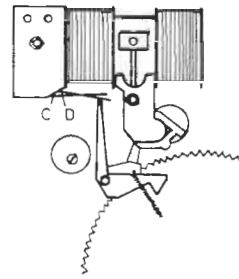

When the Motor switch is open (the armature of the mechanical relay in its mid-position) the clearance between the C and D sections of the switch should be approx. 1 mm. This is adjusted by bending the D-section of the switch.

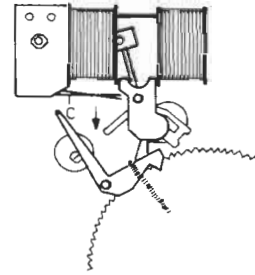

When the Motor switch is closed, the C-section of the switch should press at approx. 15 p in the direction of the arrow. This is adjusted by bending the C-section of the switch.

TECHNICAL SPECIFICATIONS

Amplifier

BEOCENTER 7700	
Type no.	1811
Power output RMS DIN	2 x 40 watts/4 ohms 2 x 30 watts/8 ohms
Power output 20-20,000 Hz	2 x 30 watts/4 ohms 2 x 25 watts/8 ohms
Harmonic distortion -20 dB	≤0.1%
Harmonic distortion	≤0.1%
Intermodulation	≤0.3%
Frequency range ±1.5 dB	20-30,000 Hz
Power bandwidth	10-50,000 Hz
Damping factor	≥25
TAPE 2 input	150 mV/470 kohms
Microphone input	0.1 mV/470 ohms
Signal-to-noise ratio phono	≥82 dB
Signal-to-noise ratio tape	≥82 dB
Channel separation 1000 Hz	≥50 dB
250-10,000 Hz	≥35 dB
Headphones output	Max. 20 V/200 ohms
TAPE 2 output (FM ±40 kHz)	500 mV/1 kohms
Bass control at 40 Hz	±11 dB
Treble control at 12,500 Hz	±11 dB
FM range	87.5 - 108 MHz
FM aerial impedance	75/240 ohms
FM sensitivity stereo 46 dB	≤25 μV/75 ohms
Frequency range ±1.5 dB	20-15,000 Hz
Harmonic distortion	≤0.4%
Stereo channel separation	≥35 dB
LW range	147-320 kHz
MW range	520-1610 kHz
Sensitivity LW 20 dB	≤100 μV
Sensitivity MW 20 dB	≤80 μV
Pickup	MMS 4
Stylus	Elliptical diamond
Radius of curvature	6 x 17 μm
Frequency range	20-20,000 Hz ±2.5 dB
Channel separation 1000 Hz	≥22 dB
50-15,000 Hz	≥17 dB
Channel difference	≤2 dB
Recommended stylus pressure	12 mN/1.2 gram
Compliance	25 μm/mN
Effective tip mass	0.4 mg
Sensitivity mV/cm/sec.	≥0.6 mV/47 kohms
Output 5 cm lateral	≥2.12 mV/47 kohms
Tonearm	Radial
Antiskating	Integrated
Stylus pressure range	0-2 gram
Speeds	33-45 rpm
Wow and flutter, DIN	≤±0.09%
Wow and flutter, WRMS	≤±0.045%
Rumble weighted	≥65 dB
Rumble unweighted	≥45 dB
Speed deviation	≤0.5%
Motor	Servo controlled DC
Compact cassette	C60-C90
Tapehead	Sendust
Noise reduction	Dolby B
Tape switch	Aut. ferro/chrome, manual metal

FM

AM

Record player

Tape recorder

Other data

Wow and flutter	<±0.15%
Speed deviation	<±1.5%
Fast forward and rewind C60	70 sec.
Frequency range chrom-metal	30-16,000 Hz ±2.5 dB
Signal-to-noise ratio	
Metal Dolby NR	>66 dB
Chrom Dolby NR	>64 dB
Ferro Dolby NR	>62 dB
Metal	>59 dB
Chrom	>57 dB
Erasure	>70 dB
Power supply	110-130-220-240 volts
Frequency	50-60 Hz
Power consumption	20-250 watts
Dimensions W x H x D	72 x 9.5 x 38 cm
Weight	16.5 kg
Subject to change without notice	

DISMANTLING
Operation section

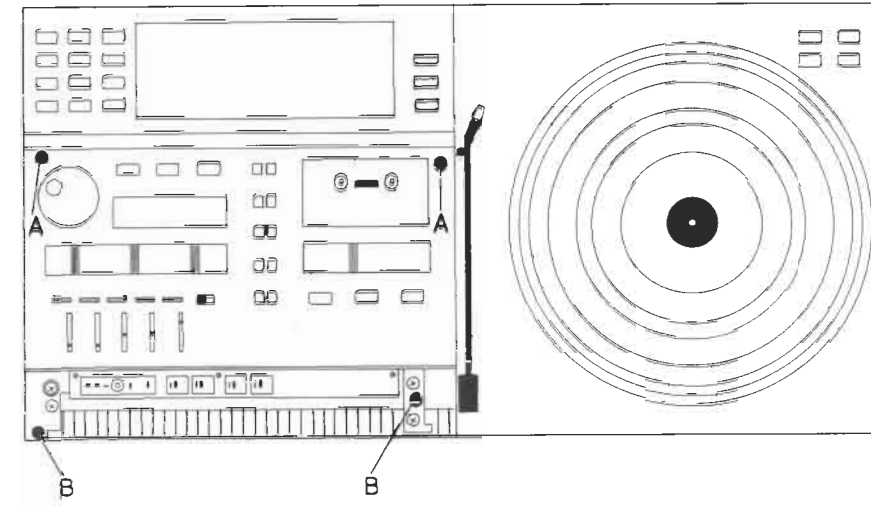

Remove screws A and B. Lift the back edge of the unit approx. 10 cms (4") and disconnect the internal connections for loudspeakers and aerial.

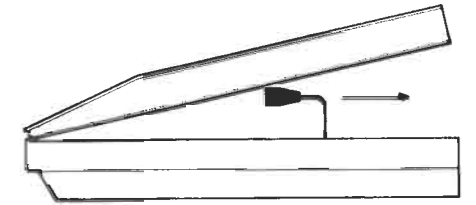

The operation chassis can now be lifted into servicing position on the support mounted on the inside of the cabinet.

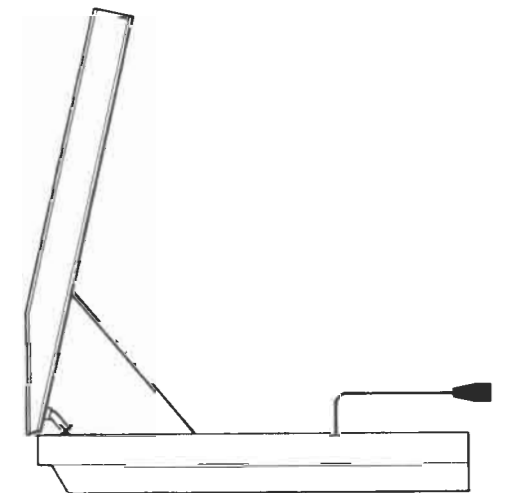

The loudspeakers can be connected direct to the wires from the output amplifier.

Record player section

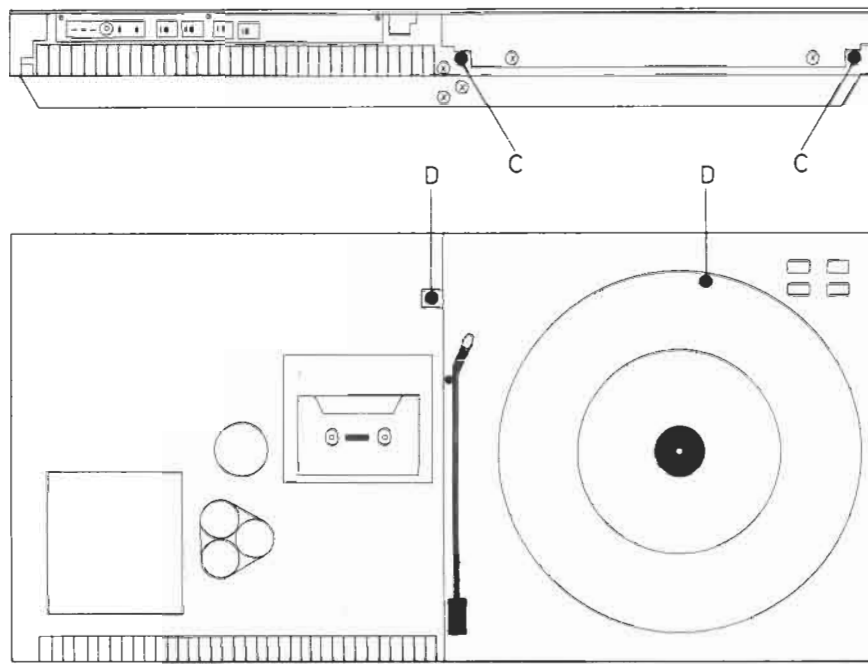

Remove screws C and D when the operating section has been lifted into servicing position. Now lift the back of the record player into servicing position just like the control section.

Removal of the front rail

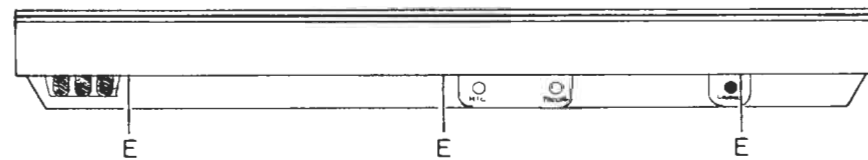

Remove the 3 screws E (2.5 mm Allen-type), and the rail can be lifted off.

Master Control Panel

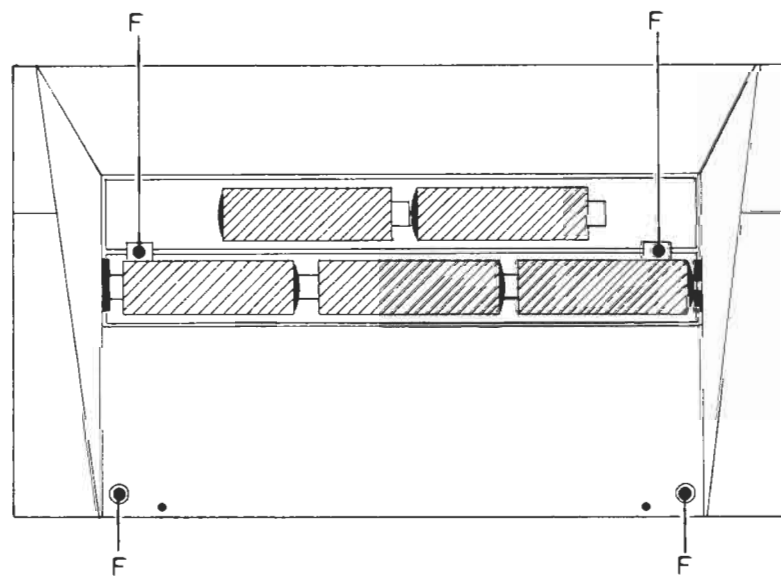

Remove the battery cover and take out one battery from the top row. Remove the 4 screws F, and the panel bottom can be removed.

SERVICE TIPS AND MODIFICATIONS

Measurement of defective output amplifier

Should a fault arise in an output amplifier resulting in DC on the loudspeaker output, the fault switch circuit will put the set in STAND-BY. The connected loudspeakers must then be disconnected and the set can now be turned on and measurements be made unless there is a direct short-circuit in the output transistors.

Replacing dial lamp

The AM module is removed. The dial housing is pushed in the direction of the arrow (A). The cover (B) can now be opened and the lamp replaced.

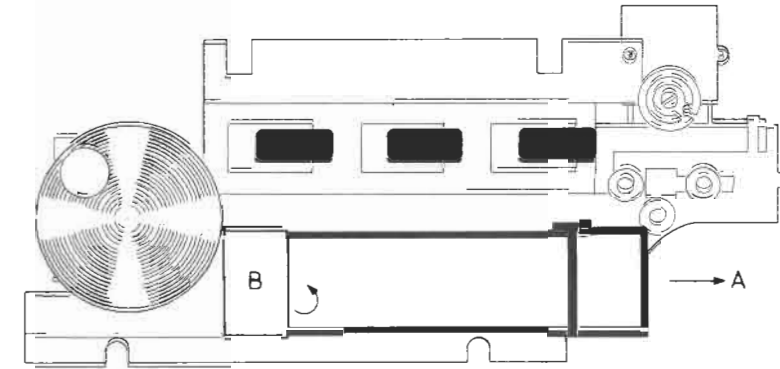

After replacement the dial housing is pushed back into its original position.

Removal of servicing hinges

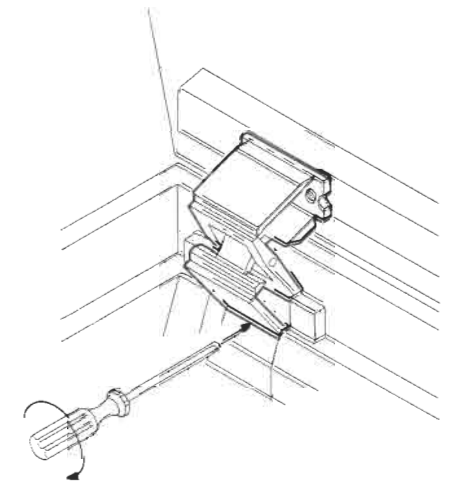

If removal of the operation chassis and the record player chassis is required, the hinges can be removed by twisting with a broad and strong screwdriver under the hinge.

Dial drive

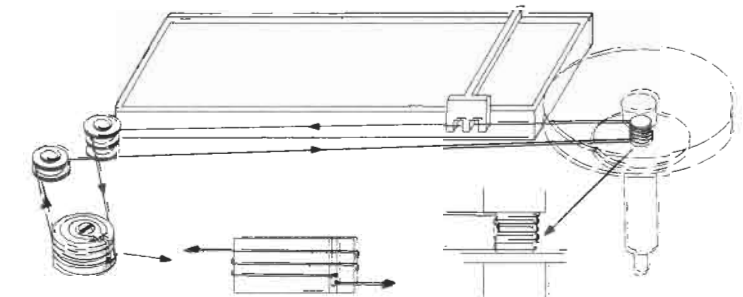

Dial cord (index no. 3955016) is cut off at a length of approx. 60 cms (23 1/2") and knotted at both ends with 55 cm (21 3/4") between the knots. The tuning capacitor is turned counter clockwise and the cord is fitted as shown in the drawing.

Cabinet repairs and panel replacement

The cabinet kit consists of a set of veneer panels with a back coat of self-adhesive tape and protective paper.

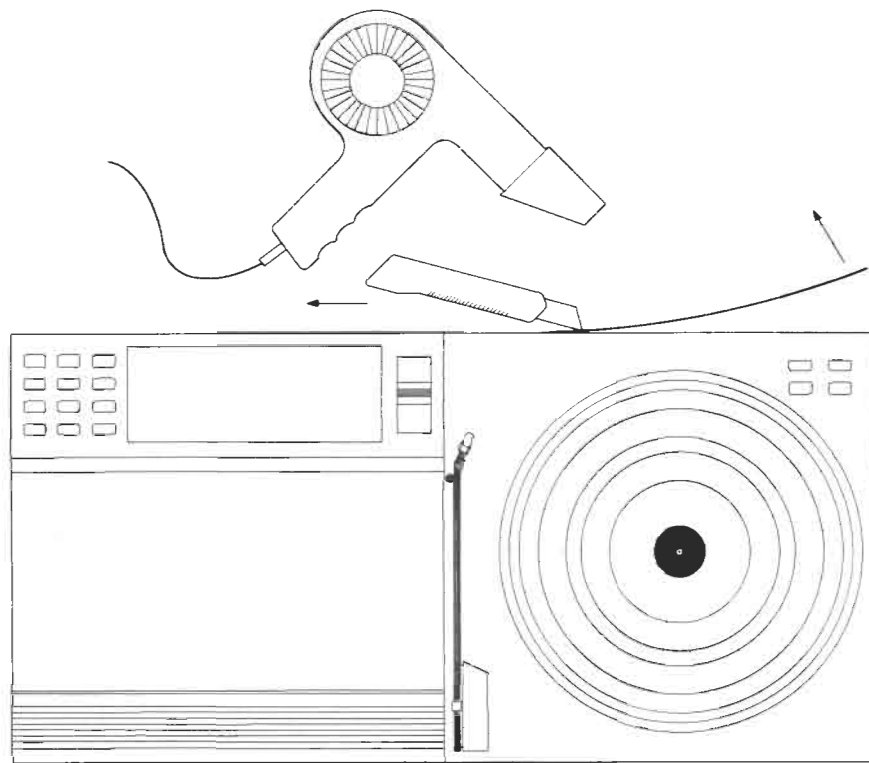

The easiest way to remove the old panels is to heat them with a hot air blower (hair drier) and slowly to peel the old veneer panels off. It is advisable to follow with a Stanley-type knife along the edge of the foam chassis while peeling the veneer off.

If the adhesive coat is intact after panel removal the new panels may be fitted direct on top of the old coat of adhesive. If, however, the old coat is rough it must be removed with benzine prior to the fitting of the new panels.

The side panels must be stuck on first and in such a way that they flush with the front edge. The front panel must be stuck on so that one corner fits the side panel after the mounting, the second corner must be cut flush by using a sharp Stanley-type knife or a mortise chisel.

Wow frequencies

Frequency	Source of failure	Pos. no.
1,1 Hz	Thrust roller	12049
1,3 Hz	Take-up reel	12044
4,3 Hz	Drive belt	12162
4,5 Hz	Take up belt	12140
5,2 Hz	Idler wheel	12041
6,0 Hz	Flywheel	12161
11,8 Hz	Cluth	12135
36,5 Hz	Pulley	12101

TEST ROUTINE FOR MICROCOMPUTER

The microcomputer has a built-in programme for auto testing. The programme is being activated by activation of the ST. BY button on the set, and will keep ST. BY activated while the RECORD button is being activated. If the Microcomputer is OK, the second digit of the digital display will read 0, and the program display will read P. If, however, there is a fault situation, the display will be displaying a number or symbol together with a P (see below table).

- 0P = Microcomputer OK
- 1P = RAM defective
- 2P = ROM defective
- 3P = Pins 3-4-5-6* LOW
- 4P = Pins 3-4-5-6 HIGH, pin 37 LOW
- 5P = Pins 24-25-34-36 LOW
- 6P = Pins 35-36 HIGH
- 7P = Pins 37 HIGH, pin 14 LOW
- 8P = Pins 8-9-10-11-12-14-15 HIGH
- 9P = Pins 26-27-28 LOW
- cP = Pins 26-27-28 HIGH
- tP = Pins 34 HIGH
- LOW = Short circuit to chassis in the Microcomputer or in the connected components (interface) on one of the pins mentioned
- HIGH = Short circuit to +5 V in the gate circuit of the Microcomputer or in the connected components (interface) on one of the pins mentioned.

*) If a fault situation is present on this pin, the P in the display will disappear.

Cancellation of fault indication on the display

After approx. 20 sec. the display will automatically cease to display. It can be turned off before the 20 sec. have elapsed by activation of one of the buttons in the centre vertical row on the primary keyboard.

FAULT-FINDING IN THE MASTER CONTROL PANEL

Due to the short transmission times it may be difficult to make measuring of the Master Control Panel. The following service hints are offered:

1. Measuring in the control circuit and the IR-transmitter: Keep volume-down constantly pressed.
2. Measuring on the IR-receiver: Short circuit pin 13 on 53IC4 to chassis and lift 53R44. Keep volume-down constantly pressed.
3. When checking the signal (40 Hz) from the LCD-drive 53IC2 to the LCD-display, the backplane (pins 23-24 on 53IC2) must always be used as reference.

Replacement of Display in Master Control Panel

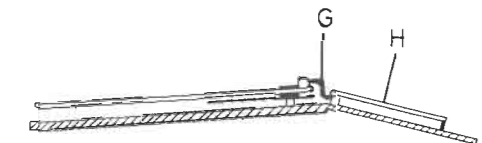

When the bottom has been removed, then remove the flex PC (G) and the plug on the main PC (PC53), and lift up the main PC (it is held by rubber bushings only). Remove the cardboard liner and the 3 screws holding the light conductor H can now be removed. After removal of the light conductor there is free access to all LCD displays. Always keep the contact surfaces between LCD display, contact rubber and flex PC clean and free of dust and grease. Clean the contact surfaces with isopropyl alcohol.

Changed Attachment of PC Board with Transmission Diodes and Display Light in Master Control Panel

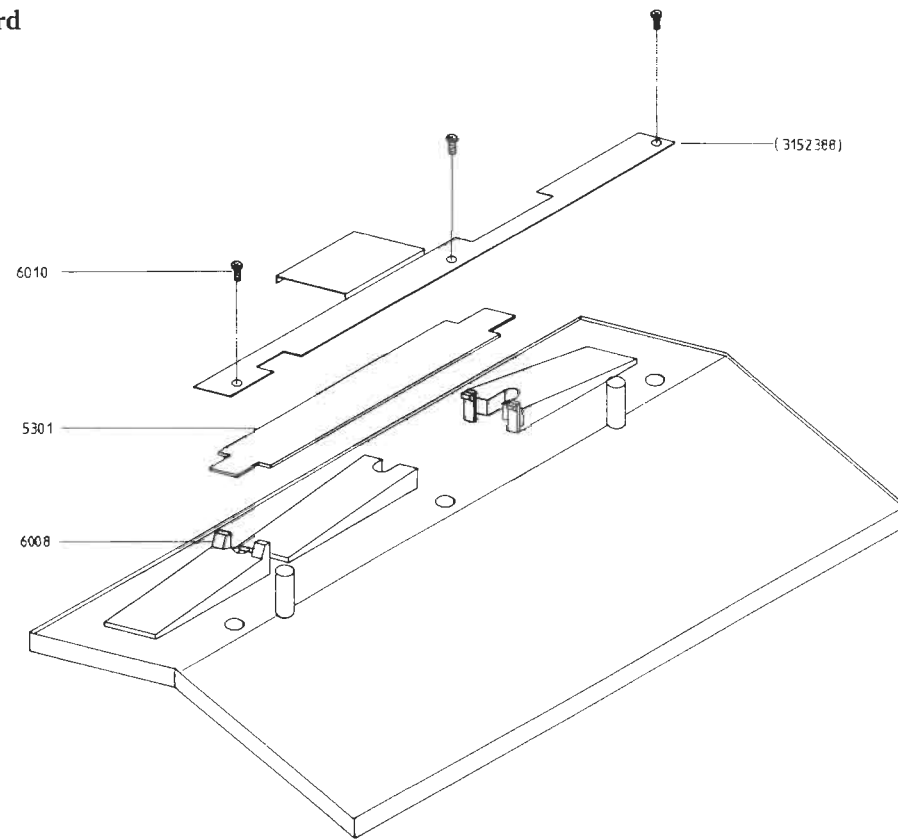

The attachment of the PC board with transmission diodes and display light (pos. 5301) has been changed shortly after productionstart.

The PC board (pos. 5301) was at productionstart fastened by plastic clips on the light emitter (pos. 6008). The attachment has been changed so that the PC board is attached by a bracket (index no. 3152388) which is fastened with the three screws pos. 6010.

The three washers pos. 6009 are omitted at the same time.

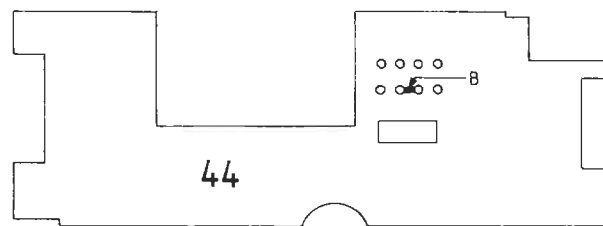

In the sets first produced approx. 1000 units, the left and right channels are placed together in the circuit board at the female jack-socket. When using the mono microphone this may result in a short circuit of the signal to chassis in the microphone's jack-plug. In order to avoid this the circuit board is disconnected in point B. Furthermore the problem can be solved by mounting a stereo jack-plug on the microphone.

The pulley of 14M1 is glued from the factory. If the glued pulley gets loose it is not necessary to replace the motor. A pulley with threaded hole and threaded pin are available for fastening of the pulley.

- Pulley 2722026
- Threaded pin 2070400

Mic. Amplifier

14M1

INSULATION TEST

Insulation test for Beocenter 7700

Each set **must** be insulation tested after dismantling. The test is to be performed when the set has been re-assembled and is ready for delivery to the customer.

Make the insulation test as follows:
Short-circuit the two plug pins of the mains plug and connect one of the terminals of the insulation tester. Connect the other terminal of the insulation tester to the chassis pin of one of headphone sockets.

N.B.!
To avoid ruining the set, it is essential that both insulator test terminals are in really good mechanical contact.

Now turn slowly the voltage control of the insulation tester until a voltage of 1.5 – 2 kV is obtained. Hold it there for 1 second, then turn slowly the voltage down again.

At no point during the testing procedure any flash-over are permissible.

FINAL TESTING

By following the below instructions all equipment functions are tested. The sequence in below table **must** be adhered to.

Pre-setting:
 Activate FM-button
 RECORD LEVEL 4-5

OPERATION	FEEDBACK		
	DISPLAY	INDICATORS	MECHANICAL REACTION
PUSHBUTTON operation			
Connect to mains	: (ST. BY COLON)		
Set clock => 1 => OK	00:00 00:01 => : (digits flashing)		
COUNTER/ COUNTER/ => CLOCK CLOCK	00:01 => :		
STORE VOLUME	After 1 sec. 2:00 . After 3 sec. :		
DISPLAY VOLUME	Immediately 2:00 , after 2 sec. :		
(Insert prerecorded tape Record inhibited). COUNTER ADDRESS => 4 times 8	000 TP1 => 8888 TP1		
RECORD OPEN	2 times 0000 then 8888 TP1		
^ => RESET => v	30...32 => 28 => 26...24		
MUTE		MUTE	
ST.BY	:		
P1 till P6	Time from connection e.g. 00:02 P1...P6	At P6 frequency scale lights	
METAL TAPE		METAL TAPE	

(Insert tape for recording) RECORD OPEN => RECORD	Time from connection P6 0000 P6	RECORD OPEN => READY FOR RECORDING. PPM scale lights, deflection on PPM	
RECORD => STOP	Tape counter => 0000 for approx. 4 sec., then tape counter	RECORDING => READY FOR RECORDING	> => > for approx. 4 sec. then STOP
TP2 => TP1	Tape counter TP2 => TP1	READY FOR RECORDING => RECORD OPEN	Stop => >
<< => RETURN	Tape counter => 0000 then tape counter	RECORD OPEN	<< => runs to point for activating TP1 then >
>> till tape run-out => COUNTER RESET	Tape counter => 0000	RECORD OPEN	>> stops at tape run-out
(Place a 17 cm record on turntable) PH	Time from connection PH		Turntable rotates, PU-arm goes to 17 cm set-down and lowers, speed 45 r.p.m.
33 => 45 => STOP => TURN			33 r.p.m. => 45 r.p.m. => stop, PU-arm returns to stop position => turntable rotates, PU-arm in stop position
TIMER 1	00:00 (the two first digits are flashing)		
TIMER 2 => 1	00:00 => 00:01 (the two rear digits are flashing)		
OK	00:00	PROGRAMMED	

Connect:

Aerial
 4 x loudspeaker
 Headphone
 Other tape deck to TAPE 2

Make: Listening test on all programmes as well as dial calibrations.

Record/replay listening test on tape deck with and without Dolby NR.

Listening test on gramophone.

Test balance (channel identification), bass, treble, loudspeaker switches, FM AUTO-MONO, LOUDNESS and dust cover light.

Test microphone connection.

MASTER CONTROL PANEL (MCP)

Activate MCP functions one by one at a distance of approx. 1 m from the Beocenter 7700.

MCP display will indicate chosen function for approx. 6 sec. after activating the function if Beocenter 7700 accepts function. If function is not accepted, the MCP display will indicate function for approx. 1 sec., and then the actual function for approx. 4 sec. If the MCP does not receive reply from the Beocenter the display will shortly indicate the chosen function followed by **NO TRANSMISSION** for approx. 6 sec.

The display indicates same symbols as buttons, however with the following exceptions:

BUTTON	DISPLAY
ST. BY	□
STOP	<< >>
RETURN	<<
RESET	◇
STATUS	The actual function

NB! INT. REMOTE ON/OFF button must be set in same position as at delivery of the set from the customer.