

Using Two-Point Modulation To Reduce Synthesizer Problems When Designing DC-Coupled GMSK Modulators

Ron Hunter and Fred Kostedt

*MX-COM, Inc.
4800 Bethania Station Road
Winston-Salem, NC 27105
336-744-5050
rhunter@mxcom.com
fkostedt@mxcom.com*

Abstract

Data communications systems that employ modulation techniques requiring good low-frequency response place unique demands on PLL-based frequency synthesizers that are commonly employed for frequency generation and stability. For example, GMSK and four-level FSK modulation schemes require modulation response extending to DC, an attribute that is not easily accommodated by many modulators.

This paper discusses the problems encountered when designing GMSK modulators with respect to the characteristics of PLL frequency synthesizers, and illustrates how two-point modulation can be used to solve them.

Introduction

The PLL frequency synthesizer presents a unique problem when designing an effective GMSK modulator. Data patterns consisting of long strings of ones or zeros have a spectral response that extends to DC. Most frequency synthesizers do not respond to this low-frequency signal because of their inherent high-pass filter characteristic when modulated at the VCO. The two-point modulation technique circumvents this problem by splitting the Gaussian filter signal, sending one portion to the VCO modulation input, and the other to the PLL master oscillator. Since the master oscillator is not in the frequency control feedback loop, it can be modulated by the low-frequency portion of the signal. Modulation at this point, combined with modulation of the VCO, produces a composite signal with a spectral response extending down to DC.

This two-point modulation technique results in an essentially constant modulation sensitivity without regard to the loop bandwidth. The loop bandwidth, which now has little effect on the modulation, may be used for other requirements, such as a wide loop bandwidth for increased switching speed.

In short, two-point modulation is an effective way to serve the needs of systems requiring a modulation frequency response extending to DC. While it is not the only technique that can circumvent the problems inherent in designing low-frequency-response systems, it has been used successfully in several types of communication systems for many years. Once understood, two-point modulation is reasonably easy to translate into highly-efficient modulators that meet the requirements of data communications systems in applications ranging from telemetry to wireless LANs.

The Phase-Locked Loop

The phase-locked loop, the typical platform for frequency synthesizers, is depicted in Figure 1. Its purpose is to allow the phase of one signal to precisely track the phase of another signal. The phase detector compares the phase of the input signal to the phase of a divided-down VCO output signal, and converts any difference between the phases into an error voltage signal. This signal is then applied to the loop filter, and the filtered output signal is used to modulate the VCO. When the PLL is in "lock", the output of the VCO is phase-locked to the input signal and changes in input signal phase will be developed at the VCO output. A PLL can be designed in many different ways depending on system design objectives. Phase detector gain, loop filter response, and VCO gain can all be set independently for a given application. Many applications do not have stringent requirements for modulator frequency response. However, certain data-oriented schemes such as GMSK and four-level FSK require high quality, low-frequency response. The frequency content of the modulating signal is determined by the pattern of the data string to be transmitted. Because of the inherently variable nature of the data signal, good frequency response for both high-frequency and low-frequency content is required for optimal data transmission (i.e., with very low bit-error rates (BER)).

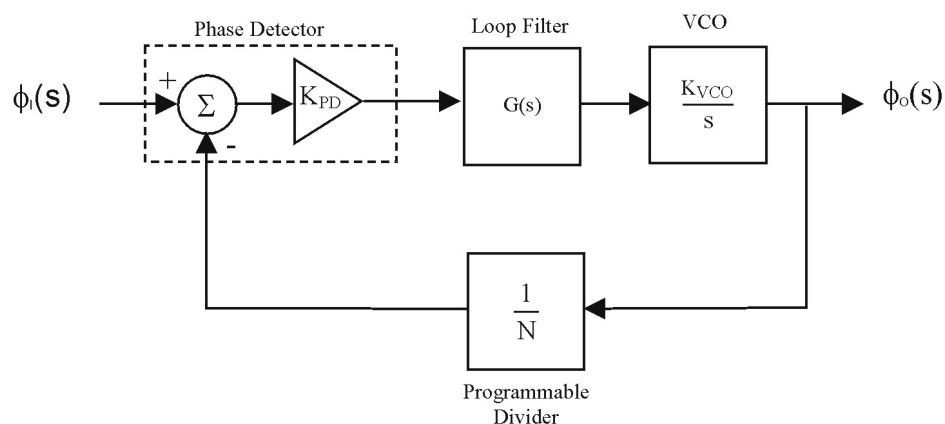

Figure 1. Typical phase-locked loop.

Modulation can be applied to different points within the PLL, such as at the VCO input and at the master oscillator¹. When modulation is applied to the input of the VCO, high-frequency content above the loop filter bandwidth of the modulating signal is developed at the VCO output. Low-frequency content that falls within the loop filter bandwidth is compensated by the PLL and is not present at the output of the VCO. This gives the PLL a high-pass characteristic with respect to the modulating signal, and modulation sensitivity is reduced at lower frequencies².

The master oscillator is another potential injection point for the modulating signal¹. The oscillator must, however, be capable of being modulated by a voltage signal. When the modulating signal is applied to the master oscillator, only the frequency content that is within the loop filter bandwidth is presented at the VCO output. This results in a low-pass response to the modulating signal (i.e. modulation sensitivity is reduced at higher frequencies)¹.

A combination of these two approaches yields the desirable result of constant modulation sensitivity without regard to loop bandwidth. This is readily achievable by applying modulation at two points within the PLL, an approach called "two-point modulation"¹.

To demonstrate how two-point modulation achieves the desired high and low frequency response, it is helpful to describe each modulation injection point along with its frequency response, and compare it to two-point modulation. The use of superposition simplifies the analysis and is used in the discussion.

Modulation Injection at the VCO

In this scenario, the modulation input is summed with the loop filter output and the composite signal is injected into the VCO. For the purpose of analysis, the second input (phase detector input) representing the master oscillator signal is presumed to be constant, which causes its effect on the system to be zero³.

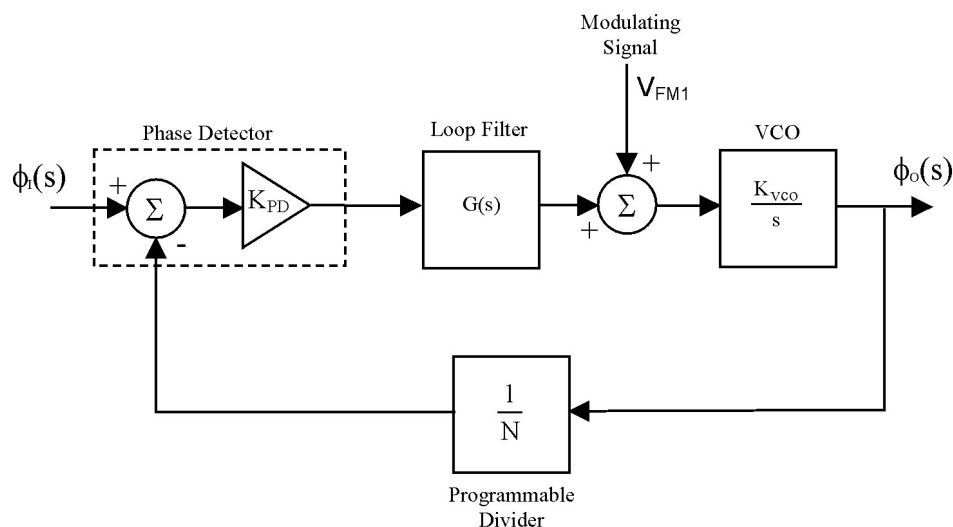
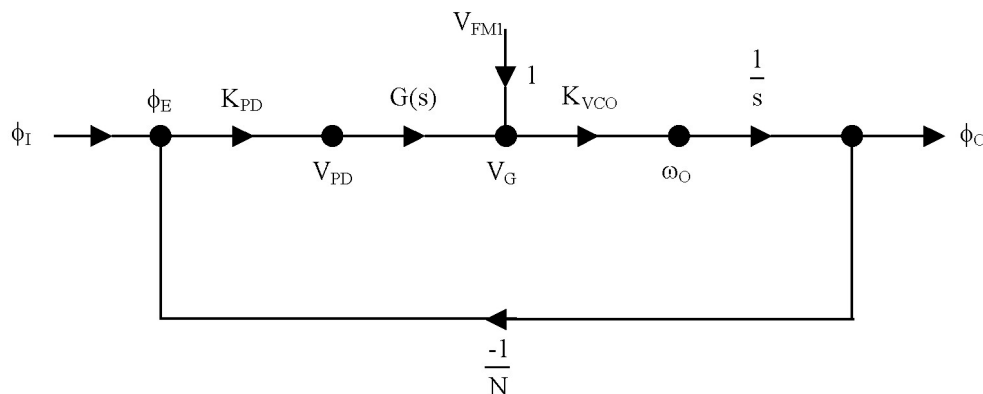

Figure 2. Modulation injection into the VCO.

In Figure 2, K_{PD} is the gain of the phase detector, K_{VCO} is the VCO gain (the $1/s$ integrator term represents the phase of the VCO output), V_{FM1} is the modulating signal applied to VCO input, N is the divider constant, ϕ_i is the phase of the input signal, ϕ_o is the phase of the output signal, and $G(s)$ is the loop filter transfer function.

The signal flow graph of this system (below) simplifies the derivation of the closed loop transfer function.



ϕ_E is the phase of the error signal, V_{PD} is the voltage signal at the output of the phase detector, V_G is the voltage input to the VCO, and ω_o is the VCO output represented as a frequency.

The closed loop transfer function for this system is:

$$\frac{\omega_o}{V_{FM1}} = \frac{K_{VCO}}{1 + \frac{K_{PD} K_{VCO} G(s)}{sN}}$$

As second-order loops are the most popular in common design practice⁵, a second order, type 2 phase-locked loop is used for analysis. Since active loop filters are the norm today⁵, an active filter will also be used for analytical purposes.

Setting $G(s)=(1+sa)/sb$, where a and b represent RC time constants, and simplifying yields:

$$\frac{\omega_o}{V_{FMI}} = \frac{s^2 K_{VCO}}{s^2 + s \frac{aK_{PD}K_{VCO}}{bN} + \frac{K_{PD}K_{VCO}}{bN}}$$

To determine the frequency response of this system the magnitude of the closed-loop transfer function must be determined. This step is simplified by parameterizing the transfer function in terms of the damping factor, ζ , and the natural frequency, ω_n . Since the denominator of the transfer function is of the form $s^2 + 2\zeta\omega_n s + \omega_n^2$, the transfer function can be parameterized once values of ζ and ω_n are known.

$$\zeta = \frac{a}{2} \sqrt{\frac{K_{PD}K_{VCO}}{bN}} = \frac{a}{2} \omega_n$$

$$\omega_n = \sqrt{\frac{K_{PD}K_{VCO}}{bN}}$$

Rewriting the transfer function in terms of ζ and ω_n yields:

$$\frac{\omega_o}{V_{FMI}} = \frac{K_{VCO}s^2}{s^2 + s2\zeta\omega_n + \omega_n^2}$$

Substituting $j\omega$ for s constitutes the next step in determining the magnitude of the transfer function. Next, the numerator and denominator must be multiplied by their complex conjugates (for any complex number C , $CC^* = |C|^2$)⁶. The transfer function can then be simplified by multiplying both numerator and denominator by $(1/\omega_n^4)$.

The final answer is:

$$\left| \frac{\omega_o}{V_{FMI}K_{VCO}} \right|^2 = \frac{\left(\frac{\omega}{\omega_n} \right)^4}{\left(\frac{\omega}{\omega_n} \right)^4 - 2 \left(\frac{\omega}{\omega_n} \right)^2 + 4\zeta^2 \left(\frac{\omega}{\omega_n} \right)^2 + 1}$$

The high-pass modulation response of this system is shown in Figure 3.

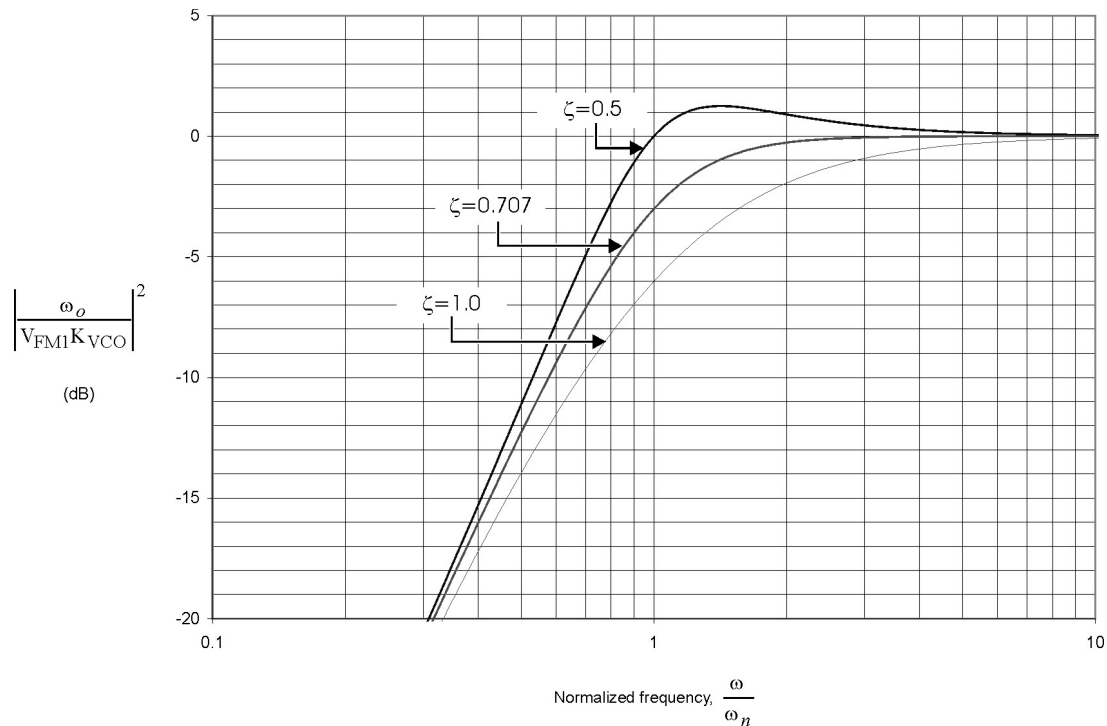

Figure 3. High-pass modulation response with VCO injection.

Modulation Injection at the Master Oscillator

In this configuration, the modulation input is applied to the master oscillator, and the modulation input to the VCO has been set to zero (Figure 4). While there are a variety of oscillators to choose from, the master oscillator used in this system must be capable of being modulated by a voltage signal. That is, the oscillator must have some type of voltage-controlled characteristic. In this figure, V_{FM2} is the modulation signal injected into the master oscillator, and K_T is the gain term of the master oscillator (the $1/s$ integrator term represents the master oscillator output in terms of phase).

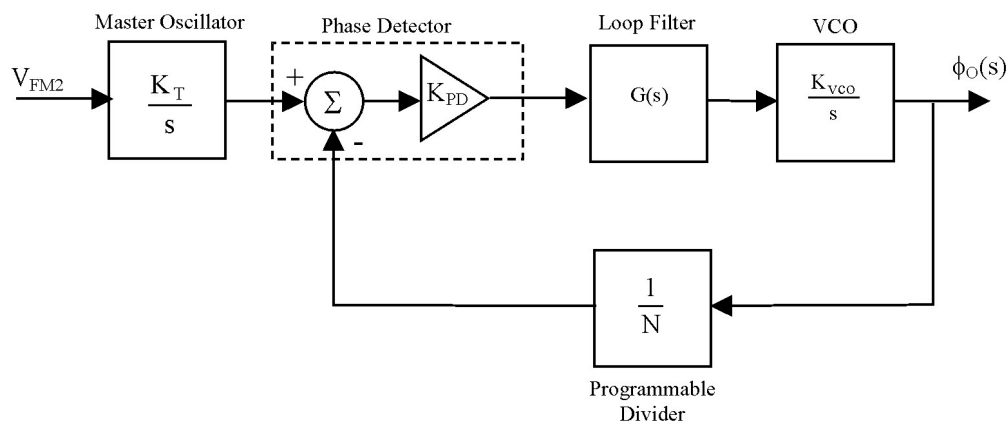
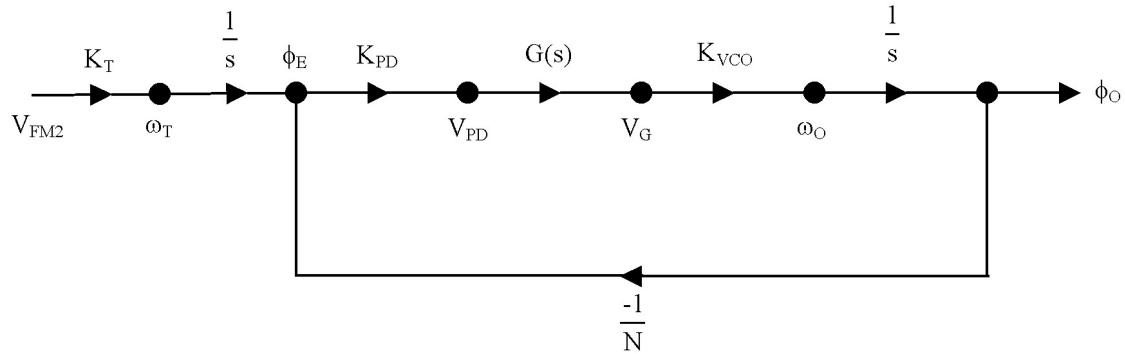

Figure 4. Modulation injection at the master oscillator.

The signal flow graph for this system is:



where ω_T is the master oscillator output expressed as a frequency. The closed-loop transfer function of this system is:

$$\frac{\omega_o}{V_{FM2}} = \frac{\frac{K_T}{s} K_{PD} K_{VCO} G(s)}{1 + \frac{K_{PD} K_{VCO} G(s)}{sN}}$$

Setting $G(s)$ to $(1+sa)/(sb)$ and simplifying yields:

$$\frac{\omega_o}{V_{FM2}} = \frac{\frac{K_T K_{PD} K_{VCO}}{bN} (1 + sa)}{s^2 + s \frac{aK_{PD} K_{VCO}}{bN} + \frac{K_{PD} K_{VCO}}{bN}}$$

This equation can be written in terms of ζ and ω_n as follows:

$$\frac{\omega_o}{V_{FM2}} = \frac{K_T N (\omega_n^2 + s2\zeta\omega_n)}{s^2 + s2\zeta\omega_n + \omega_n^2}$$

The frequency response (amplitude) of the system can be found as before:

$$\left| \frac{\omega_o}{V_{FM2} K_T N} \right|^2 = \frac{1 + 4\zeta^2 \left(\frac{\omega}{\omega_n} \right)^2}{\left(\frac{\omega}{\omega_n} \right)^4 - 2 \left(\frac{\omega}{\omega_n} \right)^2 + 4\zeta^2 \left(\frac{\omega}{\omega_n} \right)^2 + 1}$$

The low-pass modulation response of the system is shown in Figure 5.

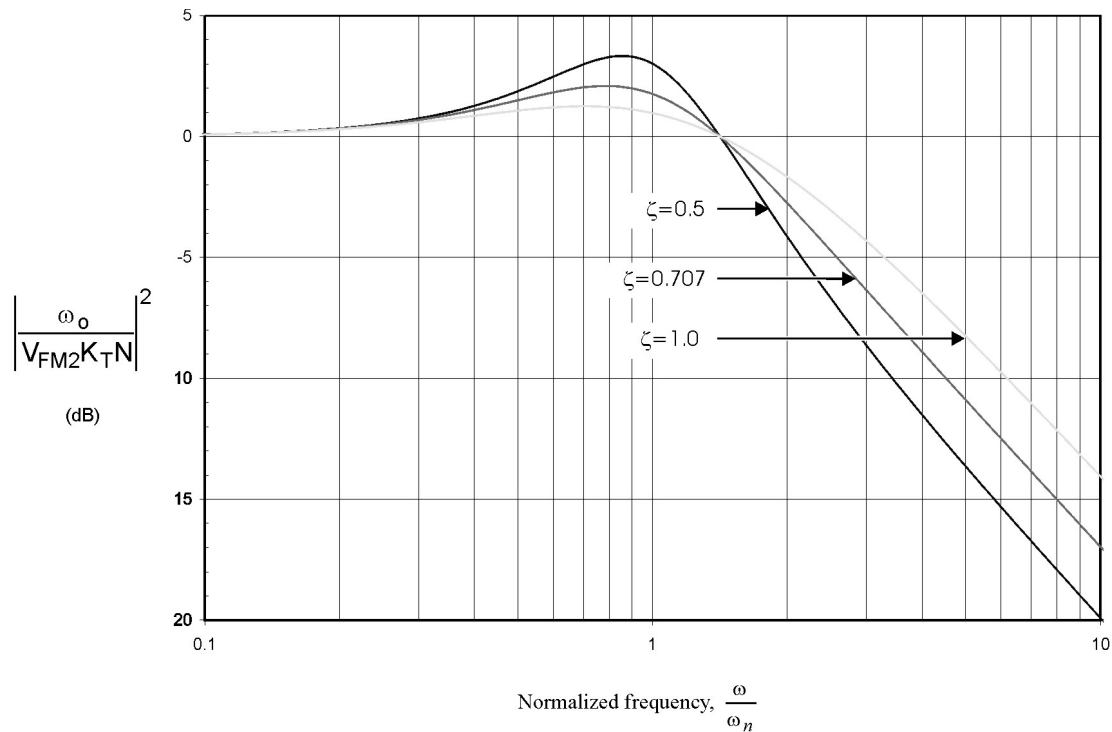

Figure 5. Low-pass modulation response with master oscillator injection.

Modulation Injection at the Master Oscillator and VCO Input

In this case, the modulated signal is injected simultaneously into both the master oscillator and the input of the VCO. A diagram of the configuration is shown in Figure 6.

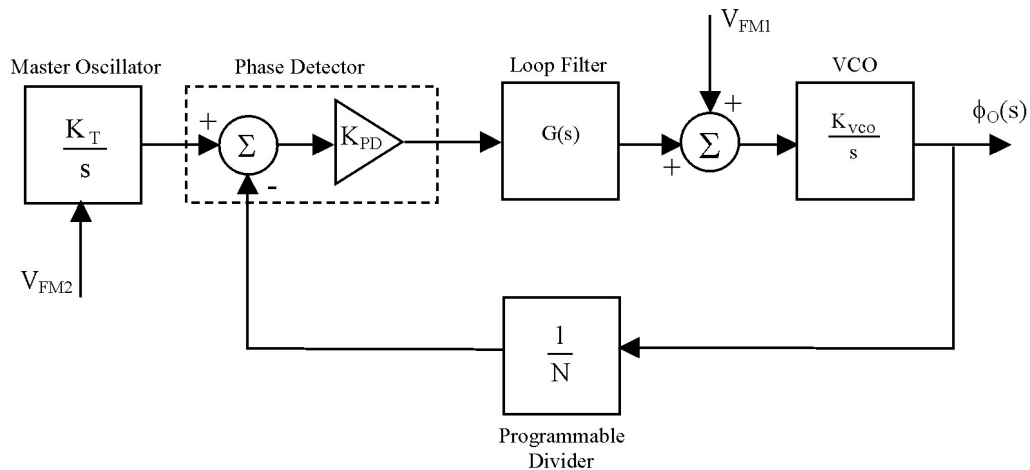
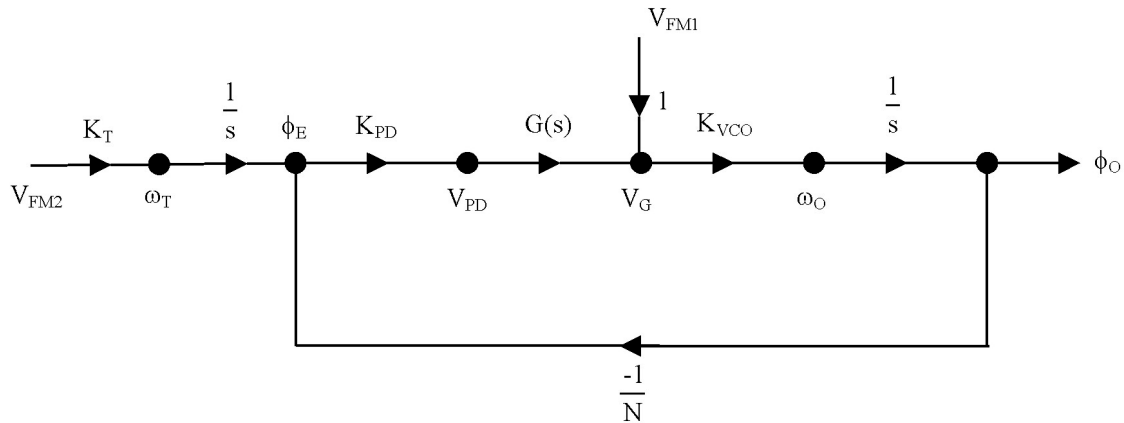

Figure 6. Simultaneous injection of modulation signal into master oscillator and VCO input.

The signal flow graph for this combination approach is as follows:



Using superposition and the previously determined transfer functions yields:

$$\frac{\omega_o}{V_{FM}} = \frac{\omega_o}{V_{FM1}} + \frac{\omega_o}{V_{FM2}}$$

This can be simplified in terms of ζ and ω_n to:

$$\frac{\omega_o}{V_{FM}} = \frac{s^2 K_{VCO} + K_T N (\omega_n^2 + s 2\zeta \omega_n)}{s^2 + s 2\zeta \omega_n + \omega_n^2}$$

Using the method described previously, the magnitude of the combined transfer function can be expressed as:

$$\left| \frac{\omega_o}{V_{FM}} \right|^2 = \frac{\left(\frac{\omega}{\omega_n} \right)^4 K_{VCO}^2 - 2 \left(\frac{\omega}{\omega_n} \right)^2 K_{VCO} K_T N + 4\zeta^2 \left(\frac{\omega}{\omega_n} \right)^2 K_T^2 N^2 + K_T^2 N^2}{\left(\frac{\omega}{\omega_n} \right)^4 - 2 \left(\frac{\omega}{\omega_n} \right)^2 + 4\zeta^2 \left(\frac{\omega}{\omega_n} \right)^2 + 1}$$

As ω approaches 0 in this equation, the value of the combined magnitude function approaches $K_T N$. As ω approaches infinity, the value of the combined magnitude function approaches K_{VCO} . In order to achieve a uniform frequency response that equals K_{VCO} , K_T can be manipulated as follows:

$$K_T N = K_{VCO}$$

$$K_T = \frac{K_{VCO}}{N}$$

With proper selection of K_T , the modulation response will be flat across all frequencies.

Practical Implementation

As can be seen from the previous discussion, modulation at two points improves the frequency response of a synthesized modulator. Modulation at either input of the phase comparator requires not only amplitude matching through its path to the phase comparator but also a conversion of the frequency modulating signal of the VCO to a phase modulating signal.

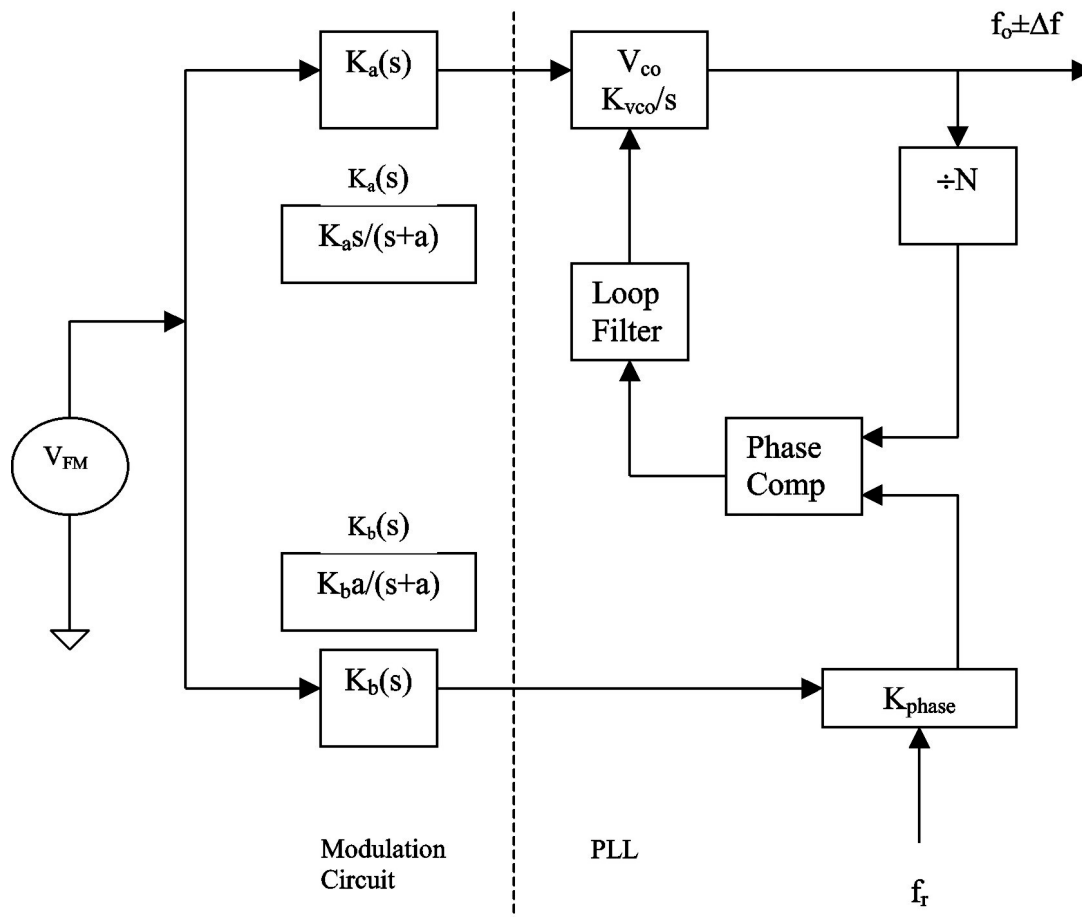

Figure 7. Complementary Filter Modulation Circuit

Two methods have been suggested in the literature to realize the perfect integrator required to convert the frequency modulating signal to a phase modulating signal. The high-pass/low-pass complementary filters suggested by Underhill¹ and Brennan³ nicely deliver a practical implementation of this conversion, as shown in Figure 7. The resultant effective modulation is free from the high pass effect of the PLL and its loop filter. It still has a high pass characteristic due to the high pass filter used in the VCO modulation path. Grimmet⁴ shows an alternate method of implementing a perfect integrator that is very inventive and impressive.

There is another possible solution for the frequency to phase conversion requirement of the proposed two-point modulation scheme.

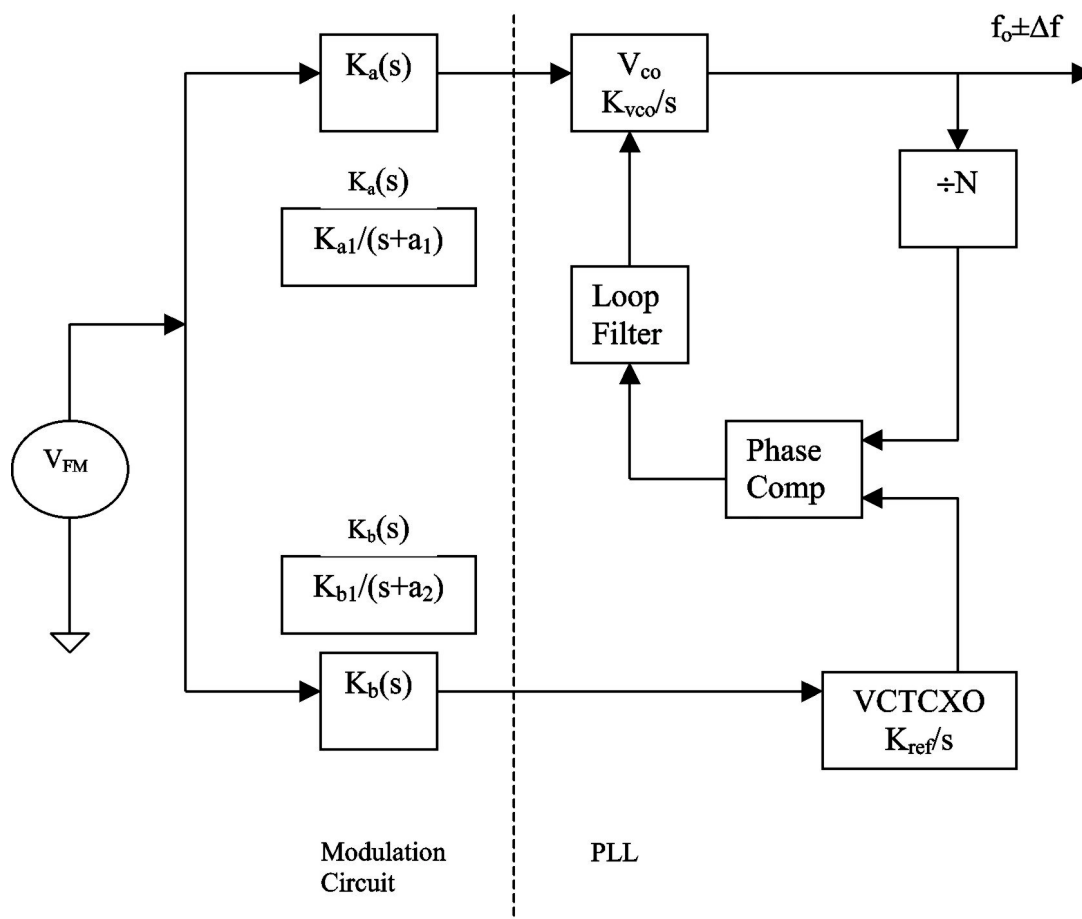

Figure 8. VCTCXO Modulation Circuit

For quite some time designs have been using temperature compensated crystal oscillators (TCXO's) as the reference signal for PLL synthesizers. The temperature compensation of these references appears as a signal that is inversely proportional to the change in frequency of the reference due to temperature. This temperature-compensating signal is a low-frequency modulation of the master oscillator. The integration inherent in a VCO transforms frequency modulation into phase modulation. As such, the voltage-controlled characteristic of the master oscillator transforms the frequency modulation of the temperature-compensating signal to the phase modulation required by the PLL at this injection point.

Modulation through the master oscillator, as shown in Figure 8, has supplied the perfect integrator needed, and our concern shifts from trying to realize a perfect integrator to ensuring that DC operating points, amplitudes, and frequency responses of the VCO are correct. Special attention should be paid to the damping factor of the loop filter. The more damped the loop, the flatter the resultant composite frequency response will be.

Figure 9 shows the frequency response of a system using the topology shown in figure 8. The loop filter was first order with a damping factor of approximately 1 and a natural frequency of approximately 1KHz. The three frequency responses shown represent modulation at the VCO, the TCXO, and at both points together. The ripple across the band is less than one dB.

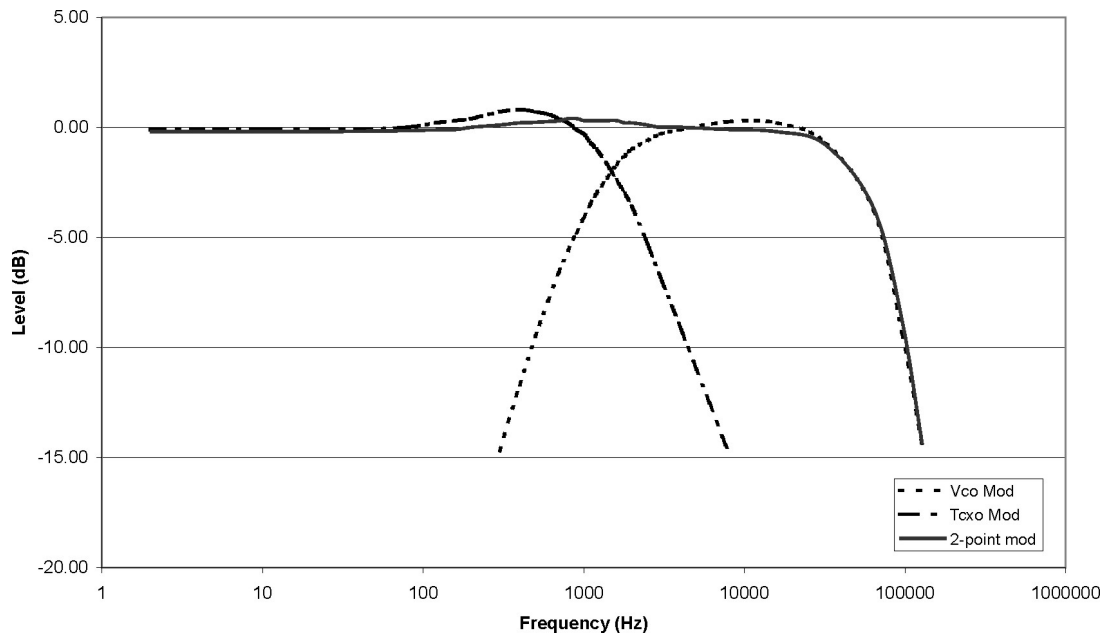

Figure 9. Modulation response with two point modulation.

Many crystal manufacturers offer voltage-controlled TCXOs that are appropriate for many systems. Of course special system requirements may call for an in house design solution. This type of two-point modulation is very effective and has been serving the needs of low frequency response systems for years. It is well worth considering as a solution for near-DC modulation requirements.

Acknowledgements

The authors wish to thank Jim Kemerling and William Farlow of MX-COM for their valuable guidance and insight.

References

1. R.I.H. Scott and M.J. Underhill, 1979. FM Modulation of Frequency Synthesizers. IERE Conference on Land Mobile Radio, Lancaster, England, September 1979.
2. P. Brennan and B. Murray, Frequency Synthesizer Using LSI Devices, *Electronic Components and Applications*. Vol. 3, No. 1, November 1980.
3. P. Brennan, 1996, *Phase-Locked Loops: Principles and Practice*. New York: McGraw-Hill.
4. S. Grimmet, Frequency Modulation in a Phase Lock Loop by Control of the Phase Inside the Loop, *RF Design*. Vol. 14, No. 6, June 1991.
5. Heinrich Meyr and Gerd Ascheld, 1990, *Synchronization in Digital Communications - Volume 1: Phase-Frequency-Locked Loops and Amplitude Control*. New York: John Wiley & Sons.
6. Zoher Karu, 1999, *Signals and Systems Made Ridiculously Simple*. Huntsville, AL: ZiZi Press.