

FLIR BLACKFLY[®]S

P/N: BFS-U3-04S2, USB3 VISION



SMALL PACKAGE, POWERFUL RESULTS

The Blackfly S combines the newest CMOS image sensors with our new and intuitive Spinnaker software development kit. The many new advanced camera features are designed to meet your complex imaging needs and speed up development time.

KEY FEATURES

- Leverage the latest **CMOS sensors** and new on-camera image processing features. Harness increased **binning** flexibility, powerful **auto-exposure** controls and robust **color transformation** tools.
- Improve cycle time using advanced camera controls and programmable logic. Utilize **sequencer**, **chunk data**, **event notification**, **counters**, **timers** and **logic blocks**.
- Accelerate your time to market using our **GenICam3 API**, **GUI API library**, detailed **API logging** and comprehensive **documentation**.

USB VISION GEN*i*CAM

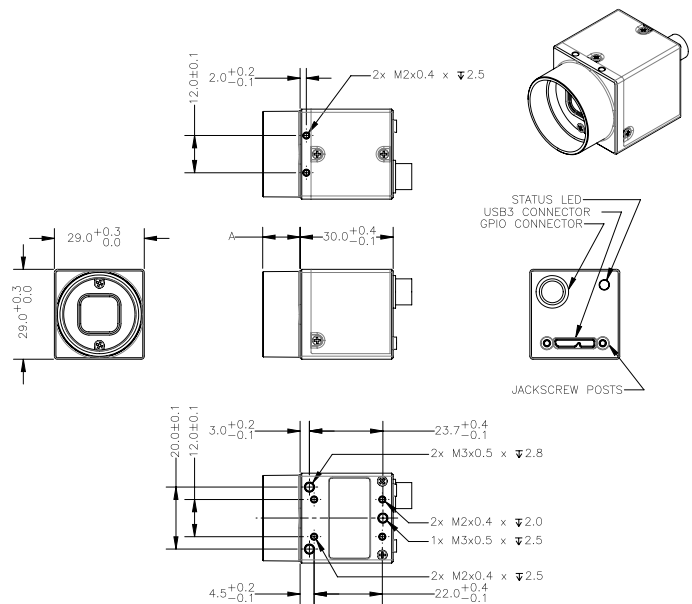

Specifications

	BFS-U3-04S2M-CS	BFS-U3-04S2C-CS
Resolution	720 x 540	
Frame Rate*	522 FPS	
Megapixels	0.4 MP	
Chroma	Mono	Color
Sensor	Sony IMX287, CMOS, 1/2.9"	
Readout Method	Global shutter	
Pixel Size	6.9 µm	
Lens Mount	CS-mount	
ADC	8-bit, 10-bit, and 12-bit	
Minimum Frame Rate**	1 FPS	
Gain Range**	0 to 47 dB	
Exposure Range**	4 µs to 30 s	
Acquisition Modes	Continuous, Single Frame, Multi Frame	
Partial Image Modes	Pixel binning, decimation, ROI	
Image Processing	Gamma, lookup table, and sharpness	Color correction matrix, gamma, lookup table, saturation, and sharpness
Sequencer	Up to 8 sets using 2 features	
Image Buffer	240 MB	
User Sets	2 user configuration sets for custom camera settings	
Flash Memory	6 MB non-volatile memory	
Opto-isolated I/O	1 input, 1 output	
Non-isolated I/O	1 bi-directional, 1 input	
Auxiliary Output	3.3 V, 120 mA maximum	
Interface	USB 3.1 Gen 1	
Power Requirements	8 - 24 V via GPIO or 5 V via USB3 interface	
Power Consumption	3 W maximum	
Dimensions/Mass	29 mm x 29 mm x 30 mm / 36 g	
Machine Vision Standard	USB3 Vision v1.0	
Compliance	CE, FCC, KCC, RoHS, REACH. The ECCN for this product is: EAR099.	
Temperature	Operating: 0°C to 50°C Storage: -30°C to 60°C	
Humidity	Operating: 20% to 80% (no condensation) Storage: 30% to 95% (no condensation)	
Warranty	3 years	

*Frame rates are measured with Device Link Throughput Limit of 380 MBps and Acquisition Frame Rate disabled. Values are rounded down to whole numbers.

**Values are the same in binning and no binning modes.

FLIR Integrated Imaging Solutions

CANADA

12051 Riverside Way
Richmond, BC, Canada
V6W 1K7
T: +1 866.765.0827 (toll free)
T: +1 604.242.9937
F: +1 604.242.9938
E: mv-sales@flir.com
www.flir.com/mv

EUROPE

T: +49 7141 488817-0
F: +49 7141 488817-99
E: mv-eusales@flir.com

CHINA

T: +86 10 8215 9938
F: +86 10 8215 9936
E: mv-chinasales@flir.com

USA

T: +1 866.765.0827 (toll free)
E: mv-na-sales@flir.com

ASIA

E: mv-asiasales@flir.com

For a full list of international distributors and offices visit www.flir.com/contact-us

©2018 FLIR® Integrated Imaging Solutions Inc. All rights reserved. Names and marks appearing on the products herein are either registered trademarks or trademarks of FLIR® Systems, Inc. and/or its subsidiaries.



INDUSTRIAL/MACHINE VISION APPLICATIONS

FLIR BLACKFLY S

P/N BFS-U3-13Y3

SMALL PACKAGE, POWERFUL RESULTS

The Blackfly S is a compact, high performance machine vision camera that allows designers to easily produce the exact images they need. With both automatic and precise manual control over image capture and on-camera pre-processing, the Blackfly S accelerates application development.

www.flir.com/mv

FEATURES

THE LATEST CMOS SENSORS

Switch between high sensitivity and low noise, and high saturation capacity and dynamic range with selectable conversion gain.

IMPROVE CYCLE TIMES

Automate more with advanced camera controls, event notifications, chunk data, counters and timers.

ACCELERATE YOUR TIME TO MARKET

FLIR's GenICam3 API with GUI library, and detailed event logging is supported by comprehensive documentation.

APPLICATIONS

AUTOMATED OPTICAL INSPECTION

MICROSCOPY ROBOT GUIDANCE

LASER BEAM PROFILING

AUTONOMOUS VEHICLE GUIDANCE



GEN*i*CAM

Pregius

SPECS	BFS-U3-13Y3M-C	BFS-U3-13Y3C-C
Resolution	1280 x 1024	
Frame Rate*	170 FPS	
Megapixels	1.3 MP	
Chroma	Mono	Color
Sensor	On Semi P1300, CMOS, 1/2"	
Readout Method	Global shutter	
Pixel Size	4.8 μ m	
Lens Mount	C-mount	
ADC	10-bit	
Minimum Frame Rate**	1 FPS	
Gain Range**	0 to 18 dB	
Exposure Range**	6 μ s to 30 s	
Acquisition Modes	Continuous, Single Frame, Multi Frame	
Partial Image Modes	Pixel binning, decimation, ROI	
Image Processing	Gamma, lookup table, and sharpness	Color correction matrix, gamma, lookup table, hue, saturation, and sharpness
Sequencer	Up to 8 sets using 6 features, including image size	
Image Buffer	240 MB	
User Sets	2 user configuration sets for custom camera settings	
Flash Memory	6 MB non-volatile memory	
Opto-isolated I/O	1 input, 1 output	
Non-isolated I/O	1 bi-directional, 1 input	
Auxiliary Output	3.3 V, 120 mA maximum	
Interface	USB 3.1 Gen 1	
Power Requirements	8 - 24 V via GPIO or 5 V via USB3 interface	
Power Consumption	3 W maximum	
Dimensions/Mass	29 mm x 29 mm x 30 mm / 36 g	
Machine Vision Standard	USB3 Vision v1.0	
Compliance	CE, FCC, KCC, RoHS, REACH. The ECCN for this product is: EAR099.	
MTBF***	6,330,000 hours @ 20°C, GB environment 1,582,000 hours @ 20°C, GM environment	
Temperature	Operating: 0°C to 50°C Storage: -30°C to 60°C	
Humidity	Operating: 20% to 80% (no condensation) Storage: 30% to 95% (no condensation)	
Warranty	3 years	

*Frame rates are measured with Device Link Throughput Limit of 380 MBps and Acquisition Frame Rate disabled. Values are rounded down to whole numbers.

**Values are the same in binning and no binning modes.

***Ambient temperature; internal camera temperature is not considered.

CANADA

12051 Riverside Way
Richmond, BC, Canada
V6W 1K7
T: +1 866.765.0827 (toll free)
T: +1 604.242.9937
F: +1 604.242.9938
E: mv-sales@flir.com
www.flir.com/mv

USA

T: +1 866.765.0827 (toll free)
E: mv-na-sales@flir.com

EUROPE

T: +49 7141 488817-0
F: +49 7141 488817-99
E: mv-eusales@flir.com

CHINA

T: +86 10 8215 9938
F: +86 10 8215 9936
E: mv-chinasales@flir.com

ASIA

E: mv-asiasales@flir.com

www.flir.com
NASDAQ: FLIR

©2019 FLIR® Integrated Imaging Solutions Inc. All rights reserved.
Names and marks appearing on the products herein are either registered trademarks or trademarks of FLIR® Systems, Inc. and/or its subsidiaries. Specifications are subject to change without notice.

VN: BFS-U3-13Y3-v2

FIND THE BEST BLACKFLY'S
FOR YOUR NEEDS



The World's Sixth Sense®



INDUSTRIAL/MACHINE VISION APPLICATIONS

FLIR BLACKFLY S

P/N BFS-U3-16S2

SMALL PACKAGE, POWERFUL RESULTS

The Blackfly S is a compact, high performance machine vision camera that allows designers to easily produce the exact images they need. With both automatic and precise manual control over image capture and on-camera pre-processing, the Blackfly S accelerates application development.

www.flir.com/mv

FEATURES

THE LATEST CMOS SENSORS

Switch between high sensitivity and low noise, and high saturation capacity and dynamic range with selectable conversion gain.

IMPROVE CYCLE TIMES

Automate more with advanced camera controls, event notifications, chunk data, counters and timers.

ACCELERATE YOUR TIME TO MARKET

FLIR's GenICam3 API with GUI library, and detailed event logging is supported by comprehensive documentation.

APPLICATIONS

AUTOMATED OPTICAL INSPECTION

MICROSCOPY ROBOT GUIDANCE

LASER BEAM PROFILING

AUTONOMOUS VEHICLE GUIDANCE



GEN*i*CAM

Pregius

SPECS	BFS-U3-16S2M-CS	BFS-U3-16S2C-CS
Resolution	1440 x 1080	
Frame Rate*	226FPS	
Megapixels	1.6 MP	
Chroma	Mono	Color
Sensor	Sony IMX273, CMOS, 1/2.9"	
Readout Method	Global shutter	
Pixel Size	3.45 µm	
Lens Mount	CS-mount	
ADC	10-bit, and 12-bit	
Minimum Frame Rate**	1 FPS	
Gain Range**	0 to 47 dB	
Exposure Range**	4 µs to 30 s	
Acquisition Modes	Continuous, Single Frame, Multi Frame	
Partial Image Modes	Pixel binning, decimation, ROI	
Image Processing	Gamma, lookup table, and sharpness	Color correction matrix, gamma, lookup table, saturation, and sharpness
Sequencer	Up to 8 sets using 2 features	
Image Buffer	240 MB	
User Sets	2 user configuration sets for custom camera settings	
Flash Memory	6 MB non-volatile memory	
Opto-isolated I/O	1 input, 1 output	
Non-isolated I/O	1 bi-directional, 1 input	
Auxiliary Output	3.3 V, 120 mA maximum	
Interface	USB 3.1 Gen 1	
Power Requirements	8 - 24 V via GPIO or 5 V via USB3 interface	
Power Consumption	3 W maximum	
Dimensions/Mass	29 mm x 29 mm x 30 mm / 36 g	
Machine Vision Standard	USB3 Vision v1.0	
Compliance	CE, FCC, KCC, RoHS, REACH. The ECCN for this product is: EAR099.	
Temperature	Operating: 0°C to 50°C Storage: -30°C to 60°C	
Humidity	Operating: 20% to 80% (no condensation) Storage: 30% to 95% (no condensation)	
Warranty	3 years	

*Frame rates are measured with Device Link Throughput Limit of 380 MBps and Acquisition Frame Rate disabled. Values are rounded down to whole numbers.

**Values are the same in binning and no binning modes.

CANADA

12051 Riverside Way
Richmond, BC, Canada
V6W 1K7
T: +1 866.765.0827 (toll free)
T: +1 604.242.9937
F: +1 604.242.9938
E: mv-sales@flir.com
www.flir.com/mv

USA

T: +1 866.765.0827 (toll free)
E: mv-na-sales@flir.com

EUROPE

T: +49 7141 488817-0
F: +49 7141 488817-99
E: mv-eusales@flir.com

CHINA

T: +86 10 8215 9938
F: +86 10 8215 9936
E: mv-chinasales@flir.com

ASIA

E: mv-asiasales@flir.com

www.flir.com
NASDAQ: FLIR

©2019 FLIR® Integrated Imaging Solutions Inc. All rights reserved. Names and marks appearing on the products herein are either registered trademarks or trademarks of FLIR® Systems, Inc. and/or its subsidiaries. Specifications are subject to change without notice.

VN: BFS-U3-16S2-v2

FIND THE BEST BLACKFLY'S
FOR YOUR NEEDS



The World's Sixth Sense®



INDUSTRIAL/MACHINE VISION APPLICATIONS

FLIR BLACKFLY® S

P/N: BFS-U3-16S7

SMALL PACKAGE, POWERFUL RESULTS

The Blackfly S is a compact, high performance machine vision camera that allows designers to easily produce the exact images they need. With both automatic and precise manual control over image capture and on-camera pre-processing, the Blackfly S accelerates application development.

www.flir.com/products/blackfly-s-usb3

FEATURES

THE LATEST CMOS SENSORS

Switch between high sensitivity and low noise, and high saturation capacity and dynamic range with selectable conversion gain.

IMPROVE CYCLE TIMES

Automate more with advanced camera controls, event notifications, chunk data, counters and timers.

ACCELERATE YOUR TIME TO MARKET

FLIR's GenICam3 API with GUI library, and detailed event logging is supported by comprehensive documentation.

APPLICATIONS

AUTOMATED OPTICAL INSPECTION

MICROSCOPY ROBOT GUIDANCE

LASER BEAM PROFILING

AUTONOMOUS VEHICLE GUIDANCE



GEN*i*CAM

Pregius

SPECS	BFS-U3-16S7M-C	BFS-U3-16S7C-C
Resolution	1600 x 1100	
Frame Rate*	97 FPS	
Megapixels	1.7 MP	
Chroma	Mono	Color
Sensor	Sony IMX432, CMOS, 1.1"	
Readout Method	Global shutter	
Pixel Size	9 µm	
Lens Mount	C-mount	
ADC	12-bit	
Minimum Frame Rate**	1 FPS	
Gain Range**	0 to 47 dB	
Exposure Range**	14 µs to 30 s	
Acquisition Modes	Continuous, Single Frame, Multi Frame	
Partial Image Modes	Pixel binning, decimation, ROI	
Image Processing	Gamma, lookup table, and sharpness	Color correction matrix, gamma, lookup table, saturation, and sharpness
Sequencer	Up to 8 sets using 6 features	
Image Buffer	240 MB	
User Sets	2 user configuration sets for custom camera settings	
Flash Memory	6 MB non-volatile memory	
Opto-isolated I/O	1 input, 1 output	
Non-isolated I/O	1 bi-directional, 1 input	
Auxiliary Output	3.3 V, 120 mA maximum	
Interface	USB 3.1 Gen 1	
Power Requirements	8 - 24 V via GPIO or 5 V via USB3 interface	
Power Consumption	4.2 W maximum	
Dimensions/Mass	29 mm x 29 mm x 39 mm / 53 g	
Machine Vision Standard	USB3 Vision v1.0	
Compliance	CE, FCC, KCC, RoHS, REACH. The ECCN for this product is: EAR099.	
Temperature	Operating: 0°C to 50°C Storage: -30°C to 60°C	
Humidity	Operating: 20% to 80% (no condensation) Storage: 30% to 95% (no condensation)	
Warranty	3 years	

*Frame rates are measured with Device Link Throughput Limit of 380 MBps and Acquisition Frame Rate disabled. Values are rounded down to whole numbers.

**Values are the same in binning and no binning modes.

CANADA

12051 Riverside Way
Richmond, BC, Canada
V6W 1K7
T: +1 866.765.0827 (toll free)
T: +1 604.242.9937
F: +1 604.242.9938
E: mv-sales@flir.com

USA

T: +1 866.765.0827 (toll free)
E: mv-na-sales@flir.com

www.flir.com/mv

EUROPE

T: +49 7141 488817-0
F: +49 7141 488817-99
E: mv-eusales@flir.com

CHINA

T: +86 10 8215 9938
F: +86 10 8215 9936
E: mv-chinasales@flir.com

ASIA

E: mv-asiasales@flir.com

www.flir.com
NASDAQ: FLIR

©2019 FLIR® Integrated Imaging Solutions Inc. All rights reserved. Names and marks appearing on the products herein are either registered trademarks or trademarks of FLIR® Systems, Inc. and/or its subsidiaries. Specifications are subject to change without notice.

VN: 19-2602-OEM-BFS-U3-16S7-v1

FIND THE BEST BLACKFLY S
FOR YOUR NEEDS



The World's Sixth Sense®



INDUSTRIAL/MACHINE VISION APPLICATIONS

FLIR BLACKFLY® S

P/N: BFS-U3-17S7

SMALL PACKAGE, POWERFUL RESULTS

The Blackfly S is a compact, high performance machine vision camera that allows designers to easily produce the exact images they need. With both automatic and precise manual control over image capture and on-camera pre-processing, the Blackfly S accelerates application development.

www.flir.com/products/blackfly-s-usb3

FEATURES

THE LATEST CMOS SENSORS

Switch between high sensitivity and low noise, and high saturation capacity and dynamic range with selectable conversion gain.

IMPROVE CYCLE TIMES

Automate more with advanced camera controls, event notifications, chunk data, counters and timers.

ACCELERATE YOUR TIME TO MARKET

FLIR's GenICam3 API with GUI library, and detailed event logging is supported by comprehensive documentation.

APPLICATIONS

AUTOMATED OPTICAL INSPECTION

MICROSCOPY ROBOT GUIDANCE

LASER BEAM PROFILING

AUTONOMOUS VEHICLE GUIDANCE



GEN*i*CAM

Pregius

SPECS	BFS-U3-17S7M-C	BFS-U3-17S7C-C
Resolution	1600 x 1100	
Frame Rate*	196 FPS	
Megapixels	1.7 MP	
Chroma	Mono	Color
Sensor	Sony IMX425, CMOS, 1.1"	
Readout Method	Global shutter	
Pixel Size	9 µm	
Lens Mount	C-mount	
ADC	10-bit / 12-bit	
Minimum Frame Rate**	1 FPS	
Gain Range**	0 to 47 dB	
Exposure Range**	9 µs to 30 s	
Acquisition Modes	Continuous, Single Frame, Multi Frame	
Partial Image Modes	Pixel binning, decimation, ROI	
Image Processing	Gamma, lookup table, and sharpness	Color correction matrix, gamma, lookup table, saturation, and sharpness
Sequencer	Up to 8 sets using 6 features	
Image Buffer	240 MB	
User Sets	2 user configuration sets for custom camera settings	
Flash Memory	6 MB non-volatile memory	
Opto-isolated I/O	1 input, 1 output	
Non-isolated I/O	1 bi-directional, 1 input	
Auxiliary Output	3.3 V, 120 mA maximum	
Interface	USB 3.1 Gen 1	
Power Requirements	8 - 24 V via GPIO or 5 V via USB3 interface	
Power Consumption	4.2 W maximum	
Dimensions/Mass	29 mm x 29 mm x 39 mm / 53 g	
Machine Vision Standard	USB3 Vision v1.0	
Compliance	CE, FCC, KCC, RoHS, REACH. The ECCN for this product is: EAR099.	
Temperature	Operating: 0°C to 50°C Storage: -30°C to 60°C	
Humidity	Operating: 20% to 80% (no condensation) Storage: 30% to 95% (no condensation)	
Warranty	3 years	

*Frame rates are measured with Device Link Throughput Limit of 380 MBps and Acquisition Frame Rate disabled. Values are rounded down to whole numbers.

**Values are the same in binning and no binning modes.

CANADA

12051 Riverside Way
Richmond, BC, Canada
V6W 1K7
T: +1 866.765.0827 (toll free)
T: +1 604.242.9937
F: +1 604.242.9938
E: mv-sales@flir.com

USA

T: +1 866.765.0827 (toll free)
E: mv-na-sales@flir.com

www.flir.com/mv

EUROPE

T: +49 7141 488817-0
F: +49 7141 488817-99
E: mv-eusales@flir.com

CHINA

T: +86 10 8215 9938
F: +86 10 8215 9936
E: mv-chinasales@flir.com

ASIA

E: mv-asiasales@flir.com

www.flir.com
NASDAQ: FLIR

©2019 FLIR® Integrated Imaging Solutions Inc. All rights reserved. Names and marks appearing on the products herein are either registered trademarks or trademarks of FLIR® Systems, Inc. and/or its subsidiaries. Specifications are subject to change without notice.

VN: 19-2602-OEM-BFS-U3-17S7-v1

FIND THE BEST BLACKFLY S
FOR YOUR NEEDS



The World's Sixth Sense®



INDUSTRIAL/MACHINE VISION APPLICATIONS

FLIR BLACKFLY® S

P/N: BFS-U3-19S4

SMALL PACKAGE, POWERFUL RESULTS

The Blackfly S is a compact, high performance machine vision camera that allows designers to easily produce the exact images they need. With both automatic and precise manual control over image capture and on-camera pre-processing, the Blackfly S accelerates application development.

www.flir.com/products/blackfly-s-usb3

FEATURES

THE LATEST CMOS SENSORS

Switch between high sensitivity and low noise, and high saturation capacity and dynamic range with selectable conversion gain.

IMPROVE CYCLE TIMES

Automate more with advanced camera controls, event notifications, chunk data, counters and timers.

ACCELERATE YOUR TIME TO MARKET

FLIR's GenICam3 API with GUI library, and detailed event logging is supported by comprehensive documentation.

APPLICATIONS

AUTOMATED OPTICAL INSPECTION

MICROSCOPY

ROBOT GUIDANCE

LASER BEAM PROFILING

AUTONOMOUS VEHICLE GUIDANCE



SPECS	BFS-U3-19S4M-C	BFS-U3-19S4C-C
Resolution	1616 x 1240	
Frame Rate*	131 FPS	
Megapixels	1.9 MP	
Chroma	Mono	Color
Sensor	Sony IMX430, CMOS, 1/1.7"	
Readout Method	Global shutter	
Pixel Size	4.5 µm	
Lens Mount	C-mount	
ADC	12-bit	
Minimum Frame Rate**	1 FPS	
Gain Range**	0 to 47 dB	
Exposure Range**	11 µs to 30 s	
Acquisition Modes	Continuous, Single Frame, Multi Frame	
Partial Image Modes	Pixel binning, decimation, ROI	
Image Processing	Gamma, lookup table, and sharpness	Color correction matrix, gamma, lookup table, saturation, and sharpness
Sequencer	Up to 8 sets using 6 features	
Image Buffer	240 MB	
User Sets	2 user configuration sets for custom camera settings	
Flash Memory	6 MB non-volatile memory	
Opto-isolated I/O	1 input, 1 output	
Non-isolated I/O	1 bi-directional, 1 input	
Auxiliary Output	3.3 V, 120 mA maximum	
Interface	USB 3.1 Gen 1	
Power Requirements	8 - 24 V via GPIO or 5 V via USB3 interface	
Power Consumption	4.2 W maximum	
Dimensions/Mass	29 mm x 29 mm x 39 mm / 53 g	
Machine Vision Standard	USB3 Vision v1.0	
Compliance	CE, FCC, RoHS, REACH. The ECCN for this product is: EAR099.	
Temperature	Operating: 0°C to 50°C Storage: -30°C to 60°C	
Humidity	Operating: 20% to 80% (no condensation) Storage: 30% to 95% (no condensation)	
Warranty	3 years	

*Frame rates are measured with Device Link Throughput Limit of 380 MBps and Acquisition Frame Rate disabled. Values are rounded down to whole numbers.

**Values are the same in binning and no binning modes.

CANADA

12051 Riverside Way
Richmond, BC, Canada
V6W 1K7
T: +1 866.765.0827 (toll free)
T: +1 604.242.9937
F: +1 604.242.9938
E: mv-sales@flir.com

USA

T: +1 866.765.0827 (toll free)
E: mv-na-sales@flir.com

www.flir.com/mv

EUROPE

T: +49 7141 488817-0
F: +49 7141 488817-99
E: mv-eusales@flir.com

CHINA

T: +86 10 8215 9938
F: +86 10 8215 9936
E: mv-chinasales@flir.com

ASIA

E: mv-asiasales@flir.com

www.flir.com
NASDAQ: FLIR

©2020 FLIR® Integrated Imaging Solutions Inc. All rights reserved. Names and marks appearing on the products herein are either registered trademarks or trademarks of FLIR® Systems, Inc. and/or its subsidiaries. Specifications are subject to change without notice.

VN: 20-0305-OEM-BFS-U3-19S4-v1

FIND THE BEST BLACKFLY S
FOR YOUR NEEDS



The World's Sixth Sense®



INDUSTRIAL/MACHINE VISION APPLICATIONS

FLIR BLACKFLY® S

P/N: BFS-U3-20S4

SMALL PACKAGE, POWERFUL RESULTS

The Blackfly S is a compact, high performance machine vision camera that allows designers to easily produce the exact images they need. With both automatic and precise manual control over image capture and on-camera pre-processing, the Blackfly S accelerates application development.

www.flir.com/products/blackfly-s-usb3

FEATURES

THE LATEST CMOS SENSORS

Switch between high sensitivity and low noise, and high saturation capacity and dynamic range with selectable conversion gain.

IMPROVE CYCLE TIMES

Automate more with advanced camera controls, event notifications, chunk data, counters and timers.

ACCELERATE YOUR TIME TO MARKET

FLIR's GenICam3 API with GUI library, and detailed event logging is supported by comprehensive documentation.

APPLICATIONS

AUTOMATED OPTICAL INSPECTION

MICROSCOPY

ROBOT GUIDANCE

LASER BEAM PROFILING

AUTONOMOUS VEHICLE GUIDANCE



SPECS	BFS-U3-20S4M-C	BFS-U3-20S4C-C
Resolution	1616 x 1240	
Frame Rate*	175 FPS	
Megapixels	2.0 MP	
Chroma	Mono	Color
Sensor	Sony IMX422, CMOS, 1/1.7"	
Readout Method	Global shutter	
Pixel Size	4.5 µm	
Lens Mount	C-mount	
ADC	10-bit / 12-bit	
Minimum Frame Rate**	1 FPS	
Gain Range**	0 to 47 dB	
Exposure Range**	9 µs to 30 s	
Acquisition Modes	Continuous, Single Frame, Multi Frame	
Partial Image Modes	Pixel binning, decimation, ROI	
Image Processing	Gamma, lookup table, and sharpness	Color correction matrix, gamma, lookup table, saturation, and sharpness
Sequencer	Up to 8 sets using 6 features	
Image Buffer	240 MB	
User Sets	2 user configuration sets for custom camera settings	
Flash Memory	6 MB non-volatile memory	
Opto-isolated I/O	1 input, 1 output	
Non-isolated I/O	1 bi-directional, 1 input	
Auxiliary Output	3.3 V, 120 mA maximum	
Interface	USB 3.1 Gen 1	
Power Requirements	8 - 24 V via GPIO or 5 V via USB3 interface	
Power Consumption	4.2 W maximum	
Dimensions/Mass	29 mm x 29 mm x 39 mm / 53 g	
Machine Vision Standard	USB3 Vision v1.0	
Compliance	CE, FCC, RoHS, REACH. The ECCN for this product is: EAR099.	
Temperature	Operating: 0°C to 50°C Storage: -30°C to 60°C	
Humidity	Operating: 20% to 80% (no condensation) Storage: 30% to 95% (no condensation)	
Warranty	3 years	

*Frame rates are measured with Device Link Throughput Limit of 380 MBps and Acquisition Frame Rate disabled. Values are rounded down to whole numbers.

**Values are the same in binning and no binning modes.

CANADA

12051 Riverside Way
Richmond, BC, Canada
V6W 1K7
T: +1 866.765.0827 (toll free)
T: +1 604.242.9937
F: +1 604.242.9938
E: mv-sales@flir.com

USA

T: +1 866.765.0827 (toll free)
E: mv-na-sales@flir.com

www.flir.com/mv

EUROPE

T: +49 7141 488817-0
F: +49 7141 488817-99
E: mv-eusales@flir.com

CHINA

T: +86 10 8215 9938
F: +86 10 8215 9936
E: mv-chinasales@flir.com

ASIA

E: mv-asiasales@flir.com

www.flir.com
NASDAQ: FLIR

©2020 FLIR® Integrated Imaging Solutions Inc. All rights reserved. Names and marks appearing on the products herein are either registered trademarks or trademarks of FLIR® Systems, Inc. and/or its subsidiaries. Specifications are subject to change without notice.

VN: 20-0305-OEM-BFS-U3-20S4-v1

FIND THE BEST BLACKFLY S
FOR YOUR NEEDS



The World's Sixth Sense®



INDUSTRIAL/MACHINE VISION APPLICATIONS

FLIR BLACKFLY S

P/N BFS-U3-23S3

SMALL PACKAGE, POWERFUL RESULTS

The Blackfly S is a compact, high performance machine vision camera that allows designers to easily produce the exact images they need. With both automatic and precise manual control over image capture and on-camera pre-processing, the Blackfly S accelerates application development.

www.flir.com/mv

FEATURES

THE LATEST CMOS SENSORS

Switch between high sensitivity and low noise, and high saturation capacity and dynamic range with selectable conversion gain.

IMPROVE CYCLE TIMES

Automate more with advanced camera controls, event notifications, chunk data, counters and timers.

ACCELERATE YOUR TIME TO MARKET

FLIR's GenICam3 API with GUI library, and detailed event logging is supported by comprehensive documentation.

APPLICATIONS

AUTOMATED OPTICAL INSPECTION

MICROSCOPY ROBOT GUIDANCE

LASER BEAM PROFILING

AUTONOMOUS VEHICLE GUIDANCE



GEN*i*CAM

Pregius

SPECS	BFS-U3-23S3M-C	BFS-U3-23S3C-C
Resolution	1920 x 1200	
Frame Rate*	163 FPS	
Megapixels	2.3 MP	
Chroma	Mono	Color
Sensor	Sony IMX392, CMOS, 1/2.3"	
Readout Method	Global shutter	
Pixel Size	3.45 µm	
Lens Mount	C-mount	
ADC	10- bit / 12-bit	
Minimum Frame Rate**	1 FPS	
Gain Range**	0 to 47 dB	
Exposure Range**	5 µs to 30 s	
Acquisition Modes	Continuous, Single Frame, Multi Frame	
Partial Image Modes	Pixel binning, decimation, ROI	
Image Processing	Gamma, lookup table, and sharpness	Color correction matrix, gamma, lookup table, saturation, and sharpness
Sequencer	Up to 8 sets using 6 features	
Image Buffer	240 MB	
User Sets	2 user configuration sets for custom camera settings	
Flash Memory	6 MB non-volatile memory	
Opto-isolated I/O	1 input, 1 output	
Non-isolated I/O	1 bi-directional, 1 input	
Auxiliary Output	3.3 V, 120 mA maximum	
Interface	USB 3.1 Gen 1	
Power Requirements	8 - 24 V via GPIO or 5 V via USB3 interface	
Power Consumption	3 W maximum	
Dimensions/Mass	29 mm x 29 mm x 30 mm / 36 g	
Machine Vision Standard	USB3 Vision v1.0	
Compliance	CE, FCC, KCC, RoHS, REACH. The ECCN for this product is: EAR099.	
Temperature	Operating: 0°C to 50°C Storage: -30°C to 60°C	
Humidity	Operating: 20% to 80% (no condensation) Storage: 30% to 95% (no condensation)	
Warranty	3 years	

*Frame rates are measured with Device Link Throughput Limit of 380 MBps and Acquisition Frame Rate disabled. Values are rounded down to whole numbers.

**Values are the same in binning and no binning modes.

CANADA

12051 Riverside Way
Richmond, BC, Canada
V6W 1K7
T: +1 866.765.0827 (toll free)
T: +1 604.242.9937
F: +1 604.242.9938
E: mv-sales@flir.com
www.flir.com/mv

USA

T: +1 866.765.0827 (toll free)
E: mv-na-sales@flir.com

EUROPE

T: +49 7141 488817-0
F: +49 7141 488817-99
E: mv-eusales@flir.com

CHINA

T: +86 10 8215 9938
F: +86 10 8215 9936
E: mv-chinasales@flir.com

ASIA

E: mv-asiasales@flir.com

www.flir.com
NASDAQ: FLIR

©2019 FLIR® Integrated Imaging Solutions Inc. All rights reserved. Names and marks appearing on the products herein are either registered trademarks or trademarks of FLIR® Systems, Inc. and/or its subsidiaries. Specifications are subject to change without notice.

VN: BFS-U3-23S3-v2

FIND THE BEST BLACKFLY'S
FOR YOUR NEEDS



The World's Sixth Sense®



INDUSTRIAL/MACHINE VISION APPLICATIONS

FLIR BLACKFLY® S

P/N: BFS-U3-27S5

SMALL PACKAGE, POWERFUL RESULTS

The Blackfly S is a compact, high performance machine vision camera that allows designers to easily produce the exact images they need. With both automatic and precise manual control over image capture and on-camera pre-processing, the Blackfly S accelerates application development.

www.flir.com/products/blackfly-s-usb3

FEATURES

THE LATEST CMOS SENSORS

Switch between high sensitivity and low noise, and high saturation capacity and dynamic range with selectable conversion gain.

IMPROVE CYCLE TIMES

Automate more with advanced camera controls, event notifications, chunk data, counters and timers.

ACCELERATE YOUR TIME TO MARKET

FLIR's GenICam3 API with GUI library, and detailed event logging is supported by comprehensive documentation.

APPLICATIONS

AUTOMATED OPTICAL INSPECTION

MICROSCOPY

ROBOT GUIDANCE

LASER BEAM PROFILING

AUTONOMOUS VEHICLE GUIDANCE



SPECS	BFS-U3-27S5M-C	BFS-U3-27S5C-C
Resolution	1936 x 1464	
Frame Rate*	95 FPS	
Megapixels	2.8 MP	
Chroma	Mono	Color
Sensor	Sony IMX429, CMOS, 2/3"	
Readout Method	Global shutter	
Pixel Size	4.5 µm	
Lens Mount	C-mount	
ADC	12-bit	
Minimum Frame Rate**	1 FPS	
Gain Range**	0 to 47 dB	
Exposure Range**	12 µs to 30 s	
Acquisition Modes	Continuous, Single Frame, Multi Frame	
Partial Image Modes	Pixel binning, decimation, ROI	
Image Processing	Gamma, lookup table, and sharpness	Color correction matrix, gamma, lookup table, saturation, and sharpness
Sequencer	Up to 8 sets using 6 features	
Image Buffer	240 MB	
User Sets	2 user configuration sets for custom camera settings	
Flash Memory	6 MB non-volatile memory	
Opto-isolated I/O	1 input, 1 output	
Non-isolated I/O	1 bi-directional, 1 input	
Auxiliary Output	3.3 V, 120 mA maximum	
Interface	USB 3.1 Gen 1	
Power Requirements	8 - 24 V via GPIO or 5 V via USB3 interface	
Power Consumption	4.2 W maximum	
Dimensions/Mass	29 mm x 29 mm x 39 mm / 53 g	
Machine Vision Standard	USB3 Vision v1.0	
Compliance	CE, FCC, RoHS, REACH. The ECCN for this product is: EAR099.	
Temperature	Operating: 0°C to 50°C Storage: -30°C to 60°C	
Humidity	Operating: 20% to 80% (no condensation) Storage: 30% to 95% (no condensation)	
Warranty	3 years	

*Frame rates are measured with Device Link Throughput Limit of 380 MBps and Acquisition Frame Rate disabled. Values are rounded down to whole numbers.

**Values are the same in binning and no binning modes.

CANADA

12051 Riverside Way
Richmond, BC, Canada
V6W 1K7
T: +1 866.765.0827 (toll free)
T: +1 604.242.9937
F: +1 604.242.9938
E: mv-sales@flir.com

USA

T: +1 866.765.0827 (toll free)
E: mv-na-sales@flir.com

www.flir.com/mv

EUROPE

T: +49 7141 488817-0
F: +49 7141 488817-99
E: mv-eusales@flir.com

CHINA

T: +86 10 8215 9938
F: +86 10 8215 9936
E: mv-chinasales@flir.com

ASIA

E: mv-asiasales@flir.com

www.flir.com
NASDAQ: FLIR

©2020 FLIR® Integrated Imaging Solutions Inc. All rights reserved. Names and marks appearing on the products herein are either registered trademarks or trademarks of FLIR® Systems, Inc. and/or its subsidiaries. Specifications are subject to change without notice.

VN: 20-0305-OEM-BFS-U3-27S5-v1

FIND THE BEST BLACKFLY S
FOR YOUR NEEDS



The World's Sixth Sense®



INDUSTRIAL/MACHINE VISION APPLICATIONS

FLIR BLACKFLY S

P/N BFS-U3-28S5

SMALL PACKAGE, POWERFUL RESULTS

The Blackfly S is a compact, high performance machine vision camera that allows designers to easily produce the exact images they need. With both automatic and precise manual control over image capture and on-camera pre-processing, the Blackfly S accelerates application development.

www.flir.com/mv

FEATURES

THE LATEST CMOS SENSORS

Switch between high sensitivity and low noise, and high saturation capacity and dynamic range with selectable conversion gain.

IMPROVE CYCLE TIMES

Automate more with advanced camera controls, event notifications, chunk data, counters and timers.

ACCELERATE YOUR TIME TO MARKET

FLIR's GenICam3 API with GUI library, and detailed event logging is supported by comprehensive documentation.

APPLICATIONS

AUTOMATED OPTICAL INSPECTION

MICROSCOPY ROBOT GUIDANCE

LASER BEAM PROFILING

AUTONOMOUS VEHICLE GUIDANCE



GEN*i*CAM

Pregius

SPECS	BFS-U3-28S5M-C	BFS-U3-28S5C-C
Resolution	1936 x 1464	
Frame Rate*	130 FPS	
Megapixels	2.8 MP	
Chroma	Mono	Color
Sensor	Sony IMX421, CMOS, 2/3"	
Readout Method	Global shutter	
Pixel Size	4.5 µm	
Lens Mount	C-mount	
ADC	10- bit / 12-bit	
Minimum Frame Rate**	1 FPS	
Gain Range**	0 to 47 dB	
Exposure Range**	10 µs to 30 s	
Acquisition Modes	Continuous, Single Frame, Multi Frame	
Partial Image Modes	Pixel binning, decimation, ROI	
Image Processing	Gamma, lookup table, and sharpness	Color correction matrix, gamma, lookup table, saturation, and sharpness
Sequencer	Up to 8 sets using 6 features	
Image Buffer	240 MB	
User Sets	2 user configuration sets for custom camera settings	
Flash Memory	6 MB non-volatile memory	
Opto-isolated I/O	1 input, 1 output	
Non-isolated I/O	1 bi-directional, 1 input	
Auxiliary Output	3.3 V, 120 mA maximum	
Interface	USB 3.1 Gen 1	
Power Requirements	8 - 24 V via GPIO or 5 V via USB3 interface	
Power Consumption	4.2 W maximum	
Dimensions/Mass	29 mm x 29 mm x 39 mm / 53 g	
Machine Vision Standard	USB3 Vision v1.0	
Compliance	CE, FCC, KCC, RoHS, REACH. The ECCN for this product is: EAR099.	
Temperature	Operating: 0°C to 50°C Storage: -30°C to 60°C	
Humidity	Operating: 20% to 80% (no condensation) Storage: 30% to 95% (no condensation)	
Warranty	3 years	

*Frame rates are measured with Device Link Throughput Limit of 380 MBps and Acquisition Frame Rate disabled. Values are rounded down to whole numbers.

**Values are the same in binning and no binning modes.

CANADA

12051 Riverside Way
Richmond, BC, Canada
V6W 1K7
T: +1 866.765.0827 (toll free)
T: +1 604.242.9937
F: +1 604.242.9938
E: mv-sales@flir.com
www.flir.com/mv

USA

T: +1 866.765.0827 (toll free)
E: mv-na-sales@flir.com

EUROPE

T: +49 7141 488817-0
F: +49 7141 488817-99
E: mv-eusales@flir.com

CHINA

T: +86 10 8215 9938
F: +86 10 8215 9936
E: mv-chinasales@flir.com

ASIA

E: mv-asiasales@flir.com

www.flir.com
NASDAQ: FLIR

©2019 FLIR® Integrated Imaging Solutions Inc. All rights reserved. Names and marks appearing on the products herein are either registered trademarks or trademarks of FLIR® Systems, Inc. and/or its subsidiaries. Specifications are subject to change without notice.

VN: BFS-U3-28S5-v2

FIND THE BEST BLACKFLY S
FOR YOUR NEEDS



The World's Sixth Sense®



INDUSTRIAL/MACHINE VISION APPLICATIONS

FLIR BLACKFLY S

P/N BFS-U3-31S4

SMALL PACKAGE, POWERFUL RESULTS

The Blackfly S is a compact, high performance machine vision camera that allows designers to easily produce the exact images they need. With both automatic and precise manual control over image capture and on-camera pre-processing, the Blackfly S accelerates application development.

www.flir.com/mv

FEATURES

THE LATEST CMOS SENSORS

Switch between high sensitivity and low noise, and high saturation capacity and dynamic range with selectable conversion gain.

IMPROVE CYCLE TIMES

Automate more with advanced camera controls, event notifications, chunk data, counters and timers.

ACCELERATE YOUR TIME TO MARKET

FLIR's GenICam3 API with GUI library, and detailed event logging is supported by comprehensive documentation.

APPLICATIONS

AUTOMATED OPTICAL INSPECTION

MICROSCOPY ROBOT GUIDANCE

LASER BEAM PROFILING

AUTONOMOUS VEHICLE GUIDANCE



GEN*i*CAM

Pregius

SPECS	BFS-U3-31S4M-C	BFS-U3-31S4C-C
Resolution	2048 x 1536	
Frame Rate*	55 FPS	
Megapixels	3.1 MP	
Chroma	Mono	Color
Sensor	Sony IMX265, CMOS, 1/1.8"	
Readout Method	Global shutter	
Pixel Size	3.45 µm	
Lens Mount	C-mount	
ADC	12-bit	
Minimum Frame Rate**	1 FPS	
Gain Range**	0 to 47 dB	
Exposure Range**	11 µs to 30 s	
Acquisition Modes	Continuous, Single Frame, Multi Frame	
Partial Image Modes	Pixel binning, decimation, ROI	
Image Processing	Gamma, lookup table, and sharpness	Color correction matrix, gamma, lookup table, hue, saturation, and sharpness
Sequencer	Up to 8 sets using 6 features	
Image Buffer	240 MB	
User Sets	2 user configuration sets for custom camera settings	
Flash Memory	6 MB non-volatile memory	
Opto-isolated I/O	1 input, 1 output	
Non-isolated I/O	1 bi-directional, 1 input	
Auxiliary Output	3.3 V, 120 mA maximum	
Interface	USB 3.1 Gen 1	
Power Requirements	8 - 24 V via GPIO or 5 V via USB3 interface	
Power Consumption	3 W maximum	
Dimensions/Mass	29 mm x 29 mm x 30 mm / 36 g	
Machine Vision Standard	USB3 Vision v1.0	
Compliance	CE, FCC, KCC, RoHS, REACH. The ECCN for this product is: EAR099.	
Temperature	Operating: 0°C to 50°C Storage: -30°C to 60°C	
Humidity	Operating: 20% to 80% (no condensation) Storage: 30% to 95% (no condensation)	
Warranty	3 years	

*Frame rates are measured with Device Link Throughput Limit of 380 MBps and Acquisition Frame Rate disabled. Values are rounded down to whole numbers.

**Values are the same in binning and no binning modes.

CANADA

12051 Riverside Way
Richmond, BC, Canada
V6W 1K7
T: +1 866.765.0827 (toll free)
T: +1 604.242.9937
F: +1 604.242.9938
E: mv-sales@flir.com
www.flir.com/mv

USA

T: +1 866.765.0827 (toll free)
E: mv-na-sales@flir.com

EUROPE

T: +49 7141 488817-0
F: +49 7141 488817-99
E: mv-eusales@flir.com

CHINA

T: +86 10 8215 9938
F: +86 10 8215 9936
E: mv-chinasales@flir.com

ASIA

E: mv-asiasales@flir.com

www.flir.com
NASDAQ: FLIR

©2019 FLIR® Integrated Imaging Solutions Inc. All rights reserved. Names and marks appearing on the products herein are either registered trademarks or trademarks of FLIR® Systems, Inc. and/or its subsidiaries. Specifications are subject to change without notice.

VN: BFS-U3-31S4-v2

FIND THE BEST BLACKFLY S
FOR YOUR NEEDS



The World's Sixth Sense®



INDUSTRIAL/MACHINE VISION APPLICATIONS

FLIR BLACKFLY S

P/N BFS-U3-32S4

SMALL PACKAGE, POWERFUL RESULTS

The Blackfly S is a compact, high performance machine vision camera that allows designers to easily produce the exact images they need. With both automatic and precise manual control over image capture and on-camera pre-processing, the Blackfly S accelerates application development.

www.flir.com/mv

FEATURES

THE LATEST CMOS SENSORS

Switch between high sensitivity and low noise, and high saturation capacity and dynamic range with selectable conversion gain.

IMPROVE CYCLE TIMES

Automate more with advanced camera controls, event notifications, chunk data, counters and timers.

ACCELERATE YOUR TIME TO MARKET

FLIR's GenICam3 API with GUI library, and detailed event logging is supported by comprehensive documentation.

APPLICATIONS

AUTOMATED OPTICAL INSPECTION

MICROSCOPY ROBOT GUIDANCE

LASER BEAM PROFILING

AUTONOMOUS VEHICLE GUIDANCE



GEN*i*CAM

Pregius

SPECS	BFS-U3-32S4M-C	BFS-U3-32S4C-C
Resolution	2048 x 1536	
Frame Rate*	118 FPS	
Megapixels	3.2 MP	
Chroma	Mono	Color
Sensor	Sony IMX252, CMOS, 1/1.8"	
Readout Method	Global shutter	
Pixel Size	3.45 µm	
Lens Mount	C-mount	
ADC	10-bit and 12-bit	
Minimum Frame Rate**	1 FPS	
Gain Range**	0 to 47 dB	
Exposure Range**	5 µs to 30 s	
Acquisition Modes	Continuous, Single Frame, Multi Frame	
Partial Image Modes	Pixel binning, decimation, ROI	
Image Processing	Gamma, lookup table, and sharpness	Color correction matrix, gamma, lookup table, hue, saturation, and sharpness
Sequencer	Up to 8 sets using 2 features, exposure and gain	
Image Buffer	240 MB	
User Sets	2 user configuration sets for custom camera settings	
Flash Memory	6 MB non-volatile memory	
Opto-isolated I/O	1 input, 1 output	
Non-isolated I/O	1 bi-directional, 1 input	
Auxiliary Output	3.3 V, 120 mA maximum	
Interface	USB 3.1 Gen 1	
Power Requirements	8 - 24 V via GPIO or 5 V via USB3 interface	
Power Consumption	3 W maximum	
Dimensions/Mass	29 mm x 29 mm x 30 mm / 36 g	
Machine Vision Standard	USB3 Vision v1.0	
Compliance	CE, FCC, KCC, RoHS, REACH. The ECCN for this product is: EAR099.	
MTBF***	4,777,000 hours @20°C, GB environment 1,194,000 hours @20°C, GM environment	
Temperature	Operating: 0°C to 50°C Storage: -30°C to 60°C	
Humidity	Operating: 20% to 80% (no condensation) Storage: 30% to 95% (no condensation)	
Warranty	3 years	

*Frame rates are measured with Device Link Throughput Limit of 380 MBps and Acquisition Frame Rate disabled. Values are rounded down to whole numbers.

**Values are the same in binning and no binning modes.

***Ambient temperature; internal camera temperature is not considered.

CANADA

12051 Riverside Way
Richmond, BC, Canada
V6W 1K7
T: +1 866.765.0827 (toll free)
T: +1 604.242.9937
F: +1 604.242.9938
E: mv-sales@flir.com
www.flir.com/mv

USA

T: +1 866.765.0827 (toll free)
E: mv-na-sales@flir.com

EUROPE

T: +49 7141 488817-0
F: +49 7141 488817-99
E: mv-eusales@flir.com

CHINA

T: +86 10 8215 9938
F: +86 10 8215 9936
E: mv-chinasales@flir.com

ASIA

E: mv-asiasales@flir.com

www.flir.com
NASDAQ: FLIR

©2019 FLIR® Integrated Imaging Solutions Inc. All rights reserved. Names and marks appearing on the products herein are either registered trademarks or trademarks of FLIR® Systems, Inc. and/or its subsidiaries. Specifications are subject to change without notice.

VN: BFS-U3-32S4-v2

FIND THE BEST BLACKFLY'S
FOR YOUR NEEDS



The World's Sixth Sense®



INDUSTRIAL/MACHINE VISION APPLICATIONS

FLIR BLACKFLY S

P/N BFS-U3-50S5

SMALL PACKAGE, POWERFUL RESULTS

The Blackfly S is a compact, high performance machine vision camera that allows designers to easily produce the exact images they need. With both automatic and precise manual control over image capture and on-camera pre-processing, the Blackfly S accelerates application development.

www.flir.com/mv

FEATURES

THE LATEST CMOS SENSORS

Switch between high sensitivity and low noise, and high saturation capacity and dynamic range with selectable conversion gain.

IMPROVE CYCLE TIMES

Automate more with advanced camera controls, event notifications, chunk data, counters and timers.

ACCELERATE YOUR TIME TO MARKET

FLIR's GenICam3 API with GUI library, and detailed event logging is supported by comprehensive documentation.

APPLICATIONS

AUTOMATED OPTICAL INSPECTION

MICROSCOPY ROBOT GUIDANCE

LASER BEAM PROFILING

AUTONOMOUS VEHICLE GUIDANCE



GEN*i*CAM

Pregius

SPECS	BFS-U3-50S5M-C	BFS-U3-50S5C-C
Resolution	2448 x 2048	
Frame Rate*	35 FPS	
Megapixels	5.0 MP	
Chroma	Mono	Color
Sensor	Sony IMX264, CMOS, 2/3"	
Readout Method	Global shutter	
Pixel Size	3.45 µm	
Lens Mount	C-mount	
ADC	12-bit	
Minimum Frame Rate**	1 FPS	
Gain Range**	0 to 47 dB	
Exposure Range**	13 µs to 30 s	
Acquisition Modes	Continuous, Single Frame, Multi Frame	
Partial Image Modes	Pixel binning, decimation, ROI	
Image Processing	Gamma, lookup table, and sharpness	Color correction matrix, gamma, lookup table, hue, saturation, and sharpness
Sequencer	Up to 8 sets using 2 features, exposure and gain	
Image Buffer	240 MB	
User Sets	2 user configuration sets for custom camera settings	
Flash Memory	1 MB non-volatile memory	
Opto-isolated I/O	1 input, 1 output	
Non-isolated I/O	1 bi-directional	
Auxiliary Output	3.3 V, 150 mA maximum	
Interface	USB 3.1 Gen 1	
Power Requirements	5 - 24 V via GPIO or 5 V via USB3 interface	
Power Consumption	3 W maximum	
Dimensions/Mass	29 mm x 29 mm x 30 mm / 36 g	
Machine Vision Standard	USB3 Vision v1.0	
Compliance	CE, FCC, KCC, RoHS, REACH. he ECCN for this product is: EAR099.	
Temperature	Operating: 0°C to 50°C Storage: -30°C to 60°C	
Humidity	Operating: 20% to 80% (no condensation) Storage: 30% to 95% (no condensation)	
Warranty	3 years	

*Frame rates are measured with Device Link Throughput Limit of 500 MBps and Acquisition Frame Rate disabled. Values are rounded down to whole numbers.

**Values are the same in binning and no binning modes.

CANADA

12051 Riverside Way
Richmond, BC, Canada
V6W 1K7
T: +1 866.765.0827 (toll free)
T: +1 604.242.9937
F: +1 604.242.9938
E: mv-sales@flir.com
www.flir.com/mv

USA

T: +1 866.765.0827 (toll free)
E: mv-na-sales@flir.com

EUROPE

T: +49 7141 488817-0
F: +49 7141 488817-99
E: mv-eusales@flir.com

CHINA

T: +86 10 8215 9938
F: +86 10 8215 9936
E: mv-chinasales@flir.com

ASIA

E: mv-asiasales@flir.com

www.flir.com
NASDAQ: FLIR

©2019 FLIR® Integrated Imaging Solutions Inc. All rights reserved. Names and marks appearing on the products herein are either registered trademarks or trademarks of FLIR® Systems, Inc. and/or its subsidiaries. Specifications are subject to change without notice.

VN: BFS-U3-50S5-v2

FIND THE BEST BLACKFLY S
FOR YOUR NEEDS



The World's Sixth Sense®



INDUSTRIAL/MACHINE VISION APPLICATIONS

FLIR BLACKFLY S

P/N BFS-U3-51S5

SMALL PACKAGE, POWERFUL RESULTS

The Blackfly S is a compact, high performance machine vision camera that allows designers to easily produce the exact images they need. With both automatic and precise manual control over image capture and on-camera pre-processing, the Blackfly S accelerates application development.

www.flir.com/mv

FEATURES

THE LATEST CMOS SENSORS

Switch between high sensitivity and low noise, and high saturation capacity and dynamic range with selectable conversion gain.

IMPROVE CYCLE TIMES

Automate more with advanced camera controls, event notifications, chunk data, counters and timers.

ACCELERATE YOUR TIME TO MARKET

FLIR's GenICam3 API with GUI library, and detailed event logging is supported by comprehensive documentation.

APPLICATIONS

AUTOMATED OPTICAL INSPECTION

MICROSCOPY ROBOT GUIDANCE

LASER BEAM PROFILING

AUTONOMOUS VEHICLE GUIDANCE



GEN*i*CAM

Pregius

SPECS	BFS-U3-51S5M-C	BFS-U3-51S5C-C
Resolution	2448 x 2048	
Frame Rate*	75 FPS	
Megapixels	5.0 MP	
Chroma	Mono	Color
Sensor	Sony IMX250, CMOS, 2/3"	
Readout Method	Global shutter	
Pixel Size	3.45 µm	
Lens Mount	C-mount	
ADC	10-bit / 12-bit	
Minimum Frame Rate**	1 FPS	
Gain Range**	0 to 47 dB	
Exposure Range**	6 µs to 30 s	
Acquisition Modes	Continuous, Single Frame, Multi Frame	
Partial Image Modes	Pixel binning, decimation, ROI	
Image Processing	Gamma, lookup table, and sharpness	Color correction matrix, gamma, lookup table, hue, saturation, and sharpness
Sequencer	Up to 8 sets using 2 features, exposure and gain	
Image Buffer	240 MB	
User Sets	2 user configuration sets for custom camera settings	
Flash Memory	1 MB non-volatile memory	
Opto-isolated I/O	1 input, 1 output	
Non-isolated I/O	1 bi-directional	
Auxiliary Output	3.3 V, 150 mA maximum	
Interface	USB 3.1 Gen 1	
Power Requirements	5 - 24 V via GPIO or 5 V via USB3 interface	
Power Consumption	3 W maximum	
Dimensions/Mass	29 mm x 29 mm x 30 mm / 36 g	
Machine Vision Standard	USB3 Vision v1.0	
Compliance	CE, FCC, KCC, RoHS, REACH. he ECCN for this product is: EAR099.	
MTBF***	4,706,000 hours @20°C, GB environment 1,177,000 hours @20°C, GM environment	
Temperature	Operating: 0°C to 50°C Storage: -30°C to 60°C	
Humidity	Operating: 20% to 80% (no condensation) Storage: 30% to 95% (no condensation)	
Warranty	3 years	

*Frame rates are measured with Device Link Throughput Limit of 500 MBps and Acquisition Frame Rate disabled. Values are rounded down to whole numbers.

**Values are the same in binning and no binning modes.

***Ambient temperature; internal camera temperature is not considered.

CANADA

12051 Riverside Way
Richmond, BC, Canada
V6W 1K7
T: +1 866.765.0827 (toll free)
T: +1 604.242.9937
F: +1 604.242.9938
E: mv-sales@flir.com
www.flir.com/mv

USA

T: +1 866.765.0827 (toll free)
E: mv-na-sales@flir.com

EUROPE

T: +49 7141 488817-0
F: +49 7141 488817-99
E: mv-eusales@flir.com

CHINA

T: +86 10 8215 9938
F: +86 10 8215 9936
E: mv-chinasales@flir.com

ASIA

E: mv-asiasales@flir.com

www.flir.com
NASDAQ: FLIR

©2019 FLIR® Integrated Imaging Solutions Inc. All rights reserved.
Names and marks appearing on the products herein are either registered trademarks or trademarks of FLIR® Systems, Inc. and/or its subsidiaries. Specifications are subject to change without notice.

VN: BFS-U3-51S5-v2

FIND THE BEST BLACKFLY'S
FOR YOUR NEEDS



The World's Sixth Sense®



INDUSTRIAL/MACHINE VISION APPLICATIONS

FLIR BLACKFLY[®] S

P/N BFS-U3-51S5PC

ENABLE NEW APPLICATIONS WITH ON-SENSOR POLARIZATION

See the world in a whole new way with the FLIR Blackfly S. Sony's Pregius sensors with on-sensor polarizing filters adds polarimetry to the FLIR Blackfly S already powerful feature-set. The USB 3.1 Gen 1 interface enables a global shutter readout at 75 FPS in a compact, low power package. This camera is ideal for building the next generation of polarimetry based industrial, traffic and UAS applications.

www.flir.com/mv

FEATURES

ON-SENSOR POLARIZING FILTERS

Enable new imaging possibilities using global shutter CMOS sensors with polarization. The Spinnaker SDK makes interpolation and analysis of polarization data easy.

DEVELOP ONCE, DEPLOY ANYWHERE

Support for a wide range of operating systems and host system hardware architectures. Easily switch to board level models for embedded systems. Simplified product iteration with consistent form factor across sensor sizes.

ACCELERATE APPLICATION DEVELOPMENT

Compatible with third party software and hardware. Less code-writing required using powerful on-camera features. Quickly build custom applications with rich sample code and descriptive API logging.

APPLICATIONS

See through transparent and reflective materials including plastic, epoxy and glass by removing unwanted reflections

Inspect difficult-to-image materials such as protective films and clear-coat

Simplify training data for autonomous vehicles by eliminating unwanted glare

Dynamic removal of glare improves UAS and ITS system performance in uncontrolled and unpredictable lighting conditions



USB
VISION

GEN<i>CAM

SPECIFICATIONS

SPECS	BFS-U3-51S5P	BFS-U3-51S5PC
Resolution	2448 x 2048	
Frame Rate*	75 FPS	
Megapixels	5.0 MP	
Chroma	Polarized	Polarized Color
Sensor	Sony IMX250MZR, CMOS, 2/3"	Sony IMX250MYR, CMOS, 2/3"
Readout Method	Global shutter	
Pixel Size	3.45 µm	
Lens Mount	C-mount	
ADC	10-bit / 12-bit	
Minimum Frame Rate**	1 FPS	
Gain Range**	0 to 47 dB	
Exposure Range**	6 µs to 30 s	20 µs to 30 s
Acquisition Modes	Continuous, Single Frame, Multi Frame	
Partial Image Modes	Pixel binning, ROI	
Image Processing	Gamma	
Sequencer	Up to 8 sets using 6 features, including image size	
Image Buffer	240 MB	
User Sets	2 user configuration sets for custom camera settings	
Flash Memory	1 MB non-volatile memory	
Opto-isolated I/O	1 input, 1 output	
Non-isolated I/O	1 bi-directional	
Auxiliary Output	3.3 V, 150 mA maximum	
Serial Port	Supported	
Interface	USB 3.1 Gen 1	
Power Requirements	5 - 24 V via GPIO or 5 V via USB3 interface	
Power Consumption	3 W maximum	
Dimensions/Mass	29 mm x 29 mm x 30 mm / 36 g	
Machine Vision Standard	USB3 Vision v1.0	
Compliance	CE, FCC, KCC, RoHS, REACH. The ECCN for this product is: EAR099.	
Temperature	Operating: 0°C to 50°C Storage: -30°C to 60°C	
Humidity	Operating: 20% to 80% (no condensation) Storage: 30% to 95% (no condensation)	
Warranty	3 years	

*Frame rates are measured with Device Link Throughput Limit of 500 MBps and Acquisition Frame Rate disabled. Values are rounded down to whole numbers.

**Values are the same in binning and no binning modes.

FLIR Integrated Imaging Solutions

CANADA

12051 Riverside Way
Richmond, BC, Canada
V6W 1K7
T: +1 866.765.0827 (toll free)
T: +1 604.242.9937
F: +1 604.242.9938
E: mv-sales@flir.com
www.flir.com/mv

USA

T: +1 866.765.0827 (toll free)
E: mv-na-sales@flir.com

EUROPE

T: +49 7141 488817-0
F: +49 7141 488817-99
E: mv-eusales@flir.com

CHINA

T: +86 10 8215 9938
F: +86 10 8215 9936
E: mv-chinasales@flir.com

ASIA

E: mv-asiasales@flir.com

www.flir.com
NASDAQ: FLIR

©2019 FLIR® Integrated Imaging Solutions Inc. All rights reserved.
Names and marks appearing on the products herein are either registered trademarks or trademarks of FLIR® Systems, Inc. and/or its subsidiaries. Specifications are subject to change without notice.

VN: BFS-U3-51S5PC-v2

FIND THE BEST BLACKFLY S
FOR YOUR NEEDS



The World's Sixth Sense®



INDUSTRIAL/MACHINE VISION APPLICATIONS

FLIR BLACKFLY[®] S

P/N: BFS-U3-63S4

SMALL PACKAGE, POWERFUL RESULTS

The Blackfly S is a compact, high performance machine vision camera that allows designers to easily produce the exact images they need. With both automatic and precise manual control over image capture and on-camera pre-processing, the Blackfly S accelerates application development.

www.flir.com/products/blackfly-s-usb3

FEATURES

THE LATEST CMOS SENSORS

Switch between high sensitivity and low noise, and high saturation capacity and dynamic range with selectable conversion gain.

IMPROVE CYCLE TIMES

Automate more with advanced camera controls, event notifications, chunk data, counters and timers.

ACCELERATE YOUR TIME TO MARKET

FLIR's GenICam3 API with GUI library, and detailed event logging is supported by comprehensive documentation.

APPLICATIONS

AUTOMATED OPTICAL INSPECTION

MICROSCOPY ROBOT GUIDANCE

LASER BEAM PROFILING

AUTONOMOUS VEHICLE GUIDANCE



SPECS	BFS-U3-63S4M-C	BFS-U3-63S4C-C
Resolution	3072 x 2048	
Frame Rate*	59.6 FPS	
Megapixels	6.3 MP	
Chroma	Mono	Color
Sensor	Sony IMX178, CMOS, 1/1.8"	
Readout Method	Rolling shutter with global reset	
Pixel Size	2.4 µm	
Lens Mount	C-mount	
ADC	10-bit / 14-bit	
Minimum Frame Rate**	1 FPS	
Gain Range**	0 to 47 dB	
Exposure Range**	8 µs to 30 s	
Acquisition Modes	Continuous, Single Frame, Multi Frame	
Partial Image Modes	Pixel binning, decimation, ROI	
Image Processing	Gamma, lookup table, and sharpness	Color correction matrix, gamma, lookup table, saturation, and sharpness
Sequencer	Up to 8 sets using 5 features, including image size	
Image Buffer	240 MB	
User Sets	2 user configuration sets for custom camera settings	
Flash Memory	6 MB non-volatile memory	
Opto-isolated I/O	1 input, 1 output	
Non-isolated I/O	1 bi-directional, 1 input	
Auxiliary Output	3.3 V, 120 mA maximum	
Interface	USB 3.1 Gen 1	
Power Requirements	8 - 24 V via GPIO or 5 V via USB3 interface	
Power Consumption	3 W maximum	
Dimensions/Mass	29 mm x 29 mm x 30 mm / 36 g	
Machine Vision Standard	USB3 Vision v1.0	
Compliance	CE, FCC, KCC, RoHS, REACH. The ECCN for this product is: EAR099.	
Temperature	Operating: 0°C to 50°C Storage: -30°C to 60°C	
Humidity	Operating: 20% to 80% (no condensation) Storage: 30% to 95% (no condensation)	
Warranty	3 years	

*Frame rates are measured with Device Link Throughput Limit of 380 MBps and Acquisition Frame Rate disabled.

**Values are the same in binning and no binning modes.

CANADA

12051 Riverside Way
Richmond, BC, Canada
V6W 1K7
T: +1 866.765.0827 (toll free)
T: +1 604.242.9937
T: +1 604.242.9938
E: mv-sales@flir.com

USA

T: +1 866.765.0827 (toll free)
E: mv-na-sales@flir.com

www.flir.com/mv

EUROPE

T: +49 7141 488817-0
F: +49 7141 488817-99
E: mv-eusales@flir.com

CHINA

T: +86 10 8215 9938
F: +86 10 8215 9936
E: mv-chinasales@flir.com

ASIA

E: mv-asiasales@flir.com

www.flir.com
NASDAQ: FLIR

©2019 FLIR® Integrated Imaging Solutions Inc. All rights reserved.
Names and marks appearing on the products herein are either registered trademarks or trademarks of FLIR® Systems, Inc. and/or its subsidiaries. Specifications are subject to change without notice.

VN: BFS-U3-63S4-v3

FIND THE BEST BLACKFLY S
FOR YOUR NEEDS



The World's Sixth Sense®



INDUSTRIAL/MACHINE VISION APPLICATIONS

FLIR BLACKFLY S

P/N BFS-U3-70S7

SMALL PACKAGE, POWERFUL RESULTS

The Blackfly S is a compact, high performance machine vision camera that allows designers to easily produce the exact images they need. With both automatic and precise manual control over image capture and on-camera pre-processing, the Blackfly S accelerates application development.

www.flir.com/mv

FEATURES

THE LATEST CMOS SENSORS

Switch between high sensitivity and low noise, and high saturation capacity and dynamic range with selectable conversion gain.

IMPROVE CYCLE TIMES

Automate more with advanced camera controls, event notifications, chunk data, counters and timers.

ACCELERATE YOUR TIME TO MARKET

FLIR's GenICam3 API with GUI library, and detailed event logging is supported by comprehensive documentation.

APPLICATIONS

AUTOMATED OPTICAL INSPECTION

MICROSCOPY ROBOT GUIDANCE

LASER BEAM PROFILING

AUTONOMOUS VEHICLE GUIDANCE



GEN*i*CAM

Pregius

SPECS	BFS-U3-70S7M-C	BFS-U3-70S7C-C
Resolution	3208 x 2200	
Frame Rate*	51 FPS	
Megapixels	7.1 MP	
Chroma	Mono	Color
Sensor	Sony IMX428, CMOS, 1.1"	
Readout Method	Global shutter	
Pixel Size	4.5 µm	
Lens Mount	C-mount	
ADC	12-bit	
Minimum Frame Rate**	1 FPS	
Gain Range**	0 to 47 dB	
Exposure Range**	9 µs to 30 s	
Acquisition Modes	Continuous, Single Frame, Multi Frame	
Partial Image Modes	Pixel binning, decimation, ROI	
Image Processing	Gamma, lookup table, and sharpness	Color correction matrix, gamma, lookup table, saturation, and sharpness
Sequencer	Up to 8 sets using 6 features	
Image Buffer	240 MB	
User Sets	2 user configuration sets for custom camera settings	
Flash Memory	6 MB non-volatile memory	
Opto-isolated I/O	1 input, 1 output	
Non-isolated I/O	1 bi-directional, 1 input	
Auxiliary Output	3.3 V, 120 mA maximum	
Interface	USB 3.1 Gen 1	
Power Requirements	8 - 24 V via GPIO or 5 V via USB3 interface	
Power Consumption	4.2 W maximum	
Dimensions/Mass	29 mm x 29 mm x 39 mm / 53 g	
Machine Vision Standard	USB3 Vision v1.0	
Compliance	CE, FCC, KCC, RoHS, REACH. The ECCN for this product is: EAR099.	
Temperature	Operating: 0°C to 50°C Storage: -30°C to 60°C	
Humidity	Operating: 20% to 80% (no condensation) Storage: 30% to 95% (no condensation)	
Warranty	3 years	

*Frame rates are measured with Device Link Throughput Limit of 380 MBps and Acquisition Frame Rate disabled. Values are rounded down to whole numbers.

**Values are the same in binning and no binning modes.

CANADA

12051 Riverside Way
Richmond, BC, Canada
V6W 1K7
T: +1 866.765.0827 (toll free)
T: +1 604.242.9937
F: +1 604.242.9938
E: mv-sales@flir.com
www.flir.com/mv

USA

T: +1 866.765.0827 (toll free)
E: mv-na-sales@flir.com

EUROPE

T: +49 7141 488817-0
F: +49 7141 488817-99
E: mv-eusales@flir.com

CHINA

T: +86 10 8215 9938
F: +86 10 8215 9936
E: mv-chinasales@flir.com

ASIA

E: mv-asiasales@flir.com

www.flir.com
NASDAQ: FLIR

©2019 FLIR® Integrated Imaging Solutions Inc. All rights reserved. Names and marks appearing on the products herein are either registered trademarks or trademarks of FLIR® Systems, Inc. and/or its subsidiaries. Specifications are subject to change without notice.

VN: BFS-U3-70S7-v2

FIND THE BEST BLACKFLY S
FOR YOUR NEEDS



The World's Sixth Sense®



INDUSTRIAL/MACHINE VISION APPLICATIONS

FLIR BLACKFLY S

P/N BFS-U3-88S6

SMALL PACKAGE, POWERFUL RESULTS

The Blackfly S is a compact, high performance machine vision camera that allows designers to easily produce the exact images they need. With both automatic and precise manual control over image capture and on-camera pre-processing, the Blackfly S accelerates application development.

www.flir.com/mv

FEATURES

THE LATEST CMOS SENSORS

Switch between high sensitivity and low noise, and high saturation capacity and dynamic range with selectable conversion gain.

IMPROVE CYCLE TIMES

Automate more with advanced camera controls, event notifications, chunk data, counters and timers.

ACCELERATE YOUR TIME TO MARKET

FLIR's GenICam3 API with GUI library, and detailed event logging is supported by comprehensive documentation.

APPLICATIONS

AUTOMATED OPTICAL INSPECTION

MICROSCOPY ROBOT GUIDANCE

LASER BEAM PROFILING

AUTONOMOUS VEHICLE GUIDANCE



GEN*i*CAM

Pregius

SPECS	BFS-U3-88S6M-C	BFS-U3-88S6C-C
Resolution	4096 x 2160	
Frame Rate*	32 FPS	
Megapixels	8.9 MP	
Chroma	Mono	Color
Sensor	Sony IMX267, CMOS, 1"	
Readout Method	Global shutter	
Pixel Size	3.45 µm	
Lens Mount	C-mount	
ADC	12-bit	
Minimum Frame Rate**	1 FPS	
Gain Range**	0 to 47 dB	
Exposure Range**	14 µs to 30 s	
Acquisition Modes	Continuous, Single Frame, Multi Frame	
Partial Image Modes	Pixel binning, decimation, ROI	
Image Processing	Gamma, lookup table, and sharpness	Color correction matrix, gamma, lookup table, saturation, and sharpness
Sequencer	Up to 8 sets using 6 features	
Image Buffer	240 MB	
User Sets	2 user configuration sets for custom camera settings	
Flash Memory	6 MB non-volatile memory	
Opto-isolated I/O	1 input, 1 output	
Non-isolated I/O	1 bi-directional, 1 input	
Auxiliary Output	3.3 V, 120 mA maximum	
Interface	USB 3.1 Gen 1	
Power Requirements	8 - 24 V via GPIO or 5 V via USB3 interface	
Power Consumption	3 W maximum	
Dimensions/Mass	29 mm x 29 mm x 30 mm / 36 g	
Machine Vision Standard	USB3 Vision v1.0	
Compliance	CE, FCC, KCC, RoHS, REACH. The ECCN for this product is: EAR099.	
Temperature	Operating: 0°C to 50°C Storage: -30°C to 60°C	
Humidity	Operating: 20% to 80% (no condensation) Storage: 30% to 95% (no condensation)	
Warranty	3 years	

*Frame rates are measured with Device Link Throughput Limit of 380 MBps and Acquisition Frame Rate disabled.

**Values are the same in binning and no binning modes.

CANADA

12051 Riverside Way
Richmond, BC, Canada
V6W 1K7
T: +1 866.765.0827 (toll free)
T: +1 604.242.9937
F: +1 604.242.9938
E: mv-sales@flir.com
www.flir.com/mv

USA

T: +1 866.765.0827 (toll free)
E: mv-na-sales@flir.com

EUROPE

T: +49 7141 488817-0
F: +49 7141 488817-99
E: mv-eusales@flir.com

CHINA

T: +86 10 8215 9938
F: +86 10 8215 9936
E: mv-chinasales@flir.com

ASIA

E: mv-asiasales@flir.com

www.flir.com
NASDAQ: FLIR

©2019 FLIR® Integrated Imaging Solutions Inc. All rights reserved.
Names and marks appearing on the products herein are either registered trademarks or trademarks of FLIR® Systems, Inc. and/or its subsidiaries. Specifications are subject to change without notice.

VN: BFS-U3-88S6-v2

FIND THE BEST BLACKFLY'S
FOR YOUR NEEDS



The World's Sixth Sense®



INDUSTRIAL/MACHINE VISION APPLICATIONS

FLIR BLACKFLY S

P/N BFS-U3-89S6

SMALL PACKAGE, POWERFUL RESULTS

The Blackfly S is a compact, high performance machine vision camera that allows designers to easily produce the exact images they need. With both automatic and precise manual control over image capture and on-camera pre-processing, the Blackfly S accelerates application development.

www.flir.com/mv

FEATURES

THE LATEST CMOS SENSORS

Switch between high sensitivity and low noise, and high saturation capacity and dynamic range with selectable conversion gain.

IMPROVE CYCLE TIMES

Automate more with advanced camera controls, event notifications, chunk data, counters and timers.

ACCELERATE YOUR TIME TO MARKET

FLIR's GenICam3 API with GUI library, and detailed event logging is supported by comprehensive documentation.

APPLICATIONS

AUTOMATED OPTICAL INSPECTION

MICROSCOPY ROBOT GUIDANCE

LASER BEAM PROFILING

AUTONOMOUS VEHICLE GUIDANCE



GEN*i*CAM

Pregius

SPECS	BFS-U3-89S6M-C	BFS-U3-89S6C-C
Resolution	4096 x 2160	
Frame Rate*	42 FPS	
Megapixels	8.9 MP	
Chroma	Mono	Color
Sensor	Sony IMX255, CMOS, 1"	
Readout Method	Global shutter	
Pixel Size	3.45 µm	
Lens Mount	C-mount	
ADC	10-bit / 12-bit	
Minimum Frame Rate**	1 FPS	
Gain Range**	0 to 47 dB	
Exposure Range**	10 µs to 30 s	
Acquisition Modes	Continuous, Single Frame, Multi Frame	
Partial Image Modes	Pixel binning, decimation, ROI	
Image Processing	Gamma, lookup table, and sharpness	Color correction matrix, gamma, lookup table, saturation, and sharpness
Sequencer	Up to 8 sets using 6 features, including image size	
Image Buffer	240 MB	
User Sets	2 user configuration sets for custom camera settings	
Flash Memory	6 MB non-volatile memory	
Opto-isolated I/O	1 input, 1 output	
Non-isolated I/O	1 bi-directional, 1 input	
Auxiliary Output	3.3 V, 120 mA maximum	
Interface	USB 3.1 Gen 1	
Power Requirements	8 - 24 V via GPIO or 5 V via USB3 interface	
Power Consumption	3 W maximum	
Dimensions/Mass	29 mm x 29 mm x 30 mm / 36 g	
Machine Vision Standard	USB3 Vision v1.0	
Compliance	CE, FCC, KCC, RoHS, REACH. The ECCN for this product is: EAR099.	
Temperature	Operating: 0°C to 50°C Storage: -30°C to 60°C	
Humidity	Operating: 20% to 80% (no condensation) Storage: 30% to 95% (no condensation)	
Warranty	3 years	

*Frame rates are measured with Device Link Throughput Limit of 380 MBps and Acquisition Frame Rate disabled. Values are rounded down to whole numbers.

**Values are the same in binning and no binning modes.

CANADA

12051 Riverside Way
Richmond, BC, Canada
V6W 1K7
T: +1 866.765.0827 (toll free)
T: +1 604.242.9937
F: +1 604.242.9938
E: mv-sales@flir.com
www.flir.com/mv

USA

T: +1 866.765.0827 (toll free)
E: mv-na-sales@flir.com

EUROPE

T: +49 7141 488817-0
F: +49 7141 488817-99
E: mv-eusales@flir.com

CHINA

T: +86 10 8215 9938
F: +86 10 8215 9936
E: mv-chinasales@flir.com

ASIA

E: mv-asiasales@flir.com

www.flir.com
NASDAQ: FLIR

©2019 FLIR® Integrated Imaging Solutions Inc. All rights reserved. Names and marks appearing on the products herein are either registered trademarks or trademarks of FLIR® Systems, Inc. and/or its subsidiaries. Specifications are subject to change without notice.

VN: BFS-U3-89S6-v2

FIND THE BEST BLACKFLY'S
FOR YOUR NEEDS



The World's Sixth Sense®



INDUSTRIAL/MACHINE VISION APPLICATIONS

FLIR BLACKFLY S

P/N BFS-U3-120S4

SMALL PACKAGE, POWERFUL RESULTS

The Blackfly S is a compact, high performance machine vision camera that allows designers to easily produce the exact images they need. With both automatic and precise manual control over image capture and on-camera pre-processing, the Blackfly S accelerates application development.

www.flir.com/mv

FEATURES

THE LATEST CMOS SENSORS

Switch between high sensitivity and low noise, and high saturation capacity and dynamic range with selectable conversion gain.

IMPROVE CYCLE TIMES

Automate more with advanced camera controls, event notifications, chunk data, counters and timers.

ACCELERATE YOUR TIME TO MARKET

FLIR's GenICam3 API with GUI library, and detailed event logging is supported by comprehensive documentation.

APPLICATIONS

AUTOMATED OPTICAL INSPECTION

MICROSCOPY ROBOT GUIDANCE

LASER BEAM PROFILING

AUTONOMOUS VEHICLE GUIDANCE



GEN*i*CAM

Pregius

SPECS	BFS-U3-120S4M-CS	BFS-U3-120S4C-CS
Resolution	4000 x 3000	
Frame Rate*	31 FPS	
Megapixels	12 MP	
Chroma	Mono	Color
Sensor	Sony IMX226, CMOS, 1/1.7"	
Readout Method	Rolling shutter with global reset	
Pixel Size	1.85 μ m	
Lens Mount	CS-mount	
ADC	10-bit / 12-bit	
Minimum Frame Rate**	1 FPS	
Gain Range**	0 to 27 dB	
Exposure Range**	10 μ s to 30 s	
Acquisition Modes	Continuous, Single Frame, Multi Frame	
Partial Image Modes	Pixel binning, decimation, ROI	
Image Processing	Gamma, lookup table, and sharpness	Color correction matrix, gamma, lookup table, saturation, and sharpness
Sequencer	Up to 8 sets using 5 features	
Image Buffer	240 MB	
User Sets	2 user configuration sets for custom camera settings	
Flash Memory	6 MB non-volatile memory	
Opto-isolated I/O	1 input, 1 output	
Non-isolated I/O	1 bi-directional, 1 input	
Auxiliary Output	3.3 V, 120 mA maximum	
Interface	USB 3.1 Gen 1	
Power Requirements	8 - 24 V via GPIO or 5 V via USB3 interface	
Power Consumption	3 W maximum	
Dimensions/Mass	29 mm x 29 mm x 30 mm / 36 g	
Machine Vision Standard	USB3 Vision v1.0	
Compliance	CE, FCC, KCC, RoHS, REACH. The ECCN for this product is: EAR099.	
Temperature	Operating: 0°C to 50°C Storage: -30°C to 60°C	
Humidity	Operating: 20% to 80% (no condensation) Storage: 30% to 95% (no condensation)	
Warranty	3 years	

*Frame rates are measured with Device Link Throughput Limit of 380 MBps and Acquisition Frame Rate disabled.

**Values are the same in binning and no binning modes.

CANADA

12051 Riverside Way
Richmond, BC, Canada
V6W 1K7
T: +1 866.765.0827 (toll free)
T: +1 604.242.9937
F: +1 604.242.9938
E: mv-sales@flir.com
www.flir.com/mv

USA

T: +1 866.765.0827 (toll free)
E: mv-na-sales@flir.com

EUROPE

T: +49 7141 488817-0
F: +49 7141 488817-99
E: mv-eusales@flir.com

CHINA

T: +86 10 8215 9938
F: +86 10 8215 9936
E: mv-chinasales@flir.com

ASIA

E: mv-asiasales@flir.com

www.flir.com
NASDAQ: FLIR

©2019 FLIR® Integrated Imaging Solutions Inc. All rights reserved. Names and marks appearing on the products herein are either registered trademarks or trademarks of FLIR® Systems, Inc. and/or its subsidiaries. Specifications are subject to change without notice.

VN: BFS-U3-120S4-v2

FIND THE BEST BLACKFLY S
FOR YOUR NEEDS



The World's Sixth Sense®