

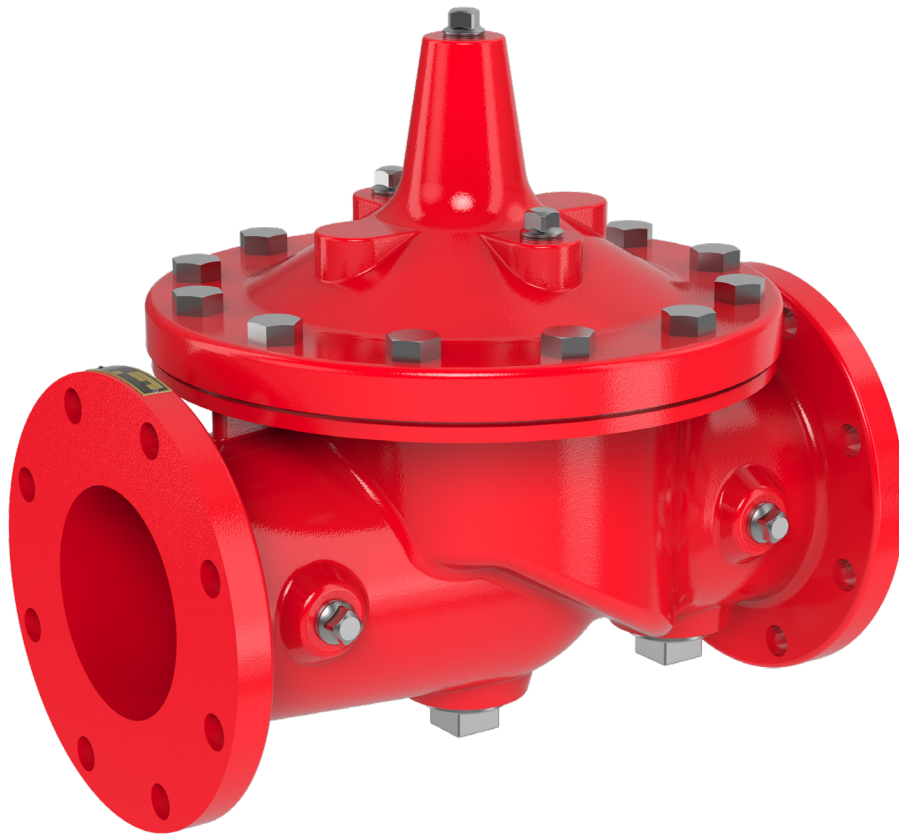

# Model 100G-UC

*UL Listed Deluge Valve*



**Installation / Operation / Maintenance**

# Model UC

## Hydraulic ON/OFF Deluge Valve with Manual Reset

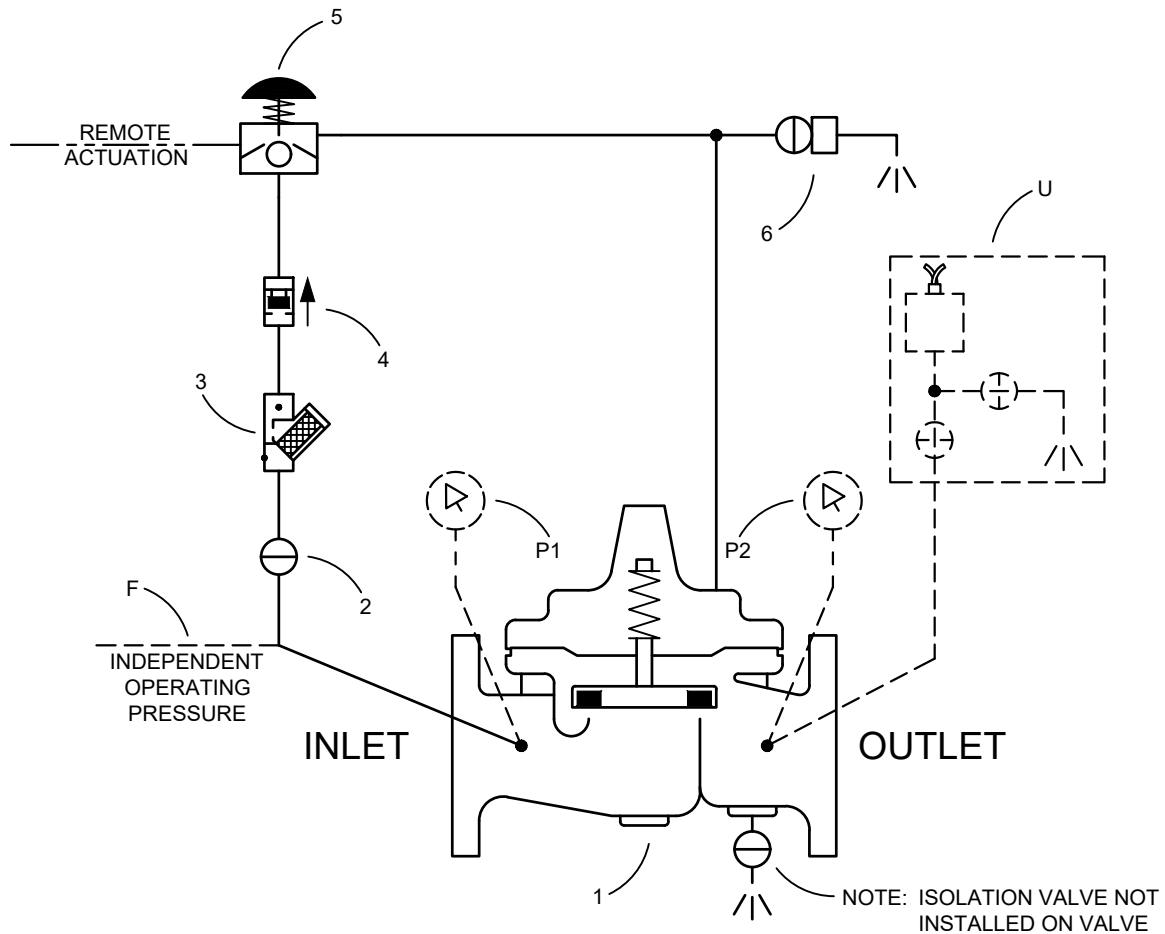

NO.	BASIC COMPONENTS	QTY
1	HYTROL MAIN VALVE	1
2	ISOLATION VALVE	1
3	STRAINER & ORIFICE ASSEMBLY	1
4	CHECK VALVE	1
5	MANUAL RESET PILOT	1
6	EMERGENCY DELUGE VALVE RELEASE	1

NO.	OPTIONAL FEATURES	QTY
F	INDEPENDENT OPERATING PRESSURE	
P	PRESSURE GAUGE ASSEMBLY	2
U	PRESSURE SWITCH ASSEMBLY	1



# Model **UC**

## Hydraulic ON/OFF Deluge Valve with Manual Reset

---

### ► OPERATING DATA

#### **Manual Reset Pilot Feature**

The manual reset pilot (6) is an automatic latching device that holds the deluge main valve (1) in its open position when it has been activated by a releasing device. When set, the manual reset pilot (6) blocks inlet pressure from entering the deluge main valve (1) cover chamber, thus effectively latches the deluge main valve (1) open. The manual reset pilot (6) allows the deluge main valve (1) to close only upon a local reset, while manually pushing the reset button. The manual reset pilot (6) consists of an integrated spring-loaded check valve, a safety ball drip drains any accidental leak to ensure that the deluge main valve (1) remains latched.

Note: The manual reset pilot (6) knob must in vertical position.

#### **Emergency Bypass Feature**

Open emergency bypass ball valve (7) relieving pressure from the main valve (1) cover chamber and the main valve (1) opens. Emergency bypass ball valve (7) must be closed during normal operation.

#### **Optional Features**

##### **(F) - Independent Operating Pressure:**

Pilot supply pressure is obtained from an independent source. (Pilot supply pressure is obtained from the main valve inlet if suffix (F) is not specified.) Note: independent operating pressure must be equal to or greater than pressure at the main valve inlet at all times.

##### **(P) - Pressure Gauge:**

Pressure gauges (P1) and (P2) provide pressure reading in the inlet and cover connections.

##### **(U) - Pressure Switch:**

Pressure switch (U) sense the pressure at the main valve (1) inlet and outlet respectively. This transmits a signal to display the flow rate through the main valve (1).

### ► CHECK LIST FOR PROPER OPERATION

- System valves open upstream and downstream.
- Air removed from the main valve cover and pilot system at all high points.
- Periodical cleaning of strainer (3) is recommended.
- Isolation valve (2) open during normal operation.
- EDVR (7) closed during normal operation.



—MODEL— **100G/2100G**  
**UL Listed Main Valve**

**Description**

The Cla-Val Model 100G/2100G is a UL Listed main valve for Cla-Val Automatic Control Valves. It is a hydraulically operated, diaphragm-actuated, globe or angle pattern valve.

This valve consists of three major components; body, diaphragm assembly, and cover. The diaphragm assembly is the only moving part. The diaphragm assembly uses a diaphragm of nylon fabric bonded with synthetic rubber. A synthetic rubber disc, contained on three and one half sides by a disc retainer and disc guide, forms a seal with the valve seat when pressure is applied above the diaphragm. The diaphragm assembly forms a sealed chamber in the upper portion of the valve, separating operating pressure from line pressure.

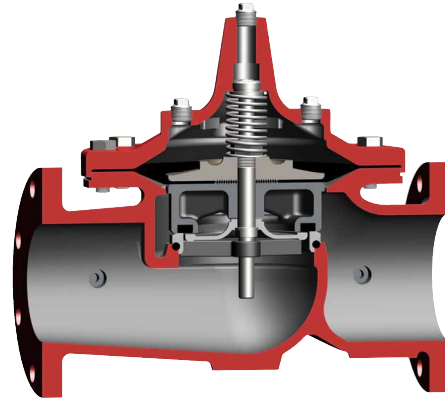

**Installation**

1. Before valve is installed, pipe lines should be flushed of all chips, scale and foreign matter.
2. It is recommended that either gate or block valves be installed on both ends of the 100G/2100G Main Valve to facilitate isolating the valve for preventive maintenance and repairs.
3. Place the valve in the line with flow through the valve in the direction indicated on the inlet nameplate. (See "Flow Direction" Section). **Note: Valve can be installed in the vertical or horizontal position.**
4. Allow sufficient room around valve to make adjustments and for disassembly.
5. Cla-Val 100G/2100G Main Valves operate with maximum efficiency when mounted in horizontal piping with the cover UP, however, other positions are acceptable. Due to size and weight of the cover and internal components of 8 inch and larger valves, installation with the cover UP is advisable. This makes internal parts readily accessible for periodic inspection.

6. Caution must be taken in the installation of this valve to insure that galvanic and/or electrolytic action does not take place. The proper use of dielectric fittings and gaskets are required in all systems using dissimilar metals.
7. If a pilot control system is installed on the 100G/2100G Main Valve, use care to prevent damage. If it is necessary to remove fittings or components, be sure they are kept clean and replaced exactly as they were.
8. After the valve is installed and the system is first pressurized, vent air from the cover chamber and pilot system tubing by loosening fittings at all high points.

**Principles of Operation**

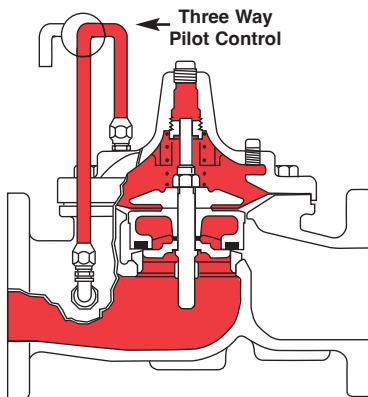

**Tight Closing Operation**

When pressure from the valve inlet (or an equivalent independent operating pressure) is applied to the diaphragm chamber the valve closes drip-tight.

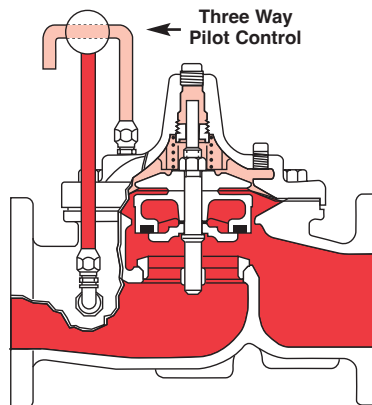

**Full Open Operation**

When pressure in diaphragm chamber is relieved to a zone of lower pressure (usually atmosphere) the line pressure (5 psi Min.) at the valve inlet opens the valve.

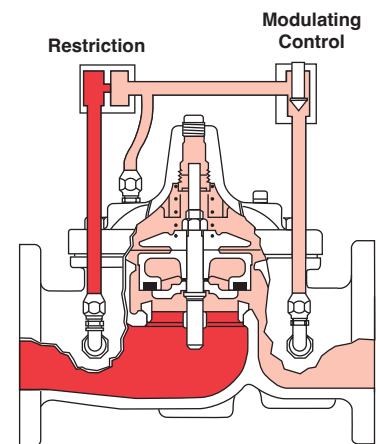

**Modulating Action**

Valve modulates when diaphragm pressure is held at an intermediate point between inlet and discharge pressure. With the use of a Cla-Val, "modulating control," which reacts to line pressure changes, the pressure above the diaphragm is varied, allowing the valve to throttle and compensate for the change.

## Flow Direction

The flow through the 100G/2100G Main Valve can be in one of two directions. When flow is “up-and-over the seat,” it is in “normal” flow and the valve will fail in the open position. When flow is “over-the seat-and down,” it is in “reverse” flow and the valve will fail in the closed position. There are no permanent flow arrow markings. **The valve must be installed according to nameplate data.**

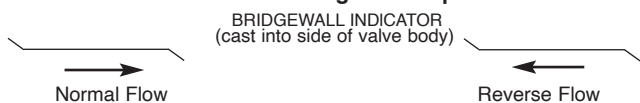

## Recommended Tools

1. Two pressure gauges with ranges suitable to the installation to be put at Main Valve inlet and outlet connections.
2. Cla-Val Model X101 Valve Position Indicator. This provides visual indication of valve position without disassembly of valve.
3. Other items are: suitable hand tools such as screwdrivers, wrenches, etc. soft jawed (brass or aluminum) vise, 400 grit wet or dry sandpaper and water for cleaning.

## Troubleshooting

The following troubleshooting information deals strictly with the Model 100G/2100G Main Valve. This assumes that all other components of the pilot control system have been checked out and are in proper working condition. (See appropriate sections in Technical Manual for complete valve).

All trouble shooting is possible without removing the valve from the line or removing the cover. It is highly recommended to permanently install a Model X101 Valve Position Indicator and two gauges in unused Main Valve inlet, outlet connections.

SYMPTOM	PROBABLE CAUSE	REMEDY
Fails to Close	Closed isolation valves in control system, or in main line.	Open Isolation valves.
	Lack of cover chamber pressure.	Check upstream pressure, pilot system, strainer, tubing, valves, or needle valves for obstruction.
	Diaphragm damaged. (See Diaphragm Check.)	Replace diaphragm.
	Diaphragm assembly inoperative. Corrosion or excessive scale build up on valve stem. (See Freedom of Movement Check)	Clean and polish stem. Inspect and replace any damaged or badly eroded part.
	Mechanical obstruction. Object lodged in valve. (See Freedom of Movement Check)	Remove obstruction.
	Worn disc. (See Tight Sealing Check)	Replace disc.
	Badly scored seat. (See Tight Sealing Check)	Replace seat.
Fails to Open	Closed upstream and/or downstream isolation valves in main line.	Open isolation valves.
	Insufficient line pressure.	Check upstream pressure. (Minimum 5 psi flowing line pressure differential.)
	Diaphragm assembly inoperative. Corrosion or excessive buildup on valve stem. (See Freedom of Movement Check)	Clean and polish stem. Inspect and replace any damaged or badly eroded part.
	Diaphragm damaged. (For valves in "reverse flow" only)	Replace diaphragm.

After checking out probable causes and remedies, the following three checks can be used to diagnose the nature of the problem before maintenance is started. They must be done in the order shown.

### Three Checks

The 100G/2100G Main Valve has only one moving part (the diaphragm and disc assembly). So, there are only three major types of problems to be considered.

**First:** Valve is stuck - that is, the diaphragm assembly is not free to move through a full stroke either from open to close or vice versa.

**Second:** Valve is free to move and can't close because of a worn out diaphragm.

**Third:** Valve leaks even though it is free to move and the diaphragm isn't leaking.

#### CAUTION:

Care should be taken when doing the troubleshooting checks on the 100G/2100G Main Valve. These checks do require the valve to open fully. This will either allow a high flow rate through the valve, or the downstream pressure will quickly increase to the inlet pressure. In some cases, this can be very harmful. Where this is the case, and there are no block valves in the system to protect the downstream piping, it should be realized that **the valve cannot be serviced under pressure.** Steps should be taken to remedy this situation before proceeding any further.

## Diaphragm Check (#1 )

1. Shut off pressure to the Main Valve by slowly closing upstream and downstream isolation valves. **SEE CAUTION.**
2. Disconnect or close all pilot control lines to the valve cover and leave only one fitting in highest point of cover open to atmosphere.
3. With the cover vented to atmosphere, slowly open upstream isolation valve to allow some pressure into the Main Valve body. Observe the open cover tapping for signs of continuous flow. It is not necessary to fully open isolating valve. Volume in cover chamber capacity chart will be displaced as valve moves to open position. Allow sufficient time for diaphragm assembly to shift positions. If there is no continuous flow, you can be quite certain the diaphragm is sound and the diaphragm assembly is tight. If the fluid appears to flow continuously this is a good reason to believe the diaphragm is either damaged or it is loose on the stem. In either case, this is sufficient cause to remove the valve cover and investigate the leakage. (See "Maintenance" Section for procedure.)

### COVER CHAMBER CAPACITY (Liquid Volume displaced when valve opens)

Valve size (inches)	Displacement	
	Gallons	Liters
3	.080	.30
4	.169	.64
6	.531	2.0
8	1.26	4.8
10	2.51	9.5
12	4.00	15.1

## Freedom of Movement Check (#2)

4. Determining the Main Valve's freedom of movement can be done by one of two methods.
5. For most valves it can be done after completing Diaphragm Check (Steps 1, 2, and 3). **SEE CAUTION.** At the end of step 3 the valve should be fully open.
6. If the valve has a Cla-Val X101 Position Indicator, observe the indicator to see that the valve opens wide. Mark the point of maximum opening.
7. Re-connect enough of the control system to permit the application of inlet pressure to the cover. Open pilot system cock so pressure flows from the inlet into the cover.
8. While pressure is building up in the cover, the valve should close smoothly. There is a hesitation in every Main Valve closure, which can be mistaken for a mechanical bind. The stem will appear to stop moving very briefly before going to the closed position. This slight pause is caused by the diaphragm flexing at a particular point in the valve's travel and is not caused by a mechanical bind.
9. When closed, a mark should be made on the X101 Valve position indicator corresponding to the "closed" position. The distance between the two marks should be approximately the stem travel shown in chart.
10. If the stroke is different than that shown in stem travel chart this is a good reason to believe something is mechanically restricting the stroke of the valve at one end of its travel. If the flow does not stop through the valve when in the indicated "closed" position, the obstruction probably is between the disc and the seat. If the flow does stop, then the obstruction is more likely

## STEM TRAVEL

(Fully Open to Fully Closed)

Valve Size (inches)		Travel (inches)	
Inches	MM	Inches	MM
3	80	0.8	20
4	100	1.1	28
6	150	1.7	43
8	200	2.3	58
10	250	2.8	71
12	300	3.4	86

in the cover. In either case, the cover must be removed, and the obstruction located and removed. The stem should also be checked for scale build-up. (See "Maintenance, section for procedure.)

11. For valves 6" and smaller, the Main Valve's freedom of movement check can also be done after all pressure is removed from the valve. **SEE CAUTION.** After closing inlet and outlet isolation valves and bleeding pressure from the valve, check that the cover chamber and the body are temporarily vented to atmosphere. Insert fabricated tool into threaded hole in top of valve stem, and lift the diaphragm assembly manually. Note any roughness. The diaphragm assembly should move smoothly throughout entire valve stroke. The tool is fabricated from rod that is threaded on one end to fit valve stem and has a "T" bar handle of some kind on the other end for easy gripping. (See chart in Step 4 of "Disassembly" Section.)

12. Place marks on this diaphragm assembly lifting tool when the valve is closed and when manually positioned open. The distance between the two marks should be approximately the stem travel shown in stem travel chart. If the stroke is different than that shown, there is a good reason to believe something is mechanically restricting the stroke of the valve. The cover must be removed, and the obstruction located and removed. The stem should also be checked for scale build-up. (See "Maintenance" Section for procedure.)

## Tight Sealing Check (#3)

13. Test for seat leakage after completing checks #1 & #2 (Steps 1 to 12). **SEE CAUTION.** Close the isolation valve downstream of the Main Valve. Apply inlet pressure to the cover of the valve, wait until it closes. Install a pressure gauge between the two closed valves using one of the two ports in the outlet side of the Main Valve. Watch the pressure gauge. If the pressure begins to climb, then either the downstream isolation valve is permitting pressure to creep back, or the Main Valve is allowing pressure to go through it. Usually the pressure at the Main Valve inlet will be higher than on the isolation valve discharge, so if the pressure goes up to the inlet pressure, you can be sure the Main Valve is leaking. Install another gauge downstream of isolating valve. If the pressure between the valves only goes up to the pressure on the isolation valve discharge, the Main Valve is holding tight, and it was just the isolation valve leaking.

## Maintenance

### Preventative Maintenance

The Cla-Val Co. Model 100G/2100G Main Valve requires no lubrication or packing and a minimum of maintenance. However, a periodic inspection schedule should be established to determine how the operating conditions of the system are affecting the valve. The effect of these actions must be determined by inspection.

### Disassembly

Inspection or maintenance can be accomplished without removing the valve from the line. Repair kits with new diaphragm and disc are recommended to be on hand before work begins.

**WARNING:** Maintenance personnel can be injured and equipment damaged if disassembly is attempted with pressure in the valve. **SEE CAUTION.**

1. Close upstream and downstream isolation valves **and independent operating pressure when used** to shut off all pressure to the valve.

2. Loosen tube fittings in the pilot system to remove pressure from valve body and cover chamber. After pressure has been released from the valve, use care to remove the controls and tubing. Note and sketch position of tubing and controls for re-assembly. The schematic in front of the Technical Manual can be used as a guide when reassembling pilot system.

3. Remove cover nuts and remove cover. If the valve has been in service for any length of time, chances are the cover will have to be loosened by driving upward along the edge of the cover with a **dull cold chisel**.

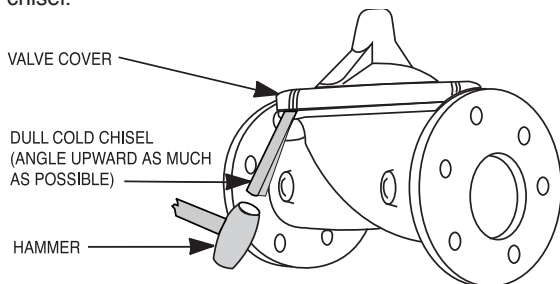

On 6" and smaller valves block and tackle or a power hoist can be used to lift valve cover by inserting proper size eye bolt in place of the center cover plug. On 8" and larger valves there are 4 holes (5/8" — 1 1/2" size) where jacking screws and/or eye bolts may be inserted for lifting purposes. **Pull cover straight up** to keep from damaging the integral seat bearing and stem.

#### COVER CENTER PLUG SIZE

Valve Size	Thread Size (NPT)
3"	1/2"
4"–6"	3/4"
8"–10"	1"
12"	1 1/4"

4. Remove the diaphragm and disc assembly from the valve body. With smaller valves this can be accomplished by hand by **pulling straight up on the stem so as not to damage the seat bearing**. On large valves, an eye bolt of proper size can be installed in the stem and the diaphragm assembly can be then lifted with a block and tackle or power hoist. Take care not to damage the stem or bearings. The valve won't work if these are damaged.

#### VALVE STEM THREAD SIZE

Valve Size	Thread Size (UNF Internal)
3"–4"	1/4–28
6"–12"	3/8–24

5. The next item to remove is the stem nut. Examine the stem threads above the nut for signs of mineral deposits or corrosion. If the threads are not clean, use a wire brush to remove as much of the residue as possible. Attach a good fitting wrench to the nut and give it a sharp "rap" rather than a steady pull. Usually several blows are sufficient to loosen the nut for further removal. On the smaller valves, the entire diaphragm assembly can be held by the stem in a vise **equipped with soft brass jaws** before removing the stem nut.

The use of a pipe wrench or a vise without soft brass jaws scars the fine finish on the stem. No amount of careful dressing can restore the stem to its original condition. Damage to the finish of the stem can cause the stem to bind in the bearings and the valve will not open or close.

6. After the stem nut has been removed, the diaphragm assembly breaks down into its component parts. Removal of the disc from the disc retainer can be a problem if the valve has been in service for a long time. Using two screwdrivers inserted along the outside edge of the disc usually will accomplish its removal. Care should be taken to preserve the spacer washers in water, particularly if no new ones are available for re-assembly.

7. The only part left in the valve body is the seat which ordinarily does not require removal. Careful cleaning and polishing of inside and outside surfaces with 400 wet/dry sandpaper will usually restore the seat's sharp edge. If, however, it is badly worn and replacement is necessary, it can be easily removed.

Seats in valve sizes 1 1/4" through 6" are threaded into the valve body. They can be removed with accessory X109 Seat Removing Tool available from the factory. On 8" and larger valves, the seat is held in place by flat head machine screws. Use a tight-fitting, long shank screwdriver to prevent damage to seat screws. If upon removal of the screws the seat cannot be lifted out, it will be necessary to use a piece of angle or channel iron with a hole drilled in the center. Place it across the body so a long stud can be inserted through the center hole in the seat and the hole in the angle iron. By tightening the nut a uniform upward force is exerted on the seat for removal.

**NOTE:** Do not lift up on the end of the angle iron as this may force the integral bearing out of alignment, causing the stem to bind.

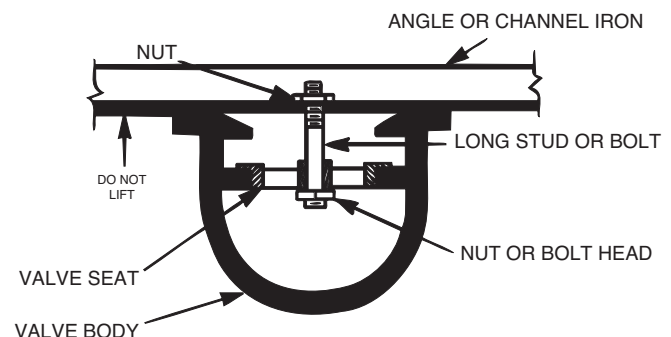

---

## Lime Deposits

One of the easiest ways to remove lime deposits from the valve stem or other metal parts is to dip them in a 5-percent muriatic acid solution just long enough for the deposit to dissolve. This will remove most of the common types of deposits. **CAUTION: USE EXTREME CARE WHEN HANDLING ACID.** Rinse parts in water before handling. If the deposit is not removed by acid, then a fine grit (400) wet or dry sandpaper can be used with water.

## Inspection of Parts

After the valve has been disassembled, each part should be examined carefully for signs of wear, corrosion, or any other abnormal condition. Usually, it is a good idea to replace the rubber parts (diaphragm and disc) unless they are free of signs of wear. These are available in a repair kit. Any other parts which appear doubtful should be replaced. **WHEN ORDERING PARTS, BE SURE TO GIVE COMPLETE NAMEPLATE DATA, ITEM NUMBER AND DESCRIPTION.**

**NOTE:** If a new disc isn't available, the existing disc can be turned over, exposing the unused surface for contact with the seat. The disc should be replaced as soon as practical.

---

## Reassembly

1. Reassembly is the reverse of the disassembly procedure. If a new disc has been installed, it may require a different number of spacer washers to obtain the right amount of "grip" on the disc. When the diaphragm assembly has been tightened to a point where the diaphragm cannot be twisted, the disc should be compressed very slightly by the disc guide. Excessive compression should be avoided. Use just enough spacer washers to hold the disc firmly without noticeable compression.

2. **MAKE SURE THE STEM NUT IS VERY TIGHT.** Attach a good fitting wrench to the nut and give it a sharp "rap" rather than a steady pull. Usually several blows are sufficient to tighten the stem nut for final tightening. Failure to do so could allow the diaphragm to pull loose and tear when subjected to pressure.

3. Carefully install the diaphragm assembly by lowering the stem through the seat bearing. Take care not to damage the stem or bearing. Line up the diaphragm holes with the stud or bolt holes on the body. on larger valves with studs, it may be necessary to hold the diaphragm assembly up part way while putting the diaphragm over the studs.

4. Put spring in place and replace cover. Make sure diaphragm is lying smooth under the cover.

5. Tighten cover nuts firmly using a cross-over pattern until all nuts are tight.

6. Test Main Valve before re-installing pilot valve system.

---

## Test Procedure After Valve Assembly

There are a few simple tests which can be made in the field to make sure the Main Valve has been assembled properly. Do these before installing pilot system and returning valve to service. These are similar to the three troubleshooting tests.

1. Check the diaphragm assembly for freedom of movement after all pressure is removed from the valve. **SEE CAUTION.** Insert fabricated tool into threaded hole in top of valve stem, and lift the diaphragm assembly manually. Note any roughness, sticking or grabbing. The diaphragm assembly should move smoothly throughout entire valve stroke. The tool is fabricated from rod that is threaded on one end to fit valve stem (See chart in Step 4 of "Disassembly" section.) and has a "T" Bar handle of some kind on the other end for easy gripping.

Place marks on this diaphragm assembly lifting tool when the valve is closed and when manually positioned open. The distance between the two marks should be approximately the stem travel shown in stem travel chart. (See "Freedom of Movement Check" section.) If the stroke is different than that shown, there is a good reason to believe something is mechanically restricting the stroke of the valve. The cover must be removed, the obstruction located and removed. (See "Maintenance" Section for procedure.)

Due to the weight of the diaphragm assembly this procedure is not possible on valves 8" and larger. on these valves, the same determination can be made by carefully introducing a low pressure-less than five psi) into the valve body with the cover vented. **SEE CAUTION.** Looking in cover center hole see the diaphragm assembly lift easily without hesitation, and then settle back easily when the pressure is removed.

2. To check the valve for drip-tight closure, a line should be connected from the inlet to the cover, and pressure applied at the inlet of the valve. If properly assembled, the valve should hold tight with as low as ten PSI at the inlet. See "Tight Sealing Check" section.)

3. With the line connected from the inlet to the cover, apply full working pressure to the inlet. Check all around the cover for any leaks. Re-tighten cover nuts if necessary to stop leaks past the diaphragm.

4. Remove pressure, then re-install the pilot system and tubing exactly as it was prior to removal. **Bleed air from all high points.**

5. Follow steps under "Start-Up and Adjustment" Section in Technical Manual for returning complete valve back to service.



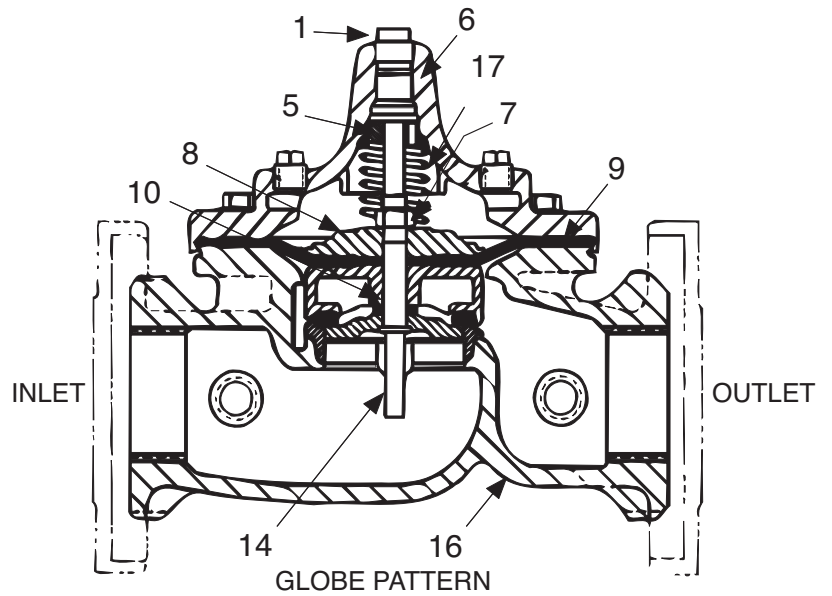
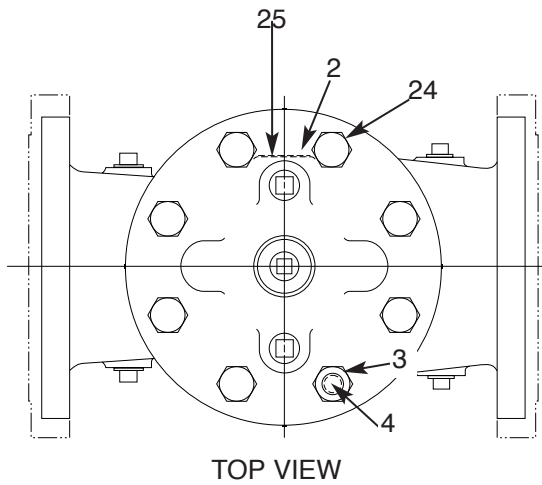

### PARTS LIST

Item	Description
1.	Pipe Plug
2.	Drive Screws (for nameplate)
3.	Hex Nut (8" and larger)
4.	Stud (8" and larger)
5.	Cover Bearing
6.	Cover
7.	Stem Nut
8.	Diaphragm Washer
9.	Diaphragm
10.	Spacer Washers
11.	Disc Guide
12.	Disc Retainer
13.	Disc
14.	Stem
15.	Seat
16.	Body
17.	Spring
22.	Flat Head Screws (8" and larger)
23.	Seat O-Ring
24.	Hex head Bolt (1 1/4" thru 4")
25.	Nameplate
26.	Upper Spring Washer (Epoxy coated valves only)
27.	Lower Spring Washer (Epoxy coated valves only)

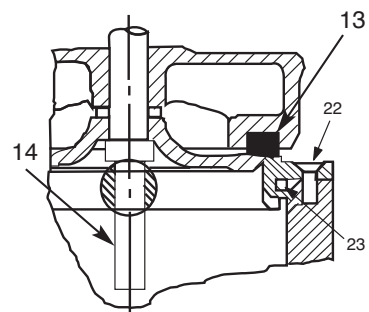
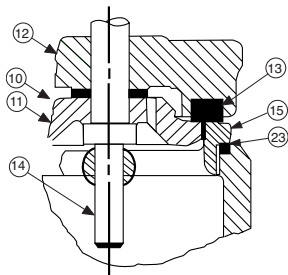
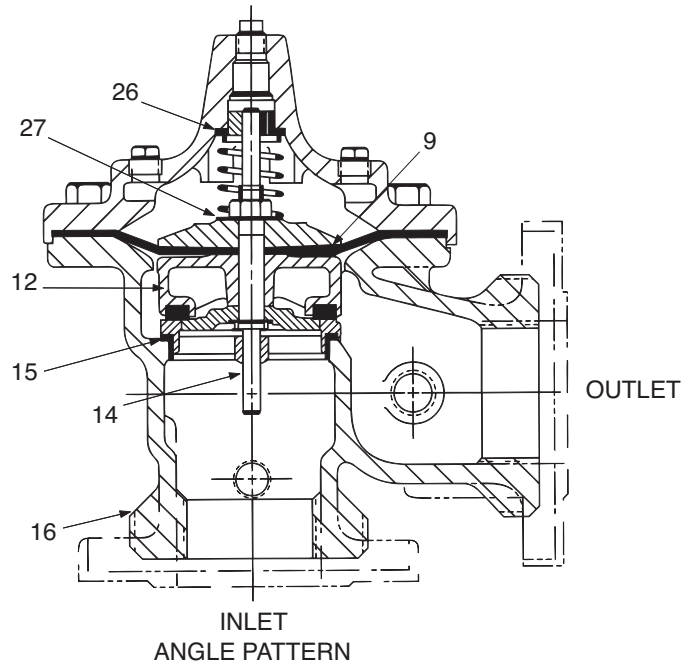



# —MODEL— 100G/2100G Main Valve Service Data



## Description 100G/2100G Main Valve

The Cla-Val Model 100G/2100G Main Valve is a main valve for Cla-Val Deluge Valves. It is a hydraulically operated, diaphragm-actuated, globe or angle pattern valve.

This valve consists of three major components; body, diaphragm assembly, and cover. The diaphragm assembly is the only moving part. The diaphragm assembly uses a diaphragm of nylon fabric bonded with synthetic rubber. A synthetic rubber disc, contained on three and one half sides by a disc retainer and disc guide, forms a seal with the valve seat when pressure is applied above the diaphragm. The diaphragm assembly forms a sealed chamber in the upper portion of the valve, separating operating pressure from line pressure.

## HYTROL Service Data

HYTROL SIZE	Stem Travel		Cover Capacity Displacement		Valve Stem Thread UNF-internal	Cover Center Plug NPT	Cover Nut or Bolt		Cover Lifting Holes UNC	Cover Plug		Cover Torque		Stem Nut**		Stem Nut Torque (ft. Lbs.)	
	mm	inches	Gallons	Liters			Thread (Bolt)	Socket		Qty	Thread	Socket	Thread	ft. Lbs.	in. Lbs.	Thread	Socket (Long)
100G	inches	mm															
	3"	80	0.080	0.30	1/4 - 28	1/2"	1/2" - 13 (B)	3/4"	8		1/2"	9/16"	30	5/8" - 18	15/16"	21	30
	4"	100	0.169	0.64	1/4 - 28	3/4"	3/4" - 10 (B)	1 1/8"	8		3/4"	5/8"	110	3/4" - 16	1 1/16"	40	60
	6"	150	0.531	2.00	3/8 - 24	3/4"	3/4" - 10 (B)	1 1/8"	12		3/4"	5/8"	110	7/8" - 14	1 5/16"	85	125
	8"	200	1.26	4.80	3/8 - 24	1"	3/4" - 10	1 1/4"	16	5/8" - 11	1"	13/16"	110	1 1/8" - 12	1 13/16"	125	185
	10"	250	2.51	9.50	3/8 - 24	1"	7/8" - 9	1 7/16"	20	3/4" - 10	1"	13/16"	160	1 1/2" - 12	1 7/8"	252	375
12"	300	3.4	4.0	15.10	3/8 - 24	1 1/4"	1 1/8" - 7	20	3/4" - 10	1"	13/16"	390	1 1/2" - 12	2 1/2"	270	400	

## BOLT/NUT TORQUING PROCEDURES ON VALVE COVERS

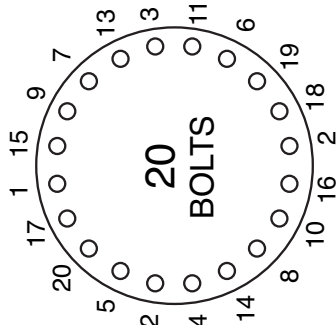
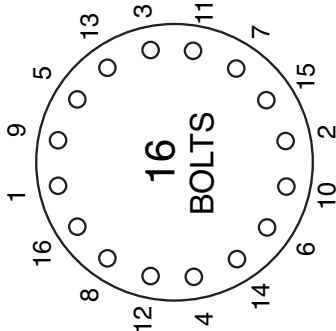
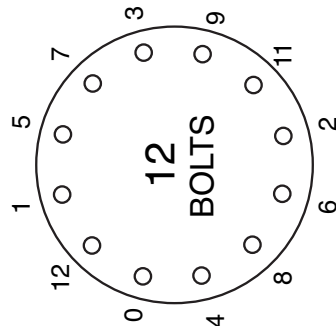
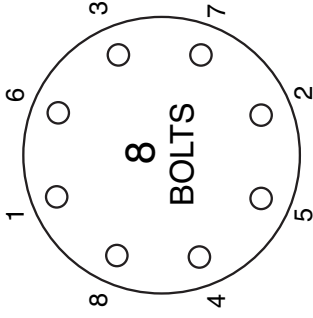
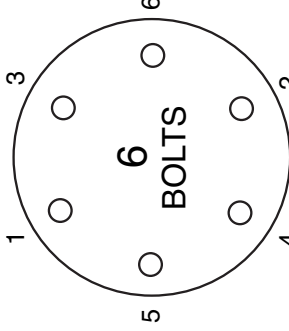
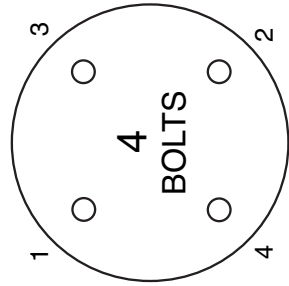

Follow this procedure when reassembling MAIN Valve:

1. Tightens bolts/nuts in a "Star" or "Cross-Over" pattern following the numbers shown above to insure that cover seats evenly on the diaphragm material and body.
2. Torque the bolt/nuts in three stages with a "Star" or "Cross-Over" pattern for each stage:
  - A. To approximately 10% of final torque.
  - B. To approximately 75% of final torque.
  - C. To final required torque.

## 100G Hytrol Main Valve Assembly

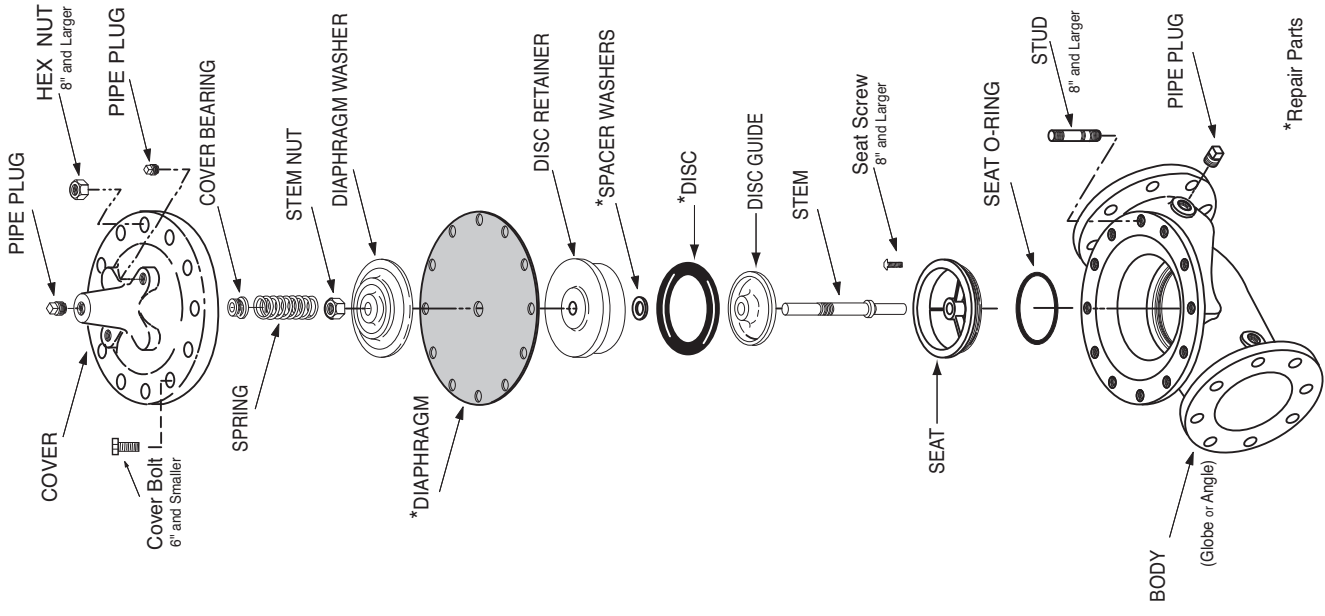

\*Repair Parts



# Model **CK2** ISOLATION VALVE

## PRODUCT FEATURES

- Model CK2 is a ball valve used for isolating components within the pilot system.

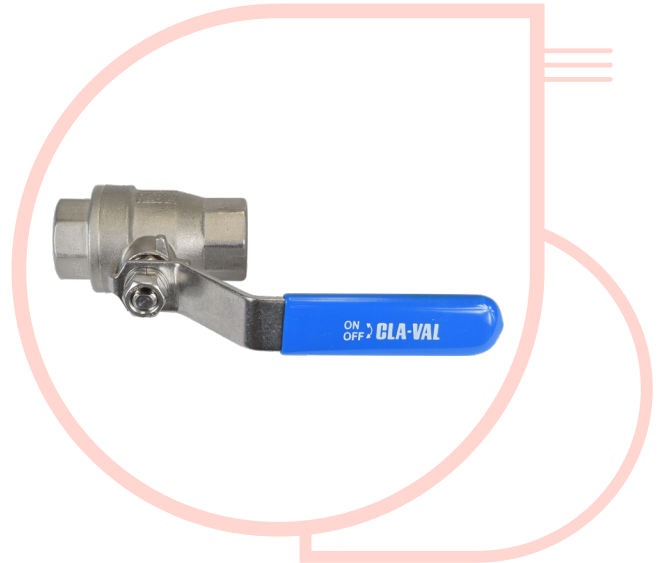

## DIMENSIONS

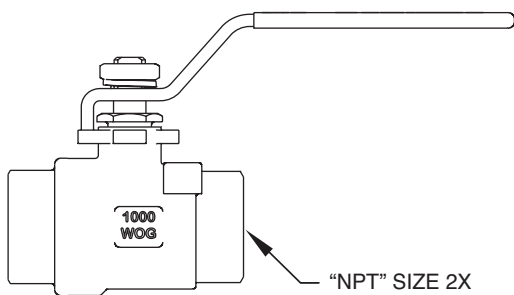
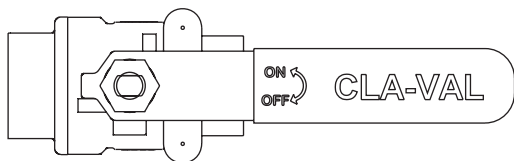

## SPECIFICATIONS

- Size:** 3/8" thru 2" NPT Threaded
- Temperature Range:** 33°F to 180°F
- Standard Materials**
  - Body:** Stainless Steel
  - Handle & Nut:** Stainless Steel
  - Ball Seal:** RPTFE
- Ends:** Threaded ANSI/ASME B1.20 1
- Pressure Ratings:** 300 psi

CLA-VAL Company

[www.cla-val.com](http://www.cla-val.com)

[info@cla-val.com](mailto:info@cla-val.com)

S-CK2 (R-12/2021)





# Model X44A

## "Y" STRAINER WITH RESTRICTION ORIFICE

### PRODUCT DESCRIPTION

The Cla-Val Model X44A 'Y' Strainer is an in-line strainer to be installed for protection of pilot systems. The Strainers are constructed of corrosion resistant materials. All sizes have blow-off connections ready for field hook-up. X44A Strainers are provided with an internal Restriction Orifice.

### DIMENSIONS

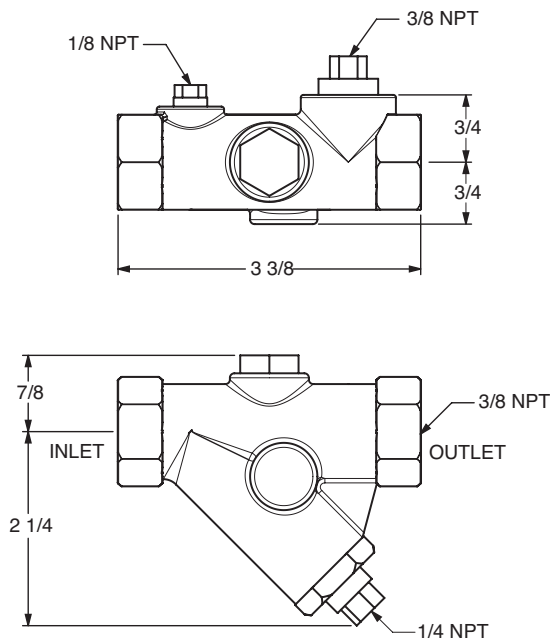

(Dimensions in inches)

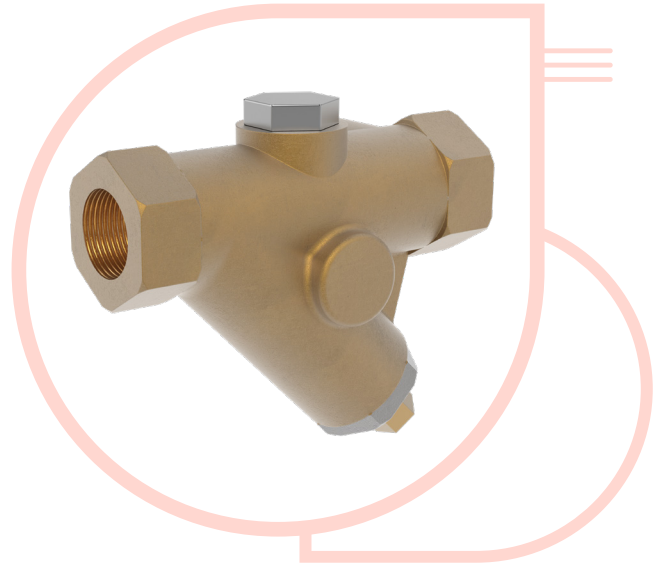

### SPECIFICATIONS

- Size:** 3/8", 1/2", 3/4", 1" NPT Threaded
- Restriction Orifice:** 1/16" (.062), 3/32" (.093), 1/8" (.125)
- Temperature Range:** 33°F to 180°F
- Standard Materials\***
  - Body:** Low Lead Bronze
  - Screen:** Stainless Steel 316 (60 mesh)
  - Orifice Restriction:** Delrin
- Ends:** Threaded ANSI/ASME B1.20 1
- Pressure Ratings:** 300 psi

\*Optional Materials Available

CLA-VAL Company  
www.cla-val.com  
info@cla-val.com  
S-X44A (R-12/2021)



# Model **CDC-1** CHECK VALVE

Sizes 3/8, 1/2, 3/4 and 1"

## PRODUCT FEATURES

- The Cla-Val Model CDC-1 Check Valve is an inline disc check valve. The valve utilizes an internal disc to allow flow in one direction while closing off against flow in the reverse direction.
- Delrin® Disc Resists Corrosion and/or Mineral Build-up
- Flow direction arrow stamped on valve body

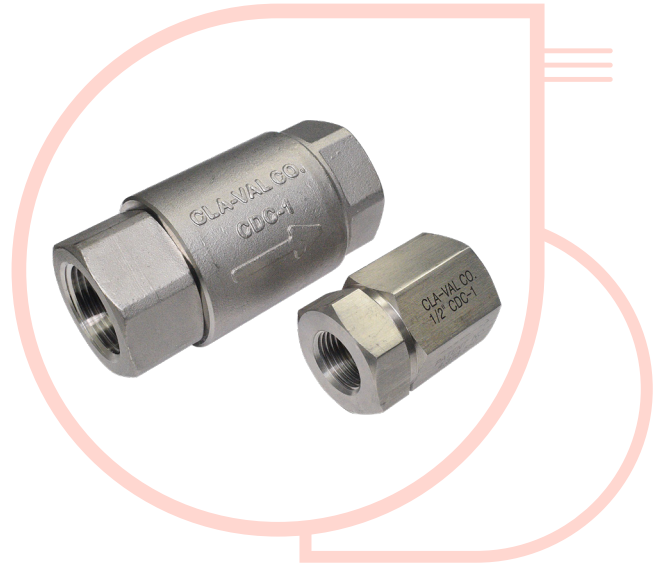

## DIMENSIONS

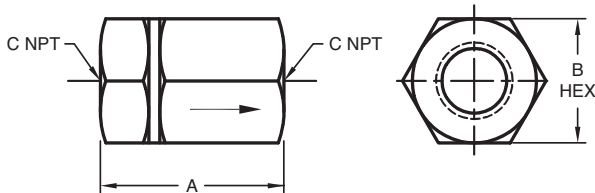

CLA-VAL CHECK VALVE (1/2" SIZE SHOWN)

Size (NPT)	A	B	C
3/8"	2.06	1.06	.38 (3/8) - 18.0 NPT
1/2"	2.12	1.38	.50 (1/2) - 14.0 NPT
3/4"	4.06	2.26	.75 (3/4) - 14.0 NPT
1"	4.06	2.19	1.00 (1) - 11.5 NPT

## SPECIFICATIONS

- Size:** 3/8", 1/2", 3/4", 1" NPT Threaded
- Temperature Range:** Water: to 180°F Max.
- Standard Materials**
  - Body:** Stainless Steel 303 (3/8", 1/2")  
Stainless Steel 316 (All Sizes Available)
  - Disc:** Delrin® (3/8", 1/2")  
Buna-N® Synthetic Rubber (3/4", 1")  
Optional EPR and Fluorocarbon
- Pressure Ratings:** 300 psi

CLA-VAL Company

www.cla-val.com

info@cla-val.com

S-CDC-1 (R-12/2021)





# Model **MRP-1** MANUAL RESET PILOT

## PRODUCT FEATURES

The Cla-Val Model MRP-1 pilot is an automatic latching device that holds the main valve in its open position when it has been activated by a releasing device. The MRP-1 blocks the inlet pressure line, preventing water from entering the main valve cover chamber, allowing the main valve to open. The pilot allows the main valve to close only upon a local reset, while manually pushing the reset button.

**Note:** The manual reset button to be mounted vertically.

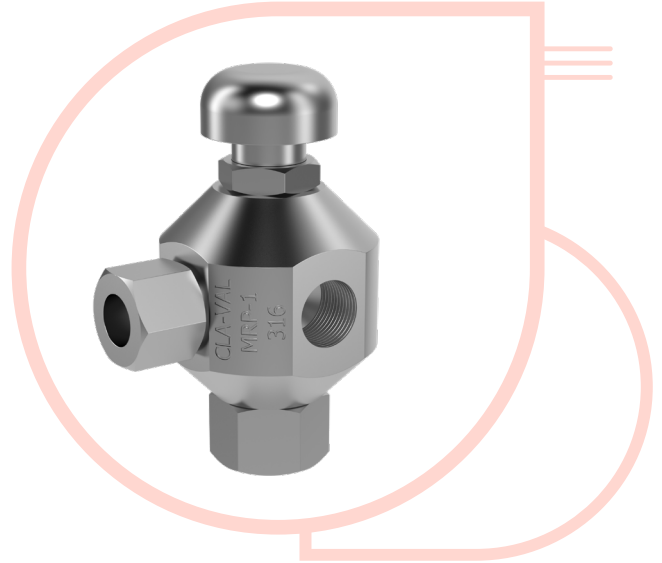

## DIMENSIONS

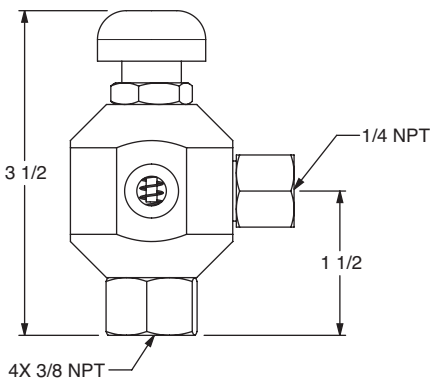
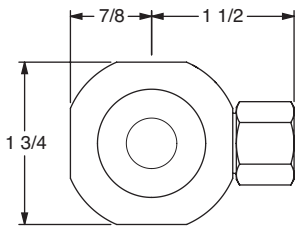

(Dimensions in inches)

## SPECIFICATIONS

<b>Size:</b>	1/4", 3/8" NPT Threaded
<b>Temperature Range:</b>	33°F to 180°F
<b>Standard Materials</b>	
<b>Body &amp; Cover:</b>	Stainless Steel
<b>Trim:</b>	Stainless Steel
<b>Rubber:</b>	Buna-N® Synthetic Rubber
<b>Ends:</b>	Threaded ANSI/ASME B1.20 1
<b>Pressure Ratings:</b>	300 psi

CLA-VAL Company

[www.cla-val.com](http://www.cla-val.com)

[info@cla-val.com](mailto:info@cla-val.com)

S-MRP-1 (R-12/2021)





# Model EDVR MANUAL RELEASE

## PRODUCT FEATURES

- The Cla-Val Model EDVR is a Manual Release control installed to bypass the primary actuation pilot. In the event of an emergency, the EDVR control is opened relieving pressure in the main valve cover, resulting in the main valve opening.

## DIMENSIONS

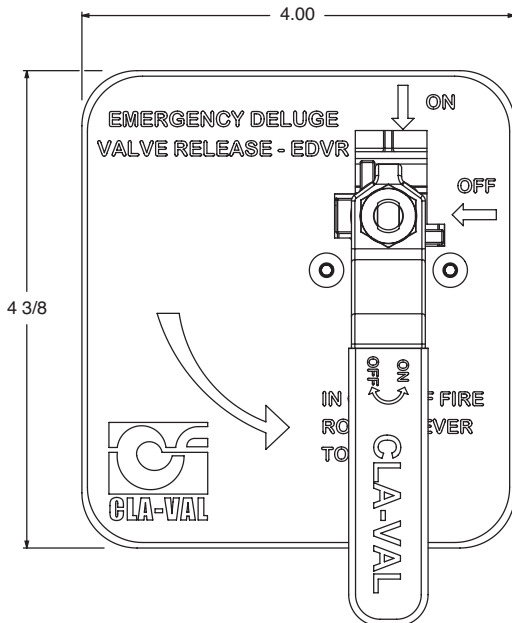

## SPECIFICATIONS

- Size:** 3/8", 1/2" NPT Threaded
- Temperature Range:** 33°F to 180°F
- Standard Materials**
  - Body:** Stainless Steel
  - Handle & Nut:** Stainless Steel
  - Ball Seal:** RPTFE
- Ends:** Threaded ANSI/ASME B1.20 1
- Pressure Ratings:** 300 psi

CLA-VAL Company  
www.cla-val.com  
info@cla-val.com  
S-EDVR (R-12/2021)



# ***CLA-VAL WARRANTY***

## **3 Year Warranty on Cla-Val Quality Products**

### **This is a Limited Warranty**

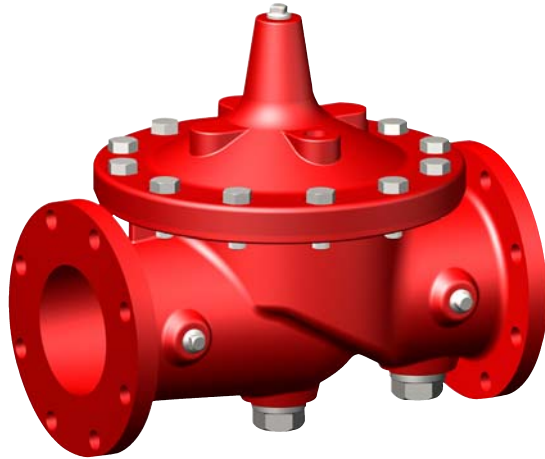

Automatic valves and controls as manufactured by Cla-Val are warranted for three years from date of shipment against manufacturing defects in material and workmanship that develop in the service for which they are designed, provided the products are installed and used in accordance with all applicable instructions and limitations issued by Cal-Val. Electronic components manufactured by Cla-Val are warranted for one year from the date of shipment.

We will repair or replace defective material, free of charge which is returned to our factory, transportation charges prepaid, provided that after inspection the material is found to have been defective at time of shipment. The warranty is expressly conditioned on the purchaser's giving Cla-Val immediate written notice upon discovery of the defect.

Components used by Cla-Val, but manufactured by others, are warranted only to the extent of that manufacturer's guarantee.

This warranty shall not apply if the product has been altered or repaired by others, and Cal-Val shall make no allowance or credit for such repairs or alterations unless authorized in writing by Cla-Val.

### **Disclaimer of Warranties & Limitation of Liability**

The foregoing warranty is exclusive and in lieu of all other warranties and representations whether expressed, implied, oral or written, including but not limited to, any implied warranties or merchantability or fitness for a particular purpose. All such other warranties and representations are hereby cancelled.

Cla-Val shall not be liable for any incidental or consequential loss, damage or expense arising directly or indirectly from the use of the product. Cla-Val shall not be liable for any damages or charges for labor or expense in making repairs or adjustments to the product. Cla-Val shall not be liable for any damages or charges sustained in the adaptation or use of its engineering data and services.

No representative of Cla-Val may change any of the foregoing or assume any additional liability or responsibility in connection with the product.

The liability of Cla-Val is limited to material replacements F.O.B. Newport Beach, California.

#### **CLA-VAL**

P O Box 1325  
Newport Beach CA  
92659-0325  
Phone: 949-722-4800  
Fax: 949-548-5441  
E-mail: claval@cla-val.com

#### **CLA-VAL CANADA**

4687 Christie Drive  
Beamsville, Ontario  
Canada LOR 1B4  
Phone: 905-563-4963  
Fax: 905-563-4040  
E-mail sales@cla-val.ca

#### **CLA-VAL EUROPE**

Chemin des Mésanges 1  
CH-1032 Romanel/  
Lausanne, Switzerland  
Phone: 41-21-643-15-55  
Fax: 41-21-643-15-50  
E-mail: cla-val@cla-val.ch

#### **CLA-VAL UK**

Dainton House, Goods Station Road  
GB - Tunbridge Wells  
Kent TN1 2 DH England  
Phone: 44-1892-514-400  
Fax: 44-1892-543-423  
E-mail: info@cla-val.co.uk

#### **CLA-VAL FRANCE**

Porte du Grand Lyon 1  
ZAC du Champ du Périer  
FR - 01700 Neyron  
Phone: 33-4-72-25-92-93  
Fax: 33-4-72-25-04-17  
E-mail: cla-val@cla-val.fr

