



Cisco Firepower 4112, 4115, 4125, and 4145 Hardware Installation Guide

First Published: 2019-06-20

Americas Headquarters

Cisco Systems, Inc.
170 West Tasman Drive
San Jose, CA 95134-1706
USA
<http://www.cisco.com>
Tel: 408 526-4000
800 553-NETS (6387)
Fax: 408 527-0883

THE SPECIFICATIONS AND INFORMATION REGARDING THE PRODUCTS IN THIS MANUAL ARE SUBJECT TO CHANGE WITHOUT NOTICE. ALL STATEMENTS, INFORMATION, AND RECOMMENDATIONS IN THIS MANUAL ARE BELIEVED TO BE ACCURATE BUT ARE PRESENTED WITHOUT WARRANTY OF ANY KIND, EXPRESS OR IMPLIED. USERS MUST TAKE FULL RESPONSIBILITY FOR THEIR APPLICATION OF ANY PRODUCTS.

THE SOFTWARE LICENSE AND LIMITED WARRANTY FOR THE ACCOMPANYING PRODUCT ARE SET FORTH IN THE INFORMATION PACKET THAT SHIPPED WITH THE PRODUCT AND ARE INCORPORATED HEREIN BY THIS REFERENCE. IF YOU ARE UNABLE TO LOCATE THE SOFTWARE LICENSE OR LIMITED WARRANTY, CONTACT YOUR CISCO REPRESENTATIVE FOR A COPY.

The Cisco implementation of TCP header compression is an adaptation of a program developed by the University of California, Berkeley (UCB) as part of UCB's public domain version of the UNIX operating system. All rights reserved. Copyright © 1981, Regents of the University of California.

NOTWITHSTANDING ANY OTHER WARRANTY HEREIN, ALL DOCUMENT FILES AND SOFTWARE OF THESE SUPPLIERS ARE PROVIDED "AS IS" WITH ALL FAULTS. CISCO AND THE ABOVE-NAMED SUPPLIERS DISCLAIM ALL WARRANTIES, EXPRESSED OR IMPLIED, INCLUDING, WITHOUT LIMITATION, THOSE OF MERCHANTABILITY, FITNESS FOR A PARTICULAR PURPOSE AND NON-INFRINGEMENT OR ARISING FROM A COURSE OF DEALING, USAGE, OR TRADE PRACTICE.

IN NO EVENT SHALL CISCO OR ITS SUPPLIERS BE LIABLE FOR ANY INDIRECT, SPECIAL, CONSEQUENTIAL, OR INCIDENTAL DAMAGES, INCLUDING, WITHOUT LIMITATION, LOST PROFITS OR LOSS OR DAMAGE TO DATA ARISING OUT OF THE USE OR INABILITY TO USE THIS MANUAL, EVEN IF CISCO OR ITS SUPPLIERS HAVE BEEN ADVISED OF THE POSSIBILITY OF SUCH DAMAGES.

Any Internet Protocol (IP) addresses and phone numbers used in this document are not intended to be actual addresses and phone numbers. Any examples, command display output, network topology diagrams, and other figures included in the document are shown for illustrative purposes only. Any use of actual IP addresses or phone numbers in illustrative content is unintentional and coincidental.

All printed copies and duplicate soft copies of this document are considered uncontrolled. See the current online version for the latest version.

Cisco has more than 200 offices worldwide. Addresses and phone numbers are listed on the Cisco website at www.cisco.com/go/offices.

Cisco and the Cisco logo are trademarks or registered trademarks of Cisco and/or its affiliates in the U.S. and other countries. To view a list of Cisco trademarks, go to this URL: <https://www.cisco.com/c/en/us/about/legal/trademarks.html>. Third-party trademarks mentioned are the property of their respective owners. The use of the word partner does not imply a partnership relationship between Cisco and any other company. (1721R)

© 2019-2023 Cisco Systems, Inc. All rights reserved.



CONTENTS

CHAPTER 1

Overview 1

Features	1
Deployment Options	5
Package Contents	5
Serial Number Location	6
Front Panel	8
Front Panel LEDs	9
Rear Panel	10
Network Modules	11
10-Gb Network Module	12
40-Gb Network Module	13
100-Gb Network Module	14
Hardware Bypass Network Modules	15
1-Gb Network Module with Hardware Bypass	16
40-Gb Network Module with Hardware Bypass	18
1-Gb SX/10-Gb SR/10-Gb LR Network Module with Hardware Bypass	19
Power Supply Modules	22
Fan Modules	24
Supported SFP/SFP+ and QSFP Transceivers	25
Hardware Specifications	28
Product ID Numbers	29
Power Cord Specifications	32

CHAPTER 2

Installation Preparation 39

Installation Warnings	39
Network Equipment-Building System (NEBS) Statements	41

Safety Recommendations	43
Maintain Safety with Electricity	43
Prevent ESD Damage	44
Site Environment	44
Site Considerations	44
Power Supply Considerations	45
Rack Configuration Considerations	45

CHAPTER 3 **Rack-Mount and Ground the Chassis** 47

Unpack and Inspect the Chassis	47
Rack-Mount the Chassis	47
Ground the Chassis	52

CHAPTER 4 **Installation, Maintenance, and Upgrade** 55

Install, Remove, and Replace the Network Module	55
Remove and Replace the Fan Module	58
Remove and Replace the SSD	60
Remove and Replace the Power Supply Module	63
Connect the DC Power Supply Module	67
Secure the Power Cord on the AC Power Supply Module	73
Install the FIPS Opacity Shield	77



CHAPTER 1

Overview

- [Features, on page 1](#)
- [Deployment Options, on page 5](#)
- [Package Contents, on page 5](#)
- [Serial Number Location, on page 6](#)
- [Front Panel, on page 8](#)
- [Front Panel LEDs, on page 9](#)
- [Rear Panel, on page 10](#)
- [Network Modules, on page 11](#)
- [Hardware Bypass Network Modules, on page 15](#)
- [Power Supply Modules, on page 22](#)
- [Fan Modules, on page 24](#)
- [Supported SFP/SFP+ and QSFP Transceivers, on page 25](#)
- [Hardware Specifications, on page 28](#)
- [Product ID Numbers, on page 29](#)
- [Power Cord Specifications, on page 32](#)

Features

The Cisco Firepower 4100 is a standalone modular security services platform. It is capable of running multiple security services simultaneously and so is targeted at the data center as a multiservice platform. The series includes the Firepower 4112, 4115, 4125, and 4145. See [Product ID Numbers, on page 29](#) for a list of the product IDs (PIDs) associated with the 4100 series.

The Firepower 4100 supports Cisco Secure Firewall Threat Defense, Cisco Secure Firewall eXtensible Operating System (FXOS), and Cisco Secure Firewall ASA software. See [Cisco Firepower 4100/9300 FXOS Compatibility](#), which lists software and hardware compatibility information for the Firepower 4100 series.

The following figure shows the Firepower 4100.

Figure 1: Firepower 4100



The following table lists the features for the Firepower 4100.

Table 1: Firepower 4100 Features

Feature	4112	4115	4125	4145
Form factor	1 RU Fits a standard 19-inch (48.3cm) square-hole rack			
Rack mount	Slide rails, mount ears, and screws included (4-post EIA-310-D rack)			
Airflow	Front to rear Cold aisle to hot aisle			
Processor	One 12-core 2.1-GHz Intel Xeon 4116	Two 12-core 2.1-GHz Intel Xeon 4116	Two 16-core 2.1-GHz Intel Xeon 6130T	Two 22-core 2.1-GHz Intel Xeon 6152
Memory	96-GB DRAM 6 x 16-GB DDR4-2400	192-GB DRAM 12 x 16-GB DDR4-2400	192-GB DRAM 12 x 16-GB DDR4-2666	384-GB DRAM 12 x 32-GB DDR4-2666
Maximum number of interfaces	24 With two 8-port network modules installed			
Management port	One Gigabit Ethernet Supports 1-Gb fiber or copper SFPs			
Serial port	One RJ-45 console			
USB port	One USB 2.0 Type A			
Network ports	Eight fixed 1-Gb and 10-Gb SFP+ ports (named Ethernet 1/1 through 1/8)			
Small form-factor pluggable (SFP) ports	Eight fixed 1-Gb and 10-Gb SFP+ ports			

Feature	4112	4115	4125	4145
Pullout asset card	Displays the serial number; on the front panel			
Grounding lug	On rear panel			
Locator beacon	On front panel			
Power switch	On rear panel			
Network modules	Two network module slots (network module 2 and network module 3)			
Supported network modules	<ul style="list-style-type: none"> • 8-port 10-Gigabit Ethernet SFP+ • 4-port 40-Gigabit Ethernet QSFP+ • 2-port 100-Gigabit Ethernet QSFP28 <p>Note First supported in threat defense 7.3.1 and ASA 9.18.1.</p> <ul style="list-style-type: none"> • 8-port 1-Gigabit Ethernet copper with hardware bypass • 2-port 40-Gigabit Ethernet QSFP+ (built-in) with hardware bypass • 6-port 1-Gigabit Ethernet SX fiber SFP (built-in) with hardware bypass • 6-port 10-Gigabit Ethernet SR fiber SFP+ (built-in) with hardware bypass • 6-port 10-Gigabit Ethernet LR fiber SFP+ (built-in) with hardware bypass 			
AC power supply	Two (1+1) power supply module slots Ships with one 1100-W AC power supply module Hot-swappable	Two (1+1) power supply module slots Ships with two 1100-W AC power supply modules Hot-swappable		
DC power supply (optional)	Two (1+1) power supply module slots 950-W DC power supply module Hot-swappable			
Redundant power	1+1			
Fan	Six fan module slots 5+1 redundancy Hot-swappable			

Feature	4112	4115	4125	4145
Storage	<p>Two SSD slots</p> <p>Ships with one 400-GB SSD installed in slot 1. Slot 1 is the primary SSD and should always be present. Slot 1 is reserved for the logical device application instance (threat defense or ASA).</p> <p>Note RAID is not supported.</p> <p>Caution The SSD must be installed in slot 1. Slot 2 is reserved only for the optional Malware Storage Pack (MSP).</p>		<p>Two SSD slots</p> <p>Ships with one 800-GB SSD installed in slot 1. Slot 1 is the primary SSD and should always be present. Slot 1 is reserved for the logical device application instance (threat defense or ASA).</p> <p>Note RAID is not supported.</p> <p>Caution The SSD must be installed in slot 1. Slot 2 is reserved only for the optional MSP.</p>	
MSP (optional)	Installed in the second SSD slot only			
Network Equipment Building Systems (NEBS) certification	—	—	Certified	—
Security standards certifications	—	<ul style="list-style-type: none"> • Common Criteria (CC) certification for the Network Device Collaborative Protection Profile (NDcPPv2.2E), VPN Gateway Module (VPNGW_MOD_v1.1), and Firewall Module (FW_MOD_v1.4e) for ASA 9.16.x. • Common Criteria (CC) and Commercial Solutions for Classified (CSFC) for FTD 6.2.x. • CC for the Network Device Collaborative Protection Profile (NDcPPv2.1) for ASA 9.12.x and FX-OS 2.6.x. • Federal Information Processing Standards (FIPS) 140-2 on ASA 9.12.x, FTD 6.4.x, and FX-OS 2.6.x. • Department of Defense Information Network Approved Product List (DoDIN APL) for ASA 9.12.x and FTD 6.4.x. • US Government Compliance for IPv6 (USGv6) for ASA 9.8.x and FTD 6.2.x. <p>Note Firepower 4112 has not yet completed the above certifications.</p> <p>Note See the "Security Certifications Compliance" chapter in the Cisco FXOS CLI Configuration Guide or Cisco FXOS Firepower Chassis Manager Configuration Guide for the procedure to enable security modes.</p>		

Deployment Options

Here are some examples of how you can deploy the Firepower 4100:

- In a data center using NGFW and ASA
- At the core/aggregation layer of a 3-tier data center in a high availability configuration
- As a dedicated multifunctional security service within converged infrastructure stacks, for example, vBlock, FlexPod, and so forth, at the access layer
- As a high-performance data center security appliance between the WAN edge and the data center core in a high availability configuration
- Inter-DC clustering deployments
- In newer spine/leaf data center designs, deployment as a leaf that exclusively offers security functions

Package Contents

The following figure shows the package contents for the Firepower 4100. Note that the contents are subject to change and your exact contents might contain additional or fewer items.

Figure 2: Firepower 4100 Package Contents

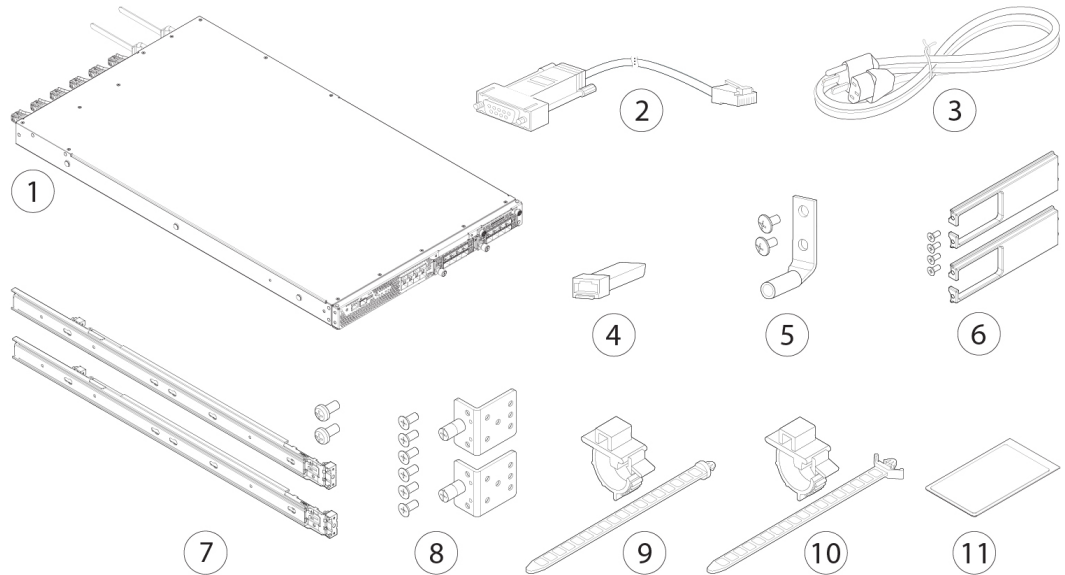

1	Firepower 4100 chassis	2	Blue console cable PC terminal adapter (part number 72-3383-01)
---	------------------------	---	---

3 Two power cords (country-specific) See Power Cord Specifications, on page 32 for a list of supported power cords.	4 10/100/1000BASE-T SFP transceiver
5 Ground lug kit (part number 69-1000359-01): <ul style="list-style-type: none"> • One ground lug #6 AWG, 90 degree, #10 post (part number 32-0608-01) • Two 10-32 x 39-8-inch Phillips Head screws (part number 48-0700-01) 	6 Cable management bracket kit (part number 69-100376-01) <ul style="list-style-type: none"> • Two cable management brackets (part number 700-106377-01) • Four 8-32 x 0.375-inch Phillips screws (part number 48-2696-01)
7 Two slide rails with two M3 x 0.5 x 6-mm screws (48-101144-01)	8 Two slide rail locking brackets (part number 700-105350-02) Six 8-32 x 0.375-inch Phillips screws (part number 48-2696-01)
9 Artesyn tie wrap and tie wrap clamp (part number 52-100204-01)	10 Flextronics tie wrap and tie wrap clamp (part number 52-100202-01)
11 <i>Cisco Secure Firepower 4100</i> This document has a URL and QR code that point to the Digital Documentation Portal. The portal contains links to the Product Information page, the Hardware Installation Guide, the Regulatory and Safety Information Guide, the Getting Started Guide, and the Easy Deployment Guide.	—

Serial Number Location





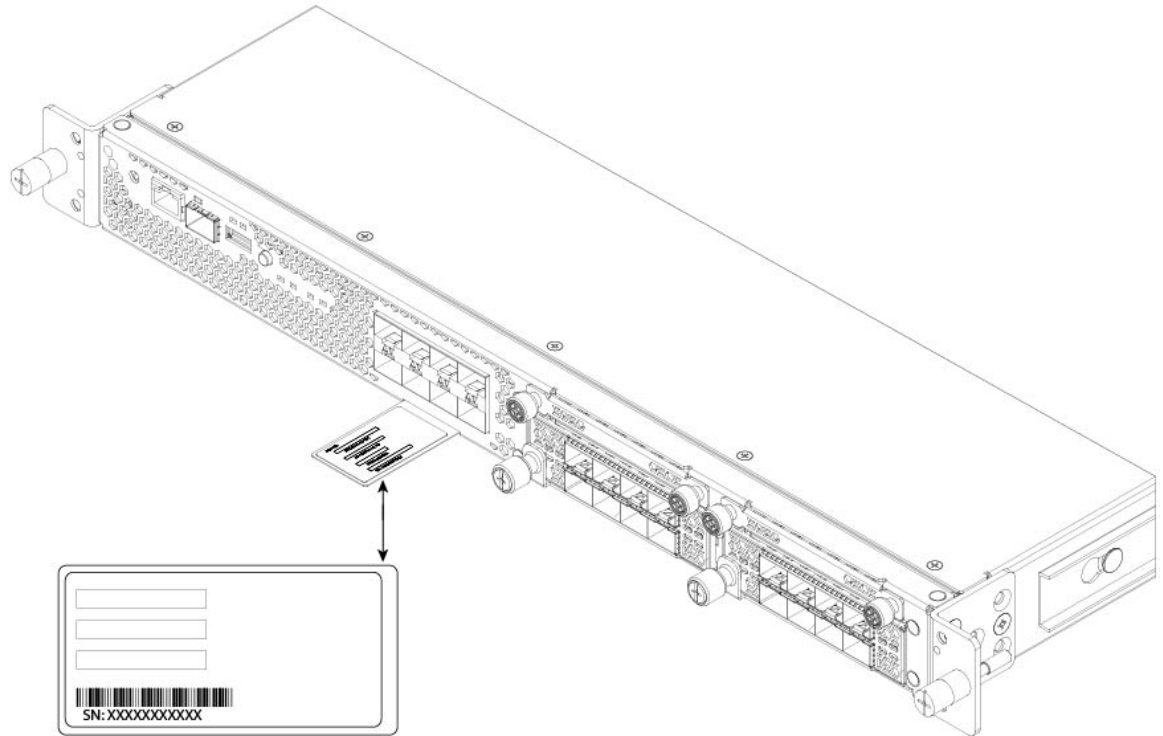





The serial number for the Firepower 4100 series chassis is located on the pullout asset card on the front panel.

Figure 3: Serial Number on the 4100 Chassis



You can also view additional model information on the compliance label located on the bottom of the chassis.

Figure 4: Compliance Label on the 4100 Chassis

			Model / Modèle / 型号 / 型號 : FPR-4115-K9		
This device complies with Part 15 of the FCC Rules. Operation is subject to the following two conditions: 1) this device may not cause harmful interference, and 2) this device must accept any interference received, including interference that may cause undesired operation.					
Desenvolvido por: Cisco Systems, Inc./ou suas afiliadas 170 West Tasman Drive San Jose, CA 95134, USA					
本标签只适用于中国大陆地区 仅适用于在海拔两千米及以下地区安全使用			Fabricado por: Flextronics International Tecnologia Ltda Av Liberdade, 6315- Predios 09,10,11 e 12 Bloco1 CEP 18.087-170- Iporanga- Sorocaba - SP CNPJ 74.404.229/0005-51 Indústria Brasileira		
 http://cisco-returns.com CAN ICES-3 (A)/NMB-3(A)					
PID VID  FPR-4115-K9		 68-5744-XX XX		Date Code 06/03/2015	
 SN: JMXXXXXXX		 FWMAF00BRA		墨西哥制造 MADE IN MEXICO	

Front Panel

The following figure shows the front panel of the Firepower 4100.

Figure 5: Firepower 4100 Front Panel

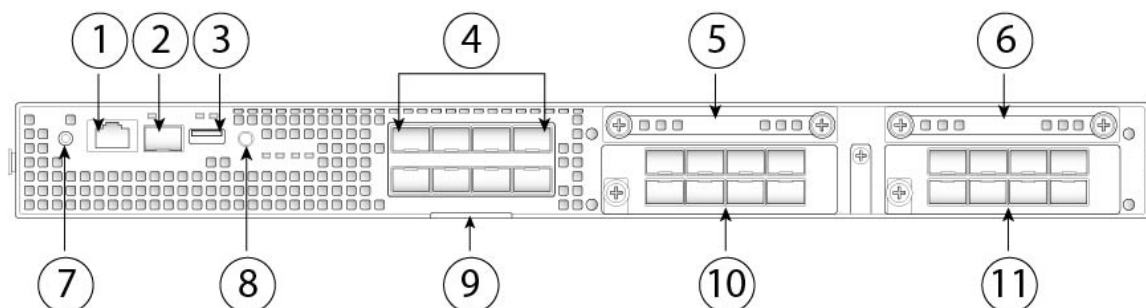

1	RJ-45 console port	2	Gigabit Ethernet management port
3	USB 2.0 Type A port	4	Eight fixed SFP+ (1-Gb/10-Gb) ports (in network module slot 1) Ethernet 1/1 through 1/8 labeled top to bottom, left to right
5	SSD 1 Reserved for the primary SSD; slot 1 must always be populated.	6	SSD 2 Reserved for the optional MSP.
7	Power LED	8	Locator LED
9	Pullout asset card	10	Network module 2 Note The 10-Gb network module is shown.
11	Network module 3 Note The 10-Gb network module is shown.		

RJ-45 Console Port

The Firepower 4100 has a standard RJ-45 console port. You can use the CLI to configure your Firepower 4100 through the RJ-45 serial console port by using a terminal server or a terminal emulation program on a computer.

The RJ-45 (8P8C) port supports RS-232 signaling to an internal UART controller. The console port does not have any hardware flow control, and does not support a remote dial-in modem. The baud rate is 9600. You can use the standard cable found in your accessory kit to convert the RJ-45 to DB-9 if necessary.

Type A USB Port

You can use the external USB Type A port to attach a data storage device. The external USB drive identifier is `disk1:`. The USB Type A port supports the following:

- Hot swapping
- USB drive formatted with FAT32
- Boot kick-start image from the Supervisor ROMMON for discovery recovery purposes
- Copy files to and from workspace:/ and volatile:/ within local-mgmt. The most relevant files are:
 - Core files
 - Ethalyzer packet captures
 - Tech-support files
 - Security module log files
- Platform bundle image upload using **download image usbA:**

The USB Type A port does *not* support Cisco Secure Package (CSP) image upload.

Network Ports

The Firepower 4100 chassis has eight fixed ports that require 1-Gb/10-Gb SFP/SFP+ transceivers (fiber or copper). They are numbered from left to right starting with 1 and are named Ethernet 1/1 through Ethernet 1/8. The 4100 also has two network module slots that support different numbers of ports depending on the network module. See [Network Modules, on page 11](#) for the supported network modules. See for [Supported SFP/SFP+ and QSFP Transceivers, on page 25](#) the list of supported transceivers.

Each port has LEDs that represent link/activity status.

Management Port

The Firepower 4100 chassis has a management port that requires a 1-Gb fiber or copper SFP.

Front Panel LEDs

The following figure and table describe the Firepower 4100 front panel LEDs.

Figure 6: Front Panel LEDs

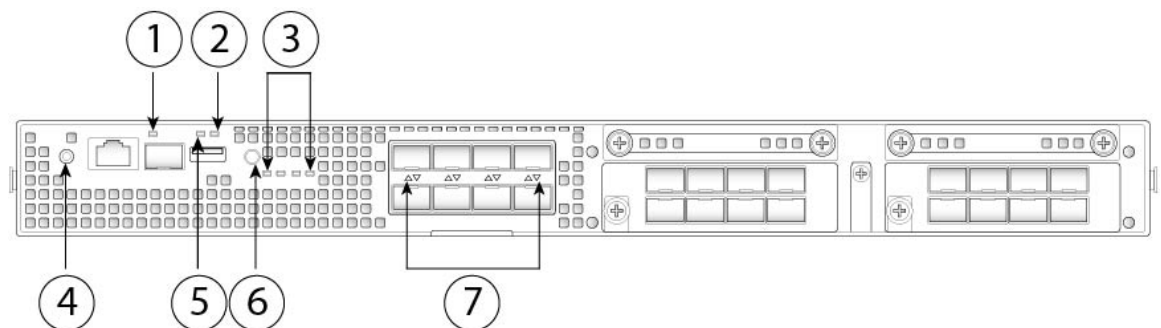

<p>1 Management</p> <ul style="list-style-type: none"> • Off—No connection or port is not in use. • Amber—No link or network failure. • Green—Link up. • Green, flashing—Network activity. 	<p>2 Health (SYS)</p> <ul style="list-style-type: none"> • Off—System is not booting yet. • Green, flashing—Power-up diagnostics are complete and system is booting up. • Green—The system has passed power-up diagnostics. • Amber—Power-up diagnostics has failed. • Amber, flashing—Alarm; power-up diagnostics are running.
<p>3 SSD</p> <ul style="list-style-type: none"> • Off— SSD not present. • Green—SSD is present; no activity. • Green, flashing—SSD is active. • Amber—SSD failure. • Amber, flashing—Rebuilding, flashes at 1 Hz. • Amber, flashing—Predictive failure analysis (PFA) and hot spare; two fast flashes at 4 Hz, pause for 0.5 seconds. 	<p>4 Power</p> <ul style="list-style-type: none"> • Off—Input power not detected. • Green, flashing—Appears only when you move the power switch from ON to OFF. System is shutting down and powers off once shutdown is completed. • Amber—System is powering up. • Green—System fully powered up. • Amber, flashing—Reserved.
<p>5 Active (ACT)</p> <p>This LED is not supported; reserved for future use.</p>	<p>6 Locator LED</p> <ul style="list-style-type: none"> • Off—Locate is off. • Blue—Locate is on.
<p>7 Network activity</p> <ul style="list-style-type: none"> • Off—No connection or port is not in use. • Amber—No link or network failure. • Green—Link up. • Green, flashing—Network activity. 	

Rear Panel

The following figure shows the rear panel of the Firepower 4100.

Figure 7: Firepower 4100 Rear Panel

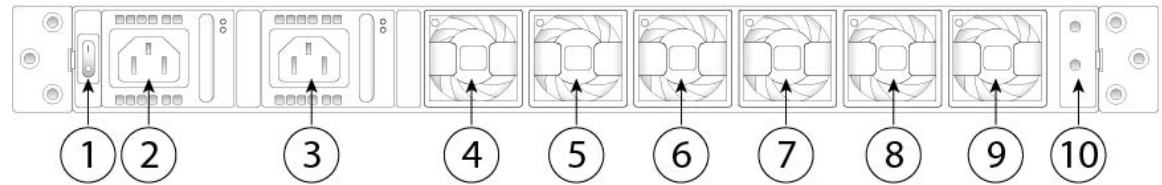

1	Power on/off switch	2	Power supply module 1
3	Power supply module 2	4	Fan module 1
5	Fan module 2	6	Fan module 3
7	Fan module 4	8	Fan module 5
9	Fan module 6	10	Location for the two-post grounding lug Note The two-post grounding lug is included in the accessory kit.

The power switch is located to the left of power supply module 1 on the rear of the chassis. It is a toggle switch that controls power to the system. If the power switch is in standby position, only the 3.3-V standby power is enabled from the power supply module and the 12-V main power is OFF. When the switch is in the ON position, the 12-V main power is turned on and the system boots.

You can shut down the chassis in one of two ways:

- Perform a graceful shutdown using the **shutdown** commands (see the [FXOS CLI Configuration Guide](#) for the procedure). This may take several minutes to complete. Then toggle the power switch to the OFF position. The power LED changes from solid green to off immediately.



Caution If you move the power switch to the OFF position before the **shutdown** command sequence is complete or if you remove the system power cords before the graceful shutdown is complete, disk corruption can occur.

- Toggle the power switch to the OFF position. The power LED changes from solid green to off.



Note After removing power from the chassis either by moving the power switch to OFF or unplugging the power cord, wait at least 10 seconds before turning power back ON.

Network Modules

The Firepower 4100 contains two network module slots that provide optical or electrical network interfaces. Network modules are optional, removable I/O modules that provide either additional ports or different interface types (1/10/40 Gb). The Firepower network modules plug into the chassis on the front panel.

For More Information

- See [10-Gb Network Module, on page 12](#) for a description of the 10-GB network module.
- See [40-Gb Network Module, on page 13](#) for a description of the 40-GB network module.
- See [100-Gb Network Module, on page 14](#) for a description of the two-port 100-Gb network module.
- See [Hardware Bypass Network Modules, on page 15](#) for the location and description of the LEDs, and the port configurations for the hardware bypass network modules.
- See [Install, Remove, and Replace the Network Module, on page 55](#) for the procedure for removing and replacing network modules.

10-Gb Network Module

The following figure shows the front panel of the 10-Gb network module (FPR4K-NM-8X10G). The FPR4K-NM-8X10G is a single-wide module that supports hot swapping. The eight ports are numbered from top to bottom, left to right.



Note Make sure you have the correct firmware package and software version installed to support this network module. For instructions on how to verify your firmware package version and to upgrade the firmware if necessary, see the [Cisco Firepower 4100/9300 FXOS Firmware Upgrade Guide](#). See [Cisco Firepower 4100/9300 FXOS Compatibility](#) for the software compatibility matrix.



Note The FPR4K-NM-8X10G is NEBS-compliant.



Note You can fit four copper SFPs in either the top row of ports or the bottom row of ports. Both rows cannot be populated at the same time, because of the port row spacing.

Figure 8: FPR4K-NM-8X10G

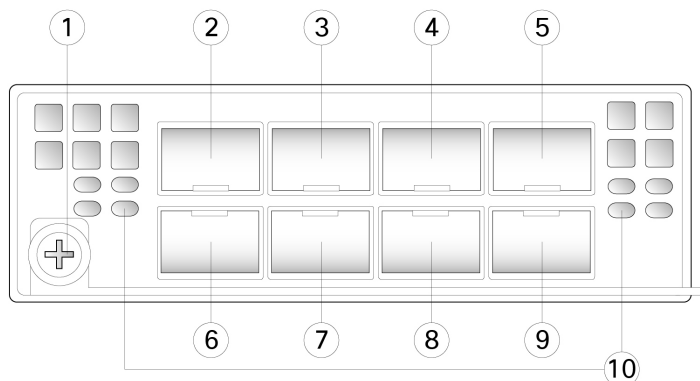

1	Captive screw/handle	2	Ethernet X/1
3	Ethernet X/3	4	Ethernet X/5
5	Ethernet X/7	6	Ethernet X/2
7	Ethernet X/4	8	Ethernet X/6
9	Ethernet X/8	10	Network activity LEDs <ul style="list-style-type: none"> • Off—No connection or port is not in use. • Amber—No link or network failure. • Green—Link up. • Green, flashing—Network activity.

For More Information

- For a list of copper SFPs, see [Supported SFP/SFP+ and QSFP Transceivers, on page 25](#).

40-Gb Network Module

The following figure shows the front panel of the 40-Gb network module (FPR4K-NM-4X40G.) The FPR4K-NM-4X40G is a single-wide module that supports hot swapping. The four ports are numbered left to right.



Note Make sure you have the correct firmware package and software version installed to support this network module. For instructions on how to verify your firmware package version and to upgrade the firmware if necessary, see the [Cisco Firepower 4100/9300 FXOS Firmware Upgrade Guide](#). See [Cisco Firepower 4100/9300 FXOS Compatibility](#) for the software compatibility matrix.



Note The FPR4K-NM-4X40G is NEBS-compliant.

Figure 9: FPR4K-NM-4X40G

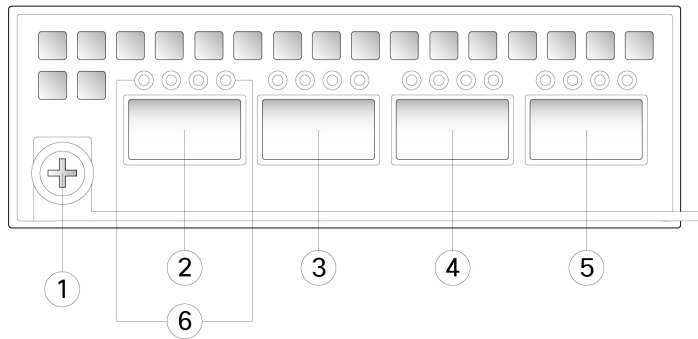

<p>1 Captive screw/handle</p>	<p>2 Network activity LEDs</p> <ul style="list-style-type: none"> • Off—No connection or port is not in use. • Amber—No link or network failure. • Green—Link up. • Green, flashing—Network activity. • 40Gb—Only the leftmost LED indicates the port status. • 4x10Gb—Each of the port LEDs indicates the status of respective 10-Gb channel.
<p>3 Ethernet X/1</p>	<p>4 Ethernet X/2</p>
<p>5 Ethernet X/3</p>	<p>6 Ethernet X/4</p>

100-Gb Network Module

The following figure shows the front panel of the 100-Gb network module (FPR4K-NM-2X100G). The FPR4K-NM-2X100G is a two-port single-wide module that supports hot swapping. The two ports are numbered left to right. The FPR4K-NM-2X100G is first supported in FTD 7.2 and ASA 9.18.



Note Make sure you have the correct firmware package and software version installed to support this network module. For instructions on how to verify your firmware package version and to upgrade the firmware if necessary, see the [Cisco Firepower 4100/9300 FXOS Firmware Upgrade Guide](#). See [Cisco Firepower 4100/9300 FXOS Compatibility](#) for the software compatibility matrix.

Figure 10: FPR4K-NM-2X100G

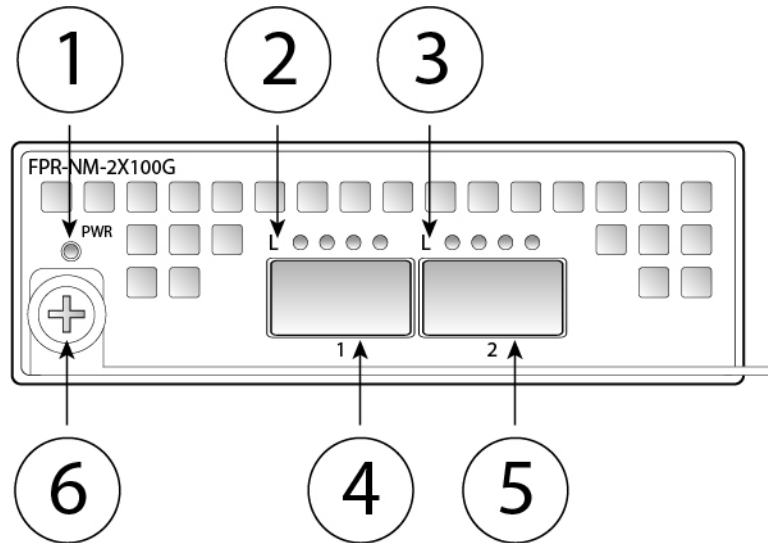

1	Power LED	2	Network activity LEDs <ul style="list-style-type: none"> • Off—No connection or port is not in use. • Amber—No link or network failure. • Green—Link up. • Green, flashing—Network activity.
3	Network activity LEDs <ul style="list-style-type: none"> • Off—No connection or port is not in use. • Amber—No link or network failure. • Green—Link up. • Green, flashing—Network activity. 	4	Ethernet X/1
5	Ethernet X/2	6	Captive screw/handle

Hardware Bypass Network Modules

Hardware bypass (also known as fail-to-wire) is a physical layer (Layer 1) bypass that allows paired interfaces to go into bypass mode so that the hardware forwards packets between these port pairs without software intervention. Hardware bypass provides network connectivity when there are software or hardware failures. Hardware bypass is useful on ports where the Firepower security appliance is only monitoring or logging traffic. The hardware bypass network modules have an optical switch that is capable of connecting the two ports when needed. The hardware bypass network modules have built-in SFPs.

Hardware bypass is supported only on a fixed set of ports. You can pair Port 1 with Port 2, Port 3 with Port 4, but you cannot pair Port 1 with Port 4 for example.



Note When the appliance switches from normal operation to hardware bypass or from hardware bypass back to normal operation, traffic may be interrupted for several seconds. A number of factors can affect the length of the interruption; for example, behavior of the optical link partner such as how it handles link faults and debounce timing; spanning tree protocol convergence; dynamic routing protocol convergence; and so on. During this time, you may experience dropped connections.

There are three configuration options for hardware bypass network modules:

- **Passive interfaces**—Connection to a single port.

For each network segment you want to monitor passively, connect the cables to one interface. This is how the nonhardware bypass network modules operate.

- **Inline interfaces**—Connection to any two like ports (10 Gb to 10 Gb for example) on one network module, across network modules, or fixed ports.

For each network segment you want to monitor inline, connect the cables to pairs of interfaces.

- **Inline with hardware bypass interfaces**—Connection of a hardware bypass paired set.

For each network segment that you want to configure inline with fail-open, connect the cables to the paired interface set.

For the 40-Gb network module, you connect the two ports to form a paired set. For the 1/10-Gb network modules, you connect the top port to the bottom port to form a hardware bypass paired set. This allows traffic to flow even if the security appliance fails or loses power.



Note If you have an inline interface set with a mix of hardware bypass and nonhardware bypass interfaces, you cannot enable hardware bypass on this inline interface set. You can only enable hardware bypass on an inline interface set if all the pairs in the inline set are valid hardware bypass pairs.

For More Information

- See [1-Gb Network Module with Hardware Bypass](#), on page 16 for a description of the 1-Gb network module.
- See [40-Gb Network Module with Hardware Bypass](#), on page 18 for a description of the 40-Gb network module.
- See [1-Gb SX/10-Gb SR/10-Gb LR Network Module with Hardware Bypass](#), on page 19 for a description of the 1-Gb SX, 10-Gb SR, and LR network modules.
- See [Install, Remove, and Replace the Network Module](#), on page 55 for the procedure for removing and replacing single-wide network modules.

1-Gb Network Module with Hardware Bypass

The following figure shows the front panel view of the 1-Gb network module with hardware bypass (FPR-NM-8X1G-F). Pair ports 1 and 2, 3 and 4, 5 and 6, and 7 and 8 to form hardware bypass paired sets.



Note Make sure you have the correct firmware package and software version installed to support this network module. For instructions on how to verify your firmware package version and to upgrade the firmware if necessary, see the [Cisco Firepower 4100/9300 FXOS Firmware Upgrade Guide](#). See [Cisco Firepower 4100/9300 FXOS Compatibility](#) for the software compatibility matrix.

Figure 11: FPR-NM-8X1G-F

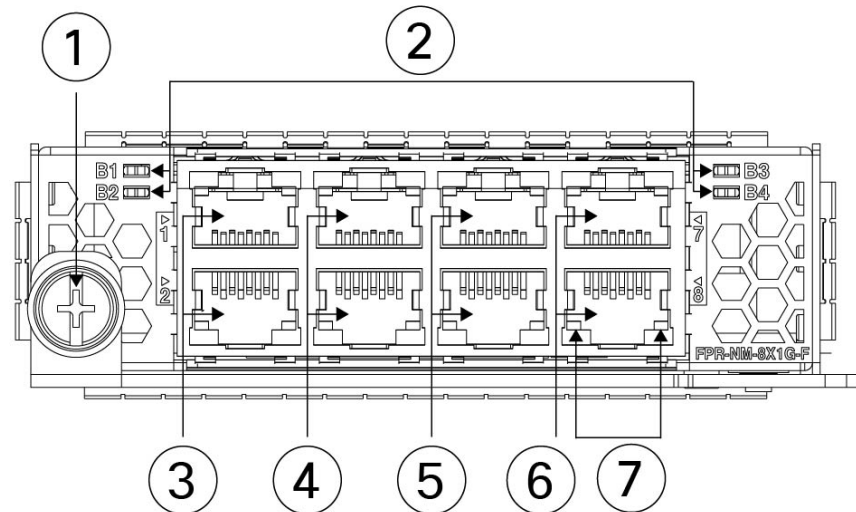

1	Captive screw/handle	2	Bypass LEDs B1 through B4 <ul style="list-style-type: none"> • Green—In standby mode. • Amber, flashing—Port is in hardware bypass mode, failure event.
3	Ethernet X/1 Ports 1 and 2 are paired together to form a hardware bypass pair. LED B1 applies to this paired port.	4	Ethernet X/2 Ports 3 and 4 are paired together to form a hardware bypass pair. LED B2 applies to this paired port.
5	Ethernet X/2 Ports 5 and 6 are paired together to form a hardware bypass pair. LED B3 applies to this paired port.	6	Ethernet X/2 Ports 7 and 8 are paired together to form a hardware bypass pair. LED B4 applies to this paired port.
7	Network activity LEDs <ul style="list-style-type: none"> • Left LED—Green indicates network activity when a 10M/100M/1G connection is made. • Right LED—Not in use at this time. 		—

40-Gb Network Module with Hardware Bypass

The following figure shows the front panel of the 40-Gb hardware bypass network module (FPR4K-NM-2X40G-F). The FPR4K-NM-2X40G-F is a single-wide module that does *not* support hot swapping. The two ports are numbered left to right. Pair the two ports to create a hardware bypass paired set.



Note Make sure you have the correct firmware package and software version installed to support this network module. For instructions on how to verify your firmware package version and to upgrade the firmware if necessary, see the [Cisco Firepower 4100/9300 FXOS Firmware Upgrade Guide](#). See [Cisco Firepower 4100/9300 FXOS Compatibility](#) for the software compatibility matrix.

Figure 12: FPR4K-NM-2X40G-F

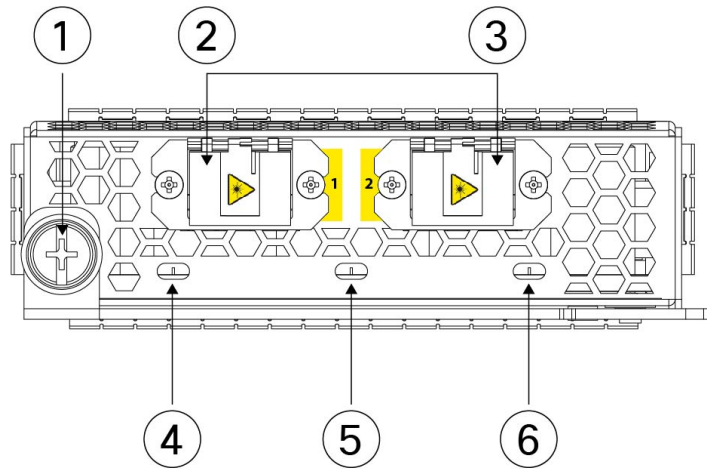

<p>1 Captive screw/handle</p>	<p>2 Port 1 Ethernet X/1 Ports 1 and 2 are paired together to form a hardware bypass pair.</p>
<p>3 Port 2 Ethernet X/2 Ports 1 and 2 are paired together to form a hardware bypass pair.</p>	<p>4 Port 1 network activity LEDs:</p> <ul style="list-style-type: none"> • Amber—No connection, or port is not in use, or no link or network failure. • Green—Link up, no network activity. • Green, flashing—Network activity.
<p>5 BP (bypass LED):</p> <ul style="list-style-type: none"> • Green—In standby mode. • Amber, flashing—Port is in hardware bypass mode, failure event. 	<p>6 Port 2 network activity LEDs:</p> <ul style="list-style-type: none"> • Amber—No connection, or port is not in use, or no link or network failure. • Green—Link up, no network activity. • Green, flashing—Network activity.

The following table describes the cable specifications needed to keep the insertion loss as low as possible.

Table 2: 40-Gb BASE-SR Cable Specifications

Interface	Supported Cable
Ethernet 40-G BASE-SR4	50 microns core diameter
850 nm wavelength	2000/4700 (OM3/4) modal bandwidth (MHz*km)
MPO-12 port adapter	50 m cable distance



Note See the [Cisco 40GBASE QSFP Modules Data Sheet](#) for specifications of the QSFP for the 40-Gb BASE-SR-4.

We recommend the following Cisco OM3 MTP/MPO cables.

Table 3: Cisco Cables

Cisco Part Number	Cable Length
CAB-ETH-40G-5M	5 m
CAB-ETH-40G-10M	10 m
CAB-ETH-40G-20M	20 m

1-Gb SX/10-Gb SR/10-Gb LR Network Module with Hardware Bypass

The following figure shows the front panel of the 1-Gb SX, 10-Gb SR and 10-Gb LR hardware bypass network modules (FPR4K-NM-6X1SX-F, FPR4K-NM-6X10SR-F, FPR4K-NM-6X10LR-F). This is a single-wide module that does *not* support hot swapping. The six ports are numbered from top to bottom, left to right. Pair ports 1 and 2, 3 and 4, and 5 and 6 to form hardware bypass paired sets.



Note Make sure you have the correct firmware package and software version installed to support this network module. For instructions on how to verify your firmware package version and to upgrade the firmware if necessary, see the [Cisco Firepower 4100/9300 FXOS Firmware Upgrade Guide](#). See [Cisco Firepower 4100/9300 FXOS Compatibility](#) for the software compatibility matrix.

Figure 13: FPR4K-NM-6X1SX-F, FPR4K-NM-6X10SR-F, FPR4K-NM-6X10LR-F

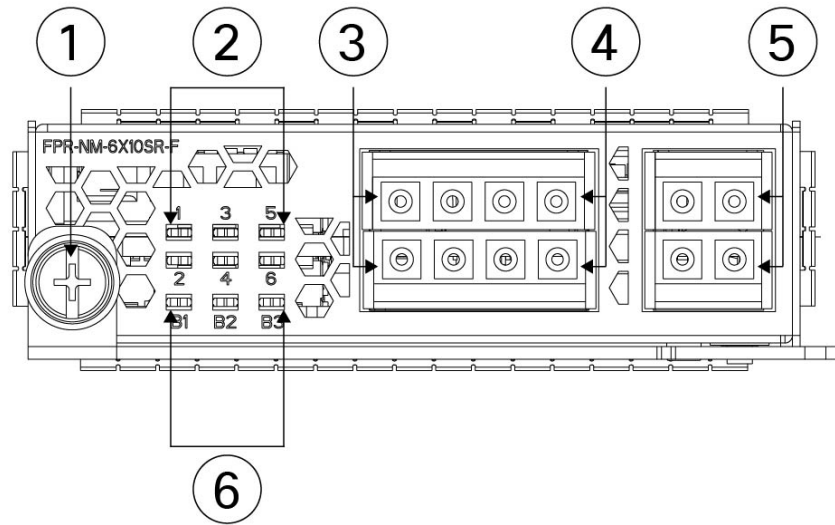

<p>1 Captive screw/handle</p>	<p>2 Six network activity LEDs:</p> <ul style="list-style-type: none"> • Amber—No connection, or port is not in use, or no link or network failure. • Green—Link up, no network activity. • Green, flashing—Network activity.
<p>3 Ethernet X/1 (top port) Ethernet X/2 (bottom port) Ports 1 and 2 are paired together to form a hardware bypass pair.</p>	<p>4 Ethernet X/3 (top port) Ethernet X/4 (bottom port) Ports 3 and 4 are paired together to form a hardware bypass pair.</p>
<p>5 Ethernet X/5 (top port) Ethernet X/6 (bottom port) Ports 5 and 6 are paired together to form a hardware bypass pair.</p>	<p>6 Bypass LEDs B1 through B3:</p> <ul style="list-style-type: none"> • Green—In standby mode. • Amber, flashing—Port is in hardware bypass mode, failure event.

The 1-Gb SX /10-Gb SR/10-Gb LR network modules have the following insertion loss measurements. Insertion loss measurements help you to troubleshoot the network by verifying cable installation and performance.

Table 4: 1-Gb SX Network Module (FPR4K-NM-6X1SX-F)

	Operating Mode	Typical	Maximum
Insertion loss	Normal	0.9 dB	1.4 dB
	Hardware bypass	1.2 dB	1.7 dB

	Core diameter (microns)	Modal bandwidth (MHz/km)	Cable distance Note Half the distance specified by the IEEE standard.
Cable and operating distance	62.5	160 (FDDI)	110 m
	62.5	200 (OM1)	137 m
	50	400	250 m
	50	500 (OM2)	275 m
	50	2000 (OM3)	500 m

Table 5: 10-Gb SR Network Module (FPR4K-NM-6X10SR-F)

	Operating Mode	Typical	Maximum
Insertion loss	Normal	0.9 dB	1.4 dB
	Hardware bypass	1.2 dB	1.7 dB
	Core diameter (microns)	Modal bandwidth (MHz/km)	Cable distance Note Half the distance specified by the IEEE standard.
Cable and operating distance	62.5	160 (FDDI)	13 m
	62.5	200 (OM1)	16.5 m
	50	400	33 m
	50	500 (OM2)	41 m
	50	2000 (OM3)	150 m
	50	4700 (OM4)	200 m

Table 6: 10-Gb LR Network Module (FPR4K-NM-6X10LR-F)

	Operating Mode	Typical	Maximum
Insertion loss	Normal	1.2 dB	1.6 dB
	Hardware bypass	1.5 dB	1.9 dB

	Core diameter (microns)	Modal bandwidth (MHz/km)	Cable distance Note Half the distance specified by the IEEE standard.
Cable and operating distance	G.652	Single mode	5 km

Power Supply Modules

The Firepower 4100 supports two AC or DC power supply modules so that dual power supply redundancy protection is available. Facing the back of the chassis, the power supply modules are numbered left to right, for example, PSU1 and PSU2.



Note The system power requirements are lower than the power supply module capabilities. See [Hardware Specifications, on page 28](#) for the system power requirements.



Note After removing power from the chassis either by moving the power switch to OFF or unplugging the power cord, wait at least 10 seconds before turning power back ON.



Attention Make sure that one power supply module is always active.

See [Remove and Replace the Power Supply Module, on page 63](#) for the procedure for removing and replacing the power supply module.

AC Power Supply

The power supplies can supply up to 1100-W power across the input voltage range. The load is shared when both power supply modules are plugged in and running at the same time. The power supply modules are hot-swappable.

Table 7: AC Power Supply Module Hardware Specifications

Description	Specification
Input voltage	100 to 240 V AC

Maximum current	13 A (at 100 V AC) Note The system power requirements are lower than the power supply module capabilities. See Hardware Specifications, on page 28 for the system power requirements.
Maximum output power	1100 W
Frequency	50 to 60 Hz
Redundancy	1+1 redundant
Efficiency at 50% load	92%

DC Power Supply

The power supplies can supply up to 950 W of power across the input voltage range. The load is shared when both power supply modules are plugged in and running at the same time. The power supply modules are hot-swappable.

Table 8: DC Power Supply Module Hardware Specifications

Description	Specification
Input voltage	-40 to -60 V DC
Maximum current	26 A (at 40 V DC)
Maximum output power	950 W
Redundancy	1+1 redundant
Efficiency at 50% load	92%

Power Supply Module LEDs

The following figure shows the two-color power supply LEDs. The LEDs are located on the upper right side.

Figure 14: Power Supply Module LEDs

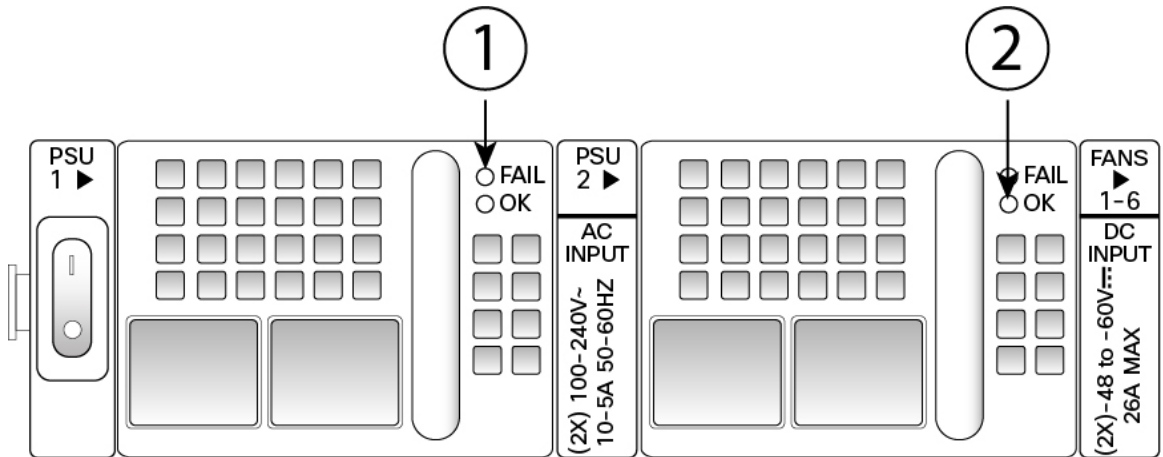

1	Amber FAIL LED	2	Green OK LED
---	----------------	---	--------------

The following table describes the power module supply LEDs and their states.

Table 9: Power Supply Module LEDs

	Amber LED (Fail Status)	Green LED (OK Status)
No power to all power supplies	Off	Off
Power supply module failure Includes overvoltage, overcurrent, overtemperature, and fan failure	On	Off
Power supply module warning events Power supply continues to operate. With high temperature, high power, and slow fan	1 Hz flashing	Off
Power is present. 3.3 VSB on (power supply module off)	Off	1 Hz flashing
Power supply module is OK and on.	Off	On

Fan Modules

The Firepower 4100 requires six fan modules, which are hot-swappable. They are installed in the rear of the chassis. The system supports operation with a single fan failure (N+1 fan redundancy), but do not run the system for an extended amount of time without all fan modules installed. Keep removal and replacement time at three minutes. Remove and replace one fan module at a time.

If you remove a fan or a fan fails, the other fans operate at full speed, which can be noisy.

The fan modules are numbered left to right, for example, FAN1, FAN2, FAN3, FAN4, FAN5, and FAN6. See [Remove and Replace the Fan Module, on page 58](#) for the procedure for removing and replacing the fan module.

The following figure shows the location of the fan LED.

Figure 15: Fan LED

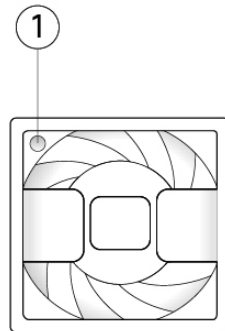

1	Two-color LED
----------	---------------

The fan module has one two-color LED, which is located on the upper left corner of the fan.

- Amber—Fan failure.
- Green—Fan running normally. It may take up to one minute for the LED status to turn green after power is on.

Supported SFP/SFP+ and QSFP Transceivers

The SFP/SFP+ transceivers are bidirectional devices with a transmitter and receiver in the same physical package. It is a hot-swappable optical or electrical (copper) interface that plugs into the SFP/SFP+ ports on the fixed ports and the network module ports, and provides Ethernet connectivity.



Warning

Use appropriate ESD procedures when inserting the transceiver. Avoid touching the contacts at the rear, and keep the contacts and ports free of dust and dirt. Keep unused transceivers in the ESD packing that they were shipped in. The following figure shows a sample SFP transceiver.

Figure 16: SFP

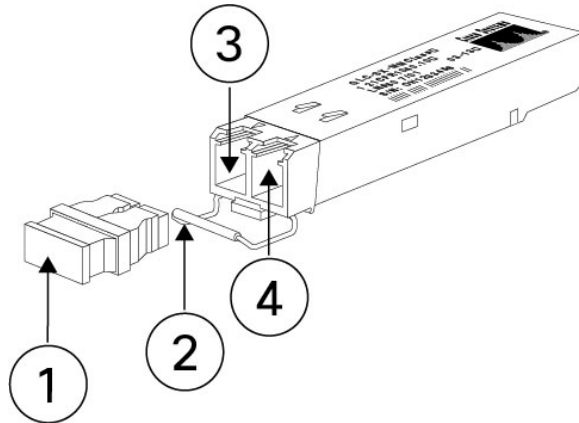

1	Dust plug	2	Bail clasp
3	Receive optical bore	4	Transmit optical bore

Safety Warnings

Take note of the following optical connection warnings:



Warning Statement 1051—Laser Radiation

Invisible laser radiation may be emitted from disconnected fibers or connectors. Do not stare into beams or view directly with optical instruments.



Warning Statement 1055—Class 1/1M Laser

Invisible laser radiation is present. Do not expose to users of telescopic optics. This applies to Class 1/1M laser products.



The following table lists the Cisco supported transceivers.

Table 10: Supported Cisco SFP/SFP+ Transceivers

Optics Type	PID
1 Gb	
1G-SX	GLC-SX-MMD
1G-LH/LX	GLC-LH-SMD
1G-EX	GLC-EX-SMD

1G-ZX	GLC-ZX-SMD
1G 1000Base-T	GLC-T
1G 1000Base-T	GLC-TE
10 Gb	
10G-SR	SFP-10G-SR
10G-SR-S	SFP-10G-SR-S
10G-LR	SFP-10G-LR
10G-LR-S	SFP-10G-LR-S
10G-LRM	SFP-10G-LRM
10G-ER	SFP-10G-ER
10G-ER-S	SFP-10G-ER-S
10G-ZR-S	SFP-10G-ZR-S
10G Cu, 1m	SFP-H10GB-CU1M
10G Cu, 1.5m	SFP-H10GB-CU1-5M
10G Cu, 2m	SFP-H10GB-CU2M
10G Cu, 2.5m	SFP-H10GB-CU2-5M
10G Cu, 3m	SFP-H10GB-CU3M
10G Cu, 5m	SFP-H10GB-CU5M
10G Cu, 7m	SFP-H10GB-ACU7M
10G Cu, 10m	SFP-H10GB-ACU10M
10G AOC, 1m	SFP-10G-AOC1M
10G AOC, 2m	SFP-10G-AOC2M
10G AOC, 3m	SFP-10G-AOC3M
10G AOC, 5m	SFP-10G-AOC5M
10G AOC, 7m	SFP-10G-AOC7M
10G AOC, 10m	SFP-10GAOC10M
40 Gb	
40G-SR4	QSFP-40G-SR4
40G-SR4-S	QSFP-40G-SR4-S

40G-CSR4	QSFP-40G-CSR4
40G-SR-BD	QSFP-40G-SR-BD
40GE-LR4	QSFP-40GE-LR4
40GE-LR4-S	QSFP-40GE-LR4-S
40G-LR4L	WSP-Q40GLR4L
40G-CU, 1M, 3M, 5M	QSFP-H40G-CU
40G-4X10G-CU, 1M, 3M, 5M	QSFP-4SFP10G-CU
40G-CU-A, 7M, 10M	QSFP-H40G-ACU
40G-4X10G-CU-A, 7M, 10M	QSFP-4X10G-AC
40G-AOC, 1M, 2M, 3M, 5M, 7M, 10M, 15M	QSFP-H40G-AOC
100Gb	
100G-FR	QSFP-100G-FR-S

Hardware Specifications

The following table contains hardware specifications for the Firepower 4100.

Table 11: Firepower 4100 Hardware Specifications

Specification	4112	4115	4125	4145
Dimensions (H x W x D)	1.75 x 16.89 x 29.7 inches (4.44 x 42.90 x 75.43 cm) 1.75 x 16.89 x 31.52 inches (4.44 x 42.90 x 80.06 cm) with fans			
Weight	39.4 lb (17.87 kg) two power supply modules, two network modules, six fans 31.4 lb (14.24 kg) no power supply modules, no network modules, no fans			
System power	AC: 100/240 V AC 10 A (at 100 V), 50 to 60 Hz DC: -40 V DC to -60 V DC, 26 A (at -40 V)			
Temperature	Operating: 32 to 104° F (0 to 40° C) at sea level 1° C reduction of maximum for every 1000 ft (305 m) above sea level Nonoperating: -40 to 149°F (-40 to 65° C)			

Specification	4112	4115	4125	4145
NEBS operating temperature Firepower 4125 only	—	—	Long term: 32 to 113° F (0 to 45° C) up to 6000 ft (1829 m) Long term: 32 to 95° F (0 to 35° C) up to 6000-13,000 ft (1829-3964 m) Short term: 23 to 131° F (-5 to 55° C) up to 6000 ft (1829 m)	—
Humidity	Operating and nonoperating: 5 to 95% noncondensing			
Altitude	Operating: 10,000 ft maximum (3048 m) Nonoperating: 15,000 ft maximum (4570 m)			
NEBS operating altitude Firepower 4125 only	—	—	0 to 13,000 ft (3962 m)	—
Sound pressure	63 dBa (typical) 74 dBa (maximum)			
Declared sound power	76 dB (typical) 87 dB (maximum)			

Product ID Numbers

The following table lists the PIDs associated with the Firepower 4100. All of the PIDs in the table are field-replaceable. If you need to get a return material authorization (RMA) for any component, see [Cisco Returns Portal](#) for more information.



Note See the **show inventory** command in the [Cisco Firepower 4100/9300 FXOS Command Reference](#), in the [Cisco Firepower Threat Defense Command Reference](#), or in the [Cisco ASA Series Command Reference](#) for the procedure to display a list of the PIDs for your Firepower 4100.

Table 12: Firepower 4100 PIDs

PID	Description
FPR4112-ASA-K9	Cisco Firepower 4112 ASA appliance, 1 RU, two network module bays
FPR4112-NGFW-K9	Cisco Firepower 4112 NGFW appliance, 1 RU, two network module bays
FPR4112-NGFW-K9	Cisco Firepower 4112 NGIPS appliance, 1 RU, two network module bays
FPR4115-ASA-K9	Cisco Firepower 4115 ASA appliance, 1 RU, two network module bays
FPR4115-NGFW-K9	Cisco Firepower 4115 NGFW appliance, 1 RU, two network module bays
FPR4115-NGIPS-K9	Cisco Firepower 4115 NGIPS appliance, 1 RU, two network module bays
FPR4125-ASA-K9	Cisco Firepower 4125 ASA appliance, 1 RU, two network module bays
FPR4125-NGFW-K9	Cisco Firepower 4125 NGFW appliance, 1 RU, two network module bays
FPR4125-NGIPS-K9	Cisco Firepower 4125 NGIPS appliance, 1 RU, two network module bays
FPR4145-ASA-K9	Cisco Firepower 4145 ASA appliance, 1 RU, two network module bays
FPR4145-NGFW-K9	Cisco Firepower 4145 NGFW appliance, 1 RU, two network module bays
FPR4145-NGIPS-K9	Cisco Firepower 4145 NGIPS appliance, 1 RU, two network module bays
FPR4K-ACC-KIT2	Firepower hardware accessory kit containing rack mounts and cables
FPR4K-ACC-KIT2=	Firepower hardware accessory kit containing rack mounts and cables (spare)
FPR4K-S-FAN	Fan
FPR4K-S-FAN=	Fan (spare)
FPR4K-NM-2X40G-F	2-port 40-Gb SR hardware bypass network module
FPR4K-NM-2X40G-F=	2-port 40-Gb SR hardware bypass network module (spare)

PID	Description
FPR4K-NM-4X40G	4-port 40-Gb QSFP+ network module
FPR4K-NM-4X40G=	4-port 40-Gb QSFP+ network module (spare)
FPR4K-NM-6X10LR-F	6-port 10-Gb LR hardware bypass network module
FPR4K-NM-6X10LR-F=	6-port 10-Gb LR hardware bypass network module (spare)
FPR4K-NM-6X10SR-F	6-port 10-Gb SR hardware bypass network module
FPR4K-NM-6X10SR-F=	6-port 10-Gb SR hardware bypass network module (spare)
FPR4K-NM-6X1SX-F	6-port 1-Gb SX fiber hardware bypass network module
FPR4K-NM-6X1SX-F=	6-port 1-Gb SX fiber hardware bypass network module (spare)
FPR4K-NM-8X10G	8-port 10-Gb SFP+ network module
FPR4K-NM-8X10G=	8-port 10-Gb SFP+ network module (spare)
FPR4K-NM-8X1G-F	8-port 1-Gb copper hardware bypass network module
FPR4K-NM-8X1G-F=	8-port 1-Gb copper hardware bypass network module (spare)
FPR4K-NM-2X100G	2-port 100-Gb single-wide network module
FPR4K-NM-2X100G=	2-port 100-Gb single-wide network module (spare)
FPR4K-NM-BLANK	Network module blank slot cover
FPR4K-NM-BLANK=	Network module blank slot cover (spare)
FPR4K-PSU-BLANK	Chassis power supply module blank slot cover
FPR4K-PSU-BLANK=	Chassis power supply module blank slot cover (spare)
FPR4K-PWR-AC-1100	1100-W AC power supply module
FPR4K-PWR-AC-1100-	1100-W AC power supply module (spare)
FPR4K-PWR-DC-950	950-W DC power supply module
FPR4K-PWR-DC-950=	950-W DC power supply module (spare)
FPR4K-RACK-MNT	Rack-mount kit
FPR4K-RACK-MNT=	Rack-mount kit (spare)
FPR4K-CBL-MGMT	Cable management brackets

PID	Description
FPR4K-CBL-MGMT=	Cable management brackets (spare)
FPR4K-SSD-BBLKD	SSD slot carrier
FPR4K-SSD-BBLKD=	SSD slot carrier (spare)
FPR4K-SSD400	400-GB SSD for Firepower 4112 and 4115
FPR4K-SSD400=	400-GB SSD for Firepower 4112 and 4115 (spare)
FPR4K-SSD800	800-GB SSD for Firepower 4125 and 4145
FPR4K-SSD800=	800-GB SSD for Firepower 4125 and 4145 (spare)

Power Cord Specifications

Each power supply has a separate power cord. Standard power cords are available for connection to the security appliance.

If you do not order the optional power cord with the system, you are responsible for selecting the appropriate power cord for the product. Using an incompatible power cord with this product may result in electrical safety hazard. Orders delivered to Argentina, Brazil, and Japan must have the appropriate power cord ordered with the system.



Note Only the approved power cords or jumper power cords provided with the security appliance are supported.

The following power cords are supported.

Figure 17: Argentina CAB-9K10A-AR

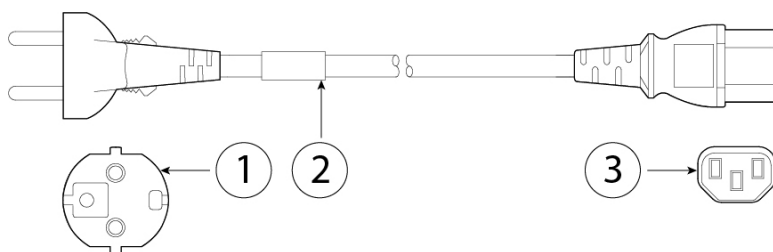

1	Plug: IRAM 2073	2	Cord set rating: 10 A, 250 V
3	Connector: IEC 60320-C15		—

Figure 18: Australia CAB-9K10A-AU

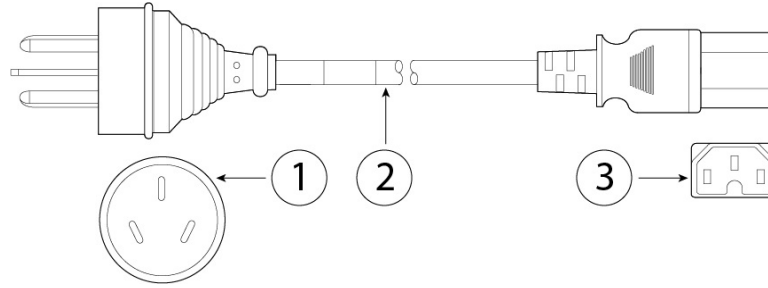

1	Plug: A.S. 3112-2000	2	Cord set rating: 10 A, 250 V
3	Connector: IEC 60320-C15		—

Figure 19: Brazil CAB-250V-10A-BR

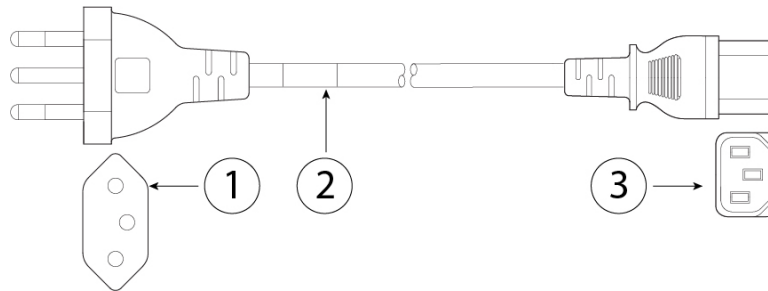

1	Plug: EL223 (NBR 14136)	2	Cord set rating: 10 A, 250 V
3	Connector: EL 701B (EN 60320/C13)		—

Figure 20: Brazil PWR-CORD-G2A-BZ

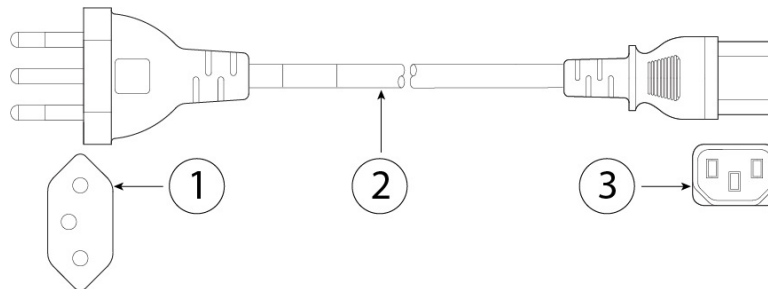

1	Plug: NBR 14136	2	Cord set rating: 10 A, 250 V
3	Connector: IEC 60320-C13		—

Figure 21: China CAB-9K10A-CH

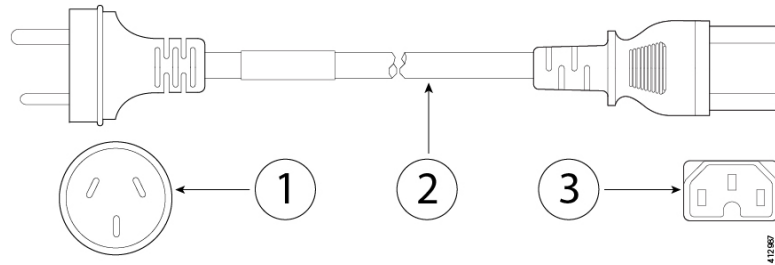

1	Plug: CCC GB2099.1, GB1002	2	Cord set rating: 10 A, 250 V
3	Connector: IEC 60320-C15		—

Figure 22: Denmark CAB-TA-DN

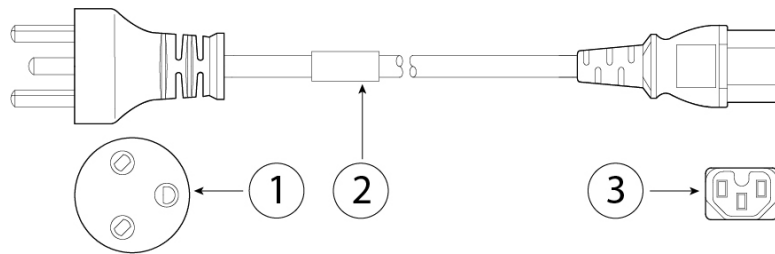

1	Plug: DK3	2	Cord set rating: 10 A, 250 V
3	Connector: IEC 60320-C13		—

Figure 23: Europe CAB-AC-EUR

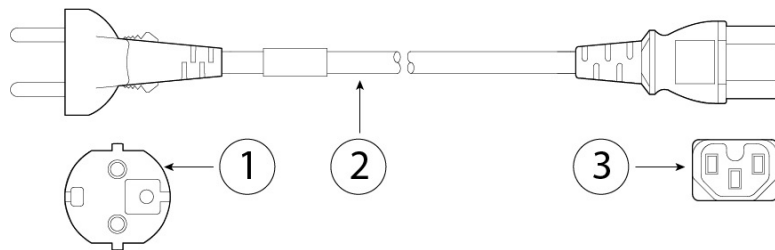

1	Plug: CEE 7/7	2	Cord set rating: 10 A, 250 V
3	Connector: IEC 60320-C15		—

Figure 24: India CAB-250V-10A-ID

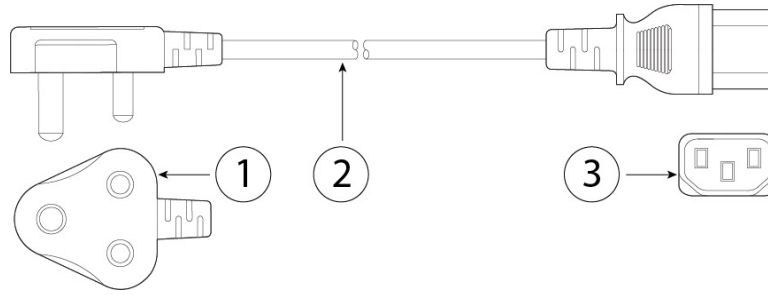

1	Plug: IS 6538-1971	2	Cord set rating: 10 A, 250 V
3	Connector: IEC 60320-C13		—

Figure 25: Israel CAB-250V-10A-IS

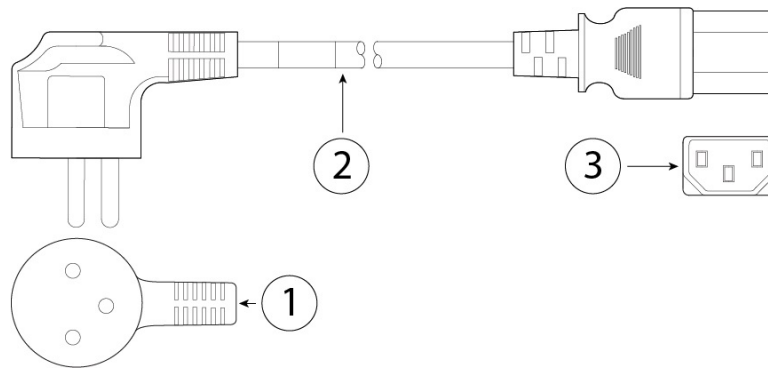

1	Plug: SI-32	2	Cord set rating: 10 A, 250 V
3	Connector: IEC 60320-C13		—

Figure 26: Italy CAB-9K10A-IT

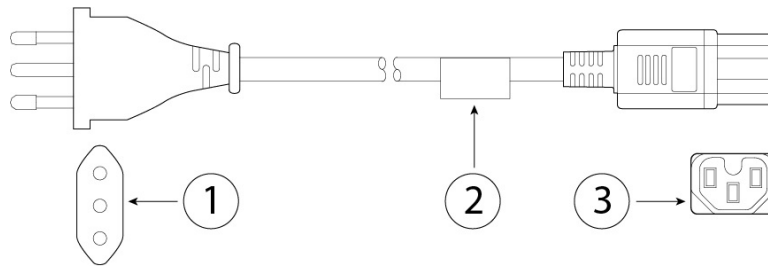

1	Plug: CEI 23-16/VII	2	Cord set rating: 10 A, 250 V
3	Connector: IEC 60320-C15		—

Figure 27: Korea CAB-9K10A-KOR

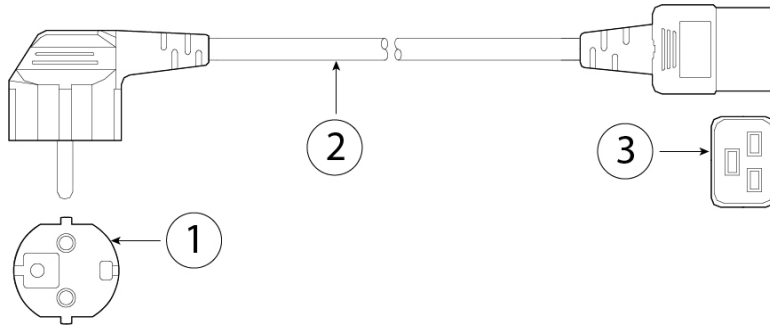

1	Plug: CEE 7/7	2	Cord set rating: 10 A, 250 V
3	Connector: IEC 60320-C19		—

Figure 28: Japan CAB-L620P-C13-JPN

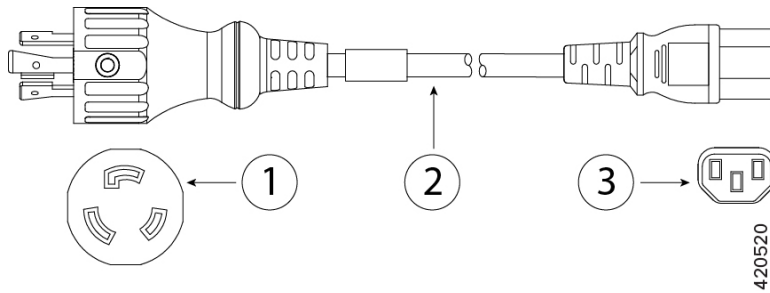

1	Plug: NEMA L6-20P	2	Cord set rating: 15 A, 250 V
3	Connector: IEC 60320-C13		—

Figure 29: Japan CAB-TA-JP

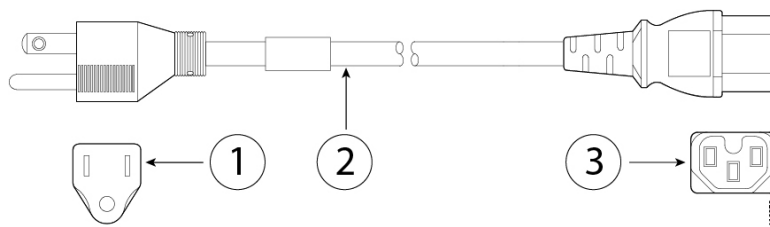

1	Plug: NEMA5-15P/JIS 8303	2	Cord set rating: 12 A, 125 V
3	Connector: IEC 60320-C15		—

Figure 30: North America CAB-TA-NA

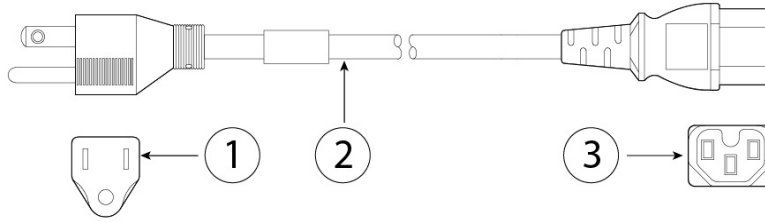

1	Plug: NEMA5-15P	2	Cord set rating: 12 A, 125 V
3	Connector: IEC 60320-C15		—

Figure 31: Saudi Arabia ATA187PWRCORD-SAUD

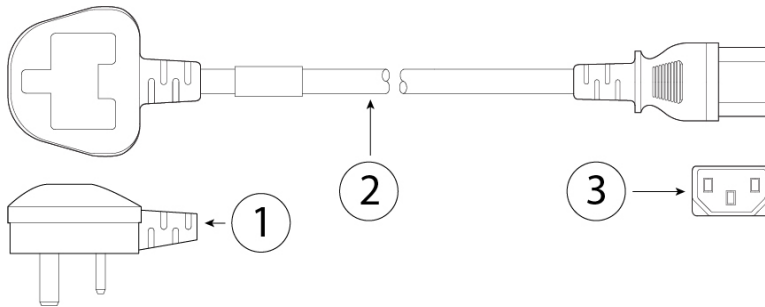

1	Plug: BS1363A/SS145	2	Cord set rating: 10 A, 250 V
3	Connector: IEC 60320-C13		—

Figure 32: South Africa CAB-9K10A-SA

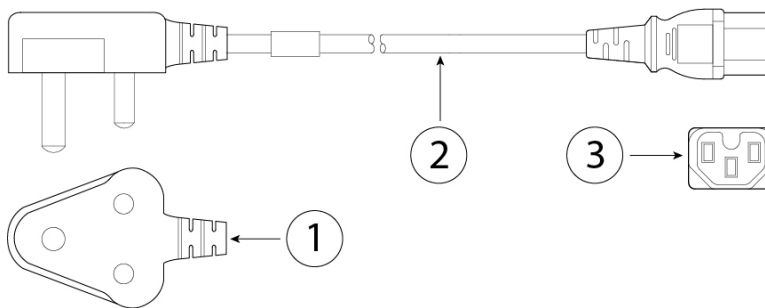

1	Plug: SABS 164	2	Cord set rating: 10 A, 250 V
3	Connector: IEC 60320-C15		—

Figure 33: Switzerland CAB-9K10A-SW

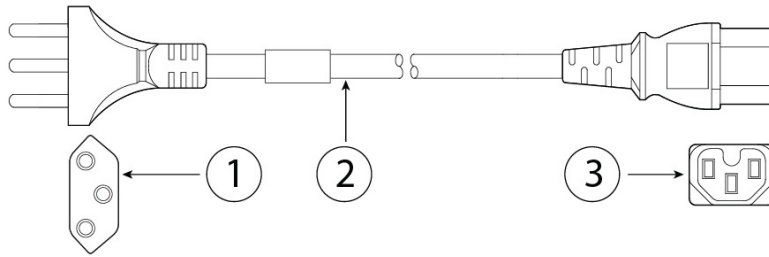

1	Plug: SEV 1011	2	Cord set rating: 10 A, 250 V
3	Connector: IEC 60320-C15		—

Figure 34: Taiwan CAB-9K10A-TWN

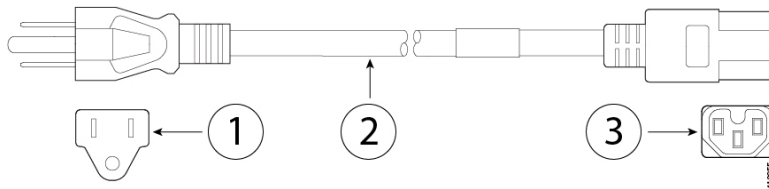

1	Plug: CNS10917-2	2	Cord set rating: 10 A, 125 V
3	Connector: IEC 60320-C15		—

Figure 35: United Kingdom CP-PWR-CORD-UK

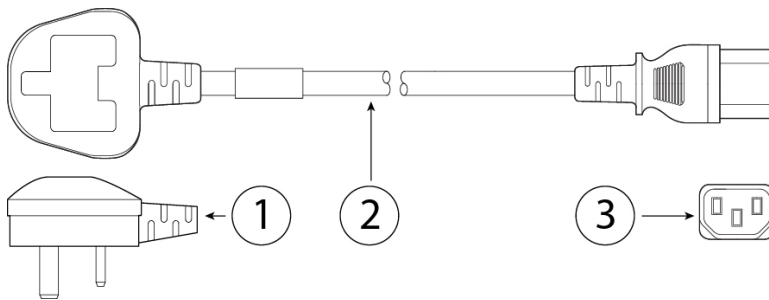

1	Plug: BS1363A/SS145	2	Cord set rating: 10 A, 250 V
3	Connector: IEC 60320-C13		—



CHAPTER 2

Installation Preparation

- [Installation Warnings, on page 39](#)
- [Network Equipment-Building System \(NEBS\) Statements, on page 41](#)
- [Safety Recommendations, on page 43](#)
- [Maintain Safety with Electricity, on page 43](#)
- [Prevent ESD Damage, on page 44](#)
- [Site Environment, on page 44](#)
- [Site Considerations, on page 44](#)
- [Power Supply Considerations, on page 45](#)
- [Rack Configuration Considerations, on page 45](#)

Installation Warnings

Be sure to read the [Regulatory and Compliance Safety Information](#) document before installing the security appliance.

Take note of the following general safety warnings:



Warning **Statement 1071**—Warning Definition

IMPORTANT SAFETY INSTRUCTIONS

Before you work on any equipment, be aware of the hazards involved with electrical circuitry and be familiar with standard practices for preventing accidents. Read the installation instructions before using, installing, or connecting the system to the power source. Use the statement number at the beginning of each warning statement to locate its translation in the translated safety warnings for this device.

SAVE THESE INSTRUCTIONS





Note **Statement 407**—Japanese Safety Instruction

You are strongly advised to read the safety instruction before using the product.

<https://www.cisco.com/web/JP/techdoc/pldoc/pldoc.html>

When installing the product, use the provided or designated connection cables/power cables/AC adapters.

〈製品仕様における安全上の注意〉
www.cisco.com/web/JP/techdoc/index.html

接続ケーブル、電源コードセット、ACアダプタ、バッテリーなどの部品は、必ず添付品または指定品をご使用ください。添付品・指定品以外をご使用になると故障や動作不良、火災の原因となります。また、電源コードセットは弊社が指定する製品以外の電気機器には使用できないためご注意ください。



Warning **Statement 1015**—Battery Handling

To reduce risk of fire, explosion or leakage of flammable liquid or gas:

- Replace the battery only with the same or equivalent type recommended by the manufacturer.
 - Do not dismantle, crush, puncture, use sharp tool to remove, short external contacts, or dispose of in fire.
 - Do not use if battery is warped or swollen.
 - Do not store or use battery in a temperature > 60° C.
 - Do not store or use battery in low air pressure environment < 69.7 kPa.
-



Warning **Statement 1029**—Blank Faceplates and Cover Panels

Blank faceplates and cover panels serve three important functions: they reduce the risk of electric shock and fire, they contain electromagnetic interference (EMI) that might disrupt other equipment, and they direct the flow of cooling air through the chassis. Do not operate the system unless all cards, faceplates, front covers, and rear covers are in place.



Warning **Statement 1073**—No User-Serviceable Parts

There are no serviceable parts inside. To avoid risk of electric shock, do not open.



Warning **Statement 1074**—Comply with Local and National Electrical Codes

To reduce risk of electric shock or fire, installation of the equipment must comply with local and national electrical codes.

**Warning Statement 1089**—Instructed and Skilled Person Definitions

An instructed person is someone who has been instructed and trained by a skilled person and takes the necessary precautions when working with equipment.

A skilled person or qualified personnel is someone who has training or experience in the equipment technology and understands potential hazards when working with equipment.

There are no serviceable parts inside. To avoid risk of electric shock, do not open.

**Warning Statement 1090**—Installation by Skilled Person

Only a skilled person should be allowed to install, replace, or service this equipment. See statement 1089 for the definition of a skilled person.

There are no serviceable parts inside. To avoid risk of electric shock, do not open.

**Warning Statement 1091**—Installation by an Instructed Person

Only an instructed person or skilled person should be allowed to install, replace, or service this equipment. See statement 1089 for the definition of an instructed or skilled person.

There are no serviceable parts inside. To avoid risk of electric shock, do not open.

**Warning Statement 9001**—Product Disposal

Ultimate disposal of this product should be handled according to all national laws and regulations.

Network Equipment-Building System (NEBS) Statements

NEBS describes the environment of a typical United States Regional Bell Operating Company (RBOC) central office. NEBS is the most common set of safety, spatial, and environmental design standards applied to telecommunications equipment in the United States. It is not a legal or regulatory requirement, but rather an industry requirement.

The following NEBS statements apply to the Firepower 4125:

**Note Statement 7001**—ESD Mitigation

This equipment may be ESD sensitive. Always use an ESD ankle or wrist strap before handling equipment. Connect the equipment end of the ESD strap to an unfinished surface of the equipment chassis or to the ESD jack on the equipment if provided.



Warning Statement 7003—Shielded Cable Shielded Cable Requirements for Intrabuilding Lightning Surge

The intrabuilding port(s) of the equipment or subassembly must use shielded intrabuilding cabling/wiring that is grounded at both ends.

The following port(s) are considered intrabuilding ports on this equipment:

Gigabit Ethernet management port

RJ-45 1 G/100 M/10 M auto duplex/auto MDI-X Base-T ports



Note Statement 7004—Special Accessories Required to Comply with GR-1089 Emission and Immunity Requirements

To comply with the emission and immunity requirements of GR-1089, shielded cables are required for the following ports:

Gigabit Ethernet management port

RJ-45 1 G/100 M/10 M auto duplex/auto MDI-X Base-T ports



Warning Statement 7005—Intrabuilding Lightning Surge and AC Power Fault

The intrabuilding port(s) of the equipment or subassembly must not be metallically connected to interfaces that connect to the outside plant (OSP) or its wiring. These interfaces are designed for use as intrabuilding interfaces only (Type 2 or Type 4 ports as described in GR-1089-CORE) and require isolation from the exposed OSP cabling. The addition of primary protectors is not sufficient protection to connect these interfaces metallically to OSP wiring.

This statement applies to the intrabuilding ports listed below:

Gigabit Ethernet management port

RJ-45 1 G/100 M/10 M auto duplex/auto MDI-X Base-T ports



Warning Statement 7012—Equipment Interfacing with AC Power Ports

Connect this equipment to AC mains that are provided with a surge protective device (SPD) at the service equipment that complies with NFPA 70, the National Electrical Code (NEC).



Note Statement 7013—Equipment Grounding Systems—Common Bonding Network (CBN)

This equipment is suitable for installations using the CBN.



Note **Statement 7016**—Battery Return Conductor

Treat the battery return conductor of this equipment as DC-I.



Note **Statement 7018**—System Recover Time

The equipment is designed to boot up in less than 30 minutes provided the neighboring devices are fully operational.



Note **Statement 8015**—Installation Location Network Telecommunications Facilities

This equipment is suitable for installation in network telecommunications facilities.



Note **Statement 8016**—Installation Location Where the National Electric Code (NEC) Applies

This equipment is suitable for installation in locations where the NEC applies.

Safety Recommendations

Observe these safety guidelines:

- Keep the area clear and dust free before, during, and after installation.
- Keep tools away from walkways, where you and others might trip over them.
- Do not wear loose clothing or jewelry, such as earrings, bracelets, or chains that could get caught in the chassis.
- Wear safety glasses if you are working under any conditions that might be hazardous to your eyes.
- Do not perform any action that creates a potential hazard to people or makes the equipment unsafe.
- Never attempt to lift an object that is too heavy for one person.

Maintain Safety with Electricity



Warning Before working on a chassis, be sure the power cord is unplugged.

Read the [Regulatory and Compliance Safety Information](#) document before installing the chassis.

Follow these guidelines when working on equipment powered by electricity:

- Before beginning procedures that require access to the interior of the chassis, locate the emergency power-off switch for the room in which you are working. Then, if an electrical accident occurs, you can act quickly to turn off the power.
- Do not work alone if potentially hazardous conditions exist anywhere in your work space.
- Never assume that power is disconnected; always check.
- Look carefully for possible hazards in your work area, such as moist floors, ungrounded power extension cables, frayed power cords, and missing safety grounds.
- Use the chassis within its marked electrical ratings and product usage instructions.
- The chassis is equipped with an AC-input power supply, which is shipped with a three-wire electrical cord with a grounding-type plug that fits into a grounding-type power outlet only. Do not circumvent this safety feature. Equipment grounding should comply with local and national electrical codes.

Prevent ESD Damage

ESD occurs when electronic components are improperly handled, and it can damage equipment and impair electrical circuitry, which can result in intermittent or complete failure of your equipment.

Always follow ESD-prevention procedures when removing and replacing components. Ensure that the chassis is electrically connected to an earth ground. Wear an ESD-preventive wrist strap, ensuring that it makes good skin contact. Connect the grounding clip to an unpainted surface of the chassis frame to safely ground ESD voltages. To properly guard against ESD damage and shocks, the wrist strap and cord must operate effectively. If no wrist strap is available, ground yourself by touching the metal part of the chassis.

For safety, periodically check the resistance value of the antistatic strap, which should be between one and 10 megohms.

Site Environment

See [Hardware Specifications, on page 28](#) for information about physical specifications.

To avoid equipment failures and reduce the possibility of environmentally caused shutdowns, plan the site layout and equipment locations carefully. If you are currently experiencing shutdowns or unusually high error rates with your existing equipment, these considerations may help you isolate the cause of failures and prevent future problems.

Site Considerations

Considering the following helps you plan an acceptable operating environment for the chassis, and avoid environmentally-caused equipment failures.

- Electrical equipment generates heat. Ambient air temperature might not be adequate to cool equipment to acceptable operating temperatures without adequate circulation. Make sure that the room in which you operate your system has adequate air circulation.

- Ensure that the chassis cover is secure. The chassis is designed to allow cooling air to flow effectively within it. An open chassis allows air leaks, which may interrupt and redirect the flow of cooling air from the internal components.
- Always follow ESD-prevention procedures to avoid damage to equipment. Damage from static discharge can cause immediate or intermittent equipment failure.

Power Supply Considerations

See [Power Supply Modules, on page 22](#) for more detailed information about the power supply in the chassis.

When installing the chassis, consider the following:

- Check the power at the site before installing the chassis to ensure that it is free of spikes and noise. Install a power conditioner, if necessary, to ensure proper voltages and power levels in the appliance-input voltage.
- Install proper grounding for the site to avoid damage from lightning and power surges.
- The chassis does not have a user-selectable operating range. Refer to the label on the chassis for the correct appliance input-power requirement.
- Several styles of AC-input power supply cords are available for the chassis; make sure that you have the correct style for your site.
- If you are using dual redundant (1+1) power supplies, we recommend that you use independent electrical circuits for each power supply.
- Install an uninterruptible power source for your site, if possible.

Rack Configuration Considerations

See [Rack-Mount the Chassis, on page 47](#) for the procedure for rack-mounting the chassis.

Consider the following when planning a rack configuration:

- Standard 19-in. (48.3 cm) 4-post EIA rack with mounting rails that conform to English universal hole spacing according to section 1 of ANSI/EIA-310-D-1992.
- The rack-mounting posts need to be 2 to 3.5 mm thick to work with the slide rail rack mounting.
- If you are mounting a chassis in an open rack, make sure that the rack frame does not block the intake or exhaust ports.
- If your rack includes closing front and rear doors, the doors must have 65 percent open perforated area evenly distributed from top to bottom to permit adequate airflow.
- Be sure enclosed racks have adequate ventilation. Make sure that the rack is not overly congested as each chassis generates heat. An enclosed rack should have louvered sides and a fan to provide cooling air.
- In an enclosed rack with a ventilation fan in the top, heat generated by equipment near the bottom of the rack can be drawn upward and into the intake ports of the equipment above it in the rack. Ensure that you provide adequate ventilation for equipment at the bottom of the rack.

- Baffles can help to isolate exhaust air from intake air, which also helps to draw cooling air through the chassis. The best placement of the baffles depends on the airflow patterns in the rack. Experiment with different arrangements to position the baffles effectively.



CHAPTER 3

Rack-Mount and Ground the Chassis

- [Unpack and Inspect the Chassis, on page 47](#)
- [Rack-Mount the Chassis, on page 47](#)
- [Ground the Chassis, on page 52](#)

Unpack and Inspect the Chassis



Note The chassis is thoroughly inspected before shipment. If any damage occurred during transportation or any items are missing, contact your customer service representative immediately. Keep the shipping container in case you need to send the chassis back due to damage.

See [Package Contents, on page 5](#) for a list of what shipped with the chassis.

- Step 1** Remove the chassis from its cardboard container and save all packaging material.
- Step 2** Compare the shipment to the equipment list provided by your customer service representative. Verify that you have all items.
- Step 3** Check for damage and report any discrepancies or damage to your customer service representative. Have the following information ready:
- Invoice number of shipper (see the packing slip)
 - Model and serial number of the damaged unit
 - Description of damage
 - Effect of damage on the installation
-

Rack-Mount the Chassis

This procedure describes how to install the Firepower 4100 in a rack using the rack kit that shipped with the chassis.

The rack is a standard Electronic Industries Association (EIA) rack. It is a 4-post-EIA-310-D, which is the current revision as specified by EIA. The vertical hole spacing alternates at .50 inches (12.70 mm) to .625 inches (15.90 mm) to .625 inches (15.90 mm) and repeats. The start and stop space is in the middle of the .50-inch holes. The horizontal spacing is 18.312 inches (465.1 mm), and the rack opening is specified as a minimum of 17.75 inches (450 mm).

You need the following to install the chassis in a rack (4-post EIA-310-D rack):

- #1 Phillips screwdriver
- Firepower 4100 rack-mount kit that contains the slide rails, mounting ears, and screws

Slide rail assemblies work with 4-post racks and cabinets with square slots, round 7.1-mm holes and 10-32-inch threaded holes on the rack post front. The slide rail works with front to back spacing of rack posts from 24 to 36 inches. The rack-mounting posts need to be 2 to 3.5 mm thick to work with the slide rail rack mounting.



Note Internal obstructions between rails can make slide rail installation more complicated. Use racks that do not have internal obstructions between rails for unhindered slide rail installation.

Safety Warnings

Take note of the following rack-mount safety warnings:



Warning Statement 1006—Chassis Warning for Rack-Mounting and Servicing

To prevent bodily injury when mounting or servicing this unit in a rack, you must take special precautions to ensure that the system remains stable. The following guidelines are provided to ensure your safety:

- This unit should be mounted at the bottom of the rack if it is the only unit in the rack.
 - When mounting this unit in a partially filled rack, load the rack from the bottom to the top with the heaviest component at the bottom of the rack.
 - If the rack is provided with stabilizing devices, install the stabilizers before mounting or servicing the unit in the rack.
-



Warning Statement 1032—Lifting the Chassis

To prevent personal injury or damage to the chassis, never attempt to lift or tilt the chassis using the handles on modules, such as power supplies, fans, or cards. These types of handles are not designed to support the weight of the unit.



Warning Statement 1047—Overheating Prevention

To reduce the risk of fire or bodily injury, do not operate the unit in an area that exceeds the maximum recommended ambient temperature of 104°F (40°C).



Warning Statement 1098 —Lifting Requirement

Two people are required to lift the heavy parts of the product. To prevent injury, keep your back straight and lift with your legs, not your back.

Step 1 Attach a rack mount bracket to each side of the chassis using the six 8-32 x .375-inch Phillips screws provided in the accessory kit.

Figure 36: Attach the Rack Mount Bracket to the Side of the Chassis

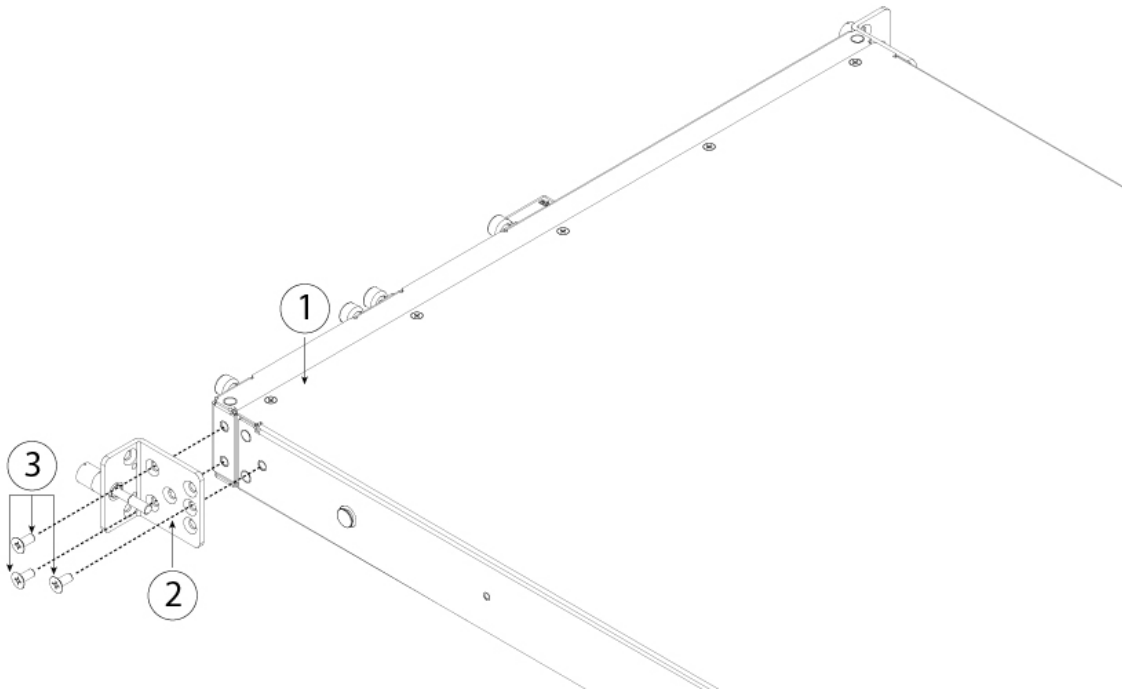

1	Chassis	2	Rack-mount bracket
3	8-32 x .375-inch Phillips screws (three per side)		

Step 2 Attach the inner rails to the sides of the chassis:

- Remove the inner rails from the slide rail assemblies.
- Align an inner rail with one side of the chassis so that the three keyed slots in the rail align with the three pegs on the side of the chassis.
- Set the keyed slots over the pegs, and then slide the rail toward the front to lock it in place on the pegs. The rear key slot has a metal clip that locks over the peg.
- Secure the inner rail to the side of the chassis using one M3 x 6 mm screw.
- Install the second inner rail to the opposite side of the chassis and secure with the other M3 x 6 mm screw.

Figure 37: Attach the Inner Rail to the Side of the Chassis

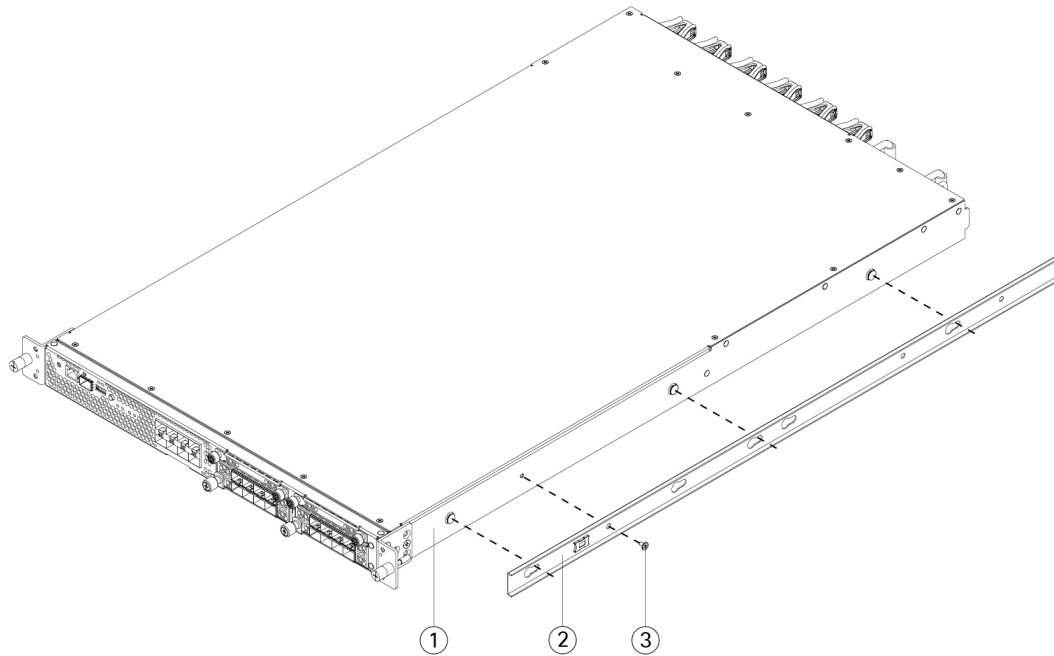

1	Chassis side by front panel	2	Inner rail
3	M3 x 6-mm screw (one per side)		

Step 3 Open the front securing plate on both slide-rail assemblies. The front end of the slide-rail assembly has a spring-loaded securing plate that must be open before you can insert the mounting pegs into the rack-post holes.

On the outside of the assembly, push the green arrow button toward the rear to open the securing plate.

Figure 38: Front Securing Mechanism Inside the Front End

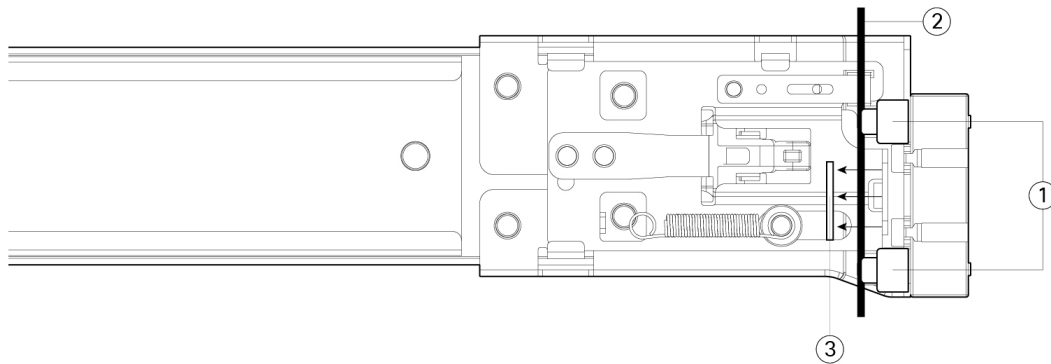

1	Front mounting pegs Note Works with square slots, 7.1-mm holes, and 10-32-threaded holes	2	Securing plate shown pulled back to open position
3	Rack post		—

Step 4

Install the slide rails into the rack:

- a) Align one slide-rail assembly front end with the front rack-post holes that you want to use.

The slide rail front end wraps around the outside of the rack post and the mounting pegs enter the rack-post holes from the outside front.

Note The rack post must be between the mounting pegs and the open securing plate.

- b) Push the mounting pegs into the rack-post holes from the outside front.
 c) Press the securing plate release button marked *PUSH*. The spring-loaded securing plate closes to lock the pegs in place.
 d) Adjust the slide-rail length, and then push the rear mounting pegs into the corresponding rear rack-post holes. The slide rail must be level front-to-rear.

The rear mounting pegs enter the rear rack-post holes from the inside of the rack post.

- e) Attach the second slide-rail assembly to the opposite side of the rack. Make sure that the two slide-rail assemblies are at the same height with each other and are level front-to-back.
 f) Pull the inner slide rails on each assembly out toward the rack front until they hit the internal stops and lock in place.

Step 5

Insert the chassis into the slide rails.

- a) Align the rear of the inner rails that are attached to the chassis sides with the front ends of the empty slide rails on the rack.
 b) Push the inner rails into the slide rails on the rack until they stop at the internal stops.
 c) Slide the release clip toward the rear on both inner rails, and then continue pushing the chassis into the rack until the mounting brackets meet the front of the slide rail.

Figure 39: Inner Rail Release Clip

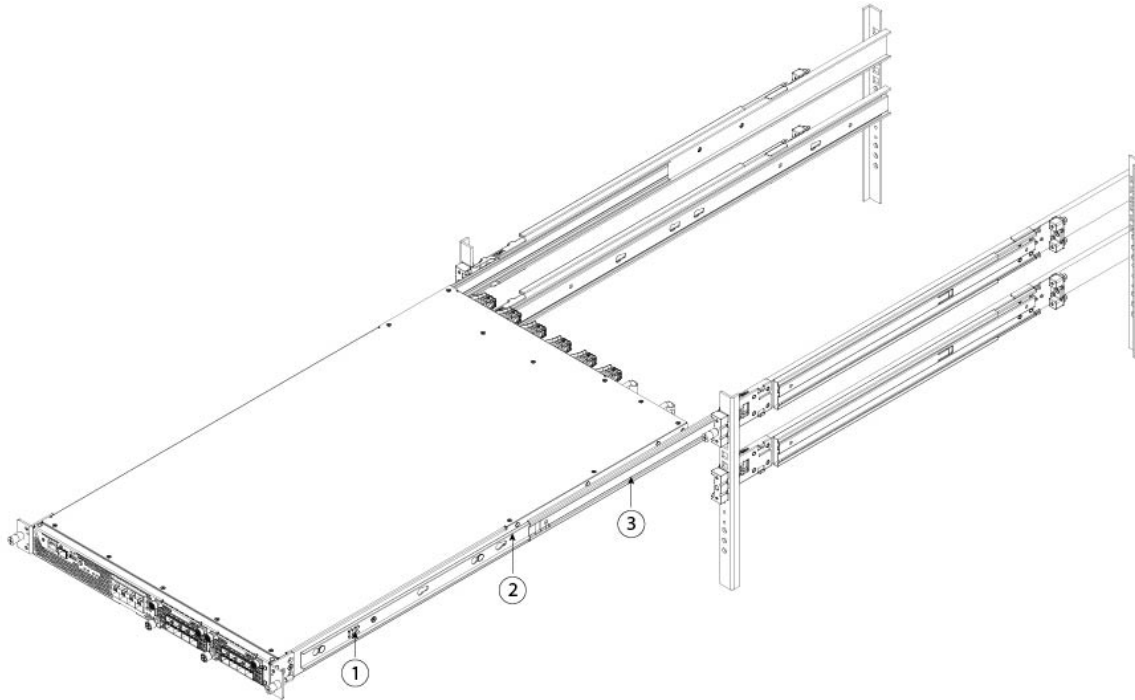

1	Inner rail release clip	2	Inner rail attached to chassis
3	Outer rail attached to rack post		

Step 6 Use the captive screws on the front of the mounting brackets to fully secure the chassis to the rack.

What to do next

Ground the chassis. See [Ground the Chassis, on page 52](#) for the procedure.

Install the FIPS opacity shield if necessary. See [Install the FIPS Opacity Shield, on page 77](#) for the procedure.

Install the cables according to your software configuration as described in the [Cisco Firepower 4100 Getting Started Guide](#).

Ground the Chassis



Note Grounding the chassis is required, even if the rack is already grounded. A grounding pad with two threaded M4 holes is provided on the chassis for attaching a grounding lug. The grounding lug must be Nationally Recognized Testing Laboratory (NRTL)-listed. In addition, a copper conductor (wires) must be used and the copper conductor must comply with National Electrical Code (NEC) code for ampacity.

You need the following items that you provide:

- Wire-stripping tool
- Crimping tool
- Grounding cable
- Two star lock washers for the 10-32 x 0.375-inch screws used to secure the ground lug
- You need the following items from the accessory kit:
 - Grounding lug #6 AWG, 90 degree, #10 post
 - Two 10-32 x 0.375-inch screws used to secure the grounding lug

Safety Warnings

Take note of the following ground connection warnings:



Warning Statement 1024—Ground Conductor

This equipment must be grounded. To reduce the risk of electric shock, never defeat the ground conductor or operate the equipment in the absence of a suitably installed ground conductor. Contact the appropriate electrical inspection authority or an electrician if you are uncertain that suitable grounding is available.

- Step 1** Use a wire-stripping tool to remove approximately 0.75 inches (19 mm) of the covering from the end of the grounding cable.
- Step 2** Insert the stripped end of the grounding cable into the open end of the grounding lug.

Figure 40: Insert the Cable into the Grounding Lug

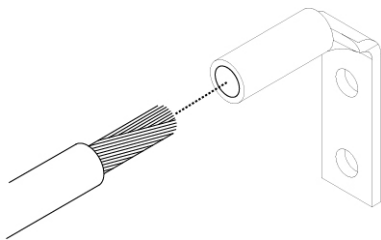

- Step 3** Use the crimping tool to secure the grounding cable in the grounding lug.
- Step 4** Remove the adhesive label from the grounding pad on the chassis.
- Step 5** Place the grounding lug against the grounding pad so that there is solid metal-to-metal contact, and insert the two screws with washers through the holes in the grounding lug and into the grounding pad.
- Step 6** Make sure that the lug and cable do not interfere with other equipment.
- Step 7** Prepare the other end of the grounding cable and connect it to an appropriate grounding point in your site to ensure adequate earth ground.
-

What to do next

Install the FIPS opacity shield if necessary. See [Install the FIPS Opacity Shield, on page 77](#) for the procedure.

Install the cables according to your default software configuration as described in the [Cisco Firepower 4100 Getting Started Guide](#).



CHAPTER 4

Installation, Maintenance, and Upgrade

- [Install, Remove, and Replace the Network Module, on page 55](#)
- [Remove and Replace the Fan Module, on page 58](#)
- [Remove and Replace the SSD, on page 60](#)
- [Remove and Replace the Power Supply Module, on page 63](#)
- [Connect the DC Power Supply Module, on page 67](#)
- [Secure the Power Cord on the AC Power Supply Module, on page 73](#)
- [Install the FIPS Opacity Shield, on page 77](#)

Install, Remove, and Replace the Network Module

Hot Swapping

Starting with FXOS 2.3.1, the Firepower 10-Gb and 40-Gb network modules (without hardware bypass support) support hot swapping, but you must hot swap with an identical network module, that is, a network module with the same PID. See [Product ID Numbers, on page 29](#) for the network module PIDs. You must bring the network module offline using the appropriate CLI commands before removing the network module from the chassis so that all network module configuration is saved. See the “Taking a Network Module Offline or Online” topic in the Security Module/Engine Management chapter in the [Cisco FXOS Firepower Chassis Manager Configuration Guide](#).



Caution

We do not recommend that you remove the network module without bringing it properly offline using the appropriate CLI commands.



Note

You must have ROMMON 1.0.10 or later on the Supervisor to support hot swapping. For the ROMMON upgrade procedure, see the “Firmware Upgrade” topic in the Image Management chapter in the [Cisco FXOS Firepower Chassis Manager Configuration Guide](#) for your software version.

To remove and replace the network modules that do *not* currently support hot swapping, power off the chassis, replace the network module, and then power the chassis back on.

Acknowledgment is necessary if you decommission and physically remove a network module and do not replace it, or if you replace it with another PID. See the “Acknowledge a Network Module” topic in

the Security Module/Engine Management chapter in the [Cisco FXOS Firepower Chassis Manager Configuration Guide](#).

Safety Warnings

Take note of the following component replacement safety warnings:



Warning **Statement 1028**—More Than One Power Supply

This unit might have more than one power supply connection. To reduce risk of electric shock, remove all connections to de-energize the unit.

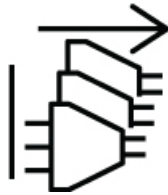

Warning **Statement 1073**—No User-Serviceable Parts

There are no serviceable parts inside. To avoid risk of electric shock, do not open.



Warning **Statement 1089**—Instructed and Skilled Person Definitions

An instructed person is someone who has been instructed and trained by a skilled person and takes the necessary precautions when working with equipment.

A skilled person or qualified personnel is someone who has training or experience in the equipment technology and understands potential hazards when working with equipment.

There are no serviceable parts inside. To avoid risk of electric shock, do not open.



Warning **Statement 1090**—Installation by Skilled Person

Only a skilled person should be allowed to install, replace, or service this equipment. See statement 1089 for the definition of a skilled person.

There are no serviceable parts inside. To avoid risk of electric shock, do not open.



Warning **Statement 1091**—Installation by an Instructed Person

Only an instructed person or skilled person should be allowed to install, replace, or service this equipment. See statement 1089 for the definition of an instructed or skilled person.

There are no serviceable parts inside. To avoid risk of electric shock, do not open.

This procedure describes how to install a network module into an empty slot that has never contained a network module, and how to remove an installed network module and replace it with another network module.

Step 1

To install a new network module for the first time into an empty slot, do the following:

- a) Power down the chassis by moving the power switch to the OFF position.
See [Rear Panel, on page 10](#) for more information about the power switch.
- b) Follow Steps 4 through 7 to install the new network module.
- c) Power on the chassis by moving the power switch to the ON position.
The state for the new network module is `OIR Failed`.
- d) To change the status of the network module to `Online`, reboot the chassis. See the "Rebooting the Firepower 4100/9300 Chassis" topic in the System Administration chapter in the [FXOS Configuration Guide](#) for your software version.

Step 2

To remove and replace an existing network module, do one of the following:

- a) Save your configuration.
- b) Power down the chassis by moving the power switch to the OFF position (if removing a network module that does *not* support hot swapping).
See [Rear Panel, on page 10](#) for more information about the power switch.
- c) Bring the network module offline using the appropriate CLI command (if removing a network module that *supports* hot swapping). All network module configuration is saved. See the "Taking a Network Module Offline or Online" topic in the Security Module/Engine Management chapter in the [FXOS Configuration Guide](#) for your software version.
- d) Continue with Step 3.

Step 3

To remove a network module from the chassis, loosen the captive screw on the lower left side of the network module and pull out the handle that is connected to the screw. This mechanically ejects the network module from the slot.

Figure 41: Remove the Network Module

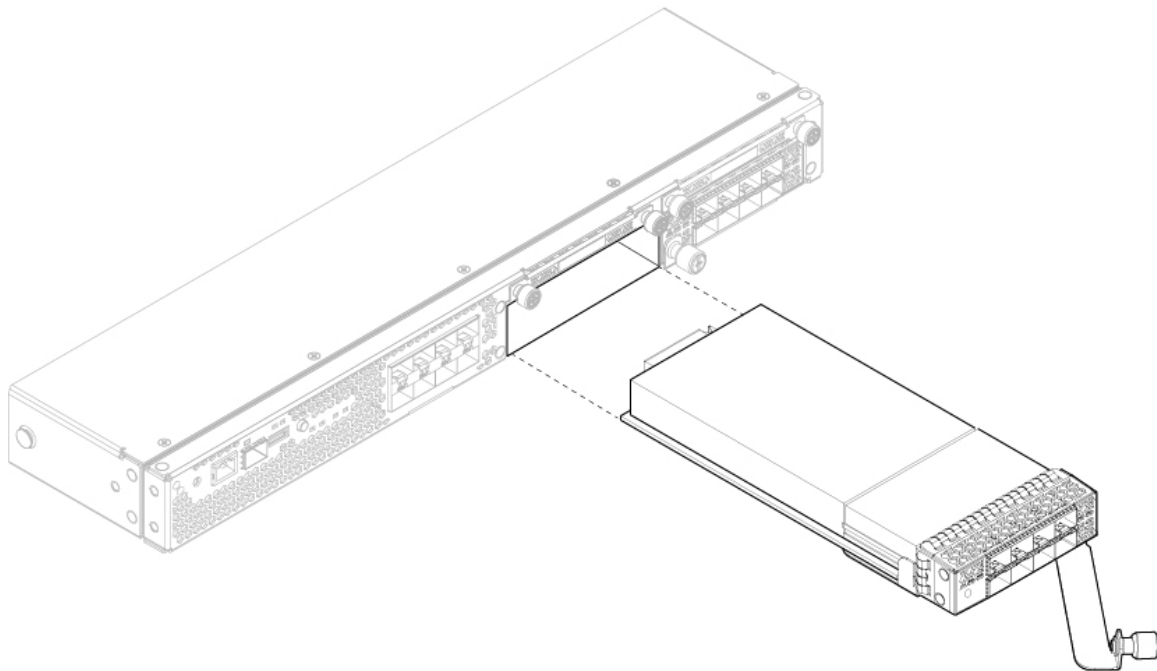

If the slot is to remain empty, install a blank faceplate to ensure proper airflow and to keep dust out of the chassis; otherwise, install another network module.

- Step 4** To replace a network module, hold the network module in front of the network module slot on the right of the chassis and pull the network module handle out.
- Step 5** Slide the network module into the slot and push it firmly into place until the handle is flush with the front of the network module.
- Step 6** Tighten the captive screw on the lower left side of the network module.
- Step 7** Do one of the following:
- Power up the chassis so that the new network module is recognized (if the new network module does *not* support hot swapping).
 - Bring the new network module online using the appropriate CLI command (if the new network module *supports* hot swapping). The saved network module configuration is automatically reapplied when the network module is back online.

Note If you install a network module that is a different PID than the original network module, the saved configuration is deleted and the default configuration is applied. You must enter the **acknowledge** command to confirm the network module PID change:

What to do next

Follow the procedures in the [FXOS Configuration Guide](#) to connect to the network module and make sure that it has been discovered correctly by the Firepower 4100.

Remove and Replace the Fan Module

You can remove and replace fan modules while the system is running. The air flow moves from front to back. If you remove a fan or a fan fails, the other fans operate at full speed, which can be noisy.

The system supports operation with a single fan failure (N+1 fan redundancy), but do not run the system for an extended amount of time without all fan modules installed. Keep removal and replacement at three minutes. Remove and replace one fan module at a time



Caution Once you have aligned the fan with the fan slot, insert the new fan within five seconds. Do not partially engage the fan module and let the fan spin in the wrong direction before fully seating it.

Safety Warnings

Take note of the following component replacement safety warnings:



Warning **Statement 1028**—More Than One Power Supply

This unit might have more than one power supply connection. To reduce risk of electric shock, remove all connections to de-energize the unit.

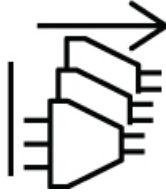

Warning **Statement 1073**—No User-Serviceable Parts

There are no serviceable parts inside. To avoid risk of electric shock, do not open.



Warning **Statement 1089**—Instructed and Skilled Person Definitions

An instructed person is someone who has been instructed and trained by a skilled person and takes the necessary precautions when working with equipment.

A skilled person or qualified personnel is someone who has training or experience in the equipment technology and understands potential hazards when working with equipment.

There are no serviceable parts inside. To avoid risk of electric shock, do not open.



Warning **Statement 1090**—Installation by Skilled Person

Only a skilled person should be allowed to install, replace, or service this equipment. See statement 1089 for the definition of a skilled person.

There are no serviceable parts inside. To avoid risk of electric shock, do not open.



Warning **Statement 1091**—Installation by an Instructed Person

Only an instructed person or skilled person should be allowed to install, replace, or service this equipment. See statement 1089 for the definition of an instructed or skilled person.

There are no serviceable parts inside. To avoid risk of electric shock, do not open.

-
- Step 1** To remove a fan module, face the rear of the chassis, and grasp the handle of the fan module.
- Step 2** Squeeze the handle to disengage the latches on the left and right of the fan module.
- Step 3** Pull the fan module out of the chassis.

Figure 42: Remove the Fan Module

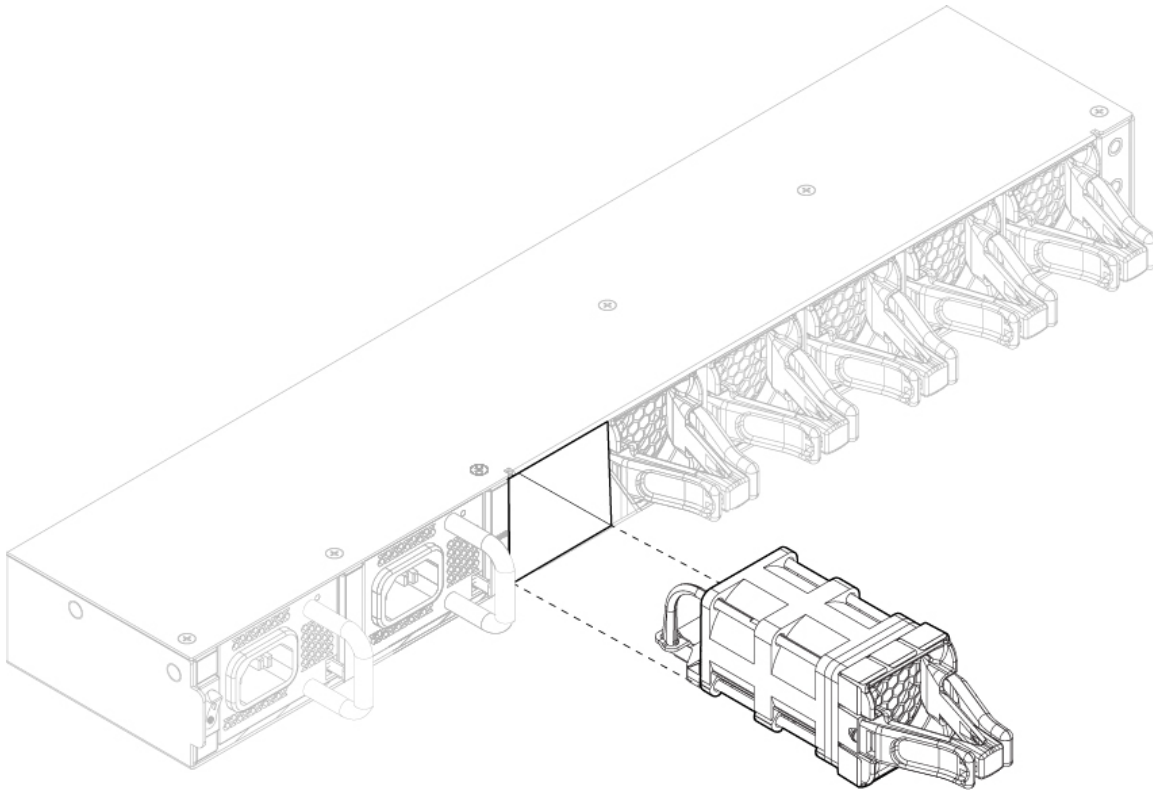

- Step 4** To replace a fan module, hold the fan module in front of the fan slot.
- Step 5** Push the fan module into the chassis until it is properly seated and the latches snap into place. If the system is powered on, listen for the fans. You should immediately hear the fans operating. If you do not hear the fans, make sure the fan module is inserted completely into the chassis and the faceplate is flush with the outside surface of the chassis.
- Step 6** Verify that the fan is operational by checking the fan module LED. See [Front Panel LEDs, on page 9](#) for a description of the fan LEDs.

Remove and Replace the SSD

Although the hardware supports removing and replacing SSDs while the system is running, the software does not currently support hot swapping. You must power down the chassis to remove and replace SSDs.



Note If your Firepower 4100 is running Firepower Threat Defense software, we recommend that you upgrade to the latest version to take advantage of software updates that enhance SSD management performance and longevity.

Your storage SSD must be installed in slot 1 and must be present. Slot 1 is reserved for the logical device application instance (threat defense or ASA). Only an optional MSP can be installed in the second SSD slot

(SSD slot 2). The MSP stores threat detection results for use in future analysis. It supports the Advanced Malware Protection software feature. The MSP is supported beginning in FXOS 2.0.1. It is used as both storage and as the Malware application repository. RAID is not supported.



Caution Do not switch the two SSDs. The storage SSD must be installed in slot 1. The optional MSP SSD must be installed in slot 2. If you remove it and install it in slot 1, all stored file capture data is lost.

Safety Warnings

Take note of the following component replacement safety warnings:



Warning **Statement 1028**—More Than One Power Supply

This unit might have more than one power supply connection. To reduce risk of electric shock, remove all connections to de-energize the unit.

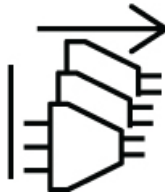

Warning **Statement 1073**—No User-Serviceable Parts

There are no serviceable parts inside. To avoid risk of electric shock, do not open.



Warning **Statement 1089**—Instructed and Skilled Person Definitions

An instructed person is someone who has been instructed and trained by a skilled person and takes the necessary precautions when working with equipment.

A skilled person or qualified personnel is someone who has training or experience in the equipment technology and understands potential hazards when working with equipment.

There are no serviceable parts inside. To avoid risk of electric shock, do not open.



Warning **Statement 1090**—Installation by Skilled Person

Only a skilled person should be allowed to install, replace, or service this equipment. See statement 1089 for the definition of a skilled person.

There are no serviceable parts inside. To avoid risk of electric shock, do not open.



Warning Statement 1091—Installation by an Instructed Person

Only an instructed person or skilled person should be allowed to install, replace, or service this equipment. See statement 1089 for the definition of an instructed or skilled person.

There are no serviceable parts inside. To avoid risk of electric shock, do not open.

- Step 1** Save your configuration.
- Step 2** Power down the chassis by moving the power switch to the OFF position. See [Features, on page 1](#) for more information about the power switch.
- Step 3** To remove an SSD, face the front of the chassis, loosen the two captive screws on the SSD, and gently pull it out of slot 1 of the chassis.

Figure 43: Remove the SSD

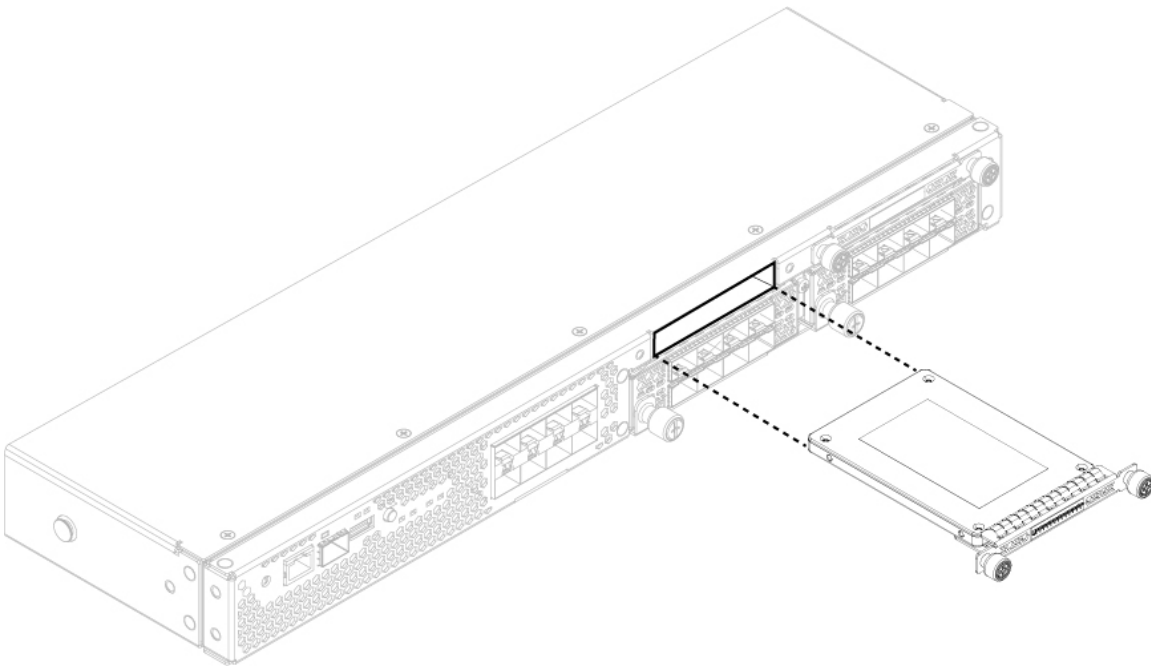

- Step 4** To replace the SSD, make sure the power switch is still in the OFF position, and then hold the SSD in front of slot 1 and push it in gently until it is seated.
- Step 5** To install the MSP SSD, make sure the power switch is still in the OFF position and then remove the blank faceplate in slot 2 by loosening the captive screws on either side of the faceplate.
- Step 6** Hold the MSP SSD in front of slot 2 and push it in gently until it is seated.
- Caution** Do not switch the two SSDs. Only the optional MSP SSD can be installed in slot 2. If you remove it and install it in slot 1, all stored file capture data is lost.
- Step 7** Tighten the captive screws on either side of the SSD.

- Step 8** Verify that the SSD is operational by checking the SSD LED. See [Front Panel LEDs, on page 9](#) for a description of the fan LEDs.
-

Remove and Replace the Power Supply Module

You can remove and replace power supply modules while the system is running.

Safety Warnings

Take note of the following power and component removal safety warnings:



Warning **Statement 1003**—DC Power Disconnection

To reduce risk of electric shock or personal injury, disconnect DC power before removing or replacing components or performing upgrades.



Warning **Statement 1005**—Circuit Breaker

This product relies on the building's installation for short-circuit (overcurrent) protection. To reduce risk of electric shock or fire, ensure that the protective device is rated not greater than:

AC: 20A

DC: 40A



Warning **Statement 1017**—Restricted Area

This unit is intended for installation in restricted access areas. Only skilled, instructed, or qualified personnel can access a restricted access area.



Warning **Statement 1022**—Disconnect Device

To reduce the risk of electric shock and fire, a readily accessible disconnect device must be incorporated in the fixed wiring.



Warning **Statement 1028**—More Than One Power Supply

This unit might have more than one power supply connection. To reduce risk of electric shock, remove all connections to de-energize the unit.



Warning **Statement 1029**—Blank Faceplates and Cover Panels

Blank faceplates and cover panels serve three important functions: they reduce the risk of electric shock and fire, they contain electromagnetic interference (EMI) that might disrupt other equipment, and they direct the flow of cooling air through the chassis. Do not operate the system unless all cards, faceplates, front covers, and rear covers are in place.



Warning **Statement 1073**—No User-Serviceable Parts

There are no serviceable parts inside. To avoid risk of electric shock, do not open.



Warning **Statement 1046**—Installing or Replacing the Unit

To reduce risk of electric shock, when installing or replacing the unit, the ground connection must always be made first and disconnected last.

If your unit has modules, secure them with the provided screws.



Warning **Statement 1089**—Instructed and Skilled Person Definitions

An instructed person is someone who has been instructed and trained by a skilled person and takes the necessary precautions when working with equipment.

A skilled person or qualified personnel is someone who has training or experience in the equipment technology and understands potential hazards when working with equipment.

There are no serviceable parts inside. To avoid risk of electric shock, do not open.



Warning Statement 1090—Installation by Skilled Person

Only a skilled person should be allowed to install, replace, or service this equipment. See statement 1089 for the definition of a skilled person.

There are no serviceable parts inside. To avoid risk of electric shock, do not open.



Warning Statement 1091—Installation by an Instructed Person

Only an instructed person or skilled person should be allowed to install, replace, or service this equipment. See statement 1089 for the definition of an instructed or skilled person.

There are no serviceable parts inside. To avoid risk of electric shock, do not open.

-
- Step 1** To remove a power supply module, face the back of the chassis and grasp the handle.
- Step 2** Press the latch found on the lower right of the power supply to disengage the power supply.
- Step 3** Place your other hand under the power supply module to support it while you slide it out of the chassis.

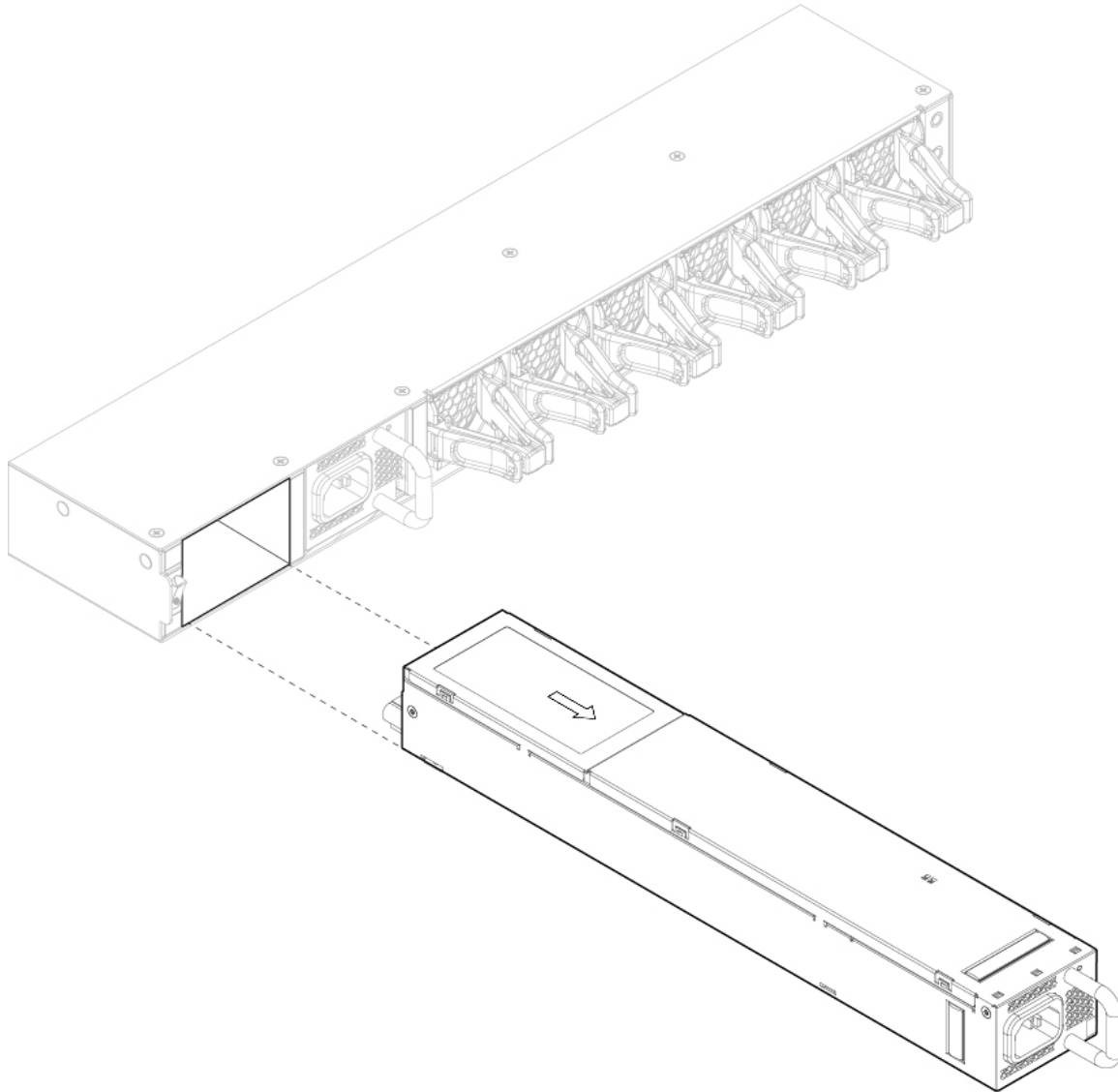
Figure 44: Remove the Power Supply Module

If the slot is to remain empty, install a blank faceplate to ensure proper airflow and to keep dust out of the chassis; otherwise, install another power supply module.

- Step 4** To replace a power supply module, hold the power supply module with both hands and slide it into the power supply module bay.
- Step 5** Push in the power supply module gently until you hear the latch engage and it is seated. Verify the power supply module is operating correctly by checking the power supply module LED. See [Power Supply Modules](#), on page 22 for a description of the power supply module LEDs.
-

Connect the DC Power Supply Module

This procedure describes how to install the DC power supply input power leads to the Firepower 4100 DC input power supply on the rear PDU of the chassis.

Before You Begin

- The color coding of the DC input power supply leads depends on the color coding of the DC power source at your site. Make sure that the lead color coding you choose for the DC input power supply matches the lead color coding used at the DC power source and verify that the power source is connected to the negative (–) terminal and to the positive (+) terminal on the power supply.
- For DC input power cables, the wire gauge is based on the National Electrical Code (NEC) and local codes for 26 amp service at nominal DC input voltage (–40/–72 VDC). One pair of cable leads, source DC (–) and source DC return (+), are required for each power distribution unit (PDU). These cables are available from any commercial cable vendor. All DC input power cables for the chassis should be 10 gauge wire and cable lengths should match within 10 percent of deviation.
- Tools needed:
 - Phillips head screwdriver
 - 10-mm wrench or socket
 - Connectors and wire for the DC circuit or circuits

Each DC input power cable is terminated at the PDU by a cable lug, as shown in the following figure.



Note DC input power cables must be connected to the PDU terminal studs in the proper positive (+) and negative (–) polarity. In some cases, the DC cable leads are labeled, which is a relatively safe indication of the polarity. However, you must verify the polarity by measuring the voltage between the DC cable leads. When making the measurement, the positive (+) lead and the negative (–) lead must always match the (+) and (–) labels on the power distribution unit.

Figure 45: DC Input Power Cable Lug

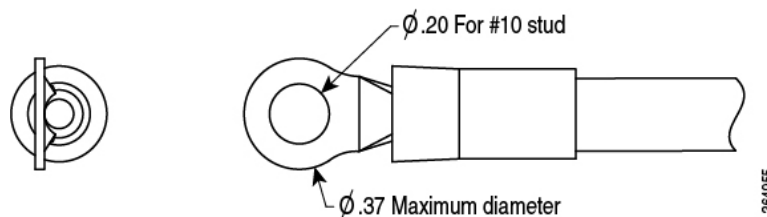

Note To avoid hazardous conditions, all components in the area where DC input power is accessible must be properly insulated. Therefore, before installing the DC cable lugs, be sure to insulate the lugs according to the manufacturer's instructions

Safety Warnings

Take note of the following power and component removal safety warnings:



Warning Statement 1003—DC Power Disconnection

To reduce risk of electric shock or personal injury, disconnect DC power before removing or replacing components or performing upgrades.



Warning Statement 1005—Circuit Breaker

This product relies on the building's installation for short-circuit (overcurrent) protection. To reduce risk of electric shock or fire, ensure that the protective device is rated not greater than:

AC: 20A

DC: 40A



Warning Statement 1017—Restricted Area

This unit is intended for installation in restricted access areas. Only skilled, instructed, or qualified personnel can access a restricted access area.



Warning Statement 1022—Disconnect Device

To reduce the risk of electric shock and fire, a readily accessible disconnect device must be incorporated in the fixed wiring.



Warning Statement 1028—More Than One Power Supply

This unit might have more than one power supply connection. To reduce risk of electric shock, remove all connections to de-energize the unit.





Warning Statement 1029—Blank Faceplates and Cover Panels

Blank faceplates and cover panels serve three important functions: they reduce the risk of electric shock and fire, they contain electromagnetic interference (EMI) that might disrupt other equipment, and they direct the flow of cooling air through the chassis. Do not operate the system unless all cards, faceplates, front covers, and rear covers are in place.



Warning Statement 1073—No User-Serviceable Parts

There are no serviceable parts inside. To avoid risk of electric shock, do not open.



Warning Statement 1046—Installing or Replacing the Unit

To reduce risk of electric shock, when installing or replacing the unit, the ground connection must always be made first and disconnected last.

If your unit has modules, secure them with the provided screws.



Warning Statement 1089—Instructed and Skilled Person Definitions

An instructed person is someone who has been instructed and trained by a skilled person and takes the necessary precautions when working with equipment.

A skilled person or qualified personnel is someone who has training or experience in the equipment technology and understands potential hazards when working with equipment.

There are no serviceable parts inside. To avoid risk of electric shock, do not open.



Warning Statement 1090—Installation by Skilled Person

Only a skilled person should be allowed to install, replace, or service this equipment. See statement 1089 for the definition of a skilled person.

There are no serviceable parts inside. To avoid risk of electric shock, do not open.



Warning Statement 1091—Installation by an Instructed Person

Only an instructed person or skilled person should be allowed to install, replace, or service this equipment. See statement 1089 for the definition of an instructed or skilled person.

There are no serviceable parts inside. To avoid risk of electric shock, do not open.

- Step 1** Install the DC power supply module in the chassis and make note of the bay number so you can connect the wiring to the correct terminals on the DC power supply module at the rear of the chassis. See [Remove and Replace the Power Supply Module, on page 63](#) for the procedure.
- Step 2** Verify that the power is off to the DC circuit on the power supply module that you are installing.
- Step 3** Make sure that all site power and grounding requirements have been met.
- Step 4** To remove the plastic cover from the terminal block, insert a flat screw driver on the side of the plastic cover and pry it off.

Figure 46: Remove the Plastic Cover

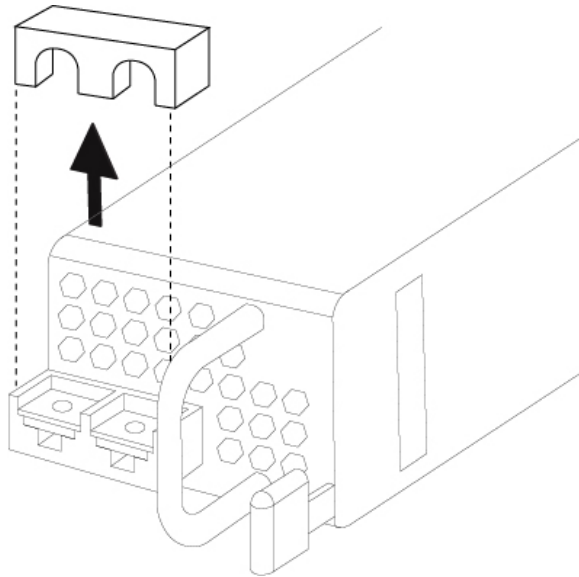

- Step 5** To prevent any contact with metal lead on the ground wire and the plastic cover, you must wrap the positive and negative lead cables with sleeving. Insulate the lug with shrink sleeving for each lead wire if using noninsulated crimp terminals. Sleeving is not required for insulated terminals.
- Step 6** Remove the two M5 screws.

Figure 47: Remove the M5 Screws

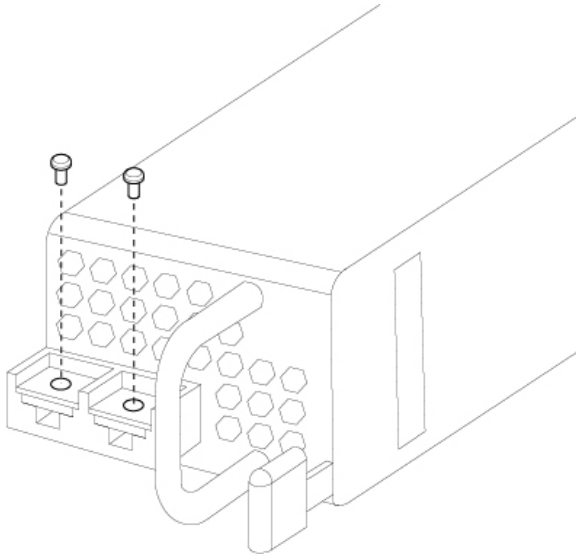

- Step 7** For easier cable management, insert the negative lead cable first. Replace the grounding lug with the cable in the following order—wire terminal, then the screw with the captive washer.

Figure 48: Insert the Cables

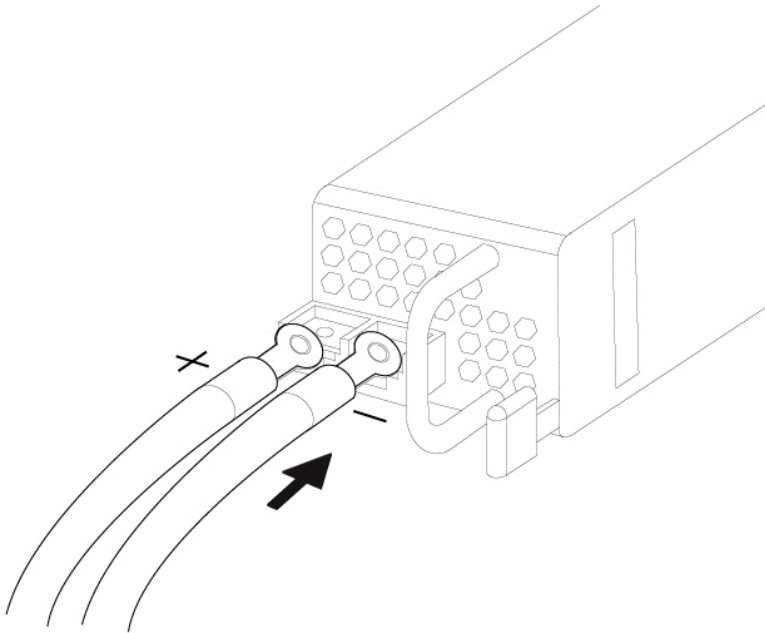

- Step 8** Tighten the M5 screw with the captive washer to the recommended torque of 5 in-lbs for the positive stud and wire. Secure the wires coming in from the terminal block so that they cannot be disturbed by casual contact.

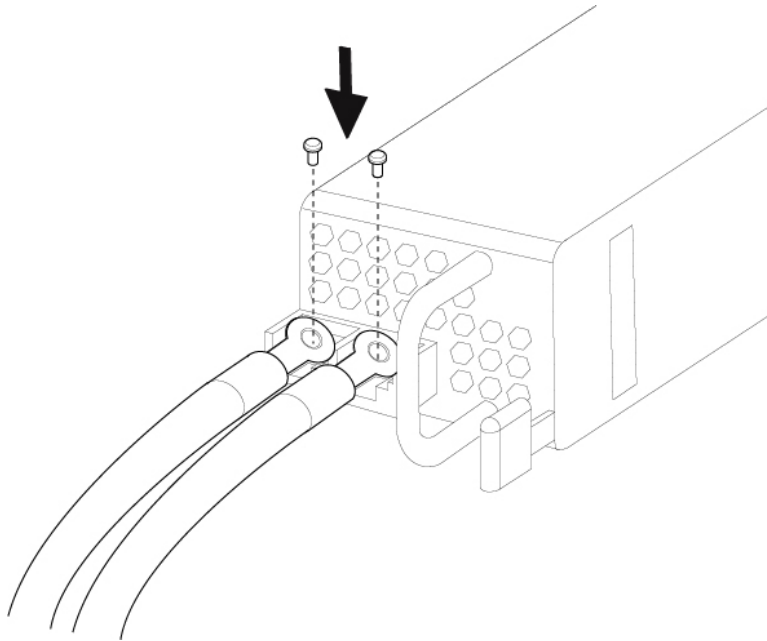
Figure 49: Tighten the M5 Screws**Step 9**

Replace the terminal block plastic cover. The plastic cover is slotted and keyed to fit correctly over the terminal block. This cover should always be in place when power is applied to the terminals.

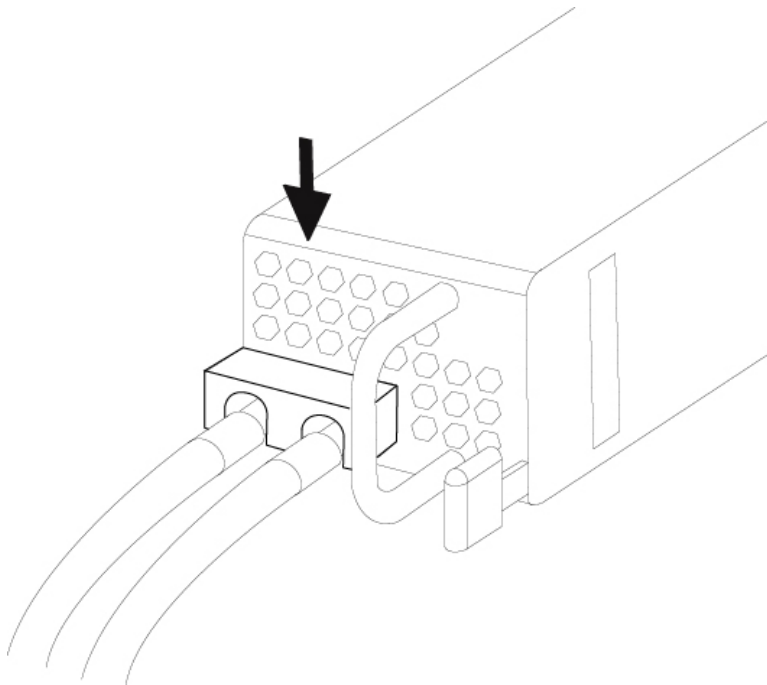
Figure 50: Replace the Plastic Cover

- Step 10** Set the DC disconnect switch in the circuit to ON. In a system with multiple power supplies, connect each power supply to a separate DC power source. In the event of a power source failure, if the second source is still available, it can maintain system operation.
- Step 11** Verify power supply operation by checking the power supply LED on the front of the chassis. See [Front Panel LEDs, on page 9](#) for a description of the LEDs.

Secure the Power Cord on the AC Power Supply Module

Tie Wrap and Clamp

To secure the power supply module against accidental removal and thus prevent disrupting system performance, use the tie wrap and clamp provided in the accessories kit that ships with your Firepower 4100. There are two different tie wrap and clamp combinations to be used with either the Flextronics or Artesyn power supply module.

To verify which power supply module you have, look at the vendor name on the top of the power supply module. If you cannot remove the power supply module, you can count the number of full hexagonal vent holes on the front of the power supply module in the row directly next to the word 'FAIL.' Flextronics has five holes and Artesyn has four holes.

The black tie wrap is used with the Flextronics power supply module and the off-white tie wrap is used with the Artesyn power supply module. The black clamp works with both. See the figures below.

Safety Warnings

Take note of the following component replacement safety warnings:



Warning Statement 1028—More Than One Power Supply

This unit might have more than one power supply connection. To reduce risk of electric shock, remove all connections to de-energize the unit.

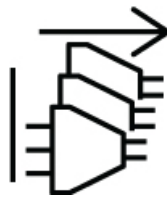

Warning Statement 1073—No User-Serviceable Parts

There are no serviceable parts inside. To avoid risk of electric shock, do not open.



Warning Statement 1089—Instructed and Skilled Person Definitions

An instructed person is someone who has been instructed and trained by a skilled person and takes the necessary precautions when working with equipment.

A skilled person or qualified personnel is someone who has training or experience in the equipment technology and understands potential hazards when working with equipment.

There are no serviceable parts inside. To avoid risk of electric shock, do not open.



Warning Statement 1090—Installation by Skilled Person

Only a skilled person should be allowed to install, replace, or service this equipment. See statement 1089 for the definition of a skilled person.

There are no serviceable parts inside. To avoid risk of electric shock, do not open.



Warning Statement 1091—Installation by an Instructed Person

Only an instructed person or skilled person should be allowed to install, replace, or service this equipment. See statement 1089 for the definition of an instructed or skilled person.

There are no serviceable parts inside. To avoid risk of electric shock, do not open.

Step 1

Attach the clamp to the tie wrap by holding the clamp with the loop side on the bottom and sliding the tie wrap through the box-shaped channel above the clamp (see the following figure).

One side of the tie wrap has evenly spaced ridges and the other is smooth. Be sure the ridged side is face up and that you slide it through the open side of the channel. You will hear a click as the tie slides through—it moves in one direction only. To remove the tie wrap from the clamp, push the lever on the closed side of the box-shaped channel and slide out the tie wrap.

Figure 51: Tie Wrap Through the Box Channel of the Clamp

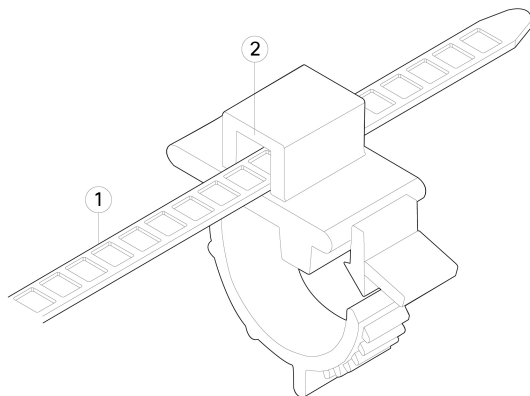

1	Tie wrap	2	Box channel
----------	----------	----------	-------------

Step 2

Attach the clamp to the power supply module:

- a) Locate the hexagonal ventilation hole on the power supply module at the center of the plug just below the power connector body (see the following figures).
- b) Plug the snapping portion of the tie wrap into the hexagonal hole.
- c) With the clamp side facing up, push the tie wrap in until it is fully engaged.

Caution Make sure you have the correct location because you cannot remove the tie wrap from the power supply module once you have installed it without damaging the tie wrap.

Figure 52: Flextronics Power Supply Module

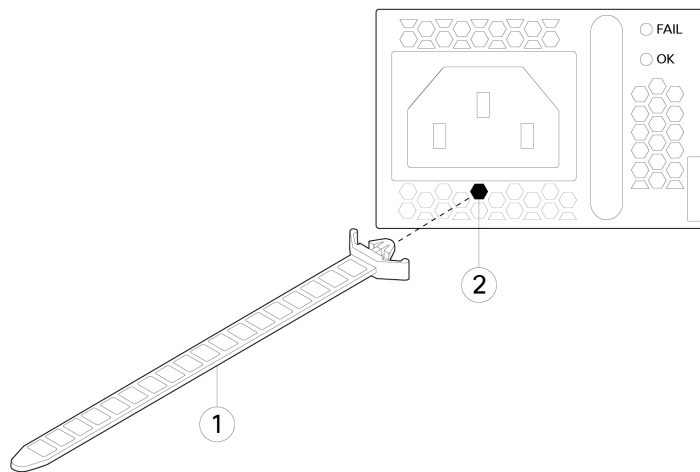

1	Flextronics tie wrap	2	Hexagonal hole
----------	----------------------	----------	----------------

Figure 53: Artesyn Power Supply Module

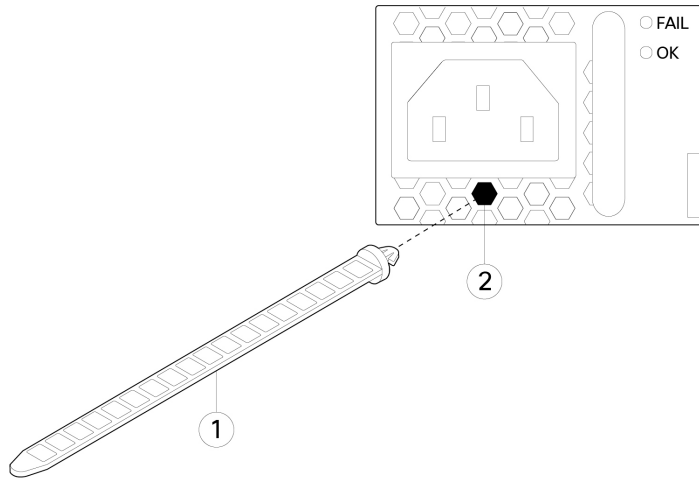

1 Artesyn tie wrap	2 Hexagonal hole
--------------------	------------------

Step 3

Secure the clamp:

- a) Plug in the power supply power cord and wrap the clamp around the over mold portion of the power cord.
- b) Squeeze the clamp ends together to the power supply so that the annular teeth engage with the mate on the clamp.
- c) Make sure the clamp fits snugly into the over mold.
- d) Adjust the clamp position on the tie wrap so that the clamp is tight against the front of the over mold and the power cord cannot be removed by lightly pulling on it.

Figure 54: Clamp on Over Mold of Power Cord

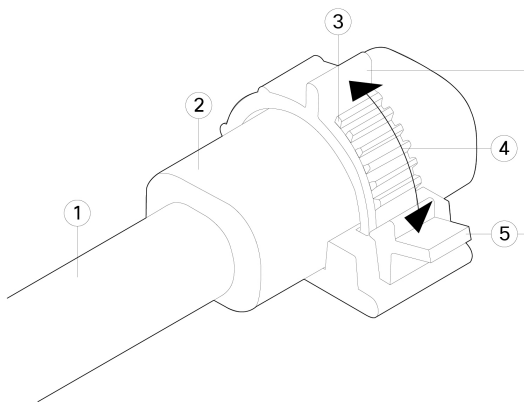

1 Power cord	2 Power cord over mold
3 Tie clamp annular teeth	4 Direction to squeeze the clamp tabs

5	Clamp release tabs		—
---	--------------------	--	---

Step 4 If you need to remove the power cord, push the release tab on the clamp to force the annular clamp teeth to disengage and the clamp opens up. You can then remove the clamp from the power cord.

Install the FIPS Opacity Shield



Caution This procedure should be performed only by the Crypto Officer.



Note Because the FIPS opacity shield covers the serial number on the chassis, you need to copy the serial number on a label and attach it to the chassis where it can be retrieved or viewed easily before you install the FIPS opacity shield. You need the serial number when you call Cisco TAC.

Before you begin

You need the following to install the FIPS opacity shield:

- #1 Phillips screwdriver
- The following items from the FIPS kit:
 - One FIPS opacity shield
 - Four 8-32 x 0.375-inch screws used to attach the FIPS opacity shield to the cable management brackets
 - 15 tamper-evident labels (TEs)
- The following items from the Firepower 4100 accessory kit:
 - Two cable management brackets
 - Four 8-32 x 0.375-inch screws used to attach the cable management brackets to the slide rail locking brackets

Step 1 Copy the serial number on a label and attach it to the chassis where it can be retrieved easily for future use if needed. To find the serial number, see [Serial Number Location, on page 6](#).

Step 2 Pull the chassis out of the rack until the release latches catch.

Step 3 If you have not already done so, attach a slide rail locking bracket to each side of the chassis using the six 8-32 x 0.375-inch Phillips screws provided in the accessory kit.

Note You should have completed this step while performing the procedure described in [Rack-Mount the Chassis, on page 47](#).

Figure 55: Attach the Slide Rail Locking Bracket to the Side of the Chassis

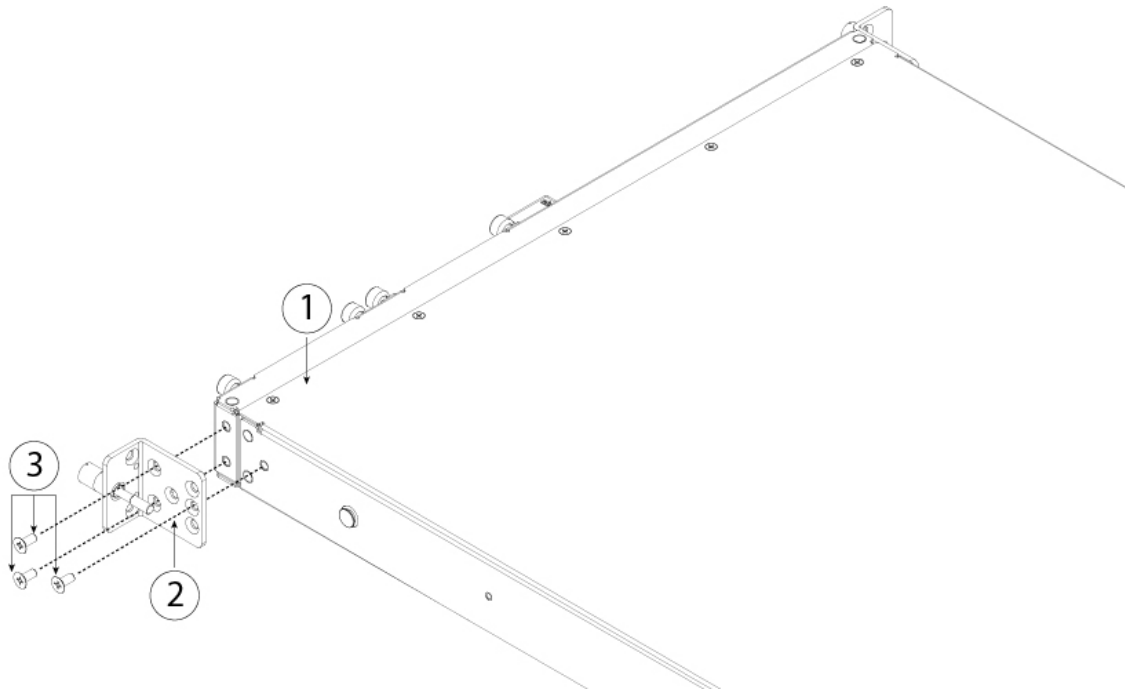

1	Chassis	2	Slide rail locking bracket
3	8-32 x 0.375-inch Phillips screws (three per side)		

Step 4

Attach a cable management bracket to each slide rail locking bracket using the four 8-32 x 0.375-inch Phillips screws provided in the accessory kit.

Figure 56: Attach the Cable Management Bracket to the Slide Rail Locking Bracket

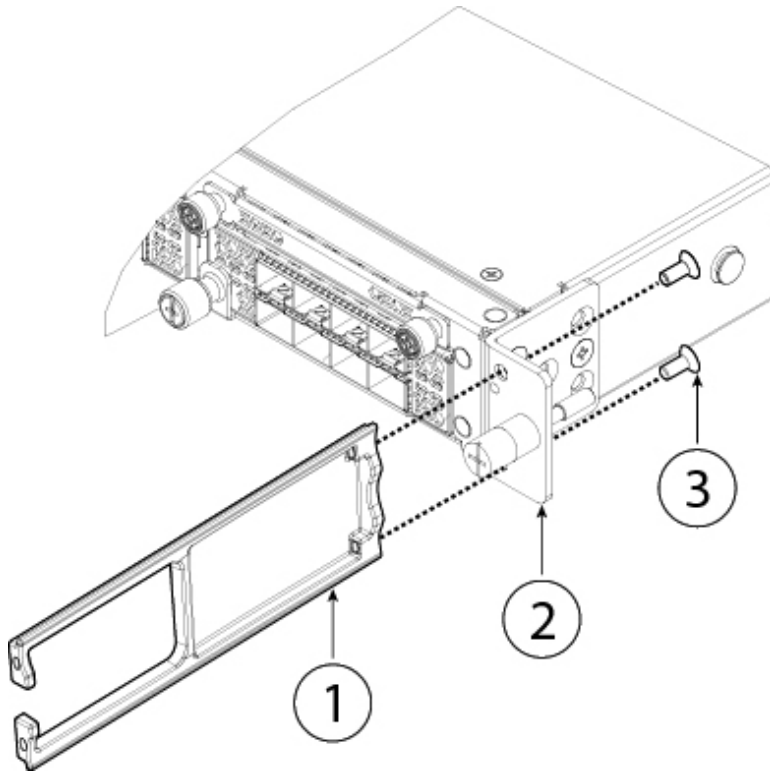

1	Cable management bracket	2	Slide rail locking bracket
3	8-32 x 0.375 inch Phillips screws (two per side)		

Step 5

Connect the cables to the ports. Install the cables according to your default software configuration as described in the [Cisco Firepower 4100 Getting Started Guide](#). Make sure that the cables have enough slack to route them through the cable mounting brackets (as shown in Step 6 below).

Note If you are installing the FIPS opacity shield after the initial product installation, the cables are connected. If the attached cables do not have enough slack to route them through the cable mounting brackets (as shown below), you will have to turn the power off on the appliance, remove the cables, route the cables through the cable mounting brackets, reattach the cables, and continue with Step 7 below.

Step 6

Route the cables through the openings in the cable management brackets.

Figure 57: Route the Cables Through the Cable Management Brackets

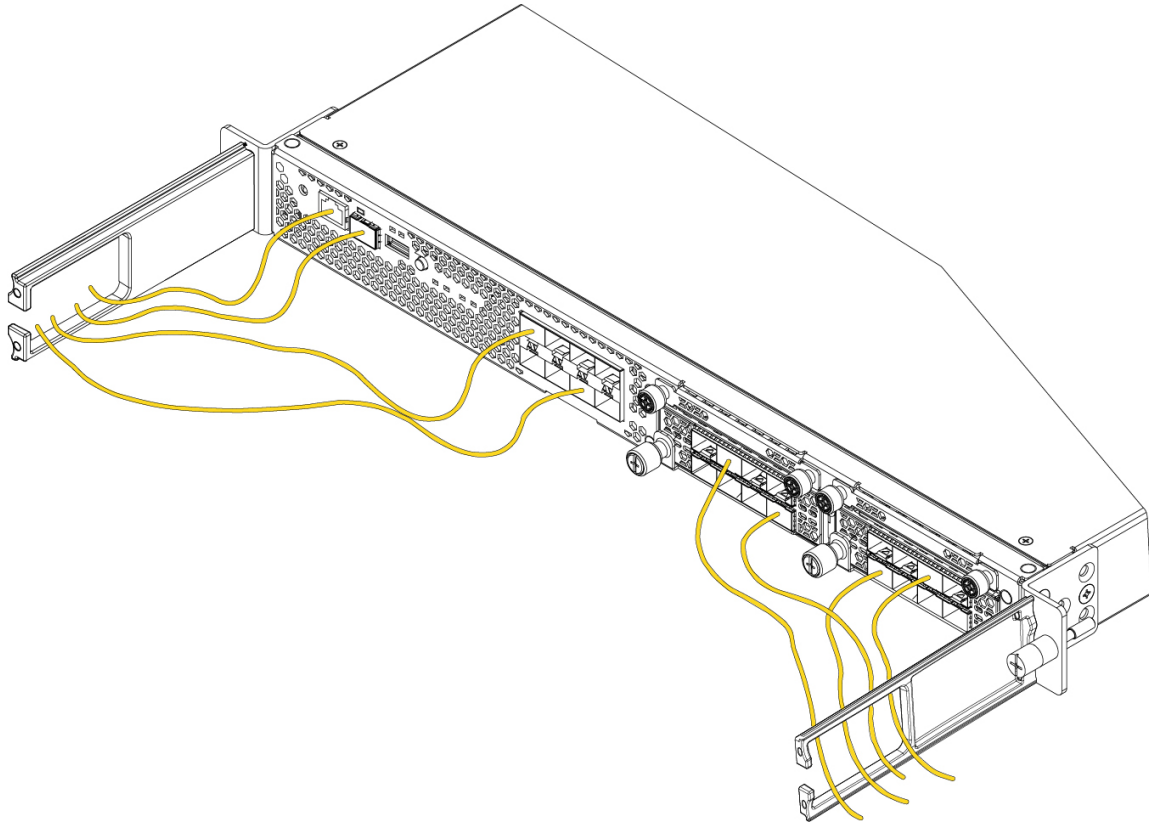

- Step 7** Attach the FIPS opacity shield to the cable management brackets using the four 8-32 x 0.375-inch Phillips screws provided in the FIPS kit.

Figure 58: Attach the FIPS Opacity Shield to the Cable Management Brackets

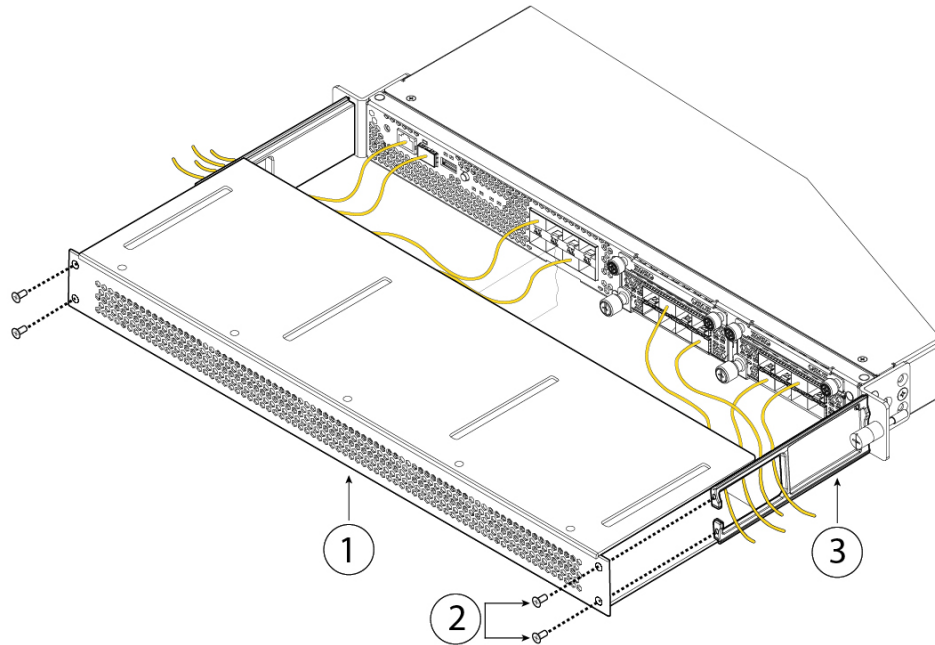

1	FIPS opacity shield	2	8-32 x 0.375-inch Phillips screws (two per side)
3	Cable management bracket		

- Step 8** Attach the 15 TELs. For information on the procedure and correct placement of the TELs, see the Tamper Evidence Label (TEL) Placement section (section 2.13) in the [FIPS 140-2 Non Proprietary Security Policy Level 2 Validation](#) document.
- Step 9** Attach the power cable to the chassis and connect it to an electrical outlet.
- Step 10** Press the power switch on the rear panel.
- Step 11** Check the power LED on the front panel. See [Front Panel LEDs](#), on page 9 for a description of the power LED. Solid green indicates that the chassis is powered on.
- Note** When you toggle the power switch from ON to OFF, it takes several seconds for the system to power down. Do not remove the power cable until the power LED is off. After removing power from the chassis either by moving the power switch to OFF or unplugging the power cord, wait at least 10 seconds before turning power back ON.
- Step 12** See the [Cisco Firepower 4100 Getting Started Guide](#) for further configuration information.

