



Cisco ASA 5585-X Adaptive Security Appliance Hardware Installation Guide

Cisco Systems, Inc.
www.cisco.com

Cisco has more than 200 offices worldwide.
Addresses, phone numbers, and fax numbers
are listed on the Cisco website at
www.cisco.com/go/offices.

THE SPECIFICATIONS AND INFORMATION REGARDING THE PRODUCTS IN THIS MANUAL ARE SUBJECT TO CHANGE WITHOUT NOTICE. ALL STATEMENTS, INFORMATION, AND RECOMMENDATIONS IN THIS MANUAL ARE BELIEVED TO BE ACCURATE BUT ARE PRESENTED WITHOUT WARRANTY OF ANY KIND, EXPRESS OR IMPLIED. USERS MUST TAKE FULL RESPONSIBILITY FOR THEIR APPLICATION OF ANY PRODUCTS.

THE SOFTWARE LICENSE AND LIMITED WARRANTY FOR THE ACCOMPANYING PRODUCT ARE SET FORTH IN THE INFORMATION PACKET THAT SHIPPED WITH THE PRODUCT AND ARE INCORPORATED HEREIN BY THIS REFERENCE. IF YOU ARE UNABLE TO LOCATE THE SOFTWARE LICENSE OR LIMITED WARRANTY, CONTACT YOUR CISCO REPRESENTATIVE FOR A COPY.

The following information is for FCC compliance of Class A devices: This equipment has been tested and found to comply with the limits for a Class A digital device, pursuant to part 15 of the FCC rules. These limits are designed to provide reasonable protection against harmful interference when the equipment is operated in a commercial environment. This equipment generates, uses, and can radiate radio-frequency energy and, if not installed and used in accordance with the instruction manual, may cause harmful interference to radio communications. Operation of this equipment in a residential area is likely to cause harmful interference, in which case users will be required to correct the interference at their own expense.

The following information is for FCC compliance of Class B devices: The equipment described in this manual generates and may radiate radio-frequency energy. If it is not installed in accordance with Cisco's installation instructions, it may cause interference with radio and television reception. This equipment has been tested and found to comply with the limits for a Class B digital device in accordance with the specifications in part 15 of the FCC rules. These specifications are designed to provide reasonable protection against such interference in a residential installation. However, there is no guarantee that interference will not occur in a particular installation.

Modifying the equipment without Cisco's written authorization may result in the equipment no longer complying with FCC requirements for Class A or Class B digital devices. In that event, your right to use the equipment may be limited by FCC regulations, and you may be required to correct any interference to radio or television communications at your own expense.

You can determine whether your equipment is causing interference by turning it off. If the interference stops, it was probably caused by the Cisco equipment or one of its peripheral devices. If the equipment causes interference to radio or television reception, try to correct the interference by using one or more of the following measures:

- Turn the television or radio antenna until the interference stops.
- Move the equipment to one side or the other of the television or radio.
- Move the equipment farther away from the television or radio.
- Plug the equipment into an outlet that is on a different circuit from the television or radio. (That is, make certain the equipment and the television or radio are on circuits controlled by different circuit breakers or fuses.)

Modifications to this product not authorized by Cisco Systems, Inc. could void the FCC approval and negate your authority to operate the product.

The Cisco implementation of TCP header compression is an adaptation of a program developed by the University of California, Berkeley (UCB) as part of UCB's public domain version of the UNIX operating system. All rights reserved. Copyright © 1981, Regents of the University of California.

NOTWITHSTANDING ANY OTHER WARRANTY HEREIN, ALL DOCUMENT FILES AND SOFTWARE OF THESE SUPPLIERS ARE PROVIDED "AS IS" WITH ALL FAULTS. CISCO AND THE ABOVE-NAMED SUPPLIERS DISCLAIM ALL WARRANTIES, EXPRESSED OR IMPLIED, INCLUDING, WITHOUT LIMITATION, THOSE OF MERCHANTABILITY, FITNESS FOR A PARTICULAR PURPOSE AND NONINFRINGEMENT OR ARISING FROM A COURSE OF DEALING, USAGE, OR TRADE PRACTICE.

IN NO EVENT SHALL CISCO OR ITS SUPPLIERS BE LIABLE FOR ANY INDIRECT, SPECIAL, CONSEQUENTIAL, OR INCIDENTAL DAMAGES, INCLUDING, WITHOUT LIMITATION, LOST PROFITS OR LOSS OR DAMAGE TO DATA ARISING OUT OF THE USE OR INABILITY TO USE THIS MANUAL, EVEN IF CISCO OR ITS SUPPLIERS HAVE BEEN ADVISED OF THE POSSIBILITY OF SUCH DAMAGES.

Cisco and the Cisco logo are trademarks or registered trademarks of Cisco and/or its affiliates in the U.S. and other countries. To view a list of Cisco trademarks, go to this URL: www.cisco.com/go/trademarks. Third-party trademarks mentioned are the property of their respective owners. The use of the word partner does not imply a partnership relationship between Cisco and any other company. (1721R)

Cisco ASA 5585-X Adaptive Security Appliance Hardware Installation Guide
©2010-2020 Cisco Systems, Inc. All rights reserved.



About This Guide

Published: September 24, 2010

Revised: October 5, 2020, OL-22567-02

The information in this guide applies to the Cisco ASA 5585-X adaptive security appliance. In this guide, references to “adaptive security appliance” and “Cisco ASA 5585-X” apply to the Cisco ASA 5585-X adaptive security appliance. This guide describes how to install the Cisco ASA 5585-X and how to perform maintenance procedures. Use this guide in conjunction with the documents listed in [Related Documentation](#), page iii.

This preface contains the following sections:

- [Audience](#), page i
- [Conventions](#), page ii
- [Related Documentation](#), page iii
- [Installation Warnings](#), page iii
- [Obtaining Documentation and Submitting a Service Request](#), page vi

Audience

This guide is for experienced network security administrators who install and maintain Cisco adaptive security appliances.

Conventions

This document uses the following conventions:

Convention	Indication
bold type	Commands, keywords and user-entered text appear in bold type .
<i>italic type</i>	Document titles, new or emphasized terms, and arguments for which you supply values are in <i>italic type</i> .
[]	Elements in square brackets are optional.
{ x y z }	Required alternative keywords are grouped in braces and separated by vertical bars.
[x y z]	Optional alternative keywords are grouped in square brackets and separated by vertical bars.
string	An unquoted set of characters. Do not use quotation marks around the string or the string will include the quotation marks.
monospace type	Terminal sessions and information the system displays are presented in monospace type.
< >	Non-printing characters such as passwords are presented in angle brackets.
[]	Default responses to system prompts are presented in square brackets.
!, #	An exclamation point (!) or a hash sign (#) at the beginning of a line of code indicates a comment line.



Note

Means *reader take note*.



Tip

Means *the following information can help you solve a problem*.



Caution

Means *reader be careful*. In this situation, you could perform an action that might result in equipment damage or loss of data.



Timesaver

Means *the described action saves time*. You can save time by performing the action described in the paragraph.



Warning

Means *reader be warned*. In this situation, you could perform an action that might result in bodily injury.

Related Documentation

For a complete list of the Cisco ASA 5500-X documentation, refer to the following URL:

<http://www.cisco.com/c/en/us/td/docs/security/asa/roadmap/asaroadmap.html>

For a complete list of Cisco ASA 5500-X series install and upgrade guides, including a list of quick-start guides for the various Security Services Processors, refer to the following URL:

<http://www.cisco.com/c/en/us/support/security/asa-5500-series-next-generation-firewalls/products-installation-guides-list.html>

For a complete list of the ASA CX and Cisco Prime Security Manager documentation, refer to the following URL:

<http://www.cisco.com/en/US/docs/security/asacx/roadmap/asacxprsmroadmap.html>

Installation Warnings

This section presents these important safety warnings:

- AC Power Warning, page iii
- Jewelry Removal Warning, page iv
- Wrist Strap Warning, page iv
- Work During Lightning Warning, page iv
- Installation Instructions Warning, page iv
- Chassis Warning for Rack-Mounting and Servicing, page iv
- Short-Circuit Protection Warning, page iv
- SELV Circuit Warning, page iv
- Ground Conductor Warning, page v
- Faceplates and Cover Panels Warning, page v
- Product Disposal Warning, page v
- Compliance with Local and National Electrical Codes Warning, page v
- TN Power Warning, page v
- Multiple Power Cords, page v
- Circuit Breaker (15A) Warning, page v
- Grounded Equipment Warning, page vi
- Safety Cover Requirement, page vi

AC Power Warning



Before working on a chassis or near power supplies, unplug the power cord on all AC units.
Statement 246

Jewelry Removal Warning



Warning

Before working on equipment that is connected to a power source, remove jewelry (including rings, necklaces, and watches). Metal objects will heat when connected to power and ground, and can cause serious burns or weld the metal object to the terminals. Statement 43

Wrist Strap Warning



Warning

During this procedure, wear grounding wrist straps to avoid ESD damage to the card. Do not directly touch the backplane with your hand or any metal tool, or you could receive a shock. Statement 94

Work During Lightning Warning



Warning

Do not work on the system, or connect or disconnect cables during periods of lightning. Statement 1001

Installation Instructions Warning



Warning

Read all installation instructions before connecting the system to a power source. Statement 1004

Chassis Warning for Rack-Mounting and Servicing



Warning

To prevent bodily injury when mounting or servicing this unit in a rack, you must take special precautions to ensure that the system remains stable. The following guidelines are provided to ensure your safety: This unit should be mounted at the bottom of the rack if it is the only unit in the rack. When mounting this unit in a partially filled rack, load the rack from the bottom to the top with the heaviest component at the bottom of the rack. If the rack is provided with stabilizing devices, install the stabilizers before mounting or servicing the unit in the rack. Statement 1006

Short-Circuit Protection Warning



Warning

This product requires short-circuit (overcurrent) protection, to be provided as part of the building installation. Install only in accordance with national and local wiring regulations. Statement 1045

SELV Circuit Warning



Warning

To avoid electric shock, do not connect safety extra-low voltage (SELV) circuits to telephone-network voltage (TNV) circuits. LAN ports contain SELV circuits, and WAN ports contain TNV circuits. Some LAN and WAN ports both use RJ-45 connectors. Use caution when connecting cables. Statement 1021

Ground Conductor Warning



This equipment must be grounded. Never defeat the ground conductor, or operate the equipment in the absence of a suitably installed ground conductor. Contact the appropriate electrical inspection authority, or an electrician if you are not certain that suitable grounding is available. Statement 1024

Faceplates and Cover Panels Warning



Blank faceplates and cover panels serve three important functions: they prevent exposure to hazardous voltages and currents inside the chassis; they restrict electromagnetic interference (EMI) that might disrupt other equipment; and they direct the flow of cooling air through the chassis. Do not operate the system unless all cards, faceplates, front covers, and rear covers are in place. Statements 1029 and 142

Product Disposal Warning



Ultimate disposal of this product should be handled according to all national laws and regulations. Statement 1040

Compliance with Local and National Electrical Codes Warning



Installation of the equipment must comply with local and national electrical codes. Statement 1074

TN Power Warning



The device is designed to work with TN power systems. Statement 19

Multiple Power Cords



This unit has more than one power cord. To reduce the risk of electric shock when servicing a unit, disconnect the power cord of the power strip into which the unit is plugged. Statement 137

Circuit Breaker (15A) Warning



This product relies on the building's installation for short-circuit (overcurrent) protection. Ensure that a fuse or circuit breaker no larger than 120 VAC, 15A U.S. (240 VAC, 10A international) is used on the phase conductors (all current-carrying conductors). Statement 13

Grounded Equipment Warning



Warning

This equipment is intended to be grounded. Ensure that the host is connected to earth ground during normal use. Statement 39

Safety Cover Requirement



Warning

The safety cover is an integral part of the product. Do not operate the unit without the safety cover installed. Operating the unit without the cover in place will invalidate the safety approvals and pose a risk of fire and electrical hazards. Statement 117

Where to Find Safety and Warning Information

For safety and warning information, see the Regulatory Compliance and Safety Information document at the following URL:

http://www.cisco.com/c/en/us/td/docs/security/asa/hw/regulatory/compliance/asa5585_rcsi.html

This RCSI document describes the international agency compliance and safety information for the Cisco ASA 5500-X series. It also includes translations of the safety warnings used in this guide.

Obtaining Documentation and Submitting a Service Request

For information on obtaining documentation, submitting a service request, and gathering additional information, see the monthly *What's New in Cisco Product Documentation*, which also lists all new and revised Cisco technical documentation, at:

<http://www.cisco.com/en/US/docs/general/whatsnew/whatsnew.html>

Subscribe to the *What's New in Cisco Product Documentation* as an RSS feed and set content to be delivered directly to your desktop using a reader application. The RSS feeds are a free service.



Introducing the Cisco ASA 5585-X

This chapter describes the Cisco ASA 5585-X and includes the following sections:

- [Product Overview, page 1-1](#)
- [Chassis Features, page 1-4](#)
- [Specifications, page 1-10](#)
- [Memory Configurations, page 1-12](#)
- [Power Supply Module Requirements, page 1-12](#)
- [SFP/SFP+ Modules, page 1-13](#)



Note

Read through the entire guide before beginning any of the installation procedures.



Warning

Only trained and qualified personnel should install, replace, or service this equipment. Statement 49



Caution

Read the safety warnings in the *Regulatory Compliance and Safety Information for the Cisco ASA 5585-X Adaptive Security Appliance* document and follow proper safety procedures when performing the steps in this guide.

Product Overview

The ASA 5585-X adaptive security appliance featuring MultiScale™ is a two-rack-unit (2RU), two-slot chassis. Supporting one of the highest performance-density firewalls on the market, the design of the ASA 5585-X provides high scalability not only in terms of throughput, but also high connection speed and maximum connections. Connection speed and maximum connection requirements are growing much faster than throughput in most customer data center networks. The capabilities of the ASA 5585-X help you simultaneously meet scalability challenges in throughput, connection capacity, and connection speed in the data center.

In addition to world-class performance, the ASA 5585-X deploys encrypted traffic inspection, port density (up to 20 interfaces depending on the model), and feature performance matching; that is, performance parity between firewall and IPS functions.

**Note**

Dual firewall mode is only supported in certain versions of ASA software. For more information, refer to the Cisco ASA Compatibility document found at this URL:
<http://www.cisco.com/en/US/docs/security/asa/compatibility/asamatrix.html>

All ASA 5585-X series adaptive security appliances ship with a core Security Services Processor (SSP); you can install an additional core SSP, IPS SSP, CX SSP, or FirePOWER SSP, or up to two network modules. You must have the core SSP to run the other modules. The core SSP resides in slot 0 (the bottom slot).

The ASA 5585-X is available with four core SSP versions:

- ASA 5585-X with Security Services Processor-10
- ASA 5585-X with Security Services Processor-20
- ASA 5585-X with Security Services Processor-40
- ASA 5585-X with Security Services Processor-60

Starting with ASA version 5.4.0.1, there is support for mixed level SSPs.

- ASA SSP-10/ASA FirePOWER SSP-40
- ASA SSP-20/ASA FirePOWER SSP-60
- ASA SSP-40/ASA FirePOWER SSP-60

**Note**

For the SSP40/60 combination, you might see an error message that this combination is not supported. You can ignore the message.

For a matrix describing which module configurations are allowed, see the [ASA Module Compatibility](#) table.

Each ASA 5585-X chassis accommodates up to two AC power supply modules, each of which contains an integrated fan; you can alternatively install a fan module in the second bay. Optional redundant, hot-swappable power supply modules are available, as well as hot-swappable fan modules in case of a fan failure.

The core SSP provides environmental monitoring, which tracks the operational status of the fan and power supply modules. In addition, it tracks the temperatures of the CPUs and the ambient temperature of the system.

**Note**

Online insertion and removal (OIR) of SSPs and network modules is not supported at this time. Small form-factor pluggable (SFP/SFP+) transceiver, power-supply module, and fan module OIR is supported.

ASDM

The ASA software supports Cisco Adaptive Security Device Manager (ASDM), which delivers world-class security management and monitoring through an intuitive, easy-to-use web-based management interface. Bundled with the adaptive security appliance, ASDM accelerates adaptive security appliance deployment with intelligent wizards, robust administration tools, and versatile monitoring services that complement the advanced integrated security and networking features offered by the adaptive security appliance. Its secure, web-based design enables anytime, anywhere access to adaptive security appliances.

ASA 5585-X SSP-10

The ASA 5585-X SSP-10 provides firewall and VPN support, and 10 interfaces (two SFP/SFP+ and eight copper Gigabit Ethernet). The SSP-10 has one power supply module and one fan module. You can replace the fan module with another power supply module for a redundant power supply configuration. The SSP-10 has one CPU, three DIMM modules, one embedded crypto-accelerator, and one dual-port 10-GB uplink for the SFP/SFP+ interfaces.

ASA 5585-X SSP-20

The ASA 5585-X SSP-20 provides firewall and VPN support, and 10 interfaces (two SFP/SFP+ and eight copper Gigabit Ethernet). The SSP-20 has one power supply module and one fan module. You can replace the fan module with another power supply module for a redundant power supply configuration. The SSP-20 has one CPU, six DIMM modules, two embedded crypto-accelerators, and one dual-port 10-GB uplink for the SFP/SFP+ interfaces.

ASA 5585-X SSP-40

The ASA 5585-X SSP-40 provides firewall and VPN support, and 10 interfaces (four SFP/SFP+ and six copper Gigabit Ethernet). The SSP-40 has one power supply module and one fan module. You can replace the fan module with another power supply module for a redundant power supply configuration. The SSP-40 has two CPUs, six DIMM modules, three embedded crypto-accelerators, and two dual-port 10-GB uplinks for the SFP/SFP+ interfaces.

ASA 5585-X SSP-60

The ASA 5585-X SSP-60 provides firewall and VPN support, and 10 interfaces (four SFP/SFP+ and six copper Gigabit Ethernet). The SSP-60 ships with two power supply modules; however, the SSP-60 can function with only one power supply module. Although the SSP-60 with an additional SSP can also operate with only one power supply module, we recommend that you install two power supply modules for extended reliability since the power supply modules operate in load-sharing mode. If one fails in this configuration, the other power supply module can still handle the full load until the failed power supply module is replaced. The SSP-60 has two CPUs, 12 DIMM modules, four embedded crypto-accelerators, and two dual-port 10-GB uplinks for the SFP/SFP+ interfaces.

**Caution**

If you remove a power supply or fan module, replace it immediately to prevent disruption of service.

You optionally can install an additional core SSP, an IPS SSP, a CX SSP, or a FirePOWER SSP in the upper slot (slot 1). For a matrix describing which module configurations are allowed, see the [ASA Module Compatibility](#) table.

**Note**

Feature limitations may apply to dual SSPs. Refer to your configuration guide for more information.

Chassis Features

This section describes the ASA 5585-X chassis features and indicators.

Grounding Lug

Figure 1-1 shows the grounding lug on the rear of the chassis.

Figure 1-1 ASA 5585-X Chassis, Rear View

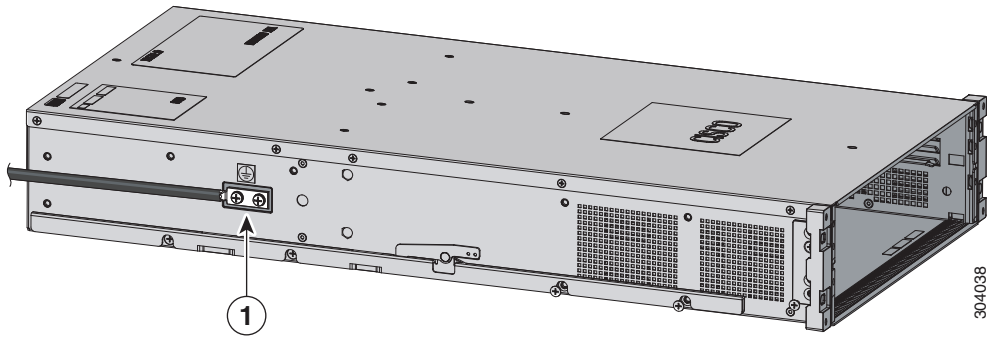

1	Grounding lug		
---	---------------	--	--

Figure 1-2 shows the front view of the ASA 5585-X SSP-10 with an IPS SSP-10 in the top slot. The appearance with one of the other available SSP-10 and SSP-20 modules in the top slot is very similar. All port numbers are numbered from right to left beginning with 0.

Front Panel: ASA 5585-X SSP-10 With Add-on SSP-10

Figure 1-2 ASA 5585-X SSP-10 With IPS SSP-10, Front Panel View

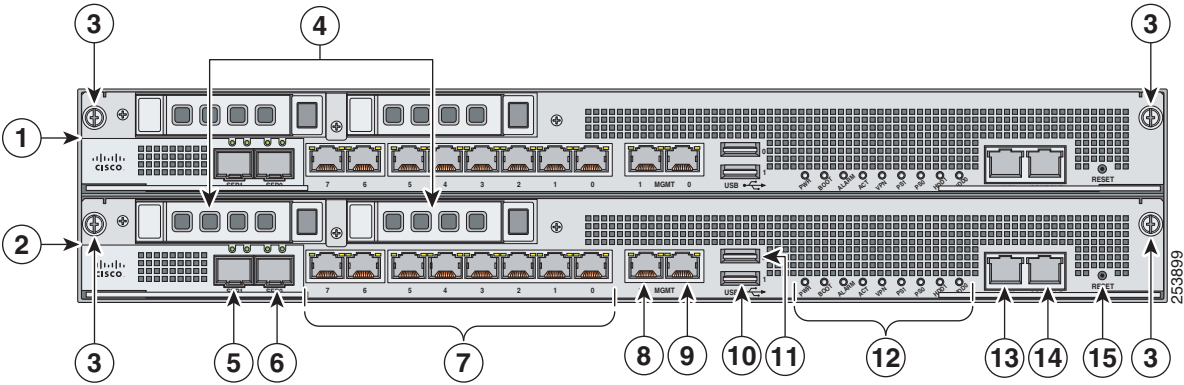

1	SSP or network module (slot 1)	2	Core SSP (slot 0)
3	Module removal screws	4	Reserved hard-disk drive bays in bottom slot; add-on module hard-disk drives in top slot ¹
5	TenGigabitEthernet 0/9 (core SSP in slot 0) TenGigabitEthernet 1/9 (add-on module in Slot 1) (10-Gb fiber, SFP, or SFP+)	6	TenGigabitEthernet 0/8 (core SSP in slot 0) TenGigabitEthernet 1/8 (add-on module in slot 1) (10-Gb fiber, SFP, or SFP+)
7	GigabitEthernet 0/0 through 0/7 (core SSP in slot 0) GigabitEthernet 1/0 through 1/7 (add-on module in slot 1) (from right to left, 1-Gb copper, RJ45)	8	Management 0/1 (core SSP in slot 0) Management 1/1 (add-on module in slot 1) (GigabitEthernet RJ45)
9	Management 0/0 (SSP in slot 0) Management 1/0 (add-on module in slot 1) (GigabitEthernet RJ45)	10	USB port
11	USB port	12	Front panel indicators
13	Auxiliary port (RJ45) ²	14	Console port (RJ45)
15	Eject ³		

1. Hard-disk drives are currently only supported by the CX and FirePOWER SSPs, one of which can reside in the top slot.
2. The RJ-45 Auxiliary port (labeled AUX on the chassis) is reserved for internal use at Cisco. The port is not functional in shipping versions of the chassis; therefore, customers cannot connect to this port to run the adaptive security appliance CLI.
3. Reserved for future OIR use.

Front Panel: ASA 5585-X SSP-40 With Add-on SSP-40

Figure 1-3 shows the front view of ASA 5585-X SSP-40 with an IPS SSP-40 in the top slot. The appearance with one of the other available SSP-40 and SSP-60 modules in the top slot is very similar.

Figure 1-3 ASA 5585-X SSP-40 With IPS SSP-40, Front Panel View

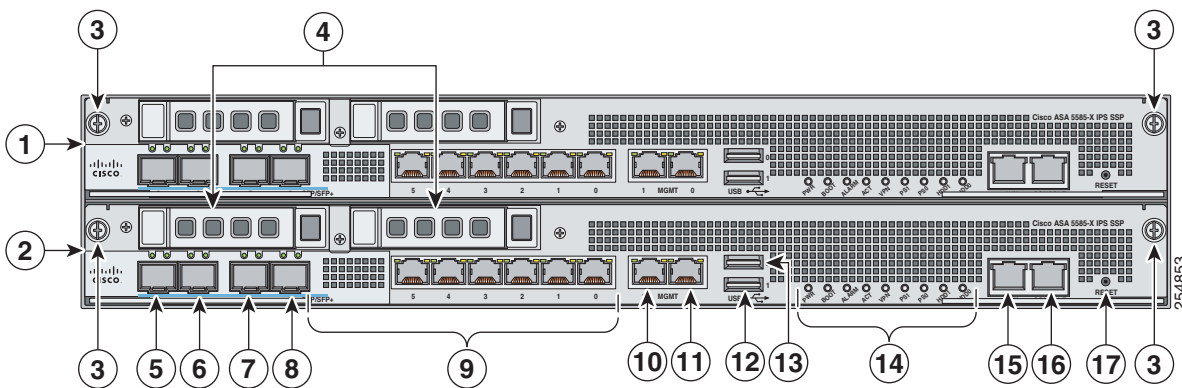

1	Add-on SSP or network module (slot 1)	2	Core SSP (slot 0)
3	Add-on module removal screws	4	Reserved bays for hard-disk drives ¹

5	TenGigabitEthernet 0/9 (core SSP in slot 0) TenGigabitEthernet 1/9 (add-on module in slot 1) (10-Gb fiber, SFP, or SFP+)	6	TenGigabitEthernet 0/8 (core SSP in slot 0) TenGigabitEthernet 1/8 (add-on module in slot 1) (10-Gb fiber, SFP, or SFP+)
7	TenGigabitEthernet 0/7 (core SSP in slot 0) TenGigabitEthernet 1/7 (add-on module in slot 1) (10-Gb fiber, SFP, or SFP+)	8	TenGigabitEthernet 0/6 (core SSP in slot 0) TenGigabitEthernet 1/6 (add-on module in slot 1) (10-Gb fiber, SFP, or SFP+)
9	GigabitEthernet 0/0 through 0/5 (core SSP in slot 0) GigabitEthernet 1/0 through 1/5 (add-on module in slot 1) (from right to left, 1-Gb copper, RJ45)	10	Management 0/1 (core SSP in slot 0) Management 1/1 (add-on module in slot 1) (GigabitEthernet RJ45)
11	Management 0/0 (core SSP in slot 0) Management 1/0 (add-on module in slot 1) (GigabitEthernet RJ45)	12	USB port
13	USB port	14	Front panel indicators
15	Auxiliary port (RJ45) ²	16	Console port (RJ45)
17	Eject ³		

1. Hard-disk drives are currently only supported by the CX and FirePOWER SSPs, one of which can reside in the top slot.
2. The RJ-45 Auxiliary port (labeled AUX on the chassis) is reserved for internal use at Cisco. The port is not functional in shipping versions of the chassis; therefore, customers cannot connect to this port to run the adaptive security appliance CLI.
3. Reserved for future OIR use.

Front Panel: Ethernet Port Indicator Lights

Table 1-1 describes the Ethernet port indicator lights.

Table 1-1 Ethernet Port Indicator Lights

Indicator	Description
Gigabit Ethernet (RJ45)	<ul style="list-style-type: none"> • Left side: <ul style="list-style-type: none"> - Green—Physical activity. - Flashing green—Network activity. • Right side: <ul style="list-style-type: none"> - Unlit—10 Mbps. - Green—100 Mbps. - Amber—1000 Mbps.

Table 1-1 Ethernet Port Indicator Lights (continued)

Indicator	Description
10-Gigabit Ethernet Fiber (SFP+)/1-Gigabit Ethernet Fiber (SFP)	<ul style="list-style-type: none"> • Left side: <ul style="list-style-type: none"> – Unlit—No 10-Gigabit Ethernet physical link. – Green—10-Gigabit Ethernet physical link. – Flashing green¹—Network activity. • Right side: <ul style="list-style-type: none"> – Unlit—No 1-Gigabit Ethernet physical link. – Green—1-Gigabit Ethernet physical link. – Flashing green¹—Network activity.
Management port	<ul style="list-style-type: none"> • Left side: <ul style="list-style-type: none"> – Green—Physical activity. – Flashing green—Network activity. • Right side: <ul style="list-style-type: none"> – Unlit—10 Mbps. – Green—100 Mbps. – Amber—1000 Mbps.

1. Rate of flashing is proportional to the percentage of number of packets or bytes received.

Front Panel Indicator Lights

Figure 1-4 shows the front panel indicator lights.

Figure 1-4 ASA 5585-X Front Panel Lights

Table 1-2 describes the front panel indicator lights on the ASA 5585-X.

Table 1-2 ASA 5585-X Front Panel Indicator Lights

Figure Label	Indicator	Description
1	PWR	Whether the system is off or on: <ul style="list-style-type: none"> • Unlit—No power. • Green—System has power.
2	BOOT	Status of the power-up diagnostics: <ul style="list-style-type: none"> • Flashing green—Power-up diagnostics are running, or the system is booting. • Green—System has passed power-up diagnostics. • Amber—Power-up diagnostics failed.
3	ALARM	Component failure: <ul style="list-style-type: none"> • Unlit—No alarm. • Amber—Critical alarm: <p>Major failure of hardware component or software module, temperature over the limit, power out of tolerance, or time to remove the module.¹</p> <p>Note May appear red on some units.</p>
4	ACT	Role of a high-availability (HA) pair: <ul style="list-style-type: none"> • Green—The active-mode unit. • Amber—The standby unit.
5	VPN	Whether a VPN tunnel has been established: <ul style="list-style-type: none"> • Green—VPN tunnel established.
6	PS1	State of the power-supply module installed on the right: <ul style="list-style-type: none"> • Unlit—No power supply module present, or no AC input. • Green—Power supply module present, on, and good. • Amber—Power or fan module off, or failed.
7	PS0	State of the power module installed on the left: <ul style="list-style-type: none"> • Unlit—No power supply module present, or no AC input. • Green—Power supply module present, on, and good. • Amber—Power or fan module off, or failed.
8	HDD1	Indicates activity on the first hard-disk drive: ² <ul style="list-style-type: none"> • Unlit—No hard-disk drive present. • Flashing green—Hard-disk drive activity. • Amber—Hard-disk drive failure.
9	HDD2	Indicates activity on the second hard-disk drive: ² <ul style="list-style-type: none"> • Unlit—No hard-disk drive present. • Flashing green—Hard-disk drive activity. • Amber—Hard-disk drive failure.

1. OIR is not available at this time.

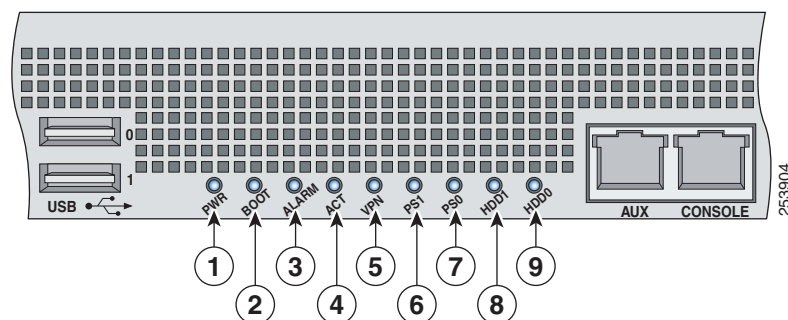
2. The hard-disk drives are only supported on the ASA CX and FirePOWER SSPs.

Back Panel: ASA 5585-X

Figure 1-5 shows the back panel features.

Figure 1-5 ASA 5585-X Back Panel Features

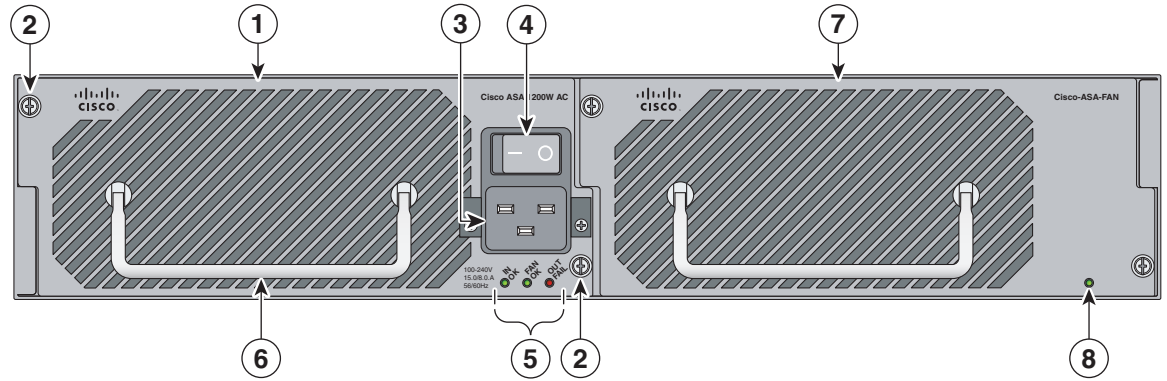

1	Power supply module (corresponds to PS1 indicator)	2	Power supply module/fan module removal screws
3	Power supply module plug	4	On/Off rocker switch for power supply module
5	Power supply module indicators	6	Power supply module or fan module handle
7	Fan module	8	Fan module indicator

Back Panel: Power Supply and Fan Modules

Figure 1-6 shows the power supply module indicator lights.

Figure 1-6 ASA 5585-X Power Supply Module and Fan Module Indicator Lights

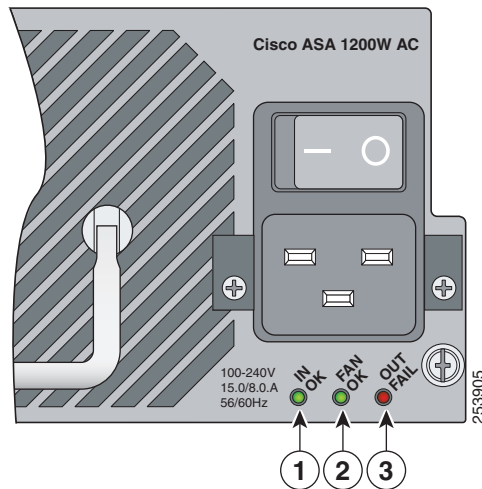

Table 1-3 describes the power supply module and fan module indicator lights.

Table 1-3 Power Supply Module and Fan Module Indicators

	Indicator	Description
1	IN OK	Status of power supply module: <ul style="list-style-type: none"> • Unlit—No AC power cord connected, or AC power switch off. • Green—AC power cord connected and AC power switch on.
2	FAN OK	Status of fan module: <ul style="list-style-type: none"> • Unlit—Fan module failure, or AC power switch off. • Green—AC power cord connected, AC power switch on, and internal fan is running.
3	OUT FAIL	<ul style="list-style-type: none"> • Red—Output voltage failure.¹

1. The power supply module has three output voltages—3.3V, 12V, and 50V.

Specifications

Table 1-4 lists the specifications for the ASA 5585-X.

Table 1-4 ASA-5585-X Specifications

Dimensions and Weight	
Height	3.47 in (8.8 cm).
Width	19 in (48.3 cm).
Depth	26.5 in (67.3 cm).
Weight	<ul style="list-style-type: none"> • 64 lb (29 kg)—ASA5585-S20-K8 with one SSP-20 and one AC power supply module • 70.85 lb (32 kg)—ASA5585-S60-2A-K9 with one SSP-60 and two AC power supply modules • 71.20 lb (32 kg)—ASA5585-S20F20XK9 with one SSP-20, one FirePower SSP-20, and two AC power supply modules • 72.8 lb—ASA5585-S60F60-K9 with one firewall SSP-60, one FirePOWER SSP-60, and two AC power supply modules
Form factor	2 RU, standard 19-inch rack-mountable.
Power	
AC Input	
Rated input voltage (per power supply module)	100 to 240 VAC.
Rated input frequency	50 to 66 Hz.
Rated input power (per power supply module)	1161 W @ 100 VAC. 1598 W @ 200 VAC.
Rated input current (per power supply module)	12A (100 VAC). 8A (200 VAC).

Table 1-4 ASA-5585-X Specifications (continued)

Typical heat dissipation	1280 BTU/hr (1 SSP). 2200 BTU/hr (2 SSPs).
Power supply output steady state (typical)	320 W (1 SSP). 670 W (1 SSP and 1 IPS SSP).
Maximum peak	370 W (1 SSP). 770 W (1 SSP and 1 IPS SSP).
DC Input	
Rated input voltage (per power supply module)	-48 VDC to -60 VDC.
Rated input power (per power supply module)	1353 W @ -48 VDC. 1403 W @ -60 VDC.
Rated input current (per power supply)	33 A.
Maximum heat dissipation	5450 BTU/hr.
Power supply output steady state (typical)	320 W (1 SSP). 670 W (1 SSP and 1 IPS SSP).
Maximum peak	370 W (1 SSP). 770 W (1 SSP and 1 IPS SSP).
Environment	
Temperature	Operating 32 to 104°F (0 to 40°C). Non-operating -40°F to 158°F (-40°C to 70°C).
Airflow	Front to back.
Relative humidity (non-condensing)	Operating 10% to 90%. Non-operating 5% to 95%.
Altitude	Operating 0 to 10,000 ft (3,050 m). Non-operating 0 to 30,000 ft (9,144 m).
Noise	65 dBa max.

Memory Configurations

The ASA 5585-X has up to six DIMM modules per CPU; DIMM population is platform-dependent. Table 1-5 shows the memory configurations.

Table 1-5 ASA 5585-X Memory Configurations

Model	SSP Memory	IPS SSP Memory
ASA 5585-X with SSP-10	6-GB DRAM	6-GB DRAM
ASA 5585-X with SSP-20	12-GB DRAM	12-GB DRAM
ASA 5585-X with SSP-40	12-GB DRAM	24-GB DRAM
ASA 5585-X with SSP-60	24-GB DRAM	48-GB DRAM



Note

The add-on core SSP, IPS SSP, CX SSP, or FirePOWER SSP must be of the same designation level as the originally installed SSP model. For example, if you have the ASA 5585-X SSP-10, you can only install another core SSP-10, an IPS SSP-10, a CX SSP-10, or a FirePOWER SSP-10.

Power Supply Module Requirements

Table 1-6 lists the power supply module requirements for the AC and DC power supply modules.

Table 1-6 Power Supply Module Requirements

AC Power Supply Module	50 V	12 V	3.3 V_STBY
Output Voltage			
Maximum	52.0 V	12.2 V	3.45 V
Nominal	50.0 V	12.0 V	3.35 V
Minimum	48.0 V	11.8 V	3.25 V
Output Current @ 200 VAC			
Maximum	17.3 A	27.0 A	1.5 A
Minimum	0	0	0
Output Current @ 100 VAC			
Maximum	17.3 A	27.0 A	1.5 A
Minimum	0	0	0
DC Power Supply Module	50 V	12 V	3.3 V_STBY
Output Voltage			
Maximum	52.0 V	12.45 V	3.45 V
Nominal	50.0 V	12.0 V	3.35 V
Minimum	48.0 V	12.05 V	3.25 V
Output Current @ -48 VDC			

Table 1-6 Power Supply Module Requirements (continued)

AC Power Supply Module	50 V	12 V	3.3 V_STBY
Maximum	17.3 A	23.0 A	1.5 A
Minimum	0	0	0
Output Current @ -60 VDC			
Maximum	17.3 A	23.0 A	1.5 A
Minimum	0	0	0

SFP/SFP+ Modules

The SFP/SFP+ module is a hot-swappable optical interface that plugs into the SFP/SFP+ ports and provides Gigabit Ethernet connectivity. The SFP and SFP+ modules are optional and not included with the ASA 5585-X; you can purchase them separately. For 1-Gb connectivity, you need the SFP; for 10-Gb connectivity, you need the SFP+. The two ports are the same, but you can only use 10-Gb with lower-model SSPs if you buy the appropriate license; otherwise, the ports are restricted to 1-Gb. The ports are always 10-Gb-enabled for higher-model SSPs (level 40 and above). The interfaces are called TenGigabitEthernet 0/x for the core SSP, and TenGigabitEthernet 1/x for the add-on SSP, whether they are 10-Gb-enabled or not.

Table 1-7 lists the SFP/SFP+ modules that the ASA 5585-X supports.

Table 1-7 SFP/SFP+ Modules

1G SFP Module	
GLC-SX-MM	1000 Base-SX SFP module
GLC-SX-MMD	1000BASE-SX short wavelength with DOM
GLC-LH-SM	1000 Base-LX/LH SFP module
GLC-LH-SMD	1000BASE-LX/LH long-wavelength with DOM.
GLC-EX-SMD	1000 Base-EX SFP module, SMF, 1310nm, with DOM
GLC-T	1000BASE-T standard
10G SFP+ Module	
SFP-10G-ER	10G ER SFP+ module
SFP-10G-SR	10G SR SFP+ module
SFP-10G-LRM	10G LRM SFP+ module
SFP-10G-LR	10G LR SFP+ module
SFP-10G-SR-S	10G SR-S SFP+ module
SFP-10G-LR-S	10G LR-S SFP+ module
SFP-10G-ER-S	10G ER-S SFP+ module
SFP-10G-ZR-S	10G ZR-S SFP+ module
SFP-H10GB-ACU7M	10GBASE-CU SFP+ Cable 7 Meter, active
SFP-H10GB-ACU10M	10GBASE-CU SFP+ Cable 10 Meter, active
SFP-H10GB-CU1M	10GBASE-CU SFP+ cable 1 meter, passive

Table 1-7 SFP/SFP+ Modules (continued)

1G SFP Module	
SFP-H10GB-CU3M	10GBASE-CU SFP+ cable 3 meter, passive
SFP-H10GB-CU5M	10GBASE-CU SFP+ cable 5 meter, passive



Preparing for Installation

This chapter describes the steps to follow before installing new hardware or performing hardware upgrades, and includes the following sections:

- [Installation Preparation, page 2-1](#)
- [Package Contents, page 2-1](#)
- [Safety Recommendations, page 2-2](#)
- [General Site Requirements, page 2-4](#)

Installation Preparation

Follow these steps before installing the Cisco ASA 5585-X:

Review the safety precautions outlined in the *Regulatory Compliance and Safety Information* document at http://www.cisco.com/c/en/us/td/docs/security/asa/hw/regulatory/compliance/asa5585_rcsi.html.

- Step 1** To familiarize yourself with the ASA and related documentation, and where to find them on cisco.com, read *Navigating the Cisco ASA 5500 Series Documentation*.
 - Step 2** Locate and read the release notes for the appropriate software version.
 - Step 3** Unpack the ASA 5585-X and place it on a stable work surface in an ESD-controlled environment.
-

Package Contents

The ASA 5585-X shipping box contains the following items you need to install the device:

- ASA 5585-X chassis
- Documentation
- 2 Yellow Ethernet cables
- Blue console cable PC terminal adapter
- Power cable 120V



Note The ASA 5585-X with SSP-10, SSP-20, and SSP-40 ships with one power supply module installed and one power cable. The ASA 5585-X with SSP-60 ships with two power supply modules installed and two power cables.

- Screws
- Cable management brackets
- Front and rear rack-mount brackets
- Slide rail kit hardware
- Slide rail kit
- System grounding accessory kit with two M4 screws and a grounding lug

Safety Recommendations

This section lists the safety precautions you should take when working with the ASA 5585-X and contains the following topics:

- [Safety Guidelines, page 2-2](#)
- [Maintaining Safety with Electricity, page 2-3](#)
- [Preventing Electrostatic Discharge Damage, page 2-3](#)

Safety Guidelines

Use the following guidelines to help ensure your safety and protect the ASA 5585-X. This list of guidelines may not address all potentially hazardous situations in your work environment, so be alert and exercise good judgment at all times.

- Keep the chassis area clear and dust-free before, during, and after installation.
- Keep tools away from walkways where you and others could trip over them.
- Do not wear loose clothing or jewelry, such as earrings, bracelets, or chains, that could get caught in the chassis.
- Wear safety glasses if you are working under any conditions that might be hazardous to your eyes.
- Do not perform any action that creates a potential hazard to people, or makes the equipment unsafe.
- Never attempt to lift an object that is too heavy for one person.



Note Removing the chassis cover to install a hardware component does not affect your Cisco warranty. Upgrading the ASA 5585-X does not require any special tools, and does not create any radio frequency leaks.

Maintaining Safety with Electricity



Warning

Before working on a chassis, or working near power supplies, unplug all power cords on AC-input units. Statement 246

Follow these guidelines when working on equipment powered by electricity:

- Before beginning procedures that require access to the interior of the chassis, locate the emergency power-off switch for the room in which you are working. Then, if an electrical accident occurs, you can act quickly to turn off the power.
- Do not work alone if potentially hazardous conditions exist anywhere in your work space.
- Never assume that power is disconnected from a circuit; always check the circuit.
- Look carefully for possible hazards in your work area, such as moist floors, ungrounded power extension cables, frayed power cords, and missing safety grounds.
- If an electrical accident occurs, proceed as follows:
 - Use caution; do not become a victim yourself.
 - Disconnect power from the system.
 - If possible, send another person to get medical aid. Otherwise, assess the condition of the victim and then call for help.
 - Determine if the person needs rescue breathing or external cardiac compressions; then take appropriate action.
- Use the ASA 5585-X chassis within its marked electrical ratings and product usage instructions.
- Install the ASA 5585-X in compliance with local and national electrical codes as listed in *Regulatory Compliance and Safety Information*.
- The ASA 5585-X models equipped with AC-input power supplies are shipped with a three-wire electrical cord with a grounding-type plug that fits only a grounding-type power outlet. Do not circumvent this safety feature. Equipment grounding should comply with local and national electrical codes.

Preventing Electrostatic Discharge Damage

Electrostatic discharge (ESD) can damage equipment and impair electrical circuitry. ESD damage occurs when electronic components are improperly handled, and can result in complete or intermittent failures.

- Always follow ESD-prevention procedures when removing and replacing components. Ensure that the chassis is electrically connected to earth ground. Wear an ESD-preventive wrist strap, ensuring that it makes good skin contact. Connect the grounding clip to an unpainted surface of the chassis frame to safely ground ESD voltages. To properly guard against ESD damage and shocks, the wrist strap and cord must operate effectively. If no wrist strap is available, ground yourself by touching the metal part of the chassis.
- For safety, periodically check the resistance value of the anti-static strap, which should be between one and 10 megohms (Mohms).

General Site Requirements

This section describes the requirements your site must meet for safe installation and operation of your ASA 5585-X. This section includes the following topics:

- [Site Environment, page 2-4](#)
- [Preventive Site Configuration, page 2-4](#)
- [Power Supply Considerations, page 2-4](#)
- [Configuring Equipment Racks, page 2-5](#)

Site Environment

Place the chassis on a desktop, or mount it on a rack. The location of the chassis and the layout of the equipment rack or wiring room are extremely important for proper system operation. Devices placed too close together, with inadequate ventilation, and inaccessible panels can cause system malfunctions and shutdowns, and can make the chassis maintenance difficult.

When planning the site layout and equipment locations, keep in mind the precautions described in the next section “[Preventive Site Configuration, page 2-4](#)” to help avoid equipment failures and reduce the possibility of environmentally caused shutdowns. If you are currently experiencing shutdowns or unusually high error rates with your existing equipment, these precautions may help you isolate the cause of failures and prevent future problems.

Preventive Site Configuration

The following precautions will help you plan an acceptable operating environment for the chassis and avoid environmentally caused equipment failures:

- Electrical equipment generates heat. Ambient air temperature might not be adequate to cool equipment to acceptable operating temperatures without adequate circulation. Ensure that the room in which you operate your system has adequate air circulation.
- Always follow the ESD-prevention procedures described previously to avoid damage to equipment. Damage from static discharge can cause immediate or intermittent equipment failure.
- Ensure that the chassis top panel is secure. The chassis is designed to allow cooling air to flow effectively within it. An open chassis allows air leaks, which may interrupt and redirect the flow of cooling air from the internal components.

Power Supply Considerations

The ASA 5585-X has an AC power supply. Observe the following:

- Check the power at the site before installing the chassis to ensure that the power is “clean” (free of spikes and noise). Install a power conditioner, if necessary, to ensure proper voltages and power levels in the source voltage.
- Install proper grounding for the site to avoid damage from lightning and power surges.
- In a chassis equipped with an AC-input power supply, use the following guidelines:
 - The chassis does not have a user-selectable operating range. Refer to the label on the chassis for the correct AC-input power requirements.

- Several styles of AC-input power supply cords are available; make sure you have the correct style for your site.
- Install an uninterruptible power source for your site, if possible.

**Warning**

If you remove a power supply or fan module, replace it immediately to prevent service disruption.

**Caution**

If ASA 5585-X is subjected to environmental overheating, it shuts down and you must manually power it up again by toggling the power switch, or unplugging the power cord and then plugging it back in.

Configuring Equipment Racks

The following tips help you plan an acceptable equipment rack configuration:

- Enclosed racks must have adequate ventilation. Ensure that the rack is not overly congested, because each chassis generates heat. An enclosed rack should have louvered sides and a fan to provide cooling air.
- When mounting a chassis in an open rack, ensure that the rack frame does not block the intake or exhaust ports. If the chassis is installed on slides, check the position of the chassis when it is seated all the way into the rack.
- In an enclosed rack with a ventilation fan in the top, excessive heat generated by equipment near the bottom of the rack can be drawn upward and into the intake ports of the equipment above it in the rack. Ensure that you provide adequate ventilation for equipment at the bottom of the rack.
- Baffles can help to isolate exhaust air from intake air, which also helps to draw cooling air through the chassis. The best placement of the baffles depends on the airflow patterns in the rack. Experiment with different arrangements to position the baffles effectively.



Installing the Cisco ASA 5585-X

This chapter describes how to ground the chassis and install the cables. It contains the following sections:

- [Installation Sequence, page 3-1](#)
- [Establishing the System Ground, page 3-1](#)
- [Connecting Cables to the ASA 5585-X, page 3-5](#)

Installation Sequence

Follow this sequence when installing the ASA 5585-X:

1. Review the preparation directions and safety instructions in [Preparing for Installation, page 2-1](#).
2. Place the ASA 5585-X on a flat, stable surface, or in a rack. Rack mounting instructions are provided in [Installing and Removing a Slide-mounted Chassis, page 4-30](#).
3. Establish the system ground; see the next section, [Establishing the System Ground, page 3-1](#).
4. Connect interface cables to the ASA 5585-X, as described in [Connecting Cables to the ASA 5585-X, page 3-5](#).

Establishing the System Ground

This section describes how to connect the system ground to the ASA 5585-X, and contains the following sections:

- [Requirements, page 3-2](#)
- [Required Tools and Equipment, page 3-2](#)
- [Connecting the System Ground, page 3-3](#)

Requirements

**Note**

The system ground is also referred to as the network-equipment building system-ground.

**Caution**

Installations that rely solely on system grounding using only an AC third-prong ground run a substantially greater risk of equipment problems and data corruption than those installations that use both the AC third-prong ground and a properly installed system ground.

The system ground provides additional grounding for EMI shielding requirements and grounding for the low-voltage supplies (DC to DC converters). You must observe the following system-grounding guidelines for your chassis:

- You must install the system ground connection with any other rack or system power ground connections that you make.
- You must connect both the system ground connection and the DC power-supply ground connection to an earth ground.
- For an ASA5585-X that is equipped with DC-input power supplies, you must install the system ground before you attach the source DC power cables to the DC terminal block. If the ASA5585-X is powered on, you must power it off before attaching the system ground. If you are installing the system ground on an ASA5585-X that is equipped with an AC-input power supplies, you do not need to power off the chassis.

**Note**

In all situations, grounding practices must comply with Section 250 of the National Electric Code (NEC) requirements, or local laws and regulations. A 6 AWG grounding wire is preferred from the chassis to the rack ground, or directly to the common bonding network (CBN). The equipment rack should also be connected to the CBN with 6 AWG grounding wire.

Required Tools and Equipment

To connect the system ground, you will need the following tools and materials:

- Grounding lug—A two-hole standard barrel lug that supports up to 6 AWG wire (supplied as part of the system grounding accessory kit).
- Grounding screws—Two M4 x 8 mm pan-head screws (supplied as part of the system grounding accessory kit).
- Grounding wire—Should be sized according to local and national installation requirements. Depending on the power supply and system, a 12 AWG to 6 AWG copper conductor is required for U.S. installations. Commercially available 6 AWG wire is recommended. The length of the grounding wire depends on the proximity of the switch to proper grounding facilities (not supplied as part of the system grounding accessory kit).
- Number 1 Phillips screwdriver.
- Wire-stripping tool to remove the insulation from the grounding wire.
- Crimping tool to crimp the grounding wire to the grounding lug.

Connecting the System Ground

To attach the grounding lug and cable to the grounding pad, follow these steps:

-
- Step 1** Use a wire-stripping tool to remove approximately 0.75 inch (19 mm) of the covering from the end of the grounding wire.
 - Step 2** Insert the stripped end of the grounding wire into the open end of the grounding lug.
 - Step 3** Crimp the grounding wire in the barrel of the grounding lug and verify that the ground wire is securely attached to the ground lug.
 - Step 4** Locate and remove the adhesive label from the system grounding pad on the back of the chassis. The location of the system grounding pad is on the left-rear side of the ASA5585-X chassis ([Figure 3-1 on page 3-4](#)).

**Caution**

The system ground serves as the primary safety ground for the ASA5585-X chassis that is equipped with DC-input power supplies. You must install the system ground before you attach the source DC power cables to the DC terminal block. If the ASA5585-X chassis is already powered on, we recommend that you remove the source DC from the ASA5585-X chassis before attaching the system ground.

- Step 5** Place the grounding wire lug against the grounding pad, making sure that there is solid metal-to-metal contact.

**Note**

The grounding lug rotates 180 degrees so that you can have the cable coming through the front or the back of the chassis.

- Step 6** Secure the grounding lug to the chassis with two M4 screws (Figure 3-1). Make sure that the grounding lug and the grounding wire do not interfere with other hardware or rack equipment.

Figure 3-1 Attaching the Grounding Lug to the Chassis

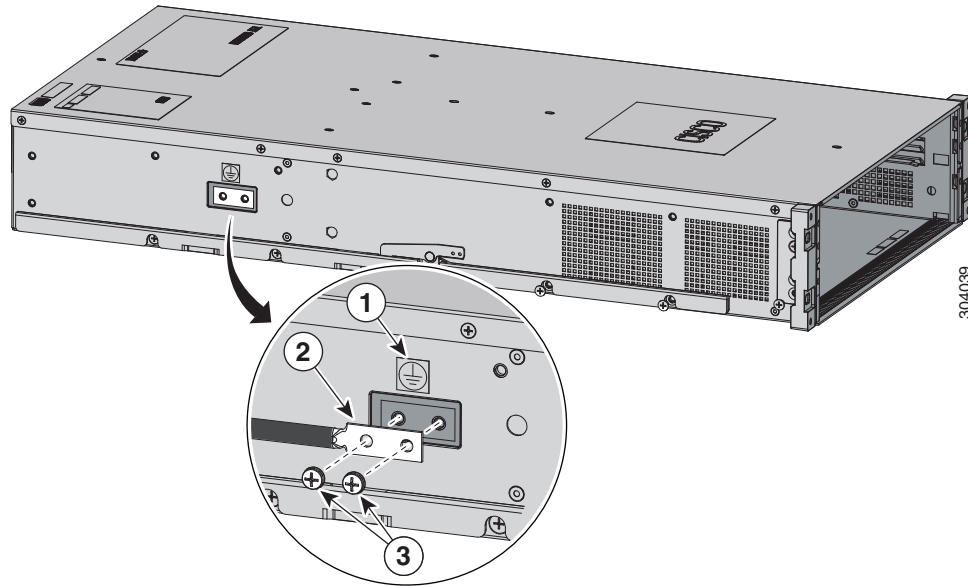

1	Ground symbol label	2	Ground lug
3	M4 screws		

- Step 7** Prepare the other end of the grounding wire, and connect it to an appropriate grounding point in your site to ensure adequate earth ground for the switch.

ASA 5585-X Cables

The ASA 5585-X supports use of the following cables:

- For the Ethernet ports, you can use either straight-through or cross-over twisted-pair cables since all RJ-45 Ethernet ports support MDI/MDIX.



Note Auto-MDI/MDIX refers to the ability of the PHY associated with a given port to sense and automatically switch (if required) the transmit and receive signaling across a twisted-pair RJ-45 cable, thereby eliminating the need for special (for example, cross-over) cables based on the connecting port.

- The management port is a 10/100/1000-Mbps Ethernet port with an RJ-45 connector. You can use a modular, RJ-45, straight-through UTP cable to connect the management port to an external hub, switch, or router. You also can use cross-over twisted-pair cables since the ports also support MDI/MDIX.

- The console and auxiliary ports are serial ports and require the use of a flat rollover cable for terminal server connectivity (and a DB9 connector for connection to a PC).
- The ASA 5585-X supports 10/100/1000 BaseT Ethernet ports. You must use at least a Category 5RJ-45 RJ-45 cable for 100/1000Base-TX operations. You can use a Category 3 cable for RJ-45 10 Base-TX operations.

Connecting Cables to the ASA 5585-X

The ASA 5585-X has two dedicated Gigabit Ethernet interfaces for device management that are called Management 0/0 and Management 0/1. The management interfaces are similar to the console port, because they only accept traffic that is destined to-the-box (versus traffic that is through-the-box).

If you install an add-on SSP, you can connect a cable to the SSP's Management 1/0 port to have remote management and monitoring of the SSP. It is not required, but if you do not connect to the Management 1/0 port, you will have to session into the SSP from the ASA 5585-X to gain access to it. Without directly connecting to the SSP, you cannot manage or monitor it over the network.

Depending on your configuration, you can configure any interface to be a management-only interface using the **management-only** command. You can also disable management-only configuration mode on the management interface. For more information about this command, see the **management-only** command in the *Cisco ASA 5580 Adaptive Security Appliance Command Reference*.



Caution

Be sure the chassis is grounded before connecting the cables.

To connect the ASA 5585-X cables to the network interfaces, follow these steps:

Step 1

Connect to the management interface, Management 0/0.

- Locate an Ethernet cable which has an RJ-45 connector on each end.
- Connect one RJ-45 connector to the Management 0/0 interface.

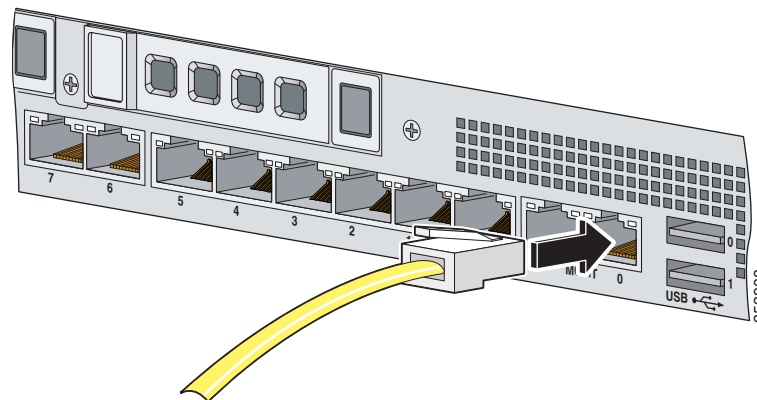

- Connect the other end of the Ethernet cable to the Ethernet port on your computer, or to your management network.

**Caution**

Management and console ports are privileged administrative ports. Connecting them to an untrusted network can create security issues.

Step 2

(Optional) Connect to the SSP console port if you want to connect to a computer to enter configuration commands.

- a. Before connecting a computer or terminal to any ports, determine the baud rate of the serial port. The baud rate of the computer or terminal must match the default baud rate (9600 baud) of the console port of the SSP.

Set up the terminal as follows: 9600 baud (default), 8 data bits, no parity, 1 stop bits, and Flow Control (FC) = Hardware.

**Note**

The console port settings are the same for all SSPs.

- b. Connect the RJ-45 to the console port and connect the other end to your computer.

Step 3

(Optional) Connect to the SFP/SFP+ port(s) if you are using fiber-optic cables.

The ASA 5585-X SSP-10 and SSP-20 have two SFP/SFP+ ports. The ASA 5585-X SSP-40 and SSP-60 have four SFP/SFP+ ports.

If you are using the fiber ports, you need an SFP+ transceiver module for 10-Gigabit Ethernet (a license may be required), or an SFP transceiver module for 1-Gigabit Ethernet (SFP and SFP+ transceiver modules are not included).

- a. Install a SFP/SFP+ transceiver module.

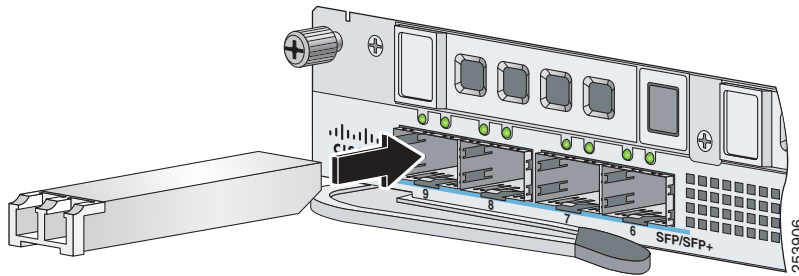

- b. Connect one end of the LC cable to the SFP/SFP+.

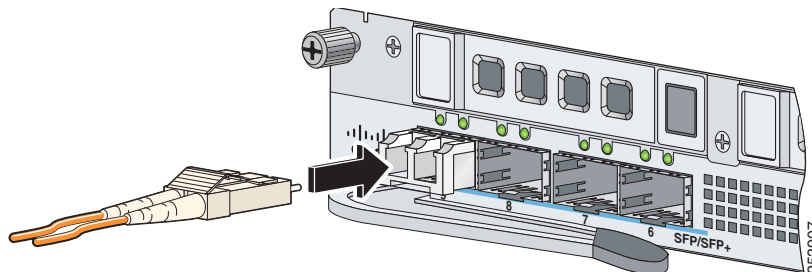

- c. Connect the other end of the LC cable to a network device, such as a router or switch.

Step 4 Install the electrical cables.

- a. Attach the power cable to the power supply module on the back of the ASA 5585-X.

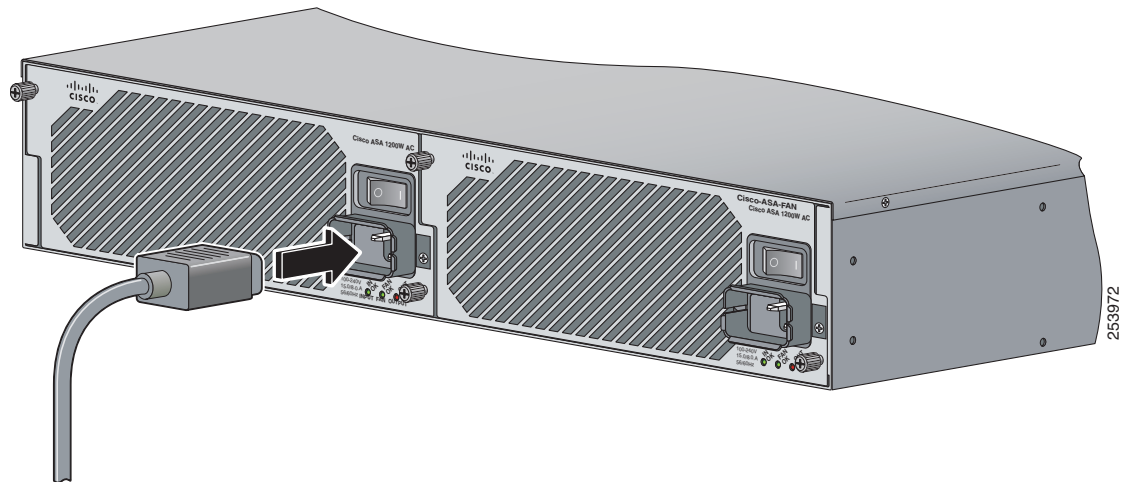

- b. If you have redundant power supply modules, you must connect both power cables to the back of the ASA 5585-X.

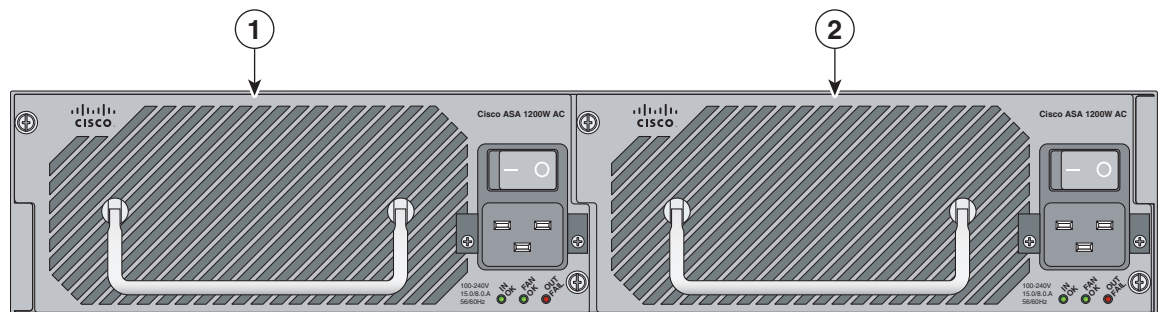

1	Power supply module (PS0)	2	Power supply module (PS1)
----------	---------------------------	----------	---------------------------

- c. Plug the power cable(s) in to a power source (we recommend a UPS).

Step 5 Power on the ASA 5585-X.**Caution**

If the appliance is subjected to environmental overheating, it shuts down and you must manually power cycle it to turn it on again.

- Step 6** Check the PWR indicator on the front panel of the ASA 5585-X to verify interface connectivity. It should be green. To verify power supply operation, check the PS0 and PS1 indicators on the front panel. They should be green. On the back panel of the ASA 5585-X, make sure the IN OK and the FAN OK indicators are green and the OUT FAIL indicator is off.



Maintenance and Upgrade Procedures

This chapter describes maintenance and upgrade procedures, and includes the following sections:

- [Removing and Installing SSPs, page 4-1](#)
- [Removing and Installing SSP Hard Disk Drives, page 4-4](#)
- [Installing and Removing Cisco ASA 5585-X Network I/O Modules, page 4-5](#)
- [Removing and Installing the Power Supply Module, page 4-11](#)
- [Removing and Installing the Fan Module, page 4-27](#)
- [Installing a Slide Rail Kit, page 4-29](#)
- [Installing and Removing a Slide-mounted Chassis, page 4-30](#)
- [Mounting the Chassis Using a Fixed Rack Mount, page 4-39](#)
- [Installing the Cable Management Brackets, page 4-41](#)
- [Troubleshooting Loose Connections, page 4-43](#)

Removing and Installing SSPs

The ASA 5585-X comes with a core Security Services Processor (SSP) already installed (SSP-10, SSP-20, SSP-40, or SSP-60). You can install an additional SSP (core SSP, IPS SSP, ASA CX SSP, or FirePOWER SSP) in slot 1.

For a matrix describing which module configurations are allowed, see the [ASA Module Compatibility](#) table.



Note

Feature limitations may apply to dual SSPs. Refer to your configuration guide for more information.

The add-on SSP will not run without the core SSP installed. The add-on SSP must be installed in the upper slot (slot 1), with the core SSP in the bottom slot (slot 0). You must power off the ASA 5585-X to remove and install SSPs; the SSPs are not hot-swappable.

To install and remove an add-on SSP in the ASA 5585-X, follow these steps:

- Step 1** If you are replacing an existing SSP, shut it down first by entering the following CLI command; otherwise continue with [Step 3](#):

```
asa# hw-module module 1 shutdown
Shutdown module in slot 1? [confirm]
```



Note The core SSP resides in slot 0 (the bottom slot) while any additional SSP resides in slot 1 (the top slot).

- Step 2** Press **Enter** to confirm.
- Step 3** Save the running config before powering off the ASA 5585-X or the configuration will be lost. Enter the following CLI command:

```
asa# write memory
```

If you are using a management application such as ASDM or CSM to manage this ASA 5585-X, you also can use that application to save the configuration.

- Step 4** Power off the ASA 5585-X.
- Step 5** Remove the power cable from the ASA 5585-X.
- Step 6** If you are installing an add-on SSP for the first time, loosen the captive screws on the upper left and right of the slot tray (slot 1), and remove it. Store it in a safe place for future use. If you are replacing an existing SSP, continue with [Step 10](#).

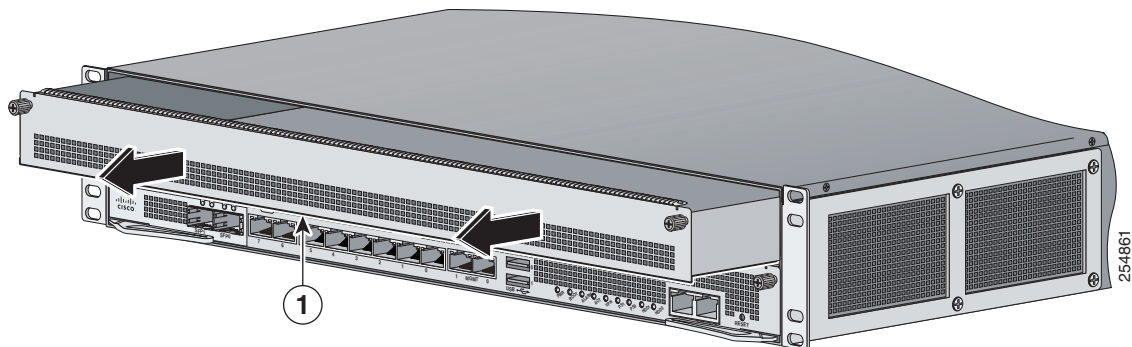

1	Slot tray		
----------	-----------	--	--



Caution You must install slot trays in all empty slots to maintain the proper air flow. This also prevents EMI, which can disrupt other equipment.

- Step 7** On the front panel of the ASA 5585-X, loosen the captive screws from either the top slot (for the add-on SSP), or bottom slot (for the core SSP).

Step 8 Grasp the ejection levers at the left and right bottom of the module slot and pull them out.

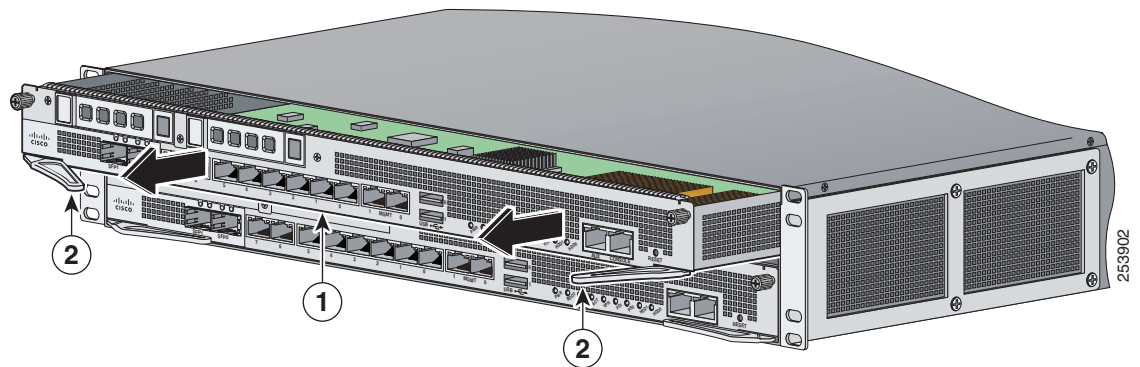

1	Module	2	Ejection levers
----------	--------	----------	-----------------

Step 9 Grasp the sides of the module and pull it all the way out of the chassis.

Step 10 Install the new module by lining it up with the slot, first ensuring the ejection levers are extended.

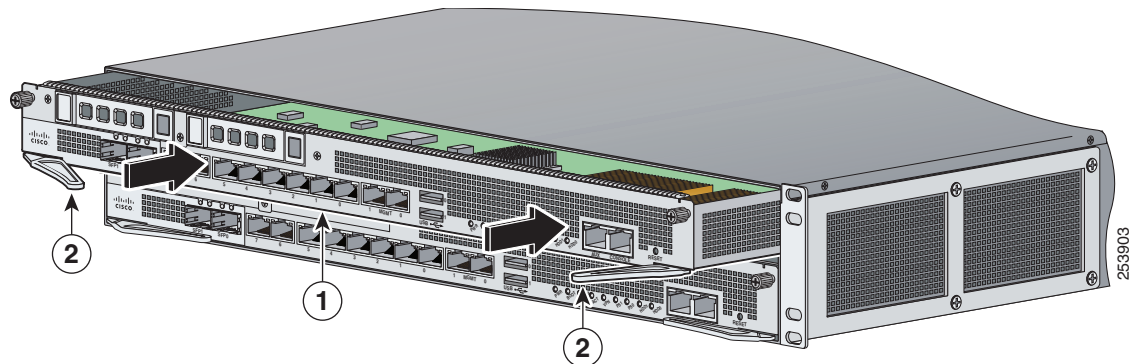

1	Module	2	Ejection levers
----------	--------	----------	-----------------

Step 11 Slide the module into the slot until it is seated and then push the ejection levers into place.

Step 12 Insert and tighten the captive screws.

Step 13 Reconnect the power cable to the ASA 5585-X.

Step 14 Power on the ASA 5585-X.

Step 15 Press **Enter** to confirm.

Step 16 Verify that the PWR indicator on the front panel is green.

Removing and Installing SSP Hard Disk Drives

The CX or FirePOWER SSP resides in slot 1 (the top slot) of the Cisco ASA 5585-X. The SSP includes two hard disk drives in a RAID 1 configuration. If one of the hard disk drives fails, you can remove and install a replacement.

Note

Make sure that you replace the SSP hard disk drives with Cisco-approved hard disk drives.

Each hard disk drive is hot-swappable. The hard disk drive resides in a carrier, which you install into the SSP's hard disk drive bay. You can use the hard disk drive with an AC or DC power supply. Each hard disk drive is shipped in a carrier, as shown in [Figure 4-1](#).

Figure 4-1 SSP Hard Disk Drive in Carrier

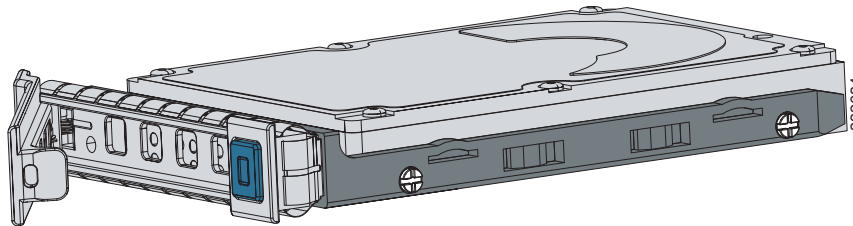
Caution

Make sure that you replace the failed hard disk drive as soon as possible; otherwise, if the remaining hard disk drive fails, all data is lost.

To remove and install a hard disk drive in the SSP, follow these steps:

- Step 1** From the front panel of the SSP, remove the hard disk drive by pressing the button on the right side of the bay until the locking lever is released. Pull out the hard disk drive.

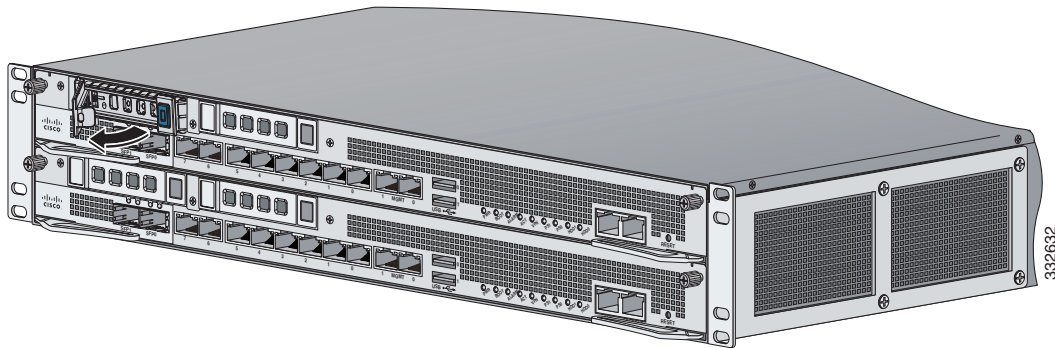

- Step 2** On the front panel of the SSP, line up the hard disk drive carrier with the hard disk drive bay and push it in until it is seated. Push the locking lever into place.

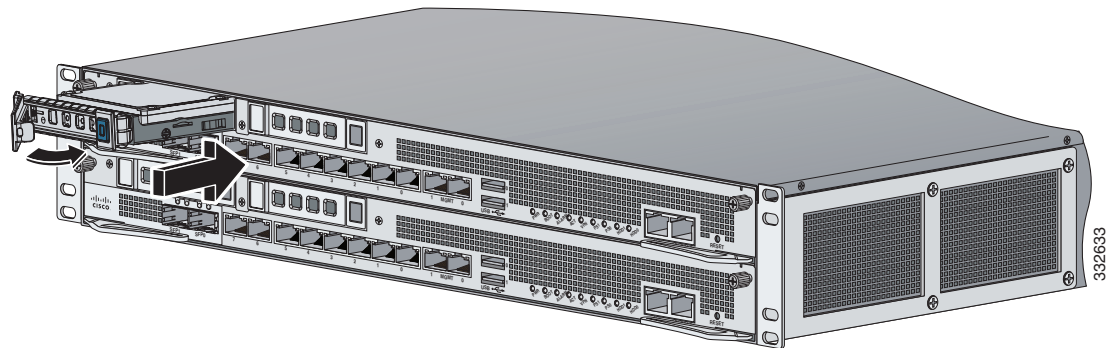

- Step 3** On the front panel of the SSP, ensure the HDD1 (left hard disk drive) and HDD0 (right hard disk drive) indicators are flashing green to indicate that the drives are active.

Installing and Removing Cisco ASA 5585-X Network I/O Modules

The ASA 5585-X comes with a core Security Services Processor (SSP-10, SSP-20, SSP-40, or SSP-60) already installed in slot 0. You can install one or two of the following optional network I/O modules in slot 1, which you divide into two slots using the accompanying slot divider:

- Cisco ASA 5585-X 4-port 10-G Network I/O Module
- Cisco ASA 5585-X 8-port 10-G Network I/O Module
- Cisco ASA 5585-X 20-port 1-G Network I/O Module

The network I/O module is not hot-swappable, so you must power off the ASA 5585-X before installing or removing the module. You must have a Phillips head screwdriver to install the slot divider that divides slot 1 into two bays.

The ports are numbered right to left, with port 0 being the far right port and the far left port is either port 3, 7, or 19 depending on whether you have a 4-, 8-, or 20-port module. The 20-port numbers go from top to bottom, and right to left. For slot 1 (top right slot), the interface is named TenGigabitEthernet 1/0 through TenGigabitEthernet 1/3. For slot 2 (top left slot) the interface is named TenGigabitEthernet 2/0 through TenGigabitEthernet 2/7.

Figure 4-2 shows the port numbering for the 4-port network I/O module.

Figure 4-2 4-Port Network I/O Module Port Numbering

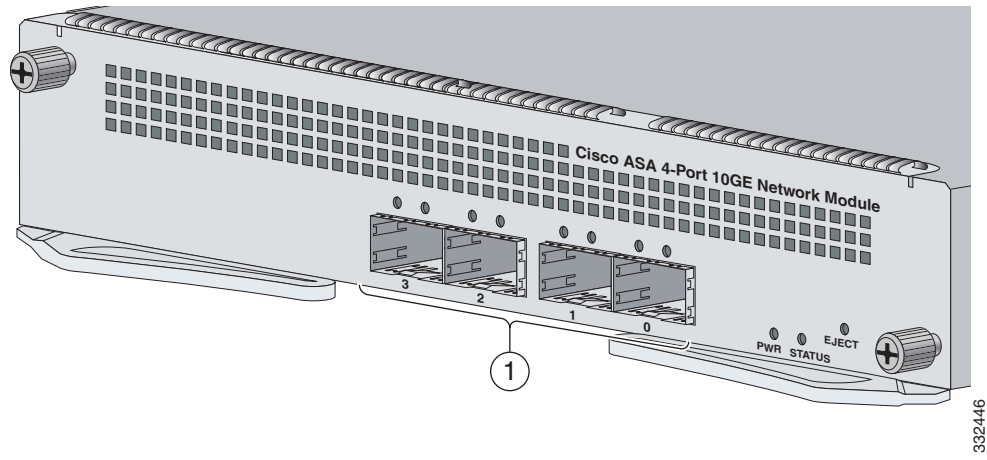

1	TenGigabitEthernet 00 through 03	
----------	----------------------------------	--

Figure 4-3 shows the port numbering for the 8-port network I/O module.

Figure 4-3 8-Port Network I/O Module Port Numbering

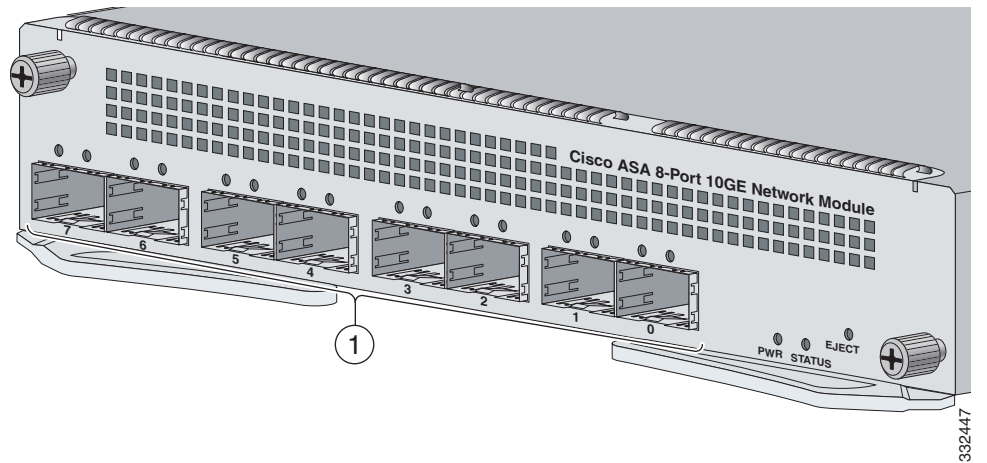

1	TenGigabitEthernet 00 through 07	
----------	----------------------------------	--

Figure 4-4 shows the port numbering for the 20-port network I/O module. For slot 0, the interface is named GigabitEthernet 0/0 through GigabitEthernet 0/19.

Figure 4-4 20-Port Network I/O Module Port Numbering

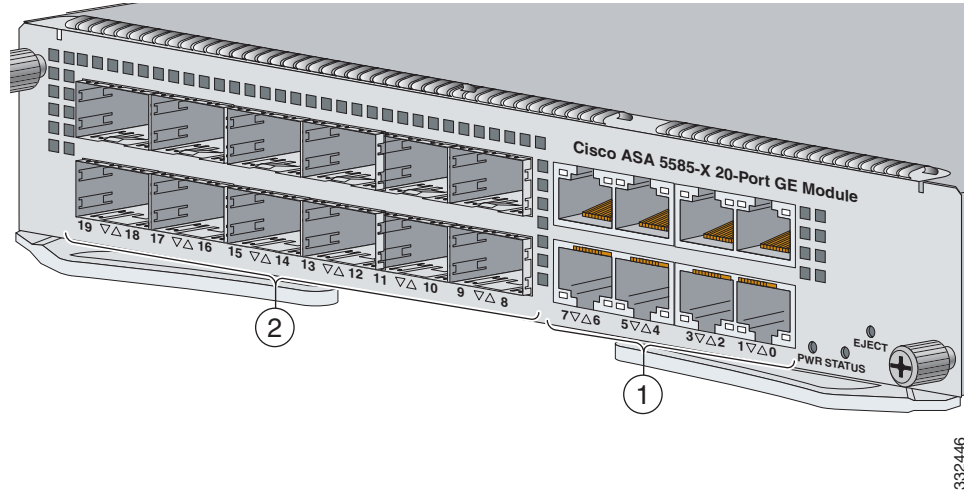

1	GigabitEthernet 00 through 07	2	GigabitEthernet 08 through 19
----------	-------------------------------	----------	-------------------------------

Caution

Be sure the ASA software version installed on your ASA 5585-X supports the network I/O modules and the accompanying SFP/SFP+ transceivers. Refer to [Cisco ASA Compatibility](#) for more information.

Table 4-1 lists the SFP/SFP+ transceiver modules supported by the ASA 5585-X.

Table 4-1 SFP/SFP+ Transceiver Modules

1G SFP Module	
GLC-SX-MM	1000 Base-SX SFP module
GLC-SX-MMD	1000BASE-SX short wavelength, with DOM
GLC-LH-SM	1000 Base-LX/LH SFP module
GLC-LH-SMD	1000BASE-LX/LH long-wavelength, with DOM
GLC-EX-SMD	1000 Base-EX SFP module, SMF, 1310nm, DOM
GLC-T	1000BASE-T standard
10G SFP+ Module	
SFP-10G-ER	10G ER SFP+ module
SFP-10G-SR	10G SR SFP+ module
SFP-10G-LRM	10G LRM SFP+ module
SFP-10G-LR	10G LR SFP+ module
SFP-H10GB-ACU7M	10GBASE-CU SFP+ Cable 7 Meter, active
SFP-H10GB-ACU10M	10GBASE-CU SFP+ Cable 10 Meter, active

Table 4-1 SFP/SFP+ Transceiver Modules (continued)

1G SFP Module	
SFP-H10GB-CU1M	10GBASE-CU SFP+ cable 1 meter, passive
SFP-H10GB-CU3M	10GBASE-CU SFP+ cable 3 meter, passive
SFP-H10GB-CU5M	10GBASE-CU SFP+ cable 5 meter, passive

**Note**

These SFP+ modules require ASA 8.2.5 or later: SFP-10G-LRM, SFP-10G-LR, SFP-H10GB-CU1M, SFP-H10GB-CU3M, and SFP-H10GB-CU5M.

**Note**

Only SFP/SFP+ transceiver modules certified by Cisco are supported on the ASA 5585-X.

**Caution**

Protect your SFP/SFP+ transceivers by inserting clean dust plugs into the SFP/SFP+ modules after extracting cables from them. Be sure to clean the surfaces of the fiber-optic cables before you plug them back into the optical bores of another SFP/SFP+ module. Avoid getting dust and other contaminants into the optical bores of your SFP/SFP+ modules. The cables do not operate correctly when obstructed with dust.

**Warning**

Because invisible laser radiation may be emitted from the aperture of the port when no cable is connected, avoid exposure to laser radiation and do not stare into open apertures. Statement 70

To install a 4-, 8-, or 20-port network I/O module and related SFP/SFP+ transceivers into the ASA 5585-X:

Step 1 Power off the security appliance.

**Caution**

Network I/O modules are not hot-swappable.

Step 2 Locate a grounding strap, and fasten it to your wrist so that it contacts bare skin. Attach the other end to the chassis.

Step 3 Loosen the captive screws on the upper left and right of the top slot tray (slot 1), and remove it (Figure 4-5). Store it in a safe place for future use.

**Caution**

You must install slot covers on all empty slots to maintain the proper air flow. This also prevents EMI, which can disrupt other equipment.

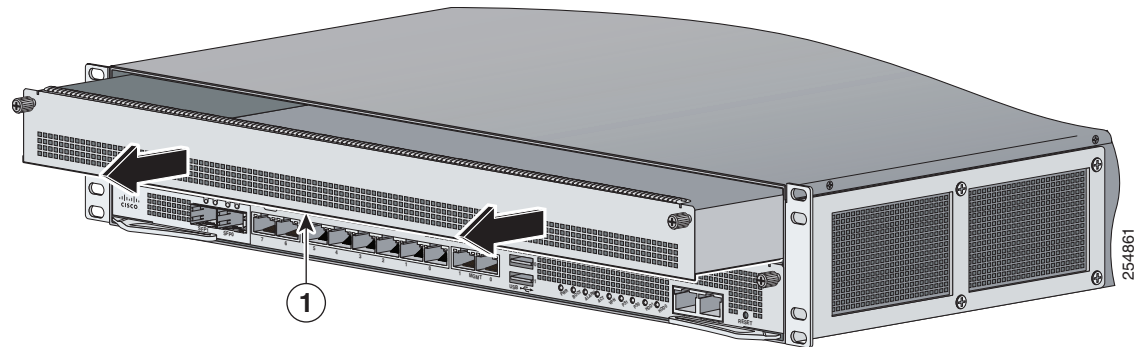
Figure 4-5 Removing the Empty Slot Tray

1	Empty slot tray		
----------	-----------------	--	--

- Step 4** Install the slot divider in the middle of slot 1 by lining up the groove on the top of the slot divider with the inside track on the top of the security appliance and sliding it in until it is seated. Tighten the captive screw with a Phillips head screwdriver ([Figure 4-6](#)).

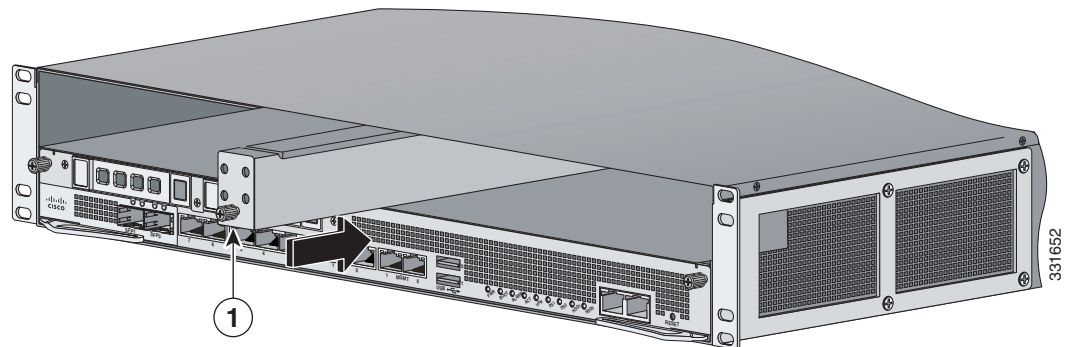
Figure 4-6 Installing the Slot Divider

1	Slot divider with captive screw		
----------	---------------------------------	--	--

- Step 5** Install a network I/O module by lining it up with either the left or the right bay of slot 1, making sure the ejection levers are extended ([Figure 4-7](#) and [Figure 4-8](#) on page 4-10).

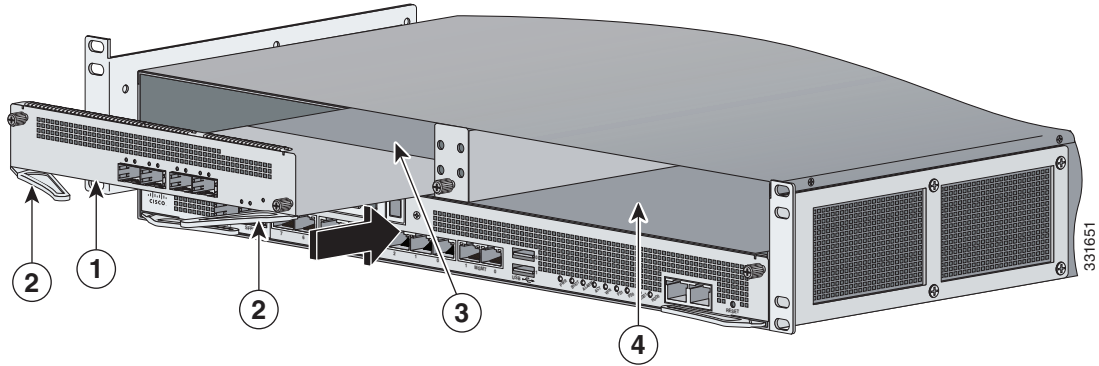
Figure 4-7 Installing a 4- or 8-Port 10-G Network I/O Module

1	4- or 8-port 10-G network module	2	Ejection levers
3	Slot 2 left bay	4	Slot 1 right bay

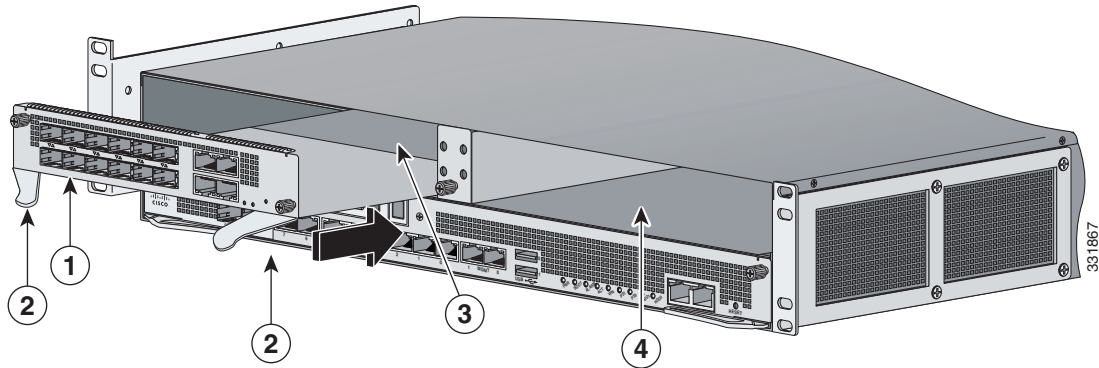
Figure 4-8 Installing a 20-Port 1-G Network I/O Module

1	20-port 1-G network I/O module	2	Ejection levers
3	Slot 2 left bay	4	Slot 1 right bay

- Step 6** Slide the network module into the slot until it is seated and push the ejection levers back into place.
- Step 7** With your fingers, tighten the captive thumb screws.
- Step 8** If you are installing only one network I/O module, install a slot cover on the empty slot bay to protect it.

**Caution**

You must install slot covers on all empty slots to maintain the proper air flow. This also prevents EMI, which can disrupt other equipment.

- Step 9** Install a SFP/SFP+ transceiver by aligning it with the I/O module port and sliding it into the port slot until it locks into position (Figure 4-9).

**Caution**

Do not remove the optical port plugs from the SFP/SFP+ until you are ready to connect the cabling.

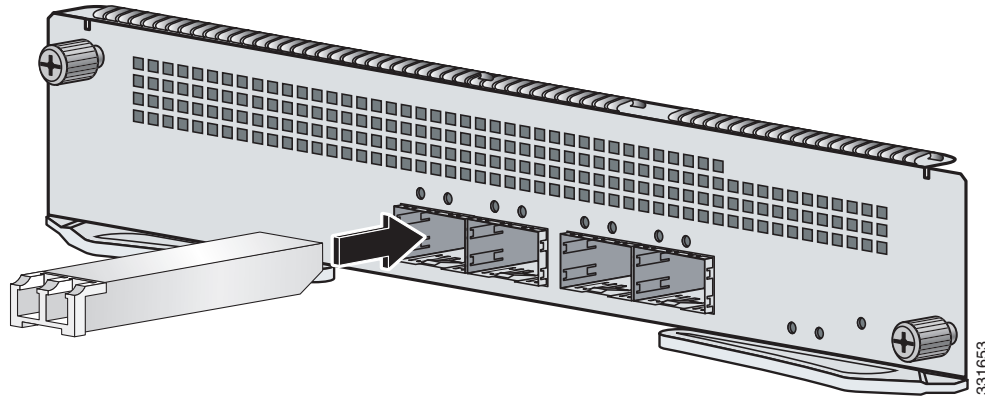
Figure 4-9 Installing the SFP/SFP+ Transceiver

- Step 10** Remove the optical port plug, and then connect one end of an LC cable to the SFP/SFP+ transceiver module (Figure 4-10).

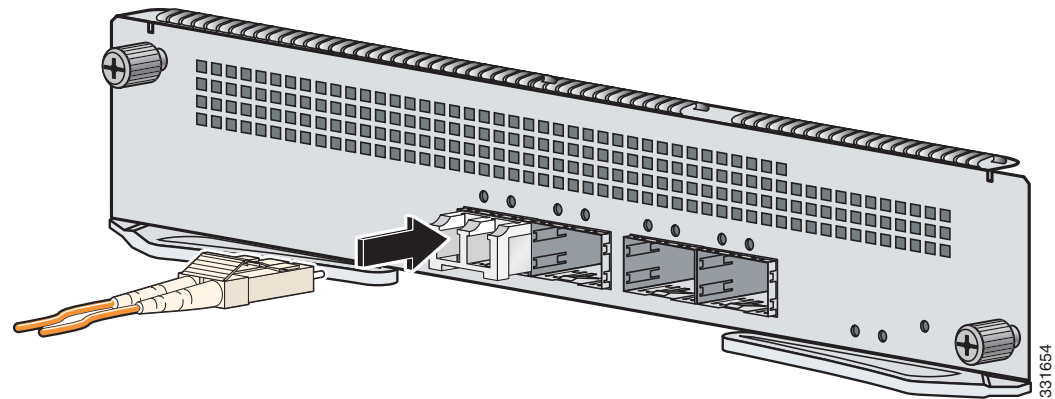
Figure 4-10 Connecting the LC Cable

- Step 11** Connect the other end of the LC cable to a network device, such as a router or a switch.
- Step 12** After connecting all necessary cables, power on the security appliance.
- Step 13** Verify that the PWR indicator on the front panel is green.

Removing and Installing the Power Supply Module

This section describes how to remove and install power supply modules in the ASA 5585-X, and includes the following topics:

- [AC/DC Power Supply Module Configurations, page 4-12](#)
- [AC Power Supply Module, page 4-12](#)
- [Removing and Installing an AC Power Supply Module, page 4-13](#)
- [DC Power Supply Module, page 4-16](#)
- [Installing the DC Power Supply Module, page 4-17](#)

- [Connecting DC Power to the ASA 5585-X](#), page 4-19
- [Removing the DC Power Supply Module](#), page 4-24

AC/DC Power Supply Module Configurations

Table 4-2 lists the AD/DC power supply module configurations for the ASA 5585-X.

Table 4-2 ASA 5585-X AC/DC Power Supply Module Configurations

Model	AC Configuration		DC Configuration
	Option 1	Option 2	Only Option
SSP-10	Two AC power supply modules	One AC power supply module One fan module	Two DC power supply modules
SSP-20	Two AC power supply modules	One AC power supply module One fan module	Two DC power supply modules
SSP-40	Two AC power supply modules	One AC power supply module One fan module	Two DC power supply modules
SSP-60	Two AC power supply modules	N/A	Two DC power supply modules

AC Power Supply Module

The ASA 5585-X ships with one AC power supply module and one fan module installed, except for the ASA 5585-X with SSP-60, which ships with two AC power supply modules installed in a load balancing/sharing configuration. The load balancing/sharing configuration ensures that if one power supply module fails, the other power supply module assumes the full load until the failed power supply module is replaced. To maintain airflow, both bays must be populated by either an AC power supply module and a fan module, or two AC power supply modules.

You can replace the fan module with a second AC power supply module in any of these models to create a redundant power-supply configuration. If you already have two AC power supply modules installed, you can install or replace either power supply module without powering off the appliance, as long as one power supply module is active and functioning correctly.

If only one power supply module is installed, do not remove the power supply module unless the appliance has been powered off. Removing the only operational power supply module causes an immediate power loss.



Note

Only the ASA 5585-X with SSP-60 supports either two AC or two DC power supply modules. Do not mix AC and DC power supply modules in the same chassis.

Figure 4-11 shows the AC power-supply module indicator lights.

Figure 4-11 AC Power Supply Module Indicator Lights

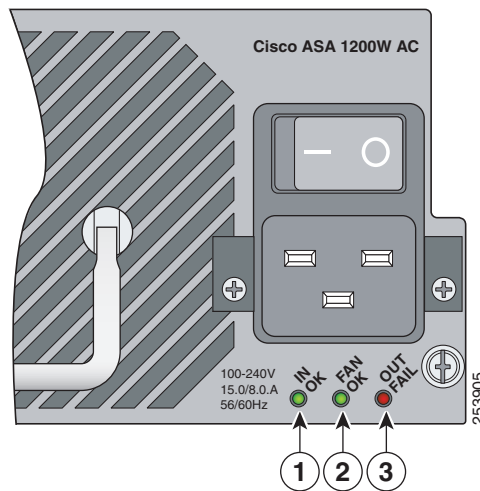

Table 4-3 describes the AC power supply module indicators.

Table 4-3 AC Power Supply Module Indicators

Figure Label	Indicator	Description
1	IN OK	Status of the power supply module: <ul style="list-style-type: none"> Off—No AC power cord connected, or AC power switch is off. Green—AC power cord connected and AC power switch is on.
2	FAN OK	Status of the fan module <ul style="list-style-type: none"> Off—Fan module failure, or AC power switch is off. Green—AC power cord connected, AC power switch is on, and internal fan is running.
3	OUT FAIL	<ul style="list-style-type: none"> Red—Output voltage failure¹

1. The power supply module has three output voltages—3.3V, 12V, and 50V.

Removing and Installing an AC Power Supply Module



Caution

If you remove a power supply or fan module, replace it immediately to prevent disruption of service.



Caution

If the appliance is subjected to environmental overheating, it shuts down and you must manually power cycle it to turn it on again.

**Caution**

To remove and install a power supply module, follow these steps:

- Step 1** If you are removing the only power supply module, power off the security appliance.
- Step 2** From the back panel of the security appliance, unplug the power supply module cable.
- Step 3** On the back of the security appliance, loosen the captive screws from the power supply module (Figure 4-12).

Figure 4-12 Removing the AC Power Supply Module

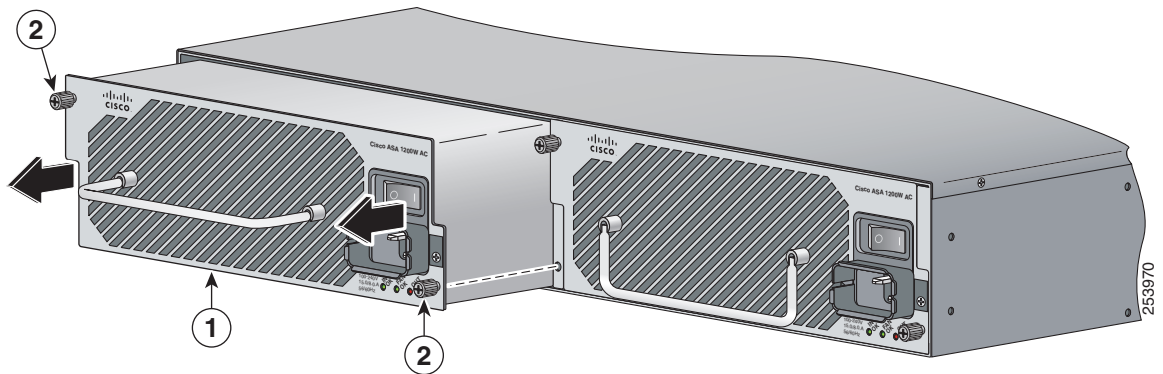

1	Power supply module and power supply module handle	2	Power supply module screws
----------	--	----------	----------------------------

- Step 4** Remove the power supply module by grasping the handle and pulling the power supply module away from the chassis.

Step 5 Install the new power supply module by aligning it with the power supply module bay and pushing it into place until it is seated (Figure 4-13).

Figure 4-13 Installing the AC Power Supply Module

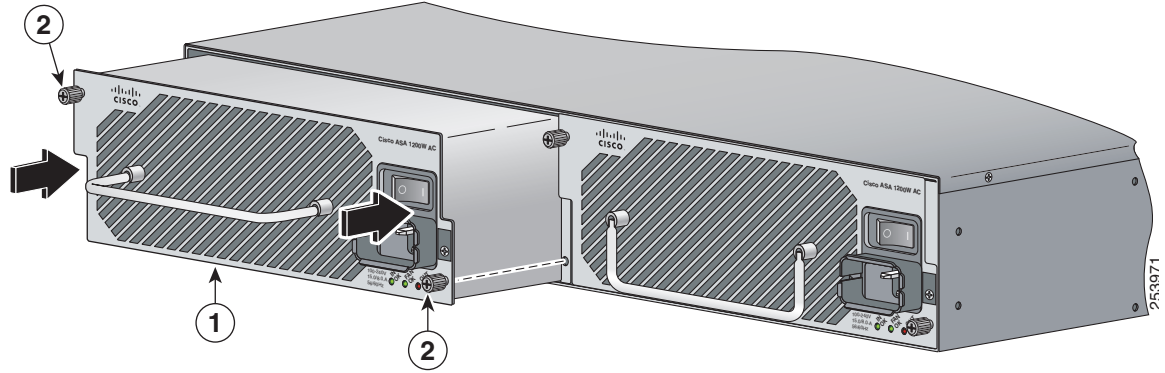

1	Power supply module and power supply module handle	2	Power supply module screws
----------	--	----------	----------------------------

Step 6 Tighten the captive screws.

Step 7 Reconnect the power cable. If you are installing two power supply modules for a redundant configuration (Figure 4-14), plug each one into a power source—we recommend a UPS.

Figure 4-14 PS0 and PS1

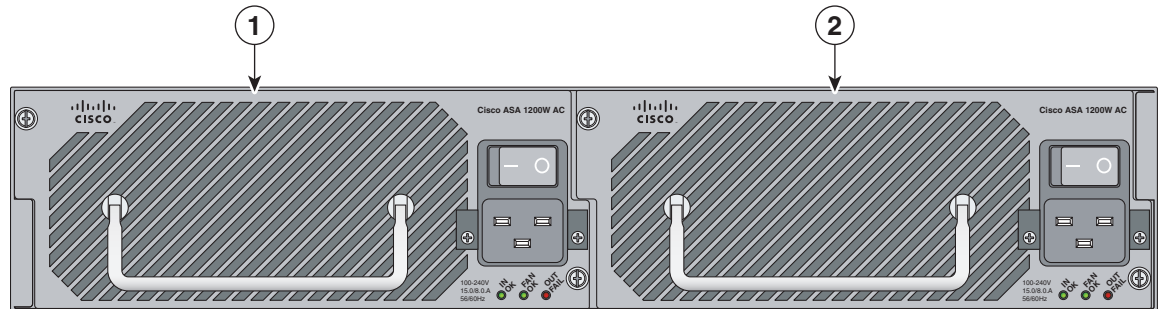

1	Power supply module (PS0)	2	Power supply module (PS1)
----------	---------------------------	----------	---------------------------

Step 8 If you had to power off the security appliance because you are removing and replacing the only power supply module, power it back on.

Step 9 Check the PS0 and PS1 indicators on the front panel to make sure they are green. On the back panel of the security appliance, make sure the IN OK and the FAN OK indicators are green and the OUT FAIL indicator is off (see Figure 4-11 and Table 4-3).

DC Power Supply Module

The ASA 5585-X ships with two DC power-supply modules installed in a load balancing/sharing configuration. This is the only supported DC power-supply module configuration. The load balancing/sharing configuration ensures that if one DC power supply module fails, the other DC power supply module assumes the full load until the failed power-supply module is replaced. To maintain air flow, both bays must be populated by two DC power-supply modules.

You can install or replace either power-supply module without powering off the appliance, as long as one power-supply module is active and functioning correctly.

Note

Only the ASA 5585-X SSP-60 supports either two AC or two DC power-supply modules. Do not mix AC and DC power-supply modules in the same chassis.

Figure 4-15 shows the DC power-supply module indicator lights and power-switch labels.

Figure 4-15 DC Power Supply Module Indicator Lights and Power Switch Labels

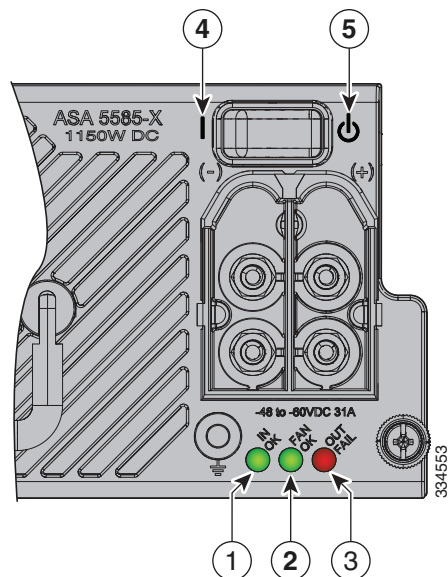

Table 4-4 describes the DC power-supply module indicators and power-switch position labels.

Table 4-4 DC Power Supply Module Indicators

Figure Label	Indicator	Description
1	IN OK	Status of power-supply module: <ul style="list-style-type: none"> • Unlit—No DC power cables connected, or DC power switch is off. • Green—DC power cables connected and DC power switch is on.
2	FAN OK	Indicates status of fan module <ul style="list-style-type: none"> • Unlit—Fan module failure, or DC power switch is off. • Green—DC power cables connected, DC power switch is on, and internal fan is running.
3	OUT FAIL	<ul style="list-style-type: none"> • Red—Output voltage failure¹
4	ON	<ul style="list-style-type: none"> • When this side of power switch is depressed, power is on.
5	STANDBY	<ul style="list-style-type: none"> • When this side of power switch is depressed, device is in stand-by mode.

1. The power-supply module has three output voltages—3.35 V, 12.5 V, and 50 V.

Installing the DC Power Supply Module

The DC power-supply module has a 1150-W output with three DC voltage outputs of 50 V, 12.25 V, and 3.35 V. The module operates between -40.5 to -72 VDC. The power-supply module shares current on the 50V and 12.25 V outputs, and can only be used in a dual (redundant) hot-pluggable configuration. The DC power-supply module operates from a single 40 A DC input circuit with at full output load of 1150 W, -40.5 VDC input, and does not exceed 33 A.

To install a DC power-supply module in the ASA 5585-X, follow these steps:

- Step 1** Remove existing modules from the appliance:
- a. If you are replacing AC power with DC power, remove both modules from the appliance (fan module and power supply module, or both power supply modules) as shown in Step 1 through Step 4 in [Removing and Installing an AC Power Supply Module, page 4-13](#). Continue with Step 2.
 - b. If you are replacing a failed DC power-supply module with a new DC power-supply module, follow the steps in [Removing the DC Power Supply Module, page 4-24](#), and then continue with Step 2.

- Step 2** Install the new power-supply module by aligning it with the power-supply module bay and pushing it into place until it is seated (Figure 4-16).

Figure 4-16 Installing the DC Power Supply Module

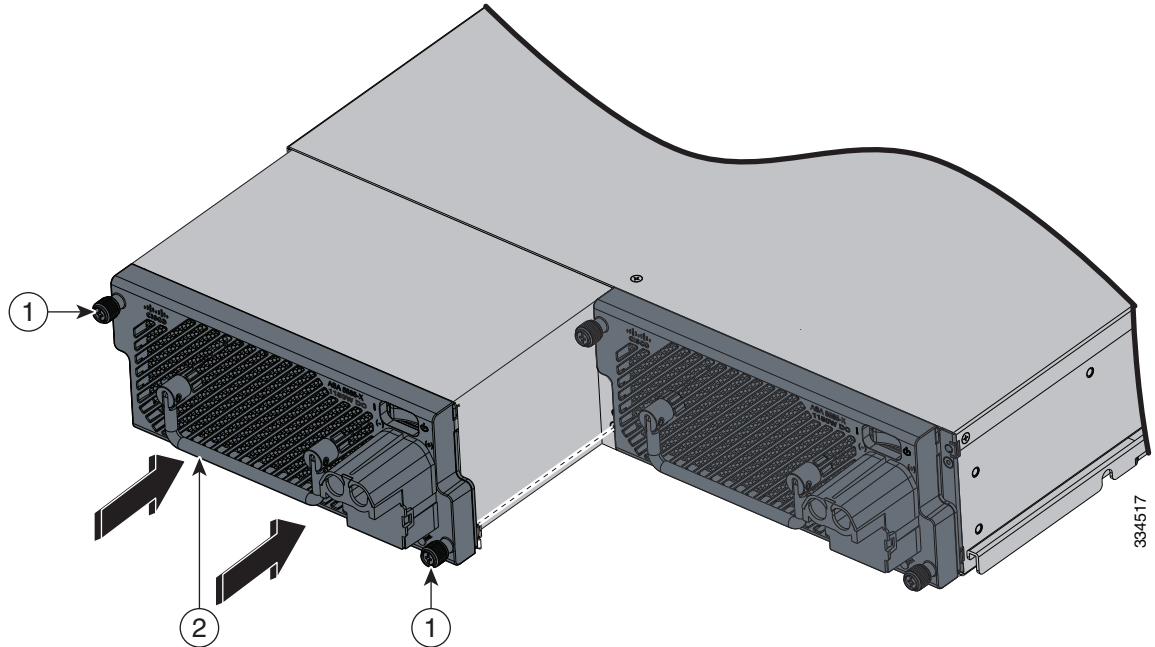

1	Power-supply module screws	2	Power-supply module and module handle
----------	----------------------------	----------	---------------------------------------

- Step 3** Tighten the captive screws.
- Step 4** Repeat Steps 2 and 3 to install the second power-supply module.



Note You must have two DC power-supply modules installed at all times.

- Step 5** Connect DC power source by following the steps in [Connecting DC Power to the ASA 5585-X](#), page 4-19.

Connecting DC Power to the ASA 5585-X

This section describes how to connect DC power to the Cisco ASA 5585-X, and contains the following topics:

- [Prerequisites, page 4-19](#)
- [Connecting the DC Power Supply, page 4-20](#)

Prerequisites



Caution

Before you connect the power supply module to a power source, be sure the chassis is properly grounded.

Use the following tools and parts to connect the DC power-supply module:

- 5/16-inch nut-driver
- M4 nut-driver
- Source DC cable lugs with the following requirements:
 - Two holes with 0.62 ± 0.02 -inch spacing between the hole centers to accommodate the power-supply terminal posts.
 - A 90-degree bend in the barrel to allow the source DC cables to exit the terminal block.
- Source DC ground wire lugs with the following requirements:
 - A single hole that can accommodate the 4-mm ground post.
 - Either a straight or bent barrel.



Note

The source DC cable and the terminal block lugs should be sized according to local and national installation requirements and electrical codes. Use only copper wire. We recommend FCI Burndy type YA4CL-2TC10-90 and Panduit type LCD10-10AF-L dual-hole 90 degree lugs, or the equivalent.



Note

These parts and tools are not supplied as part of the chassis accessory kit or the DC power-supply module kit. You must purchase them separately.

Table 4-5 shows the source DC cable and ground cable-lug tightening torque ratings.

Table 4-5 Lug Torque Ratings

Lug	Maximum Torque	Recommended Torque
Source DC cable lugs	4.07Nm	2.5Nm
Source DC ground cable lugs	2.5Nm	2Nm



Warning

Before performing any of the following procedures, ensure that power is removed from the DC circuit. Statement 1003.

**Warning**

This unit is intended for installation in restricted-access areas. A restricted-access area can be accessed only through the use of a special tool, lock and key, or other means of security.

Statement 1017

**Warning**

This product requires short-circuit (overcurrent) protection, to be provided as part of the building installation. Install only in accordance with national and local wiring regulations. Statement 1045

**Warning**

Hazardous voltage or energy may be present on DC power terminals. Always replace cover when terminals are not in service. Be sure uninsulated conductors are not accessible when cover is in place. Statement 1075

More Information

For the procedure for connecting the system ground, see [Establishing the System Ground, page 3-1](#).

Connecting the DC Power Supply

To connect source DC to the DC-input power supply, follow these steps:

-
- Step 1** Set the power switch or circuit breaker to the off (0) position on the source DC circuit that feeds the power supply you are installing.
- As an added precaution, place the appropriate safety flag and lock-out devices at the source-power circuit breaker, or place a piece of adhesive tape over the circuit breaker handle to prevent accidental power restoration while you are working on the circuit.
- Step 2** Verify that the power switch on the power supply you are installing is in the STANDBY (⚡) position.

- Step 3** Remove the terminal block cover by simultaneously squeezing the left and right sides of the terminal block, and at the same time pulling the cover off the terminal block; set the cover aside (Figure 4-17).

Figure 4-17 Removing the Terminal Block Cover

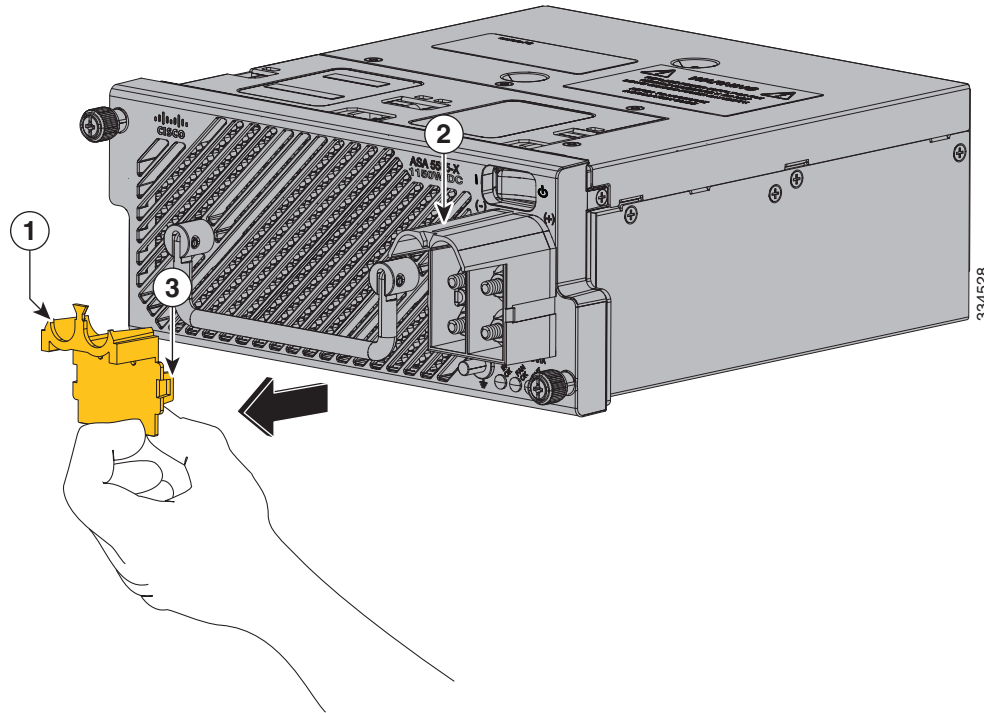

1	Terminal block cover	2	Terminal block
3	Terminal block cover clip		

- Step 4** Using a 5/16-inch nut-driver, loosen and remove the four nut and lock-washer pairs on the terminal block posts. Set the nuts and lock-washers aside.
- Step 5** Using an M4 nut-driver, loosen and remove the nut and lock-washer from the power supply ground terminal.
- Step 6** Attach the source DC power cable lugs to the source DC cables.
- Step 7** Attach the source DC ground wire lug to the source DC ground wire.
- Step 8** Connect the source DC cables to the terminal block in this order (Figure 4-18 on page 4-22):
- Position the ground cable lug on the power supply ground terminal post. Slide the lock-washer over the ground post and tighten the nut to secure the source DC ground wire. Do not over-tighten the nut (see Table 4-5).
 - Position the negative (–) source DC cable lug on the power-supply negative (–) terminal posts. Slide the lock-washers over the terminal posts and tighten the nuts to secure the source lug to the posts. Do not over-tighten the nuts (see Table 4-5).
 - Position the positive (+) source DC cable lug on the power supply positive (+) terminal posts. Slide the lock-washers over the terminal posts and tighten the nuts to secure the source lug to the posts. Do not over-tighten the nuts (see Table 4-5).

**Note**

The terminal block on the 1150 W DC-input power supply is labeled negative (–)—that is, the two left-side posts—and positive (+)—the two right side posts. The ground post is located on the DC-input power supply faceplate, separate from the terminal block.

Figure 4-18 Attaching the Source DC Cables to the Power Supply Module

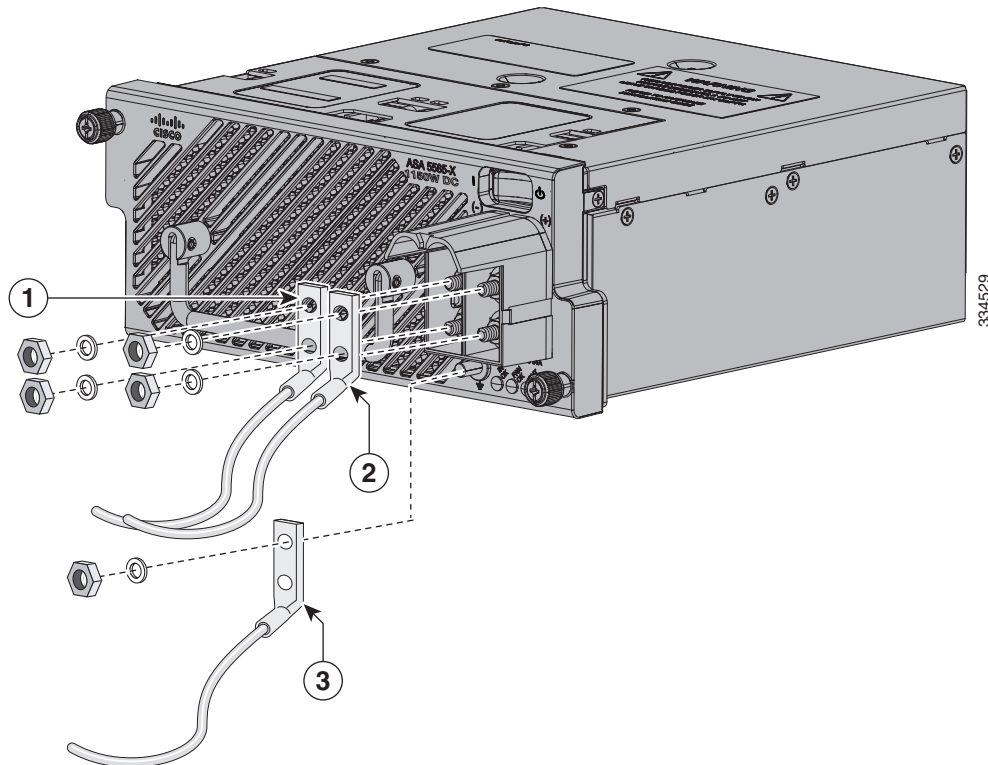

1	Source DC negative (–) cable	2	Source DC positive (+) cable
3	Source DC ground cable		

Step 9 Route the two source DC cables out of the terminal block, position the terminal block cover over the terminal block, and snap the cover into place (Figure 4-19 on page 4-23). Make sure that both the top and the bottom clips on the terminal block cover have fully engaged the tabs on the terminal block.

**Caution**

To prevent short circuit or shock hazard after wiring the DC-input power supply, you must re-install the terminal block cover.

Figure 4-19 Reinstalling the Terminal Block Cover

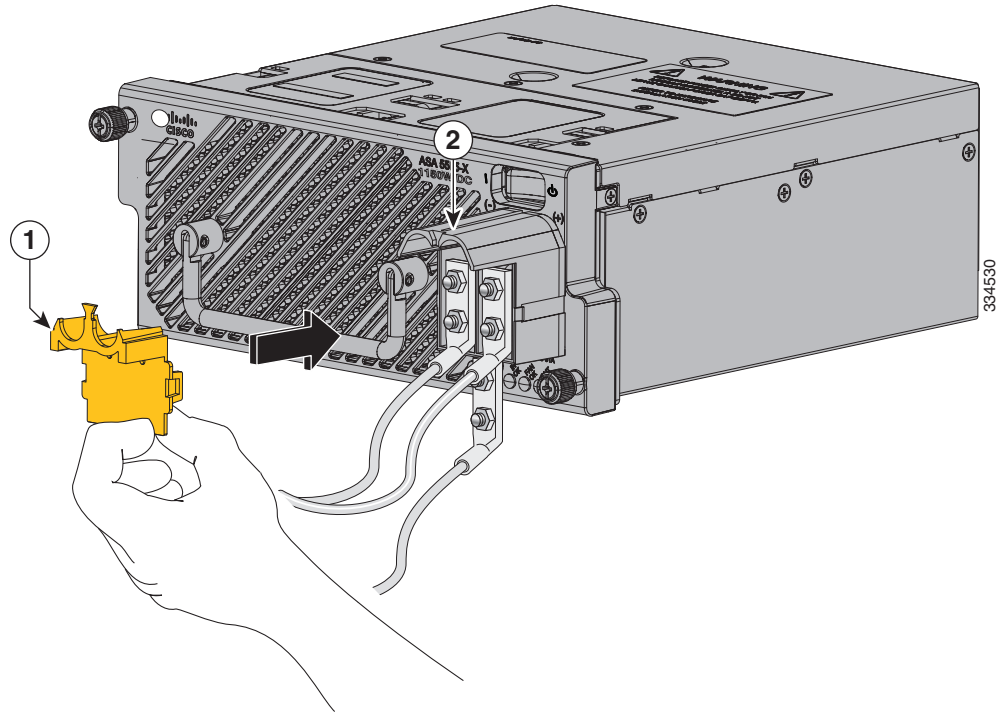

1 Terminal block cover	2 Terminal block
------------------------	------------------

Step 10 Repeat Steps 2 through 9 to connect power to the second power-supply module.



Note You must have two DC power-supply modules installed at all times.

Step 11 Remove any safety flag and lockout devices, or any tape, from the source DC circuit breaker switch handle.

Step 12 Verify that the power cable ends at the power source are connected.

Step 13 Restart power by moving the circuit breaker switch handle to the on (!) position.

Step 14 If you powered off the appliance because you are removing and replacing both power supply modules, power it back on. If you replaced only one power supply module, the power source is already on. You can hot swap the module you are replacing and then turn its power back on.

- Step 15** Check the PS0 and PS1 indicators on the front panel to make sure they are green. On the back panel of the appliance, make sure the IN OK and the FAN OK indicators are green and the OUT FAIL indicator is off (see [Figure 4-20](#) and [Table 4-4](#) on page 4-17).

Figure 4-20 PS0 and PS1

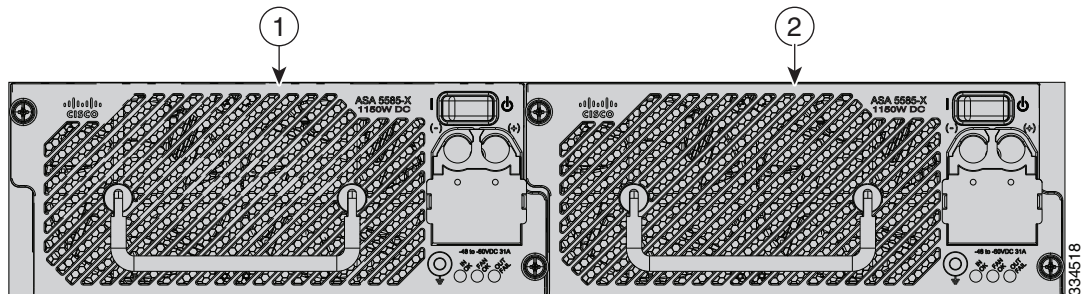

1	Power supply module (PS0)	2	Power supply module (PS1)
---	---------------------------	---	---------------------------

Removing the DC Power Supply Module

Use the following tools and parts to disconnect the DC power supply module:

- 5/16-inch nut-driver
- M4 nut-driver



Warning

Before performing any of the following procedures, ensure that power is removed from the DC circuit. Statement 1003.



Warning

This unit is intended for installation in restricted-access areas. A restricted-access area can be accessed only through the use of a special tool, lock and key, or other means of security. Statement 1017



Warning

This product requires short-circuit (overcurrent) protection, to be provided as part of the building installation. Install only in accordance with national and local wiring regulations. Statement 1045



Warning

Hazardous voltage or energy may be present on DC power terminals. Always replace cover when terminals are not in service. Be sure uninsulated conductors are not accessible when cover is in place. Statement 1075

Follow these steps to disconnect the source DC to the DC-input power supply and remove the DC power-supply module:

- Step 1** Set the power switch or circuit breaker to the off (0) position on the source DC circuit that feeds the power supply that you are installing.
- As an added precaution, place the appropriate safety flag and lockout devices at the source power circuit breaker, or place a piece of adhesive tape over the circuit breaker handle to prevent accidental power restoration while you are working on the circuit.
- Step 2** Verify that the power switch on the power supply you are removing is in the STANDBY (Ⓛ) position.
- Step 3** Remove the terminal block cover by simultaneously squeezing the left and right sides of the terminal block, and at the same time pull the cover off the terminal block; set the cover aside (Figure 4-21).

Figure 4-21 Removing the Terminal Block Cover

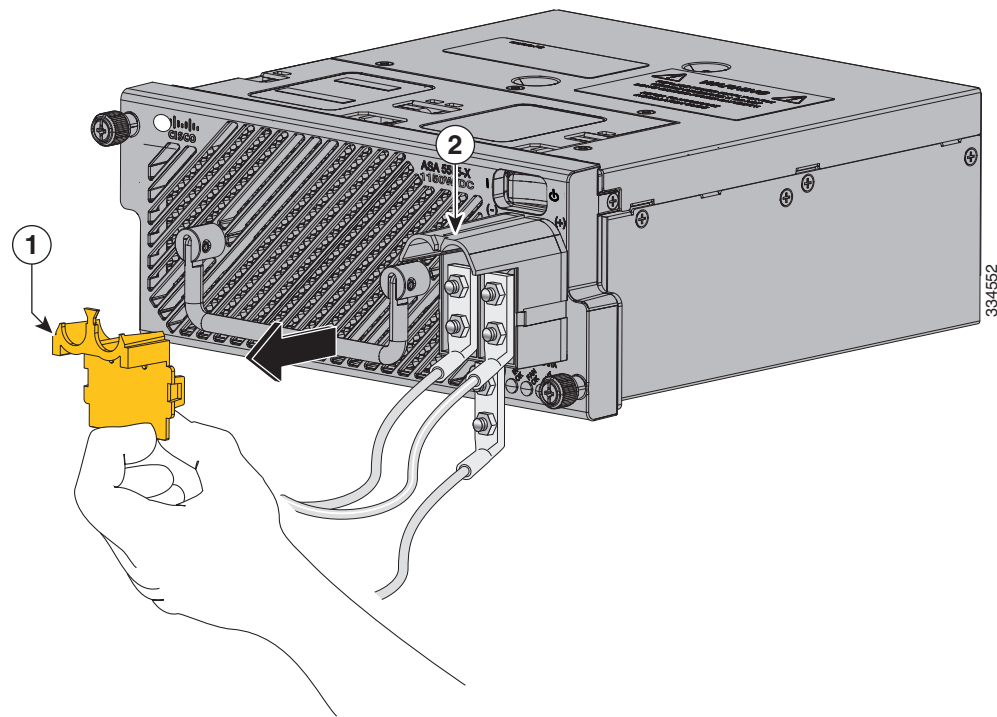

1	Terminal block cover	2	Terminal block
3	Terminal block cover clip		

- Step 4** Using a 5/16-inch nut-driver, loosen and remove the four nut and lock-washer pairs from the DC power lugs. Set the nuts and lock-washers aside (Figure 4-22 on page 4-26).

- Step 5** Using an M4 nut-driver, loosen and remove the nut and lock-washer from the power-supply ground wire lug (Figure 4-22).

Figure 4-22 Removing the Source DC Cables from the Power Supply Module

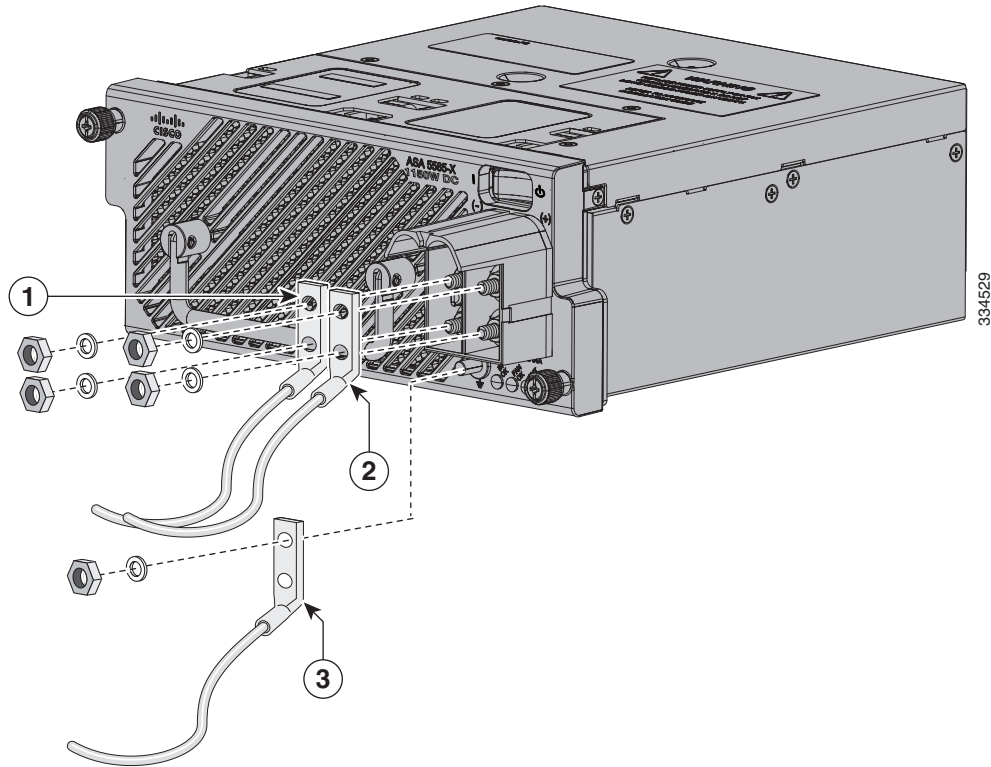

1	Source DC negative (-) cable	2	Source DC positive (+) cable
3	Source DC ground cable		

- Step 6** Remove the DC negative, positive, and ground cables.

- Step 7** On the back of the security appliance, loosen the captive screws from the power supply module (Figure 4-23).

Figure 4-23 Removing the DC Power Supply Module

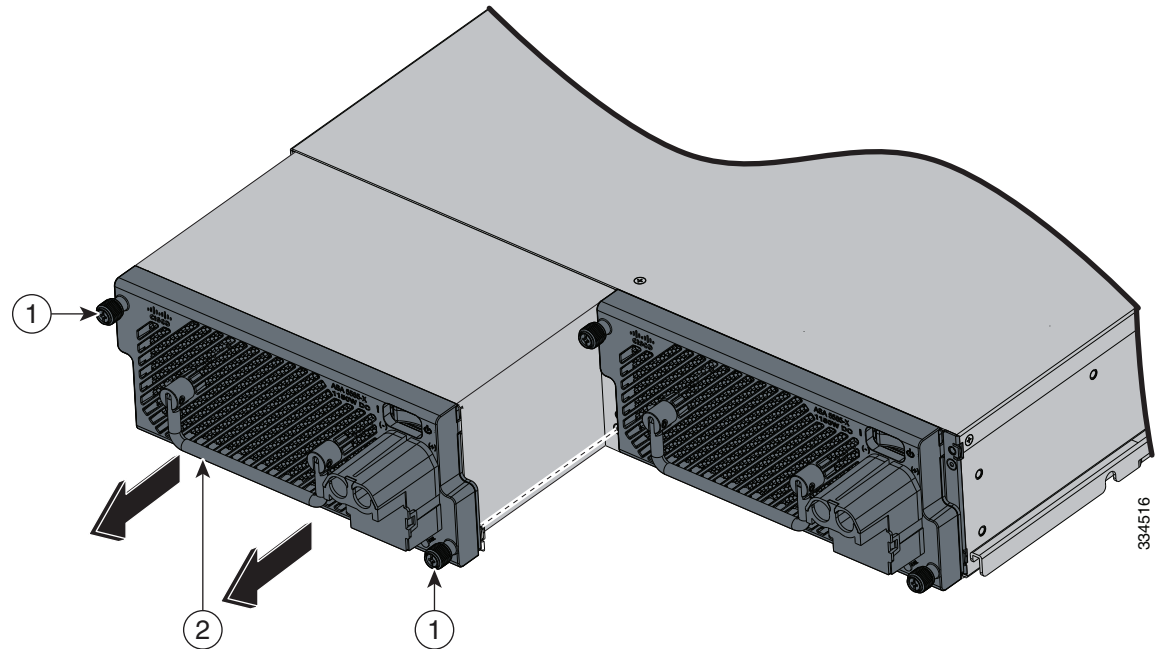

1	Power supply module screws	2	Power supply module and module handle
----------	----------------------------	----------	---------------------------------------

- Step 8** Remove the power-supply module by grasping the handle and pulling the module out of the chassis.

Removing and Installing the Fan Module

The ASA 5585-X ships with one fan module and one power-supply module installed, except for the ASA 5585-X SSP-60, which ships with two power-supply modules. You can replace the fan module in the ASA 5585-X if necessary. The fan module is hot-pluggable. You can install or replace the fan module without powering down the ASA 5585-X, as long as the power-supply module is active and functioning correctly. To maintain airflow, both bays must be populated by either a power-supply module and a fan module, or two power-supply modules.



Note A power-supply module is required for the system to operate.



Caution If you remove a power-supply or fan module, replace it immediately to prevent service disruption.

To remove and install a fan module, follow these steps:

- Step 1** From the right-hand side of the back panel of the ASA 5585-X loosen the captive fan-module screws until they release.

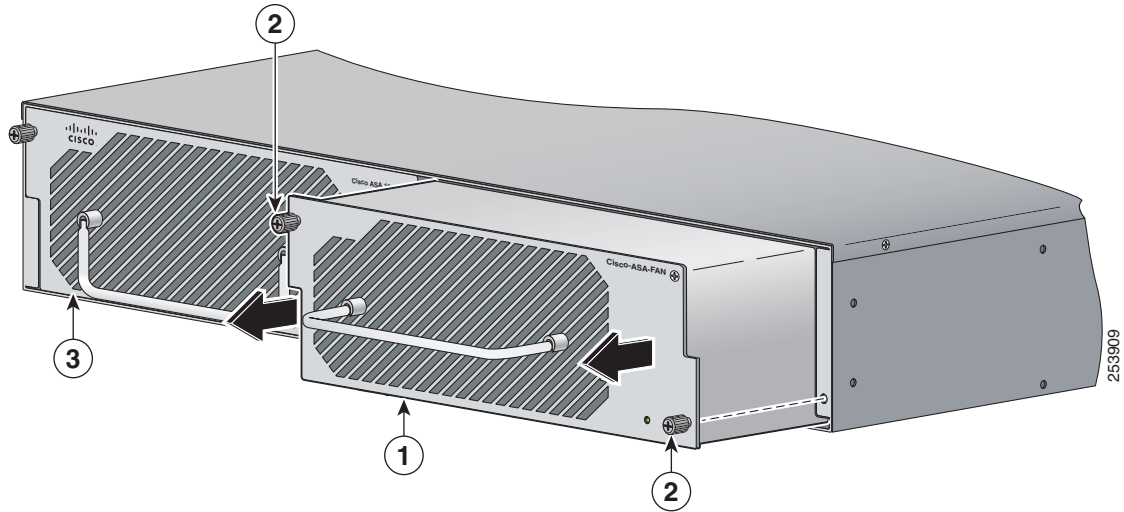

1	Fan module and module handle	2	Fan module screws
3	Power supply module		

- Step 2** Remove the fan module by grasping the handle and pulling the fan module away from the chassis.

- Step 3** Install the new fan module by aligning it with the fan module bay and pushing it into place until it is seated.

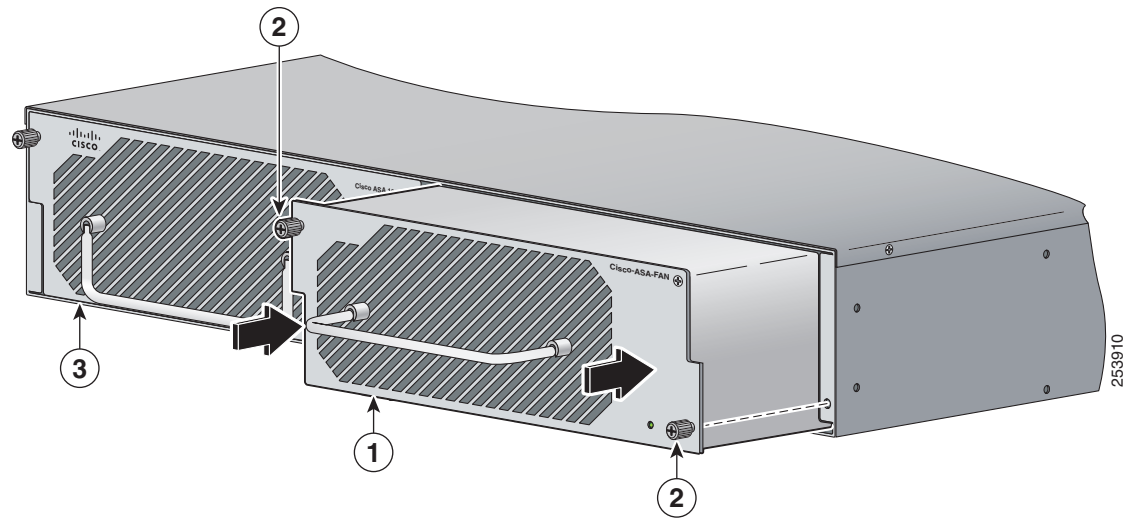

1	Fan module and module handle	2	Fan module screw
3	Power supply module		

- Step 4** Tighten the captive screws.
- Step 5** Verify that the fan indicator on the lower right-hand of the back panel is green.

Installing a Slide Rail Kit

Before installing the appliance in a rack-mount slide rail, you must install the slide rail kit hardware.



Note

The slide rail kit hardware ships with the ASA 5585-X.

To install the slide rail kit hardware on the ASA 5585-X, follow these steps:

- Step 1** Power off the appliance.
- Step 2** Remove the power cable from the appliance.
- Step 3** If your appliance has the fixed cable-management brackets, do the following:
- Remove the cable-management brackets from the front sides of the appliance.
 - Remove the appliance from the rack.
 - Remove the front brackets, left and right side brackets, and left and right rear brackets from the appliance.

Figure 4-24 shows all of the brackets that can be removed for the fixed rack mount.

Figure 4-24 Brackets for the Fixed Rack Mount

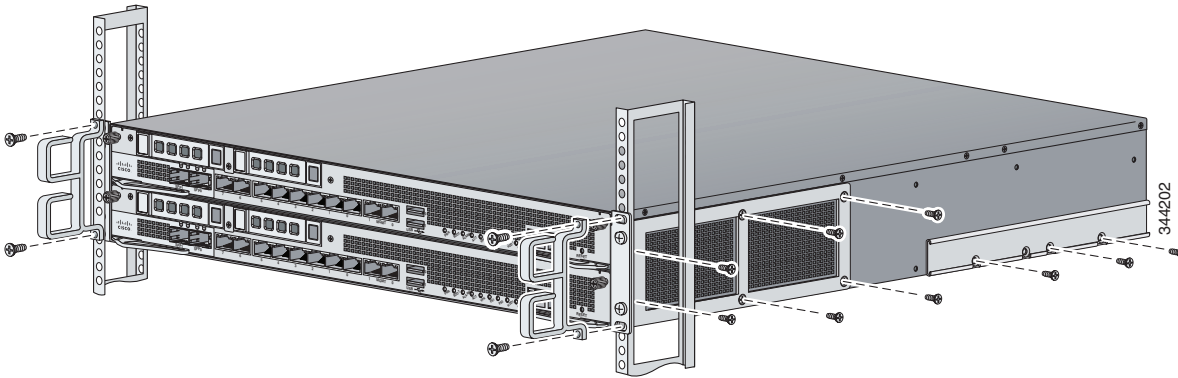

Attach the slide rail hardware (front brackets, and left and right side brackets) to the appliance. The brackets are labeled RIGHT and LEFT. This prepares the appliance for installation in the rack using the slide rail kit. Figure 4-25 shows all of the brackets you need to install on the appliance.

Figure 4-25 Brackets for the Slide Rail Kit

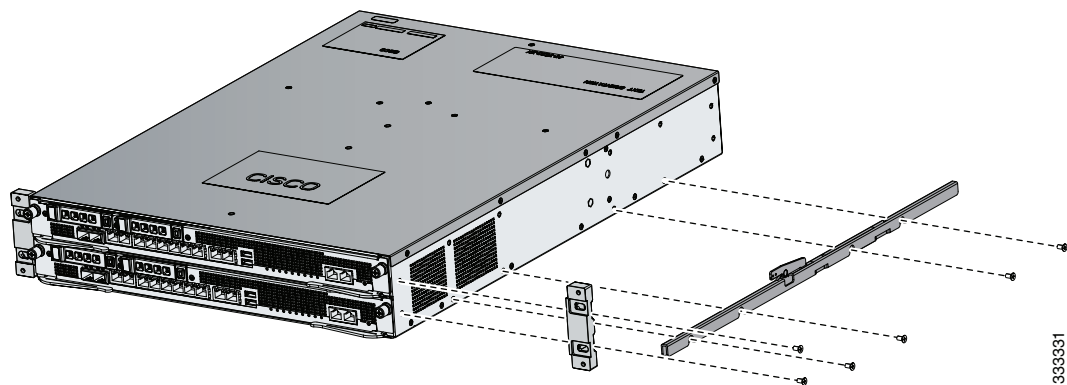

Installing and Removing a Slide-mounted Chassis



Note

A slide rail kit ships with the ASA 5585-X.

After you have installed slide rail hardware on the appliance, you can install the slide rails in the rack and install the chassis. This section describes how to install and remove rack slide rails and the ASA 5585-X, and contains the following sections:

- [Package Contents, page 4-31](#)
- [Installing the Chassis in the Rack, page 4-31](#)
- [Removing the Chassis from the Rack, page 4-37](#)

Package Contents

The slide rail kit package contains the following items:

- Left and right slide rails
- Six #10-32 screws
- Two #10-32 cage nuts

Installing the Chassis in the Rack

To install the chassis in the rack using the slide rail kit, follow these steps:

- Step 1** Press the latch on the end of the slide rail and push forward to engage the pins in the rack until the clip clicks and locks around the rack post (Figure 4-26).



Note The slide rails are labeled 'left' and 'right.' Install the left slide rail on the left side of the rack and the right slide rail on the right side of the rack.

Figure 4-26 Press and Push to Install the Slide Rail

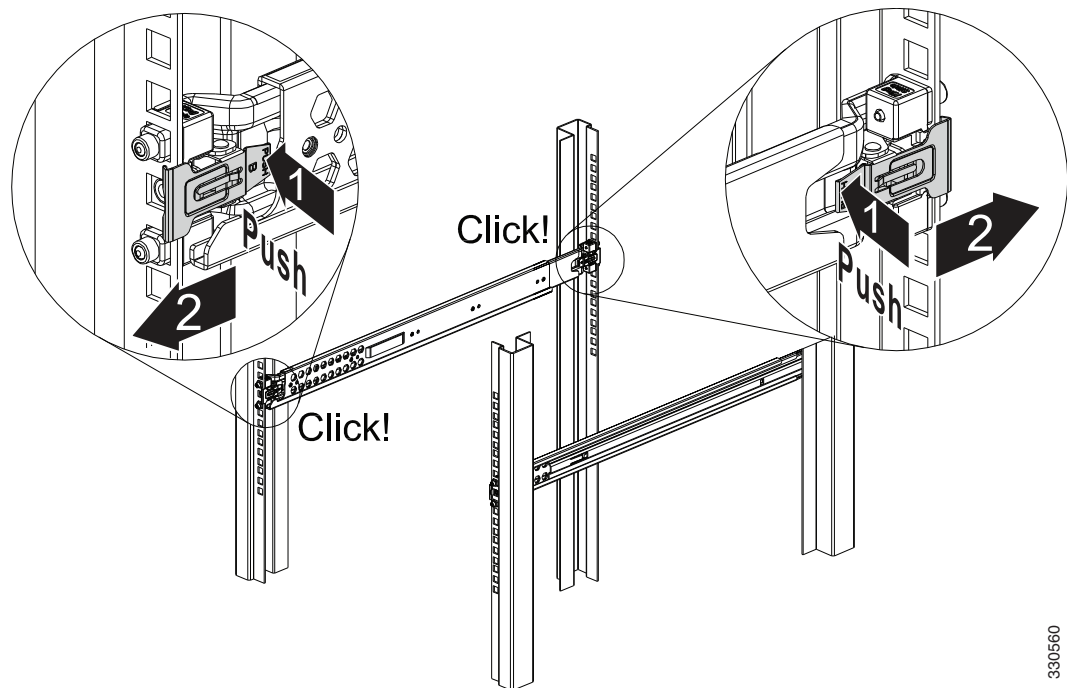

For square hole posts, square studs must be attached fully inside the square hole on the rack rail. For threaded hole posts, the round stud must fully enter inside the threaded hole rack rail (Figure 4-27).



Note After installing the square or round studs into the rack post, verify that the locking clip is fully seated and secure against the rack rail.

Figure 4-27 Square Studs for Square Hole Post

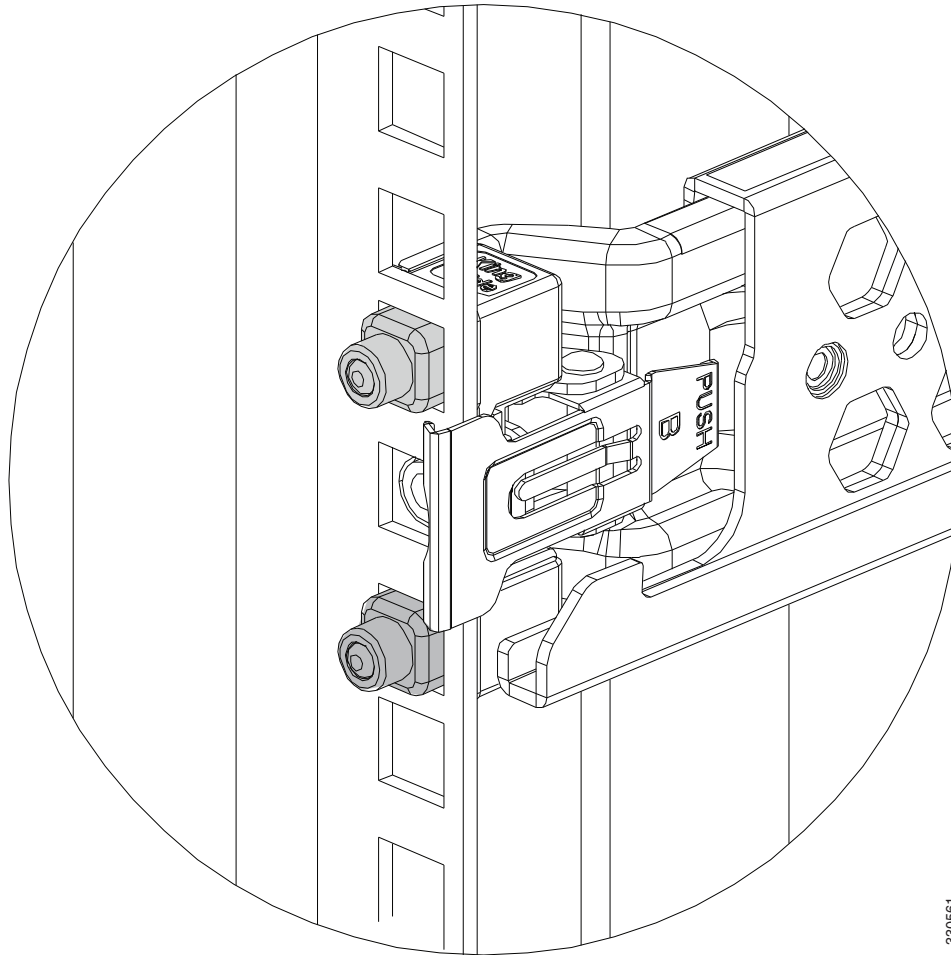

- Step 2** Secure the slide rail to the rack post with the provided #10-32 screws by tightening the screws at the front and rear end of the slide rail to the rack post (Figure 4-28). Both front and rear rack posts must be secured with the screws before you install the chassis.



Caution

It is critical that the screws are installed and secured to the front and rear end of the slide rails.



Note

The rack opening (the distance from the front to back rack uprights) should be between 26.5 and 38 inches.

Figure 4-28 **Securing the Slide Rail to the Rack Post**

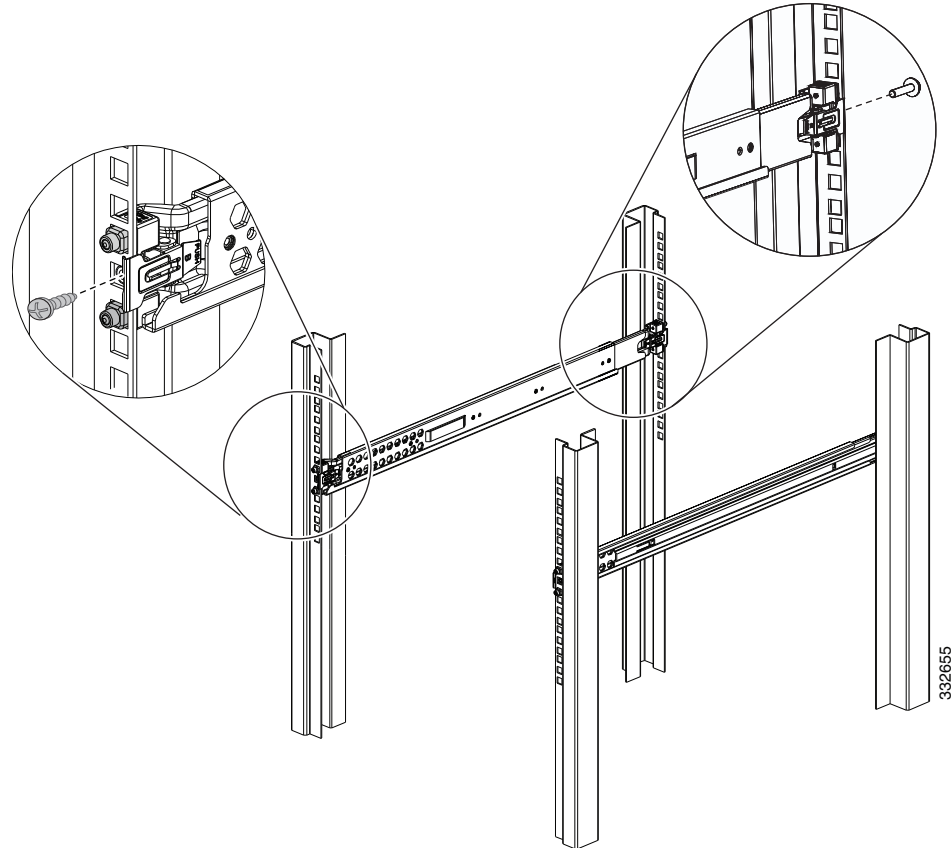

- Step 3** For square hole racks, install one #10-32 cage nut on each side of the rack rail (Figure 4-29). Leave one square hole spacing above the slide rail. The cage nut will be used later to secure the chassis to the rack post. For threaded hole racks, no additional hardware is needed.

Figure 4-29 Installing the #10-32 Cage Nuts

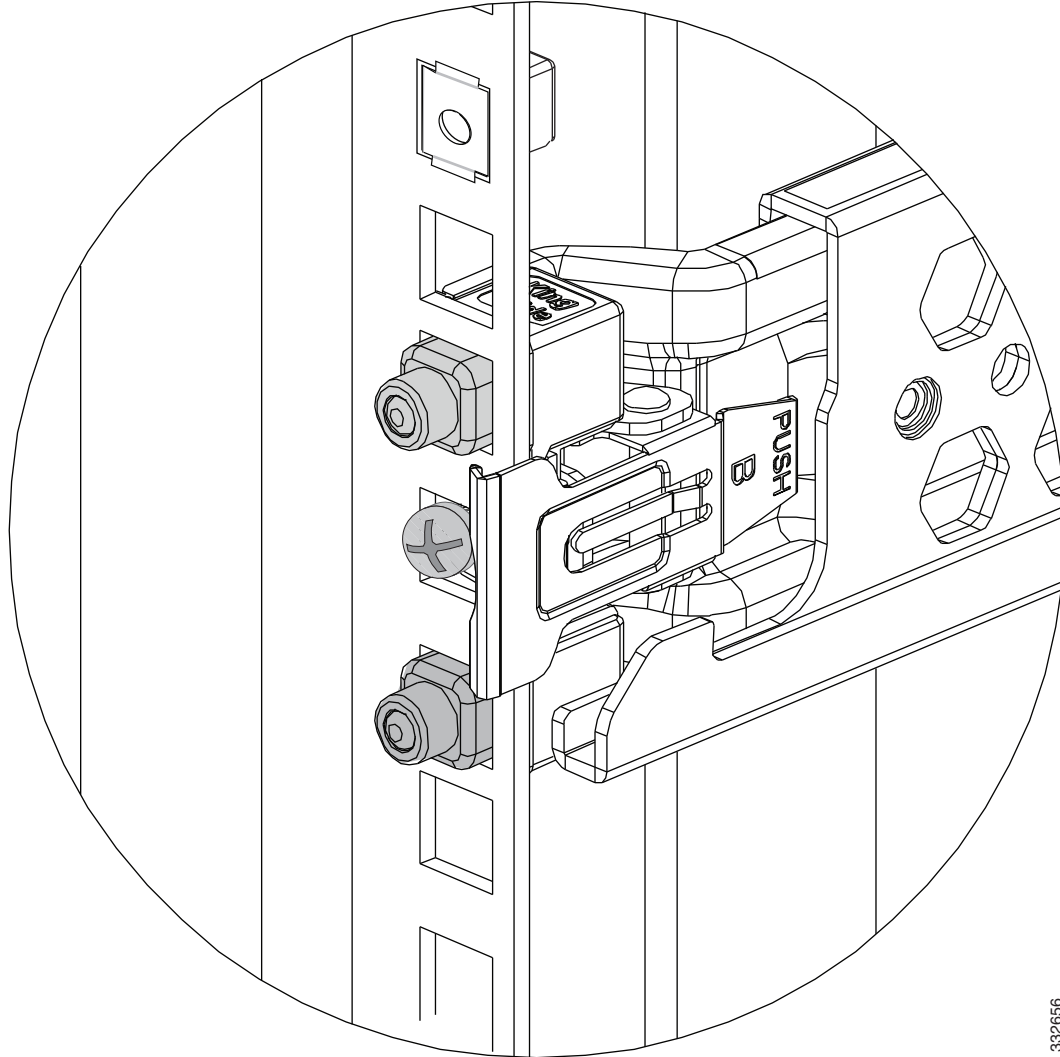

332656

- Step 4** Install the chassis on the outer rail. Make sure that the U-bars are aligned to the outer rail evenly, then push the chassis into the rack (Figure 4-30).



Caution

Before installing the chassis, make sure that the slide rails are properly installed and that the perforated holes on the outer slide rail align with the perforated holes on the chassis.

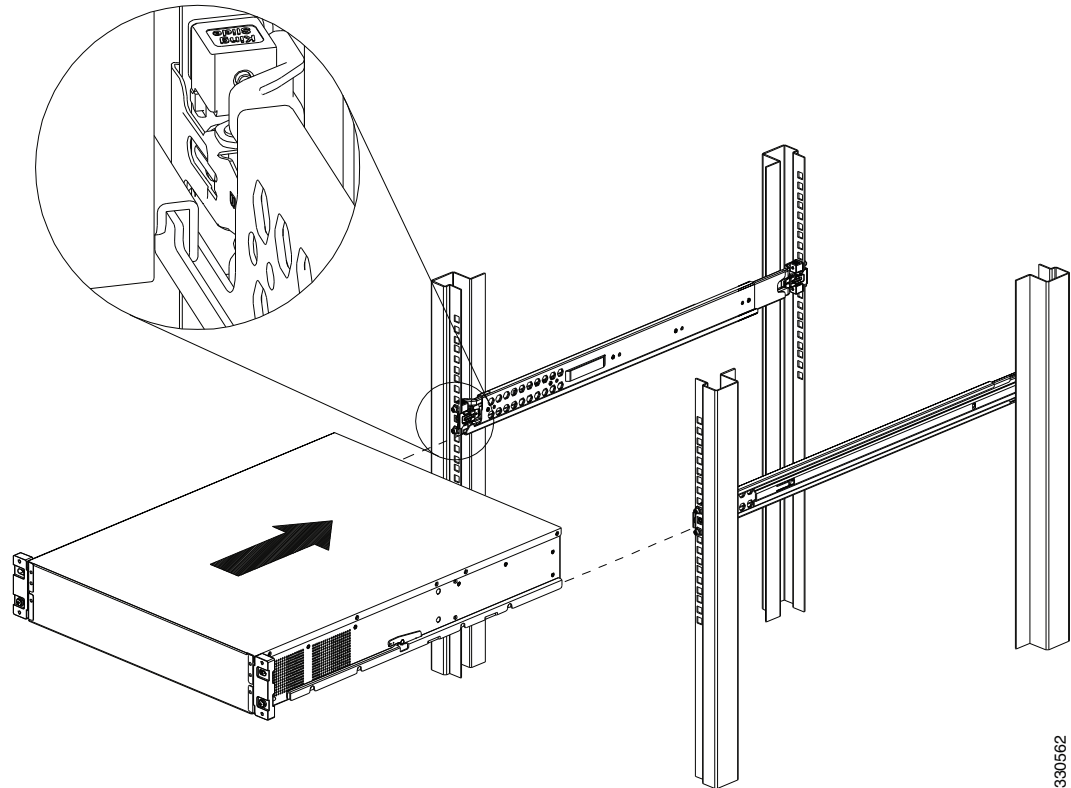
Figure 4-30 *Installing the Chassis on the Outer Rail*

330562

- Step 5** Tighten the screws to secure the chassis to the rack (Figure 4-31). Use the upper hole to secure the chassis to the rack.
- For square hole racks, secure the chassis to the rack by installing the #10-32 screw into the cage nut that you installed in Step 3.
 - For threaded hole racks, secure the front of the chassis by installing the #10-32 screws into the rack threaded hole.

Figure 4-31 *Securing the Chassis to the Outer Rail*

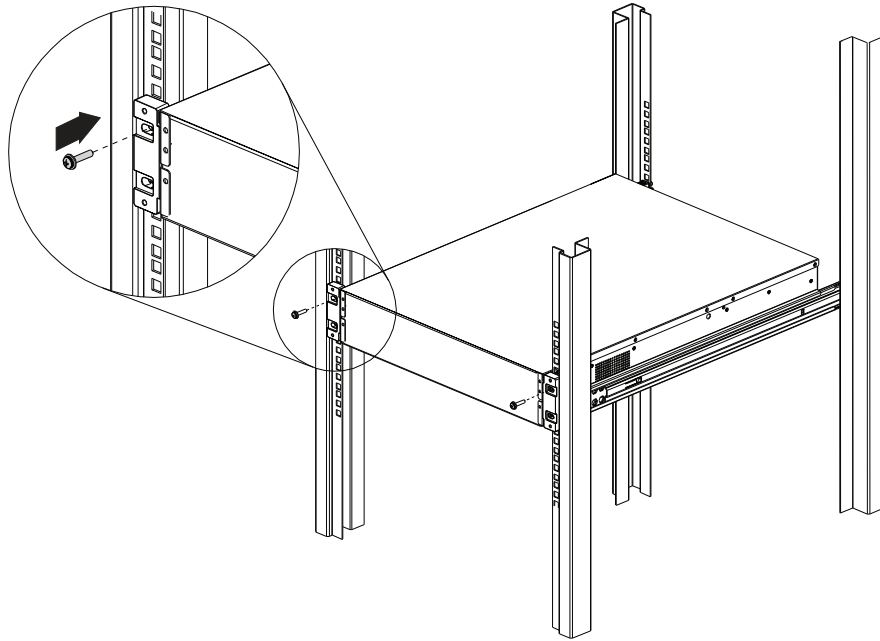

330563

Removing the Chassis from the Rack

To remove the chassis from the rack, follow these steps:

- Step 1** Remove the screws from the front brackets of the rail post (Figure 4-32).

Figure 4-32 Removing the Screws from the Outer Rail

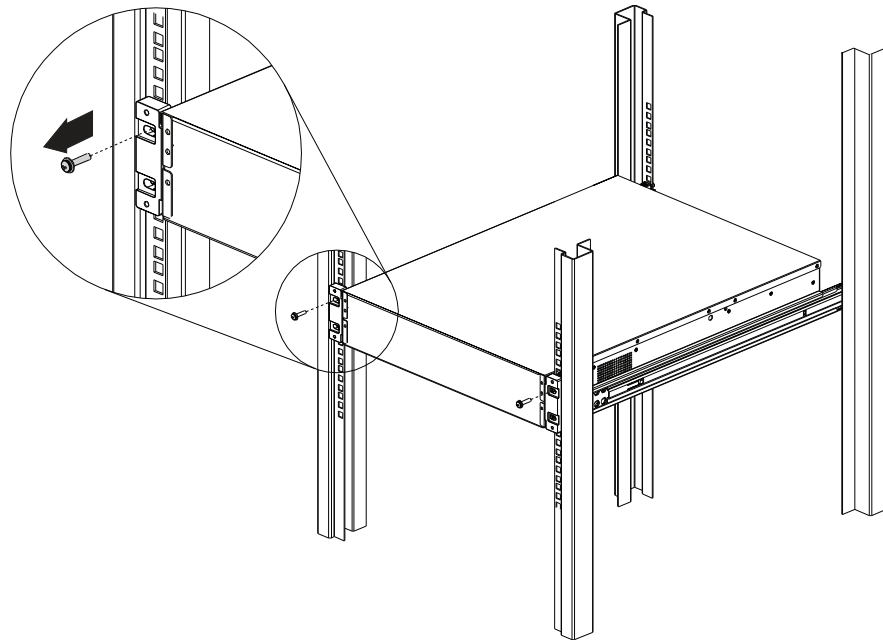

- Step 2** Pull the chassis out to the locked position.

330599

- Step 3** Press down the release hook to remove the chassis from the rack (Figure 4-33).

Figure 4-33 Pressing Down the Release Hook

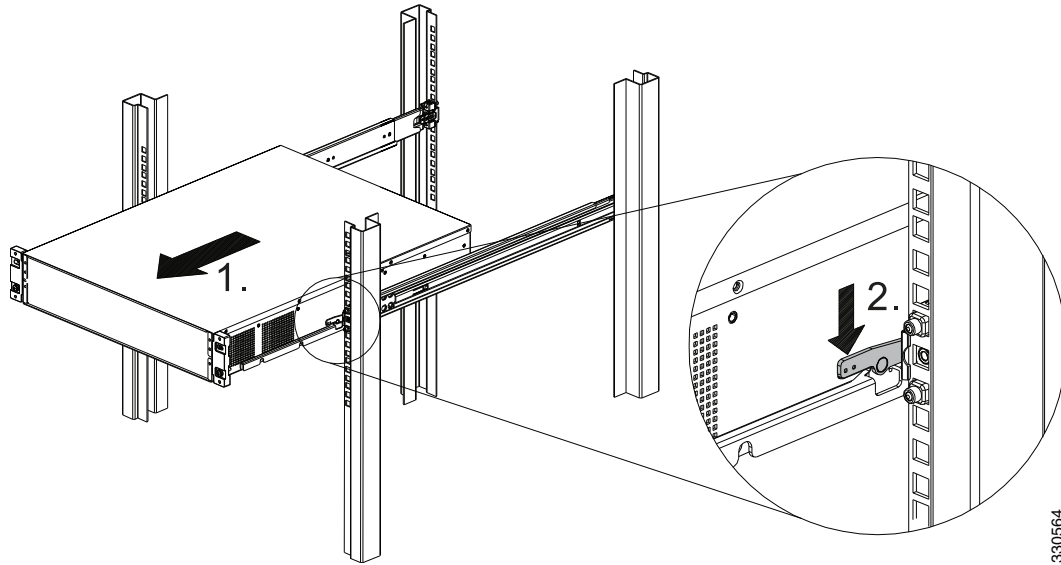

- Step 4** Remove the two screws from the front and rear of the rack that are securing the slide rail, and release the latch and pull out the rails (Figure 4-34).

Figure 4-34 Releasing the Latch to Pull Out the Rails

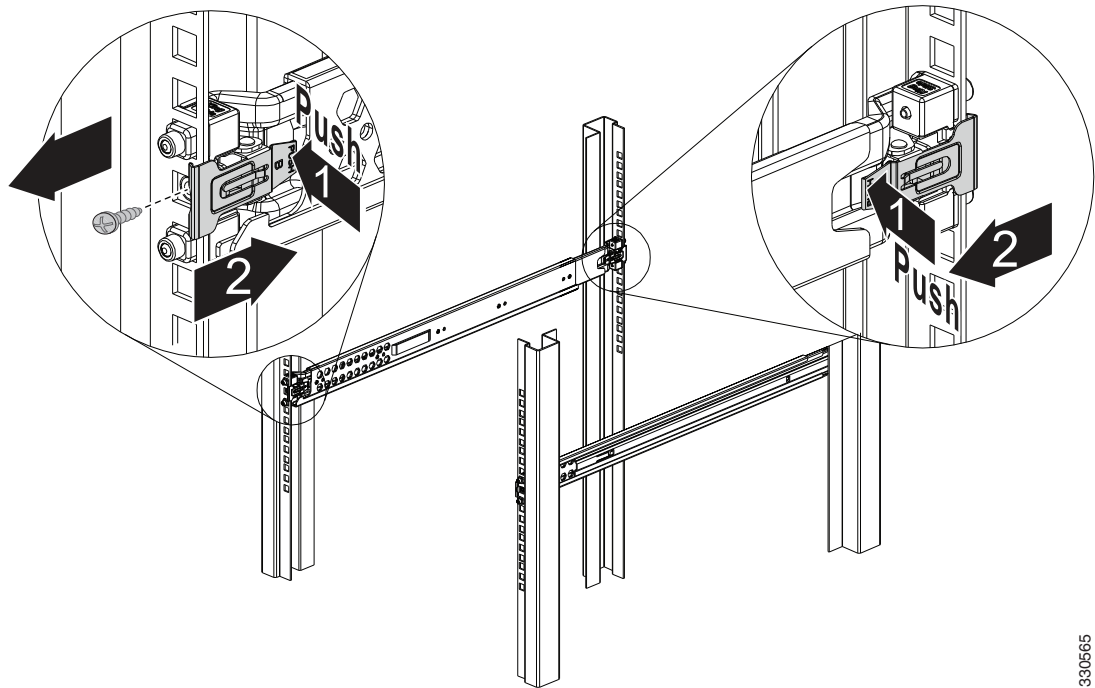

Mounting the Chassis Using a Fixed Rack Mount

If you are not able to use the slide rail kit in your rack installation, an optional fixed rack-mount solution is available. You can install fixed front and rear rack-mount brackets on the ASA 5585-X so that you can easily mount it in a rack.

To fixed-mount the ASA 5585-X, follow these steps:

- Step 1** If the adaptive security appliance is already operational and not rack-mounted, or if you are replacing an adaptive security appliance with the ASA 5585-X, do the following:
- Power off the adaptive security appliance.
 - Remove the power cable from the adaptive security appliance.
 - Remove the old adaptive security appliance from the rack.
- Step 2** Position the front bracket on the side of the adaptive security appliance and line up the bracket screws with the screw holes on the adaptive security appliance.

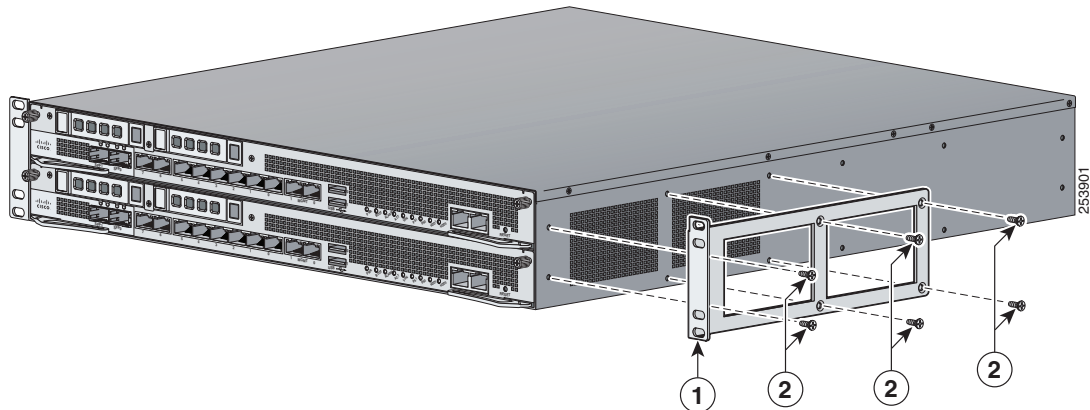

1	Bracket	2	Bracket screws
----------	---------	----------	----------------

- Step 3** Tighten the screws into the chassis.
- Step 4** Repeat this procedure on the other side of the chassis.
- Step 5** You can now mount the chassis in a rack; go to [Step 12](#). If using the optional rear rack rails, continue with Step 6.
- Step 6** Attach one of the rear brackets using three M4 screws.

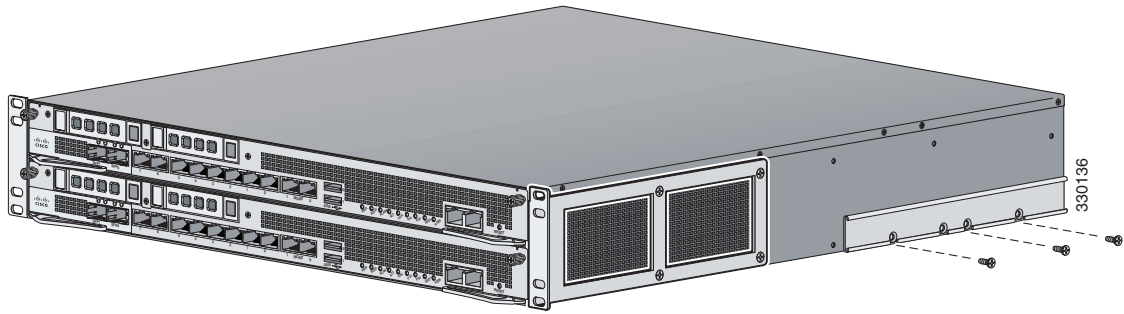

Step 7 Repeat to attach the second bracket to the other side of the chassis.

Step 8 Measure the distance between the front and rear rack rails and select the proper slide-mount brackets.



Note The slide-mount brackets let you install the rear of the chassis to the rear rack rails. The brackets are designed to slide within the installed rear brackets and accommodate a range of rack depths.

Step 9 Install the proper slide-mount brackets on to the rear bracket on the chassis.

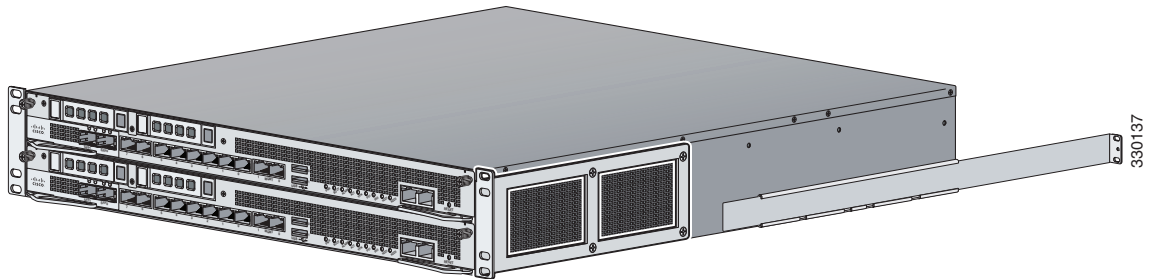

Step 10 For added security, screw in the front slide rail brackets to the rack.

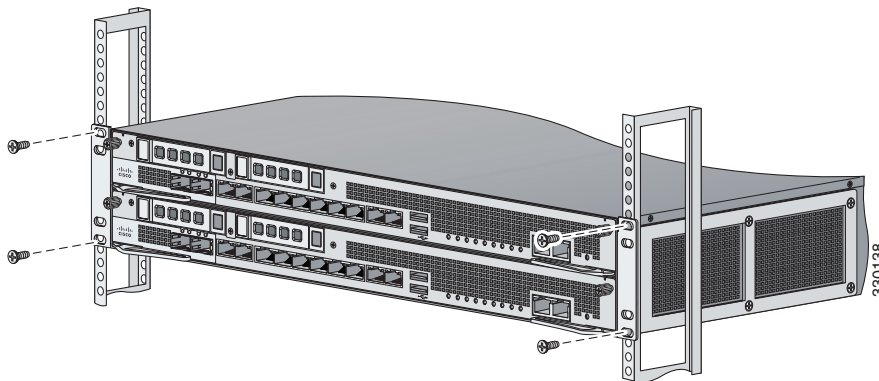

Step 11 Secure the slide brackets to the corresponding holes in the rear rack rail using the screws provided.

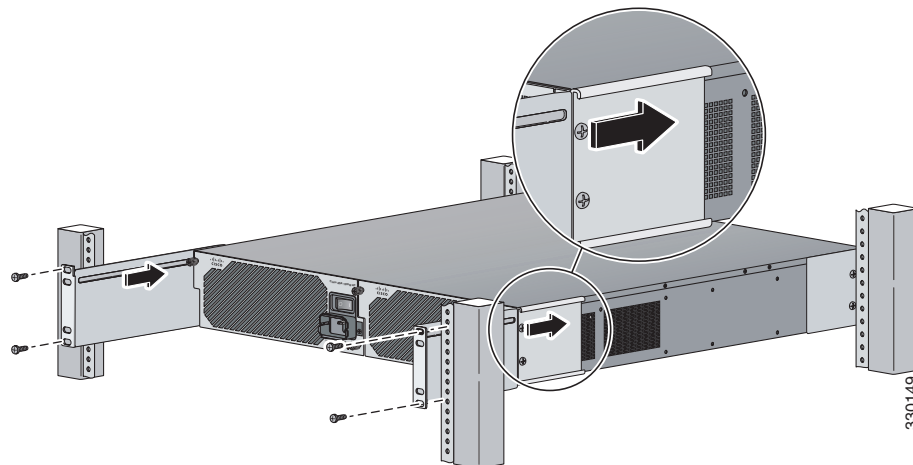

- Step 12** Re-attach the power cable to the adaptive security appliance.
 - Step 13** Power on the adaptive security appliance.
-

Installing the Cable Management Brackets

The ASA 5585-X ships with two cable management brackets that you can use to organize the cables connected to the adaptive security appliance.

To install the cable management brackets on the ASA 5585-X, follow these steps:

- Step 1** Power off the adaptive security appliance.
- Step 2** Remove the power cable from the adaptive security appliance.
- Step 3** Position the cable management brackets on the front side of the adaptive security appliance, and line up the bracket screws with the screw holes on the adaptive security appliance. [Figure 4-35](#) shows the cable management bracket for the fixed rack mount, and [Figure 4-36 on page 4-42](#) shows the cable management bracket for the slide rail.

Figure 4-35 Cable Management Brackets for the Fixed Rack Mount

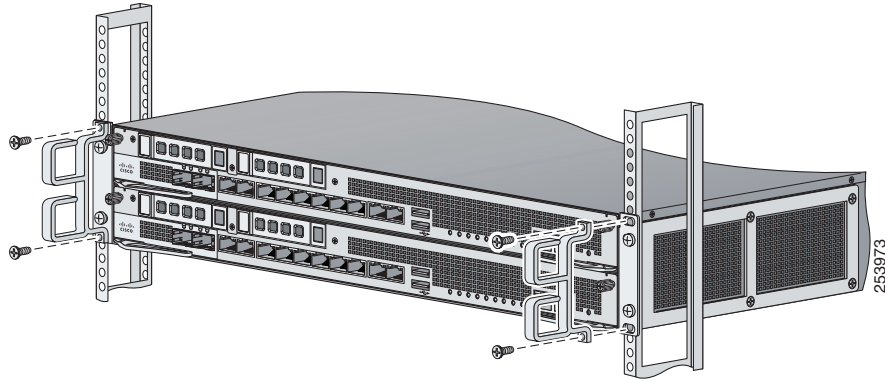
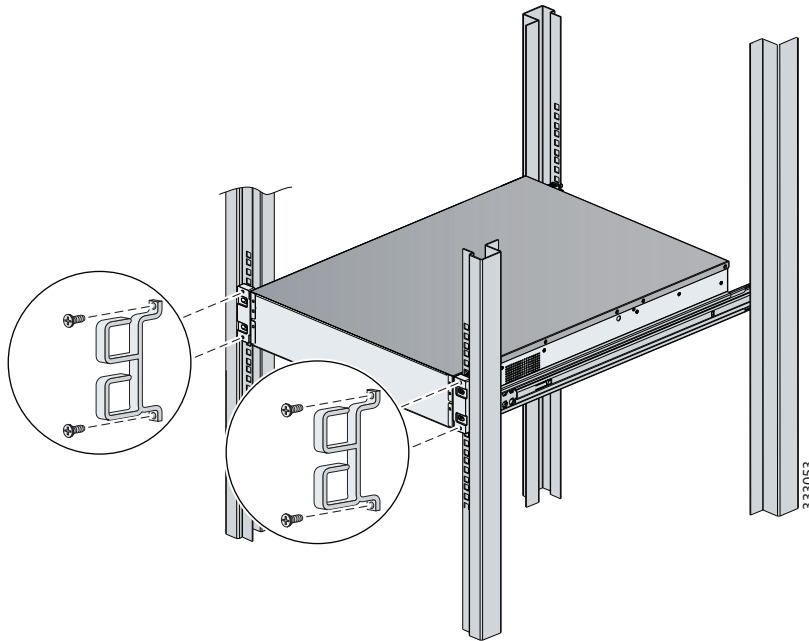

Figure 4-36 Cable Management Brackets for the Slide Rail



- Step 4** Tighten the screws into the rack.
- Step 5** Re-attach the power cable to the adaptive security appliance.
- Step 6** Organize the cables through the cable management brackets on the adaptive security appliance.
- Step 7** Power on the adaptive security appliance.

Troubleshooting Loose Connections

Perform the following actions to troubleshoot loose connections on adaptive security appliances:

- Make sure all power cords are securely connected.
- Make sure all cables are properly aligned and securely connected for all external and internal components.
- Remove and check all data and power cables for damage. Make sure no cables have bent pins or damaged connectors.
- Make sure each connector is properly seated.
- If a device has latches, make sure they are completely closed and locked.
- Check any interlock or interconnect indicators that indicate a component is not connected properly.
- If problems continue, remove and re-install each connector, checking the connectors and sockets for bent pins or other damage.



Cable Pinouts

This appendix describes the ASA 5585-X Ethernet, management, console, and auxiliary ports, and includes the following sections:

- [ASA 5585-X Cables, page 5-1](#)
- [RJ-45 Ethernet Ports, page 5-2](#)
- [Management 10/100/1000 Ethernet Port, page 5-3](#)
- [Console and Auxiliary Ports \(RJ-45\), page 5-3](#)
- [DB9 Connector, page 5-5](#)

ASA 5585-X Cables

The ASA 5585-X uses the following cables:

- For the Ethernet ports, you can use either straight-through or cross-over twisted-pair cables since all RJ-45 Ethernet ports support MDI/MDIX.



Note Auto-MDI/MDIX refers to the ability of the PHY associated with a given port to sense and automatically switch (if required) the transmit and receive signaling across a twisted-pair RJ-45 cable, thereby eliminating the need for special (for example, cross-over) cables based on the connecting port.

- The management ports are 10/100/1000 Mbps-capable; you can also use either straight-through or cross-over twisted-pair cables since the ports also support MDI/MDIX.
- The console and auxiliary ports are serial ports and require the use of a flat rollover cable for terminal server connectivity (and a DB9 connector for connection to a PC).

RJ-45 Ethernet Ports

The ASA 5585-X supports 10/100/1000BaseT ports. You must use at least a Category 5 cable for 100/1000Base-TX operations. You can use a Category 3 cable for 10Base-TX operations.

Figure 5-1 shows the 10/100BaseT (RJ-45) port pinouts.

Figure 5-1 10/100 Port Pinouts

Pin	Label	1 2 3 4 5 6 7 8
1	TD+	
2	TD-	
3	RD+	
4	NC	
5	NC	
6	RD-	
7	NC	
8	NC	

Figure 5-2 shows the 10/100/1000BaseT (RJ-45) port pinouts.

Figure 5-2 10/100/1000 Port Pinouts

Pin	Label	1 2 3 4 5 6 7 8
1	TP0+	
2	TP0-	
3	TP1+	
4	TP2+	
5	TP2-	
6	TP1-	
7	TP3+	
8	TP3-	

Management 10/100/1000 Ethernet Port

The management port is a 10/100/1000-Mbps Ethernet port with an RJ-45 connector. You can use a modular, RJ-45, straight-through UTP cable to connect the management port to an external hub, switch, or router.

Figure 5-3 lists the cable pinouts for 10/100/1000BASE-T management port cable pinouts (MDI/MDIX).

Figure 5-3 10/100/1000 BASE-T Management Port Cable Pinouts (MDI/MDIX)

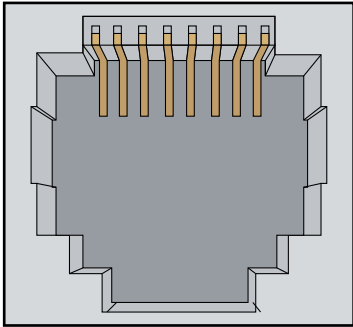
Pin	Label	1 2 3 4 5 6 7 8
1	TP0+	
2	TP0-	
3	TP1+	
4	TP2+	
5	TP2-	
6	TP1-	
7	TP3+	
8	TP3-	

148410

Console and Auxiliary Ports (RJ-45)

Figure 5-4 shows the RJ 45 cable.

Figure 5-4 RJ-45 Cable

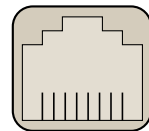

87654321

RJ-45 connector

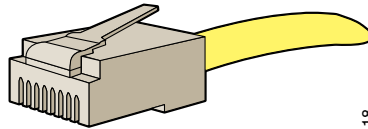

148418

To identify the RJ-45 cable type, hold the two ends of the cable next to each other so that you can see the colored wires inside the ends, as shown in [Figure 5-5](#).

Figure 5-5 *RJ-45 Cable Identification*

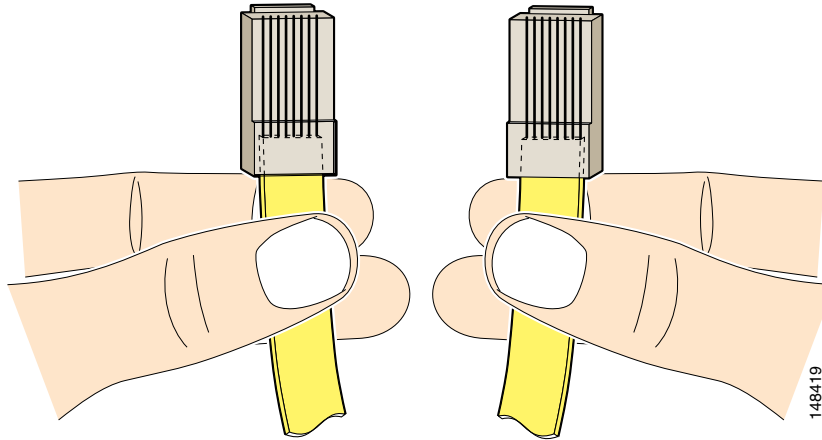

Examine the sequence of colored wires to determine the type of RJ-45 cable, as follows:

- Straight-through—The colored wires are in the same sequence at both ends of the cable.
- Cross-over—The first (far left) colored wire at one end of the cable is the third colored wire at the other end of the cable.
- Roll-over—The colored wires are in the opposite sequence at either end of the cable.

[Table 5-1](#) lists the roll-over (console) cable pinouts for RJ-45.

Table 5-1 *RJ-45 Roll-Over (Console) Cable Pinouts*

Pin	Pin
1	8
2	7
3	6
4	5
5	4
6	3
7	2
8	1

DB9 Connector

Table 5-2 lists the cable pinouts for RJ-45 to DB-9.

Table 5-2 Cable Pinouts for RJ-45 to DB-9

Signal	Console Port	RJ-45 Pin	DB-9 Pin	Signal
RTS	1	8	7	CTS
DTR	2	7	4	DSR
TxD	3	6	3	RxD
GND	4	5	5	GND
GND	5	4	5	GND
RxD	6	3	2	TxD
DSR	7	2	6	DTR
CTS	8	1	8	RTS



A

- adaptive security appliances loose connections [4-43](#)
- ASA 5585-X
 - AC power module indicators
 - illustration [4-13](#)
 - AC power supply module configurations [4-12](#)
 - ASDM [1-2](#)
 - back panel features [1-4, 1-9](#)
 - back panel features (illustration) [1-9](#)
 - cable management brackets
 - described [4-41](#)
 - installing [4-41](#)
 - cable support [3-4, 5-1](#)
 - connecting cables [3-5](#)
 - console port [3-6](#)
 - DC power module indicators
 - described [4-17](#)
 - illustration [4-16](#)
 - DC power supply module configurations [4-16](#)
 - described [1-1](#)
 - Ethernet port indicators [1-6](#)
 - fan modules
 - installing [4-28](#)
 - removing [4-28](#)
 - front panel features [1-4](#)
 - front panel features (illustration) [1-4](#)
 - front panel indicators
 - described [1-8](#)
 - illustration [1-7](#)
 - installing
 - cable management brackets [4-41](#)
 - network modules [4-8](#)
 - SFP/SFP+ modules [3-6](#)
 - slide rail kit hardware [4-29](#)
 - SSPs [4-2](#)
 - Management 0/0 [3-5](#)
 - management port described [3-5](#)
 - MDI/MDIX support [3-4, 5-1](#)
 - memory requirements [1-12](#)
 - models [1-1](#)
 - network I/O modules [4-5](#)
 - packing box contents [2-1](#)
 - power module indicators
 - described [1-10, 4-13](#)
 - illustration [1-9](#)
 - power supply modules
 - installing [4-14](#)
 - removing [4-14](#)
 - requirements [1-12](#)
 - rack mounting [4-39](#)
 - removing
 - SSPs [4-2](#)
 - SFP ports [3-6](#)
 - slide rail kit hardware
 - installing [4-29](#)
 - specifications [1-10](#)
- ASA 5585-X SSP-10
 - described [1-3](#)
 - memory requirements [1-12](#)
- ASA 5585-X SSP-20
 - described [1-3](#)
 - memory requirements [1-12](#)
- ASA 5585-X SSP-40
 - described [1-3](#)
 - memory requirements [1-12](#)

ASA 5585-X SSP-60

described [1-3](#)

memory requirements [1-12](#)

C

cable pinouts

RJ-45 to DB-9 [5-5](#)

Cisco Adaptive Security Device Manager. See ASDM. [1-2](#)

Cisco warranty [2-2](#)

console port described [3-6](#)

D

DC power supply modules

installing [4-17](#)

removing [4-17](#)

E

electrostatic discharge. See ESD.

equipment racks

tips [2-5](#)

ventilation fans [2-5](#)

ESD

described [2-3](#)

preventing [2-3](#)

F

fan modules

hot-pluggable [4-27](#)

installing [4-28](#)

OIR [4-27](#)

removing [4-28](#)

fans

equipment racks [2-5](#)

ventilation [2-5](#)

I

installing

network modules (ASA 5585-X) [4-8](#)

IPS 4510

AC power module indicators

illustration [4-13](#)

power module indicators

described [4-13](#)

specifications [1-10](#)

supported SFP+ modules [1-13, 4-7](#)

supported SFP modules [1-13, 4-7](#)

IPS 4520

AC power module indicators

illustration [4-13](#)

power module indicators

described [4-13](#)

specifications [1-10](#)

supported SFP+ modules [1-13, 4-7](#)

supported SFP modules [1-13, 4-7](#)

L

loose connections on adaptive security appliances [4-43](#)

M

Management 0/0 port described [3-5](#)

Management 0/1 described [3-5](#)

N

network I/O modules

ASA 5585-X [4-5](#)

O

OIR

not supported for modules [1-2](#)

supported
 fan modules [1-2](#)
 power supply modules [1-2](#)
 SFP/SFP+ modules [1-2](#)

P

ports

console [3-6](#)
 Management 0/0 [3-5](#)
 Management 0/1 [3-5](#)
 SFP [3-6](#)

power supply modules

installing (ASA 5585-X) [4-14](#)
 installing (IPS 4510) [4-14](#)
 installing (IPS 4520) [4-14](#)
 redundant configuration [4-12](#)
 removing (ASA 5585-X) [4-14](#)
 removing (IPS 4510) [4-14](#)
 removing (IPS 4520) [4-14](#)

R

rack-mounting the chassis [4-39](#)
 RJ-45 to DB-9 cable pinouts [5-5](#)

S

safety [2-2](#)

Security Services Processor. See SSP. [1-2](#)

SFP+ modules

described [1-13](#)
 supported (table) [1-13, 4-7](#)

SFP modules

described [1-13](#)
 supported (table) [1-13, 4-7](#)

SFP port (illustration) [3-6](#)

SSP-10

components [1-3](#)

described [1-3](#)

SSP-20

components [1-3](#)
 described [1-3](#)

SSP-40

components [1-3](#)
 described [1-3](#)

SSP-60

components [1-3](#)
 described [1-3](#)

SSPs

slot 0 [4-1](#)

T

troubleshooting adaptive security appliance loose connections [4-43](#)

W

warranty [2-2](#)

