

Preface

Thank you for purchasing the series AC drive.

The series AC drive is a general-purpose high-performance current vector control AC drive. It can implement the control of asynchronous motor . It increases the user programmable function, background monitoring software and communication bus function, and supports multi-kind PG cards. It is used to drive various automation production equipment involving textile, paper-making, wiredrawing, machine tool, packing, food, fan and pump.

This manual describes the correct use of the series AC drive, including selection, parameter setting, commissioning, maintenance & inspection. Read and understand the manual before use and forward the manual to the end user.

Notes

- The drawings in the manual are sometimes shown without covers or protective guards. Remember to install the covers or protective guards as specified first, and then perform operations in accordance with the instructions.
- The drawings in the manual are shown for description only and may not match the product you purchased.
- The instructions are subject to change, without notice, due to product upgrade, specification modification as well as efforts to increase the accuracy and convenience of the manual.
- Contact our agents or customer service center if you have problems during the use.

Safety Information and Precautions



In this manual, the notices are graded based on the degree of danger:

 **DANGER** indicates that failure to comply with the notice will result in severe personal injury or even death.



 **WARNING** indicates that failure to comply with the notice will result in personal injury or property damage.





Read this manual carefully so that you have a thorough understanding. Installation, commissioning or maintenance may be performed in conjunction with this chapter. We will assume no liability or responsibility for any injury or loss caused by improper operation.



Safety Information

Use Stage	Safety Grade	Precautions
Before installation	 DANGER	<ul style="list-style-type: none"> Do not install the equipment if you find water seepage, component missing or damage upon unpacking. Do not install the equipment if the packing list does not conform to the product you received.
	 WARNING	<ul style="list-style-type: none"> Handle the equipment with care during transportation to prevent damage to the equipment. Do not use the equipment if any component is damaged or missing. Failure to comply will result in personal injury. Do not touch the components with your hands. Failure to comply will result in static electricity damage.
During installation	 DANGER	<ul style="list-style-type: none"> Install the equipment on incombustible objects such as metal, and keep it away from combustible materials. Failure to comply may result in a fire. Do not loosen the fixed screws of the components, especially the screws with red mark.

User Manual

Use Stage	Safety Grade	Precautions
During installation	 WARNING	<ul style="list-style-type: none">• Do not drop wire end or screw into the AC drive. Failure to comply will result in damage to the AC drive.• Install the AC drive in places free of vibration and direct sunlight.• When two AC drives are laid in the same cabinet, arrange the installation positions properly to ensure the cooling effect.
At wiring	 DANGER	<ul style="list-style-type: none">• Wiring must be performed only by qualified personnel under instructions described in this manual. Failure to comply may result in unexpected accidents.• A circuit breaker must be used to isolate the power supply and the AC drive. Failure to comply may result in a fire.• Ensure that the power supply is cut off before wiring. Failure to comply may result in electric shock.• Tie the AC drive to ground properly by standard. Failure to comply may result in electric shock.
	 WARNING	<ul style="list-style-type: none">• Never connect the power cables to the output terminals (U, V, W) of the AC drive. Pay attention to the marks of the wiring terminals and ensure correct wiring. Failure to comply will result in damage to the AC drive.• Never connect the braking resistor between the DC bus terminals (+) and (-). Failure to comply may result in a fire.• Use wire sizes recommended in the manual. Failure to comply may result in accidents.• Use a shielded cable for the encoder, and ensure that the shielding layer is reliably grounded.

Use Stage	Safety Grade	Precautions
Before power-on	 DANGER	<ul style="list-style-type: none"> • Check that the following requirements are met: <ul style="list-style-type: none"> – The voltage class of the power supply is consistent with the rated voltage class of the AC drive. – The input terminals (R, S, T) and output terminals (U, V, W) are properly connected. – No short-circuit exists in the peripheral circuit. – The wiring is secured. Failure to comply will result in damage to the AC drive • Do not perform the voltage resistance test on any part of the AC drive because such test has been done in the factory. Failure to comply will result in accidents.
	 WARNING	<ul style="list-style-type: none"> • Cover the AC drive properly before power-on to prevent electric shock. • All peripheral devices must be connected properly under the instructions described in this manual. Failure to comply will result in accidents
After power-on	 DANGER	<ul style="list-style-type: none"> • Do not open the AC drive's cover after power-on. Failure to comply may result in electric shock. • Do not touch any I/O terminal of the AC drive. Failure to comply may result in electric shock.
	 WARNING	<ul style="list-style-type: none"> • Do not touch the rotating part of the motor during the motor auto-tuning or running. Failure to comply will result in accidents. • Do not change the default settings of the AC drive. Failure to comply will result in damage to the AC drive
During operation	 WARNING	<ul style="list-style-type: none"> • Do not touch the fan or the discharging resistor to check the temperature. Failure to comply will result in personal burnt. • Signal detection must be performed only by qualified personnel during operation. Failure to comply will result in personal injury or damage to the AC drive.

Use Stage	Safety Grade	Precautions
During operation	 DANGER	<ul style="list-style-type: none"> Do not touch the fan or the discharging resistor to check the temperature. Failure to comply will result in personal burnt. Signal detection must be performed only by qualified personnel during operation. Failure to comply will result in personal injury or damage to the AC drive.
	 WARNING	<ul style="list-style-type: none"> Avoid objects falling into the AC drive when it is running. Failure to comply will result in damage to the AC drive. Do not start/stop the AC drive by turning the contactor ON/OFF. Failure to comply will result in damage to the AC drive.
During maintenance	 DANGER	<ul style="list-style-type: none"> Repair or maintenance of the AC drive may be performed only by qualified personnel. Failure to comply will result in personal injury or damage to the AC drive. Do not repair or maintain the AC drive at power-on. Failure to comply will result in electric shock. Repair or maintain the AC drive only ten minutes after the AC drive is powered off. This allows for the residual voltage in the capacitor to discharge to a safe value. Failure to comply will result in personal injury. Ensure that the AC drive is disconnected from all power supplies before starting repair or maintenance on the AC drive. Set and check the parameters again after the AC drive is replaced. All the pluggable components must be plugged or removed only after power-off. The rotating motor generally feeds back power to the AC drive. As a result, the AC drive is still charged even if the motor stops, and the power supply is cut off. Thus ensure that the AC drive is disconnected from the motor before starting repair or maintenance on the AC drive.

General Precautions

1) Requirement on residual current device (RCD)

The AC drive generates high leakage current during running, which flows through the protective earthing (PE) conductor. Thus install a type-B RCD at primary side of the power supply. When selecting the RCD, you should consider the transient and steady- state leakage current to ground that may be generated at startup and during running of the AC drive. You can select a specialized RCD with the function of suppressing high harmonics or a general-purpose RCD with relatively large residual current.

2) High leakage current warning

The AC drive generates high leakage current during running, which flows through the PE conductor. Earth connection must be done before connection of power supply. Earthing shall comply with local regulations and related IEC standards.

3) Motor insulation test

Perform the insulation test when the motor is used for the first time, or when it is reused after being stored for a long time, or in a regular check-up, in order to prevent the poor insulation of motor windings from damaging the AC drive. The motor must be disconnected from the AC drive during the insulation test. A 500-V mega-Ohm meter is recommended for the test. The insulation resistance must not be less than 5 M Ω .

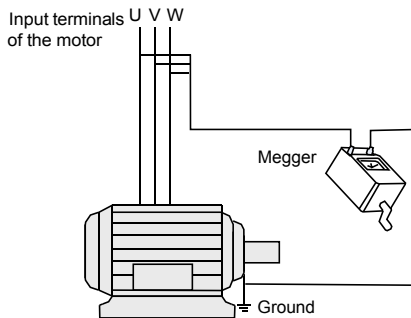

4) Thermal protection of motor

If the rated capacity of the motor selected does not match that of the AC drive, especially when the AC drive's rated power is greater than the motor's, adjust the motor protection parameters on the operation panel of the AC drive or install a thermal relay in the motor circuit for protection.

5) Running at over 50 Hz

The AC drive provides frequency output of 0 to 3200 Hz (Up to 300 Hz is supported if the AC drive runs in CLVC and SFVC mode). If the AC drive is required to run at over 50 Hz, consider the capacity of the machine.

6) Vibration of mechanical device

The AC drive may encounter the mechanical resonance point at some output frequencies, which can be avoided by setting the skip frequency.

7) Motor heat and noise

The output of the AC drive is pulse width modulation (PWM) wave with certain harmonic frequencies, and therefore, the motor temperature, noise, and vibration are slightly greater than those when the AC drive runs at power frequency (50 Hz).

8) Voltage-sensitive device or capacitor on output side of the AC drive

Do not install the capacitor for improving power factor or lightning protection voltage-sensitive resistor on the output side of the AC drive because the output of the AC drive is PWM wave. Otherwise, the AC drive may suffer transient overcurrent or even be damaged.

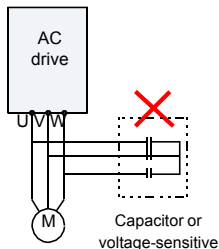

9) Contactor at the I/O terminal of the AC drive

When a contactor is installed between the input side of the AC drive and the power supply, the AC drive must not be started or stopped by switching the contactor on or off. If the AC drive has to be operated by the contactor, ensure that the time interval between switching is at least one hour since frequent charge and discharge will shorten the service life of the capacitor

inside the AC drive.

When a contactor is installed between the output side of the AC drive and the motor, do not turn off the contactor when the AC drive is active. Otherwise, modules inside the AC drive may be damaged.

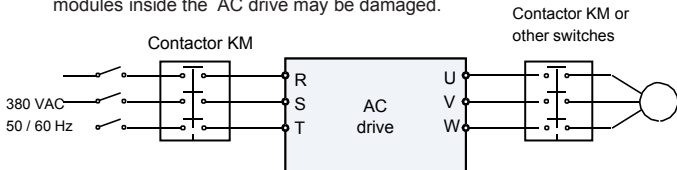

Do not start /stop the AC drive by switching the contactor on /off . If the AC drive has to be operated by the contactor , ensure that the time interval is at least one hour .

Turn on /off the contactor when the AC drive has no output . Otherwise, modules inside the AC drive may be damaged .

10) When external voltage is out of rated voltage range

The AC drive must not be used outside the allowable voltage range specified in this manual. Otherwise, the AC drive's components may be damaged. If required, use a corresponding voltage step-up or step-down device.

11) Prohibition of three-phase input changed into two-phase input

Do not change the three-phase input of the AC drive into two-phase input. Otherwise, a fault will result or the AC drive will be damaged.

12) Surge suppressor

The AC drive has a built-in voltage dependent resistor (VDR) for suppressing the surge voltage generated when the inductive loads (electromagnetic contactor, electromagnetic relay, solenoid valve, electromagnetic coil and electromagnetic brake) around the AC drive are switched on or off. If the inductive loads generate a very high surge voltage, use a surge suppressor for the inductive load or also use a diode.

Note

Do not connect the surge suppressor on the output side of the AC.

13) Altitude and de-rating

In places where the altitude is above 1000 m and the cooling effect reduces

due to thin air, it is necessary to de-rate the AC drive. Contact us for technical support.

14) Some special usages

If wiring that is not described in this manual such as common DC bus is applied, contact the agent or us for technical support.

15) Disposal

The electrolytic capacitors on the main circuits and PCB may explode when they are burnt. Poisonous gas is generated when the plastic parts are burnt. Treat them as ordinary industrial waste.

16) Adaptable Motor

- The standard adaptable motor is adaptable four-pole squirrel-cage asynchronous induction motor or PMSM. For other types of motor, select a proper AC drive according to the rated motor current.
- The cooling fan and rotor shaft of non-variable-frequency motor are coaxial, which results in reduced cooling effect when the rotational speed declines. If variable speed is required, add a more powerful fan or replace it with variable-frequency motor in applications where the motor overheats easily.
- The standard parameters of the adaptable motor have been configured inside the AC drive. It is still necessary to perform motor auto-tuning or modify the default
- values based on actual conditions. Otherwise, the running result and protection performance will be affected.
- The AC drive may alarm or even be damaged when short-circuit exists on cables or inside the motor. Therefore, perform insulation short-circuit test when the motor and cables are newly installed or during routine maintenance. During the test, make sure that the AC drive is disconnected from the tested part.

Product Information

Designation Rules and Nameplate of the DRIVE

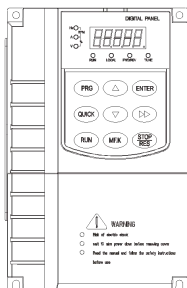

Nameplate

AC drive model

Power class

Rated input Rated

output

ManufacturingSN

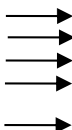

MODEL:

POWER: 1.5KW¹⁾INPUT: 3PH AC380V 5A 50Hz/60Hz²⁾OUTPUT: 3PH AC 0~380V 3.8A 0~300Hz²⁾S/N :

Electrical Installation

Description of Main Circuit Terminals

Description of Main Circuit Terminals of Three-phase AC drive

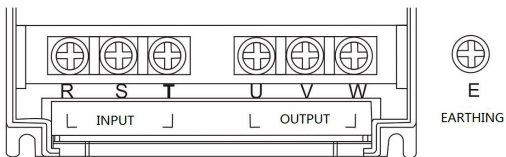
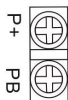

Description of Control Circuit Terminals

Terminal Arrangement of Control Circuit

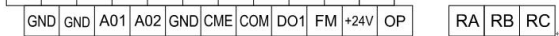

Wiring of AC Drive Control Circuit

Wiring mode of the AC drive control circuit

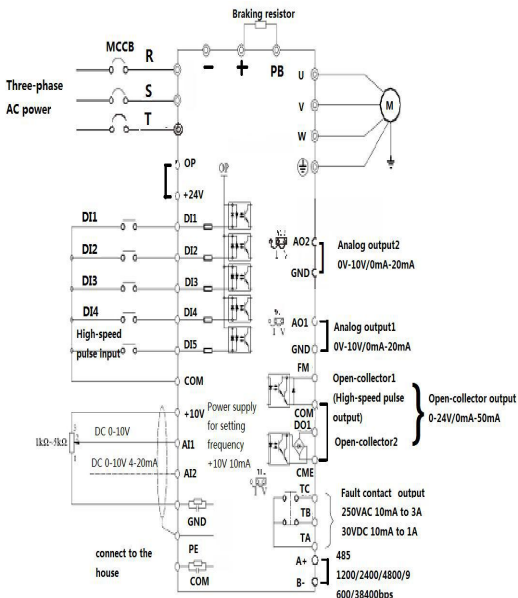

Note

- All the series AC drives have the same wiring mode. The figure here shows the wiring of single-phase 220 VAC drive. ⊙ indicates main circuit terminal, while ○ indicates control circuit terminal.
- When the external operation panel is connected, the display of the operation panel on the DRIVE goes off.

Physical Appearance and Overall Dimensions of the DRIVE

Physical appearance and overall dimensions of the DRIVE (plastic housing)

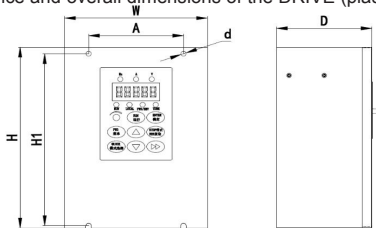

Model	H (mm)	H1 (mm)	W (mm)	A (mm)	D (mm)	Mounting Hole diameter (mm)
0. 75KW	263	252	130	90	145	Φ5
1. 5KW						
2. 2KW						
3. 7KW						
5. 5KW	265	255	152	90	157	Φ6
7. 5KW	370	360	182	140	152	Φ6
11KW						
15KW						
18. 5KW	375	364	265	220	155	Φ7. 5
22KW	400	384	275	220	170	Φ7. 5
30KW						
37KW	560	540	375	260	247	Φ10
45KW						
55KW						
75KW	718	697	342	260	266	Φ10
90KW						
110KW						

Overall dimensions and mounting hole dimensions of the DRIVE

Operation, Display and Application Examples

Operation Panel

You can modify the parameters, monitor the working status and start or stop the Drive by operating the operation panel, as shown in the following figure. Diagram of the operation panel.

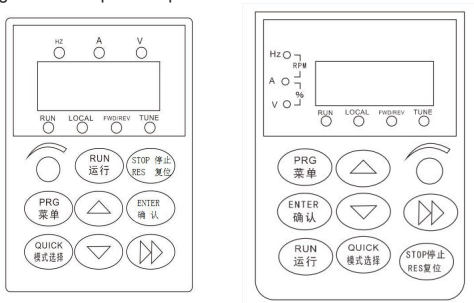

Description of Indicators

- RUN

ON indicates that the AC drive is in the running state, and OFF indicates that the AC drive is in the stop state

- LOCAL/REMOT

It indicates whether the AC drive is operated by means of operation panel, terminals or communication.

○ LOCAL/REMOT: OFF	Operation panel control
● LOCAL/REMOT: ON	Terminal control
◐ LOCAL/REMOT: blinking	Communication control

- FWD/REV

ON indicates reverse rotation, and OFF indicates forward rotation.

- TUNE/TC

User Manual

When the indicator is ON, it indicates torque control mode. When the indicator is blinking slowly, it indicates the auto-tuning state. When the indicator is blinking quickly, it indicates the fault state.

● Unit Indicators

● means that the indicator is ON, and ○ means that the indicator is OFF.

● —RPM—○% ○ —V Hz: unit of frequency

○ —RPM—●% ○ —V A: unit of current

○ —RPM—○% ● —V V: unit of voltage









● —RPM—●% ○ —V RPM: unit of rotational speed

○ —RPM—●% ● —V %: percentage

Digital Display

The 5-digit LED display is able to display the set frequency, output frequency, monitoring data and fault codes.

Description of Keys on the Operation Panel

Key	Name	Function
	Programming	Enter or exit Level I menu.
	Confirm	Enter the menu interfaces level by level, and confirm the parameter setting.
	Increment	Increase data or function code.
	<u>Decrement</u>	Decrease data or function code.
	Shift	Select the displayed parameters in turn in the stop or running state, and select the digit to be modified when modifying parameters.
	RUN	Start the AC drive in the operation panel control mode.
	Stop/Reset	Stop the AC drive when it is in the running state and perform the reset operation when it is in the fault state. The functions of this key are restricted in P7-02.
	<u>Multifunction</u>	Perform function <u>switchover</u> (such as quick <u>switchover</u> of command source or direction) according to the setting of P7-01.
	Menu mode selection	Perform <u>switchover</u> between menu modes according to the setting of PP-03.

Viewing and Modifying Function Code

The operation panel of the drive adopts three-level menu.

The three-level menu consists of function code group (Level I), function code (Level II), and function code setting value (level III), as shown in the following figure.

Operation procedure on the operation panel

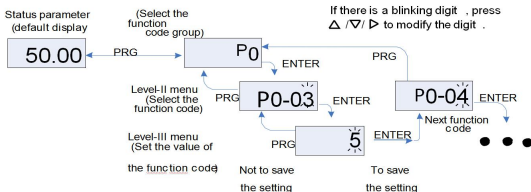

You can return to Level II menu from Level III menu by pressing **PRG** or **ENTER**.

- After you press **ENTER**, the system saves the parameter setting first, and then goes back to Level II menu and shifts to the next function code.
- After you press **PRG**, the system does not save the parameter setting, but directly returns to Level II menu and remains at the current function code.

Here is an example of changing the value of P3-02 to 15.00 Hz.

Figure 4-3 Example of changing the parameter value

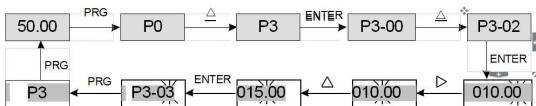

In Level III menu, if the parameter has no blinking digit, it means that the parameter cannot

be modified. This may be because:

- Such a function code is only readable, such as, AC drive model, actually detected parameter and running record parameter.
- Such a function code cannot be modified in the running state and can only be changed at stop.

Setting and Auto-tuning of Motor Parameters

Motor Auto-tuning

To obtain the motor parameters, the AC drive can perform dynamic auto-tuning or static auto-tuning. For the asynchronous motor that cannot be disconnected from

User Manual

the load, you can input the motor parameters of the same model that was successfully auto-tuned before.

	Application	Result
No-load dynamic	It is applied to applications where the motor (synchronous motor or asynchronous motor) can be disconnected from the load.	Best
With-load dynamic	It is applied to applications where the motor (synchronous motor or asynchronous motor) cannot be disconnected from the load.	OK
Static auto-tuning	It is applied to applications where the motor (asynchronous motor only) cannot be disconnected from the load and dynamic auto-tuning is not allowed.	Poor
Manual input	It is applied to applications where the motor (asynchronous motor only) cannot be disconnected from the load. Input the motor parameters of the same model that was successfully auto-tuned before into function codes P1-00 to P1-10.	OK

The following motor auto-tuning description takes motor 1 as an example. The auto-tuning of motor 2, 3, and 4 is the same and only the function codes are changed correspondingly.

The process of motor auto-tuning is as follows:

- 1) If the motor can be disconnected from the load, disconnect the motor from the load mechanically after power-off so that the motor can run without load.
- 2) After power-on, set P0-02 (Command source selection) to 0 (Operation panel control).

Motor	Parameter
Motor 1	P1-00: Motor type selection P1-01: Rated motor power P1-02: Rated motor voltage P1-03: Rated motor current P1-04: Rated motor frequency P1-05: Rated motor rotational speed
Motor 2	H2-00 to H2-05, defined the same as P-00 to P1-05
Motor3	H3-00 to H3-05, defined the same as P1-00 to P1-05
Motor 4	H4-00 to H4-05, defined the same as P1-00 to P1-05

- 3) Input the motor nameplate parameters (such as P1-00 to P1-05) correctly and input the following parameters based on the actually selected motor.

User Manual

For asynchronous motor, set P1-37 (Auto-tuning selection) to 2 (Asynchronous motor complete auto-tuning). For motors 2, 3, or 4, the corresponding function code is H2-37/ H3-37/ H4-37. Press **ENTER** on the operation panel. The operation panel displays:



Then press **RUN** on the operation panel. The AC drive will drive the motor to accelerate/decelerate and run in the forward/reverse direction, and the RUN indicator is ON. The auto-tuning lasts approximately 2 minutes. When the preceding display information disappears and the operation panel returns to the normal parameter display status, it indicates that the auto-tuning is complete.

Function Code Table

Group P and Group H are standard function parameters. Group S includes the monitoring function parameters.

The symbols in the function code table are described as follows:

"☆": The parameter can be modified when the AC drive is in either stop or running state. "★": The parameter cannot be modified when the AC drive is in the running state.

"●": The parameter is the actually measured value and cannot be modified.

"**": The parameter is factory parameter and can be set only by the manufacturer.

Standard Function Parameters

Function Code	Parameter Name	Setting Range	Default	Property
Group P0: Standard Function Parameters				
P0000	G/P type display	1: G type (constant torque load) 2: P type (variable torque load e.g. fan and pump)	Model dependent	●
P0001	Motor 1 control mode	0: Sensorless flux vector control (SFVC) 1: Closed-loop vector control (CLVC) 2: Voltage/Frequency (V/F) control	2	★
P0002	Command source selection	0: Operation panel control (LED off) 1: Terminal control (LED on) 2: Communication control (LED blinking)	0	☆
P0003	Main frequency source X selection	0: Digital setting (non-retentive at power failure) 1: Digital setting (retentive at power failure) 2: AI1 3: AI2 4: Keyboard potentiometer 5: Pulse setting (DI5) 6: Multi-reference 7: Simple PLC 8: PID 9: Communication setting	4	★

User Manual

P0004	Auxiliary frequency source Y selection	The same as F0-03 (Main frequency source X selection)	0 0	★
P0005	Range of auxiliary frequency Y for X and Y operation	0: Relative to maximum frequency 1: Relative to main frequency X	0 0	☆
P0006	Range of auxiliary frequency Y for X and Y operation	0%–150%	100%	☆
P0007	Frequency source selection	Unit's digit (Frequency source selection)	00	☆
		0: Main frequency source X 1: X and Y operation (operation relationship determined by ten's digit) 2: Switchover between X and Y 3: Switchover between X and "X and Y operation" 4: Switchover between Y and "X and Y operation"		
		Ten's digit (X and Y operation relationship)		
		0: X+Y 1: X-Y 2: Maximum 3: Minimum		
P0008	Preset frequency	0.00 to maximum frequency (valid when frequency source is digital setting)	50.00 Hz	☆
P0009	Rotation direction	0: Same direction 1: Reverse direction	0	☆
P0010	Maximum frequency	50.00–500.00 Hz	50.00 Hz	
P0011	Source of frequency upper limit	0: Set by P0-12 1: AI1 2: AI2 3: AI3 4: Pulse setting (DI5) 5: Communication setting	3	★

User Manual

P0012	Frequency upper limit	Frequency lower limit (P0-14) to maximum frequency (P0-10)	50.00 Hz	☆
P0013	Frequency upper limit offset	0.00 Hz to maximum frequency (P0-10)	0.00 Hz	☆
P0014	Frequency lower limit	0.00 Hz to frequency upper limit (P0-12)	0.00 Hz	☆
P0015	Carrier frequency	0.5–16.0 kHz	Model dependent	☆
P0016	Carrier frequency adjustment with temperature	0: No 1: Yes	1	☆
P0017	Acceleration time 1	0.00–650.00s (P0-19 = 2) 0.0–6500.0s (P0-19 = 1) 0–65000s (P0-19 = 0)	Model dependent	☆
P0018	Deceleration time 1	0.00–650.00s (P0-19 = 2) 0.0–6500.0s (P0-19 = 1) 0–65000s (P0-19 = 0)	Model dependent	☆
P0019	Acceleration/Deceleration time unit	0:1s 1: 0.1s 2: 0.01s	1	★
P0020	Retaining			
P0021	Frequency offset of auxiliary frequency source for X and Y operation	0.00 Hz to maximum frequency (P0-10)	0.00 Hz	☆
P0022	Frequency reference resolution	1: 0.1Hz 2: 0.01 Hz	2	★
P0023	Retentive of digital setting frequency upon power failure	0: Not retentive 1: Retentive	0	☆
P0024	Motor parameter group selection	0: Motor parameter group 1 1: Motor parameter group 2	0	
P0025	Acceleration/Deceleration time base frequency	0: Maximum frequency (P0-10) 1: Set frequency 2: 100 Hz	0	★

User Manual

P0026	Base frequency for UP/ DOWN modification during running	0: Running frequency 1: Set frequency	0	★
P0027	Binding command source to frequency source	Unit's digit (Binding operation panel command to frequency source) 0: No binding 1: Frequency source by digital setting 2: AI1 3: AI2 4: AI3 5: Pulse setting (DI5) 6: Multi-reference Ten's digit (Binding terminal command to frequency source) 0–9, same as unit's digit Hundred's digit (Binding communication command to frequency source) 0–9, same as unit's digit	000	☆
P0028	Serial communication protocol	0: Modbus protocol 1: Profibus-DP bridge 2: CANopen bridge	0	☆
Group P1: Motor 1 Parameters				
P0029	Motor type selection	0: Common asynchronous motor 1: Variable frequency asynchronous motor	0	★
P0030	Rated motor power	0.1–1000.0 kW	Model dependent	★
P0031	Rated motor voltage	1–2000 V	Model dependent	★
P0032	Rated motor current	0.01–655.35 A (AC drive power ≤ 55 kW) 0.1–6553.5 A (AC drive power >	Model dependent	★
P0033	Rated motor frequency	0.01 Hz to maximum frequency	Model dependent	★

User Manual

P0034	Rated motor rotational speed	1–65535 RPM	Model dependent	★
P0035	Stator resistance (asynchronous motor)	0.001–65.535 Ω (AC drive power ≤ 55 kW) 0.0001–6.5535 Ω (AC drive power > 55 kW)	Model dependent	★
P0036	Rotor resistance (asynchronous motor)	0.001–65.535 Ω (AC drive power ≤ 55 kW) 0.0001–6.5535 Ω (AC drive power > 55 kW)	Model dependent	★
P0037	Leakage inductive reactance (asynchronous motor)	0.01–655.35 mH (AC drive power ≤ 55 kW) 0.001–65.535 mH (AC drive)	Model dependent	★
P0038	Mutual inductive reactance (asynchronous motor)	0.1–6553.5 mH (AC drive power ≤ 55 kW) 0.01–655.35 mH (AC drive power > 55 kW)	Model dependent	★
P0039	No-load current (asynchronous motor)	0.01 to P0032 (AC drive power ≤ 55 kW) 0.1 to P0032 (AC drive power > 55 kW)	Model dependent	★
P0045	Stator resistance (synchronous motor)	0.001–65.535 Ω (AC drive power ≤ 55 kW) 0.0001–6.5535 Ω (AC drive power > 55 kW)	Model dependent	★
P0046	Shaft D inductance (synchronous motor)	0.01–655.35 mH (AC drive power ≤ 55 kW) 0.001–65.535 mH (AC drive power > 55 kW)	Model dependent	★
P0047	Shaft Q inductance (synchronous motor)	0.01–655.35 mH (AC drive power ≤ 55 kW) 0.001–65.535 mH (AC drive power > 55 kW)	Model dependent	★
P0049	Back EMF (synchronous motor)	0.1–6553.5 V	Model dependent	★
P0056	Encoder pulses per revolution	1–65535	1024	★
P0057	Encoder type	0: ABZ incremental encoder 1: UVW incremental encoder 2: Resolver 3: SIN/COS encoder 4: Wire-saving UVW encoder	0	★

User Manual

P0059	A/B phase sequence of ABZ incremental encoder	0: Forward 1: Reserve	0	★
P0060	Encoder installation angle	0.0°–359.9°	0.0°	★
P0061	U, V, W phase sequence of UVW encoder	0: Forward 1: Reverse	0	★
P0062	UVW encoder angle offset	0.0°–359.9°	0.0°	★
P0063	Number of pole pairs of resolver	1–65535	1	★
P0065	Encoder wire-break fault detection time	0.0s: No action 0.1–10.0s	0.0s	★
P0066	Auto-tuning selection	0: No auto-tuning 1: Asynchronous motor static auto-tuning 2: Asynchronous motor complete auto-tuning 11: Synchronous motor with-load auto-tuning 12: Synchronous motor no-load auto-tuning	0	★
Group P2: Vector Control Parameters				
P0067	Speed loop proportional gain 1	0–100	3	☆
P0068	Speed loop integral time 1	0.01–10.00s	0.50s	☆
P0069	Switchover frequency 1	0.00 to P0072	5.00 Hz	☆
P0070	Speed loop proportional gain 2	0–100	2	☆
P0071	Speed loop integral time 2	0.01–10.00s	1.00s	☆
P0072	Switchover frequency 2	P0069 to maximum output frequency	10.00 Hz	☆
P0073	Vector control slip gain	50%–200%	100%	☆
P0074	Time constant of speed loop filter	0.000–0.100s	0.000s	☆

User Manual

P0075	Vector control over- excitation gain	0–200	64	☆
P0076	Torque upper limit source in speed control mode	0: P0077 1: AI1 2: AI2 3: AI3 4: Pulse setting (DI5) 5: Communication setting	0	☆
P0077	Digital setting of torque upper limit in speed control mode	0.0%–200.0%	150.0%	☆
P0080	Excitation adjustment proportional gain	0–60000	2000	☆
P0081	Excitation adjustment integral gain	0–60000	1300	☆
P0082	Torque adjustment proportional gain	0–60000	2000	☆
P0083	Torque adjustment integral gain	0–60000	1300	☆
P0084	Speed loop integral property	Unit's digit: integral separation 0: Disabled 1: Enabled	0	☆

User Manual

Group P3: V/F Control Parameters				
P0090	V/F curve setting	0: Linear V/F 1: Multi-point V/F 2: Square V/F 3: 1.2-power V/F 4: 1.4-power V/F 6: 1.6-power V/F 8: 1.8-power V/F 9: Reserved 10: V/F complete separation 11: V/F half separation	0	★
P0091	Torque boost	0.0% (fixed torque boost) 0.1%–30.0%	Model dependent	☆
P0092	Cut-off frequency of torque boost	0.00 Hz to maximum output frequency	50.00 Hz	★
P0093	Multi-point V/F frequency 1(F1)	0.00 Hz to P0095	0.00 Hz	★
P0094	Multi-point V/F voltage 1 (V1)	0.0%–100.0%	0.0%	★
P0095	Multi-point V/F frequency 2 (F2)	P0093 to P0097	0.00 Hz	★
P0096	Multi-point V/F voltage 2 (V2)	0.0%–100.0%	0.0%	★
P0097	Multi-point V/F frequency 3 (F3)	P0095 to rated motor frequency (P0033)	0.00 Hz	
P0098	Multi-point V/F voltage 3 (V3)	0.0%–100.0%	0.0%	★
P0099	V/F slip compensation gain	0%–200.0%	0.0%	☆
P0100	V/F over-excitation gain	0–200	64	☆
P0101	V/F oscillation suppression gain	0–100	Model dependent	☆

User Manual

P0103	Voltage source for V/F separation	<p>0: Digital setting (P0104)</p> <p>1: AI1</p> <p>2: AI2</p> <p>3: AI3</p> <p>4: Pulse setting (DI5)</p> <p>5: Multi-reference</p> <p>6: Simple PLC</p> <p>7: PID</p> <p>8: Communication</p> <p>setting 100.0% corresponds to the rated</p>	0	☆
P0104	Voltage digital setting for V/F separation	0 V to rated motor voltage	0 V	☆
P0105	Voltage rise time of V/F separation	<p>0.0–1000.0s</p> <p>It indicates the time for the voltage rising from 0 V to rated motor voltage.</p>	0.0s	☆
P0106	Voltage decline time of V/F separation	<p>0.0–1000.0s</p> <p>It indicates the time for the voltage to decline from rated motor voltage to 0 V.</p>	0.0s	☆
P0107	Stop mode selection upon V/F separation	<p>0: Frequency and voltage declining to 0 independently</p> <p>1: Frequency declining after voltage declines to 0</p>	0	☆

Group P4: Input Terminals				
P0108	DI1 function selection	0: No function 1: Forward RUN (FWD)	1	★
P0109	DI2 function selection	2: Reverse RUN (REV) 3: Three-line control	2	★
P0110	DI3 function selection	4: Forward JOG (FJOG) 5: Reverse JOG (RJOG) 6: Terminal UP 7: Terminal DOWN 8: Coast to stop 9: Fault reset (RESET) 10: RUN pause 11: Normally open (NO) input of external fault 12: Multi-reference terminal 1 13: Multi-reference terminal 2 14: Multi-reference terminal 3 15: Multi-reference terminal 4 16: Terminal 1 for acceleration/ deceleration time selection 17: Terminal 2 for acceleration/ deceleration time selectn	9	★
P0111	DI4 function selection	18: Frequency source switchover 19: UP and DOWN setting clear (terminal, operation panel) 20: Command source switchover terminal 1 21: Acceleration/Deceleration prohibited	12	★
P0112	DI5 function selection	22: PID pause 23: PLC status reset 24: Swing pause 25: Counter input 26: Counter reset 27: Length count input 28: Length reset 29: Torque control prohibited	13	★

User Manual

Function Code	Parameter Name	Setting Range	Default	Property
P0121	DI6 function selection	30: Pulse input (enabled only for DI5) 31:Reserved 32: Immediate DC braking 33: Normally closed (NC) input of external fault 34: Frequency modification forbidden	0	★
P4-14				
P4-15				
P0114	DI7 function selection	35: Reverse PID action direction 36: External STOP terminal 1 37: Command source switchover terminal 2 38: PID integral pause	0	★
P0115	DI8 function selection	39: Switchover between main frequency source X and preset frequency 40:Switchover between auxiliary frequency source Y and preset frequency	0	★
P0116	DI9 function selection	41: Motor selection terminal 1 42: Motor selection terminal 2 43:PIDparameter switchover 44: User-defined fault 1 45: User-defined fault 2 46: Speed control/Torque control switchover 47: Emergency stop 48: External STOP terminal 2 49: Deceleration DC braking 50: Clear the current running time 51:Switchover between two-line mode and three-line mode	0	★
P0117	DI10 function selection		0	★
P0118	DI filter time	0.000–1.000s	0.010s	☆
P0119	Terminal command mode	0: Two-line mode 1 1: Two-line mode 2 2: Three-line mode 1 3: Three-line mode 2	0	★
P0120	Terminal UP/DOWN rate	0.01–65.535 Hz/s	1.00 Hz/s	☆
P0121	AI curve 1 minimum input	0.00 V to P0123	0.00 V	☆

Function Code	Parameter Name	Setting Range	Default	Property
P0141	AI curve selection	Unit's digit (AI1 curve selection)	321	☆
		Curve 1 (2 points, see P0121to P0124)		
		Curve 2 (2 points, see P0126to P0129)		
		Curve 3 (2 points, see P0131to P0134)		
		Curve 4 (4 points)		
		Curve 5 (4 points)		
		Ten's digit (AI2 curve selection)		
		Curve 1 to curve 5 (same as AI1)		
		Hundred's digit (AI3 curve selection)		
		Curve 1 to curve 5 (same as AI1)		
P0142	Setting for AI less than minimum input	Unit's digit (Setting for AI1 less than minimum input)	000	☆
		0: Minimum value		
		1: 0.0%		
		Ten's digit (Setting for AI2 less than minimum input)		
		0, 1 (same as AI1)		
		Hundred's digit (Setting for AI3 less than minimum input)		
		0, 1 (same as AI1)		
P0143	DI1 delay time	0.0–3600.0s	0.0s	★
P0144	DI2 delay time	0.0–3600.0s	0.0s	★
P0145	DI3 delay time	0.0–3600.0s	0.0s	★
P0146	DI valid mode selection 1	Thousand's digit (DI4 valid mode)	00000	★
		0, 1 (same as DI1)		
		Ten thousand's digit (DI5 valid mode)		
		0, 1 (same as DI1)		

Group P5: Output Terminals				
P0148	FM terminal output mode	0: Pulse output (FMP) 1: Switch signal output (FMR)	0	☆
P0149	FMR function (open-collector output terminal)	0: No output 1: AC drive running 2: Fault output (stop) 3: Frequency-level detection FDT1 output 4: Frequency reached 5: Zero-speed running (no output at stop) 6: Motor overload pre-warning 7: AC drive overload pre-warning 8: Set count value reached 9: Designated count value reached	0	☆
P0150	Relay function (T/A-T/B-T/C)	10: Length reached 11: PLC cycle complete 12: Accumulative running time reached 13: Frequency limited	2	☆

Function Code	Parameter Name	Setting Range	Default	Property
P0151	Extension card relay function (P/A-P/B-P/C)	14: Torque limited 15: Ready for RUN	0	☆
P0152	DO1 function selection (open-collector output terminal)	16: AI1 larger than AI2 17: Frequency upper limit reached 18: Frequency lower limit reached (no output at stop) 19: Undervoltage state output 20: Communication setting 21: Reserved 22: Reserved 23: Zero-speed running 2 (having output at stop) 24: Accumulative power-on time reached 25: Frequency level detection FDT2 output 26: Frequency 1 reached 27: Frequency 2 reached 28: Current 1 reached 29: Current 2 reached 30: Timing reached 31: AI1 input limit exceeded 32: Load becoming 0 33: Reverse running 34: Zero current state 35: Module temperature reached 36: Software current limit exceeded 37: Frequency lower limit reached (having output at stop) 38: Alarm output 39: Motor overheat warning 40: Current running time reached	1	☆
P0153	Extension card DO2 function	41: Fault output (There is no output if it is the coast to stop fault and undervoltage occurs.)	4	☆

User Manual

Function Code	Parameter Name	Setting Range	Default	Property
P0154	FMP function selection	0:Running frequency	0	☆
P0155	AO1 function selection	1: Set frequency 2: Output current 3:Outputtorque(absolute value)	0	☆
P0156	AO2 function selection	4: Output power 5: Output voltage 6:Pulse input 7: AI1 8: AI2 9: AI3 10: Length 11: Count value 12: Communication setting 13: Motor rotational speed 14: Output current 15: Output voltage 16:Output torque (actual value) 17: Inverter output torque	1	☆
P0157	Maximum FMP output frequency	0.01–100.00 kHz	50.00 kHz	☆
P0158	AO1 offset coefficient	-100.0%–100.0%	0.0%	☆
P0159	AO1 gain	-10.00–10.00	1.00	☆
P0163	AO2 offset coefficient	-100.0%–100.0%	0.00%	☆
P0164	AO2 gain	-10.00–10.00	1.00	☆
P0165	FMR output delay time	0.0–3600.0s	0.0s	☆
P0166	Relay 1 output delay time	0.0–3600.0s	0.0s	☆
P0167	Relay 2 output delay time	0.0–3600.0s	0.0s	☆
P0168	DO1 output delay time	0.0–3600.0s	0.0s	☆
P0169	DO2 output delay time	0.0–3600.0s	0.0s	☆

User Manual

Function Code	Parameter Name	Setting Range	Default	Property
P0170	DO valid mode selection	Unit's digit (FMR valid mode)	00000	☆
		0: Positive logic 1: Negative logic		
		Ten's digit (Relay 1 valid mode)		
		0, 1 (same as FMR)		
		Hundred's digit (Relay 2 valid mode)		
		0, 1 (same as FMR)		
		Thousand's digit (DO1 valid mode)		
		0, 1 (same as FMR)		
		Ten thousand's digit (DO2 valid mode)		
		0, 1 (same as FMR)		

Group P6: Start/Stop Control

P0171	Start mode	0: Direct start 1: Rotational speed tracking restart 2: Pre-excited start (asynchronous motor)	0	☆
P0172	Rotational speed tracking mode	0: From frequency at stop 1: From zero speed 2: From maximum frequency	0	★
P0173	Rotational speed tracking speed	1–100	20	☆
P0174	Startup frequency	0.00–10.00 Hz	0.00 Hz	☆
P0175	Startup frequency holding time	0.0–100.0s	0.0s	★
P0176	Startup DC braking current/ Pre-excited current	0%–100%	0%	★
P0177	Startup DC braking time/ Pre-excited time	0.0–100.0s	0.0s	★

User Manual

P0178	Acceleration/Deceleration mode	0: Linear acceleration/ deceleration 1: S-curve acceleration/ deceleration A 2: S-curve acceleration/ deceleration B	0	★
P0179	Time proportion of S-curve start segment	0.0% to (100.0% – F6-09)	30.0%	★
P0180	Time proportion of S-curve end segment	0.0% to (100.0% – F6-08)	30.0%	★
P0181	Stop mode	0: Decelerate to stop 1: Coast to stop	0	☆
P0182	Initial frequency of stop DC braking	0.00 Hz to maximum frequency	0.00 Hz	☆
P0183	Waiting time of stop DC braking	0.0–100.0s	0.0s	☆
P0184	Stop DC braking current	0%–100%	0%	☆
P0185	Stop DC braking time	0.0–100.0s	0.0s	☆
P0186	Brake use ratio	0%–100%	100%	☆

Group P7: Operation Panel and Display

User Manual

P0188	MF.K Key function selection	0: MF.K key disabled 1: Switchover between operation panel control and remote command control (terminal or communication) 2: Switchover between forward rotation and reverse rotation 3: Forward JOG 4: Reverse JOG	0	★
P0189	STOP/RESET key function	0: STOP/RESET key enabled only in operation panel control 1: STOP/RESET key enabled in any operation mode	0	☆

<p>P0190</p>	<p>LED display running parameters 1</p>	<p>0000–FFFF Bit00: Running frequency 1 (Hz) Bit01: Set frequency (Hz) Bit02: Bus voltage (V) Bit03: Output voltage (V) Bit04: Output current (A) Bit05: Output power (kW) Bit06: Output torque (%) Bit07: DI input status Bit08: DO output status Bit09: AI1 voltage (V) Bit10: AI2 voltage (V) Bit11: AI3 voltage (V) Bit12: Count value Bit13: Length value Bit14: Load speed display Bit15: PID setting</p>	<p>1F</p>	<p>☆</p>
<p>P0191</p>	<p>LED display running parameters 2</p>	<p>0000–FFFF Bit00: PID feedback Bit01: PLC stage Bit02: Pulse setting frequency (kHz) Bit03: Running frequency 2 (Hz) Bit04: Remaining running time Bit05: AI1 voltage before correction (V) Bit06: AI2 voltage before correction (V) Bit07: AI3 voltage before correction (V) Bit08: Linear speed Bit09: Current power-on time (Hour) Bit10: Current running time (Min) Bit11: Pulse setting frequency (Hz) Bit12: Communication setting value Bit13: Encoder feedback speed (Hz) Bit14: Main frequency X display (Hz) Bit15: Auxiliary frequency Y display (Hz)</p>	<p>0</p>	<p>☆</p>

User Manual

Function Code	Parameter Name	Setting Range	Default	Property
P0192	LED display stop parameters	0000–FFFF Bit00: Set frequency (Hz) Bit01: Bus voltage (V) Bit02: DI input status Bit03: DO output status Bit04: AI1 voltage (V) Bit05: AI2 voltage (V) Bit06: AI3 voltage (V) Bit07: Count value Bit08: Length value Bit09: PLC stage Bit10: Load speed Bit11: Psetting Bit12: Pulse setting frequency (kHz)	33	☆
P0193	Load speed display coefficient	0.0001–6.5000	1.0000	☆
P0194	Heatsink temperature of inverter module	0.0–100.0°C	-	●
P0195	Temporary software version	-	-	●
P0196	Accumulative running time	0–65535 h	-	●
P0197	Product number	-	-	●
P0198	Software version	-	-	●
P0199	Number of decimal places for load speed display	0: 0 decimal place 1: 1 decimal place 2: 2 decimal places 3: 3 decimal places	1	●
P0200	Accumulative power-on time	0–65535 h	0 h	●
P0201	Accumulative power	0–65535 kWh		●
Group P8: Auxiliary Functions				
P0202	JOG running frequency	0.00 Hz to maximum frequency	2.00 Hz	☆
P0203	JOG acceleration time	0.0–6500.0s	20.0s	☆
P0204	JOG deceleration time	0.0–6500.0s	20.0s	☆
P0205	Acceleration time 2	0.0–6500.0s	Model dependent	☆
P0206	Deceleration time 2	0.0–6500.0s	Model dependent	☆

User Manual

Function Code	Parameter Name	Setting Range	Default	Propert
P0207	Acceleration time 3	0.0–6500.0s	Model depende	☆
P0208	Deceleration time 3	0.0–6500.0s	Model depende	☆
P0209	Acceleration time 4	0.0–500.0s	Model depende	☆
P0210	Deceleration time 4	0.0–6500.0s	Model depende	☆
P0211	Jump frequency 1	0.00 Hz to maximum frequency	0.00 Hz	☆
P0212	Jump frequency 2	0.00 Hz to maximum frequency	0.00 Hz	☆
P0213	Frequency jump amplitude	0.00 Hz to maximum frequency	0.01 Hz	☆
P0214	Forward/Reverse rotation dead-zone time	0.0–3000.0s	0.0s	☆
P0215	Reverse control	0: Enabled 1: Disabled	0	☆
P0216	Running mode when set frequency lower than frequency lower limit	0: Run at frequency lower limit 1: Stop 2: Run at zero speed	0	☆
P0217	Droop control	0.00–10.00 Hz	0.00	☆
P0218	Accumulative power-on time threshold	0–65000 h	0 h	☆
P0219	Accumulative running time threshold	0–65000 h	0	☆
P0220	Startup protection	0: No 1: Yes	0	☆
P0221	Frequency detection value (FDT1)	0.00 Hz to maximum frequency	50.00	☆
P0222	Frequency detection hysteresis (FDT hysteresis 1)	0.0%–100.0% (FDT1 level)	5.0%	☆
P0223	Detection range of frequency reached	0.00–100% (maximum frequency)	0.0%	☆

User Manual

P0224	Jump frequency during acceleration/deceleration	0: Disabled1: Enabled	0	☆
P0227	Frequency switchover point between acceleration time 1 and acceleration time 2	0.00 Hz to maximum frequency	0.00 Hz	☆
P0228	Frequency switchover point between deceleration time 1 and deceleration time 2	0.00 to maximum frequency	0.00 Hz	☆
P0229	Terminal JOG preferred	0: Disabled1: Enabled	0	☆

P0230	Frequency detection value (FDT2)	0.00 to maximum frequency	50.00 Hz	☆
P0231	Frequency detection hysteresis (FDT hysteresis 2)	0.0%–100.0% (FDT2 level)	5.0%	☆
P0232	Any frequency reaching detection value 1	0.00 Hz to maximum frequency	50.00 Hz	☆
P0233	Any frequency reaching detection amplitude 1	0.0%–100.0% (maximum frequency)	0.0%	☆
P0234	Any frequency reaching detection value 2	0.00 Hz to maximum frequency	50.00 Hz	☆
P0235	Any frequency reaching detection amplitude 2	0.0%–100.0% (maximum frequency)	0.0%	☆
P0236	Zero current detection level	0.0%–300.0% (rated motor current)	5.0%	☆
P0237	Zero current detection delay time	0.00–600.00s	0.10s	☆
P0238	Output overcurrent threshold	% (no detection) %–300.0% (rated motor current)	200.0%	☆
P0239	Output overcurrent detection delay time	0.00–600.00s	0.00s	☆
P0240	Any current reaching 1	0.0%–300.0% (rated motor current)	100.0%	☆
P0241	Any current reaching 1 amplitude	0.0%–300.0% (rated motor current)	0.0%	☆

User Manual

P0242	Any current reaching 2	0.0%–300.0% (rated motor current)	100.0%	☆
P0243	Any current reaching 2 amplitude	0.0%–300.0% (rated motor current)	0.0%	☆
P0244	Timing function	0: Disabled 1: Enabled	0	☆
P0245	Timing duration source	0: P8-44 1: AI1 2: AI2 3: AI3 (100% of analog input corresponds to the value of P0246)	0	☆
P0246	Timing duration	0.0–6500.0 min	0.0 min	☆
P0247	AI1 input voltage lower limit	0.00 V to P0248	3.10 V	☆
P0248	AI1 input voltage upper limit	P0247 to 10.00 V	6.80 V	☆
P0249	Module temperature threshold	0–100°C	75°C	☆
P0250	Cooling fan control	0: Fan working during running 1: Fan working continuously	0	☆
P0251	Wakeup frequency	Dormant frequency (P0253) to maximum frequency (P0010)	0.00 Hz	☆
P0252	Wakeup delay time	0.0–6500.0s	0.0s	☆
P0253	Dormant frequency	0.00 Hz to wakeup frequency (P0251)	0.00 Hz	☆
P0254	Dormant delay time	0.0–6500.0s	0.0s	☆
P0255	Current running time reached	0.0–6500.0 min	0.0 min	☆
Group P9: Fault and Protection				
P0256	Motor overload protection selection	0: Disabled 1: Enabled	1	☆
P0257	Motor overload protection gain	0.20–10.00	1.00	☆
P0258	Motor overload warning coefficient	50%–100%	80%	☆
P0263	Short-circuit to ground upon power-on	0: Disabled 1: Enabled	1	☆
P0264	Fault auto reset times	0–20	0	☆

User Manual

P0266	DO action during fault auto reset	0: Not act 1: Act	0	☆
P0267	Time interval of fault auto reset	0.1s–100.0s	1.0s	☆
P0268	Input phase loss protection/ contactor energizing protection selection	Unit's digit: Input phase loss protection Ten's digit: Contactor energizing protection 0: Disabled 1: Enabled	11	☆

User Manual

Function Code	Parameter Name	Setting Range	Default	Property
P0269	Output phase loss protection selection	0: Disabled 1: Enabled	1	☆
P0270	1st fault type	0: No fault 1: Reserved 2: Overcurrent during acceleration 3: Overcurrent during deceleration 4: Overcurrent at constant speed 5: Overvoltage during acceleration 6: Overvoltage during deceleration 7: Overvoltage at constant speed 8: Buffer resistance overload 9: Undervoltage 10: AC drive overload 11: Motor overload 12: Power input phase loss 13: Power output phase loss 14: Module overheat 15: External equipment fault 16: Communication fault 17: Contactor fault 18: Current detection fault 19: Motor auto-tuning fault 20: Encoder/PG card fault 21: EEPROM read-write fault 22: AC drive hardware fault 23: Short circuit to ground 24: Reserved 25: Reserved 26: Accumulative running time reached 27: User-defined fault 1 28: User-defined fault 2 29: Accumulative power-on time reached 30: Load becoming 0 31: PID feedback lost during running	-	●
P0271	2nd fault type			●

User Manual

Function Code	Parameter Name	Setting Range	Default	Propert
P0272	3rd (latest) fault type	40: With-wave current limit fault 41: Motor switchover fault during running 42: Too large speed deviation 43: Motor over-speed 45: Motor overheat 51: Initial position fault	-	•
P0273	Frequency upon 3rd fault	-	-	•
P0274	Current upon 3rd fault	-	-	•
P0275	Bus voltage upon 3rd fault	-	-	•
P0276	DI status upon 3rd fault	-	-	•
P0277	Output terminal status upon 3rd fault	-	-	•
P0278	AC drive status upon 3rd fault	-	-	•
P0279	Power-on time upon 3rd fault	-	-	•
P0280	Running time upon 3rd fault	-	-	•
P0283	Frequency upon 2nd fault	-	-	•
P0284	Current upon 2nd fault	-	-	•
P0285	Bus voltage upon 2nd fault	-	-	•
P0286	DI status upon 2nd fault	-	-	•
P0287	Output terminal status upon 2nd fault	-	-	•
P0288	AC drive status upon 2nd fault	-	-	•
P0289	Power-on time upon 2nd fault	-	-	•
P0290	Running time upon 2nd fault	-	-	•
P0293	Frequency upon 1st fault	-	-	•
P0294	Current upon 1st fault	-	-	•
P0295	Bus voltage upon 3rd fault	-	-	•
P0296	DI status upon 1st fault	-	-	•
P0297	Output terminal status upon 1st fault	-	-	•
P0298	AC drive status upon 1st fault			
P0299	Power-on time upon 1st fault			

User Manual

P0300	Running time upon 1st fault			
P0303	Fault protection action selection 1	Unit's digit (Motor overload, Err11)	00000	☆
		0: Coast to stop 1: Stop according to the stop mode 2: Continue to run		
		Ten's digit (Power input phase loss, Err12)		
		Same as unit's digit		
		Hundred's digit (Power output phase loss, Err13)		
		Same as unit's digit		
		Thousand's digit (External equipment fault, Err15)		
		Same as unit's digit		
		Ten thousand's digit (Communication fault, Err16)		
		Same as unit's digit		
P0304	Fault protection action selection 2	Unit's digit (Encoder fault, Err20)	00000	☆
		0: Coast to stop 1: Switch over to V/F control, stop according to the stop mode 2: Switch over to V/F control, continue to run		
		Ten's digit (EEPROM read-write fault, Err21)		
		0: Coast to stop 1: Stop according to the stop mode		
		Hundred's digit: reserved		
		Thousand's digit (Motor overheat, Err25)		
		Same as unit's digit in P9-47		
		Ten thousand's digit (Accumulative running time reached)		
Same as unit's digit in P9-47				
		Unit's digit (User-defined fault 1, Err27)		

		Same as unit's digit in P0303		
		Ten's digit (User-defined fault 2, Err28)		
		Same as unit's digit in P0303		
		Hundred's digit (Accumulative power-on time reached, Err29)		
		Same as unit's digit in P0303		
		Thousand's digit (Load becoming 0, Err30)		
		0: Coast to stop 1: Stop according to the stop mode 2: Continue to run at 7% of rated motor frequency and resume		
		Ten thousand's digit (PID feedback lost during running, Err31)		
		Same as unit's digit in P0303		
P0306	Fault protection action selection 4	Unit's digit (Too large speed deviation, Err42)	00000	☆
		Same as unit's digit in P0303		
		Ten's digit (Motor over-speed, Err43)		
		Same as unit's digit in P0303		
		Hundred's digit (Initial position fault, Err51)		
		Same as unit's digit in P0303		
		Thousand's digit (Speed feedback fault, Err52)		
		Same as unit's digit in P0303		
		Ten thousand's digit: Reserved		

P0310	Frequency selection for continuing to run upon fault	0: Current running frequency 1: Set frequency 2: Frequency upper limit 3: Frequency lower limit 4: Backup frequency upon abnormality	0	☆
P0311	Backup frequency upon abnormality	0.0%–100.0% (maximum frequency)	100.0%	☆
P0312	Type of motor temperature sensor	0: No temperature sensor 1: PT100 2: PT1000	0	☆
P0313	Motor overheat protection threshold	0–200°C	110°C	☆
P0314	Motor overheat warning threshold	0–200°C	90°C	☆
P0315	Action selection at instantaneous power	0: Invalid 1: Decelerate 2: Decelerate to stop	0	☆
P0316	Action pause judging voltage at instantaneous	80.0%–100.0%	90.0%	☆
P0317	Voltage rally judging time at instantaneous power	0.00–100.00s	0.50s	☆
P0318	Action judging voltage at instantaneous power	60.0%–100.0% (standard bus voltage)	80.0%	☆
P0319	Protection upon load becoming 0	0: Disabled 1: Enabled	0	☆
P0320	Detection level of load becoming 0	0.0%–100.0% (rated motor current)	10.0%	☆
P0321	Detection time of load becoming 0	0.0–60.0s	1.0s	☆
P0323	Over-speed detection value	0.0%–50.0% (maximum frequency)	20.0%	☆
P0324	Over-speed detection time	0.0–60.0s	1.0s	☆

User Manual

P0325	Detection value of too large speed deviation	0.0%–50.0% (maximum frequency)	20.0%	☆
P0326	Detection time of too large speed deviation	0.0–60.0s	5.0s	☆
Group PA: Process Control PID Function				
P0327	PID setting source	0: PA-01 1: AI1 2: AI2 3: AI3 4: Pulse setting (DI5) 5: Communication setting 6: Multi-reference	0	☆
P0328	PID digital setting	0.0%–100.0%	50.0%	☆
P0329	PID feedback source	0: AI1 1: AI2 2: AI3 3: AI1 – AI2 4: Pulse setting (DI5) 5: Communication setting 6: AI1 + AI2 7: MAX (AI1 , AI2) 8: MIN (AI1 , AI2)	0	☆
P0330	PID action direction	0: Forward action 1: Reverse action	0	☆
P0331	PID setting feedback range	0–65535	1000	☆
P0332	Proportional gain Kp1	0.0–100.0	20.0	☆
P0333	Integral time Ti1	0.01–10.00s	2.00s	☆
P0334	Differential time Td1	0.00–10.000	0.000s	☆
P0335	Cut-off frequency of PID reverse rotation	0.00 to maximum frequency	2.00 Hz	☆
P0336	PID deviation limit	0.0%–100.0%	0.0%	☆
P0337	PID differential limit	0.00%–100.00%	0.10%	☆
P0338	PID setting change time	0.00–650.00s	0.00s	☆
P0339	PID feedback filter time	0.00–60.00s	0.00s	☆
P0340	PID output filter time	0.00–60.00s	0.00s	☆
P0341	Reserved	-	-	☆
P0342	Proportional gain Kp2	0.0–100.0	20.0	☆
P0343	Integral time Ti2	0.01–10.00s	2.00s	☆
P0344	Differential time Td2	0.000–10.000s	0.000s	☆

User Manual

P0345	PID parameter switchover condition	0: No switchover 1: Switchover via DI 2: Automatic switchover based on deviation	0	☆
P0346	PID parameter switchover deviation 1	0.0% to P0347	20.0%	☆
P0347	PID parameter switchover deviation 2	P0346 to 100.0%	80.0%	☆
P0348	PID initial value	0.0%–100.0%	0.0%	☆
P0349	PID initial value holding time	0.00–650.00s	0.00s	☆
P0350	Maximum deviation between two PID outputs in forward	0.00%–100.00%	1.00%	☆
P0351	Maximum deviation between two PID outputs in reverse direction	0.00%–100.00%	1.00%	☆
P0352	PID integral property	Unit's digit (Integral separated)	0	☆
		0: Invalid 1: Valid		
		Ten's digit (Whether to stop integral operation when the output reaches the limit)		
		0: Continue integral operation 1: Stop integral operation		
P0353	Detection value of PID feedback	0.0%: Not judging feedback loss 0.1%–100.0%	0.0%	☆
P0354	Detection time of PID feedback loss	0.0–20.0s	0.0s	☆
P0355	PID operation at stop	0: No PID operation at stop 1: PID operation at stop	0	☆
Group PB: Swing Frequency, Fixed Length and Count				
P0365	Swing frequency setting mode	0: Relative to the central frequency 1: Relative to the maximum frequency	0	☆
P0366	Swing frequency	0.0%–100.0%	0.0%	☆
P0367	Jump frequency amplitude	0.0%–50.0%	0.0%	☆
P0368	Swing frequency cycle	0.0–3000.0s	10.0s	☆

User Manual

P0369	Triangular wave rising time coefficient	0.0%–100.0%	50.0%	☆
P0370	Set length	0–65535 m	1000 m	☆
P0371	Actual length	0–65535 m	0 m	☆
P0372	Number of pulses per	0.1–6553.5	100.0	☆
P0373	Set count value	1–65535	1000	☆
P0374	Designated count value	1–65535	1000	☆
Group PC: Multi-Reference and Simple PLC Function				
P0375	Reference 0	-100.0%–100.0%	0.0%	☆
P0376	Reference 1	-100.0%–100.0%	0.0%	☆
P0377	Reference 2	-100.0%–100.0%	0.0%	☆
P0378	Reference 3	-100.0%–100.0%	0.0%	☆
P0379	Reference 4	-100.0%–100.0%	0.0%	☆
P0380	Reference 5	-100.0%–100.0%	0.0%	☆
P0381	Reference 6	-100.0%–100.0%	0.0%	☆
P0382	Reference 7	-100.0%–100.0%	0.0%	☆
P0383	Reference 8	-100.0%–100.0%	0.0%	☆
P0384	Reference 9	-100.0%–100.0%	0.0%	☆
P0385	Reference 10	-100.0%–100.0%	0.0%	☆
P0386	Reference 11	-100.0%–100.0%	0.0%	☆
P0387	Reference 12	-100.0%–100.0%	0.0%	☆
P0388	Reference 13	-100.0%–100.0%	0.0%	☆
P0389	Reference 14	-100.0%–100.0%	0.0%	☆
P0390	Reference 15	-100.0%–100.0%	0.0%	☆
P0391	Simple PLC running mode	0: Stop after the AC drive runs one cycle 1: Keep final values after the AC drive runs one cycle	0	☆
P0392	Simple PLC retentive selection	Unit's digit (Retentive upon power failure) 0: No 1: Yes Ten's digit (Retentive upon stop) 0: No 1: Yes	00	☆
P0393	Running time of simple PLC reference 0	0.0–6553.5s (h)	0.0s (h)	☆

User Manual

P0394	Acceleration/deceleration time of simple PLC reference 0	0-3	0	☆
P0395	Running time of simple PLC reference 1	0.0-6553.5s (h)	0.0s (h)	☆
P0396	Acceleration/deceleration time of simple PLC reference 1	0-3	0	☆
P0397	Running time of simple PLC reference 2	0.0-6553.5s (h)	0.0s (h)	☆
P0398	Acceleration/deceleration time of simple PLC reference 2	0-3	0	☆
P0399	Running time of simple PLC reference 3	0.0-6553.5s (h)	0.0s (h)	☆
P0400	Acceleration/deceleration time of simple PLC reference 3	0-3	0	☆
P0401	Running time of simple PLC reference 4	0.0-6553.5s (h)	0.0s (h)	☆
P0402	Acceleration/deceleration time of simple PLC reference 4	0-3	0	☆
P0403	Running time of simple PLC reference 5	0.0-6553.5s (h)	0.0s (h)	☆
P0404	Acceleration/deceleration time of simple PLC reference 5	0-3	0	☆
P0405	Running time of simple PLC reference 6	0.0-6553.5s (h)	0.0s (h)	☆
P0406	Acceleration/deceleration time of simple PLC reference 6	0-3	0	☆
P0407	Running time of simple PLC reference 7	0.0-6553.5s (h)	0.0s (h)	☆
P0408	Acceleration/deceleration time of simple PLC reference 7	0-3	0	☆
P0409	Running time of simple PLC reference 8	0.0-6553.5s (h)	0.0s (h)	☆
P0410	Acceleration/deceleration time of simple PLC reference 8	0-3	0	☆
P0411	Running time of simple PLC reference 9	0.0-6553.5s (h)	0.0s	☆

User Manual

P0412	Acceleration/deceleration time of simple PLC reference 9	0-3	0	☆
P0413	Running time of simple PLC reference 10	0.0-6553.5s (h)	0.0s	☆
P0414	Acceleration/deceleration time	0-3	0	☆
P0415	Running time of simple PLC reference 11	0.0-6553.5s (h)	0.0s	☆
P0416	Acceleration/deceleration time of simple PLC reference 11	0-3	0	☆
P0417	Running time of simple PLC reference 12	0.0-6553.5s (h)	0.0s (h)	☆
P0418	Acceleration/deceleration time of simple PLC reference 12	0-3	0	☆
P0419	Running time of simple PLC reference 13	0.0-6553.5s (h)	0.0s (h)	☆
P0420	Acceleration/deceleration time of simple PLC reference 13	0-3	0	☆
P0421	Running time of simple PLC reference 14	0.0-6553.5s (h)	0.0s (h)	☆
P0422	Acceleration/deceleration time of simple PLC reference 14	0-3	0	☆
P0423	Running time of simple PLC reference 15	0.0-6553.5s (h)	0.0s (h)	☆
P0424	Acceleration/deceleration time of simple PLC reference 15	0-3	0	☆
P0425	Time unit of simple PLC running	0: s (second) 1:h (hour)	0	☆
P0426	Reference 0 source	0: Set by P0375 1: AI1 2: AI2 3: AI3 4: Pulse setting 5: PID 6: Set by preset frequency (P0008), modified via terminal UP/ DOWN	0	☆

Function Code	Parameter Name	Setting Range	Default	Property
Group PD: Communication Parameters				
P0427	Baud rate	Unit's digit (Modbus baud rate)	6005	☆
		0: 300 BPs 1: 600 BPs 2: 1200 BPs 3: 2400 BPs 4: 4800 BPs 5: 9600 BPs 6: 19200 BPs		
		Ten's digit (PROFIBUS-DP baud rate)		
		0: 115200 BPs 1: 208300 BPs 2: 256000 BPs		
		Hundred's digit (reserved)		
		Thousand's digit (CANlink baud rate)		
		0: 20 1: 50 2: 100 3: 125 4: 250 5: 500 6: 1 M		

User Manual

P0428	Data format	0: No check, data format <8,N,2> 1: Even parity check, data format <8,E,1> 2: Odd Parity check, data format <8,O,1> 3: No check, data format <8,N,1> Valid for Modbus	0	☆
P0429	Local address	0: Broadcast address 1–249 Valid for Modbus, PROFIBUS-DP and CANlink	1	☆

Function Code	Parameter Name	Setting Range	Default	Property
P0430	Response delay	0–20 ms Valid for Modbus	2 ms	☆
P0431	Communication timeout	0.0s (invalid) 0.1–60.0s Valid for Modbus, PROFIBUS-DP and CANopen	0.0s	☆
P0432	Modbus protocol selection and PROFIBUS-DP data format	Unit's digit: Modbus protocol	30	☆
		0: Non-standard Modbus protocol 1: Standard Modbus protocol Ten's digit: PROFIBUS-DP data format 0: PPO1 format 1: PPO2 format 2: PPO3 format		
P0433	Communication reading current resolution	0: 0.01A 1: 0.1A	0	☆
Group PE: User-defined Parameters				
P0435	User-defined function code 0		P0-10	☆
P0436	User-defined function code 1		P0-00 to PP-xx	☆
P0437	User-defined function code 2		H0-00 to Hx-xx	☆
P0438	User-defined function code 3		S0-xx to S0-xx	☆
P0439	User-defined function code 4		P0-08	☆
P0440	User-defined function code 5		P0-17	☆
P0441	User-defined function code 6		P0-18	☆
P0442	User-defined function code 7		P3-00	☆
P0443	User-defined function code 8		P3-01	☆

User Manual

P0444	User-defined function code 9		P4-00	☆
P0445	User-defined function code 10		P4-01	☆
P0446	User-defined function code 11		P4-02	☆
P0447	User-defined function code 12		P5-04	☆
P0448	User-defined function code 13		P5-07	☆
P0449	User-defined function code 14		P6-00	☆

Function Code	Parameter Name	Setting Range	Default	Property
P0450	User-defined function code 15	P0-00 to PP-xx	P6-10	☆
P0451	User-defined function code 16	H0-00 to Hx-xx	P0-00	☆
P0452	User-defined function code 17	S0-xx to S0-xx	P0-00	☆
P0453	User-defined function code 18		P0-00	☆
P0454	User-defined function code 19		P0-00	☆
P0455	User-defined function code 20		P0-00	☆

Group PP: Function Code Management

P0469	User password	0–65535	0	☆
P0470	Restore default settings	0: No operation 01: Restore factory settings except motor parameters 02: Clear records 04: Restore user backup parameters 05: Back up current user parameters	0	★
P0471	AC drive parameter display property	Unit's digit (Group U display selection) 0: Not display 1: Display Ten's digit (Group A display selection) 0: Not display 1: Display	11	★

User Manual

P0472	Individualized parameter display property	Unit's digit (User-defined parameter display selection)	00	☆
		0: Not display 1: Display		
		Ten's digit (User-modified parameter display selection)		
		0: Not display 1: Display		
P0473	Parameter modification property	0: Modifiable 1: Not modifiable	0	☆
Group H0: Torque Control and Restricting Parameters				
P0475	Speed/Torque control selection	0: Speed control 1: Torque control	0	★
P0476	Torque setting source in torque control	0: Digital setting (A0-03) 1: AI1 2: AI2 3: AI3 4: Pulse setting (DI5) 5: Communication setting 6: MIN (AI1, AI2) 7: MAX (AI1, AI2) Full range of values 1–7 corresponds to the digital setting of A0-03.	0	★
P0478	Torque digital setting in torque control	-200.0%–200.0%	150.0%	☆
P0480	Forward maximum frequency in torque control	0.00 Hz to maximum frequency (P0-10)	50.00 Hz	☆
P0481	Reverse maximum frequency in torque control	0.00 Hz to maximum frequency (P0-10)	50.00 Hz	☆
P0482	Acceleration time in torque control	0.00–65000s	0.00s	☆

User Manual

P0483	Deceleration time in torque control	0.00–65000s	0.00s	☆
Group H1: Virtual DI (VDI)/Virtual DO (VDO)				
P0484	VDI1 function selection	0–59	0	★
P0485	VDI2 function selection	0–59	0	★
P0486	VDI3 function selection	0–59	0	★
P0487	VDI4 function selection	0–59	0	★
P0488	VDI5 function selection	0–59	0	★
P0489	VDI state setting mode	Unit's digit (VDI1)	00000	★
		0: Decided by state of VDOx 1: Decided by A1-06		
		Ten's digit (VDI2)		
		0, 1 (same as VDI1)		
		Hundred's digit (VDI3)		
		0, 1 (same as VDI1)		
		Thousand's digit (VDI4)		
		0, 1 (same as VDI1)		
P0490	VDI state selection	Unit's digit (VDI1)	00000	★
		0: Invalid 1: Valid		
		Ten's digit (VDI2)		
		0, 1 (same as VDI1)		
		Hundred's digit (VDI3)		
		0, 1 (same as VDI1)		
		Thousand's digit (VDI4)		
		0, 1 (same as VDI1)		
P0491	Function selection for AI1 used as DI	0–59	0	★
P0492	Function selection for AI2 used as DI	0–59	0	★
P0493	Function selection for AI3 used as DI	0–59	0	★

User Manual

P0494	State selection for AI used as DI	Unit's digit (AI1)	000	★
		0: High level valid		
		1: Low level valid		
		Ten's digit (AI2)		
		0, 1 (same as unit's digit)		
		Hundred's digit (AI3)		
0, 1 (same as unit's digit)				
Function Code	Parameter Name	Setting Rang	Default	Property
P0495	VDO1 function selection	0: Short with physical DIx internally 1–40: Refer to function selection	0	☆
P0496	VDO2 function selection	0: Short with physical DIx internally 1–40: Refer to function selection of physical DO in group P5.	0	☆
P0497	VDO3 function selection	0: Short with physical DIx internally 1–40: Refer to function selection of physical DO in group P5.	0	☆
P0498	VDO4 function selection	0: Short with physical DIx internally 1–40: Refer to function selection	0	☆
P0499	VDO5 function selection	0: Short with physical DIx internally 1–40: Refer to function selection of physical DO in group P5.	0	☆
P0500	VDO1 output delay	0.0–3600.0s	0.0s	☆
P0501	VDO2 output delay	0.0–3600.0s	0.0s	☆
P0502	VDO3 output delay	0.0–3600.0s	0.0s	☆
P0503	VDO4 output delay	0.0–3600.0s	0.0s	☆
P0504	VDO5 output delay	0.0–3600.0s	0.0s	☆
P0505	VDO state selection	Unit's digit (VDO1)	00000	☆
		0: Positive logic		
		1: Reverse logic		
		Ten's digit (VDO2)		
		0, 1 (same as unit's digit)		
		Hundred's digit (VDO3)		
		0, 1 (same as unit's digit)		
		Thousand's digit (VDO4)		
		0, 1 (same as unit's digit)		
Ten thousand's digit (VDO5)				
0, 1 (same as unit's digit)				

Function Code	Parameter Name	Min. Unit	Communication Address
Group S0: Standard Monitoring Parameters			
P0961	Running frequency (Hz)	0.01 Hz	7000H
P0962	Set frequency (Hz)	0.01 Hz	7001H
P0963	Bus voltage	0.1 V	7002H
P0964	Output voltage	1 V	7003H
P0965	Output current	0.01 A	7004H
P0966	Output power	0.1 kW	7005H
P0967	Output torque	0.1%	7006H
P0968	DI state	1	7007H
P0969	DO state	1	7008H
P0970	AI1 voltage (V)	0.01 V	7009H
P0971	AI2 voltage (V)/current (mA)	0.01 V/0.01 mA	700AH
P0972	AI3 voltage (V)	0.01 V	7007BH
P0973	Count value	1	700CH
P0974	Length value	1	700DH
P0975	Load speed	1	700EH
P0976	PID setting	1	700FH
P0977	PID feedback	1	7010H
P0978	PLC stage	1	7011H
P0979	Input pulse frequency (Hz)	0.01 kHz	7012H
P0980	Feedback speed	0.01 Hz	7013H
P0981	Remaining running time	0.1 Min	7014H
P0982	AI1 voltage before correction	0.001 V	7015H
P0983	AI2 voltage (V)/current (mA) before correction	0.01 V/0.01 mA	7016H

Function Code	Parameter Name	Min. Unit	Communication Address
Group S0: Standard Monitoring Parameters			
P0984	AI3 voltage before correction	0.001 V	7017H
P0985	Linear speed	1 m/Min	7018H
P0986	Accumulative power-on time	1 Min	7019
P0987	Accumulative running time	0.1 Min	701AH
P0988	Pulse input frequency	1 Hz	701BH
P0989	Communication setting value	0.01%	701CH
P0990	Encoder feedback speed	0.01 Hz	701DH
P0991	Main frequency X	0.01 Hz	701EH
P0992	Auxiliary frequency Y	0.01 Hz	701FH
P0993	Viewing any register address value	1	7020H
P0994	Motor temperature	1°C	7022H
P0995	Target torque	0.1%	7023H
P0996	Resolver position	1	7024H
P0997	Power factor angle	0.1°	7025H
P0998	ABZ position	1	7026H
P0999	Target voltage upon V/F separation	1 V	7027H
P1000	Output voltage upon V/F separation	1V	7028H
P1001	DI state visual display	1	7029H
P1002	DO state visual display	1	702AH
P1003	DI function state visual display 1	1	702BH
P1004	DI function state visual display 2	1	702CH
P1005	Fault information	1	702DH
P1013	Phase Z counting	1	703AH
P1014	Current set frequency	0.01%	703BH
P1015	Current running frequency	0.01%	703CH
P1016	AC drive running state	1	703DH
P1017	Current fault code	1	703EH
P1018	Sent value of point-point communication	0.01%	703FH
P1019	Received value of point-point communication	0.01%	7040H
P1020	Torque upper limit	0.1%	7041H

Maintenance and Troubleshooting

Routine Repair and Maintenance of the DRIVE

Warranty Agreement

- 1) Free warranty only applies to the AC drive itself.
- 2) We will provide 18-month warranty (starting from the leave-factory date as indicated on the barcode) for the failure or damage under normal use conditions. If the equipment has been used for over 18 months, reasonable repair expenses will be charged.
- 3) Reasonable repair expenses will be charged for the damages due to the following causes:
 - Improper operation without following the instructions
 - Fire, flood or abnormal voltage.
 - Using the AC drive for non-recommended function
- 4) The maintenance fee is charged according to uniform standard. If there is an agreement, the agreement prevails.

Faults and Solutions

The DRIVE provides a total of 24 pieces of fault information and protective functions. After a fault occurs, the AC drive implements the protection function, and displays the fault code on the operation panel (if the operation panel is available).

Before contacting us for technical support, you can first determine the fault type, analyze the causes, and perform troubleshooting according to the following tables. If the fault cannot be rectified, contact the agent or us

Err22 is the AC drive hardware overcurrent or overvoltage signal. In most situations, hardware overvoltage fault causes Err22.

Fault Name	Display	Possible Causes	Solutions
Inverter unit protection	Err01	1: The output circuit is grounded or short circuited. 2: The connecting cable of the motor is too long. 3: The module overheats. 4: The internal connections become loose. 5: The main control board is faulty. 6: The drive board is faulty. 7: The inverter module is faulty.	1: Eliminate external faults. 2: Install a reactor or an output filter. 3: Check the air filter and the cooling fan. 4: Connect all cables properly. 5: Contact the agent or us.
Overcurrent during acceleration	Err02	1: The output circuit is grounded or short circuited. 2: Motor auto-tuning is not performed. 3: The acceleration time is too short. 4: Manual torque boost or V/F curve is not appropriate. 5: The voltage is too low. 6: The startup operation is performed on the rotating motor. 7: A sudden load is added during acceleration. 8: The AC drive model is of too small power class.	1: Eliminate external faults. 2: Perform the motor auto-tuning. 3: Increase the acceleration time. 4: Adjust the manual torque boost or V/F curve. 5: Adjust the voltage to normal range. 6: Select rotational speed tracking restart or start the motor after it stops. 7: Remove the added load. 8: Select an AC drive of higher power class.

Overcurrent during deceleration	Err03	<p>1: The output circuit is grounded or short circuited.</p> <p>2: Motor auto-tuning is not performed.</p> <p>3: The deceleration time is too short.</p> <p>4: The voltage is too low.</p> <p>5: A sudden load is added during deceleration.</p> <p>6: The braking unit and braking resistor are not installed.</p>	<p>1: Eliminate external faults.</p> <p>2: Perform the motor auto-tuning.</p> <p>3: Increase the deceleration time.</p> <p>4: Adjust the voltage to normal range.</p> <p>5: Remove the added load.</p> <p>6: Install the braking unit and braking resistor.</p>
---------------------------------	-------	---	---

Overcurrent at constant speed	Err04	<p>1: The output circuit is grounded or short circuited.</p> <p>2: Motor auto-tuning is not performed.</p> <p>3: The voltage is too low.</p> <p>4: A sudden load is added during operation.</p> <p>5: The AC drive model is of too small power class.</p>	<p>1: Eliminate external faults.</p> <p>2: Perform the motor auto-tuning.</p> <p>3: Adjust the voltage to normal range.</p> <p>4: Remove the added load.</p> <p>5: Select an AC drive of higher power class.</p>
Overvoltage during acceleration	Err05	<p>1: The input voltage is too high.</p> <p>2: An external force drives the motor during acceleration.</p> <p>3: The acceleration time is too short.</p> <p>4: The braking unit and braking resistor are not installed.</p>	<p>1: Adjust the voltage to normal range.</p> <p>2: Cancel the external force or install a braking resistor.</p> <p>3: Increase the acceleration time.</p> <p>4: Install the braking unit and braking resistor.</p>

Overvoltage during deceleration	Err06	<ol style="list-style-type: none"> 1: The input voltage is too high. 2: An external force drives the motor during deceleration. 3: The deceleration time is too short. 4: The braking unit and braking resistor are not installed. 	<ol style="list-style-type: none"> 1: Adjust the voltage to normal range. 2: Cancel the external force or install the braking resistor. 3: Increase the deceleration time. 4: Install the braking unit and braking resistor.
Overvoltage at constant speed	Err07	<ol style="list-style-type: none"> 1: The input voltage is too high. 2: An external force drives the motor during deceleration. 	<ol style="list-style-type: none"> 1: Adjust the voltage to normal range. 2: Cancel the external force or install the braking resistor.
Control power supply fault	Err08	The input voltage is not within the allowable range.	Adjust the input voltage to the allowable range.
Undervoltage	Err09	<ol style="list-style-type: none"> 1: Instantaneous power failure occurs on the input power supply. 2: The AC drive's input voltage is not within the allowable range. 3: The bus voltage is abnormal. 4: The rectifier bridge and buffer resistor are faulty. 5: The drive board is faulty. 6: The main control board is faulty. 	<ol style="list-style-type: none"> 1: Reset the fault. 2: Adjust the voltage to normal range. 3: Contact the agent .
AC drive overload	Err10	<ol style="list-style-type: none"> 1: The load is too heavy or locked-rotor occurs on the motor. 2: The AC drive model is of too small power class. 	<ol style="list-style-type: none"> 1: Reduce the load and check the motor and mechanical condition. 2: Select an AC drive of higher power class.
Motor overload	Err11	<ol style="list-style-type: none"> 1: P9-01 is set improperly. 2: The load is too heavy or locked-rotor occurs on the motor. 	<ol style="list-style-type: none"> 1: Set P9-01 correctly. 2: Reduce the load and check the motor and the mechanical condition.

User Manual

Power input phase loss	Err12	<p>1: The three-phase power input is abnormal.</p> <p>2: The drive board is faulty.</p> <p>3: The lightning board is faulty.</p>	<p>1: Eliminate external faults.</p> <p>2: Contact the agent or us</p>
Power output phase loss	Err13	<p>1: The cable connecting the AC drive and the motor is faulty.</p> <p>2: The AC drive's three-phase outputs are unbalanced when the motor is running.</p>	<p>1: Eliminate external faults.</p> <p>2: Check whether the motor three-phase winding is normal.</p> <p>3: Contact the agent or us</p>
Module overheat	Err14	<p>1: The ambient temperature is too high.</p> <p>2: The air filter is blocked.</p> <p>3: The fan is damaged.</p> <p>4: The thermally sensitive resistor of the module is damaged.</p>	<p>1: Lower the ambient temperature.</p> <p>2: Clean the air filter.</p> <p>3: Replace the damaged fan.</p> <p>4: Replace the damaged thermally sensitive resistor.</p>
External equipment fault	Err15	<p>1: External fault signal is input via DI.</p> <p>2: External fault signal is input via virtual I/O.</p>	Reset the operation.
Communication fault	Err16	<p>1: The host computer is in abnormal state.</p> <p>2: The communication cable is faulty.</p> <p>3: P0-28 is set improperly.</p>	<p>1: Check the cabling of host computer.</p> <p>2: Check the communication cabling.</p> <p>3: Set P0-28 correctly.</p>
Contactors fault	Err17	<p>1: The drive board and power supply are faulty.</p>	<p>1: Replace the faulty drive board or power supply board.</p> <p>2: Replace the faulty</p>
Current detection fault	Err18	<p>1: The HALL device is faulty.</p> <p>2: The drive board is faulty.</p>	<p>1: Replace the faulty HALL device.</p> <p>2: Replace the faulty drive</p>
Motor auto-tuning fault	Err19	<p>1: The motor parameters are not set according to the nameplate.</p> <p>2: The motor auto-tuning times out.</p>	<p>1: Set the motor parameters according to the nameplate properly.</p>

Encoder fault	Err20	1: The encoder type is incorrect. 2: The cable connection of the encoder is incorrect. 3: The encoder is damaged. 4: The PG card is faulty.	1: Set the encoder type correctly based on the actual situation. 2: Eliminate external faults. 3: Replace the damaged
EEPROM read-write fault	Err21	The EEPROM chip is damaged.	Replace the main control board.
AC drive hardware fault	Err22	1: Overvoltage exists. 2: Overcurrent exists.	1: Handle based on overvoltage. 2: Handle based on overcurrent.
Short circuit to ground	Err23	The motor is short circuited to the ground.	Replace the cable or motor.
Accumulative running time	Err26	The accumulative running time reaches the setting value.	Clear the record through the parameter initialization
User-defined fault 1	Err27	1: The user-defined fault 1 signal is input via DI. 2: User-defined fault 1 signal is input	Reset the operation.
User-defined fault 2	Err28	1: The user-defined fault 2 signal is input via DI. 2: The user-defined fault 2 signal is input via virtual I/O.	Reset the operation.
Accumulative power-on time reached	Err29	The accumulative power-on time reaches the setting value.	Clear the record through the parameter initialization function.
Load becoming 0	Err30	The AC drive running current is lower than P9-64.	Check that the load is disconnected or the setting of P9-64 and P9-65 is correct.
PID feedback lost during running	Err31	The PID feedback is lower than the setting of PA-26.	Check the PID feedback signal or set PA-26 to a proper value.

User Manual

Pulse-by-pulse current limit fault	Err40	1: The load is too heavy or locked-rotor occurs on the motor. 2: The AC drive model is of too small power class.	1: Reduce the load and check the motor and mechanical condition. 2: Select an AC drive of higher power class.
Motor switchover fault during running	Err41	Change the selection of the motor via terminal during running of the AC drive.	Perform motor switchover after the AC drive stops.
Too large speed deviation	Err42	1: The encoder parameters are set incorrectly. 2: The motor auto-tuning is not performed.	1: Set the encoder parameters properly. 2: Perform the motor auto-tuning.
Motor over-speed	Err43	1: The encoder parameters are set incorrectly. 2: The motor auto-tuning is not performed. 3: P9-69 and P9-70 are set incorrectly.	1: Set the encoder parameters properly. 2: Perform the motor auto-tuning. 3: Set P9-69 and P9-70 correctly based on the actual situation.
Motor overheat	Err45	1: The cabling of the temperature sensor becomes loose. 2: The motor temperature is too high.	1: Check the temperature sensor cabling and eliminate the cabling fault. 2: Lower the carrier frequency or adopt other heat radiation measures.
Initial position fault	Err51	The motor parameters are not set based on the actual situation.	Check that the motor parameters are set correctly and whether the setting of rated current is too small.

Common Faults and Solutions

You may come across the following faults during the use of the AC drive. Refer to the following table for simple fault analysis.

SN	Fault	Possible Causes	Solutions
1	There is no display at power-on.	1: There is no power supply to the AC drive or the power input to the AC drive is too low. 2: The power supply of the switch on the drive board of the AC drive is faulty. 3: The rectifier bridge is damaged. 4: The control board or the operation panel is faulty.	1: Check the power supply. 2: Check the bus voltage. 3: Re-connect the 8-core and 28-core cables. 4: Contact the agent or us for technical support.
2	"HC" is displayed at power-on.	1: The cable between the drive board and the control board is in poor contact. 2: Related components on the control board are damaged. 3: The motor or the motor cable is short circuited to the ground.	1: Re-connect the 8-core and 28-core cables. 2: Contact the agent or us for technical support.
3	"Err23" is displayed at power-on.	1: The motor or the motor output cable is short-circuited to the ground. 2: The AC drive is damaged.	1: Measure the insulation of the motor and the output cable with a megger. 2: Contact the agent or us for technical support.
4	The AC drive display is normal upon power-on. But "HC" is displayed after running and stops	1: The cooling fan is damaged or locked-rotor occurs. 2: The external control terminal cable is short circuited.	1: Replace the damaged fan. 2: Eliminate external fault.
5	Err14 (module overheat) fault is reported frequently.	1: The setting of carrier frequency is too high. 2: The cooling fan is damaged, or the air filter is blocked. 3: Components inside the drive are damaged (thermalcoupler or others).	1: Reduce the carrier frequency (P0-15). 2: Replace the fan and clean the air filter. 3: Contact the agent or us for technical support.

6	The motor does not rotate after the AC drive runs.	<ol style="list-style-type: none"> 1: Check the motor and the motor cables. 2: The AC drive parameters are set improperly (motor parameters). 3: The cable between the drive board and the control board is in poor contact. 	<ol style="list-style-type: none"> 1: Ensure the cable between the AC drive and the motor is normal. 2: Replace the motor or clear mechanical faults. 3: Check and re-set motor parameters.
7	The DI terminals are disabled.	<ol style="list-style-type: none"> 1: The parameters are set incorrectly. 2: The external signal is incorrect. 3: The jumper bar across OP and +24 V becomes loose. 4: The control board is faulty. 	<ol style="list-style-type: none"> 1: Check and reset the parameters in group F4. 2: Re-connect the external signal cables. 3: Re-confirm the jumper bar across OP and +24 V.
8	The motor speed is always low in CLVC mode.	<ol style="list-style-type: none"> 1: The encoder is faulty. 2: The encoder cable is connected incorrectly or in poor contact. 3: The PG card is faulty. 4: The drive board is faulty. 	<ol style="list-style-type: none"> 1: Replace the encoder and ensure the cabling is proper. 2: Replace the PG card. 3: Contact the agent or us for technical support.
9	The AC drive reports overcurrent and overvoltage frequently.	<ol style="list-style-type: none"> 1: The motor parameters are set improperly. 2: The acceleration/deceleration time is improper. 	<ol style="list-style-type: none"> 1: Re-set motor parameters or re-perform the motor auto-tuning. 2: Set proper acceleration/deceleration time.
10	Err17 is reported upon power-on or running.	The soft startup contactor is not picked up.	<ol style="list-style-type: none"> 1: Check whether the contactor cable is loose. 2: Check whether the contactor is faulty. 3: Check whether 24 V power supply of the contactor is faulty. 4: Contact the agent or us for technical support.
11	88888 is displayed upon	Related component on the control board is damaged.	Replace the control board.

Warranty Agreement

1. The warranty period of the product is 18 months (refer to the barcode on the equipment). During the warranty period, if the product fails or is damaged under the condition of normal use by following the instructions, We will be responsible for free maintenance.
2. Within the warranty period, maintenance will be charged for the damages caused by the following reasons:
 - a. Improper use or repair/modification without prior permission
 - b. Fire, flood, abnormal voltage, other disasters and secondary disaster
 - c. Hardware damage caused by dropping or transportation after procurement
 - d. Improper operation
 - e. Trouble out of the equipment (for example, external device)
3. If there is any failure or damage to the product, please correctly fill out the Product Warranty Card in detail.
4. The maintenance fee is charged according to the latest Maintenance Price List.
5. The Product Warranty Card is not re-issued. Please keep the card and present it to the maintenance personnel when asking for maintenance.
6. If there is any problem during the service, contact our agent or us directly.
7. This agreement shall be interpreted by us.

Product Warranty Card

Customer information	Add. of unit:	
	Name of unit: P.C.:	Contact person:
		Tel.:
Product information	Product model:	
	Body barcode (Attach here):	
	Name of agent:	
Failure information	(Maintenance time and content):	
	Maintenance personnel:	

High-Performance AC Drive