



CASTER CONCEPTS

Beyond Standard.



GROUND SUPPORT EQUIPMENT

Heavy Duty Industrial Casters

Whether you need to move 5,000 or 250,000 lbs. rely on our experts, from initial engineering to reconfigured solutions.

www.CasterConcepts.com



MODERN SUSPENSION CASTERS

We offer a completely aluminum line of casters that are ideal for outdoor applications, aluminum weighs less and is non-corrosive to withstand the elements. Our heavy duty shock absorbing aluminum casters have a 6,500 lbs maximum capacity per caster, while our extremely rugged and durable steel line of casters, offers a maximum capacity of 25,000 lbs per caster.

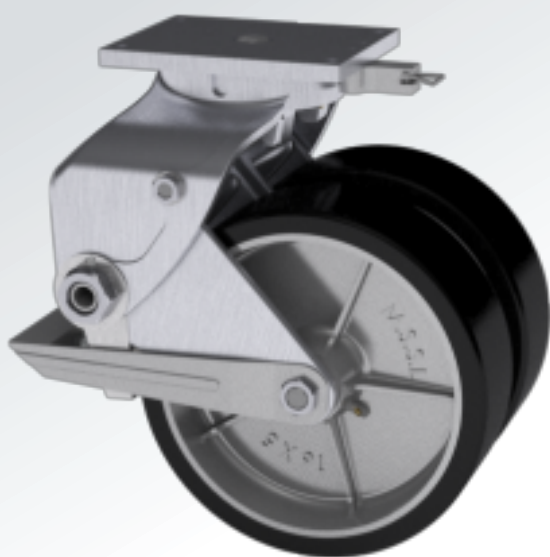

339 SERIES

- > **Caster Size:** 16" x 5"
- > **Wheel Type:** Mold on Rubber | 95A Poly Aluminum
- > **Max Capacity:** 6500 Lbs.
- > **Caster Info:** 339 Series is ideal for Asphalt Paving Machinery, High Abuse Cargo Dollies and Heavy Duty Material Handling.

138 SERIES

- > **Caster Size:** 10" x 4"
- > **Wheel Type:** Mold on Rubber | 95A Poly Aluminum
- > **Max Capacity:** 5000 Lbs.
- > **Caster Info:** 138 Series is ideal for Aircraft Engine Stands, Heavy Tooling Fixtures, Airborne Transport Stands and Extra Heavy Duty Material Handling Carts



MODERN SUSPENSION: CASE STUDY



Situation: The United States Air Force needed to replace casters for aircraft maintenance stands used to change windows on military aircraft. The carts were hard to roll, requiring a significant amount of force exertion. The replacement casters had to withstand the environmental challenges that are caused by outdoor use, including humidity, rain water, high heat and other such challenges.

Challenge: Create a caster that can reduce push force, while supporting the weight capacity and overcome the environmental challenges.

Solution: A completely aluminum caster, with a custom top plate and modified polyurethane tread formulation.

Benefits: Push force was reduced noticeably, the Technical Sergeant in charge of acquisition stated “They are 10 times easier to move around the aircraft”. In addition, aluminum resists corrosion, ensuring consistent performance and longer use life.



SHOCK ABSORBING CASTERS

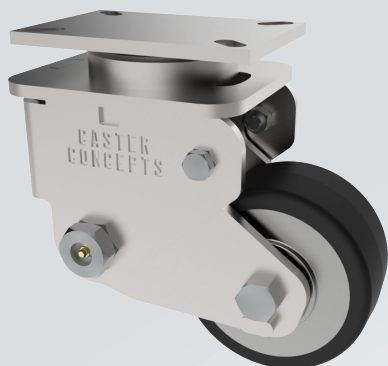

73 SERIES

CASTER MAX WEIGHT LIMIT	1,100 Lbs.
WHEEL TYPE	Phenolic Resin Standard Polyurethane H.D. T/R 85A Polyurethane Mold On Rubber 95A Standard Polyurethane
CASTER SIZE	5.25 x 7.25
CASTER INFO	Our 73 series shock absorbing casters have swivel sections that are constructed of high alloy steel and are precision machined for close tolerances and long life.

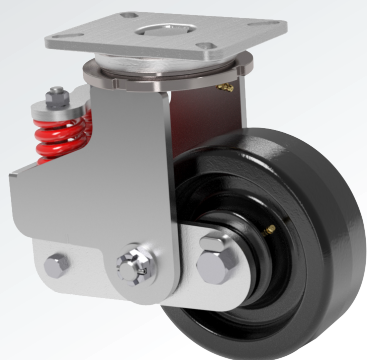

74 SERIES

CASTER MAX WEIGHT LIMIT	1,500 Lbs.
WHEEL TYPE	Phenolic Resin Standard Polyurethane H.D. T/R 85A Polyurethane Mold On Rubber 95A Standard Polyurethane
CASTER SIZE	8 x 3 10 x 3 12 x 3
CASTER INFO	The 74 series vertical mounted spring caster excels in reducing noise and protecting cargo from unexpected shocks.



83 SERIES

CASTER MAX WEIGHT LIMIT	1,700 Lbs.
WHEEL TYPE	Phenolic Resin H.D. T/R 85A Polyurethane Mold On Rubber 95A Standard Polyurethane
CASTER SIZE	6 x 7.5
CASTER INFO	The 83 series' shock absorbing capabilities offer several benefits as well including noise reduction and cargo protection.



SHOCK ABSORBING CASTERS

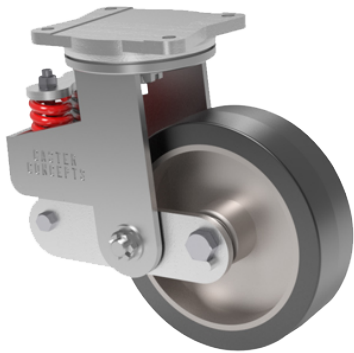

CASTER MAX WEIGHT LIMIT	2,500 Lbs.	84 SERIES
WHEEL TYPE	Phenolic Resin H.D. T/R 85A Polyurethane Mold On Rubber 95A Standard Polyurethane	
CASTER SIZE	8 x 3 10 x 3 12 x 3	
CASTER INFO	Vertical mounted spring casters are ideal for pre-loading, because they are designed to not deflect until the pre-loaded capacity is exceeded.	

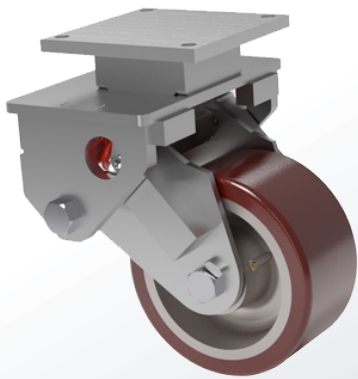

CASTER MAX WEIGHT LIMIT	4,000 Lbs.	93 SERIES
WHEEL TYPE	H.D. 95A Standard Polyurethane Forged Steel 95A Standard Polyurethane	
CASTER SIZE	10 x 4 10 x 5	
CASTER INFO	93 series shock absorbing casters have swivel sections that are constructed of high alloy steel and are precision machined for close tolerances and long life.	

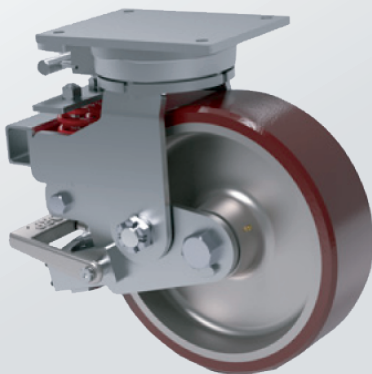

CASTER MAX WEIGHT LIMIT	3,800 Lbs.	94 SERIES
WHEEL TYPE	H.D. 95A Standard Polyurethane H.D. T/R 85A Polyurethane Mold On Rubber 95A Standard Polyurethane	
CASTER SIZE	10 x 4 12 x 4	
CASTER INFO	The 90 series extra heavy duty casters are manufactured to withstand abusive applications. The heat treated raceways are designed to prevent brinelling of the raceways.	



SWIVEL ON SWIVEL CASTER (SOS)



A kingpinless, maintenance free swivel section rig is mounted on top of a larger, kingpinless, maintenance free rig. This innovative design achieves benefits no traditional caster can.

- > **Caster Size:** 6" x 2" | 8" x 2" | 10" x 2"
- > **Wheel Type:** Twergo | 85A Poly | 95A Poly | HPPT 92A
- > **Max Capacity:** 1800 Lbs.
- > **Caster Info:** SoS is ideal for minimizing and potentially eliminating operator fatigue as well as getting in and out of tight spaces easily.



EXCEPTIONAL ERGONOMIC BENEFITS

- > Significantly minimizes operator fatigue by reducing force exerted
- > Virtually eliminates side shifting, moves forward and back in a straight line, requires minimal space to spin casters 180* (castering)
- > Makes maneuvering much easier, reducing exertion and stress on operators
- > The swivel on swivel design reduces the turn radius needed to rotate the caster 180*, the swivel sections can rotate in opposite directions, requiring less space and force exerted, to maneuver
- > Swivel lead is the longest we have achieved on any caster, reducing the amount of force needed to rotate when the wheels are not all parallel, and eliminating flutter on powered applications



SWIVEL ON SWIVEL: CASE STUDY

CUSTOMER: ENGINEERING SERVICES FIRM

Application: Crane Cart
Situation: How do you change huge solar panel tiles on the roof of a skyscraper?



Challenge: A solar panel is located on the roof top of skyscraper, set at 30° angle facing the sun. The tiles on the panel weigh over a hundred pounds and can measure as long as 8 feet, making it very difficult to replace broken and delaminated panels.

Our client designed a rig with a hoist, essentially a crane on a cart, to roll down on the solar panel and replace tiles. They needed casters that could support the weight, and also dissipate the pressure applied to the casters, reducing the risk of damage to the panels.

Solution: Our engineers worked with the firm to design a top plate with its own swivel section, that could also support three casters with dual pneumatic wheels. This design reduced resistance and made maneuvering much easier, which is very important when your thousands of feet in the air on a downward angle.

The pneumatic wheels reduced risk of damage to the tiles, and could withstand the elements.



- > **Wheel Type:** Twergo
- > **Max Capacity:** 4200 Lbs.
- > **Caster Info:** TWERGO® reduces initial and continuous push force, as well as force exerted to turn. The Twin and Triple wheel designs have independently spinning wheels that can rotate in either direction at any rate, minimizing friction when turning and maneuvering.

WHEEL SIZES

4" x 2"	4" x 3"	5" x 2"	5" x 3"	6" x 2"	6" x 3"	8" x 2"	8" x 3"	10" x 2"	10" x 3"	12" x 3"
---------	---------	---------	---------	---------	---------	---------	---------	----------	----------	----------

TWERGO® reduces by an average of 25 percent the amount of force a user must exert to start, stop and turn a cart. This also means that a user can move a cart loaded with 25 percent more items without increasing force exerted. Here's an example: If a cart using conventional heavy-duty casters requires 40 pounds of initial push for to start moving a load weighing 2,500 pounds, TWERGO®, on average, would require only 30 pounds of initial push force. Adding 25 percent more weight to the cart would create a total load weight of 3,125 pounds, but would still only require 40 pounds of initial push force.



TWERGO®: CASE STUDY

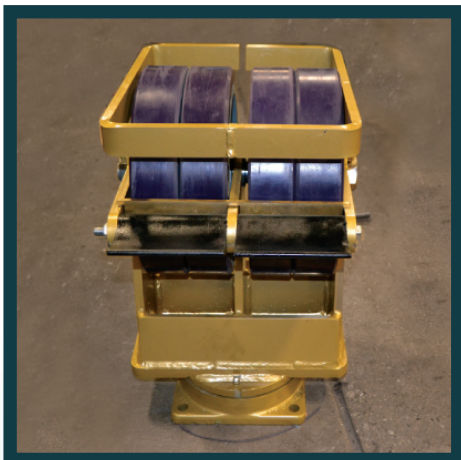
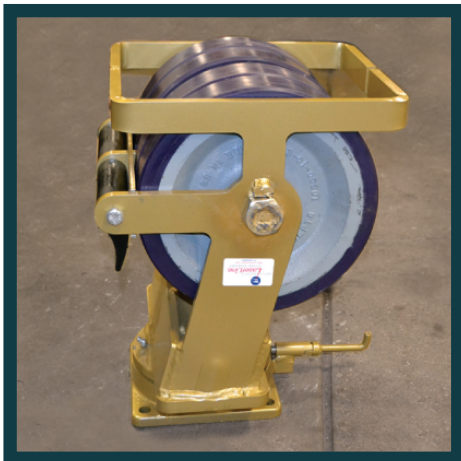

CUSTOMER: A TOOLING FABRICATOR WORKING WITH A MAJOR AEROSPACE MANUFACTURER

Situation: The customer had been very happy with our previous TWERGO® product and needed casters for a work platform. They requested heavy duty casters with a variety of ergonomic and safety capabilities, while also including overall height and psi limitations.

Challenge: Our customer needed a TWERGO® product larger than any other TWERGO® we had created thus far. The desired casters also required added safety features including, locks, brakes, and toe guards.

Solution: Our engineers designed our largest TWERGO® wheel's to date in order to hold a weight capacity of 14,000lbs per caster as well as getting the psi down to 727. This was achieved by using a dual wheel 12 x 5 thick tread HPPT wheel and making it into four 12 x 2-1'2" wheels. Ultimately this extended the weight capacity while still giving our customer the satisfaction of having TWERGO® wheels and maximizing safety capabilities.



TWERGO® LITE



- > **Wheel Size:** 6" x 2" | 8" x 2"
- > **Wheel Type:** Twergo
- > **Max Capacity:** 1600 Lbs.
- > **The Benefits of Twergo® Lite:**
 - Ergonomic, reduce force exerted to start and continue rolling
 - Durable and Strong with a Cast Iron Core
 - Maintenance Free, bearings never need greasing

The single wheel version of our extraordinary TWERGO® wheels, utilizes the same patented face design to reduce initial and continuous push force. TWERGO® Lite makes it easier to push a cart, reducing the amount of energy exerted by the operator. TWERGO® Lite is the ultimate 2" wide wheel. It is designed to replace standard caster wheels by adding significant ergonomic benefits, without significantly increasing the price. TWERGO® Lite has a cast iron core, making it durable and strong enough to handle challenging environments. A tapered tread design helps to resist debris and push it away.



TWERGO® LITE: CASE STUDY

TWERGO® Lite reduces push force so much, that the cart or trolley can be pushed with just two fingers!

CUSTOMER: THE LARGEST YARN DISTRIBUTOR IN NORTH AMERICA

Situation: Carts with an 800lb load were difficult to move, especially for female operators. The owner of the company decided to try 3 different “ergonomic” casters from 3 different manufacturers, all 3 caster models were very close in price.

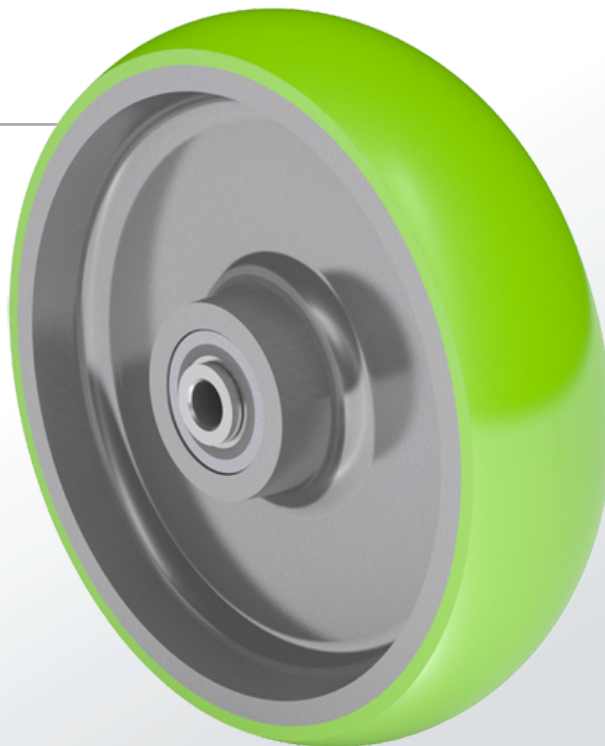

Solution: The distributor decided to conduct a study to find which ergonomic caster wheels would help better maneuver the carts the distribution center operators were having trouble moving. The distributor bought a set of our TWERGO® Lite heavy duty wheels and two other ergonomic caster wheels, all similar in price. After testing all three sets, the individual was amazed at how easy it was to push the 800lb cart with TWERGO® Lite wheels. “I was able to push my [fully loaded] cart with just two fingers.”

Benefit: The distributor was so thrilled with the quality of the TWERGO® Lite wheels bought from Caster Concepts® Inc. that the distributor ordered a set for every cart in the distribution center. In order to make his business more efficient, plant is now fully equipped with TWERGO® Lite wheels.



INDUSTRY APPLICATIONS

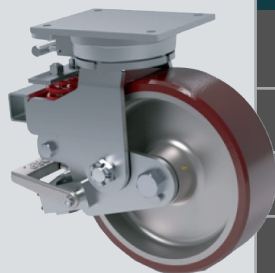

Customer: Aerospace Tooling Design Company 94 Series SKU: SPD08062006	
CASTER MAX WEIGHT LIMIT	9,400 Lbs.
WHEEL TYPE	95A H.D. Standard Polyurethane
CASTER SIZE	16 x 5
CASTER INFO	Laser cut formed legs provide additional strength when side loading or skidding is prevalent in the application. The exceptional strength makes it an ideal choice for rugged jobs in need of a high load capacity.



Customer: Industrial Equipment Supplier 71 Series SKU: SPD03112003	
CASTER MAX WEIGHT LIMIT	4,500 Lbs.
WHEEL TYPE	Foam Filled Pneumatic Wheel with 1" RB
CASTER SIZE	18 x 6
CASTER INFO	Well suited for medium duty towing applications where shock loads are present such as machinery dollies, mobile military equipment, aircraft maintenance stands, and aircraft crew stairs.

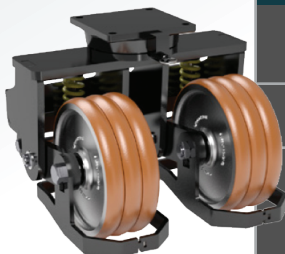

Customer: Aerospace Tooling Design Company 2-94 Series SKU: SPD15062202	
CASTER MAX WEIGHT LIMIT	10,000 Lbs.
WHEEL TYPE	TWERGO® T/R-95 (Burnt Orange)
CASTER SIZE	12 x 3
CASTER INFO	The 94 series-extra heavy duty casters are manufactured to withstand abusive applications.



Customer: Logistics Company 2-93 Series SKU: SPD971015	
CASTER MAX WEIGHT LIMIT	8,000 Lbs.
WHEEL TYPE	H.D. Hard Poly (1" Black-70D)
CASTER SIZE	10 x 5
CASTER INFO	Our 93 series shock absorbing casters have swivel sections that are constructed of high alloy steel and are precision machined for close tolerances and long life.



INDUSTRY APPLICATIONS: PHOTOS

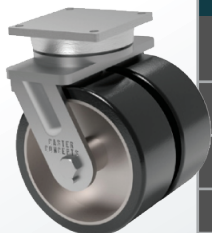
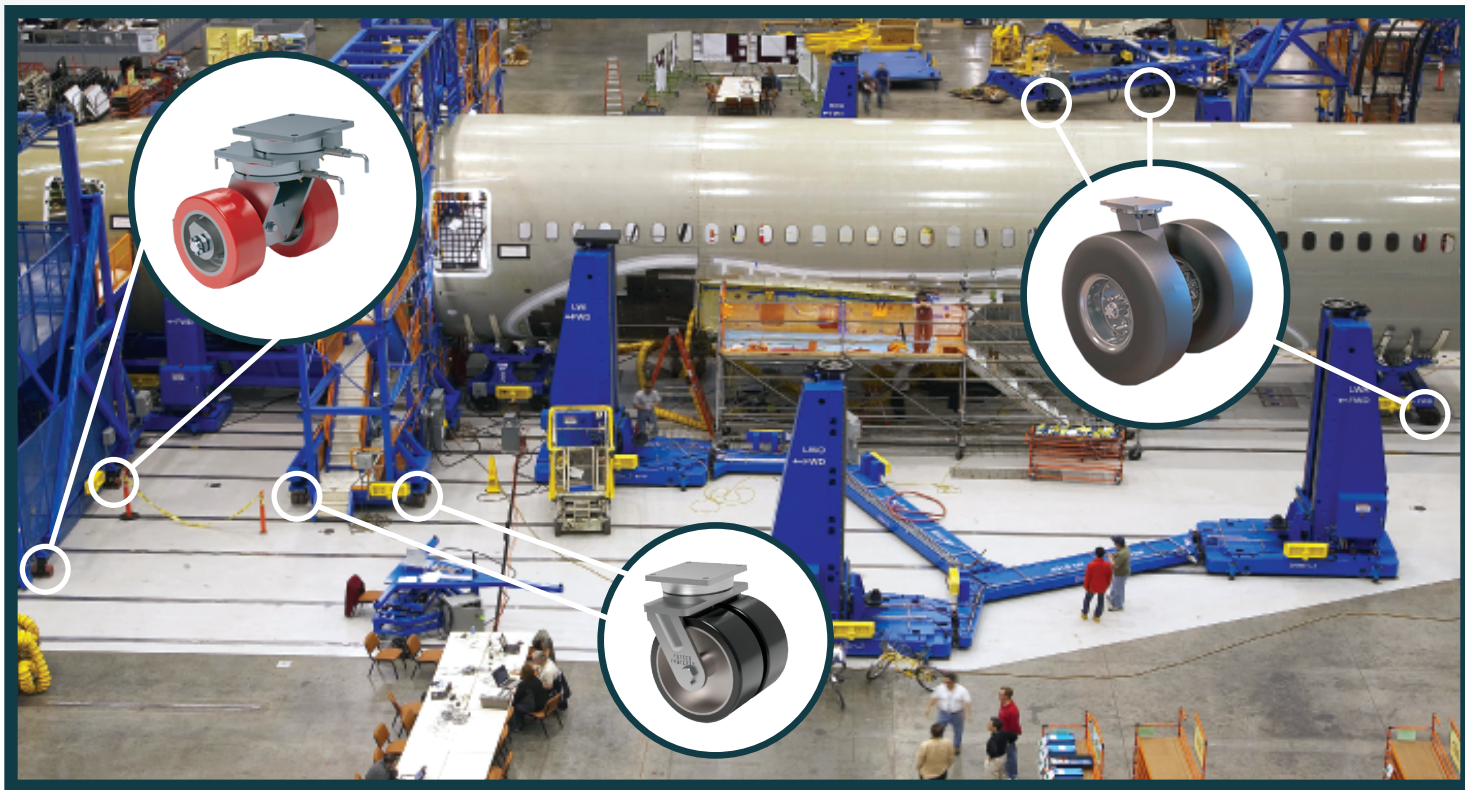

2-91 Series SKU: 2-91-16509-67-1	
CASTER MAX WEIGHT LIMIT	18,000 Lbs.
WHEEL TYPE	H.D. Hard Poly (1" Black-70D)
CASTER SIZE	16 x 5
CASTER INFO	2-91 series is valued for its simplicity while providing a tough caster for industrial applications.



2-99 Series SKU: 2-99-22909-69-1SP	
CASTER MAX WEIGHT LIMIT	35,000 Lbs.
WHEEL TYPE	85A H.D. Soft Poly
CASTER SIZE	14 x 14
CASTER INFO	The 2-99 series extra heavy duty caster is designed and built to carry the heaviest loads while also delivering the longest cycle life.

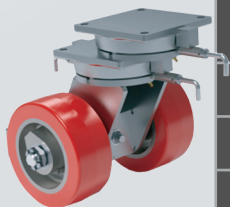

2-91 Series SKU: SPD060608	
CASTER MAX WEIGHT LIMIT	35,000 Lbs.
WHEEL TYPE	85A T/R Compound - H.D. Soft Poly
CASTER SIZE	16 x 5
CASTER INFO	2-91 series is valued for its simplicity while providing a tough caster for industrial applications.

For further information
please contact us at:

888.799.7166
16000 E. Michigan Ave.,
Albion, MI 49224

www.CasterConcepts.com



CASTER CONCEPTS

Beyond Standard.