American-Lincoln®

**Operator's
Manual &
Parts List**



**SC7750 IC
Sweeper/
Scrubber**

Beginning with Serial Number 683179

READ THIS BOOK

This book has important information for the use and safe operation of this machine. Failure to read this book prior to operating or attempting any service or maintenance procedure to your machine could result in injury to you or to other personnel; damage to the machine or to other property could occur as well. You must have training in the operation of this machine before using it.

Si Ud. o sus operadores no pueden leer el Inglés, se hacen explicar este manual completamente antes de tratar el manejo o servicio de esta máquina.

All directions given in this book are as seen from the operator's position at the rear of the machine.

TABLE OF CONTENTS

CHAPTER 1

SPECIFICATIONS	1-6
MACHINE DIMENSIONS	1-9
STANDARD HARDWARE & TORQUE VALUES	1-10
HYDRAULIC TORQUE REQUIREMENTS	1-11
DECIMAL - METRIC CONVERSION TABLE	1-12
MACHINE PREPARATION	1-13
SAFETY INSTRUCTIONS	1-14
OPERATION OF CONTROLS AND GAUGES	1-16
LIGHT SWITCH	1-16
HORN BUTTON	1-16
CHECK ENGINE LIGHT	1-16
KEY SWITCH	1-17
ENGINE SPEED SWITCH	1-17
HOUR METER	1-17
FUEL GAUGE	1-17
SEAT POSITION ADJUSTMENT	1-17
FILTER SHAKER SWITCH	1-18
GLOW PLUG SWITCH	1-18
SEAT COMPARTMENT PROP LATCH	1-18
HOPPER SAFETY ARM	1-18
SIDE BROOM LEVER	1-19
SIDE BROOM ADJUSTMENT	1-19
MAIN BROOM LEVER	1-19
MAIN BROOM ADJUSTMENT	1-19
DUST CONTROL SWITCH	1-20
SCRUB DECK SWITCH	1-20
SCRUB DECK HEAVY PRESSURE SWITCH	1-20
SQUEEGEE SWITCH	1-20
SOLUTION CONTROL	1-21
NON-RECYCLING OR STANDARD SCRUBBING SYSTEM	1-21
RECYCLING OR ESP/AUTOFIL SYSTEM	1-21
DISCONNECT WATER HOSE	1-21
WARNING BANK	1-22
ENGINE TEMPERATURE LIGHT (WARNING LIGHT)	1-22
ENGINE OIL PRESSURE LIGHT (WARNING LIGHT)	1-22
CLOGGED FILTER LIGHT (WARNING LIGHT)	1-22
HOPPER TEMPERATURE LIGHT (WARNING LIGHT)	1-22
SOLUTION LOW LIGHT (WARNING LIGHT)	1-22
RECOVERY HIGH LIGHT (WARNING LIGHT)	1-22
FOOT BRAKE	1-23
PARKING BRAKE	1-23
FWD/REV FOOT PEDAL	1-23
HOPPER LIFT LEVER	1-24
HOPPER DUMP DOOR LEVER	1-24
TURN SIGNAL	1-25
THROTTLE	1-25
BACK-UP ALARM SWITCH	1-25
FILTER PANEL LATCH	1-26
HOPPER TEMPERATURE SENSOR	1-26
ENGINE COMPARTMENT LATCH	1-26
HYDRAULIC RESERVOIR LEVEL SIGHT GAUGE	1-27
MAIN BROOM COMPARTMENT DOORS	1-27
SEAT COMPARTMENT COVER	1-27
HOPPER DOOR LEVER	1-28
HOPPER LIFT LEVER	1-28
HOPPER FILTER COMPARTMENT COVER	1-28
ESP SYSTEM OPERATING INSTRUCTIONS	1-29
ESP RECYCLING CONTROL PANEL	1-29
ESP RECYCLING SYSTEM ON/OFF SWITCH	1-29
DETERGENT FLOW KNOB	1-29
HOPPER SAFETY LOCK ARM	1-29
THE SCRUBBING SYSTEM - HOW IT WORKS	1-30
THE NON-RECYCLING OR STANDARD SCRUBBING SYSTEM - HOW IT WORKS	1-30
RECOVERY OR ESP SYSTEM - HOW IT WORKS	1-31
THE SWEEPING & DUST CONTROL SYSTEMS - HOW THEY WORK	1-31

TABLE OF CONTENTS

OPERATING INSTRUCTIONS	1-32
DUST CONTROL	1-32
BEFORE STARTING THE ENGINE	1-32
PRE-START CHECKLIST	1-32
STARTING GAS ENGINES	1-33
STARTING PROPANE ENGINES	1-33
STARTING DIESEL ENGINES	1-33
EMPTYING THE DEBRIS HOPPER	1-33
POST-OPERATION CHECKLIST	1-34
IC MACHINE STORAGE	1-34
HELPFUL HINTS FOR CLEANING OPERATION	1-35
SERVICE CHART	1-36
SERVICE PRECAUTIONS	1-38
SERVICE INSTRUCTIONS	1-39
MAIN BROOM	1-39
CHECKING THE MAIN BROOM SWEEP PATTERN	1-39
ADJUSTING THE MAIN BROOM HEIGHT	1-39
REPLACING THE MAIN BROOM	1-39
MAIN BROOM LEVEL ADJUSTMENT	1-39
SIDE BROOM	1-40
CHECKING THE SIDE BROOM SWEEP PATTERN	1-40
ADJUSTING THE SIDE BROOM HEIGHT	1-40
REPLACING THE SIDE BROOM	1-40
HOPPER SERVICE	1-41
HOPPER	1-41
CLEANING THE HOPPER	1-41
CHECKING THE HOPPER SEALS	1-41
DUST CONTROL FILTER	1-41
CHECKING THE DUST CONTROL FILTER	1-41
CLEANING THE DUST CONTROL FILTER	1-41
REPLACING THE DUST CONTROL FILTER	1-42
DUST FLAPS	1-42
CHECKING THE DUST FLAPS	1-42
ADJUSTING THE DUST FLAPS	1-42
BRAKES	1-43
ADJUSTING THE BRAKE PEDAL	1-43
ADJUSTING THE BRAKES	1-43
GENERAL MACHINE MAINTENANCE	1-44
FILLING THE HYDRAULIC RESERVOIR	1-44
CLEANING THE HYDRAULIC SYSTEM	1-44
REPLACING THE RETURN FILTER ELEMENT	1-44
REPLACING THE SCRUB BRUSH	1-45
COVERS AND LATCHES	1-45
SOLUTION LOW WARNING LIGHT	1-45
RECOVERY HIGH WARNING LIGHT	1-45
SOLUTION CONTROL	1-45
RECYCLING PUMP ESP SYSTEM	1-46
RECYCLING PUMP STORAGE	1-46
REAR SQUEEGEE	1-46
SQUEEGEE CASTER WHEELS	1-46
ADJUSTING CASTERS	1-46
AIR INTAKE SYSTEM	1-47
REPLACING THE AIR FILTER ELEMENT	1-47
AIR FILTER	1-48
COOLING SYSTEM	1-49
COOLANT LEVEL	1-49
RADIATOR	1-49
BATTERY	1-50
GAS TANK	1-50
NEUTRAL ADJUSTMENT	1-51
LP SYSTEM	1-52
LP SAFETY PRECAUTIONS	1-52
LP VAPORIZER - REGULATOR QUICK CHECK	1-53
LP VAPOR WITHDRAWAL SYSTEM	1-53
LP CHECKLIST	1-53
LP FUEL TANKS	1-54
USE AND CARE OF LP TANKS	1-55
CHANGING THE LP TANKS	1-55

TABLE OF CONTENTS

STORING LP FUEL TANKS	1-55
PARTS LIST LEGEND	1-56
GENERAL TROUBLESHOOTING	1-57
CHECK ENGINE LIGHT CODES	1-59
ORDERING PARTS	1-62
 CHAPTER 2 PARTS	
MAIN BROOM LEVER	2-4
SIDE BROOM	2-6
SIDE BROOM PULLEY	2-7
SIDE BROOM LEVER	2-8
SIDE BROOM LIFT SYSTEM	2-10
BROOM CHAMBER FLAPS & SEALS	2-12
BROOM CHAMBER DOORS	2-14
HOPPER	2-16
HOPPER LID/COVER	2-20
HOPPER DUMP DOOR	2-21
HOPPER DOOR CYLINDER	2-22
HOPPER CONTROL VALVE	2-23
SCRUB DECK (46")	2-24
SCRUB DECK & SQUEEGEE (53")	2-28
SIDE SQUEEGEES (46")	2-32
REAR SQUEEGEES (46")	2-34
SQUEEGEE LIFT	2-36
SWING SQUEEGEE SUPPORT	2-38
SOLUTION TANK	2-40
SOLUTION FEED	2-42
RECOVERY TANK	2-44
RECOVERY TANK DRAIN SYSTEM	2-48
FRONT BUMPER	2-49
FRONT WHEEL	2-50
WHEEL WELL FLAP	2-51
REAR WHEEL ASSEMBLY	2-52
BRAKE PEDAL	2-54
FORWARD/REVERSE CONTROL	2-56
FRAME	2-58
SAFETY ARM	2-59
STEERING COLUMN	2-60
VAC FAN	2-62
VAC MOTOR MANIFOLD	2-64
FILTER SHAKER	2-66
SEAT & FLOOR ASSEMBLY	2-68
HYDRAULIC HOSE/SCHEMATIC DIAGRAM	2-70
MAIN BROOM HYDRAULICS	2-72
SIDE BROOM HYDRAULICS	2-73
HOPPER LIFT HYDRAULICS	2-74
HOPPER DUMP DOOR HYDRAULICS	2-75
HOPPER CONTROL CHECK VALVE HYDRAULICS	2-76
SCRUB DECK HYDRAULICS	2-77
SCRUB DECK LIFT HYDRAULICS	2-78
SQUEEGEE LIFT HYDRAULICS	2-79
HYDRAULIC RESERVOIR	2-80
DRIVE WHEEL HYDRAULICS	2-82
VAC MOTOR HYDRAULICS	2-83
HYDRAULIC PUMP (WHEEL DRIVE)	2-84
HYDRAULIC MAIN CONTROL VALVE	2-86
HYDRAULIC CYLINDER CONTROL VALVE	2-88
HYDRAULIC RETURN BLOCK	2-90
VAC FAN HOPPER HYDRAULICS	2-92
STEERING 90° - 90° HYDRAULICS	2-93
COVERS	2-94
FORD 416EFI GAS ENGINE - HARDWARE	2-96
FORD 416EFI GAS ENGINE - AIR INTAKE, EXHAUST	2-98
FORD 416EFI GAS ENGINE - FUEL SYTEM	2-100

TABLE OF CONTENTS

FUEL TANK - GAS	2-102
FORD 416EFI ENGINE (GAS) - RADIATOR & HOSES	2-104
FORD 416EFI ENGINE (GAS & LP) - FUEL COMPUTER & OIL FILTER	2-106
FORD 416EFI LP ENGINE - FUEL SYTEM	2-108
FUEL TANK - LP	2-112
FORD 416EFI LP ENGINE - AIR INTAKE, EXHAUST	2-116
FORD 416EFI LP ENGINE - HARDWARE	2-118
FORD 416EFI ENGINE (LP) - RADIATOR & HOSES	2-120
MITSUBISHI S4L2 DIESEL ENGINE - HARDWARE	2-122
MITSUBISHI S4L2 DIESEL ENGINE - FUEL SYSTEM	2-124
MITSUBISHI S4L2 DIESEL ENGINE - THROTTLE ASSY.	2-126
FUEL TANK - DIESEL	2-128
MITSUBISHI S4L2 DIESEL ENGINE - RADIATOR, FAN	2-132
MITSUBISHI S4L2 DIESEL ENGINE - AIR CLEANER	2-132
MITSUBISHI S4L2 DIESEL ENGINE - EXHAUST SYSTEM	2-133
BATTERY ELECTRICAL ASSEMBLY - GAS/LP	2-134
BATTERY ELECTRICAL ASSEMBLY - DIESEL	2-135
DECALS	2-136
INSTRUMENT PANEL	2-138
CE KIT	2-140
INSTRUMENT PANEL CONNECTION DRAWING	2-141
ELECTRICAL SCHEMATIC	2-142
MACHINE HARNESS CONNECTION DIAGRAM	2-143
HARNESS ROUTING	2-144
FORD 416EFI ENGINE HARNESS	2-145
MITSUBISHI S4L2 DIESEL ENGINE HARNESS	2-146
FLOOR PANEL CONNECTION DIAGRAM	2-147
CHAPTER 3 OPTIONS	
BRUSHES OPTION	3-2
HOPPER THERMO-SENSOR SHUTDOWN OPTION	3-4
BACK-UP ALARM OPTION	3-6
REAR WORK LIGHT OPTION	3-8
OVERHEAD GUARD OPTION	3-9
AMBER SAFETY LIGHT OPTION WITH OVERHEAD GUARD	3-10
AMBER SAFETY LIGHT OPTION WITHOUT OVERHEAD GUARD	3-11
ESP/AUTOFIL OPTION	3-12
ESP/AUTOFIL WIRING	3-18
FIRE EXTINGUISHER	3-20
FLAME ARRESTING GAS CAP	3-21
CLOGGED FILTER OPTION	3-22
SPRAY WAND OPTION	3-24
WET SWEEP BYPASS/THERMO SENSOR OPTION	3-28
RETRACTABLE SEATBELT OPTION	3-32
RETRACTABLE SEATBELT OPTION (LP ONLY)	3-33
SUSPENSION SEAT OPTION	3-34
SEAT SWITCH KIT	3-35
PAD DRIVER OPTION (16")	3-36
PAD DRIVER OPTION (18")	3-37
OIL COOLER OPTION	3-38
VACUUM WAND OPTION	3-39
VAC HOSE SERVICE KIT	3-40
SPARE PARTS LIST - 46" MACHINE	3-41
SPARE PARTS LIST - 53" MACHINE	3-42
SPARE PARTS LIST - GAS/LP/DIESEL (GENERAL)	3-43
ENGINE SERVICE PARTS - MITSUBISHI S4L2 DIESEL	3-44
ENGINE SERVICE PARTS - FORD 416EFI GAS/LP	3-45

SPECIFICATIONS

CLEANING PATH

Scrubbing	46 Inches (116.84 cm) or 53" (134.62cm)
Sweeping	60 Inches (152.40 cm)
Edge Cleaning	6 Inches (15.24 cm) Right Side 53 Inches (134.62 cm) Only

TRAVEL SPEED

0-6 MPH

STEERING

Rack & Pinion 90°-90° Hydraulic Power Steering
Adjustable Steering Column

TURNING RADIUS

Left	74.5 Inches (189.23 cm)
Right	74.5 Inches (189.23 cm)
Aisle "U" Turn	110.0 Inches (279.40 cm)

DIMENSIONS

Length	102.5 Inches (265.43 cm)
Width	55.0 Inches (132.08 cm)
Height	55.5 Inches (140.97 cm)
Height w/ Overhead Guard	78.75 Inches (197.49 cm)
Wheel Base	50.8 Inches (128.90 cm)

WEIGHT

Standard Machine	2900 lbs. (1305.0 Kg)
------------------	-----------------------

TIRES

Front	Solid Rubber (Front & Rear) Two (2) 16" (41cm) x 3.75" (8.26 cm)
Rear	One (1) 16" (41 cm) x 4.00" (10.16 cm)

RAMP CLIMBING

Sweeping	6 Degrees
Transporting	8 Degrees

ENGINE DATA

Ford TSG416 EFI Engine	
Bore and Stroke	3.23" x 2.97" (82.1 mm x 75.5 mm)
Oil Capacity	4.4 quarts (4.2 liters)
Displacement	4 cylinders, 1.6 liters (97.5 CID)
Fuel	87 A.K.I. (Standard unleaded) ASI grade HD-5 for LP versions
Mitsubishi S4L2 Diesel	
Bore and Stroke	3.07" x 3.62" (78 x 92 mm)
Oil Capacity	5.6 quarts (5.4 liters) - w/standard oil pan
Displacement	4 cylinders, 1.8 liters (107.3 cu. in.)
Fuel	ASTM No. 2-D

MAIN BROOM

One-piece plastic core disposable type. Broom position can be set to "restricted down" or "free floating."

Length	45 Inches (114 cm)
Diameter	14 Inches (35.6 cm)
Bristle Length	3.25 Inches (8.26 cm)

Optional Bristle Type	Nylon (Herringbone) High Density Nylon	Proex and Wire Poly and Wire
-----------------------	---	---------------------------------

Main Broom Lift Main Broom Arms	Hard Linkage Patented (No-Tool Broom Change)
------------------------------------	---

SIDE BROOM

Side Broom Size	21-inch (53.34 cm) Diameter
Side Broom Bracket	Swing Away Shock Mount
Side Broom Lift	Cable

INSTRUMENTS AND CONTROLS

Fuel Gauge	Main Broom Lever (Activates Immediately when lowered)
Key Switch	Rectangular Hour Meter
Headlight/Taillight Switch	Side Broom Lever (Activates Immediately when lowered)
2-Position Throttle Switch	Engine Oil Pressure Light
Squeegee Switch	Recovery High Light
Scrub Deck Switch	Clogged Filter Light (OPTION)
Scrub Deck Heavy Load Switch	Horn Button
Hopper Temperature Light (OPTION)	Glow Plug (Diesel)
Solution Low Light	Solution Control
Coolant Temperature Light	Hopper Up/Down
Check Engine Light (Gas, LP)	Dump Door Open/Closed
	Filter Shaker Switch

SCRUBBING SYSTEM

Brush Size-46"	Three (3) 16" (40.64 cm) Diameter Brushes
Brush Size-53"	Three (3) 17.88" (45.42 cm) Diameter Brushes
Brush Drive	Hydraulic Motors, Off in Neutral (after 2-second delay)
Brush Drive Lift	Hydraulic Cylinder
Scrub Load	Ground Clearance 250 lbs. (112.50 Kg) or 400 lbs. (180.0 Kg)

SQUEEGEE

Vacuum/Squeegee	55.5-inch (140.97 cm) Wide Swing, Gum Rubber Outer Blade
Side Squeegees (2)	Patented Configuration
Squeegee Lift	Cylinder and Cable, Auto-Lift in Reverse
Squeegee Hose	2-inch (5.08 cm) Diameter

TANKS

Solution Tank	70 Gallon (264.96 Liters) Polyethylene
Recovery Tank	70 Gallon (264.96 Liters) Polyethylene
Solution Metering	Variable to 3.0 GPM

HOPPER

Capacity	10 Cubic Feet (.2832 Cubic Meters), 700 lbs. (315 Kg)
Dump and Lift	Variable Dump with Dump Door
Filter	78 Sq. Ft. (72,464 Sq. Cm)
Dump Height	60-Inch (152.40 cm) Variable Dump
Reach Into Dumpster	11 Inches (27.94 cm)

SPECIFICATIONS

SYSTEM FLUID CAPACITIES

Fuel Tank	10.0 Gallons (37.95 Liters)
Hydraulic System	9.0 Gallons (34.07 Liters), Swing Out for Service

OPTIONAL EQUIPMENT

Seat Belt	Back Up Alarm
Wet Sweep Bypass/Thermo-Sensor	Push-Pull Light Switch (Work Light)
Amber Safety Light	Headlight/Taillight Switch
ESP & Autofil Recycling System	Overhead Guard
Pad Drivers	Non-Marking Tires
Oil Cooler	Scrub Brushes
46" Scrub Option (Field-Installed) (Gas)	53" Scrub Option (Field-Installed)
Spray Wand Option	Vacuum Wand Option
Fire Extinguisher	Clogged Filter

MACHINE DIMENSIONS

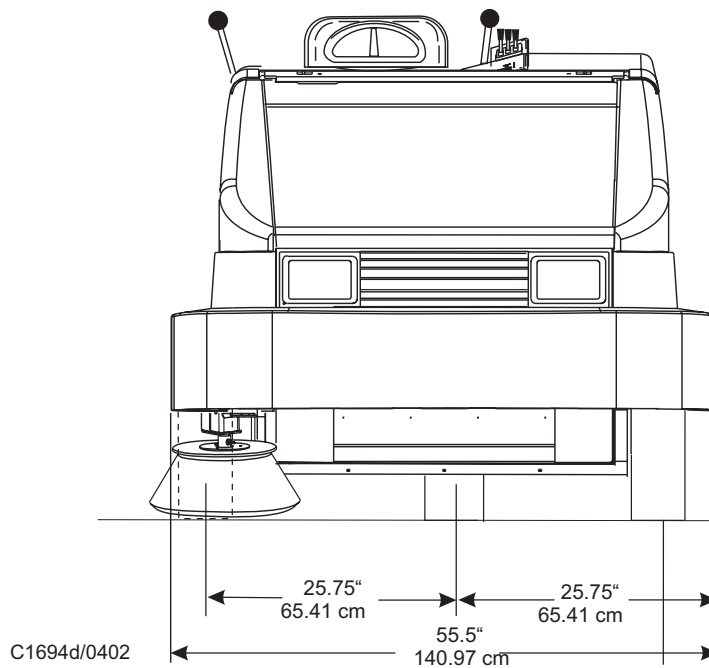
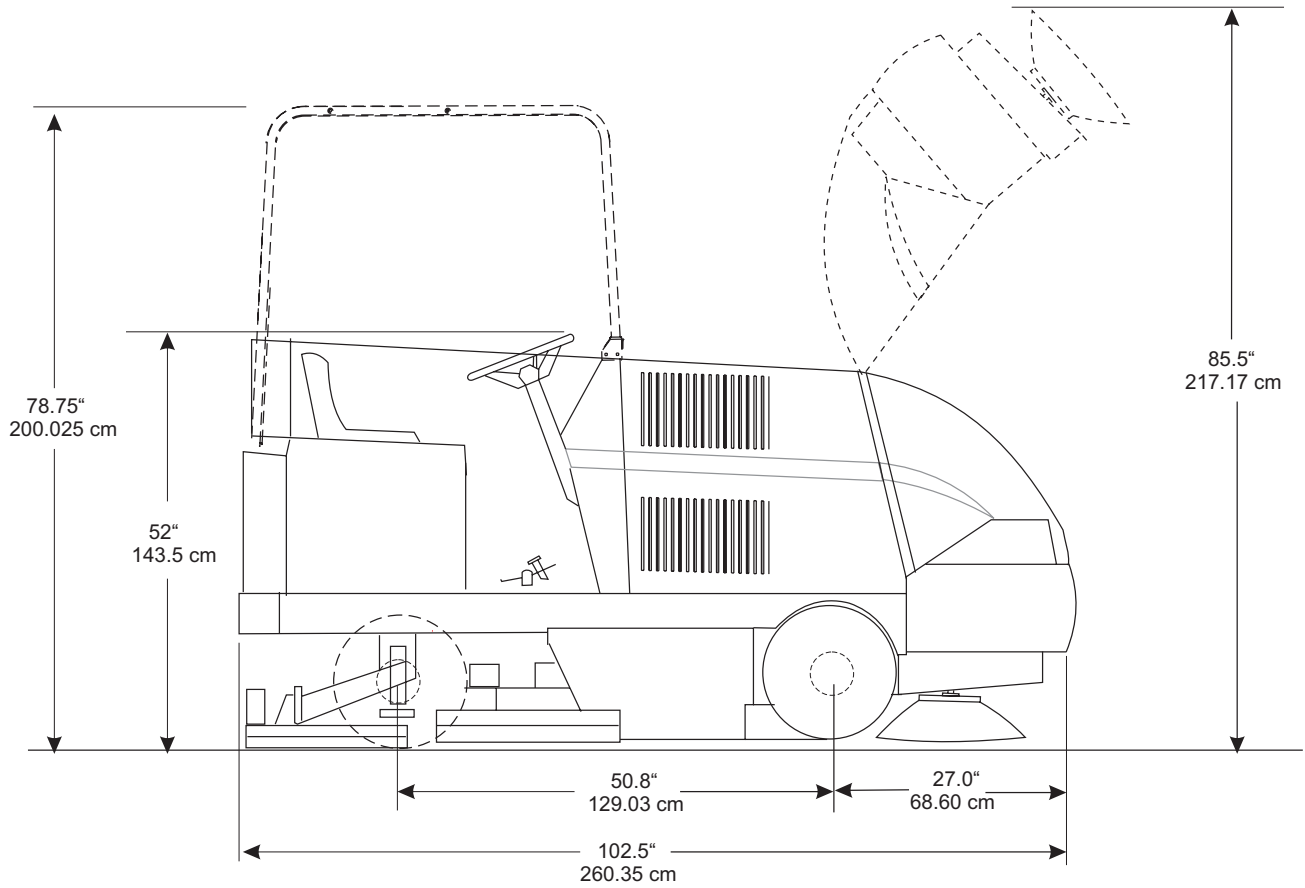

BOLT IDENTIFICATION

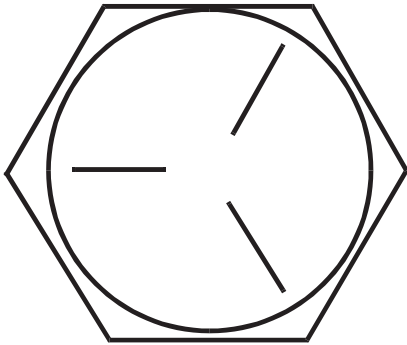

SAE - Grade 5

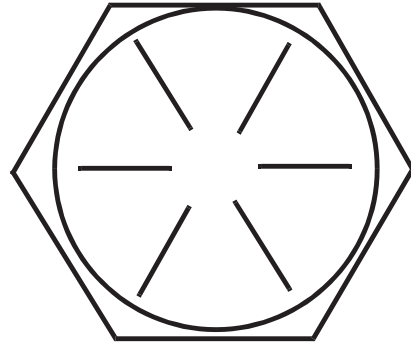

SAE - Grade 8

Screw Size	Grade 5 Plated		Grade 8 Plated		410H Stainless		Brass	Type F & T & BT		Type B, AB
	C	F	C	F	C	F		C	F	
*6	14	15	-	-	18	20	5	20	23	21
*8	27	28	-	-	33	35	9	37	41	34
*10	39	43	-	-	47	54	13	49	64	49
*1/4	86	108	130	151	114	132	32	120	156	120
5/16	15	17	22	24	19	22	6	-	-	-
3/8	28	31	40	44	34	39	10	-	-	-
7/16	44	49	63	70	55	62	16	-	-	-
1/2	68	76	95	108	85	95	-	-	-	-
9/16	98	110	138	155	-	-	-	-	-	-
5/8	135	153	191	216	-	-	-	-	-	-
3/4	239	267	338	378	-	-	-	-	-	-
7/8	387	-	545	-	-	-	-	-	-	-
1	579	-	818	-	-	-	-	-	-	-

C = Coarse Thread

F = Fine Thread

* = Torque values for #6 through 1/4 are lb./in. All others are lb./ft.

NOTE

Decrease the torque by 20% when using thread lubricant
The torque tolerance is \pm on torque values.

+

C2000/9905

HYDRAULIC TORQUE REQUIREMENTS

HYDRAULIC TORQUE REQUIREMENTS

Refer to the following chart for torque values on all hydraulic hoses and fittings.

Nominal SAE Dash Size	O-Ring Face Seal End		SAE O-Ring Boss End	
	Thread Size Inch	Swivel Nut Torque	Thread Size Inch	Str. Fitting or Locknut Torque
		LB-FT		LB-FT
-3	*	*	3/8-24	8-10
-4	9/16-18	10-12	7-16-20	14-16
-5	*	*	1/2-20	18-20
-6	11/16-16	18-20	9/16-18	24-25
-8	13/16-16	32-35	3/4-16	50-60
-10	1-14	46-50	7/8-14	72-80
-12	1 3/16-12	65-70	1 1/16-12	125-135
-14	1 3/16-12	65-70	1 3/16-12	160-180
-16	1 7-16-12	92-100	1 5/16-12	200-220
-20	1 11/16-12	125-140	1 5/8-12	210-280
-24	2-12	150-165	1 7/8-12	270-360

* O-Ring face seal type end not defined for this tube size.

NOTE

Parts must be lightly oiled with hydraulic fluid.

C-2002

DECIMAL-METRIC CONVERSION TABLE

DECIMAL-METRIC CONVERSION TABLE

Fraction	Decimal	Millimeter	Fraction	Decimal	Millimeter
$\frac{1}{64}$	0.015625	0.3969	$\frac{33}{64}$	0.515625	13.0969
$\frac{1}{32}$	0.03125	0.7938	$\frac{17}{32}$	0.53125	13.4938
$\frac{3}{64}$	0.046875	1.1906	$\frac{35}{64}$	0.546875	13.8906
$\frac{1}{16}$	0.0625	1.5875	$\frac{9}{16}$	0.5625	14.2875
$\frac{5}{64}$	0.078125	1.9844	$\frac{37}{64}$	0.578125	14.6844
$\frac{3}{32}$	0.09375	2.3813	$\frac{19}{32}$	0.59375	15.0813
$\frac{7}{64}$	0.109375	2.7781	$\frac{39}{64}$	0.609375	15.4781
$\frac{1}{8}$	0.125	3.1750	$\frac{5}{8}$	0.625	15.8750
$\frac{9}{64}$	0.140625	3.5719	$\frac{41}{64}$	0.640625	16.2719
$\frac{5}{32}$	0.15625	3.9688	$\frac{21}{32}$	0.65625	16.6688
$\frac{11}{64}$	0.171875	4.3656	$\frac{43}{64}$	0.671875	17.0656
$\frac{3}{16}$	0.1875	4.7625	$\frac{11}{16}$	0.6875	17.4625
$\frac{13}{64}$	0.203125	5.1594	$\frac{45}{64}$	0.703125	17.8594
$\frac{7}{32}$	0.21875	5.5563	$\frac{23}{32}$	0.71875	18.2563
$\frac{15}{64}$	0.234375	5.9531	$\frac{47}{64}$	0.734375	18.6531
$\frac{1}{4}$	0.25	6.3500	$\frac{3}{4}$	0.75	19.0500
$\frac{17}{64}$	0.265625	6.7469	$\frac{49}{64}$	0.765625	19.4469
$\frac{9}{32}$	0.28125	7.1438	$\frac{25}{32}$	0.78125	19.8438
$\frac{19}{64}$	0.296875	7.5406	$\frac{51}{64}$	0.796875	20.2406
$\frac{5}{16}$	0.3125	7.9375	$\frac{13}{16}$	0.8125	20.6375
$\frac{21}{64}$	0.328125	8.3344	$\frac{53}{64}$	0.828125	21.0344
$\frac{11}{32}$	0.34375	8.7313	$\frac{27}{32}$	0.84375	21.4313
$\frac{23}{64}$	0.359375	9.1281	$\frac{55}{64}$	0.859375	21.8281
$\frac{3}{8}$	0.375	9.5250	$\frac{7}{8}$	0.875	22.2250
$\frac{25}{64}$	0.390625	9.9219	$\frac{57}{64}$	0.890625	22.6219
$\frac{13}{32}$	0.40625	10.3188	$\frac{29}{32}$	0.90625	23.0188
$\frac{27}{64}$	0.421875	10.7156	$\frac{59}{64}$	0.921875	23.4156
$\frac{7}{16}$	0.4375	11.1125	$\frac{15}{16}$	0.9375	23.8125
$\frac{29}{64}$	0.453125	11.5094	$\frac{61}{64}$	0.953125	24.2094
$\frac{15}{32}$	0.46875	11.9063	$\frac{31}{32}$	0.96875	24.6063
$\frac{31}{64}$	0.484375	12.3031	$\frac{63}{64}$	0.984375	25.0031
$\frac{1}{2}$	0.5	12.7000	1	1.0000	25.4000

C-2001

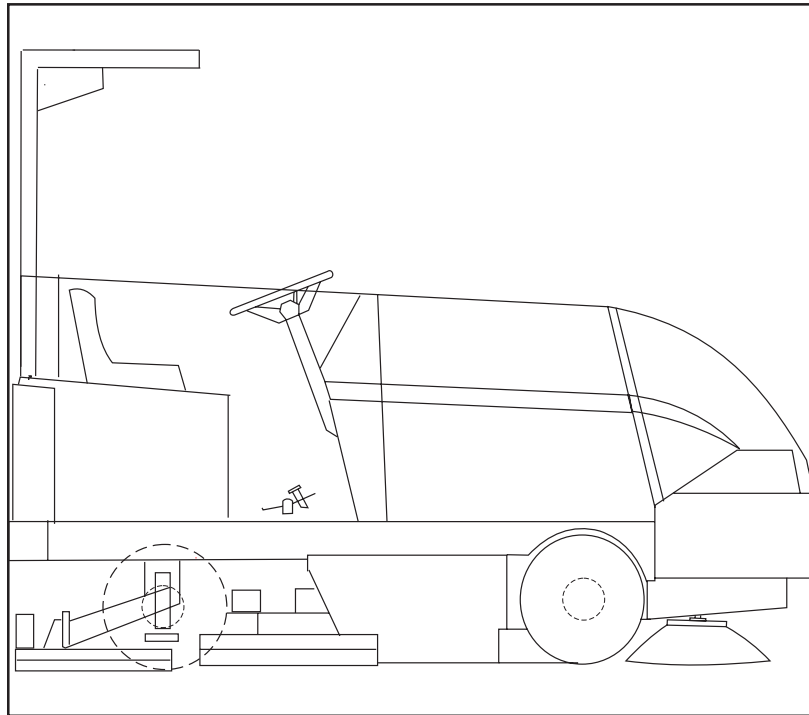

C1694c

FIGURE 1

YOUR SC7750 IC MACHINE HAS BEEN SHIPPED COMPLETE, BUT DO NOT ATTEMPT TO OPERATE WITHOUT FOLLOWING THESE INSTRUCTIONS.

PREPARING THE MACHINE FOR OPERATION

1. Connect and tighten battery cables.
2. Fill the tank with REGULAR GRADE gasoline. (Diesel fuel if equipped with diesel engine.)



WARNING

Never fill the tank while the engine is running. Always be sure the gasoline container and sweeper are electrically connected before pouring gasoline. This can easily be done by providing an insulated wire (permanently attached to container) with a battery clip on the other end.

3. Check engine crankcase oil level. Although properly lubricated at the factory, check before starting the engine. No special break in oil is used and recommended number of operating hours before the initial oil change is the same as normal. See Maintenance.
4. Check radiator coolant level. Permanent type antifreeze is added at the factory to provide protection to approximately -35°F (37°C). To retain this protection level, always add ½ part water to ½ part antifreeze.
5. Check oil level in the hydraulic reservoir located at the center of the machine beside the engine. The oil fill level should be halfway on sight glass. If oil is needed, add HYDRAULIC FLUID ONLY, automatic transmission fluid FORD type "F." After the first 50 operating hours, service must be performed on your engine to ensure future high performance and trouble free operation. See Maintenance.

NOTE

After the first 50 operating hours, service must be performed on your engine to ensure future high performance and trouble-free operation. See Maintenance.

SAFETY INSTRUCTIONS

THE FOLLOWING STATEMENTS ARE USED THROUGHOUT THIS MANUAL AS INDICATED IN THE DESCRIPTIONS:



DANGER

To warn of immediate hazards which will result in severe personal injury or death.



WARNING

To warn of hazards or unsafe practices which could result in severe personal injury or death.



CAUTION

To warn of hazards or unsafe practices which could result in minor personal injury.



ATTENTION

To warn of unsafe practices which could result in extensive equipment damage.

NOTE

To give important information or to warn of unsafe practices which could result in equipment damage.



WARNING

THE FOLLOWING INFORMATION SIGNALS POTENTIALLY DANGEROUS CONDITIONS TO THE OPERATOR OR EQUIPMENT. READ THIS MANUAL CAREFULLY. KNOW WHEN THESE CONDITIONS CAN EXIST. THEN, TAKE NECESSARY STEPS TO TRAIN MACHINE OPERATING PERSONNEL. FOR THE SAFE OPERATION OF THIS MACHINE, READ AND UNDERSTAND ALL WARNINGS, CAUTIONS AND NOTES.



WARNING

Machines can ignite flammable materials and vapors. Do not use with or near flammables such as gasoline, grain dust, solvents, and thinners.



WARNING

Heavy machinery. Improper use can cause personal injury.



WARNING

Operate only when lids, doors, and access panels are securely closed.



WARNING

Use care when reversing machine in confined area.



WARNING

When servicing the machine, disconnect the battery first to prevent possible injury.



WARNING

Always empty the hopper and disconnect the battery before doing maintenance.



WARNING

You must have training in the operation of this machine before using it.

READ THE INSTRUCTION BOOK.



WARNING

Do not operate this machine unless it is completely assembled.



WARNING

Do not use this machine as a step or furniture.



WARNING

Stop and leave this machine on a level surface. When you stop the machine, put the power switch in the "OFF" position and engage the Wheel Lock.



WARNING

To prevent injury and damage to the machine, do not lift the machine or move it to an edge of a stair or loading dock.

 **WARNING**

Always wear eye protection and protective clothing when working near battery. Remove all jewelry. Do not put tools or other metal objects across the battery terminals or across the top of battery.

 **WARNING**

Only authorized personnel must do maintenance and repairs. Tighten all fasteners. Maintain adjustments according to the specifications given in the service manual for the machine. Keep the electrical parts of the machine dry. For storage, keep the machine in a building.

 **WARNING**

Make sure all labels, decals, warnings, cautions and instructions are fastened to the machine. Purchase new labels and decals from American-Lincoln.

 **WARNING**

The operator must exhibit extreme caution when negotiating, turning, and traveling across grades or ramps. Start, stop, change direction, travel and brake smoothly. Slow down when turning.

 **WARNING**

Avoid uneven surfaces and loose materials. Watch for obstructions, especially overhead.

 **WARNING**

Operate only from the designated operator's position. Stay inside the body of the machine. Keep hands and feet on the designated controls. Always operate in well-lighted areas.

 **WARNING**

Do not carry passengers on the machine. Set the Wheel Lock when leaving the machine. Chock (block) the wheels if the machine is parked on a grade (ramp), or is being prepared for maintenance.

 **WARNING**

Never leave the operator's compartment when the engine is running.

 **WARNING**

Report damage or faulty operation immediately. Do not operate the machine until repairs have been completed. Only authorized personnel should do maintenance and repairs.

 **WARNING**

To maintain the stability of this machine in normal operation, the overhead guard, counterweights, rear bumper guard or any similar equipment installed by the manufacturer as original equipment should never be removed. If it becomes necessary to remove such equipment for repair or maintenance, this equipment must be reinstalled before the machine is placed back into operation.

 **WARNING**

Electrical hazard. Shocks can cause serious personal injury. Unplug the battery before cleaning or servicing. To avoid possible injury or property damage, read the Operator's Manual before servicing the machine. Authorized personnel should do maintenance and repairs.

FOR SAFETY, OBSERVE THE FOLLOWING WARNINGS. FAILURE TO COMPLY MAY CREATE A SERIOUS RISK OF INJURY TO YOU AND OTHERS. THIS MACHINE SHOULD NOT BE USED IN HAZARDOUS LOCATIONS INCLUDING AREAS OF VOLATILE DUST OR VAPOR CONCENTRATIONS.

Operators must be trained and qualified to operate this machine. They must also understand the operator's manual before starting.

Use caution when mounting or dismounting the machine particularly on wet slippery surfaces.

Do not dump the hopper over an open pit or dock. Do not dump the hopper when positioned on a grade (ramp). The machine must be level (horizontal).

OPERATION OF CONTROLS AND GAUGES

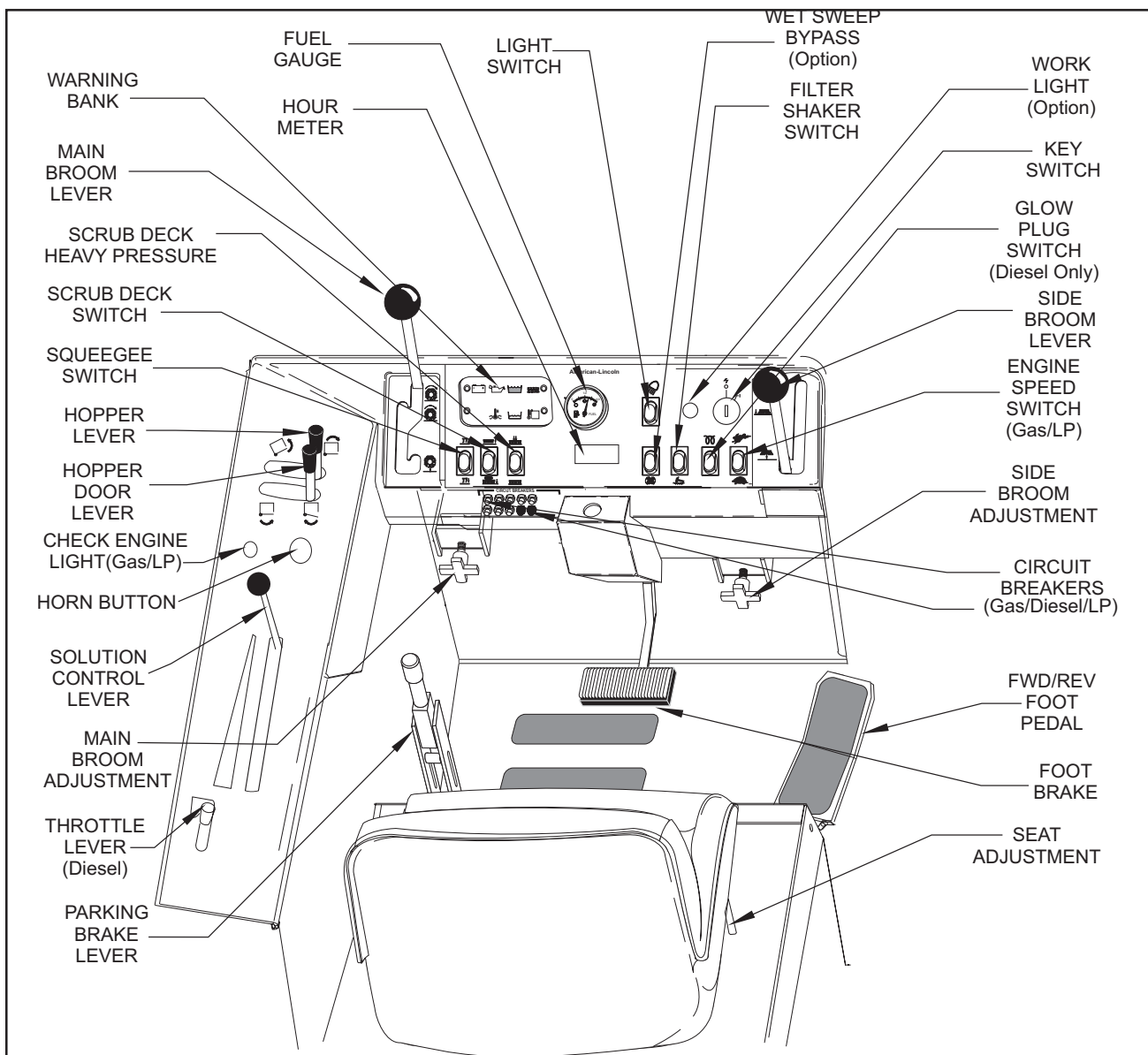

P5034b-1ecp

FIGURE 2

LIGHT SWITCH (See Figure 2)

The light switch is located on the front instrument panel to the right of the fuel gauge. It will work various light options that are available for this machine, such as:

- * HEAD LIGHTS
- * TAIL LIGHTS
- * INSTRUMENT LIGHTS

HORN BUTTON (See Figure 2)

The horn button is located on the left side console. Push the button with your finger to sound the horn. The horn button is always active.

CHECK ENGINE LIGHT (Gas, LP Only) (See Figure 2)

The check engine light is located on the left side console. If the light comes on, it indicates a problem with the engine. Flip the switch located on/near the air cleaner bracket in the engine compartment, count the number of times the panel light flashes, then go to "Engine Check Light Codes" at the end of this chapter to determine the problem.

OPERATION OF CONTROLS AND GAUGES

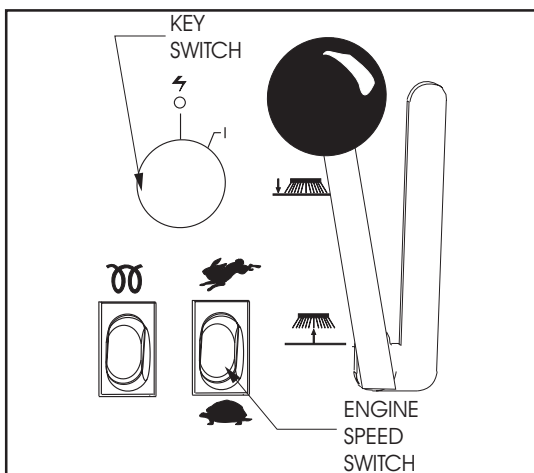

C1631A FIGURE 3

KEY SWITCH (See Figure 3)

The keyed ignition switch is located on the instrument panel to the left of the side broom lever. The key switch is a two-position switch that controls power to the machine systems and accessories.

The “OFF” position (O position) will shut off the engine.

The IGN/ON position (I position) provides power to all machine systems and accessories.

The “START” position (one position clockwise of I position) is momentary and provides power to the starter motor.

NOTE

To re-engage, the starter key must be returned to the “OFF” position.

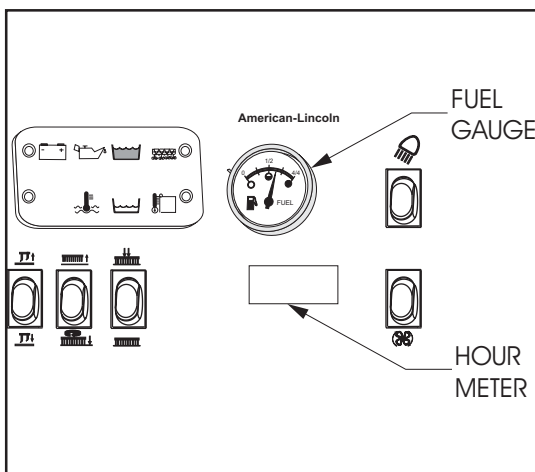

C1633 FIGURE 4

ENGINE SPEED SWITCH (Gas, LP) (See Figure 3)

A two-position switch controls the engine, which is located on the instrument panel to the left of the side broom lever. The switch position determines the governed operating speed of the engine.

Place the speed switch in the “IDLE” position to start the machine.

Place the speed switch in the “FAST” position for transport and when normal sweeping action is desired.

HOUR METER (See Figure 4)

The hour meter is located on the instrument panel above the engine speed switch. The meter is activated when the engine begins running. The meter indicates the actual “run” time of the machine. The meter can be used to determine when maintenance should be done on the machine.

FUEL GAUGE (See Figure 4)

The fuel gauge is located on the instrument panel to the right of the main broom lever and indicates the level of fuel in the tank. The key switch powers the fuel gauge. The key switch must be in the “ON” position for the fuel gauge to work. The fuel gauge is not included on machines that use Liquid Propane fuel.

SEAT POSITION ADJUSTMENT (See Figure 5)

The seat position adjustment lever is located on the right side of the seat base. The lever is spring loaded to the “LOCK” position.

To adjust the seat, push “FORWARD” on the lever and move the seat to the desired position. Then release the lever to “LOCK” the seat into place.

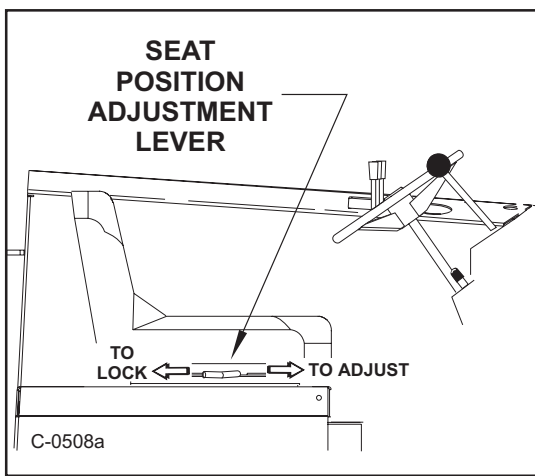

C0508A-2 FIGURE 5

OPERATION OF CONTROLS AND GAUGES

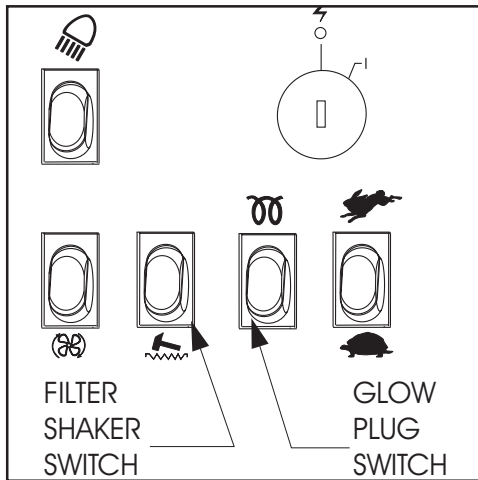

C1640-2 FIGURE 6

FILTER SHAKER SWITCH (See Figure 6)

The filter shaker switch is located on the instrument panel below the ignition switch. This is a momentary switch that will activate the filter shaker motors for 20 to 30 seconds to clear the dust control filter. The Impeller fan will stop when the filter shaker has been activated. The filter shaker will only operate with the hopper in the “DOWN” position.

Use the filter shaker to clear the filter when the dust control light comes on (warning bank) and just before dumping the hopper.

GLOW PLUG SWITCH (Diesel) (See Figure 6)

Under no circumstances should any other unauthorized starting aids be used at the same time as Glow Plugs. The Glow Plug Switch is located to the right of the steering column on the front face of the instrument console. Use the following procedure to operate.

1. Before operating the starter motor, press the “GLOW PLUG” switch for 20 to 30 seconds.
2. With the “GLOW PLUG” switch still depressed, engage the starter motor until the engine starts.
3. Continue to press the “GLOW PLUG” switch for a few seconds after the engine has started until even running has been obtained.
4. If the engine does not start, disengage the starter motor, but keep the “GLOW PLUG” switch depressed for a further 10 to 15 seconds, when a further attempt should be made to start the engine, keeping the Glow Plugs energized while starting and for a few seconds after the engine has fired until it is running smoothly.

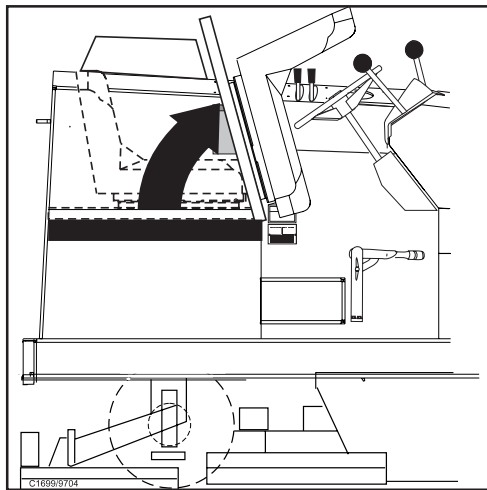

C1699a FIGURE 7

SEAT COMPARTMENT PROP LATCH (See Figure 7)

The seat compartment latch is located under the seat compartment cover and is used to hold the cover open.

To hold the seat compartment cover open, lift the cover and rotate the latch.

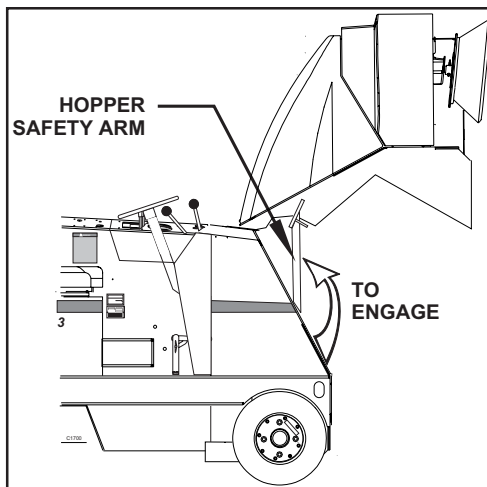

C1700 FIGURE 8

HOPPER SAFETY LOCK ARM (See Figure 8)

The hopper safety arm is located near the right front wheel well. The safety arm will prevent the hopper from dropping unexpectedly during service/maintenance.

TO ENGAGE THE SAFETY ARM:

1. Empty hopper
2. Set the parking brake.
3. Raise the hopper.
4. Lift safety arm to engage the slot on the hopper frame.
5. When work has been completed, replace the safety arm to the stowed position.



WARNING

When the hopper is raised, the safety arm must be engaged before ANY work is done under the hopper.

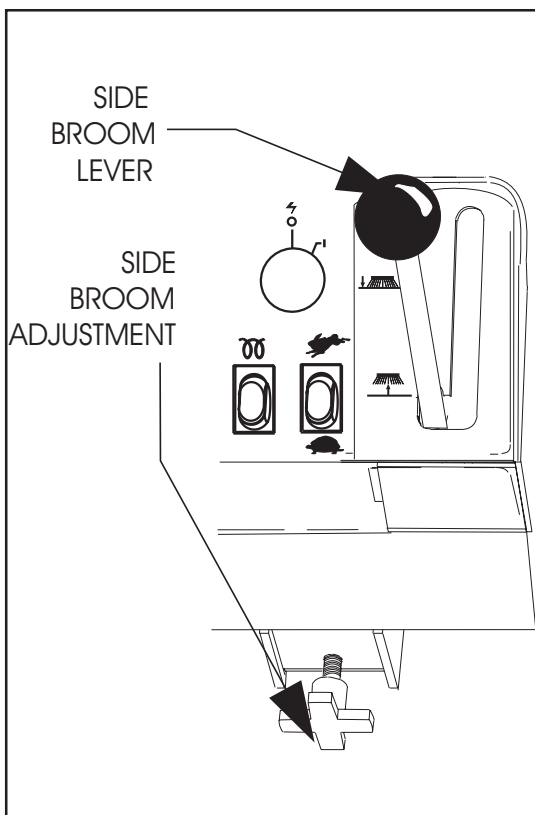

C1641 **FIGURE 9**

SIDE BROOM LEVER (See Figure 9)

The Side Broom Lever is located to the right of the instrument console. The handle pulled back and turned to the left, will raise the side broom and lock it into position.

To raise the side broom pull the lever back into the “UP” position.

To lower the side broom, move the lever out of the “UP” position and move it forward to the “DOWN” position.

NOTE

IF THE MAIN BROOM IS ENGAGED, THE SIDE BROOM WILL AUTOMATICALLY ENGAGE WHEN LOWERED.

SIDE BROOM ADJUSTMENT (See figure 9)

The side broom lever has an adjustment for changing the sweep height to compensate for broom wear. The side broom adjustment is located under the right side of the instrument panel.

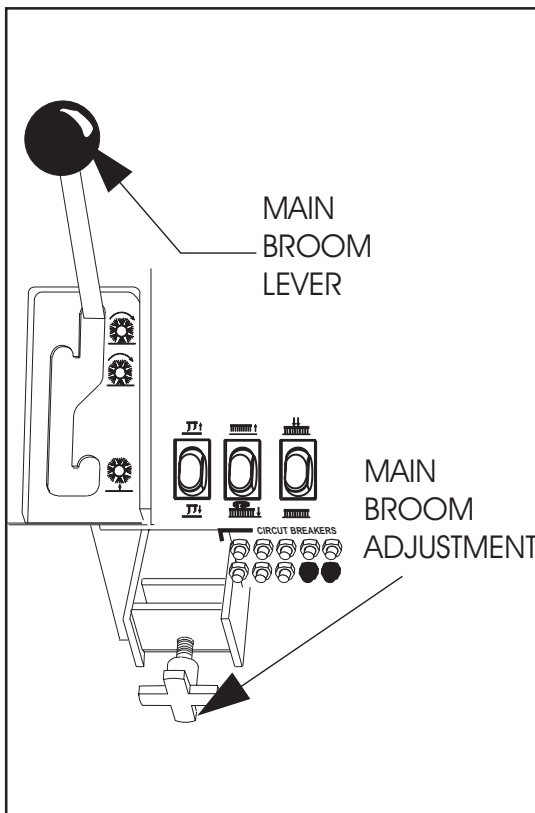

C1642-1 **FIGURE 10**

MAIN BROOM LEVER (See figure 10)

The main broom lever is located on the left side of the instrument panel. The main broom lever has three positions and controls the main broom sweep height.

To lower the main broom, grasp the lever and move it to the left out of the “UP” position, and place it in the “SWEEP” or “FLOAT” position.

The “SWEEP” position is used for normal sweeping and should be used under most sweeping conditions (approximately 2” broom pattern).

The “FLOAT” position is used for sweeping very uneven surfaces only. Using the float position will cause premature wear on the main broom if used under normal operating conditions for extended periods of time (approximately 4” broom pattern).

NOTE

The Main Broom will automatically engage when lowered to the sweep position or the float position. The hopper must be completely closed.

MAIN BROOM ADJUSTMENT (See Figure 10)

The main broom lever has an adjustment for changing the sweep height to compensate for broom wear. The main broom adjustment is located under the left side of the instrument panel.

OPERATION OF CONTROLS AND GAUGES

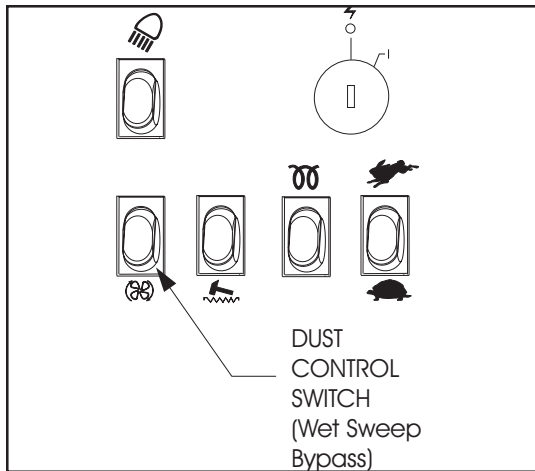

C1640-1 FIGURE 11

DUST CONTROL SWITCH (Wet Sweep Bypass Option - Option for All Machines) (See Figure 11)

The Dust Control Switch is a two position switch located on the instrument panel next to the filter shaker switch. The switch controls the vacuum fan in the dust control system.

To turn on the dust control system for “NORMAL” sweeping, press on the top portion of the switch. To turn off the dust control system for sweeping in wet conditions, press the lower portion of the switch. This will prevent the filter from being damaged by water pickup while sweeping.

SCRUB DECK SWITCH (See Figure 12)

The brushes switch is located on the console to the left of the steering wheel in the “SCRUBBING” section. This switch in the position marked “LOWER” will lower the scrub brush deck and activate the three scrub brushes. The heavy pressure switch cannot be activated unless this switch is in the “LOWER” position. This switch in the “RAISE” position will stop the brushes from rotating and raise the scrub brush deck

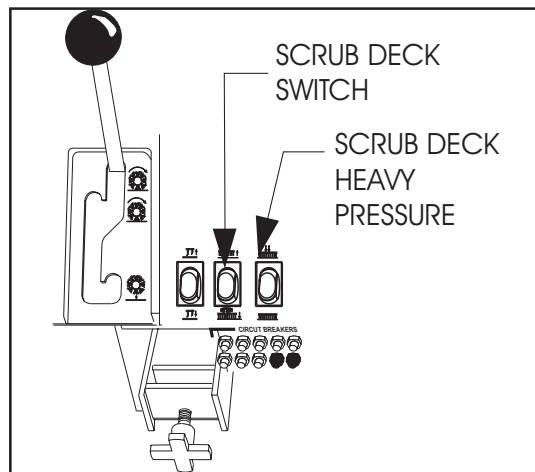

C1642A FIGURE 12

NOTE

Lowering the scrub deck will not start the brushes rotating the foot pedal must be moved to engage the scrub brushes. If the machine stops moving for 2 seconds or more the brushes will automatically stop rotating until the machine starts moving again.

SCRUB DECK HEAVY PRESSURE SWITCH (See Figure 12)

The scrub deck heavy pressure switch is located on the console to the left of the steering wheel in the “SCRUBBING” section. This switch applies additional downward pressure to the scrub brushes. This switch has two positions down “NORMAL” and up “HEAVY”. This switch cannot be activated unless the scrub deck switch is in the “LOWER” position, the switch will light when it can be activated.

SQUEEGEE SWITCH (See Figure 13)

The squeegee blade switch is located on the console to the left of the steering wheel in the “SCRUBBING” section. This switch in the position marked “LOWER” will lower the squeegee and activate the squeegee vacuum. This switch in the “RAISE” position will stop the squeegee vacuum and raise the squeegee. A switch activated by the forward-reverse foot pedal will automatically raise the squeegee if it is in the lowered position and the machine is in reverse.

The switch has a center position to raise the squeegee with the vacuum in to allow vacuuming the water left on the squeegee recovery hose. This prevents water from dripping on the floor with the squeegee “UP.”

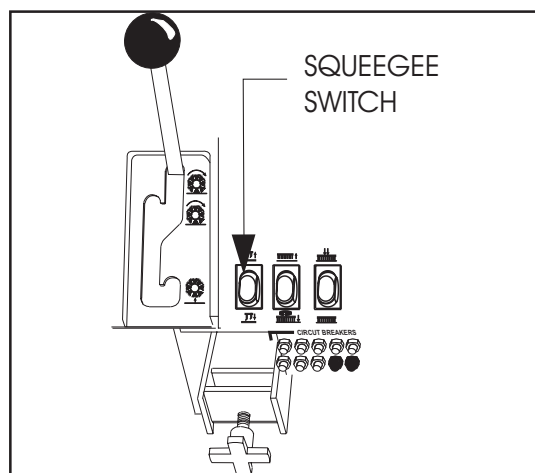

C1642B FIGURE 13

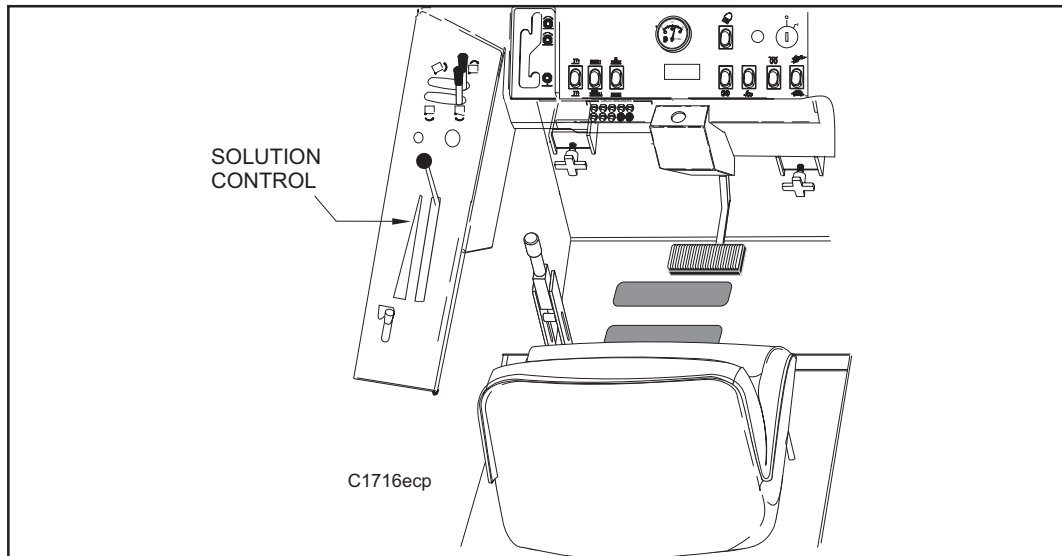

C1716ecp

FIGURE 14

SOLUTION CONTROL (See Figure 14)

To apply solution to the scrub brushes, pull the solution control lever back until the desired setting is reached. The solution rate is continuously variable from off to approximately 1-3/4 GPM at low and 3 GPM at high. To stop application of solution push forward on the lever until it stops at the "off" position. The solution warning light will illuminate when the solution tank is low, marking the end of the scrubbing cycle.

NOTE

For best results, discontinue application of solution 10 feet before stopping or making a 90° or 180° turn.

NON-RECYCLING OR STANDARD SCRUBBING SYSTEM

1. Make sure the solution control lever is in the "off" (FORWARD) position.
2. Open the solution tank cover (Vacuum Assembly)
3. Fill the tank with 70 gallons of water and the correct mixture of American-Lincoln #100 Industrial Cleaner for the job on hand.
4. Close the solution tank cover (Vacuum Assembly).

RECYCLING OR ESP & AUTOFIL SYSTEM

1. Make sure the solution control lever is in the "off" position.
2. Connect hose to autofil coupling.
3. Turn the key switch to the "ACC" position.
4. Turn on the water hose valve.
5. Fill the detergent tank with American-Lincoln #100 Industrial Cleaner.
6. The system will fill the solution and recovery tank to proper levels and shut off the water flow.

TO DISCONNECT WATER HOSE

1. Leave ignition switch in the "on" position
2. Turn the water off at the source
3. "Tip" the float switch on the solution tank to depressurize the water hose before disconnecting

WARNING

To prevent oversudsing and machine damage, use only AMERICAN-LINCOLN Industrial Cleaner Solution #100. DO NOT put gasoline, combustible or flammable material in the solution, detergent, or recovery tanks.

OPERATION OF CONTROLS AND GAUGES

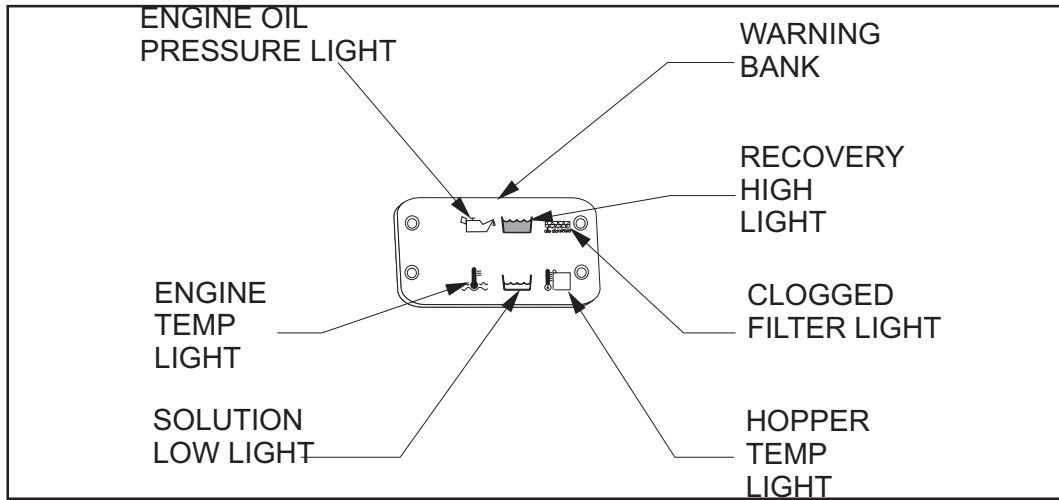

C1636 IC

FIGURE 15

WARNING BANK (See Figure 15)

The Warning Bank is located on the instrument panel and provides the operator with seven fault/status indicators for engine and sweeper systems. The operator should monitor the indicators while sweeping. It is very important that the operator be familiar with the meaning of each indicator.

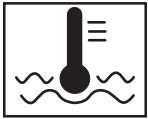

ENGINE TEMPERATURE LIGHT

The engine temperature light illuminates to indicate an engine cooling system fault. When this occurs the operator must turn off the sweeper immediately and have the cooling system serviced by a qualified service technician.

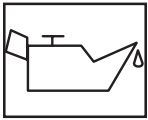

ENGINE OIL PRESSURE LIGHT

When the oil pressure drops below approximately 5 PSI an automatic protection circuit shuts down the engine and illuminates the light to indicate low engine oil pressure. When this occurs, have the machine serviced by a qualified service technician.

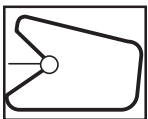

CLOGGED FILTER LIGHT (Option)

The clogged filter light illuminates to indicate that the dust control filter is clogged. When this occurs, stop the machine and use the filter shaker to clear the dirt and debris from the filter. After using the filter shaker, continue sweeping.



HOPPER TEMPERATURE LIGHT (Option)

When the temperature of the air moving through the hopper dust control system exceeds 140° F, an automatic protection feature shuts down the dust control fan and illuminates the hopper temperature light. When this occurs, shut down the machine and carefully investigate for a possible fire in the hopper, then manually reset the switch.

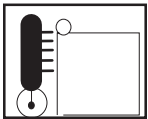

SOLUTION LOW LIGHT

The solution low warning light will illuminate when the solution tank is empty, indicating the end of the scrubbing cycle.

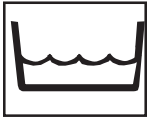

RECOVERY HIGH LIGHT

The recovery high warning light will illuminate approximately 5 minutes before the recovery tank is full, giving ample time to complete the scrubbing cycle, before the mechanical float shuts off the vacuum to the recovery tank.

OPERATION OF CONTROLS AND GAUGES

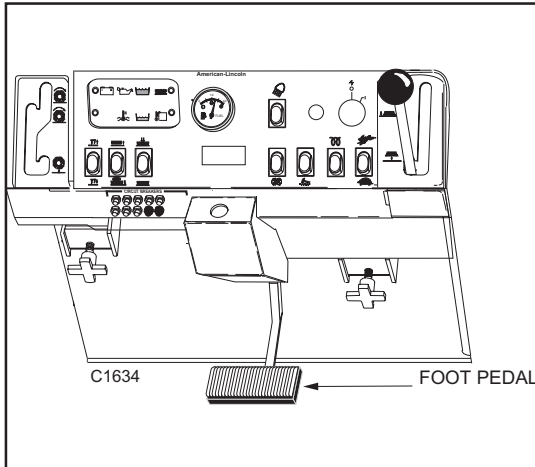

C1634-1 FIGURE 16

FOOT BRAKE (See Figure 16)

The foot brake pedal is located on the floor of the operator's compartment to the left of the directional control pedal. To stop, use the front wheel brakes, by putting pressure on the brake pedal.

PARKING BRAKE (See Figure 17)

The parking brake lever is located on the operator's compartment left side panel near the floor. When engaged, the parking brake "locks" the foot pedal in the down position.

To engage the parking brake, place lever in the upright position.

To disengage the parking brake, move the lever forward.

To adjust the parking brake "grab", turn the knob on the top of the lever. To increase the "grab", turn the knob in a clockwise direction.

To decrease the "grab", turn the knob in a counterclockwise direction.

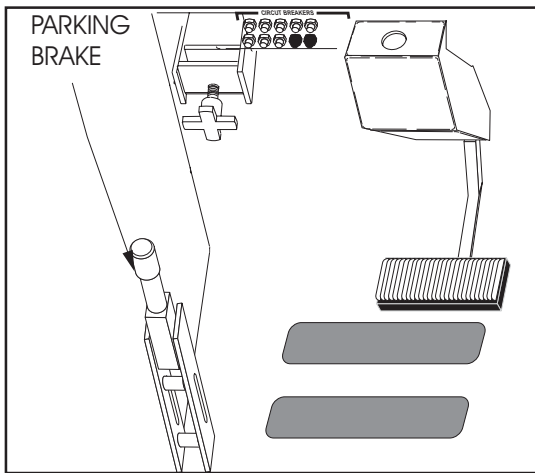

C1635 FIGURE 17

FWD/REV FOOT PEDAL (See Figure 18)

The foot pedal is located on the floor of the operator's compartment to the right of the brake pedal. The foot pedal provides control of direction/speed. The pedal height is adjustable to provide for operator comfort.

To adjust the foot pedal height for operator comfort;

1. Remove the hairpin cotter from the adjustment pin.
2. Remove adjustment pin from the foot pedal assembly.
3. Align the holes in the lower bracket with one of the four adjustment holes on the foot pedal to set the foot pedal height.
4. With the holes aligned at the desired height, insert the adjustment pin.
5. Re-install the hairpin cotter.

TO GO FORWARD: Place pressure on the upper portion of the pedal. Speed increases when additional pressure is placed on the pedal.

TO GO BACKWARD: Place pressure on the lower portion of the pedal. Speed decreases when additional pressure is placed on the pedal.

TO STOP: Allow the pedal to return to the centered position.

To increase braking action while moving in reverse gently put pressure on the upper portion of the pedal.

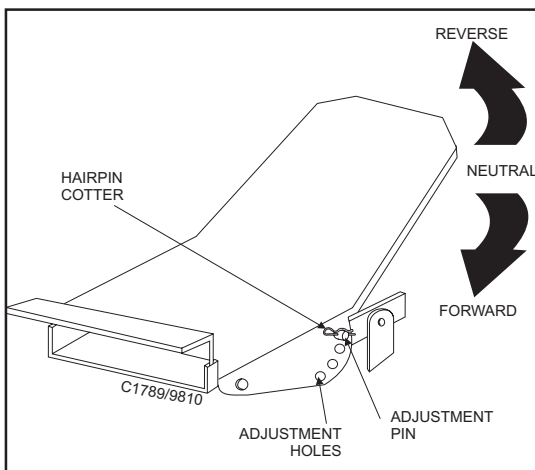

C1789 FIGURE 18

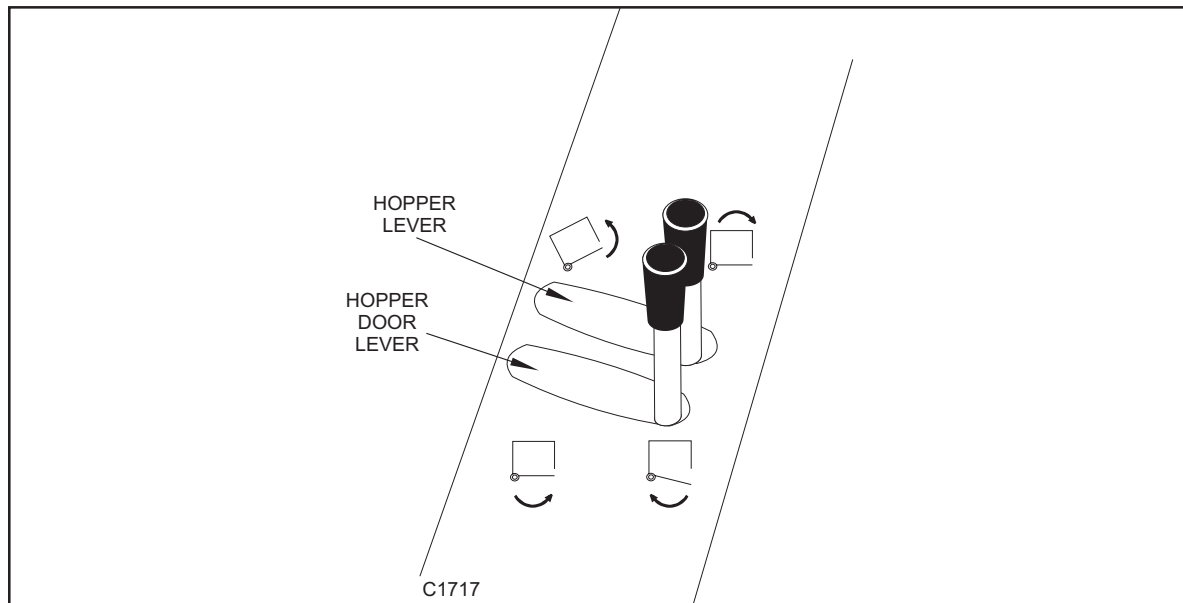

C1717

FIGURE 19

NOTE

The main broom, side broom, dust control and filter shaker turn off automatically when the hopper is dumping and/or the dump door is in a closed position. SEE HOPPER LIFT and HOPPER DUMP DOOR.

HOPPER LIFT LEVER (See Figure 19)

The hopper lift lever is located to the left of the steering wheel on the left side of the driver's compartment. This lever, which is marked "HOPPER", raises and lowers the debris hopper to ease unloading.



WARNING

The hopper may drop unexpectedly and cause injury.
ALWAYS engage the safety arm before working under the hopper.

HOPPER DUMP DOOR LEVER (See Figure 19)

The hopper dump door lever is located to the left of the steering wheel on the left of the driver compartment. This lever opens and closes the hopper door. This lever is located below the hopper lift door and is marked "DUMP DOOR".

NOTE

A switch triggered by the hopper and dump door's position control the sweeping functions, main broom, side broom, dust control, and filter shaker. The hopper must be down and the dump door open to allow these to function.

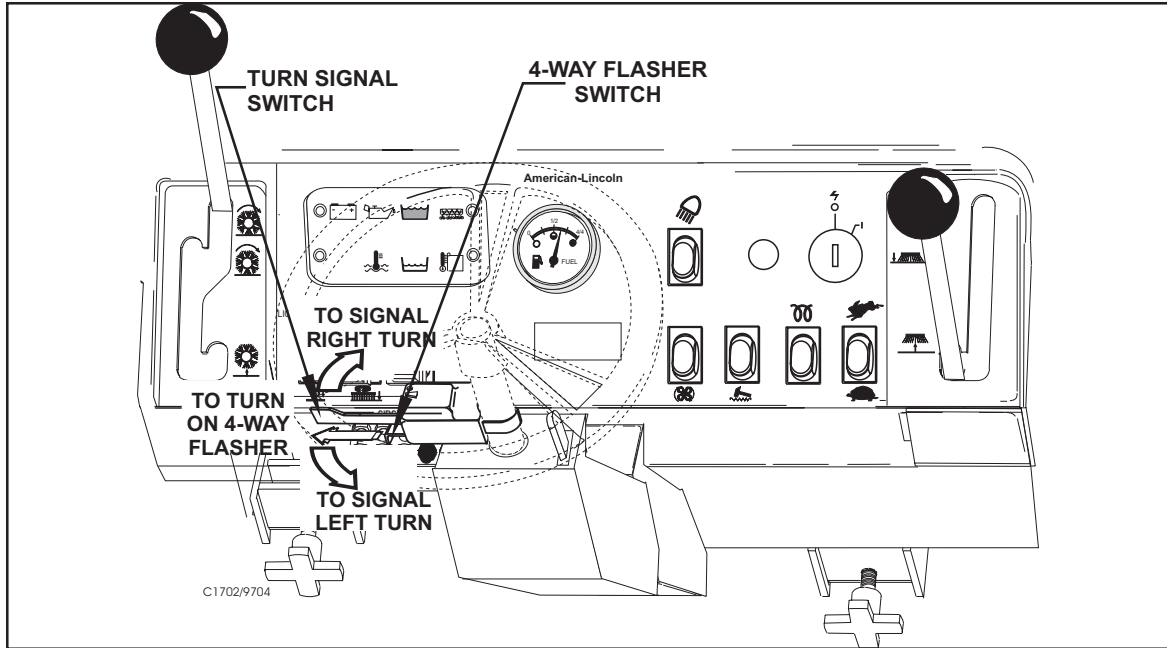

C1702

FIGURE 20

TURN SIGNAL - 4-Way (Option) (See Figure 20)

The turn signal option is located on the steering column and works as automotive turn signals work, forward on the lever for right and back on the lever for left. The 4-way flasher will activate when the turn signal lever is pulled out.

THROTTLE LEVER (Diesel Only) (See Figure 2)

The throttle lever is located on the left side console. There are 2 throttle speed positions - IDLE and FAST. To operate, grasp lever and push up and left to locking notch. To reduce to idle, grasp the lever and push up and to the right (away from locking notch). Let the lever lower until it rests at the bottom of the slot. "Load" (brooms and/or brushes and/or dust control operating) and "No Load" (brooms, brushes & dust control off) RPMs are the same for gas and LP equipment; The will be a slight drop between "Load" and "No Load" RPMs with diesels. Always return the throttle lever to the idle position before turning off the key to stop the engine.

MACHINE		RPMs	
		IDLE	"NO LOAD"
SWEEPER/ SCRUBBER (1 speed)	Gas/LP	950	2050
	Diesel	950	2150
SWEEPER (2 speed levels)	Gas/LP	1st	950
		2nd	950
	Diesel	1st	950
		2nd	950

BACK-UP ALARM SWITCH (Option) (See Figure 20)

The back-up alarm is operated by a switch that is located under the lower section of the accelerator and directional control pedal. The alarm makes a loud audible noise when the machine is being driven in reverse.

OPERATION OF CONTROLS AND GAUGES

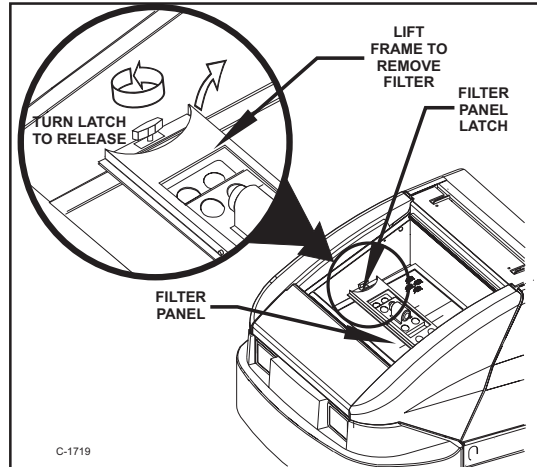

C1719 FIGURE 21

FILTER PANEL LATCH (See Figure 21)

The filter panel is located in the hopper filter compartment and will need to be removed periodically for cleaning or replacement. Removal of the filter panel requires no tools. The hopper cover must be opened to gain access to the filter compartment. The panel filter is held in place by a hinged frame and latch.

To remove the panel filter, turn the knob counterclockwise and lift the hinged frame.

The panel filter can now be lifted out and cleaned or replaced (see Filter Cleaning instructions in this manual).

To install the replacement panel filter, lower the frame and turn the knob clockwise to lock the filter in place.

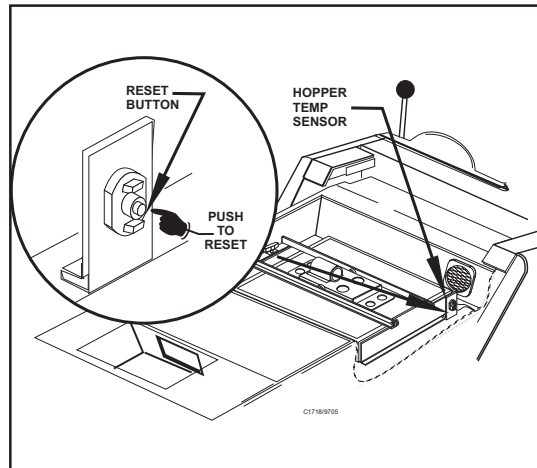

C1718 FIGURE 22

HOPPER TEMP SENSOR (Option) (See Figure 22)

The temp sensor switch monitors the hopper air temperature near the vac fan. When the temperature of the air moving through the hopper exceeds 140°F, the switch is tripped. It turns off the dust control fan and illuminates the hopper temp light on the warning bank.

The hopper temp sensor can be reset thermal switch which is located in the hopper filter compartment near the vacuum fan intake.

When the hopper temp light illuminates, carefully investigate for a possible fire in the hopper.

To reset the temp sensor, press the reset button.

ENGINE COMPARTMENT LATCH (See Figure 23)

The engine cover encloses the entire engine, radiator and hydraulic reservoir assembly. The cover can be lifted to allow easy access to the engine and hydraulics for service and inspection.



WARNING

Operate Only When Lids, Doors, And Access Panels Are Securely Closed.

To open the cover, lift the cover latch lever up and turn the latch ¼ turn. Lift the cover open.

NOTE

The overhead guard option has a safety latch for storing open cover.

After closing the engine cover, check it to be certain the latch has fully engaged and is latched.

NOTE

Side covers can be removed for service.

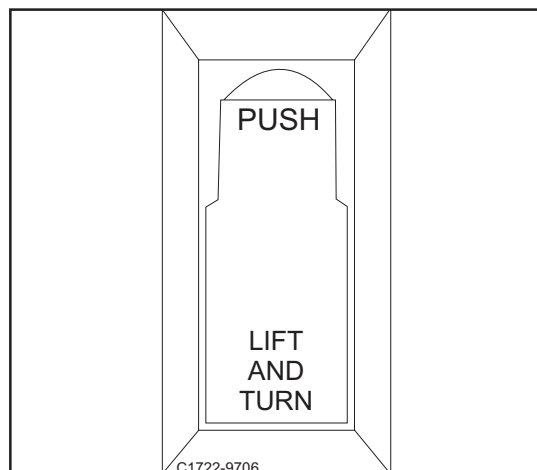

C1722 FIGURE 23

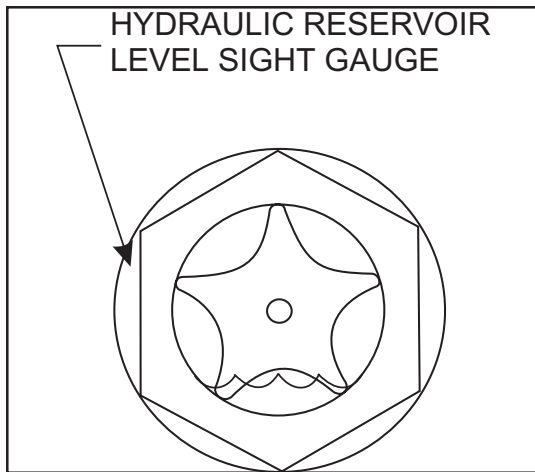

C1730 FIGURE 24

HYDRAULIC RESERVOIR LEVEL SIGHT GAUGE

(See Figure 24)

The sight gauge is located on the inside of the hydraulic reservoir in the engine compartment. The sight gauge is used to indicate the level of fluid in the reservoir. The fluid level must be visible in the sight gauge when the hopper is in the down position.

MAIN BROOM COMPARTMENT DOORS (See Figure 25)

The main broom compartment doors are located behind the front tires on both sides of the machine. The doors provide access to the main broom for service or inspection.



WARNING

Operate Only When Lids, Doors, And Access Panels Are Securely Closed.

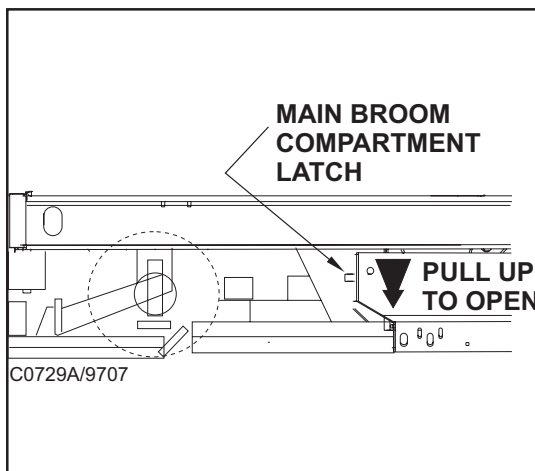

C0729A FIGURE 25

Open the right side door to remove or replace the main broom. The right side door is an integral part of the main broom drive system and must be closed for operation.

Open the left side broom door for inspection. Check the drive hub for banding and shrink-wrap which have a tendency to get tangled in the broom driver.

To open the main broom door, reach inside the hole in the door and lift up on the latch handle.

The door latch will automatically engage when the door is closed.

NOTE

Side squeegees mount on doors and the scrub deck must be lowered to slide the doors and squeegees into place.

NOTE

For proper function of side squeegees, side squeegees must be positioned so the lift strap is above the scrub deck lift brackets. Damage to the side squeegees could occur if not in the correct position.

SEAT COMPARTMENT COVER (See Figure 26)

The seat compartment cover opens to allow easy access to various components that will need to be inspected or serviced periodically. The cover opens forward and has a safety latch to hold the cover in the open position.

On Gas/Diesel/LP powered machines, the seat compartment contains the fuel tank.

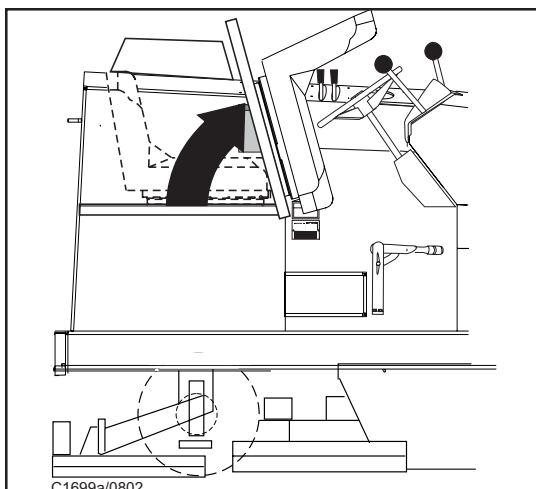

C1699a FIGURE 26

OPERATION OF CONTROLS AND GAUGES

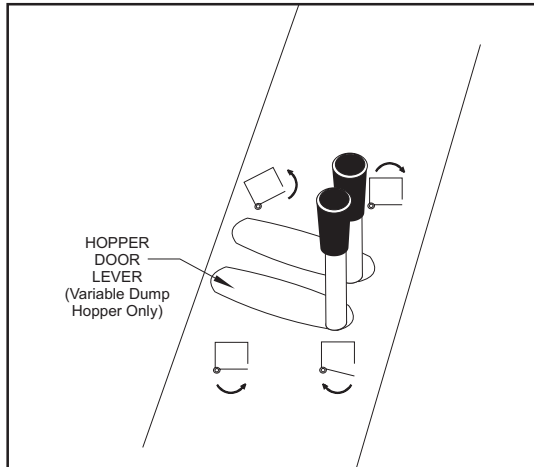

C1717A FIGURE 27

HOPPER DOOR LEVER (See Figure 27)

The hopper door lever is located on the operator's compartment and is used to close and open the hopper dump door. The lever is a two position hydraulic valve that is spring loaded to the center position which "HOLDS" the hopper door in position.

To open the hopper dump door for sweeping or dumping, push the lever to the "OPEN" direction.

To close the hopper dump door for dumping or transporting, push the lever fully back in the "CLOSE" direction, and hold for 3 seconds or until you hear the door close.

NOTE (Gas)

The dump door will automatically open when the main broom is engaged and the hopper is lowered.

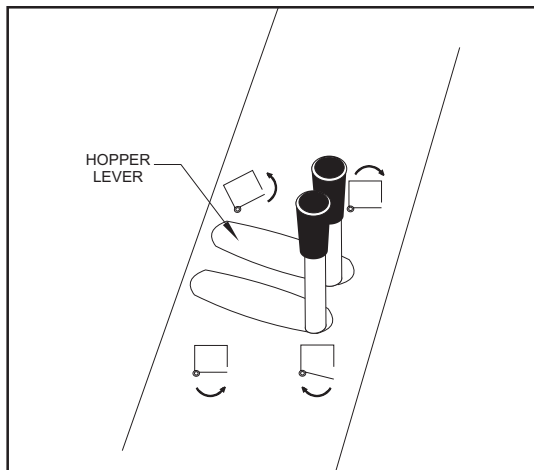

C1717B FIGURE 28

HOPPER LIFT LEVER (See Figure 28)

The hopper lift lever is located on the operator's compartment console. The lever is a two position hydraulic valve that controls the operation of the hopper lift system. The lever is spring loaded to the center position which stops hopper movement and "HOLDS" the hopper at the present position.

To raise the hopper for dumping, move the lever to the "RAISE" position and hold until the hopper reaches the desired height, then release.



WARNING

The hopper may drop unexpectedly and cause injury, always engage the safety arm before working under the hopper.

To lower the hopper after dumping, move the lever to the "LOWER" position until the hopper is fully lowered and seated in the machine, then release.

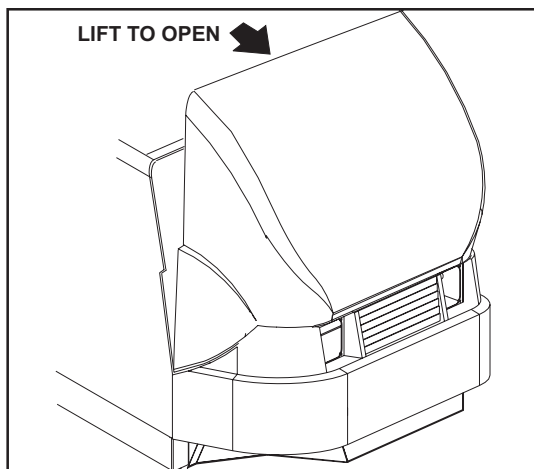

C1725A-IC FIGURE 29

HOPPER FILTER COMPARTMENT COVER (See Figure 29)

The hopper filter compartment cover is located on the top of the hopper and opens forward for access to the filter compartment for service and inspection of the dust control filter and optional hopper temp sensor.

Inspect the cover gaskets daily. Replace any cover gaskets that show signs of deterioration. Failure to maintain the gaskets in serviceable condition will degrade dust control at the floor and will result in less than optimal sweeping performance.

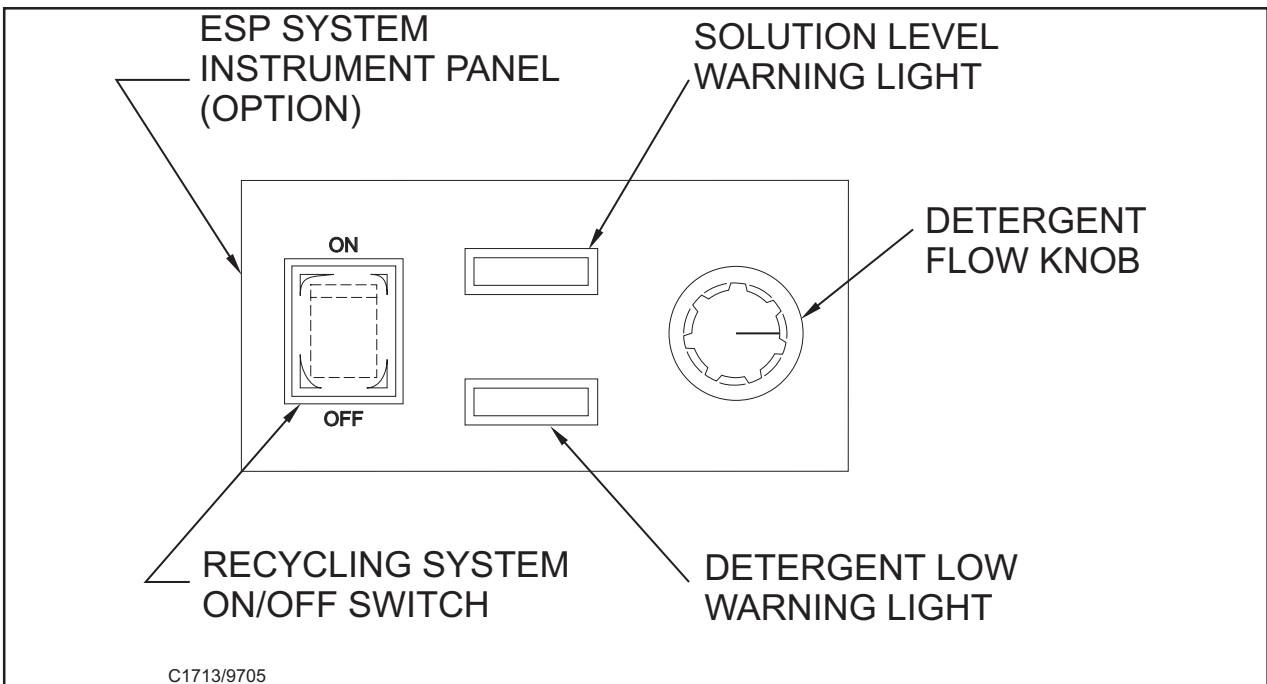

C1713

FIGURE 30

THE ESP RECYCLING CONTROL PANEL (See Figure 30)

THE ESP RECYCLING SYSTEM ON/OFF SWITCH

This switch turns the ESP recycling system on and off.

NOTE

The solution control lever must be on "FULL" for ESP operation.

SOLUTION LEVEL WARNING LIGHT

The solution level warning light will go out when the solution tank is empty. Some solution will remain in the recovery tank at the end.

DETERGENT LOW WARNING LIGHT

The detergent light will illuminate when the detergent tank is low, warning the operator to add detergent.

DETERGENT FLOW KNOB

This rotary knob controls the detergent flow into the scrubbing solution. The operator may choose from any detergent setting, for light to heavy cleaning applications. The detergent light will illuminate when the detergent tank is low, warning the operator to add detergent.

ESP SYSTEM OPERATING INSTRUCTIONS

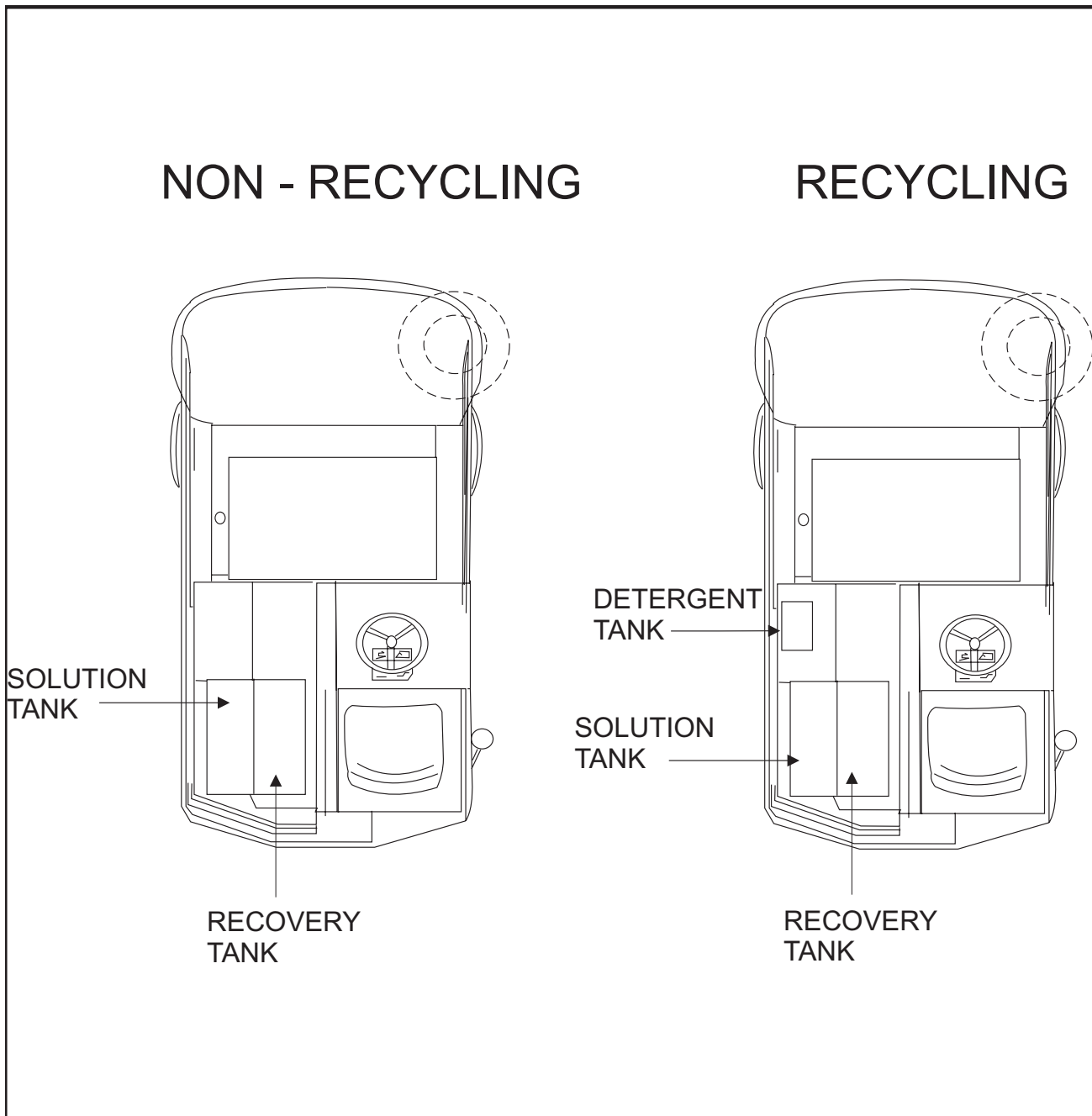

C1728

FIGURE 32

THE SCRUBBING SYSTEM - HOW IT WORKS

There are two scrubbing systems available for the SC7750 machine, the non-recycling or standard scrubbing system and the recycling or ESP scrubbing system.

THE NON-RECYCLING OR STANDARD SCRUBBING SYSTEM - HOW IT WORKS

During the scrubbing process, detergent solution water from the solution tank is fed to the solution line. There it is fed to the floor where three disc scrubbing brushes work to dislodge soil.

After scrubbing, the dirty solution is vacuumed from the floor and discharged into the containment chamber in the forward portion of the recovery tank, where a system of baffles helps to clarify the solution.

Sensors in each tank will indicate, by lights on the control panel, when the water in the solution tank is too low or when the water in the recovery tank is too high.

ESP SYSTEM OPERATING INSTRUCTIONS

THE RECOVERY OR ESP AND AUTOFIL SYSTEM - HOW IT WORKS

During the scrubbing process, filtered water from the solution tank is fed to the solution line, where it combines with detergent from the metering pump. This mixture is then fed to the floor where three disc scrubbing brushes work to dislodge soil.

After scrubbing, the dirty solution is vacuumed from the floor and discharged into the recovery tank. At intervals, a float switch activates the recycling pump, which sends filtered solution from the recovery tank to the solution tank. Detergent is added continuously to solution water from the flow valve.

The autofil system distributes water from the supply hose into the recovery and solution tanks. Then a solenoid valve is closed when the proper level in the solution tank is reached.

NOTE

**Both tanks must be drained and cleaned before filling.
Tuck solution tank drain hose behind bumper during operation**

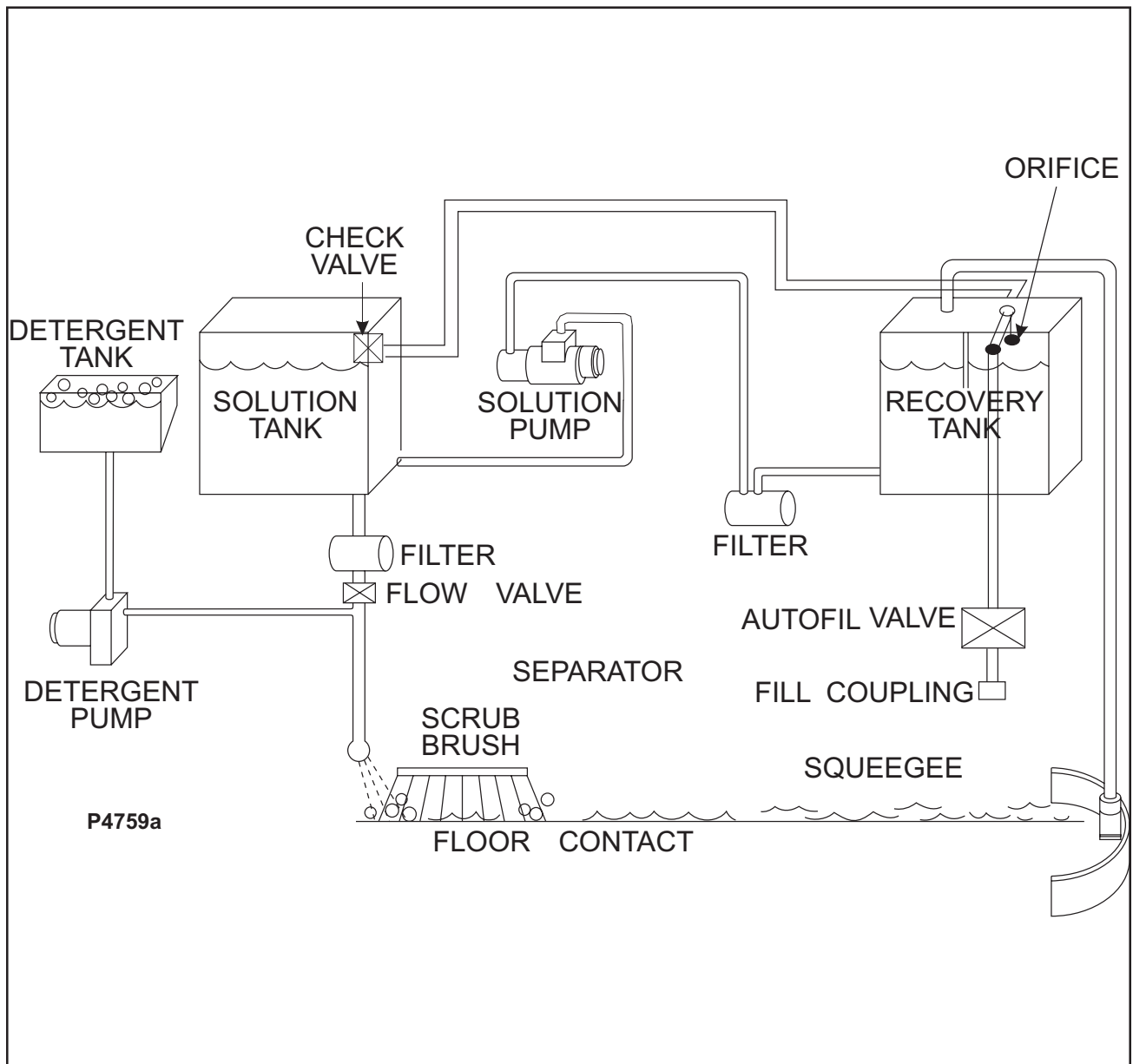

P4759A

FIGURE 33

OPERATING INSTRUCTIONS

THE VARIABLE DUMP SWEEPING AND DUST CONTROL SYSTEMS-HOW THEY WORK

Variable Dump SC7750 machines are equipped with a sweeping and dust control system. (See Figure 34)

DUST CONTROL

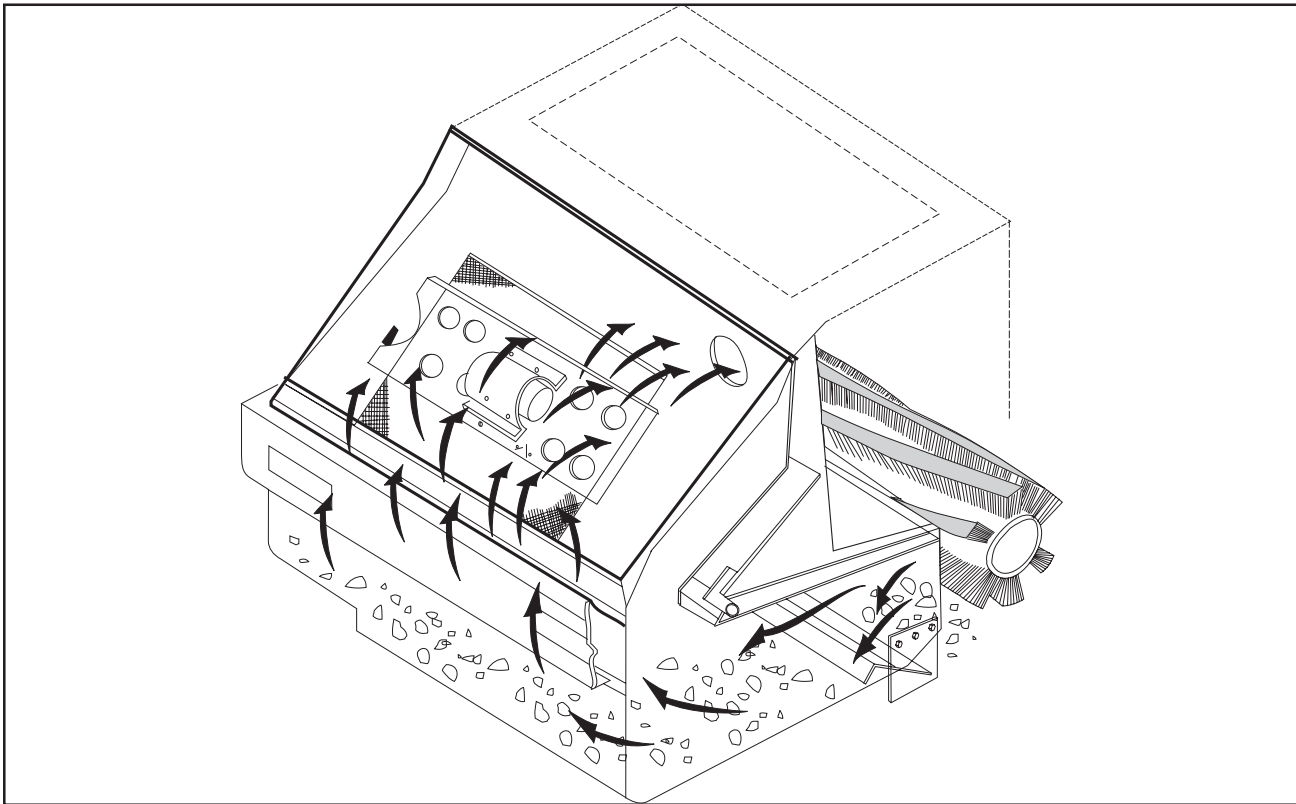

C1731

FIGURE 34

BEFORE STARTING THE ENGINE

1. Set parking brake.
2. Make sure all controls are in the "OFF" position.
3. Be sure the directional control pedal is in neutral.

NOTE

Before starting the engine, perform the pre-start checklist.

PRE-START CHECKLIST

1. Clean engine air filter element.
2. Check engine oil level.
3. Check radiator coolant level.
4. Check hydraulic fluid level.
5. Check fuel level.
6. Check all systems for leaks.
7. Check brakes and controls for proper operation.
8. Check broom patterns.
9. Check to ensure that all covers, panels and access doors are securely closed.

NOTE

To prevent possible fire, never fill fuel tank while the engine is running. Always be sure gasoline container and machine are grounded before dispensing gas. This can be done by permanently attaching an insulated wire with a battery clip on the end to the gasoline container.



WARNING

When the machine has been stored in below freezing temperatures, run the engine at not over ½ throttle with the machine standing still for 5-10 minutes to warm the engine and hydraulic oil.

STARTING GAS ENGINES

Turn key to “START” position until engine starts, then release. (Key switch will return to the “I” position.)

STARTING PROPANE ENGINES

Perform these checks in addition to the Pre-Start checklist

1. Check connections for leaks.
2. Open the LP storage tank valve.
3. Check the regulator.
4. Set the engine speed control to the “IDLE” (low) speed setting.
5. Turn key to “START” until engine starts, then release. (Key switch will return to the “I” position.)

STARTING DIESEL ENGINES

When starting the diesel engine, it should be noted that under no circumstances should ether or any other starting fluids be used in conjunction with the glow plugs. Do not use the glow plugs for more than 20 seconds at a time or damage to the plugs may result. The key switch must be placed in the “I” position before using the glow plug switch.

1. Perform the pre-start checks.
2. Turn the key switch to the “I” position and place the engine speed switch on the high speed position.
3. Push and hold the glow plugs switch for 5-10 seconds. Under cold starting conditions, the glow plug switch may be held longer, but do not hold the switch for more than 20 seconds to prevent damage to the glow plugs.
4. Turn the key switch to the start position and hold until the engine starts. If the engine does not start immediately, release the key switch after 15 seconds to prevent damage to the starter.

EMPTYING THE DEBRIS HOPPER

1. Place the engine speed switch in the “Fast” position.
2. Engage the parking brake.
3. Move the hopper dump door lever to the “CLOSE” position until the door is closed.
4. Move the hopper lift lever to the “RAISE” position until the hopper reaches the desired height.
5. Disengage the parking brake.
6. Drive forward slowly with hopper raised to clear the refuse container before opening hopper dump door.
7. Engage the parking brake.
8. Push the hopper dump door lever forward to the “OPEN” position. This will allow debris in the hopper to fall out into the refuse container.
9. Move the hopper dump door lever to the “CLOSE” position until the door is closed.
10. Disengage the parking brake.
11. Drive in reverse slowly to clear the refuse container.
12. Engage the parking brake.
13. Move the hopper lift lever forward to the “LOWER” position and hold until the hopper is closed.
14. Move the hopper dump door lever to the “OPEN” position until the dump door opens.



WARNING

Do not turn off the engine with the hopper in the lifted position.

NOTE

After stopping the engine, perform these post-operation checks.

OPERATING INSTRUCTIONS

POST-OPERATION CHECKLIST

1. Clean the debris hopper.
2. Check sweeping brooms for wear or damage.
3. Check all flaps for wear, damage and adjustment.
4. Fill the fuel tank.
5. Check all systems for leaks.
6. Close the LP storage tank valve (LP powered machines only).
7. Check squeegees for damage.



WARNING

**The gasoline tank fill cap is located behind the driver's seat.
Do not mistake the hydraulic reservoir for the gasoline tank.**

GASOLINE-POWERED MACHINES

Machines to be stored over 30 days should be completely drained of fuel to prevent gum deposits from forming on essential engine parts, fuel filter, and tank.

The use of a fuel additive, such as STA-BIL, or an equivalent, will minimize the formation of fuel gum deposits during storage. Such an additive may be added to the gasoline in the fuel tank of the engine.

The following procedures should be used to prepare the machine for storage:

1. Remove all fuel from the tank. Run the engine until it stops from lack of fuel.
2. While the engine is still warm, drain oil from the crankcase. Refill with fresh oil.
3. Remove spark plug, pour approximately ½ ounce (15 grams) of engine oil into the cylinder and crank slowly to distribute oil. Replace spark plug.
4. Store in a clean and dry area.

HELPFUL HINTS FOR CLEANING OPERATION

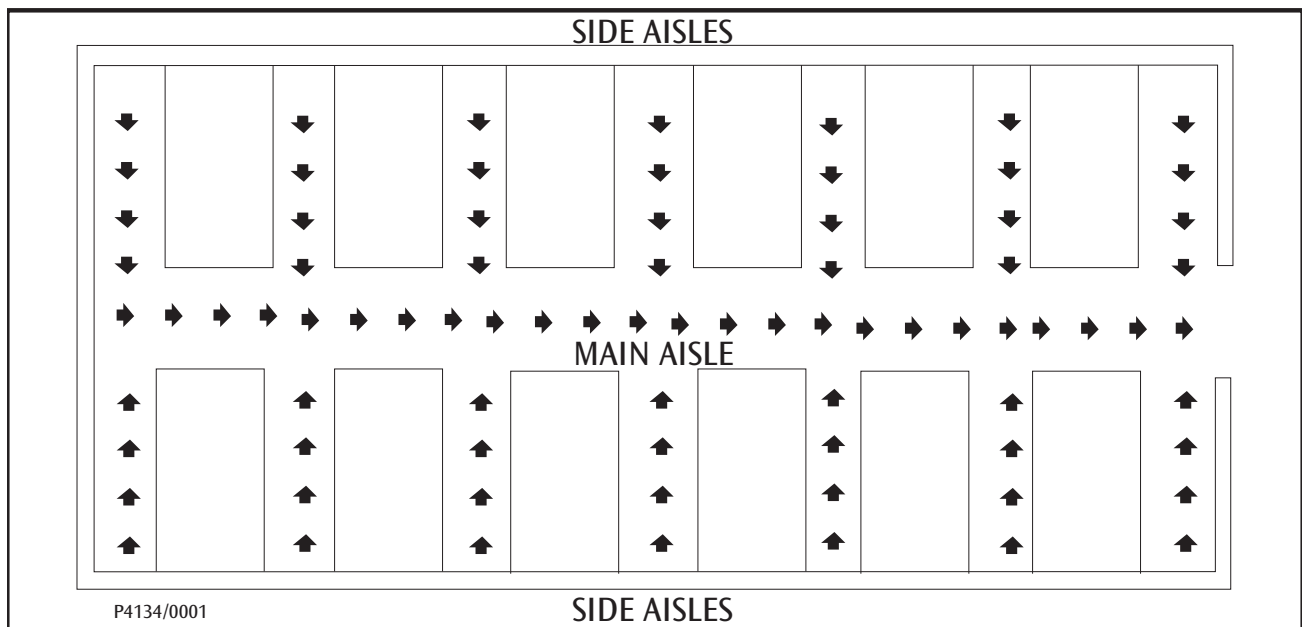

P4134

FIGURE 35



WARNING

Do not turn the steering wheel sharply when the machine is in motion. The machine is very responsive to movement of the steering wheel. Do not make sudden turns. Scrub in straight paths. Do not bump posts. Do not scrape the sides of the machine.

When the machine is in motion, do not push the directional/speed control pedal all the way forward. This is the same as starting in “High” and will put a strain on the motor and drive system.

1. Plan your sweeping and scrubbing in advance. Try to arrange long runs with minimum stopping and starting. Sweep debris from narrow aisles out into main aisles ahead of time. Do an entire floor or section at one time.
2. Pick up oversize debris before sweeping.
3. Allow a few inches of overlap of sweep and scrub paths. This will eliminate leaving dirty patches.
4. Do not turn steering wheel too sharply when the machine is in motion. The machine is very responsive to movement of the steering wheel, so avoid sudden turns.
5. Try to follow as straight a path as possible. Avoid bumping into posts or scraping the sides of the machine.
6. When placing the machine in motion, avoid slamming the directional control pedal all the way forward quickly. This is equivalent to starting in “High” and puts needless strain on the engine and drive system.
7. Always allow the machine to warm up before operating in cold temperatures.
8. Periodically turn the sweeping broom end-over-end to prevent the bristles from “setting” in one direction.

NOTE

Replace the sweeping broom when the bristles are worn to 3 inch (8cm) length. Replace disc brushes when bristles are reduced to ½ inch (1.3 cm) in length. Replace squeegee rubbers when all usable edges have become rounded with wear, impairing the wiping action.

SERVICE CHART

SERVICE CHART

Check items for proper operation. If service is required, please contact an authorized American-Lincoln distributor. For best performance, replace worn parts with genuine American-Lincoln parts.

BREAK-IN

During the initial break-in period of the engine, the crankcase oil and filter should be changed after 20 hours.

EVERY 8 HOURS or DAILY operation check and clean/adjust if necessary:

1. Inspect panel filters for damage and clean them.
2. Check engine oil level.
3. Check hydraulic fluid level.
4. Check radiator core for blockage.
5. Check all flaps for wear or damage.
6. Check brooms for wear or damage, adjust as required.
7. Check panel filters (clean side) for leakage.
8. Check brake pedal and parking brake.
9. Check for LP/DIESEL odor at connections.
10. Check water separator.
11. Check engine air cleaner.
12. Check hydraulic oil filter.
13. Check coolant level.
14. Check battery electrolyte level.
15. Check belt tension.
16. Check all fluid system components for leaks.

50 HOUR (WEEKLY) MAINTENANCE CHECKLIST

17. Check solution tank (recycling or ESP system).
18. Check solution filter screen (recycling or ESP system).
19. Check recovery tank.
20. Check recovery tank screens and filters.
21. Inspect scrub brushes for wear or damage.
22. Inspect rear and side squeegees for wear or damage.
23. Check tension on all belts.
24. Check battery electrolyte level (unless maintenance-free battery).
25. Check all hydraulic hoses for wear or cuts.
26. Rotate main brush (end-over-end).
27. Clean or replace panel filters.
28. Lubricate dump system and drive wheel pivot points.

Perform recommended engine maintenance (see engine manual if applicable).

100 HOUR MAINTENANCE CHECKLIST

29. Change crankcase oil.
30. Change engine oil filter.
31. Lubricate drive wheel, swivel wheel bearings, and steering rack guide (engine side above rear wheel).
32. Lubricate front wheel bearings.
33. Lubricate all moving joints.
34. Check brake shoes for wear and adjust accordingly.
35. Lubricate all 3 DANHOUSER bushings with NAPA #765-1363 or equivalent anti-seize lubricant. The bushings are located on the steering, scrub deck lift, squeegee lift, variable dump hopper door.
36. Check fuel hose for leaks or deterioration.
37. Check radiator hoses and clamps.
38. Clean or replace engine air filter element as necessary.

Perform recommended engine maintenance (see engine manual if applicable).

250 HOUR MAINTENANCE CHECKLIST

39. Lubricate squeegee casters.
40. Clean solution tank and filter screen.
41. Replace engine air filter element.
42. Flush radiator coolant system.
43. Remove spark plugs - clean or replace. (LP, Gas)
44. Check distributor and points - service or replace. (LP, Gas)
45. Clean and lubricate governor linkage. (Diesel)
46. Replace fuel filter.
47. Replace hydraulic filter element.

Perform recommended engine maintenance (see engine manual if applicable).

400 HOUR MAINTENANCE CHECKLIST

48. Clean hydraulic reservoir.
49. Clean hydraulic intake strainer.
50. Change hydraulic fluid.

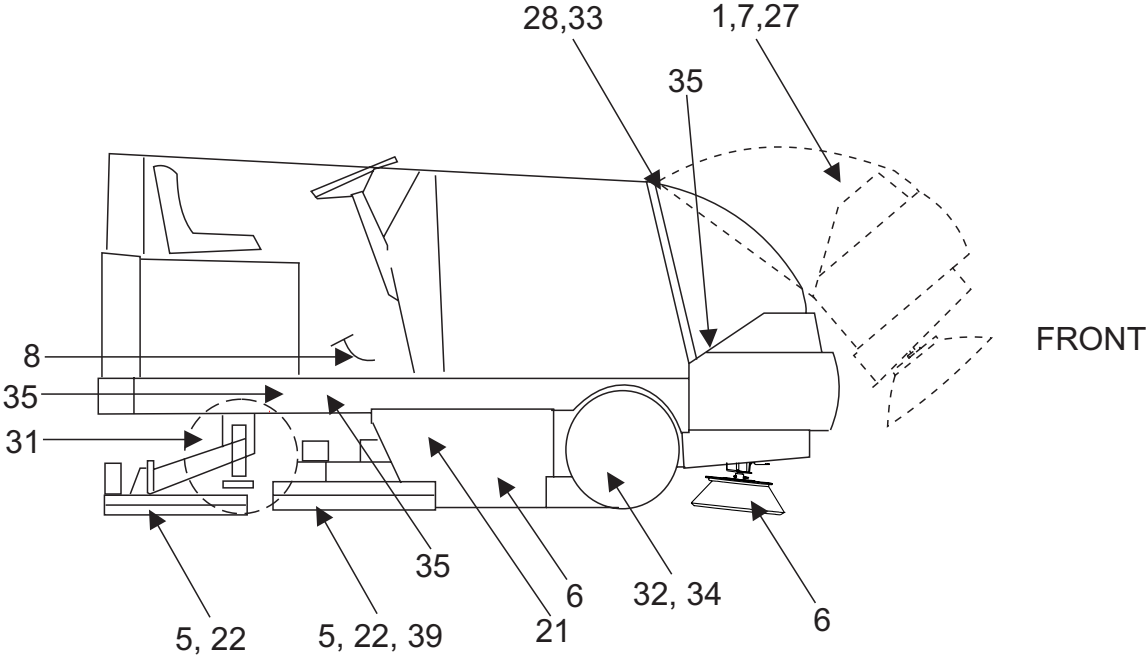
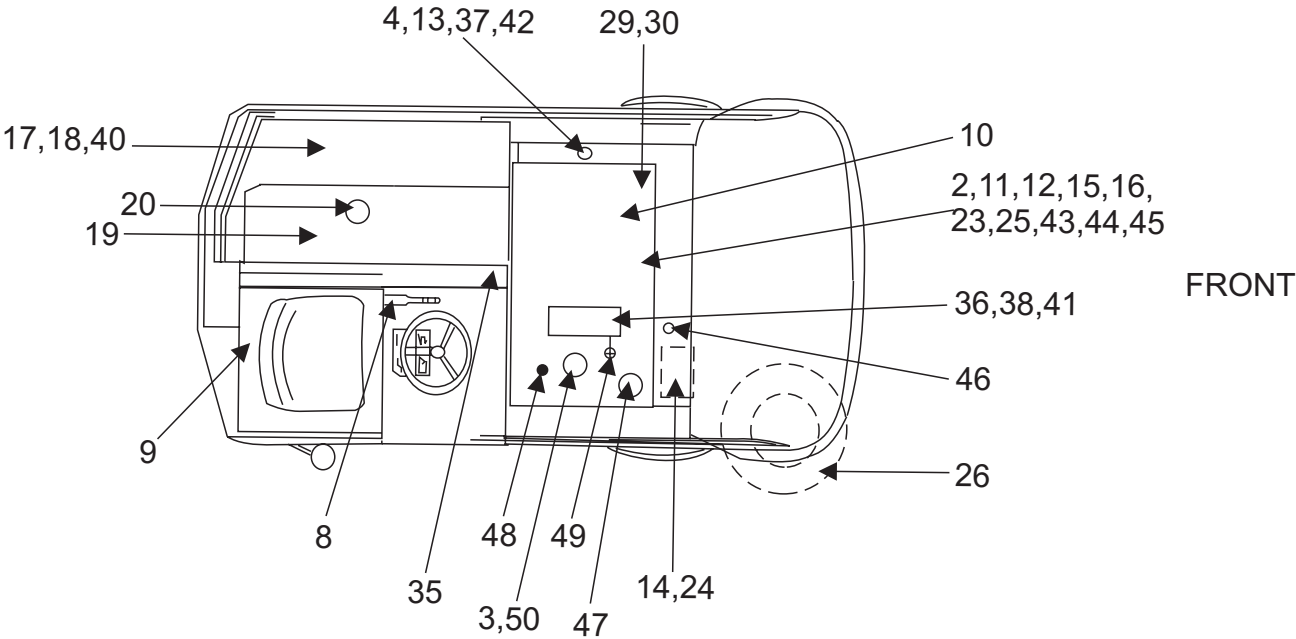

C1729

SERVICE PRECAUTIONS

SERVICE PRECAUTIONS

For safety, read and follow the service precautions below. Know the hazards associated with the equipment you are working on to prevent personal injury or damage to equipment.

For service assistance, consult your nearest American-Lincoln Dealer. For best performance, replace worn parts with genuine American-Lincoln parts.

Refer all Maintenance and Service Requirements to Qualified Maintenance Personnel.



WARNING

Do not attempt to Service this Machine until you have read and understand all Safety Warnings associated with the equipment you are working on.



WARNING

Only authorized personnel should do electrical repairs. Consult your American-Lincoln Authorized Service Person to do service procedures. Use only genuine American-Lincoln parts.



WARNING

Unexpected movement could cause injury. Always park on a level surface, turn key off, and engage parking brake before working on the machine.



WARNING

Only authorized personnel should do maintenance and repairs. Always empty the hopper and disconnect the batteries before doing any maintenance. Keep all fasteners tight. Keep adjustments according to the specifications as shown in the Service Manual for this machine.



WARNING

Always wear eye protection and protective clothing when working near battery. Do not put tools or other metal objects across the tops of the battery. NO SMOKING.



WARNING

The hopper could fall and cause serious injury. Always engage the hopper safety arm before working under the hopper.



WARNING

Moving the fan and belt may cause injury. Stay clear of moving parts.



WARNING

Pinch points may cause injury. Stay clear of moving parts.



WARNING

To maintain the stability of this machine in normal operation, the overhead guard, or any similar equipment installed by the manufacturer as original equipment should not be removed. If it becomes necessary to remove such equipment for repair or maintenance, this equipment must be reinstalled before the machine is placed back in operation.



WARNING

To prevent injury or engine damage, do not remove the radiator cap under any conditions while the engine is running or when it is hot. To prevent burns from steam or scalding hot coolant being expelled from the radiator, use extreme care when removing the radiator cap. Wait until the engine has cooled.

SWEEPING SYSTEM SERVICE**MAIN BROOM**

To prevent the broom from “setting” in one direction and to provide the maximum life of the broom it is recommended that the broom be turned end over end periodically.

CHECKING THE MAIN BROOM SWEEP PATTERN

Check the main broom sweep pattern after changing the broom or when poor sweeping performance is encountered while sweeping.

1. While the machine is not moving, lower the main broom to the “SWEEP” position and let machine sweep in one spot for a short period of time.
2. Before moving the machine, raise main broom lever to the “UP” position and move the sweeper forward enough to see the pattern left by the main broom bristles on the floor.
3. Check the width of the pattern on the floor to determine if the main broom requires adjustment.

-A normal sweep pattern left on the floor will be between 1 and 2 inches wide.

-A pattern that is more than 2 inches wide indicates the broom linkage needs to be adjusted “UP.”

-A pattern that is less than 1 inch wide indicates the broom linkage needs to be adjusted “DOWN.”

ADJUSTING THE MAIN BROOM HEIGHT

When changing the sweep height adjustment it is recommended that the bolt be adjusted 1 turn at a time. After adjustment, recheck the sweep pattern to determine if further adjustment is necessary.

-Turn the adjustment knob counterclockwise to INCREASE the sweep pattern width.

-Turn the adjustment knob clockwise to DECREASE the sweep pattern width.

REPLACING THE MAIN BROOM

The Main Broom should be replaced when the bristles become worn to less than 2". The main broom is held in place by the right side broom door. This feature provides for easy removal and installation of the main broom without the need for special tools or equipment. Follow the instructions below for main broom removal & replacement.

1. Park sweeper on a smooth level surface, engage parking brake, turn key switch to “O”, place the main broom lever in the “SWEEP” position.
2. Lift the door latch to open the right side broom door.
3. Swing the broom drive idler hub out to clear the main broom.
4. Remove the broom from the broom compartment.
5. Install the replacement broom. Pay special attention to the slots on the broom, it may be necessary to rotate the broom so the tabs on the drive hub align with the slots on the broom.
6. Swing the idler hub to engage the main broom and close the access door. Check the door latch for proper engagement when closed.
7. Check the Main Broom sweep pattern and adjust as necessary.

MAIN BROOM LEVEL ADJUSTMENT

The main broom level is factory set and should not need adjustment. If the level becomes out of adjustment and the broom bristle contact pattern is not an even 1" to 2" wide, the broom arm lift frame will need to be adjusted. The frame is supported by two plates located inside the broom doors. The carriage bolts that secure the plates to the frame will need to be loosened. The frame can then be leveled and the bolts re-tightened.

SERVICE INSTRUCTIONS

SIDE BROOM SERVICE

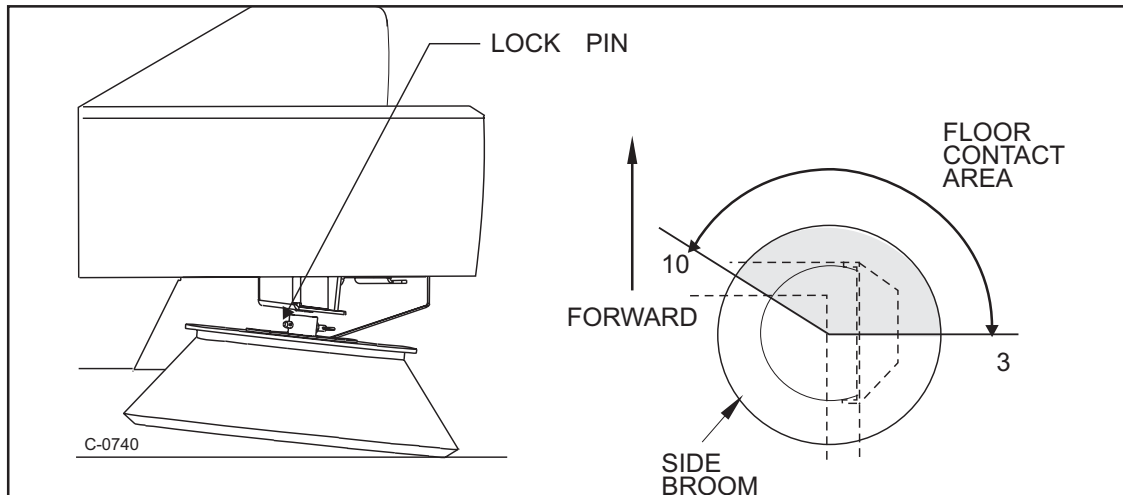

C0740

FIGURE 36

SIDE BROOM

The Side Broom sweeping angle is not adjustable. However, the height of the side brooms can be adjusted to compensate as the broom becomes worn from use. Always check and adjust the sweep pattern after changing the side broom.

CHECKING THE SIDE BROOM SWEEP PATTERN ADJUSTING THE SIDE BROOM HEIGHT

Turn the side broom adjustment knob to change the side broom sweep height. Recheck for proper sweep pattern after adjustment.

- Turn the adjustment knob counterclockwise to INCREASE the sweep pattern width.
- Turn the adjustment knob clockwise to DECREASE the sweep pattern width.

REPLACING THE SIDE BROOM

Change the side brooms when the bristles become worn to less than 3 inches length.

1. Park the machine on a smooth level surface, turn key switch to "O" Position and engage parking brake.
2. Place the side brooms lever in the "UP" position.
3. Remove the lock pin that holds the broom flange to the motor shaft.
4. Disassemble the flange from the broom by removing the screws that hold the flange to the broom.
5. Assemble the flange to the replacement broom and fasten using the hardware removed.
6. Install the replacement broom on the shaft and insert the lockpin.

HOPPER SERVICE

1. Park the machine on a smooth level surface.
2. Place the side broom lever in the "DOWN" position.
3. Move the brooms control lever to the "ON" position.
4. While staying in place allow the side broom to sweep for a short period of time. (Allow enough time for the side brooms to leave a clean footprint on the floor).
5. Place the side broom lever in the "UP" position.
6. Move the brooms control lever to the "OFF" position.
7. Back the sweeper away from the area where the pattern was left.
8. Turn the key switch to the "OFF" position and engage the parking brake.
9. Leave the operator's compartment and check the pattern to determine the floor contact area.
10. Determine if adjustment to the side brooms height is necessary by examining the floor contact area. The broom should contact the floor as shown in Figure 36. Adjust the side broom height if the contact area on the floor does not match the diagram.

HOPPER SERVICE

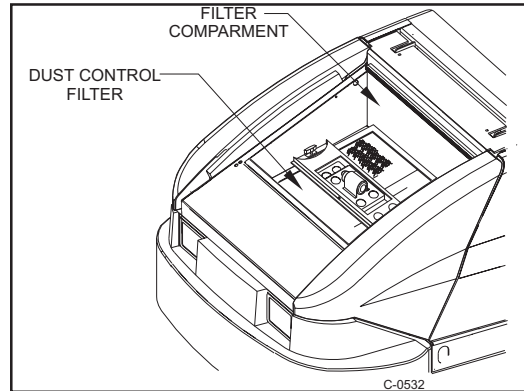

c0532 **FIGURE 37**

HOPPER

The hopper houses the debris compartment, the dust control filter and the removable dust baffle. For maximum performance and service life, keep the hopper clean and inspect the seals and flaps daily. Clean the hopper prior to parking the sweeper at the end of the day. A clean hopper will make inspecting the flaps and seals much easier and will prevent premature deterioration of hopper components. Do not leave the hopper full of debris while in storage or when parked for extended periods of time

CLEANING THE HOPPER

Once the hopper has been emptied the insides of the hopper should be rinsed out with water.

CHECKING THE HOPPER SEALS

The hopper seals are important to positive dust control while sweeping. Damaged seals will reduce vacuum pressure at the broom. Inspect for cuts, tears and proper positioning of the seal material. Replace all seals that become damaged.

DUST CONTROL FILTER

The dust control filter should be checked daily for damage and cleaned if necessary. A damaged filter must be replaced to prevent damage to other dust control system components. Inspect the filter for tears in the filter media or excessive dirt lodged in the pleats. A tear in the filter media will allow dirt to pass through the filter and can be easily seen as a dirty patch on the top side on the filter. Cleaning of the filter is necessary when the filter shaker fails to adequately clean the pleats.

CHECKING THE DUST CONTROL FILTER

1. Park the machine on a smooth level surface, turn the key switch to the "O" position and engage the parking brake.
2. Raise the hopper lid for access to the filter compartment.
3. Turn the filter latch, lift the filter frame and remove the filter.
4. Inspect the panel filter for tears and clean or replace if necessary.
5. Reinstall the filter, lower the filter frame and engage the filter latch.
6. Close the hopper cover.

CLEANING THE DUST CONTROL FILTER

Clean the dust control filter when the shaker fails to adequately clear the filter. The filter can be cleaned with compressed air not to exceed 100 PSI.

To clean the filter with compressed air, apply the compressed air to the topside of the panel to backflush the lodged dirt from the filter pleats. Be careful to not damage the filter media while cleaning.

The filter can be cleaned with a solution of soap and water. If this cleaning method is used do not use the filter until it has completely dried.

SERVICE INSTRUCTIONS

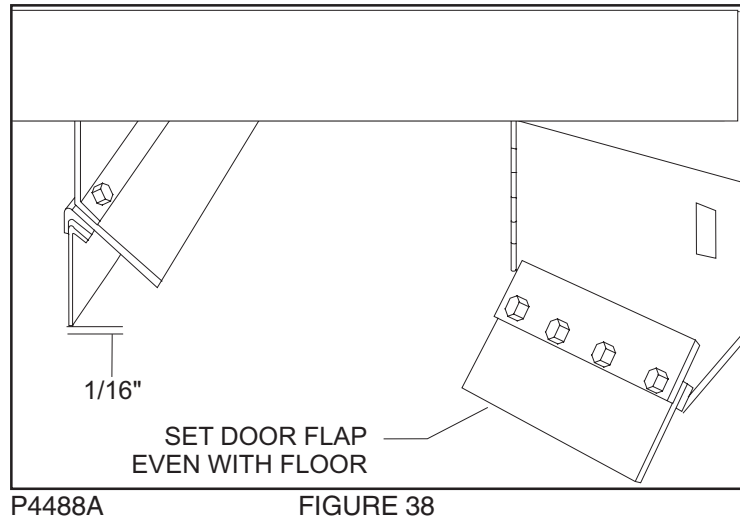

REPLACING THE DUST CONTROL FILTER

Change the filter panel when damage is evident.

1. Park the machine on a smooth level surface, turn the key switch to the "O" position and engage the parking brake.
2. Open the hopper compartment cover to gain access to the filter compartment.
3. Turn the latch on the hinged frame counterclockwise and lift the frame .
4. Remove the filter panel.
5. Install replacement filter, lower the hinged frame and engage the latch.
6. Lower the filter compartment cover.

DUST FLAPS

The dust flaps are very important to sweeping and dust control and are susceptible to damage and should be inspected daily and maintained in good condition.

CHECKING THE DUST FLAPS

The dust flaps are used on the wheel well, broom chamber and broom door. Inspect the flaps daily and replace any flap that shows signs of wear or deterioration. All flaps should be replaced when worn or damaged to the point that they can no longer perform their normal function. The adjustable flaps have slotted mounting holes to facilitate adjustment.

ADJUSTING THE DUST FLAPS

Adjust the flaps so there is a 1/8" to 1/16" gap between the floor and the bottom edge of the flaps. The rear flap adjustment is 1/16" (16 cm.) above the floor.

1. Park the machine on a smooth level surface and engage the parking brake.
2. Loosen the flap retaining screws and adjust the flap to clear the floor and leave a 1/16" to 1/8" gap.
3. Tighten flap-retaining screws while holding flap in position.
4. Drive the machine on a smooth surface and recheck the flaps for proper floor clearance.

BRAKE SERVICE

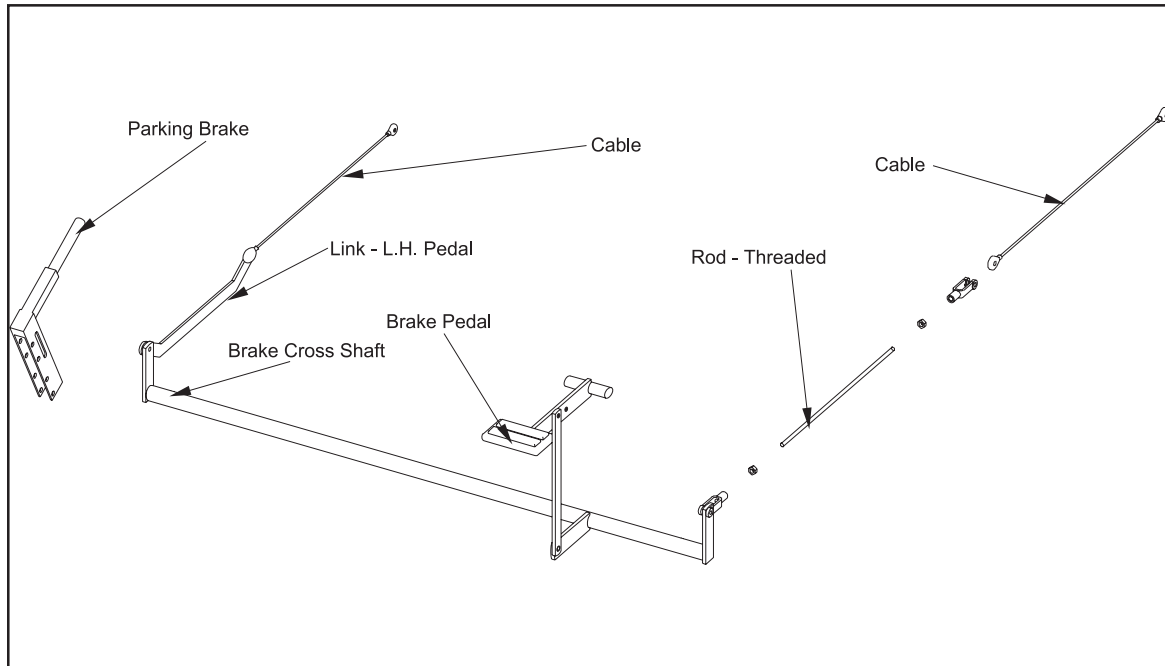

C1720

FIGURE 39

BRAKES

The service brakes are located on the front wheels and are operated by the brake pedal and the parking brake lever. Check the brakes daily for proper operation and inspect the brake pads for wear every 100 hours of operation.

ADJUSTING THE BRAKE PEDAL

Perform this adjustment to ensure proper pedal height and linkage operation. The brakes are properly adjusted when the brakes hold the sweeper on an 8-degree ramp. The brakes need adjusted if the Pedal travels closer than one (1) inch to the floor of the operator's compartment when the brakes are fully engaged.



WARNING

**The hopper could fall and cause serious injury.
Always engage the hopper safety arm before working under the hopper.**



WARNING

Always park on a level surface, chock tires and observe safety procedures when adjusting the brakes.

ADJUSTING THE BRAKES

When adjusting the brake clevis, follow these steps.

1. Right hand brake cable slack.
2. Adjust parking brake for maximum engagement.
3. With parking brake lever "off" check L.H. wheel must rotate with minimum drag. (Not completely free)
4. Adjust R.H. brake to provide minimum drag when released.

GENERAL MACHINE MAINTENANCE

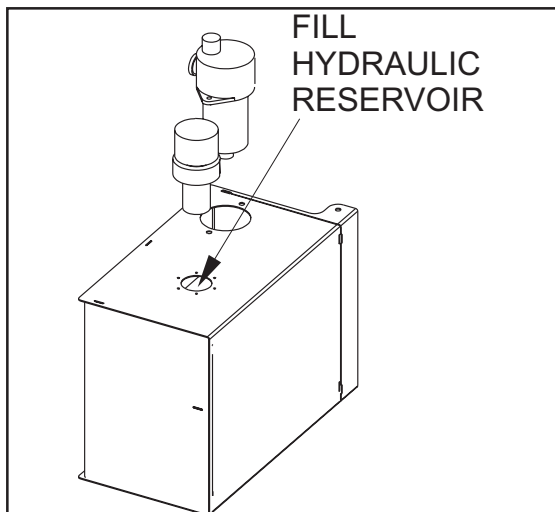

C1691A FIGURE 40

FILLING THE HYDRAULIC RESERVOIR

1. Access to the hydraulic reservoir is located in the engine compartment.
2. Open the hydraulic reservoir breather filter cap.
3. Remove any debris that is in the breather filter cap screen.
4. Fill the reservoir until the fluid is at the "FULL" line on the hydraulic fluid sight gauge. The sight gauge is located on the center side of the hydraulic reservoir.
5. Close the hydraulic reservoir breather filter cap.
6. Close the engine compartment cover.

CLEANING THE HYDRAULIC SYSTEM

1. Put a drop cloth on the floor.
2. Drive the machine onto the drop cloth.
3. Set the parking brake.
4. Open the engine covers.
5. Put a container under the reservoir drain to catch the reservoir fluid. Pivot the reservoir out.
6. Remove the drain plug. The reservoir fluid will drain. Do not use the drained fluid to refill the hydraulic reservoir. Dispose of the used fluid.
7. Flush the interior of the hydraulic reservoir with clean fluid.
8. Put the reservoir plug, removed in step six, back in the hydraulic tank drain and tighten it. A pipe thread sealer is required on the plug.
9. Open the breather filter cap.
10. Fill the reservoir with new FORD type "F" automotive transmission fluid. The capacity of the tank is 10 gallons. Fill to the "FULL" line on the hydraulic fluid sight gauge.
11. Close the breather filter cap. Rotate the reservoir into the engine compartment.
12. Replace the engine covers.

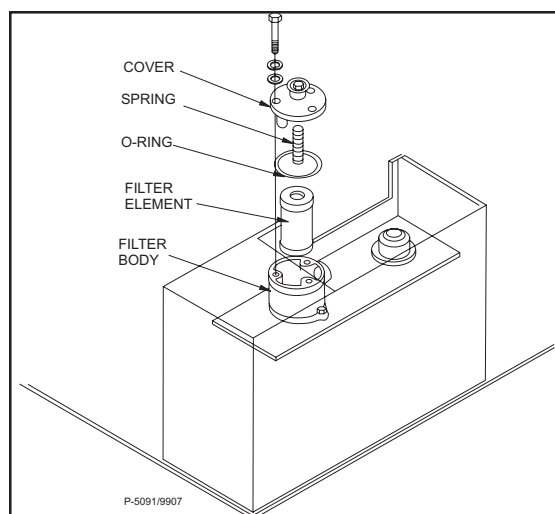

P5091 FIGURE 41

REPLACING THE RETURN FILTER ELEMENT

1. Replace the return filter element after 250 hours of machine run time.
2. Unscrew the fasteners from the filter assembly cover and retain.
3. Remove the cover and the compression spring and retain.
4. Discard the old filter element.
5. Position the new filter element inside the filter body.
6. Put the compression spring in position. Wipe the cover magnet free of any metal filings or debris.
7. Place O-ring (moisten with clean hydraulic fluid) and cover into position.
8. Reattach fasteners to the filter cover.
9. Clean any hydraulic reservoir fluid spills. The fluid can damage painted surfaces of the machine.

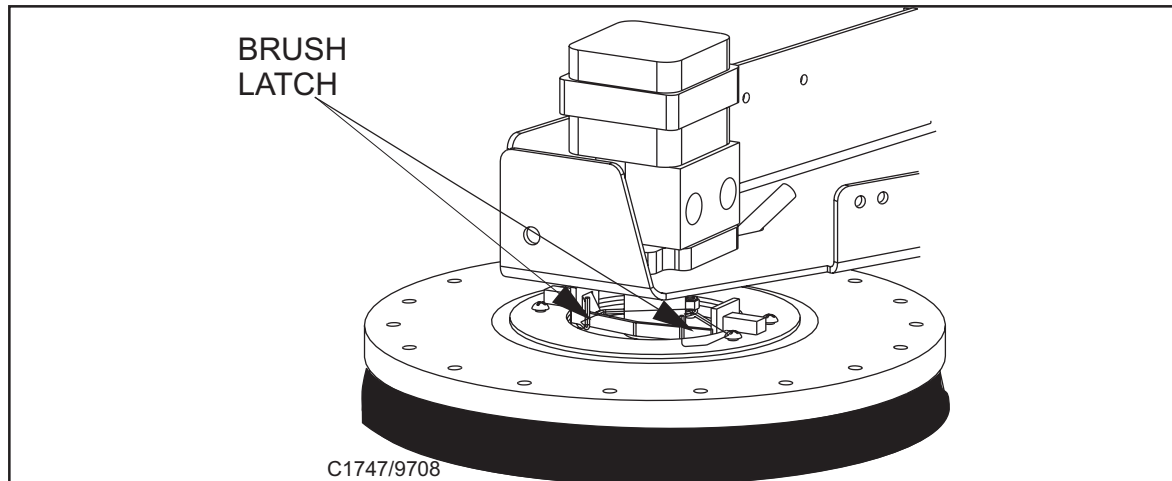

C1747

FIGURE 42

REPLACING THE SCRUB BRUSH

1. Raise the scrub brush deck by pressing the “Scrub Brush” switch on the instrument panel.
2. Press the brush latches in to release the scrub brush.
3. Remove the old scrub brush.
4. Snap the new brush into place.

COVERS AND LATCHES

The covers have been designed to allow access, either by hinge or removal, to all areas of the machine. No maintenance is required.

SOLUTION LOW WARNING LIGHT

The solution low warning light will illuminate when the solution tank is low. This part of the level control system requires no maintenance. If the system fails to operate, consult the Electrical Troubleshooting Guide.

RECOVERY HIGH WARNING LIGHT

The recovery high warning will illuminate approximately 5 minutes before loss of vacuum to the recovery tank. This part of the level control system requires no maintenance, except for daily cleaning of the tank level switch. If the system fails to operate, consult the Electrical Troubleshooting Guide.

SOLUTION CONTROL (Non-Recycling or Standard)

The solution control lever controls the amount of solution applied to the scrubbing brushes.

The solution control should shut off completely with the lever in the (front) “off” position. If complete shut off does not occur, the control valve should be adjusted.

SOLUTION CONTROL (Recycling or ESP System)

In the recycling mode, the solution control lever is also used to activate the detergent pump. If the detergent pump fails to operate (engine running) when the solution control lever is moved into the low to high range, first check the circuit by manually activating the switch. If the detergent pump does not operate at this time, a further electrical or mechanical check is required (see Electrical Troubleshooting Guide or Detergent Pump Troubleshooting).

GENERAL MACHINE MAINTENANCE

RECYCLING PUMP ESP SYSTEM

The recycling pump is located under the seat. The pump is electric and except for daily cleaning of the pump intake screens, it requires no regular maintenance.

RECYCLING PUMP STORAGE

Always drain pump for extended storage, especially when freezing temperatures may be encountered.

REAR SQUEEGEE

The squeegee will require service when the inner edges of the blades become round with wear, impairing the wiping action or water pickup. To service the rear squeegee use the following steps:

1. Loosen the four aluminum knobs (item 10, these hold the squeegee tool to the squeegee support).
2. Remove the squeegee tool and turn upside down to service the blades or caster wheels. The squeegee blades are designed to flip over and use another unworn edge (items 5 & 6).

To service the blades

1. Loosen the clamp bolts which clamp items 8 & 9 together.
2. Loosen far enough to slip the end clamp brackets off the squeegee tool. This will allow flipping the blades or installing new blades.
3. Install blades so that the outer blade is 3/16" longer than the inner blades. This is achieved by assembling the top edge of the blade against the squeegee tool weldment.
4. Re-install the squeegee clamp band and tighten the clamp bolt.

SQUEEGEE CASTER WHEELS

There are 2 grease fittings on each caster wheel. The casters should be greased each time the blades are serviced.

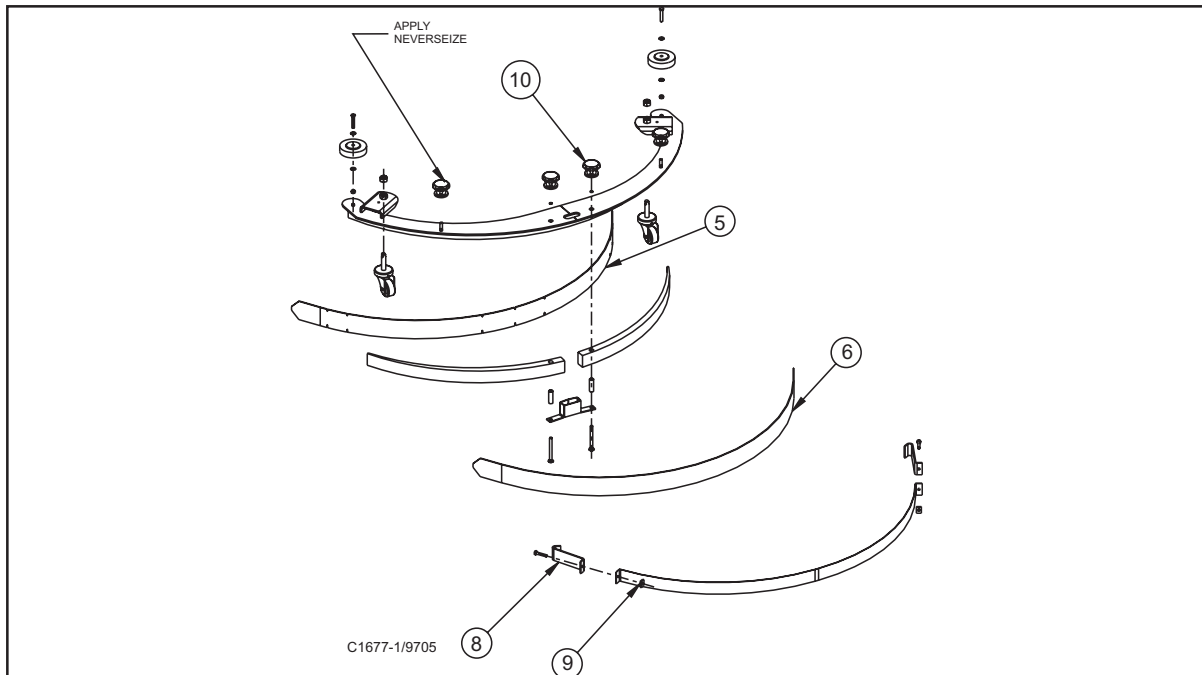

C1677-1

FIGURE 43

ADJUSTING CASTERS

Lower the squeegee on a flat surface, making sure the rear squeegee blade is perpendicular to the surface. Adjust the caster 3/16" above the flat surface. Lock the jam nuts.

AIR INTAKE SYSTEM

NOTE

Monitor the air filter indicator daily

The importance of replacing the air filter at the appropriate time cannot be overemphasized. Even a small amount of dirt ingested through the air intake system will wear out a set of piston rings in just a few hours.

Always cover the air intake when removing the air filter for replacement. Keep all other air intake components, such as hoses and clamps, secure and in good condition to prevent intake of unfiltered air.

AIR FILTER

The elements contained within this air filter are NOT reusable. There is no interim cleaning involved other than a daily emptying of the dust collector housed in the filter cap. Squeeze and release the rubber valve on the filter cap several times to expel any dust or dirt that has accumulated. Replace BOTH the safety and main filter elements when the filter service indicator reaches the red band. The indicator will remain at the red band level even after the engine has been shut down. Reset the indicator by depressing the black button at the bottom.

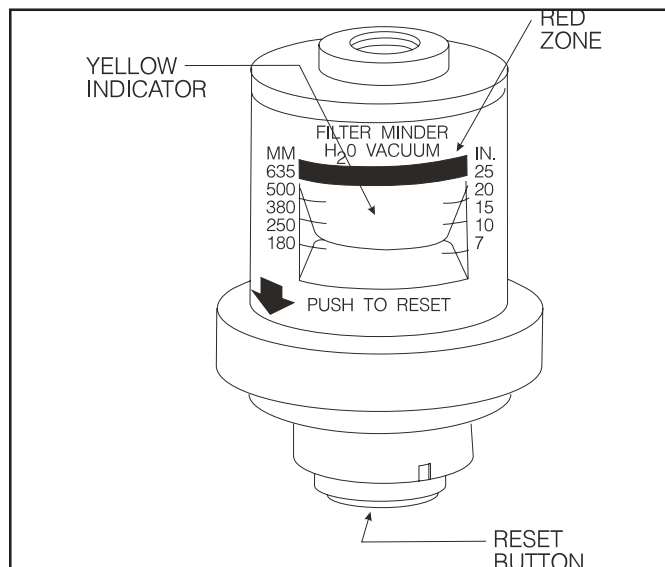

P4713

FIGURE 44

TO REPLACE AIR FILTER ELEMENTS

1. Stop the engine and engage the machine parking brake.

 **WARNING**

Always park on a level surface, stop the engine, and engage parking brake before working on the machine to keep it from creeping or rolling.

2. Unhook the two latches on the filter housing
3. Remove the cap
4. Clean dust collector (housed in cap) by squeezing and releasing the rubber valve several times
5. Remove both filter elements and discard
6. Insert new safety and main filter elements
7. Replace cap and close latches

GENERAL MACHINE MAINTENANCE

SAFETY AIR CLEANER

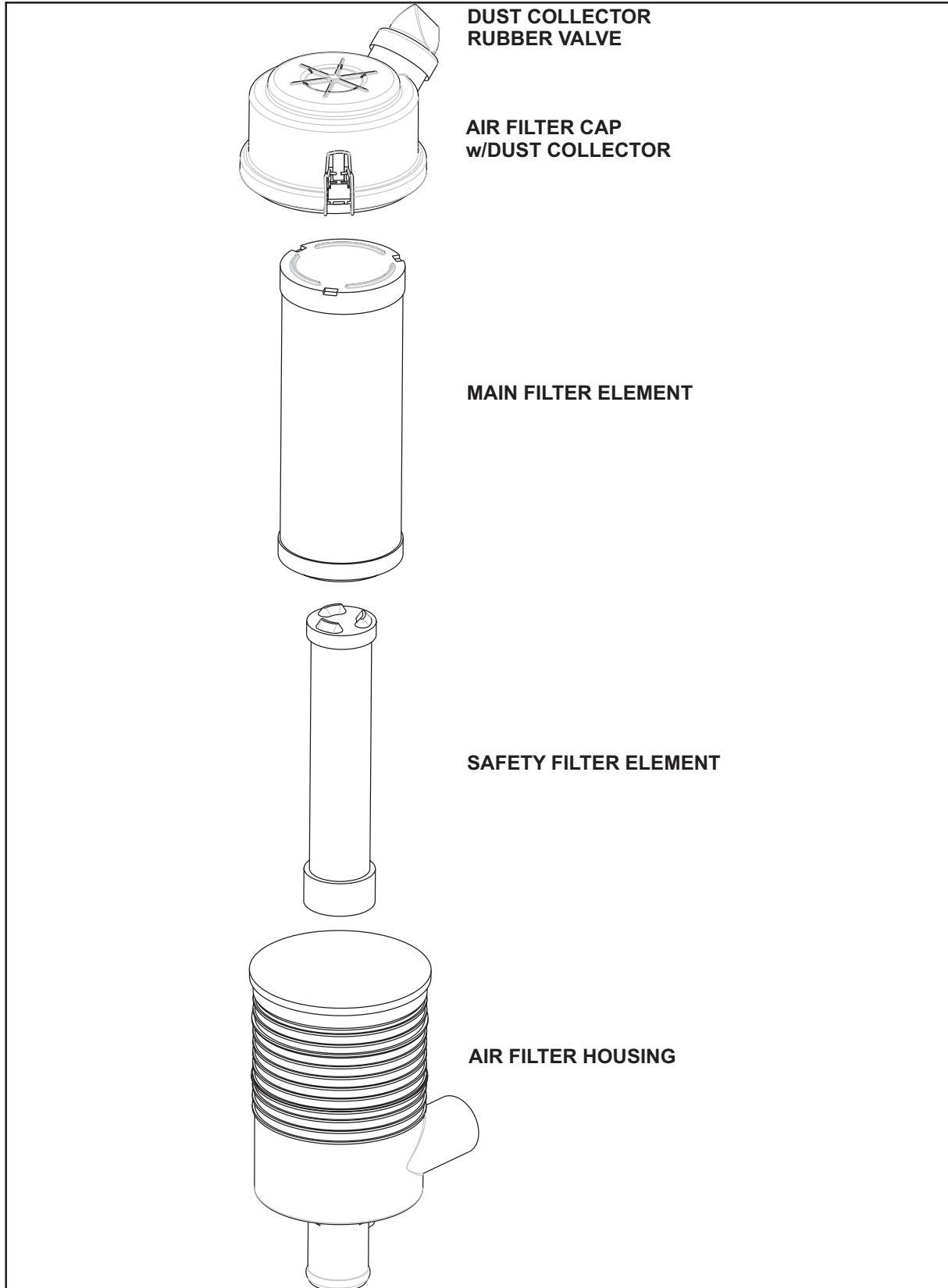
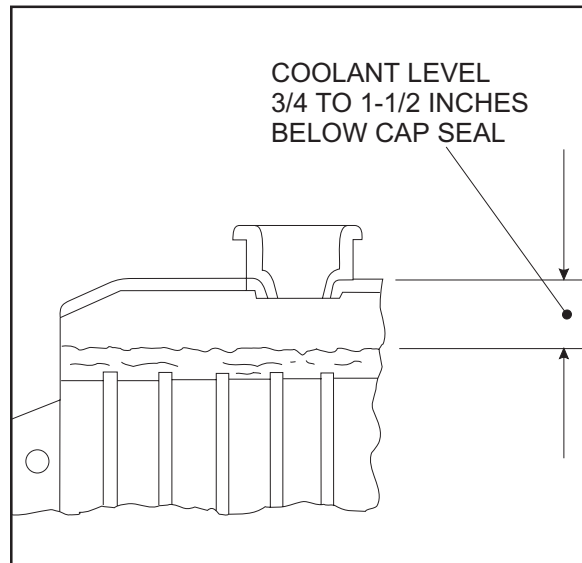

FIGURE 45

COOLING SYSTEM

COOLANT LEVEL

Check the coolant level in the radiator daily, only when the engine is cool. Maintain the coolant level at approximately $\frac{3}{4}$ inches (1.9cm) below the filler neck seat on the radiator when the coolant is cool. Whenever coolant level checks are made, check the condition of the radiator cap rubber seal. Make sure it is clean. Rinse off with clean water if necessary. When replacing the cap on the radiator, also make sure the radiator filler neck is clean.



P4404-1 FIGURE 49

 **WARNING**

Never remove the radiator cap under any conditions while the engine is operating. Failure to follow these instructions could result in damage to the cooling system or engine and/or personal injury. To avoid having scalding hot coolant or steam blow out of the radiator, use extreme care when removing the cap from a hot radiator. If possible, wait until the engine has cooled, then wrap a thick cloth around the radiator cap and turn it slowly to the first stop. Step back while the pressure is released from the cooling system. When you are sure all the pressure has been released, press down on the cap (still with a cloth) turn and remove it. Do not add coolant to an engine that has become overheated until the engine cools. Adding coolant to an extremely hot engine can result in a cracked block or cylinder head.

Use only a permanent type coolant that meets FORD specification ESE-M97B44-A such as FORD Cooling System Fluid. Refer to the coolant chart on the container for additional antifreeze protection information. Do not use alcohol or methanol antifreeze or mix them with the specified coolant. Plain water may be used in an emergency, but replace it with the specified coolant as quickly as possible to avoid damage to the system. With only water in the system, do not let the engine run hot.

RADIATOR

Inspect the exterior of the radiator for obstructions. Remove all bugs, dirt or foreign material with a soft brush or cloth. Use care to avoid damaging the fins. If available, use compressed air or a stream of water in the opposite direction to normal airflow. Open door for access. Check all hoses and connections for leaks. If any of the hoses are cracked, frayed, or feel spongy, they should be replaced.

DRIVE BELTS

The drive belt(s) should be properly adjusted at all times. Loose drive belts cause improper alternator, fan and water pump operation and overheating. Overtightening the belt may result in excessive wear on the alternator and water pump bearings, as well as premature wear on the belt itself. Therefore, it is recommended that proper belt tension be maintained.

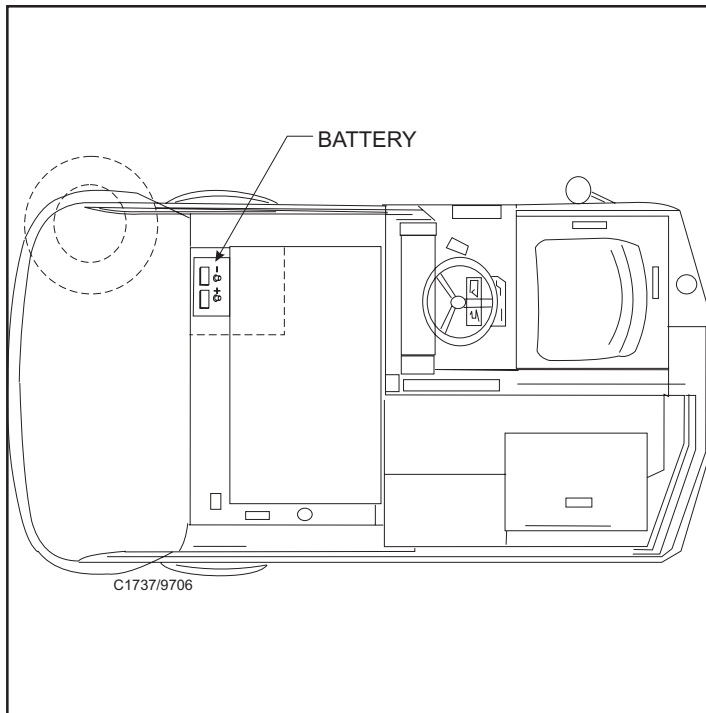

C1737

FIGURE 50

BATTERY

The battery is located in front of the operator's compartment, in the engine area. Can be easily accessed through the hopper door. To remove the battery loosen bolt holding battery bracket in place.

Keep the top of the battery clean and dry. Keep the terminals and connectors clean. To clean the top of the battery, use a damp cloth with a weak solution of ammonia or bicarbonate of soda. To clean the terminals and connectors, use a terminal and connector-cleaning tool.



WARNING

NEVER allow the soda solution to enter the cells. This will permanently discharge the battery.

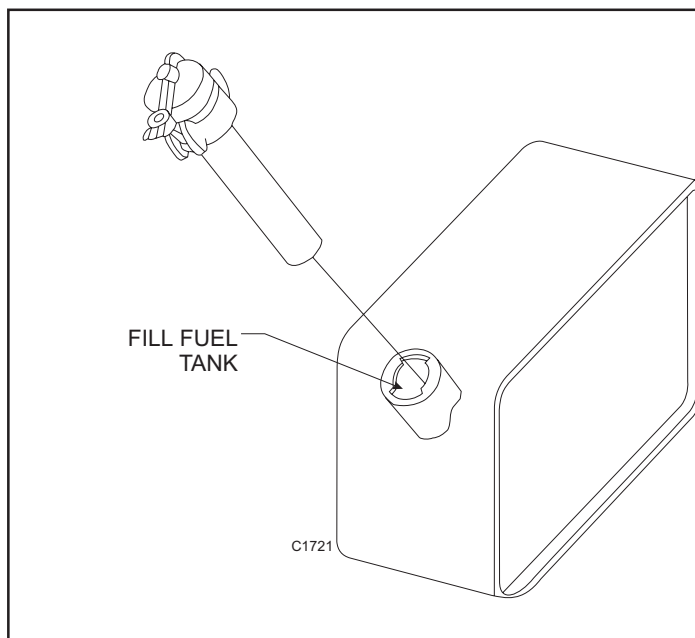

C1721

FIGURE 51

GAS TANK

The gas tank is located under the driver's seat. It may be filled from the rear of the machine.

NEUTRAL ADJUSTMENT

NOTE

Orientation of the transmission arm assembly depends upon which engine is installed in the SC7750 Sweeper Scrubber.

NOTE

Adjustment directions given are as seen from the operator's position in the driver's seat.

1. Check engine no load RPM : 2050 RPM for gas and LP; 2150 for diesel. Check hydraulic reservoir oil level.
2. Raise the rear of the machine onto jack stands so the rear wheel is off the ground.
3. Loosen the jam nut away from the adjustment nut.
4. If the rear drive wheel is turning forward, turn the adjustment nut counterclockwise (this will lengthen the threaded shaft). If the rear drive wheel is turning in reverse, turn the adjustment nut clockwise (this will shorten the threaded shaft).
5. Tighten the jam nut against the threaded shaft.
6. Test for operation of neutral with the engine at full throttle. If the rear drive wheel turns, repeat adjustment steps 3, 4 and 5.

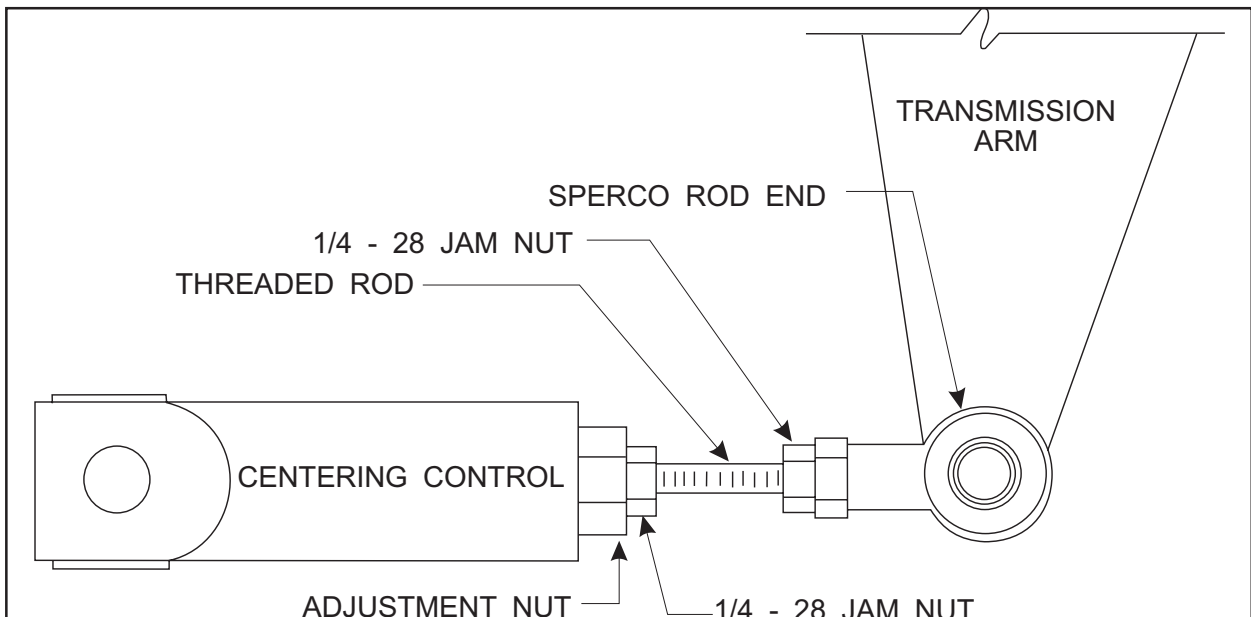

P-5093

LP SAFETY PRECAUTIONS

 **WARNING**

Keep cigarettes, sparks, and open flames away when working on LP equipment, when inspecting for gas leaks, or when LP tanks are present.

 **WARNING**

Check all components for proper operation. Replace LP components when needed. Never bypass defective safety components.

 **WARNING**

Check routing of all LP hoses. Keep them away from sharp edges, exhaust manifolds, or other hot surfaces. Check for signs of abrasion or deterioration.

 **WARNING**

Check for gas odor before and during starting operations. If gas odor is noticed, stop and check for leaks or component malfunction.

 **WARNING**

Make sure the LP tank is free of dents or gouges.

 **WARNING**

Keep the engine properly tuned.

 **WARNING**

Make sure the LP tank is securely mounted on the machine with the retainer bracket clamping the tank and with the locating pin in position.

 **WARNING**

Make sure service coupling is clean and free of damage. Make sure service coupling of tank matches machine servicing coupling.

 **WARNING**

Park the machine in a shaded, cool area when not in use.

 **WARNING**

Keep the LP tank service valve closed when the tank is not in use.

 **WARNING**

Never overfill the LP tank. Fill the LP tank to the recommended weight stamped on the tank.

 **WARNING**

Use care in handling LP tanks. Never drop or drag them.

 **WARNING**

Always store and transport LP fuel tanks with the safety relief valve in the “UP” position.

 **WARNING**

Avoid contact with the LP fuel to avoid frostbite.

 **WARNING**

When the machine is to stand unused for a period of time (overnight), park it in a designated area. Shut off the service valve at the tank and operate engine until the remaining fuel is consumed. Turn off key.

LP FUEL SYSTEM

The LP fuel system consists of several components not found on the gasoline system. The LP fuel system also contains the associated mounting hardware and plumbing for the LP components. The major LP components are as follows:

1. Throttle plate & mixer
2. Combination water-heated vaporizer & regulator
3. Megajector
4. LP fuel tank, valves & fittings

These components are factory set; attempts at adjusting these components should only be made by authorized service personnel.

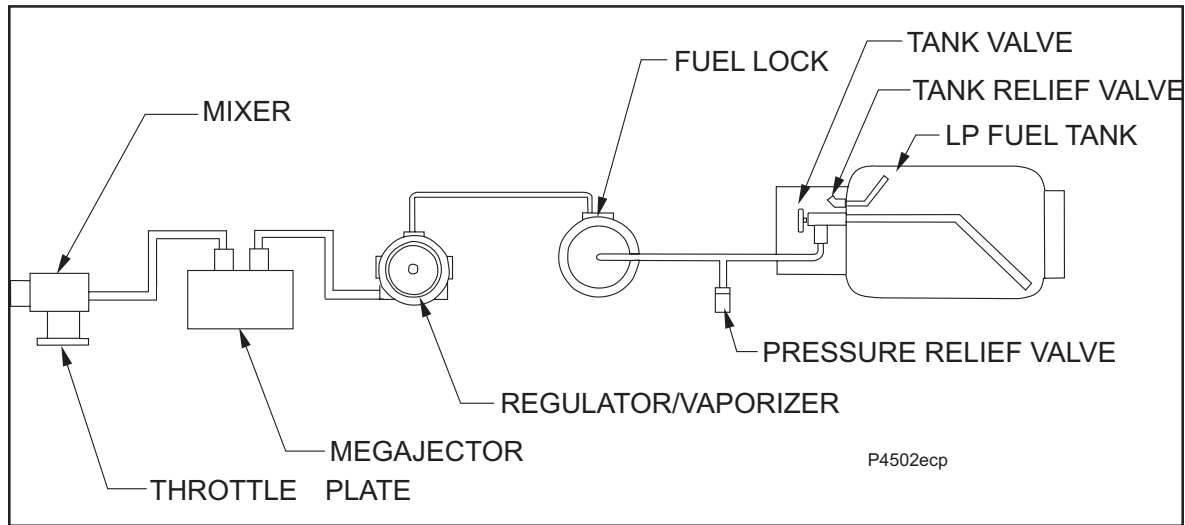

P4502ecp

FIGURE 53

LP VAPOR WITHDRAWAL SYSTEM

The liquid fuel flows from the tank under its own pressure to the pressure relief valve. This valve is normally closed, which prevents fuel from escaping into the atmosphere. When the engine is running, LP then flows through the open fuel lock (lock automatically closes when engine is shut down) and into the vaporizer/regulator where it is converted to a gaseous state. (The regulator reduces the tank pressure and makes the flow more constant.) As the vaporized LP moves through the Megajector, the Megajector meters the amount of LP necessary to be piped into the mixer where it is then introduced into the air flow and sent to the combustion chamber.

LP FUEL VAPORIZER-REGULATOR QUICK CHECK

Turn on the key switch and open the radiator cap. Check the coolant for bubbles. If bubbles are present, the vaporizer may have a leaking gasket or may have developed a pinhole leak, allowing the LP fuel to enter the cooling system.

LP CHECKLIST

This checklist can be performed quickly and should be done before every use. Be sure to make all necessary checks as listed on the Maintenance Chart discussed earlier.

1. Check connections for leaks.
2. Open the LP storage tank valve.
3. Check the regulator. Momentarily press the fuel primer on the regulator cover to bleed air out of the system.
4. Start the machine's engine.

LP TANK COMPONENTS

LP FUEL TANKS

The LP tank is located under the driver's seat. Use only the proper size and type of LP tank. The SC7750 LP powered sweeper/scrubber uses a 33.5 lb. Liquid withdraw tank. The DOT designation of the tank is DOT 4BW-240. Standard D.O.T. LP fuel tank sizes have 14, 20, 33.5, and 43.5 pound capacities. The liquid volume permitted in these containers is less than the total volume of the cylinder. This provides for expansion of the LP fuel in the case of a temperature increase above the normal amount. Excessive heat may cause the fuel to expand too much, causing the safety relief valve to vent some LP fuel, relieving internal tank pressure.

Each tank is marked showing the type of construction (liquid or vapor), the manufacturer, the date of manufacture, the capacity, the weight, and the date of requalification. D.O.T. fuel tanks must be requalified (checked) periodically. This requalification must be recorded and maintained for the life of the container.

LP fuel tanks are equipped with the following approved valves and fittings:

- * Safety Relief Valve - This is a spring-loaded valve that relieves excessive pressures which may develop in the tank due to unusual conditions.
- * Liquid Service Valve - Liquid is withdrawn from the tank through this valve. The LP tank may be filled through this valve if the tank is not equipped with a filter valve.
- * Excessive Flow Valve - This valve is part of the liquid service valve. It is mounted inside the tank and prevents LP fuel from leaving the LP tank in the event of accidental breakage of external fittings or hoses.
- * Filler Valve - This valve is optional. If this valve is not present, the tank is filled through the service valve.
- * Liquid Level Gauge - This gauge is optional.

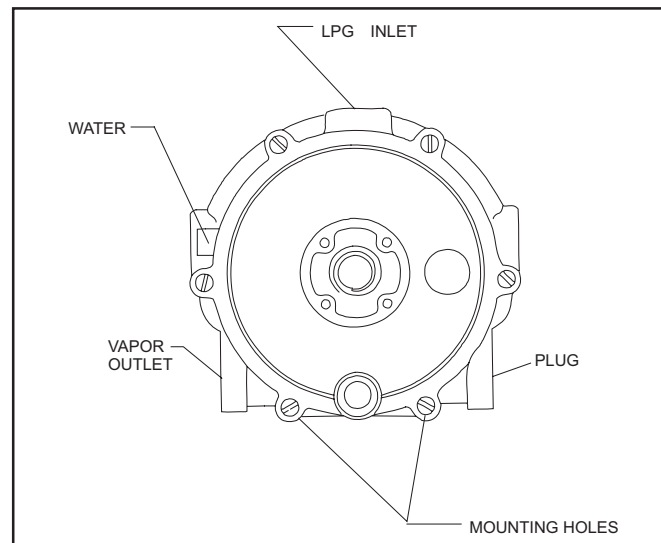

P4563ecp

FIGURE 54

USE AND CARE OF LP TANKS

If an LP tank is damaged or leaking, it should be immediately removed to a designated safe area and the proper personnel should be notified. Do not attempt to make repairs to the cylinder regardless of its condition. Repairs must be made by qualified personnel.

The care an LP tank receives has a direct bearing on how long the tank can be used safely. LP tanks must not be dropped, dragged, or slid across any surface. To move the LP tank, use a hand truck or roll the tank on its foot ring while it is being held in a position slightly off the vertical.

CHANGING LP TANKS

Refueling machines with LP tanks is an important process. Refueling is accomplished by replacing the empty LP tank with a full tank.

The tank changing operation presents an opportunity for the machine operator to carefully inspect the tank, tank fittings, the fuel lines and fuel line fittings. If abnormal wear is detected, the operator should report these findings to the appropriate personnel for immediate action.

CHANGING THE LP TANK

1. Park the machine in a designated safe area and set the parking brake.
2. Close the tank valve.
3. Remove the quick-disconnect coupling from the tank valve.
4. Inspect the machine's fuel lines and the quick-disconnect coupling for damage or abnormal wear.
5. Remove the empty tank from the holding device.
6. Inspect the tank and tank fittings for damage or abnormal wear. Handle the tank carefully. It must not be dropped or mishandled.
7. Store the LP tank in a designated safe area.
8. Select a full LP tank and observe for damage or leaks.
9. Carefully install the full tank in the machine so the tank-centering pin enters the aligning hole in the tank collar. This assures that the tank is positioned properly and allows for proper operation of the safety relief valve, liquid level gauge, and service valves.
10. Fasten the tank-retaining bracket so the tank is locked into position.
11. Reconnect the fuel line to the tank-servicing coupling.
12. Open the service valve slowly and check for leaks. If a leak is found, close the valve immediately and notify the appropriate personnel.
13. If no leaks are detected, the engine is ready to start. Do not start the engine unless the operator is in position with the directional control pedal in the neutral position.

STORING LP FUEL TANKS

Whether the storage is inside or outside, the LP tanks should not be in the vicinity of combustible materials or high temperature sources such as ovens or furnaces. This may cause the heat to raise the pressure of the fuel to a point where the safety relief valves would begin operation. Care should be taken to ensure that the cylinders are stored in such a manner that if the safety relief valves are triggered, the vapor will be relieved rather than any liquid.

Valves on empty tanks must be closed during storage and transportation.

PARTS LIST LEGEND

ABBREVIATIONS - SCREWS

ADJ	= Adjusting Screw
ADJ.SP	= Adjusting Plunger Screw
BHM	= Binding Head Machine Screw
BHS	= Button Head Socket Screw
CAPT.SL	= Captivated Slotted Screw
CAPT.WG	= Captivated Wing Screw
FHM	= Flat Head Machine Screw
FIL.HM	= Filister Head Machine Screw
HHC	= Hexagon Head Cap Screw
HHM	= Hexagon Head Machine Screw
HIHD	= 1/2 High Head Screw
HSHC	= Hexagonal Socket Head Cap Screw
HSFHC	= Hexagonal Socket Flat Head Cap Screw
KNH	= Knurled Head Screw
MHHC	= Metric Hexagon Head Cap Screw
PHM	= Pan Head Machine Screw
RHD	= Round Head Drive Screw
RHM	= Round Head Machine Screw
RHW	= Round Head Wood Screw
SHC	= Shiny Crown Cap Screw
SHTB	= Shoulder Thumb Screw
SQ	= Square Head Screw
TB	= Thumb Screw
THM	= Truss Head Machine Screw
WELD	= Weld Stud
WG	= Wing Screw

ABBREVIATIONS - SETSCREWS

HS	= Hexagonal Socket Setscrew
S	= Slotted Setscrew
SH	= Square Head Setscrew
-KCP	= Knurled Cup Point Setscrew
-CP	= Cup Point Setscrew
-OP	= Oval Point Setscrew
-FDP	= Full Dog Point Setscrew
-HDP	= Half Dog Point Setscrew
-FP	= Flat Point Setscrew
-COP	= Cone Point Setscrew

GENERAL TROUBLESHOOTING

<u>PROBLEM</u>	<u>PROBABLE CAUSE</u>	<u>REMEDY</u>
Sweeping Does Not Function.	<ol style="list-style-type: none"> 1. Dump door open 2. Hopper is raised 3. Hopper switch out of adjustment 	<ol style="list-style-type: none"> 1. Close dump door. 2. Lower hopper 3. Adjust hopper switch
Poor Water Pick-Up At Squeegee.	<ol style="list-style-type: none"> 1. Side or rear squeegee are worn or damaged. 2. Clogging in water pick-up. 3. Air leaks in suction hose and connection 4. Air leaks at recovery tank cover and/or manifold gaskets. 5. Poor vacuum 6. Drain hose or drain plug leakage or not closed properly. 	<ol style="list-style-type: none"> 1. Examine squeegee rubber blade for cuts or worn spots. Replace if necessary. 2. Repair or replace hose and connections. 3. Repair or replace gaskets. 4. Check vacuum motor. 5. Check seal on recovery tank. 6. Close, repair or replace drain plug in recovery tank.
Water Spills From Squeegee.	<ol style="list-style-type: none"> 1. Side squeegee blades, poor contact with floor. 2. Squeegee blades worn or damaged. 3. Too much solution being applied before making turns. 4. Brushes rotating opposite direction. 	<ol style="list-style-type: none"> 1. Readjust blades for proper contact. 2. Replace and adjust 3. Shut off solution flow 5 to 10 feet. 4. Check position of switches
Lack Of Suction At Rear.	<ol style="list-style-type: none"> 1. Clogged suction hose or pick-up tool. 2. Loose connections between suction hose & squeegee or between hoses of manifold inlet. 3. Vacuum motor not operating. 4. Vacuum float cage clogged. 5. Vacuum float shut off 	<ol style="list-style-type: none"> 1. Disconnect suction hose from squeegee, flush squeegee & hoses thoroughly. 2. Check all hose connections for looseness or damage. 3. Check hydraulic motor in recovery. 4. Clean perforated metal thoroughly. 5. Excessive solution in recovery drain tank. Excessive foam build up, change cleaning chemical mixture. Use A-L approved materials.

GENERAL TROUBLESHOOTING

<u>PROBLEM</u>	<u>PROBABLE CAUSE</u>	<u>REMEDY</u>
Poor Scrubbing	<ol style="list-style-type: none"> 1. Worn scrubbing brushes 2. Incorrect method of operation 3. Wrong cleaning agent or mixture 4. Poor solution distribution 	<ol style="list-style-type: none"> 1. Inspect brushes. If they are worn to ½" (1.3 cm) or less, replace all 3 brushes 2. Check scrubbing procedures, brush pressure, type of brush solution flow & cleaning chemical used. For extreme conditions double scrubbing may be necessary. 3. Use A-L recommended materials 4. Clean out distribution tube & metering holes to brushes. Checks feed hose & clean if necessary. Check valve & cable control system.
Engine Runs, But Machine Will Not Move On Level Ground	<ol style="list-style-type: none"> 1. Foot pedal and/or linkage jammed or not adjusted. 2. Front wheels jammed or brakes locked 3. Hydraulic pump trouble. 4. Rear wheel hydraulic motor, broken shaft key, broken shaft etc. 	<ol style="list-style-type: none"> 1. Check pedal linkage 2. Check wheels & brakes 3. Check & repair pump, check tow valve. See Cessna information 4. Check & repair. See Char-Lynn information.
Machine Moves Slowly	<ol style="list-style-type: none"> 1. Low hydraulic oil level 2. Brake dragging 3. Hydraulic oil temperature too high 4. Worn hydraulic pump or drive motor 	<ol style="list-style-type: none"> 1. Add oil to the reservoir 2. Check brakes 3. Check oil level. Add SAE 5 ATF if required 4. See Cessna or Char-Lynn information
Hydraulic Pump Making Excessive Noise	<ol style="list-style-type: none"> 1. Clogged inlet strainer or suction line 2. Air bubbles in hydraulic fluid 3. Hydraulic pump is worn or damaged 	<ol style="list-style-type: none"> 1. Clean inlet strainer line. Drain & flush reservoir if oil is dirty. Refill with clean SAE 5 ATF. 2. Check for low hydraulic fluid level, leaking fitting or hoses 3. See Cessna pump information

CHECK ENGINE LIGHT CODES

CATEGORY	DESCRIPTION	CODE NUMBER
MAP	MAP high pressure	231
	MAP low voltage	232
TIP	TIP high voltage	1111
	TIP low voltage	1111
FP	FP high voltage	1111
	FP low voltage	1111
ECT/CHT	ECT/CHT high voltage	221
	ECT/CHT low voltage	222
	ECT higher than expected 1	223
	ECT higher than expected 2	224
	CHT higher than expected 1	223
	CHT higher than expected 2	224
IAT	IAT high voltage	211
	IAT low voltage	212
	IAT higher than expected 1	213
	IAT higher than expected 2	214
BP	BP high pressure	234
	BP low pressure	235
Knock	Knock sensor open	253
	Excessive knock signal	254
Battery Voltage	Voltage high	162
	Voltage low	161
5V External	5VE high voltage	632
	5VE low voltage	631
TPS	TPS1 high voltage	531
	TPS1 low voltage	532
	TPS2 high voltage	533
	TPS2 low voltage	534
	TPS1 higher than TPS2	535
	TPS1 lower than TPS2	536
	Unable to reach higher TPS	537
	Unable to reach lower TPS	538
FPP	FPP1 high voltage	511
	FPP1 low voltage	512
	FPP2 high voltage	521
	FPP2 low voltage	522
	FPP1 higher than IVS limit	513
	FPP1 lower than IVS limit	514
	FPP2 higher than IVS limit	523
	FPP2 lower than IVS limit	524
	FPP1 higher than FPP2	515
	FPP1 lower than FPP2	516
Governor Interlock	IVS/Brake interlock failure	545





CHECK ENGINE LIGHT CODES

CATEGORY	DESCRIPTION	DESCRIPTION	CODE NUMBER
Auxiliary Analog Inputs	AUX analog PD1 high		163
	AUX analog PD1 low		164
	AUX analog PU1 high		541
	AUX analog PU1 low		542
	AUX analog PU2 high		543
	AUX analog PU2 low		544
Engine Speed	Max govern speed override		551
	Fuel rev limit		552
	Spark rev limit		553
Oil Pressure	Oil pressure low		215
Adaptive Learn	AL high gasoline bank1		141
	AL high gasoline bank2		151
	AL low gasoline bank1		142
	AL low gasoline bank2		152
	AL high LPG		143
	AL low LPG		144
	AL high NG		145
	AL low NG		146
Closed Loop	CL high gasoline bank1		121
	CL high gasoline bank2		131
	CL low gasoline bank1		122
	CL low gasoline bank2		132
	CL high LPG		111
	CL low LPG		124
	CL high NG		125
	CL low NG		126
Catalyst Monitor	Gasoline cat monitor		133
	LPG cat monitor		134
	NG cat monitor		135
EGO Sensors	EGO open/lazy bank1		112
	EGO open/lazy bank2/post-cat		113
	EGO open/lazy post-cat		114
Injectors	Injector Loop Open or Low-Side Short to Ground	Injector 1	311
		Injector 2	313
		Injector 3	315
		Injector 4	321
	Injector Coil Shorted	Injector 1	312
		Injector 2	314
		Injector 3	316
		Injector 4	322

CHECK ENGINE LIGHT CODES

CATEGORY	DESCRIPTION	DESCRIPTION	CODE NUMBER
Spark Coil Primary	Primary Loop Open or Low-Side Short to Ground	Coil 1	411
		Coil 2	413
		Coil 3	415
		Coil 4	421
	Primary Coil Shorted	Coil 1	412
		Coil 2	414
		Coil 3	416
		Coil 4	422
Fuel Pump Feedback	F Pump Loop Open or High-Side Short to Ground		351
	F Pump High-Side Shorted to Power		352
MegaJector Diagnostics	MegaJector delivery pressure higher than expected		353
	MegaJector delivery pressure lower than expected		354
	MegaJector comm lost		355
	MegaJector voltage supply high		361
	MegaJector voltage supply low		362
	MegaJector internal actuator fault detection		363
	MegaJector internal circuitry fault detection		364
Crank/Cam Sensors	Cam loss		244
	Cam sync noise		245
	Crank sync noise		242
	Never crank synced at start		243
Internal Processor Diagnostics	COP failure		611
	RTI 1 loss		614
	RTI 2 loss		655
	RTI 3 loss		656
	A/D loss		613
	Invalid interrupt		612
	Flash checksum invalid		615
RAM failure		616	
RS-485 Network	Rx Inactive		641
	Rx Noise		642
	Invalid Packet Format		643
	Shutdown Request		644

Parts may be ordered from American-Lincoln® authorized distributors. Record the American-Lincoln® serial plate information to avoid delays in filling your order:

Model: Part No.: Fuel: IPX3 Weight:	Serial No.: Code: Rated Power:
 	
	 <small>56100775</small> <small>Made in USA by American-Lincoln®</small>

1. Use the model number, catalog number, and serial number when ordering.
2. Give the part number, description, and quantity of parts needed.
3. Give shipping instructions for either freight, UPS, or parcel post.

Parts and supplies listed in this manual can be ordered from the following address:

Nilfisk-Advance, Inc. American-Lincoln Div.	American-Lincoln authorized distributor
14600 21st Avenue North Plymouth, MN 55447 1-800-214-7700	

MACHINE CATALOG NUMBERS

- | | |
|---------|--------------------------|
| 505-825 | 46" GAS VARIABLE DUMP |
| 505-826 | 46" LP VARIABLE DUMP |
| 505-827 | 46" DIESEL VARIABLE DUMP |
| 505-828 | 53" GAS VARIABLE DUMP |
| 505-829 | 53" LP VARIABLE DUMP |
| 505-830 | 53" DIESEL VARIABLE DUMP |

TABLE OF CONTENTS - CHAPTER 2

Main Broom Lever	2-4
Side Broom	2-6
Side Broom Pulley	2-7
Side Broom Lever	2-8
Side Broom Lift System	2-10
Broom Chamber Flaps & Seals	2-12
Broom Chamber Doors	2-14
Hopper	2-16
Hopper Lid/Cover	2-20
Hopper Dump Door	2-21
Hopper Door Cylinder	2-22
Hopper Control Valve	2-23
Scrub Deck (46")	2-24
Scrub Deck & Squeegee (53")	2-28
Side Squeegees (46")	2-32
Rear Squeegees (46")	2-34
Squeegee Lift	2-36
Swing Squeegee Support	2-38
Solution Tank	2-40
Solution Feed	2-42
Recovery Tank	2-44
Recovery Tank Drain System	2-48
Front Bumper	2-49
Front Wheel	2-50
Wheel Well Flap	2-51
Rear Wheel Assembly	2-52
Brake Pedal	2-54
Forward/Reverse Control	2-56
Frame	2-58
Safety Arm	2-59
Steering Column	2-60
Vac Fan	2-62
Vac Motor Manifold	2-64
Filter Shaker	2-66
Seat & Floor Assembly	2-68
Hydraulic Hose/Schematic Diagram	2-70
Main Broom Hydraulics	2-72
Side Broom Hydraulics	2-73
Hopper Lift Hydraulics	2-74
Hopper Dump Door Hydraulics	2-75
Hopper Control Check Valve Hydraulics	2-76
Scrub Deck Hydraulics	2-77
Scrub Deck Lift Hydraulics	2-78
Squeegee Lift Hydraulics	2-79
Hydraulic Reservoir	2-80
Drive Wheel Hydraulics	2-82
Vac Motor Hydraulics	2-83
Hydraulic Pump (Wheel Drive)	2-84
Hydraulic Main Control Valve	2-86
Hydraulic Cylinder Control Valve	2-88
Hydraulic Return Block	2-90
Vac Fan Hopper Hydraulics	2-92
Steering 90° - 90° Hydraulics	2-93
Covers	2-94
Ford 416EFI GAS Engine - Hardware	2-96

TABLE OF CONTENTS - CHAPTER 2

Ford 416EFI GAS Engine - Air Intake, Exhaust	2-98
Ford 416EFI GAS Engine - Fuel Sytem	2-100
Fuel Tank - Gas	2-102
Ford 416EFI Engine (GAS) - Radiator & Hoses	2-104
Ford 416EFI Engine (GAS & LP) - Fuel Computer & Oil Filter	2-106
Ford 416EFI LP Engine - Fuel Sytem	2-108
Fuel Tank - LP	2-112
Ford 416EFI LP Engine - Air Intake, Exhaust	2-116
Ford 416EFI LP Engine - Hardware	2-118
Ford 416EFI Engine (LP) - Radiator & Hoses	2-120
Mitsubishi S4L2 Diesel Engine - Hardware	2-122
Mitsubishi S4L2 Diesel Engine - Fuel System	2-124
Mitsubishi S4L2 Diesel Engine - Throttle Assy.	2-126
Fuel Tank - Diesel	2-128
Mitsubishi S4L2 Diesel Engine - Radiator, Fan	2-132
Mitsubishi S4L2 Diesel Engine - Air Cleaner	2-132
Mitsubishi S4L2 Diesel Engine - Exhaust System	2-133
Battery Electrical Assembly - Gas/LP	2-134
Battery Electrical Assembly - Diesel	2-135
Decals	2-136
Instrument Panel	2-138
CE Kit	2-140
Instrument Panel Connection Drawing	2-141
Electrical Schematic	2-142
Machine Harness Connection Diagram	2-143
Harness Routing	2-144
Ford 416EFI Engine Harness	2-145
Mitsubishi S4L2 Diesel Engine Harness	2-146
Floor Panel Connection Diagram	2-147

MAIN BROOM - PARTS LIST

<u>KEY NO.</u>	<u>PART NUMBER</u>	<u>DESCRIPTION</u>	<u>QTY.</u>
1	7-03-04226	Lift Frame, Main Broom	1
2	8-16-00041	Drive, Broom Arm	1
3	0882-040	Hydraulic Motor, Main Broom	1
	2-00-03838	Key (comes w/motor)	
	0880-448	Motor Seal Kit (Service Part)	
4	2-00-04895	Fitting, Straight Connector	1
5	2-00-04885	Fitting, 90° Elbow (O-Ring)	2
6	8-33-09046-1	Hub, Broom Driver	1
7	8-58-05160	Locking Plate, Broom Driver	1
8	2-95-04182	Nut, 3/8-16 Elastic Stop	5
9	7-03-04158	Arm, Main Broom Idler	1
10	2-00-04889	Bearing, Main Broom Idler	1
11	8-33-09090	Idler, Main Broom (machined)	1
12	2-00-04890	Retaining Ring, Main Broom Idler	1
13	8-75-01157	Thrust Washer	1
14	7-08-01023	Bracket, Broom Link Pivot, RH	1
15	7-08-01024	Bracket, Broom Link Pivot, LH	1
16	7-42-05167	Link, Broom	1
17	2-00-05266	Pin, 3/8 DIA	1
18	2-00-05249	Hair Pin (Cotter)	1
19	7-39-00034	Knob, 3/8 x 16 x 2 LG	1
20	2-95-04182	Nut, 3/8-16 Elastic Stop Nut	1
21	7-39-00033	Knob, 5/16-18 Adjustable Handle	1
22	7-41-05118	Lever, Main Broom	1
23	8-39-00003	Knob	1
24	8-82-00058	Switch	1

HARDWARE USED:

H9	2-00-00426	Flat Washer, .500 x .219 x .063	2
H25	2-00-00594	Nut, Hex 1/4-20 x .437 x .218	4
H47	2-00-00232	Screw, 3/8-16 x .750 HHC	6
H50	2-00-00234	Screw, 3/8-16 x 1.500 HHC	1
H52	2-00-00402	Flat Washer, .750 x .390 x .094	1
H53	2-00-02310	Lock Washer, Helical Spring 3/8 Med.	6
H72	2-00-00518	Lock Washer, Helical Spring	7
H78	2-00-05187	Carriage Bolt, 3/8-16 x 1.250	4
H86	2-00-03575	Carriage Bolt, 1/4-20 x .750	4
H92	2-00-04801	Flat Washer, .875 x .375 x .125	5
H96	2-00-02605	Screw, 3/8-16 x 4.500 HHC, Cadmium Plated	1
H106	2-00-04886	Screw, 3/8-16 x .500 HSHC	2
H107	2-00-04887	Screw, Main Broom Control	1
H109	2-00-00522	Lock Washer, 3/4 Helical Spring	1
H110	2-00-03039	Screw, 1/4-20 x .625 HSHC	3
H191	2-00-00602	Nut, MSCR - Hex, 8-32	2
H325	2-00-00092	Screw, Ph.RHM #8-32 x 1.75 Zn.	2

SIDE BROOM

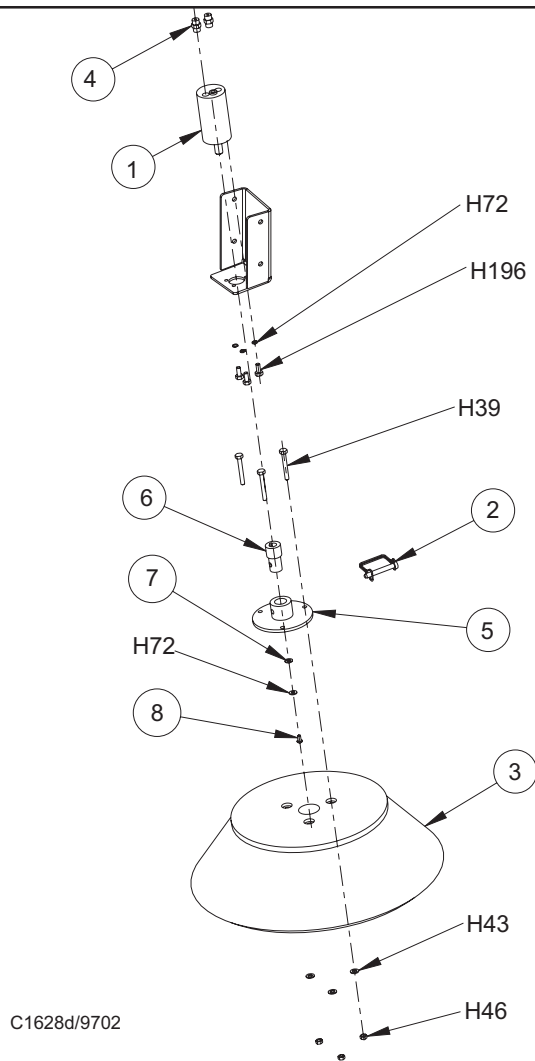

<u>KEY NO.</u>	<u>PART NUMBER</u>	<u>DESCRIPTION</u>	<u>QTY.</u>
1	0885-061	Motor, Side Broom	Ref.
2	8-55-08122	Pin, SB Flange	1
3	8-08-03211	Side Broom	1
4	2-00-04918	Fitting	Ref.
5	8-33-09091	Hub, SB (Weldment)	1
6	7-72-03030	Sleeve, SB	1
7	2-00-04689	Washer, 11/16 OD x .260 I.D. x .050	1
8	2-00-04750	Screw, Btn HD Skt.	1

HARDWARE USED:

H39	2-00-00218	Screw, 5/16-18 x 2.000 HHC	3
H43	2-00-00409	Flat Washer, .687 x .344 x .062	3
H46	2-00-00644	Nut, 5/16-18 Insert Fiber	3
H72	2-00-00518	Lock Washer, Helical Spring	4
H196	2-00-05350	Screw, 1/4-28 x .630 HHC	3

C1628d/9704

SIDE BROOM PULLEY

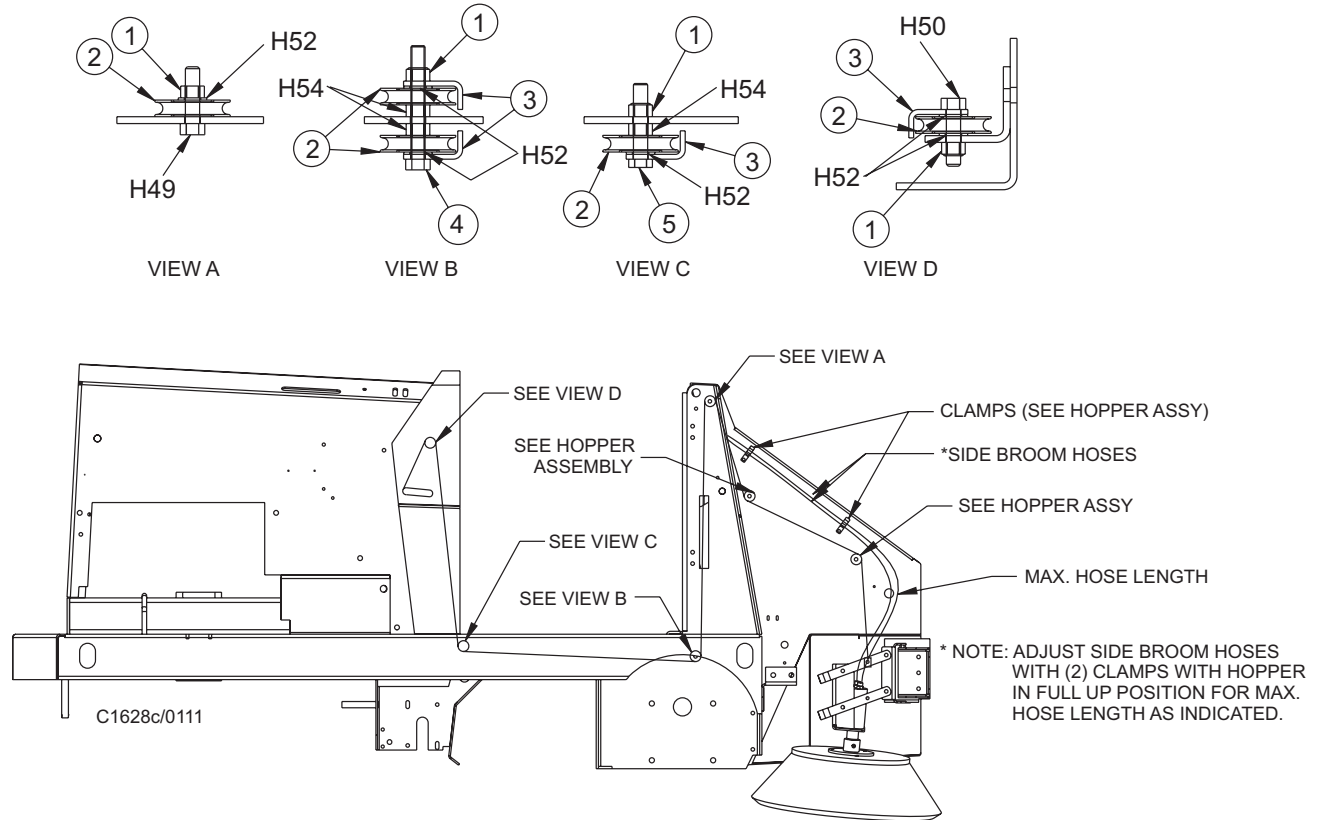

KEY NO.	PART NUMBER	DESCRIPTION	QTY.
1	2-95-04182	Fiber Nut	4
2	7-60-00160	Pulley , Cable	Ref.
3	7-13-07130	Clip, Cable Retainer	Ref.
4	2-00-05384	Screw, 3/8-16 x 3.0 HHC	1
5	2-00-00235	Screw, 3/8-16 x 1.75 HHC	1

HARDWARE USED:

H49	2-00-00209	Screw, 3/8-16 x 1.25 HHC	1
H50	2-00-00234	Screw, 3/8-16 x 1.50 HHC	1
H52	2-00-00402	Flat Washer, .750 x .390 x .094	4
H54	2-00-02360	Nut, Hex. 3/8-16	3

C1628c/0111

SIDE BROOM LEVER - PARTS LIST

<u>KEY NO.</u>	<u>PART NUMBER</u>	<u>DESCRIPTION</u>	<u>QTY.</u>
1	7-10-00030	Cable	Ref.
2	8-39-00003	Control Knob	1
3	7-66-00170	Lever Handle - SB	1
4	8-39-00013	Knob Assembly	1
5	8-08-00773	Broom Lift - MB-SB Weldment	1
6	8-08-00866	Bracket - Angle Adj.-SB	1
7	8-50-03002	Broom Adj Block	1
8	7-60-00160	Pulley, Cable	4
9	2-95-04182	Fiber Nut	2
10	7-08-00851	Bracket - Angle Adj.-SB	1
11	7-13-07130	Clip - Cable Retainer	4
12	8-82-00058	Switch	1

HARDWARE USED:

H26	2-00-00641	Nut, 1/4-20 Insert Fiber	1
H34	2-00-00208	Screw, 5/16-18 x .750 HHC	1
H37	2-00-00207	Screw, 5/16-18 x 1.250 HHC	1
H46	2-00-00644	Nut, 5/16-18 Insert Fiber	1
H52	2-00-00402	Flat Washer, .750 x .390 x .094	1
H54	2-00-02360	Nut, Hex. 3/8-16	2
H85	2-00-00650	Nut, Cap 3/8-16 Low Crown	1
H113	2-00-03333	Screw, 3/8-16 x 3.750 HHC	1
H121	2-00-00090	Screw, #8-32 x 1.500 RHM	2
H191	2-00-00602	Nut, MSCA - Hex, 8-32	2
H229	2-00-01490	Screw, .25-20 x .875 HHC STL	2
H230	2-00-00466	Flat Washer, .625 x .203 x .031	2
H265	2-00-00506	Lock Washer, Int Tooth #8 Dia Screw	2
H326	2-00-00235	Screw HHC .375-16 x 1.75	1

C1628/9912

SIDE BROOM LEVER - EXPLODED VIEW

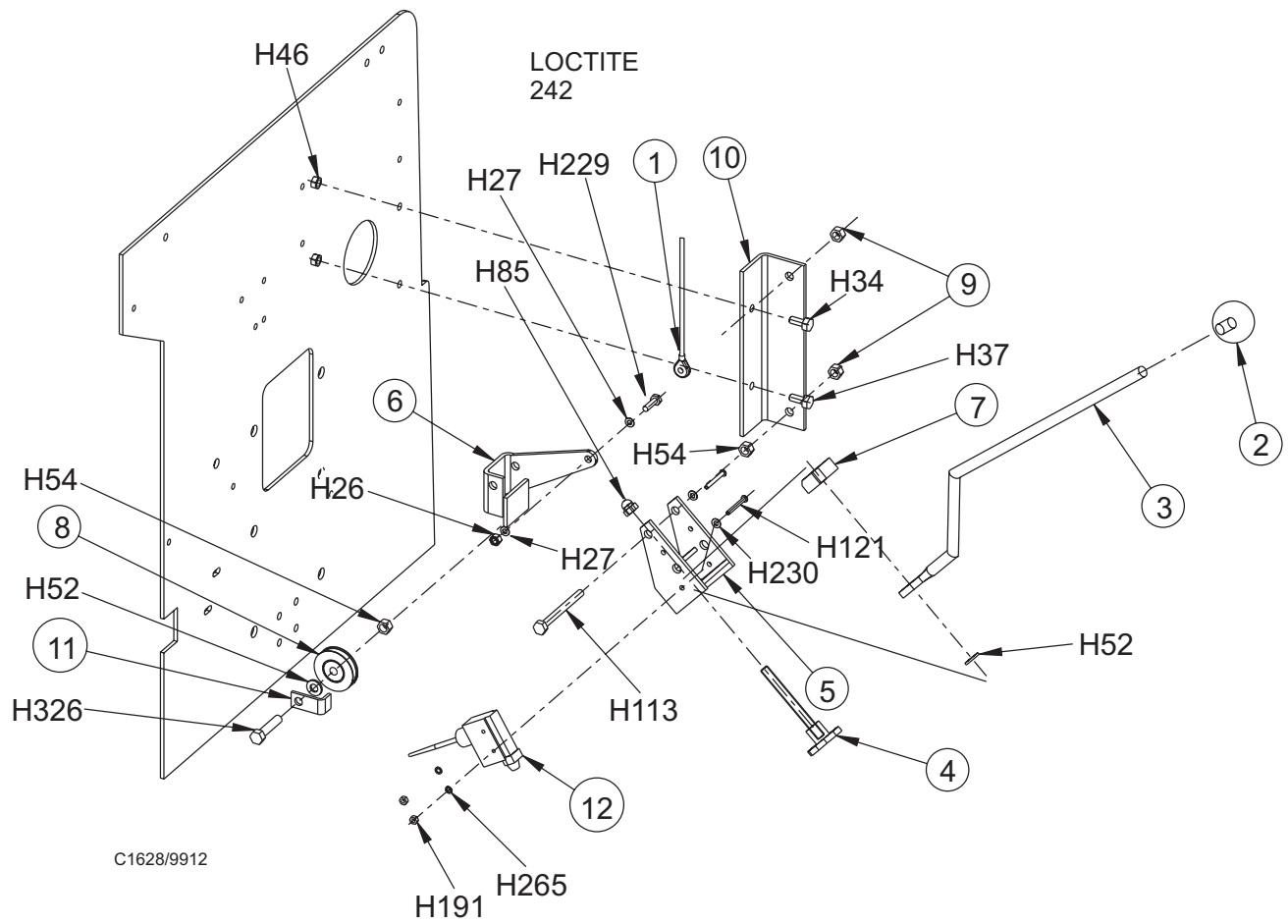

SIDE BROOM LIFT SYSTEM - PARTS LIST

<u>KEY NO.</u>	<u>PART NUMBER</u>	<u>DESCRIPTION</u>	<u>QTY.</u>
1	7-08-00847	Bracket - Side Broom	1
2	8-08-00790	Bracket - Side Broom	1
3	8-42-05136	Link - Side Broom Lift	2
4	8-08-00846	Pivot Bracket - Side Broom	1
5	2-95-04182	Nut, 3/8-16 Elastic Stop	13
6	7-76-00101	Spring - Brush Load	2
7	7-10-00030	Cable - Side Broom	Ref
8	7-66-00180	Rod - Threaded	1
9	8-14-01006	Clevis	1
10	2-95-01999	Nut - Hex Jam, .25-28 ZN	1

HARDWARE USED:

H25	2-00-00594	Nut, Hex, 1/4-20 x .437 x .218	6
H43	2-00-00409	Flat Washer, .687 x .344 x .062	2
H45	2-00-00585	Nut, Hex. 5/16-18 x .503 x .265	2
H46	2-00-00644	Nut, 5/16-18 Insert Fiber	2
H48	2-00-00233	Screw, 3/8-16 x 1.000 HHC	8
H49	2-00-00209	Screw, 3/8-16 x 1.250 HHC	8
H52	2-00-00402	Flat Washer, .750 x .390 x .094	4
H54	2-00-02360	Nut, Hex. 3/8-16	2
H173	2-00-02709	Screw, 5/16-18 x 1.500	2

C1628bx/0203

SIDE BROOM LIFT SYSTEM - EXPLODED VIEW

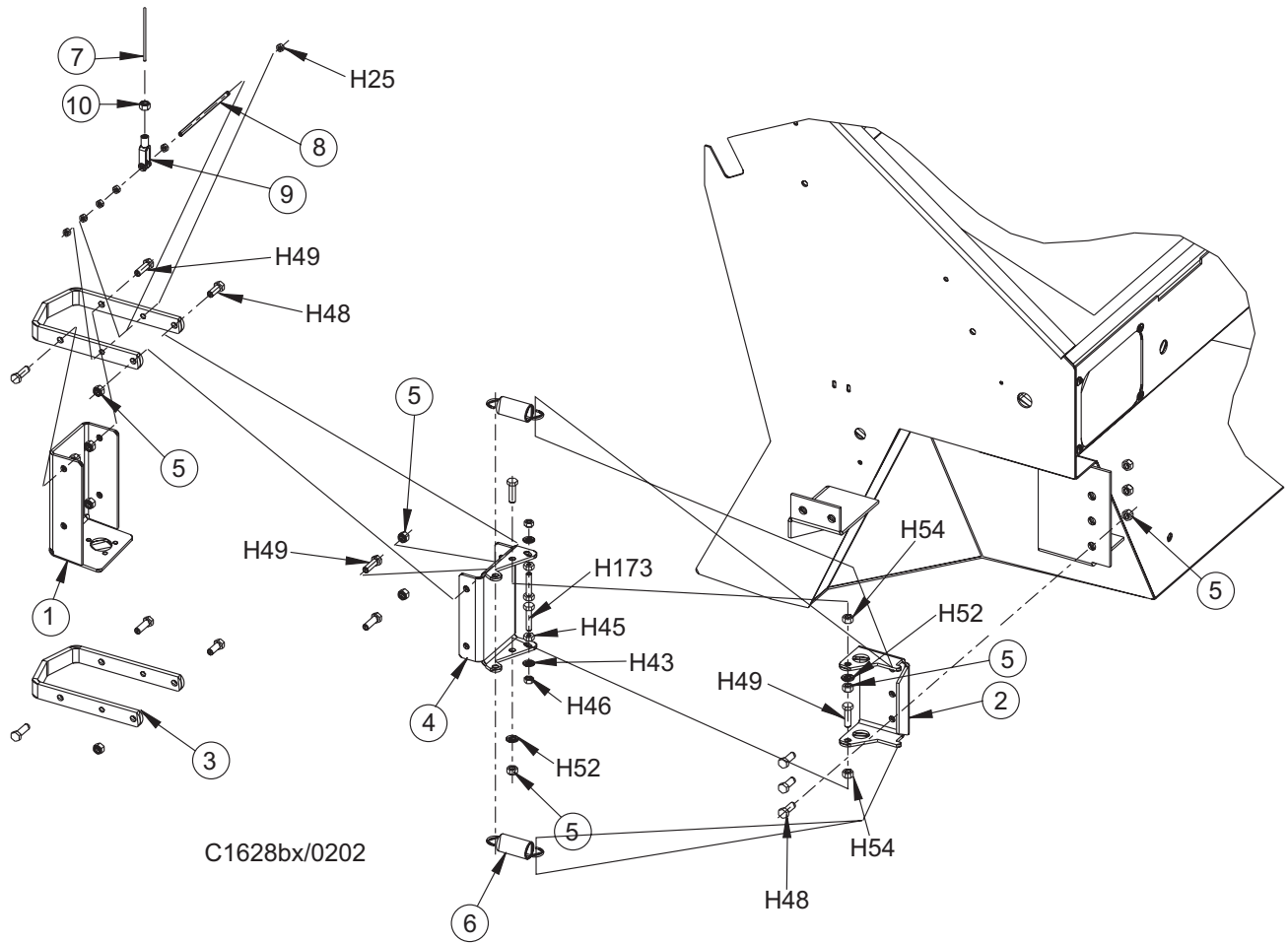

BROOM CHAMBER FLAPS & SEALS- PARTS LIST

<u>KEY NO.</u>	<u>PART NUMBER</u>	<u>DESCRIPTION</u>	<u>QTY.</u>
1*	7-25-08071	Flap, Br. Ch. Outer	1
2	7-13-07167	Clamp, Br. Ch. Inner	1
3*	7-25-08072	Flap, Br. Ch. Inner	1
4	7-13-07168	Clamp, Br. Ch. Outer	1
5	8-29-00257	Gasket	1
6	8-29-00232	Gasket	1
7	8-29-00234	Gasket	1
8	8-29-00233	Gasket	3
9	8-21-04048	Edging	2
10	8-29-00256	Gasket	1
11	7-21-03003	Edging	1
12	7-21-04031	Edging	4
13	8-82-00030	Horn Button	1
14	2-00-00641	Nut, 1/4 Fiber Insert	8
15	2-00-02196	Screw, 1/4-20 x 1.0	8
16	2-00-04312	Screw, #10-24 x .63 HWH	8

*Assemble items 1 & 3 with the larger chamber to the left side of the machine.

C1620d/9-03

BROOM CHAMBER FLAPS & SEALS - EXPLODED VIEW

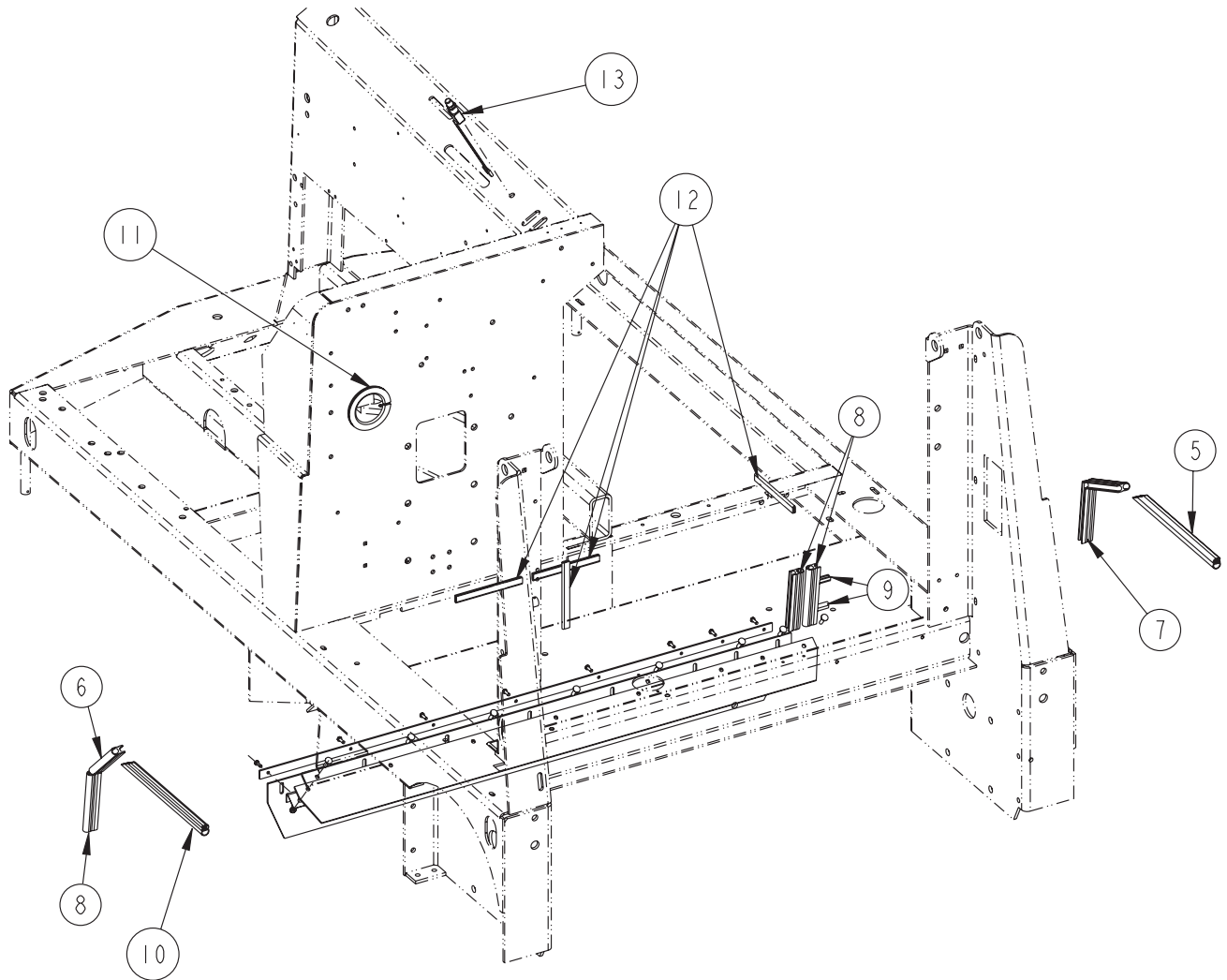

ADJUST TO (.06-.19)
ON LEVEL FLOOR

C1620D

BROOM CHAMBER DOORS - PARTS LIST

<u>KEY NO.</u>	<u>PART NUMBER</u>	<u>DESCRIPTION</u>	<u>QTY.</u>
1	7-19-08057	Broom Door Weldment (RH)	1
1	7-19-08058	Broom Door Weldment (LH)	1
2	8-41-00052	Latch	2
3	7-57-05038	Pivot Retainer	2
4	8-39-00015	Latch Knob - Broom door	2
5	7-13-07171	Clamp	1
6	8-25-08212	Flap	2
7	8-13-07145	Clamp	2
8	7-57-05042	Pivot, Side Squeegee	2
9	2-00-00203	Screw, 1/4-20 x 1.50 HHC	4
10	2-00-00641	Nut, 1/4-20 Insert Fiber	12
11	2-00-03702	Washer, .625 x .281 x .063	4
12	2-00-02708	Screw, 5/16-18 x 1.0 HHM	4
13	2-00-00409	Flat Washer, .687 x .344 x .062	2
14	2-00-00644	Nut, 5/16-18 Insert Fiber	6
15	2-00-02196	Carriage Bolt, 1/4-20 x 1.0 RHM	8

71128/9-04

BROOM CHAMBER DOORS - EXPLODED VIEW

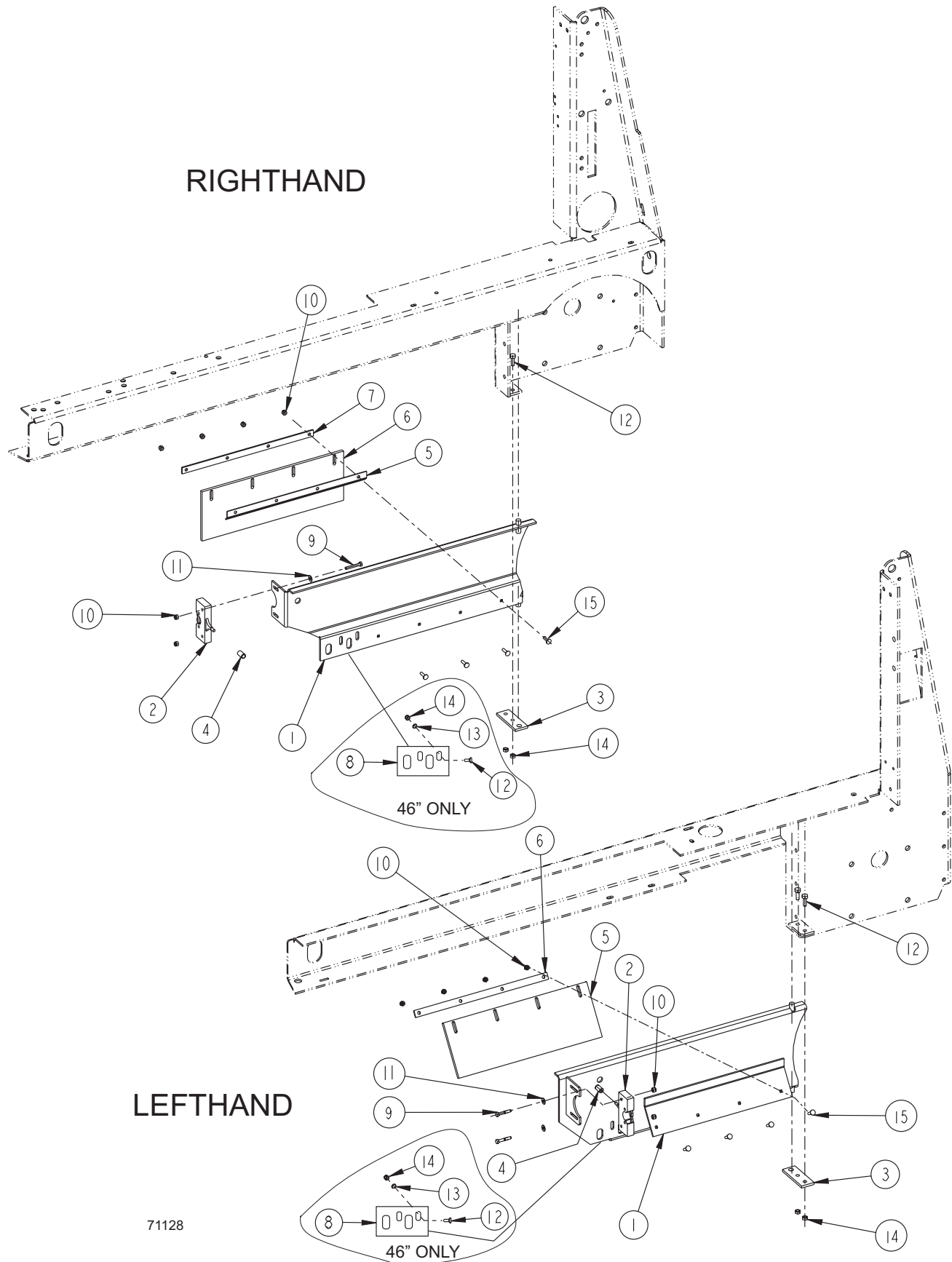

HOPPER ASSEMBLY - PARTS LIST

<u>KEY NO.</u>	<u>PART NUMBER</u>	<u>DESCRIPTION</u>	<u>QTY.</u>
1	7-32-06018	Hopper	1
2	8-17-05022	Lift Cylinder	Ref.
3	7-25-08070	Flap, Hopper	1
4	7-13-07173	Clamp, Hopper Flap	1
5	2-00-00566	Grease Zerk	2
6	7-55-08148	Pin, Hopper Pivot	2
7	2-00-05024	Washer	6
8	2-00-00776	Cotter Pin	4
9	8-55-08112	Pin, Cylinder	2
10	8-09-01082	Star Bushing	1
11	8-09-01083	Bushing, Liquid Tight	1
12	7-20-06012	Duct, 6"	Ref.
13	8-20-06036	Duct, 12"	Ref.
14	8-82-00058	Switch	1
15	2-00-05054	Fitting, Hydraulic	Ref.
16	2-00-04589	Fitting, Hydraulic, 90°	Ref.

HARDWARE USED:

H9	2-00-00426	Flat Washer, .500 x .219 x .063	8
H25	2-00-00594	Nut, Hex. 1/4-20 x .437 x .218	8
H26	2-00-00641	Nut, 1/4-20 Insert Fiber	7
H46	2-00-00644	Nut, 5/16-18 Insert Fiber	2
H69	2-00-01255	Screw, 5/16-18 x .875 HHC	2
H86	2-00-03575	Carriage Bolt, 1/4-20 x .750	7
H89	2-00-01372	Nut, Fiber Insert #8-32 Steel	4
H325	2-00-00092	Screw, Ph.RHM #8-32 x 1.75 Zn.	4

C1671/0402

HOPPER ASSEMBLY cont. - PARTS LIST

<u>KEY NO.</u>	<u>PART NUMBER</u>	<u>DESCRIPTION</u>	<u>QTY.</u>
1	8-82-00058	Switch	1
2	7-29-00240	Gasket	1
3	7-08-02017	Bracket, Switch	1
4	7-81-00190	Support, Cylinder (Welded)	1
5	2-00-00221	Screw, 1/4-20 x .750 HHC	2
6	2-00-04967	Screw, 1/2-13 x 2.50 HHM	1
7	2-00-02371	Nut, 1/2-13 Steel Hex Jam	1
8	2-00-00405	Flat Washer, 1.063 x .531 x .094	1
9	2-00-04936	Nut, 1/2-13 Fiber Lock	1
10	2-00-02617	Screw, 1/2-13 x 3.50 HHC	1
11	2-00-00090	Screw, #8-32 x 1.50 RHM	2
12	2-00-00426	Flat Washer, .500 x .219 x .063	4
13	2-00-00594	Nut, 1/4-20 x .437 x .218	2
14	2-00-00518	Lock Washer, 1/4 Medium	2
15	2-00-01372	Nut, #8-32 Fiber Insert	2
16	7-32-06018	Hopper	1
17*	7-29-00333	Gasket, Hopper	1
18	7-20-06012	Duct, Wire (6")	1
19*	8-20-06036	Duct, Wire (12")	1
20	7-21-04022	Edging	2
21	7-75-01066	Spacer	2
22	2-00-04603	Clamp, 1/2 O.D. Double Hose	2
23	7-60-00160	Pulley, Cable	2
24	7-13-07130	Clip, Cable Retainer	2
25	2-00-02602	Screw, 3/8-16 x 3.25	2
26	2-00-00221	Bolt, 1/4-20 x .75 Fin. Hex Head	2
27	2-00-00641	Nut, 1/4-20 Insert Fiber	2
28	2-95-04182	Nut, 3/8-16 Hex Stop	2
29	8-40-05051	Headlight	2
30	2-00-04795	Screw, 10-24 x .75	8
31	2-00-00594	Nut, Hex. 1/4-20 x .437 x .218	4
32	7-10-00030	Cable, Side Broom	1

C1671 IC-revD/6-05

HOPPER ASSEMBLY cont. - EXPLODED VIEW

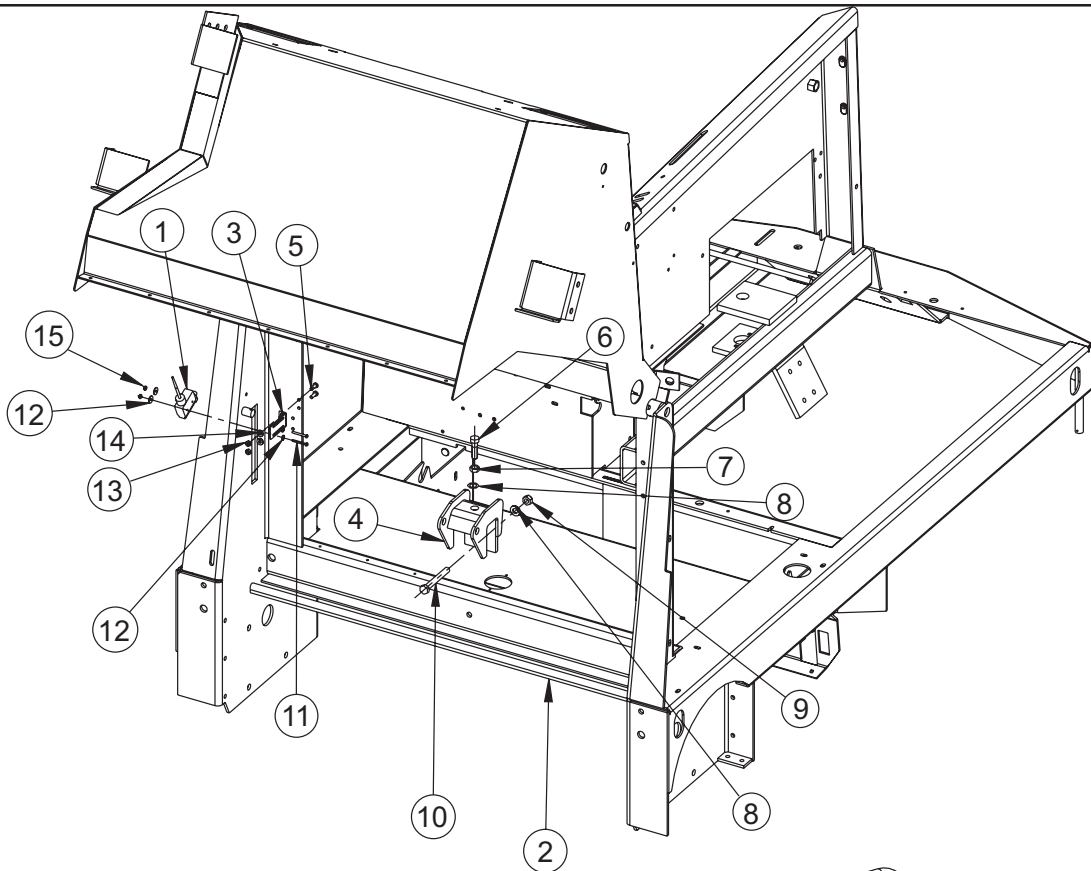

C1671 IC-revD

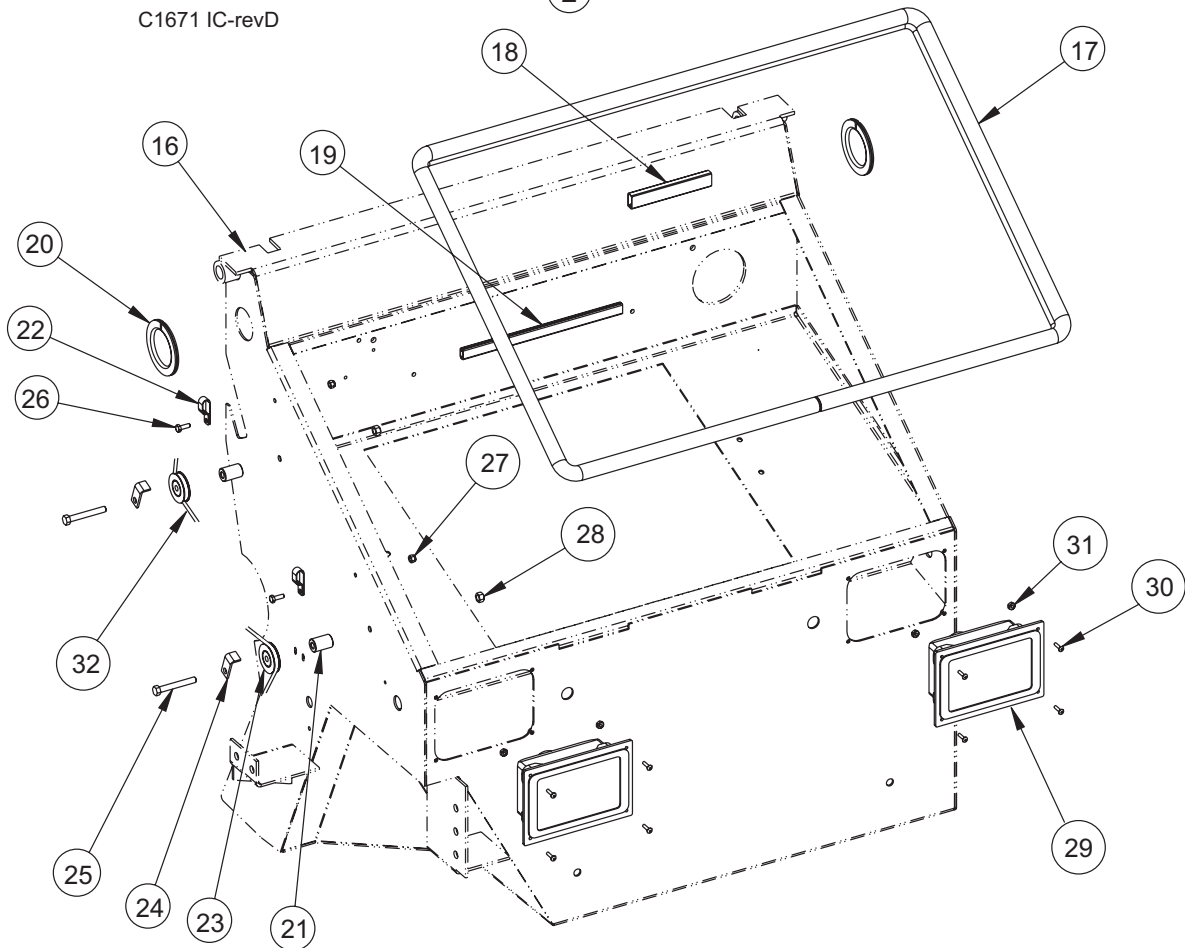

HOPPER LID/COVER

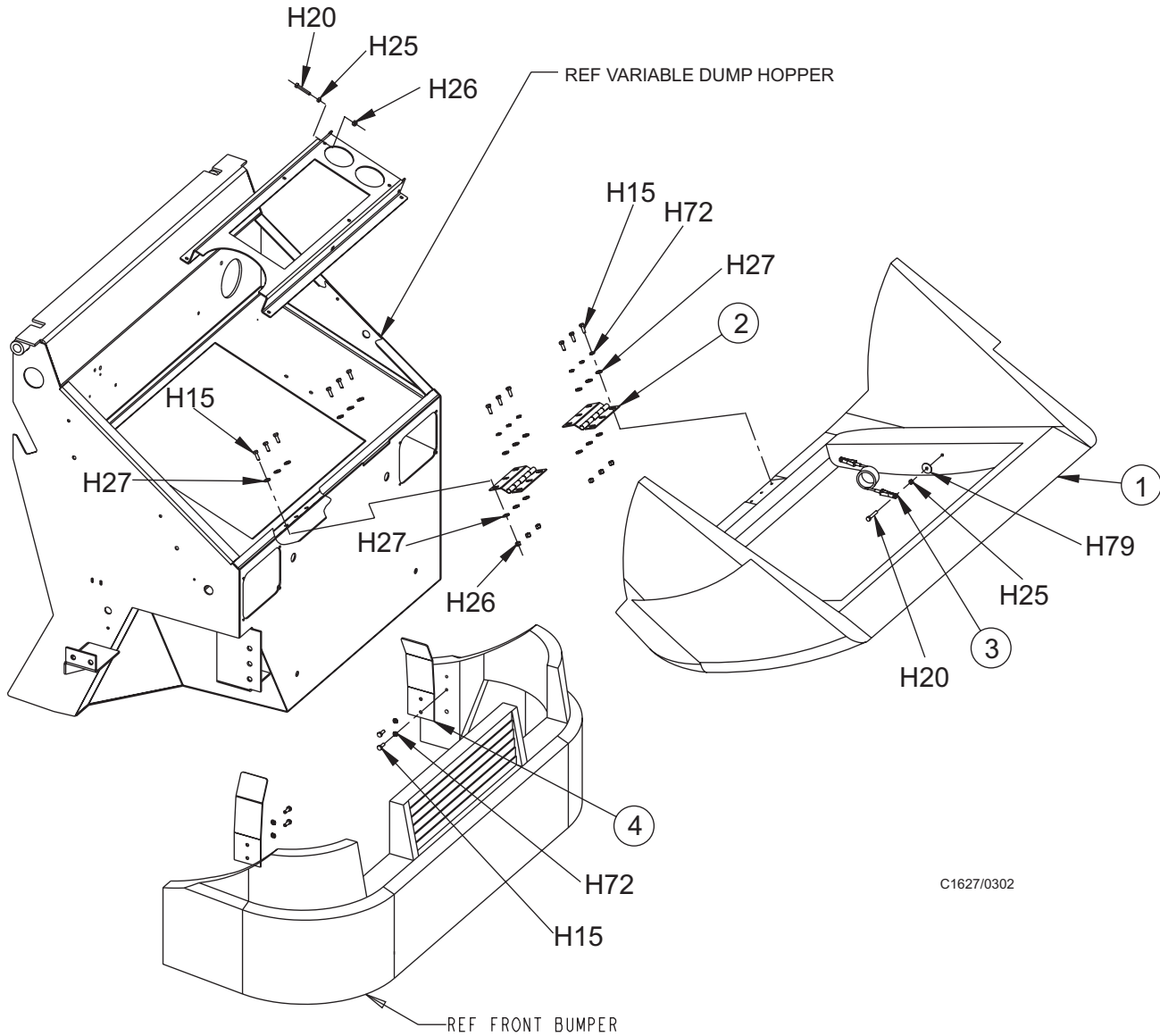

C1627/0302

<u>KEY NO.</u>	<u>PART NUMBER</u>	<u>DESCRIPTION</u>	<u>QTY.</u>
1*	7-16-07411	Cover, Hopper	1
2	7-32-00039	Hinge	2
3	8-10-00027	Cable	1
4	7-41-00035	Latch, Hopper Cover	2

HARDWARE USED:

H15	2-00-00221	Screw, 1/4-20 x .750 HHC	13
H20	2-00-00203	Screw, 1/4-20 x 1.500 HHC	2
H25	2-00-00594	Nut, Hex 1/4-20 x .437 x .218	2
H26	2-00-00641	Nut, 1/4-20 Insert Fiber	7
H27	2-00-03702	Washer, .625 x .218 x .063	18
H72	2-00-00518	Lock Washer, Helical Spring	10
H79	2-00-01676	Flat Washer, 1.062 x .265 x .062	1

*If you are ordering a replacement cover, you must also order: 1 of 8-18-00525 (American-Lincoln decal)

C1627/0302

HOPPER DUMP DOOR

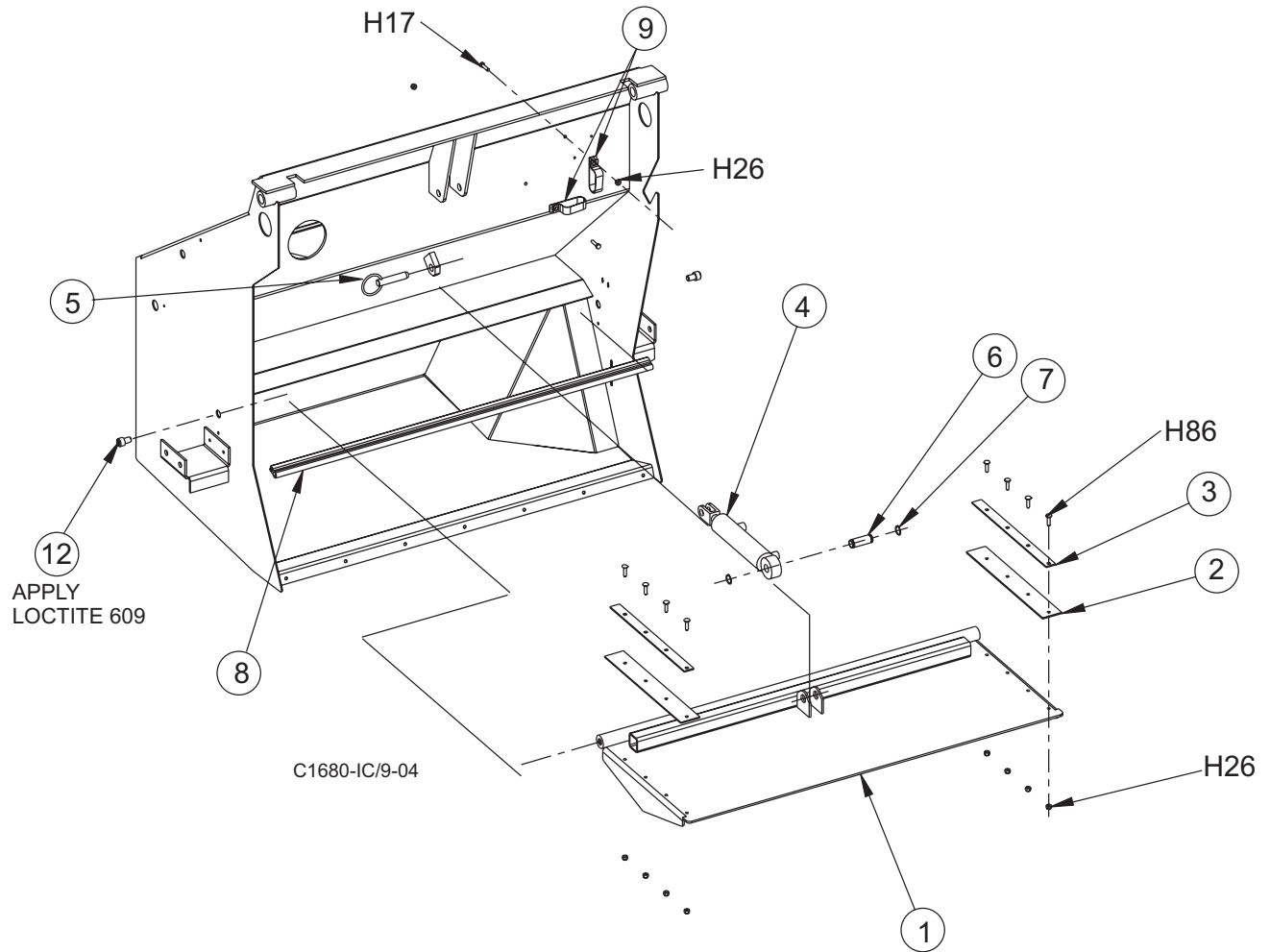

<u>KEY NO.</u>	<u>PART NUMBER</u>	<u>DESCRIPTION</u>	<u>QTY.</u>
1	7-19-08056	Door - Hopper (Welded)	1
2	8-68-05087	Seal - Dump Door	2
3	8-13-07140	Clamp - Door Seal	2
4	7-17-05011	Cylinder	Ref.
5	7-55-08121	Pin - Door Cylinder	1
6	8-55-08123	Pin - 3/7 Dia.	1
7	2-00-00540	Retaining Ring - 3/4 Dia.	2
8	7-29-00237	Gasket - Dump Door	1
9	2-00-04603	Clamp	2
12	7-23-03116	Screw, Special	2

HARDWARE USED:

H17	2-00-00205	Screw, 1/4-20 x 1.0 HHC	3
H26	2-00-00641	Nut, 1/4-20 Insert Fiber	10
H86	2-00-03575	Carriage Bolt, 1/4-20 x .75	8

C1680-IC/9-04

HOPPER DUMP DOOR CYLINDER

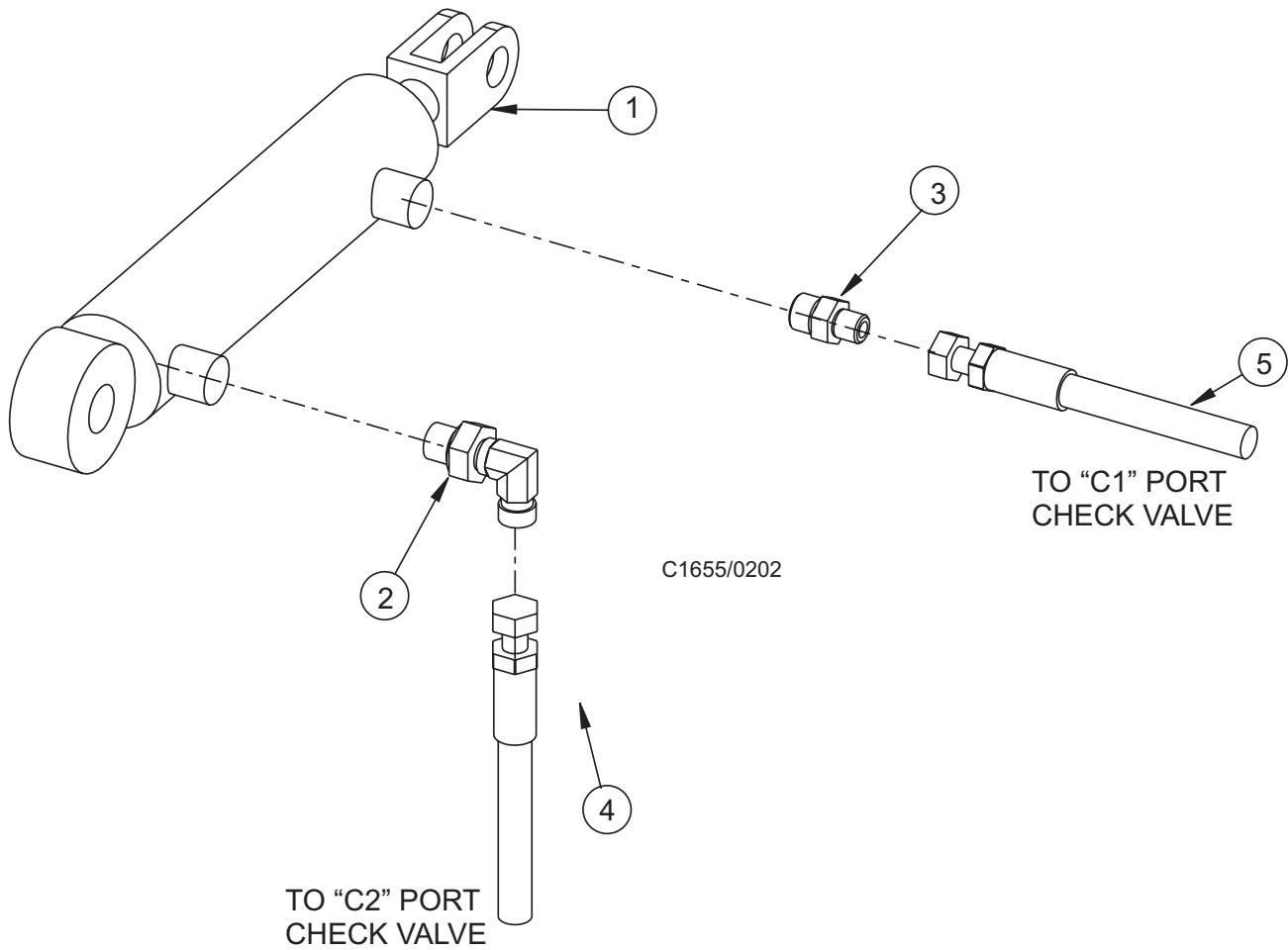

KEY NO.	PART NUMBER	DESCRIPTION	QTY.
1	7-17-05011 7-70-00021	Cylinder, Lift Cylinder Seal Kit (service part)	1
2	2-00-04926	#4 SAE to #4 ORS 90°	1
3	2-00-04895	#4 SAE to #4 ORS	1
4	7-33-02342	#4 Hose STR 92.5"	Ref
5	8-33-02216	#4 Hose STR 88.0"	Ref

C1655/0202

HOPPER CONTROL VALVE

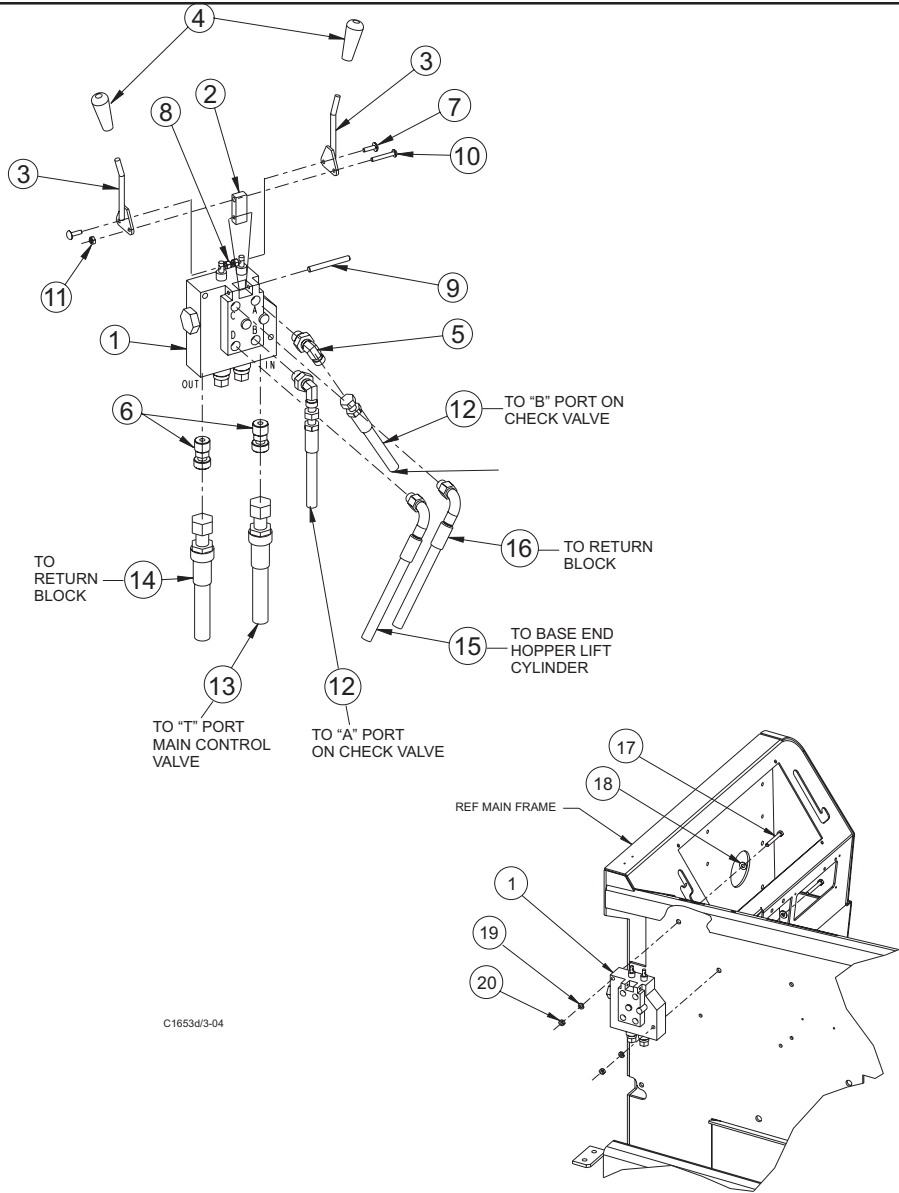

C1653d/3-04

<u>KEY NO.</u>	<u>PART NUMBER</u>	<u>DESCRIPTION</u>	<u>QTY.</u>
1	8-88-00053	Control Valve Assy.	1
	0880-367	Valve Seal Kit (service part)	
2	7-42-05127	Link, Valve Lever Pivot	1
3	7-41-05105	Lever (for valve 8-88-00053)	2
4	7-31-06059	Handle	2
5	2-00-04926	Fitting, 9/16-18 x 9/16-18 Elbow	2
6	2-00-04970	Fitting, #8 SAE 8 ORS Connector	2
7	2-00-03062	Screw, #10 - 24 x 5/8 LG	2
8	2-00-01246	Nut, #10-24 Elastic Stop	2
9	2-00-00868	Roll Pin (1/4 dia. x 7/8 lg.)	1
10	2-00-00074	Screw, #12-24. RH Philips, 1.25 LG	1
11	2-00-00637	Hex Nut, #12-24 Fiber Insert	1
12	7-33-02349	#4 Hose STR - 90° 11.75"	Ref.
13	7-33-02222	#8 Hose STR 26.0"	1
14	7-33-02298	#8 Hose STR 48.0"	1
15	7-33-02352	#4 Hose STR - 90° Swivel 71.0"	1
16	7-33-02350	#4 Hose STR - 90° Swivel 43.0"	1
17	2-00-02589	Screw, 1/4-20 x 2.0 HHC	2
18	2-00-03702	Washer, .625 x .281 x .063	2
19	2-00-00518	Lock Washer, Helical Spring	2
20	2-00-00594	Hex Nut, 1/4-20 x .437 x .218	2

C1653d/3-04

SCRUB DECK (46")

<u>KEY NO.</u>	<u>PART NUMBER</u>	<u>DESCRIPTION</u>	<u>QTY.</u>
1	0782-111	Motor, Hydraulic	Ref.
2	7-33-09031	Hub, Brush Drive	3
3	7-41-00027	Latch, Brush Drive	3
4	7-03-04123	Arm, Brush Drive	3
5	2-00-04851	Washer, Engine Mount	3

HARDWARE USED:

H15	2-00-00221	Screw, 1/4-20 x .750 HHC	3
H26	2-00-00641	Nut, 1/4-20 Insert Fiber	3
H39	2-00-00218	Screw, 5/16-18 x 2.000 HHC	3
H44	2-00-00530	Lock Washer, 5/16 HS Med.	3
H63	2-00-02312	Lock Washer, 1/2 HS Med.	6
H64	2-00-00596	Nut, Hex. 1/2-13 x .750 x .437	6
H213	2-00-01254	Screw, 1/2-13 x 1.500 HHCS	6

C1629b/0202

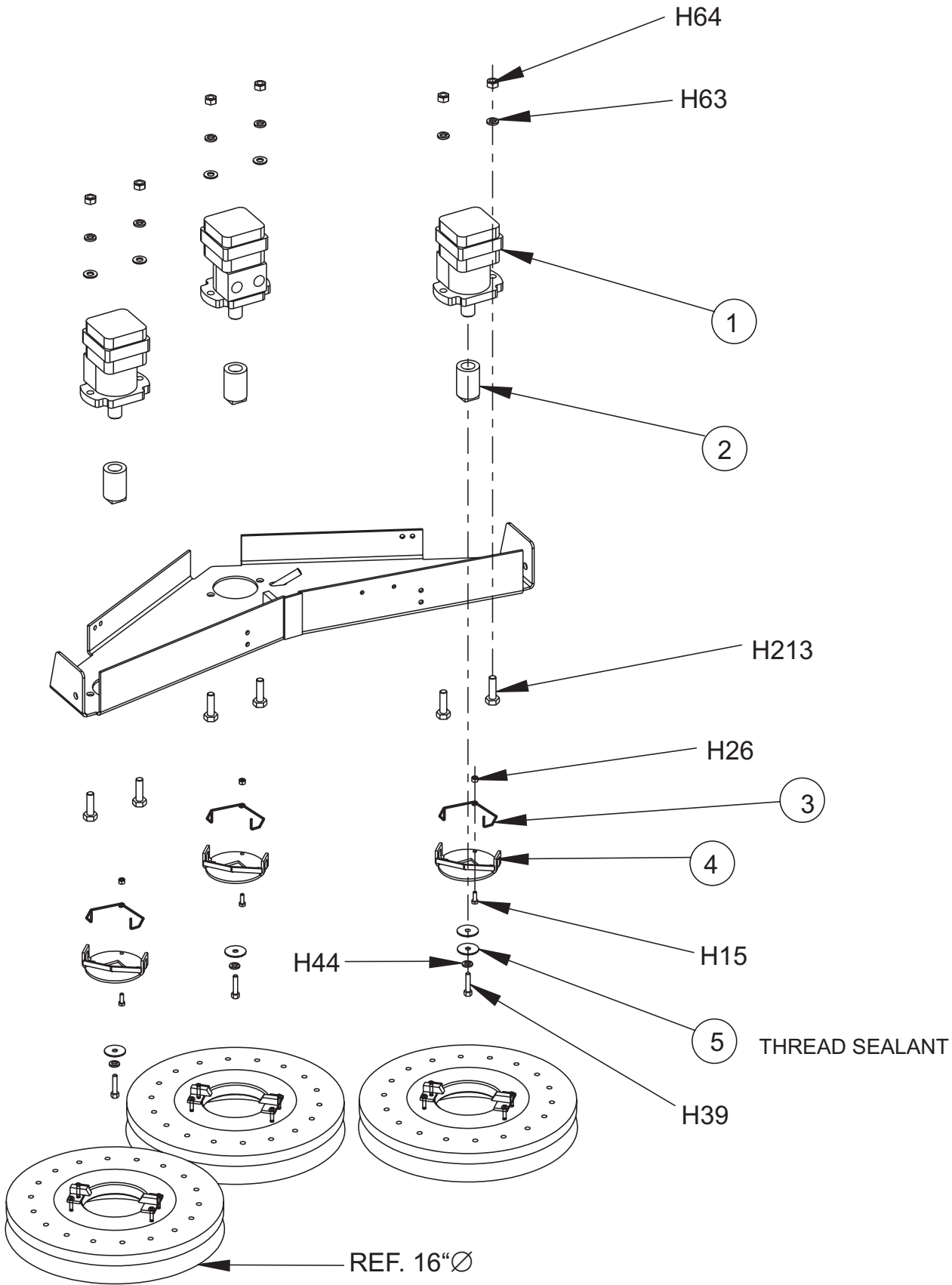

SCRUB DECK (46") - cont. - PARTS LIST

<u>KEY NO.</u>	<u>PART NUMBER</u>	<u>DESCRIPTION</u>	<u>QTY.</u>
1	7-27-07176	Brush Deck (Weldment)	1
2	7-42-05129	Link - Brush Drive	2
3	2-00-03407	Clamp	6
4	7-78-05026	Stop - Scrub Frame - RH	1
5	7-78-05025	Stop - Scrub Frame - LH	1
6	7-03-00055	Arm - Side Squeegee Lift - LH	1
7	7-03-00053	Arm - Side Squeegee Lift - RH	1
8	2-00-05378	Fitting - 90° Barb	1
9	7-08-00437	Welded Tee	1
10	7-25-02012	Fitting - Straight Barb	1
11	2-00-04487	Tee	1
12	2-00-05342	Fitting - Straight Barb	2
13	7-33-02339	Hose - 22"	1
14			
15	7-33-02360	Hose - 8"	1
16	7-33-02361	Hose - 17"	1

HARDWARE USED:

H26	2-00-00641	Nut, 1/4-20 Insert Fiber	2
H27	2-00-03702	Washer, .625 x .281 x .063	2
H35	2-00-02708	Screw, 5/16-18 x 1.000 HHM	8
H43	2-00-00409	Flat Washer, .687 x .344 x .062	10
H46	2-00-00644	Nut, 5/16-18 Insert Fiber	8
H57	2-00-00240	Screw, 1/2-13 x 1.250 HHC	4
H65	2-00-04936	Nut, 1/2-13 Fiber Lock	4
H229	2-00-01490	Screw, 1/4-20 x .875 HHC STL	2

C1629/0202

SCRUB DECK (46") - cont. - EXPLODED VIEW

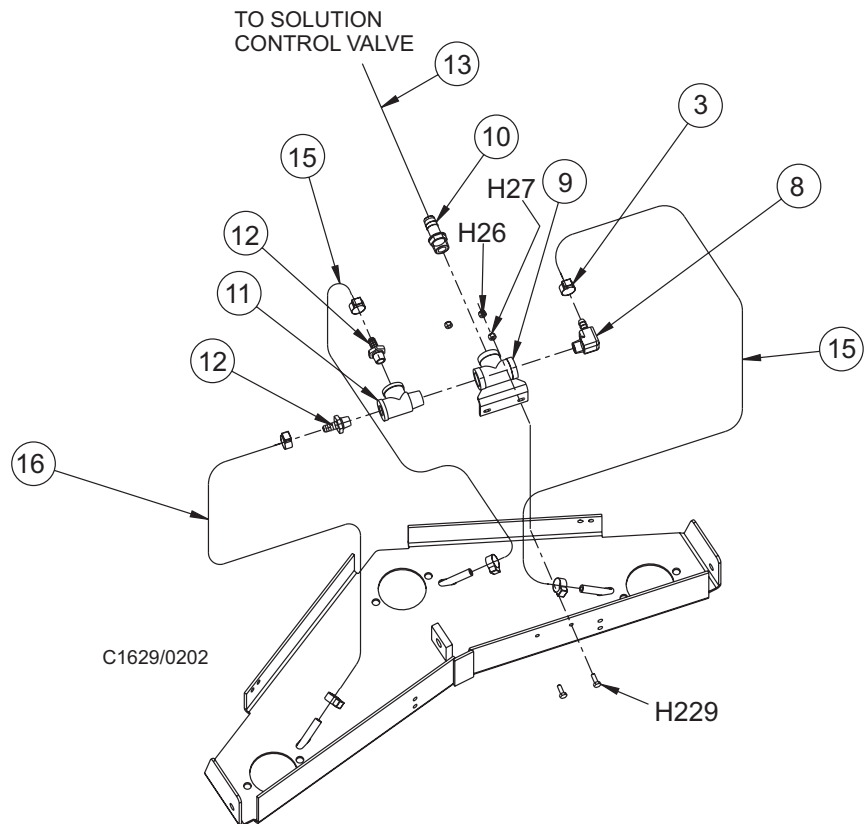
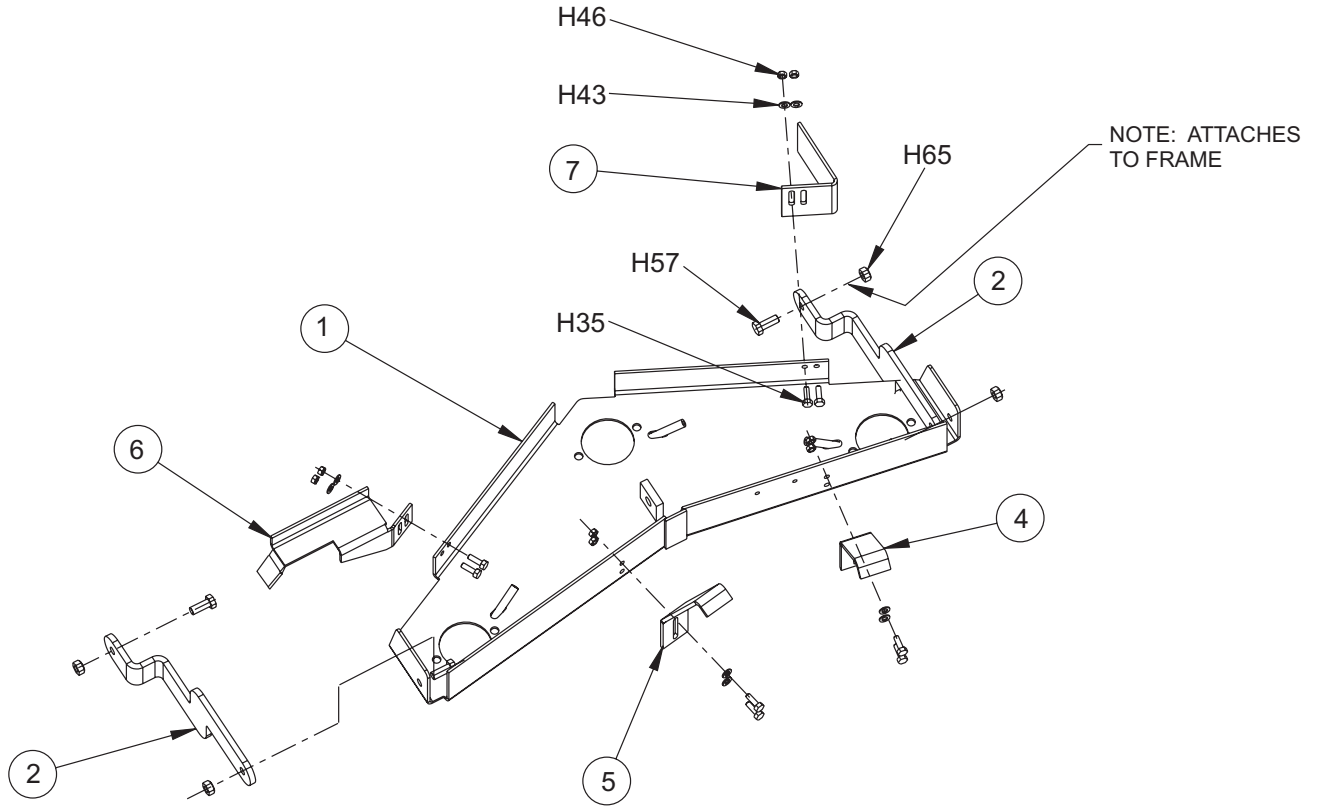

SCRUB DECK & SQUEEGEE (53") - PARTS LIST

<u>KEY NO.</u>	<u>PART NUMBER</u>	<u>DESCRIPTION</u>	<u>QTY</u>
1	7-27-07181	Brush Deck (Weldment)	1
2	7-42-05135	Link-Brush RH	1
3	7-57-05039	Pivot Brush Drive	2
4	7-42-05134	Link- Brush Frame LH	1
5	7-42-05132	Link- Side Squeegee	2
6	7-76-00114	Spring	1
7	7-30-08016	Guide-Brush Frame Arm	1
8	2-00-03407	Clamp	6
9	2-00-05378	Fitting-90° Barb	1
10	7-08-00437	Welded Tee	1
11	7-25-02012	Fitting-Straight Barb	1
12	2-00-04487	Tee	1
13	2-00-05342	Fitting-Straight Barb	2
14	7-33-02339	Hose-22"	1
15	7-33-02360	Hose- 8"	2
16	7-33-02361	Hose- 17"	1

HARDWARE USED:

H15	2-00-00221	Screw, 1/4-20 x .750 HHC	2
H26	2-00-00641	Nut, 1/4-20 Insert Fiber	2
H34	2-00-00208	Screw, 5/16-18 x .750 HHC	2
H35	2-00-02708	Screw, 5/16-18 x 1.000 HHM	4
H43	2-00-00409	Flat Washer, .687 x .344 x .062	4
H44	2-00-00530	Lock Washer, 5/16 HS Med	2
H46	2-00-00644	Nut, 5/16-18 Insert Fiber	4
H48	2-00-00233	Screw, 3/8-196 x .750 HHC	2
H58	2-00-00241	Screw, 1/2-13 x 1.750 HHC	2
H65	2-00-04936	Nut, 1/2-13 Fiber Lock	2
H236	2-00-02369	Nut, Hex Jam, .38-16	2
H260	2-00-00615	Nut, Hex Finish .63-22	2
H262	2-00-00617	Nut, Hex Finish .75-16	1
H263	2-00-02313	Lock Washer, Helical Spring .63 Scr Med	2
H264	2-00-02622	Screw-HHC .625-11 x 2.5 Gl 5 Zinc	2

C1602b/9804

SCRUB DECK & SQUEEGEE (53") - EXPLODED VIEW

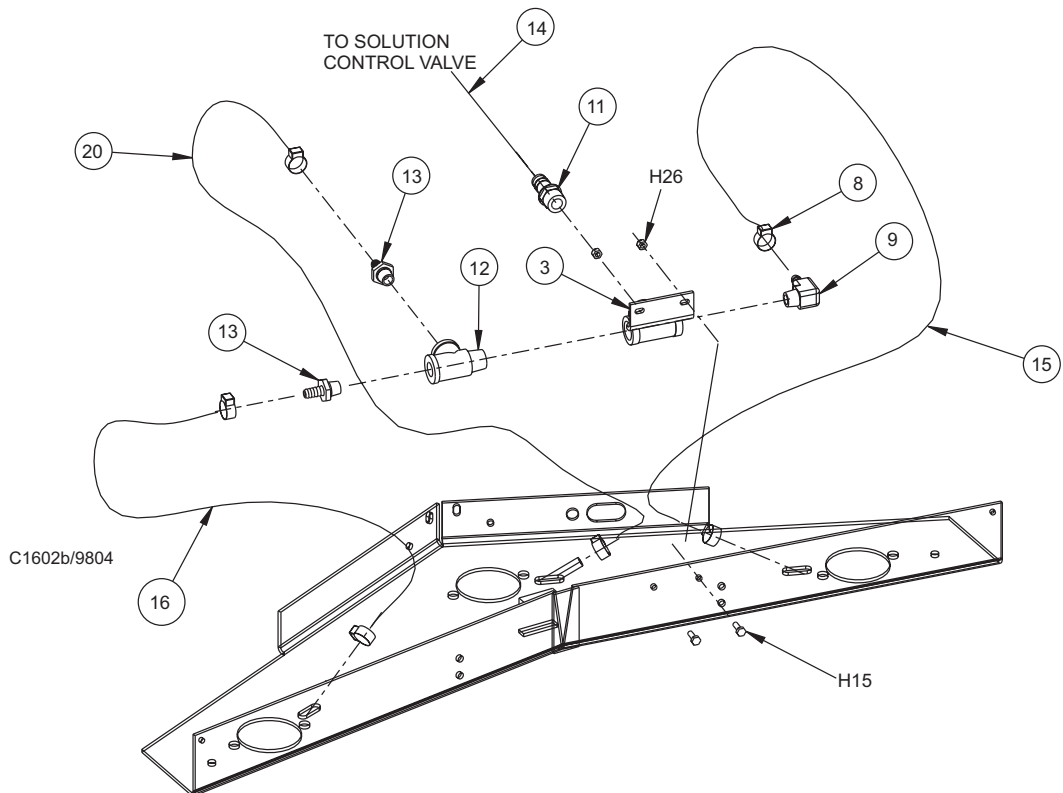
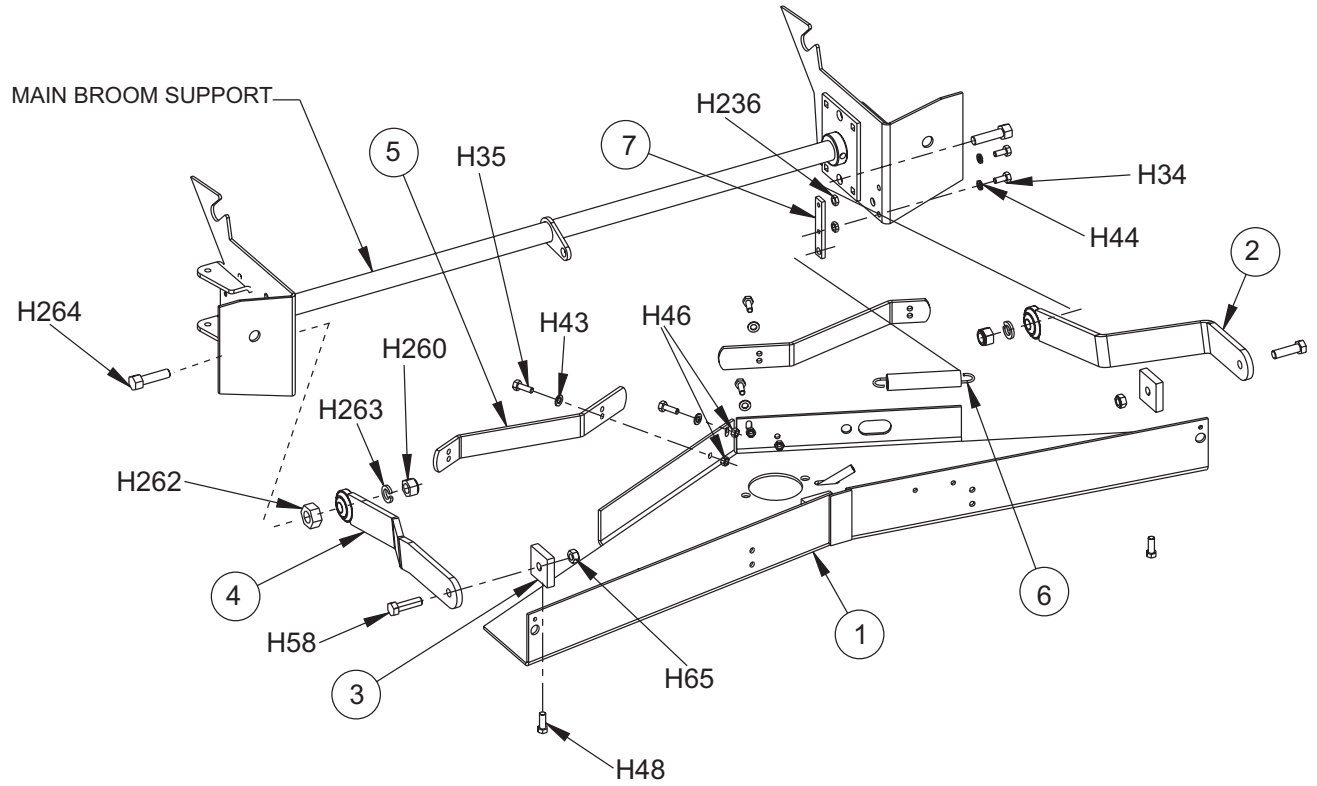

SCRUB DECK & SQUEEGEE (53") - cont. - PARTS LIST

<u>KEY NO.</u>	<u>PART NUMBER</u>	<u>DESCRIPTION</u>	<u>QTY</u>
1	0782-111	Motor, Hydraulic	Ref.
2	7-33-09031	Hub, Brush Drive	3
3	7-41-00027	Latch, Brush Drive	3
4	7-03-04123	Arm, Brush Drive	3
5	2-00-00868	Roll Pin	2
6	7-78-05026	Stop- Scrub Frame-RH	1
7	7-78-05031	Stop- Scrub Frame-LH	1
8	7-86-08042	LH Side Squeegee Tool	1
9	7-86-08043	RH Side Squeegee Tool	1
10	7-77-00113	Rubber Inner Side Squeegee	2
11	7-77-00112	Rubber Outer Side Squeegee	2
12	7-13-07175	Clamp RH Side Squeegee	1
13	7-13-07174	Clamp RH Side Squeegee	1
14	7-55-08151	Pin, Lock	2

HARDWARE USED:

H15	2-00-00221	Screw 1/4-20 x .750 HHC	15
H26	2-00-00641	Screw, 1/4-20 x .750 HHC	3
H27	2-00-03702	Washer, .625 x .281 x .063	12
H38	2-00-00225	Screw, 5/16-18 x 1.500 HHC	3
H44	2-00-00530	Lock Washer, 5/16 HS Med	3
H46	2-00-00644	Nut, 5/16-18 Insert Fiber	2
H63	2-00-02312	Lock Washer, 1/2 HS Med	6
H64	2-00-00596	Nut, Hex 1/2-13 x .750 x .437	6
H72	2-00-00518	Lock Washer, Helical Spring	12
H178	2-00-00206	Screw, 5/16-18 x 1.000 HHC	2
H213	2-00-01254	Screw, 1/2-13 x 1.500 HHCS	6
H229	2-00-01490	Screw, .25-20 x .875 HHC STL	12

C1602c/0302

SCRUB DECK & SQUEEGEE (53") - EXPLODED VIEW

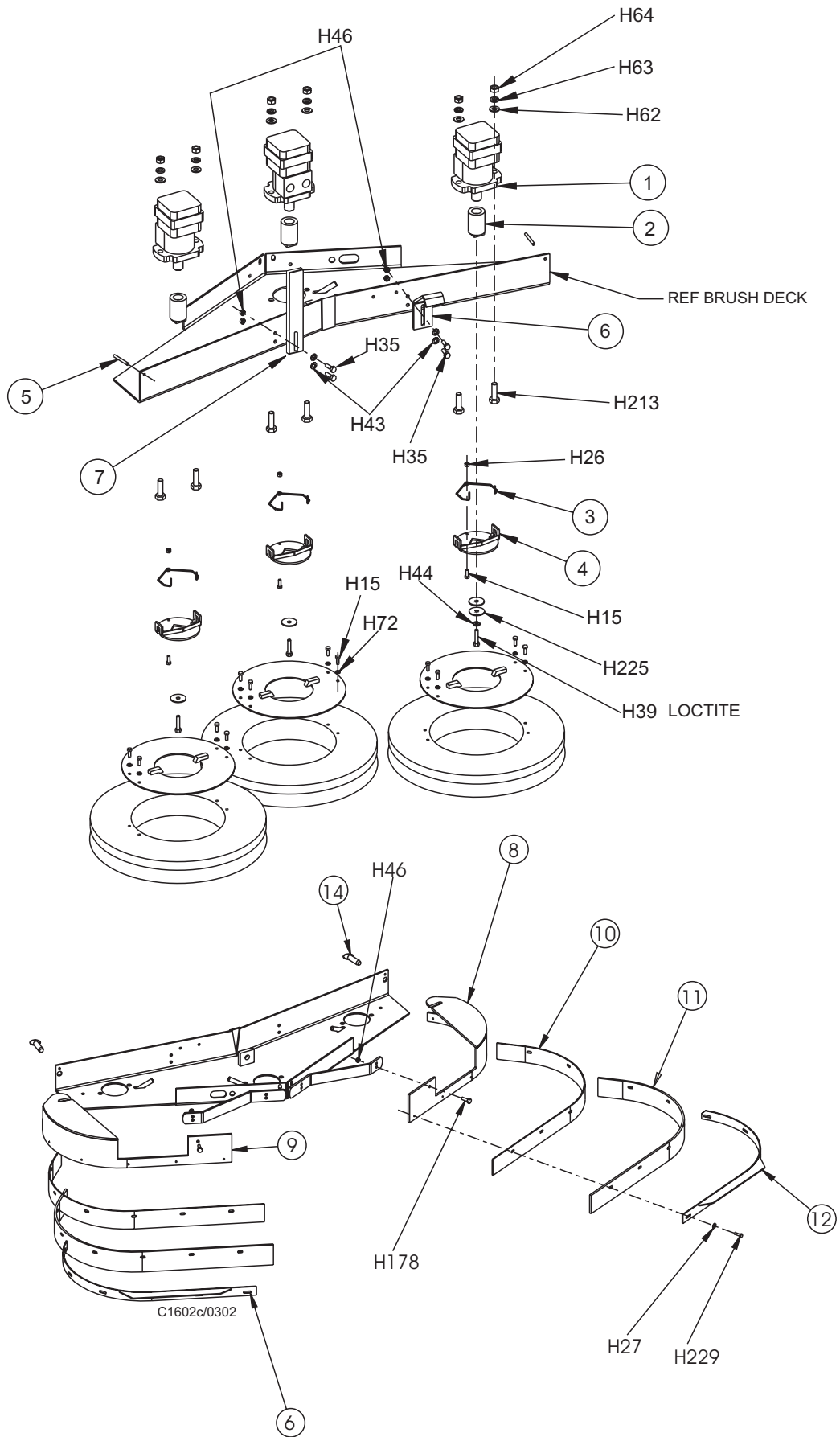

SIDE SQUEEGEE (46")

<u>KEY NO.</u>	<u>PART NUMBER</u>	<u>DESCRIPTION</u>	<u>QTY.</u>
1	7-86-08035	Weldment - LH Bracket	1
2	7-77-00111	Squeegee - Rubber - Side	1
3	7-13-07165	Strap	1
4	2-00-05320	Hair Pin	1
5	7-77-00114	Rubber Side Squeegee	1
6	7-57-05042	Pivot, Side Squeegee	2
7	7-55-08151	Lock Up Pin	1
8	7-86-08036	Weldment - RH Bracket	1

HARDWARE USED:

H17	2-00-00205	Screw, 1/4-20 x 1.250 HHC	12
H26	2-00-00641	Nut, 1/4-20 Insert Fiber	12
H27	2-00-03702	Washer, .625 x .281 x .063	12
H35	2-00-02708	Screw, 5/16 - 18 x 1.00 HHM	4
H43	2-00-00409	Flat Washer, .687 x .344 x .062	4
H46	2-00-00644	Nut, 5/16 - 18 Insert Fiber	4
H62	2-00-00405	Flat Washer, 1.063 x .531 x .094	2

C1606/0202

SIDE SQUEEGEE (46")

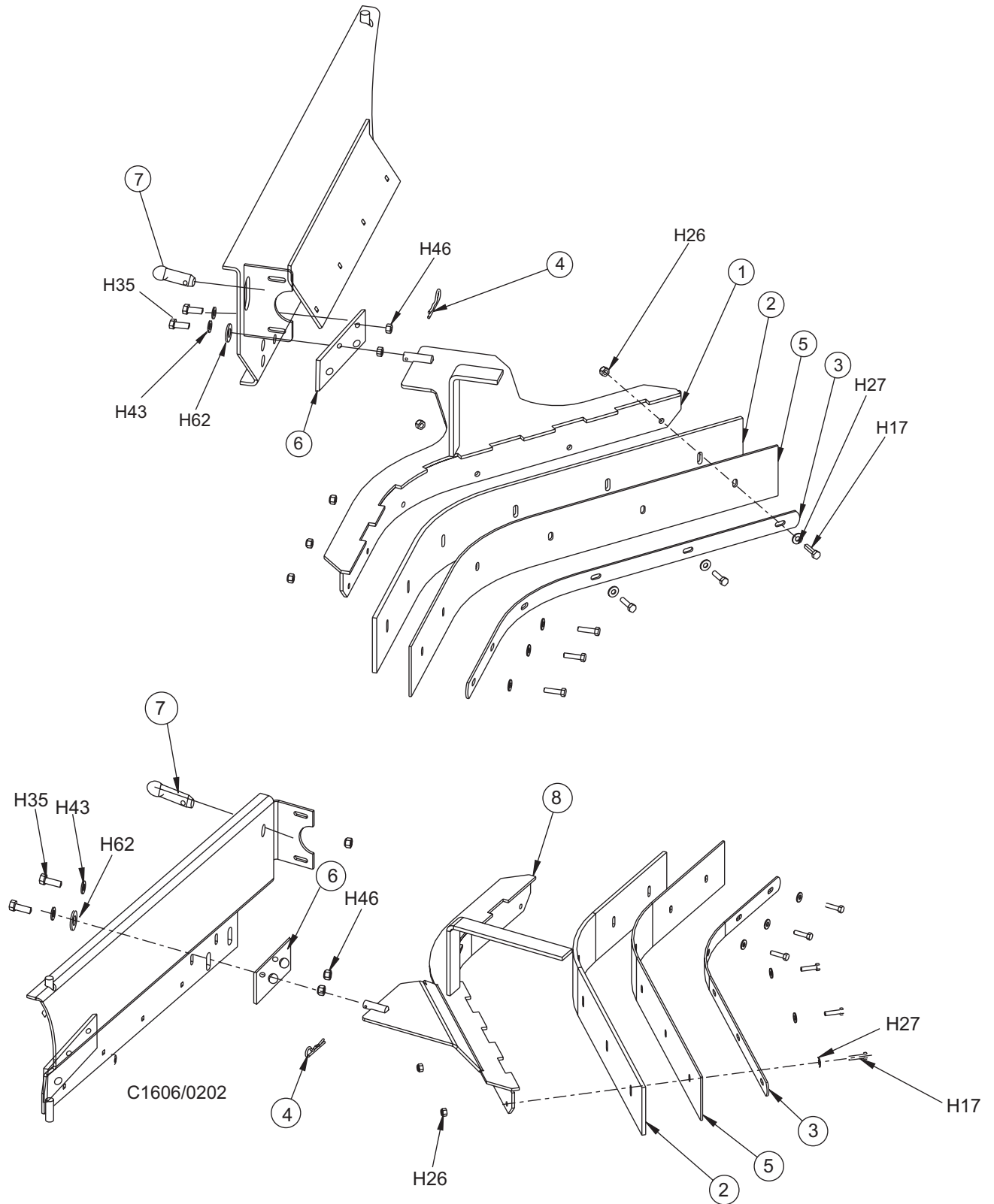

REAR SQUEEGEE (46")

<u>KEY NO.</u>	<u>PART NUMBER</u>	<u>DESCRIPTION</u>	<u>QTY.</u>
1	7-86-08038	Squeegee - Weldment	1
2	7-20-06010	Duct - Squeegee Inlet	1
3	7-75-01164	Spacer - Bushing	2
4	7-75-01169	Spacer - Squeegee	2
5	7-77-00110	Squeegee - Rubber - Inner	1
6	7-77-00109	Squeegee - Rubber - Outer	1
7	7-79-00088	Strap - Squeegee Clamp	1
8	7-13-07157	Clamp - End Squeegee	2
9	7-13-07156	Clamp - Nut	2
10	7-39-00026	Knob - Squeegee	4
11	7-89-08073	Wheel - Caster	2
12	2-14-00184	Wheel	2
13	2-00-04962	O-Ring	2
14	2-00-05343	Carriage Bolt, 3/8-16 x 3.000 STL.	2
15	2-00-05344	Hex Tap Bolt, 5/16-18 x 1.750 SS	2
16	2-00-00615	Nut, Hex Finish .625-11	2
HARDWARE USED:			
H51	2-00-00216	Screw, 3/8-16 x 2.000 HHC	2
H52	2-00-00402	Flat Washer, .750 x .390 x .094	4
H54	2-00-02360	Nut, Hex. 3/4-16 STL.	2

C1677/9802

REAR SQUEEGEE (46")

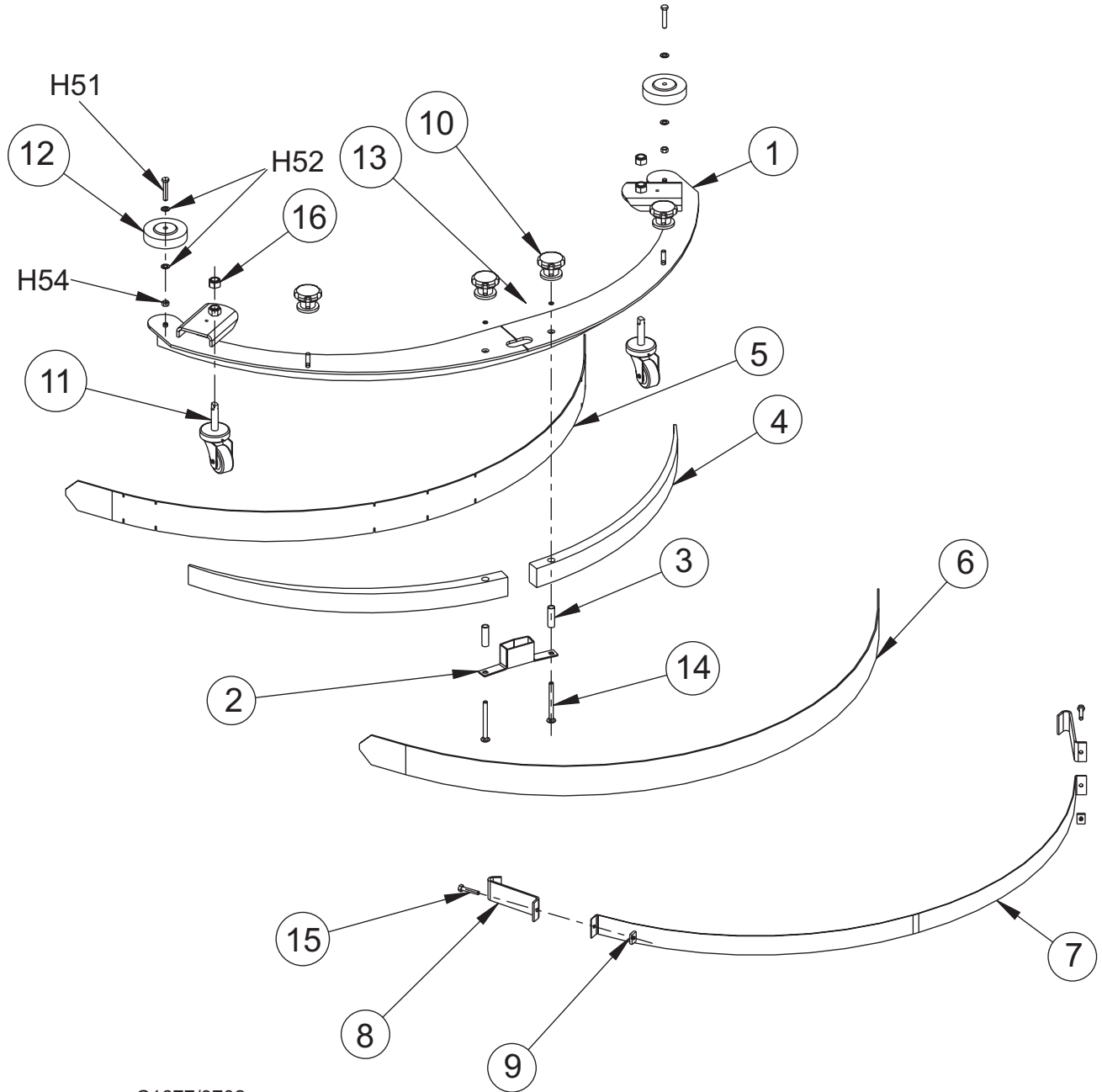

C1677/9702

SQUEEGEE LIFT - PARTS LIST

<u>KEY NO.</u>	<u>PART NUMBER</u>	<u>DESCRIPTION</u>	<u>QTY.</u>
1	7-41-05107	Lever , Squeegee Lift	1
2	7-17-05019	Hydraulic Cylinder	1
	0780-402	Cylinder Seal Kit (service part)	
3	2-00-03293	Hex Nut, 3/4-10 Finished	1
4	2-00-03296	Screw, 3/8-16 x 4.000 HHC	1
5	2-00-00522	Lock Washer, 3/4 Helical Spring	1
6	7-15-01022	Collar, Setscrew	2
7	7-66-00179	Rod	1
8	7-09-01138	Bushing	1
9	2-95-04182	Nut, 3/8-16 Elastic Stop	1
10	2-00-00432	Flat Washer, 1.125 x .766 x .063	2
11	7-25-02101	Fitting, Recovery Tank Dual Port	REF
12	2-00-00196	Carriage Bolt, 5/16-18 x 1.000	1
13	2-00-02216	Clamp, Hose	1
14	7-13-05076	Chain, Squeegee Lift	2
15	7-13-05082	Chain, Squeegee Lift	1
16	2-00-00409	Flat Washer, .687 x .344 x .062	7
17	2-00-00644	Nut, 5/16-18, Insert Fiber	4
18	2-00-00585	Hex Nut, 5/16-18	2
19	2-00-00225	Screw, 5/16-18 x 1.50 HHC	2
20	2-00-02708	Screw, 5/16-18 x 1.00 HHM	1
21	7-33-02599	Hose, Rear Squeegee Vacuum	1

C1630b/0603

SQUEEGEE LIFT - EXPLODED VIEW

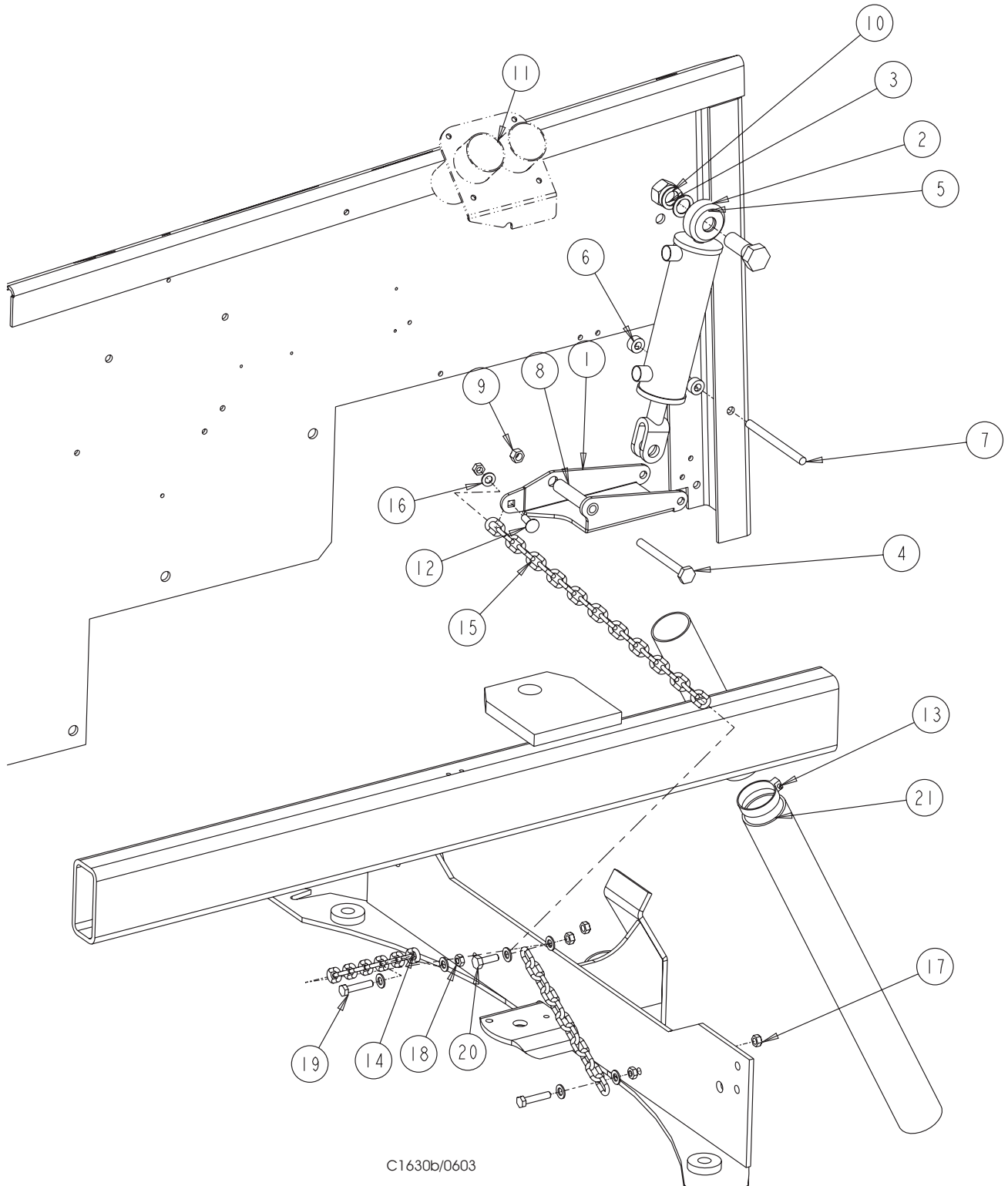

C1630b/0603

SWING SQUEEGEE SUPPORT - PARTS LIST

<u>KEY NO.</u>	<u>PART NUMBER</u>	<u>DESCRIPTION</u>	<u>QTY.</u>
1	7-08-00853	Weldment, Bracket, RH Assembly	1
2	7-08-00852	Weldment, Bracket, LH Assembly	1
3	7-70-05174	Shaft	2
4	8-15-01002	Collar, Setscrew	6
5	7-81-00185	Support, Squeegee	2
6	7-03-04156-1	Arm, Squeegee	4
7	7-55-08144	Weldment, Rear Pin Assembly	2
8	7-86-08068	Squeegee Support (Weldment)	1
9	7-08-00839	Bracket, Angle	2
10	7-76-00114	Spring	2
11	2-95-04182	Nut, 3/8-16 Elastic Stop	12
12	7-13-07104	Clamp, Hose	1
13	7-09-01057	Bushing, Brush Lift	8
14	7-89-08073	Caster	1

HARDWARE USED:

H38	2-00-00225	Screw, 5/16-18 x 1.500 HHC	2
H43	2-00-00409	Flat Washer, .687 x .344 x .062	4
H45	2-00-00585	Hex Nut, 5/16-18 x .500 x .265	4
H46	2-00-00644	Nut, 5/16-18, Insert Fiber	8
H49	2-00-00209	Screw, 3/8-16 x 1.250 HHC	8
H50	2-00-00234	Screw, 3/8-16 x 1.500 HHC	4
H94	2-00-00410	Flat Washer, .875 x .375 x .060	1
H150	2-00-00211	Screw, 5/16-18 x 1.750 HHC	2
H237	2-00-05356	Screw, 5/16-18 x 1.25 Grade 8	8

C1669/0202

SWING SQUEEGEE SUPPORT - EXPLODED VIEW

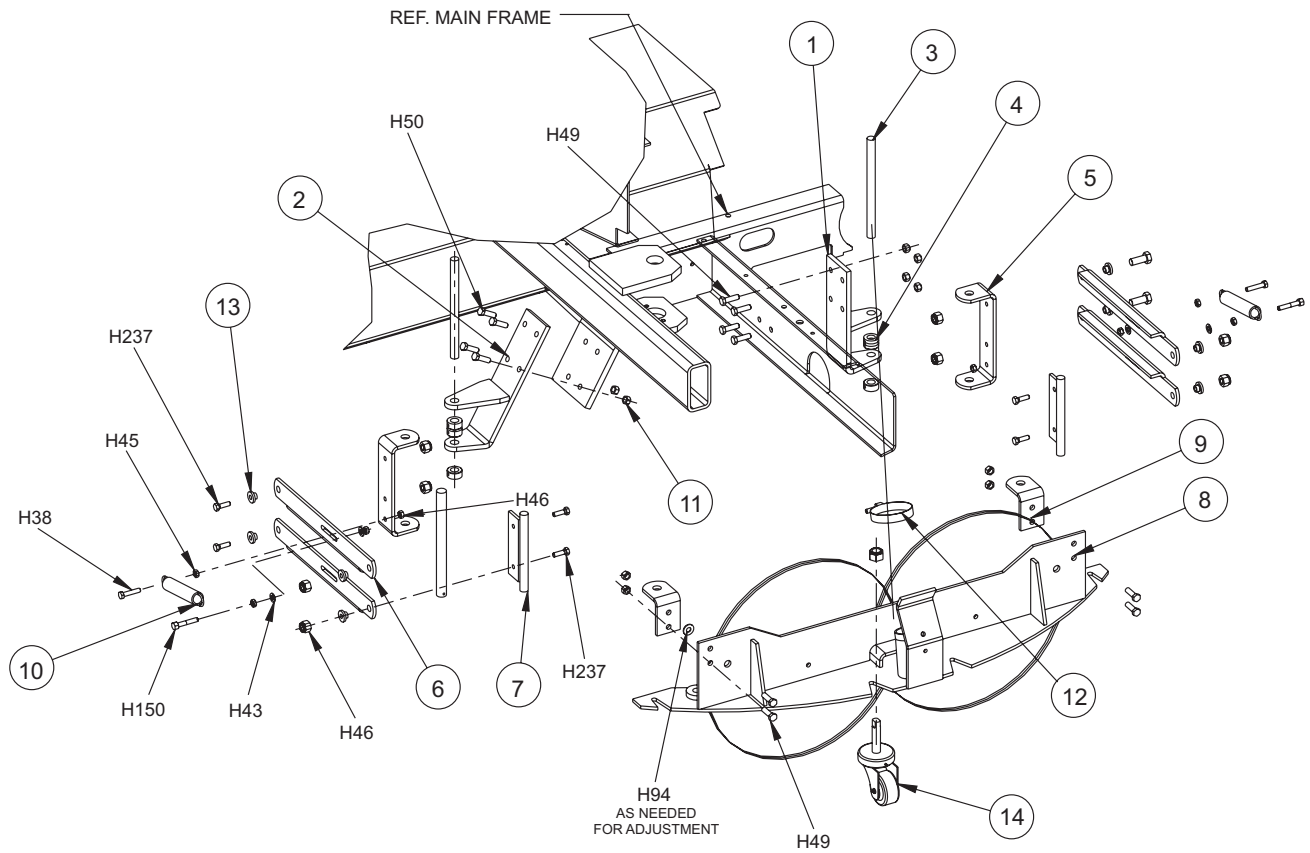

SOLUTION TANK - PARTS LIST

<u>KEY NO.</u>	<u>PART NUMBER</u>	<u>DESCRIPTION</u>	<u>QTY.</u>
1*	7-83-04206	Solution Tank	1
2	0775-217	Solution Float (Yellow)	1
3	7-09-01124	Bulk Head Fitting	1
4	7-24-04034	Strainer	1
5	2-95-03047	Washer	1
6	2-00-05132	90° Barb Fitting	1
7	7-57-05037	Bracket	1
8	2-00-02220	Hose Clamp	1
9	7-25-02095	Drain Plug	1
10	7-87-02188	Tube - Float Switch	1
11	2-00-05028	Gasket	2
12	7-29-00225	Gasket	2
13	7-09-01122	Bushing	1
14	7-30-05099	Guard - Solution Tank	1
15	2-95-02518	Pipe Nipple, Close 3/4 NPT	1
16	7-29-00225	Gasket	1
17	2-95-03047	Washer	3
18	2-00-00222	Screw, 1/4-20 x 1.25 HHM	2
19	2-00-00594	Nut, Hex 1/4-20 x .437 x .218	2
20	2-00-03702	Washer, .625 x .281 x .063	4
21	2-00-04687	Lock Washer, Helical Spring ¼ Med.	1
22	2-00-04688	Nut, 1/4-20 Hex.	1
23	2-00-00232	Screw, .375-16 x .75 HHC	2
24	2-00-02310	Lock Washer, Helical Spring 3/8 Med.	2
25	2-00-00518	Lock Washer, Helical Spring	2
26	2-00-00402 (if needed)	Flat Washer, .750 x .391 x .093	1
27	2-00-04851	Washer, Engine Mount	1
28	2-00-05122	Screw-HHC, .25-20 x 2.00	1
29	2-00-04590	Washer	2
30	2-00-05236	Flat Washer, 2.00 x .281 x .063	2

*If you are ordering a replacement tank, you must also order the following:

- 1 of 8-18-00539 (SC7750 decal)(provides 2)
- 2 of 8-18-00524 (American-Lincoln decal)

C2182/0903

SOLUTION TANK - EXPLODED VIEW

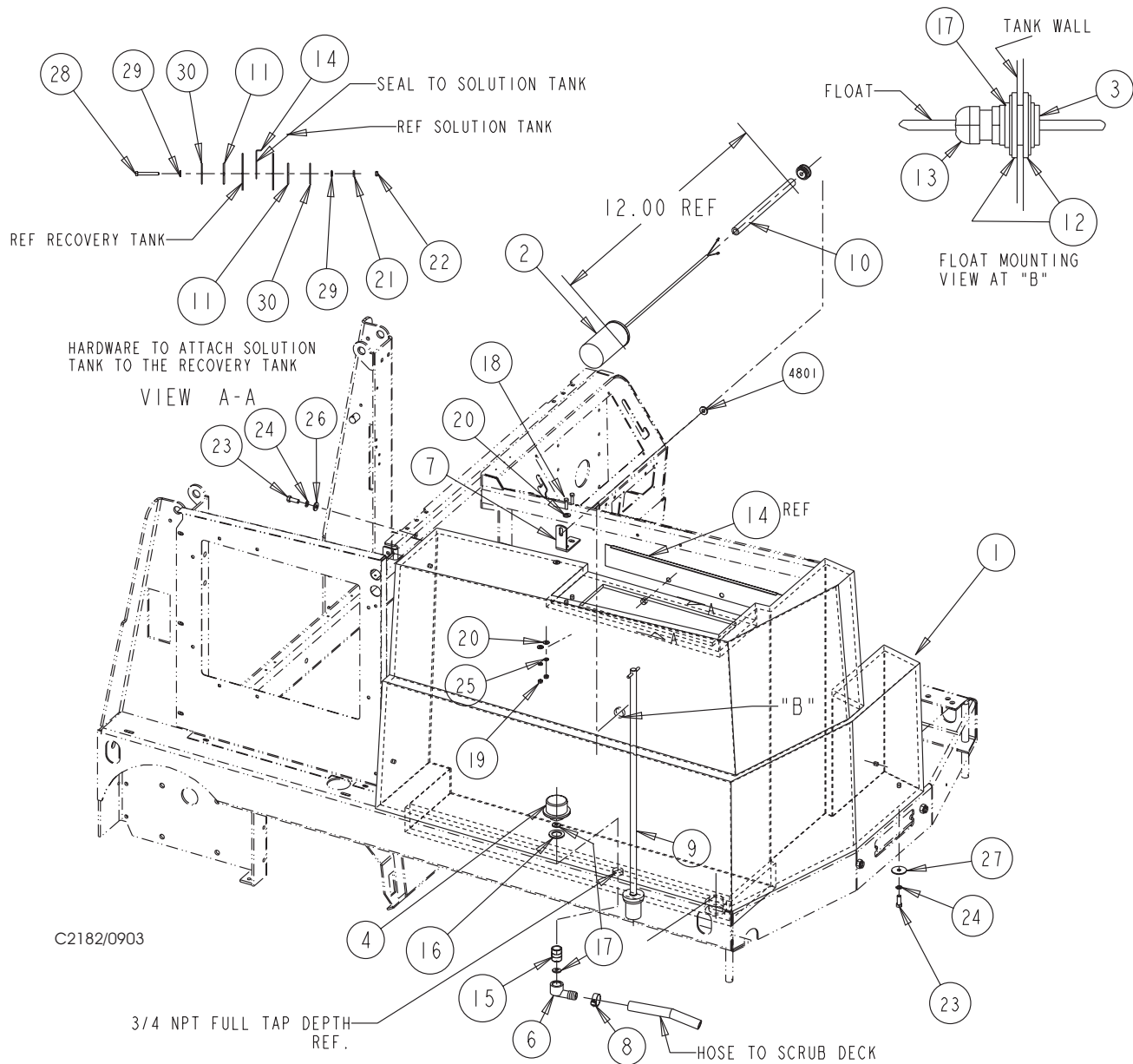

C2182/0903

SOLUTION FEED - PARTS LIST

<u>KEY NO.</u>	<u>PART NUMBER</u>	<u>DESCRIPTION</u>	<u>QTY.</u>
1	7-08-00922	Bracket- Solution Pipe	1
2	7-25-02012	Fitting - Hose to ¾ - 14 NPT	2
3	7-33-02339	Hose - Solution Feed	1
4	2-00-03586	Pipe Nipple ¾ NPT x 2.00	1
5	7-88-00027	Ball Valve	1
6	2-00-02220	Hose Clamp	1
7	7-41-05085	Lever	1
8	2-00-03382	Spring Washer	2
9	7-09-01057	Bushing	3
10	7-42-05128	Link	1
11	7-41-05108	Lever Assembly	1
12	8-39-00002	Knob	1
13	7-33-02339	Hose-Solution Feed	1
14	2-00-02475	Plug	1
HARDWARE USED:			
H17	2-00-00205	Screw, ¼ - 20 x 1000 HHC	2
H26	2-00-00641	Nut, ¼ -20 Insert Fiber	2
H27	2-00-03702	Washer, .625 x .281 x .063	2
H37	2-00-00207	Screw, 5/16 -18 x 1.250 HHC	2
H43	2-00-00409	Flat Washer, .687 x .344 x .062	7
H46	2-00-00644	Nut, 5/16-18 Insert Fiber	3
H150	2-00-00211	Screw, 5/16 - 20 x 1.750 HHC	1

C1668ecp/2-04

SOLUTION FEED - EXPLODED VIEW

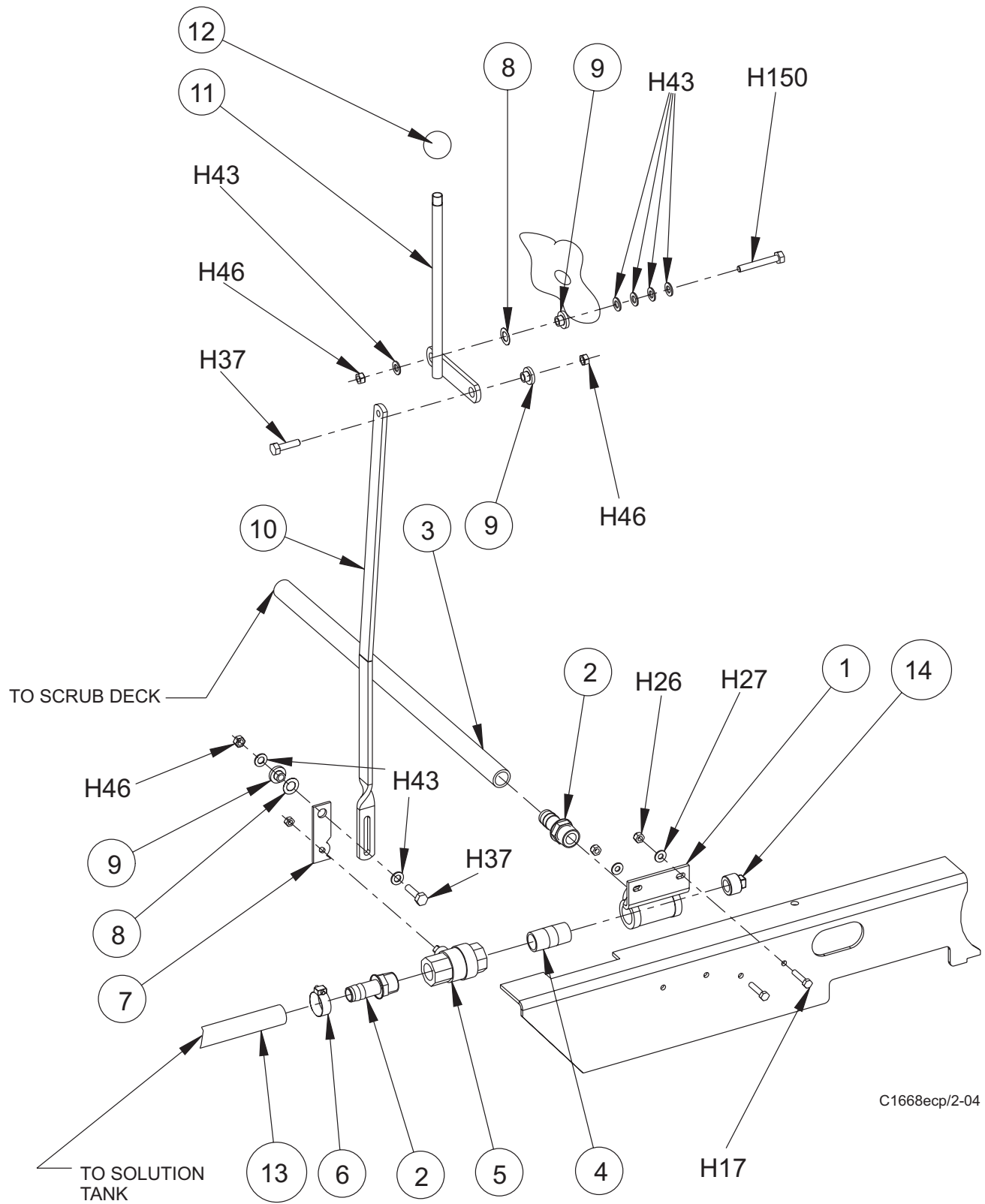

RECOVERY TANK

<u>KEY NO.</u>	<u>PART NUMBER</u>	<u>DESCRIPTION</u>	<u>QTY</u>
1*	7-83-04223	Recovery Tank	1
2	7-32-00048	Hinge, Tank Lid	1
3	7-48-00048	Lid, Vacuum	1
4	7-31-06082	Handle, Cover	1
5	2-00-02216	Clamp, Hose	1
6	7-62-05119	Cage, 4" Float	1
7	7-62-05120	Cage, 4" Float	1
8	7-26-04010	Ball, 4" Float	1
9	2-00-00519	Lock Washer, #10-24 Helical Spring	4
10	2-00-00049	Screw, 10-24 x .50 ZN PL	4
11	7-29-00297	Gasket, Tank Lid	1
12	7-09-01155	Bushing, Hinge Pivot	1
13	2-00-00591	Nut, 1/2-20 Hex Jam	1
14	2-00-00641	Nut, 1/4-20 Fiber Insert	10
15	7-29-00298	Gasket, Recovery Tank	1
16	2-00-03041	Screw, HSHC, 1/4-20 x 1.25 LG	10
17	2-00-03702	Washer, .625 x .281 x .063	10

*If you are ordering a replacement tank, you must also order the following:

- 1 of 8-18-00539 (SC7750 decal)(provides 2)
- 2 of 8-18-00524 (American-Lincoln decal)

C1670h/0803

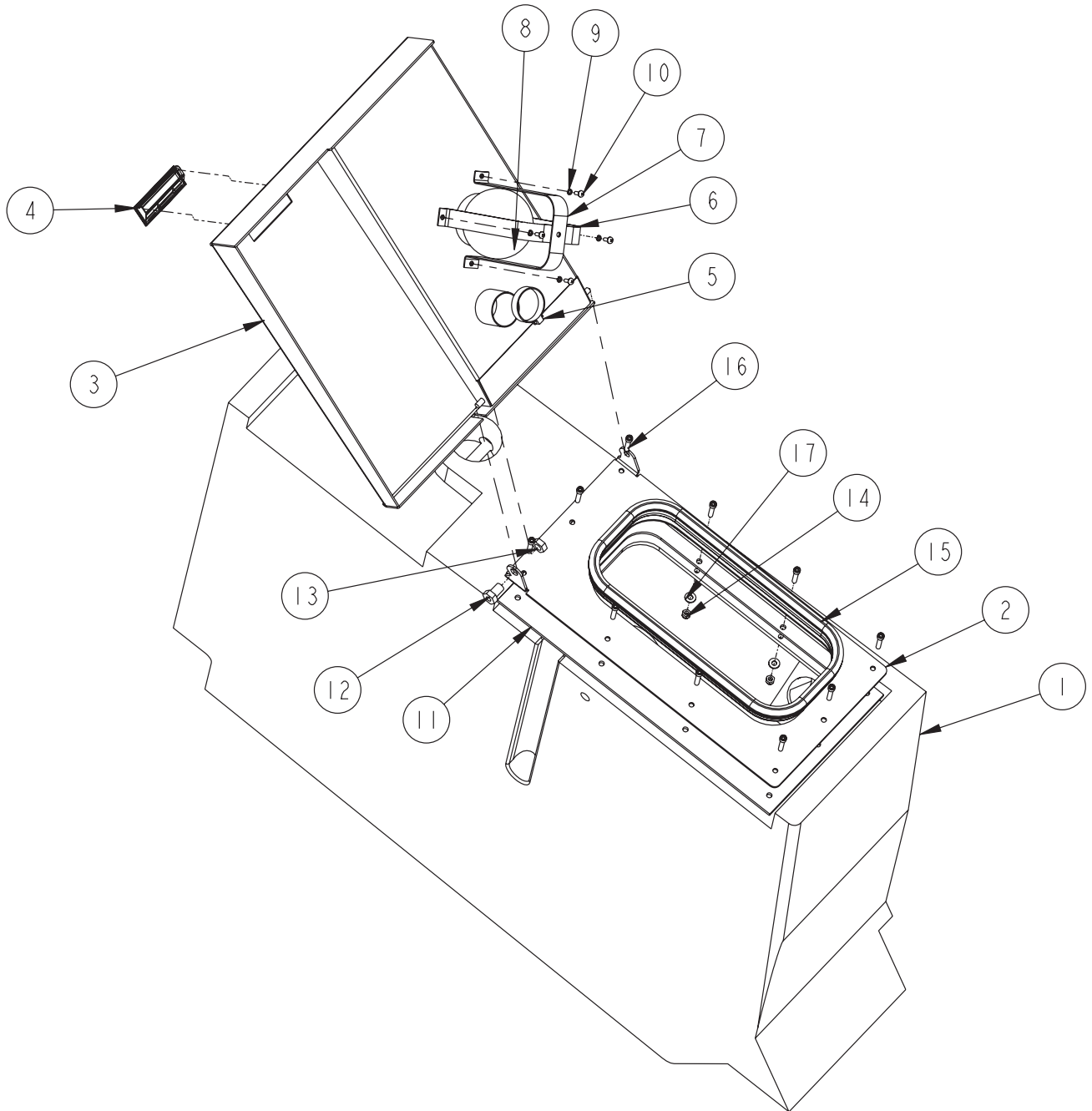

RECOVERY TANK (CON'T)

<u>KEY NO.</u>	<u>PART NUMBER</u>	<u>DESCRIPTION</u>	<u>QTY</u>
1*	7-83-04223	Recovery Tank	REF
2	7-29-00276	Gasket, Tank Drain Dual	1
3	7-25-02101	Fitting, Recovery Tank Dual Port	1
4	2-00-02216	Clamp, Hose	4
5	7-71-00010	Shim, Tank Spacer	2
6	7-33-02461	Hose, Vacuum Recovery	1
7	7-09-01124	Bulkhead Fitting	1
8	7-29-00225	Gasket, Black Neoprene	2
9	7-09-01122	Bushing	1
10	0775-164	Float Switch (gray)	1
11	7-16-07454	Cover, Solution Tank Lid	1
12	7-08-01131	Bracket, Hose	1
13	2-00-00809	Screw, HSHC, .31-18 x 1.00	4
14	7-33-02397	Hose, Squeegee	2
15	2-00-05028	Washer, Flat, 2.00 OD x .281 x .125	2
16	2-00-05236	Washer, Flat, 2.00 OD x .28 x .08	2
17	2-00-04590	Washer, Sealing	2
18	2-00-05122	Screw, 1/4-20 x 2.00 LG SS	1
19	2-00-04688	Nut, 1/4-20 Hex	1
20	7-33-02386	Hose, Vacuum	1

*If you are ordering a replacement tank, you must also order the following:

- 1 of 8-18-00539 (SC7750 decal)(provides 2)
- 2 of 8-18-00524 (American-Lincoln decal)

C1670-IC/9-04

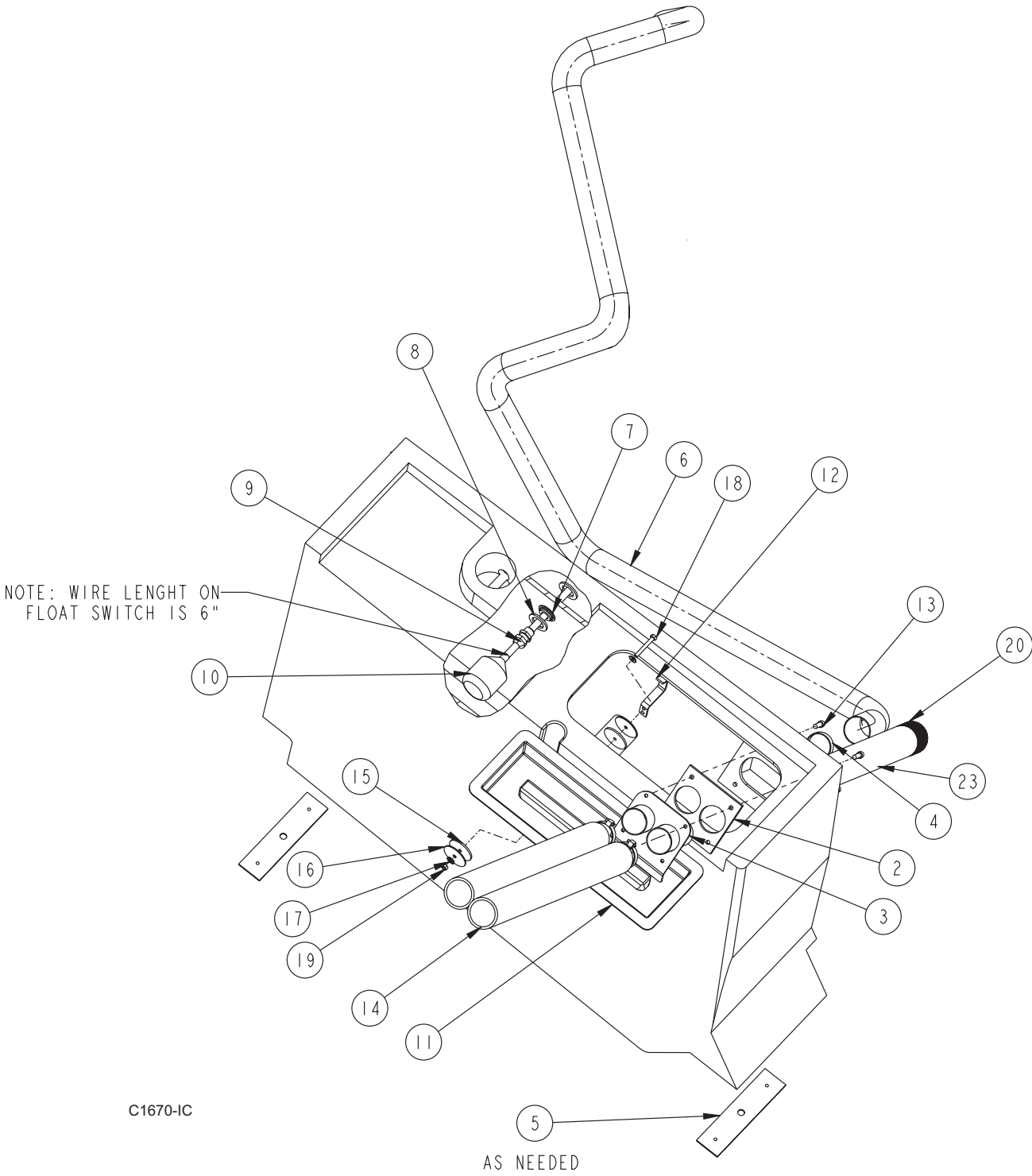

RECOVERY TANK DRAIN SYSTEM

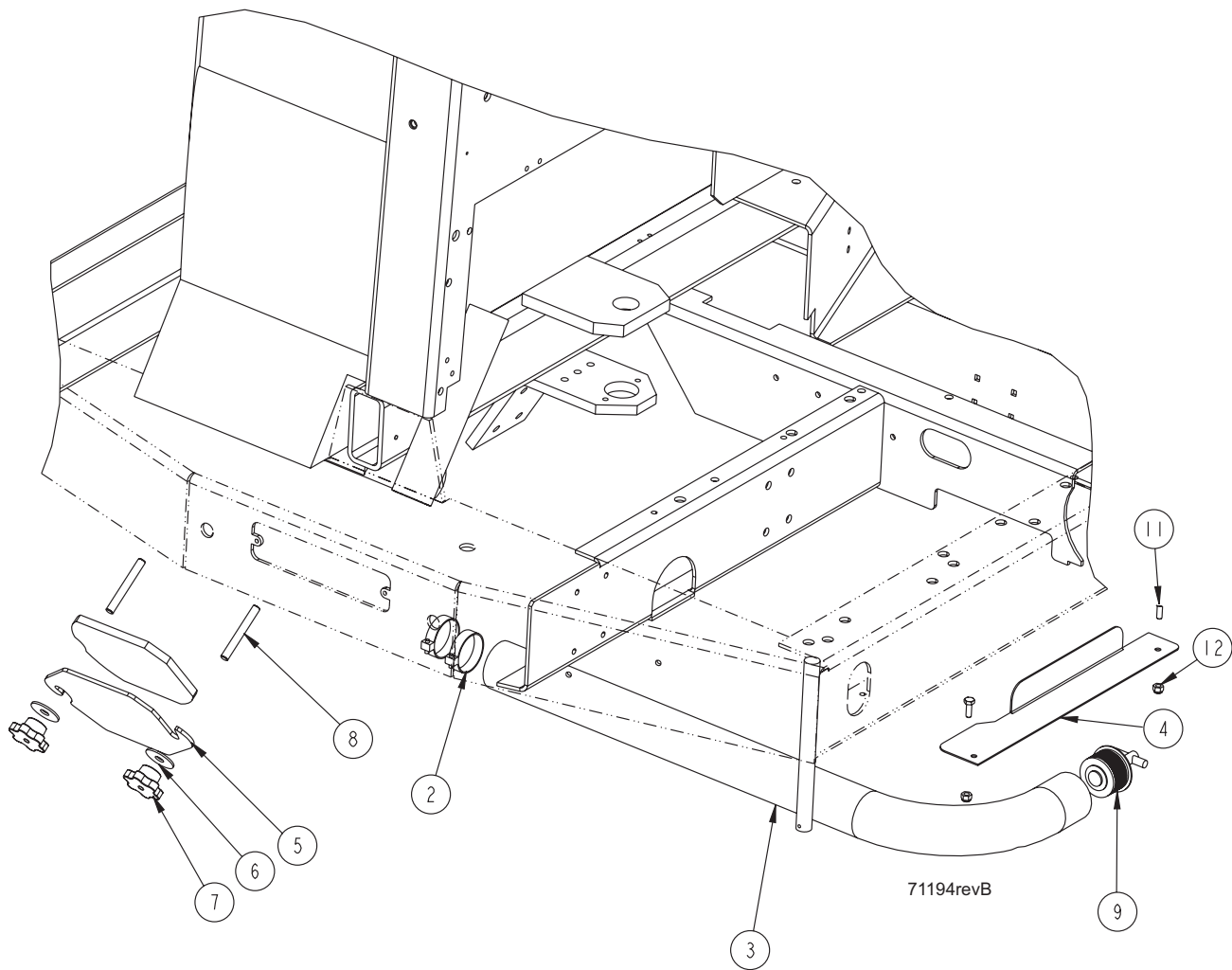

<u>KEY NO.</u>	<u>PART NUMBER</u>	<u>DESCRIPTION</u>	<u>QTY.</u>
1	7-83-04223	Recovery Tank	REF
2	2-00-02216	Clamp, Hose	2
3	7-33-02696	Hose, Drain	1
4	7-08-07107	Bracket, Drain Hose	1
5	7-19-08089	Door, Recovery Drain	1
6	2-95-04012	Washer, 1.50 OD x .468 x .093	2
7	25201A	Knob	2
8	7-80-05086	Stud, Clean-Out Door	2
9	7-25-02110	Plug, Drain	1
10	7-29-00318	Gasket, Recovery Tank Drain	1
11	2-00-00221	Bolt, 1/4-20 x 3/4 Fin. Hex Head	2
12	2-00-00641	Nut, 1/4-20 Fiber Insert	2

71194revB/1-05

FRONT BUMPER

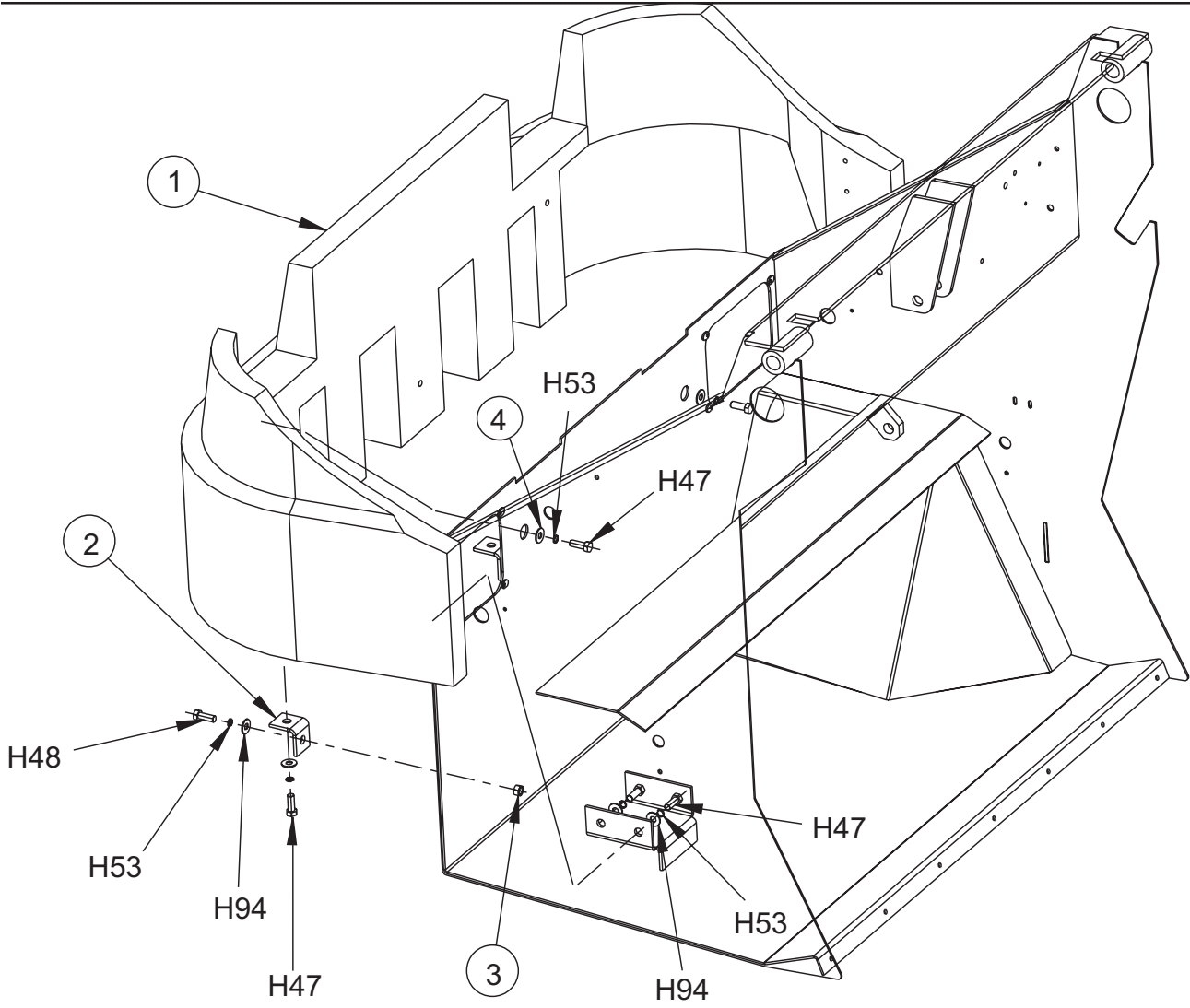

C1675/9702

<u>KEY NO.</u>	<u>PART NUMBER</u>	<u>DESCRIPTION</u>	<u>QTY.</u>
1	7-08-07075	Front Bumper	1
2	7-08-00863	Bracket - Bumper	2
3	2-00-05347	Threaded insert, 3/8 - 16	2
4	2-00-04851	Engine Mount Washer	2
HARDWARE USED:			
H47	2-00-00232	Screw, 3/8 - 16 x .750 HHC	8
H48	2-00-00233	Screw, 3/8-16 x .750 HHC	10
H53	2-00-02310	Lock Washer, Helical Spring 3/8 Med.	10
H94	2-00-00410	Flat Washer, .875 x .375 x .060	12

C1675/9702

FRONT WHEEL

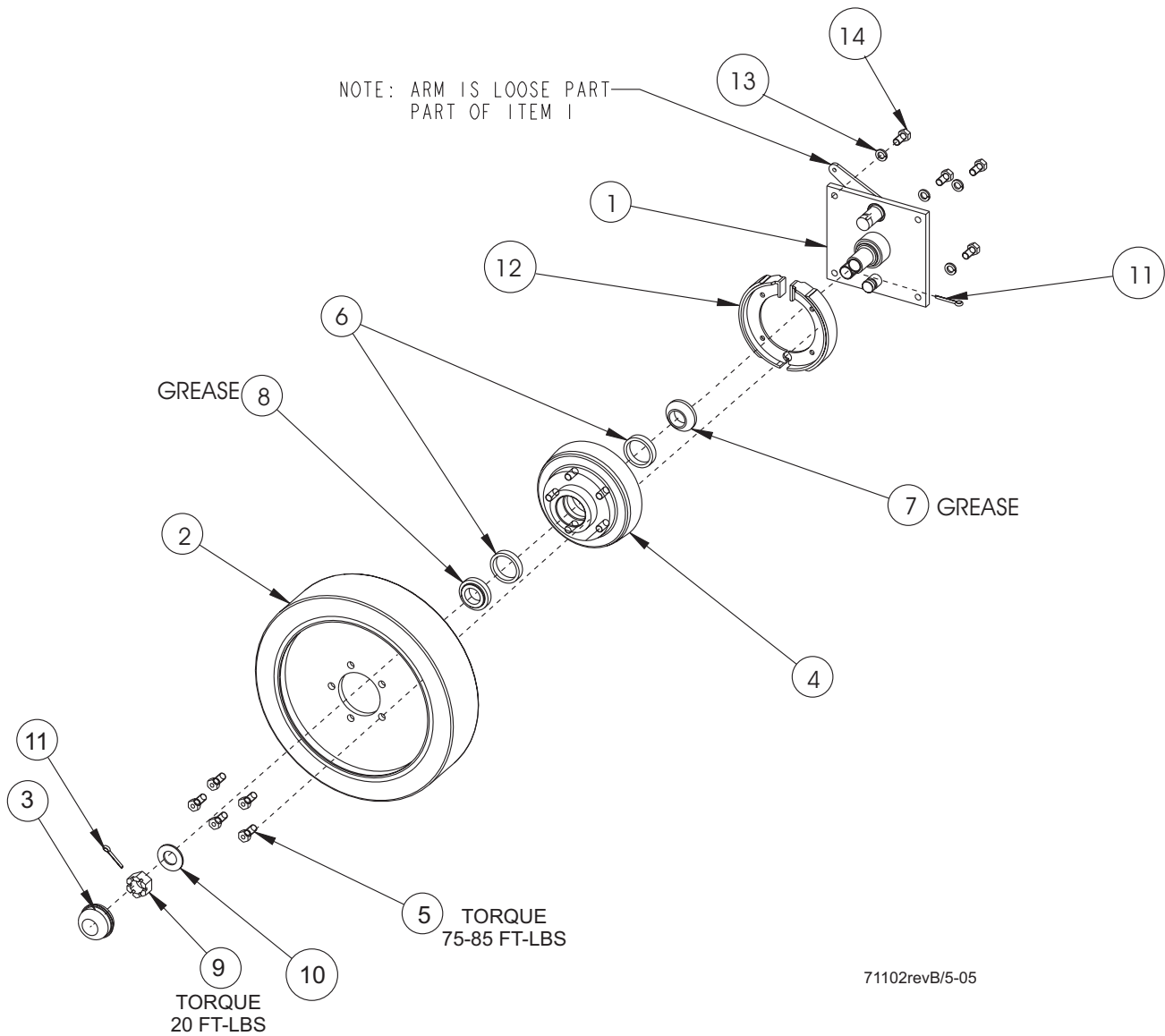

<u>KEY NO.</u>	<u>PART NUMBER</u>	<u>DESCRIPTION</u>	<u>QTY.</u>
1	0860-571	Knott Brake	2
2*	7-89-08098	Molded Wheel	2
3	8-11-00030	Grease Cap	2
4	8-33-09089	Hub and Drum	2
5	8-80-05035	Stud	10
6	2-00-04621	Bearing Cup	4
7	2-00-02079	Bearing Cone (Sealed)	2
8	2-00-04622	Bearing Cone	2
9	2-00-05026	Nut	2
10	2-00-05024	Flat Washer	2
11	2-00-02436	Cotter Pin	2
12	8-71-05007	Brake Shoe	2
13	2-00-02312	Lock Washer, 1/2 HS Med.	8
14	2-00-02689	Screw, 1/2-20 x 1.0 HHC	8

71102revB/5-05

WHEEL WELL FLAP

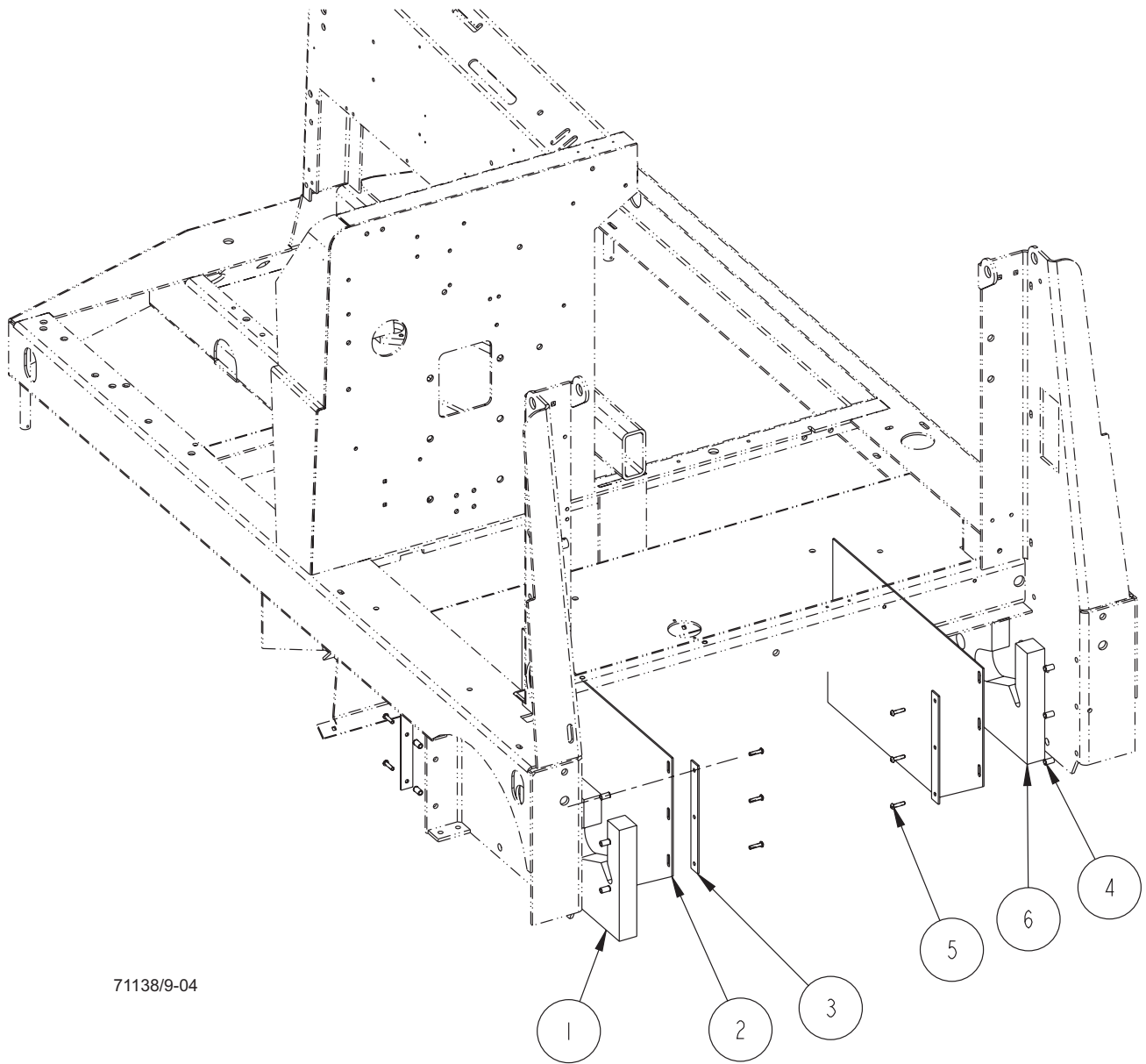

71138/9-04

KEY NO.	PART NUMBER	DESCRIPTION	QTY.
1	7-68-05016	Seal, RH Wheel Well	1
2	7-25-08074	Flap, Wheel Well	2
3	8-13-07148	Clamp, Wheel Well Flap	4
4	2-00-05261	Insert, 1/4-20 Threaded	12
5	2-00-04877	Screw, 1/4-20 x 1.0 BHS w/Nylok	12
6	7-68-05017	Seal, LH Wheel Well	1

71138/9-04

REAR WHEEL ASSEMBLY - PARTS LIST

<u>KEY NO.</u>	<u>PART NUMBER</u>	<u>DESCRIPTION</u>	<u>QTY.</u>
1	7-81-00212	Support-Wheel	1
2	0885-092	Hydraulic Motor (Seal Kit: 0880-687)	REF.
3	2-00-04621	Bearing - Outer Race (Cup Only)	2
4	2-00-02079	Roller Bearing	2
6	8-55-08131	Pin - Pivot - Rear Wheel	1
7	2-00-02436	Cotter Pin (.18 Dia.)	1
8	2-00-05026	Nut, (Slotted Head)	1
9	2-00-05024	Flat Washer	1
10	0797-049-1	Wheel Assembly	1
	7-89-08072-1	Press-on Tire (service)	1
	7-33-09041	Rim (service)	1
12	7-17-05010	Hydraulic Cylinder	REF.
	7-70-00021	Cylinder Seal Kit (service)	1
13	7-62-00006	Rack	1
14	2-00-00566	Grease Zerk	1
15	2-00-04892	Fitting 90°	REF.
16	2-00-05227	Stud M14 x 1.50	5
17	2-00-04974	Straight Fitting	REF.
18	7-30-08015	Slide Rack	1
19	7-33-09028	Hub, Drive Wheel	1
20	7-23-03101	Nut, M14 x 1.50	5
21	2-00-02557	Grease Zerk 90°	1
22	7-13-07176	Clamp - Pivot Pin	1
23	8-75-01136	Flat Washer	2
24	2-00-00591	Jam Nut	1
25	7-11-00048	Cap, 7/8 Hex Nut	1
HARDWARE USED:			
H34	2-00-00208	Screw, 5/16-18 x .75 HHC	2
H35	2-00-02708	Screw, 5/16 - 18 x 1.0 HHM	3
H44	2-00-00530	Lock Washer, 5/16 HS Med.	5
H61	2-00-02616	Screw, 1/2-13 x 3.0 HHC	4
H65	2-00-04936	Nut, 1/2-13 Fiber Insert	4
H109	2-00-00522	Lock Washer, 3/4 Helical Spring	1
H155	2-00-05044	Lock Washer, M14 Split	4
H221	2-00-03335	Screw, Hex SOC Cap .312-18 x .500	2
H270	2-00-05341	Screw-HHC .75-10 x 2.00	1
H271	2-00-03293	Nut-Hex-Fin .75-10	1

C1609A/8-04

REAR WHEEL ASSEMBLY - EXPLODED VIEW

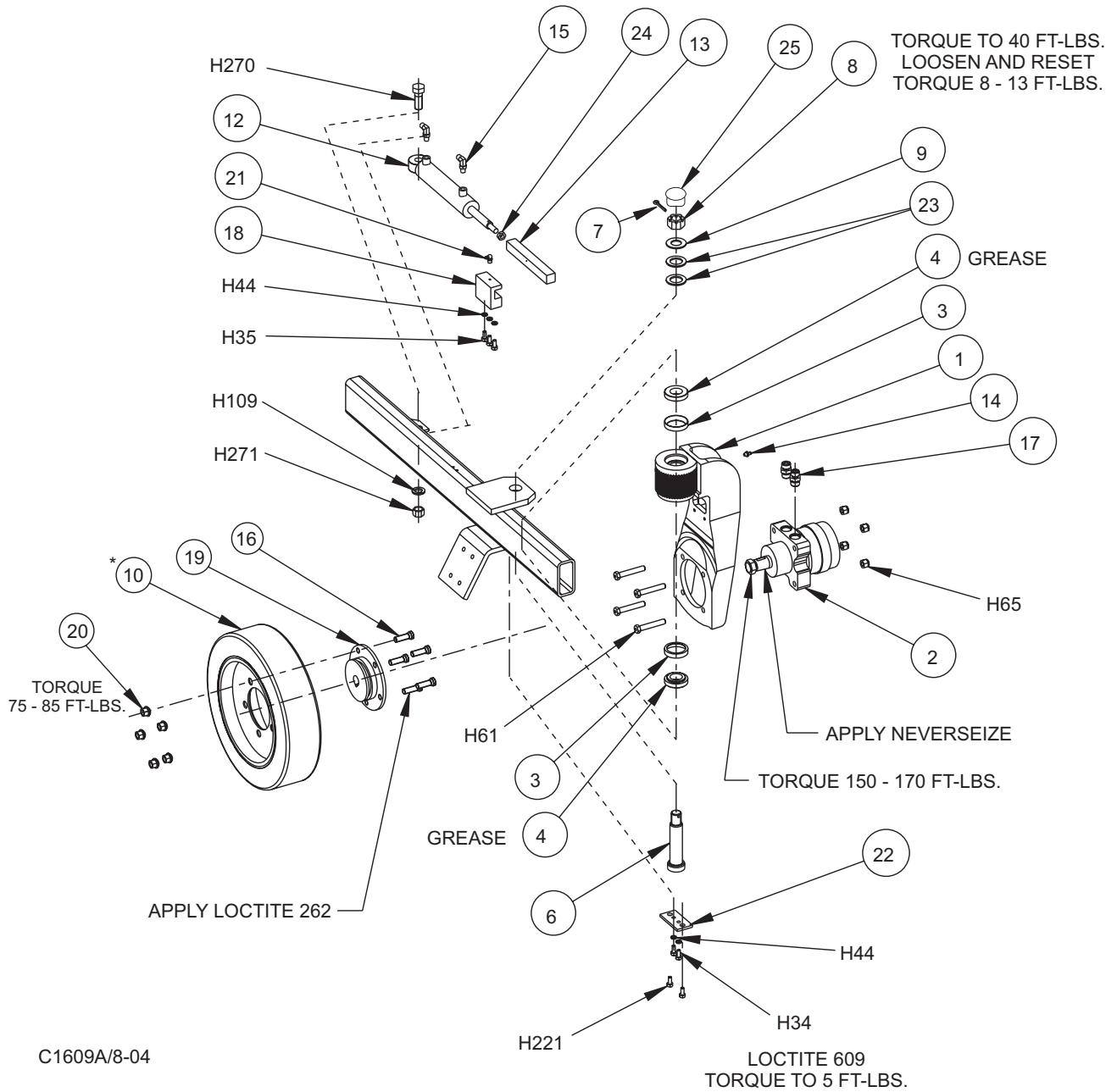

C1609A/8-04

BRAKE PEDAL - PARTS LIST

<u>KEY NO.</u>	<u>PART NUMBER</u>	<u>DESCRIPTION</u>	<u>QTY.</u>
1	7-17-00014	Brake Cross Shaft	1
2	7-55-00018	Brake Pedal	1
3	7-42-05126	Link - Brake Pedal	1
4	7-57-05036	Pivot - Brake Pedal	1
5	7-42-05131	Link - L.H. Pedal	1
6	8-10-00043	Cable	2
7	7-41-05083	Parking Brake Lever	1
8	8-10-00038	Cable	1
9	7-75-01163	Spacer - Lever Mounting	2
9	8-75-01181	Spacer-Filter Mount	2
10	7-81-00193	Support	1
11	7-50-05145	Pad - Pedal	1
12	8-66-00162	Rod - Threaded (10")	1
13	8-14-01006	Clevis	2
14	2-95-01999	Jam Nut	2
15	2-95-04182	3/8-16 Elastic Stop Nut	3
16			
17	7-60-00160	Pulley	2
18	7-13-07130	Retainer	2
19	2-00-05169	Clamp	1
20	2-00-05330	Threaded Insert	2
21	2-00-05384	Screw - HHM .375-16 x 3.00	1
22	2-00-05385	Screw - HHM .375-16 x 1.75	1
HARDWARE USED:			
H15	2-00-00221	Screw, 1/4-20 x .750 HHC	2
H17	2-00-00205	Screw, 1/4-20 x 1.000 HHC	4
H26	2-00-00641	Nut, 1/4-20 Fiber Insert	4
H27	2-00-03702	Washer, .625 x .281 x .063	3
H35	2-00-02708	Screw, 5/16-18 x 1.000 HHM	6
H38	2-00-00225	Screw, 5/16-18 x 1.500 HHC	1
H39	2-00-00218	Screw, 5/16 - 18 x .063 HHC	1
H41	2-00-02597	Screw, 5/16 - 18 x 3.250 HHC	1
H43	2-00-00409	Flat Washer, .687 x .344 x .062	1
H46	2-00-00644	Nut, 5/16 - 18 Fiber Insert	7
H54	2-00-02360	Nut, 3/8 - 16 Hex	3
H111	2-00-03296	Screw, 3/8-16 x 4.00 HHC	1
H232	2-00-04909	Yoke, Pin Assembly	2
H365	2-00-04182	Bushing	2

C1610/0202

BRAKE PEDAL - EXPLODED VIEW

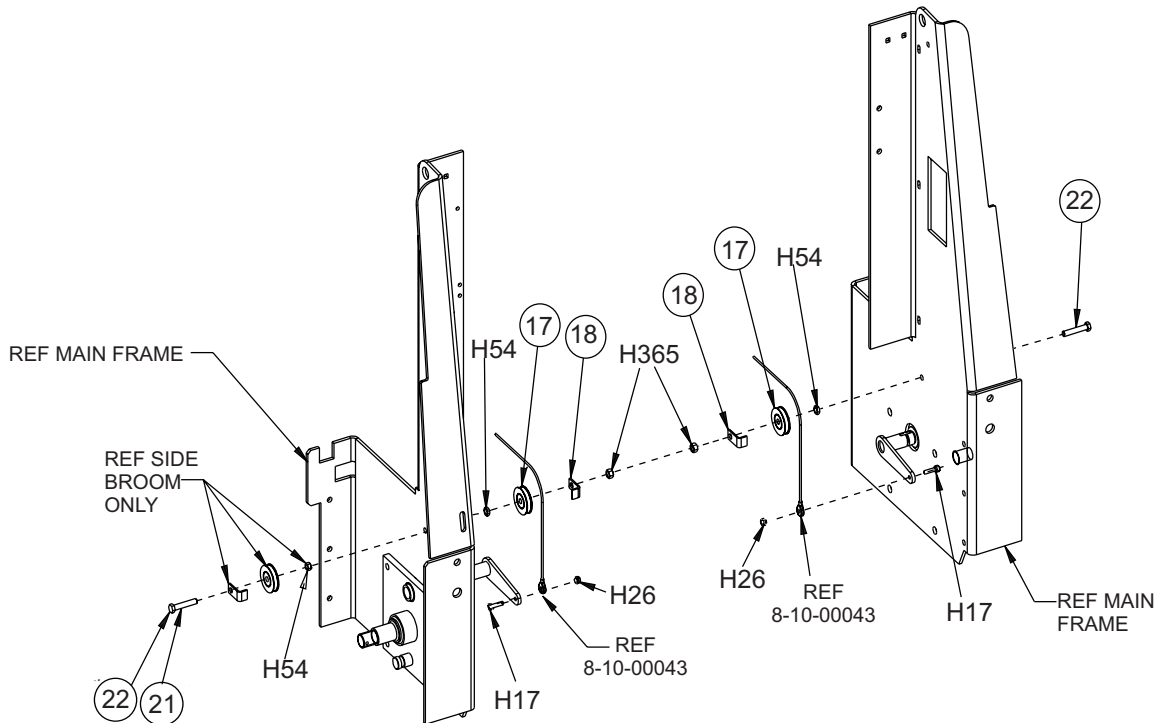
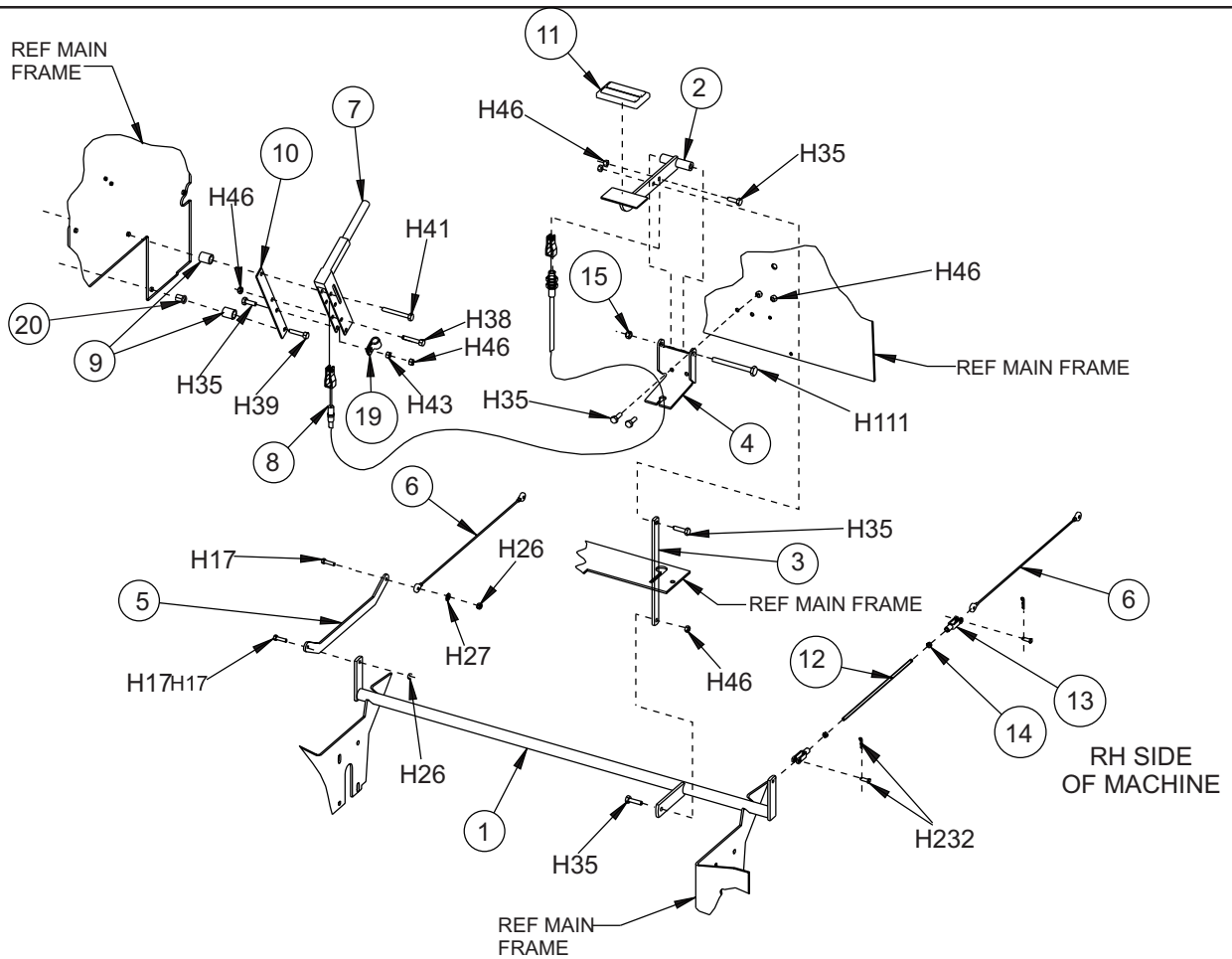

C1610/0202

FORWARD/REVERSE CONTROL - PARTS LIST

<u>KEY NO.</u>	<u>PART NUMBER</u>	<u>DESCRIPTION</u>	<u>QTY.</u>
1	7-58-05274	Floor Plate	1
2	2-00-05246	Pin, FWD/REV Pedal Pivot	1
3	2-00-05249	Cotter Pin	3
4	7-25-02050	Rod End	2
5	2-95-01999	Jam Nut	2
6	7-42-05136	Link, Pedal to Pump (Diesel)	1
	7-42-05194	Link, Pedal to Pump (Gas/LP)	1
7	7-03-04164	Arm, Pump Control Ext.	1
8	8-03-04300	Arm, Pump Control	1
9	7-66-00147	Rod, Threaded 1/4-28 x 3.0	1
10	8-16-00025	Centering Control	1
11	7-55-00022	Adj. Foot Pedal	1
12	2-00-05247	Pin	2
13	8-55-00036	Pedal Base	1
14	8-08-00782	Bracket	1
15	8-82-00030	Switch, Horn	1
16	7-13-07096	Adjustable Clamp	3
17	7-64-00021	Relay	1
18	8-64-05009	Relay	3
19	7-08-00870	Bracket, Switch	1
20	8-82-00058	Switch	2
21	0795-162	Wire Harness	1
22	8-08-00781	Bracket, Hydroback (Gas)	1
22	7-08-00949	Bracket, Hydroback (Diesel)	1
23	2-95-01999	Jam Nut	5
24	8-66-00169	Threaded Rod	1
HARDWARE USED:			
H9	2-00-00426	Flat Washer, .500 x .219 x .063	10
H15	2-00-00221	Screw, 1/4-20 x .750 HHC	2
H25	2-00-00594	Nut, Hex 1/4-20 x .437 x .218	2
H27	2-00-03702	Washer, .625 x .281 x .063	2
H36	2-00-00196	Carriage Bolt, 5/16-18 x 1.000	2
H46	2-00-00644	Nut, 5/16-18, Insert Fiber	2
H57	2-00-00240	Screw, 1/2-13 x 1.250 HHC	1
H62	2-00-00405	Flat Washer, 1.063 x .531 x .094	1
H65	2-00-04936	Nut, 1/2-13 Fibre Lock	1
H72	2-00-00518	Lock Washer, Helical Spring	6
H89	2-00-01372	Nut, Fiber Insert #8-32 Steel	2
H114	2-00-00633	Nut, Fiber 1/4-28	2
H121	2-00-00090	Screw, #8-32 x 1.500 RHM	4
H168	2-00-05261	Insert, 1/4-20	2
H191	2-00-00602	Nut, MSCR - Hex, 8-32	5
H196	2-00-05350	Screw 1/4 - 28 x .63 HHC	1
H229	2-00-01490	Screw, .25 - 20 x .875 HHC STL	2
H265	2-00-00506	Lock Washer, Int Tooth #8 Dia Screw	9
H266	2-00-05371	Screw-RHM #8-32 x 2.38	2
H267	2-00-00068	Screw-RHM #8-32 x .63	2
H292	2-00-02293	Lockwasher, 5/8 Int.	1

FORWARD/REVERSE CONTROL - EXPLODED VIEW

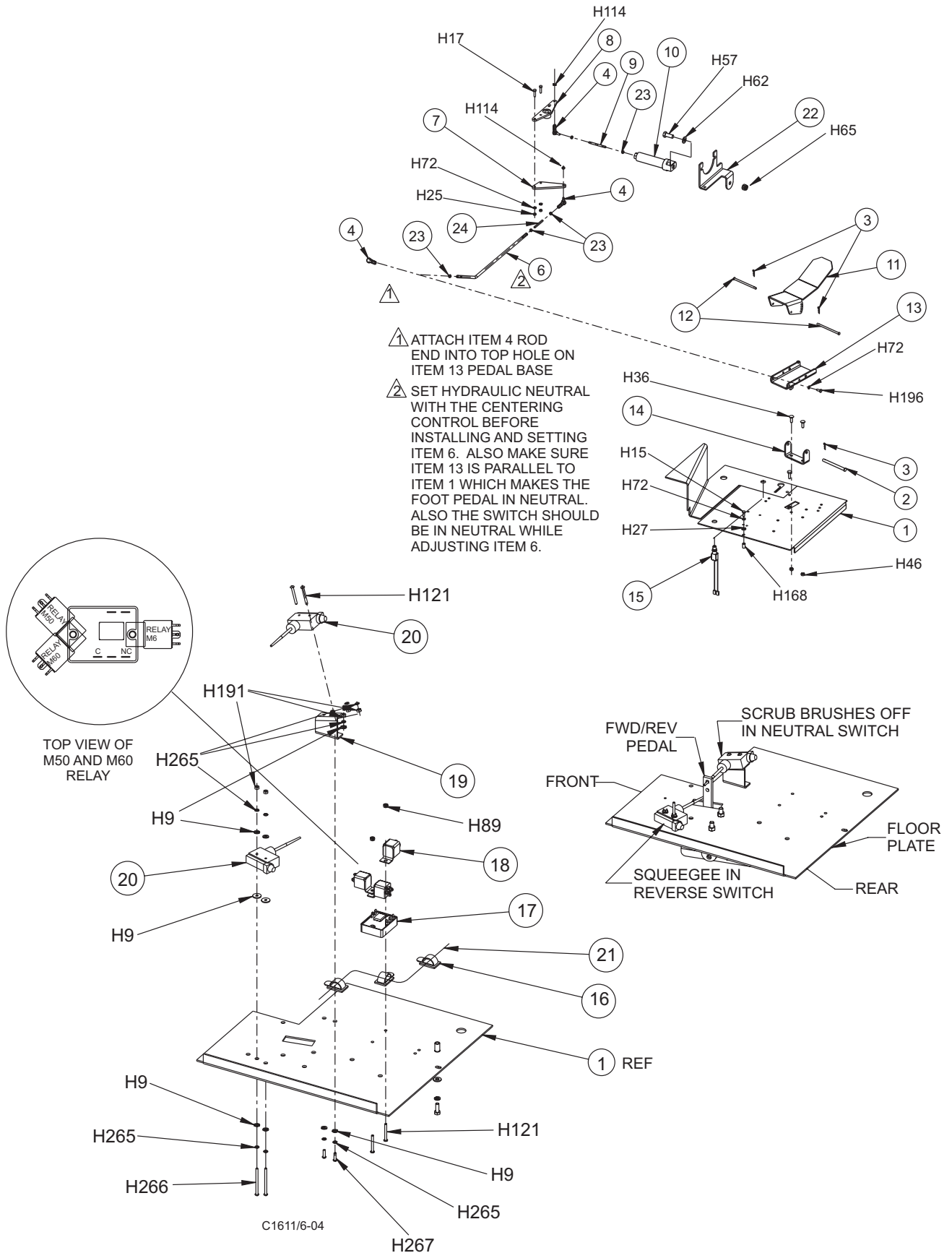

FRAME

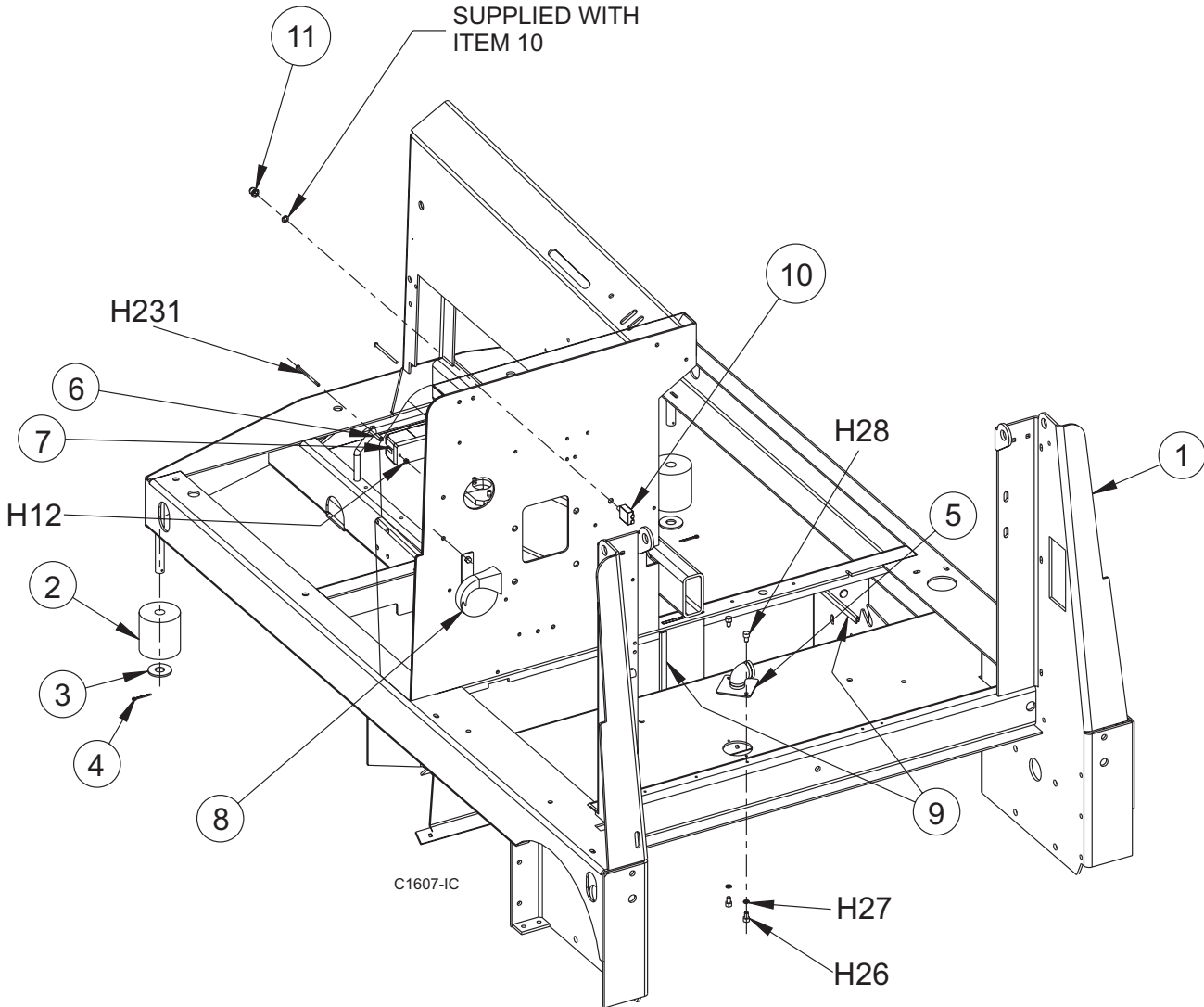

<u>KEY NO.</u>	<u>PART NUMBER</u>	<u>DESCRIPTION</u>	<u>QTY.</u>
1	7-27-07241	Main Frame	1
2	7-66-05009	Roller Bumper	2
3	8-75-01157	Washer, (2" x .812 x .157)	2
4	2-00-00776	Cotter Pin (.12 x 1.25)	12
5	7-16-07398	Cover Plate - Weldment	Ref.
6	8-75-01207	Spacer	2
7	8-40-05044	Tail Light	1
8	8-32-09013	Horn	1
9	7-21-04031	Edging-Brush Drive Support	2
10	7-64-00032	Circuit Breaker (50 AMP)	1
11	8-11-00051	Boot - Circuit Breaker	1

HARDWARE USED:

H12	2-00-01246	Nut, Hex. Fiber Insert #10-24	2
H26	2-00-00641	Nut, 1/4-20 Insert Fiber	2
H27	2-00-03702	Washer, .625 x .281 x .063	2
H28	2-00-04685	Screw, 1/4-20 x .750 HHC	2
H231	2-00-02933	Screw, #10-24 x 3.50	2

C1607-IC/10-04

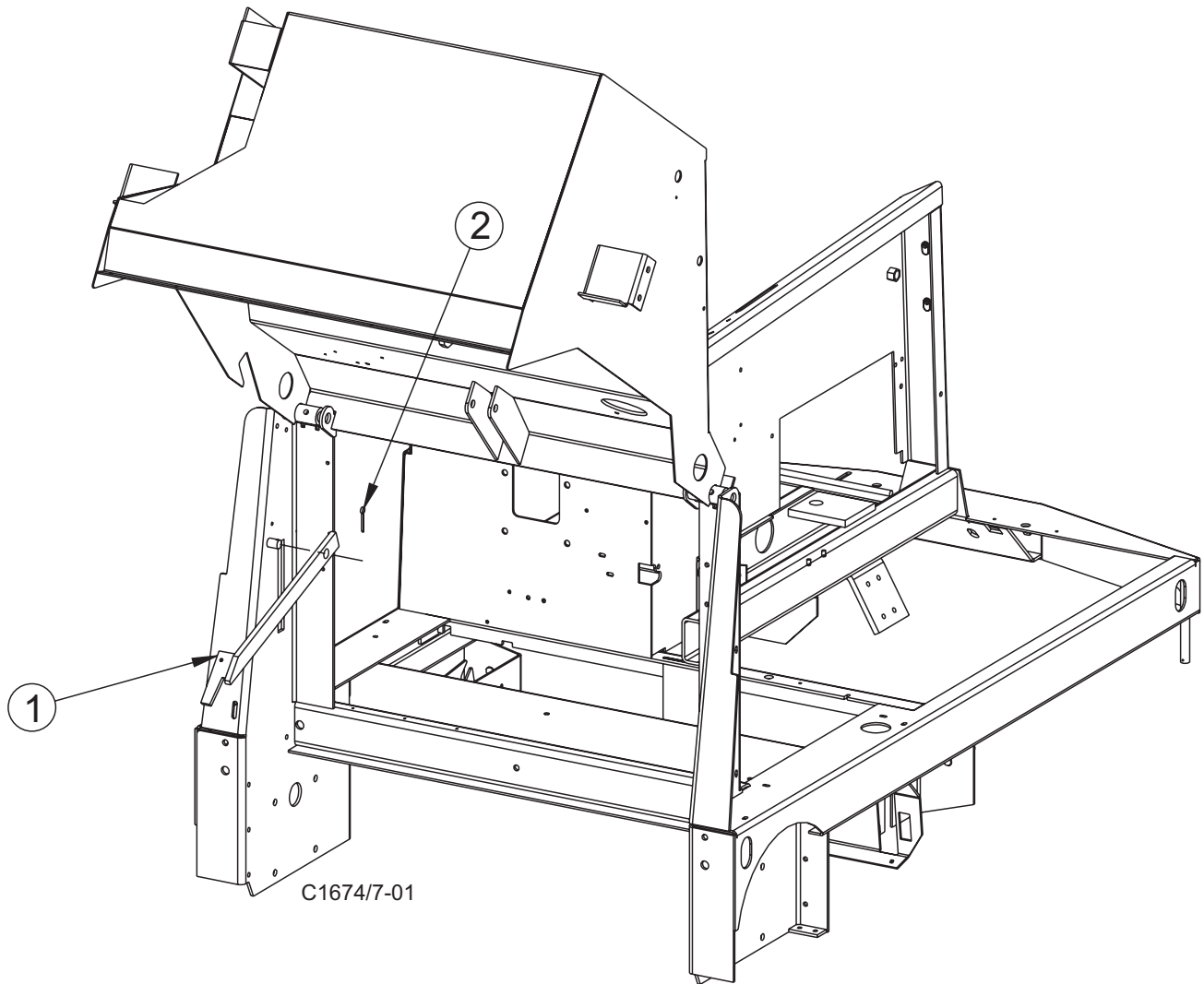

<u>KEY NO.</u>	<u>PART NUMBER</u>	<u>DESCRIPTION</u>	<u>QTY.</u>
1	7-81-00198	Safety Arm Weldment	1
2	2-00-02436	Cotter Pin	1

C1674/7-01

STEERING COLUMN - PARTS LIST

<u>KEY NO.</u>	<u>PART NUMBER</u>	<u>DESCRIPTION</u>	<u>QTY.</u>
1	7-33-05124	Housing, Steering Valve	1
2	8-60-05034	Steering Control Unit (4.88 CIR/1100 PSI)	Ref.
3	7-81-00202	Support, Steering	1
4	8-11-00022	Cap, Steering Wheel	1
5	8-89-08016	Steering Wheel	1
6	7-41-00038	Latch	1
7	7-76-00051	Spring	1
8	8-31-06083	Grip Latch	1
9	2-95-04182	3/8-16 Lock Nut	2
10	2-00-05330	5/16-18 THD Insert	4
11	8-33-02360	Hose, Heat Shield	1
HARDWARE USED:			
H15	2-00-00221	Screw, 1/4 - 20 x .750 HHC	1
H26	2-00-00641	Nut, 1/4-20 Insert Fiber	1
H44	2-00-00530	Lock Washer, 5/16 Helical Spring Med.	4
H48	2-00-00233	Screw, 3/8-16 x 1.000 HHC	2
H154	2-00-04363	ScrewScrew, M8-1.250 x .750	4
H178	2-00-00206	Screw, 5/16 - 18 x 1.000 HHC	4

C1616/0402

STEERING COLUMN - EXPLODED VIEW

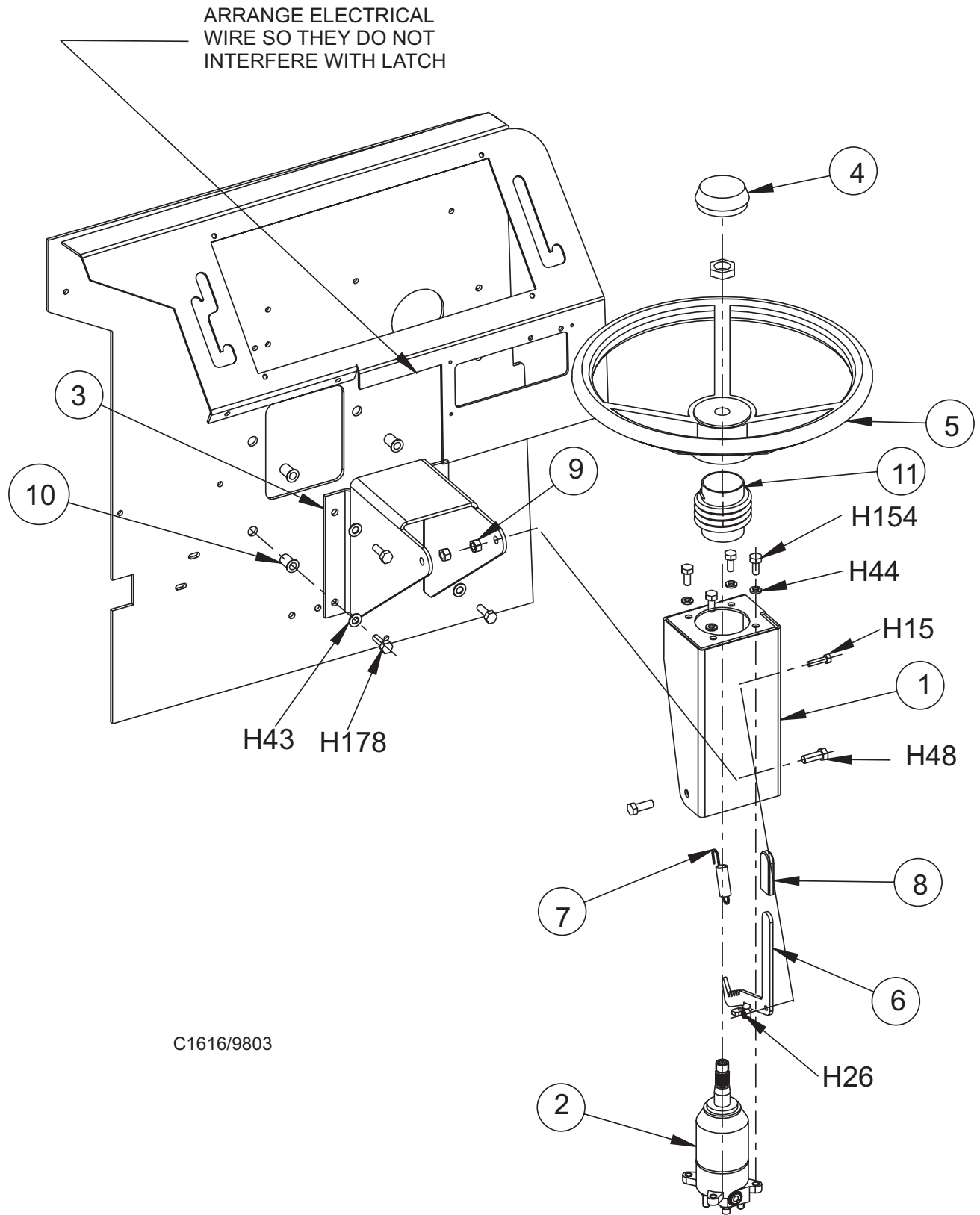

C1616/9803

VAC FAN - PARTS LIST

<u>KEY NO.</u>	<u>PART NUMBER</u>	<u>DESCRIPTION</u>	<u>QTY.</u>
1	0882-048 7-70-00020	Vacuum Motor Motor Seal Kit (service part)	1
2	7-08-00848	Bracket - Vac Fan	1
3	8-72-00005	Vacuum Fan Exhaust Duct	1
4	8-23-00012	Fan Impeller	1
5	8-30-05169	Guard - Impeller	1
6	8-29-00183	Gasket - Blower	1
7	2-00-04885	Fitting - 90°	2
8	2-00-05347	Lock Nut	2
9	2-00-04892	Fitting - 90° Elbow (O-Ring)	Ref.
10	2-00-03454	Clamp - Hose	1
11	8-33-02271	Hose - Blower Exhaust	1
12	2-00-02655	Screw, 5/16-18 x 4.500 HHC	4
13	2-00-00484	Flat Washer, .625 x .375 x .046	2
14	2-00-00644	Nut, 5/16-18 Insert Fiber	4
15	2-00-04801	Flat Washer, .875 x .375 x .125	2
16	2-00-00233	Screw, 3/8-16 x 1.0 HHC	2
17	2-00-00632	Nut, Fiber Insert 3/8-24 Steel	1
18	2-00-00641	Nut, 1/4-20 Insert Fiber	4

C1673/0206

VAC FAN - EXPLODED VIEW

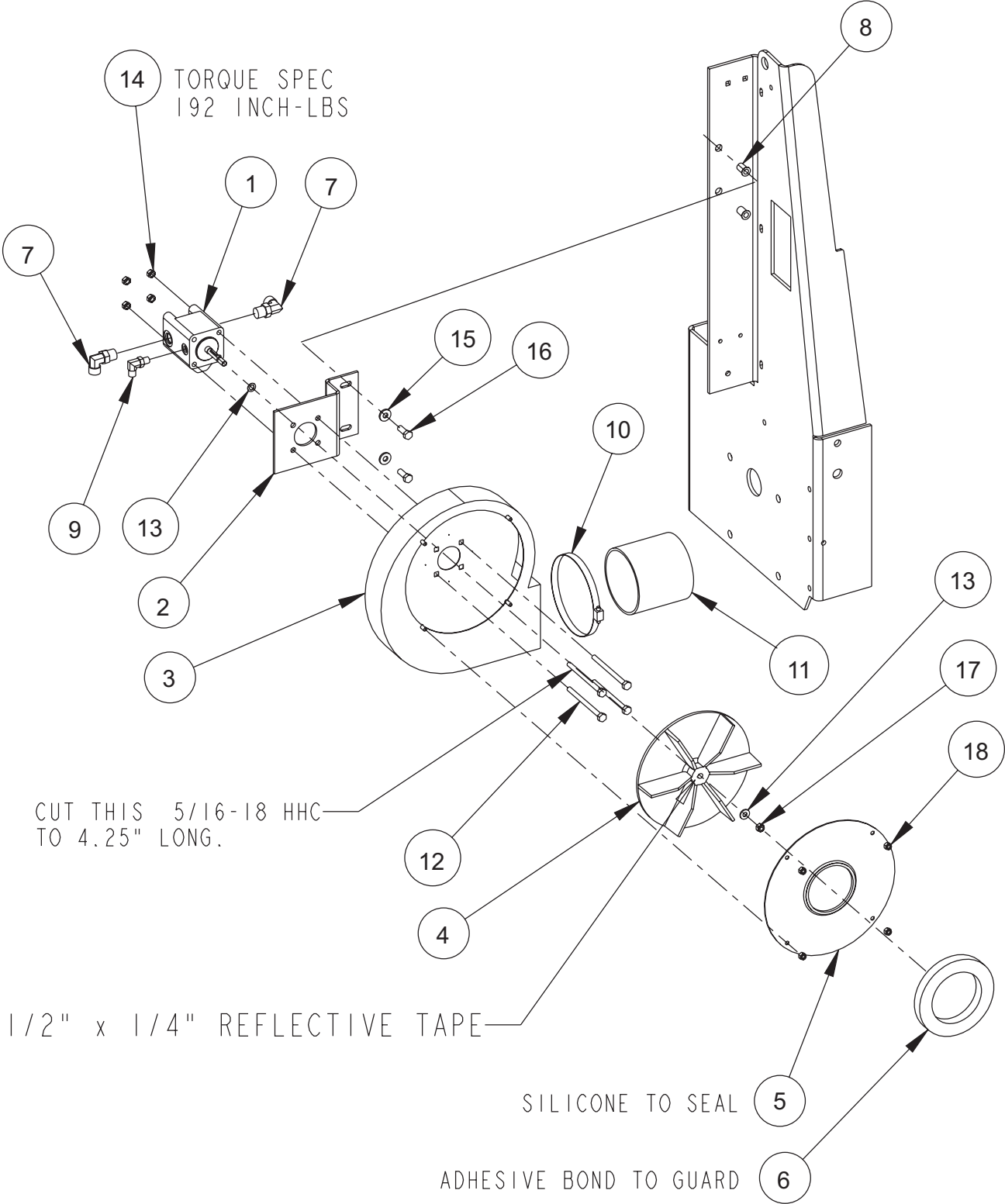

VAC MOTOR MANIFOLD - PARTS LIST

<u>KEY NO.</u>	<u>PART NUMBER</u>	<u>DESCRIPTION</u>	<u>QTY.</u>
1	7-20-06022	FAN, DUCT	1
2	7-75-01233	SPACER, VAC	12
3	7-16-07474	COVER, FAN	1
4	0885-095	HYDRAULIC MOTOR - DUST CONTROL	1
5	2-00-00484	FLAT WASHER, .625 x .375 x .046	2
6	7-34-04002	IMPELLER	1
7	7-33-05147	HOUSING, VAC EXHAUST	1
8	7-08-07112	BRACKET, VAC MOTOR ASSEMBLY	1
9	2-00-00203	SCREW, 1/4-20 X 1.1/2" HEX HEAD	12
10	8 2-00-00518	LOCK WASHER, 1/4" HELICAL SPRING	28
11	2-00-00594	NUT, 1/4-20 HEX	12
12	2-00-02310	LOCK WASHER, 3/8" HELICAL SPRING	2
13	2-00-05381	SCREW, HHC .375-24X1.00 GR 8 ZN	2
14	2-00-02708	SCREW, 5/16-18 x 1.00 HEX HEAD	4
15	2-00-00530	LOCK WASHER, 5/16"	4
16	2-00-00585	NUT, 5/16-18 HEX	4
17	2-00-00402	WASHER, 25/64" ID X 3/4" OD	1
18	2-00-03412	NUT, 3/8-24 LOCK	1
19	2-00-03702	WASHER, .625 x .281 x .063	16
20	2-00-00220	SCREW, 1/4-20 X .625 HHC	16
21	7-21-07005	ELBOW	1
22	7-87-02236	TUBE, RECOVERY VACUUM	1
23	7-33-02629	HOSE, VACUUM	1
24	7-34-09030	INSULATION, VAC FAN	1
25	7-34-09031	INSULATION, VAC FAN	1
26	2-00-02216	CLAMP, HOSE	4
27	7-29-00319	GASKET, VAC MANIFOLD	1
28	7-72-03035	SLEEVE, VAC HOSE	1

C2198revC/6-04

VAC MOTOR MANIFOLD - EXPLODED VIEW

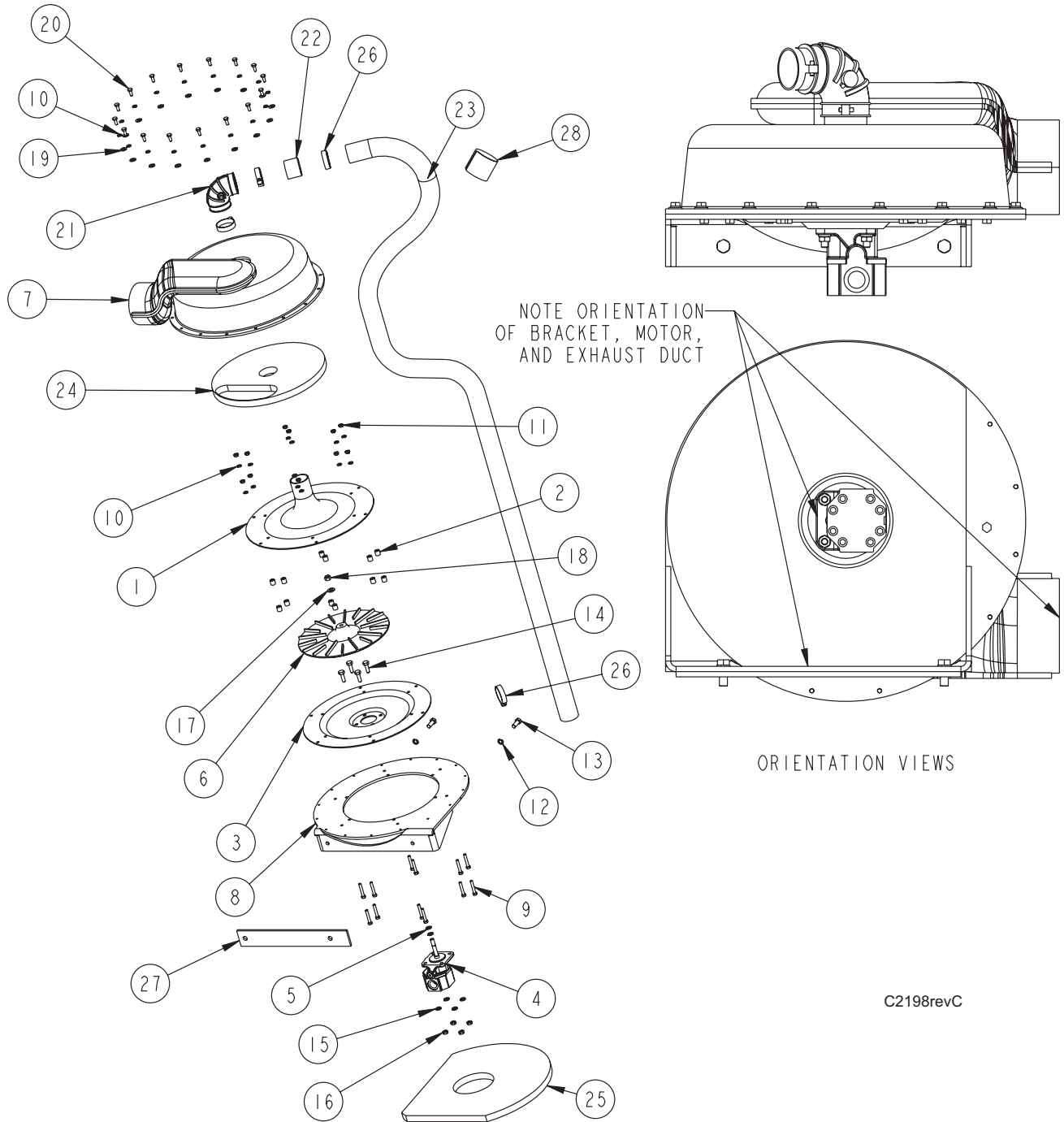

FILTER SHAKER - PARTS LIST

<u>KEY NO.</u>	<u>PART NUMBER</u>	<u>DESCRIPTION</u>	<u>QTY.</u>
1	8-13-07139	Clamp, Filter	1
2	8-55-08119	Pin, Shaker Pod	1
3	2-00-03589	½" Stop Collar	2
4	8-58-05284	Plate, Shaker	1
5	8-03-04302	Arm, Shaker	1
6	8-16-07406	Cover, Filter Shaker Motor	1
7	0860-623	Motor, Filter Shaker (12 VDC)	1
8	8-89-04019	Weight	1
9	8-24-04148	Filter	1
	8-24-04148-2	POLY Filter Option	
10	8-13-07121	Mounting, Shaker Angle	1
11	8-41-00053	Latch	1
12	8-90-07433	Wire, Hopper Shaker	1
13	8-08-00826	Mounting, Shaker Angle	1
14	7-80-05080	Stud, Latch	1
15	8-10-00027	Cable, Hopper	1
16	2-00-00641	Nut, 1/4-20 Fiber Insert	6
17	2-00-03702	Washer, .625 x .281 x .063	6
18	2-00-00208	Screw, 5/16-18 x .75 HHC	4
19	2-00-00207	Screw, 5/16-18 x 1.25 HHC	1
20	2-00-00644	Nut, 5/16-18 Fiber Insert	4
21	2-00-02310	Lock Washer, 3/8 Helical Spring	1
22	2-00-02360	Nut, 3/8-16 Hex	2
23	2-00-00405	Flat Washer, 1.063 x .531 x .094	3
24	2-00-03575	Carriage Bolt, 1/4-20 d .750	6
25	2-00-05359	Nut, 5/16-18 Serrated Flange	4
26	2-00-00203	Screw, 1/4-20 x 1.5 HHC	1
27	2-00-00263	Set Screw, 1/4-20 x 1/4	1

71135-IC/10-04

SEAT AND FLOOR ASSEMBLY - PARTS LIST

<u>KEY NO.</u>	<u>PART NUMBER</u>	<u>DESCRIPTION</u>	<u>QTY.</u>
1	7-33-05124	Housing - Seat & Fuel	1
2	8-08-00834	Bracket	1
3	8-32-00044	Hinge - Door	2
4	8-52-00186	Panel - Seat Mtg	1
5	2-00-00530	Lock Washer, 5/16 HS Med	4
6	2-00-00644	Nut, 5/16-18 Insert Fiber	5
7	2-00-03569	Carriage Bolt, 5/16-18 x .750	1
8	2-00-05330	Threaded Insert, 5/16-18	4
9	2-00-00409	Flat Washer, .687 x .344 x .062	3
10	2-00-00206	Screw, 5/16-18 x 1.000 HHC	2
11	2-00-02708	Screw, 5/16-18 x 1.000HHM	2
12	2-00-01951	Carriage Bolt, 1/4-20 x 1.250	1
13	2-00-01676	Flat Washer, 1.062 x .265 x .062	6
14	2-00-00641	Nut, 1/4-20 Insert Fiber	8
15	2-00-00594	Nut, Hex 1/4-20 x .437 x .218	1
16	7-23-03048	Washer-Spring-Shakeproof	1
17	8-41-00064	Latch - Seat Panel	1
18	2-00-03575	Carriage Bolt, 1/4-20 x .750	7
19	7-72-05005	Seat (Slide) Adjuster Kit	1
20	7-69-00008	Seat	1

C1617/0903

SEAT AND FLOOR ASSEMBLY - EXPLODED VIEW

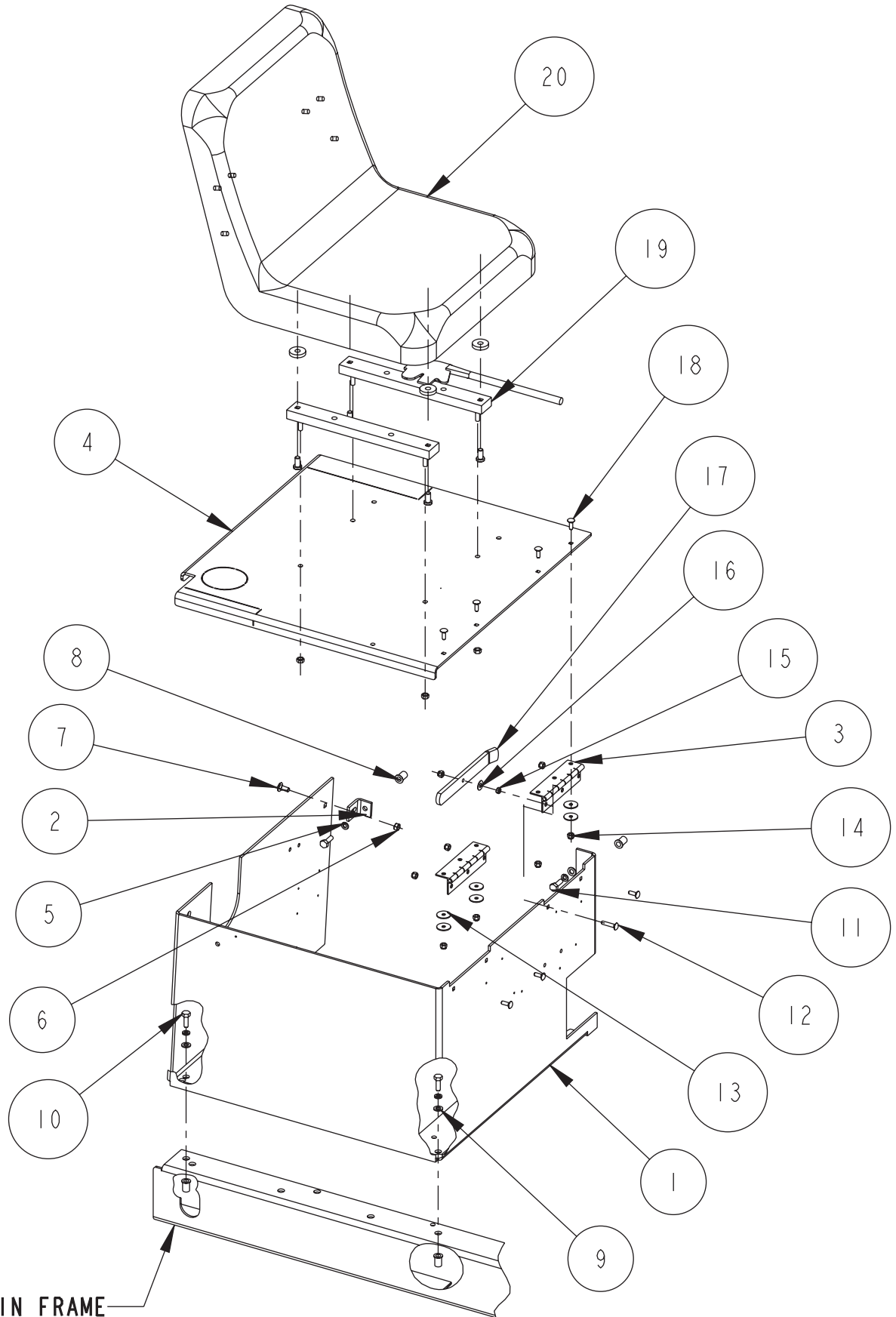

REF MAIN FRAME

HYDRAULIC HOSE DIAGRAM/SCHEMATIC - PARTS LIST

<u>KEY NO.</u>	<u>PART NUMBER</u>	<u>DESCRIPTION</u>	<u>QTY.</u>
1	7-33-02200	#8 Hose Ors. Str.-45° Ends	77.0"
2	7-33-02200	#8 Hose Ors. Str.-45° Ends	77.0"
3	7-33-02186	#4 Hose Ors. Str. Ends	30.0"
4	8-33-02185	#4 Hose Ors. Str. Ends	56.0"
5	8-33-02218	#4 Hose Ors. Str. Ends	60.0"
6	7-33-02343	#4 Hose Ors. Str.-90° Ends	43.5"
7	7-33-02190	#4 Hose Ors. Str.-90° Ends	67.0"
8	7-33-02190	#4 Hose Ors. Str.-90° Ends	67.0"
9	7-33-02225	#4 Hose Ors. Str.-90° Ends	38.0"
10	7-33-02366	#4 Hose Ors. Str.-90° Ends	34.0"
11	8-33-02324	#8 Hose Ors. Str. Ends	72.0"
12	7-33-02323	#8 Hose Ors. Str.-90° Ends	55.0"
13	7-33-02332	#8 Hose Ors. Str.-90° Ends	102.0"
14	7-33-02190	#4 Hose Ors. Str. Ends	67.0"
15	7-33-02190	#4 Hose Ors. Str. Ends	67.0"
16	7-33-02349	#4 Hose Ors. Str.-90° Ends	11.75"
17	8-33-02199	#4 Hose Ors. Str.-90° Ends	21.0"
18	8-33-02199	#4 Hose Ors. Str.-90° Ends	21.0"
19	8-33-02191	#8 Hose Ors. Str. Ends	56.5"
20	7-33-02428	#8 Hose Ors. Str.-90° Ends	57.0"
21	7-33-02351	#12 Hose Ors. Str.-90° Ends	33.0"
22	7-33-02222	#8 Hose Ors. Str. Ends	26.0"
23	7-33-02348	#8 Hose Ors. Str. Ends	32.0"
24	7-33-02349	#4 Hose Ors. Str. Ends	11.75"
25	7-33-02349	#4 Hose Ors. Str. Ends	11.75"
26	7-33-02350	#4 Hose Ors. Str.-90° Swivel Ends	43.0"
27	7-33-02298	#8 Hose Ors. Str. Ends	48.0"
29	8-33-02353	#12 Hose Ors. Str.-45° Ends (Option)	12.5"
30	7-33-02203	#12 Hose Ors. Str.-90° Ends (Option)	20.0"
31	7-33-02221	#12 Hose Ors. Str. Ends (Option)	48.0"
32	7-33-02351	#12 Hose Ors. Str.-90° Ends (Option)	33.0"
33	7-33-02352	#4 Hose Ors. Str.-90° Swivel Ends	71.0"
34	8-33-02216	#4 Hose Ors. Str. Ends	88.0"
35	7-33-02342	#4 Hose Ors. Str. Ends	92.5"
36	7-33-02353	#4 Hose Ors. Str.-90° Ends (Option)	98.5"
37	7-33-02353	#4 Hose Ors. Str.-90° Ends (Option)	98.5"
38	7-33-02191	#4 Hose Ors. Str.-90° Ends.	42.0"
39	7-33-02191	#4 Hose Ors. Str.-90° Ends.	42.0"
40	7-33-02222	#8 Hose Ors. Str. Ends	26.0"
41	8-33-02200	#8 Hose Ors. Str.-90° Ends	55.0"
42	8-33-02194	#12 Hose Ors. Str. Ends	32.0"
43	7-33-02327	#8 Hose Ors. Str.-90° Ends-46" Scrub Deck	15.25"
	7-33-02326	#8 Hose Ors. Str.-90° Ends-53" Scrub Deck	17.0"
44	7-33-02354	#8 Hose Ors. Str.-90° Ends-46" Scrub Deck	13.5"
	7-33-02327	#8 Hose Ors. Str.-90° Ends-53" Scrub Deck	15.25"
45	7-33-02365	#8 Hose Ors. Str.-45° Ends	30.0"
46	7-33-02347	#8 Hose Ors. Str.-90° Ends	49.0"
47	7-33-02222	#8 Hose Ors. Str. Ends	26.0"
48	8-33-02181	#4 Hose Ors. Str. Ends	18.0"

C1692ecp/10-04

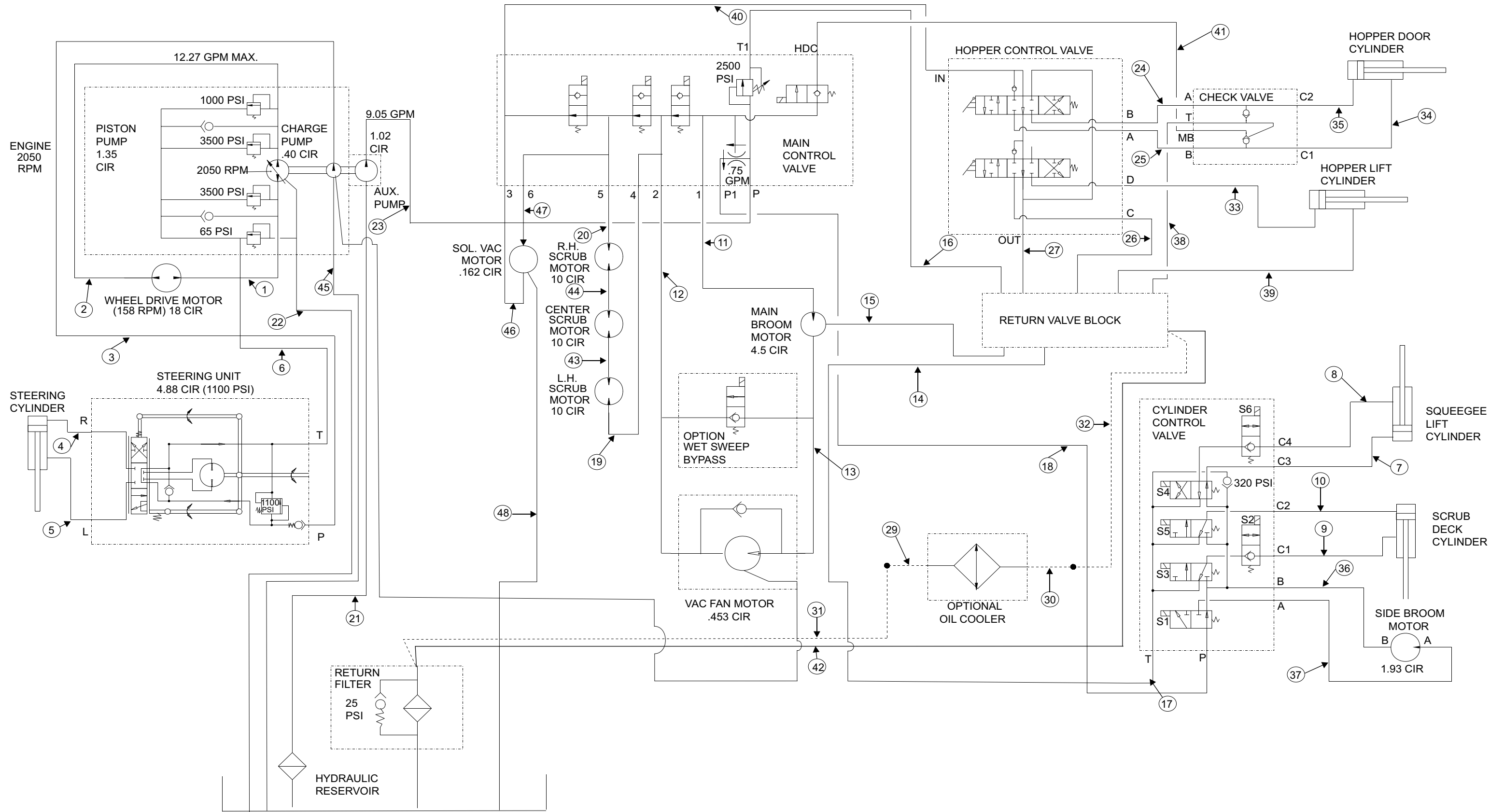

MAIN BROOM HYDRAULICS

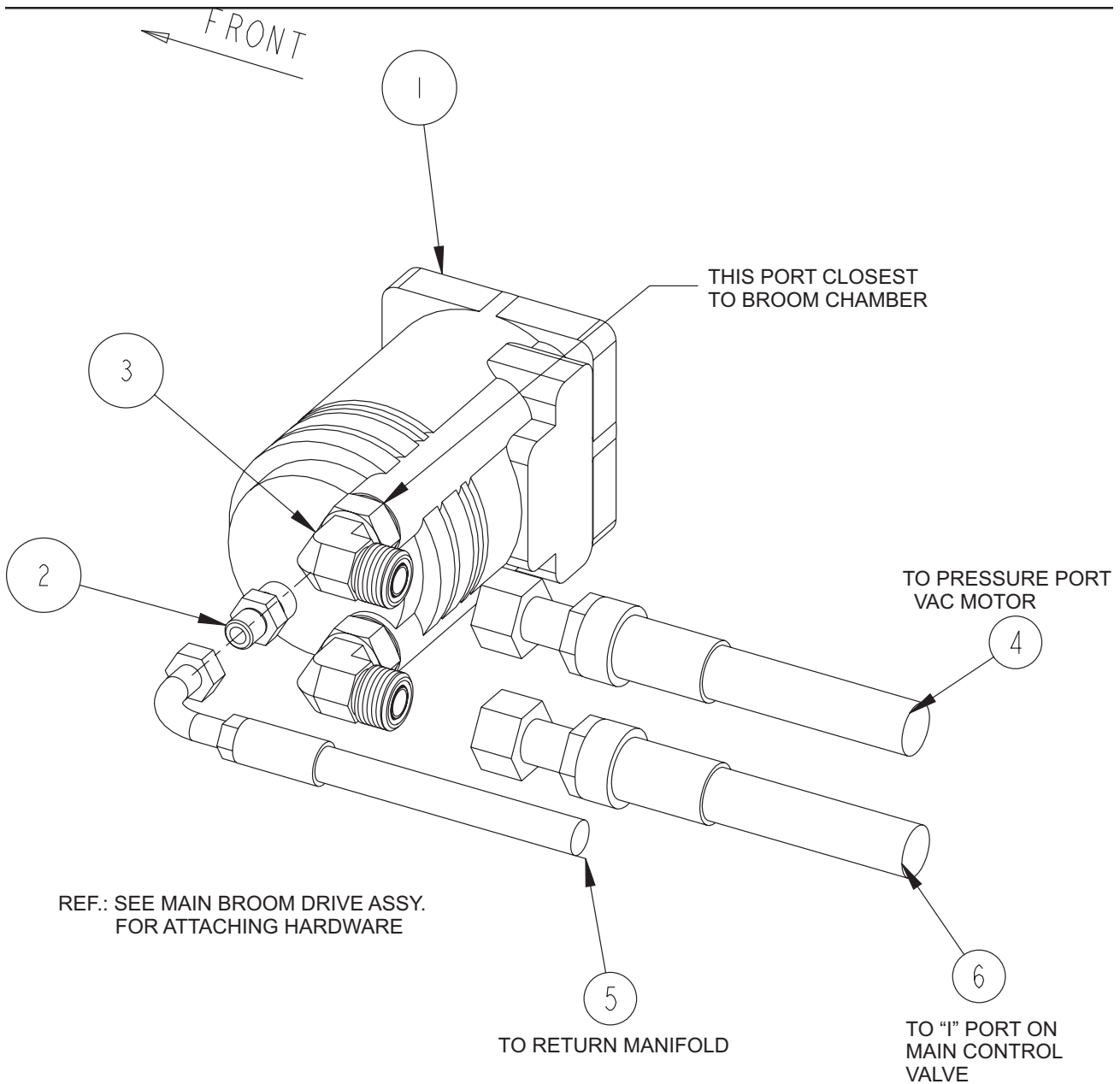

C1662ecp-IC

KEY NO.	PART NUMBER	DESCRIPTION	QTY.
1	0882-040 2-00-03838 0880-448	Hyd. Motor Key (comes w/motor) Motor Seal Kit (Service Part)	1
2	2-00-04895	Fitting, Straight Connector	1
3	2-00-04885	Fitting, 90° Elbow (O-Ring)	2
4	7-33-02332	Hose, #8 ORS STR-90°, 102"	Ref
5	8-33-02200	Hose, #4 ORS STR-90°, 55"	Ref
6	8-33-02324	Hose, #8 ORS STR-STR, 72"	Ref

C1662ecp-IC/9-04

SIDE BROOM HYDRAULICS

TO PORT "B" ON CYLINDER
CONTROL VALVE

TO PORT "A" ON CYLINDER
CONTROL VALVE

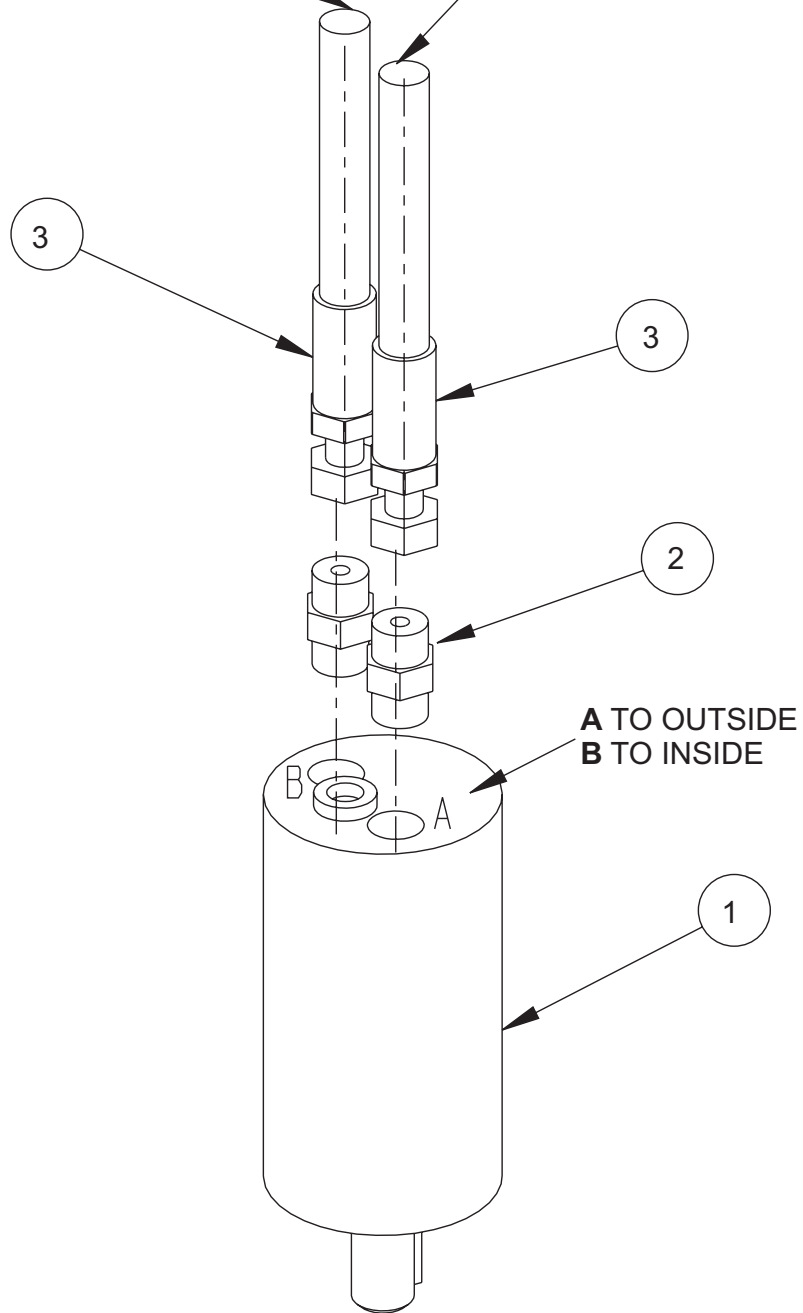

KEY NO.	PART NUMBER	DESCRIPTION	QTY.
1	0885-061	Hyd. Motor	1
	0780-144	Motor Seal Kit (service part)	
2	2-00-04918	Straight Fitting	2
3	7-33-02353	Hose, 98.5"	Ref

C1658/0402

American-Lincoln®
SC7750 IC

2-73

HOPPER LIFT HYDRAULICS

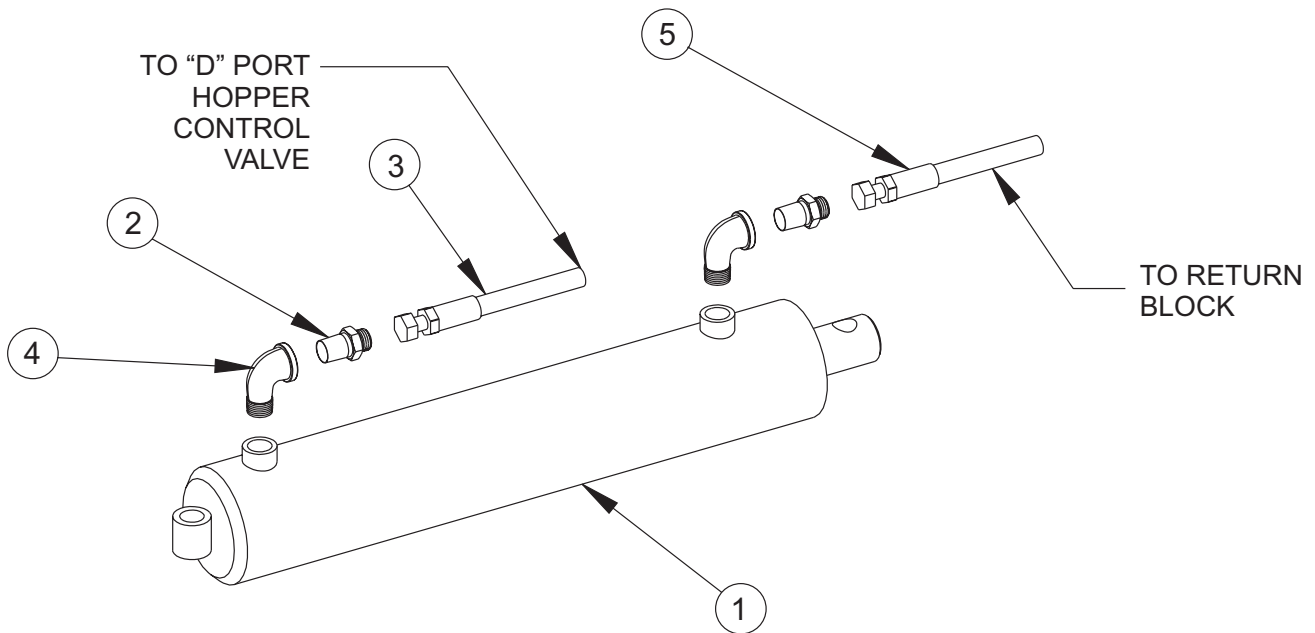

<u>KEY NO.</u>	<u>PART NUMBER</u>	<u>DESCRIPTION</u>	<u>QTY.</u>
1	8-17-05022	Cylinder, Rotation	1
	0880-183-1	Cylinder Seal Kit (service part)	
2	2-00-05054	Fitting, 9/16-18 to 3/8-18 Adapter	2
3	7-33-02352	Hose, #4 ORS 0-90° Swivel 71"	Ref
4	2-00-04589	Fitting, 3/8 to 3/8 90° Street Elbow	1
5	7-33-02191	Hose, #4 ORS, 0-90° , 42"	Ref

C1654ecp-IC/9-04

HOPPER DUMP DOOR HYDRAULICS

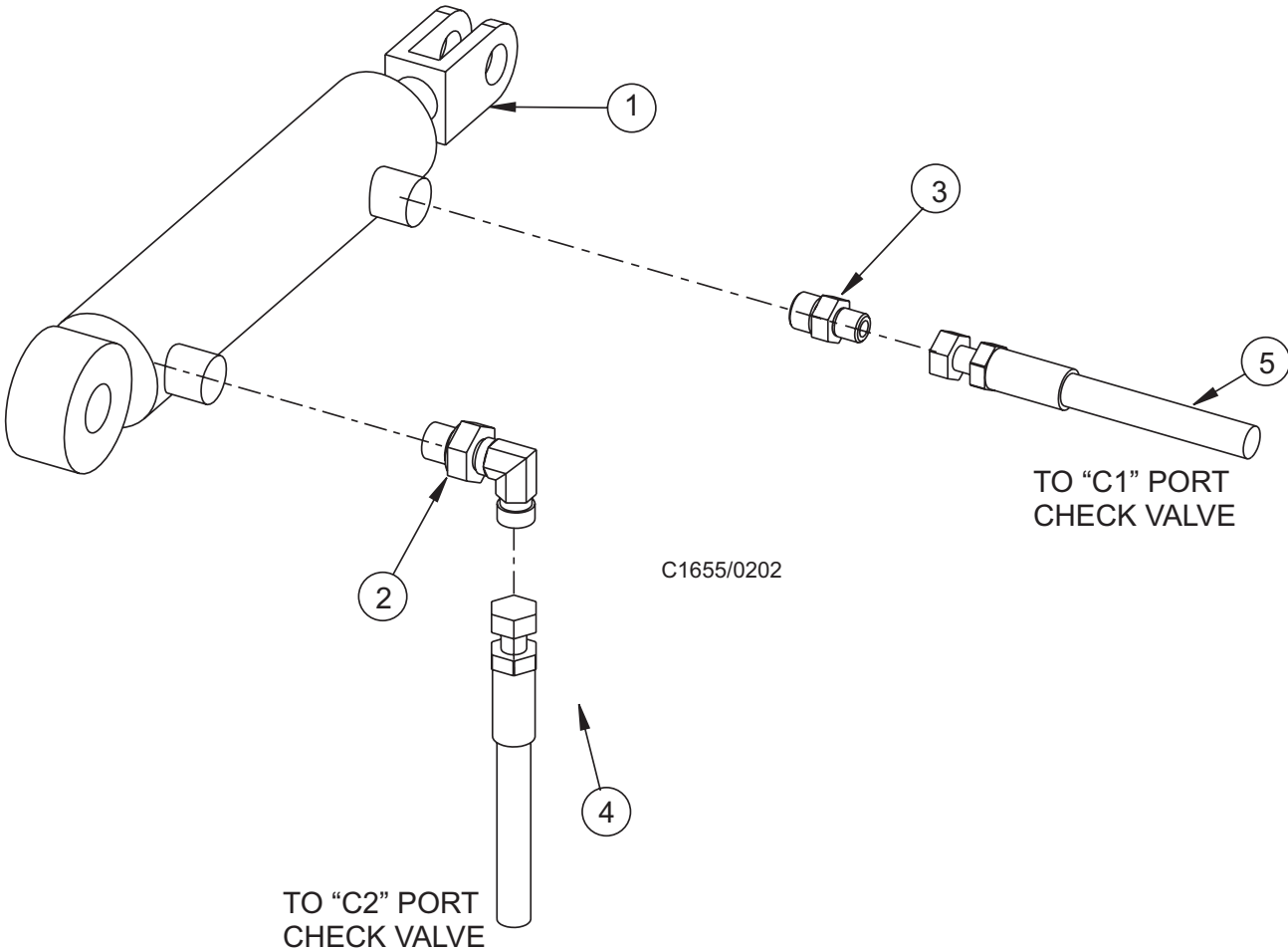

<u>KEY NO.</u>	<u>PART NUMBER</u>	<u>DESCRIPTION</u>	<u>QTY.</u>
1	7-17-05011	Cylinder	1
	7-70-00021	Cylinder Seal Kit (service part)	
2	2-00-04926	#4 SAE to #4 ORS 90°	1
3	2-00-04895	#4 SAE to #4 ORS	1
4	7-33-02342	#4 Hose STR 92.5"	Ref
5	8-33-02216	#4 Hose STR 88.0"	Ref

C1655/0402

HOPPER CONTROL CHECK VALVE HYDRAULICS

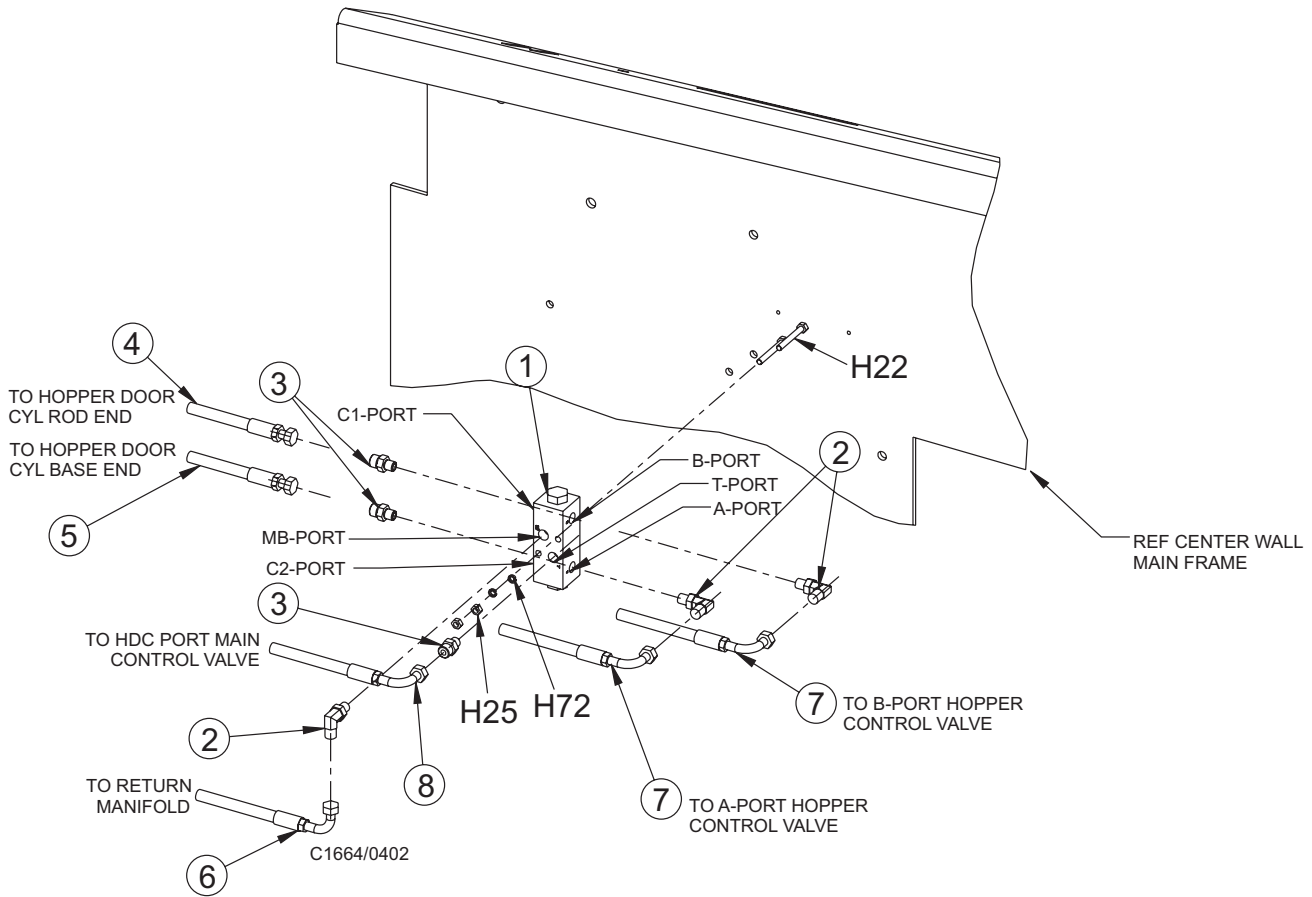

KEY NO.	PART NUMBER	DESCRIPTION	QTY.
1	8-88-00064	Check Valve Assembly	1
2	2-00-04892	Fitting - #4 SAE to #4 ORS 90°	3
3	2-00-04895	Fitting - #4 SAE to #4 ORS	3
4	8-33-02216	Hose - #4 ORS STR Ends, 88.0"	Ref.
5	7-33-02342	Hose #4 ORS STR Ends, 92.5"	Ref.
6	7-33-02191	Hose #4 ORS STR - 90° 42.0"	Ref.
7	7-33-02394	Hose #4 ORS STR - 90° 11.75"	Ref.
8	8-33-02200	Hose #4 ORS STR Ends 55.0"	Ref.

HARDWARE USED:

H22	2-00-02589	Screw, 1/4-20 x 2.000 HHC	2
H25	2-00-00594	Nut, Hex 1/4-20 x .437 x .218	2
H72	2-00-00518	Lock Washer, Helical Spring	2

C1664/9804

SCRUB DECK LIFT HYDRAULICS

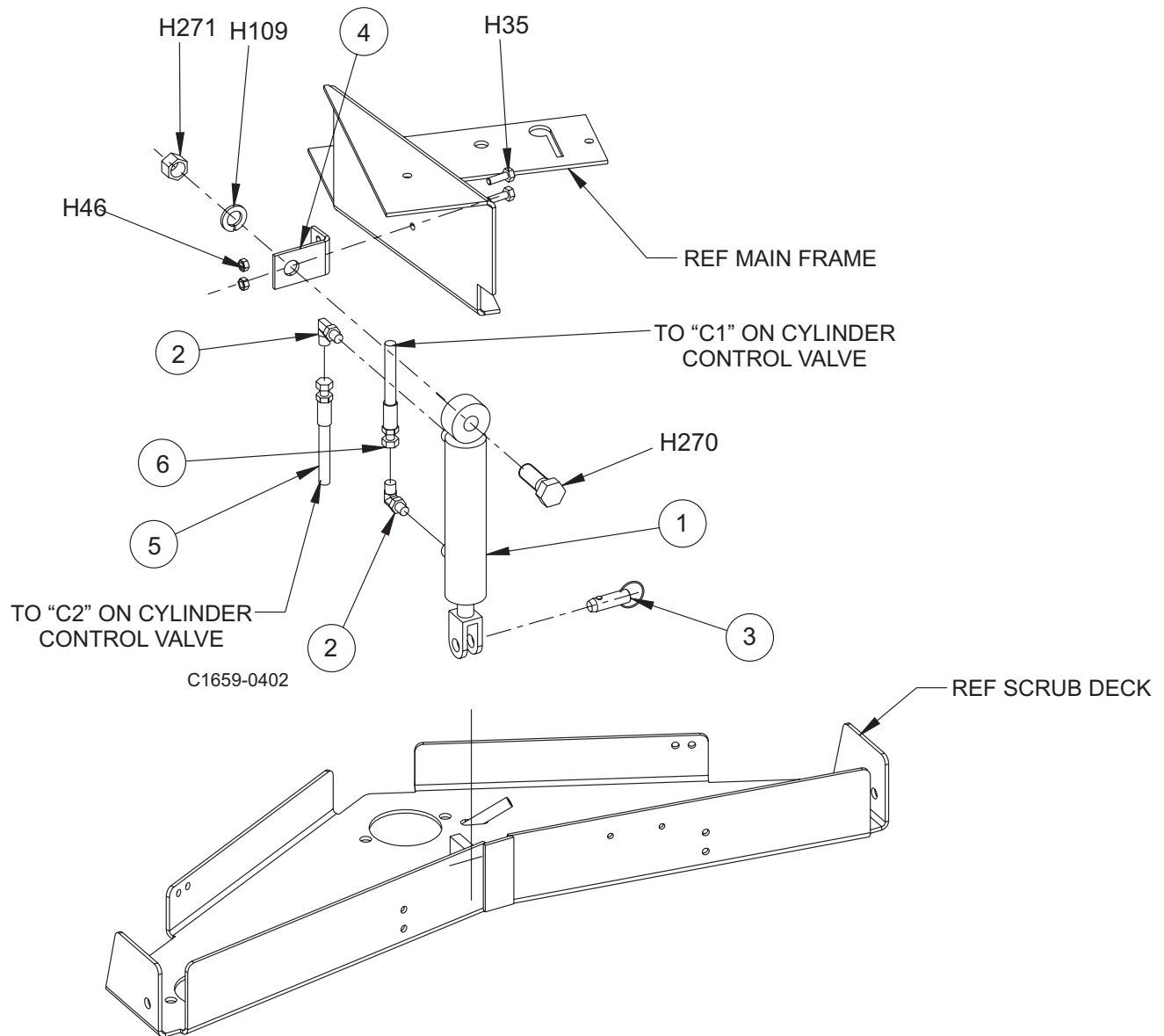

<u>KEY NO.</u>	<u>PART NUMBER</u>	<u>DESCRIPTION</u>	<u>QTY.</u>
1	7-17-05011	Cylinder , Lift	1
	7-70-00021	Cylinder Seal Kit (service part)	
2	2-00-04892	Fitting, 90° Elbow (O-Ring)	2
3	7-55-08151	Pin, Lock-Up	1
4	7-08-01022	Bracket, Cylinder Pivot	1
5	7-33-02366	Hose 34.0"	1
6	7-33-02225	Hose 38.0"	1

HARDWARE USED:

H35	2-00-02708	Screw, 5/16-18 x 1.000 HHM	2
H46	2-00-00644	Nut, 5/16-18, Insert Fiber	2
H109	2-00-00522	Lock Washer, 3/4 Helical Spring	1
H270	2-00-05341	Screw, HHC .75-10 x 2.00	1
H271	2-00-03293	Nut-Hex-Fin .75-10	1

C1659/0202

SCRUB DECK HYDRAULICS

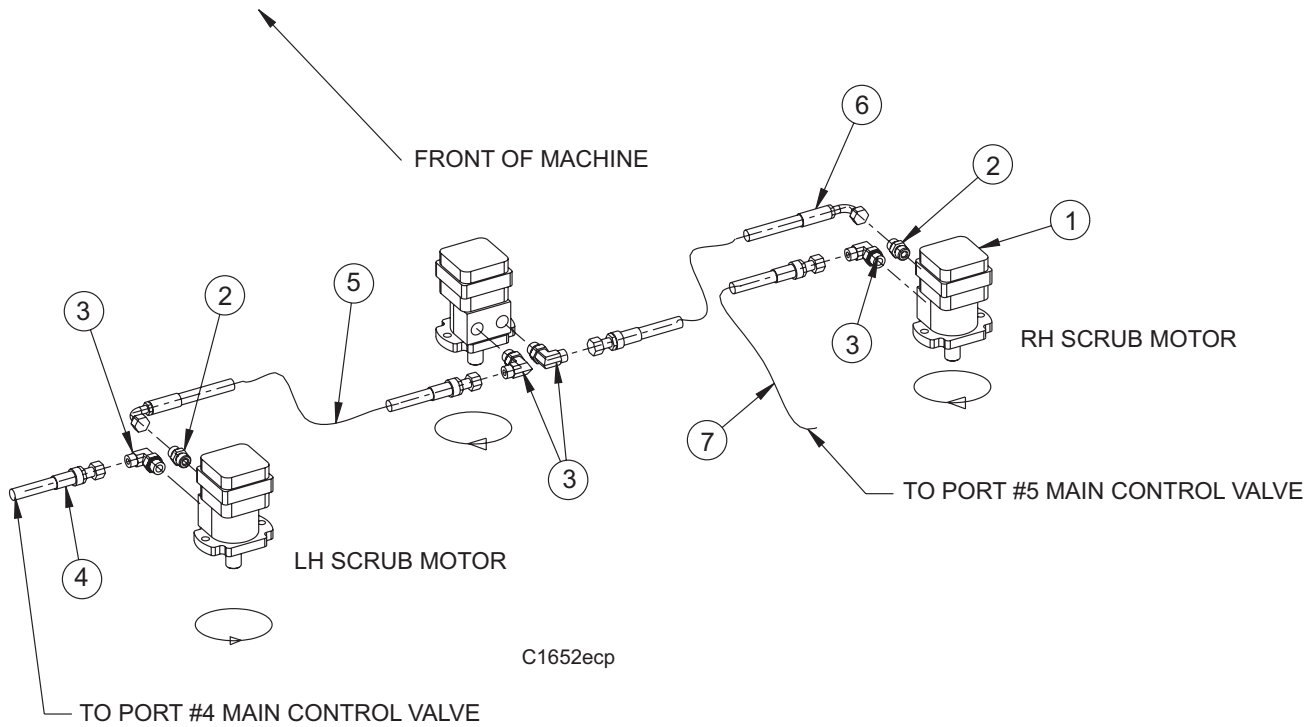

<u>KEY NO.</u>	<u>PART NUMBER</u>	<u>DESCRIPTION</u>	<u>QTY.</u>
1	0782-111 0780-070	Hydraulic Motor Motor Seal Kit (service part)	3
2	2-00-04974	#10 SAE to #8 ORS	2
3	2-00-04921	#10 SAE to #8 ORS, 90°	4
4	7-33-02347	#8 Hose STR - 90° 49.0"	Ref.
5	7-33-02354	#8 Hose STR - 90° 13.5"	Ref.
5*	7-33-02327	#8 Hose STR - 90° 15.25"	Ref.
6	7-33-02327	#8 Hose STR - 90° 15.25"	Ref.
6*	7-33-02326	#8 Hose STR - 90° 15.25"	Ref.
7	7-33-02428	#8 Hose STR - 90° 57"	Ref.

* These hoses are for 53" Scrub Deck

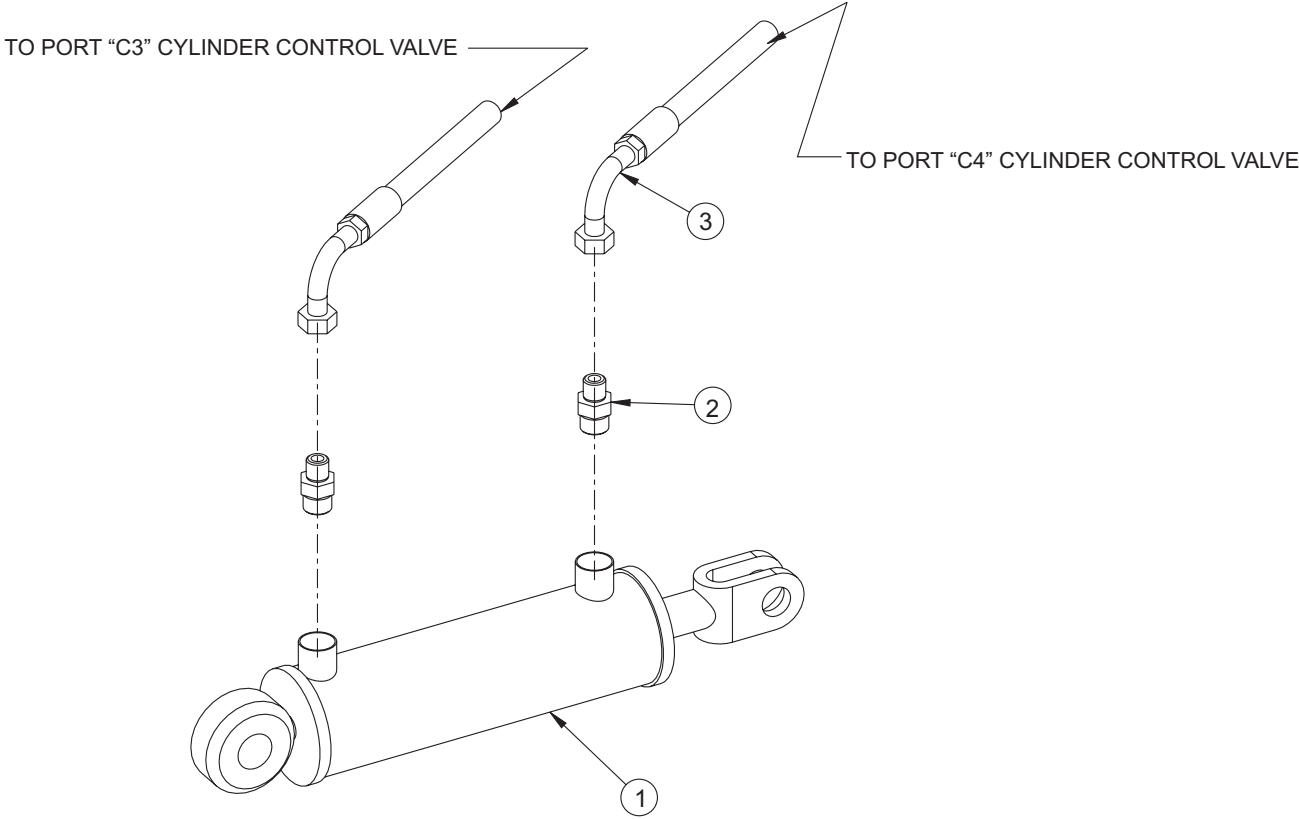

C1656/0402

<u>KEY NO.</u>	<u>PART NUMBER</u>	<u>DESCRIPTION</u>	<u>QTY.</u>
1	7-17-05019 0780-402	Cylinder Cylinder Seal Kit (service part)	1
2	2-00-04895	#4 SAE to #4 ORS	2
3	7-33-02190	#4 Hose ORS STR-90 67.0"	Ref

C1656/0402

HYDRAULIC RESERVOIR - PARTS LIST

<u>KEY NO.</u>	<u>PART NUMBER</u>	<u>DESCRIPTION</u>	<u>QTY.</u>
1	7-83-04219	Hydraulic Reservoir	1
2	7-08-00878	Bracket, Reservoir Mtg	2
3	7-24-04031	Filter, Return (Immersed)	1
4	8-11-00026	Filter Cap, Reservoir	1
5	8-24-04115	Strainer	1
6	8-48-05033	Sight Gauge	1
7	2-00-05265	Fitting, 90° ORS/Male NPTF	1
8	2-00-05203	Fitting, STR ORS 13/16-16 x 1/2 NPT	1
9	2-00-02474	Plug, 1/2 NPT	1
10	2-00-05387	Fitting, #12 ORS x 3/4-14 NPT	1
11	2-95-04182	Nut, Elastic Stop Nut	6
12	2-00-00233	Screw, 3/8-16 x 1.000 HHC	6
13	2-00-05261	Insert, Threaded	2
14	2-00-00518	Lock Washer, Helical Spring	2
15	2-00-00205	Bolt, 1/4-20 x 1.0 Fin. Hex Head	2
16	2-00-05262	Insert, 10-24 Threaded	6
17	2-00-00056	Screw, 10-24 x .75 RHM	6
18	2-00-05436	Fitting, ORFS M to NPTF M 08 x 12	1
19	2-00-04892	Fitting, 90° Elbow (O-Ring)	1

C1691ecp/6-04

HYDRAULIC RESERVOIR - EXPLODED VIEW

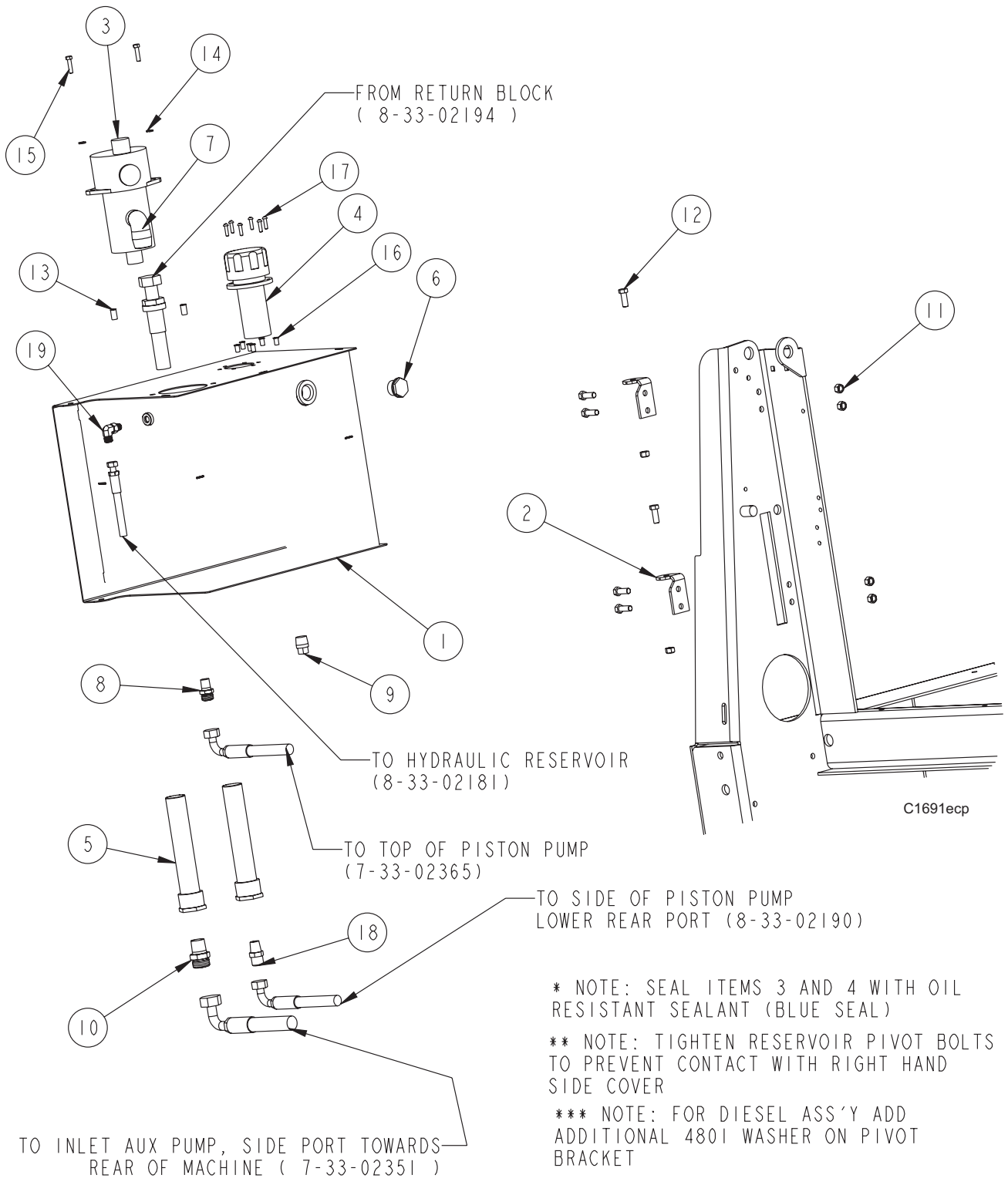

DRIVE WHEEL HYDRAULICS

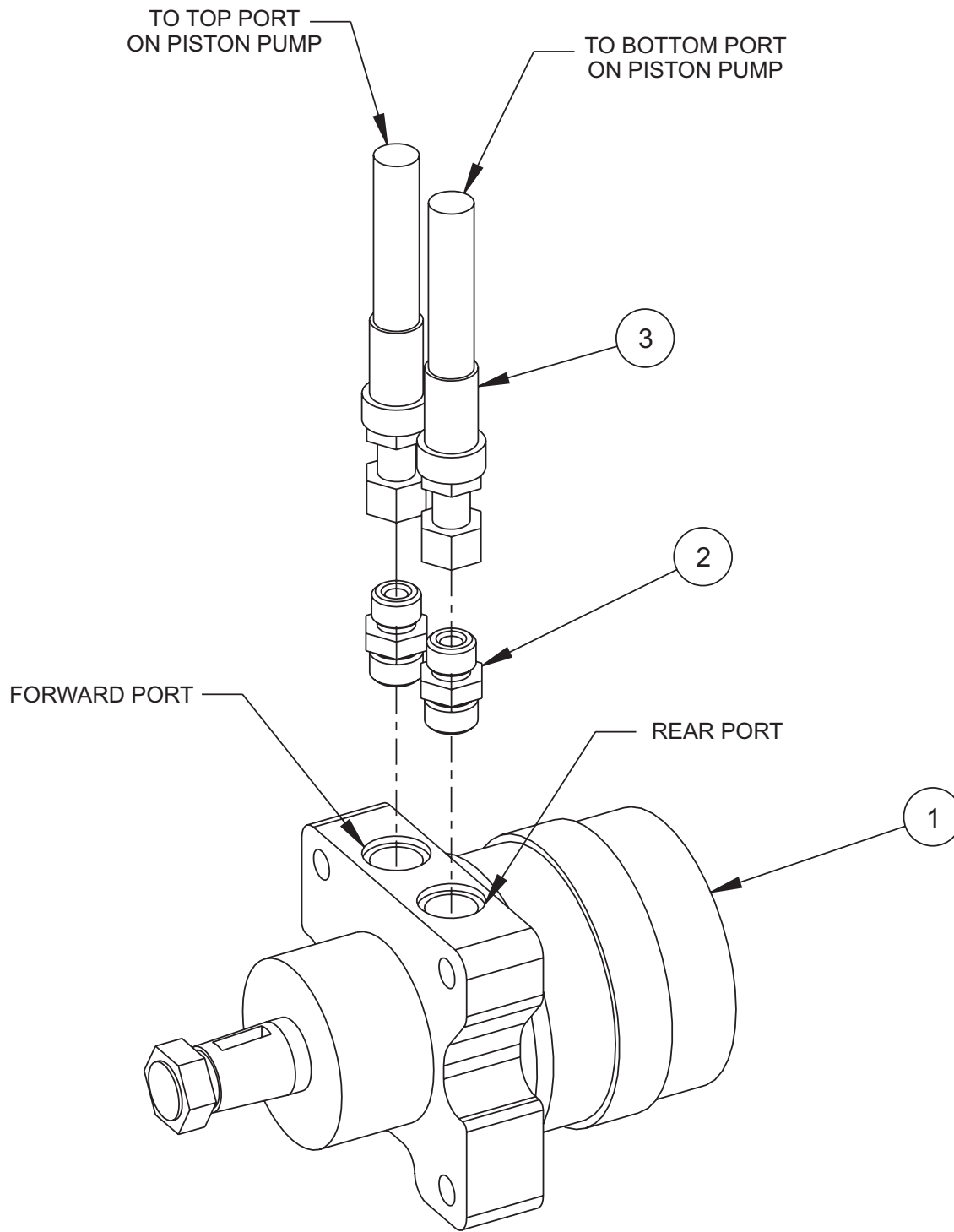

<u>KEY NO.</u>	<u>PART NUMBER</u>	<u>DESCRIPTION</u>	<u>QTY.</u>
1	0885-092	Hydraulic Motor	1
2	2-00-04974	Fitting #8 ORS to #10 SAE Connector	2
3	8-33-02196	Hose - #8 ORS STR Ends 75.5"	Ref.

C1661/9804

VAC MOTOR HYDRAULICS - EXPLODED VIEW

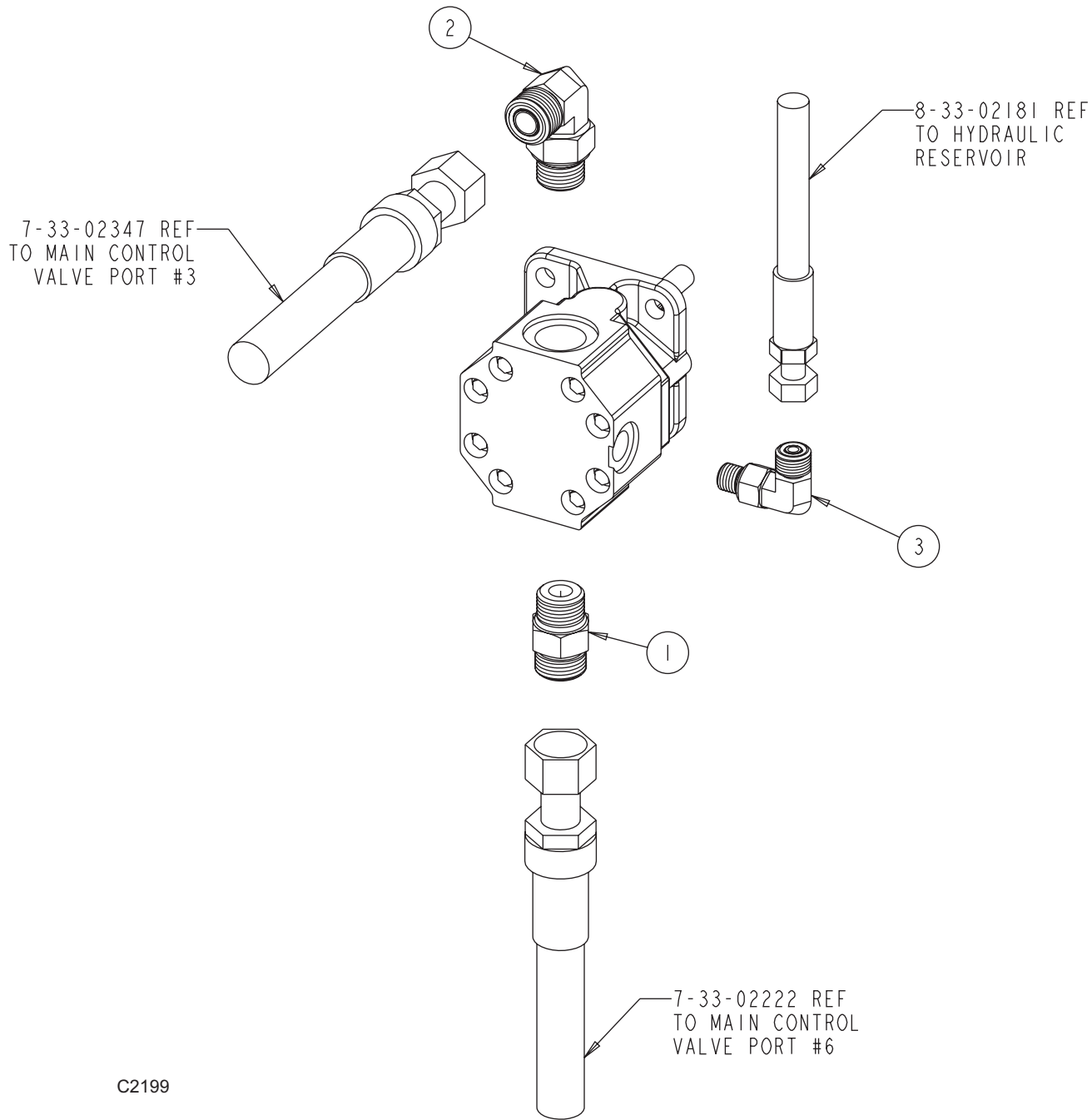

C2199

KEY NO.	PART NUMBER	DESCRIPTION	QTY.
1	2-00-04970	Fitting, Str. -8 ORS x -8 SAE	1
2	2-00-04885	Fitting, 90° Elbow (O-Ring)	1
3	2-00-04892	Fitting, 90° Elbow (O-Ring)	1

C2199/3-04

HYDRAULIC PUMP (WHEEL DRIVE) - PARTS LIST

<u>KEY NO.</u>	<u>PART NUMBER</u>	<u>DESCRIPTION</u>	<u>QTY.</u>
1	7-60-05023-1	Piston Pump	1
2	0885-067	Gear Pump	1
3	0880-404	Seal Kit	1
4	2-00-04970	Fitting-Connector	2
5	2-00-04885	Fitting-90° Elbow	1
6	2-00-05264	Fitting-ST-#4-#8	2
7	2-00-04920	Fitting-90° #16 SAE-12 ORS	1
8	7-78-05023	Pump Stop	1
9	2-00-04921	Fitting-#10 SAE to 8 ORS-90°	1
10	2-00-04983	O-Ring	1
11	7-33-02351	Hose #12ORS STR-90° 33"	Ref
12	7-33-02348	Hose #8ORS STR-90° 32"	Ref
13	7-33-02343	Hose #4ORS STR-90° 43.5"	Ref
14	7-33-02365	Hose #8ORS STR-45° 30"	Ref
15	7-33-02200	Hose #8ORS STR-45° 77"	Ref
16	7-33-02186	Hose #4ORS STR ends 30"	Ref
17	7-33-02348	Hose #8ORS STR-90° 32"	Ref
18	2-00-04978	Fitting-Branch Tee #8ORS	1
19	2-00-04924	Fitting-Reducer #8 ORS to 4	1
20	2-00-04939	Fitting-Reducer Nut	1
21	8-33-02176	Hose-#4ORS STR-90° 21"	Ref

HARDWARE USED:

H49	2-00-00209	Screw, 3/8-16 x 1.250 HHC	2
H52	2-00-00402	Flat Washer, .750 x .390 x .094	2
H53	2-00-02310	Lock Washer, Helical Spring 3/8 Med.	2

C1649/0203

HYDRAULIC PUMP (WHEEL DRIVE) - EXPLODED VIEW

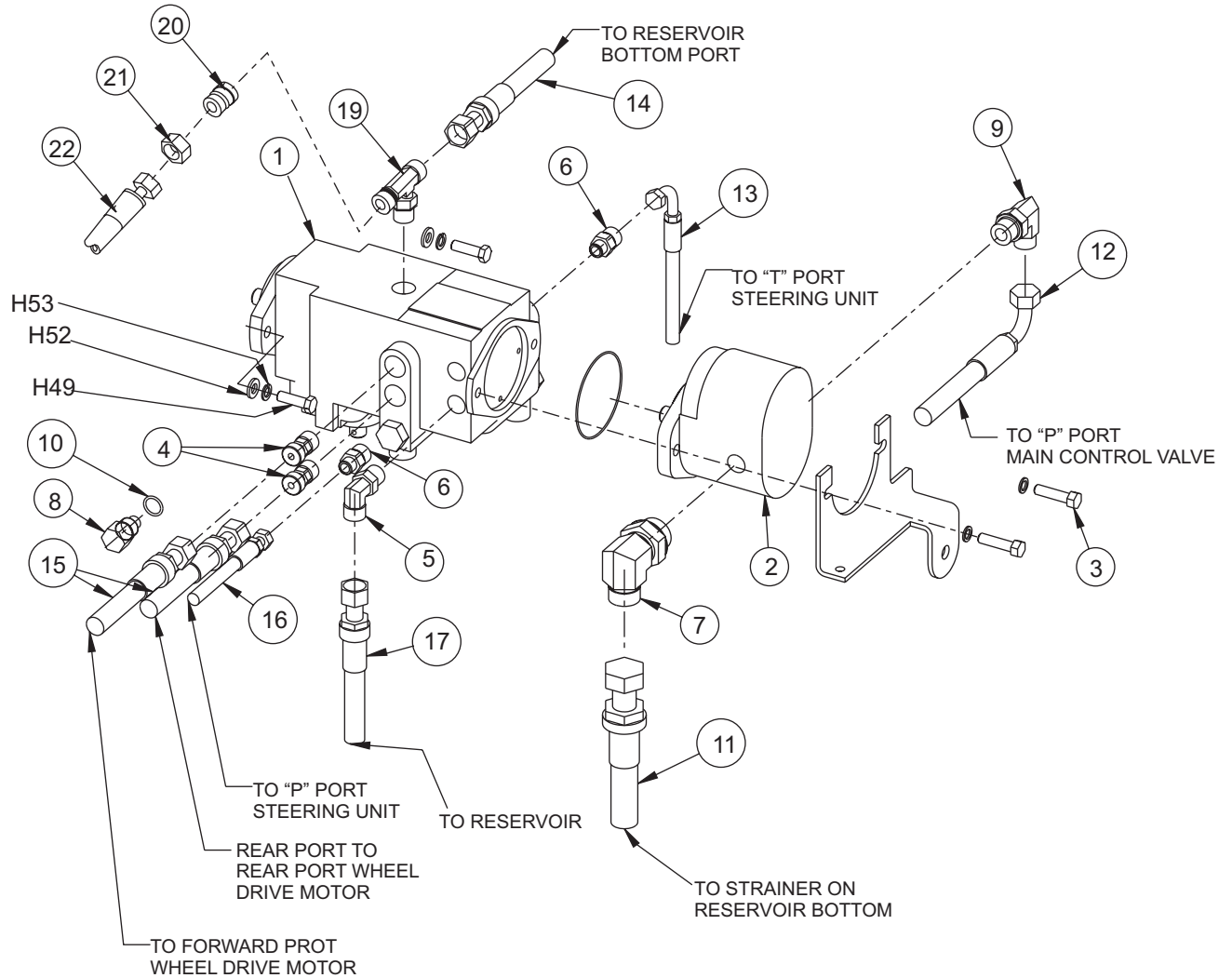

HYDRAULIC MAIN CONTROL VALVE - PARTS LIST

<u>KEY NO.</u>	<u>PART NUMBER</u>	<u>DESCRIPTION</u>	<u>QTY.</u>
1	7-88-00108	Main Control Valve	1
2	2-00-04885	Fitting, 90° Elbow (O-Ring)	4
3	2-00-04970	Fitting, Str. -8 ORS x -8 SAE	4
4	2-00-05264	Fitting, #8 SAE to #4 ORS Connector	1
5	2-00-04895	Fitting, Straight Connector	2
6	2-00-04928	Fitting, 13/16-16 x13/16-16 Tee	1
7	2-00-04957	Cap, 8 ORS	1
8	2-00-05276	Screw, 3/16-18 x 5.50 HHC	2
9	2-00-00518	Lock Washer, 1/4" Helical Spring	2
10	2-00-00594	Nut, 1/4-20 Hex	2

C1650ecp/6-04

HYDRAULIC MAIN CONTROL VALVE - EXPLODED VIEW

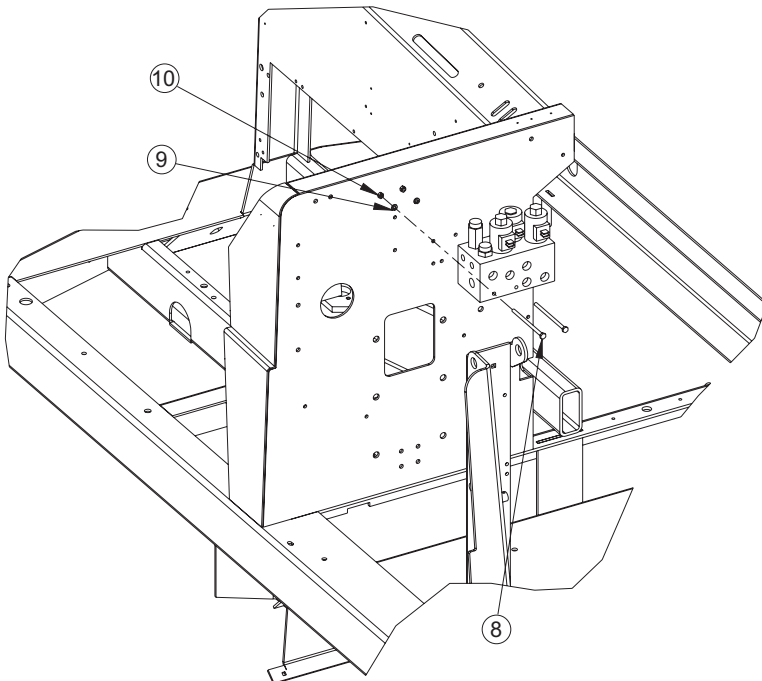
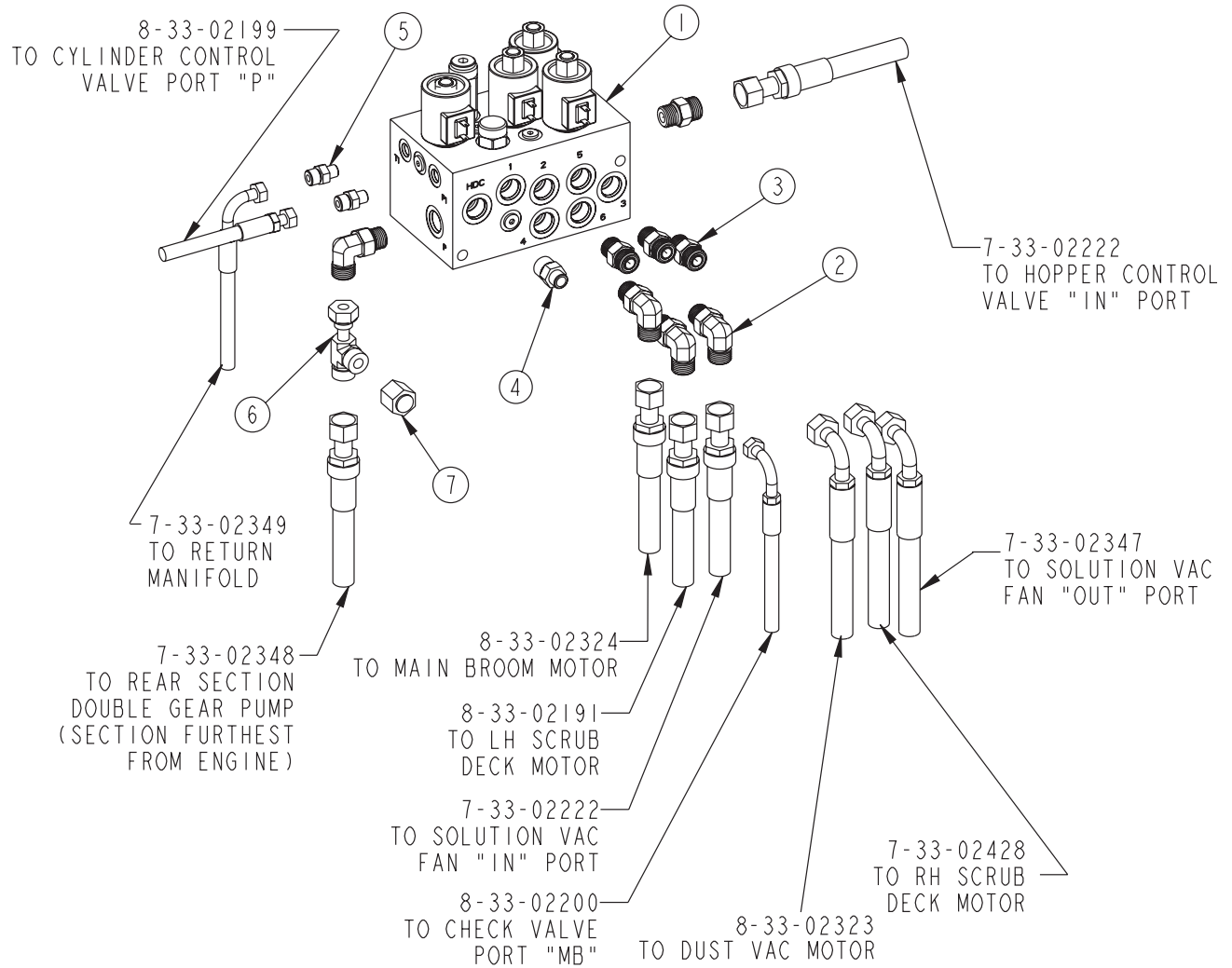

C1650ecprevE

HYDRAULIC CYLINDER CONTROL VALVE - PARTS LIST

<u>KEY NO.</u>	<u>PART NUMBER</u>	<u>DESCRIPTION</u>	<u>QTY.</u>
1	7-88-00069	Valve, Cylinder Control	1
2	2-00-04895	#4 SAE to #4 ORS Fitting	7
3	2-00-04892	#4 SAE to #4 ORS, 90°	1
4	8-33-02199	#4 Hose STR - 90° 24.5"	Ref.
5	8-33-02199	#4 Hose STR - 90° 24.5"	1
6	7-33-02353	#4 Hose STR - 90° 98.5"	Ref.
7	7-12-02034	Relief Valve Cartridge	1
8	7-33-02225	#4 Hose STR- 90° 38.0"	Ref.
9	7-33-02190	#4 Hose STR - 90° 67.0"	Ref.
10	7-33-02366	#4 Hose STR - 90° 34.0"	Ref.

HARDWARE USED:

H25	2-00-00594	Nut, Hex 1/4-20 x .437 x .218	2
H72	2-00-00518	Lock Washer, helical Spring	2
H172	2-00-04986	Screw, 1/4-20 x 4.500	2

C1651/9905

HYDRAULIC CYLINDER CONTROL VALVE - EXPLODED VIEW

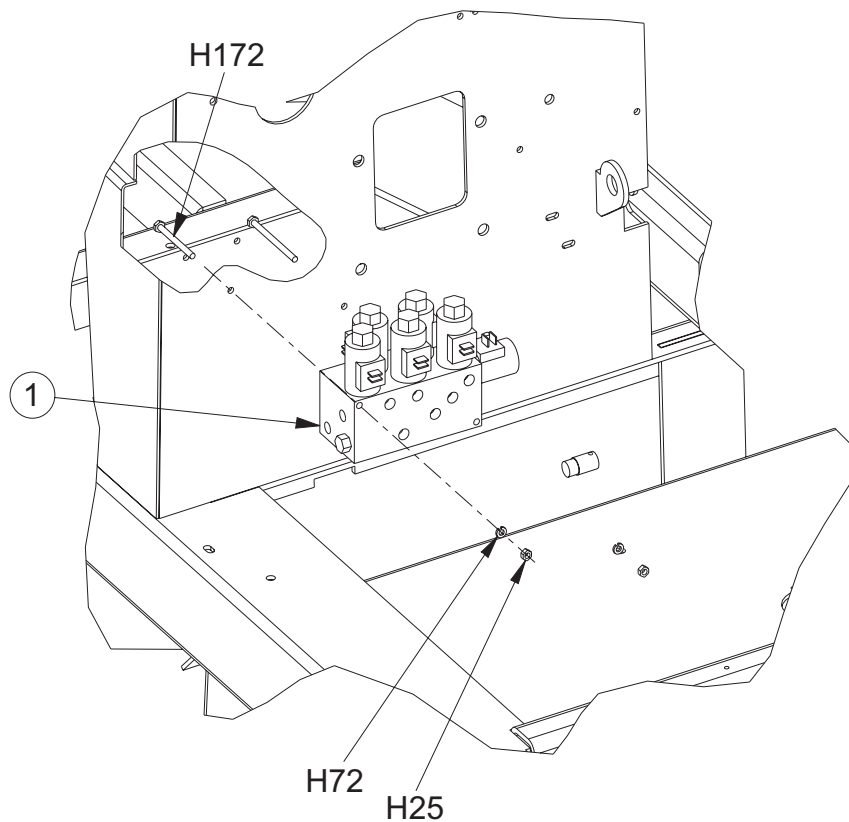
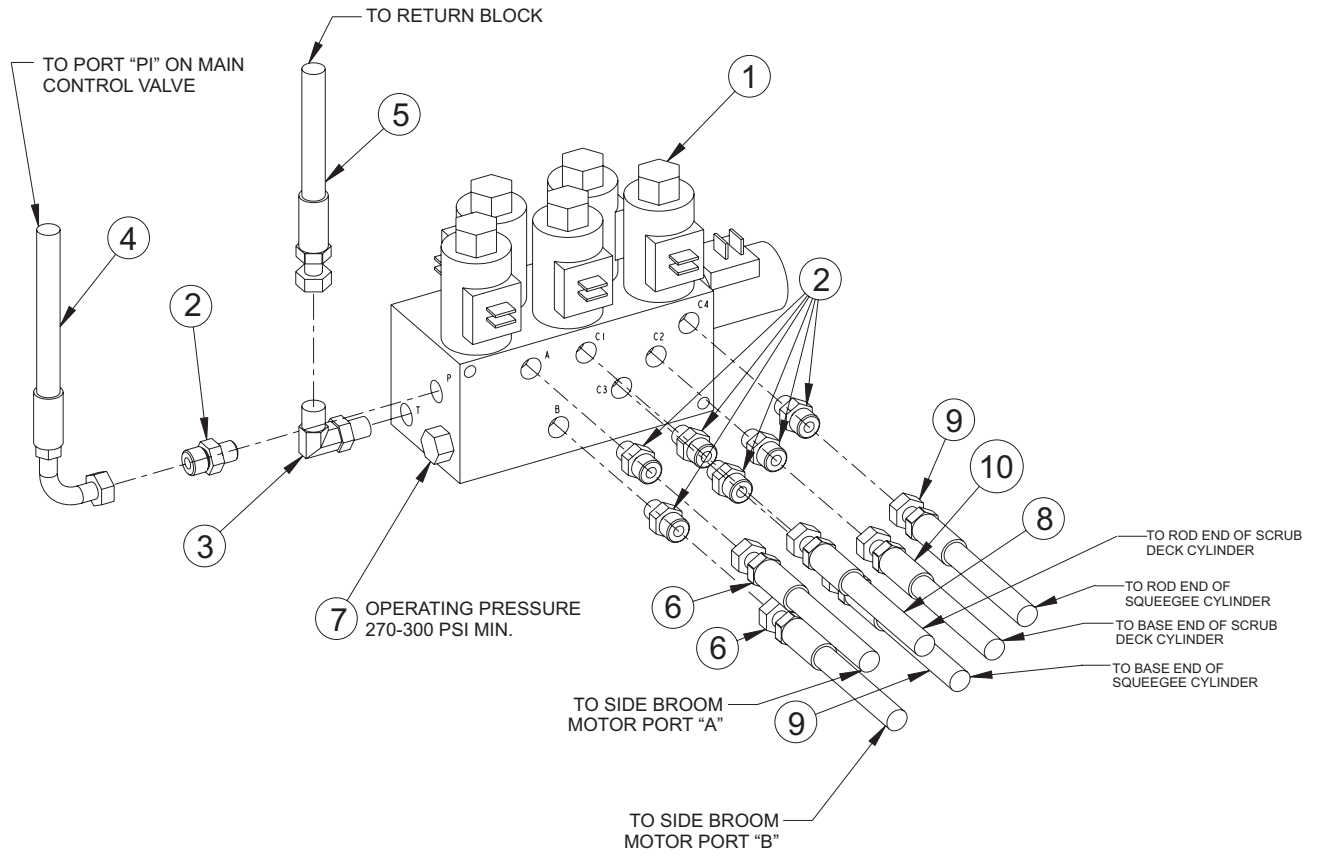

HYDRAULIC RETURN BLOCK - PARTS LIST

<u>KEY NO.</u>	<u>PART NUMBER</u>	<u>DESCRIPTION</u>	<u>QTY.</u>
1	7-48-00019	Return Block	1
2	2-00-05264	Fitting, Connector #8SAE - #4ORS	1
3	2-00-04885	Fitting, 90° Elbow (O-Ring)	1
4	2-00-05265	Fitting, 90° ORS/Male NPTF	1
5	2-00-04892	Fitting, 90° Elbow (O-Ring)	1
6	2-00-04895	Fitting, Straight Connector	4
7	7-33-02191	Hose, #4 ORS 0-90, 42.0"	Ref
8	8-33-02190	Hose, #4 ORS 0-90, 55.0"	Ref
9	7-33-02350	Hose, #4 ORS 0-90, Swivel 43.0"	Ref
10	7-33-02191	Hose, #4 ORS 0-45, 50.5"	Ref
11	8-33-02199	Hose, #4 ORS 0-90, 21.0"	Ref
12	8-33-02194	Hose, #12 ORS 0-90, 20.0"	Ref
13	2-00-05196	Plug, 3/4-16 O-Ring Boss	1
14	7-33-02298	Hose, #8 ORS STR, 42.0"	Ref
15	7-33-02349	Hose, #4 ORS 0-90, 11.75"	Ref

71124-07-IC/10-04

HYDRAULIC RETURN BLOCK - EXPLODED VIEW

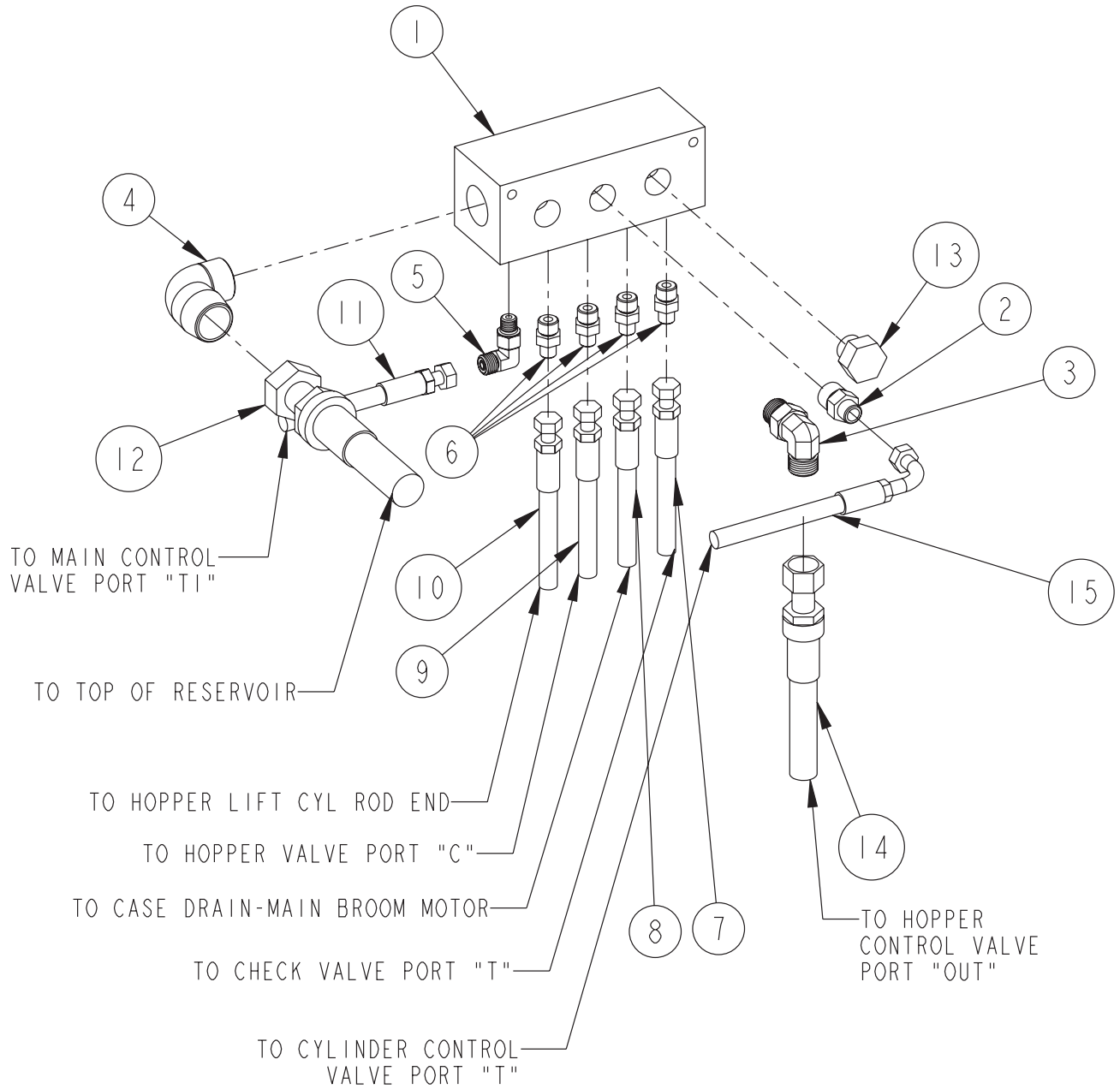

71124-07-IC/10-04

VAC FAN HOPPER HYDRAULICS

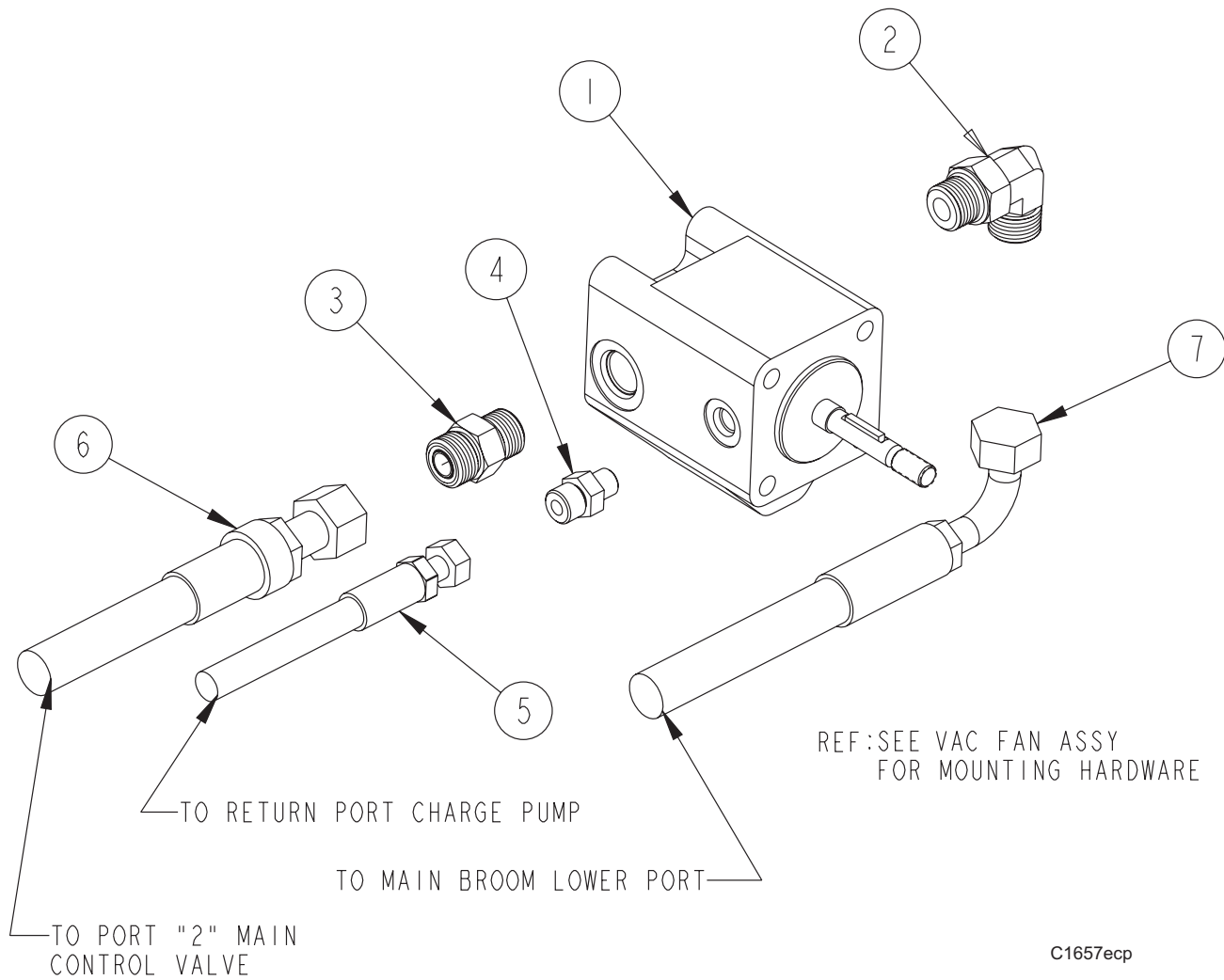

KEY NO.	PART NUMBER	DESCRIPTION	QTY.
1	0882-048 7-70-00020	Motor, Hydraulic Vacuum Motor Seal Kit (service Kit)	1
2	2-00-04885	Fitting, 90° Elbow (O-Ring)	1
3	2-00-04970	Fitting, Str., -8 ORS x -8 SAE	1
4	2-00-04895	Fitting, Straight Connector	1
5	7-33-02190	Hose, #4 ORS STR Ends, 66.0"	Ref
6	7-33-02323	Hose, #8 0-90°, 55.0"	Ref
7	7-33-02332	Hose, #8 ORS 0-90° Ends, 102.0"	Ref

C1657ecp/6-04

STEERING 90° - 90° HYDRAULICS

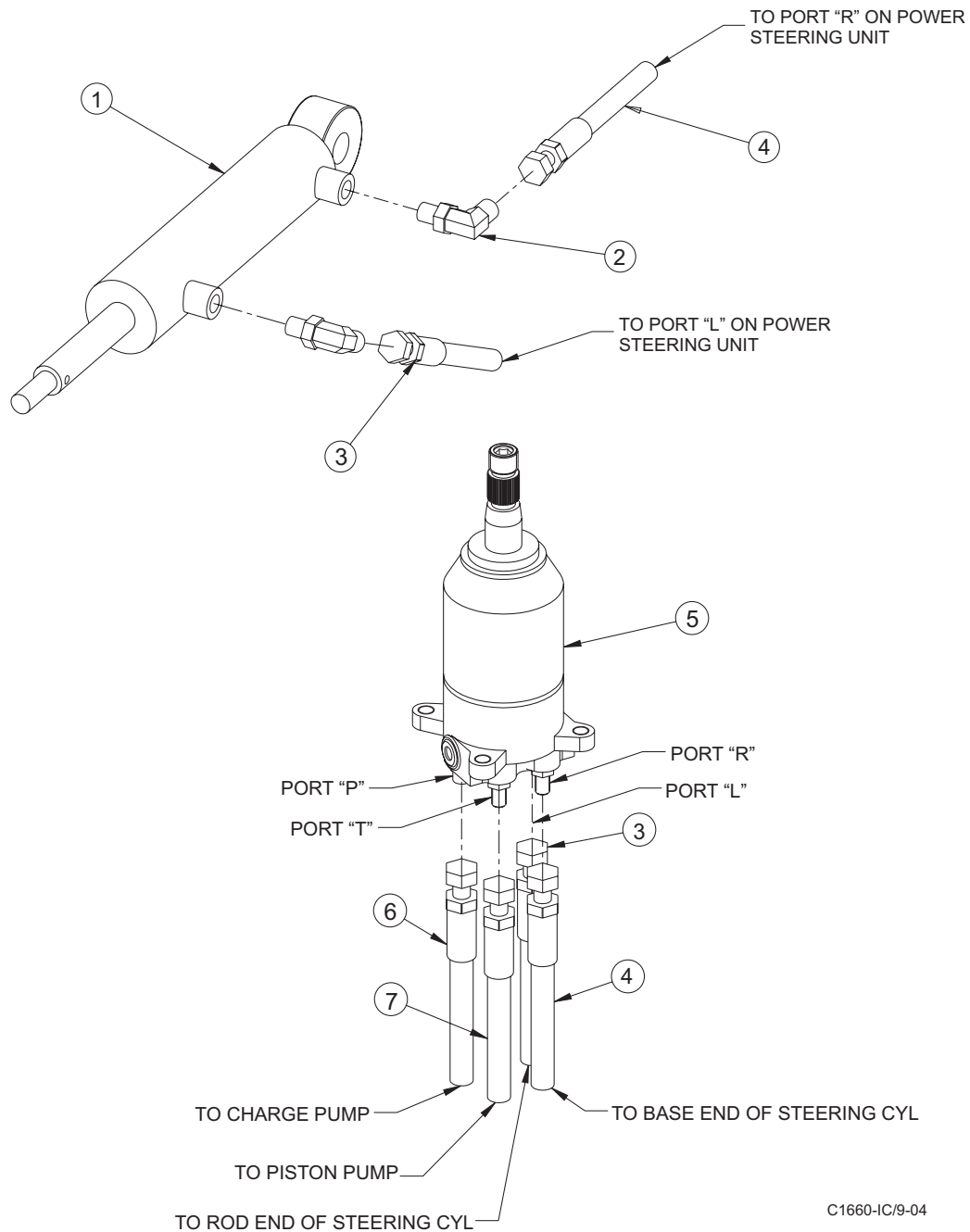

KEY NO.	PART NUMBER	DESCRIPTION	QTY.
1	7-17-05010 7-70-00021	Cylinder, Power Steering Cylinder Seal Kit (service part)	1
2	2-00-04892	Fitting, 90° Elbow (O-Ring)	2
3	8-33-02218	Hose, #4 STR Ends 60.0"	Ref
4	8-33-02185	Hose, #4 STR Ends 56.0"	Ref
5	8-60-05034	Steering Control Unit	1
6	7-33-02186	Hose, #4 STR-90° 30.0"	Ref
7	7-33-02343	Hose, #4 STR Ends 43.5"	Ref

C1660-IC/9-04

COVERS - PARTS LIST

<u>KEY NO.</u>	<u>PART NUMBER</u>	<u>DESCRIPTION</u>	<u>QTY.</u>
1	2-00-00585	Nut, 5/16-18 Hex	3
2	7-52-00199	Panel, Heat Baffle	1
3	7-81-00192	Support, Top Cover	1
4	8-32-00046	Hinge	2
5	7-52-00201	Panel, Heat Baffle (Gas/LP Only)	1
6	7-16-07396	Cover, LH Side	1
7	7-16-07385	Cover, RH Side	1
8	7-41-00062	Latch, RH Side	1
9	7-16-07383	Cover, Engine	1
10	2-00-00196	Carriage Bolt, 5/16-18 x 1.00	2
11	2-00-00644	Nut, 5/16-18, Insert Fiber	19
12	2-00-02708	Screw, 5/16-18 x 1.000 HHM	3
13	2-00-00409	Flat Washer, .687 x .344 x .062	20
14	2-00-00205	Screw, 1/4-20 x 1.000 HHC	3
15	2-00-03569	Carriage Bolt, .31-18 x .75	6
16	2-00-00208	Screw, 5/16-18 x .750 HHC	6
17	8-41-00040	Latch	1
18	7-52-00200	Panel, Heat Baffle (Diesel Only)	1

C1612ecp/6-04

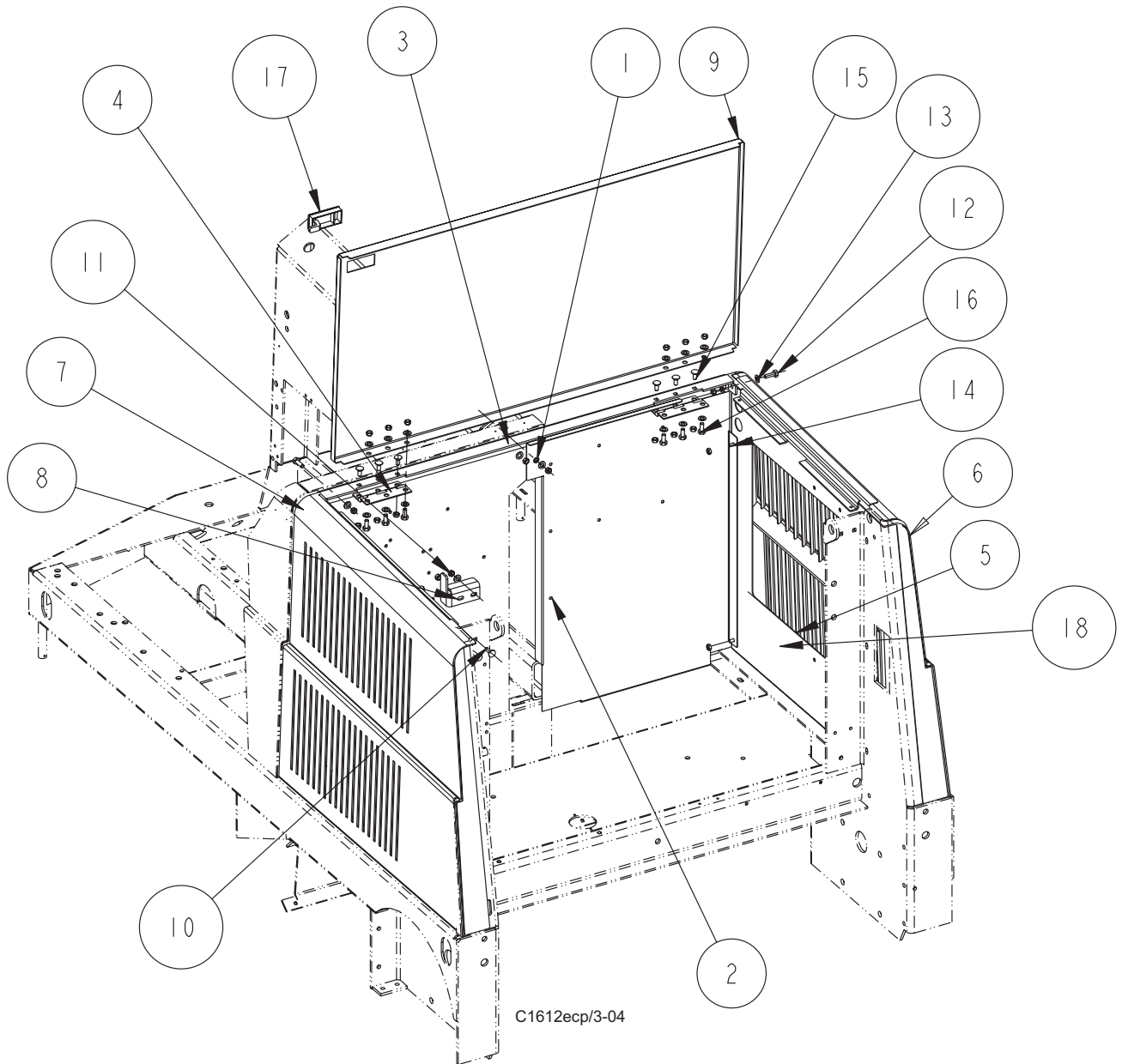
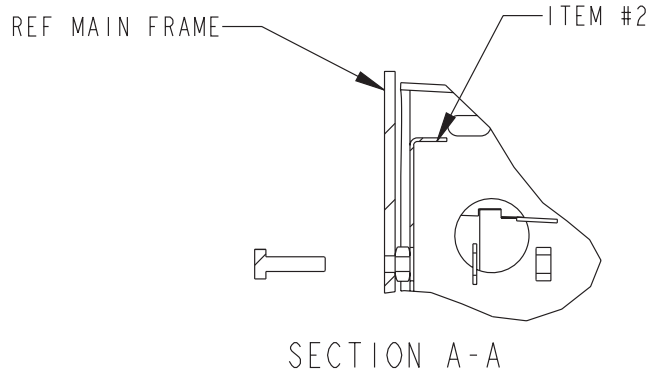

FORD 416EFI GAS ENGINE (HARDWARE) - PARTS LIST

<u>KEY NO.</u>	<u>PART NUMBER</u>	<u>DESCRIPTION</u>	<u>QTY.</u>
1<	7-16-05047	Coupling, Engine/Pump	1
2<	7-58-05338	Plate, Starter	1
3<	7-33-05145	Housing, Pump Mount	1
4	7-08-01185	Bracket, Tube Support Front	1
5	7-08-01179	Bracket, Right Front Leg	1
6	7-08-01180	Bracket, Left Front Leg	1
7	7-08-01181	Bracket, Cross	1
8	7-08-01183	Bracket, Alternator	1
9	7-35-00017	Isolator, Engine Mount (Red Dot)	5
10	2-00-05067	Spacer, Snubbing Washer	8
11	2-00-02617	Screw, 1/2-13 x 3.5 lg., SS	4
12	7-08-01186	Bracket, Tube Support Back	1
13	7-08-01182	Bracket, Cross	1
14	7-81-00274	Support, Engine	1
15	2-00-05955	Flat Washer, 1.25 ID x 2.00 OD x .25	3
16	7-75-01249	Spacer, Engine Mount	1
17	2-00-04816	Bolt, 1/2-13 x 4.0 Hex	1
18	2-00-04936	Nut, 1/2-13 Elastic Lock	5
19	2-00-05329	Bolt, .39 dia. x 1.57 lg.	2
20	2-00-00402	Washer, 25/64 ID x 3/4 OD	4
21	2-00-00209	Bolt, 3/8-16 x 1.25 Hex Head	4
22	2-00-01254	Screw, 1/2-13 x 1.50 Hex	2
23	2-00-05963	Screw, M8 x 1.25 x 15mm 8.8 Blox HHC	6
24	2-00-04363	Screw, M8 x 1.25 x 20mm	7
25	2-00-00641	Nut, 1/4-20 Fiber Insert	2
26	2-00-05922	Bolt, M10-1.5 x 30mm Hex Head	1
27	2-00-05041	Lock Washer, M8 Helical Spring	4
28	2-95-04182	Nut, 3/8-16 Hex Stop	4
29	0777-047	Engine, 416EFI Gas	REF
	0777-058	Engine, 416EFI Gas (Export Only)	REF

<Comes with Engine Assy.

C2202/3-04

FORD 416EFI GAS ENGINE (HARDWARE) - EXPLODED VIEW

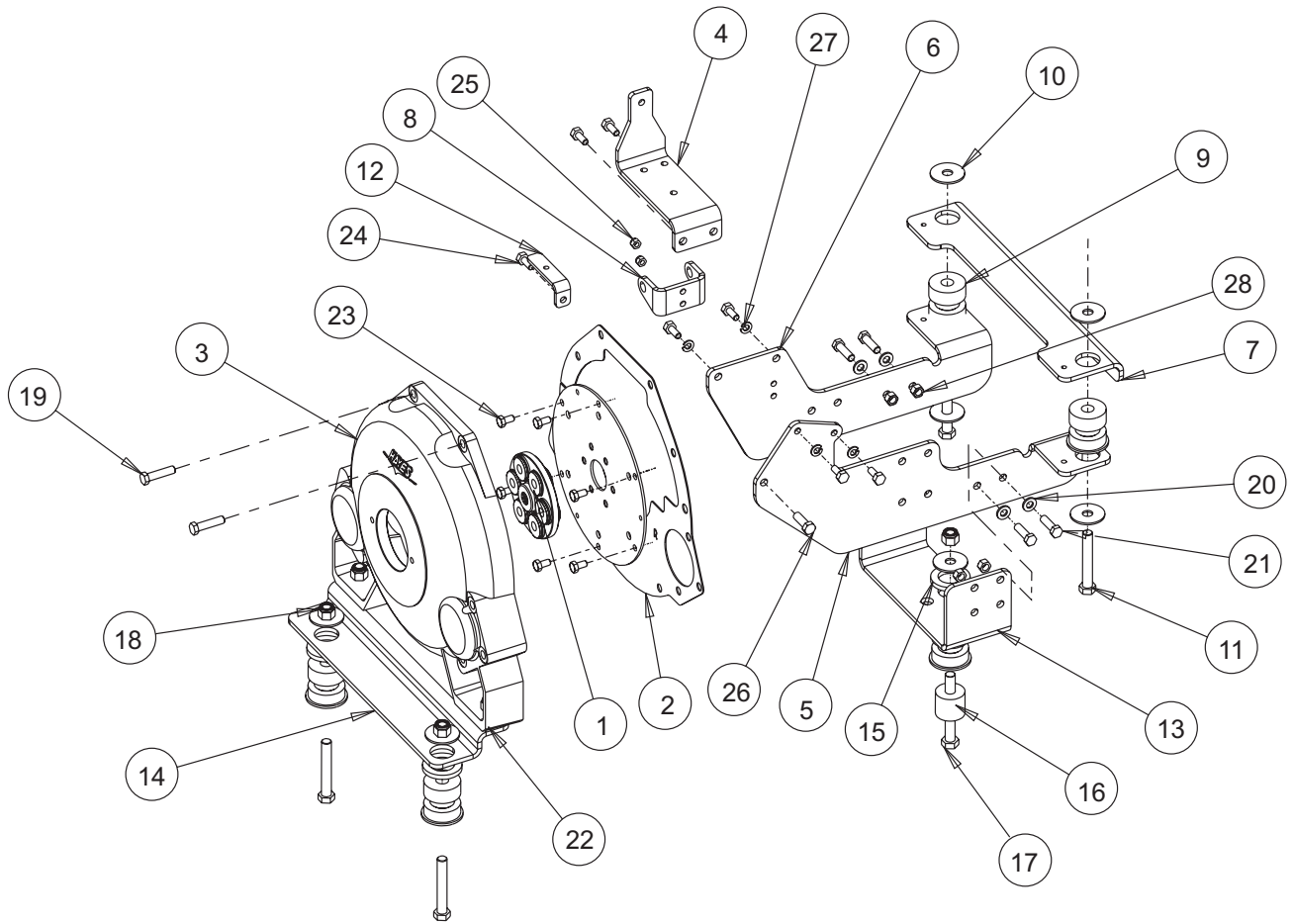

C2202

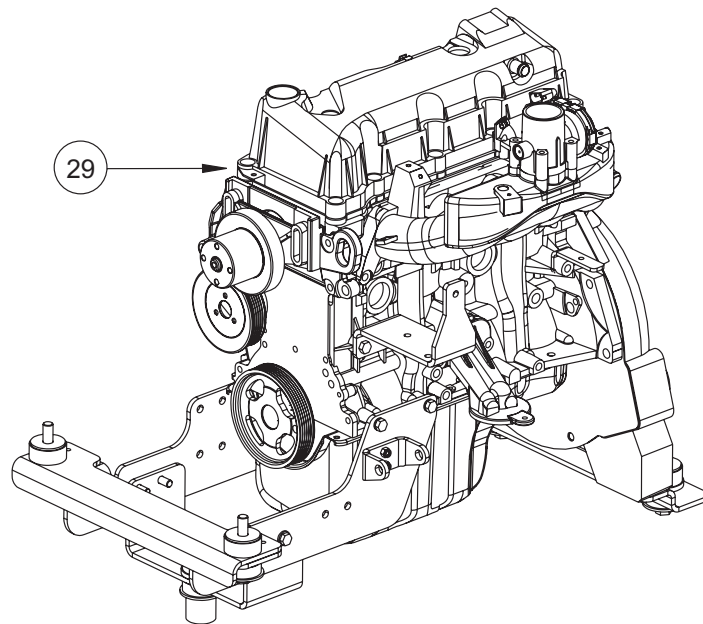

FORD 416EFI GAS ENGINE (AIR INTAKE, EXHAUST) - PARTS LIST

<u>KEY NO.</u>	<u>PART NUMBER</u>	<u>DESCRIPTION</u>	<u>QTY.</u>
1	0777-047	Engine, 416EFI Gas	REF
2	7-33-02607	Hose, Air Intake	1
3	7-08-02051	Bracket, Air Cleaner	1
4	7-13-07231	Band, Filter	1
5	7-24-04083	Filter Assy., Air Cleaner	1
6	2-00-00207	Screw, 5/16-18 x 1.25 Hex Head	2
7	2-00-00409	Flat Washer, .687 x .344 x .062	2
8	2-00-00644	Nut, 5/16-18 Fiber Insert Hex	2
9	2-00-02216	Clamp, Hose	2
10	7-24-04087	Filter Service Indicator (20" WC)	1
11	2-00-05329	Bolt, .39 dia. x 1.57	REF
12<	7-87-02234	Tube, Exhaust	1
13	7-58-05340	Plate, Exhaust Flange	1
14<~	7-11-04037	Catalytic Converter	1
15*	7-87-02225	Tube, Exhaust	1
16	7-49-00041	Muffler	1
17	7-56-04061	Pipe, Exhaust	1
18	7-87-02227	Tube, Exhaust	1
19	2-00-05970	Clamp, Muffler, 2"	2
20	2-00-04040	Clamp, Muffler, 1.25"	3

<North American Only

*Export Only

~Comes with Engine Assy.

C2002-2/2-04

FORD 416EFI GAS ENGINE (AIR INTAKE, EXHAUST) - EXPLODED VIEW

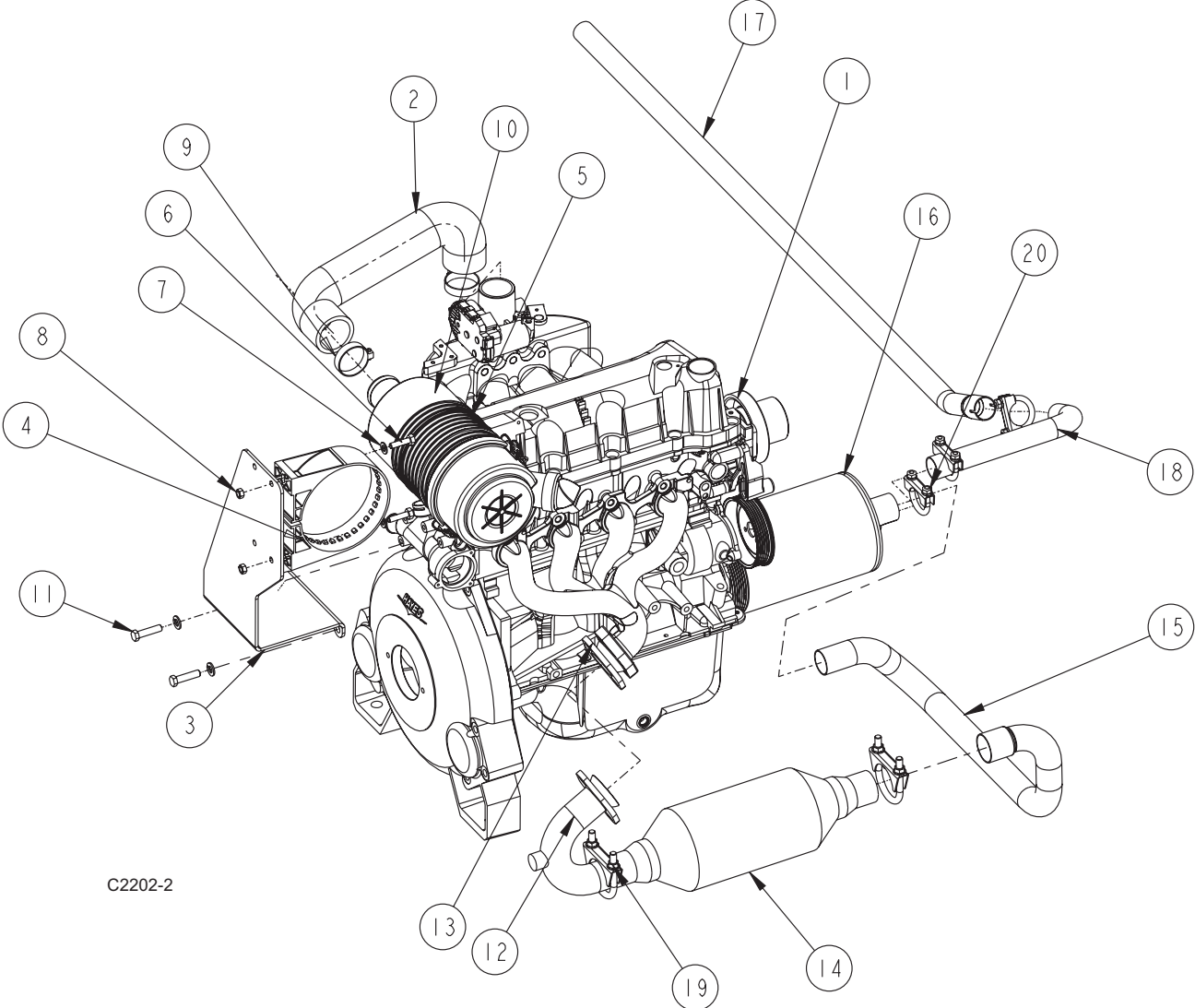

FORD 416EFI GAS ENGINE (FUEL SYSTEM) - PARTS LIST

<u>KEY NO.</u>	<u>PART NUMBER</u>	<u>DESCRIPTION</u>	<u>QTY.</u>
1	Ref	Main Frame	1
2	7-08-01222	Bracket, Fuel Pump Mounting	1
3<	7-08-01187	Bracket, Fuel Pump	2
4<	7-08-01188	Bracket, Fuel Filter	1
5	2-00-00205	Bolt, 1/4-20 Fin. Hex Head	4
6	2-00-03702	Washer, .625 x .281 x .063	4
7	2-00-00641	Nut, 1/4-20 Fiber Insert	4
8<	0769-030	Pump, Fuel	1
9<	7-24-04067	Filter, Fuel	1
10	7-33-02639	Hose, Fuel Low Pressure	1
11	7-33-02631	Hose, Fuel Return Line	1
12	8-33-02386	Hose, Fuel	1
13	2-00-06113	Clamp, Hose	6
14	7-33-02676	Hose, Fuel Line	1

<Comes with Engine Assy.

C2202-1PP/6-05

FORD 416EFI GAS ENGINE (FUEL SYSTEM) - EXPLODED VIEW

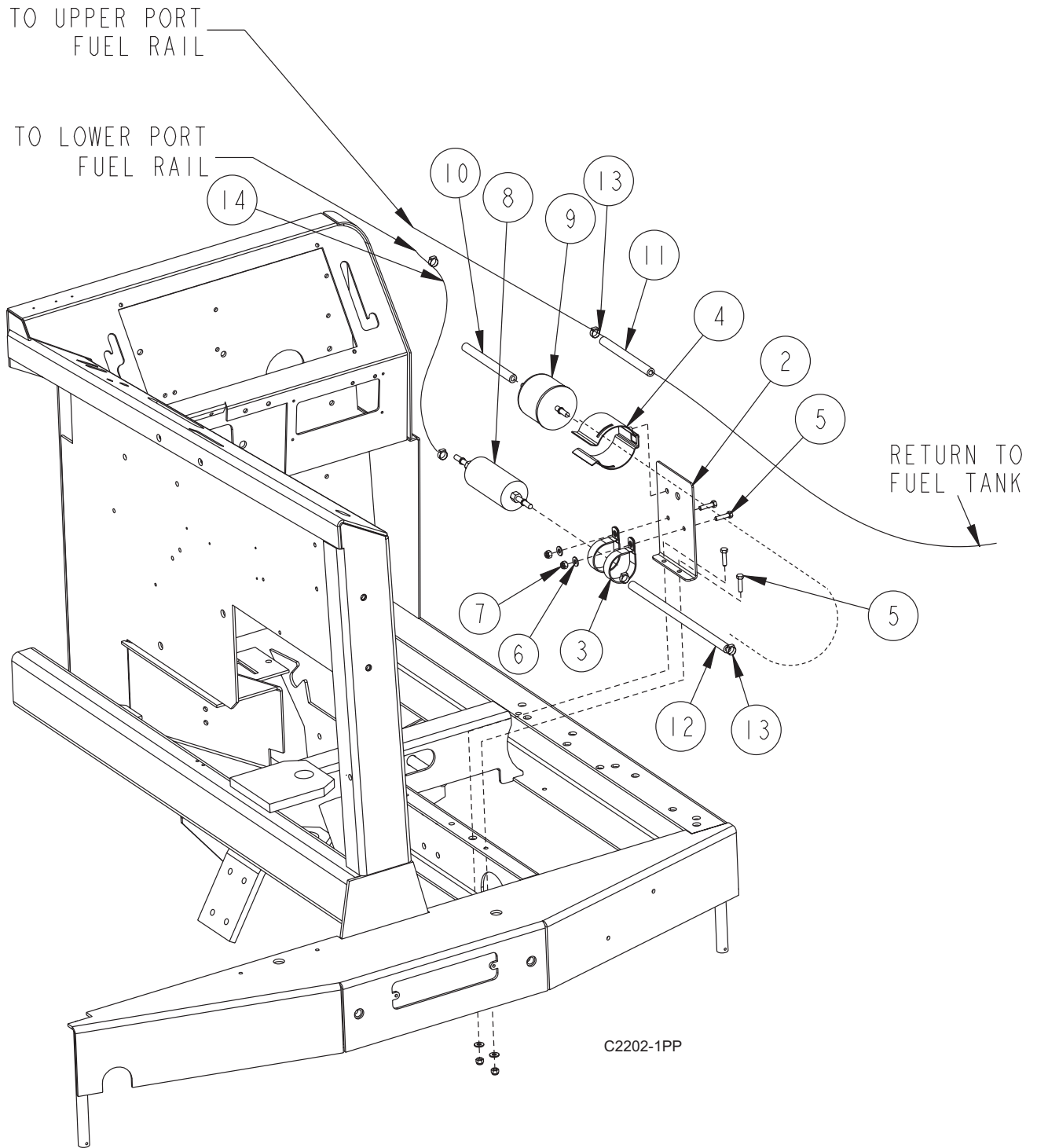

FUEL TANK - GAS - PARTS LIST

<u>KEY NO.</u>	<u>PART NUMBER</u>	<u>DESCRIPTION</u>	<u>QTY</u>
1	8-83-04029	Fuel Tank	1
2	8-26-04003	Float/Sender	1
3	7-11-00029	Cap	1
4	8-56-05021	Fitting, 90°	2
5	2-00-03829	Star Washer	1
6	7-87-02184	Fuel Line	1
7	2-00-04618	Fitting, Female Swivel	2
8	7-33-02337	Hose - 64.5" Fuel Line	1
9	2-00-05261	THD Insert - 1/4-20	4
10	2-95-04388	Hose Clamp	2
11	2-00-00512	Star Washer	1
12	2-00-00205	Screw, 1/4-20 x 1.000 HHC	4
13	2-00-00518	Lock Washer, Helical Spring	4
14	2-00-01676	Flat Washer, 1.062 x .265 x .062	4

C1613ecp/6-04

FUEL TANK - GAS - EXPLODED VIEW

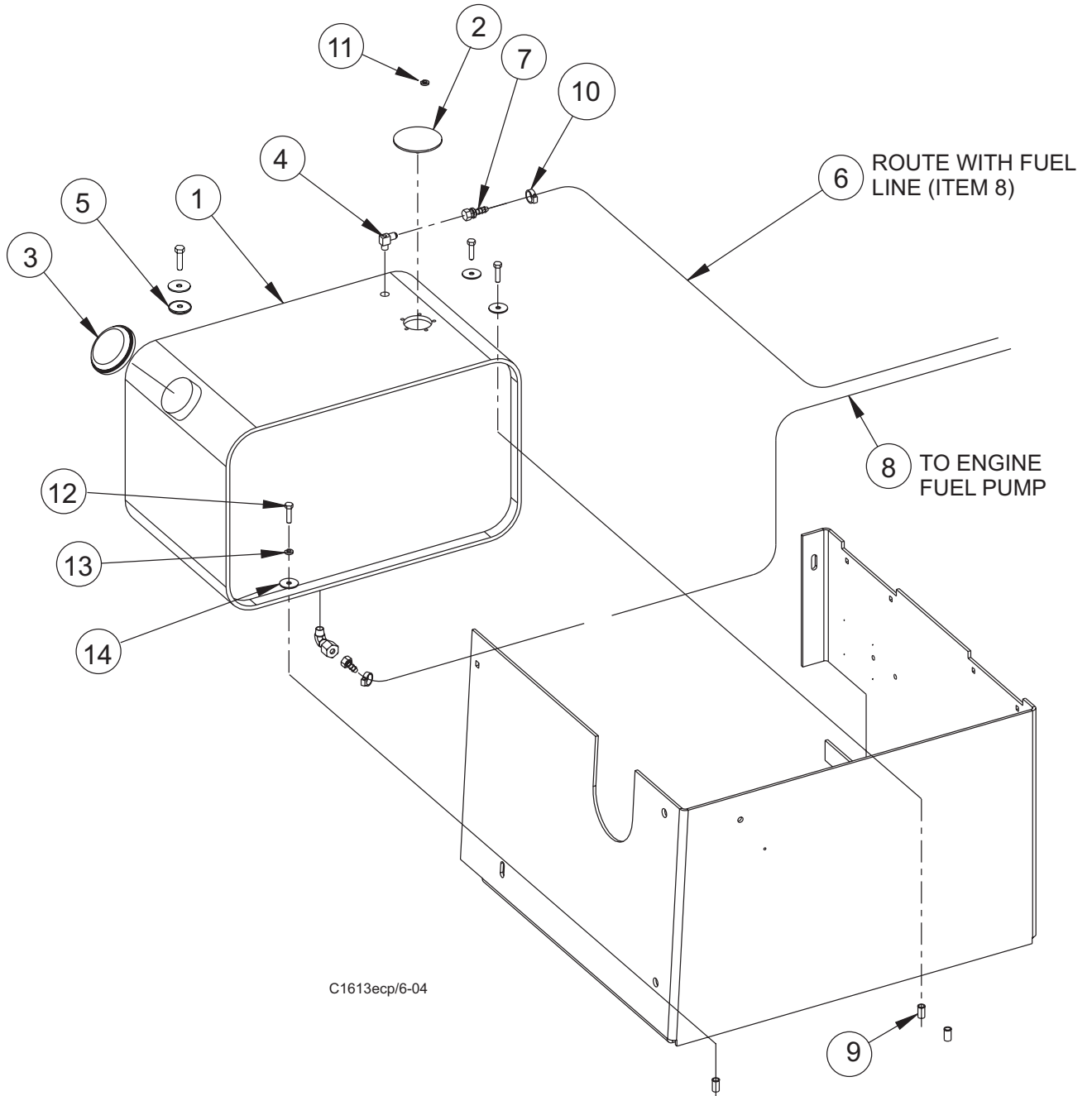

C1613ecp/6-04

FORD 416EFI GAS ENGINE - RADIATOR & HOSES

<u>KEY NO.</u>	<u>PART NUMBER</u>	<u>DESCRIPTION</u>	<u>QTY.</u>
1	0777-047	Engine, 416EFI Gas	1
	0777-058	Engine, 416EFI Gas (Export Only)	1
2	7-62-01008	Radiator	1
3	7-35-00028	Isolator, M8-1.25, 32 x 32	1
4	7-87-02930	Connector, 410.0 x 25.40 dia. Straight	2
5	7-33-02612	Hose, Back, 27 ID, 20R4, 23000057T	1
6	7-33-02611	Hose, Back, 27 ID, 20R4, 23000057B	1
7	7-33-02610	Hose, Front, 25 ID, 20R4, 23000072T	1
8	7-33-02609	Hose, Front, 25 ID, 20R4, 23000072B	1
9	7-08-01184	Support, Upper	1
10	7-52-00201	Panel, Radiator	1
11	2-00-02220	Clamp, Hose	6
12	2-00-03404	Clamp	3
13	2-00-05956	Plug, Radiator Outlet	1
14	7-07-02002	Overflow Bottle Assy. (1 liter)	1
15	2-00-00232	Bolt, 3/8-16 Fin. Hex Head	2
16	2-95-04182	Nut, 3/8-16 Hex Stop	2
17	2-00-03702	Washer, .625 x .281 x .063	2
18	2-00-00219	Bolt, 1/4-20 Fin. Hex Head	1
19	2-00-05963	Screw, M8 x 1.25 x 15mm 8.8 Blox HHC	1
20	2-00-02310	Lock Washer, 3/8 Helical Spring	1
21	2-00-05964	Nut, M8 x 1.25	1
22	7-33-02657	Hose, Overflow Drain	1
23	7-33-02655	Hose, Radiator to Engine Vent	1
24	2-95-04388	Clamp, Hose	4
25	7-29-00192	Gasket, Oil Cooler	4
26	8-13-07088	Clip	2
27	2-00-02589	Bolt, 1/4-20 Fin. Hex Head	2
28	2-00-00641	Nut, 1/4-20 Fiber Insert	2
29	7-33-02643	Hose, 1/4" ID x 36" long (Black)	1

C2202-3PP/6-04

FORD 416EFI GAS ENGINE - RADIATOR & HOSES

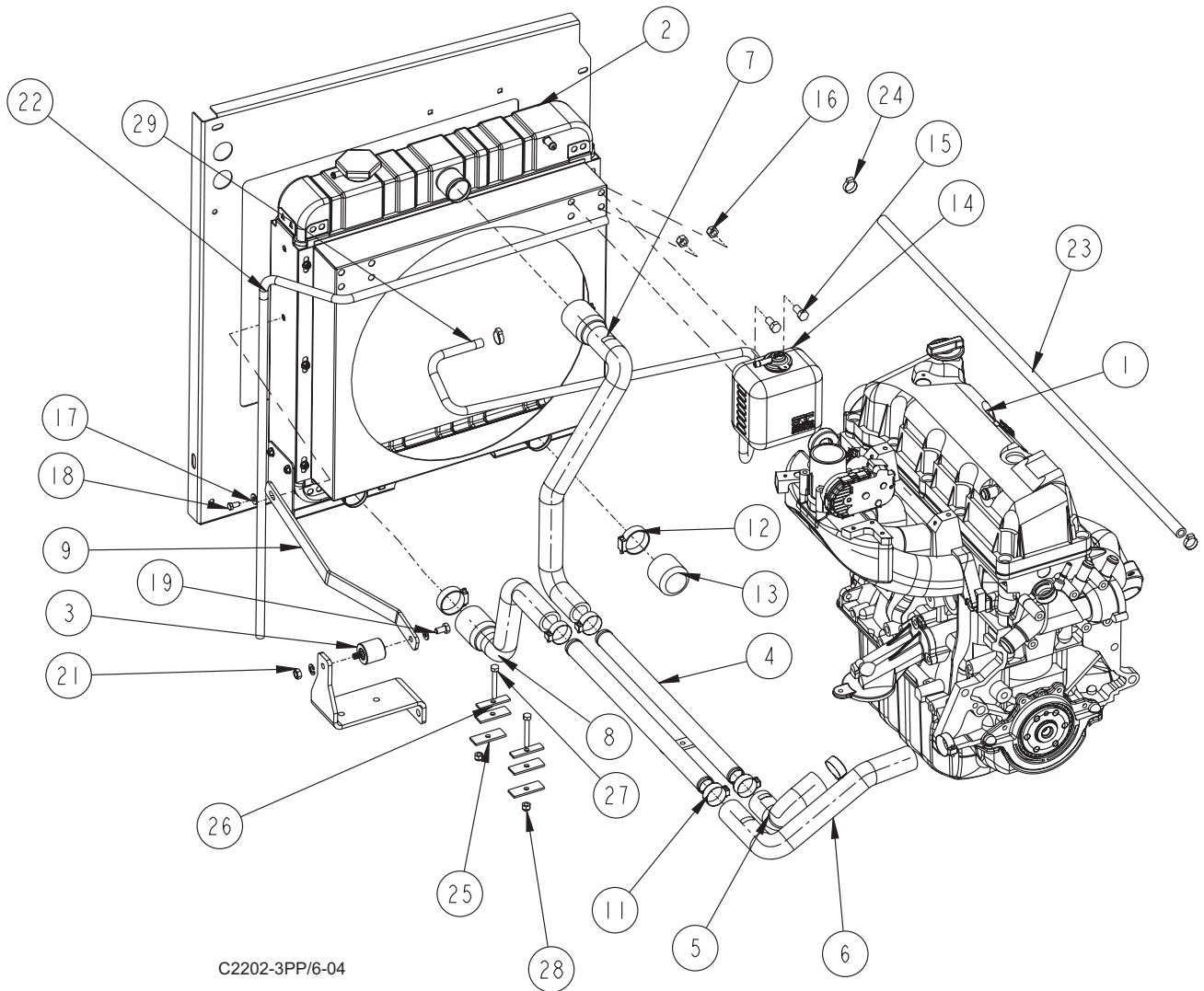

FORD 416EFI ENGINE - FUEL COMPUTER, OIL FILTER - GAS/LP

<u>KEY NO.</u>	<u>PART NUMBER</u>	<u>DESCRIPTION</u>	<u>QTY.</u>
1	2-00-05377	Fitting, Oil Drain	1
2	7-16-07398	Cover, Oil Drain	1
3	2-00-05342	Barb, 3/4 NPT x 1/2" Hose	1
4	2-00-05362	Plug, 1/2 NPT Hex Soc Pipe	1
5	2-00-03407	Clamp, Wittek #10P Hose	2
6	7-52-00199	Panel, Heat Baffle	1
7	0769-031	EPM w/Calibration (LP-N. America)	1
	0769-032	EPM w/Calibration (LP-Export)	1
	7-11-04042	Engine Performance Module (GAS)	1
8	8-08-00927	Bracket, Relay Box	1
9	7-33-02542	Hose, Oil Drain	1
10	2-00-02589	Bolt, 1/4-20 Fin. Hex Head	4
11	2-00-00594	Nut, 1/4-20 Hex	10
12	2-00-00518	Lock Washer, 1/4-20 Helical Spring	6
13	2-00-00219	Bolt, 1/4-20 Fin. Hex Head	2
14	7-08-01215	Cap, Oil Filter Mounting	1
15	7-24-04090	Filter, Oil	1
16	7-58-05339	Plate, Oil Filter Block-Off	1
17	2-00-02196	Carriage Bolt, 1/4-20 x 1.0 lg.	2
18	2-00-00641	Nut, 1/4-20 Fiber Insert	2
19*	2-00-05203	Fitting, STR ORS 13/16-16 x 1/2 NPT	2
20*	2-00-05195	Fitting, -8 ORS x 3/8 NPT STR	2
21*	7-33-02699	Hose, 8 ORS Long Drop 90 (22.5")	2

*Service Kit #0780-653

C2220/3-05

FORD 416EFI ENGINE - FUEL COMPUTER, OIL FILTER - GAS/LP

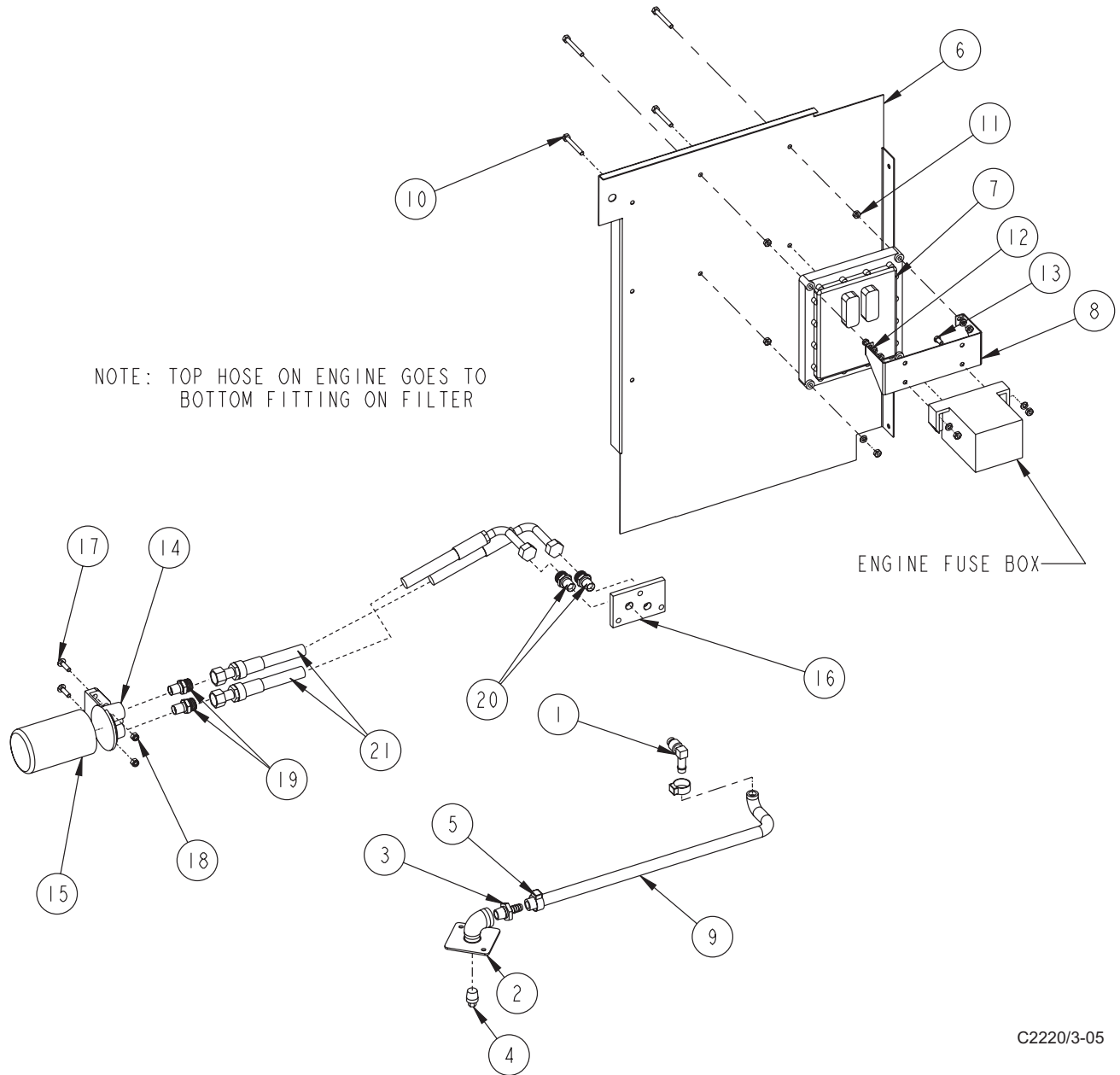

C2220/3-05

LP FUEL SYSTEM (416EFI) - NORTH AMERICA

<u>KEY NO.</u>	<u>PART NUMBER</u>	<u>DESCRIPTION</u>	<u>QTY.</u>
1<	7-11-04045	Megajector	REF
2	7-08-01217	Bracket, LP Regulator	1
3<	7-11-04043	LP Regulator	REF
4	2-00-05972	Fitting, 3/8 NPT x 5/8 90° Hose	2
5	2-00-05674	Fitting, 1/4 NPT Hex Nipple (Brass)	1
6<	7-88-00110	Valve, LP Safety	REF
7	2-00-05678	Fitting, 1/4 NPT 90° Street Elbow (Brass)	1
8	2-00-05942	Fitting, 1/4 NPT x 1/8 NPT x 3/8 JIC TEE	1
9	8-82-00046	Switch, Oil Pressure	1
10	2-00-00518	Lock Washer, 1/4 Helical Spring	4
11	2-00-05528	Screw, M6 x 1.0 x 12mm HHC	4
12	8-33-02634	Hose, 5/8 ID LP Heater (70.8")	1
13	8-33-02635	Hose, 5/8 ID LP Heater (80.4")	1
14	8-33-02636	Hose, 3/4 ID LP Low Pressure (10")	1
15	8-33-02637	Hose, 5/8 ID LP Low Pressure (48")	1
16	8-33-02638	Hose, 1/4 ID LP Low Pressure (59")	1
17	2-00-00205	Bolt, 1/4-20 x 1.0 Fin. Hex Head	2
18	2-00-03702	Washer, .625 x .281 x .063	2
19	2-00-00641	Nut, 1/4-20 Fiber Insert	2
20	2-00-00519	Lock Washer, #10-24 Helical Spring	2
21	2-00-00049	Screw, 10-24 x .50 RHM	2
22	2-00-03407	Clamp, Wittek #10P Hose	4
23	2-95-04388	Clamp, Hose	4
24<	7-33-02654	Hose, LP High Pressure (19.25")	REF

<Comes w/Engine Assembly

C2216revG/10-04

LP FUEL SYSTEM (416EFI) - NORTH AMERICA

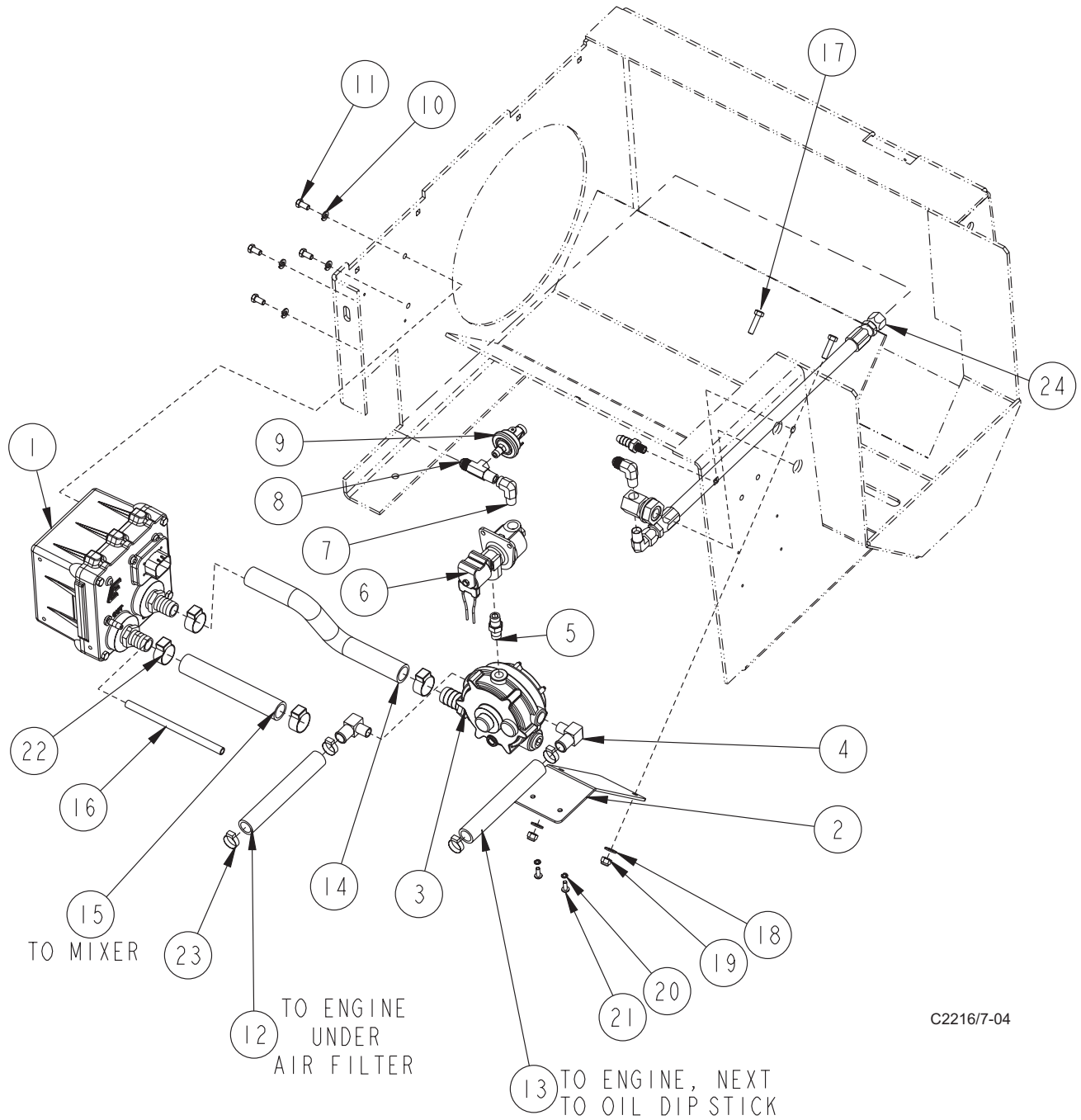

LP FUEL SYSTEM (416EFI) - CE & EX MODELS

<u>KEY NO.</u>	<u>PART NUMBER</u>	<u>DESCRIPTION</u>	<u>QTY.</u>
1	7-33-05123	Housing, LP Seat	Ref.
2	2-00-03407	Clamp, Wittek #10P Hose	4
3	7-08-01285	Bracket, LP Regulator	1
4<	7-11-04046	LP Regulator	1
5	2-00-05674	Fitting, 1/4 NPT Hex Nipple	1
6<	7-88-00110	Valve, LP Safety	1
7<	2-00-06093	Fitting, Bulkhead	Ref.
8	8-56-05023	Fitting, 1/4 NPT x 3/8 Tube Flair Elbow	Ref.
9*	7-88-00117	Kit, LP SafetyValves	1
10	2-00-05972	Fitting, 3/8 NPT x 5/8 90° Hose	2
11	2-00-00205	Bolt, 1/4-20 x 1.0 Fin. Hex Head	2
12	2-00-00641	Nut, 1/4-20 Fiber Insert	2
13*	2-00-05997	Fitting, 3/8 Hose Barb x 1/8 NPT	1
14*	7-33-02692	Hose, LP (18")	1
15<	2-00-04787	Fitting, 1/8 NPT x 1/4 Hose Barb, 90° Elbow	Ref.
16*	7-33-02647	Hose, 1/4" ID Vapor (44")	1
17~	7-33-02638	Hose, 1/4" ID LP Low Pressure (59")	1
18*	2-00-06099	Fitting, SS 90° Elbow, 3/8Tube x 1/4 NPT	2
19*	7-87-02253	Tube, LP High Pressure	1
20*	2-00-06107	Relay, Lektron Safety	1
21	2-00-06087	Fitting, 1/2 NPT x 5/8 Hose, 90°	1
22	7-33-02672	Hose, 5/8" ID Heater (67")	1
23	7-33-02673	Hose, 5/8" ID Heater (60")	1
24*	7-33-02674	Hose, 5/8" ID LP Low Pressure (50")	1
25~<	7-33-02637	Hose, 5/8" ID LP Low Pressure (48")	1
26~<	7-33-02654	Hose, LP High Pressure (19.25")	Ref.
27	2-00-06085	Fitting, 3/8 NPT x 5/8 90° Elbow Hose	1
28	2-95-04388	Clamp, Hose	2
29	2-00-05363	Clamp, Hose	2
30	2-00-06094	Fitting, 1/4 NPT LP Relief Vent	1
31	2-00-05281	Plug, Fuel Gauge	1

<Comes w/Engine Assembly

*CE Models Only

~EX Models Only

C2215revG/10-04

LP FUEL SYSTEM (416EFI) - CE & EX MODELS

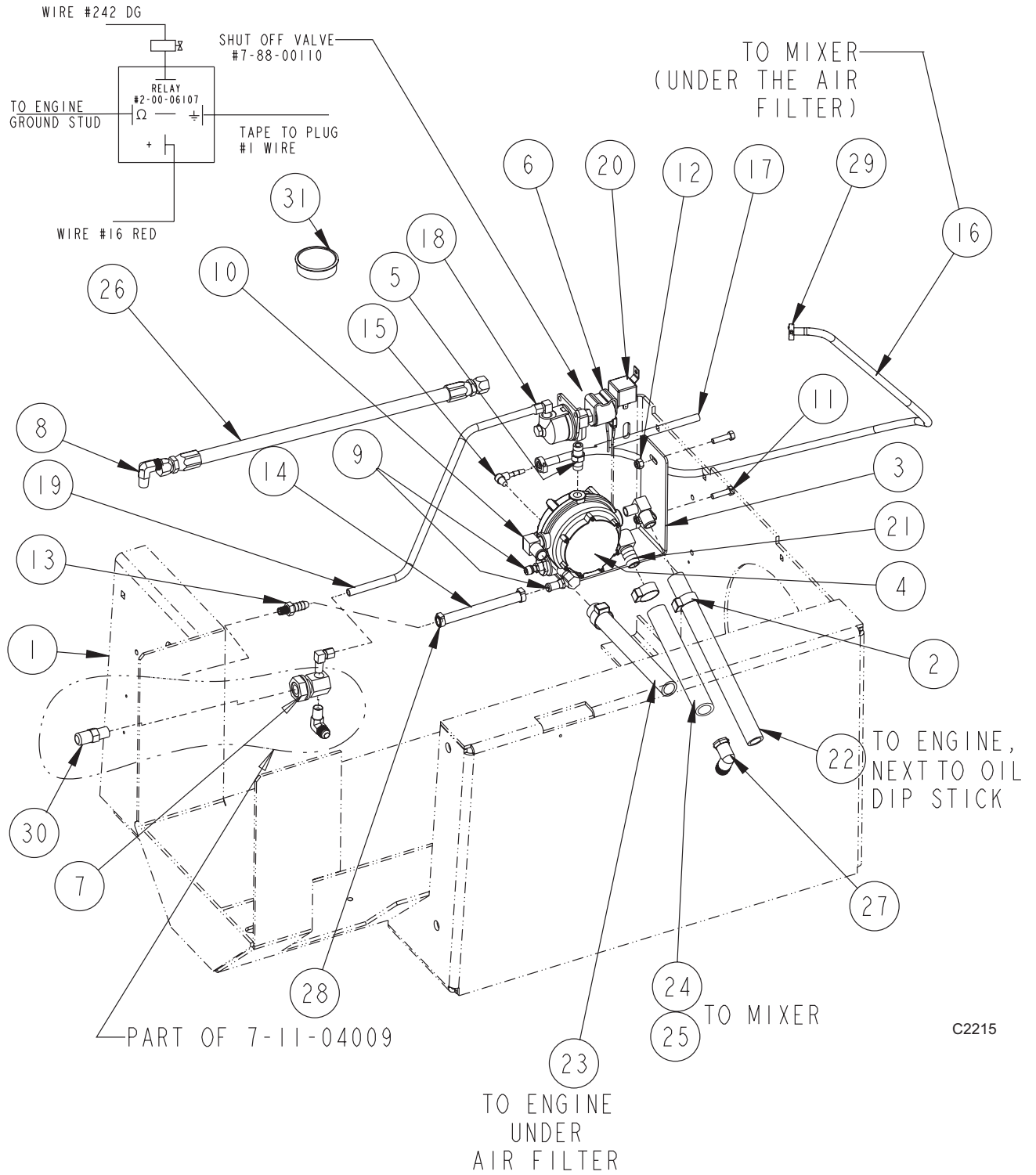

C2215

LP TANK - PARTS LIST

<u>KEY NO.</u>	<u>PART NUMBER</u>	<u>DESCRIPTION</u>	<u>QTY.</u>
1	7-33-05123	Housing, LP Seat	1
2	8-83-04016	LP Tank	1
3	8-16-07372	Cover, LP Tank	1
4	8-32-00044	Hinge	Ref.
5	8-13-07146	Clamp, LP Tank	1
6	8-50-05061	Pad, LP Tank	1
7	2-00-05283	Plug Button	1
8	7-11-04035	Low LP Light Kit	1
9	8-41-00064	Stop, Seat Deck	Ref.
10	2-00-01951	Carriage Bolt, 1/4 - 20 x 1/4	1
11	8-08-00834	Bracket	1
12	7-23-03048	Spring Washer 5/16	Ref.
13	8-32-00050	Hinge	Ref.
14	2-00-02711	Screw, 3/4 - 16 x 2.750 HHM	1
15	2-00-04801	Flat Washer, .875 x .375 x .125	2
16	2-00-00219	Screw, 1/4 - 20 x .500 HHC	4
17	2-00-02310	Lock Washer, Helical Spring 3/8 Med.	1
18	2-00-02360	Nut, 3/8 - 16 Hex	1
19	2-00-03569	Carriage Bolt, 5/16 - 18 x .750	1
20	2-00-00196	Carriage Bolt, 5/16 - 18 x 1.000	2
21	2-00-00644	Nut, 5/16 - 18 Insert Fiber	3
22	2-00-04190	Bolt Carriage .25-20 x .63	7
23	2-00-00594	Nut, Hex 1/4 - 20 x .437 x .218	Ref.
24	2-00-01676	Flat Washer, 1.062 x .265 x .062'	6
25	2-00-00641	Nut Insert-Fibre .25-20	8

C1708b/0603

FUEL TANK - LP - EXPLODED VIEW

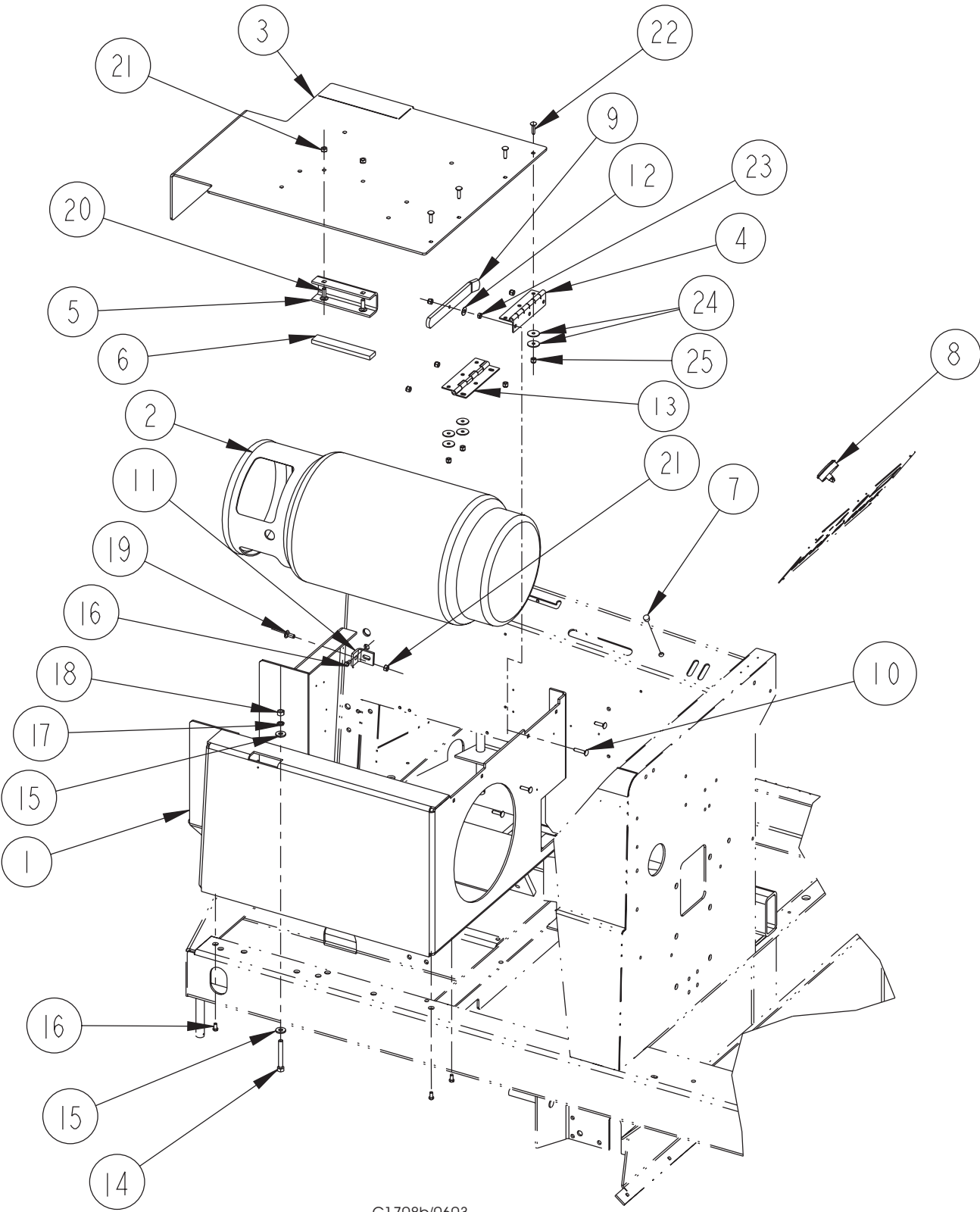

C1708b/0603

LP TANK (CON'T) - PARTS LIST

<u>KEY NO.</u>	<u>PART NUMBER</u>	<u>DESCRIPTION</u>	<u>QTY.</u>
1	N3-0042-1	7141F Female Connector	1
2	N2-1107	Fitting ¼ NPT x 3/8 SAE 90°	2
3	N8-3001	Hose 44.5" + N2-0015 EA End	1
4	N3-0037	Bulkhead Fitting	1
5	N2-1108	Fitting ¼ NPT x 3/8 SAE St.	1
6	N3-3001-116	5/16 Hose x 116" + N2-0015 Ends	1

C1709/0603

LP TANK (CON'T) - EXPLODED VIEW

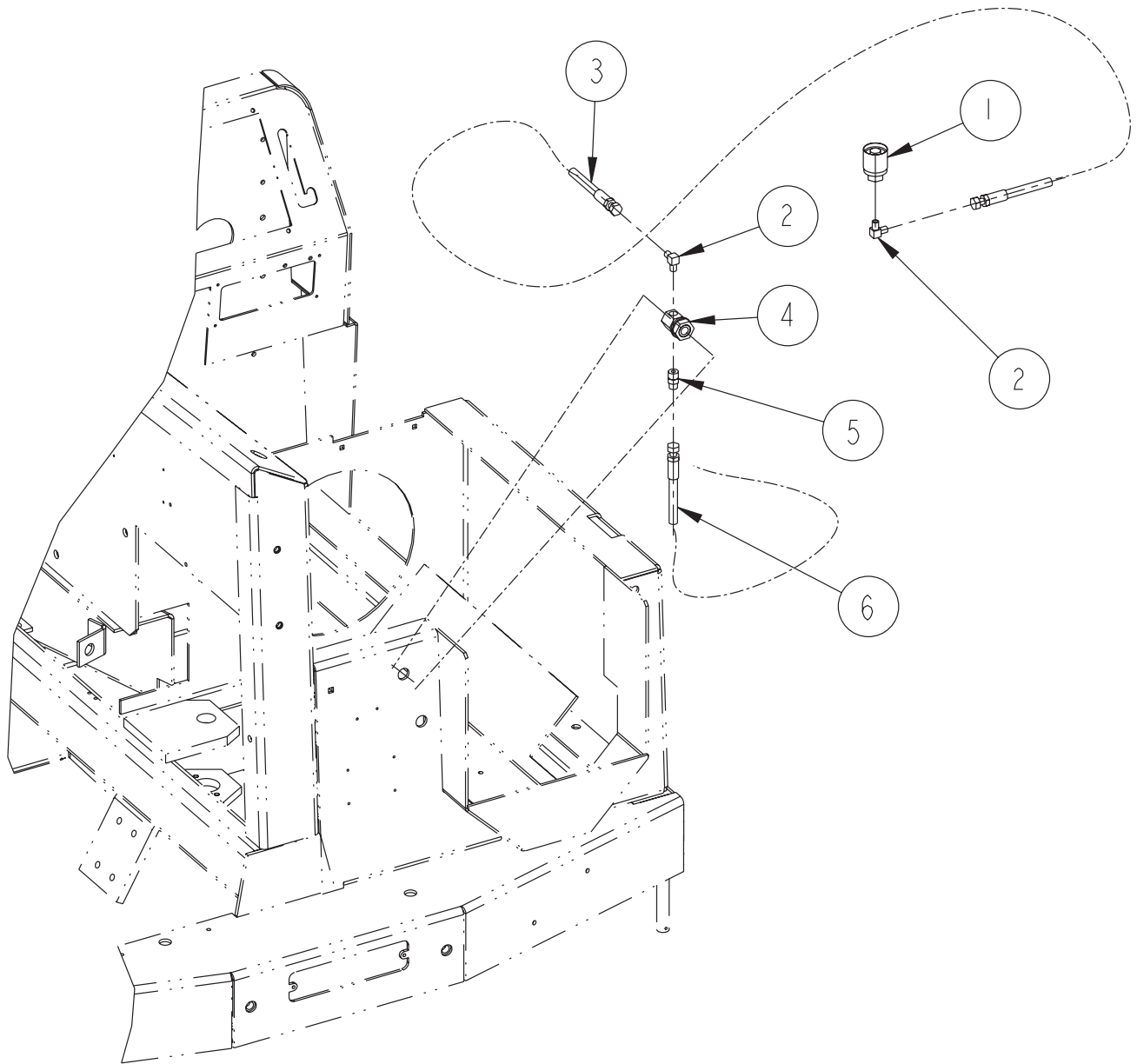

C1709/0603

FORD 416EFI LP ENGINE (AIR INTAKE, EXHAUST) - PARTS LIST

<u>KEY NO.</u>	<u>PART NUMBER</u>	<u>DESCRIPTION</u>	<u>QTY.</u>
1	0777-048	Engine, 416EFI LP	REF
	0777-059	Engine, 416EFI LP (Export Only)	REF
2	7-08-02051	Bracket, Air Cleaner	1
3	7-13-07231	Band, Filter	1
4	7-24-04083	Filter Assy., Air Cleaner	1
5	2-00-00207	Screw, 5/16-18 x 1.25 Hex Head	2
6	2-00-00409	Flat Washer, .687 x .344 x .062	2
7	2-00-00644	Nut, 5/16-18 Fiber Insert Hex	2
8	8-33-02633	Hose, Air Intake	1
9	2-00-02216	Clamp, Hose	2
10	7-24-04087	Filter Service Indicator (20" WC)	1
11	2-00-05042	Lock Washer, M10 Helical Spring	2
12	2-00-05329	Bolt, .39 dia. x 1.57	2
13<	7-87-02234	Tube, Exhaust	1
14<	7-58-05340	Plate, Exhaust Flange	1
15<~	7-11-04037	Catalytic Converter	1
16	7-87-02225	Tube, Exhaust	1
17	7-49-00041	Muffler	1
18	7-56-04061	Pipe, Exhaust	1
19	7-87-02227	Tube, Exhaust	1
20	2-00-05970	Clamp, Muffler, 2"	2
21*	2-00-04040	Clamp, Muffler, 1.25"	3
22*	7-87-02249	Tube, Exhaust	1
23*	2-00-06090	Plug, 18mm x 1.5	1
24*	2-00-05149	Clamp, 1/75 Muffler	2
25*	7-34-09016	Insulating Sleeve	1
26	2-00-02215	Clamp, Hose	2

<North American Only

*Export Only

~Comes with Engine Assy.

C2200revG/10-04

FORD 416EFI LP ENGINE (AIR INTAKE, EXHAUST) - EXPLODED VIEW

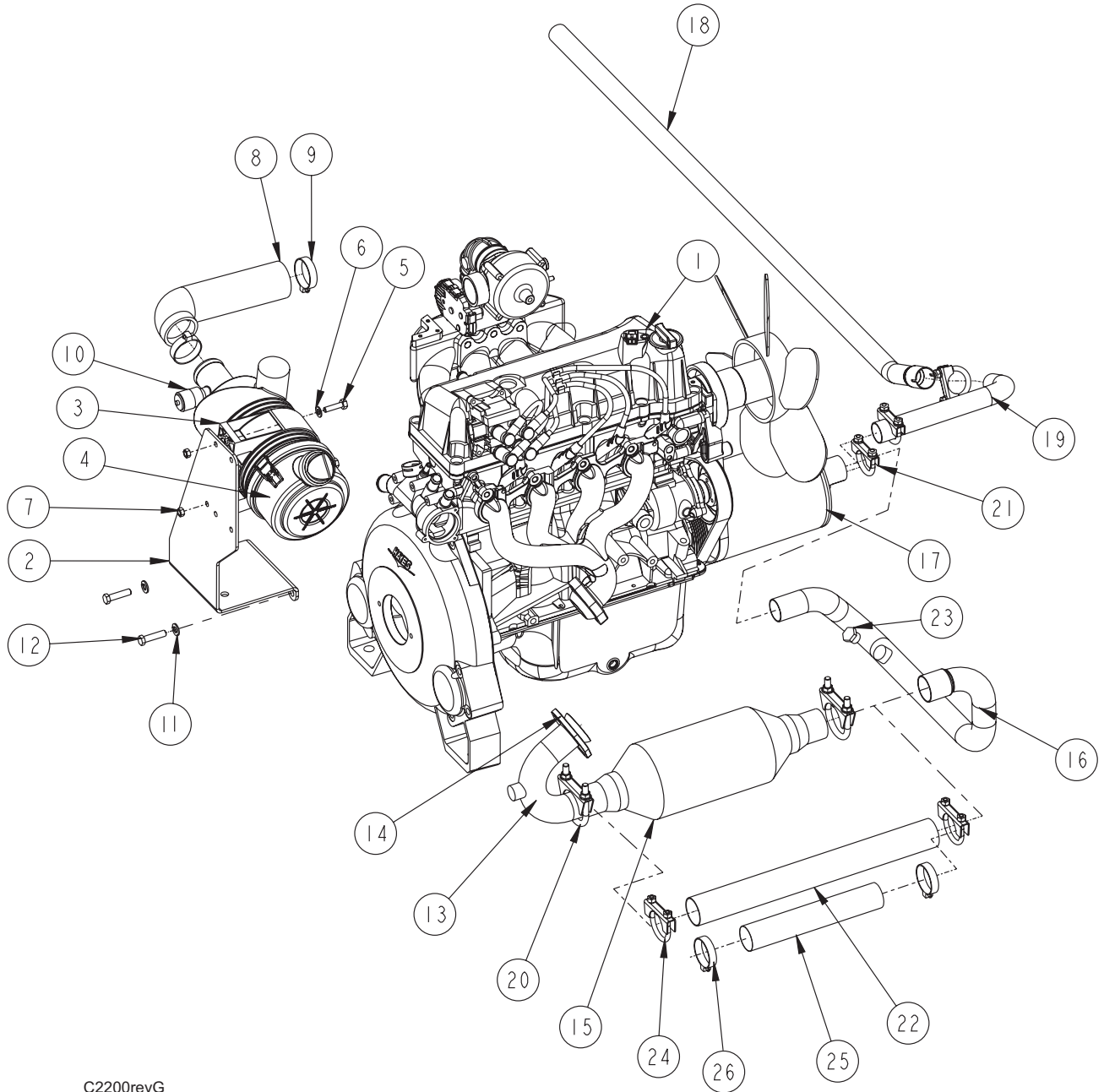

C2200revG

FORD 416EFI LP ENGINE (HARDWARE) - PARTS LIST

<u>KEY NO.</u>	<u>PART NUMBER</u>	<u>DESCRIPTION</u>	<u>QTY.</u>
1<	7-16-05047	Coupling, Engine/Pump	1
2<	7-58-05338	Plate, Starter	1
3<	7-33-05145	Housing, Pump Mount	1
4	7-08-01185	Bracket, Tube Support Front	1
5	7-08-01179	Bracket, Right Front Leg	1
6	7-08-01180	Bracket, Left Front Leg	1
7	7-08-01181	Bracket, Cross	1
8	7-08-01183	Bracket, Alternator	1
9	7-03-04254	Arm, Alternator	1
10	7-35-00017	Isolator, Engine Mount (Red Dot)	5
11	2-00-05067	Spacer, Snubbing Washer	6
12	2-00-02682	Screw, 1/2-13 x 2.75	2
13	7-08-01186	Bracket, Tube Support Back	1
14	7-08-01182	Bracket, Cross	1
15	7-81-00274	Support, Engine	1
16	2-00-05955	Flat Washer, 1.25 ID x 2.00 OD x .25	3
17	7-75-01249	Spacer, Engine Mount	1
18	2-00-05329	Bolt, .39 dia. x 1.57 lg.	2
19	2-00-02617	Screw, 1/2-13 x 3.5 lg., SS	2
20	2-00-00405	Flat Washer, 1.063 x .531 x .094	1
21	2-00-04936	Nut, 1/2-13 Elastic Lock	5
22	2-00-00402	Washer, 25/64 ID x 3/4 OD	4
23	2-00-00209	Bolt, 3/8-16 x 1.25 Hex Head	4
24	2-00-00241	Bolt, 1/2-13 x 1.75 Hex Head	2
25	2-00-05963	Screw, M8 x 1.25 x 15mm 8.8 Blox HHC	6
26	2-00-04363	Screw, M8 x 1.25 x 20mm	3
27	2-00-00641	Nut, 1/4-20 Fiber Insert	2
28	2-00-05922	Bolt, M10-1.5 x 30mm Hex Head	1
29	2-00-00530	Lock Washer, 5/16	4
30	2-00-04948	Screw, M8 x 1.25 x 25mm	4
31	2-00-04914	Screw, 1/2-13 x 4.5 lg.	1
32	2-95-04182	Nut, 3/8-16 Hex Stop	4
33	0777-048	Engine, 416EFI LP	REF
	0777-059	Engine, 416EFI LP (Export Only)	REF

<Comes with Engine Assy.

C2201revG/10-04

FORD 416EFI LP ENGINE (HARDWARE) - EXPLODED VIEW

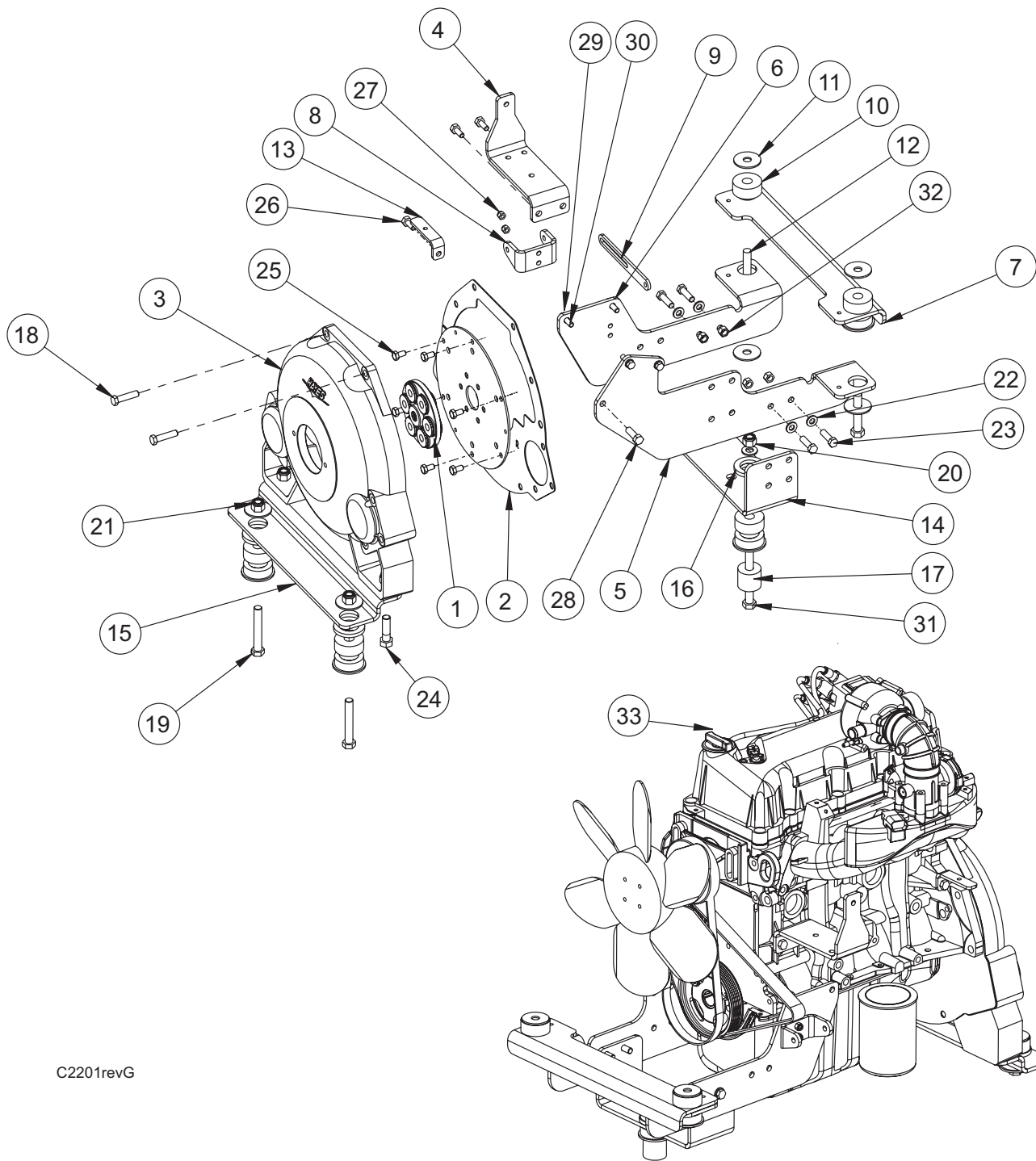

C2201revG

FORD 416EFI LP ENGINE - RADIATOR & HOSES

<u>KEY NO.</u>	<u>PART NUMBER</u>	<u>DESCRIPTION</u>	<u>QTY.</u>
1	0777-048	Engine, 416EFI LP	1
2	0777-059	Engine, 416EFI LP (Export Only)	1
3	7-62-01008	Radiator	1
4	7-35-00028	Isolator, M8-1.25, 32 x 32	1
5	7-87-02930	Connector, 410.0 x 25.40 dia. Straight	2
6	7-33-02612	Hose, Back, 27 ID, 20R4, 23000057T	1
7	7-33-02611	Hose, Back, 27 ID, 20R4, 23000057B	1
8	7-33-02610	Hose, Front, 25 ID, 20R4, 23000072T	1
9	7-33-02609	Hose, Front, 25 ID, 20R4, 23000072B	1
10	7-08-01184	Support, Upper	1
11	7-52-00201	Panel, Radiator	1
12	2-00-02220	Clamp, Hose	6
13	2-00-03404	Clamp	3
14	2-00-05956	Plug, Radiator Outlet	1
15	7-07-02002	Overflow Bottle Assy. (1 liter)	1
16	2-00-05963	Screw, M8 x 1.25 x 15mm 8.8 Blox HHC	1
17	2-00-03702	Washer, .625 x .281 x .063	2
18	2-00-00219	Bolt, 1/4-20 Fin. Hex Head	1
19	2-00-02310	Lock Washer, 3/8 Helical Spring	1
20	2-00-05964	Nut, M8 x 1.25	1
21	7-33-02657	Hose, Overflow Drain	1
22	7-33-02643	Hose, 1/4" ID x 36" long (Black)	1
23	7-33-02655	Hose, Radiator to Engine Vent	1
24	2-95-04388	Clamp, Hose	4
25	7-08-01186	Bracket, Misc. Tube Support Back	1
26	2-00-00530	Lock Washer, 5/16	3
27	2-00-00409	Flat Washer, .687 x .344 x .062	1
28	2-00-04363	Screw, HHC, M8 x 1.25 x 20mm	1
29	7-29-00192	Gasket, Oil Cooler	4
30	8-13-07088	Clip	2
31	2-00-02589	Bolt, 1/4-20 x 2.0 Fin. Hex Head	2
32	2-00-00641	Nut, 1/4-20 Fiber Insert	2
33	2-00-05042	Lock Washer, M10 Helical Spring	2
34	2-00-05922	Bolt, M10 x 1.5 x 30mm	2

C2202-3revG/10-04

FORD 416EFI LP ENGINE - RADIATOR & HOSES

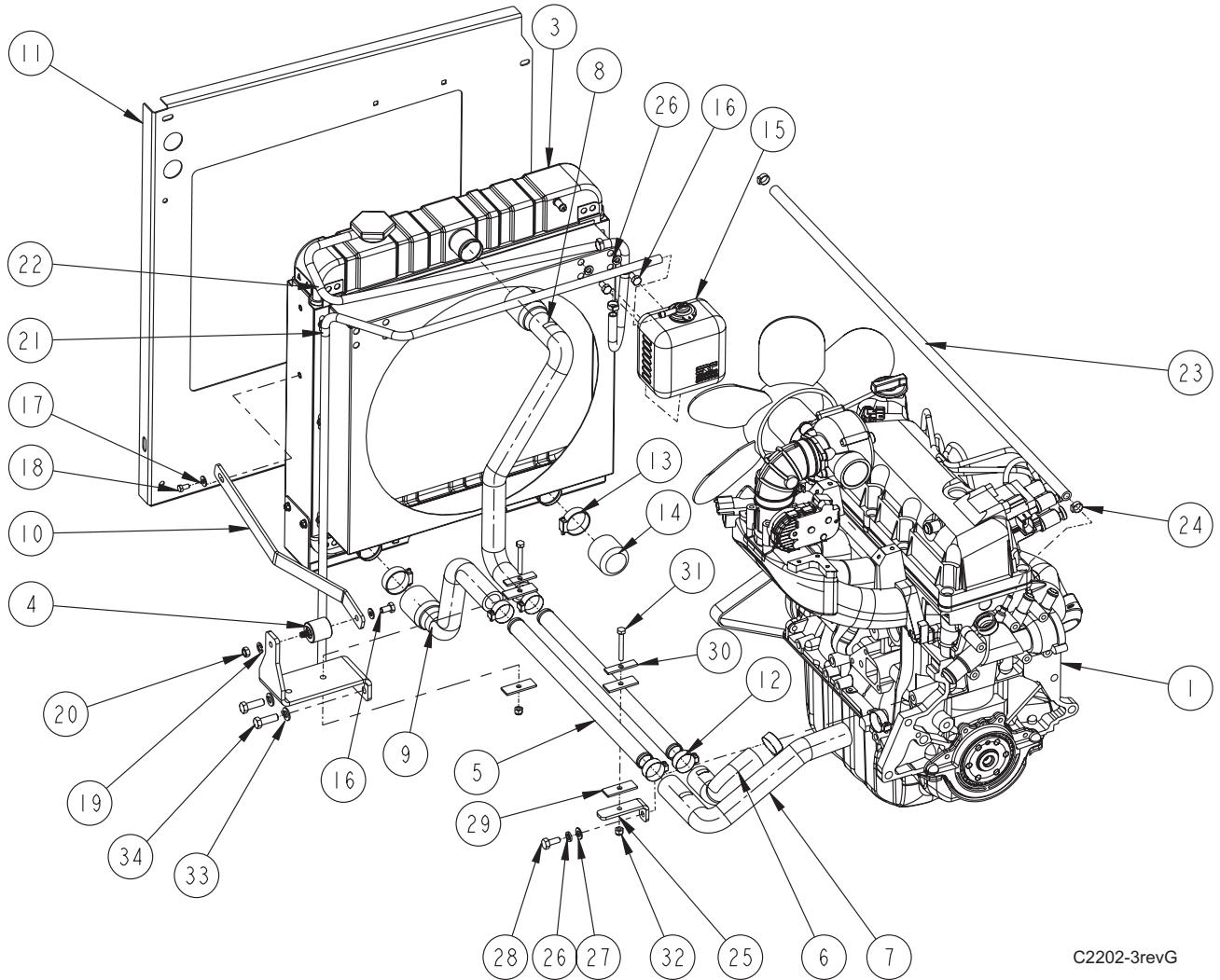

C2202-3revG

MITSUBISHI S4L2 DIESEL ENGINE (HARDWARE) - PARTS LIST

<u>KEY NO.</u>	<u>PART NUMBER</u>	<u>DESCRIPTION</u>	<u>QTY.</u>
1	0777-049	Engine, Mitsubishi S4L2 Diesel	1
2	7-08-02042	Bracket, Right Rear Mount	1
3	7-08-01176	Bracket, Front Mount	1
4	7-08-01177	Bracket, Front Mount	1
5	7-75-01246	Spacer, Engine Mount	1
6	7-08-02043	Bracket, Left Rear Mount	1
7	7-08-01175	Bracket, Front Mount	1
8	7-08-02041	Bracket, Front Mount	1
9	7-35-00017	Isolator, Engine Mount (Red Dot)	4
10	2-00-05067	Spacer, Snubbing Washer	8
11	8-90-07328	Wire, Ground to Frame	1
12	2-00-02617	Screw, 1/2-13 x 3.5	4
13	2-00-00405	Flat Washer, 1.063 x .531 x .094	4
14	2-00-04936	Nut, 1/2-13 Elastic Lock	4
15	2-00-05043	Washer, 25/64 ID x 3/4 OD	16
16	2-00-05960	Screw, M12 x 1.25 x 25mm HHC	12
17	2-00-05962	Screw, M12 x 1.25 x 45mm HHC	4
18	2-00-05955	Washer, 1.25 ID x 2.0 OD x .25	4
19	2-00-00402	Washer, 25/64 ID x 3/4 OD	8
20	2-00-00209	Bolt, 3/8-16 x 1.25 Hex Head	4
21	2-95-04182	Nut, 3/8-16 Hex Stop	4
22	2-00-00409	Flat Washer, .687 x .344 x .062	8
23	2-00-00207	Screw, 5/16-18 x 1.25 Hex Head	4
24	2-00-00644	Nut, 5/16-18 Insert Fiber Hex	4

C2203-1/2-04

MITSUBISHI S4L2 DIESEL ENGINE (HARDWARE) - EXPLODED VIEW

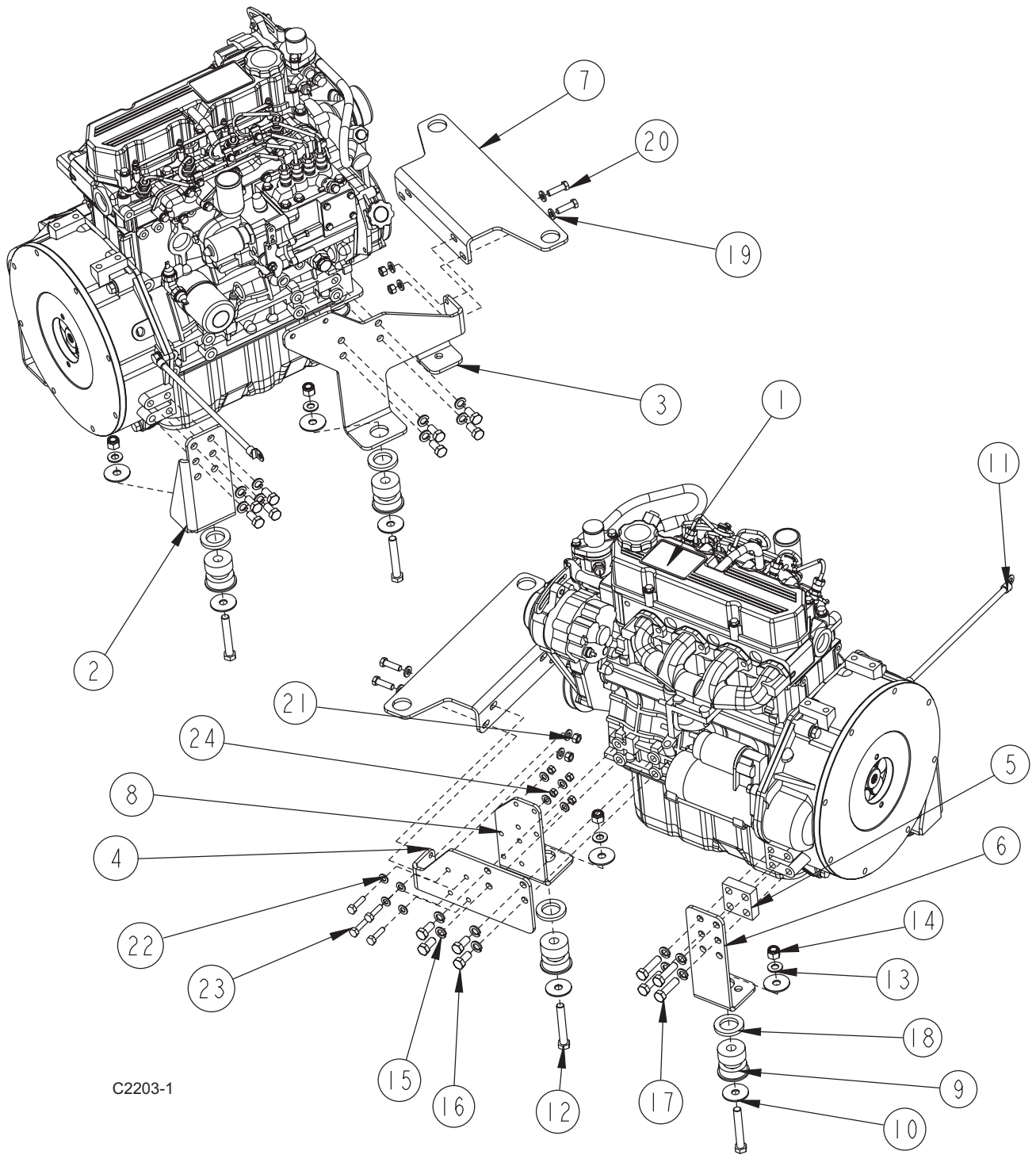

C2203-1

MIT S4L2 DIESEL (FUEL SYSTEM) - PARTS LIST

revised 2/07

<u>KEY NO.</u>	<u>PART NUMBER</u>	<u>DESCRIPTION</u>	<u>QTY.</u>
1	7-24-04078	Filter, Diesel Fuel - Assembly	1
2	2-00-00232	Bolt, 3/8-16 Fin. Hex Head	2
3	7-16-07398	Cover, Oil Drain	1
4	2-00-05342	Barb, 3/4 NPT x 1/2" Hose	1
5	2-00-05377	Fitting, Oil Drain	1
6	7-33-02358	Hose, Oil Drain	1
7	2-00-03407	Clamp, Witteck #10P Hose	2
8	8-60-05028	Pump, Fuel	1
9	2-00-00205	Bolt, 1/4-20 Fin. Hex Head	2
10	2-00-03702	Washer, .625 x .281 x .063	2
11	2-00-00641	Nut, 1/4-20 Fiber Insert	2
12	7-33-02630	Hose, Fuel	1
13	7-33-02631	Hose, Fuel	1
14	7-33-02632	Hose, Fuel	1
15	2-95-04388	Clamp, Hose	3

C2203-2/2-04

MIT S4L2 DIESEL (FUEL SYSTEM) - EXPLODED VIEW

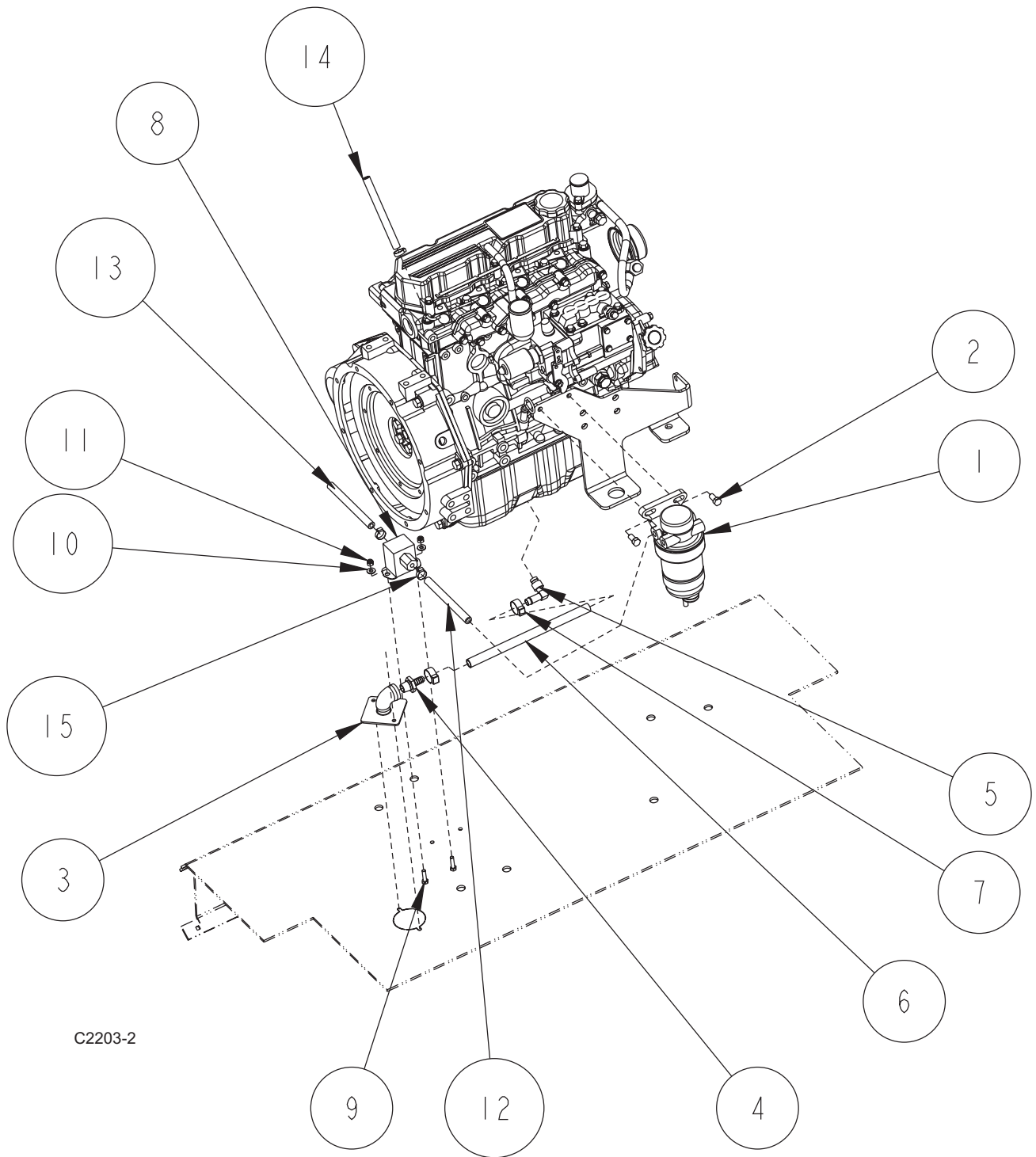

C2203-2

MIT S4L2 DIESEL (THROTTLE ASSY.) - PARTS LIST

<u>KEY NO.</u>	<u>PART NUMBER</u>	<u>DESCRIPTION</u>	<u>QTY.</u>
1	7-08-02048	Bracket, Throttle	1
2	2-00-05041	Lock Washer, M8 Helical Spring	2
3	2-00-04363	Screw, M8 x 1.25 x 20mm HHC	2
4	8-13-07094	Clamp, Conduit	1
5	7-10-00024	Cable, Throttle (80")	1
6	2-00-00501	Washer, 1/4 ID x .44 OD x .046	2
7	2-00-00056	Screw, #10-24 x 3/4 RHM	2
8	2-00-01246	Nut, 10-24 Elastic Stop	2
9	2-00-00626	Nut, 10-32 Hex	1
10	8-25-02036	Connector, Ball Joint	1
11	2-00-00633	Nut, 1/4-28 Fiber Insert	1
12	8-08-00936	Bracket, Murphy	1

C220 3/5-04

MIT S4L2 DIESEL (THROTTLE ASSY.) - EXPLODED VIEW

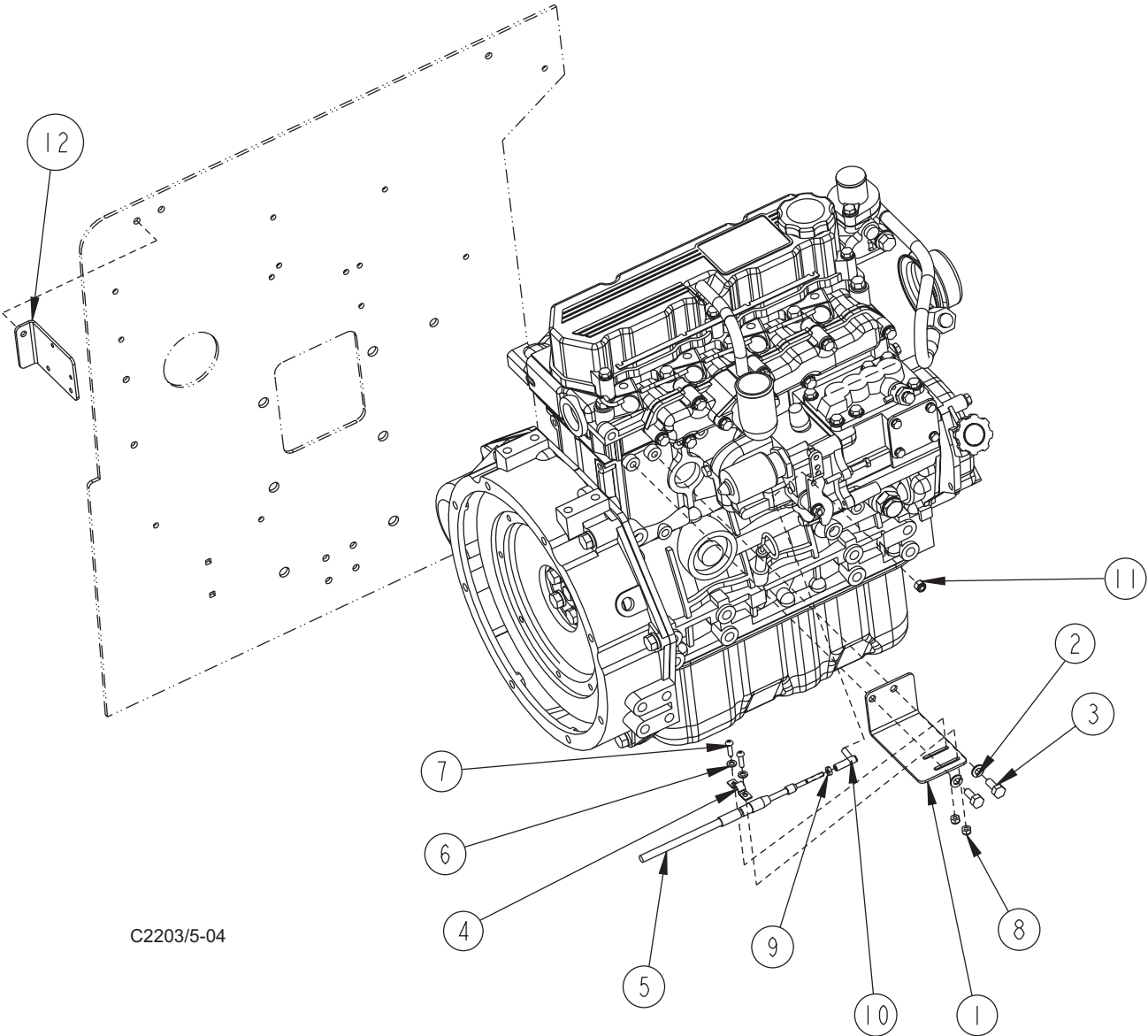

C2203/5-04

FUEL TANK - DIESEL - PARTS LIST

<u>KEY NO.</u>	<u>PART NUMBER</u>	<u>DESCRIPTION</u>	<u>QTY</u>
1	8-83-04029	Fuel Tank	1
2	8-26-04003	Float/Sender	1
3	7-11-00029	Cap	1
4	8-56-05021	Fitting, 90°	2
5	2-00-03829	Star Washer	1
6	7-87-02184	Fuel Line	1
7	2-00-04618	Fitting, Female Swivel	2
8	7-33-02337	Hose - 64.5" Fuel Line	1
9	2-00-05261	THD Insert - 1/4-20	4
10	2-95-04388	Hose Clamp	2
11	2-00-00512	Star Washer	1
12	2-00-00205	Screw, 1/4-20 x 1.000 HHC	4
13	2-00-00518	Lock Washer, Helical Spring	4
14	2-00-01676	Flat Washer, 1.062 x .265 x .062	4

C1613ecp/6-04

FUEL TANK - DIESEL - EXPLODED VIEW

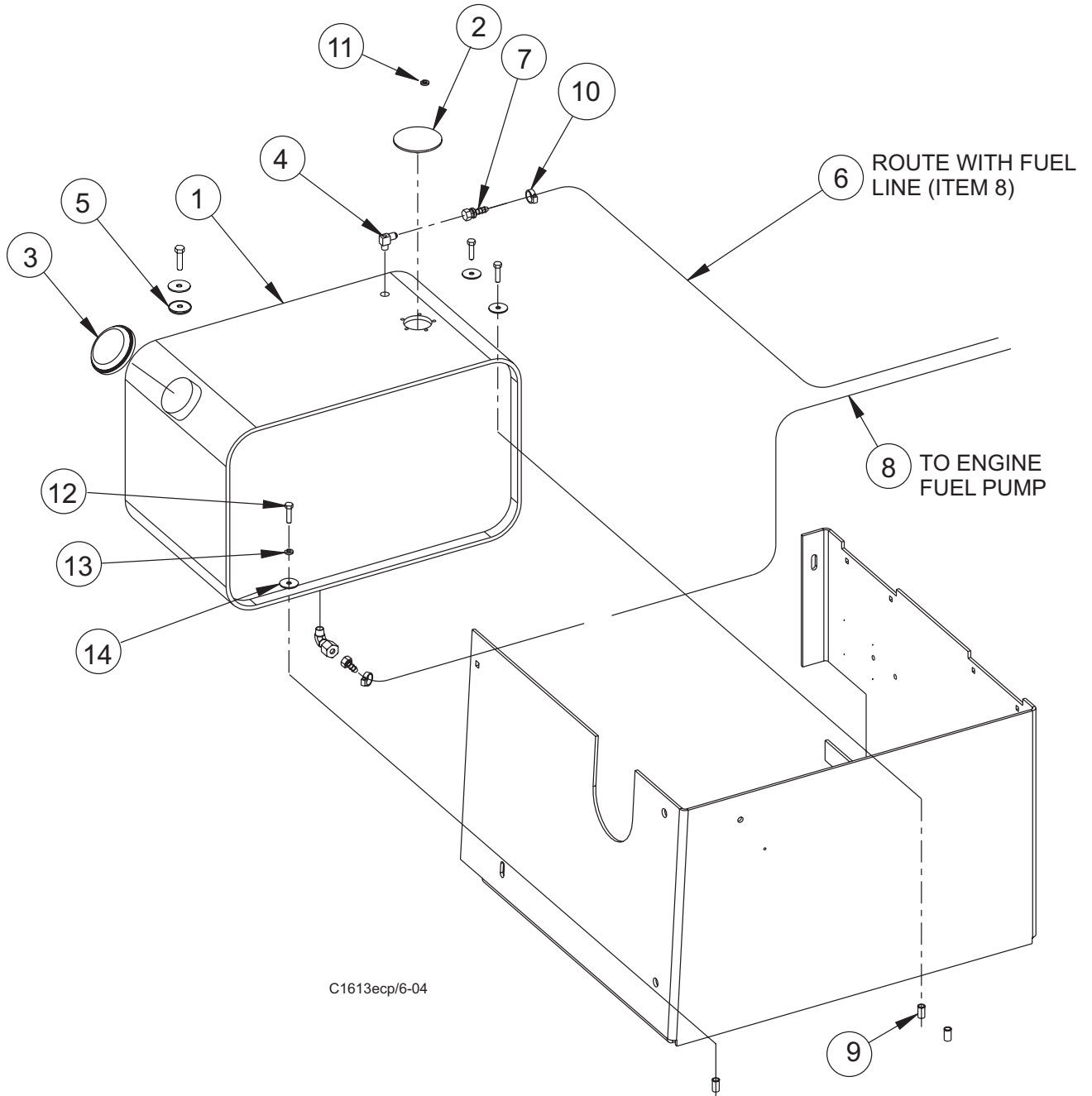

C1613ecp/6-04

MIT S4L2 DIESEL ENGINE (RADIATOR, FAN) - PARTS LIST

<u>KEY NO.</u>	<u>PART NUMBER</u>	<u>DESCRIPTION</u>	<u>QTY.</u>
1	7-33-02604	Hose, Upper Radiator	1
2	7-33-02605	Hose, Lower Radiator	1
3	7-35-00017	Isolator, Engine Mount (Red Dot)	2
4	2-00-05955	Washer, 1.25 ID x 2.00 OD x .25	2
5	7-62-01008	Radiator	1
6	2-00-05956	Plug, Radiator Outlet	1
7	2-00-03404	Clamp, Witteck C24P	5
8	2-00-05067	Spacer, Snubbing Washer	2
9	7-08-02047	Bracket, Radiator	1
10	7-35-00028	Isolator, M8-1.25 32 x 32	1
11	2-00-05041	Lock Washer, M8 Helical Spring	2
12	2-00-05964	Nut, M8 x 1.25	1
13	7-08-02046	Bracket, Radiator	1
14	2-00-05963	Screw, M8 x 1.25 x 15mm 8.8 Blox HHC	1
15	7-07-02002	Overflow Bottle Assy. (1 liter)	1
16	7-75-01250	Spacer, Breeza Fan	1
17	7-23-00023	Fan, S4L2 Engine	1
18	2-00-00247	Screw, 1/2-13 x 2.50 HHC	2
19	2-00-05722	Bolt, M6 x 30mm HHC	4
20	2-00-00518	Lock Washer, 1/4 Helical Spring	4
21	7-33-02657	Hose, Overflow Drain	1
22	7-33-02643	Hose, 1/4" ID x 36" long (Black)	1
23	2-95-04388	Clamp, Hose	2

C2203-3PP/6-04

MIT S4L2 DIESEL ENGINE (RADIATOR, FAN) - EXPLODED VIEW

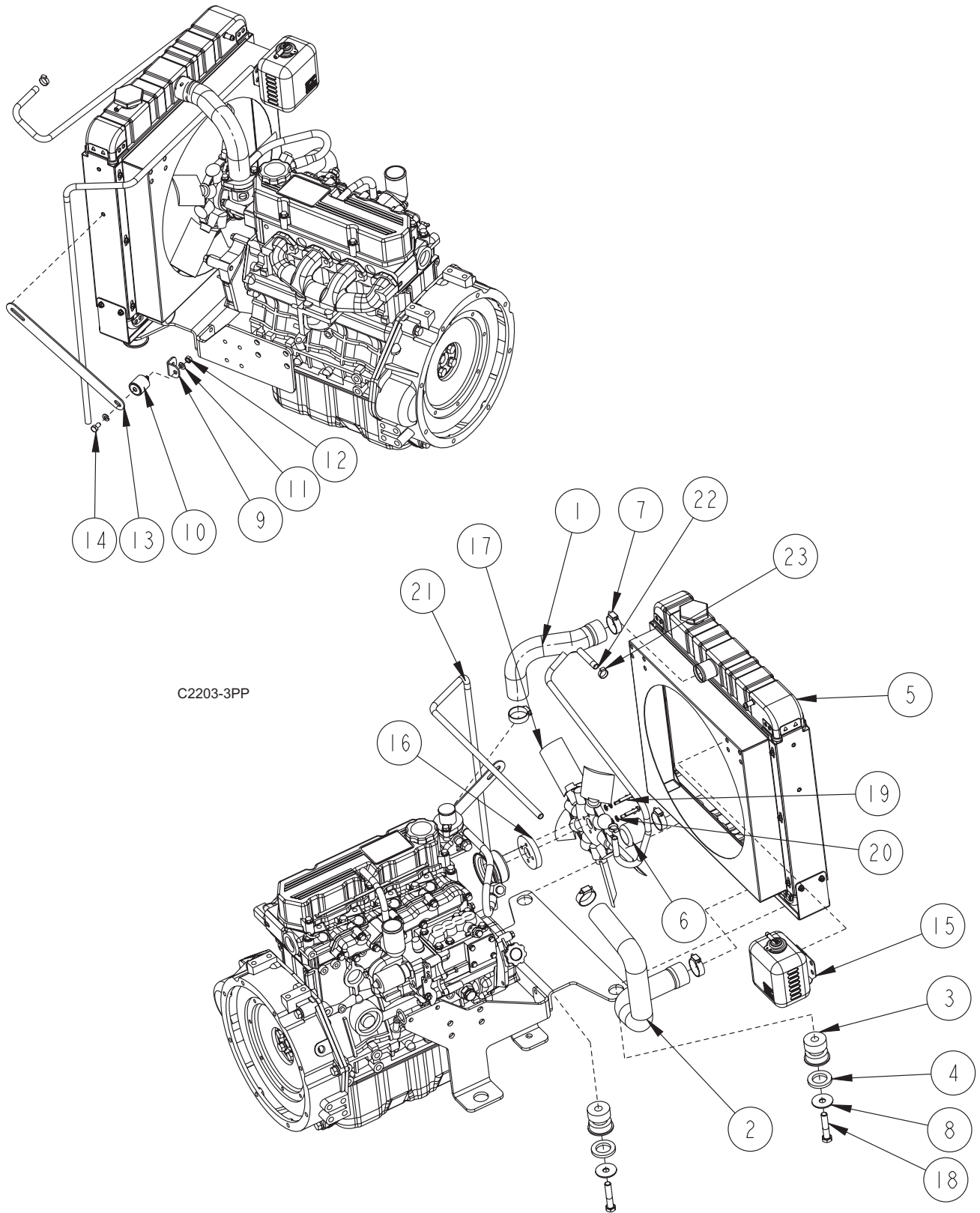

MIT S4L2 DIESEL ENGINE - AIR CLEANER

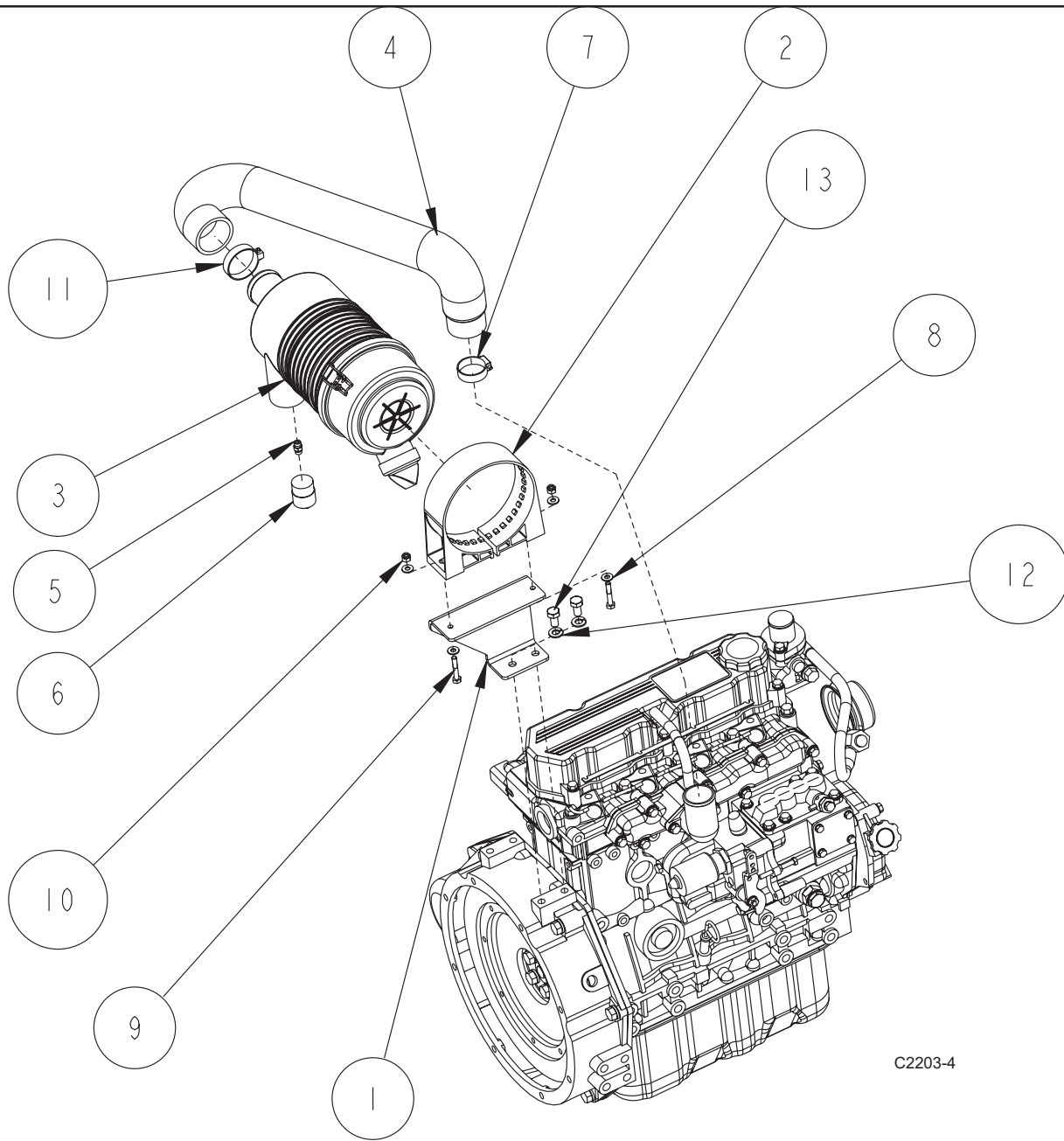

C2203-4

KEY NO.	PART NUMBER	DESCRIPTION	QTY.
1	7-08-02044	Bracket, Air Cleaner	1
2	7-13-07231	Band, Filter	1
3	7-24-04083	Filter Assy., Air Cleaner	1
4	7-33-02608	Hose, Air Intake	1
5	2-95-02519	Nipple, 1/8 NPT Close	1
6	7-24-04087	Filter Service Indicator (20" WC)	1
7	2-00-03404	Clamp	1
8	2-00-03702	Washer, .625 x .281 x .063	4
9	2-00-00203	Screw, 1/4-20 x 1.50 Hex Head	2
10	2-00-00641	Nut, 1/4-20 Fiber Insert	2
11	2-00-02216	Clamp, Hose	1
12	2-00-05042	Lock Washer, M10 Helical Spring	2
13	2-00-05958	Screw, M10 x 1.25 x 20mm HHC	2

C2203-4/2-04

BATTERY ELECTRICAL ASSEMBLY - GAS/LP

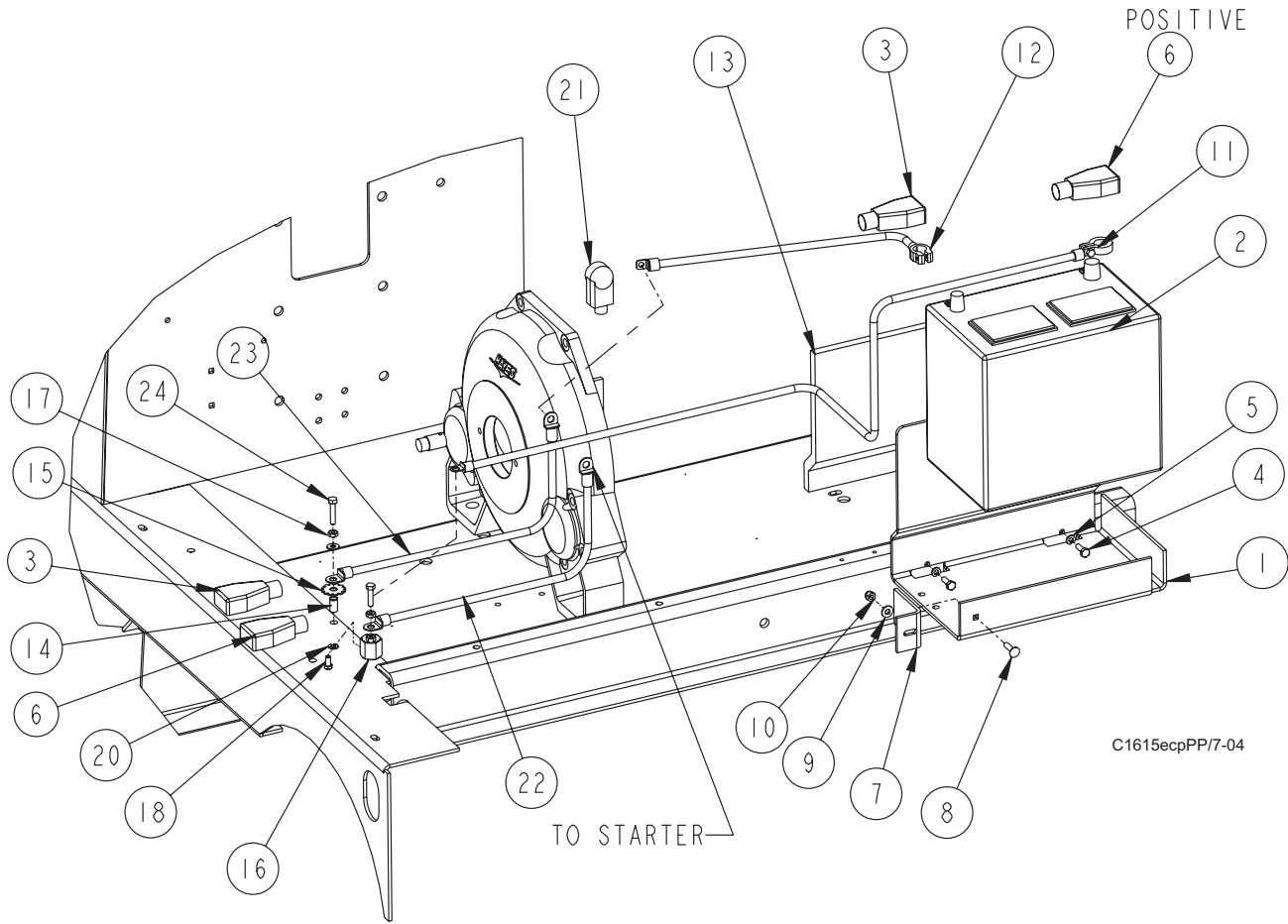

KEY NO.	PART NUMBER	DESCRIPTION	QTY
1	7-08-07111	Bracket, Battery	1
2	0875-008	Battery	1
3	2-00-05173	Insulator, Battery (Black Boot)	2
4	2-00-00221	Bolt, 1/4-20 x 3/4 Fin. Hex Head	2
5	2-00-00518	Lock Washer, 1/4" Helical Spring	2
6	2-00-05171	Insulator, Battery (Red Boot)	2
7	7-13-07109	Bracket, Battery	1
8	2-00-02196	Carriage Bolt, 1/4-20 x 1.000 RHM	1
9	2-00-03702	Washer, .625 x .281 x .063	2
10	2-00-00641	Nut, 1/4-20 Fiber Insert	1
11	7-90-07502	Wire, Red Battery Connection (48")	1
12	7-90-07281	Cable, Black Battery (1AWG, 36")	1
13	7-34-09022-1	Panel, Insulation	1
14	2-00-05261	Insert, 1/4-20 Threaded	1
15	2-00-03829	Lock Washer, 3/8 Int./Ext. Tooth	1
16	8-35-00021	Isolator	1
17	2-00-00594	Nut, 1/4-20 Hex	3
18	2-00-00220	Bolt, 1/4-20 x .63 Fin. Hex Head	1
19	2-00-04203	Boot, Rubber Terminal	1
20	2-00-00518	Lock Washer, 1/4 Helical Spring	1
21	2-00-04203	Boot, Rubber Terminal	1
22	8-90-07444	Wire, 6-gaugem 37" long	1
23	7-90-07251	Wire, Ground to Engine, 1 AWG x 21" long	1
24	2-00-00222	Bolt, 1/4-20 x 1.25 Fin. Hex Head	2

C1615ecpPP/7-04

BATTERY ELECTRICAL ASSEMBLY - DIESEL

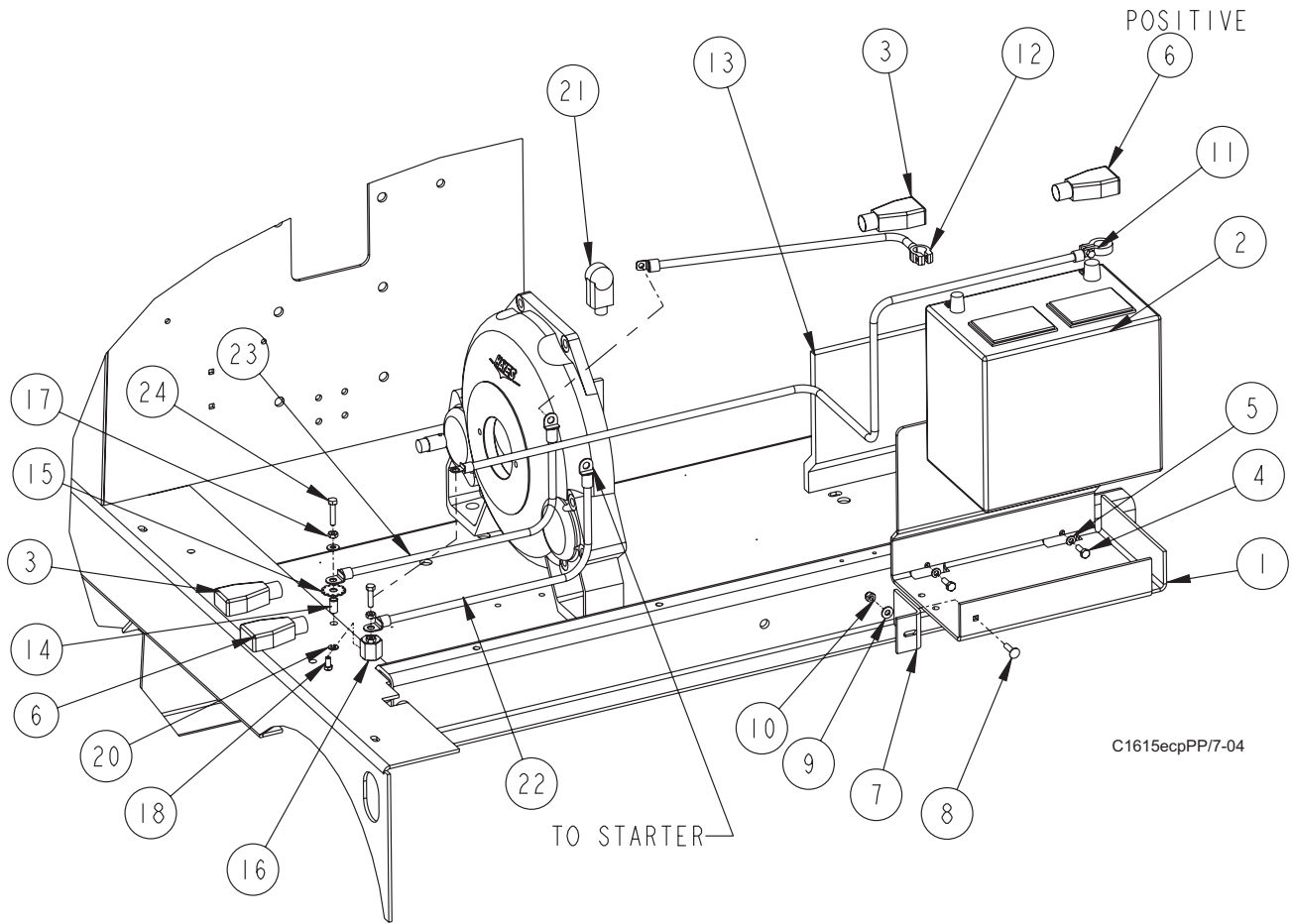

KEY NO.	PART NUMBER	DESCRIPTION	QTY.
1	7-08-07111	Bracket, Battery	1
2	2-00-05173	Insulator, Battery (Black Boot)	2
3	2-00-00221	Bolt, 1/4-20 x 3/4 Fin. Hex Head	2
4	2-00-00518	Lock Washer, 1/4" Helical Spring	2
5	2-00-05171	Insulator, Battery (Red Boot)	2
6	7-13-07109	Bracket, Battery	1
7	2-00-02196	Carriage Bolt, 1/4-20 x 1.000 RHM	1
8	2-00-03702	Washer, .625 x .281 x .063	2
9	2-00-00641	Nut, 1/4-20 Fiber Insert	2
10	7-90-07502	Wire, Red Battery Connection (48")	1
11	7-90-07281	Cable, Black Battery (1AWG, 36")	1
12	7-34-09022-1	Panel, Insulation	1
13	2-00-05261	Insert, 1/4-20 Threaded	1
14	2-00-03829	Lock Washer, 3/8 Int./Ext. Tooth	1
15	8-35-00021	Isolator	1
16	2-00-00594	Nut, 1/4-20 Hex	3
17	7-90-07408	Wire, 6 GA	1
18	7-90-07251	Wire, Ground to Engine (1 AWG x 21")	1
19	0875-057	Battery	1
20	2-00-00220	Bolt, 1/4-20 x .63 Fin. Hex Head	1
21	2-00-04203	Boot, Rubber Terminal	1
22	2-00-00518	Lock Washer, 1/4 Helical Spring	1
23	2-00-00222	Bolt, 1/4-20 x 1.25 Fin. Hex Head	2

C1615-1ecpPP/7-04

DECALS - PARTS LIST

<u>KEY NO.</u>	<u>PART NUMBER</u>	<u>DESCRIPTION</u>	<u>QTY.</u>
1	8-18-00515	Instrument Panel	1
2	8-18-00520	Left Side Panel	1
3	8-18-00506	Main Broom	1
4	8-18-00507	Side Broom	1
5*	REF	ATF/Dextron Fluid Only	1
7	8-18-00490	Bi-Directional Pedal/horizontal	1
8<	8-18-00487	Blank Square - Option Covers	1
9*	REF	Gasoline Only (Gas models)	1
		Diesel Fuel Only (Diesel models)	1
10*	REF	Do Not Use with Flammables	1
12*	REF	Exhaust Warning	1
13*	REF	Fire Hazard-Fuel Could Explode	1
14*	REF	Moving Belts-Stay Clear	1
15*	REF	Moving Fan Blade-Stay Clear	1
16*	REF	No Gasoline or Combustibles	1
17*	REF	Patent/Patents Pending	1
18*	REF	Surface Hot-Stay Clear	1
19*	REF	Turn Off-Lock Wheel	1
20*	REF	Cover/Hopper Could Close	3
21*	REF	No Step	4
22*	REF	Pinch Point-Stay Clear	9
23	8-18-00539	SC7750	1
25	8-18-00524	American-Lincoln (small)	2
26	8-18-00525	American-Lincoln (medium)	1
27	REF	Serial Plate	1
28	7-50-05136	Non Skid (Edge)	3
29	8-50-05055	Non Skid	1
30	2-00-04115	Rivet	2
31	8-18-00552	Check Engine	1

***Contained in Warning Decal Kit 0760-892**

<Can be ordered separately but is also included in 0760-892

C1693Becp-IC/9-04

DECAL - EXPLODED VIEW

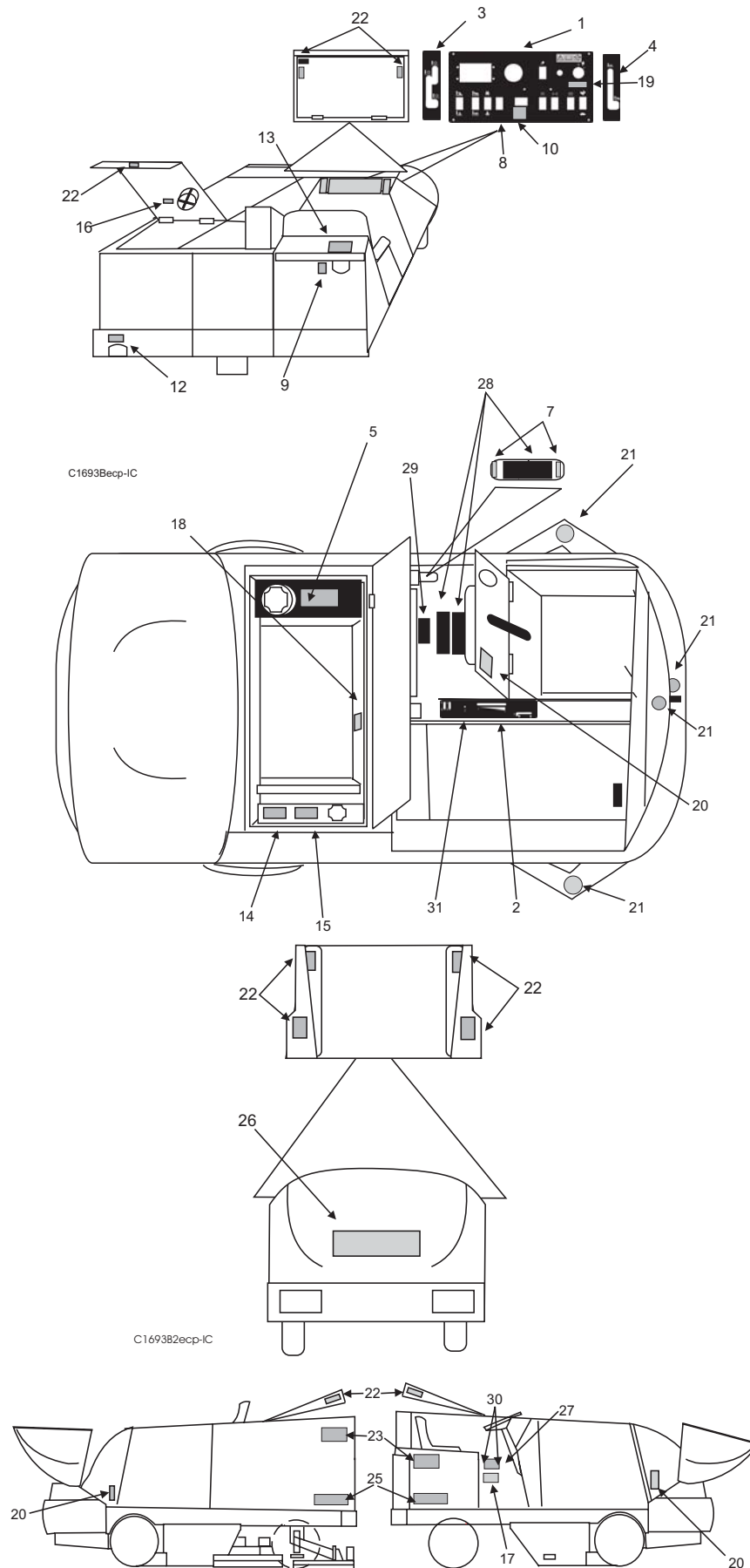

INSTRUMENT PANEL - PARTS LIST

<u>KEY NO.</u>	<u>PART NUMBER</u>	<u>DESCRIPTION</u>	<u>QTY.</u>
1	7-52-00147	Panel, 7750 IC Instrument	1
2	7-82-00026	Switch, Anti Restart Key (Ign. Key Only: 2-60-02272)	1
3	7-82-00039	Switch, Single Pole/Single Throw (On-On)	1
4	8-48-05032	Gauge, Fuel	1
5	8-82-00027	Switch, Light	1
6	7-82-00041	Switch, Double Pole/Triple Throw (On-On-On)	1
7*	7-82-00039	Switch, Single Pole/Single Throw (On-On)	2
8	2-00-05375	Switch, Blank McGill	5
9	8-82-00062	Switch, Rocker (SPST)	2
10	7-48-05029	Hour Meter	1
11	8-08-00838	Panel, Relay	1
12	2-00-05337	Screw, 8-32 x .75 BHSC	6
13	2-00-01372	Lock Nut, 8-32 Fiber Hex	6
14	7-41-08007	Panel, Warning Light	1
15	8-75-01223	Spacer, Panel	4
16	7-52-00209	Panel, Warning Light Back	1
17	8-40-05057	Red Light, 12V	4
18	8-40-05056	Amber Light, 12V	3
19	2-00-04897	Screw, 10-24 x 1.25	1
20	8-64-05010	Module, Time Delay	1
21	8-64-05009	Relay, 4-Prong 12 VDC	1
22	2-00-01246	Nut, 10-24 Elastic Stop	1
23	7-11-04035	Kit, Low LP Indicator	1
24	8-18-00515	Decal, Instrument Panel	1
25	0795-216	Harness, Wiring	1
26~	0775-216	Diode Assembly	1
27<	0775-218	Diode Assembly	1
28<	0775-246	Diode Assembly	1
29	7-52-00179	Panel, Circuit Breaker	1
30	8-64-00008	Circuit Breaker, 15 Amp	8
31	2-00-04757	Plug Button, .375 dia.	2
32	8-11-00044	Boot	8

*Not used on Diesel models

~Installed between Scrub switches (see Instrument Panel Connection drawing)

<Installed on Squeegee switch (see Instrument Panel Connection drawing)

72008revD/1-05

INSTRUMENT PANEL - EXPLODED VIEW

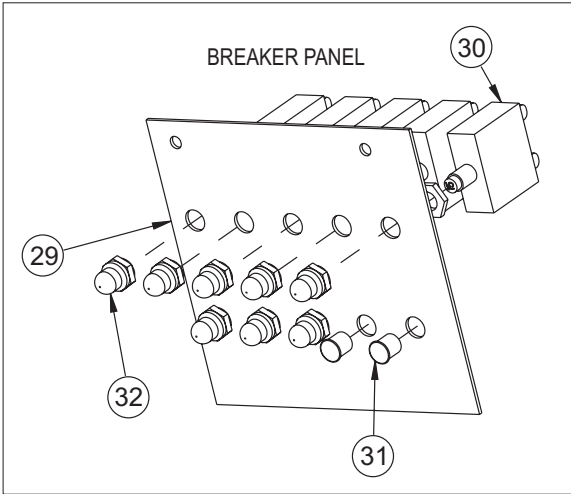
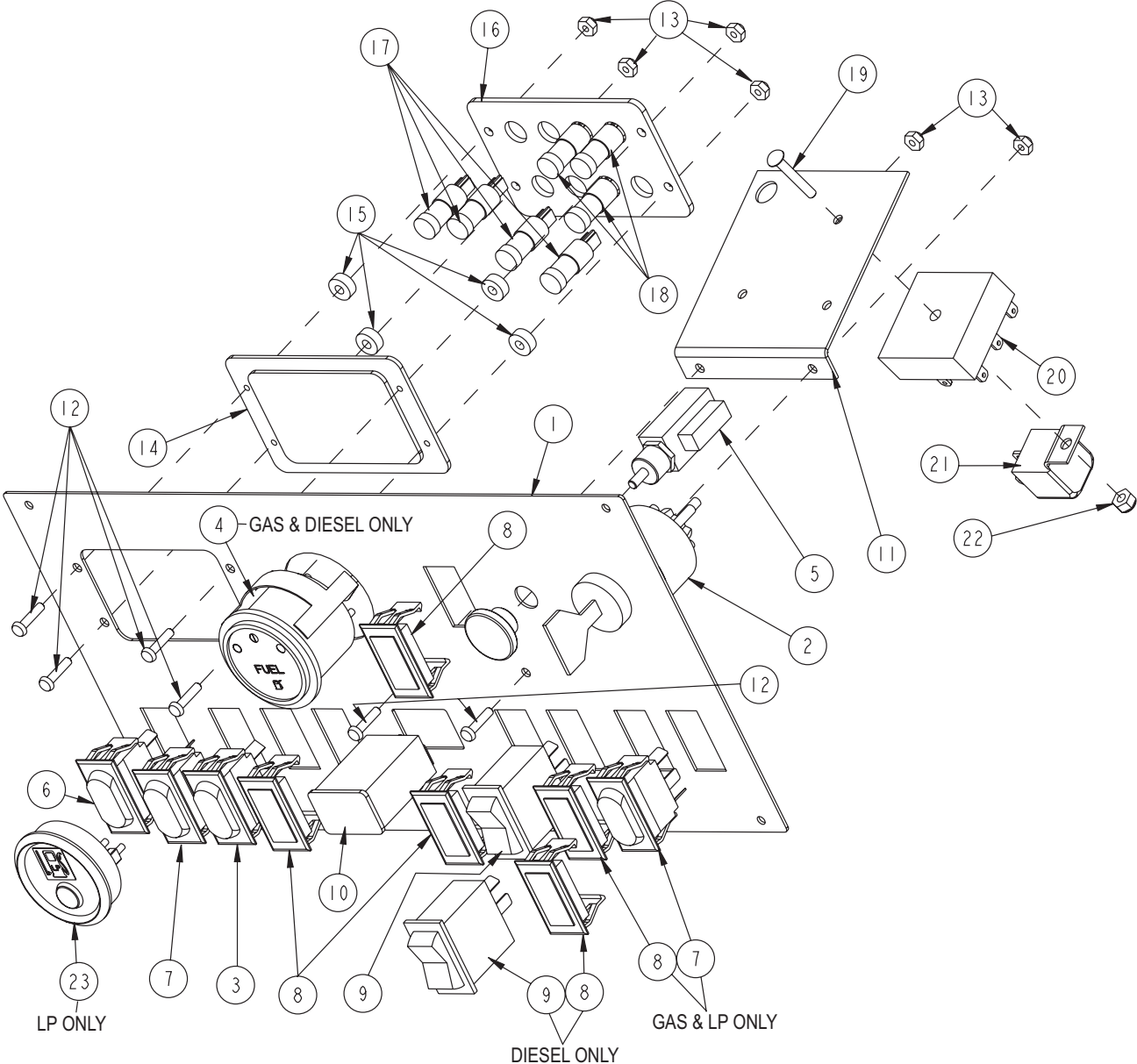

72008revD/1-05

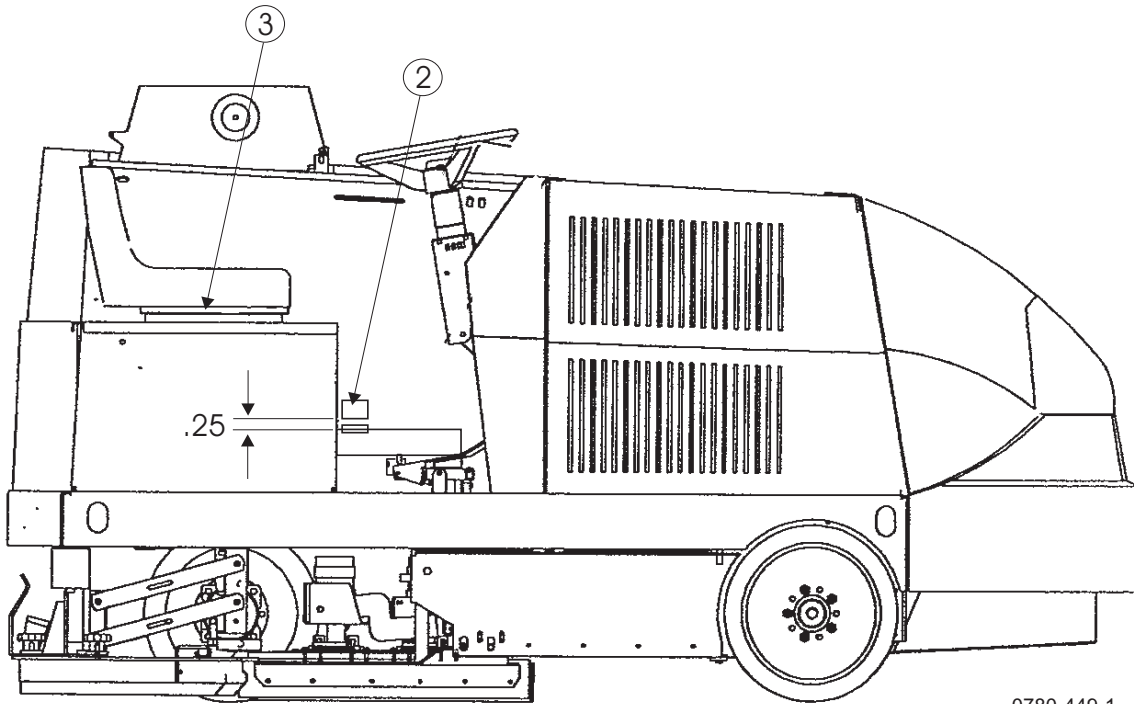

0780-449-1

KEY NO.	PART NUMBER	DESCRIPTION	QTY.
1*	0780-439	Back-Up Alarm (not shown)	1
2	REF	Serial Number Plate	1
3*	0780-471	Seat Switch (not shown)	1

*See Chapter 3 - Options for parts lists & assembly diagrams

0780-449-1/7-04

BACK VIEW OF INSTRUMENT PANEL

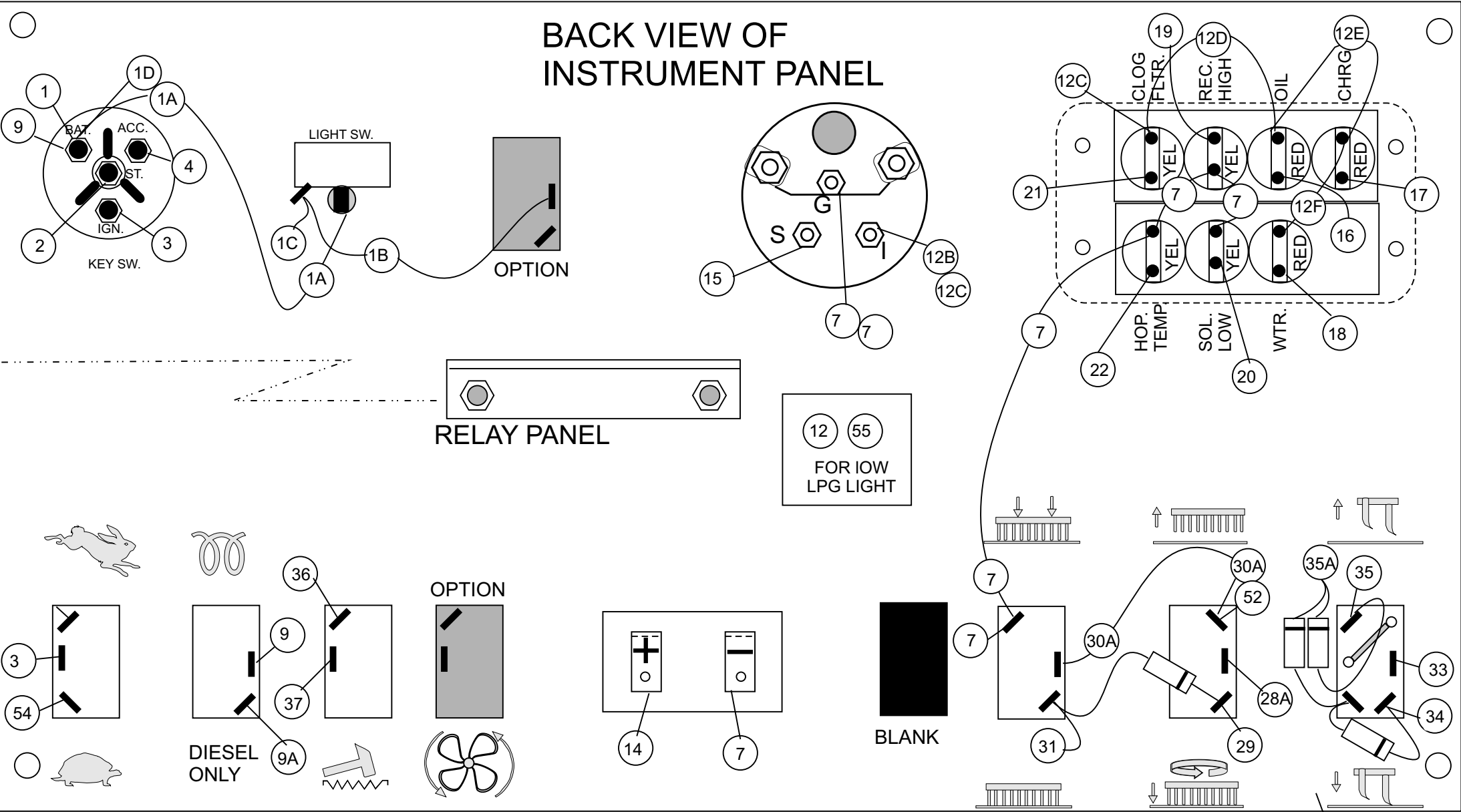
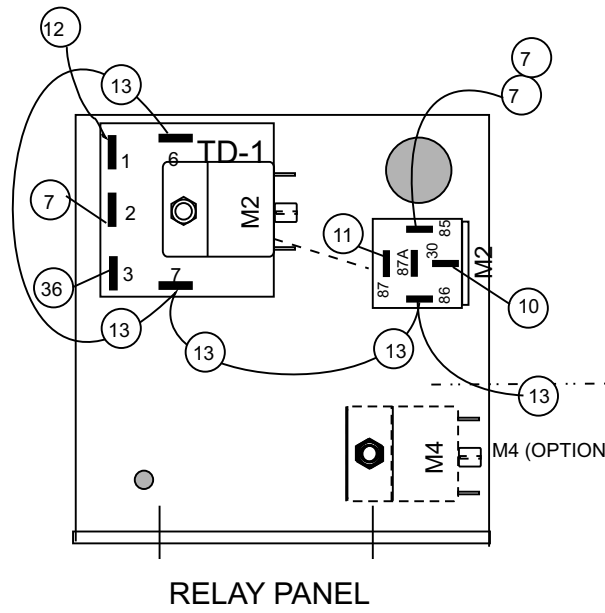

WIRE #	COLOR
1,1A,1B,1C,1D,1E	RED
2,2A,2B	ORANGE
3	YELLOW
4	LT. GREEN
5	LT. BLUE
7	BLACK
9,9A	TAN
10	PURPLE
11	RED
12,12A,12B,12C, 12D, 12E, 12F	ORANGE
13, 13A, 13B	YELLOW
14	LT. GREEN
15	LT. BLUE
16, 16A	WHITE
17	GRAY
18	TAN
19, 19A	PURPLE
20	RED
21	ORANGE
22	YELLOW
23	TAN
28, 28A	PURPLE
29	RED
30A	ORANGE
31	YELLOW
33, 33A, 33B, 33C, 33D	LT. BLUE
34	WHITE
35, 35A	GRAY
36, 36A, 36B	TAN
37	PURPLE
52	RED
54	ORANGE
55	RED
56	RED

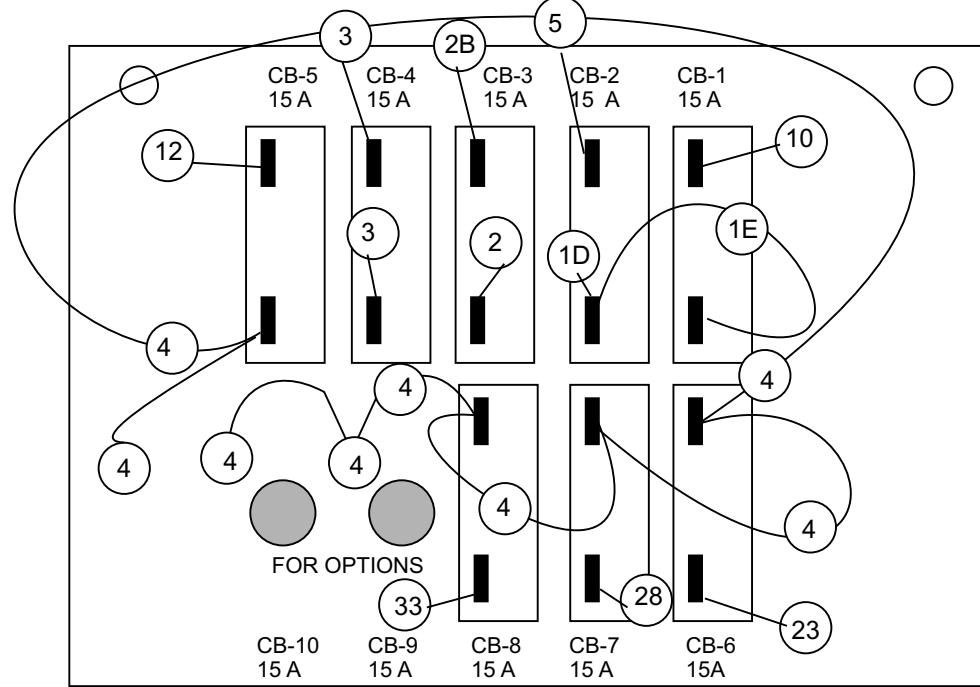

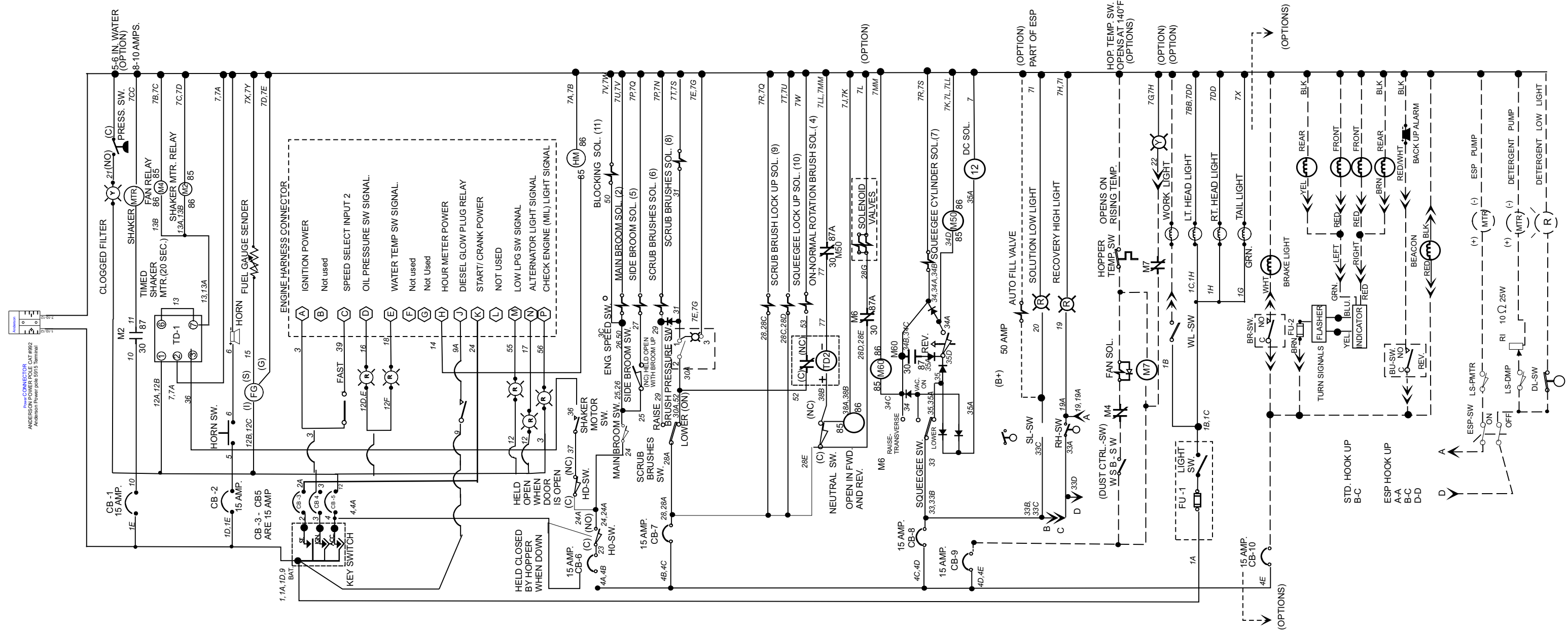

MACHINE HARNESS CONNECTION DIAGRAM

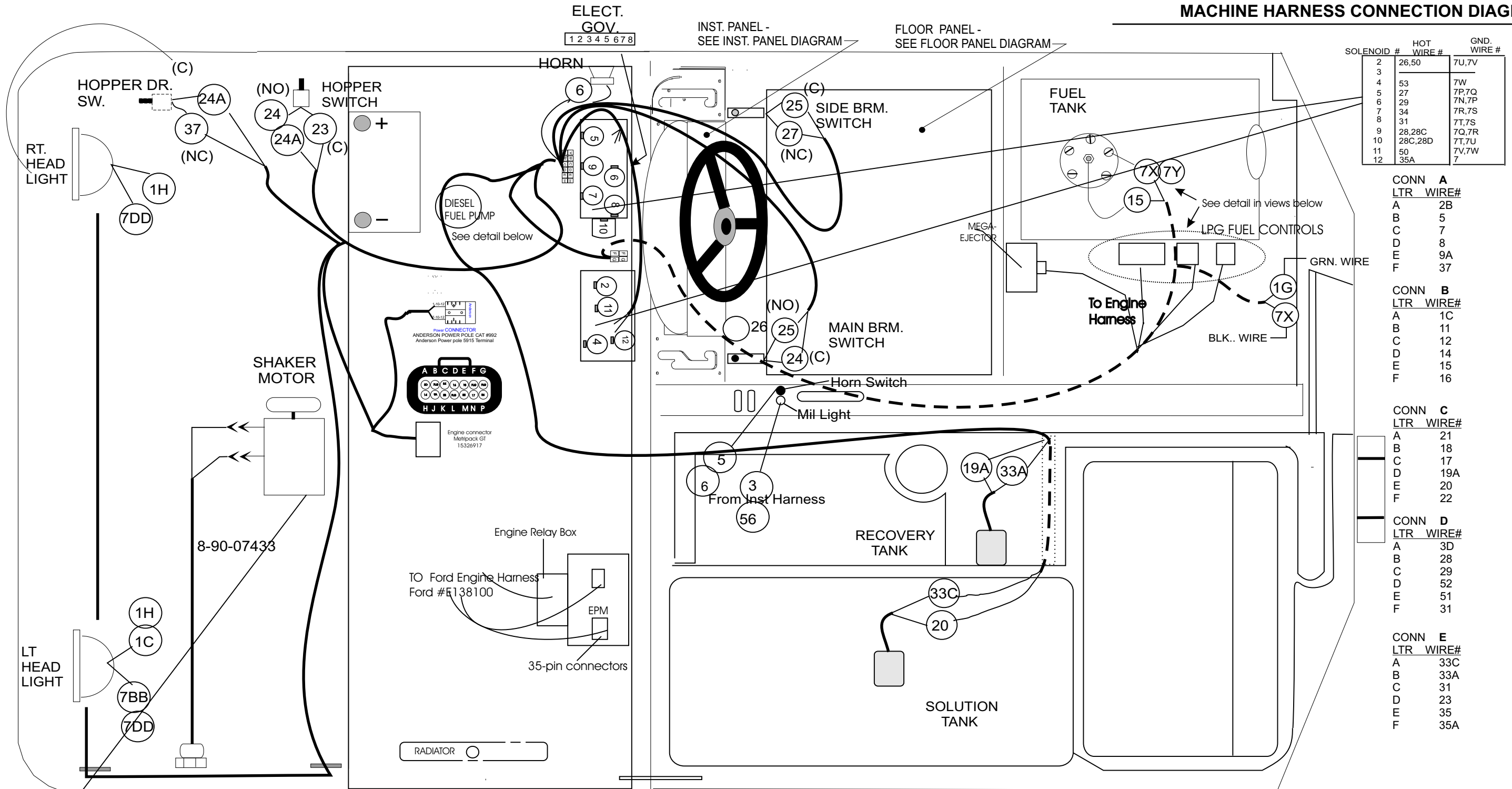

SOLENOID #	HOT WIRE #	GND. WIRE #
2	26,50	7U,7V
3		
4	53	7W
5	27	7P,7Q
6	29	7N,7P
7	34	7R,7S
8	31	7T,7S
9	28,28C	7Q,7R
10	28C,28D	7T,7U
11	50	7V,7W
12	35A	7

CONN A

LTR	WIRE#
A	2B
B	5
C	7
D	8
E	9A
F	37

CONN B

LTR	WIRE#
A	1C
B	11
C	12
D	14
E	15
F	16

CONN C

LTR	WIRE#
A	21
B	18
C	17
D	19A
E	20
F	22

CONN D

LTR	WIRE#
A	3D
B	28
C	29
D	52
E	51
F	31

CONN E

LTR	WIRE#
A	33C
B	33A
C	31
D	23
E	35
F	35A

CONNECTOR H
WIRE #1

SHAKER MOTOR
WIRE #
11
7CC

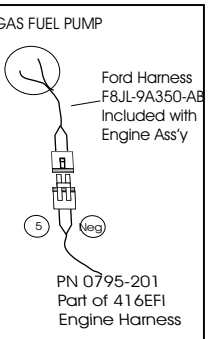
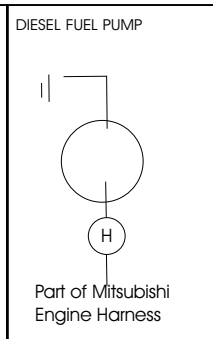
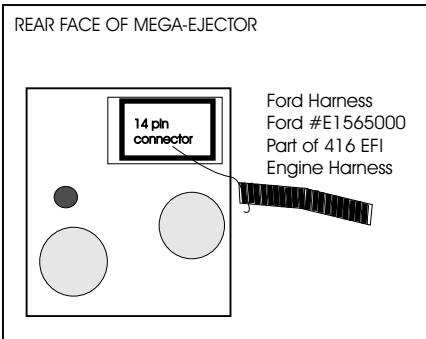
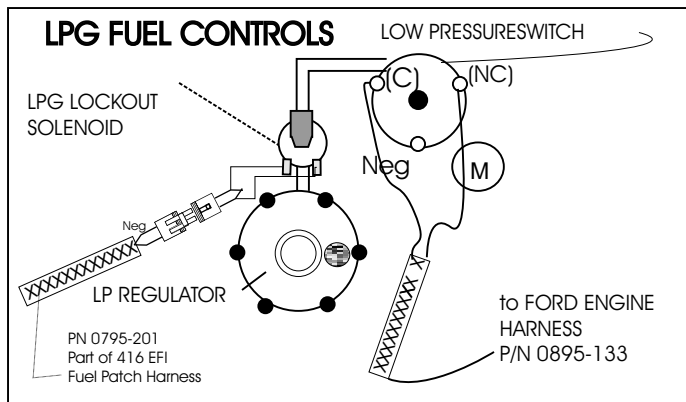

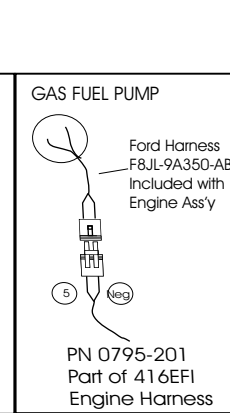
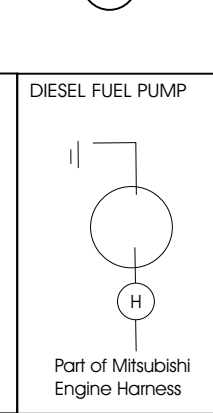
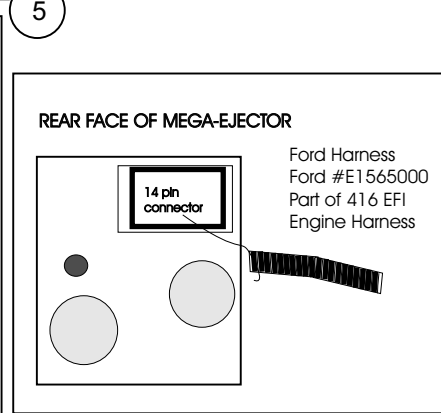
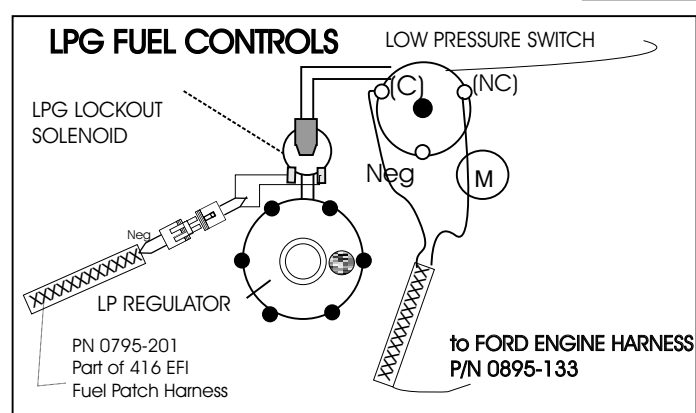
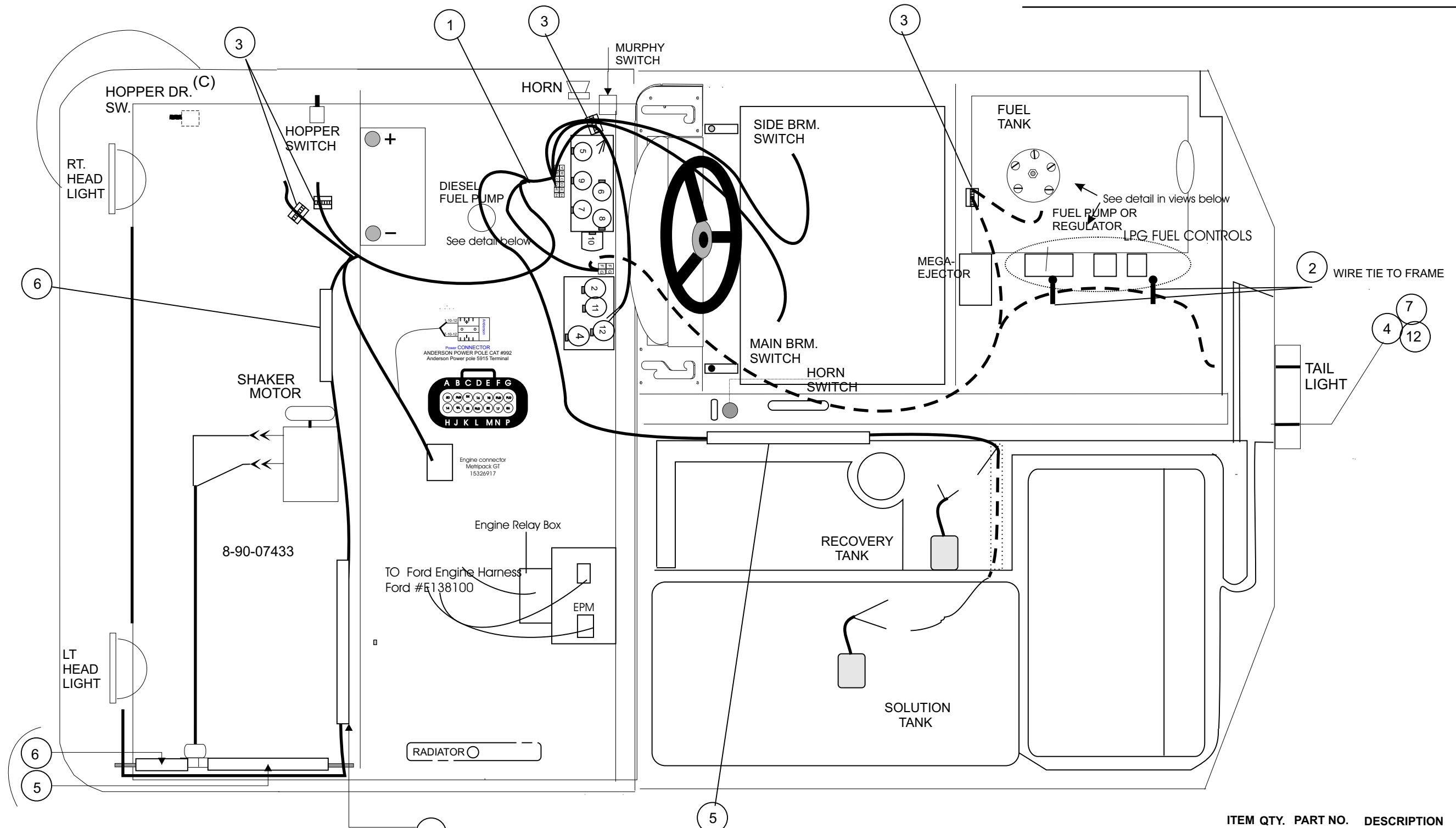

ITEM	QTY.	PART NO.	DESCRIPTION
1	1	0795-179	HARN.-MACH.
2	2	2-00-04345	TYE-RAP
3	4	7-13-07096	CLAMP
4	1	2-00-01246	NUT-10-24 LOCK
5	4	8-20-06043	DUCT 12"
6	2	7-20-06012	DUCT 6"
7	1	2-00-02933	SCREW
12	1	8-75-01207	SPACER

CONNECTION DRAWING for INTERFACE HARNESS PN/ 0895-133

42 Pin Ford EPM
Connector

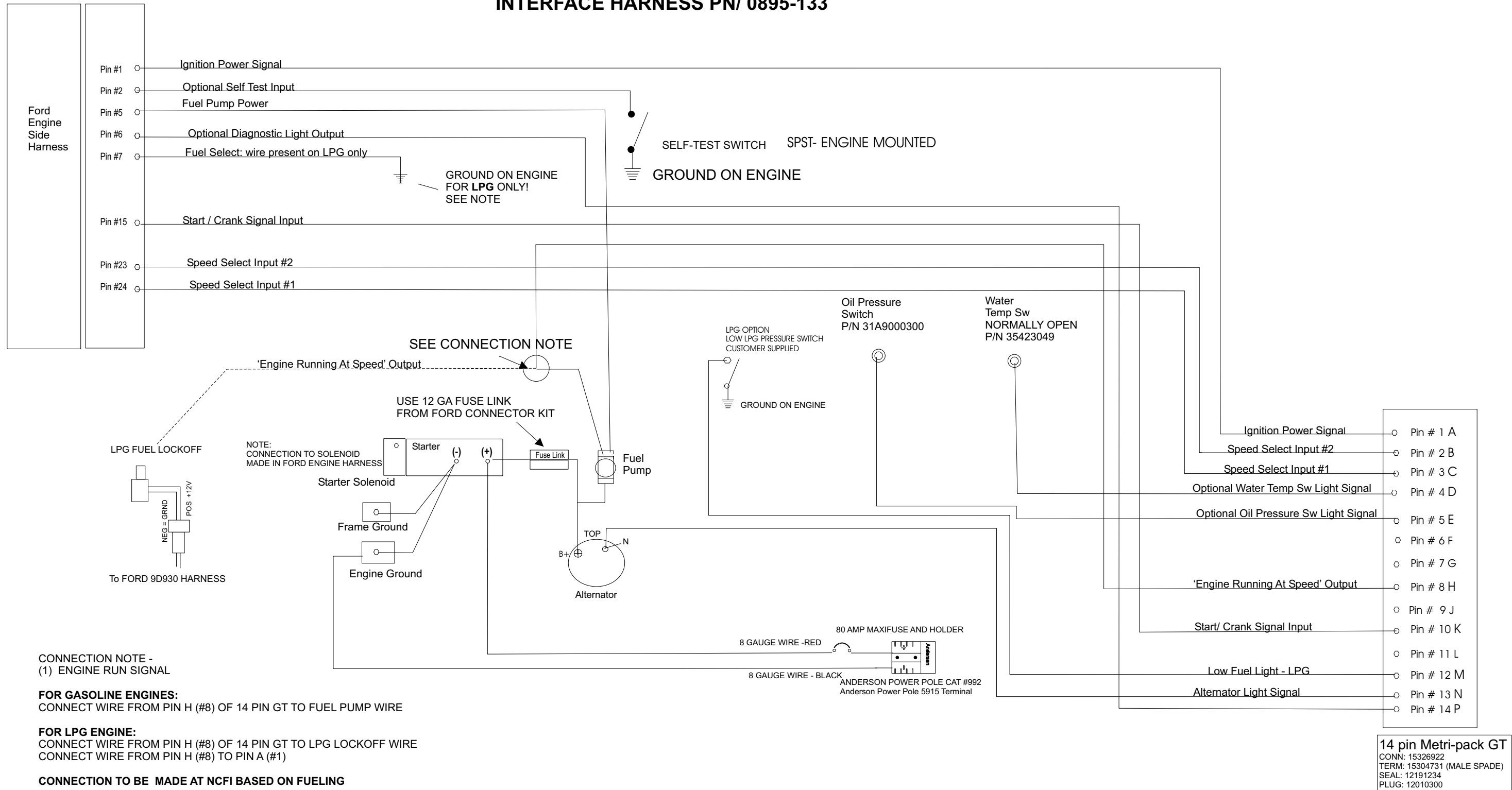

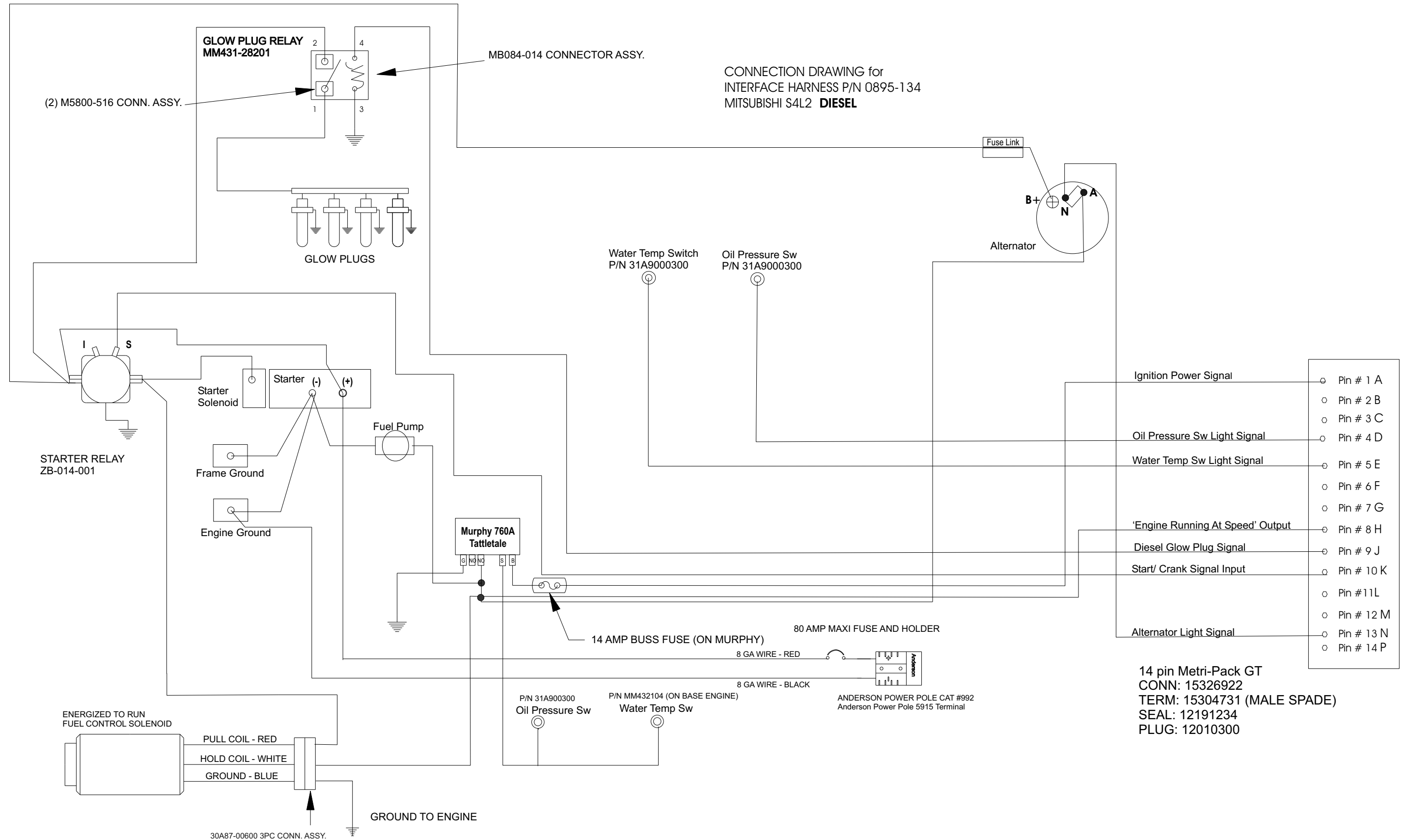

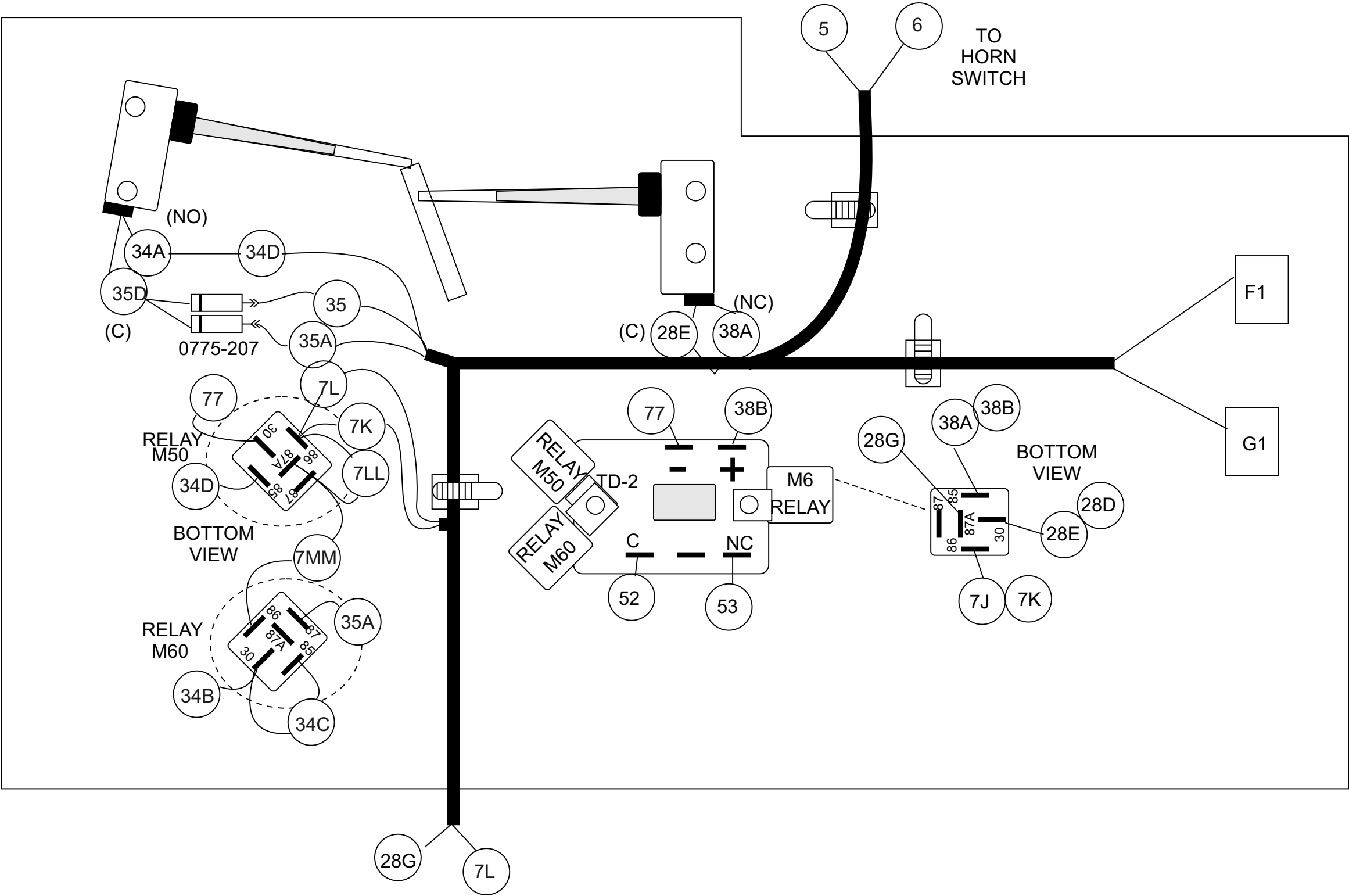

TABLE OF CONTENTS - CHAPTER 3 - OPTIONS

Brushes Option	3-2
Hopper Thermo-Sensor Shutdown Option	3-4
Back-Up Alarm Option	3-6
Rear Work Light Option	3-8
Turn Signals Option	3-10
Overhead Guard Option	3-12
Amber Safety Light Option with Overhead Guard	3-14
Amber Safety Light Option without Overhead Guard	3-16
ESP/Autofil Option	3-18
ESP/ Autofil Wiring	3-24
Fire Extinguisher	3-26
Flame Arresting Gas Cap	3-27
Clogged Filter Option	3-28
Spray Wand Option	3-30
Spray Wand Option Wiring	3-32
Wet Sweep Bypass/Thermo Sensor Option	3-34
Retractable Seatbelt Option	3-38
Retractable Seatbelt Option (LP ONLY)	3-39
Suspension Seat Option	3-40
Seat Switch Kit	3-41
Pad Driver Option (16")	3-42
Pad Driver Option (18")	3-43
Vacuum Wand Option	3-44
Vac Hose Service Kit	3-46
High Torque Drive Motor Option	3-47
Tire Options	3-48
Stainless Steel Variable Dump Hopper Option	3-49
Cam Style Hopper Switch Option	3-50
Wrap-Around Bumpers Option	3-51
Extended Recovery Tank Drain System Option	3-52
Spare Parts List - 46" Machine	3-54
Spare Parts List - 53" Machine	3-55
Engine Service Parts - Ford 416EFI Gas/LP	3-56
Engine Service Parts - Mitsubishi S4L2 Diesel	3-57

BROOM & BRUSH OPTIONS

<u>KEY NO.</u>	<u>PART NUMBER</u>	<u>DESCRIPTION</u>	<u>QTY.</u>
1	8-08-03217	Main Broom, Proex & Wire	1
1	8-08-03218	Main Broom, Poly & Wire (8-Row)	1
1	8-08-03219	Main Broom, Nylon (8-Row)	1
1	8-08-03220	Main Broom, High Density Nylon	1
1	8-08-03221	Main Broom, High Density Wire & Fiber	1
2	0765-256	Scrub Brush Assy, 16" Black Nylon	3
	7-08-03261-1	Brush Only	3
2	0765-257	Scrub Brush Assy, 16" Amerfil	3
	7-08-03264-1	Brush Only	3
2	0765-258	Scrub Brush Assy, 16" Supergrit	3
	7-08-03265-1	Brush Only	3
2	0765-259	Scrub Brush Assy, 16" Soft Nylon	3
	7-08-03266-1	Brush Only	3
2	0765-260	Scrub Brush Assy, 18" Black Nylon	3
	7-08-03170-1	Brush Only	3
2	0765-265	Scrub Brush Assy., 16" Clean Grit	3
	7-08-03271	Brush Only	3
2	0765-261	Scrub Brush Assy, Amerfil 18"	3
	7-08-03172-1	Brush Only	3
2	0765-262	Scrub Brush Assy, Supergrit 18"	3
	7-08-03205-1	Brush Only	3
2	0765-263	Scrub Brush Assy, Soft Nylon 18"	3
	7-08-03262-1	Brush Only	3
2	0765-266	Scrub Brush Assy, 18" Clean Grit	3
	7-08-03269	Brush Only	3
3	0880-439	Wire Side Broom Assy.	1
	8-08-03199	Broom Only	1
3	8-08-03211	Side Broom, Nylon	1
3	8-08-03212	Side Broom, Polypropylene	1
4	7-19-02034	Disc, 18" Brush Driver	1
4	7-19-02035	Disc, 16" & 18" Brush Driver	1
5	8-58-05248	Plate, Side Broom Retainer	1
6	2-00-00081	Screw, 1/4-20 x 1.0 RHM	4
7	2-00-04121	Screw, 10-13 x .75 Pan Head Wood	3

C1710/9805

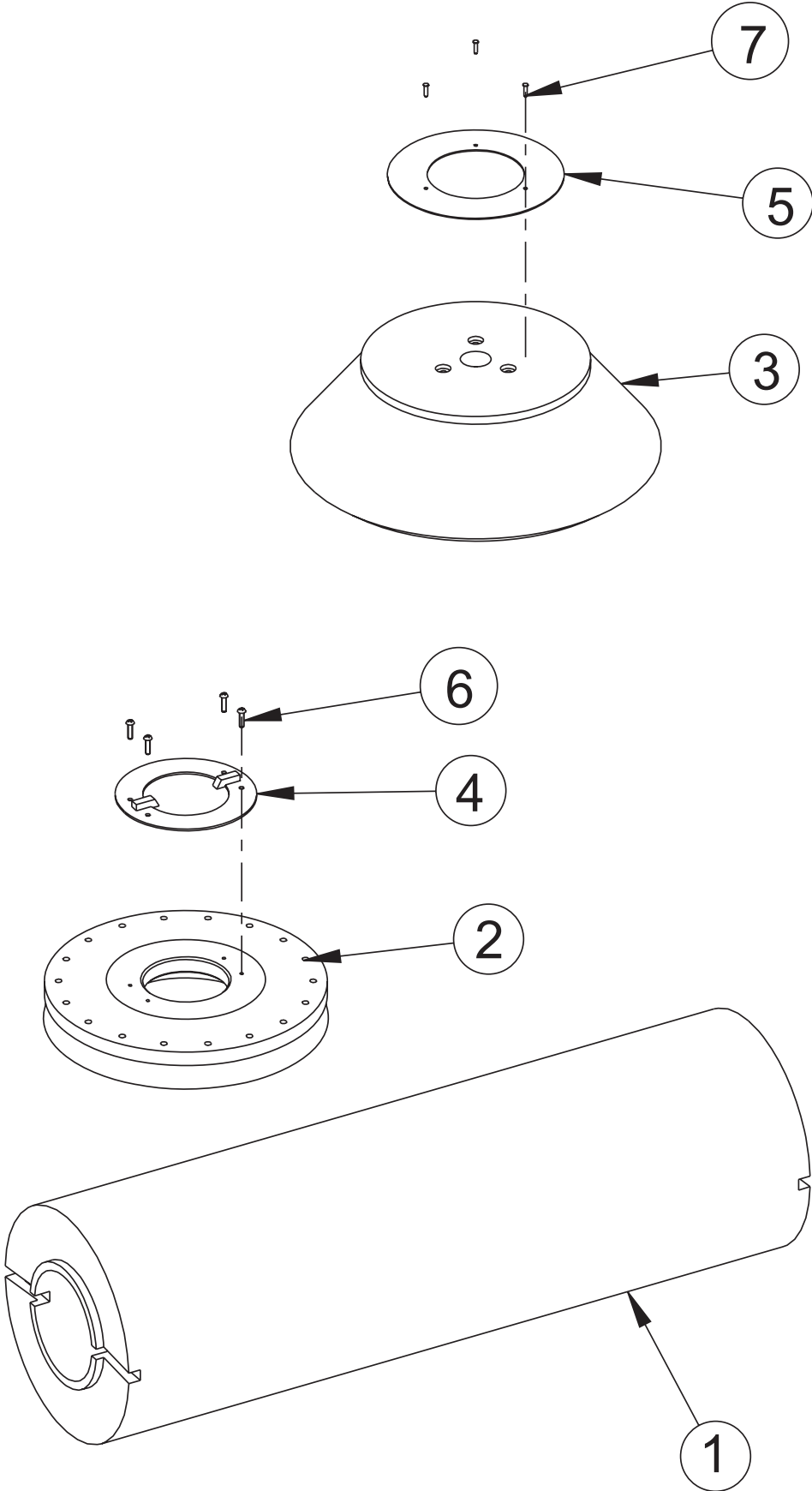

C1710/9712

HOPPER THERMO-SENSOR SHUTDOWN OPTION

OPTION 0780-451

<u>KEY NO.</u>	<u>PART NUMBER</u>	<u>DESCRIPTION</u>	<u>QTY</u>
1	7-52-00148	Panel-Circuit Breaker	Ref.
2	8-64-00008	Circuit Breaker- 15 AMP	1
3	8-11-00044	Boot	1
4	8-64-00019	Relay- 36V	1
5	8-08-00803	Bracket-Temperature Switch	1
6	8-82-00056	Switch-Thermostat	1
7	2-00-05261	Threaded Insert-1/4-20	1
8	2-00-04716	Terminal- #10 SS	1
9	2-00-03418	Terminal- .25 FISO Female	6
10	2-00-04708	Terminal- .25 FISO Female	1
11	2-00-04578	Terminal- .156 Male Bullet	1
12	2-00-04479	Connector- 3 Way	1
13	3-61-00189	Wire- 16 AWG, Black	35'

HARDWARE USED:

H12	2-00-01246	Nut, Hex Fiber Insert #10-24	3
H24	2-00-00220	Screw, 1/4-20 x .625 HHC	1
H27	2-00-03702	Washer, .625 x .281 x .063	1
H72	2-00-00518	Lock Washer, Helical Spring	1
H100	2-00-03062	Screw, #10-24 x .625 THM	3

C1782/9805

HOPPER THERMO-SENSOR SHUTDOWN OPTION

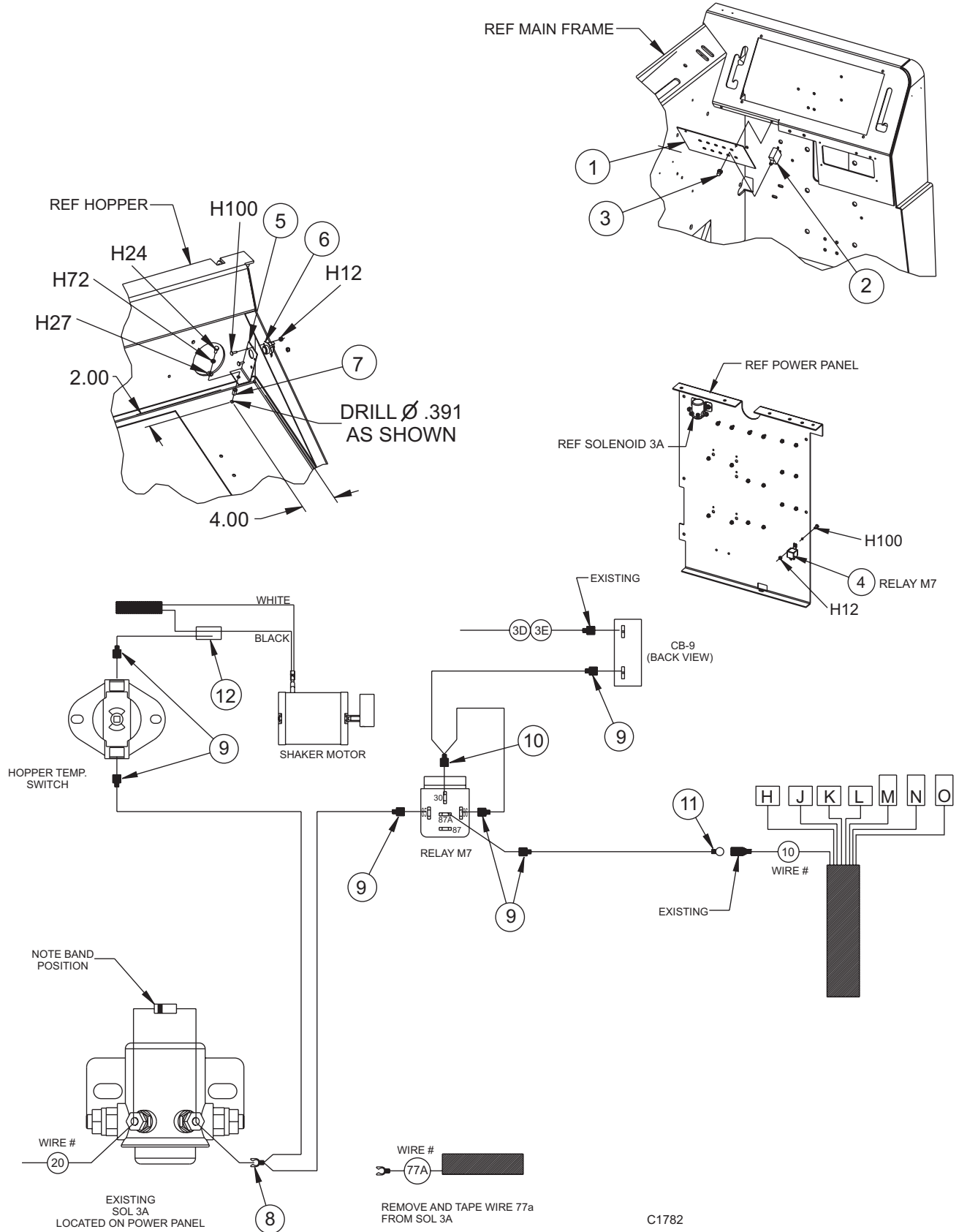

C1782

BACK-UP ALARM OPTION

OPTION NO. 0780-439

<u>KEY NO.</u>	<u>PART NUMBER</u>	<u>DESCRIPTION</u>	<u>QTY.</u>
1	8-11-00044	Cap, Instrument Panel (Boot)	1
2	8-64-00008	Circuit Breaker 15 Amp	1
3	8-82-00058	Switch	2
4	8-08-02040	Bracket	1
5	7-52-00148	Panel-Circuit Breaker	Ref.
6	8-32-09009	Back-Up Alarm	1
7	2-00-00828	Ring Terminal	1
8	8-90-07434	Wing Wire	1
9	8-11-00015	Terminal	1
10	2-00-04742	Terminal	2
11	2-00-04626	Terminal	1
12	2-00-04578	Terminal Male Bullet	1
13	2-00-00828	Ring Terminal	

HARDWARE USED:

H9	2-00-00426	Flat Washer, .500 x .219 x .063	7
H15	2-00-00221	Screw, 1/4-20 x .750 HHC	2
H26	2-00-00641	Nut, 1/4-20 Insert Fiber	2
H43	2-00-00409	Flat Washer, .687 x .344 x .062	2
H89	2-00-01372	Nut, Insert Fiber, #8-32 Steel	4
H121	2-00-00090	Screw, #8-32 x 1.500 RHM	2
H141	2-00-00501	Washer, Internal Lock	2
H191	2-00-00602	Nut, MSCR-Hex, 8-32	4
H265	2-00-00506	Lock Washer, Int Tooth #8 Dia Screw	3
H266	2-00-05371	Screw-RHM #8-32 x 2.38	1

C1753/9805

BACK-UP ALARM OPTION

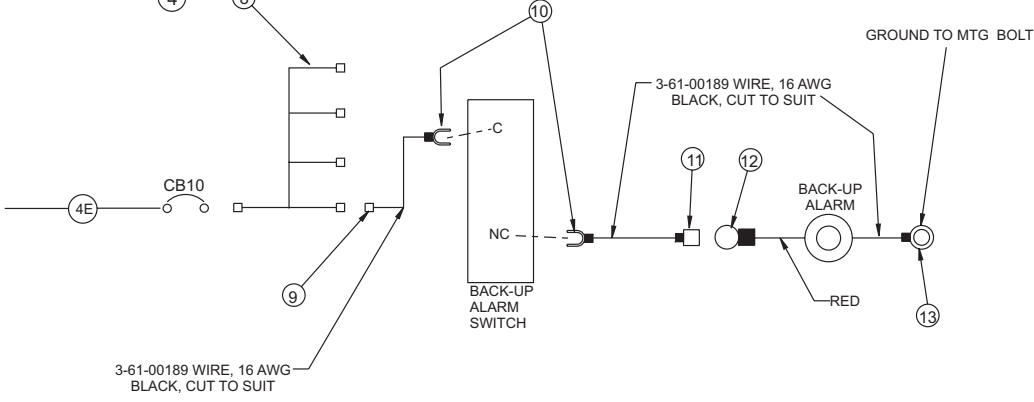
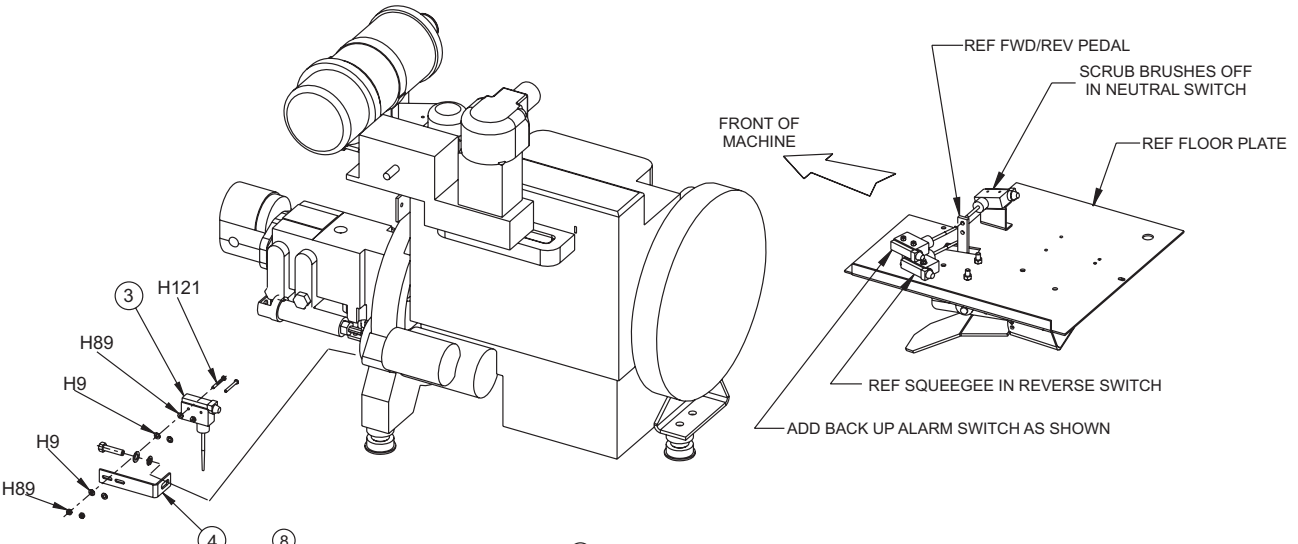
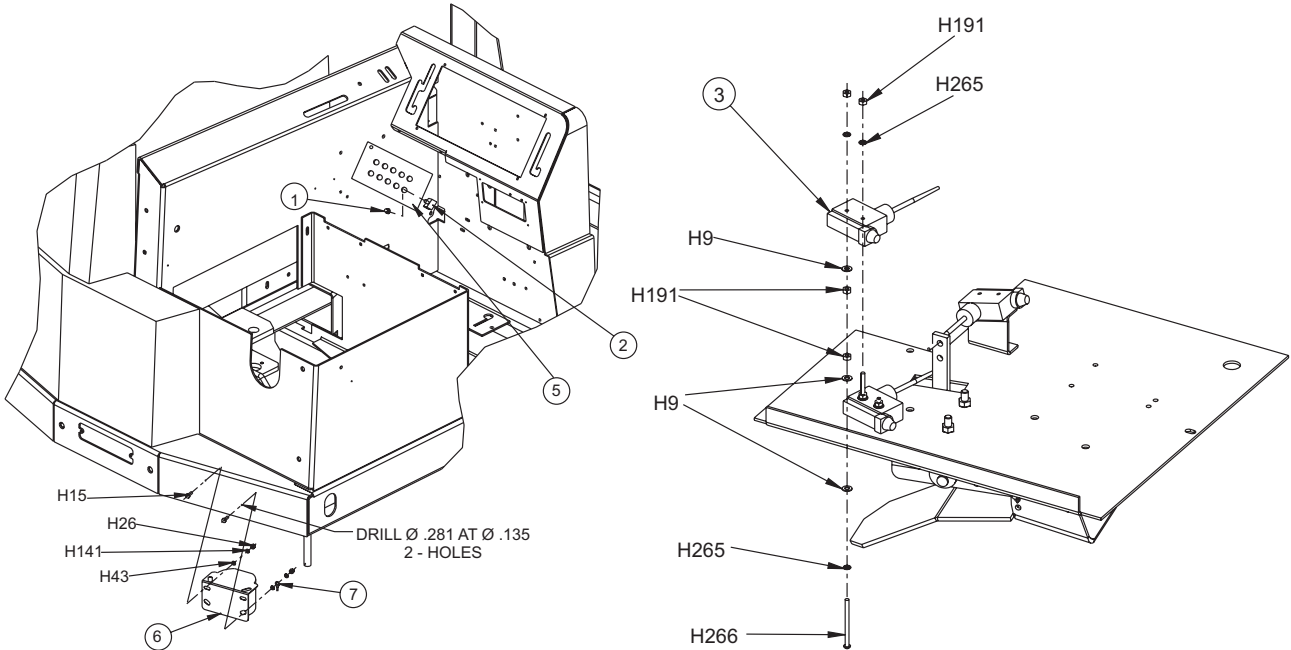

C1753-IC/9-04

REAR WORK LIGHT OPTION

OPTION NO. 0780-437

<u>KEY NO.</u>	<u>PART NUMBER</u>	<u>DESCRIPTION</u>	<u>QTY.</u>
1	8-40-05022	Light 12V	1
2	2-00-04578	Terminal	1
3	8-82-00059	Switch	1
4	2-00-03418	Terminal- .25 FISO	1
5	2-00-05048	Ring Terminal .38	1
6	2-00-02303	Washer, Internal Lock	1
7	2-00-04626	Terminal- .156 Female Bullet	1
9	3-61-00193	Wire, 16 Gauge Red	-
10	3-61-00192	Wire, 16 Gauge Brown	-
<u>HARDWARE USED:</u>			
H48	2-00-00233	Screw, 3/8-16 x 1.000 HHC	1
H52	2-00-00402	Flat Washer, .750 x .390 x .094	1

C1744/9805

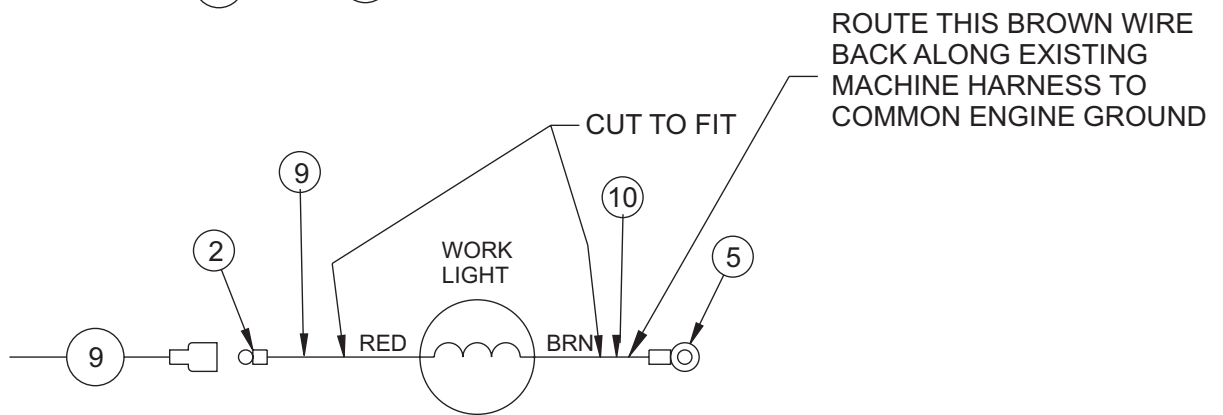
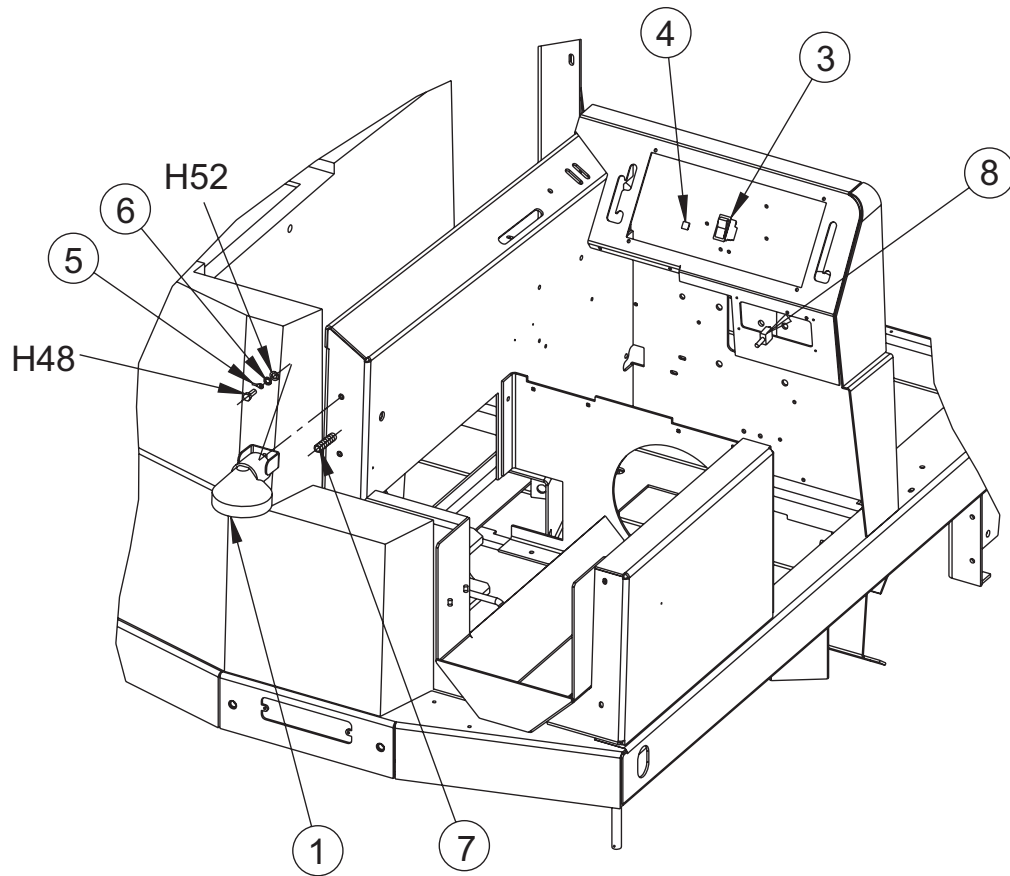

C1744/9709

TURN SIGNALS OPTION

OPTION 0780-696

<u>KEY NO.</u>	<u>PART NUMBER</u>	<u>DESCRIPTION</u>	<u>QTY.</u>
1	7-08-01144	Bracket, Light	1
2	7-08-01145	Bracket, Light	1
3	2-00-05261	Insert, 1/4-20	4
4	2-00-00518	Lock Washer, 1/4 Helical Spring	4
5	8-40-05046	Light, Turn Signal	2
6	2-00-00221	Bolt, 1/4-20 x 3/4 Fin. Hex Head	4
7	2-00-00039	Screw, #10-24 x 1.0	4
8	2-00-01246	Nut, #10-24 Elastic Stop	4
9	8-20-06037	Duct, Wire	2
10	8-41-03009	Lens, Turn Signal	2
11	8-60-05034	Steering Control Unit	1
12	8-82-00025	Switch, Turn Signal	1
13	8-33-02360	Hose, Heat Shield	1
14	8-64-00008	Circuit Breaker (15 amp)	1

0780-696/1-06

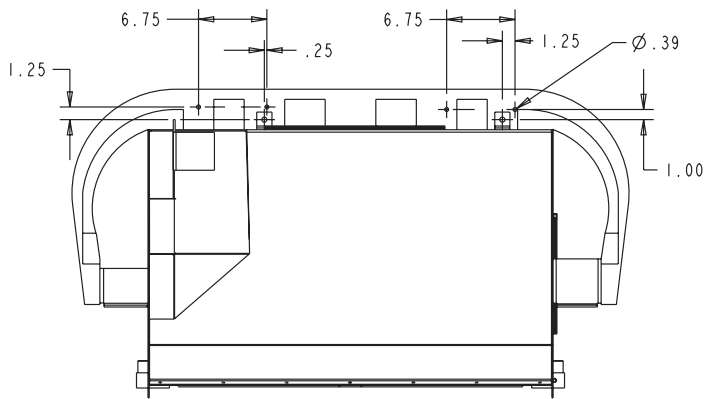
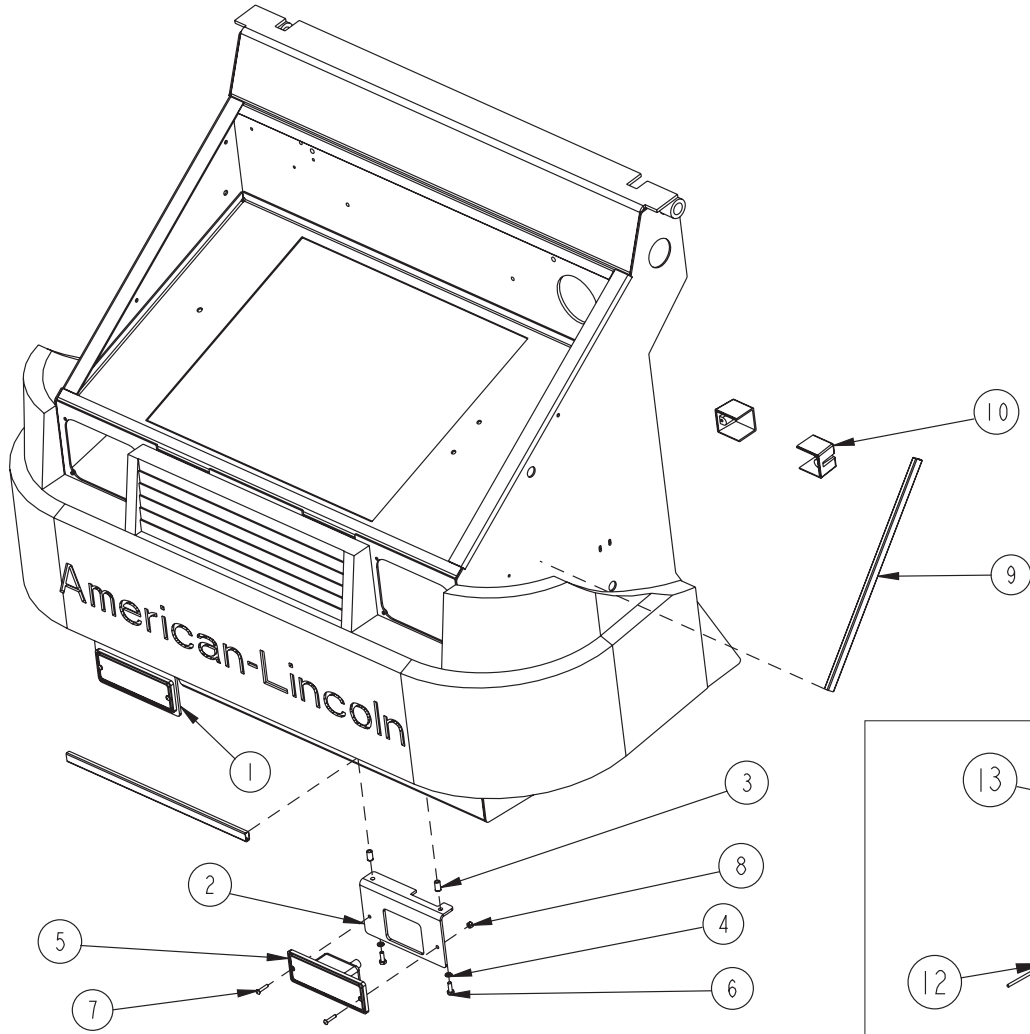

0780-696/1-06

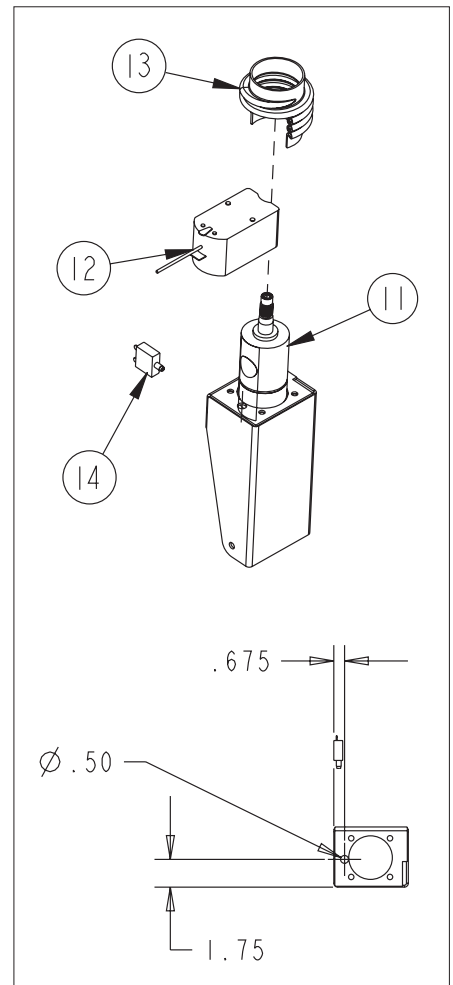

OVERHEAD GUARD OPTION

OPTION NO. 0780-417

<u>KEY NO.</u>	<u>PART NUMBER</u>	<u>DESCRIPTION</u>	<u>QTY.</u>
1	8-30-05174	Overhead Guard Top Weld	1
2	7-81-00200	Overhead Guard Leg Weld - RH	1
3	7-81-00199	Overhead Guard Leg Weld - LH	1
4	2-00-05134	Plug Button	8
5	2-95-04182	Fibre Nut	8
6	2-00-05347	THD Insert - 3/8	2
7	7-41-00037	Latch - Engine Cover	1
HARDWARE USED:			
H22	2-00-02589	Screw, 1/4-20 x 2.000 HHC	1
H26	2-00-00641	Nut, 1/4-20 Insert Fiber	1
H48	2-00-00233	Screw, 3/8-16 x 1.000 HHC	10
H53	2-00-02310	Lock Washer, Helical Spring 3/8 Med.	4
H131	2-00-03855	Carriage bolt, 3/8-16 x 1.000	2

C1696/9809

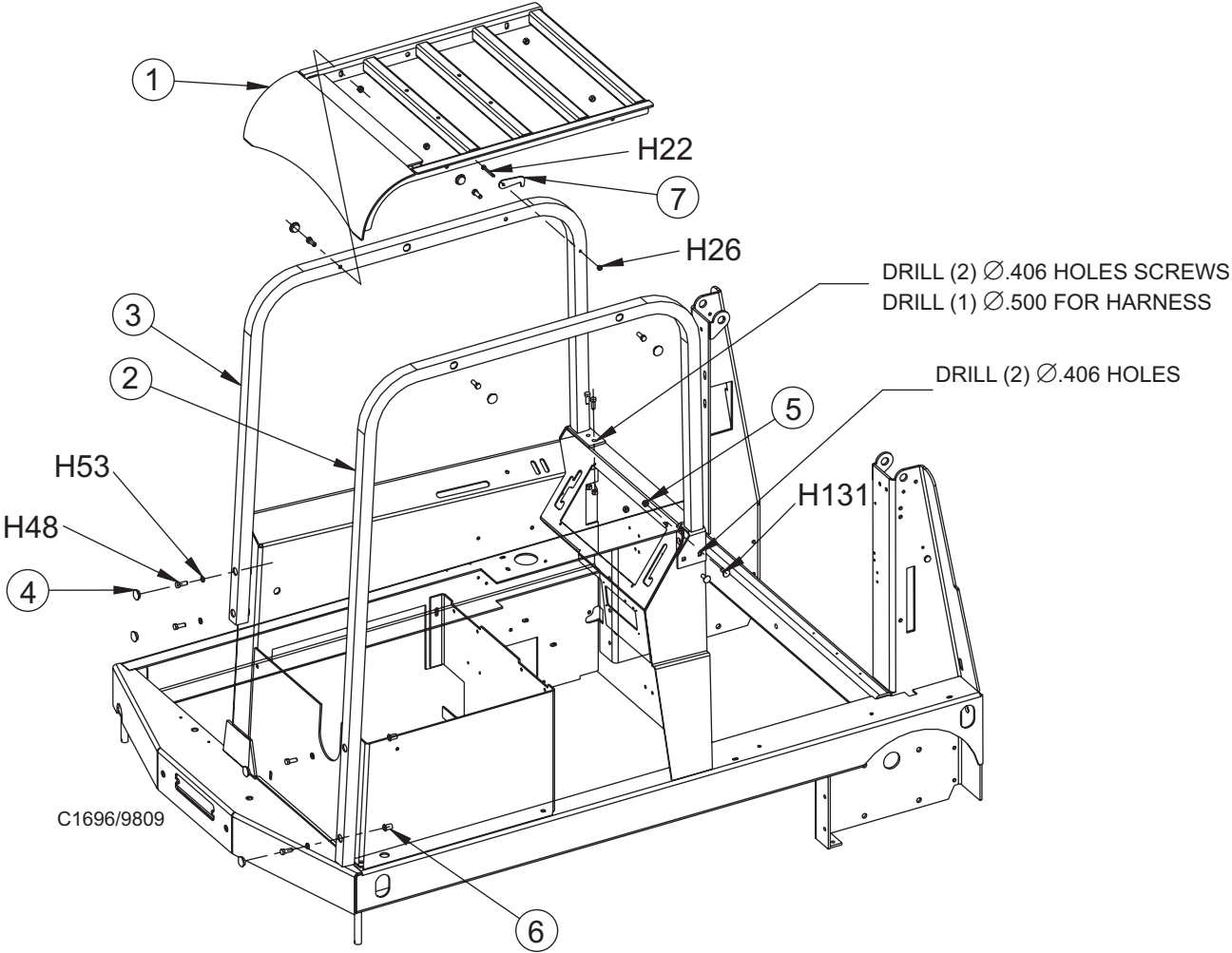

AMBER SAFETY LIGHT OPTION W/ OVERHEAD GUARD OPTION

OPTION NO. 0780-436

<u>KEY NO.</u>	<u>PART NUMBER</u>	<u>DESCRIPTION</u>	<u>QTY.</u>
1	8-40-05036	Amber Strobe	1
	8-40-05020	Red Strobe	1
2	8-58-05228	Panel, Light support	1
3	8-20-06036	Duct, Wire	1
4	2-00-01915	Grommet	2
5	2-00-05261	Threaded Insert	4
6	7-52-00148	Panel, Circuit Breaker	Ref.
7	8-64-00008	Circuit Breaker, 15 AMP	1
8	8-11-00044	Cap, Boot	1
9	8-90-07434	Wing Wire	1
10	3-61-00193	Wire, 16 AWG Red	7.5'
11	8-11-00015	Terminal	2
12	2-00-04578	Terminal	2
13	2-00-04626	Terminal	1
14	2-00-04281	Terminal	1
<u>HARDWARE USED:</u>			
H12	2-00-01246	Nut, Hex Fiber Insert #10-24	2
H17	2-00-00205	Screw, 1/4-20 x 1.000 HHC	4
H72	2-00-00518	Lock Washer, Helical Spring	4
H115	2-00-03063	Screw, #10-24 x .750 THM	2

C1750-IC/9-04

AMBER SAFETY LIGHT OPTION W/ OVERHEAD GUARD OPTION

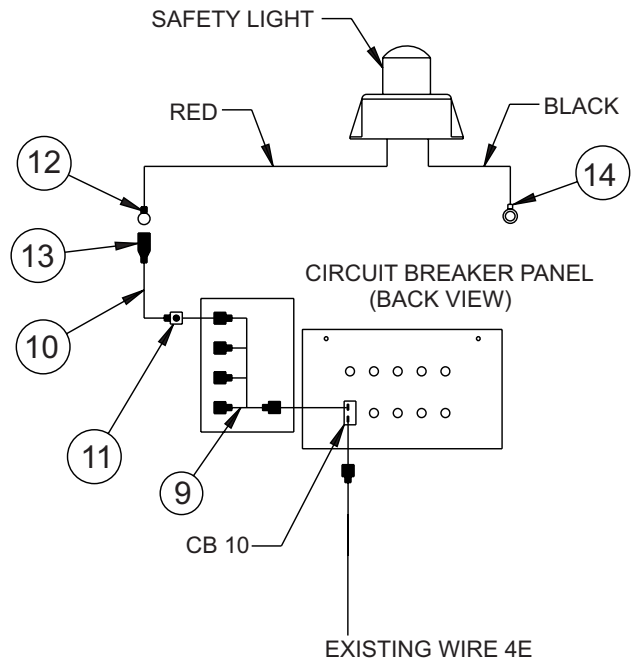
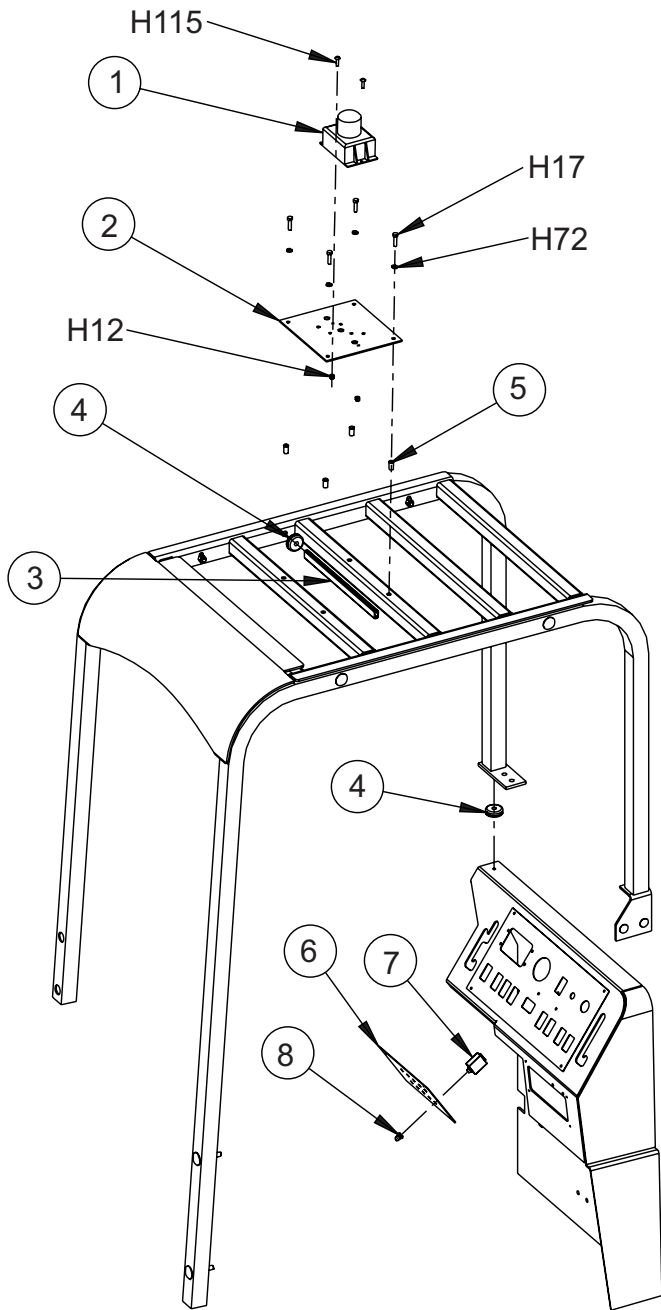

C1750-IC/9-04

AMBER SAFETY LIGHT OPTION W/O OVERHEAD GUARD OPTION

OPTION NO. 0780-444

<u>KEY NO.</u>	<u>PART NUMBER</u>	<u>DESCRIPTION</u>	<u>QTY.</u>
1	8-40-05036	Amber Strobe - 12 - 48 VDC	1
2	7-81-00204	Support, Warning Light	1
3	2-00-00491	Grommet	1
4	2-00-04200	Grommet	1
5	2-00-05134	Plug Button	3
6	7-52-00148	Panel, Circuit Breaker	Ref.
7	8-64-00008	Circuit Breaker, 15 AMP	1
8	8-11-00044	Cap, Instrument Panel Boot	1
9	8-90-07434	Wing Wire	1
10	8-11-00015	Terminal	1
11	2-00-04626	Terminal	2
12	2-00-04578	Terminal	2
13	2-00-04281	Terminal #10 Ring	1
14	3-61-00193	Wire, 16 AWG Red.	15'
15	2-00-04345	Tye-Rap	*

*As Needed

HARDWARE USED:

H12	2-00-01246	Nut, Hex Fiber Insert #10-24	2
H48	2-00-00233	Screw, 3/8-15 x 1.000 HHC	2
H53	2-00-02310	Lock Washer, Helical Spring 3/8 Med.	2
H115	2-00-03063	Screw, #10-24 x .750 THM	2

C1749-IC/9-04

AMBER SAFETY LIGHT OPTION W/O OVERHEAD GUARD OPTION

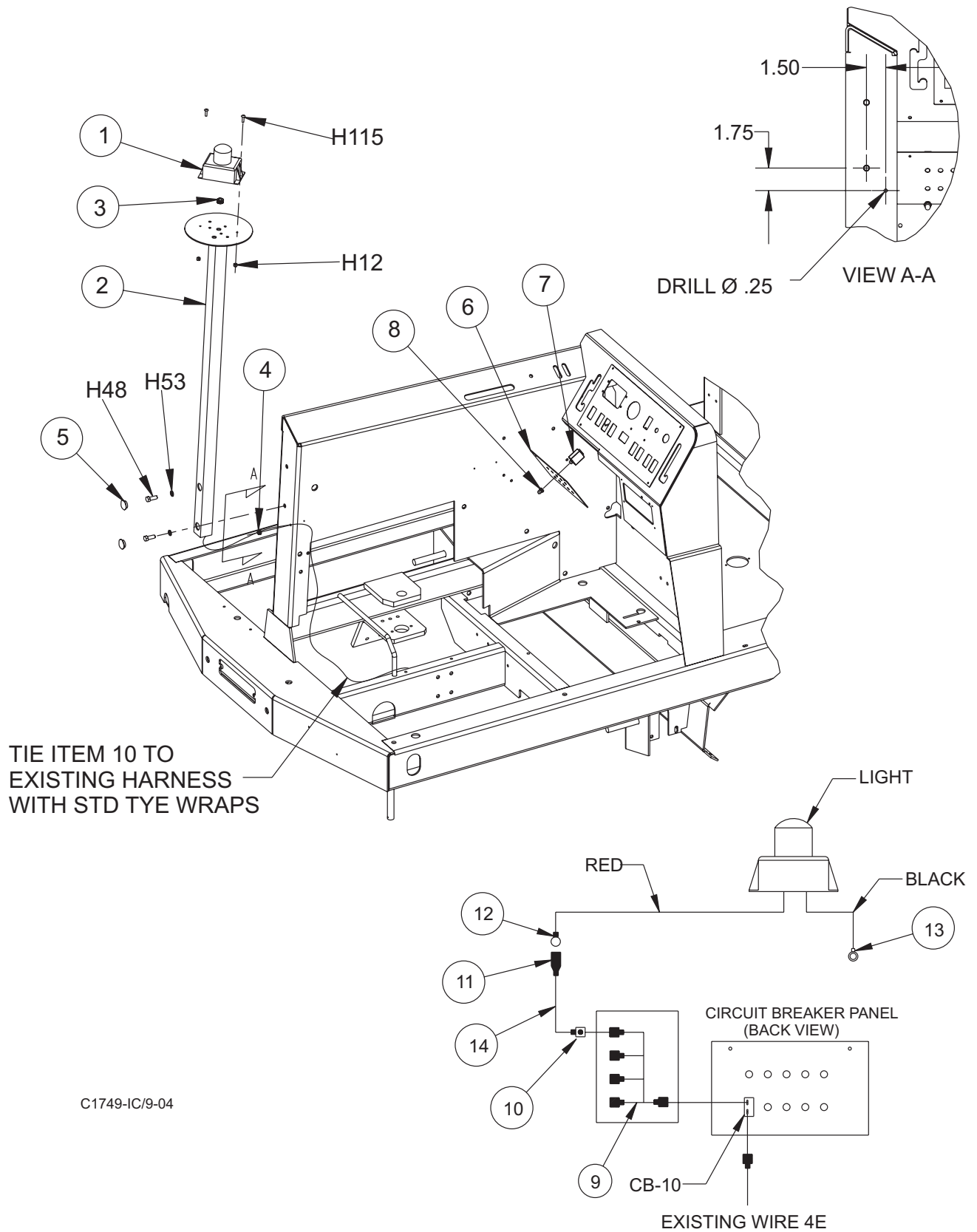

ESP/AUTOFIL OPTION**OPTION 0780-463**

<u>KEY NO.</u>	<u>PART NUMBER</u>	<u>DESCRIPTION</u>	<u>QTY.</u>
1	7-88-00078	Valve - Autofil	1
2	7-25-02087	Connector - Quick Disconnect	1
3	7-25-02088	Coupling	1
4	7-25-02053	Fitting - 90° ¾ Tube	1
5	7-25-02012	Fitting - Hose to ¾-14 NPT	1
6	2-95-02516	Nipple - ½ NPT Close	1
7	2-00-02475	Plug - ¾ NPT	1
8	7-25-02090	Plug - Oriface	1
9	2-95-02537	Fitting - Tee ½ NPT	1
10	2-00-04722	Fitting - ½ NPT - ½ Hose	1
11	2-00-05342	Fitting - ¾ NPT - ½ Hose	1
12	2-00-04736	Coupling - ¾ NPT	1
13	2-95-02518	Nipple - ¾ Close	1
14	7-88-00031	Check Valve	1
15	7-33-02371	Hose - ¾ x 14" LG	1
16	7-33-02360	Hose - ½ x 8" LG	1
17	7-09-01124	Bushing - Bulkhead Fitting	Ref.
18	7-09-01122	Bushing	Ref.
19	7-87-02188	Tube - Float Switch	Ref.
20	0775-217	Solution Float (Yellow)	Ref.
21	2-00-02217	Hose Clamp	1
22	7-87-02153	Drain Tube	1
23	2-95-03047	Washer	4
24	2-00-04345	Tye-Rap	2
25	7-29-00225	Gasket	3

HARDWARE USED:

H308	2-00-05388	Sealing Washer 46/53 ESP OPT	1
------	------------	------------------------------	---

C1682/9907

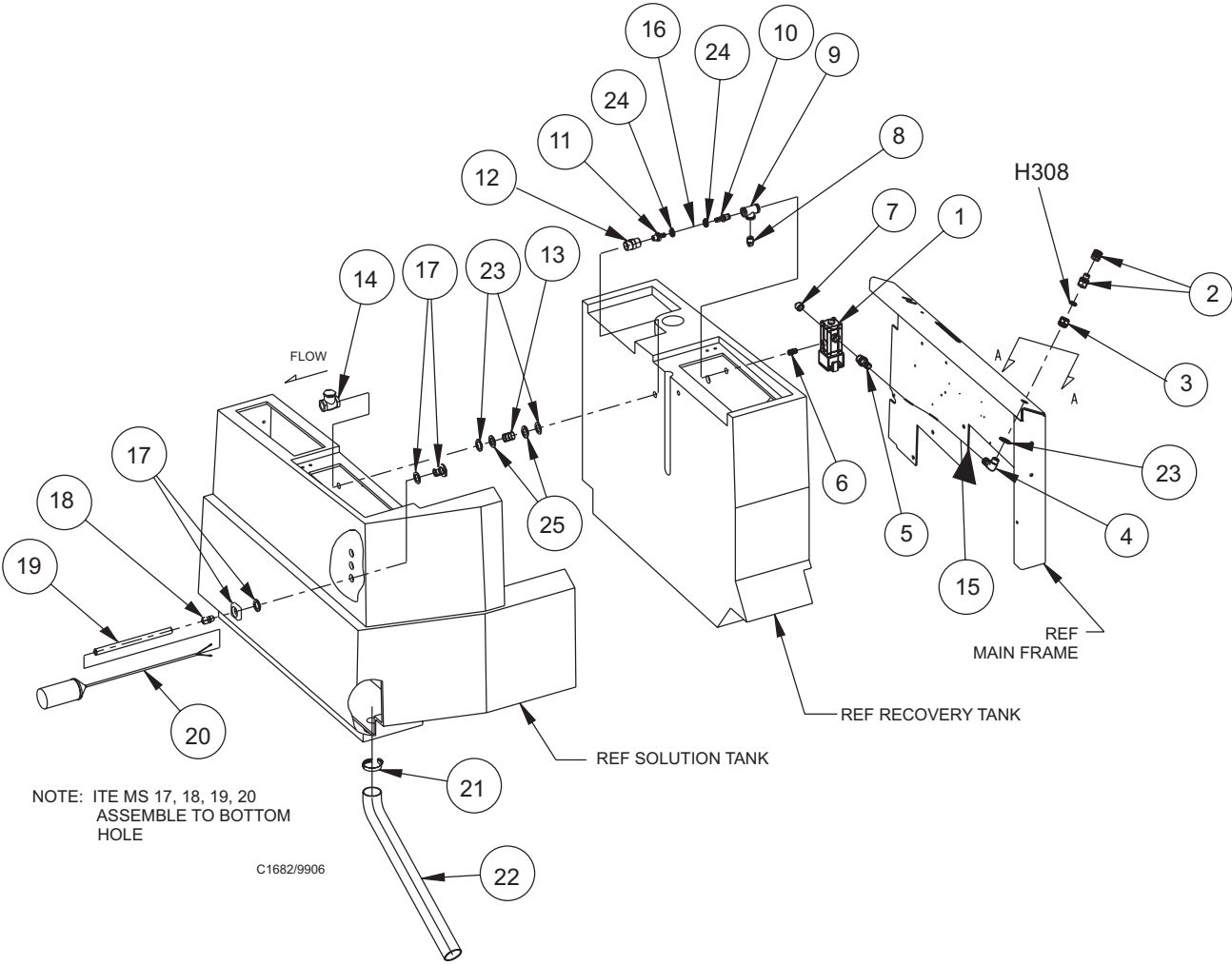

ESP/AUTOFIL OPTION (cont.)

<u>KEY NO.</u>	<u>PART NUMBER</u>	<u>DESCRIPTION</u>	<u>QTY.</u>
1	7-83-04172	Tank, Detergent	1
2	7-82-00017	Float	1
3	2-00-05003	Fitting, Reducer	1
4	7-25-02080	Fitting, Bulkhead (Det. Float)	2
5	2-00-04654	Fitting 90°	4
6	7-13-07084	Clamp, Hose	2
7	2-00-05346	Fitting, Bulkhead (Det. Tank)	2
8	2-95-04267	Nipple, ¼ NPT x 3.0" LG	1
9	2-00-04736	Coupling, ¾ NPT	1
10	2-00-05132	Fitting, 90 ° ¾ NPT ¼ Tube	1
11	7-24-04027	Filter	1
12	7-25-02089	Coupling, ¾ NPT (PVC)	1
13	7-25-02038	Fitting, 90°	1
14	2-00-02220	Clamp, Hose	1
15			
16	2-00-04551	Terminal, .156 Male Bullet	1
17	2-00-04584	Terminal, .156 Female Bullet	1
18	7-33-02372	Hose, 3/8 ID x18" LG	2
19	7-11-00031	Filter Assembly	1
20	2-00-05131	Nipple	1
21	2-74-00001	Fitting - Plastic	1
22	2-95-03047	Washer	1
23	3-73-00060	Bumper	5"
24	3-73-00065	Gakset	4 ft.
25	7-29-00225	Gasket	2

HARDWARE USED:

H126	2-00-03466	Screw, #10-16 x .50	8
H309	2-00-01081	Screw, #8-32 x .50	6

C1682a/9907

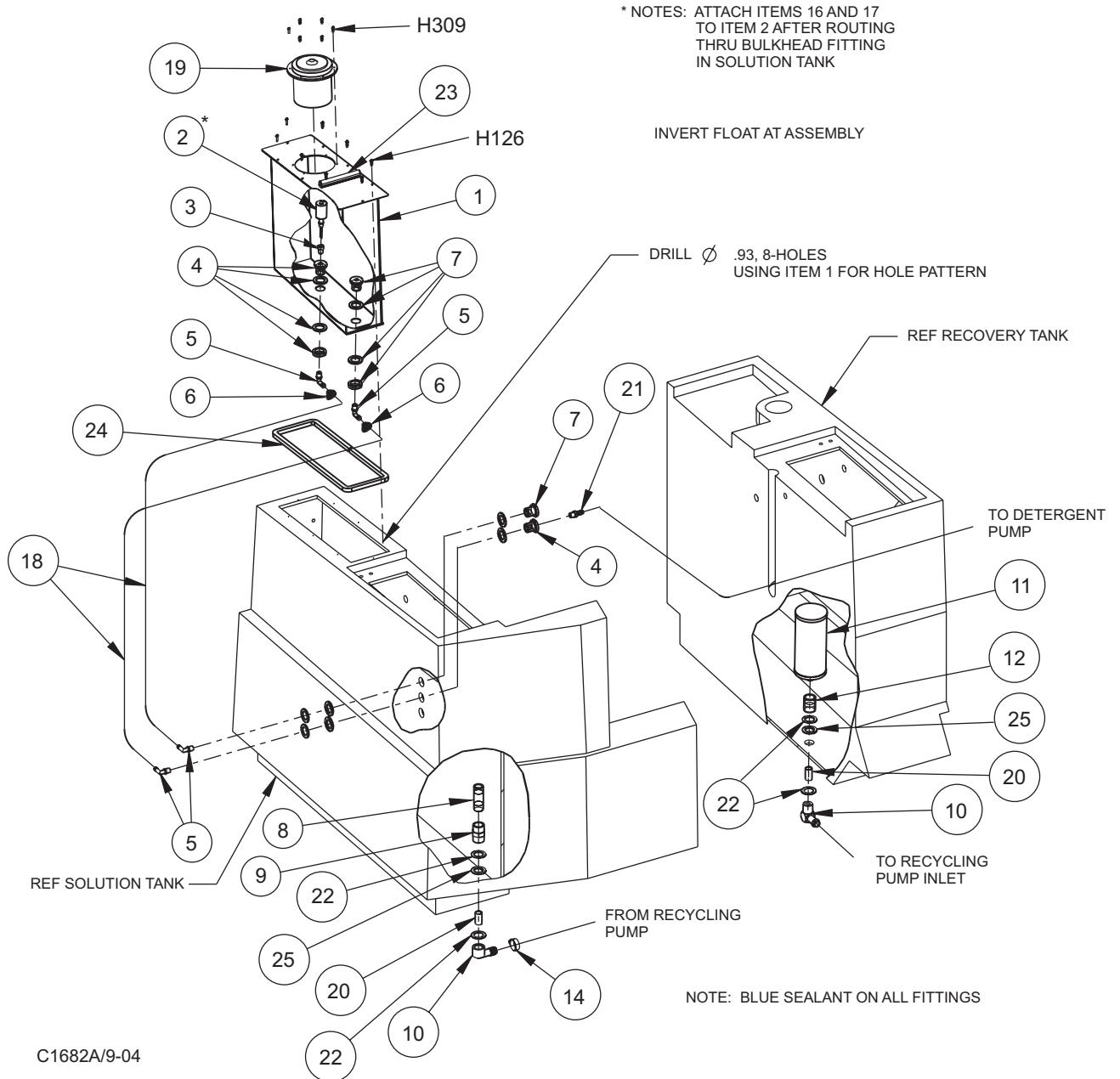

C1682A/9-04

ESP/AUTOFIL OPTION (cont.)

<u>KEY NO.</u>	<u>PART NUMBER</u>	<u>DESCRIPTION</u>	<u>QTY.</u>
1	7-60-05031	Detergent Pump	1
2	8-75-01207	Spacer	2
3	7-60-05025	Recycling Pump (12V)	1
6	8-08-00845	Bracket	1
7	7-23-03056	Nut, Special	1
8	8-82-00058	Switch	2
9	2-00-05396	Fitting, 90° Elbow	1
10	2-00-03407	Hose Clamp	2
11	2-00-05412	Reducer Connector	2
12	7-33-02370	Hose - .75 ID x 50" LG	2
13	7-33-02368	Hose - 3/8 ID x 18" LG	1
14	7-33-02367	Hose - .25 ID x 30" LG	1
15	7-33-02387	Hose- .75 ID x 72" LG	1
16	2-00-00089	Screw, #10-24 x 1.50 RHM	4
17	2-00-00426	Flat Washer, .500 x .219 x .063	8
18	2-00-01246	Nut, Hex Fiber Insert #10-24	10
19	2-00-00205	Screw, 1/4-20 x 1.00 HHC	2
20	2-00-02587	Screw, 1/4-20 x 1.250 HHC	2
21	2-00-00594	Nut, Hex 1/4-20 x .437 x .218	2
22	2-00-00641	Nut, 1/4-20 Insert Fiber	4
23	2-00-03702	Washer, .625 x .281 x .063	2
24	2-00-00585	Nut, Hex 5/16-18 x .500 x .265	1
25	2-00-00602	Nut, MSCR - hex 8-32	2
26	2-00-02933	Screw, Mach. 10-24 x 3.50	2
27	2-00-00227	Screw-HHC .313-18 x 2.25	1
28	2-00-00506	Lock Washer, Int Tooth #8 Dia Screw	2
29	2-00-05371	Screw-RHM #8-32 x 2.38	2

C1682b/9-04

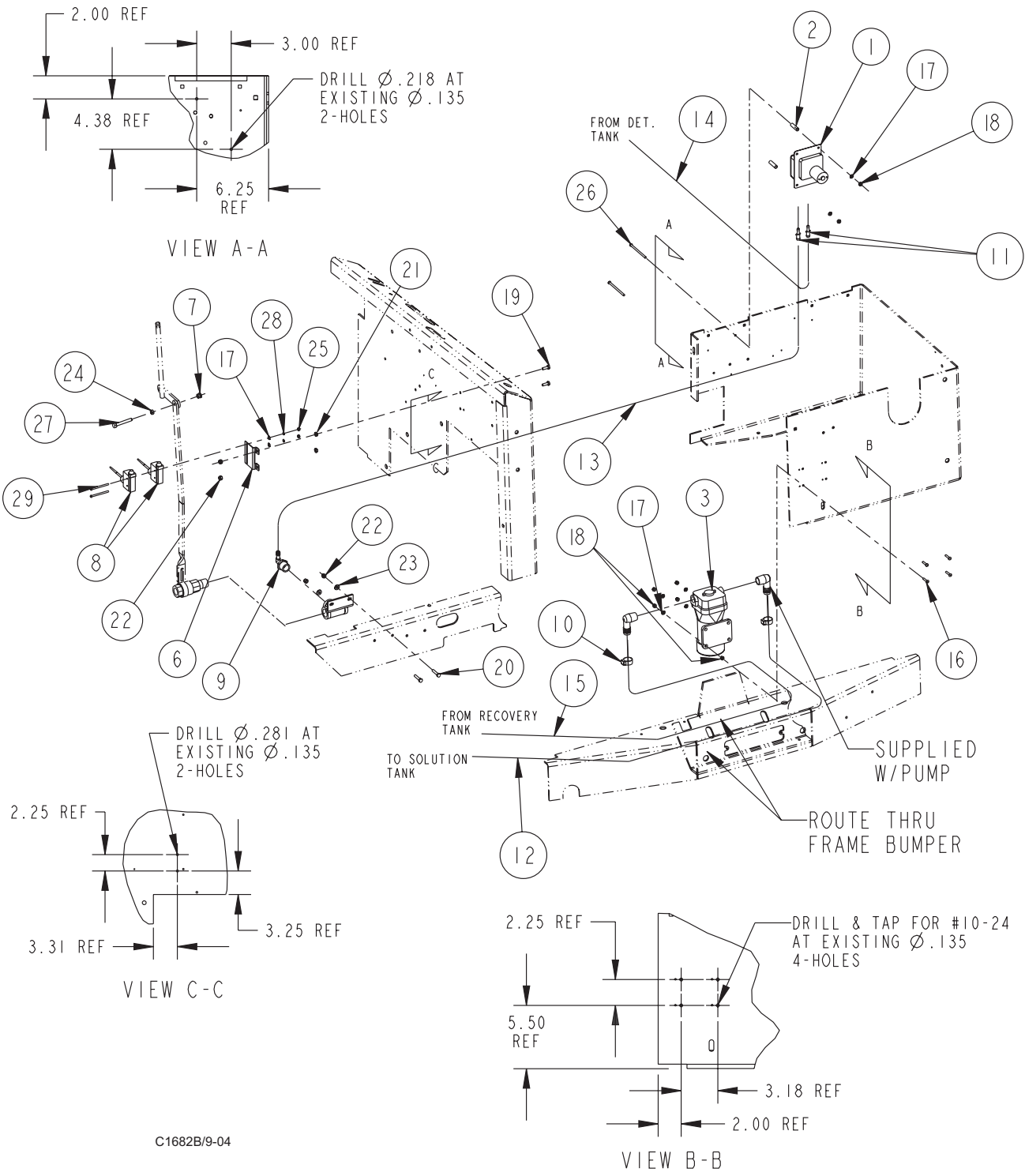

C1682B/9-04

ESP/ AUTOFIL OPTION WIRING

<u>KEY NO.</u>	<u>PART NUMBER</u>	<u>DESCRIPTION</u>	<u>QTY.</u>
1	0795-122	ESP Wiring Harness	1
2		Hole Plug	1
3	7-52-00082	ESP instrument Panel	1
4	7-82-00022	Switch, On/Off DPS	1
5	7-40-05028	Light	2
6	7-39-00021	Knob	1
7	2-00-03059	Screw. #10 - 24 x .375 RHM	2
8	8-11-00015	Terminal, .250 FISO	2
9	7-30-05057	Guard, Rheostat	1
10	7-18-00136	Decal, Detergent Flow	1

HARDWARE USED:

H11	2-00-00605	Nut, Hex MS #10 - 24 THDS	2
H124	2-00-02296	Lock Washer, #10 Ext.	2
H190	2-00-00529	Lock Washer, Helical Spring #8 Med.	2

C1682c/9709

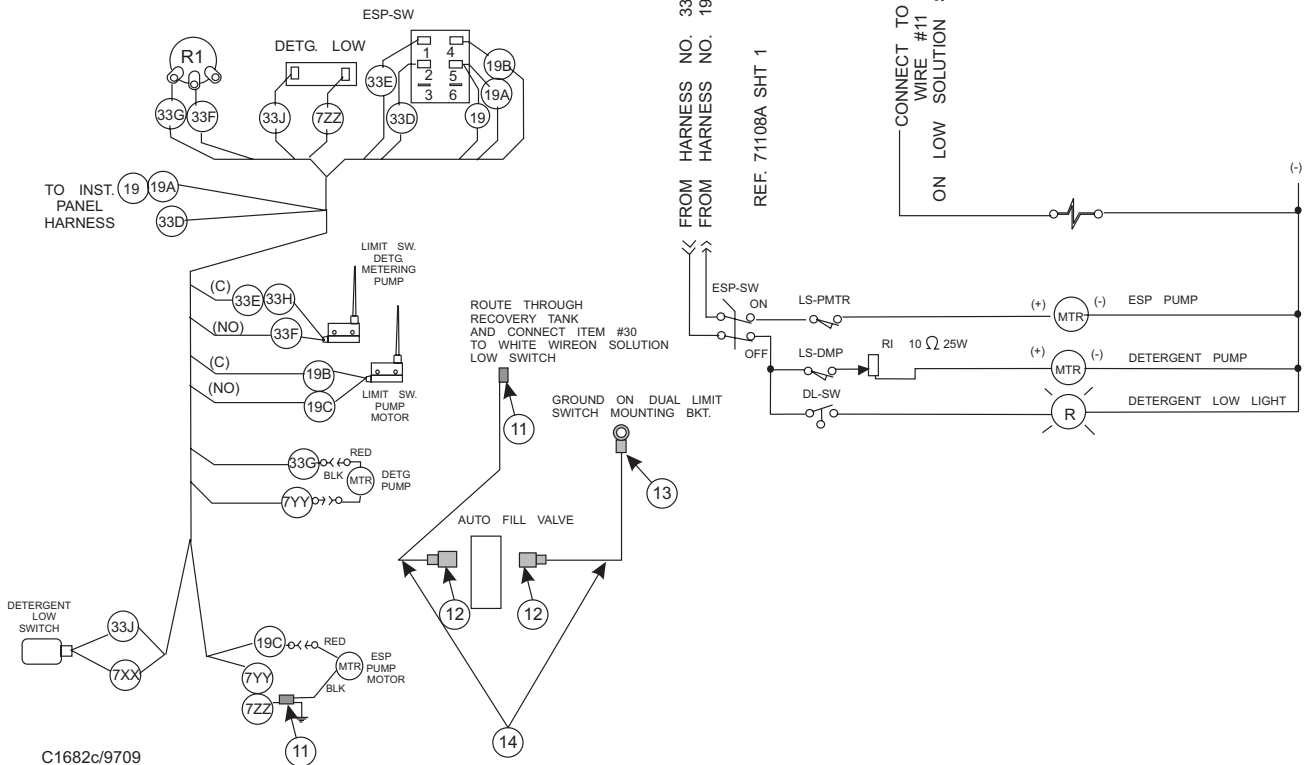
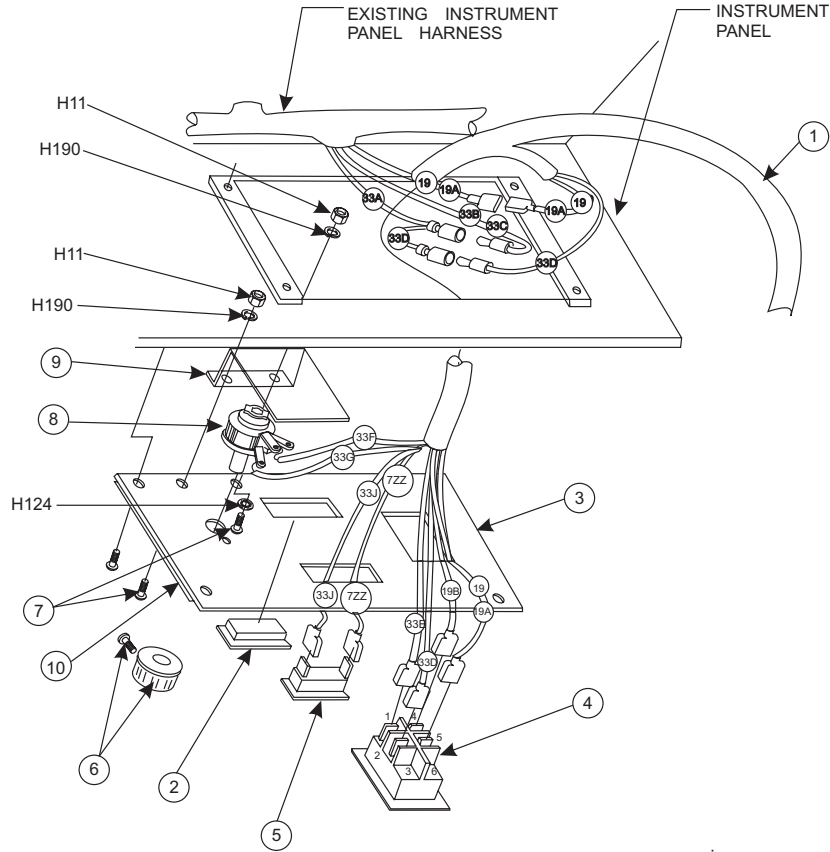

FIRE EXTINGUISHER OPTION

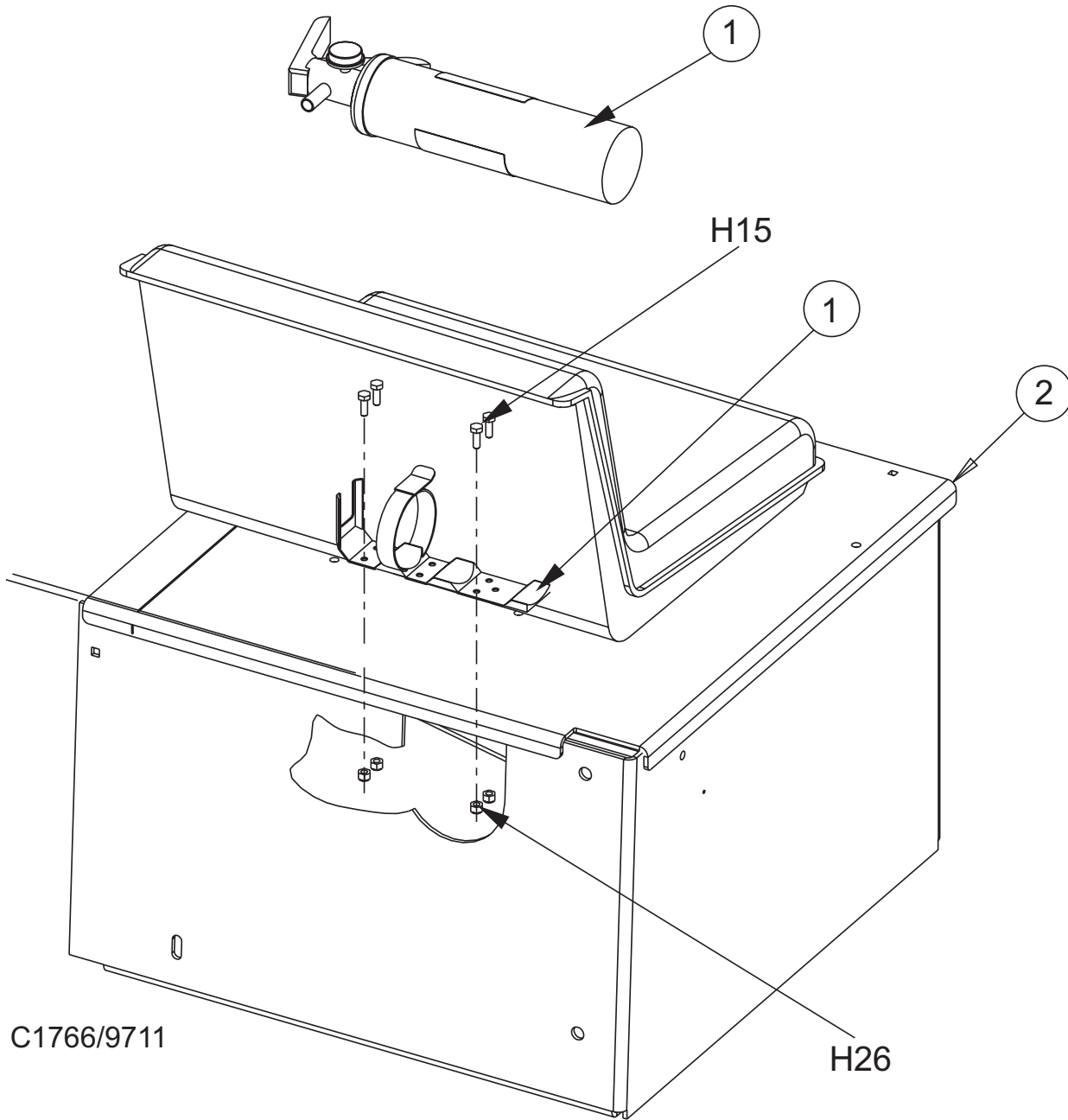

OPTION 0780-453

KEY NO.	PART NUMBER	DESCRIPTION	QTY.
1	8-83-04033	Fire Extinguisher	1
2	8-52-00186	Panel-Seat MTG	1

HARDWARE USED:

H15	2-00-00221	Screw, 1/4-20 X .750 HHC	4
H26	2-00-00641	Nut, 1/4-20 Insert Fiber	4

C1766/9711

PROTECTO-SEAL GAS CAP OPTION

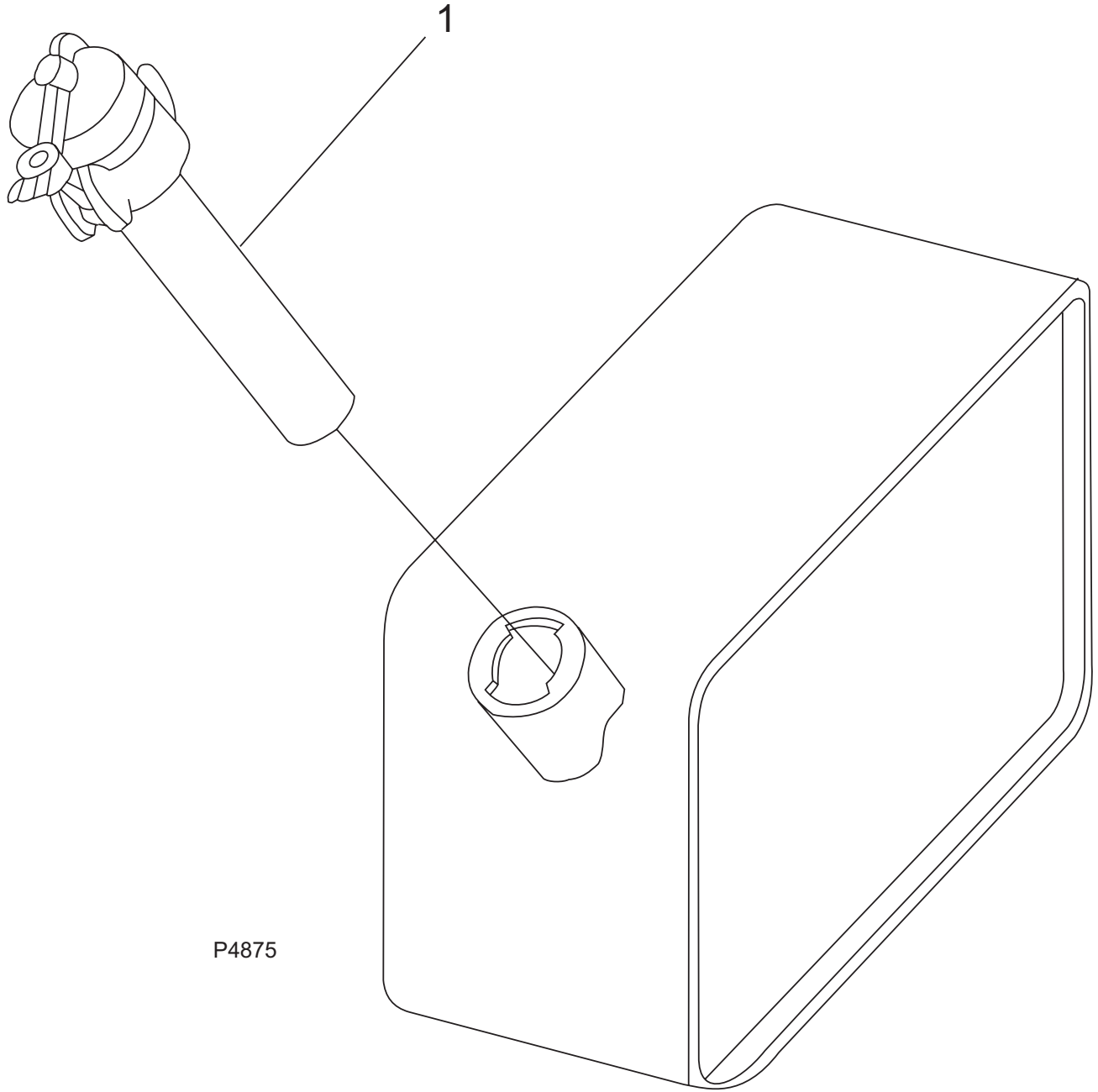

P4875

<u>KEY NO.</u>	<u>PART NUMBER</u>	<u>DESCRIPTION</u>	<u>QTY.</u>
1	8-11-00024	Protecto-Seal Gas Cap	1

P4875/9-04

CLOGGED FILTER INDICATOR OPTION

OPTION 0780-448

<u>KEY NO.</u>	<u>PART NUMBER</u>	<u>DESCRIPTION</u>	<u>QTY.</u>
1	8-63-05008	Switch, Pressure Dif.	1
2	8-24-04075	Filter Plug	1
3	2-00-04518	Fitting, 1/8 NPT - 1/4 Tube	1
4	7-87-02155	Hose, 3/8 - 9"LG	1
5	2-00-04345	Tye-Raps	10
6	8-09-01083	Grommet	1

HARDWARE USED:

H6	2-00-00049	Screw, #10-24 x .500 RHM	2
H12	2-00-01246	Nut, Hex Fiber Insert # 10 - 24	2

C1761/0111

CLOGGED FILTER INDICATOR OPTION

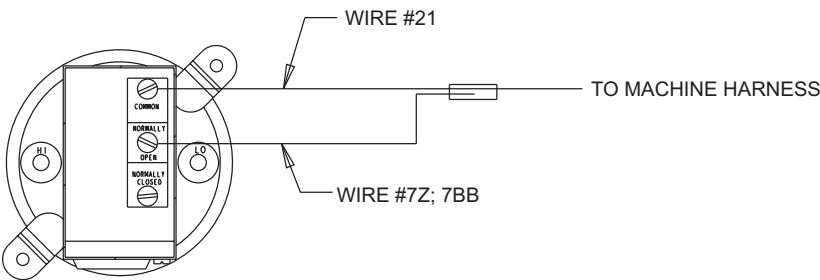
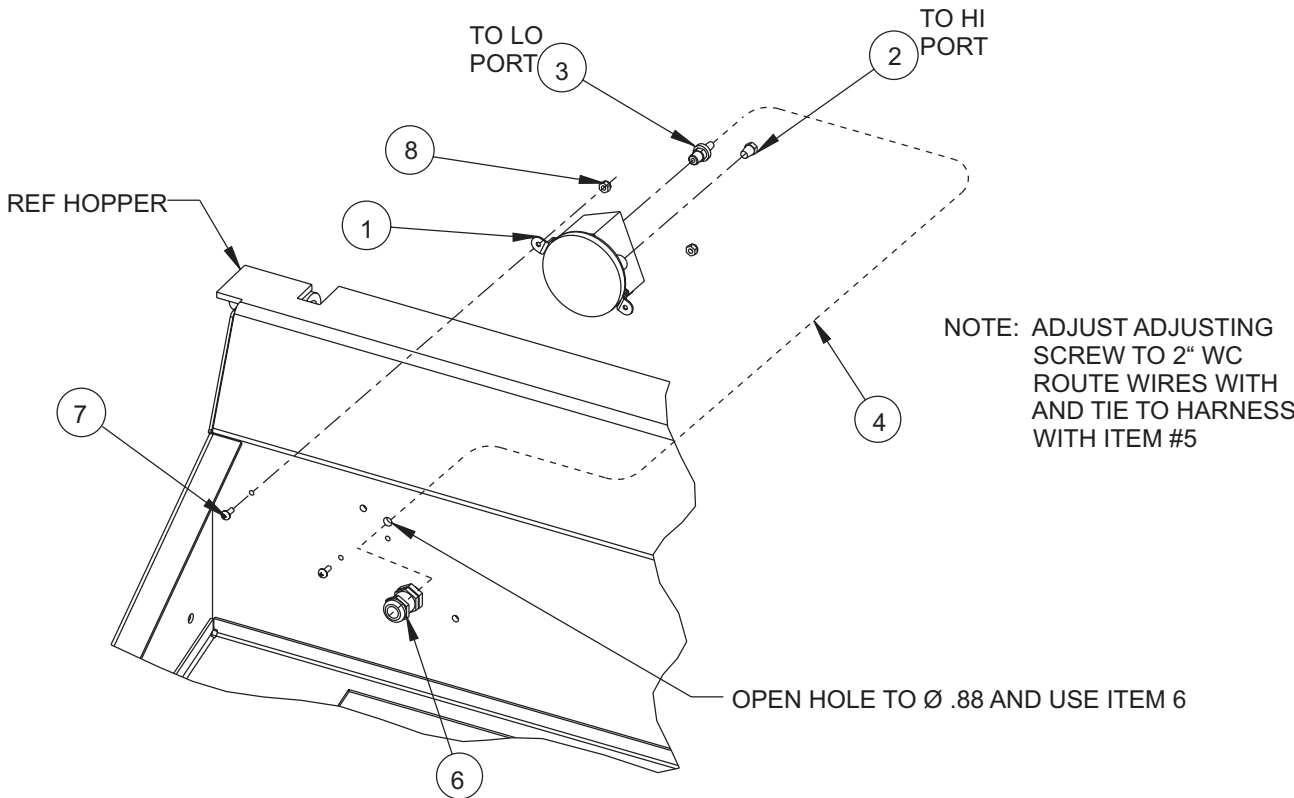

BACK VIEW OF
REGULATOR SWITCH

1761-IC/9-04

SPRAY WAND OPTION

OPTION 0780-446

<u>KEY NO.</u>	<u>PART NUMBER</u>	<u>DESCRIPTION</u>	<u>QTY.</u>
1	0261-029	Hose Assembly	1
2	7-88-00058	Valve - Solution (1/4 NPT)	1
3	7-16-05028	Coupling, Quick Disconnect	2
4	2-00-05206	Reducer	2
5	8-56-05026	45° Street Elbow	1
6	639804	Wand Assembly	1
7	7-13-07139	Clamp Valve	2
8	2-00-05207	Adapter	2
9	7-13-07140	Clamp Hose	5
10	7-33-02306	Solution Feed Hose	1
11	2-00-05208	Adapter	1
12	7-50-01002	Spray Nozzle	1
13	638828	Squeegee Tool Assembly	1
14	7-60-05022	Water Pump (12VDC)	1
15	7-25-02073	Fitting, 90° Elbow	2
16	7-03-00047	Adapter	2
17	2-95-04388	Hose Clamp	5
18	7-25-02037	Tee (3/4 important)	1
19	7-25-02052	Fitting, Straight	2
20	2-00-03407	Hose Clamp	3
21	2-00-04655	Fitting, 90° Elbow	1
22	7-03-00044	Hose Adapter	1
23	2-00-05211	Adapter	1
24	7-08-00769	Bracket, Hose Connection	1
25	2-00-00415	Washer	2
26	2-00-03875	Pipe Nipple, Close	1
27	7-18-00217	Decal	1
28	2-00-03499	Switch	1
29	7-18-00121	Decal - Warning	1
30	3-71-03025	Hose - 3/8" Clear	3'
31	3-71-00081	Hose	5'
32	2-00-00039	Screw, 10-24 x 1.000 RHM	4
33	2-00-00460	Flat Washer, .437 x .192 x .031-s	4
34	2-00-01246	Nut, Hex Fiber Insert #10-24	4
35	2-00-00221	Screw, 1/4-20 x .750 HHC	1
36	2-00-00503	Lock Washer, 1/4 Ext	2
37	2-00-00594	Nut, Hex 1/4-20 x .437 x .218	1
38	2-00-00089	Screw, 10-24 x 1.500 RHM	2
39	2-00-04686	Lock Washer - Helical #10 Scr. Med. SST	2
40	2-00-00605	Nut, Hex MS # 10-24 x .375 x .125	2

C1760/0206

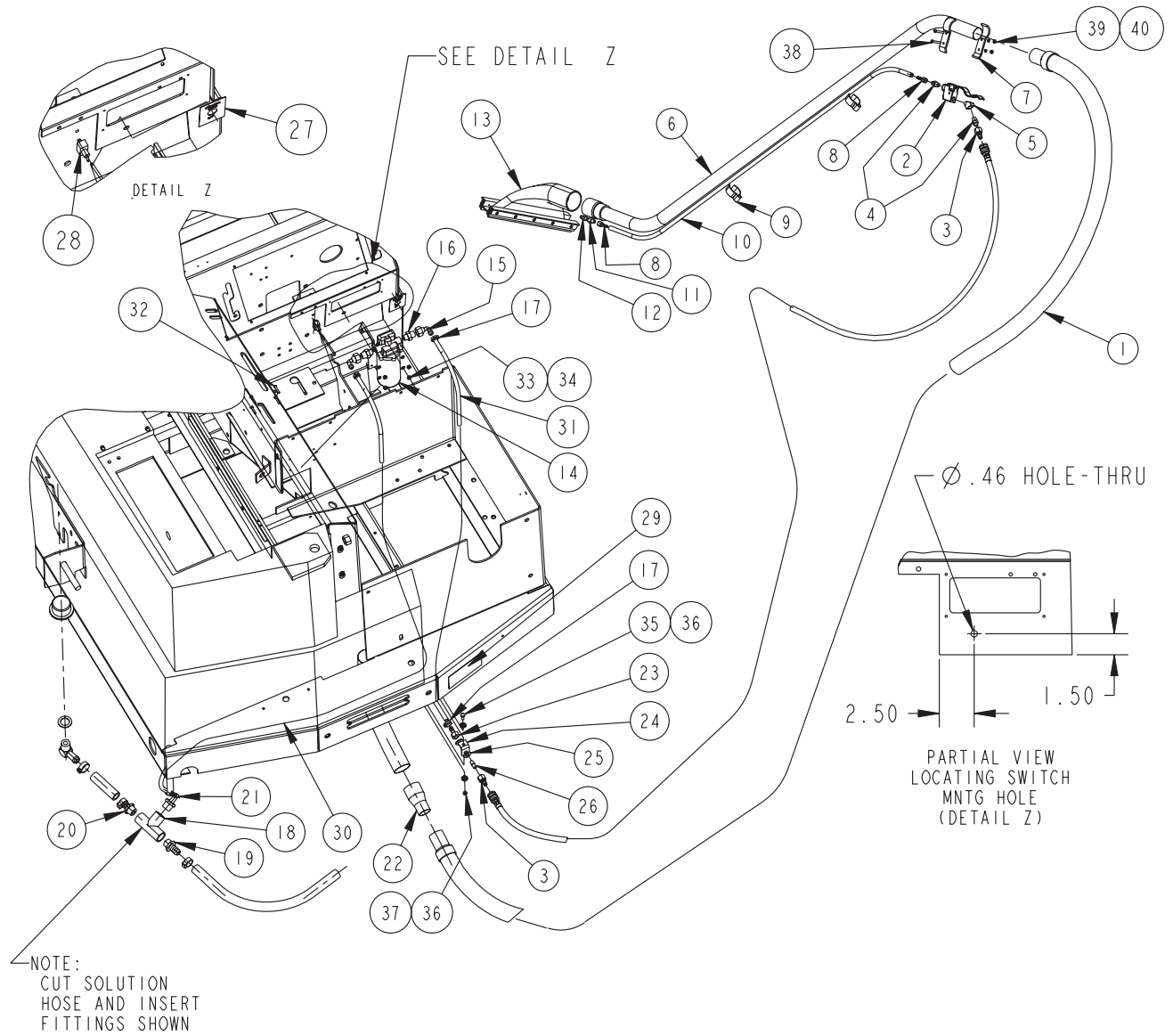

SPRAY WAND OPTION WIRING

<u>KEY NO.</u>	<u>PART NUMBER</u>	<u>DESCRIPTION</u>	<u>QTY.</u>
1	7-60-05022	Water Pump - 12 VDC	1
2	8-64-00008	Circuit Breaker	1
3	2-00-03418	Terminal, .25 FISO	3
4	2-00-04626	Terminal, .156 Fem. Bullet	1
5	2-00-04578	Terminal, .156 Male Bullet	1
6	2-00-04281	Terminal, #10 Ring	1
7	3-61-00189	Wire, 16 AWG	-
8	8-90-07434	Wing Wire	1
9	8-11-00015	Terminal-.25 FISO Male	1
10	2-00-03499	Switch, Toggle	Ref.

C1762-IC/9-04

SPRAY WAND OPTION WIRING

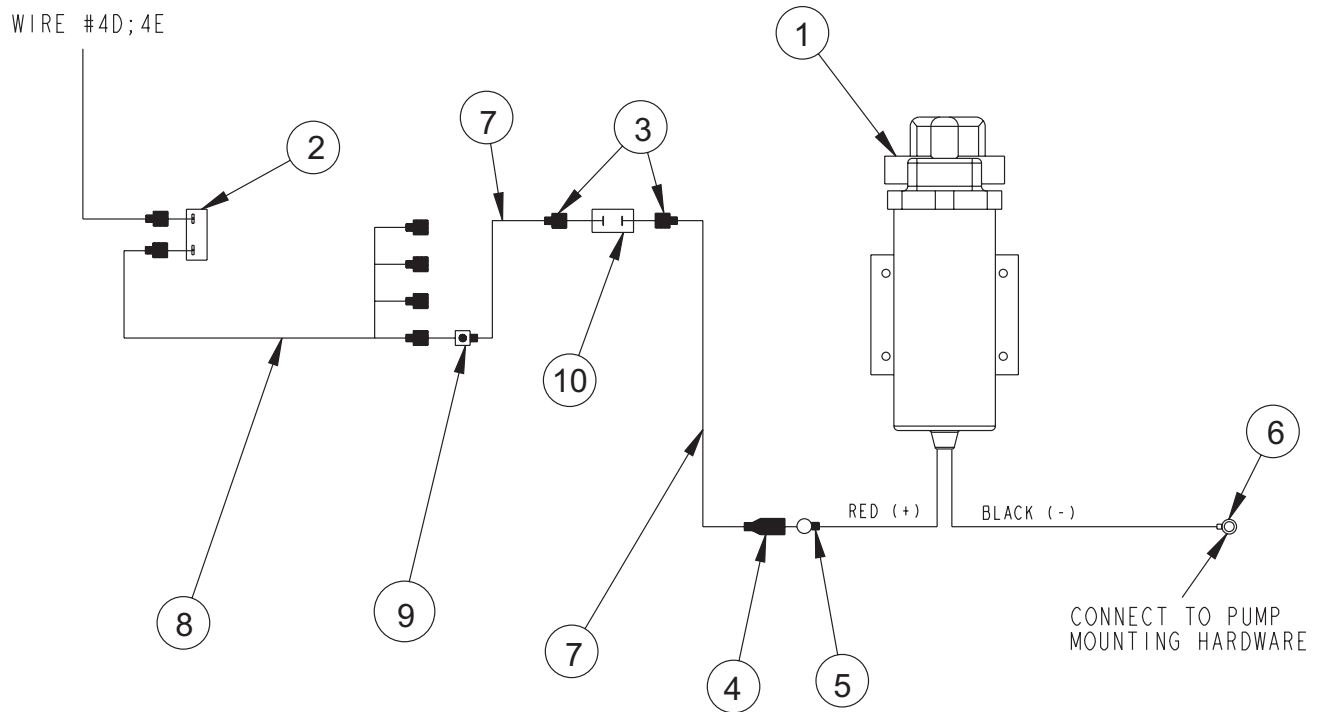

NOTE: ROUTE WITH EXISTING HARNESS USING TIE-RAPS WHEN NEEDED

WET SWEEP BYPASS/THERMO SENSOR OPTION

OPTION NO. 0780-435

<u>KEY NO.</u>	<u>PART NUMBER</u>	<u>DESCRIPTION</u>	<u>QTY.</u>
1	8-82-00056	Switch - Thermostat	1
2	8-08-00803	Switch - Bracket	1
3	8-64-05009	Relay (M4; M7)	2
4	8-64-00008	Circuit Breaker 15A	1
5	8-09-01083	Bushing - Liq. Tight	Ref.
6	8-11-00044	Boot - Switch	1
7	8-82-00059	Switch - On/Off (SPST)	1
8	7-52-00147	Instrument Panel	Ref.
9	7-52-00148	Circuit Breaker Panel	Ref.
10	8-08-00838	Relay Panel	Ref.
11	7-20-06012	Duct - 6"	Ref.
12	2-00-05261	Threaded Insert	1
13	2-00-00208	Screw, 5/16-18 x .750 HHC	Ref.
14	2-00-00220	Screw, 1/4-20 x .625 HHC	1
15	2-00-03702	Washer, .625 x .281 x .063	1
16	2-00-00518	Lock Washer, Helical Spring	1
17	2-00-03062	Screw, #10-24 x .625 THM	2
18	2-00-01246	Nut, Hex Fiber Insert #10-24	1

C1752e/0903

WET SWEEP BYPASS/THERMO SENSOR OPTION

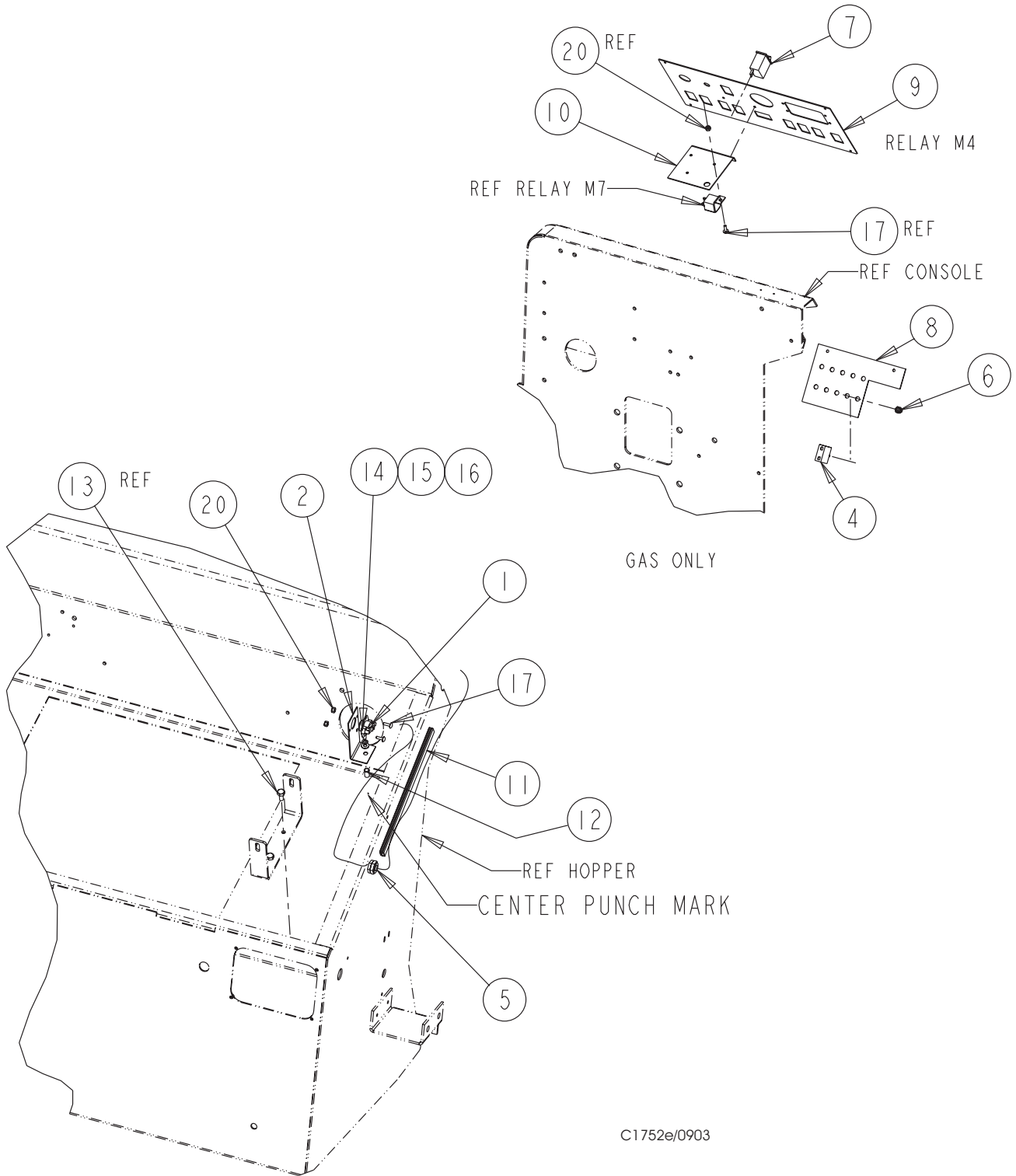

C1752e/0903

WET SWEEP BYPASS/THERMO SENSOR OPTION (con't.)

OPTION NO. 0780-435 (cont)

<u>KEY NO.</u>	<u>PART NUMBER</u>	<u>DESCRIPTION</u>	<u>QTY.</u>
1	8-88-00042	Solenoid Valve	1
2	2-00-04885	Fitting, 90° Elbow, O-Ring	4
3	8-08-00590	Bracket	1
4	2-00-01980	Screw, 1/4-20 x 2.500 HHC	2
5	2-00-00641	Nut, Fiber Insert 1/4-20	2
6	2-00-04928	Fitting, 13/16-16 x 13/16-16 Tee	2
7	7-33-02325	Hose, #8 45 x STR x 34" LG	2
8	2-00-05046	Fitting, -8 ORS Swivel, 90° Elbow	1
9	7-15-01031	Collar, Clamp	2
10	0875-117	Diode Assembly	1
11	2-00-03418	Terminal - .25 FISO	13
12	2-00-04708	Terminal - .25 FISO	3
13	2-00-04578	Terminal - .156 M Bullet	1
14	3-61-00189	Wire - 16 AWG, Black	35'

C1754e/0903

WET SWEEP BYPASS/THERMO SENSOR OPTION (con't.)

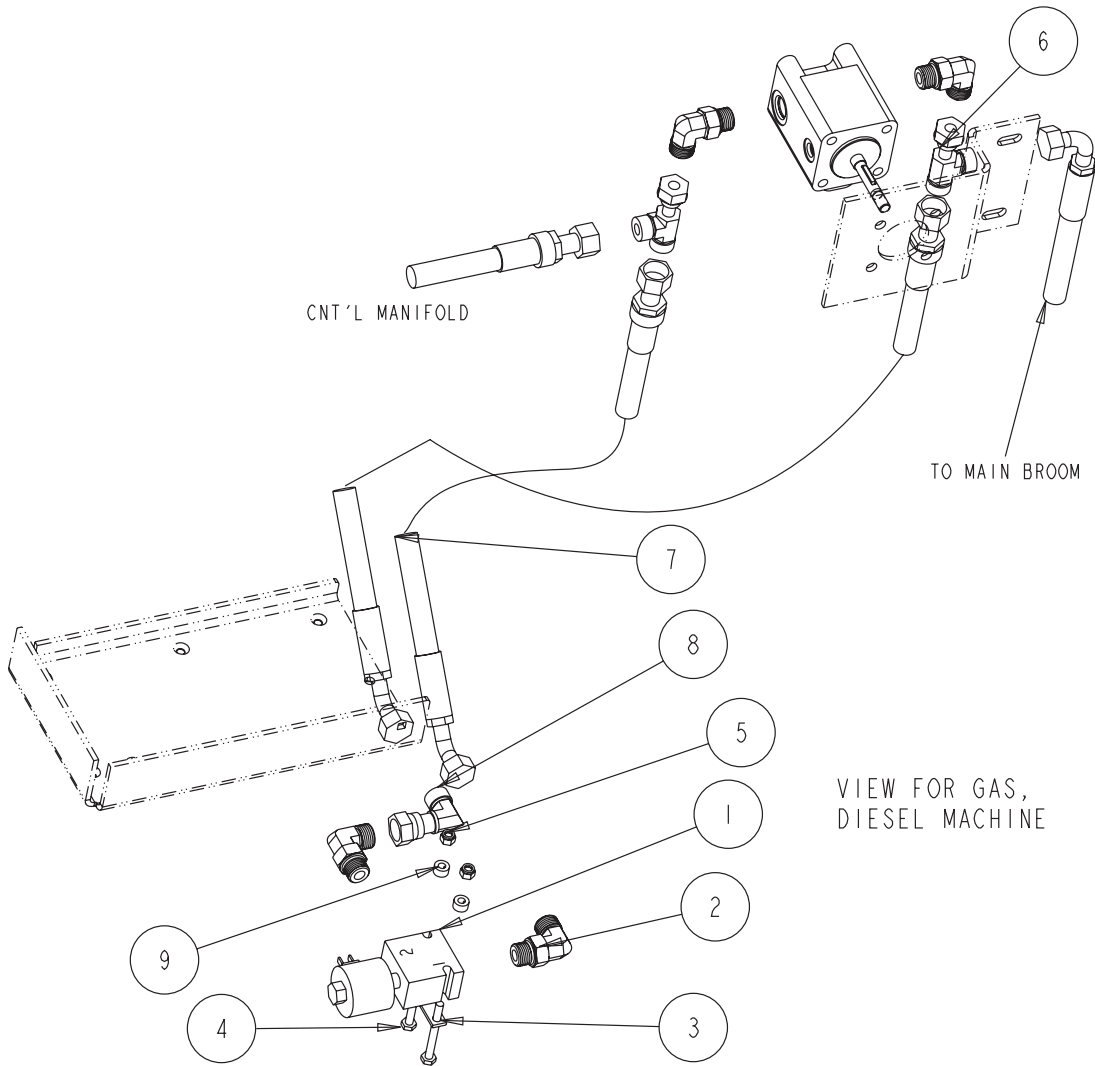

C1754e/0903

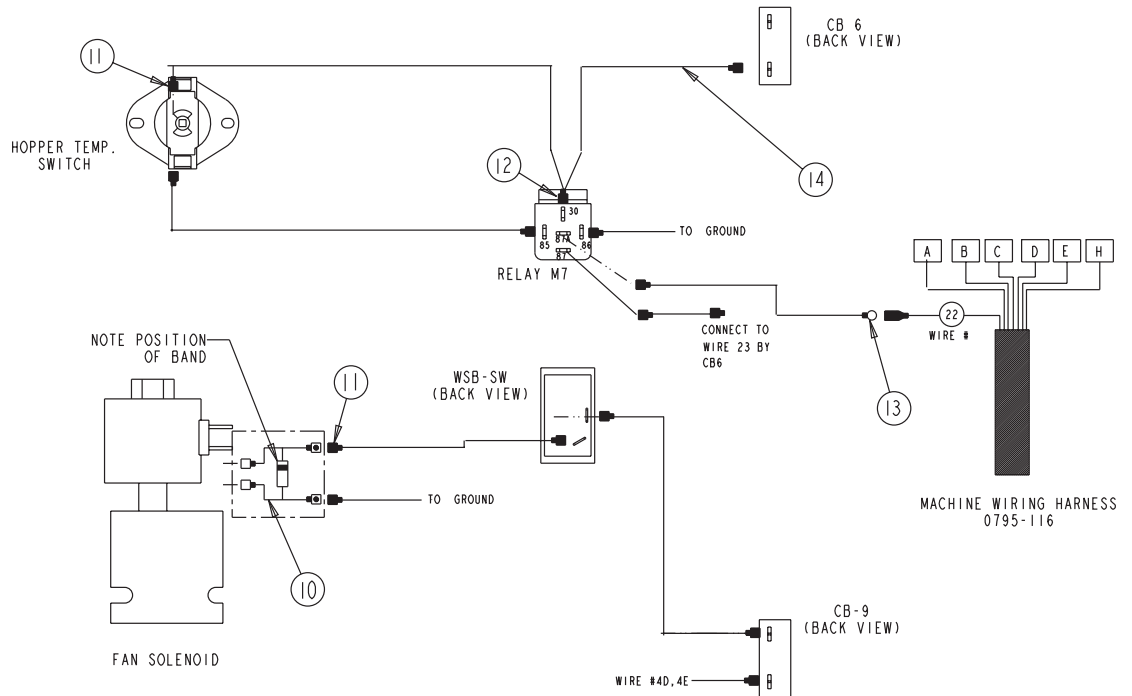

RETRACTABLE SEATBELT OPTION

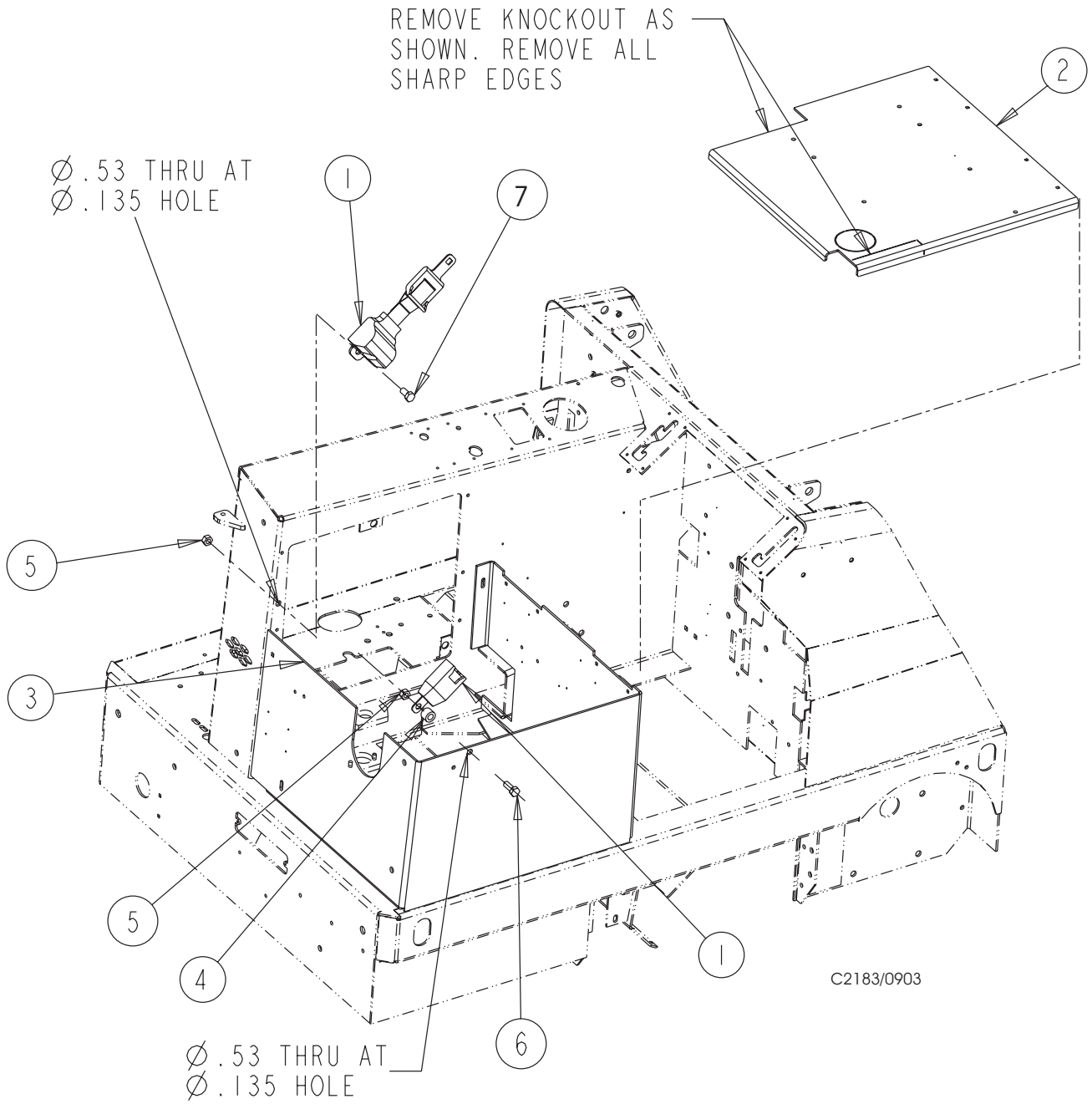

OPTION NO. 0880-723

<u>KEY NO.</u>	<u>PART NUMBER</u>	<u>DESCRIPTION</u>	<u>QTY.</u>
1	2-00-05391	Seatbelt, Retractable	1
2	8-52-00186	Panel, Seal Mounting	REF
3	8-33-05124	Housing, Seat (Gas, Diesel)	REF
4	7-75-01099	Spacer, Idler Pulley	1
5	2-00-04936	Nut, 1/2-13 Fiber Insert	1
6	2-00-00240	Screw, 1/2-13 x 1.25 HHC	1
7	2-00-00239	Screw, 1/2-13 x 1.00 HHC	1

C2183/0399

RETRACTABLE SEATBELT OPTION - LP ONLY

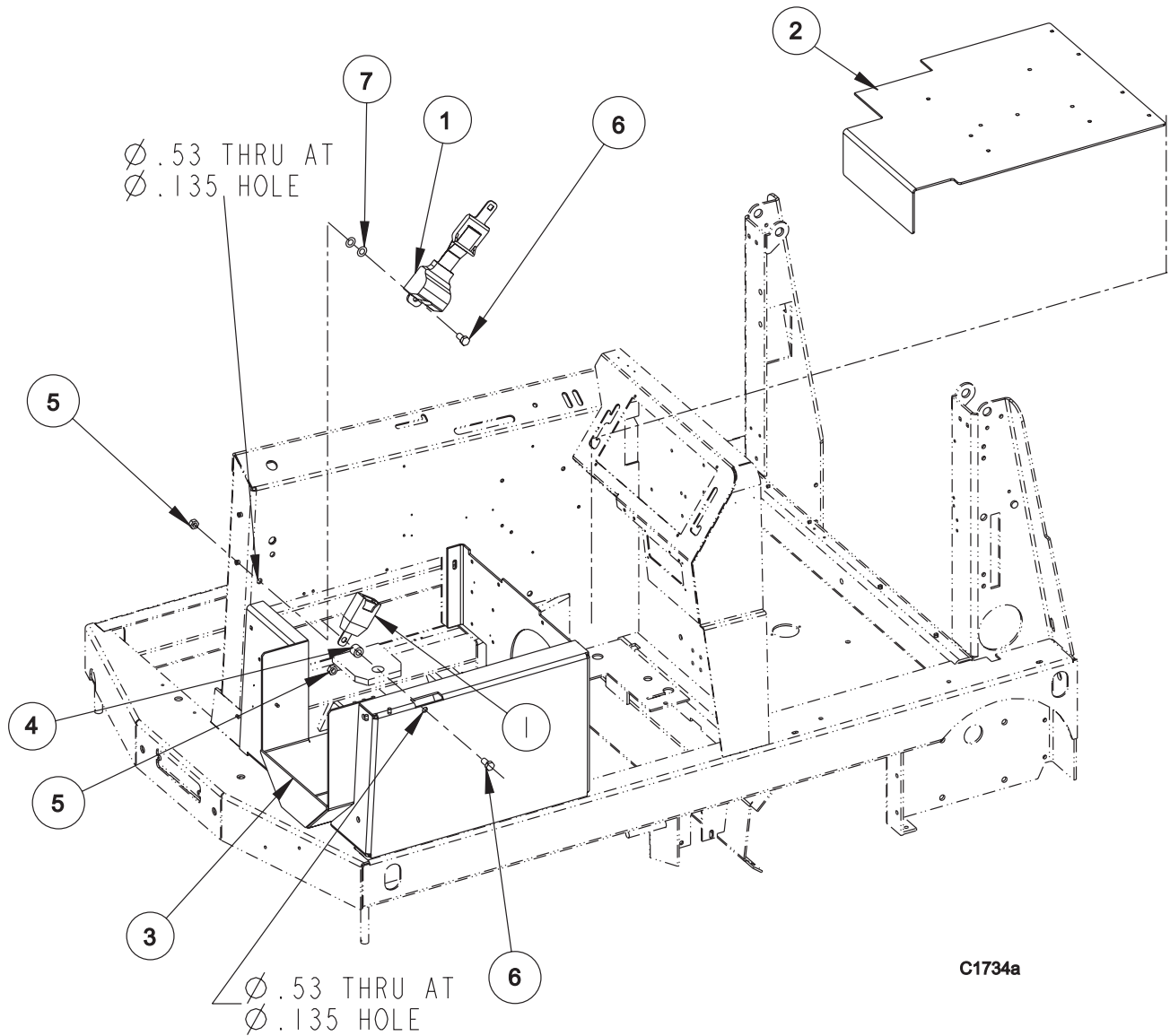

OPTION 0780-431 (LP ONLY)

<u>KEY NO.</u>	<u>PART NUMBER</u>	<u>DESCRIPTION</u>	<u>QTY.</u>
1	2-00-05391	Retractable Seat Belt	1
2	8-16-07372	Cover, LP Tank	Ref.
3	7-33-05123	Housing, LP Seat	Ref.
4	7-75-01099	Spacer, Idler Pulley	1
5	2-00-04936	Nut, 1/2-13 Fiber Insert	2
6	2-00-00239	Screw, 1/2-13 x 1.0 HHC	2
7	2-00-00420	Flat Washer, 1.0 x .51 x .063	2

C1743b/3-99

SUSPENSION SEAT OPTION

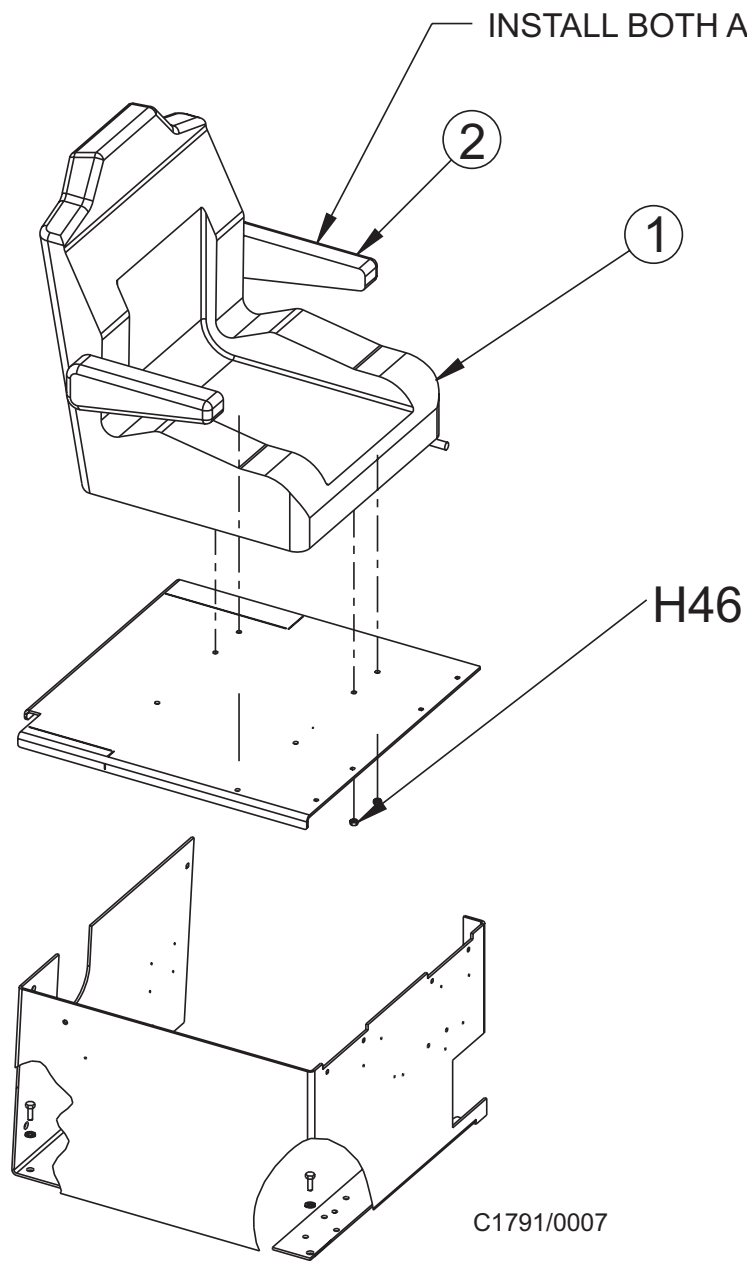

NOTE: DO NOT USE SEAT MOUNTED SEATBELT ON THIS MACHINE

OPTION 0780-456

<u>KEY NO.</u>	<u>PART NUMBER</u>	<u>DESCRIPTION</u>	<u>QTY.</u>
1	8-69-00019	Seat - Suspension	1
2	8-03-04320	Kit - Arm Rest	1
<u>HARDWARE USED:</u>			
H46	2-00-00644	Nut, 5/16-18, Insert Fiber	4

C1791/0007

SEAT SWITCH KIT OPTION

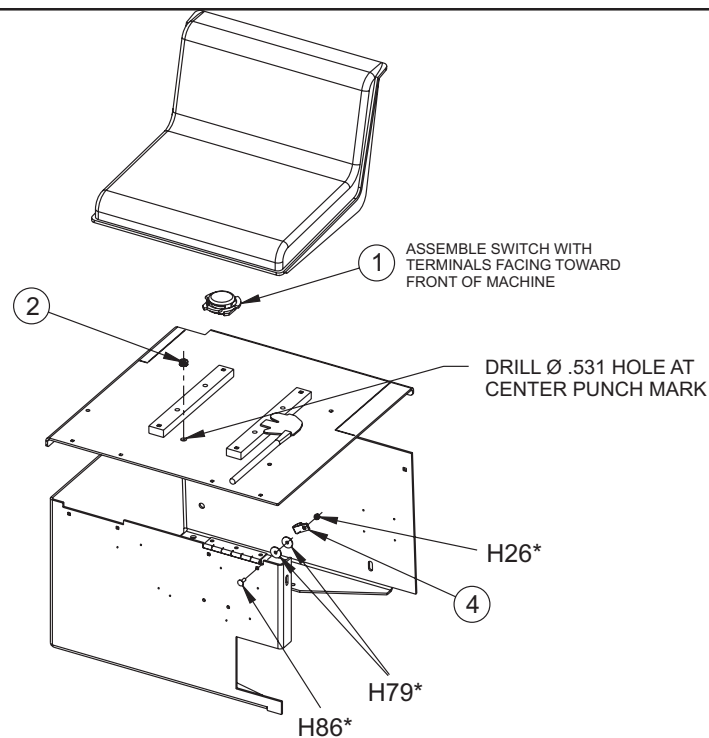

* USE EXISTING HARDWARE

NOTE: REMOVE EXISTING WIRE 6B FROM SOLENOID 1A AND RECONNECT TO SEAT SWITCH HARNESS WITH BUTT SPLICE. CONNECT OTHER WIRE FROM SEAT SWITCH HARNESS TO SOLENOID 1A AS SHOWN.

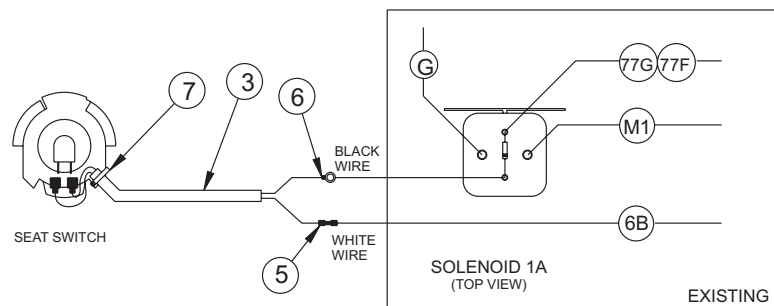

C1792/0007

OPTION 0780-471

KEY NO.	PART NUMBER	DESCRIPTION	QTY.
1	8-82-00064	Switch - Seat	1
2	2-00-00491	Grommet	1
3	0875-126	Assy-Wire, Seat Switch	1
4	2-00-04564	Clamp	1
5	2-00-01128	Terminal - Butt Splice	1
6	2-00-04281	Terminal - Ring Terminal	1
7	2-00-04345	Tye-raps	10

SEAT SWITCH HARNESS NOTES:

- 1) After sliding seat all the way to the rear pull seat switch tight through grommet.
- 2) Route seat switch harness under seat, through grommet, and attach to existing machine harness Using Tye-raps as needed.
- 3) Coil extra wire from seat switch harness and tie with Tye-raps.

C1792/0007

PAD DRIVER OPTION (16")

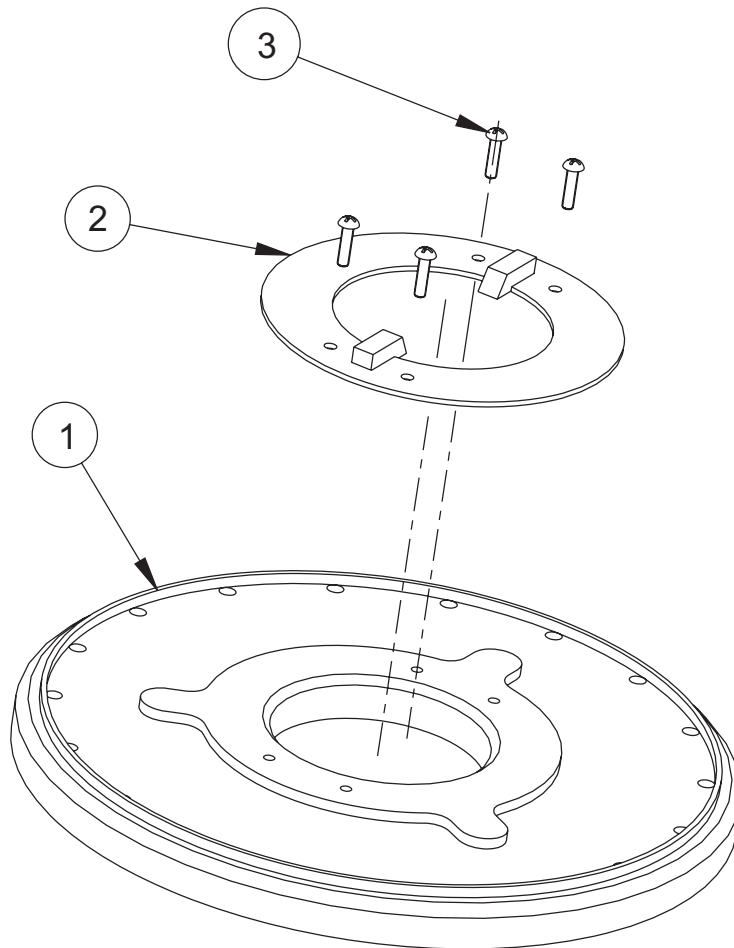

C1741/9707

OPTION NO. 0780-434

<u>KEY NO.</u>	<u>PART NUMBER</u>	<u>DESCRIPTION</u>	<u>QTY.</u>
1	7-19-02035	Disc - Driver	1
2	7-20-00010	Pad Driver - 16" Diameter	1
3	2-00-00081	Screw, 1/4-20 x 1.000 RHM	4

PAD HOLDERS FOR THIS OPTION

- 4 Lefthand (complete) 7-32-03013
- 4a Lefthand (lower piece only) 7-32-03014



- 5 Righthand (complete) 7-32-03015
- 5a Righthand (lower piece only) 7-32-03016



C1741/9707

PAD DRIVER OPTION (18")

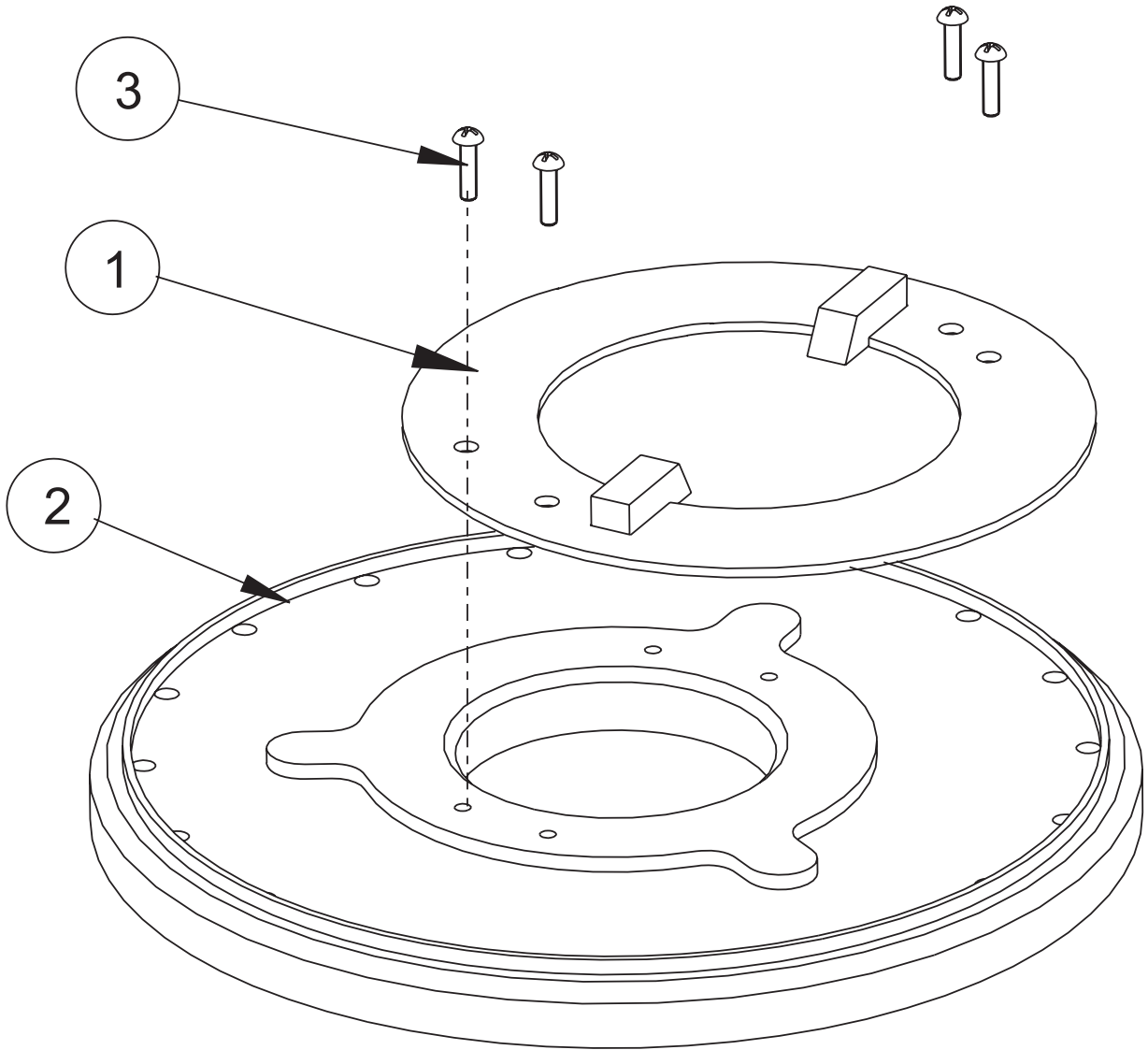

C1741b/9707

OPTION NO. 0780-445

<u>KEY NO.</u>	<u>PART NUMBER</u>	<u>DESCRIPTION</u>	<u>QTY.</u>
1	7-19-02035	Disc - Driver 18"	1
2	7-20-00012	Pad Driver - 18"	1
3	2-00-00081	Screw, 1/4-20 x 1.000 HHC	4

C1741b/9712

VACUUM WAND OPTION

OPTION 0780-457

<u>KEY NO.</u>	<u>PART NUMBER</u>	<u>DESCRIPTION</u>	<u>QTY.</u>
1	19501A	Lower Wand (includes Key #6)	1
2	7-03-00044	Hose Adapter	1
3	19202A	Squeegee Tool	1
4	7-55-08128	Pin	Ref.
5	7-33-02213	Hose, 1 ½ x 15'	1
6	68701A	Lower Wand	1

C1444/9804

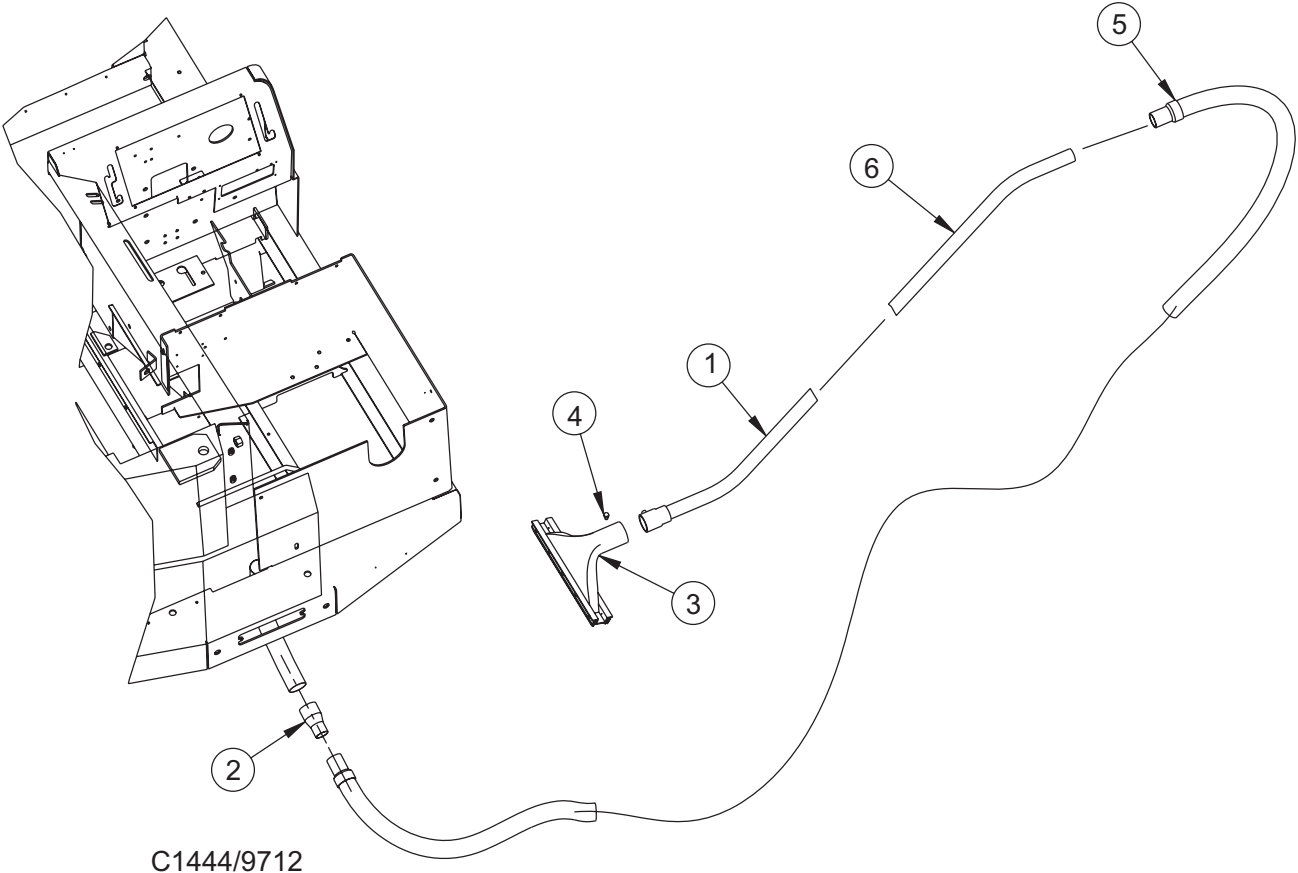

C1444/9712

VAC HOSE SERVICE KIT

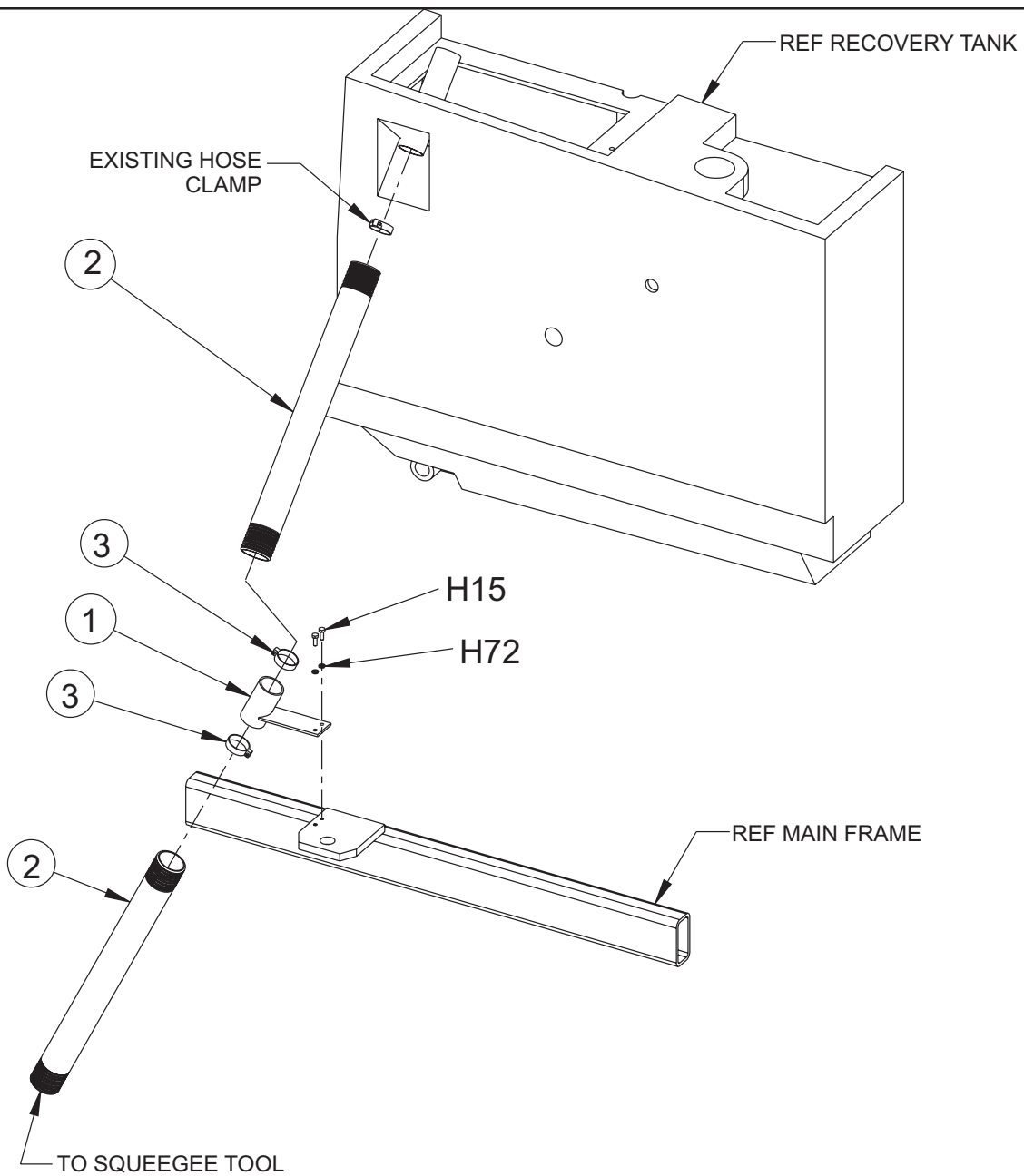

C1788/9807

<u>KEY NO.</u>	<u>PART NUMBER</u>	<u>DESCRIPTION</u>	<u>QTY</u>
1	7-25-02097	Fitting-Vac. Hose Coupling (Welded)	1
2	7-33-02386	Hose-Vacuum	2
3	2-00-02216	Hose Clamp	2

HARDWARE USED:

H15	2-00-00221	Screw, 1/4-20 x .750 HHC	2
H72	2-00-00518	Lock Washer, Helical Spring	2

C1788/9807

HIGH TORQUE DRIVE MOTOR OPTION

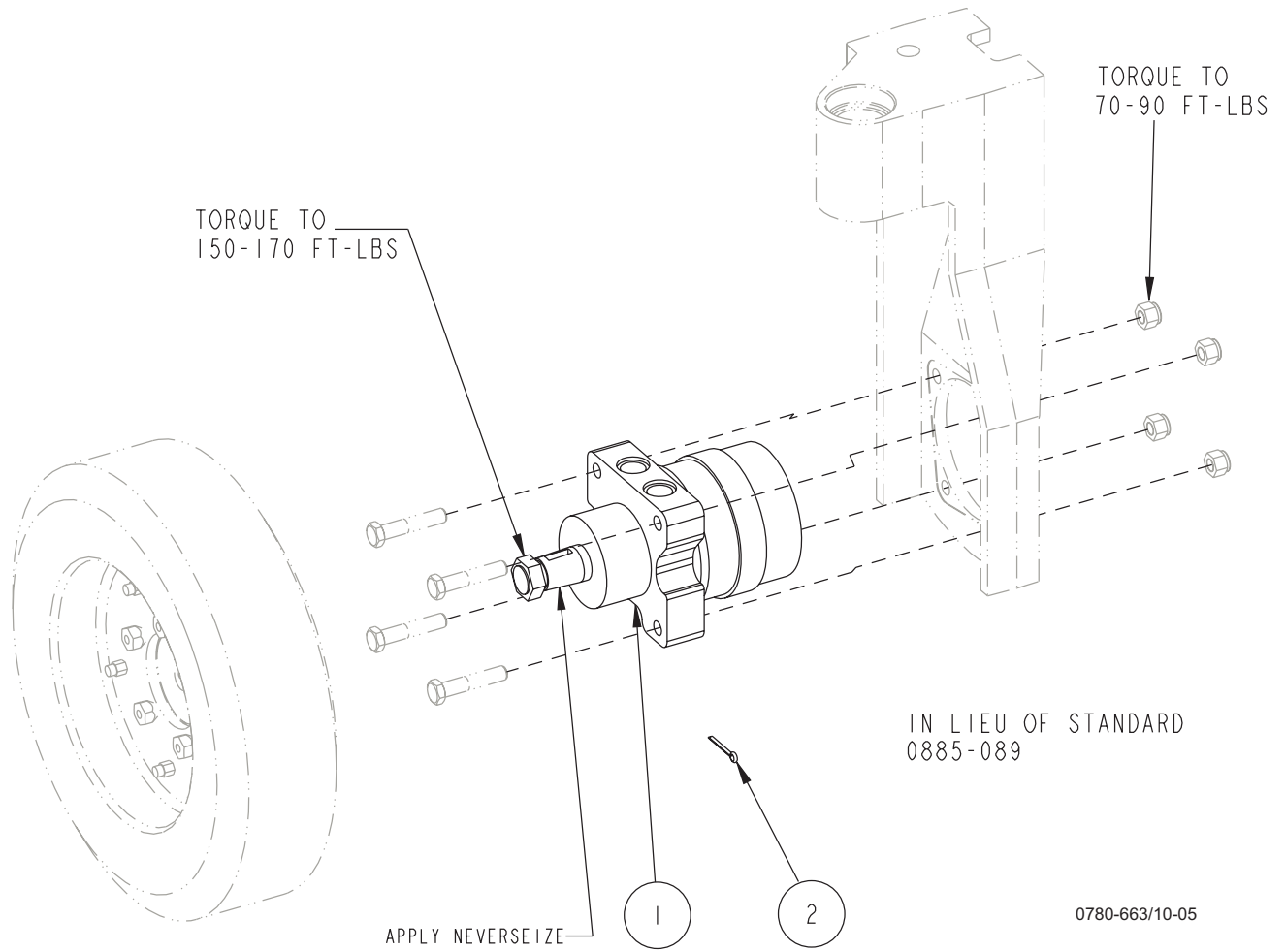

OPTION 0780-663

<u>KEY NO.</u>	<u>PART NUMBER</u>	<u>DESCRIPTION</u>	<u>QTY</u>
1	0785-087	Motor, Hydraulic Drive	1
2	2-00-00776	Cotter Pin, 1/8 dia. x 1.5" long	1

0780-663/10-05

TIRE OPTIONS

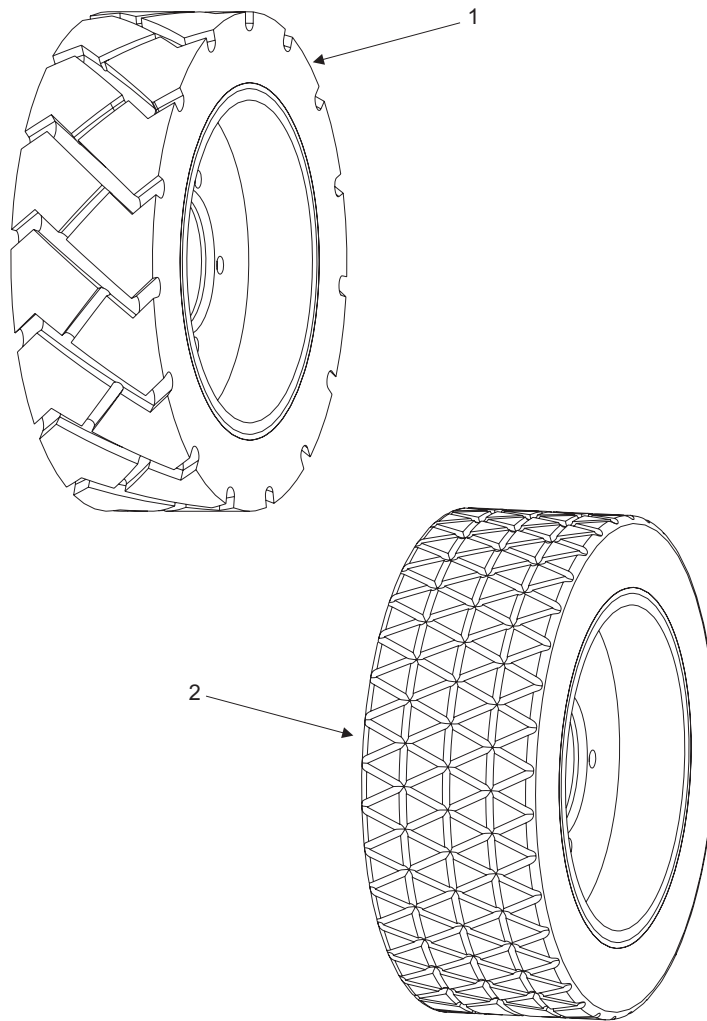

<u>KEY NO.</u>	<u>PART NUMBER</u>	<u>DESCRIPTION</u>	<u>QTY.</u>
1*	0780-700	Non-Marking Mono-Grip Drive Wheel	1
*Service Parts			
7-89-08271	Wheel Assy.		
7-85-06027	Tire Only		
7-33-09041-1	Hub		
2~	0780-705	High Traction Drive Wheel	1
~Service Parts			
7-89-08270	Wheel Assy.		
7-85-06026	Tire Only		
7-33-09041-1	Hub		

0780-700-705/12-05

STAINLESS STEEL VD HOPPER OPTION

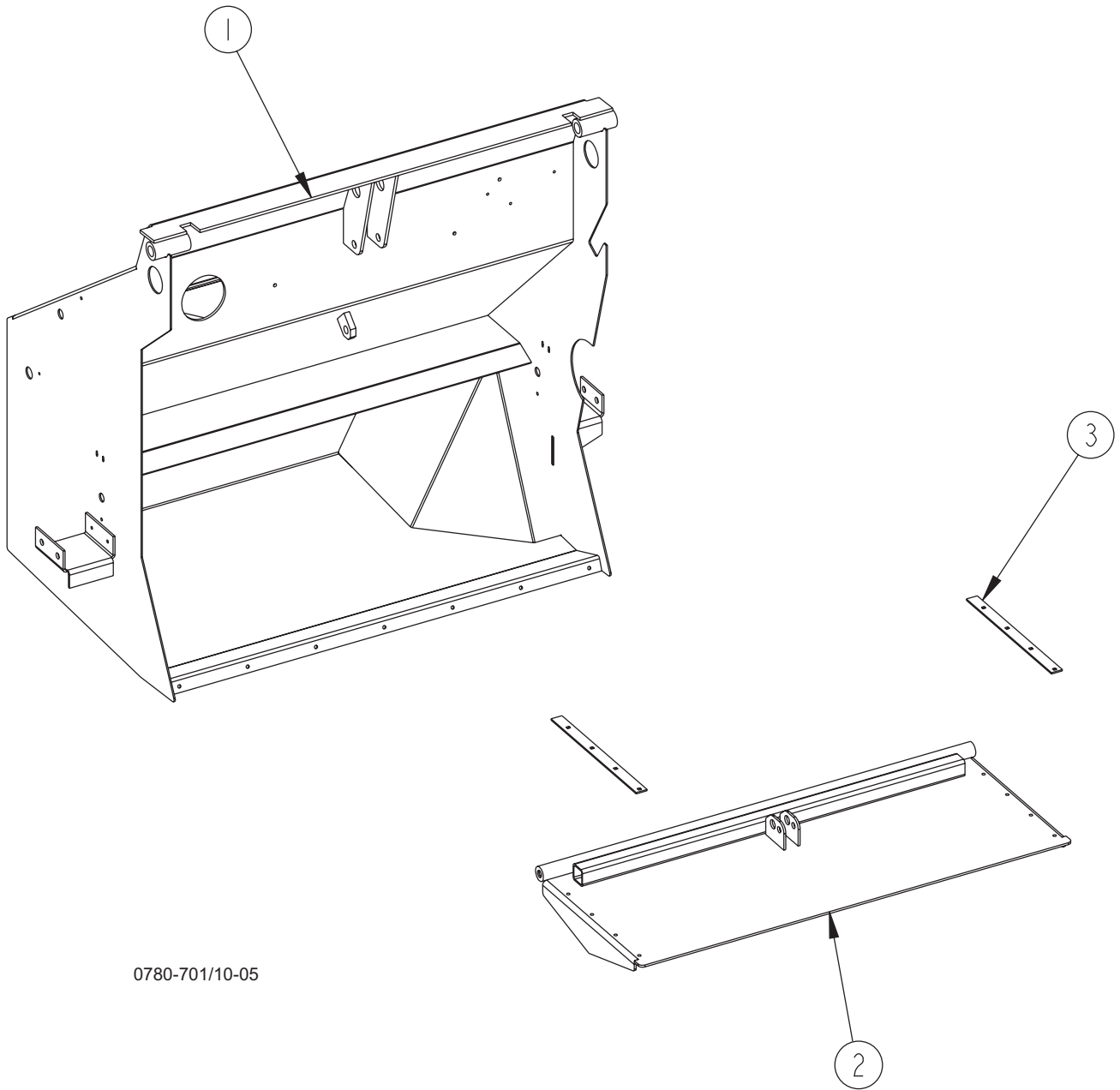

0780-701/10-05

OPTION 0780-701

<u>KEY NO.</u>	<u>PART NUMBER</u>	<u>DESCRIPTION</u>	<u>QTY</u>
1	7-32-06018-1	Hopper, Variable Dump	1
2	7-19-08056-1	Door, Welded Hopper	1
3	8-13-07140-1	Clamp, Dump Seal	1

0780-701/10-05

CAM-STYLE HOPPER SWITCH OPTION

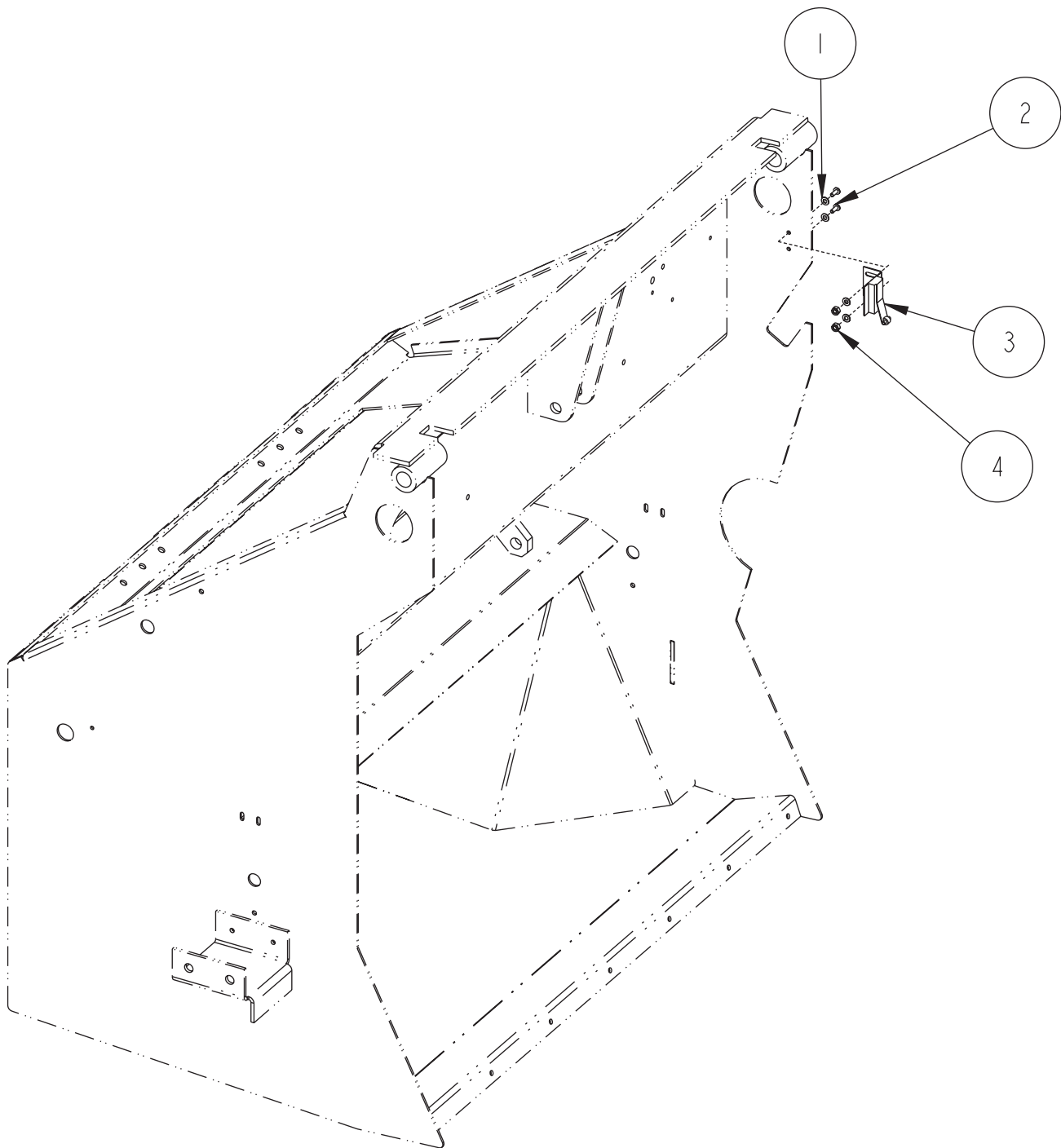

OPTION 0780-707

<u>KEY NO.</u>	<u>PART NUMBER</u>	<u>DESCRIPTION</u>	<u>QTY</u>
1	2-00-00426	Flat Washer, .500 x .219 x .063	4
2	2-00-00049	Screw, 10-24 x 1/2	2
3*	7-82-00059	Switch	1
4	2-00-01246	Nut, #10-24 Elastic Stop	2

*Wires same as existing switch

0780-707/10-05

WRAP-AROUND BUMPER OPTION

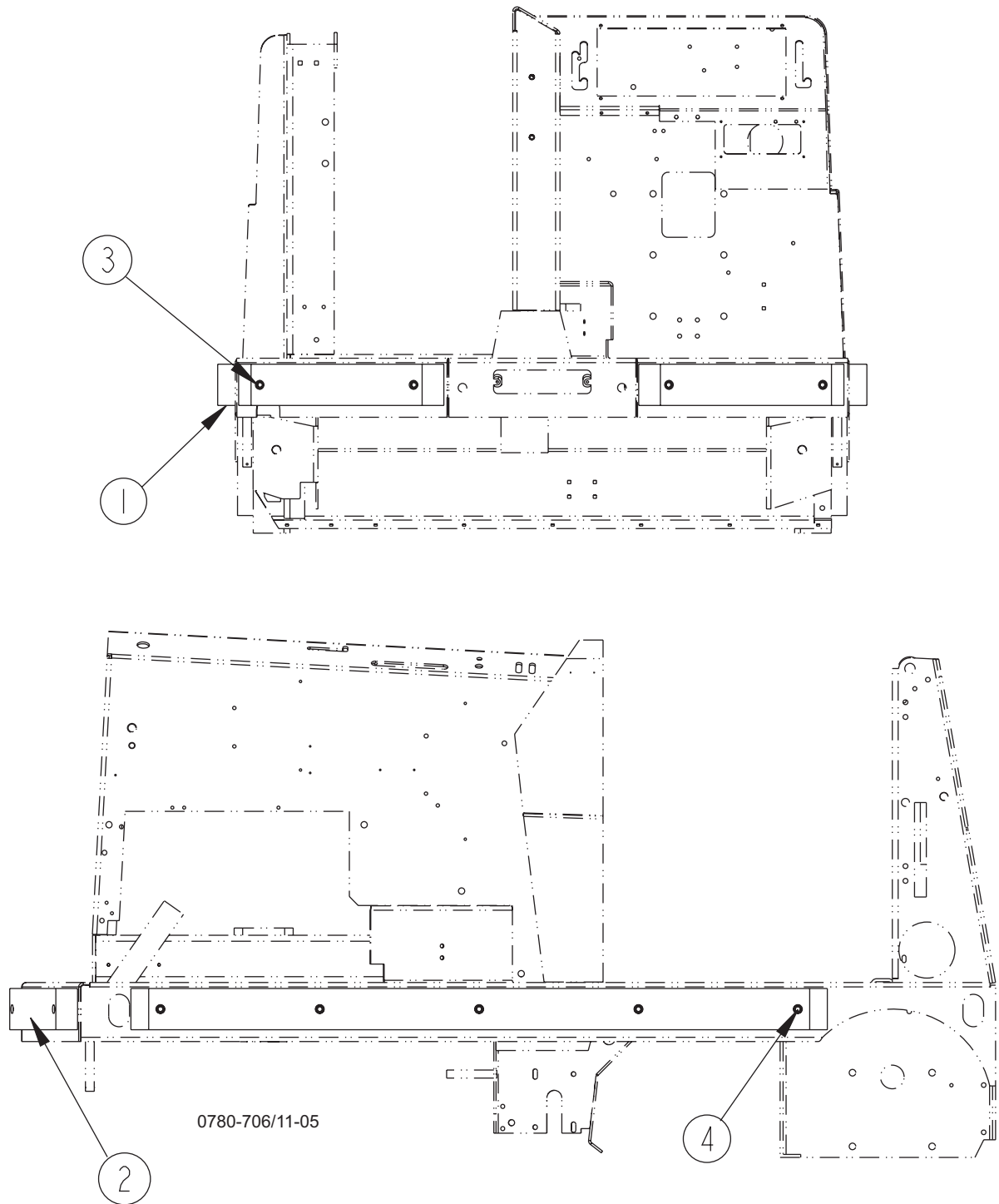

OPTION 0780-706

<u>KEY NO.</u>	<u>PART NUMBER</u>	<u>DESCRIPTION</u>	<u>QTY</u>
1	7-08-07130	Bumper, Poly (59.0")	2
2	7-08-07131	Bumper, Poly (18.0")	2
3	2-00-00409	Flat Washer, .687 x .344 x .062	14
4	2-00-06543	Screw, 1/4-20 x 2.0	14

0780-706/11-05

ROLLER BUMPER OPTION

OPTION 0780-703

<u>KEY NO.</u>	<u>PART NUMBER</u>	<u>DESCRIPTION</u>	<u>QTY</u>
1	7-58-05362	Spacer, Bumper	2
2	7-08-07116	Bumper (weldment), LH Rear	2
3	7-66-05011-1	Roller, Bumper	6
4	7-08-07117	Bumper (weldment), Front	2
5	7-70-05188	Pin, Roller Bumper/Side Broom	2
6	7-70-05175	Pin, Roller Bumper	2
7	2-00-00540	Retainer Ring, Ext. #5100-75 for 3/4 D	8
8	2-00-004801	Flat Washer, 1.0 x .39 x .06	14
9	2-00-04182	Nut, #3/8-16 Hex Stop	15
10	2-00-00234	Screw, 3/8-16 x 1.50	8
11	2-00-00233	Bolt, 3/8-16 x 1.0 Fin. Hex Head	6

0780-703/11-05

ROLLER BUMPER OPTION

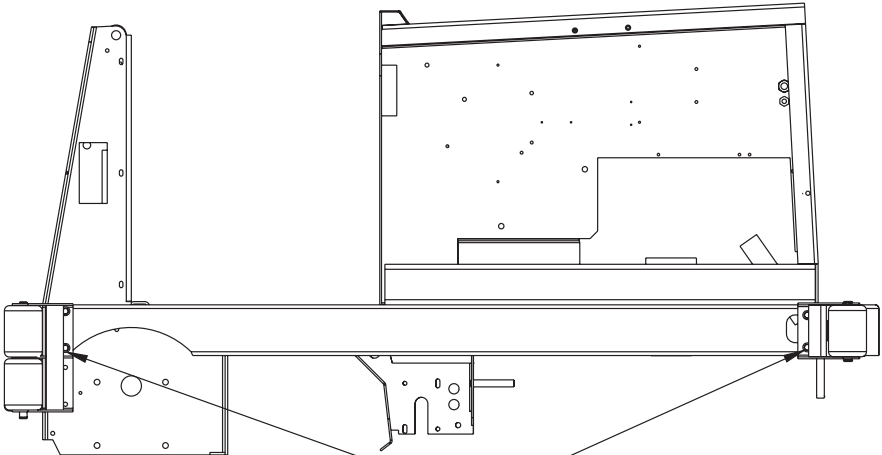
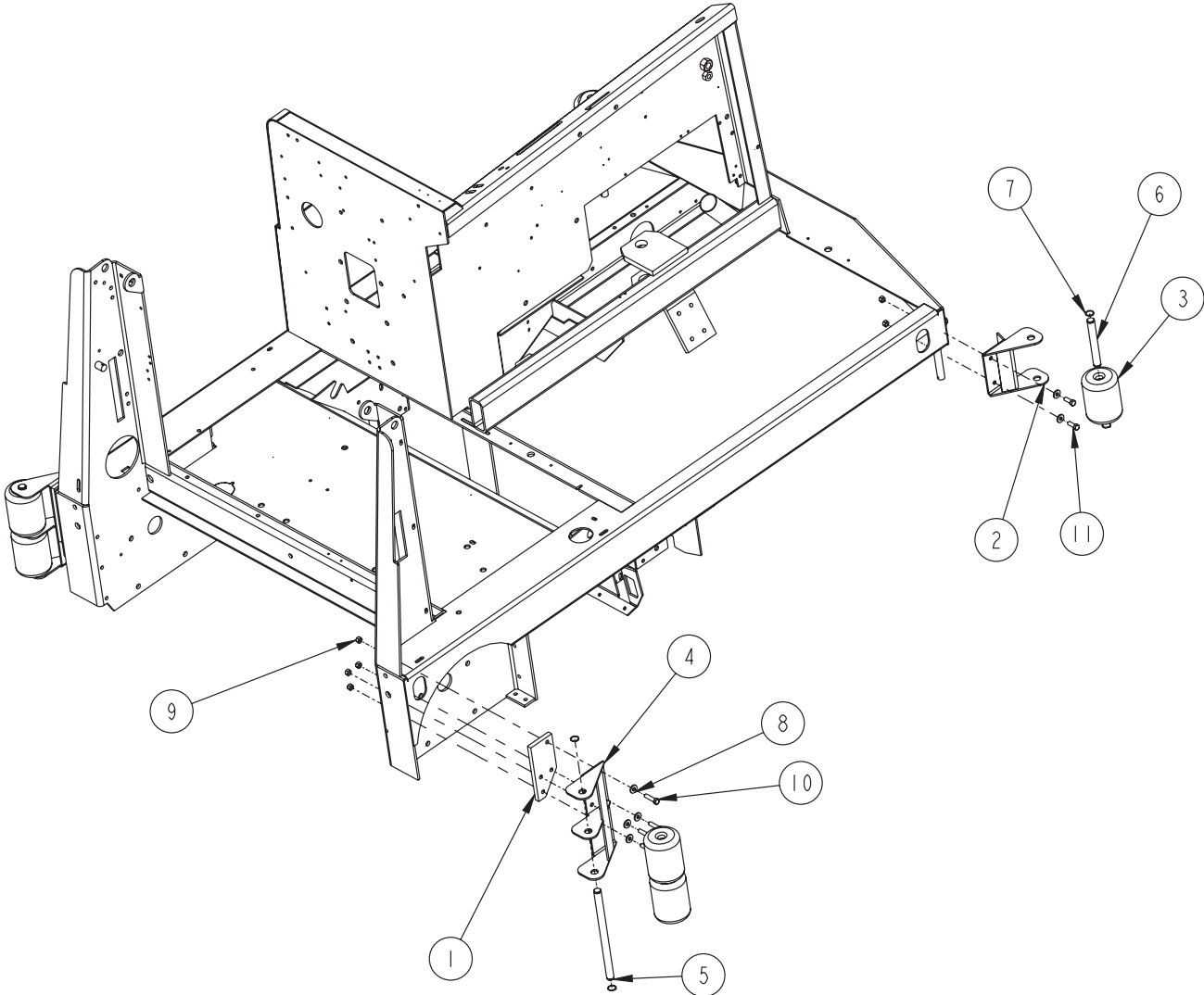

DRILL $\varnothing 0.532$ HOLE (14X)
USE BRACKETS AS TEMPLATE

0780-703/11-05

EXTENDED RECOVERY TANK DRAIN OPTION

OPTION 0780-704

<u>KEY NO.</u>	<u>PART NUMBER</u>	<u>DESCRIPTION</u>	<u>QTY</u>
1	7-33-05151	Extension, Clean-Out Door	1
2	7-29-00318-1	Gasket, Drain	1
3	7-29-00250-1	Gasket, Drain	1
4	7-19-08099	Door, Recovery Tank Drain	1
5	2-00-00410	Flat Washer, .875 x .375 x .060	2
6	25201A	Knob	2
7	7-33-02591	Hose Assy., Drain	1
8	2-00-02216	Clamp, Hose	1
9	2-00-00216	Bolt, 3/8-16 x 2.0 Hex Head	1
10	7-15-01022	Collar w/setscrew	1
11	2-95-04182	Nut, 3/8-16 Hex Stop	1
12	7-58-08001	Plug	1
13	7-25-02033	Plug, Hose	1
14	2-00-03466	Screw, 10-16 x 1/2 Self-Tapping	1
15	7-08-01138-1	Bracket, Drain Hose	2
16	2-00-04590	Washer, Sealing	4
17	2-00-04689	11/16 OD x .26 ID x .050	4
18	2-00-04699	Screw, 1/4-20 x 2.75 HHC	4
19	2-00-04687	Lock Washer, 1/4" Helical Spring	4
20	2-00-04688	Nut, 1/4-20 Hex	4

0780-704/11-05

EXTENDED RECOVERY TANK DRAIN OPTION

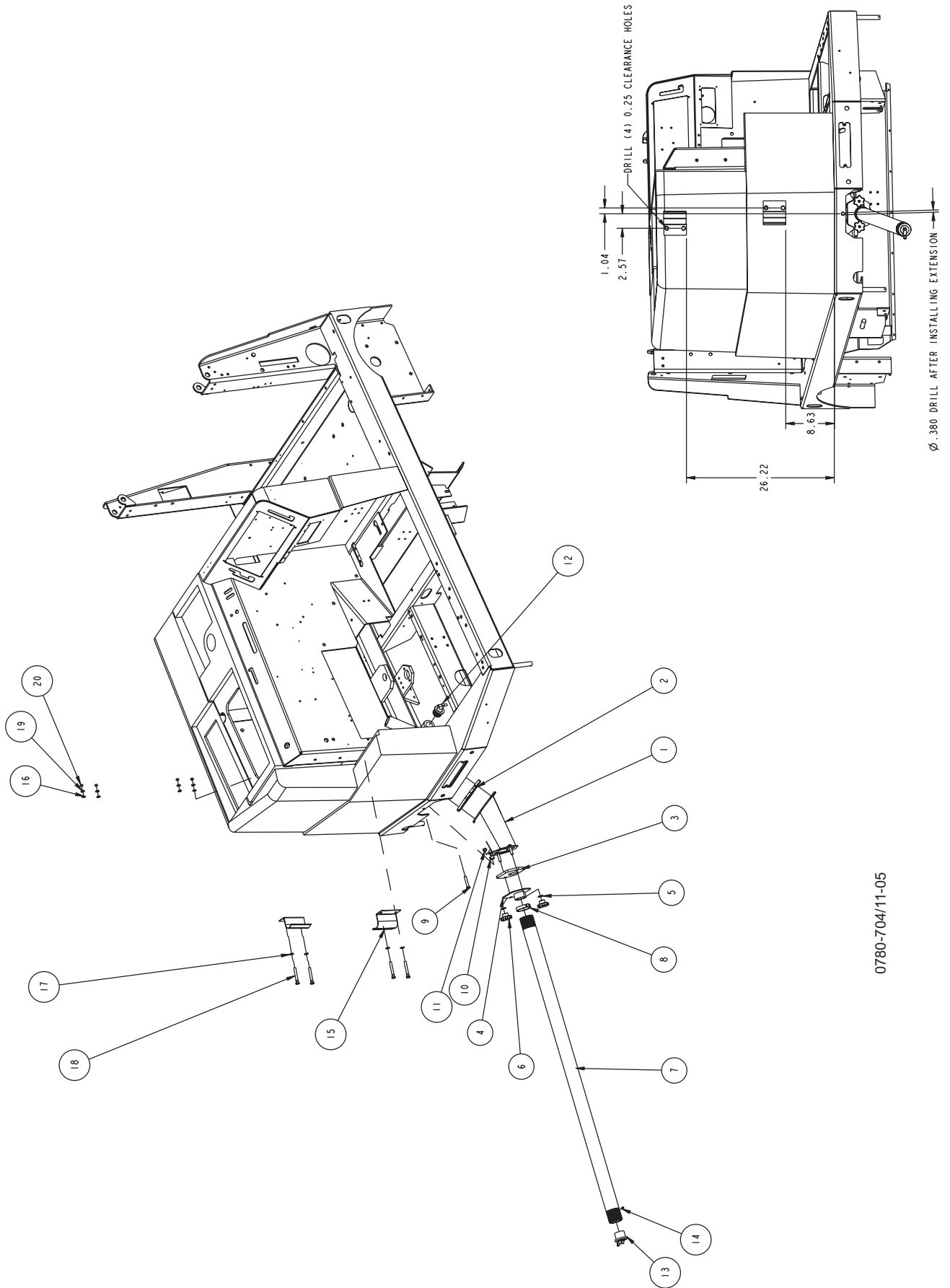

0780-704/11-05

SPARE PARTS LIST - 46" MACHINE

OPTION 0760-514 BROOM and HOPPER CHAMBER COMPONENTS

7-25-08070	Hopper Flap	1
7-25-08071	Flap - BC Outer	1
7-25-08072	Flap - BC Inner	1
8-29-00257	Gasket	1
8-29-00232	Gasket	1
8-29-00234	Gasket	1
8-29-00233	Gasket	3
8-21-04048	Edging	2
8-29-00256	Gasket	1
7-21-03003	Edging	3
7-21-04031	Edging	1
8-25-08212	Flap Door	2
8-24-04148	Dust Filter Element	1

SQUEEGEE COMPONENTS

7-77-00109	Outer Rubber Squeegee	1
7-77-00110	Inner Rubber Squeegee	1
7-77-00111	Side Squeegee Outer Rubber	2
7-77-00114	Side Squeegee Inner Rubber	2

SPARE PARTS LIST - 53" MACHINE

OPTION NO. 0760-515 53" BROOM and HOPPER CHAMBER COMPONENTS

7-25-08070	Hopper Flap	1
7-25-08071	Flap - BC Outer	1
7-25-08072	Flap - BC Inner	1
8-29-00257	Gasket	1
8-29-00232	Gasket	1
8-29-00234	Gasket	1
8-29-00233	Gasket	3
8-21-04048	Edging	2
8-29-00256	Gasket	1
7-21-03003	Edging	3
7-21-04031	Edging	1
8-25-08212	Flap Door	2
8-24-04148	Dust Filter Element	1

53" REAR SQUEEGEE COMPONENTS

7-77-00105	Outer Swing Squeegee Rubber	1
7-77-00115	Inner Swing Squeegee Rubber	1
7-77-00112	Outer Side Squeegee Rubber	2
7-77-00113	Inner Side Squeegee Rubber	2

OPTION 0780-418 53" SCRUB DECK & SQUEEGEE

7-86-08041	Squeegee-Weldment	1	7-33-02359	Hose-6"	1
7-20-06010	Duct-Squeegee Inlet	1	7-33-02361	Hose - 17"	1
7-75-01164	Spacer-Bushing	2	7-42-05132	Link - Side Squeegee	2
7-75-01169	Spacer-Squeegee	2	7-30-08016	Guide - Brush Frame Arm	1
7-77-00110	Squeegee-Rubber-Inner	1	7-76-00114	Spring	1
7-77-00109	Squeegee-Rubber-Outer	1	7-33-00360	Hose - 8"	2
7-79-00088	Strap-Squeegee Clamp	1	7-33-09031	Hub-Brush Drive	3
7-13-07157	Clamp-End Squeegee	2	7-03-04123	Arm-Brush Drive	3
7-13-07156	Clamp-Nut	2	7-78-05026	Stop-Scrub Frame RH	1
7-39-00026	Knob-Squeegee	4	7-78-05025	Stop-Scrub Frame LH	1
7-89-08073	Wheel-Caster	2	7-08-00437	Welding Tee	1
7-27-07181	Brush Deck Weldment	1	7-33-02339	Hose-22"	1
7-42-05135	Link - Brush RH	1	7-86-08042	LH Side Squeegee Tool	1
0782-111	Motor-Hyd	1	7-86-08043	RH Side Squeegee Tool	1
7-57-05039	Pivot Brush Drive	2	7-77-00113	Rubber Inner Side Squ.	2
7-42-05134	Link - Brush Frame LH	1	7-77-00112	Rubber Outer Side Squ.	2
7-41-00027	Latch-Brush Drive	3	7-13-07175	Clamp RH Side Squeegee	1
7-25-02012	Fitting - Straight Barb	1	7-13-07174	Clamp RH Side Squeegee	1
7-55-08151	Pin-Lock	2			

ENGINE SERVICE PARTS - FORD 416 GAS/LP

OPTION NO. 0780-622
ENGINE-RELATED COMPONENTS
Ford 416 Gas & LP Engines

7-24-04085*	Engine Air Filter (Main)	1
7-24-04086*	Engine Air Filter (Safety)	1
2-00-05990	Belt, Alternator/Water Pump	1
7-24-04067	Fuel Filter	1
8-24-04156	Engine Oil Filter	1

*Both filters should be replaced at the same time

ADDITIONAL FORD 416 ENGINE SERVICE PARTS

<u>PART NO.</u>	<u>DESCRIPTION</u>	<u>QTY.</u>
7-23-00025	Fan	1
2-00-06092	Belt, Fan	1
0780-652	Thermostat	1
8-82-00070	Switch, Water Temperature	1
7-11-04073	Sensor, Water Temperature	1
8-82-00046	Switch, Oil Pressure	1
7-11-04071	Mixer, Ford 416 LP Engine (EXPORT)	1
7-11-04054	Mixer, Ford 416 LP Engine (N. Am. certified)	1
7-88-00110	LP Safety Valve	1
7-88-00126	PCV Valve	1
7-11-04062	HEGO Sensor (Pre Cat)	1
7-11-04055	TMap Sensor	1
7-11-04065	Light, Malfunction Indicator	1
7-11-04066	O ₂ Sensor (Post Cat Monitor)	1
7-75-03007	Spark Plug	4
7-90-08017	Spark Plug Wire #1	1
7-90-08018	Spark Plug Wire #2	1
7-90-08019	Spark Plug Wire #3	1
7-90-08020	Spark Plug Wire #4	1
7-14-07015	Coil Pack	1
7-11-04041	Throttle Body	1
7-21-07005	Elbow, Vacuum	1
7-11-04046	LP Regulator (EXPORT)	1
7-11-04043	LP Regulator (N.Am. certified)	1
7-11-04045	MegaJector (N. Am. certified)	1
7-11-04037	Catalytic Converter	1
0775-292	Alternator	1
2-00-05990	Belt, Alternator/Water Pump	1
0775-291	Starter	1
7-29-00336	Gasket, Cylinder Head	1
0769-030	Fuel Pump	1
7-60-05062	Water Pump	1
7-29-00335	Gasket, Water Pump	1
7-11-04041	Throttle Body	1
7-21-07005	Elbow, Vacuum	1
0769-031	EPM w/Calibration (N. Am. certified)	1
0769-032	EPM w/Calibration (EXPORT)	1
7-08-01188	Bracket, Fuel Filter	1
8-24-04156	Oil Filter	1
8-24-04067	Fuel Filter	1
2-00-04641	Fitting, 3/8 NPT Close Nipple	1
2-00-06539	Fitting, 3/8 NPT - 5/8 Hose Nipple	1
2-00-06540	Fitting, NPT Brass "T"	1
2-00-05447	Fitting, 5/8 Nylon Hose "T"	1
2-86-00394	Operators Handbook	
2-86-00395	Parts Catalog	

OPTION NO. 0780-623
ENGINE-RELATED COMPONENTS
Mitsubishi S4L2 Diesel Engine

7-24-04085*	Engine Air Filter (Main)	1
7-24-04086*	Engine Air Filter (Safety)	1
2-00-05989	Belt, Alternator/Fan	1
7-24-04088	Fuel Filter Element	1
7-24-04099	Engine Oil Filter	1

*Both filters should be replaced at the same time

ADDITIONAL MITSUBISHI S4L2 ENGINE SERVICE PARTS

<u>PART NUMBER</u>	<u>DESCRIPTION</u>	<u>QTY</u>
7-24-04099	Oil Filter	1
7-84-08017	Thermostat	1
7-29-00313	Gasket, Thermostat	1
7-60-05049	Water Pump	1
7-29-00311	Gasket, Water Pump	1
7-75-03005	Glow Plug	4
7-64-00041	Relay, Glow Plug (installed on wire harness)	1
0775-288	Alternator	1
2-00-05989	Belt, Alternator/Fan	1
7-29-00337	Gasket, Cylinder Head	1
7-56-04075	Pipe, Cylinder #1	1
7-56-04076	Pipe, Cylinder #2	1
7-56-04077	Pipe, Cylinder #3	1
7-56-04078	Pipe, Cylinder #4	1
7-82-00056	Switch, Water Temperature	1
8-82-00070	Sending Unit, Water Temperature	1
0775-286	Starter	1
2-00-04982	Fitting, 1/8 NPT Street Tee	1
7-82-00055	Switch, Oil Pressure	2
0895-134	Wiring Harness	1
7-16-05044	Coupling, Engine	1
7-58-05335	Casting, Pump Plate	1
7-64-00040	Relay, Murphy (installed on wire harness)	1
7-24-04088	Fuel Filter Element	1
2-86-00383	Operators Handbook	
2-86-00384	Parts Catalog	
2-86-00405	Service Manual	

American-Lincoln®

14600 21st Avenue North
Plymouth, MN 55447-3408
www.americanlincoln.com
Phone: 800-331-7692
Fax: 877-877-2586
©2006 American-Lincoln