

**Please do not upload this copyright pdf document to any other website. Breach of copyright may result in a criminal conviction.**

This Acrobat document was generated by me, Colin Hinson, from a document held by the Henlow Signals Museum, believed to be out of copyright. It is presented here (for free) and this pdf version of the document is my copyright in much the same way as a photograph would be. If you believe the document to be under other copyright, please contact me.

The document should have been downloaded from my website <https://blunham.com/Radar>, or any mirror site named on that site. If you downloaded it from elsewhere, please let me know (particularly if you were charged for it). You can contact me via my Genuki email page: <https://www.genuki.org.uk/big/eng/YKS/various?recipient=colin>

**You may not copy the file for onward transmission of the data nor attempt to make monetary gain by the use of these files. If you want someone else to have a copy of the file, point them at the website. (<https://blunham.com/Radar>). Please do not point them at the file itself as it may move or the site may be updated.**

It should be noted that most of the pages are identifiable as having been processed by me.

---

I put a lot of time into producing these files which is why you are met with this page when you open the file.

In order to generate this file, I need to scan the pages, split the double pages and remove any edge marks such as punch holes, clean up the pages, set the relevant pages to be all the same size and alignment. I then run Omnipage (OCR) to generate the searchable text and then generate the pdf file.

Hopefully after all that, I end up with a presentable file. If you find missing pages, pages in the wrong order, anything else wrong with the file or simply want to make a comment, please drop me a line (see above).

It is my hope that you find the file of use to you personally – I know that I would have liked to have found some of these files years ago – they would have saved me a lot of time !

Colin Hinson

In the village of Blunham, Bedfordshire.

**INSTRUCTION  
MANUAL  
FT-107M**

**YAESU MUSEN CO., LTD.**

# YAESU ALL SOLID STATE HF SSB TRANSCEIVER FT-107M



## GENERAL DESCRIPTION

The FT-107M is a precision-engineered, high-performance HF transceiver of advanced design, featuring all band coverage (160–10 meters) on SSB, CW, AM, and FSK. This transceiver operates at an input power of 240 watts on SSB/CW, and 80 watts on AM/FSK.

The all-solid-state design allows instant band changes, without so much as a preselector adjustment. Digital plus analog frequency display is used in this transceiver, with an advanced LSI frequency counter providing accurate frequency readout without calibration when switching modes. VOX, an RF speech processor, and a built-in SWR meter are included for maximum versatility.

Yaesu's exciting memory circuitry is available as an option, providing up to twelve channels of frequency memory, with clarifier adjustment allowing offset from memory channels. And Yaesu's new Digital Memory Shift (DMS) allows up to 500 kHz offset from any memory channel, in 100 Hz steps programmed by a photo-interrupter control. When the memory option is installed, an optional scanning microphone may be used to provide up/down scanning with fingertip ease, using pushbuttons on the microphone.

The FT-107M receiver section features a Schottky diode ring mixer, plus individually-tuned input bandpass filter networks, for excellent intercept characteristics. An audio peak/notch filter is also included, in addition to Yaesu's variable IF bandwidth feature, which uses two 8-pole filters to provide continuously variable width of the IF passband from 300 Hz to 2.4 kHz.

Designed for operation from a 13.5 VDC supply, the FT-107M may be used with either the FP-107 internal AC power supply or the FP-107E external AC power supply/speaker console. Either supply will provide excellent regulation, for many years of satisfying operation.

We recommend that you read the following pages carefully, so as to derive maximum enjoyment from the feature-packed FT-107M.

# SPECIFICATIONS

## GENERAL

### Frequency coverage:

160 m	1.8 – 2.0 MHz
80 m	3.5 – 4.0 MHz
40 m	7.0 – 7.5 MHz
30 m	10.0 – 10.5 MHz
20 m	14.0 – 14.5 MHz
17 m	18.0 – 18.5 MHz
15 m	21.0 – 21.5 MHz
12 m	24.5 – 25.0 MHz
10 m	28.0 – 29.9 MHz

### Power requirements:

DC 13.5 volts  $\pm$  10 %

### Power consumption:

DC 1.5 amps receive  
20 amps transmit

### Size:

334 (W) x 129 (H) x 400 (D) mm  
including heat sink

### Weight:

Approx. 12.5 kg.

## TRANSMITTER

### Emission type:

LSB, USB(A3J), CW(A1), AM(A3), FSK(F1)

### Power input:

240 watts DC (SSB, CW)  
80 watts DC (AM, FSK)

### Carrier suppression:

Better than 40 dB at 14 MHz

### Unwanted sideband suppression:

Better than 50 dB (14 MHz, 1 kHz)

### Spurious radiation:

Better than 50 dB down

### Transmitter frequency response:

350–2700 Hz (–6 dB)

### Third order distortion products:

Better than 31 dB down

### Negative feedback:

6 dB at 14 MHz

### Transmitter frequency stability:

$\pm$ 300 Hz after 10 minute warmup; less than  
100 Hz after 300 minute warmup

### Modulation type:

A3J : balanced modulator

A3 : amplitude modulation of a low power  
stage

FSK shift: 170 Hz

### Antenna output impedance:

50 ohms, unbalanced

### Microphone input impedance:

500–600 ohms (low impedance)

## RECEIVER

### Sensitivity:

0.25  $\mu$ V for S/N 10 dB (SSB, CW, FSK)  
1.0  $\mu$ V for S/N 10 dB (AM)

### Image rejection:

Better than 60 dB (160-12 m)  
Better than 50 dB (10 m)

### IF rejection:

Better than 70 dB

### Selectivity:

SSB 2.4 kHz at 6 dB down, 4.0 kHz at 60 dB  
down  
CW (with optional 600 Hz CW filter)  
600 Hz at 6 dB down, 1.2 kHz at 60 dB down  
AM (with optional 6 kHz AM filter)  
6 kHz at 6 dB down, 12 kHz at 60 dB down

### RF attenuator:

20 dB  $\pm$  3 dB

### APF, Notch frequency response:

300 Hz to 1.4 kHz

### Bandwidth control:

Continuous from 2.4 kHz to 300 Hz

### Audio output impedance:

4–16 ohms

### Audio output:

3 watts at 10 % THD, 4 ohm load

# SEMICONDUCTORS

## Transistor

2SA564A	2	2SC1674L	1
2SA733	5	2SC1815GR	10
2SA952L	13	2SC1815Y	12
2SC372Y	2	2SC1959Y	4
2SC380Y	25	2SC2290	2
(2SC380TM-Y)		2SC2331	1
2SC535A	1	2SC2395	2
2SC735Y	1	2SD235Y	1
2SC1000GR	3	MPS-A13	1
2SC1583	2	2N4427	2
2SC1589	1		

## FET

2SK19GR	17	3SK73	2
3SK51-03	7	J-310	1

## IC

μPA54H	1	MSM9520RS	1
μPC324C	1	MC14011B	1
μPC2002H	1	MC14016P	1
ΓA7060P	1	NJM78L05	1
TA7063P	1	μPC14305	1
SN76514N	1	μPC14308	3
34024P	1		

## Germanium Diode

1N270(GB)	18	1S1007(GB)	
-----------	----	------------	--

## Silicon Diode

10D1	2	1S1555	1
10D10	4		

## Schottky Barrier Diode

1SS16	10		
-------	----	--	--

## Varactor Diode

FC63	1	1S2236	
1S2209	1		

## Zener Diode

YZ-033	1	WZ090	
--------	---	-------	--

## LED

LN224RP	7	GD4203SRD	
---------	---	-----------	--

## LED Display

5082-7623	6		
-----------	---	--	--

## ACCESSORIES

The following accessories are included with your FT-107M

DC Power cord	1
Speaker plug	1
RCA plug	1
DC fuse (20A)	1
Extender legs (30 mm)	2
Pad for legs	2

### FT-107 SERIES MODEL CHART

FEATURE	FT-107M
ALL BAND CRYSTALS	☐
MEMORY UNIT/DMS	x
CW FILTER	x
AM FILTER	x
RF SPEECH PROCESSOR	
MICROPHONE (STANDARD)	x
MICROPHONE (SCANNING)	x
AC POWER SUPPLY	x

= Standard feature    x - Available option

### CAUTION

WHEN REPLACING FUSES IN THE DC CABLE, USE ONLY A 20 AMPERE FUSE. OUR WARRANTY DOES NOT COVER DAMAGE CAUSED BY USE OF AN IMPROPER FUSE. NEVER CONNECT AC POWER DIRECTLY TO THE REAR PANEL DC POWER CONNECTOR.

## FRONT PANEL CONTROLS AND SWITCHES

This transceiver has been specifically designed for ease of operation. However, the operator may not be familiar with the function of some of the controls, and improper adjustment thereof may de-

grade transceiver performance. Therefore, be certain that you understand the function of every control and switch before operating the FT-107M.

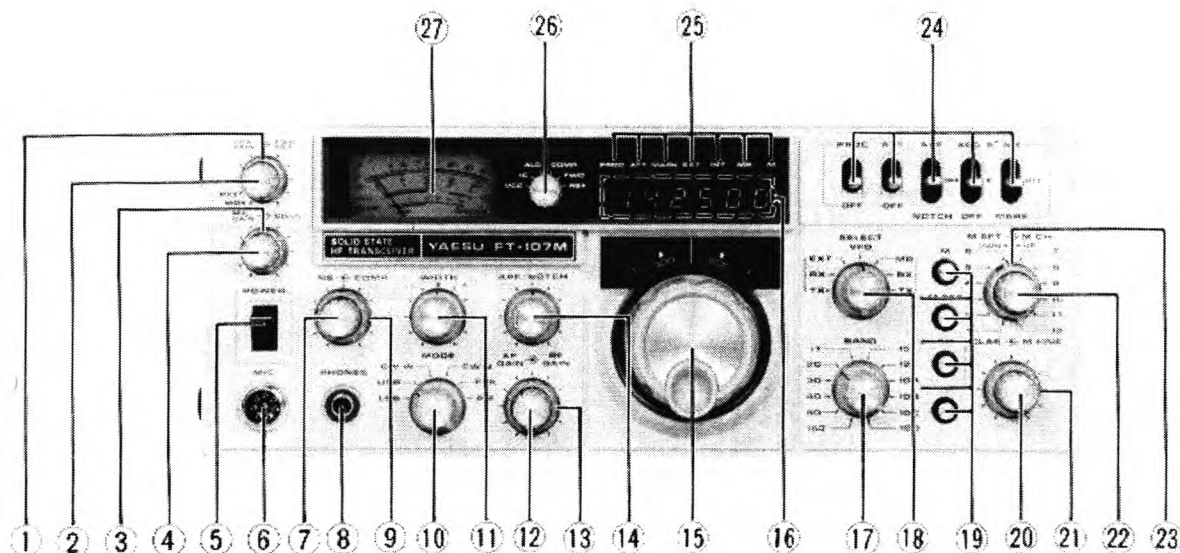

### (1) FWD SET

This switch sets the SWR meter sensitivity level.

### (2) VOX GAIN

This control selects MOX/PTT/VOX relay control, as well as adjustment of the VOX (voice-operated TX/RX switching) circuit. The PTT position provides push-to-talk operation from a microphone PTT switch or a footswitch. The MOX position provides manual transmit; this switch must be returned to the PTT position for receiver recovery.

### (3) DRIVE

On CW, FSK, and AM, this control sets the carrier level. On SSB, with the RF processor ON, this control sets the drive level.

### (4) MIC GAIN

This control sets the AM and SSB microphone amplifier gain level.

### (5) POWER

This is the main power on/off switch for the transceiver.

### (6) MIC

This eight-pin connector accepts the microphone audio input, as well as the push-to-talk (PTT) and scanning control lines.

### (7) NB

This control varies the noise blanker threshold level.

### (8) PHONES

This is a standard two-pin phone jack for output to your headphones. The impedance is 4 ohms, and the internal speaker will be cut off when a plug is inserted into this jack.

### (9) COMP

This control sets the compression level for the RF speech processor.

### (10) MODE

This switch selects the desired mode: LSB, USB, CW-W, CW-N, FSK, and AM. When the optional 600 Hz CW filter is installed, the CW-W position will use the two 8-pole SSB filters, while the CW-N position will use the 6-pole CW filter and the 8-pole SSB filter used for the variable bandwidth feature.

### (11) WIDTH

This control varies the IF bandwidth (except on AM) from 2.4 kHz down to 600 Hz.

### (12) AF GAIN

This control varies the audio output level from the speaker or headphones. Clockwise rotation increases the audio output level.

### (13) RF GAIN

This control varies the gain of the receiver RF and IF amplifiers. For proper S-meter operation, this meter should be set fully clockwise.

### (14) APF/NOTCH

This control varies the frequency response of the audio peak/notch filter. The peak/notch filter may be varied over the range 300 Hz-1500 Hz.

### (15) MAIN TUNING KNOB

This is the main frequency tuning dial for the transceiver.

### (16) ANALOG AND DIGITAL DISPLAYS

The analog display is calibrated every 50 kHz, with 1 kHz marks providing finer resolution. The digital display provides resolution to 100 Hz.

### (17) BAND

This switch selects the desired band.

### (18) SELECT SWITCH

This switch selects the means of frequency control for the transceiver. The details below apply to the fully equipped FT-107M.

**TX EXT** The transmit frequency is controlled by the FV-107 external VFO (option), while the receive frequency is controlled by the FT-107M internal VFO.

**RX EXT** The receive frequency is controlled by the FV-107 external VFO (option), while the transmit frequency is controlled by the FT-107M internal VFO.

**EXT** The transceive frequency is controlled by the FV-107 external VFO (option)

**MR** The transceive frequency is controlled by the memory unit and/or the DMS (Digital Memory Shift) control.

**RX MR** The receive frequency is controlled by the memory unit and/or DMS, while the transmit frequency is controlled by the internal VFO.

**TX MR** The transmit frequency is controlled by the memory unit and/or DMS, while the receive frequency is controlled by the internal VFO.

### (19) PUSH SWITCHES (M, M SET, TX CLAR, RX CLAR)

**M** Push the M button to store a frequency in memory.

**M SET** Push this switch to activate the DMS system.

**TX CLAR, RX CLAR** While using the internal VFO or memory, push the TX CLAR switch to provide offset from the TX frequency. Push the RX CLAR button to provide offset of the receive frequency, and push both buttons to provide offset of the transceive frequency from the dial frequency.

### (20) CLARIFIER

The CLARIFIER allows offset from the VFO or memory frequency, according to the selection made by pushing the TX CLAR and/or RX CLAR buttons.

### (21) M FINE

This control allows fine tuning during memory operation.

### (22) M SET

This control activates the DMS system, allowing offset tuning from a memory channel in 100 Hz steps. The M FINE control may, in turn, be used to tune between the 100 Hz steps.

### (23) M CH

This control selects the desired memory channel.

### (24) LEVER SWITCHES

**PROC** This switch activates the RF speech processor.

**ATT** This switch activates a 20 dB attenuator in the incoming signal path.

- APF/NOTCH** This control selects either the Audio Peak Filter (APF) or the audio notch filter.
- AGC** This switch selects the AGC recovery time constant. Selection of slow, fast, and AGC OFF is possible.
- NB/MARK** This switch selects the noise blanker (NB) or the crystal calibrator. The latter feature is useful in receiver servicing, as it provides a signal at the antenna input which will serve as a reference.

**(25) INDICATORS (PROC, ATT, MARK, EXT, INT, MR, M)**

These indicators show the operating condition for the speech processor (PROC), the 20 dB attenuator (ATT), the crystal calibrator (MARK), external or internal VFO (EXT, INT), and the memory system (MR, M).

**(26) METER SWITCH**

This switch selects meter indication of Vcc, Ic, ALC, compression (COMP), forward relative power (FWD), and reflected relative power (REF).

**(27) METER**

The meter will display transceiver operating conditions, according to the setting of the meter switch.

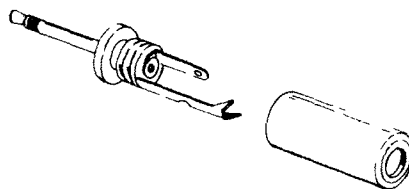
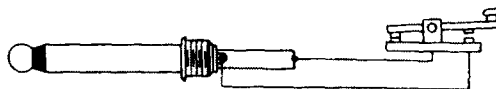

**KEY PLUG CONNECTIONS**

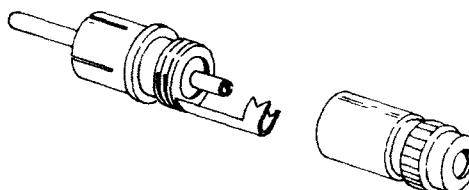

**PHONO PLUG CONNECTIONS**

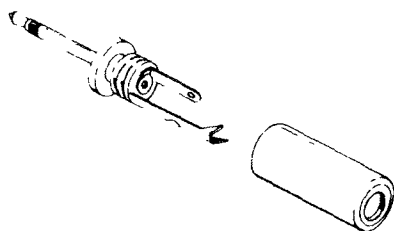

**HEADPHONE CONNECTIONS**

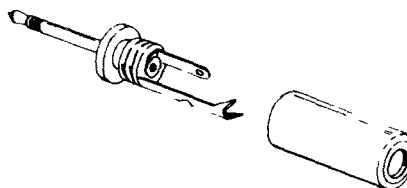
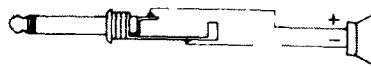

**EXTERNAL SPEAKER CONNECTIONS**



## REAR PANEL CONNECTIONS

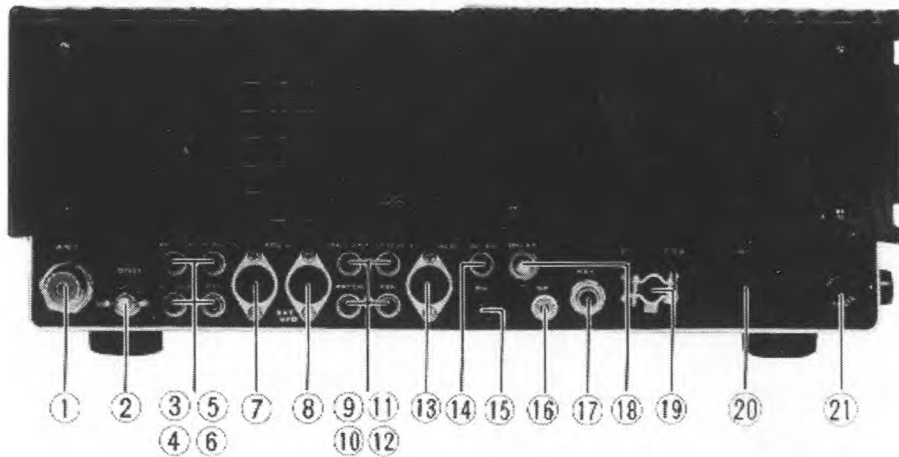

### (1) ANT

This is a standard UHF type female jack for connection to the antenna.

### (2) GND

For best performance and safety, a good ground should be connected at this point.

### (3) RF OUT

This jack provides 300 mV RMS at 50 ohms for connection to the FTV-107R transverter.

### (4) AF OUT

This is an audio output jack, providing 200 mV of audio output for recording purposes. This jack is not disabled by insertion of a headphone or speaker plug into their respective jacks.

### (5) IF OUT 2

This is wideband IF output for use with a band scope (such as the YO-901).

### (6) PTT

This jack accepts push-to-talk control. When using a footswitch, it should be connected at this point.

### (7) ACC 2

This is a 7 pin DIN jack for use with the FTV-107R transverter.

### (8) EXT VFO

This is a 6 pin DIN jack for interconnection to the FV-107 external VFO.

### (9) RCV ANT

This jack provides for connection of an external receiver to the main station antenna. This jack is switched to the antenna in the receive mode only.

### (10) PATCH

This is an auxiliary microphone input for use with a phone patch, etc.

### (11) IF OUT 1

This jack provides narrow-band IF output for use with a monitor scope (such as the YO-901).

### (12) FSK

This jack provides input for the FSK keying lead from your FSK terminal. The standard shift of 170 Hz is used.

### (13) ACC 1

This is a 5 pin DIN jack for connection to a linear amplifier or other station equipment. Included are make and break relay connections, as well as the external ALC line.

**(14) +8 V**

This is a +8 volt DC line for connection to the FC-107 antenna tuner meter lamp.

**(15) BU (BACKUP)**

This jack is for connection to an external +3 V DC power source, in order to hold the FT-107M memory circuits when the transceiver is turned off.

**(16) SP**

This is a miniature phone jack for connection to an external speaker. Insertion of a plug into this jack automatically cuts off the internal speaker.

**(17) KEY**

Your key plug may be inserted at this point. Key-up voltage is 7 volts, while key down current is 1.5 mA.

**(18) DELAY**

This control varies the receiver recovery time constant for the VOX circuitry.

**(19) DC 13.5 V**

The DC cable should be connected at this point. **Never** connect AC power to the DC cable. Failure to observe this simple precaution will void the warranty. During AC operation with the FP-107, insert the DC dummy plug (supplied with the AC power supply) into this jack.

**(20) AC**

When using the internal FP-107 AC power supply option, the AC cord is connected at this point. Be certain to observe the proper voltage when using the FT-107.

**(21) FUSE**

When using the FP-107 AC power supply, the AC line fuse is inserted at this point. For 100/110/117 VAC, use only a 10 amp fuse, and for 200/220/234 VAC, use only a 5 amp fuse.

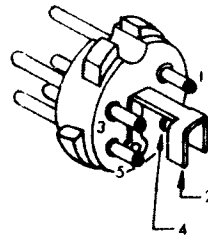

PIN No.	Function
1	-ALC IN
2	GND
3	TX GND
4	GND
5	RX GND

**ACC 1 PLUG CONNECTIONS  
(FOR LINEAR AMPLIFIER)**

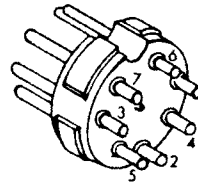

PIN No.	Function
1	CONTROL
2	8V
3	13.5V
4	CONTROL
5	8V
6	RX GND
7	TX GND

**ACC 2 PLUG CONNECTIONS  
(FOR FTV-107R TRANSVERTER)**

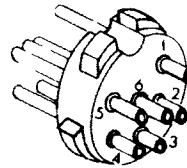

PIN No.	Function
1	EXT VFO IN
2	GND
3	EXT 8V
4	AGC
5	13.5V
6	8V

**EXT VFO PLUG CONNECTIONS  
(FOR FV-107 EXTERNAL VFO)**

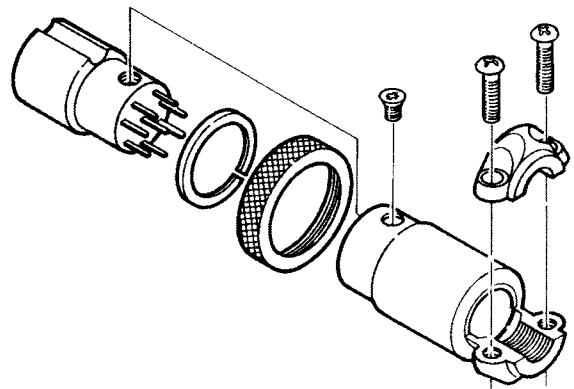

**MICROPHONE PLUG**

# MICROPHONE CONNECTIONS



YM-34

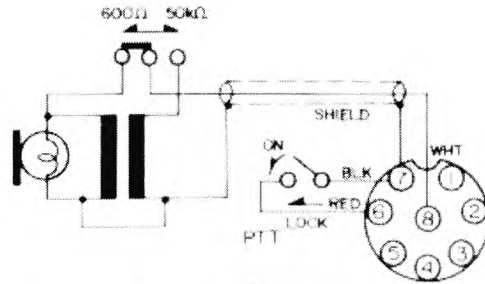

YM-34 MICROPHONE CONNECTIONS



YM-35

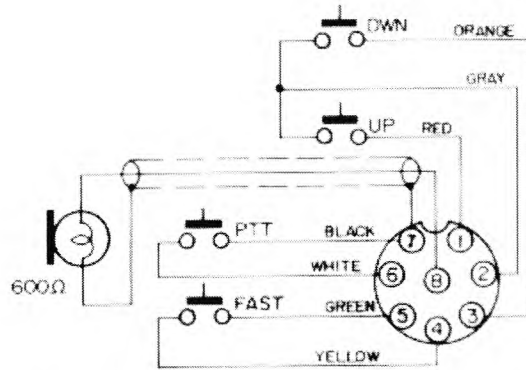

YM-35 MICROPHONE CONNECTIONS



YM-36

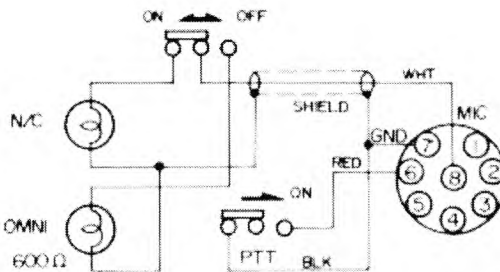

YM-36 MICROPHONE CONNECTIONS



YM-37

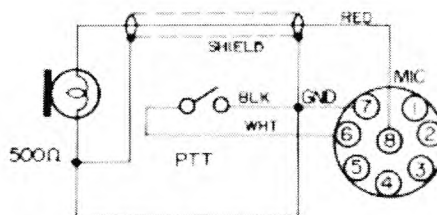

YM-37 MICROPHONE CONNECTIONS

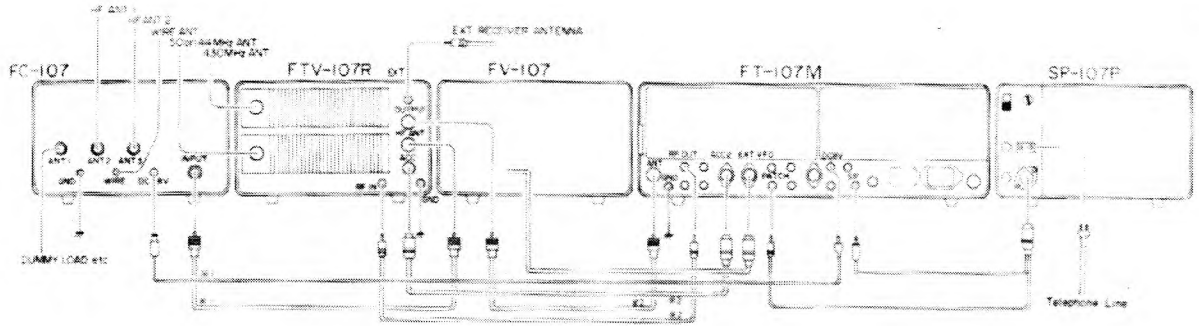
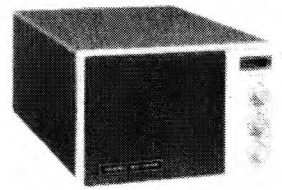
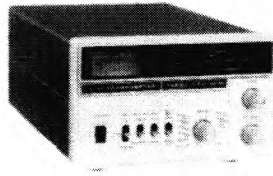
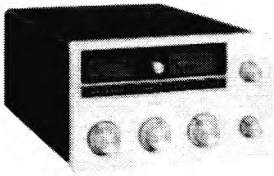

INTERCONNECTIONS

# INSTALLATION

The FT-107M is designed to be a single-unit transceiver for top-performance base station or mobile operation. For operation from AC mains, the optional FP-107 internal power supply or FP-107E external power supply/speaker are available from your Yaesu dealer. Please read the following sections carefully, so as to understand the important steps required for a successful installation.

## PRELIMINARY INSPECTION

Upon opening the packing carton, immediately give the transceiver a thorough visual inspection. Check to see that the controls and switches are all working freely, and inspect the cabinet for any signs of damage. If any damage has been sustained, contact the shipping company immediately, and document the damage completely. Save the packing carton and foam packing material for possible use at a later date.

## BASE STATION INSTALLATION

The FT-107M requires a power supply of 13.5 VDC at 20 amps for proper operation. The FP-107 internal power supply and FP-107E external power

supply/speaker console provide this voltage with excellent regulation. These options are available from your Yaesu dealer.

Before attempting operation of the FP-107 or FP-107E from AC mains, check to see that the voltage specification on the rear of the supply matches your local supply voltage. This inspection **must** be made before applying power to the equipment.

### WARNING

Operation of the FT-107M directly from AC mains, from improper DC voltages, or with an improper fuse shall void the warranty on this equipment. Likewise, operation of the FP-107 or FP-107E from improper voltages or use of an improper fuse shall void the warranty.

Please refer to the power transformer primary connection chart when changing supply voltages.

The transceiver should be connected to a good earth ground. The ground lead should be made of a heavy, braided wire, and should be connected to the GND terminal on the rear apron of the transceiver. The ground wire connection to the station ground buss should not be longer than 10 feet.

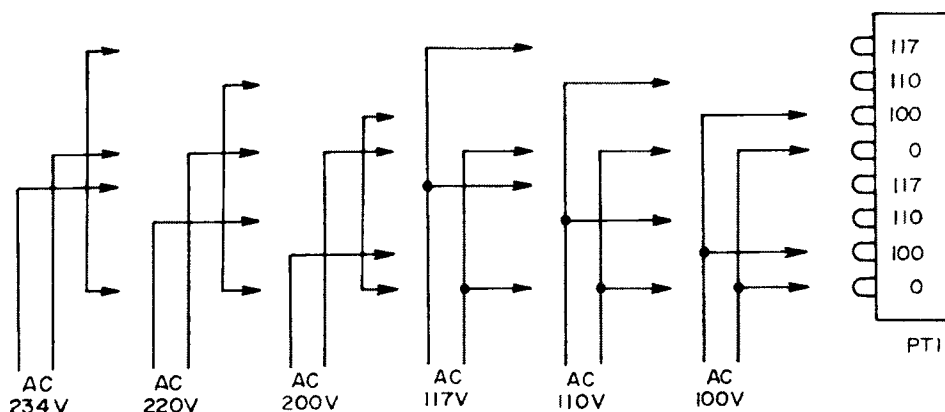

### FP-107 POWER TRANSFORMER PRIMARY CONNECTIONS

\* (Refer to FP-107E manual for transformer information for that model)

### FP-107E Installation

Once the power transformer and fuse inspections have been duly completed, connect the AC cable of the FP-107E to the wall outlet. Insert the DC plug from the FP-107E into the FT-107M rear panel DC 13.5 V jack.

### FP-107 Installation

The internal FP-107 option can be installed in a matter of minutes.

First remove the black covers from the rear panel. One of these covers the PA heat sink, while another covers the empty space to be occupied by the power supply. Remove the top cover of the FT-107M.

Recheck the wiring of the FP-107 transformer primary.

Connect the four pin female connector (red/black) from the FP-107 to P7 (red/black) of the FT-107M. Connect the large two-pin female connector (white/gray) from the FP-107 to P8 (white/gray) of the FT-107M. Connect the smaller 2 pin female connector (yellow pair) to the SENSOR 1 terminal of the CONTROL Unit. Refer to Figure 3 for details.

Slide the power supply rack into the chamber adjacent to the power amplifier stage. Secure the power supply rack using the four bolts marked "A" in Figure 3. Now install the large rear panel cover supplied with the power supply, using the six bolts used for the previous rear panel covers. These bolts are marked "B" in Figure 3.

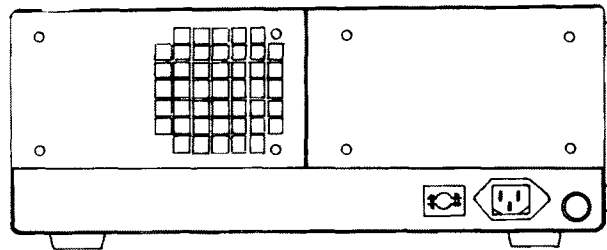

Figure 1  
Rear apron before FP-107 installation

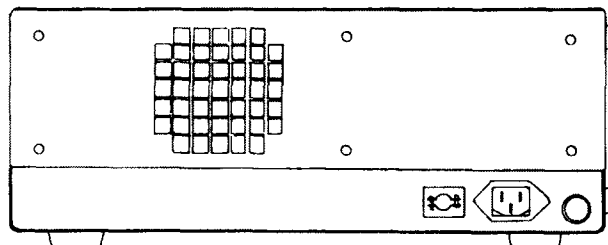

Figure 2  
Rear apron after FP-107 installation

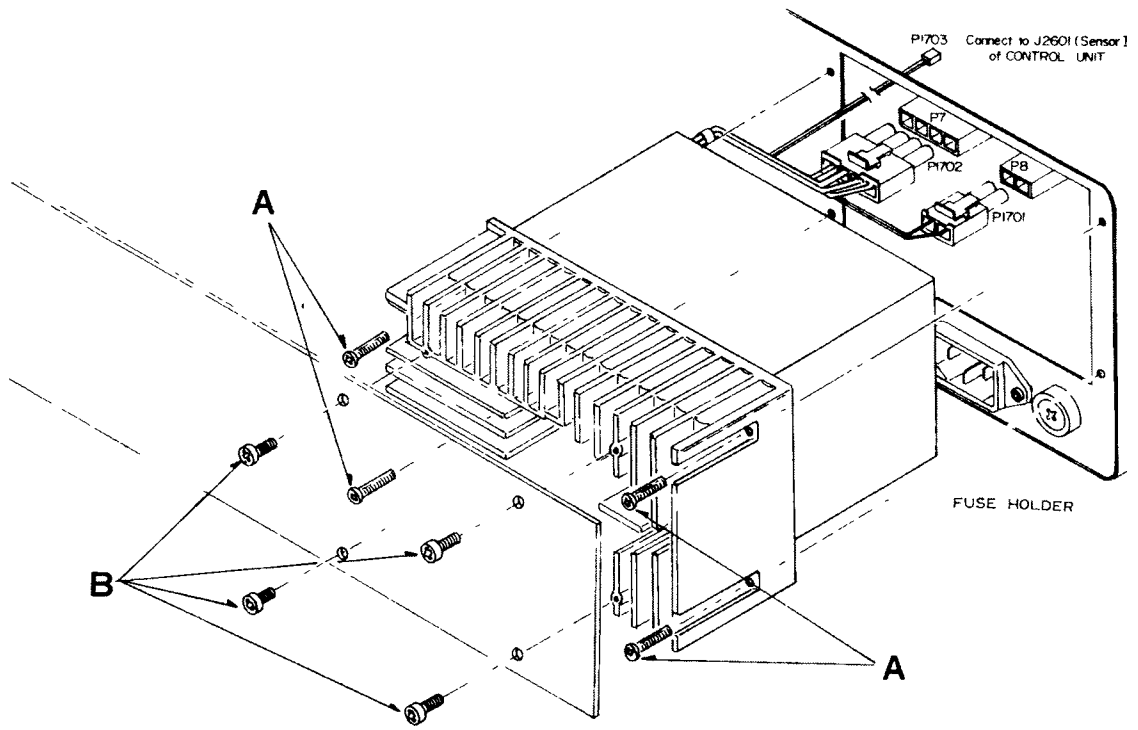

Figure 3

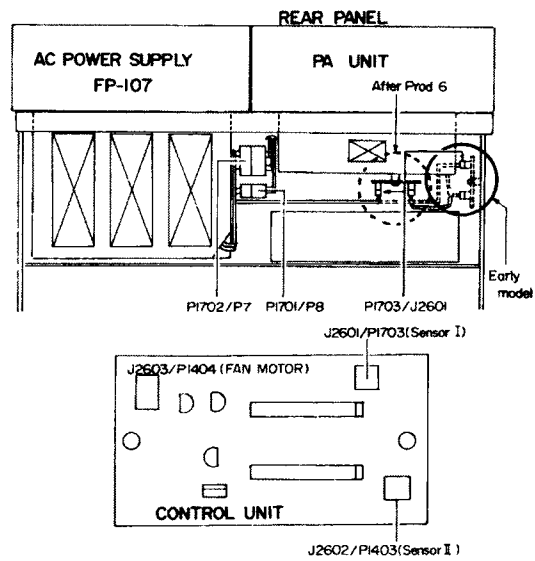

Figure 4

## MOBILE INSTALLATION

The FT-107M is designed for operation from 13.5 volts DC, at 20 amps maximum current on voice peaks. As such, it provides exceptional performance as a mobile station. The DC cable is a standard accessory for the FT-107M.

For under-dash mounting, a special mobile mounting bracket is available from your Yaesu dealer. The FT-107M should be located away from heater ducts, and a minimum of two inches of air space on all sides is recommended, in order to allow proper air flow around the cabinet. Especially critical is the area around the heat sink fan exhaust port.

The DC cable comes equipped with a 20 amp fuse the positive line. Use only a 20 amp fuse in this socket.

When making battery connections, be absolutely certain to observe the proper polarity of the supply voltage. Connect the RED cable lead to the POSITIVE battery terminal, and connect the BLACK lead to the NEGATIVE battery terminal. Reversed connections could cause permanent damage to the transceiver.

### CAUTION

OUR WARRANTY DOES NOT COVER DAMAGE CAUSED BY IMPROPER SUPPLY CONNECTIONS NOR DAMAGE CAUSED BY USE OF AN IMPROPER FUSE.

It is recommended that the power connections be made directly to the battery, instead of to the ignition switch, etc. The battery provides considerable filtering action against ignition noise, while connection to the ignition switch can place the power line in a noisy circuit. Keep the power cable as short as possible, and keep the lead away from ignition cables.

### WARNING

Permanent damage will occur if reversed supply polarity voltage is applied to this transceiver. Our warranty does not cover damage caused by reversed supply polarity.

Before connecting the DC power cable to the transceiver, check the battery voltage with the engine running (battery charging). If the voltage exceeds 15 volts DC, the vehicle voltage regulator should be adjusted, so as to limit the maximum charging voltage to less than 15 VDC. As well, do not operate the transceiver if the DC supply falls below 12 volts. The transceiver should always be turned off when the car is started, to prevent voltage transient from possibly causing damage to the transistor circuits of the radio.

## ANTENNA CONSIDERATIONS

The FT-107M is designed for use into a 50 ohm resistive load. While minor deviations from the 50 ohm figure are of no consequence, the automatic final protection (AFP) circuitry will reduce the power output if high SWR conditions are encountered.

However, your FT-107M AFP circuitry and final amplifier components are tolerant of the minor SWR conditions present in many amateur installations. At an SWR of 3:1, for example, 75% of full rated output power will be obtained.

The Yaesu RSL series of mobile antennas is available from your Yaesu dealer, for mobile installations.



## DIAL CALIBRATION

The FT-107M digital display is a true frequency counter, so no calibration is required. When changing sidebands, the digital display will also change 3 kHz.

### Analog Dial Calibration

#### SSB

- (1) Set the MODE switch to the desired mode, USB or LSB.
- (2) Set the NB/MARK switch to MARK.
- (3) Rotate the VFO dial to the nearest 25 kHz point, as indicated on the digital display. Now align the analog dial skirt so that the bold calibration marking on the skirt is aligned with the vertical calibration point on the subdial window.

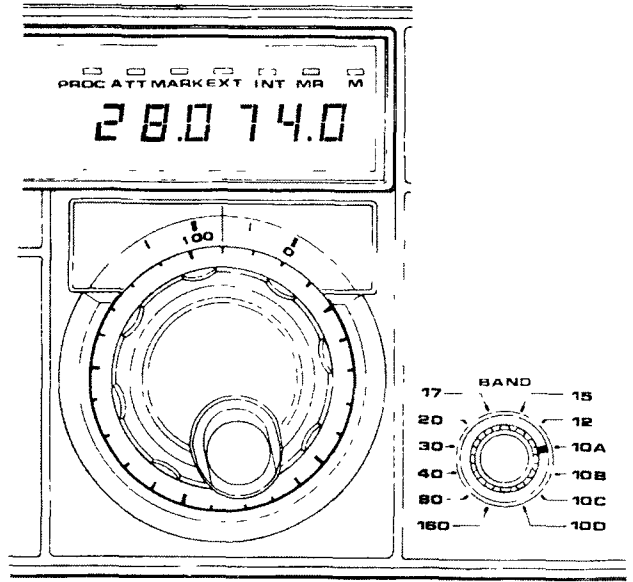

Figure 5.

## BOTTOM PANEL FEET

The feet on the bottom panel may be changed, if it is desired to change the viewing angle for the VFO. In the accessory kit for your FT-107M, there are two extender feet with mounting pads. These may be installed either in front or in back, according to the requirements of your station. Refer to the drawing for mounting details.

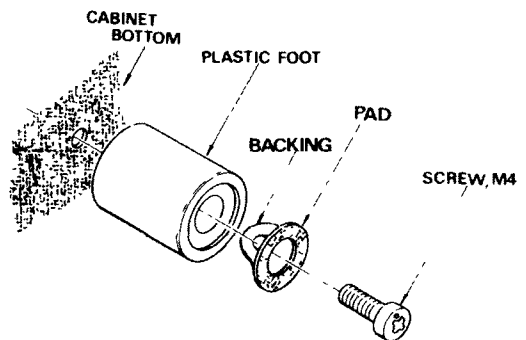

Figure 6.

# OPERATION

The tuning procedure for this transceiver is not complicated. However, care must be exercised when operating this equipment so that peak performance is obtained. The following paragraphs describe the procedure for operating the FT-107M.

## INITIAL CHECK

Before connecting the transceiver to the DC power source, be certain that a fuse of the proper rating is in use. When using the FP-107 or FP-107E AC Power Supply, be certain that the voltage specification for the power supply matches your local AC supply voltage.

## FREQUENCY SELECTION

Frequency selection on the FT-107M is by means of a digital as well as an analog display. The digital display reads the true frequency, with accounting for the carrier frequency. Therefore, no recalibration of the display is necessary when changing modes. The calibrator is chiefly useful for making receiver adjustments.

The digital display allows resolution to 100 Hz, while the analog skirt on the main dial allows 1 kHz. One revolution of the main tuning dial corresponds to a frequency change of 25 kHz. The marker signal may be used to set the 5 kHz marking of the analog dial skirt.

Further coarse frequency determination may be made through the main dial window, which contains a sub-dial calibrated every 50 kHz.

## RECEIVE OPERATION

(1) Connect a 50 ohm antenna to the rear panel ANT jack. Preset the controls and switches as follows:

POWER ..... OFF  
VOX GAIN ..... PTT  
NB ..... Fully counterclockwise  
MODE ..... Desired mode  
WIDTH ..... 12 o'clock position  
AF GAIN . Adjust later for comfortable level  
RF GAIN ..... Fully clockwise  
APF/NOTCH knob ... 12 o'clock position

BAND ..... Desired band  
RX CLAR ..... OFF  
CLARIFIER ..... 12 o'clock position  
M FINE ..... 12 o'clock position  
ATT ..... OFF  
APF/NOTCH switch ..... OFF  
AGC ..... F  
NB/MARK switch ..... OFF  
METER ..... VCC

- (2) Turn the POWER switch ON. The meter lamp and digital display will become illuminated. The meter needle should deflect to within the VCC range at the right side of the meter scale.
- (3) Adjust the AF GAIN control for a comfortable listening level. There is no "preselector" or other peaking required for this receiver, because the preselector networks are all preset.
- (4) When pulse-type noise is encountered, turn the NB switch ON. NOW, rotate the control clockwise until the noise pulses are eliminated. The best setting of the blanker for overall receiver performance is one that just eliminates the noise pulses, without being advanced too far. No noise blanker will eliminate all types of noise, but the FT-107M blanker is a state of the art design that provides significantly improved blanking capability over earlier designs.
- (5) For varying the width of the IF passband, rotate the width control. In the IF, two 8-pole crystal filters are used. One filter is fixed, and presents a boundary for the bandwidth. The center frequency of the IF is then varied across the passband of the second filter, using a mixing technique that results in no change of pitch on the received signal.

The result is continuously variable bandwidth, from 2.4 kHz down to approximately 300 Hz. This system is highly effective in eliminating high-pitched "buckshot" on SSB, as well as interfering CW signals.

The WIDTH system is defeated during AM operation, and the received signal bypasses the second IF filter.

- (6) Under conditions of very heavy QRM, while operating CW, the APF (Audio Peak Filter) may be activated. Switch the APF/NOTCH lever to APF, and tune the APF/NOTCH control for maximum enhancement of the desired signal. The operator will observe that the background noise will be reduced dramatically, resulting in excellent signal to noise ratio.
- (7) For elimination of an interfering carrier within the AF passband, set the APF/NOTCH switch to NOTCH. Then rotate the APF/NOTCH control carefully for the best nulling of the offending carrier. The notch is extremely sharp, so tuning is critical, but the excellent notch depth is extremely effective in eliminating interference.
- (8) The RX CLARIFIER may be used if the incoming signal is drifting. Press the RX CLAR button, and rotate the CLARIFIER control, to activate the receiver offset tuning. The TX button may be pushed to allow offset of the transmit frequency, and both the TX and RX buttons may be pushed together to allow offsetting of the transceiver frequency from the dial frequency.
- (9) AGC time constant setting may be accomplished by setting the AGC switch for the desired recovery time, slow or fast. The AGC system may also be defeated by setting this switch to OFF.
- (10) For extremely strong signals, a 20 dB attenuator may be switched into the incoming receive line. Set the ATT switch to ON for this purpose.

## TRANSMITTER OPERATION

The FT-107M transmitter is extremely easy to use, requiring only presetting of the controls and switches. No tuning procedure, other than an initial setting of the mic gain and RF processor level, is required.

When transmitting, it is important that you always have a dummy load or matched antenna connected to the antenna jack. The automatic final protection unit will reduce power if an improper load is connected.

When transmitting, **never** change the position of the MODE, BAND, nor the SELECT switch. It is possible for the final amplifier transistors to be damaged by transients generated by this kind of abuse. Please follow this simple precaution without fail.

The FT-107M contains a heat-sensing protection circuit for the final amplifier. Do not transmit at full power (e.g. key-down CW) for more than 30 seconds. If you have been key down for a 30 second period, we recommend two minutes of standby operation to allow the final transistors to recover to normal operating temperature.

The following paragraphs describe transmitter operation. If our guidelines are followed, the FT-107M will provide many years of trouble-free operation.

## PRELIMINARY CHECKS

- (1) Preset the controls and switches as follows.
  - VOX GAIN ..... PTT position
  - FWD SET ..... 12 o'clock position
  - MIC GAIN ..... Fully counterclockwise
  - DRIVE ..... Fully counterclockwise
  - COMP ..... Fully counterclockwise
  - MODE ..... FSK
  - DIAL ..... Desired frequency
  - BAND ..... Desired band
  - SELECT ..... VFO
  - TX CLAR ..... OFF
  - PROC ..... OFF
  - METER switch ..... IC
- (2) Connect a matched antenna to the antenna jack.
- (3) Set the VOX GAIN control to MOX.

- (4) Advance the DRIVE control so that the IC reading on the meter reaches exactly 10 amperes.
- (5) Set the METER switch to FWD, and adjust the FWD SET control so that the meter needle is aligned with the FWD SET position on the meter scale.
- (6) Set the METER switch to REF. The meter needle should be within the REF scale area for full power operation. The REF area covers SWR readings of up to 2 : 1, the area which will result in essentially no reduction in power output. If the needle rests above the REF area, remedial work on your antenna system may be in order. Alternatively, the FC-107 Antenna Coupler may be used to provide a 50 ohm load for your transceiver.
- (7) For the above test procedure, please be sure to check the frequency before transmitting. Also, use the minimum power necessary to obtain a full scale reading on the FWD SET step. If less than 10 amps of IC will provide this reading, by all means use the lower power level.

## SSB OPERATION

- (1) Connect your microphone to the front panel MIC jack.
- (2) Preset the controls and switches as follows:  
MODE . . . . . Desired mode, LSB or USB  
METER switch . . . . . ALC  
MIC GAIN . . . . . 10 o'clock position  
DRIVE . . . . . Set for full output
- (3) Close the microphone PTT switch, and speak into the microphone in a normal voice. Adjust the MIC GAIN control so that the ALC meter needle does not go beyond the ALC range of the meter. With the meter switch set to IC, the reading on voice peaks will be roughly 5 amps, or about 1/3 to 1/2 of the full power single-tone meter reading.
- (4) To adjust the RF speech processor, place the PROC switch ON. Speak into the microphone in a normal voice, and do not change the MIC GAIN setting performed in step (3). Advance

the COMP control to the 10 o'clock position, and adjust the DRIVE control so that the ALC meter needle does not go beyond the ALC range of the meter. Now adjust the COMP control with the meter switch set to COMP; the meter should indicate between 5 and 10 on the COMP scale during voice peak conditions.

While some initial adjustment of the MIC GAIN, COMP, and DRIVE control may be required, be careful not to overdrive the transmitter, for best spectral purity. When speaking into the microphone in a long syllable (such as the word "four"), do not advance the DRIVE control beyond the point where the IC or forward power reading ceases to increase.

- (5) To set the VOX circuitry, advance the VOX GAIN control on the front panel so that your voice activates the transmitter. The rear panel DELAY control will allow the operator to set the VOX time constant for the desired hang time after you have finished speaking. The ANTITRIP control, VR<sub>4003</sub>, is located on the IF Unit, and it may be adjusted as necessary to prevent the speaker output from activating the VOX. Do not use more VOX GAIN nor ANTITRIP than necessary.

## CW OPERATION

- (1) Insert your key plug into the rear panel KEY jack. Key up voltage is 7 VDC, and key-down current is 1.5 mA, so most all electronic keyers will work without modification with the FT-107M.
- (2) If you use a footswitch, connect its plug to the rear apron PTT jack.
- (3) Set the MODE switch to CW-W or CW-N, and set the VOX GAIN control to PTT.
- (4) Activate the transmitter (close the footswitch or set the VOX GAIN control to MOX), and go key down. Adjust the DRIVE control for the desired power input, up to a maximum reading of about 18A on the IC meter.

- (5) For semi-break-in operation, advance the VOX GAIN control to the point where the VOX relay is activated by the sidetone audio signal. The DELAY control, located on the rear panel, may be adjusted to control the VOX relay hang time.
- (6) For QRP operation, reduce the level set by the DRIVE control. The power output may be reduced to 0 watts, if desired.

### FSK OPERATION

The FT-107M is designed for 170 Hz FSK operation.

- (1) Connect the lead from your terminal unit to the rear panel FSK jack.
- (2) Set the MODE switch to FSK, and set the VOX GAIN control to MOX. Advance the DRIVE control for a reading of 5 amps on the IC meter. Do **not** operate the FT-107M on FSK at the same power levels as stipulated in the sections regarding SSB and CW operation.
- (3) The keying signal from your terminal will now activate the FT-107M transmitter. When using the optional CW filter, the CW filter will automatically be selected during FSK operation.

### AM OPERATION

- (1) Set the MODE switch to AM, the METER switch to IC, and rotate the MIC GAIN and DRIVE controls fully counterclockwise.
- (2) Close the microphone PTT switch, and advance the DRIVE control until the reading on the IC meter reaches 5 amps.
- (3) Speak into the microphone in a normal voice, and advance the MIC GAIN control until a slight downward deflection of the IC meter is noted on voice peaks. Do not advance the MIC GAIN control too far, as any excess energy above that required for full modulation will be wasted in spurious emissions.
- (4) In the AM mode, the RF speech processor and variable IF bandwidth control are not usable.

### SELECT SWITCHES/MEMORY OPERATION

(Note: The memory unit is an available option for the FT-107M)

Frequency control on the FT-107M is by means of the internal VFO, the memory and DMS circuitry, an external VFO (such as the FV-107), or various combinations of the three. The SELECT switch will determine the circuitry in control of each mode, and the selection procedure is described below:

VFO	This position selects TX/RX operation on the FT-107M internal VFO.
MR	This position selects TX/RX operation on the FT-107M memory system.
RX MR	This position selects RX operation on the memory, with TX operation on the FT-107M internal VFO.
TX MR	This operation selects TX operation on the memory, with RX operation on the FT-107M internal VFO.
EXT	This position selects TX/RX operation on the FV-107 external VFO.
RX EXT	This position selects RX operation on the FV-107, with TX operation on the FT-107M internal VFO.
TX EXT	This position selects TX operation on the FV-107, with RX operation on the FT-107M internal VFO.

In addition, changing of and offset from memory channels is controlled from the front panel. The controls of interest are as follows:

M	This button is used to store a frequency in memory.
M SFT	This button activates the DMS circuit.
RX CLAR	This button selects offset tuning of the receive frequency during VFO or memory operation.
TX CLAR	This button selects offset tuning of the transmit frequency during VFO or memory operation.
T/R CLAR	When both buttons are pushed, offset tuning of the transceive frequency is provided.

M FINE	The memory fine tuning control provides a very fine tuning adjustment for memory channels. The available offset range is approximately $\pm 500$ Hz, making this control ideal for tuning between the 100 Hz DMS steps.
M SFT (knob)	The Digital Memory Shift (DMS) circuitry is controlled by the M SFT knob. When a memory channel is programmed, and the M SFT button is pushed, the memory frequency can be shifted up or down in 100 Hz steps, up to and slightly beyond the 500 kHz limits of the normal VFO range.
M CH	The memory channel selector chooses the desired memory channel.

## TYPICAL MEMORY OPERATION

Operation of the memory system and DMS circuitry is perhaps best described by the use of several examples. Following the examples, some advanced programming techniques will be discussed.

- (1) You are operating on a net on 3970 kHz and must QSY down 10 kHz to handle a piece of traffic. With the SELECT switch set to VFO, set the main tuning dial to 3970 kHz. Press M to memorize 3970 kHz in the desired memory channel. Now move the main dial down to 3960 kHz to handle the message. When finished, set the SELECT switch to MR for instant return to 3970 kHz, the net frequency. For return to 3960 kHz, again select VFO.
- (2) You are operating split frequency on 40 meter phone, and you hear DX1DX on 7090 kHz, listening for calls on 7205 kHz. With the SELECT switch on VFO, tune to 7090 kHz, and press M to store that frequency in channel 1. Now turn the main dial to 7205 kHz, and set the SELECT switch to RX MR; you will now be listening on 7090 kHz, while transmitting on 7205 kHz. To listen to the pile-up of stations on 7205 kHz calling DX1DX, set the SELECT switch to VFO; you will now be listening on 7205 kHz.

If DX1DX starts to drift, press the RX CLAR button, and use the clarifier. Alternatively, for slight drifting, use the M FINE control. If DX1DX decides to QSY 10 kHz, press the M SFT button, and rotate the M SFT control to the new frequency (e.g. 7080 kHz). The M SFT control will not affect the transmit frequency, because the SELECT switch is set to RX MR, and control of the transmit frequency is by the VFO.

- (3) You find DX1DX on 21270 kHz, working stations by order of call area. You also find DX0AA on 14145 kHz, listening on 14205 kHz, also by call area. The memory and no tune-up capability make this situation easy to cover.

First, tune to 21270 kHz on the VFO, set the M CH switch to 1, and press M. Now, set the bandswitch to 14 MHz, and the dial to 14145 kHz. Set the M CH switch to 2, and press M. Now move the main dial to 14205 kHz.

To check DX0AA's frequency (14145 kHz), set the SELECT switch to RX MR. To check DX1DX's frequency, set the bandswitch to 21 MHz and the M CH switch to 1. If DX1DX is acknowledging your call area, set the SELECT switch to MR and call him. To recheck DX0AA, set the bandswitch to 14 MHz, and the M CH switch to 2. If DX0AA is listening for your call area, switch to RX MR for RX on 14145 Hz and TX on 14205 kHz.

Because there is no "preselector tuning" control, nor any transmitter peaking whatsoever, it may be seen that several stations on different bands may be checked in a matter of seconds, without touching a VFO dial.

## NOTES ON DMS OPERATION

The DMS control will allow offsetting of the memory frequency in 100 Hz steps. Every several steps, however, a slight momentary “chirp” in the memory frequency may be observed. This is caused by a relocking of the memory circuitry during shift operation, and it is entirely normal. The “chirp” lasts only a small fraction of a second, and no frequency stability whatsoever will result on that “step”. The design technique that produces the brief “chirp” also ensures clean local oscillator operation, important for good dynamic range of the receiver.

When you turn on the M SFT button, perform a shift using the M SFT knob, then turn the M SFT button OFF, the memory will return to the original memory frequency. However, when you push the M SFT button on again, you will **not** return to the previous shift frequency; you will start on the original memory frequency, and a new shift must be programmed. An alternative solution is shown in the “Advanced Programming of Memory Channels” section, below.

When using the M SFT control, it will frequently be useful to use the M FINE control for tuning between the 100 Hz steps, especially on CW. The M FINE control should, otherwise, be set to the 12 o'clock position. When a frequency is stored in memory, then recalled, the M FINE control shifts the memory frequency based on the position of the M FINE control at the time of frequency entry. Therefore, one can see that the offset capability of the M FINE control will be reduced if it is not preset to the 12 o'clock position.

## ADVANCED PROGRAMMING OF MEMORY CHANNELS

The parallel storage system used in the FT-107M memory allows a degree of flexibility not found in other memory systems: the ability to program a new memory frequency having shifted an earlier memory frequency. An example will show how this technique can be used to good advantage.

Let us say that DXØAA is transmitting on 14195 kHz, tuning between 14225 and 14250 kHz; watching DXØAA's operating practice, you notice that he listens for stations at 5 kHz intervals within the above range. Here's how to proceed:

Tune the main dial to 14195 kHz, set the M CH switch to 1, and push M. Now set the SELECT switch to RX MR, and press the M SFT button. Rotate the M SFT knob until you find the station DXØAA is working on 14225 kHz (check the transmit frequency of DXØAA instantly by switching the SELECT switch to VFO to follow the calling sequence). Now set the M CH switch to 2, and press M. If the next QSO is with a station on 14230 kHz, rotate the M SFT knob again to that frequency, set the M CH switch to 3, and press M. Follow this sequence until you have DXØAA's favored listening frequencies in memory. Now you can switch to TX MR, turn M SFT OFF, and select the memory channel corresponding to the most likely listening frequency for DXØAA, because 14225 kHz, 14230 kHz, 14235 kHz, etc. will all have been stored in successive memory channels. Use the transmit clarifier, if desired, to make a minor change in a frequency.

You may continue to shift off of any memory channel, and use it to program a new memory channel, up to the limit of 12 total memory channels. This technique can also be used to advantage when operating on a net, if you want to store and check several frequencies without leaving the net frequency (on the VFO).

## SCANNING OPERATION WITH YM-35 MICROPHONE (OPTION)

The YM-35 scanning microphone (option) can be used to provide up/down scanning, as well as scanning speed control, for convenient operation. The YM-35 can only be used with a memory-equipped FT-107M, because it depends on the memory system for its scanning capability.

First, program any memory frequency as a starting point. Now set the M SET button to ON, and press the UP or DN scanning button on the YM-35. For as long as you hold the UP or DN switch down, scanning will occur. Release the scanning switch to stop the scan.

To activate the fast scanning feature, press both the UP or DN switch and the FAST switch. Release both switches for stopping of the scan.

## CW/AM FILTER (OPTION) INSTALLATION

- (1) Remove the top case by removing the mounting screws, as shown in Figure 9.
- (2) Remove the FILTER Unit from its mounting position, shown on page 23.
- (3) For CW filter installation, remove jumpers "B" from the foil side of the board. For AM filter installation, remove the jumpers marked "A" in Figure 7.
- (4) Mount the filter to be installed in the position shown in Figure 7. The CW filter is mounted using a nut, lockwasher, and spring washer. The nut should be tightened so that it is snug, but excessive torque should not be applied. Refer to Figure 8 for mounting details.
- (5) When the CW filter is installed, the CW-W position will select CW operation using the SSB filter, while the CW-N position will select operation using the CW filter. The CW filter will also be switched into the line for FSK operation.

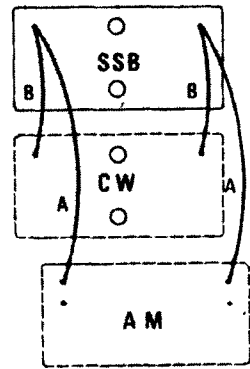

Figure 7.

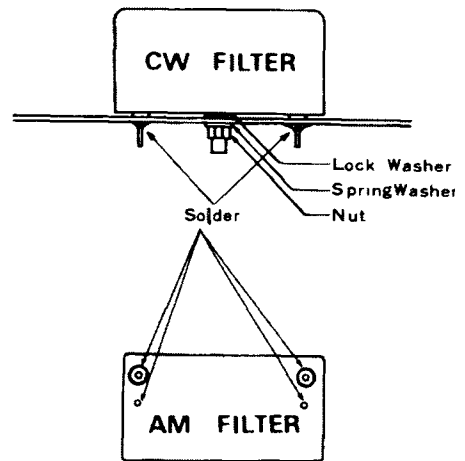

Figure 8.

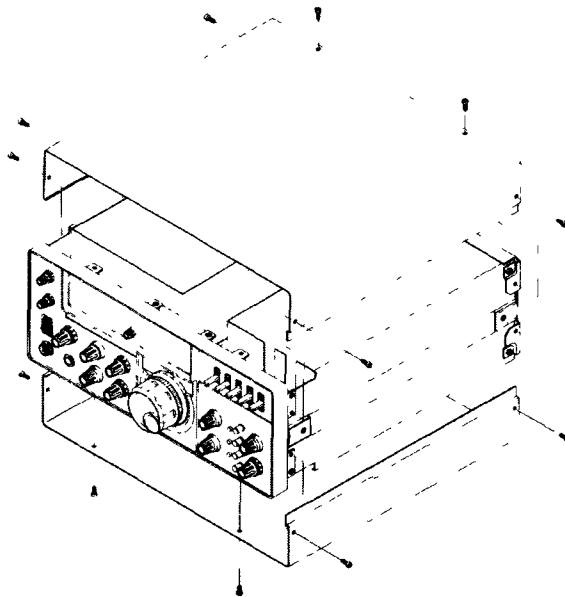

Figure 9



## INSTALLATION OF DMS UNIT AND MEMORY BACKUP BATTERIES (OPTION)

Installation of the DMS unit is easily accomplished in minutes. There are no soldered connections required for this installation.

Remove the top cover of the transceiver, as shown in Figure 9.

Install the DMS Unit in the position shown in Figure 10. Do not force the connection, but gentle pressure will easily seat the circuit board in its edge connector. Secure the circuit board with the two nuts provided.

The holder for the optional backup battery should be installed in the position shown in Figure 10. Connect the battery connector to the battery holder. "AA" size penlight cells (two required) may then be used to activate the memory backup feature (batteries not supplied). Be certain to observe the proper polarity of the batteries before connecting the connector to the battery holder.

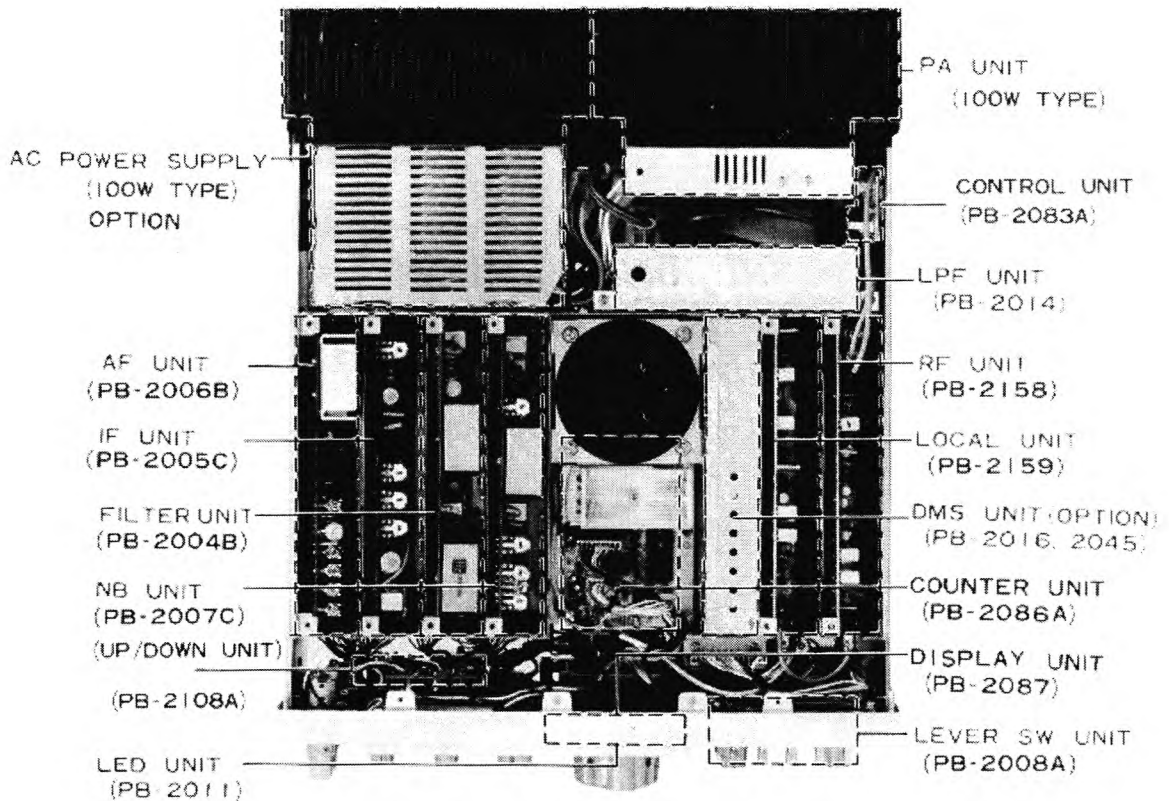

TOP VIEW

Figure 10

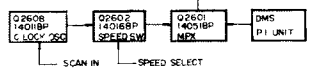
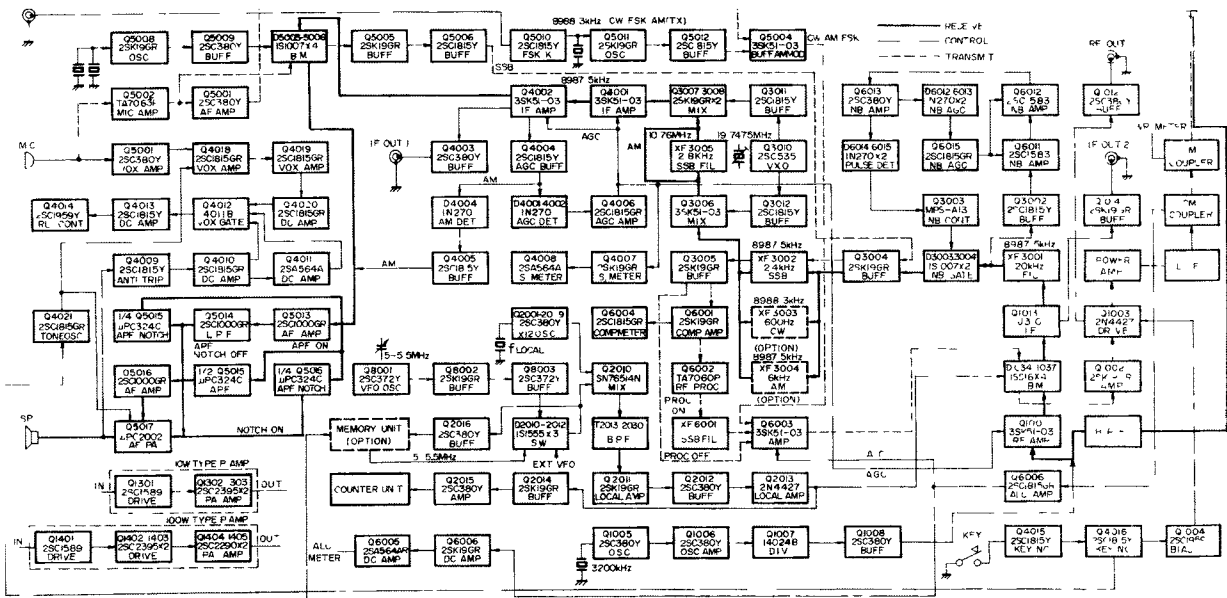

FLOCAL

160m	15 9845MHz	10mA	42 4875MHz
80m	17 9845MHz	10mB	42 9875MHz
40m	21 4845MHz	10mC	43 4875MHz
30m	24 4875MHz	10mD	43 9875MHz
20m	28 4875MHz		
17m	32 4875MHz		
15m	34 4875MHz		
12m	38 9875MHz		

**FT-107 Series  
BLOCK DIAGRAM**

## CIRCUIT DESCRIPTION

The block diagram, and the following circuit description, should provide you with a better understanding of the design of the FT-107M. Refer to the schematic diagram for specific component details.

### RECEIVER

The RF signal from the antenna is passed through antenna relay RL<sub>2</sub>, lamp fuse F<sub>1801</sub>, a high-pass filter ( $f_c = 1.7$  MHz), and delivered to the RF Unit via the RF Mother board.

### RF UNIT (PB-2158)

The RF signal is amplified by RF amplifier Q<sub>1001</sub> (3SK51-03), a dual-gate MOSFET with superior linearity and low noise figure. The input and output of the RF amplifier are protected by preset bandpass filter networks for each band, for protection against strong out-of-band signals. The RF signal is then fed to the first mixer, D<sub>1034</sub> – D<sub>1037</sub> (1SS16), a Schottky-barrier doubly-balanced mixer, for excellent intercept characteristics. The RF signal is mixed with a local signal delivered from the LOCAL Unit, resulting in a 8.9875 MHz first IF. The IF signal is then amplified by Q<sub>1010</sub> (J310) and delivered to the FILTER Unit.

### FILTER UNIT (PB-2004)

The IF signal at pin 38 of the FILTER Unit is passed through a monolithic filter, XF<sub>3001</sub>, which has a 20 kHz bandwidth, providing protection from in-band IMD while allowing a wide bandwidth for noise blanking. Noise blanker diodes D<sub>3003</sub> and D<sub>3004</sub> are placed between T<sub>3003</sub> and T<sub>3004</sub>, and they function as an on/off switch controlled by noise blanker driver Q<sub>3003</sub> (MPS-A13); the necessary delay time for matching the noise pulse to the blanking signal is provided by XF<sub>3001</sub>.

The IF signal then undergoes an impedance transformation at source follower Q<sub>3004</sub> (2SK19GR), and is passed through the SSB filter XF<sub>3002</sub> (or the optional AM or CW filters). Selection of the filter to be used is performed by one of diode switches D<sub>3004</sub> – D<sub>3013</sub> (1S1007), depending on the mode of operation.

The IF signal is then fed to gate 1 of the IF first mixer, Q<sub>3006</sub> (3SK51-03), where the IF signal is heterodyned with a 19.7475 MHz  $\pm \Delta f$  local signal delivered from crystal oscillator Q<sub>3010</sub> (2SC535A) and buffer amplifier Q<sub>3012</sub> (2SC1815Y), resulting in a signal of 10.75 MHz  $\pm \Delta f$ . The new 10.76 MHz signal is passed through crystal filter XF<sub>3005</sub>, and delivered to IF second mixer Q<sub>3007</sub>/Q<sub>3008</sub> (2SK19GR), where the filtered signal is heterodyned with the 19.7475  $\pm \Delta f$  local signal delivered from Q<sub>3001</sub> (2SC1815Y), producing an 8.985 MHz IF signal, the same as the original IF.

This process varies the 10.76 MHz IF signal across the passband of XF<sub>3005</sub>, without producing a change in the main 8.9875 MHz IF. The combination of filters XF<sub>3002</sub> and XF<sub>3005</sub> provides continuously variable width of the IF passband. The frequency of crystal oscillator Q<sub>3001</sub> is controlled by varactor diode D<sub>3025</sub> (1S2209).

In the AM mode, the IF signal is passed through diode switches D<sub>3021</sub> and D<sub>3022</sub> (1S1007), and does not pass through XF<sub>3005</sub>.

### IF UNIT (PB-2005)

The IF signal from pin 3 is amplified by Q<sub>4001</sub> and Q<sub>4002</sub> (3SK51-03), and immediately fed to pin 18, for delivery to the AF Unit.

In the AM mode, the IF signal is coupled from the drain of Q<sub>4002</sub> via C<sub>4016</sub> to buffer amplifier Q<sub>4004</sub> (2SC1815Y). From there, the signal is fed to AM detector diode D<sub>4004</sub> (1N270), and delivered, through buffer Q<sub>4005</sub> (2SC1815Y), to the AF Unit.

A portion of the output from Q<sub>4004</sub> is rectified by D<sub>4001</sub> and D<sub>4002</sub> (1N270), producing a DC voltage for AGC purposes. The AGC voltage is amplified by Q<sub>4006</sub> (2SC1815GR) and fed to gate 2 of the RF and IF amplifiers, controlling the gain of those stages. When the AGC switch is turned OFF, the RF GAIN control provides a manual means of controlling the gains of those stages, so that gain control is never lost.

The AGC signal is further amplified by Q<sub>4007</sub> (2SK19GR) and Q<sub>4008</sub> (2SA564A) for signal strength indication on the front panel S-meter.

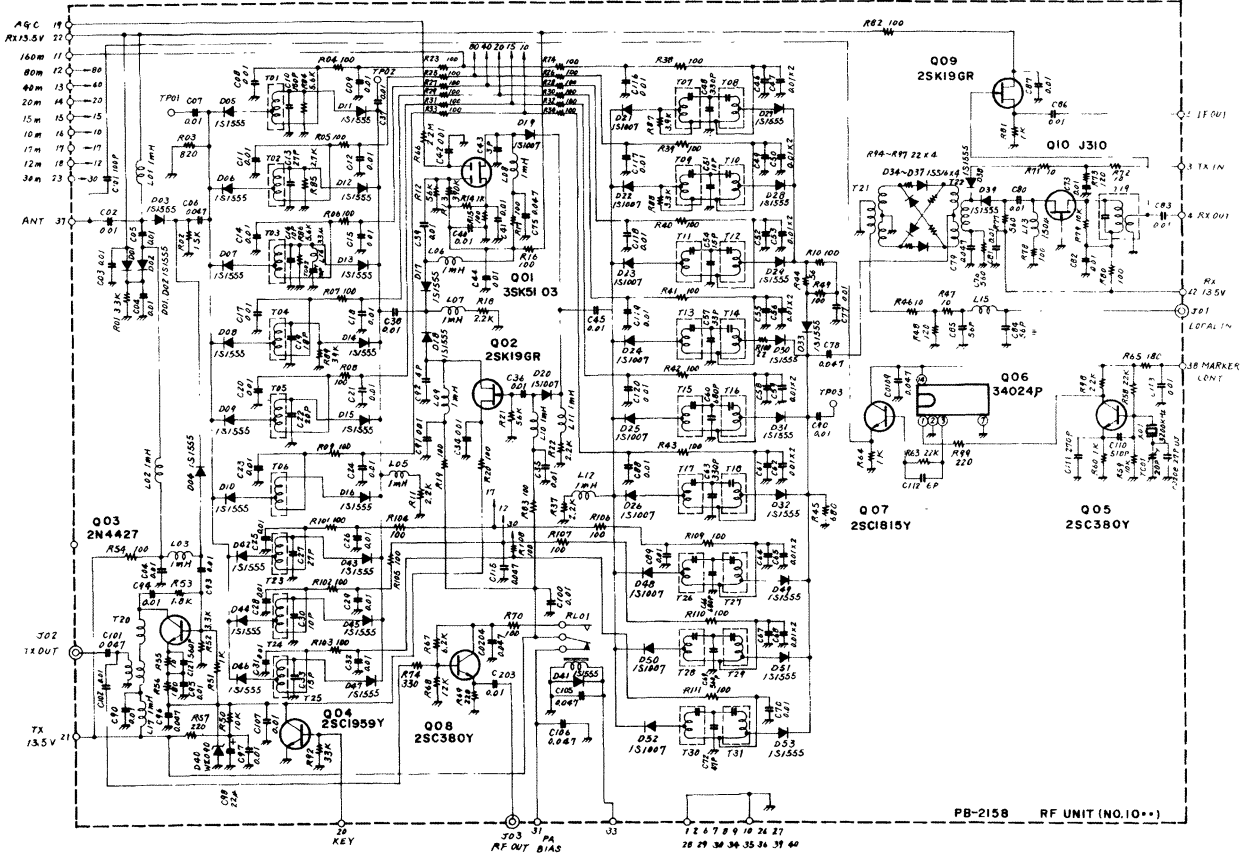

PB-2158 RF UNIT (NO.10..)

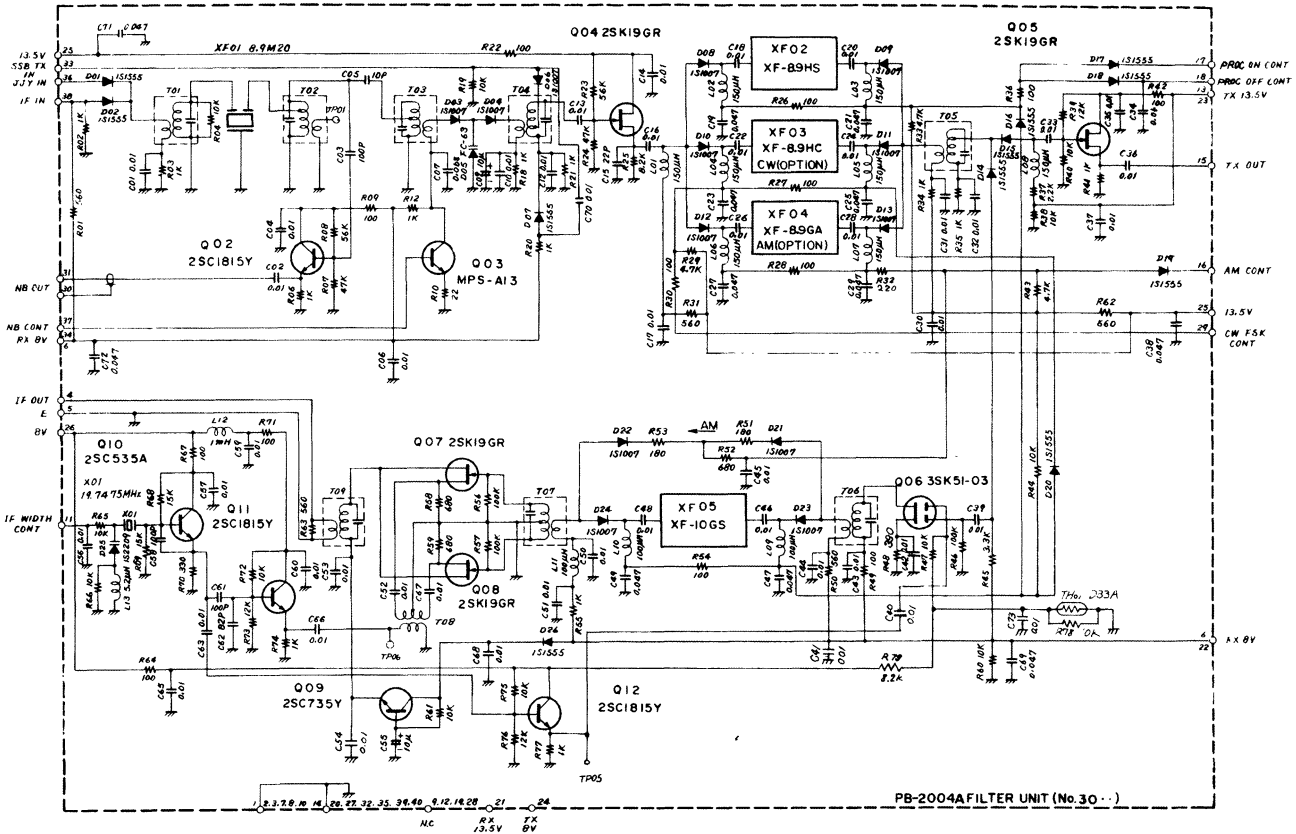

PB-2004A FILTER UNIT (No. 30)

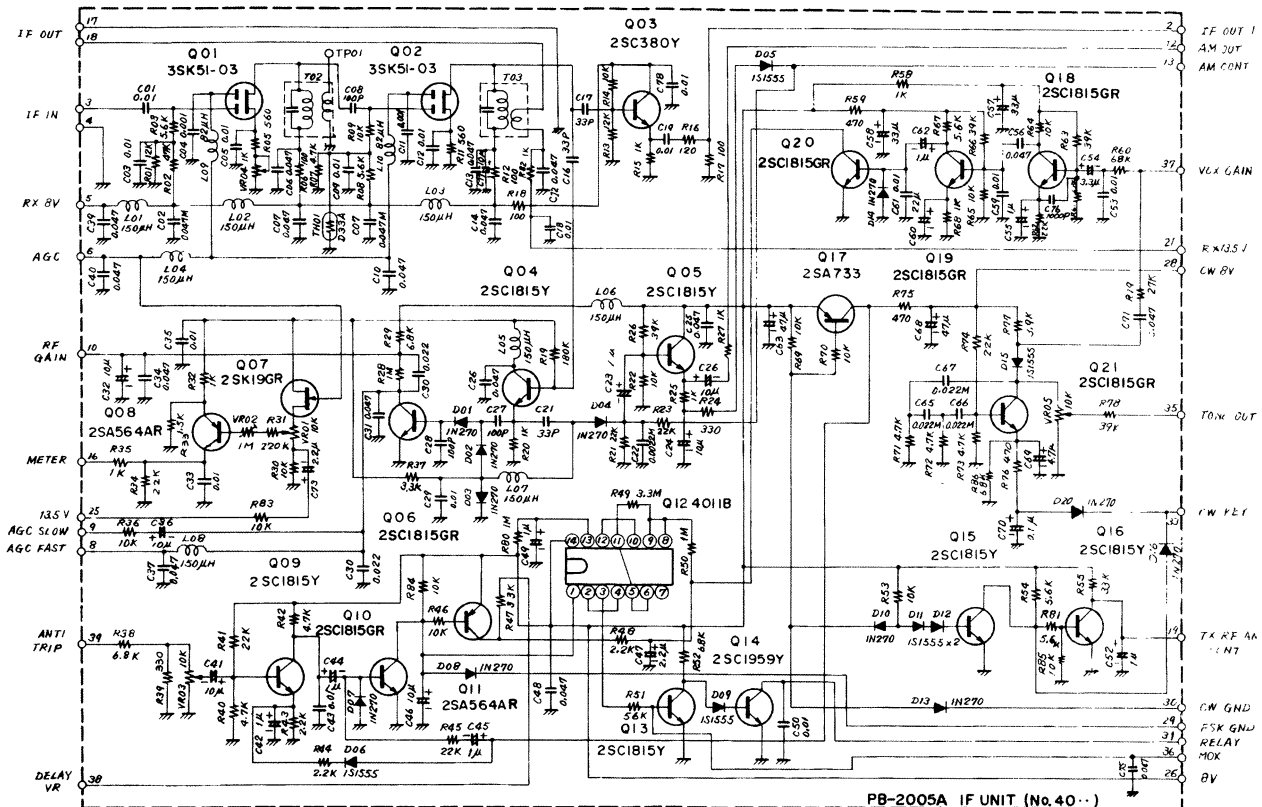

PB-2005A IF UNIT (No. 40...)

PB-2006A AF UNIT (No. 50...)

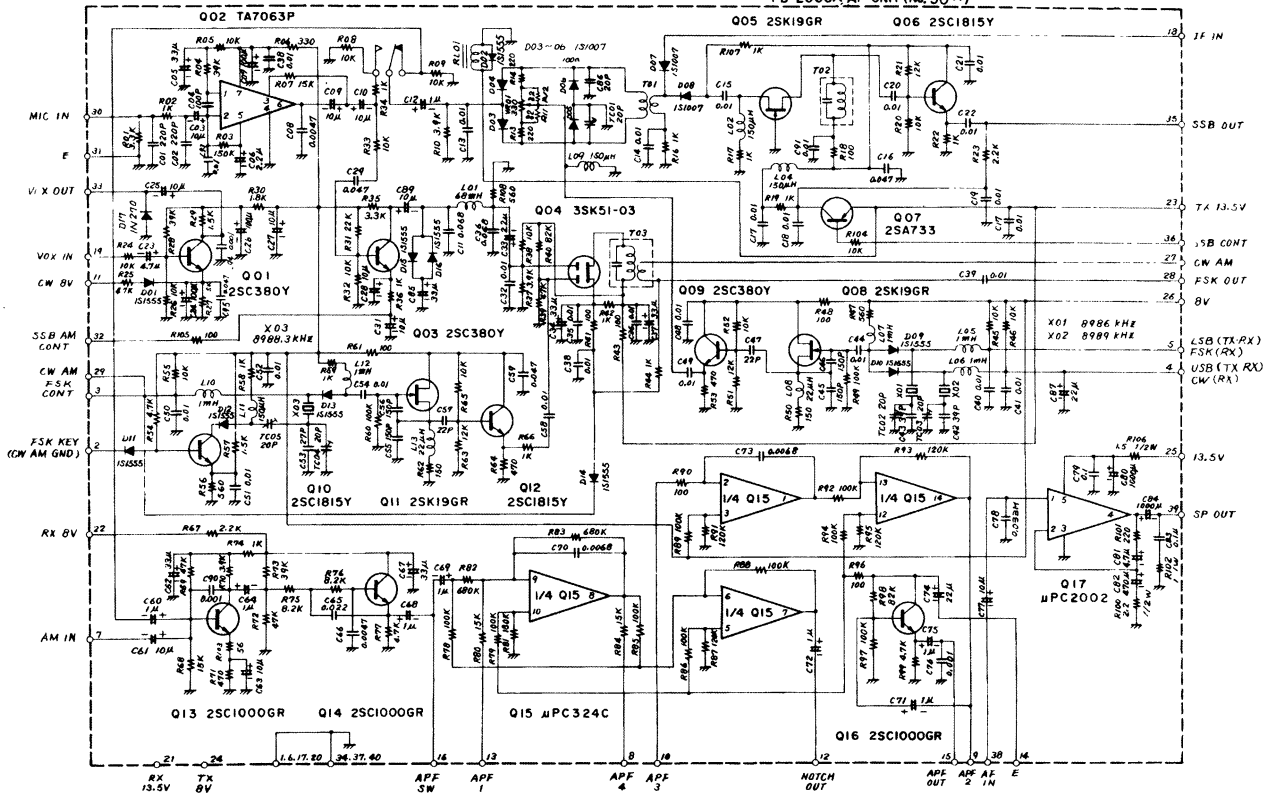

## AF UNIT (PB-2006)

The incoming SSB/CW/FSK IF signal is fed through diode switch  $D_{5007}$  (1S1007), and delivered to the ring demodulator, consisting of  $D_{5003}$   $D_{5006}$  (1S1007), which demodulates the IF signal into audio using the carrier signal delivered from  $Q_{5009}$  (2SC380Y).

The carrier oscillator,  $Q_{5008}$  (2SK19GR), oscillates at 8986 kHz for LSB and FSK, and at 8989 kHz for USB and CW. Diode  $D_{5009}$  (1S1555) conducts to activate  $X_{5001}$  for LSB/FSK, while  $D_{5010}$  (1S1555) conducts to activate  $X_{5002}$  for USB/CW. The carrier signal from  $Q_{5008}$  is amplified by  $Q_{5009}$  for delivery to the ring demodulator.

The audio output from the ring is amplified by  $Q_{5016}$  and  $Q_{5017}$  (2SC1000GR), and delivered through the APF/NOTCH switch and AF GAIN control  $VR_{2a}$  to the audio output amplifier,  $Q_{5017}$  ( $\mu$ PC 2002H), which delivers 3 watts of audio output to the speaker. The audio spectrum is shaped at  $Q_{5014}$  by a low pass filter of  $f_o = 2.7$  kHz,  $-12$  dB/octave.

Operational amplifier  $Q_{5015}$  ( $\mu$ PC324C) is placed in the audio circuit by the APF/NOTCH switch on the front panel. For APF operation, a selective active filter is formed by two sections of  $Q_{5015}$ , and the output is amplified by  $Q_{5016}$  (2SC1000GR) prior to delivery to  $Q_{5017}$ . Two sections of  $Q_{5015}$  are also used for the high-Q notch filter.  $VR_3$  provides for adjustment of the center frequency of the audio peak and notch filters.

In the AM mode, the output from buffer  $Q_{4005}$  is fed to the base of  $Q_{5013}$  for amplification, in the same way as the signals on the other modes.

## PROTECTOR UNIT (PB-2146)

The incoming RF signal is fed to a 1.7 MHz high-pass filter through a lamp fuse which protects the RF amplifier and mixer against extremely strong signals. This signal is then fed to the RF Unit.

If an excessive current flows through the Power Amp Unit,  $Q_{1802}$  (2SA733) will act to reduce the drive level and to protect the Power Amp Unit.

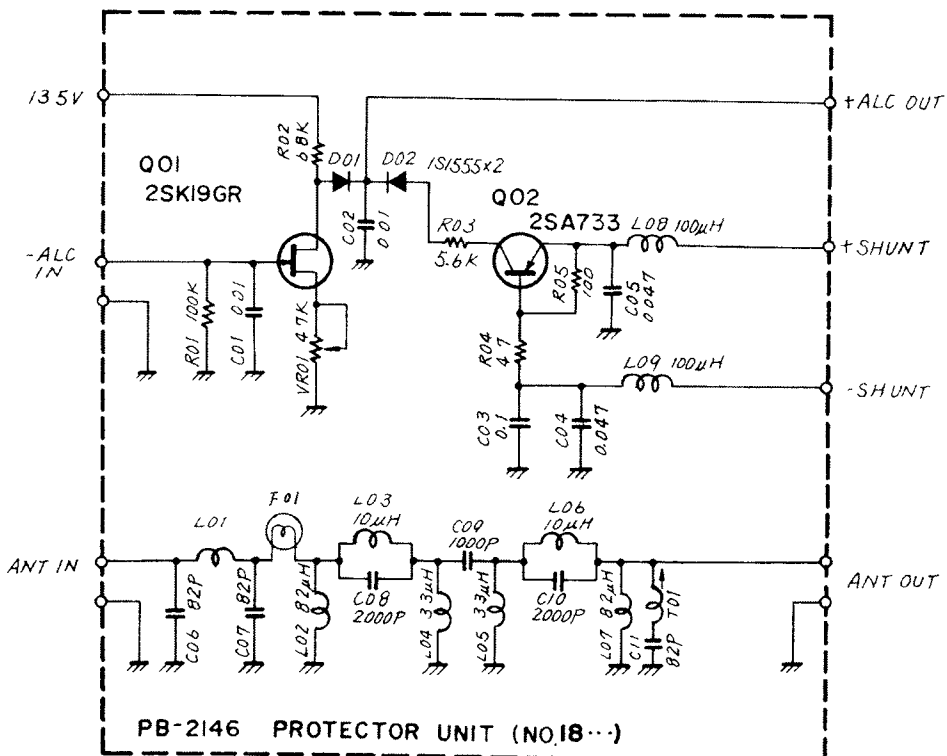



## NB UNIT (PB-2007)

After filtering at XF<sub>3001</sub>, a portion of the 8.9 MHz IF signal is fed through buffer Q<sub>3002</sub> (2SC1815Y), located on the FILTER Unit, to amplifier Q<sub>6901</sub> and Q<sub>6012</sub>, (2SC1583), and further amplified by Q<sub>6013</sub> (2SC380Y).

When a carrier or noise-free modulated signal is received, the IF signal is rectified by D<sub>6012</sub> and D<sub>6013</sub> (1N270), producing a DC voltage. The DC voltage is amplified by Q<sub>6015</sub> (ESC1815Y), which charges C<sub>6053</sub>, for AGC purposes. The AGC voltage is used to control the gain of Q<sub>6011</sub> and Q<sub>6012</sub>.

When pulse-type noise is received, D<sub>6014</sub> and D<sub>6015</sub> (1N270) rectify the IF signal, producing a DC voltage which controls the noise blanker switch, Q<sub>3003</sub>.

Noise pulses have a very short duration, but high amplitude. Because of the very slow time constant of the C<sub>6043</sub>/R<sub>6046</sub> discharge path, AGC voltage is not induced by these short-duration pulses. Therefore, Q<sub>6011</sub> and Q<sub>6012</sub> operate at full gain, providing maximum voltage to the base of Q<sub>3003</sub>. When a pulse is received, Q<sub>3003</sub> biases D<sub>3004</sub> to block the signal path momentarily. When a noise pulse and a desired signal are received simultaneously, the blanking action is not impaired, because the relative amplitude difference between the desired signal and the noise pulse is still high. The front panel noise blanker level control varies the DC voltage applied to the base of Q<sub>3003</sub>.

## MARKER GENERATOR (RF UNIT)

A 25 kHz marker generator is provided, for alignment and testing purposes. Marker generator Q<sub>1005</sub> (2SC380Y) generates a basic 3200 Hz crystal-controlled signal, which is amplified by Q<sub>1006</sub> (2SC380Y) and divided into 25 kHz multiples by Q<sub>1007</sub> (F4024P), a binary counter. The 25 kHz signal is applied through buffer Q<sub>1008</sub> (2SC380Y) to the input of the RF amplifiers, making the marker a useful input signal for alignment purposes.

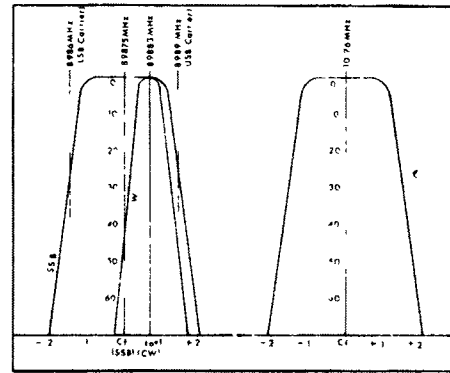

Filter passbands

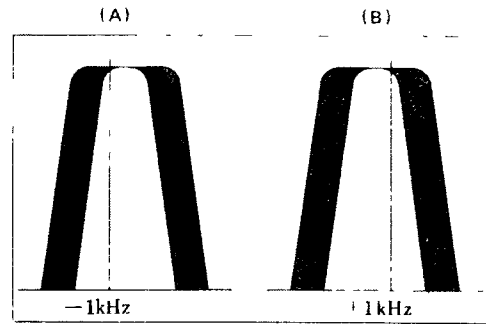

WIDTH control action

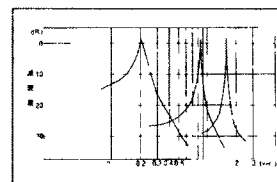

Audio peak filter

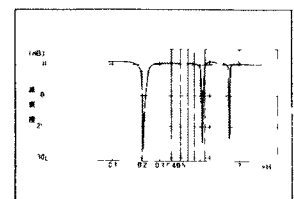

Audio notch filter

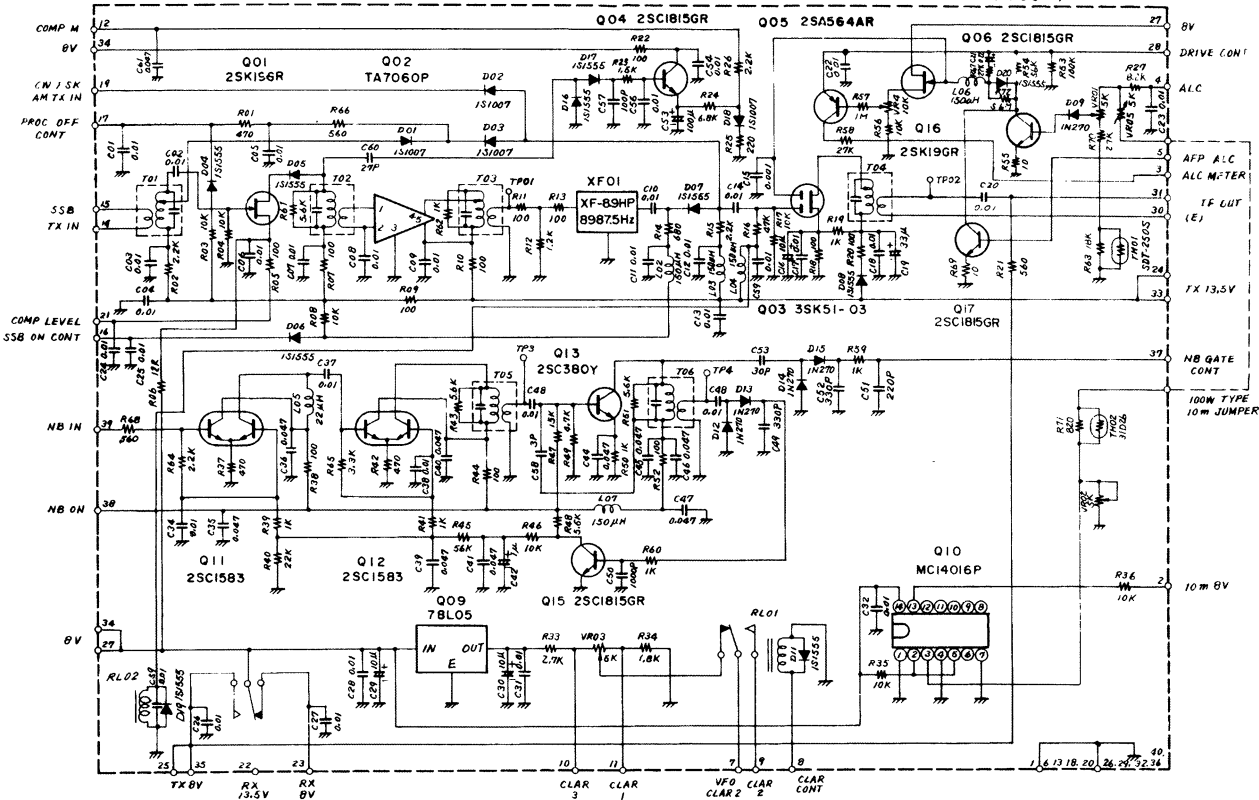

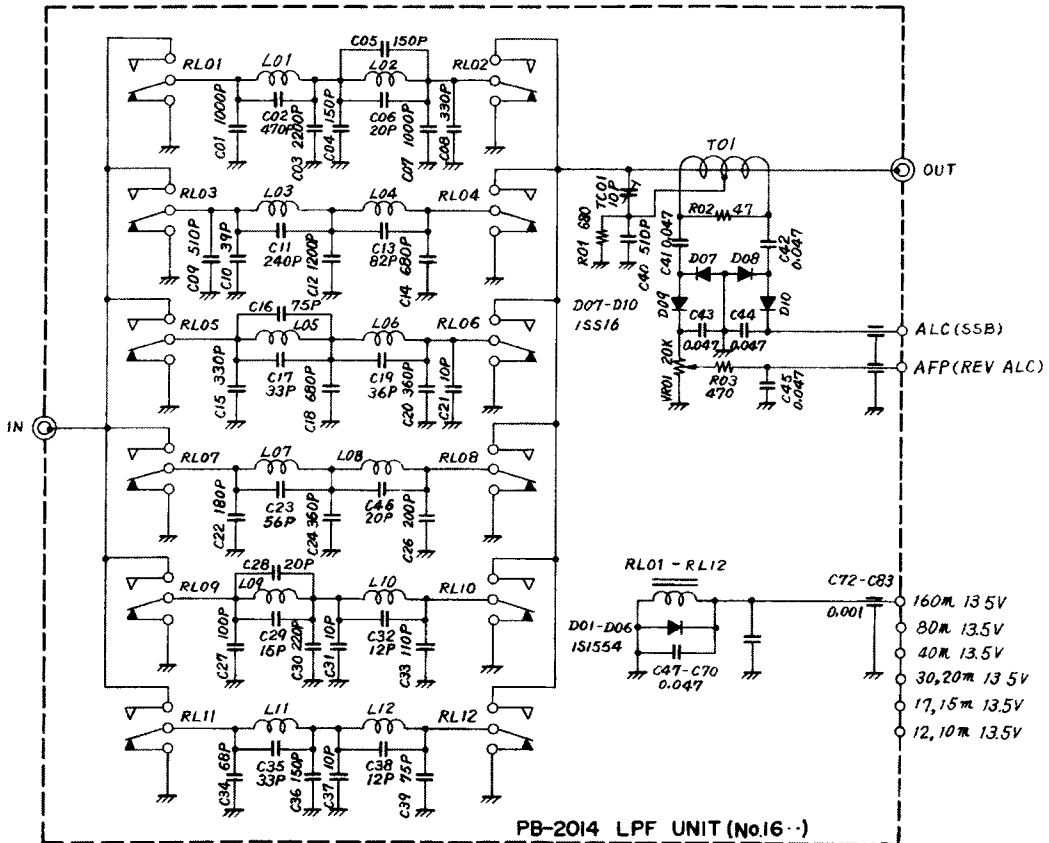
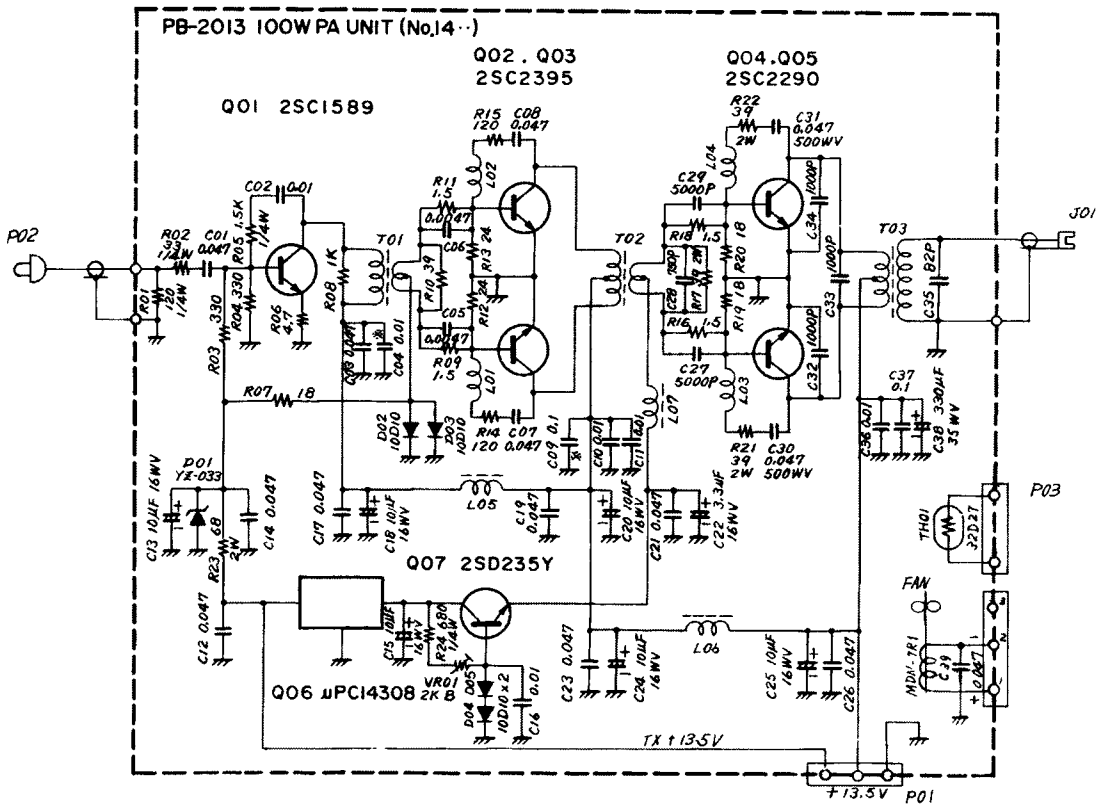

## TRANSMITTER

### SSB MODE

The speech signal from the microphone jack is fed through MIC GAIN control VR6a to pin 30 of the AF Unit.

### AF UNIT (PB-2006)

The speech signal is amplified by microphone amplifier Q<sub>5002</sub> (TA7063P) and fed through relay RL<sub>5001</sub> to the ring modulator, D<sub>5003</sub>–D<sub>5006</sub>, where the speech signal modulates the carrier signal delivered from Q<sub>5009</sub>. The resulting double sideband signal is amplified by buffers Q<sub>5005</sub> (2SK19CR) and Q<sub>5008</sub> (2SC1815Y), and delivered to pin 33 of the FILTER Unit.

### FILTER UNIT (PB-2004)

The 8.9875 MHz double sideband signal is amplified by buffer Q<sub>3004</sub>, and passed through sideband filter XF<sub>3002</sub> by diode switches D<sub>3008</sub> and D<sub>3009</sub>. The filtered SSB signal is then amplified by buffer Q<sub>3005</sub> (2SK19GR) and fed to pin 15 of the NB Unit.

### NB UNIT (PB-2007)

When the RF processor is OFF, the SSB IF signal is amplified by Q<sub>6003</sub> (3SK51-03) and delivered to the ring mixer, located on the RF Unit. When the processor switch is ON, the IF signal is amplified by buffer Q<sub>6001</sub> (2SK19GR) and further amplified by limiter Q<sub>6002</sub> (TA7060P), where signals that exceed a preset clipping level are sliced out.

This highly clipped SSB signal is passed through crystal filter XF<sub>6001</sub>, which removes RF harmonics that result from clipping. The IF signal is then amplified by Q<sub>6003</sub>, and delivered to the diode ring on the RF Unit.

A portion of the output from Q<sub>6001</sub> is amplified by Q<sub>6004</sub> (2SC1815Y) for indication of the compression level on the front panel meter.

### RF UNIT (PB-2158)

The IF signal from pin 3 is delivered to the ring mixer, D<sub>1034</sub>–D<sub>1037</sub> (1SS16), where the IF signal is mixed with a local signal delivered from Q<sub>2013</sub> (2N4427), producing the RF output signal. The RF signal is then amplified by Q<sub>1002</sub> (2SK19GR) and Q<sub>1003</sub> (2N4427) and fed to the 100W PA Unit.

A portion of the output from Q<sub>1003</sub> is fed through buffer Q<sub>1012</sub> (2SC380Y) to the RF OUT jack, for use with the FTV-107R transverter.

### 100W PA UNIT

The RF signal from the RF Unit is fed to pre-driver Q<sub>1401</sub> (2SC1589), amplified by drivers Q<sub>1402</sub> and Q<sub>1403</sub> (2SC2395), and amplified by final PA transistors Q<sub>1404</sub> and Q<sub>1405</sub> (2SC2290), which provide approximately 100 watts of RF output. Both the driver and final PA stages are operated in a push-pull configuration.

In order to assure high linearity for the amplifier, R<sub>1414</sub>, R<sub>1421</sub>, R<sub>1422</sub>, C<sub>1407</sub>, C<sub>1408</sub>, C<sub>1430</sub>, and C<sub>1431</sub> provide control voltage for Q<sub>1402</sub>–Q<sub>1405</sub>. This technique, known as RF negative feedback, assures that 3rd order IMD products will be kept to a minimum.

Bias voltage for Q<sub>1401</sub>–Q<sub>1403</sub> is provided by D<sub>1401</sub> (YZ033), which sets the bias at 3 volts. Thermal compensation for the bias line is provided by D<sub>1402</sub> and D<sub>1403</sub> (10D10).

The supply line for the final transistors is regulated at 8 volts by Q<sub>1406</sub> (μPC14308), while Q<sub>1407</sub> (2SD235Y) and D<sub>1404</sub>/D<sub>1405</sub> (10D10) provide thermal compensation.

Thermistor TH<sub>01</sub> senses the operating temperature of the final transistors, for control of the heat sink fan motor via the CONTROL Unit.

### LPF (LOW-PASS FILTER) UNIT (PB-2014)

The RF output from the PA is fed to the LPF Unit, where individually-tuned low-pass filter networks for each band are selected by relays RL<sub>1601</sub>–RL<sub>1612</sub>. A CM coupler, located in the output line, provides sample signals to be used for SSB ALC and AFP (Automatic Final Protection) voltage.

## CM COUPLER UNIT (PB-2056)

The output from the LPF Unit is fed to the CM COUPLER Unit, where a directional coupler provides for relative forward and reverse power indication on the front panel meter.

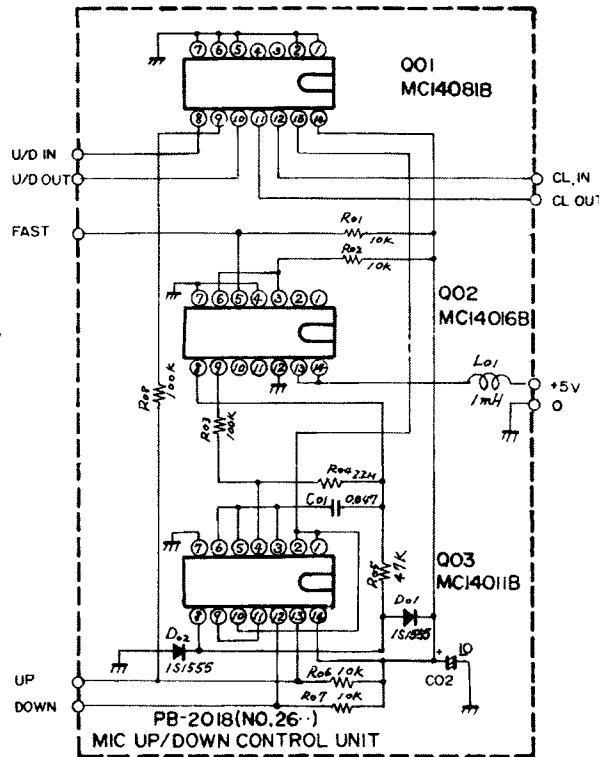
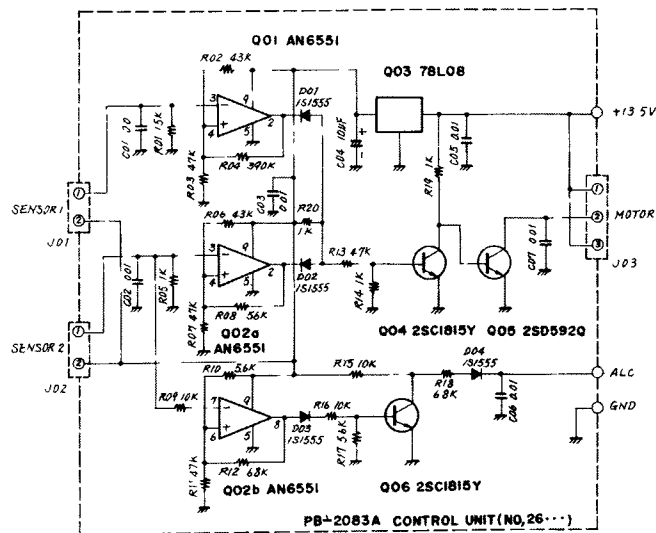
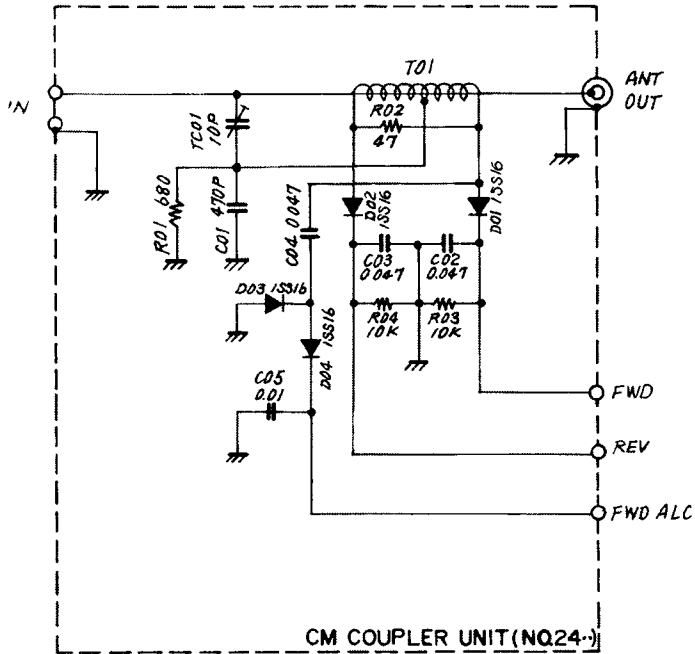

## CW MODE

The CW carrier is generated by crystal oscillator Q<sub>5011</sub> (2SK19GR) and amplified by Q<sub>5011</sub> (2SC1815Y) and Q<sub>5004</sub> (3SK51-03). The carrier signal is then delivered to Q<sub>6003</sub>, and from there the signal path is identical to that of the SSB signal.

The key lead from the key jack controls transistor switches Q<sub>4015</sub> and Q<sub>4016</sub> (2SC1815Y), which turn bias controller Q<sub>1004</sub> (2SC1959) on and off. The output from Q<sub>1004</sub> is applied to the emitter lead of driver Q<sub>1003</sub>, providing keying of the output amplifier line.

Q<sub>4016</sub> also controls sidetone oscillator Q<sub>4021</sub> (2SC1815GR), which provides an audio keyed tone of approximately 800 Hz. The output of Q<sub>4021</sub> is applied both to AF amplifier Q<sub>5017</sub>, for delivery to the speaker, and to the VOX circuit, for semi -break - in operation.

## FSK MODE

The output from an external terminal unit is applied to the rear panel FSK jack, which is connected to keying transistor Q<sub>5010</sub> (2SC1815Y). The switching action of Q<sub>5010</sub> causes trimmer capacitor TC<sub>5005</sub> to be switched into the tuning circuit for CW carrier crystal X<sub>5003</sub>, providing for 170 Hz FSK shift. The carrier signal generated by crystal oscillator Q<sub>5011</sub> then follows a path identical to the one followed on CW.

## AM MODE

The output from microphone amplifier Q<sub>5002</sub> is further amplified by Q<sub>5001</sub> (2SC380Y) and delivered to Q<sub>5004</sub>, which acts as a modulator in the AM mode. The speech signal modulates the 8988.3 kHz carrier signal, and the output from the modulator is then fed to Q<sub>6003</sub> and the remainder of the amplifier chain.

## COMMON CIRCUITS

### VFO UNIT (PB-1440B-3490)

A modified Colpitts-type oscillator is used to generate a 5.0 5.5 MHz VFO signal, resulting in a 500 kHz tuning range. The VFO frequency is varied by VC<sub>801</sub>, which is geared to a precision dial tuning mechanism. Temperature compensation is provided by the sub-blades of VC<sub>801</sub>.

Varactor diode D<sub>801</sub> is in series with C<sub>807</sub>, and the combination of the two is in parallel with TC<sub>801</sub>. By closing the CLARIFIER switch, the VFO frequency may be varied  $\pm 2.5$  kHz by adjusting the front panel CLARIFIER control.

The output from oscillator Q<sub>801</sub> (2SC372Y) is fed through buffer amplifier Q<sub>802</sub> (2SK19GR) and further buffered at Q<sub>803</sub> (2SC372Y). The amplified signal is passed through a low-pass filter and delivered to the output terminal.

### LOCAL UNIT (PB-2159)

The premix local signal is generated by crystal oscillators Q<sub>2001</sub>–Q<sub>2009</sub>, Q<sub>2017</sub>–Q<sub>2019</sub> (2SC380Y), the oscillator in use being selected by diode switches D<sub>2001</sub>–D<sub>2009</sub>, D<sub>2025</sub>–D<sub>2027</sub> (1S1555). The output from the oscillator is fed through a low-pass filter to the local mixer.

The 5.0 5.5 MHz local signal from the VFO, memory, or external VFO is fed to double-balanced mixer Q<sub>2010</sub> (SN76514), where the VFO signal is mixed with the premix local signal, resulting in the output premix signal shown in Table 1.

The premix signal is passed through a bandswitched bandpass filter, which eliminates spurious signals on the premix output. Selection of the desired filter is performed by diode switches D<sub>2013</sub>–D<sub>2024</sub>, D<sub>2028</sub>–D<sub>2033</sub> (1S1555). The filtered signal is then amplified by a three-stage amplifier chain consisting of Q<sub>2011</sub> (2SK19GR), Q<sub>2012</sub> (2SC380Y), and Q<sub>2013</sub> (2N4427). The signal is then delivered to the PREMIX OUT terminal of the circuit board.

A portion of the output from Q<sub>2013</sub> is amplified by buffer Q<sub>2014</sub> (2SK19GR) and amplifier Q<sub>2015</sub> (2SC380Y) for delivery to the frequency counter for display purposes.

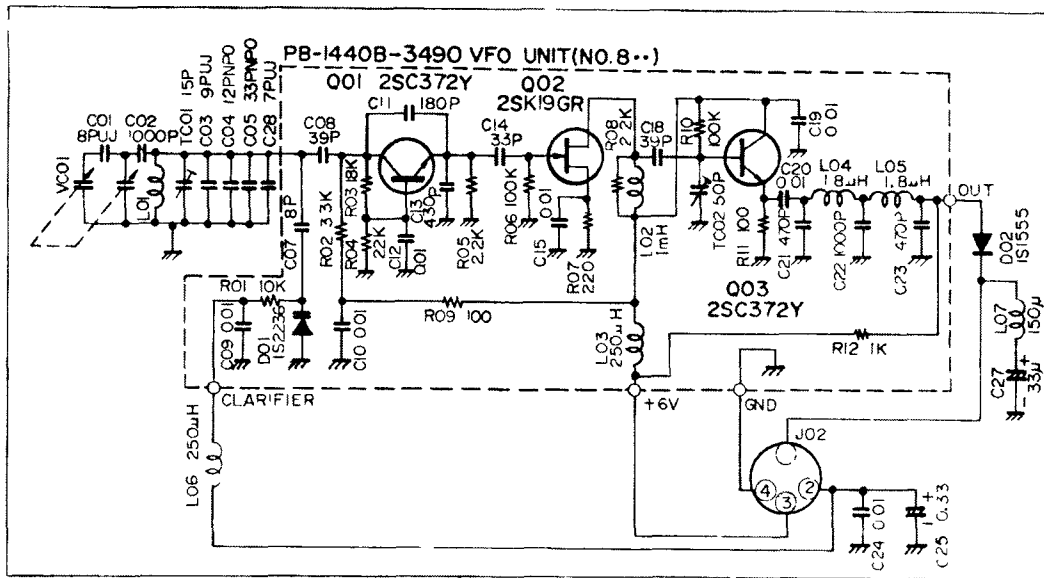

		XCO Frequency	PREMIX OUT Frequency
160m	X <sub>2001</sub>	15.9845MHz	10.4875~10.9875MHz
80m	X <sub>2002</sub>	17.9845MHz	12.4875~12.9875MHz
40m	X <sub>2003</sub>	21.4845MHz	15.9875~16.4875MHz
30m	X <sub>2012</sub>	24.4875MHz	18.9875~19.4875MHz
20m	X <sub>2004</sub>	28.4875MHz	22.9875~23.4875MHz
17m	X <sub>2010</sub>	32.4875MHz	26.9875~27.4875MHz
15m	X <sub>2005</sub>	35.4875MHz	29.9875~30.4875MHz
12m	X <sub>2011</sub>	38.9875MHz	33.4875~33.9875MHz
10m A	X <sub>2006</sub>	42.4875MHz	36.9875~37.4875MHz
10m B	X <sub>2007</sub>	42.9875MHz	37.4875~37.9875MHz
10m C	X <sub>2008</sub>	43.4875MHz	37.9875~38.4875MHz
10m D	X <sub>2009</sub>	43.9875MHz	38.4875~38.9875MHz

Table 1

	Nominal Premix Local Frequency	L S B	U S B	CW, AM
160m	10.4875-10.9875(MHz)	10.486-10.986(MHz)	10.489-10.989(MHz)	10.4883-10.9883(MHz)
80m	12.4875-12.9875	12.486-12.986	12.489-12.989	12.4883-12.9883
40m	15.9875-16.4875	15.986-16.486	15.989-16.489	15.9883-16.4883
30m	18.9875-19.4875	18.986-19.486	18.989-19.489	18.9883-19.4883
20m	22.9875-23.4875	22.986-23.486	22.989-23.489	22.9883-23.4883
17m	26.9875-27.4875	26.986-27.486	26.989-27.489	26.9883-27.4883
15m	29.9875-30.4875	29.986-30.486	29.989-30.489	29.9883-30.4883
12m	33.4875-33.9875	33.486-33.986	33.489-33.989	33.4883-33.9883
10m A	36.9875-37.4875	36.986-37.486	36.989-37.489	36.9883-37.4883
10m B	37.4875-37.9875	37.486-37.986	37.489-37.989	37.4883-37.9883
10m C	37.9875-38.4875	37.986-38.486	37.989-38.489	37.9883-38.4883
10m D	38.4875-38.9875	38.486-38.986	38.489-38.989	38.4883-38.9883

Table 2

LOCAL UNIT PB-2159 (NO. 20)

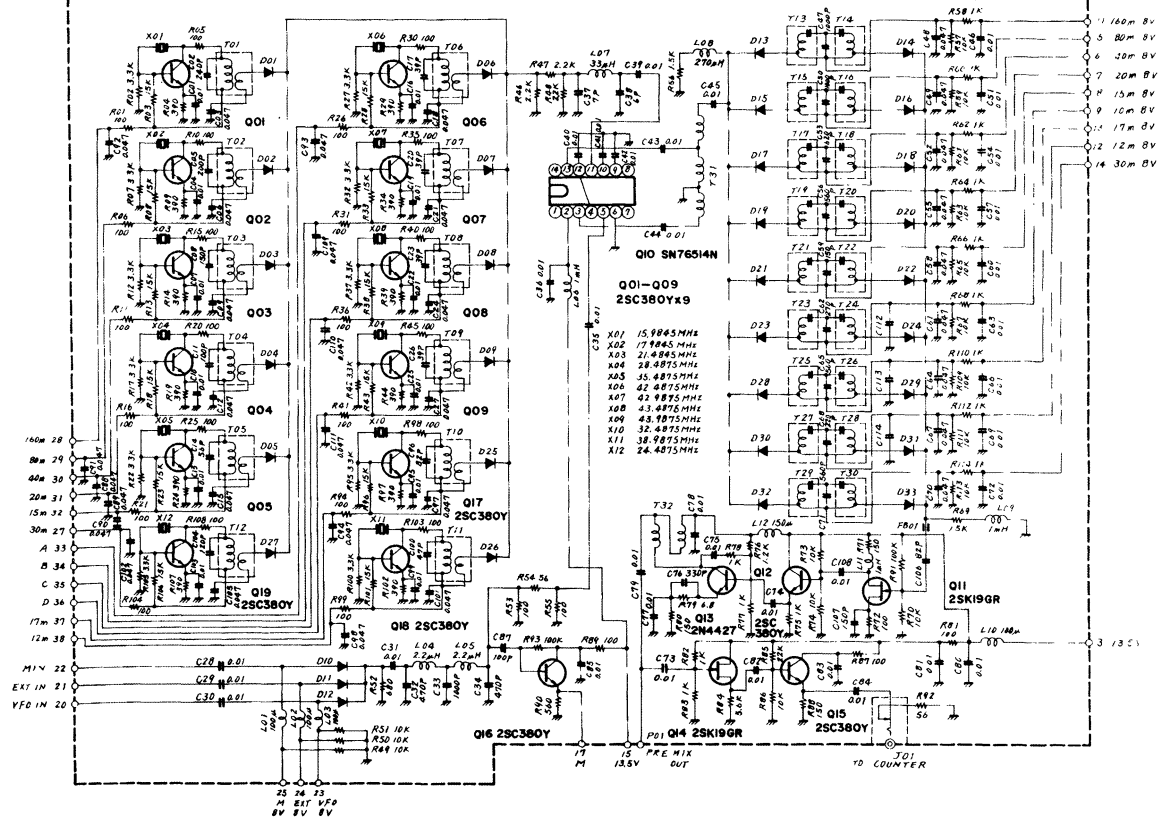



HP5082 - 7623x6

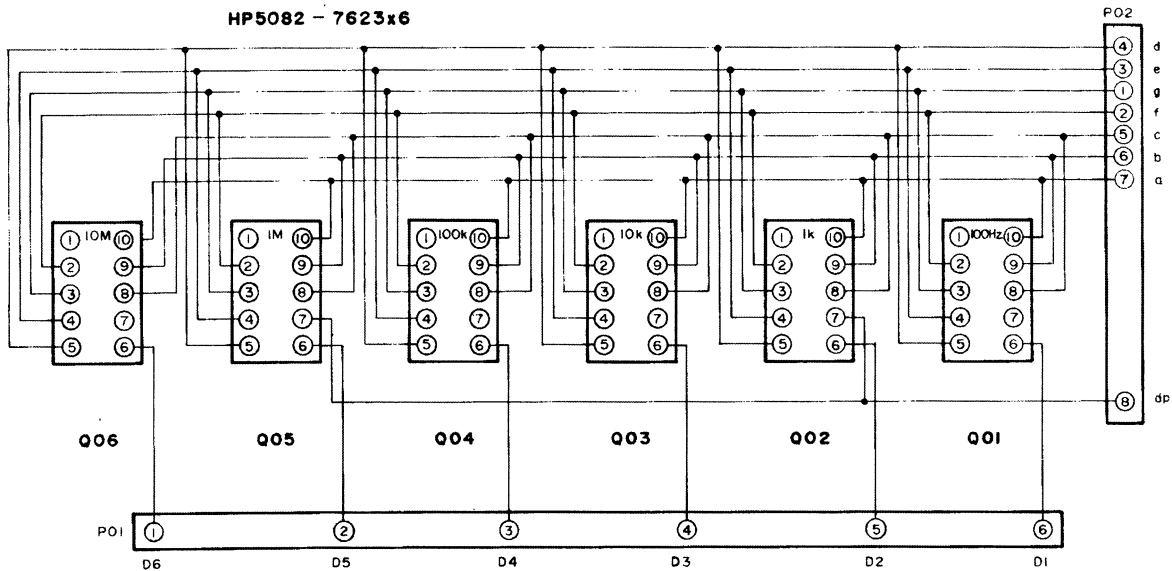

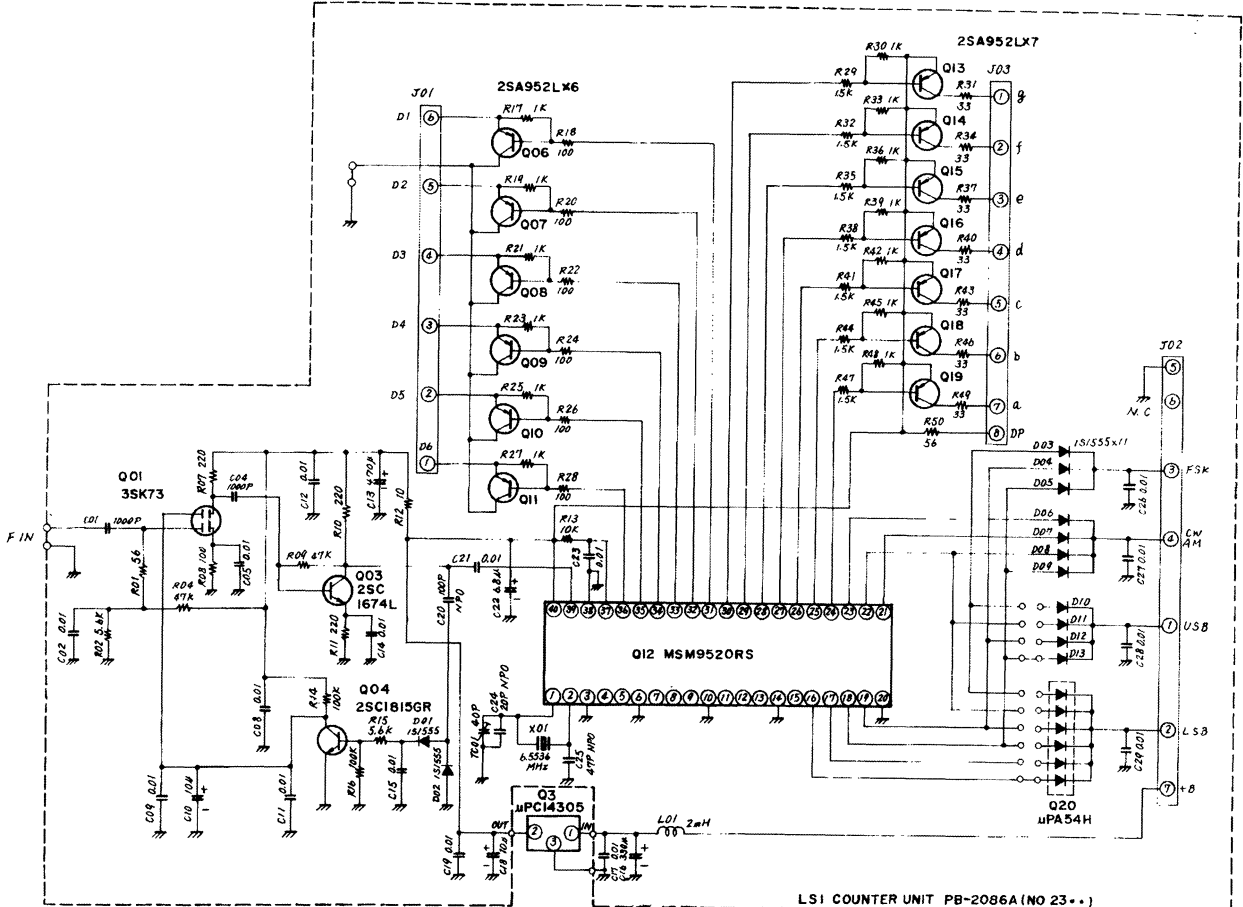

## COUNTER UNIT (PB-2086A/PB-2087)

The local oscillator signal is applied to Large-Scale Integrated Circuit (LSI) chip for display on the front panel digital display.

The premix signal from the LOCAL Unit is applied to the F IN terminal and amplified by Q2301(3SK73). The amplified signal is further amplified by Q2303 (2SC1674) and delivered to the LSI counter chip, Q2321 (MSM9520RS). A portion of the output from Q2303 is amplified by Q2304 (2SC1815Y) and fed to gate 2 of Q2301 and Q2302, controlling the gain of those amplifiers.

The output from the LSI is fed to the display. The output from pins 24 through 30 is delivered to segment drivers Q2313-Q2319 (2SA952L) and digit drivers Q2306-Q2311 (2SA952L) through a dynamic drive configuration. Display is performed by D2201-D2206 (HP5082-7623), seven-segment light-emitting diodes.

## POWER SUPPLY

When the optional FP-107 AC Power Supply is installed, it will provide the required 13.5 VDC at 20 amps for the FT-107M. AC input voltages of 100/110/117/200/220/234 volts at 50/60 Hz may be used.

The output from the power transformer is rectified by a full wave bridge rectifier. The rectified voltage is stabilized by a voltage regulator, consisting of Q1 (2N5685) and Q202 (2SA1012), while current limiting is provided by Q201 (2SK19BL). The comparator function of the voltage regulator is performed by Q203 (2SA950).

The input 13.5 VDC line from the FP-107 (or the external DC power line) is used for the PA Unit, the meter lamp, and for relay switching. RL1 provides relay switching for the TX 13.5V and RX 13.5 V lines.

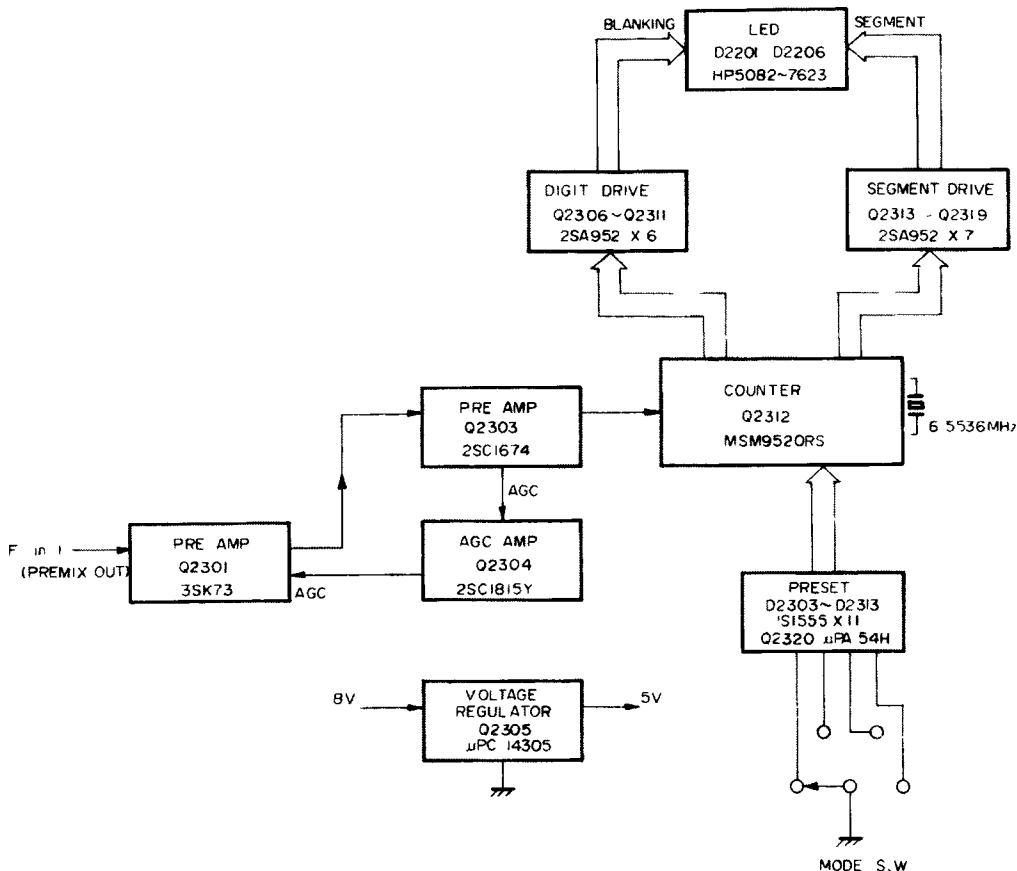

The 13.5 volt line is stabilized at 8 volts by Q<sub>1</sub> ( $\mu$ PC14308), for use in the transistor circuits. The 8 volt line is further stabilized by Q<sub>2</sub> ( $\mu$ PC-14308) for the VFO circuitry, which requires a highly stable power source.

Transistor switches Q<sub>6007</sub>/Q<sub>6008</sub> (2SC1959Y), located on the NB Unit, provide switched 8 volts for the transmit and receive circuits.

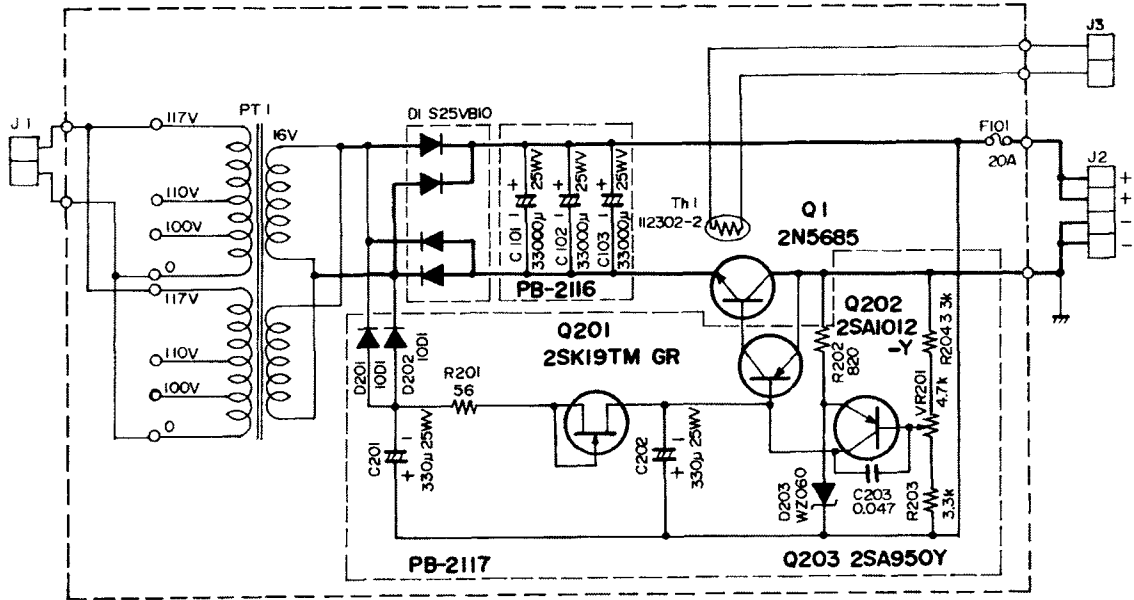

**FP 107  
CIRCUIT DIAGRAM**

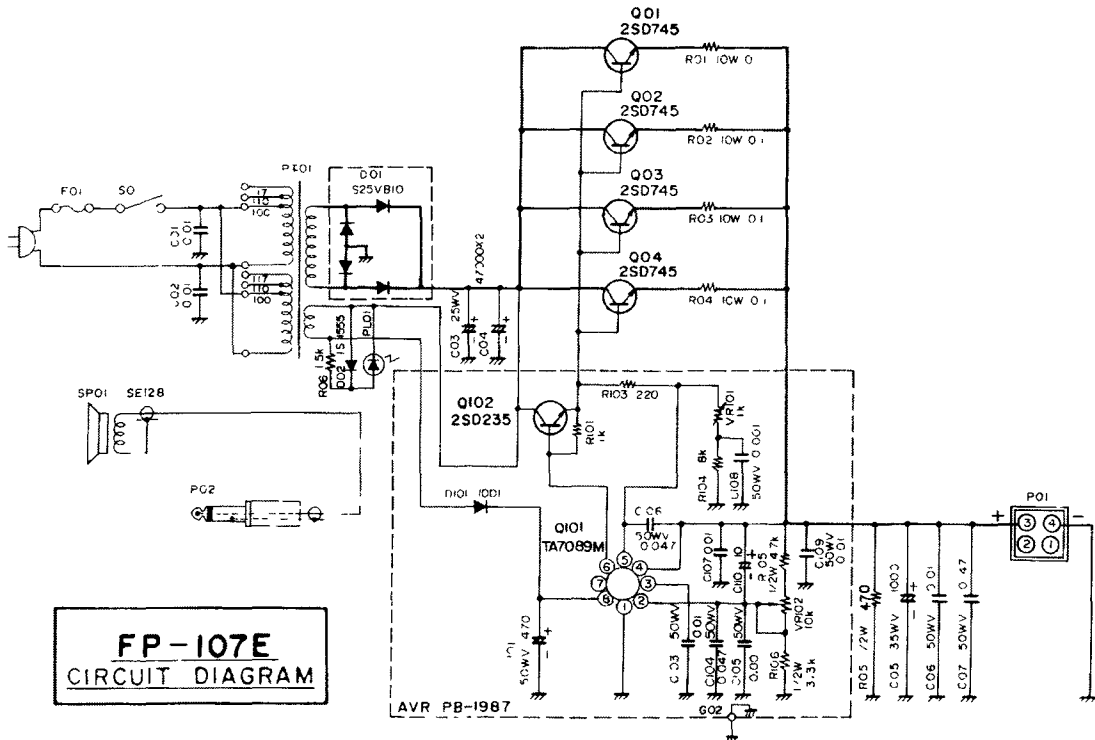

**FP-107E  
CIRCUIT DIAGRAM**

## DMS UNIT

While a complete description of the Digital Memory Shift and memory circuitry is beyond the scope of this manual, reference to the block diagram of the DMS, along with the following description, should provide the owner with a better understanding of this design technique.

The 5.0–5.5 MHz VFO signal is fed to a counter gate, driven by a crystal controlled clock signal. The pulses which pass through the counter gate are fed to a five digit decade counter, which counts the VFO frequency. The digitally encoded output from the decade counter is delivered to the memory RAM for storage.

The output from the RAM is fed through an UP/DOWN counter to preset the programmable divider. On the DMS Unit, a 25.48–25.98 MHz signal is produced from the Voltage Controlled Oscillator (VCO). This signal is fed to a mixer, where the VCO signal is mixed with a 20.48 MHz reference signal, producing a 5.0–5.5 MHz signal, which is fed to the programmable divider.

The output from the programmable divider (at approximately 1 kHz) is fed to a phase detector, where the phase of the signal is compared to that of a 1 kHz reference signal, producing an error voltage. The error voltage is fed through a low-pass filter, which removes any ripple on the signal. The error voltage is then used to control varactor diodes in the VCO, locking it on the desired frequency.

When the memory frequency is recalled, the VCO output is fed to another mixer, where the 25.48–25.98 MHz signal is mixed with a  $20.48 \pm \Delta f$  signal, resulting in a 5.0–5.5 MHz signal which is fed to the PLL (instead of the VFO signal). During memory fine tuning or clarifier operation (using the memory), the frequency of the 20.48 MHz voltage controlled crystal oscillator (VCXO) is varied, changing the 5.0–5.5 MHz output signal slightly in frequency.

During memory shift operation, the output pulses from the photo-interrupter circuitry are applied to the UP/DOWN so as to preset the programmable divider, thereby shifting the output from the memory RAM so as to provide the desired shifting the memory channel frequency.

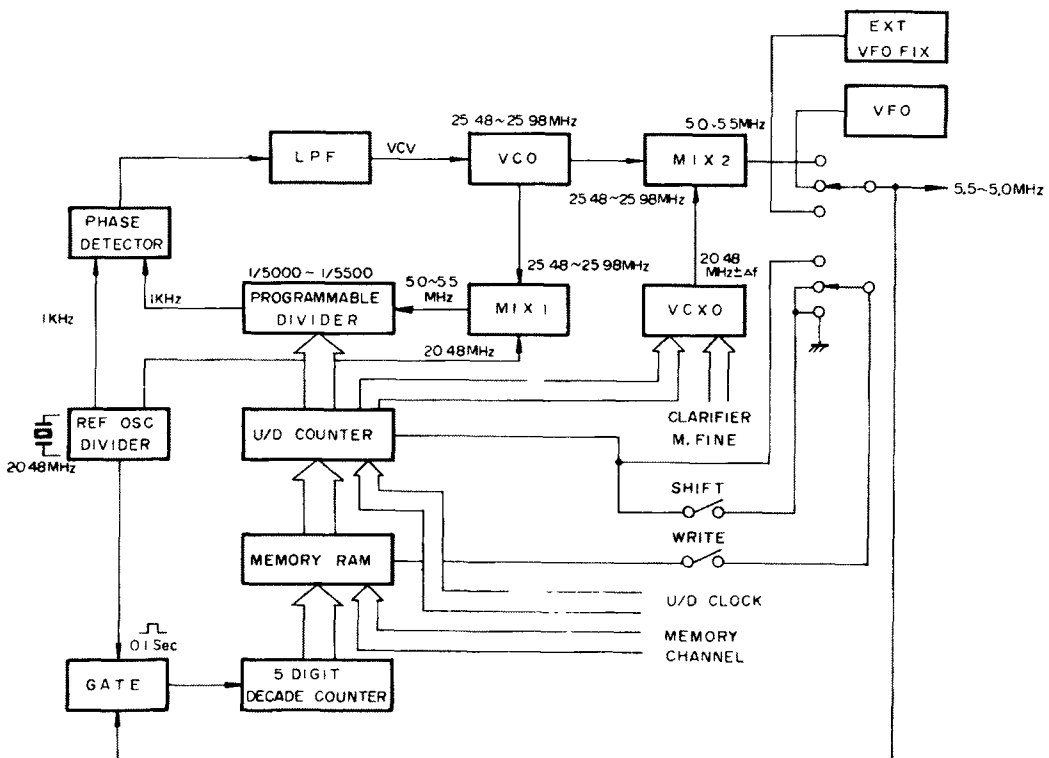

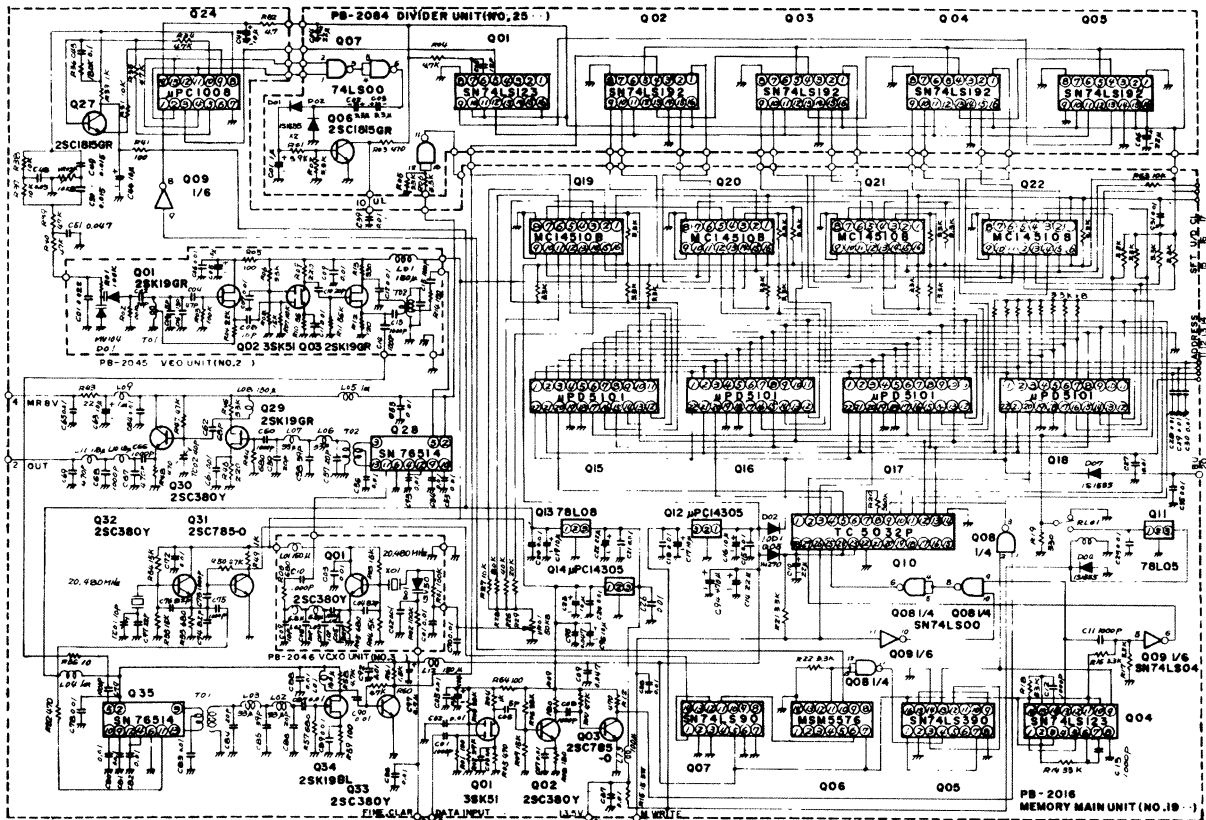

DMS UNIT CIRCUIT DIAGRAM

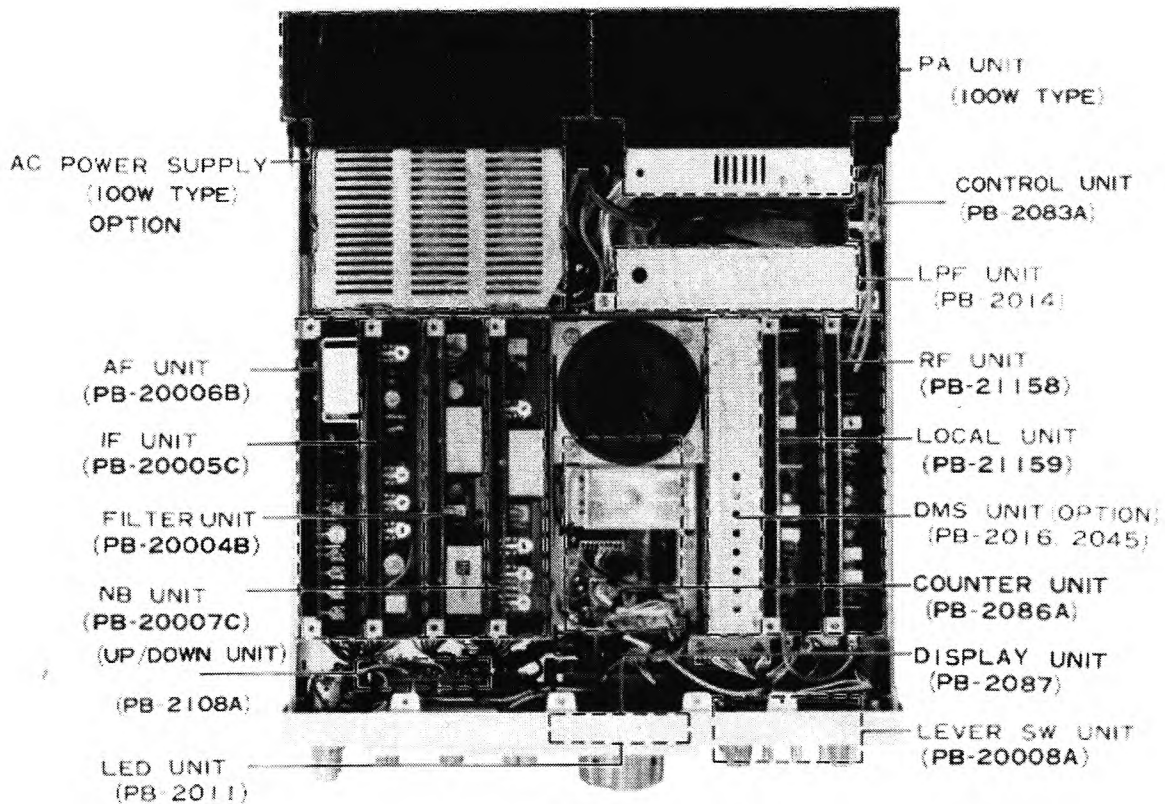

TOP VIEW

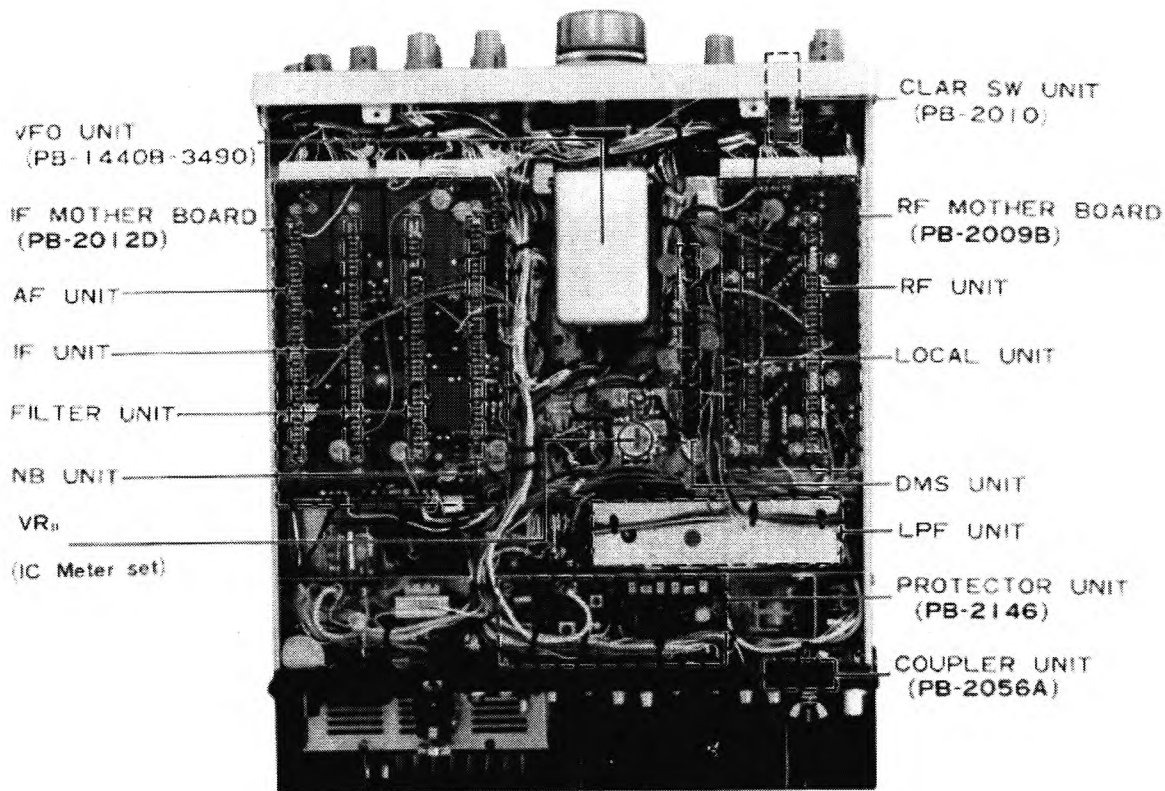

BOTTOM VIEW

# MAINTENANCE & ALIGNMENT

## GENERAL

This transceiver has been carefully aligned and tested at the factory prior to shipment. With normal use, it should not require other than the usual attention given to electronic equipment.

Service or replacement of a major component may require substantial adjustment; under no circumstances, though, should realignment be attempted unless the operation of the transceiver is fully understood, the malfunction has been carefully analyzed, and the fault has definitely been traced to misalignment. Sudden difficulties are almost always caused by component failure rather than misalignment.

Service work should only be performed by experienced personnel, using the proper test equipment.

## CAUTION

Never operate this transceiver in the transmit mode without a matched antenna or dummy load connected to the rear panel antenna receptacle. While the final transistors are protected against high antenna system SWR, accurate testing and evaluation of faults will be impossible if a proper load is not used.

## WARNING

**DANGEROUS VOLTAGES ARE PRESENT WITHIN THIS EQUIPMENT. USE EXTREME CAUTION WHEN WORKING ON THE TRANSCEIVER WITH THE COVERS REMOVED, ESPECIALLY IN THE VICINITY OF THE POWER SUPPLY CIRCUITRY. OBSERVE SAFETY PRECAUTIONS AT ALL TIMES.**

## EQUIPMENT REQUIRED

- (1) RF Signal Generator: Hewlett-Packard Model 606A or equivalent, with one volt output at 50 ohms, and frequency coverage to 30 MHz.
- (2) Vacuum Tube voltmeter: Hewlett-Packard Model 410B or equivalent, with an RF probe good to 40 MHz.
- (3) Dummy Load/Wattmeter: Yaesu Model YP-150 or equivalent, with 50 ohm non-reactive load impedance, rated to 150 watts average power.
- (4) AF Signal Generator: Hewlett-Packard Model 200AB or equivalent.
- (5) A general coverage receiver covering 1.8–30 MHz, with a 100 kHz crystal calibrator.
- (6) Frequency Counter: Yaesu Model YC-500 or equivalent, with resolution to 0.01 kHz and frequency coverage to 40 MHz.
- (7) Oscilloscope: Hewlett-Packard Model 1740A or equivalent.

## VOX CIRCUIT ALIGNMENT

### 1. Antitrip level setting

- a) Tune in a signal on the FT-107M receiver, and adjust the AF GAIN control for a normal listening level on the speaker. Position the microphone near the speaker, with the MODE switch in the USB or LSB position. Increase the VOX GAIN control on the front panel until the speaker output causes the VOX relay to trip. Now set the ANTITRIP potentiometer, VR<sub>4003</sub> (located on the IF Unit), to the point where the speaker output does not activate the VOX.
- b) Now place the microphone in the normal operating position. Speak into the microphone in a normal voice to see if the VOX relay activates normally. If your voice does not activate the VOX, VR<sub>4003</sub> may be advanced too far. Do not use more VOX GAIN nor ANTITRIP than needed.

### 2. VOX relay delay setting

- a) Adjust the rear panel DELAY control (VR<sub>8</sub>) for the desired VOX relay hang time. This may require a different adjustment for phone and CW operation, owing to different operating techniques. When using a foot-switch, the VOX GAIN control is rotated fully counterclockwise, so no adjustment of the DELAY control is required in this case.



## S-METER ADJUSTMENT

- a) Preset the controls and switches as follow:  
 BAND ..... 20  
 MODE ..... USB  
 DIAL ..... 14.250 MHz  
 RF GAIN ..... fully clockwise  
 Connect a signal generator to the antenna jack.
- b) Adjust VR<sub>4001</sub> for a 0 reading on the S meter scale with no signal present.
- c) Apply a 100 dB signal from the signal generator, and adjust VR<sub>4002</sub> for a reading of S9+60 dB on the generator signal.

## IF WIDTH ALIGNMENT

- a) Preset the controls and switches as follows:  
 BAND ..... 20  
 DIAL ..... 14.250 MHz  
 RF GAIN ..... Fully clockwise  
 WIDTH ..... To the 12 o'clock position  
 MODE ..... USB
- b) Connect a frequency counter to TP<sub>3006</sub> (located on the FILTER Unit). Adjust VR<sub>102</sub> (located on the CLAR SW Unit) for a reading of exactly 19.745 MHz on the counter.

## CW SIDETONE ALIGNMENT

- a) Adjust VR<sub>4005</sub>, located on the IF Unit, for the desired CW sidetone output level.

## MARKER ALIGNMENT

- a) Preset the controls and switches as follows:  
 BAND ..... 30 m  
 MODE ..... AM
- b) Tune in the signal from WWV or JJY, and switch on the marker. Adjust TC<sub>1001</sub> (located on the RF Unit) for a zero beat with the standard frequency station. The zero beat point is that at which the heterodyne beat between the marker signal and WWV/JJY disappears.
- c) The alignment may also be made in the SSB mode. When modulation ceases on the standard frequency station, adjust TC<sub>1001</sub> so that the marker frequency is exactly the same as that of the WWV/JJY carrier.

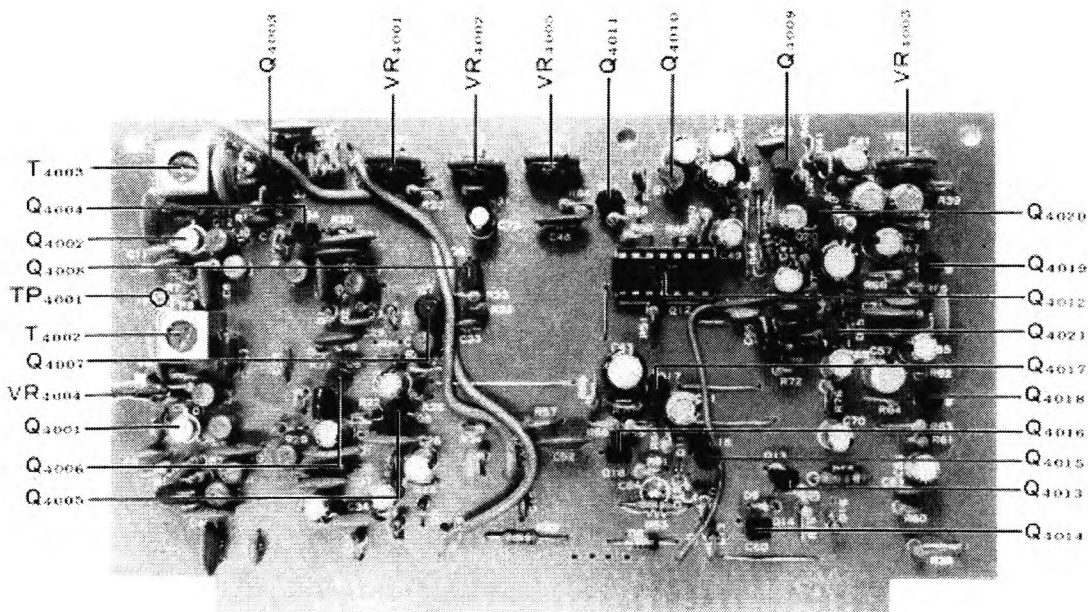

IF UNIT

## CARRIER POINT ADJUSTMENT

### (1) SSB Carrier Point Alignment

- a) Preset the controls and switches as follows:  
 BAND ..... 20  
 DIAL ..... 14.250 MHz  
 MODE ..... LSB
- b) Connect an audio oscillator to the microphone jack MIC IN terminal (pin 8 ), and close the PTT switch. Set the audio oscillator output to 1 kHz, and adjust its level so that the power output reaches 60 watts as indicated on a dummy load/wattmeter.
- c) Set the audio oscillator frequency to 350 Hz, but do not change its level. Adjust TC<sub>5002</sub> (FILTER Unit) for a power output of exactly 15 watts. Release the PTT switch.
- d) Set the MODE switch to USB, and adjust TC<sub>5003</sub> (FILTER Unit) for an identical 15 watt output reading on the wattmeter while transmitting.
- e) Rotate the RF GAIN control fully clockwise, and set the WIDTH control to the 12 o'clock position. Switch between the USB and LSB modes while listening to the background noise. If there is any difference in the pitch, VR<sub>102</sub> may require readjustment. See the IF WIDTH ALIGNMENT section above.

### (2) Carrier Balance Adjustment

- a) Preset the controls and switches as follows:  
 BAND ..... 20  
 DIAL ..... 14.250 MHz  
 MODE ..... USB  
 Remove the audio oscillator and any other equipment from the MIC jack.
- b) Connect the RF probe of a VTVM to the antenna jack, and set the VOX GAIN switch to MOX. Adjust VR<sub>5001</sub> and TC<sub>5001</sub> (located on the AF Unit) for a minimum reading on the VTVM.
- c) If a VTVM is not handy, you may use a communications receiver for this alignment step. Tune the receiver to 14.250 MHz, and set the VOX GAIN control to MOX. With no modulation, adjust VR<sub>5001</sub> and TC<sub>5001</sub> for a minimum S-meter reading (or minimum signal level, if no S-meter reading occurs).
- d) Switch between USB and LSB, and compare the output levels with no modulation. Some adjustment of VR<sub>5001</sub> and TC<sub>5001</sub> may be necessary to achieve good carrier nulling on both modes.

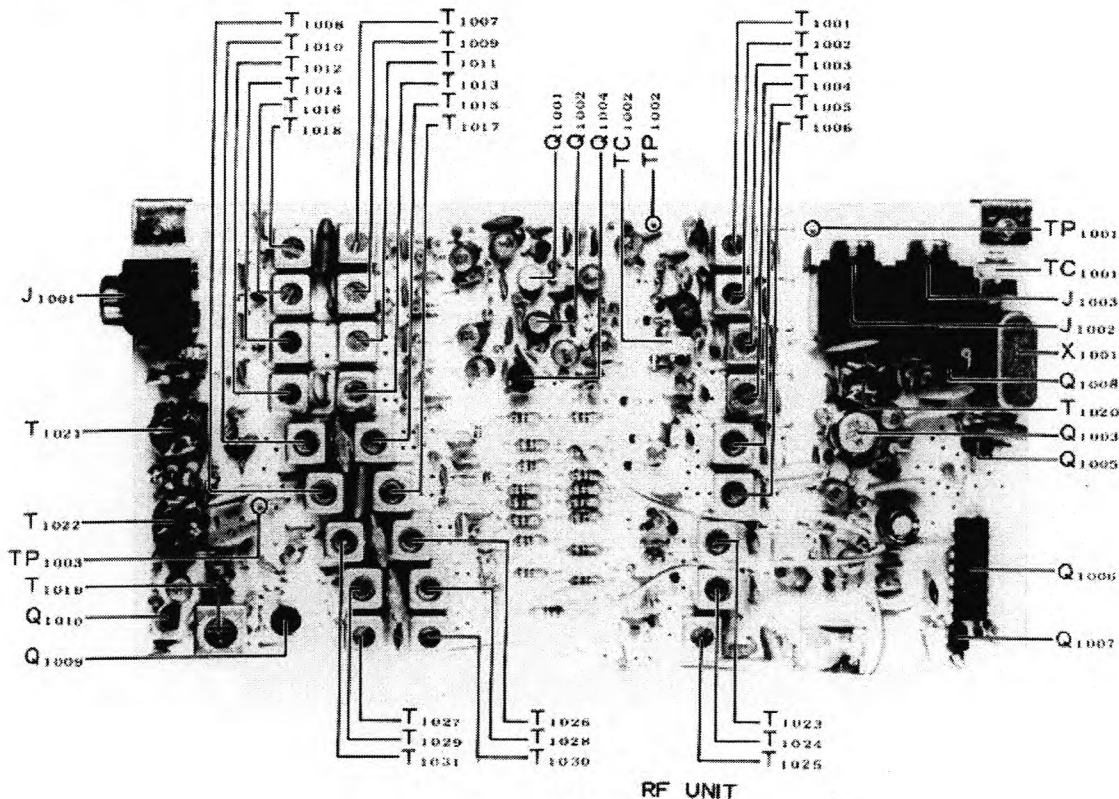

### (3) CW/FSK Carrier Point Alignment

- a) Connect a frequency counter to TP<sub>5003</sub>, located on the IF Unit. Set the MODE switch to CW, and adjust TC<sub>5004</sub> (IF Unit) for a reading of exactly 8988.295 kHz on the counter.
- b) Set the MODE switch to FSK, and adjust TC<sub>5005</sub> (IF Unit) for a reading of exactly 8988.125 kHz on the counter. As there is some interaction of adjustments, set the MODE switch again to CW, and recheck the reading of 8988.295 kHz for that mode. Then again check the FSK reading.

### CLARIFIER ALIGNMENT

- a) Set the MODE switch to USB, and connect a signal generator to the antenna jack. Apply a signal of about S7 level on any band, and tune the receiver to the generator signal with the clarifier OFF. Set the CLAR control to the 12 o'clock position, and note the beat note of the input signal.
- b) Push the CLAR button, and note the beat note of the input signal. If it changes at all in pitch, adjust VR<sub>6003</sub> (located on the NB Unit) so that the frequency is the same as that noted when the clarifier was off. Switch back and forth between the OFF and ON modes to check the calibration.

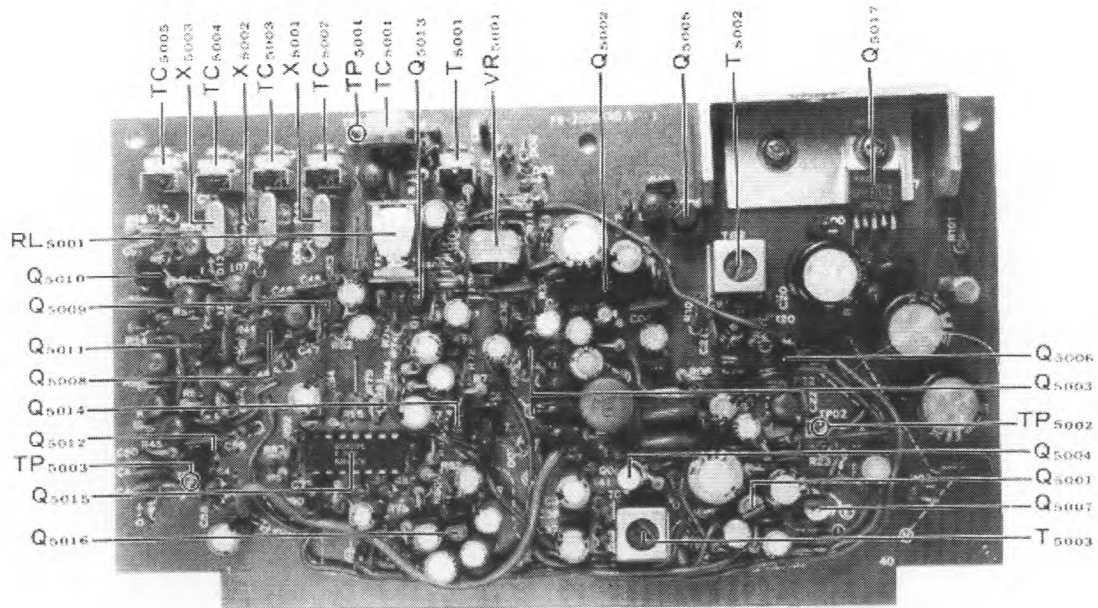

AF UNIT

## MEMORY CLARIFIER ALIGNMENT (Memory-equipped models only)

- a) After completing the above alignment of the VFO clarifier, store the signal generator frequency in memory. Now set the SELECT switch to MR, and note the pitch of the beat note with the clarifier OFF. Now switch the clarifier on, and note the tone of the input signal. If it changes at all, adjust VR<sub>101</sub> (located on the CLAR SW Unit) so that the frequency is the same as when the clarifier was off.

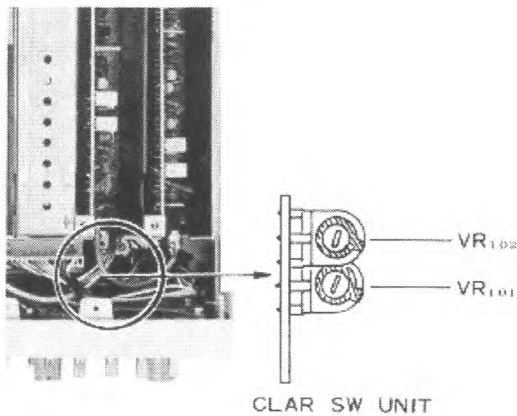

## ALC METER ZERO ADJUSTMENT

- a) Set the MODE switch to USB, and disconnect the microphone from the MIC jack. Set the METER switch to ALC.
- b) Set the VOX GAIN control to MOX, and adjust VR<sub>6004</sub> so that the ALC meter needle rests exactly on the left hand edge of the meter calibration scale.

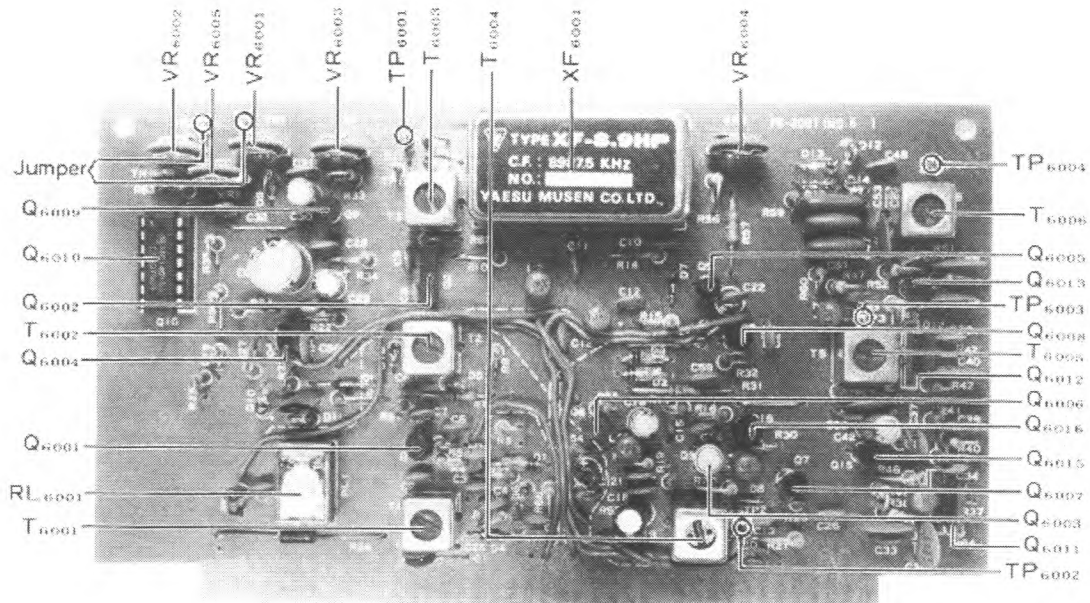
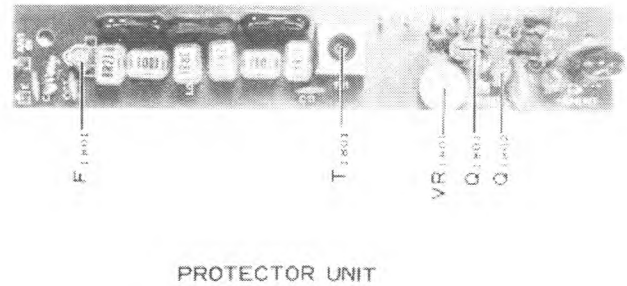

NB UNIT

## IC METER CALIBRATION

- a) Remove P<sub>1401</sub> from its connector. Install an ammeter in the 13.5 volt line between P<sub>1401</sub> and its jack.
- b) Set the BAND switch to 20, and set the MODE switch to FSK. Connect a dummy load to the antenna jack.
- c) Set the VOX GAIN switch to MOX, and advance the DRIVE control until the current reading on the ammeter reaches 15 amperes.
- d) Now note the reading on the front panel IC meter. If the meter reading is not 15 amperes, remove the case of the transceiver. Remove the internal speaker from its mounting position to expose VR<sub>9</sub>. Again set the VOX GAIN control to MOX, and adjust VR<sub>9</sub> for a reading of exactly 15 amperes on the meter. This alignment should not be necessary unless you have recently replaced the front panel meter.

## ALC ADJUSTMENT

- a) On the NB Unit, locate the jumper wire adjacent to VR<sub>6005</sub> (on the front panel side). Remove one end of this jumper temporarily.

- b) Preset the controls and switches as follows:  
 BAND ..... 160  
 DRIVE ..... Fully counterclockwise  
 VR<sub>6001</sub> (NB Unit) ..... Fully clockwise  
 MODE ..... FSK
- c) Close the MOX switch, and adjust VR<sub>6001</sub> for a reading of 12 watts on the meter.
- d) Now reinstall the jumper lifted in step (a). Close the MOX switch, and do not touch the DRIVE control. Adjust VR<sub>6005</sub> for a reading of 110 watts on the wattmeter. Now set the DRIVE control fully clockwise, and adjust VR<sub>6005</sub> slightly for a reading of 110 watts on the wattmeter.

## DIRECTIONAL COUPLER BALANCE (LPF Unit)

- a) Set the BAND switch to 20, and set the MODE switch to FSK. Connect a DC voltmeter between pin 3 of P<sub>16</sub> on the IF MOTHER BOARD (AFP IN) and ground.
- b) Close the MOX switch, and adjust the DRIVE control level for a medium power output. Adjust TC<sub>1601</sub> for a minimum reading on the voltmeter. If a good dip cannot be obtained, reduce the power output.

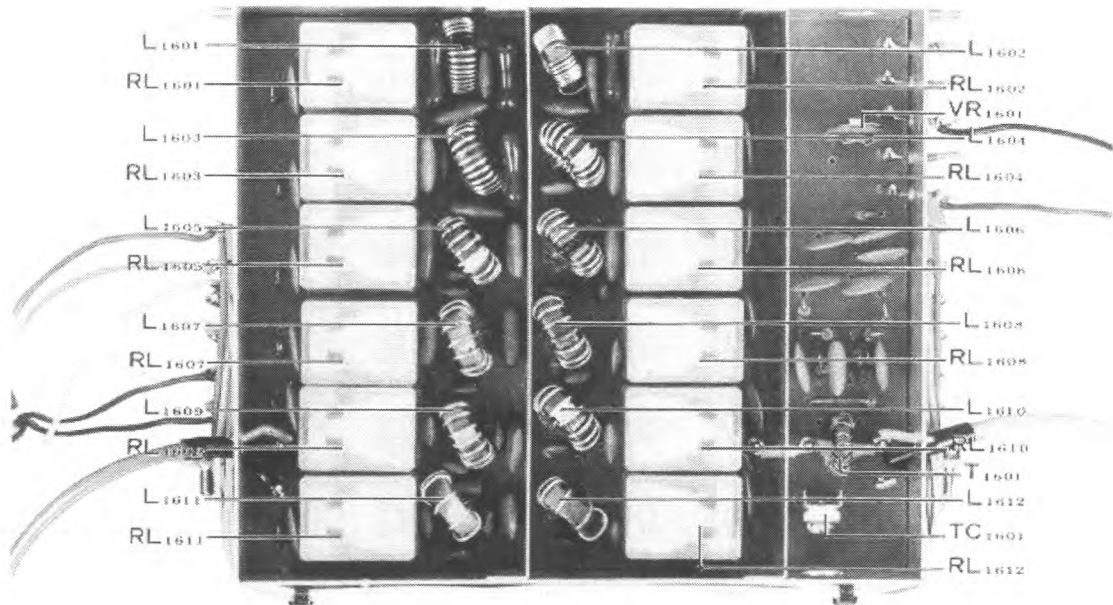

LPF UNIT

## AFP ALIGNMENT

(NOTE: DO NOT ATTEMPT THIS ALIGNMENT UNLESS THE PROPER DUMMY LOADS AND MEASURING EQUIPMENT ARE USED)

- (1) Set the BAND switch to 80, and the MODE switch to FSK. Set the DRIVE control for a power output of 100 watts into a 50 ohm dummy load.
- (2) Connect three 50 ohm dummy loads in parallel, so as to present a 17 ohm load to the amplifier (3:1 SWR with reference to 50 ohms). Close the MOX switch, and adjust VR<sub>1601</sub> (LPF Unit) for 75 watts power output as indicated on the wattmeter.

## DIRECTION COUPLER BALANCE (COUPLER Unit)

- a) Set the BAND switch to 20, the MODE switch to FSK, and the METER switch to REF. Connect a 50 ohm dummy load to the antenna jack.
- b) Close the MOX switch, and adjust TC<sub>2401</sub> for a minimum reading on the reflected power meter. Do this alignment first at a low power reading, then at a high power reading (for fine adjustment).

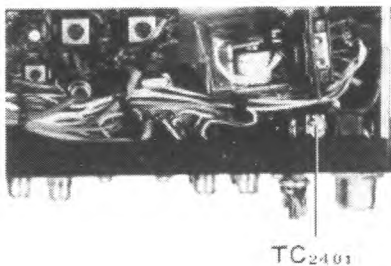

## VFO ALIGNMENT

The FT-107M VFO is not a unit that should require servicing. Most cases of "VFO trouble" can be traced to other areas, such as instability in a supply voltage. The frequency determining circuitry of the VFO is extremely critical in its alignment, and for this reason we recommend that all VFO repair cases be handled by an authorized Yaesu representative.

From a service standpoint, the following controls are of interest:

TC<sub>801</sub> sets the band edge of the VFO range.

TC<sub>802</sub> sets the VFO output level. It should be adjusted for a reading of 150 mV on a VTVM.

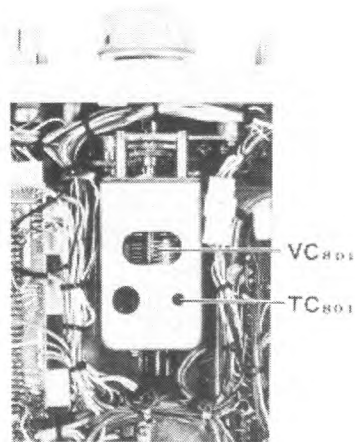

## PREMIX/LOCAL UNIT ALIGNMENT

(NOTE: THE ALIGNMENT OF THE PREMIX AND LOCAL OSCILLATOR CIRCUITS DIRECTLY AFFECTS THE LEVEL OF SPURIOUS SIGNALS ON BOTH TRANSMIT AND RECEIVE. DO NOT ATTEMPT ANY PORTION OF THIS ALIGNMENT PROCEDURE IF YOU DO NOT HAVE THE PROPER TEST EQUIPMENT)

- Set the SELECT switch to EXT VFO. Connect a 4.0 -6.5 MHz sweep generator to the EXT VFO input jack on the rear panel of the transceiver. Remove the plug connected to P<sub>2001</sub> (LOCAL Unit), and connect a high-impedance probe of an oscilloscope to the line at P<sub>2001</sub>. Do not insert a dummy plug at P<sub>2001</sub>, or else the 50 ohm termination will be removed from the circuit; this termination is desired.
- Refer to Figure 11, and adjust the cores of the transformers shown for a flat response across a 600 kHz range centered on the middle of each band.
- Remove the scope probe from the line to P<sub>2001</sub>, and connect the RF probe of VTVM to the same point. Refer to Figure 12 and adjust the transformers on each band for a reading of exactly 600 mV on the VTVM. For all bands except 160, perform this alignment with the main tuning dial set to the center of the band; for 160 meters, make the alignment at 1.900 MHz.

## RF BANDPASS ALIGNMENT

- Connect a sweep generator to TP<sub>1002</sub>, and connect an oscilloscope (through a detector) to TP<sub>1003</sub>. Refer to Figure 13 and apply the required sweep output. Adjust the cores of the transformers shown in Figure 13 for the pattern shown in Figure 14.
- Connect a signal generator to the antenna jack, and inject a 100 dB signal at 8.9875 MHz. Adjust TC<sub>1002</sub> for a minimum reading on the S-meter.
- Recheck the alignment of T<sub>1003</sub> after adjusting TC<sub>1002</sub>, as there is some interaction of the adjustments.

BAND	TRANSFORMER	PASSBAND
160m	T <sub>2013</sub> , T <sub>2014</sub>	10.4 -11.0MHz
80m	T <sub>2015</sub> , T <sub>2016</sub>	12.4-13.0
40m	T <sub>2017</sub> , T <sub>2018</sub>	15.9-16.5
30m	T <sub>2029</sub> , T <sub>2030</sub>	18.9-19.5
20m	T <sub>2019</sub> , T <sub>2020</sub>	22.9-23.5
17m	T <sub>2025</sub> , T <sub>2026</sub>	26.9-27.5
15m	T <sub>2021</sub> , T <sub>2022</sub>	29.9 30.5
12m	T <sub>2027</sub> , T <sub>2028</sub>	33.5 34.0
10m	T <sub>2023</sub> , T <sub>2024</sub>	36.9- 39.0

Figure 11

BAND	CRYSTAL	FREQUENCY	TRANSFORMER
160m	X <sub>2001</sub>	15.9845MHz	T <sub>2001</sub>
80m	X <sub>2002</sub>	17.9845MHz	T <sub>2002</sub>
40m	X <sub>2003</sub>	21.4845MHz	T <sub>2003</sub>
30m	X <sub>2012</sub>	24.4875MHz	T <sub>2012</sub>
20m	X <sub>2004</sub>	28.4875MHz	T <sub>2004</sub>
17m	X <sub>2010</sub>	32.4875MHz	T <sub>2010</sub>
15m	X <sub>2005</sub>	35.4875MHz	T <sub>2005</sub>
12m	X <sub>2011</sub>	38.9875MHz	T <sub>2011</sub>
10m A	X <sub>2006</sub>	42.4875MHz	T <sub>2006</sub>
10m B	X <sub>2007</sub>	42.9875MHz	T <sub>2007</sub>
10m C	X <sub>2008</sub>	43.4875MHz	T <sub>2008</sub>
10m D	X <sub>2009</sub>	43.9875MHz	T <sub>2009</sub>

Figure 12

	BPF XFMR	ANT XFMR	A B SWEEP	C
160m	T <sub>1007</sub> , T <sub>1008</sub>	T <sub>1001</sub>	1.8- 2.0MHz	A djust for less than 3 dB ripple
80m	T <sub>1009</sub> , T <sub>1010</sub>	T <sub>1002</sub>	3.5- 4.0MHz	
40m	T <sub>1011</sub> , T <sub>1012</sub>	T <sub>1003</sub> , TC <sub>1002</sub> ★	7.0- 7.5MHz	
30m	T <sub>1030</sub> , T <sub>1031</sub>	T <sub>1025</sub>	10.0-10.5MHz	
20m	T <sub>1013</sub> , T <sub>1014</sub>	T <sub>1004</sub>	14.0-14.5MHz	
17m	T <sub>1026</sub> , T <sub>1027</sub>	T <sub>1023</sub>	18.0-18.5MHz	
15m	T <sub>1015</sub> , T <sub>1016</sub>	T <sub>1005</sub>	21.0-21.5MHz	
12m	T <sub>1028</sub> , T <sub>1029</sub>	T <sub>1024</sub>	24.5-25.0MHz	
10m	T <sub>1017</sub> , T <sub>1018</sub>	T <sub>1006</sub>	28.0-30.0MHz	

★ TC<sub>1002</sub> to the 1/2 position for step (b).

Figure 13

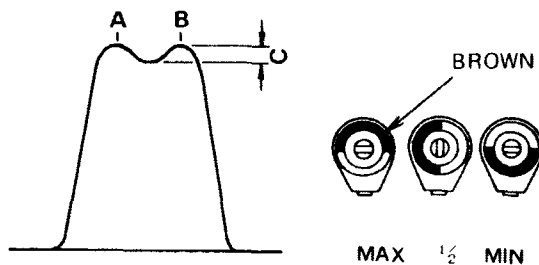
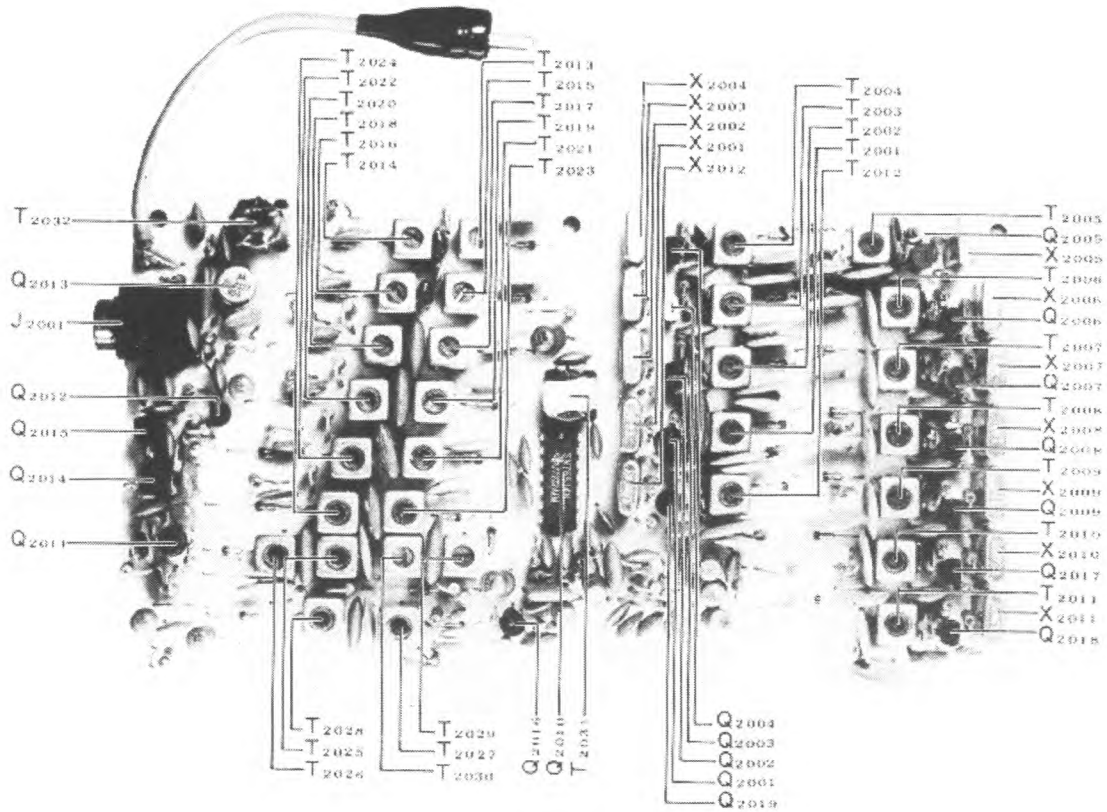

Figure 14

## OTHER TRANSFORMER ALIGNMENTS

Adjust the transformers shown in the chart below for the response shown in the chart.

UNIT	TRANSFORMER	ADJUSTMENT
RF	T <sub>1019</sub>	RX: Max. S-meter reading on marker.
NB	T <sub>6001</sub> , T <sub>6004</sub> T <sub>6002</sub> , T <sub>6003</sub>	TX SSB, PROC OFF: Max. power output. TX SSB, PROC ON: Max. power output.
IF	T <sub>4002</sub> , T <sub>4003</sub>	RX: Max. S-meter reading on marker.
FILTER	T <sub>3001</sub> , T <sub>3002</sub> , T <sub>3003</sub> , T <sub>3004</sub> , T <sub>3005</sub> , T <sub>3006</sub> , T <sub>3007</sub> , T <sub>3009</sub>	RX: Max. S-meter reading on marker.
AF	T <sub>5002</sub> T <sub>5003</sub>	TX SSB: Max. power output. TX FSK: Max. power output.



LOCAL UNIT



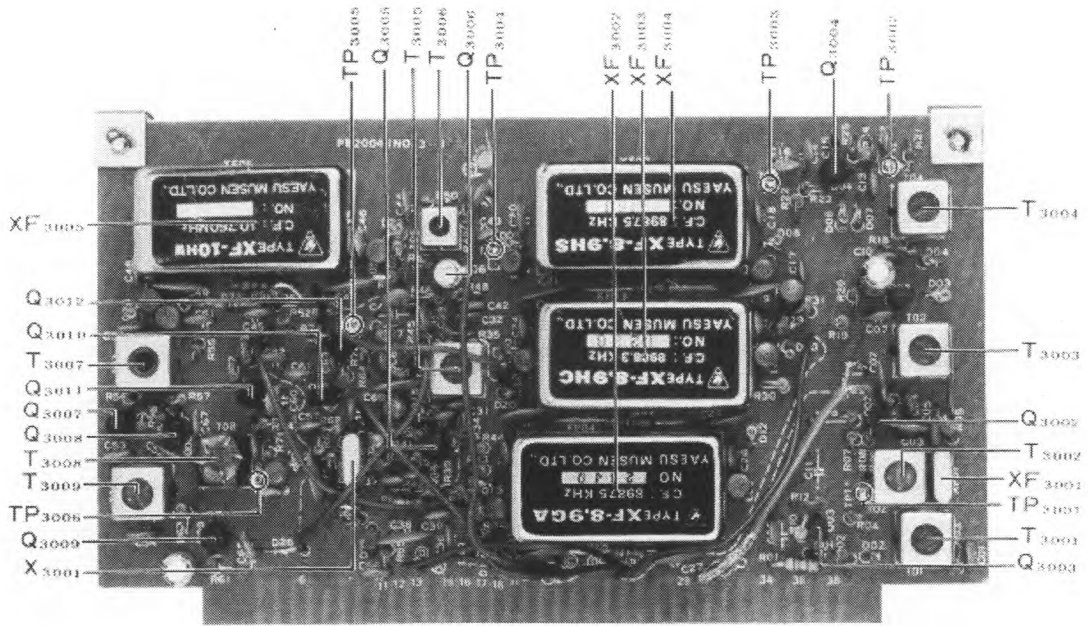

FILTER UNIT

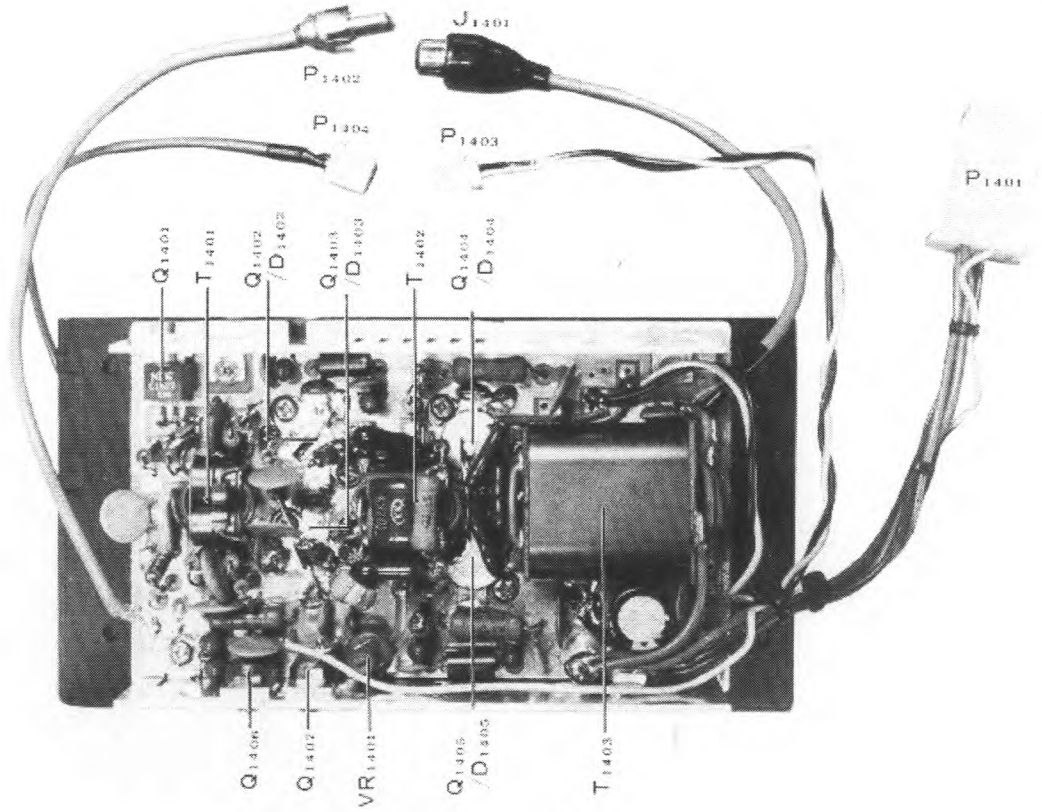

100W PA UNIT

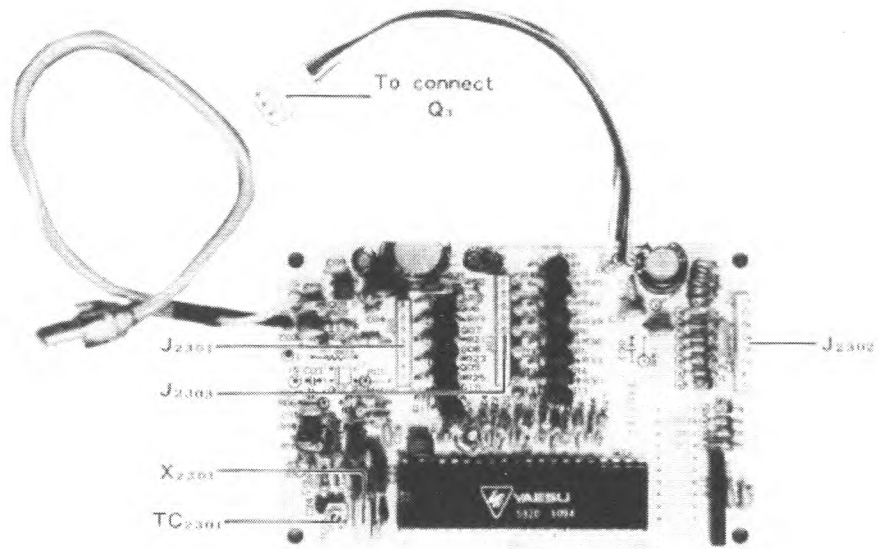

COUNTER UNIT

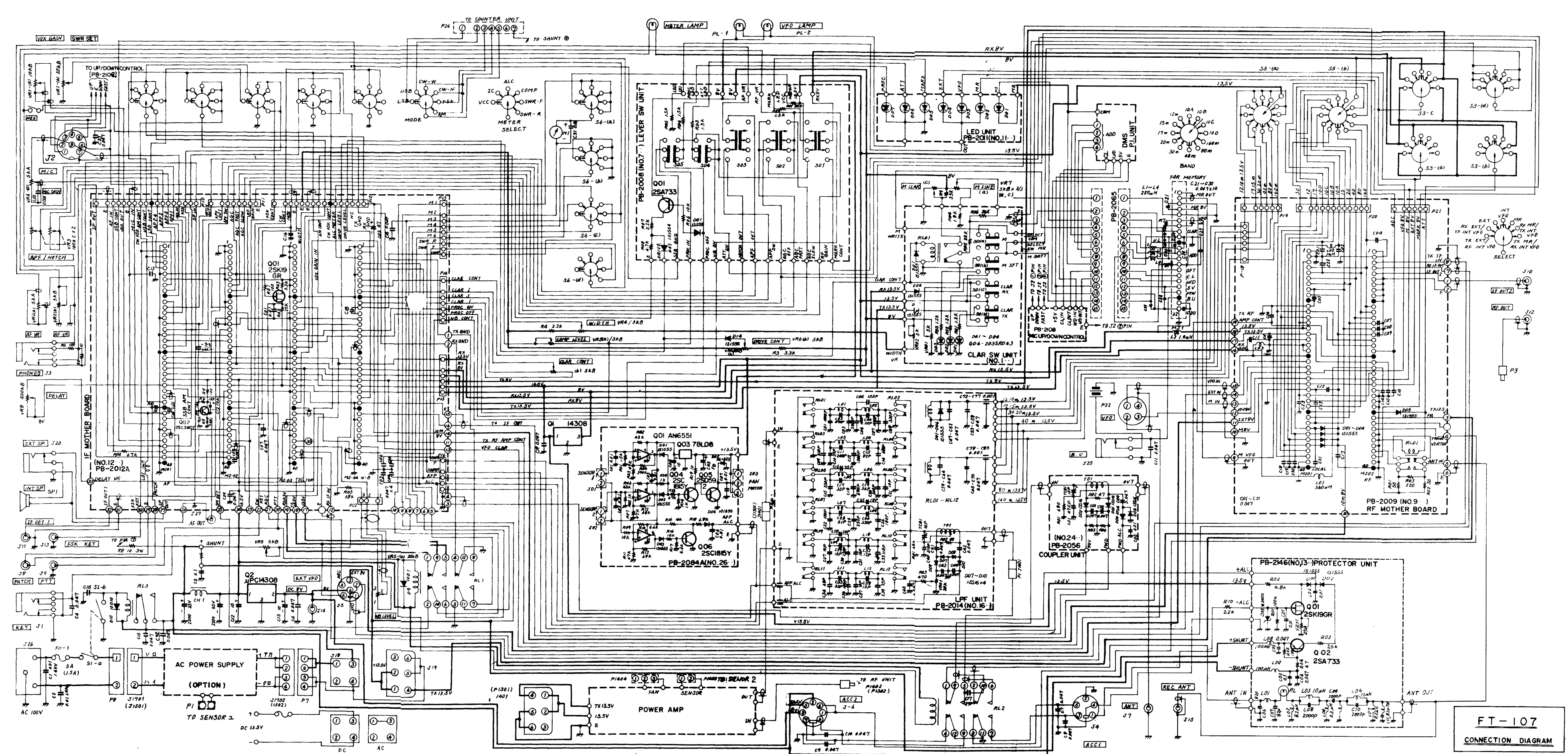

FT-107  
CONNECTION DIAGRAM