

Fast and Furious Arcade Operator's Manual



FAST & FURIOUS ARCADE



Table of Contents

OPERATION	5
TRANSPORTING	5
HANDLING COMPONENTS	5
DISCONNECT POWER	5
GROUNDING.....	5
ELECTRICAL SHOCKS.....	5
MONITOR	5
VOLTAGE.....	5
POWER CORD	5
SURGE SUPPRESSOR.....	6
WATER AND OTHER LIQUID SOURCES	6
CONNECTORS.....	6
COMPUTER.....	6
VENTILATION	6
HAZARD TO EPILEPTICS.....	6
MANUAL.....	6
SPECIFICATIONS.....	7
Product Specifications	8
ELECTRICAL POWER	8
TEMPERATURE	8
HUMIDITY	8
DIMENSIONS.....	8
Fuse Replacement Guide	8
12V POWER DISTRIBUTION.....	8
Setup	9
SAFETY NOTICE	9
UNPACK MATERIALS	9
REQUIRED TOOLS	9
CABINET ASSEMBLY	10
Lower Monitor Installation	10
Top Monitor Mounting Bracket Installation	11

Fast and Furious Arcade

Top Monitor Hanger Bracket Installation	12
Top Monitor Assembly Installation.....	13
HDMI/AC Cables and Monitor Rear Cover Plate Installation.....	14
Cabinet Joiner Bracket Installation	15
Motion Cabinet Installation	16
CARD READER INSTALLATION AND SETUP.....	17
CHECK ELECTRICAL SETTINGS.....	18
STARTUP GAME	18
SAMSUNG MONITOR SETTINGS.....	19
Diagnostic and Adjustments	20
BASIC FUNCTIONAL TEST ON INITIAL POWER UP	21
TEST MENUS	22
Main Menu.....	22
Diagnostics	23
Pricing Adjustments (Cash)	24
Pricing Adjustments (Tokens)	25
Pricing Adjustments (Swipes).....	26
Game Settings	27
System Settings.....	28
Audits	29
Resets Menu	30
Volume	31
Calibration.....	32
Utilities	33
System Information.....	34
CHOOSING THE RIGHT PRICING ADJUSTMENTS FOR YOUR LOCATION	35
PC HARDWARE	36
PC HARD DRIVE RECOVERY	37
Troubleshooting	38
Technical Support.....	43
Electrical and Mechanical Illustrations.....	44

Safety

Operation

Before operating game, read this manual. Failure to properly install and operate this game could result in malfunction or accident. Operate the game in accordance with the manual.

Transporting

The cabinet is very heavy. Because the monitor is high, the cabinet is also very top-heavy. Use appropriate care when moving or transporting cabinet. It contains fragile glass and electronic components. Avoid rough handling.

Handling Components

Many components are extremely sensitive to handling, environmental and Electrostatic Discharge (ESD) events—especially the computer. Do not handle it roughly. Before servicing, call your distributor and inquire about the PC warranty. Use proper ESD procedures when servicing. Protect components from harmful environmental conditions, such as extreme temperatures, excessive moisture or other damaging effects.

Disconnect Power

Always turn the power off and unplug the unit before servicing or making adjustments unless otherwise instructed. Installing or repairing components while power is on can damage the components and void the warranty.

Grounding

Avoid electrical shock. Do not plug in AC power until you have inspected and properly grounded the unit. Only plug into a grounded, three-wire outlet. Do not use a “cheater” plug or cut off the ground pin on the line cord.

Electrical Shocks

There is no isolation transformer in the cabinet. Disconnect AC power before servicing. However, be aware that lethal voltages can remain in the electronic components even when AC power is disconnected. Use extreme caution when servicing. Verify that there is a working ground connection. If the unit sustains water damage, cease using it immediately and unplug AC power.

Monitor

The monitor contains no user serviceable parts. Do not attempt to service the monitor.

Voltage

Each game is manufactured for a specific AC voltage. Before applying power, verify that the AC voltage matches the game’s specified voltage rating.

Power Cord

If the power cord is damaged or lost, replace it with an identical cord as supplied by the manufacturer or an authorized service agent.

Surge Suppressor

It is recommended that you plug your game's power cord into a surge suppressor to help protect from power surges that may damage sensitive electronic components.

Water and Other Liquid Sources

Do not install game near sprinkler or other water jet sources. Do not use water jet to clean game. Keep minimum clearance behind game and wall for proper ventilation but also prevent access of liquid from spills and sprays from entering ventilation holes.

Connectors

When servicing machine, ensure all connectors mate properly. If connectors do not slip in easily, do not force them. Connectors are often keyed and only connect one way. Check for correct orientation.

Computer

The computer contains sensitive components, including a hard drive. Do not handle it roughly. Call your distributor before servicing its internal components. Ask about warranty information as it relates to the PC. Cycle AC power on or off with the cabinet power switch.

A dongle has been inserted into one of the USB ports. This is required for game play.

Do not remove the dongle except for troubleshooting purposes.

Ventilation

It is critical that the game is installed in a manner that allows for proper ventilation and air flow. Game must be installed such that there is a minimum amount of clearance between the wall or another game to allow good air circulation through the game cooling fans and vents.

Hazard to Epileptics

A small portion of the population has an epileptic condition that may cause seizures. Affected persons experience seizures while watching some television pictures or playing certain video games. People who have not had seizures may still have an undetected epileptic condition. If anyone in your family has experienced epilepsy symptoms (seizures or loss of awareness), consult your physician before using video games. While children play video games, a parent should observe. Be alert to the following symptoms: dizziness, altered vision, eye or muscle twitching, involuntary movements, loss of awareness, disorientation or convulsions. If you or your child experiences these symptoms, discontinue use immediately and consult your physician.

Manual

Keep this manual available and ready for use. If the game fails to function properly, turn off the machine and unplug the AC line cord. Contact your local distributor. You may not reproduce this document or any of its contents without written authorization from Raw Thrills, Inc.

Specifications

For reasons such as performance, this product's specifications may change without notice. Federal patent, copyright and other intellectual property laws protect the content, devices and design of the game and its equipment.



- This machine features moving parts and should only be serviced by a trained and experienced technician.
- Disconnect all power and air supply before servicing the machine.
- Keep area around the machine clear and free of objects that present a trip hazard. Allow for plenty of room for players to safely enter and exit the machine.
- Observe ALL of the following guidelines to prevent injury, accident, or damage.
 - Maximum of one person on the machine at any time.
 - If a player fatigues or experiences motion sickness or is unable to continue the game for any reason, stop the game motion immediately by pressing the MOTION STOP button. Allow the person to rest and exit the game with assistance if needed.
 - Remain seated for the entire duration of the game. Do not stand or exit while the game is moving. Press the MOTION STOP button before exiting the game.
 - Keep hands and legs inside the game at all times while in motion. Remain in the game until game comes to a complete stop.
 - Do not attempt to reach for objects on the floor or near the game when it is moving. Stay clear and stand at a safe distance while game is in motion.
 - Small children should always be accompanied by a parent or guardian.
- The machine is equipped with safety features which the operator and the player need to be familiar with:
 - MOTION STOP button is located on the left side of the seat pedestal, under the dash. This button will stop the motion feature once pressed.
 - Bellows around the moving part of the machine prevent access between the base and the moving part. Make sure that the bellows are not damaged or showing signs of excessive wear that could lead to failure. Replace the bellows when this occurs. Use only tamperproof screw fasteners as specified.
 - The machine is designed so that there is no unintended movement in the absence of a logic signal as might be experienced during a power outage. Make sure that the machine is safe to operate before turning power back ON.
- Critical parts should be maintained and inspected regularly for safe operation. If those critical parts are damaged, broken, or installed incorrectly, replace them, or install correctly. Use only manufacturer's specified parts for continued safety and reliability. Contact your distributor to order replacement parts.

Product Specifications

Electrical Power

MULTIPLE POWER SUPPLY ENTRIES

Warning: Before obtaining access to terminals, all supply circuits must be disconnected.

Attention: Avant d'accéder aux bornes, tous les circuits d'alimentation doivent être déconnectés.

United States, Canada (ETL)

Voltage: 120VAC / 60 Hz

Operating AC Current: 20 Amps (10 Amps per entry)

International (CE)

Voltage: 230VAC / 50Hz

Operating AC Current: 10 Amps (5 Amps per entry)

Temperature

50° F to 104° F

(10° C to 40° C)

Humidity

Must not exceed 95% relative humidity

Dimensions

8'10 3/4"H x 4'9 1/4"W x 9'11 1/4"D (271.15cm H x 145.42cm W x 302.90cm D)

Approximate weight 1100lbs. (500kg)

Single cabinet setup recommended minimum floor space requirement:

10'H x 8'1 1/4"W x 15'3 1/2"D (304.8cm H x 247.015cm W x 466.09cm D) *see pg. 46 for diagram*****

Twin cabinet setup recommended minimum floor space requirement:

12'H x 12'10 1/2"W x 15'3 1/2"D (365.76cm H x 483.87cm W x 466.09cm D) *see pg. 48 for diagram*****

Fuse Replacement Guide

NOTE: FOR CONTINUED PROTECTION AGAINST FIRE AND ELECTRICAL DAMAGE, USE ONLY SPECIFIED FUSE TYPE AND VALUE.

12V Power Distribution

Please see unit for specified fuse labeling.

Abbreviations:

5A 250V	5A, 250VAC Fast Acting 3AG Fuse	Littlefuse 0312005.MXP (or equivalent)
---------	---------------------------------	--

Setup

Safety Notice

Installing this product requires three individuals able to lift heavy objects safely. Two 6-foot step ladders (minimum height) are required as part of the installation process. Make sure that you are familiar with the manual contents, game setup, and operations before you begin the installation process. Do not push or pull on the decorative items such as the monitor bracket or spoiler to move the game. Doing so can damage the decorative items. Be aware of your surroundings and individuals around you during the installation process for your safety and the safety of others. Work only in an area with sufficient lighting and a clean level surface.

Unpack Materials

1. Place the shipping crate(s) on a flat, stable surface.
2. Cut the banding straps and remove the cardboard lids.
3. Lift off the large cardboard containers surrounding the cabinet assembly and remove any shipping cleats.
4. Remove the keys from the front dash.
5. Check for shipping damage to the following:
 - Monitor(s)
 - Monitor bracket
 - Cabinet decals
6. Check the AC line cords for visible signs of damage.

Pay particular attention to the plug and line cord insulation.

Required Tools

- Drill Driver
- Phillips Bit
- T-15 Tamper Resist Torx Bit
- T-20 Tamper Resist Torx Bit
- T-27 Tamper Resist Torx Bit
- Ratcheting Wrench
- 7/16" Socket
- 13mm Socket
- (2) 6ft Step Ladders (Minimum Height)

Cabinet Assembly

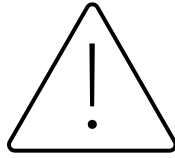

CAUTION

UNDER NO CIRCUMSTANCES SHOULD THIS GAME BE OPERATED UNLESS ALL INSTALLATION PROCEDURES HAVE BEEN COMPLETED AND ALL SAFETY FEATURES HAVE BEEN POSITIVELY TESTED AND ARE FULLY FUNCTIONAL!

*******It is recommended that the main cabinet be moved to or very near its desired operational location before beginning any of the setup tasks (see pg. 46 (Single Game) or pg. 48 (Twin Games) for footprint measurements).*******

Lower Monitor Installation

1. Remove the upper and lower back doors from the cabinet.
2. Unpack monitor and use packaging to stand monitor in an upright position on the floor.
3. Insert the (4) spacers (*fig. a* DETAIL A below) included with the monitor mounting kit into the (4) mounting holes on the back of the monitor. ***These spacers must be used to maintain a proper air space and keep the monitor from overheating.***
4. Set monitor up onto cabinet ledge, line up with mounting slots in cabinet and hold monitor to face of cabinet as shown (*fig. a* below).
5. Use (4) 8Mx65MM screws (*fig. a* DETAIL A below), with (1) washer on each screw to secure monitor. Do not tighten screws until final setup is completed, minor adjustments may be required if setting up multiple linked games.
6. Plug AC cord into AC socket and install the HDMI-DVI cable into HDMI 1 at rear of monitor and the DVI port on the graphics card at rear of PC.
7. Set the upper/lower monitor cross bracket on top of the cabinet with channel capturing the top of the lower monitor and secure using (4) #8 wood screws (*fig. a* below).

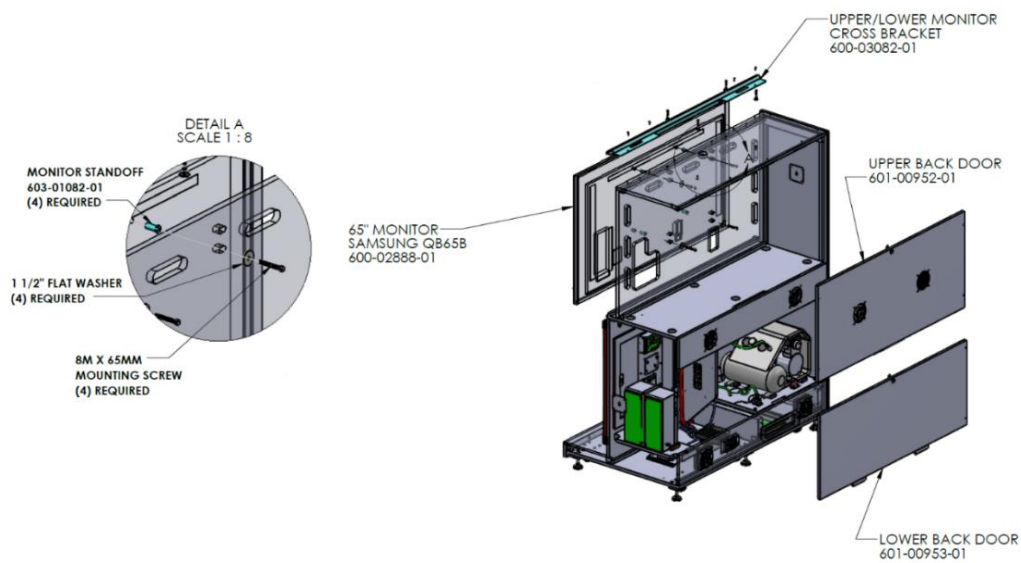

fig. a

Top Monitor Mounting Bracket Installation

The upper monitor assembly weighs approximately 95 lbs. and the installation requires a minimum of three people, using two 6-foot step ladders (minimum height). It is strongly recommended that the game NOT be moved with the monitor installed in the operational (upright) position.

1. Set top monitor mounting bracket in position on top of the main cabinet, align 2" hole and (4) slots in bracket with the holes in the top of the cabinet. Hold in place while finger tightening (4) 1/4-20 x 1" screw, lock and flat washer into holes in top of cabinet (*fig. b* Detail B below).
2. Securely tighten after all assembly is complete.

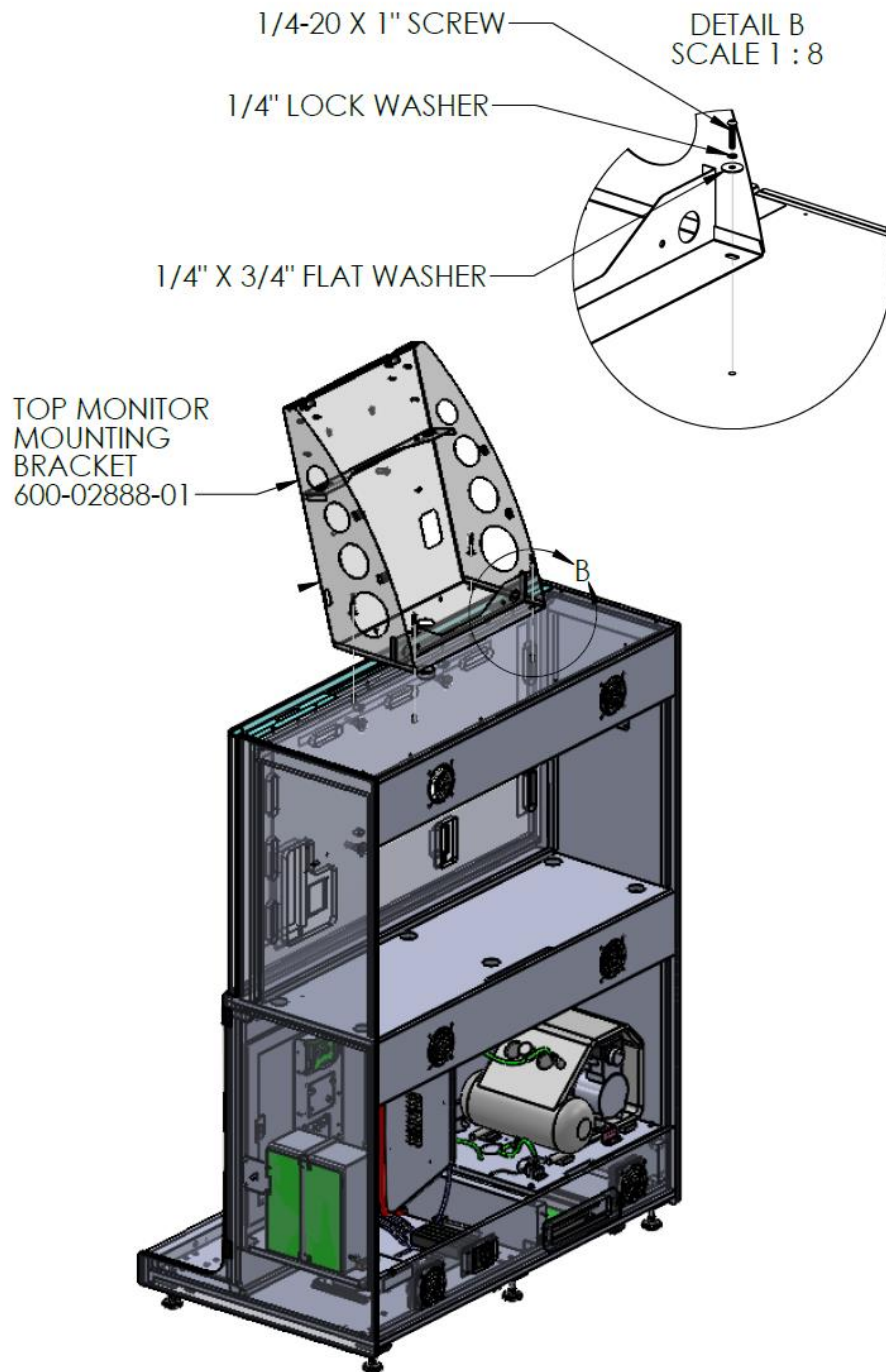

fig. b

Top Monitor Hanger Bracket Installation (Samsung QB65B Monitor)

For Samsung BE65T see instructions on page 46

1. Unpack remaining monitor and lay face down on a soft surface.
2. Install the standoff spacers into the (4) mounting holes in the back of the monitor (*fig. c* below).
3. Set hanger bracket in the position shown so the top mounting holes line up with the upper standoffs (*fig. c* below).
4. Insert (2) 8Mx50MM screws, flat and lock washer (*fig c* below) and tighten hanger bracket to monitor securely. ***DO NOT OVERTIGHTEN***

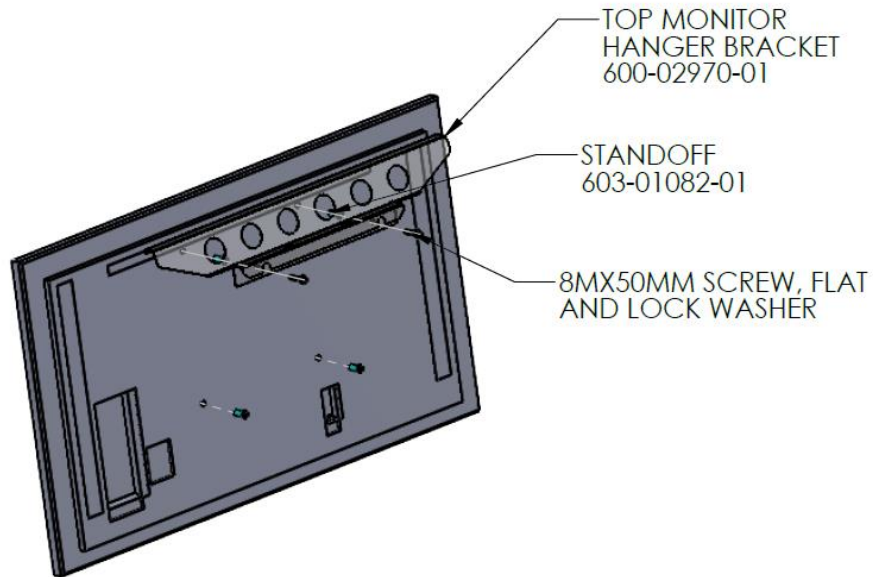

fig. c

Completed Assembly

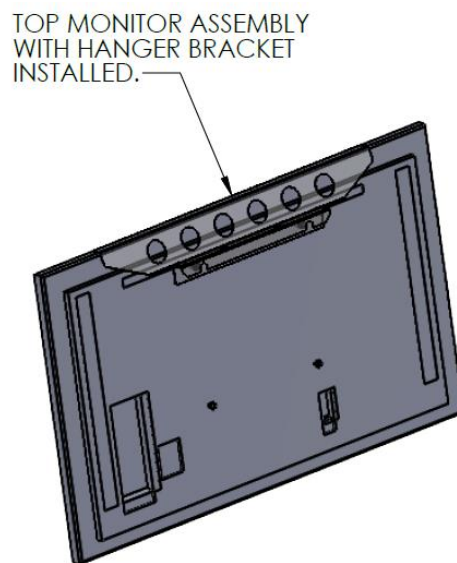

fig. d

Top Monitor Assembly Installation

1. Using (2) people, hang the top monitor hanger over the top mounting bracket and lower the bottom of the monitor into the channel below (*fig. e* below).
2. Install the lower (2) standoff spacers into the lower holes in the back of the monitor (*fig. e* below).
3. Install (2) remaining 8Mx50MM screws, flat and lock washer (*fig. e* below) and tighten monitor to bracket securely. *****DO NOT OVERTIGHTEN*****
4. *****IMPORTANT STEP***** Install (2) ¼-20x1" screws, flat and lock washers (*fig. e* below) to the top of the bracket to secure the upper monitor assembly.

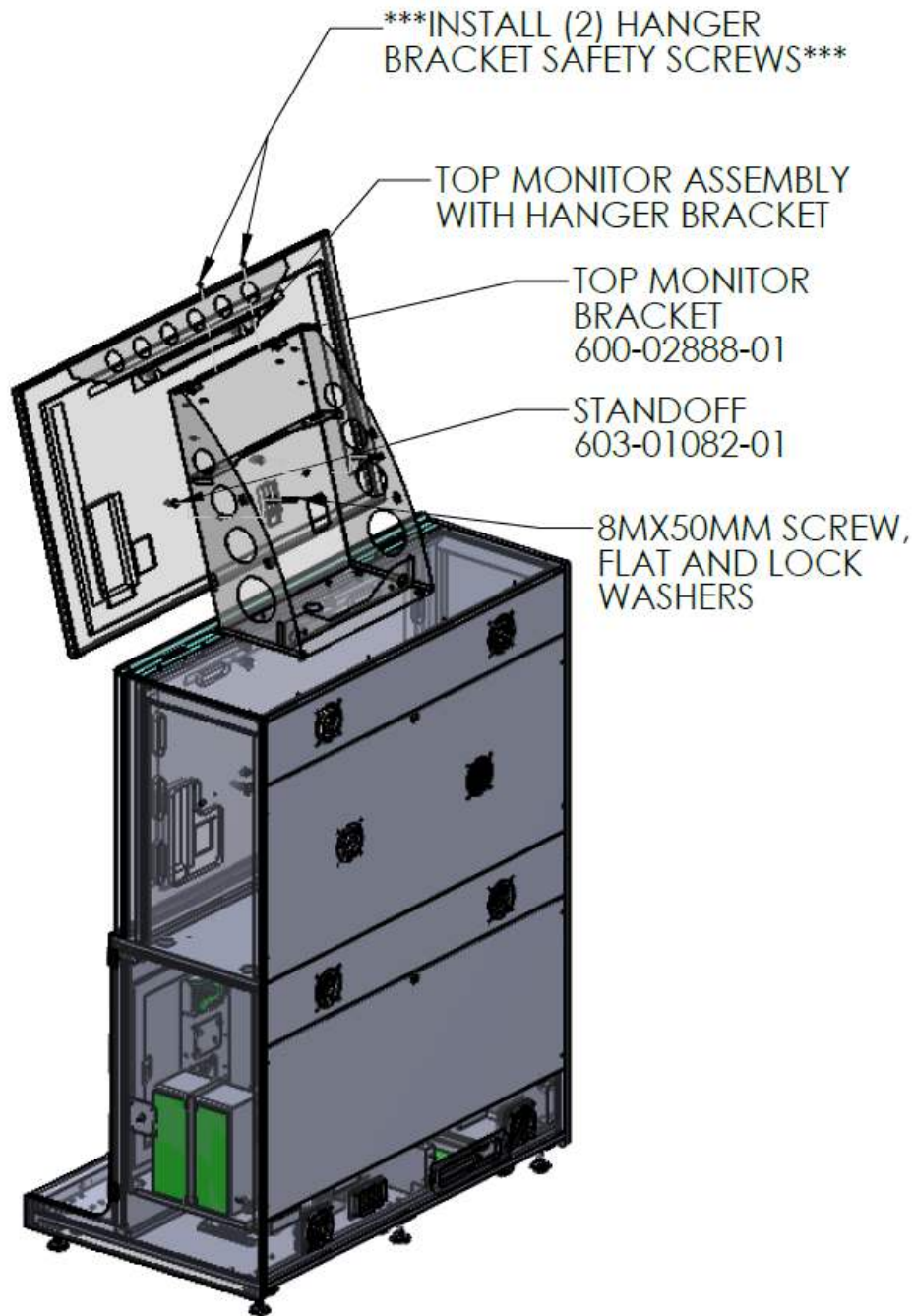

fig. e

HDMI/AC Cables and Monitor Rear Cover Plate Installation

1. Plug AC cord into AC socket on the rear of top monitor and feed AC cable down through the 2" center hole in top of cabinet (*fig. f* below).
2. Install HDMI cable to top monitor in HDMI 1 and feed through side slot and center hole in cabinet top (*fig. f* below). Connect to the HDMI port on the video card at rear of PC.
3. Install the rear cover plate with ¼-20 x ½ screws, and flat washers provided (*fig. f* Detail C below).

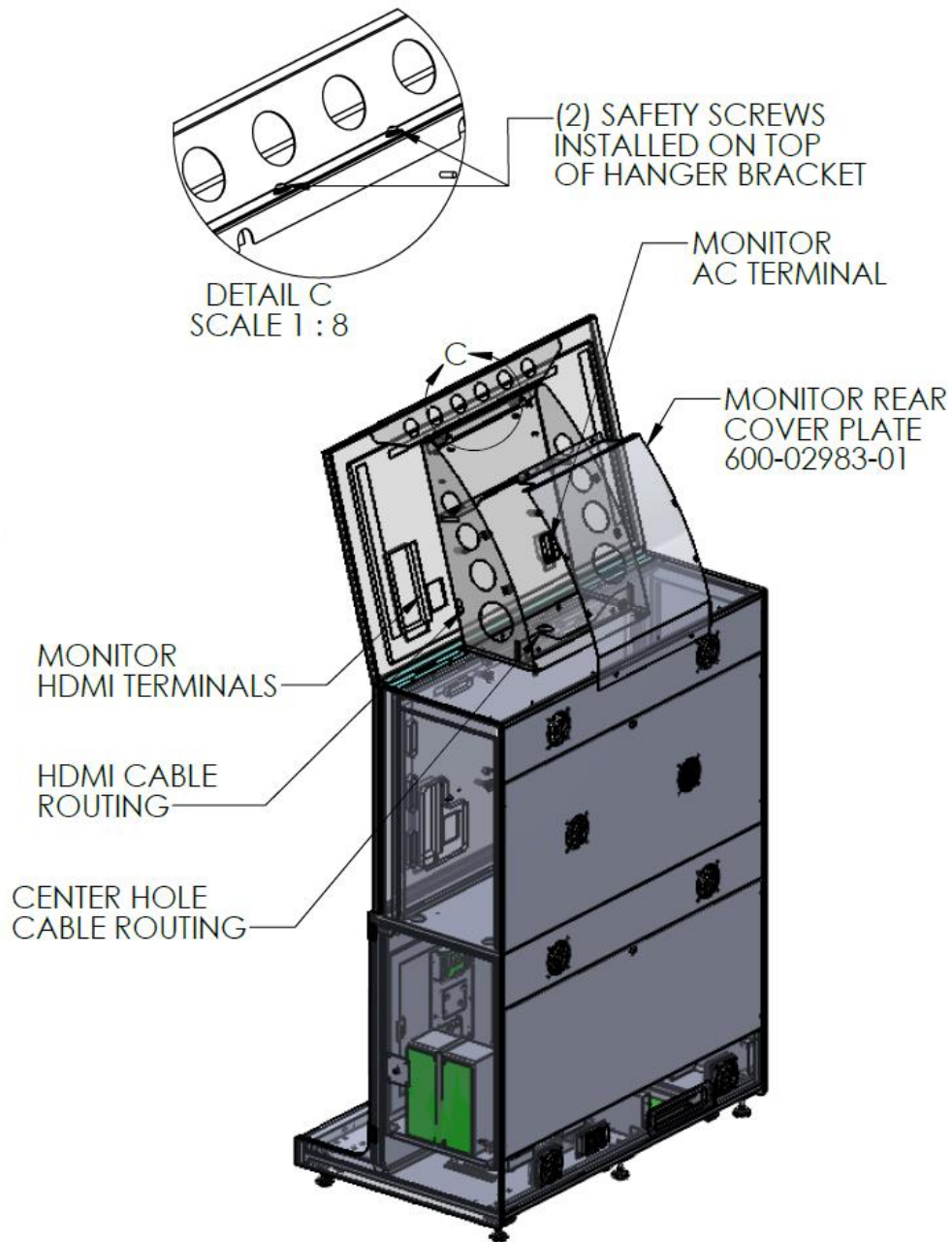

fig. f

Cabinet Joiner Bracket Installation

1. Install the joiner bracket to main cabinet with (4) 1/4-20 x 2" screws, flat and lock washers. (*fig. g* Detail D below).
2. Set the cover plate to the side, it is not needed at this time.

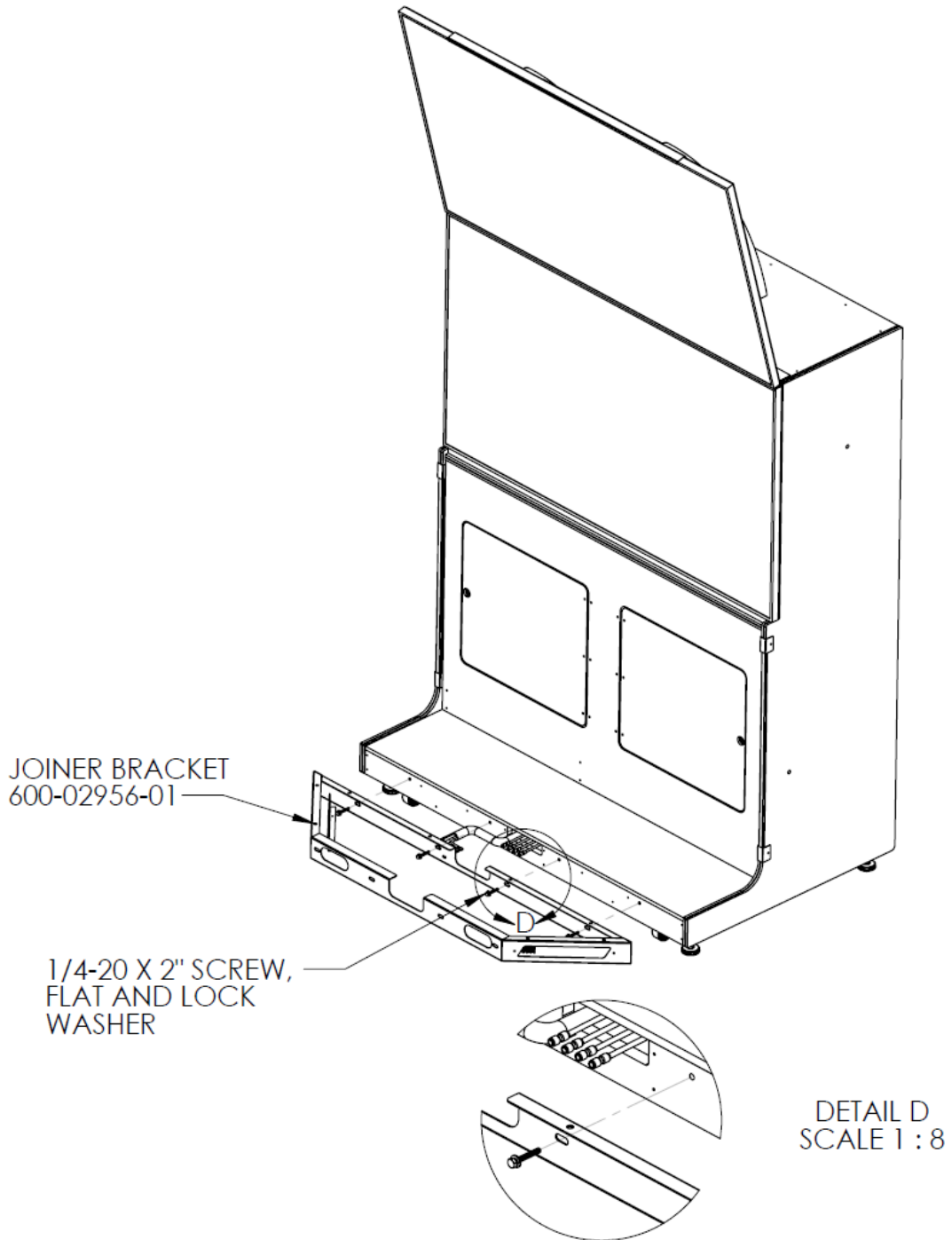

fig. g

Motion Cabinet Installation

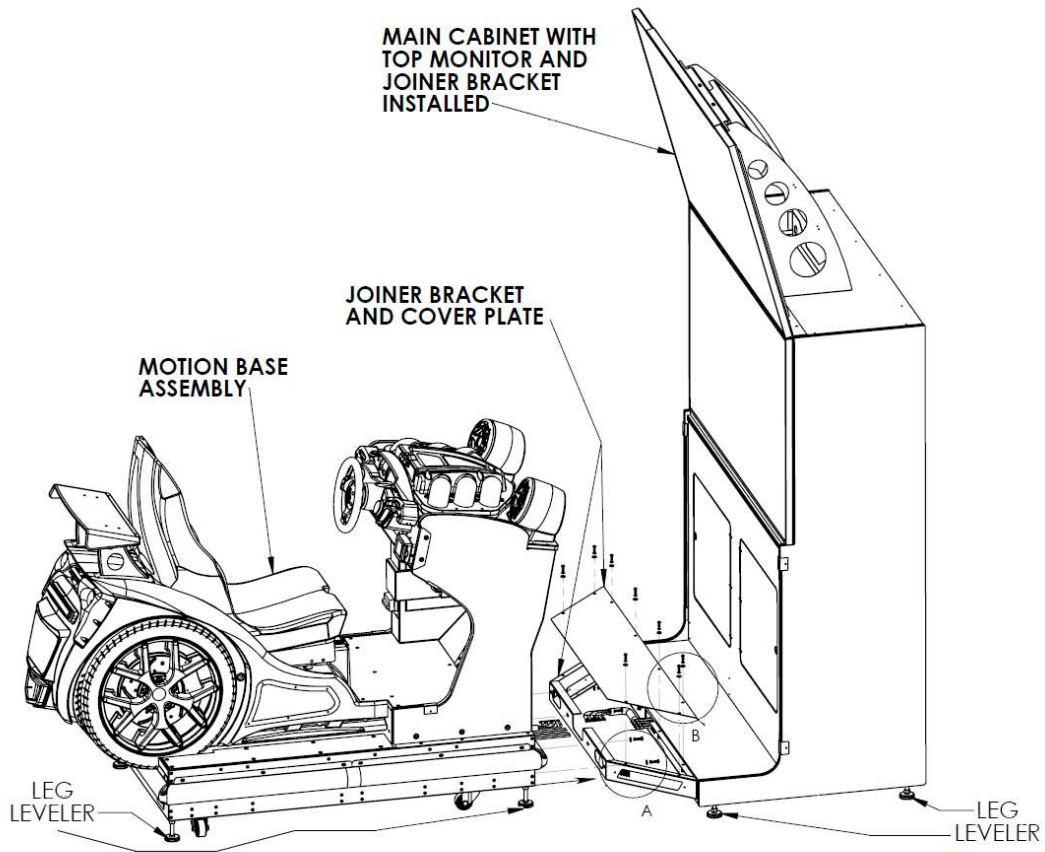

fig. h

1. Push motion base assembly flush with the joiner bracket (*fig. h* above).
2. Connect all matching cable and air hose connections inside of the pan of the joiner bracket.
3. Install (4) ¼-20 x 1" screws, flat and lock washers to secure the motion base to the cabinet joiner bracket and main cabinet (*fig. i* Detail A below).
4. With the cabinet in the desired location, set all leg levelers on the cabinet and motion base in the down position.
5. Use supplied (8) ¼-20 x ½" screws, lock and flat washers (*fig. i* Detail B below) to secure the cover plate to the joiner bracket.

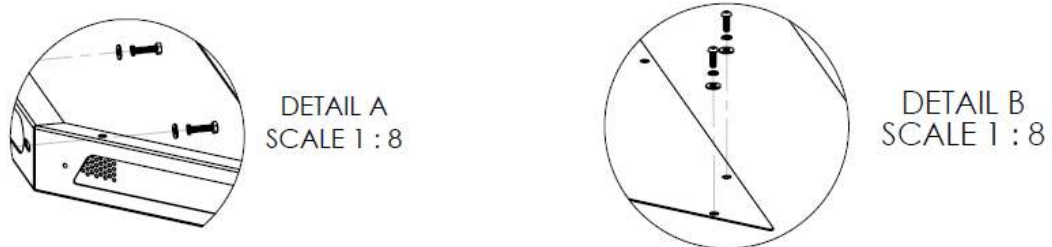

fig. i

Card Reader Installation and Setup

Due to the rising popularity of aftermarket debit card systems for cashless or coinless operation of amusement machines (i.e. Embed, Intercard, Semnox), this Fast & Furious Arcade cabinet is equipped with UCL compatible harnessing to ensure that the installation process is easier and less prone to miswiring.

UCL, or Universal Card Link, is a debit card standard established by the American Amusement Machine Association. Visit <https://coin-op.org/standardization/> for the latest UCL standard and manual information.

The UCL connections on the game use pins 1, 2, 6, 8, and 9. The other pins are unused. Each UCL connector can supply up to 1A at 12VDC.

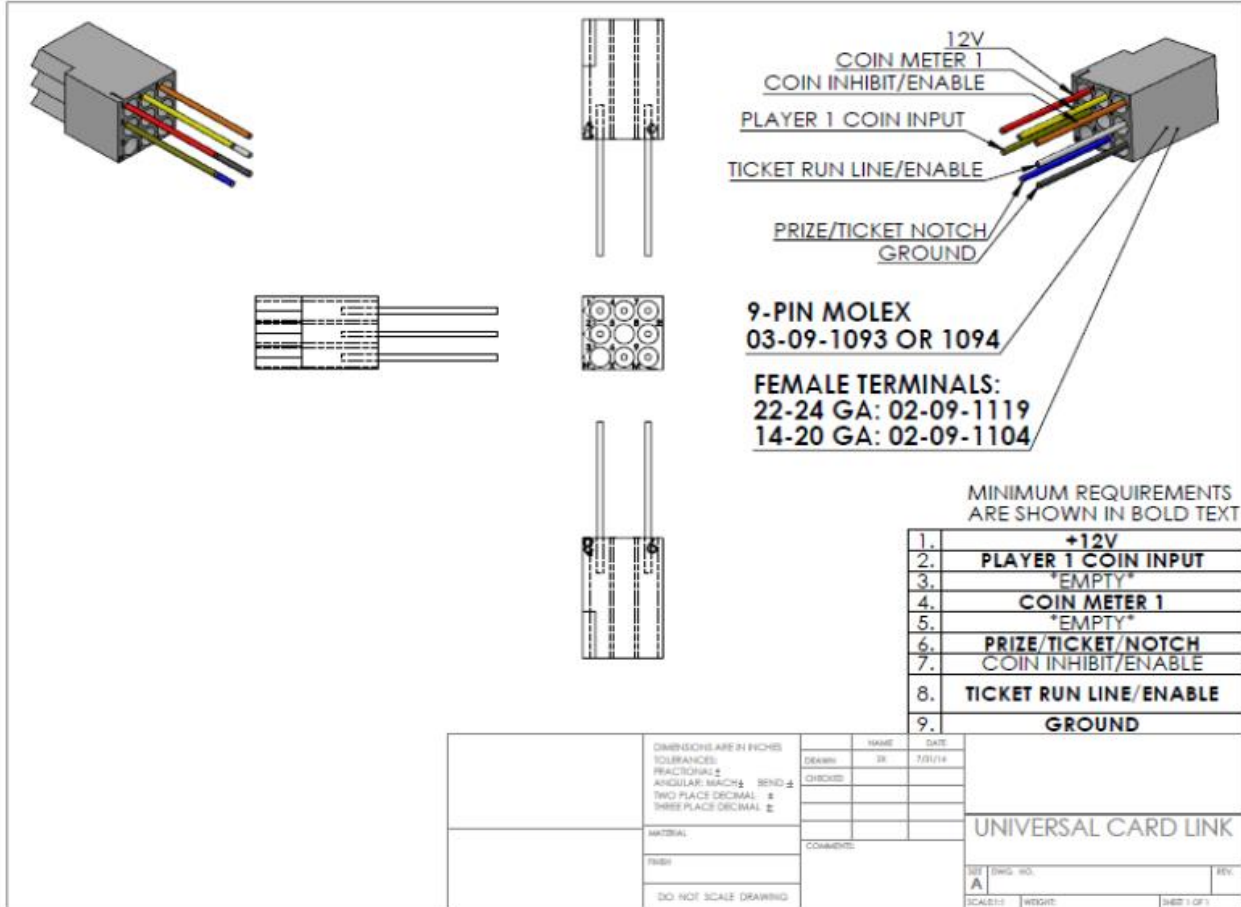

You can choose to use 1 card reader in the pricing adjustments section of the test menu. It is recommended to use 1 card reader for best results and player access.

There is (1) supplied connection, located on the driver cabinet assembly behind the dash plate to the right of the steering wheel. It is recommended that the card reader be mounted to the bottom right corner of the dash, using the provided UCL connector and provided mounting holes. *****See pg. 45 for mounting instructions*****

Check Electrical Settings

1. Verify the voltage in the nearest AC outlet.
2. Verify the AC outlet ground connection is present and working.

*****Recommended: Game on dedicated breaker to prevent capacity overload (20A@120VAC, 10A@230VAC)*****

*****Recommended: UPS (Uninterruptible Power Supply)*****

Startup Game

1. Plug the two line cords into an AC outlet (**Recommended: plug the line cords into a dedicated breaker to prevent capacity overload (20A@120VAC, 10A@230VAC)**).
2. Turn the main cabinet power switches on (there are two switches, GAME and COMPRESSOR).
3. Calibrate the steering (follow onscreen prompts).
4. Calibrate the gas and brake pedals (follow onscreen prompts)
5. Calibrate the motion platform (follow onscreen prompts)
6. Calibrate the camera (follow onscreen prompts).
*****MACHINE IS NOT OPERATIONAL WITHOUT FIRST CALIBRATING THE HARDWARE*****
7. Verify the game and all components are operating normally. See *Basic Functional Test on Initial Power Up* in the *Diagnostics and Adjustments* section for the recommended procedure.
8. Complete the monitor setup for both monitors (next page).

*****IMPORTANT*****

PLEASE FOLLOW INSTRUCTIONS TO SET UP MONITORS

SAMSUNG MONITOR SETTINGS

Model #QB65B

STEP 1: Verify game is connected to monitor in HDMI IN 1 at rear of both monitors (top monitor connects to HDMI port on video card at rear of PC, bottom monitor connects to DVI port on video card at rear of PC).

STEP 2: Power on GAME cabinet and MONITORS, wait about 30 seconds.

1. Installation Type: Basic Setup
2. Language: English (Select "Hello")
3. Wireless Connection: SKIP <right arrow>
4. Display Orientation: Landscape
5. PlayVia: Magicinfo: SKIP
6. Connection to Magicinfo server: SKIP
7. Set Date/Time
8. Set PIN: Save the PIN in a secure place as this will be needed in STEP 5 (below)
9. Select Done

STEP 3: Press the "SOURCE" button on the remote. Navigate to "HDMI 1."

STEP 4: Press "MENU" on the remote to enter the settings menu.

STEP 5: Verify the settings below, navigating with the remote:

- SYSTEM
 - POWER CONTROL
 - AUTO POWER ON: ON
 - MAX POWER SAVING: OFF
 - STANDBY CONTROL: OFF
 - POWER BUTTON: POWER ON ONLY
 - AUTO SOURCE SWITCHING
 - AUTO SOURCE SWITCHING: OFF
 - SECURITY – Enter PIN from STEP 2.8 (above)
 - BUTTON LOCK: ON

Diagnostic and Adjustments

The Service Button Panel has four buttons, three of which can navigate the menu system.

The control panel buttons can also advance through test menu screens.

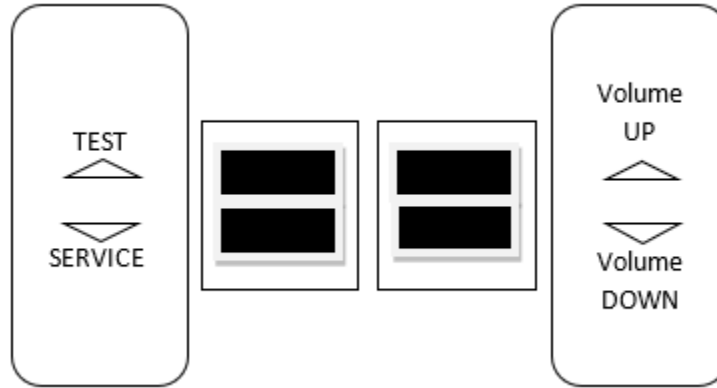

Navigating the Test Menu	
Button	Action
TEST (Not in Test Menu)	Enters Test Menu
TEST (In Test Menu)	Selects Highlighted Option
SERVICE (On Main Menu)	Exits Test Menu
SERVICE (Not on Main Menu)	Cancel Selection
VOLUME UP/Tunes Button	Move Up
VOLUME DOWN/View Button	Move Down
Start Buttons	Selects Highlighted Option
Stop Motion Button	Return to Previous Screen

When in the Pricing Menu, an on-screen message acknowledges changes or when you exit a selection without making a change.

Basic Functional Test on Initial Power Up

1. Enter the Input Test and verify all switch inputs are working.
2. Enter the Monitor Test and verify the monitor is working properly.
3. Enter the Sound Test and verify the audio works and is not distorted.
4. Enter the Light Test and verify that all the lights are working properly.
5. Enter the Coin Meter Test and verify the coin meter is working properly.
6. Enter the Watchdog Test and verify the game reboots.
7. Upon a successful reboot, you are ready to adjust pricing, volume and other functions.

Test Menu

Main Menu

Choose from all available operator settings and menus here. You can use the test menu bracket and volume buttons to navigate. The View/Tunes buttons also are available to use for easier navigation through these menus.

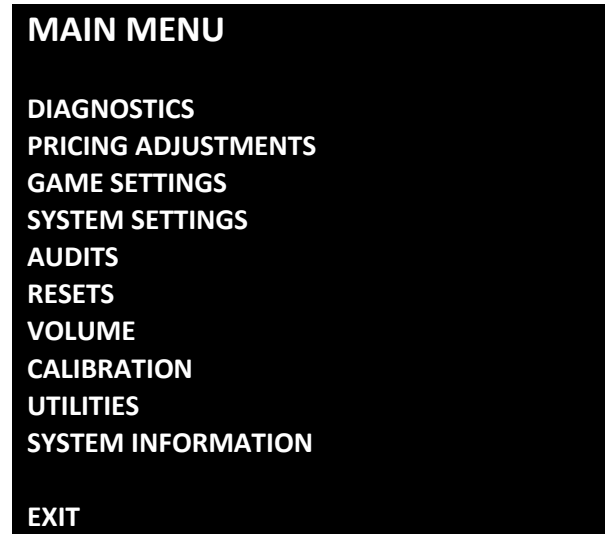

Diagnostics

Verify or diagnose the operations of all game functions.

DIAGNOSTICS

INPUT TEST

VIDEO TEST

AUDIO TEST

NETWORK TEST

CABINET LIGHTS TEST

WHEEL FORCE FEEDBACK TEST

CABINET MOTION TEST

DRAIN VALVE TEST

METER TEST

TICKET TEST

CAMERA TEST

QR HIGH SCORE TEST

QR ACCOUNT TEST

WATCHDOG TEST

EXIT

- **Input Test**: Test input hardware such as switches.
- **Video Test**: Checks color pattern of monitors.
- **Audio Test**: Test audio using 100Hz and 1000Hz.
- **Network Test**: Test the connectivity between linked games.
- **Cabinet Lights Test**: Tests all LED cabinet lighting together and individually.
- **Wheel Force Feedback Test**: Test steering wheel force feedback.
- **Cabinet Motion Test**: Test the functionality of the motion platform.
- **Drain Valve Test**: Test the drain valve.
- **Meter Test**: Test the functionality of the mechanical coin meter inside the cabinet.
- **Ticket Test**: Test the functionality of the ticket mech.
- **Camera Test**: Test the functionality of the camera.
- **QR High Score Test**: Test the functionality of the QR high score code.
- **QR Account Test**: Test the functionality of the QR system.
- **Watchdog Test**: Test the functionality of the Watchdog (if successful the cabinet will power off and reboot).

Pricing Adjustments (Cash)

Set pricing and payout adjustments for game operation.

PRICING ADJUSTMENTS (CASH)

FREEPLAY
CURRENCY INPUT
CURRENCY TYPE
COIN VALUE
COINS TO PLAY
COINS TO CONTINUE
COINS TO UPGRADE
MAX CREDITS

BONUS PRICING
E TICKET MODE

EXIT

- **Freeplay**: Turn free play mode on or off.
- **Currency Input**: Change the currency input.
- **Currency Type**: Change the currency type.
- **Coin Value**: Change the money value of the coin.
- **Coins to Play**: Adjust the amount of coins to start a game.
- **Coins to Continue**: Adjust the amount of coins to continue a game.
- **Coins to Upgrade**: Adjust the amount of coins to upgrade the player's car before the start of the race.
- **Max Credits**: Adjust the maximum number of credits.
- **Bonus Pricing**: Turn on (default off) to allow players to pay for multiple races at a discount.
- **E Ticket Mode**: N/A for cash settings.

Pricing Adjustments (Tokens)

Set pricing and payout adjustments for game operation.

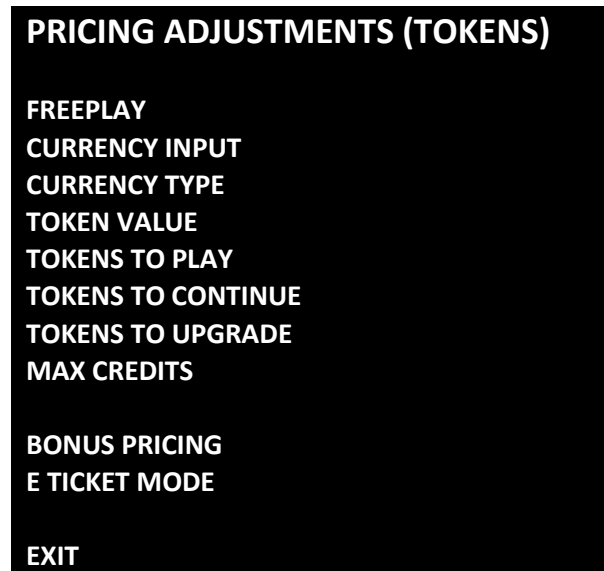

- **Freeplay**: Turn free play mode on or off.
- **Currency Input**: Change the currency input.
- **Currency Type**: Change the currency type.
- **Token Value**: Change the money value of the token.
- **Tokens to Play**: Adjust the amount of tokens to start a game.
- **Tokens to Continue**: Adjust the amount of tokens to continue a game.
- **Tokens to Upgrade**: Adjust the amount of tokens to upgrade the players car before the start of the race.
- **Max Credits**: Adjust the maximum number of credits.
- **Bonus Pricing**: Turn on (default off) to allow players to pay for multiple races at a discount.
- **E Ticket Mode**: N/A for cash settings.

Pricing Adjustments (Swipes)

Set pricing and payout adjustments for game operation.

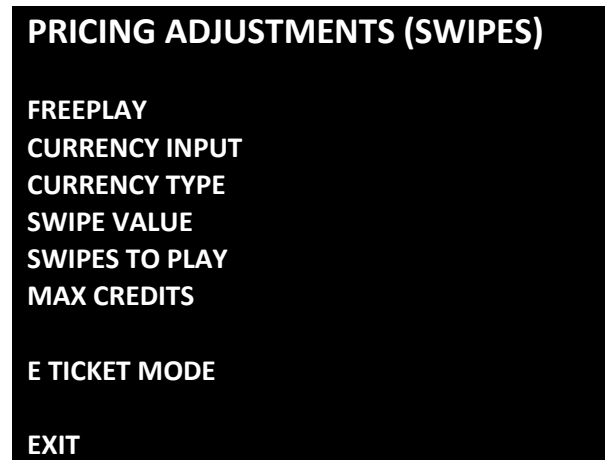

- **Freeplay**: Turn free play mode on or off.
- **Currency Input**: Change the currency input.
- **Currency Type**: Change the currency type.
- **Swipe Value**: Money value of the swipe.
- **Swipes to Play**: Adjust the amount of swipes to start a game.
- **Max Credits**: Adjust the maximum number of credits.
- **E Ticket Mode**: Turn E Tickets on or off (default off).

Game Settings

Adjust game settings for operation.

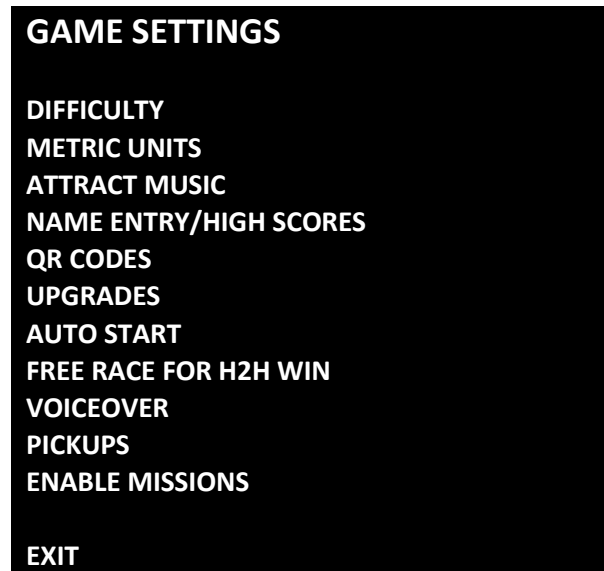

- **Difficulty**: Adjust the game difficulty.
- **Metric Units**: Use metric units like KPH and meters.
- **Attract Music**: How often should music play in attract mode.
- **Name Entry/High Scores**: Turn on or off (default on). When on, players may enter their name and show high scores after finishing a race.
- **QR Codes**: Turn on or off (default off). When on, the venue and location must be set. This allows players to scan a QR code after race to share their high scores on social media sites. Additionally, this enables QR player login during car select or track select, so the player can view their achievements online, along with saving their QR login info.
- **Upgrades**: Turn on or off (default on). When on, this allows the players to purchase upgrades before the start of a race.
- **Auto Start**: Start the game when player inserts credits.
- **Free Race for H2H Win**: Turn on or off (default off). When on, the winner of a head to head race against another player will receive a free race.
- **Voiceover**: Enable/disable voiceovers during a race and in the menus.
- **Pickups**: Enable/disable pickups. This includes nitro and electric pickups.
- **Enable Missions**: Enable missions gameplay or make game just a race only.

System Settings

This menu allows for customization of various system settings.

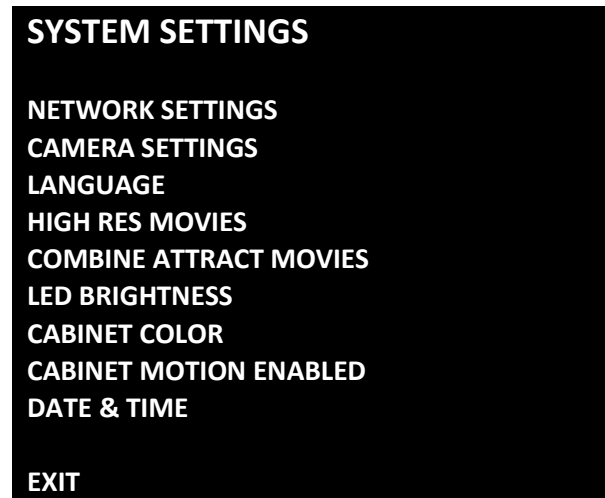

- **Network Settings**: Turn on for linked games (leave off if operating a single game). **The cabinets must be numbered in order from left to right. This ensures gameplay elements display correctly.**
- **Camera Settings**: Change settings for photo camera (on or off).
- **Language**: Set in-game language.
- **High Res Movies**: Play highest resolution movies possible. Turn off if you experience stuttering.
- **Combine Attract Movies**: Combine attract movie screens across networked games.
- **LED Brightness**: Adjust the brightness of the cabinet LED lights.
- **Cabinet Color**: Specify the color of the cabinet plastics.
- **Cabinet Motion Enabled**: Enable motion springs
- **Date & Time**: Use to set the date and time.

Audits

Audit screen helps assess game performance, find intermittent problems, decide whether to adjust game difficulty and help maximize game earnings.

There are no special menu options for this test menu entry.

Resets Menu

Resets menu allows for the resetting of various machine settings and audits.

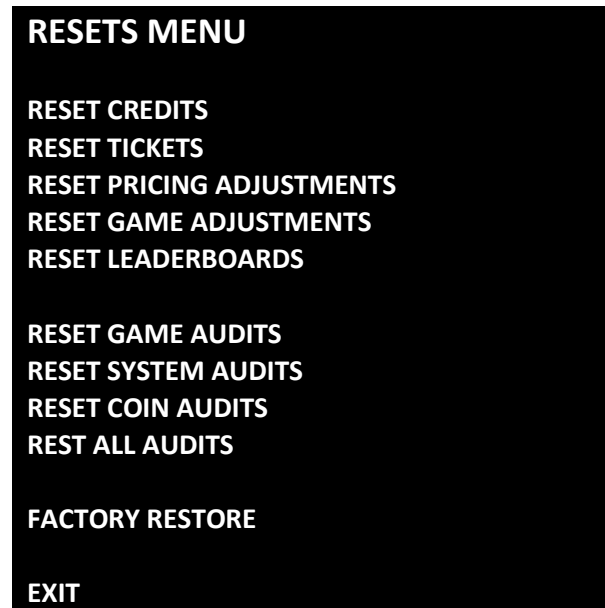

- **Reset Credits:** Reset credits to zero (0).
- **Reset Tickets:** Clears out all tickets owed on the game.
- **Reset Pricing Adjustments:** Reset all pricing settings to default.
- **Reset Game Adjustments:** Reset all game settings to default.
- **Reset Leaderboards:** Reset all high score tables.
- **Reset Game Audits:** Reset all game related audits.
- **Reset System Audits:** Reset all system audits.
- **Reset Coin Audits:** Reset all coin audits.
- **Reset All Audits:** Reset all audits.
- **Factory Restore:** Restore game to default factory settings.

Volume

Volume adjustments.



- **Game Volume**: Adjust the volume during gameplay (from 0 to 20).
- **Attract Volume**: Adjust the volume during the attract mode sequences (from 0 to 20).
- **Credit Volume**: Adjust the volume of the credit chime (from 0 to 20).

Calibration

Calibration of hardware.

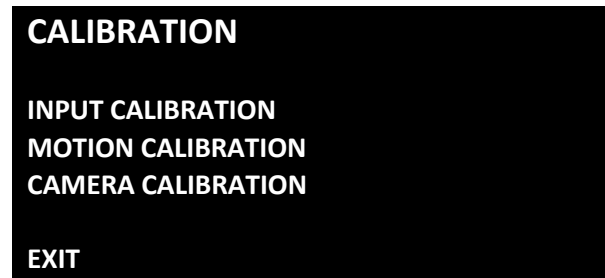

- **Input Calibration**: Calibrate the input POTS such as steering.
- **Motion Calibration**: Calibrate cabinet motion.
- **Camera Calibration**: Calibrate camera orientation.

Utilities

Miscellaneous operator tools.

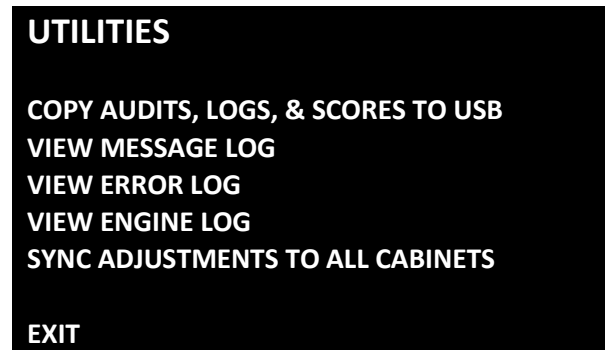

- **Copy audits, logs, & scores to USB:** Copy all audits and diagnostics to USB drive.
- **View Message Log:** Examine logged messages from the game.
- **View Error Log:** Examine error messages from the game.
- **View Engine Log:** Examine game engine messages.
- **Sync Adjustments to All Cabinets:** Sync all game, pricing, and volume settings with all networked games.

System Information

This screen allows you to see various information about the software and hardware.

- Serial Number
- Software Revision
- Build Date
- RIO PCB
- RIO Firmware
- Dongle Version
- Cabinet Type
- Game Template

There are no special menu options for this test menu entry.

Choosing the Right Pricing Adjustments for Your Location

Card Swipe Locations

- Make Sure Your Game is Set to **Swipes Mode**:
 1. Hold the Test Button for 2 seconds to enter the Test Menu.
 2. Select “Pricing Adjustments” from the menu.
 3. Select “Currency Input” from the menu.
 4. Select “Card Swipes” from the menu.
 5. Exit out of “Currency Input” menu.
 6. While back in “Pricing Adjustments” menu, set “Swipe Value” to the currency equivalent of your swipe, or the payout will be incorrect. **THIS SETTING IS EXTREMELY IMPORTANT!** (Example: If the card swipe is worth \$1.50 in your card system, set the swipe value to \$1.50 as well).

Coin/Token Locations

- Make Sure Your **Pricing & Coin Value** are Correct:
 1. Hold the Test Button for 2 seconds to enter the Test Menu.
 2. Select “Pricing Adjustments” from the menu.
 3. Select “Currency Input” from the menu.
 4. Select “Cash” or “Tokens” from the menu.
 5. Exit out of “Currency Input” menu.
 6. While back in “Pricing Adjustments” menu
 - a. Select “Coins to Play” and set the desired amount of coins per game of Fast and Furious Arcade.
 - b. After setting the coins per play, set “Coin Value” to the currency equivalent of your coin, or the payout will be incorrect. **THIS SETTING IS EXTREMELY IMPORTANT!** (Example: If your coin is worth \$0.25, set “Coin Value” to \$0.25 as well).

PC Hardware

Your *Fast & Furious Arcade* game uses a **Lenovo M70t Desktop PC**.



(above: *Lenovo M70t Desktop PC*)

NOTICE

WARNING: DO NOT ENTER THE BIOS SETTINGS MENU! Modifying the BIOS settings will cause your game to stop functioning. In order to boot, new security features verify the BIOS settings against factory settings, including timestamp.

PC Hard Drive Recovery

Symptoms requiring a PC hard drive recovery include:

- File test reports bad or missing files.
- Game fails to finish loading during setup.
- After resetting the AC power, an error is reported.
- Erratic Game or Attract Mode behavior.

The only way to repair corrupt files is to reinstall the software as described below:

Computer

The computer contains sensitive components. Do not handle roughly. Contact your distributor before servicing its internal components. Ask about warranty information as it relates to the PC.

Do **not** use the PC on/off switch. Turn AC power on or off with the cabinet power switch.

Steps to reinstall the software (the game ships with (1) USB drive which is used in the steps below):

(USB Thumb Drive is used on the *Lenovo M70t*)

*****ATTENTION: An approved “Business Account” on rawthrills.com is required to complete software installation. Please complete account activation before installing software!*****

*****See website for details: <https://rawthrills.com/raw-web/login>*****

1. With game and PC on, verify that the RIO2 board has power. If not, see Troubleshooting.
2. Open the upper back door of the cabinet.
3. Insert the recovery USB thumb drive (included in your game) into an open USB port on the PC.
4. Turn cabinet power switch to OFF. Wait 30 seconds.
5. Turn cabinet power switch to ON. Wait for install menu to load.
6. Once the install menu has loaded, press the Test button on the service bracket to select the installation program and then press the Test button to confirm that you want to continue with the installation.
7. Follow on screen instructions to begin recovery.
8. If recovery does not begin, check to ensure USB Drive is inserted correctly and is not damaged.
9. Initial software loading may take several minutes. Check progress periodically.
Do not interrupt power or reset the game during recovery.
10. When software has been loaded, a message indicates that restore is complete. When instructed to remove USB Drive, wait 15 seconds then remove the drive from the PC.
11. Turn cabinet power switch off. Wait 30 seconds. Turn the cabinet on again.



12. Scan the QR code to the left or [click here \(if viewing on electronic device\)](#) for instructions on completing setup.

Troubleshooting

Warning: Review the Safety section before making any adjustments to the game.

Problem	Possible Cause	Solution
Game will not power up.	Game not plugged in.	Plug game into AC outlet.
	Game not turned on.	Turn on main power switch.
	Game fuse is blown.	Check and replace fuse. See Specification section for fuse values.
	No power to receptacle.	Test AC outlet and plug game into powered outlet.
	PC BIOS set incorrectly.	Contact your distributor.
	Flash Drive Installer is left connected to PC.	Disconnect Flash Drive Installer and power cycle the game.
Buttons do not work.	Faulty micro switch.	Replace the micro switch on the button and re-test. Verify that the wires are connected to the correct spades on the micro switch.
	Faulty wiring.	Disconnect the cabinet from AC power. Verify that all wires are firmly connected to each button and the PCB. Verify that no wires are frayed or improperly shorting to ground. Verify that wires are connected to the correct spades on the micro switches.
	Faulty PCB.	Ensure all connections to PCB are secure. Replace PCB if faulty.
Neither buttons nor audio work.	PCB connected to faulty USB port (boot message may indicate not detected)	To test a USB port, turn off the game, disconnect the device from the port, and then connect the game dongle to the port. Reboot the game. A No Dongle message indicates the port is bad. If the game starts, the port is working. After the test, reconnect all devices to the correct USB ports and reboot.

Fast and Furious Arcade

Problem	Possible Cause	Solution
No sound or bad sound.	Bad connection.	Check connection to speakers.
	Volume set too low.	Use VOL UP button on Test panel to raise volume
	Faulty wiring.	Verify all wires are firmly connected to the speakers and the audio PCB. Verify that audio PCB is connected to the computer via USB cable.
	Blown speakers.	Remove the grill and inspect each speaker for visible damage. Run the Sound Test from System Tests in the Operator Menu to verify each speaker is working.
	Reversed wires.	A weak or low muffled sound is a sign of reversed speaker wires. Check for reversed wires on each speaker.
	Faulty PCB.	To verify audio is working at the computer, disconnect the USB cable coming from the audio PCB and connect stereo headphones to the green computer audio port.
Constant low audio hum.	Faulty power supply.	Check external DC supply and the PC supply.
	Open ground.	Check all ground wires in cabinet. Ensure AC wall outlet is properly grounded.
RIO2 disconnected	USB cable disconnected.	Check USB connection from PC to RIO2 board.
	No power to RIO2 board.	Check for proper voltage (+5V, +12V) at RIO2 P1 connector.
No motion during gameplay.	Compressor height sensors are not calibrated.	Calibrate the motion platform height sensors (see Calibration in the Test Menu section).
Message on screen: Game dongle not found. Please RECONNECT the game dongle.	Dongle missing or disconnected.	Find the dongle cable and reseal in USB port.
	Faulty USB port.	Insert dongle cable in different USB port.

Fast and Furious Arcade

Problem	Possible Cause	Solution
Message on screen: Insufficient RAM, 16GB required.	Loose or disconnected RAM stick.	Contact your distributor for service.
	Faulty RAM stick.	Contact your distributor for service.
Message on screen: GFX card missing. Please RECONNECT the GFX card.	Loose or disconnected graphics card.	Contact your distributor for service.
	Faulty graphics card.	Contact your distributor for service.
Game does not load.	PC hard drive failure.	Recover hard drive. See Flash Installer Document or contact your distributor for the latest software revision.
PC Drive test reports “bad” or “missing” files.		
Game fails to finish loading.		
After resetting, game still reports an error.		
Erratic game mode or attract mode.		
WARNING! Data files Corrupted. (Game Operation May Become Unstable.)		
Game Resets	Bad file.	Run Flash Installer.
No Video	PC not turned on.	Turn PC power switch on. Ensure IEC cable tightly plugged in. Trace cable back to source to ensure continuity.
	Video cable not secure.	Check and secure HDMI connector(s) to Monitor(s). Check and secure DVI or HDMI connector(s) to PC.
	Cabinet was powered on too quickly after a manual shutdown/power loss	Shut off cabinet via both switches at rear of cabinet. Leave off for 30 seconds, then power back on.

Fast and Furious Arcade

Problem	Possible Cause	Solution
Coin meter does not click during test.	No pulse to meter.	Check wiring from meter to PCB board.
	Faulty meter.	Replace coin meter.
	Blown fuse(s) on PCB	Replace 12vdc 5A fuse(s) on PCB.
Exits Test Mode every 3 seconds.	Test button stuck in ON position.	Slide or toggle button off after Test Menu appears
Improper number of credits given when bills are inserted.	Incorrect setting in Pricing Adjustments.	Adjust pricing settings.
	Faulty wiring.	Disconnect cabinet from AC power. Verify wires are firmly connected to bill validator and ground wires are properly connected. Verify no wires are frayed or shorting to ground.
Compressor does not turn on/low humming noise coming from the compressor	Compressor power cut off while it was running.	Shut off cabinet via both switches at rear of cabinet. Leave off for 3 minutes, then power back on.
Onscreen message: "Version Mismatch" appears after reinstalling/updating software	One or more cabinets is running a different version of software.	Enter test menu on each cabinet. Check the version number in the top left corner. Using the USB drive that came with your game (or a USB drive from your distributor) install latest version to any mismatched cabinets (<i>see pg. 37 for installation procedure</i>). Once installation is complete, power cycle all cabinets. The message should disappear.
	Software install/update did not complete correctly.	
Top and bottom monitor images are reversed	Connections at PC are connected to the incorrect ports.	Verify that top monitor HDMI cable is connected to the HDMI port on the video card at rear of PC. Verify that bottom monitor HDMI-DVI cable is connected to the DVI port on video card at rear of PC. If not, swap the cables around and reboot the cabinet.

Fast and Furious Arcade

Problem	Possible Cause	Solution
Linked game monitor displays are not displaying linked attract properly	Cabinets are number incorrectly.	Test menu – System Settings – Network Settings: Verify that the cabinets are numbered from left to right in numerical order.

Technical Support

For an authorized distributor near you, check the Raw Thrills website at www.rawthrills.com

Betson's Raw Thrills Technical Support Hotline

Phone: 1-800-753-2513

FAX: 1-201-438-5019

Email: rtsupport@betson.com



All Raw Thrills assembly and service videos:

rawthrills.com/assembly-and-service-videos/

Electrical and Mechanical Illustrations

- Pg. 45 – Card Reader Mounting Instructions**
- Pg. 46 – Samsung BE65T Upper Monitor Assembly Instructions**
- Pg. 47 – Single Game Operational Dimensions**
- Pg. 48 – Single Game Assembly Diagram**
- Pg. 49 – Twin Game Operational Dimensions**
- Pg. 50 – Twin Game Setup and Marquee Installation Diagram**
- Pg. 51 – Main Cabinet Assembly Diagram**
- Pg. 52 – Monitor Mounting and Bracket Assembly/Cabinet Joiner Assembly Diagram**
- Pg. 53 – Air Compressor Assembly and Related Components (USA) 120V Version & (UK, INTL) 230V Version Diagram**
- Pg. 54 – Air Manifold Assembly/Air Regulator Assembly Diagram**
- Pg. 55 – I/O and Hardware Board Assembly Diagram**
- Pg. 56 – Twin Game Marquee Assembly and Installation Diagram**
- Pg. 57 – Motion Platform Assembly Diagram**
- Pg. 58 – Lower Base and Safety Bellows Assembly Diagram**
- Pg. 59 – Motion Base and Pedestal Assembly Diagram**
- Pg. 60 – Driver Cabinet and Dash Assembly Diagram**
- Pg. 61 – Hood Deck and Speaker Assembly**
- Pg. 62 – Audio Amplifier DIP Switch Settings**
- Pg. 63 – System Diagram – Pneumatic System**
- Pg. 64 – System Diagram – Main (Power Distribution)**
- Pg. 65 – System Diagram – Main (Front Door)**
- Pg. 66 – System Diagram – Lower Seat Cabinet**
- Pg. 67 – System Diagram – Compressor & Seat Cabinet Dash**
- Pg. 68 – System Diagram – Seat & Wheels**
- Pg. 69 – System Diagram – PC & Monitors**

FAST AND FURIOUS ARCADE CARD READER MOUNTING

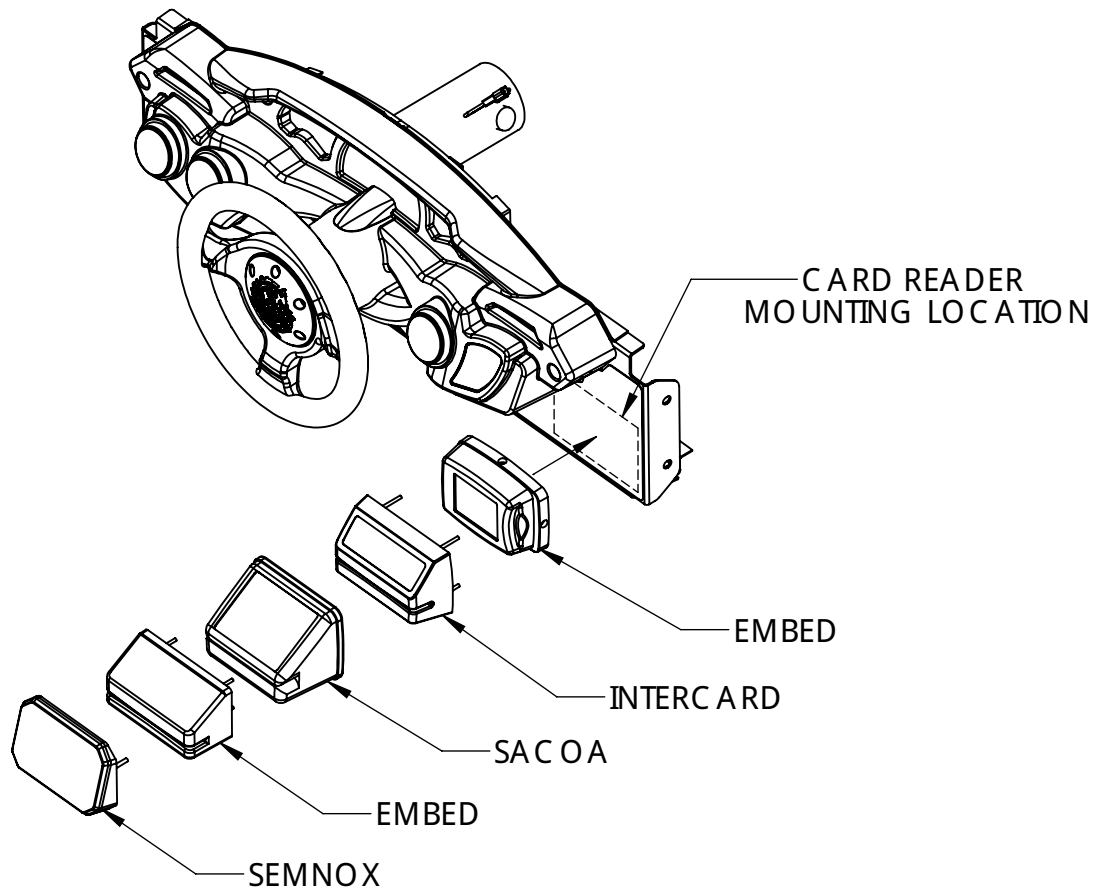

A SERIES OF HOLES ARE PROVIDED IN DASH PLATE FOR A VARIETY OF COMMONLY USED CARD READERS. THE DASH DECAL ON THE FRONT OF THE PLATE C OVERS THESE HOLES.

- 1) C HOOSE THE HOLE PATTERN THAT MATC HES YOUR CARD READER.
- 2) USE A UTILITY KNIFE TO POKE OUT THOSE HOLES IN THE DECAL.
- 3) DRILLING IS REQUIRED FOR CABLE ROUTING THRO UGH DASH PLATE... (USING A STEP DRILL BIT FOR THE C ABLE HOLE IS REC OMMENDED).
- 4) IN SOME C ASES MOUNTING STUDS WILL NEED TO BE REPLAC ED WITH SC REWS IF THERE IS INTERFERENC E WITH THE C ABINET WHEN C LOSING .

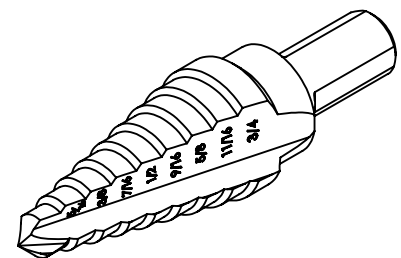
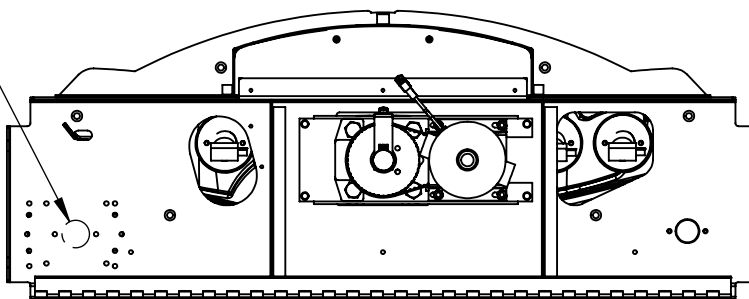

STEP DRILL BIT

INSTRUCTIONS FOR DOMESTIC GAMES USING SAMSUNG BE65T MONITOR ONLY

1) INSTALL UPPER MONITOR HANGER EXTENSION PLATE

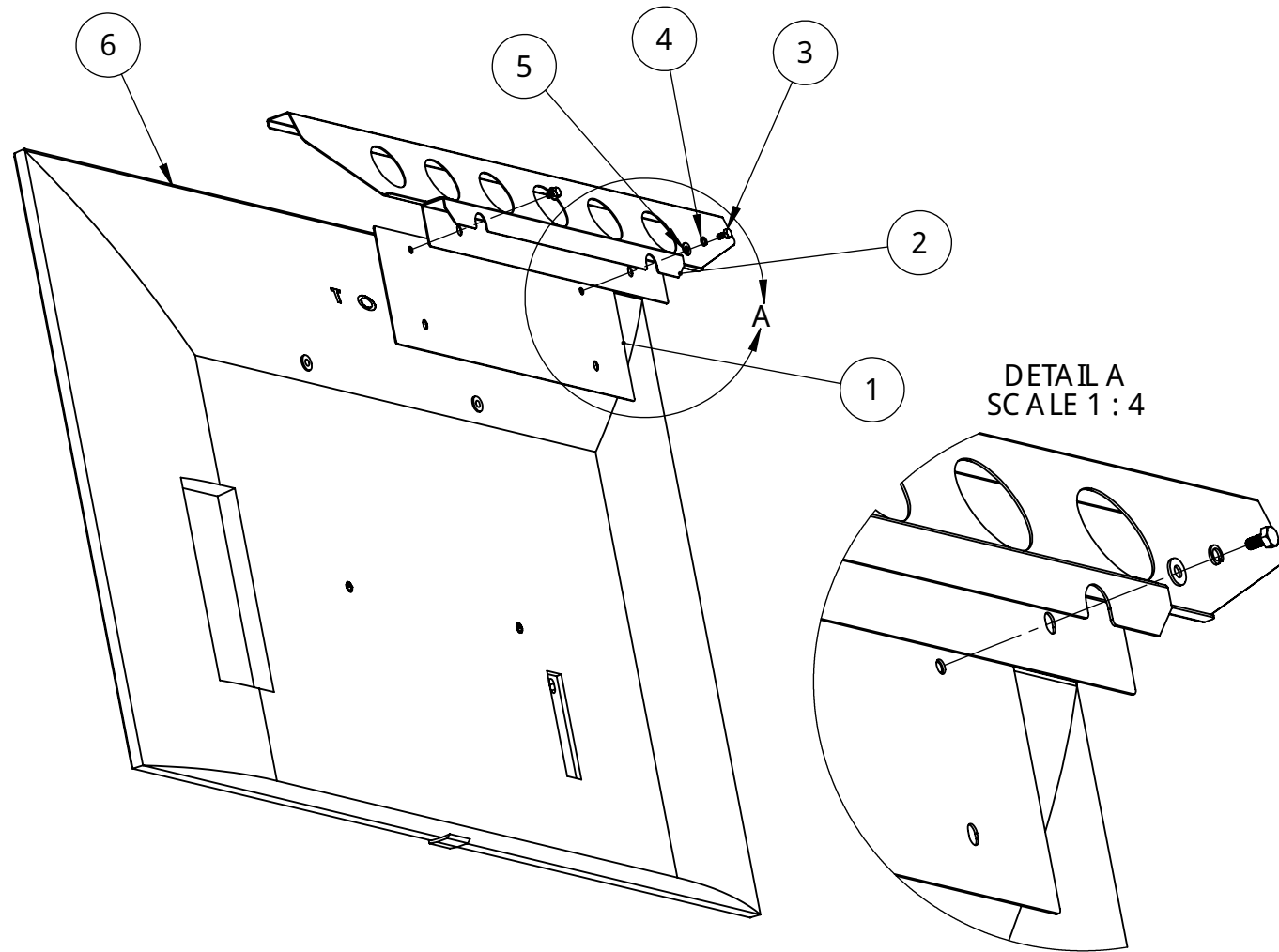

2) INSTALL UPPER MONITOR HANGER ASSEMBLY TO MONITOR SAMSUNG BE65T

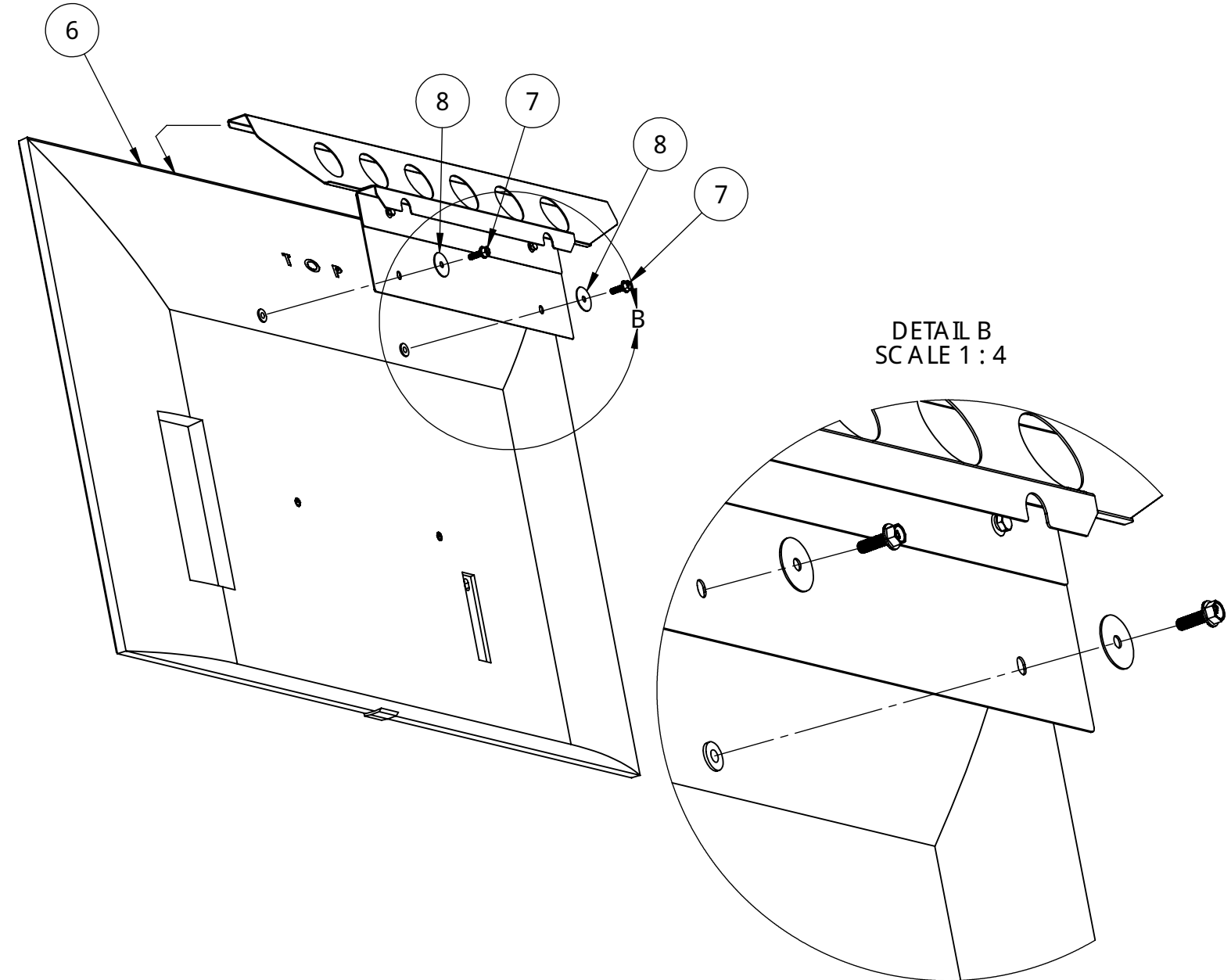

ITEM NO.	PART NUMBER	DESCRIPTION	QTY.
1	600-03232-01	F&F-65 LCD Hanger Bracket-Extension Plate	1
2	600-02970-01	F&F LCD HANGER BRACKET WELDMENT	1
3	91309A544	1/4-20 x 1/2" Hex Head	2
4	1_4 LOCK WASHER	1/4" LOCK WASHER	2
5	FLAT_WASHER-REG	1/4"ID X 5/8" OD FLAT_WASHER	2
6	Samsung BE65T	65" Commercial Grade LED TV (Samsung BE65T)	1
7	90386A109	M8 X 25MM Serrated-Flange Hex Head Screws	4
8	91090A119	Zinc-Plated Steel Oversized Washer	4

1) Install (item 1) 600-03232-01 / extension plate to (item 2) 600-02970-01 / hanger bracket using two (items 3,4 & 5) 1/4-20 x 1/2" hex head bolts with lock and flat washers.

2) Install the completed hanger assembly to the (item 6) monitor as shown, (with front edge capturing the top of the monitor) using two (item 7) 8M x 25mm bolts with (item 8) flat washers.

3) Follow the upper monitor installation instructions from the manual to complete the upper monitor installation by hanging the monitor assembly over the top of the monitor bracket and using the remaining bolts and washers to secure it.

FAST AND FURIOUS ARCADE SINGLE GAME OPERATIONAL DIMENSIONS

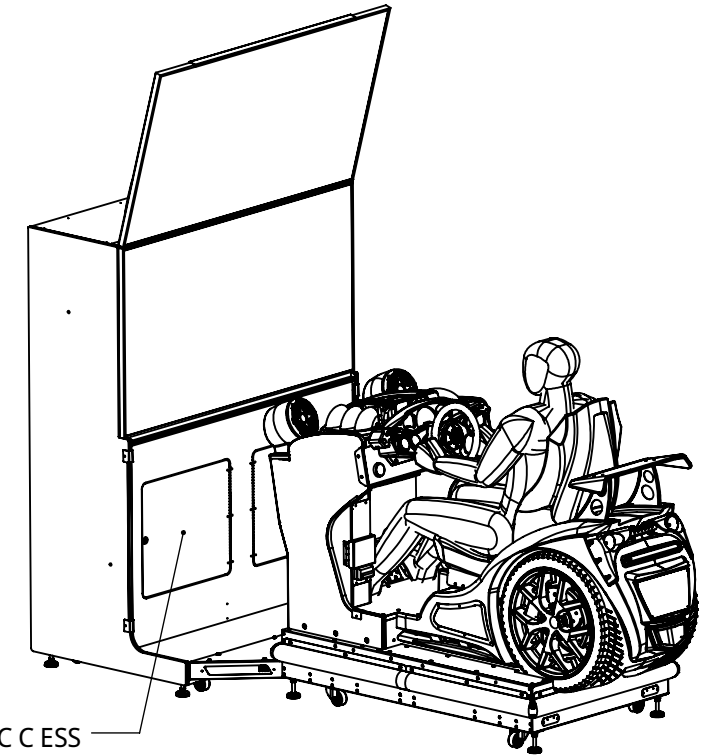
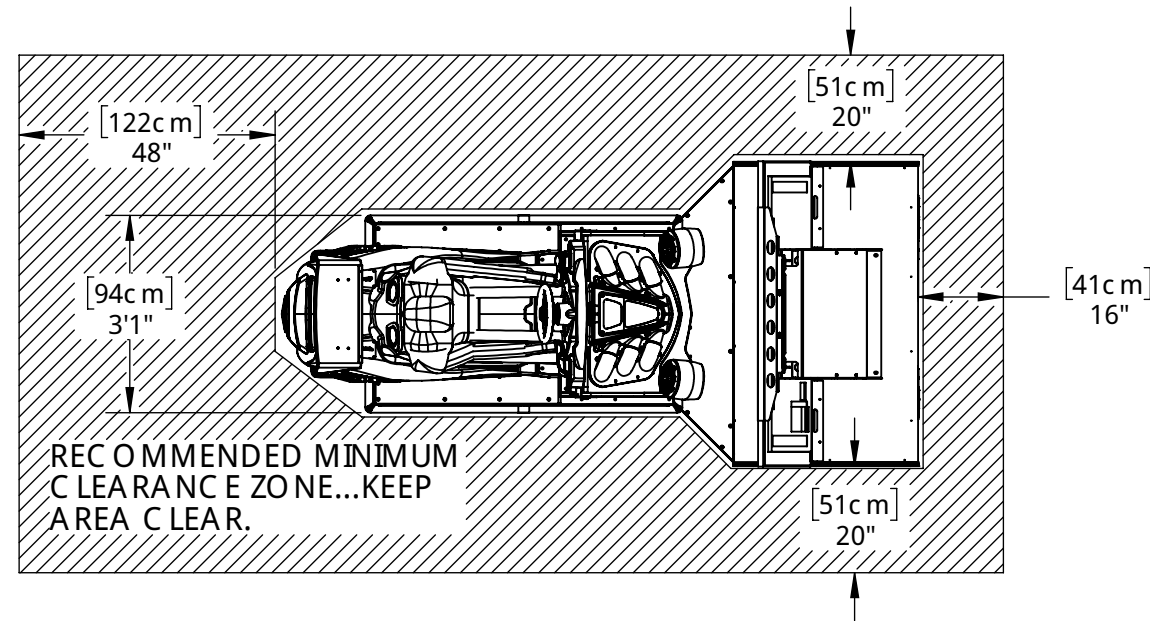

FRONT ACCESS DOOR FOR AIR COMPRESSOR RELATED COMPONENTS

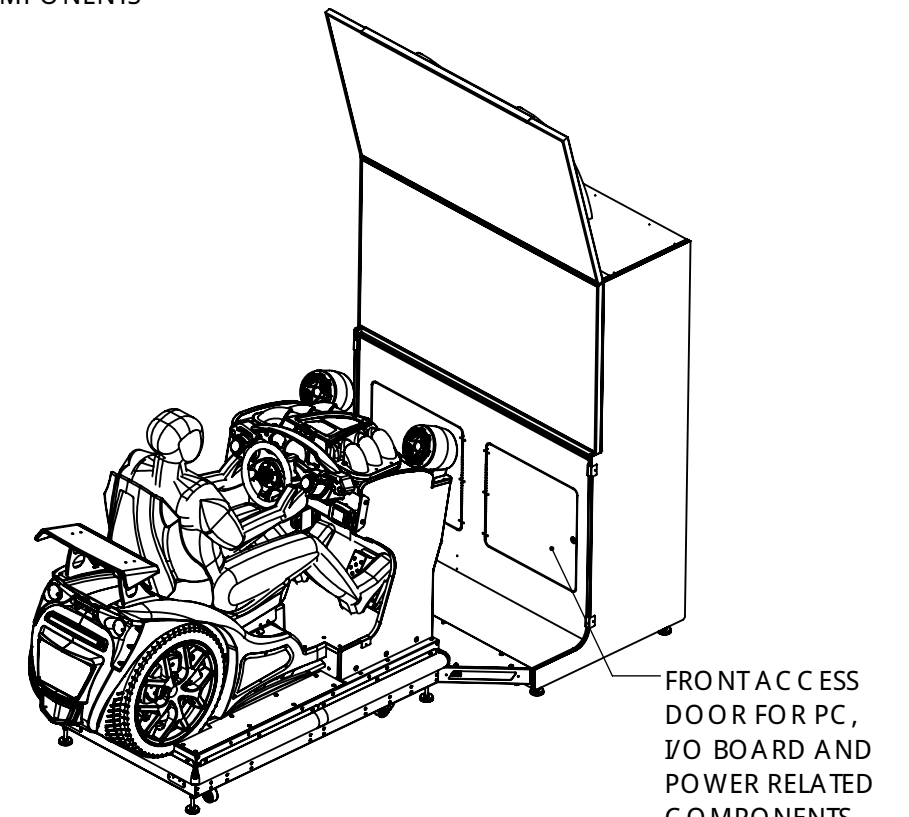
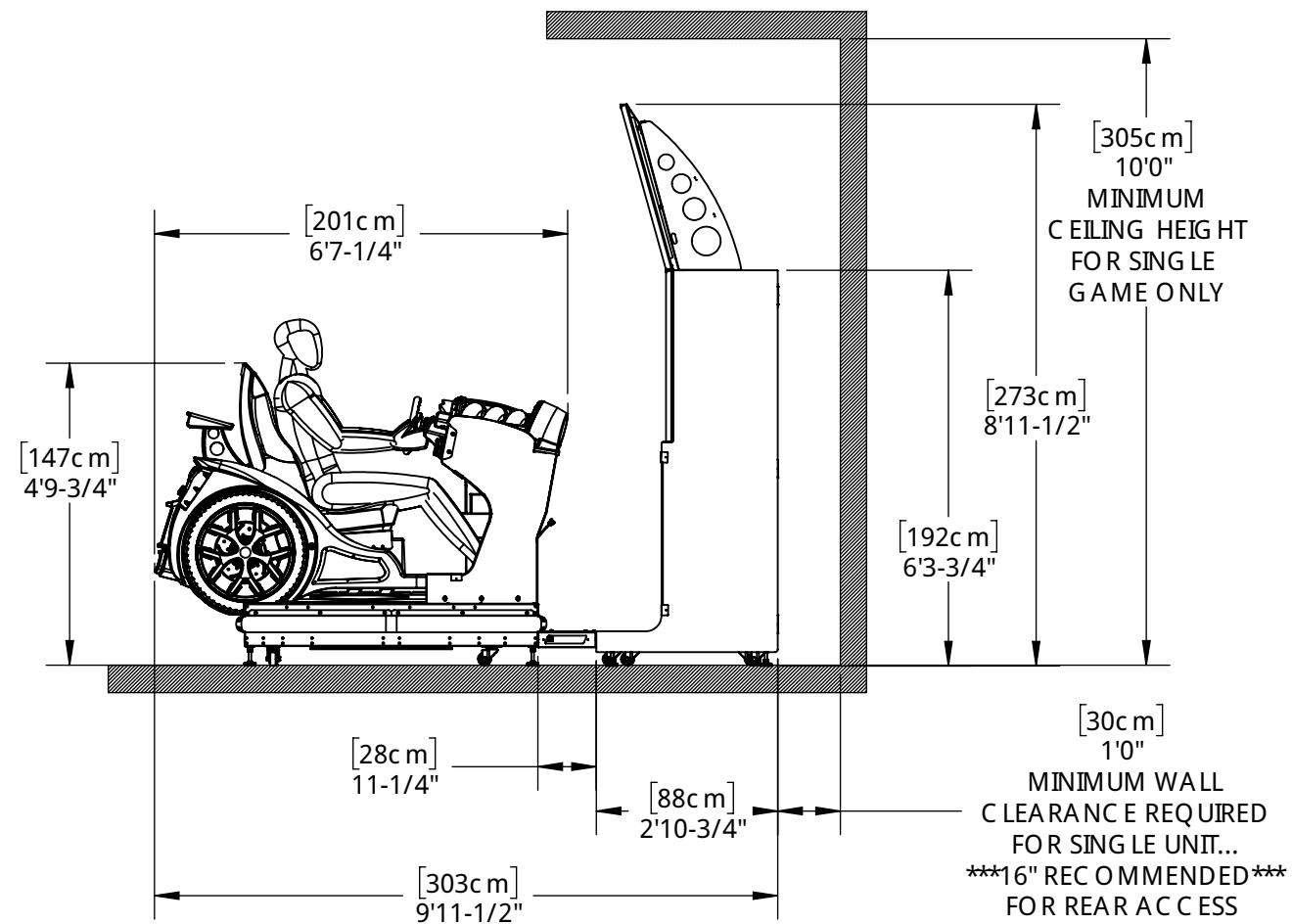
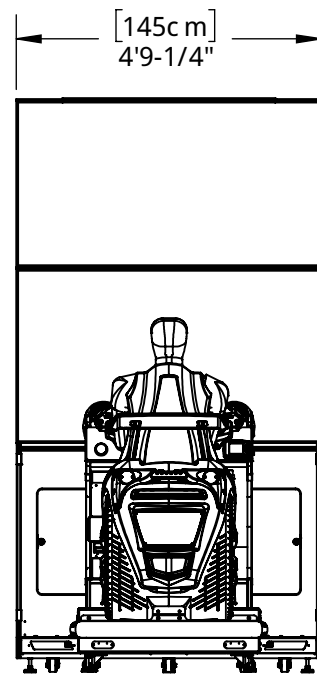

FRONT ACCESS DOOR FOR PC, I/O BOARD AND POWER RELATED COMPONENTS.

FAST AND FURIOUS ARCADE "SINGLE" GAME ASSEMBLY DIAGRAM

ASSEMBLED DIMENSIONS
8'-10 3/4" H X 4'-9 1/4" W X 9'-11 1/2" L
APPROXIMATE TOTAL WEIGHT - 1100 LBS
Motion Cabinet - 525 lbs
Main Cabinet without monitors - 385 lbs
2 Monitors - 50 lbs each - 100 lbs
Top Monitor Bracket/Rear Cover - 35 lbs
Cabinet Joiner Bracket & Cover 30 lbs

TOP MONITOR BRACKET &
REAR COVER PLATE
ASSEMBLY-35 LBS

TOP MONITOR
ASSEMBLY-55 LBS
(with hanger
bracket installed)

TOP MOTION BASE
ASSEMBLY-
MOTION BASE FULLY
ASSEMBLED - 525 LBS

BOTTOM MONITOR
ASSEMBLY-50 LBS

SAFETY BELLOWS
ASSEMBLY

BOTTOM MOTION
BASE ASSEMBLY

JOINER BRACKET
ASSEMBLY -30LBS

MAIN CABINET -
385 LBS

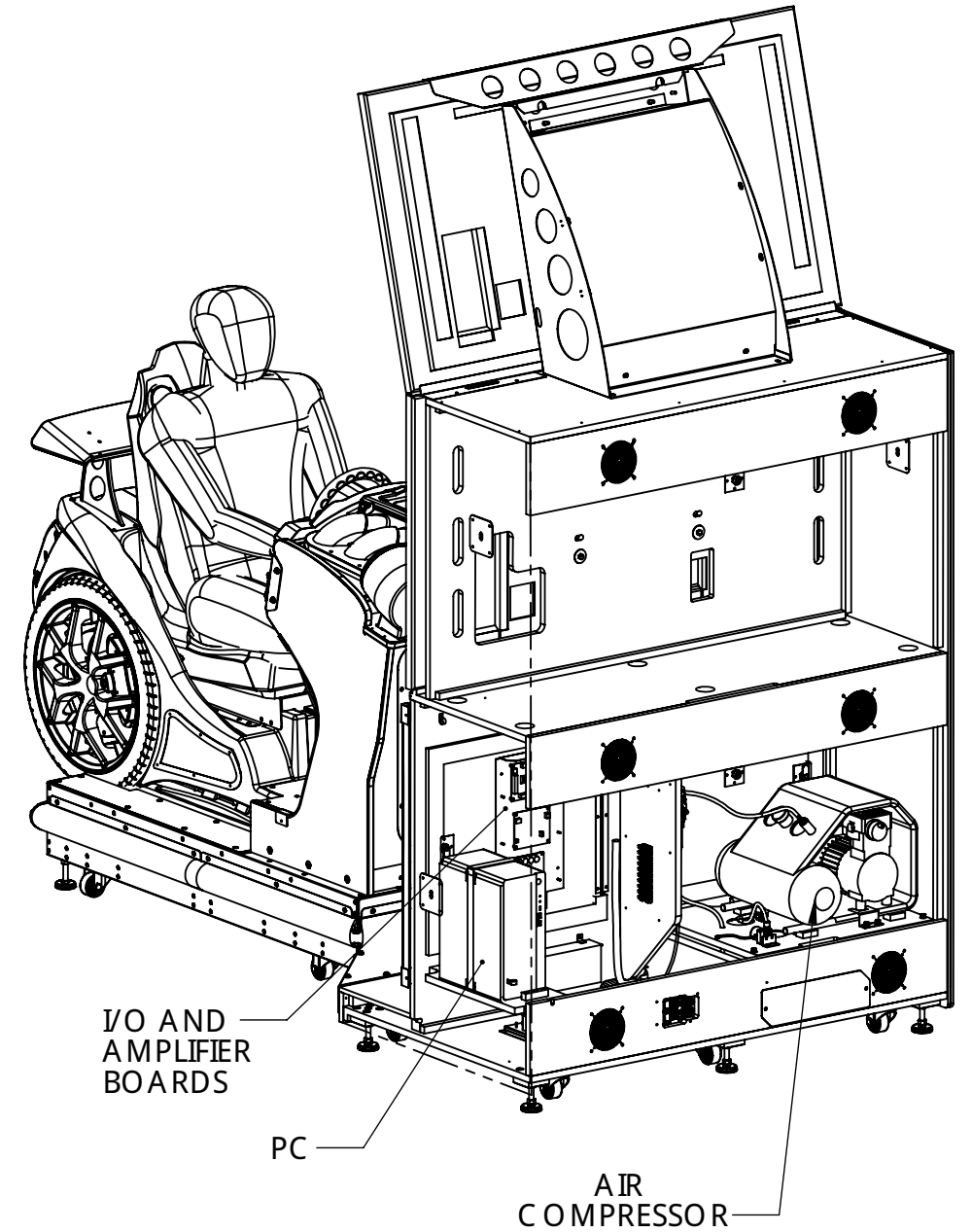

FAST AND FURIOUS ARCADE
TWO "MULTI-GAME"
OPERATIONAL DIMENSIONS

***LINK UP TO 8 GAMES

***LEVEL FLOOR SURFACE DESIRED

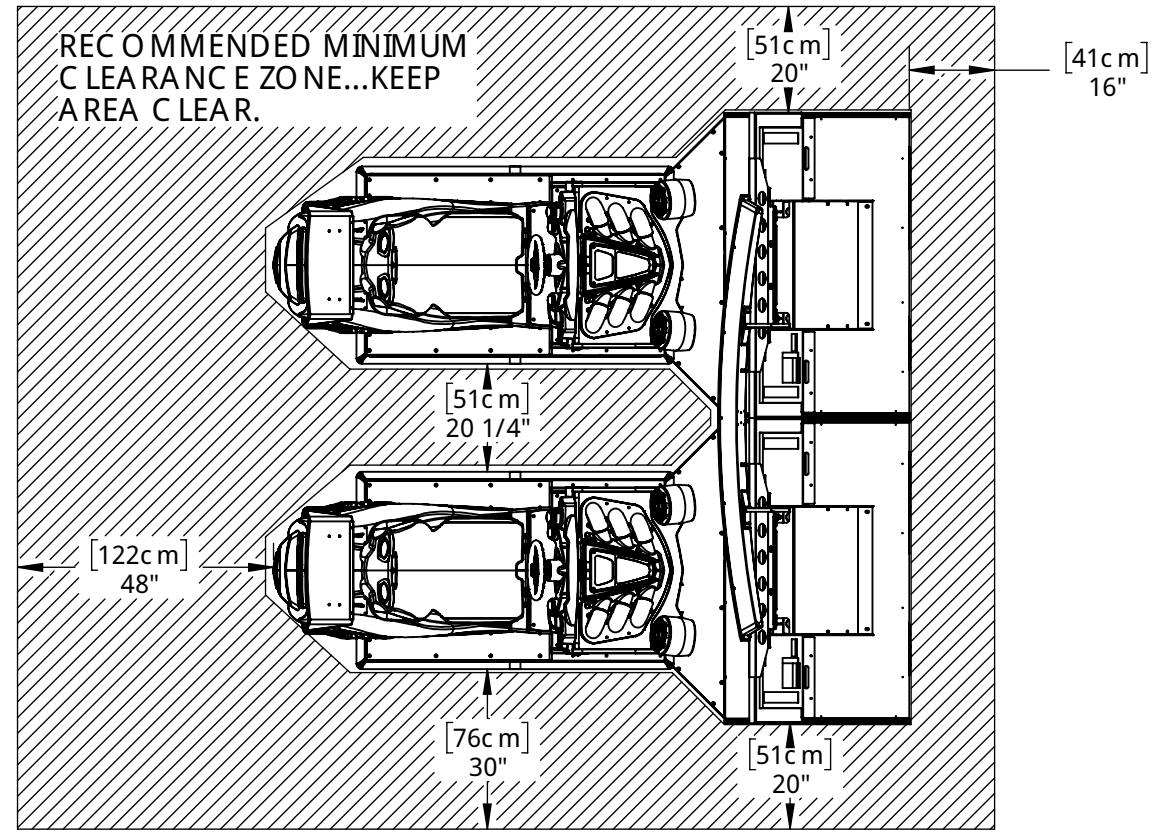

MULTI-GAME MARQUEE STRADDLES BOTH GAMES.
 REMOVE MARQUEE IF MOVING ONE GAME FOR REAR
 ACC ESS TO C ABINET IS REQ UIRED FOR SERVIC E.
 SEE MULTI-GAME MARQ UEE INST ALLATI ON
 DIAG RAM FOR FURTHER DET AILS.

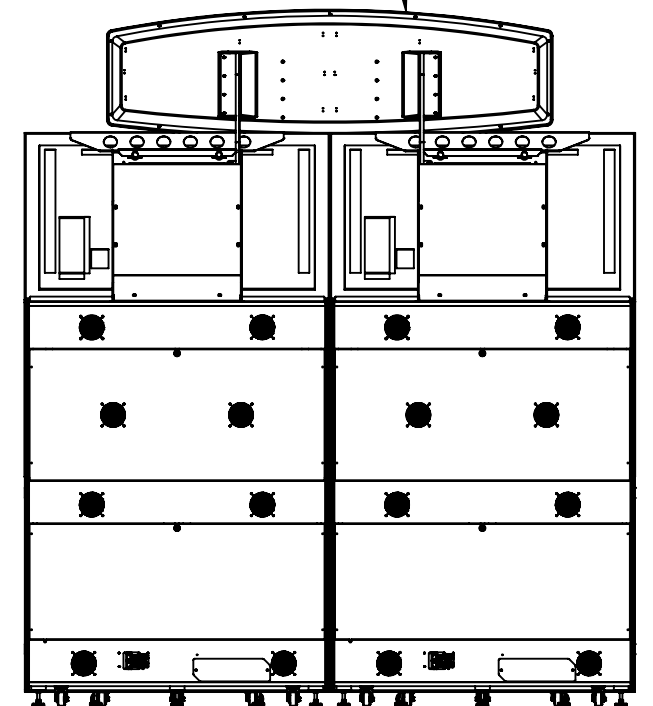
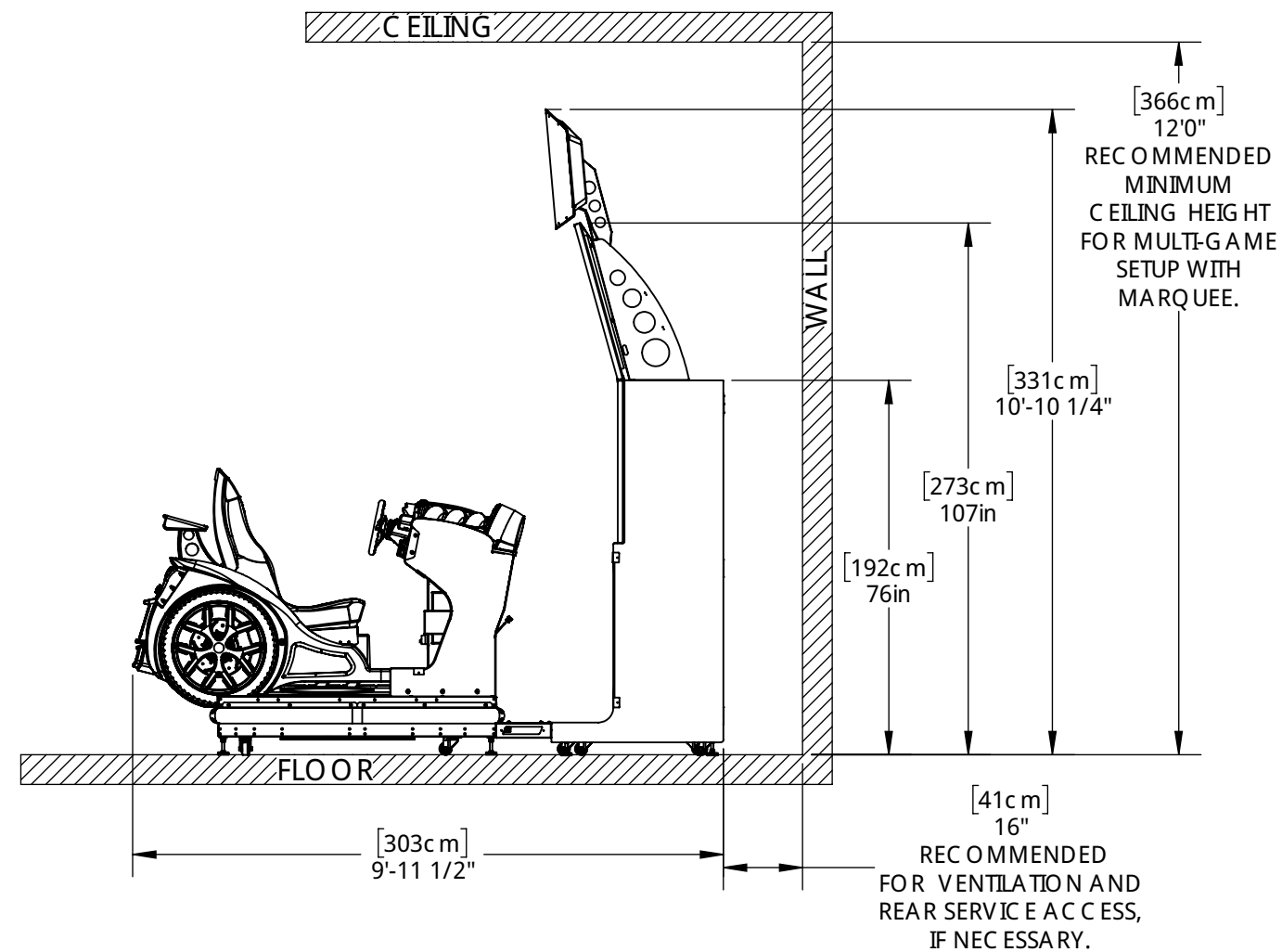
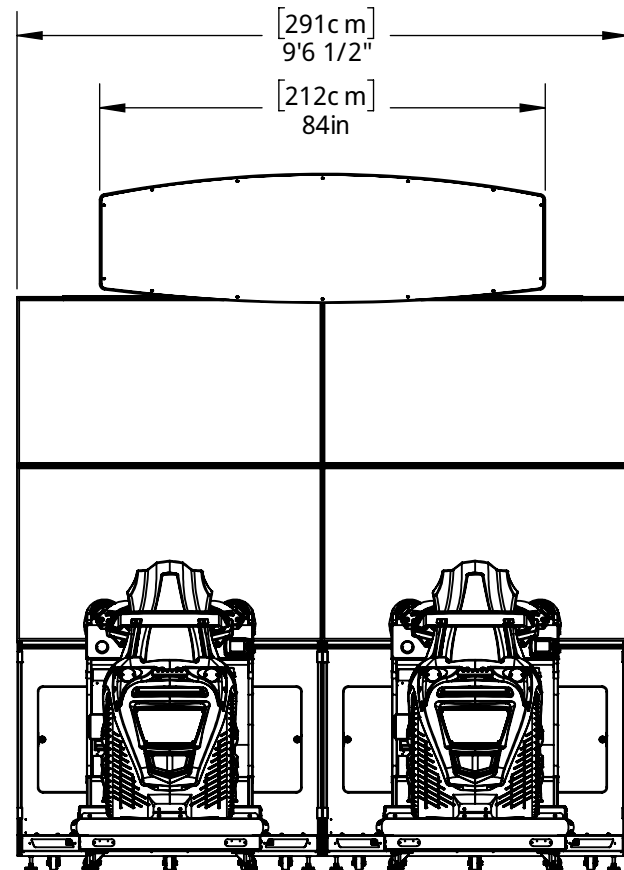

FAST AND FURIOUS MULTI-GAME SETUP AND MARQUEE INSTALLATION

AFTER INDIVIDUAL GAME SETUP IS COMPLETE, GAMES ARE ALIGNED NEXT TO EACH OTHER AND LEG LEVELERS ARE LOWERED, THE MARQUEE INSTALLATION CAN BE COMPLETED AS FOLLOWS.

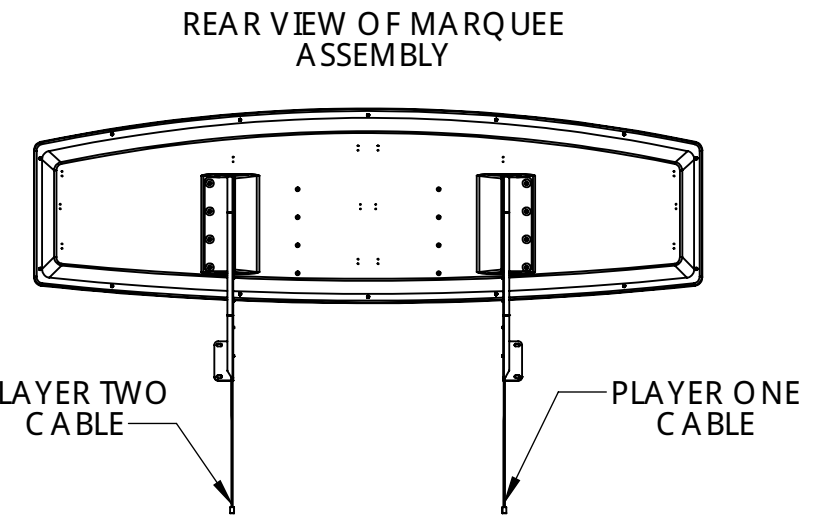
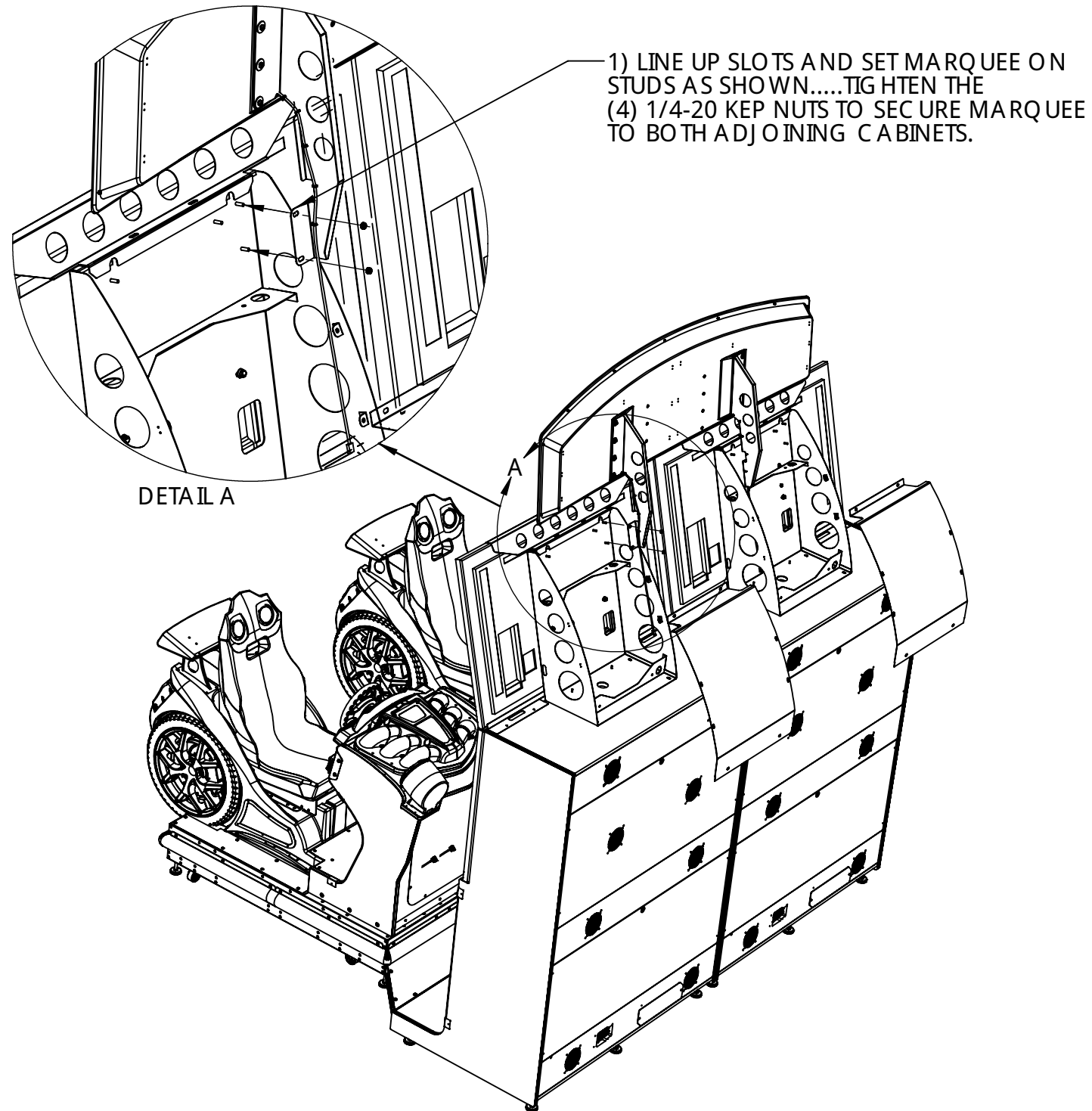

2) ROUTE CABLES THROUGH RESPECTIVE CABINET HOLES AND CONNECT INSIDE CABINET TO MARQUEE CABLE ON BOTH CABINETS.

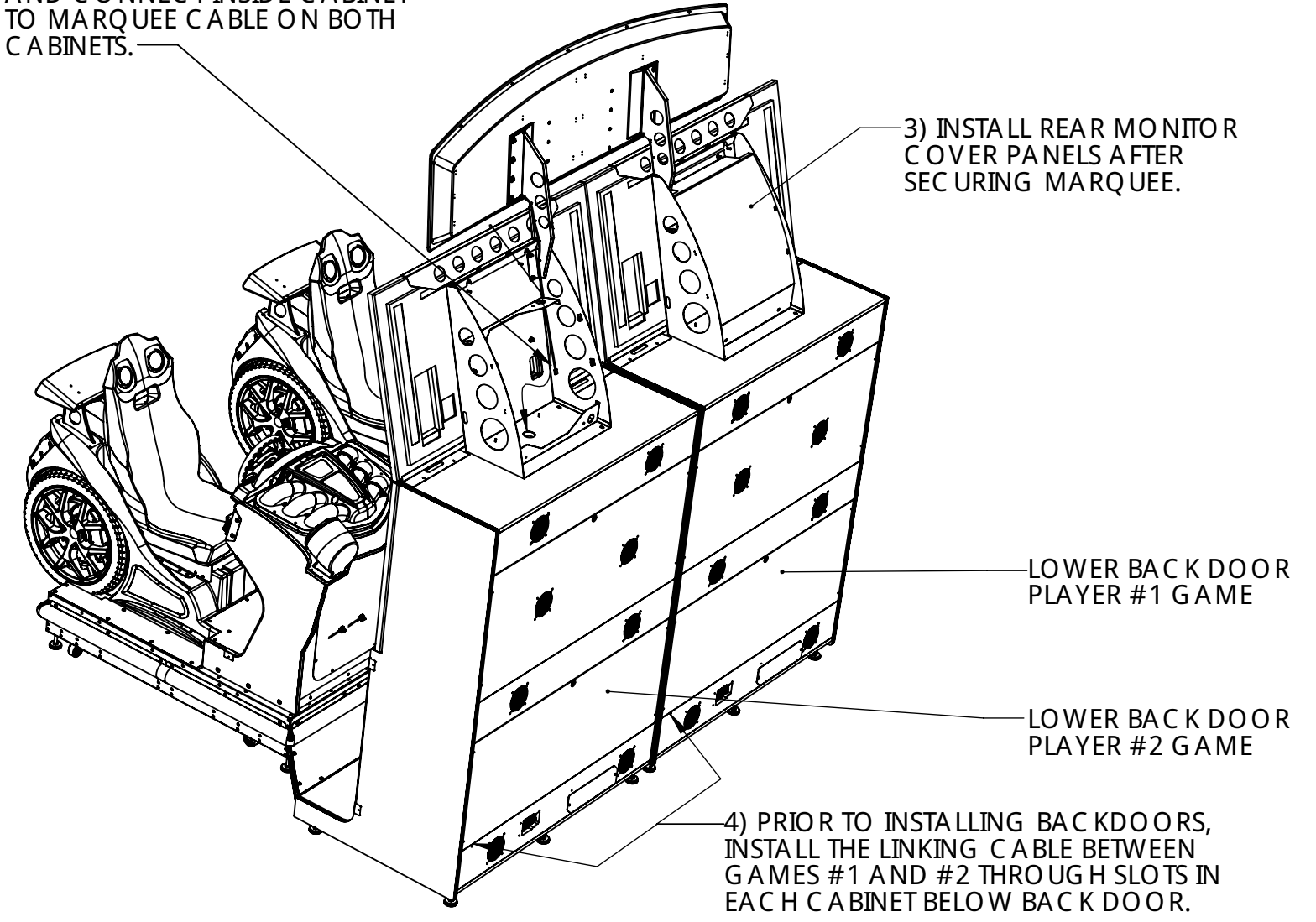

FAST AND FURIOUS ARCADE MAIN CABINET ASSEMBLY

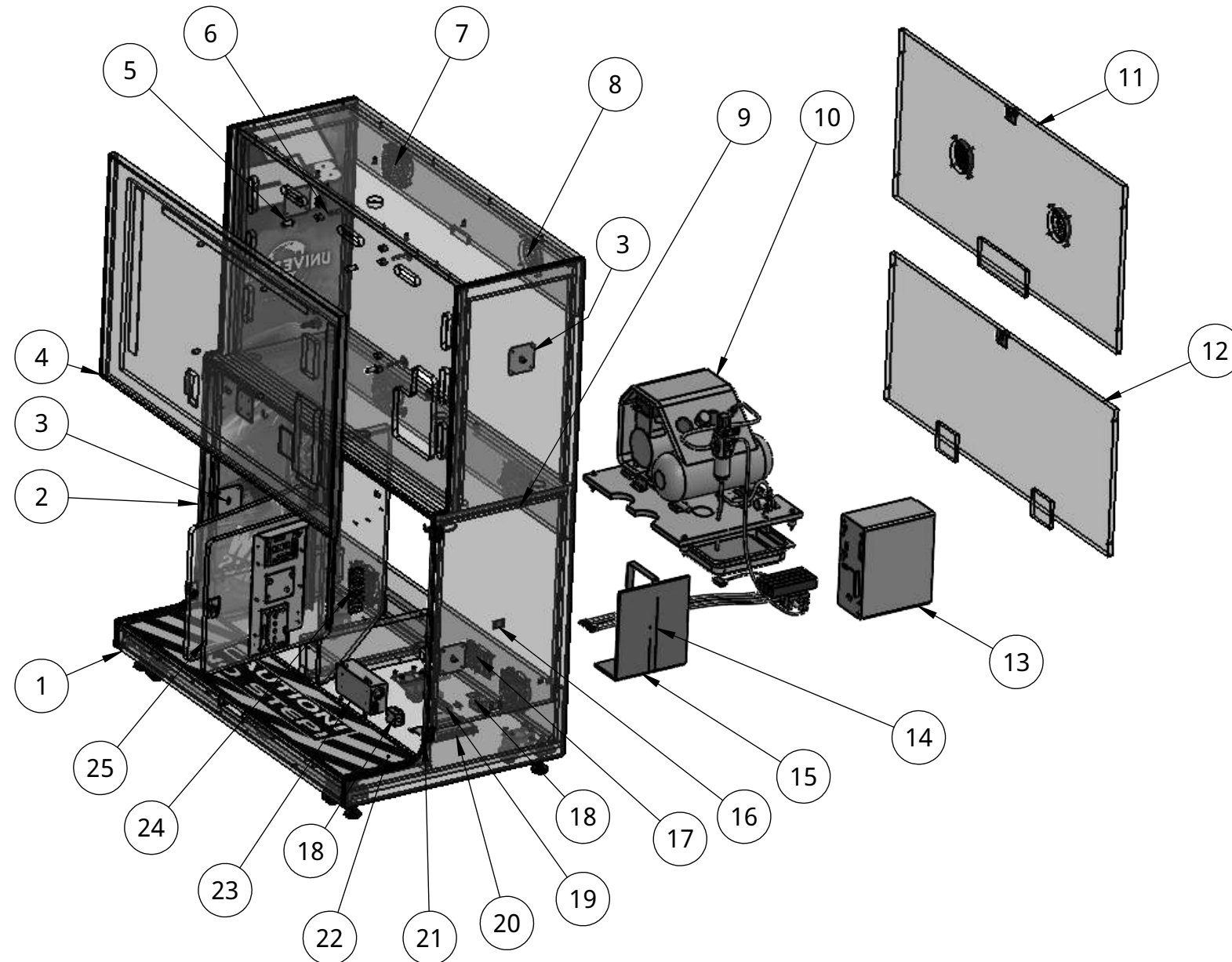

ITEM NO.	PART NUMBER	DESCRIPTION	QTY.
1	601-00951-01	F&F MAIN CABINET ASSEMBLY	1
2	Cab LED Strip	30" Cabinet LED Trim and LED Strip	2
3	600-02986-01	F&F Cab Side Connect Plate (4)	4
4	Samsung 65 Commercial grade LCD-Lower	Same as Upper Monitor	1
5	SAMSUNG_QB65N-VESA_Spacer	Samsung Monitor Spacer	4
6	65mm_Lock_2 Flat	65mm_Lock Washer_2 Flat Washers	4
7	Fan Assy	DC fan and wire guard assembly	1
8	800-00001-00	120mm Wire Fan Guard	1
9	Fan Assy w TACH and PWM	DC fan and wire guard assembly	4
10	Compressor Related Assy	See Assembly Diagram	1
11	F&F Back Door - Upper Main Cabinet	F&F Back Door - Upper Main Cabinet	1
12	F&F Back Door Lower Main Cabinet	F&F Back Door Lower Main Cabinet	1
13	850-00035-01 Lenovo M70t	Lenovo M70t	1
14	PC - Strap Assy	PC - Strap Assy.SLDASM	1
15	Foam Sheet for PC	7x6x.75 Foam Sponge	1
16	600-00891-01	Securing Nylon Strap Plate	3
17	AC Double-Inlet Sub-Assy	See Assembly Diagram	1
18	800-00040-01	6210AXXSZS-DC 3 / 6210DSX-1: Solid State Relay	2
19	601-00580-01	PC Wood Cleat	2
20	Power Line Filter Assy	See Assembly Diagram	1
21	600-02915-01	F&F LED Wide Bracket (8)	4
22	606-02003-01	F&F- Main Cab Floor Caution	1
23	330-00003-01	HRP-600-12: 600W, 12V Dual Voltage Power Supply	1
24	Fuse block x 10	Fuse block x 10	1
25	F&F Main Cab Front Door (2)	F&F Main Cab Front Door (2)	2
26	Compressor Monitor Board Assembly	See Assembly Diagram	1
27	600-02499-01	VRK-Drip Tray Access Plate	1
28	Cable Clamp Small	1/2" Cable Clamp	13
29	CABLE-BUNDLE-CAB	For Illustration Only-See Cable Layout	1
30	RIO 2-HARDWARE-ASSY-NITRO	RIO 2-HARDWARE-ASSY-NITRO	1

FAST AND FURIOUS ARCADE
TOP MONITOR MOUNTING AND
BRACKET ASSEMBLY

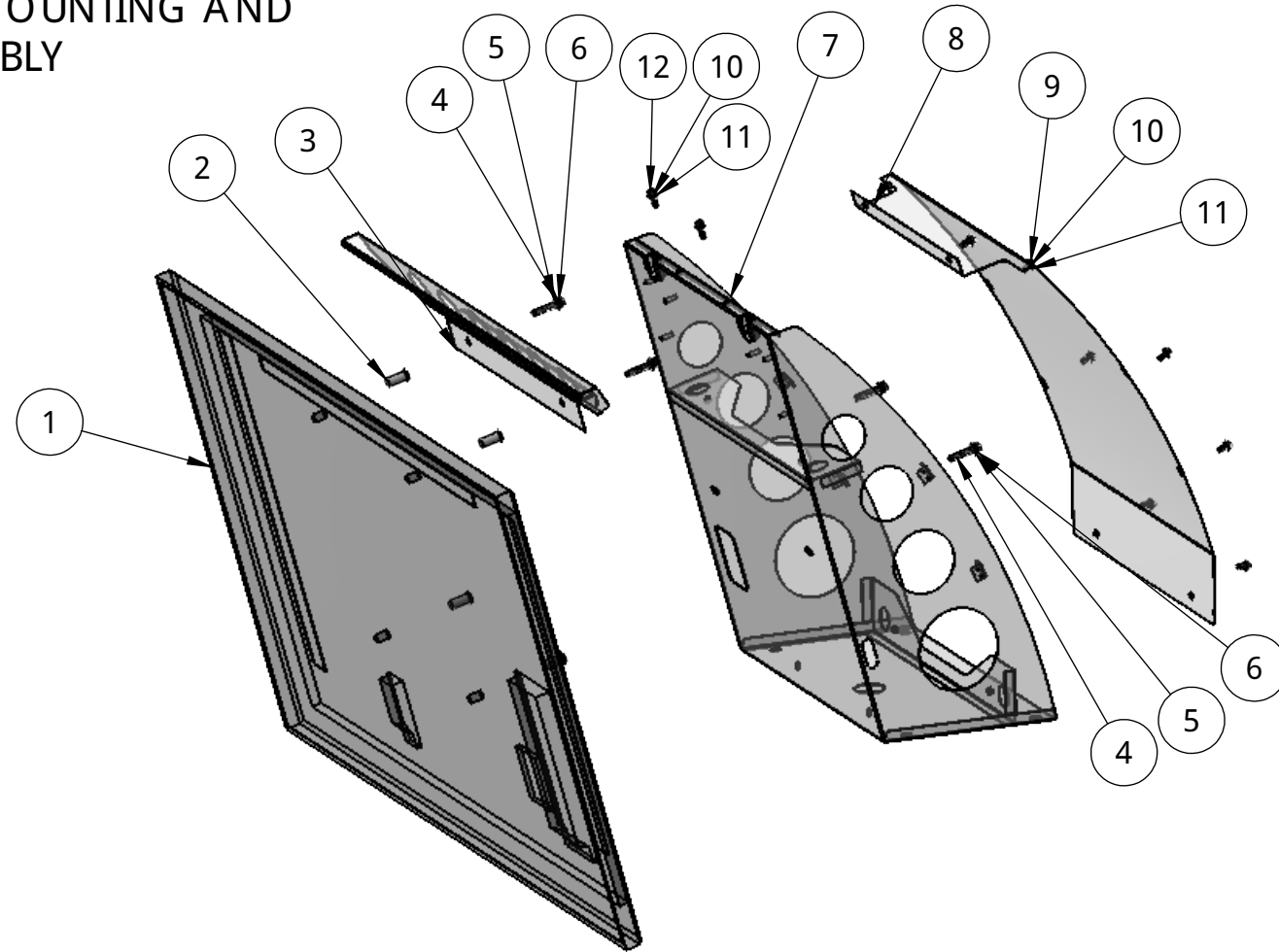

ITEM NO.	PART NUMBER	DESCRIPTION	QTY.
1	809-00016-01-	Samsung QB65B- 65" Commercial grade LCD	1
2	SAMSUNG_QB65N-VESA_Spacer	Samsung Monitor Spacer	4
3	600-02970-01-A	F&F-65 LCD Hanger Bracket	1
4	91280A546	M8x50mm_Medium-Strength Class 8.8 Steel Hex Head Screw	4
5	90770A030	.344 ID x.750 OD x .060 Steel Washer	4
6	91102A030	.322_Zinc-Plated Steel Split Lock Washer	4
7	600-02888-01-1	F&F Upper Monitor Mounting Bracket	1
8	600-02983-01	F&F Rear Monitor Cover panel	1
9	91900A845	PIN-IN-TORX BUTTON SOCKET CAP SCREW	8
10	1_4 LOCK WASHER	1/4" LOCK WASHER	10
11	FLAT_WASHER-REG	1/4"ID X 5/8" OD FLAT_WASHER	10
12	91309A544	1_4-20 x 1 Hex Head Screw	2
17	1 Inch Bead Weld		4

FAST AND FURIOUS ARCADE
CABINET JOINER BRACKET ASSEMBLY

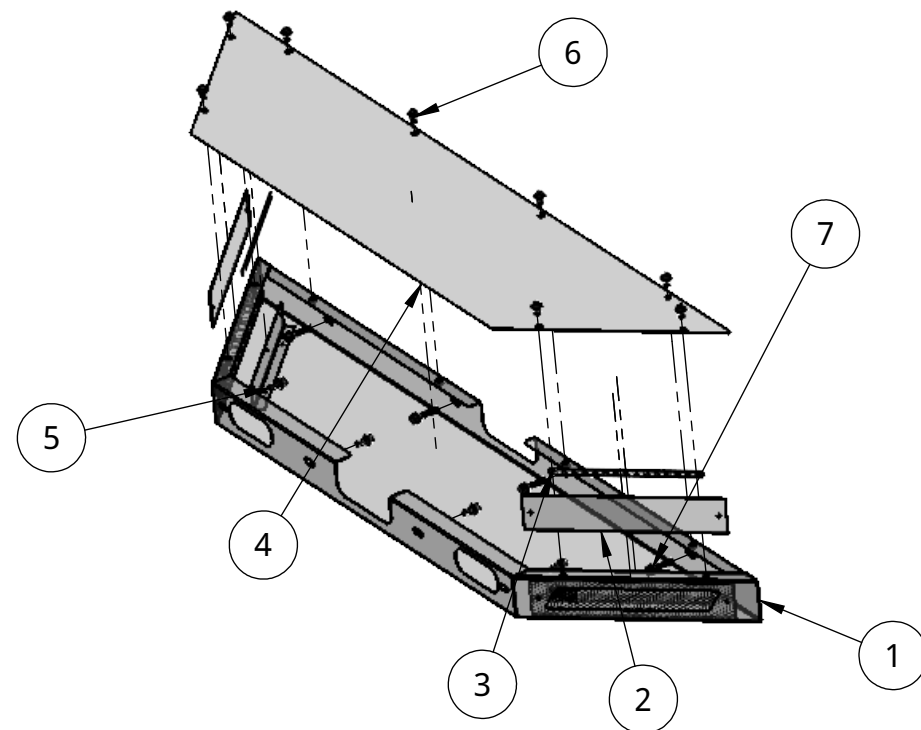

ITEM NO.	PART NUMBER	DESCRIPTION	QTY.
1	600-02956-01	F&F-Production Joiner Bracket	1
2	600-02985-01	F&F Joiner HDPE Lens (2)	2
3	500-00184-01-25	25CM 10in LED Strip (RGB with foam tape)	2
4	600-02957-01	F&F-Production Joiner Bracket Cover	1
5	1_4-20 x1-Hex Lock and Flat Assy	1/4-20 x1" Screw w Lock and Flat Washers	4
6	1_4-20 x75-Lock and Reg Flat Assy	1_4-20 x75 Screw w Lock and Flat Washers	8
7	1_4-20 x2-Hex Lock and Flat Assy	1/4-20 x1" Screw w Lock and Flat Washers	4

FAST AND FURIOUS ARCADE
AIR COMPRESSOR ASSEMBLY AND
RELATED COMPONENTS
(USA) 120V VERSION

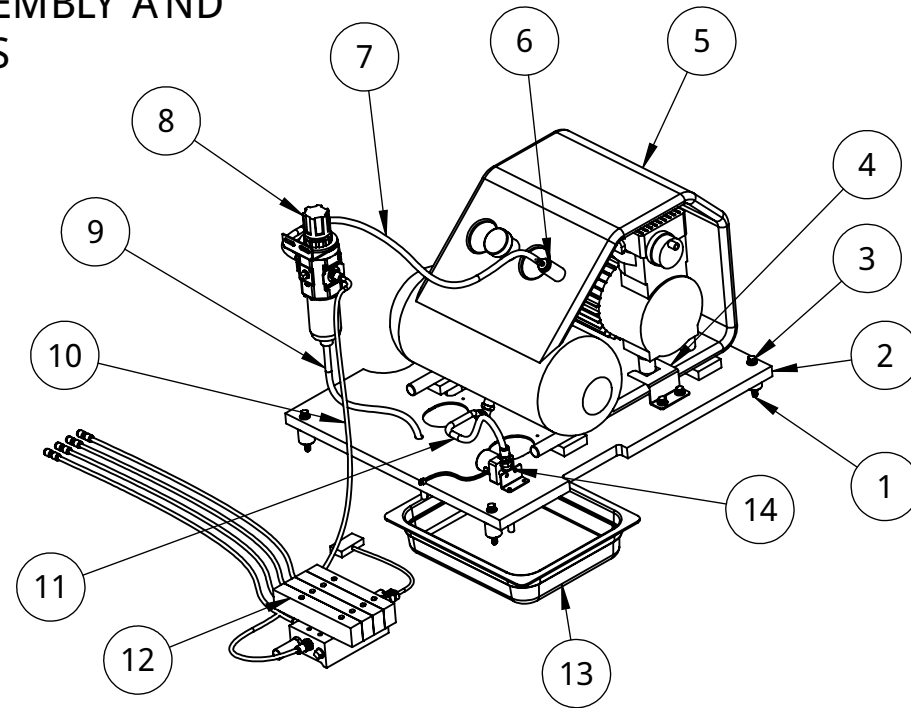

ITEM NO.	PART NUMBER	DESCRIPTION	QTY.
1	93945K117	93945K117_Vibration-Damping Sandwich Mount with Stud and Insert	4
2	601-00986-01	F&F Compressor Shelf	1
3	1_4-20 x125-Hex Lock and Flat Assy	1/4-20 x1.25" Screw w Lock and Flat Washers	8
4	600-02621-01	01-2959 BRACKET-COMPRESSOR-DLX-JP	2
5	604-00066-01	Ma k it a Quiet Series 1 HP, 2 Gallon, Oil Free, Electric Air Compressor, 120VAC, CSA/US Listed	1
6	6718K72	303 Stainless Steel Industrial Quick-Disconnect Hose Coupling for Air-Barbed	1
7	Compressor to Regulator hose 3_8	3/8" OD x 18" Long Air Hose	1
8	FILTER REGULATOR ASSY	C KD-W3000-8N-W-F1-B3W	1
9	Regulator Drain Hose 3_8	3/8" OD x 18" Long Air Hose	1
10	Regulator to Manifold Hose 1_4	1/4" OD x 48" Long Air Hose	1
11	Compressor line to Purge Valve	3/8" OD x 10" Long Air Hose	1
12	Manifold_&_Fitting_Assy	See Assembly Diagram	1
13	Tub and Sponge Assy	10 x 12 Tub, 10 x 8 Sponge	1
14	AS-3640	Compressor Solenoid Assembly-Drain Valve	1
15	604-00067-01	Eluan 230V / 50Hz (CE Compressor)	1
16	601-00987-01	F&F-Eluan Compressor Wheel Chock (CE ONLY)	1
17	Compressor-Strap Assy	Compressor-Strap Assy (CE ONLY)	1
18	600-00891-01	Securing Nylon Strap Plate	2

FAST AND FURIOUS ARCADE
AIR COMPRESSOR ASSEMBLY AND
RELATED COMPONENTS
(UK, INTL) 230V VERSION

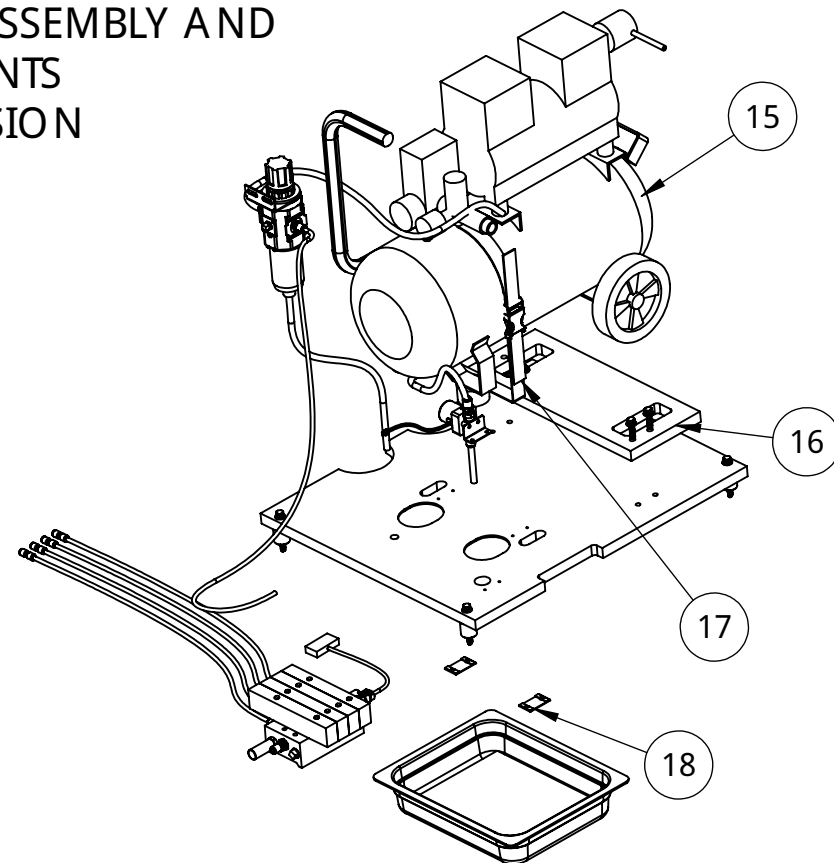

FAST AND FURIOUS ARCADE
AIR MANIFOLD ASSEMBLY

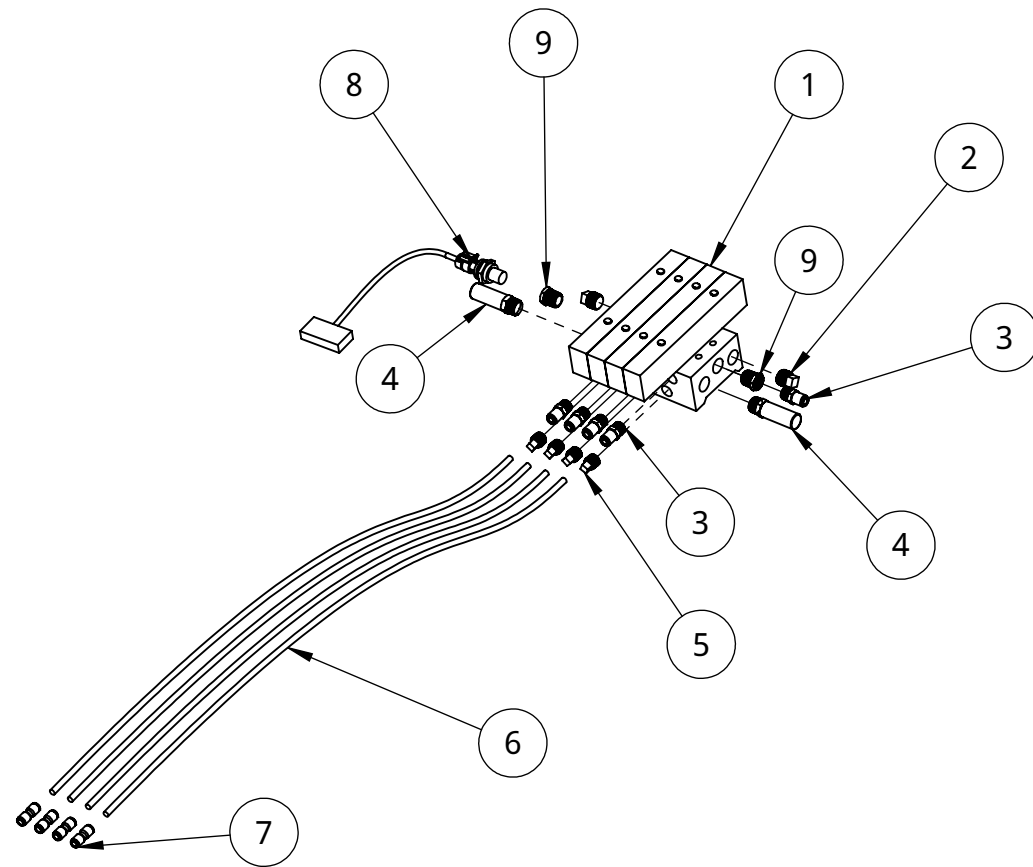

ITEM NO.	PART NUMBER	DESCRIPTION	QTY.
1	604-00045-01	C KD / M4KB330-08N-4-DC 12V 4 Station Manifold	1
2	44605K233	Plug, 3/8 Pipe Size	2
3	5779K109	Push-to-Connect Tube Fitting for Air, Straight Adapter for 1/4" Tube OD x 1/4 NPT Male	5
4	1213T12	High-Noise Reducing Mufflers, Plastic, 3/8 NPT Male, 177 scfm, 2-5/16" High	2
5	44605K232	Plug, 1/4 Pipe Size	4
6	Manifold to Spring Hose 1.4 OD, Coupling	Manifold to Spring Air line, 1/4" OD to 1/4" OD push to connect coupling	4
7	5779K14	Fitting Push-to-Connect 1/4-1/4 Female (5779K14)	4
8	500-00195-01	Pressure Sensor	1
9	50785K63	Bushing Reducer, 3/8" Male x 1/4" Female	2

FAST AND FURIOUS ARCADE
AIR REGULATOR ASSEMBLY

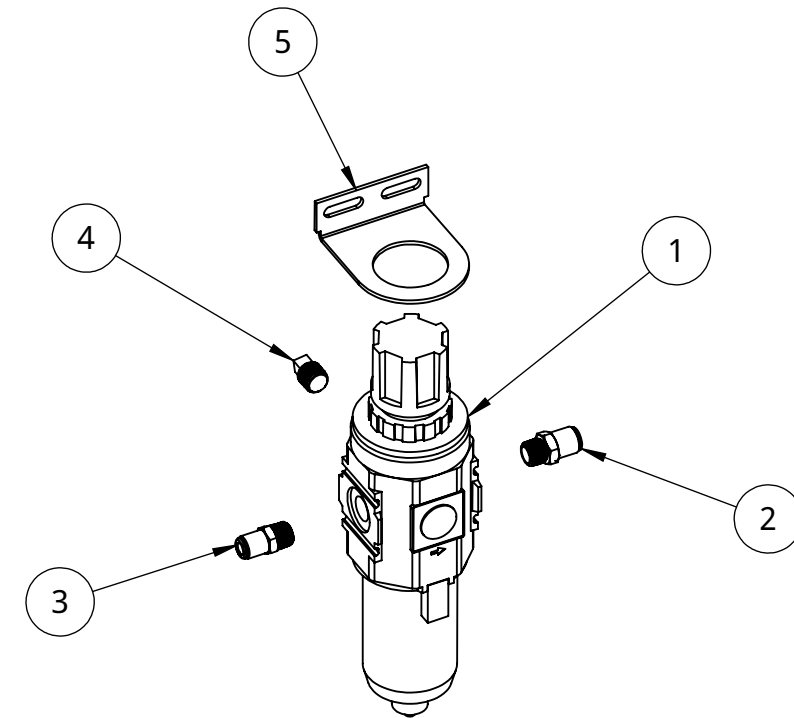

ITEM NO.	PART NUMBER	DESCRIPTION	QTY.
1	604-00046-01	C KD-W3000-8N-W-F1 1/4" NPT 5 micron Filter/Regulator w normal closed auto-drain	1
2	5779K391	Fitting -3/8 OD Push-to-Connect / 1/4 NPT Male - (5779K391)	1
3	5779K109	Push-to-Connect Tube Fitting for Air, Straight Adapter for 1/4" Tube OD x 1/4 NPT Male	1
4	44605K232	Plug, 1/4 Pipe Size	1
5	604-00048-01	C KD-B330 L BRACKET FOR W3000-8N-W-F1	1

FAST AND FURIOUS ARCADE I/O AND HARDWARE BOARD ASSEMBLY

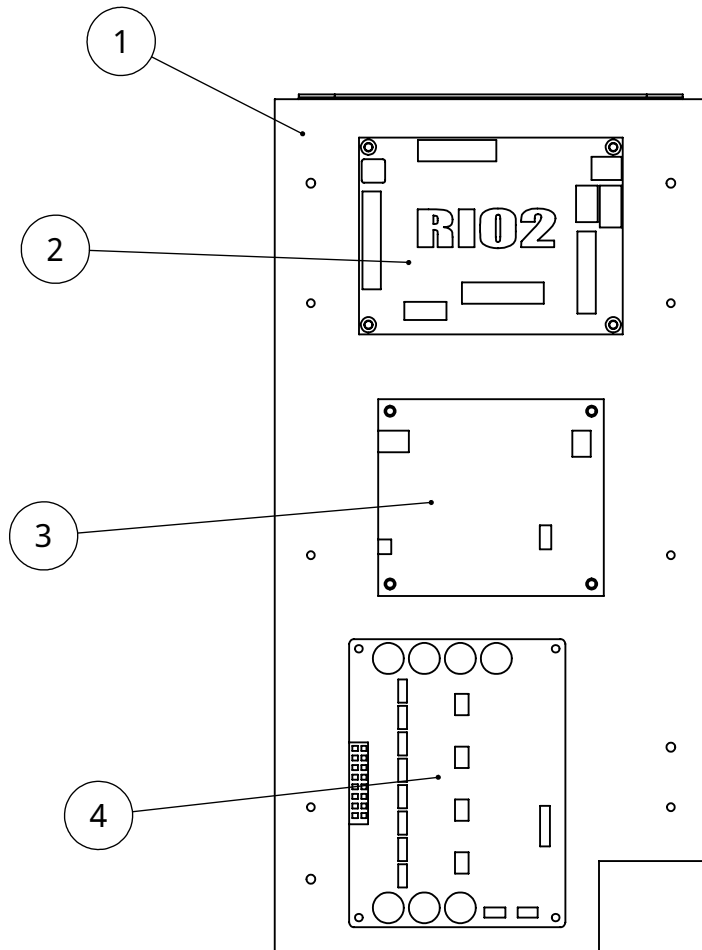

ITEM NO.	PART NUMBER	DESCRIPTION	QTY.
1	600-02576-01	RIO 2-BACKPLANE-NITRO	1
2	500-00199-05	PC BOARD- RIO 2	1
3	500-00251-01	USB-H-BRIDGE-MOTOR-DRIVER-PCBA	1
4	380-00010-01	8-CHANNEL-AUDIO-AMP-PCBA	1

FAST AND FURIOUS ARCADE MULTI-GAME MARQUEE ASSEMBLY AND INSTALLATION

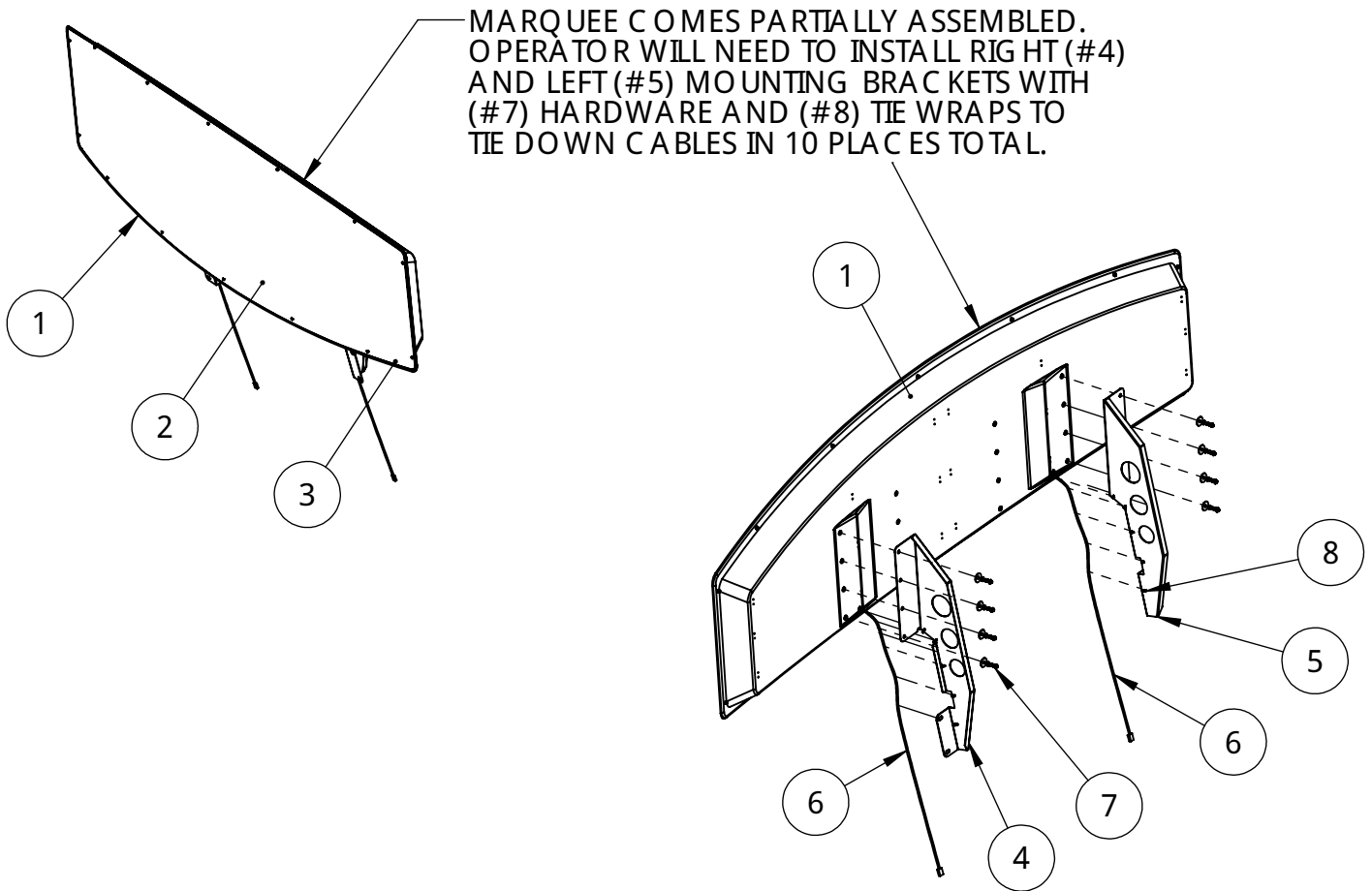

ITEM NO.	PART NUMBER	DESCRIPTION	QTY.
1	603-01066-01-ASSY	Fast and Furious Multi-Game Marquee Pan	1
2	600-02929-01	F&F-Double Wide Marquee .11 Clear PETG	1
3	606-02005-01	F&F-Double Wide Marquee Translight	1
4	600-02973-01	F&F-Marquee Bracket Single Cruis'n Style Right	1
5	600-02974-01	F&F-Marquee Bracket Single Cruis'n Style Left	1
6	Marquee LED Cable	Marquee LED Cable	2
7	1_4-20 x75-Lock and Flat Assy	1_4-20 x75 Screw w Lock and Flat Washers	8
8	Tie Wrap	Included with Marquee kit	10

FAST AND FURIOUS ARCADE MOTION PLATFORM ASSEMBLY

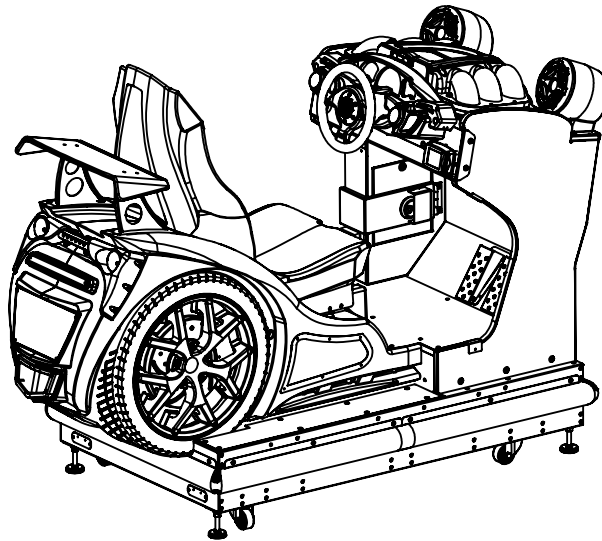

UPPER MOTION
BASE ASSEMBLY

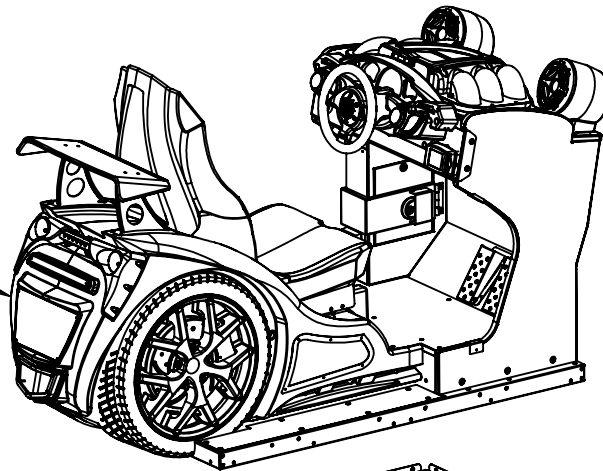

SAFETY BELLOWS
ASSEMBLY

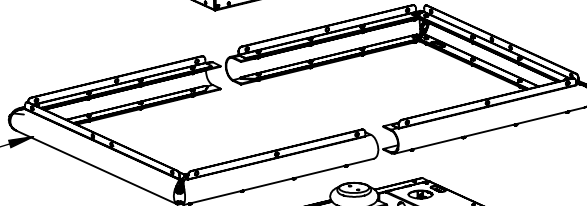

LOWER MOTION
BASE ASSEMBLY

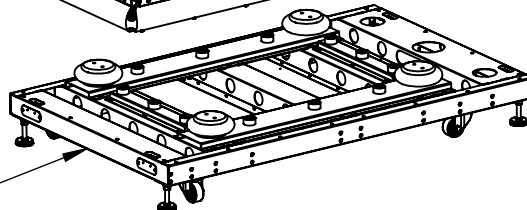

FAST AND FURIOUS ARCADE LOWER BASE ASSEMBLY

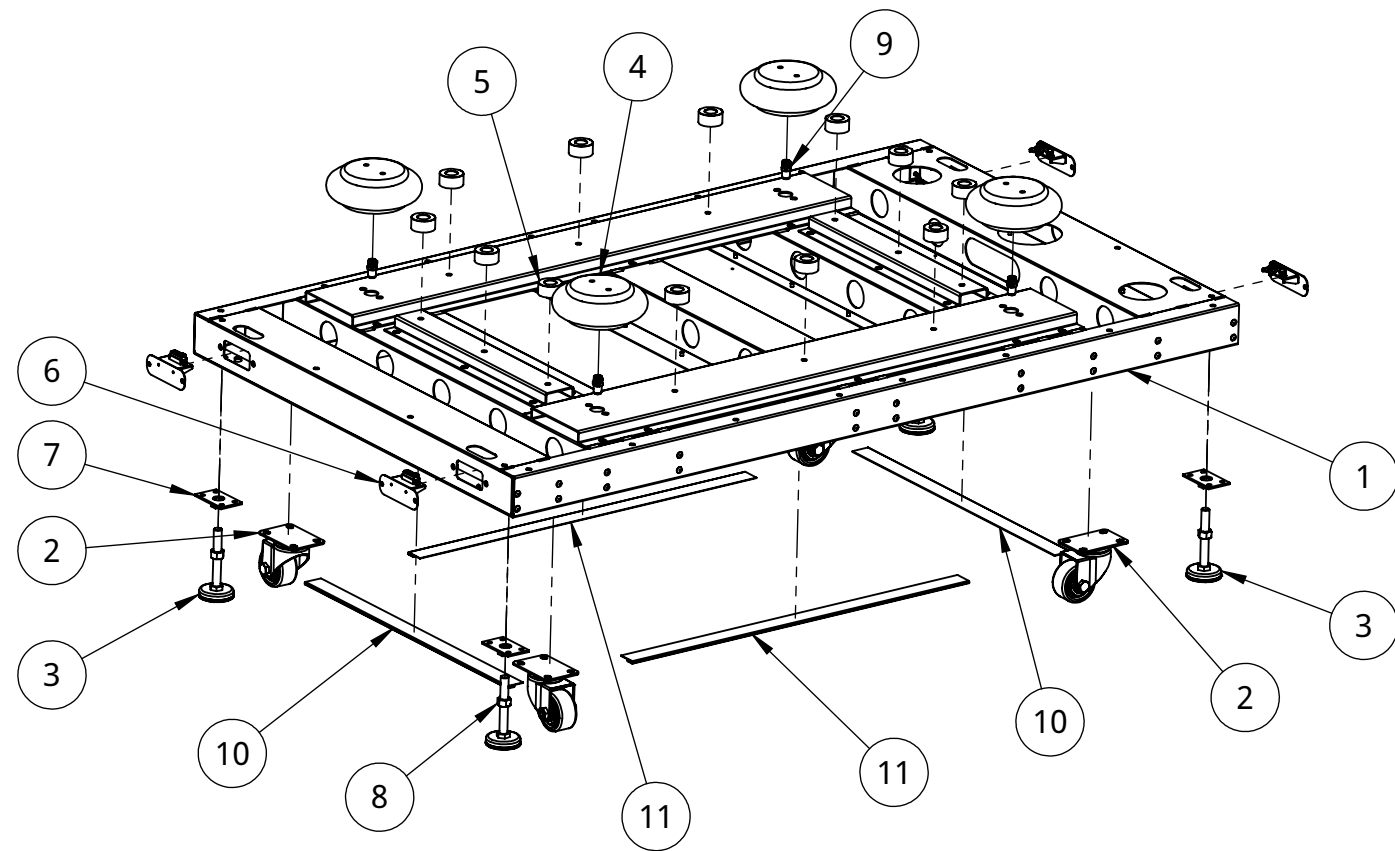

ITEM NO.	PART NUMBER	DESCRIPTION	QTY.
1	608-00243-01	F&F Bottom Motion Base	1
2	800-00087-01-	2.5 Inch Caster Assy J UL	4
3	800-00004-00	3" LEG LEVELER	4
4	800-00074-01	AIR SPRING ITT Enidine / YIFS 70-10 CI 1/4 NPT	4
5	9540K36	Unthreaded Bumper, SBR Rubber, 1-1/2" Od, 3/4" High	12
6	Sensor Sub-Assy	Sensor Sub-Assy	4
7	600-01633-01	PLATE-LEG-LEVELER-DLX-J P	4
8	95462A033	Medium-Strength Steel Hex Nut	4
9	5779K109	Push-to-Connect Tube Fitting for Air, Straight Adapter for 1/4" Tube OD x 1/4 NPT Male	4
10	RGBLED-EXTRUSION-ASSY-20in	50CM RGB (CA-3980)	2
11	RGBLED-EXTRUSION-ASSY-24	60CM RGB (CA-5114)	2

FAST AND FURIOUS ARCADE SAFETY BELLOWS ASSEMBLY

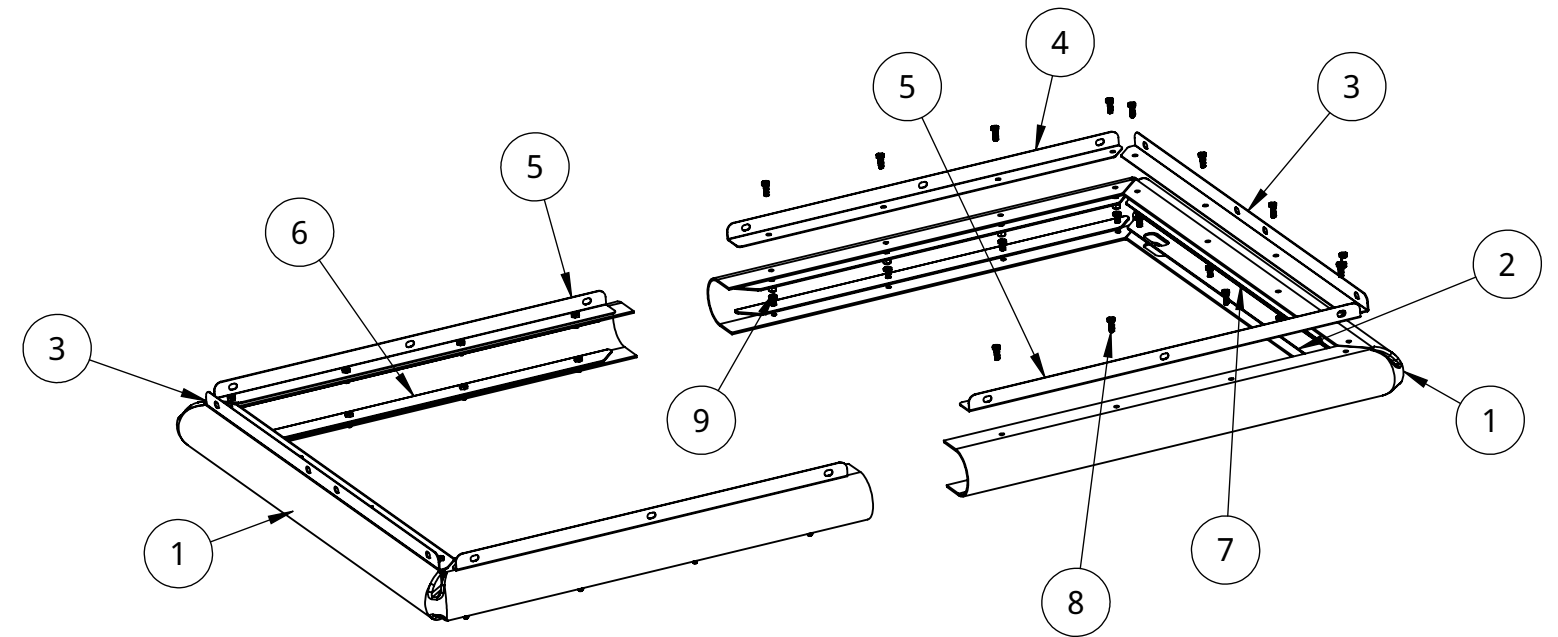

ITEM NO.	PART NUMBER	DESCRIPTION	QTY.
1	600-02893-01-	Rubber Safety Skirt	2
2	600-02993-01	F&F Safety Skirt Long Hem Bracket (Slotted)	2
3	600-02894-01	F&F Safety Skirt Upper Cross Bracket	2
4	600-02896-01	F&F Safety Skirt Upper Short Angle Side Bracket -1 (2)	2
5	600-02897-01	F&F Safety Skirt Upper Short Angle Side Bracket -2 (2)	2
6	600-02898-01	F&F Safety Skirt Short Hem Side Bracket (8)	8
7	600-02895-01	F&F Safety Skirt Long Hem Bracket	2
8	92865A540	1/4-20 X 3/4 CAP SCREW	48
9	90640A129	1/4-20 Steel Nylon-Insert Locknut	24

**FAST AND FURIOUS ARCADE
MOTION BASE ASSEMBLY
DIAGRAM**

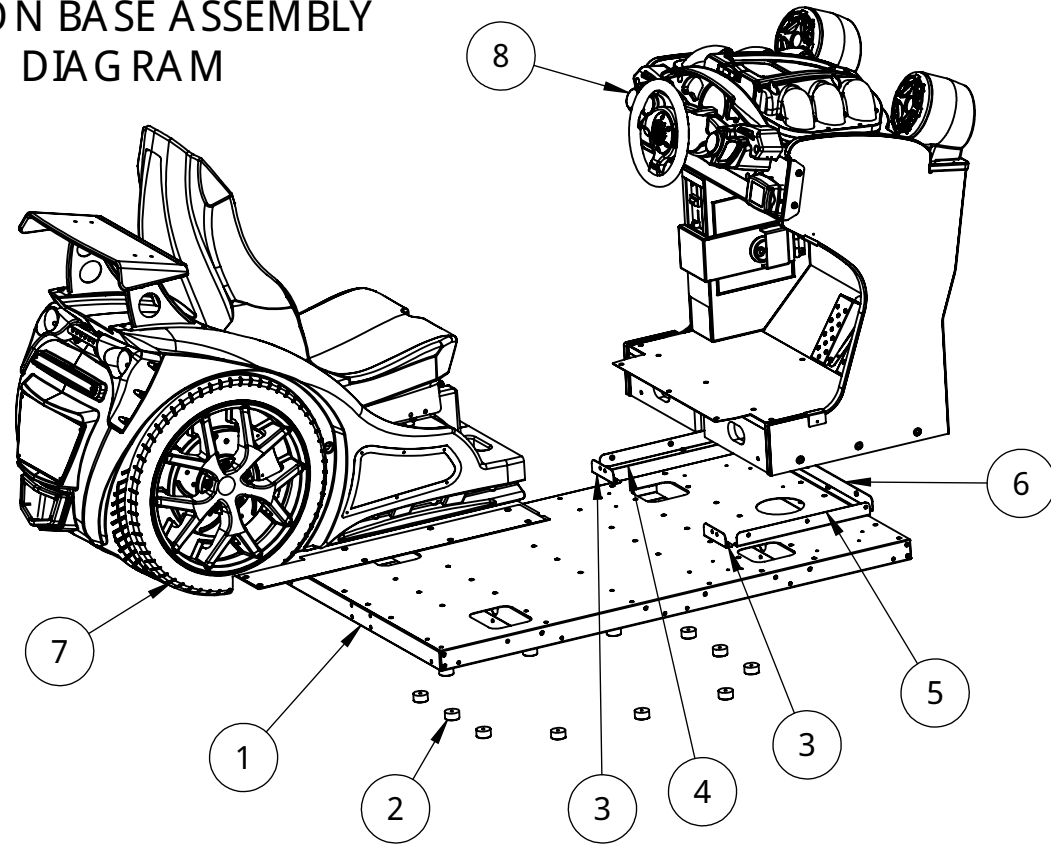

ITEM NO.	PART NUMBER	DESCRIPTION	QTY.
1	608-00244-01	F&F Top Motion Base	1
2	9540K36	Unthreaded Bumper, SBR Rubber, 1-1/2" Od, 3/4" High	12
3	600-03081-01	F&F-Driver Cab Bracket - Front (2)	2
4	600-03080-01	F&F-Driver Cab Bracket - Left	1
5	600-03079-01	F&F-Driver Cab Bracket - Right	1
6	600-03078-01	F&F-Driver Cab Bracket - Rear	1
7	F&F-MOTION-PEDESTAL ASSY-PROD-1	F&F-PEDESTAL ASSY	1
8	F&F Control Cab Production-Final Assy	F&F Control Cab Production	1

**FAST AND FURIOUS ARCADE
PEDESTAL ASSEMBLY**

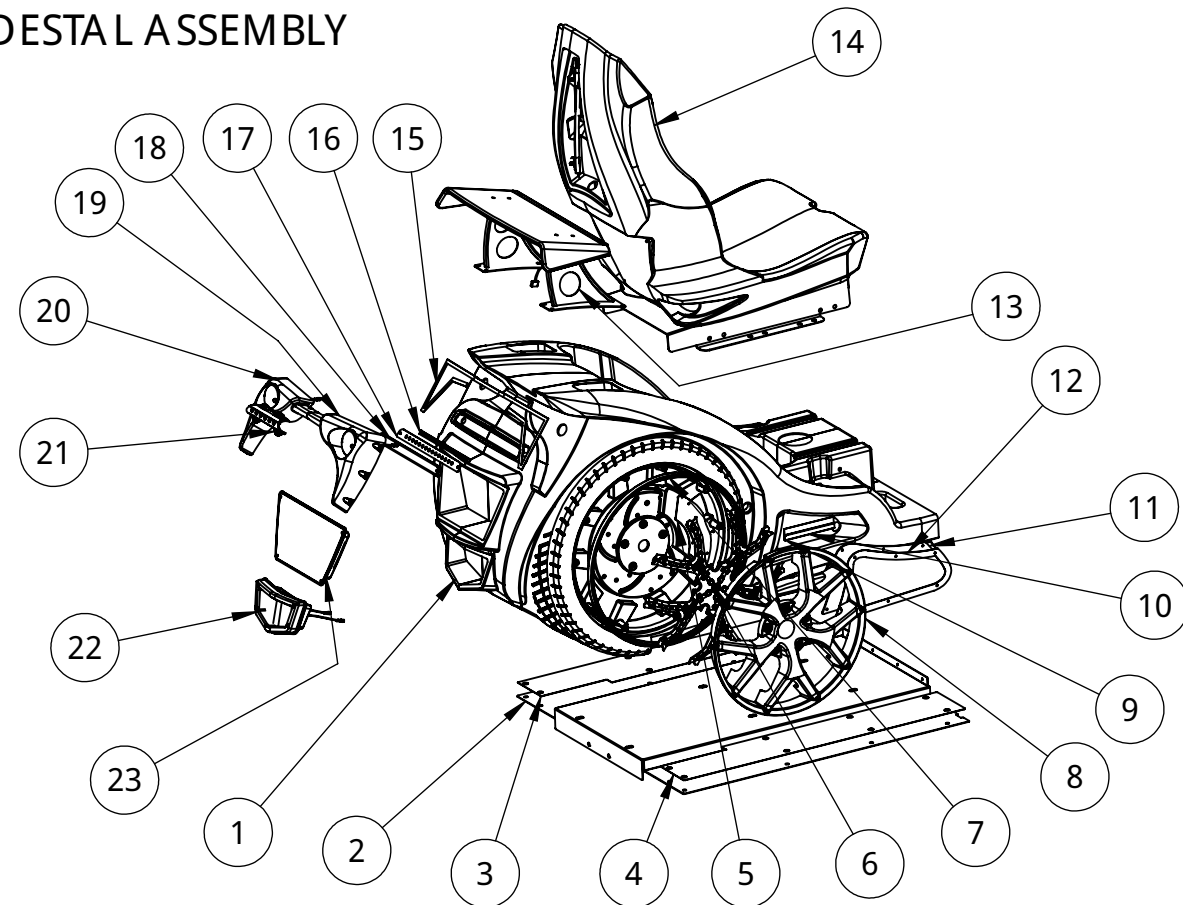

ITEM NO.	PART NUMBER	DESCRIPTION	QTY.
1	603-01064-01	F&F SEAT PEDESTAL (MOD 603-00774-01)	1
2	600-02875-01	F&F Pedestal Mount-PROD	1
3	606-02002-01	Motion Floor Graphic (KEEP CLEAR) L	1
4	606-02001-01	Motion Floor Graphic (KEEP CLEAR) R	1
5	606-01206-01	Cruis'n-Brake Caliper (2) Req'd	1
6	Wheel LED Assy	F&F Wheel LED Assembly	2
7	WHEEL-LED T-MOLDING-ASSY	WHEEL-ROB-LED T-MOLDING-ASSY	2
8	603-00769-01	Cruis'n - Wheel / Chrome (2) req'd	2
9	500-00184-15	RGB LED with Foam Tape 15CM	2
10	603-00762-6	LED Extrusion-6"	2
11	600-02887-01	F&F Pedestal Side Grill 1/8" HDPE Lens (2)	2
12	600-02885-01	F&F Pedestal Side Grill R	1
13	F&F Spoiler Assy - PRODUCTION	F&F Spoiler Assy - PRODUCTION	1
14	CruisnSeatAssy	CruisnSeatAssy (See Details)	1
15	500-00162-01-122CM	122CM Tail Light White LED.SLDPRT	1
16	500-00131-10 (CA-3989)	Cruis'n - Brake light RGB LED 10"	1
17	600-01881-01	Cruis'n-Ped Horizontal Light Mask	1
18	600-01882-01	Cruis'n-Ped Horizontal Light Overlay	1
19	RearTailLightAssy-R	RearTailLightAssy-R	1
20	RearTailLightAssy-L	RearTailLightAssy-L	1
21	603-00803-01	Cruis'n - Center Tail light Cover (IM)	1
22	Cruis'n Tail Pipe-Assy	Cruis'n Tail Pipe-Assy (see exploded)	1
23	F&F License-Plate-Assy	Cruis'n License-Plate-Assy (see exploded)	1
25	600-02886-01	F&F Pedestal Side Grill L	1

FAST AND FURIOUS ARCADE DRIVER CABINET ASSEMBLY

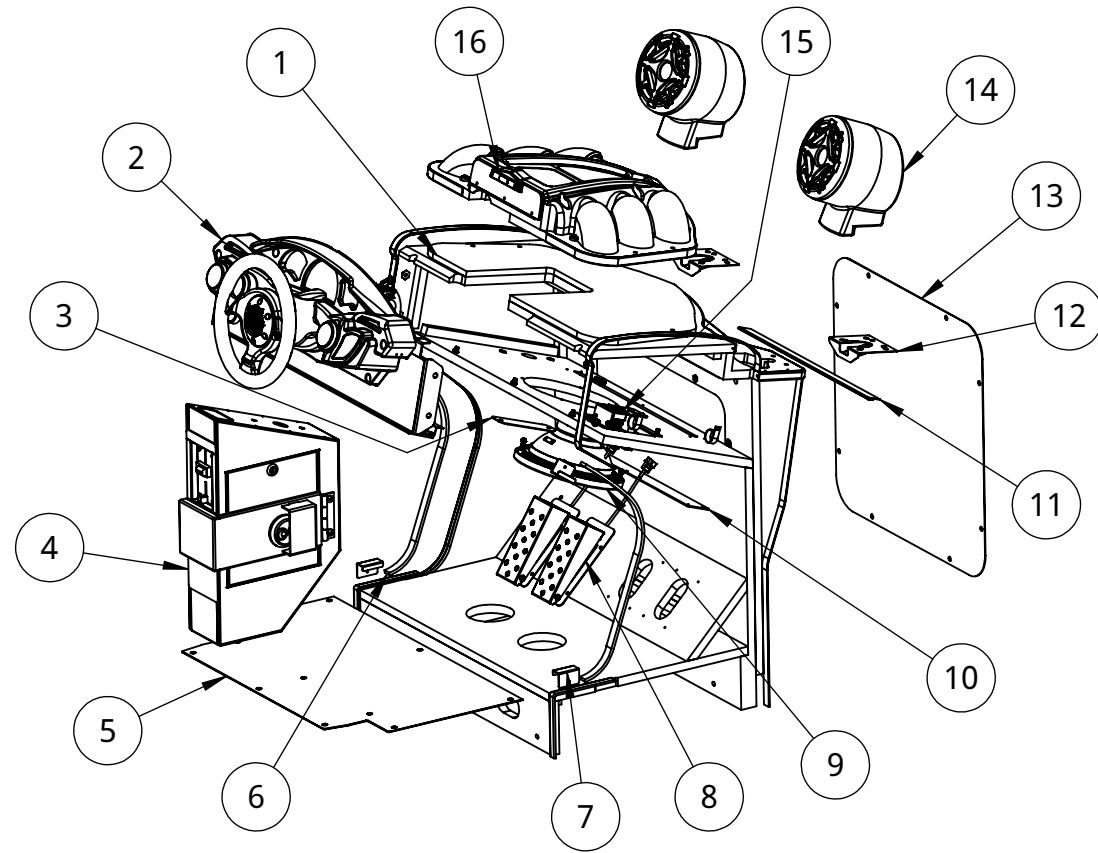

ITEM NO.	PART NUMBER	DESCRIPTION	QTY.
1	601-00950-01	F&F CONTROL CABINET	1
2	F&F PROD-Dash-Assy	Cruis'n-Dash-Assy (See Exploded)	1
3	600-03041-01	F&F-Coin Vault Cover Plate	1
4	F&F-Vault-Final Assembly	***SPECIAL ORDER ONLY***	1
5	600-02880-01	F&F Control Cab Treadplate	1
6	Driver Cab LED Strip	RGB LED Strip and TMolding (CA-5114)	2
7	600-02915-01	F&F LED Wide Bracket (8)	4
8	604-00014-01	Modular Pedal with 5k Potentiometer (50-8194-02)	2
9	SB3-8inWoofers-Assy	SUPERBIKES 3-8inWoofers-Assy	1
10	600-01917-01	Cruis'n-UNDERDASH CLEAR PETG	1
11	LED-EXTRUSION-ASSY-18 in	LED-EXTRUSION-ASSY-18 in (CA-4454)	1
12	600-02883-01	F&F Speaker Cover Plate (2)	2
13	600-02984-01	F&F Driver Cabinet- Rear Cover panel	1
14	Speaker-Assy-Mini	SEE DETAILS	2
15	F&F Test Bracket Door Assy	F&F Test Bracket Door Assy	1
16	F&F Hood Deck Assembly	F&F Hood Deck Assembly	1

FAST AND FURIOUS ARCADE DASH ASSEMBLY

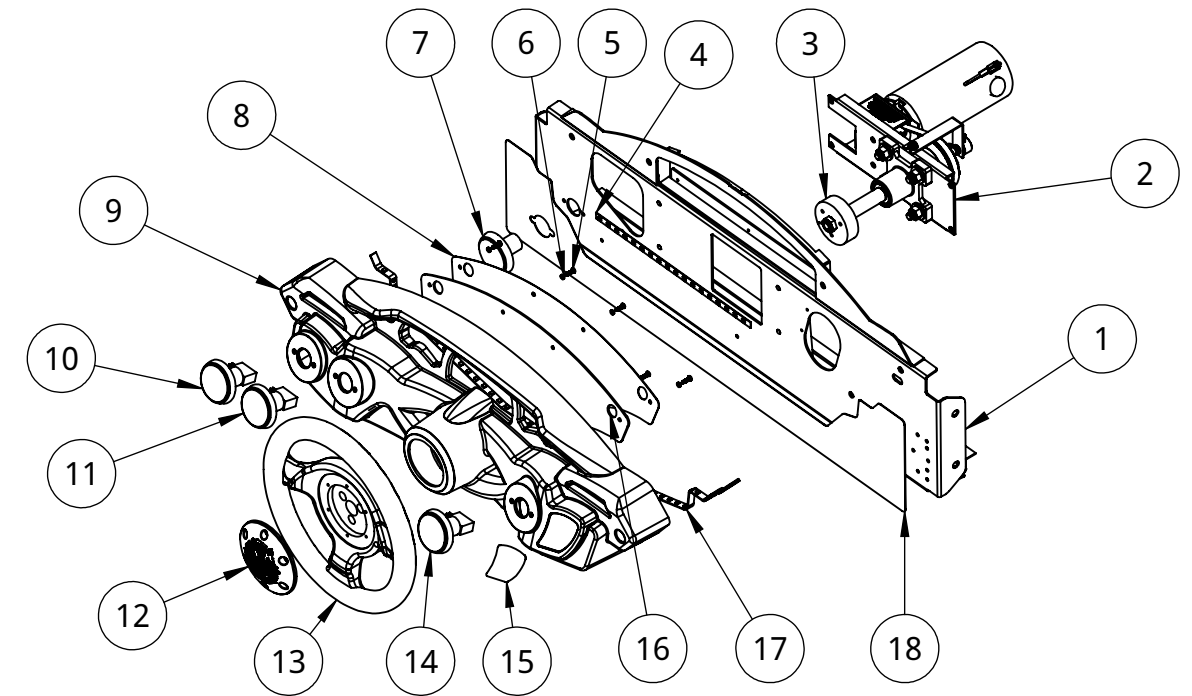

ITEM NO.	PART NUMBER	DESCRIPTION	QTY.
1	600-02879-01-1	F&F-Dash Plate	1
2	604-00002-00-1	Steering Mech, 20VDC Motor	1
3	2-1-03-00-00-004	split hub f 5/8" shaft & 1/4"-20 taps-270 wheel	1
4	Dash LED Strip-30C M (CA-4770)	Dash LED Strip-30C M White w foam tape	1
5	94629A680	94629A680	6
6	90133A005	90133A005-# 6 Neoprene Washer	6
7	702-00118-01	Large Yellow Round Button- 6V LED, CKGD .187 Motion Stop legend	1
8	606-02053-01	F&F Instrument Panel-White Styrene 30 mil	1
9	603-00770-01	F&F-Dash-InjMolded	1
10	702-00123-01	Round Orange Gold sw/6V LED F&F w Tunes legend	1
11	702-00122-01	Round Blue Gold sw/6V LED F&F w View legend	1
12	603-00789-01	Cruis'n Steering Wheel Cap	1
13	2-1-03-00-00-001	STEERING -WHEEL-SOFT-HAPP	1
14	702-00121-01	Round Green Gold sw/6V LED F&F w Start/Nitro legend	1
15	606-01998-01	F&F- Dash Right Decal-VINYL	1
16	600-01843-01	Cruis'n-Dash Inst Panel-Clear overlay	1
17	Dash LED Strip-75C M (CA-4944)	Dash LED Strip-75C M wht w foam tape	1
18	606-02004-01	F&F- DECAL Dash Lower w Motion Stop	1

FAST AND FURIOUS ARCADE HOOD DECK ASSEMBLY

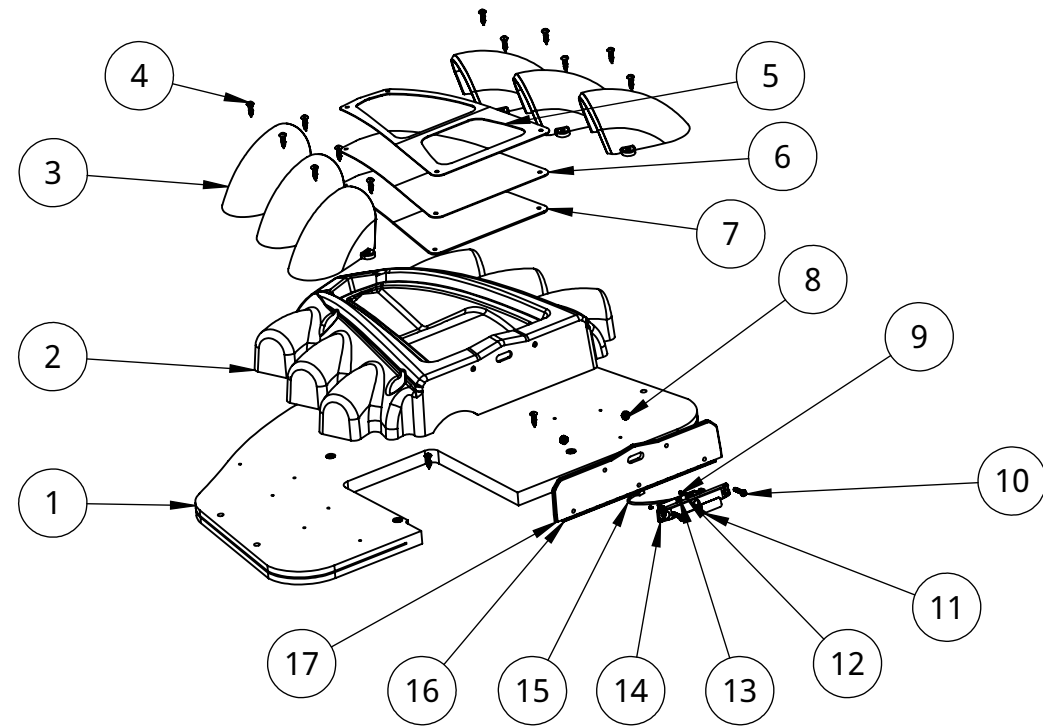

FAST AND FURIOUS ARCADE SPEAKER ASSEMBLY

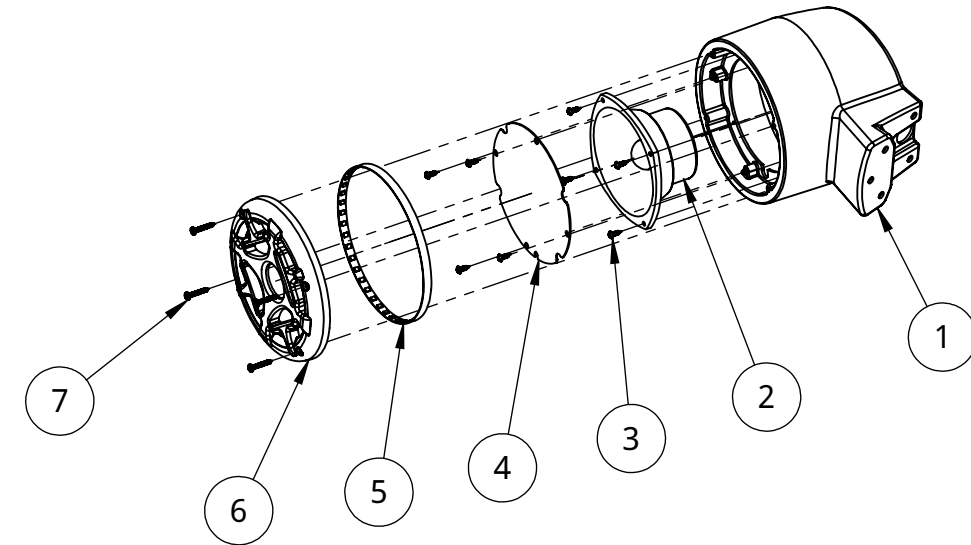

ITEM NO.	PART NUMBER	DESCRIPTION	QTY.
1	601-00989-01	F&F Control Cab Top Dash	1
2	603-01065-01	F&F-Inj Molded Hood with Cutout-Chrome (from SB3)	1
3	603-01057-01	F&F Hood Tube (6) Per	6
4	95638A245	Tamper-Resistant Torx Rounded Head Screws	16
5	600-02394-01	SB3- Blower Frame	1
6	600-02155-01	SB3- Blower Grill	1
7	600-02955-01	F&F-Blower Lens (1/8" White PETG)	1
8	90675A195	Steel Locknut with External-Tooth Lock Washer	2
9	99461A605	MMC 99461A605 Pan Head Phillips 18-8 Stainless Steel 1-32-#0 Drive	2
10	93701A408	8-32x3/4 TORXTAMPER-BLK	2
11	600-01790-01	Camera Dust Cover	1
12	Camera-Tie Wrap	Camera-Tie Wrap	1
13	500-00185-01	Moto-GP Webcam	1
14	603-00963-01	Camera-Housing/Superbikes 3	1
15	810-00162-01	USB camera cable	1
16	500-00184-01-25	25CM 10in LED Strip (RGB with foam tape)	1
17	600-02914-01	F&F PROTO -Camera .25 Acrylic Edgglow	1

ITEM NO.	PART NUMBER	DESCRIPTION	QTY.
1	603-00867-01	SB3 Speaker Housing-RM (BLACK)	1
2	2-1-10-00-00-000	5.25 Full Range Speaker, 8 ohm	1
3	90935A194	90935A194 PAN HEAD PHILLIPS SCREW FOR SHEET METAL	8
4	600-02154-01	SB3- Speaker Grill	1
5	500-00184-01-56	RGB with Foam Tape-56 cm Speakers	1
6	603-00890-01	SB3 Speaker Cover-IM (Plated)	1
7	90925A199	TORX DRIVE SCREW FOR SHEET METAL	4

Audio Amplifier DIP Switch Settings

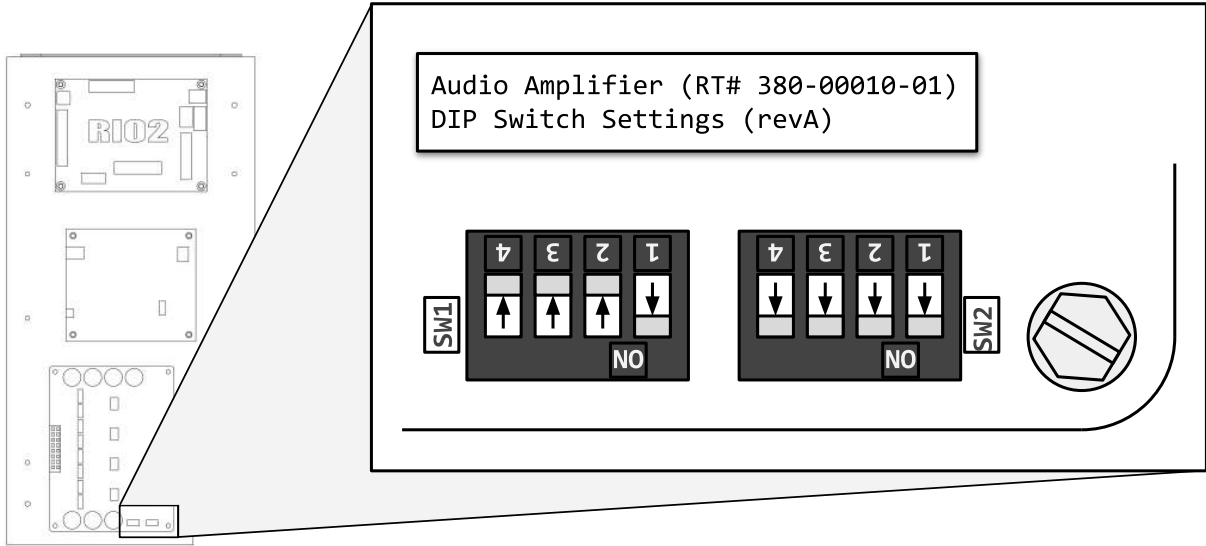

FAST AND FURIOUS ARCADE PNEUMATIC SYSTEM DIAGRAM REV A

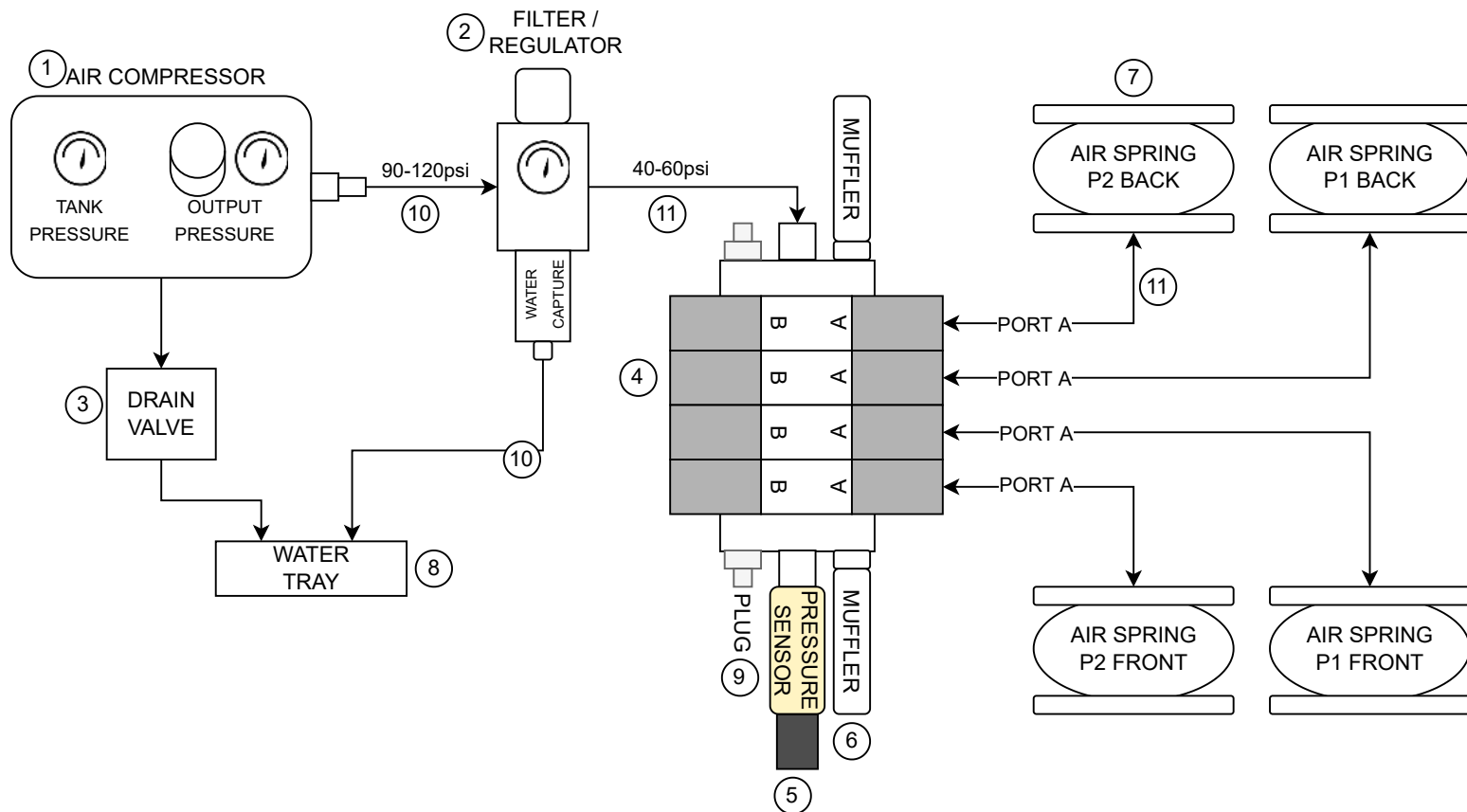

ITEM NO.	PART NUMBER	DESCRIPTION	QTY.
1 (120VAC)	604-00066-01	120V UL/CSA AIR COMPRESSOR - MAKITA MAC210Q	1
1 (230VAC)	604-00067-01	230V CE AIR COMPRESSOR - ELUAN EWS24	1
2	604-00046-01	AIR FILTER / REGULATOR ASSEMBLY	1
3	604-00060-01	12V SOLENOID DRAIN VALVE	1
4	604-00045-01	4 STATION AIR MANIFOLD ASSEMBLY	1
5	500-00195-01	PRESSURE SENSOR	1
6	604-00068-01	HIGH FLOW NOISE REDUCING MUFFLER	2
7	800-00074-01	AIR SPRING	4
8	600-01437-01	AIR COMPRESOR CONDENSATION TRAY	1
9	604-00069-01	STEEL, HEX-SOCKET PLUG, 3/8 PIPE SIZE	2
10	5648K71	POLYURETHANE TUBING, 0.245" ID, 3/8" OD, 0.065" WALL THICKNESS	-
11	5648K74	POLYURETHANE TUBING, 1/8" ID, 1/4" OD, .062" WALL THICKNESS	-

Earth GNDs:
#739: RIO2 plate
#776: RIO2 plate -> AC line filter plate

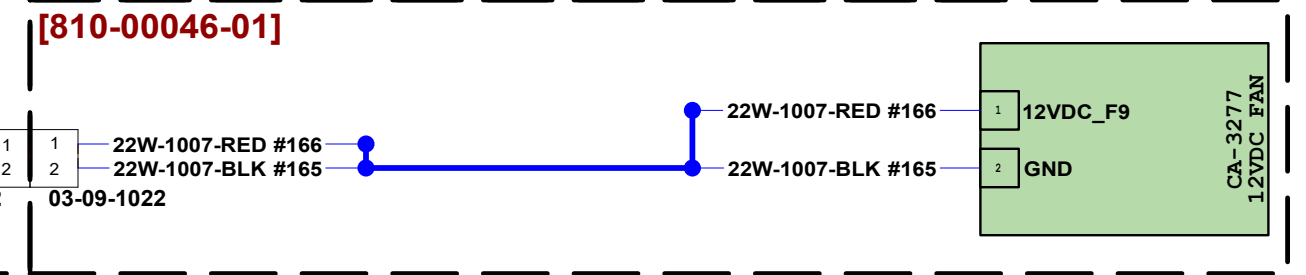
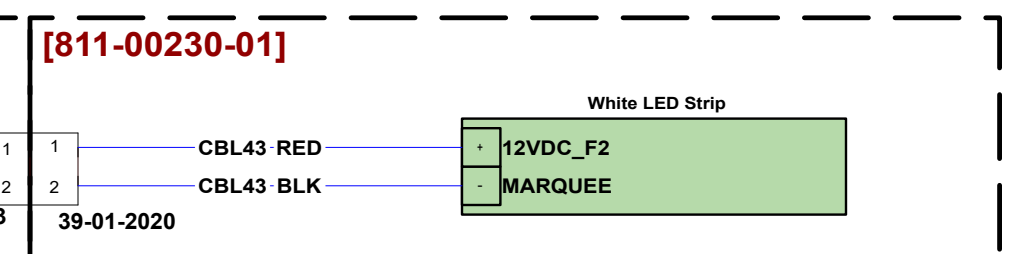
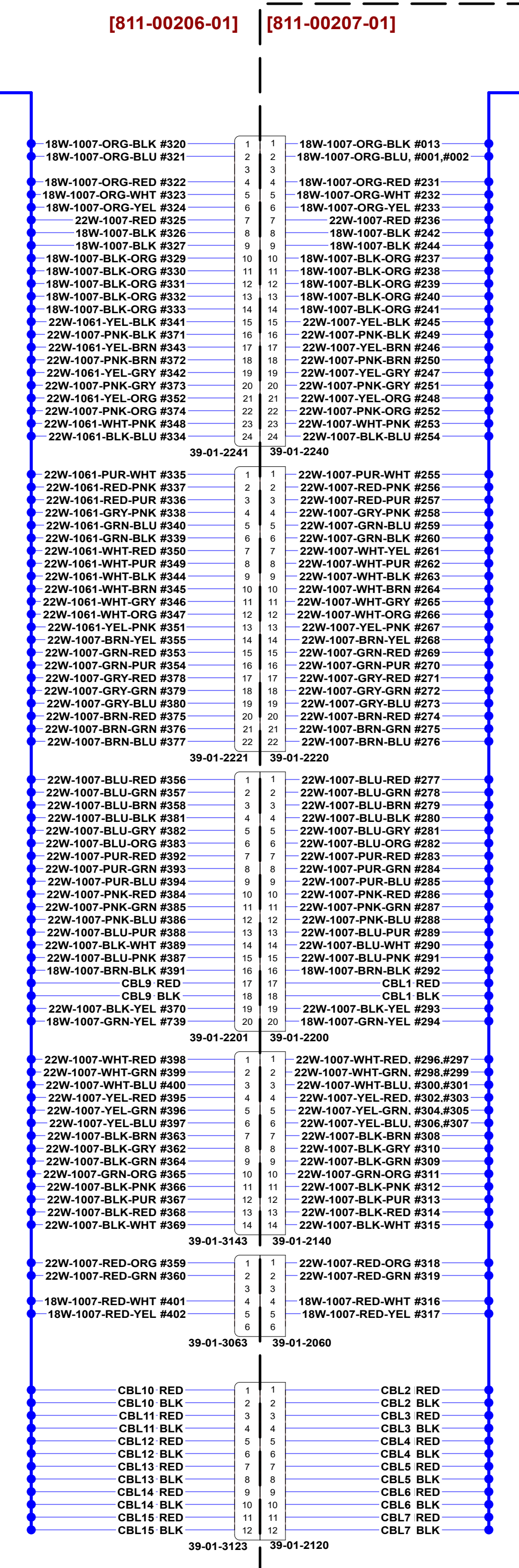
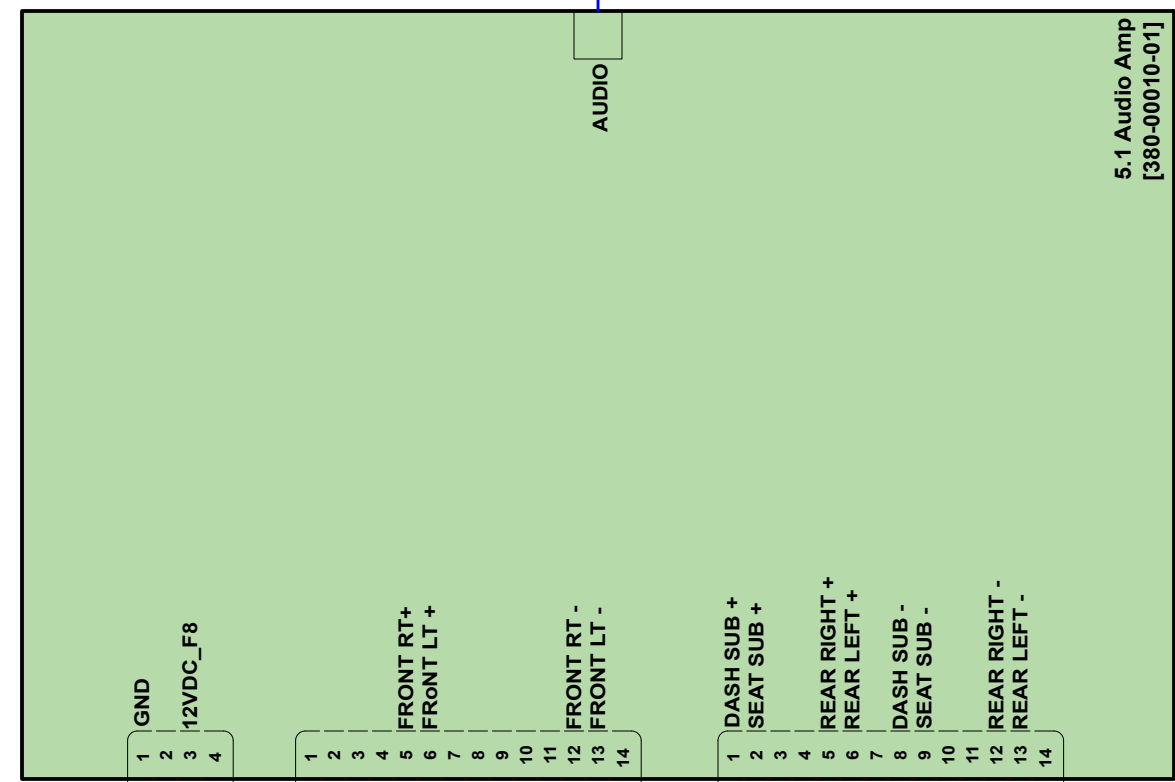
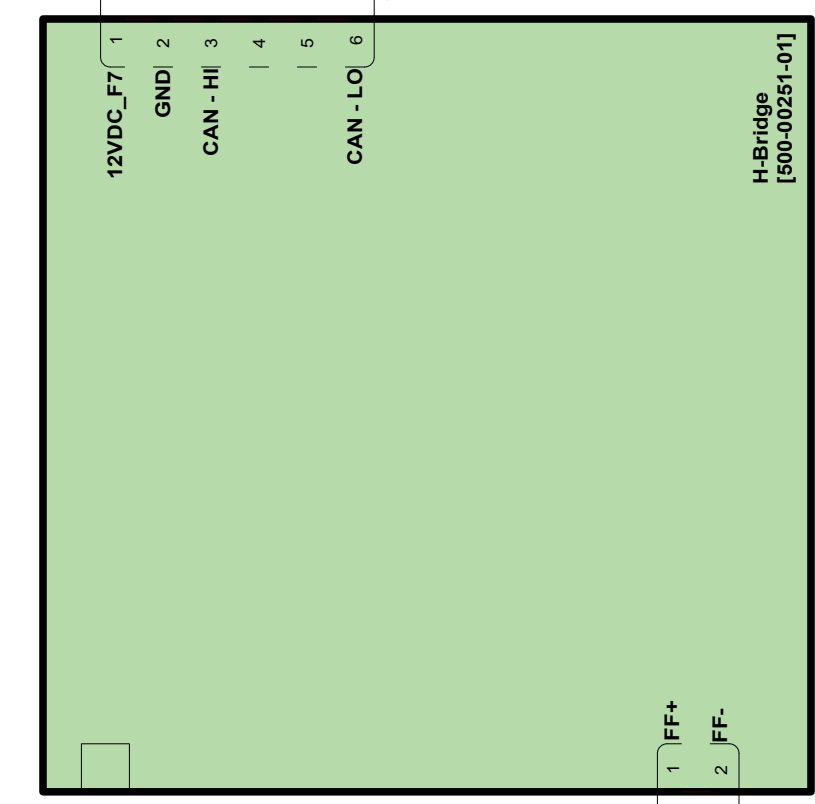
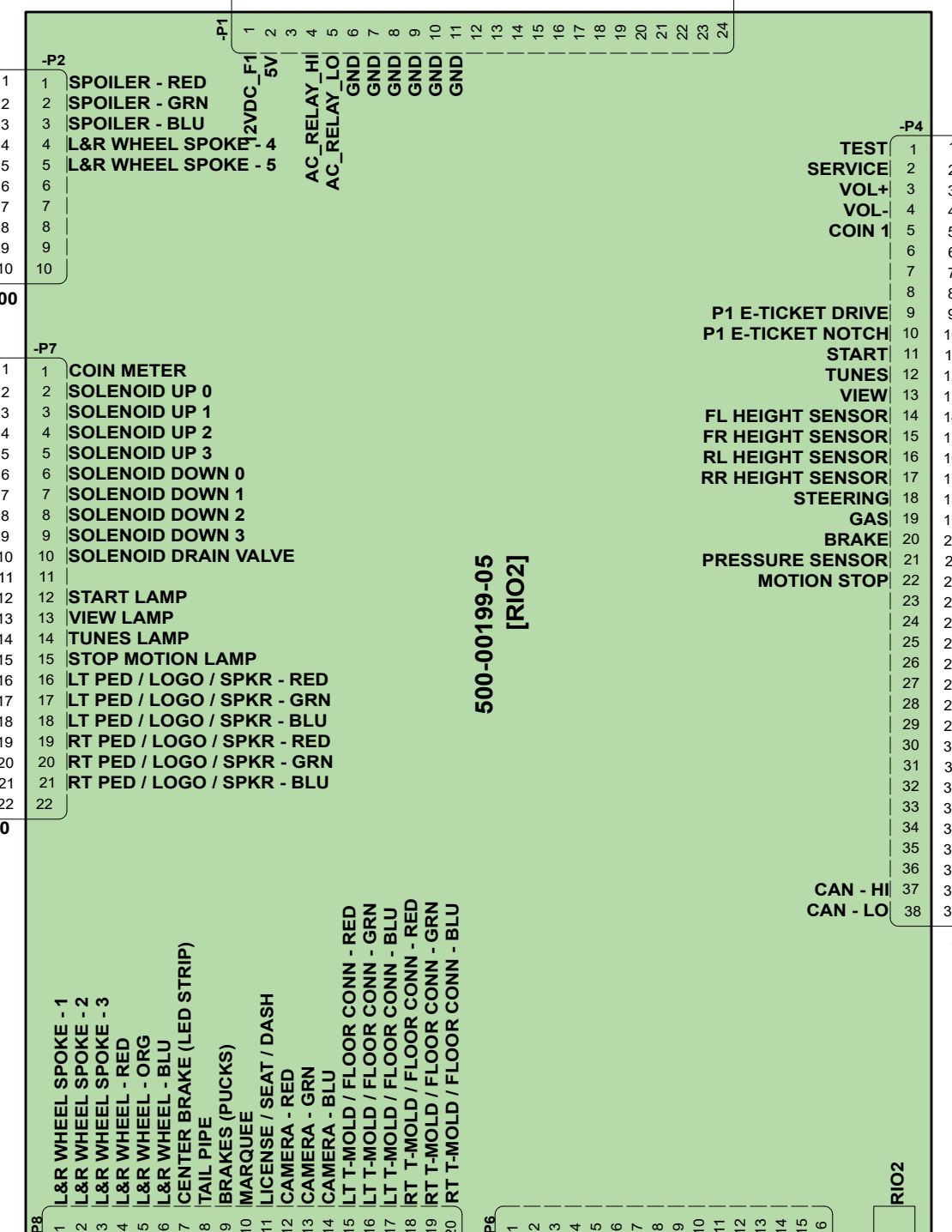
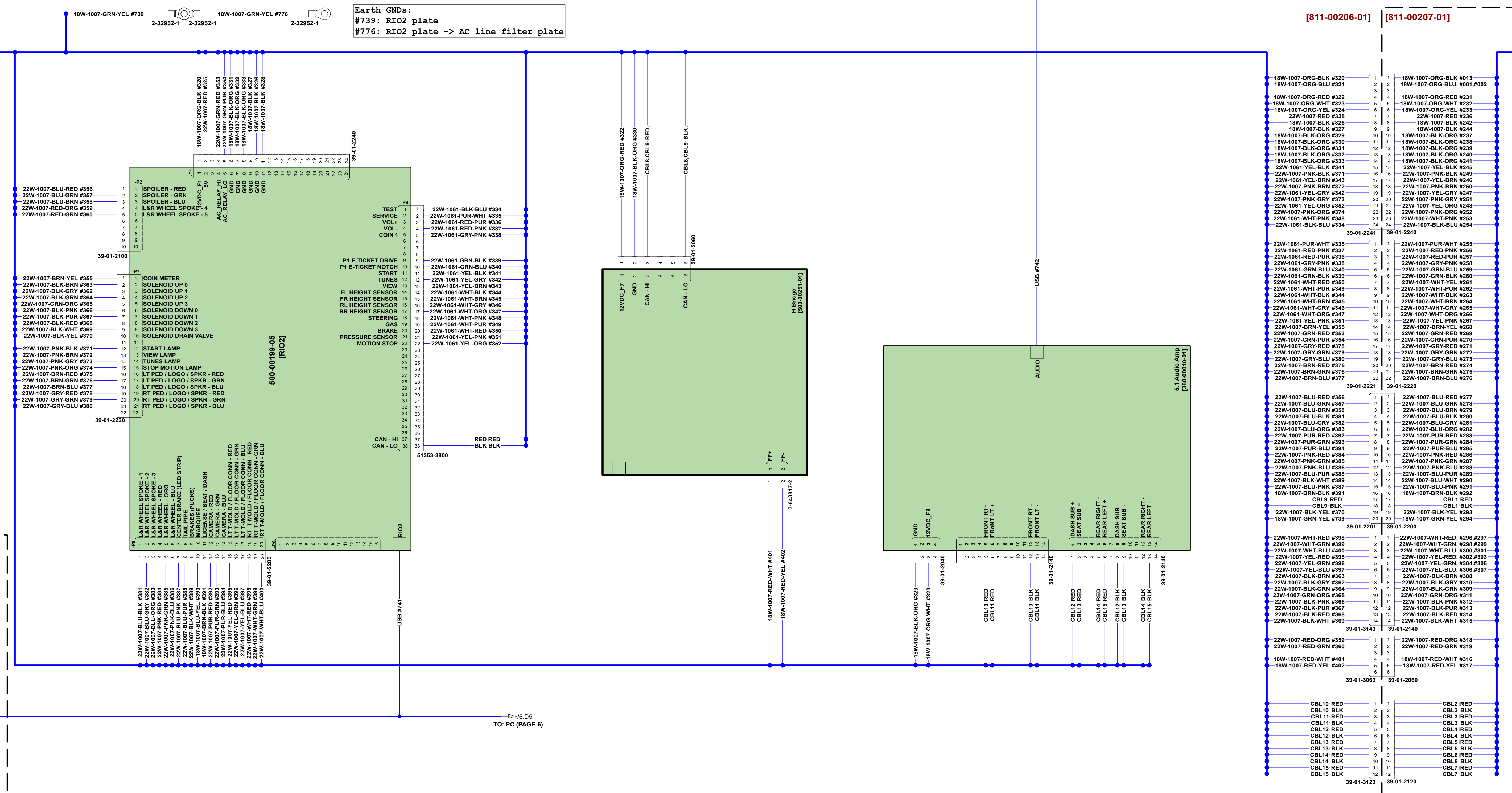

Production edits. Removed 811-00221-01	JHM	2022.09.01	F	Designed	Date	2022.04.05	REV	E	ANSI D
Changes to main harnesses	JHM	2022.07.13	D						
LED changes and additions	JHM	2022.07.06	C						
MINOR EDITS	JTN	2022.04.18	B						
INITIAL	JTN	2022.04.05	A						
DESCRIPTION	BY	DATE	REV						



Raw Thrills, Inc.
5441 Fargo Ave.
Skokie, IL 60077
tel: 847.679.8373
fax: 847.679.8538

TITLE: FAST AND FURIOUS ARCADE:
DWG: Main (Front door)
SHEET: 2

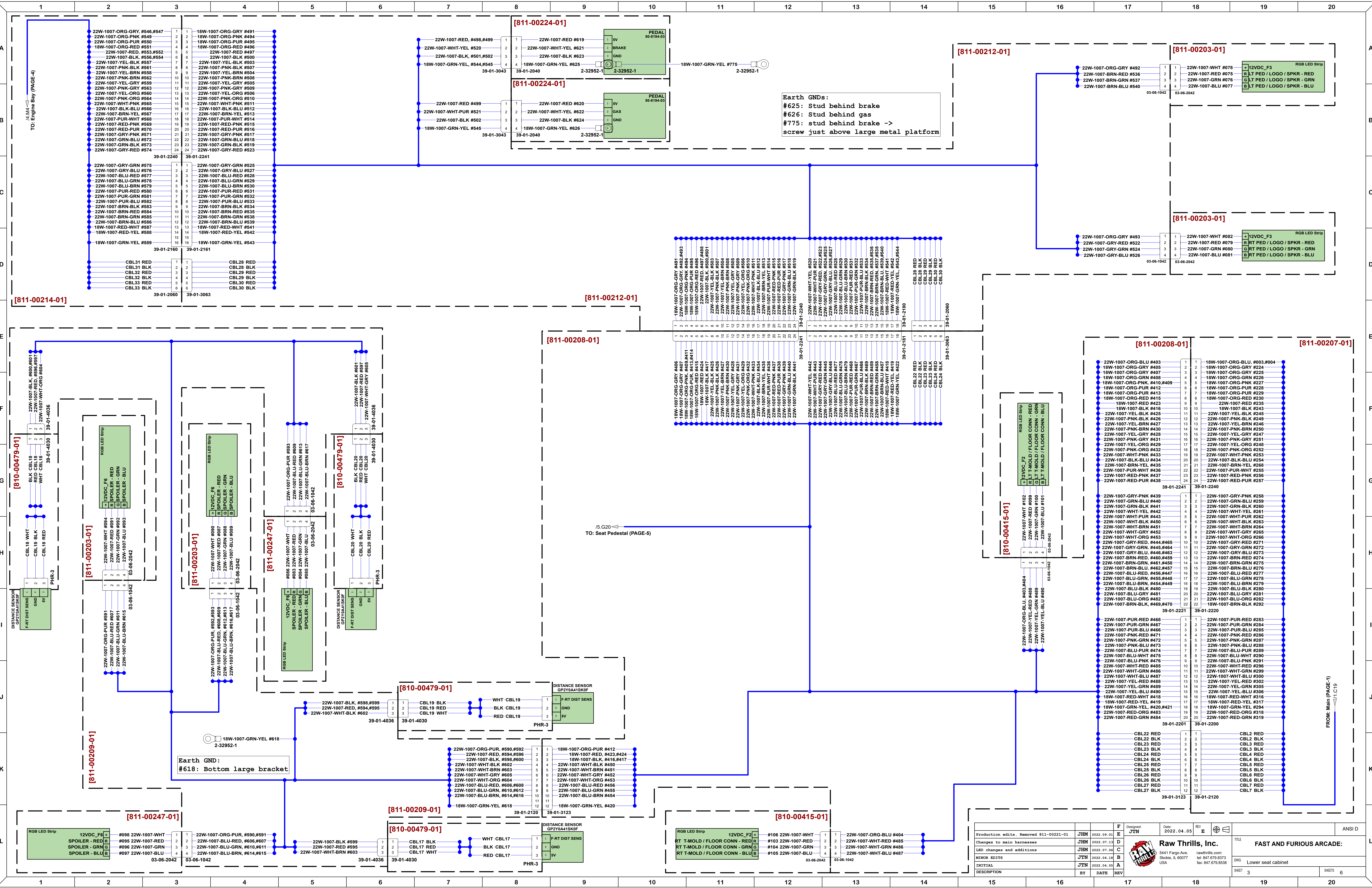

Earth GNDs:
 #625: Stud behind brake
 #626: Stud behind gas
 #775: stud behind brake ->
 screw just above large metal platform

Earth GND:
 #618: Bottom large bracket

Production edits. Removed 811-00221-01	JHM	2022.09.01	F	Designed	JVN	2022.04.05	REV	E	ANSI D
Changes to main harnesses	JHM	2022.07.13	D	Checked	JVN		REV	E	
LED changes and additions	JHM	2022.07.06	C	Created	JVN		REV	E	
MINOR EDITS	JVN	2022.04.18	B	Approved	JVN		REV	E	
INITIAL	JVN	2022.04.05	A	Assembled	JVN		REV	E	
DESCRIPTION	BY	DATE	REV						

Raw Thrills, Inc.
 5441 Fargo Ave.
 Skokie, IL 60077
 tel: 847.679.8373
 fax: 847.679.8538
 rawthrills.com

FAST AND FURIOUS ARCADE:
 Lower seat cabinet

SHEET 3 OF 6

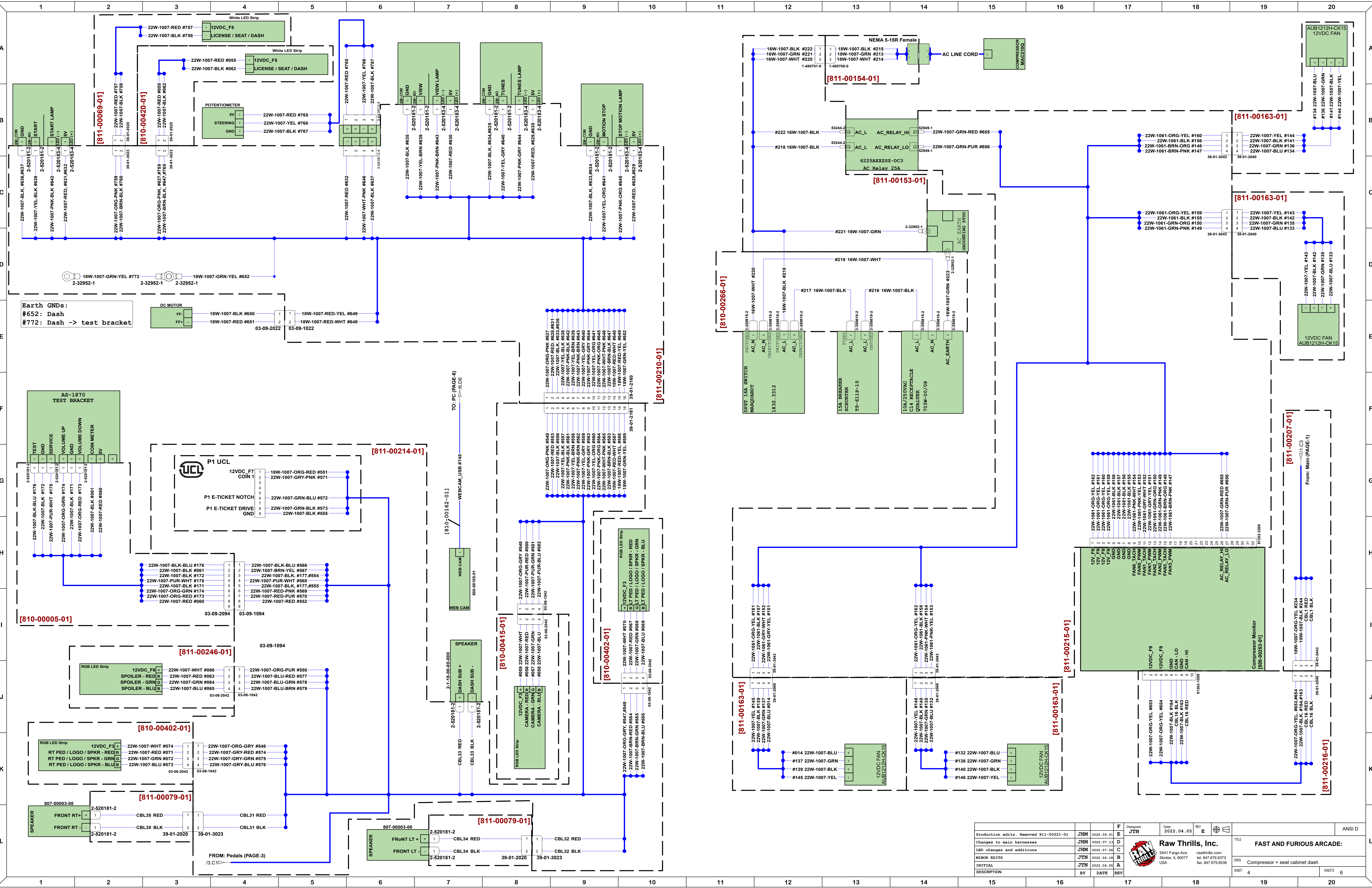

Production edits. Removed 811-00221-01	JHM	2022.09.01	F	Designed	JTN	Date	2022.04.05	REV	E	ANSI D
Changes to main harnesses	JHM	2022.07.13	D							
LED changes and additions	JHM	2022.07.04	C							
MINOR EDITS	JTN	2022.04.18	B							
INITIAL	JTN	2022.04.05	A							
DESCRIPTION	BY	DATE	REV							

Raw Thrills, Inc.
5441 Fargo Ave.
Stokio, IL 60077
tel: 847.679.8373
fax: 847.679.8538

TITLE: **FAST AND FURIOUS ARCADE:**

DWG: Compressor + seat cabinet dash

SHEET: 4

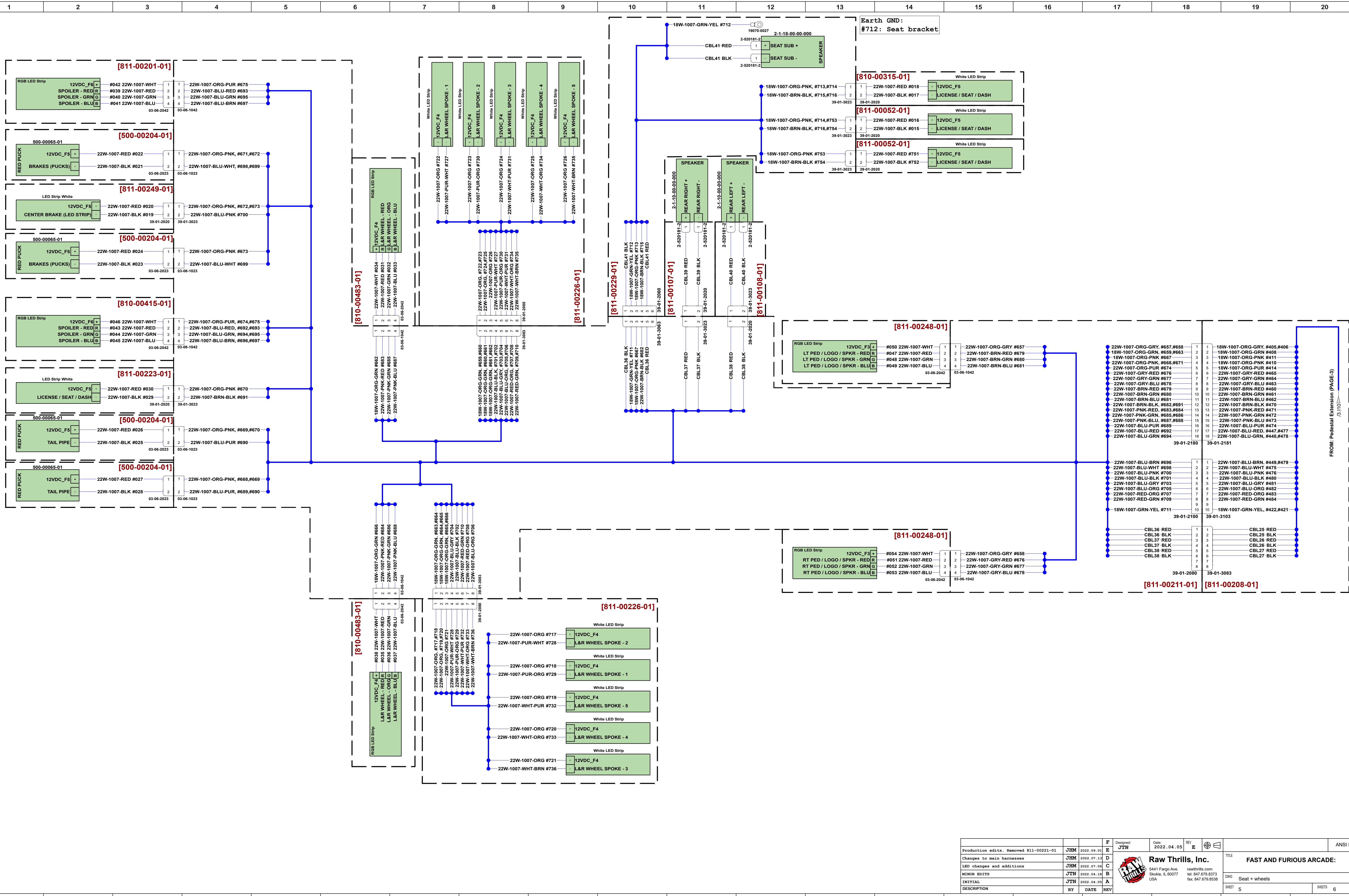

Production edits. Removed 811-00221-01	JHM	2022.09.13	F	Designed: JTM	Date: 2022.04.05	REV	E	ANSI D
Changes to main harnesses	JHM	2022.07.13	E					
LED changes and additions	JHM	2022.07.06	C					
MINOR EDITS	JTM	2022.04.18	B					
INITIAL	JTM	2022.04.05	A					
DESCRIPTION	BY	DATE	REV					

Raw Thrills, Inc. 5441 Fargo Ave. Skokie, IL 60077 tel: 847.679.8373 fax: 847.679.8538		TITLE FAST AND FURIOUS ARCADE:
DWG Seat + wheels		SHEETS 5 of 6

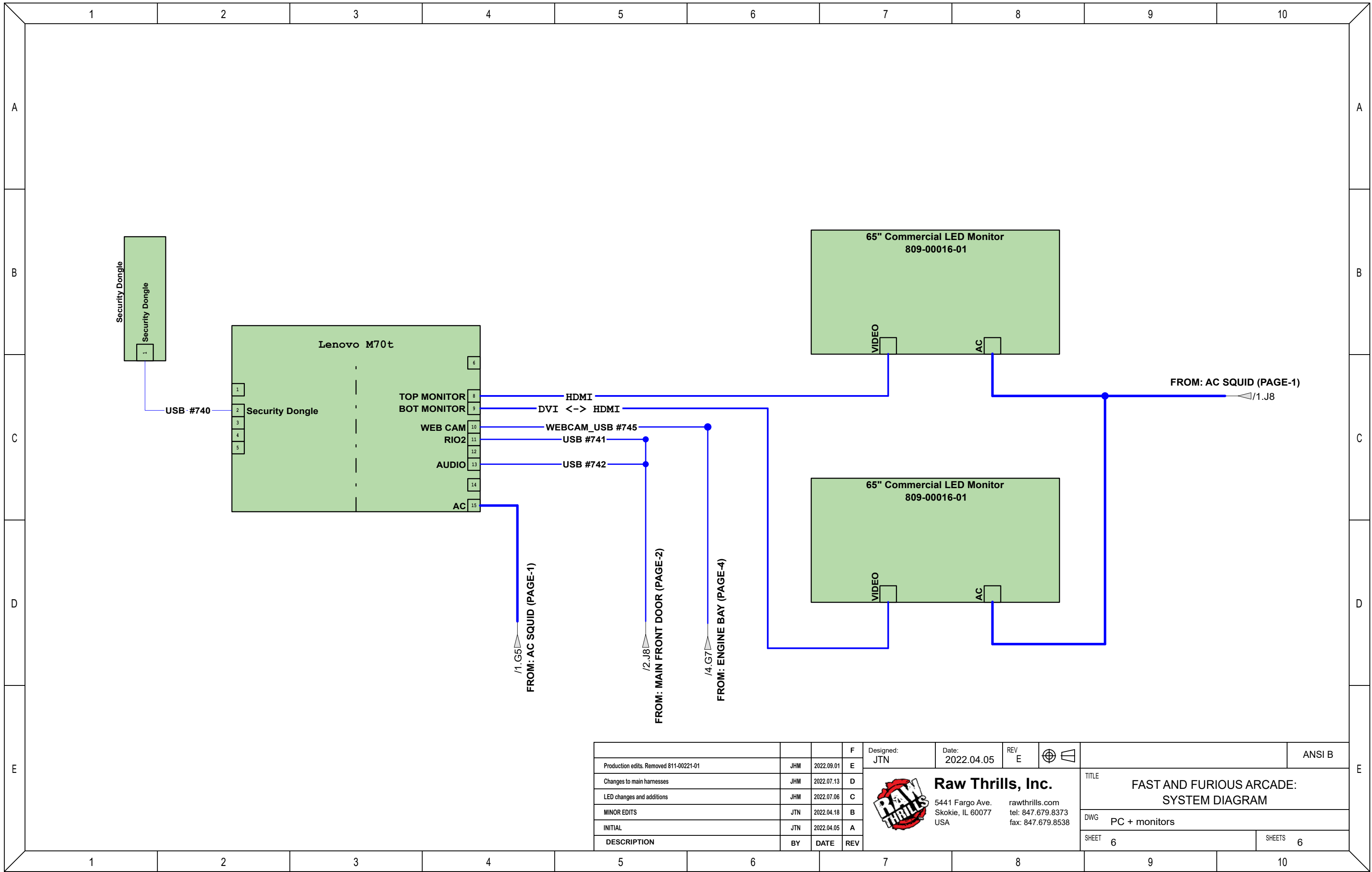

DESCRIPTION	BY	DATE	REV
Production edits. Removed 811-00221-01	JHM	2022.09.01	E
Changes to main harnesses	JHM	2022.07.13	D
LED changes and additions	JHM	2022.07.06	C
MINOR EDITS	JTN	2022.04.18	B
INITIAL	JTN	2022.04.05	A

Designed: JTN	Date: 2022.04.05	REV E	ANSI B
 Raw Thrills, Inc. 5441 Fargo Ave. Skokie, IL 60077 USA		rawthrills.com tel: 847.679.8373 fax: 847.679.8538	

TITLE	FAST AND FURIOUS ARCADE: SYSTEM DIAGRAM	
DWG	PC + monitors	
SHEET	6	SHEETS 6