

Fire Line Basket Strainer with Flushing Drain

Model FP-60F-01-D/DV

The BERMAD FP-60F-01-D/DV Basket Strainers are intended to be installed in fire protection pipelines primarily to prevent the clogging of fire sprinkler nozzles and other debris sensitive components in water or foam fire systems.

The BERMAD FP-60F-01-D/DV is designed for in-line maintenance available with a large diameter flushing outlet for immediate and easy screen cleaning. In addition easy in-line access to the basket screen is enabled, requiring only the cover removal.

The FP-60F-01-D/DV strainers are also well suited for use upstream of Pressure Control Valves and Deluge valves as well as other debris sensitive Fire System Devices.

The ratio of the FP-60F-01-D/DV strainer's basket area to its inlet pipe area is larger than 10:1, ensuring continued system performance even in the most debris-ridden firewater.

The high capacity of the FP-60F-01-D/DV also results in a lower pressure drop and allows longer intervals between cleaning and servicing.

NFPA 11, 13, 15 and 16 standards state that listed strainers shall be provided in the main pipeline of all systems using nozzles where the water is likely to contain obstructive material. Strainers shall be capable of removing all solids of sufficient size to obstruct fire protection devices and equipment waterways.



Bermad Model FP-60F-01-D



Bermad Model FP-60F-01-DV

Features and Benefits

- **UL-Listed and ULC size** for Fire systems
- **Low pressure drop** – Safety and reliability, ensures firewater availability
- **Easy in-line maintenance** – Large diameter flushing valve for fast and easy interim cleaning
- **Suitable to prevent clogging** – Nozzles, sprinklers or other types of fire system discharge outlets. Designed to trap foreign material of 3.2mm (1/8") diameter or larger
- **Large screen basket** – Large basket area, increasing system reliability and safety
- **Suitable for installation in any position** - Refer to installation and maintenance section
- **Compatible for use with corrosive fluids and harsh environments** – High Build Epoxy coated body/cover and stainless steel 316 screen
- **Suitable for Foam Systems** – For use with foam proportioners or foam generators in compliance with NFPA 11 requirements.

Approvals

UL-Listed Strainers, Pipeline (HLCV)

ULC Certified for Canada Strainers, Pipeline (HLCV7)

Typical Applications

- Water spray systems
- Deluge systems
- Fire monitors
- Automatic sprinkler systems
- Foam proportioner/generator provided in the water line
- Upstream of Pressure Control valves
- Upstream of a Sensitive System Devices

Options

Consult BERMAD for other Material of Constructions or other available specifications.

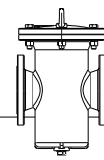

Design Engineer Guide

The BERMAD FP-60F-01-D/DV Basket strainers are for use in firewater supply and are capable of preventing the entrance of solids of sufficient size that might block or clog the fire protection nozzles or other devices sensitive to debris contaminated firewater.

Install the FP-60F-01-D/DV strainer upstream of the sprinkler valve, deluge valve, pressure control valve or any other debris sensitive system device.

The Strainer must be located where there is adequate clearance for complete removal of the basket screen assembly to enable easy extraction and inspection of the strainer basket. Take into consideration the release of water when draining the entire volume of the strainer and piping, as is required before maintenance or inspection.

Install the strainer such that there will be adequate drainage for the dirty water exhausted during the cleaning of the strainer screen using the flushing valve.

The drain connection should be typically fitted with an appropriately sized normally closed valve and drain piping.

The FP-60F-01-D/DV Basket Strainers are recommended to be installed in a horizontal position with the strainer cover and flushing valve to the side, to facilitate flushing.

The strainers shall be installed and maintained in compliance with the NFPA-25 standard in the addition to the authorities having jurisdiction instruction.

The NFPA-11 standard requires that a listed strainer with a screen area to pipe cross section area ratio of 10:1 shall be used with foam proportioners or foam generators, and should be installed in the water pipeline upstream of the water control valve.

The NFPA 13, 15 and 16 standards stipulate that a Listed Strainer shall be provided in the main pipeline of all systems utilizing nozzles with waterways less than $\frac{3}{8}$ " (9.5 mm) and for any system where the water is likely to contain obstructive material. Strainers shall be capable of removing from the water all solids of sufficient size to obstruct the nozzles.

Engineer Specifications

The Fire Line Strainer shall be a basket type strainer UL listed for 250 psi / 17.2 bar.

The strainer shall be with high flow capacity and low pressure loss.

The strainer shall include a flushing valve capable of quickly and efficiently cleaning the strainer screen without removing the strainer cover, or closing system pressure.

The strainer body and cover shall be ductile iron ASTM A536 65-45-12 with anti-corrosion Fusion Bonded High Build Epoxy RAL 3002 coating internally and externally, all other wetted parts shall be stainless steel 316.

The screen shall be inline removable basket type, made of stainless steel 316 with screen holes diameter of 3.2 mm ($\frac{1}{8}$ "), meeting the requirements of the NFPA codes and standards. The Strainer basket screen area shall be at least 10:1 compared to the cross-sectional area of the pipeline.

Strainer maintenance, inspection or service shall be carried out in-line and without disassembly of the strainer body from the pipeline. The Strainer shall be supplied pre-assembled with stainless steel bolting, hydraulically tested by a factory certified to ISO-9001 standard.

Typical Installations

Deluge / Sprinkler System (see illustration)

The BERMAD FP-60F-01-D/DV strainer should be installed upstream of the Deluge, Foam system or Automatic Sprinkler system, preventing debris particles from clogging the nozzles.

Automatic Pressure Control System (see illustration)

The BERMAD FP-60F-01-D/DV strainer is ideal to be installed upstream of the BERMAD Pressure Control Valve, preventing the fouling of valve sealing surfaces and keeping the waterways clear from obstructions.

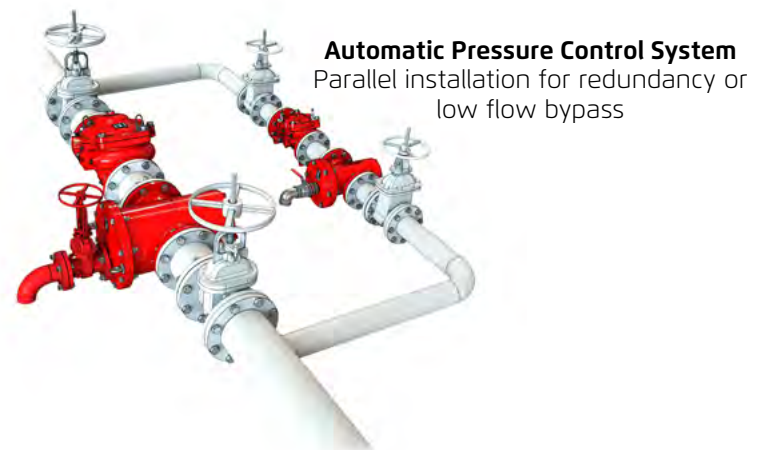
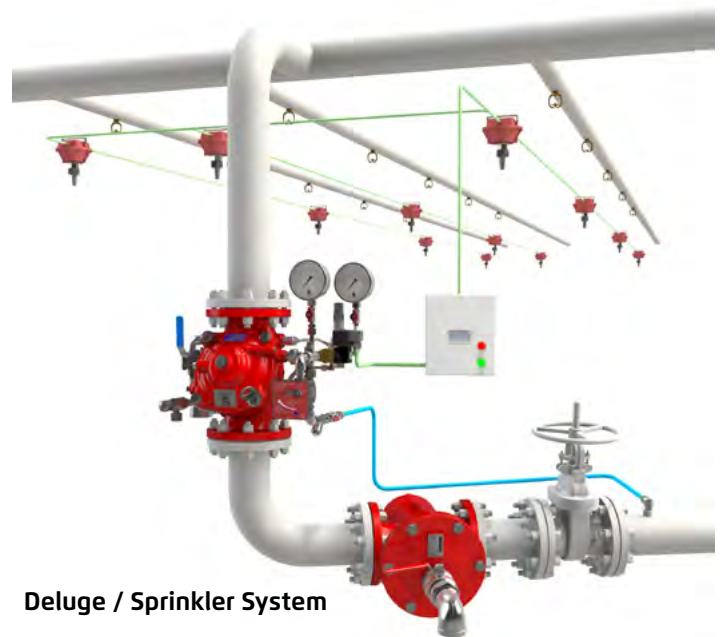

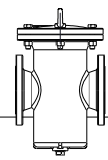

Installation

Provide basket removal clearances and strainer installation provisions in accordance with the requirements given in the Design Engineer Guide section above. Install the strainer with the flow arrow on the body pointing in the desired flow direction.

The strainer shall be installed on the pipeline upstream of the sprinklers, pressure control valve, deluge valve or other sensitive system device. Install a listed isolating valve upstream of the strainer. An adequate support shall be provided to carry the system installation as well as the dynamic loads.

It is recommended to install a differential pressure gauge rooted to upstream and downstream of the FP-60F-D/DV strainer, in order to show strainer blockage. The maximum allowable differential pressure across the strainer is 7 psi or 0.5 bar at maximum system flow.

Placing In Service

Verify that all strainer cover bolts are well tightened, close the drain plug and/or drain valve, slowly open the supply-isolating valve and check that there are no leakages. Observe the system pressure gauge: it should indicate that the normal supply of water pressure is maintained.

Maintenance

The following inspection procedure must be performed as indicated, in addition to specific requirements of any applicable standards. Any damage or performance deficiency must be immediately corrected.

The fire system shall be inspected, tested, and maintained by qualified service personnel in accordance with local requirements and/or national codes.

Preventive Maintenance

The frequency of inspection should be determined according to the quality of the firewater in use, even so it is recommended that the strainers basket screen be flushed clean at least annually in addition to after each operation or system flow test.

For the model FP-60F-01-DV that includes a flushing drainvalve, strainer cover removal for cleaning may be avoided when a differential pressure gauge / transmitter across the strainer is provided. This device will indicate if the pressure differential is below the maximum allowable 7 psi (0.5 bar) across the strainer screen at the maximum system flow rate. If so, this shows that the screen is not dangerously blocked and a flush cleaning with the drain valve should prove sufficient. However it is recommended to remove the strainer cover at least annually for inspection.

Inspection and Cleaning

Verify that the strainer is depressurized and drained before the disassembly of any strainer component.

The strainer basket screen should be cleaned after each system operation or flow test and during routine inspections, as follows:

For strainers fitted with a large diameter flushing valve:

1. Fully open the flushing drain valve for at least 5 seconds or until the flushed water becomes visibly clear.
2. Close the flushing valve tight.

For periodic inspection and cleaning of screens for strainers without a flushing valve:

1. The system must be shut down and completely drained.
2. Remove the strainer cover and the basket screen.
3. Clean out the basket screen, as well as the interior of the strainer body.
4. Reinstall the basket screen, make sure that the basket is fully inserted into the strainer body and is correctly orientated.
5. Inspect the gasket o-ring and replace if needed.
6. Reinstall the strainer cover, gradually cross tighten diametrically and sequentially all bolts so as to apply uniform load for the cover seal.



(for Illustration Only)

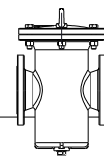

Technical Data

- Available sizes:** 3, 4, 6, 8, 10 and 12"
- End connections standard:** ANSI B16.42 #150RF
- Design pressure / Pressure rating:** 300 psi (20.7 bar)
- UL-Listed pressure:** 250 psi (17.2 bar)
- Pressure drop:** 3 psi at 15 ft/sec (0.2 bar at 4.57 m/sec) approx, see note 3
- Max allowable differential pressure:** 7 psi / 0.5 bar, refer to notes 3 and 4
- Screen hole diameter:** 1/8 inch (3.2 mm) holes diameter
- Basket screen area to pipe cross-sectional area ratio:** 10:1 (min)
- Basket screen free flow area ratio:** 40% (min)
- Drain/Blow-Off port diameter:** for 3 & 4" strainers 2" drain/flushing valve
for 6 to 12" strainers 3" drain/flushing valve
- Temperature rating:** 90°C / 194°F

Standard Materials of Construction

Item	Description	Material
1	Body	Ductile Iron ASTM A536 65-45-12, Coated*
2	Cover	Ductile Iron ASTM A536 65-45-12, Coated*
3	O ring	EPDM, Asbestos Free
4	Bolting	Stainless steel 304
5	Screen	Stainless steel 316
6	Lifting Eye	Stainless steel 304
7	Drain Plug	Stainless steel 316
8	Drain Port Flange (6" - 12")	Ductile Iron ASTM A536 65-45-12, Coated*
9	Drain Port Plug (3 & 4")	2" ISO-7-Rp Stainless steel 316
10	Data Plate	Stainless Steel 304

* Coating: Fusion Bonded High Build Epoxy RAL 3002, internal and external.

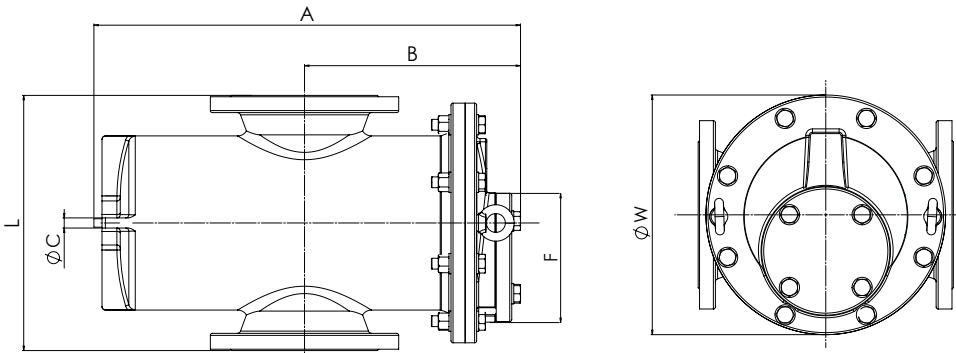

Dimensions and Weights

Size	3"		4"		6"		8"		10"		12"	
DN	80		100		150		200		250		300	
Units	mm	in	mm	in	mm	in	mm	in	mm	in	mm	in
L	250	9.8	292	11.5	378	14.9	476	18.7	560	22.0	680	26.8
A	310	12.2	410	16.1	545	21.5	685	27.0	772	30.4	958	37.7
B	150	5.9	195	7.7	275	10.8	310	12.2	360	14.2	460	18.1
W	263	10.4	305	12.0	391	15.4	485	19.1	572	22.5	693	27.3
C	20	0.75	25	1	25	1	40	1.5	40	1.5	50	2
D	3.2	0.13	3.2	0.13	3.2	0.13	3.2	0.13	3.2	0.13	3.2	0.13
F	2" ISO-7-Rp		2" ISO-7-Rp		"3 #150		"3 #150		"3 #150		"3 #150	
Weight kg/lbs	23	51	42	93	72	159	130	287	190	419	285	628

Flow Properties

Size	3"		4"		6"		8"		10"		12"	
Units	metric	US	metric	US	metric	US	metric	US	metric	US	metric	US
Kv ⁽¹⁾ / Cv ⁽¹⁾	168	194	275	317	551	636	1001	1156	1665	1923	2027	2341
Leq ⁽²⁾ m / ft	9	30	14	46	28	93	36	118	43	140	70	228

- Notes:**
- ⁽¹⁾ Flow coefficient Kv: flow in m³/h at 1 bar differential pressure, Cv: flow in gpm at 1 psi differential pressure; The pressure loss calculation formula: $\Delta p = SG (Q / Cv \text{ or } Kv)^2$
 - ⁽²⁾ Leq: Equivalent pipe length for turbulent flow in clean commercial steel pipe (SCH 40)
 - ⁽³⁾ Max allowable pressure drop: 7 psi (0.5 bar) across the strainer, basket screen shall be cleaned when pressure drop exceeds value determined at maximum flow

Ordering Information

Size in/DN	ANSI#150RF with Drain Outlet	Part Number
3"/80	FP-3"-60F-01-H-C-A5-ER-D	60F03HCA5N00001-D-ER
4"/100	FP-4"-60F-01-H-C-A5-ER-D	60F04HCA5N00001-D-ER
6"/150	FP-6"-60F-01-H-C-A5-ER-D	60F06HCA5N00001-D-ER
8"/200	FP-8"-60F-01-H-C-A5-ER-D	60F08HCA5N00001-D-ER
10"/250	FP-10"-60F-01-H-C-A5-ER-D	60F10HCA5N00001-D-ER
12"/300	FP-12"-60F-01-H-C-A5-ER-D	60F12HCA5N00001-D-ER

Size in/DN	ANSI#150RF with Drain Valve	Part Number
3"/80	FP-3"-60F-01-H-C-A5-ER-DV	60F03HCA5N00001-DV-ER
4"/100	FP-4"-60F-01-H-C-A5-ER-DV	60F04HCA5N00001-DV-ER
6"/150	FP-6"-60F-01-H-C-A5-ER-DV	60F06HCA5N00001-DV-ER
8"/200	FP-8"-60F-01-H-C-A5-ER-DV	60F08HCA5N00001-DV-ER
10"/250	FP-10"-60F-01-H-C-A5-ER-DV	60F10HCA5N00001-DV-ER
12"/300	FP-12"-60F-01-H-C-A5-ER-DV	60F12HCA5N00001-DV-ER

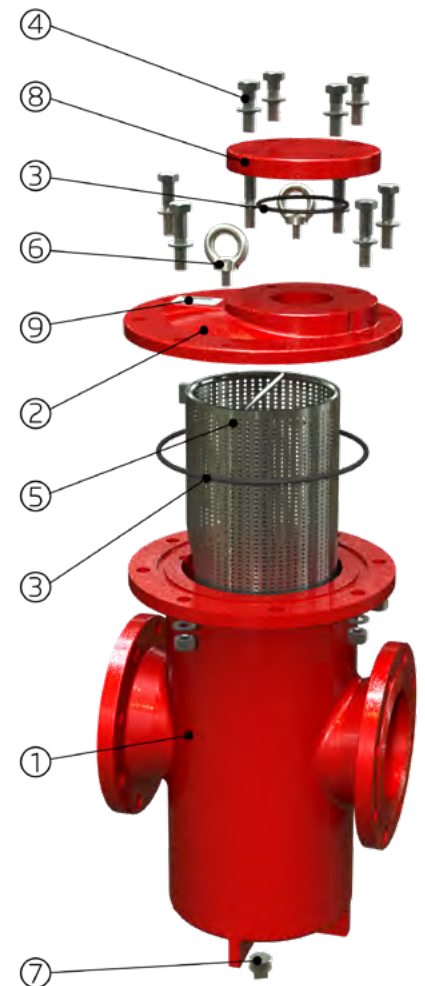

(for Illustration Only)

