



ELECTRIC MOTORS, GEARMOTORS AND DRIVES

ALUMINUM GEAR REDUCERS CATALOG 7050

Effective: 8/01/04

Supersedes: Catalog 5050
Catalog 7050;
dated Feb, 2003



Bravo
ALUMINUM GEAR REDUCERS

and **LeCENTRIC** aluminum reducers offer thousands of stock power transmission solutions

LeCENTRIC



As the first full line (1/4 through 7-1/2 HP) of industrial aluminum inline gear reducers, LeCENTRIC™ offers unsurpassed advantages in terms of weight, efficiency and interchangeability. LeCENTRIC™ reducers are loaded with long life features industrial equipment users have come to expect. Standard features include hardened and ground gearing (AGMA Class 10 or better) for enhanced efficiency and noise reduction; heavy duty output shaft for superior torque and overhung load capacities; oversized bearings on input and output shafts, synthetic oil and premium Viton oil seals and more!

Perhaps LeCENTRIC™'s most intriguing feature is its modular construction, which allows for the in-field addition of a specific base or flange needed to make LeCENTRIC™ a bolt-in replacement for dozens of popular reducer brands. LeCENTRIC™ is the smart choice for bolt-in replacement of popular reducers such as SEW, Nord, David Brown, Dodge, Brook Hansen and more!

Bravo
ALUMINUM GEAR REDUCERS



LEESON continues to offer the Bravo® reducers through a partnership with Hydromec of Italy. Hydromec, with over 40 years of industrial drive manufacturing experience, is a major producer of adjustable speed drives, in addition to worm and coaxial gear reducers for Europe and other international markets. Components of the Bravo® reducers are jointly produced in Italy and LEESON's gear manufacturing facilities.

Designers and manufacturers of commercial and industrial machinery targeting compact and lightweight products welcome the Bravo® worm reducers as an alternative to traditional cast iron units. Bravo® reducers weigh up to two-thirds less and are one-third smaller than comparable cast iron designs. With hollow output shafts as standard, extremely compact and cost effective drive solutions are easy to achieve.

Using a unique modular construction, a variety of accessory mountings are possible without disassembling the reducer including foot kits, reaction arms, output flanges and shaft kits. Bravo® reducers are now available with IEC motorized inputs and metric outputs, which makes them an excellent replacement of popular reducers such as Bonfiglioli, Motovario, STM, SITI and more!

NEW PRODUCTS:

◆ **70-102:1 BRAVO® SINGLE STAGE RATIOS**

See rating tables pages 69-82

◆ **METRIC BRAVO® SELECTIONS**

See dimension pages 84-97

◆ **BRAVO® WORM-WORM
DOUBLE REDUCTION**

See page 98

◆ **BRAVO® HELICAL-WORM
DOUBLE REDUCTION**

See page 120

◆ **BRAVO® SERIES 512
30 MM CENTER DISTANCE**

See page 70

By combining a LeCENTRIC™ or Bravo® reducer with any of our hundreds of in-stock c-face motors, a performance-matched GEAR+MOTOR™ is created instantly with single source responsibility. AC or DC, single phase or three phase, even hard-to-find configurations such as explosion proof and Washguard™ GEAR+MOTORS™they're all available off the shelf from LEESON.



LEESON is a subsidiary of REGAL-BELOIT CORPORATION, a worldwide manufacturer of mechanical and electrical motion control products. LEESON sales offices and warehouses are located throughout North America.

TABLE OF CONTENTS

LeCENTRIC™ INLINE GEAR REDUCERS

Product Features Page 4

Quick Selections

Reducers and Gear+Motors™
1/4 HP — 7½ HP 6

Catalog Number System 38

Maximum Rating Tables
Double Reduction Reducers 40
Triple Reduction Reducers 44

Dimensions

Motorized Reducers 48
Non-Motorized Reducers 50
NEMA Motor Mounting 57
Gear+Motors™ 57

Interchange Guide

Mod-Squad Services 52
Output Flange Selections 53
Torque Foot Selections 53
Interchange Base Selections 54

Technical Information 58

BRAVO® WORM GEAR REDUCERS

Product Features 64

Single Reduction Reducers 66
Model Number System 68
Maximum Rating Tables 69
Quick Selection Tables 75
Weights 83
Dimensions 84

Double Reduction Worm/Worm Reducers 98
Model Number System 100
Maximum Rating Tables 101
Quick Selection Tables 103
Weights 107
Dimensions 108

Double Reduction Helical/Worm Reducers 120
Model Number System 122
Maximum Rating Tables 123
Quick Selection Tables 125
Weights 129
Dimensions 130

Modified Stock Reducers 144
Accessory Kits 145
Additional Capabilities 147
Technical Information 149

MOTORS AND DRIVES 154
GENERAL INFORMATION 171
TERMS AND CONDITIONS 177



LeCENTRIC™ GEAR REDUCERS

PAGES 4-51



LeCENTRIC™ INTERCHANGE KITS & ACCESSORIES

PAGES 52-63



BRAVO® SINGLE REDUCTION REDUCERS

PAGES 64-97



BRAVO® WORM / WORM DOUBLE REDUCTION REDUCERS

PAGES 98-119



BRAVO® HELICAL / WORM DOUBLE REDUCTION REDUCERS

PAGES 120-142



BRAVO® ACCESSORY KITS

PAGES 143-153



MOTORS & DRIVES

PAGES 154-170

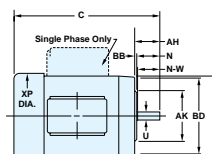

GENERAL INFORMATION

PAGES 171-179





LeCENTRIC™ REDUCERS ARE FILLED WITH MOBILGEAR SHC 320 SYNTHETIC OIL as standard. All sizes are considered "lubed for life." Specify mounting position at time of order. Refer to page 60 for available positions.

REMOVABLE INSPECTION COVER allows periodic inspection of gearing during routine maintenance.

ALL GEARING IS HARDENED AND GROUND (AGMA Class 10 or better), for enhanced efficiency and noise reduction. Double reduction units are 96–97% efficient.

BEARING SPANS OPTIMIZED to allow for maximum overhung load capacity, enhanced durability and reliability—while minimizing shaft deflection.

RATIOS UP TO 63:1 in two-stage units and up to 278:1 in three-stage units to maximize efficiency and reduce overall case size.

SINGLE-PIECE ALUMINUM ALLOY HOUSING vacuum impregnated with Resinol RT (MIL-STD 276) for protection and sealing. No secondary finish required but readily accepts paint. Combines light weight with high tensile strength. Precision machined for alignment of bearings and gearing.

MOUNTING DIMENSIONS ARE INTERCHANGEABLE with many popular reducers, including SEW, David Brown, Nord, Dodge, and Brook Hansen. See pages 54-55 for details.

ROBUST OUTPUT SHAFT of high strength steel alloy for superior torque and overhung load capacities.

PREMIUM VITON® SEALS provide extra protection against entry of contaminants or loss of lubrication. Tandem seals available on input and output.

REMOVABLE MOUNTING BASE allows interchange with dozens of competitive units.

BOLT-ON OUTPUT FLANGE also available to allow interchange with many industry-standard sizes.

OVERSIZED BALL BEARINGS on both input and output shafts.

PERMANENTLY MARKED NAMEPLATE with output torque, ratio and maximum input horsepower.

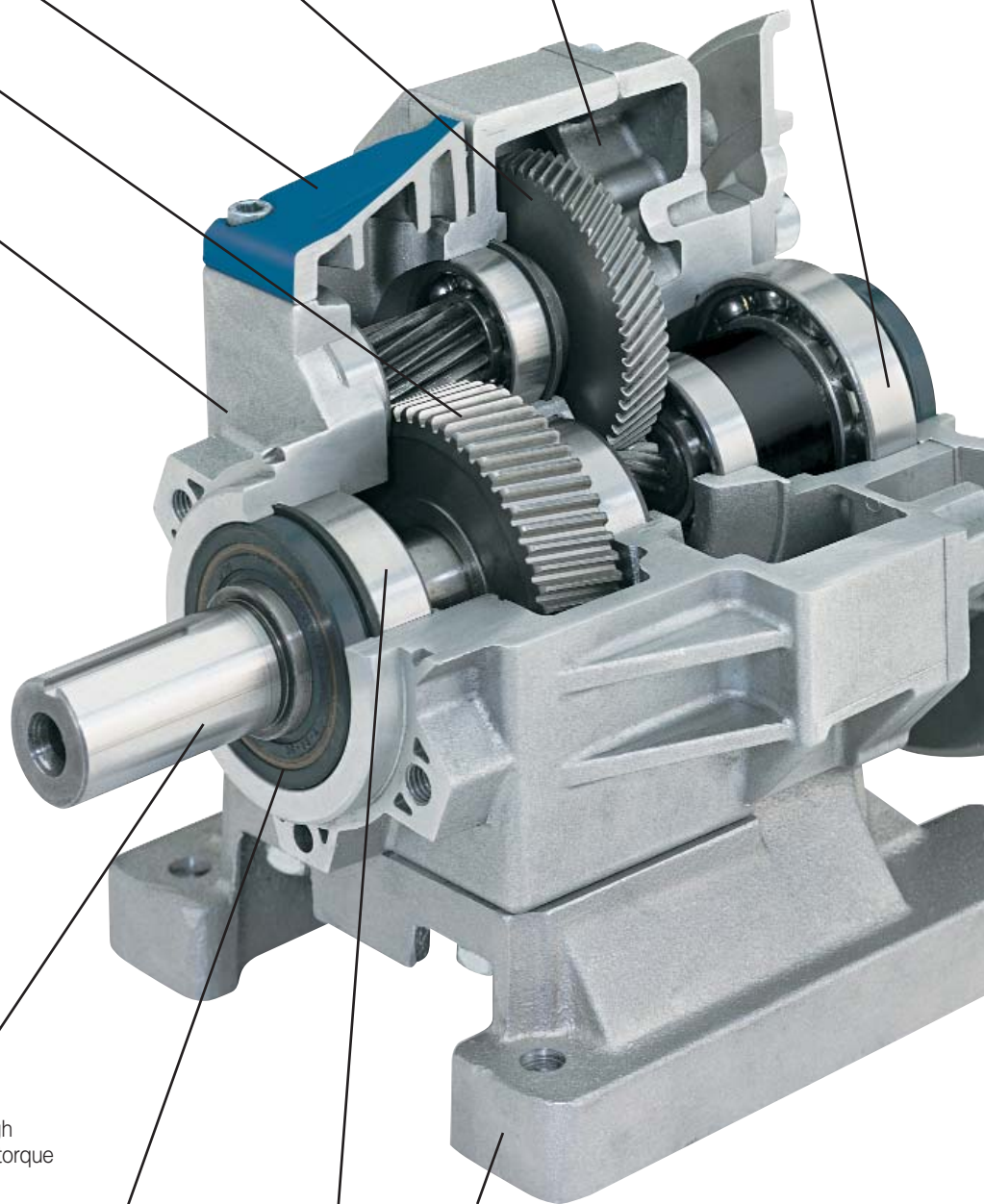

WIDE RANGE OF STYLES: Double or Triple Reduction...Base or Flange Mount!



LeCentric™ Gear Reducers & GEAR+MOTORS™

LeCENTRIC™ reducers are available in a wide range of styles to meet your every need. Start with a basic motorized or non-motorized unit, in double or triple reduction. Select from base or flange mount models. Order your LeCENTRIC™ reducer ready-to-run, with final assembly provided free-of-charge by the LEESON Mod-Squad.™ Or decide to complete the final configuration yourself, using easy-to-install LeCENTRIC™ Accessory Kits shown on page 52.

To make your job even easier, we've matched hundreds of LEESON motors with LeCENTRIC™ reducers and offer factory shipment of completely assembled Gear+Motors™, ready to install in your application. A Quick Selection Guide to many of the B1 Base Mount Gear+Motor™ options can be found in this catalog (pages 8-37). Included are TEFC single and three phase motors and DC SCR motors, as well as explosion-proof models.

ALUMINUM NEMA C FACE input flange (motorized quill input models) with machined fits for precision alignment of motor and bearings.

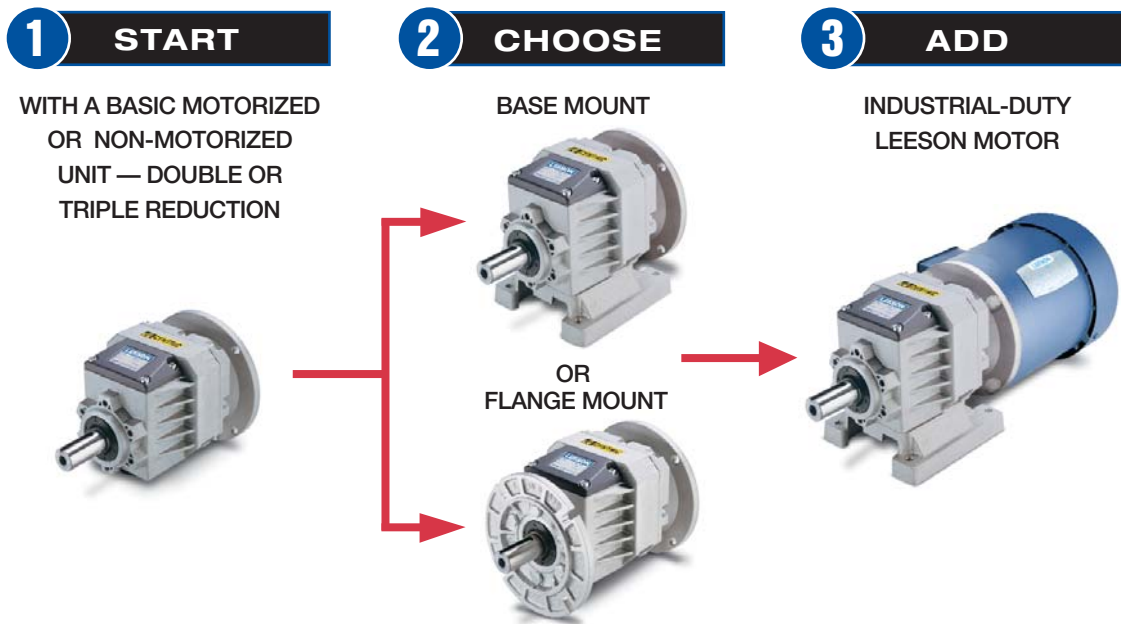

DIRECT INTERCHANGE CHARTS

LeCENTRIC™ reducers serve as dependable, bolt-in replacements for many popular brands. See page 52 for specific information about interchangeability.

	FOOT MOUNT	FLANGE MOUNT		FOOT MOUNT	FLANGE MOUNT
SEW	✓	✓	Grove	✓	✓
Bonfiglioli	✓	✓	Hansen	✓	✓
Brook Hansen	✓	✓	Lenze	✓	✓
Browning	✓	✓	Leroy Somer	✓	✓
David Brown	✓	✓	Motovario	✓	✓
Dodge Quantis	✓	✓	Nord	✓	✓
Falk	✓	✓	Stober	✓	✓
Flender/Motox	✓	✓	Sumitomo	✓	✓

SEW CASE SIZE INTERCHANGE

The LeCENTRIC™ Inline Reducers interchange with SEW R7 Series, SEW R Series, David Brown, Nord, Hansen, and others using Interchange Base B1.

A Quick Reference Guide to the SEW case size interchange is below.

LEESON LeCENTRIC™	SEW R Series	SEW R7 Series
717	30	17
727	40	27
747	60	47
757	60	57



"HOW TO USE" QUICK SELECTIONS



How To Use Quick Selections

Maximum Rating Tables for Double Reduction Gear Reducers are shown on pages 40-43. Triple Reduction Maximum Rating Tables are shown on pages 44-47. Selection of the appropriate gear reducer can be made using those tables or the Quick Selections on the following pages.

BEFORE YOU START:

Identify the Service Factor of the application.

Determine the actual input horsepower of the motor by multiplying the motor's nameplate horsepower by the Service Factor.

Determine the output speed (RPM) required at output shaft of reducer.

Identify the mounting style required by your application from the style charts shown on pages 52-55. Note the different bases and flanges to interchange with various competitive units.

To select the proper gear reducer size, use the Quick Selections as shown:

LeCentric™ Gear Reducers & GEAR+MOTORS™

QUICK SELECTIONS
DOUBLE AND TRIPLE REDUCTION

700 Series Motorized NEMA Frame 1750 RPM

1/3 HP Gear Reducer Quick Selections

Output Speed (RPM)	Service Factor ▼	Output Torque (lb-in)	Overhung Load (lbs.)	Ratio	Motorized 1 Base Mount Catalog No.
503	15.05	40	204	3.48	P7172001.B1
405	12.29	49	216	4.32	P7172002.B1
318	9.56	63	230	5.50	P7172003.B1
275	8.25	73	250	6.36	P7172004.B1
241	7.25	83	260	7.26	P7172005.B1
222	6.69	90	266	7.89	P7172006.B1
			284	10.04	P7172008.B1
			293	11.64	P7172009.B1
			295	12.26	P7172010.B1
					P7172011.B1
					P7172012.B1
					P7172013.B1
					P7172014.B1
79	3.15	253			
67	2.61	307	420	26.30	
67	3.79	307	615	26.30	
60	2.39	333	435	29.40	
60	3.55	333	629	29.40	
52	2.15	372	459	33.50	
52	3.21	372	645	33.50	
49	1.91	416	470	35.90	
49	2.79	416	658	35.90	
46	1.82	434	478	38.37	
46	2.58	434	660	38.37	
46	2.64	420	660	38.34	
40	1.67	484	495	43.69	
40	2.45	484	674	43.69	
37	1.45	540	507	46.80	
37	1.97	540	674	46.80	
36	4.30	555	1028	49.00	
35	1.42	553	510	50.64	
35	2.12	553	674	50.64	

2 Locate output RPM column on left side of the table. All ratings are based on an input speed of 1750 RPM. Scroll down to the output speed (RPM) required. Output speeds are rounded to the nearest whole number. For exact output speed, divide 1750 by the ratio listed.

3 Move to the Service Factor column and find one suitable to meet the application requirements. Refer to page 172 for AGMA recommended service factors.

4 Check load capacities against the needs of your application. Do not exceed the overhung load (OHL) shown in the table. Detailed instructions for calculating the actual overhung load are shown on page 58. If overhung and thrust loads will be applied simultaneously or if the load exceeds listed capacities, contact LEESON.

5 Select motor frame size.

6 Identify the catalog number of the reducer by continuing to the right. See page 38 for detailed information on building an exact catalog number. The B1 suffix can be replaced with optional Mod-Squad codes as detailed on page 52.

7 This Quick Selection is only for motorized B1 base mount reducers and Gear+Motors™. For other reducer configurations, refer to the Quick Selections for Triple Reduction Gear Reducers.



“HOW TO USE” QUICK SELECTIONS



LeCentric™ Gear Reducers & GEAR+MOTORS™

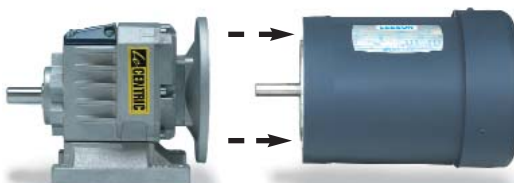

STOCK GEAR+MOTORS™

Start with a LeCentric™ reducer and add a LEESON industrial-duty NEMA C face motor to produce a GEAR+MOTOR™.

A wide variety of single phase, three phase and DC motors—suitable for almost every industrial application need—have been pre-selected and assembled to reducers to provide a variety of torque and output speed combinations...ready for shipment. Saves time and expense.

MODIFIED STOCK GEAR+MOTORS™

All stock GEAR+MOTORS™ can also be modified by the addition of any of the accessories shown on page 52. Specify the stock GEAR+MOTOR™ and the accessory item or Mod-Squad Service desired.

Mod-Squad Gearmotor Assembly Service

Can't find the right gearmotor to suit your need from the preselected units. Refer to pages 154-165 for the industry's widest range of stock NEMA C face motors. Select the motor and the reducer you want. LEESON's

Gear Mod-Squad will assemble and ship your custom selected gearmotor. Simply specify the reducer and the motor (by catalog numbers) and order Mod-Squad Service GM1.

Accessory items can also be assembled to custom selected gearmotors. Simply add the Mod-Squad service number to your order. See pages 52-55. **NOTE:** A GEAR+ MOTOR™ catalog number consists of the gear reducer catalog number followed by the motor's catalog number.



QUICK SELECTIONS DOUBLE AND TRIPLE REDUCTION



LeCentric™ Gear Reducers & GEAR+MOTORS™



TEFC, 3 Phase 230/480V		TEFC, 1 Phase 115/230V		DC SCR 90V		DC SCR 180V		Explosion-Proof, 3 Phase 230/480V		Explosion-Proof, 1 Phase 115/230V	
Catalog No.	Wgt. (lbs.)	Catalog No.	Wgt. (lbs.)	Catalog No.	Wgt. (lbs.)	Catalog No.	Wgt. (lbs.)	Catalog No.	Wgt. (lbs.)	Catalog No.	Wgt. (lbs.)
P7172001.B1-101769	31	P7172001.B1-101766	33	P7172001.B1-098004	34	P7172001.B1-098005	33	P7172001.B1-111931	42	P7172001.B1-111075	52
P7172002.B1-101769	31	P7172002.B1-101766	33	P7172002.B1-098004	34	P7172002.B1-098005	33	P7172002.B1-111931	42	P7172002.B1-111075	52
P7172003.B1-101769	31	P7172003.B1-101766	33	P7172003.B1-098004	34	P7172003.B1-098005	33	P7172003.B1-111931	42	P7172003.B1-111075	52
P7172004.B1-101769	31	P7172004.B1-101766	33	P7172004.B1-098004	34	P7172004.B1-098005	33	P7172004.B1-111931	42	P7172004.B1-111075	52
P7172005.B1-101769	31	P7172005.B1-101766	33	P7172005.B1-098004	34	P7172005.B1-098005	33	P7172005.B1-111931	42	P7172005.B1-111075	52
P7172006.B1-101769	31	P7172006.B1-101766	33	P7172006.B1-098004	34	P7172006.B1-098005	33	P7172006.B1-111931	42	P7172006.B1-111075	52
P7172008.B1-101769	31	P7172008.B1-101766	33	P7172008.B1-098004	34	P7172008.B1-098005	33	P7172008.B1-111931	42	P7172008.B1-111075	52
P7172009.B1-101769	31	P7172009.B1-101766	33	P7172009.B1-098004	34	P7172009.B1-098005	33	P7172009.B1-111931	42	P7172009.B1-111075	52
P7172010.B1-101769	31	P7172010.B1-101766	33	P7172010.B1-098004	34	P7172010.B1-098005	33	P7172010.B1-111931	42	P7172010.B1-111075	52
P7172011.B1-101769	31	P7172011.B1-101766	33	P7172011.B1-098004	34	P7172011.B1-098005	33	P7172011.B1-111931	42	P7172011.B1-111075	52
P7172012.B1-101769	31	P7172012.B1-101766	33	P7172012.B1-098004	34	P7172012.B1-098005	33	P7172012.B1-111931	42	P7172012.B1-111075	52
P7172013.B1-101769	31	P7172013.B1-101766	33	P7172013.B1-098004	34	P7172013.B1-098005	33	P7172013.B1-111931	42	P7172013.B1-111075	52
P7172014.B1-101769	31	P7172014.B1-101766	33	P7172014.B1-098004	34	P7172014.B1-098005	33	P7172014.B1-111931	42	P7172014.B1-111075	52
P7172015.B1-101769	31	P7172015.B1-101766	33	P7172015.B1-098004	34	P7172015.B1-098005	33	P7172015.B1-111931	42	P7172015.B1-111075	52
P7172016.B1-101769	31	P7172016.B1-101766	33	P7172016.B1-098004	34	P7172016.B1-098005	33	P7172016.B1-111931	42	P7172016.B1-111075	52
P7172017.B1-101769	31	P7172017.B1-101766	33	P7172017.B1-098004	34	P7172017.B1-098005	33	P7172017.B1-111931	42	P7172017.B1-111075	52
P7272017.B1-101769	31	P7272017.B1-101766	33	P7272017.B1-098004	34	P7272017.B1-098005	33	P7272017.B1-111931	42	P7272017.B1-111075	52
P7173001.B1-101769	32	P7173001.B1-101766	34	P7173001.B1-098004	35	P7173001.B1-098005	34	P7173001.B1-111931	43	P7173001.B1-111075	53
P7273001.B1-101769	32	P7273001.B1-101766	34	P7273001.B1-098004	35	P7273001.B1-098005	34	P7273001.B1-111931	43	P7273001.B1-111075	53
P7172018.B1-101769	31	P7172018.B1-101766	33	P7172018.B1-098004	34	P7172018.B1-098005	33	P7172018.B1-111931	42	P7172018.B1-111075	52
P7272018.B1-101769	31	P7272018.B1-101766	33	P7272018.B1-098004	34	P7272018.B1-098005	33	P7272018.B1-111931	42	P7272018.B1-111075	52
P7172019.B1-101769	31	P7172019.B1-101766	33	P7172019.B1-098004	34	P7172019.B1-098005	33	P7172019.B1-111931	42	P7172019.B1-111075	52
P7272019.B1-101769	31	P7272019.B1-101766	33	P7272019.B1-098004	34	P7272019.B1-098005	33	P7272019.B1-111931	42	P7272019.B1-111075	52
P7173002.B1-101769	32	P7173002.B1-101766	34	P7173002.B1-098004	35	P7173002.B1-098005	34	P7173002.B1-111931	43	P7173002.B1-111075	53
P7273002.B1-101769	32	P7273002.B1-101766	34	P7273002.B1-098004	35	P7273002.B1-098005	34	P7273002.B1-111931	43	P7273002.B1-111075	53
P7173003.B1-101769	32	P7173003.B1-101766	34	P7173003.B1-098004	35	P7173003.B1-098005	34	P7173003.B1-111931	43	P7173003.B1-111075	53
P7273003.B1-101769	32	P7273003.B1-101766	34	P7273003.B1-098004	35	P7273003.B1-098005	34	P7273003.B1-111931	43	P7273003.B1-111075	53
P7172020.B1-101769	31	P7172020.B1-101766	33	P7172020.B1-098004	34	P7172020.B1-098005	33	P7172020.B1-111931	42	P7172020.B1-111075	52
P7272020.B1-101769	31	P7272020.B1-101766	33	P7272020.B1-098004	34	P7272020.B1-098005	33	P7272020.B1-111931	42	P7272020.B1-111075	52
P7472018.B1-101769	43	P7472018.B1-101766	45	P7472018.B1-098004	46	P7472018.B1-098005	45	P7472018.B1-111931	54	P7472018.B1-111075	64
P7173004.B1-101769	32	P7173004.B1-101766	34	P7173004.B1-098004	35	P7173004.B1-098005	34	P7173004.B1-111931	43	P7173004.B1-111075	53
P7273004.B1-101769	32	P7273004.B1-101766	34	P7273004.B1-098004	35	P7273004.B1-098005	34	P7273004.B1-111931	43	P7273004.B1-111075	53

7 Identify motor requirements for Gear+Motor™ selections.

8 Identify the catalog number of the Gear+Motor™ by continuing to the right. See page 38 for detailed information on building an exact catalog number. The B1 suffix can be replaced with optional Mod-Squad codes as detailed on page 52.

9 Verify physical dimensions using the dimensional drawings shown on pages 48-51.

10 Identify reducer mounting position on page 60.



QUICK SELECTIONS
DOUBLE AND TRIPLE REDUCTION



**700 Series
Motorized Quill Input
NEMA Frame Selections
1750 RPM Input**

This Quick Selection is only for motorized B1 base mount reducers and Gear+Motors™. For other reducer configurations, see the Maximum Rating Tables beginning on page 40.



1/4 HP Gear Reducer Quick Selections								
Output Speed (RPM)	Service Factor ▼	Output Torque (lb-in)	Overhung ● Load (lbs.)	Ratio	Number of Reductions	Weight ◆ (lbs.)	Motor Frame	Motorized B1 Base Mount Catalog No.
503	20.07	30	204	3.48	2	11	56C	P7172001.B1
405	16.27	37	216	4.32	2	11	56C	P7172002.B1
318	12.54	48	230	5.50	2	11	56C	P7172003.B1
275	10.95	55	250	6.36	2	11	56C	P7172004.B1
241	9.56	63	260	7.26	2	11	56C	P7172005.B1
222	8.85	68	266	7.89	2	11	56C	P7172006.B1
174	9.20	87	284	10.04	2	11	56C	P7172008.B1
150	7.92	101	293	11.64	2	11	56C	P7172009.B1
132	6.96	115	305	13.26	2	11	56C	P7172010.B1
114	6.00	133	321	15.37	2	11	56C	P7172011.B1
108	5.60	143	335	16.20	2	11	56C	P7172012.B1
93	4.84	164	350	18.80	2	11	56C	P7172013.B1
81	4.28	187	374	21.54	2	11	56C	P7172014.B1
79	4.16	191	375	22.26	2	11	56C	P7172015.B1
67	3.44	233	420	26.30	2	11	56C	P7172016.B1
60	3.16	252	435	29.40	2	11	56C	P7172017.B1
52	2.84	282	459	33.50	3	12	56C	P7173001.B1
49	2.52	315	470	35.90	2	11	56C	P7172018.B1
46	2.40	329	478	38.37	2	11	56C	P7172019.B1
46	2.48	319	478	38.34	3	12	56C	P7173002.B1
40	2.20	366	495	43.69	3	12	56C	P7173003.B1
37	1.92	409	507	46.80	2	11	56C	P7172020.B1
37	2.60	409	674	46.80	2	11	56C	P7272020.B1
35	1.84	432	510	50.67	2	11	56C	P7172021.B1
35	2.56	432	674	50.67	2	11	56C	P7272021.B1
35	1.88	419	510	50.64	3	12	56C	P7173004.B1
33	1.76	458	520	53.40	3	12	56C	P7173005.B1
33	2.56	458	674	53.40	3	12	56C	P7273005.B1
29	4.16	522	1050	60.90	2	23	56C	P7472019.B1
29	1.56	505	525	61.22	3	12	56C	P7173006.B1
29	2.32	505	674	61.22	3	12	56C	P7273006.B1
28	1.97	540	532	61.80	2	11	56C	P7172022.B1
28	1.80	540	674	61.80	2	11	56C	P7272022.B1
28	1.52	523	532	62.00	3	12	56C	P7173007.B1
26	4.32	564	1075	66.22	3	24	56C	P7473006.B1

- ◆ Weight does not include oil.
- ▼ Service Factor is based on maximum torque rating of reducer. Refer to page 171 for special application considerations.
- Overhung load is calculated at centerline of output shaft.

QUICK REFERENCE	
OTHER REDUCER CONFIGURATIONS	Page 38
OUTPUT FLANGE SELECTIONS	53
INTERCHANGE BASE SELECTIONS	54



QUICK SELECTIONS
DOUBLE AND TRIPLE REDUCTION



LeCentric™ Gear Reducers & GEAR+MOTORS™



1/4 HP Gear+Motor™ Quick Selections

TEFC, 3 Phase 230/460V		TEFC, 1 Phase 115/230V		DC SCR 90V		DC SCR 180V	
Catalog No.	Wgt. ♦ (lbs.)	Catalog No.	Wgt. ♦ (lbs.)	Catalog No.	Wgt. ♦ (lbs.)	Catalog No.	Wgt. ♦ (lbs.)
P7172001.B1-101767	30	P7172001.B1-102866	32	P7172001.B1-098002	30	P7172001.B1-098003	33
P7172002.B1-101767	30	P7172002.B1-102866	32	P7172002.B1-098002	30	P7172002.B1-098003	33
P7172003.B1-101767	30	P7172003.B1-102866	32	P7172003.B1-098002	30	P7172003.B1-098003	33
P7172004.B1-101767	30	P7172004.B1-102866	32	P7172004.B1-098002	30	P7172004.B1-098003	33
P7172005.B1-101767	30	P7172005.B1-102866	32	P7172005.B1-098002	30	P7172005.B1-098003	33
P7172006.B1-101767	30	P7172006.B1-102866	32	P7172006.B1-098002	30	P7172006.B1-098003	33
P7172008.B1-101767	30	P7172008.B1-102866	32	P7172008.B1-098002	30	P7172008.B1-098003	33
P7172009.B1-101767	30	P7172009.B1-102866	32	P7172009.B1-098002	30	P7172009.B1-098003	33
P7172010.B1-101767	30	P7172010.B1-102866	32	P7172010.B1-098002	30	P7172010.B1-098003	33
P7172011.B1-101767	30	P7172011.B1-102866	32	P7172011.B1-098002	30	P7172011.B1-098003	33
P7172012.B1-101767	30	P7172012.B1-102866	32	P7172012.B1-098002	30	P7172012.B1-098003	33
P7172013.B1-101767	30	P7172013.B1-102866	32	P7172013.B1-098002	30	P7172013.B1-098003	33
P7172014.B1-101767	30	P7172014.B1-102866	32	P7172014.B1-098002	30	P7172014.B1-098003	33
P7172015.B1-101767	30	P7172015.B1-102866	32	P7172015.B1-098002	30	P7172015.B1-098003	33
P7172016.B1-101767	30	P7172016.B1-102866	32	P7172016.B1-098002	30	P7172016.B1-098003	33
P7172017.B1-101767	30	P7172017.B1-102866	32	P7172017.B1-098002	30	P7172017.B1-098003	33
P7173001.B1-101767	31	P7173001.B1-102866	33	P7173001.B1-098002	31	P7173001.B1-098003	34
P7172018.B1-101767	30	P7172018.B1-102866	32	P7172018.B1-098002	30	P7172018.B1-098003	33
P7172019.B1-101767	30	P7172019.B1-102866	32	P7172019.B1-098002	30	P7172019.B1-098003	33
P7173002.B1-101767	31	P7173002.B1-102866	33	P7173002.B1-098002	31	P7173002.B1-098003	34
P7173003.B1-101767	31	P7173003.B1-102866	33	P7173003.B1-098002	31	P7173003.B1-098003	34
P7172020.B1-101767	30	P7172020.B1-102866	32	P7172020.B1-098002	30	P7172020.B1-098003	33
P7272020.B1-101767	30	P7272020.B1-102866	32	P7272020.B1-098002	30	P7272020.B1-098003	33
P7172021.B1-101767	30	P7172021.B1-102866	32	P7172021.B1-098002	30	P7172021.B1-098003	33
P7272021.B1-101767	30	P7272021.B1-102866	32	P7272021.B1-098002	30	P7272021.B1-098003	33
P7173004.B1-101767	31	P7173004.B1-102866	33	P7173004.B1-098002	31	P7173004.B1-098003	34
P7173005.B1-101767	31	P7173005.B1-102866	33	P7173005.B1-098002	31	P7173005.B1-098003	34
P7273005.B1-101767	31	P7273005.B1-102866	33	P7273005.B1-098002	31	P7273005.B1-098003	34
P7472019.B1-101767	42	P7472019.B1-102866	44	P7472019.B1-098002	42	P7472019.B1-098003	45
P7173006.B1-101767	31	P7173006.B1-102866	33	P7173006.B1-098002	31	P7173006.B1-098003	34
P7273006.B1-101767	31	P7273006.B1-102866	33	P7273006.B1-098002	31	P7273006.B1-098003	34
P7172022.B1-101767	30	P7172022.B1-102866	32	P7172022.B1-098002	30	P7172022.B1-098003	33
P7272022.B1-101767	30	P7272022.B1-102866	32	P7272022.B1-098002	30	P7272022.B1-098003	33
P7173007.B1-101767	31	P7173007.B1-102866	33	P7173007.B1-098002	31	P7173007.B1-098003	34
P7473006.B1-101767	43	P7473006.B1-102866	45	P7473006.B1-098002	43	P7473006.B1-098003	46

Gear+Motor™ catalog numbers are comprised of the reducer catalog number followed by the motor catalog number.

TABLE CONTINUES ON NEXT PAGE

IN THIS CATALOG

RPM = Revolutions Per Minute
HP = Horsepower
TQ = Torque (lb.-in.)
OHL = Overhung Load In Pounds At Centerline Of Output Shaft With No Thrust Load.
TL = Thrust Load (lbs.) - Output Shaft

SELECT REDUCER MOUNTING POSITION ON PAGE 60



QUICK SELECTIONS
DOUBLE AND TRIPLE REDUCTION



**700 Series
Motorized Quill Input
NEMA Frame Selections
1750 RPM Input**

This Quick Selection is only for motorized B1 base mount reducers and Gear+Motors™. For other reducer configurations, see the Maximum Rating Tables beginning on page 40.



1/4 HP Gear Reducer Quick Selections								
Output Speed (RPM)	Service Factor ▼	Output Torque (lb-in)	Overhung ● Load (lbs.)	Ratio	Number of Reductions	Weight ◆ (lbs.)	Motor Frame	Motorized B1 Base Mount Catalog No.
25	1.36	586	540	70.95	3	12	56C	P7173008.B1
25	2.00	586	674	70.95	3	12	56C	P7273008.B1
25	4.04	586	1079	71.01	3	24	56C	P7473007.B1
24	1.28	611	540	73.33	3	12	56C	P7173009.B1
23	1.24	637	540	74.50	3	12	56C	P7173010.B1
23	1.84	637	674	74.50	3	12	56C	P7273010.B1
23	3.72	637	1091	76.69	3	24	56C	P7473008.B1
21	3.48	698	1096	82.30	3	24	56C	P7473009.B1
21	3.44	698	1096	83.59	3	24	56C	P7473010.B1
20	1.08	733	540	86.80	3	12	56C	P7173011.B1
20	1.56	733	674	86.80	3	12	56C	P7273011.B1
19	3.08	771	1105	92.78	3	24	56C	P7473011.B1
18	1.00	814	540	96.85	3	12	56C	P7173012.B1
18	1.48	814	674	96.85	3	12	56C	P7273012.B1
17	1.36	862	674	102.80	3	12	56C	P7273013.B1
17	2.72	862	1112	104.68	3	24	56C	P7473012.B1
15	2.44	977	1124	117.22	3	24	56C	P7473013.B1
15	1.16	977	674	126.40	3	12	56C	P7273014.B1
14	2.24	1047	1130	126.65	3	24	56C	P7473014.B1
13	1.04	1127	674	135.69	3	12	56C	P7273015.B1
13	2.12	1127	1136	135.74	3	24	56C	P7473015.B1
13	2.96	1127	1472	135.74	3	29	56C	P7573037.B1
12	1.96	1221	1150	145.68	3	24	56C	P7473016.B1
12	2.76	1221	1475	145.68	3	29	56C	P7573038.B1
11	1.80	1332	1168	157.40	3	24	56C	P7473017.B1
11	2.56	1332	1492	157.40	3	29	56C	P7573039.B1
11	2.44	1332	1492	164.23	3	29	56C	P7573040.B1
9.4	1.56	1559	1186	185.29	3	24	56C	P7473019.B1
9.4	2.16	1559	1498	185.29	3	29	56C	P7573041.B1
8.6	1.40	1704	1186	204.12	3	24	56C	P7473020.B1
8.6	1.96	1704	1502	204.12	3	29	56C	P7573042.B1
7.8	1.28	1879	1195	224.18	3	24	56C	P7473021.B1
7.8	1.80	1879	1510	224.18	3	29	56C	P7573043.B1
6.3	1.04	2326	1214	278.62	3	24	56C	P7473022.B1
6.3	1.44	2326	1510	278.62	3	29	56C	P7573044.B1

- ◆ Weight does not include oil.
- ▼ Service Factor is based on maximum torque rating of reducer. Refer to page 171 for special application considerations.
- Overhung load is calculated at centerline of output shaft.

QUICK REFERENCE
OTHER REDUCER CONFIGURATIONS Page 38
OUTPUT FLANGE SELECTIONS 53
INTERCHANGE BASE SELECTIONS 54



QUICK SELECTIONS
DOUBLE AND TRIPLE REDUCTION



LeCentric™ Gear Reducers & GEAR+MOTORS™



1/4 HP Gear+Motor™ Quick Selections							
TEFC, 3 Phase 230/460V		TEFC, 1 Phase 115/230V		DC SCR 90V		DC SCR 180V	
Catalog No.	Wgt. ♦ (lbs.)	Catalog No.	Wgt. ♦ (lbs.)	Catalog No.	Wgt. ♦ (lbs.)	Catalog No.	Wgt. ♦ (lbs.)
P7173008.B1-101767	31	P7173008.B1-102866	33	P7173008.B1-098002	31	P7173008.B1-098003	34
P7273008.B1-101767	31	P7273008.B1-102866	33	P7273008.B1-098002	31	P7273008.B1-098003	34
P7473007.B1-101767	43	P7473007.B1-102866	45	P7473007.B1-098002	43	P7473007.B1-098003	46
P7173009.B1-101767	31	P7173009.B1-102866	33	P7173009.B1-098002	31	P7173009.B1-098003	34
P7173010.B1-101767	31	P7173010.B1-102866	33	P7173010.B1-098002	31	P7173010.B1-098003	34
P7273010.B1-101767	31	P7273010.B1-102866	33	P7273010.B1-098002	31	P7273010.B1-098003	34
P7473008.B1-101767	43	P7473008.B1-102866	45	P7473008.B1-098002	43	P7473008.B1-098003	46
P7473009.B1-101767	43	P7473009.B1-102866	45	P7473009.B1-098002	43	P7473009.B1-098003	46
P7473010.B1-101767	43	P7473010.B1-102866	45	P7473010.B1-098002	43	P7473010.B1-098003	46
P7173011.B1-101767	31	P7173011.B1-102866	33	P7173011.B1-098002	31	P7173011.B1-098003	34
P7273011.B1-101767	31	P7273011.B1-102866	33	P7273011.B1-098002	31	P7273011.B1-098003	34
P7473011.B1-101767	43	P7473011.B1-102866	45	P7473011.B1-098002	43	P7473011.B1-098003	46
P7173012.B1-101767	31	P7173012.B1-102866	33	P7173012.B1-098002	31	P7173012.B1-098003	34
P7273012.B1-101767	31	P7273012.B1-102866	33	P7273012.B1-098002	31	P7273012.B1-098003	34
P7273013.B1-101767	31	P7273013.B1-102866	33	P7273013.B1-098002	31	P7273013.B1-098003	34
P7473012.B1-101767	43	P7473012.B1-102866	45	P7473012.B1-098002	43	P7473012.B1-098003	46
P7473013.B1-101767	43	P7473013.B1-102866	45	P7473013.B1-098002	43	P7473013.B1-098003	46
P7273014.B1-101767	31	P7273014.B1-102866	33	P7273014.B1-098002	31	P7273014.B1-098003	34
P7473014.B1-101767	43	P7473014.B1-102866	45	P7473014.B1-098002	43	P7473014.B1-098003	46
P7273015.B1-101767	31	P7273015.B1-102866	33	P7273015.B1-098002	31	P7273015.B1-098003	34
P7473015.B1-101767	43	P7473015.B1-102866	45	P7473015.B1-098002	43	P7473015.B1-098003	46
P7573037.B1-101767	48	P7573037.B1-102866	50	P7573037.B1-098002	48	P7573037.B1-098003	51
P7473016.B1-101767	43	P7473016.B1-102866	45	P7473016.B1-098002	43	P7473016.B1-098003	46
P7573038.B1-101767	48	P7573038.B1-102866	50	P7573038.B1-098002	48	P7573038.B1-098003	51
P7473017.B1-101767	43	P7473017.B1-102866	45	P7473017.B1-098002	43	P7473017.B1-098003	46
P7573039.B1-101767	48	P7573039.B1-102866	50	P7573039.B1-098002	48	P7573039.B1-098003	51
P7573040.B1-101767	48	P7573040.B1-102866	50	P7573040.B1-098002	48	P7573040.B1-098003	51
P7473019.B1-101767	43	P7473019.B1-102866	45	P7473019.B1-098002	43	P7473019.B1-098003	46
P7573041.B1-101767	48	P7573041.B1-102866	50	P7573041.B1-098002	48	P7573041.B1-098003	51
P7473020.B1-101767	43	P7473020.B1-102866	45	P7473020.B1-098002	43	P7473020.B1-098003	46
P7573042.B1-101767	48	P7573042.B1-102866	50	P7573042.B1-098002	48	P7573042.B1-098003	51
P7473021.B1-101767	43	P7473021.B1-102866	45	P7473021.B1-098002	43	P7473021.B1-098003	46
P7573043.B1-101767	48	P7573043.B1-102866	50	P7573043.B1-098002	48	P7573043.B1-098003	51
P7473022.B1-101767	43	P7473022.B1-102866	45	P7473022.B1-098002	43	P7473022.B1-098003	46
P7573044.B1-101767	48	P7573044.B1-102866	50	P7573044.B1-098002	48	P7573044.B1-098003	51

Gear+Motor™ catalog numbers are comprised of the reducer catalog number followed by the motor catalog number.

IN THIS CATALOG

RPM = Revolutions Per Minute
HP = Horsepower
TQ = Torque (lb-in.)
OHL = Overhung Load In Pounds At Centerline Of Output Shaft With No Thrust Load.
TL = Thrust Load (lbs.) - Output Shaft

SELECT REDUCER MOUNTING POSITION ON PAGE 60

LeCentric™ Gear Reducers & GEAR+MOTORS™



QUICK SELECTIONS
DOUBLE AND TRIPLE REDUCTION



**700 Series
Motorized Quill Input
NEMA Frame Selections
1750 RPM Input**

This Quick Selection is only for motorized B1 base mount reducers and Gear+Motors™. For other reducer configurations, see the Maximum Rating Tables beginning on page 40.



1/3 HP Gear Reducer Quick Selections								
Output Speed (RPM)	Service Factor ▼	Output Torque (lb-in)	Overhung ● Load (lbs.)	Ratio	Number of Reductions	Weight ◆ (lbs.)	Motor Frame	Motorized B1 Base Mount Catalog No.
503	15.05	40	204	3.48	2	11	56C	P7172001.B1
405	12.29	49	216	4.32	2	11	56C	P7172002.B1
318	9.56	63	230	5.50	2	11	56C	P7172003.B1
275	8.25	73	250	6.36	2	11	56C	P7172004.B1
241	7.25	83	260	7.26	2	11	56C	P7172005.B1
222	6.69	90	266	7.89	2	11	56C	P7172006.B1
174	6.97	115	284	10.04	2	11	56C	P7172008.B1
150	6.00	133	293	11.64	2	11	56C	P7172009.B1
132	5.27	151	305	13.26	2	11	56C	P7172010.B1
114	4.55	175	321	15.37	2	11	56C	P7172011.B1
108	4.24	188	335	16.20	2	11	56C	P7172012.B1
93	3.67	217	350	18.80	2	11	56C	P7172013.B1
81	3.24	246	374	21.54	2	11	56C	P7172014.B1
79	3.15	253	375	22.26	2	11	56C	P7172015.B1
67	2.61	307	420	26.30	2	11	56C	P7172016.B1
67	3.79	307	615	26.30	2	11	56C	P7272016.B1
60	2.39	333	435	29.40	2	11	56C	P7172017.B1
60	3.55	333	629	29.40	2	11	56C	P7272017.B1
52	2.15	372	459	33.50	3	12	56C	P7173001.B1
52	3.21	372	645	33.50	3	12	56C	P7273001.B1
49	1.91	416	470	35.90	2	11	56C	P7172018.B1
49	2.79	416	658	35.90	2	11	56C	P7272018.B1
46	1.82	434	478	38.37	2	11	56C	P7172019.B1
46	2.58	434	660	38.37	2	11	56C	P7272019.B1
46	2.64	420	660	38.34	3	12	56C	P7273002.B1
40	1.67	484	495	43.69	3	12	56C	P7173003.B1
40	2.45	484	674	43.69	3	12	56C	P7273003.B1
37	1.45	540	507	46.80	2	11	56C	P7172020.B1
37	1.97	540	674	46.80	2	11	56C	P7272020.B1
36	4.30	555	1028	49.00	2	23	56C	P7472018.B1
35	1.42	553	510	50.64	3	12	56C	P7173004.B1
35	2.12	553	674	50.64	3	12	56C	P7273004.B1
35	1.28	570	674	50.67	2	11	56C	P7272021.B1
33	1.33	604	520	53.40	3	12	56C	P7173005.B1
33	1.94	604	674	53.40	3	12	56C	P7273005.B1
32	3.97	604	1041	54.73	3	24	56C	P7473004.B1
31	3.79	624	1050	57.13	3	24	56C	P7473005.B1

- ◆ Weight does not include oil.
- ▼ Service Factor is based on maximum torque rating of reducer. Refer to page 171 for special application considerations.
- Overhung load is calculated at centerline of output shaft.

QUICK REFERENCE
OTHER REDUCER CONFIGURATIONS Page 38
OUTPUT FLANGE SELECTIONS 53
INTERCHANGE BASE SELECTIONS 54



QUICK SELECTIONS
DOUBLE AND TRIPLE REDUCTION



LeCentric™ Gear Reducers & GEAR+MOTORS™



1/3 HP Gear+Motor™ Quick Selections											
TEFC, 3 Phase 230/460V		TEFC, 1 Phase 115/230V		DC SCR 90V		DC SCR 180V		Explosion-Proof, 3 Phase 230/460V		Explosion-Proof, 1 Phase 115/230V	
Catalog No.	Wgt.♦ (lbs.)	Catalog No.	Wgt.♦ (lbs.)	Catalog No.	Wgt.♦ (lbs.)	Catalog No.	Wgt.♦ (lbs.)	Catalog No.	Wgt.♦ (lbs.)	Catalog No.	Wgt.♦ (lbs.)
P7172001.B1-101769	31	P7172001.B1-101766	33	P7172001.B1-098004	34	P7172001.B1-098005	33	P7172001.B1-111931	42	P7172001.B1-111075	52
P7172002.B1-101769	31	P7172002.B1-101766	33	P7172002.B1-098004	34	P7172002.B1-098005	33	P7172002.B1-111931	42	P7172002.B1-111075	52
P7172003.B1-101769	31	P7172003.B1-101766	33	P7172003.B1-098004	34	P7172003.B1-098005	33	P7172003.B1-111931	42	P7172003.B1-111075	52
P7172004.B1-101769	31	P7172004.B1-101766	33	P7172004.B1-098004	34	P7172004.B1-098005	33	P7172004.B1-111931	42	P7172004.B1-111075	52
P7172005.B1-101769	31	P7172005.B1-101766	33	P7172005.B1-098004	34	P7172005.B1-098005	33	P7172005.B1-111931	42	P7172005.B1-111075	52
P7172006.B1-101769	31	P7172006.B1-101766	33	P7172006.B1-098004	34	P7172006.B1-098005	33	P7172006.B1-111931	42	P7172006.B1-111075	52
P7172008.B1-101769	31	P7172008.B1-101766	33	P7172008.B1-098004	34	P7172008.B1-098005	33	P7172008.B1-111931	42	P7172008.B1-111075	52
P7172009.B1-101769	31	P7172009.B1-101766	33	P7172009.B1-098004	34	P7172009.B1-098005	33	P7172009.B1-111931	42	P7172009.B1-111075	52
P7172010.B1-101769	31	P7172010.B1-101766	33	P7172010.B1-098004	34	P7172010.B1-098005	33	P7172010.B1-111931	42	P7172010.B1-111075	52
P7172011.B1-101769	31	P7172011.B1-101766	33	P7172011.B1-098004	34	P7172011.B1-098005	33	P7172011.B1-111931	42	P7172011.B1-111075	52
P7172012.B1-101769	31	P7172012.B1-101766	33	P7172012.B1-098004	34	P7172012.B1-098005	33	P7172012.B1-111931	42	P7172012.B1-111075	52
P7172013.B1-101769	31	P7172013.B1-101766	33	P7172013.B1-098004	34	P7172013.B1-098005	33	P7172013.B1-111931	42	P7172013.B1-111075	52
P7172014.B1-101769	31	P7172014.B1-101766	33	P7172014.B1-098004	34	P7172014.B1-098005	33	P7172014.B1-111931	42	P7172014.B1-111075	52
P7172015.B1-101769	31	P7172015.B1-101766	33	P7172015.B1-098004	34	P7172015.B1-098005	33	P7172015.B1-111931	42	P7172015.B1-111075	52
P7172016.B1-101769	31	P7172016.B1-101766	33	P7172016.B1-098004	34	P7172016.B1-098005	33	P7172016.B1-111931	42	P7172016.B1-111075	52
P7272016.B1-101769	31	P7272016.B1-101766	33	P7272016.B1-098004	34	P7272016.B1-098005	33	P7272016.B1-111931	42	P7272016.B1-111075	52
P7172017.B1-101769	31	P7172017.B1-101766	33	P7172017.B1-098004	34	P7172017.B1-098005	33	P7172017.B1-111931	42	P7172017.B1-111075	52
P7272017.B1-101769	31	P7272017.B1-101766	33	P7272017.B1-098004	34	P7272017.B1-098005	33	P7272017.B1-111931	42	P7272017.B1-111075	52
P7173001.B1-101769	32	P7173001.B1-101766	34	P7173001.B1-098004	35	P7173001.B1-098005	34	P7173001.B1-111931	43	P7173001.B1-111075	53
P7273001.B1-101769	32	P7273001.B1-101766	34	P7273001.B1-098004	35	P7273001.B1-098005	34	P7273001.B1-111931	43	P7273001.B1-111075	53
P7172018.B1-101769	31	P7172018.B1-101766	33	P7172018.B1-098004	34	P7172018.B1-098005	33	P7172018.B1-111931	42	P7172018.B1-111075	52
P7272018.B1-101769	31	P7272018.B1-101766	33	P7272018.B1-098004	34	P7272018.B1-098005	33	P7272018.B1-111931	42	P7272018.B1-111075	52
P7172019.B1-101769	31	P7172019.B1-101766	33	P7172019.B1-098004	34	P7172019.B1-098005	33	P7172019.B1-111931	42	P7172019.B1-111075	52
P7272019.B1-101769	31	P7272019.B1-101766	33	P7272019.B1-098004	34	P7272019.B1-098005	33	P7272019.B1-111931	42	P7272019.B1-111075	52
P7273002.B1-101769	32	P7273002.B1-101766	34	P7273002.B1-098004	35	P7273002.B1-098005	34	P7273002.B1-111931	43	P7273002.B1-111075	53
P7173003.B1-101769	32	P7173003.B1-101766	34	P7173003.B1-098004	35	P7173003.B1-098005	34	P7173003.B1-111931	43	P7173003.B1-111075	53
P7273003.B1-101769	32	P7273003.B1-101766	34	P7273003.B1-098004	35	P7273003.B1-098005	34	P7273003.B1-111931	43	P7273003.B1-111075	53
P7172020.B1-101769	31	P7172020.B1-101766	33	P7172020.B1-098004	34	P7172020.B1-098005	33	P7172020.B1-111931	42	P7172020.B1-111075	52
P7272020.B1-101769	31	P7272020.B1-101766	33	P7272020.B1-098004	34	P7272020.B1-098005	33	P7272020.B1-111931	42	P7272020.B1-111075	52
P7472018.B1-101769	43	P7472018.B1-101766	45	P7472018.B1-098004	46	P7472018.B1-098005	45	P7472018.B1-111931	54	P7472018.B1-111075	64
P7173004.B1-101769	32	P7173004.B1-101766	34	P7173004.B1-098004	35	P7173004.B1-098005	34	P7173004.B1-111931	43	P7173004.B1-111075	53
P7273004.B1-101769	32	P7273004.B1-101766	34	P7273004.B1-098004	35	P7273004.B1-098005	34	P7273004.B1-111931	43	P7273004.B1-111075	53
P7272021.B1-101769	31	P7272021.B1-101766	33	P7272021.B1-098004	34	P7272021.B1-098005	33	P7272021.B1-111931	42	P7272021.B1-111075	52
P7173005.B1-101769	32	P7173005.B1-101766	34	P7173005.B1-098004	35	P7173005.B1-098005	34	P7173005.B1-111931	43	P7173005.B1-111075	53
P7273005.B1-101769	32	P7273005.B1-101766	34	P7273005.B1-098004	35	P7273005.B1-098005	34	P7273005.B1-111931	43	P7273005.B1-111075	53
P7473004.B1-101769	44	P7473004.B1-101766	46	P7473004.B1-098004	47	P7473004.B1-098005	46	P7473004.B1-111931	55	P7473004.B1-111075	65
P7473005.B1-101769	44	P7473005.B1-101766	46	P7473005.B1-098004	47	P7473005.B1-098005	46	P7473005.B1-111931	55	P7473005.B1-111075	65

Gear+Motor™ catalog numbers are comprised of the reducer catalog number followed by the motor catalog number.

TABLE CONTINUES ON NEXT PAGE

IN THIS CATALOG

- _____ RPM = Revolutions Per Minute
- _____ HP = Horsepower
- _____ TQ = Torque (lb.-in.)
- _____ OHL = Overhung Load In Pounds At Centerline Of Output Shaft With No Thrust Load.
- _____ TL = Thrust Load (lbs.) - Output Shaft

SELECT REDUCER MOUNTING POSITION ON PAGE 60

LeCentric™ Gear Reducers & GEAR+MOTORS™



QUICK SELECTIONS
DOUBLE AND TRIPLE REDUCTION



**700 Series
Motorized Quill Input
NEMA Frame Selections
1750 RPM Input**

This Quick Selection is only for motorized B1 base mount reducers and Gear+Motors™. For other reducer configurations, see the Maximum Rating Tables beginning on page 40.



1/3 HP Gear Reducer Quick Selections								
Output Speed (RPM)	Service Factor ▼	Output Torque (lb-in)	Overhung ● Load (lbs.)	Ratio	Number of Reductions	Weight ◆ (lbs.)	Motor Frame	Motorized B1 Base Mount Catalog No.
29	3.15	688	1050	60.90	2	23	56C	P7472019.B1
29	1.18	667	525	61.22	3	12	56C	P7173006.B1
29	1.76	667	674	61.22	3	12	56C	P7273006.B1
28	1.12	713	532	61.80	2	11	56C	P7172022.B1
28	1.49	713	674	61.80	2	11	56C	P7272022.B1
28	1.15	691	532	62.00	3	12	56C	P7173007.B1
26	3.27	744	1075	66.22	3	24	56C	P7473006.B1
25	1.03	774	540	70.95	3	12	56C	P7173008.B1
25	1.52	774	674	70.95	3	12	56C	P7273008.B1
25	3.06	774	1079	71.01	3	24	56C	P7473007.B1
24	0.97	806	540	73.33	3	12	56C	P7173009.B1
24	1.39	806	674	73.33	3	12	56C	P7273009.B1
23	1.39	841	674	74.50	3	12	56C	P7273010.B1
23	2.82	841	1091	76.69	3	24	56C	P7473008.B1
21	2.64	921	1096	82.30	3	24	56C	P7473009.B1
20	1.18	967	674	86.80	3	12	56C	P7273011.B1
19	2.33	1018	1102	92.78	3	24	56C	P7473011.B1
18	1.12	1075	674	96.85	3	12	56C	P7273012.B1
17	1.03	1138	674	102.80	3	12	56C	P7273013.B1
17	2.06	1138	1112	104.68	3	24	56C	P7473012.B1
17	2.91	1138	1454	104.68	3	29	56C	P7573034.B1
15	1.85	1289	1124	117.22	3	24	56C	P7473013.B1
15	2.61	1289	1461	117.22	3	29	56C	P7573035.B1
14	1.70	1382	1130	126.65	3	24	56C	P7473014.B1
14	2.39	1382	1468	126.65	3	29	56C	P7573036.B1
13	1.61	1488	1136	135.74	3	24	56C	P7473015.B1
13	2.24	1488	1472	135.74	3	29	56C	P7573037.B1
12	1.48	1612	1150	145.68	3	24	56C	P7473016.B1
12	2.09	1612	1475	145.68	3	29	56C	P7573038.B1
11	1.36	1758	1168	157.40	3	24	56C	P7473017.B1
11	1.94	1758	1492	157.40	3	29	56C	P7573039.B1
11	1.33	1758	1168	164.23	3	24	56C	P7473018.B1
11	1.85	1758	1492	164.23	3	29	56C	P7573040.B1
9.4	1.18	2058	1186	185.29	3	24	56C	P7473019.B1
9.4	1.64	2058	1498	185.29	3	29	56C	P7573041.B1
8.6	1.06	2249	1186	204.12	3	24	56C	P7473020.B1
8.6	1.48	2249	1502	204.12	3	29	56C	P7573042.B1
7.8	0.97	2480	1195	224.18	3	24	56C	P7473021.B1
7.8	1.36	2480	1510	224.18	3	29	56C	P7573043.B1
6.3	1.09	3070	1510	278.62	3	29	56C	P7573044.B1

- ◆ Weight does not include oil.
- ▼ Service Factor is based on maximum torque rating of reducer. Refer to page 171 for special application considerations.
- Overhung load is calculated at centerline of output shaft.

QUICK REFERENCE	
OTHER REDUCER CONFIGURATIONS	Page 38
OUTPUT FLANGE SELECTIONS	53
INTERCHANGE BASE SELECTIONS	54



QUICK SELECTIONS
DOUBLE AND TRIPLE REDUCTION



LeCentric™ Gear Reducers & GEAR+MOTOR™



TEFC, 3 Phase 230/460V		TEFC, 1 Phase 115/230V		DC SCR 90V		DC SCR 180V		Explosion-Proof, 3 Phase 230/460V		Explosion-Proof, 1 Phase 115/230V	
Catalog No.	Wgt. (lbs.)	Catalog No.	Wgt. (lbs.)	Catalog No.	Wgt. (lbs.)	Catalog No.	Wgt. (lbs.)	Catalog No.	Wgt. (lbs.)	Catalog No.	Wgt. (lbs.)
P7472019.B1-101769	43	P7472019.B1-101766	45	P7472019.B1-098004	46	P7472019.B1-098005	45	P7472019.B1-111931	54	P7472019.B1-111075	64
P7173006.B1-101769	32	P7173006.B1-101766	34	P7173006.B1-098004	35	P7173006.B1-098005	34	P7173006.B1-111931	43	P7173006.B1-111075	53
P7273006.B1-101769	32	P7273006.B1-101766	34	P7273006.B1-098004	35	P7273006.B1-098005	34	P7273006.B1-111931	43	P7273006.B1-111075	53
P7172022.B1-101769	31	P7172022.B1-101766	33	P7172022.B1-098004	34	P7172022.B1-098005	33	P7172022.B1-111931	42	P7172022.B1-111075	52
P7272022.B1-101769	31	P7272022.B1-101766	33	P7272022.B1-098004	34	P7272022.B1-098005	33	P7272022.B1-111931	42	P7272022.B1-111075	52
P7173007.B1-101769	32	P7173007.B1-101766	34	P7173007.B1-098004	35	P7173007.B1-098005	34	P7173007.B1-111931	43	P7173007.B1-111075	53
P7473006.B1-101769	44	P7473006.B1-101766	46	P7473006.B1-098004	47	P7473006.B1-098005	46	P7473006.B1-111931	55	P7473006.B1-111075	65
P7173008.B1-101769	32	P7173008.B1-101766	34	P7173008.B1-098004	35	P7173008.B1-098005	34	P7173008.B1-111931	43	P7173008.B1-111075	53
P7273008.B1-101769	32	P7273008.B1-101766	34	P7273008.B1-098004	35	P7273008.B1-098005	34	P7273008.B1-111931	43	P7273008.B1-111075	53
P7473007.B1-101769	44	P7473007.B1-101766	46	P7473007.B1-098004	47	P7473007.B1-098005	46	P7473007.B1-111931	55	P7473007.B1-111075	65
P7173009.B1-101769	32	P7173009.B1-101766	34	P7173009.B1-098004	35	P7173009.B1-098005	34	P7173009.B1-111931	43	P7173009.B1-111075	53
P7273009.B1-101769	32	P7273009.B1-101766	34	P7273009.B1-098004	35	P7273009.B1-098005	34	P7273009.B1-111931	43	P7273009.B1-111075	53
P7273010.B1-101769	32	P7273010.B1-101766	34	P7273010.B1-098004	35	P7273010.B1-098005	34	P7273010.B1-111931	43	P7273010.B1-111075	53
P7473008.B1-101769	44	P7473008.B1-101766	46	P7473008.B1-098004	47	P7473008.B1-098005	46	P7473008.B1-111931	55	P7473008.B1-111075	65
P7473009.B1-101769	44	P7473009.B1-101766	46	P7473009.B1-098004	47	P7473009.B1-098005	46	P7473009.B1-111931	55	P7473009.B1-111075	65
P7273011.B1-101769	32	P7273011.B1-101766	34	P7273011.B1-098004	35	P7273011.B1-098005	34	P7273011.B1-111931	43	P7273011.B1-111075	53
P7473011.B1-101769	44	P7473011.B1-101766	46	P7473011.B1-098004	47	P7473011.B1-098005	46	P7473011.B1-111931	55	P7473011.B1-111075	65
P7273012.B1-101769	32	P7273012.B1-101766	34	P7273012.B1-098004	35	P7273012.B1-098005	34	P7273012.B1-111931	43	P7273012.B1-111075	53
P7273013.B1-101769	32	P7273013.B1-101766	34	P7273013.B1-098004	35	P7273013.B1-098005	34	P7273013.B1-111931	43	P7273013.B1-111075	53
P7473012.B1-101769	44	P7473012.B1-101766	46	P7473012.B1-098004	47	P7473012.B1-098005	46	P7473012.B1-111931	55	P7473012.B1-111075	65
P7573034.B1-101769	49	P7573034.B1-101766	51	P7573034.B1-098004	52	P7573034.B1-098005	51	P7573034.B1-111931	60	P7573034.B1-111075	70
P7473013.B1-101769	44	P7473013.B1-101766	46	P7473013.B1-098004	47	P7473013.B1-098005	46	P7473013.B1-111931	55	P7473013.B1-111075	65
P7573035.B1-101769	49	P7573035.B1-101766	51	P7573035.B1-098004	52	P7573035.B1-098005	51	P7573035.B1-111931	60	P7573035.B1-111075	70
P7473014.B1-101769	44	P7473014.B1-101766	46	P7473014.B1-098004	47	P7473014.B1-098005	46	P7473014.B1-111931	55	P7473014.B1-111075	65
P7573036.B1-101769	49	P7573036.B1-101766	51	P7573036.B1-098004	52	P7573036.B1-098005	51	P7573036.B1-111931	60	P7573036.B1-111075	70
P7473015.B1-101769	44	P7473015.B1-101766	46	P7473015.B1-098004	47	P7473015.B1-098005	46	P7473015.B1-111931	55	P7473015.B1-111075	65
P7573037.B1-101769	49	P7573037.B1-101766	51	P7573037.B1-098004	52	P7573037.B1-098005	51	P7573037.B1-111931	60	P7573037.B1-111075	70
P7473016.B1-101769	44	P7473016.B1-101766	46	P7473016.B1-098004	47	P7473016.B1-098005	46	P7473016.B1-111931	55	P7473016.B1-111075	65
P7573038.B1-101769	49	P7573038.B1-101766	51	P7573038.B1-098004	52	P7573038.B1-098005	51	P7573038.B1-111931	60	P7573038.B1-111075	70
P7473017.B1-101769	44	P7473017.B1-101766	46	P7473017.B1-098004	47	P7473017.B1-098005	46	P7473017.B1-111931	55	P7473017.B1-111075	65
P7573039.B1-101769	49	P7573039.B1-101766	51	P7573039.B1-098004	52	P7573039.B1-098005	51	P7573039.B1-111931	60	P7573039.B1-111075	70
P7473018.B1-101769	44	P7473018.B1-101766	46	P7473018.B1-098004	47	P7473018.B1-098005	46	P7473018.B1-111931	55	P7473018.B1-111075	65
P7573040.B1-101769	49	P7573040.B1-101766	51	P7573040.B1-098004	52	P7573040.B1-098005	51	P7573040.B1-111931	60	P7573040.B1-111075	70
P7473019.B1-101769	44	P7473019.B1-101766	46	P7473019.B1-098004	47	P7473019.B1-098005	46	P7473019.B1-111931	55	P7473019.B1-111075	65
P7573041.B1-101769	49	P7573041.B1-101766	51	P7573041.B1-098004	52	P7573041.B1-098005	51	P7573041.B1-111931	60	P7573041.B1-111075	70
P7473020.B1-101769	44	P7473020.B1-101766	46	P7473020.B1-098004	47	P7473020.B1-098005	46	P7473020.B1-111931	55	P7473020.B1-111075	65
P7573042.B1-101769	49	P7573042.B1-101766	51	P7573042.B1-098004	52	P7573042.B1-098005	51	P7573042.B1-111931	60	P7573042.B1-111075	70
P7473021.B1-101769	44	P7473021.B1-101766	46	P7473021.B1-098004	47	P7473021.B1-098005	46	P7473021.B1-111931	55	P7473021.B1-111075	65
P7573043.B1-101769	49	P7573043.B1-101766	51	P7573043.B1-098004	52	P7573043.B1-098005	51	P7573043.B1-111931	60	P7573043.B1-111075	70
P7573044.B1-101769	49	P7573044.B1-101766	51	P7573044.B1-098004	52	P7573044.B1-098005	51	P7573044.B1-111931	60	P7573044.B1-111075	70

Gear+Motor™ catalog numbers are comprised of the reducer catalog number followed by the motor catalog number.

IN THIS CATALOG

RPM = Revolutions Per Minute
HP = Horsepower
TQ = Torque (lb.-in.)
OHL = Overhung Load In Pounds At Centerline Of Output Shaft With No Thrust Load.
TL = Thrust Load (lbs.) - Output Shaft

SELECT REDUCER MOUNTING POSITION ON PAGE 60



QUICK SELECTIONS
DOUBLE AND TRIPLE REDUCTION



**700 Series
Motorized Quill Input
NEMA Frame Selections
1750 RPM Input**

This Quick Selection is only for motorized B1 base mount reducers and Gear+Motors™. For other reducer configurations, see the Maximum Rating Tables beginning on page 40.



1/2 HP Gear Reducer Quick Selections								
Output Speed (RPM)	Service Factor ▼	Output Torque (lb-in)	Overhung ● Load (lbs.)	Ratio	Number of Reductions	Weight ◆ (lbs.)	Motor Frame	Motorized B1 Base Mount Catalog No.
503	10.03	60	204	3.48	2	11	56C	P7172001.B1
405	8.02	75	216	4.32	2	11	56C	P7172002.B1
318	6.34	95	230	5.50	2	11	56C	P7172003.B1
275	5.47	110	250	6.36	2	11	56C	P7172004.B1
241	4.78	126	260	7.26	2	11	56C	P7172005.B1
222	4.43	136	266	7.89	2	11	56C	P7172006.B1
174	4.60	174	284	10.04	2	11	56C	P7172008.B1
150	3.96	202	293	11.64	2	11	56C	P7172009.B1
132	3.48	229	305	13.26	2	11	56C	P7172010.B1
114	3.00	265	321	15.37	2	11	56C	P7172011.B1
108	2.80	285	335	16.20	2	11	56C	P7172012.B1
108	4.06	285	520	16.20	2	11	56C	P7272012.B1
93	2.42	329	350	18.80	2	11	56C	P7172013.B1
93	3.50	329	535	18.80	2	11	56C	P7272013.B1
81	2.14	373	374	21.54	2	11	56C	P7172014.B1
81	3.20	373	562	21.54	2	11	56C	P7272014.B1
79	2.08	383	375	22.26	2	11	56C	P7172015.B1
79	3.11	383	562	22.26	2	11	56C	P7272015.B1
67	1.72	465	420	26.30	2	11	56C	P7172016.B1
67	2.50	465	615	26.30	2	11	56C	P7272016.B1
60	1.58	504	435	29.40	2	11	56C	P7172017.B1
60	2.34	504	629	29.40	2	11	56C	P7272017.B1
52	1.42	564	459	33.50	3	12	56C	P7173001.B1
52	2.12	564	645	33.50	3	12	56C	P7273001.B1
52	4.20	564	918	34.01	3	24	56C	P7473001.B1
49	1.26	630	470	35.90	2	11	56C	P7172018.B1
49	1.84	630	660	35.90	2	11	56C	P7272018.B1
46	1.20	658	478	38.37	2	11	56C	P7172019.B1
46	1.70	637	663	38.37	2	11	56C	P7272019.B1
44	3.60	666	988	39.79	3	24	56C	P7473002.B1
43	3.44	704	988	40.50	2	23	56C	P7472016.B1
40	1.10	733	495	43.69	3	12	56C	P7173003.B1
40	1.62	733	674	43.69	3	12	56C	P7273003.B1
40	3.00	756	1012	44.23	2	23	56C	P7472017.B1

- ◆ Weight does not include oil.
- ▼ Service Factor is based on maximum torque rating of reducer. Refer to page 171 for special application considerations.
- Overhung load is calculated at centerline of output shaft.

QUICK REFERENCE	
OTHER REDUCER CONFIGURATIONS	Page 38
OUTPUT FLANGE SELECTIONS	53
INTERCHANGE BASE SELECTIONS	54



QUICK SELECTIONS
DOUBLE AND TRIPLE REDUCTION



LeCentric™ Gear Reducers & GEAR+MOTORS™



1/2 HP Gear+Motor™ Quick Selections											
TEFC, 3 Phase 230/460V		TEFC, 1 Phase 115/230V		DC SCR 90V		DC SCR 180V		Explosion-Proof, 3 Phase 230/460V		Explosion-Proof, 1 Phase 115/230V	
Catalog No.	Wgt.♦ (lbs.)	Catalog No.	Wgt.♦ (lbs.)	Catalog No.	Wgt.♦ (lbs.)	Catalog No.	Wgt.♦ (lbs.)	Catalog No.	Wgt.♦ (lbs.)	Catalog No.	Wgt.♦ (lbs.)
P7172001.B1-102860	33	P7172001.B1-102862	36	P7172001.B1-098000	35	P7172001.B1-098008	36	P7172001.B1-111930	47	P7172001.B1-111085	56
P7172002.B1-102860	33	P7172002.B1-102862	36	P7172002.B1-098000	35	P7172002.B1-098008	36	P7172002.B1-111930	47	P7172002.B1-111085	56
P7172003.B1-102860	33	P7172003.B1-102862	36	P7172003.B1-098000	35	P7172003.B1-098008	36	P7172003.B1-111930	47	P7172003.B1-111085	56
P7172004.B1-102860	33	P7172004.B1-102862	36	P7172004.B1-098000	35	P7172004.B1-098008	36	P7172004.B1-111930	47	P7172004.B1-111085	56
P7172005.B1-102860	33	P7172005.B1-102862	36	P7172005.B1-098000	35	P7172005.B1-098008	36	P7172005.B1-111930	47	P7172005.B1-111085	56
P7172006.B1-102860	33	P7172006.B1-102862	36	P7172006.B1-098000	35	P7172006.B1-098008	36	P7172006.B1-111930	47	P7172006.B1-111085	56
P7172008.B1-102860	33	P7172008.B1-102862	36	P7172008.B1-098000	35	P7172008.B1-098008	36	P7172008.B1-111930	47	P7172008.B1-111085	56
P7172009.B1-102860	33	P7172009.B1-102862	36	P7172009.B1-098000	35	P7172009.B1-098008	36	P7172009.B1-111930	47	P7172009.B1-111085	56
P7172010.B1-102860	33	P7172010.B1-102862	36	P7172010.B1-098000	35	P7172010.B1-098008	36	P7172010.B1-111930	47	P7172010.B1-111085	56
P7172011.B1-102860	33	P7172011.B1-102862	36	P7172011.B1-098000	35	P7172011.B1-098008	36	P7172011.B1-111930	47	P7172011.B1-111085	56
P7172012.B1-102860	33	P7172012.B1-102862	36	P7172012.B1-098000	35	P7172012.B1-098008	36	P7172012.B1-111930	47	P7172012.B1-111085	56
P7272012.B1-102860	33	P7272012.B1-102862	36	P7272012.B1-098000	35	P7272012.B1-098008	36	P7272012.B1-111930	47	P7272012.B1-111085	56
P7172013.B1-102860	33	P7172013.B1-102862	36	P7172013.B1-098000	35	P7172013.B1-098008	36	P7172013.B1-111930	47	P7172013.B1-111085	56
P7272013.B1-102860	33	P7272013.B1-102862	36	P7272013.B1-098000	35	P7272013.B1-098008	36	P7272013.B1-111930	47	P7272013.B1-111085	56
P7172014.B1-102860	33	P7172014.B1-102862	36	P7172014.B1-098000	35	P7172014.B1-098008	36	P7172014.B1-111930	47	P7172014.B1-111085	56
P7272014.B1-102860	33	P7272014.B1-102862	36	P7272014.B1-098000	35	P7272014.B1-098008	36	P7272014.B1-111930	47	P7272014.B1-111085	56
P7172015.B1-102860	33	P7172015.B1-102862	36	P7172015.B1-098000	35	P7172015.B1-098008	36	P7172015.B1-111930	47	P7172015.B1-111085	56
P7272015.B1-102860	33	P7272015.B1-102862	36	P7272015.B1-098000	35	P7272015.B1-098008	36	P7272015.B1-111930	47	P7272015.B1-111085	56
P7172016.B1-102860	33	P7172016.B1-102862	36	P7172016.B1-098000	35	P7172016.B1-098008	36	P7172016.B1-111930	47	P7172016.B1-111085	56
P7272016.B1-102860	33	P7272016.B1-102862	36	P7272016.B1-098000	35	P7272016.B1-098008	36	P7272016.B1-111930	47	P7272016.B1-111085	56
P7172017.B1-102860	33	P7172017.B1-102862	36	P7172017.B1-098000	35	P7172017.B1-098008	36	P7172017.B1-111930	47	P7172017.B1-111085	56
P7272017.B1-102860	33	P7272017.B1-102862	36	P7272017.B1-098000	35	P7272017.B1-098008	36	P7272017.B1-111930	47	P7272017.B1-111085	56
P7173001.B1-102860	34	P7173001.B1-102862	37	P7173001.B1-098000	36	P7173001.B1-098008	37	P7173001.B1-111930	48	P7173001.B1-111085	57
P7273001.B1-102860	34	P7273001.B1-102862	37	P7273001.B1-098000	36	P7273001.B1-098008	37	P7273001.B1-111930	48	P7273001.B1-111085	57
P7473001.B1-102860	46	P7473001.B1-102862	49	P7473001.B1-098000	48	P7473001.B1-098008	49	P7473001.B1-111930	60	P7473001.B1-111085	69
P7172018.B1-102860	33	P7172018.B1-102862	36	P7172018.B1-098000	35	P7172018.B1-098008	36	P7172018.B1-111930	47	P7172018.B1-111085	56
P7272018.B1-102860	33	P7272018.B1-110056	36	P7272018.B1-098000	35	P7272018.B1-098008	36	P7272018.B1-111930	47	P7272018.B1-111085	56
P7172019.B1-102860	33	P7172019.B1-102862	36	P7172019.B1-098000	35	P7172019.B1-098008	36	P7172019.B1-111930	47	P7172019.B1-111085	56
P7272019.B1-102860	33	P7272019.B1-102862	36	P7272019.B1-098000	35	P7272019.B1-098008	36	P7272019.B1-111930	47	P7272019.B1-111085	56
P7473002.B1-102860	46	P7473002.B1-102862	49	P7473002.B1-098000	48	P7473002.B1-098008	49	P7473002.B1-111930	60	P7473002.B1-111085	69
P7472016.B1-102860	45	P7472016.B1-102862	48	P7472016.B1-098000	47	P7472016.B1-098008	48	P7472016.B1-111930	59	P7472016.B1-111085	68
P7173003.B1-102860	34	P7173003.B1-102862	37	P7173003.B1-098000	36	P7173003.B1-098008	37	P7173003.B1-111930	48	P7173003.B1-111085	57
P7273003.B1-102860	34	P7273003.B1-102862	37	P7273003.B1-098000	36	P7273003.B1-098008	37	P7273003.B1-111930	48	P7273003.B1-111085	57
P7472017.B1-102860	45	P7472017.B1-102862	48	P7472017.B1-098000	47	P7472017.B1-098008	48	P7472017.B1-111930	59	P7472017.B1-111085	68

Gear+Motor™ catalog numbers are comprised of the reducer catalog number followed by the motor catalog number.

TABLE CONTINUES ON NEXT PAGE

IN THIS CATALOG

RPM = Revolutions Per Minute
HP = Horsepower
TQ = Torque (lb.-in.)
OHL = Overhung Load In Pounds At Centerline Of Output Shaft With No Thrust Load.
TL = Thrust Load (lbs.) - Output Shaft

SELECT REDUCER MOUNTING POSITION ON PAGE 60



QUICK SELECTIONS
DOUBLE AND TRIPLE REDUCTION



**700 Series
Motorized Quill Input
NEMA Frame Selections
1750 RPM Input**

This Quick Selection is only for motorized B1 base mount reducers and Gear+Motors™. For other reducer configurations, see the Maximum Rating Tables beginning on page 40.



1/2 HP Gear Reducer Quick Selections								
Output Speed (RPM)	Service Factor ▼	Output Torque (lb-in)	Overhung ● Load (lbs.)	Ratio	Number of Reductions	Weight ◆ (lbs.)	Motor Frame	Motorized B1 Base Mount Catalog No.
37	0.96	818	507	46.80	2	11	56C	P7172020.B1
37	1.30	818	674	46.80	2	11	56C	P7272020.B1
37	3.02	792	1028	47.22	3	24	56C	P7473003.B1
36	2.84	840	1028	49.00	2	23	56C	P7472018.B1
35	1.40	837	674	50.64	3	12	56C	P7273004.B1
35	1.28	864	674	50.67	2	11	56C	P7272021.B1
33	1.28	916	674	53.40	3	12	56C	P7273005.B1
32	2.62	916	1041	54.73	3	24	56C	P7473004.B1
31	2.50	945	1050	57.13	3	24	56C	P7473005.B1
29	2.08	1043	1050	60.90	2	23	56C	P7472019.B1
29	2.66	1043	1367	60.90	2	28	56C	P7572038.B1
29	1.16	1011	674	61.22	3	12	56C	P7273006.B1
28	1.10	1047	674	62.00	3	12	56C	P7273007.B1
26	2.16	1127	1075	66.22	3	24	56C	P7473006.B1
25	1.00	1172	674	70.95	3	12	56C	P7273008.B1
25	2.02	1172	1079	71.01	3	24	56C	P7473007.B1
23	1.86	1274	1091	76.69	3	24	56C	P7473008.B1
23	2.62	1274	1414	76.69	3	29	56C	P7573030.B1
21	1.74	1396	1096	82.30	3	24	56C	P7473009.B1
21	2.44	1396	1422	82.30	3	29	56C	P7573031.B1
19	1.54	1542	1102	92.78	3	24	56C	P7473011.B1
19	2.18	1542	1430	92.78	3	29	56C	P7573033.B1
17	1.36	1724	1112	104.68	3	24	56C	P7473012.B1
17	1.92	1724	1454	104.68	3	29	56C	P7573034.B1
15	1.22	1954	1124	117.22	3	24	56C	P7473013.B1
15	1.72	1954	1461	117.22	3	29	56C	P7573035.B1
14	1.12	2093	1130	126.65	3	24	56C	P7473014.B1
14	1.58	2093	1468	126.65	3	29	56C	P7573036.B1
13	1.06	2254	1136	135.74	3	24	56C	P7473015.B1
13	1.48	2254	1472	135.74	3	29	56C	P7573037.B1
12	0.98	2442	1150	145.68	3	24	56C	P7473016.B1
12	1.38	2442	1475	145.68	3	29	56C	P7573038.B1
11	1.28	2664	1492	157.40	3	29	56C	P7573039.B1
11	1.22	2664	1492	164.23	3	29	56C	P7573040.B1
9.4	1.10	3118	1498	185.29	3	29	56C	P7573041.B1
8.6	0.98	3408	1502	204.12	3	29	56C	P7573042.B1

- ◆ Weight does not include oil.
- ▼ Service Factor is based on maximum torque rating of reducer. Refer to page 171 for special application considerations.
- Overhung load is calculated at centerline of output shaft.

QUICK REFERENCE
OTHER REDUCER CONFIGURATIONS Page 38
OUTPUT FLANGE SELECTIONS 53
INTERCHANGE BASE SELECTIONS 54



QUICK SELECTIONS
DOUBLE AND TRIPLE REDUCTION



LeCentric™ Gear Reducers & GEAR+MOTORS™



1/2 HP		Gear+Motor™ Quick Selections									
TEFC, 3 Phase 230/460V		TEFC, 1 Phase 115/230V		DC SCR 90V		DC SCR 180V		Explosion-Proof, 3 Phase 230/460V		Explosion-Proof, 1 Phase 115/230V	
Catalog No.	Wgt.♦ (lbs.)	Catalog No.	Wgt.♦ (lbs.)	Catalog No.	Wgt.♦ (lbs.)	Catalog No.	Wgt.♦ (lbs.)	Catalog No.	Wgt.♦ (lbs.)	Catalog No.	Wgt.♦ (lbs.)
P7172020.B1-102860	33	P7172020.B1-102862	36	P7172020.B1-098000	35	P7172020.B1-098008	36	P7172020.B1-111930	47	P7172020.B1-111085	56
P7272020.B1-102860	33	P7272020.B1-102862	36	P7272020.B1-098000	35	P7272020.B1-098008	36	P7272020.B1-111930	47	P7272020.B1-111085	56
P7473003.B1-102860	46	P7473003.B1-102862	49	P7473003.B1-098000	48	P7473003.B1-098008	49	P7473003.B1-111930	60	P7473003.B1-111085	69
P7472018.B1-102860	45	P7472018.B1-102862	48	P7472018.B1-098000	47	P7472018.B1-098008	48	P7472018.B1-111930	59	P7472018.B1-111085	68
P7273004.B1-102860	34	P7273004.B1-102862	37	P7273004.B1-098000	36	P7273004.B1-098008	37	P7273004.B1-111930	48	P7273004.B1-111085	57
P7272021.B1-102860	33	P7272021.B1-102862	36	P7272021.B1-098000	35	P7272021.B1-098008	36	P7272021.B1-111930	47	P7272021.B1-111085	56
P7273005.B1-102860	34	P7273005.B1-102862	37	P7273005.B1-098000	36	P7273005.B1-098008	37	P7273005.B1-111930	48	P7273005.B1-111085	57
P7473004.B1-102860	46	P7473004.B1-102862	49	P7473004.B1-098000	48	P7473004.B1-098008	49	P7473004.B1-111930	60	P7473004.B1-111085	69
P7473005.B1-102860	46	P7473005.B1-102862	49	P7473005.B1-098000	48	P7473005.B1-098008	49	P7473005.B1-111930	60	P7473005.B1-111085	69
P7472019.B1-102860	45	P7472019.B1-102862	48	P7472019.B1-098000	47	P7472019.B1-098008	48	P7472019.B1-111930	59	P7472019.B1-111085	68
P7572038.B1-102860	50	P7572038.B1-102862	53	P7572038.B1-098000	52	P7572038.B1-098008	53	P7572038.B1-111930	64	P7572038.B1-111085	73
P7273006.B1-102860	34	P7273006.B1-102862	37	P7273006.B1-098000	36	P7273006.B1-098008	37	P7273006.B1-111930	48	P7273006.B1-111085	57
P7273007.B1-102860	34	P7273007.B1-102862	37	P7273007.B1-098000	36	P7273007.B1-098008	37	P7273007.B1-111930	48	P7273007.B1-111085	57
P7473006.B1-102860	46	P7473006.B1-102862	49	P7473006.B1-098000	48	P7473006.B1-098008	49	P7473006.B1-111930	60	P7473006.B1-111085	69
P7273008.B1-102860	34	P7273008.B1-102862	37	P7273008.B1-098000	36	P7273008.B1-098008	37	P7273008.B1-111930	48	P7273008.B1-111085	57
P7473007.B1-102860	46	P7473007.B1-102862	49	P7473007.B1-098000	48	P7473007.B1-098008	49	P7473007.B1-111930	60	P7473007.B1-111085	69
P7473008.B1-102860	46	P7473008.B1-102862	49	P7473008.B1-098000	48	P7473008.B1-098008	49	P7473008.B1-111930	60	P7473008.B1-111085	69
P7573030.B1-102860	51	P7573030.B1-102862	54	P7573030.B1-098000	53	P7573030.B1-098008	54	P7573030.B1-111930	65	P7573030.B1-111085	74
P7473009.B1-102860	46	P7473009.B1-102862	49	P7473009.B1-098000	48	P7473009.B1-098008	49	P7473009.B1-111930	60	P7473009.B1-111085	69
P7573031.B1-102860	51	P7573031.B1-102862	54	P7573031.B1-098000	53	P7573031.B1-098008	54	P7573031.B1-111930	65	P7573031.B1-111085	74
P7473011.B1-102860	46	P7473011.B1-102862	49	P7473011.B1-098000	48	P7473011.B1-098008	49	P7473011.B1-111930	60	P7473011.B1-111085	69
P7573033.B1-102860	51	P7573033.B1-102862	54	P7573033.B1-098000	53	P7573033.B1-098008	54	P7573033.B1-111930	65	P7573033.B1-111085	74
P7473012.B1-102860	46	P7473012.B1-102862	49	P7473012.B1-098000	48	P7473012.B1-098008	49	P7473012.B1-111930	60	P7473012.B1-111085	69
P7573034.B1-102860	51	P7573034.B1-102862	54	P7573034.B1-098000	53	P7573034.B1-098008	54	P7573034.B1-111930	65	P7573034.B1-111085	74
P7473013.B1-102860	46	P7473013.B1-102862	49	P7473013.B1-098000	48	P7473013.B1-098008	49	P7473013.B1-111930	60	P7473013.B1-111085	69
P7573035.B1-102860	51	P7573035.B1-102862	54	P7573035.B1-098000	53	P7573035.B1-098008	54	P7573035.B1-111930	65	P7573035.B1-111085	74
P7473014.B1-102860	46	P7473014.B1-102862	49	P7473014.B1-098000	48	P7473014.B1-098008	49	P7473014.B1-111930	60	P7473014.B1-111085	69
P7573036.B1-102860	51	P7573036.B1-102862	54	P7573036.B1-098000	53	P7573036.B1-098008	54	P7573036.B1-111930	65	P8573036.B1-111085	74
P7473015.B1-102860	46	P7473015.B1-102862	49	P7473015.B1-098000	48	P7473015.B1-098008	49	P7473015.B1-111930	60	P7473015.B1-111085	69
P7573037.B1-102860	51	P7573037.B1-102862	54	P7573037.B1-098000	53	P7573037.B1-098008	54	P7573037.B1-111930	65	P7573037.B1-111085	74
P7473016.B1-102860	46	P7473016.B1-102862	49	P7473016.B1-098000	48	P7473016.B1-098008	49	P7473016.B1-111930	60	P7473016.B1-111085	69
P7573038.B1-102860	51	P7573038.B1-102862	54	P7573038.B1-098000	53	P7573038.B1-098008	54	P7573038.B1-111930	65	P7573038.B1-111085	74
P7573039.B1-102860	51	P7573039.B1-102862	54	P7573039.B1-098000	53	P7573039.B1-098008	54	P7573039.B1-111930	65	P7573039.B1-111085	74
P7573040.B1-102860	51	P7573040.B1-102862	54	P7573040.B1-098000	53	P7573040.B1-098008	54	P7573040.B1-111930	65	P7573040.B1-111085	74
P7573041.B1-102860	51	P7573041.B1-102862	54	P7573041.B1-098000	53	P7573041.B1-098008	54	P7573041.B1-111930	65	P7573041.B1-111085	74
P7573042.B1-102860	51	P7573042.B1-102862	54	P7573042.B1-098000	53	P7573042.B1-098008	54	P7573042.B1-111930	65	P7573042.B1-111085	74

Gear+Motor™ catalog numbers are comprised of the reducer catalog number followed by the motor catalog number.

IN THIS CATALOG

- _____ RPM = Revolutions Per Minute
- _____ HP = Horsepower
- _____ TQ = Torque (lb-in.)
- _____ OHL = Overhung Load In Pounds At Centerline
Of Output Shaft With No Thrust Load.
- _____ TL = Thrust Load (lbs.) - Output Shaft

SELECT REDUCER MOUNTING POSITION ON PAGE 60



QUICK SELECTIONS
DOUBLE AND TRIPLE REDUCTION



**700 Series
Motorized Quill Input
NEMA Frame Selections
1750 RPM Input**

This Quick Selection is only for motorized B1 base mount reducers and Gear+Motors™. For other reducer configurations, see the Maximum Rating Tables beginning on page 40.



3/4 HP Gear Reducer Quick Selections								
Output Speed (RPM)	Service Factor ▼	Output Torque (lb-in)	Overhung ● Load (lbs.)	Ratio	Number of Reductions	Weight ♦ (lbs.)	Motor Frame	Motorized B1 Base Mount Catalog No.
503	6.69	90	204	3.48	2	11	56C	P7172001.B1
405	5.38	112	216	4.32	2	11	56C	P7172002.B1
318	4.21	143	230	5.50	2	11	56C	P7172003.B1
275	3.65	165	250	6.36	2	11	56C	P7172004.B1
241	3.20	188	260	7.26	2	11	56C	P7172005.B1
222	2.95	204	266	7.89	2	11	56C	P7172006.B1
174	3.07	261	284	10.04	2	11	56C	P7172008.B1
150	2.64	303	293	11.64	2	11	56C	P7172009.B1
150	3.93	303	445	11.64	2	11	56C	P7272009.B1
132	2.32	344	305	13.26	2	11	56C	P7172010.B1
132	3.47	344	476	13.26	2	11	56C	P7272010.B1
114	2.00	398	321	15.37	2	11	56C	P7172011.B1
114	2.99	398	508	15.37	2	11	56C	P7272011.B1
108	1.87	428	335	16.20	2	11	56C	P7172012.B1
108	2.71	428	520	16.20	2	11	56C	P7272012.B1
93	1.61	493	350	18.80	2	11	56C	P7172013.B1
93	2.33	493	535	18.80	2	11	56C	P7272013.B1
81	1.43	560	374	21.54	2	11	56C	P7172014.B1
81	2.13	560	562	21.54	2	11	56C	P7272014.B1
79	1.39	574	375	22.26	2	11	56C	P7172015.B1
79	2.07	574	562	22.26	2	11	56C	P7272015.B1
70	3.55	628	877	24.98	2	23	56C	P7472013.B1
67	1.15	698	420	26.30	2	11	56C	P7172016.B1
67	1.67	698	615	26.30	2	11	56C	P7272016.B1
60	1.05	756	435	29.40	2	11	56C	P7172017.B1
60	1.56	756	629	29.40	2	11	56C	P7272017.B1
60	3.31	756	900	29.41	2	23	56C	P7472014.B1
52	1.41	845	645	33.50	3	12	56C	P7273001.B1
52	2.80	845	918	34.01	3	24	56C	P7473001.B1
49	2.70	926	922	35.58	2	23	56C	P7472015.B1
49	1.23	945	660	35.90	2	11	56C	P7272018.B1
46	1.13	986	663	38.37	2	11	56C	P7272019.B1
46	1.16	956	663	38.34	3	12	56C	P7273002.B1
44	2.40	999	988	39.79	3	24	56C	P7473002.B1
43	2.29	1055	988	40.50	2	23	56C	P7472016.B1

- ♦ Weight does not include oil.
- ▼ Service Factor is based on maximum torque rating of reducer. Refer to page 171 for special application considerations.
- Overhung load is calculated at centerline of output shaft.

QUICK REFERENCE	
OTHER REDUCER CONFIGURATIONS	Page 38
OUTPUT FLANGE SELECTIONS	53
INTERCHANGE BASE SELECTIONS	54



QUICK SELECTIONS
DOUBLE AND TRIPLE REDUCTION



LeCentric™ Gear Reducers & GEAR+MOTORS™



3/4 HP		Gear+Motor™ Quick Selections									
TEFC, 3 Phase 230/460V		TEFC, 1 Phase 115/230V		DC SCR 90V		DC SCR 180V		Explosion-Proof, 3 Phase 230/460V		Explosion-Proof, 1 Phase 115/230V	
Catalog No.	Wgt.♦ (lbs.)	Catalog No.	Wgt.♦ (lbs.)	Catalog No.	Wgt.♦ (lbs.)	Catalog No.	Wgt.♦ (lbs.)	Catalog No.	Wgt.♦ (lbs.)	Catalog No.	Wgt.♦ (lbs.)
P7172001.B1-110047	36	P7172001.B1-110057	39	P7172001.B1-098032	38	P7172001.B1-098069	38	P7172001.B1-111935	55	P7172001.B1-111086	61
P7172002.B1-110047	36	P7172002.B1-110057	39	P7172002.B1-098032	38	P7172002.B1-098069	38	P7172002.B1-111935	55	P7172002.B1-111086	61
P7172003.B1-110047	36	P7172003.B1-110057	39	P7172003.B1-098032	38	P7172003.B1-098069	38	P7172003.B1-111935	55	P7172003.B1-111086	61
P7172004.B1-110047	36	P7172004.B1-110057	39	P7172004.B1-098032	38	P7172004.B1-098069	38	P7172004.B1-111935	55	P7172004.B1-111086	61
P7172005.B1-110047	36	P7172005.B1-110057	39	P7172005.B1-098032	38	P7172005.B1-098069	38	P7172005.B1-111935	55	P7172005.B1-111086	61
P7172006.B1-110047	36	P7172006.B1-110057	39	P7172006.B1-098032	38	P7172006.B1-098069	38	P7172006.B1-111935	55	P7172006.B1-111086	61
P7172008.B1-110047	36	P7172008.B1-110057	39	P7172008.B1-098032	38	P7172008.B1-098069	38	P7172008.B1-111935	55	P7172008.B1-111086	61
P7172009.B1-110047	36	P7172009.B1-110057	39	P7172009.B1-098032	38	P7172009.B1-098069	38	P7172009.B1-111935	55	P7172009.B1-111086	61
P7272009.B1-110047	36	P7272009.B1-110057	39	P7272009.B1-098032	38	P7272009.B1-098069	38	P7272009.B1-111935	55	P7272009.B1-111086	61
P7172010.B1-110047	36	P7172010.B1-110057	39	P7172010.B1-098032	38	P7172010.B1-098069	38	P7172010.B1-111935	55	P7172010.B1-111086	61
P7272010.B1-110047	36	P7272010.B1-110057	39	P7272010.B1-098032	38	P7272010.B1-098069	38	P7272010.B1-111935	55	P7272010.B1-111086	61
P7172011.B1-110047	36	P7172011.B1-110057	39	P7172011.B1-098032	38	P7172011.B1-098069	38	P7172011.B1-111935	55	P7172011.B1-111086	61
P7272011.B1-110047	36	P7272011.B1-110057	39	P7272011.B1-098032	38	P7272011.B1-098069	38	P7272011.B1-111935	55	P7272011.B1-111086	61
P7172012.B1-110047	36	P7172012.B1-110057	39	P7172012.B1-098032	38	P7172012.B1-098069	38	P7172012.B1-111935	55	P7172012.B1-111086	61
P7272012.B1-110047	36	P7272012.B1-110057	39	P7272012.B1-098032	38	P7272012.B1-098069	38	P7272012.B1-111935	55	P7272012.B1-111086	61
P7172013.B1-110047	36	P7172013.B1-110057	39	P7172013.B1-098032	38	P7172013.B1-098069	38	P7172013.B1-111935	55	P7172013.B1-111086	61
P7272013.B1-110047	36	P7272013.B1-110057	39	P7272013.B1-098032	38	P7272013.B1-098069	38	P7272013.B1-111935	55	P7272013.B1-111086	61
P7172014.B1-110047	36	P7172014.B1-110057	39	P7172014.B1-098032	38	P7172014.B1-098069	38	P7172014.B1-111935	55	P7172014.B1-111086	61
P7272014.B1-110047	36	P7272014.B1-110057	39	P7272014.B1-098032	38	P7272014.B1-098069	38	P7272014.B1-111935	55	P7272014.B1-111086	61
P7172015.B1-110047	36	P7172015.B1-110057	39	P7172015.B1-098032	38	P7172015.B1-098069	38	P7172015.B1-111935	55	P7172015.B1-111086	61
P7272015.B1-110047	36	P7272015.B1-110057	39	P7272015.B1-098032	38	P7272015.B1-098069	38	P7272015.B1-111935	55	P7272015.B1-111086	61
P7472013.B1-110047	48	P7472013.B1-110057	51	P7472013.B1-098032	50	P7472013.B1-098069	50	P7472013.B1-111935	67	P7472013.B1-111086	73
P7172016.B1-110047	36	P7172016.B1-110057	39	P7172016.B1-098032	38	P7172016.B1-098069	38	P7172016.B1-111935	55	P7172016.B1-111086	61
P7272016.B1-110047	36	P7272016.B1-110057	39	P7272016.B1-098032	38	P7272016.B1-098069	38	P7272016.B1-111935	55	P7272016.B1-111086	61
P7172017.B1-110047	36	P7172017.B1-110057	39	P7172017.B1-098032	38	P7172017.B1-098069	38	P7172017.B1-111935	55	P7172017.B1-111086	61
P7272017.B1-110047	36	P7272017.B1-110057	39	P7272017.B1-098032	38	P7272017.B1-098069	38	P7272017.B1-111935	55	P7272017.B1-111086	61
P7472014.B1-110047	48	P7472014.B1-110057	51	P7472014.B1-098032	50	P7472014.B1-098069	50	P7472014.B1-111935	67	P7472014.B1-111086	73
P7273001.B1-110047	37	P7273001.B1-110057	40	P7273001.B1-098032	39	P7273001.B1-098069	39	P7273001.B1-111935	56	P7273001.B1-111086	62
P7473001.B1-110047	49	P7473001.B1-110057	52	P7473001.B1-098032	51	P7473001.B1-098069	51	P7473001.B1-111935	68	P7473001.B1-111086	74
P7472015.B1-110047	48	P7472015.B1-110057	51	P7472015.B1-098032	50	P7472015.B1-098069	50	P7472015.B1-111935	67	P7472015.B1-111086	73
P7272018.B1-110047	36	P7272018.B1-110057	39	P7272018.B1-098032	38	P7272018.B1-098069	38	P7272018.B1-111935	55	P7272018.B1-111086	61
P7272019.B1-110047	36	P7272019.B1-110057	39	P7272019.B1-098032	38	P7272019.B1-098069	38	P7272019.B1-111935	55	P7272019.B1-111086	61
P7273002.B1-110047	37	P7273002.B1-110057	40	P7273002.B1-098032	39	P7273002.B1-098069	39	P7273002.B1-111935	56	P7273002.B1-111086	62
P7473002.B1-110047	49	P7473002.B1-110057	52	P7473002.B1-098032	51	P7473002.B1-098069	51	P7473002.B1-111935	68	P7473002.B1-111086	74
P7472016.B1-110047	48	P7472016.B1-110057	51	P7472016.B1-098032	50	P7472016.B1-098069	50	P7472016.B1-111935	67	P7472016.B1-111086	73

Gear+Motor™ catalog numbers are comprised of the reducer catalog number followed by the motor catalog number.

TABLE CONTINUES ON NEXT PAGE

IN THIS CATALOG

RPM = Revolutions Per Minute
HP = Horsepower
TQ = Torque (lb-in.)
OHL = Overhung Load In Pounds At Centerline Of Output Shaft With No Thrust Load.
TL = Thrust Load (lbs.) - Output Shaft

SELECT REDUCER MOUNTING POSITION ON PAGE 60

LeCentric™ Gear Reducers & GEAR+MOTORS™



QUICK SELECTIONS
DOUBLE AND TRIPLE REDUCTION



**700 Series
Motorized Quill Input
NEMA Frame Selections
1750 RPM Input**

This Quick Selection is only for motorized B1 base mount reducers and Gear+Motors™. For other reducer configurations, see the Maximum Rating Tables beginning on page 40.



3/4 HP Gear Reducer Quick Selections

Output Speed (RPM)	Service Factor ▼	Output Torque (lb-in)	Overhung ● Load (lbs.)	Ratio	Number of Reductions	Weight ◆ (lbs.)	Motor Frame	Motorized B1 Base Mount Catalog No.
40	1.08	1099	674	43.69	3	12	56C	P7273003.B1
40	2.00	1134	1012	44.23	2	23	56C	P7472017.B1
40	2.44	1134	1304	44.23	2	28	56C	P7572036.B1
37	2.01	1188	1028	47.22	3	24	56C	P7473003.B1
36	1.89	1261	1028	49.00	2	23	56C	P7472018.B1
36	2.19	1261	1330	49.00	2	28	56C	P7572037.B1
32	1.75	1374	1041	54.73	3	24	56C	P7473004.B1
32	2.45	1374	1354	54.73	3	29	56C	P7573026.B1
31	1.67	1418	1050	57.13	3	24	56C	P7473005.B1
31	2.35	1418	1354	57.13	3	29	56C	P7573027.B1
29	1.39	1565	1050	60.90	2	23	56C	P7472019.B1
29	1.77	1565	1367	60.90	2	28	56C	P7572038.B1
26	1.44	1691	1075	66.22	3	24	56C	P7473006.B1
26	2.03	1691	1519	66.22	3	29	56C	P7573028.B1
25	1.35	1758	1079	71.01	3	24	56C	P7473007.B1
25	1.89	1758	1398	71.01	3	29	56C	P7573029.B1
23	1.24	1911	1091	76.69	3	24	56C	P7473008.B1
23	1.75	1911	1414	76.69	3	29	56C	P7573030.B1
21	1.16	2093	1091	82.30	3	24	56C	P7473009.B1
21	1.63	2093	1422	82.30	3	29	56C	P7573031.B1
21	1.15	2093	1091	83.59	3	24	56C	P7473010.B1
19	1.03	2314	1102	92.78	3	24	56C	P7473011.B1
19	1.45	2314	1430	92.78	3	29	56C	P7573033.B1
17	1.28	2586	1454	104.68	3	29	56C	P7573034.B1
15	1.15	2931	1461	117.22	3	29	56C	P7573035.B1
14	1.05	3140	1468	126.65	3	29	56C	P7573036.B1
13	0.99	3382	1472	135.74	3	29	56C	P7573037.B1

- ◆ Weight does not include oil.
- ▼ Service Factor is based on maximum torque rating of reducer. Refer to page 171 for special application considerations.
- Overhung load is calculated at centerline of output shaft.

QUICK REFERENCE	
OTHER REDUCER CONFIGURATIONS	Page 38
OUTPUT FLANGE SELECTIONS	53
INTERCHANGE BASE SELECTIONS	54



QUICK SELECTIONS
DOUBLE AND TRIPLE REDUCTION



LeCentric™ Gear Reducers & GEAR+MOTORS™



3/4 HP Gear+Motor™ Quick Selections											
TEFC, 3 Phase 230/460V		TEFC, 1 Phase 115/230V		DC SCR 90V		DC SCR 180V		Explosion-Proof, 3 Phase 230/460V		Explosion-Proof, 1 Phase 115/230V	
Catalog No.	Wgt.♦ (lbs.)	Catalog No.	Wgt.♦ (lbs.)	Catalog No.	Wgt.♦ (lbs.)	Catalog No.	Wgt.♦ (lbs.)	Catalog No.	Wgt.♦ (lbs.)	Catalog No.	Wgt.♦ (lbs.)
P7273003.B1-110047	37	P7273003.B1-110057	40	P7273003.B1-098032	39	P7273003.B1-098069	39	P7273003.B1-111935	56	P7273003.B1-111086	62
P7472017.B1-110047	48	P7472017.B1-110057	51	P7472017.B1-098032	50	P7472017.B1-098069	50	P7472017.B1-111935	67	P7472017.B1-111086	73
P7572036.B1-110047	53	P7572036.B1-110057	56	P7572036.B1-098032	55	P7572036.B1-098069	55	P7572036.B1-111935	72	P7572036.B1-111086	78
P7473003.B1-110047	49	P7473003.B1-110057	52	P7473003.B1-098032	51	P7473003.B1-098069	51	P7473003.B1-111935	68	P7473003.B1-111086	74
P7472018.B1-110047	48	P7472018.B1-110057	51	P7472018.B1-098032	50	P7472018.B1-098069	50	P7472018.B1-111935	67	P7472018.B1-111086	73
P7572037.B1-110047	53	P7572037.B1-110057	56	P7572037.B1-098032	55	P7572037.B1-098069	55	P7572037.B1-111935	72	P7572037.B1-111086	78
P7473004.B1-110047	49	P7473004.B1-110057	52	P7473004.B1-098032	51	P7473004.B1-098069	51	P7473004.B1-111935	68	P7473004.B1-111086	74
P7573026.B1-110047	54	P7573026.B1-110057	57	P7573026.B1-098032	56	P7573026.B1-098069	56	P7573026.B1-111935	73	P7573026.B1-111086	79
P7473005.B1-110047	49	P7473005.B1-110057	52	P7473005.B1-098032	51	P7473005.B1-098069	51	P7473005.B1-111935	68	P7473005.B1-111086	74
P7573027.B1-110047	54	P7573027.B1-110057	57	P7573027.B1-098032	56	P7573027.B1-098069	56	P7573027.B1-111935	73	P7573027.B1-111086	79
P7472019.B1-110047	48	P7472019.B1-110057	51	P7472019.B1-098032	50	P7472019.B1-098069	50	P7472019.B1-111935	67	P7472019.B1-111086	73
P7572038.B1-110047	53	P7572038.B1-110057	56	P7572038.B1-098032	55	P7572038.B1-098069	55	P7572038.B1-111935	72	P7572038.B1-111086	78
P7473006.B1-110047	49	P7473006.B1-110057	52	P7473006.B1-098032	51	P7473006.B1-098069	51	P7473006.B1-111935	68	P7473006.B1-111086	74
P7573028.B1-110047	54	P7573028.B1-110057	57	P7573028.B1-098032	56	P7573028.B1-098069	56	P7573028.B1-111935	73	P7573028.B1-111086	79
P7473007.B1-110047	49	P7473007.B1-110057	52	P7473007.B1-098032	51	P7473007.B1-098069	51	P7473007.B1-111935	68	P7473007.B1-111086	74
P7573029.B1-110047	54	P7573029.B1-110057	57	P7573029.B1-098032	56	P7573029.B1-098069	56	P7573029.B1-111935	73	P7573029.B1-111086	79
P7473008.B1-110047	49	P7473008.B1-110057	52	P7473008.B1-098032	51	P7473008.B1-098069	51	P7473008.B1-111935	68	P7473008.B1-111086	74
P7573030.B1-110047	54	P7573030.B1-110057	57	P7573030.B1-098032	56	P7573030.B1-098069	56	P7573030.B1-111935	73	P7573030.B1-111086	79
P7473009.B1-110047	49	P7473009.B1-110057	52	P7473009.B1-098032	51	P7473009.B1-098069	51	P7473009.B1-111935	68	P7473009.B1-111086	74
P7573031.B1-110047	54	P7573031.B1-110057	57	P7573031.B1-098032	56	P7573031.B1-098069	56	P7573031.B1-111935	73	P7573031.B1-111086	79
P7473010.B1-110047	49	P7473010.B1-110057	52	P7473010.B1-098032	51	P7473010.B1-098069	51	P7473010.B1-111935	68	P7473010.B1-111086	74
P7473011.B1-110047	49	P7473011.B1-110057	52	P7473011.B1-098032	51	P7473011.B1-098069	51	P7473011.B1-111935	68	P7473011.B1-111086	74
P7573033.B1-110047	54	P7573033.B1-110057	57	P7573033.B1-098032	56	P7573033.B1-098069	56	P7573033.B1-111935	73	P7573033.B1-111086	79
P7573034.B1-110047	54	P7573034.B1-110057	57	P7573034.B1-098032	56	P7573034.B1-098069	56	P7573034.B1-111935	73	P7573034.B1-111086	79
P7573035.B1-110047	54	P7573035.B1-110057	57	P7573035.B1-098032	56	P7573035.B1-098069	56	P7573035.B1-111935	73	P7573035.B1-111086	79
P7573036.B1-110047	54	P7573036.B1-110057	57	P7573036.B1-098032	56	P7573036.B1-098069	56	P7573036.B1-111935	73	P7573036.B1-111086	79
P7573037.B1-110047	54	P7573037.B1-110057	57	P7573037.B1-098032	56	P7573037.B1-098069	56	P7573037.B1-111935	73	P7573037.B1-111086	79

Gear+Motor™ catalog numbers are comprised of the reducer catalog number followed by the motor catalog number.

IN THIS CATALOG

RPM = Revolutions Per Minute
HP = Horsepower
TQ = Torque (lb-in.)
OHL = Overhung Load In Pounds At Centerline Of Output Shaft With No Thrust Load.
TL = Thrust Load (lbs.) - Output Shaft

SELECT REDUCER MOUNTING POSITION ON PAGE 60



QUICK SELECTIONS
DOUBLE AND TRIPLE REDUCTION



**700 Series
Motorized Quill Input
NEMA Frame Selections
1750 RPM Input**

This Quick Selection is only for motorized B1 base mount reducers and Gear+Motors™. For other reducer configurations, see the Maximum Rating Tables beginning on page 40.



1 HP Gear Reducer Quick Selections								
Output Speed (RPM)	Service Factor ▼	Output Torque (lb-in)	Overhung Load (lbs.) ●	Ratio	Number of Reductions	Weight ♦ (lbs.)	Motor Frame	Motorized B1 Base Mount Catalog No.
503	5.02	120	204	3.48	2	11	56C	P7172001.B1
405	4.04	149	216	4.32	2	11	56C	P7172002.B1
318	3.17	190	230	5.50	2	11	56C	P7172003.B1
275	2.73	220	250	6.36	2	11	56C	P7172004.B1
275	2.73	220	376	6.36	2	11	56C	P7272004.B1
241	2.40	251	260	7.26	2	11	56C	P7172005.B1
241	4.24	251	391	7.26	2	11	56C	P7272005.B1
222	2.21	273	266	7.89	2	11	56C	P7172006.B1
222	3.70	273	400	7.89	2	11	56C	P7272006.B1
174	2.30	348	284	10.04	2	11	56C	P7172008.B1
174	3.42	348	420	10.04	2	11	56C	P7272008.B1
150	1.98	403	293	11.64	2	11	56C	P7172009.B1
150	2.95	403	445	11.64	2	11	56C	P7272009.B1
132	1.74	458	305	13.26	2	11	56C	P7172010.B1
132	2.60	458	474	13.26	2	11	56C	P7272010.B1
114	1.50	531	321	15.37	2	11	56C	P7172011.B1
114	2.24	531	510	15.37	2	11	56C	P7272011.B1
108	1.40	571	335	16.20	2	11	56C	P7172012.B1
108	2.03	571	520	16.20	2	11	56C	P7272012.B1
105	4.36	576	711	16.62	2	23	56C	P7472011.B1
93	1.21	658	350	18.80	2	11	56C	P7172013.B1
93	1.75	658	535	18.80	2	11	56C	P7272013.B1
87	3.60	695	780	20.10	2	23	56C	P7472012.B1
81	1.07	747	374	21.54	2	11	56C	P7172014.B1
81	1.60	747	562	21.54	2	11	56C	P7272014.B1
79	1.04	766	375	22.26	2	11	56C	P7172015.B1
79	1.55	766	562	22.26	2	11	56C	P7272015.B1
70	2.66	864	877	24.98	2	23	56C	P7472013.B1
67	1.25	931	615	26.30	2	11	56C	P7272016.B1
60	1.17	1008	629	29.40	2	11	56C	P7272017.B1
60	2.48	1008	900	29.41	2	23	56C	P7472014.B1

- ♦ Weight does not include oil.
- ▼ Service Factor is based on maximum torque rating of reducer. Refer to page 171 for special application considerations.
- Overhung load is calculated at centerline of output shaft.

QUICK REFERENCE
OTHER REDUCER CONFIGURATIONS Page 38
OUTPUT FLANGE SELECTIONS 53
INTERCHANGE BASE SELECTIONS 54



QUICK SELECTIONS
DOUBLE AND TRIPLE REDUCTION



LeCentric™ Gear Reducers & GEAR+MOTORS™



1 HP Gear+Motor™ Quick Selections											
TEFC, 3 Phase 230/460V		TEFC, 1 Phase 115/230V		DC SCR 90V		DC SCR 180V		Explosion-Proof, 3 Phase 230/460V		Explosion-Proof, 1 Phase 115/230V	
Catalog No.	Wgt.♦ (lbs.)	Catalog No.	Wgt.♦ (lbs.)	Catalog No.	Wgt.♦ (lbs.)	Catalog No.	Wgt.♦ (lbs.)	Catalog No.	Wgt.♦ (lbs.)	Catalog No.	Wgt.♦ (lbs.)
P7172001.B1-110048	39	P7172001.B1-110058	43	P7172001.B1-108022	51	P7172001.B1-108023	51	P7172001.B1-111926	57	P7172001.B1-110852	64
P7172002.B1-110048	39	P7172002.B1-110058	43	P7172002.B1-108022	51	P7172002.B1-108023	51	P7172002.B1-111926	57	P7172002.B1-110852	64
P7172003.B1-110048	39	P7172003.B1-110058	43	P7172003.B1-108022	51	P7172003.B1-108023	51	P7172003.B1-111926	57	P7172003.B1-110852	64
P7172004.B1-110048	39	P7172004.B1-110058	43	P7172004.B1-108022	51	P7172004.B1-108023	51	P7172004.B1-111926	57	P7172004.B1-110852	64
P7272004.B1-110048	39	P7272004.B1-110058	43	P7272004.B1-108022	51	P7272004.B1-108023	51	P7272004.B1-111926	57	P7272004.B1-110852	64
P7172005.B1-110048	39	P7172005.B1-110058	43	P7172005.B1-108022	51	P7172005.B1-108023	51	P7172005.B1-111926	57	P7172005.B1-110852	64
P7272005.B1-110048	39	P7272005.B1-110058	43	P7272005.B1-108022	51	P7272005.B1-108023	51	P7272005.B1-111926	57	P7272005.B1-110852	64
P7172006.B1-110048	39	P7172006.B1-110058	43	P7172006.B1-108022	51	P7172006.B1-108023	51	P7172006.B1-111926	57	P7172006.B1-110852	64
P7272006.B1-110048	39	P7272006.B1-110058	43	P7272006.B1-108022	51	P7272006.B1-108023	51	P7272006.B1-111926	57	P7272006.B1-110852	64
P7172008.B1-110048	39	P7172008.B1-110058	43	P7172008.B1-108022	51	P7172008.B1-108023	51	P7172008.B1-111926	57	P7172008.B1-110852	64
P7272008.B1-110048	39	P7272008.B1-110058	43	P7272008.B1-108022	51	P7272008.B1-108023	51	P7272008.B1-111926	57	P7272008.B1-110852	64
P7172009.B1-110048	39	P7172009.B1-110058	43	P7172009.B1-108022	51	P7172009.B1-108023	51	P7172009.B1-111926	57	P7172009.B1-110852	64
P7272009.B1-110048	39	P7272009.B1-110058	43	P7272009.B1-108022	51	P7272009.B1-108023	51	P7272009.B1-111926	57	P7272009.B1-110852	64
P7172010.B1-110048	39	P7172010.B1-110058	43	P7172010.B1-108022	51	P7172010.B1-108023	51	P7172010.B1-111926	57	P7172010.B1-110852	64
P7272010.B1-110048	39	P7272010.B1-110058	43	P7272010.B1-108022	51	P7272010.B1-108023	51	P7272010.B1-111926	57	P7272010.B1-110852	64
P7172011.B1-110048	39	P7172011.B1-110058	43	P7172011.B1-108022	51	P7172011.B1-108023	51	P7172011.B1-111926	57	P7172011.B1-110852	64
P7272011.B1-110048	39	P7272011.B1-110058	43	P7272011.B1-108022	51	P7272011.B1-108023	51	P7272011.B1-111926	57	P7272011.B1-110852	64
P7172012.B1-110048	39	P7172012.B1-110058	43	P7172012.B1-108022	51	P7172012.B1-108023	51	P7172012.B1-111926	57	P7172012.B1-110852	64
P7272012.B1-110048	39	P7272012.B1-110058	43	P7272012.B1-108022	51	P7272012.B1-108023	51	P7272012.B1-111926	57	P7272012.B1-110852	64
P7472011.B1-110048	51	P7472011.B1-110058	55	P7472011.B1-108022	63	P7472011.B1-108023	63	P7472011.B1-111926	69	P7472011.B1-110852	76
P7172013.B1-110048	39	P7172013.B1-110058	43	P7172013.B1-108022	51	P7172013.B1-108023	51	P7172013.B1-111926	57	P7172013.B1-110852	64
P7272013.B1-110048	39	P7272013.B1-110058	43	P7272013.B1-108022	51	P7272013.B1-108023	51	P7272013.B1-111926	57	P7272013.B1-110852	64
P7472012.B1-110048	51	P7472012.B1-110058	55	P7472012.B1-108022	63	P7472012.B1-108023	63	P7472012.B1-111926	69	P7472012.B1-110852	76
P7172014.B1-110048	39	P7172014.B1-110058	43	P7172014.B1-108022	51	P7172014.B1-108023	51	P7172014.B1-111926	57	P7172014.B1-110852	64
P7272014.B1-110048	39	P7272014.B1-110058	43	P7272014.B1-108022	51	P7272014.B1-108023	51	P7272014.B1-111926	57	P7272014.B1-110852	64
P7172015.B1-110048	39	P7172015.B1-110058	43	P7172015.B1-108022	51	P7172015.B1-108023	51	P7172015.B1-111926	57	P7172015.B1-110852	64
P7272015.B1-110048	39	P7272015.B1-110058	43	P7272015.B1-108022	51	P7272015.B1-108023	51	P7272015.B1-111926	57	P7272015.B1-110852	64
P7472013.B1-110048	51	P7472013.B1-110058	55	P7472013.B1-108022	63	P7472013.B1-108023	63	P7472013.B1-111926	69	P7472013.B1-110852	76
P7272016.B1-110048	39	P7272016.B1-110058	43	P7272016.B1-108022	51	P7272016.B1-108023	51	P7272016.B1-111926	57	P7272016.B1-110852	64
P7272017.B1-110048	39	P7272017.B1-110058	43	P7272017.B1-108022	51	P7272017.B1-108023	51	P7272017.B1-111926	57	P7272017.B1-110852	64
P7472014.B1-110048	51	P7472014.B1-110058	55	P7472014.B1-108022	63	P7472014.B1-108023	63	P7472014.B1-111926	69	P7472014.B1-110852	76

Gear+Motor™ catalog numbers are comprised of the reducer catalog number followed by the motor catalog number.

TABLE CONTINUES ON NEXT PAGE

IN THIS CATALOG

RPM = Revolutions Per Minute
HP = Horsepower
TQ = Torque (lb-in.)
OHL = Overhung Load In Pounds At Centerline Of Output Shaft With No Thrust Load.
TL = Thrust Load (lbs.) - Output Shaft

SELECT REDUCER MOUNTING POSITION ON PAGE 60



QUICK SELECTIONS
DOUBLE AND TRIPLE REDUCTION



**700 Series
Motorized Quill Input
NEMA Frame Selections
1750 RPM Input**

This Quick Selection is only for motorized B1 base mount reducers and Gear+Motors™. For other reducer configurations, see the Maximum Rating Tables beginning on page 40.



1 HP Gear Reducer Quick Selections								
Output Speed (RPM)	Service Factor ▼	Output Torque (lb-in)	Overhung ● Load (lbs.)	Ratio	Number of Reductions	Weight ◆ (lbs.)	Motor Frame	Motorized B1 Base Mount Catalog No.
52	1.06	1127	645	33.50	3	12	56C	P7273001.B1
52	2.10	1127	918	34.01	3	24	56C	P7473001.B1
52	2.96	1127	1060	34.01	3	29	56C	P7573023.B1
49	2.03	1235	922	35.58	2	23	56C	P7472015.B1
49	2.43	1235	1079	35.58	2	28	56C	P7572034.B1
44	1.80	1332	988	39.79	3	24	56C	P7473002.B1
44	2.53	1332	1192	39.79	3	29	56C	P7573024.B1
43	1.72	1407	988	40.50	2	23	56C	P7472016.B1
43	1.82	1407	1192	40.50	2	28	56C	P7572035.B1
40	1.50	1513	1012	44.23	2	23	56C	P7472017.B1
40	1.83	1513	1304	44.23	2	28	56C	P7572036.B1
37	1.51	1584	1028	47.22	3	24	56C	P7473003.B1
37	2.13	1584	1323	47.22	3	29	56C	P7573025.B1
36	1.42	1681	1028	49.00	2	23	56C	P7472018.B1
36	1.64	1681	1330	49.00	2	28	56C	P7572037.B1
32	1.31	1832	1041	54.73	3	24	56C	P7473004.B1
32	1.84	1832	1354	54.73	3	29	56C	P7573026.B1
31	1.25	1891	1050	57.13	3	24	56C	P7473005.B1
31	1.76	1891	1354	57.13	3	29	56C	P7573027.B1
29	1.04	2086	1050	60.90	2	23	56C	P7472019.B1
29	1.33	2086	1367	60.90	2	28	56C	P7572038.B1
26	1.08	2254	1075	66.22	3	24	56C	P7473006.B1
26	1.52	2254	1398	66.22	3	29	56C	P7573028.B1
25	1.01	2345	1079	71.01	3	24	56C	P7473007.B1
25	1.42	2345	1398	71.01	3	29	56C	P7573029.B1
23	1.31	2548	1414	76.69	3	29	56C	P7573030.B1
21	1.22	2791	1422	82.30	3	29	56C	P7573031.B1
21	1.20	2791	1422	83.59	3	29	56C	P7573032.B1
19	1.09	3085	1430	92.78	3	29	56C	P7573033.B1
17	0.96	3448	1454	104.68	3	29	56C	P7573034.B1

- ◆ Weight does not include oil.
- ▼ Service Factor is based on maximum torque rating of reducer. Refer to page 171 for special application considerations.
- Overhung load is calculated at centerline of output shaft.

QUICK REFERENCE	
OTHER REDUCER CONFIGURATIONS	Page 38
OUTPUT FLANGE SELECTIONS	53
INTERCHANGE BASE SELECTIONS	54



QUICK SELECTIONS
DOUBLE AND TRIPLE REDUCTION



LeCentric™ Gear Reducers & GEAR+MOTORS™



1 HP Gear+Motor™ Quick Selections											
TEFC, 3 Phase 230/460V		TEFC, 1 Phase 115/230V		DC SCR 90V		DC SCR 180V		Explosion-Proof, 3 Phase 230/460V		Explosion-Proof, 1 Phase 115/230V	
Catalog No.	Wgt. (lbs.)	Catalog No.	Wgt. (lbs.)	Catalog No.	Wgt. (lbs.)	Catalog No.	Wgt. (lbs.)	Catalog No.	Wgt. (lbs.)	Catalog No.	Wgt. (lbs.)
P7273001.B1-110048	40	P7273001.B1-110058	44	P7273001.B1-108022	52	P7273001.B1-108023	52	P7273001.B1-111926	58	P7273001.B1-110852	65
P7473001.B1-110048	52	P7473001.B1-110058	56	P7473001.B1-108022	64	P7473001.B1-108023	64	P7473001.B1-111926	70	P7473001.B1-110852	77
P7573023.B1-110048	57	P7573023.B1-110058	61	P7573023.B1-108022	69	P7573023.B1-108023	69	P7573023.B1-111926	75	P7573023.B1-110852	82
P7472015.B1-110048	51	P7472015.B1-110058	55	P7472015.B1-108022	63	P7472015.B1-108023	63	P7472015.B1-111926	69	P7472015.B1-110852	76
P7572034.B1-110048	56	P7572034.B1-110058	60	P7572034.B1-108022	68	P7572034.B1-108023	68	P7572034.B1-111926	74	P7572034.B1-110852	81
P7473002.B1-110048	52	P7473002.B1-110058	56	P7473002.B1-108022	64	P7473002.B1-108023	64	P7473002.B1-111926	70	P7473002.B1-110852	77
P7573024.B1-110048	57	P7573024.B1-110058	61	P7573024.B1-108022	69	P7573024.B1-108023	69	P7573024.B1-111926	75	P7573024.B1-110852	82
P7472016.B1-110048	51	P7472016.B1-110058	55	P7472016.B1-108022	63	P7472016.B1-108023	63	P7472016.B1-111926	69	P7472016.B1-110852	76
P7572035.B1-110048	56	P7572035.B1-110058	60	P7572035.B1-108022	68	P7572035.B1-108023	68	P7572035.B1-111926	74	P7572035.B1-110852	81
P7472017.B1-110048	51	P7472017.B1-110058	55	P7472017.B1-108022	63	P7472017.B1-108023	63	P7472017.B1-111926	69	P7472017.B1-110852	76
P7572036.B1-110048	56	P7572036.B1-110058	60	P7572036.B1-108022	68	P7572036.B1-108023	68	P7572036.B1-111926	74	P7572036.B1-110852	81
P7473003.B1-110048	52	P7473003.B1-110058	56	P7473003.B1-108022	64	P7473003.B1-108023	64	P7473003.B1-111926	70	P7473003.B1-110852	77
P7573025.B1-110048	57	P7573025.B1-110058	61	P7573025.B1-108022	69	P7573025.B1-108023	69	P7573025.B1-111926	75	P7573025.B1-110852	82
P7472018.B1-110048	51	P7472018.B1-110058	55	P7472018.B1-108022	63	P7472018.B1-108023	63	P7472018.B1-111926	69	P7472018.B1-110852	76
P7572037.B1-110048	56	P7572037.B1-110058	60	P7572037.B1-108022	68	P7572037.B1-108023	68	P7572037.B1-111926	74	P7572037.B1-110852	81
P7473004.B1-110048	52	P7473004.B1-110058	56	P7473004.B1-108022	64	P7473004.B1-108023	64	P7473004.B1-111926	70	P7473004.B1-110852	77
P7573026.B1-110048	57	P7573026.B1-110058	61	P7573026.B1-108022	69	P7573026.B1-108023	69	P7573026.B1-111926	75	P7573026.B1-110852	82
P7473005.B1-110048	52	P7473005.B1-110058	56	P7473005.B1-108022	64	P7473005.B1-108023	64	P7473005.B1-111926	70	P7473005.B1-110852	77
P7573027.B1-110048	57	P7573027.B1-110058	61	P7573027.B1-108022	69	P7573027.B1-108023	69	P7573027.B1-111926	75	P7573027.B1-110852	82
P7472019.B1-110048	51	P7472019.B1-110058	55	P7472019.B1-108022	63	P7472019.B1-108023	63	P7472019.B1-111926	69	P7472019.B1-110852	76
P7572038.B1-110048	56	P7572038.B1-110058	60	P7572038.B1-108022	68	P7572038.B1-108023	68	P7572038.B1-111926	74	P7572038.B1-110852	81
P7473006.B1-110048	52	P7473006.B1-110058	56	P7473006.B1-108022	64	P7473006.B1-108023	64	P7473006.B1-111926	70	P7473006.B1-110852	77
P7573028.B1-110048	57	P7573028.B1-110058	61	P7573028.B1-108022	69	P7573028.B1-108023	69	P7573028.B1-111926	75	P7573028.B1-110852	82
P7473007.B1-110048	52	P7473007.B1-110058	56	P7473007.B1-108022	64	P7473007.B1-108023	64	P7473007.B1-111926	70	P7473007.B1-110852	77
P7573029.B1-110048	57	P7573029.B1-110058	61	P7573029.B1-108022	69	P7573029.B1-108023	69	P7573029.B1-111926	75	P7573029.B1-110852	82
P7573030.B1-110048	57	P7573030.B1-110058	61	P7573030.B1-108022	69	P7573030.B1-108023	69	P7573030.B1-111926	75	P7573030.B1-110852	82
P7573031.B1-110048	57	P7573031.B1-110058	61	P7573031.B1-108022	69	P7573031.B1-108023	69	P7573031.B1-111926	75	P7573031.B1-110852	82
P7573032.B1-110048	57	P7573032.B1-110058	61	P7573032.B1-108022	69	P7573032.B1-108023	69	P7573032.B1-111926	75	P7573032.B1-110852	82
P7573033.B1-110048	57	P7573033.B1-110058	61	P7573033.B1-108022	69	P7573033.B1-108023	69	P7573033.B1-111926	75	P7573033.B1-110852	82
P7573034.B1-110048	57	P7573034.B1-110058	61	P7573034.B1-108022	69	P7573034.B1-108023	69	P7573034.B1-111926	75	P7573034.B1-110852	82

Gear+Motor™ catalog numbers are comprised of the reducer catalog number followed by the motor catalog number.

IN THIS CATALOG

RPM = Revolutions Per Minute
HP = Horsepower
TQ = Torque (lb-in.)
OHL = Overhung Load In Pounds At Centerline Of Output Shaft With No Thrust Load.
TL = Thrust Load (lbs.) - Output Shaft

SELECT REDUCER MOUNTING POSITION ON PAGE 60



QUICK SELECTIONS
DOUBLE AND TRIPLE REDUCTION



**700 Series
Motorized Quill Input
NEMA Frame Selections
1750 RPM Input**

This Quick Selection is only for motorized B1 base mount reducers and Gear+Motors™. For other reducer configurations, see the Maximum Rating Tables beginning on page 40.



1 1/2 HP Gear Reducer Quick Selections								
Output Speed (RPM)	Service Factor ▼	Output Torque (lb-in)	Overhung ● Load (lbs.)	Ratio	Number of Reductions	Weight ◆ (lbs.)	Motor Frame	Motorized B1 Base Mount Catalog No.
503	3.34	180	204	3.48	2	11	143-5TC	P7172023.B1
405	2.69	224	216	4.32	2	11	143-5TC	P7172024.B1
405	3.46	224	289	4.32	2	11	143-5TC	P7272024.B1
318	2.11	285	230	5.50	2	11	143-5TC	P7172025.B1
318	3.11	285	350	5.50	2	11	143-5TC	P7272025.B1
275	1.82	330	250	6.36	2	11	56C	P7172004.B1
275	2.88	330	376	6.36	2	11	143-5TC	P7272026.B1
241	1.60	377	260	7.26	2	11	56C	P7172005.B1
241	2.83	377	391	7.26	2	11	143-5TC	P7272027.B1
222	1.47	409	266	7.89	2	11	56C	P7172006.B1
222	2.47	409	400	7.89	2	11	143-5TC	P7272028.B1
220	5.82	413	579	7.96	2	23	143-5TC	P7472026.B1
185	5.11	491	615	9.45	2	23	143-5TC	P7472027.B1
174	1.53	522	284	10.04	2	11	56C	P7172008.B1
174	2.28	522	420	10.04	2	11	143-5TC	P7272030.B1
153	4.39	593	658	11.43	2	23	143-5TC	P7472028.B1
150	1.32	605	293	11.64	2	11	56C	P7172009.B1
150	1.97	605	445	11.64	2	11	56C	P7272009.B1
132	1.16	688	305	13.26	2	11	56C	P7172010.B1
132	1.73	688	476	13.26	2	11	56C	P7272010.B1
123	3.12	738	693	14.21	2	23	143-5TC	P7472029.B1
114	1.00	796	321	15.37	2	11	56C	P7172011.B1
114	1.49	796	508	15.37	2	11	56C	P7272011.B1
108	1.35	856	520	16.20	2	11	56C	P7272012.B1
105	2.91	864	711	16.62	2	23	143-5TC	P7472030.B1

- ◆ Weight does not include oil.
- ▼ Service Factor is based on maximum torque rating of reducer. Refer to page 171 for special application considerations.
- Overhung load is calculated at centerline of output shaft.

QUICK REFERENCE	
OTHER REDUCER CONFIGURATIONS	Page 38
OUTPUT FLANGE SELECTIONS	53
INTERCHANGE BASE SELECTIONS	54



QUICK SELECTIONS
DOUBLE AND TRIPLE REDUCTION



LeCentric™ Gear Reducers & GEAR+MOTORS™



1 1/2 HP Gear+Motor™ Quick Selections							
TEFC, 3 Phase 230/460V		TEFC, 1 Phase 115/230V		DC SCR 180V		Explosion-Proof, 3 Phase 230/460V	
Catalog No.	Wgt.♦ (lbs.)	Catalog No.	Wgt.♦ (lbs.)	Catalog No.	Wgt.♦ (lbs.)	Catalog No.	Wgt.♦ (lbs.)
P7172023.B1-120037	46	P7172023.B1-120017	60	P7172023.B1-108262**	62	56C Available Only	—
P7172024.B1-120037	46	P7172024.B1-120017	60	P7172024.B1-108262**	62	56C Available Only	—
P7272024.B1-120037	46	P7272024.B1-120017	60	P7272024.B1-108262**	62	56C Available Only	—
P7172025.B1-120037	46	P7172025.B1-120017	60	P7172025.B1-108262**	62	56C Available Only	—
P7272025.B1-120037	46	P7272025.B1-120017	60	P7272025.B1-108262**	62	56C Available Only	—
P7172004.B1-110125	44	P7172004.B1-110420	50	P7172004.B1-108092	62	P7172004.B1-111941	63
P7272026.B1-120037	46	P7272026.B1-120017	60	P7272026.B1-108262**	62	56C Available Only	—
P7172005.B1-110125	44	P7172005.B1-110420	50	P7172005.B1-108092	62	P7172005.B1-111941	63
P7272027.B1-120037	46	P7272027.B1-120017	60	P7272027.B1-108262**	62	56C Available Only	—
P7172006.B1-110125	44	P7172006.B1-110420	50	P7172006.B1-108092	62	P7172006.B1-111941	63
P7272028.B1-120037	46	P7272028.B1-120017	60	P7272028.B1-108262**	62	56C Available Only	—
P7472026.B1-120037	58	P7472026.B1-120017	72	P7472026.B1-108262**	74	56C Available Only	—
P7472027.B1-120037	58	P7472027.B1-120017	72	P7472027.B1-108262**	74	56C Available Only	—
P7172008.B1-110125	44	P7172008.B1-110420	50	P7172008.B1-108092	62	P7172008.B1-111941	63
P7272030.B1-120037	46	P7272030.B1-120017	60	P7272030.B1-108262**	62	56C Available Only	—
P7472028.B1-120037	58	P7472028.B1-120017	72	P7472028.B1-108262**	74	56C Available Only	—
P7172009.B1-110125	44	P7172009.B1-110420	50	P7172009.B1-108092	62	P7172009.B1-111941	63
P7272009.B1-110125	44	P7272009.B1-110420	50	P7272009.B1-108092	62	P7272009.B1-111941	63
P7172010.B1-110125	44	P7172010.B1-110420	50	P7172010.B1-108092	62	P7172010.B1-111941	63
P7272010.B1-110125	44	P7272010.B1-110420	50	P7272010.B1-108092	62	P7272010.B1-111941	63
P7472029.B1-120037	58	P7472029.B1-120017	72	P7472029.B1-108262**	74	56C Available Only	—
P7172011.B1-110125	44	P7172011.B1-110420	50	P7172011.B1-108092	62	P7172011.B1-111941	63
P7272011.B1-110125	44	P7272011.B1-110420	50	P7272011.B1-108092	62	P7272011.B1-111941	63
P7272012.B1-110125	44	P7272012.B1-110420	50	P7272012.B1-108092	62	P7272012.B1-111941	63
P7472030.B1-120037	58	P7472030.B1-120017	72	P7472030.B1-108262**	74	56C Available Only	—

Gear+Motor™ catalog numbers are comprised of the reducer catalog number followed by the motor catalog number.

**NEMA 145TC frame shaft 7/8" x 2 1/4" and NEMA 56C removable base.

TABLE CONTINUES ON NEXT PAGE

IN THIS CATALOG

RPM = Revolutions Per Minute
HP = Horsepower
TQ = Torque (lb-in.)
OHL = Overhung Load In Pounds At Centerline Of Output Shaft With No Thrust Load.
TL = Thrust Load (lbs.) - Output Shaft

SELECT REDUCER MOUNTING POSITION ON PAGE 60



QUICK SELECTIONS
DOUBLE AND TRIPLE REDUCTION



**700 Series
Motorized Quill Input
NEMA Frame Selections
1750 RPM Input**

This Quick Selection is only for motorized B1 base mount reducers and Gear+Motors™. For other reducer configurations, see the Maximum Rating Tables beginning on page 40.



1 1/2 HP Gear Reducer Quick Selections								
Output Speed (RPM)	Service Factor ▼	Output Torque (lb-in)	Overhung ● Load (lbs.)	Ratio	Number of Reductions	Weight ♦ (lbs.)	Motor Frame	Motorized B1 Base Mount Catalog No.
93	1.17	986	535	18.80	2	11	56C	P7272013.B1
87	2.40	1043	780	20.10	2	23	143-5TC	P7472031.B1
87	3.65	1043	900	20.10	2	28	143-5TC	P7572069.B1
81	1.07	1120	562	21.54	2	11	56C	P7272014.B1
70	1.77	1297	877	24.98	2	23	143-5TC	P7472032.B1
70	2.93	1297	944	24.98	2	28	143-5TC	P7572070.B1
60	1.65	1513	900	29.41	2	23	56C	P7472014.B1
60	1.97	1513	1012	29.41	2	28	143-5TC	P7572071.B1
52	1.40	1691	918	34.01	3	24	56C	P7473001.B1
52	1.97	1691	1060	34.01	3	29	143-5TC	P7573067.B1
49	1.35	1852	922	35.58	2	23	56C	P7472015.B1
49	1.62	1852	1079	35.58	2	28	56C	P7572034.B1
44	1.20	1998	988	39.79	3	24	56C	P7473002.B1
44	1.69	1998	1192	39.79	3	29	56C	P7573024.B1
43	1.15	2111	988	40.50	2	23	56C	P7472016.B1
43	1.22	2111	1192	40.50	2	28	56C	P7572035.B1
40	1.00	2269	1012	44.23	2	23	56C	P7472017.B1
40	1.22	2269	1304	44.23	2	28	56C	P7572036.B1
37	1.01	2376	1028	47.22	3	24	56C	P7473003.B1
37	1.42	2376	1330	47.22	3	29	56C	P7573025.B1
36	1.09	2521	1330	49.00	2	28	56C	P7572037.B1
32	1.23	2747	1354	54.73	3	29	56C	P7573026.B1
31	1.17	2836	1354	57.13	3	29	56C	P7573027.B1
26	1.01	3382	1398	66.22	3	29	56C	P7573028.B1

- ♦ Weight does not include oil.
- ▼ Service Factor is based on maximum torque rating of reducer. Refer to page 171 for special application considerations.
- Overhung load is calculated at centerline of output shaft.

QUICK REFERENCE	
OTHER REDUCER CONFIGURATIONS	Page 38
OUTPUT FLANGE SELECTIONS	53
INTERCHANGE BASE SELECTIONS	54



QUICK SELECTIONS
DOUBLE AND TRIPLE REDUCTION



LeCentric™ Gear Reducers & GEAR+MOTORS™



1 1/2 HP Gear+Motor™ Quick Selections							
TEFC, 3 Phase 230/460V		TEFC, 1 Phase 115/230V		DC SCR 180V		Explosion-Proof, 3 Phase 230/460V	
Catalog No.	Wgt.♦ (lbs.)	Catalog No.	Wgt.♦ (lbs.)	Catalog No.	Wgt.♦ (lbs.)	Catalog No.	Wgt.♦ (lbs.)
P7272013.B1-110125	44	P7272013.B1-110420	50	P7272013.B1-108092	62	P7272013.B1-111941	63
P7472031.B1-120037	58	P7472031.B1-120017	72	P7472031.B1-108262**	74	56C Available Only	—
P7572069.B1-120037	63	P7572069.B1-120017	77	P7572069.B1-108262**	79	56C Available Only	—
P7272014.B1-110125	44	P7272014.B1-110420	50	P7272014.B1-108092	62	P7272014.B1-111941	63
P7472032.B1-120037	58	P7472032.B1-120017	72	P7472032.B1-108262**	74	56C Available Only	—
P7572070.B1-120037	63	P7572070.B1-120017	77	P7572070.B1-108262**	79	56C Available Only	—
P7472014.B1-110125	56	P7472014.B1-110420	62	P7472014.B1-108092	74	P7472014.B1-111941	75
P7572071.B1-120037	63	P7572071.B1-120017	77	P7572071.B1-108262**	79	56C Available Only	—
P7473001.B1-110125	57	P7473001.B1-110420	63	P7473001.B1-108092	75	P7473001.B1-111941	76
P7573067.B1-120037	64	P7573067.B1-120017	78	P7573067.B1-108262**	80	56C Available Only	—
P7472015.B1-110125	56	P7472015.B1-110420	62	P7472015.B1-108092	74	P7472015.B1-111941	75
P7572034.B1-110125	61	P7572034.B1-110420	67	P7572034.B1-108092	79	P7572034.B1-111941	80
P7473002.B1-110125	57	P7473002.B1-110420	63	P7473002.B1-108092	75	P7473002.B1-111941	76
P7573024.B1-110125	62	P7573024.B1-110420	68	P7573024.B1-108092	80	P7573024.B1-111941	81
P7472016.B1-110125	56	P7472016.B1-110420	62	P7472016.B1-108092	74	P7472016.B1-111941	75
P7572035.B1-110125	61	P7572035.B1-110420	67	P7572035.B1-108092	79	P7572035.B1-111941	80
P7472017.B1-110125	56	P7472017.B1-110420	62	P7472017.B1-108092	74	P7472017.B1-111941	75
P7572036.B1-110125	61	P7572036.B1-110420	67	P7572036.B1-108092	79	P7572036.B1-111941	80
P7473003.B1-110125	57	P7473003.B1-110420	63	P7473003.B1-108092	75	P7473003.B1-111941	76
P7573025.B1-110125	62	P7573025.B1-110420	68	P7573025.B1-108092	80	P7573025.B1-111941	81
P7572037.B1-110125	61	P7572037.B1-110420	67	P7572037.B1-108092	79	P7572037.B1-111941	80
P7573026.B1-110125	62	P7573026.B1-110420	68	P7573026.B1-108092	80	P7573026.B1-111941	81
P7573027.B1-110125	62	P7573027.B1-110420	68	P7573027.B1-108092	80	P7573027.B1-111941	81
P7573028.B1-110125	62	P7573028.B1-110420	68	P7573028.B1-108092	80	P7573028.B1-111941	81

Gear+Motor™ catalog numbers are comprised of the reducer catalog number followed by the motor catalog number.

**NEMA 145TC frame shaft 7/8" x 2 1/4" and NEMA 56C removable base.

IN THIS CATALOG

RPM = Revolutions Per Minute
HP = Horsepower
TQ = Torque (lb-in.)
OHL = Overhung Load In Pounds At Centerline Of Output Shaft With No Thrust Load.
TL = Thrust Load (lbs.) - Output Shaft

SELECT REDUCER MOUNTING POSITION ON PAGE 60



QUICK SELECTIONS
DOUBLE AND TRIPLE REDUCTION



**700 Series
Motorized Quill Input
NEMA Frame Selections
1750 RPM Input**

This Quick Selection is only for motorized B1 base mount reducers and Gear+Motors™. For other reducer configurations, see the Maximum Rating Tables beginning on page 40.



2 HP Gear Reducer Quick Selections								
Output Speed (RPM)	Service Factor ▼	Output Torque (lb-in)	Overhung ● Load (lbs.)	Ratio	Number of Reductions	Weight ◆ (lbs.)	Motor Frame	Motorized B1 Base Mount Catalog No.
503	2.50	241	204	3.48	2	11	143-5TC	P7172023.B1
503	2.94	241	268	3.48	2	11	143-5TC	P7272023.B1
405	2.01	299	216	4.32	2	11	143-5TC	P7172024.B1
405	2.60	299	289	4.32	2	11	143-5TC	P7272024.B1
318	1.58	381	230	5.50	2	11	143-5TC	P7172025.B1
318	2.34	381	350	5.50	2	11	143-5TC	P7272025.B1
288	5.25	420	522	6.07	2	23	143-5TC	P7472023.B1
275	1.37	440	250	6.36	2	11	143-5TC	P7172026.B1
275	2.16	440	376	6.36	2	11	143-5TC	P7272026.B1
257	5.11	471	540	6.81	2	23	143-5TC	P7472024.B1
241	1.20	502	260	7.26	2	11	143-5TC	P7172027.B1
241	2.12	502	391	7.26	2	11	143-5TC	P7272027.B1
222	1.10	545	266	7.89	2	11	143-5TC	P7172028.B1
222	1.85	545	400	7.89	2	11	143-5TC	P7272028.B1
220	4.37	550	579	7.96	2	23	143-5TC	P7472026.B1
185	3.83	654	615	9.45	2	23	143-5TC	P7472027.B1
174	1.15	695	284	10.04	2	11	143-5TC	P7172030.B1
174	1.71	695	420	10.04	2	11	143-5TC	P7272030.B1
153	3.29	791	658	11.43	2	23	143-5TC	P7472028.B1
150	0.99	807	293	11.64	2	11	143-5TC	P7172031.B1
150	1.47	807	445	11.64	2	11	143-5TC	P7272031.B1
132	1.30	917	476	13.26	2	11	143-5TC	P7272032.B1
123	2.34	984	693	14.21	2	23	143-5TC	P7472029.B1
123	3.87	984	850	14.21	2	28	143-5TC	P7572067.B1
114	1.12	1061	508	15.37	2	11	143-5TC	P7272033.B1
108	1.02	1142	520	16.20	2	11	143-5TC	P7272034.B1
105	2.18	1152	711	16.62	2	23	143-5TC	P7472030.B1
105	3.31	1152	872	16.62	2	28	143-5TC	P7572068.B1
87	1.80	1391	780	20.10	2	23	143-5TC	P7472031.B1
87	2.74	1391	900	20.10	2	28	143-5TC	P7572069.B1
70	1.33	1729	877	24.98	2	23	143-5TC	P7472032.B1
70	2.20	1729	944	24.98	2	28	143-5TC	P7572070.B1
60	1.24	2017	900	29.41	2	23	143-5TC	P7472033.B1
60	1.48	2017	1012	29.41	2	28	143-5TC	P7572071.B1
52	1.05	2254	918	34.01	3	24	143-5TC	P7473023.B1
52	1.48	2254	1060	34.01	3	29	143-5TC	P7573067.B1
49	1.01	2470	922	35.58	2	23	143-5TC	P7472034.B1
49	1.21	2470	1079	35.58	2	28	143-5TC	P7572072.B1
44	1.27	2664	1192	39.79	3	29	143-5TC	P7573068.B1
37	1.07	3168	1330	47.22	3	29	143-5TC	P7573069.B1

- ◆ Weight does not include oil.
- ▼ Service Factor is based on maximum torque rating of reducer. Refer to page 171 for special application considerations.
- Overhung load is calculated at centerline of output shaft.

QUICK REFERENCE	
OTHER REDUCER CONFIGURATIONS	Page 38
OUTPUT FLANGE SELECTIONS	53
INTERCHANGE BASE SELECTIONS	54



QUICK SELECTIONS
DOUBLE AND TRIPLE REDUCTION



LeCentric™ Gear Reducers & GEAR+MOTORS™



TEFC, 3 Phase 230/460V		TEFC, 1 Phase 115/230V		DC SCR 180V		Explosion-Proof, 3 Phase 230/460V	
Catalog No.	Wgt.♦ (lbs.)	Catalog No.	Wgt.♦ (lbs.)	Catalog No.	Wgt.♦ (lbs.)	Catalog No.	Wgt.♦ (lbs.)
P7172023.B1-120038	47	P7172023.B1-120060	58	P7172023.B1-128010	89	P7172023.B1-121178	70
P7272023.B1-120038	47	P7272023.B1-120060	58	P7272023.B1-128010	89	P7272023.B1-121178	70
P7172024.B1-120038	47	P7172024.B1-120060	58	P7172024.B1-128010	89	P7172024.B1-121178	70
P7272024.B1-120038	47	P7272024.B1-120060	58	P7272024.B1-128010	89	P7272024.B1-121178	70
P7172025.B1-120038	47	P7172025.B1-120060	58	P7172025.B1-128010	89	P7172025.B1-121178	70
P7272025.B1-120038	47	P7272025.B1-120060	58	P7272025.B1-128010	89	P7272025.B1-121178	70
P7472023.B1-120038	59	P7472023.B1-120060	70	P7472023.B1-128010	101	P7472023.B1-121178	82
P7172026.B1-120038	47	P7172026.B1-120060	58	P7172026.B1-128010	89	P7172026.B1-121178	70
P7272026.B1-120038	47	P7272026.B1-120060	58	P7272026.B1-128010	89	P7272026.B1-121178	70
P7472024.B1-120038	59	P7472024.B1-120060	70	P7472024.B1-128010	101	P7472024.B1-121178	82
P7172027.B1-120038	47	P7172027.B1-120060	58	P7172027.B1-128010	89	P7172027.B1-121178	70
P7272027.B1-120038	47	P7272027.B1-120060	58	P7272027.B1-128010	89	P7272027.B1-121178	70
P7172028.B1-120038	47	P7172028.B1-120060	58	P7172028.B1-128010	89	P7172028.B1-121178	70
P7272028.B1-120038	47	P7272028.B1-120060	58	P7272028.B1-128010	89	P7272028.B1-121178	70
P7472026.B1-120038	59	P7472026.B1-120060	70	P7472026.B1-128010	101	P7472026.B1-121178	82
P7472027.B1-120038	59	P7472027.B1-120060	70	P7472027.B1-128010	101	P7472027.B1-121178	82
P7172030.B1-120038	47	P7172030.B1-120060	58	P7172030.B1-128010	89	P7172030.B1-121178	70
P7272030.B1-120038	47	P7272030.B1-120060	58	P7272030.B1-128010	89	P7272030.B1-121178	70
P7472028.B1-120038	59	P7472028.B1-120060	70	P7472028.B1-128010	101	P7472028.B1-121178	82
P7172031.B1-120038	47	P7172031.B1-120060	58	P7172031.B1-128010	89	P7172031.B1-121178	70
P7272031.B1-120038	47	P7272031.B1-120060	58	P7272031.B1-128010	89	P7272031.B1-121178	70
P7272032.B1-120038	47	P7272032.B1-120060	58	P7272032.B1-128010	89	P7272032.B1-121178	70
P7472029.B1-120038	59	P7472029.B1-120060	70	P7472029.B1-128010	101	P7472029.B1-121178	82
P7572067.B1-120038	64	P7572067.B1-120060	75	P7572067.B1-128010	106	P7572067.B1-121178	87
P7272033.B1-120038	47	P7272033.B1-120060	58	P7272033.B1-128010	89	P7272033.B1-121178	70
P7272034.B1-120038	47	P7272034.B1-120060	58	P7272034.B1-128010	89	P7272034.B1-121178	70
P7472030.B1-120038	59	P7472030.B1-120060	70	P7472030.B1-128010	101	P7472030.B1-121178	82
P7572068.B1-120038	64	P7572068.B1-120060	75	P7572068.B1-128010	106	P7572068.B1-121178	87
P7472031.B1-120038	59	P7472031.B1-120060	70	P7472031.B1-128010	101	P7472031.B1-121178	82
P7572069.B1-120038	64	P7572069.B1-120060	75	P7572069.B1-128010	106	P7572069.B1-121178	87
P7472032.B1-120038	59	P7472032.B1-120060	70	P7472032.B1-128010	101	P7472032.B1-121178	82
P7572070.B1-120038	64	P7572070.B1-120060	75	P7572070.B1-128010	106	P7572070.B1-121178	87
P7472033.B1-120038	59	P7472033.B1-120060	70	P7472033.B1-128010	101	P7472033.B1-121178	82
P7572071.B1-120038	64	P7572071.B1-120060	75	P7572071.B1-128010	106	P7572071.B1-121178	87
P7473023.B1-120038	60	P7473023.B1-120060	71	P7473023.B1-128010	102	P7473023.B1-121178	83
P7573067.B1-120038	65	P7573067.B1-120060	76	P7573067.B1-128010	107	P7573067.B1-121178	88
P7472034.B1-120038	59	P7472034.B1-120060	70	P7472034.B1-128010	101	P7472034.B1-121178	82
P7572072.B1-120038	64	P7572072.B1-120060	75	P7572072.B1-128010	106	P7572072.B1-121178	87
P7573068.B1-120038	65	P7573068.B1-120060	76	P7573068.B1-128010	107	P7573068.B1-121178	88
P7573069.B1-120038	65	P7573069.B1-120060	76	P7573069.B1-128010	107	P7573069.B1-121178	88

Gear+Motor™ catalog numbers are comprised of the reducer catalog number followed by the motor catalog number.

IN THIS CATALOG

RPM = Revolutions Per Minute
HP = Horsepower
TQ = Torque (lb-in.)
OHL = Overhung Load In Pounds At Centerline Of Output Shaft With No Thrust Load.
TL = Thrust Load (lbs.) - Output Shaft

SELECT REDUCER MOUNTING POSITION ON PAGE 60

LeCentric™ Gear Reducers & GEAR+MOTORS™



QUICK SELECTIONS
DOUBLE AND TRIPLE REDUCTION



**700 Series
Motorized Quill Input
NEMA Frame Selections
1750 RPM Input**

This Quick Selection is only for motorized B1 base mount reducers and Gear+Motors™. For other reducer configurations, see the Maximum Rating Tables beginning on page 40.



3 HP Gear Reducer Quick Selections

Output Speed (RPM)	Service Factor ▼	Output Torque (lb-in)	Overhung ● Load (lbs.)	Ratio	Number of Reductions	Weight ◆ (lbs.)	Motor Frame	Motorized B1 Base Mount Catalog No.
503	1.67	361	204	3.48	2	11	143-5TC	P7172023.B1
503	1.96	361	268	3.48	2	11	143-5TC	P7272023.B1
485	3.93	374	450	3.61	2	25	182-4TC	P7472039.B1
414	4.09	438	474	4.23	2	25	182-4TC	P7472040.B1
405	1.34	448	216	4.32	2	11	143-5TC	P7172024.B1
405	1.73	448	289	4.32	2	11	143-5TC	P7272024.B1
349	4.23	520	491	5.01	2	25	182-4TC	P7472041.B1
318	1.56	571	350	5.50	2	11	143-5TC	P7272025.B1
289	3.50	628	522	6.07	2	25	182-4TC	P7472042.B1
275	1.44	660	376	6.36	2	11	143-5TC	P7272026.B1
257	3.41	706	540	6.81	2	25	182-4TC	P7472043.B1
257	4.05	706	646	6.81	2	30	182-4TC	P7572100.B1
241	1.41	753	391	7.26	2	11	143-5TC	P7272027.B1
222	1.23	818	400	7.89	2	11	143-5TC	P7272028.B1
220	2.91	825	579	7.96	2	25	182-4TC	P7472045.B1
220	3.85	825	663	7.96	2	30	182-4TC	P7572102.B1
185	2.55	981	615	9.45	2	25	182-4TC	P7472046.B1
185	3.06	981	674	9.45	2	30	182-4TC	P7572103.B1
174	1.14	1043	420	10.04	2	11	143-5TC	P7272030.B1
153	2.19	1186	658	11.43	2	25	182-4TC	P7472047.B1
153	2.90	1186	778	11.43	2	30	182-4TC	P7572104.B1
123	1.56	1476	693	14.21	2	25	182-4TC	P7472048.B1
123	2.58	1476	850	14.21	2	30	182-4TC	P7572105.B1
105	1.45	1729	711	16.62	2	25	182-4TC	P7472049.B1
105	2.20	1729	872	16.62	2	30	182-4TC	P7572106.B1
87	1.20	2086	780	20.10	2	23	143-5TC	P7472031.B1
87	1.82	2086	900	20.10	2	30	182-4TC	P7572107.B1
70	1.47	2593	944	24.98	2	28	143-5TC	P7572070.B1
60	0.98	3025	1012	29.41	2	28	143-5TC	P7572071.B1
52	0.99	3382	1060	34.01	3	29	143-5TC	P7573067.B1

- ◆ Weight does not include oil.
- ▼ Service Factor is based on maximum torque rating of reducer. Refer to page 171 for special application considerations.
- Overhung load is calculated at centerline of output shaft.

QUICK REFERENCE
OTHER REDUCER CONFIGURATIONS Page 38
OUTPUT FLANGE SELECTIONS 53
INTERCHANGE BASE SELECTIONS 54



QUICK SELECTIONS
DOUBLE AND TRIPLE REDUCTION



LeCentric™ Gear Reducers & GEAR+MOTORS™



3 HP Gear+Motor™ Quick Selections							
TEFC, 3 Phase 230/460V		TEFC, 1 Phase 115/230V		DC SCR 180V		Explosion-Proof, 3 Phase 230/460V	
Catalog No.	Wgt.♦ (lbs.)	Catalog No.	Wgt.♦ (lbs.)	Catalog No.	Wgt.♦ (lbs.)	Catalog No.	Wgt.♦ (lbs.)
P7172023.B1-121035	58	Available in 182-4TC Only	—	P7172023.B1-108502**	100	Available in 182-4TC Only	—
P7272023.B1-121035	58	Available in 182-4TC Only	—	P7272023.B1-108502**	100	Available in 182-4TC Only	—
P7472039.B1-131491	85	P7472039.B1-131545	122	Available in 143-5TC Only	—	P7472039.B1-158003	116
P7472040.B1-131491	85	P7472040.B1-131545	122	Available in 143-5TC Only	—	P7472040.B1-158003	116
P7172024.B1-121035	58	Available in 182-4TC Only	—	P7172024.B1-108502**	100	Available in 182-4TC Only	—
P7272024.B1-121035	58	Available in 182-4TC Only	—	P7272024.B1-108502**	100	Available in 182-4TC Only	—
P7472041.B1-131491	85	P7472041.B1-131545	122	Available in 143-5TC Only	—	P7472041.B1-158003	116
P7272025.B1-121035	58	Available in 182-4TC Only	—	P7272025.B1-108502**	100	Available in 182-4TC Only	—
P7472042.B1-131491	85	P7472042.B1-131545	122	Available in 143-5TC Only	—	P7472042.B1-158003	116
P7272026.B1-121035	58	Available in 182-4TC Only	—	P7272026.B1-108502**	100	Available in 182-4TC Only	—
P7472043.B1-131491	85	P7472043.B1-131545	122	Available in 143-5TC Only	—	P7472043.B1-158003	116
P7572100.B1-131491	90	P7572100.B1-131545	127	Available in 143-5TC Only	—	P7572100.B1-158003	121
P7272027.B1-121035	58	Available in 182-4TC Only	—	P7272027.B1-108502**	100	Available in 182-4TC Only	—
P7472044.B1-131491	85	P7472044.B1-131545	122	Available in 143-5TC Only	—	P7472044.B1-158003	116
P7272028.B1-121035	58	Available in 182-4TC Only	—	P7272028.B1-108502**	100	Available in 182-4TC Only	—
P7472045.B1-131491	85	P7472045.B1-131545	122	Available in 143-5TC Only	—	P7472045.B1-158003	116
P7572102.B1-131491	90	P7572102.B1-131545	127	Available in 143-5TC Only	—	P7572102.B1-158003	121
P7272029.B1-121035	58	Available in 182-4TC Only	—	P7272029.B1-108502**	100	Available in 182-4TC Only	—
P7472046.B1-131491	85	P7472046.B1-131545	122	Available in 143-5TC Only	—	P7472046.B1-158003	116
P7572103.B1-131491	90	P7572103.B1-131545	127	Available in 143-5TC Only	—	P7572103.B1-158003	121
P7272030.B1-121035	58	Available in 182-4TC Only	—	P7272030.B1-108502**	100	Available in 182-4TC Only	—
P7472047.B1-131491	85	P7472047.B1-131545	122	Available in 143-5TC Only	—	P7472047.B1-158003	116
P7572104.B1-131491	90	P7572104.B1-131545	127	Available in 143-5TC Only	—	P7572104.B1-158003	121
P7472048.B1-131491	85	P7472048.B1-131545	122	Available in 143-5TC Only	—	P7472048.B1-158003	116
P7572105.B1-131491	90	P7572105.B1-131545	127	Available in 143-5TC Only	—	P7572105.B1-158003	121
P7472049.B1-131491	85	P7472049.B1-131545	122	Available in 143-5TC Only	—	P7472049.B1-158003	116
P7572106.B1-131491	90	P7572106.B1-131545	127	Available in 143-5TC Only	—	P7572106.B1-158003	121
P7472031.B1-121035	70	Available in 182-4TC Only	—	P7472031.B1-108502**	112	Available in 182-4TC Only	—
P7572107.B1-131491	90	P7572107.B1-131545	127	Available in 143-5TC Only	—	P7572107.B1-158003	121
P7572070.B1-121035	75	Available in 182-4TC Only	—	P7572070.B1-108502**	117	Available in 182-4TC Only	—
P7572071.B1-121035	75	Available in 182-4TC Only	—	P7572071.B1-108502**	117	Available in 182-4TC Only	—
P7573067.B1-121035	76	Available in 182-4TC Only	—	P7573067.B1-108502**	118	Available in 182-4TC Only	—

Gear+Motor™ catalog numbers are comprised of the reducer catalog number followed by the motor catalog number.

** NEMA 145TC face mounting with removable NEMA 182T rigid base.

IN THIS CATALOG

RPM = Revolutions Per Minute
HP = Horsepower
TQ = Torque (lb-in.)
OHL = Overhung Load In Pounds At Centerline Of Output Shaft With No Thrust Load.
TL = Thrust Load (lbs.) - Output Shaft

SELECT REDUCER MOUNTING POSITION ON PAGE 60



QUICK SELECTIONS
DOUBLE AND TRIPLE REDUCTION



**700 Series
Motorized Quill Input
NEMA Frame Selections
1750 RPM Input**

This Quick Selection is only for motorized B1 base mount reducers and Gear+Motors™. For other reducer configurations, see the Maximum Rating Tables beginning on page 40.



5 HP Gear Reducer Quick Selections

Output Speed (RPM)	Service Factor ▼	Output Torque (lb-in)	Overhung ● Load (lbs.)	Ratio	Number of Reductions	Weight ◆ (lbs.)	Motor Frame	Motorized B1 Base Mount Catalog No.
485	2.36	624	450	3.61	2	25	182-4TC	P7472039.B1
414	2.45	731	474	4.23	2	25	182-4TC	P7472040.B1
349	2.54	867	491	5.01	2	25	182-4TC	P7472041.B1
349	2.65	867	603	5.01	2	30	182-4TC	P7572098.B1
289	2.10	1047	522	6.07	2	25	182-4TC	P7472042.B1
289	2.65	1047	629	6.07	2	30	182-4TC	P7572099.B1
257	2.04	1177	540	6.81	2	25	182-4TC	P7472043.B1
257	2.43	1177	646	6.81	2	30	182-4TC	P7572100.B1
220	1.75	1375	579	7.96	2	25	182-4TC	P7472045.B1
220	2.31	1375	663	7.96	2	30	182-4TC	P7572102.B1
185	1.53	1635	615	9.45	2	25	182-4TC	P7472046.B1
185	1.84	1635	674	9.45	2	30	182-4TC	P7572103.B1
153	1.32	1977	658	11.43	2	25	182-4TC	P7472047.B1
153	1.74	1977	778	11.43	2	30	182-4TC	P7572104.B1
123	1.55	2460	850	14.21	2	30	182-4TC	P7572105.B1
105	1.32	2881	872	16.62	2	30	182-4TC	P7572106.B1
87	1.09	3477	900	20.10	2	30	182-4TC	P7572107.B1

7½ HP Gear Reducer Quick Selections

485	1.57	936	450	3.61	2	25	182-4TC	P7472039.B1
485	1.76	936	534	3.61	2	30	182-4TC	P7572096.B1
414	1.64	1096	474	4.23	2	25	182-4TC	P7472040.B1
414	1.76	1096	566	4.23	2	30	182-4TC	P7572097.B1
349	1.69	1300	491	5.01	2	25	182-4TC	P7472041.B1
349	1.76	1300	603	5.01	2	30	182-4TC	P7572098.B1
289	1.40	1570	522	6.07	2	25	182-4TC	P7472042.B1
289	1.76	1570	629	6.07	2	30	182-4TC	P7572099.B1
257	1.36	1766	540	6.81	2	25	182-4TC	P7472043.B1
257	1.62	1766	646	6.81	2	30	182-4TC	P7572100.B1
220	1.16	2063	579	7.96	2	25	182-4TC	P7472045.B1
220	1.54	2063	663	7.96	2	30	182-4TC	P7572102.B1
185	1.02	2453	615	9.45	2	25	182-4TC	P7472046.B1
185	1.22	2453	674	9.45	2	30	182-4TC	P7572103.B1
153	1.16	2966	778	11.43	2	30	182-4TC	P7572104.B1
123	1.03	3689	850	14.21	2	30	182-4TC	P7572105.B1

- ◆ Weight does not include oil.
- ▼ Service Factor is based on maximum torque rating of reducer. Refer to page 171 for special application considerations.
- Overhung load is calculated at centerline of output shaft.

QUICK REFERENCE

OTHER REDUCER CONFIGURATIONS	Page 38
OUTPUT FLANGE SELECTIONS	53
INTERCHANGE BASE SELECTIONS	54



QUICK SELECTIONS
DOUBLE AND TRIPLE REDUCTION



LeCentric™ Gear Reducers & GEAR+MOTORS™



5 HP Gear+Motor™ Quick Selections					
TEFC, 3 Phase 230/460V		TEFC, 1 Phase 115/230V		Explosion-Proof, 3 Phase 230/460V	
Catalog No.	Wgt. ♦ (lbs.)	Catalog No.	Wgt. ♦ (lbs.)	Catalog No.	Wgt. ♦ (lbs.)
P7472039.B1-131492	97	P7472039.B1-131540	137	P7472039.B1-158005	150
P7472040.B1-131492	97	P7472040.B1-131540	137	P7472040.B1-158005	150
P7472041.B1-131492	97	P7472041.B1-131540	137	P7472041.B1-158005	150
P7572098.B1-131492	102	P7572098.B1-131540	142	P7572098.B1-158005	155
P7472042.B1-131492	97	P7472042.B1-131540	137	P7472042.B1-158005	150
P7572099.B1-131492	102	P7572099.B1-131540	142	P7572099.B1-158005	155
P7472043.B1-131492	97	P7472043.B1-131540	137	P7472043.B1-158005	150
P7572100.B1-131492	102	P7572100.B1-131540	142	P7572100.B1-158005	155
P7472045.B1-131492	97	P7472045.B1-131540	137	P7472045.B1-158005	150
P7572102.B1-131492	102	P7572102.B1-131540	142	P7572102.B1-158005	155
P7472046.B1-131492	97	P7472046.B1-131540	137	P7472046.B1-158005	150
P7572103.B1-131492	102	P7572103.B1-131540	142	P7572103.B1-158005	155
P7472047.B1-131492	97	P7472047.B1-131540	137	P7472047.B1-158005	150
P7572104.B1-131492	102	P7572104.B1-131540	142	P7572104.B1-158005	155
P7572105.B1-131492	102	P7572105.B1-131540	142	P7572105.B1-158005	155
P7572106.B1-131492	102	P7572106.B1-131540	142	P7572106.B1-158005	155
P7572107.B1-131492	102	P7572107.B1-131540	142	P7572107.B1-158005	155
7 1/2 HP Gear+Motor™ Quick Selections					
P7472039.B1-131606	135	—	—	—	—
P7572096.B1-131606	140	—	—	—	—
P7472040.B1-131606	135	—	—	—	—
P7572097.B1-131606	140	—	—	—	—
P7472041.B1-131606	135	—	—	—	—
P7572098.B1-131606	140	—	—	—	—
P7472042.B1-131606	135	—	—	—	—
P7572099.B1-131606	140	—	—	—	—
P7472043.B1-131606	135	—	—	—	—
P7572100.B1-131606	140	—	—	—	—
P7472045.B1-131606	135	—	—	—	—
P7572102.B1-131606	140	—	—	—	—
P7472046.B1-131606	135	—	—	—	—
P7572103.B1-131606	140	—	—	—	—
P7572104.B1-131606	140	—	—	—	—
P7572105.B1-131606	140	—	—	—	—

Gear+Motor™ catalog numbers are comprised of the reducer catalog number followed by the motor catalog number.

IN THIS CATALOG

- _____ RPM = Revolutions Per Minute
- _____ HP = Horsepower
- _____ TQ = Torque (lb.-in.)
- _____ OHL = Overhung Load In Pounds At Centerline Of Output Shaft With No Thrust Load.
- _____ TL = Thrust Load (lbs.) - Output Shaft

SELECT REDUCER MOUNTING POSITION ON PAGE 60



LEESON 700 Series Gear Reducer Catalog Number Nomenclature

All stock and custom 700 series reducers are identified by a catalog number – for example P7272001.B1. The catalog number appears on the nameplate and describes pertinent features of the reducer. An example follows, along with a listing of the various letters and positions used.

Reducers and renewal parts should be ordered using the catalog number. If a base or flange is factory assembled to a reducer, the assigned suffix code (i.e. B1) will be added to the catalog number. Accessories that are field installed will not be noted on the reducer nameplate. Reducers furnished without a base or flange will have a suffix code of "00."

Catalog numbers 5000 and higher (for example P7475001.B1) are custom reducers manufactured for a specific application. The machinery or equipment manufacturer should be contacted for replacement reducers. Renewal parts can be ordered from LEESON by catalog number.

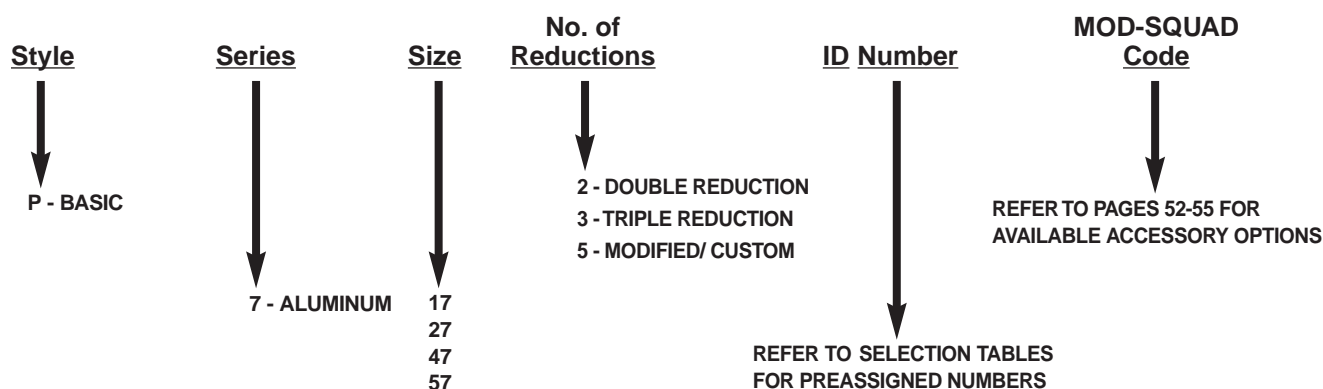

Sample Catalog Number

Standard aluminum construction, double reduction, size 27, with SEW interchange base.

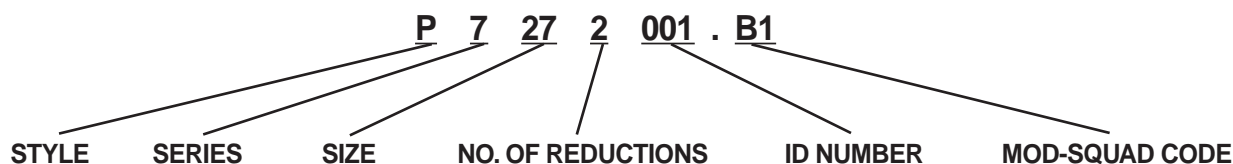

SPECIFY REDUCER MOUNTING POSITION AT TIME OF ORDER. REFER TO PAGE 60 FOR POSSIBLE MOUNTING POSITIONS. LeCENTRIC REDUCERS WILL BE FACTORY FILLED WITH OIL FOR POSITION H3 UNLESS OTHERWISE SPECIFIED.

Typical Nameplate

LEESON			
MAX INPUT HP @ 1750 RPM	5.18	OUTPUT TORQUE (IN-LBS)	623
CATALOG NO.	P7272001.B1	RATIO	3.48 :1
MOUNTING POSITION	H3	DATE CODE	BO4
LEESON ELECTRIC GRAFTON, WISCONSIN 53024			



“HOW TO USE” MAXIMUM RATING TABLES



LeCentric™ Gear Reducers & GEAR+MOTORS™

How To Use Maximum Rating Tables

Maximum Rating Tables for Double Reduction Gear Reducers are shown on pages 40-43. Triple Reduction Maximum Rating Tables are shown on pages 44-47. Selection of the appropriate gear reducer can be made using these tables or the Quick Selections on pages 8-37.

BEFORE YOU START:

- Identify the Service Factor** of the application.
- Determine the actual input horsepower** of the motor by multiplying the motor's nameplate horsepower by the Service Factor.
- Determine the output speed (RPM)** required at output shaft of reducer.

Identify the mounting style required by your application from the style charts shown on pages 52-55. Note the different bases and flanges to interchange with various competitive units.

To select the proper gear reducer size, use the Maximum Rating Tables as shown:

LeCentric™ Gear Reducers & GEAR+MOTORS™

DOUBLE REDUCTION MAXIMUM RATING TABLES
717 SERIES • ALUMINUM CASE

717 Series • 1.0 S.F. • Aluminum Case • 1750 RPM Input

Output Speed (RPM)	Output Torque (lb-in.)	Input HP	Ratio	Output* OHL (lbs.)	NON-MOTORIZED	MOTORIZED
					Basic Reducer Catalog Number**	Motor Frame Basic Reducer Catalog Number**
503	602	5.00	3.48	204	P7172045.XX	56C 143-5TC P7172001.XX P7172023.XX
405	602	4.03	4.32	216	P7172046.XX	56C 143-5TC P7172002.XX P7172024.XX
318	602	2.80	5.50	230	P7172047.XX	56C 143-5TC P7172003.XX P7172025.XX
275	602	2.74	6.36	250	P7172048.XX	56C 143-5TC P7172004.XX P7172026.XX
241	602	2.40	7.26	260	P7172049.XX	56C 143-5TC P7172005.XX P7172027.XX
207	602	2.21	7.89	266	P7172050.XX	56C 143-5TC P7172006.XX P7172028.XX
173	798	2.30	10.04	284	P7172052.XX	56C P7172008.XX
140	798	1.98	11.64	293	P7172053.XX	
106	798	1.74	13.26	305	P7172054.XX	
73	798	1.50	15.37	321	P7172055.XX	
40	108	798	1.40	16.20	335	56C 143-5TC P7172012.XX P7172034.XX
27	93	798	1.21	18.80	350	56C 143-5TC P7172013.XX P7172035.XX
14	81	798	1.07	21.54	374	56C 143-5TC P7172014.XX P7172036.XX
11		1.04	22.26	375	P7172059.XX	56C 143-5TC P7172015.XX P7172037.XX
8		0.86	26.30	420	P7172060.XX	56C P7172016.XX
6		0.79	29.40	435	P7172061.XX	56C P7172017.XX
5		0.63	35.90	470	P7172062.XX	56C P7172018.XX
4		0.60	38.37	478	P7172063.XX	56C P7172019.XX
3		0.48	46.80	507	P7172064.XX	56C P7172020.XX
2	35	798	0.46	50.67	510	56C P7172065.XX
1	28	798	0.37	61.80	532	56C P7172066.XX

Basic Motorized Quill Input Reducer

Basic Non-Motorized Input Reducer

*Overhung load is calculated at centerline of output shaft.
**Catalog numbers are for basic reducer without base or output flange.

1 Find the appropriate Maximum Rating Tables pages for your basic mounting style. The tables begin on page 40.

5 Select motor frame size if reducer is to have a motorized input.

2 Locate output RPM column on left side of the table. All ratings are based on an input speed of 1750 RPM. Scroll down to the output speed (RPM) required. Output speeds are rounded to the nearest whole number. For exact output speed, divide 1750 by the ratio listed.

3 Move across the table to the Input HP column until you find a rating that is equal to or greater than the actual input horsepower required. Once located, check the top of the table to identify the correct gear reducer size (717, 727, 747, 757, etc.).

4 Check load capacities against the needs of your application. Do not exceed the overhung load (OHL) capacity shown in the table. Detailed instructions for calculating the actual overhung load are shown on page 58. If overhung and thrust loads will be applied simultaneously or if the load exceeds listed capacities, contact LEESON.

6 Identify the catalog number of the reducer by continuing to the right. See page 38 for detailed information on building an exact catalog number. The XX suffix will be replaced with optional Mod-Squad codes as detailed on page 52.

7 Verify physical dimensions using the dimensional drawings shown on pages 48.51.

8 Determine reducer mounting position from page 60.

39

CALL NOW 800-985-6929

http://www.automatedpt.com

Email: charles@automatedpt.com



DOUBLE REDUCTION MAXIMUM RATING TABLES

717 SERIES • ALUMINUM CASE



717 Series • 1.0 S.F. • Aluminum Case • 1750 RPM Input



Basic Motorized
Quill Input Reducer



Basic Non-Motorized
Input Reducer

Output Speed (RPM)	Output Torque (lb-in.)	Input HP	Ratio	Output* OHL (lbs.)	NON-MOTORIZED	MOTORIZED QUILL INPUT	
					Basic Reducer Catalog Number**	Motor Frame	Basic Reducer Catalog Number**
503	602	5.00	3.48	204	P7172045.XX	56C 143-5TC	P7172001.XX P7172023.XX
405	602	4.03	4.32	216	P7172046.XX	56C 143-5TC	P7172002.XX P7172024.XX
318	602	2.80	5.50	230	P7172047.XX	56C 143-5TC	P7172003.XX P7172025.XX
275	602	2.74	6.36	250	P7172048.XX	56C 143-5TC	P7172004.XX P7172026.XX
241	602	2.40	7.26	260	P7172049.XX	56C 143-5TC	P7172005.XX P7172027.XX
222	602	2.21	7.89	266	P7172050.XX	56C 143-5TC	P7172006.XX P7172028.XX
174	798	2.30	10.04	284	P7172052.XX	56C 143-5TC	P7172008.XX P7172030.XX
150	798	1.98	11.64	293	P7172053.XX	56C 143-5TC	P7172009.XX P7172031.XX
132	798	1.74	13.26	305	P7172054.XX	56C 143-5TC	P7172010.XX P7172032.XX
114	798	1.50	15.37	321	P7172055.XX	56C 143-5TC	P7172011.XX P7172033.XX
108	798	1.40	16.20	335	P7172056.XX	56C 143-5TC	P7172012.XX P7172034.XX
93	798	1.21	18.80	350	P7172057.XX	56C 143-5TC	P7172013.XX P7172035.XX
81	798	1.07	21.54	374	P7172058.XX	56C 143-5TC	P7172014.XX P7172036.XX
79	798	1.04	22.26	375	P7172059.XX	56C 143-5TC	P7172015.XX P7172037.XX
67	798	0.86	26.30	420	P7172060.XX	56C	P7172016.XX
60	798	0.79	29.40	435	P7172061.XX	56C	P7172017.XX
49	798	0.63	35.90	470	P7172062.XX	56C	P7172018.XX
46	798	0.60	38.37	478	P7172063.XX	56C	P7172019.XX
37	798	0.48	46.80	507	P7172064.XX	56C	P7172020.XX
35	798	0.46	50.67	510	P7172065.XX	56C	P7172021.XX
28	798	0.37	61.80	532	P7172066.XX	56C	P7172022.XX

*Overhung load is calculated at centerline of output shaft.
**Catalog numbers are for basic reducer without base or output flange.

WHEN ORDERING, SUBSTITUTE THE XX SUFFIX WITH REQUIRED MOD-SQUAD CODE. FOR AVAILABLE INTERCHANGE BASE AND OUTPUT FLANGE CODES SEE PAGES 52-55.

IN THIS CATALOG

RPM = Revolutions Per Minute
HP = Horsepower
TQ = Torque (lb-in.)
OHL = Overhung Load In Pounds At Centerline Of Output Shaft With No Thrust Load.
TL = Thrust Load (lbs.) - Output Shaft

SELECT REDUCER MOUNTING POSITION ON PAGE 60



**DOUBLE REDUCTION
MAXIMUM RATING TABLES**
727 SERIES • ALUMINUM CASE



LeCentric™ Gear Reducers & GEAR-MOTORS™

727 Series • 1.0 S.F. • Aluminum Case • 1750 RPM Input

Output Speed (RPM)	Output Torque (lb-in.)	Input HP	Ratio	Output* OHL (lbs.)	NON-MOTORIZED	MOTORIZED QUILL INPUT
					Basic Reducer Catalog Number**	Motor Frame Basic Reducer Catalog Number**
503	708	5.88	3.48	268	P7272045.XX	56C 143-5TC P7272001.XX P7272023.XX
405	775	5.19	4.32	289	P7272046.XX	56C 143-5TC P7272002.XX P7272024.XX
318	887	4.67	5.50	350	P7272047.XX	56C 143-5TC P7272003.XX P7272025.XX
275	949	4.32	6.36	376	P7272048.XX	56C 143-5TC P7272004.XX P7272026.XX
241	1065	4.24	7.26	391	P7272049.XX	56C 143-5TC P7272005.XX P7272027.XX
222	1065	3.90	7.89	400	P7272050.XX	56C 143-5TC P7272006.XX P7272028.XX
174	1190	3.43	10.04	420	P7272052.XX	56C 143-5TC P7272008.XX P7272030.XX
150	1190	2.96	11.64	445	P7272053.XX	56C 143-5TC P7272009.XX P7272031.XX
132	1190	2.60	13.26	476	P7272054.XX	56C 143-5TC P7272010.XX P7272032.XX
114	1190	2.24	15.37	508	P7272055.XX	56C 143-5TC P7272011.XX P7272033.XX
108	1158	2.03	16.20	520	P7272056.XX	56C 143-5TC P7272012.XX P7272034.XX
93	1158	1.75	18.80	535	P7272057.XX	56C 143-5TC P7272013.XX P7272035.XX
81	1190	1.60	21.54	562	P7272058.XX	56C 143-5TC P7272014.XX P7272036.XX
79	1190	1.55	22.26	562	P7272059.XX	56C 143-5TC P7272015.XX P7272037.XX
67	1158	1.25	26.30	615	P7272060.XX	56C 143-5TC P7272016.XX P7272038.XX
60	1190	1.17	29.40	629	P7272061.XX	56C 143-5TC P7272017.XX P7272039.XX
49	1158	0.92	35.90	660	P7272062.XX	56C P7272018.XX
46	1127	0.85	38.37	663	P7272063.XX	56C P7272019.XX
37	1065	0.65	46.80	674	P7272064.XX	56C P7272020.XX
35	1127	0.64	50.67	674	P7272065.XX	56C P7272021.XX
28	1065	0.49	61.80	674	P7272066.XX	56C P7272022.XX



Basic Motorized Quill Input Reducer



Basic Non-Motorized Input Reducer

*Overhung load is calculated at centerline of output shaft.
**Catalog numbers are for basic reducer without base or output flange.

WHEN ORDERING, SUBSTITUTE THE XX SUFFIX WITH REQUIRED MOD-SQUAD CODE. FOR AVAILABLE INTERCHANGE BASE AND OUTPUT FLANGE CODES SEE PAGES 52-55.

SELECT REDUCER MOUNTING POSITION ON PAGE 60

IN THIS CATALOG

RPM = Revolutions Per Minute
HP = Horsepower
TQ = Torque (lb-in.)
OHL = Overhung Load In Pounds At Centerline Of Output Shaft With No Thrust Load.
TL = Thrust Load (lbs.) - Output Shaft



DOUBLE REDUCTION MAXIMUM RATING TABLES

747 SERIES • ALUMINUM CASE



747 Series • 1.0 S.F. • Aluminum Case • 1750 RPM Input



Basic Motorized
Quill Input Reducer



Basic Non-Motorized
Input Reducer

Output Speed (RPM)	Output Torque (lb-in.)	Input HP	Ratio	Output* OHL (lbs.)	NON-MOTORIZED	MOTORIZED QUILL INPUT	
					Basic Reducer Catalog Number**	Motor Frame	Basic Reducer Catalog Number**
485	1473	11.80	3.61	450	P7472058.XX	143-5TC 182-4TC	P7472020.XX P7472039.XX
414	1792	12.27	4.23	474	P7472059.XX	143-5TC 182-4TC	P7472021.XX P7472040.XX
349	2200	12.69	5.01	491	P7472060.XX	143-5TC 182-4TC	P7472022.XX P7472041.XX
288	2200	10.49	6.07	522	P7472061.XX	143-5TC 182-4TC	P7472023.XX P7472042.XX
257	2404	10.22	6.81	540	P7472062.XX	143-5TC 182-4TC	P7472024.XX P7472043.XX
220	2404	8.73	7.96	579	P7472064.XX	143-5TC 182-4TC	P7472026.XX P7472045.XX
185	2502	7.66	9.45	615	P7472065.XX	143-5TC 182-4TC	P7472027.XX P7472046.XX
153	2600	6.58	11.43	658	P7472066.XX	143-5TC 182-4TC	P7472028.XX P7472047.XX
123	2300	4.68	14.21	693	P7472067.XX	143-5TC 182-4TC	P7472029.XX P7472048.XX
105	2502	4.36	16.62	711	P7472068.XX	56C 143-5TC 182-4TC	P7472011.XX P7472030.XX P7472049.XX
87	2502	3.60	20.10	780	P7472069.XX	56C 143-5TC 182-4TC	P7472012.XX P7472031.XX P7472050.XX
70	2300	2.66	24.98	877	P7472070.XX	56C 143-5TC 182-4TC	P7472013.XX P7472032.XX P7472051.XX
60	2502	2.46	29.41	900	P7472071.XX	56C 143-5TC	P7472014.XX P7472033.XX
49	2502	2.03	35.58	922	P7472072.XX	56C 143-5TC	P7472015.XX P7472034.XX
43	2404	1.72	40.50	988	P7472073.XX	56C 143-5TC	P7472016.XX P7472035.XX
40	2300	1.50	44.23	1012	P7472074.XX	56C 143-5TC	P7472017.XX P7472036.XX
36	2404	1.42	49.00	1028	P7472075.XX	56C 143-5TC	P7472018.XX P7472037.XX
29	2200	1.04	60.90	1050	P7472076.XX	56C 143-5TC	P7472019.XX P7472038.XX

*Overhung load is calculated at centerline of output shaft.

**Catalog numbers are for basic reducer without base or output flange.

WHEN ORDERING, SUBSTITUTE THE XX SUFFIX WITH REQUIRED MOD-SQUAD CODE. FOR AVAILABLE INTERCHANGE BASE AND OUTPUT FLANGE CODES SEE PAGES 52-55.

IN THIS CATALOG

RPM = Revolutions Per Minute
HP = Horsepower
TQ = Torque (lb-in.)
OHL = Overhung Load In Pounds At Centerline Of Output Shaft With No Thrust Load.
TL = Thrust Load (lbs.) - Output Shaft

SELECT REDUCER MOUNTING POSITION ON PAGE 60



**DOUBLE REDUCTION
MAXIMUM RATING TABLES**
757 SERIES • ALUMINUM CASE



LeCentric™ Gear Reducers & GEAR-MOTORS™

757 Series • 1.0 S.F. • Aluminum Case • 1750 RPM Input

Output Speed (RPM)	Output Torque (lb-in.)	Input HP	Ratio	Output* OHL (lbs.)	NON-MOTORIZED	MOTORIZED QUILL INPUT	
					Basic Reducer Catalog Number**	Motor Frame	Basic Reducer Catalog Number**
485	1651	13.22	3.61	534	P7572134.XX	143-5TC 182-4TC	P7572058.XX P7572096.XX
414	1932	13.23	4.23	566	P7572135.XX	143-5TC 182-4TC	P7572059.XX P7572097.XX
349	2293	13.23	5.01	603	P7572136.XX	143-5TC 182-4TC	P7572060.XX P7572098.XX
288	2774	13.23	6.07	629	P7572137.XX	143-5TC 182-4TC	P7572061.XX P7572099.XX
257	2860	12.15	6.81	646	P7572138.XX	143-5TC 182-4TC	P7572062.XX P7572100.XX
220	3180	11.55	7.96	663	P7572140.XX	143-5TC 182-4TC	P7572064.XX P7572102.XX
185	3000	9.18	9.45	674	P7572141.XX	143-5TC 182-4TC	P7572065.XX P7572103.XX
153	3442	8.71	11.43	778	P7572142.XX	143-5TC 182-4TC	P7572066.XX P7572104.XX
123	3800	7.73	14.21	850	P7572143.XX	143-5TC 182-4TC	P7572067.XX P7572105.XX
105	3800	6.61	16.62	872	P7572144.XX	143-5TC 182-4TC	P7572068.XX P7572106.XX
87	3800	5.47	20.10	900	P7572145.XX	143-5TC 182-4TC	P7572069.XX P7572107.XX
70	3800	4.40	24.98	944	P7572146.XX	143-5TC 182-4TC	P7572070.XX P7572108.XX
60	3000	2.95	29.41	1012	P7572147.XX	56C 143-5TC	P7572033.XX P7572071.XX
49	3000	2.44	35.58	1079	P7572148.XX	56C 143-5TC	P7572034.XX P7572072.XX
43	2567	1.83	40.50	1192	P7572149.XX	56C 143-5TC	P7572035.XX P7572073.XX
40	2800	1.83	44.23	1304	P7572150.XX	56C 143-5TC	P7572036.XX P7572074.XX
36	2777	1.64	49.00	1330	P7572151.XX	56C 143-5TC	P7572037.XX P7572075.XX
29	2800	1.33	60.90	1367	P7572152.XX	56C 143-5TC	P7572038.XX P7572076.XX

*Overhung load is calculated at centerline of output shaft.
**Catalog numbers are for basic reducer without base or output flange.



Basic Motorized Quill Input Reducer



Basic Non-Motorized Input Reducer

WHEN ORDERING, SUBSTITUTE THE XX SUFFIX WITH REQUIRED MOD-SQUAD CODE. FOR AVAILABLE INTERCHANGE BASE AND OUTPUT FLANGE CODES SEE PAGES 52-55.

SELECT REDUCER MOUNTING POSITION ON PAGE 60

IN THIS CATALOG

- _____ RPM = Revolutions Per Minute
- _____ HP = Horsepower
- _____ TQ = Torque (lb-in.)
- _____ OHL = Overhung Load In Pounds At Centerline Of Output Shaft With No Thrust Load.
- _____ TL = Thrust Load (lbs.) - Output Shaft



TRIPLE REDUCTION MAXIMUM RATING TABLES

717 SERIES • ALUMINUM CASE



717 Series • 1.0 S.F. • Aluminum Case • 1750 RPM Input



Basic Motorized
Quill Input Reducer



Basic Non-Motorized
Input Reducer

Output Speed (RPM)	Output Torque (lb-in.)	Input HP	Ratio	Output* OHL (lbs.)	NON-MOTORIZED	MOTORIZED QUILL INPUT	
					Basic Reducer Catalog Number**	Motor Frame	Basic Reducer Catalog Number**
52	798	0.71	33.50	459	P7173017.XX	56C	P7173001.XX
46	798	0.62	38.34	478	P7173018.XX	56C	P7173002.XX
40	798	0.55	43.69	495	P7173019.XX	56C	P7173003.XX
35	798	0.47	50.64	510	P7173020.XX	56C	P7173004.XX
33	798	0.44	53.40	520	P7173021.XX	56C	P7173005.XX
29	798	0.39	61.22	525	P7173022.XX	56C	P7173006.XX
28	798	0.38	62.00	532	P7173023.XX	56C	P7173007.XX
25	798	0.34	70.95	540	P7173024.XX	56C	P7173008.XX
24	798	0.32	73.33	540	P7173025.XX	56C	P7173009.XX
23	798	0.31	74.50	540	P7173026.XX	56C	P7173010.XX
20	798	0.27	86.80	540	P7173027.XX	56C	P7173011.XX
18	798	0.25	96.85	540	P7173028.XX	56C	P7173012.XX
17	798	0.23	102.80	540	P7173029.XX	56C	P7173013.XX
15	798	0.20	126.40	540	P7173030.XX	56C	P7173014.XX
13	798	0.18	135.69	540	P7173031.XX	56C	P7173015.XX
10	798	0.14	165.20	540	P7173032.XX	56C	P7173016.XX

*Overhung load is calculated at centerline of output shaft.
**Catalog numbers are for basic reducer without base or output flange.

WHEN ORDERING, SUBSTITUTE THE XX SUFFIX WITH REQUIRED MOD-SQUAD CODE. FOR AVAILABLE INTERCHANGE BASE AND OUTPUT FLANGE CODES SEE PAGES 52-55.

SELECT REDUCER MOUNTING POSITION ON PAGE 60

IN THIS CATALOG

RPM = Revolutions Per Minute
HP = Horsepower
TQ = Torque (lb-in.)
OHL = Overhung Load In Pounds At Centerline Of Output Shaft With No Thrust Load.
TL = Thrust Load (lbs.) - Output Shaft



**TRIPLE REDUCTION
MAXIMUM RATING TABLES**

727 SERIES • ALUMINUM CASE



LeCentric™ Gear Reducers & GEAR+MOTORS™

727 Series • 1.0 S.F. • Aluminum Case • 1750 RPM Input

Output Speed (RPM)	Output Torque (lb-in.)	Input HP	Ratio	Output* OHL (lbs.)	NON-MOTORIZED	MOTORIZED QUILL INPUT	
					Basic Reducer Catalog Number**	Motor Frame	Basic Reducer Catalog Number**
52	1189	1.06	33.50	645	P7273017.XX	56C	P7273001.XX
46	1118	0.87	38.34	663	P7273018.XX	56C	P7273002.XX
40	1189	0.81	43.69	674	P7273019.XX	56C	P7273003.XX
35	1189	0.70	50.64	674	P7273020.XX	56C	P7273004.XX
33	1162	0.64	53.40	674	P7273021.XX	56C	P7273005.XX
29	1189	0.58	61.22	674	P7273022.XX	56C	P7273006.XX
28	1162	0.55	62.00	674	P7273023.XX	56C	P7273007.XX
25	1189	0.50	70.95	674	P7273024.XX	56C	P7273008.XX
24	1118	0.46	73.33	674	P7273025.XX	56C	P7273009.XX
23	1162	0.46	74.50	674	P7273026.XX	56C	P7273010.XX
20	1162	0.39	86.80	674	P7273027.XX	56C	P7273011.XX
18	1189	0.37	96.85	674	P7273028.XX	56C	P7273012.XX
17	1171	0.34	102.80	674	P7273029.XX	56C	P7273013.XX
15	1162	0.29	126.40	674	P7273030.XX	56C	P7273014.XX
13	1189	0.26	135.69	674	P7273031.XX	56C	P7273015.XX
10	1162	0.21	165.20	674	P7273032.XX	56C	P7273016.XX

*Overhung load is calculated at centerline of output shaft.
**Catalog numbers are for basic reducer without base or output flange.



Basic Motorized Quill Input Reducer



Basic Non-Motorized Input Reducer

WHEN ORDERING, SUBSTITUTE THE XX SUFFIX WITH REQUIRED MOD-SQUAD CODE. FOR AVAILABLE INTERCHANGE BASE AND OUTPUT FLANGE CODES SEE PAGES 52-55.

SELECT REDUCER MOUNTING POSITION ON PAGE 60

IN THIS CATALOG

RPM = Revolutions Per Minute
HP = Horsepower
TQ = Torque (lb-in.)
OHL = Overhung Load In Pounds At Centerline Of Output Shaft With No Thrust Load.
TL = Thrust Load (lbs.) - Output Shaft



TRIPLE REDUCTION MAXIMUM RATING TABLES

747 SERIES • ALUMINUM CASE



747 Series • 1.0 S.F. • Aluminum Case • 1750 RPM Input



Basic Motorized
Quill Input Reducer



Basic Non-Motorized
Input Reducer

Output Speed (RPM)	Output Torque (lb-in.)	Input HP	Ratio	Output* OHL (lbs.)	NON-MOTORIZED	MOTORIZED QUILL INPUT	
					Basic Reducer Catalog Number**	Motor Frame	Basic Reducer Catalog Number**
52	2396	2.10	34.01	918	P7473045.XX	56C 143-5TC	P7473001.XX P7473023.XX
44	2396	1.80	39.79	988	P7473046.XX	56C 143-5TC	P7473002.XX P7473024.XX
37	2396	1.51	47.22	1028	P7473047.XX	56C 143-5TC	P7473003.XX P7473025.XX
32	2396	1.31	54.73	1041	P7473048.XX	56C 143-5TC	P7473004.XX P7473026.XX
31	2396	1.25	57.13	1050	P7473049.XX	56C 143-5TC	P7473005.XX P7473027.XX
26	2396	1.08	66.22	1075	P7473050.XX	56C 143-5TC	P7473006.XX P7473028.XX
25	2396	1.01	71.01	1079	P7473051.XX	56C 143-5TC	P7473007.XX P7473029.XX
23	2396	0.93	76.69	1091	P7473052.XX	56C 143-5TC	P7473008.XX P7473030.XX
21	2396	0.87	82.30	1091	P7473053.XX	56C 143-5TC	P7473009.XX P7473031.XX
21	2396	0.86	83.59	1091	P7473054.XX	56C 143-5TC	P7473010.XX P7473032.XX
19	2396	0.77	92.78	1102	P7473055.XX	56C	P7473011.XX
17	2396	0.68	104.68	1112	P7473056.XX	56C	P7473012.XX
15	2396	0.61	117.22	1124	P7473057.XX	56C	P7473013.XX
14	2396	0.56	126.65	1130	P7473058.XX	56C	P7473014.XX
13	2396	0.53	135.74	1136	P7473059.XX	56C	P7473015.XX
12	2396	0.49	145.68	1150	P7473060.XX	56C	P7473016.XX
11	2396	0.45	157.40	1168	P7473061.XX	56C	P7473017.XX
11	2396	0.44	164.23	1186	P7473062.XX	56C	P7473018.XX
9.4	2396	0.39	185.29	1186	P7473063.XX	56C	P7473019.XX
8.6	2396	0.35	204.12	1186	P7473064.XX	56C	P7473020.XX
7.8	2396	0.32	224.18	1195	P7473065.XX	56C	P7473021.XX
6.3	2396	0.26	278.62	1214	P7473066.XX	56C	P7473022.XX

*Overhung load is calculated at centerline of output shaft.
**Catalog numbers are for basic reducer without base or output flange.

WHEN ORDERING, SUBSTITUTE THE XX SUFFIX WITH REQUIRED MOD-SQUAD CODE. FOR AVAILABLE INTERCHANGE BASE AND OUTPUT FLANGE CODES SEE PAGES 52-55.

IN THIS CATALOG

RPM = Revolutions Per Minute
HP = Horsepower
TQ = Torque (lb-in.)
OHL = Overhung Load In Pounds At Centerline Of Output Shaft With No Thrust Load.
TL = Thrust Load (lbs.) - Output Shaft

SELECT REDUCER MOUNTING POSITION ON PAGE 60



TRIPLE REDUCTION MAXIMUM RATING TABLES

757 SERIES • ALUMINUM CASE



LeCentric™ Gear Reducers & GEAR-MOTORS™

757 Series • 1.0 S.F. • Aluminum Case • 1750 RPM Input

Output Speed (RPM)	Output Torque (lb-in.)	Input HP	Ratio	Output* OHL (lbs.)	NON-MOTORIZED	MOTORIZED QUILL INPUT	
					Basic Reducer Catalog Number**	Motor Frame	Basic Reducer Catalog Number**
52	3372	2.96	34.01	1060	P7573111.XX	56C 143-5TC	P7573023.XX P7573067.XX
44	3372	2.53	39.79	1192	P7573112.XX	56C 143-5TC	P7573024.XX P7573068.XX
37	3372	2.13	47.22	1330	P7573113.XX	56C 143-5TC	P7573025.XX P7573069.XX
32	3372	1.84	54.73	1354	P7573114.XX	56C 143-5TC	P7573026.XX P7573070.XX
31	3372	1.76	57.13	1354	P7573115.XX	56C 143-5TC	P7573027.XX P7573071.XX
26	3372	1.52	66.22	1398	P7573116.XX	56C 143-5TC	P7573028.XX P7573072.XX
25	3372	1.42	71.01	1398	P7573117.XX	56C 143-5TC	P7573029.XX P7573073.XX
23	3372	1.31	76.69	1414	P7573118.XX	56C 143-5TC	P7573030.XX P7573074.XX
21	3372	1.22	82.30	1422	P7573119.XX	56C 143-5TC	P7573031.XX P7573075.XX
21	3372	1.20	83.59	1422	P7573120.XX	56C 143-5TC	P7573032.XX P7573076.XX
19	3372	1.09	92.78	1430	P7573121.XX	56C 143-5TC	P7573033.XX P7573077.XX
17	3372	0.96	104.68	1454	P7573122.XX	56C 143-5TC	P7573034.XX P7573078.XX
15	3372	0.86	117.22	1461	P7573123.XX	56C 143-5TC	P7573035.XX P7573079.XX
14	3372	0.79	126.65	1468	P7573124.XX	56C	P7573036.XX
13	3372	0.74	135.74	1472	P7573125.XX	56C	P7573037.XX
12	3372	0.69	145.68	1475	P7573126.XX	56C	P7573038.XX
11	3372	0.64	157.40	1492	P7573127.XX	56C	P7573039.XX
11	3372	0.61	164.23	1492	P7573128.XX	56C	P7573040.XX
9.4	3372	0.54	185.29	1498	P7573129.XX	56C	P7573041.XX
8.6	3372	0.49	204.12	1502	P7573130.XX	56C	P7573042.XX
7.8	3372	0.45	224.18	1510	P7573131.XX	56C	P7573043.XX
6.3	3372	0.36	278.62	1510	P7573132.XX	56C	P7573044.XX

*Overhung load is calculated at centerline of output shaft.

**Catalog numbers are for basic reducer without base or output flange.



Basic Motorized Quill Input Reducer



Basic Non-Motorized Input Reducer

WHEN ORDERING, SUBSTITUTE THE XX SUFFIX WITH REQUIRED MOD-SQUAD CODE. FOR AVAILABLE INTERCHANGE BASE AND OUTPUT FLANGE CODES SEE PAGES 52-55.

IN THIS CATALOG

RPM = Revolutions Per Minute
HP = Horsepower
TQ = Torque (lb-in.)
OHL = Overhung Load In Pounds At Centerline Of Output Shaft With No Thrust Load.
TL = Thrust Load (lbs.) - Output Shaft

SELECT REDUCER MOUNTING POSITION ON PAGE 60



DIMENSIONS
MOTORIZED • BASE MOUNT

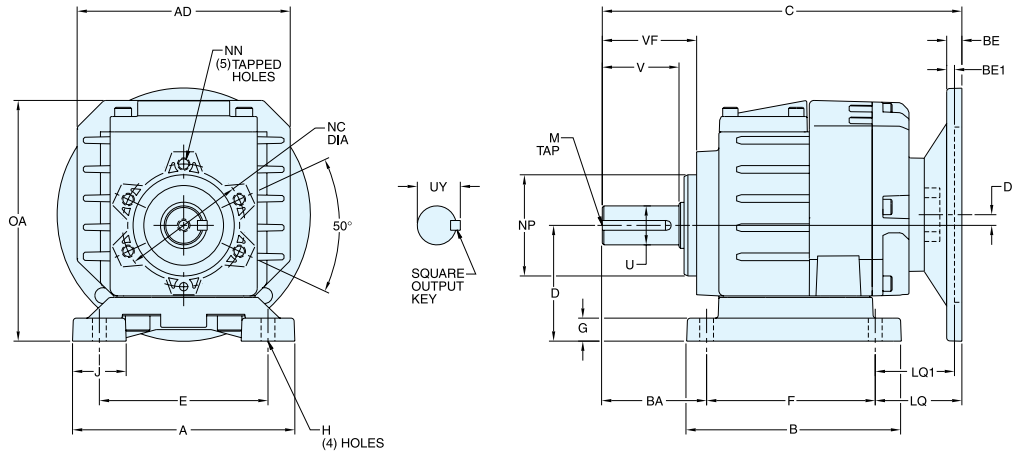

Motorized Quill Input, Double Reduction (B1 Base Mount Shown)

Series	A	AD	B	BA	C		D	DB	E	F	G	H	J	LQ		M	
					56/140	180								56/140	180	TAP	DEPTH
717	5.71	5.47	5.51	2.28	8.83	NA	2.95	0.27	4.33	4.33	0.59	0.35	1.38	2.23	NA	1/4-20	0.62
727	5.71	5.47	6.02	2.95	9.23	NA	3.54	0.27	4.33	5.12	0.79	0.35	1.38	1.16	NA	5/16-18	0.75
747	6.69	7.01	7.76	3.54	11.49	12.02	4.53	0.21	5.31	6.50	0.94	0.55	1.65	1.45	1.98	5/16-18	0.75
757	6.69	7.95	7.76	3.54	12.20	12.73	4.53	0.61	5.31	6.50	0.94	0.55	1.65	2.16	2.69	5/16-18	0.75

Series	NC	NP	NN		OA	U +0.000/ -0.001	UY	V	VF	OUTPUT KEY
			TAP	DEPTH						
717	3.15	2.60	M8	0.67	6.12	0.750	0.83	1.57	2.02	3/16 x 1.12
727	3.15	2.60	M8	0.67	6.71	1.000	1.11	1.97	2.40	1/4 x 1.62
747	4.84	4.17	M10	0.71	8.52	1.250	1.36	2.36	2.97	1/4 x 2.00
757	4.84	4.17	M10	0.71	8.58	1.250*	1.36	2.36	2.97	1/4 x 2.00

Motorized Quill Input, Triple Reduction (B1 Base Mount Shown)

Series	A	AD	B	BA	C	D	DB	E	F	G	H	J	LQ	M	
														TAP	DEPTH
717	5.71	5.47	5.51	2.28	9.60	2.95	0.13	4.33	4.33	0.59	0.35	1.38	2.99	1/4-20	0.62
727	5.71	5.47	6.02	2.95	10.00	3.54	0.13	4.33	5.12	0.79	0.35	1.38	1.93	5/16-18	0.75
747	6.69	7.01	7.76	3.54	11.83	4.53	0.59	5.31	6.50	0.94	0.55	1.65	1.83	5/16-18	0.75
757	6.69	7.95	7.76	3.54	12.55	4.53	0.61	5.31	6.50	0.94	0.55	1.65	2.51	5/16-18	0.75

Series	NC	NP	NN		OA	U +0.000/ -0.001	UY	V	VF	OUTPUT KEY
			TAP	DEPTH						
717	3.15	2.60	M8	0.67	6.12	0.750	0.83	1.57	2.02	3/16 x 1.12
727	3.15	2.60	M8	0.67	6.71	1.000	1.11	1.97	2.40	1/4 x 1.62
747	4.84	4.17	M10	0.71	8.52	1.250	1.36	2.36	2.97	1/4 x 2.00
757	4.84	4.17	M10	0.71	8.58	1.250*	1.36	2.36	2.97	1/4 x 2.00

*1.375" diameter shaft is available. Contact LEESON for availability.

B1 Base Mount is shown. See pages 54 & 55 for all available interchange bases

For NEMA motor mounting dimensions see page 57



DIMENSIONS
MOTORIZED • FLANGE MOUNT



LeCentric™ Gear Reducers & GEAR+MOTORS™

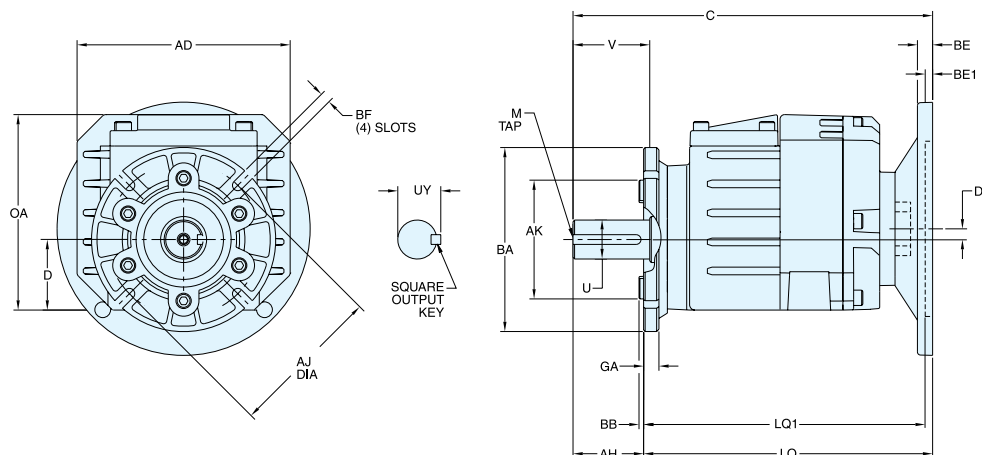

Motorized Quill Input, Double Reduction (F1 Flange Mount Shown)

Series	AD	AH	AJ	AK ■	BA	BB	BF	C		D	DB	GA
								56/140	180			
717	5.47	1.41	3.94	3.15	4.72	0.12	0.28	8.83	N/A	1.81	0.27	0.39
727	5.47	1.79	3.94	3.15	4.72	0.12	0.28	9.23	N/A	1.81	0.27	0.39
747	7.01	2.24	5.12	4.33	6.30	0.14	0.43	11.49	12.02	2.76	0.21	0.61
757	7.95	2.60	5.12	4.33	6.30	0.14	0.43	12.20	12.73	2.76	0.61	0.61

Series	LQ 56C/140TC	LQ1	M		OA	U +0.000/ -0.001	UY	V	OUTPUT KEY
			TAP	DEPTH					
717	7.42	N/A	1/4-20	0.62	5.02	0.750	0.83	1.57	3/16 x 1.12
727	7.44	N/A	5/16-18	0.75	5.02	1.000	1.11	1.97	1/4 x 1.62
747	9.25	9.78	5/16-18	0.75	6.75	1.250	1.36	2.36	1/4 x 2.00
757	10.00	10.53	5/16-18	0.75	6.81	1.250*	1.36	2.36	1/4 x 2.00

Motorized Quill Input, Triple Reduction (F1 Flange Mount Shown)

Series	AD	AH	AJ	AK ■	BA	BB	BF	C	D	DB	GA
717	5.47	1.41	3.94	3.15	4.72	0.12	0.28	9.60	1.81	0.13	0.39
727	5.47	1.79	3.94	3.15	4.72	0.12	0.28	10.00	1.81	0.13	0.39
747	7.01	2.24	5.12	4.33	6.30	0.14	0.43	11.83	2.76	0.59	0.61
757	7.95	2.60	5.12	4.33	6.30	0.14	0.43	12.55	2.76	0.61	0.61

Series	LQ 56C/140TC	LQ1	M		OA	U +0.000/ -0.001	UY	V	OUTPUT KEY
			TAP	DEPTH					
717	8.19	N/A	1/4-20	0.62	5.02	0.750	0.83	1.57	3/16 x 1.12
727	8.21	N/A	5/16-18	0.75	5.02	1.000	1.11	1.97	1/4 x 1.62
747	9.59	9.78	5/16-18	0.75	6.75	1.250	1.36	2.36	1/4 x 2.00
757	10.35	10.53	5/16-18	0.75	6.81	1.250*	1.36	2.36	1/4 x 2.00

*1.375" diameter shaft is available. Contact LEESON for availability.
 ■ Tolerance of AK on flanges with BA dimension under 6.30" is -0.0014 to -0.0028".
 Flanges with a BA of 6.30" or larger have a AK tolerance of -0.0017 to -0.0033".

F1 Flange Mount is shown. See page 53 for all available output flanges

For NEMA motor mounting dimensions see page 57



DIMENSIONS
NON-MOTORIZED • FLANGE MOUNT



LeCentric™ Gear Reducers & GEAR+MOTORS™

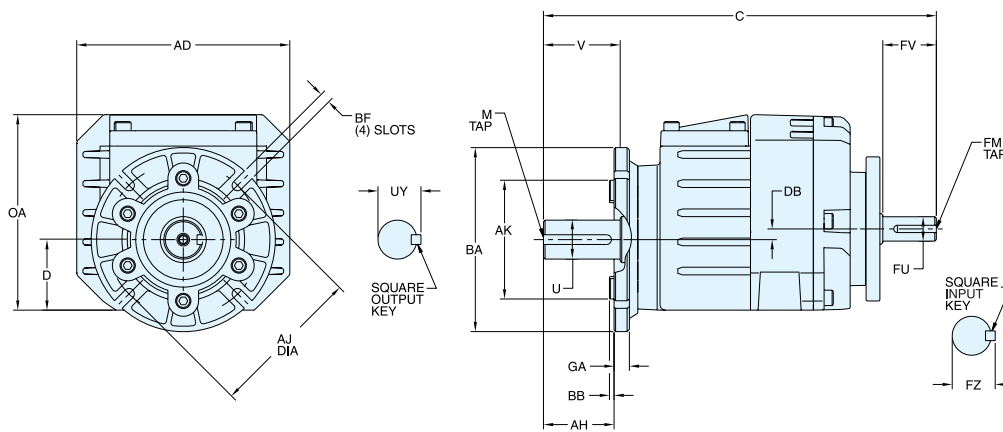

Non-Motorized, Double Reduction (F1 Flange Mount Shown)

Series	AD	AH	AJ	AK■	BA	BB	BF	C	D	DB	FM		FU +0.000/ -0.001	FV	FZ
											TAP	DEPTH			
717	5.47	1.41	3.94	3.15	4.72	0.12	0.28	9.88	1.81	0.27	1/4-20	0.62	0.625	1.57	0.70
727	5.47	1.79	3.94	3.15	4.72	0.12	0.28	10.26	1.81	0.27	1/4-20	0.62	0.625	1.57	0.70
747	7.01	2.24	5.12	4.33	6.30	0.14	0.43	13.00	2.76	0.21	5/16-18	0.75	0.750▲	1.97	0.83
757	7.95	2.60	5.12	4.33	6.30	0.14	0.43	13.67	2.76	0.61	5/16-18	0.75	0.750▲	1.97	0.83

Series	GA	LQ 56C140TC		LQ1 180TC	M		OA	U +0.000/ -0.001	UY	V	INPUT KEY	OUTPUT KEY
		2-Stage	3-Stage		TAP	DEPTH						
717	0.39	7.42	8.19	N/A	1/4-20	0.62	5.02	0.750	0.83	1.57	3/16 x 1.12	3/16 x 1.12
727	0.39	7.44	8.21	N/A	1/4-20	0.62	5.02	1.000	1.11	1.97	3/16 x 1.12	1/4 x 1.62
747	0.61	9.25	9.59	9.78	5/16-18	0.75	6.75	1.250	1.36	2.36	3/16 x 1.50	1/4 x 2.00
757	0.61	10.00	10.35	10.53	5/16-18	0.75	6.81	1.250*	1.36	2.36	3/16 x 1.50	1/4 x 2.00

Non-Motorized, Triple Reduction (F1 Flange Mount Shown)

Series	AD	AH	AJ	AK■	BA	BB	BF	C	D	DB	FM		FU +0.000/ -0.001	FV	FZ
											TAP	DEPTH			
717	5.47	1.41	3.94	3.15	4.72	0.12	0.28	10.06	1.81	0.13	1/4-20	0.62	0.625	1.57	0.70
727	5.47	1.79	3.94	3.15	4.72	0.12	0.28	10.44	1.81	0.13	1/4-20	0.62	0.625	1.57	0.70
747	7.01	2.24	5.12	4.33	6.30	0.14	0.43	12.92	2.76	0.59	5/16-18	0.75	0.750	1.57	0.83
757	7.95	2.60	5.12	4.33	6.30	0.14	0.43	13.60	2.76	0.61	5/16-18	0.75	0.750	1.57	0.83

Series	GA	LQ 56C140TC		LQ1 180TC	M		OA	U +0.000/ -0.001	UY	V	INPUT KEY	OUTPUT KEY
		2-Stage	3-Stage		TAP	DEPTH						
717	0.39	7.42	8.19	N/A	1/4-20	0.62	5.02	0.750	0.83	1.57	3/16 x 1.12	3/16 x 1.12
727	0.39	7.44	8.21	N/A	5/16-18	0.75	5.02	1.000	1.11	1.97	3/16 x 1.12	1/4 x 1.62
747	0.61	9.25	9.59	9.78	5/16-18	0.75	6.75	1.250	1.36	2.36	3/16 x 1.50	1/4 x 2.00
757	0.61	10.00	10.35	10.53	5/16-18	0.75	6.81	1.250*	1.36	2.36	3/16 x 1.50	1/4 x 2.00

* 1.375" diameter shaft is available. Contact LEESON for availability.
 ▲ 0.875" diameter shaft is available on 2-stage reducers only. Contact LEESON for availability.
 ■ Tolerance of AK on flanges with BA dimension under 6.30" is -0.0014 to -0.0028". Flanges with a BA of 6.30" or larger have a AK tolerance of -0.0017 to -0.0033".

F1 Flange Mount is shown. See page 53 for all available output flanges

For NEMA motor mounting dimensions see page 57



**INTERCHANGE GUIDE –
BASES & OUTPUT FLANGES**

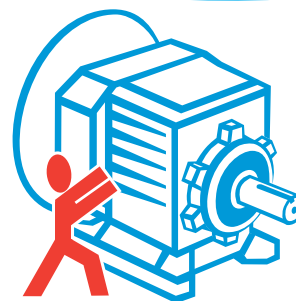

MOD-SQUAD™
IN-LINE MODIFICATIONS

Free Mod-Squad™ Service Or Assemble It Yourself!

Any of the preferred stock 700 Series reducers are available on a quick shipment basis, assembled with an interchange base or output flange by the **LEESON Gear Mod-Squad**—at no charge for the labor! Just pay for the accessory item. To order, specify the basic reducer catalog number and the Mod-Squad™ suffix code. Output flanges are listed on page 53. Interchange bases are listed on pages 54-55.

Or **assemble it yourself** by ordering the appropriate basic reducer and accessory kit (see options below).

LeCentric™ Interchange
Kits & Accessories

START

Select
Basic Reducer
Double or Triple Reduction

SEE MAX RATINGS PP. 40-47



Motorized Quill Input



Non-Motorized Input

CHOOSE

Base Mount



OR

Flange Mount



SEE INTERCHANGE BASE P. 54



Motorized Quill Input
Base Mount



Non-Motorized Input
Base Mount



Motorized Quill Input
Flange Mount



Non-Motorized Input
Flange Mount

ADD

Torque Foot for High-Shock Applications
(Base Mount Only)



SEE TORQUE FOOT P. 53



Motorized Quill Input
Base Mount
w/Torque Foot



Non-Motorized Input
Base Mount
w/Torque Foot



OUTPUT FLANGE SELECTIONS



LeCentric™ Interchange Kits & Accessories

717 Series • Flange Mount • Mod-Squad Codes Accessory Kits

Output Flange Options:	Mod-Squad Suffix Code (XX)	Accessory Kit No.	Critical Interchange Dimensions (Inches)									
			AH	AJ	AK	BA	BB	BF	GA	LQ		
No Flange	00	N/A										
Option 1	F1	G175701	1.41	3.94	3.15	4.72	0.12	0.28	0.39	7.42	8.19	
Option 2	F2	G175702	1.41	4.53	3.74	5.51	0.12	0.35	0.39	7.42	8.19	
Option 3	F3	G175703	1.41	5.12	4.33	6.30	0.14	0.35	0.39	7.42	8.19	
Option 4	F4	G175704	1.41	6.54	5.12	7.87	0.14	0.43	0.43	7.42	8.19	

727 Series • Flange Mount • Mod-Squad Codes Accessory Kits

Output Flange Options:	Mod-Squad Suffix Code (XX)	Accessory Kit No.	Critical Interchange Dimensions (Inches)									
			AH	AJ	AK	BA	BB	BF	GA	LQ		
No Flange	00	N/A										
Option 1	F1	G175701	1.79	3.94	3.15	4.72	0.12	0.28	0.39	7.44	8.21	
Option 2	F2	G175702	1.79	4.53	3.74	5.51	0.12	0.35	0.39	7.44	8.21	
Option 3	F3	G175703	1.79	5.12	4.33	6.30	0.14	0.35	0.39	7.44	8.21	
Option 4	F4	G175704	1.79	6.54	5.12	7.87	0.14	0.43	0.43	7.44	8.21	

747 Series • Flange Mount • Mod-Squad Codes Accessory Kits

Output Flange Options:	Mod-Squad Suffix Code (XX)	Accessory Kit No.	Critical Interchange Dimensions (Inches)											
			AH	AJ	AK	BA	BB	BF	GA	LQ		LQ1		
No Flange	00	N/A												
Option 1	F1	G175705	2.24	5.12	4.33	6.30	0.14	0.43	0.61	9.25	9.59	9.78		
Option 2	F2	G175706	2.30	6.46	5.12	7.87	0.14	0.43	0.51	9.19	9.53	9.72		
Option 3	F3	G175707	2.30	8.47	7.09	9.84	0.16	0.55	0.61	9.19	9.53	9.72		

757 Series • Flange Mount • Mod-Squad Codes Accessory Kits

Output Flange Options:	Mod-Squad Suffix Code (XX)	Accessory Kit No.	Critical Interchange Dimensions (Inches)											
			AH	AJ	AK	BA	BB	BF	GA	LQ		LQ1		
No Flange	00	N/A												
Option 1	F1	G175705	2.60	5.12	4.33	6.30	0.14	0.43	0.61	10.00	10.35	10.53		
Option 2	F2	G175706	2.66	6.46	5.12	7.87	0.14	0.43	0.51	9.94	10.29	10.47		
Option 3	F3	G175707	2.66	8.47	7.09	9.84	0.16	0.55	0.61	9.94	10.29	10.47		

■ Tolerance of AK on flanges with BA dimension under 6.30" is -0.0014 to -0.0028". Flanges with a BA of 6.30" or larger have a AK tolerance of -0.0017 to -0.0033".

Output Flange Mounting Dimensions

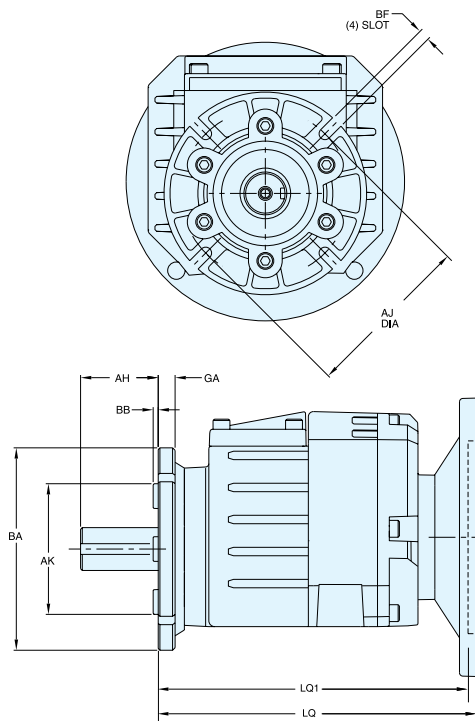

TORQUE FOOT SELECTIONS

The torque foot is available on base mounted reducers. The torque foot allows load transfer from bearing cage to foundation, including the external load capacity of the reducer. The torque foot should be considered where the application involves reversing loads or high shock loads to the system.

Torque Foot Mounting Dimensions (Inches)

Series	Accessory Kit No.	T
717	G175708	0.20
727	G175708	0.20
747	G175709	0.25
757	G175709	0.25

Note: Torque Foot is usable **only** on the B1 base mount.

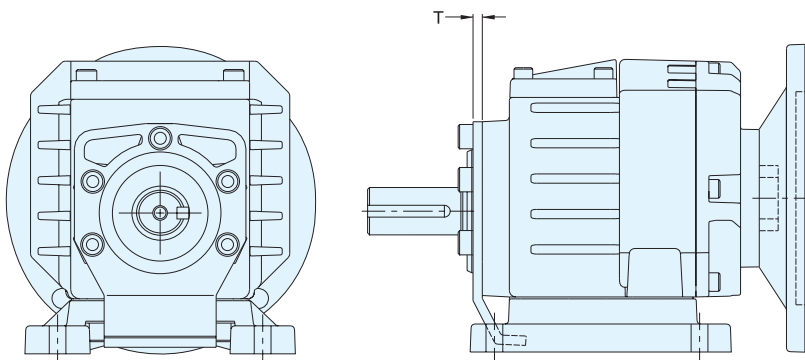



INTERCHANGE BASE SELECTIONS



LeCentric™ Interchange Kits & Accessories

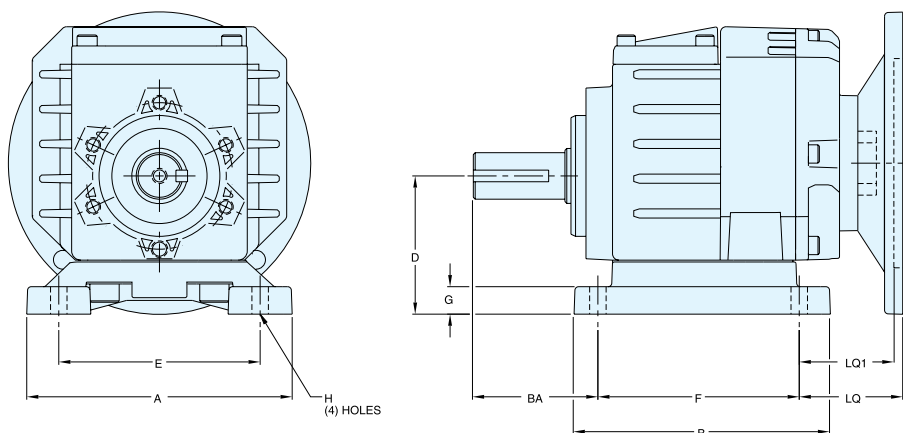

**Base Mounting Dimensions
Motorized Quill Input**

717 Series • Interchange Base Selections • Mod-Squad Codes • Accessory Kits

Interchange With:	Mod-Squad Suffix Code (XX)	Accessory Kit No.	Critical Interchange Dimensions (Inches)										LQ - 56C/140TC				
			A	B	BA	BC		D	E	F	G	H	2-Stage	3-Stage			
						2-Stage	3-Stage										
No Base	00	N/A															
SEW R17	B1	G175710	5.71	5.51	2.28	3.28	3.45	2.95	4.33	4.33	0.59	0.35	2.23	2.99			
SEW R32	B1	G175710	5.71	5.51	2.28	4.25	4.43	2.95	4.33	3.35	0.59	0.35	3.20	3.97			
Bonfiglioli C10	B2**	G175711	5.71	5.51	2.28	4.17	4.35	3.35	4.33	3.43	0.99	0.35	3.12	3.89			
Brook Hansen SFN03B	B1	G175710	5.71	5.51	2.28	3.28	3.45	2.95	4.33	3.35	0.59	0.35	2.23	2.99			
Browning CbN20	B1	G175710	5.71	5.51	2.28	3.28	3.45	2.95	4.33	3.35	0.59	0.35	2.23	2.99			
David Brown M03	B1	G175710	5.71	5.51	2.28	3.28	3.45	2.95	4.33	3.35	0.59	0.35	2.23	2.99			
Falk 03UC	B1	G175710	5.71	5.51	2.28	3.28	3.45	2.95	4.33	3.35	0.59	0.35	2.23	2.99			
Grove 2032/3	B1	G175710	5.71	5.51	2.28	3.28	3.45	2.95	4.33	3.35	0.59	0.35	2.23	2.99			
Hansen 0	B1	G175710	5.71	5.51	2.28	3.28	3.45	2.95	4.33	3.35	0.59	0.35	2.23	2.99			
Lenze 4	B3	G175712	5.67	4.41	2.01	4.88	5.06	3.15	4.13	2.99	0.40	0.35	3.83	4.60			
Leroy Somer NXT N20	B1	G175710	5.71	5.51	2.28	3.28	3.45	2.95	4.33	3.35	0.59	0.35	2.23	2.99			
Motovario 032/3	B1	G175710	5.71	5.51	2.28	3.28	3.45	2.95	4.33	3.15	0.59	0.35	2.23	2.99			
Nord SK02	B4	G175713	5.67	4.41	1.97	5.55	5.73	3.39	4.33	2.36	0.64	0.35	4.50	5.27			
Nord SK172	B1	G175710	5.71	5.51	2.28	3.28	3.45	2.95	4.33	4.33	0.59	0.35	2.23	2.99			
Stober C002/3	B5	G175714	5.67	4.41	2.17	5.27	5.45	3.23	4.33	2.44	0.48	0.28	4.22	4.99			
Sumitomo 4085	B6	G175715	5.67	4.41	1.85	5.67	5.85	3.15	4.72	2.36	0.40	0.35	4.62	5.39			

727 Series • Interchange Base Selections • Mod-Squad Codes • Accessory Kits

Interchange With:	Mod-Squad Suffix Code (XX)	Accessory Kit No.	Critical Interchange Dimensions (Inches)										LQ - 56C/140TC				
			A	B	BA	BC		D	E	F	G	H	2-Stage	3-Stage			
						2-Stage	3-Stage										
No Base	00	N/A															
SEW R27	B1	G175717	5.71	6.02	2.95	2.20	2.38	3.54	4.33	5.12	0.79	0.35	1.15	2.99			
SEW R37	B1	G175717	5.71	6.02	2.95	2.20	2.38	3.54	4.33	5.12	0.79	0.35	1.15	2.99			
SEW R40	B1	G175717	5.71	6.02	2.95	2.20	2.38	3.54	4.33	5.12	0.79	0.35	1.15	2.99			
Bonfiglioli C20	B2	G175718	6.10	5.35	2.68	3.35	3.53	3.94	5.12	4.23	0.67	0.43	2.32	3.09			
Brook Hansen SFN15B	B1	G175717	5.71	6.02	2.95	2.20	2.38	3.54	4.33	5.12	0.79	0.35	1.15	2.99			
Browning CbN21	B3	G175719	5.31	6.12	2.63	1.13	1.31	3.15	4.33	6.50	0.62	0.35	0.10	0.87			
David Brown M04	B1	G175717	5.71	6.02	2.95	2.20	2.38	3.54	4.33	5.12	0.79	0.35	1.15	2.99			
Dodge Quantis HB38	B1	G175717	5.71	6.02	2.95	2.20	2.38	3.54	4.33	5.12	0.79	0.35	1.15	2.99			
Falk 04UC	B1	G175717	5.71	6.02	2.95	2.20	2.38	3.54	4.33	5.12	0.79	0.35	1.15	2.99			
Flender / Motox D30	B1	G175717	5.71	6.02	2.95	2.20	2.38	3.54	4.33	5.12	0.79	0.35	1.15	2.99			
Grove 2042/3	B1	G175717	5.71	6.02	2.95	2.20	2.38	3.54	4.33	5.12	0.79	0.35	1.15	2.99			
Hansen 1	B3	G175719	5.31	6.12	2.63	1.13	1.31	3.15	4.33	6.50	0.62	0.35	0.10	0.87			
Lenze 5	B4	G175720	7.09	5.47	2.63	4.09	4.27	3.94	4.92	3.54	0.66	0.43	3.06	3.83			
Leroy Somer NXT N21	B3	G175719	5.31	6.12	2.63	1.13	1.31	3.15	4.33	6.50	0.62	0.35	0.10	0.87			
Motovario 042/3	B5	G175721	5.71	5.08	2.95	3.96	4.14	3.15	4.33	3.35	0.59	0.35	2.93	3.70			
Nord SK272	B1	G175717	5.71	5.98	2.95	2.20	2.38	3.54	4.33	5.12	0.71	0.35	1.15	2.99			
Stober C102/3	B7	G175723	7.09	5.47	2.64	4.86	5.04	4.02	5.91	2.76	0.74	0.35	3.83	4.60			
Sumitomo 4097	B8	G175724	7.09	5.47	2.36	4.36	4.54	3.94	5.90	3.54	0.66	0.43	3.33	4.10			



INTERCHANGE BASE SELECTIONS

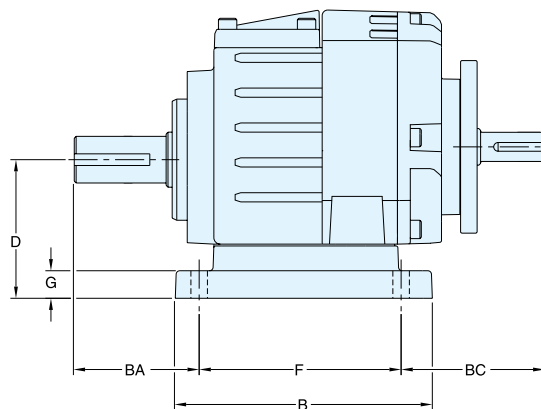
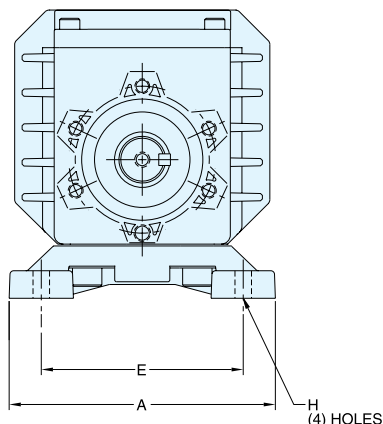

**Base Mounting Dimensions
Non-Motorized Input**

LeCentric™ Interchange Kits & Accessories

747 Series • Interchange Base Selections • Mod-Squad Codes • Accessory Kits

Interchange With:	Mod-Squad Suffix Code (XX)	Accessory Kit No.	Critical Interchange Dimensions (Inches)										LQ - 56C/140TC		LQ1		
			A	B	BA	BC		D	E	F	G	H	2-Stage	3-Stage	180TC		
No Base	00	N/A															
SEW R47	B1	G175725	6.69	7.76	3.54	2.96	2.88	4.53	5.31	6.50	0.94	0.55	1.45	1.83	1.98		
SEW R60	B1	G175725	6.69	7.76	3.54	2.96	2.88	4.53	5.31	6.50	0.94	0.55	1.45	1.83	1.98		
Bonfiglioli C30	B2	G175726	7.48	6.14	3.07	4.83	4.75	4.33	6.30	5.10	0.79	0.43	3.32	3.66	3.85		
Brook Hansen SFN25B	B1	G175725	6.69	7.76	3.54	2.96	2.88	4.53	5.31	6.50	0.94	0.55	1.45	1.83	1.98		
Browning CbN22	B3	G175727	7.52	8.58	3.01	2.43	2.35	3.94	5.31	7.56	0.75	0.55	0.92	1.26	1.45		
David Brown M06	B1	G175725	6.69	7.76	3.54	2.96	2.88	4.53	5.31	6.50	0.94	0.55	1.45	1.83	1.98		
Dodge Quantis HB48	B1	G175725	6.69	7.76	3.54	2.96	2.88	4.53	5.31	6.50	0.94	0.55	1.45	1.83	1.98		
Falk 06UC	B1	G175725	6.69	7.76	3.54	2.96	2.88	4.53	5.31	6.50	0.94	0.55	1.45	1.83	1.98		
Flender/ Motox D40	B1	G175725	6.69	7.76	3.54	2.96	2.88	4.53	5.31	6.50	0.94	0.55	1.45	1.83	1.98		
Grove 2062	B1	G175725	6.69	7.76	3.54	2.96	2.88	4.53	5.31	6.50	0.94	0.55	1.45	1.83	1.98		
Hansen 2	B3	G175727	7.52	8.58	3.01	2.43	2.35	3.94	5.31	7.56	0.75	0.55	0.92	1.26	1.45		
Lenze 6	B4	G175728	7.87	6.59	3.25	5.58	5.50	4.92	6.30	4.17	0.92	0.53	4.07	4.41	4.60		
Leroy Somer NXT N22	B3	G175727	7.52	8.58	3.01	2.43	2.35	3.94	5.31	7.56	0.75	0.55	0.92	1.26	1.45		
Motovario 052	B5	G175729	7.48	5.51	3.54	5.52	5.44	4.33	5.31	3.94	0.71	0.43	4.01	4.35	4.54		
Nord SK22	B6	G175730	7.87	6.59	3.30	6.55	6.47	4.92	6.30	3.15	0.92	0.43	5.04	5.38	5.57		
Nord SK472	B1	G175725	6.69	7.76	3.54	2.96	2.88	4.53	5.31	6.50	0.94	0.55	1.45	1.83	1.98		
Stober C202	B7	G175731	7.87	6.59	3.11	6.54	6.46	4.53	6.69	3.35	0.53	0.43	5.03	5.37	5.56		

757 Series • Interchange Base Selections • Mod-Squad Codes • Accessory Kits

Interchange With:	Mod-Squad Suffix Code (XX)	Accessory Kit No.	Critical Interchange Dimensions (Inches)										LQ - 56C/140TC		LQ1		
			A	B	BA	BC		D	E	F	G	H	2-Stage	3-Stage	180TC		
No Base	00	N/A															
SEW R57	B1**	G175732	6.69	7.76	3.94	3.63	3.56	4.53	5.31	6.50	0.94	0.55	2.16	2.51	2.69		
SEW R60	B1	G175732	6.69	7.76	3.54	3.63	3.56	4.53	5.31	6.50	0.94	0.55	2.16	2.51	2.69		
Bonfiglioli C30	B2	G175733	7.48	6.14	3.07	5.90	5.97	4.33	6.30	5.10	0.79	0.43	4.43	4.78	4.96		
Bonfiglioli C40	B9	G175740	8.50	7.30	3.54	4.64	4.71	5.12	7.09	5.89	0.71	0.55	3.17	3.52	3.70		
Brook Hansen SFN25B	B1	G175732	6.69	7.76	3.54	3.63	3.56	4.53	5.31	6.50	0.94	0.55	2.16	2.51	2.69		
Browning CbN22	B3	G175734	7.52	8.58	3.01	3.50	3.57	3.94	5.31	7.56	0.75	0.55	2.03	2.38	2.56		
David Brown M06	B1	G175732	6.69	7.76	3.54	3.63	3.56	4.53	5.31	6.50	0.94	0.55	2.16	2.51	2.69		
Dodge Quantis HB48	B1	G175732	6.69	7.76	3.54	3.63	3.56	4.53	5.31	6.50	0.94	0.55	2.16	2.51	2.69		
Falk 06UC	B1	G175732	6.69	7.76	3.54	3.63	3.56	4.53	5.31	6.50	0.94	0.55	2.16	2.51	2.69		
Flender/ Motox D40	B1	G175732	6.69	7.76	3.54	3.63	3.56	4.53	5.31	6.50	0.94	0.55	2.16	2.51	2.69		
Grove 2062	B1	G175732	6.69	7.76	3.54	3.63	3.56	4.53	5.31	6.50	0.94	0.55	2.16	2.51	2.69		
Hansen 2	B3	G175734	7.52	8.58	3.01	3.50	3.57	3.94	5.31	7.56	0.75	0.55	2.03	2.38	2.56		
Lenze 6	B4	G175735	7.87	6.59	3.25	6.65	6.72	4.92	6.30	4.17	0.92	0.53	5.18	5.53	5.71		
Leroy Somer NXT N22	B3	G175734	7.52	8.58	3.01	3.50	3.57	3.94	5.31	7.56	0.75	0.55	2.03	2.38	2.56		
Motovario 052	B5	G175736	7.48	5.51	3.54	6.59	6.66	4.33	5.31	3.94	0.71	0.43	5.12	5.47	5.65		
Nord SK22	B6	G175737	7.97	6.59	3.30	7.62	7.69	4.92	6.30	3.15	0.92	0.43	6.15	6.50	6.68		
Nord SK572	B1**	G175732	6.69	7.76	3.94	3.63	3.56	4.53	5.31	6.50	0.94	0.55	2.16	2.51	2.69		
Stober C202	B7	G175738	7.87	6.59	3.11	7.61	7.68	4.53	6.69	3.35	0.53	0.43	6.14	6.49	6.67		

** Requires optional 1.375" diameter shaft to obtain stated BA dimension. Contact LEESON for availability.



APPROXIMATE WEIGHTS (LBS.)▲

Reducer Style	Size			
	717	727	747	757
2-Stage				
Motorized 56C/140TC - W/ Base	13	13	26	33
Motorized 180TC - W/ Base	N/A	N/A	28	35
Shaft Input W/ Base	13	13	26	33
Motorized 56C/140TC - W/ Output Flange	12	12	26	33
Motorized 180TC - W/ Flange	N/A	N/A	28	35
Shaft Input W/ Output Flange	12	12	26	33
3-Stage				
Motorized 56C/140TC - W/ Base	14	14	27	32
Shaft Input W/ Base	14	14	27	32
Motorized 56C/140TC - W/ Output Flange	13	13	27	32
Shaft Input W/ Output Flange	13	13	27	32
Accessories				
Base	2	2	3	3
Output Flange	1	1	3	3
Torque Foot	1	1	2	2

▲Weight does not include oil.

AVAILABLE MOTOR FRAMES

Reducer Size	# of Stages	56C	143-5TC	182-4TC
717	2-Stage	X	X	
	3-Stage	X		
727	2-Stage	X	X	
	3-Stage	X		
747	2-Stage	X	X	X
	3-Stage	X	X	
757	2-Stage	X	X	X
	3-Stage	X	X	

AVAILABLE INPUT & OUTPUT SHAFTS

Output Shaft Options

Reducer Size	U +0.000/ -0.001	UY	V	KEY	M	
					TAP	DEPTH
717	0.750	0.83	1.57	3/16 x 1.12 SQ	1/4-20	0.62
727	1.000	1.11	1.97	1/4 x 1.62 SQ	5/16-18	0.75
747	1.250	1.36	2.36	1/4 x 2.00 SQ	5/16-18	0.75
	1.375**	1.51	2.76	5/16 x 2.25 SQ	3/8-16	0.88

**Optional size. Contact LEESON for availability. The standard shaft diameters are shown in dimensional pages.

Input Shaft Options

Reducer Size	U +0.000/ -0.001	UY	V	KEY	M	
					TAP	DEPTH
717	0.625	0.70	1.57	3/16 x 1.12	1/4-20	0.62
727	0.625	0.70	1.57	3/16 x 1.12	1/4-20	0.62
747	0.750	0.83	1.97	3/16 x 1.50	5/16-18	0.75
	0.875**					
757	0.750	0.83	1.97	3/16 x 1.50	5/16-18	0.75
	0.875**					

**Optional size for 2 stage ratios only. Contact LEESON for availability. The standard shaft diameters are shown in dimensional pages.

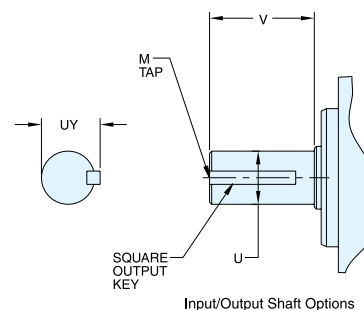

LeCentric™ Interchange Kits & Accessories

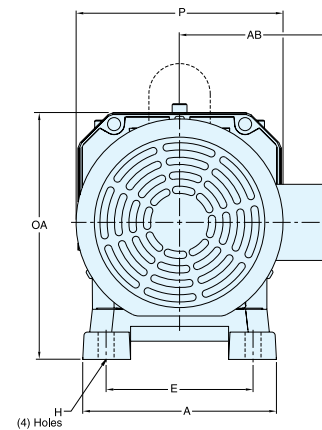
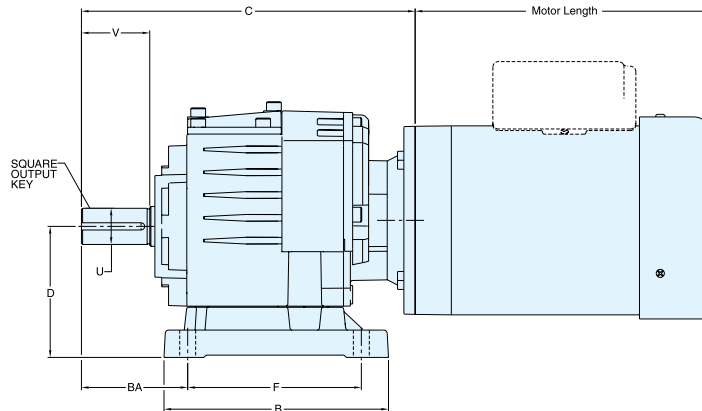

LeCentric™ Interchange Kits & Accessories

Gear+Motor™ Dimensions (Inches)

Series	A	AB		B	BA	C			D	E	F	H	OA	P		U +0.000/ -0.000	V	OUTPUT KEY
		56C/140TC	180TC			2-Stage 56/140	180	3-Stage 56/140						56C/140TC	180TC			
717	5.71	5.31	6.38	5.51	2.28	8.83	NA	9.60	2.95	4.33	4.33	0.35	6.12	6.59	8.47	0.750	1.57	3/16 x 1.12
727	5.71	5.31	6.38	6.02	2.95	9.23	NA	10.00	3.54	4.33	5.12	0.35	6.71	6.59	8.47	1.000	1.97	1/4 x 1.62
747	6.69	5.31	6.38	7.76	3.54	11.49	12.02	11.83	4.53	5.31	6.50	0.55	8.52	6.59	8.47	1.250	2.36	1/4 x 2.00
757	6.69	5.31	6.38	7.76	3.54	12.20	12.73	12.47	4.53	5.31	6.50	0.55	8.58	6.59	8.47	1.250*	2.36	1/4 x 2.00

Refer to page 173 for motor length dimensions.

* 1.375" diameter shaft is available. Contact LEESON for availability.

Motor Mounting Position

Conduit box position viewed from input side of reducer.

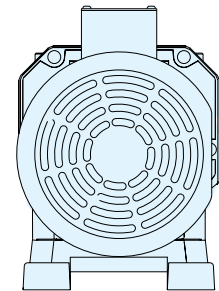
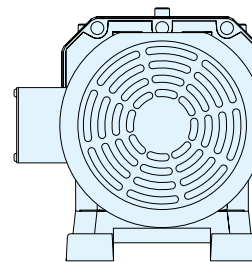
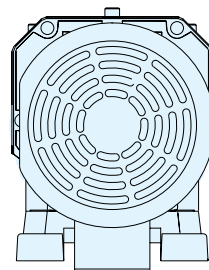
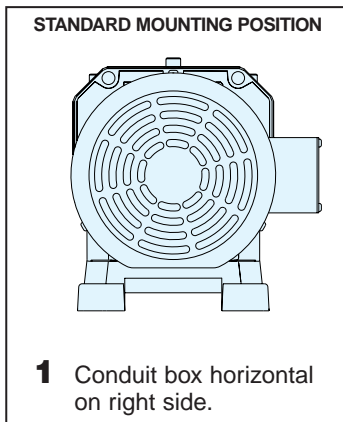



TECHNICAL INFORMATION



OVERHUNG LOADS AND THRUST LOADS

An overhung load exists when a force is applied at right angles to a shaft beyond the shaft's outermost bearing. Pulleys, sheaves and sprockets will cause an overhung load when used as a power take-off. The amount of overhung load will vary, depending on the type of power take-off used and its mounting location on the shaft. The LeCentric™ overhung load ratings listed in this catalog and in selection tables are calculated at the centerline of the shaft.

Overhung load ratings are listed for each reducer size and should not be exceeded. If the basic reducer is selected using a service factor, that factor must also be used in the equations below.

Output Shaft OHL =

$$\frac{126000 \times \text{Input HP} \times \text{Overhung Load Factor} \times \text{Efficiency}}{\text{Pitch Diameter (of sprocket, pulley or sheave)} \times \text{Output RPM}}$$

Input Shaft OHL =

$$\frac{126000 \times \text{Input HP} \times \text{Overhung Load Factor}}{\text{Pitch Diameter (of sprocket, pulley or sheave)} \times \text{Input RPM}}$$

Overhung Load Factors—

Sprocket	1.00
Gear Pinion	1.25
V-Belt Sheave or Pulley	1.50
Flat Belt	2.50

Maximum Overhung Load Capacities

External Load Applied	Drive Size				
	717	727	747	757	
Input Shaft OHL (lbs.)	2-Stage	112	112	180	180
	3-Stage	100	100	135	135
Output Shaft OHL (lbs.)	Refer to Selection Tables for overhung load variable by output RPM.				

NOTE: The overhung load capacities in the catalog are calculated at centerline of shaft extension with no thrust load.

OVERHUNG LOAD AT
CENTER OF SHAFT
EXTENSION

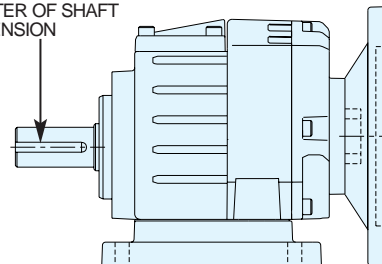

Torque and Horsepower

Torque as it is related to gear reducers is defined as a twisting motion resulting in rotational movement. Horsepower is a measure of the rate of doing work, and depends on speed of rotation and the radius of rotation.

$$\frac{\text{TQ(In-lb)} = (\text{HP} \times 6325)}{\text{RPM}}$$

$$\frac{\text{HP(Rotational)} = \text{TQ(In-Lb)} \times \text{RPM}}{63025}$$

$$\frac{\text{TQ(ft-lb)} = (\text{HP} \times 5252)}{\text{RPM}}$$

$$\frac{\text{HP(Rotational)} = \text{TQ(ft-lb)} \times \text{RPM}}{5252}$$

$$\text{TQ(In-lb)} = W \times R$$

$$\frac{\text{HP(Linear)} = W \times V}{33000}$$

Efficiency

The efficiency of a Worm Gear Speed Reducer is dependent on input speed, lead angle of the worm, type of lubricant, ambient temperature and many other variables. The efficiency for speed reducer can be easily calculated as follows.

$$\text{Efficiency(Total)} = \text{Eff}_1 + \text{Eff}_2 + \text{Eff}_3$$

Additional Engineering Equations and Conversion Factors

$$\text{Velocity(FPM)} = V = .2618 \times D \times \text{RPM}$$

$$\text{Rotational Speed} = \text{RPM} = \frac{V}{(.2618 \times D)}$$

$$\text{Ratio} = \frac{\text{Input RPM}}{\text{Output RPM}} = \frac{\text{No. Teeth in Driver}}{\text{No. Teeth in Driven}} = \frac{\text{Diameter of Driver}}{\text{Diameter of Driven}}$$

$$\text{Ratio(Total)} = R_1 + R_2 + R_3$$

$$1 \text{ inch} = 25.4 \text{ MM}$$

$$1 \text{ lb} = 4.448 \text{ N}$$

$$1 \text{ in-lb} = .11298 \text{ Nm}$$

$$1 \text{ HP} = 746 \text{ Watts} = .746 \text{ kW}$$

$$1 \text{ kW} = 1.34 \text{ HP}$$

$$^{\circ}\text{F} = 9/5 \times ^{\circ}\text{C} + 32$$

$$^{\circ}\text{C} = 5/9 \times (^{\circ}\text{F} - 32)$$

Where:

D = Diameter (inches)

HP = Horsepower

R = Radius (inches)

RPM - Rotational Speed

TQ = Torque

V = linear velocity (FPM)

W = force or tension (lbs)

TECHNICAL INFORMATION

General Operation

LeCentric™ Interchange Kits & Accessories

1. Run the motor which drives the reducer and check the direction of reducer output rotation. Consult motor nameplate for instructions to reverse the direction of rotation.
2. Attaching the load: On direct coupled installations, check shaft and coupling alignment between speed reducer and loading mechanism. On chain/sprocket and belt/pulley installation, locate the sprocket or pulley as close to the oil seal as possible to minimize overhung load. Check to verify that the overhung load does not exceed specifications published in the catalog.
3. High momentum loads: If coasting to a stop is undesirable, a braking mechanism should be provided to the speed reducer output or the driven mechanism.

CAUTION The system of connected rotating parts must be free from critical speed, torsional or other type vibration, no matter how induced. The responsibility for this system analysis lies with the purchaser of the speed reducer.

Installation Instructions

The following instructions apply to standard Leeson LeCentric™ type reducers with base or flange mounting in motorized and non-motorized double and triple reduction options.

1. Mount the unit to a rigid flat surface using grade 5 or higher fasteners. The mounting fasteners should be the largest standard size that will fit in the base mounting hole. Shim as required under flange or base feet which do not lie flat against the mounting surface.
2. LeCentric™ reducers are filled with proper amount of oil from LEESON. Oil quantity is based on mounting position, as indicated on reducer nameplate. Unless otherwise indicated with order, all reducers are filled to level indicated for position H3. If position other than the one indicated on nameplate is required, refer to page 60 for alternate mounting positions and for oil quantities.
3. Connect motor to speed reducer.
4. LeCentric™ reducers are designed to operate without a vent. Installation of a vent is not required.

CAUTION DO NOT CHANGE MOUNTING POSITIONS WITHOUT CONTACTING FACTORY. Altering the mounting position may require special lubrication provisions which must be factory installed.

CAUTION Do not operate the reducer without making sure it contains the correct amount of oil. Confirm that mounting position on nameplate matches application requirement from page 60. Do not overfill or underfill with oil, or injury to personnel, reducer or other equipment may result.

CAUTION A unit cannot be used as an integral part of a machine superstructure which would impose additional loads on the unit other than those imposed by the torque being transmitted either through a shaft-mounted arrangement, and any shaft mounted power transmitting device. (e.g. sprockets, pulleys, couplings)

CAUTION For safe operation and to maintain the unit warranty, when changing a factory installed fastener for any reason it becomes the responsibility of the person making the change to properly account for fastener grade, thread engagement, load, tightening torque and the means of torque retention.

Lubrication

All standard reducers ordered from the factory are filled with Mobilgear® SHC 320 synthetic oil to operate within a -25 to +113°F ambient temperature range. Lubrication quantities are specified on page 60 for various mounting positions. Prior to startup, verify that the mounting position on nameplate matches required position (see page 60). LeCentric™ reducers are filled to proper amount of oil based on mounting position printed on nameplate. **All LeCentric™ Gear Reducers will be filled with oil for position "H3" unless otherwise specified.** If the ambient temperature will be outside the range for the lubricant installed at the factory, drain and refill the reducer with the proper viscosity lubricant prior to use. Consult the factory for alternate lubricants.

Change Intervals: LeCentric™ units utilize extreme pressure lubricants which protect the teeth in the event of the oil thinning out due to local temperature rise, or high pressure due to accidental overloads. LeCentric™ reducers are "lubed-for-life" and do not require regular oil changes under normal industrial operating conditions and environments. If the reducers are operated in severe environments (i.e. high or low temperatures, high altitudes), oil changes may be required. High ambient temperatures cause the oil to thin out and reduce its protective qualities. In such cases it will be necessary to utilize heavier grades than shown. Conversely, low temperatures will necessitate a thinner grade, otherwise trouble may be experienced with burning out of motors at starting. In this condition, the pour point of the oil must be less than the lowest ambient temperature to be encountered. Refer to installation manual provided with reducer for approved lubricants and suppliers.

CAUTION In the Food and Drug Industry (including animal food), consult the lubrication supplier for recommendation of lubricants which are acceptable to the Food and Drug Administration and/or other authoritative bodies having jurisdiction.

CAUTION Do not mix different oils in the reducer. Oils should be compatible with Viton® seal material.

CAUTION Oil should be changed/checked if reducer is used in severe environment.

CAUTION SYNTHETIC LUBRICANTS IN FOOD PROCESSING INDUSTRY Synthetic lubricants may contain toxic substances and should not be used in the food processing industry without the lubricant manufacturer's approval. Lubricants which meet USDA "H1" classification are suitable for food processing applications.

REFER TO PAGE 175 FOR MORE IMPORTANT SAFETY INFORMATION



TECHNICAL INFORMATION



REDUCER MOUNTING POSITIONS

Carefully follow lubrication instructions and installation manuals furnished with the gear reducer. All standard LeCENTRIC™ Inline Reducers are factory filled with Mobilgear SHC 320 synthetic oil. The mounting position is stamped on all LeCENTRIC™ Reducer nameplates. Position H3 is standard. Specify mounting position of reducer for correct oil fill at LEESON. Positions H3-H8 are horizontal mounts. Positions V5 and V6 are vertical mounts.

LeCentric™ Interchange Kits & Accessories

H3 (Standard Position)

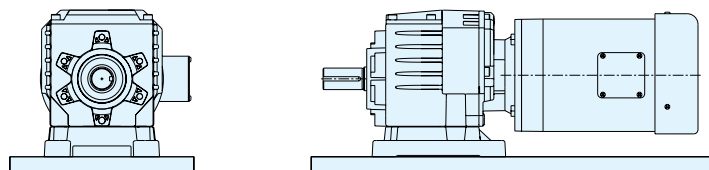

Standard mounting position is H3. All reducers will be filled to this level, unless otherwise specified.

H6

H7

H8

V5

V6*

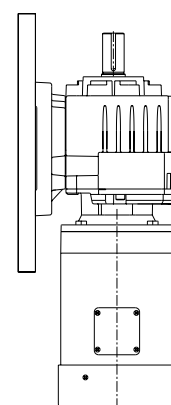
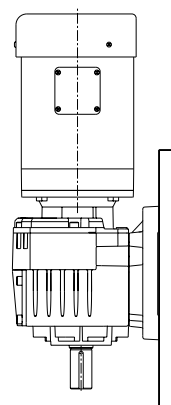
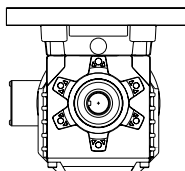
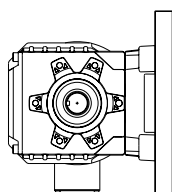
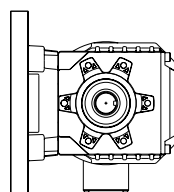

**Not Recommended

Lube Quantities (Ounces)

Reducer Size		H3	H6	H7	H8	V5	V6
717	2-Stage	8.5	10	13.5	13.5	13.5	17
	3-Stage	10	12	15	15	15	18.5
727	2-Stage	8.5	10	13.5	13.5	13.5	17
	3-Stage	10	12	15	15	15	18.5
747	2-Stage	15	19	34	37	37	39
	3-Stage	25.5	25.5	35.5	39	40.5	40.5
757	2-Stage	19	29	37	40.5	40.5	42
	3-Stage	25.5	30.5	39	42	44.0	46

Note: Multiply the above quantities by 0.06 to obtain the equivalent weight of oil in pounds.

16 oz = 1 Pint
 2 Pints = 1 Quart
 4 Quarts = 1 Gallon
 1 Gallon = 128 oz.

TECHNICAL INFORMATION

Maintenance Instructions

Your LEESON reducer is tested and adjusted at the factory. Dismantling or replacement of components must be done by LEESON to maintain the warranty.

LeCentric™ reducers are lubed-for-life and do not require regularly scheduled oil changes/checks. However, if the reducer is used in a severe environment, it is recommended that the oil is checked or changed every 6000 hrs. or after 2 years of operation. If the oil level is low, (refer to page 60 for mounting positions) add proper lubrication through the filler plug.

If seal leakage has resulted in the loss of a significant amount of oil, it may be necessary to add more lubricant. For normal ambient temperature conditions, LEESON recommends Mobilgear® SHC320 synthetic gear oil for all LeCentric™ reducers.

CAUTION Mounting bolts should be routinely checked to ensure that the unit is firmly anchored for proper operation.

Seal Replacement: The LeCentric™ line of speed reducers utilize premium quality seals which are the state-of-the-art in sealing technology. Seals are, however, a wear item and eventually need to be replaced. Replacement can be easily accomplished by following the steps below:

CAUTION 1. Lock out and tag out the reducer's power source.

CAUTION 2. Remove any load from the input and/or output shafts of the reducer prior to disconnecting any drive components.

3. Remove appropriate drive components to gain access to seal to be replaced.

4. Drain oil if seal is below oil level.

5. Remove the worn seal without damaging the shaft surface or the seal bore. This can be done by drilling a 0.062" diameter hole in the casing (being careful not to drill into the bearing behind the seal). Screw a #10 sheet metal screw into the hole and pry out the seal.

6. Clean the seal bore in housing of sealant.

7. Before installing the new seal, use electrical tape to cover any keyways on the shaft to prevent seal lip damage.

8. Grease the seal lips with bearing grease and apply a sealant to the seal bore in housing.

9. Slide the seal onto the shaft being careful not to fold the inner lip over on any shaft steps.

10. Press the seal into its bore with a sleeve that presses on the seal casing, being careful to keep the seal square in its bore.

11. Refill reducer to proper level with appropriate lubricant.

CAUTION Always check for proper oil level after filling. Do not overfill or underfill with oil, or injury to personnel, reducer or other equipment may result.

CAUTION Do not mix different oils in the reducer.

12. Reconnect any drive components disconnected in Step 3. Make sure components are properly aligned.

Class of Service

All capacity ratings are based on proper application of American Gear Manufacturers Association (AGMA) service factors as given on page 172. Load conditions must be within cataloged ratings published in the current LEESON Catalog.

Warranty From LEESON Electric - Refer to page 177 for warranty terms and conditions.

REFER TO PAGE 175 FOR MORE IMPORTANT SAFETY INFORMATION



TECHNICAL INFORMATION



LeCentric™ Interchange Kits & Accessories

**PARTS LIST
Basic Double Reduction
(Motorized Input Shown)**

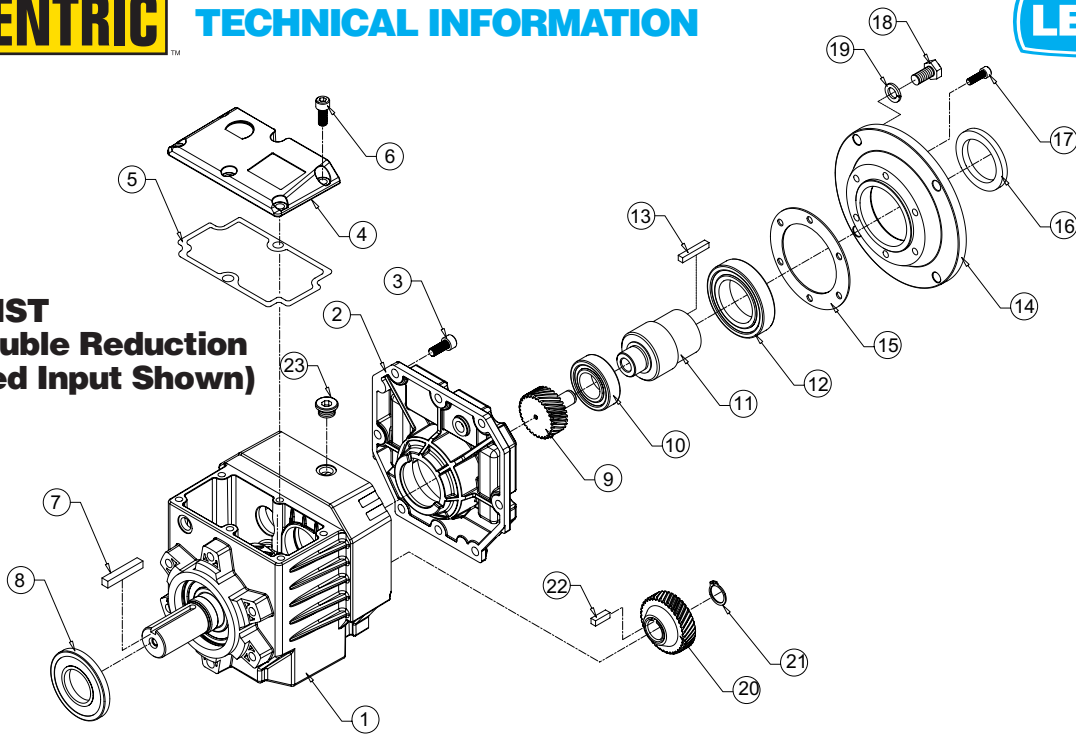

ITEM #	DESCRIPTION	ITEM #	DESCRIPTION	ITEM #	DESCRIPTION
1*	OUTPUT HOUSING	9	INPUT PINION	17	CAP SCREW
2	INPUT HOUSING	10	INPUT BEARING	18	HEX HEAD CAP SCREW
3	CAP SCREW	11	INPUT QUILL SHAFT	19	LOCKWASHER
4	INSPECTION COVER	12	INPUT BEARING	20	INPUT GEAR
5	COVER SEAL	13	INPUT QUILL SHAFT KEY	21	RETAINING RING
6	CAP SCREW	14	INPUT MOTOR FLANGE	22	OUTPUT PINION KEY
7	OUTPUT EXTENSION KEY	15	INPUT FLANGE SHIM	23	PIPE PLUG
8	OUTPUT SEAL	16	INPUT SEAL		

* Output module has shaft and low speed gear set pre-assembled into housing. Output seal is also pre-assembled at LEESON.

**PARTS LIST
Basic Triple Reduction
(Motorized Input Shown)**

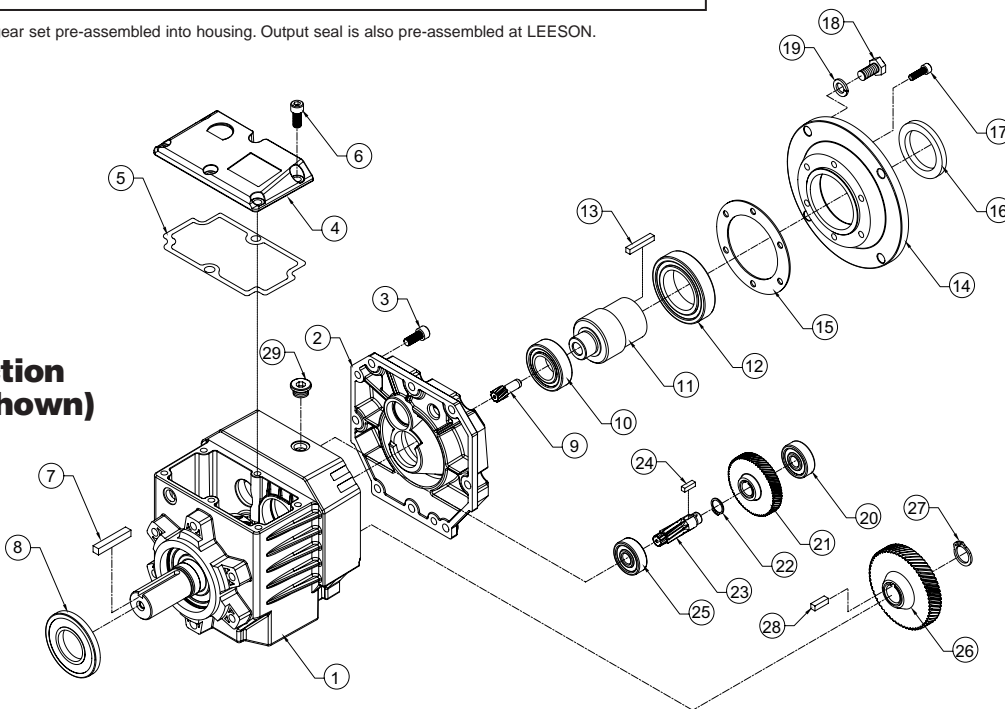

ITEM #	DESCRIPTION	ITEM #	DESCRIPTION	ITEM #	DESCRIPTION
1	OUTPUT MODULE	9	INPUT PINION	17	CAP SCREW
2	INPUT COVER	10	INPUT BEARING	18	HEX HEAD CAP SCREW
3	CAP SCREW	11	INPUT QUILL SHAFT	19	LOCKWASHER
4	INSPECTION COVER	12	INPUT BEARING	20	INTERMEDIATE BEARING
5	COVER SEAL	13	INPUT QUILL SHAFT KEY	21	INPUT GEAR
6	CAP SCREW	14	INPUT MOTOR FLANGE	22	RETAINING RING
7	OUTPUT EXTENSION KEY	15	INPUT FLANGE SHIM	23	INTERMEDIATE PINION
8	OUTPUT SEAL	16	INPUT SEAL	24	INTERMEDIATE PINION KEY
				25	INTERMEDIATE BEARING
				26	INTERMEDIATE GEAR
				27	RETAINING RING
				28	OUTPUT PINION KEY
				29	PIPE PLUG

* Output module has shaft and low speed gear set pre-assembled into housing. Output seal is also pre-assembled at LEESON.



LeCentric™ Interchange Kits & Accessories

**PARTS LIST
Shaft Input**

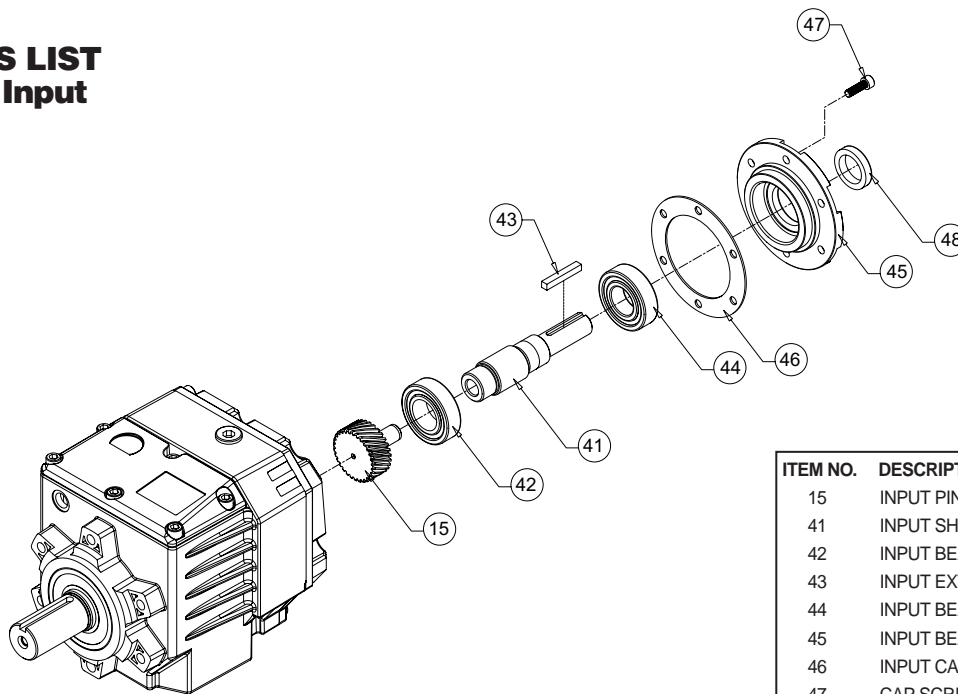

ITEM NO.	DESCRIPTION
15	INPUT PINION
41	INPUT SHAFT
42	INPUT BEARING
43	INPUT EXTENSION KEY
44	INPUT BEARING
45	INPUT BEARING CAGE
46	INPUT CAGE SHIM
47	CAP SCREW
48	INPUT SEAL

**PARTS LIST
Base Mount and Torque Foot**

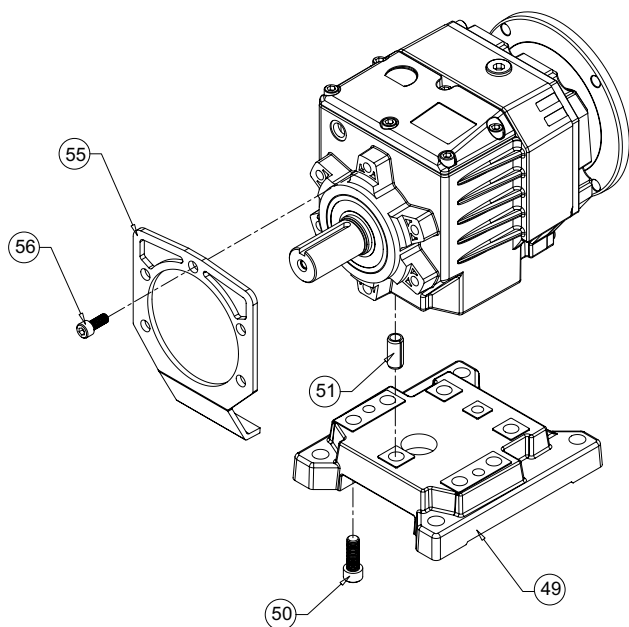

**PARTS LIST
Flange Mount**

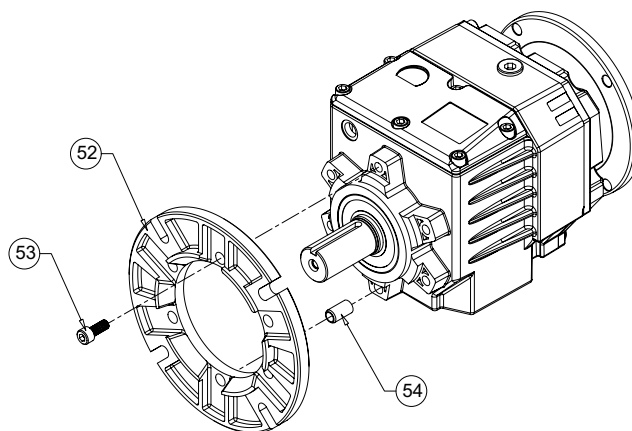

ITEM NO.	DESCRIPTION
49	MOUNTING BASE
50	CAP SCREW
51	MOUNTING PIN
52	OUTPUT FLANGE
53	CAP SCREW
54	MOUNTING PIN
55	TORQUE FOOT
56	CAP SCREW



Bravo! An Alternative For Machine

Vent Free Design. No breather or vents to leak! Factory lubricated for life with synthetic, semi-fluid gear lubricant with an operating range of +5°F to +220°F (-15°C to +104°C).

oil free **



vent free **

Bravo® Single
Reduction Reducers

NEMA C flange with quill input accepts 56C, 143-5TC and 182-4TC motor frames.

or

B5 & B14 IEC metric flange options with quill input accepts D56, D63, D71, D80, D90, D100 and D112 motor frames.



Bravo® up to two-thirds lighter and one-third smaller than cast iron reducer of similar center distance!

LEESON
HYDRO • MEC

Single-piece aluminum alloy housing is vacuum impregnated with Resinol RT (MIL-STD 276) for protection and sealing. No secondary finish required but readily accepts paint. Combines light weight with high tensile strength. Precision machined for alignment of bearings and gearing.

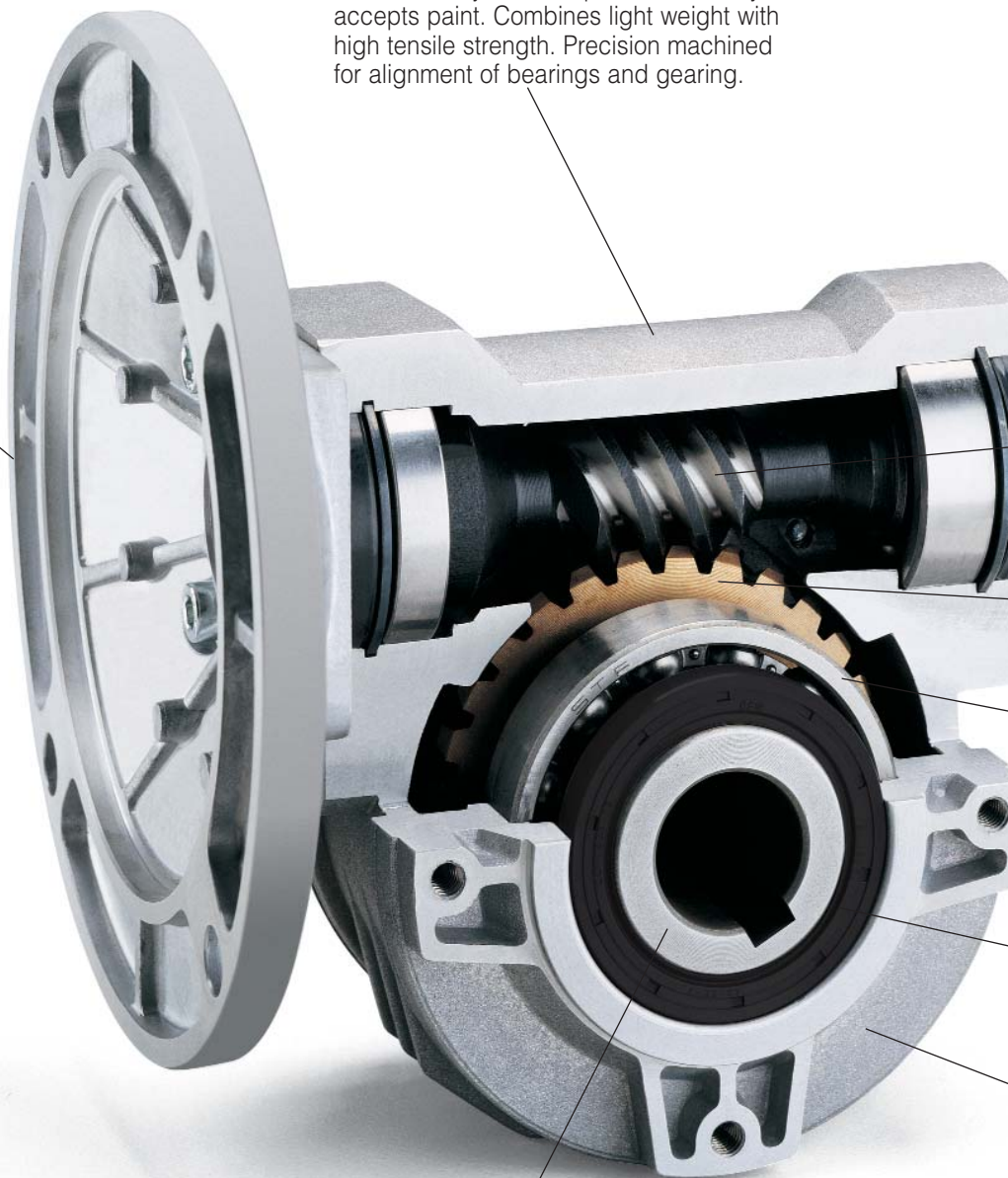

Hollow output shaft mounting is standard at no extra cost. Reduces total drive envelope size, weight and cost. Solid shaft single and double output is available.

Designers

Bravo®

ALUMINUM GEAR REDUCERS

Oversized bearings support positively-retained, high speed shaft for higher shock load capacity — ideal for frequent starting and reversing applications. Premium, Nitrile® high temperature seals each end.

Single-piece alloy steel input shaft and worm shaft. High helix angle worm is case-hardened (Rc 58-60), ground, teeth are profiled and radiused, for noise reduction and enhanced efficiency.

Bronze alloy worm gear is centrifugally cast onto an iron hub for maximum strength, lubricity and superior life.

Oversized bearings for radial load capability and maximum hollow output shaft diameters.

Premium, high-temperature Nitrile® output seals.

Impregnated and machined bearing caps with exterior machined surfaces mate to a variety of mounting accessories. Extra-deep thread engagement provided for greater support strength. Zinc plated hardware. No need to remove bearing covers to mount/change accessory kits.

** 534 Series is filled with Mobil SHC 634 synthetic oil and is furnished with a vent. Operating temperature range of 534 Series is -25°F to +220°F (-32°C to +104°C)

START WITH ONE OF FOUR BASIC UNITS...

Motorized HMQ



Motorized BMQ



Non-Motorized H



Non-Motorized B



AND ADD MOUNTING ACCESSORIES...

Reaction Arm R



Horizontal T Base



FL Flange (Long)



F Flange (Short)

TO CREATE DOZENS OF GEAR AND GEARMOTOR COMBINATIONS



HOLLOW OUTPUT SHAFT MOUNTED (See "How to Specify" on page 68.)

MOTORIZED QUILL INPUT

HMQ



Ratings: Pages 70-74
Dimensions: Page 84



RHMQ



Ratings: Pages 70-74
Dimensions: Page 86

FHMQ



Ratings: Pages 70-74
Dimensions: Page 88

NON-MOTORIZED SOLID INPUT SHAFT

H



Ratings: Pages 70-74
Dimensions: Page 84



RH



Ratings: Pages 70-74
Dimensions: Page 86

FH



Ratings: Pages 70-74
Dimensions: Page 88

SOLID OUTPUT SHAFT (See "How to Specify" on page 68.)

MOTORIZED QUILL INPUT

BMQ



Ratings: Pages 70-74
Dimensions: Page 85



RMQ



(◆Non-Standard Option)

Ratings: Pages 70-74
Dimensions: Page 87

FMQ



Ratings: Pages 70-74
Dimensions: Page 89

NON-MOTORIZED SOLID INPUT SHAFT

B



Ratings: Pages 70-74
Dimensions: Page 85



R



(◆Non-Standard Option)

Ratings: Pages 70-74
Dimensions: Page 87

F



Ratings: Pages 70-74
Dimensions: Page 89

MOUNTING ACCESSORIES

Select the appropriate mounting accessories from this wide variety of options.

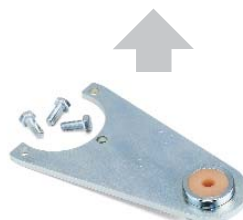

REACTION ARM R



F FLANGE (SHORT FLANGE)

◆ Non-Standard Option assemblies may be useful in certain applications. Please contact LEESON with application details.



SINGLE REDUCTION MOUNTING STYLE GUIDE **Bravo**
ALUMINUM GEAR REDUCERS

FLHMQ



Ratings: Pages 70-74
Dimensions: Page 90

THMQ



(❖Non-Standard Option)
Ratings: Pages 70-74
Dimensions: Page 92

UHMQ



(❖Non-Standard Option)
Ratings: Pages 70-74
Dimensions: Page 94

JHMQ



(❖Non-Standard Option)
Ratings: Pages 70-74
Dimensions: Page 96

FLH



Ratings: Pages 70-74
Dimensions: Page 90

TH



(❖Non-Standard Option)
Ratings: Pages 70-74
Dimensions: Page 92

UH



(❖Non-Standard Option)
Ratings: Pages 70-74
Dimensions: Page 94

JH



(❖Non-Standard Option)
Ratings: Pages 70-74
Dimensions: Page 96

FLMQ



Ratings: Pages 70-74
Dimensions: Page 91

TMQ



Ratings: Pages 70-74
Dimensions: Page 93

UMQ



(❖Non-Standard Option)
Ratings: Pages 70-74
Dimensions: Page 95

JMQ



Ratings: Pages 70-74
Dimensions: Page 97

FL



Ratings: Pages 70-74
Dimensions: Page 91

T



Ratings: Pages 70-74
Dimensions: Page 93

U



(❖Non-Standard Option)
Ratings: Pages 70-74
Dimensions: Page 95

J



Ratings: Pages 70-74
Dimensions: Page 97



FL FLANGE
(LONG FLANGE)



HORIZONTAL BASE
(WORM OVER ASSEMBLY)



HORIZONTAL BASE
(WORM UNDER ASSEMBLY)



HORIZONTAL BASE
(VERTICAL INPUT SHAFT)

Bravo® Single Reduction Reducers



LEESON 500 Series Gear Reducer Model Number Nomenclature

All stock and custom 500 series reducers are identified by a model number. The model number appears on the nameplate and describes pertinent features of the reducer. An example follows, along with a listing of the various letters and positions used.

NOTE: All reducers also have a catalog number—for example W5180001. Reducers and renewal parts should be ordered by catalog number. If a stock reducer has been factory modified by the addition of an optional base for example, the modification number T518, for example, is stamped in the blank column of the nameplate. Accessories that are field installed will not be noted on the nameplate.

Catalog numbers 5000 (for example, W5185000) and higher are custom reducers manufactured for a specific application. The machinery or equipment manufacturer should be contacted for replacement reducers. Renewal parts can be ordered from LEESON by catalog number.

TYPICAL NAMEPLATE

LEESON		HYDRO-MEC	
MAX INPUT HP @ 1750 RPM	1.49	OUTPUT TORQUE (IN-LBS)	595
DESC.	HMQ52014H5616	RATIO	14:1
CATALOG NO.	W5200080	DATE CODE	A04
LEESON ELECTRIC <small>GRAFFTON, WISCONSIN 53024</small>		MOD	

Bravo® Single Reduction Reducers

Style

SOLID OUTPUT SHAFT
BMQ – Motorized, Quill Input
B – Non-Flanged
 See pages 66 & 67 for other styles.

HOLLOW OUTPUT SHAFT
HMQ – Motorized, Quill Input
H – Non-Flanged
 See pages 66 & 67 for other styles.

Series

See Selection Tables on pages 70-74 for all available ratios

Ratio

Output Shaft Orientation

- L – Left-hand Output Shaft*
 - R – Right-hand Output Shaft*
 - D – Double Output Shaft
 - H – Hollow Output Shaft
- * Viewed from drive end of reducer.

Motor Flange

Shaft Dimension Code

ALUMINUM 500 SERIES CENTER DISTANCES

Series	Center Distance	
	(Inches)	(mm)
512	1.18	30
518	1.77	45
520	1.97	50
525	2.48	63
534	3.35	85

NEMA Input Flange Code	For NEMA Frame
56	56C
140	143-5TC
180	182-4TC
IEC Input Flange Code	For IEC Frame
56B14	56B14
56B5	56B5
63B14	63B14
63B5	63B5
71B14	71B14
71B5	71B5
80B14	80B14
80B5	80B5
90B14	90B14
90B5	90B5
100B14	100B14/112B14
100B5	100B5/112B5

OUTPUT SHAFT DIMENSION CODE ▲

Series	NEMA/Inch Options		IEC/Metric Options	
	Shaft Dia.	Shaft* Code	Shaft Dia.	Shaft Code
512	N/A	N/A	14mm	14
518	3/4"	12	18mm	18
520	1"	16	25mm	25
525	1-1/8"	18	25mm	25
534	1-1/2"	24	35mm	35

*Shaft Diameter in 1/16ths of an inch.

▲ Diameters and shaft codes of hollow bore styles are identical to those of solid shaft styles. Reducers with NEMA inputs will have inch-dimensioned output shafts and reducers with IEC inputs will have metric dimensioned output shafts as standard.

Sample Model Number

Solid Shaft

Motorized Quill Input, Single Reduction Reducer, 1.77" Center Distance, 14:1 Ratio, Left Hand Output Shaft, and 5/8" Input Bore with NEMA 56C Flange.

BMQ **518** **14** **L** **56** **12**
 Style Series Ratio Mounting Assembly Motor Input Flange Shaft Code

Hollow Shaft

Motorized Quill Input, Single Reduction Reducer, 1.77" Center Distance, 14:1 Ratio, 3/4" Hollow Output Shaft, and 5/8" Input Bore with NEMA 56C Flange.

HMQ **518** **14** **H** **56** **12**
 Style Series Ratio Mounting Assembly Motor Input Flange Shaft Code



SINGLE REDUCTION "HOW TO USE" MAXIMUM RATING TABLES

How To Use Maximum Rating Tables

Maximum Rating Tables for Single Reduction Gear Reducers are shown on pages 70-74. Selection of the appropriate gear reducer can be made using these tables or the Quick Selection Tables (pages 76-82).

BEFORE YOU START:

Identify the Service Factor of the application (see page 171).

Determine the actual input horsepower of the motor by multiplying the motor's nameplate horsepower by the Service Factor.

Determine the output speed (RPM) required at output shaft of reducer.

Identify the mounting style required by your application from the style charts shown on pages 66-67. Note the basic mounting style (BMQ, HMQ, etc.).

To select the proper gear reducer size, use the Maximum Rating Tables as shown:

1 Find the appropriate Maximum Rating Tables pages for your basic mounting style. The tables begin on page 70.



SINGLE REDUCTION MAXIMUM RATING TABLES

518 SERIES • ALL STYLES

2 Locate the Input RPM and Output RPM columns on the left side of the table. Scroll down the Input RPM column to locate a listing where the desired input speed corresponds to the output speed required in your application. (Input RPM listings are rounded to the nearest hundred. Your actual input speed of 1750 can be correlated to 1800 with no material change in performance.)

4 Select motor frame size.

Style HMQ

Ratio	Input RPM	Output RPM	Input HP	Output HP	Output Torque (lb-in)	NEMA/C Input Flange*	Left Hand Catalog No.	Right Hand Catalog No.	Double Extension Catalog No.	Hollow Output Catalog No.
7	1750	250	1.378	1.103	278	56C	W5180031	W5180041	W5180051	W5180071
	1150	164	0.950	0.760	292					
10	1750	175	0.981	0.775	279	56C	W5180032	W5180042	W5180052	W5180072
	1150	115	0.679	0.536	294					
14	1750	125	0.871	0.670	338	56C	W5180033	W5180043	W5180053	W5180073
	1150	82	0.602	0.463	356					
21	1750	83	0.796	0.533	405	56C	W5180034	W5180044	W5180054	W5180074
	1150	55	0.555	0.372	426					
28	1750	63	0.631	0.410	410	56C	W5180035	W5180045	W5180055	W5180075
	1150	47	0.494	0.321	431					
37	1750	47	0.490	0.309	414	56C	W5180036	W5180046	W5180056	W5180076
	1150	31	0.340	0.214	436					
46	1750	38	0.397	0.234	388	56C	W5180037	W5180047	W5180057	W5180077
	1150	25	0.274	0.162	408					
60	1750	25	0.363	0.203	442	56C	W5180038	W5180048	W5180058	W5180078
	1150	18.2	0.250	0.140	465					
70	1750	25.0	0.204	0.110	278	56C	W5180039	W5180049	W5180059	W5180079
	1150	16.4	0.137	0.074	292					
102	1750	17.2	0.144	0.070	261	56C	W5180040	W5180050	W5180060	W5180080
	1150	11.3	0.098	0.048	275					

5 Identify catalog number of the basic reducer by continuing to the right. See page 68 for detailed information on building an exact model number.

6 Verify physical dimensions using the dimensional drawings shown on pages 84-97.

3 Move across the table to the Input HP column until you find a rating that is equal to or greater than the actual input horsepower required. Once located, check the top of the table to identify the correct gear reducer size (512, 518, 520, etc.).

* Contact LEESON for metric IEC input flange options available.

Bravo® Single Reduction Reducers

Bravo SINGLE REDUCTION
ALUMINUM GEAR REDUCERS
MAXIMUM RATING TABLES
512 SERIES • ALL STYLES



Style BMQ

Style HMQ



512 Series • Style BMQ & HMQ • 1.0 S.F.

Ratio	Input RPM	Output RPM	Input HP	Output HP	Output Torque (lb-in)	IEC Metric Input Flange*	Left Hand Catalog No.	Right Hand Catalog No.	Double Extension Catalog No.	Hollow Output Catalog No.
7	1750	250	0.764	0.611	154	56B14	W5120025	W5120033	W5120041	W5120081
	1150	164	0.528	0.422	162	63B14	W5120049	W5120057	W5120065	W5120089
10.6	1750	165	0.510	0.398	152	56B14	W5120026	W5120034	W5120042	W5120082
	1150	108	0.353	0.275	160	63B14	W5120050	W5120058	W5120066	W5120090
15	1750	117	0.441	0.322	174	56B14	W5120027	W5120035	W5120043	W5120083
	1150	77	0.305	0.223	183	63B14	W5120051	W5120059	W5120067	W5120091
19	1750	92	0.386	0.270	185	56B14	W5120028	W5120036	W5120044	W5120084
	1150	61	0.268	0.187	195	63B14	W5120052	W5120060	W5120068	W5120092
30	1750	58	0.299	0.185	200	56B14	W5120029	W5120037	W5120045	W5120085
	1150	38	0.206	0.128	210	63B14	W5120053	W5120061	W5120069	W5120093
39	1750	45	0.246	0.140	197	56B14	W5120030	W5120038	W5120046	W5120086
	1150	29	0.170	0.097	207	63B14	W5120054	W5120062	W5120070	W5120094
61	1750	29	0.168	0.084	184	56B14	W5120031	W5120039	W5120047	W5120087
	1150	18.9	0.116	0.058	194	63B14	W5120055	W5120063	W5120071	W5120095
80	1750	21.9	0.106	0.051	146	56B14	W5120032	W5120040	W5120048	W5120088
	1150	14.4	0.073	0.035	154	63B14	W5120056	W5120064	W5120072	W5120096

* Contact LEESON for other metric IEC input flange options available.

Style B

Style H



512 Series • Style B & H • 1.0 S.F.

Ratio	Input RPM	Output RPM	Input HP	Output HP	Output Torque (lb-in)	Left Hand Catalog No.	Right Hand Catalog No.	Double Extension Catalog No.	Hollow Output Catalog No.
7	1750	250	0.764	0.611	154		CONTACT LEESON		CONTACT LEESON
	1150	164	0.528	0.422	162				CONTACT LEESON
10.6	1750	165	0.510	0.398	152		CONTACT LEESON		CONTACT LEESON
	1150	108	0.353	0.275	160				CONTACT LEESON
15	1750	117	0.441	0.322	174		CONTACT LEESON		CONTACT LEESON
	1150	77	0.305	0.223	183				CONTACT LEESON
19	1750	92	0.386	0.270	185		CONTACT LEESON		CONTACT LEESON
	1150	61	0.268	0.187	195				CONTACT LEESON
30	1750	58	0.299	0.185	200		CONTACT LEESON		CONTACT LEESON
	1150	38	0.206	0.128	210				CONTACT LEESON
39	1750	45	0.246	0.140	197		CONTACT LEESON		CONTACT LEESON
	1150	29	0.170	0.097	207				CONTACT LEESON
61	1750	29	0.168	0.084	184		CONTACT LEESON		CONTACT LEESON
	1150	18.9	0.116	0.058	194				CONTACT LEESON
80	1750	21.9	0.106	0.051	146		CONTACT LEESON		CONTACT LEESON
	1150	14.4	0.073	0.035	154				CONTACT LEESON



**SINGLE REDUCTION
MAXIMUM RATING TABLES**
518 SERIES • ALL STYLES



518 Series • Style BMQ & HMQ • 1.0 S.F.

Ratio	Input RPM	Output RPM	Input HP	Output HP	Output Torque (lb-in)	NEMA C Input Flange*	Style BMQ			Style HMQ
							Left Hand Catalog No.	Right Hand Catalog No.	Double Extension Catalog No.	Hollow Output Catalog No.
7	1750	250	1.378	1.103	278	56C	W5180031	W5180041	W5180051	W5180071
	1150	164	0.950	0.760	292					
10	1750	175	0.981	0.775	279	56C	W5180032	W5180042	W5180052	W5180072
	1150	115	0.679	0.536	294					
14	1750	125	0.871	0.670	338	56C	W5180033	W5180043	W5180053	W5180073
	1150	82	0.602	0.463	356					
21	1750	83	0.796	0.533	405	56C	W5180034	W5180044	W5180054	W5180074
	1150	55	0.555	0.372	426					
28	1750	63	0.631	0.410	410	56C	W5180035	W5180045	W5180055	W5180075
	1150	47	0.494	0.321	431					
37	1750	47	0.490	0.309	414	56C	W5180036	W5180046	W5180056	W5180076
	1150	31	0.340	0.214	436					
46	1750	38	0.397	0.234	388	56C	W5180037	W5180047	W5180057	W5180077
	1150	25	0.274	0.162	408					
60	1750	29	0.363	0.203	442	56C	W5180038	W5180048	W5180058	W5180078
	1150	19.2	0.250	0.140	465					
70	1750	25.0	0.204	0.110	278	56C	W5180039	W5180049	W5180059	W5180079
	1150	16.4	0.137	0.074	292					
102	1750	17.2	0.144	0.070	261	56C	W5180040	W5180050	W5180060	W5180080
	1150	11.3	0.098	0.048	275					

* Contact LEESON for metric IEC input flange options available.

Bravo® Single Reduction Reducers

518 Series • Style B & H • 1.0 S.F.

Ratio	Input RPM	Output RPM	Input HP	Output HP	Output Torque (lb-in)	Style B			Style H
						Left Hand Catalog No.	Right Hand Catalog No.	Double Extension Catalog No.	Hollow Output Catalog No.
7	1750	250	1.378	1.103	278	W5180001	W5180011	W5180021	W5180061
	1150	164	0.950	0.760	292				
10	1750	175	0.981	0.775	279	W5180002	W5180012	W5180022	W5180062
	1150	115	0.679	0.536	294				
14	1750	125	0.871	0.670	338	W5180003	W5180013	W5180023	W5180063
	1150	82	0.602	0.463	356				
21	1750	83	0.796	0.533	405	W5180004	W5180014	W5180024	W5180064
	1150	55	0.555	0.372	426				
28	1750	63	0.631	0.410	410	W5180005	W5180015	W5180025	W5180065
	1150	47	0.494	0.321	431				
37	1750	47	0.490	0.309	414	W5180006	W5180016	W5180026	W5180066
	1150	31	0.340	0.214	436				
46	1750	38	0.397	0.234	388	W5180007	W5180017	W5180027	W5180067
	1150	25	0.274	0.162	408				
60	1750	29	0.363	0.203	442	W5180008	W5180018	W5180028	W5180068
	150	19.2	0.250	0.140	465				
70	1750	25.0	0.204	0.110	278	W5180009	W5180019	W5180029	W5180069
	1150	16.4	0.137	0.074	292				
102	1750	17.2	0.144	0.070	261	W5180010	W5180020	W5180030	W5180070
	1150	11.3	0.098	0.048	275				

Bravo SINGLE REDUCTION
ALUMINUM GEAR REDUCERS MAXIMUM RATING TABLES
520 SERIES • ALL STYLES



Style BMQ

Style HMQ



520 Series • Style BMQ & HMQ • 1.0 S.F.

Ratio	Input RPM	Output RPM	Input HP	Output HP	Output Torque (lb-in)	NEMA C Input Flange*	Left Hand Catalog No.	Right Hand Catalog No.	Double Extension Catalog No.	Hollow Output Catalog No.
7	1750	250	2.472	2.027	511	56C	W5200034	W5200045	W5200056	W5200078
	1150	164	1.707	1.400	538					
10	1750	175	1.961	1.569	565	56C	W5200035	W5200046	W5200057	W5200079
	1150	115	1.355	1.084	594					
14	1750	125	1.494	1.180	595	56C	W5200036	W5200047	W5200058	W5200080
	1150	82	1.031	0.814	626					
18	1750	97	1.196	0.897	583	56C	W5200037	W5200048	W5200059	W5200081
	1150	64	0.830	0.622	613					
26	1750	67	0.889	0.613	577	56C	W5200038	W5200049	W5200060	W5200082
	1150	44	0.614	0.424	607					
36	1750	49	0.684	0.472	607	56C	W5200039	W5200050	W5200061	W5200083
	1150	32	0.470	0.324	639					
43	1750	41	0.604	0.399	613	56C	W5200040	W5200051	W5200062	W5200084
	1150	27	0.419	0.276	645					
60	1750	29	0.486	0.282	613	56C	W5200041	W5200052	W5200063	W5200085
	1150	19.2	0.335	0.194	645					
68	1750	25.7	0.420	0.239	580	56C	W5200042	W5200053	W5200064	W5200086
	1150	16.9	0.289	0.165	610					
80	1750	21.9	0.368	0.199	569	56C	W5200043	W5200054	W5200065	W5200087
	1150	14.4	0.246	0.133	599					
100	1750	17.5	0.295	0.147	516	56C	W5200044	W5200055	W5200066	W5200088
	1150	11.5	0.207	0.103	543					

* Contact LEESON for metric IEC input flange options available.

Style B

Style H



520 Series • Style B & H • 1.0 S.F.

Ratio	Input RPM	Output RPM	Input HP	Output HP	Output Torque (lb-in)	Left Hand Catalog No.	Right Hand Catalog No.	Double Extension Catalog No.	Hollow Output Catalog No.
7	1750	250	2.472	2.027	511	W5200001	W5200012	W5200023	W5200067
	1150	164	1.707	1.400	538				
10	1750	175	1.961	1.569	565	W5200002	W5200013	W5200024	W5200068
	1150	115	1.355	1.084	594				
14	1750	125	1.494	1.180	595	W5200003	W5200014	W5200025	W5200069
	1150	82	1.031	0.814	626				
18	1750	97	1.196	0.897	583	W5200004	W5200015	W5200026	W5200070
	1150	64	0.830	0.622	613				
26	1750	67	0.889	0.613	577	W5200005	W5200016	W5200027	W5200071
	1150	44	0.614	0.424	607				
36	1750	49	0.684	0.472	607	W5200006	W5200017	W5200028	W5200072
	1150	32	0.470	0.324	639				
43	1750	41	0.604	0.399	613	W5200007	W5200018	W5200029	W5200073
	1150	27	0.419	0.276	645				
60	1750	29	0.486	0.282	613	W5200008	W5200019	W5200030	W5200074
	1150	19.2	0.335	0.194	645				
68	1750	25.7	0.420	0.239	580	W5200009	W5200020	W5200031	W5200075
	1150	16.9	0.289	0.165	610				
80	1750	21.9	0.368	0.199	569	W5200010	W5200021	W5200032	W5200076
	1150	14.4	0.246	0.133	599				
100	1750	17.5	0.295	0.147	516	W5200011	W5200022	W5200033	W5200077
	1150	11.5	0.207	0.103	543				



**SINGLE REDUCTION
MAXIMUM RATING TABLES**
525 SERIES • ALL STYLES



Style BMQ

Style HMQ

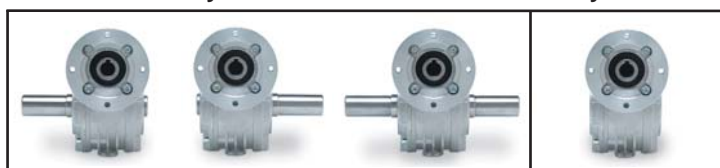

525 Series • Style BMQ & HMQ • 1.0 S.F.

Ratio	Input RPM	Output RPM	Input HP	Output HP	Output Torque (lb-in)	NEMA C Input Flange*	Left Hand Catalog No.	Right Hand Catalog No.	Double Extension Catalog No.	Hollow Output Catalog No.
7	1750	250	5.24	4.35	1097	56C	W5250034	W5250045	W5250056	W5250111
	1150	164	3.62	3.01	1155	140TC	W5250067	W5250078	W5250089	W5250122
10	1750	175	4.19	3.39	1222	56C	W5250035	W5250046	W5250057	W5250112
	1150	115	2.90	2.35	1287	140TC	W5250068	W5250079	W5250090	W5250123
15	1750	117	2.85	2.25	1214	56C	W5250036	W5250047	W5250058	W5250113
	1150	77	1.98	1.56	1278	140TC	W5250069	W5250080	W5250091	W5250124
19	1750	92	2.24	1.75	1197	56C	W5250037	W5250048	W5250059	W5250114
	1150	61	1.56	1.22	1260	140TC	W5250070	W5250081	W5250092	W5250125
24	1750	73	1.92	1.44	1246	56C	W5250038	W5250049	W5250060	W5250115
	1150	48	1.33	1.00	1312	140TC	W5250071	W5250082	W5250093	W5250126
30	1750	58	1.58	1.17	1274	56C	W5250039	W5250050	W5250061	W5250116
	1150	38	1.09	0.81	1341	140TC	W5250072	W5250083	W5250094	W5250127
36	1750	49	1.46	1.00	1281	56C	W5250040	W5250051	W5250062	W5250117
	1150	32	1.01	0.68	1349	140TC	W5250073	W5250084	W5250095	W5250128
45	1750	39	1.11	0.73	1182	56C	W5250041	W5250052	W5250063	W5250118
	1150	25.6	0.78	0.51	1244	140TC	W5250074	W5250085	W5250096	W5250129
67	1750	26.1	0.73	0.44	1069	56C	W5250042	W5250053	W5250064	W5250119
	1150	17.2	0.51	0.30	1125	140TC	W5250075	W5250086	W5250097	W5250130
80	1750	21.9	0.63	0.36	1034	56C	W5250043	W5250054	W5250065	W5250120
	1150	14.4	0.42	0.24	1089	140TC	W5250076	W5250087	W5250098	W5250131
94	1750	18.6	0.51	0.26	878	56C	W5250044	W5250055	W5250066	W5250121
	1150	12.2	0.34	0.18	924	140TC	W5250077	W5250088	W5250099	W5250132

Bravo® Single Reduction Reducers

* Contact LEESON for metric IEC input flange options available.

Style B

Style H



525 Series • Style B & H • 1.0 S.F.

Ratio	Input RPM	Output RPM	Input HP	Output HP	Output Torque (lb-in)	Left Hand Catalog No.	Right Hand Catalog No.	Double Extension Catalog No.	Hollow Output Catalog No.
7	1750	250	5.24	4.35	1097	W5250001	W5250012	W5250023	W5250100
	1150	164	3.62	3.01	1155				
10	1750	175	4.19	3.39	1222	W5250002	W5250013	W5250024	W5250101
	1150	115	2.90	2.35	1287				
15	1750	117	2.85	2.25	1214	W5250003	W5250014	W5250025	W5250102
	1150	77	1.98	1.56	1278				
19	1750	92	2.24	1.75	1197	W5250004	W5250015	W5250026	W5250103
	1150	61	1.56	1.22	1260				
24	1750	73	1.92	1.44	1246	W5250005	W5250016	W5250027	W5250104
	1150	48	1.33	1.00	1312				
30	1750	58	1.58	1.17	1274	W5250006	W5250017	W5250028	W5250105
	1150	38	1.09	0.81	1341				
36	1750	49	1.46	1.00	1281	W5250007	W5250018	W5250029	W5250106
	1150	32	1.01	0.68	1349				
45	1750	39	1.11	0.73	1182	W5250008	W5250019	W5250030	W5250107
	1150	25.6	0.78	0.51	1244				
67	1750	26.1	0.73	0.44	1069	W5250009	W5250020	W5250031	W5250108
	1150	17.2	0.51	0.30	1125				
80	1750	21.9	0.63	0.36	1034	W5250010	W5250021	W5250032	W5250109
	1150	14.4	0.42	0.24	1089				
94	1750	18.6	0.51	0.26	878	W5250011	W5250022	W5250033	W5250110
	1150	12.2	0.34	0.18	924				

Bravo SINGLE REDUCTION
ALUMINUM GEAR REDUCERS
MAXIMUM RATING TABLES
534 SERIES • ALL STYLES



Style BMQ

Style HMQ



534 Series • BMQ & HMQ • 1.0 S.F.

Ratio	Input RPM	Output RPM	Input HP	Output HP	Output Torque (lb-in)	NEMA C Input Flange*	Left Hand Catalog No.	Right Hand Catalog No.	Double Extension Catalog No.	Hollow Output Catalog No.
7	1750	250	8.26	7.27	1832	180TC	W5340109	W5340121	W5340133	W5340181
	1150	164	5.70	5.02	1929					
10	1750	175	7.62	6.10	2196	140TC	W5340074	W5340086	W5340098	W5340170
	1150	115	5.27	4.22	2312					
14	1750	125	5.91	4.61	2323	140TC	W5340075	W5340087	W5340099	W5340171
	1150	82	4.08	3.18	2446					
20	1750	88	3.91	3.09	2212	140TC	W5340076	W5340088	W5340100	W5340172
	1150	58	2.71	2.14	2329					
28	1750	63	3.37	2.53	2528	140TC	W5340078	W5340090	W5340102	W5340174
	1150	41	2.31	1.73	2661					
38	1750	46	2.34	1.66	2279	56C	W5340043	W5340055	W5340067	W5340163
	1150	30	1.61	1.14	2399					
52	1750	34	1.82	1.20	2229	56C	W5340045	W5340057	W5340069	W5340165
	1150	22.1	1.24	0.82	2347					
67	1750	26.1	1.56	1.01	2458	56C	W5340046	W5340058	W5340070	W5340166
	1150	17.2	1.07	0.70	2588					
96	1750	18.2	0.99	0.52	1735	56C	W5340048	W5340060	W5340072	W5340168
	1150	12.0	0.66	0.35	1827					

* Contact LEESON for additional NEMA and metric IEC input flange options available.

Style B

Style H



534 Series • Styles B & H • 1.0 S.F.

Ratio	Input RPM	Output RPM	Input HP	Output HP	Output Torque (lb-in)	Left Hand Catalog No.	Right Hand Catalog No.	Double Extension Catalog No.	Hollow Output Catalog No.
7	1750	250	8.26	7.27	1832	W5340001	W5340013	W5340025	W5340145
	1150	164	5.70	5.02	1929				
10	1750	175	7.62	6.10	2196	W5340002	W5340014	W5340026	W5340146
	1150	115	5.27	4.22	2312				
14	1750	125	5.91	4.61	2323	W5340003	W5340015	W5340027	W5340147
	1150	82	4.08	3.18	2446				
20	1750	88	3.91	3.09	2212	W5340004	W5340016	W5340028	W5340148
	1150	58	2.71	2.14	2329				
28	1750	63	3.37	2.53	2528	W5340006	W5340018	W5340030	W5340150
	1150	41	2.31	1.73	2661				
38	1750	46	2.34	1.66	2279	W5340007	W5340019	W5340031	W5340151
	1150	30	1.61	1.14	2399				
52	1750	34	1.82	1.20	2229	W5340009	W5340021	W5340033	W5340153
	1150	22.1	1.24	0.82	2347				
67	1750	26.1	1.56	1.01	2458	W5340010	W5340022	W5340034	W5340154
	1150	17.2	1.07	0.70	2588				
96	1750	18.2	0.99	0.52	1735	W5340012	W5340024	W5340036	W5340156
	1150	12.0	0.66	0.35	1827				

Bravo® Single Reduction Reducers



SINGLE REDUCTION
"HOW TO USE"
QUICK SELECTIONS **Bravo**
ALUMINUM GEAR REDUCERS

How To Use Quick Selections

Maximum Rating Tables for Single Reduction Gear Reducers are shown on pages 70-74. Selection of the appropriate gear reducer can be made using those tables or the Quick Selections on the following pages.

BEFORE YOU START:

Identify the Service Factor of the application (see page 171).

Determine the actual input horsepower of the motor by multiplying the motor's nameplate horsepower by the Service Factor.

Determine the output speed (RPM) required at output shaft of reducer.

Identify the mounting style required by your application from the style charts shown on pages 66-67. Note the basic mounting style (BMQ, HMQ, etc.).

To select the proper gear reducer size, use the Quick Selections as shown:

Bravo SINGLE REDUCTION QUICK SELECTIONS
ALUMINUM GEAR REDUCERS



Bravo® Single Reduction Reducers

Style BMQ Motorized NEMA & IEC 1750 RPM

1 Find the appropriate Quick Selections page. The tables begin on page 76 and are organized by motor HP.

4 Check load capacities against the needs of your application. Do not exceed the overhung load (OHL) shown in the table. Detailed instructions for calculating the actual overhung load are shown on page 150. If overhung and thrust loads will be applied simultaneously or if the load exceeds listed capacities, contact LEESON.

Bravo® Single Reduction Reducers

1/6 HP / 0.12 KW					Gear Reducers							
Output Speed (RPM)	Service Factor	Output Torque (lb-in)	Overhung Load (lbs.)	Ratio	Motor Frame	IEC	Weight (lbs.)	Model Number	Catalog No.	Weight (lbs.)	Model Number	Catalog No.
250	4.77	32	135	7	--	56 B14	3	BMQ512-7-L-56B14-14	W5120025	3	HMQ512-7-H-56B14-14	W5120081
250	8.62	32	202	7	56C	◆	7	BMQ518-7-L-56-12	W5180031	6	HMQ518-7-H-56-12	W5180071
175	6.13	46	214	10	56C	◆	7	BMQ518-10-L-56-12	W5180032	6	HMQ518-10-H-56-12	W5180072
						56 B14	3	BMQ512-10.6-L-56B14-14	W5120026	3	HMQ512-10.6-H-56B14-14	W5120082
						◆	7	BMQ518-14-L-56-12	W5180033	6	HMQ518-14-H-56-12	W5180073
						56 B14	3	BMQ512-15-L-56B14-14	W5120027	3	HMQ512-15-H-56B14-14	W5120083
						56 B14	3	BMQ512-19-H-56B14-14	W5120028	3	HMQ512-19-H-56B14-14	W5120084
						◆	7	BMQ518-21-H-56-12	W5180034	6	HMQ518-21-H-56-12	W5180074
						◆	7	BMQ520-26-H-56-16	W5200035	7	HMQ520-26-H-56-16	W5200082
						◆	6	BMQ518-28-H-56-12	W5180036	6	HMQ518-28-H-56-12	W5180075
58	1.86	108	214	30	--	56 B14	3	BMQ512-37-L-56B14-14	W5120037	3	HMQ512-37-H-56B14-14	W5120085
47	3.06	135	315	37	56C	◆	7	BMQ518-37-L-56-12	W5180036	6	HMQ518-37-H-56-12	W5180076
45	1.54	128	236	39	--	56 B14	3	BMQ512-39-L-56B14-14	W5120030	3	HMQ512-39-H-56B14-14	W5120086
41	3.78	162	460	43	56C	◆	9	BMQ520-43-L-56-16	W5200040	7	HMQ520-43-H-56-16	W5200087
38	2.48	157	360	46	56C	◆	7	BMQ518-46-L-56-12	W5180037	6	HMQ518-46-H-56-12	W5180077
29	2.27	195	382	60	56C	◆	7	BMQ518-60-L-56-12	W5180038	6	HMQ518-60-H-56-12	W5180078
28.7	1.06	174	270	61	--	56 B14	3	BMQ512-61-L-56B14-14	W5120031	3	HMQ512-61-H-56B14-14	W5120087
26.1	2.62	221	562	68	56C	◆	9	BMQ520-68-L-56-16	W5200042	7	HMQ520-68-H-56-16	W5200088
25.7	1.28	218	405	70	56C	◆	7	BMQ518-70-L-56-12	W5180039	6	HMQ518-70-H-56-12	W5180079
21.9	2.30	248	583	80	56C	◆	9	BMQ520-80-L-56-16	W5200043	7	HMQ520-80-H-56-16	W5200089
18.6	3.11	282	877	94	56C	◆	14	BMQ525-94-L-56-20	W5250044	12	HMQ525-94-H-56-20	W5250090
17.5	1.79	288	596	100	56C	◆	9	BMQ518-100-L-56-12	W5180040	7	HMQ518-100-H-56-12	W5180080

2 Locate output RPM column on left side of the table. All ratings are based on an input speed of 1750 RPM. Scroll down to the output speed (RPM) required. Output speeds may be rounded to the nearest whole number. For exact output speed, divide 1750 by the ratio listed.

3 Move to the Service Factor column and find one suitable to meet the application requirements. Refer to page 171 recommended service factors.

5 Select motor frame size.

6 Identify the catalog number & model number of the basic reducer by continuing to the right. See page 68 for detailed information on building an exact model number. Catalog numbers in the quick selection tables are for units with left hand and hollow shaft extensions. Other styles can be substituted as needed.

7 Verify physical dimensions using the dimensional drawings shown on pages 84-97.



**Style BMQ & HMQ
Motorized Quill Input
NEMA & IEC Frame Selections
1750 RPM Input**



Bravo® Single Reduction Reducers

1/6 HP / 0.12 KW Gear Reducer Quick Selections												
Output Speed (RPM)	Service Factor▼	Output Torque (lb-in)	Overhung Load (lbs.)●	Ratio	Motor Frame		Weight (lbs.)	Style BMQ Left Hand Output		Weight (lbs.)	Style HMQ Hollow Output	
					NEMA	IEC		Model Number	Catalog No.		Model Number	Catalog No.
250	4.77	32	135	7	--	56 B14	3	BMQ512-7-L-56B14-14	W5120025	3	HMQ512-7-H-56B14-14	W5120081
250	8.62	32	202	7	56C	◆	7	BMQ518-7-L-56-12	W5180031	6	HMQ518-7-H-56-12	W5180071
175	6.13	46	214	10	56C	◆	7	BMQ518-10-L-56-12	W5180032	6	HMQ518-10-H-56-12	W5180072
165	3.19	48	146	10.6	--	56 B14	3	BMQ512-10.6-L-56B14-14	W5120026	3	HMQ512-10.6-H-56B14-14	W5120082
125	5.44	62	248	14	56C	◆	7	BMQ518-14-L-56-12	W5180033	6	HMQ518-14-H-56-12	W5180073
117	2.77	63	180	15	--	56 B14	3	BMQ512-15-L-56B14-14	W5120027	3	HMQ512-15-H-56B14-14	W5120083
92	2.41	77	180	19	--	56 B14	3	BMQ512-19-L-56B14-14	W5120028	3	HMQ512-19-H-56B14-14	W5120084
83	4.98	81	259	21	56C	◆	7	BMQ518-21-L-56-12	W5180034	6	HMQ518-21-H-56-12	W5180074
67	5.56	104	382	26	56C	◆	9	BMQ520-26-L-56-16	W5200038	7	HMQ520-26-H-56-16	W5200082
63	3.94	104	292	28	56C	◆	7	BMQ518-28-L-56-12	W5180035	6	HMQ518-28-H-56-12	W5180075
58	1.86	108	214	30	--	56 B14	3	BMQ512-30-L-56B14-14	W5120029	3	HMQ512-30-H-56B14-14	W5120085
47	3.06	135	315	37	56C	◆	7	BMQ518-37-L-56-12	W5180036	6	HMQ518-37-H-56-12	W5180076
45	1.54	128	236	39	--	56 B14	3	BMQ512-39-L-56B14-14	W5120030	3	HMQ512-39-H-56B14-14	W5120086
41	3.78	162	460	43	56C	◆	9	BMQ520-43-L-56-16	W5200040	7	HMQ520-43-H-56-16	W5200084
38	2.48	157	360	46	56C	◆	7	BMQ518-46-L-56-12	W5180037	6	HMQ518-46-H-56-12	W5180077
29	2.27	195	382	60	56C	◆	7	BMQ518-60-L-56-12	W5180038	6	HMQ518-60-H-56-12	W5180078
28.7	1.06	174	270	61	--	56 B14	3	BMQ512-61-L-56B14-14	W5120031	3	HMQ512-61-H-56B14-14	W5120087
26.1	2.62	221	562	68	56C	◆	9	BMQ520-68-L-56-16	W5200042	7	HMQ520-68-H-56-16	W5200086
25.7	1.28	218	405	70	56C	◆	7	BMQ518-70-L-56-12	W5180039	6	HMQ518-70-H-56-12	W5180079
21.9	2.30	248	583	80	56C	◆	9	BMQ520-80-L-56-16	W5200043	7	HMQ520-80-H-56-16	W5200087
18.6	3.11	282	877	94	56C	◆	14	BMQ525-94-L-56-18	W5250044	12	HMQ525-94-H-56-18	W5250121
17.5	1.79	288	596	100	56C	◆	9	BMQ520-100-L-56-16	W5200044	7	HMQ520-100-H-56-16	W5200088

- ▼ Service Factor is based on maximum torque rating of reducer. Refer to page 171 for special application considerations.
- Output shaft overhung load rating is based on load applied at center of output shaft extension (solid output shaft style).
- ◆ Reducers are available with metric IEC input flanges. Refer to page 83 for frame options available. Metric IEC input selections will have a metric output shaft as standard. Contact LEESON for catalog number information.

This Quick Selection is only for style BMQ (left hand output) & HMQ (hollow output) reducers. For other reducer configurations, see the MAXIMUM RATING TABLES beginning on page 70.



**Style BMQ & HMQ
Motorized Quill Input
NEMA & IEC Frame Selections
1750 RPM Input**



Bravo® Single Reduction Reducers

1/4 HP / 0.18 KW Gear Reducer Quick Selections													
Output Speed (RPM)	Service Factor▼	Output Torque (lb-in)	Overhung Load (lbs.)●	Ratio	Motor Frame		Weight (lbs.)	Style BMQ Left Hand Output		Weight (lbs.)	Style HMQ Hollow Output		
					NEMA	IEC		Model Number	Catalog No.		Model Number	Catalog No.	
250	3.05	50	135	7	--	63B14	3	BMQ512-7-L-63B14-14	W5120049	3	HMQ512-7-H-63B14-14	W5120089	
250	5.51	50	202	7	56C	◆	7	BMQ518-7-L-56-12	W5180031	6	HMQ518-7-H-56-12	W5180071	
175	3.92	71	214	10	56C	◆	7	BMQ518-10-L-56-12	W5180032	6	HMQ518-10-H-56-12	W5180072	
175	7.84	72	292	10	56C	◆	9	BMQ520-10-L-56-16	W5200035	7	HMQ520-10-H-56-16	W5200079	
165	2.04	74	146	10.6	--	63B14	3	BMQ512-10.6-L-63B14-14	W5120050	3	HMQ512-10.6-H-63B14-14	W5120090	
125	3.48	97	248	14	56C	◆	7	BMQ518-14-L-56-12	W5180033	6	HMQ518-14-H-56-12	W5180073	
125	5.98	100	326	14	56C	◆	9	BMQ520-14-L-56-16	W5200036	7	HMQ520-14-H-56-16	W5200080	
117	1.77	98	180	15	--	63B14	3	BMQ512-15-L-63B14-14	W5120051	3	HMQ512-15-H-63B14-14	W5120091	
97	4.79	122	337	18	56C	◆	9	BMQ520-18-L-56-16	W5200037	7	HMQ520-18-H-56-16	W5200081	
92	1.54	120	180	19	--	63B14	3	BMQ512-19-L-63B14-14	W5120052	3	HMQ512-19-H-63B14-14	W5120092	
83	3.18	127	259	21	56C	◆	7	BMQ518-21-L-56-12	W5180034	6	HMQ518-21-H-56-12	W5180074	
67	3.56	162	382	26	56C	◆	9	BMQ520-26-L-56-16	W5200038	7	HMQ520-26-H-56-16	W5200082	
63	2.52	163	292	28	56C	◆	7	BMQ518-28-L-56-12	W5180035	6	HMQ518-28-H-56-12	W5180075	
58	1.19	168	214	30	--	63B14	3	BMQ512-30-L-63B14-14	W5120053	3	HMQ512-30-H-63B14-14	W5120093	
49	2.74	222	427	36	56C	◆	9	BMQ520-36-L-56-16	W5200039	7	HMQ520-36-H-56-16	W5200083	
47	1.96	211	315	37	56C	◆	7	BMQ518-37-L-56-12	W5180036	6	HMQ518-37-H-56-12	W5180076	
45	0.99	200	236	39	--	63B14	3	BMQ512-39-L-63B14-14	W5120054	3	HMQ512-39-H-63B14-14	W5120094	
41	2.42	254	460	43	56C	◆	9	BMQ520-43-L-56-16	W5200040	7	HMQ520-43-H-56-16	W5200084	
38	1.59	245	360	46	56C	◆	7	BMQ518-46-L-56-12	W5180037	6	HMQ518-46-H-56-12	W5180077	
29	1.45	304	382	60	56C	◆	7	BMQ518-60-L-56-12	W5180038	6	HMQ518-60-H-56-12	W5180078	
29	1.95	315	540	60	56C	◆	9	BMQ520-60-L-56-16	W5200041	7	HMQ520-60-H-56-16	W5200085	
26.1	2.94	364	854	67	56C	◆	14	BMQ525-67-L-56-18	W5250042	12	HMQ525-67-H-56-18	W5250119	
25.7	1.68	345	562	68	56C	◆	9	BMQ520-68-L-56-16	W5200042	7	HMQ520-68-H-56-16	W5200086	
21.9	1.47	387	583	80	56C	◆	9	BMQ520-80-L-56-16	W5200043	7	HMQ520-80-H-56-16	W5200087	
21.9	2.53	408	866	80	56C	◆	14	BMQ525-80-L-56-18	W5250043	12	HMQ525-80-H-56-18	W5250120	
18.6	1.99	440	877	94	56C	◆	14	BMQ525-94-L-56-18	W5250044	12	HMQ525-94-H-56-18	W5250121	
7.5	1.15	450	596	100	56C	◆	9	BMQ520-100-L-56-16	W5200044	7	HMQ520-100-H-56-16	W5200088	

- ▼ Service Factor is based on maximum torque rating of reducer. Refer to page 171 for special application considerations.
- Output shaft overhung load rating is based on load applied at center of output shaft extension (solid output shaft style).
- ◆ Reducers are available with metric IEC input flanges. Refer to page 83 for frame options available. Metric IEC input selections will have a metric output shaft as standard. Contact LEESON for catalog number information.

This Quick Selection is only for style BMQ (left hand output) & HMQ (hollow output) reducers. For other reducer configurations, see the MAXIMUM RATING TABLES beginning on page 70.



Style BMQ & HMQ Motorized Quill Input NEMA Frame Selections 1750 RPM Input



Bravo® Single Reduction Reducers

1/3 HP / 0.25 KW

Gear Reducer Quick Selections

Output Speed (RPM)	Service Factor ▼	Output Torque (lb-in)	Overhung Load (lbs.) ●	Ratio	Motor Frame ◆	Style BMQ Left Hand Output			Style HMQ Hollow Output		
						Weight (lbs.)	Model Number	Catalog No.	Weight (lbs.)	Model Number	Catalog No.
250	4.18	67	202	7	56C	7	BMQ518-7-L-56-12	W5180031	6	HMQ518-7-H-56-12	W5180071
175	2.97	94	214	10	56C	7	BMQ518-10-L-56-12	W5180032	6	HMQ518-10-H-56-12	W5180072
175	5.94	95	292	10	56C	9	BMQ520-10-L-56-16	W5200035	7	HMQ520-10-H-56-16	W5200079
125	2.64	128	248	14	56C	7	BMQ518-14-L-56-12	W5180033	6	HMQ518-14-H-56-12	W5180073
125	4.53	131	326	14	56C	9	BMQ520-14-L-56-16	W5200036	7	HMQ520-14-H-56-16	W5200080
97	3.63	161	337	18	56C	9	BMQ520-18-L-56-16	W5200037	7	HMQ520-18-H-56-16	W5200081
83	2.41	168	259	21	56C	7	BMQ518-21-L-56-12	W5180034	6	HMQ518-21-H-56-12	W5180074
73	5.83	214	571	24	56C	14	BMQ525-24-L-56-18	W5250038	12	HMQ525-24-H-56-18	W5250115
67	2.69	214	382	26	56C	9	BMQ520-26-L-56-16	W5200038	7	HMQ520-26-H-56-16	W5200082
63	1.91	215	292	28	56C	7	BMQ518-28-L-56-12	W5180035	6	HMQ518-28-H-56-12	W5180075
58	4.80	265	618	30	56C	14	BMQ525-30-L-56-18	W5250039	12	HMQ525-30-H-56-18	W5250116
49	2.07	293	427	36	56C	9	BMQ520-36-L-56-16	W5200039	7	HMQ520-36-H-56-16	W5200083
49	4.44	289	674	36	56C	14	BMQ525-36-L-56-18	W5250040	12	HMQ525-36-H-56-18	W5250117
47	1.49	279	315	37	56C	7	BMQ518-37-L-56-12	W5180036	6	HMQ518-37-H-56-12	W5180076
46	7.10	321	944	38	56C	29	BMQ534-38-L-56-24	W5340043	24	HMQ534-38-H-56-24	W5340163
41	1.83	335	460	43	56C	9	BMQ520-43-L-56-16	W5200040	7	HMQ520-43-H-56-16	W5200084
39	3.36	352	753	45	56C	14	BMQ525-45-L-56-18	W5250041	12	HMQ525-45-H-56-18	W5250118
38	1.20	323	360	46	56C	7	BMQ518-46-L-56-12	W5180037	6	HMQ518-46-H-56-12	W5180077
34	5.52	404	1034	52	56C	29	BMQ534-52-L-56-24	W5340045	24	HMQ534-52-H-56-24	W5340165
29	1.10	402	382	60	56C	7	BMQ518-60-L-56-12	W5180038	6	HMQ518-60-H-56-12	W5180078
29	1.47	416	540	60	56C	9	BMQ520-60-L-56-16	W5200041	7	HMQ520-60-H-56-16	W5200085
26.1	2.24	478	854	67	56C	14	BMQ525-67-L-56-18	W5250042	12	HMQ525-67-H-56-18	W5250119
26.1	4.75	518	1113	67	56C	29	BMQ534-67-L-56-24	W5340046	24	HMQ534-67-H-56-24	W5340166
25.7	1.26	461	562	68	56C	9	BMQ520-68-L-56-16	W5200042	7	HMQ520-68-H-56-16	W5200086
21.9	1.11	513	583	80	56C	9	BMQ520-80-L-56-16	W5200043	7	HMQ520-80-H-56-16	W5200087
21.9	1.91	541	866	80	56C	14	BMQ525-80-L-56-18	W5250043	12	HMQ525-80-H-56-18	W5250120
18.6	1.51	581	877	94	56C	14	BMQ525-94-L-56-18	W5250044	12	HMQ525-94-H-56-18	W5250121
18.2	2.86	606	1270	96	56C	29	BMQ534-96-L-56-24	W5340048	24	HMQ534-96-H-56-24	W5340168

- ▼ Service Factor is based on maximum torque rating of reducer. Refer to page 171 for special application considerations.
- Output shaft overhung load rating is based on load applied at center of output shaft extension (solid output shaft style).
- ◆ NEMA input selections shown. Reducers are also available with metric IEC input flanges. Refer to page 83 for frame options available. Metric IEC input selections will have a metric output shaft as standard. Contact LEESON for catalog number information.

This Quick Selection is only for style BMQ (left hand output) & HMQ (hollow output) reducers. For other reducer configurations, see the MAXIMUM RATING TABLES beginning on page 70.



**Style BMQ & HMQ
Motorized Quill Input
NEMA Frame Selections
1750 RPM Input**



1/2 HP / 0.37 KW						Gear Reducer Quick Selections					
Output Speed (RPM)	Service Factor▼	Output Torque (lb-in)	Overhung Load (lbs.)●	Ratio	Motor Frame◆	Style BMQ Left Hand Output			Style HMQ Hollow Output		
						Weight (lbs.)	Model Number	Catalog No.	Weight (lbs.)	Model Number	Catalog No.
250	2.76	101	202	7	56C	7	BMQ518-7-L-56-12	W5180031	6	HMQ518-7-H-56-12	W5180071
175	1.96	142	214	10	56C	7	BMQ518-10-L-56-12	W5180032	6	HMQ518-10-H-56-12	W5180072
175	3.92	144	292	10	56C	9	BMQ520-10-L-56-16	W5200035	7	HMQ520-10-H-56-16	W5200079
125	1.74	194	248	14	56C	7	BMQ518-14-L-56-12	W5180033	6	HMQ518-14-H-56-12	W5180073
125	2.99	199	326	14	56C	9	BMQ520-14-L-56-16	W5200036	7	HMQ520-14-H-56-16	W5200080
117	5.71	213	495	15	56C	14	BMQ525-15-L-56-18	W5250036	12	HMQ525-15-H-56-18	W5250113
97	2.39	244	337	18	56C	9	BMQ520-18-L-56-16	W5200037	7	HMQ520-18-H-56-16	W5200081
92	4.48	267	526	19	56C	14	BMQ525-19-L-56-18	W5250037	12	HMQ525-19-H-56-18	W5250114
83	1.59	254	259	21	56C	7	BMQ518-21-L-56-12	W5180034	6	HMQ518-21-H-56-12	W5180074
73	3.85	324	571	24	56C	14	BMQ525-24-L-56-18	W5250038	12	HMQ525-24-H-56-18	W5250115
67	1.78	325	382	26	56C	9	BMQ520-26-L-56-16	W5200038	7	HMQ520-26-H-56-16	W5200082
63	1.26	325	292	28	56C	7	BMQ518-28-L-56-12	W5180035	6	HMQ518-28-H-56-12	W5180075
63	6.74	375	843	28	56C	29	BMQ534-28-L-56-24	W5340042	24	HMQ534-28-H-56-24	W5340162
58	3.17	402	618	30	56C	14	BMQ525-30-L-56-18	W5250039	12	HMQ525-30-H-56-18	W5250116
49	1.37	444	427	36	56C	9	BMQ520-36-L-56-16	W5200039	7	HMQ520-36-H-56-16	W5200083
49	2.93	437	674	36	56C	14	BMQ525-36-L-56-18	W5250040	12	HMQ525-36-H-56-18	W5250117
47	0.98	422	315	37	56C	7	BMQ518-37-L-56-12	W5180036	6	HMQ518-37-H-56-12	W5180076
46	4.69	486	944	38	56C	29	BMQ534-38-L-56-24	W5340043	24	HMQ534-38-H-56-24	W5340163
41	1.21	507	460	43	56C	9	BMQ520-43-L-56-16	W5200040	7	HMQ520-43-H-56-16	W5200084
39	2.22	533	753	45	56C	14	BMQ525-45-L-56-18	W5250041	12	HMQ525-45-H-56-18	W5250118
34	3.64	612	1034	52	56C	29	BMQ534-52-L-56-24	W5340045	24	HMQ534-52-H-56-24	W5340165
29	0.97	630	540	60	56C	9	BMQ520-60-L-56-16	W5200041	7	HMQ520-60-H-56-16	W5200085
26.1	1.48	724	854	67	56C	14	BMQ525-67-L-56-18	W5250042	12	HMQ525-67-H-56-18	W5250119
26.1	3.13	785	1113	67	56C	29	BMQ534-67-L-56-24	W5340046	24	HMQ534-67-H-56-24	W5340166
21.9	1.26	820	866	80	56C	14	BMQ525-80-L-56-18	W5250043	12	HMQ525-80-H-56-18	W5250120
18.6	1.00	881	877	94	56C	14	BMQ525-94-L-56-18	W5250044	12	HMQ525-94-H-56-18	W5250121
18.2	1.89	918	1270	96	56C	29	BMQ534-96-L-56-24	W5340048	24	HMQ534-96-H-56-24	W5340168

Bravo® Single Reduction Reducers

- ▼ Service Factor is based on maximum torque rating of reducer. Refer to page 171 for special application considerations.
- Output shaft overhung load rating is based on load applied at center of output shaft extension (solid output shaft style).
- ◆ NEMA input selections shown. Reducers are also available with metric IEC input flanges. Refer to page 83 for frame options available. Metric IEC input selections will have a metric output shaft as standard. Contact LEESON for catalog number information.

This Quick Selection is only for style BMQ (left hand output) & HMQ (hollow output) reducers. For other reducer configurations, see the MAXIMUM RATING TABLES beginning on page 70.



**Style BMQ & HMQ
Motorized Quill Input
NEMA Frame Selections
1750 RPM Input**



Bravo® Single Reduction Reducers

3/4 HP / 0.55 KW

Gear Reducer Quick Selections

Output Speed (RPM)	Service Factor▼	Output Torque (lb-in)	Overhung Load (lbs.)●	Ratio	Motor Frame◆	Style BMQ Left Hand Output			Style HMQ Hollow Output		
						Weight (lbs.)	Model Number	Catalog No.	Weight (lbs.)	Model Number	Catalog No.
250	1.84	151	202	7	56C	7	BMQ518-7-L-56-12	W5180031	6	HMQ518-7-H-56-12	W5180071
250	3.30	155	270	7	56C	9	BMQ520-7-L-56-16	W5200034	7	HMQ520-7-H-56-16	W5200078
175	1.31	213	214	10	56C	7	BMQ518-10-L-56-12	W5180032	6	HMQ518-10-H-56-12	W5180072
175	2.61	216	292	10	56C	9	BMQ520-10-L-56-16	W5200035	7	HMQ520-10-H-56-16	W5200079
175	5.59	219	427	10	56C	14	BMQ525-10-L-56-18	W5250068	12	HMQ525-10-H-56-18	W5250123
125	1.16	291	248	14	56C	7	BMQ518-14-L-56-12	W5180033	6	HMQ518-14-H-56-12	W5180073
125	1.99	299	326	14	56C	9	BMQ520-14-L-56-16	W5200036	7	HMQ520-14-H-56-16	W5200080
125	7.88	295	663	14	56C	29	BMQ534-14-L-56-24	W5340039	24	HMQ534-14-H-56-24	W5340159
117	3.80	319	495	15	56C	14	BMQ525-15-L-56-18	W5250069	12	HMQ525-15-H-56-18	W5250124
97	1.60	365	337	18	56C	9	BMQ520-18-L-56-16	W5200037	7	HMQ520-18-H-56-16	W5200081
92	2.99	401	526	19	56C	14	BMQ525-19-L-56-18	W5250037	12	HMQ525-19-H-56-18	W5250114
88	5.21	424	731	20	56C	29	BMQ534-20-L-56-24	W5340040	24	HMQ534-20-H-56-24	W5340160
83	1.06	382	259	21	56C	7	BMQ518-21-L-56-12	W5180034	6	HMQ518-21-H-56-12	W5180074
73	2.57	486	571	24	56C	14	BMQ525-24-L-56-18	W5250038	12	HMQ525-24-H-56-18	W5250115
67	1.19	487	382	26	56C	9	BMQ520-26-L-56-16	W5200038	7	HMQ520-26-H-56-16	W5200082
63	4.49	563	843	28	56C	29	BMQ534-28-L-56-24	W5340042	24	HMQ534-28-H-56-24	W5340162
58	2.11	603	618	30	56C	14	BMQ525-30-L-56-18	W5250039	12	HMQ525-30-H-56-18	W5250116
49	0.91	666	427	36	56C	9	BMQ520-36-L-56-16	W5200039	7	HMQ520-36-H-56-16	W5200083
49	1.95	656	674	36	56C	14	BMQ525-36-L-56-18	W5250040	12	HMQ525-36-H-56-18	W5250117
46	3.12	730	944	38	56C	29	BMQ534-38-L-56-24	W5340043	24	HMQ534-38-H-56-24	W5340163
39	1.48	800	753	45	56C	14	BMQ525-45-L-56-18	W5250041	12	HMQ525-45-H-56-18	W5250118
34	2.43	918	1034	52	56C	29	BMQ534-52-L-56-24	W5340045	24	HMQ534-52-H-56-24	W5340165
26.1	0.98	1087	854	67	56C	14	BMQ525-67-L-56-18	W5250042	12	HMQ525-67-H-56-18	W5250119
26.1	2.09	1177	1113	67	56C	29	BMQ534-67-L-56-24	W5340046	24	HMQ534-67-H-56-24	W5340166
18.2	1.26	1377	1270	96	56C	29	BMQ534-96-L-56-24	W5340048	24	HMQ534-96-H-56-24	W5340168

- ▼ Service Factor is based on maximum torque rating of reducer. Refer to page 171 for special application considerations.
- Output shaft overhung load rating is based on load applied at center of output shaft extension (solid output shaft style).
- ◆ NEMA input selections shown. Reducers are also available with metric IEC input flanges. Refer to page 83 for frame options available. Metric IEC input selections will have a metric output shaft as standard. Contact LEESON for catalog number information.

This Quick Selection is only for style BMQ (left hand output) & HMQ (hollow output) reducers. For other reducer configurations, see the MAXIMUM RATING TABLES beginning on page 70.



**Style BMQ & HMQ
Motorized Quill Input
NEMA Frame Selections
1750 RPM Input**



1.0 HP / 0.75 KW						Gear Reducer Quick Selections					
Output Speed (RPM)	Service Factor▼	Output Torque (lb-in)	Overhung Load (lbs.)●	Ratio	Motor◆ Frame	Style BMQ Left Hand Output			Style HMQ Hollow Output		
						Weight (lbs.)	Model Number	Catalog No.	Weight (lbs.)	Model Number	Catalog No.
250	1.38	202	202	7	56C	7	BMQ518-7-L-56-12	W5180031	6	HMQ518-7-H-56-12	W5180071
250	2.47	207	270	7	56C	9	BMQ520-7-L-56-16	W5200034	7	HMQ520-7-H-56-16	W5200078
175	0.98	285	214	10	56C	7	BMQ518-10-L-56-12	W5180032	6	HMQ518-10-H-56-12	W5180072
175	1.96	288	292	10	56C	9	BMQ520-10-L-56-16	W5200035	7	HMQ520-10-H-56-16	W5200079
175	4.19	292	427	10	140TC	14	BMQ525-10-L-140-18	W5250068	12	HMQ525-10-H-140-18	W5250123
125	1.49	398	326	14	56C	9	BMQ520-14-L-56-16	W5200036	7	HMQ520-14-H-56-16	W5200080
125	5.91	393	663	14	140TC	29	BMQ534-14-L-140-24	W5340075	24	HMQ534-14-H-140-24	W5340171
117	2.85	426	495	15	140TC	14	BMQ525-15-L-140-18	W5250069	12	HMQ525-15-H-140-18	W5250124
97	1.20	487	337	18	56C	9	BMQ520-18-L-56-16	W5200037	7	HMQ520-18-H-56-16	W5200081
92	2.24	534	526	19	140TC	14	BMQ525-19-L-140-18	W5250070	12	HMQ525-19-H-140-18	W5250125
88	3.91	566	731	20	140TC	29	BMQ534-20-L-140-24	W5340076	24	HMQ534-20-H-140-24	W5340172
73	1.92	648	571	24	56C	14	BMQ525-24-L-56-18	W5250038	12	HMQ525-24-H-56-18	W5250115
63	3.37	750	843	28	140TC	29	BMQ534-28-L-140-24	W5340078	24	HMQ534-28-H-140-24	W5340174
58	1.58	804	618	30	56C	14	BMQ525-30-L-56-18	W5250039	12	HMQ525-30-H-56-18	W5250116
49	1.46	875	674	36	56C	14	BMQ525-36-L-56-18	W5250040	12	HMQ525-36-H-56-18	W5250117
46	2.34	973	944	38	140TC	29	BMQ534-38-L-140-24	W5340079	24	HMQ534-38-H-140-24	W5340175
39	1.11	1067	753	45	56C	14	BMQ525-45-L-56-18	W5250041	12	HMQ525-45-H-56-18	W5250118
34	1.82	1223	1034	52	56C	29	BMQ534-52-L-56-24	W5340045	24	HMQ534-52-H-56-24	W5340165
26.1	1.57	1570	1113	67	56C	29	BMQ534-67-L-56-24	W5340046	24	HMQ534-67-H-56-24	W5340166
18.2	0.95	1835	1270	96	56C	29	BMQ534-96-L-56-24	W5340048	24	HMQ534-96-H-56-24	W5340168
1-1/2 HP / 1.1 KW						Gear Reducer Quick Selections					
250	1.65	310	270	7	56C	9	BMQ520-7-L-56-16	W5200034	7	HMQ520-7-H-56-16	W5200078
250	3.50	314	405	7	140TC	14	BMQ525-7-L-140-18	W5250067	12	HMQ525-7-H-140-18	W5250122
175	1.31	432	292	10	56C	9	BMQ520-10-L-56-16	W5200035	7	HMQ520-10-H-56-16	W5200079
175	2.79	438	427	10	140TC	14	BMQ525-10-L-140-18	W5250068	12	HMQ525-10-H-140-18	W5250123
175	5.08	432	607	10	140TC	29	BMQ534-10-L-140-24	W5340074	24	HMQ534-10-H-140-24	W5340170
125	1.00	597	326	14	56C	9	BMQ520-14-L-56-16	W5200036	7	HMQ520-14-H-56-16	W5200080
125	3.94	590	663	14	140TC	29	BMQ534-14-L-140-24	W5340075	24	HMQ534-14-H-140-24	W5340171
117	1.90	638	495	15	56C	14	BMQ525-15-L-56-18	W5250036	12	HMQ525-15-H-56-18	W5250113
92	1.49	802	526	19	56C	14	BMQ525-19-L-56-18	W5250037	12	HMQ525-19-H-56-18	W5250114
88	2.61	849	731	20	140TC	29	BMQ534-20-L-140-24	W5340076	24	HMQ534-20-H-140-24	W5340172
73	1.28	971	571	24	56C	14	BMQ525-24-L-56-18	W5250038	12	HMQ525-24-H-56-18	W5250115
63	2.25	1125	843	28	140TC	29	BMQ534-28-L-140-24	W5340078	24	HMQ534-28-H-140-24	W5340174
58	1.06	1206	618	30	56C	14	BMQ525-30-L-56-18	W5250039	12	HMQ525-30-H-56-18	W5250116
49	0.98	1312	674	36	56C	14	BMQ525-36-L-56-18	W5250040	12	HMQ525-36-H-56-18	W5250117
46	1.56	1459	944	38	56C	29	BMQ534-38-L-56-24	W5340043	24	HMQ534-38-H-56-24	W5340163
34	1.21	1835	1034	52	56C	29	BMQ534-52-L-56-24	W5340045	24	HMQ534-52-H-56-24	W5340165
26.1	1.04	2363	1113	67	56C	29	BMQ534-67-L-56-24	W5340046	24	HMQ534-67-H-56-24	W5340166

Bravo® Single Reduction Reducers

- ▼ Service Factor is based on maximum torque rating of reducer. Refer to page 171 for special application considerations.
- Output shaft overhung load rating is based on load applied at center of output shaft extension (solid output shaft style).
- ◆ NEMA input selections shown. Reducers are also available with metric IEC input flanges. Refer to page 83 for frame options available. Metric IEC input selections will have a metric output shaft as standard. Contact LEESON for catalog number information.

This Quick Selection is only for style BMQ (left hand output) & HMQ (hollow output) reducers. For other reducer configurations, see the MAXIMUM RATING TABLES beginning on page 70.



**Style BMQ & HMQ
Motorized Quill Input
NEMA Frame Selections
1750 RPM Input**



Bravo® Single Reduction Reducers

2 HP / 1.5 KW Gear Reducer Quick Selections

Output Speed (RPM)	Service Factor▼	Output Torque (lb-in)	Overhung Load (lbs.)●	Ratio	Motor◆ Frame	Style BMQ Left Hand Output			Style HMQ Hollow Output		
						Weight (lbs.)	Model Number	Catalog No.	Weight (lbs.)	Model Number	Catalog No.
250	1.24	413	270	7	56C	9	BMQ520-7-L-56-16	W5200034	7	HMQ520-7-H-56-16	W5200078
250	2.62	418	405	7	140TC	14	BMQ525-7-L-140-18	W5250067	12	HMQ525-7-H-140-18	W5250122
250	4.13	444	562	7	140TC	29	BMQ534-7-L-140-24	W5340073	24	HMQ534-7-H-140-24	W5340169
175	0.98	576	292	10	56C	9	BMQ520-10-L-56-16	W5200035	7	HMQ520-10-H-56-16	W5200079
175	2.09	583	427	10	140TC	14	BMQ525-10-L-140-18	W5250068	12	HMQ525-10-H-140-18	W5250123
175	3.81	576	607	10	140TC	29	BMQ534-10-L-140-24	W5340074	24	HMQ534-10-H-140-24	W5340170
125	2.95	787	663	14	140TC	29	BMQ534-14-L-140-24	W5340075	24	HMQ534-14-H-140-24	W5340171
117	1.43	851	495	15	56C	14	BMQ525-15-L-56-18	W5250036	12	HMQ525-15-H-56-18	W5250113
92	1.12	1069	526	19	56C	14	BMQ525-19-L-56-18	W5250037	12	HMQ525-19-H-56-18	W5250114
88	1.95	1132	731	20	140TC	29	BMQ534-20-L-140-24	W5340076	24	HMQ534-20-H-140-24	W5340172
73	0.96	1295	571	24	56C	14	BMQ525-24-L-56-18	W5250038	12	HMQ525-24-H-56-18	W5250115
63	1.68	1501	843	28	140TC	29	BMQ534-28-L-140-24	W5340078	24	HMQ534-28-H-140-24	W5340174
46	1.17	1946	944	38	140TC	29	BMQ534-38-L-140-24	W5340079	24	HMQ534-38-H-140-24	W5340175

3.0 HP / 2.2 KW Gear Reducer Quick Selections

250	1.75	628	405	7	140TC	14	BMQ525-7-L-140-18	W5250067	12	HMQ525-7-H-140-18	W5250122
250	2.75	666	562	7	180TC	29	BMQ534-7-L-180-24	W5340109	24	HMQ534-7-H-180-24	W5340181
175	1.40	875	427	10	140TC	14	BMQ525-10-L-140-18	W5250068	12	HMQ525-10-H-140-18	W5250123
175	2.54	864	607	10	180TC	29	BMQ534-10-L-180-24	W5340110	24	HMQ534-10-H-180-24	W5340182
125	1.97	1180	663	14	180TC	29	BMQ534-14-L-180-24	W5340111	24	HMQ534-14-H-180-24	W5340183
117	0.95	1277	495	15	140TC	14	BMQ525-15-L-140-18	W5250069	12	HMQ525-15-H-140-18	W5250124
88	1.30	1697	731	20	180TC	29	BMQ534-20-L-180-24	W5340112	24	HMQ534-20-H-180-24	W5340184
63	1.12	2251	843	28	180TC	29	BMQ534-28-L-180-24	W5340114	24	HMQ534-28-H-180-24	W5340186

5.0 HP / 3.7 KW Gear Reducer Quick Selections

250	1.65	1109	562	7	180TC	29	BMQ534-7-L-180-24	W5340109	24	HMQ534-7-H-180-24	W5340181
175	1.52	1441	607	10	180TC	29	BMQ534-10-L-180-24	W5340110	24	HMQ534-10-H-180-24	W5340182
125	1.18	1966	663	14	180TC	29	BMQ534-14-L-180-24	W5340111	24	HMQ534-14-H-180-24	W5340183

7.5 HP / 1.5 KW Gear Reducer Quick Selections

250	1.10	1664	562	7	180TC	29	BMQ534-7-L-180-24	W5340109	24	HMQ534-7-H-180-24	W5340181
175	1.02	2161	607	10	180TC	29	BMQ534-10-L-180-24	W5340110	24	HMQ534-10-H-180-24	W5340182

- ▼ Service Factor is based on maximum torque rating of reducer. Refer to page 171 for special application considerations.
- Output shaft overhung load rating is based on load applied at center of output shaft extension (solid output shaft style).
- ◆ NEMA input selections shown. Reducers are also available with metric IEC input flanges. Refer to page 83 for frame options available. Metric IEC input selections will have a metric output shaft as standard. Contact LEESON for catalog number information.

This Quick Selection is only for style BMQ (left hand output) & HMQ (hollow output) reducers. For other reducer configurations, see the MAXIMUM RATING TABLES beginning on page 70.



SINGLE REDUCTION • APPROXIMATE WEIGHTS^Δ (LBS.)

Reducer Style	Reducer Size					Reducer Style	Reducer Size				
	512	518	520	525	534		512	518	520	525	534
Solid Output Shaft Models						Hollow Output Shaft Models					
BMQ	3	7	9	14	29	HMQ	3	6	7	12	24
B	3	6	9	14	27	H	3	5	7	12	22
TMQ, UMQ, JMQ	5	9	11	17	34	THMQ, UHMQ	5	8	9	15	29
T, U, J	5	8	11	17	32	JHMQ	5	7	9	15	27
FMQ, RMQ	4	8	10	16	32	FHMQ, RHMQ	4	7	8	14	27
F, R	4	7	10	16	30	FH, RH	4	6	8	14	25
FLMQ	4	9	11	17	34	FLHMQ	4	8	9	15	29
FL	4	8	11	17	32	FLH	4	7	9	15	27

^Δ Weights include grease and oil.

REDUCER ACCESSORIES • APPROXIMATE WEIGHTS (LBS.)

Accessory	Reducer Size				
	512	518	520	525	534
T/U - Base	2	2	2	3	5
J - Base	2	2	2	3	5
F - Flange	1	1	1	2	3
FL - Flange	1	2	2	3	5
R - Reaction Arm	1	1	1	2	3

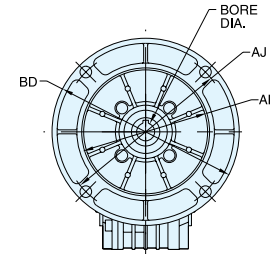

SINGLE REDUCTION • MOTOR FRAME COMBINATIONS

Reducer Size	NEMA or IEC Frame Size	Dimensions - Inches (MM)				Available Ratios																		
		AK	AJ	BD	Bore Dia.	10.6	15	19	30	39	61	80	7	10	14	18	26	36	43	60	68	80	100	
512	IEC 56B5	3.15 (80)	3.94 (100)	4.72 (120)	(9)	■	■	■	■	■	■	■	■	■	■	■	■	■	■	■	■	■	■	■
	IEC 56B14	1.97 (50)	2.56 (65)	3.15 (80)	(9)	■	■	■	■	■	■	■	■	■	■	■	■	■	■	■	■	■	■	■
	IEC 63B5	3.74 (95)	4.53 (115)	5.51 (140)	(11)	●	●	●	●	●	●	●	●	●	●	●	●	●	●	●	●	●	●	●
	IEC 63B14	2.36 (60)	2.95 (75)	3.54 (90)	(11)	●	●	●	●	●	●	●	●	●	●	●	●	●	●	●	●	●	●	●
518	NEMA 56C	4.50	5.88	6.50	0.625	●	●	●	●	●	●	●	●	●	●	●	●	●	●	●	●	●	●	●
	IEC 56B14	1.97 (50)	2.56 (65)	3.15 (80)	(9)	■	■	■	■	■	■	■	■	■	■	■	■	■	■	■	■	■	■	■
	IEC 63B5	3.74 (95)	4.53 (115)	5.51 (140)	(11)	■	■	■	■	■	■	■	■	■	■	■	■	■	■	■	■	■	■	■
	IEC 63B14	2.36 (60)	2.95 (75)	3.54 (90)	(11)	■	■	■	■	■	■	■	■	■	■	■	■	■	■	■	■	■	■	■
	IEC 71B5	4.33 (110)	5.12 (130)	6.30 (160)	(14)	●	●	●	●	●	●	●	●	●	●	●	●	●	●	●	●	●	●	●
	IEC 71B14	2.76 (70)	3.35 (85)	4.13 (105)	(14)	●	●	●	●	●	●	●	●	●	●	●	●	●	●	●	●	●	●	●
520	NEMA 56C	4.50	5.88	6.50	0.625	●	●	●	●	●	●	●	●	●	●	●	●	●	●	●	●	●	●	●
	IEC 56B14	1.97 (50)	2.56 (65)	3.15 (80)	(9)	■	■	■	■	■	■	■	■	■	■	■	■	■	■	■	■	■	■	■
	IEC 63B5	3.74 (95)	4.53 (115)	5.51 (140)	(11)	■	■	■	■	■	■	■	■	■	■	■	■	■	■	■	■	■	■	■
	IEC 63B14	2.36 (60)	2.95 (75)	3.54 (90)	(11)	■	■	■	■	■	■	■	■	■	■	■	■	■	■	■	■	■	■	■
	IEC 71B5	4.33 (110)	5.12 (130)	6.30 (160)	(14)	■	■	■	■	■	●	●	●	●	●	●	●	●	●	●	●	●	●	●
	IEC 71B14	2.76 (70)	3.35 (85)	4.13 (105)	(14)	■	■	■	■	■	●	●	●	●	●	●	●	●	●	●	●	●	●	●
	IEC 80B5	5.12 (130)	6.50 (165)	7.87 (200)	(19)	●	●	●	●	●	●	●	●	●	●	●	●	●	●	●	●	●	●	●
	IEC 80B14	3.15 (80)	3.94 (100)	4.72 (120)	(19)	●	●	●	●	●	●	●	●	●	●	●	●	●	●	●	●	●	●	●
525	NEMA 56C	4.50	5.88	6.50	0.625	■	■	■	■	■	■	■	■	■	■	■	■	■	■	■	■	■	■	■
	NEMA 140TC	4.50	5.88	6.50	0.875	●	●	●	●	●	●	●	●	●	●	●	●	●	●	●	●	●	●	●
	IEC 63B5	3.74 (95)	4.53 (115)	5.51 (140)	(11)	■	■	■	■	■	■	■	■	■	■	■	■	■	■	■	■	■	■	■
	IEC 71B5	4.33 (110)	5.12 (130)	6.30 (160)	(14)	■	■	■	■	■	■	■	■	■	■	■	■	■	■	■	■	■	■	■
	IEC 71B14	2.76 (70)	3.35 (85)	4.13 (105)	(14)	■	■	■	■	■	■	■	■	■	■	■	■	■	■	■	■	■	■	■
	IEC 80B5	5.12 (130)	6.50 (165)	7.87 (200)	(19)	■	■	■	■	■	■	■	■	■	■	■	■	■	■	■	■	■	■	■
	IEC 80B14	3.15 (80)	3.94 (100)	4.72 (120)	(19)	■	■	■	■	■	■	■	■	■	■	■	■	■	■	■	■	■	■	■
	IEC 90B5	5.12 (130)	6.50 (165)	7.87 (200)	(24)	●	●	●	●	●	●	●	●	●	●	●	●	●	●	●	●	●	●	●
	IEC 90B14	3.74 (95)	4.53 (115)	5.51 (140)	(24)	●	●	●	●	●	●	●	●	●	●	●	●	●	●	●	●	●	●	●
	534	NEMA 56C	4.50	5.88	6.50	0.625	■	■	■	■	■	■	■	■	■	■	■	■	■	■	■	■	■	■
NEMA 140TC		4.50	5.88	6.50	0.875	■	■	■	■	■	■	■	■	■	■	■	■	■	■	■	■	■	■	■
NEMA 180TC		8.50	7.25	9.00	1.125	●	●	●	●	●	●	●	●	●	●	●	●	●	●	●	●	●	●	●
IEC 71B5		4.33 (110)	5.12 (130)	6.30 (160)	(14)	■	■	■	■	■	■	■	■	■	■	■	■	■	■	■	■	■	■	■
IEC 80B5		5.12 (130)	6.50 (165)	7.87 (200)	(19)	■	■	■	■	■	■	■	■	■	■	■	■	■	■	■	■	■	■	■
IEC 80B14		3.15 (80)	3.94 (100)	4.72 (120)	(19)	■	■	■	■	■	■	■	■	■	■	■	■	■	■	■	■	■	■	■
IEC 90B5		5.12 (130)	6.50 (165)	7.87 (200)	(24)	■	■	■	■	■	■	■	■	■	■	■	■	■	■	■	■	■	■	■
IEC 90B14		3.74 (95)	4.53 (115)	5.51 (140)	(24)	■	■	■	■	■	■	■	■	■	■	■	■	■	■	■	■	■	■	■
IEC 100/112 B5		7.09 (180)	8.46 (215)	9.84 (250)	(28)	●	●	●	●	●	●	●	●	●	●	●	●	●	●	●	●	●	●	●
IEC 100/112 B14		4.33 (110)	5.12 (130)	6.30 (160)	(28)	●	●	●	●	●	●	●	●	●	●	●	●	●	●	●	●	●	●	●

* Reducer selections are available. Refer to dimensional pages for additional dimensions and special conditions for flange mounting hole alignment.

■ Reducer selections are available. A bushing will be provided with reducer to achieve input bore diameter shown. Refer to dimensional pages for additional dimensions and special conditions for flange mounting hole alignment.

Bravo® Single Reduction Reducers

STYLE HMQ

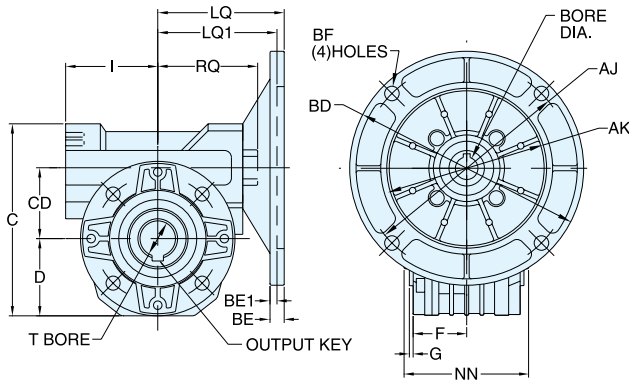

ASSEMBLIES

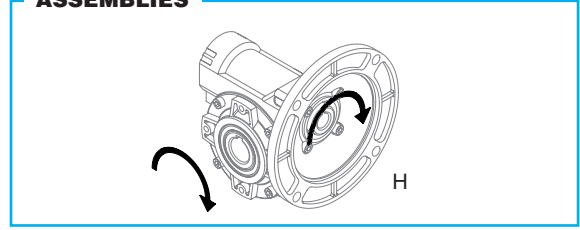

REVERSE ALL ARROWS FOR OPPOSITE INPUT SHAFT ROTATION. CONTACT FACTORY FOR OTHER MOUNTINGS OR ASSEMBLY POSITIONS.

STYLE HMQ DIMENSIONS - Inches (MM)

Series	C	CD	D	F	G	I	LQ* 56/140	LQ1* 180	NN	RQ	T* +0.0015 -0.0000	OUTPUT KEY*
512	3.54	1.18	1.54	1.18	0.08	1.81	*	N/A	2.16	2.21	(14) ●	(5) ●
518	4.76	1.77	1.93	1.38	0.08	2.16	3.33	N/A	2.56	2.60	0.750	3/16 X 1.00
520	5.33	1.97	2.15	1.50	0.12	2.56	3.51	N/A	3.19	2.83	1.000	1/4 X 1.62
525	6.69	2.48	2.76	1.77	0.19	3.11	4.08	N/A	4.72	3.58	1.125	1/4 X 2.00
534	9.15	3.35	3.72	2.52	0.14	3.86	4.83	5.35	5.31	4.33	1.500	3/8 X 2.00

● Dimension is in MM. Key is not provided with metric reducer options as standard.

Metric bore tolerance is H7.

* Metric options are available. Refer to dimensions on opposite page. Contact LEESON for availability of metric options.

STYLE H

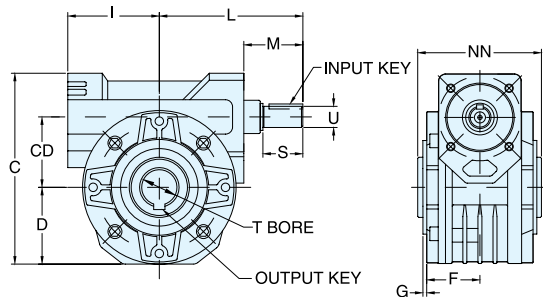

ASSEMBLIES

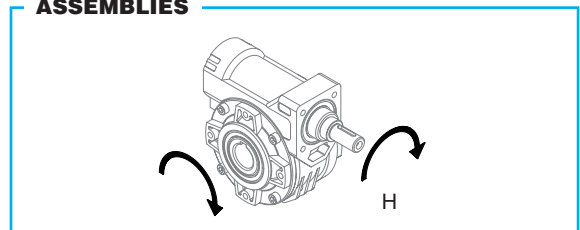

REVERSE ALL ARROWS FOR OPPOSITE INPUT SHAFT ROTATION. CONTACT FACTORY FOR OTHER MOUNTINGS OR ASSEMBLY POSITIONS.

STYLE H DIMENSIONS - Inches**

Series	C	CD	D	F	G	I	L	M	NN	S	T +0.0015 -0.0000	U +0.000 -0.001	INPUT KEY	OUTPUT KEY
518	4.76	1.77	1.93	1.38	0.08	2.16	3.86	1.67	2.56	1.18	0.750	0.625	3/16 X 1.00	3/16 X 1.00
520	5.33	1.97	2.15	1.50	0.12	2.56	4.11	1.74	3.19	1.18	1.000	0.625	3/16 X 1.00	1/4 X 1.62
525	6.69	2.48	2.76	1.77	0.19	3.11	5.43	2.24	4.72	1.75	1.125	0.750	3/16 x 1.50	1/4 X 2.00
534	9.15	3.35	3.72	2.52	0.14	3.86	6.38	2.52	5.31	1.75	1.500	0.875	3/16 X 1.50	3/8 X 2.00

** Series 512 is available in this style. Contact LEESON for details



STYLE BMQ

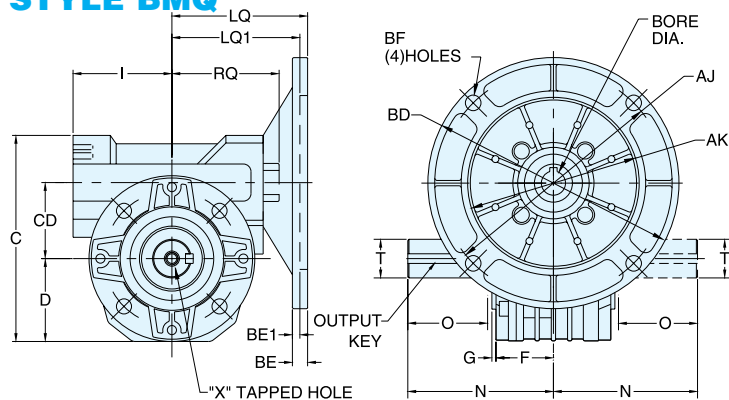

ASSEMBLIES

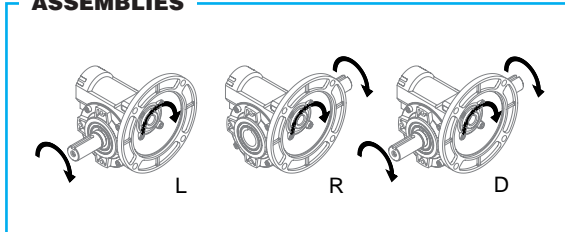

REVERSE ALL ARROWS FOR OPPOSITE INPUT SHAFT ROTATION. CONTACT FACTORY FOR OTHER MOUNTINGS OR ASSEMBLY POSITIONS.

STYLE BMQ DIMENSIONS - Inches (MM)

Series	C	CD	D	F	G	I	LQ* 56/140	LQ1* 180	N	O*	RQ	T* +0.000 -0.001	X		OUTPUT KEY*
													Tap Size	Depth	
512	3.54	1.18	1.54	1.18	0.08	1.81	*	N/A	2.48	1.01	2.21	(14)★	N/A	N/A	(5) ★
518	4.76	1.77	1.93	1.38	0.08	2.16	3.33	N/A	2.97	1.26	2.60	0.750	1/4-20 UNC	0.62	3/16 x 1.00
520	5.33	1.97	2.15	1.50	0.12	2.56	3.51	N/A	3.94	2.05	2.83	1.000	5/16-18 UNC	0.75	1/4 X 1.62
525	6.69	2.48	2.76	1.77	0.19	3.11	4.08	N/A	4.85	2.36	3.58	1.125	5/16-18 UNC	0.75	1/4 X 2.00
534	9.15	3.35	3.72	2.52	0.14	3.86	4.83	5.35	5.55	2.36	4.33	1.500	5/16-18 UNC	0.75	3/8 X 2.00

★ Dimension is in MM. Key is not provided with metric reducer options as standard. Metric shaft diameter tolerance is -0.005/-0.020. Series 512 is available with an inch dimensioned output shaft. Contact LEESON for details.

* Metric options are available. Refer to dimensions below. Contact LEESON for availability of metric options.

STYLE B

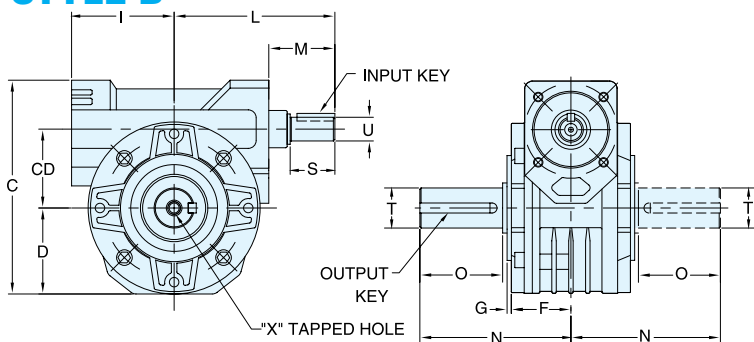

ASSEMBLIES

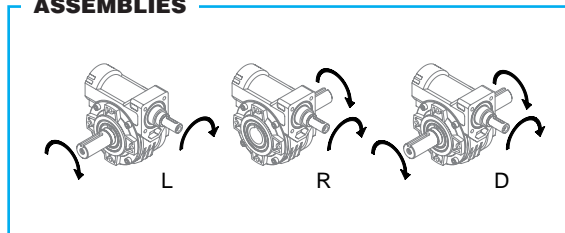

REVERSE ALL ARROWS FOR OPPOSITE INPUT SHAFT ROTATION. CONTACT FACTORY FOR OTHER MOUNTINGS OR ASSEMBLY POSITIONS.

STYLE B DIMENSIONS - Inches**

Series	C	CD	D	F	G	I	L	M	N	O	S	T +0.000 -0.001	U +0.000 -0.001	X		INPUT KEY	OUTPUT KEY
														Tap Size	Depth		
518	4.76	1.77	1.93	1.38	0.08	2.16	3.86	1.67	2.97	1.26	1.18	0.750	0.625	1/4-20 UNC	0.62	3/16 X 1.00	3/16 X 1.00
520	5.33	1.97	2.15	1.50	0.12	2.56	4.11	1.74	3.94	2.05	1.18	1.000	0.625	5/16-18 UNC	0.75	3/16 X 1.00	1/4 X 1.62
525	6.69	2.48	2.76	1.77	0.19	3.11	5.43	2.24	4.85	2.36	1.75	1.125	0.750	5/16-18 UNC	0.75	3/16 x 1.50	1/4 X 2.00
534	9.15	3.35	3.72	2.52	0.14	3.86	6.38	2.52	5.55	2.36	1.75	1.500	0.875	5/16-18 UNC	0.75	3/16 X 1.50	3/8 X 2.00

** Series 512 is available in this style. Contact LEESON for details

MOTOR MOUNTING DIMENSIONS

NEMA DIMENSIONS - Inches

Frame	AJ	AK	BD	BE	BE1	BF	Input Bore Dia	Input Keyway▲
56C	5.88	4.50	6.50	0.38	N/A	0.41	0.625	3/16 x 3/32
140TC	5.88	4.50	6.50	0.38	N/A	0.41	0.875	3/16 x 3/32
180TC	7.25	8.50	9.00	N/A	0.50	0.53	1.125	1/4 x 1/8

OPTIONAL METRIC DIMENSIONS - MM

Series	LQ1◆					T ✓	O	N	Output Keyway	
	IEC B5 & B14 Options									
	D56D	D63D	D71D	D80D	D90D	D100LD■	(standard for metric units)			
512	62.5◆	62.5	N/A	N/A	N/A	N/A	14	25	63	5
518	74◆□	74◆	74	N/A	N/A	N/A	18	32	75	6
520	81.5◆□	81.5◆	81.5	81.5	N/A	N/A	25	52	100	8
525	N/A	99.5◆◇	99.5◆	99.5◆	99.5	N/A	25	60	123	8
534	N/A	N/A	124◆◇	124	124	124	35	60	141	10

OPTIONAL METRIC DIMENSIONS - MM

IEC Frame	B5					B14◆					Input Bore Dia	Input Keyway▲
	AJ	AK	BD	BE	BF	AJ	AK	BD	BE	BF◆		
D56D	100	80	120	10	7	65◆	50	80	7	6.5	9	3 x 1.5
D63D	115	95	140	11	9	75◆	60	90	5.5	5.5	11	4 x 2
D71D	130	110	160	10	9	85◆	70	105	8	6.5	14	5 x 2.5
D80D	165	130	200	12	11	100◆	80	120	10	7	19	6 x 3
D90D	165	130	200	12	11	115	95	140	11	9	24	8 x 3.5
D100LD■	215	180	250	13	14	130	110	160	10	9	28	8 x 3.5

◆ Contact LEESON for availability of metric input options. The output bore and/or solid output shaft extension will be metric as standard with metric input options.

▲ Keyway width by depth

◆ AJ Mounting holes are rotated 45° from positions shown on B14 input options as follows: D56D(A/J), D63D(Series 518 & 520), D71D & D80D(Series 525)

◆ Dimensions are maximum (B5 and B14 options)

◇ B14 option not available

□ B5 Option not available

■ Also applies to frame size D112MD

✓ Solid metric output shaft diameter tolerance is -0.005/-0.020. Hollow bore tolerance is H7.

Bravo® Single Reduction Reducers

STYLE RHMQ

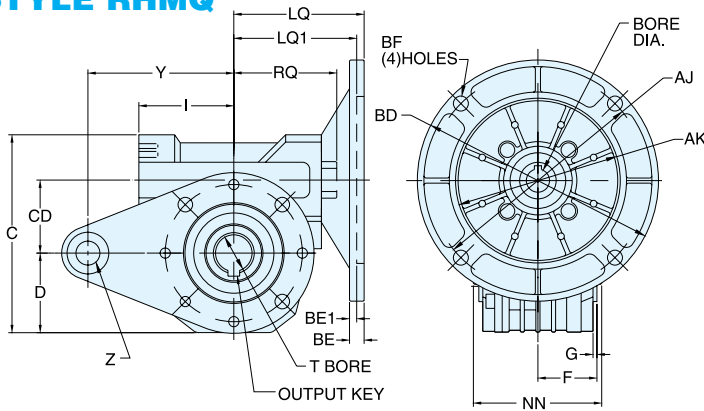

ASSEMBLIES

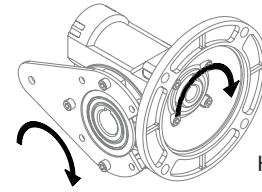

REVERSE ALL ARROWS FOR OPPOSITE INPUT SHAFT ROTATION. CONTACT FACTORY FOR OTHER MOUNTINGS OR ASSEMBLY POSITIONS.

STYLE RHMQ DIMENSIONS - Inches (MM)

Series	C	CD	D	F	G	I	LQ* 56/140	LQ1* 180	NN	RQ	T* +0.0015 -0.0000	Y	Z	OUTPUT KEY*
512	3.54	1.18	1.54	1.18	0.08	1.81	*	N/A	2.16	2.21	(14)●	3.94	0.315	(5)●
518	4.76	1.77	1.93	1.38	0.08	2.16	3.33	N/A	2.56	2.60	0.750	3.94	0.315	3/16 X 1.00
520	5.33	1.97	2.15	1.50	0.12	2.56	3.51	N/A	3.19	2.83	1.000	3.94	0.315	1/4 X 1.62
525	6.69	2.48	2.76	1.77	0.19	3.11	4.08	N/A	4.72	3.58	1.125	5.91	0.394	1/4 X 2.00
534	9.15	3.35	3.72	2.52	0.14	3.86	4.83	5.35	5.31	4.33	1.500	7.87	0.787	3/8 X 2.00

● Dimension is in MM. Key is not provided with metric reducer options as standard. Metric bore tolerance is H7.

* Metric options are available. Refer to dimensions on opposite page. Contact LEESON for availability of metric options.

STYLE RH

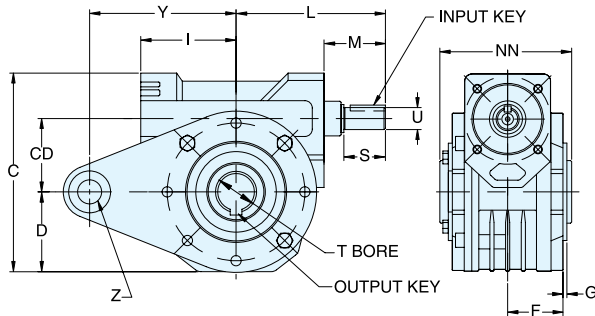

ASSEMBLIES

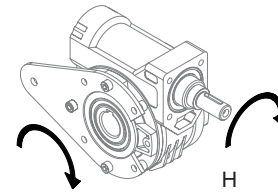

REVERSE ALL ARROWS FOR OPPOSITE INPUT SHAFT ROTATION. CONTACT FACTORY FOR OTHER MOUNTINGS OR ASSEMBLY POSITIONS.

STYLE RH DIMENSIONS - Inches**

Series	C	CD	D	F	G	I	L	M	NN	S	T +0.0015 -0.0000	U +0.000 -0.001	Y	Z	INPUT KEY	OUTPUT KEY
518	4.76	1.77	1.93	1.38	0.08	2.16	3.86	1.67	2.56	1.18	0.750	0.625	3.94	0.315	3/16 X 1.00	3/16 X 1.00
520	5.33	1.97	2.15	1.50	0.12	2.56	4.11	1.74	3.19	1.18	1.000	0.625	3.94	0.315	3/16 X 1.00	1/4 X 1.62
525	6.69	2.48	2.76	1.77	0.19	3.11	5.43	2.24	4.72	1.75	1.125	0.750	5.91	0.394	3/16 x 1.50	1/4 X 2.00
534	9.15	3.35	3.72	2.52	0.14	3.86	6.38	2.52	5.31	1.75	1.500	0.875	7.87	0.787	3/16 X 1.50	3/8 X 2.00

** Series 512 is available in this style. Contact LEESON for details

REFER TO PAGE 146 FOR DETAILED DIMENSIONS OF REACTION ARM.

Bravo® Single Reduction Reducers



STYLE RMQ

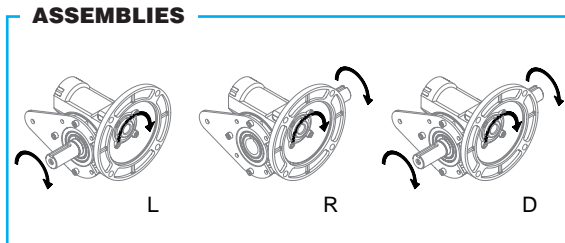
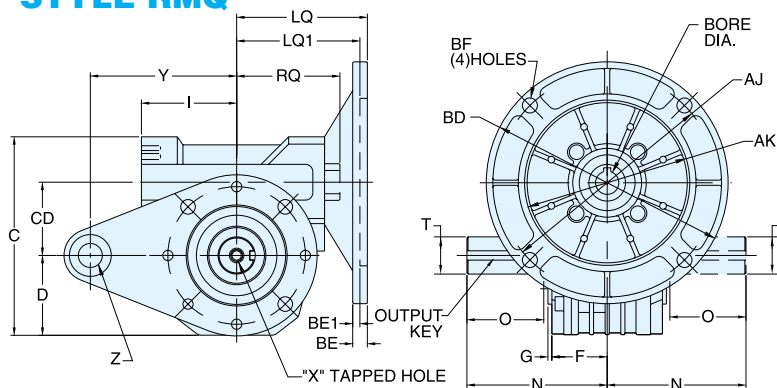

REVERSE ALL ARROWS FOR OPPOSITE INPUT SHAFT ROTATION. CONTACT FACTORY FOR OTHER MOUNTINGS OR ASSEMBLY POSITIONS.

Bravo® Single Reduction Reducers

STYLE RMQ DIMENSIONS - Inches (MM)

Series	C	CD	D	F	G	I	LQ* 56/140	LQ1* 180	N	O*	RQ	T* +0.000 -0.001	X		Y	Z	OUTPUT KEY*
													Tap Size	Depth			
512	3.54	1.18	1.54	1.18	0.08	1.81	*	N/A	2.48	1.01	2.21	(14)★	N/A	N/A	3.94	0.315	(5)★
518	4.76	1.77	1.93	1.38	0.08	2.16	3.33	N/A	2.97	1.26	2.60	0.750	1/4-20 UNC	0.62	3.94	0.315	3/16 x 1.00
520	5.33	1.97	2.15	1.50	0.12	2.56	3.51	N/A	3.94	2.05	2.83	1.000	5/16-18 UNC	0.75	3.94	0.315	1/4 X 1.62
525	6.69	2.48	2.76	1.77	0.19	3.11	4.08	N/A	4.85	2.36	3.58	1.125	5/16-18 UNC	0.75	5.91	0.394	1/4 X 2.00
534	9.15	3.35	3.72	2.52	0.14	3.86	4.83	5.35	5.55	2.36	4.33	1.500	5/16-18 UNC	0.75	7.87	0.787	3/8 X 2.00

★ Dimension is in MM. Key is not provided with metric reducer options as standard. Metric shaft diameter tolerance is -0.005/-0.020. Series 512 is available with an inch dimensioned output shaft. Contact LEESON for details.

* Metric options are available. Refer to dimensions below. Contact LEESON for availability of metric options.

STYLE R

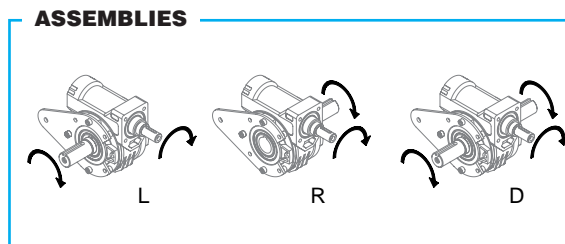
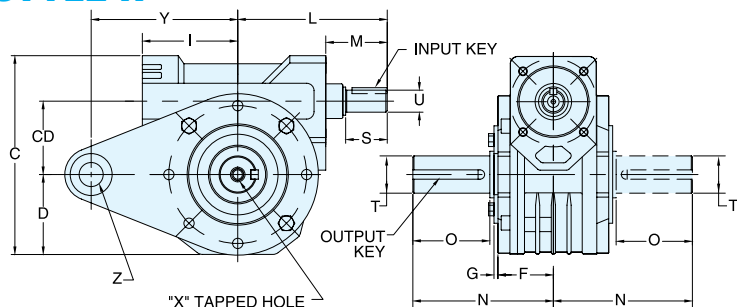

REVERSE ALL ARROWS FOR OPPOSITE INPUT SHAFT ROTATION. CONTACT FACTORY FOR OTHER MOUNTINGS OR ASSEMBLY POSITIONS.

STYLE R DIMENSIONS - Inches**

Series	C	CD	D	F	G	I	L	M	N	O	S	T +0.000 -0.001	U +0.000 -0.001	X		Y	Z	INPUT KEY	OUTPUT KEY
														Tap Size	Depth				
518	4.76	1.77	1.93	1.38	0.08	2.16	3.86	1.67	2.97	1.26	1.18	0.750	0.625	1/4-20 UNC	0.62	3.94	0.315	3/16 X 1.00	3/16 X 1.00
520	5.33	1.97	2.15	1.50	0.12	2.56	4.11	1.74	3.94	2.05	1.18	1.000	0.625	5/16-18 UNC	0.75	3.94	0.315	3/16 X 1.00	1/4 X 1.62
525	6.69	2.48	2.76	1.77	0.19	3.11	5.43	2.24	4.85	2.36	1.75	1.125	0.750	5/16-18 UNC	0.75	5.91	0.394	3/16 x 1.50	1/4 X 2.00
534	9.15	3.35	3.72	2.52	0.14	3.86	6.38	2.52	5.55	2.36	1.75	1.500	0.875	5/16-18 UNC	0.75	7.87	0.787	3/16 X 1.50	3/8 X 2.00

** Series 512 is available in this style. Contact LEESON for details

MOTOR MOUNTING DIMENSIONS

NEMA DIMENSIONS - Inches

Frame	AJ	AK	BD	BE	BE1	BF	Input Bore Dia	Input Keyway▲
56C	5.88	4.50	6.50	0.38	N/A	0.41	0.625	3/16 x 3/32
140TC	5.88	4.50	6.50	0.38	N/A	0.41	0.875	3/16 x 3/32
180TC	7.25	8.50	9.00	N/A	0.50	0.53	1.125	1/4 x 1/8

OPTIONAL METRIC DIMENSIONS♦ - MM

Series	LQ1♦						T ✓	O	N	Output Keyway
	IEC B5 & B14 Options									
	D56D	D63D	D71D	D80D	D90D	D100LD■	(standard for metric units)			
512	62.5♦	62.5	N/A	N/A	N/A	N/A	14	25	63	5
518	74♦□	74♦	74	N/A	N/A	N/A	18	32	75	6
520	81.5♦□	81.5♦	81.5	81.5	N/A	N/A	25	52	100	8
525	N/A	99.5♦	99.5♦	99.5♦	99.5	N/A	25	60	123	8
534	N/A	N/A	124♦	124	124	124	35	60	141	10

OPTIONAL METRIC DIMENSIONS♦ - MM

IEC Frame	B5					B14♦					Input Bore Dia	Input Keyway▲
	AJ	AK	BD	BE	BF	AJ	AK	BD	BE	BF♦		
D56D	100	80	120	10	7	65♦	50	80	7	6.5	9	3 x 1.5
D63D	115	95	140	11	9	75♦	60	90	5.5	5.5	11	4 x 2
D71D	130	110	160	10	9	85♦	70	105	8	6.5	14	5 x 2.5
D80D	165	130	200	12	11	100♦	80	120	10	7	19	6 x 3
D90D	165	130	200	12	11	115	95	140	11	9	24	8 x 3.5
D100LD■	215	180	250	13	14	130	110	160	10	9	28	8 x 3.5

♦ Contact LEESON for availability of metric input options. The output bore and/or solid output shaft extension will be metric as standard with metric input options.

▲ Keyway width by depth

♦ AJ Mounting holes are rotated 45° from positions shown on B14 input options as follows: D56D(All), D63D(Series 518 & 520), D71D & D80D(Series 525)

♦ Dimensions are maximum (B5 and B14 options)

♦ B14 option not available

□ B5 Option not available

■ Also applies to frame size D112MD

✓ Solid metric output shaft diameter tolerance is -0.005/-0.020.

Hollow bore tolerance is H7.

STYLE FHMQ

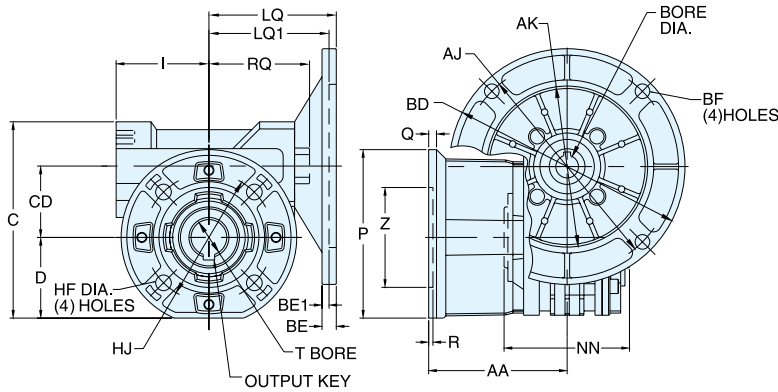

ASSEMBLIES

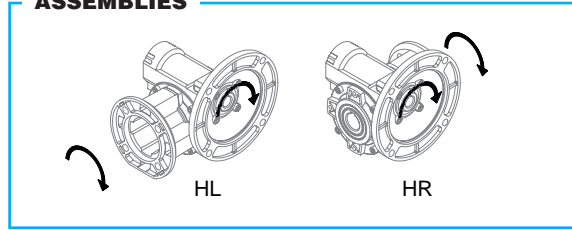

REVERSE ALL ARROWS FOR OPPOSITE INPUT SHAFT ROTATION. CONTACT FACTORY FOR OTHER MOUNTINGS OR ASSEMBLY POSITIONS.

STYLE FHMQ DIMENSIONS - Inches (MM)

Series	AA	C	CD	D	HF	HJ	I	LQ* 56/140	LQ1* 180	NN	P	Q	R	RQ +0.0015 -0.0000	T*	Z	OUTPUT KEY*
512	1.99	3.54	1.18	1.54	0.276	2.68	1.81	*	N/A	2.16	3.15	0.24	0.236	2.21	(14)_	1.968	(5)_
518	2.38	4.76	1.77	1.93	0.335	3.43	2.16	3.33	N/A	2.56	4.33	0.35	0.354	2.60	0.750	2.362	3/16 X 1.00
520	3.35	5.33	1.97	2.15	0.413	3.54	2.56	3.51	N/A	3.19	4.84	0.47	0.354	2.83	1.000	2.756	1/4 X 1.62
525	3.39	6.69	2.48	2.76	0.413	5.91	3.11	4.08	N/A	4.72	6.89	0.51	0.276	3.58	1.125	4.528	1/4 X 2.00
534	4.25	9.15	3.35	3.72	0.512	6.93	3.86	4.83	5.35	5.31	8.07	0.63	0.197	4.33	1.500	5.984	3/8 X 2.00

● Dimension is in MM. Key is not provided with metric reducer options as standard.
Metric bore tolerance is H7.
* Metric options are available. Refer to dimensions on opposite page.
Contact LEESON for availability of metric options.

STYLE FH

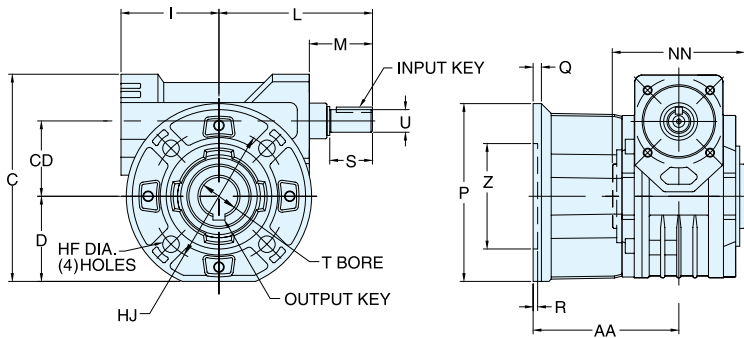

ASSEMBLIES

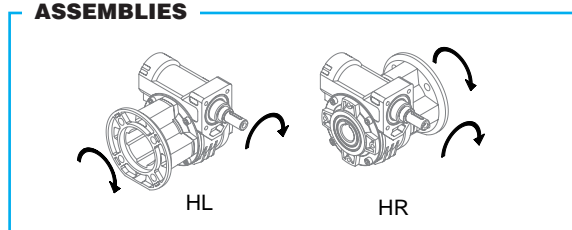

REVERSE ALL ARROWS FOR OPPOSITE INPUT SHAFT ROTATION. CONTACT FACTORY FOR OTHER MOUNTINGS OR ASSEMBLY POSITIONS.

STYLE FH DIMENSIONS - Inches**

Series	AA	C	CD	D	HF	HJ	I	L	M	NN	P	Q	R	S +0.0015 -0.0000	T +0.000 -0.001	U	Z	INPUT KEY	OUTPUT KEY
518	2.38	4.76	1.77	1.93	0.335	3.43	2.16	3.86	1.67	2.56	4.33	0.35	0.354	1.18	0.750	0.625	2.362	3/16 X 1.00	3/16 X 1.00
520	3.35	5.33	1.97	2.15	0.413	3.54	2.56	4.11	1.74	3.19	4.84	0.47	0.354	1.18	1.000	0.625	2.756	3/16 X 1.00	1/4 X 1.62
525	3.39	6.69	2.48	2.76	0.413	5.91	3.11	5.43	2.24	4.72	6.89	0.51	0.276	1.75	1.125	0.750	4.528	3/16 x 1.50	1/4 X 2.00
534	4.25	9.15	3.35	3.72	0.512	6.93	3.86	6.38	2.52	5.31	8.07	0.63	0.197	1.75	1.500	0.875	5.984	3/16 X 1.50	3/8 X 2.00

** Series 512 is available in this style. Contact LEESON for details

Bravo® Single Reducers



SINGLE REDUCTION DIMENSIONS



STYLE FMQ

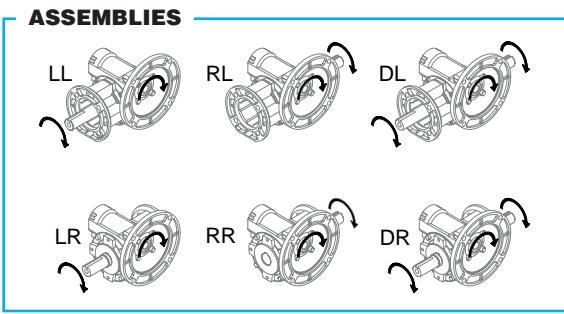
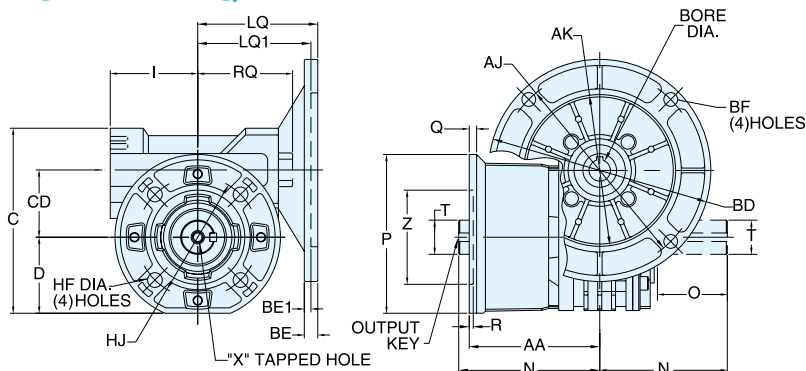

STYLE FMQ DIMENSIONS - Inches (MM)

Series	AA	C	CD	D	I	HF	HJ	LQ* 56/140	LQ1* 180	N	O*	P	Q	R	RQ	T* +0.000 -0.001	X		Z	OUTPUT KEY*	
																	Tap Size	Depth			
512	1.99	3.54	1.18	1.54	1.81	0.276	2.68	*	N/A	2.48	1.01	3.15	0.24	0.236	2.21	+0.000 -0.001	(14)*	N/A	0.62	1.968	(5)*
518	2.38	4.76	1.77	1.93	2.16	0.335	3.43	3.33	N/A	2.97	1.26	4.33	0.35	0.354	2.60	0.750	1/4-20 UNC	0.62	2.362	3/16 x 1.00	
520	3.35	5.33	1.97	2.15	2.56	0.413	3.54	3.51	N/A	3.94	2.05	4.84	0.47	0.354	2.83	1.000	5/16-18 UNC	0.75	2.756	1/4 X 1.62	
525	3.39	6.69	2.48	2.76	3.11	0.413	5.91	4.08	N/A	4.85	2.36	6.89	0.51	0.276	3.58	1.125	5/16-18 UNC	0.75	4.528	1/4 X 2.00	
534	4.25	9.15	3.35	3.72	3.86	0.512	6.93	4.83	5.35	5.55	2.36	8.07	0.63	0.197	4.33	1.500	5/16-18 UNC	0.75	5.984	3/8 X 2.00	

REVERSE ALL ARROWS FOR OPPOSITE INPUT SHAFT ROTATION. CONTACT FACTORY FOR OTHER MOUNTINGS OR ASSEMBLY POSITIONS.

* Dimension is in MM. Key is not provided with metric reducer options as standard. Metric shaft diameter tolerance is -0.005/-0.020. Series 512 is available with an inch dimensioned output shaft. Contact LEESON for details.
* Metric options are available. Refer to dimensions below. Contact LEESON for availability of metric options.

STYLE F

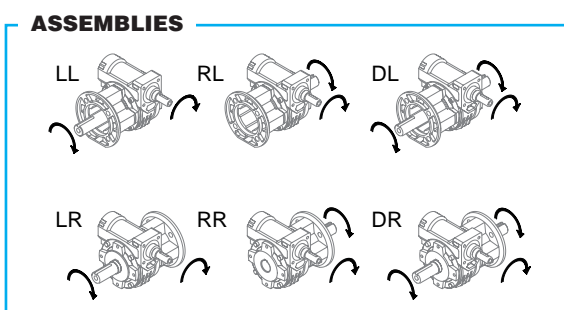
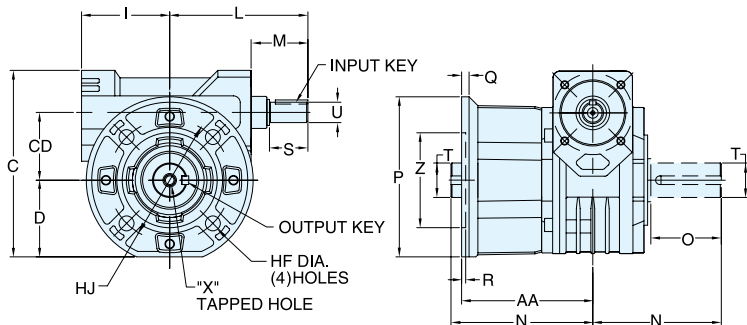

STYLE F DIMENSIONS - Inches**

Series	AA	C	CD	D	HF	HJ	I	L	M	N	O	P	Q	R	S +0.000 -0.001	T +0.000 -0.001	U	X		Z	INPUT KEY	OUTPUT KEY
																		Tap Size	Depth			
518	2.38	4.76	1.77	1.93	0.335	3.43	2.16	3.86	1.67	2.97	1.26	4.33	0.35	0.354	1.18	0.750	0.625	1/4-20 UNC	0.62	2.362	3/16 X 1.00	3/16 X 1.00
520	3.35	5.33	1.97	2.15	0.413	3.54	2.56	4.11	1.74	3.94	2.05	4.84	0.47	0.354	1.18	1.000	0.625	5/16-18 UNC	0.75	2.756	3/16 X 1.00	1/4 X 1.62
525	3.39	6.69	2.48	2.76	0.413	5.91	3.11	5.43	2.24	4.85	2.36	6.89	0.51	0.276	1.75	1.125	0.750	5/16-18 UNC	0.75	4.528	3/16 x 1.50	1/4 X 2.00
534	4.25	9.15	3.35	3.72	0.512	6.93	3.86	6.38	2.52	5.55	2.36	8.07	0.63	0.197	1.75	1.500	0.875	5/16-18 UNC	0.75	5.984	3/16 X 1.50	3/8 X 2.00

** Series 512 is available in this style. Contact LEESON for details

MOTOR MOUNTING DIMENSIONS

NEMA DIMENSIONS - Inches

Frame	AJ	AK	BD	BE	BE1	BF	Input Bore Dia	Input Keyway▲
56C	5.88	4.50	6.50	0.38	N/A	0.41	0.625	3/16 x 3/32
140TC	5.88	4.50	6.50	0.38	N/A	0.41	0.875	3/16 x 3/32
180TC	7.25	8.50	9.00	N/A	0.50	0.53	1.125	1/4 x 1/8

OPTIONAL METRIC DIMENSIONS* - MM

Series	LQ1♦						T ✓	O	N	Output Keyway
	IEC B5 & B14 Options									
	D56D	D63D	D71D	D80D	D90D	D100LD■	(standard for metric units)			
512	62.5♦	62.5	N/A	N/A	N/A	N/A	14	25	63	5
518	74♦□	74♦	74	N/A	N/A	N/A	18	32	75	6
520	81.5♦□	81.5♦	81.5	81.5	N/A	N/A	25	52	100	8
525	N/A	99.5♦	99.5♦	99.5♦	99.5	N/A	25	60	123	8
534	N/A	N/A	124♦	124	124	124	35	60	141	10

OPTIONAL METRIC DIMENSIONS* - MM

IEC Frame	B5					B14♦					Input Bore Dia	Input Keyway▲
	AJ	AK	BD	BE	BF	AJ	AK	BD	BE	BF♦		
D56D	100	80	120	10	7	65♦	50	80	7	6.5	9	3 x 1.5
D63D	115	95	140	11	9	75♦	60	90	5.5	5.5	11	4 x 2
D71D	130	110	160	10	9	85♦	70	105	8	6.5	14	5 x 2.5
D80D	165	130	200	12	11	100♦	80	120	10	7	19	6 x 3
D90D	165	130	200	12	11	115	95	140	11	9	24	8 x 3.5
D100LD■	215	180	250	13	14	130	110	160	10	9	28	8 x 3.5

♦ Contact LEESON for availability of metric input options. The output bore and/or solid output shaft extension will be metric as standard with metric input options.
▲ Keyway width by depth
♦ AJ Mounting holes are rotated 45° from positions shown on B14 input options as follows:D56D(All), D63D(Series 518 & 520), D71D & D80D(Series 525)
♦ Dimensions are maximum (B5 and B14 options)
♦ B14 option not available
□ B5 Option not available
■ Also applies to frame size D112MD
✓ Solid metric output shaft diameter tolerance is -0.005/-0.020. Hollow bore tolerance is H7.

Bravo® Single Reduction Reducers

STYLE FLHMQ

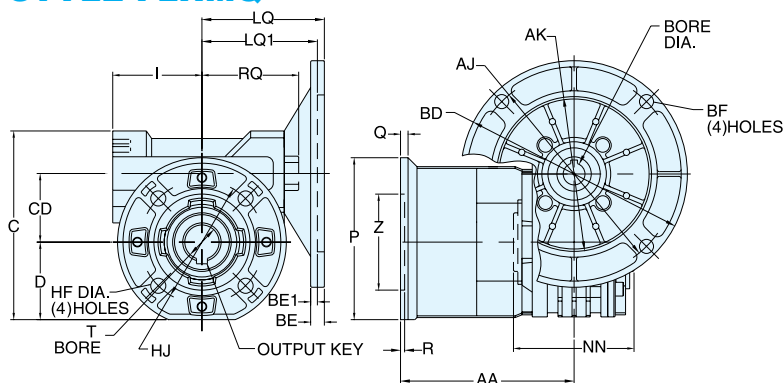

ASSEMBLIES

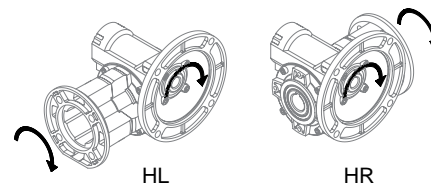

REVERSE ALL ARROWS FOR OPPOSITE INPUT SHAFT ROTATION. CONTACT FACTORY FOR OTHER MOUNTINGS OR ASSEMBLY POSITIONS.

Bravo® Single Reduction Reducers

STYLE FLHMQ DIMENSIONS - Inches (MM)

Series	AA	C	CD	D	HF	HJ	I	LQ* 56/140	LQ1* 180	NN	P	Q	R	RQ	T* +0.0015 -0.0000	Z	OUTPUT KEY*
512	2.19	3.54	1.18	1.54	0.335	3.43	1.81	*	N/A	2.16	4.33	0.24	0.236	2.21	(14)●	2.362	(5)●
518	3.56	4.76	1.77	1.93	0.335	3.43	2.16	3.33	N/A	2.56	4.33	0.35	0.354	2.60	0.750	2.362	3/16 X 1.00
520	4.51	5.33	1.97	2.15	0.413	3.54	2.56	3.51	N/A	3.19	4.84	0.47	0.354	2.83	1.000	2.756	1/4 X 1.62
525	4.57	6.69	2.48	2.76	0.413	5.91	3.11	4.08	N/A	4.72	6.89	0.51	0.276	3.58	1.125	4.528	1/4 X 2.00
534	5.85	9.15	3.35	3.72	0.512	6.93	3.86	4.83	5.35	5.31	8.07	0.63	0.197	4.33	1.500	5.984	3/8 X 2.00

● Dimension is in MM. Key is not provided with metric reducer options as standard.
Metric bore tolerance is H7.
* Metric options are available. Refer to dimensions on opposite page.
Contact LEESON for availability of metric options.

STYLE FLH

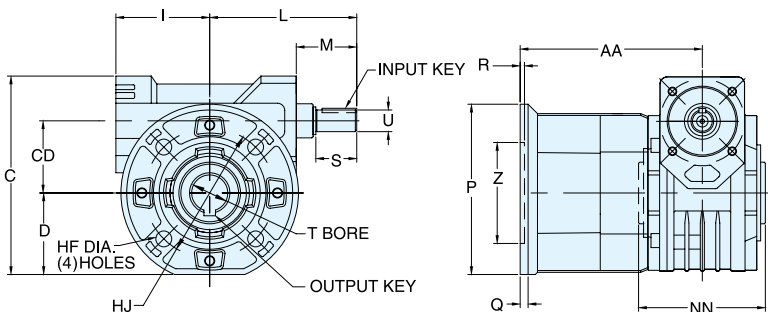

ASSEMBLIES

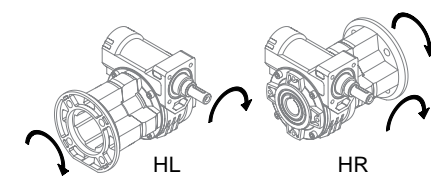

REVERSE ALL ARROWS FOR OPPOSITE INPUT SHAFT ROTATION. CONTACT FACTORY FOR OTHER MOUNTINGS OR ASSEMBLY POSITIONS.

STYLE FLH DIMENSIONS - Inches**

Series	AA	C	CD	D	HF	HJ	I	L	M	NN	P	Q	R	S +0.0015 -0.0000	T +0.000 -0.001	U	Z	INPUT KEY	OUTPUT KEY
518	3.56	4.76	1.77	1.93	0.335	3.43	2.16	3.86	1.67	2.56	4.33	0.35	0.354	1.18	0.750	0.625	2.362	3/16 X 1.00	3/16 X 1.00
520	4.51	5.33	1.97	2.15	0.413	3.54	2.56	4.11	1.74	3.19	4.84	0.47	0.354	1.18	1.000	0.625	2.756	3/16 X 1.00	1/4 X 1.62
525	4.57	6.69	2.48	2.76	0.413	5.91	3.11	5.43	2.24	4.72	6.89	0.51	0.276	1.75	1.125	0.750	4.528	3/16 X 1.50	1/4 X 2.00
534	5.85	9.15	3.35	3.72	0.512	6.93	3.86	6.38	2.52	5.31	8.07	0.63	0.197	1.75	1.500	0.875	5.984	3/16 X 1.50	3/8 X 2.00

** Series 512 is available in this style. Contact LEESON for details



SINGLE REDUCTION DIMENSIONS



STYLE FLMQ

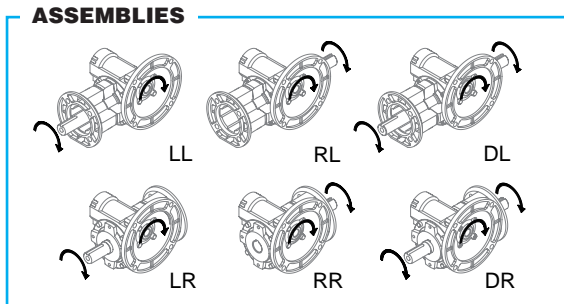
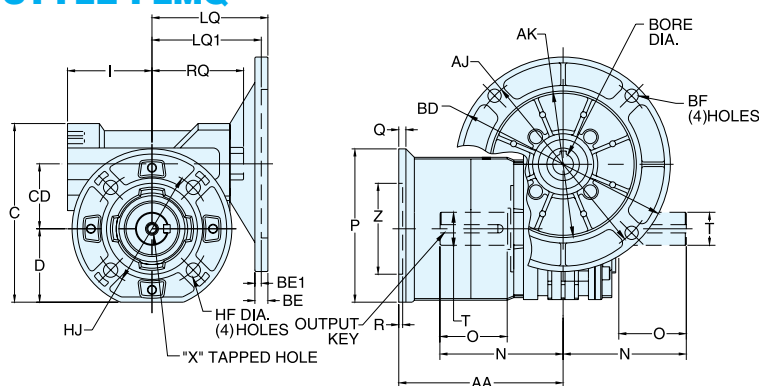

REVERSE ALL ARROWS FOR OPPOSITE INPUT SHAFT ROTATION. CONTACT FACTORY FOR OTHER MOUNTINGS OR ASSEMBLY POSITIONS.

STYLE FLMQ DIMENSIONS - Inches (MM)

Series	AA	C	CD	D	I	HF	HJ	LQ* 56/140	LQ1* 180	N	O*	P	Q	R	RQ	T* +0.000 -0.001	X		Z	OUTPUT KEY*
																	Tap Size	Depth		
512	2.19	3.54	1.18	1.54	1.81	0.335	3.43	*	N/A	2.48	1.01	4.33	0.24	0.236	2.21	(14)★	N/A	N/A	2.362	(5)★
518	3.56	4.76	1.77	1.93	2.16	0.335	3.43	3.33	N/A	2.97	1.26	4.33	0.35	0.354	2.60	0.750	1/4-20 UNC	0.62	2.362	3/16 x 1.00
520	4.51	5.33	1.97	2.15	2.56	0.413	3.54	3.51	N/A	3.94	2.05	4.84	0.47	0.354	2.83	1.000	5/16-18 UNC	0.75	2.756	1/4 X 1.62
525	4.57	6.69	2.48	2.76	3.11	0.413	5.91	4.08	N/A	4.85	2.36	6.89	0.51	0.276	3.58	1.125	5/16-18 UNC	0.75	4.528	1/4 X 2.00
534	5.85	9.15	3.35	3.72	3.86	0.512	6.93	4.83	5.35	5.55	2.36	8.07	0.63	0.197	4.33	1.500	5/16-18 UNC	0.75	5.984	3/8 X 2.00

★ Dimension is in MM. Key is not provided with metric reducer options as standard. Metric shaft diameter tolerance is -0.005/-0.020. Series 512 is available with an inch dimensioned output shaft. Contact LEESON for details.
* Metric options are available. Refer to dimensions below. Contact LEESON for availability of metric options.

STYLE FL

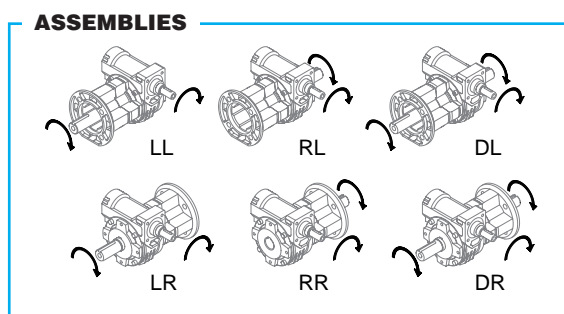
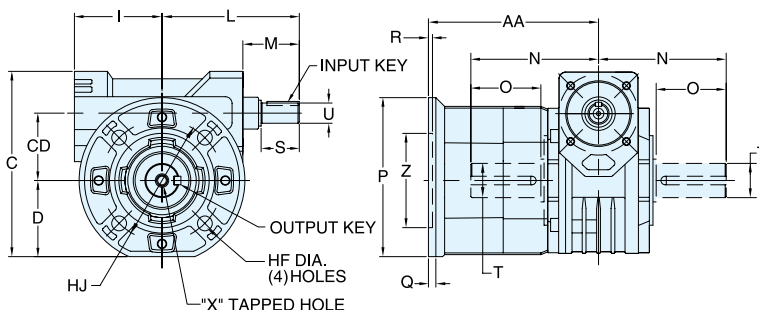

REVERSE ALL ARROWS FOR OPPOSITE INPUT SHAFT ROTATION. CONTACT FACTORY FOR OTHER MOUNTINGS OR ASSEMBLY POSITIONS.

STYLE FL DIMENSIONS - Inches**

Series	AA	C	CD	D	HF	HJ	I	L	M	N	O	P	Q	R	S	T +0.000 -0.001	U +0.000 -0.001	X		Z	INPUT KEY	OUTPUT KEY
																		Tap Size	Depth			
518	3.56	4.76	1.77	1.93	0.335	3.43	2.16	3.86	1.67	2.97	1.26	4.33	0.35	0.354	1.18	0.750	0.625	1/4-20 UNC	0.62	2.362	3/16 X 1.00	3/16 X 1.00
520	4.51	5.33	1.97	2.15	0.413	3.54	2.56	4.11	1.74	3.94	2.05	4.84	0.47	0.354	1.18	1.000	0.625	5/16-18 UNC	0.75	2.756	3/16 X 1.00	1/4 X 1.62
525	4.57	6.69	2.48	2.76	0.413	5.91	3.11	5.43	2.24	4.85	2.36	6.89	0.51	0.276	1.75	1.125	0.750	5/16-18 UNC	0.75	4.528	3/16 x 1.50	1/4 X 2.00
534	5.85	9.15	3.35	3.72	0.512	6.93	3.86	6.38	2.52	5.55	2.36	8.07	0.63	0.197	1.75	1.500	0.875	5/16-18 UNC	0.75	5.984	3/16 X 1.50	3/8 X 2.00

** Series 512 is available in this style. Contact LEESON for details

MOTOR MOUNTING DIMENSIONS

NEMA DIMENSIONS - Inches

Frame	AJ	AK	BD	BE	BE1	BF	Input Bore Dia	Input Keyway▲
56C	5.88	4.50	6.50	0.38	N/A	0.41	0.625	3/16 x 3/32
140TC	5.88	4.50	6.50	0.38	N/A	0.41	0.875	3/16 x 3/32
180TC	7.25	8.50	9.00	N/A	0.50	0.53	1.125	1/4 x 1/8

OPTIONAL METRIC DIMENSIONS* - MM

Series	LQ1♦						T ✓	O	N	Output Keyway
	IEC B5 & B14 Options									
	D56D	D63D	D71D	D80D	D90D	D100LD■				
512	62.5♦	62.5	N/A	N/A	N/A	N/A	14	25	63	5
518	74♦□	74♦	74	N/A	N/A	N/A	18	32	75	6
520	81.5♦□	81.5♦	81.5	81.5	N/A	N/A	25	52	100	8
525	N/A	99.5♦	99.5♦	99.5♦	N/A	N/A	25	60	123	8
534	N/A	N/A	124◇	124	124	124	35	60	141	10

OPTIONAL METRIC DIMENSIONS* - MM

IEC Frame	B5					B14+					Input Bore Dia	Input Keyway▲
	AJ	AK	BD	BE	BF	AJ	AK	BD	BE	BF♦		
D56D	100	80	120	10	7	65♦	50	80	7	6.5	9	3 x 1.5
D63D	115	95	140	11	9	75♦	60	90	5.5	5.5	11	4 x 2
D71D	130	110	160	10	9	85♦	70	105	8	6.5	14	5 x 2.5
D80D	165	130	200	12	11	100♦	80	120	10	7	19	6 x 3
D90D	165	130	200	12	11	115	95	140	11	9	24	8 x 3.5
D100LD■	215	180	250	13	14	130	110	160	10	9	28	8 x 3.5

♦ Contact LEESON for availability of metric input options. The output bore and/or solid output shaft extension will be metric as standard with metric input options.

▲ Keyway width by depth

♦ AJ Mounting holes are rotated 45° from positions shown on B14 input options as follows: D56D(AI), D63D(Series 518 & 520), D71D & D80D(Series 525)

◆ Dimensions are maximum (B5 and B14 options)

◇ B14 option not available

□ B5 Option not available

■ Also applies to frame size D112MD

✓ Solid metric output shaft diameter tolerance is -0.005/-0.020. Hollow bore tolerance is H7.

Bravo® Single Reduction Reducers

STYLE THMQ

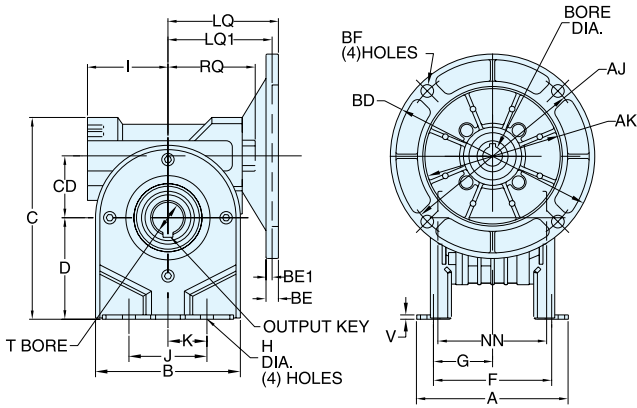

ASSEMBLIES

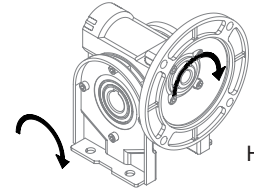

REVERSE ALL ARROWS FOR OPPOSITE INPUT SHAFT ROTATION. CONTACT FACTORY FOR OTHER MOUNTINGS OR ASSEMBLY POSITIONS.

STYLE THMQ DIMENSIONS - Inches (MM)

Series	A	B	C	CD	D	F	G	H	I	J	K	LQ* 56/140	LQ1* 180	NN	RQ	T* +0.0015 -0.0000	V	OUTPUT KEY*
512	3.43	3.07	4.17	1.18	2.17	2.60	1.30	0.256	1.81	1.97	0.99	*	N/A	2.16	2.21	(14)●	0.12	(5)●
518	3.94	3.86	5.67	1.77	2.83	3.17	1.59	0.413	2.16	1.97	0.99	3.33	N/A	2.56	2.60	0.750	0.12	3/16 X 1.00
520	4.84	4.45	6.42	1.97	3.23	3.94	1.97	0.413	2.56	2.48	1.24	3.51	N/A	3.19	2.83	1.000	0.14	1/4 X 1.62
525	5.67	5.24	7.87	2.48	3.94	4.35	2.18	0.413	3.11	3.74	1.87	4.08	N/A	4.72	3.58	1.125	0.16	1/4 X 2.00
534	7.17	7.09	11.02	3.35	5.59	5.71	2.86	0.413	3.86	5.51	2.76	4.83	5.35	5.31	4.33	1.500	0.20	3/8 X 2.00

● Dimension is in MM. Key is not provided with metric reducer options as standard. Metric bore tolerance is H7.
* Metric options are available. Refer to dimensions on opposite page. Contact LEESON for availability of metric options.

STYLE TH

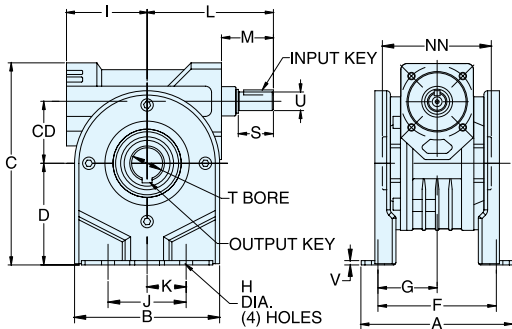

ASSEMBLIES

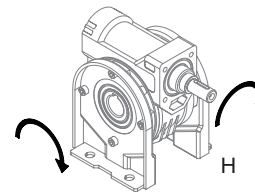

REVERSE ALL ARROWS FOR OPPOSITE INPUT SHAFT ROTATION. CONTACT FACTORY FOR OTHER MOUNTINGS OR ASSEMBLY POSITIONS.

STYLE TH DIMENSIONS - Inches**

Series	A	B	C	CD	D	F	G	H	I	J	K	L	M	NN	S	T +0.0015 -0.0000	U +0.000 -0.001	V	INPUT KEY	OUTPUT KEY
518	3.94	3.86	5.67	1.77	2.83	3.17	1.59	0.413	2.16	1.97	0.99	3.86	1.67	2.56	1.18	0.750	0.625	0.12	3/16 X 1.00	3/16 X 1.00
520	4.84	4.45	6.42	1.97	3.23	3.94	1.97	0.413	2.56	2.48	1.24	4.11	1.74	3.19	1.18	1.000	0.625	0.14	3/16 X 1.00	1/4 X 1.62
525	5.67	5.24	7.87	2.48	3.94	4.35	2.18	0.413	3.11	3.74	1.87	5.43	2.24	4.72	1.75	1.125	0.750	0.16	3/16 X 1.50	1/4 X 2.00
534	7.17	7.09	11.02	3.35	5.59	5.71	2.86	0.413	3.86	5.51	2.76	6.38	2.52	5.31	1.75	1.500	0.875	0.20	3/16 X 1.50	3/8 X 2.00

** Series 512 is available in this style. Contact LEESON for details

Bravo® Single Reduction Reducers



STYLE TMQ

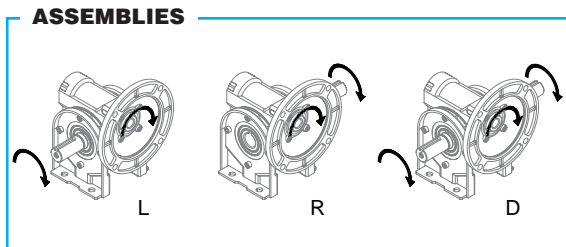
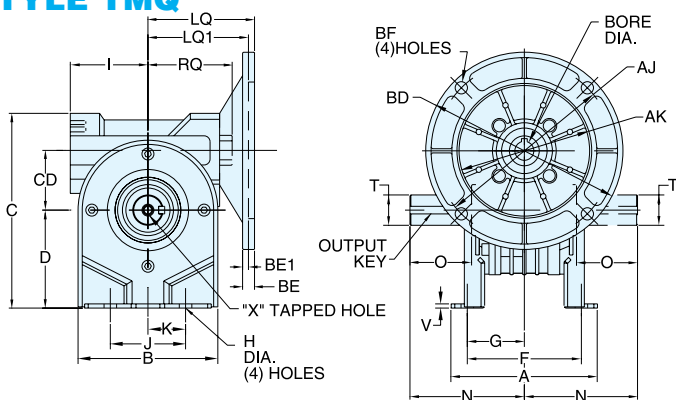

REVERSE ALL ARROWS FOR OPPOSITE INPUT SHAFT ROTATION. CONTACT FACTORY FOR OTHER MOUNTINGS OR ASSEMBLY POSITIONS.

STYLE TMQ DIMENSIONS - Inches (MM)

Series	A	B	C	CD	D	F	G	H	I	J	K	LQ* 56/140	LQ1* 180	N	O	RQ	T* +0.000 -0.001	V	X		OUTPUT KEY*
																			Tap Size	Depth	
512	3.43	3.07	4.17	1.18	2.17	2.60	1.30	0.256	1.81	1.97	0.99	*	N/A	2.48	1.01	2.21	(14)★	0.12	N/A	N/A	(5)♣
518	3.94	3.86	5.67	1.77	2.83	3.17	1.59	0.413	2.16	1.97	0.99	3.33	N/A	2.97	1.26	2.60	0.750	0.12	1/4-20 UNC	0.62	3/16 X 1.00
520	4.84	4.45	6.42	1.97	3.23	3.94	1.97	0.413	2.56	2.48	1.24	3.51	N/A	3.94	2.05	2.83	1.000	0.14	5/16-18 UNC	0.75	1/4 X 1.62
525	5.67	5.24	7.87	2.48	3.94	4.35	2.18	0.413	3.11	3.74	1.87	4.08	N/A	4.85	2.36	3.58	1.125	0.16	5/16-18 UNC	0.75	1/4 X 2.00
534	7.17	7.09	11.02	3.35	5.59	5.71	2.86	0.413	3.86	5.51	2.76	4.83	5.35	5.55	2.36	4.33	1.500	0.20	5/16-18 UNC	0.75	3/8 X 2.00

STYLE T

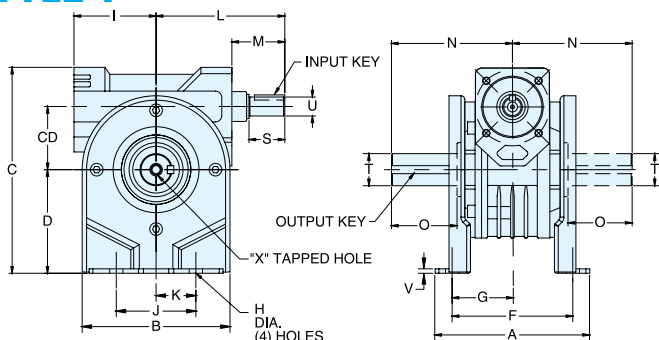

♣ Dimension is in MM. Key is not provided with metric reducer options as standard. Metric shaft diameter tolerance is -0.005/-0.020. Series 512 is available with an inch dimensioned output shaft. Contact LEESON for details.

* Metric options are available. Refer to dimensions below. Contact LEESON for availability of metric options.

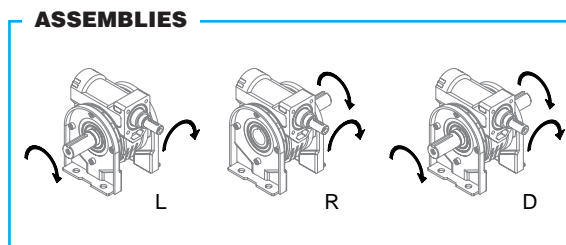

REVERSE ALL ARROWS FOR OPPOSITE INPUT SHAFT ROTATION. CONTACT FACTORY FOR OTHER MOUNTINGS OR ASSEMBLY POSITIONS.

STYLE T DIMENSIONS - Inches**

Series	A	B	C	CD	D	F	G	H	I	J	K	L	M	N	O	S +0.000 -0.001	T +0.000 -0.001	U	V	X		INPUT KEY	OUTPUT KEY
																				Tap Size	Depth		
518	3.94	3.86	5.67	1.77	2.83	3.17	1.59	0.413	2.16	1.97	0.99	3.86	1.67	2.97	1.26	1.18	0.750	0.625	0.12	1/4-20 UNC	0.62	3/16 X 1.00	3/16 X 1.00
520	4.84	4.45	6.42	1.97	3.23	3.94	1.97	0.413	2.56	2.48	1.24	4.11	1.74	3.94	2.05	1.18	1.000	0.625	0.14	5/16-18 UNC	0.75	3/16 X 1.00	1/4 X 1.62
525	5.67	5.24	7.87	2.48	3.94	4.35	2.18	0.413	3.11	3.74	1.87	5.43	2.24	4.85	2.36	1.75	1.125	0.750	0.16	5/16-18 UNC	0.75	3/16 X 1.50	1/4 X 2.00
534	7.17	7.09	11.02	3.35	5.59	5.71	2.86	0.413	3.86	5.51	2.76	6.38	2.52	5.55	2.36	1.75	1.500	0.875	0.20	5/16-18 UNC	0.75	3/16 X 1.50	3/8 X 2.00

** Series 512 is available in this style. Contact LEESON for details

MOTOR MOUNTING DIMENSIONS

NEMA DIMENSIONS - Inches

Frame	AJ	AK	BD	BE	BE1	BF	Input Bore Dia	Input Keyway▲
56C	5.88	4.50	6.50	0.38	N/A	0.41	0.625	3/16 x 3/32
140TC	5.88	4.50	6.50	0.38	N/A	0.41	0.875	3/16 x 3/32
180TC	7.25	8.50	9.00	N/A	0.50	0.53	1.125	1/4 x 1/8

OPTIONAL METRIC DIMENSIONS♣ - MM

Series	LQ1♣				T ✓	O (standard for metric units)	N	Output Keyway
	IEC B5 & B14 Options							
	D56D	D63D	D71D	D80D	D90D	D100LD■		
512	62.5♣	62.5	N/A	N/A	N/A	N/A	14	5
518	74♣□	74♣	74	N/A	N/A	N/A	18	6
520	81.5♣□	81.5♣	81.5	81.5	N/A	N/A	25	8
525	N/A	99.5♣	99.5♣	99.5	N/A	N/A	25	8
534	N/A	N/A	124♣	124	124	124	35	10

OPTIONAL METRIC DIMENSIONS♣ - MM

IEC Frame	B5					B14♣					Input Bore Dia	Input Keyway▲
	AJ	AK	BD	BE	BF	AJ	AK	BD	BE	BF♣		
D56D	100	80	120	10	7	65♣	50	80	7	6.5	9	3 x 1.5
D63D	115	95	140	11	9	75♣	60	90	5.5	5.5	11	4 x 2
D71D	130	110	160	10	9	85♣	70	105	8	6.5	14	5 x 2.5
D80D	165	130	200	12	11	100♣	80	120	10	7	19	6 x 3
D90D	165	130	200	12	11	115	95	140	11	9	24	8 x 3.5
D100LD■	215	180	250	13	14	130	110	160	10	9	28	8 x 3.5

♣ Contact LEESON for availability of metric input options. The output bore and/or solid output shaft extension will be metric as standard with metric input options.

▲ Keyway width by depth

♣ AJ Mounting holes are rotated 45° from positions shown on B14 input options as follows: D56D(All), D63D(Series 518 & 520), D71D & D80D(Series 525)

♣ Dimensions are maximum (B5 and B14 options)

♣ B14 option not available

♣ B5 Option not available

♣ Also applies to frame size D112MD

✓ Solid metric output shaft diameter tolerance is -0.005/-0.020. Hollow bore tolerance is H7.

Bravo® Single Reduction Reducers

STYLE UHMQ

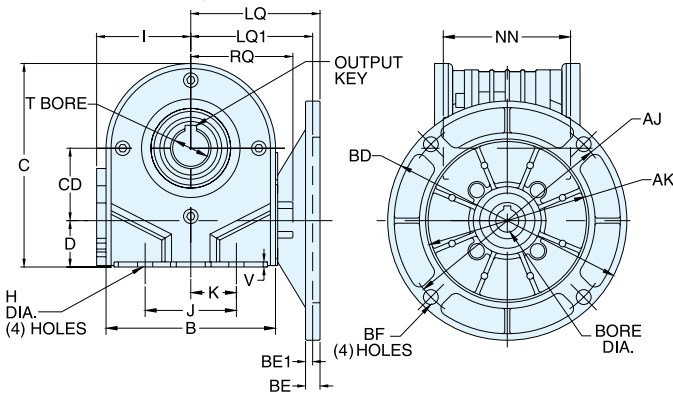

ASSEMBLIES

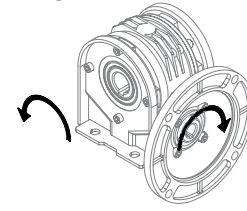

REVERSE ALL ARROWS FOR OPPOSITE INPUT SHAFT ROTATION. CONTACT FACTORY FOR OTHER MOUNTINGS OR ASSEMBLY POSITIONS.

STYLE UHMQ DIMENSIONS - Inches (MM)

Series	A [^]	B	C	CD	D	F [^]	G [^]	H	I	J	K	LQ [*] 56/140	LQ1 [*] 180	NN	RQ	T [*] +0.0015 -0.0000	V	OUTPUT KEY [*]
512	3.43	3.07	3.70	1.18	0.98	2.60	1.30	0.256	1.81	1.97	0.99	*	N/A	2.16	2.21	(14)●	0.12	(5)●
518	3.94	3.86	4.76	1.77	1.06	3.17	1.59	0.413	2.16	1.97	0.99	3.33	N/A	2.56	2.60	0.750	0.12	3/16 X 1.00
520	4.84	4.45	5.45	1.97	1.26	3.94	1.97	0.413	2.56	2.48	1.24	3.51	N/A	3.19	2.83	1.000	0.14	1/4 X 1.62
525	5.67	5.24	6.69	2.48	1.45	4.35	2.18	0.413	3.11	3.74	1.87	4.08	N/A	4.72	3.58	1.125	0.16	1/4 X 2.00
534	7.17	7.09	9.31	3.35	2.24	5.71	2.86	0.413	3.86	5.51	2.76	4.83	5.35	5.31	4.33	1.500	0.20	3/8 X 2.00

● Dimension is in MM. Key is not provided with metric reducer options as standard.
Metric bore tolerance is H7.
* Metric options are available. Refer to dimensions on opposite page.
Contact LEESON for availability of metric options.
[^] Refer to style UH for reference to this dimension.

STYLE UH

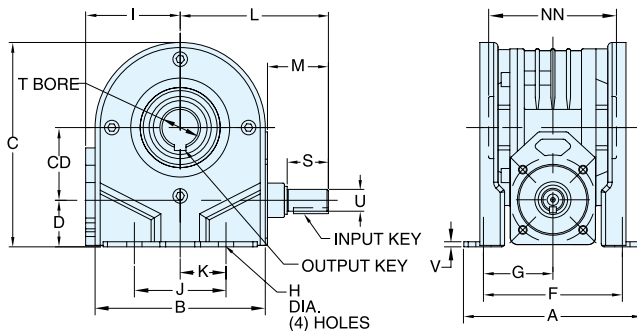

ASSEMBLIES

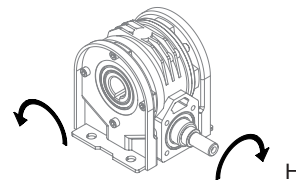

REVERSE ALL ARROWS FOR OPPOSITE INPUT SHAFT ROTATION. CONTACT FACTORY FOR OTHER MOUNTINGS OR ASSEMBLY POSITIONS.

STYLE UH DIMENSIONS - Inches**

Series	A	B	C	CD	D	F	G	H	I	J	K	L	M	NN	S	T +0.0015 -0.0000	U +0.000 -0.001	V	INPUT KEY	OUTPUT KEY
518	3.94	3.86	4.76	1.77	1.06	3.17	1.59	0.413	2.16	1.97	0.99	3.86	1.67	2.56	1.18	0.750	0.625	0.12	3/16 X 1.00	3/16 X 1.00
520	4.84	4.45	5.45	1.97	1.26	3.94	1.97	0.413	2.56	2.48	1.24	4.11	1.74	3.19	1.18	1.000	0.625	0.14	3/16 X 1.00	1/4 X 1.62
525	5.67	5.24	6.69	2.48	1.45	4.35	2.18	0.413	3.11	3.74	1.87	5.43	2.24	4.72	1.75	1.125	0.750	0.16	3/16 x 1.50	1/4 X 2.00
534	7.17	7.09	9.31	3.35	2.24	5.71	2.86	0.413	3.86	5.51	2.76	6.38	2.52	5.31	1.75	1.500	0.875	0.20	3/16 X 1.50	3/8 X 2.00

** Series 512 is available in this style. Contact LEESON for details

Bravo® Single Reduction Reducers



STYLE UMQ

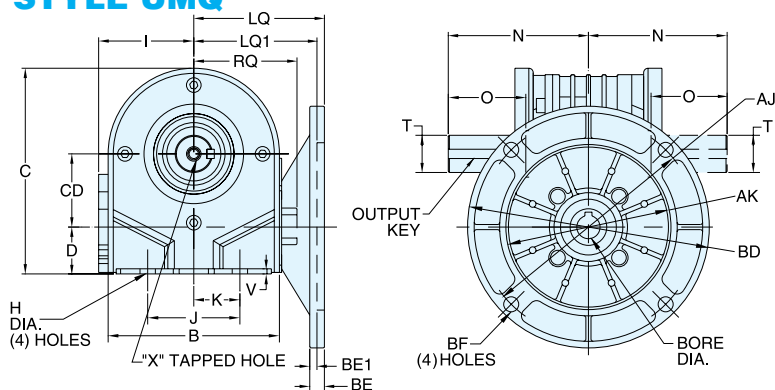

ASSEMBLIES

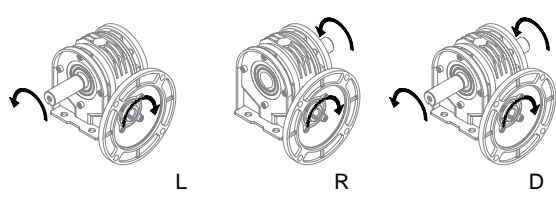

REVERSE ALL ARROWS FOR OPPOSITE INPUT SHAFT ROTATION. CONTACT FACTORY FOR OTHER MOUNTINGS OR ASSEMBLY POSITIONS.

STYLE UMQ DIMENSIONS - Inches (MM)

Series	A ^A	B	C	CD	D	F ^A	G ^A	H	I	J	K	LQ* 56/140	LQ1* 180	N	O	RQ	T* +0.000 -0.001	V	X		OUTPUT KEY*
																			Tap Size	Depth	
512	3.43	3.07	3.70	1.18	0.98	2.60	1.30	0.256	1.81	1.97	0.99	*	N/A	2.48	1.01	2.21	(14)♦	0.12	N/A	N/A	(5)♦
518	3.94	3.86	4.76	1.77	1.06	3.17	1.59	0.413	2.16	1.97	0.99	3.33	N/A	2.97	1.26	2.60	0.750	0.12	1/4-20 UNC	0.62	3/16 X 1.00
520	4.84	4.45	5.45	1.97	1.26	3.94	1.97	0.413	2.56	2.48	1.24	3.51	N/A	3.94	2.05	2.83	1.000	0.14	5/16-18 UNC	0.75	1/4 X 1.62
525	5.67	5.24	6.69	2.48	1.45	4.35	2.18	0.413	3.11	3.74	1.87	4.08	N/A	4.85	2.36	3.58	1.125	0.16	5/16-18 UNC	0.75	1/4 X 2.00
534	7.17	7.09	9.31	3.35	2.24	5.71	2.86	0.413	3.86	5.51	2.76	4.83	5.35	5.55	2.36	4.33	1.500	0.20	5/16-18 UNC	0.75	3/8 X 2.00

♦ Dimension is in MM. Key is not provided with metric reducer options as standard. Metric shaft diameter tolerance is -0.005/-0.020. Series 512 is available with an inch dimensioned output shaft. Contact LEESON for details.

* Metric options are available. Refer to dimensions below. Contact LEESON for availability of metric options.

^A Refer to style U for reference to this dimension.

STYLE U

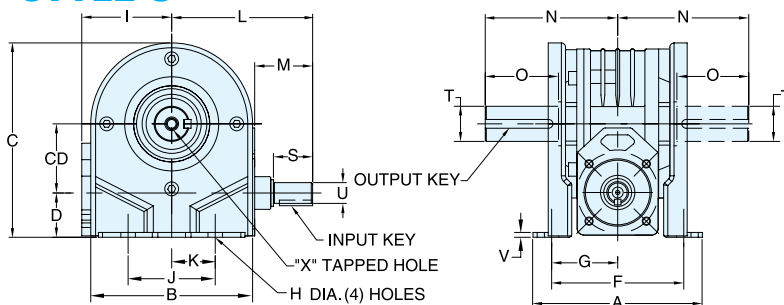

ASSEMBLIES

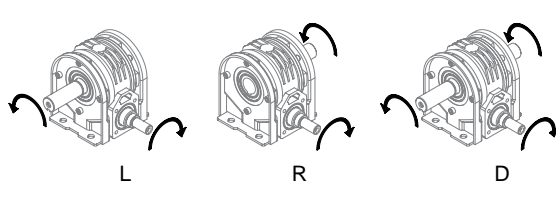

REVERSE ALL ARROWS FOR OPPOSITE INPUT SHAFT ROTATION. CONTACT FACTORY FOR OTHER MOUNTINGS OR ASSEMBLY POSITIONS.

STYLE U DIMENSIONS - Inches**

Series	A	B	C	CD	D	F	G	H	I	J	K	L	M	N	O	S	T +0.000 -0.001	U +0.000 -0.001	V	X		INPUT KEY	OUTPUT KEY
																				Tap Size	Depth		
518	3.94	3.86	4.76	1.77	1.06	3.17	1.59	0.413	2.16	1.97	0.99	3.86	1.67	2.97	1.26	1.18	0.750	0.625	0.12	1/4-20 UNC	0.62	3/16 X 1.00	3/16 X 1.00
520	4.84	4.45	5.45	1.97	1.26	3.94	1.97	0.413	2.56	2.48	1.24	4.11	1.74	3.94	2.05	1.18	1.000	0.625	0.14	5/16-18 UNC	0.75	3/16 X 1.00	1/4 X 1.62
525	5.67	5.24	6.69	2.48	1.45	4.35	2.18	0.413	3.11	3.74	1.87	5.43	2.24	4.85	2.36	1.75	1.125	0.750	0.16	5/16-18 UNC	0.75	3/16 x 1.50	1/4 X 2.00
534	7.17	7.09	9.31	3.35	2.24	5.71	2.86	0.413	3.86	5.51	2.76	6.38	2.52	5.55	2.36	1.75	1.500	0.875	0.20	5/16-18 UNC	0.75	3/16 X 1.50	3/8 X 2.00

** Series 512 is available in this style. Contact LEESON for details

MOTOR MOUNTING DIMENSIONS

NEMA DIMENSIONS - Inches

Frame	AJ	AK	BD	BE	BE1	BF	Input Bore Dia	Input Keyway▲
56C	5.88	4.50	6.50	0.38	N/A	0.41	0.625	3/16 x 3/32
140TC	5.88	4.50	6.50	0.38	N/A	0.41	0.875	3/16 x 3/32
180TC	7.25	8.50	9.00	N/A	0.50	0.53	1.125	1/4 x 1/8

OPTIONAL METRIC DIMENSIONS* - MM

Series	LQ1♦						T ✓	O	N	Output Keyway
	IEC B5 & B14 Options									
	D56D	D63D	D71D	D80D	D90D	D100LD■				
512	62.5♦	62.5	N/A	N/A	N/A	N/A	14	25	63	5
518	74♦□	74♦	74	N/A	N/A	N/A	18	32	75	6
520	81.5♦□	81.5♦	81.5	81.5	N/A	N/A	25	52	100	8
525	N/A	99.5♦	99.5♦	99.5♦	99.5	N/A	25	60	123	8
534	N/A	N/A	124♦	124	124	124	35	60	141	10

♦ Contact LEESON for availability of metric input options. The output bore and/or solid output shaft extension will be metric as standard with metric input options.

▲ Keyway width by depth

♦ AJ Mounting holes are rotated 45° from positions shown on B14 input options as follows: D56D(AII), D63D(Series 518 & 520), D71D & D80D(Series 525)

♦ Dimensions are maximum (B5 and B14 options)

♦ B14 option not available

□ B5 Option not available

■ Also applies to frame size D112MD

✓ Solid metric output shaft diameter tolerance is -0.005/-0.020. Hollow bore tolerance is H7.

OPTIONAL METRIC DIMENSIONS* - MM

IEC Frame	B5					B14♦					Input Bore Dia	Input Keyway▲
	AJ	AK	BD	BE	BF	AJ	AK	BD	BE	BF♦		
D56D	100	80	120	10	7	65♦	50	80	7	6.5	9	3 x 1.5
D63D	115	95	140	11	9	75♦	60	90	5.5	5.5	11	4 x 2
D71D	130	110	160	10	9	85♦	70	105	8	6.5	14	5 x 2.5
D80D	165	130	200	12	11	100♦	80	120	10	7	19	6 x 3
D90D	165	130	200	12	11	115	95	140	11	9	24	8 x 3.5
D100LD■	215	180	250	13	14	130	110	160	10	9	28	8 x 3.5

Bravo® Single
Reduction Reducers

STYLE JHMQ

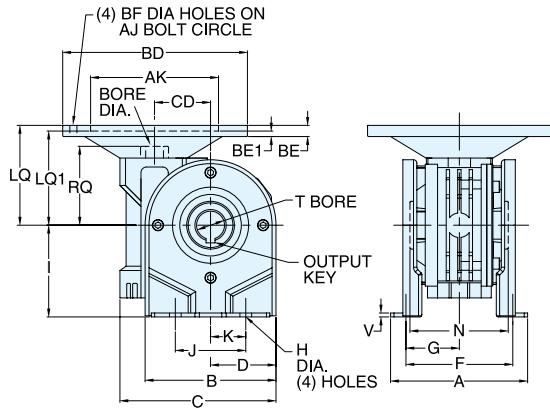

ASSEMBLIES

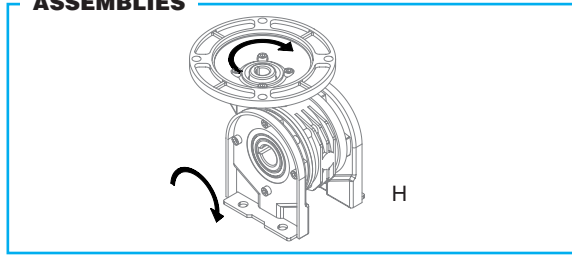

REVERSE ALL ARROWS FOR OPPOSITE INPUT SHAFT ROTATION. CONTACT FACTORY FOR OTHER MOUNTINGS OR ASSEMBLY POSITIONS.

STYLE JHMQ DIMENSIONS - Inches (MM)

Series	A	B	C	CD	D	F	G	H	I	J	K	LQ* 56/140	LQ1* 180	NN	RQ	T* +0.0015 -0.0000	V	OUTPUT KEY*
512	3.43	3.07	3.54	1.18	1.54	2.60	1.30	0.256	2.16	1.97	0.99	*	N/A	2.16	2.21	(14)●	0.12	(5)●
518	3.94	3.86	4.76	1.77	1.93	3.17	1.59	0.413	2.83	1.97	0.99	3.33	N/A	2.56	2.60	0.750	0.12	3/16 X 1.00
520	4.84	4.45	5.45	1.97	2.23	3.94	1.97	0.413	3.22	2.48	1.24	3.51	N/A	3.19	2.83	1.000	0.14	1/4 X 1.62
525	5.67	5.24	6.69	2.48	2.76	4.35	2.18	0.413	3.94	3.74	1.87	4.08	N/A	4.72	3.58	1.125	0.16	1/4 X 2.00
534	7.17	7.09	9.15	3.35	3.72	5.71	2.86	0.413	5.59	5.51	2.76	4.83	5.35	5.31	4.33	1.500	0.20	3/8 X 2.00

● Dimension is in MM. Key is not provided with metric reducer options as standard.
Metric bore tolerance is H7.
* Metric options are available. Refer to dimensions on opposite page.
Contact LEESON for availability of metric options.

STYLE JH

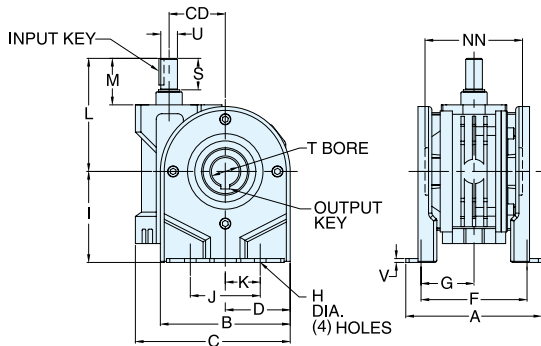

ASSEMBLIES

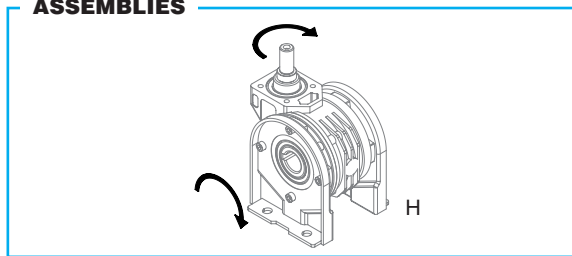

REVERSE ALL ARROWS FOR OPPOSITE INPUT SHAFT ROTATION. CONTACT FACTORY FOR OTHER MOUNTINGS OR ASSEMBLY POSITIONS.

STYLE JH DIMENSIONS - Inches**

Series	A	B	C	CD	D	F	G	H	I	J	K	L	M	NN	S	T +0.0015 -0.0000	U +0.000 -0.001	V	INPUT KEY	OUTPUT KEY
518	3.94	3.86	4.76	1.77	1.93	3.17	1.59	0.413	2.83	1.97	0.99	3.86	1.67	2.56	1.18	0.750	0.625	0.12	3/16 X 1.00	3/16 X 1.00
520	4.84	4.45	5.45	1.97	2.23	3.94	1.97	0.413	3.22	2.48	1.24	4.11	1.74	3.19	1.18	1.000	0.625	0.14	3/16 X 1.00	1/4 X 1.62
525	5.67	5.24	6.69	2.48	2.76	4.35	2.18	0.413	3.94	3.74	1.87	5.43	2.24	4.72	1.75	1.125	0.750	0.16	3/16 x 1.50	1/4 X 2.00
534	7.17	7.09	9.15	3.35	3.72	5.71	2.86	0.413	5.59	5.51	2.76	6.38	2.52	5.31	1.75	1.500	0.875	0.20	3/16 X 1.50	3/8 X 2.00

** Series 512 is available in this style. Contact LEESON for details

Bravo® Single Reduction Reducers



STYLE JMQ

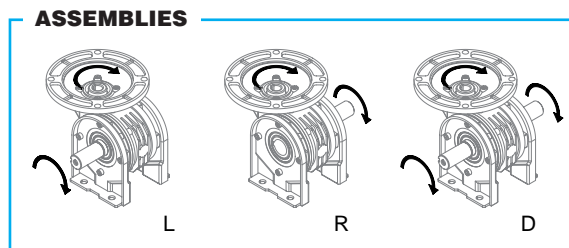
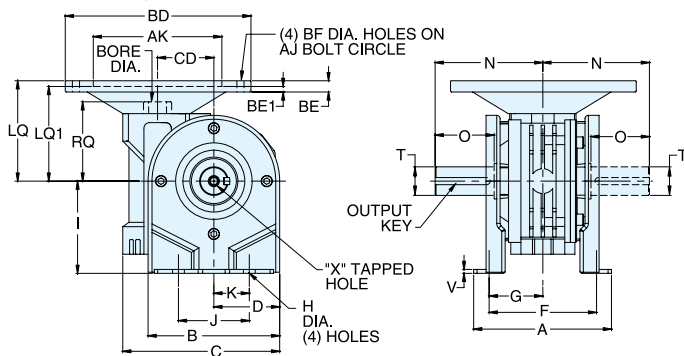

REVERSE ALL ARROWS FOR OPPOSITE INPUT SHAFT ROTATION. CONTACT FACTORY FOR OTHER MOUNTINGS OR ASSEMBLY POSITIONS.

STYLE JMQ DIMENSIONS - Inches (MM)

Series	A	B	C	CD	D	F	G	H	I	J	K	LQ* 56/140	LQ1* 180	N	O	RQ	T* +0.000 -0.001	V	X		OUTPUT KEY*
																			Tap Size	Depth	
512	3.43	3.07	3.54	1.18	1.54	2.60	1.30	0.256	2.16	1.97	0.99	*	N/A	2.48	1.01	2.21	(14)*	0.12	N/A	N/A	(5)*
518	3.94	3.86	4.76	1.77	1.93	3.17	1.59	0.413	2.83	1.97	0.99	3.33	N/A	2.97	1.26	2.60	0.750	0.12	1/4-20 UNC	0.62	3/16 X 1.00
520	4.84	4.45	5.45	1.97	2.23	3.94	1.97	0.413	3.22	2.48	1.24	3.51	N/A	3.94	2.05	2.83	1.000	0.14	5/16-18 UNC	0.75	1/4 X 1.62
525	5.67	5.24	6.69	2.48	2.76	4.35	2.18	0.413	3.94	3.74	1.87	4.08	N/A	4.85	2.36	3.58	1.125	0.16	5/16-18 UNC	0.75	1/4 X 2.00
534	7.17	7.09	9.15	3.35	3.72	5.71	2.86	0.413	5.59	5.51	2.76	4.83	5.35	5.55	2.36	4.33	1.500	0.20	5/16-18 UNC	0.75	3/8 X 2.00

* Dimension is in MM. Key is not provided with metric reducer options as standard. Metric shaft diameter tolerance is -0.005/-0.020. Series 512 is available with an inch dimensioned output shaft. Contact LEESON for details.

* Metric options are available. Refer to dimensions below. Contact LEESON for availability of metric options.

STYLE J

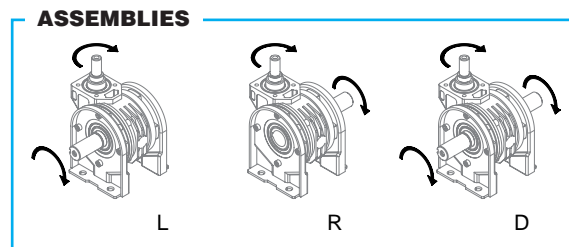
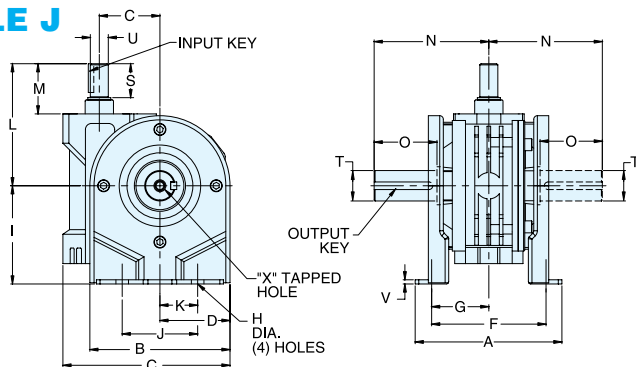

REVERSE ALL ARROWS FOR OPPOSITE INPUT SHAFT ROTATION. CONTACT FACTORY FOR OTHER MOUNTINGS OR ASSEMBLY POSITIONS.

STYLE J DIMENSIONS - Inches**

Series	A	B	C	CD	D	F	G	H	I	J	K	L	M	N	O	S	T +0.000 -0.001	U +0.000 -0.001	V	X		INPUT KEY	OUTPUT KEY
																				Tap Size	Depth		
518	3.94	3.86	4.76	1.77	1.93	3.17	1.59	0.413	2.83	1.97	0.99	3.86	1.67	2.97	1.26	1.18	0.750	0.625	0.12	1/4-20 UNC	0.62	3/16 X 1.00	3/16 X 1.00
520	4.84	4.45	5.45	1.97	2.23	3.94	1.97	0.413	3.22	2.48	1.24	4.11	1.74	3.94	2.05	1.18	1.000	0.625	0.14	5/16-18 UNC	0.75	3/16 X 1.00	1/4 X 1.62
525	5.67	5.24	6.69	2.48	2.76	4.35	2.18	0.413	3.94	3.74	1.87	5.43	2.24	4.85	2.36	1.75	1.125	0.750	0.16	5/16-18 UNC	0.75	3/16 x 1.50	1/4 X 2.00
534	7.17	7.09	9.15	3.35	3.72	5.71	2.86	0.413	5.59	5.51	2.76	6.38	2.52	5.55	2.36	1.75	1.500	0.875	0.20	5/16-18 UNC	0.75	3/16 X 1.50	3/8 X 2.00

** Series 512 is available in this style. Contact LEESON for details

MOTOR MOUNTING DIMENSIONS

NEMA DIMENSIONS - Inches

Frame	AJ	AK	BD	BE	BE1	BF	Input Bore Dia	Input Keyway▲
56C	5.88	4.50	6.50	0.38	N/A	0.41	0.625	3/16 x 3/32
140TC	5.88	4.50	6.50	0.38	N/A	0.41	0.875	3/16 x 3/32
180TC	7.25	8.50	9.00	N/A	0.50	0.53	1.125	1/4 x 1/8

OPTIONAL METRIC DIMENSIONS* - MM

Series	LQ1♦						T ✓ (standard for metric units)	O	N	Output Keyway
	IEC B5 & B14 Options									
	D56D	D63D	D71D	D80D	D90D	D100LD■				
512	62.5♦	62.5	N/A	N/A	N/A	N/A	14	25	63	5
518	74♦□	74♦	74	N/A	N/A	N/A	18	32	75	6
520	81.5♦□	81.5♦	81.5	81.5	N/A	N/A	25	52	100	8
525	N/A	99.5♦	99.5♦	99.5♦	99.5	N/A	25	60	123	8
534	N/A	N/A	124♦	124	124	124	35	60	141	10

OPTIONAL METRIC DIMENSIONS* - MM

IEC Frame	B5					B14♦					Input Bore Dia	Input Keyway▲
	AJ	AK	BD	BE	BF	AJ	AK	BD	BE	BF		
D56D	100	80	120	10	7	65♦	50	80	7	6.5	9	3 x 1.5
D63D	115	95	140	11	9	75♦	60	90	5.5	5.5	11	4 x 2
D71D	130	110	160	10	9	85♦	70	105	8	6.5	14	5 x 2.5
D80D	165	130	200	12	11	100♦	80	120	10	7	19	6 x 3
D90D	165	130	200	12	11	115	95	140	11	9	24	8 x 3.5
D100LD■	215	180	250	13	14	130	110	160	10	9	28	8 x 3.5

♦ Contact LEESON for availability of metric input options. The output bore and/or solid output shaft extension will be metric as standard with metric input options.

▲ Keyway width by depth

♦ AJ Mounting holes are rotated 45° from positions shown on B14 input options as follows: D56D(All), D63D(Series 518 & 520), D71D & D80D(Series 525)

♦ Dimensions are maximum (B5 and B14 options)

♦ B14 option not available

□ B5 Option not available

■ Also applies to frame size D112MD

✓ Solid metric output shaft diameter tolerance is -0.005/-0.020.

Hollow bore tolerance is H7.

Bravo® Single Reduction Reducers



DOUBLE REDUCTION • WORM/WORM MOUNTING STYLE GUIDE



HOLLOW OUTPUT SHAFT MOUNTED (See “How to Specify” on page 100.)

MOTORIZED QUILL INPUT

DHMQ



DRHMQ



DFHMQ



Ratings: Pages 101-102
Dimensions: Page 108

Ratings: Pages 101-102
Dimensions: Page 146

Ratings: Pages 101-102
Dimensions: Page 110

NON-MOTORIZED SOLID INPUT SHAFT

DH



DRH



DFH



Ratings: Pages 101-102
Dimensions: Page 108

Ratings: Pages 101-102
Dimensions: Page 146

Ratings: Pages 101-102
Dimensions: Page 110

SOLID OUTPUT SHAFT (See “How to Specify” on page 100.)

MOTORIZED QUILL INPUT

DMQ



DRMQ



DFMQ



Ratings: Pages 101-102
Dimensions: Page 109

(⚡Non-Standard Option)
Ratings: Pages 101-102
Dimensions: Page 146

Ratings: Pages 101-102
Dimensions: Page 111

NON-MOTORIZED SOLID INPUT SHAFT

D



DR



DF



Ratings: Pages 101-102
Dimensions: Page 109

(⚡Non-Standard Option)
Ratings: Pages 101-102
Dimensions: Page 146

Ratings: Pages 101-102
Dimensions: Page 111

MOUNTING ACCESSORIES

Select the appropriate mounting accessories from this wide variety of options.



REACTION ARM R



F FLANGE (SHORT FLANGE)

⚡ Non-Standard Option assemblies may be useful in certain applications. Please contact LEESON with application details.



DOUBLE REDUCTION • WORM/WORM MOUNTING STYLE GUIDE



DFLHMQ



Ratings: Pages 101-102
Dimensions: Page 112

DTHMQ



(❖Non-Standard Option)
Ratings: Pages 101-102
Dimensions: Page 114

DUHMQ



(❖Non-Standard Option)
Ratings: Pages 101-102
Dimensions: Page 116

DJHMQ



(❖Non-Standard Option)
Ratings: Pages 101-102
Dimensions: Page 118

DFLH



Ratings: Pages 101-102
Dimensions: Page 112

DTH



(❖Non-Standard Option)
Ratings: Pages 101-102
Dimensions: Page 114

DUH



(❖Non-Standard Option)
Ratings: Pages 101-102
Dimensions: Page 116

DJH



(❖Non-Standard Option)
Ratings: Pages 101-102
Dimensions: Page 118

DFLMQ



Ratings: Pages 101-102
Dimensions: Page 113

DTMQ



Ratings: Pages 101-102
Dimensions: Page 115

DUMQ



Ratings: Pages 101-102
Dimensions: Page 117

DJMQ



Ratings: Pages 101-102
Dimensions: Page 119

DFL



Ratings: Pages 101-102
Dimensions: Page 113

DT



Ratings: Pages 101-102
Dimensions: Page 115

DU



Ratings: Pages 101-102
Dimensions: Page 117

DJ



Ratings: Pages 101-102
Dimensions: Page 119



FL FLANGE
(LONG FLANGE)



HORIZONTAL BASE
(WORM OVER ASSEMBLY)



HORIZONTAL BASE
(WORM UNDER ASSEMBLY)



HORIZONTAL BASE
(VERTICAL INPUT SHAFT)

Bravo® Worm / Worm
Double Reduction



LEESON 500 Series Gear Reducer Model Number Nomenclature

All stock and custom 500 series reducers are identified by a model number. The model number appears on the nameplate and describes pertinent features of the reducer. An example follows, along with a listing of the various letters and positions used.

NOTE: All reducers also have a catalog number—for example W5180001. Reducers and renewal parts should be ordered by catalog number. If a stock reducer has been factory modified by the addition of an optional base for example, the modification number T518, for example, is stamped in the blank column of the nameplate. Accessories that are field installed will not be noted on the nameplate.

Catalog numbers 5000 (for example, W5185000) and higher are custom reducers manufactured for a specific application. The machinery or equipment manufacturer should be contacted for replacement reducers. Renewal parts can be ordered from LEESON by catalog number.

TYPICAL NAMEPLATE

LEESON		HYDRO-MEC	
MAX INPUT HP @ 1750 RPM	.246	OUTPUT TORQUE (IN-LBS)	460
DESC.	DMQ51898L5612	RATIO	98:1
CATALOG NO.		DATE CODE	A04
LEESON ELECTRIC GRAFTON, WISCONSIN 53024		MOD	

Bravo® Worm / Worm Double Reduction



SOLID OUTPUT SHAFT
DMQ – Motorized, Quill Input
D – Non-Flanged
See pages 98 & 99 for other styles.

HOLLOW OUTPUT SHAFT
DHMQ – Motorized, Quill Input
DH – Non-Flanged
See pages 98 & 99 for other styles.

- L – Left-hand Output Shaft*
 - R – Right-hand Output Shaft*
 - D – Double Output Shaft
 - H – Hollow Output Shaft
- * Viewed from drive end of reducer.

Assembly numbers 1-6 are available. Refer to dimensional layout on pages 108-119.

See Selection Tables on pages 101-102 for all available ratios

ALUMINUM 500 SERIES CENTER DISTANCES

Series	Center Distance	
	(Inches)	(mm)
518	1.77	45
520	1.97	50
525	2.48	63
534	3.35	85

NEMA Input Flange Code	For NEMA Frame
56	56C
140	143-5TC

IEC Input Flange Code	For IEC Frame
56B14	56B14
63B14	63B14
63B5	63B5
71B14	71B14
71B5	71B5

OUTPUT SHAFT DIMENSION CODE ▲

Series	NEMA/Inch Options		IEC/Metric Options	
	Shaft Dia.	Shaft* Code	Shaft Dia.	Shaft Code
518	3/4"	12	18mm	18
520	1"	16	25mm	25
525	1-1/8"	18	25mm	25
534	1-1/2"	24	35mm	35

*Shaft Diameter in 1/16ths of an inch.

▲ Diameters and shaft codes of hollow bore styles are identical to those of solid shaft styles. Reducers with NEMA inputs will have inch dimensioned output shafts and reducers with IEC inputs will have metric dimensioned output shafts as standard.

Sample Model Number

Solid Shaft

Motorized Quill Input, Double Reduction Reducer, 1.77" Center Distance, 3600:1 Ratio, Left Hand Output Shaft, Parallel Input & Output Shafts and 5/8" Input Bore with NEMA 56C Flange.

Hollow Shaft

Motorized Quill Input, Double Reduction Reducer, 1.77" Center Distance, 3600:1 Ratio, 3/4" Hollow Output Shaft, Parallel Input & Output Shafts and 5/8" Input Bore with NEMA 56C Flange.

DMQ **518** **3600** **L** **1** **56** **12**
 Style Series Ratio Output Shaft Mounting Assembly Motor Input Shaft Code

DHMQ **518** **3600** **H** **1** **56** **12**
 Style Series Ratio Output Shaft Mounting Assembly Motor Input Shaft Code



**DOUBLE REDUCTION • WORM/WORM
MAXIMUM RATING TABLES**



518 & 520 SERIES • ALL STOCK STYLES



518 Series • 1.0 S.F.

Ratio	Input RPM	Output RPM	Input HP	Output HP	Output Torque (lb-in)
70	1750	25.00	0.332	0.182	460
	1150	16.43	0.230	0.126	485
98	1750	17.86	0.246	0.130	460
	1150	11.73	0.170	0.090	485
147	1750	11.90	0.190	0.095	504
	1150	7.82	0.132	0.066	531
210	1750	8.33	0.139	0.067	504
	1150	5.48	0.096	0.046	531
294	1750	5.95	0.106	0.048	504
	1150	3.91	0.073	0.033	531
441	1750	3.97	0.088	0.032	504
	1150	2.61	0.061	0.022	531
588	1750	2.98	0.072	0.024	504
	1150	1.96	0.050	0.017	531
777	1750	2.25	0.060	0.018	504
	1150	1.48	0.042	0.012	531
966	1750	1.81	0.054	0.014	504
	1150	1.19	0.037	0.010	531
1288	1750	1.36	0.045	0.011	504
	1150	0.893	0.031	0.008	531
1702	1750	1.03	0.037	0.008	504
	1150	0.676	0.026	0.006	531
2220	1750	0.788	0.030	0.006	504
	1150	0.518	0.021	0.004	531
3600	1750	0.486	0.018	0.004	460
	1150	0.319	0.012	0.002	485

520 Series • 1.0 S.F.

Ratio	Input RPM	Output RPM	Input HP	Output HP	Output Torque (lb-in)
70	1750	25.00	0.573	0.309	780
	1150	16.43	0.396	0.214	821
98	1750	17.86	0.425	0.221	780
	1150	11.73	0.294	0.153	821
140	1750	12.50	0.305	0.158	799
	1150	8.21	0.211	0.110	841
182	1750	9.62	0.259	0.122	799
	1150	6.32	0.179	0.084	841
260	1750	6.73	0.198	0.085	799
	1150	4.42	0.137	0.059	841
364	1750	4.81	0.145	0.061	799
	1150	3.16	0.100	0.042	841
546	1750	3.21	0.107	0.041	799
	1150	2.11	0.074	0.028	841
676	1750	2.59	0.091	0.033	799
	1150	1.70	0.063	0.023	841
962	1750	1.82	0.072	0.023	799
	1150	1.20	0.050	0.016	841
1260	1750	1.39	0.065	0.018	799
	1150	0.913	0.045	0.012	841
1591	1750	1.10	0.056	0.014	799
	1150	0.723	0.039	0.010	841
2220	1750	0.788	0.045	0.009	757
	1150	0.518	0.031	0.007	797
3600	1750	0.486	0.028	0.006	757
	1150	0.319	0.019	0.004	797

Bravo® Worm / Worm
Double Reduction



DOUBLE REDUCTION • WORM/WORM MAXIMUM RATING TABLES

525 & 534 SERIES • ALL STOCK STYLES



525 Series • 1.0 S.F.

Ratio	Input RPM	Output RPM	Input HP	Output HP	Output Torque (lb-in)
70	1750	25.00	1.396	0.768	1935
	1150	16.43	0.966	0.531	2037
105	1750	16.67	0.948	0.512	1935
	1150	10.95	0.655	0.354	2037
150	1750	11.67	0.689	0.358	1935
	1150	7.67	0.477	0.248	2037
210	1750	8.33	0.556	0.256	1935
	1150	5.48	0.385	0.177	2037
300	1750	5.83	0.426	0.179	1935
	1150	3.83	0.295	0.124	2037
420	1750	4.17	0.328	0.128	1935
	1150	2.74	0.227	0.089	2037
630	1750	2.78	0.259	0.085	1935
	1150	1.83	0.179	0.059	2037
840	1750	2.08	0.206	0.064	1935
	1150	1.37	0.143	0.044	2037
1110	1750	1.58	0.162	0.049	1935
	1150	1.04	0.112	0.034	2037
1380	1750	1.27	0.139	0.039	1935
	1150	0.833	0.096	0.027	2037
1800	1750	0.972	0.115	0.030	1935
	1150	0.639	0.079	0.021	2037
2160	1750	0.810	0.096	0.025	1935
	1150	0.532	0.066	0.017	2037
4020	1750	0.435	0.064	0.013	1935
	1150	0.286	0.044	0.009	2037

534 Series • 1.0 S.F.

Ratio	Input RPM	Output RPM	Input HP	Output HP	Output Torque (lb-in)
70	1750	25.00	1.577	0.899	2266
	1150	16.43	1.091	0.622	2386
98	1750	17.86	1.127	0.642	2266
	1150	11.73	0.779	0.444	2386
140	1750	12.50	0.920	0.534	2690
	1150	8.21	0.636	0.369	2832
196	1750	8.93	0.733	0.381	2690
	1150	5.87	0.507	0.264	2832
280	1750	6.25	0.798	0.375	3784
	1150	4.11	0.553	0.260	3983
392	1750	4.46	0.609	0.268	3784
	1150	2.93	0.421	0.185	3983
588	1750	2.98	0.484	0.179	3784
	1150	1.96	0.335	0.124	3983
784	1750	2.23	0.394	0.134	3784
	1150	1.47	0.273	0.093	3983
1036	1750	1.69	0.307	0.101	3784
	1150	1.11	0.213	0.070	3983
1288	1750	1.36	0.272	0.082	3784
	1150	0.893	0.188	0.056	3983
1680	1750	1.04	0.181	0.053	3186
	1150	0.685	0.126	0.036	3354
2280	1750	0.768	0.144	0.039	3186
	1150	0.504	0.099	0.027	3354
3120	1750	0.561	0.113	0.028	3186
	1150	0.369	0.079	0.020	3354

Bravo® Worm / Worm
Double Reduction



DOUBLE REDUCTION • WORM/WORM "HOW TO USE" QUICK SELECTION TABLES



How To Use Quick Selections

Maximum Rating Tables for Double Reduction Gear Reducers are shown on pages 101-102. Selection of the appropriate gear reducer can be made using those tables or the Quick Selections on the following pages.

BEFORE YOU START:

Identify the Service Factor of the application (see page 171).

Determine the actual input horsepower of the motor by multiplying the motor's nameplate horsepower by the Service Factor.

Determine the output speed (RPM) required at output shaft of reducer.

Identify the mounting style required by your application from the style charts shown on pages 98-99. Note the basic mounting style (DMQ, DHMQ, etc.).

To select the proper gear reducer size, use the Quick Selections as shown:

**DOUBLE REDUCTION • WORM/WORM
QUICK SELECTIONS**

1 Find the appropriate Quick Selections page. The tables begin on page 104 and are organized by motor HP.

2 Locate output RPM column on left side of the table. All ratings are based on an input speed of 1750 RPM. Scroll down to the output speed (RPM) required. Output speeds may be rounded to the nearest whole number. For exact output speed, divide 1750 by the ratio listed.

3 Move to the Service Factor column and find one suitable to meet the application requirements. Refer to page 171 for AGMA recommended service factors.

4 Check load capacities against the needs of your application. Do not exceed the overhung load (OHL) shown in the table. Detailed instructions for calculating the actual overhung load are shown on page 150. If overhung and thrust loads will be applied simultaneously or if the load exceeds listed capacities, contact LEESON.

5 Select motor frame size.

6 Identify the model number of the basic reducer by continuing to the right. See page 100 for detailed information on building an exact model number. Model numbers for solid and hollow output shaft styles are shown in quick selection tables. To complete model number, select shaft hand and mounting assembly from dimensional pages.

7 Verify physical dimensions using the dimensional drawings shown on pages 108-119.

1/6 HP / 0.12 KW

Gear Reducer Quick Selections

Output Speed (RPM)	Service Factor	Output Torque (lb-in)	Overhung Load (lbs.)	Ratio	Motor Frame	Weight (lbs.)	Style DMQ Solid Output		Style DHMQ Hollow Output	
							Model Number	Weight (lbs.)	Model Number	Weight (lbs.)
25.0	2.07	222	405	70	56C	13	DMQ518-70-_-56-12	12	DHMQ518-70-H_-56-12	
25.0	3.58	218	562	70	56C	15	DMQ520-70-_-56-16	13	DHMQ520-70-H_-56-16	
17.9	1.54	299	427	98	56C	13	DMQ518-98-_-56-12	12	DHMQ518-98-H_-56-12	
				98	56C	15	DMQ520-98-_-56-16	13	DHMQ520-98-H_-56-16	
				100	56C	15	DMQ520-100-_-56-16	13	DHMQ520-100-H_-56-16	
				14	56C	15	DMQ520-14-_-56-16	13	DHMQ520-14-H_-56-16	
				14	56C	15	DMQ520-14-_-56-16	13	DHMQ520-14-H_-56-16	
				15	56C	15	DMQ520-15-_-56-16	13	DHMQ520-15-H_-56-16	
				18	56C	15	DMQ520-18-_-56-16	13	DHMQ520-18-H_-56-16	
8.93	4.58	587	1304	196	56C	35	DMQ534-196-_-56-24	30	DHMQ534-196-H_-56-24	
8.33	3.47	557	899	210	56C	20	DMQ525-210-_-56-18	18	DHMQ525-210-H_-56-18	
6.73	1.24	644	629	260	56C	15	DMQ520-260-_-56-16	13	DHMQ520-260-H_-56-16	
6.25	4.99	758	1304	280	56C	35	DMQ534-280-_-56-24	30	DHMQ534-280-H_-56-24	
5.83	2.66	726	899	300	56C	20	DMQ525-300-_-56-18	18	DHMQ525-300-H_-56-18	
4.46	3.80	995	1304	392	56C	35	DMQ534-392-_-56-24	30	DHMQ534-392-H_-56-24	
4.17	2.05	943	899	420	56C	20	DMQ525-420-_-56-18	18	DHMQ525-420-H_-56-18	
2.98	3.02	1250	1304	588	56C	35	DMQ534-588-_-56-24	30	DHMQ534-588-H_-56-24	
2.78	1.62	1197	899	630	56C	20	DMQ525-630-_-56-18	18	DHMQ525-630-H_-56-18	
2.23	2.46	1537	1304	784	56C	35	DMQ534-784-_-56-24	30	DHMQ534-784-H_-56-24	
2.08	1.29	1503	899	840	56C	20	DMQ525-840-_-56-18	18	DHMQ525-840-H_-56-18	
1.69	1.92	1969	1304	1036	56C	35	DMQ534-1036-_-56-24	30	DHMQ534-1036-H_-56-24	
1.58	1.01	1915	899	1110	56C	20	DMQ525-1110-_-56-18	18	DHMQ525-1110-H_-56-18	
1.36	1.70	2224	1304	1288	56C	35	DMQ534-1288-_-56-24	30	DHMQ534-1288-H_-56-24	
1.04	1.13	2812	1304	1680	56C	35	DMQ534-1680-_-56-24	30	DHMQ534-1680-H_-56-24	

Bravo® Worm / Worm Double Reduction



**Style DMQ & DHMQ
Motorized Quill Input
NEMA Frame Selections
1750 RPM Input**



Bravo® Worm / Worm Double Reduction

1/6 HP / 0.12 KW Gear Reducer Quick Selections									
Output Speed (RPM)	Service Factor▼	Output Torque (lb-in)	Overhung Load (lbs.)●	Ratio	Motor◆ Frame	Style DMQ Solid Output		Style DHMQ Hollow Output	
						Weight (lbs.)	Model Number■	Weight (lbs.)	Model Number■
25.0	2.07	222	405	70	56C	13	DMQ518-70-__-56-12	12	DHMQ518-70-H_-56-12
25.0	3.58	218	562	70	56C	15	DMQ520-70-__-56-16	13	DHMQ520-70-H_-56-16
17.9	1.54	299	427	98	56C	13	DMQ518-98-__-56-12	12	DHMQ518-98-H_-56-12
17.9	2.66	293	596	98	56C	15	DMQ520-98-__-56-16	13	DHMQ520-98-H_-56-16
16.7	5.93	326	888	105	56C	20	DMQ525-105-__-56-18	18	DHMQ525-105-H_-56-18
12.5	1.90	419	629	140	56C	15	DMQ520-140-__-56-16	13	DHMQ520-140-H_-56-16
12.5	5.75	468	1304	140	56C	35	DMQ534-140-__-56-24	30	DHMQ534-140-H_-56-24
11.9	1.19	424	450	147	56C	13	DMQ518-147-__-56-12	12	DHMQ518-147-H_-56-12
11.7	4.32	448	899	150	56C	20	DMQ525-150-__-56-18	18	DHMQ525-150-H_-56-18
9.62	1.62	493	629	182	56C	15	DMQ520-182-__-56-16	13	DHMQ520-182-H_-56-16
8.93	4.58	587	1304	196	56C	35	DMQ534-196-__-56-24	30	DHMQ534-196-H_-56-24
8.33	3.47	557	899	210	56C	20	DMQ525-210-__-56-18	18	DHMQ525-210-H_-56-18
6.73	1.24	644	629	260	56C	15	DMQ520-260-__-56-16	13	DHMQ520-260-H_-56-16
6.25	4.99	758	1304	280	56C	35	DMQ534-280-__-56-24	30	DHMQ534-280-H_-56-24
5.83	2.66	726	899	300	56C	20	DMQ525-300-__-56-18	18	DHMQ525-300-H_-56-18
4.46	3.80	995	1304	392	56C	35	DMQ534-392-__-56-24	30	DHMQ534-392-H_-56-24
4.17	2.05	943	899	420	56C	20	DMQ525-420-__-56-18	18	DHMQ525-420-H_-56-18
2.98	3.02	1252	1304	588	56C	35	DMQ534-588-__-56-24	30	DHMQ534-588-H_-56-24
2.78	1.62	1197	899	630	56C	20	DMQ525-630-__-56-18	18	DHMQ525-630-H_-56-18
2.23	2.46	1537	1304	784	56C	35	DMQ534-784-__-56-24	30	DHMQ534-784-H_-56-24
2.08	1.29	1503	899	840	56C	20	DMQ525-840-__-56-18	18	DHMQ525-840-H_-56-18
1.69	1.92	1969	1304	1036	56C	35	DMQ534-1036-__-56-24	30	DHMQ534-1036-H_-56-24
1.58	1.01	1915	899	1110	56C	20	DMQ525-1110-__-56-18	18	DHMQ525-1110-H_-56-18
1.36	1.70	2224	1304	1288	56C	35	DMQ534-1288-__-56-24	30	DHMQ534-1288-H_-56-24
1.04	1.13	2812	1304	1680	56C	35	DMQ534-1680-__-56-24	30	DHMQ534-1680-H_-56-24

- ◆ NEMA input selections shown. Reducers are also available with metric IEC input flanges. Refer to page 107 for frame options available. Metric IEC input selections will have a metric output shaft as standard. Contact LEESON for catalog number information.
- ▼ Service Factor is based on maximum torque rating of reducer. Refer to page 171 for special application considerations.
- Output shaft overhung load rating is based on load applied at center of output shaft extension (solid output shaft style).
- Double reduction reducer selections should be ordered using the model numbers shown. Replace “__” with appropriate mounting position. Refer to dimensional pages for mounting position options.

This Quick Selection is only for style DMQ (solid output) & DHMQ (hollow output) reducers. For other reducer configurations, see the MAXIMUM RATING TABLES beginning on page 101.



DOUBLE REDUCTION • WORM/WORM QUICK SELECTIONS



**Style DMQ & DHMQ
Motorized Quill Input
NEMA Frame Selections
1750 RPM Input**



1/4 HP / 0.18 KW						Gear Reducer Quick Selections			
Output Speed (RPM)	Service Factor▼	Output Torque (lb-in)	Overhung● Load (lbs.)	Ratio	Motor◆ Frame	Style DMQ Solid Output		Style DHMQ Hollow Output	
						Weight (lbs.)	Model Number■	Weight (lbs.)	Model Number■
25.0	1.33	347	405	70	56C	13	DMQ518-70-_-56-12	12	DHMQ518-70-H_-56-12
25.0	2.29	340	562	70	56C	15	DMQ520-70-_-56-16	13	DHMQ520-70-H_-56-16
17.9	0.99	467	427	98	56C	13	DMQ518-98-_-56-12	12	DHMQ518-98-H_-56-12
17.9	1.70	458	596	98	56C	15	DMQ520-98-_-56-16	13	DHMQ520-98-H_-56-16
17.9	4.52	502	1259	98	56C	35	DMQ534-98-_-56-24	30	DHMQ534-98-H_-56-24
16.7	3.80	509	888	105	56C	20	DMQ525-105-_-56-18	18	DHMQ525-105-H_-56-18
12.5	1.22	655	629	140	56C	15	DMQ520-140-_-56-16	13	DHMQ520-140-H_-56-16
12.5	3.68	731	1304	140	56C	35	DMQ534-140-_-56-24	30	DHMQ534-140-H_-56-24
11.7	2.76	700	899	150	56C	20	DMQ525-150-_-56-18	18	DHMQ525-150-H_-56-18
9.62	1.04	770	629	182	56C	15	DMQ520-182-_-56-16	13	DHMQ520-182-H_-56-16
8.93	2.93	917	1304	196	56C	35	DMQ534-196-_-56-24	30	DHMQ534-196-H_-56-24
8.33	2.22	870	899	210	56C	20	DMQ525-210-_-56-18	18	DHMQ525-210-H_-56-18
6.25	3.19	1185	1304	280	56C	35	DMQ534-280-_-56-24	30	DHMQ534-280-H_-56-24
5.83	1.70	1135	899	300	56C	20	DMQ525-300-_-56-18	18	DHMQ525-300-H_-56-18
4.46	2.43	1554	1304	392	56C	35	DMQ534-392-_-56-24	30	DHMQ534-392-H_-56-24
4.17	1.31	1474	899	420	56C	20	DMQ525-420-_-56-18	18	DHMQ525-420-H_-56-18
2.98	1.93	1956	1304	588	56C	35	DMQ534-588-_-56-24	30	DHMQ534-588-H_-56-24
2.78	1.03	1870	899	630	56C	20	DMQ525-630-_-56-18	18	DHMQ525-630-H_-56-18
2.23	1.58	2402	1304	784	56C	35	DMQ534-784-_-56-24	30	DHMQ534-784-H_-56-24
1.69	1.23	3077	1304	1036	56C	35	DMQ534-1036-_-56-24	30	DHMQ534-1036-H_-56-24
1.36	1.09	3476	1304	1288	56C	35	DMQ534-1288-_-56-24	30	DHMQ534-1288-H_-56-24
1/3 HP / 0.25 KW						Gear Reducer Quick Selections			
25.0	1.01	458	405	70	56C	13	DMQ518-70-_-56-12	12	DHMQ518-70-H_-56-12
25.0	1.74	449	562	70	56C	15	DMQ520-70-_-56-16	13	DHMQ520-70-H_-56-16
25.0	4.23	458	854	70	56C	20	DMQ525-70-_-56-18	18	DHMQ525-70-H_-56-18
17.9	1.29	604	596	98	56C	15	DMQ520-98-_-56-16	13	DHMQ520-98-H_-56-16
17.9	3.42	662	1259	98	56C	35	DMQ534-98-_-56-24	30	DHMQ534-98-H_-56-24
16.7	2.88	673	888	105	56C	20	DMQ525-105-_-56-18	18	DHMQ525-105-H_-56-18
12.5	2.79	965	1304	140	56C	35	DMQ534-140-_-56-24	30	DHMQ534-140-H_-56-24
11.7	2.09	924	899	150	56C	20	DMQ525-150-_-56-18	18	DHMQ525-150-H_-56-18
8.93	2.22	1211	1304	196	56C	35	DMQ534-196-_-56-24	30	DHMQ534-196-H_-56-24
8.33	1.68	1149	899	210	56C	20	DMQ525-210-_-56-18	18	DHMQ525-210-H_-56-18
6.25	2.42	1564	1304	280	56C	35	DMQ534-280-_-56-24	30	DHMQ534-280-H_-56-24
5.83	1.29	1498	899	300	56C	20	DMQ525-300-_-56-18	18	DHMQ525-300-H_-56-18
4.46	1.84	2052	1304	392	56C	35	DMQ534-392-_-56-24	30	DHMQ534-392-H_-56-24
4.17	0.99	1945	899	420	56C	20	DMQ525-420-_-56-18	18	DHMQ525-420-H_-56-18
2.98	1.47	2582	1304	588	56C	35	DMQ534-588-_-56-24	30	DHMQ534-588-H_-56-24
2.23	1.19	3171	1304	784	56C	35	DMQ534-784-_-56-24	30	DHMQ534-784-H_-56-24

Bravo® Worm / Worm Double Reduction

◆ NEMA input selections shown. Reducers are also available with metric IEC input flanges. Refer to page 107 for frame options available. Metric IEC input selections will have a metric output shaft as standard. Contact LEESON for catalog number information.

▼ Service Factor is based on maximum torque rating of reducer. Refer to page 171 for special application considerations.

● Output shaft overhung load rating is based on load applied at center of output shaft extension (solid output shaft style).

■ Double reduction reducer selections should be ordered using the model numbers shown. Replace “_” with appropriate mounting position. Refer to dimensional pages for mounting position options.

This Quick Selection is only for style DMQ (solid output) & DHMQ (hollow output) reducers. For other reducer configurations, see the MAXIMUM RATING TABLES beginning on page 101.



**Style DMQ & DHMQ
Motorized Quill Input
NEMA Frame Selections
1750 RPM Input**



Bravo® Worm / Worm Double Reduction

1/2 HP / 0.37 KW Gear Reducer Quick Selections

Output Speed (RPM)	Service Factor▼	Output Torque (lb-in)	Overhung Load (lbs.)●	Ratio	Motor Frame◆	Style DMQ Solid Output		Style DHMQ Hollow Output	
						Weight (lbs.)	Model Number■	Weight (lbs.)	Model Number■
25.0	1.15	681	562	70	56C	15	DMQ520-70-__-56-16	13	DHMQ520-70-H_-56-16
25.0	2.79	693	854	70	56C	20	DMQ525-70-__-56-18	18	DHMQ525-70-H_-56-18
17.9	2.26	1003	1259	98	56C	35	DMQ534-98-__-56-24	30	DHMQ534-98-H_-56-24
16.7	1.90	1019	888	105	56C	20	DMQ525-105-__-56-18	18	DHMQ525-105-H_-56-18
12.5	1.84	1462	1304	140	56C	35	DMQ534-140-__-56-24	30	DHMQ534-140-H_-56-24
11.7	1.38	1401	899	150	56C	20	DMQ525-150-__-56-18	18	DHMQ525-150-H_-56-18
8.93	1.47	1835	1304	196	56C	35	DMQ534-196-__-56-24	30	DHMQ534-196-H_-56-24
8.33	1.11	1740	899	210	56C	20	DMQ525-210-__-56-18	18	DHMQ525-210-H_-56-18
6.25	1.60	2370	1304	280	56C	35	DMQ534-280-__-56-24	30	DHMQ534-280-H_-56-24
4.46	1.22	3109	1304	392	56C	35	DMQ534-392-__-56-24	30	DHMQ534-392-H_-56-24
2.98	0.97	3913	1304	588	56C	35	DMQ534-588-__-56-24	30	DHMQ534-588-H_-56-24

3/4 HP / 0.55 KW Gear Reducer Quick Selections

25.0	1.86	1040	854	70	56C	20	DMQ525-70-__-56-18	18	DHMQ525-70-H_-56-18
25.0	2.10	1078	1124	70	56C	35	DMQ534-70-__-56-24	30	DHMQ534-70-H_-56-24
17.9	1.51	1505	1259	98	56C	35	DMQ534-98-__-56-24	30	DHMQ534-98-H_-56-24
16.7	1.27	1528	888	105	56C	20	DMQ525-105-__-56-18	18	DHMQ525-105-H_-56-18
12.5	1.23	2193	1304	140	56C	35	DMQ534-140-__-56-24	30	DHMQ534-140-H_-56-24
11.7	0.92	2101	899	150	56C	20	DMQ525-150-__-56-18	18	DHMQ525-150-H_-56-18
8.93	0.98	2752	1304	196	56C	35	DMQ534-196-__-56-24	30	DHMQ534-196-H_-56-24
6.25	1.06	3555	1304	280	56C	35	DMQ534-280-__-56-24	30	DHMQ534-280-H_-56-24

1 HP / 0.75 KW Gear Reducer Quick Selections

25.0	1.40	1387	854	70	56C	20	DMQ525-70-__-56-18	525	DHMQ525-70-H_-56-18
25.0	1.58	1437	1124	70	56C	35	DMQ534-70-__-56-24	534	DHMQ534-70-H_-56-24
17.9	1.13	2007	1259	98	56C	35	DMQ534-98-__-56-24	534	DHMQ534-98-H_-56-24
16.7	0.95	2038	888	105	56C	20	DMQ525-105-__-56-18	525	DHMQ525-105-H_-56-18
12.5	0.92	2924	1304	140	56C	35	DMQ534-140-__-56-24	534	DHMQ534-140-H_-56-24

◆ NEMA input selections shown. Reducers are also available with metric IEC input flanges. Refer to page 107 for frame options available. Metric IEC input selections will have a metric output shaft as standard. Contact LEESON for catalog number information.

▼ Service Factor is based on maximum torque rating of reducer. Refer to page 171 for special application considerations.

● Output shaft overhung load rating is based on load applied at center of output shaft extension (solid output shaft style).

■ Double reduction reducer selections should be ordered using the model numbers shown. Replace " __ " with appropriate mounting position. Refer to dimensional pages for mounting position options.

This Quick Selection is only for style DMQ (solid output) & DHMQ (hollow output) reducers. For other reducer configurations, see the MAXIMUM RATING TABLES beginning on page 101.



DOUBLE REDUCTION • WORM/WORM WEIGHTS



DOUBLE REDUCTION • APPROXIMATE WEIGHTS^Δ (LBS.)

Reducer Style	Reducer Size				Reducer Style	Reducer Size			
	518	520	525	534		518	520	525	534
Solid Output Shaft Models					Hollow Output Shaft Models				
DMQ	13	15	20	35	DHMQ	12	13	18	30
D	12	15	20	33	DH	11	13	18	28
DTMQ, DUMQ	15	17	23	40	DTHMQ, DUHMQ	14	15	21	35
DT, DU	14	17	23	38	DTH, DUH	13	15	21	33
DJMQ	15	17	23	40	DJHMQ	14	15	21	35
DJ	14	17	23	38	DJH	13	15	21	33
DFMQ	14	16	22	38	DFHMQ	13	14	20	33
DF	13	16	22	36	DFH	12	14	20	31
DFLMQ	15	17	23	40	DFLHMQ	14	15	21	35
DFL	14	17	23	38	DFLH	13	15	21	33
DRMQ	14	16	22	38	DRHMQ	13	14	20	33
DR	13	16	22	36	DRH	12	14	20	31

^Δ Weights include grease and oil.

REDUCER ACCESSORIES • APPROXIMATE WEIGHTS (LBS.)

Accessory	Reducer Size			
	518	520	525	534
T/U - Base	2	2	3	5
J - Base	2	2	3	5
F - Flange	1	1	2	3
FL - Flange	2	2	3	5
R - Reaction Arm	1	1	2	3

DOUBLE REDUCTION • MOTOR FRAME COMBINATIONS

NEMA or IEC Frame Size	Dimensions - Inches (MM)				Reducer Size			
	AK	AJ	BD	Bore Dia.	518	520	525	534
NEMA 56C	4.50	5.88	6.50	0.625	●	●	●	●
IEC 56B14	1.97 (50)	2.56 (65)	3.15 (80)	(9)	■	■	■	■
IEC 63B5	3.74 (95)	4.53 (115)	5.51 (140)	(11)	■	■	■	■
IEC 63B14	2.36 (60)	2.95 (75)	3.54 (90)	(11)	■	■	■	■
IEC 71B5	4.33 (110)	5.12 (130)	6.30 (160)	(14)	●	●	●	●
IEC 71B14	2.76 (70)	3.35 (85)	4.13 (105)	(14)	●	●	●	●

- Reducer selections are available. Refer to dimensional pages for additional dimensions and special conditions for flange mounting hole alignment.
- Reducer selections are available. A bushing will be provided with reducer to achieve input bore diameter shown. Refer to dimensional pages for additional dimensions and special conditions for flange mounting hole alignment.

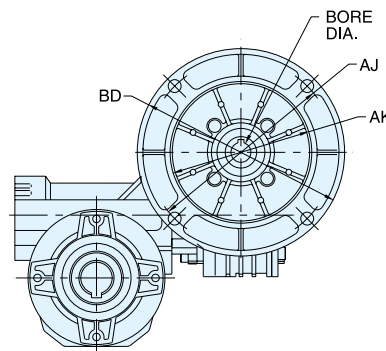

Bravo® Worm / Worm Double Reduction

DOUBLE REDUCTION • WORM/WORM • EXACT RATIO COMBINATIONS

518			520		
TOTAL RATIO	P 518	S 518	TOTAL RATIO	P 518	S 520
70	7	10	70	7	10
98	7	14	98	7	14
147	21	7	140	10	14
210	21	10	182	7	26
294	21	14	260	10	26
441	21	21	364	14	26
588	21	28	546	21	26
777	21	37	676	26	26
966	46	21	962	37	26
1288	46	28	1260	21	60
1702	46	37	1591	37	43
2220	60	37	2220	37	60
3600	60	60	3600	60	60

525			534		
TOTAL RATIO	P 518	S 525	TOTAL RATIO	P 518	S 534
70	7	10	70	7	10
105	7	15	98	7	14
150	10	15	140	7	20
210	7	30	196	7	28
300	10	30	280	10	28
420	14	30	392	14	28
630	21	30	588	14	42
840	28	30	784	28	28
1110	37	30	1036	37	28
1380	46	30	1288	46	28
1800	60	30	1680	60	28
2160	60	36	2280	60	38
4020	67	60	3120	60	52

P = Primary stage reducer ratio
S = Secondary stage reducer ratio

Bravo® DOUBLE REDUCTION • WORM/WORM DIMENSIONS

ALUMINUM GEAR REDUCERS



STYLE DHMQ

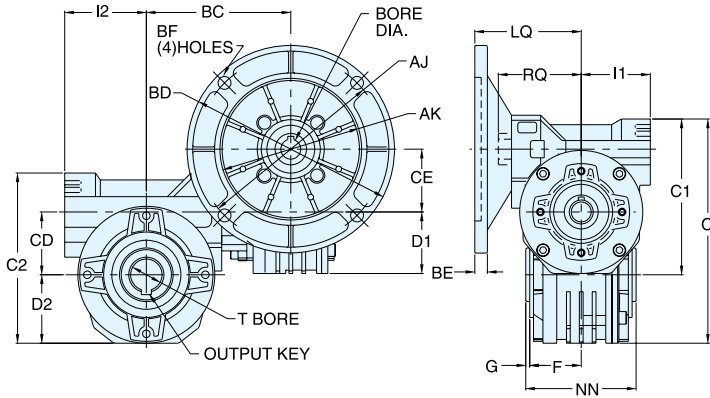

ASSEMBLIES

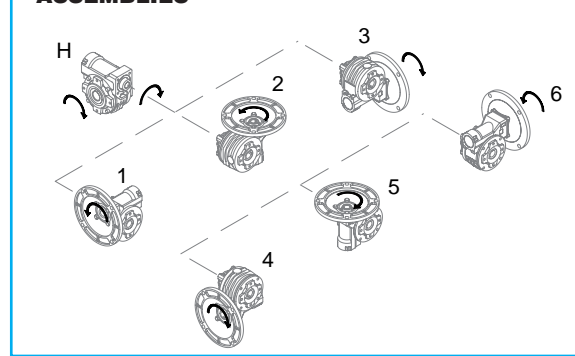

REVERSE ALL ARROWS FOR OPPOSITE INPUT SHAFT ROTATION. CONTACT FACTORY FOR OTHER MOUNTINGS OR ASSEMBLY POSITIONS.

STYLE DHMQ DIMENSIONS - Inches

Series	BC	C	C1	C2	CD	CE	D1	D2	F	G	I1	I2	LQ* 56C	NN	RQ	T* +0.0015 -0.0000	OUTPUT KEY*
518	4.35	6.42	4.76	4.76	1.77	1.77	1.93	1.93	1.38	0.08	2.16	2.16	3.33	2.56	2.60	0.750	3/16 X 1.00
520	4.53	7.30	4.76	5.33	1.97	1.77	1.93	2.15	1.50	0.12	2.16	2.56	3.33	3.19	2.60	1.000	1/4 X 1.62
525	5.75	9.17	4.76	6.69	2.48	1.77	1.93	2.76	1.77	0.19	2.16	3.11	3.33	4.72	2.60	1.125	1/4 X 2.00
534	6.76	12.00	4.76	9.15	3.35	1.77	1.93	3.72	2.52	0.14	2.16	3.86	3.33	5.31	2.60	1.500	3/8 X 2.00

* Metric options are available. Refer to dimensions on opposite page. Contact LEESON for availability of metric options.

Bravo® Worm / Worm Double Reduction

STYLE DH

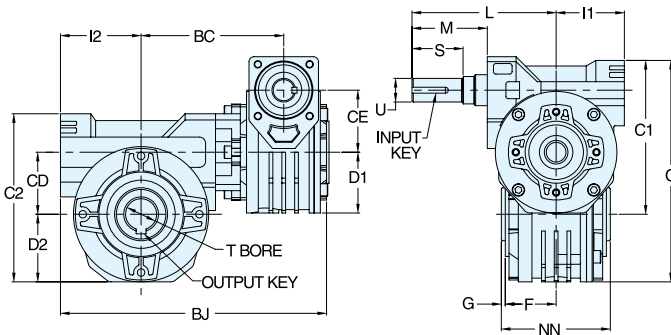

ASSEMBLIES

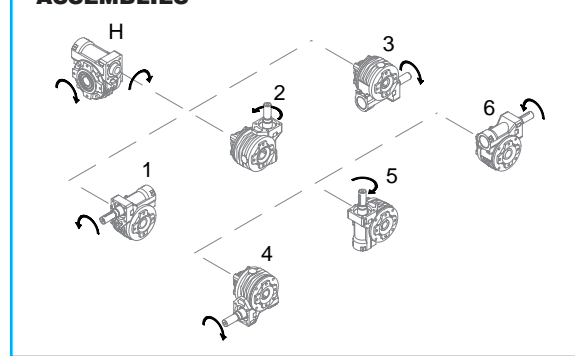

REVERSE ALL ARROWS FOR OPPOSITE INPUT SHAFT ROTATION. CONTACT FACTORY FOR OTHER MOUNTINGS OR ASSEMBLY POSITIONS.

STYLE DH DIMENSIONS - Inches

Series	BC	BJ	C	C1	C2	CD	CE	D1	D2	F	G	I1	I2	L	M	NN	S	T +0.0015 -0.0000	U +0.000 -0.001	INPUT KEY	OUTPUT KEY
518	4.35	7.90	6.42	4.76	4.76	1.77	1.77	1.93	1.93	1.38	0.08	2.16	2.16	3.86	1.67	2.56	1.18	0.750	0.625	3/16 X 1.00	3/16 X 1.00
520	4.53	8.47	7.30	4.76	5.33	1.97	1.77	1.93	2.15	1.50	0.12	2.16	2.56	3.86	1.67	3.19	1.18	1.000	0.625	3/16 X 1.00	1/4 X 1.62
525	5.75	10.24	9.17	4.76	6.69	2.48	1.77	1.93	2.76	1.77	0.19	2.16	3.11	3.86	1.67	4.72	1.18	1.125	0.625	3/16 X 1.00	1/4 X 2.00
534	6.76	12.01	12.00	4.76	9.15	3.35	1.77	1.93	3.72	2.52	0.14	2.16	3.86	3.86	1.67	5.31	1.18	1.500	0.625	3/16 X 1.00	3/8 X 2.00



DOUBLE REDUCTION • WORM/WORM DIMENSIONS



STYLE DMQ

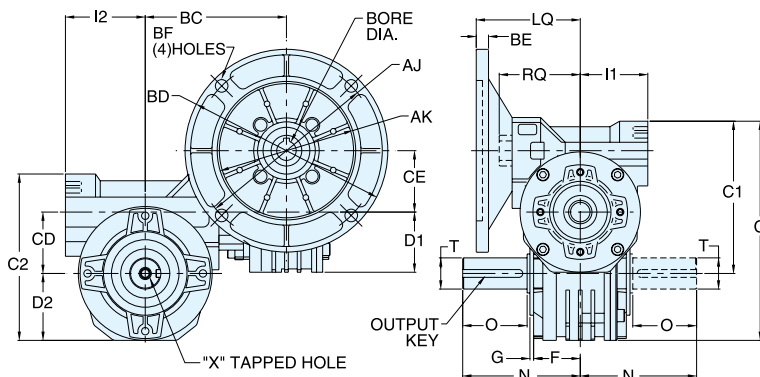

ASSEMBLIES

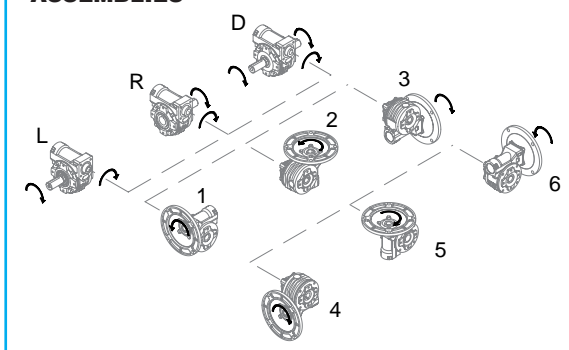

REVERSE ALL ARROWS FOR OPPOSITE INPUT SHAFT ROTATION. CONTACT FACTORY FOR OTHER MOUNTINGS OR ASSEMBLY POSITIONS.

STYLE DMQ DIMENSIONS - Inches

Series	BC	C	C1	C2	CD	CE	D1	D2	F	G	I1	I2	LQ* 56C	N	O*	RQ	T* +0.000 -0.001	X		OUTPUT KEY*
																		Tap Size	Depth	
518	4.35	6.42	4.76	4.76	1.77	1.77	1.93	1.93	1.38	0.08	2.16	2.16	3.33	2.97	1.26	2.60	0.750	1/4-20 UNC	0.62	3/16 x 1.00
520	4.53	7.30	4.76	5.33	1.97	1.77	1.93	2.15	1.50	0.12	2.16	2.56	3.33	3.94	2.05	2.60	1.000	5/16-18 UNC	0.75	1/4 X 1.62
525	5.75	9.17	4.76	6.69	2.48	1.77	1.93	2.76	1.77	0.19	2.16	3.11	3.33	4.85	2.36	2.60	1.125	5/16-18 UNC	0.75	1/4 X 2.00
534	6.76	12.00	4.76	9.15	3.35	1.77	1.93	3.72	2.52	0.14	2.16	3.86	3.33	5.55	2.36	2.60	1.500	5/16-18 UNC	0.75	3/8 X 2.00

* Metric options are available. Refer to dimensions below. Contact LEESON for availability of metric options.

STYLE D

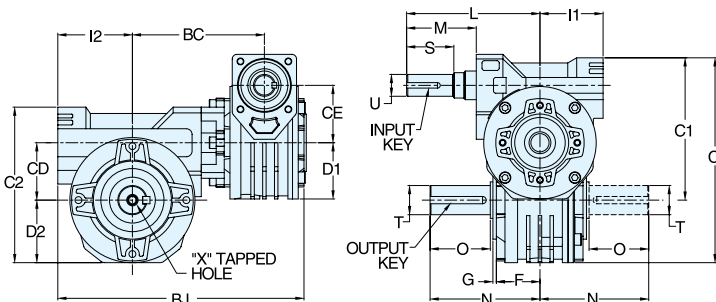

ASSEMBLIES

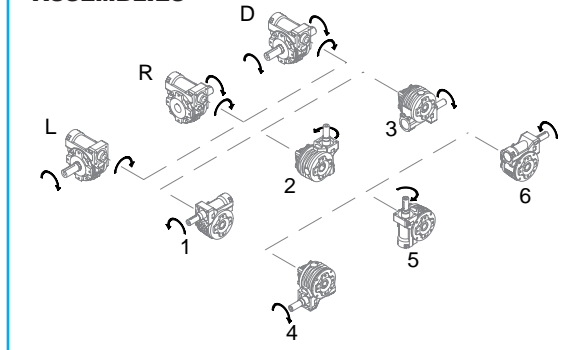

REVERSE ALL ARROWS FOR OPPOSITE INPUT SHAFT ROTATION. CONTACT FACTORY FOR OTHER MOUNTINGS OR ASSEMBLY POSITIONS.

STYLE D DIMENSIONS - Inches

Series	BC	BJ	C	C1	C2	CD	CE	D1	D2	F	G	I1	I2	L	M	N	O	S	T +0.000 -0.001	U +0.000 -0.001	X		INPUT KEY	OUTPUT KEY
																					Tap Size	Depth		
518	4.35	7.90	6.42	4.76	4.76	1.77	1.77	1.93	1.93	1.38	0.08	2.16	2.16	3.86	1.67	2.97	1.26	1.18	0.750	0.625	1/4-20 UNC	0.62	3/16 X 1.00	3/16 X 1.00
520	4.53	8.47	7.30	4.76	5.33	1.97	1.77	1.93	2.15	1.50	0.12	2.16	2.56	3.86	1.67	3.94	2.05	1.18	1.000	0.625	5/16-18 UNC	0.75	3/16 X 1.00	1/4 X 1.62
525	5.75	10.24	9.17	4.76	6.69	2.48	1.77	1.93	2.76	1.77	0.19	2.16	3.11	3.86	1.67	4.85	2.36	1.18	1.125	0.625	5/16-18 UNC	0.75	3/16 X 1.00	1/4 X 2.00
534	6.76	12.01	12.00	4.76	9.15	3.35	1.77	1.93	3.72	2.52	0.14	2.16	3.86	3.86	1.67	5.55	2.36	1.18	1.500	0.625	5/16-18 UNC	0.75	3/16 X 1.00	3/8 X 2.00

MOTOR MOUNTING DIMENSIONS

NEMA DIMENSIONS - Inches

Frame	AJ	AK	BD	BE	BF	Input Bore Dia	Input Keyway▲
56C	5.88	4.50	6.50	0.38	0.41	0.625	3/16 x 3/32

OPTIONAL METRIC DIMENSIONS* - MM

Series	LQ♦			T H7	O	N	Output Keyway
	IEC B5 & B14 Options						
	D56D■	D63D	D71D	(standard for metric units)			
518	74♦	74♦	74	18	32	75	6
520	74♦	74♦	74	25	52	100	8
525	74♦	74♦	74	25	60	123	8
534	74♦	74♦	74	35	60	141	10

OPTIONAL METRIC DIMENSIONS* - MM

IEC Frame	B5					B14♦					Input Bore Dia	Input Keyway▲
	AJ	AK	BD	BE	BF	AJ	AK	BD	BE	BF♦		
D56D	N/A	N/A	N/A	N/A	N/A	65♦	50	80	7	6.5	9	3 x 1.5
D63D	115	95	140	11	9	75♦	60	90	5.5	5.5	11	4 x 2
D71D	130	110	160	10	9	85♦	70	105	8	6.5	14	5 x 2.5

♦ Contact LEESON for availability of metric input options. The output bore and/or solid output shaft extension will be metric as standard with metric input options.

▲ Keyway width by depth

♦ AJ Mounting holes are rotated 45° from positions shown on B14 input options as follows: D56D(All), D63D(All)

♦ Dimensions are maximum (B5 and B14 options)

■ B5 Option not available

Bravo® Worm / Worm Double Reduction

Bravo® DOUBLE REDUCTION • WORM/WORM DIMENSIONS

ALUMINUM GEAR REDUCERS



STYLE DFHMQ

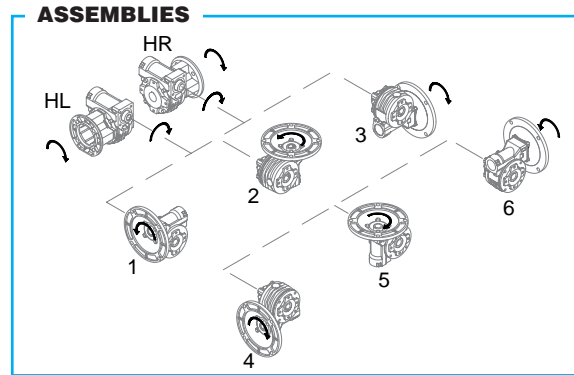
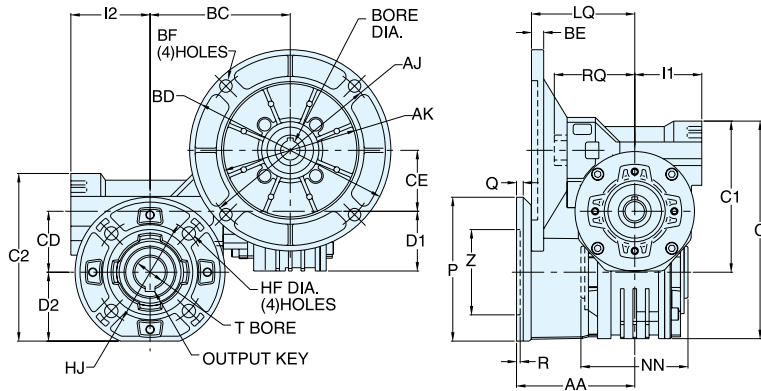

REVERSE ALL ARROWS FOR OPPOSITE INPUT SHAFT ROTATION. CONTACT FACTORY FOR OTHER MOUNTINGS OR ASSEMBLY POSITIONS.

STYLE DFHMQ DIMENSIONS - Inches

Series	AA	BC	C	C1	C2	CD	CE	D1	D2	HF	HJ	I1	I2	LQ* 56C	NN	P	Q	R	RQ	T* +0.0015 -0.0000	Z	OUTPUT KEY*
518	2.38	4.35	6.42	4.76	4.76	1.77	1.77	1.93	1.93	0.335	3.43	2.16	2.16	3.33	2.56	4.33	0.35	0.354	2.60	0.750	2.362	3/16 X 1.00
520	3.35	4.53	7.30	4.76	5.33	1.97	1.77	1.93	2.15	0.413	3.54	2.16	2.56	3.33	3.19	4.84	0.47	0.354	2.60	1.000	2.756	1/4 X 1.62
525	3.39	5.75	9.17	4.76	6.69	2.48	1.77	1.93	2.76	0.413	5.91	2.16	3.11	3.33	4.72	6.89	0.51	0.276	2.60	1.125	4.528	1/4 X 2.00
534	4.25	6.76	12.00	4.76	9.15	3.35	1.77	1.93	3.72	0.512	6.93	2.16	3.86	3.33	5.31	8.07	0.63	0.197	2.60	1.500	5.984	3/8 X 2.00

* Metric options are available. Refer to dimensions on opposite page. Contact LEESON for availability of metric options.

Bravo® Worm / Worm Double Reduction

STYLE DFH

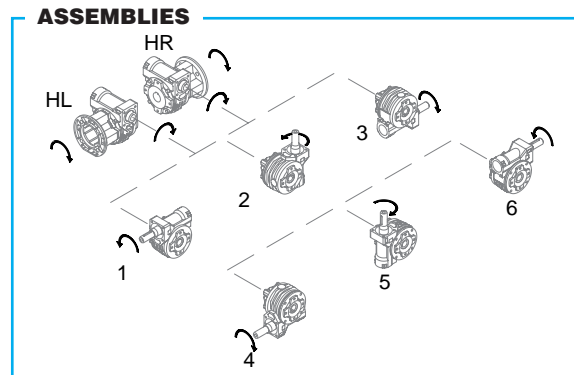
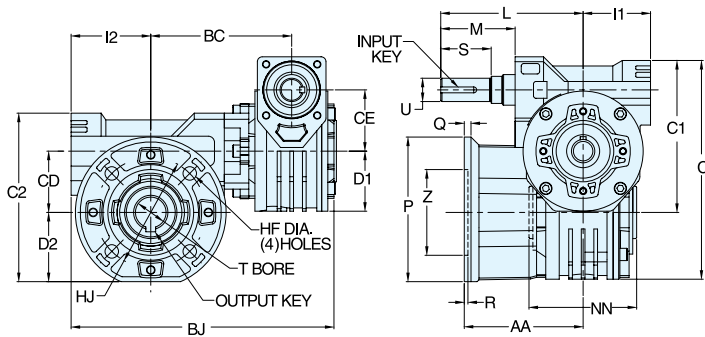

REVERSE ALL ARROWS FOR OPPOSITE INPUT SHAFT ROTATION. CONTACT FACTORY FOR OTHER MOUNTINGS OR ASSEMBLY POSITIONS.

STYLE DFH DIMENSIONS - Inches

Series	AA	BC	BJ	C	C1	C2	CD	CE	D1	D2	HF	HJ	I1	I2	L	M	NN	P	Q	R	S	T +0.0015 -0.0000	U +0.000 -0.001	Z	INPUT KEY	OUTPUT KEY
518	2.38	4.35	7.90	6.42	4.76	4.76	1.77	1.77	1.93	1.93	0.335	3.43	2.16	2.16	3.86	1.67	2.56	4.33	0.35	0.354	1.18	0.750	0.625	2.362	3/16 X 1.00	3/16 X 1.00
520	3.35	4.53	8.47	7.30	4.76	5.33	1.97	1.77	1.93	2.15	0.413	3.54	2.16	2.56	3.86	1.67	3.19	4.84	0.47	0.354	1.18	1.000	0.625	2.756	3/16 X 1.00	1/4 X 1.62
525	3.39	5.75	10.24	9.17	4.76	6.69	2.48	1.77	1.93	2.76	0.413	5.91	2.16	3.11	3.86	1.67	4.72	6.89	0.51	0.276	1.18	1.125	0.625	4.528	3/16 X 1.00	1/4 X 2.00
534	4.25	6.76	12.01	12.00	4.76	9.15	3.35	1.77	1.93	3.72	0.512	6.93	2.16	3.86	3.86	1.67	5.31	8.07	0.63	0.197	1.18	1.500	0.625	5.984	3/16 X 1.00	3/8 X 2.00



DOUBLE REDUCTION • WORM/WORM DIMENSIONS **Bravo**
ALUMINUM GEAR REDUCERS

STYLE DFMQ

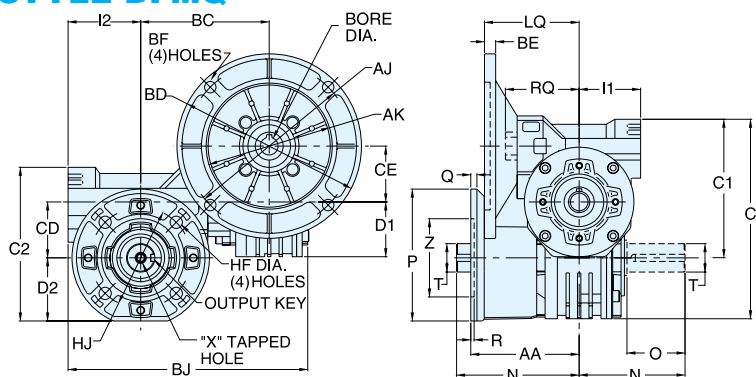

ASSEMBLIES

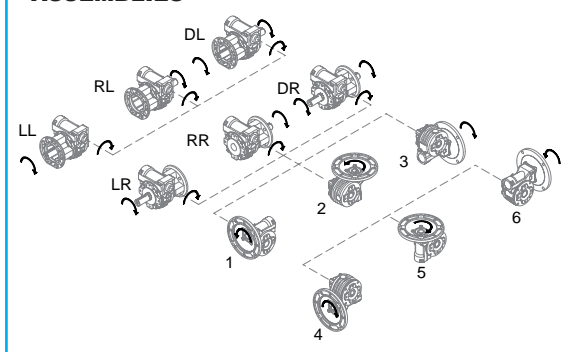

REVERSE ALL ARROWS FOR OPPOSITE INPUT SHAFT ROTATION. CONTACT FACTORY FOR OTHER MOUNTINGS OR ASSEMBLY POSITIONS.

STYLE DFMQ DIMENSIONS - Inches

Series	AA	BC	C	C1	C2	CD	CE	D1	D2	HF	HJ	I1	I2	LQ* 56C	N	O*	P	Q	R	RQ	T* +0.000 -0.001	X		Z	OUTPUT KEY*
																						Tap Size	Depth		
518	2.38	4.35	6.42	4.76	4.76	1.77	1.77	1.93	1.93	0.335	3.43	2.16	2.16	3.33	2.97	1.26	4.33	0.35	0.354	2.60	0.750	1/4-20 UNC	0.62	2.362	3/16 x 1.00
520	3.35	4.53	7.30	4.76	5.33	1.97	1.77	1.93	2.15	0.413	3.54	2.16	2.56	3.33	3.94	2.05	4.84	0.47	0.354	2.60	1.000	5/16-18 UNC	0.75	2.756	1/4 X 1.62
525	3.39	5.75	9.17	4.76	6.69	2.48	1.77	1.93	2.76	0.413	5.91	2.16	3.11	3.33	4.85	2.36	6.89	0.51	0.276	2.60	1.125	5/16-18 UNC	0.75	4.528	1/4 X 2.00
534	4.25	6.76	12.00	4.76	9.15	3.35	1.77	1.93	3.72	0.512	6.93	2.16	3.86	3.33	5.55	2.36	8.07	0.63	0.197	2.60	1.500	5/16-18 UNC	0.75	5.984	3/8 X 2.00

* Metric options are available. Refer to dimensions below. Contact LEESON for availability of metric options.

STYLE DF

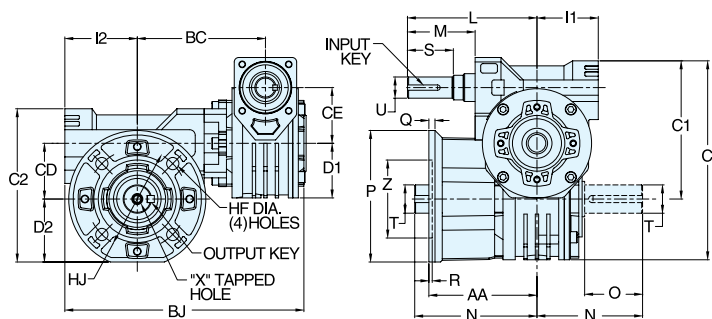

ASSEMBLIES

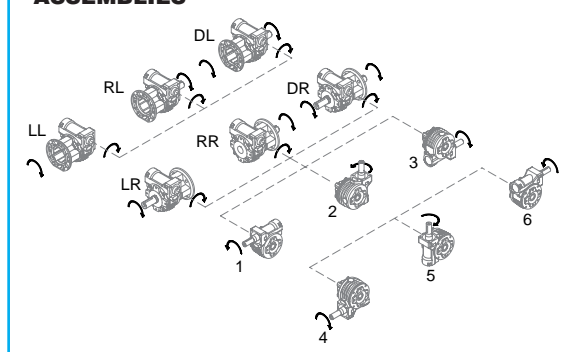

REVERSE ALL ARROWS FOR OPPOSITE INPUT SHAFT ROTATION. CONTACT FACTORY FOR OTHER MOUNTINGS OR ASSEMBLY POSITIONS.

STYLE DF DIMENSIONS - Inches

Series	AA	BC	BJ	C	C1	C2	CD	CE	D1	D2	HF	HJ	I1	I2	L	M	N	O	P	Q	R	S	T +0.000 -0.001	U +0.000 -0.001	X		Z	INPUT KEY	OUTPUT KEY
																									Tap Size	Depth			
518	2.38	4.35	7.90	6.42	4.76	4.76	1.77	1.77	1.93	1.93	0.335	3.43	2.16	2.16	3.86	1.67	2.97	1.26	4.33	0.35	0.354	1.18	0.750	0.625	1/4-20 UNC	0.62	2.362	3/16 X 1.00	3/16 X 1.00
520	3.35	4.53	8.47	7.30	4.76	5.33	1.97	1.77	1.93	2.15	0.413	3.54	2.16	2.56	3.86	1.67	3.94	2.05	4.84	0.47	0.354	1.18	1.000	0.625	5/16-18 UNC	0.75	2.756	3/16 X 1.00	1/4 X 1.62
525	3.39	5.75	10.24	9.17	4.76	6.69	2.48	1.77	1.93	2.76	0.413	5.91	2.16	3.11	3.86	1.67	4.85	2.36	6.89	0.51	0.276	1.18	1.125	0.625	5/16-18 UNC	0.75	4.528	3/16 X 1.00	1/4 X 2.00
534	4.25	6.76	12.01	12.00	4.76	9.15	3.35	1.77	1.93	3.72	0.512	6.93	2.16	3.86	3.86	1.67	5.55	2.36	8.07	0.63	0.197	1.18	1.500	0.625	5/16-18 UNC	0.75	5.984	3/16 X 1.00	3/8 X 2.00

MOTOR MOUNTING DIMENSIONS

NEMA DIMENSIONS - Inches

Frame	AJ	AK	BD	BE	BF	Input Bore Dia	Input Keyway▲
56C	5.88	4.50	6.50	0.38	0.41	0.625	3/16 x 3/32

OPTIONAL METRIC DIMENSIONS* - MM

Series	LQ♦			T H7	O	N	Output Keyway
	IEC B5 & B14 Options						
	D56D■	D63D	D71D				
518	74*	74*	74	18	32	75	6
520	74*	74*	74	25	52	100	8
525	74*	74*	74	25	60	123	8
534	74*	74*	74	35	60	141	10

OPTIONAL METRIC DIMENSIONS* - MM

IEC Frame	B5					B14♦					Input Bore Dia	Input Keyway▲
	AJ	AK	BD	BE	BF	AJ	AK	BD	BE	BF♦		
D56D	N/A	N/A	N/A	N/A	N/A	65*	50	80	7	6.5	9	3 x 1.5
D63D	115	95	140	11	9	75*	60	90	5.5	5.5	11	4 x 2
D71D	130	110	160	10	9	85*	70	105	8	6.5	14	5 x 2.5

* Contact LEESON for availability of metric input options. The output bore and/or solid output shaft extension will be metric as standard with metric input options.

▲ Keyway width by depth

♦ AJ Mounting holes are rotated 45° from positions shown on B14 input options as follows: D56D(All), D63D(All)

◆ Dimensions are maximum (B5 and B14 options)

■ B5 Option not available

Bravo® Worm / Worm Double Reduction



DOUBLE REDUCTION • WORM/WORM DIMENSIONS



STYLE DFLHMQ

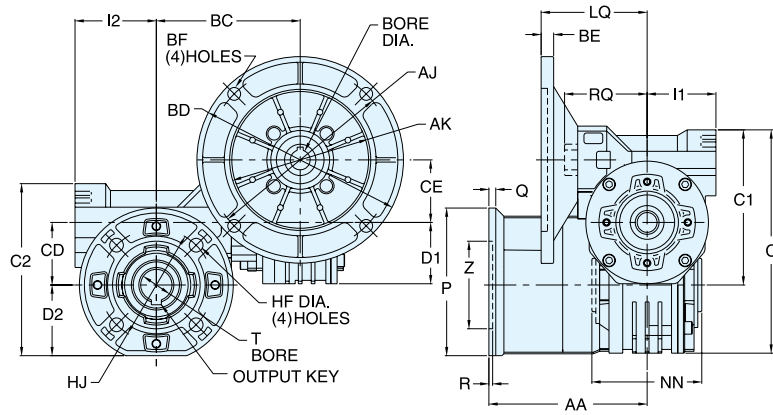

ASSEMBLIES

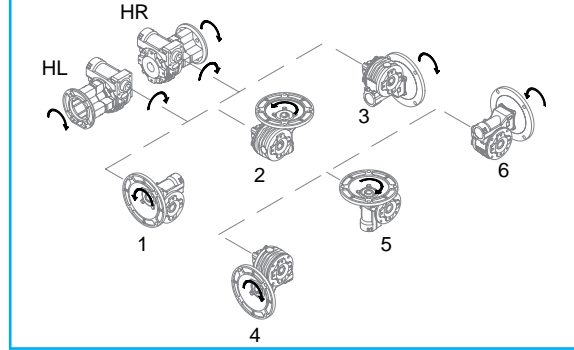

REVERSE ALL ARROWS FOR OPPOSITE INPUT SHAFT ROTATION. CONTACT FACTORY FOR OTHER MOUNTINGS OR ASSEMBLY POSITIONS.

STYLE DFLHMQ DIMENSIONS - Inches

Series	AA	BC	C	C1	C2	CD	CE	D1	D2	HF	HJ	I1	I2	LQ* 56C	NN	P	Q	R	RQ	T* +0.0015 -0.0000	Z	OUTPUT KEY*
518	3.56	4.35	6.42	4.76	4.76	1.77	1.77	1.93	1.93	0.335	3.43	2.16	2.16	3.33	2.56	4.33	0.35	0.354	2.60	0.750	2.362	3/16 X 1.00
520	4.51	4.53	7.30	4.76	5.33	1.97	1.77	1.93	2.15	0.413	3.54	2.16	2.56	3.33	3.19	4.84	0.47	0.354	2.60	1.000	2.756	1/4 X 1.62
525	4.57	5.75	9.17	4.76	6.69	2.48	1.77	1.93	2.76	0.413	5.91	2.16	3.11	3.33	4.72	6.89	0.51	0.276	2.60	1.125	4.528	1/4 X 2.00
534	5.85	6.76	12.00	4.76	9.15	3.35	1.77	1.93	3.72	0.512	6.93	2.16	3.86	3.33	5.31	8.07	0.63	0.197	2.60	1.500	5.984	3/8 X 2.00

* Metric options are available. Refer to dimensions on opposite page. Contact LEESON for availability of metric options.

Bravo® Worm / Worm Double Reduction

STYLE DFLH

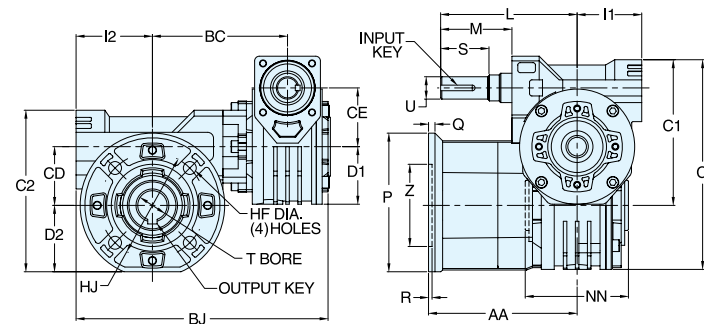

ASSEMBLIES

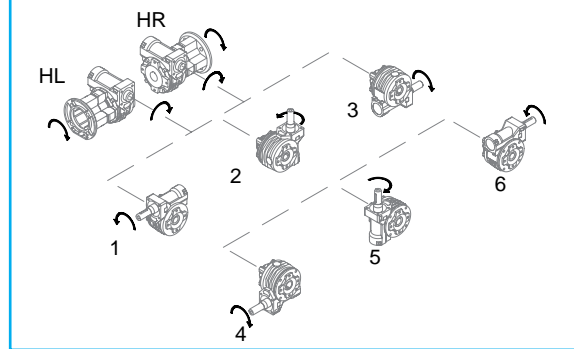

REVERSE ALL ARROWS FOR OPPOSITE INPUT SHAFT ROTATION. CONTACT FACTORY FOR OTHER MOUNTINGS OR ASSEMBLY POSITIONS.

STYLE DFLH DIMENSIONS - Inches

Series	AA	BC	BJ	C	C1	C2	CD	CE	D1	D2	HF	HJ	I1	I2	L	M	NN	P	Q	R	S	T +0.0015 -0.0000	U +0.000 -0.001	Z	INPUT KEY	OUTPUT KEY
518	3.56	4.35	7.90	6.42	4.76	4.76	1.77	1.77	1.93	1.93	0.335	3.43	2.16	2.16	3.86	1.67	2.56	4.33	0.35	0.354	1.18	0.750	0.625	2.362	3/16 X 1.00	3/16 X 1.00
520	4.51	4.53	8.47	7.30	4.76	5.33	1.97	1.77	1.93	2.15	0.413	3.54	2.16	2.56	3.86	1.67	3.19	4.84	0.47	0.354	1.18	1.000	0.625	2.756	3/16 X 1.00	1/4 X 1.62
525	4.57	5.75	10.24	9.17	4.76	6.69	2.48	1.77	1.93	2.76	0.413	5.91	2.16	3.11	3.86	1.67	4.72	6.89	0.51	0.276	1.18	1.125	0.625	4.528	3/16 X 1.00	1/4 X 2.00
534	5.85	6.76	12.01	12.00	4.76	9.15	3.35	1.77	1.93	3.72	0.512	6.93	2.16	3.86	3.86	1.67	5.31	8.07	0.63	0.197	1.18	1.500	0.625	5.984	3/16 X 1.00	3/8 X 2.00



DOUBLE REDUCTION • WORM/WORM DIMENSIONS



STYLE DFLMQ

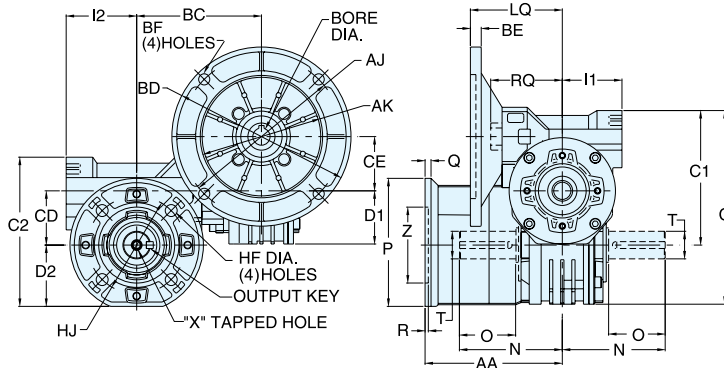

ASSEMBLIES

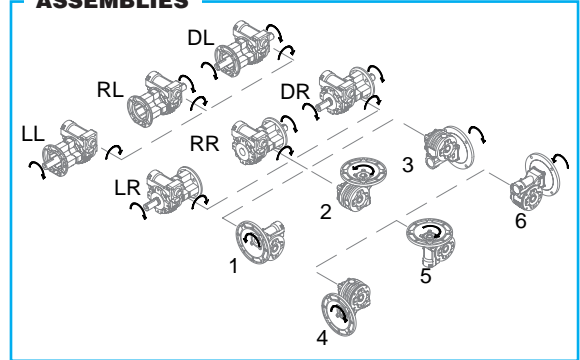

REVERSE ALL ARROWS FOR OPPOSITE INPUT SHAFT ROTATION. CONTACT FACTORY FOR OTHER MOUNTINGS OR ASSEMBLY POSITIONS.

STYLE DFLMQ DIMENSIONS - Inches

Series	AA	BC	C	C1	C2	CD	CE	D1	D2	HF	HJ	I1	I2	LQ* .56C	N	O*	P	Q	R	RQ	T* +0.000 -0.001	X Tap Size Depth		Z	OUTPUT KEY*
518	3.56	4.35	6.42	4.76	4.76	1.77	1.77	1.93	1.93	0.335	3.43	2.16	2.16	3.33	2.97	1.26	4.33	0.35	0.354	2.60	0.750	1/4-20 UNC	0.62	2.362	3/16 x 1.00
520	4.51	4.53	7.30	4.76	5.33	1.97	1.77	1.93	2.15	0.413	3.54	2.16	2.56	3.33	3.94	2.05	4.84	0.47	0.354	2.60	1.000	5/16-18 UNC	0.75	2.756	1/4 X 1.62
525	4.57	5.75	9.17	4.76	6.69	2.48	1.77	1.93	2.76	0.413	5.91	2.16	3.11	3.33	4.85	2.36	6.89	0.51	0.276	2.60	1.125	5/16-18 UNC	0.75	4.528	1/4 X 2.00
534	5.85	6.76	12.00	4.76	9.15	3.35	1.77	1.93	3.72	0.512	6.93	2.16	3.86	3.33	5.55	2.36	8.07	0.63	0.197	2.60	1.500	5/16-18 UNC	0.75	5.984	3/8 X 2.00

* Metric options are available. Refer to dimensions below. Contact LEESON for availability of metric options.

STYLE DFL

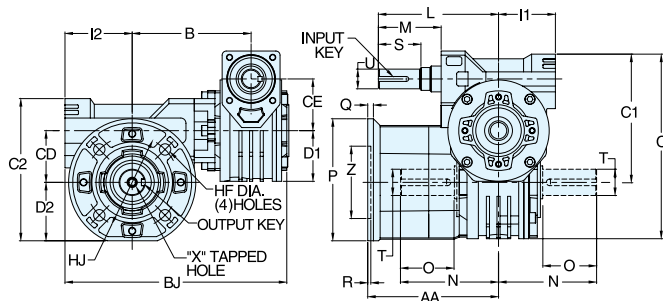

ASSEMBLIES

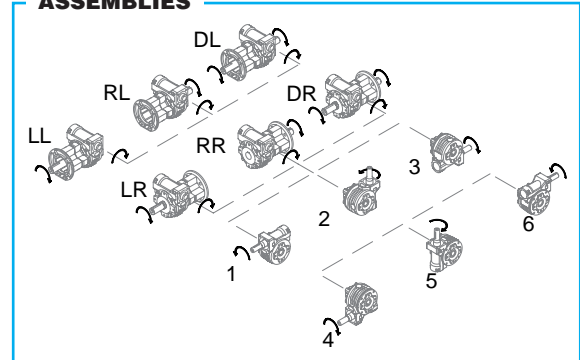

REVERSE ALL ARROWS FOR OPPOSITE INPUT SHAFT ROTATION. CONTACT FACTORY FOR OTHER MOUNTINGS OR ASSEMBLY POSITIONS.

STYLE DFL DIMENSIONS - Inches

Series	AA	BC	BJ	C	C1	C2	CD	CE	D1	D2	HF	HJ	I1	I2	L	M	N	O	P	Q	R	S	T +0.000 -0.001	U +0.000 -0.001	X Tap Size Depth		Z	INPUT KEY	OUTPUT KEY
518	3.56	4.35	7.90	6.42	4.76	4.76	1.77	1.77	1.93	1.93	0.335	3.43	2.16	2.16	3.86	1.67	2.97	1.26	4.33	0.35	0.354	1.18	0.750	0.625	1/4-20 UNC	0.62	2.362	3/16 X 1.00	3/16 X 1.00
520	4.51	4.53	8.47	7.30	4.76	5.33	1.97	1.77	1.93	2.15	0.413	3.54	2.16	2.56	3.86	1.67	3.94	2.05	4.84	0.47	0.354	1.18	1.000	0.625	5/16-18 UNC	0.75	2.756	3/16 X 1.00	1/4 X 1.62
525	4.57	5.75	10.24	9.17	4.76	6.69	2.48	1.77	1.93	2.76	0.413	5.91	2.16	3.11	3.86	1.67	4.85	2.36	6.89	0.51	0.276	1.18	1.125	0.625	5/16-18 UNC	0.75	4.528	3/16 X 1.00	1/4 X 2.00
534	5.85	6.76	12.01	12.00	4.76	9.15	3.35	1.77	1.93	3.72	0.512	6.93	2.16	3.86	3.86	1.67	5.55	2.36	8.07	0.63	0.197	1.18	1.500	0.625	5/16-18 UNC	0.75	5.984	3/16 X 1.00	3/8 X 2.00

MOTOR MOUNTING DIMENSIONS

NEMA DIMENSIONS - Inches

Frame	AJ	AK	BD	BE	BF	Input Bore Dia	Input Keyway▲
56C	5.88	4.50	6.50	0.38	0.41	0.625	3/16 x 3/32

OPTIONAL METRIC DIMENSIONS* - MM

Series	LQ♦			T H7	O (standard for metric units)	N	Output Keyway
	IEC B5 & B14 Options D56D■ D63D D71D						
518	74♦	74♦	74	18	32	75	6
520	74♦	74♦	74	25	52	100	8
525	74♦	74♦	74	25	60	123	8
534	74♦	74♦	74	35	60	141	10

OPTIONAL METRIC DIMENSIONS* - MM

IEC Frame	B5					B14♦					Input Bore Dia	Input Keyway▲
	AJ	N/A	BD	BE	BF	AJ	AK	BD	BE	BF♦		
D56D	N/A	N/A	N/A	N/A	N/A	65♦	50	80	7	6.5	9	3 x 1.5
D63D	115	95	140	11	9	75♦	60	90	5.5	5.5	11	4 x 2
D71D	130	110	160	10	9	85♦	70	105	8	6.5	14	5 x 2.5

♦ Contact LEESON for availability of metric input options. The output bore and/or solid output shaft extension will be metric as standard with metric input options.

▲ Keyway width by depth

♦ AJ Mounting holes are rotated 45° from positions shown on B14 input options as follows: D56D(All), D63D(All)

♦ Dimensions are maximum (B5 and B14 options)

■ B5 Option not available

Bravo® Worm / Worm Double Reduction

Bravo® DOUBLE REDUCTION • WORM/WORM DIMENSIONS

ALUMINUM GEAR REDUCERS



STYLE DTHMQ

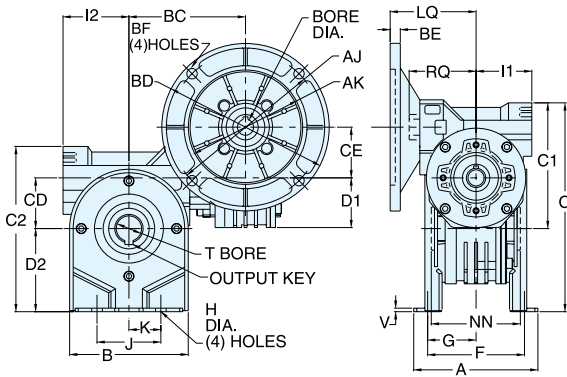

ASSEMBLIES

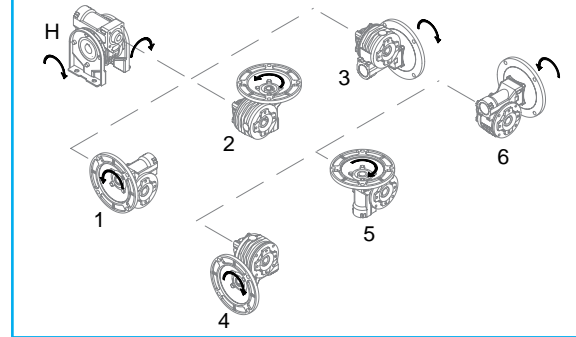

REVERSE ALL ARROWS FOR OPPOSITE INPUT SHAFT ROTATION. CONTACT FACTORY FOR OTHER MOUNTINGS OR ASSEMBLY POSITIONS.

STYLE DTHMQ DIMENSIONS - Inches

Series	A	B	BC	C	C1	C2	CD	CE	D1	D2	F	G	H	I1	I2	J	K	LQ* 56C	NN	RQ	T* +0.0015 -0.0000	V	OUTPUT KEY*
518	3.94	3.86	4.35	7.32	4.76	5.67	1.77	1.77	1.93	2.83	3.17	1.59	0.413	2.16	2.16	1.97	0.99	3.33	2.56	2.60	0.750	0.12	3/16 X 1.00
520	4.84	4.45	4.53	8.38	4.76	6.42	1.97	1.77	1.93	3.23	3.94	1.97	0.413	2.16	2.56	2.48	1.24	3.33	3.19	2.60	1.000	0.14	1/4 X 1.62
525	5.67	5.24	5.75	10.35	4.76	7.87	2.48	1.77	1.93	3.94	4.35	2.18	0.413	2.16	3.11	3.74	1.87	3.33	4.72	2.60	1.125	0.16	1/4 X 2.00
534	7.17	7.09	6.76	13.86	4.76	11.02	3.35	1.77	1.93	5.59	5.71	2.86	0.413	2.16	3.86	5.51	2.76	3.33	5.31	2.60	1.500	0.20	3/8 X 2.00

* Metric options are available. Refer to dimensions on opposite page. Contact LEESON for availability of metric options.

Bravo® Worm / Worm Double Reduction

STYLE DTH

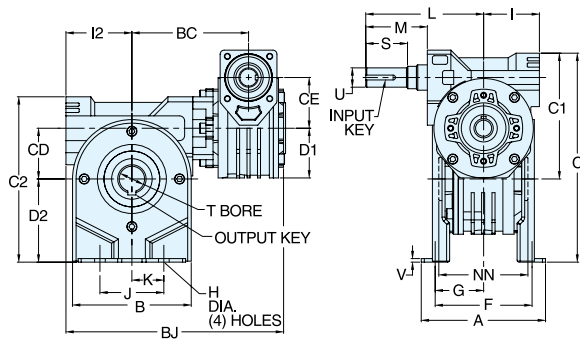

ASSEMBLIES

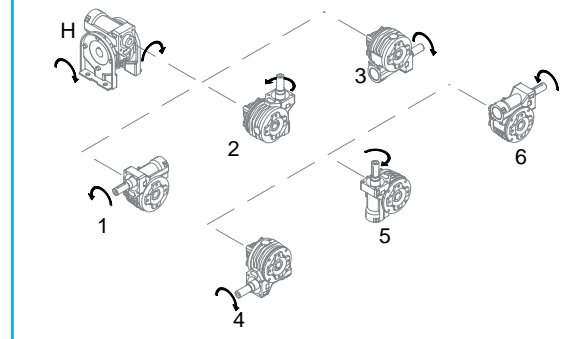

REVERSE ALL ARROWS FOR OPPOSITE INPUT SHAFT ROTATION. CONTACT FACTORY FOR OTHER MOUNTINGS OR ASSEMBLY POSITIONS.

STYLE DTH DIMENSIONS - Inches

Series	A	B	BC	BJ	C	C1	C2	CD	CE	D1	D2	F	G	H	I1	I2	J	K	L	M	NN	S	T +0.0015 -0.0000	U +0.000 -0.001	V	INPUT KEY	OUTPUT KEY
518	3.94	3.86	4.35	7.90	7.32	4.76	5.67	1.77	1.77	1.93	2.83	3.17	1.59	0.413	2.16	2.16	1.97	0.99	3.86	1.67	2.56	1.18	0.750	0.625	0.12	3/16 X 1.00	3/16 X 1.00
520	4.84	4.45	4.53	8.47	8.38	4.76	6.42	1.97	1.77	1.93	3.23	3.94	1.97	0.413	2.16	2.56	2.48	1.24	3.86	1.67	3.19	1.18	1.000	0.625	0.14	3/16 X 1.00	1/4 X 1.62
525	5.67	5.24	5.75	10.24	10.35	4.76	7.87	2.48	1.77	1.93	3.94	4.35	2.18	0.413	2.16	3.11	3.74	1.87	3.86	1.67	4.72	1.18	1.125	0.625	0.16	3/16 X 1.00	1/4 X 2.00
534	7.17	7.09	6.76	12.01	13.86	4.76	11.02	3.35	1.77	1.93	5.59	5.71	2.86	0.413	2.16	3.86	5.51	2.76	3.86	1.67	5.31	1.18	1.500	0.625	0.20	3/16 X 1.00	3/8 X 2.00



DOUBLE REDUCTION • WORM/WORM DIMENSIONS



STYLE DTMQ

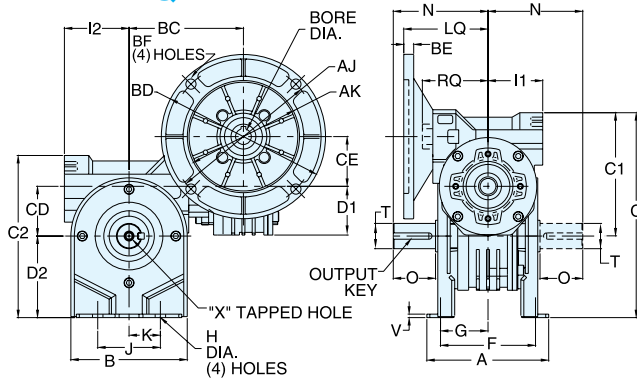

ASSEMBLIES

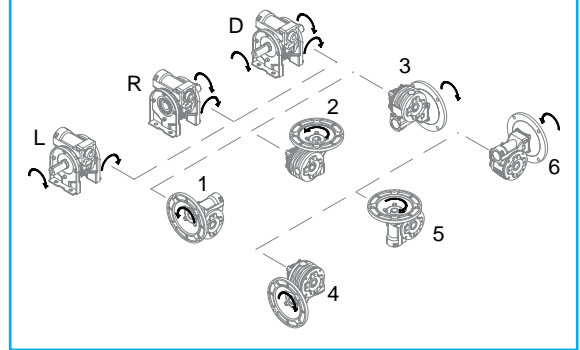

REVERSE ALL ARROWS FOR OPPOSITE INPUT SHAFT ROTATION. CONTACT FACTORY FOR OTHER MOUNTINGS OR ASSEMBLY POSITIONS.

STYLE DTMQ DIMENSIONS - Inches

Series	A	B	BC	C	C1	C2	CD	CE	D1	D2	F	G	H	I1	I2	J	K	LQ* 56C	N	O*	RQ	T* +0.000 -0.001	V	X Tap Size Depth		OUTPUT KEY*
518	3.94	3.86	4.35	7.32	4.76	5.67	1.77	1.77	1.93	2.83	3.17	1.59	0.413	2.16	2.16	1.97	0.99	3.33	2.97	1.26	2.60	0.750	0.12	1/4-20 UNC	0.62	3/16 x 1.00
520	4.84	4.45	4.53	8.38	4.76	6.42	1.97	1.77	1.93	3.23	3.94	1.97	0.413	2.16	2.56	2.48	1.24	3.33	3.94	2.05	2.60	1.000	0.14	5/16-18 UNC	0.75	1/4 x 1.62
525	5.67	5.24	5.75	10.35	4.76	7.87	2.48	1.77	1.93	3.94	4.35	2.18	0.413	2.16	3.11	3.74	1.87	3.33	4.85	2.36	2.60	1.125	0.16	5/16-18 UNC	0.75	1/4 x 2.00
534	7.17	7.09	6.76	13.86	4.76	11.02	3.35	1.77	1.93	5.59	5.71	2.86	0.413	2.16	3.86	5.51	2.76	3.33	5.55	2.36	2.60	1.500	0.20	5/16-18 UNC	0.75	3/8 x 2.00

* Metric options are available. Refer to dimensions below. Contact LEESON for availability of metric options.

STYLE DT

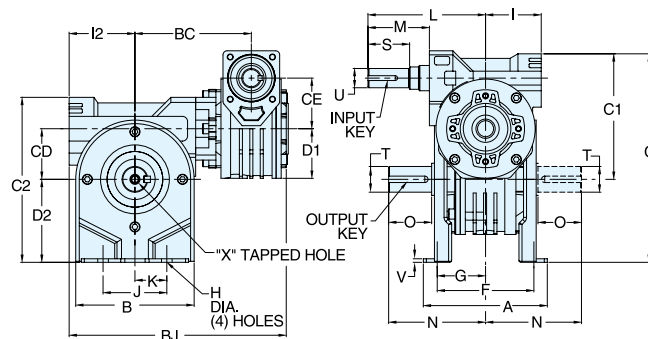

ASSEMBLIES

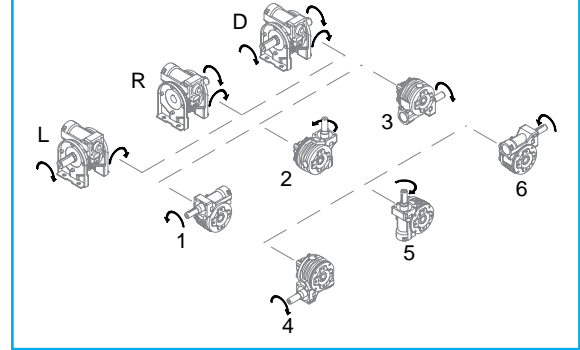

REVERSE ALL ARROWS FOR OPPOSITE INPUT SHAFT ROTATION. CONTACT FACTORY FOR OTHER MOUNTINGS OR ASSEMBLY POSITIONS.

STYLE DT DIMENSIONS - Inches

Series	A	B	BC	BJ	C	C1	C2	CD	CE	D1	D2	F	G	H	I1	I2	J	K	L	M	N	O	S	T +0.000 -0.001	U +0.000 -0.001	V	X Tap Size Depth		INPUT KEY	OUTPUT KEY
518	3.94	3.86	4.35	7.90	7.32	4.76	5.67	1.77	1.77	1.93	2.83	3.17	1.59	0.413	2.16	2.16	1.97	0.99	3.86	1.67	2.97	1.26	1.18	0.750	0.625	0.12	1/4-20 UNC	0.62	3/16 X 1.00	3/16 X 1.00
520	4.84	4.45	4.53	8.47	8.38	4.76	6.42	1.97	1.77	1.93	3.23	3.94	1.97	0.413	2.16	2.56	2.48	1.24	3.86	1.67	3.94	2.05	1.18	1.000	0.625	0.14	5/16-18 UNC	0.75	3/16 X 1.00	1/4 X 1.62
525	5.67	5.24	5.75	10.24	10.35	4.76	7.87	2.48	1.77	1.93	3.94	4.35	2.18	0.413	2.16	3.11	3.74	1.87	3.86	1.67	4.85	2.36	1.18	1.125	0.625	0.16	5/16-18 UNC	0.75	3/16 X 1.00	1/4 X 2.00
534	7.17	7.09	6.76	12.01	13.86	4.76	11.02	3.35	1.77	1.93	5.59	5.71	2.86	0.413	2.16	3.86	5.51	2.76	3.86	1.67	5.55	2.36	1.18	1.500	0.625	0.20	5/16-18 UNC	0.75	3/16 X 1.00	3/8 X 2.00

MOTOR MOUNTING DIMENSIONS

NEMA DIMENSIONS - Inches

Frame	AJ	AK	BD	BE	BF	Input Bore Dia	Input Keyway▲
56C	5.88	4.50	6.50	0.38	0.41	0.625	3/16 x 3/32

OPTIONAL METRIC DIMENSIONS* - MM

Series	LQ♦			T H7	O	N	Output Keyway
	IEC B5 & B14 Options D56D■ D63D D71D						
518	74♦	74♦	74	18	32	75	6
520	74♦	74♦	74	25	52	100	8
525	74♦	74♦	74	25	60	123	8
534	74♦	74♦	74	35	60	141	10

OPTIONAL METRIC DIMENSIONS* - MM

IEC Frame	B5					B14♦					Input Bore Dia	Input Keyway▲
	AJ	AK	BD	BE	BF	AJ	AK	BD	BE	BF♦		
D56D	N/A	N/A	N/A	N/A	N/A	65♦	50	80	7	6.5	9	3 x 1.5
D63D	115	95	140	11	9	75♦	60	90	5.5	5.5	11	4 x 2
D71D	130	110	160	10	9	85♦	70	105	8	6.5	14	5 x 2.5

♦ Contact LEESON for availability of metric input options. The output bore and/or solid output shaft extension will be metric as standard with metric input options.

▲ Keyway width by depth

♦ AJ Mounting holes are rotated 45° from positions shown on B14 input options as follows: D56D(All), D63D(All)

♦ Dimensions are maximum (B5 and B14 options)

■ B5 Option not available

Bravo® Worm / Worm Double Reduction



DOUBLE REDUCTION • WORM/WORM DIMENSIONS



STYLE DUMQ

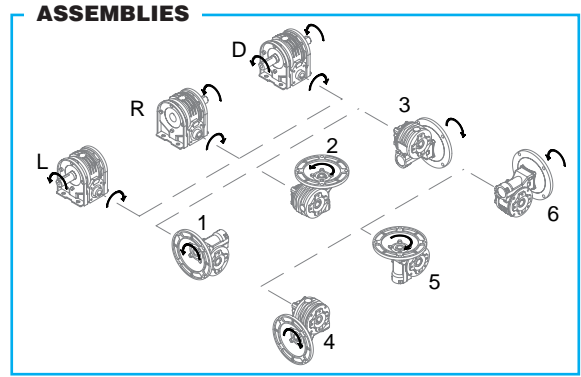
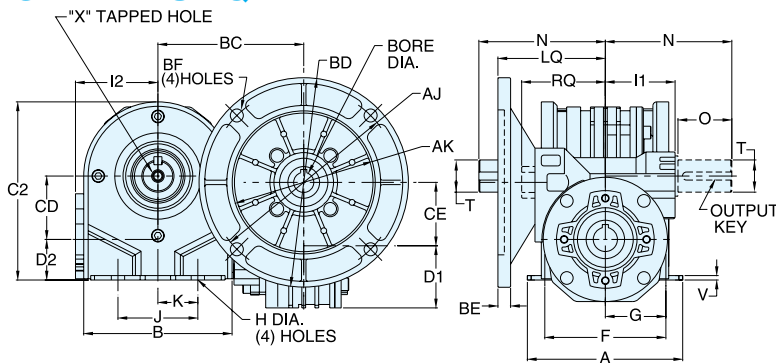

REVERSE ALL ARROWS FOR OPPOSITE INPUT SHAFT ROTATION. CONTACT FACTORY FOR OTHER MOUNTINGS OR ASSEMBLY POSITIONS.

STYLE DUMQ DIMENSIONS - Inches

Series	A	B	BC	C2	CD	CE	D1	D2	F	G	H	I1	I2	J	K	LQ* 56C	N	O*	RQ	T* +0.000 -0.001	V	X		OUTPUT KEY*
																						Tap Size	Depth	
518	3.94	3.86	4.35	4.76	1.77	1.77	1.93	1.06	3.17	1.59	0.413	2.16	2.16	1.97	0.99	3.33	2.97	1.26	2.60	0.750	0.12	1/4-20 UNC	0.62	3/16 x 1.00
520	4.84	4.45	4.53	5.45	1.97	1.77	1.93	1.26	3.94	1.97	0.413	2.16	2.56	2.48	1.24	3.33	3.94	2.05	2.60	1.000	0.14	5/16-18 UNC	0.75	1/4 X 1.62
525	5.67	5.24	5.75	6.69	2.48	1.77	1.93	1.45	4.35	2.18	0.413	2.16	3.11	3.74	1.87	3.33	4.85	2.36	2.60	1.125	0.16	5/16-18 UNC	0.75	1/4 X 2.00
534	7.17	7.09	6.76	9.31	3.35	1.77	1.93	2.24	5.71	2.86	0.413	2.16	3.86	5.51	2.76	3.33	5.55	2.36	2.60	1.500	0.20	5/16-18 UNC	0.75	3/8 X 2.00

* Metric options are available. Refer to dimensions below. Contact LEESON for availability of metric options.

STYLE DU

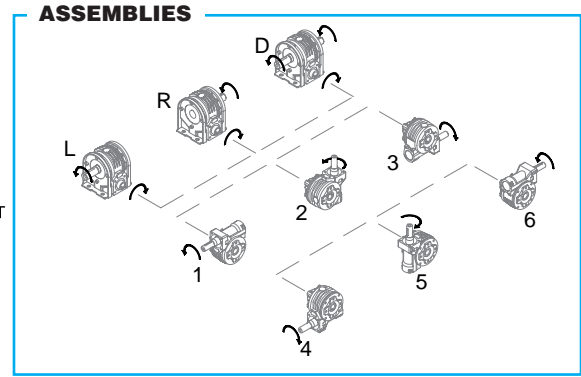
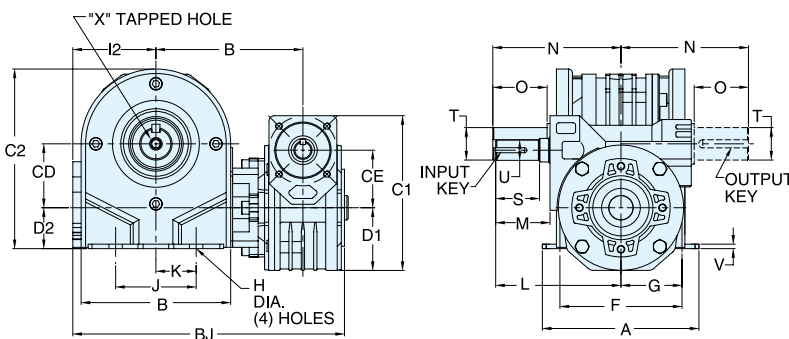

REVERSE ALL ARROWS FOR OPPOSITE INPUT SHAFT ROTATION. CONTACT FACTORY FOR OTHER MOUNTINGS OR ASSEMBLY POSITIONS.

STYLE DU DIMENSIONS - Inches

Series	A	B	BC	BJ	C1	C2	CD	CE	D1	D2	F	G	H	I2	J	K	L	M	N	O	S	T	U +0.000 -0.001	V	X		INPUT KEY	OUTPUT KEY
																									Tap Size	Depth		
518	3.94	3.86	4.35	7.90	4.76	4.76	1.77	1.77	1.93	1.06	3.17	1.59	0.413	2.16	1.97	0.99	3.86	1.67	2.97	1.26	1.18	0.750	0.625	0.12	1/4-20 UNC	0.62	3/16 X 1.00	3/16 X 1.00
520	4.84	4.45	4.53	8.47	4.76	5.45	1.97	1.77	1.93	1.26	3.94	1.97	0.413	2.56	2.48	1.24	3.86	1.67	3.94	2.05	1.18	1.000	0.625	0.14	5/16-18 UNC	0.75	3/16 X 1.00	1/4 X 1.62
525	5.67	5.24	5.75	10.24	4.76	6.69	2.48	1.77	1.93	1.45	4.35	2.18	0.413	3.11	3.74	1.87	3.86	1.67	4.85	2.36	1.18	1.125	0.625	0.16	5/16-18 UNC	0.75	3/16 X 1.00	1/4 X 2.00
534	7.17	7.09	6.76	12.01	4.76	9.31	3.35	1.77	1.93	2.24	5.71	2.86	0.413	3.86	5.51	2.76	3.86	1.67	5.55	2.36	1.18	1.500	0.625	0.20	5/16-18 UNC	0.75	3/16 X 1.00	3/8 X 2.00

MOTOR MOUNTING DIMENSIONS

NEMA DIMENSIONS - Inches

Frame	AJ	AK	BD	BE	BF	Input Bore Dia	Input Keyway▲
56C	5.88	4.50	6.50	0.38	0.41	0.625	3/16 x 3/32

OPTIONAL METRIC DIMENSIONS* - MM

Series	LQ♦			T H7	O	N	Output Keyway
	IEC B5 & B14 Options	D56D■	D63D				
518	74♦	74♦	74	18	32	75	6
520	74♦	74♦	74	25	52	100	8
525	74♦	74♦	74	25	60	123	8
534	74♦	74♦	74	35	60	141	10

OPTIONAL METRIC DIMENSIONS* - MM

IEC Frame	B5					B14♦					Input Bore Dia	Input Keyway▲
	AJ	AK	BD	BE	BF	AJ	AK	BD	BE	BF♦		
D56D	N/A	N/A	N/A	N/A	N/A	65♦	50	80	7	6.5	9	3 x 1.5
D63D	115	95	140	11	9	75♦	60	90	5.5	5.5	11	4 x 2
D71D	130	110	160	10	9	85♦	70	105	8	6.5	14	5 x 2.5

♦ Contact LEESON for availability of metric input options. The output bore and/or solid output shaft extension will be metric as standard with metric input options.

▲ Keyway width by depth

♦ AJ Mounting holes are rotated 45° from positions shown on B14 input options as follows: D56D(All), D63D(All)

♦ Dimensions are maximum (B5 and B14 options)

■ B5 Option not available

Bravo® Worm / Worm Double Reduction

Bravo® DOUBLE REDUCTION • WORM/WORM DIMENSIONS

ALUMINUM GEAR REDUCERS



STYLE DJHMQ

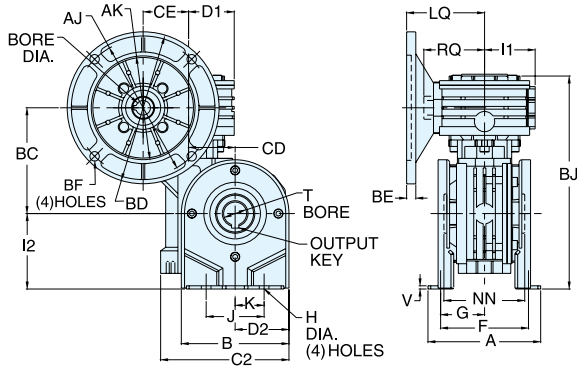

ASSEMBLIES

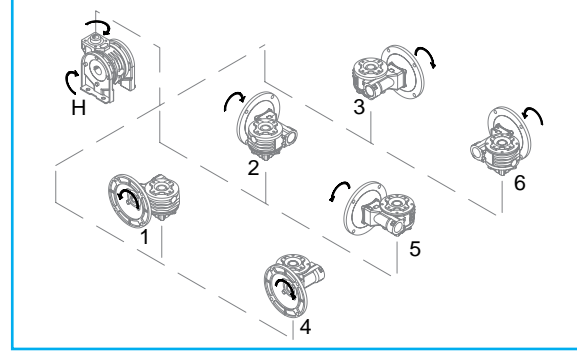

REVERSE ALL ARROWS FOR OPPOSITE INPUT SHAFT ROTATION. CONTACT FACTORY FOR OTHER MOUNTINGS OR ASSEMBLY POSITIONS.

STYLE DJHMQ DIMENSIONS - Inches

Series	A	B	BC	BJ	C2	CD	CE	D1	D2	F	G	H	I1	I2	J	K	LQ* 56C	NN	RQ	T* +0.0015 -0.0000	V	OUTPUT KEY*
518	3.94	3.86	4.35	8.57	4.76	1.77	1.77	1.93	1.93	3.17	1.59	0.413	2.16	2.83	1.97	0.99	3.33	2.56	2.60	0.750	0.12	3/16 X 1.00
520	4.84	4.45	4.53	9.13	5.33	1.97	1.77	1.93	2.15	3.94	1.97	0.413	2.16	3.22	2.48	1.24	3.33	3.19	2.60	1.000	0.14	1/4 X 1.62
525	5.67	5.24	5.75	11.07	6.69	2.48	1.77	1.93	2.76	4.35	2.18	0.413	2.16	3.94	3.74	1.87	3.33	4.72	2.60	1.125	0.16	1/4 X 2.00
534	7.17	7.09	6.76	13.74	9.15	3.35	1.77	1.93	3.72	5.71	2.86	0.413	2.16	5.59	5.51	2.76	3.33	5.31	2.60	1.500	0.20	3/8 X 2.00

* Metric options are available. Refer to dimensions on opposite page. Contact LEESON for availability of metric options.

STYLE DJH

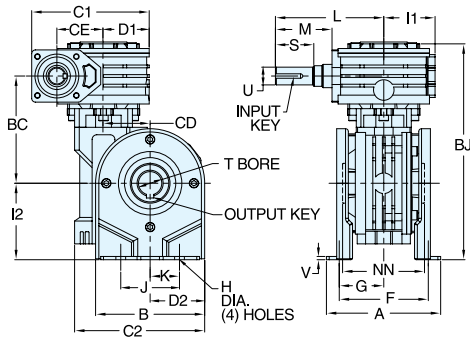

ASSEMBLIES

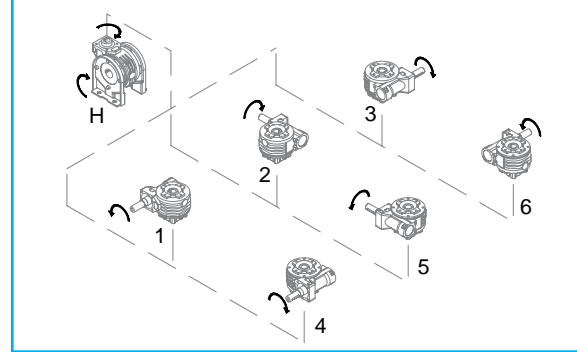

REVERSE ALL ARROWS FOR OPPOSITE INPUT SHAFT ROTATION. CONTACT FACTORY FOR OTHER MOUNTINGS OR ASSEMBLY POSITIONS.

STYLE DJH DIMENSIONS - Inches

Series	A	B	BC	BJ	C1	C2	CD	CE	D1	D2	F	G	H	I1	I2	J	K	L	M	NN	S	T +0.0015 -0.0000	U +0.000 -0.001	V	INPUT KEY	OUTPUT KEY
518	3.94	3.86	4.35	8.57	4.76	4.76	1.77	1.77	1.93	1.93	3.17	1.59	0.413	2.16	2.16	1.97	0.99	3.86	1.67	2.56	1.18	0.750	0.625	0.12	3/16 X 1.00	3/16 X 1.00
520	4.84	4.45	4.53	9.13	4.76	5.33	1.97	1.77	1.93	2.15	3.94	1.97	0.413	2.16	2.56	2.48	1.24	3.86	1.67	3.19	1.18	1.000	0.625	0.14	3/16 X 1.00	1/4 X 1.62
525	5.67	5.24	5.75	11.07	4.76	6.69	2.48	1.77	1.93	2.76	4.35	2.18	0.413	2.16	3.11	3.74	1.87	3.86	1.67	4.72	1.18	1.125	0.625	0.16	3/16 X 1.00	1/4 X 2.00
534	7.17	7.09	6.76	13.74	4.76	9.15	3.35	1.77	1.93	3.72	5.71	2.86	0.413	2.16	3.86	5.51	2.76	3.86	1.67	5.31	1.18	1.500	0.625	0.20	3/16 X 1.00	3/8 X 2.00

Bravo® Worm / Worm Double Reduction



DOUBLE REDUCTION • WORM/WORM DIMENSIONS



STYLE DJMQ

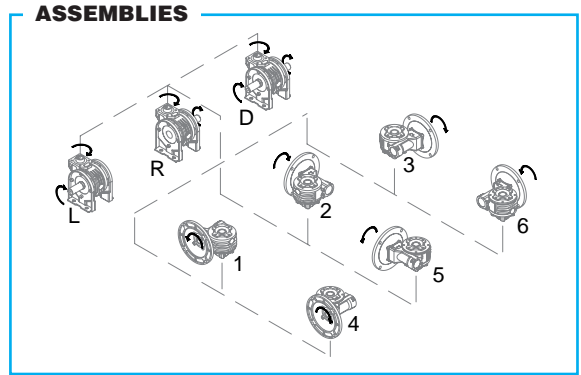
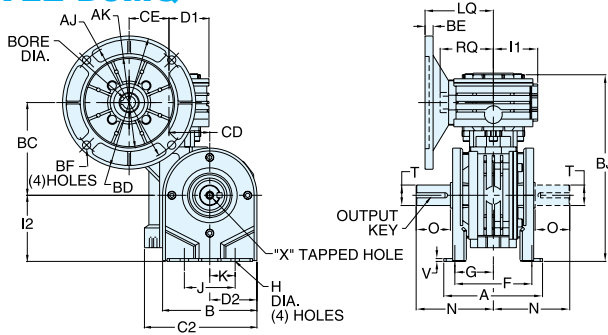

REVERSE ALL ARROWS FOR OPPOSITE INPUT SHAFT ROTATION. CONTACT FACTORY FOR OTHER MOUNTINGS OR ASSEMBLY POSITIONS.

STYLE DJMQ DIMENSIONS - Inches

Series	A	B	BC	BJ	C2	CD	CE	D1	D2	F	G	H	I1	I2	J	K	LQ* 56C	N	O*	RQ	T* +0.000 -0.001	V	X		OUTPUT KEY*
																						Tap Size	Depth		
518	3.94	3.86	4.35	8.57	4.76	1.77	1.77	1.93	1.93	3.17	1.59	0.413	2.16	2.83	1.97	0.99	3.33	2.97	1.26	2.60	0.750	0.12	1/4-20 UNC	0.62	3/16 x 1.00
520	4.84	4.45	4.53	9.13	5.33	1.97	1.77	1.93	2.15	3.94	1.97	0.413	2.16	3.22	2.48	1.24	3.33	3.94	2.05	2.60	1.000	0.14	5/16-18 UNC	0.75	1/4 X 1.62
525	5.67	5.24	5.75	11.07	6.89	2.48	1.77	1.93	2.76	4.35	2.18	0.413	2.16	3.94	3.74	1.87	3.33	4.85	2.36	2.60	1.125	0.16	5/16-18 UNC	0.75	1/4 X 2.00
534	7.17	7.09	6.76	13.74	9.15	3.35	1.77	1.93	3.72	5.71	2.86	0.413	2.16	5.59	5.51	2.76	3.33	5.55	2.36	2.60	1.500	0.20	5/16-18 UNC	0.75	3/8 X 2.00

* Metric options are available. Refer to dimensions below. Contact LEESON for availability of metric options.

STYLE DJ

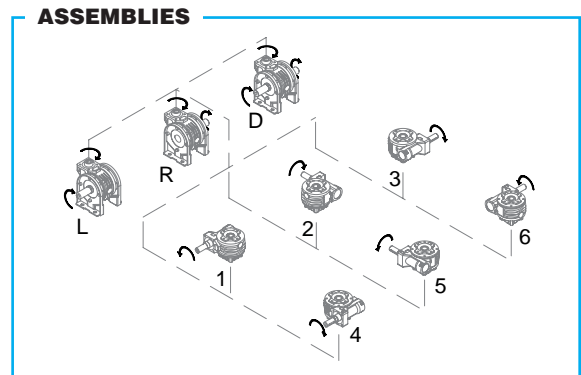
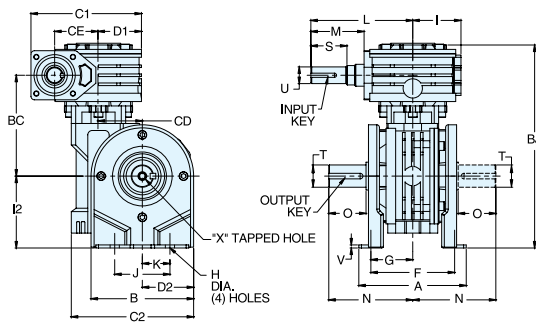

REVERSE ALL ARROWS FOR OPPOSITE INPUT SHAFT ROTATION. CONTACT FACTORY FOR OTHER MOUNTINGS OR ASSEMBLY POSITIONS.

STYLE DJ DIMENSIONS - Inches

Series	A	B	BC	BJ	C1	C2	CD	CE	D1	D2	F	G	H	I1	I2	J	K	L	M	N	O	S	T +0.000 -0.001	U +0.000 -0.001	V	X		INPUT KEY	OUTPUT KEY
																						Tap Size	Depth						
518	3.94	3.86	4.35	8.57	4.76	4.76	1.77	1.77	1.93	1.93	3.17	1.59	0.413	2.16	2.83	1.97	0.99	3.86	1.67	2.97	1.26	1.18	0.750	0.625	0.12	1/4-20 UNC	0.62	3/16 X 1.00	3/16 X 1.00
520	4.84	4.45	4.53	9.13	4.76	5.33	1.97	1.77	1.93	2.15	3.94	1.97	0.413	2.16	3.22	2.48	1.24	3.86	1.67	3.94	2.05	1.18	1.000	0.625	0.14	5/16-18 UNC	0.75	3/16 X 1.00	1/4 X 1.62
525	5.67	5.24	5.75	11.07	4.76	6.89	2.48	1.77	1.93	2.76	4.35	2.18	0.413	2.16	3.94	3.74	1.87	3.86	1.67	4.85	2.36	1.18	1.125	0.625	0.16	5/16-18 UNC	0.75	3/16 X 1.00	1/4 X 2.00
534	7.17	7.09	6.76	13.74	4.76	9.15	3.35	1.77	1.93	3.72	5.71	2.86	0.413	2.16	5.59	5.51	2.76	3.86	1.67	5.55	2.36	1.18	1.500	0.625	0.20	5/16-18 UNC	0.75	3/16 X 1.00	3/8 X 2.00

MOTOR MOUNTING DIMENSIONS

NEMA DIMENSIONS - Inches

Frame	AJ	AK	BD	BE	BF	Input Bore Dia	Input Keyway▲
56C	5.88	4.50	6.50	0.38	0.41	0.625	3/16 x 3/32

OPTIONAL METRIC DIMENSIONS* - MM

Series	LQ♦			T H7	O	N	Output Keyway
	IEC B5 & B14 Options						
	D56D■	D63D	D71D				
518	74♦	74♦	74	18	32	75	6
520	74♦	74♦	74	25	52	100	8
525	74♦	74♦	74	25	60	123	8
534	74♦	74♦	74	35	60	141	10

OPTIONAL METRIC DIMENSIONS* - MM

IEC Frame	B5					B14♦					Input Bore Dia	Input Keyway▲
	AJ	AK	BD	BE	BF	AJ	AK	BD	BE	BF♦		
D56D	N/A	N/A	N/A	N/A	N/A	65♦	50	80	7	6.5	9	3 x 1.5
D63D	115	95	140	11	9	75♦	60	90	5.5	5.5	11	4 x 2
D71D	130	110	160	10	9	85♦	70	105	8	6.5	14	5 x 2.5

♦ Contact LEESON for availability of metric input options. The output bore and/or solid output shaft extension will be metric as standard with metric input options.

▲ Keyway width by depth

♦ AJ Mounting holes are rotated 45° from positions shown on B14 input options as follows: D56D(All), D63D(All)

♦ Dimensions are maximum (B5 and B14 options)

■ B5 Option not available

Bravo® Worm / Worm Double Reduction



DOUBLE REDUCTION • HELICAL/WORM MOUNTING STYLE GUIDE



HOLLOW OUTPUT SHAFT MOUNTED (See "How to Specify" on page 122.)

DXHMQ

DXRHMQ

DXFHMQ

MOTORIZED QUILL INPUT



Ratings: Pages 123-124
Dimensions: Page 130

Ratings: Pages 123-124
Dimensions: Page 146

Ratings: Pages 123-124
Dimensions: Page 132

DXH

DXRH

DXFH

NON-MOTORIZED SOLID INPUT SHAFT



Ratings: Pages 123-124
Dimensions: Page 130

Ratings: Pages 123-124
Dimensions: Page 146

Ratings: Pages 123-124
Dimensions: Page 132

SOLID OUTPUT SHAFT (See "How to Specify" on page 122.)

DXMQ

DXRMQ

DXFMQ

MOTORIZED QUILL INPUT



Ratings: Pages 123-124
Dimensions: Page 131

(❖Non-Standard Option)
Ratings: Pages 123-124
Dimensions: Page 146

Ratings: Pages 123-124
Dimensions: Page 133

DX

DXR

DXF

NON-MOTORIZED SOLID INPUT SHAFT

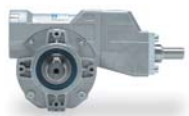

Ratings: Pages 123-124
Dimensions: Page 131

(❖Non-Standard Option)
Ratings: Pages 123-124
Dimensions: Page 146

Ratings: Pages 123-124
Dimensions: Page 133

MOUNTING ACCESSORIES

Select the appropriate mounting accessories from this wide variety of options.

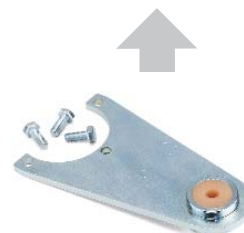

REACTION ARM R



F FLANGE (SHORT FLANGE)

❖ Non-Standard Option assemblies may be useful in certain applications. Please contact LEESON with application details.



DOUBLE REDUCTION • HELICAL/WORM MOUNTING STYLE GUIDE



DXFLHMQ



Ratings: Pages 123-124
Dimensions: Page 134

DXTHMQ



(❖Non-Standard Option)
Ratings: Pages 123-124
Dimensions: Page 136

DXUHMQ



(❖Non-Standard Option)
Ratings: Pages 123-124
Dimensions: Page 138

DXJHMQ



(❖Non-Standard Option)
Ratings: Pages 123-124
Dimensions: Page 140

DXFLH



Ratings: Pages 123-124
Dimensions: Page 134

DXTH



(❖Non-Standard Option)
Ratings: Pages 123-124
Dimensions: Page 136

DXUH



(❖Non-Standard Option)
Ratings: Pages 123-124
Dimensions: Page 138

DXJH



(❖Non-Standard Option)
Ratings: Pages 123-124
Dimensions: Page 140

DXFLMQ



Ratings: Pages 123-124
Dimensions: Page 135

DXTMQ



Ratings: Pages 123-124
Dimensions: Page 137

DXUMQ



Ratings: Pages 123-124
Dimensions: Page 139

DXJMQ



Ratings: Pages 123-124
Dimensions: Page 141

DXFL



Ratings: Pages 123-124
Dimensions: Page 135

DXT



Ratings: Pages 123-124
Dimensions: Page 137

DXU



Ratings: Pages 123-124
Dimensions: Page 139

DXJ



Ratings: Pages 123-124
Dimensions: Page 141



FL FLANGE
(LONG FLANGE)



HORIZONTAL BASE
(WORM OVER ASSEMBLY)



HORIZONTAL BASE
(WORM UNDER ASSEMBLY)



HORIZONTAL BASE
(VERTICAL INPUT SHAFT)

Bravo® Helical / Worm
Double Reduction

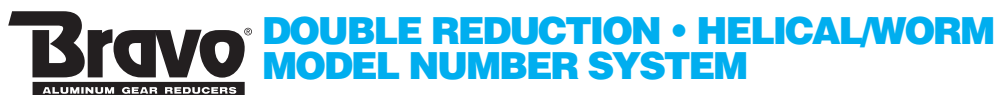

LEESON 500 Series Gear Reducer Model Number Nomenclature

All stock and custom 500 series reducers are identified by a model number. The model number appears on the nameplate and describes pertinent features of the reducer. An example follows, along with a listing of the various letters and positions used.

NOTE: All reducers also have a catalog number—for example W5180001. Reducers and renewal parts should be ordered by catalog number. If a stock reducer has been factory modified by the addition of an optional base for example, the modification number T518, for example, is stamped in the blank column of the nameplate. Accessories that are field installed will not be noted on the nameplate.

Catalog numbers 5000 (for example, W5185000) and higher are custom reducers manufactured for a specific application. The machinery or equipment manufacturer should be contacted for replacement reducers. Renewal parts can be ordered from LEESON by catalog number.

TYPICAL NAMEPLATE

LEESON		HYDRO-MEC	
MAX INPUT HP @ 1750 RPM	0.100	OUTPUT TORQUE (IN-LBS)	420
DESC.	DXMQ518258L5612	RATIO	258:1
CATALOG NO.		DATE CODE	A04
LEESON ELECTRIC SCHAFFER, WISCONSIN 53084		MOD	



SOLID OUTPUT SHAFT
DXMQ – Motorized, Quill Input
DX – Non-Flanged
 See pages 120-121 for other styles.

HOLLOW OUTPUT SHAFT
DXHMQ – Motorized, Quill Input
DXH – Non-Flanged
 See pages 120-121 for other styles.

See Selection Tables on pages 123-124 for all available ratios

- L** – Left-hand Output Shaft*
 - R** – Right-hand Output Shaft*
 - D** – Double Output Shaft
 - H** – Hollow Output Shaft
- * Viewed from drive end of reducer.

OUTPUT SHAFT DIMENSION CODE ▲

Series	NEMA/Inch Options		IEC/Metric Options	
	Shaft Dia.	Shaft* Code	Shaft Dia.	Shaft Code
518	3/4"	12	18mm	18
520	1"	16	25mm	25
525	1-1/8"	18	25mm	25
534	1-1/2"	24	35mm	35

*Shaft Diameter in 1/16ths of an inch.

▲ Diameters and shaft codes of hollow bore styles are identical to those of solid shaft styles. Reducers with NEMA inputs will have inch dimensioned output shafts and reducers with IEC inputs will have metric dimensioned output shafts as standard.

ALUMINUM 500 SERIES CENTER DISTANCES

Series	Center Distance	
	(Inches)	(mm)
518	1.77	45
520	1.97	50
525	2.48	63
534	3.35	85

NEMA Input Flange Code	For NEMA Frame
56	56C
140	143-5TC
IEC Input Flange Code	For IEC Frame
63B14	63B14
63B5	63B5
71B14	71B14
71B5	71B5
80B14	80B14
80B5	80B5
90B14	90B14
90B5	90B5

Sample Model Number

Solid Shaft

Motorized Quill Input, Double Reduction Reducer, 1.77" Center Distance, 258:1 Ratio, Left Hand Output Shaft, and 5/8" Input Bore with NEMA 56C Flange.

DXMQ **518** **258** **L** **56** **12**
 Style Series Ratio Output Shaft Motor Input Shaft Code

Hollow Shaft

Motorized Quill Input, Double Reduction Reducer, 1.77" Center Distance, 258:1 Ratio, 3/4" Hollow Output Shaft, and 5/8" Input Bore with NEMA 56C Flange.

DXHMQ **518** **258** **H** **56** **12**
 Style Series Ratio Output Shaft Motor Input Shaft Code
 Flange



DOUBLE REDUCTION • HELICAL/WORM MAXIMUM RATING TABLES

518 & 520 SERIES • ALL STOCK STYLES



518 Series • 1.0 S.F.

Exact Ratio*	Input RPM	Output RPM	Input HP	Output HP	Output Torque (lb-in)
30.1	1750	58.1	0.523	0.387	420
	1150	38.2	0.363	0.269	443
43	1750	40.7	0.377	0.271	420
	1150	26.7	0.261	0.188	443
60.2	1750	29.07	0.323	0.194	420
	1150	19.10	0.224	0.134	443
90.3	1750	19.38	0.227	0.129	420
	1150	12.74	0.157	0.090	443
120.4	1750	14.53	0.183	0.097	420
	1150	9.55	0.127	0.067	443
159.1	1750	11.00	0.150	0.073	420
	1150	7.23	0.104	0.051	443
197.8	1750	8.85	0.125	0.059	420
	1150	5.81	0.087	0.041	443
258	1750	6.78	0.100	0.045	420
	1150	4.46	0.070	0.031	443
301	1750	5.81	0.068	0.027	294
	1150	3.82	0.047	0.019	310
438.6	1750	3.99	0.052	0.019	294
	1150	2.62	0.036	0.013	310

* Contact LEESON for additional ratio options available.

520 Series • 1.0 S.F.

Exact Ratio*	Input RPM	Output RPM	Input HP	Output HP	Output Torque (lb-in)
30.1	1750	58.1	0.714	0.543	589
	1150	38.2	0.494	0.376	620
43	1750	40.7	0.507	0.380	589
	1150	26.7	0.350	0.263	620
60.2	1750	29.1	0.394	0.272	589
	1150	19.1	0.272	0.188	620
77.4	1750	22.61	0.396	0.241	673
	1150	14.86	0.274	0.167	708
111.8	1750	15.65	0.274	0.167	673
	1150	10.29	0.189	0.116	708
154.8	1750	11.30	0.215	0.121	673
	1150	7.43	0.149	0.083	708
184.9	1750	9.46	0.180	0.088	589
	1150	6.22	0.125	0.061	620
258	1750	6.78	0.135	0.063	589
	1150	4.46	0.093	0.044	620
292.4	1750	5.98	0.109	0.048	504
	1150	3.93	0.075	0.033	531
344	1750	5.09	0.068	0.027	336
	1150	3.34	0.047	0.019	354
430	1750	4.07	0.060	0.022	336
	1150	2.67	0.042	0.015	354

* Contact LEESON for additional ratio options available.

Bravo® Helical / Worm
Double Reduction



**DOUBLE REDUCTION • HELICAL/WORM
MAXIMUM RATING TABLES**

525 & 534 SERIES • ALL STOCK STYLES



525 Series • 1.0 S.F.

Exact Ratio*	Input RPM	Output RPM	Input HP	Output HP	Output Torque (lb-in)
29.5	1750	59.4	1.767	1.307	1387
	1150	39.0	1.221	0.903	1460
37.2	1750	47.0	1.417	1.034	1387
	1150	30.9	0.981	0.716	1460
46.5	1750	37.6	1.340	0.938	1572
	1150	24.7	0.927	0.649	1655
55.8	1750	31.4	1.224	0.783	1572
	1150	20.6	0.845	0.541	1655
69.8	1750	25.09	1.026	0.626	1572
	1150	16.49	0.710	0.433	1655
87.8	1750	19.94	0.731	0.526	1664
	1150	13.10	0.506	0.364	1752
110.9	1750	15.78	0.595	0.417	1664
	1150	10.37	0.412	0.288	1752
138.6	1750	12.63	0.505	0.333	1664
	1150	8.30	0.350	0.231	1752
166.3	1750	10.52	0.463	0.278	1664
	1150	6.91	0.320	0.192	1752
207.9	1750	8.42	0.359	0.198	1480
	1150	5.53	0.249	0.137	1558
309.5	1750	5.65	0.260	0.133	1480
	1150	3.72	0.180	0.092	1558
369.6	1750	4.73	0.236	0.111	1480
	1150	3.11	0.164	0.077	1558
434.3	1750	4.03	0.166	0.070	1093
	1150	2.65	0.115	0.048	1151

* Contact LEESON for additional ratio options available.

534 Series • 1.0 S.F.

Exact Ratio*	Input RPM	Output RPM	Input HP	Output HP	Output Torque (lb-in)
32.3	1750	54.1	3.207	2.309	2690
	1150	35.6	2.221	1.599	2831
46.2	1750	37.9	2.311	1.618	2690
	1150	24.9	1.598	1.118	2831
58.9	1750	29.7	2.247	1.506	3195
	1150	19.5	1.553	1.041	3363
80.6	1750	21.71	1.804	1.101	3195
	1150	14.27	1.248	0.761	3363
103.9	1750	16.85	1.311	0.787	2943
	1150	11.07	0.907	0.544	3098
129.4	1750	13.53	1.053	0.632	2943
	1150	8.89	0.728	0.437	3098
175.6	1750	9.97	0.844	0.532	3363
	1150	6.55	0.584	0.368	3540
240.2	1750	7.28	0.696	0.369	3195
	1150	4.79	0.482	0.256	3363
309.5	1750	5.65	0.551	0.286	3195
	1150	3.72	0.382	0.198	3363
422.1	1750	4.15	0.373	0.194	2943
	1150	2.72	0.257	0.134	3098
443.5	1750	3.95	0.351	0.158	2522
	1150	2.59	0.242	0.109	2653
604.8	1750	2.89	0.289	0.116	2522
	1150	1.90	0.200	0.080	2653

* Contact LEESON for additional ratio options available.

Bravo® Helical / Worm
Double Reduction



DOUBLE REDUCTION • HELICAL/WORM "How to Use" Quick Selection Tables



How To Use Quick Selections

Maximum Rating Tables for Double Reduction Gear Reducers are shown on pages 123-124. Selection of the appropriate gear reducer can be made using those tables or the Quick Selections on the following pages.

BEFORE YOU START:

Identify the Service Factor of the application (see page 171).

Determine the actual input horsepower of the motor by multiplying the motor's nameplate horsepower by the Service Factor.

Determine the output speed (RPM) required at output shaft of reducer.

Identify the mounting style required by your application from the style charts shown on pages 120-121. Note the basic mounting style (DXMQ, DXHMQ, etc.).

To select the proper gear reducer size, use the Quick Selections as shown:

DOUBLE REDUCTION • HELICAL/WORM QUICK SELECTIONS

Style DXMQ Motorized NEMA Frame Selections 1750 RPM Input

1/4 HP / 0.18 KW Gear Reducer Quick Selections

Output Speed (RPM)	Service Factor	Output Torque (lb-in)	Overhung Load (lbs.)	Ratio	Motor Frame	Style DXMQ Solid Output		Style DXHMQ Hollow Output	
						Weight (lbs.)	Model Number	Weight (lbs.)	Model Number
58	2.09	201	299	30.1	56C	9	DXMQ518-30.1-56-12	8	DXHMQ518-30.1-H-56-12
58	2.85	206	414	30.1	56C	11	DXMQ520-30.1-56-16	9	DXHMQ520-30.1-H-56-16
41	1.59	264	348	43	56C	9	DXMQ518-43-56-12	8	DXHMQ518-43-H-56-12
41	2.14	275	483	43	56C	11	DXMQ520-43-56-16	9	DXHMQ520-43-H-56-16
38	6.70	235	764	46.5	56C	19	DXMQ525-46.5-56-18	17	DXHMQ525-46.5-H-56-18
					56C	19	DXMQ525-55.8-56-18	17	DXHMQ525-55.8-H-56-18
					56C	9	DXMQ518-60.2-56-12	8	DXHMQ518-60.2-H-56-12
					56				DXHMQ520-60.2-H-56-16
					56				DXHMQ525-69.8-H-56-18
					56				DXHMQ520-77.4-H-56-16
					56				DXHMQ525-87.8-H-56-18
					56				DXHMQ534-103.9-H-56
					56	19	DXMQ525-110.9-56-18	17	DXHMQ525-110.9-H-56
					56C	11	DXMQ520-111.8-56-16	9	DXHMQ520-111.8-H-56
					56C	47	DXMQ534-129.4-56-24	42	DXHMQ534-129.4-H-56
					56C	19	DXMQ525-138.6-56-18	17	DXHMQ525-138.6-H-56
					56C	19	DXMQ525-166.3-56-18	17	DXHMQ525-166.3-H-56
					56C	47	DXMQ534-175.6-56-24	42	DXHMQ534-175.6-H-56
					56C	19	DXMQ525-207.9-56-18	17	DXHMQ525-207.9-H-56
					56C	47	DXMQ534-240.2-56-24	42	DXHMQ534-240.2-H-56
					56C	19	DXMQ525-309.5-56-18	17	DXHMQ525-309.5-H-56
					56C	47	DXMQ534-309.5-H-56	42	DXHMQ534-309.5-H-56
					56C	47	DXMQ534-422.1-H-56	42	DXHMQ534-422.1-H-56
					56C	47	DXMQ534-443.5-H-56	42	DXHMQ534-443.5-H-56
					56C	47	DXMQ534-604.8-H-56	42	DXHMQ534-604.8-H-56

1/3 HP / 0.25 KW Gear Reducer Quick Selections

58	1.58	265	299	30.1	56C	9	DXMQ518-30.1-56-12	8	DXHMQ518-30.1-H-56-12
58	2.16	272	414	30.1	56C	11	DXMQ520-30.1-56-16	9	DXHMQ520-30.1-H-56-16

2 Locate output RPM column on left side of the table. All ratings are based on an input speed of 1750 RPM. Scroll down to the output speed (RPM) required. Output speeds may be rounded to the nearest whole number. For exact output speed, divide 1750 by the ratio listed.

3 Move to the Service Factor column and find one suitable to meet the application requirements. Refer to page 171 for AGMA recommended service factors.

4 Check load capacities against the needs of your application. Do not exceed the overhung load (OHL) shown in the table. Detailed instructions for calculating the actual overhung load are shown on page 150. If overhung and thrust loads will be applied simultaneously or if the load exceeds listed capacities, contact LEESON.

5 Select motor frame size.

6 Identify the model number of the basic reducer by continuing to the right. See page 122 for detailed information on building an exact model number. Model numbers for solid and hollow output shaft styles are shown in quick selection tables. To complete model number, select shaft hand and mounting assembly from dimensional pages.

7 Verify physical dimensions using the dimensional drawings shown on pages 130-141.

Bravo® Helical / Worm Double Reduction

Bravo® Helical / Worm Double Reduction



**Style DXMQ & DXHMQ
Motorized Quill Input
NEMA Frame Selections
1750 RPM Input**

1/4 HP / 0.18 KW						Gear Reducer Quick Selections			
Output Speed (RPM)	Service Factor ▼	Output Torque (lb-in)	Overhung Load (lbs.) ●	Ratio	Motor Frame ◆	Style DXMQ Solid Output		Style DXHMQ Hollow Output	
						Weight (lbs.)	Model Number ■	Weight (lbs.)	Model Number ■
58	2.09	201	299	30.1	56C	9	DXMQ518-30.1-__-56-12	8	DXHMQ518-30.1-H-56-12
58	2.85	206	414	30.1	56C	11	DXMQ520-30.1-__-56-16	9	DXHMQ520-30.1-H-56-16
41	1.59	264	348	43	56C	9	DXMQ518-43-__-56-12	8	DXHMQ518-43-H-56-12
41	2.14	275	483	43	56C	11	DXMQ520-43-__-56-16	9	DXHMQ520-43-H-56-16
38	6.70	235	764	46.5	56C	19	DXMQ525-46.5-__-56-18	17	DXHMQ525-46.5-H-56-18
31	4.83	325	798	55.8	56C	19	DXMQ525-55.8-__-56-18	17	DXHMQ525-55.8-H-56-18
29.1	1.29	326	393	60.2	56C	9	DXMQ518-60.2-__-56-12	8	DXHMQ518-60.2-H-56-12
29.1	1.57	375	528	60.2	56C	11	DXMQ520-60.2-__-56-16	9	DXHMQ520-60.2-H-56-16
25.1	4.11	383	854	69.8	56C	19	DXMQ525-69.8-__-56-18	17	DXHMQ525-69.8-H-56-18
22.6	1.58	425	573	77.4	56C	11	DXMQ520-77.4-__-56-16	9	DXHMQ520-77.4-H-56-16
19.9	2.92	570	877	87.8	56C	19	DXMQ525-87.8-__-56-18	17	DXHMQ525-87.8-H-56-18
16.9	5.26	559	1259	103.9	56C	47	DXMQ534-103.9-__-56-24	42	DXHMQ534-103.9-H-56-24
15.8	2.38	698	899	110.9	56C	19	DXMQ525-110.9-__-56-18	17	DXHMQ525-110.9-H-56-18
15.7	1.10	612	629	111.8	56C	11	DXMQ520-111.8-__-56-16	9	DXHMQ520-111.8-H-56-16
13.5	4.20	700	1304	129.4	56C	47	DXMQ534-129.4-__-56-24	42	DXHMQ534-129.4-H-56-24
12.6	2.02	825	899	138.6	56C	19	DXMQ525-138.6-__-56-18	17	DXHMQ525-138.6-H-56-18
10.5	1.85	900	899	166.3	56C	19	DXMQ525-166.3-__-56-18	17	DXHMQ525-166.3-H-56-18
9.97	3.38	996	1304	175.6	56C	47	DXMQ534-175.6-__-56-24	42	DXHMQ534-175.6-H-56-24
8.42	1.44	1029	899	207.9	56C	19	DXMQ525-207.9-__-56-18	17	DXHMQ525-207.9-H-56-18
7.28	2.79	1147	1304	240.2	56C	47	DXMQ534-240.2-__-56-24	42	DXHMQ534-240.2-H-56-24
5.65	1.04	1422	899	309.5	56C	19	DXMQ525-309.5-__-56-18	17	DXHMQ525-309.5-H-56-18
5.65	2.20	1450	1304	309.5	56C	47	DXMQ534-309.5-__-56-24	42	DXHMQ534-309.5-H-56-24
4.15	1.49	1974	1304	422.1	56C	47	DXMQ534-422.1-__-56-24	42	DXHMQ534-422.1-H-56-24
3.95	1.41	1795	1304	443.5	56C	47	DXMQ534-443.5-__-56-24	42	DXHMQ534-443.5-H-56-24
2.89	1.16	2181	1304	604.8	56C	47	DXMQ534-604.8-__-56-24	42	DXHMQ534-604.8-H-56-24
1/3 HP / 0.25 KW						Gear Reducer Quick Selections			
58	1.58	265	299	30.1	56C	9	DXMQ518-30.1-__-56-12	8	DXHMQ518-30.1-H-56-12
58	2.16	273	414	30.1	56C	11	DXMQ520-30.1-__-56-16	9	DXHMQ520-30.1-H-56-16
41	1.15	365	348	43	56C	9	DXMQ518-43-__-56-12	8	DXHMQ518-43-H-56-12
41	1.55	380	483	43	56C	11	DXMQ520-43-__-56-16	9	DXHMQ520-43-H-56-16
38	4.10	383	764	46.5	56C	19	DXMQ525-46.5-__-56-18	17	DXHMQ525-46.5-H-56-18
31	3.66	429	798	55.8	56C	19	DXMQ525-55.8-__-56-18	17	DXHMQ525-55.8-H-56-18
29.1	0.98	429	393	60.2	56C	9	DXMQ518-60.2-__-56-12	8	DXHMQ518-60.2-H-56-12
29.1	1.19	493	528	60.2	56C	11	DXMQ520-60.2-__-56-16	9	DXHMQ520-60.2-H-56-16

Bravo® Helical / Worm Double Reduction

- ◆ NEMA input selections shown. Reducers are also available with metric IEC input flanges. Refer to page 129 for frame options available. Metric IEC input selections will have a metric output shaft as standard. Contact LEESON for catalog number information.
- ▼ Service Factor is based on maximum torque rating of reducer. Refer to page 171 for special application considerations.
- Output shaft overhung load rating is based on load applied at center of output shaft extension (solid output shaft style).
- Double reduction reducer selections should be ordered using the model numbers shown. Replace “_” with appropriate mounting position. Refer to dimensional pages for mounting position options.

TABLE CONTINUES ON NEXT PAGE

This Quick Selection is only for style DXHMQ (solid output) & DXMQ (hollow output) reducers. For other reducer configurations, see the MAXIMUM RATING TABLES beginning on page 123.



DOUBLE REDUCTION • HELICAL WORM QUICK SELECTIONS



**Style DXMQ & DXHMQ
Motorized Quill Input
NEMA Frame Selections
1750 RPM Input**

1/3 HP / 0.25 KW						Gear Reducer Quick Selections			
Output Speed (RPM)	Service Factor▼	Output Torque (lb-in)	Overhung Load (lbs.)●	Ratio	Motor Frame◆	Style DXMQ Solid Output		Style DXHMQ Hollow Output	
						Weight (lbs.)	Model Number■	Weight (lbs.)	Model Number■
25.1	3.11	505	854	69.8	56C	19	DXMQ525-69.8-__-56-18	17	DXHMQ525-69.8-H-56-18
22.6	1.20	561	573	77.4	56C	11	DXMQ520-77.4-__-56-16	9	DXHMQ520-77.4-H-56-16
21.7	5.46	585	1169	80.6	56C	47	DXMQ534-80.6-__-56-24	42	DXHMQ534-80.6-H-56-24
19.9	2.21	752	877	87.8	56C	19	DXMQ525-87.8-__-56-18	17	DXHMQ525-87.8-H-56-18
16.9	3.99	738	1259	103.9	56C	47	DXMQ534-103.9-__-56-24	42	DXHMQ534-103.9-H-56-24
15.8	1.81	921	899	110.9	56C	19	DXMQ525-110.9-__-56-18	17	DXHMQ525-110.9-H-56-18
13.5	3.18	924	1304	129.4	56C	47	DXMQ534-129.4-__-56-24	42	DXHMQ534-129.4-H-56-24
12.6	1.53	1089	899	138.6	56C	19	DXMQ525-138.6-__-56-18	17	DXHMQ525-138.6-H-56-18
10.5	1.40	1188	899	166.3	56C	19	DXMQ525-166.3-__-56-18	17	DXHMQ525-166.3-H-56-18
9.97	2.56	1314	1304	175.6	56C	47	DXMQ534-175.6-__-56-24	42	DXHMQ534-175.6-H-56-24
8.42	1.09	1359	899	207.9	56C	19	DXMQ525-207.9-__-56-18	17	DXHMQ525-207.9-H-56-18
7.28	2.11	1514	1304	240.2	56C	47	DXMQ534-240.2-__-56-24	42	DXHMQ534-240.2-H-56-24
5.65	1.67	1914	1304	309.5	56C	47	DXMQ534-309.5-__-56-24	42	DXHMQ534-309.5-H-56-24
4.15	1.13	2606	1304	422.1	56C	47	DXMQ534-422.1-__-56-24	42	DXHMQ534-422.1-H-56-24
3.95	1.06	2369	1304	443.5	56C	47	DXMQ534-443.5-__-56-24	42	DXHMQ534-443.5-H-56-24

1/2 HP / 0.37 KW						Gear Reducer Quick Selections			
Output Speed (RPM)	Service Factor▼	Output Torque (lb-in)	Overhung Load (lbs.)●	Ratio	Motor Frame◆	Style DXMQ Solid Output		Style DXHMQ Hollow Output	
						Weight (lbs.)	Model Number■	Weight (lbs.)	Model Number■
59	3.51	395	629	29.5	56C	19	DXMQ525-29.5-__-56-18	17	DXHMQ525-29.5-H-56-18
58	1.04	402	299	30.1	56C	9	DXMQ518-30.1-__-56-12	8	DXHMQ518-30.1-H-56-12
58	1.43	413	414	30.1	56C	11	DXMQ520-30.1-__-56-16	9	DXHMQ520-30.1-H-56-16
47	2.83	489	697	37.2	56C	19	DXMQ525-37.2-__-56-18	17	DXHMQ525-37.2-H-56-18
41	1.02	576	483	43	56C	11	DXMQ520-43-__-56-16	9	DXHMQ520-43-H-56-16
38	4.63	580	1007	46.2	56C	47	DXMQ534-46.2-__-56-24	42	DXHMQ534-46.2-H-56-24
38	2.71	580	764	46.5	56C	19	DXMQ525-46.5-__-56-18	17	DXHMQ525-46.5-H-56-18
31	2.42	651	798	55.8	56C	19	DXMQ525-55.8-__-56-18	17	DXHMQ525-55.8-H-56-18
29.7	4.49	711	1079	58.9	56C	47	DXMQ534-58.9-__-56-24	42	DXHMQ534-58.9-H-56-24
25.1	2.05	766	854	69.8	56C	19	DXMQ525-69.8-__-56-18	17	DXHMQ525-69.8-H-56-18
21.7	3.61	886	1169	80.6	56C	47	DXMQ534-80.6-__-56-24	42	DXHMQ534-80.6-H-56-24
19.9	1.46	1140	877	87.8	56C	19	DXMQ525-87.8-__-56-18	17	DXHMQ525-87.8-H-56-18
16.9	2.63	1119	1259	103.9	56C	47	DXMQ534-103.9-__-56-24	42	DXHMQ534-103.9-H-56-24
15.8	1.19	1396	899	110.9	56C	19	DXMQ525-110.9-__-56-18	17	DXHMQ525-110.9-H-56-18
13.5	2.10	1401	1304	129.4	56C	47	DXMQ534-129.4-__-56-24	42	DXHMQ534-129.4-H-56-24
12.6	1.01	1651	899	138.6	56C	19	DXMQ525-138.6-__-56-18	17	DXHMQ525-138.6-H-56-18
9.97	1.69	1991	1304	175.6	56C	47	DXMQ534-175.6-__-56-24	42	DXHMQ534-175.6-H-56-24
7.28	1.39	2294	1304	240.2	56C	47	DXMQ534-240.2-__-56-24	42	DXHMQ534-240.2-H-56-24
5.65	1.10	2900	1304	309.5	56C	47	DXMQ534-309.5-__-56-24	42	DXHMQ534-309.5-H-56-24

Bravo® Helical / Worm Double Reduction

◆ NEMA input selections shown. Reducers are also available with metric IEC input flanges. Refer to page 129 for frame options available. Metric IEC input selections will have a metric output shaft as standard. Contact LEESON for catalog number information.

▼ Service Factor is based on maximum torque rating of reducer. Refer to page 171 for special application considerations.

● Output shaft overhung load rating is based on load applied at center of output shaft extension (solid output shaft style).

■ Double reduction reducer selections should be ordered using the model numbers shown. Replace “__” with appropriate mounting position. Refer to dimensional pages for mounting position options.

This Quick Selection is only for style DXHMQ (solid output) & DXMQ (hollow output) reducers. For other reducer configurations, see the MAXIMUM RATING TABLES beginning on page 123.



**Style DXMQ & DXHMQ
Motorized Quill Input
NEMA Frame Selections
1750 RPM Input**

3/4 HP / 0.55 KW Gear Reducer Quick Selections									
Output Speed (RPM)	Service Factor▼	Output Torque (lb-in)	Overhung Load (lbs.)●	Ratio	Motor Frame◆	Style DXMQ Solid Output		Style DXHMQ Hollow Output	
						Weight (lbs.)	Model Number■	Weight (lbs.)	Model Number■
59	2.34	593	629	29.5	56C	19	DXMQ525-29.5-__-56-18	17	DXHMQ525-29.5-H-56-18
54	4.27	630	881	32.3	56C	47	DXMQ534-32.3-__-56-24	42	DXHMQ534-32.3-H-56-24
47	1.89	734	697	37.2	56C	19	DXMQ525-37.2-__-56-18	17	DXHMQ525-37.2-H-56-18
38	3.09	871	1007	46.2	56C	47	DXMQ534-46.2-__-56-24	42	DXHMQ534-46.2-H-56-24
38	1.81	871	764	46.5	56C	19	DXMQ525-46.5-__-56-18	17	DXHMQ525-46.5-H-56-18
31	1.61	976	798	55.8	56C	19	DXMQ525-55.8-__-56-18	17	DXHMQ525-55.8-H-56-18
29.7	3.03	1056	1079	58.9	56C	47	DXMQ534-58.9-__-56-24	42	DXHMQ534-58.9-H-56-24
25.1	1.37	1149	854	69.8	56C	19	DXMQ525-69.8-__-56-18	17	DXHMQ525-69.8-H-56-18
21.7	2.40	1329	1169	80.6	56C	47	DXMQ534-80.6-__-56-24	42	DXHMQ534-80.6-H-56-24
19.9	0.97	1710	877	87.8	56C	19	DXMQ525-87.8-__-56-18	17	DXHMQ525-87.8-H-56-18
16.9	1.75	1678	1259	103.9	56C	47	DXMQ534-103.9-__-56-24	42	DXHMQ534-103.9-H-56-24
13.5	1.40	2101	1304	129.4	56C	47	DXMQ534-129.4-__-56-24	42	DXHMQ534-129.4-H-56-24
9.97	1.13	2987	1304	175.6	56C	47	DXMQ534-175.6-__-56-24	42	DXHMQ534-175.6-H-56-24
1 HP / 0.75 KW Gear Reducer Quick Selections									
59	1.75	790	629	29.5	56C	19	DXMQ525-29.5-__-56-18	17	DXHMQ525-29.5-H-56-18
54	3.20	840	881	32.3	56C	47	DXMQ534-32.3-__-56-24	42	DXHMQ534-32.3-H-56-24
47	1.42	979	697	37.2	56C	19	DXMQ525-37.2-__-56-18	17	DXHMQ525-37.2-H-56-18
38	2.32	1161	1007	46.2	56C	47	DXMQ534-46.2-__-56-24	42	DXHMQ534-46.2-H-56-24
38	1.35	1161	764	46.5	56C	19	DXMQ525-46.5-__-56-18	17	DXHMQ525-46.5-H-56-18
31	1.21	1301	798	55.8	56C	19	DXMQ525-55.8-__-56-18	17	DXHMQ525-55.8-H-56-18
29.7	2.27	1408	1079	58.9	56C	47	DXMQ534-58.9-__-56-24	42	DXHMQ534-58.9-H-56-24
25.1	1.02	1538	854	69.8	56C	19	DXMQ525-69.8-__-56-18	17	DXHMQ525-69.8-H-56-18
21.7	1.83	1748	1169	80.6	56C	47	DXMQ534-80.6-__-56-24	42	DXHMQ534-80.6-H-56-24
16.9	1.32	2238	1259	103.9	56C	47	DXMQ534-103.9-__-56-24	42	DXHMQ534-103.9-H-56-24
13.5	1.05	2801	1304	129.4	56C	47	DXMQ534-129.4-__-56-24	42	DXHMQ534-129.4-H-56-24
1-1/2 HP / 1.1 KW Gear Reducer Quick Selections									
59	1.17	1186	629	29.5	56C	19	DXMQ525-29.5-__-56-18	17	DXHMQ525-29.5-H-56-18
54	2.13	1261	881	32.3	56C	47	DXMQ534-32.3-__-56-24	42	DXHMQ534-32.3-H-56-24
38	1.54	1746	1007	46.2	56C	47	DXMQ534-46.2-__-56-24	42	DXHMQ534-46.2-H-56-24
29.7	1.50	2133	1079	58.9	56C	47	DXMQ534-58.9-__-56-24	42	DXHMQ534-58.9-H-56-24
21.7	1.22	2621	1169	80.6	56C	47	DXMQ534-80.6-__-56-24	42	DXHMQ534-80.6-H-56-24

◆ NEMA input selections shown. Reducers are also available with metric IEC input flanges. Refer to page 129 for frame options available. Metric IEC input selections will have a metric output shaft as standard. Contact LEESON for catalog number information.

▼ Service Factor is based on maximum torque rating of reducer. Refer to page 171 for special application considerations.

● Output shaft overhung load rating is based on load applied at center of output shaft extension (solid output shaft style).

■ Double reduction reducer selections should be ordered using the model numbers shown. Replace “__” with appropriate mounting position. Refer to dimensional pages for mounting position options.

This Quick Selection is only for style DXHMQ (solid output) & DXMQ (hollow output) reducers. For other reducer configurations, see the MAXIMUM RATING TABLES beginning on page 123.



DOUBLE REDUCTION • HELICAL/WORM MOTOR FRAME COMBINATIONS

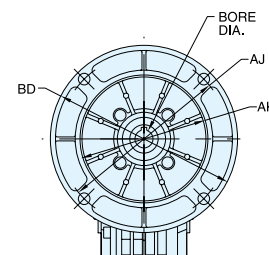

DOUBLE REDUCTION • HELICAL/WORM • MOTOR FRAME COMBINATIONS

Reducer Size	NEMA or IEC Frame Size	Dimensions - Inches (MM)				Available Ratios									
		AK	AJ	BD	Bore Dia.	30.1	43	60.2	90.3	120.4	159.1	197.8	258	301	438.6
518	NEMA 56C	4.50	5.88	6.50	0.625	•	•	•	•	•	•	•	•	•	•
	IEC 63B5	3.74 (95)	4.53 (115)	5.51 (140)	(11)	■	■	■	■	■	■	■	■	■	■
	IEC 63B14	2.36 (60)	2.95 (75)	3.54 (90)	(11)	■	■	■	■	■	■	■	■	■	■
	IEC 71B5	4.33 (110)	5.12 (130)	6.30 (160)	(14)	•	•	•	•	•	•	•	•	•	•
	IEC 71B14	2.76 (70)	3.35 (85)	4.13 (105)	(14)	•	•	•	•	•	•	•	•	•	•
520	NEMA 56C	4.50	5.88	6.50	0.625	•	•	•	•	•	•	•	•	•	•
	IEC 63B5	3.74 (95)	4.53 (115)	5.51 (140)	(11)	■	■	■	■	■	■	■	■	■	■
	IEC 63B14	2.36 (60)	2.95 (75)	3.54 (90)	(11)	■	■	■	■	■	■	■	■	■	■
	IEC 71B5	4.33 (110)	5.12 (130)	6.30 (160)	(14)	•	•	•	•	•	•	•	•	•	•
	IEC 71B14	2.76 (70)	3.35 (85)	4.13 (105)	(14)	•	•	•	•	•	•	•	•	•	•
525	NEMA 56C	4.50	5.88	6.50	0.625	■	■	■	■	■	■	■	■	■	■
	NEMA 140TC	4.50	5.88	6.50	0.875	•	•	•	•	•	•	•	•	•	•
	IEC 63B5	3.74 (95)	4.53 (115)	5.51 (140)	(11)	■	■	■	■	■	■	■	■	■	■
	IEC 63B14	2.36 (60)	2.95 (75)	3.54 (90)	(11)	■	■	■	■	■	■	■	■	■	■
	IEC 71B5	4.33 (110)	5.12 (130)	6.30 (160)	(14)	■	■	■	■	■	■	■	■	■	■
	IEC 71B14	2.76 (70)	3.35 (85)	4.13 (105)	(14)	■	■	■	■	■	■	■	■	■	■
	IEC 80B5	5.12 (130)	6.50 (165)	7.87 (200)	(19)	■	■	■	■	•	•	•	•	•	•
	IEC 80B14	3.15 (80)	3.94 (100)	4.72 (120)	(19)	■	■	■	■	•	•	•	•	•	•
	IEC 90B5	5.12 (130)	6.50 (165)	7.87 (200)	(24)	•	•	•	•	•	•	•	•	•	•
	IEC 90B14	3.74 (95)	4.53 (115)	5.51 (140)	(24)	•	•	•	•	•	•	•	•	•	•
534	NEMA 56C	4.50	5.88	6.50	0.625	■	■	■	■	■	■	■	■	■	■
	NEMA 140TC	4.50	5.88	6.50	0.875	•	•	•	•	•	•	•	•	•	•
	IEC 63B5	3.74 (95)	4.53 (115)	5.51 (140)	(11)	■	■	■	■	■	■	■	■	■	■
	IEC 71B5	4.33 (110)	5.12 (130)	6.30 (160)	(14)	■	■	■	■	■	■	■	■	■	■
	IEC 71B14	2.76 (70)	3.35 (85)	4.13 (105)	(14)	■	■	■	■	■	■	■	■	■	■
	IEC 80B5	5.12 (130)	6.50 (165)	7.87 (200)	(19)	■	■	■	■	•	•	•	•	•	•
	IEC 80B14	3.15 (80)	3.94 (100)	4.72 (120)	(19)	■	■	■	■	•	•	•	•	•	•
	IEC 90B5	5.12 (130)	6.50 (165)	7.87 (200)	(24)	•	•	•	•	•	•	•	•	•	•
	IEC 90B14	3.74 (95)	4.53 (115)	5.51 (140)	(24)	•	•	•	•	•	•	•	•	•	•

* Reducer selections are available. Refer to dimensional pages for additional dimensions and special conditions for flange mounting hole alignment.
 ■ Reducer selections are available. A bushing will be provided with reducer to achieve input bore diameter shown. Refer to dimensional pages for additional dimensions and special conditions for flange mounting hole alignment.

DOUBLE REDUCTION • HELICAL/WORM • EXACT RATIO COMBINATIONS

518			520			525			534		
TOTAL RATIO	P HELICAL	S 518	TOTAL RATIO	P HELICAL	S 520	TOTAL RATIO	P HELICAL	S 525	TOTAL RATIO	P HELICAL	S 534
30.1	4.3	7	30.1	4.3	7	29.5	1.55	19	32.3	4.62	7
43	4.3	10	43	4.3	10	37.2	1.55	24	46.2	4.62	10
60.2	4.3	14	60.2	4.3	14	46.5	1.55	30	58.9	1.55	38
90.3	4.3	21	77.4	4.3	18	55.8	1.55	36	80.6	1.55	52
120.4	4.3	28	111.8	4.3	26	69.8	1.55	45	103.9	1.55	67
159.1	4.3	37	154.8	4.3	36	87.8	4.62	19	129.4	4.62	28
197.8	4.3	46	184.9	4.3	43	110.9	4.62	24	175.6	4.62	38
258	4.3	60	258	4.3	60	138.6	4.62	30	240.2	4.62	52
301	4.3	70	292.4	4.3	68	166.3	4.62	36	309.5	4.62	67
438.6	4.3	102	344	4.3	80	207.9	4.62	45	422.1	6.3	67
			430	4.3	100	309.5	4.62	67	443.5	4.62	96
						369.6	4.62	80	604.8	6.3	96
						434.3	4.62	94			

Bravo® Helical / Worm Double Reduction

Bravo® DOUBLE REDUCTION • HELICAL/WORM DIMENSIONS

ALUMINUM GEAR REDUCERS



STYLE DXHMQ

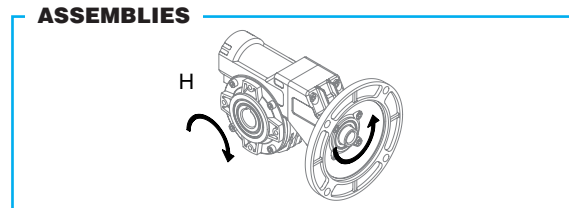
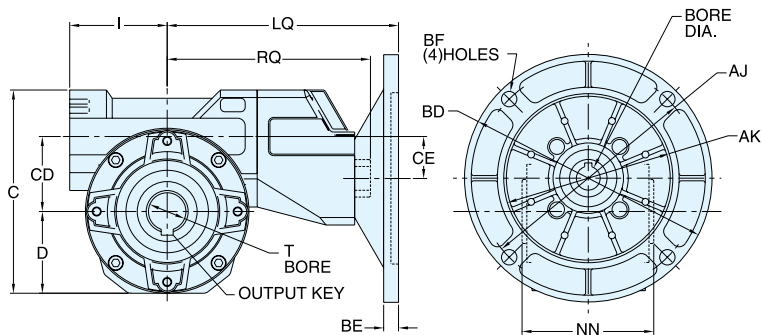

REVERSE ALL ARROWS FOR OPPOSITE INPUT SHAFT ROTATION. CONTACT FACTORY FOR OTHER MOUNTINGS OR ASSEMBLY POSITIONS.

STYLE DXHMQ DIMENSIONS - Inches

Series	C	CD	CE	D	F [^]	G [^]	I	LQ* 56/140	NN	RQ	T* +0.0015 -0.0000	OUTPUT KEY*
518	4.76	1.77	1.10	1.93	1.38	0.08	2.16	6.23	2.56	5.59	0.750	3/16 X 1.00
520	5.33	1.97	1.10	2.15	1.50	0.12	2.56	6.41	3.19	5.77	1.000	1/4 X 1.62
525	6.69	2.48	1.50	2.76	1.77	0.19	3.11	7.17	4.72	6.49	1.125	1/4 X 2.00
534	9.15	3.35	1.50	3.72	2.52	0.14	3.86	7.84	5.31	7.42	1.500	3/8 X 2.00

* Metric options are available. Refer to dimensions on opposite page.
Contact LEESON for availability of metric options.
[^] Refer to Style DXH for reference to this dimension.

STYLE DXH

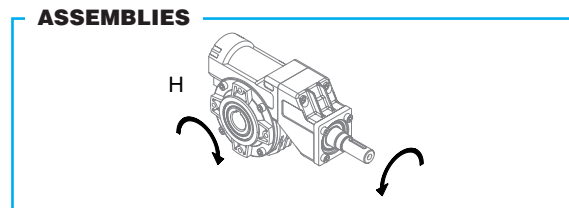
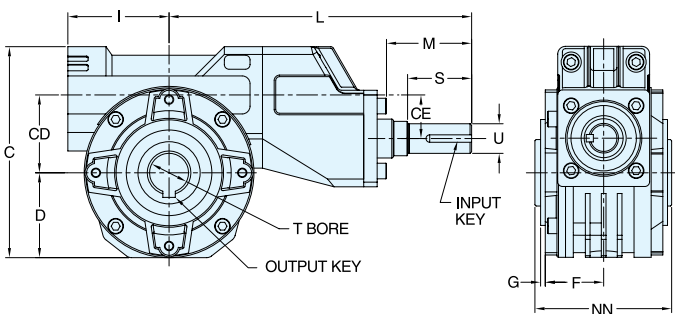

REVERSE ALL ARROWS FOR OPPOSITE INPUT SHAFT ROTATION. CONTACT FACTORY FOR OTHER MOUNTINGS OR ASSEMBLY POSITIONS.

STYLE DXH DIMENSIONS - Inches

Series	C	CD	CE	D	F	G	I	L	M	NN	S	T +0.0015 -0.0000	U +0.000 -0.001	INPUT KEY	OUTPUT KEY
518	4.76	1.77	1.10	1.93	1.38	0.08	2.16	6.65	1.65	2.56	1.42	0.750	0.625	3/16 X 1.12	3/16 X 1.00
520	5.33	1.97	1.10	2.15	1.50	0.12	2.56	6.83	1.83	3.19	1.42	1.000	0.625	3/16 X 1.12	1/4 X 1.62
525	6.69	2.48	1.50	2.76	1.77	0.19	3.11	8.54	2.00	4.72	1.65	1.125	0.750	3/16 X 1.50	1/4 X 2.00
534	9.15	3.35	1.50	3.72	2.52	0.14	3.86	9.21	2.65	5.31	1.65	1.500	0.750	3/16 X 1.50	3/8 X 2.00

Bravo® Helical / Worm Double Reduction



DOUBLE REDUCTION • HELICAL WORM DIMENSIONS



STYLE DXMQ

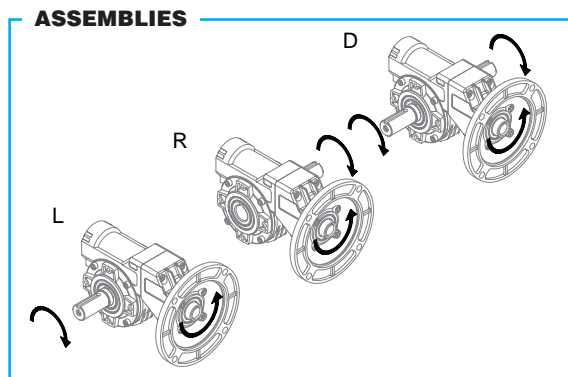
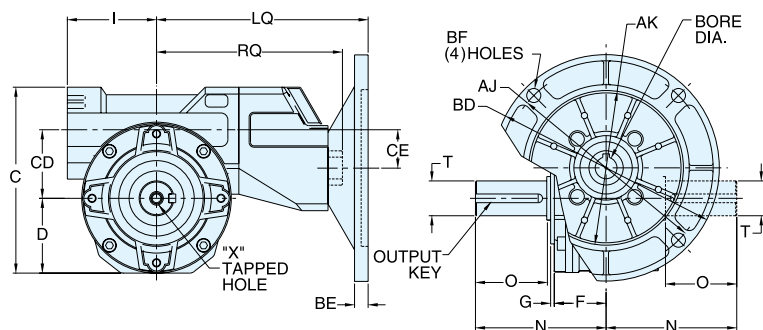

REVERSE ALL ARROWS FOR OPPOSITE INPUT SHAFT ROTATION. CONTACT FACTORY FOR OTHER MOUNTINGS OR ASSEMBLY POSITIONS.

STYLE DXMQ DIMENSIONS - Inches

Series	C	CD	CE	D	F	G	I	LQ* 56/140	N	O*	RQ	T* +0.000 -0.001	X		OUTPUT KEY*
													Tap Size	Depth	
518	4.76	1.77	1.10	1.93	1.38	0.08	2.16	6.23	2.97	1.26	5.59	0.750	1/4-20 UNC	0.62	3/16 x 1.00
520	5.33	1.97	1.10	2.15	1.50	0.12	2.56	6.41	3.94	2.05	5.77	1.000	5/16-18 UNC	0.75	1/4 X 1.62
525	6.69	2.48	1.50	2.76	1.77	0.19	3.11	7.17	4.85	2.36	6.49	1.125	5/16-18 UNC	0.75	1/4 X 2.00
534	9.15	3.35	1.50	3.72	2.52	0.14	3.86	7.84	5.55	2.36	7.42	1.500	5/16-18 UNC	0.75	3/8 X 2.00

* Metric options are available. Refer to dimensions below. Contact LEESON for availability of metric options.

STYLE DX

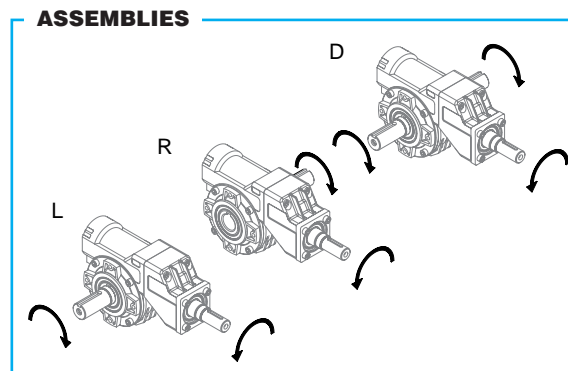
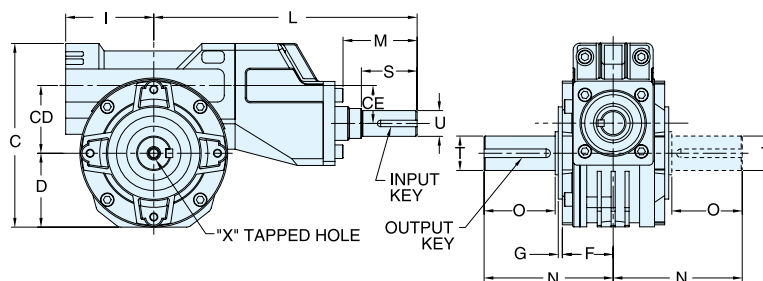

REVERSE ALL ARROWS FOR OPPOSITE INPUT SHAFT ROTATION. CONTACT FACTORY FOR OTHER MOUNTINGS OR ASSEMBLY POSITIONS.

STYLE DX DIMENSIONS - Inches

Series	C	CD	CE	D	F	G	I	L	M	N	O	S	T +0.000 -0.001	U +0.000 -0.001	X		INPUT KEY	OUTPUT KEY
															Tap Size	Depth		
518	4.76	1.77	1.10	1.93	1.38	0.08	2.16	6.65	1.65	2.97	1.26	1.42	0.750	0.625	1/4-20 UNC	0.62	3/16 X 1.12	3/16 X 1.00
520	5.33	1.97	1.10	2.15	1.50	0.12	2.56	6.83	1.83	3.94	2.05	1.42	1.000	0.625	5/16-18 UNC	0.75	3/16 X 1.12	1/4 X 1.62
525	6.69	2.48	1.50	2.76	1.77	0.19	3.11	8.54	2.00	4.85	2.36	1.65	1.125	0.750	5/16-18 UNC	0.75	3/16 X 1.50	1/4 X 2.00
534	9.15	3.35	1.50	3.72	2.52	0.14	3.86	9.21	2.65	5.55	2.36	1.65	1.500	0.750	5/16-18 UNC	0.75	3/16 X 1.50	3/8 X 2.00

Bravo® Helical / Worm Double Reduction

MOTOR MOUNTING DIMENSIONS

NEMA DIMENSIONS - Inches

Frame	AJ	AK	BD	BE	BF	Input Bore Dia	Input Keyway▲
56C	5.88	4.50	6.50	0.38	0.41	.625	3/16 x 3/32
140TC	5.88	4.50	6.50	0.38	0.41	.875	3/16 x 3/32

OPTIONAL METRIC DIMENSIONS* - MM

Series	LQ♦				T H7	O (standard for metric units)	N	Output Keyway
	IEC B5 & B14 Options							
	D63D	D71D	D80D	D90D				
518	136 ♦	136	N/A	N/A	18	32	75	6
520	141 ♦	141	N/A	N/A	25	52	100	8
525	179 ♦	179 ♦	179 ♦	179 ♦	25	60	123	8
534	197 ■	197 ♦	197 ♦	197	35	60	141	10

OPTIONAL METRIC DIMENSIONS* - MM

IEC Frame	B5					B14♦					Input Bore Dia	Input Keyway▲
	AJ	AK	BD	BE	BF	AJ	AK	BD	BE	BF♦		
D63D	115	95	140	11	9	75♦	60	90	5.5	5.5	11	4 x 2
D71D	130	110	160	10	9	85♦	70	105	8	6.5	14	5 x 2.5
D80D	165	130	200	12	11	100♦	80	120	10	7	19	6 x 3
D90D	165	130	200	12	11	115	95	140	11	9	24	8 x 3.5

♦ Contact LEESON for availability of metric input options. The output bore and/or solid output shaft extension will be metric as standard with metric input options.

▲ Keyway width by depth

♦ AJ Mounting holes are rotated 45° from positions shown on B14 input options as follows:
D63D(All), D71D & D80D(Series 525 & 534)

♦ Dimensions are maximum (B5 and B14 options)

■ B14 Option not available

Bravo® DOUBLE REDUCTION • HELICAL/WORM DIMENSIONS



STYLE DXFHMQ

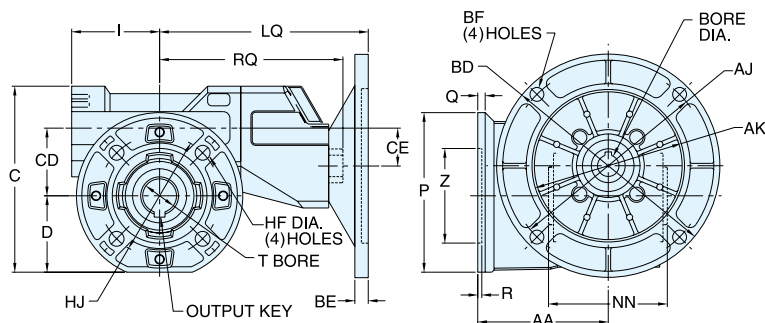

ASSEMBLIES

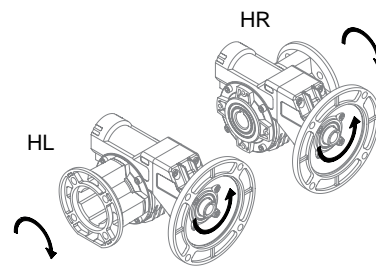

REVERSE ALL ARROWS FOR OPPOSITE INPUT SHAFT ROTATION. CONTACT FACTORY FOR OTHER MOUNTINGS OR ASSEMBLY POSITIONS.

STYLE DXFHMQ DIMENSIONS - Inches

Series	AA	C	CD	CE	D	HF	HJ	I	LQ* 56/140	NN	P	Q	R	RQ	T* +0.0015 -0.0000	Z	OUTPUT KEY*
518	2.38	4.76	1.77	1.10	1.93	0.335	3.43	2.16	6.23	2.56	4.33	0.35	0.354	5.59	0.750	2.362	3/16 X 1.00
520	3.35	5.33	1.97	1.10	2.15	0.413	3.54	2.56	6.41	3.19	4.84	0.47	0.354	5.77	1.000	2.756	1/4 X 1.62
525	3.39	6.69	2.48	1.50	2.76	0.413	5.91	3.11	7.17	4.72	6.89	0.51	0.276	6.49	1.125	4.528	1/4 X 2.00
534	4.25	9.15	3.35	1.50	3.72	0.512	6.93	3.86	7.84	5.31	8.07	0.63	0.197	7.42	1.500	5.984	3/8 X 2.00

* Metric options are available. Refer to dimensions on opposite page. Contact LEESON for availability of metric options.

Bravo® Helical / Worm Double Reduction

STYLE DXFH

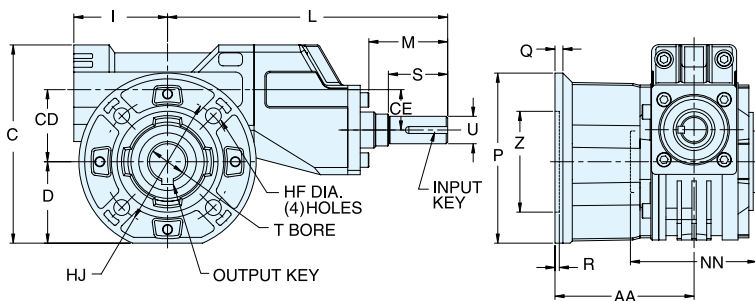

ASSEMBLIES

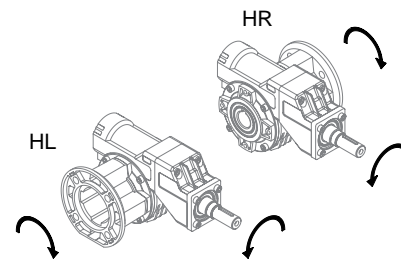

REVERSE ALL ARROWS FOR OPPOSITE INPUT SHAFT ROTATION. CONTACT FACTORY FOR OTHER MOUNTINGS OR ASSEMBLY POSITIONS.

STYLE DXFH DIMENSIONS - Inches

Series	AA	C	CD	CE	D	HF	HJ	I	L	M	NN	P	Q	R	S	T +0.0015 -0.0000	U +0.000 -0.001	Z	INPUT KEY	OUTPUT KEY
518	2.38	4.76	1.77	1.10	1.93	0.335	3.43	2.16	6.65	1.65	2.56	4.33	0.35	0.354	1.42	0.750	0.625	2.362	3/16 X 1.12	3/16 X 1.00
520	3.35	5.33	1.97	1.10	2.15	0.413	3.54	2.56	6.83	1.83	3.19	4.84	0.47	0.354	1.42	1.000	0.625	2.756	3/16 X 1.12	1/4 X 1.62
525	3.39	6.69	2.48	1.50	2.76	0.413	5.91	3.11	8.54	2.00	4.72	6.89	0.51	0.276	1.65	1.125	0.750	4.528	3/16 X 1.50	1/4 X 2.00
534	4.25	9.15	3.35	1.50	3.72	0.512	6.93	3.86	9.21	2.65	5.31	8.07	0.63	0.197	1.65	1.500	0.750	5.984	3/16 X 1.50	3/8 X 2.00



DOUBLE REDUCTION • HELICAL WORM DIMENSIONS



STYLE DXFMQ

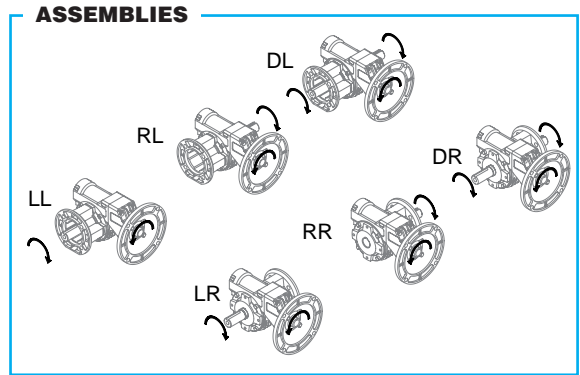
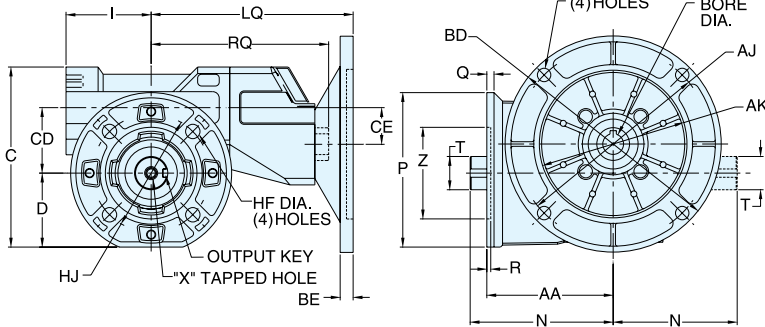

REVERSE ALL ARROWS FOR OPPOSITE INPUT SHAFT ROTATION. CONTACT FACTORY FOR OTHER MOUNTINGS OR ASSEMBLY POSITIONS.

STYLE DXFMQ DIMENSIONS - Inches

Series	AA	C	CD	CE	D	HF	HJ	I	LQ* 56/140	N	O*	P	Q	R	RQ	T* +0.000 -0.001	X		Z	OUTPUT KEY*
																	Tap Size	Depth		
518	2.38	4.76	1.77	1.10	1.93	0.335	3.43	2.16	6.23	2.97	1.26	4.33	0.35	0.354	5.59	0.750	1/4-20 UNC	0.62	2.362	3/16 x 1.00
520	3.35	5.33	1.97	1.10	2.15	0.413	3.54	2.56	6.41	3.94	2.05	4.84	0.47	0.354	5.77	1.000	5/16-18 UNC	0.75	2.756	1/4 X 1.62
525	3.39	6.69	2.48	1.50	2.76	0.413	5.91	3.11	7.17	4.85	2.36	6.89	0.51	0.276	6.49	1.125	5/16-18 UNC	0.75	4.528	1/4 X 2.00
534	4.25	9.15	3.35	1.50	3.72	0.512	6.93	3.86	7.84	5.55	2.36	8.07	0.63	0.197	7.42	1.500	5/16-18 UNC	0.75	5.984	3/8 X 2.00

* Metric options are available. Refer to dimensions below. Contact LEESON for availability of metric options.

STYLE DXF

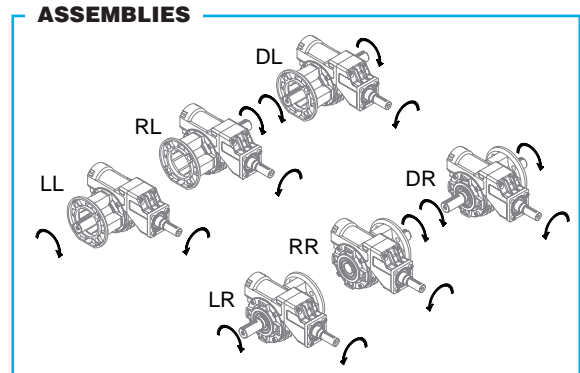
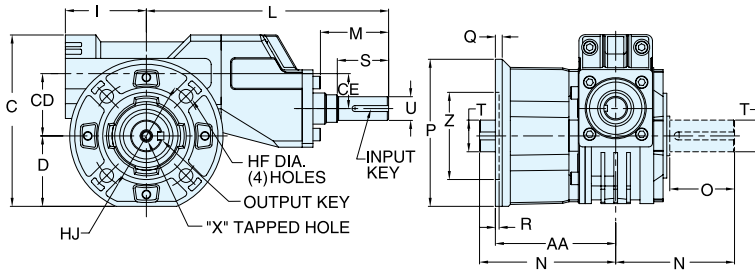

REVERSE ALL ARROWS FOR OPPOSITE INPUT SHAFT ROTATION. CONTACT FACTORY FOR OTHER MOUNTINGS OR ASSEMBLY POSITIONS.

Bravo® Helical / Worm Double Reduction

STYLE DXF DIMENSIONS - Inches

Series	AA	C	CD	CE	D	HF	HJ	I	L	M	N	O	P	Q	R	S	T +0.000 -0.001	U +0.000 -0.001	X		Z	INPUT KEY	OUTPUT KEY
																			Tap Size	Depth			
518	2.38	4.76	1.77	1.10	1.93	0.335	3.43	2.16	6.65	1.65	2.97	1.26	4.33	0.35	0.354	1.42	0.750	0.625	1/4-20 UNC	0.62	2.362	3/16 X 1.12	3/16 X 1.00
520	3.35	5.33	1.97	1.10	2.15	0.413	3.54	2.56	6.83	1.83	3.94	2.05	4.84	0.47	0.354	1.42	1.000	0.625	5/16-18 UNC	0.75	2.756	3/16 X 1.12	1/4 X 1.62
525	3.39	6.69	2.48	1.50	2.76	0.413	5.91	3.11	8.54	2.00	4.85	2.36	6.89	0.51	0.276	1.65	1.125	0.750	5/16-18 UNC	0.75	4.528	3/16 X 1.50	1/4 X 2.00
534	4.25	9.15	3.35	1.50	3.72	0.512	6.93	3.86	9.21	2.65	5.55	2.36	8.07	0.63	0.197	1.65	1.500	0.750	5/16-18 UNC	0.75	5.984	3/16 X 1.50	3/8 X 2.00

MOTOR MOUNTING DIMENSIONS

NEMA DIMENSIONS - Inches

Frame	AJ	AK	BD	BE	BF	Input Bore Dia	Input Keyway▲
56C	5.88	4.50	6.50	0.38	0.41	.625	3/16 x 3/32
140TC	5.88	4.50	6.50	0.38	0.41	.875	3/16 x 3/32

OPTIONAL METRIC DIMENSIONS - MM

Series	LQ♦				T H7	O (standard for metric units)	N	Output Keyway
	IEC B5 & B14 Options							
	D63D	D71D	D80D	D90D				
518	136 ♦	136	N/A	N/A	18	32	75	6
520	141 ♦	141	N/A	N/A	25	52	100	8
525	179 ♦	179 ♦	179 ♦	179	25	60	123	8
534	197 ■	197 ♦	197 ♦	197	35	60	141	10

OPTIONAL METRIC DIMENSIONS - MM

IEC Frame	B5					B14♦					Input Bore Dia	Input Keyway▲
	AJ	AK	BD	BE	BF	AJ	AK	BD	BE	BF♦		
D63D	115	95	140	11	9	75♦	60	90	5.5	5.5	11	4 x 2
D71D	130	110	160	10	9	85♦	70	105	8	6.5	14	5 x 2.5
D80D	165	130	200	12	11	100♦	80	120	10	7	19	6 x 3
D90D	165	130	200	12	11	115	95	140	11	9	24	8 x 3.5

- ♦ Contact LEESON for availability of metric input options. The output bore and/or solid output shaft extension will be metric as standard with metric input options.
- ▲ Keyway width by depth
- ♦ AJ Mounting holes are rotated 45° from positions shown on B14 input options as follows:
D63D(All), D71D & D80D(Series 525 & 534)
- ♦ Dimensions are maximum (B5 and B14 options)
- B14 Option not available

Bravo® DOUBLE REDUCTION • HELICAL/WORM DIMENSIONS



STYLE DXFLHMQ

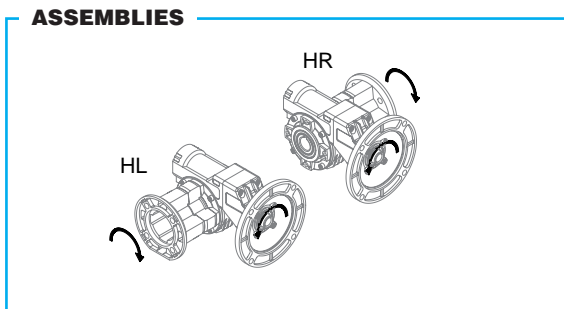
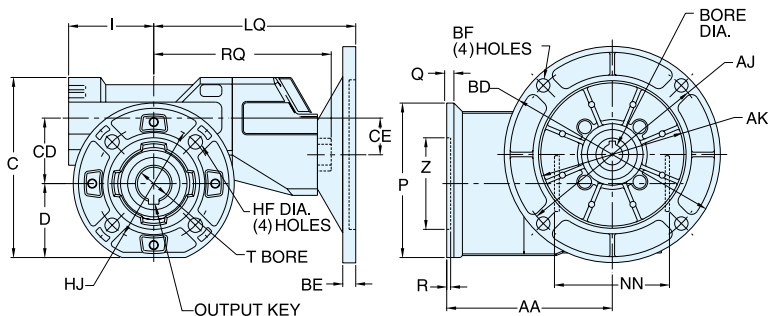

REVERSE ALL ARROWS FOR OPPOSITE INPUT SHAFT ROTATION. CONTACT FACTORY FOR OTHER MOUNTINGS OR ASSEMBLY POSITIONS.

STYLE DXFLHMQ DIMENSIONS - Inches

Series	AA	C	CD	CE	D	HF	HJ	I	LQ* 56/140	NN	P	Q	R	RQ	T* +0.0015 -0.0000	Z	OUTPUT KEY*
518	3.56	4.76	1.77	1.10	1.93	0.335	3.43	2.16	6.23	2.56	4.33	0.35	0.354	5.59	0.750	2.362	3/16 X 1.00
520	4.51	5.33	1.97	1.10	2.15	0.413	3.54	2.56	6.41	3.19	4.84	0.47	0.354	5.77	1.000	2.756	1/4 X 1.62
525	4.57	6.69	2.48	1.50	2.76	0.413	5.91	3.11	7.17	4.72	6.89	0.51	0.276	6.49	1.125	4.528	1/4 X 2.00
534	5.85	9.15	3.35	1.50	3.72	0.512	6.93	3.86	7.84	5.31	8.07	0.63	0.197	7.42	1.500	5.984	3/8 X 2.00

* Metric options are available. Refer to dimensions on opposite page. Contact LEESON for availability of metric options.

Bravo® Helical / Worm Double Reduction

STYLE DXFLH

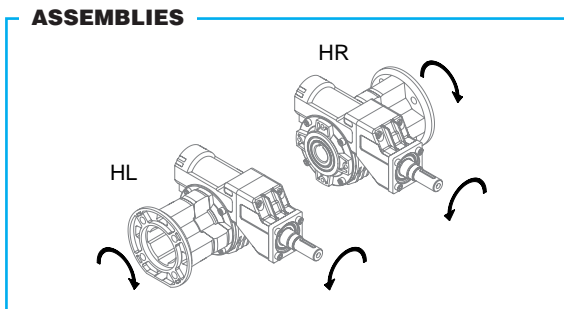
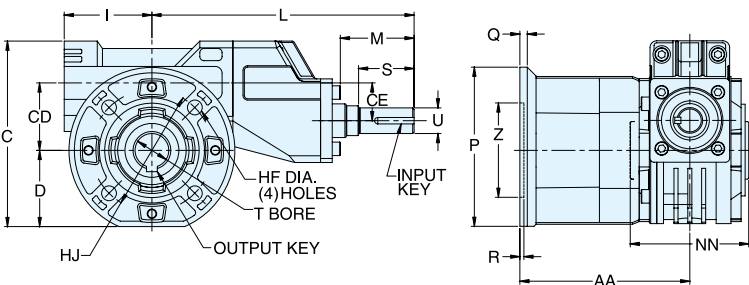

REVERSE ALL ARROWS FOR OPPOSITE INPUT SHAFT ROTATION. CONTACT FACTORY FOR OTHER MOUNTINGS OR ASSEMBLY POSITIONS.

STYLE DXFLH DIMENSIONS - Inches

Series	AA	C	CD	CE	D	HF	HJ	I	L	M	NN	P	Q	R	S	T +0.0015 -0.0000	U +0.000 -0.001	Z	INPUT KEY	OUTPUT KEY
518	3.56	4.76	1.77	1.10	1.93	0.335	3.43	2.16	6.65	1.65	2.56	4.33	0.35	0.354	1.42	0.750	0.625	2.362	3/16 X 1.12	3/16 X 1.00
520	4.51	5.33	1.97	1.10	2.15	0.413	3.54	2.56	6.83	1.83	3.19	4.84	0.47	0.354	1.42	1.000	0.625	2.756	3/16 X 1.12	1/4 X 1.62
525	4.57	6.69	2.48	1.50	2.76	0.413	5.91	3.11	8.54	2.00	4.72	6.89	0.51	0.276	1.65	1.125	0.750	4.528	3/16 X 1.50	1/4 X 2.00
534	5.85	9.15	3.35	1.50	3.72	0.512	6.93	3.86	9.21	2.65	5.31	8.07	0.63	0.197	1.65	1.500	0.750	5.984	3/16 X 1.50	3/8 X 2.00



DOUBLE REDUCTION • HELICAL WORM DIMENSIONS



STYLE DXFLMQ

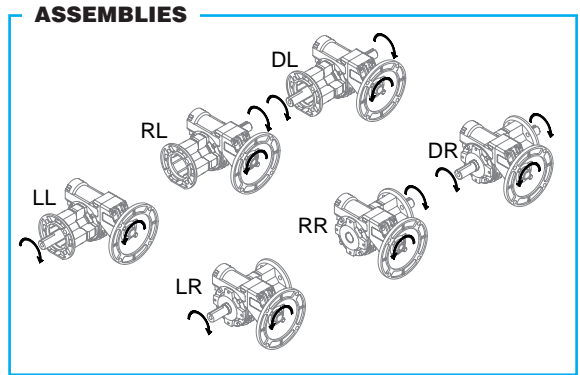
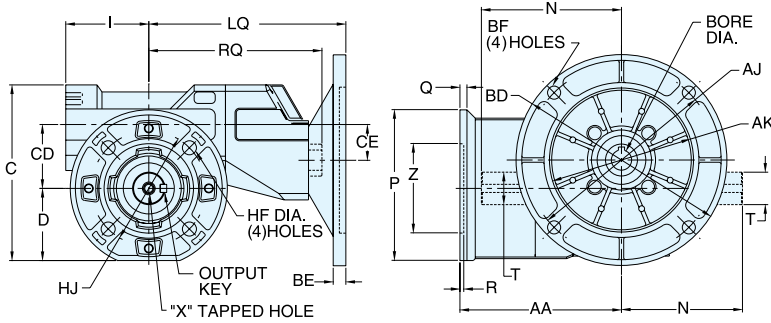

REVERSE ALL ARROWS FOR OPPOSITE INPUT SHAFT ROTATION. CONTACT FACTORY FOR OTHER MOUNTINGS OR ASSEMBLY POSITIONS.

STYLE DXFLMQ DIMENSIONS - Inches

Series	AA	C	CD	CE	D	HF	HJ	I	LQ* 56/140	N	O*	P	Q	R	RQ	T* +0.000 -0.001	X		Z	OUTPUT KEY*
																	Tap Size	Depth		
518	3.56	4.76	1.77	1.10	1.93	0.335	3.43	2.16	6.23	2.97	1.26	4.33	0.35	0.354	5.59	0.750	1/4-20 UNC	0.62	2.362	3/16 x 1.00
520	4.51	5.33	1.97	1.10	2.15	0.413	3.54	2.56	6.41	3.94	2.05	4.84	0.47	0.354	5.77	1.000	5/16-18 UNC	0.75	2.756	1/4 X 1.62
525	4.57	6.69	2.48	1.50	2.76	0.413	5.91	3.11	7.17	4.85	2.36	6.89	0.51	0.276	6.49	1.125	5/16-18 UNC	0.75	4.528	1/4 X 2.00
534	5.85	9.15	3.35	1.50	3.72	0.512	6.93	3.86	7.84	5.55	2.36	8.07	0.63	0.197	7.42	1.500	5/16-18 UNC	0.75	5.984	3/8 X 2.00

* Metric options are available. Refer to dimensions below. Contact LEESON for availability of metric options.

STYLE DXFL

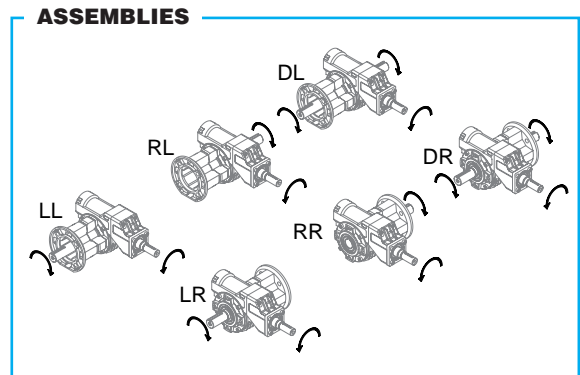
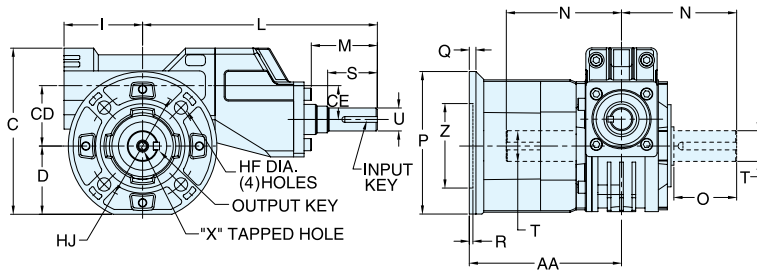

REVERSE ALL ARROWS FOR OPPOSITE INPUT SHAFT ROTATION. CONTACT FACTORY FOR OTHER MOUNTINGS OR ASSEMBLY POSITIONS.

STYLE DXFL DIMENSIONS - Inches

Series	AA	C	CD	CE	D	HF	HJ	I	L	M	N	O	P	Q	R	S	T +0.000 -0.001	U +0.000 -0.001	X		Z	INPUT KEY	OUTPUT KEY
																			Tap Size	Depth			
518	3.56	4.76	1.77	1.10	1.93	0.335	3.43	2.16	6.65	1.65	2.97	1.26	4.33	0.35	0.354	1.42	0.750	0.625	1/4-20 UNC	0.62	2.362	3/16 X 1.12	3/16 X 1.00
520	4.51	5.33	1.97	1.10	2.15	0.413	3.54	2.56	6.83	1.83	3.94	2.05	4.84	0.47	0.354	1.42	1.000	0.625	5/16-18 UNC	0.75	2.756	3/16 X 1.12	1/4 X 1.62
525	4.57	6.69	2.48	1.50	2.76	0.413	5.91	3.11	8.54	2.00	4.85	2.36	6.89	0.51	0.276	1.65	1.125	0.750	5/16-18 UNC	0.75	4.528	3/16 X 1.50	1/4 X 2.00
534	5.85	9.15	3.35	1.50	3.72	0.512	6.93	3.86	9.21	2.65	5.55	2.36	8.07	0.63	0.197	1.65	1.500	0.750	5/16-18 UNC	0.75	5.984	3/16 X 1.50	3/8 X 2.00

Bravo® Helical / Worm Double Reduction

MOTOR MOUNTING DIMENSIONS

NEMA DIMENSIONS - Inches

Frame	AJ	AK	BD	BE	BF	Input Bore Dia	Input Keyway▲
56C	5.88	4.50	6.50	0.38	0.41	.625	3/16 x 3/32
140TC	5.88	4.50	6.50	0.38	0.41	.875	3/16 x 3/32

OPTIONAL METRIC DIMENSIONS* - MM

Series	LQ♦				T H7	O	N	Output Keyway
	IEC B5 & B14 Options							
	D63D	D71D	D80D	D90D				
518	136 ♦	136	N/A	N/A	18	32	75	6
520	141 ♦	141	N/A	N/A	25	52	100	8
525	179 ♦	179 ♦	179 ♦	179	25	60	123	8
534	197 ■	197 ♦	197 ♦	197	35	60	141	10

OPTIONAL METRIC DIMENSIONS* - MM

IEC Frame	B5					B14♦					Input Bore Dia	Input Keyway▲
	AJ	AK	BD	BE	BF	AJ	AK	BD	BE	BF♦		
D63D	115	95	140	11	9	75♦	60	90	5.5	5.5	11	4 x 2
D71D	130	110	160	10	9	85♦	70	105	8	6.5	14	5 x 2.5
D80D	165	130	200	12	11	100♦	80	120	10	7	19	6 x 3
D90D	165	130	200	12	11	115	95	140	11	9	24	8 x 3.5

- ♦ Contact LEESON for availability of metric input options. The output bore and/or solid output shaft extension will be metric as standard with metric input options.
- ▲ Keyway width by depth
- ♦ AJ Mounting holes are rotated 45° from positions shown on B14 input options as follows:
D63D(All), D71D & D80D(Series 525 & 534)
- ♦ Dimensions are maximum (B5 and B14 options)
- B14 Option not available

Bravo® DOUBLE REDUCTION • HELICAL/WORM DIMENSIONS

ALUMINUM GEAR REDUCERS



STYLE DXTHMQ

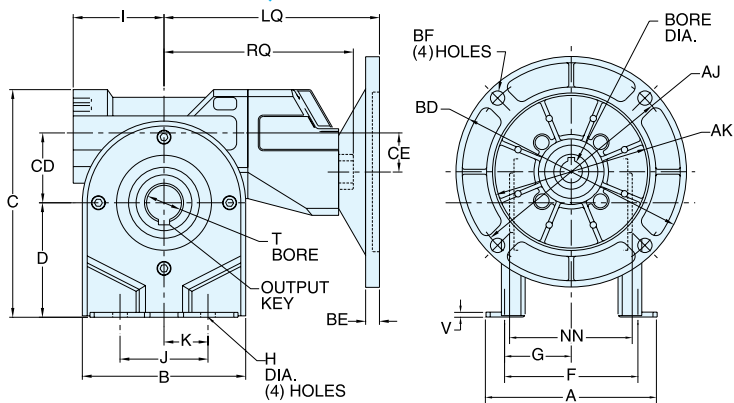

ASSEMBLIES

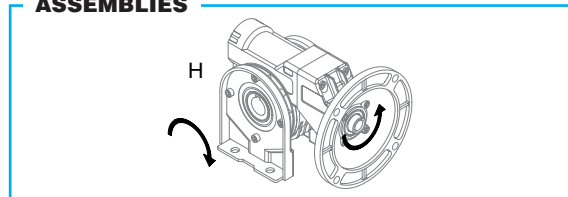

REVERSE ALL ARROWS FOR OPPOSITE INPUT SHAFT ROTATION. CONTACT FACTORY FOR OTHER MOUNTINGS OR ASSEMBLY POSITIONS.

STYLE DXTHMQ DIMENSIONS - Inches

Series	A	B	C	CD	CE	D	F	G	H	I	J	K	LQ* 56/140	NN	RQ	T* +0.0015 -0.0000	V	OUTPUT KEY*
518	3.94	3.86	5.67	1.77	1.10	2.83	3.17	1.59	0.413	2.16	1.97	0.99	6.23	2.56	5.59	0.750	0.12	3/16 X 1.00
520	4.84	4.45	6.42	1.97	1.10	3.23	3.94	1.97	0.413	2.56	2.48	1.24	6.41	3.19	5.77	1.000	0.14	1/4 X 1.62
525	5.67	5.24	7.87	2.48	1.50	3.94	4.35	2.18	0.413	3.11	3.74	1.87	7.17	4.72	6.49	1.125	0.16	1/4 X 2.00
534	7.17	7.09	11.02	3.35	1.50	5.59	5.71	2.86	0.413	3.86	5.51	2.76	7.84	5.31	7.42	1.500	0.20	3/8 X 2.00

* Metric options are available. Refer to dimensions on opposite page. Contact LEESON for availability of metric options.

STYLE DXTH

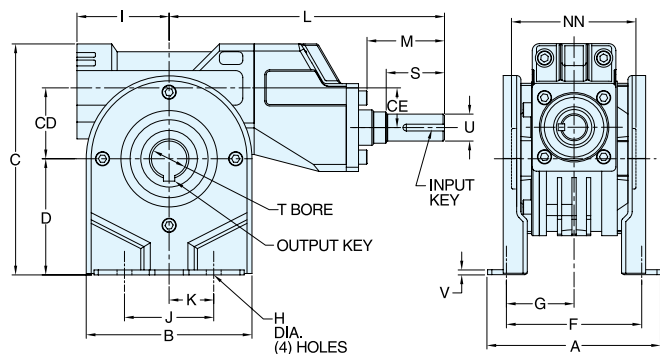

ASSEMBLIES

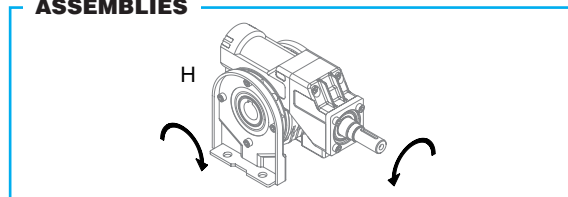

REVERSE ALL ARROWS FOR OPPOSITE INPUT SHAFT ROTATION. CONTACT FACTORY FOR OTHER MOUNTINGS OR ASSEMBLY POSITIONS.

STYLE DXTH DIMENSIONS - Inches

Series	A	B	C	CD	CE	D	F	G	H	I	J	K	L	M	NN	S	T +0.0015 -0.0000	U +0.000 -0.001	V	INPUT KEY	OUTPUT KEY
518	3.94	3.86	5.67	1.77	1.10	2.83	3.17	1.59	0.413	2.16	1.97	0.99	6.65	1.65	2.56	1.42	0.750	0.625	0.12	3/16 X 1.12	3/16 X 1.00
520	4.84	4.45	6.42	1.97	1.10	3.23	3.94	1.97	0.413	2.56	2.48	1.24	6.83	1.83	3.19	1.42	1.000	0.625	0.14	3/16 X 1.12	1/4 X 1.62
525	5.67	5.24	7.87	2.48	1.50	3.94	4.35	2.18	0.413	3.11	3.74	1.87	8.54	2.00	4.72	1.65	1.125	0.750	0.16	3/16 X 1.50	1/4 X 2.00
534	7.17	7.09	11.02	3.35	1.50	5.59	5.71	2.86	0.413	3.86	5.51	2.76	9.21	2.65	5.31	1.65	1.500	0.750	0.20	3/16 X 1.50	3/8 X 2.00



DOUBLE REDUCTION • HELICAL/WORM DIMENSIONS **Bravo** ALUMINUM GEAR REDUCERS

STYLE DXTMQ

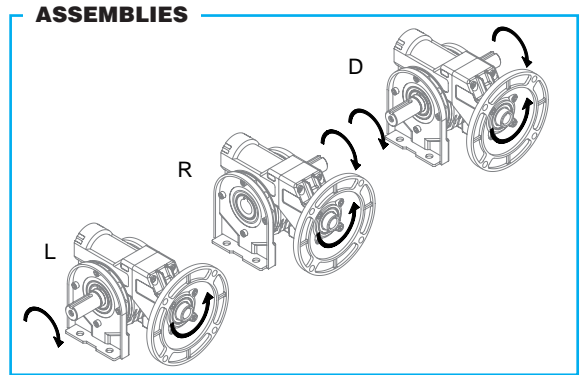
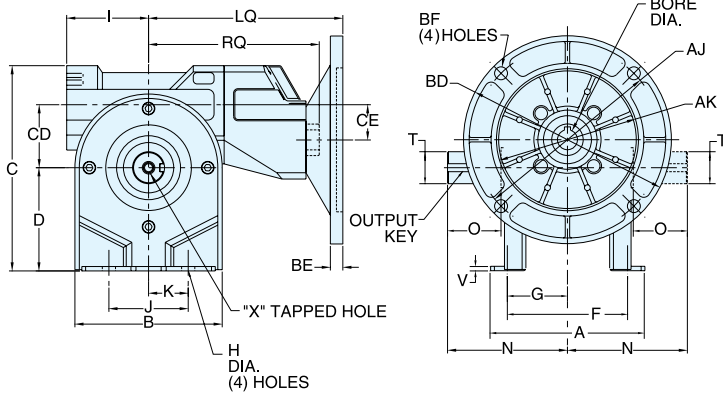

REVERSE ALL ARROWS FOR OPPOSITE INPUT SHAFT ROTATION. CONTACT FACTORY FOR OTHER MOUNTINGS OR ASSEMBLY POSITIONS.

STYLE DXTMQ DIMENSIONS - Inches

Series	A	B	C	CD	CE	D	F	G	H	I	J	K	LQ* 56/140	N	O*	RQ	T* +0.000 -0.001	V	X		OUTPUT KEY*
																			Tap Size	Depth	
518	3.94	3.86	5.67	1.77	1.10	2.83	3.17	1.59	0.413	2.16	1.97	0.99	6.23	2.97	1.26	5.59	0.750	0.12	1/4-20 UNC	0.62	3/16 x 1.00
520	4.84	4.45	6.42	1.97	1.10	3.23	3.94	1.97	0.413	2.56	2.48	1.24	6.41	3.94	2.05	5.77	1.000	0.14	5/16-18 UNC	0.75	1/4 x 1.62
525	5.67	5.24	7.87	2.48	1.50	3.94	4.35	2.18	0.413	3.11	3.74	1.87	7.17	4.85	2.36	6.49	1.125	0.16	5/16-18 UNC	0.75	1/4 x 2.00
534	7.17	7.09	11.02	3.35	1.50	5.59	5.71	2.86	0.413	3.86	5.51	2.76	7.84	5.55	2.36	7.42	1.500	0.20	5/16-18 UNC	0.75	3/8 x 2.00

* Metric options are available. Refer to dimensions below. Contact LEESON for availability of metric options.

STYLE DXT

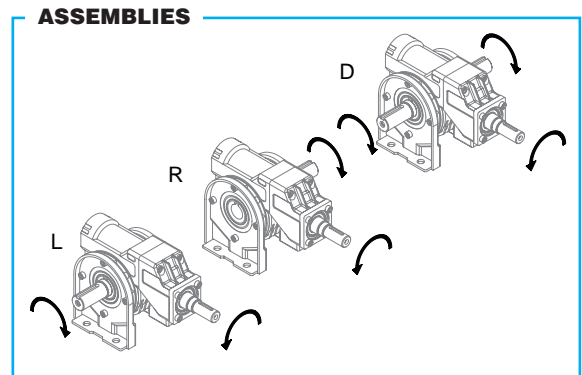
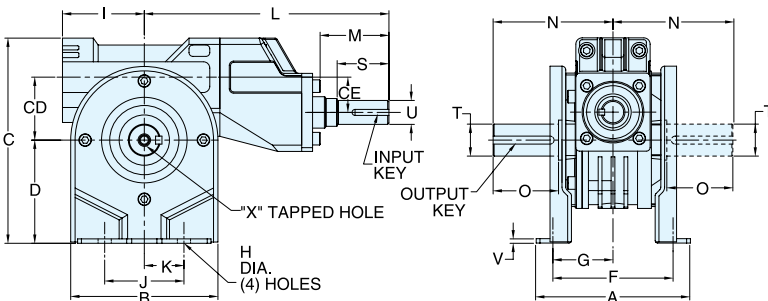

REVERSE ALL ARROWS FOR OPPOSITE INPUT SHAFT ROTATION. CONTACT FACTORY FOR OTHER MOUNTINGS OR ASSEMBLY POSITIONS.

STYLE DXT DIMENSIONS - Inches

Series	A	B	C	CD	CE	D	F	G	H	I	J	K	L	M	N	O	S	T +0.000 -0.001	U +0.000 -0.001	V	X		INPUT KEY	OUTPUT KEY
																					Tap Size	Depth		
518	3.94	3.86	5.67	1.77	1.10	2.83	3.17	1.59	0.413	2.16	1.97	0.99	6.65	1.65	2.97	1.26	1.42	0.750	0.625	0.12	1/4-20 UNC	0.62	3/16 X 1.12	3/16 X 1.00
520	4.84	4.45	6.42	1.97	1.10	3.23	3.94	1.97	0.413	2.56	2.48	1.24	6.83	1.83	3.94	2.05	1.42	1.000	0.625	0.14	5/16-18 UNC	0.75	3/16 X 1.12	1/4 X 1.62
525	5.67	5.24	7.87	2.48	1.50	3.94	4.35	2.18	0.413	3.11	3.74	1.87	8.54	2.00	4.85	2.36	1.65	1.125	0.750	0.16	5/16-18 UNC	0.75	3/16 X 1.50	1/4 X 2.00
534	7.17	7.09	11.02	3.35	1.50	5.59	5.71	2.86	0.413	3.86	5.51	2.76	9.21	2.65	5.55	2.36	1.65	1.500	0.750	0.20	5/16-18 UNC	0.75	3/16 X 1.50	3/8 X 2.00

Bravo® Helical / Worm
Double Reduction

MOTOR MOUNTING DIMENSIONS

NEMA DIMENSIONS - Inches

Frame	AJ	AK	BD	BE	BF	Input Bore Dia	Input Keyway▲
56C	5.88	4.50	6.50	0.38	0.41	.625	3/16 x 3/32
140TC	5.88	4.50	6.50	0.38	0.41	.875	3/16 x 3/32

OPTIONAL METRIC DIMENSIONS* - MM

Series	LQ♦				T H7	O	N	Output Keyway
	IEC B5 & B14 Options							
	D63D	D71D	D80D	D90D	(standard for metric units)			
518	136 ♦	136	N/A	N/A	18	32	75	6
520	141 ♦	141	N/A	N/A	25	52	100	8
525	179 ♦	179 ♦	179 ♦	179	25	60	123	8
534	197 ■	197 ♦	197 ♦	197	35	60	141	10

OPTIONAL METRIC DIMENSIONS* - MM

IEC Frame	B5					B14♦					Input Bore Dia	Input Keyway▲
	AJ	AK	BD	BE	BF	AJ	AK	BD	BE	BF		
D63D	115	95	140	11	9	75♦	60	90	5.5	5.5	11	4 x 2
D71D	130	110	160	10	9	85♦	70	105	8	6.5	14	5 x 2.5
D80D	165	130	200	12	11	100♦	80	120	10	7	19	6 x 3
D90D	165	130	200	12	11	115	95	140	11	9	24	8 x 3.5

♦ Contact LEESON for availability of metric input options. The output bore and/or solid output shaft extension will be metric as standard with metric input options.

▲ Keyway width by depth

♦ AJ Mounting holes are rotated 45° from positions shown on B14 input options as follows:
D63D(All), D71D & D80D(Series 525 & 534)

♦ Dimensions are maximum (B5 and B14 options)

■ B14 Option not available

STYLE DXUHMQ

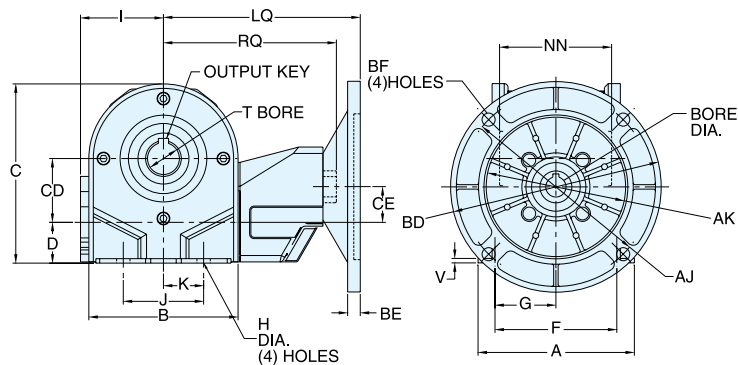

ASSEMBLIES

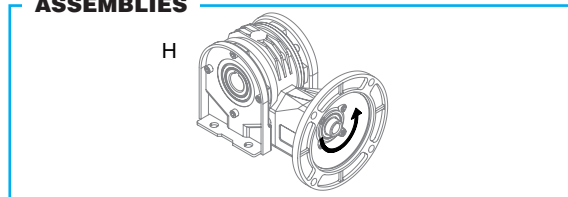

REVERSE ALL ARROWS FOR OPPOSITE INPUT SHAFT ROTATION. CONTACT FACTORY FOR OTHER MOUNTINGS OR ASSEMBLY POSITIONS.

STYLE DXUHMQ DIMENSIONS - Inches

Series	A	B	C	CD	CE	D	F	G	H	I	J	K	LQ* 56/140	NN	RQ	T* +0.0015 -0.0000	V	OUTPUT KEY*
518	3.94	3.86	4.76	1.77	1.10	1.06	3.17	1.59	0.413	2.16	1.97	0.99	6.23	2.56	5.59	0.750	0.12	3/16 X 1.00
520	4.84	4.45	5.45	1.97	1.10	1.26	3.94	1.97	0.413	2.56	2.48	1.24	6.41	3.19	5.77	1.000	0.14	1/4 X 1.62
525	5.67	5.24	6.69	2.48	1.50	1.45	4.35	2.18	0.413	3.11	3.74	1.87	7.17	4.72	6.49	1.125	0.16	1/4 X 2.00
534	7.17	7.09	9.31	3.35	1.50	2.24	5.71	2.86	0.413	3.86	5.51	2.76	7.84	5.31	7.42	1.500	0.20	3/8 X 2.00

* Metric options are available. Refer to dimensions on opposite page. Contact LEESON for availability of metric options.

STYLE DXUH

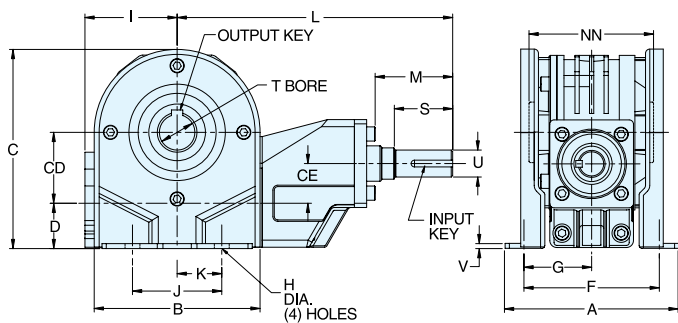

ASSEMBLIES

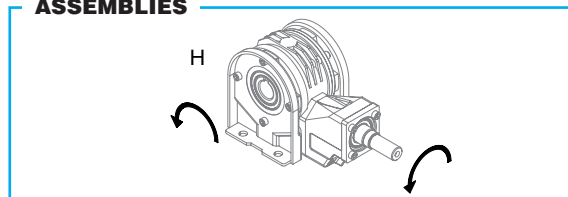

REVERSE ALL ARROWS FOR OPPOSITE INPUT SHAFT ROTATION. CONTACT FACTORY FOR OTHER MOUNTINGS OR ASSEMBLY POSITIONS.

STYLE DXUH DIMENSIONS - Inches

Series	A	B	C	CD	CE	D	F	G	H	I	J	K	L	M	NN	S	T +0.0015 -0.0000	U +0.000 -0.001	V	INPUT KEY	OUTPUT KEY
518	3.94	3.86	4.76	1.77	1.10	1.06	3.17	1.59	0.413	2.16	1.97	0.99	6.65	1.65	2.56	1.42	0.750	0.625	0.12	3/16 X 1.12	3/16 X 1.00
520	4.84	4.45	5.45	1.97	1.10	1.26	3.94	1.97	0.413	2.56	2.48	1.24	6.83	1.83	3.19	1.42	1.000	0.625	0.14	3/16 X 1.12	1/4 X 1.62
525	5.67	5.24	6.69	2.48	1.50	1.45	4.35	2.18	0.413	3.11	3.74	1.87	8.54	2.00	4.72	1.65	1.125	0.750	0.16	3/16 X 1.50	1/4 X 2.00
534	7.17	7.09	9.31	3.35	1.50	2.24	5.71	2.86	0.413	3.86	5.51	2.76	9.21	2.65	5.31	1.65	1.500	0.750	0.20	3/16 X 1.50	3/8 X 2.00



DOUBLE REDUCTION • HELICAL/WORM DIMENSIONS **Bravo**
ALUMINUM GEAR REDUCERS

STYLE DXUMQ

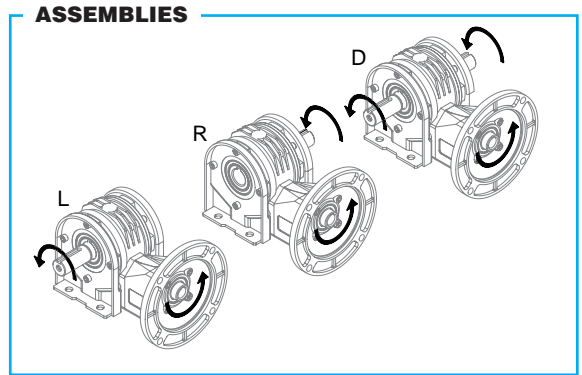
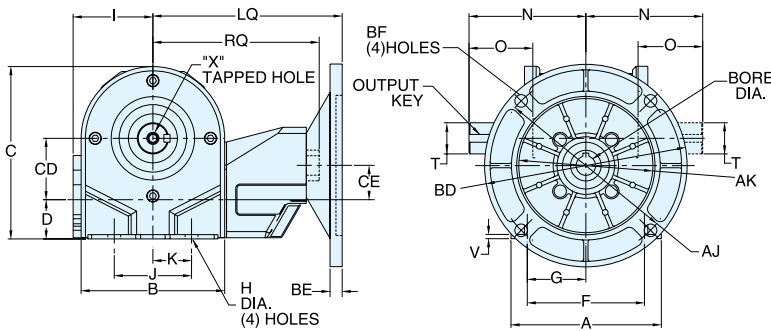

REVERSE ALL ARROWS FOR OPPOSITE INPUT SHAFT ROTATION. CONTACT FACTORY FOR OTHER MOUNTINGS OR ASSEMBLY POSITIONS.

STYLE DXUMQ DIMENSIONS - Inches

Series	A	B	C	CD	CE	D	F	G	H	I	J	K	LQ* 56/140	N	O*	RQ	T* +0.000 -0.001	V	X		OUTPUT KEY*
																			Tap Size	Depth	
518	3.94	3.86	4.76	1.77	1.10	1.06	3.17	1.59	0.413	2.16	1.97	0.99	6.23	2.97	1.26	5.59	0.750	0.12	1/4-20 UNC	0.62	3/16 x 1.00
520	4.84	4.45	5.45	1.97	1.10	1.26	3.94	1.97	0.413	2.56	2.48	1.24	6.41	3.94	2.05	5.77	1.000	0.14	5/16-18 UNC	0.75	1/4 X 1.62
525	5.67	5.24	6.69	2.48	1.50	1.45	4.35	2.18	0.413	3.11	3.74	1.87	7.17	4.85	2.36	6.49	1.125	0.16	5/16-18 UNC	0.75	1/4 X 2.00
534	7.17	7.09	9.31	3.35	1.50	2.24	5.71	2.86	0.413	3.86	5.51	2.76	7.84	5.55	2.36	7.42	1.500	0.20	5/16-18 UNC	0.75	3/8 X 2.00

* Metric options are available. Refer to dimensions below. Contact LEESON for availability of metric options.

STYLE DXU

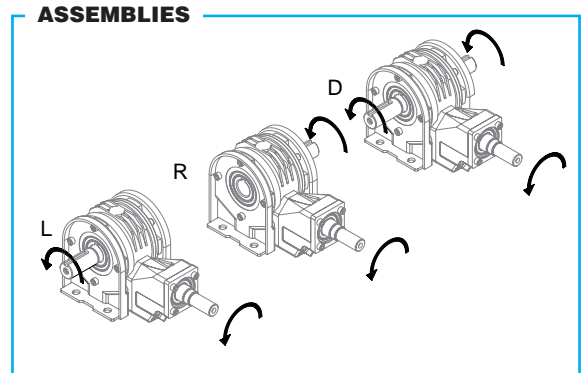
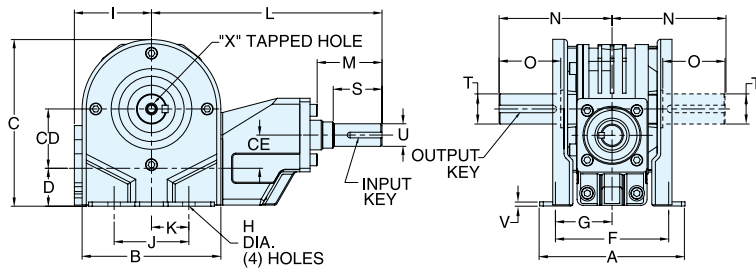

REVERSE ALL ARROWS FOR OPPOSITE INPUT SHAFT ROTATION. CONTACT FACTORY FOR OTHER MOUNTINGS OR ASSEMBLY POSITIONS.

STYLE DXU DIMENSIONS - Inches

Series	A	B	C	CD	CE	D	F	G	H	I	J	K	L	M	N	O	S	T +0.000 -0.001	U +0.000 -0.001	V	X		INPUT KEY	OUTPUT KEY
																					Tap Size	Depth		
518	3.94	3.86	4.76	1.77	1.10	1.06	3.17	1.59	0.413	2.16	1.97	0.99	6.65	1.65	2.97	1.26	1.42	0.750	0.625	0.12	1/4-20 UNC	0.62	3/16 X 1.12	3/16 X 1.00
520	4.84	4.45	5.45	1.97	1.10	1.26	3.94	1.97	0.413	2.56	2.48	1.24	6.83	1.83	3.94	2.05	1.42	1.000	0.625	0.14	5/16-18 UNC	0.75	3/16 X 1.12	1/4 X 1.62
525	5.67	5.24	6.69	2.48	1.50	1.45	4.35	2.18	0.413	3.11	3.74	1.87	8.54	2.00	4.85	2.36	1.65	1.125	0.750	0.16	5/16-18 UNC	0.75	3/16 X 1.50	1/4 X 2.00
534	7.17	7.09	9.31	3.35	1.50	2.24	5.71	2.86	0.413	3.86	5.51	2.76	9.21	2.65	5.55	2.36	1.65	1.500	0.750	0.20	5/16-18 UNC	0.75	3/16 X 1.50	3/8 X 2.00

Bravo® Helical / Worm Double Reduction

MOTOR MOUNTING DIMENSIONS

NEMA DIMENSIONS - Inches

Frame	AJ	AK	BD	BE	BF	Input Bore Dia	Input Keyway▲
56C	5.88	4.50	6.50	0.38	0.41	.625	3/16 x 3/32
140TC	5.88	4.50	6.50	0.38	0.41	.875	3/16 x 3/32

OPTIONAL METRIC DIMENSIONS - MM

Series	LQ♦				T H7	O (standard for metric units)	N	Output Keyway
	IEC B5 & B14 Options							
	D63D	D71D	D80D	D90D				
518	136 ♦	136	N/A	N/A	18	32	75	6
520	141 ♦	141	N/A	N/A	25	52	100	8
525	179 ♦	179 ♦	179 ♦	179	25	60	123	8
534	197 ■	197 ♦	197 ♦	197	35	60	141	10

OPTIONAL METRIC DIMENSIONS - MM

IEC Frame	B5					B14♦					Input Bore Dia	Input Keyway▲
	AJ	AK	BD	BE	BF	AJ	AK	BD	BE	BF♦		
D63D	115	95	140	11	9	75♦	60	90	5.5	5.5	11	4 x 2
D71D	130	110	160	10	9	85♦	70	105	8	6.5	14	5 x 2.5
D80D	165	130	200	12	11	100♦	80	120	10	7	19	6 x 3
D90D	165	130	200	12	11	115	95	140	11	9	24	8 x 3.5

- ♦ Contact LEESON for availability of metric input options. The output bore and/or solid output shaft extension will be metric as standard with metric input options.
- ▲ Keyway width by depth
- ♦ AJ Mounting holes are rotated 45° from positions shown on B14 input options as follows:
D63D(All), D71D & D80D(Series 525 & 534)
- ♦ Dimensions are maximum (B5 and B14 options)
- B14 Option not available

STYLE DXJHMQ

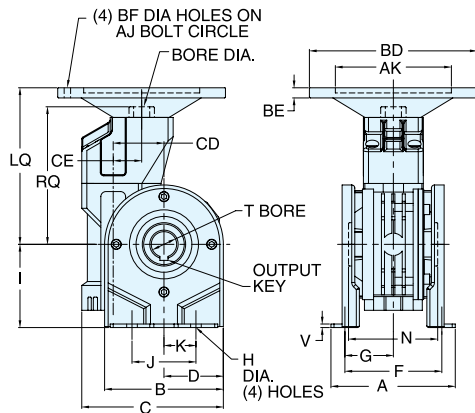

ASSEMBLIES

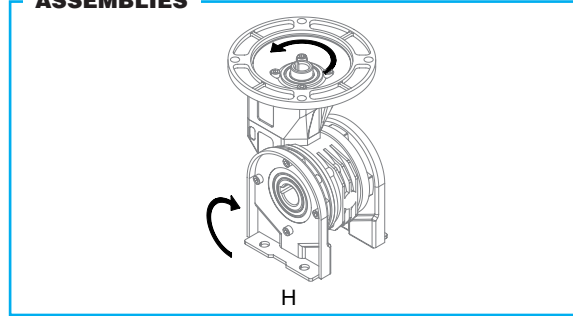

REVERSE ALL ARROWS FOR OPPOSITE INPUT SHAFT ROTATION. CONTACT FACTORY FOR OTHER MOUNTINGS OR ASSEMBLY POSITIONS.

STYLE DXJHMQ DIMENSIONS - Inches

Series	A	B	C	CD	CE	D	F	G	H	I	J	K	LQ* 56/140	NN	RQ	T* +0.0015 -0.0000	V	OUTPUT KEY*
518	3.94	3.86	4.76	1.77	1.10	1.93	3.17	1.59	0.413	2.83	1.97	0.99	6.23	2.56	5.59	0.750	0.12	3/16 X 1.00
520	4.84	4.45	5.45	1.97	1.10	2.23	3.94	1.97	0.413	3.22	2.48	1.24	6.41	3.19	5.77	1.000	0.14	1/4 X 1.62
525	5.67	5.24	6.69	2.48	1.50	2.76	4.35	2.18	0.413	3.94	3.74	1.87	7.17	4.72	6.49	1.125	0.16	1/4 X 2.00
534	7.17	7.09	9.15	3.35	1.50	3.72	5.71	2.86	0.413	5.59	5.51	2.76	7.84	5.31	7.42	1.500	0.20	3/8 X 2.00

* Metric options are available. Refer to dimensions on opposite page. Contact LEESON for availability of metric options.

STYLE DXJH

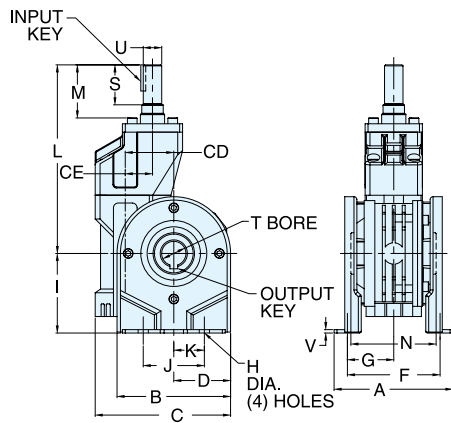

ASSEMBLIES

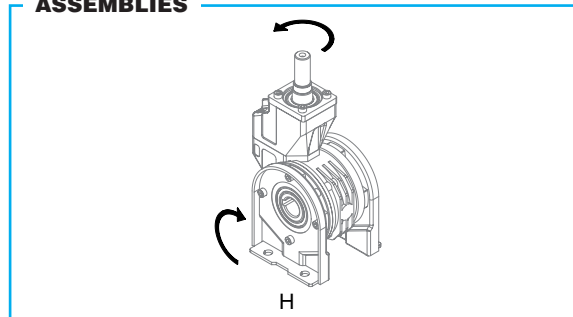

REVERSE ALL ARROWS FOR OPPOSITE INPUT SHAFT ROTATION. CONTACT FACTORY FOR OTHER MOUNTINGS OR ASSEMBLY POSITIONS.

STYLE DXJH DIMENSIONS - Inches

Series	A	B	C	CD	CE	D	F	G	H	I	J	K	L	M	NN	S	T +0.0015 -0.0000	U +0.000 -0.001	V	INPUT KEY	OUTPUT KEY
518	3.94	3.86	4.76	1.77	1.10	1.93	3.17	1.59	0.413	2.83	1.97	0.99	6.65	1.65	2.56	1.42	0.750	0.625	0.12	3/16 X 1.12	3/16 X 1.00
520	4.84	4.45	5.45	1.97	1.10	2.23	3.94	1.97	0.413	3.22	2.48	1.24	6.83	1.83	3.19	1.42	1.000	0.625	0.14	3/16 X 1.12	1/4 X 1.62
525	5.67	5.24	6.69	2.48	1.50	2.76	4.35	2.18	0.413	3.94	3.74	1.87	8.54	2.00	4.72	1.65	1.125	0.750	0.16	3/16 X 1.50	1/4 X 2.00
534	7.17	7.09	9.15	3.35	1.50	3.72	5.71	2.86	0.413	5.59	5.51	2.76	9.21	2.65	5.31	1.65	1.500	0.750	0.20	3/16 X 1.50	3/8 X 2.00



DOUBLE REDUCTION • HELICAL/WORM DIMENSIONS **Bravo** ALUMINUM GEAR REDUCERS

STYLE DXJMQ

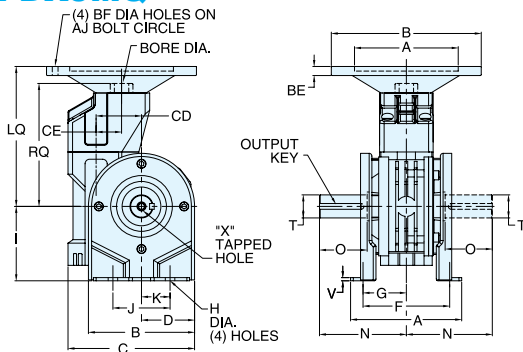

ASSEMBLIES

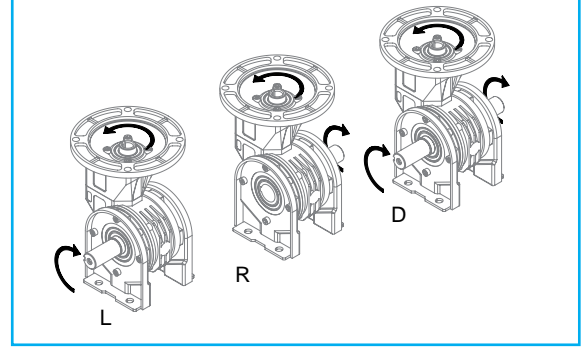

REVERSE ALL ARROWS FOR OPPOSITE INPUT SHAFT ROTATION. CONTACT FACTORY FOR OTHER MOUNTINGS OR ASSEMBLY POSITIONS.

STYLE DXJMQ DIMENSIONS - Inches

Series	A	B	C	CD	CE	D	F	G	H	I	J	K	LQ* 56/140	N	O*	RQ	T* +0.000 -0.001	V	X		OUTPUT KEY*
																			Tap Size	Depth	
518	3.94	3.86	4.76	1.77	1.10	1.93	3.17	1.59	0.413	2.83	1.97	0.99	6.23	2.97	1.26	5.59	0.750	0.12	1/4-20 UNC	0.62	3/16 x 1.00
520	4.84	4.45	5.45	1.97	1.10	2.23	3.94	1.97	0.413	3.22	2.48	1.24	6.41	3.94	2.05	5.77	1.000	0.14	5/16-18 UNC	0.75	1/4 X 1.62
525	5.67	5.24	6.69	2.48	1.50	2.76	4.35	2.18	0.413	3.94	3.74	1.87	7.17	4.85	2.36	6.49	1.125	0.16	5/16-18 UNC	0.75	1/4 X 2.00
534	7.17	7.09	9.15	3.35	1.50	3.72	5.71	2.86	0.413	5.59	5.51	2.76	7.84	5.55	2.36	7.42	1.500	0.20	5/16-18 UNC	0.75	3/8 X 2.00

* Metric options are available. Refer to dimensions below. Contact LEESON for availability of metric options.

STYLE DXJ

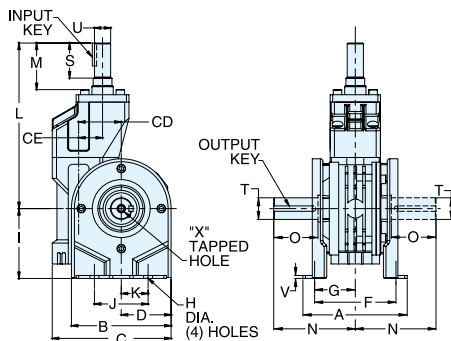

ASSEMBLIES

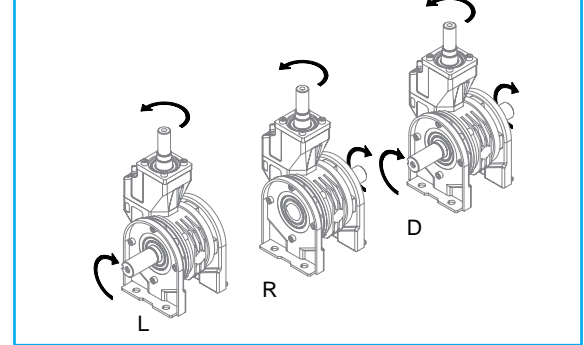

REVERSE ALL ARROWS FOR OPPOSITE INPUT SHAFT ROTATION. CONTACT FACTORY FOR OTHER MOUNTINGS OR ASSEMBLY POSITIONS.

STYLE DXJ DIMENSIONS - Inches

Series	A	B	C	CD	CE	D	F	G	H	I	J	K	L	M	N	O	S	T +0.000 -0.001	U +0.000 -0.001	V	X		INPUT KEY	OUTPUT KEY
																					Tap Size	Depth		
518	3.94	3.86	4.76	1.77	1.10	1.93	3.17	1.59	0.413	2.83	1.97	0.99	6.65	1.65	2.97	1.26	1.42	0.750	0.625	0.12	1/4-20 UNC	0.62	3/16 X 1.12	3/16 X 1.00
520	4.84	4.45	5.45	1.97	1.10	2.23	3.94	1.97	0.413	3.22	2.48	1.24	6.83	1.83	3.94	2.05	1.42	1.000	0.625	0.14	5/16-18 UNC	0.75	3/16 X 1.12	1/4 X 1.62
525	5.67	5.24	6.69	2.48	1.50	2.76	4.35	2.18	0.413	3.94	3.74	1.87	8.54	2.00	4.85	2.36	1.65	1.125	0.750	0.16	5/16-18 UNC	0.75	3/16 X 1.50	1/4 X 2.00
534	7.17	7.09	9.15	3.35	1.50	3.72	5.71	2.86	0.413	5.59	5.51	2.76	9.21	2.65	5.55	2.36	1.65	1.500	0.750	0.20	5/16-18 UNC	0.75	3/16 X 1.50	3/8 X 2.00

Bravo® Helical / Worm
Double Reduction

MOTOR MOUNTING DIMENSIONS

NEMA DIMENSIONS - Inches

Frame	AJ	AK	BD	BE	BF	Input Bore Dia	Input Keyway▲
56C	5.88	4.50	6.50	0.38	0.41	.625	3/16 x 3/32
140TC	5.88	4.50	6.50	0.38	0.41	.875	3/16 x 3/32

OPTIONAL METRIC DIMENSIONS* - MM

Series	LQ♦				T H7	O	N	Output Keyway
	IEC B5 & B14 Options							
	D63D	D71D	D80D	D90D	(standard for metric units)			
518	136 ♦	136	N/A	N/A	18	32	75	6
520	141 ♦	141	N/A	N/A	25	52	100	8
525	179 ♦	179 ♦	179 ♦	179	25	60	123	8
534	197 ■	197 ♦	197 ♦	197	35	60	141	10

OPTIONAL METRIC DIMENSIONS* - MM

IEC Frame	B5					B14♦					Input Bore Dia	Input Keyway▲
	AJ	AK	BD	BE	BF	AJ	AK	BD	BE	BF♦		
D63D	115	95	140	11	9	75♦	60	90	5.5	5.5	11	4 x 2
D71D	130	110	160	10	9	85♦	70	105	8	6.5	14	5 x 2.5
D80D	165	130	200	12	11	100♦	80	120	10	7	19	6 x 3
D90D	165	130	200	12	11	115	95	140	11	9	24	8 x 3.5

- ♦ Contact LEESON for availability of metric input options. The output bore and/or solid output shaft extension will be metric as standard with metric input options.
- ▲ Keyway width by depth
- ♦ AJ Mounting holes are rotated 45° from positions shown on B14 input options as follows:
D63D(All), D71D & D80D(Series 525 & 534)
- ♦ Dimensions are maximum (B5 and B14 options)
- B14 Option not available



HELICAL/WORM REDUCTION • APPROXIMATE WEIGHTS^Δ (LBS.)

Reducer Style	Reducer Size			
	518	520	525	534
Solid Output Shaft Models				
DXMQ	9	11	19	47
DX	8	11	19	47
DXTMQ, DXUMQ	11	13	22	52
DXT, DXU	10	13	22	52
DXJMQ	11	13	22	52
DXJ	10	13	22	52
DXFMQ	10	12	21	50
DXF	9	12	21	50
DXFLMQ	11	13	22	52
DXFL	10	13	22	52
DRMQ	10	12	21	50
DXR	9	12	21	50
Hollow Output Shaft Models				
DXHMQ	8	9	17	42
DXH	7	9	17	42
DXTHMQ, DXUHMQ	10	11	20	47
DXTH, DXUH	9	11	20	47
DXJHMQ	10	11	20	47
DXJH	9	11	20	47
DXFHMQ	9	10	19	45
DXFH	8	10	19	45
DXFLHMQ	10	11	20	47
DXFLH	9	11	20	47
DXRHMQ	9	10	19	45
DXRH	8	10	19	45

^Δ Weight includes grease/ oil.

REDUCER ACCESSORIES • APPROXIMATE WEIGHTS (LBS.)

Accessory	Reducer Size			
	518	520	525	534
T/U - Base	2	2	3	5
J - Base	2	2	3	5
F - Flange	1	1	2	3
FL - Flange	2	2	3	5
R - Reaction Arm	1	1	2	3



GEAR+MOTOR™ DIMENSIONS

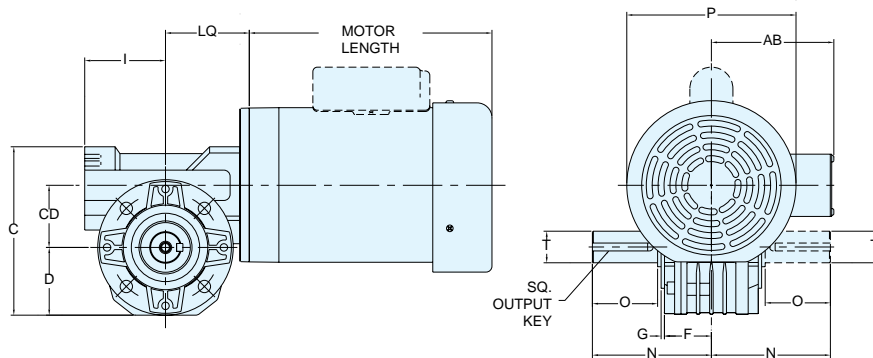

BMQ STYLE DIMENSIONS - Inches(MM)

Series	C	CD	D	F	G	I	N	O	T +0.000 -0.001	OUTPUT KEY
512	3.54 (89.9)	1.18 (30)	1.54 (39)	1.18 (30)	0.08 (2)	1.81(46)	2.48 (63.0)	1.01(25.7)	(14)*	(5)
518	4.76 (121)	1.77 (45)	1.93 (49)	1.38 (35)	0.08 (2)	2.16 (55)	2.97 (75.4)	1.26 (32.0)	0.750	3/16 x 1.00
520	5.33 (135)	1.97 (50)	2.15 (54.5)	1.50 (38)	0.12 (3)	2.56 (65)	3.94 (100.1)	2.05 (52.1)	1.000	1/4 X 1.62
525	6.69 (170)	2.48 (63)	2.76 (70)	1.77 (45)	0.19 (5)	3.11 (79)	4.85 (123.2)	2.36 (59.9)	1.125	1/4 X 2.00
534	9.15 (232)	3.35 (85)	3.72 (94.5)	2.52 (64)	0.14 (3.5)	3.86 (98)	5.55 (141.0)	2.36 (59.9)	1.500	3/8 X 2.00

* Tolerance is -0.005/ -0.0020.

NEMA MOTOR MOUNTING DIMENSIONS - Inches

Series	AB		LQ		P	
	56C/140TC	180TC	56C/140TC	180TC	56C/140TC	180TC
518	5.31	N/A	3.33	N/A	7.16	9.22
520	5.31	N/A	3.51	N/A	7.16	9.22
525	5.31	N/A	4.08	N/A	7.16	9.22
534	5.31	6.44	4.83	5.35	7.16	9.22

Refer to page 173 for NEMA motor length dimensions.

IEC MOTOR MOUNTING DIMENSIONS -Inches

Contact LEESON for outline drawings of specific IEC BRAVO® Gear+Motor™ combinations.
Refer to page 173 for IEC motor dimensions.

MOTOR MOUNTING POSITIONS

Conduit box position viewed from input side of reducer.

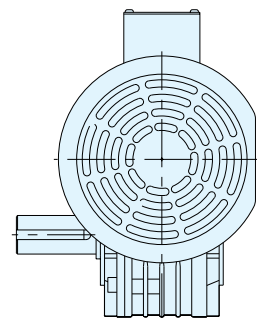
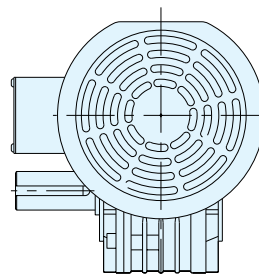
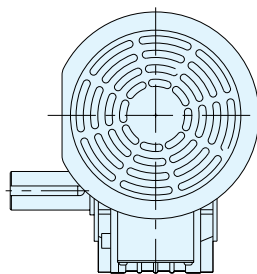
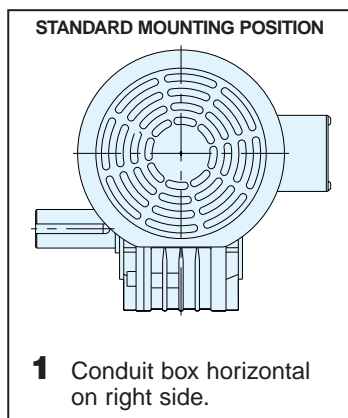

Bravo®
Accessory Kits



Quick shipment is standard on all LEESON BRAVO® stock and modified stock gear reducers. A wide range of mounting styles are offered and are listed on the accompanying chart. Start with one of the stock reducer styles shown—add an accessory—and create a new mounting style.

**STYLE T, U OR J
HORIZONTAL
BASE**



**MOTORIZED
C FLANGE
QUILL INPUT**



(Style BMQ Shown)

Type	Stock Reducer Style	T Base Worm Over	U Base Worm Under	J Base Vertical Input
Single Reduction Solid Shaft	BMQ	TMQ	UMQ*	JMQ
Single Reduction Hollow Shaft	HMQ	THMQ	UHMQ*	JHMQ
Double Reduction Worm/Worm Solid Shaft	DMQ	DTMQ	DUMQ*	DJMQ
Double Reduction Worm/Worm Hollow Shaft	DHMQ	DTHMQ	DUHMQ*	DJHMQ
Double Reduction Helical/Worm Solid Shaft	DXMQ	DXTMQ	DXUMQ*	DXJMQ
Double Reduction Helical/Worm Hollow Shaft	DXHMQ	DXTHMQ	DXUHMQ*	DXJHMQ
Single Reduction Solid Shaft	B	T	U*	J
Single Reduction Hollow Shaft	H	TH	UH*	JH
Double Reduction Worm/Worm Solid Shaft	D	DT	DU*	DJ
Double Reduction Worm/Worm Hollow Shaft	DH	DTH	DUH*	DJH
Double Reduction Helical/Worm Solid Shaft	DX	DXT	DXU*	DXJ
Double Reduction Helical/Worm Hollow Shaft	DXH	DXTH	DXUH*	DXJH

NON-FLANGED



(Style B Shown)

* Not a recommended mounting style. Consult LEESON for selection assistance.

Bravo®
Accessory Kits



**STYLE F
OUTPUT
FLANGE**



**STYLE FL
OUTPUT
FLANGE**



**STYLE R
REACTION
ARM**



**Free Mod-Squad™
Service
Or Assemble It
Yourself!**



Any of the modified stock gear reducers shown are available on a quick-shipment basis, factory assembled by the **LEESON Gear Mod-Squad**—at no charge for the labor! Just pay for the accessory item. To order, specify the stock reducer and the Gear Mod-Squad Service Number (see below).

Or **assemble it yourself** by ordering the appropriate stock reducer and accessory kit (see below).

Before ordering, check the dimensional information available in this catalog.

More LEESON BRAVO® accessories, options and assembly services are available. See next page.

F SHORT OUTPUT FLANGE	FL LONG OUTPUT FLANGE	R REACTION ARM Shaft
FMQ	FLMQ	RMQ
FHMQ	FLHMQ	RHMQ
DFMQ	DFLMQ	DRMQ
DFHMQ	DFLHMQ	DRHMQ
DXFMQ	DXFLMQ	DXRMQ
DXFHMQ	DXFLHMQ	DXRHMQ
F	FL	R
FH	FLH	RH
DF	DFL	DR
DFH	DFLH	DRH
DXF	DXFL	DXR
DXFH	DXFLH	DXRH

Ordering Information

Style T, U or J - Horizontal Base

Series	Accessory Kit Only Catalog No.	Mod-Squad™ Service Number			Weight (lbs)
		Style T	Style U	Style J	
512	G175231	T512	U512	J512	2
518	G175205	T518	U518	J518	2
520	G175206	T520	U520	J520	2
525	G175207	T525	U525	J525	3
534	G175208	T534	U534	J534	5

Style F - Short Output Flange

Series	Accessory Kit Only Catalog No.	Mod-Squad™ Service Number	Weight (lbs)
		Style F	
512	G175232	F512	1
518	G175209	F518	1
520	G175210	F520	1
525	G175211	F525	2
534	G175212	F534	3

Style FL - Long Output Flange

Series	Accessory Kit Only Catalog No.	Mod-Squad™ Service Number	Weight (lbs)
		Style FL	
512	G175233	FL512	1
518	G175213	FL518	2
520	G175214	FL520	2
525	G175215	FL525	3
534	G175216	FL534	5

Style R - Reaction Arm

Series	Accessory Kit Only Catalog No.	Mod-Squad™ Service Number	Weight (lbs)
		Style R	
512	G175234	R512	1
518	G175201	R518	1
520	G175202	R520	1
525	G175203	R525	2
534	G175204	R534	3

Refer to page 146 for reaction arm dimensions.

Bravo®
Accessory Kits

**SOLID OUTPUT SHAFT
Accessory Kits**



**SINGLE EXTENSION
INCH DIMENSIONS***

**SINGLE EXTENSION
METRIC DIMENSIONS†**

**DOUBLE EXTENSION
INCH DIMENSIONS***

**DOUBLE EXTENSION
METRIC DIMENSIONS†**

Series	Accessory Kit Only Catalog No.	Weight (lbs)
512	CONTACT LEESON	
518	G175236	2
520	G175237	3
525	G175521	3
534	G175238	6

Series	Accessory Kit Only Catalog No.	Weight (lbs)
512	G175240	2
518	G175241	2
520	G175242	3
525	G175243	3
534	G175244	6

Series	Accessory Kit Only Catalog No.	Weight (lbs)
512	CONTACT LEESON	
518	G175221	3
520	G175222	4
525	G175223	4
534	G175224	7

Series	Accessory Kit Only Catalog No.	Weight (lbs)
512	G175245	3
518	G175246	3
520	G175247	4
525	G175248	4
534	G175249	7

* Shaft dimensions are in inches. These shafts will only fit into reducers with inch dimensioned output bores.

† Shaft dimensions are in millimeters. These shafts will only fit into reducers with metric dimensioned output bores.

* Shaft dimensions are in inches. These shafts will only fit into reducers with inch dimensioned output bores.

† Shaft dimensions are in millimeters. These shafts will only fit into reducers with metric dimensioned output bores.

Motorized C-Face Quill Input Bushing Kits

NEMA Bushing Kits ◊ - Inches

Frame Conversion	Input Quill Bore Size (Inch)	Accessory Kit Only Catalog No.	Weight (lbs)
180TC to 140TC	1-1/8 to 7/8	G175230	0.5
180TC to 56C	1-1/8 to 5/8	G175229	0.4
140TC to 56C	7/8 to 5/8	G175228	0.4

◊ Bushing reduces the bore size of input quill to accommodate a smaller motor shaft diameter. The application may also require a different input flange size. Bushings are not intended to be used in output bores.

IEC Bushing Kits ◊ - MM

Frame Conversion	Input Quill Bore Size (mm)	Accessory Kit Only Catalog No.	Weight (lbs)
D63 to D56	11 to 9	G175259	0.4
D71 to D63	14 to 11	G175251	0.4
D71 to D56	14 to 9	G175252	0.4
D80 to D71	19 to 14	G175253	0.4
D80 to D63	19 to 11	G175254	0.4
D90 to D80	24 to 19	G175255	0.4
D90 to D71	24 to 14	G175256	0.4
DF100/112 to D90	28 to 24	G175257	0.5
DF100/112 to D80	28 to 19	G175258	0.5

◊ Bushing reduces the bore size of input quill to accommodate a smaller motor shaft diameter. The application may also require a different input flange size. Bushings are not intended to be used in output bores.

Double Reduction Adapter Kits

Series	Accessory Kit Only Catalog No.	Primary Unit Size	Secondary Unit Quill Size	Weight (lbs)
518	G175225	518	0.625	1
520	G175225	518	0.625	1
525	G175226	518	0.875	1
534	G175227	518	1.125	1.5

Protection Cap Accessory Kits Ω

Series	Accessory Kit Only Catalog No.	Weight (lbs)
512	G175250	0.3
518	G175217	0.3
520	G175218	0.3
525	G175219	0.4
534	G175220	0.6



Ω This protective cap covers the unused output bore for single extension assemblies. Check OSHA requirements and review installation manual to assure all safety requirements of gear reducer installation are met.

**Style R Reaction Arm
Dimensions**

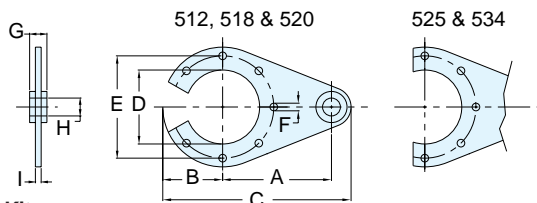

Style R - Reaction Arm Kits

Series	A	B	C	D	E	F	G	H	I
512	3.94	1.57	6.22	1.97	2.56	0.28	0.16	0.31	0.16
518	3.94	1.77	6.22	1.97	2.56	0.28	0.16	0.31	0.16
520	3.94	2.17	6.81	2.68	3.70	0.28	0.16	0.31	0.16
525	5.91	2.17	9.25	2.95	3.54	0.35	0.79	0.39	0.24
534	7.87	3.15	12.60	4.33	5.12	0.43	0.98	0.79	0.24

Refer to page 145 for accessory kits available.

Bravo®
Accessory Kits



ADDITIONAL CAPABILITIES



LEESON Bravo® reducers are available with many special options on request. Select from the common options below or contact LEESON with specific application requests. Contact LEESON for availability of reducers with special features.

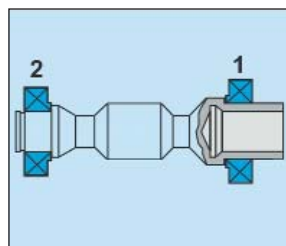

Tapered roller bearings on input worm shaft

REDUCER SIZE	1	2
512	--	--
518	--	--
520	32005X	30204
525	32007X	30205
534	32009X	30206

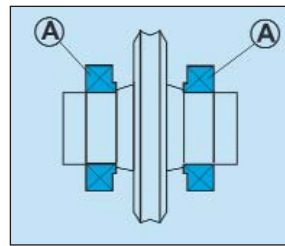

Tapered roller bearings on output shaft

REDUCER SIZE	A
512	--
518	--
520	32008X
525	32009X
534	32011X

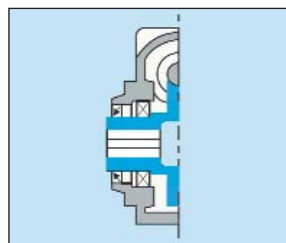

Stainless steel (AISI 303) or bronze output bore

REDUCER SIZE	MAX DIAMETER INCHES (MM)
512	0.550 (14)
518	0.875 (22.2)
520	1.1875 (30.16)
525	1.3125 (33.33)
534	1.625 (41.27)

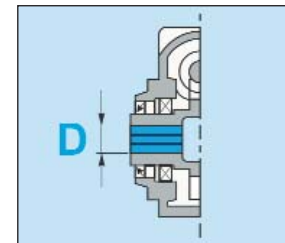

Non-standard output bore

REDUCER SIZE	MAX DIAMETER INCHES (MM)
512	0.550 (14)
518	0.875 (22.2)
520	1.1875 (30.16)
525	1.3125 (33.33)
534	1.625 (41.27)

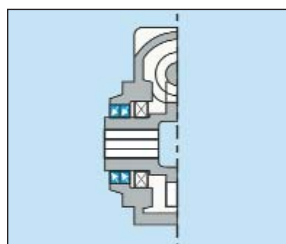

Double output seals

REDUCER SIZE	SEAL SIZE (MM)
512	--
518	--
520	--
525	45/62/7
534	55/80/8

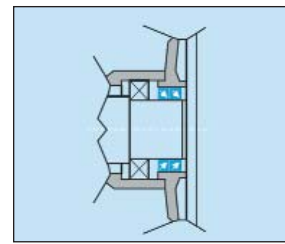

Double input seals

REDUCER SIZE	SEAL SIZE (MM)
512	20/30/7
518	25/40/7
520	25/40/7 or 30/40/7
525	35/47/7
534	45/62/7

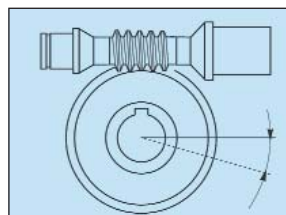

Minimum backlash gearing

ALL SIZES AVAILABLE. CONTACT LEESON WITH REQUIREMENTS.

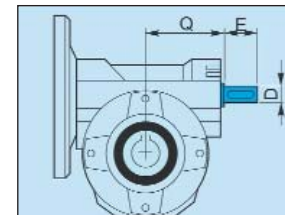

Double input worm shaft extension

ALL SIZES AVAILABLE. CONTACT LEESON WITH REQUIREMENTS.

SPECIAL OPTIONS NOT PICTURED INCLUDE:

- Epoxy paint
- Custom mounting accessories
- Custom ratios
- NEMA input flange/ metric dimensioned output shaft combinations
- IEC input flange/ inch dimensioned output shaft combinations
- Special solid output shaft extensions

Bravo®
Accessory Kits

Bravo® SERIES 12 SUB-FHP

ALUMINUM GEAR REDUCERS RIGHT ANGLE DC GEARMOTORS



SERIES 12 SUB-FHP

Electrical Specifications:

Both SCR (90 volt) and Low Voltage (12 volt) right angle gearmotors. The 90 volt motors are performance matched for continuous service over a 60:1 speed range. All have constant torque throughout the speed range when powered by a full-wave, unfiltered SCR-type 115 volt input adjustable speed control having a typical form factor of 1.3 to 1.4. The low voltage motors are also performance matched for continuous duty. Motors are designed for battery power or can be used with a low voltage controller with form factor up to 1.05.



Mechanical Specifications:

This worm-type right-angle gearing features hardened, steel worm with bronze worm wheel for long life and quiet operation. Single-piece die cast aluminum alloy housing is vacuum impregnated with Resinol RT for protection and sealing. This gearbox combines light weight with high tensile strength along with being precision machined for alignment of bearings and gearing. For optimum seal life, we use high-temperature Nitrile seals. Gearbox provided with solid output shaft, but can be converted to a hollow output shaft mounting by using snap-ring pliers and remove the snap ring and solid output shaft. Also the T-base feet are bolted to the gearbox, but can easily be removed and converted to face mounting.



RIGHT-ANGLE DC • SCR 90 VOLT RATED TEFC • 1.0 SERVICE FACTOR

Input HP	F.L. Torque (In.-Lbs.)	Output RPM	Catalog Number	Enclosure	Gearmotor Type & Frame	Ratio to 1	Arm Volts DC	Full Load Amps. DC
1/8*	125	28	M1135292	TENV	12B60-34D	61	90	1.6
1/8*	87	45	M1135291	TENV	12B39-34D	39	90	1.6
1/4	158	58	M1135290	TEFC	12B30-34G	30	90	2.8
1/4	100	90	M1135289	TEFC	12B19-34G	19	90	2.6
1/4	85	115	M1135288	TEFC	12B15-34G	15	90	2.6
1/4	61	167	M1135287	TEFC	12B11-34G	10.6	90	2.6
1/4	46	250	M1135286	TEFC	12B7-34G	7	90	2.6

* Supplied with TENV motor enclosure

RIGHT-ANGLE DC • LOW VOLTAGE (12V) TENV • 1.0 SERVICE FACTOR

Input HP	F.L. Torque (In.-Lbs.)	Output RPM	Catalog Number	Enclosure	Gearmotor Type & Frame	Ratio to 1	Arm Volts DC	Full Load Amps. DC
1/8	134	27	M1135285	TENV	12B60-34C	61	12	14
1/8	94	45	M1135284	TENV	12B39-34C	39	12	15
1/4	158	58	M1135297	TENV	12B30-34F	30	12	24
1/4	100	90	M1135296	TENV	12B19-34F	19	12	24
1/4	85	115	M1135295	TENV	12B15-34F	15	12	23
1/4	61	167	M1135294	TENV	12B11-34F	10.6	12	21
1/4	46	250	M1135293	TENV	12B7-34F	7	12	23

NOTES:

1. Conduit box not supplied with the gearmotor. Mounting provisions are provided and can use conduit box kit catalog number M1760007 found in the stock motor catalog (1050).
2. For solid double output shaft, consult factory.

Bravo® Accessory Kits

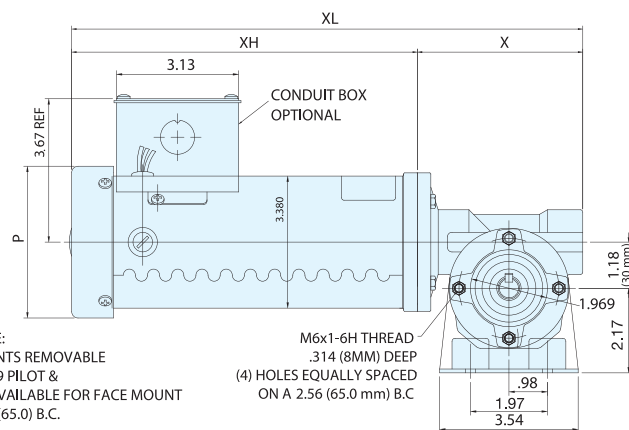

FOOTNOTE:
BASEMOUNTS REMOVABLE
1.969 x .079 PILOT &
(4) M6x1 AVAILABLE FOR FACE MOUNT
ON A 2.56 (65.0) B.C.

M6x1-6H THREAD
.314 (8MM) DEEP
(4) HOLES EQUALLY SPACED
ON A 2.56 (65.0 mm) B.C

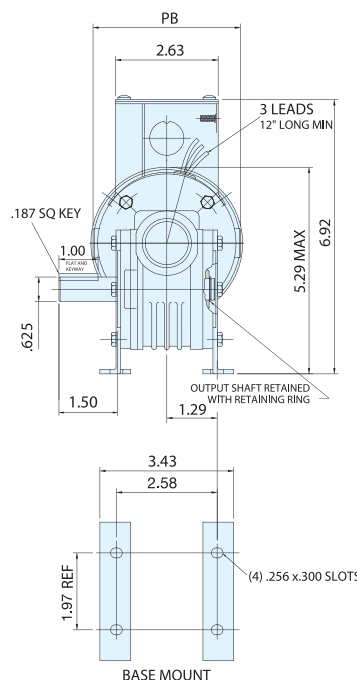

SCR 90 VOLT RATED DIMENSIONS (INCHES)

P	X	XL	XH	PB
3.38	4.32	11.07	6.75	4.00
3.38	4.32	11.07	6.75	4.00
3.88	4.32	13.16	8.84	3.76
3.88	4.32	13.16	8.84	3.76
3.88	4.32	13.16	8.84	3.76
3.88	4.32	13.16	8.84	3.76
3.88	4.32	13.16	8.84	3.76
3.88	4.32	13.16	8.84	3.76

LOW VOLTAGE (12V) DIMENSIONS (INCHES)

P	X	XL	XH	PB
3.38	4.32	10.57	6.25	4.21
3.38	4.32	10.57	6.25	4.21
3.38	4.32	10.57	6.25	4.21
3.38	4.32	11.82	7.5	4.21
3.38	4.32	11.82	7.5	4.21
3.38	4.32	11.82	7.5	4.21
3.38	4.32	11.82	7.5	4.21
3.38	4.32	11.82	7.5	4.21



Overhung Load & Thrust Loads

An overhung load exists when a force is applied at right angles to a shaft beyond the shaft's outermost bearing. Pulleys, sheaves and sprockets will cause an overhung load when used as a power take-off. The amount of overhung load will vary, depending on the type of power take-off used and its mounting location on the shaft. The Bravo® Overhung Load ratings listed in this catalog are calculated at the centerline of the shaft.

Overhung load ratings are listed for each reducer size and should not be exceeded. If the basic reducer is selected using a service factor, that factor must also be used in the equations below.

Output Shaft OHL =

$$\frac{126000 \times \text{Motor HP} \times \text{Output HP Rating} \times \text{Overhung Load Factor}}{\text{Pitch Diameter (of sprocket, pulley or sheave)} \times \text{Input HP Rating} \times \text{Output RPM}}$$

Input Shaft OHL =

$$\frac{126000 \times \text{Motor HP} \times \text{Overhung Load Factor}}{\text{Pitch Diameter (of sprocket, pulley or sheave)} \times \text{Input RPM}}$$

Overhung Load Factors—

Sprocket	1.00
Gear Pinion	1.25
V-Belt Sheave or Pulley	1.50
Flat Belt	2.50

Torque and Horsepower

Torque as it is related to gear reducers is defined as a twisting motion resulting in rotational movement. Horsepower is a measure of the rate of doing work, and depends on speed of rotation and the radius of rotation.

$\frac{\text{TQ(In-lb)} = (\text{HP} \times 6325)}{\text{RPM}}$	$\frac{\text{HP(Rotational)} = \text{TQ(In-Lb)} \times \text{RPM}}{63025}$
$\frac{\text{TQ(ft-lb)} = (\text{HP} \times 5252)}{\text{RPM}}$	$\frac{\text{HP(Rotational)} = \text{TQ(ft-lb)} \times \text{RPM}}{5252}$
$\text{TQ(In-lb)} = W \times R$	$\frac{\text{HP(Linear)} = W \times V}{33000}$

Efficiency

The efficiency of a Worm Gear Speed Reducer is dependent on input speed, lead angle of the worm, type of lubricant, ambient temperature and many other variables. The efficiency for speed reducer can be easily calculated as follows.

$$\text{Efficiency(Total)} = \text{Eff}_1 + \text{Eff}_2 + \text{Eff}_3$$

Additional Engineering Equations and Conversion Factors

$$\text{Velocity(FPM)} = V = .2618 \times D \times \text{RPM}$$

$$\text{Rotational Speed} = \text{RPM} = \frac{V}{(.2618 \times D)}$$

$$\text{Ratio} = \frac{\text{Input RPM}}{\text{Output RPM}} = \frac{\text{No. Teeth in Driver}}{\text{No. Teeth in Driven}} = \frac{\text{Diameter of Driver}}{\text{Diameter of Driven}}$$

$$\text{Ratio(Total)} = \text{Ratio}_1 + \text{Ratio}_2 + \text{Ratio}_3$$

$$1 \text{ inch} = 25.4 \text{ MM}$$

$$1 \text{ lb} = 4.448 \text{ N}$$

$$1 \text{ in-lb} = .11298 \text{ Nm}$$

$$1 \text{ HP} = 746 \text{ Watts} = .746 \text{ kW}$$

$$1 \text{ kW} = 1.34 \text{ HP}$$

$$^{\circ}\text{F} = 9/5 \times ^{\circ}\text{C} + 32$$

$$^{\circ}\text{C} = 5/9 \times (^{\circ}\text{F} - 32)$$

Where:

D = Diameter (inches)

HP = Horsepower

R = Radius (inches)

RPM - Rotational Speed

TQ = Torque

V = linear velocity (FPM)

W = force or tension (lbs)

Maximum Overhung Load[‡] and Thrust Load Ratings (lbs.)

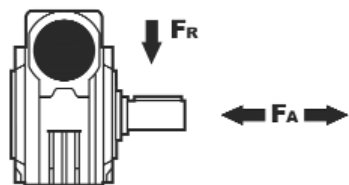

Single Reduction Output Shaft Ratings[‡]

Output RPM	Series									
	512		518		520		525		534	
	F _A	F _R	F _A	F _R	F _A	F _R	F _A	F _R	F _A	F _R
200	27	135	40	200	54	270	81	405	112	562
150	31	157	45	225	63	315	90	450	130	652
100	36	180	50	248	68	338	104	518	135	675
75	40	202	54	270	76	382	112	562	157	787
50	45	225	58	315	86	428	135	675	180	900
25	56	281	68	405	108	562	158	855	225	1125
15	63	315	90	450	126	629	180	899	261	1304

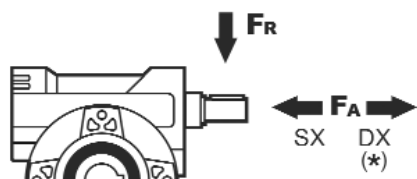

Single Reduction Input Shaft Ratings[‡]

Input RPM	Series									
	512		518		520		525		534	
	F _A	F _R	F _A	F _R	F _A	F _R	F _A	F _R	F _A	F _R
1750	4	21	9	43	16	79	19	93	33	167

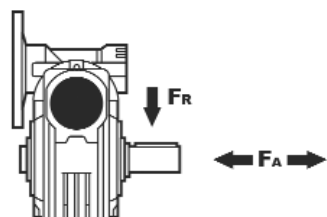

Double Reduction Worm/Worm Output Shaft Ratings[‡]

Output RPM	Series							
	518		520		525		534	
	F _A	F _R	F _A	F _R	F _A	F _R	F _A	F _R
25	68	405	108	562	158	855	225	1125
15	90	450	126	629	180	899	261	1304

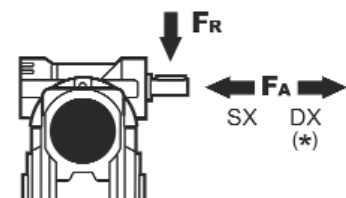

Double Reduction Worm/Worm Input Shaft Ratings[‡]

Input RPM	Series							
	518		520		525		534	
	F _A	F _R	F _A	F _R	F _A	F _R	F _A	F _R
1750	9	43	9	43	9	43	9	43

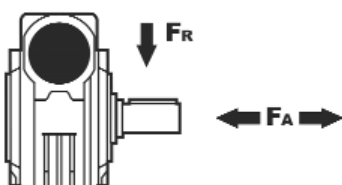

Double Reduction Helical/Worm Output Shaft Ratings[‡]

Output RPM	Series							
	518		520		525		534	
	F _A	F _R	F _A	F _R	F _A	F _R	F _A	F _R
75	54	270	76	382	112	562	157	787
50	58	315	86	428	135	675	180	900
25	68	405	108	562	158	855	225	1125
15	90	450	126	629	180	899	261	1304

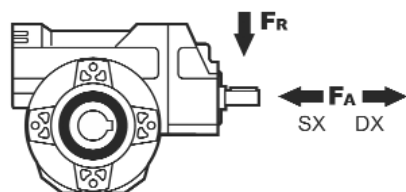

Double Reduction Helical/Worm Input Shaft Ratings[‡]

Input RPM	Series							
	518		520		525		534	
	F _A	F _R	F _A	F _R	F _A	F _R	F _A	F _R
1750	9	46	9	46	13	63	22	112

F_R = Radial load rating = overhung load (lbs)

F_A = Axial load rating = thrust rating (lbs)

* Axial loads in the DX direction should be avoided.

‡ Overhung load is located at centerline of shaft extension for solid input/ output shaft style

Bravo[®] Accessory Kits



GEAR REDUCER DRIVE SHAFT RECOMMENDATIONS

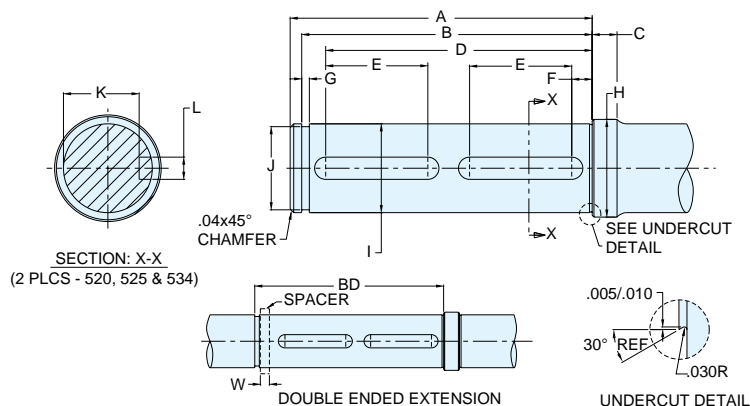

There are several possible methods to retain a drive shaft into the hollow bore of a gear reducer. A few common options are listed below:

- Retain drive shaft with a retaining ring (illustrated above)
- Retain drive shaft with a locknut
- Retain drive shaft with a thrust plate and fastener
- Retain drive shaft with a collar and setscrew
- Retain drive shaft with a recessed plate and fastener

DRIVEN SHAFT RECOMMENDATIONS ● HOLLOW BORE IN INCHES

Dimensions - Inches

Series	A	B +/- 0.0025	C	D	F	Retaining Ring Groove		Mfg. No. (Waldes Truarcc)	H	I +/- 0.0005	Keyway			Double Extension Details	
						G +0.005/- 0.000	J +/- 0.002				E	K +/- 0.0025	L +/- 0.001	BD +/- 0.0025	W* +/- 0.001
518	2.80	2.6445	0.43	N/A	0.18	0.086	0.703	5160-75	0.88	0.749	1.15	0.6365	0.1875	3.0755	0.430
520	3.50	3.2725	0.30	3.00	0.23	0.086	0.937	5160-98	1.12	0.999	1.15	0.8565	0.250	3.5735	0.300
525	5.00	4.8225	0.13	4.25	0.22	0.103	1.058	5160-112	1.25	1.124	1.53	0.9785	0.250	4.9535	0.130
534	5.65	5.4315	0.53	5.00	0.28	0.120	1.405	5160-150	1.75	1.499	1.65	1.2815	0.375	5.9625	0.530

* Dimension "W" refers to the width of spacer used.

DRIVEN SHAFT RECOMMENDATIONS ● HOLLOW BORE IN MILLIMETERS

Dimensions - MM

Series	A	B +/- 0.064	C	D	F	Retaining Ring Groove		Mfg. No. (Waldes Truarcc)	H	I - 0.005/ -0.020	Keyway			Double Extension Details	
						G +0.12/- 0.00	J +/- 0.05				E	K +/- 0.05	L +0.015/-0.000	BD +/- 0.064	W* +/- 0.02
512	60.5	56.223	10	N/A	5	1.1	13	5100-55	19.1	14	20.2	10.8	5	66.383	10.16
518	71.1	67.170	11	N/A	5	1.4	16	5160-66	22.4	18	30.2	14.5	6	78.118	10.92
520	88.9	83.120	8	76.2	5	2.3	23.5	5160-98	28.4	25	30.2	21.0	8	90.767	7.62
525	127.0	122.492	3	108.0	8	2.6	26	5160-106	31.8	28	40.2	24.0	8	125.819	3.30
534	143.5	137.960	14	127.0	9	2.6	32.8	5160-137	44.5	35	50.2	30.0	10	151.448	13.46

* Dimension "W" refers to the width of spacer used.

BOLT CIRCLE DIMENSIONS - mm

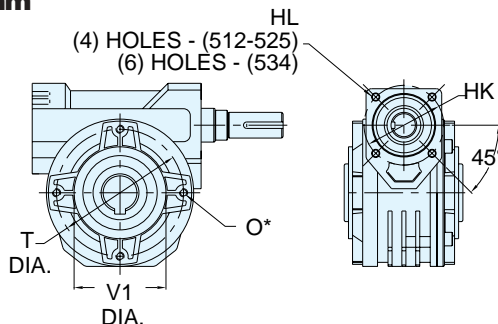

	O*	T DIA.	V1 DIA. (h8)	HL	HK DIA.
512	4 - M6 x 9	VIEW - A	65	50	M5 x 11
518	4 - M6 x 14	VIEW - A	65	50	M6 x 15
520	4 - M6 x 9	VIEW - A	94	68	M6 x 16
525	8 - M8 x 17	VIEW - B	90	75	M8 x 17
534	4 - M10 x 8	VIEW - C	130	110	M6 x 16

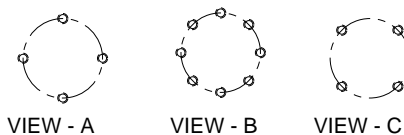

Bravo®
Accessory Kits



General Operation

1. Run the motor which drives the reducer and check the direction of reducer output rotation. Consult motor nameplate for instructions to reverse the direction of rotation.
2. Attaching the load: On direct coupled installations, check shaft and coupling alignment between speed reducer and loading mechanism. On chain/sprocket and belt/pulley installation, locate the sprocket or pulley as close to the oil seal as possible to minimize overhung load. Check to verify that the overhung load does not exceed specifications published in the catalog.
3. High momentum loads: If coasting to a stop is undesirable, a braking mechanism should be provided to the speed reducer output or the driven mechanism.

CAUTION The system of connected rotating parts must be free from critical speed, torsional or other type vibration, no matter how induced. The responsibility for this system analysis lies with the purchaser of the speed reducer.

Installation Instructions

The following instructions apply to standard Leeson Bravo® type reducers with base or flange mounting in motorized and non-motorized single and double reduction options.

1. Mount the unit to a rigid flat surface using grade 5 or higher fasteners. The mounting fasteners should be the largest standard size that will fit in the base mounting hole. Shim as required under flange or base feet which do not lie flat against the mounting surface.
2. Carefully follow lubrication instructions and installation manual furnished with the gear reducer. All standard Bravo® reducers are properly filled at LEESON with sufficient lubricant quantity for nearly any mounting position.

Series 512-525: Series 512-525 utilize a vent-free design and are Factory filled with synthetic semi-fluid grease formulated for lifetime lubrication & wide operating temperature range (+5F to +220F). It is not necessary to change the lubricant in reducer series 512-525 unless the reducer is used in a severe environment. If these reducers will be used in severe environment or if lubricant must be replaced, contact LEESON.

Series 534: Series 534 utilizes a vent and is Factory filled with Mobil SHC-634 oil, a synthesized hydrocarbon formulated for long life & wide operating temperature range (-25F to +220F).

Do not confuse Mobil SHC-634 with Mobilgear 634. Mobilgear 634 is an EP type gear oil not suitable for use in the Bravo® worm reducers.

3. Connect motor to speed reducer.

CAUTION DO NOT CHANGE MOUNTING POSITIONS WITHOUT CONTACTING FACTORY. Altering the mounting position may require special lubrication provisions which must be factory installed.

CAUTION Do not operate the reducer without making sure it contains the correct amount of oil. Confirm that mounting position on nameplate matches application requirement per Figure 1. Do not overfill or underfill with oil, or injury to personnel, reducer or other equipment may result.

CAUTION A unit cannot be used as an integral part of a machine superstructure which would impose additional loads on the unit other than those imposed by the torque being transmitted either through a shaft-mounted arrangement, and any shaft mounted power transmitting device. (e.g. sprockets, pulleys, couplings)

CAUTION For safe operation and to maintain the unit warranty, when changing a factory installed fastener for any reason it becomes the responsibility of the person making the change to properly account for fastener grade, thread engagement, load, tightening torque and the means of torque retention.

Lubrication

Carefully follow lubrication instructions and installation manual furnished with the gear reducer. All standard Bravo® reducers are properly filled at LEESON with sufficient lubricant quantity for nearly any mounting position.

Change oil only when performing maintenance that requires gearbox disassembly or if the reducer is operated in a severe environment. If oil must be replaced in Series 534 reducers, use only Mobil SHC-634.

CAUTION Lubricant should be changed more often if gear reducer is used in a severe environment. (ie: humid, wet, caustic, etc)

CAUTION In the Food and Drug industry (including animal food), consult the lubrication supplier for recommendation of lubricants which are acceptable to the Food and Drug Administration and/or other authoritative bodies having jurisdiction.

CAUTION Do not mix different lubricants in the reducer.

SPECIAL LUBRICATION REQUIREMENTS — Sizes 518-534

- Reducer is mounted with input worm shaft vertical
- Input speed is sustained less than 900 RPM

NOTE: The reducer may require modifications to assure proper lubrication in these applications. Contact LEESON for more detail.

For lubrication requirements of helical reducers (primaries of helical worm reducers and ratio multipliers), contact LEESON.

Lubrication type	Series				
	512	518	520	525	534
Grease (lbs)	0.14	0.2	0.35	0.84	--
Oil (ounces)	--	--	--	--	41

16 oz. = 1 pint	1 quart = .9463 liter
2 pints = 1 quart	1 gallon = 3.785 liter
4 quarts = 1 gallon	1 lb = .4535 kg.
1 gallon = 128 oz.	

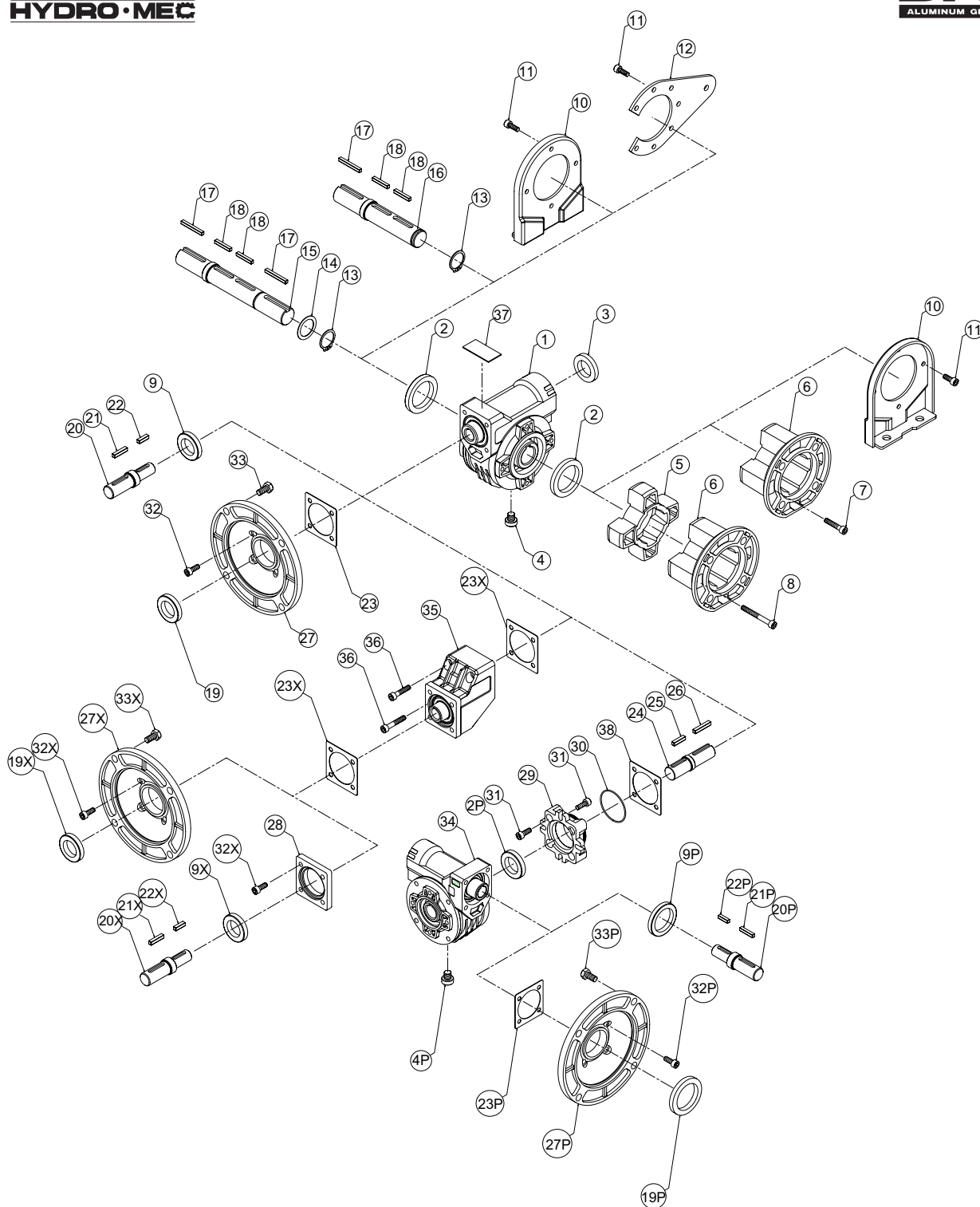

Bravo®
Accessory Kits

ITEM #	DESCRIPTION						
1	GEAR MODULE	11	SOCKET HEAD CAPSCREW	20,20P,20X	INPUT SHAFT - NON-MOTORIZED INPUT	29	CONNECTOR FLANGE - DOUBLE REDUCTION
2,2P	OIL SEAL - OUTPUT	12	REACTION ARM	21,21P,21X	KEY - INPUT (EXTENSION)	30	O-RING
3	RCA SEAL PLUG	13	RETAINING RING	22,22P,22X	KEY -INPUT (INTERNAL)	31	SOCKET HEAD CAPSCREW
4,4P	DRAIN PLUG	14	SPACER	23,23P,23X	GASKET	32,32P,32X	SOCKET HEAD CAPSCREW
5	FL-SPACER	15	OUTPUT SHAFT - DOUBLE EXTENSION	24	CONNECTOR SHAFT	33,33P,33X	HEX HEAD CAPSCREW
6	F-FLANGE	16	OUTPUT SHAFT - SINGLE EXTENSION	25	KEY	34	PRIMARY GEAR MODULE - DOUBLE REDUCTION
7	SOCKET HEAD CAPSCREW	17	KEY-OUTPUT (EXTENSION)	26	KEY	35	HELICAL STEP MODULE - DOUBLE REDUCTION
8	SOCKET HEAD CAPSCREW	18	KEY-OUTPUT (INTERNAL)	27,27P,27X	FLANGE - MOTORIZED INPUT	36	SOCKET HEAD CAPSCREW
9,9P,9X	OIL SEAL - NON-MOTORIZED INPUT	19,19P,19X	OIL SEAL - MOTORIZED INPUT	28	INPUT COVER	37	NAMEPLATE
10	HORIZONTAL BASE					38	GASKET



C FACE MOTORS • SINGLE PHASE

LESS BASE • CAPACITOR START • GENERAL PURPOSE



DRIP-PROOF • C FACE LESS BASE • SINGLE PHASE

HP	RPM 60 Hz	NEMA Frame	Catalog Number	App. Wgt. (lbs.)	Voltage	Over- load Prot.	F.L. Amps 230V	"C" Dim. (Inches)
1/4	1725
	1725	S56C	100023	17	115/208-230	None	2.7	9.24
	1725	S56C	101521	17	115/208-230	Auto.	2.7	9.24
1/3	1725
	1725	S56C	100024	17	115/208-230	None	3.3	9.24
	1725	S56C	100018	18	115/208-230	Man.	3.3	9.24
1/2	1725
	1725	S56C	100025	19	115/208-230	None	4.4	9.99
	1725	S56C	100019	21	115/208-230	Man.	4.4	9.99
3/4	1725	S56C	100026	24	115/208-230	None	5.4	10.99
	1725	S56C	100021	24	115/208-230	Man.	5.4	10.99
	1725	S56C	101523	26	115/208-230	Auto.	5.4	10.99
1	1725	56C	110220	30	115/208-230	None	6.4	10.88
	1725	56C	110036	27	115/208-230	Man.	6.4	10.88
	1725	143TC	121002	31	115/208-230	None	6.4	11.28
1 1/2	1725	56C	110388☆	38	115/208-230	None	8.6	11.84
	1725	56C	110037☆	39	115/208-230	Man.	8.6	11.84
	1725
2	1725
	1725	145TC	120073☆	49	115/230	None	10.5	13.28
	1725
3	1740	184TC	131544	73	115/208-230	None	16.9	14.19
5	1740	184TC	131539☆	81	230	None	21.0	14.69

TEFC • C FACE LESS BASE • SINGLE PHASE

NEMA Frame	Catalog Number	App. Wgt. (lbs.)	Voltage	Over- load Prot.	F.L. Amps 230V	"C" Dim. (Inches)
...
S56C	102868♣	22	115/208-230	None	2.3	9.80
S56C	102866	18	115/208-230	None	2.7	9.44
...
S56C	101766	22	115/208-230	None	3.3	9.94
S56C	102867♣	23	115/208-230	None	2.6	10.30
S56C	102869♣	25	115/208-230	Man.	2.6	10.30
...
S56C	102862♣	21	115/208-230	None	4.0	10.69
S56C	102865♣	22	115/208-230	Man.	4.0	10.69
S56C	102871	24	115/208-230	Auto.	4.0	10.69
56C	110057♣	25	115/208-230	None	5.4	11.31
56C	110040♣	26	115/208-230	Man.	5.4	11.31
56C	110308♣	28	115/208-230	Auto.	5.4	11.31
56C	110058♣	33	115/208-230	None	6.4	11.81
56C	110041♣	29	115/208-230	Man.	6.4	11.81
143TC	121001	32	115/208-230	None	6.4	12.25
56C	110420☆	37	115/208-230	None	8.6	12.81
56C	110042☆	40	115/208-230	Man.	8.6	12.81
145TC	120017☆	40	115/208-230	None	8.6	13.75
56C	112136☆	41	115/230	None	9.2	13.31
145TC	120060☆	45	115/230	Man.	10.0	14.25
182TC	131516	64	115/208-230	None	12.4	14.47
184TC	131545	82	115/208-230	None	16.8	16.47
184TC	131540☆	104	230	None	23.0	17.47

Motors in this column have NEMA Service Factors except as noted by ♣, which have 1.15 Service Factors.



EXPLOSION-PROOF MOTORS

SINGLE & THREE PHASE

SINGLE PHASE • C FACE LESS BASE

CLASS I, GROUPS C & D —

CLASS II, GROUPS F & G • W/CONDUIT BOX

HP	RPM 60 Hz	NEMA Frame	Catalog Number	App. Wgt. (lbs.)	Voltage	Over- load Prot.	F.L. Amps 230V	% F.L. Eff.	"C" Dim. (Inches)
1/3	1725	56C	111075●	41	115/208-230	Auto.	2.9	70.0	12.37
1/2	1725	56C	111085	45	115/208-230	Auto.	4.0	65.0	13.96
3/4	1725	56C	111086	50	115/208-230	Auto.	5.4	70.0	14.46
1	1725	56C	110852	53	115/208-230	Auto.	6.4	75.0	14.46

- ☆ Capacitor start/capacitor run design for reduced amperage, others are capacitor start/induction run.
- These motors are totally enclosed, non-ventilated—Others are fan cooled.
- ▲ These motors are satisfactory for operation on 50 Hz power supply at full rated horsepower.
- ▶ Shaft extension has keyway and flat 180° apart for ease of mounting.
Useable shaft is 1 1/2" long by 1/2" diameter, 1/8" keyway.

THREE PHASE • C FACE LESS BASE

CLASS I, GROUPS C & D—

CLASS II, GROUPS F & G • W/CONDUIT BOX

HP	RPM 60 Hz▲	NEMA Frame	Catalog Number	App. Wgt. (lbs.)	Voltage	Over- load Prot.	F.L. Amps 230V	% F.L. Eff.	"C" Dim. (Inches)
1/3	1725	56C	111931▲●	29	208-230/460	Auto.	1.7	76.0	10.87
1/2	1725	56C	111930▲●	34	208-230/460	Auto.	1.7	75.0	11.37
3/4	1725	56C	111935▲	36	208-230/460	Auto.	2.6	75.0	12.46
1	1725	56C	111926▲	46	208-230/460	Auto.	3.4	78.0	13.46
1 1/2	1725	56C	111941	46	208-230/460	Auto.	4.4	80.0	13.96
2	1725	145TC	121178	50	208-230/460	Auto.	6.0	84.0	15.53
3	1740	182TC	158003Ⓞ	91	230/460	T-Stat	8.8	80.0	15.62
5	1740	184TC	158005Ⓞ	110	230/460	T-Stat	13.4	82.5	16.12

Ⓞ Explosion-proof motors are Class I, Group D—Class II, Groups F & G.

SEE CATALOG 1050 FOR HAZARDOUS LOCATION APPLICATION NOTES.

C FACE MOTORS • THREE PHASE

LESS BASE • GENERAL PURPOSE



DRIP-PROOF • C FACE LESS BASE • THREE PHASE

HP	RPM 60 Hz	NEMA Frame	Catalog Number	App. Wgt. (lbs.)	Voltage	FL. Amps 230V	% FL. Eff.	"C" Dim. (Inches)
1/4	1725
	1725
1/3	1725	S56C	100048	17	208-230/460	1.6	64.3	9.49
	1725
1/2	1725	S56C	100049	21	208-230/460	2.0	68.0	9.99
	1725
3/4	1725	S56C	100050	24	208-230/460	2.8	75.0	10.49
1	1725	56C	110043	22	208-230/460	4.2	78.5	10.38
	1725	143TC	120172	26	208-230/460	4.2	78.5	11.28
1½	1725	56C	110044	27	208-230/460	5.6	78.5	10.88
	1725	145TC	120081	34	208-230/460	5.6	78.5	11.78
2	1725	56C	115553	32	208-230/460	6.2	78.5	11.19
	1725	145TC	120035	33	208-230/460	6.2	78.5	12.28
3	1725
	1725	145TC	121405	45	208-230/460	8.6	82.5	13.12
	1740	182TC	131489	43	230/460	8.0	80.0	11.69
5	1725	184TC	131490	55	208-230/460	14.2	84.0	12.69
7½	1740	184TC	131739	108	230/460	20.0	87.0	14.70

TEFC • C FACE LESS BASE • THREE PHASE

NEMA Frame	Catalog Number	App. Wgt. (lbs.)	Voltage	FL. Amps 230V	% FL. Eff.	"C" Dim. (Inches)
S56C	101648 ●	17	208-230/460	1.0	78.0	9.56
S56C	101767	19	208-230/460	1.4	58.0	9.69
S56C	101769	20	208-230/460	1.6	64.3	9.69
S56C	102863 ●	19	208-230/460	1.3	77.0	9.56
S56C	102861 ●	23	208-230/460	1.8	77.0	10.06
S56C	102860	19	208-230/460	2.0	73.0	10.19
56C	110047	22	208-230/460	2.8	77.0	10.81
56C	110048	24	208-230/460	3.8	77.0	11.31
143TC	120024	26	208-230/460	3.8	77.0	11.75
56C	110125	29	208-230/460	5.0	78.5	11.81
145TC	120037	32	208-230/460	5.0	80.0	12.75
56C	110451	34	208-230/460	6.2	81.5	12.81
145TC	120038	35	208-230/460	6.2	81.5	12.75
56C	113890 ♣	43	208-230/460	8.6	82.5	13.81
145TC	121035 ♣	44	230/460	8.6	82.5	14.25
182TC	131491	52	230/460	9.0	82.5	13.97
184TC	131492	64	230/460	13.2	82.5	14.48
184TC	131606	66	208-230/460	19.6	87.0	16.47

● These motors are totally enclosed, non-ventilated—Others are fan cooled.
 † Class F insulated.
 ♣ These totally enclosed three phase motors have 1.0 service factors.

SHADED FRAME INDICATES CAST IRON CONSTRUCTION

Motors & Drives



WATTSAYER® PREMIUM EFFICIENCY MOTORS

GENERAL PURPOSE • THREE PHASE

WATTSAYER® Inverter-Duty Premium Efficiency Motor

The WATTSAYER® line of premium efficiency motors is now *inverter capable*. LEESON's unique IRIS™ voltage-spike-resistant insulation system is standard at no extra cost. WATTSAYER® motors carry a three-year warranty in general purpose and inverter fed applications. These motors meet or exceed most utility rebate programs and the EPACT federally mandated efficiency levels. The efficiency ratings have been verified to IEEE 112B test standards by LEESON's NVLAP-Certified lab.



THREE PHASE • TEFC • C FACE LESS BASE 208-230/460V

HP	RPM 60 Hz	NEMA Frame	Catalog Number	App. Wgt. (lbs.)	Meets NEMA Premium	F.L. Amps 230V	3/4 Load Eff.	% F.L. Eff.	"C" Dim. (Inches)
1/3	1725	S56C	102696	22	N/A	1.3	73.5	77.0	10.19
1/2	1725	S56C	101780	25	N/A	1.8	73.8	77.0	10.69
3/4	1725	56C	114213	27	N/A	2.7	80.2	81.5	11.31
1	1725	56C	114638	34	N/A	3.4	84.7	85.5	12.81
	1725	143TC	121067	36	✓	3.4	84.7	85.5	13.25
1½	1725	145TC	121066	41	✓	5.6	86.1	86.5	13.75
2	1725	145TC	121065	45	✓	5.8	86.7	86.5	14.26
3	1760	182TC	131503	72	✓	7.8	89.0	89.5	14.96
5	1760	184TC	131501	90	✓	12.8	90.1	89.5	15.97

All WATTSAYER® motors have normally closed thermostats for over-temperature alert.

THREE PHASE • DRIP-PROOF • C FACE LESS BASE 208-230/460V

HP	RPM 60 Hz	NEMA Frame	Catalog Number	App. Wgt. (lbs.)	Meets NEMA Premium	F.L. Amps 230V	3/4 Load Eff.	% F.L. Eff.	"C" Dim. (Inches)
1/3	1725	S56C	102695	22	N/A	1.3	73.5	77.0	10.24
1/2	1725	S56C	102200	25	N/A	1.8	73.8	77.0	10.74
3/4	1725	56C	114934	29	N/A	2.4	80.4	81.5	10.86
1	1725	143TC	121064	32	✓	3.4	84.7	85.5	12.12
1½	1725	145TC	121063	36	✓	5.6	86.1	86.5	13.12
2	1725	145TC	121071	41	✓	5.8	86.7	86.5	13.62
3	1760	182TC	131518	75	✓	7.8	90.2	89.5	14.20
5	1760	184TC	131517	96	✓	12.8	90.1	89.5	15.20

All WATTSAYER® motors have normally closed thermostats for over-temperature alert.



50 HERTZ MOTORS THREE PHASE

General Specifications:

Totally enclosed fan cooled, 12-lead motors designed specifically for 50 Hz service. These motors are intended for equipment built in North America and destined for use in 50 Hz service areas of the world.



Features:

These NEMA frame motors are designed to North American performance standards, but for 50 Hz service. Suitable for 220/380 volt, 50 Hz, or 440 volt, 50 Hz, three phase power. Torques exceed NEMA performance standards for Design B motors and produce the full rated horsepower at 50 Hz speeds.

Construction meets IEC, IP54 degree of protection standards and utilizes external fan cooling (IEC cooling method IC41). Gasketed conduit box is in the North American standardized F1 location, with leads.

THREE PHASE • TEFC • C FACE LESS BASE • IP54

KW/HP	RPM 50 Hz	NEMA Frame	Catalog Number	App. Wgt. (lbs.)	Voltage	F.L. Amps 380 V.	% F.L. Eff.	"C" Dim. (Inches)
0.18/¼	1425	S56C	102184	18	220/380/440	1.00	56.0	9.44
	1425	56C	114889	18	220/380/440	1.10	68.0	10.31
0.25/⅓	1425	S56C	102689	19	220/380/440	1.10	65.0	9.69
	1425	56C	114889	18	220/380/440	1.10	68.0	10.31
	950	56C	114892	28	220/380/440	1.50	68.0	11.31
0.37/½	1425	S56C	102694	20	220/380/440	1.40	72.0	10.19
	1425	56C	114891	20	220/380/440	1.15	73.0	10.81
0.55¾	1425	56C	114894	27	220/380/440	1.85	74.0	11.31
	1425	56C	114896	28	220/380/440	2.00	77.0	11.31
		1425	143TC	121272	31	220/380/440	2.00	77.0
0.75/1	950	145TC	121273	39	220/380/440	2.65	73.0	13.25
	1440	145TC	121275	37	220/380/440	3.30	75.5	12.75
1.1/1½	1440	145TC	121277	40	220/380/440	3.65	81.5	13.75
1.5/2	1440	182TC	131506	63	220/380/440	4.70	84.0	13.97
2.2/3	1440	184TC	131508	82	220/380/440	8.10	85.0	15.47

▲ These motors are satisfactory for operation on 50 hertz power supply at full rated horsepower.
† Class F insulated.



BRAKEMOTORS
SINGLE & THREE PHASE



LEESON BRAKEMOTORS



Fail-safe positive, stop and hold brakemotors. Brakes are spring set. Load is stopped automatically when power is turned off. LEESON brakemotors feature a power off manual release for convenience, and for use in case of a power failure. The manual release

resets automatically. The standard brake is manufactured by Stearns. The brake coil leads are brought into the conduit box of the motor for easy connection and may be connected to operate when power to the motor is shut off, or to be actuated independent of power to the motor. Three phase motors have brake coils rated 230/460 VAC, 60 Hz. Single phase brake coils are 115/230 VAC, 60 Hz.

THREE PHASE • DRIP-PROOF • C FACE LESS BASE

HP	RPM 60 Hz	NEMA Frame	Brake Rating (ft-lbs)	Catalog Number	App. Wgt. (lbs.)	Voltage	FL. Amps 230V	% FL. Eff.	"C" Dim. (Inches)
1/2	1725	56C	3	114156	28	208-230/460	2.0	74.0	13.56
3/4	1725	56C	6	114157	38	208-230/460	2.8	77.0	14.06
1	1725	56C	6	114166	40	208-230/460	3.4	78.5	14.06
1 1/2	1725	145TC	10	120372	43	208-230/460	5.6	78.5	15.50
2	1725	145TC	10	120373	47	208-230/460	6.2	78.5	16.00
3	1740	182TC	15	131624	56	208-230/460	10.0	80.0	16.40
5	1740	184TC	25	131625	76	208-230/460	14.2	84.0	17.35

THREE PHASE • TEFC • C FACE LESS BASE

HP	RPM 60 Hz	NEMA Frame	Brake Rating (ft-lbs)	Catalog Number	App. Wgt. (lbs.)	Voltage	FL. Amps 230V	% FL. Eff.	"C" Dim. (Inches)
1/3	1725	56C	3	114158●	26	208-230/460	1.3	72.0	13.56
1/2	1725	56C	3	114159	26	208-230/460	2.0	74.0	15.06
3/4	1725	56C	6	114160	34	208-230/460	2.8	77.0	15.06
1	1725	56C	6	114161	31	208-230/460	3.6	77.0	15.56
	1725	143TC	6	121556	34	208-230/460	3.8	77.0	17.00
1 1/2	1725	145TC	10	120331	40	208-230/460	5.0	78.5	17.00
2	1725	145TC	10	120332	51	208-230/460	6.0	84.0	18.00
3	1740	182TC	15	131610	69	230/460	9.0	84.0	18.73
5	1740	184TC	25	131611	92	230/460	13.2	86.0	19.18

● These motors are totally enclosed, non-ventilated.

**BRAKEKITS™ AND
COUPLER BRAKES**



LEESON BRAKEKITS™

Kit of components to convert 56 through 256T frame stock TEFC motors to fail-safe brakemotors. Kit mounts on fan end of motor. Kits for 56-184T steel frame motors include totally enclosed Stearns AC brake, replacement cast fan cover, shaft extension, fan and hardware. Kits for 213T-256T cast iron frame motors **do not include brake**, but are designed for Stearns 87,000 series brake.

Two 1/2" NPT holes with 18" leads are provided for connections. The BRAKEKIT™ adds 5 1/8" to the overall length of 56 and 143-5T frame, and 5 7/8" to the overall length of 182-184T frame.

BRAKEKITS™

Brake Rating (ft-lbs)	Mounts to NEMA Frame	Max. HP @ 1725rpm	Cat. No. 115-208/230 V Brake Coil Voltage	Cat. No. 208-230/460 V Brake Coil Voltage	Cat. No. 575 V Brake Coil Voltage	App. Wt. (lbs.)
3	56/143-5T	1	175659	175139	175177	10
6	56/143-5T	2	175660	175140	175178	10
10	56/143-5T	3	175662	175141	175179	10
15	182-4T	3	--	175696	175698	12
25	182-4T	5	--	175697	175699	12

- 56/143-5T frame Brakekits cannot be used on S56 frame motors.
- Use the 182-4T frame Brakekits on motors having catalog numbers with a "G" prefix or that are 131454 or higher.
- 182-4T frame Brakekits can also be used on single-phase 4-pole (1725RPM) motors, but can only be connected for 208-230V. All brake coils are single phase.
- 182-4T frame Brakekits cannot be used with single or three-phase 2-pole (3450RPM) motors.

DOUBLE NEMA C FACE



Mounts directly to the face and shaft of NEMA 56 face motors and provides a NEMA 56C face and shaft for the load.

The 6 foot-pound brake mounts to NEMA 56C face motors or to NEMA 143-5TC face motors using the optional hub (included). Output face and shaft of the brake is NEMA 56C.

A 1/2" NPT hole with 15" leads is provided for connection. Totally enclosed construction. Overall length less the output shaft is 5 1/8".

BRAKE SELECTION

Motor HP	Brakemotor RPM Torque Rating of Brake (Lb-Ft)		
	3450	1725	1140
1/3	3	3	3
1/2	3	3	3
3/4	3	6	6
1	3	6	6
1 1/2	6	10	10
2	6	10	15
3	10	15	25
5	15	25	—

In this table, brake torque ratings are no less than 140% of the motor full load torque. Match HP & frame size of motor with appropriately rated BRAKEKIT™

Motors & Drives

COUPLER BRAKES

For Both Single and Three Phase Motors

Cat. No. 115/208-230V Single Phase	Cat. No. 208-230/460V Three Phase	Cat. No. 575V Three Phase	Brake Rating (ft-lbs)	Max. HP @ 1725 rpm	Mounts to NEMA Frame	Coupler Brake Output Shaft and Face	App. Wt. (lbs.)
175131	175970	175153	3	1	56C	5/8", 56C	13
175132	175971	175154	6	2	56C/143-5TC	5/8", 56C	14



DC MOTORS
SUB-FHP • SCR RATED

SUB-FHP MOTORS

General Specifications:

Precision subfractional horsepower DC permanent magnet motors designed for use with full wave non-filtered SCR controls for adjustable speed applications requiring dynamic braking and constant torque throughout the speed range.



31/34 Frame

Mechanical Features:

Compact space saving designs. Ball bearings. Long-life brushes for demanding applications. Brushes easily replaced without disassembly of the motor. Standard mounted conduit box on 31 and 34 frame models simplifies connections.

Electrical Features:

Continuous duty with full wave un-filtered rectified SCR (thyristor) controls. Linear speed torque characteristics throughout the speed range. High starting torques. Reversible rotation from a simple two lead connection.

SCR RATED (90 & 180 V) • TENV • SQUARE FLANGE OR C FACE

HP	Full Load RPM	Frame	Catalog Number	App. Wgt. (lbs.)	Arm. Volts DC	Control Volts AC Input	F.L. Amps DC
1/6	1750	34E56C	M1130054	11	90	115	1.7
	1750	34E56C	M1130119	11	180	230	0.9
1/4	1750	34G56C	M1130055**	13	90	115	2.7
	1750	34G56C	M1130120**	13	180	230	1.3

** These motors are totally enclosed fan cooled.

34-FRAME, NEMA C FACE, LESS BASE

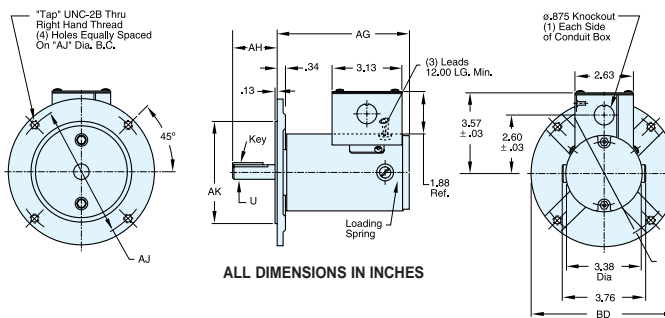

ALL DIMENSIONS IN INCHES

56C FACE MOUNT

Frame	AG	P*	U	AH	AH-BB	KEY	AJ	TAP	AK	BD
34E56C	6.87	3.38	.625	2.06	1.93	.19 SQ	5.875	3/8-16	4.50	6.50
34G56C	8.59	3.38	.625	2.06	1.93	.19 SQ	5.875	3/8-16	4.50	6.50

*For 1/4 HP 34 frame TEFC designs. Fan cover diameter is 3.88".



DC MOTORS
NEMA FRAME • C FACE WITH REMOVABLE BASE

NEMA FRAME MOTORS • SCR RATED

General Specifications:

High voltage permanent magnet DC motors are typically used with an SCR (thyristor) controller in applications requiring adjustable speed and constant torque throughout the speed range. They are also widely used in applications requiring dynamic braking or adjustable speed/reversing capabilities.



Mechanical Features:

Low profile space-saving design. Unique brush holder design provides easy access to brushes and integral constant pressure brush/spring assembly for servicing. Large over-sized brushes assure longer brush life. Heavy-duty, stamped steel, bolt-on base (removable). NEMA C face mounting at no additional cost. Rugged die cast aluminum endshields with cast iron bearing inserts. Permanently lubricated sealed ball bearings. May be converted NEMA 48 base and/or C face using modification kits noted below.

Electrical Features:

Input power of 115 or 230 volts rectified AC when used with an appropriate SCR control. Linear speed/torque characteristics over entire speed range. High starting torque for heavy load applications. Capable of dynamic braking for faster stops. Reversible rotation with simple two-lead connection. For further information on Direct Current Motors, request Bulletin 1600.

TEFC • SCR RATED 90 & 180 VOLTS
NEMA 56C • C FACE WITH REMOVABLE BASE

HP	Full Load RPM	NEMA Frame	Catalog Number	App. Wgt. (lbs.)	Arm. Volts DC	Control Volts AC Input	F.L. Amps DC	"C" Dim. (Inches)
1/4	1750	SS56C	098002	19	90	115	2.5	10.81
	1750	SS56C	098003	22	180	230	1.4	11.31
1/3	1750	SS56C	098004	23	90	115	3.5	11.31
	1750	SS56C	098005	23	180	230	1.7	11.31
1/2	1750	SS56C	098000	26	90	115	5.0	11.81
	1750	S56C	108014	29	90	115	5.0	12.81
	1750	SS56C	098008	25	180	230	2.5	11.81
	1750	S56C	108015	30	180	230	2.5	12.81
3/4	1750	SS56C	098032	36	90	115	7.6	13.81
	1750	S56C	108018	38	90	115	7.6	13.81
	1750	SS56C	098069	36	180	230	3.8	13.81
	1750	S56C	108019	35	180	230	3.8	13.81
1	1750	S56C	108022	47	90	115	10.0	16.31
	1750	S56C	108023	39	180	230	5.0	14.81
1 1/2	1750	S56C	108092	53	180	230	7.6	16.88
	1750	S56/145TC	108262	54	180	230	7.6	17.38
	1750	145TC	128000	70	180	230	7.5	18.34
2	1750	145TC	128010	83	180	230	9.5	19.34
	1750	182/145TC	128001	84	180	230	9.5	19.34
3	1750	182/145TC	108502	88	180	230	14.0	21.75

◀ NEMA 145TC face mounting with removable NEMA 182T rigid base.

■ NEMA 145TC frame shaft 7/8 x 2-1/4" and NEMA 56 removable base.

Σ If base is removed, do not reinstall bolts without using washers to compensate for thickness of base.

PWM RATED PM DC MOTORS

The DC motors listed above have been designed for use on unfiltered SCR (Thyristor) type rectified AC input. These motors may also be used with PWM (pulse width modulated) type DC adjustable speed drives at a higher HP rating. Contact LEESON for re-rating data.

Motors & Drives

DC MOTORS



NEMA FRAME • LOW VOLTAGE 12 & 24 VOLTS

NEMA FRAME LOW VOLTAGE MOTORS

General Specifications:

Low voltage permanent magnet DC motors are suitable for installations having battery or solar powered operations, or generator supplied low voltage DC.

Mechanical Features:

Unique brush holder design provides easy access to brushes and integral, constant pressure brush/spring assembly for servicing. Larger over-sized brushes assure longer brush life. Heavy-duty, stamped steel, bolt-on base (removable). NEMA C face mounting flange at no additional cost. High strength rolled steel frame. Rugged die cast aluminum endshields with steel bearing inserts. Permanently lubricated sealed ball bearings.



Electrical Features:

High starting torques for heavy load applications. Linear speed/torque characteristics over entire speed range. Capable of dynamic braking for faster stops. Reversible rotation and simple two-lead connection. Convenient wiring access.

LOW VOLTAGE (12 & 24V) • TENV/TEFC NEMA C FACE WITH REMOVABLE BASE

HP	Full Load RPM	NEMA Frame	Catalog Number	App. Wgt. (lbs.)	Arm. Volts DC	FL. Amps DC	"C" Dim. (Inches)
1/4	1800	S56C	108045♣	21	12	21.0	10.44
	1800	S56C	108046♣	24	12	27.0	11.44
1/3	1800	S56C	108050♣	22	24	13.5	10.94
	1800	S56C	108047♣	29	12	39.0	12.44
1/2	1800	S56C	108051♣	29	24	20.0	11.94
	1800	S56C	108048♦**	30	12	58.0	13.81
3/4	1800	S56C	108052**	30	24	29.0	12.81
	1800	S56C	108322♦**	39	12	80.0	13.81
1	1800	S56C	108053♦**	37	24	39.0	13.81

- ♣ Built-in conduit box located at 12:00.
- ♦ Studs at 12:00.
- Σ If base is removed, do not reinstall bolts without using washers to compensate for thickness of base.
- ** These motors are totally enclosed fan cooled.

METRIC (IEC) FRAME • LOW VOLTAGE (24V) • TEFC/TENV • MODULAR DESIGN

kW/HP	Full Load RPM	IEC Frame	Catalog Number	FL. Amps DC	C Dim. (inches)
0.06/1/12	1800	56	M1110026^●	3.4	6.34
0.18/1/4	1800	63	M1130207*	10.0	8.75
	1800	63	M1130297^	10.0	8.75
	1800	71	098065	11.0	10.77
0.37/1/2	1800	71	098067	20.0	12.27
0.75/1	1800	80	108455♦	39.0	14.64

IMPORTANT: IEC 71 and 80 frame motors in this chart are round body and require either B14 face or B5 flange kits shown below.

- * Dedicated B5 Flange
- ^ Dedicated B14 Face
- These motors are totally enclosed, non-ventilated. Others are TEFC/IC41 cooling – external cooling fan on motor shaft.

DC MOTORS



METRIC (IEC) FRAME • SCR RATED

FLANGE AND FACE KITS FOR DC METRIC (IEC) FRAME MOTORS

An advantage of LEESON'S modular design concept is the possible use of a different diameter B5 flange or B14 face than is normally assigned to a motor by IEC dimensional standards. This flexibility makes it possible to accommodate a wide variety of gear reducers, pumps and similar close coupled motor mounted loads.



Round body DC Metric IEC motors will accept any of the flange or face kits listed.

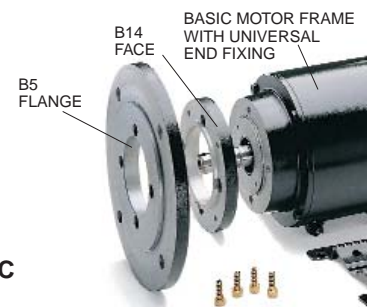

Motors & Drives

B5 FLANGE KITS (For DC Metric Motors Only)

IEC Frame	Catalog Number	App. Wgt. (lbs.)	BD Flange Dia. (mm)	AK Register (mm)	BF Hole (mm)	AJ Bolt Circle (mm)
71	175106	2	160	110	9	130
80	175108	3	200	130	12	165
90S/90L	175108	3	200	130	12	165
100L/112M	175137	5	250	180	15	215

B14 FACE KITS (For DC Metric Motors Only)

IEC Frame	Catalog Number	App. Wgt. (lbs.)	BD Flange Dia. (mm)	AK Register (mm)	BF Tap (mm)	AJ Bolt Circle (mm)
71	175107	1	105	70	6	85
80	175109	1	120	80	6	100
90S/90L	175129	1	140	95	6	115
100L/112M	175130	2	160	110	6	130



DC MOTORS
METRIC (IEC) FRAME • SCR RATED

DC METRIC (IEC) FRAME MOTORS IP54

General Specifications:

These metric dimensioned motors are built to IEC 34-1 electrical and mechanical standards.

The IEC 63 and smaller frames are stocked with an integral B5 flange or B14 face less base. An optional B3 rigid base kit is available.

A unique modular approach for IEC 71 frame and larger allows the motor to be field modified to B3 rigid base mounted construction, B5 flange mounted or B14 face mounted construction using conversion kits. Please note that one or more of the mounting kits must be used with IEC motors of these frame sizes. See listing on previous page for B5 flange and B14 face kits.

Electrical & Mechanical Features:

A terminal board is provided for connections. All fasteners are metric. Electrical and mechanical features are the same as listed for the NEMA frame motors on page 158. Tachometer mounting kits are available—please contact LEESON for data.



B5 IEC 56 & 63



B14 IEC 56 & 63



- ✕ For 230 VAC input controls.
- These motors are totally enclosed, non-ventilated. Other ratings utilize IC41 cooling—external cooling fan on motor shaft.

TOTALLY ENCLOSED • SCR RATED 180 VOLTS[⊘] WITH B5 FLANGE

KW/HP	Full Load RPM	IEC Frame	Catalog Number	App. Wgt. (lbs.)	F.L. Amps DC	"C" Dim. Inches (mm)
0.06/1/12	1800	56	M1130146●	8	0.5	6.24 (158.6)
0.09/1/8	1800	56	M1130147●	10	0.7	7.55 (191.7)
0.12/1/6	1800	63	M1130148	7	0.9	8.30 (210.8)
0.18/1/4	1800	63	M1130149	13	1.3	9.50 (241.3)

TOTALLY ENCLOSED • SCR RATED 180 VOLTS[⊘] WITH B14 FACE

KW/HP	Full Load RPM	IEC Frame	Catalog Number	App. Wgt. (lbs.)	F.L. Amps DC	"C" Dim. Inches (mm)
0.06/1/12	1800	56	M1130136●	8	0.5	6.24 (158.6)
0.09/1/8	1800	56	M1130137●	14	0.7	7.55 (191.7)
0.12/1/6	1800	63	M1130138	8	0.9	8.30 (210.8)
0.18/1/4	1800	63	M1130139	10	1.3	9.50 (241.3)

TEFC • SCR RATED 180 VOLTS[⊘] • ROUND BODY

KW/HP	Full Load RPM	IEC Frame	Catalog Number	App. Wgt. (lbs.)	F.L. Amps DC	"C" Dim. Inches (mm)
0.25/1/3	1800	71	098014	23	1.7	11.28 (286.5)
0.37/1/2	1800	71	098015	26	2.5	11.78 (299.2)
0.55/3/4	1800	80	108369	34	3.5	14.64 (371.9)
0.75/1	1800	80	108370	48	4.6	17.14 (435.4)
1.1/1 1/2	1800	80	108371	52	7.0	17.14 (435.4)
	1800	90L	118007	64	7.5	18.97 (481.8)
1.5/2	1800	90L	118008	84	9.5	20.47 (519.9)
2.2/3	1800	112M	118014	90	14.0	21.79 (553.5)

IMPORTANT: These round body motors require either a B14 face or B5 flange kit. Catalog number 118014 comes complete with IEC 112 B14 face and B3 foot; shaft diameter is 24mm.

CONDENSED DIMENSIONS • DC METRIC (IEC) FRAME MOTORS

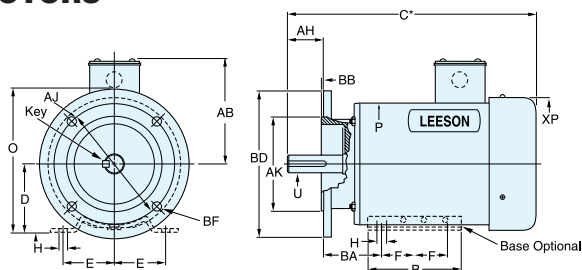

IEC FRAME DIMENSIONS (Millimeters)

IEC Frame	Mounting					Shaft						B14 Face/B5 Flange					General								
	2E	2F	BA	D	H	U	AH [◇]	KEY	S	R	TAP	AJ	AK	BD	BF	BB	AB	XP	B	O					
56	90	71	36	56	6	9	20	15	3	7.0	M3	65	100	50	80	80	120	M5	7	2.5	2.5	83	96	90	99
63	100	80	40	63	7	11	23	19	4	9.0	M4	75	115	60	95	90	140	M5	9	2.5	3.0	116	96	96	108
71	112	90	45	71	7	14	30	26	5	11.5	M5	85	130	70	110	105	160	M6	9	2.5	3.5	114	130	105	132
80	125	100	50	80	10	19	40	33	6	16.0	M6	100	165	80	130	120	200	M6	12	3.0	3.5	124	149	127	151
90S	140	100	56	90	10	24	50	36	8	20.5	M8	115	165	95	130	140	200	M8	12	3.0	3.5	135	182	152	173
90L	140	125	56	90	10	24	50	36	8	20.5	M8	115	165	95	130	140	200	M8	12	3.0	3.5	135	182	152	173
100L	160	140	63	100	12	28	60	41	8	24.5	M10	130	215	110	180	160	250	M8	15	3.5	4.0	135	182	176	173
112M	190	140	70	112	12	28	60	41	8	24.5	M10	130	215	110	180	160	250	M8	15	3.5	4.0	162	231	176	225

◇ Without face or flange AH shaft dimension is 12mm longer.
* For overall length, see motor listing.

AC & DC METRIC (IEC) MOTORS

RIGID BASE WITH FLANGE



B3/B5 FLANGE-MOUNTED METRIC MOTORS • 230/460V

Metric-dimensioned, AC motors meeting North American performance standards, including 1.15 service factor and EPACT efficiencies. Motors have both B5 flange mounting and B3 base.

Typically used for replacement on machine tools, textile machinery and other equipment with metric dimensions but requiring the heavy-duty torque and performance characteristics of motors designed for use in North America.

IP55 weatherproof enclosures, 60/50 Hz interchangeability (60Hz 230/460V & 50Hz 200/400V), dual stamped nameplates, CE mark, and F3 conduit box location. Kits are available for field conversion from B3 to B3/B5 or B3/B14.

Motors are available in one of two frame constructions: aluminum or cast iron. Aluminum frame models are designated with a 192000 series catalog number; cast iron models are 193000 series.



THREE PHASE • IP55 • 1.15 S.F.

HP-KW	RPM 60 Hz	IEC Frame	Catalog Number	App. Wgt. (lbs.)	Voltage	F.L. Amps 230V	% F.L. Eff.	"C" Dim. (Inches)
1/4-0.18	1700	D63D	192015	11	230/460	1.0	68.0	8.54
1/3-0.25	1700	D71D	192025	13	230/460	1.4	68.0	9.45
1/2-0.37	1695	D71D	192035	14	230/460	1.8	74.0	9.45
3/4-0.55	1690	D80D	192045	18	230/460	2.5	74.0	11.10
1-0.75	1725	D80D	192055	26	230/460	3.2	80.0	11.10
1 1/2-1.1	1740	D90SD	192065	37	230/460	4.6	85.5	12.60
2-1.5	1710	D90LD	192075	38	230/460	5.8	84.0	12.60
3-2.2	1750	DF100LD	193085	84	230/460	8.2	87.5	14.96
4-3	1740	DF100LD	193095	84	230/460	10.4	85.5	14.96
5 1/2-4	1740	DF112MD	193105	104	230/460	15.0	87.5	15.75

Note: Aluminum motors have removable feet for round-body applications.



SHADED FRAME INDICATES CAST IRON CONSTRUCTION

Catalog numbers in green are EPACT motors.

AC METRIC (IEC) MOTORS

THREE PHASE • RIGID BASE WITH FACE



B3/B14 FACE-MOUNTED METRIC MOTORS • 230/460V

Metric-dimensioned, AC motors meeting North American performance standards, including 1.15 service factor and EPACT efficiencies. These motors have both B14 face mounting and B3 base.

Typically used for replacement on machine tools, textile machinery and other equipment with metric dimensions but requiring the heavy-duty torque and performance characteristics of motors designed for use in North America.

IP55 weatherproof enclosures, 60/50 Hz interchangeability (60Hz 230/460V & 50Hz 200/400V), dual stamped nameplates, CE mark, and F3 conduit box location. Kits are available for field conversion from B3 to B3/B5 or B3/B14.



Motors are available in one of two frame constructions: aluminum or cast iron. Aluminum frame models are designated with a 192000 series catalog number; cast iron models are 193000 series.

THREE PHASE • IP55 • 1.15 S.F.

HP-KW	RPM 60 Hz	IEC Frame	Catalog Number	App. Wgt. (lbs.)	Voltage	F.L. Amps 230V	% F.L. Eff.	"C" Dim. (Inches)
1/4-0.18	1700	D63C	192018	11	230/460	1.0	68.0	8.55
1/3-0.25	1700	D71C	192028	13	230/460	1.4	68.0	9.46
1/2-0.37	1700	D71C	192038	14	230/460	1.8	74.0	9.46
3/4-0.55	1700	D80C	192048	18	230/460	2.5	74.0	11.11
1-0.75	1700	D80C	192058	26	230/460	3.2	80.0	11.11
1 1/2-1.1	1700	D90SC	192068	37	230/460	4.6	85.5	12.61
2-1.5	1700	D90LC	192078	38	230/460	5.8	84.0	12.61
3-2.2	1750	DF100LC	193088	84	230/460	8.2	87.5	14.97
4-3	1750	DF100LC	193098	84	230/460	10.4	85.5	14.97
5 1/2-4	1750	DF112MC	193108	104	230/460	15.0	87.5	15.76

Note: Aluminum motors have removable feet for round-body applications.

SHADED FRAME INDICATES CAST IRON CONSTRUCTION

Catalog numbers in green are EPACT motors.

Motors & Drives



WASHGUARD® MOTORS
WHITE EPOXY • SINGLE & THREE PHASE

NEMA FRAME • WASHGUARD®

LEESON WASHGUARD® motors are designed for extended life in applications requiring regular washdown as in food processing, or otherwise wet, high humidity environments. WASHGUARD® motors retard the entrance of water during cleaning operations and release any water that does enter the motor. Extra protection for the motor's interior prevents rust and corrosion build-up and drains release trapped moisture to insure a longer life than possible with a standard motor.



Mechanical Protection Features:

High quality, corrosion resistant 303 stainless steel shaft plus lubricated spring-loaded contact seals and patented, "V" ring Forsheda seal deflect water, protect bearings and the motor's interior. Double sealed, oversized bearings with high temperature moisture resistant lubricant are used.



Frame, base, endshields, armature and interior components protected by enamel and polyester compounds of outstanding adhesion and resistance to moisture, acids, alkalis and oil.

Cast conduit box with threaded entrance, drain holes and tough, high temperature

Nitrile gaskets keep water out and resist deflection under high pressure washdowns Conduit box cover and fan cover, when used, are type 304 stainless steel.

Four drains in each endshield at 3,6,9, and 12 o'clock purge water, and can be repositioned for maximum effectiveness regardless of the motor's mounting.

Machined fits are sealed, and nylon gaskets are used to seal bolt heads. Stainless steel data plate.



Chemically inert static free fan is positively positioned on the shaft by opposing flats, shoulder and snap ring arrangement and protected by heavy gauge, stainless steel fan guards. Finished in USDA approved tough white epoxy for

superior corrosion resistance and protection against harsh caustic cleaning solutions.



PROTECTED WITH RUST-OLEUM® COATINGS

WASHGUARD® • NEMA C FACE • REMOVABLE BASE TENV & TEFC • SCR RATED 90 & 180 VOLTS

HP	Full Load RPM	NEMA Frame	Catalog Number	App. Wgt. (lbs.)	Arm. Volts DC	Control Volts AC Input	F.L. Amps DC	"C" Dim. (Inches)
1/4	1750	S56C	108423●	23	90	115	2.7	10.69
1/3	1750	S56C	108424●	26	90	115	3.5	11.69
1/2	1750	S56C	108226●	38	90	115	4.9	13.69
	1750	S56C	108227●	43	180	230	2.4	13.69
3/4	1750	S56C	108228●	53	90	115	7.0	15.69
	1750	S56C	108229●	50	180	230	3.5	15.69
1	1750	S56C	108230	45	90	115	10.0	15.81
	1750	S56C	108231	42	180	230	5.0	14.81
1½	1750	S56C	108232	50	180	230	7.6	15.81

SINGLE PHASE • TEFC • C FACE LESS BASE

Featuring Electronic Solid State Encapsulated Switch

HP	RPM 60 Hz	NEMA Frame	Catalog Number	App. Wgt. (lbs.)	Voltage	Over-load Prot.	F.L. Amps 230V	"C" Dim. (Inches)
1/3	1725	56C	114311	27	115/208-230	None	3.2	10.69
1/2	1725	56C	114313	29	115/208-230	None	4.4	11.19
3/4	1725	56C	114315	31	115/208-230	None	5.4	11.69
1	1725	56C	114317	34	115/208-230	None	6.4	12.19
1½	1725	56C	114319	43	115/208-230	None	9.5	13.69

THREE PHASE • TENV and TEFC C FACE LESS BASE

HP	RPM 60 Hz	NEMA Frame	Catalog Number	App. Wgt. (lbs.)	Voltage	F.L. Amps 230V	% F.L. Eff.	"C" Dim. (Inches)
1/4	1725	56C	113649●	19	208-230/460	1.1	68.0	9.56
1/3	1725	56C	113954●	19	208-230/460	1.3	72.0	9.56
1/2	1725	56C	113473●	22	208-230/460	1.8	78.5	10.06
3/4	1725	56C	113019●	28	208-230/460	2.5	80.0	10.56
1	1725	56C	113020●	32	208-230/460	3.2	80.0	11.56
	1725	143TC	120760●	35	208-230/460	3.2	80.0	11.75
1½	1725	56C	113021●	44	208-230/460	4.2	84.0	13.06
	1725	145TC	120761●	47	208-230/460	4.2	84.0	13.25
2	1725	56C	114616	48	208-230/460	6.2	81.5	12.69
	1725	145TC	120762	39	208-230/460	6.2	81.5	12.75
3	1740	182TC	131596	61	230/460	9.0	82.5	14.47
5	1740	184TC	131597	72	230/460	13.2	82.5	14.47

WASHGUARD® • IEC FRAME • TENV IP55 B5 FLANGE WITH REMOVABLE B3 BASE ▲ SCR RATED 180 VOLTS

Rated HP	Output kW	Full Load RPM	IEC Frame	Catalog Number	App. Wgt. (lbs.)	Arm. Volts DC	F.L. Amps DC	"C" Dim. (Inches)
1/2	.37	1750	71	098040	22	180	2.5	10.69
3/4	.55	1750	80	108407	52	180	3.5	16.02

† Class F insulated.

● These motors are totally enclosed, non ventilated – others are fan cooled.

▲ If base is removed, do not reinstall bolts without using washers to compensate for thickness of base.

WASHGUARD® II MOTORS
STAINLESS FRAME • THREE PHASE



Super Duck



LEESON Severe Duty, stainless frame, WASHGUARD® II motors are designed for superior extended service in severe environments. Typical applications include food processing areas requiring frequent sanitation procedures using high pressure cleaning with concentrated caustic solutions, areas of high humidity and in chemical environments.

Mechanical Protection Features
 These motors have an *entirely paint free exterior* with 300 series stainless steel motor body, conduit box lid, shaft extension, hardware, fasteners and an etched motor data plate.

To enhance chemical and corrosion resistance, all surfaces of the endbells and conduit box are processed using a U.S. Department of Agriculture approved technique. This proprietary process has been tested and qualified for more than 2,500 hours of salt spray endurance for external surfaces, and 1,000 hours for internal surfaces. This process has proven successful in food washdown applications and has shown excellent corrosion resistance.

Shaft seals, slingers and one-way stainless steel drains retard entrance of contaminants and water into the motor. Multiple, repositional drains provided for all angle mounting, release any water that does enter the motor from hose downs or condensation. Chemically resistant, tough nitrile gaskets and a threaded entrance for power connection also restrict entrance to the motor's interior. Nylon gaskets are used to seal bolt heads.

Bearings used are double sealed and prelubricated with moisture resistant Exxon POLYREX® EM high temperature lubricant.

Electrical Performance and Protection Features

Efficiencies meet EPACT mandates for *covered* motors when tested without shaft seals. High temperature, moisture resistant IRIS insulation system assures long life on inverter service. Windings are immersed and cured in polyester insulating compound.

Standards and Approvals

UL component recognized, file number E57948, guide number PRGY2. Energy efficiency ratings are verified by an independent testing laboratory.

CSA Energy Efficiency Verification Program, report number EEV 78720-1.

Construction is CSA Certified for safety report number LR33543.

WASHGUARD® II motors are certified to the Baking Industry Sanitation Standard #29 and listed under BISSC authorization number 769.

STAINLESS FRAME • TENV > • C FACE LESS BASE

HP	RPM 60 Hz	NEMA Frame	Catalog Number	App. Wgt. (lbs.)	Voltage	FL. Amps 230V	% F.L. Eff.	"C" Dim. (Inches)
1/2	1725	56C	114394	30	208-230/460	1.6	78.5	11.06
3/4	1725	56C	114395	34	208-230/460	2.3	80.0	11.56
1	1725	56C	114437	44	208-230/460	3.0	81.5	12.06
	1725	143TC	121109	40	208-230/460	3.0	81.5	12.13
1 1/2	1725	56C	114581 >	45	208-230/460	4.4	84.0	12.69
	1725	145TC	121350 >	40	208-230/460	4.4	84.0	12.75
2	1725	56C	114582 >	51	208-230/460	6.0	84.0	14.19
	1725	145TC	121351 >	51	208-230/460	6.0	84.0	14.25

> All ratings TENV except 1 1/2 & 2 HP, which is TEFC with stainless steel fan cover and chemically inert fan.

CHEMICAL RESISTANCE RATING CHART

CHEMICAL	CONCENTRATION	COMPONENT-RESISTANCE	
		STAINLESS STEEL PARTS	ENDBELLS & CONDUIT BOX
WATER:			
De-Ionized Boiling	100%	Excellent	Excellent
Salt (Immersed)	30%	Excellent	Excellent
Salt (Spray)	5%	Excellent	Excellent
Tap - 250°F/120°C @ 10,000 PSI	100%	Excellent	Excellent
ACIDS:			
Hydrochloric	35%	Poor	Very Good
Sulfuric	25%	Poor	Excellent
Nitric	35%	Excellent	Good
Picric	Saturated Solution	Excellent	Very Good
BASE:			
Caustic	100%	Excellent	Excellent
Caustic	12.5 pH	Excellent	Excellent
Caustic - 125°F/50°C	9.5 pH	Excellent	Excellent
SOLVENTS:			
	--	Excellent	Excellent

Motors & Drives





WASHGUARD® ALL-STAINLESS MOTORS
ALL-STAINLESS • THREE PHASE • SINGLE PHASE

PREMIUM
STAINLESS STEEL DUCK



For maximum service in the most critically clean or corrosive environments, nothing beats LEESON's new WASHGUARD® All-Stainless Motors.

Specifically designed to meet the demanding sanitation requirements of the pharmaceutical and food processing industries, these motors are also ideal in severe chemical-processing applications involving nitric acid and caustic lye. In fact, WASHGUARD® All-Stainless Motors include IEEE 841 severe-duty features right out of the box!

Mechanical Protection Features:

Exterior components are entirely of 300 series stainless steel, including frame, base, endshields, conduit box, box cover and hardware. Plus, the full-fact etched stainless steel nameplate is blind riveted to the conduit box eliminating rivet holes in the frame as a source of entry for moisture. Nothing on the motor's exterior is painted or coated in any way.

Endshields are o-ring sealed to the frame. Double-lip shaft seals, o-rings, and gaskets are made from chemically resistant Viton® material. Hydrophobic breathers in the opposite shaft endbell and conduit box equalize pressure without allowing moisture to enter the motor. Double-sealed bearings are pre-lubricated with moisture-resistant high-temperature grease.



Electrical Performance and Protection Features

WASHGUARD® efficiencies meet EPACT mandates for non-exempt motors when tested without shaft seals. For extra moisture resistance, windings are immersed and cured in polyester insulating compound. And LEESON's exclusive IRIS™ Inverter-Rated Insulation System provided extra protection and long life, especially in inverter-fed applications.

Standards and Approvals

UL component recognized, file number E57948, guide number PRGY2. Energy efficiency ratings are verified by an independent testing laboratory. CSA Energy Efficiency Verification Program, report number EEV 78720-1.

Construction is CSA Certified for safety report number LR33543 and listed under BISSC authorization number 769.

ALL-STAINLESS THREE PHASE • TENV/TEFC • C FACE LESS BASE

HP	RPM 60 Hz	NEMA Frame	Catalog Number	App. Wgt. (lbs.)	Voltage	FL. Amps 230V	% F.L. Eff.	"C" Dim. (Inches)
1/2	1750	56C	116166●	22	208-230/460	1.6	78.5	11.21
3/4	1750	56C	116168●	37	208-230/460	2.3	80.0	11.71
1	1750	56C	116170●	38	208-230/460	3.0	81.5	12.21
	1750	143TC	121523●	39	208-230/460	3.0	81.5	12.28
1½	1750	145TC	121525	46	208-230/460	4.4	84.0	13.69
2	1750	145TC	121527	47	208-230/460	6.0	87.5	14.19
3	1750	182TC	131923	67	208-230/460	8.2	87.5	14.87
5	1750	184TC	131924	79	208-230/460	13.0	87.5	15.37

●These motors are totally enclosed, non-ventilated—Others are fan cooled.

ALL-STAINLESS SINGLE PHASE • TENV/TEFC • C FACE LESS BASE

HP	RPM 60 Hz	NEMA Frame	Catalog Number	App. Wgt. (lbs.)	Voltage	Over- load Prot.	FL. Amps 230V	"C" Dim. (Inches)
1/3	1750	56C	116349●	25	115/208-230	None	2.7	12.20
1/2	1750	56C	116350●	29	115/208-230	None	3.3	12.70
3/4	1750	56C	116351●	31	115/208-230	None	3.8	12.70
1	1750	56C	116352●	34	115/208-230	None	4.5	13.70
1½	1750	145TC	121624	43	115/208-230	None	8.6	14.19
2	1750	145TC	121633	60	115/208-230	None	9.2	13.96

● These motors are totally enclosed, non-ventilated—Others are fan cooled.

CHEMICAL RESISTANCE RATING CHART

CHEMICAL	CONCENTRATION	ALL STAINLESS COMPONENTS
WATER:		
De-ionized Boiling	100%	Excellent
Salt (Immersed)	30%	Excellent
Salt (Spray)	5%	Excellent
Tap - 250°F/120°C @ 10,000 PSI	100%	Excellent
ACIDS:		
Hydrochloric	35%	Poor
Sulfuric	25%	Poor
Nitric	35%	Excellent
Picric	Saturated Solution	Excellent
BASE:		
Caustic	100%	Excellent
Caustic	12.5 pH	Excellent
Caustic - 125°F/50°C	9.5 pH	Excellent
SOLVENTS:	--	Excellent

Motors & Drives

WASHGUARD® ALL-STAINLESS MOTORS
ALL-STAINLESS • THREE PHASE



WASHGUARD® SST™

This new member of LEESON's family of tough ducks is designed for long life in demanding washdown applications. LEESON's new FHP WASHGUARD® SST™ All-Stainless motors are Stainless Steel Tough!

Built with all stainless steel external components to prevent corrosion and well sealed against moisture and condensation to protect internal components, the Washguard® SST™ all-stainless motors are able to withstand the severe washdown environments found in the food processing, chemical processing, and beverage industries.

Mechanical Protection Features:

All exterior components – frame, base, endshields, fan guard, shaft, hardware, conduit box and cover – are made from 300 series stainless steel for maximum corrosion resistance. Nameplate data is permanently laser-etched into the motor frame – no Mylar nameplate that can wash off or riveted metal nameplate to trap dirt. No paint or any type of coating is used on the exterior of the motor.

Sealant is applied to endshield and frame fits before assembly to prevent water entry. Shaft seals on both ends of TEFC motors – shaft end only on TENV. Double-sealed bearings have high performance Exxon Polyrex EM grease. Conduit box is fully gasketed half-split design with flanged cover and body gasket with lead separator. Anti-corrosion coating on rotor prevents corrosion. Four quadrant drain locations on each endbell allow drainage of condensation in any mounting position. Stainless steel T-drains are provided to prevent liquids from splashing into the drain locations. Motors are shipped with a T-drain assembled in the six o'clock position on the opposite endshield. Another T-drain is shipped loose in the conduit box for installation at the lowest point of the shaft-end endshield. For a totally sealed motor, a spare pipe plug is included to replace the pre-installed T-drain.

Mechanical performance is further enhanced by over-sized bearings, heavy 12 gauge base, shaft-end bearing is locked internally to limit axial endplay, and specially designed shaft extension resists breakage at bearing journal.

Electrical Performance and Protection Features:

FHP Washguard® SST™ full load efficiencies meet EPACT standards for non-exempt motors when tested without shaft seals. For extra moisture resistance, windings are immersed and cured in polyester insulating varnish. LEESON's exclusive IRIS™ Inverter-Rated Insulation System provides extra protection and long life, especially in inverter driven applications.

Standards and Approvals:

UL component recognized, file number E57948, guide number PRGY2. Energy efficiency ratings are verified by an independent testing laboratory.

CSA Energy Efficiency Verification Program, report number EEV 78720-1.

Construction is CSA Certified for safety report number LR33543.

Motor is CE marked for European acceptance.

ALL-STAINLESS • TENV/TEFC • C FACE LESS BASE

HP	RPM 60 Hz	NEMA Frame	Catalog Number	App. Wgt. (lbs.)	Voltage	FL. Amps 230V	% F.L. Eff.	"C" Dim. (Inches)
1/3	1750	56C	191202●	29	208-230/460	1.3	78.5	9.40
1/2	1750	56C	191205●	32	208-230/460	1.6	81.5	9.40
3/4	1750	56C	191208●	38	208-230/460	2.3	82.5	9.40
1	1750	56C	191290●	48	208-230/460	3.0	81.0	13.50
	1750	56C	191213	46	208-230/460	3.0	82.5	13.40
	1750	143TC	191214	47	208-230/460	3.0	82.5	13.87
1½	1750	56C	191219	47	208-230/460	4.8	84.0	13.40
	1750	145TC	191220	48	208-230/460	4.8	84.0	13.87
2	1750	56C	191225	51	208-230/460	5.8	84.0	13.40
	1750	145TC	191226	52	208-230/460	5.8	84.0	13.87

● These motors are totally enclosed, non-ventilated—Others are fan cooled.

Motors & Drives





AC ADJUSTABLE SPEED DRIVES

MICRO SERIES INVERTERS

MICRO SERIES INVERTER DRIVES

Full feature, ultra-friendly operation. Programs and reads-out in plain English.

- Intelligent Power Module-IGBT's with a 16 bit Intel microprocessor.
- User choice programming with:
 - ✓ Choice of "Quick Start" factory presets.
 - ✓ Built-In English programmable options via the key touch-pad.
- Output Frequency: 0-120 Hz.
- Overload Current Capacity: 150% for one minute, based on nominal output of the control.
- Speed reference signal. Choice of potentiometer, 0-10VDC or 4-20mA inputs.
- Analog output signal, 0-10VDC, speed or load.
- Two auxiliary contacts: One form C relay and one open collector output.
- Preset speeds: Four.
- Slip compensation.
- Adjustable carrier frequency.
- Adjustable acceleration and deceleration times.
- Forward/Reverse.
- DC braking—time and voltage adjustable.
- Password protected.
- Constant torque—with adjustable current limit.
- 150% overload capacity for one minute based on nominal output rating of the control.
- Rugged, heavy-gauge steel enclosures with barrier type terminal strips.
- Underwriters Laboratories Listed.



NEMA 1

Speedmaster® Micro Series compact inverters offer "big drive" features for adapting standard or premium efficiency three phase motors to adjustable speed operation. Utilizing the latest micro-processor and advanced IGBT power conversion devices, these high performance controls program and read-out in plain English, eliminating the frustration and time involved in looking-up confusing coded symbols. Complete, rugged steel enclosures for NEMA 1 (IP31) or NEMA 4/12 (IP65) service do not require additional enclosure protection as with many plastic-housed compact drives. Built-in thermal overload protection reduces additional costs. Heavy duty wiring terminals accessible via three conduit openings on the bottom of the housing for power in/out and input/output signals speeds installation and reduces installation costs.



NEMA 1 (IP31) • THREE PHASE INPUT/OUTPUT

	HP	Output Amps	Input Voltage:☆	Catalog Number	App. Wgt. (lbs.)	Dimension Key
200-240 Volts	1/2	2.2	200-240	174914	6	B
	1	4.0	200-240	174915	6	C
	1 1/2	5.2	200-240	174916	6	C
	2	6.8	200-240	174917	9	E
	3	9.6	200-240	174918	9	E
	5	15.2	200-240	174919	11	F
	7 1/2	25.0	200-240	174545	13	M
400-480 Volts	10	28.0	200-240	174551	15	L
	1	2.0	400-480	174920	6	B
	2	3.4	400-480	174921	7	D
	3	4.8	400-480	174922	9	E
	5	7.6	400-480	174923	9	E
	7 1/2	11.0	400-480	174924	11	I
	10	14.0	400-480	174552	13	M

☆ User programmable for 50Hz and other voltage inputs



Standard at no extra cost on all LEESON stock NEMA three phase motors, 1 HP and larger, is the exclusive Inverter Rated Insulation System (IRIS™), providing superior protection against voltage spikes induced by variable frequency drives.

WASHGUARD® NEMA 4/12 (IP65/IP54) THREE PHASE INPUT/OUTPUT

	HP	Output Amps	Input Voltage:☆	Catalog Number	App. Wgt. (lbs.)	Dimension Key
200-240 Volts	1/2	2.2	200-240	174935	8	G
	1	4	200-240	174936	8	G
	1 1/2	5.2	200-240	174482	8	Y
	2	6.8	200-240	174937	10	H
	3	9.6	200-240	174938	11	J
	5	15.2	200-240	174730	11	K
	7 1/2	22	200-240	174734	27	Q
400-480 Volts	10	28	200-240	174737	32	U
	1	2	400-480	174939	8	G
	2	3.4	400-480	174940	10	H
	3	4.8	400-480	174941	10	H
	5	7.6	400-480	174942	11	J
	7 1/2	11	400-480	174548	11	K
	10	14	400-480	174554	11	Q

WASHGUARD® NEMA 4X (IP65) THREE PHASE INPUT/OUTPUT

	HP	Output Amps	Input Voltage:☆	Catalog Number	App. Wgt. (lbs.)	Dimension Key
200-240 Volts	1/2	2.2	200-240	174527	8	G
	1	4	200-240	174528	8	G
	1 1/2	5.2	200-240	174529	8	Y
	2	6.8	200-240	174530	10	H
	3	9.6	200-240	174531	11	J
	5	15.2	200-240	174732	11	K
	7 1/2	22	200-240	174735	27	Q
400-480 Volts	10	28	200-240	174738	32	U
	1	2	400-480	174532	8	G
	2	3.4	400-480	174533	10	H
	3	4.8	400-480	174534	10	H
	5	7.6	400-480	174535	11	J
	7 1/2	11	400-480	174745	11	K
	10	14	400-480	174747	11	Q

Motors & Drives

WASHGUARD® NEMA 4/12 (IP65/IP54) EPOXY COATED

FOOD-SAFE epoxy finish. No external cooling fan required on NEMA 4 (IP65) drives. NEMA 12 drives have external cooling fan. Fully gasketed, water, oil and dust-tight enclosure.



WASHGUARD® NEMA 4/12

WASHGUARD® NEMA 4X (IP65) STAINLESS STEEL

300-SERIES STAINLESS STEEL enclosures are fully gasketed to withstand frequent washdown in corrosive or caustic environments.



WASHGUARD® NEMA 4X

AC ADJUSTABLE SPEED DRIVES MICRO SERIES INVERTERS



MICRO SERIES INVERTER DRIVES

Single Phase Input with 230V three phase output. NEMA 1 enclosure. These Speedmaster® Micro Series inverters have the same features as units shown on the previous page. All can be programmed in plain English, eliminating the difficulties of using coded symbols.



NEMA 1 SINGLE PHASE

NEMA 1 (IP31) • SINGLE PHASE INPUT 230V THREE PHASE OUTPUT

(Use with three phase 230V motor)

HP	Output Amps 230 VAC	Input Voltage	Catalog Number	App. Wgt. (lbs.)	Dimension Key
1/4	1.4	115/230	174930	5	A
1/2	2.2	115/230	174997	7	AC
1	4.0	115/230	174931	7	D
1 1/2	5.2	115/230	174932	7	D
2	6.8	200-230	174933	9	E
3	9.6	200-230	174934	9	E

NEMA 1 ONLY

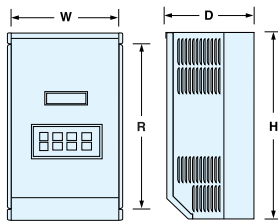

NEMA 4/12 WASHGUARD® ONLY

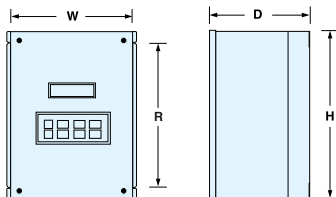

NEMA 1 & NEMA 4/12

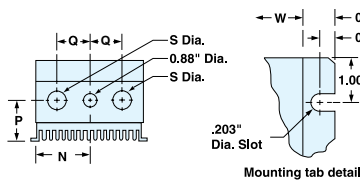

MICRO SERIES INVERTER DIMS. (Inches) • NEMA 1, NEMA 4/12 & NEMA 4X

Dimension Key	H	W	D	N	P	Q	R	S
A	7.50	4.70	3.33	2.35	1.60	1.37	5.50	0.88
B	7.50	4.70	3.63	2.35	1.90	1.37	5.50	0.88
C	7.50	4.70	4.33	2.35	2.60	1.37	5.50	0.88
D	7.50	6.12	4.22	3.77	2.40	1.37	5.50	0.88
E	7.50	6.12	5.12	3.77	3.30	1.37	5.50	0.88
F	7.88	7.86	5.94	5.13	3.95	1.50	5.88	1.13
G	7.88	6.12	4.35	3.06	2.70	1.37	5.88	0.88
H	7.88	7.86	4.90	4.80	3.25	1.37	5.88	0.88
I	9.38	7.86	6.25	5.13	3.95	1.50	7.38	1.13
J	7.88	7.86	5.90	4.80	4.25	1.37	5.88	0.88
K	9.75	10.26	7.20	5.13	5.25	2.00	7.75	1.13
L	11.25	7.86	6.84	3.93	4.19	2.00	7.75	1.38
M	9.38	7.86	6.84	3.93	4.19	2.00	5.88	1.13
N	12.75	7.86	6.84	3.93	4.19	2.00	9.25	1.38
O	12.75	7.86	7.40	3.93	4.19	2.00	9.25	1.38
P	12.75	10.26	7.74	5.13	5.00	2.50	9.25	1.38
Q	11.75	10.26	8.35	5.13	5.75	2.00	9.75	1.13
R	9.38	7.86	7.40	3.93	4.19	2.00	5.88	1.13
S	12.75	10.26	8.25	5.13	5.00	2.50	9.25	1.38
T	15.75	10.26	8.35	5.13	5.75	2.50	12.25	1.38
U	13.75	10.26	8.35	5.13	5.75	2.00	11.75	1.38
V	15.75	10.26	8.35	5.13	5.75	2.00	13.75	1.38
W	19.75	10.26	8.55	5.13	5.75	2.50	16.25	1.75
X	7.88	7.86	3.75	4.80	2.10	1.37	5.88	0.88
Y	7.88	6.12	5.25	3.06	3.60	1.37	5.88	0.88
Z	20.25	10.26	8.35	5.13	5.75	2.00	16.25	1.38
AA	15.75	10.26	8.35	5.13	5.75	2.00	11.75	1.38
AB	21.00	13.72	8.35	5.13	6.10	2.00	16.25	1.38
AC	7.50	6.12	3.63	3.77	1.80	1.37	5.50	0.88
AD	7.88	6.12	3.63	3.06	2.00	1.37	5.88	0.88

Motors & Drives

WASHGUARD® NEMA 4 (IP65) • SINGLE PHASE INPUT 230V THREE PHASE OUTPUT

HP	Output Amps	Input Voltage	Catalog Number	App. Wgt. (lbs.)	Disc. Sym.	Dimension Key
1/4	1.4	115/230	174996	8	A	AD
1/2	2.2	115/230	174998	8	A	X
1	4	115/230	174999	11	A	H
1 1/2	5.2	115/230	174515	11	A	H
2	6.8	208-230	174475	11	A	H
3	9.6	208-230	174729	12	A	J

WASHGUARD® NEMA 4X (IP65) • SINGLE PHASE INPUT 230V THREE PHASE OUTPUT

HP	Output Amps	Input Voltage	Catalog Number	App. Wgt. (lbs.)	Disc. Sym.	Dimension Key
1/4	1.4	115/230	174519	8	A	AD
1/2	2.2	115/230	174520	8	A	X
1	4	115/230	174521	11	A	H
1 1/2	5.2	115/230	174517	11	A	H
2	6.8	208-230	174525	11	A	H
3	9.6	208-230	174526	12	A	J



AC ADJUSTABLE SPEED DRIVES

SM PLUS SUB-MICRO INVERTERS

SM PLUS SUB-MICRO INVERTER DRIVES

BIG performance from an ultra-compact design. Provides 18 isolated I/O terminals plus RS485 Modbus® serial communication. Other features include:

- Removable electronic programming module allows off-line set-up and program replication.
- Input line voltage calibration—optimizes over and under voltage trip levels
- Current limit to 180% with frequency foldback
- Adjustable carrier frequency (4 to 10 kHz)
- Adjustable V/Hz
- Output frequency to 240 Hz
- Seven preset speeds
- Automatic restart after fault
- Control via drive face, terminal strip or optional remote keypad
- Coast or ramp to stop
- Independent Accel and Decel adjustment
- Forward only or forward and reverse direction
- Adjustable DC injection braking
- Speed reference: Keypad, 0-10 VDC, or 4-20 mA
- Speed reference calibration
- Speed and load indicating output signal selection: 0-10 VDC or 4-20mA
- Output signal calibration
- I²t motor thermal overload protection; meets UL requirements for motor protection in single motor applications
- Fixed boost for high starting torque
- Accel boost for high torque accelerating at any speed
- Slip compensation
- Three-digit LED display
- Password protection
- Fault history: Stores eight previous trips
- Terminal status indication
- Default parameter reset
- IP20 enclosure



SM PLUS

SINGLE PHASE INPUT/THREE PHASE OUTPUT

	HP	Output Amps 230 VAC	Input Voltage ⚡	Catalog Number	App. Wgt.(lbs.)	Dimension Key
115/230 Volts	1	2.0	115/230	174492	4	B1
	1 1/2	6.0	115/230	174445	5	B1

SINGLE OR THREE PHASE INPUT/THREE PHASE OUTPUT

	HP	Output Amps	Input Voltage ⚡	Catalog Number	App. Wgt.(lbs.)	Dimension Key
200-230 Volts	1/4	1.4	200-230	174452	2	A1
	1/2	2.2	200-230	174453	2	A1
	1	4.2	200-230	174454	3	A2
	1 1/2	6.0	200-230	174493	4	B1
	2	6.8	200-230	174494	5	B2
	3	9.6	200-230	174495	5	B2
	5	15.2	200-230	174444	8	C1

THREE PHASE INPUT/OUTPUT

	HP	Output Amps	Input Voltage ⚡	Catalog Number	App. Wgt.(lbs.)	Dimension Key	
200-230 Volts	1	4.2	200-230	174455	3	A2	
	1 1/2	6.0	200-230	174456	3	A3	
	2	6.8	200-230	174457	4	A3	
	3	9.6	200-230	174458	4	A3	
	5	15.2	200-230	174446	4	B2	
	7 1/2	22.0	200-230	174438	8	C1	
	10	28.0	200-230	174439	8	C1	
	460-480 Volts	1/2	1.1	460-480	174459	2	A1
		1	2.1	460-480	174460	3	A2
		1 1/2	3.0	460-480	174461	3	A3
2		3.4	460-480	174462	4	A3	
3		4.8	460-480	174463	4	A3	
5		7.6	460-480	174447	5	B2	
7 1/2		11.0	460-480	174440	8	C1	
	10	14.0	460-480	174441	8	C1	

⚡ User programmable for 50Hz and other voltage inputs



DIMENSIONS ON PAGE ???

Motors & Drives

SPECIFICATIONS:

Storage Temperature	-20° to 70° C
Ambient Operating Temperature	0° to 50° C
Ambient Humidity	<95% (non-condensing)
Maximum Altitude	3300 ft (1000m) above sea level
Input Line Voltages	115/230 VAC, 200-230 VAC, 460-480 VAC, and 550-575 VAC
Input Voltage Tolerance	+10%, -15%
Input Frequency Tolerance	48 to 62 Hz
Output Wave Form	Sine Coded PWM
Output Frequency	0-240 Hz
Carrier Frequency	4 kHz to 10 kHz

Enclosure	IP20
Service Factor	1.0
Efficiency	up to 98%
Power Factor (displacement)	>0.96
Overload Current Capacity	150% for 60 seconds 180% for 20 seconds
Speed Reference Follower	0-10 VDC, 4-20 mA
Control Voltage	15 VDC
Analog Outputs	0-10 VDC or 2-10 VDC: Proportional to frequency or load
Digital Outputs	Open-collector: 40 mA at 30 VDC
Power Supply for Aux. Relays	40 mA at 12 VDC

AC ADJUSTABLE SPEED DRIVES SM SERIES SUB-MICRO INVERTERS



SM SERIES SUB-MICRO INVERTER DRIVES

For applications requiring a simpler drive without the advanced features of the SM-Plus drive. Provides 11 isolated I/O terminals with one Form A relay output. Other features include:

- Removable electronic programming module allows off-line set-up and program replication.
- Input line voltage calibration—optimizes over and under voltage trip levels
- Current limit to 180% with frequency foldback
- Adjustable carrier frequency (4 to 10 kHz)
- Adjustable V/Hz
- Output frequency to 240 Hz
- Seven preset speeds
- Automatic restart after fault
- Control via drive face, terminal strip or optional remote keypad
- Coast or ramp to stop
- Independent Accel and Decel adjustment
- Forward only or forward and reverse direction
- Adjustable DC injection braking
- Speed reference: Keypad, 0-10 VDC, or 4-20 mA
- Speed reference calibration
- Speed and load indicating output signal selection: 0-10 VDC or 4-20mA
- I²t motor thermal overload protection; meets UL requirements for motor protection in single motor applications
- Fixed boost for high starting torque
- Accel boost for high torque accelerating at any speed
- Slip compensation
- Three-digit LED display
- Password protection
- Fault history: Stores eight previous trips
- Terminal status indication
- Default parameter reset
- IP20 enclosure with finger safe terminals



SM SERIES

SINGLE PHASE INPUT/THREE PHASE OUTPUT

	HP	Output Amps 230 VAC	Input Voltage	Catalog Number	App. Wgt.(lbs.)	Dimension Key
110-120 Volts	1/3	1.7	110-120	174263	2	A5
	1/2	2.4	110-120	174264	2	A5
	1	4.2	110-120	174265	3	B5
	1 1/2	6.0	110-120	174266	3	B5

SINGLE PHASE INPUT/THREE PHASE OUTPUT

	HP	Output Amps	Input Voltage	Catalog Number	App. Wgt.(lbs.)	Dimension Key
208-240 Volts	1/3	1.7	208-240	174267	2	A5
	1/2	2.4	208-240	174268	2	A5
	1	4.2	208-240	174270	3	A6
	1 1/2	6.0	208-240	174271	4	B5
	2	7.0	208-240	174272	5	B5
	3	9.6	208-240	174273	5	B6

THREE PHASE INPUT/THREE PHASE OUTPUT

	HP	Output Amps	Input Voltage	Catalog Number	App. Wgt.(lbs.)	Dimension Key
208-240 Volts	1/2	2.4	208-240	174274	2	A5
	1	4.2	208-240	174276	2	A6
	1 1/2	6.0	208-240	174277	3	A7
	2	7.0	208-240	174278	3	A7
	3	9.6	208-240	174279	3	B6
	5	15.2	208-240	174288	5	B6

THREE PHASE INPUT/THREE PHASE OUTPUT

	HP	Output Amps	Input Voltage	Catalog Number	App. Wgt.(lbs.)	Dimension Key
400-480 Volts	1/2	1.1	400-480	174281	2	A1
	1	2.1	400-480	174282	3	A2
	1 1/2	3.0	400-480	174283	3	A3
	2	3.4	400-480	174284	4	A3
	3	4.8	400-480	174286	4	B2
	5	7.8	400-480	174287	5	B2



DIMENSIONS: SM AND SM PLUS INVERTERS

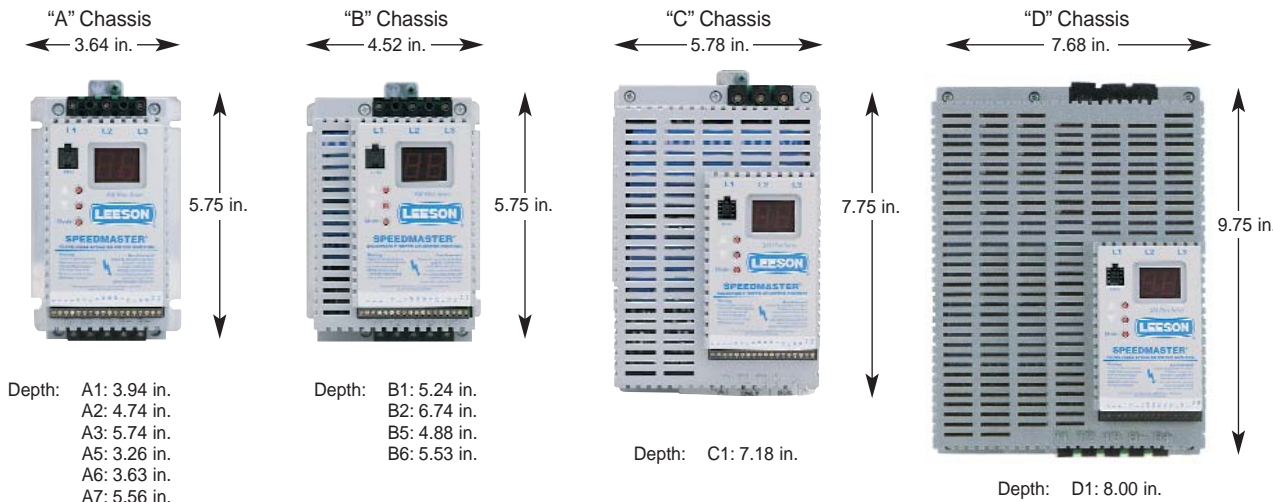

Dimensions shown for reference only. Contact LEESON for detailed drawing.

Motors & Drives



DC ADJUSTABLE SPEED DRIVES

SCR THYRISTOR CONTROLS



NEMA 4/12
TOTALLY ENCLOSED



LEESON Speedmaster® DC controls are general purpose drives designed for use with permanent magnet type direct current motors. NEMA 1 enclosed drives are suitable for most industrial applications, with the NEMA 4X enclosures best suited for washdown or outdoor installations or for extremely dusty applications. Chassis only units are available for building into equipment, machinery or existing enclosures. Most controls have a dual voltage switch allowing the control to be used on 115 or 230 volt, single phase, 50/60 Hertz service. However, the proper voltage motor should be selected for use with the power supply input, i.e., 90 volt DC motors for 115 volt input or 180 volt motors for 230 volt input service. Installation and adjustment instructions are included.

SCR/Thyristor drives are available in unidirectional and electro-mechanical type reversing styles for NEMA frame ratings and sub-fractional HP sizes.

Regenerative, four quadrant controls in NEMA 4X or chassis style available for applications requiring more precise motion control. These controls will produce both motoring and braking torque regulation for NEMA frame 1/4 HP through 2 HP motors.

Pulse Width Modulated (PWM) controls are available in NEMA 1 and chassis style units for subfractional HP frame motors from 1/40 through 1/4 HP. Due to their improved form factor, these PWM controls will result in quieter operation, lower operating temperatures, longer brush life, and greater motor overload capacity than for the same motor on an SCR type control.

SCR CONTROLS • ENCLOSED • SINGLE PHASE 50/60 HZ

Description	Catalog Number	Output Current Amps	HP Range		App. Wgt. (lbs.)
			115V	230V	
NEMA 1 General Purpose					
—Non-Reversing	174307	10	1/8 to 1 (H)	1/4 to 2 (H)	5
—Reversing with dynamic braking	174308	10	1/8 to 1 (H)	1/4 to 2 (H)	5
—Heat Sink	174316	—	—	—	1
NEMA 4X Washdown—Dust-Tight					
—Non-Reversing, Plastic Enclosure	174102	10	1/4 to 1	1/4 to 2	6
—Non-Reversing, Plastic Enclosure with Signal Follower	174103	10	1/4 to 1	1/4 to 2	7
—Reversing, Plastic Enclosure *	174107	10	1/4 to 1	1/4 to 2	7
NEMA 4					
—Non-Reversing 3HP	174709	15	—	3	8

SCR CONTROLS • OPEN CHASSIS

Description	Catalog Number	Output Current Amps	HP Range		App. Wgt. (lbs.)
			115V	230V	
Chassis with Speed Pot-Non Reversing	174311	10	1/8 to 1 (J)	1/4 to 2 (J)	1
Chassis Heat Sink (K)	174314	—	—	—	1

REGENERATIVE SCR DRIVES • FOUR QUADRANT • FULL WAVE

Description	Catalog Number	Output Current Amps	HP Range		App. Wgt. (lbs.)
			115V	230V	
NEMA 4X Washdown ✓	175720	10	1/4 to 1 (K)	1/2 to 2 (K)	8
Open Chassis with Speed Pot ✓	175721	10	1/4 to 1 (K)	1/2 to 2 (K)	2
Chassis Heat Sink (K)	175722	—	—	—	2

- * Drive does not have dynamic braking. Motor shaft must be at zero speed before reversing.
- (H) Heat sink #174316 is required for NEMA 1 type 3/4 and 1HP 115V and 1 1/2 and 2HP 230V
- (J) Chassis Heat Sink #174314 required for 3/4 and 1HP 115V and 1 1/2 and 2HP 230V
- (K) Chassis Heat sink #175722 required for 1HP and above.
- ✓ Regenerative drives are reversible and have regenerative braking.

TECHNICAL INFORMATION



CONDENSED GLOSSARY OF MOTOR AND GEARING TERMS

Axial Movement - Often called "endplay." The endwise movement of motor or gear shafts. Usually expressed in thousandths of an inch.

Back Driving - Driving the output shaft of a reducer — using it to increase speed rather than reduce speed. Worm gear reducers are not suitable for service as speed increasers.

Backlash - Rotational movement of the output shaft clockwise and counter clockwise, while holding the input shaft stationary. Usually expressed in thousandths of an inch and measure at a specific radius at the output shaft.

Center Distance - A basic measurement or size reference for worm gear reducers, measured from the centerline of the worm to the centerline of the worm wheel.

Drip-Proof - Venting in end frame and/or main frame located to prevent drops of liquid from falling into motor within 15 angle from vertical. Designed for use in areas that are reasonably dry, clean, and well ventilated (usually indoors). If installed outdoors, it is recommended that the motor be protected with a cover that does not restrict the flow of air to the motor.

Efficiency - A ratio of the input power compared to the output, usually expressed as a percentage.

Explosion-Proof Motors - These motors meet Underwriters Laboratories and Canadian Standards Association standards for use in hazardous (explosive) locations, as indicated by the UL label affixed to the motor. Locations are considered hazardous because the atmosphere does or may contain gas, vapor, or dust in explosive quantities.

Flanged Reducer - Usually used to refer to a reducer having provisions for close coupling of a motor either via a hollow (quill) shaft or flexible coupling. Most often a NEMA C face motor is used.

Gear+Motor™ - LEESON's registered trademark for a separable gear and NEMA C face motor as opposed to an integral gearmotor. Integral gearmotors suffer from lack of application and availability constraints as well as having inherent service issues when one or the other component needs replacement.

Input Horsepower - The power applied to the input shaft of a reducer. The input horsepower rating of a reducer is the maximum horsepower the reducer can safely handle.

Mechanical Rating - The maximum power or torque a reducer can transmit. LEESON reducers typically have a safety margin equal to 200% or more of its mechanical rating allowing momentary overloads during start-up or other transient overload conditions.

Motor Selection - See the technical section of LEESON's Stock Motor Catalog 1050, request LEESON's book, Practical Motor Basics or contact LEESON's District Office for expert assistance.

Mounting Position - The relationship of the input and output shafts of a reducer relative to horizontal.

Output Horsepower - The amount of horsepower available at the output shaft of the reducer. Output horsepower is always less than the input horsepower due to the efficiency of the reducer.

Overhung Load - A force applied at right angles to a shaft beyond the shaft's outermost bearing. This shaft-bending load must be supported by the bearing. Overhung load ratings are listed for each reducer size and should not be exceeded.

Prime Mover - In industry, the prime mover is most often an electric motor. Occasionally engines, hydraulic or air motors are used. Special application considerations are called for when other than an electric motor is the prime mover.

Self-Locking - The inability of a reducer to be driven backwards by its load. As a matter of safety, no LEESON reducer should be considered self-locking.

Service Factor for Gearing - A method of adjusting a reducer's load carrying characteristics to reflect the application's load characteristics. AGMA (American Gear Manufacturer's Association) has established standardized service factor information.

Service Factor for Motors - Refers to a motor's ability to handle a load greater than the motor's rated HP on a continuous basis. Most LEESON motors have a continuous duty service factor of 1.15 or higher. This ability of the motor is intended to handle momentary or transient overloads or unusual service conditions and should not be utilized when sizing motors for continuous service. For assistance in motor selection please contact your LEESON's District Office.

Thermal Rating - The power or torque a reducer can transmit continuously. This rating is based upon the reducer's ability to dissipate the heat caused by friction.

Thrust Load - Force imposed on a shaft parallel to a shaft's axis. Thrust loads are often induced by the driven machine. Take care to be sure the thrust load rating of the reducer is sufficient that its shafts and bearings can absorb the load without premature failure.

Totally Enclosed Non-Ventilated (TENV) - No vent openings, tightly enclosed to prevent the free exchange of air, but not airtight. Has no external cooling fan and relies on convection for cooling. Suitable for use where exposed to dirt or dampness, but not for hazardous (explosive) locations.

Totally Enclosed Fan Cooled (TEFC) - Same as the TENV except has external fan as an integral part of the motor, to provide cooling by blowing air around the outside frame of the motor.

WORM GEAR REDUCER SERVICE FACTORS

Proper determination of an application's service factor characteristics is critical for maximum reducer life and trouble free service. See the definition of service factor in the glossary.

All LEESON reducers and Gear+Motors™ are sized for applications having an AGMA defined service of 1.0, unless otherwise stated. (Alternately, 1.0 service factor is sometimes expressed as "Class I Service".) Reducers in such applications operate on a continuous duty basis, for 10 hours per day or less, and are free of recurrent shock loads. When operating characteristics are different than noted, the input horsepower and torque ratings listed must be divided by the service factor selected from the table below. This table applies to reducers with an electric or hydraulic motor input.

SPECIAL APPLICATION CONSIDERATIONS

CAUTION : Please contact LEESON for assistance in applications not listed or for applications with unusual characteristics. Including the following:

- Input speeds not listed in catalog
- Frequent starting or repetitive shock applications
- Selection of reducers for man lifts or people moving equipment
- High energy loads, including stalling

WORM REDUCERS:

- Starting or momentary overloads exceeding 200% of gear reducer mechanical capacity (100% overload)

SERVICE FACTOR TABLE

Duration of Service (Hours per day)	Uniform Load	Moderate Shock	Heavy Shock	Extreme Shock
Occasional 1/2 Hour	—*	—*	1.00	1.25
Less than 3 Hours	1.00	1.00	1.25	1.50
3 - 10 Hours	1.00	1.25	1.50	1.75
Over 10 Hours	1.25	1.50	1.75	2.00

* Unspecified service factors should be 1.00 or as agreed upon by the user and manufacturer.

When a single or multi-cylinder engine is the input power, the service factor selected from the table above should be increased by multiplying the value by the factor selected from the table below.

Service Factor Conversion Table for Engine Driven Applications.

Hydraulic or Electric Motor	Single Cylinder Engines	Multi-Cylinder Engines
1.00	1.50	1.25
1.25	1.75	1.50
1.50	2.00	1.75
1.75	2.25	2.00
2.00	2.50	2.25

On the next page, AGMA standardized service factor data is listed for a wide variety of applications operating 3 to 10 hours per day and for 10 hours or more per day.



TECHNICAL INFORMATION

A.G.M.A. SERVICE FACTORS

Application	Service Factor					
	3-10 Hours	Over 10 Hours				
AGITATORS						
Pure Liquids	1.00	1.25				
Liquids & Solids	1.25	1.50				
Liquids-Variable Density	1.25	1.50				
APRON CONVEYORS						
Uniformly Loaded or Fed	1.00	1.25				
Heavy Duty	1.25	1.50				
APRON FEEDERS	1.25	1.50				
ASSEMBLY CONVEYORS						
Uniformly Loaded or Fed	1.00	1.25				
Heavy Duty	1.25	1.50				
BARGE HAUL PULLERS	1.50	1.75				
BARKING						
Drums (Coupling Connected)		1.75				
Mechanical		1.75				
BAR SCREENS (Sewage)	1.00	1.25				
BELT CONVEYORS						
Uniformly Loaded or Fed	1.00	1.25				
Heavy Duty	1.25	1.50				
BELT FEEDERS	1.25	1.50				
BLOWERS						
Centrifugal	1.00	1.25				
Lobe	1.25	1.50				
Vane	1.00	1.25				
BOLTING MACHINERY	1.00	1.25				
BREWING & DISTILLING						
Bottling Machinery	1.00	1.25				
Brew Kettles, Cont. Duty	1.00	1.25				
Can Filling Machines	1.00	1.25				
Cookers-Cont. Duty	1.00	1.25				
Mash Tubs-Cont. Duty	1.00	1.25				
Scale Hoppers-Frequent Starts	1.25	1.50				
BUCKET						
Conveyors Uniform	1.00	1.25				
Conveyors Heavy Duty	1.25	1.50				
Elevators Cont.	1.00	1.25				
Elevators Uniform	1.00	1.25				
Elevators Heavy Duty	1.25	1.50				
CALENDARS						
Rubber		1.50				
Textile	1.25	1.50				
CANE KNIVES		1.50				
CAN FILLING MACHINES	1.00	1.25				
CAR DUMPERS	1.50	1.75				
CAR PULLERS	1.25	1.50				
CENTRIFUGAL						
Blowers, Compressors, Discharge Elevator, Fans or Pumps	1.00	1.25				
CHAIN CONVEYORS						
Uniformly Loaded or Fed	1.00	1.25				
Heavy Duty	1.25	1.50				
CLARIFIERS	1.00	1.25				
CLASSIFIERS	1.25	1.50				
CLAY WORKING INDUSTRY						
Brick Press	1.75	2.00				
Briquette Machines	1.75	2.00				
Clay Working Machinery	1.25	1.50				
Plug Mills	1.25	1.50				
COMPRESSORS						
Centrifugal	1.00	1.25				
Lobe	1.25	1.50				
Reciprocating:						
Multi-Cylinder	1.25	1.50				
Single Cylinder	1.50	1.75				
CONCRETE MIXERS						
Continuous	1.25	1.50				
Intermittent	1.25	1.50				
CONVEYORS-Uniformly Loaded or Fed						
Apron, Assembly, Belt, Bucket, Chain, Flight, Oven, Screw	1.00	1.25				
CONVEYORS-Severe Duty						
Live Roll		Contact Factory				
Reciprocating, Shaker	1.50	1.75				
COOLING TOWER FANS		Contact Factory				
CRANES						
Dry Dock Cranes		Contact Factory				
Main Hoist	1.00	1.25				
Bridge and Trolley Travel		Contact Factory				
CRUSHERS						
Ore or Stone	1.50	1.75				
Sugar		1.50				
DISC FEEDERS	1.00	1.25				
DOUBLE ACTING PUMPS						
2 or more Cylinders	1.25	1.50				
Single Cylinder		Contact Factory				
DRAW BENCH (Metal Mills)						
Carriage & Main Drive	1.25	1.50				
DREDGES						
Cable Reels, Conveyors	1.25	1.50				
Cutter Head & Jig Drives	1.75	2.00				
Maneuvering Winches, Pumps	1.25	1.50				
Screen Drives	1.50	1.75				
Stackers, Utility Winches	1.25	1.50				
ELEVATORS						
Bucket-Uniform Load	1.00	1.25				
Bucket-Heavy Duty	1.25	1.50				
Bucket-Continuous	1.00	1.25				
Centrifugal Discharge	1.00	1.25				
Escalators		Not Approved				
Freight		Not Approved				
Gravity Discharge	1.00	1.25				
Man Lifts, Passenger		Not Approved				
EXTRUDERS (Plastic)						
Film Sheet, Coating, Rods, Pipe Tubing	1.25	1.25				
Blow Molders, Pre-plasticizers		1.50				
FANS						
Centrifugal	1.00	1.25				
COOLING TOWERS						
Forced Draft		Contact Factory				
Induced Draft	1.25	1.50				
Large (Mine, etc.)	1.25	1.50				
Large Industrial	1.25	1.50				
Light (Small Diameter)	1.00	1.25				
FEEDERS						
Apron, Belt	1.25	1.50				
Disc	1.00	1.25				
Reciprocating	1.25	2.00				
Screw	1.25	1.50				
FLIGHT						
Conveyors, Uniform	1.00	1.25				
Conveyors, Heavy	1.25	1.50				
FOOD INDUSTRY						
Beet Slicers	1.25	1.50				
Bottling, Can Filling Mach.	1.00	1.25				
Cereal Cookers	1.00	1.25				
Dough Mixers, Meat Grinders	1.25	1.50				
HAMMER MILLS	1.50	1.75				
HOISTS						
Heavy Duty	1.75	2.00				
Medium Duty	1.25	1.50				
Skip Hoist	1.25	1.50				
INDUCED DRAFT FANS	1.25	1.50				
LAUNDRY WASHERS AND TUMBLERS	1.25	1.50				
LINE SHAFTS						
Driving Processing Equipment	1.25	1.50				
Other Line Shafts, Light	1.00	1.25				
LUMBER INDUSTRY						
Barkers-Spindle Feed	1.25	1.50				
Barkers-Main Drive	1.75	1.75				
Carriage Drive		Contact Factory				
CONVEYORS						
Burner	1.25	1.50				
Main or Heavy Duty	1.50	1.50				
Main Log	1.75	2.00				
Re-saw Merry-Go-Round	1.25	1.50				
Slab	1.75	2.00				
Transfer	1.25	1.50				
Chains-Floor	1.50	1.50				
Chains-Green	1.50	1.75				
Cut-Off Saws-Chain & Drag	1.50	1.75				
Debarking Drums	1.75	2.00				
Feeds-Edger	1.25	1.50				
Feeds-Gang	1.50	1.50				
Feeds-Trimmer	1.25	1.50				
Log Deck	1.50	1.50				
Log Hauls-Incline Well Type	1.50	1.50				
Log Turning Devices	1.50	1.50				
Planer Feed	1.25	1.50				
Planer Tilting Hoist	1.50	1.50				
Rolls-Live-Off Bearing-Roll Cases	1.50	1.50				
Sorting Table, Tipple Hoist	1.25	1.50				
Transfers-Chain & Craneway	1.50	1.75				
Tray Drives	1.25	1.50				
Veneer Lathe Drives		Contact Factory				
MACHINE TOOLS						
Auxiliary Drives	1.00	1.25				
Bending Rolls	1.25	1.50				
Main Drives	1.25	1.50				
Notching Press (Belted)		Contact Factory				
Plate Planers	1.50	1.75				
Punch Press (Geared)	1.50	1.75				
Tapping Machines	1.50	1.75				
METAL MILLS						
Draw Bench Carriages & Main Drives	1.25	1.50				
Pinch, Dryer and Scrubber		Contact Factory				
Rolls Reversing		1.25				
Slitters	1.25	1.50				
Table Conveyors Non-Reversing		1.25				
Group Drives	1.25	1.50				
Individual Drives	1.50	1.75				
Reversing Wire Drawing & Flattening Machines	1.25	1.50				
Wire Winding Machines	1.25	1.50				
MILLS, ROTARY						
Ball and Rod Mills with Spur Ring Gear		1.75				
with Helical Ring Gear		1.50				
Direct Connect		1.50				
Cement Kilns, Dryers, Coolers, Pebble, Plain & Wedge Bar Mills		1.50				
Tumbling Barrels	1.50	1.75				
MIXERS (Also see Agitators)						
Concrete, Cont. & Int.	1.25	1.50				
Constant Density	1.00	1.25				
Variable Density	1.25	1.50				
OIL INDUSTRY						
Chillers	1.25	1.50				
Oil Well Pumping		Contact Factory				
Paraffin Filter Press	1.25	1.50				
Rotary Kilns	1.25	1.50				
PAPER MILLS		Contact Factory				
PASSENGER ELEVATORS		Contact Factory				
PLATE PLANERS	1.50	1.75				
PRINTING PRESSES		Contact Factory				
PUMPS						
Centrifugal	1.00	1.25				
Proportioning	1.75	1.50				
Reciprocating		1.25				
Single Act, 3 or more Cyl.	1.25	1.50				
Double Act, 2 or 2 Cyl.	1.25	1.50				
Single Act, 1 or 2 Cyl.		Contact Factory				
Double Act, 1 Cyl.		Contact Factory				
Rotary: Gear, Lobe, Vane	1.00	1.25				
PUNCH PRESSES (Gear Driven)	1.50	1.75				
RUBBER & PLASTIC INDUSTRIES						
Calendars		1.50				
Crackers		1.75				
Laboratory Equipment		1.50				
Mills (2 on line)		1.50				
Mills (3 on line)		1.25				

TECHNICAL INFORMATION **LEESON**

MOTOR DIMENSIONS AC & DC MOTORS • NEMA C FACE

CRITICAL MOUNTING DIMENSIONS

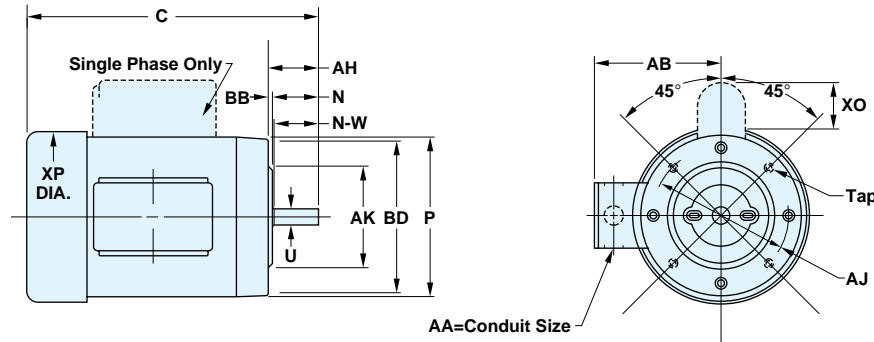

The condensed dimensions shown on these pages are for general reference only and are not for construction. The "C" dimension for each catalog item is included in this catalog. Certified drawings of all ratings are available for construction purposes.

NEMA SHAFT AND KEYWAY DIMENSIONS (Inches)

NEMA SHAFT (U)	KEYWAY DIMENSIONS (R)	(S)	NEMA SHAFT (U)	KEYWAY DIMENSIONS (R)	(S)
5/8	33/64	3/16	2-3/8	2-1/64	5/8
7/8	49/64	3/16	2-1/2	2-3/16	5/8
1-1/8	63/64	1/4	2-7/8	2-29/64	3/4
1-3/8	1-13/64	5/16	3-3/8	2-7/8	7/8
1-5/8	1-13/32	3/8	3-7/8	3-5/16	1

■ S is keyway width.
U minus R is keyway depth.

NEMA DIMENSIONS (Inches)

Frame Size ▲	N	P	U	N-W	AA	AB	AH	AJ	AK	BB	BD	XO	XP	TAP	KEY
S56	1 ¹⁵ / ₁₆	5 ¹⁹ / ₃₂	5/8	1 ⁷ / ₈	1/2	4 ⁷ / ₈	2 ¹ / ₁₆	5 ⁷ / ₈	4 ¹ / ₂	1/8	6 ¹ / ₂	2 ¹ / ₄	5 ⁷ / ₈	3/8-16	3/16
56	1 ¹⁵ / ₁₆	6 ¹⁹ / ₃₂	5/8	1 ⁷ / ₈	1/2	5 ⁵ / ₁₆	2 ¹ / ₁₆	5 ⁷ / ₈	4 ¹ / ₂	1/8	6 ¹ / ₂	2 ¹ / ₄	7 ³ / ₃₂	3/8-16	3/16
143T	2 ³ / ₈	6 ¹⁹ / ₃₂	7/8	2 ¹ / ₄	3/4	5 ⁵ / ₁₆	2 ¹ / ₈	5 ⁷ / ₈	4 ¹ / ₂	1/8	6 ¹ / ₂	2 ¹ / ₄	7 ³ / ₃₂	3/8-16	3/16
145T	2 ³ / ₈	6 ¹⁹ / ₃₂	7/8	2 ¹ / ₄	3/4	5 ⁵ / ₁₆	2 ¹ / ₈	5 ⁷ / ₈	4 ¹ / ₂	1/8	6 ¹ / ₂	2 ¹ / ₄	7 ³ / ₃₂	3/8-16	3/16
182T	2 ⁷ / ₈	8 ¹⁵ / ₃₂	1 ¹ / ₈	2 ³ / ₄	3/4	6 ³ / ₈	2 ⁵ / ₈	7 ¹ / ₄	8 ¹ / ₂	1/4	8 ⁷ / ₈	2 ¹ / ₄	9 ³ / ₃₂	1/2-13	1/4
184T	2 ⁷ / ₈	8 ¹⁵ / ₃₂	1 ¹ / ₈	2 ³ / ₄	3/4	6 ³ / ₈	2 ⁵ / ₈	7 ¹ / ₄	8 ¹ / ₂	1/4	8 ⁷ / ₈	2 ¹ / ₄	9 ³ / ₃₂	1/2-13	1/4
S213T	3 ¹ / ₂	8 ¹⁵ / ₃₂	1 ³ / ₈	3 ³ / ₈	1	8 ⁵ / ₁₆	3 ³ / ₈	7 ¹ / ₄	8 ¹ / ₂	1/4	9 ³ / ₃₂	2 ¹ / ₄	11 ³ / ₃₂	1/2-13	5/16
213T	—	10 ¹³ / ₁₆	1 ³ / ₈	3 ³ / ₈	1	8 ⁵ / ₁₆	3 ³ / ₈	7 ¹ / ₄	8 ¹ / ₂	1/4	9	2 ¹ / ₄	11 ³ / ₃₂	1/2-13	5/16
215T	—	10 ¹³ / ₁₆	1 ³ / ₈	3 ³ / ₈	1	8 ⁵ / ₁₆	3 ³ / ₈	7 ¹ / ₄	8 ¹ / ₂	1/4	9	2 ¹ / ₄	11 ³ / ₃₂	1/2-13	5/16
254TC	—	13 ¹ / ₄	1 ⁵ / ₈	4	1 ¹ / ₄	11 ⁹ / ₈	3 ³ / ₄	7 ¹ / ₄	8 ¹ / ₂	1/4	9 ⁵ / ₈	—	12 ⁷ / ₈	1/2-13	3/8
256TC	—	13 ¹ / ₄	1 ⁵ / ₈	4	1 ¹ / ₄	11 ⁹ / ₈	3 ³ / ₄	7 ¹ / ₄	8 ¹ / ₂	1/4	9 ⁵ / ₈	—	12 ⁷ / ₈	1/2-13	3/8

▲ Blue shading denotes dimensions established by NEMA standard MG1, others are unique to LEESON, and will vary with each manufacturer.

DIMENSIONS **LEESON** AC METRIC (IEC) MOTORS

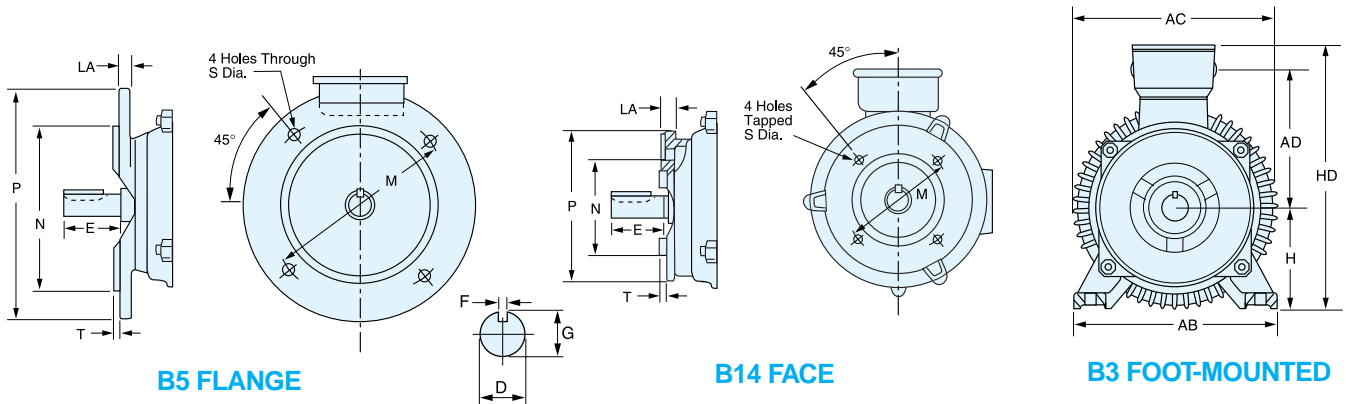

METRIC (IEC) FRAME DIMENSIONS (Millimeters)

Frame	Mounting			Shaft						General			B5 Flange					B14 Face						
	H	AB	K	D	E	F	G	ED	DH	AC	AD	HD	M	N	P	S	T	LA	M	N	P	S	T	LA
D56	56	107	6	9	20	3	7.5	8	M3 x 8	—	—	—	100	80	120	7	2.5	7	65	50	80	M5	2.5	7
D63	63	122	7	11	23	4	8.5	10	M4 x 10	126	84	171	115	95	140	10	3.0	7	75	60	90	M5	2.5	7
D71	71	136	7	14	30	5	11.0	20	M5 x 12.5	141	94	191	130	110	160	10	3.5	7	85	70	105	M6	2.5	9
D80	80	154	10	19	40	6	15.5	25	M6 x 16	159	102	206	165	130	200	12	3.5	12	100	80	120	M6	3.0	9
D90S	90	172	10	24	50	8	20.0	32	M8 x 19	180	112	229	165	130	200	12	3.5	12	115	95	140	M8	3.0	9
D90L	90	172	10	24	50	8	20.0	32	M8 x 19	180	112	229	165	130	200	12	3.5	12	115	95	140	M8	3.0	9
DF100L	100	205	12	28	60	8	24.0	40	M10 x 22	205	130	270	215	180	250	15	4.0	11	130	110	160	M8	3.5	14
DF112M	112	230	12	28	60	8	24.0	40	M10 x 22	240	150	300	215	180	250	15	4.0	12	130	110	160	M8	3.5	11

The overall length dimension for each catalog item is listed in the motor section of this catalog. Frames DF100L through DF112M, conduit box is located in the center of the frame.

General Information



TECHNICAL INFORMATION

U.L., CSA, ISO AND OTHER STANDARDS & APPROVALS – MOTORS

UNDERWRITERS LABORATORIES INC.

- All motor models listed with prefix "C" have U.L. component recognition (without thermal overload). File Number E57948, Guide Number PRGY2.
- All units have U.L. recognized Class B, F or H insulation systems unless otherwise noted. File Number E55555, Guide Number OBJY2.
- Single phase motors with a model number prefix of "A" or "M" (automatic or manual protectors) have U.L. recognized protector winding combinations and component recognition. File Number E57955, Guide Number XEWR2.
- Three phase motors with a model number prefix of "A" or "M" (automatic or manual protectors) have U.L. recognized protector winding combinations plus have capability of providing U.L. recognized primary single phasing which is included in our U.L. file E57955, Guide Number XEWR2.
- Explosion-Proof, single and three phase for 56, 143T and 145T frames: File Number E75276, Guide Number PTDR.
Explosion-Proof motors 182T and larger: File Number E12044, Guide Number PTDR.
Explosion-Proof motors DC motors 48 frame: File Number E75276, Guide Number PTDR..
- Permanent Magnet DC motors except PZ and P300 gearmotors are recognized components under File Number E57948, Guide Number PRGY2.
- PZ and P300 Permanent Magnet DC gearmotors: File number E49849 or E49747, Guide Number PRGY2.
- Speedmaster SCR Drives, Component Recognition, File E132235, Guide Number NMMS2, except catalog numbers 174902 and 174903.
- Speedmaster SCR Drives, catalog numbers 174902 and 174903. File Number E154901, Guide Number NMFT2.
- Speedmaster AC Adjustable Speed Drives, File Number E161242. Canadian UL covered by File Number E161242 also, Guide Number NMMS.

CANADIAN STANDARDS ASSOCIATION

- Motor construction for all single and three phase NEMA 42 through S254T frame, IEC/metric 63 through 90L frame, and all sub-fractional horsepower motors: Report Number L33543, Guide Number 260-0-0..
- Motor construction for all steel or cast iron three phase NEMA 182T through 447T frame and IEC/metric 100L through 250M frame motors: Report Number LR62104.
- Thermally protected single phase motors through 7 $\frac{1}{2}$ HP, Report Number LR33543.
- All Farm Duty motors 1/3 HP through 7 $\frac{1}{2}$ HP, Report Number LR33543
- Explosion proof single and three phase for 56, 143T and 145T frames: File Number LR47667.
Explosion-Proof motors 182T and larger: File Number LR21839 and LR47504.
Explosion-Proof DC motors 48 frame: File Number LR701080.
- Permanent Magnet DC motors are listed under File Number LR33543.
- Multi-Speed Motors, steel or cast iron, 182T through 447T frames are listed under file number LR33543.
- Speedmaster SCR Drives, catalog numbers 174902 and 174903. File Number LR75790.

MOTOR EFFICIENCY VERIFICATION

Energy Efficiency Verification - Full load efficiency ratings of three phase, single speed, NEMA/EEMAC Design A or B squirrel cage induction motors, 1 through 200 HP, 230, 460 or 575 volts, 60 Hz, in totally enclosed and open, drip-proof enclosures for non-hazardous applications, CSA Report Number EEV 78720-1. Tested to CSA 390 (IEEE 112B) Standards. The Grafton testing facility is qualified for CSA energy efficiency performance testing of polyphase induction motors. The Grafton Testing Facility is NVLAB recognized for energy efficiency testing of electric motors to EPACT requirements of the Department of Energy.

ISO QUALITY CERTIFICATION

Grafton and Saukville, Wisconsin administrative, design and manufacturing facility, ISO 9001, Certificate Number RvC #93-102. EN29001, BS5750: Part 1 and ANSI/ASQC Q91-19.

Black River Falls, Wisconsin manufacturing facility, ISO 9002, Certificate Number RvC #93-090.

Mississauga (Toronto), Ontario, administrative, distribution facility, ISO 9002, Certificate Number QMI #003027.

Hanover, Ontario, manufacturing facility, ISO 9002, Certificate Number QMI #003028.

BAKING INDUSTRY SANITATION STANDARDS COMMITTEE

WASHGUARD® II, stainless steel washdown duty motors, NEMA frames 56, 143T, 145T, 182T and 184T are certified to Standard No. 29 for Electric Motors and Accessory Equipment, authorization number 769. The WBMQ Series of gear reducers are BISSC certified to Standard No. 29 for Electric Motors and Accessory Equipment, authorization number 941.

SAUDI ARABIAN STANDARDS ORGANIZATION

SCCP Ref. No.: R-100157

The CE Mark

CE is an acronym for the French phrase "Conformite Europeene" and is similar to the UL or CSA marks of North America. However, unlike UL or CSA which require independent laboratory testing, the CE mark can be applied by the motor manufacturer through "self certifying" that its products are designed to the appropriate standards. The European Union has issued 24 directives related to the CE mark. Three Directives apply to electric motors.

Low Voltage Directive (73/23/EEC) This directive applies to electrical equipment operating in the voltage range of 50-1000 volts AC or 75-1500 volts DC. Virtually all LEESON motors (except low voltage DC) are included in this directive.

Based on our testing to the applicable electrical and mechanical standards EN60034 and IEC 34, LEESON certifies conformity to this directive. All three phase 50 Hz stock motors comply with the nameplate designations, lead markings and connection diagrams required. A "Declaration of Conformity" accompanies these motors and a CE label is applied.

Machinery Directive (89/3392/EEC) This directive applies to machinery that may contain certain motors. This is an issue with equipment manufacturers and requires the use of a motor meeting the Low Voltage Directive and requires a "Declaration of Incorporation" document which means that only the motor complies with the requirements of the Low Voltage Directive. A CE label is applied to the motor but it remains the responsibility of the equipment manufacturer to obtain certification for the finished product.

Electromagnetic Compatibility (EMC) Directive (89/336/EEC) This directive addresses the final product and is again a concern for the equipment manufacturer. Since this Directive addresses electromagnetic interference (EMI) concerns, it does not affect three phase AC motors because they do not produce EMI. DC motors, however, do produce EMI. How much of the "noise" is emitted outside the machine depends on a host of factors. LEESON's Engineering Department can assist OEM's in applying DC motors in machinery destined for Europe and requiring certification to the EMC Directive.



**WARNINGS AND CAUTIONS
ELECTRICAL****IMPORTANT INFORMATION
PLEASE READ CAREFULLY**

This catalog is not intended to provide operational instructions. Appropriate LEESON Electric instructions provided with the motor and precautions attached to the motor should be read carefully prior to installation, operation and/or maintenance of the equipment. Injury to personnel or motor failure may be caused by improper installation, maintenance or operation.

The following and information is supplied to you for your protection and to provide you with many years of trouble free and safe operation of your LEESON Electric product:



- Disconnect power and lock out driven equipment before working on a motor.
- Always keep hands and clothing away from moving parts.
- The lifting support on the motor is not to be used to lift the entire machine. Only the motor attached directly to the support may be safely lifted by the support.
- Install and ground per local and national codes.
- Discharge all capacitors before servicing a single phase motor.
- Misapplication of a motor in hazardous environment can cause fire or an explosion and result in serious injury. Only the end user, local authority having jurisdiction, and/or insurance underwriter are qualified to identify the appropriate class(es), group(s), division and temperature code LEESON Electric personnel cannot evaluate or recommend what motors may be suitable for use in hazardous environments. If a motor is name plated for hazardous locations, do not operate the motor without all of the grease and drain plugs installed.
- Never attempt to measure the temperature rise of a motor by touch. Temperature rise must be measured by thermometer, resistance, resistance, imbedded detector or thermocouple.
- Motors with automatic reset thermal protectors will automatically restart when the protector temperature drops sufficiently. Do not use motors with automatic reset thermal protectors in applications where automatic restart will be hazardous to personnel or equipment.
- Motors with manual reset thermal protectors may start unexpectedly after the protector trips when the surrounding air is at +20° Fahrenheit or lower. If the manual reset protector trips, disconnect motor from its power supply. After the protector cools (five minutes or more), it can be reset and power may be applied to the motor.
- Connect all protective device leads, marked P1, P2, etc., per instructions supplied with the motor.
- Operation of a motor at other than its nameplate rating may result in fire, damage to equipment or serious injury to personnel.
- For safety, Buyer or User should provide protective guards over all shaft extensions and any moving apparatus mounted thereon. The User is responsible for checking all applicable safety codes in his area and providing suitable guards. Failure to do so may result in bodily injury and/or damage to equipment.



- Consult qualified personnel with questions and all electrical repairs must be performed by trained and qualified personnel only.
- For motors nameplated as "belted duty only", do not operate the motor without belts properly installed.
- Motors and/or driven equipment should not be operated faster than their rated speed.
- For inverter applications, follow the inverter manufacturer's installation guidelines.
- Make sure the motor is properly secured and aligned before operation.

In the event of the resale of any of the goods, in whatever form, Resellers/Buyers will include the following language in a conspicuous place and in a conspicuous manner in a written agreement covering such sale:

The manufacturer makes no warranty or representations, express or implied, by operation of law or otherwise, as to the merchantability or fitness for a particular purpose of the goods sold hereunder. Buyer acknowledges that it alone has determined that the goods purchased hereunder will suitably meet the requirements of their intended use. In no event will the manufacturer be liable for consequential, incidental or other damages. Even if the repair or replacement remedy shall be deemed to have failed of its essential purpose under Section 2-719 of the Uniform Commercial Code, the manufacturer shall have no liability to Buyer for consequential damages.

Resellers/Buyers agree to also include this entire document including the warnings and cautions above in a conspicuous place and in a conspicuous manner in writing to instruct users on the safe usage of the product.

This information should be read together with all other printed information supplied by LEESON Electric.

For more information contact: **LEESON Electric**, Subsidiary of REGAL-BELOIT CORPORATION, 2100 Washington Street, Grafton, WI 53024
Phone: 262-377-8810 or Fax: 262-377-3440



IMPORTANT INFORMATION

PLEASE READ CAREFULLY



The following and information is supplied to you for your protection and to provide you with many years of trouble free and safe operation of your LEESON Electric product:

Read **ALL** instructions prior to operating reducer. Injury to personnel or reducer failure may be caused by improper installation, maintenance or operation.



- Written authorization from LEESON Electric is required to operate or use reducers in man lift or people moving devices.
- Check to make certain application does not exceed the allowable load capacities published in the current catalog.
- Buyer shall be solely responsible for determining the adequacy of the product for any and all uses to which Buyer shall apply the product. The application by Buyer shall not be subject to any implied warranty of fitness for a particular purpose.
- For safety, Buyer or User should provide protective guards over all shaft extensions and any moving apparatus mounted thereon. The User is responsible for checking all applicable safety codes in his area and providing suitable guards. Failure to do so may result in bodily injury and/or damage to equipment.
- Hot oil and reducers can cause severe burns. Use extreme care when removing lubrication plugs and vents.
- Make certain that the power supply is disconnected before attempting to service or remove any components. Lock out the power supply and tag it to prevent unexpected application of power.
- Reducers are not to be considered fail safe or self-locking devices. If these features are required, a properly sized, independent holding device should be utilized. Reducers should not be used as a brake.
- Any brakes that are used in conjunction with a reducer must be sized or positioned in such a way so as to not subject the reducer to loads beyond the catalog rating.
- Lifting supports including eyebolts are to be used for vertically lifting the gearbox only and no other associated attachments or motors.
- Use of an oil with an EP additive on units with backstops may prevent proper operation of the backstop. Injury to personnel, damage to the reducer or other equipment may result.
- Overhung loads subject shaft bearings and shafts to stress which may cause premature bearing failure and/or shaft breakage from bending fatigue, if not sized properly.



- Test run unit to verify operation. If the unit tested is a prototype, that unit must be of current production.
- If the speed reducer cannot be located in a clear and dry area with access to adequate cooling air supply, then precautions must be taken to avoid the ingestion of contaminants such as water and the reduction in cooling ability due to exterior contaminants.
- Mounting bolts should be routinely checked to ensure that the unit is firmly anchored for proper operation.

In the event of the resale of any of the goods, in whatever form, Resellers/Buyers will include the following language in a conspicuous place and in a conspicuous manner in a written agreement covering such sale:

The manufacturer makes no warranties or representations, express or implied, by operation of law or otherwise, as to the merchantability or fitness for a particular purpose of the goods sold hereunder. Buyer acknowledges that it alone has determined that the goods purchased hereunder will suitably meet the requirements of their intended use. In no event will the manufacturer be liable for consequential, incidental or other damages. Even if the repair or replacement remedy shall be deemed to have failed of its essential purpose under Section 2-719 of the Uniform Commercial Code, the manufacturer shall have no liability to Buyer for consequential damages.

Resellers/Buyers agree to also include this entire document including the warnings and cautions above in a conspicuous place and in a conspicuous manner in writing to instruct users on the safe usage of the product.

This information should be read together with all other printed information supplied by LEESON Electric.

TERMS AND CONDITIONS

TERMS AND CONDITIONS OF SALES QUOTATIONS ARE MADE AND ORDERS ARE ACCEPTED BY SELLER ONLY TO THESE TERMS AND CONDITIONS:

1. AGREEMENT AND MODIFICATION OF SALES TERMS.

The agreement between LEESON Electric and Buyer ("Sales Contract") is with respect to the sale of goods described on the other side hereof (the "goods"). Any Terms and Conditions contained in any purchase order or other form of communication from LEESON Electric's customers, which are additional to or different from these Terms and Conditions, shall be deemed rejected by LEESON Electric unless expressly accepted in writing by LEESON Electric.

2. ACCEPTANCE OF ORDERS.

Acceptance by LEESON Electric of Buyer's purchase order(s) is expressly conditioned upon Buyer's assent to these Terms and Conditions. Buyer will be deemed to have assented to such Terms and Conditions unless LEESON Electric receives written notice of any objections within 10 days after Buyer's receipt of this form or in all events prior to any delivery or other performance by LEESON Electric of Buyer's order if less than 10 days.

3. QUOTATIONS.

Quotations by LEESON Electric shall be deemed to be offers by LEESON Electric to sell the goods described therein subject to these Terms and Conditions, and acceptance of such offers is expressly limited to acceptance by Buyer of all of these Terms and Conditions within 30 days from the date of the quotation or as specified. Purchase orders submitted by Buyer for the goods quoted by LEESON Electric shall be subject to and will be deemed to constitute acceptance of these Terms and Conditions. All purchase orders will be subject to approval by LEESON Electric.

4. TERMINATION OR MODIFICATION.

The Sales Contract may be modified or terminated only upon LEESON Electric's express written consent, which consent will at all times be conditioned on Buyer's agreement to pay LEESON Electric's modification or termination charge including, but not limited to expenses and costs plus a reasonable profit, except that any goods completed on or before LEESON Electric's acceptance of termination shall be accepted and paid in full by Buyer.

5. PRICES AND TERMS.

Fulfillment of Buyer's order is contingent upon the availability of materials. The price of the goods sold pursuant to the Sales Contract shall be based upon LEESON Electric's prices in effect at the time of shipment and any acceptance of the order will be on the basis of the freight rates in effect at the time of shipment. In the event of an increase or decrease in the applicable freight charges before the material is shipped, such changes in freight charges will be for the account of Buyer. Price advances, discounts, extras and terms and conditions are subject to changes without notice. Unless otherwise provided on the front side hereof, price is F.O.B. LEESON Electric's point of shipment, and terms of payment shall be net 30 days from date of invoice. LEESON Electric may assess finance and service charges of 1-1/2 percent per month (or the highest rate allowed by state law) on invoices not paid within stated payment terms. Open account credit status is offered at the discretion of the LEESON Electric. LEESON Electric may discontinue open account status or change credit limit as warranted, in its opinion, by the financial condition and/or credit history of the Buyer. LEESON Electric may require full or partial payment or payment guarantees in advance of shipment whenever, in its opinion, the financial condition and/or credit history of Buyer so warrants. In addition, LEESON Electric may, at any time, suspend performance of any order or require payment in cash, security or other adequate assurance satisfactory to LEESON Electric when, in LEESON Electric's opinion, the financial condition and/or credit history of Buyer warrants such action.

6. TAXES.

Prices do not include sales, use or other similar federal, state or local taxes. Buyer shall either have a tax-exemption certificate on file with the LEESON Electric or pay to LEESON Electric, in addition to the price of the goods, any and all applicable taxes, which may be invoiced separately at a later date.

7. DESIGN; EXTRA WORK; BUYER'S MATERIAL.

(a) If any order accepted by LEESON Electric contemplates the preparation of special designs by LEESON Electric, Buyer issuing such order will have a responsible representative specifically approve all designs prepared by LEESON Electric. (b) If Buyer requests extra work not included in the quotation or original order, Buyer will pay for the extra work at reasonable rates as determined by LEESON Electric. (c) In the event spoilage/damage occurs on orders where Buyer furnishes any material, LEESON Electric shall not be liable for replacement of or damage to such material.

8. RISK OF LOSS, TITLE, SECURITY INTEREST.

Delivery shall occur, and risk of loss shall pass to Buyer, upon delivery of the material to a carrier at the F.O.B. point of shipment. Transportation shall be at Buyer's sole risk and expense, and any claims for losses or damage in transit shall be against the carrier only. However, LEESON Electric retains title to all products until paid for in full in cash and Buyer agrees to perform all acts necessary to provide a fully perfected security interest in the goods in favor of LEESON Electric. LEESON Electric may, at its option, repossess the same, upon Buyer's default in payment hereunder, and charge Buyer with any deficiency.

9. DELIVERIES AND QUANTITIES.

(a) Delivery dates are not guaranteed but are estimated on the basis of immediate receipt by LEESON Electric of all information to be furnished by Buyer and the absence of delay, direct

or indirect, resulting from or contributed to by circumstances beyond LEESON Electric's reasonable control. If the goods are non-catalog goods, LEESON Electric may ship overages or underages to the extent of 10 percent of quantity ordered, and Buyer shall pay for such quantity based upon the unit price of the goods. LEESON Electric shall not be required to maintain closer control of quantity, unless specifically agreed to by LEESON Electric in writing. Quantities of all items may be determined by weight. Any claims for shortage must be within 10 days from the date of receipt of the goods by Buyer, and in every case the weights found in any particular shipment, including tare, must be given and LEESON Electric advised as to the method used by Buyer in computing the count of parts. (b) In the event that Buyer is unable to accept delivery of the goods at time of shipment, LEESON Electric shall invoice Buyer for the full purchase price as if shipment had been made and: (i) if LEESON Electric is able to store such goods in its own facilities, Buyer will pay LEESON Electric the reasonable handling and storage charges for the period of such storage, and (ii) if LEESON Electric is unable to store such goods at its own facility, LEESON Electric reserves the right to arrange handling and storage in a suitable bonded warehouse for the Buyer at Buyer's expense. In cases where handling and storage become necessary, it shall be Buyer's responsibility to notify LEESON Electric when shipment is to be made. LEESON Electric will make necessary arrangements for shipment at Buyer's expense.

10. RETURNED GOODS.

Goods may not be returned. However, if LEESON Electric consents in writing or upon verbal authorization to the return of goods for any reason, Buyer, who also shall assume all risk of loss of such returned goods until actual receipt by LEESON Electric, must prepay transportation charges.

11. INSPECTION, ACCEPTANCE.

Buyer shall inspect the goods immediately upon the receipt thereof. All claims by Buyer (including claims for shortages), except only those provided for under the WARRANTY AND LIMITATIONS OF LIABILITY and PATENTS clauses below, must be asserted in writing by Buyer within a 10 day period or they are waived. If this contract involves partial performances, all such claims must be asserted within a 10-day period for each partial performance. Rejection may be only for defects substantially impairing the value of products or work. Buyer's remedy for lesser defects shall be those provided for under the Warranty and Liability clauses. THERE SHALL BE NO REVOCATION OF ACCEPTANCE. If Buyer wrong-fully rejects, revokes or delays acceptance of items or work tendered under this contract, or fails to make a payment due on or before delivery, or repudiates this contract, LEESON Electric shall, at its option, have a right to recover as damages, either the price as stated herein (upon recovery of the price, the items involved shall become the property of the Buyer) or the profit (including reasonable overhead) which the LEESON Electric would make from performance together with incidental damages and reasonable cost.

12. WARRANTIES AND LIMITATIONS OF LIABILITY.

(a) LEESON Electric warrants to the Buyer that its motors, gearmotors, DC controllers, and AC drives are free from defects in workmanship and materials when operated under normal conditions and in accordance with nameplate characteristic limits. This warranty shall be in effect for a period of 12 months from date of installation, but in no event be in effect for more than 18 months from date of manufacture, with the following exceptions: i) EPACT motors ("G" prefix), which are warranted for a period of 24 months from date of installation but for not more than 30 months from date of manufacture, ii) Wattsaver Premium Efficiency three phase motors and Speedmaster Inverter-Duty motors are warranted for a period of 36 months from the date of installation but for not more than 42 months from the date of manufacture, & iii) Motor brakes provided as coupler brakes, brake kits, or as part of brakemotors are covered by the manufacturers (Stearns or Dings) warranties.

(b) LEESON Electric's sole obligation under the foregoing warranties is limited to either, at LEESON Electric's option, replacing or repairing defective goods (or defective parts thereof) within the warranty period. LEESON Electric shall not be liable under any circumstances, for consequential or incidental damages, including, but not limited to personal injury or labor costs. This warranty does not cover the cost of removal, installation, or re-testing of the new or repaired goods or parts, or any other direct or incidental expenses incurred in shipping the product to or from LEESON Electric. Replacement goods or parts are warranted for the remainder of the warranty period applicable to the goods originally supplied by LEESON Electric. All claims for allegedly defective goods must be made within 10 days after Buyer learns of such alleged defects. All claims not made in writing and received by LEESON Electric within such 10 day period shall be deemed waived. With prior approval from LEESON Electric, Buyer shall return a sample of the alleged defective part, freight prepaid, for LEESON Electric's inspection, and no other goods shall be returned to LEESON Electric's District Office/Warehouse, nearest factory, or Authorized Service Center without LEESON Electric's written consent. This warranty shall not extend to goods subjected to misuse, abuse, neglect, accident or improper installation or maintenance, incorrect lubrication, incorrect electrical connection, improper power supply, or goods which have been altered or repaired by anyone other than LEESON Electric or its authorized representative;



(c) Under no circumstances will LEESON Electric be responsible for any expense in connection with any repairs made by anyone other than LEESON Electric or an Authorized Service Center, unless such repairs have been specifically authorized in writing by the LEESON Electric Service and Warranty Department.

(d) In the case of motors, drives, gears and reducers manufactured or marketed by LEESON Electric, LEESON Electric warrants only that such products, when shipped, shall be capable of delivering the service rating as indicated in LEESON Electric's written documents, including quotations and catalogs or as noted on such products, providing such equipment is properly installed, connected, and maintained, correctly lubricated, operating under normal conditions with competent supervision, and within the load limits and voltage range for which it was sold, and provided further that the equipment is free from critical speed, torsional or other type vibration, no matter how induced;

(e) If any prototype or sample was provided to the Buyer, it was used merely to illustrate the general type and quality of goods and not to warrant that goods shipped would be of that type or quality;

(f) UNLESS AUTHORIZED IN WRITING BY A CORPORATE OFFICER OR VICE PRESIDENT, NO AGENT, EMPLOYEE OR REPRESENTATIVE OF LEESON ELECTRIC HAS ANY AUTHORITY TO BIND LEESON ELECTRIC TO ANY AFFIRMATION, REPRESENTATION OR WARRANTY CONCERNING THE GOODS SOLD UNDER THE SALES CONTRACT AND ANY SUCH AFFIRMATION, REPRESENTATION OR WARRANTY HAS NOT FORMED A PART OF THE BASIS OF THE BARGAIN AND SHALL BE UNENFORCEABLE;

(g) THE FOREGOING WARRANTIES ARE EXCLUSIVE AND IN LIEU OF ALL OTHER WARRANTIES OF MERCHANTABILITY, FITNESS FOR A PARTICULAR PURPOSE AND/OR ANY OTHER TYPE, WHETHER EXPRESS OR IMPLIED;

(h) Products manufactured and work not performed by LEESON Electric are warranted only to the extent and in the manner that the same are warranted to LEESON Electric by LEESON Electric's vendors, and then only to the extent that LEESON Electric is reasonably able to enforce such warranty. In enforcing such warranty, it is understood LEESON Electric shall have no obligation to initiate litigation unless Buyer undertakes to pay all costs and expenses therefor, including but not limited to Attorney's fees, and indemnifies LEESON Electric against any liability to LEESON Electric's vendors arising out of such litigation;

(i) THE FOREGOING IS LEESON ELECTRIC'S ONLY OBLIGATION AND BUYER'S EXCLUSIVE REMEDY FOR BREACH OF WARRANTY. BUYER'S FAILURE TO SUBMIT A CLAIM AS PROVIDED ABOVE SHALL SPECIFICALLY WAIVE ALL CLAIMS FOR DAMAGES OR OTHER RELIEF INCLUDING BUT NOT LIMITED TO CLAIMS BASED ON LATENT DEFECTS. EVEN IF THE REPAIR OR REPLACEMENT REMEDY SHALL BE DEEMED TO HAVE FAILED OF ITS ESSENTIAL PURPOSE UNDER SECTION 2-719 OF THE UNIFORM COMMERCIAL CODE, LEESON ELECTRIC SHALL HAVE NO LIABILITY TO BUYER FOR CONSEQUENTIAL DAMAGES, SUCH AS LOST PROFITS, LOST REVENUE, DAMAGE TO OTHER EQUIPMENT OR LIABILITY OR INJURY TO A THIRD PARTY. IN NO EVENT SHALL BUYER BE ENTITLED TO INCIDENTAL, CONSEQUENTIAL, OR SPECIAL DAMAGES, NOR SHALL LEESON ELECTRIC'S LIABILITY EXCEED THE PURCHASE PRICE OF THE GOODS. ANY ACTION ARISING HEREUNDER OR RELATED HERETO MUST BE COMMENCED WITHIN ONE (1) YEAR AFTER THE CAUSE OF ACTION OCCURS OR IT SHALL BE BARRED, NOTWITHSTANDING ANY STATUTORY PERIOD OF LIMITATIONS TO THE CONTRARY; and

(j) In the event of the resale of any of the goods, in whatever form, Buyer will include the following language in a conspicuous place and in a conspicuous manner in a written agreement covering such resale: "THE MANUFACTURER MAKES NO WARRANTIES OR REPRESENTATIONS, EXPRESS OR IMPLIED, BY OPERATION OF LAW OR OTHERWISE, AS TO THE MERCHANTABILITY OR FITNESS FOR A PARTICULAR PURPOSE OF THE GOODS SOLD HEREUNDER. BUYER ACKNOWLEDGES THAT IT ALONE HAS DETERMINED THAT THE GOODS PURCHASED HEREUNDER WILL SUITABLY MEET THE REQUIREMENTS OF THEIR INTENDED USE. IN NO EVENT WILL MANUFACTURER BE LIABLE FOR CONSEQUENTIAL, INCIDENTAL OR OTHER DAMAGES."

13. REMEDIES AND LIMITATIONS OF LIABILITY.

In the event Buyer claims LEESON Electric has breached any of its obligations under the Sales Contract, whether of warranty or otherwise, LEESON Electric may request the return of goods and tender to Buyer, at LEESON Electric's option, a replacement shipment of goods. If LEESON Electric so requests the return of the goods, the goods will be redelivered to LEESON Electric in accordance with LEESON Electric's instructions and at Buyer's expense. Except as herein provided, LEESON Electric shall have no further obligation under the Sales Contract. The remedies contained in this paragraph and paragraph 12 hereof shall constitute the sole recourse of Buyer against LEESON Electric for breach of any of LEESON Electric's obligations under the Sales Contract, whether warranty or otherwise.

14. TECHNICAL ADVICE.

Any technical advice furnished or recommendation made by LEESON Electric or any representative of LEESON Electric concerning any use or application of any of the goods is believed to be reliable, but LEESON ELECTRIC MAKES NO WARRANTY, EXPRESSED OR IMPLIED, ON RESULTS TO BE OBTAINED. BUYER ASSUMES ALL RESPONSIBILITY FOR LOSS OR DAMAGE RESULTING FROM THE HANDLING OR USE OF ANY OF THE GOODS.

15. FORCE MAJEURE.

LEESON Electric shall not be liable for failure to perform its obligations under the Sales Contract in whole or in part caused by the occurrence of any contingencies beyond the reasonable control either of LEESON Electric or of suppliers of LEESON Electric. If any such contingency occurs, LEESON Electric may allocate goods and deliveries among LEESON Electric's customers.

16. ASSIGNMENT AND DELEGATION.

No right or interest in the Sales Contract shall be assigned by Buyer without LEESON Electric's prior written consent, and no delegation of any obligation owed, or to the performance of any obligation by Buyer shall be made without LEESON Electric's prior written consent. Any attempt at assignment or delegation shall be wholly void and totally ineffective for all purposes unless made in conformity with this paragraph.

17. PATTERNS AND TOOLING.

Unless otherwise agreed to in writing with Buyer, LEESON Electric shall retain title to and possession of all special tooling, patterns and dies whether paid for by Buyer or not, but such special tooling, patterns and dies that are specifically paid for by Buyer will be held by LEESON Electric exclusively for the manufacture of Buyer's goods for not more than 2 years after the date of Buyer's last order requiring their use. LEESON Electric will exercise reasonable care in handling and storing any tooling, patterns or dies specifically paid for by Buyer, but LEESON Electric shall not be liable for damage or loss thereof.

18. PATENTS. LEESON ELECTRIC MAKES NO REPRESENTATION OR WARRANTY WITH RESPECT TO THE PATENTABILITY OF THE GOODS OR THAT ANY OF THE GOODS WILL BE FREE FROM CLAIMS OF INFRINGEMENT.

Buyer agrees to indemnify and defend LEESON Electric in any such suit, action or proceeding for any claim resulting from actual or alleged infringement of any domestic or foreign letters patent for (i) any feature, construction or design incorporated at Buyer's request in any goods or to adapt such goods to the particular use of Buyer or Buyer's customers or (ii) any additions, changes or adaptations made by Buyer or Buyer's customers after delivery of the goods.

19. CONFIDENTIAL INFORMATION.

All drawings, diagrams, specifications, technical data and other materials furnished by LEESON Electric and identified by LEESON Electric as confidential are and shall remain the exclusive property of LEESON Electric and shall be returned to LEESON Electric upon request. Buyer agrees to treat such information and material as confidential and not to reproduce or disclose such information or materials without LEESON Electric's prior written consent. This paragraph does not apply to any information already known to and readily accessible in the trade or which may become so through no fault of Buyer.

20. CHANGES.

LEESON Electric may, at any time, without notice, make changes (whether in design, material, improvements or otherwise) in any catalog goods, and may discontinue the manufacture of any catalog goods, all in its sole discretion, without incurring any obligations of any kind as a result thereof, whether for failure to fill an order of Buyer or otherwise.

21. CANCELLATION.

The Buyer may not cancel purchase orders without the prior written consent of LEESON Electric. This consent will be conditioned on Buyer's agreement to pay LEESON Electric's cancellation charge. Purchase orders for goods that are substantially complete, as judged by LEESON Electric, may not be cancelled; and will be shipped and invoiced at the price on the order. For goods that are not substantially complete, the cancellation charge shall amount to all costs and expenses incurred by LEESON Electric and arising out of or in connection with Buyer's order, net of recoverability, but in no event less than 10% of the total invoice price of the equipment or more than the total invoice price.

22. INSTALLATION.

Installation of the goods shall be by Buyer unless otherwise specifically stated in the Sales Contract.

23. SEVERABILITY.

If any term or provision contained in the Sales Contract is declared or held invalid by a court of competent jurisdiction, such declaration or holding shall not affect the validity of any other term, clause or provision contained herein.

24. GOVERNING LAW AND LIMITATION.

(a) The formation and performance of the Sales Contract shall be deemed to have been made and governed by the Uniform Commercial Code as adopted in the state of LEESON Electric's principal place of business; (b) Buyer hereby agrees to the jurisdiction of any state or federal court located in the county of LEESON Electric's principal place of business. Buyer waives any objection based on forum non conveniens and any objection to venue of any action instituted hereunder, and consents to the granting of such legal or equitable relief as is deemed appropriate by a court of competent jurisdiction; (c) LEESON Electric represents that the goods will be produced in compliance with the Fair Labor Standards Act of 1938, as amended; and (d) Attorney's Fees – Buyer agrees to pay all of LEESON Electric's costs and expenses of collection and litigation, including but not limited to attorney's fees and costs.

Revised, May 2004

DISTRICT SALES OFFICES AND WAREHOUSES
 SALES OFFICE AND WAREHOUSE

 SALES OFFICE ONLY

LEESON District Sales Offices & Warehouses can provide complete information including price and availability on both standard stock and special motors.

- ARKANSAS, Little Rock**
 District Mgr., Phil Newby
 501/568-6468
 Fax: 501/568-6604
- CALIFORNIA, Los Angeles**
 District Mgr., Felix Wilson
 323/278-7979
 Fax: 323/278-7955
- CALIFORNIA, San Francisco**
 District Mgr., Jim Cyr
 925/960-9600
 Fax: 920/960-9640
- COLORADO, Denver**
 District Mgr., Tom Turner
 303/331-6500
 Fax: 303/331-6510
- CONNECTICUT, Hartford**
 District Mgr., Bob Maher
 860/646-9665
 Fax: 860/643-2982
- FLORIDA, Tampa**
 District Mgr., Bill Taylor
 813/740-2571
 Fax: 813/663-9104
- GEORGIA, Atlanta**
 District Mgr., Walter Brooks
 770/933-0453
 Fax: 770/933-0549
- ILLINOIS, Chicago**
 District Manager
 Terry Wells
 630/458-9511
 Fax: 630/458-1923
- INDIANA, Indianapolis**
 District Mgr., Rich Deering
 317/821-3700
 Fax: 317/821-3710
- IOWA, Des Moines**
 District Mgr., John Marshalla
 515/263-1880
 Fax: 515/263-0460
- KANSAS, Kansas City**
 District Mgr., Jim Gleeson
 913/599-6983
 Fax: 913/599-6987
- MARYLAND/Baltimore**
 District Mgr., Craig Brisbane
 570/325-3684
 Fax: 570/325-3870
- MICHIGAN, Grand Rapids**
 District Mgr., Greg Norris
 616/249-8430
 Fax: 616/249-8628
- MINNESOTA, Minneapolis**
 District Mgr., John Marshalla
 952/935-8273
 Fax: 952/935-8399
- MISSOURI, St. Louis**
 District Managers
 Pat and Ken Avender
 314/714-1460
 Fax: 314/714-1461
- NEW JERSEY/METRO NEW YORK/LONG ISLAND**
 (Plainfield, NJ 18229)
 Contact: Dave Beck
 570/325-3684
 Fax: 570/325-3870
- NEW YORK, Syracuse**
 District Mgr., Chris Everett
 315/431-4536
 Fax: 315/431-4541
- NORTH CAROLINA, Charlotte**
 District Mgrs., Steve McAbee and Doug Landgraf
 803/396-8200
 Fax: 803/396-8208
- OHIO, Cincinnati**
 District Mgr., Ken Simko
 513/755-1000
 Fax: 513/755-1081
- OHIO, Cleveland**
 District Mgr., Matt Simko
 440/951-5117
 Fax: 440/975-3575
 800/331-2911 (W.PA, WV)
- OKLAHOMA, Oklahoma City**
 Contact: Owen Stone
 405/348-5700
 Fax: 405/348-0600
- OREGON, Portland**
 Contact: Todd VandeKamp
 360/687-8007
 Fax: 360/687-8009
- PENNSYLVANIA, Allentown**
 District Mgr., Craig Brisbane
 570/325-3684
 Fax: 570/325-3870
- PENNSYLVANIA, Philadelphia**
 District Mgr., Craig Brisbane
 570/325-3684
 Fax: 570/325-3870
- TEXAS, Dallas**
 District Mgr., Homer Rodden
 972/245-2017
 Fax: 972/245-2328
- TEXAS, Houston**
 District Mgr., Homer Rodden
 972/245-2017
 Fax: 972/245-2328
- UTAH, Salt Lake City**
 District Mgr., Tom Turner
 800/730-5290
 Fax: 303/331-6510
- WASHINGTON, Seattle**
 District Mgr., Mike Cercone
 425/775-8300
 Fax: 425/712-7098
- WISCONSIN, Milwaukee**
 District Mgr., Tom Bares
 414/352-3580
 Fax: 414/352-3207
- ASIA**
 - CHINA, Shanghai**
 (+86) 21-625-317-00
 Fax: (+86) 21-625-587-07
 - CENTRAL AMERICA, SOUTH AMERICA & CARIBBEAN**
FLORIDA, Miami
 Contact: Manny Garcia, Jr.
 (+1) 305/220-4423
 Fax: (+1) 305/220-5945
 - EUROPE**
ITALY, Bologna
 (+39) 051-731-487
 Fax: (+39) 051-734-943

LEESON CANADA

- ALBERTA, Edmonton**
 Branch Mgr., Marie Flaman
 780/437-3380
 Fax: 780/434-3448
- BRITISH COLUMBIA, Vancouver**
 Branch Supv., Alan Jamieson
 604/941-0352
 Fax: 604/941-0659
- MANITOBA, Winnipeg**
 Branch Mgr., Charlie Vogel
 204/786-6802
 Fax: 204/786-6934
- NEW BRUNSWICK, Moncton**
 Branch Mgr., Ken Sheehan
 506/383-8883
 Fax: 506/383-8887
- ONTARIO, Toronto**
 National Sales Mgr., Frank Pesce
 905/670-4770
 Fax: 905/670-4378
- QUEBEC, Montreal**
 Branch Mgr., Richard Haines
 514/337-8020
 Fax: 514/337-0773

LEESON Electric
 Grafton, WI 53024-0241 U.S.A.

Telephone: 262/377-8810, Fax: 262/377-9025
 In Canada: 905/670-4770 Fax: 905/670-4378

www.leeson.com

Call or write for free literature, or download from our web site.



IRONMAN™ Reducers Ideal For Heavy-Duty Use

Heavy-duty IRONMAN™ BY OHIO GEAR™ gear reducers are the perfect complement to Bravo® and LeCentric™ aluminum gear reducers. IRONMAN™ BY OHIO GEAR™ reducers are built tough and feature cast iron construction for extended life in industrial applications. Full details are provided in Catalog 8050, which is available upon request.

Bravo®, LeCentric™ and IRONMAN™ BY OHIO GEAR™ reducers match easily with LEESON motors, which

are offered off-the-shelf in nearly 4,000

different sizes and styles. With LEESON, you're sure

to find the motor, gearmotor or drive you need—

when you need it. Full information is available in

Stock Catalog 1050. For your free copy, give us a

call or visit our web site at www.leeson.com.



FOR MORE INFORMATION CONTACT:

LEESON ELECTRIC

GRAFTON, WISCONSIN 53024-0241 U.S.A.
TEL (262)377-8810 FAX (262)377-9025 www.leeson.com

A Subsidiary of REGAL-BELOIT CORPORATION

*REGAL-BELOIT is a worldwide manufacturer
of mechanical and electrical motion control products.*



CATALOG 7050 4171S/SK/8-04/25M/SELLS
Specifications and prices subject to change without notice.

© LEESON ELECTRIC, 2004

PRINTED IN U.S.A.

