

# SwitchBlade x8 | I2

Layer 3+ Chassis Switch

## AT-SBx8 | CFC400

Controller Fabric Card (AlliedWare Plus v5.4.6-1)

AT-SBx8 | I2 Chassis

AT-SBx8 | GT24 Ethernet Line Card

AT-SBx8 | GT40 Ethernet Line Card

AT-SBx8 | GP24 Ethernet PoE Line Card

AT-SBx8 | GS24a Ethernet SFP Line Card

AT-SBx8 | XS6 Ethernet SFP+ Line Card

AT-SBx8 | XLEM Ethernet SFP Line Card and Expansion Slot

AT-SBx8 | XLEM/Q2 Expansion Module

AT-SBx8 | XLEM/XS8 Expansion Module

AT-SBx8 | XLEM/XT4 Expansion Module

AT-SBxPWRSYS1 and AT-SBxPWRSYS2 System Power Supplies

AT-SBxPWRPOE1 PoE Power Supply

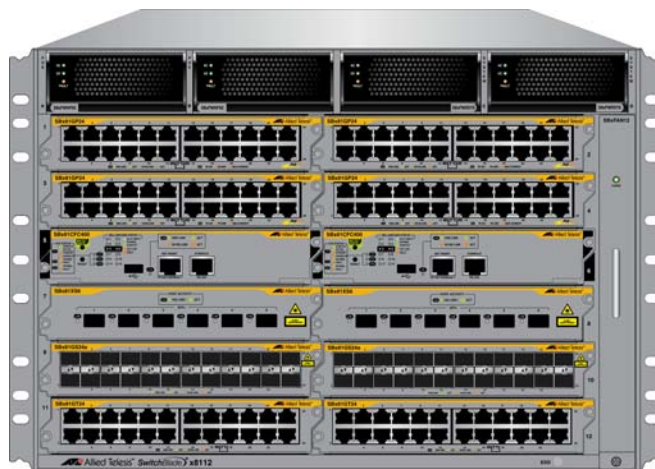

## Installation Guide

the **solution** : the **network**

Copyright © 2016 Allied Telesis, Inc.

All rights reserved. No part of this publication may be reproduced without prior written permission from Allied Telesis, Inc.

Allied Telesis and the Allied Telesis logo are trademarks of Allied Telesis, Incorporated. All other product names, company names, logos or other designations mentioned herein are trademarks or registered trademarks of their respective owners.

Allied Telesis, Inc. reserves the right to make changes in specifications and other information contained in this document without prior written notice. The information provided herein is subject to change without notice. In no event shall Allied Telesis, Inc. be liable for any incidental, special, indirect, or consequential damages whatsoever, including but not limited to lost profits, arising out of or related to this manual or the information contained herein, even if Allied Telesis, Inc. has been advised of, known, or should have known, the possibility of such damages.

# Electrical Safety and Emissions Standards

---

This product meets the following standards

## U.S. Federal Communications Commission

### Radiated Energy

Note: This equipment has been tested and found to comply with the limits for a Class A digital device pursuant to Part 15 of FCC Rules. These limits are designed to provide reasonable protection against harmful interference when the equipment is operated in a commercial environment. This equipment generates, uses, and can radiate radio frequency energy and, if not installed and used in accordance with this instruction manual, may cause harmful interference to radio communications. Operation of this equipment in a residential area is likely to cause harmful interference in which case the user will be required to correct the interference at his own expense.

Note: Modifications or changes not expressly approved of by the manufacturer or the FCC, can void your right to operate this equipment.

## Industry Canada

This Class A digital apparatus complies with Canadian ICES-003.

Cet appareil numérique de la classe A est conforme à la norme NMB-003 du Canada.

## European Union Restriction of the Use of Certain Hazardous Substances (RoHS) in Electrical and Electronic Equipment

This Allied Telesis RoHS-compliant product conforms to the European Union Restriction of the Use of Certain Hazardous Substances (RoHS) in Electrical and Electronic Equipment. Allied Telesis ensures RoHS conformance by requiring supplier Declarations of Conformity, monitoring incoming materials, and maintaining manufacturing process controls.

EMI/RFI Emissions: FCC Class A, EN55022 Class A, EN61000-3-2, EN61000-3-3, CISPR Class A, VCCI Class A, AS/NZS Class A

**Warning:** In a domestic environment this product may cause radio interference in which case the user may be required to take adequate measures.

Immunity: EN55024

Electrical Safety: EN60950-1 (TUV), UL 60950-1 (cUL<sub>US</sub>), EN60825

Safety Agency Approvals: cUL<sub>US</sub>, TUV, C-TICK, CE



Laser Safety

EN60825

## Translated Safety Statements

---

**Important:** The  indicates that a translation of the safety statement is available in a PDF document titled “Translated Safety Statements” on our web site at <http://www.alliedtelesis.com/support>.

# Contents

---

<b>Preface</b> .....	<b>15</b>
Safety Symbols Used in this Document .....	16
Contacting Allied Telesis .....	17
<b>Chapter 1: Chassis and Power Supplies</b> .....	<b>19</b>
AT-SBx8112 Chassis .....	20
Slots for the Ethernet Line and Controller Cards .....	23
Power Supplies and Power Supply Slots .....	24
LEDs .....	26
AT-SBxFAN12 Module .....	29
LED .....	29
Power Supply Interfaces (Opto-couplers) .....	30
LED .....	30
<b>Chapter 2: Ethernet Line Cards</b> .....	<b>33</b>
Ethernet Line Cards .....	34
AT-SBx81GT24 Line Card .....	36
LEDs .....	36
AT-SBx81GT40 Line Card .....	38
LEDs .....	39
AT-SBx81GP24 PoE Line Card .....	41
LEDs .....	42
AT-SBx81GS24a SFP Line Card .....	44
LEDs .....	44
AT-SBx81XS6 SFP+ Line Card .....	46
LEDs .....	46
AT-SBx81XLEM Line Card .....	48
LEDs .....	48
AT-SBx81XLEM/Q2 Expansion Module .....	50
LED .....	50
AT-SBx81XLEM/XS8 Expansion Module .....	52
LED .....	52
AT-SBx81XLEM/XT4 Expansion Module .....	54
LEDs .....	54
Twisted Pair Ports .....	55
Connector Type .....	55
Speed .....	55
Duplex Mode .....	55
Maximum Distance .....	56
Cable Requirements .....	56
Automatic MDIX Detection .....	58
Port Pinouts .....	58
Power over Ethernet on the AT-SBx81GP24 Line Card .....	59
Powered Device Classes .....	59
Power Budget .....	60
PoE Wiring .....	60

<b>Chapter 3: AT-SBx81CFC400 Controller Fabric Card .....</b>	<b>63</b>
Controller Fabric Cards for the AT-SBx8112 Chassis.....	64
Hardware Components of the AT-SBx81CFC400 Card.....	66
Guidelines .....	68
Dual Controller Cards .....	70
SYS Status LEDs.....	72
eco-friendly Button .....	74
SBx Linecard Status LEDs.....	75
Console (RS-232) Port.....	76
Ethernet Management Port (NET MGMT) .....	77
NET MGMT LED .....	77
USB Port.....	79
Reset Button .....	80
AlliedWare Plus Software Releases for the Hardware Components .....	82
<b>Chapter 4: Safety Precautions and Site Requirements .....</b>	<b>83</b>
Reviewing Safety Precautions .....	84
Selecting a Site for the SwitchBlade x8112 Chassis Switch .....	88
Installation Tools and Material .....	90
<b>Chapter 5: Installing the Chassis in an Equipment Rack .....</b>	<b>91</b>
Required Tools and Material.....	92
Preparing the Equipment Rack.....	93
Unpacking the AT-SBx8112 Chassis.....	96
Adjusting the Equipment Rack Brackets.....	98
Installing the AT-SBx8112 Chassis in the Equipment Rack.....	100
Removing the Shipping Brace .....	103
Installing the Chassis Grounding Wire.....	104
<b>Chapter 6: Installing the Power Supplies .....</b>	<b>107</b>
Protecting Against Electrostatic Discharge (ESD) .....	108
Installing AT-SBxPWRSYS1 or AT-SBxPWRSYS2 AC System Power Supplies.....	109
Installing AT-SBxPWRPOE1 PoE Power Supplies.....	115
Installing AT-SBxPWRSYS1 DC System Power Supplies.....	120
<b>Chapter 7: Installing the AT-SBx81CF400 Control Card and Ethernet Line Cards .....</b>	<b>127</b>
Guidelines to Handling the Controller and Line Cards.....	128
Installing the AT-SBx81CF400 Controller Fabric Card .....	130
Installing Expansion Modules in AT-SBx81XLEM Ethernet Line Cards.....	136
Installing the Ethernet Line Cards.....	144
Installing the Blank Slot Covers .....	149
<b>Chapter 8: Installing Transceivers and Cabling the Ports .....</b>	<b>151</b>
Cabling Guidelines for the Twisted Pair Ports .....	152
Connecting Cables to the AT-SBx81GT40 Line Card .....	153
Guidelines to Installing SFP, SFP+, or QSFP+ Transceivers .....	155
Installing SFP or SFP+ Transceivers.....	156
Installing AT-SP10TW Direct Connect Cables.....	161
Installing AT-QSFPCU Cables.....	164
Installing AT-QSFPSR, AT-QSFPSR4, or AT-QSFPLR4 Transceivers.....	166
Cabling the NET MGMT Port on the AT-SBx81CFC400 Card.....	168
<b>Chapter 9: Powering On the Chassis .....</b>	<b>171</b>
Verifying the Installation.....	172
Powering On AT-SBxPWRSYS1 or AT-SBxPWRSYS2 AC System Power Supplies .....	173
Powering On AT-SBxPWRPOE1 Power Supplies.....	177
Powering On the AT-SBxPWRSYS1 DC System Power Supply .....	180
Choosing a Method for Attaching the Grounding Wire .....	182

Connecting the Grounding Wire with the Grounding Terminal.....	182
Connecting the Grounding Wire with Bare Wire .....	185
Choosing a Method for Attaching the Power Wires .....	187
Connecting the DC Power Wires with the Straight Terminals.....	187
Connecting the DC Power Wires with the Right Angle Terminals.....	196
Connecting Bare DC Power Wires.....	202
Monitoring the Initialization Process .....	206
Using the LEDs to Monitor the Initialization Process .....	206
Using the Console Port to Monitor the Initialization Process .....	206
<b>Chapter 10: Verifying the Hardware Operations of the Chassis .....</b>	<b>209</b>
Using the LEDs to Verify the Chassis.....	210
Using Local Management to Verify the Chassis.....	212
Starting a Local Management Session .....	212
Entering the AlliedWare Plus Operating System Commands .....	213
<b>Chapter 11: Troubleshooting .....</b>	<b>215</b>
AT-SBxPWRSYS1, AT-SBxPWRSYS2, and AT-SBxPWRPOE1 Power Supplies .....	216
AT-SBxPWRSYS1 DC System Power Supply .....	218
Ethernet Line Cards.....	220
Twisted Pair Ports .....	222
Power Over Ethernet.....	224
Fiber Optic or Twisted Pair Transceivers .....	226
AT-SBx81CFC400 Controller Fabric Card .....	228
AT-SBxFAN12 Fan Module .....	229
Local (Console) Management Session.....	230
Power Supply Interfaces (Opto-couplers).....	231
<b>Chapter 12: Replacing Modules .....</b>	<b>233</b>
Replacing the AT-SBxPWRSYS1, AT-SBxPWRSYS2, or AT-SBxPWRPOE1 Power Supply .....	234
Replacing the AT-SBxPWRSYS1 DC Power Supply .....	240
Replacing Ethernet Line Cards.....	251
Replacing Expansion Modules in AT-SBx81XLEM Line Cards.....	253
Replacing the AT-SBx81CFC400 Controller Fabric Card .....	259
Replacing the AT-SBxFAN12 Fan Module .....	261
Removing the AT-SBxFAN12 Fan Module .....	261
Installing a New AT-SBxFAN12 Fan Module .....	265
<b>Appendix A: Technical Specifications .....</b>	<b>269</b>
Physical Specifications .....	270
Environmental Specifications .....	272
Power Specifications .....	273
Safety and Electromagnetic Emissions Certifications .....	276
Port Pinouts .....	277





# Figures

---

Figure 1: AT-SBx8112 Chassis .....	20
Figure 2: Front View of the AT-SBx8112 Chassis .....	21
Figure 3: Rear View of the AT-SBx8112 Chassis .....	22
Figure 4: AT-SBx8112 Chassis with Line Cards, Controller Cards, and Power Supplies .....	22
Figure 5: Ethernet Line and Controller Cards Slots .....	23
Figure 6: Power Supply Units .....	24
Figure 7: Power Supply Slots .....	25
Figure 8: AT-SBxFAN12 Module .....	29
Figure 9: Power Supply Interfaces (Opto-couplers).....	30
Figure 10: Ethernet Line Cards .....	34
Figure 11: Expansion Modules for the AT-SBx81XLEM Line Card .....	35
Figure 12: AT-SBx81GT24 Line Card.....	36
Figure 13: Port LEDs on the AT-SBx81GT24 Line Card .....	37
Figure 14: AT-SBx81GT40 Line Card.....	38
Figure 15: Port LEDs on an RJ Point 5 Cable Connector for the AT-SBx81GT40 Line Card .....	39
Figure 16: Port LEDs on an RJ Point 5 Cable Connector for the AT-SBx81GT40 Line Card .....	39
Figure 17: AT-SBx81GP24 PoE Line Card.....	41
Figure 18: Port LEDs on the AT-SBx81GP24 PoE Line Card .....	42
Figure 19: AT-SBx81GS24a SFP Line Card .....	44
Figure 20: Port LEDs on the AT-SBx81GS24a SFP Line Card .....	45
Figure 21: AT-SBx81XS6 Line Card.....	46
Figure 22: SFP+ Slot LEDs on the AT-SBx81XS6 Line Card.....	46
Figure 23: AT-SBx81XLEM SFP Line Card.....	48
Figure 24: Port LEDs for the SFP Slots on the AT-SBx81XLEM Line Card .....	49
Figure 25: AT-SBx81XLEM/Q2 Expansion Module .....	50
Figure 26: AT-SBx81XLEM/XS8 Expansion Module .....	52
Figure 27: AT-SBx81XLEM/XT4 Expansion Module .....	54
Figure 28: Controller Fabric Cards for the AT-SBx8112 Chassis .....	64
Figure 29: AT-SBx81CFC400 Controller Fabric Card .....	66
Figure 30: 100 - 125 VAC 125 V NEMA 5-20 Plug and Receptacle.....	89
Figure 31: Reserving Vertical Rack Space.....	94
Figure 32: Rack Mounting Hole Locations.....	95
Figure 33: Components of the AT-SBx8112 Chassis .....	96
Figure 34: Components of the AT-SBx8112 Chassis (Continued) .....	97
Figure 35: Rack Mounting Bracket Locations .....	99
Figure 36: Rack Bracket Locations for Reverse Position of Chassis.....	99
Figure 37: Lifting the AT-SBx8112 Chassis into the Equipment Rack.....	101
Figure 38: Installing the Rack Mount Screws .....	102
Figure 39: Removing the Shipping Brace .....	103
Figure 40: Stripping the Grounding Wire .....	104
Figure 41: Removing the Grounding Lug.....	104
Figure 42: Attaching the Grounding Wire to the Grounding Lug.....	105
Figure 43: Installing the Grounding Lug and Wire .....	105
Figure 44: ESD Socket and Wrist Strap .....	108
Figure 45: Power Supply Slots .....	110
Figure 46: Removing the Blank Slot Cover from Power Supply Slot C .....	110
Figure 47: Items Included with the AT-SBxPWRSYS1 or AT-SBxPWRSYS2 AC System Power Supply .....	111
Figure 48: Unlocking the Handle on the Power Supply .....	112
Figure 49: Inserting the AT-SBxPWRSYS1 or AT-SBxPWRSYS2 AC System Power Supply .....	112

Figure 50: Lowering the Handle on the AT-SBxPWRSYS1 or AT-SBxPWRSYS2 AC System Power Supply .....	113
Figure 51: Removing the Blank Slot Cover from Power Supply Slot A.....	116
Figure 52: Items Included with the AT-SBxPWRPOE1 Power Supply Module.....	117
Figure 53: Unlocking the Handle on the AT-SBxPWRPOE1 Power Supply .....	118
Figure 54: Inserting the AT-SBxPWRPOE1 Power Supply .....	118
Figure 55: Locking the Handle on the AT-SBxPWRPOE1 Power Supply .....	119
Figure 56: Removing the Blank Slot Cover from Power Supply Slot C.....	121
Figure 57: Items Included with the AT-SBxPWRSYS1 DC Power Supply Module.....	122
Figure 58: On/Off Switch on the AT-SBxPWRSYS1 DC Power Supply .....	123
Figure 59: Loosening the Handle locking Screw on the AT-SBxPWRSYS1 DC System Power Supply .....	123
Figure 60: Raising Handle on the AT-SBxPWRSYS1 DC Power Supply .....	124
Figure 61: Inserting the AT-SBxPWRSYS1 DC System Power Supply.....	124
Figure 62: Locking the Handle on the AT-SBxPWRSYS1 DC System Power Supply.....	125
Figure 63: Aligning a Card in a Slot.....	129
Figure 64: Slots 5 and 6 for the AT-SBx81CF400 Card.....	130
Figure 65: Items Included with the AT-SBx81CF400 Controller Card .....	131
Figure 66: Removing the AT-SBx81CF400 Controller Fabric Card from the Anti-static Bag.....	131
Figure 67: Removing the Battery Insulator .....	132
Figure 68: Opening the Locking Handles on the AT-SBx81CF400 Controller Fabric Card.....	132
Figure 69: Aligning the AT-SBx81CF400 Card in the Chassis Slot .....	133
Figure 70: Closing the Locking Levers on the AT-SBx81CF400 Controller Fabric Card.....	134
Figure 71: Tightening the Thumb Screws on the AT-SBx81CF400 Card.....	135
Figure 72: Removing the AT-SBx81XLEM Line Card from the Anti-static Bag .....	137
Figure 73: Removing the Screws on the Blank Slot Cover on the AT-SBx81XLEM Line Card .....	137
Figure 74: Removing the Blank Slot Cover from the AT-SBx81XLEM Line Card.....	138
Figure 75: Retracting the Retaining Pin on the AT-SBx81XLEM Line Card .....	139
Figure 76: Removing the Expansion Module from the Anti-static Bag.....	139
Figure 77: Sliding the Expansion Module into the AT-SBx81XLEM Line Card.....	140
Figure 78: Seating the Expansion Module on the Connector in the AT-SBx81XLEM Line Card.....	141
Figure 79: Securing the Expansion Module.....	141
Figure 80: Releasing the Retaining Pin .....	142
Figure 81: Blank Slot Cover for the AT-SBx81XLEM Line Card.....	142
Figure 82: Returning the Line Card to its Anti-static Bag.....	143
Figure 83: Slots 1 to 4 and 7 to 12 for the Ethernet Line Cards.....	144
Figure 84: Removing a Blank Slot Cover.....	145
Figure 85: Removing an Ethernet Line Card from the Anti-static Bag .....	145
Figure 86: Aligning an Ethernet Line Card in a Chassis Slot.....	146
Figure 87: Seating an Ethernet Line Card on the Backplane Connector .....	147
Figure 88: Tightening the Thumb Screws on an Ethernet Line Card.....	147
Figure 89: Installing a Blank Slot Cover.....	149
Figure 90: Tightening the Thumbscrews on a Blank Slot Cover.....	149
Figure 91: RJ Point 5 Cable Connector for AT-SBx81GT40 Line Card .....	153
Figure 92: Connecting Cables to Ports on the AT-SBx81GT40 Line Card.....	154
Figure 93: Removing the Dust Cover from an SFP or SFP+ Slot.....	157
Figure 94: Inserting an SFP or SFP+ Transceiver.....	157
Figure 95: Installing an SFP+ Transceiver in the AT-SBx81XS6 Line Card .....	158
Figure 96: Removing the Dust Cover from a Transceiver.....	159
Figure 97: Verifying the Position of the Handle on a Transceiver.....	159
Figure 98: Attaching a Fiber Optic Cable to a Transceiver .....	160
Figure 99: Removing the Dust Cover From an SFP+ Slot.....	161
Figure 100: Installing the AT-SP10TW Cable in the AT-SBx81XS6 Line Card .....	162
Figure 101: Installing the AT-SP10TW Cable in the AT-SBx81XLEM/XS8 Expansion Module.....	163
Figure 102: Removing the Dust Cover from a Slot on the AT-SBx81XLEM/Q2 Expansion Module.....	164
Figure 103: Sliding the AT-QSFPCU Cable into the Slot.....	165
Figure 104: AC Sockets on the Rear Panel of the AT-SBx8112 Chassis.....	174
Figure 105: Connecting the AC Power Cord for the AT-SBxPWRSYS1 or AT-SBxPWRSYS2 AC System Power Supply.....	175
Figure 106: Securing the Power Cord for the AT-SBxPWRSYS1 or AT-SBxPWRSYS2 AC Power Supply to an Anchor .....	176
Figure 107: Connecting the AC Power Cord for the AT-SBxPWRPOE1 Power Supply.....	177

Figure 108: Securing the Power Cord for the AT-SBxPWRPOE1 Power Supply to an Anchor .....	178
Figure 109: Dress and Secure AC Power Cords .....	179
Figure 110: Components of the AT-SBxPWRSYS1 DC Power Supply .....	181
Figure 111: Grounding Wire Terminal .....	182
Figure 112: Stripping the Stranded Grounding Wire.....	182
Figure 113: Attaching the Stranded Grounding Wire to the Grounding Terminal .....	182
Figure 114: Removing the Nut and Washer from the Grounding Post .....	183
Figure 115: Installing the Grounding Wire .....	184
Figure 116: Stripping the solid or Stranded Grounding Wire .....	185
Figure 117: Attaching the Bare Grounding Wire to the Grounding Post.....	185
Figure 118: Securing the Bare Grounding Wire to the Grounding Post.....	186
Figure 119: Power Wire Terminals .....	187
Figure 120: Stripping the Power Wires.....	188
Figure 121: Attaching the Power Wires to the Straight Terminal Lugs.....	188
Figure 122: On/Off Switch on the AT-SBxPWRSYS1 DC Power Supply .....	189
Figure 123: Opening the Plastic Cover.....	190
Figure 124: Removing the Terminal Screws.....	191
Figure 125: Connecting the Positive (+) Power Wire with a Straight Terminal.....	192
Figure 126: Connecting the Negative (-) Power Wire with a Straight Terminal .....	193
Figure 127: Closing the Plastic Cover over the Terminal Connectors .....	194
Figure 128: Tightening the Handle Locking Screw .....	195
Figure 129: Stripping the Power Wires.....	196
Figure 130: Attaching the Power Wires to the Right Angle Terminals.....	196
Figure 131: Removing the Plastic Cover .....	197
Figure 132: Removing the Terminal Screws.....	198
Figure 133: Connecting the Positive (+) Power Wire with a Right Angle Terminal.....	199
Figure 134: Connecting the Negative (-) Power Wire with a Right Angle Terminal .....	200
Figure 135: Tightening the Handle Locking Screw .....	201
Figure 136: Stripping Solid or Stranded DC Power Wires.....	202
Figure 137: Connecting the Positive Wire With Bare Wire .....	203
Figure 138: Connecting the Negative Lead Wire with Bare Wire .....	204
Figure 139: Initialization Messages .....	207
Figure 140: Initialization Messages (Continued).....	208
Figure 141: Connecting the Management Cable to the Console RS-232 Port.....	212
Figure 142: SHOW VERSION Command.....	213
Figure 143: SHOW CARD Command.....	214
Figure 144: Disconnecting the AC Power Cord from the AC Socket on the Back Panel.....	235
Figure 145: Lifting the Locking Handle on the Power Supply .....	236
Figure 146: Removing the Power Supply from the Chassis .....	237
Figure 147: Installing a Blank Power Supply Slot Cover .....	238
Figure 148: Lowering the Locking Handle on the Power Supply Slot Cover .....	239
Figure 149: Loosening the Screw on the Locking Handle .....	240
Figure 150: Opening the Plastic Window over the Terminal Block.....	241
Figure 151: Removing the Negative Lead Wire.....	242
Figure 152: Removing the Positive Lead Wire from the Terminal Block .....	243
Figure 153: Reinstalling the Screws on the Positive and Negative Terminals.....	244
Figure 154: Closing the Plastic Cover .....	245
Figure 155: Removing the Grounding Wire .....	246
Figure 156: Reinstalling the Nut and Washer on the Grounding Post.....	247
Figure 157: Lifting the Locking Handle and Removing the Power Supply.....	248
Figure 158: Installing a Blank Power Supply Slot Cover .....	249
Figure 159: Lowering the Locking Handle on the Power Supply Slot Cover .....	250
Figure 160: Removing the Screws from the Expansion Module.....	254
Figure 161: Retracting the Retaining Pin on the AT-SBx81XLEM Line Card.....	254
Figure 162: Disconnecting the Expansion Module from the AT-SBx81XLEM Line Card .....	255
Figure 163: Sliding the Expansion Module from the AT-SBx81XLEM Line Card .....	256
Figure 164: Storing the Expansion Module in an Anti-static Bag.....	256
Figure 165: Sliding the Blank Slot Cover into the AT-SBx81XLEM Line Card .....	257
Figure 166: Securing the Blank Slot Cover.....	257
Figure 167: Releasing the Retaining Pin .....	258

List of Figures

Figure 168: Loosening the Screw on the AT-SBxFAN12 Fan Module.....	262
Figure 169: Loosening the AT-SBxFAN12 Fan Module from the Backplane Connector .....	263
Figure 170: Withdrawing the AT-SBxFAN12 Fan Module 51 mm (2 In.) from the Chassis .....	264
Figure 171: Removing the AT-SBxFAN12 Fan Module from the Chassis .....	265
Figure 172: Installing a New AT-SBxFAN12 Fan Module.....	266
Figure 173: Securing the AT-SBxFAN12 Fan Module on the Backplane Connector.....	267
Figure 174: Tightening the Screw on the AT-SBxFAN12 Fan Module .....	268
Figure 175: Pin Numbers for RJ-45 and RJ Point 5 Ports (Front View).....	277

# Tables

---

Table 1. LEDs on the AT-SBxPWRSYS1 and AT-SBxPWRSYS2 Power Supplies .....	27
Table 2. LEDs on the AT-SBxPWRSYS1 DC System Power Supply .....	27
Table 3. LEDs on the AT-SBxPWRPOE1 PoE Power Supply .....	28
Table 4. Power LED on the AT-SBxFAN12 Module .....	29
Table 5. Power LED on the Power Supply Interface .....	31
Table 6. Types of Supported Transceivers .....	35
Table 7. Port LEDs on the AT-SBx81GT24 Line Card .....	37
Table 8. Port LEDs on the AT-SBx81GT40 Line Card .....	40
Table 9. Port LEDs on the AT-SBx81GP24 PoE Line Card .....	42
Table 10. Port LEDs on the AT-SBx81GS24a SFP Line Card .....	45
Table 11. SFP+ Slot LEDs on the AT-SBx81XS6 Line Card .....	47
Table 12. SFP Slot LEDs on the AT-SBx81XLEM Line Card .....	49
Table 13. QSFP+ Slot LEDs for the AT-SBx81XLEM/Q2 Expansion Module .....	50
Table 14. Slot LEDs on the AT-SBx81XLEM/XS8 Module .....	52
Table 15. Port LEDs on the AT-SBx81XLEM/XT4 Module .....	54
Table 16. Twisted Pair Cable for the AT-SBx81GT24 and AT-SBx81GT40 Line Cards .....	56
Table 17. Twisted Pair Cable for the AT-SBx81GP24 Line Card .....	57
Table 18. Twisted Pair Cable for the AT-SBx81XLEM/XT4 Expansion Module .....	58
Table 19. IEEE802.3af and IEEE802.3at Powered Device Classes .....	59
Table 20. Maximum Number of Powered Devices .....	60
Table 21. Components on the AT-SBx81CFC400 Controller Fabric Card .....	66
Table 22. SYS (System) Status LEDs .....	72
Table 23. SBx Linecard Status LEDs .....	75
Table 24. NET MGMT Port LED .....	78
Table 25. AlliedWare Plus Operating System Releases for the Hardware Components .....	82
Table 26. Front Panel to Rack Rail Dimensions .....	98
Table 27. Transceiver Support .....	156
Table 28. Product Dimensions .....	270
Table 29. Product Weights .....	270
Table 30. Environmental Specifications .....	272
Table 31. Acoustic Noise Test Components .....	272
Table 32. AC Voltage and Frequency Requirements .....	273
Table 33. DC Voltage Requirements .....	273
Table 34. Typical Power Savings in eco-friendly Mode .....	273
Table 35. Maximum Power Consumption .....	274
Table 36. Maximum Power Efficiency .....	274
Table 37. Heat Dissipation .....	274
Table 38. Available Power Over Ethernet with One PoE Power Supply .....	275
Table 39. Available Power Over Ethernet with Two PoE Power Supplies .....	275
Table 40. PoE Mode on the AT-SBx81GP24 PoE Line Card .....	276
Table 41. Safety and Electromagnetic Emissions .....	276
Table 42. MDI Pin Signals (10Base-T or 100Base-TX) .....	277
Table 43. MDI-X Pin Signals (10Base-T or 100Base-TX) .....	277
Table 44. 1000Base-T or 10GBase-T Connector Pinouts .....	278



# Preface

---

This guide contains the hardware installation instructions for the Layer 3+ SwitchBlade x8112 Chassis Switch. The preface contains the following sections:

- “Safety Symbols Used in this Document” on page 16
- “Contacting Allied Telesis” on page 17

---

**Note**

This version of the installation guide applies to release 5.4.6-1 of the AlliedWare Plus™ Operating System for the SwitchBlade x8112 Chassis Switch and AT-SBx81CFC400 Controller Fabric Card.

---

## Safety Symbols Used in this Document

---

This document uses the following conventions.

---

**Note**

Notes provide additional information.

---



---

**Caution**

Cautions inform you that performing or omitting a specific action may result in equipment damage or loss of data.

---



---

**Warning**

Warnings inform you that performing or omitting a specific action may result in bodily injury.

---



---

**Warning**

Laser warnings inform you that an eye or skin hazard exists due to the presence of a Class 1 laser device.

---



## Contacting Allied Telesis

---

If you need assistance with this product, you may contact Allied Telesis technical support by going to the Support & Services section of the Allied Telesis web site at **[www.alliedtelesis.com/support](http://www.alliedtelesis.com/support)**. You can find links for the following services on this page:

- ❑ 24/7 Online Support — Enter our interactive support center to search for answers to your product questions in our knowledge database, to check support tickets, to learn about RMAs, and to contact Allied Telesis technical experts.
- ❑ USA and EMEA phone support — Select the phone number that best fits your location and customer type.
- ❑ Hardware warranty information — Learn about Allied Telesis warranties and register your product online.
- ❑ Replacement Services — Submit a Return Merchandise Authorization (RMA) request via our interactive support center.
- ❑ Documentation — View the most recent installation and user guides, software release notes, white papers, and data sheets for your products.
- ❑ Software Downloads — Download the latest software releases for your managed products.

For sales or corporate information, go to **[www.alliedtelesis.com/purchase](http://www.alliedtelesis.com/purchase)** and select your region.



## Chapter 1

# Chassis and Power Supplies

---

This chapter describes the Layer 3+ SwitchBlade x8112 Chassis Switch in the following sections:

- ❑ “AT-SBx8112 Chassis” on page 20
- ❑ “Slots for the Ethernet Line and Controller Cards” on page 23
- ❑ “Power Supplies and Power Supply Slots” on page 24
- ❑ “AT-SBxFAN12 Module” on page 29
- ❑ “Power Supply Interfaces (Opto-couplers)” on page 30

---

### **Note**

This version of the installation guide applies to release 5.4.6-1 of the AlliedWare Plus™ Operating System for the SwitchBlade x8112 Chassis Switch and AT-SBx81CFC400 Controller Fabric Card.

---

## AT-SBx8112 Chassis

---

The SwitchBlade x8112 product is a modular Layer 3+ Ethernet switch. The main components are the AT-SBx8112 Chassis, Ethernet line cards, a controller card, system power supply, Power over Ethernet Plus (PoE+) power supply, and fan module.

The AT-SBx8112 Chassis is shown in Figure 1.

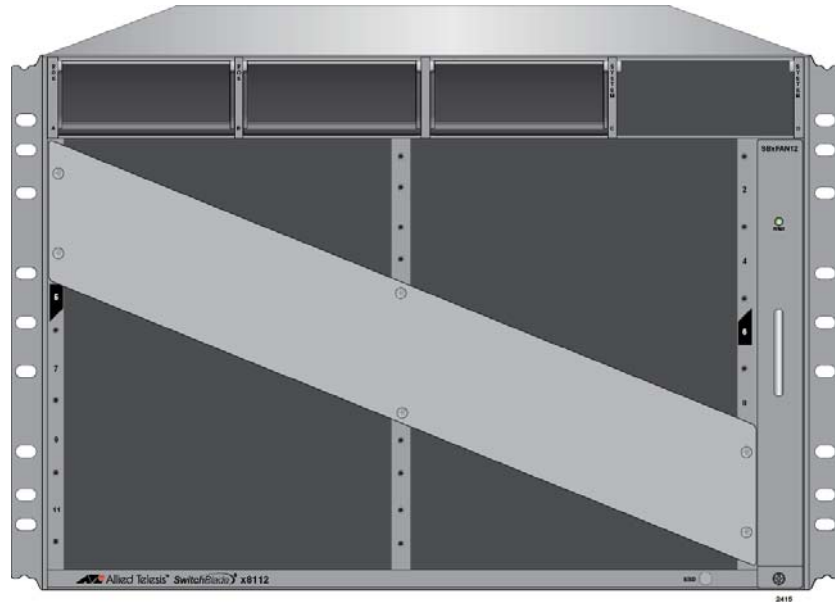

Figure 1. AT-SBx8112 Chassis

The chassis has slots for the following components:

- Ten Ethernet line cards
- Two AT-SBx81CFC400 Controller Fabric Cards
- Two AC or DC system power supplies
- Two Power over Ethernet Plus (PoE+) power supplies
- One AT-SBxFAN12 Fan Module

The chassis components are identified in Figure 2 on page 21 and Figure 3 on page 22.

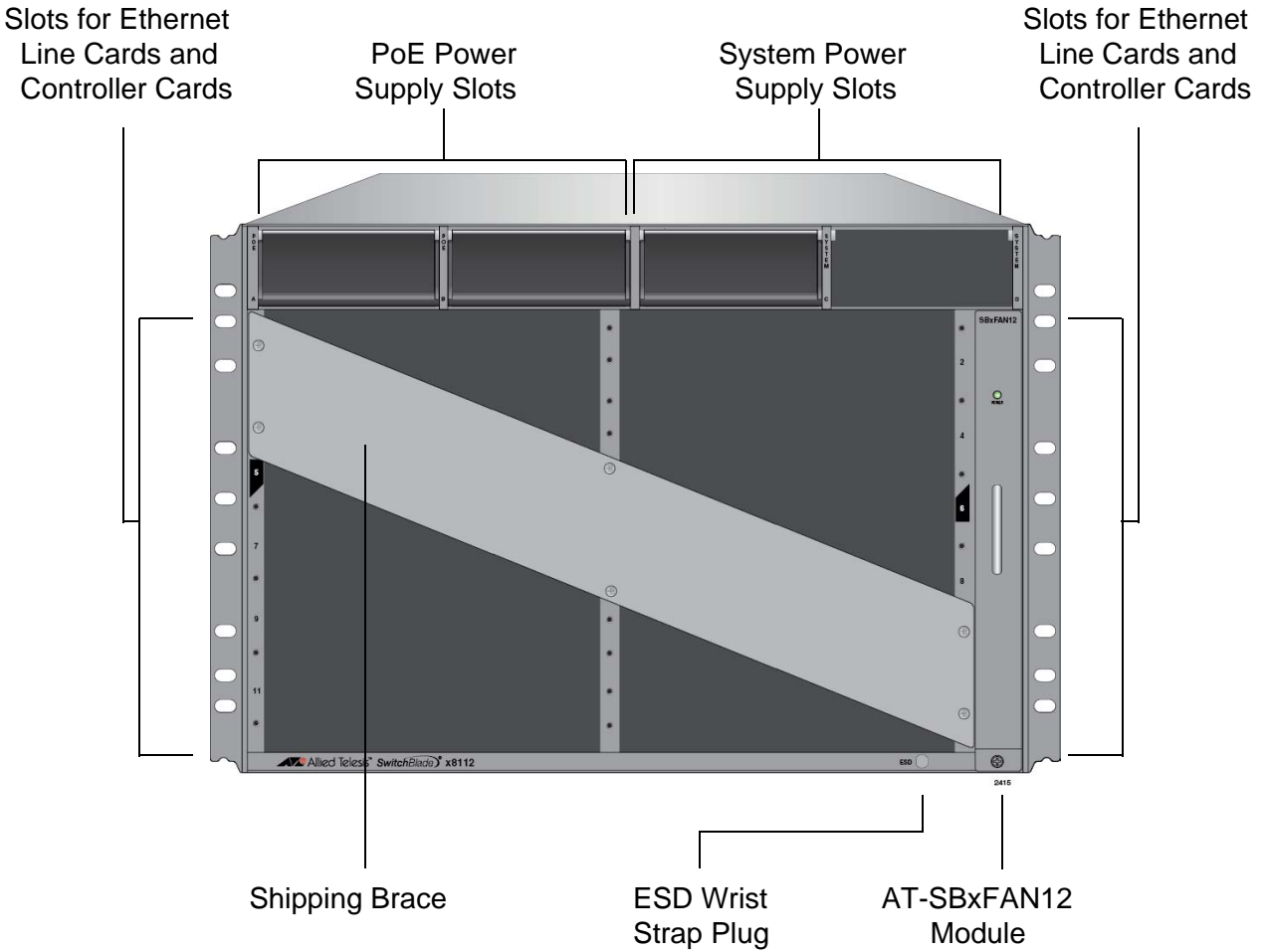

Figure 2. Front View of the AT-SBx8112 Chassis

**Note**

Do not remove the shipping brace from the front of the chassis until after the unit is installed in the equipment rack. You might bend the chassis and cause misalignment of the slots and card guides if you lift the chassis into the equipment rack without the shipping brace.

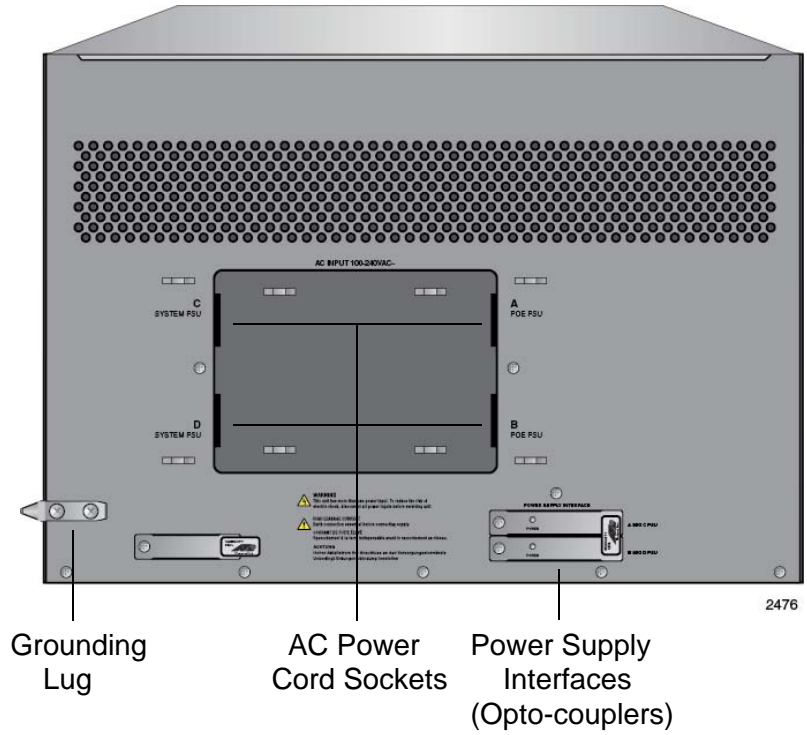

Figure 3. Rear View of the AT-SBx8112 Chassis

Figure 4 is an example of a fully populated chassis.

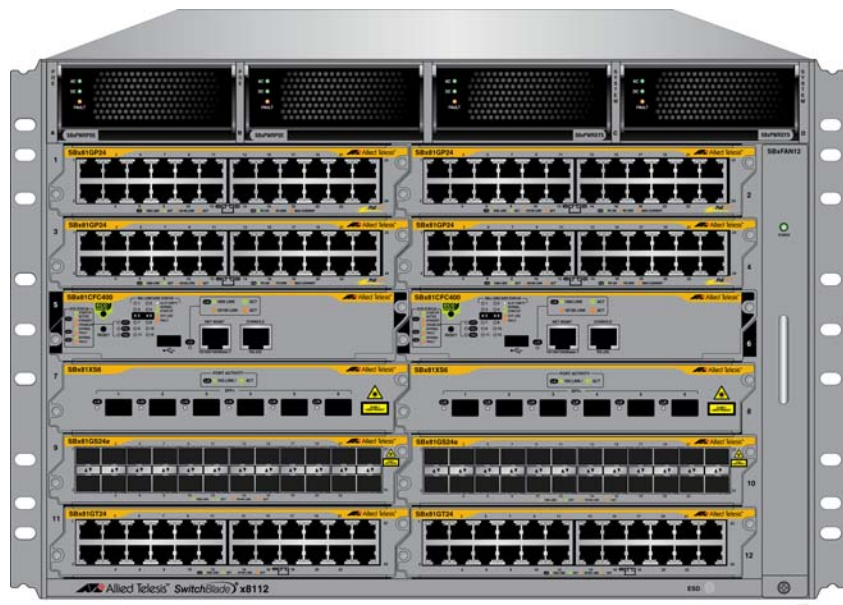
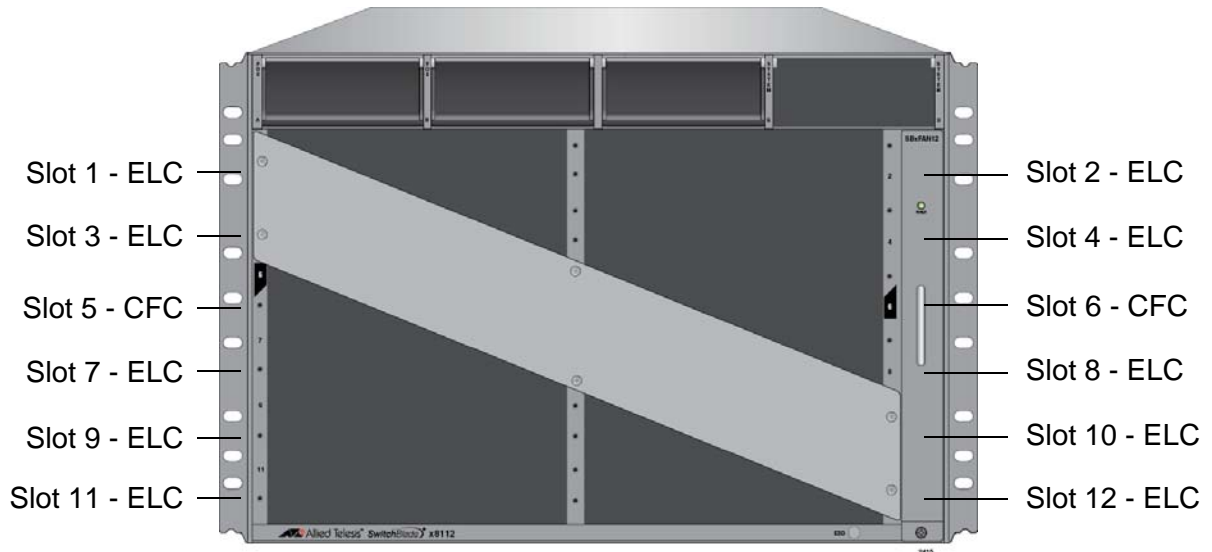

Figure 4. AT-SBx8112 Chassis with Line Cards, Controller Cards, and Power Supplies

## Slots for the Ethernet Line and Controller Cards

The chassis has slots for ten Ethernet line cards and two AT-SBx81CFC400 Controller Fabric Cards. The slot definitions are predefined and cannot be changed. Figure 5 identifies the slots.



ELC - Ethernet Line Card slot  
CFC - Controller Fabric Card slot

Figure 5. Ethernet Line and Controller Cards Slots

Slots 1 to 4 and 7 to 12 are for the Ethernet line cards. The cards may be installed in any order or variety in the slots. The only exception is the AT-SBx81XLEM Line Card, which is supported in slots 1 to 4, 8, and 10, but not slots 7, 9, 11, or 12. For more information on the Ethernet cards, refer to Chapter 2, "Ethernet Line Cards" on page 33

Slots 5 and 6 are for the AT-SBx81CFC400 Controller Fabric Card. The chassis must have at least one controller card. Installing a second controller card in the chassis provides these benefits:

- Management redundancy
- Increased traffic bandwidth

For more information on the controller card, refer to Chapter 3, "AT-SBx81CFC400 Controller Fabric Card" on page 63.

## Power Supplies and Power Supply Slots

There are four power supplies for the chassis. They are shown in Figure 6.



2342

AT-SBxPWRSYS1 AC Power Supply for the Ethernet line cards, controller card, and fan module.

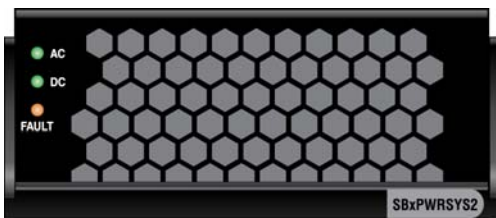

4032

AT-SBxPWRSYS2 AC Power Supply for the Ethernet line cards, controller card, and fan module.



2344

AT-SBxPWRPOE1 AC Power Supply with 1200 W PoE budget for the ports on the AT-SBx81GP24 PoE Ethernet Line Card.



2508

AT-SBxPWRSYS1 DC Power Supply for the Ethernet line cards, controller card, and fan module.

Figure 6. Power Supply Units

---

### Note

Allied Telesis is discontinuing the AT-SBxPWRSYS1 AC Power Supply and replacing it with the AT-SBxPWRSYS2 AC Power Supply.

---

The power supplies are installed in the four slots across the top of the front of the chassis. The slots are labelled A to D. Refer to Figure 7 on page 25.



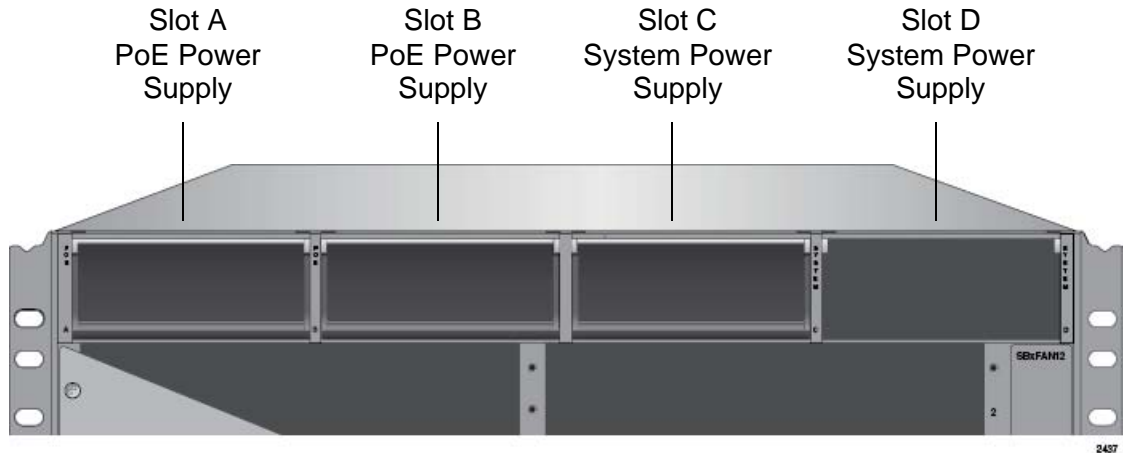

Figure 7. Power Supply Slots

Slots C and D are for system power supplies. The three system power supplies are listed here:

- AT-SBxPWRSYS1 AC Power Supply
- AT-SBxPWRSYS2 AC Power Supply
- AT-SBxPWRSYS1 DC Power Supply

System power supplies provide power for all the hardware components of the chassis, except for the PoE feature on the ports of the AT-SBx81GP24 PoE Line Card. Please review the following items concerning the system power supplies:

- The chassis must have at least one system power supply.
- A single power supply can power a fully populated chassis.
- Installing a second system power supply adds power redundancy to the chassis.
- System power supplies are installed in slots C and D of the chassis.
- If you are installing only one system power supply, you may install it in either slot.
- The AT-SBxPWRSYS1 and AT-SBxPWRSYS2 AC System Power Supplies use the AC connectors on the back panel of the chassis and are intended for AC environments.
- The AT-SBxPWRSYS1 DC System Power Supply has DC power connectors on its front panel and is intended for DC environments.
- The system power supplies are hot swappable. You do not have to power off the unit to replace a power supply.
- The AT-SBxPWRSYS1 AC and AT-SBxPWRSYS2 AC System Power Supplies are compatible and can be used in the same

chassis.

- ❑ The AT-SBxPWRSYS2 AC System Power Supply was added to the management software in release 5.4.5-1. It will work with earlier releases, but Allied Telesis recommends updating the software on controller cards with previous versions to the latest release to ensure full compatibility.

---

**Note**

The AT-SBxPWRSYS1 DC Power Supply is not compatible with the other system or PoE power supplies and should not be operated in the same chassis with other power supplies. You may, however, operate the chassis for a short period of time with AC and DC power supplies if you are converting it from one type of power supply to another, such as from AC to DC. This allows you to transition the chassis without having to power it off.

---

Slots A and B are for the AT-SBxPWRPOE1 AC Power Supply. The unit provides power to the PoE feature on the twisted pair ports on the AT-SBx81GP24 Line Card. For more information, refer to “Power over Ethernet on the AT-SBx81GP24 Line Card” on page 59. Please review the following items concerning the PoE power supply:

- ❑ You may install either one or two power supplies in the chassis.
- ❑ PoE power supplies are installed in slots A and B of the chassis.
- ❑ If you are installing only one power supply, you may install it in either slot A or B.
- ❑ A single PoE power supply provide up to 1200 watts of power for PoE. Two PoE power supplies provide up to 2400 watts of power.
- ❑ The PoE power supply is hot swappable. You do not have to power off the chassis to install or replace it.
- ❑ The total number of powered devices the chassis can support on the ports on AT-SBx81GP24 Line Cards depends on the number of AT-SBxPWRPOE1 AC Power Supplies in the chassis and the power requirements of the devices. For instance, a chassis can support 40 ports of Class 4, PoE+ (IEEE 802.3at) powered devices with one power supply or 80 ports with two power supplies. For further information, refer to “Power over Ethernet on the AT-SBx81GP24 Line Card” on page 59.

---

**Note**

Power supplies are not included with the chassis and must be purchased separately.

---

**LEDs** The LEDs on the AT-SBxPWRSYS1 and AT-SBxPWRSYS2 System Power Supplies are described in Table 1 on page 27.

Table 1. LEDs on the AT-SBxPWRSYS1 and AT-SBxPWRSYS2 Power Supplies

LED	State	Description
AC	Solid Green	The power supply is receiving AC power that is within the normal operating range.
	Off	The power supply is not receiving power from the AC power source.
DC	Solid Green	The power supply is providing DC power that is within the normal operating range.
	Off	The power supply is not generating DC power or the power is outside the normal operating range.
Fault	Solid Amber	A power supply has detected a fault condition, such as an under-voltage, or over-temperature condition.
	Off	The power supply is operating normally or is powered off.

The LEDs on the AT-SBxPWRSYS1 DC System Power Supply are described in Table 2.

Table 2. LEDs on the AT-SBxPWRSYS1 DC System Power Supply

LED	State	Description
DC IN	Solid Green	The power supply is receiving DC power that is within the normal operating range.
	Off	The power supply is not receiving power from the DC power source.
DC OUT	Solid Green	The DC power that the module is providing to the chassis components is within the normal operating range.
	Off	The power supply is not generating DC power or the power is outside the normal operating range.
Fault	Solid Amber	The power supply has detected a fault condition, such as an under-voltage, or over-temperature condition.
	Off	The power supply is operating normally or is powered off.

The LEDs on the AT-SBxPWRPOE1 PoE Power Supply are described in

Table 3.

Table 3. LEDs on the AT-SBxPWRPOE1 PoE Power Supply

<b>LED</b>	<b>State</b>	<b>Description</b>
AC	Solid Green	The power supply is receiving AC power that is within the normal operating range.
	Off	The power supply is not receiving power from the AC power source.
DC	Solid Green	The DC power provided by the power supply to the line cards over the backplane is within the normal operating range.
	Off	The power supply is not providing any DC power or the power is not within the normal operating range.
Fault	Solid Amber	The power supply has detected a fault condition, such as an under-voltage or over-temperature condition.
	Off	The power supply is operating normally or is powered off.

## AT-SBxFAN12 Module

The AT-SBxFAN12 Module, shown in Figure 8, is the cooling unit for the chassis. It is a field- replaceable assembly that is factory installed and shipped with the AT-SBx8112 Chassis.

The module is controlled by the AT-SBx81CFC400 Controller Fabric Card. The fan speeds are automatically adjusted according to the internal operating temperature of the switch. The fans are at their lowest speed when the ambient temperature coming into the fan is approximately 20° C. The fan speeds increase to provide additional cooling as the ambient temperature rises.



Figure 8. AT-SBxFAN12 Module

---

**Note**

Only an authorized service technician should replace the fan module.

---

**LED** The POWER LED on the AT-SBxFAN12 Module is described in Table 4.

Table 4. Power LED on the AT-SBxFAN12 Module

LED	State	Description
Power	Solid Green	The AT-SBxFAN12 Module is receiving power.
	OFF	The AT-SBxFAN12 Module is not receiving power or has failed.

## Power Supply Interfaces (Opto-couplers)

---

The chassis has two power supply interfaces, also referred to as opto-couplers, in the lower right corner on the rear panel. The interfaces, labeled Power Supply Interface, are used by the active master controller card to obtain status information from the power supplies. The interfaces are shown in Figure 9.

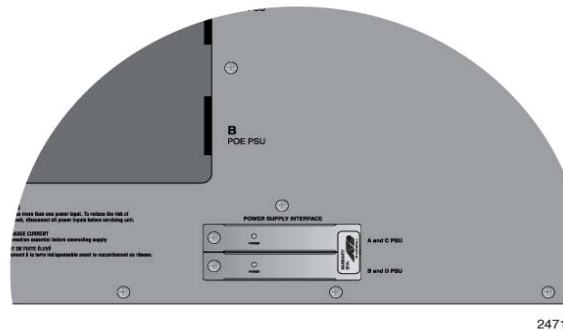

Figure 9. Power Supply Interfaces (Opto-couplers)

The controller card uses the top interface to communicate with the power supplies in slots A and C, and the bottom interface to communicate with the power supplies in slots B and D.



### Caution

Power supply modules are hot swappable, but power supply interfaces are not hot swappable. Power supply interfaces should only be serviced by an authorized service technician.

---

**LED** Each interface has one LED, labeled Power. The LED is described in Table 5 on page 31.

Table 5. Power LED on the Power Supply Interface

LED	State	Description
Power	Solid Green	The interface is operating normally.
	Off	<p>The possible causes of this LED state are listed here:</p> <ul style="list-style-type: none"> <li>- The corresponding power supply slots of the interface are empty.</li> <li>- The power supplies in the power supply slots are powered off or have failed.</li> <li>- The power supplies in the power supply slots are powered on and functioning normally, but the power supply interface has failed.</li> </ul>





## Chapter 2

# Ethernet Line Cards

---

This chapter describes the Ethernet line cards for the SwitchBlade x8112 Chassis Switch in the following sections:

- ❑ “Ethernet Line Cards” on page 34
- ❑ “AT-SBx81GT24 Line Card” on page 36
- ❑ “AT-SBx81GT40 Line Card” on page 38
- ❑ “AT-SBx81GP24 PoE Line Card” on page 41
- ❑ “AT-SBx81GS24a SFP Line Card” on page 44
- ❑ “AT-SBx81XS6 SFP+ Line Card” on page 46
- ❑ “AT-SBx81XLEM Line Card” on page 48
- ❑ “AT-SBx81XLEM/Q2 Expansion Module” on page 50
- ❑ “AT-SBx81XLEM/XS8 Expansion Module” on page 52
- ❑ “AT-SBx81XLEM/XT4 Expansion Module” on page 54
- ❑ “Twisted Pair Ports” on page 55
- ❑ “Power over Ethernet on the AT-SBx81GP24 Line Card” on page 59

## Ethernet Line Cards

The AT-SBx81CFC400 Controller Fabric Card supports the Ethernet line cards shown in Figure 10.

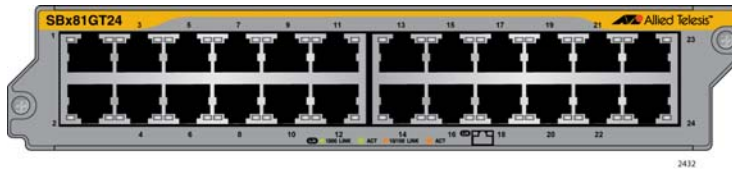

AT-SBx81GT24 Ethernet Line Card with 24 10/100/1000Base-T twisted pair ports.

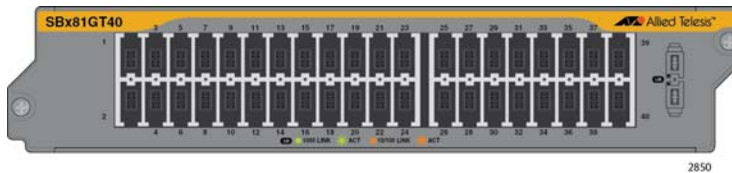

AT-SBx81GT40 Ethernet Line Card with 40 10/100/1000Base-T twisted pair ports, with RJ point 5 connectors.

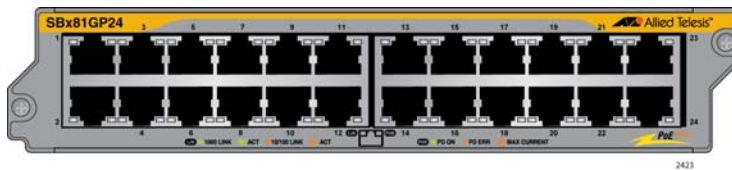

AT-SBx81GP24 Ethernet Line Card with 24 10/100/1000Base-T twisted pair ports, with PoE+.

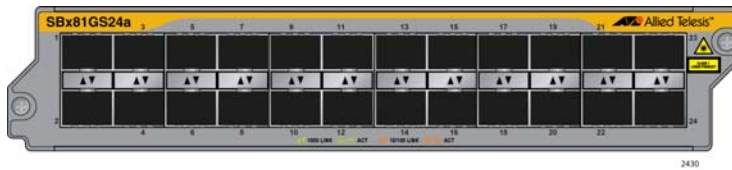

AT-SBx81GS24a SFP Ethernet Card with 24 slots for 100 or 1000Mbps, fiber optic or twisted pair SFP transceivers.

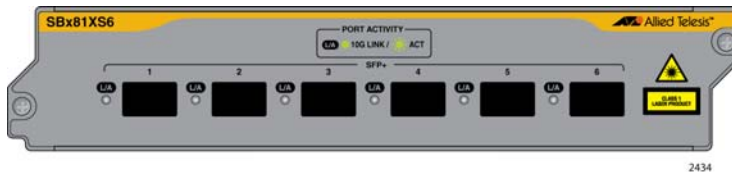

AT-SBx81XS6 SFP+ Ethernet Card with six slots for 10Gbps, fiber optic SFP+ transceivers, or Twinax direct connect cables.

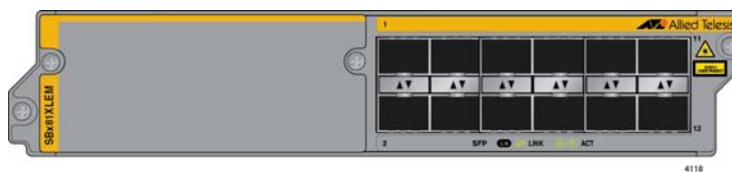

AT-SBx81XLEM SFP Ethernet Card with twelve slots for 1000Mbps, fiber optic or twisted pair SFP transceivers, and one expansion slot.

Figure 10. Ethernet Line Cards

The expansion modules for the AT-SBx81XLEM Line Card are illustrated in Figure 11 on page 35.

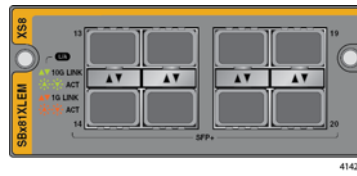

AT-SBx81XLEM/XS8 Module with eight slots for 1Gbps SFP or 10Gbps SFP+ transceivers, or AT-SP10TW Direct Connect Cables.



AT-SBx81XLEM/Q2 Module with two slots for 40Gbps QSFP+ transceivers, or AT-QSFPCU Direct Connect Cables.

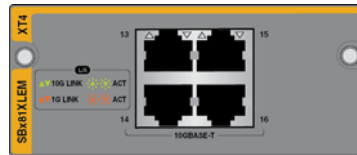

AT-SBx81XLEM/XT4 Module with four 1Gbps or 10Gbps twisted pair ports.

Figure 11. Expansion Modules for the AT-SBx81XLEM Line Card

The types of transceivers supported by line cards and expansion modules with transceiver slots are listed in Table 6. For a list of available transceivers, refer to the AT-SBx8112 and AT-SBx81CFC400 data sheets on the Allied Telesis web site.

Table 6. Types of Supported Transceivers

Ethernet Line Cards and Expansion Modules	100Mbps SFP Transceivers	1Gbps SFP Transceivers	10Gbps SFP+ Transceivers or AT-SP10TW Cables <sup>a</sup>	40Gbps AT-QSFP Transceivers or AT-QSFPCU Cables <sup>b</sup>
AT-SBx81GS24a Line Card	Yes	Yes	No	No
AT-SBx81XS6 Line Card	No	No	Yes	No
AT-SBx81XLEM Line Card <sup>c</sup>	No	Yes	No	No
AT-SBx81XLEM/XS8 Expansion Module	No	Yes	Yes	No
AT-SBx81XLEM/Q2 Expansion Module	No	No	No	Yes

a. Available in lengths of 1, 3, and 7 meters. The model names are AT-SP10TW1, AT-SP10TW3, and AT-SP10TW7, respectively.

b. Available in lengths of 1 and 3 meters. The models names are AT-QSFP1CU and AT-QSFP3CU, respectively.

c. Transceiver slots 1 to 12.

## AT-SBx81GT24 Line Card

The AT-SBx81GT24 Line Card, shown in Figure 12, is a Gigabit Ethernet switch.

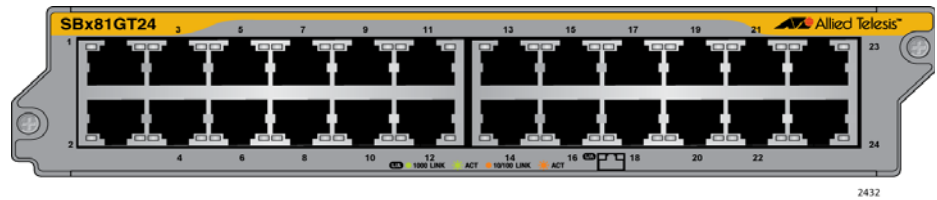

Figure 12. AT-SBx81GT24 Line Card

Here are the main features of the line card:

- ❑ 24 10/100/1000Base-T ports
- ❑ RJ-45 connectors
- ❑ 100 meters (328 feet) maximum operating distance per port
- ❑ Auto-Negotiation for speed and duplex mode
- ❑ Automatic MDIX detection for ports operating at 10/100Base-TX, (Automatic MDIX detection does not apply to 1000Base-T operation.)
- ❑ Port Link/Activity (L/A) LEDs
- ❑ 16K entry MAC address table
- ❑ 12 Mb buffer memory
- ❑ Jumbo frame support:
  - 9710 bytes for ports operating at 10 or 100 Mbps.
  - 10240 bytes for ports operating at 1000 Mbps
- ❑ Non-blocking full wire speed switching on all packet sizes, with two AT-SBx81CFC400 Controller Fabric Cards
- ❑ Hot swappable

The cable requirements for the ports on the AT-SBx81GT24 Line Card are listed in Table 16 on page 56.

**LEDs** Each port on the AT-SBx81GT24 Line Card has two LEDs. The LEDs are shown in Figure 13 on page 37 and described in Table 7 on page 37.

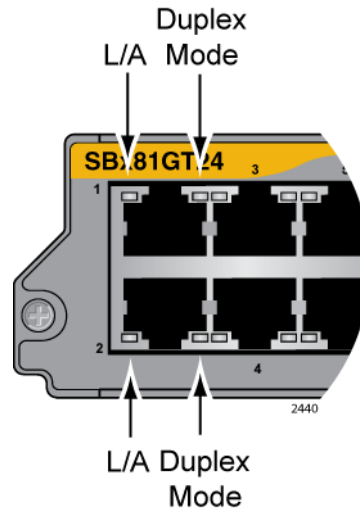

Figure 13. Port LEDs on the AT-SBx81GT24 Line Card

Table 7. Port LEDs on the AT-SBx81GT24 Line Card

LED	State	Description
L/A	Solid Green	The port has established a 1000 Mbps link to a network device.
	Flashing Green	The port is transmitting or receiving data at 1000 Mbps.
	Solid Amber	The port has established a 10 or 100 Mbps link to a network device.
	Flashing Amber	The port is transmitting or receiving data at 10 or 100.
	Off	The port has not established a link with another network device or the LEDs are turned off. To turn on the LEDs, use the eco-friendly button.
Duplex Mode	Solid Green	The port is operating in full duplex mode.
	Solid Amber	The port is operating in half duplex mode.
	Flashing amber	The port is operating in half duplex mode, with collisions.
	Off	The port has not established a link with another network device or the LEDs are turned off. To turn on the LEDs, use the eco-friendly button.

## AT-SBx81GT40 Line Card

The AT-SBx81GT40 Line Card, shown in Figure 14, is a Gigabit Ethernet switch.

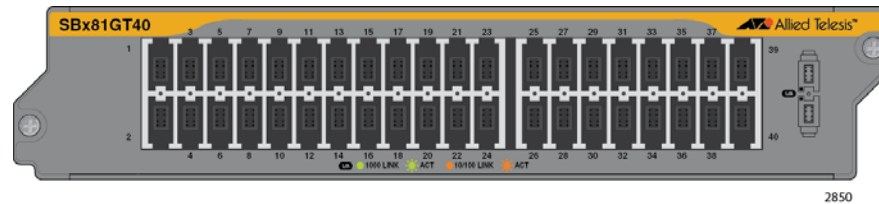

Figure 14. AT-SBx81GT40 Line Card

Here are the main features of the line card:

- ❑ 40 10/100/1000Base-T ports
- ❑ RJ point 5 connectors
- ❑ 100 meters (328 feet) maximum operating distance per port
- ❑ Auto-Negotiation for speed
- ❑ Full-duplex mode only
- ❑ Automatic MDIX detection for ports operating at 10/100Base-TX, (Automatic MDIX detection does not apply to 1000Base-T operation.)
- ❑ Port Link/Activity (L/A) LEDs
- ❑ 32K entry MAC address table
- ❑ 32 Mb buffer memory
- ❑ Jumbo frame support:
  - 10240 octets for tagged and untagged traffic between ports on the same line card
  - 10232 octets for untagged traffic between ports on different line cards
  - 10236 octets for tagged traffic between ports on different line cards
- ❑ Non-blocking full wire speed switching on all packet sizes, with two AT-SBx81CFC400 Controller Fabric Cards
- ❑ Hot swappable

---

### Note

The ports on the line card do not support half-duplex operation.

---

The cable requirements for the ports on the AT-SBx81GT40 Line Card are listed in Table 16 on page 56.

**LEDs** The LEDs for a port on the AT-SBx81GT40 Line Card are found on the RJ point 5 cable connector. The LEDs are shown in Figure 15.

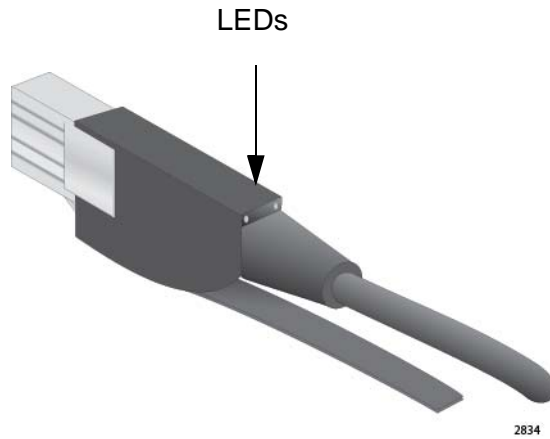

Figure 15. Port LEDs on an RJ Point 5 Cable Connector for the AT-SBx81GT40 Line Card

Only the left LED is active. Refer to Figure 16. It displays link and activity information about a port. The states of the LED are defined in Table 8 on page 40.

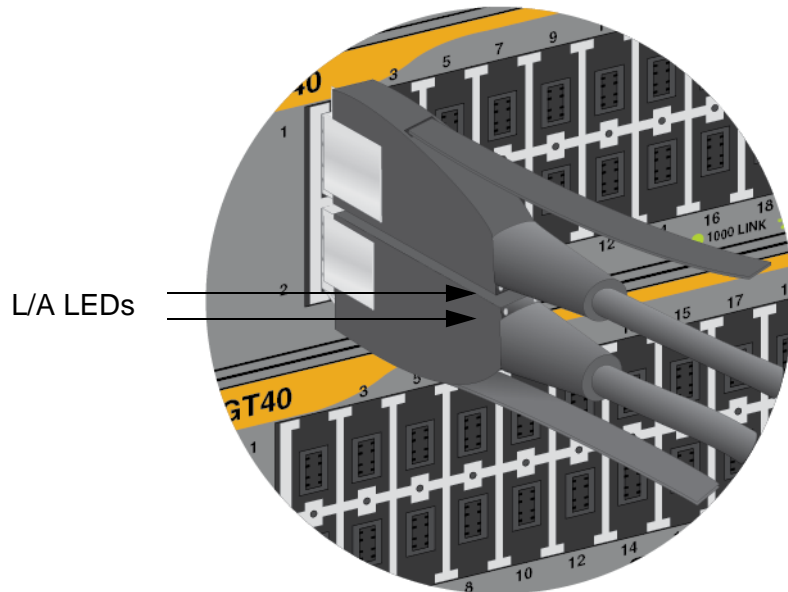

Figure 16. Port LEDs on an RJ Point 5 Cable Connector for the AT-SBx81GT40 Line Card

Table 8. Port LEDs on the AT-SBx81GT40 Line Card

LED	State	Description
L/A	Solid Green	The port has established an 1000 Mbps link to a network device.
	Flashing Green	The port is transmitting or receiving data at 1000 Mbps.
	Solid Amber	The port has established a 10 or 100 Mbps link to a network device.
	Flashing Amber	The port is transmitting or receiving data at 10 or 100.
	Off	The port has not established a link with another network device or the LEDs are turned off. To turn on the LEDs, use the eco-friendly button.
Right LED	-	This LED is not used.



## AT-SBx81GP24 PoE Line Card

The AT-SBx81GP24 PoE Line Card, shown in Figure 17, is a Gigabit Ethernet switch with Power over Ethernet Plus (PoE+) on all the ports.

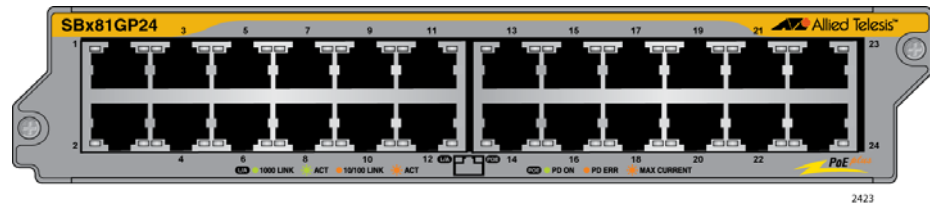

Figure 17. AT-SBx81GP24 PoE Line Card

Here are the main features of the line card:

- 24 10/100/1000Base-T ports
- RJ-45 connectors
- 100 meters (328 feet) maximum operating distance per port
- Auto-Negotiation for speed and duplex mode
- Automatic MDIX detection for ports operating at 10/100Base-TX, (Automatic MDIX detection does not apply to 1000Base-T operation.)
- Port Link/Activity (L/A) and PoE+ LEDs
- 16K entry MAC address table
- 12 Mb buffer memory
- PoE+ on all ports
- Up to 30W per port for PoE+
- PoE device classes 0 to 4
- Jumbo frame support:
  - 9710 bytes for ports operating at 10 or 100 Mbps.
  - 10240 bytes for ports operating at 1000 Mbps
- Non-blocking full wire speed switching on all packet sizes, with two AT-SBx81CFC400 Controller Fabric Cards
- Hot swappable

The cable requirements of the PoE ports on the AT-SBx81GP24 Ethernet Line Card are listed in Table 17 on page 57.

**LEDs** Each port on the AT-SBx81GP24 PoE Line Card has two LEDs. The LEDs are shown in Figure 18 and described in Table 9.

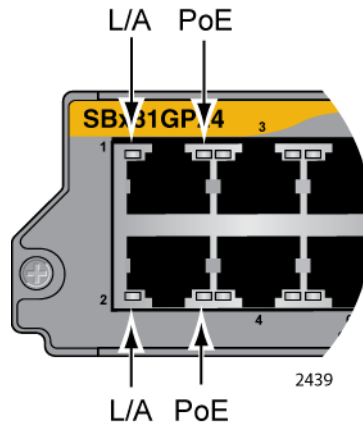

Figure 18. Port LEDs on the AT-SBx81GP24 PoE Line Card

Table 9. Port LEDs on the AT-SBx81GP24 PoE Line Card

LED	State	Description
L/A	Solid Green	The port has established an 1000 Mbps link to a network device.
	Flashing Green	The port is transmitting or receiving data at 1000 Mbps.
	Solid Amber	The port has established a 10 or 100 Mbps link to a network device.
	Flashing Amber	The port is transmitting or receiving data at 10 or 100 Mbps.
	Off	The port has not established a link with another network device or the LEDs are turned off. To turn on the LEDs, use the eco-friendly button.
PoE	Green	The switch is detecting a powered device (PD) on the port and is delivering power to it.
	Solid Amber	The switch has shutdown PoE+ on the port because of a fault condition.
	Flashing Amber	The switch is detecting a PD on the port but is not delivering power to it because the maximum power budget has been reached.

Table 9. Port LEDs on the AT-SBx81GP24 PoE Line Card (Continued)

LED	State	Description
PoE	Off	<p>This LED state can result from the following conditions:</p> <ul style="list-style-type: none"> <li><input type="checkbox"/> The port is not connected to a PD.</li> <li><input type="checkbox"/> The PD is powered off.</li> <li><input type="checkbox"/> The port is disabled in the management software.</li> <li><input type="checkbox"/> PoE is disabled on the port.</li> <li><input type="checkbox"/> The LEDs on the Ethernet line cards are turned off. To turn on the LEDs, use the eco-friendly button.</li> </ul>

## AT-SBx81GS24a SFP Line Card

The AT-SBx81GS24a SFP Line Card, shown in Figure 19, is a Gigabit Ethernet switch.

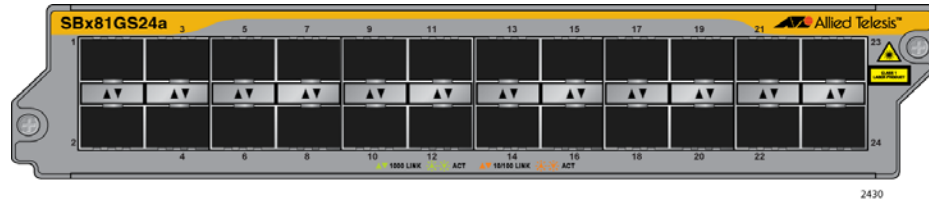

Figure 19. AT-SBx81GS24a SFP Line Card

Here are the main features of the line card:

- ❑ 24 slots for small form-factor pluggable (SFP) transceivers
- ❑ Supports 100Base-FX and 1000Base-SX/LX fiber optic transceivers
- ❑ Supports 100Base-BX and 1000Base-BX bidirectional (BiDi) fiber optic transceivers
- ❑ Supports 10/100/1000Base-T and 1000Base-T twisted pair transceivers
- ❑ Port Link/Activity (L/A) LEDs
- ❑ 32K entry MAC address table
- ❑ 24 Mb buffer memory
- ❑ Jumbo frame support:
  - 9710 bytes for ports operating at 10 or 100 Mbps.
  - 10240 bytes for ports operating at 1000 Mbps
- ❑ Non-blocking full wire speed switching on all packet sizes, with two AT-SBx81CFC400 Controller Fabric Cards.
- ❑ Hot swappable

Contact your Allied Telesis sales representative for a list of supported transceivers.

**LEDs** The SFP slots on the AT-SBx81GS24a SFP Line Card have one LED each, as shown in Figure 20 on page 45 and described in Table 10 on page 45.

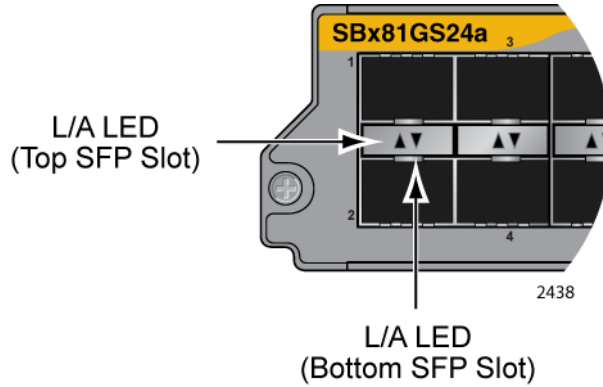

Figure 20. Port LEDs on the AT-SBx81GS24a SFP Line Card

Table 10. Port LEDs on the AT-SBx81GS24a SFP Line Card

LED State	Description
Solid Amber	The SFP transceiver in the slot has established a 10 or 100 Mbps link to a network device.
Blinking Amber	The SFP transceiver is transmitting and/or receiving data at 10 or 100 Mbps.
Solid Green	The SFP transceiver in the slot has established an 1000 Mbps link to a network device.
Blinking Green	The SFP transceiver is transmitting and/or receiving data at 1000 Mbps.
Off	The slot is empty or the SFP transceiver has not established a link to a network device.

## AT-SBx81XS6 SFP+ Line Card

The AT-SBx81XS6 Line Card, shown in Figure 21, is a 10Gbps Ethernet switch.

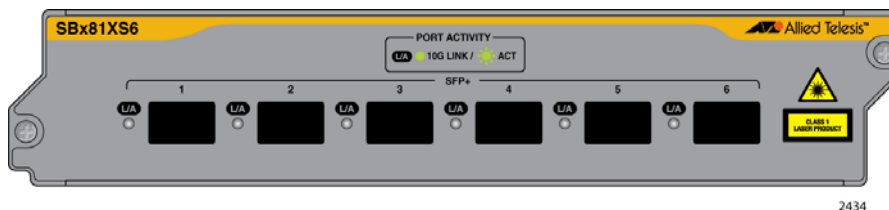

Figure 21. AT-SBx81XS6 Line Card

Here are the main features of the line card:

- ❑ Six slots for 10Gbps SFP+ transceivers
- ❑ Supports 10GBase-SR/LR fiber optic transceivers
- ❑ Supports AT-SP10TW direct connect twinax cables with SFP+ transceiver-style connectors
- ❑ Port Link/Activity (L/A) LEDs
- ❑ 32K entry MAC address table
- ❑ 24 Mb buffer memory
- ❑ Jumbo frame support:
  - 9710 bytes for ports operating at 10 or 100 Mbps.
  - 10240 bytes for ports operating at 1000 Mbps
- ❑ Hot swappable

Contact your Allied Telesis sales representative for a list of supported transceivers.

**LEDs** The AT-SBx81XS6 Line Card has one LED for each SFP+ slot. The LED is shown in Figure 22 and described in Table 11 on page 47.

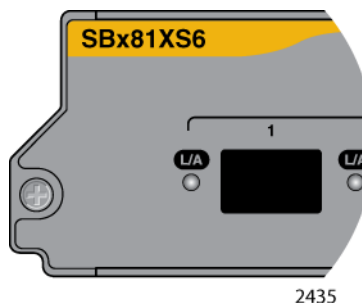

Figure 22. SFP+ Slot LEDs on the AT-SBx81XS6 Line Card

Table 11. SFP+ Slot LEDs on the AT-SBx81XS6 Line Card

LED	State	Description
L/A	Solid Green	The transceiver has established a link with a network device.
	Flashing Green	The transceiver is transmitting or receiving data at 10 Gbps.
	Off	<p>This LED state can result from the following conditions:</p> <ul style="list-style-type: none"> <li>❑ The transceiver slot is empty.</li> <li>❑ The transceiver has not established a link with a network device.</li> <li>❑ The LEDs on the Ethernet line cards are turned off. To turn on the LEDs, use the eco-friendly button.</li> </ul>

## AT-SBx81XLEM Line Card

---

The AT-SBx81XLEM SFP Line Card, shown in Figure 23, is a Gigabit Ethernet switch with a slot for an expansion module.

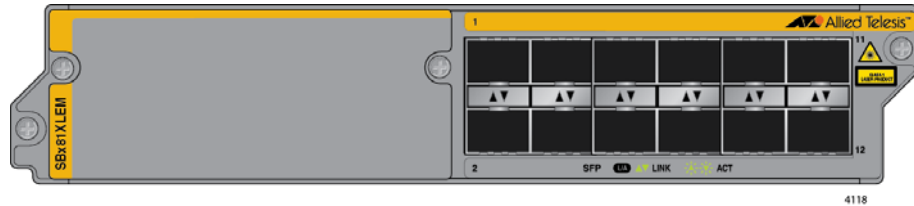

Figure 23. AT-SBx81XLEM SFP Line Card

Here are the main features of the line card:

- Twelve slots for small form-factor pluggable (SFP) transceivers
- Supports 1000Base-SX/LX fiber optic transceivers
- Supports 1000Base-BX bidirectional (BiDi) fiber optic transceivers
- Supports 1000Base-T twisted pair transceivers (full-duplex mode only)
- One slot for an expansion module
- Port Link/Activity (L/A) LEDs
- 128K entry MAC address table
- 32 Mb buffer memory
- Jumbo frame support up to 10240 bytes
- Hot swappable

---

**Note**

The AT-SBx81XLEM SFP Line Card is hot swappable. However, installing, removing, or replacing an expansion module requires removing the line card from the chassis.

---

---

**Note**

The twelve SFP slots do not support 10 or 100Mbps transceivers.

---

For a list of supported transceivers, refer to the SwitchBlade x8100 data sheet on the Allied Telesis web site.

**LEDs** Each SFP slot on the AT-SBx81XLEM Line Card has one LED. The LED is shown in Figure 24 on page 49 and described in Table 12 on page 49.



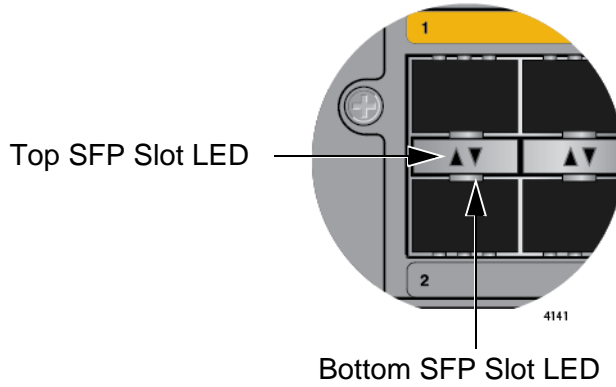

Figure 24. Port LEDs for the SFP Slots on the AT-SBx81XLEM Line Card

Table 12. SFP Slot LEDs on the AT-SBx81XLEM Line Card

LED State	Description
Solid Green	The SFP transceiver in the slot has established a 1000 Mbps link to a network device.
Blinking Green	The transceiver is transmitting and/or receiving data at 1000 Mbps.
Off	The slot is empty or the transceiver has not established a link to a network device.

## AT-SBx81XLEM/Q2 Expansion Module

The AT-SBx81XLEM/Q2 Module, shown in Figure 25, is an expansion module for the AT-SBx81XLEM Line Card. It installs in the slot in the card.

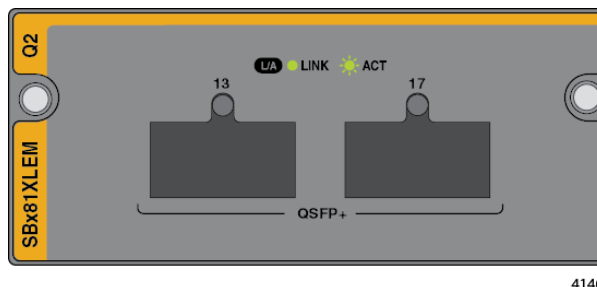

Figure 25. AT-SBx81XLEM/Q2 Expansion Module

The main features of the module are listed here:

- ❑ Two slots for 40 Gbps QSFP+ transceivers
- ❑ Supports AT-QSFPSR, AT-QSFPSR4, and AT-QSFPLR4 transceivers
- ❑ Supports AT-QSFP1CU and AT-QSFP3CU direct connect cables
- ❑ Port Link/Activity (L/A) LEDs
- ❑ Jumbo frame support up to 10240 bytes

### Note

The AT-SBx81XLEM/Q2 Module supports revision B of the AT-QSFPSR4 transceiver. It does not support revision A. The revision level of the transceiver is printed on the transceiver label, after the serial number. You can also display it with the `SHOW SYSTEM PLUGGABLE DETAIL` command in the AlliedWare Plus operating system.

For a list of supported transceivers, refer to the SwitchBlade x8100 data sheet on the Allied Telesis web site.

**LED** Each slot has one LED. The states of the LED are described in Table 13 on page 50.

Table 13. QSFP+ Slot LEDs for the AT-SBx81XLEM/Q2 Expansion Module

LED State	Description
Solid Green	The QSFP+ transceiver in the slot has established a 40Gbps link to a network device.

Table 13. QSFP+ Slot LEDs for the AT-SBx81XLEM/Q2 Expansion Module (Continued)

LED State	Description
Blinking Green	The transceiver is transmitting and/or receiving data.
Off	The slot is empty or the transceiver has not established a link to a network device.

---

**Note**

The AT-SBx81XLEM/Q2 Module does not support 40G DAC auto-negotiation. Allied Telesis recommends disabling auto-negotiation on transceiver link partners to ensure proper operation.

---

## AT-SBx81XLEM/XS8 Expansion Module

The AT-SBx81XLEM/XS8 Module is another expansion module for the AT-SBx81XLEM Line Card. Refer to Figure 26.

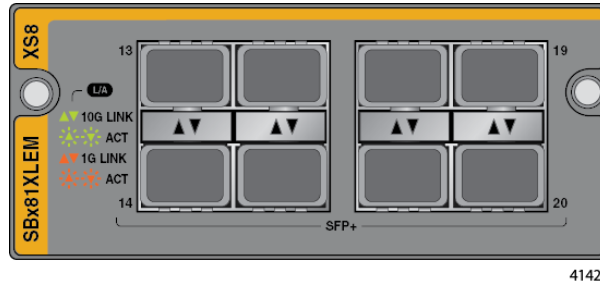

Figure 26. AT-SBx81XLEM/XS8 Expansion Module

The main features of the module are listed here:

- ❑ Eight slots for 1Gbps SFP or 10Gbps SFP+ transceivers
- ❑ Supports 10GBase-SR/LR fiber optic transceivers
- ❑ Supports AT-SP10TW direct connect twinax cables with SFP+ transceiver-style connectors
- ❑ Supports 1000Base-SX/LX fiber optic transceivers
- ❑ Supports 1000Base-BX bidirectional (BiDi) fiber optic transceivers
- ❑ Supports 1000Base-T twisted pair transceivers (full-duplex mode only)
- ❑ Port Link/Activity (L/A) LEDs
- ❑ Jumbo frame support up to 10240 bytes

For a list of supported transceivers, refer to the SwitchBlade x8100 data sheet on the Allied Telesis web site.

**LED** Each slot has one LED. The LED states are defined in Table 14.

Table 14. Slot LEDs on the AT-SBx81XLEM/XS8 Module

LED State	Description
Solid Amber	The SFP transceiver in the slot has established a 1Gbps link to a network device.
Blinking Amber	The transceiver is transmitting and/or receiving data at 1Gbps.
Solid Green	The transceiver in the slot has established a 10Gbps link to a network device.

Table 14. Slot LEDs on the AT-SBx81XLEM/XS8 Module (Continued)

<b>LED State</b>	<b>Description</b>
Blinking Green	The transceiver is transmitting and/or receiving data at 10Gbps.
Off	The slot is empty or the transceiver has not established a link to a network device.

## AT-SBx81XLEM/XT4 Expansion Module

The AT-SBx81XLEM/XT4 Module is an expansion module for the AT-SBx81XLEM Line Card. Refer to Figure 27.

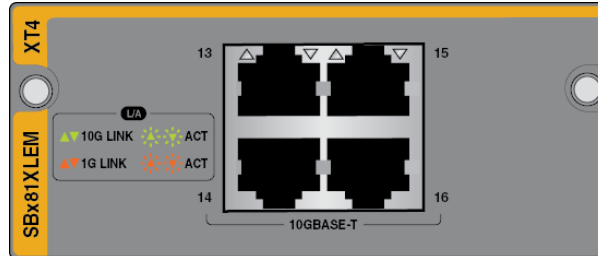

Figure 27. AT-SBx81XLEM/XT4 Expansion Module

The main features of the module are listed here:

- ❑ Four ports with RJ-45 connectors for twisted pair cables
- ❑ Ports support 1000Base-T or 10GBase-T operation
- ❑ 100 meters (328 feet) maximum operating distance per port
- ❑ Auto-Negotiation for speed
- ❑ Full-duplex mode only
- ❑ Port Link/Activity (L/A) LEDs
- ❑ Jumbo frame support up to 10240 bytes
- ❑ Non-blocking full wire speed switching on all packet sizes, with two AT-SBx81CFC400 Controller Fabric Cards

**LEDs** Each port has one LED. The LED states are defined in Table 15.

Table 15. Port LEDs on the AT-SBx81XLEM/XT4 Module

LED State	Description
Solid Amber	The port in the slot has established a 1Gbps link to a network device.
Blinking Amber	The port is transmitting and/or receiving data at 1Gbps.
Solid Green	The port has established a 10Gbps link to a network device.
Blinking Green	The port is transmitting and/or receiving data at 10Gbps.
Off	The port is not connected to a network device or the device is not powered on.

## Twisted Pair Ports

---

This section applies to the twisted pair ports on the following line cards and expansion module:

- AT-SBx81GT24 Line Card
- AT-SBx81GT40 Line Card
- AT-SBx81GP24 Line Card
- AT-SBx81XLEM/XT4 Expansion Module

### Connector Type

The ports on the line cards and expansion module have 8-pin RJ-45 connectors, except for the AT-SBx81GT40 Line Card, which have 8-pin RJ point 5 connectors.

The ports use four pins at 10 or 100 Mbps and all eight pins at 1000 Mbps or 10 Gbps. The pin assignments are listed in “Port Pinouts” on page 277.

### Speed

The possible port speeds are listed here:

- AT-SBx81GT24, AT-SBx81GT40, and AT-SBx81GP24 Line Cards - 10, 100, or 1000 Mbps
- AT-SBx81XLEM/XT4 Expansion Module - 1000 Mbps or 10 Gbps

The switch can set the speeds automatically through Auto-Negotiation, the default setting, or you can manually set the them with the AlliedWare Plus Operating System.

---

#### Note

Twisted-pair ports have to be set to Auto-Negotiation to operate at 1000 Mbps or 10 Gbps.

---

### Duplex Mode

The twisted-pair ports on the AT-SBx81GT24 and AT-SBx81GP24 Line Cards can operate in either half- or full-duplex mode at 10 or 100 Mbps. Ports operating at 1000 Mbps can only operate in full-duplex mode. The twisted-pair ports are IEEE 802.3u-compliant and Auto-Negotiate the duplex mode setting.

You can disable Auto-Negotiation on the ports and set the duplex mode manually.

**Note**

Switch ports that are connected to 10 or 100 Mbps end nodes that are not using Auto-Negotiation should not use Auto-Negotiation to set their speed and duplex mode settings, because duplex mode mismatches might occur. You should disable Auto-Negotiation and set the speed and duplex mode settings manually with the AlliedWare Plus Operating System.

**Note**

The ports on the AT-SBx81GT40 Line Card and AT-SBx81XLEM/XT4 Expansion Module only support full-duplex mode.

**Maximum Distance**

The ports have a maximum operating distance of 100 meters (328 feet).

**Cable Requirements**

The cable requirements for the ports on the AT-SBx81GT24 and AT-SBx81GT40 Line Cards are listed in Table 16.

Table 16. Twisted Pair Cable for the AT-SBx81GT24 and AT-SBx81GT40 Line Cards

Cable Type	10Mbps	100Mbps	1000Mbps
Standard TIA/EIA 568-B-compliant Category 3 shielded or unshielded cabling with 100 ohm impedance and a frequency of 16 MHz.	Yes	Yes	No
Standard TIA/EIA 568-A-compliant Category 5 or TIA/EIA 568-B-compliant Enhanced Category 5 (Cat 5e) shielded or unshielded cabling with 100 ohm impedance and a frequency of 100 MHz.	Yes	Yes	Yes
Standard TIA/EIA 568-B-compliant Category 6 shielded cabling.	Yes	Yes	Yes
Standard TIA/EIA 568-C-compliant Category 6a shielded cabling.	Yes	Yes	Yes



**Note**

Patch cables for the AT-SBx81GT40 Line Card, in lengths of 1 meter and 3 meters with RJ point 5 and RJ-45 connectors, are available from Allied Telesis. Contact your Allied Telesis sales representative for information.

The cable requirements for the PoE ports on the AT-SBx81GP24 Ethernet Line Card are given in Table 17 on page 57.

Table 17. Twisted Pair Cable for the AT-SBx81GP24 Line Card

Cable Type	10Mbps			100Mbps			1000Mbps		
	Non-PoE	PoE	PoE+	Non-PoE	PoE	PoE+	Non-PoE	PoE	PoE+
Standard TIA/EIA 568-B-compliant Category 3 shielded or unshielded cabling with 100 ohm impedance and a frequency of 16 MHz.	Yes	No	No	Yes	No	No	No	No	No
Standard TIA/EIA 568-A-compliant Category 5 shielded or unshielded cabling with 100 ohm impedance and a frequency of 100 MHz.	Yes	Yes	No	Yes	Yes	No	Yes	No	No
Standard TIA/EIA 568-B-compliant Enhanced Category 5 (Cat 5e) shielded or unshielded cabling with 100 ohm impedance and a frequency of 100 MHz.	Yes	Yes	Yes	Yes	Yes	Yes	Yes	Yes	Yes
Standard TIA/EIA 568-B-compliant Category 6 shielded cabling.	Yes	Yes	Yes	Yes	Yes	Yes	Yes	Yes	Yes
Standard TIA/EIA 568-C-compliant Category 6a shielded cabling.	Yes	Yes	Yes	Yes	Yes	Yes	Yes	Yes	Yes

The cable requirements for the ports on the AT-SBx81XLEM/XT4 Expansion Module are listed in Table 18 on page 58.

Table 18. Twisted Pair Cable for the AT-SBx81XLEM/XT4 Expansion Module

Cable Type	1000Mbps	10Gbps
Standard TIA/EIA 568-B-compliant Category 6 shielded cabling.	Yes	No
Standard TIA/EIA 568-C-compliant Category 6a shielded cabling.	Yes	Yes

**Automatic MDIX Detection**

The 10/100/1000 Mbps twisted-pair ports on the AT-SBx81GT24, AT-SBx81GT40, and AT-SBx81GP24 Line Cards are IEEE 802.3ab compliant and feature automatic MDIX detection when operating at 10 or 100 Mbps. (Automatic MDIX detection does not apply to 1000 Mbps or 10 Gbps.) This feature automatically configures the ports to MDI or MDI-X depending on the wiring configurations of the end nodes.

Ports connected to network devices that do not support automatic MDIX detection default to MDIX.

You may disable automatic MDIX detection on the individual ports and configure the MDI/MDI-X settings manually with the POLARITY command.

**Port Pinouts**

Refer to Table 42 on page 277 for the pinouts of the twisted-pair ports when they operate at 10 or 100 Mbps in the MDI configuration and Table 43 on page 277 for the MDI-X configuration. For the port pinouts when they operate at 1000 Mbps or 10 Gbps, refer to Table 44 on page 278.

## Power over Ethernet on the AT-SBx81GP24 Line Card

This section applies to the twisted-pair ports on the AT-SBx81GP24 PoE Line Card. Power over Ethernet (PoE) is a mechanism by which ports supply power to network devices over the same twisted pair cables that carry the network traffic. This feature can simplify network installation and maintenance because it allows you to use the switch as a central power source for other network devices.

Devices that receive their power over Ethernet cables are called powered devices (PD), examples of which include wireless access points, IP telephones, web cams, and even other Ethernet switches. A PD connected to a port on the switch receives both network traffic and power over the same twisted-pair cable.

The AT-SBx81GP24 Line Card automatically determines whether a device connected to a port is a PD. A PD has a signature resistor or signature capacitor that the line card can detect over the Ethernet cabling. If the resistor or capacitor is present, the switch assumes that the device is a PD.

A port connected to a network node that is not a PD (that is, a device that receives its power from another power source) functions as a regular Ethernet port, without PoE. The PoE feature remains enabled on the port but no power is delivered to the device.

### Powered Device Classes

The IEEE 802.3af and 802.3at standards define five powered device classes. The classes are defined by the power requirements of the powered devices. The classes are shown in Table 19. The AT-SBx81GP24 Line Card supports all five classes.

Table 19. IEEE802.3af and IEEE802.3at Powered Device Classes

Class	Usage	Maximum Power Output on the PoE Port	PD Power Range
0	Default	15.4W	.044W to 12.95W
1	Optional	4.0W	0.44W to 3.84W
2	Optional	7.0W	3.84W to 6.49W
3	Optional	15.4W	6.49W to 12.95W
4	Optional	30.0W	12.95W to 25.9W

## Power Budget

The power for PoE on the ports on the AT-SBx81GP24 Line Card is provided by the AT-SBxPWRPOE1 Power Supply. A single power supply can provide up to 1200 watts of power for powered devices. You may install two power supplies in the chassis for a total of 2400 watts for the powered devices.

The number of powered devices the chassis can support at one time depends on the number of AT-SBxPWRPOE1 Power Supplies in the chassis and the power requirements of the powered devices in your network. Table 20 lists the maximum number of powered devices by class, for one or two power supplies. The numbers assume that the powered devices require the maximum amount of power for their classes.

---

### Note

The maximum number of PoE ports in the SwitchBlade x8112 Switch is 240 ports.

---

Table 20. Maximum Number of Powered Devices

Class	Maximum Number of Ports with One PoE PSU (1200 W)	Maximum Number of Ports with Two PoE PSU's (2400 W)
0	77	155
1	240	240
2	171	240
3	77	155
4	40	80

## PoE Wiring

The IEEE 802.3af and 802.3at standards define two methods for delivering power to powered devices over the four pairs of strands that comprise a standard Ethernet twisted-pair cable. The methods are called Alternatives A and B. In Alternative A, power is supplied to powered devices on strands 1, 2, 3, and 6, which are the same strands that carry the 10/100Base-TX network traffic. In Alternative B, power is delivered on strands 4, 5, 7, and 8. These are the unused strands.

---

### Note

1000BASE-T cables carry the network traffic on all eight strands of the Ethernet cable.

---

The PoE implementation on the AT-SBx81GP24 Line Card is Alternative

A. Power is transmitted on strands 1, 2, 3, and 6. Thus, the line card can support PDs that receive power using Alternative A.

PDs that comply with the IEEE 802.3af and 802.3at standards are required to support both power delivery methods. However, non-standard PDs and PDs that were manufactured before the completion of the IEEE 802.3af and 802.3at standards and that support only Alternative B will not work with the AT-SBx81GP24 PoE Line Card.



## Chapter 3

# AT-SBx81CFC400 Controller Fabric Card

---

This chapter describes the AT-SBx81CFC400 Controller Fabric Card in the following sections:

- ❑ “Controller Fabric Cards for the AT-SBx8112 Chassis” on page 64
- ❑ “Hardware Components of the AT-SBx81CFC400 Card” on page 66
- ❑ “Guidelines” on page 68
- ❑ “Dual Controller Cards” on page 70
- ❑ “SYS Status LEDs” on page 72
- ❑ “eco-friendly Button” on page 74
- ❑ “SBx Linecard Status LEDs” on page 75
- ❑ “Console (RS-232) Port” on page 76
- ❑ “Ethernet Management Port (NET MGMT)” on page 77
- ❑ “USB Port” on page 79
- ❑ “Reset Button” on page 80
- ❑ “AlliedWare Plus Software Releases for the Hardware Components” on page 82

## Controller Fabric Cards for the AT-SBx8112 Chassis

There are two controller fabric cards for the AT-SBx8112 Chassis. The cards are listed here:

- ❑ AT-SBx81CFC400 Card
- ❑ AT-SBx81CFC960 Card

The controller fabric cards are shown in Figure 28.

### AT-SBx81CFC400 Controller Fabric Card

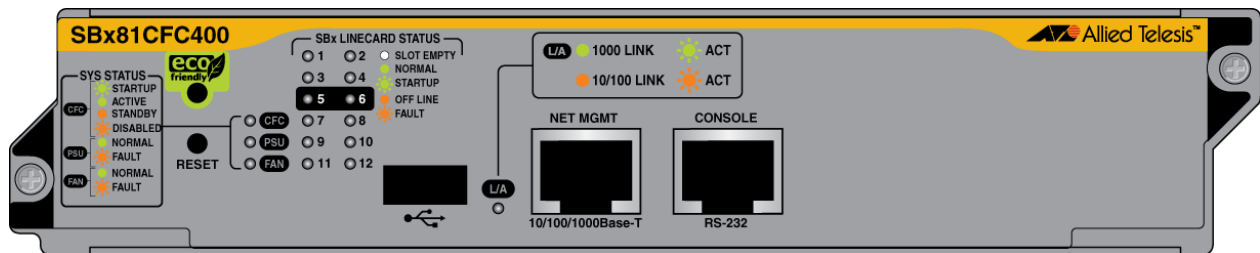

2425

### AT-SBx81CFC960 Controller Fabric Card

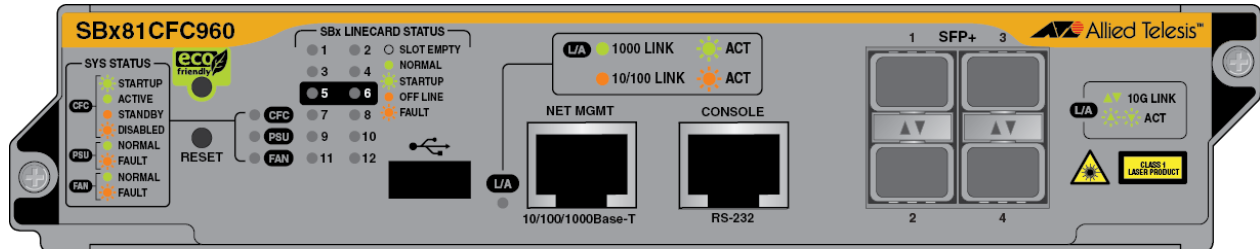

3273

Figure 28. Controller Fabric Cards for the AT-SBx8112 Chassis

Two main differences between the controller cards are described here:

- ❑ The AT-SBx81CFC960 Controller Fabric Card has four SFP+ slots. You may use the slots to add four additional networking ports to the chassis or to build a stack of two chassis with the VCStack Plus feature. The AT-SBx81CFC400 Controller Fabric Card does not have SFP+ slots and, consequently, does not support the VCStack Plus feature.
- ❑ The AT-SBx81CFC400 Card supports the five Ethernet line cards in Figure 10 on page 34. The AT-SBx81CFC960 Card supports the same cards, plus the AT-SBx81XS16 Card, which has sixteen slots for SFP+ transceivers. The AT-SBx81CFC400 Card does not support the AT-SBx81XS16 Card.



This manual describes the AT-SBx81CFC400 Controller Fabric Card. For information on the AT-SBx81CFC960 Card, refer to the SwitchBlade x8112 *Chassis Switch and AT-SBx81CFC960 Card Installation Guide*.

---

**Note**

You may not install both types of controller cards in the same chassis. When installing two controller cards in a chassis, be sure both cards are the same type.

---

## Hardware Components of the AT-SBx81CFC400 Card

The components on the controller card are identified in Figure 29 and briefly described in Table 21.

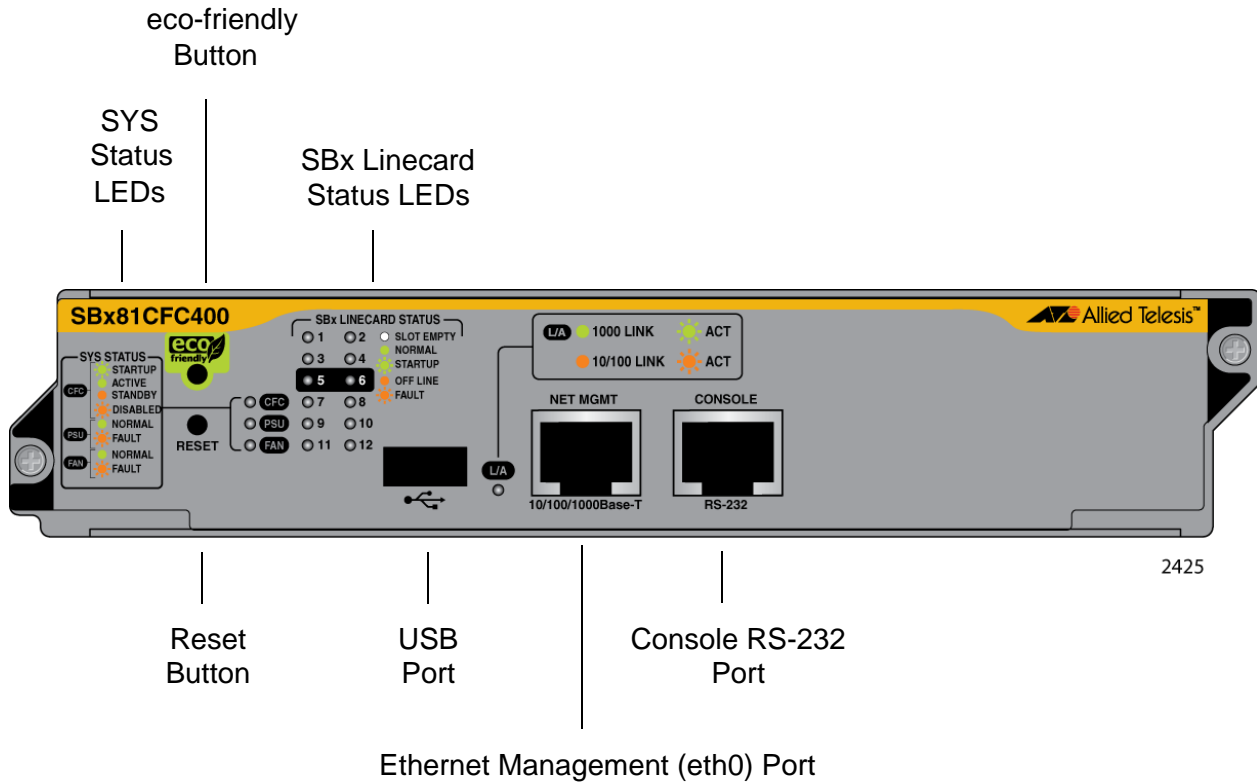

Figure 29. AT-SBx81CFC400 Controller Fabric Card

Table 21. Components on the AT-SBx81CFC400 Controller Fabric Card

Component	Description
SYS Status LEDs	Displays general status information about the controller card, power supplies, and fan module. For more information, refer to “SYS Status LEDs” on page 72.
eco-friendly Button	Turns the LEDs on and off. For more information, refer to “eco-friendly Button” on page 74.
SBx Linecard Status LEDs	Displays general information about the controller and Ethernet line cards. For more information, refer to “SBx Linecard Status LEDs” on page 75.

Table 21. Components on the AT-SBx81CFC400 Controller Fabric Card

<b>Component</b>	<b>Description</b>
Console RS-232 Port	Provides local management of the switch. The switch does not require an IP address for local management. For more information, refer to “Console (RS-232) Port” on page 76.
NET MGMT (eth0) Port	Provides maintenance access to the controller card. For more information, refer to “Ethernet Management Port (NET MGMT)” on page 77.
USB Port	Used with a USB flash memory drive for management functions, such as storing backup copies of the switch configuration or transferring configurations between switches. For more information, refer to “USB Port” on page 79.
Reset Button	Resets the controller and Ethernet line cards. For more information, refer to “Reset Button” on page 80.

## Guidelines

---

Here are some of the functions of the controller card:

- ❑ Chassis Management — The controller card is used to monitor and configure the parameter settings on the Ethernet line cards. The controller card supports local management sessions through the Console RS-232 port and remote management sessions with Telnet, Secure Shell (SSH), or SNMP clients on workstations on your network.
- ❑ Management software — The controller card stores its own management software as well as the management software for the Ethernet line cards. It downloads the firmware to the cards over the backplane in the chassis when the chassis is powered on or reset, as part of the initialization process.
- ❑ Configuration Settings — The controller card also maintains a configuration database in which it stores its own settings as well as the settings of the Ethernet line cards. When a change is made to a configuration setting on a line card, the controller card transmits the change over the backplane to the appropriate line card and updates its configuration database. The database is retained even when the chassis is powered off because controller card stores it in nonvolatile memory. You may download the database to a management workstation or network server to maintain a history of configurations or to transfer a configuration to multiple chassis.
- ❑ Backplane Control — The chassis has a backplane. The Ethernet line cards use the backplane to forward traffic to each other when the ingress and egress ports of packets are located on different cards. The backplane is managed by the controller card. The bandwidth of the backplane depends on the number of controller cards in the chassis. Each line card slot has up to 40Gbps of backplane bandwidth when the chassis has one AT-SBx81CFC400 Controller Fabric Card and up to 80Gbps with two controller cards.

Here are the guidelines to the controller card:

- ❑ The chassis must have at least one controller card. The line cards do not forward traffic if the chassis does not have at least one controller card.
- ❑ The chassis can have either one or two controller cards.
- ❑ Two controller cards are recommended for redundancy and to increase the per slot backplane bandwidth from 40 to 80Gbps.
- ❑ The controller cards are installed in slots 5 and 6 in the chassis.

Here are other features of the controller card:

- ❑ LEDs for monitoring the status of the Ethernet line cards.
- ❑ Power-saving eco-friendly button for turning the port and status LEDs on and off on the line cards and control cards.
- ❑ Reset switch for resetting the chassis.
- ❑ SD card slot for data storage and retrieval.
- ❑ Console RS-232 for local management.
- ❑ NET MGMT port and inband interface for remote Telnet, SSH, and SNMP management.
- ❑ Hot swappable.

## Dual Controller Cards

---

You may install either one or two controller cards in the chassis. Here are the advantages to having two controller cards in the chassis.

- ❑ Having a second controller card improves the performance of the chassis by increasing the backplane bandwidth for the Ethernet line cards. Two controller cards increase the bandwidth for each slot to up to 80 Gbps.
- ❑ Installing a second controller card adds redundancy. If a controller card fails in the chassis, the second card enables the Ethernet line cards to maintain network operations.

Here are the guidelines to dual controller cards:

- ❑ One card operates as the active master card and the other as the standby master card. You can determine the state of a controller card by the M/S LED. For information, refer to “SYS Status LEDs” on page 72.
- ❑ The controller cards automatically determine their states when the chassis is powered on or reset. The card that boots up first is designated as the active master card. If both cards boot up at the same time, the card in slot 5 is designated as the active master card.
- ❑ All management sessions have to be conducted through the active controller card.
- ❑ You have to use the Console RS-232 port on the active controller card to establish a local management session with the chassis.
- ❑ When the chassis is powered on or reset, the two controller cards perform an initialization process, part of which involves the inactive card synchronizing its management files with the active card. During this phase of the initialization process, which may take several minutes, the inactive card does not participate with the active card in forwarding traffic over the backplane and its SFP+ slots are nonfunctional. After the inactive card has finished the initialization process, it joins with the active card in forwarding traffic on the backplane. For more information, refer to “Monitoring the Initialization Process” on page 206.

Two controller cards provide an active/active architecture. The packet processors on both controller cards are fully utilized, doubling the available backplane bandwidth to up to 80Gbps per line card slot.

One of the controller cards becomes the active master. In normal operations, this is the controller card in slot 5. The active master manages the system and processes CPU bound network traffic. The standby master runs all network protocol modules and is kept in sync with the active master card, so as to be available in hot-standby for near instantaneous fail over, if required.

If the active master card is hot-swapped out, the standby master becomes the active master. It takes over all control functions almost instantaneously. Testing has shown no noticeable disruption to streaming video.

You can determine the state of the controller card by viewing the CFC LED on the card. The controller card is the active master when the LED is solid green and the standby master when the LED is solid amber.

## SYS Status LEDs

The SYS (System) Status LEDs on the controller fabric card display general status information about the controller card, power supplies, and fan module. The LEDs are defined in Table 22 on page 72.

Table 22. SYS (System) Status LEDs

LED	State	Description
CFC	Solid Green	Indicates that the AT-SBx81CFC400 Controller Fabric Card is operating normally as the active master controller card.
	Flashing Green	Indicates that the controller card is initializing its management software or synchronizing its database with the active master controller card.
	Solid Amber	Indicates that the controller card is operating normally as the standby master controller card.
	Flashing Amber	Indicates that the controller card is disabled. An active master controller card might disable a standby master controller card if the two cards have incompatible versions of the management software and are unable to resolve the problem, possibly because of insufficient free flash memory.
PSU	Solid Green	Indicates that the power supplies are operating properly.
	Flashing Amber	<p>Indicates that a power supply is experiencing a problem. Possible causes are:</p> <ul style="list-style-type: none"> <li>❑ The input AC voltage from a power source is not within the normal operating range of a power supply module.</li> <li>❑ The output DC voltage from a power supply module to the line cards is not within the normal operating range.</li> <li>❑ A power supply is experiencing high temperature.</li> <li>❑ A power supply has failed.</li> </ul> <p>Check the status LEDs on the individual power supply modules to determine which module has a fault condition.</p>



Table 22. SYS (System) Status LEDs (Continued)

<b>LED</b>	<b>State</b>	<b>Description</b>
FAN	Solid Green	Indicates that the fan module is operating properly.
	Flashing Amber	Indicates that the fan module has a problem. The fans are operating below the normal operating range or have stopped.

## **eco-friendly Button**

---

You may use the eco-friendly button on the controller card to turn the LEDs on or off. You may turn off the LEDs when you are not using them to monitor the control and Ethernet line cards, to conserve electricity. When the LEDs are off, the overall power consumption of the chassis is slightly reduced, approximately 3 watts in a system with 240 active copper ports.

The button controls all of the port LEDs on the Ethernet line cards and controller card, except for the CFC LED, which is always on, and the L/A LED for the NET MGMT port. The button does not control the LEDs on the fan module and power supply systems.

## SBx Linecard Status LEDs

The SBx Linecard Status LEDs display general status information about the Ethernet line cards and controller cards. There is one LED for each slot. If the chassis has two controller cards, the SBx Status LEDs on both cards are active. The LEDs are defined in Table 23.

Table 23. SBx Linecard Status LEDs

LEDs	State	Description
1 to 12	Off	Indicates that the slot is empty.
	Solid Green	Indicates that the Ethernet line or controller card is operating normally.
	Flashing Green	Indicates that the card is booting up, running in test mode, or loading its configuration settings.
	Solid Amber	<p>Indicates that the card is in an off-line state. Possible causes are:</p> <ul style="list-style-type: none"> <li>❑ An Ethernet line card that displays this LED state may have encountered a problem initializing the management software.</li> <li>❑ An Ethernet line card that displays this LED state might not be able to boot up because the controller card does not have the appropriate load file and needs to be updated to the most recent release of the AlliedWare Plus Operating System.</li> <li>❑ A standby master controller card that displays this LED state may have been disabled by the active master controller card because the cards have incompatible versions of the AlliedWare Plus Operating System and were unable to resolve the problem, possibly because of insufficient free flash memory.</li> </ul> <p>You may remove a line or controller card from the chassis when it is in this state.</p>
	Flashing Amber	Indicates that the card is reporting a fault condition. Use the management commands to determine the specific problem.

## **Console (RS-232) Port**

---

The Console Port is used to conduct local management sessions with the switch. Local management sessions are established with a terminal or PC with a terminal emulation program, and the management cable that comes with the card.

Local management is not conducted over a network. Consequently, the AT-SBx81CFC400 Controller Fabric Card does not need an Internet Protocol (IP) address for this type of management.

Your initial management session with the switch must be a local management session. For instructions on how to start a local management session, refer to “Using Local Management to Verify the Chassis” on page 212 or the Software Reference for SwitchBlade x8100 Series Switches.

## Ethernet Management Port (NET MGMT)

---

The controller card uses the NET MGMT port as a separate routed eth0 interface. The interface is not part of the switching matrix of the Ethernet line cards, but the CPU on the controller card can route traffic in or out of the port from the line cards.

Here are the guidelines to using the port:

- ❑ The port should only be used for initial configuration and maintenance access to the chassis.
- ❑ If the chassis has two controller cards, you must use the NET MGMT port on the active controller card to access the switch. The NET MGMT port on the standby controller card is inactive. To determine the status of the controller cards, refer to the CFC LEDs, described in Table 22 on page 72.
- ❑ The NET MGMT port has a standard RJ-45 8-pin connector and operates at 10, 100, or 1000 Mbps in either half- or full-duplex mode.
- ❑ The cable requirements for the port are the same as the ports on the AT-SBx81GT24 Line Card, listed in Table 16 on page 56. For the port pinouts, refer to “Port Pinouts” on page 277.
- ❑ The default setting for the port is Auto-Negotiation, which sets the speed and duplex mode automatically. You may disable Auto-Negotiation and configure the port manually.
- ❑ The wiring configuration of the NET MGMT port is set automatically with automatic MDIX detection. You may disable automatic MDIX detection and set the wiring configuration manually.
- ❑ The port is referred to as eth0 in the management software.

For instructions on how to configure the NET MGMT port, refer to the Software Reference for SwitchBlade x8100 Series Switches.

### **NET MGMT LED**

The Network Management (NET MGMT) port on the AT-SBx81CFC400 Controller Fabric Card has one Status LED, described in Table 24 on page 78.

Table 24. NET MGMT Port LED

<b>LED</b>	<b>State</b>	<b>Description</b>
L/A	Solid Green	The port has a valid 1000 Mbps link.
	Flashing Green	The port is transmitting or receiving data at 1000 Mbps.
	Solid Amber	The port has a valid 10 or 100 Mbps link.
	Flashing Amber	The port is transmitting or receiving data at 10 or 100 Mbps.
	Off	The port has not established a link to a network device.

## USB Port

---

The USB port supports a flash drive. You may use a flash drive to perform the following management functions:

- ❑ Use Allied Telesis Management Framework to provide a centralized network backup location.
- ❑ Store backup copies of the configuration files on the AT-SBx81CFC400 Controller Fabric Card.
- ❑ Transfer configuration files between controller cards in different chassis that are to have similar configurations.
- ❑ Transfer release and GUI files between controller cards.
- ❑ Store or transfer log files.
- ❑ Store or transfer debug files (for example, the output of the SHOW TECH-SUPPORT command).
- ❑ Boot the AlliedWare Plus Operating System and master configuration file from flash drive.

The port is compatible with USB v1.0 and v2.0 flash drives. Operating the controller card with a flash drive is optional.

## Reset Button

---

You may use the Reset button to reset either the controller card or all of the cards in the chassis. The action depends on the number of AT-SBx81CFC400 Controller Cards in the chassis and, if the chassis has two controller cards, whether you reset the active or standby master controller card.

The possible actions are described here:

- ❑ If the chassis has only one controller card, pressing the Reset button resets the controller card and all of the Ethernet line cards in the chassis. You may perform this function if the chassis and line cards are experiencing a problem.



### Caution

The controller and Ethernet line cards do not forward network traffic for about three minutes while they initialize the AlliedWare Plus Operating System and configure their parameter settings. Some network traffic may be lost.

---

- ❑ If the chassis has two controller cards, pressing the Reset button on the active master controller card resets the controller card, but not the Ethernet line cards. The standby master controller card immediately becomes the new active master card and the Ethernet line cards continue to forward traffic. The reset controller card is unavailable for about two minutes while it initializes its AlliedWare Plus Operating System, after which it becomes the standby master controller card in the chassis.

---

### Note

The available bandwidth of the backplane in the chassis is reduced for about one minute while the reset controller card initializes its management software. This may reduce network performance.

---

- ❑ If the chassis has two controller cards, pressing the Reset button on the standby master controller card resets that card, but not the active master controller card or the Ethernet line cards.

---

### Note

The available bandwidth of the backplane in the chassis is reduced for about one minute while the standby master controller card initializes its management software and synchronizes its database with the active master controller card. This may reduce network performance.

---



---

**Note**

To reset individual line cards in the chassis, use the REBOOT or RELOAD command in the AlliedWare Plus Operating System.

---

## AlliedWare Plus Software Releases for the Hardware Components

Table 25 lists the releases of the AlliedWare Plus Operating System for the hardware components of the SwitchBlade x8112 product.

Table 25. AlliedWare Plus Operating System Releases for the Hardware Components

<b>Model Name</b>	<b>Initial Release</b>
AT-SBx8112 Chassis	5.4.2
AT-SBx81GT24 Line Card	5.4.2
AT-SBx81GT40 Line Card	5.4.3
AT-SBx81GP24 Line Card	5.4.2
AT-SBx81GS24a Line Card	5.4.2
AT-SBx81XS6 Line Card	5.4.2
AT-SBx81XLEM Line Card	5.4.6-1
AT-SBx81XLEM/Q2 Expansion Module	5.4.6-1
AT-SBx81XLEM/XS8 Expansion Module	5.4.6-1
AT-SBx81XLEM/XT4 Expansion Module	5.4.6-1
AT-SBx81CFC400 Controller Card	5.4.2
AT-SBxPWRSYS1 AC System Power Supply	5.4.2
AT-SBxPWRSYS2 AC System Power Supply	5.4.5-1
AT-SBxPWRPOE1 PoE Power Supply	5.4.2
AT-SBxPWRSYS1 DC System Power Supply	5.4.3
AT-SBxFAN12 Fan Module	5.4.2

## Chapter 4

# Safety Precautions and Site Requirements

---

This chapter contains the safety precautions and guidelines for selecting a site for the chassis. The chapter contains the following sections:

- “Reviewing Safety Precautions” on page 84
- “Selecting a Site for the SwitchBlade x8112 Chassis Switch” on page 88
- “Installation Tools and Material” on page 90

## Reviewing Safety Precautions

---

Please review the following safety precautions before you begin to install the switch.

---

### Note

The  indicates that a translation of the safety statement is available for viewing in portable document format (PDF) titled **Translated Safety Statements** from our web site at [www.alliedtelesis.com/support](http://www.alliedtelesis.com/support).

---



---

### Warning

Class 1 Laser product.  L1

---



---

### Warning

Do not stare into the laser beam.  L2

---



---

### Warning

To prevent electric shock, do not remove the cover. No user-serviceable parts inside. This unit contains hazardous voltages and should only be opened by a trained and qualified technician. To avoid the possibility of electric shock, disconnect electric power to the product before connecting or disconnecting the LAN cables.  E1

---



---

### Warning

Do not work on equipment or cables during periods of lightning activity.  E2

---



---

### Warning

Power cord is used as a disconnection device. To de-energize equipment, disconnect the power cord.  E3

---



---

### Warning

Class I Equipment. This equipment must be earthed. The power plug must be connected to a properly wired earth ground socket outlet. An improperly wired socket outlet could place hazardous voltages on accessible metal parts.  E4

---

---

**Note**

Pluggable Equipment. The socket outlet shall be installed near the equipment and shall be easily accessible. ⚡ E5

---

**Caution**

Air vents must not be blocked and must have free access to the room ambient air for cooling. ⚡ E6

---

**Warning**

Operating Temperature. This product is designed for a maximum ambient temperature of 40° degrees C. ⚡ E7

---

---

**Note**

All Countries: Install product in accordance with local and National Electrical Codes. ⚡ E8

---

**Warning**

When installing this equipment, always ensure that the frame ground connection is installed first and disconnected last. ⚡ E11

---

**Caution**

Circuit Overloading: Consideration should be given to the connection of the equipment to the supply circuit and the effect that overloading of circuits might have on over current protection and supply wiring. Appropriate consideration of equipment nameplate ratings should be used when addressing this concern. ⚡ E21

---

**Caution**

Risk of explosion if battery is replaced by an incorrect type. Replace only with the same or equivalent type recommended by the manufacturer. Dispose of used batteries according to the manufacturer's instructions.

**Attention:** Le remplacement de la batterie par une batterie de type incorrect peut provoquer un danger d'explosion. La remplacer uniquement par une batterie du même type ou de type équivalent recommandée par le constructeur. Les batteries doivent être éliminées conformément aux instructions du constructeur. ⚡ E22

---



---

**Warning**

Mounting of the equipment in the rack should be such that a hazardous condition is not created due to uneven mechanical loading. *↪* E25

---



---

**Warning**

Remove all metal jewelry, such as rings and watches, before installing or removing a line card from a powered-on chassis. *↪* E26

---



---

**Warning**

The chassis may be heavy and awkward to lift. Allied Telesis recommends that you get assistance when mounting the chassis in an equipment rack. *↪* E28

---



---

**Warning**

This unit might have more than one power cord. To reduce the risk of electric shock, disconnect all power cords before servicing the unit. *↪* E30

---

---

**Note**

If installed in a closed or multi-unit rack assembly, the operating ambient temperature of the rack environment may be greater than the room ambient temperature. Therefore, consideration should be given to installing the equipment in an environment compatible with the manufacturer's maximum rated ambient temperature (T<sub>mra</sub>). *↪* E35

---



---

**Caution**

Installation of the equipment in a rack should be such that the amount of air flow required for safe operation of the equipment is not compromised. *↪* E36

---



---

**Warning**

Reliable earthing of rack-mounted equipment should be maintained. Particular attention should be given to supply connections other than direct connections to the branch circuits (e.g., use of power strips). *↪* E37

---



**Warning**

To reduce the risk of electric shock, the PoE ports on this product must not connect to cabling that is routed outside the building where this device is located. E40

---



**Warning**

This product may have multiple AC power cords installed. To de-energize this equipment, disconnect all power cords from the device. E43

---



**Caution**

An Energy Hazard exists inside this equipment. Do not insert hands or tools into open chassis slots or sockets. E44

---



**Warning**

This equipment shall be installed in a Restricted Access location. E45

---



**Warning**

High Leakage Current exists in this chassis. Connect external ground wire before connecting AC power supply(s). E46

---

## Selecting a Site for the SwitchBlade x8112 Chassis Switch

---

Please perform the following procedure to determine the suitability of the site for the chassis:

1. Verify that the equipment rack is safely secured so that it will not tip over. You should install devices starting at the bottom of the rack, with the heavier devices near the bottom.
2. Verify that the power outlets for the chassis are located near the unit and are easily accessible.
3. Verify that the power sources are on different A/C circuits to protect the unit from a power circuit failure.
4. Verify that the site has dedicated power circuits or power conditioners to supply reliable electrical power to the network devices.
5. Verify that the site allows for easy access to the ports on the front of the chassis so that you can easily connect and disconnect the network cables, as well as view the unit's LEDs.
6. Verify that the site allows for adequate air flow around the unit and through the cooling vents. The ventilation direction for the main section of the chassis is from left to right (when facing the front of the chassis), with the fan module drawing air out of the chassis. The power supplies have fans that draw air from the front to the back.
7. Verify that the site has a reliable and earth (grounded) power supply source, preferably dedicated and filtered.
8. Verify that the twisted pair cabling is not exposed to sources of electrical noise, such as radio transmitters, broadband amplifiers, power lines, electric motors, and fluorescent fixtures.
9. Verify that the site protects the chassis from moisture, water, and dust.

Here are other guidelines to consider:

- Switch ports are suitable for intra-building connections, or where non-exposed cabling is required.
- Do not place objects on top of the chassis.
- The power cords provided with the AT-SBxPWRSYS1, AT-SBxPWRSYS2, and AT-SBxPWRPOE1 Power Supplies for 100-125 VAC installations have 20 Amp, 125 V NEMA 5-20P plugs. The plugs are only compatible with NEMA 5-20R receptacles. See Figure 30 on page 89.



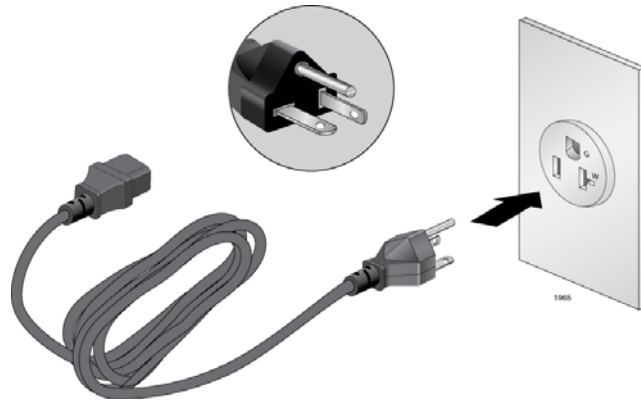

Figure 30. 100 - 125 VAC 125 V NEMA 5-20 Plug and Receptacle

## Installation Tools and Material

---

Here are the installation tools and material you need to have to install the product.

Installing the chassis in an equipment rack requires the following items:

- #2 Phillips-head screwdriver
- Six equipment rack screws
- Flat-head screwdriver
- #2 Phillips-head 10 inch-lbs torque screwdriver (optional)

The grounding wire requires the following items:

- #2 Phillips-head screwdriver
- Crimping tool
- 10 AWG stranded grounding wire
- #2 Phillips-head 20 inch-lbs torque screwdriver (optional)

The AT-SBxPWRSYS1 DC Power Supply requires the following items:

- Two 8 AWG power wires
- One 10 AWG stranded grounding wire
- 8 mm wrench
- #1 Phillips-head screwdriver
- #3 Phillips-head screwdriver
- #3 Phillips-head 30 to 40 inch-lbs torque screwdriver (optional)

The AT-SBx81CFC400 Controller Fabric Card and Ethernet line cards require the following items:

- #2 Phillips-head screwdriver
- #2 Phillips-head, 5 inch-lbs torque screwdriver (optional)

## Chapter 5

# Installing the Chassis in an Equipment Rack

---

This chapter describes how to install the AT-SBx8112 Chassis in an equipment rack. This chapter contains the following sections:

- ❑ “Required Tools and Material” on page 92
- ❑ “Preparing the Equipment Rack” on page 93
- ❑ “Unpacking the AT-SBx8112 Chassis” on page 96
- ❑ “Adjusting the Equipment Rack Brackets” on page 98
- ❑ “Installing the AT-SBx8112 Chassis in the Equipment Rack” on page 100
- ❑ “Removing the Shipping Brace” on page 103
- ❑ “Installing the Chassis Grounding Wire” on page 104

## Required Tools and Material

---

Here is a list of the tools and screws for mounting the chassis in an equipment rack:

- ❑ #2 Phillips-head screwdriver
- ❑ Eight equipment rack screws
- ❑ #2 Phillips-head 10 inch-lbs torque screwdriver (optional)

Here is a list of the tools and wire for installing the grounding wire on the chassis:

- ❑ #2 Phillips-head screwdriver
- ❑ Crimping tool
- ❑ 10 AWG stranded grounding wire
- ❑ #2 Phillips-head 20 inch-lbs torque screwdriver (optional)



### **Warning**

The chassis may be heavy and awkward to lift. Allied Telesis recommends that you get assistance when mounting the chassis in an equipment rack. *ES* E30

---

## Preparing the Equipment Rack

---

This section explains how to prepare the equipment rack for the chassis. The procedure requires the following items:

- ❑ #2 Phillips-head screwdriver (not provided)
- ❑ Two equipment rack screws (not provided)

To prepare the equipment rack for the AT-SBx8112 Chassis, perform the following procedure:



### Caution

The chassis is heavy and should be mounted as low as possible in the equipment rack to maximize vertical stability.

---

1. Reserve 311.1 mm (12.25") of vertical rack space for the installation of the AT-SBx8112 Chassis, as shown in Figure 31 on page 94.
2. Do not mount any other equipment within 152.4 mm (6") above this space during installation. This additional vertical space is temporary and allows you enough room to lift and tilt the chassis into its position in the equipment rack without hitting other equipment, as shown in Figure 37 on page 101. You may use this additional space for other network equipment after the chassis is installed.

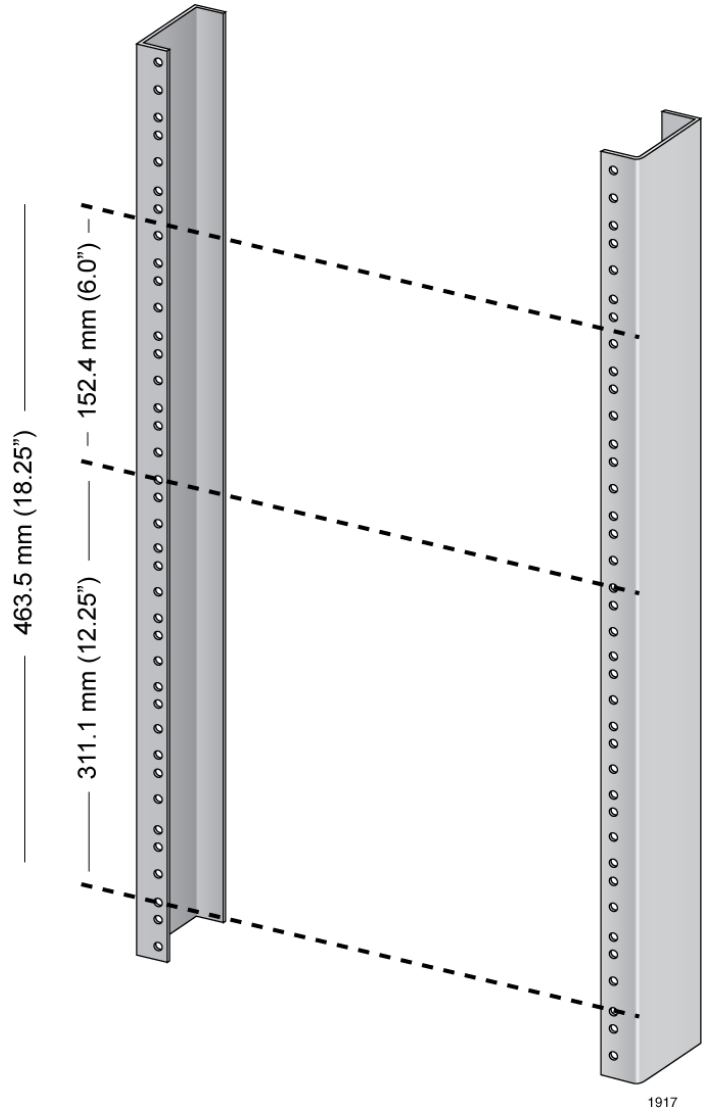

Figure 31. Reserving Vertical Rack Space

3. Identify the lowest 1/2" screw hole pattern on the rack mounting rails within the space reserved for the AT-SBx8112 Chassis.
4. Install one rack mount screw in each vertical rail, at the same height in the top screw hole of the lowest 1/2" hole pattern, as shown in Figure 32. The screws are used to support the chassis while you secure it to the rack. Do not fully tighten these two screws at this time. The screw heads should protrude from the rack approximately 6.4 mm (.25 in).

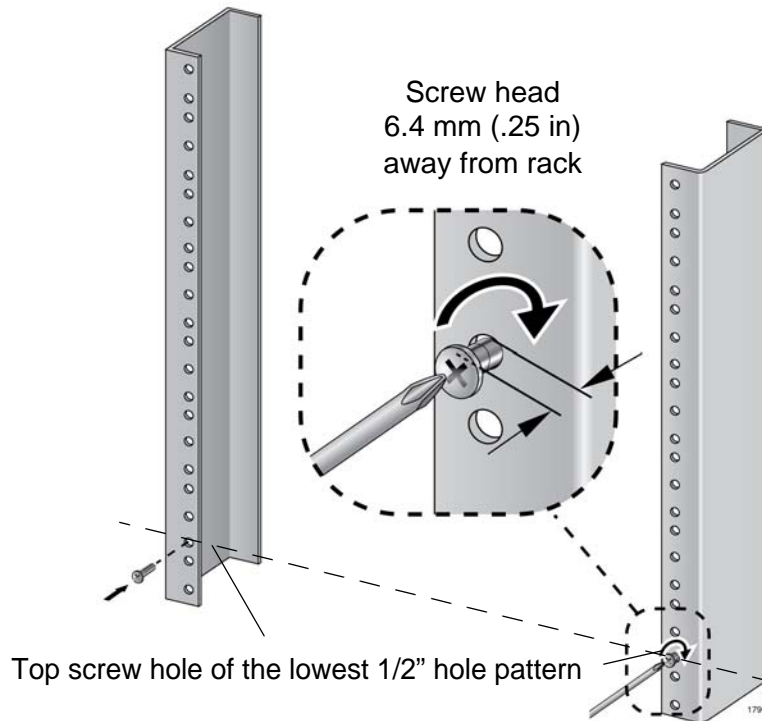

Figure 32. Rack Mounting Hole Locations

5. After installing the two screws in the equipment rack, go to "Unpacking the AT-SBx8112 Chassis" on page 96.

## Unpacking the AT-SBx8112 Chassis

---

To unpack the AT-SBx8112 Chassis, perform the following procedure:

1. Remove all components from the shipping package.
2. Verify the contents of the shipping container by referring to Figure 33 here and Figure 34 on page 97. If any item is missing or damaged, contact your Allied Telesis sales representative for assistance.

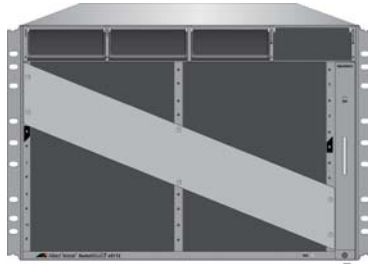

One AT-SBx8112 Chassis



One AT-SBxFAN12 Module pre-installed in the vertical slot on the right side of the front panel

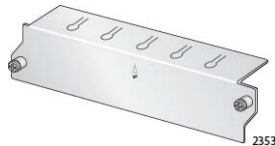

Ten blank line card slot covers



Three blank power supply slot covers pre-installed in power supply slots A to C on the front panel



One grounding lug pre-installed in the lower left corner on the back panel

Figure 33. Components of the AT-SBx8112 Chassis





Two equipment rack brackets pre-installed on the sides of the chassis.

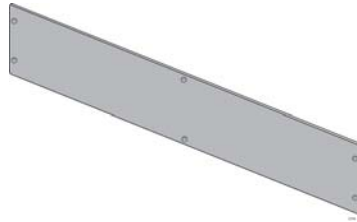

One shipping brace pre-installed diagonally across the line card slots on the front panel



One wrist strap

Figure 34. Components of the AT-SBx8112 Chassis (Continued)

## Adjusting the Equipment Rack Brackets

The chassis has two pre-installed equipment rack brackets. You may adjust the brackets so that the front of the chassis is flush with, extends beyond, or is recessed behind the front of the equipment rack. You may also install the brackets so that the rear panel of the chassis is flush with the front of the equipment rack.

You adjust the brackets by removing them and re-installing them in different positions on the sides of the chassis. The different bracket positions are listed in Table 26 and illustrated in Figure 35 on page 99 and Figure 36 on page 99. Please review the following information before moving the brackets:

- Position A, the default position, positions the chassis so that the front of the unit is flush with the front of the equipment rack.
- Position B recesses the front of the chassis by 27.39 mm (1.1 in).
- Positions C to E extend the front of the chassis beyond the front of the rack from 27.39 mm (1.1 in) to 140.85 mm (5.545 in).
- Position F installs the chassis with the rear panel flush with the front of the equipment rack.
- To install the rack mount brackets in position “E,” you have to remove the two chassis screws from the bottom-middle section of the chassis and re-install them in front where the rack mount bracket screws were originally, as shown in Figure 35 on page 99.
- The dimension (X) between the front panel and the rack rails is given for each rack mounting bracket position in Table 26.

Table 26. Front Panel to Rack Rail Dimensions

Figure #	Front Panel Position	Dimension X Front Panel to Rack Rail
35	A (Factory Installed - Flush)	3.69 mm (0.145 in)
35	B (Recessed)	-27.39 mm (-1.078 in)
35	C	27.39 mm (1.078 in)
35	D	47.71 mm (1.878 in)
35	E	140.85 mm (5.545 in)
36	F (Reverse Position)	374.16 mm (14.731 in)

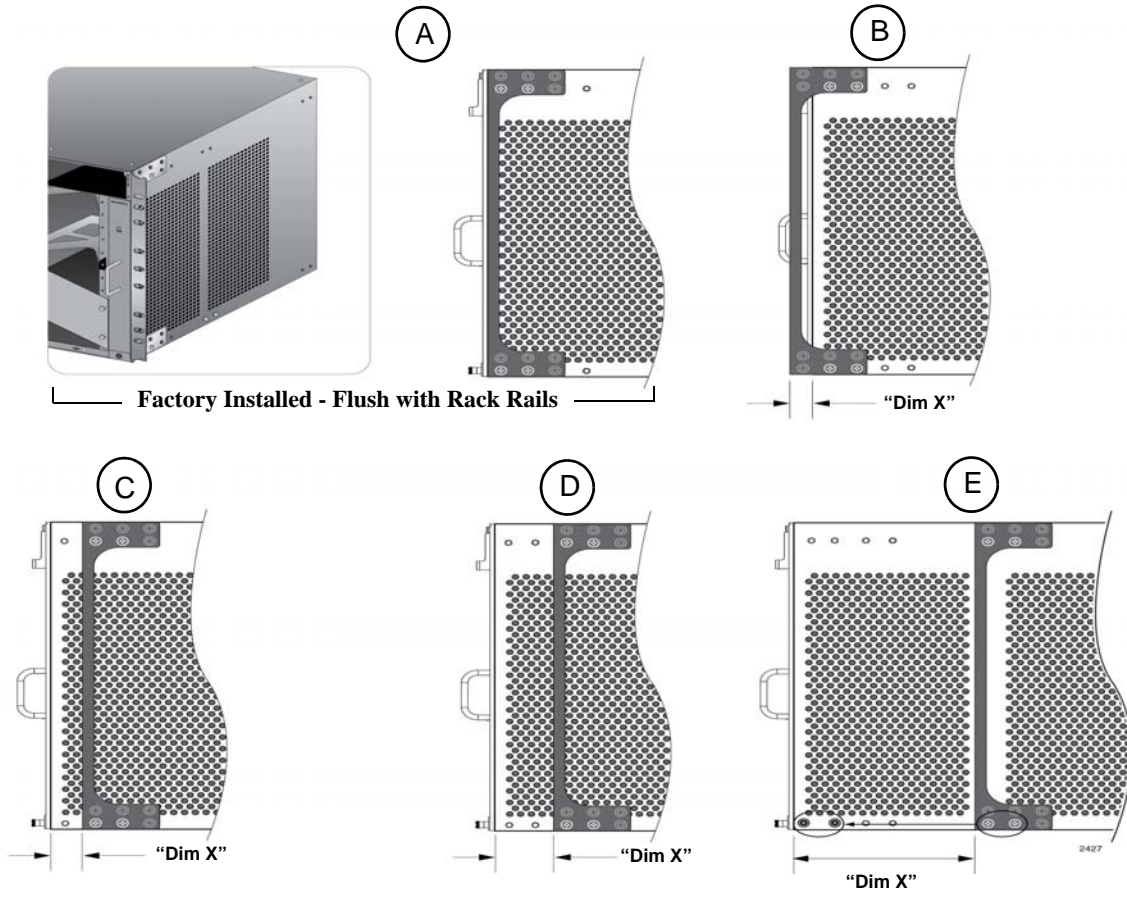

Figure 35. Rack Mounting Bracket Locations

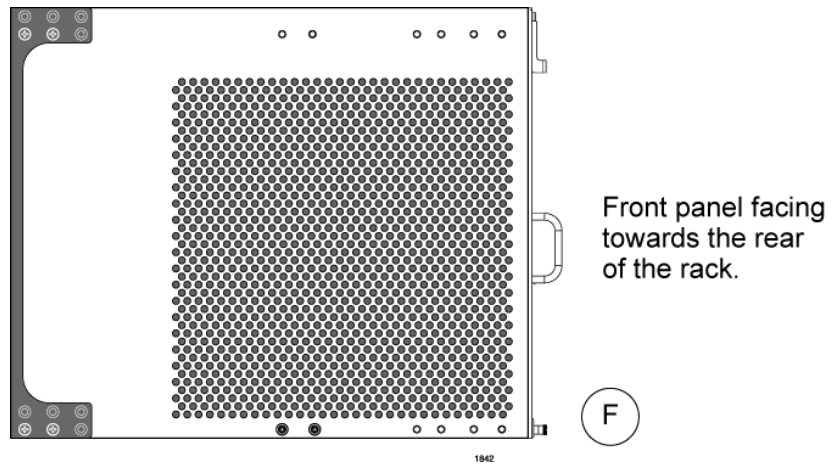

Figure 36. Rack Bracket Locations for Reverse Position of Chassis

## Installing the AT-SBx8112 Chassis in the Equipment Rack

---

The procedure in this section explains how to install the chassis in the equipment rack. The procedure requires the following items:

- #2 Phillips-head screwdriver (not provided)
- Six equipment rack screws (not provided)
- #2 Phillips-head, 10 inch-lbs torque screwdriver (optional — not provided)



### Caution

Do not remove the shipping brace from the front of the AT-SBx8112 Chassis until after the unit is securely mounted in the rack. The plate prevents twisting of the chassis frame and mechanical misalignment of the line card slots during shipping and installation.

---



### Warning

The chassis may be heavy and awkward to lift. Allied Telesis recommends that you get assistance when mounting the chassis in an equipment rack. *See* E30

---



### Warning

To prevent injuring yourself or damaging the device, do not attempt to install the chassis in the equipment rack alone. Allied Telesis recommends a minimum of three people for this procedure.

---

Before installing the chassis in the rack, review the following checklist:

- Did you reserve sufficient space in the equipment rack for the chassis and install two screws in the rack on which to rest the chassis while securing it to the rack? If not, then perform “Preparing the Equipment Rack” on page 93.
- Did you adjust the brackets so that the front of the chassis will be positioned correctly in the equipment rack for your installation? If not, then perform “Adjusting the Equipment Rack Brackets” on page 98.

To install the AT-SBx8112 Chassis in the equipment rack, perform the following procedure:

1. While facing the front of the chassis, tilt the top of the chassis toward you, as shown in Figure 37 on page 101.

2. Lift the AT-SBx8112 Chassis into the equipment rack and set the bottom of the equipment rack brackets firmly on the two equipment rack screws you installed in “Preparing the Equipment Rack” on page 93, as shown in Figure 37.

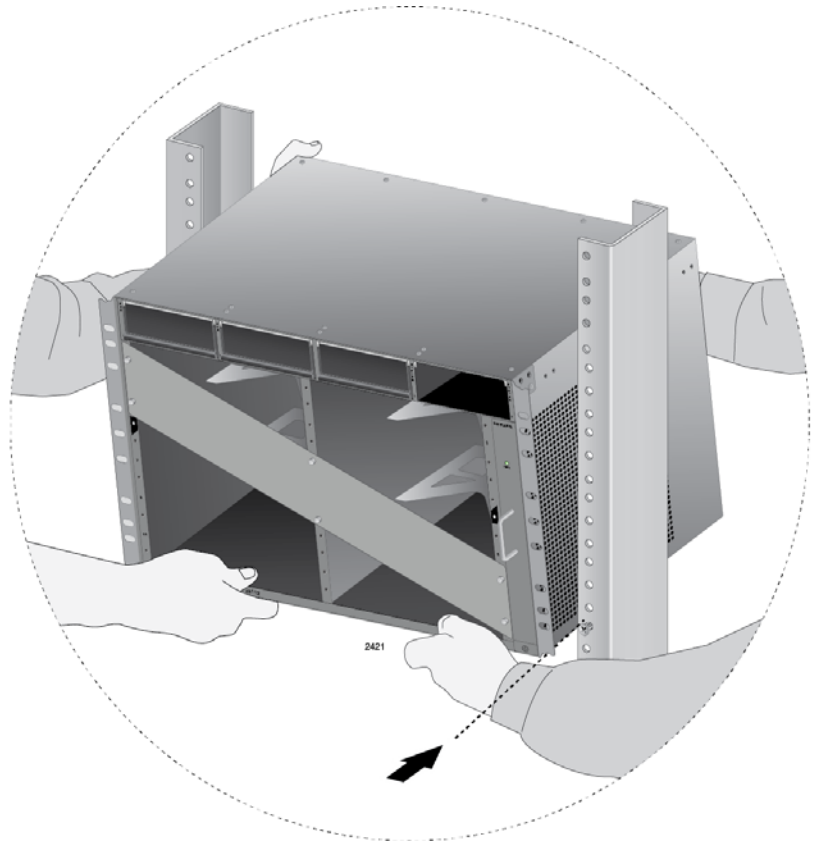

Figure 37. Lifting the AT-SBx8112 Chassis into the Equipment Rack

3. With the bottom of the rack mount ears resting on the two rack mount screws, tilt the top of the chassis back until both rackmount brackets are flush and parallel with the vertical rack rails.
4. Install six rack mount screws (not provided) to secure the chassis to the equipment rack, as shown in Figure 38 on page 102.

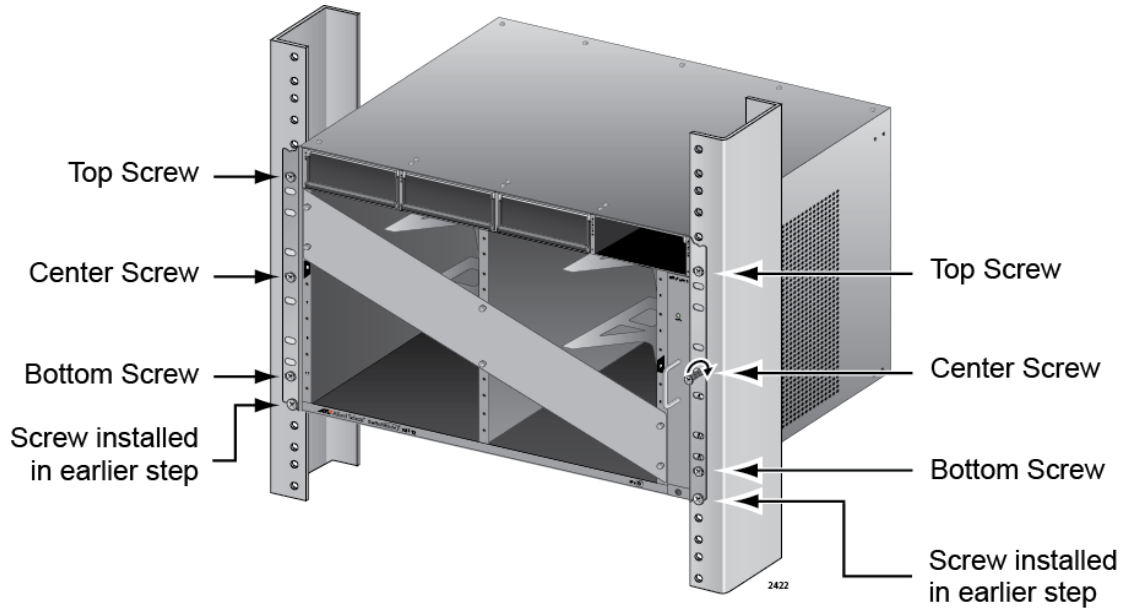

Figure 38. Installing the Rack Mount Screws

5. Tighten all eight screws to secure the chassis to the equipment rack, Allied Telesis recommends tightening the screws to 10 inch-lbs.
6. Go to “Removing the Shipping Brace” on page 103.

## Removing the Shipping Brace

Now that the chassis is installed in the equipment rack, you may remove the shipping brace from the front of the unit. To remove the shipping brace, remove the six mounting screws with a #2 Phillips-head screwdriver (not provided). Refer to Figure 39.

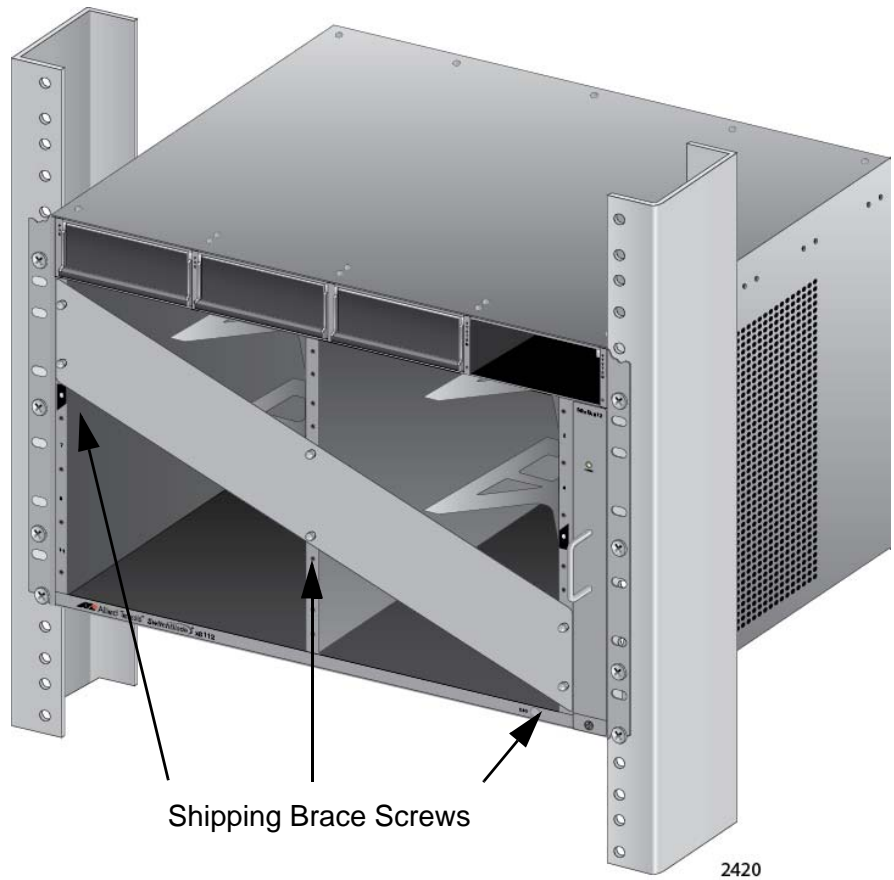

Figure 39. Removing the Shipping Brace

After removing the shipping plate, go to “Installing the Chassis Grounding Wire” on page 104.

## Installing the Chassis Grounding Wire

---

This procedure explains how to connect a grounding wire to the chassis. The chassis requires a permanent connection for the line cards and power supplies to a good earth ground. The procedure requires the following items:

- ❑ Grounding lug (pre-installed on the rear panel of the chassis)
- ❑ #2 Phillips-head screwdriver (not provided)
- ❑ Crimping tool (not provided)
- ❑ 10 AWG stranded grounding wire (not provided)
- ❑ #2 Phillips-head, 20 inch-lbs torque screwdriver (optional — not provided)

To connect the chassis to an earth ground, perform the following procedure:

1. Prepare an adequate length of stranded grounding wire (10 AWG) for the ground connection by stripping it as shown in Figure 40.

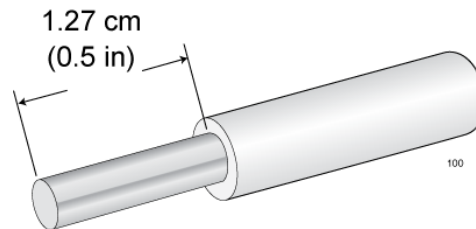

Figure 40. Stripping the Grounding Wire

2. Remove the two screws that secure the grounding lug to the rear panel of the chassis, as shown in Figure 41.

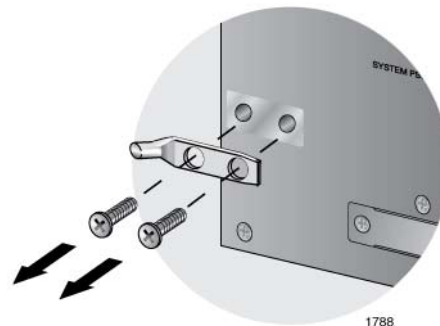

Figure 41. Removing the Grounding Lug



3. Insert one end of the grounding wire into the grounding lug, as shown in Figure 42, and use a crimping tool to secure the wire to the grounding lug.

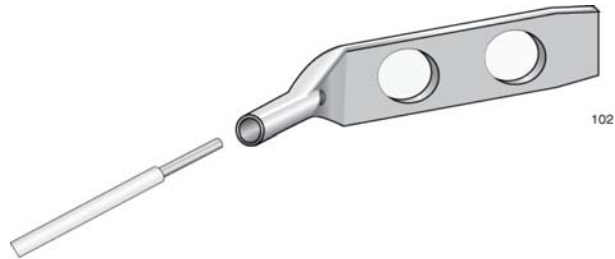

Figure 42. Attaching the Grounding Wire to the Grounding Lug

4. Install the grounding lug on the rear panel of the chassis, as shown in Figure 43.

Allied Telesis recommends tightening the screws to 20 inch-lbs.

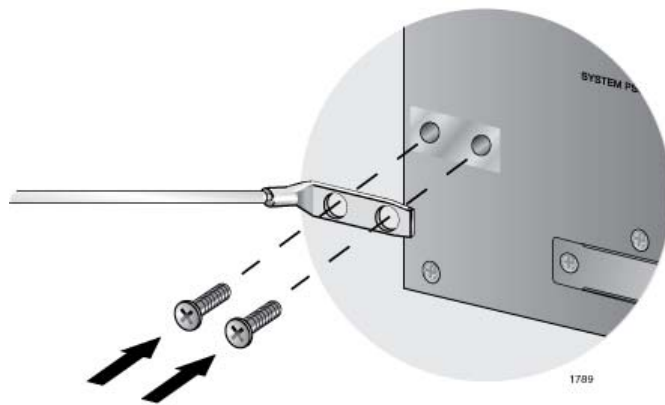

Figure 43. Installing the Grounding Lug and Wire

5. Connect the other end of the grounding wire to the building protective earth.
6. Go to Chapter 6, "Installing the Power Supplies" on page 107.



## Chapter 6

# Installing the Power Supplies

---

This chapter explains how to install the power supplies. It has the following sections:

- ❑ “Protecting Against Electrostatic Discharge (ESD)” on page 108
- ❑ “Installing AT-SBxPWRSYS1 or AT-SBxPWRSYS2 AC System Power Supplies” on page 109
- ❑ “Installing AT-SBxPWRPOE1 PoE Power Supplies” on page 115
- ❑ “Installing AT-SBxPWRSYS1 DC System Power Supplies” on page 120

## Protecting Against Electrostatic Discharge (ESD)

---

To protect the equipment from damage by Electrostatic Discharge (ESD) during the installation procedure, observe proper ESD protection when handling the SwitchBlade x8112 line cards and power supplies. You should be properly grounded with a wrist or foot strap.



### Caution

Electrostatic Discharge (ESD) can damage the components on the SwitchBlade x8112 line cards and power supplies. Be sure to follow proper ESD procedures during the installation.

---

To guard against ESD, perform this procedure:

1. Verify that the chassis is electrically connected to earth ground.
2. Connect the wrist strap that comes with the chassis to the ESD socket in the bottom right corner of the AT-SBx8112 Chassis, shown in Figure 44. This ensures that ESD voltages safely flow to ground.

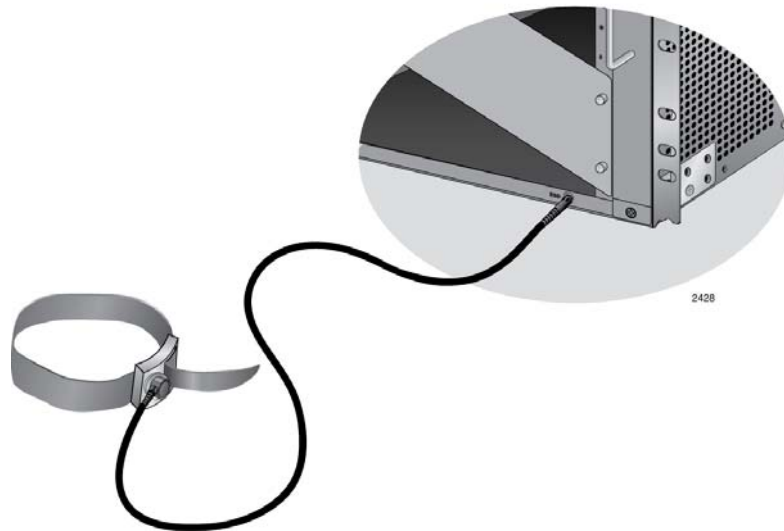

Figure 44. ESD Socket and Wrist Strap

3. When you put on the ESD-preventive wrist strap, be sure it makes good contact with your skin.

## Installing AT-SBxPWRSYS1 or AT-SBxPWRSYS2 AC System Power Supplies

---

The chassis must have at least one system power supply. For background information, refer to “Power Supplies and Power Supply Slots” on page 24.



---

### Caution

The electronic components in the power supply can be damaged by electro-static discharges (ESD). Follow the procedure in “Protecting Against Electrostatic Discharge (ESD)” on page 108 to guard against ESD damage when unpacking and installing the power supply.

---



---

### Caution

The following procedure assumes that this is the initial installation of the chassis and that the chassis is powered off. However, if you are installing a new AT-SBxPWRSYS2 Power Supply in an active, operational chassis, you should connect the AC power cord to the appropriate connector on the back panel of the unit before installing the power supply. Otherwise, the active master controller card might restart its operating system when you install the power supply. This can result in a temporary interruption of network operations of the chassis if it has only one controller card. This guideline does not apply to the AT-SBxPWRSYS1 AC or DC Power Supply or the AT-SBxPWRPOE1 Power Supply.

---

To install AT-SBxPWRSYS1 or AT-SBxPWRSYS2 AC System Power Supplies, perform the following procedure:

1. Choose a slot in the chassis for the system power supply.

System power supplies are installed in slots C and D in the chassis. Refer to Figure 45 on page 110. If you are installing only one power supply, you may install it in either slot, but Allied Telesis recommends slot D because the slot does not come with a blank power supply panel.

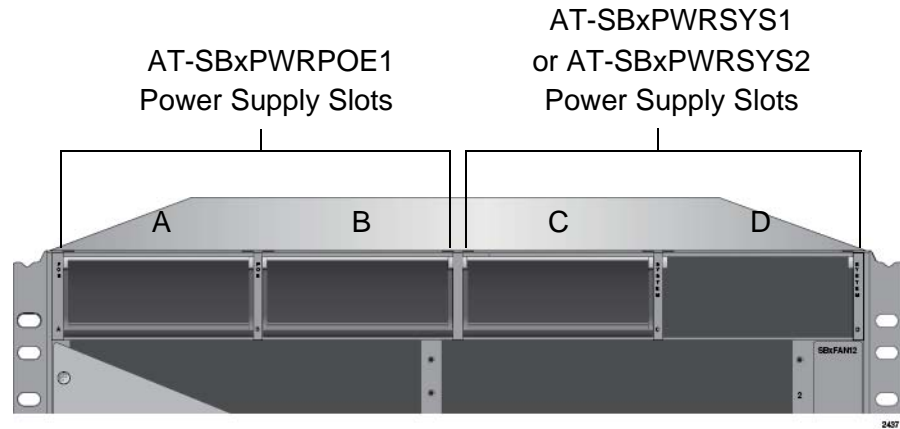

Figure 45. Power Supply Slots



**Caution**

The AT-SBxPWRSYS1 and AT-SBxPWRSYS2 AC System Power Supplies will not work in slot A or B.

2. If the chassis already has a power supply in slot D, remove the blank power supply panel from slot C by lifting the blank panel handle and sliding it out of the slot, as shown in Figure 46.



Figure 46. Removing the Blank Slot Cover from Power Supply Slot C

3. Remove the new power supply from the shipping package and verify the package contents, listed in Figure 47.

If any item is missing or damaged, contact your Allied Telesis sales representative for assistance.



One AT-SBxPWRSYS1 or AT-SBxPWRSYS2 AC System Power Supply



One regional AC power cord



One tie wrap

Figure 47. Items Included with the AT-SBxPWRSYS1 or AT-SBxPWRSYS2 AC System Power Supply

---

**Note**

Store the packaging material in a safe location. You must use the original shipping material if you need to return the unit to Allied Telesis.

---

---

**Note**

The tie wrap is used to secure the power cord to the chassis in “Powering On AT-SBxPWRSYS1 or AT-SBxPWRSYS2 AC System Power Supplies” on page 173.

---

4. Move the locking handle on the power supply to the unlocked or up position. See Figure 48.



Figure 48. Unlocking the Handle on the Power Supply

5. Align and insert the power supply into the power supply slot. Figure 49 shows the power supply installed in slot D.

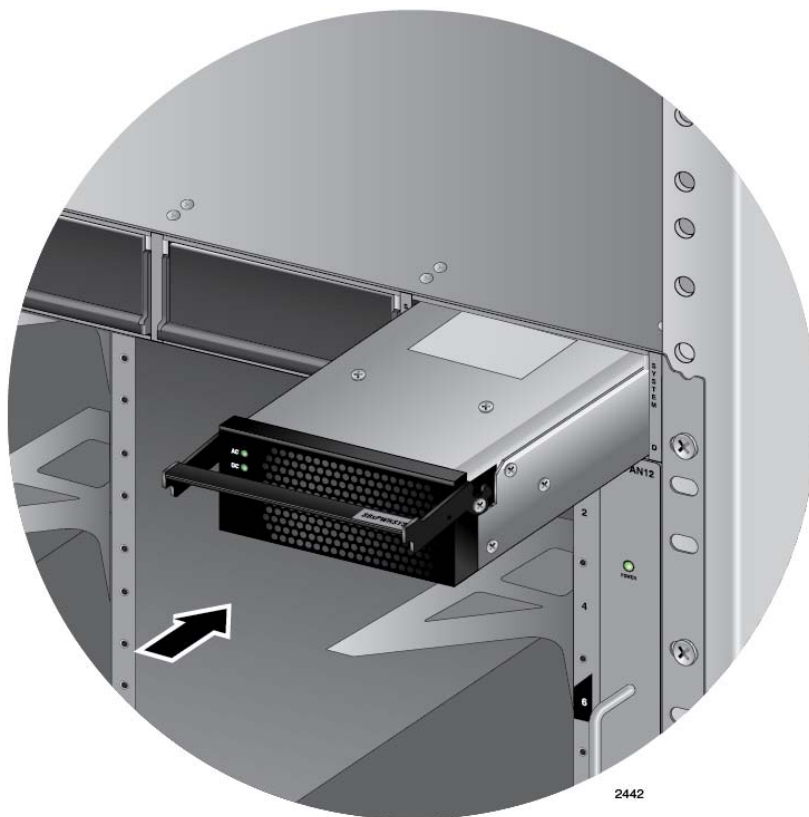

Figure 49. Inserting the AT-SBxPWRSYS1 or AT-SBxPWRSYS2 AC System Power Supply



6. Lower the power supply locking handle to secure the power supply to the chassis, as shown in Figure 50.



Figure 50. Lowering the Handle on the AT-SBxPWRSYS1 or AT-SBxPWRSYS2 AC System Power Supply

---

**Note**

If the module does not fully seat in the chassis slot, check to be sure you are installing a system power supply and not a PoE power supply. The model name of the module is included on a label on the locking handle. For more information, refer to “Power Supplies and Power Supply Slots” on page 24.

---

7. To install a second system power supply, repeat this procedure.
8. After installing the AT-SBxPWRSYS1 or AT-SBxPWRSYS2 AC System Power Supplies, do one of the following:
  - If you purchased the AT-SBxPWRPOE1 Power Supply for the ports on the AT-SBx81GP24 PoE Line Cards, go to “Installing AT-SBxPWRPOE1 PoE Power Supplies” on page 115.
  - Otherwise, go to Chapter 7, “Installing the AT-SBx81CF400 Control Card and Ethernet Line Cards” on page 127.

---

**Note**

Retain the tie wrap that comes with the power supply. You will use it to secure the power cord to the chassis when you power on the unit in “Powering On AT-SBxPWRSYS1 or AT-SBxPWRSYS2 AC System Power Supplies” on page 173.

---

## Installing AT-SBxPWRPOE1 PoE Power Supplies

---

This section contains the installation procedure for the AT-SBxPWRPOE1 Power Supply, for the PoE+ ports on the AT-SBx81GP24 PoE Line Card. For background information, refer to “Power Supplies and Power Supply Slots” on page 24.



---

**Caution**

The electronic components in the power supply can be damaged by electro-static discharges (ESD). Follow the procedure in “Protecting Against Electrostatic Discharge (ESD)” on page 108 to guard against ESD damage when unpacking and installing the power supply.

---

To install the power supply, perform the following procedure:

1. Choose a slot for the AT-AT-SBxPWRPOE1 System Power Supply in the chassis.

You may install it in either slot A or B, shown in Figure 45 on page 110.

2. Raise the handle on the blank panel covering the selected slot and slide the panel from the chassis. Figure 51 on page 116 illustrates the removal of the blank panel from slot A.

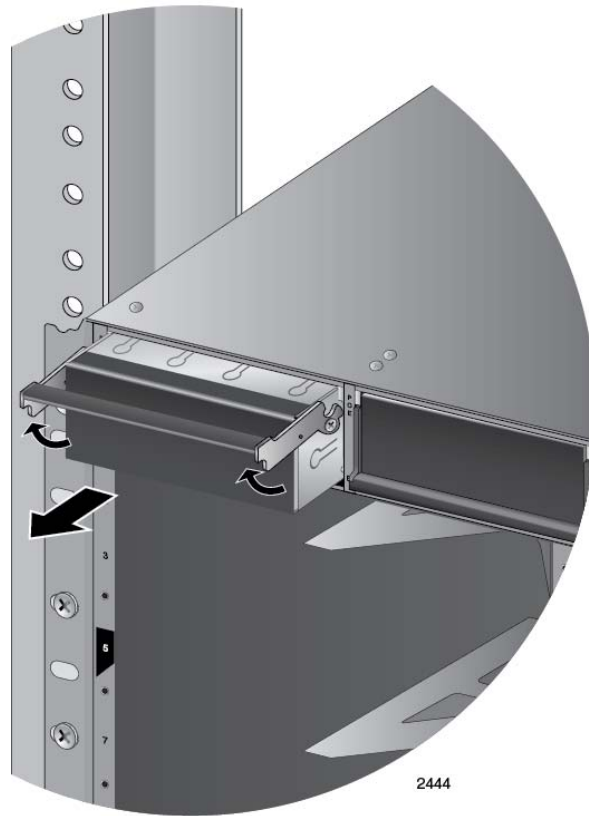

Figure 51. Removing the Blank Slot Cover from Power Supply Slot A

3. Remove the power supply from the shipping package and verify that the shipping package contains the items listed in Figure 52 on page 117.

If any item is missing or damaged, contact your Allied Telesis sales representative for assistance.



One AT-SBxPWRPOE1  
Power Supply Module



One regional AC power cord

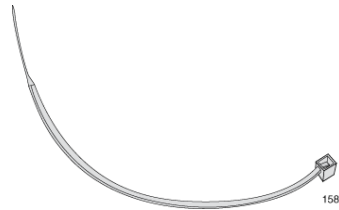

One tie wrap

Figure 52. Items Included with the AT-SBxPWRPOE1 Power Supply Module

---

**Note**

Store the packaging material in a safe location. You must use the original shipping material if you need to return the unit to Allied Telesis.

---

---

**Note**

The tie wrap is used to secure the power cord to the chassis in “Powering On AT-SBxPWRPOE1 Power Supplies” on page 177.

---

4. Raise the locking handle on the AT-SBxPWRPOE1 Power Supply, as shown Figure 53 on page 118.

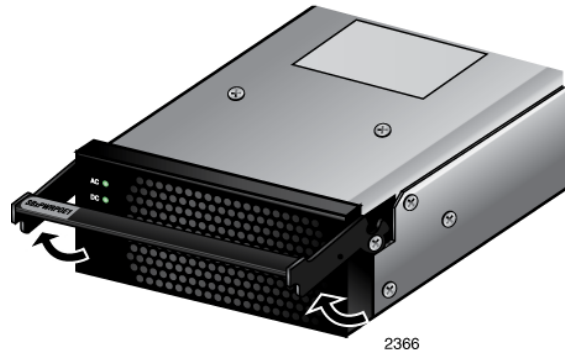

Figure 53. Unlocking the Handle on the AT-SBxPWRPOE1 Power Supply

5. Align and insert the AT-SBxPWRPOE1 Module into slot A or B. Figure 54 shows the power supply module aligned in slot A.



**Caution**

The AT-SBxPWRPOE1 AC Power Supply will not work in slot C or D.

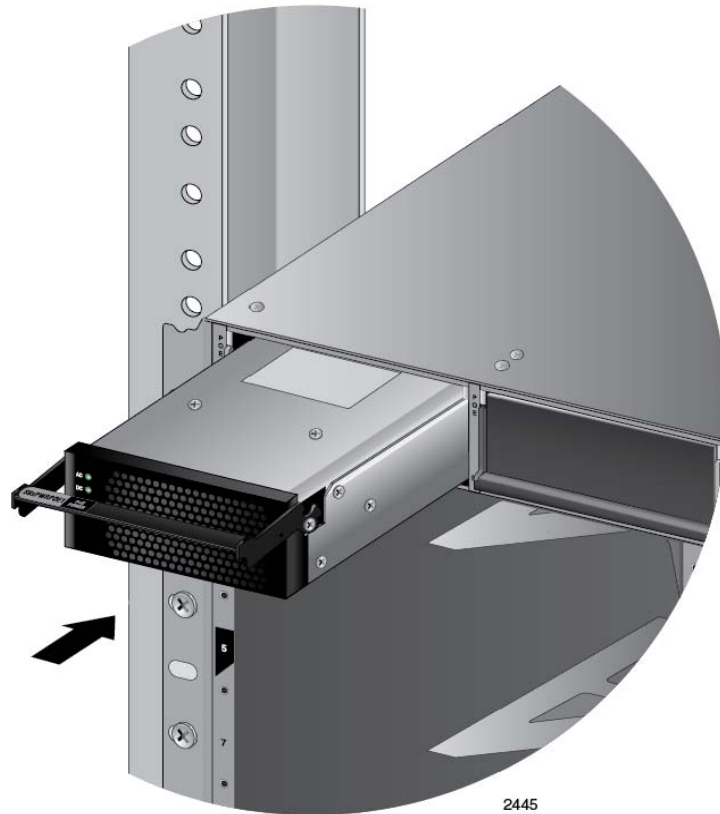

Figure 54. Inserting the AT-SBxPWRPOE1 Power Supply

6. Lower the locking handle of the power supply module to secure the module in the slot, as shown in Figure 55.



Figure 55. Locking the Handle on the AT-SBxPWRPOE1 Power Supply

---

**Note**

If the module does not fully seat in the chassis slot, check to be sure you are installing a PoE power supply and not a system power supply. The model name of the module is included on a label on the locking handle. For more information, refer to “Power Supplies and Power Supply Slots” on page 24.

---

7. To install a second AT-SBxPWRPOE1 Power Supply, repeat this procedure.
8. After installing the AT-SBxPWRPOE1 Power Supplies, go to Chapter 7, “Installing the AT-SBx81CF400 Control Card and Ethernet Line Cards” on page 127.

---

**Note**

Retain the tie wrap that comes with the power supply. You use it to secure the power cord to the chassis when you power on the unit in “Powering On AT-SBxPWRPOE1 Power Supplies” on page 177.

---

## Installing AT-SBxPWRSYS1 DC System Power Supplies

---

This section contains the installation procedure for AT-SBxPWRSYS1 DC System Power Supplies. For background information, refer to “Power Supplies and Power Supply Slots” on page 24.



### Caution

The electronic components in the power supply can be damaged by electro-static discharges (ESD). Follow the procedure in “Protecting Against Electrostatic Discharge (ESD)” on page 108 to guard against ESD damage when unpacking and installing the power supply.

---

To install the power supply, perform the following procedure:

1. Choose a slot in the chassis for the AT-AT-SBxPWRSYS1 DC System Power Supply.

System power supplies are installed in slots C and D in the chassis. Refer to Figure 45 on page 110. If you are installing only one power supply, you may install it in either slot, but Allied Telesis recommends slot D because the slot does not come with a blank power supply panel.



### Caution

The AT-SBxPWRSYS1 DC System Power Supply will not work in slot A or B.

---

2. If the chassis already has a power supply in slot D, remove the blank power supply panel from slot C by lifting the blank panel handle and sliding it out of the slot, as shown in Figure 56 on page 121.



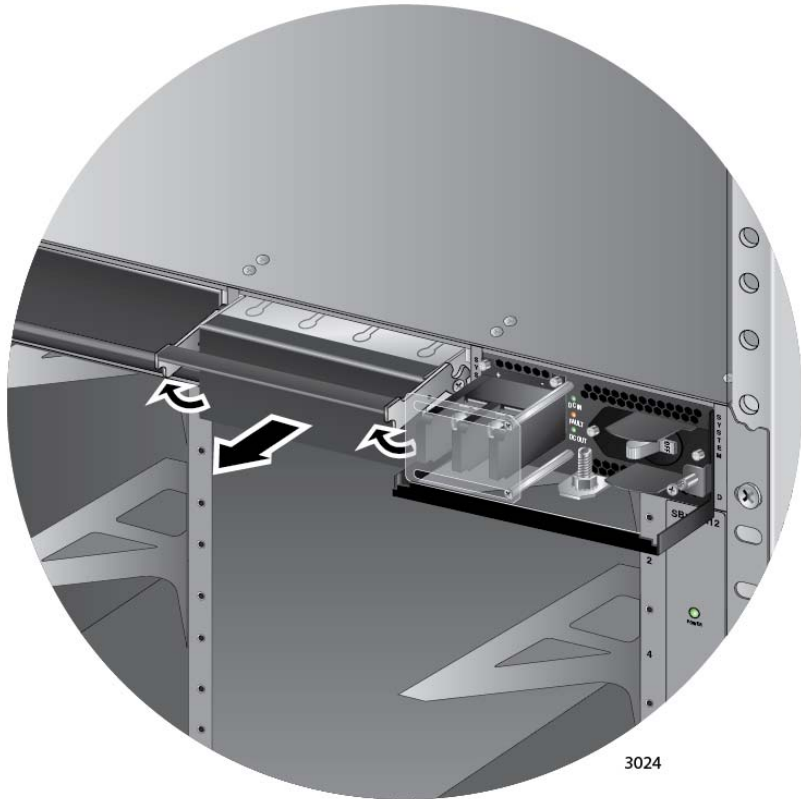
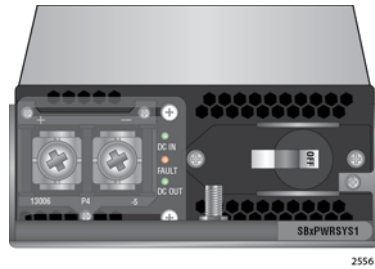

Figure 56. Removing the Blank Slot Cover from Power Supply Slot C

3. Remove the power supply from the shipping package and verify that the shipping package contains the items listed in Figure 57 on page 122.

If any item is missing or damaged, contact your Allied Telesis sales representative for assistance.



One AT-SBxPWRSYS1 DC System Power Supply



Two straight power wire ring lugs



One grounding wire ring lug



Two right angle power wire ring lugs

Figure 57. Items Included with the AT-SBxPWRSYS1 DC Power Supply Module

---

**Note**

Store the packaging material in a safe location. You must use the original shipping material if you need to return the unit to Allied Telesis.

---

4. Verify that the On/Off switch on the power supply is in the Off position. Refer to Figure 58 on page 123.

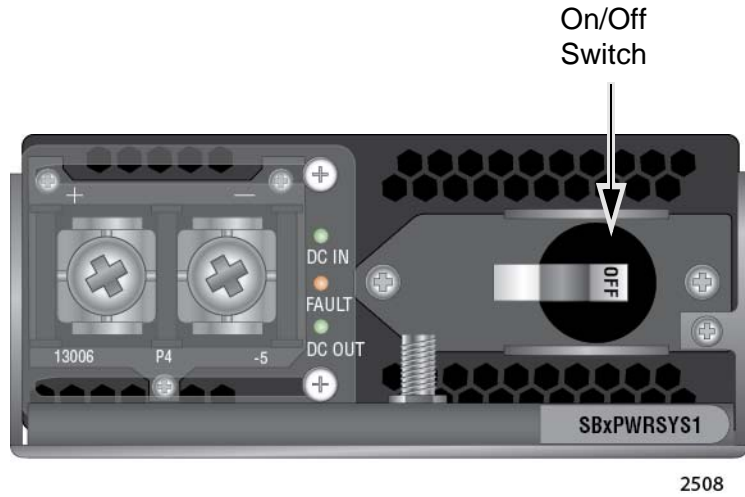

Figure 58. On/Off Switch on the AT-SBxPWRSYS1 DC Power Supply

5. With a #2 Phillips-head screwdriver, loosen the handle locking screw on the power supply, as shown in Figure 59.

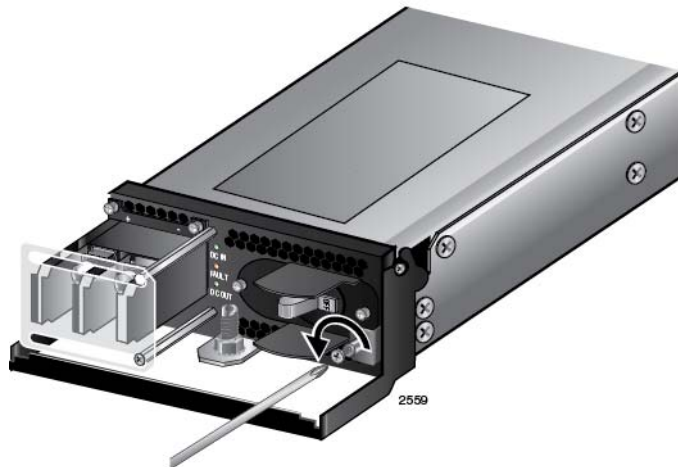

Figure 59. Loosening the Handle locking Screw on the AT-SBxPWRSYS1 DC System Power Supply

6. Raise the locking handle on the power supply, as shown Figure 60 on page 124.



Figure 60. Raising Handle on the AT-SBxPWRSYS1 DC Power Supply

7. Align and insert the AT-SBxPWRSYS1 Module into slot C or D. Figure 61 shows the power supply installed in slot D.



**Caution**

The AT-SBxPWRSYS1 DC System Power Supply will not work in slot A or B.

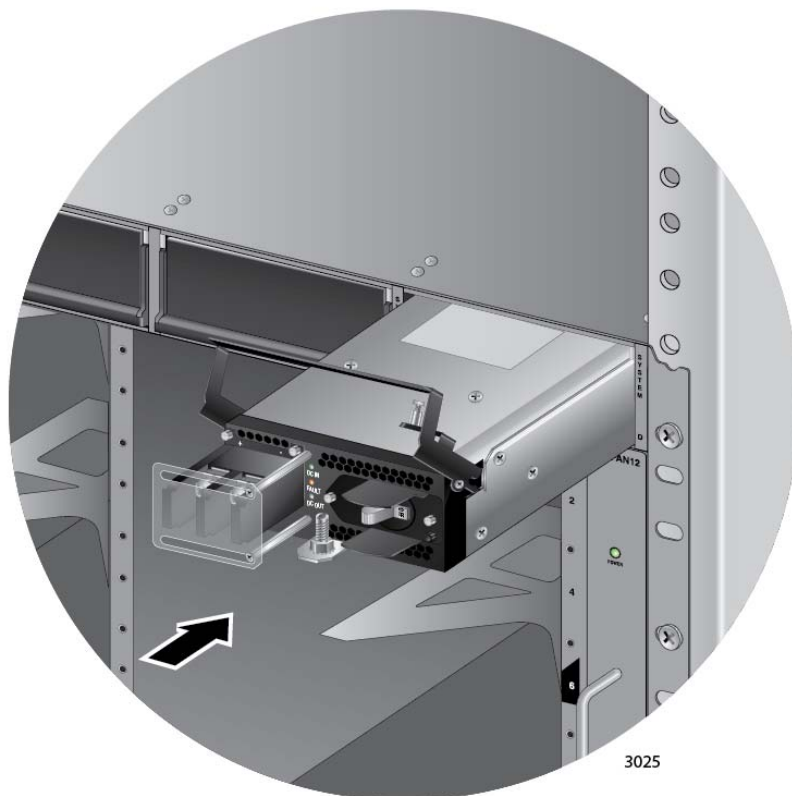

Figure 61. Inserting the AT-SBxPWRSYS1 DC System Power Supply

8. Lower the locking handle of the power supply module to secure the module in the slot, as shown in Figure 62.

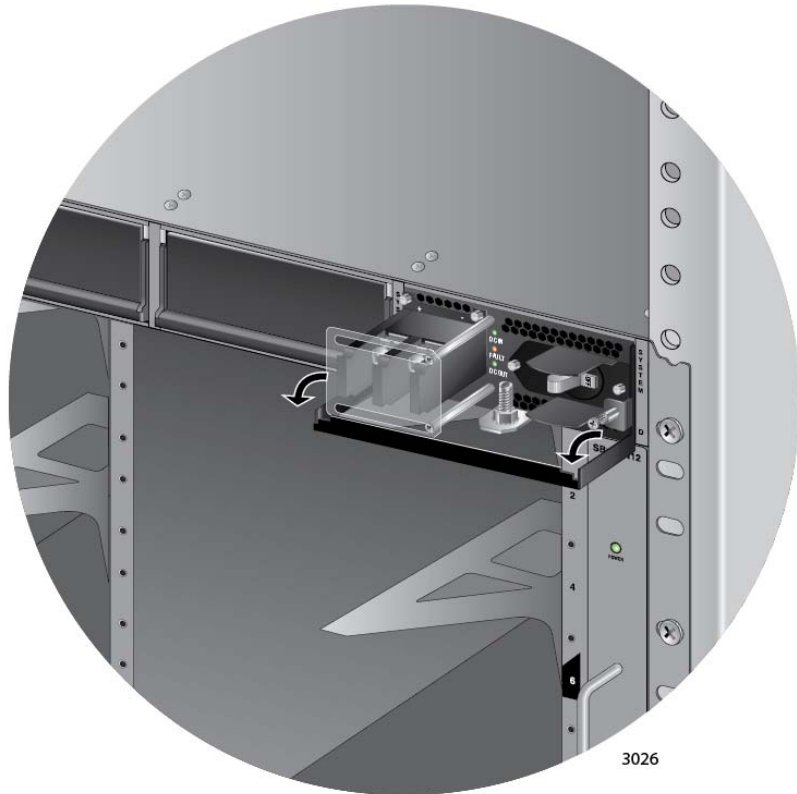

Figure 62. Locking the Handle on the AT-SBxPWRSYS1 DC System Power Supply

---

**Note**

Do not tighten the handle locking screw yet. You may need to slightly lift the handle to move the plastic guard panel when you connect the positive and negative wires in “Powering On the AT-SBxPWRSYS1 DC System Power Supply” on page 180.

---

9. To install a second AT-SBxPWRSYS1 DC System Power Supply, repeat this procedure.
10. After installing the power supplies, go to Chapter 7, “Installing the AT-SBx81CF400 Control Card and Ethernet Line Cards” on page 127.

---

**Note**

Retain the five wire ring lugs that come with the power supply. You use them to wire the power supply in “Powering On the AT-SBxPWRSYS1 DC System Power Supply” on page 180.

---



## Chapter 7

# Installing the AT-SBx81CF400 Control Card and Ethernet Line Cards

---

This chapter describes how to install the controller fabric card and Ethernet line cards. The chapter has the following sections:

- ❑ “Guidelines to Handling the Controller and Line Cards” on page 128
- ❑ “Installing the AT-SBx81CF400 Controller Fabric Card” on page 130
- ❑ “Installing Expansion Modules in AT-SBx81XLEM Ethernet Line Cards” on page 136
- ❑ “Installing the Ethernet Line Cards” on page 144
- ❑ “Installing the Blank Slot Covers” on page 149

## Guidelines to Handling the Controller and Line Cards

---

Please observe the following guidelines when handling the controller and Ethernet line cards:

- The cards are hot swappable and can be installed or removed while the chassis is powered on.



### Warning

The expansion modules for the AT-SBx81XLEM Line Card are not hot swappable. You must remove the line card from the chassis before installing or removing an expansion module.

---

- Always wear an anti-static device when handling the cards.



### Caution

The electronic components on the controller and line cards can be damaged by electro-static discharges (ESD). Follow the procedure in “Protecting Against Electrostatic Discharge (ESD)” on page 108 to guard against ESD damage when unpacking and installing the line cards.

---

- Hold a card by its faceplate and edges.
- Never touch the electronic components on the top or bottom of a card.
- To avoid damaging the components on the bottom of a card, do not set it down on a table or desk. If you need to set down a card, return it to its anti-static bag and packaging container.
- Do not remove a card from its anti-static bag until you are ready to install it in the chassis.
- If you need to remove a card from the chassis, immediately return it in its anti-static bag and packaging container.
- Never hold or lift a controller card by the handles on the front faceplate. You might bend or damage the handles.



### Caution

You must keep a controller or Ethernet line card level as you slide it into or out of the chassis. You might damage the components on the top or bottom of a card if you slide it at an angle. Refer to Figure 63 on page 129.

---



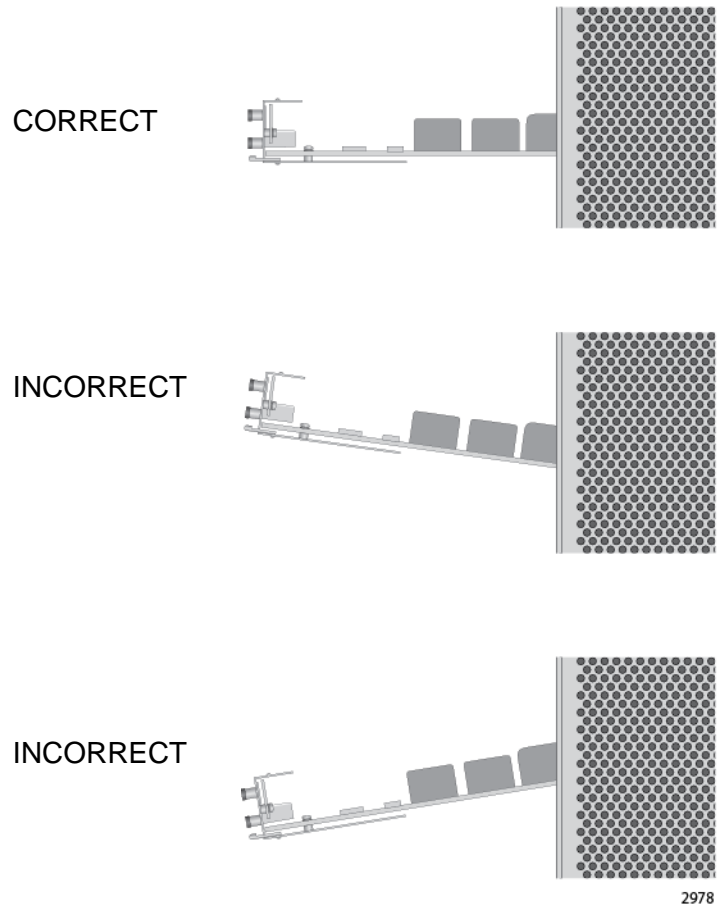

Figure 63. Aligning a Card in a Slot

## Installing the AT-SBx81CF400 Controller Fabric Card

---

This section contains the installation procedure for the AT-SBx81CF400 Controller Fabric Card. You may install either one or two controller cards in the unit. The chassis must have at least one controller card. The cards must be installed in slots 5 and 6 in the chassis.

---

### Note

Please review “Guidelines to Handling the Controller and Line Cards” on page 128 before performing this procedure.

---

This procedure requires the following tools:

- ❑ #2 Phillips-head screwdriver (not provided)
- ❑ #2 Phillips-head, 5 inch-lbs torque screwdriver (optional — not provided))

To install the AT-SBx81CF400 Card, perform the following procedure:

1. Choose a slot in the chassis for the AT-SBx81CF400 Controller Fabric Card.

The card must be installed in slot 5 or 6, shown in Figure 64. If you are installing only one controller card, Allied Telesis recommends installing it in slot 5.

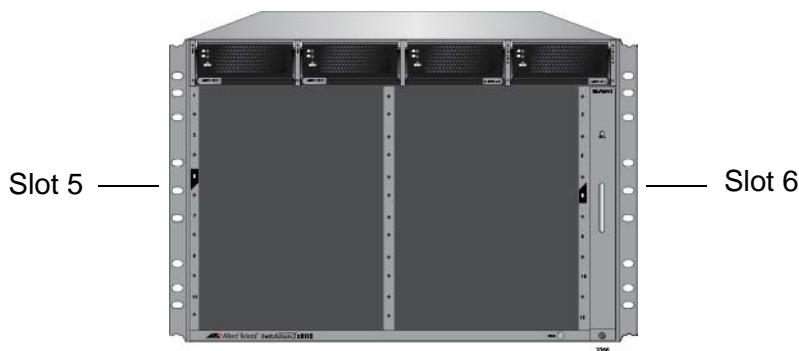

Figure 64. Slots 5 and 6 for the AT-SBx81CF400 Card

2. Remove the new AT-SBx81CF400 Controller Fabric Card from the shipping package and verify the package contents, listed in Figure 65 on page 131.

If any item is missing or damaged, contact your Allied Telesis sales representative for assistance.

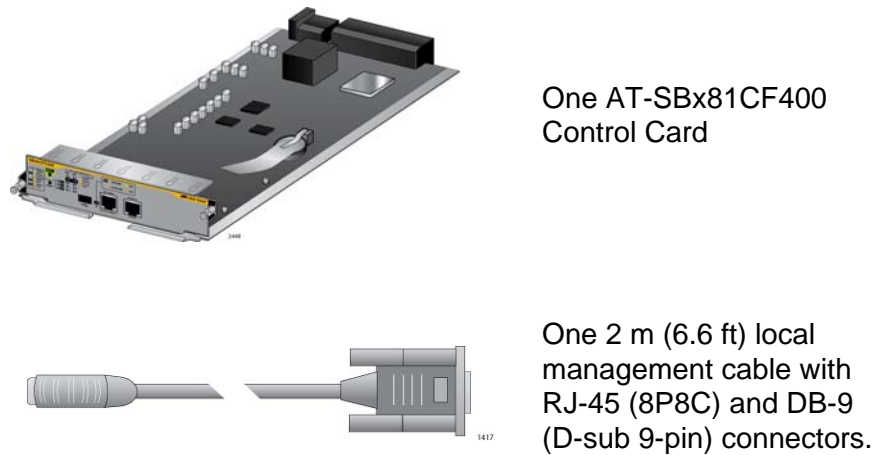

Figure 65. Items Included with the AT-SBx81CF400 Controller Card

---

**Note**

Store the packaging material in a safe location. You should use the original shipping material if you need to return the unit to Allied Telesis.

---

3. Carefully remove the controller card from the anti-static bag. Refer to Figure 66.



Figure 66. Removing the AT-SBx81CF400 Controller Fabric Card from the Anti-static Bag

4. Carefully remove the battery insulator tab on the controller card by sliding it out from between the battery and battery clip, as shown in Figure 67 on page 132.

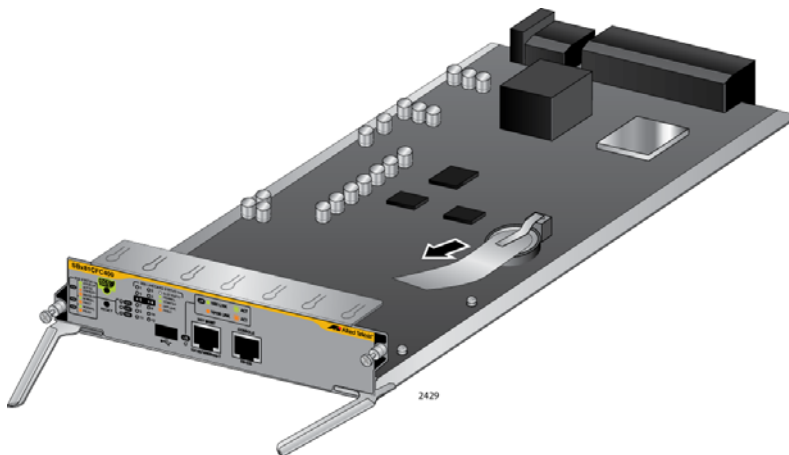

Figure 67. Removing the Battery Insulator

5. Move the locking handles on the front panel to the open position, as shown in Figure 68.

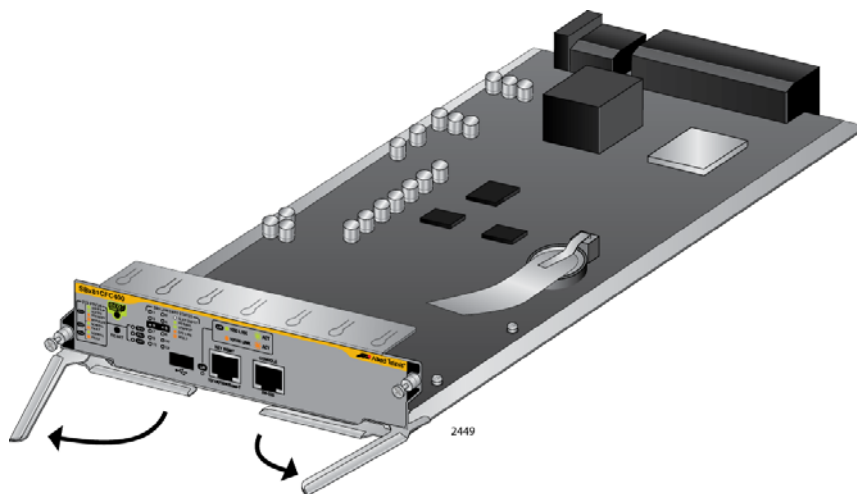

Figure 68. Opening the Locking Handles on the AT-SBx81CF400 Controller Fabric Card

6. Align the edges of the AT-SBx81CF400 Controller Fabric Card with the internal chassis card guides in slot 5 or 6 of the AT-SBx8112 Chassis. Figure 69 on page 133 shows the AT-SBx81CF400 Card aligned in slot 5.

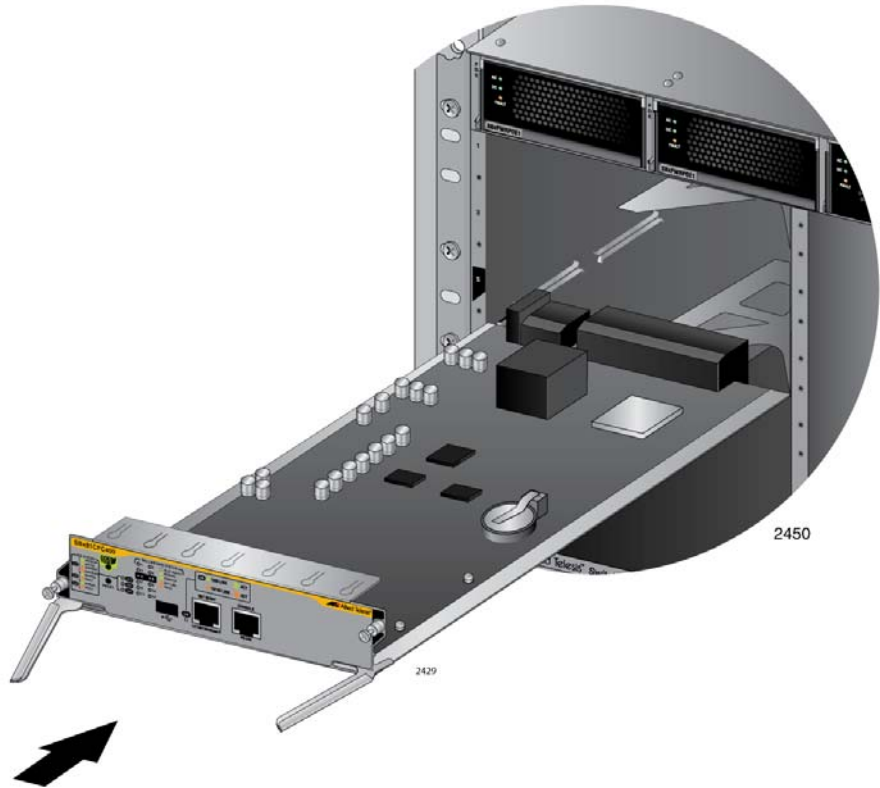

Figure 69. Aligning the AT-SBx81CF400 Card in the Chassis Slot

7. Carefully slide the card into the slot.



**Caution**

Keep the card level with the chassis as you slide it into the slot. You might damage the components on the top or bottom of the card if you slide it in at an angle. Refer to Figure 63 on page 129.



**Caution**

Do not force the AT-SBx81CF400 Card into the slot. If you feel resistance, remove it and try again. Be sure that the edges of the card are properly aligned with the card guides.

8. When you feel the card make contact with the connector on the backplane of the chassis, carefully close the two locking levers on the front panel of the controller card to secure it in the chassis, as shown in Figure 70 on page 134.



Figure 70. Closing the Locking Levers on the AT-SBx81CF400 Controller Fabric Card

9. Finger tighten the two thumbscrews on the card to secure the card to the chassis, as shown in Figure 71 on page 135.



Figure 71. Tightening the Thumb Screws on the AT-SBx81CF400 Card

10. Tighten the screws with a # 2 Phillips-head screwdriver to secure the controller card to the chassis.

Allied Telesis recommends tightening the screws to 5 inch-lbs.

11. if the chassis is to have two AT-SBx81CF400 Controller Fabric Cards, repeat this procedure to install the second card.
12. Go to “Installing the Ethernet Line Cards” on page 144.

## Installing Expansion Modules in AT-SBx81XLEM Ethernet Line Cards

---

This section contains the procedure for installing an expansion module in the AT-SBx81XLEM Ethernet Line Card. If you did not purchase AT-SBx81XLEM Ethernet Line Cards, skip this procedure and go to “Installing the Ethernet Line Cards” on page 144.



### Caution

You must install the expansion module before installing the AT-SBx81XLEM Ethernet Line Card in the chassis. Attempting to install the module when the line card is installed in the chassis will damage the module and card. If the card is already installed in the chassis, remove it by performing the procedure in “Replacing Ethernet Line Cards” on page 251.

---

### Note

Please review “Guidelines to Handling the Controller and Line Cards” on page 128 before performing this procedure.

---

The illustrations in the procedure show the AT-SBx81XLEM/XS8 Expansion Module. The procedure is the same for all expansion modules.

To install an expansion module in the AT-SBx81XLEM Ethernet Line Card, perform the following procedure:

1. Remove the AT-SBx81XLEM Ethernet Line Card from the shipping package. If it is missing or damaged, contact your Allied Telesis sales representative for assistance.

---

### Note

Store the packaging material in a safe location. You should use the original shipping material if you need to return the unit to Allied Telesis.

---

2. Carefully remove the card from the anti-static bag. Refer to Figure 72 on page 137.





Figure 72. Removing the AT-SBx81XLEM Line Card from the Anti-static Bag

3. Place the card on a level surface.
4. With a #2 Phillips-head screwdriver, remove the two screws that secure the blank slot cover to the card. Refer to Figure 73.

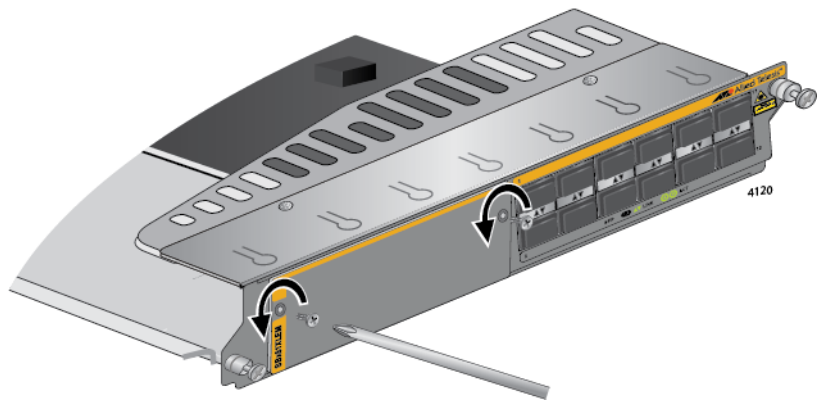

Figure 73. Removing the Screws on the Blank Slot Cover on the AT-SBx81XLEM Line Card

5. Slide the blank slot cover from the slot. Refer to Figure 74 on page 138.

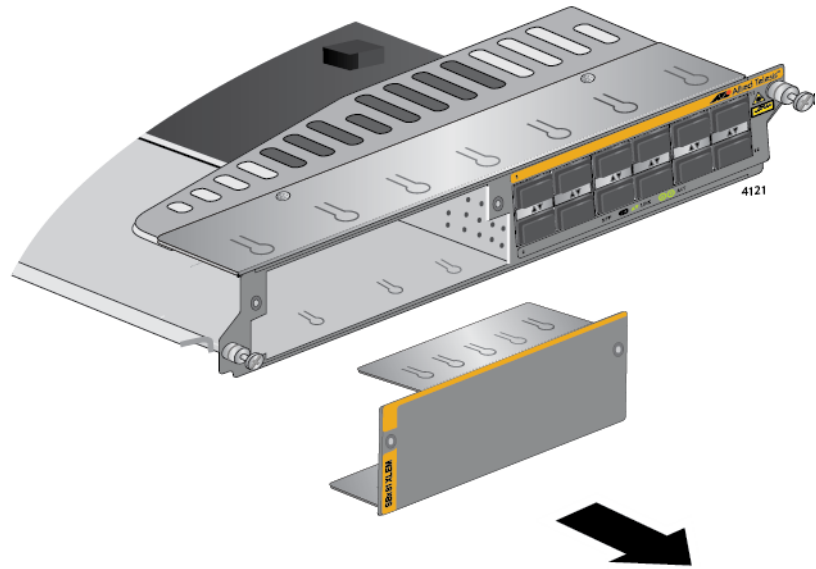

Figure 74. Removing the Blank Slot Cover from the AT-SBx81XLEM Line Card

6. With your thumb and forefinger, pull out the retaining pin on the side of the line card and turn it clockwise one quarter turn so that it remains in the retracted position. Refer to Figure 75 on page 139.

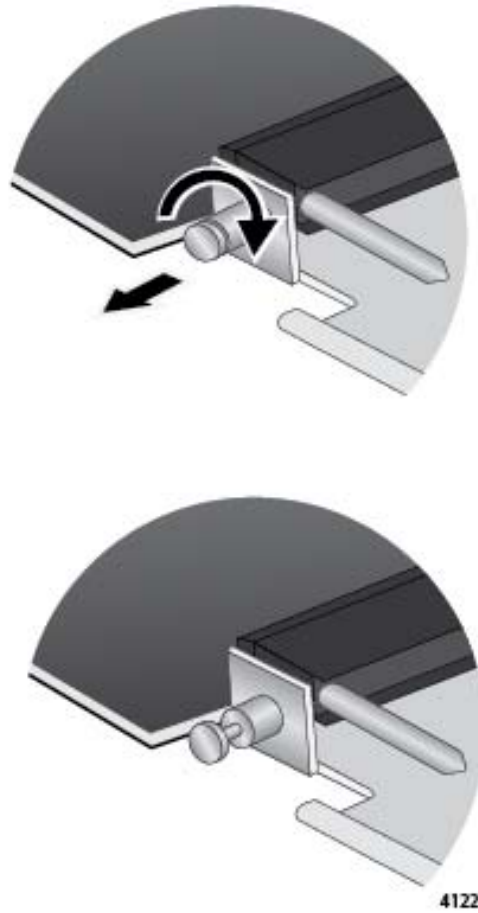

Figure 75. Retracting the Retaining Pin on the AT-SBx81XLEM Line Card

7. Remove the expansion module from its shipping container and anti-static bag. Refer to Figure 76.

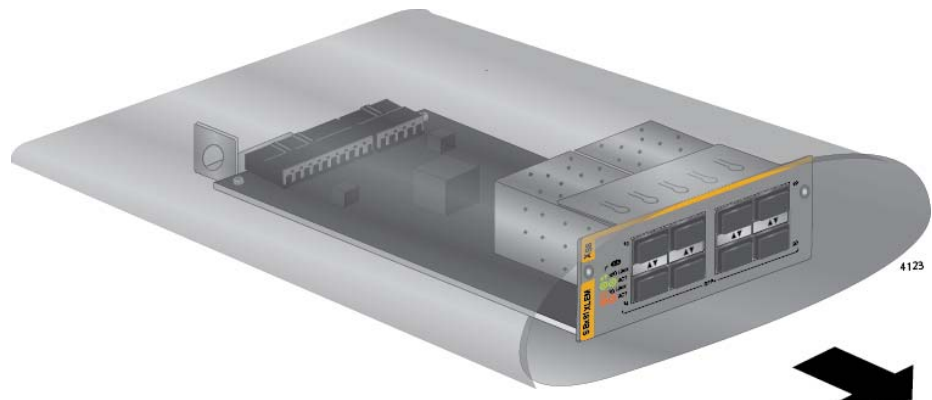

Figure 76. Removing the Expansion Module from the Anti-static Bag

- Carefully align the expansion module in the slot, as shown in Figure 77, and slide it into the line card.



**Caution**

Keep the module level with the line card as you slide it into the slot. You might damage the components on the top or bottom of the module if you slide it in at an angle. Refer to Figure 63 on page 129.



**Caution**

Do not force the card into the slot. If you feel resistance, remove the card and try again.

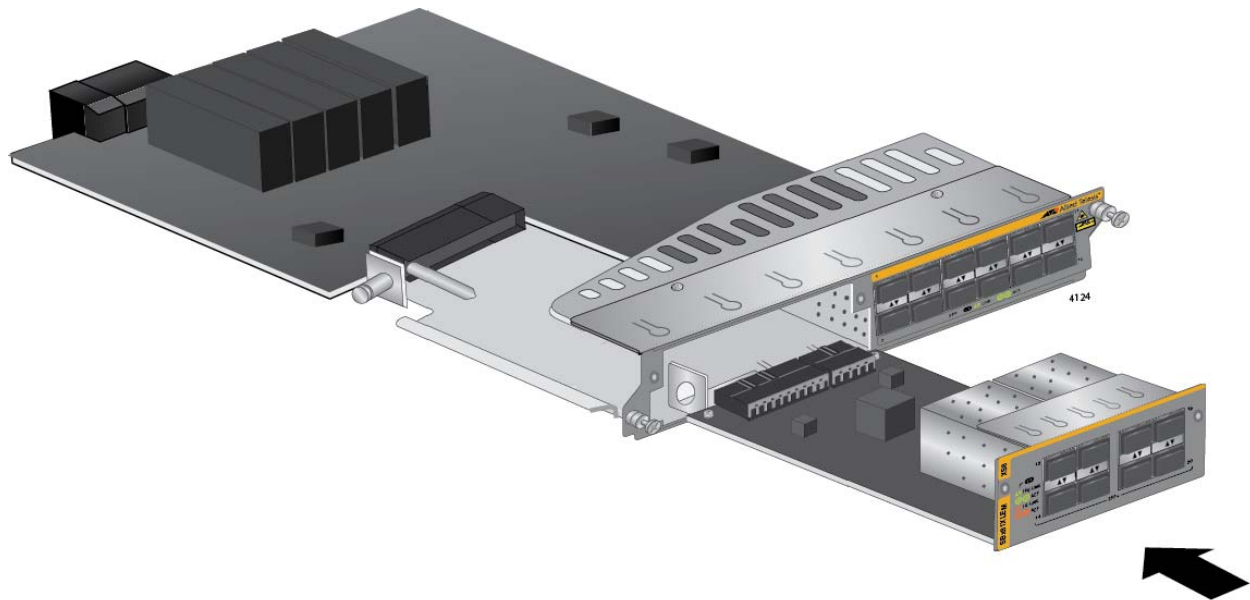

Figure 77. Sliding the Expansion Module into the AT-SBx81XLEM Line Card

- When the expansion module makes contact with the connector inside the line card, gently press on both sides of the faceplate to seat the module on the connector. Refer to Figure 78 on page 141. The module is fully installed when its faceplate is flush against the faceplate of the AT-SBx81XLEM Line Card.

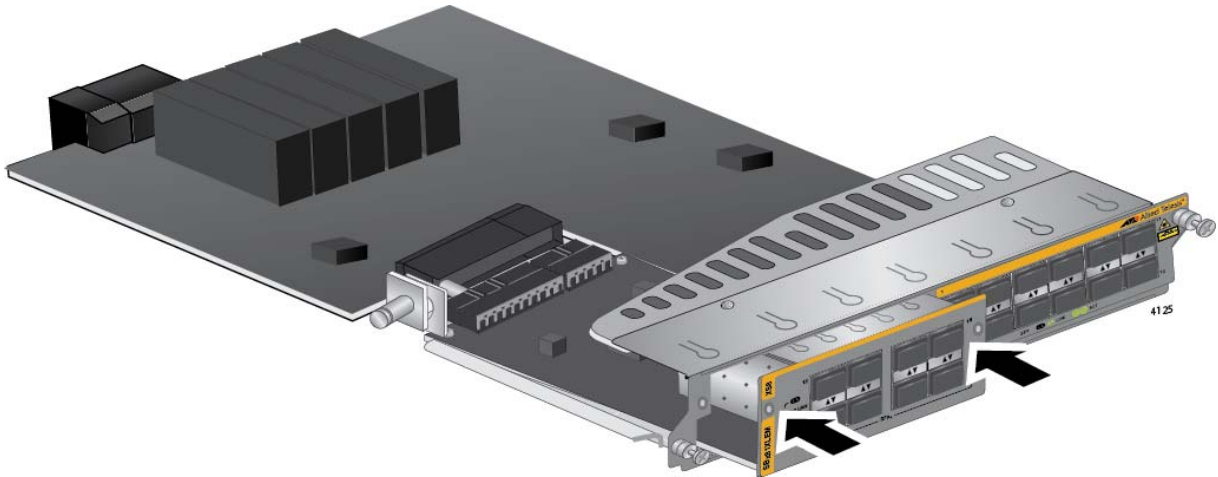

Figure 78. Seating the Expansion Module on the Connector in the AT-SBx81XLEM Line Card

10. With a Phillips-head screwdriver, install the two screws from step 4 to secure the expansion module to the line card. Refer to Figure 79.

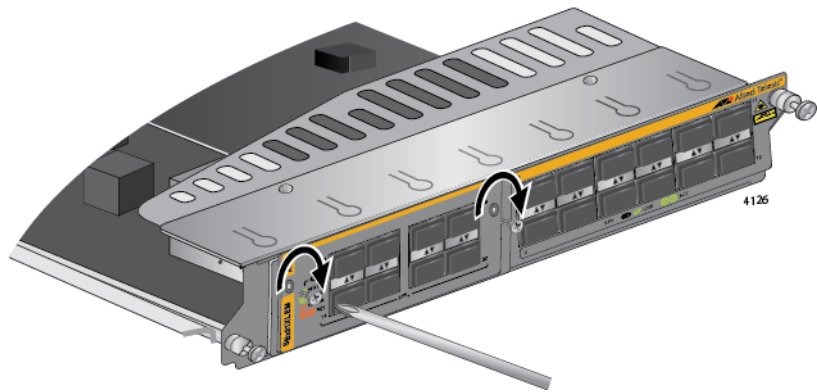

Figure 79. Securing the Expansion Module

11. Turn the retaining pin on the side of the line card one quarter turn to release it. Refer to Figure 80 on page 142.

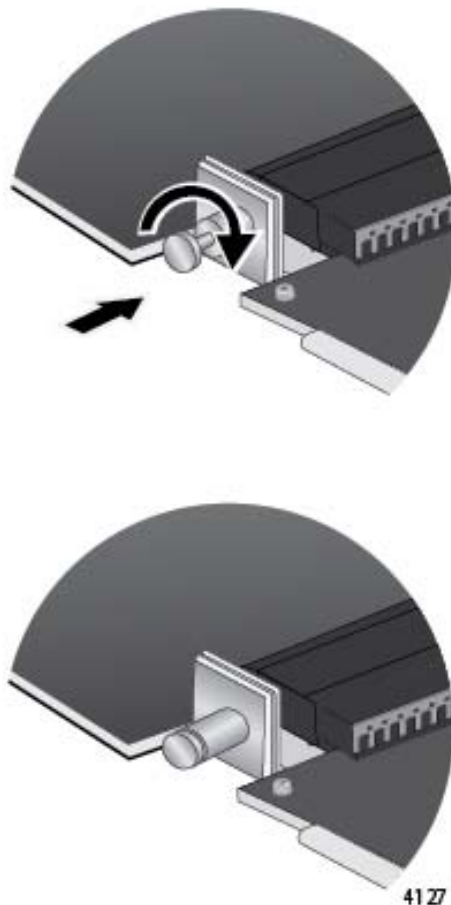

Figure 80. Releasing the Retaining Pin

12. Retain the blank slot cover removed in step 5 and shown in Figure 81 by storing it in a safe location. You should reinstall it on the AT-SBx81XLEM Line Card if, at a later date, you remove the expansion module.



Figure 81. Blank Slot Cover for the AT-SBx81XLEM Line Card

13. If you are not installing the line card in the chassis now, return it to its anti-static bag and shipping container to protect it from damage. Refer to Figure 82 on page 143.



Figure 82. Returning the Line Card to its Anti-static Bag

14. For instructions on how to install the line card in the chassis, go to “Installing the Ethernet Line Cards” on page 144.

## Installing the Ethernet Line Cards

---

This section contains the installation procedure for the Ethernet line cards. The illustrations show the AT-SBx81GP24 Line Card, but the procedure is the same for all the cards.

---

**Note**

Please review “Guidelines to Handling the Controller and Line Cards” on page 128 before performing this procedure.

---

This procedure requires the following tools:

- ❑ #2 Phillips-head screwdriver (not provided)
- ❑ #2 Phillips-head, 5 inch-lbs torque screwdriver (optional — not provided)

To install the Ethernet line cards, perform the following procedure:

1. Choose a slot in the chassis for the Ethernet line card. The Ethernet line cards can be installed in slots 1 to 4 and 7 to 12. The slots are shown in Figure 83.

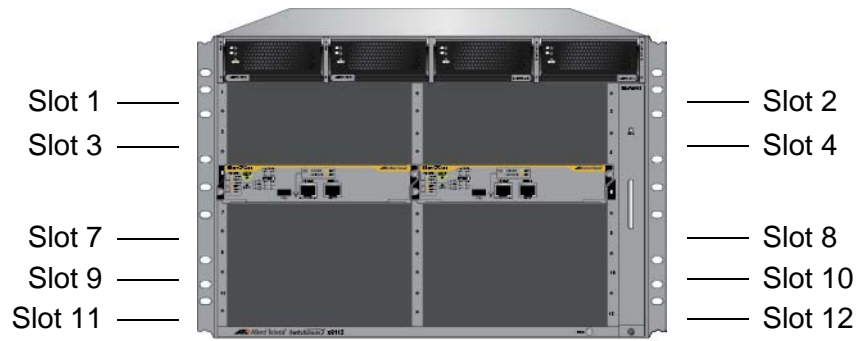

Figure 83. Slots 1 to 4 and 7 to 12 for the Ethernet Line Cards

2. If the selected slot for the line card is covered with a blank slot cover, use a #2 Phillips-head screwdriver to loosen the two captive screws on the cover and remove it from the chassis. Refer to Figure 84 on page 145.



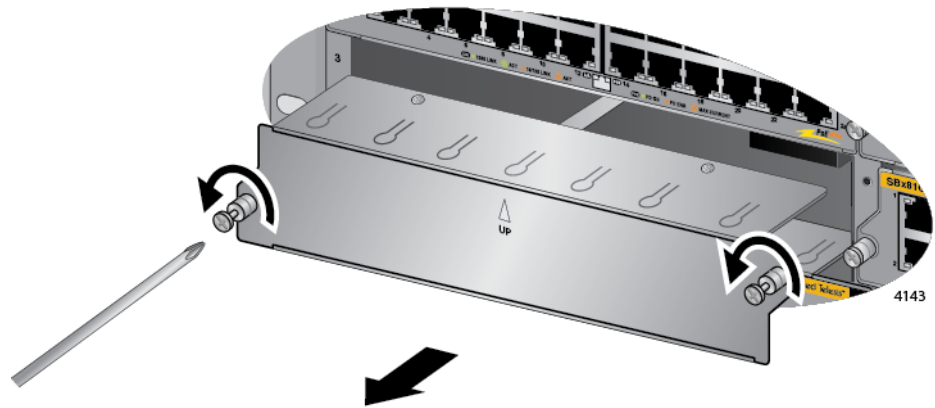

Figure 84. Removing a Blank Slot Cover

3. Remove the line card from the shipping package. If it is missing or damaged, contact your Allied Telesis sales representative for assistance.

---

**Note**

Store the packaging material in a safe location. You should use the original shipping material if you need to return the unit to Allied Telesis.

---

4. Carefully remove the Ethernet line card from the anti-static bag. Refer to Figure 85.

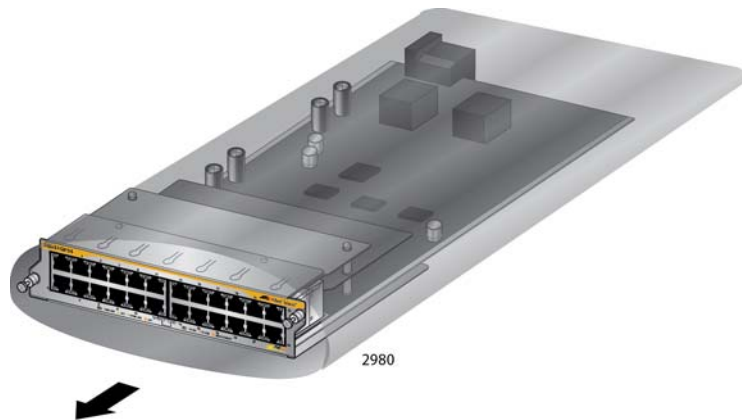

Figure 85. Removing an Ethernet Line Card from the Anti-static Bag

5. Align the line card with the internal chassis card guides in the selected slot in the chassis.

Figure 86 on page 146 shows an Ethernet line card aligned with slot 1.

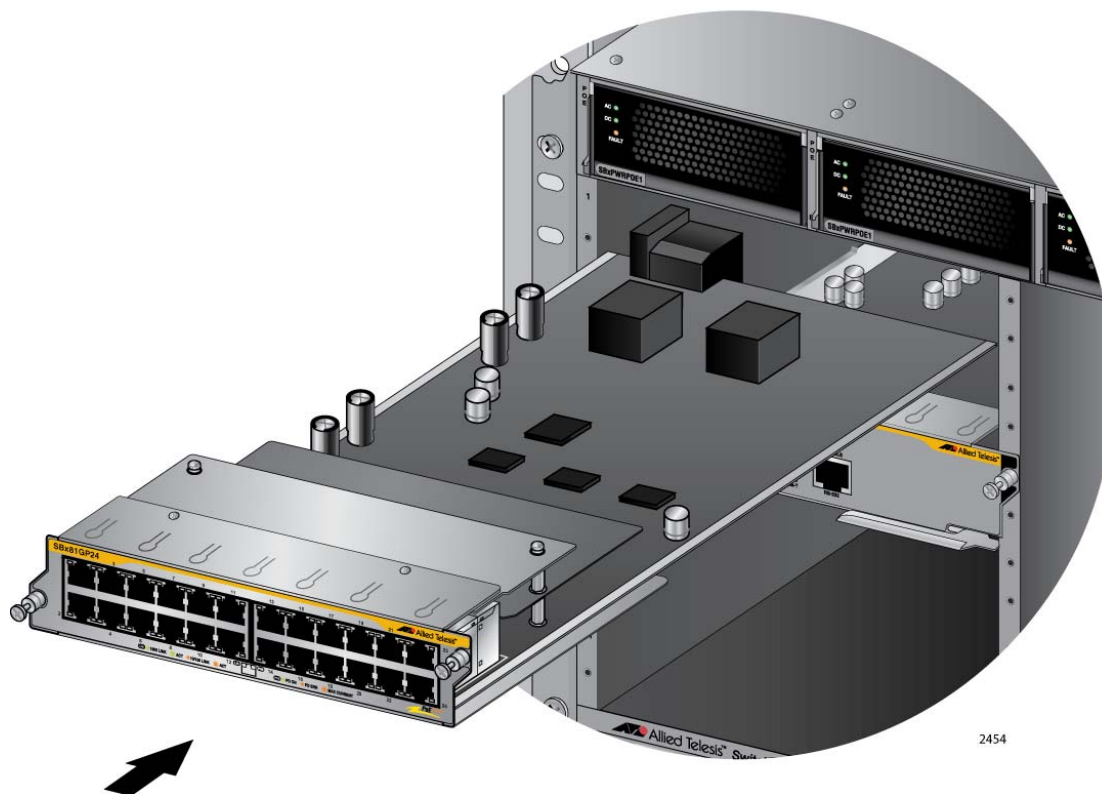

Figure 86. Aligning an Ethernet Line Card in a Chassis Slot

- Carefully slide the card into the slot.



**Caution**

Keep the card level with the chassis as you slide it into the slot. You might damage the components on the top or bottom of the card if you slide it in at an angle. Refer to Figure 63 on page 129.



**Caution**

Do not force the card into the slot. If you feel resistance, remove the card and try again. Be sure that the edges of the card are properly aligned with the card guides.

- When you feel the line card make contact with the connector on the backplane of the chassis, gently press on both sides of the faceplate to seat the card on the connector. Refer to Figure 87 on page 147.



Figure 87. Seating an Ethernet Line Card on the Backplane Connector

8. Finger tighten the two thumbscrews on the sides of the line card to secure it to the chassis, as shown in Figure 88.



Figure 88. Tightening the Thumb Screws on an Ethernet Line Card

9. Tighten the two screws with a # 2 Phillips-head screwdriver to secure the line card to the chassis.

Allied Telesis recommends tightening the screws to 5 inch-lbs.

10. Repeat this procedure to install the remaining Ethernet line cards.
11. After installing the line cards, go to “Installing the Blank Slot Covers” on page 149.

## Installing the Blank Slot Covers

After installing the AT-SBx81CF400 Controller Fabric Cards and Ethernet line cards, check the front panel for unused slots and cover them with the blank slot covers included with the chassis, as explained in this procedure. The fan module may not be able to maintain adequate airflow across the control and line cards if the chassis is not completely enclosed. If there are no unused slots, go to Chapter 8, “Installing Transceivers and Cabling the Ports” on page 151.

To install the blank panels on the unused slots, perform the following procedure:

1. Position a blank slot cover over an unused slot, as shown in Figure 89. The up arrow on the panel must be pointing up.

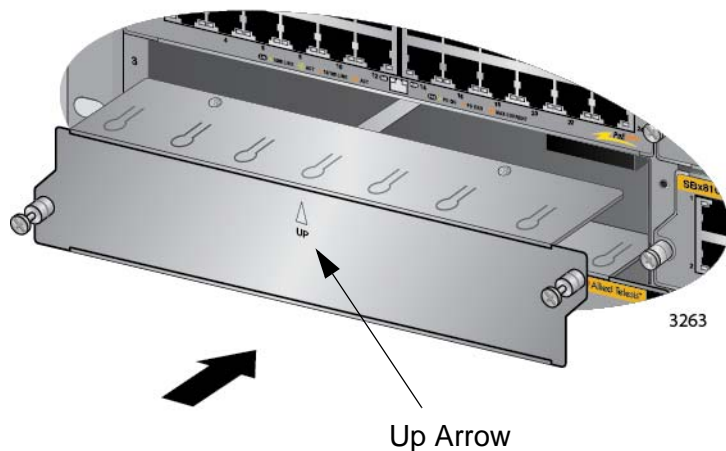

Figure 89. Installing a Blank Slot Cover

2. Finger tighten the two thumbscrews to attach the blank panel to the chassis, as shown in Figure 90.

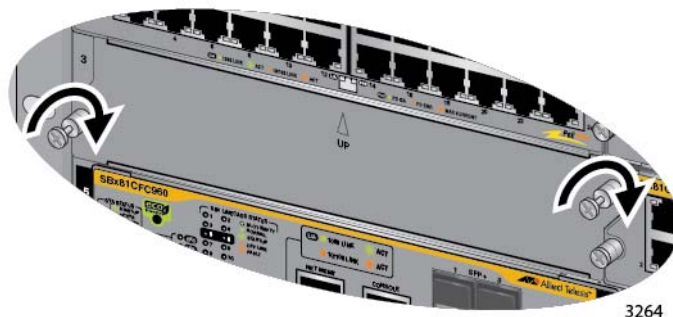

Figure 90. Tightening the Thumbscrews on a Blank Slot Cover

3. Tighten the two screws with a # 2 Phillips-head screwdriver to secure the blank slot cover to the chassis.

Allied Telesis recommends tightening the screws to 5 inch-lbs.

4. Repeat this procedure to cover the remaining empty slots with blank slot covers.
5. Store any unused blank panels in a secure location for future use.
6. Go to Chapter 8, “Installing Transceivers and Cabling the Ports” on page 151.

## Chapter 8

# Installing Transceivers and Cabling the Ports

---

This chapter explains how to cable the ports on the line cards and expansion modules. The chapter has the following sections:

- ❑ “Cabling Guidelines for the Twisted Pair Ports” on page 152
- ❑ “Guidelines to Installing SFP, SFP+, or QSFP+ Transceivers” on page 155
- ❑ “Installing SFP or SFP+ Transceivers” on page 156
- ❑ “Installing AT-SP10TW Direct Connect Cables” on page 161
- ❑ “Installing AT-QSFPCU Cables” on page 164
- ❑ “Installing AT-QSFPSR, AT-QSFPSR4, or AT-QSFPLR4 Transceivers” on page 166
- ❑ “Cabling the NET MGMT Port on the AT-SBx81CFC400 Card” on page 168

## Cabling Guidelines for the Twisted Pair Ports

---

This section applies to the twisted pair ports on the following line cards and expansion module:

- ❑ AT-SBx81GT24 Line Card
- ❑ AT-SBx81GP24 Line Card
- ❑ AT-SBx81GT40 Line Card
- ❑ AT-SBx81XLEM/XT4 Expansion Module

Here are the guidelines to cabling the ports:

- ❑ The twisted pair ports on the AT-SBx81GT24 and AT-SBx81GP24 Line Cards and AT-SBx81XLEM/XT4 Expansion Module have 8-pin RJ45 connectors.
- ❑ The 10/100/1000Base-T twisted pair ports on the AT-SBx81GT40 Line Card have 8-pin RJ point 5 connectors.
- ❑ The cable specifications for the 10/100/1000Base-T ports on the AT-SBx81GT24 and AT-SBx81GT40 Line Cards are listed in Table 16 on page 56.
- ❑ The cable specifications for the 10/100/1000Base-T ports on the AT-SBx81GP24 Line Card are listed in Table 17 on page 57.
- ❑ The cable specifications for the 1000Base-T/10GBase-T ports on the AT-SBx81XLEM/XT4 Expansion Module are listed in Table 18 on page 58.
- ❑ The connectors on the cables should fit snugly into the ports, and the tabs should lock the connectors into place.
- ❑ The default setting for PoE on the ports on the AT-SBx81GP24 Line Card is enabled.
- ❑ The default speed setting for the ports is Auto-Negotiation. This setting is appropriate for ports connected to network devices that also support Auto-Negotiation.
- ❑ The default speed setting of Auto-Negotiation is not appropriate for ports connected to network devices that do not support Auto-Negotiation and have fixed speeds or 10 or 100 Mbps. For those switch ports, disable Auto-Negotiation and set the port's speed manually to match the speeds of the network devices.
- ❑ The 10/100/1000Base-T ports must be set to Auto-Negotiation, the default setting, to operate at 1000Mbps.
- ❑ The default duplex mode setting for the ports is Auto-Negotiation. This setting is appropriate for ports connected to network devices that also support Auto-Negotiation for duplex modes.
- ❑ The default duplex mode setting of Auto-Negotiation is not



appropriate for ports connected to network devices that do not support Auto-Negotiation and have a fixed duplex mode. Disable Auto-Negotiation on those ports and set their duplex modes manually to avoid the possibility of duplex mode mismatches. A switch port using Auto-Negotiation defaults to half-duplex if it detects that the end node is not using Auto-Negotiation. This can result in a mismatch if the end node is operating at a fixed duplex mode of full-duplex.

- ❑ The default wiring configuration of the ports is automatic MDIX detection, which configures the MDI/MDIX setting automatically. This setting is appropriate for switch ports that are connected to network devices that also support the feature.
- ❑ The default wiring configuration of automatic MDIX detection is not appropriate for ports that are connected to network devices that do not support the feature. On those ports, you should disable automatic MDIX detection and set the wiring configuration manually with the POLARITY command.

### Connecting Cables to the AT- SBx81GT40 Line Card

Here are a few additional guidelines to connecting cables to ports on the AT-SBx81GT40 Line Card:

- ❑ The ports require the RJ point 5 cable connector shown in Figure 91.



Figure 91. RJ Point 5 Cable Connector for AT-SBx81GT40 Line Card

- ❑ To connect a cable to a port in the top role on the line card, orient the connector with the release tab on top. To connect a cable to a port in the bottom role, orient the connector with the release tab on the bottom. Refer to Figure 92 on page 154.
- ❑ To remove a cable from a port, pull gently on the release tab and slide the cable connector from the port.

---

#### Note

Patch cables for the AT-SBx81GT40 Line Card, in lengths of 1 meter and 3 meters with RJ point 5 and RJ-45 connectors, are available from Allied Telesis. Contact your Allied Telesis sales representative for information.

---

Connecting a cable to a port in the top row.

Release Tab

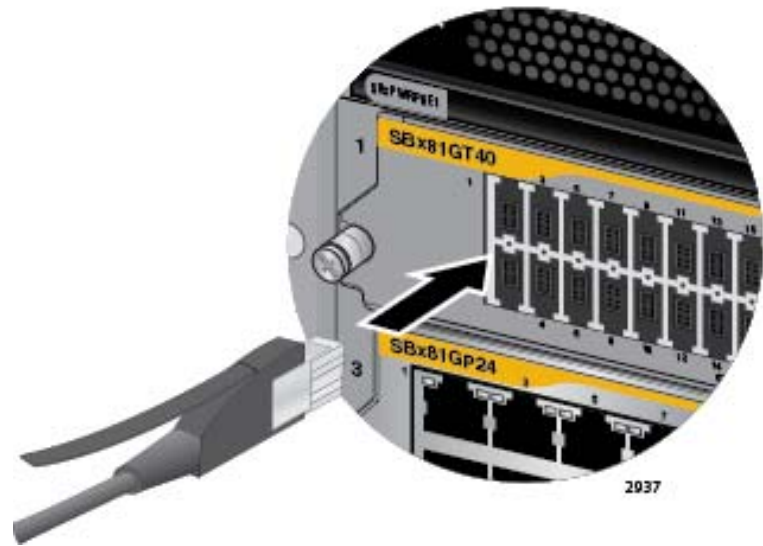
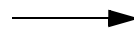

Connecting a cable to a port in the bottom row.



Figure 92. Connecting Cables to Ports on the AT-SBx81GT40 Line Card

## Guidelines to Installing SFP, SFP+, or QSFP+ Transceivers

---

Please review the following guidelines before installing fiber optic transceivers in the line cards and expansion modules:

- ❑ You should verify that the line cards and expansion modules support the transceivers. Refer to Table 6 on page 35 and the SwitchBlade x8112 data sheet on the Allied Telesis web site.
- ❑ You should install a transceiver in a line card before connecting its network cable.
- ❑ A fiber optic transceiver is dust sensitive. Always keep the protective cover in the optical bores when a fiber optic cable is not installed, or when you store the transceiver. When you do remove this cover, retain it for future use.
- ❑ The operational specifications and fiber optic cable requirements of the transceivers are provided in the documents included with the devices.
- ❑ The transceivers and direct connect cables are hot-swappable. You may install them while the chassis is powered on.
- ❑ Unnecessary removal or insertion of transceivers can lead to premature failures.



### Warning

Transceivers can be damaged by static electricity. Follow the procedure in “Protecting Against Electrostatic Discharge (ESD)” on page 108 to guard against ESD damage when unpacking and installing the devices.

---



### Caution

The temperature of an operational transceiver can exceed 70 C (158 F). Exercise caution when removing or handling a transceiver with unprotected hands.

---

## Installing SFP or SFP+ Transceivers

This section applies to the following line cards and expansion module:

- ❑ AT-SBx81GS24a
- ❑ AT-SBx81XS6
- ❑ AT-SBx81XLEM
- ❑ AT-SBx81XLEM/XS8

Table 27 lists the basic types of transceivers supported by the above Ethernet line cards. For model names of specific transceivers, refer to the SwitchBlade x8100 data sheet on the Allied Telesis web site.

Table 27. Transceiver Support

Device	100Mbps SFP Transceivers	1Gbps SFP Transceivers	10Gbps SFP+ Transceivers or AT-SP10TW Cables <sup>a</sup>
AT-SBx81GS24a Line Card	Yes	Yes	No
AT-SBx81XS6 Line Card	No	No	Yes
AT-SBx81XLEM Line Card <sup>b</sup>	No	Yes	No
AT-SBx81XLEM/XS8 Expansion Module	No	Yes	Yes

a. Available in lengths of 1, 3, and 7 meters.

b. Transceiver slots 1 to 12.

Please review the information in “Guidelines to Installing SFP, SFP+, or QSFP+ Transceivers” on page 155 before performing this procedure.

The illustrations show the AT-SBx81GS24a Line Card. The procedure is the same for all the devices.

To install SFP or SFP+ transceivers in line cards, perform the following procedure:

1. Remove the transceiver from its shipping container and store the packaging material in a safe location.
2. Remove the dust cover from the SFP slot chosen for the transceiver. Figure 93 on page 157 shows the removal of the cover from slot 1.



Figure 93. Removing the Dust Cover from an SFP or SFP+ Slot

---

**Note**

Do not remove the dust plug from a transceiver slot if you are not installing the transceiver at this time. The dust plug protects the line card from dust contamination.

---

- Slide the transceiver into the slot until it clicks into place.

To install the transceiver into an odd numbered slot, position it with the handle is on top as you slide it into the slot. To install the transceiver into an even numbered slot, position it with the handle on the bottom. Refer to Figure 94 on page 157.

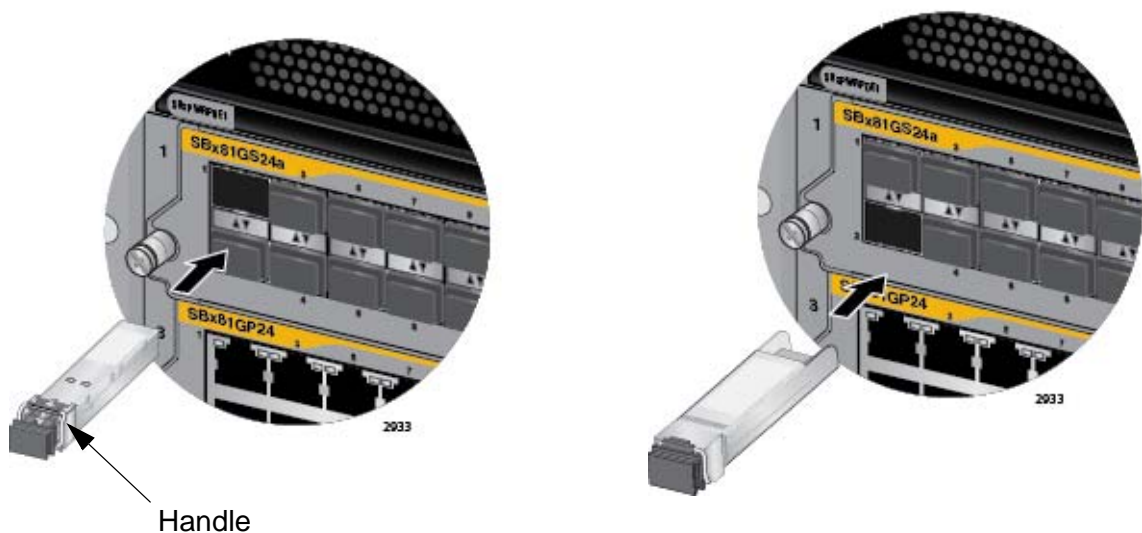

Figure 94. Inserting an SFP or SFP+ Transceiver

For slots on the AT-SBx81XS6 Line Card, position the handle on top. Refer to Figure 95.



Figure 95. Installing an SFP+ Transceiver in the AT-SBx81XS6 Line Card

---

**Note**

If you are ready to attach the fiber optic cable to the transceiver, continue with the next step. Otherwise, repeat steps 1 to 3 to install the remaining SFP transceivers in the line cards.

---

4. Remove the protective cover from the transceiver. Refer to Figure 96 on page 159.

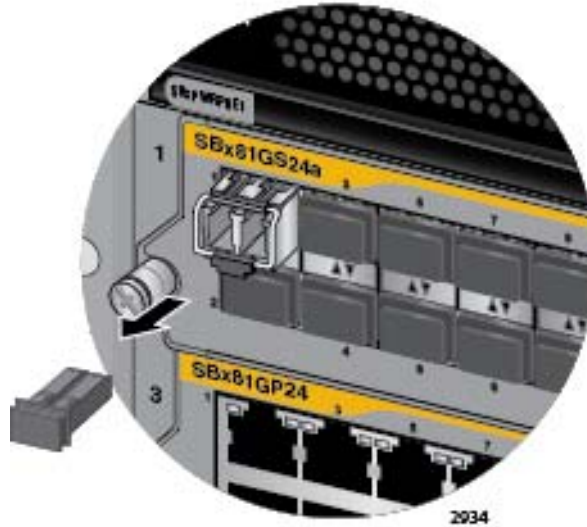

Figure 96. Removing the Dust Cover from a Transceiver

---

**Note**

The dust cover protects the fiber optic port on the SFP transceiver from dust contamination. It should not be removed until you are ready to connect the fiber optic cable.

---

5. Before connecting the cable, verify the position of the handle on the transceiver. The handle should be in the up position if the transceiver is in the top row on the line card, as shown in Figure 97, or the down position if the transceiver is in the bottom row.

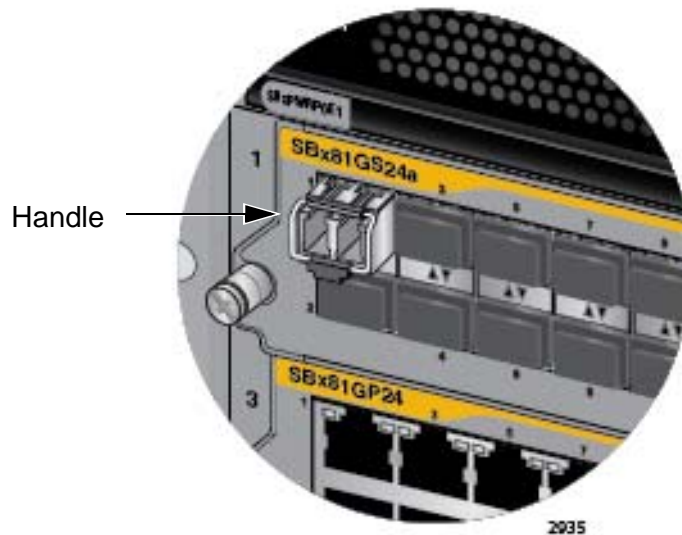

Figure 97. Verifying the Position of the Handle on a Transceiver

6. Connect the fiber optic cable to the port on the transceiver, as shown in Figure 98. The connector should snap into the port.

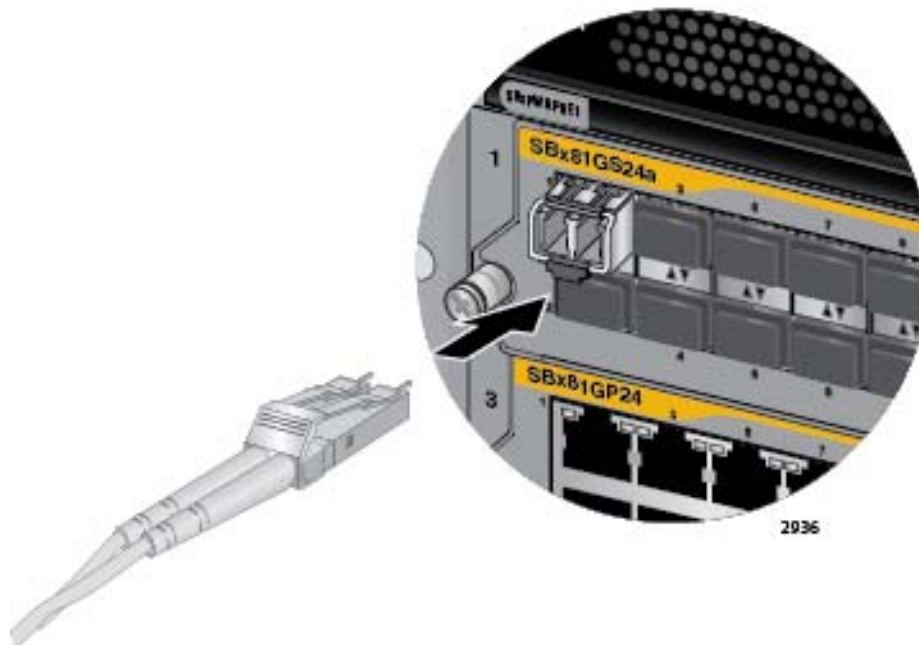

Figure 98. Attaching a Fiber Optic Cable to a Transceiver

7. Repeat this procedure to install additional transceivers.
8. After installing and cabling the transceivers, do one of the following:
  - To install and cable additional transceivers, go to the appropriate section in this chapter for instructions.
  - After cabling all the ports in the chassis, go to Chapter 9, "Powering On the Chassis" on page 171.



## Installing AT-SP10TW Direct Connect Cables

This procedure explains how to connect AT-SP10TW direct connect Twinax cables to the SFP+ slots in the following devices:

- ❑ AT-SBx81XS6 Line Card
- ❑ AT-SBx81XLEM/XS8 Expansion Module

The cables may be used in place of fiber optic cables and transceivers for 10 Gbps links of up to 7 meters.

---

**Note**

The AT-SP10TW Cables are not supported in the AT-SBx81GS24a Line Card or slots 1 to 12 in the AT-SBx81XLEM Line Card.

---

Please review the information in “Guidelines to Installing SFP, SFP+, or QSFP+ Transceivers” on page 155 before performing this procedure.

The illustrations show the AT-SBx81XS6 Line Card. The procedure is the same for all supported devices.

To install AT-SP10TW Cables, perform the following procedure:

1. Remove the dust plug from an SFP+ slot. You may install AT-SP10TW Cables in any of the slots in the line card or expansion module. Refer to Figure 99.



Figure 99. Removing the Dust Cover From an SFP+ Slot

---

**Note**

Do not remove the dust plug from an SFP+ slot if you are not installing the transceiver at this time. The dust plug protects the line card from dust contamination.

---

2. Slide the connector into the slot until it clicks into place.

To install the cable in a slot in the AT-SBx81XS6 Line Card, position the release tab on top. Refer to Figure 100.



Figure 100. Installing the AT-SP10TW Cable in the AT-SBx81XS6 Line Card

To install the cable in an even numbered slot in the AT-SBx81XLEM/XS8 Expansion Module, position the release tab on top as you slide the connector into the slot. To install the cable in an odd numbered slot, position the connector so that the release tab is on the bottom. Refer to Figure 101 on page 163.



Figure 101. Installing the AT-SP10TW Cable in the AT-SBx81XLEM/XS8 Expansion Module

3. Install the other end of the cable into an SFP+ slot on another network device.
4. Repeat this procedure to install additional AT-SP10TW Cables.

---

**Note**

To remove the connector and cable from the slot, gently push on the connector, pull on the release tab, and slide the connector from the slot.

---

5. After installing the AT-SP10TW Cables, do one of the following:
  - To install and cable additional transceivers, go to the appropriate section in this chapter for instructions.
  - After cabling all the ports in the chassis, go to Chapter 9, "Powering On the Chassis" on page 171.

## Installing AT-QSFPCU Cables

---

This section contains instructions on how to install AT-QSFPCU Cables in the AT-SBx81XLEM/Q2 Expansion Module for the AT-SBx81XLEM Line Card. You can use the cables in place of fiber optic cables and transceivers for 40GbE links of up to 1 or 3 meters. The model names of the cables are listed here:

- ❑ AT-QSFP1CU - 1 meter
- ❑ AT-QSFP3CU - 3 meters

---

### Note

The AT-QSFPCU Cables are only supported in the AT-SBx81XLEM/Q2 Expansion Module.

---

Please review “Guidelines to Installing SFP, SFP+, or QSFP+ Transceivers” on page 155 before performing this procedure.

To install AT-QSFPCU Cables, perform the following procedure:

1. Remove the dust cover from a slot on the AT-SBx81XLEM/Q2 Expansion Module. Refer to Figure 102.

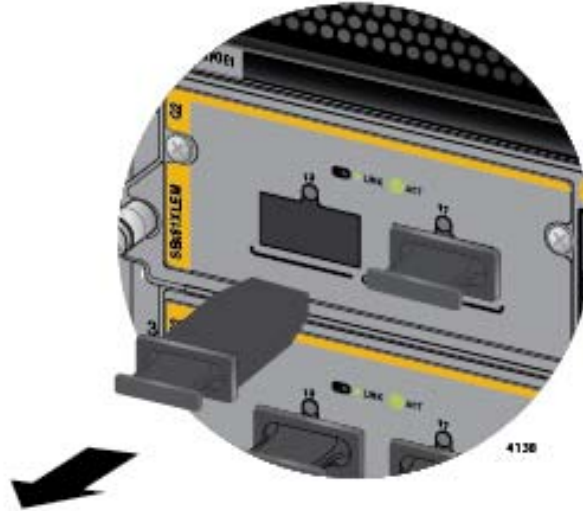

Figure 102. Removing the Dust Cover from a Slot on the AT-SBx81XLEM/Q2 Expansion Module

2. Orient the connector on the AT-QSFPCU Cable with the release tab on top and slide it into the slot until it clicks into place. Refer to Figure 103 on page 165.

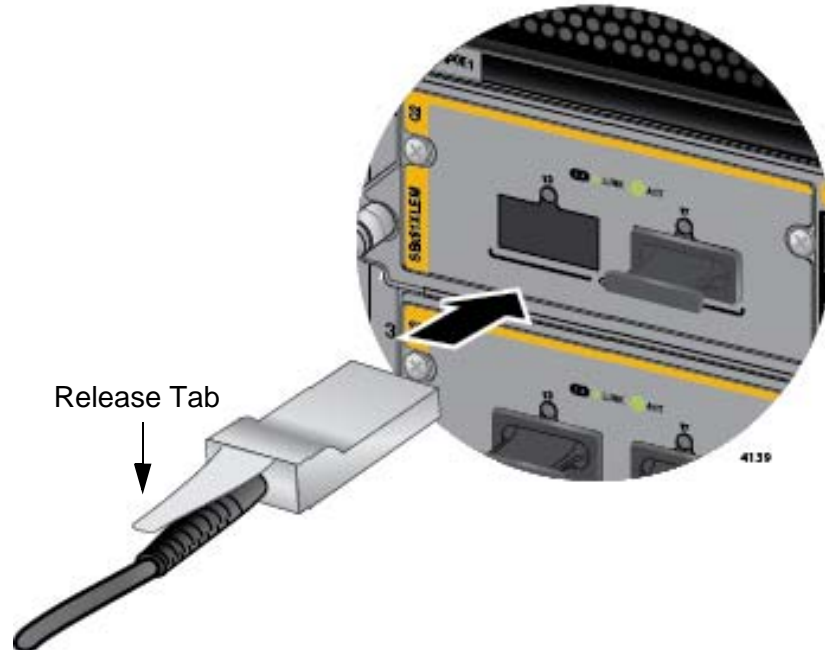

Figure 103. Sliding the AT-QSFPCU Cable into the Slot

3. Install the other end of the cable into a compatible QSFP+ slot on another network device.
4. Repeat this procedure to install additional AT-QSFPCU Cables.

---

**Note**

To remove the connector and cable from the slot, gently push on the connector, pull on the release tab, and slide the connector from the slot.

---

5. After installing the AT-QSFPCU Cables, do one of the following:
  - To install and cable additional transceivers, go to the appropriate section in this chapter for instructions.
  - After cabling all the ports in the chassis, go to Chapter 9, “Powering On the Chassis” on page 171.

## Installing AT-QSFPSR, AT-QSFPSR4, or AT-QSFPLR4 Transceivers

---

This section contains the procedure for installing AT-QSFPSR, AT-QSFPSR4, or AT-QSFPLR4 transceivers in the slots on the AT-SBx81XLEM/Q2 Expansion Module.

---

**Note**

The AT-QSFPSR, AT-QSFPSR4, and AT-QSFPLR4 transceivers are only supported in the AT-SBx81XLEM/Q2 Expansion Module.

---

---

**Note**

The AT-SBx81XLEM/Q2 Module supports revision B of the AT-QSFPSR4 transceiver. It does not support revision A. The revision level of the transceiver is printed on the transceiver label, after the serial number. You can also display it with the `SHOW SYSTEM PLUGGABLE DETAIL` command in the AlliedWare Plus operating system.

---

Please review “Guidelines to Installing SFP, SFP+, or QSFP+ Transceivers” on page 155 before performing this procedure.

To install AT-QSFPSR, AT-QSFPSR4, or AT-QSFPLR4 transceivers, perform the following procedure:

1. Remove the dust cover from a slot on the AT-SBx81XLEM/Q2 Expansion Module. Refer to Figure 102 on page 164.
2. Slide a transceiver into the slot until it clicks into place.
3. Attach a fiber optic cable to the transceiver.
4. Repeat steps 1 to 3 to install and cable transceivers in the other slots of the expansion module.
5. Connect the cables to compatible QSFP ports in other network devices.

---

**Note**

To remove the connector and cable from the slot, gently push on the connector, pull on the release tab, and slide the connector from the slot.

---

6. After installing the transceivers, do one of the following:
  - To install and cable additional transceivers, go to the appropriate

section in this chapter for instructions.

- After cabling all the ports in the chassis, go to Chapter 9, “Powering On the Chassis” on page 171.

## Cabling the NET MGMT Port on the AT-SBx81CFC400 Card

---

For background information on the NET MGMT port on the controller card, refer to “Ethernet Management Port (NET MGMT)” on page 77.

---

### Note

The NET MGMT port is referred to as “eth0” in the management software.

---

Here are the guidelines to using the NET MGMT port:

- ❑ The cabling requirements of the port are the same as the ports on the AT-SBx81GT24 Line Card, in Table 16 on page 56.
- ❑ The default speed setting for the port is Auto-Negotiation. This setting is appropriate if the port is connected to a network device that also support Auto-Negotiation.
- ❑ The default speed setting of Auto-Negotiation is not appropriate if the port is connected to a network device that does not support Auto-Negotiation and has a fixed speed of 10 or 100 Mbps. In this situation, disable Auto-Negotiation and set the port’s speed manually to match the speed of the network device.
- ❑ The port must be set to Auto-Negotiation, the default setting, to operate at 1000Mbps.
- ❑ The default duplex mode setting for the port is Auto-Negotiation. This setting is appropriate if the port is connected to a network device that also support Auto-Negotiation for the duplex mode.
- ❑ The default duplex mode setting of Auto-Negotiation is not appropriate if the port is connected to a network device that does not support Auto-Negotiation and has a fixed duplex mode. In this situation, you should disable Auto-Negotiation on the port and set its duplex mode manually to avoid the possibility of a duplex mode mismatch. With Auto-Negotiation, the port defaults to half-duplex if it detects that the end node is not using Auto-Negotiation. This can result in a mismatch if the end node is operating at a fixed duplex mode of full-duplex.
- ❑ The default wiring configuration of the port is automatic MDIX detection, which configures the MDI/MDIX setting automatically. This setting is appropriate for port if it is connected to a network device that also support the feature.
- ❑ The default wiring configuration of automatic MDIX detection is not appropriate for the NET MGMT port if it is connected to a network device that does not support the feature. You should disable automatic MDIX detection and set the wiring configuration manually with the POLARITY command.



After cabling the NET MGMT port, do one of the following:

- ❑ To install and cable additional transceivers, go to the appropriate section in this chapter for instructions.
- ❑ After cabling all the ports in the chassis, go to Chapter 9, “Powering On the Chassis” on page 171.



## Chapter 9

# Powering On the Chassis

---

This chapter describes how to power on the chassis and monitor the initialization process. The chapter contains the following sections:

- ❑ “Verifying the Installation” on page 172
- ❑ “Powering On AT-SBxPWRSYS1 or AT-SBxPWRSYS2 AC System Power Supplies” on page 173
- ❑ “Powering On AT-SBxPWRPOE1 Power Supplies” on page 177
- ❑ “Powering On the AT-SBxPWRSYS1 DC System Power Supply” on page 180
- ❑ “Monitoring the Initialization Process” on page 206

## Verifying the Installation

---

Please perform the following procedure before powering on the chassis:

1. Verify that the grounding lug on the back panel of the chassis is properly grounded. For instructions, refer to “Installing the Chassis Grounding Wire” on page 104.
2. Verify that all the empty slots on the front panel of the chassis are covered with slot covers. If there are open slots, perform the procedure “Installing the Blank Slot Covers” on page 149.
3. Verify that dust plugs are installed in all empty SFP and SFP+ slots on the AT-SBx81GS24a and AT-SBx81XS6 Line Cards, and the AT-SBx81CFC400 Controller Fabric Card.
4. Verify that dust covers are installed on all SFP and SFP+ transceivers that do not have cables.
5. Verify that the chassis has at least one AT-SBx81CFC400 Controller Fabric Card in slot 5 or 6.
6. Verify that the chassis has at least one system power supply in slot C or D.
7. If the chassis has AT-SBx81GP24 Line Cards, verify that the chassis has at least one AT-SBxPWRPOE1 Power Supply in slot A or B.
8. When you installed the AT-SBx81CFC400 Controller Fabric Card, did you remove the battery insulator, shown in Figure 67 on page 132? If not, remove the controller card from the chassis, remove the insulator from the battery, and reinstall the card.

You may now power on the chassis. For instructions, refer to the appropriate section in this chapter:

- ❑ “Powering On AT-SBxPWRSYS1 or AT-SBxPWRSYS2 AC System Power Supplies” on page 173
- ❑ “Powering On AT-SBxPWRPOE1 Power Supplies” on page 177
- ❑ “Powering On the AT-SBxPWRSYS1 DC System Power Supply” on page 180

If the chassis has both system and PoE power supplies, you may power them on in any order or simultaneously.

## Powering On AT-SBxPWRSYS1 or AT-SBxPWRSYS2 AC System Power Supplies

---

The procedure in this section explains how to power on AT-SBxPWRSYS1 or AT-SBxPWRSYS2 AC System Power Supplies in slots C and D on the front panel. If you have not already installed the power supplies, refer to “Installing AT-SBxPWRSYS1 or AT-SBxPWRSYS2 AC System Power Supplies” on page 109 for installation instructions.

---

**Note**

If the chassis has both system and PoE power supplies, you may power them on in any order or simultaneously.

---



---

**Caution**

If the chassis has two AT-SBxPWRSYS2 Power Supplies, you must power them on within 90 seconds of each other. Otherwise, the active master controller card might restart its operating software, which will delay the initialization process of the chassis.

---

To power on the AC system power supplies, perform the following procedure:

1. Identify AC sockets C and D in the recessed panel on the back panel of the chassis, shown in Figure 104 on page 174. These sockets are for the AC system power supplies in slots C and D on the front panel of the chassis.



Figure 104. AC Sockets on the Rear Panel of the AT-SBx8112 Chassis

2. Plug the AC power cord that comes with the power supply into a plug whose corresponding slot on the front panel has a system power supply.

If there are two system power supplies, you may power on either supply first. In the illustration in Figure 105 on page 175 an AC power cord is connected to connector D for the system power supply in slot D on the front panel.



Figure 105. Connecting the AC Power Cord for the AT-SBxPWRSYS1 or AT-SBxPWRSYS2 AC System Power Supply

3. Use the twist tie included with the power supply to secure the cord to an anchor on the chassis to protect it from being accidentally pulled out, as shown in Figure 106 on page 176.

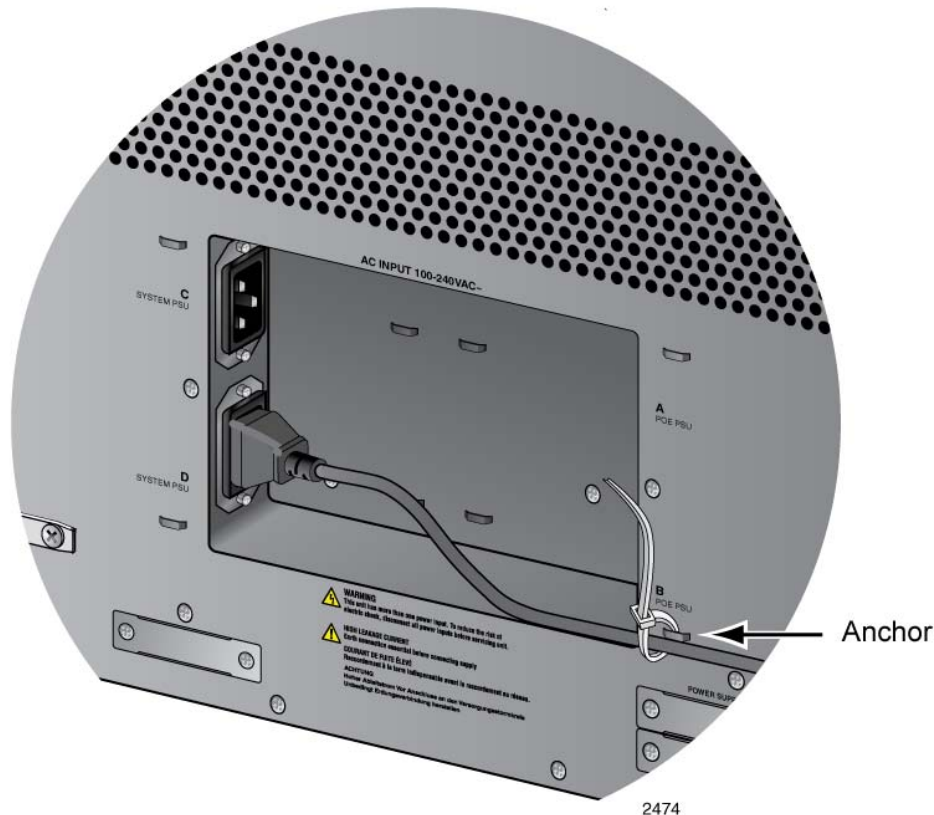

Figure 106. Securing the Power Cord for the AT-SBxPWRSYS1 or AT-SBxPWRSYS2 AC Power Supply to an Anchor

4. Connect the power cord to an appropriate AC power source to power on the power supply.
5. If the chassis has two AT-SBxPWRSYS1 or AT-SBxPWRSYS2 AC System Power Supplies, repeat this procedure to power on the second power supply.



**Caution**

If the chassis has two AT-SBxPWRSYS2 Power Supplies, you must power them on within 90 seconds of each other. Otherwise, the active master controller card might restart its operating software, which will delay the initialization process of the chassis.

After powering on the AC system power supplies, do one of the follow:

- ❑ If the chassis has AT-SBxPWRPOE1 PoE Power Supplies, perform the procedure in “Powering On AT-SBxPWRPOE1 Power Supplies” on page 177.
- ❑ Otherwise, go to “Monitoring the Initialization Process” on page 206.



## Powering On AT-SBxPWRPOE1 Power Supplies

If you have not already installed the AT-SBxPWRPOE1 Power Supplies, refer to “Installing AT-SBxPWRPOE1 PoE Power Supplies” on page 115 for installation instructions. To power on the power supplies, perform the following procedure:

1. Identify AC sockets A and B in the recessed panel on the back panel of the chassis, shown in Figure 104 on page 174. The sockets are for the AT-SBxPWRPOE1 Power Supplies in slots A and B on the front panel of the chassis.
2. Plug the AC power cord that comes with the power supply into one of the plugs, as shown in Figure 107.

The plug should have a power supply in the corresponding slot in the front panel. If the chassis has two AT-SBxPWRPOE1 Power Supplies, you may power on either supply first.

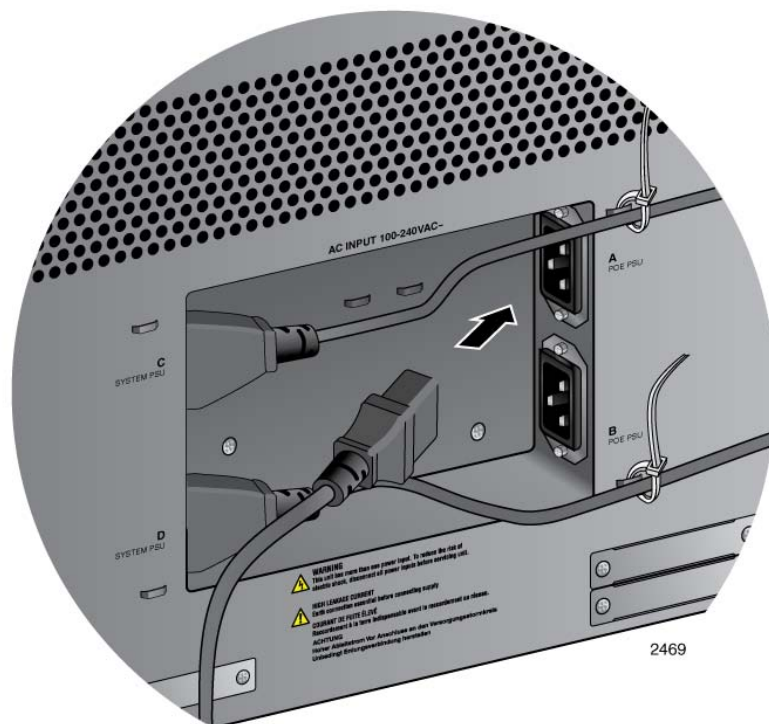

Figure 107. Connecting the AC Power Cord for the AT-SBxPWRPOE1 Power Supply

3. Use the twist tie that comes with the power supply to secure the cord to an anchor on the chassis, as shown in Figure 108.

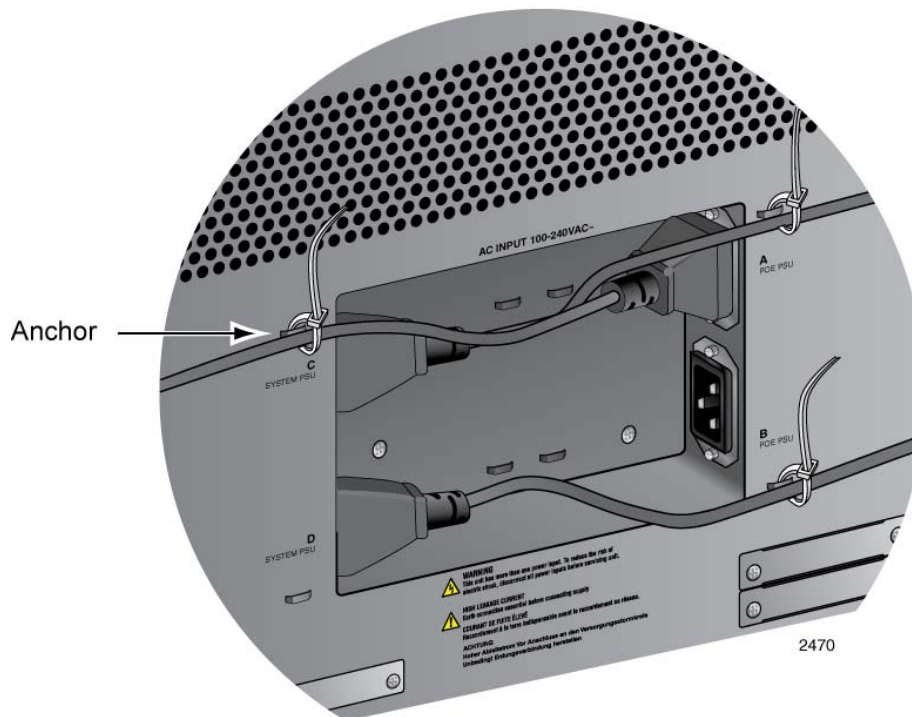
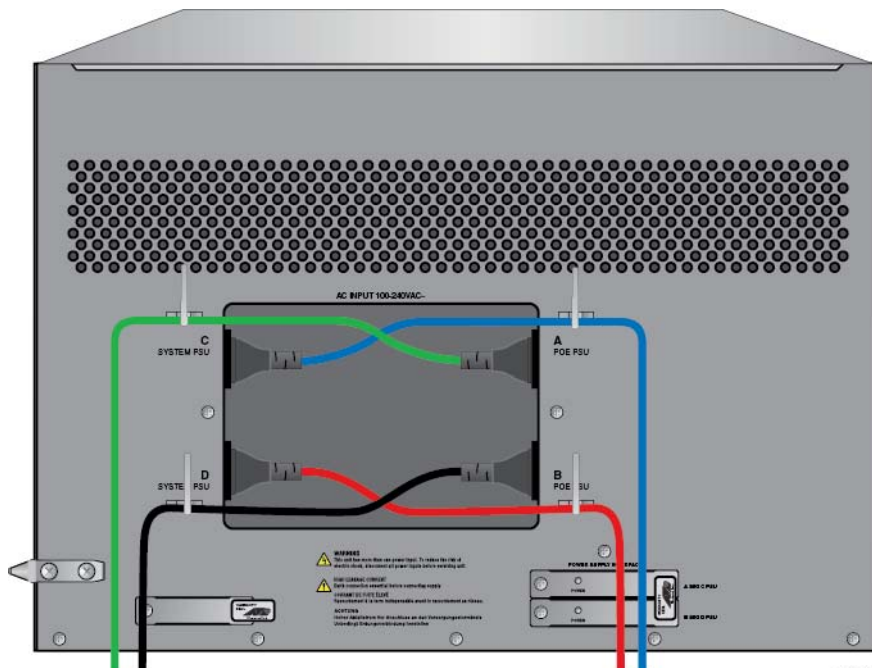

Figure 108. Securing the Power Cord for the AT-SBxPWRPOE1 Power Supply to an Anchor

4. Connect the power cord to an appropriate AC power source to power on the power supply.
5. If the chassis has two AT-SBxPWRPOE1 Power Supplies, repeat this procedure to power on the second power supply.

Figure 109 on page 179 is an illustration of the power cords for a chassis with four power supplies.



- A POE PSU power cord
- B POE PSU power cord
- C System PSU power cord
- D System PSU power cord

NOTE: The power cords shown in this figure are in color for clarity only.  
All power cords are black.

Figure 109. Dress and Secure AC Power Cords

6. Go to “Monitoring the Initialization Process” on page 206.

## Powering On the AT-SBxPWRSYS1 DC System Power Supply

---

This section contains instructions on how to power on the AT-SBxPWRSYS1 DC Power Supply. For installation instructions, refer to “Installing AT-SBxPWRSYS1 DC System Power Supplies” on page 120.

The power supply unit has a ground connection and positive and negative DC terminals. You may install the ground and power lead wires with the terminal lugs that come with the unit or with bare wire. The wire requirements are slightly different for terminal installation versus bare wire installation. Here are the wire requirements if you are using the terminals that come with the power supply:

- ❑ Two 8 AWG stranded power wires (not provided)
- ❑ One 10 AWG stranded grounding wire (not provided)

Here are the wire requirements for bare wire installation:

- ❑ Two 8 AWG solid or stranded power wires (not provided)
- ❑ One 10 AWG solid or stranded grounding wire (not provided)

Here is a list of the required tools:

- ❑ Crimping tool (not provided)
- ❑ 8 mm wrench (not provided)
- ❑ #1, #2, and #3 Phillips-head screwdrivers (not provided)
- ❑ #3 Phillips-head 30 to 40 inch-lbs Phillips-head torque screwdriver (optional - not provided)

Here are the procedures for powering on the AT-SBxPWRSYS1 DC Power Supply:

- ❑ “Choosing a Method for Attaching the Grounding Wire” on page 182
- ❑ “Connecting the Grounding Wire with the Grounding Terminal” on page 182
- ❑ “Connecting the Grounding Wire with Bare Wire” on page 185
- ❑ “Choosing a Method for Attaching the Power Wires” on page 187
- ❑ “Connecting the DC Power Wires with the Straight Terminals” on page 187
- ❑ “Connecting the DC Power Wires with the Right Angle Terminals” on page 196
- ❑ “Connecting Bare DC Power Wires” on page 202

The components of the power supply are identified in Figure 110.

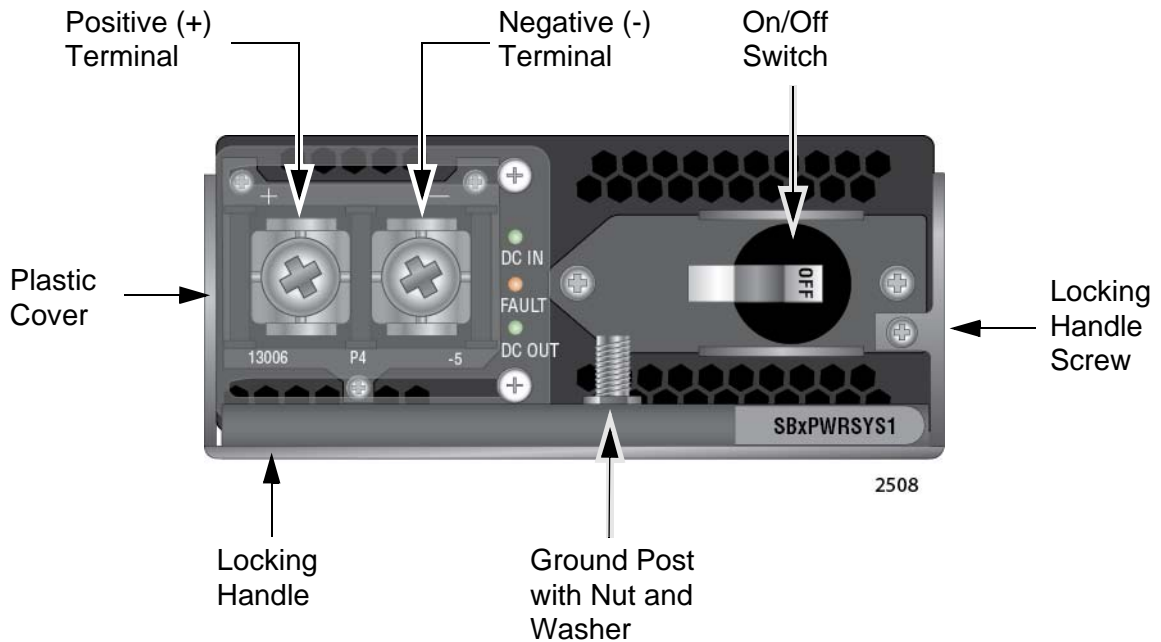

Figure 110. Components of the AT-SBxPWRSYS1 DC Power Supply



#### Warning

As a safety precaution, install a circuit breaker with a minimum value of 50 Amps between the equipment and the DC power source.

Always connect the wires to the LAN equipment first before you connect the wires to the circuit breaker. Do not work with HOT feeds to avoid the danger of physical injury from electrical shock. Always be sure that the circuit breaker is in the OFF position before connecting the wires to the breaker. *E9*



#### Warning

For centralized DC power connection, install only in a restricted access area. *E23*

#### Note

A tray cable is required to connect the power source if the unit is powered by centralized DC power. The tray cable must be a UL listed Type TC tray cable and rated at 600 V and 90 degrees C, with two conductors, 8 AWG. *E24*

## Choosing a Method for Attaching the Grounding Wire

You may attach the grounding wire to the power supply using the supplied terminal, shown in Figure 111, or bare wire.



Figure 111. Grounding Wire Terminal

The two methods are described in the following sections:

- “Connecting the Grounding Wire with the Grounding Terminal”
- “Connecting the Grounding Wire with Bare Wire” on page 185

## Connecting the Grounding Wire with the Grounding Terminal

To attach a grounding wire with the grounding terminal provided with the power supply, perform the following procedure:

1. Prepare an adequate length of stranded 10 AWG grounding wire by stripping it as shown in Figure 112.

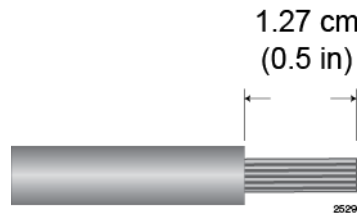

Figure 112. Stripping the Stranded Grounding Wire

---

### Note

You must use stranded wire when using the grounding terminal to connect the ground wire to the grounding post. You may not use solid wire.

---

2. Insert the grounding wire into the grounding terminal provided with the power supply and use a crimping tool to secure it to the grounding terminal. See Figure 113,

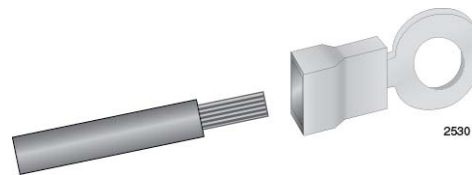

Figure 113. Attaching the Stranded Grounding Wire to the Grounding Terminal

3. Use an 8 mm wrench to remove the grounding post nut and washer, shown in Figure 114, from the power supply.

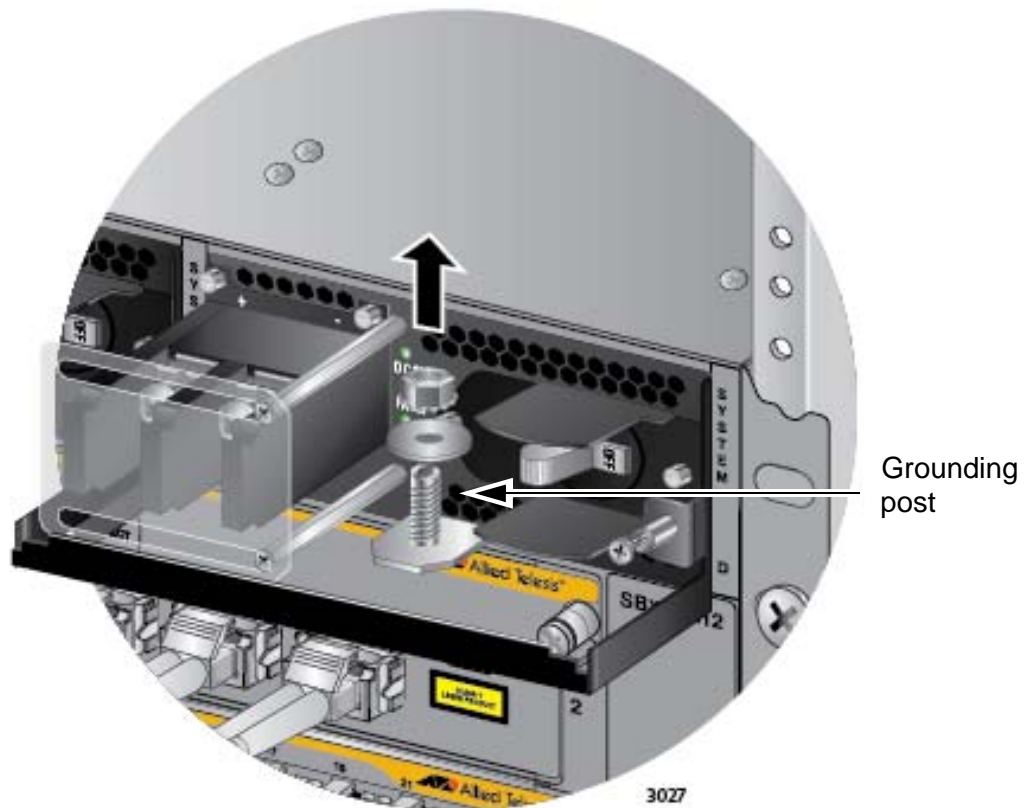

Figure 114. Removing the Nut and Washer from the Grounding Post

4. Attach the grounding lug and wire to the grounding post and secure them with the nut and washer removed in the previous step, and an 8 mm wrench.

Review the following before installing the grounding wire:

- You should angle the wire to the right so that you can open the plastic window to access the positive and negative terminals on the terminal block.
- You may route the cable either above or below the locking handle.
- Allied Telesis recommends tightening the nut and washer to 26 inch-lbs.

The grounding wire is illustrated in Figure 115 on page 184.

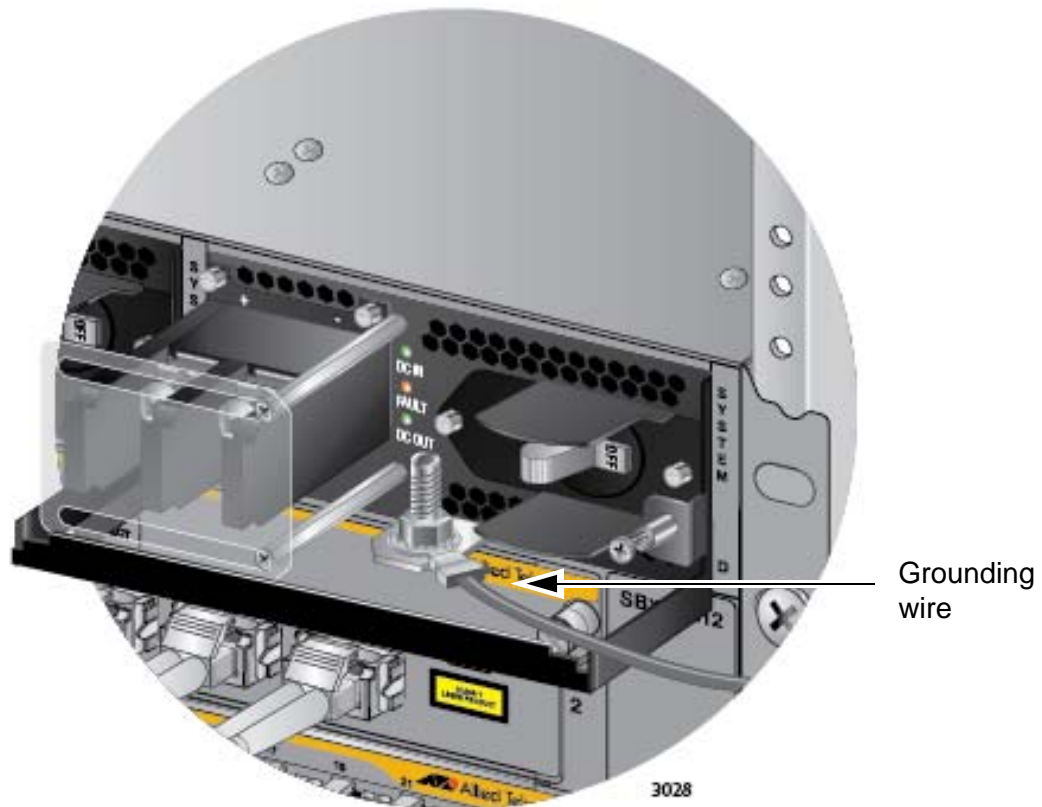

Figure 115. Installing the Grounding Wire

5. Connect the other end of the grounding wire to the building protective earth.



**Warning**

When installing this equipment, always ensure that the power supply ground connection is installed first and disconnected last. ⚡ E11

**Note**

This system will work with a positive grounded or negative grounded DC system. ⚡ E13

After connecting the grounding wire, go to “Choosing a Method for Attaching the Power Wires” on page 187.



## Connecting the Grounding Wire with Bare Wire

To attach the grounding wire to the power supply with bare wire, perform the following procedure:

1. Prepare an adequate length of solid or stranded 10 AWG grounding wire by stripping it as shown in Figure 116.

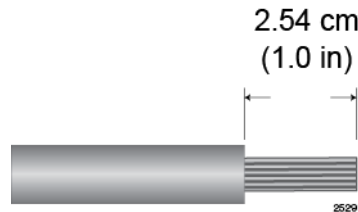

Figure 116. Stripping the solid or Stranded Grounding Wire

2. Use an 8 mm wrench to remove the grounding post nut and washer, shown in Figure 114 on page 183, from the grounding post on the power supply.
3. Wrap the grounding wire clockwise around the base of the grounding post, as shown in Figure 117.



Figure 117. Attaching the Bare Grounding Wire to the Grounding Post

4. Secure the wire with the nut and washer removed in step 2, and an 8 mm wrench, as shown in Figure 118.

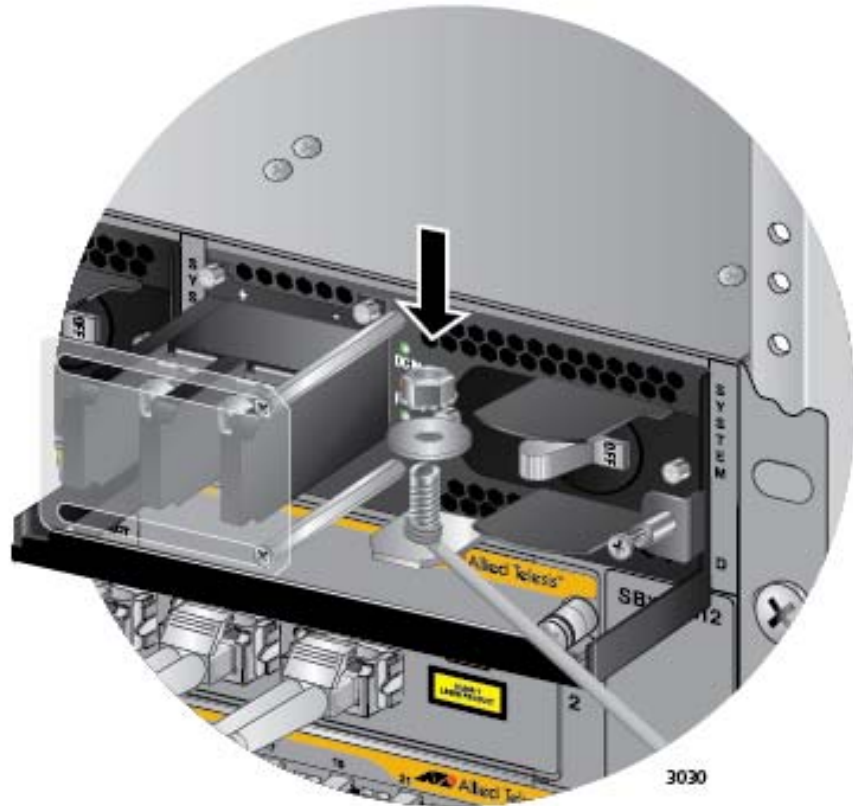

Figure 118. Securing the Bare Grounding Wire to the Grounding Post

Allied Telesis recommends tightening the nut and washer to 26 inch-lbs.

After connecting the grounding wire, go to “Choosing a Method for Attaching the Power Wires” on page 187.

## Choosing a Method for Attaching the Power Wires

The AT-SBxPWRSYS1 DC Power Supply comes with the two sets of power wire terminals shown in Figure 119. You may use either set to connect the positive (+) and negative (-) wires to the terminal block on the power supply. The straight terminals are used to route the wires above or below the terminal block. The right angle terminals are used to route the power wires directly away from the terminal block.

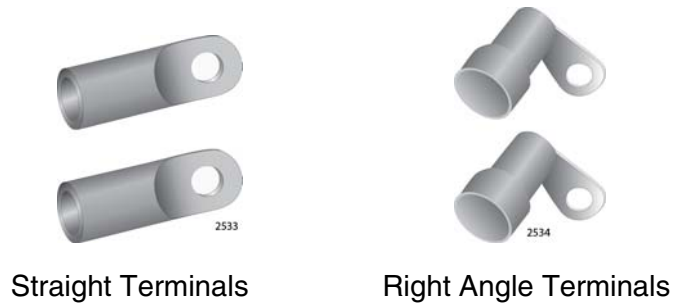

Figure 119. Power Wire Terminals

---

### Note

The right angle terminals require the removal of the plastic cover from the terminal block.

---

You may also install the wires using bare wires.

Here are the procedures to wiring the positive and negative terminal block on the power supply:

- “Connecting the DC Power Wires with the Straight Terminals”
- “Connecting the DC Power Wires with the Right Angle Terminals” on page 196
- “Connecting Bare DC Power Wires” on page 202

## Connecting the DC Power Wires with the Straight Terminals

To use the straight terminals to connect the DC power wires to the positive and negative terminals on the power supply, perform the following procedure:

1. Prepare adequate lengths of two stranded 8 AWG power wires by stripping them as shown in Figure 120 on page 188.



### Warning

Do not strip more than the recommended amount of wire. Stripping more than the recommended amount can create a safety hazard by leaving exposed wire on the terminal block after installation. E10

---

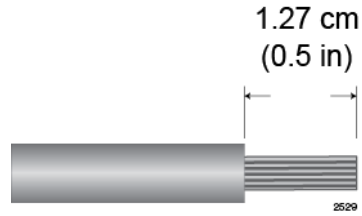

Figure 120. Stripping the Power Wires

---

**Note**

You must use stranded wires with the terminal lugs. You may not use solid wires.

---

2. Insert the power wires into the terminals included with the power supply and use a crimping tool to secure the wires to the terminals. See Figure 121.

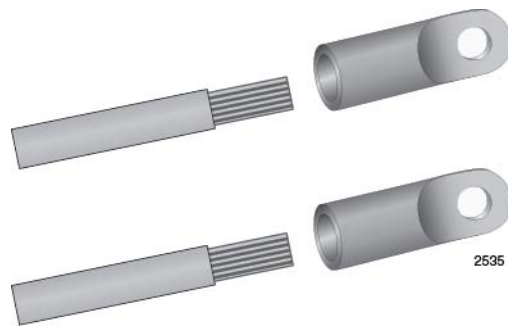

Figure 121. Attaching the Power Wires to the Straight Terminal Lugs

3. Verify that the On/Off switch on the AT-SBxPWRSYS1 DC Power Supply is in the Off position. Refer to Figure 122 on page 189.

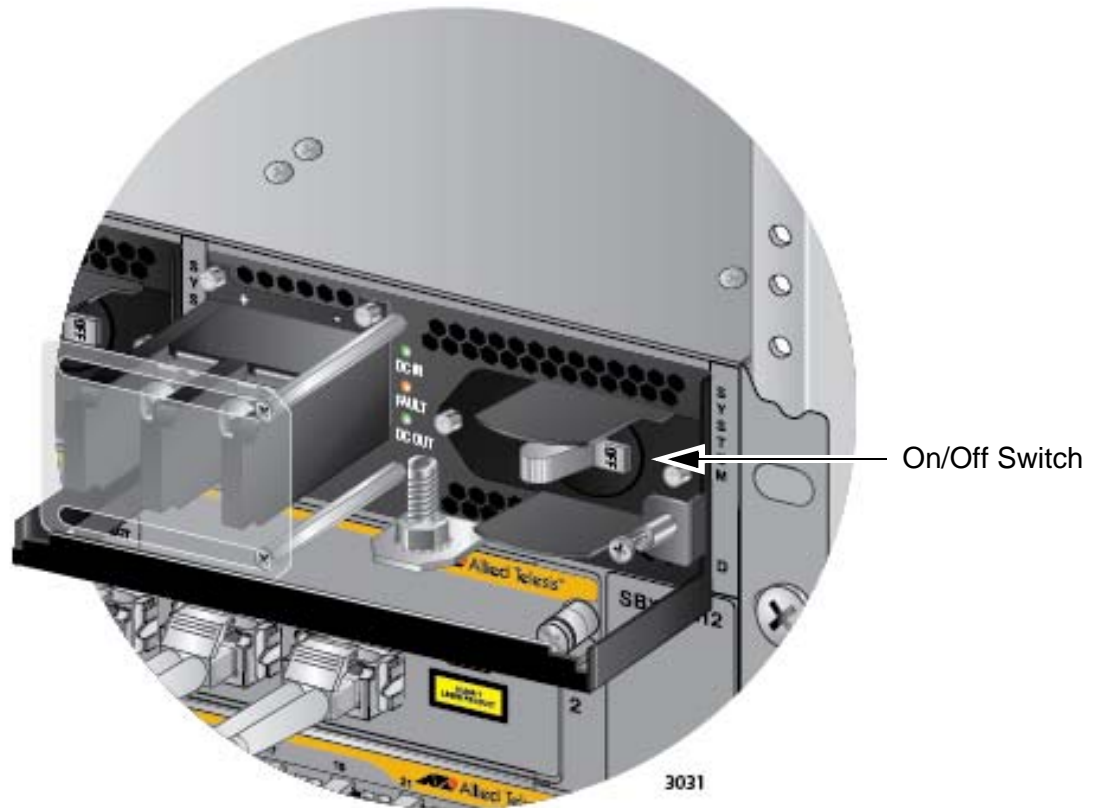

Figure 122. On/Off Switch on the AT-SBxPWRSYS1 DC Power Supply

4. Use a #1 Phillips-head screwdriver to loosen the two screws on the plastic cover over the positive and negative terminals on the power supply and slide the cover to the right, as shown in Figure 123 on page 190. You may need to lift the locking handle slightly to access the bottom screw.



Figure 123. Opening the Plastic Cover

5. Use a #3 Phillips-head screwdriver to remove the two screws from the positive and negative terminals, as shown in Figure 124 on page 191.



Figure 124. Removing the Terminal Screws

6. With a #3 Phillips-head screwdriver, connect the positive (+) power lead wire to the positive terminal on the power supply, with one of the terminal screws removed in the previous step. The positive terminal is on the left. You may attach the terminals with the wires either above or below the terminal block. Figure 125 on page 192 shows the positive wire above the terminal block.

Allied Telesis recommends tightening the screw to 30 to 40 inch-lbs.

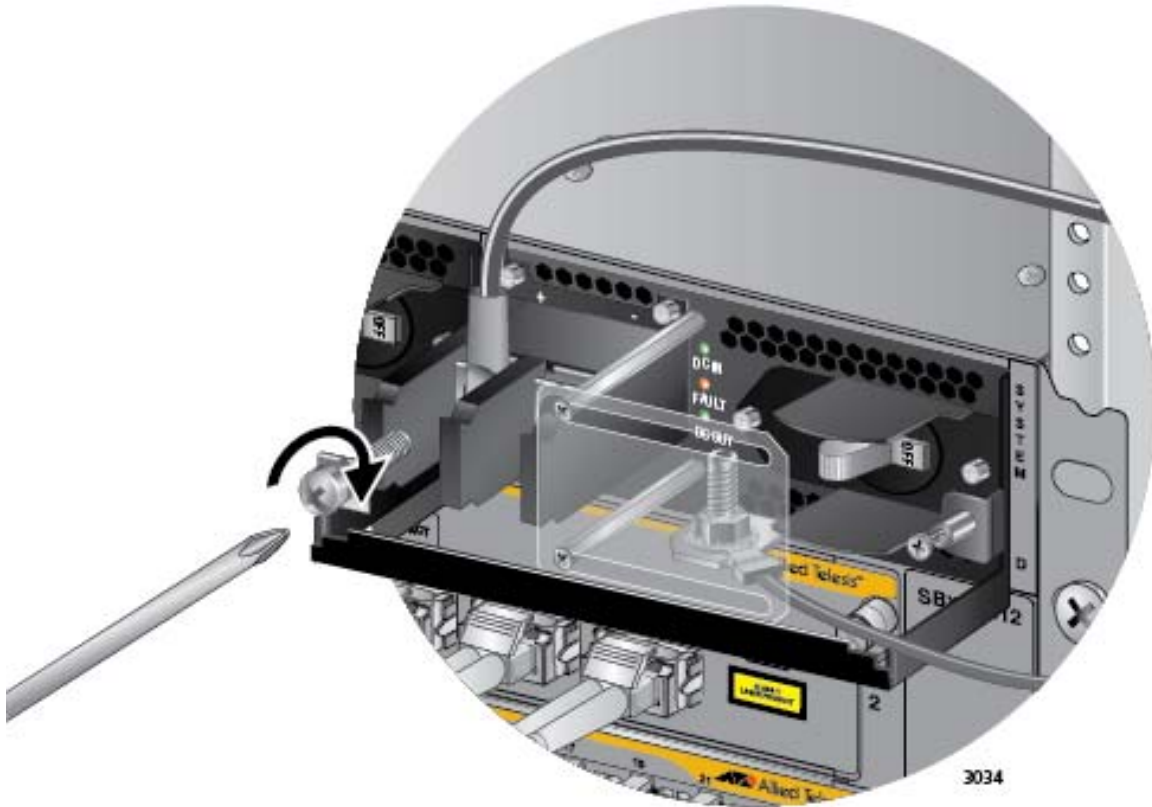

Figure 125. Connecting the Positive (+) Power Wire with a Straight Terminal

7. With a #3 Phillips-head screwdriver, connect the negative (-) power lead wire to the negative terminal on the power supply, with the remaining terminal screw removed in step 5. The negative terminal is on the right. You may attach the terminals with the wires either above or below the terminal block. Figure 126 on page 193 shows the wires above the terminal block.

Allied Telesis recommends tightening the screw to 30 to 40 inch-lbs.



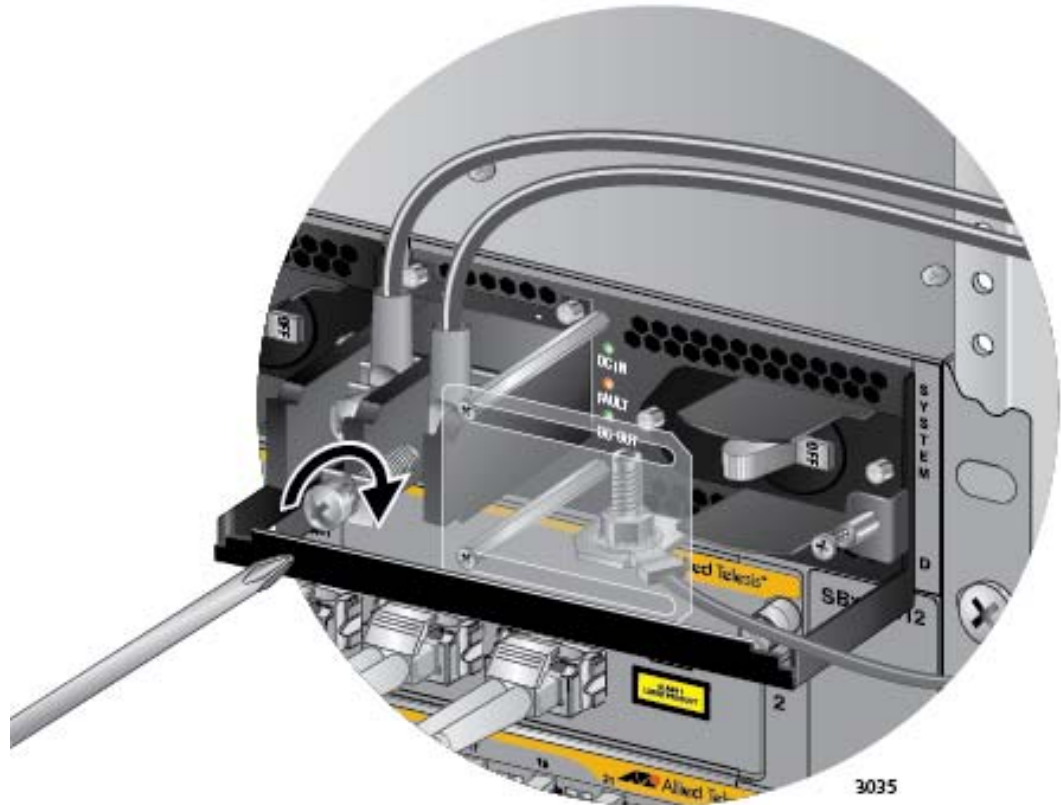

Figure 126. Connecting the Negative (-) Power Wire with a Straight Terminal



#### Warning

Check to see if there are any exposed copper strands coming from the installed wires. When this installation is done correctly there should be no exposed copper wire strands extending from the terminal block. Any exposed wiring can conduct harmful levels of electricity to persons touching the wires. ⚡ E12

8. Slide the plastic cover to the left and lightly tighten the two screws with a #1 Phillips-head screwdriver to secure the cover. See Figure 127 on page 194. You might need to lift the locking handle slightly to access the bottom screw.



#### Caution

Do not over tighten the screws or you may crack or break the plastic cover.



Figure 127. Closing the Plastic Cover over the Terminal Connectors

9. With a #2 Phillips-head screwdriver, tighten the handle locking screw to secure the power supply to the chassis. See Figure 128 on page 195.

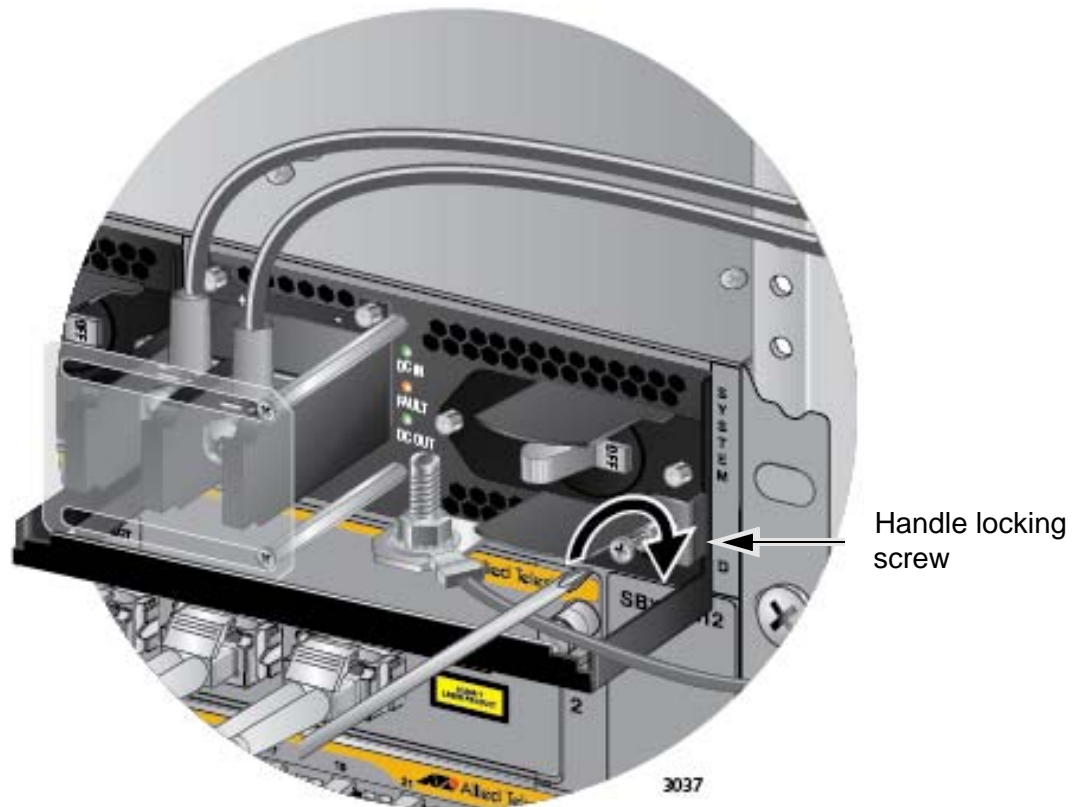

Figure 128. Tightening the Handle Locking Screw

10. Before attaching the power wires from the power supply to the circuit breaker in the wiring closet, check that the circuit breaker is off.
11. Connect the power wires to the circuit breaker.
12. Turn the circuit breaker on.
13. Turn the On/Off switch on the power supply to the On position. See Figure 122 on page 189.
14. Do one of the following:
  - If the chassis has two AT-SBxPWRSYS1 DC Power Supplies, repeat this procedure to power on the second power supply.
  - Otherwise, go to “Monitoring the Initialization Process” on page 206.

## Connecting the DC Power Wires with the Right Angle Terminals

To connect the DC power wires to the positive and negative terminals on the power supply with the right angle terminals, perform the following procedure:

1. Prepare adequate lengths of two stranded 8 AWG power wires by stripping them as shown in Figure 129.



### Warning

Do not strip more than the recommended amount of wire. Stripping more than the recommended amount can create a safety hazard by leaving exposed wire on the terminal block after installation. E10

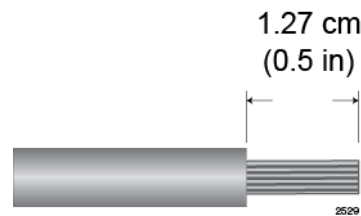

Figure 129. Stripping the Power Wires

### Note

You must use stranded wires with the terminal lugs. You may not use solid wires.

2. Verify that the On/Off switch on the AT-SBxPWRSYS1 DC Power Supply is in the Off position. Refer to Figure 122 on page 189.
3. Insert the power wires into the right angle terminals included with the power supply and use a crimping tool to secure the wires to the terminals. See Figure 130,

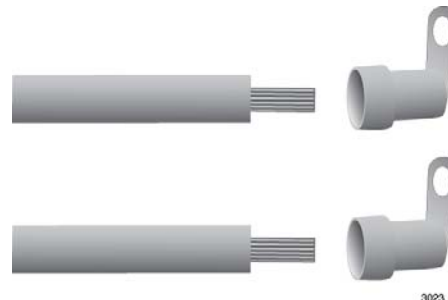

Figure 130. Attaching the Power Wires to the Right Angle Terminals

- Using a #1 Phillips-head screwdriver, remove the two screws that secure the plastic cover over the positive and negative terminals and remove the plastic cover from the power supply, as shown in Figure 131. You may need to lift the locking handle slightly to access the bottom screw.

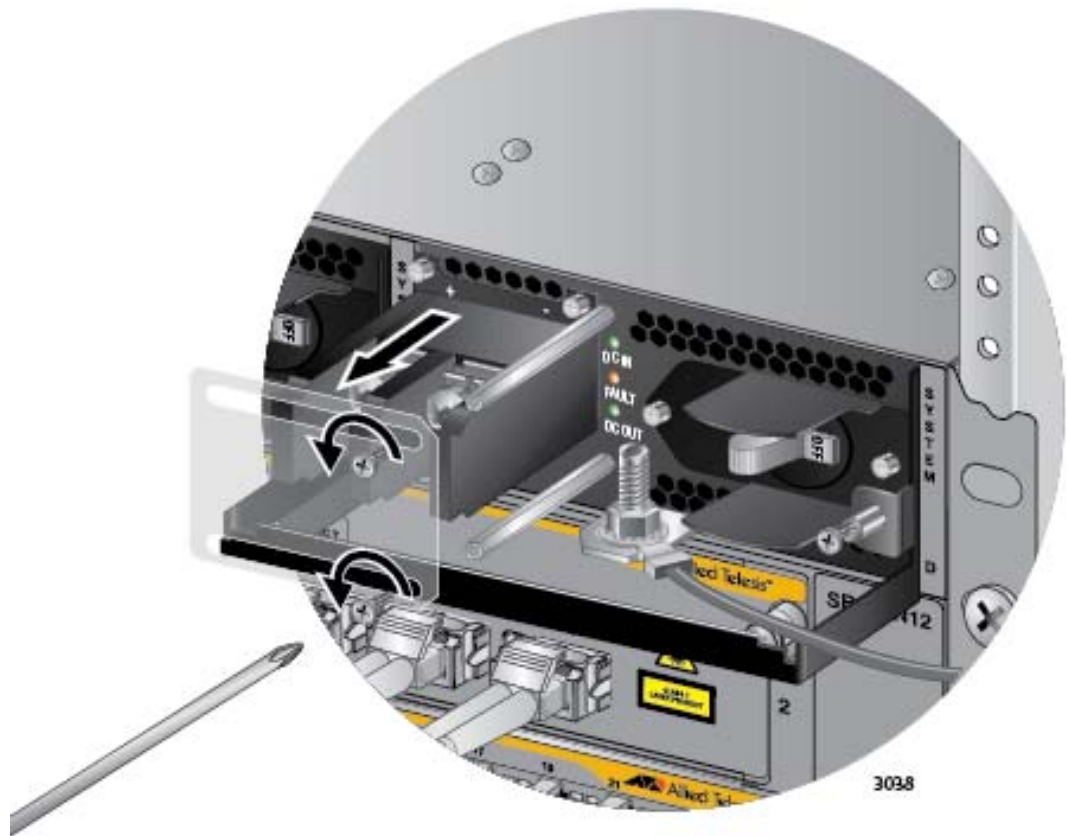

Figure 131. Removing the Plastic Cover

---

**Note**

The plastic cover is not used with the right angle terminals.

---

- Use a #3 Phillips-head screwdriver to remove the two screws from the positive and negative terminals, as shown in Figure 132 on page 198.



Figure 132. Removing the Terminal Screws

6. With a #3 Phillips-head screwdriver, connect the positive (+) power lead wire to the positive terminal on the power supply, with one of the terminal screws removed in the previous step. The positive terminal is on the left. Refer to Figure 133 on page 199.

Allied Telesis recommends tightening the screw to 30 to 40 inch-lbs.

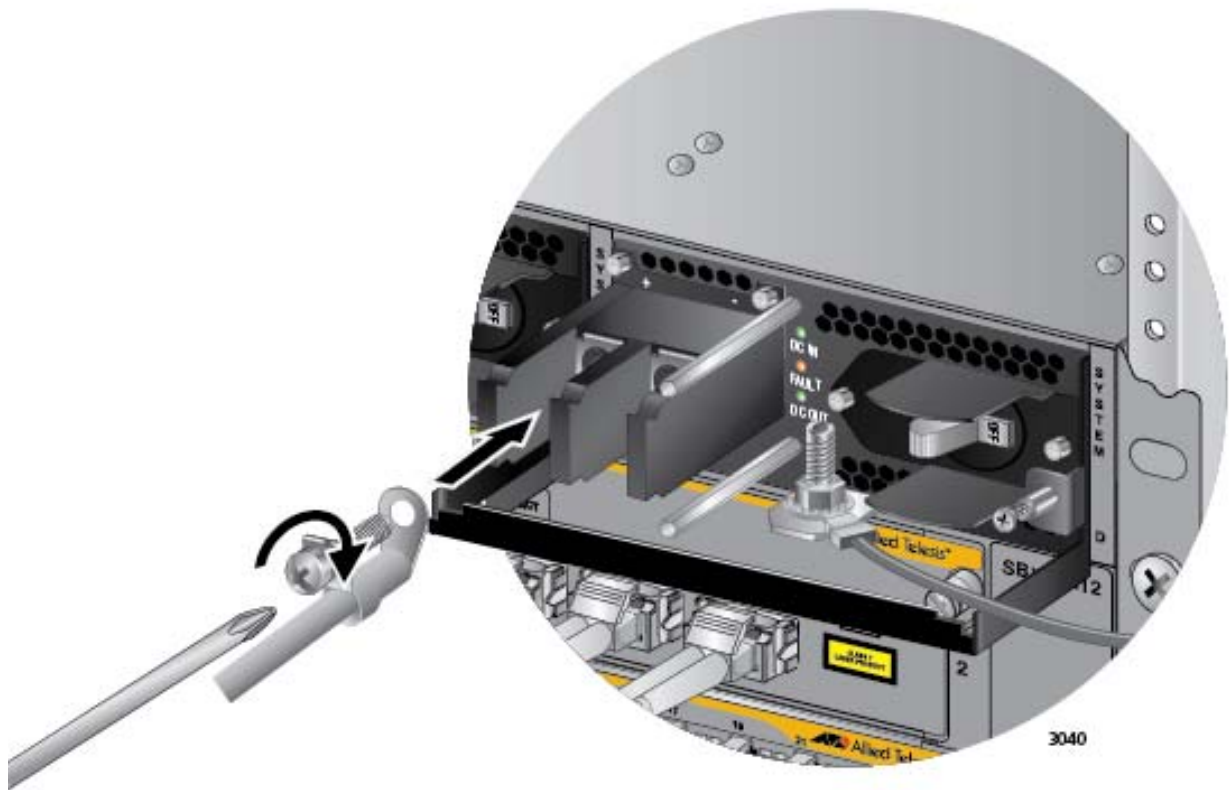

Figure 133. Connecting the Positive (+) Power Wire with a Right Angle Terminal

7. With a #3 Phillips-head screwdriver, connect the negative (-) power lead wire to the negative terminal on the power supply, with the remaining terminal screw removed in step 5. The negative terminal is on the right. Refer to Figure 134 on page 200.

Allied Telesis recommends tightening the screw to 30 to 40 inch-lbs.



Figure 134. Connecting the Negative (-) Power Wire with a Right Angle Terminal



**Warning**

Check to see if there are any exposed copper strands coming from the installed wires. When this installation is done correctly there should be no exposed copper wire strands extending from the terminal block. Any exposed wiring can conduct harmful levels of electricity to persons touching the wires. ⚡ E12

8. With a #2 Phillips-head screwdriver, tighten the handle locking screw to secure the power supply to the chassis. See Figure 135 on page 201.



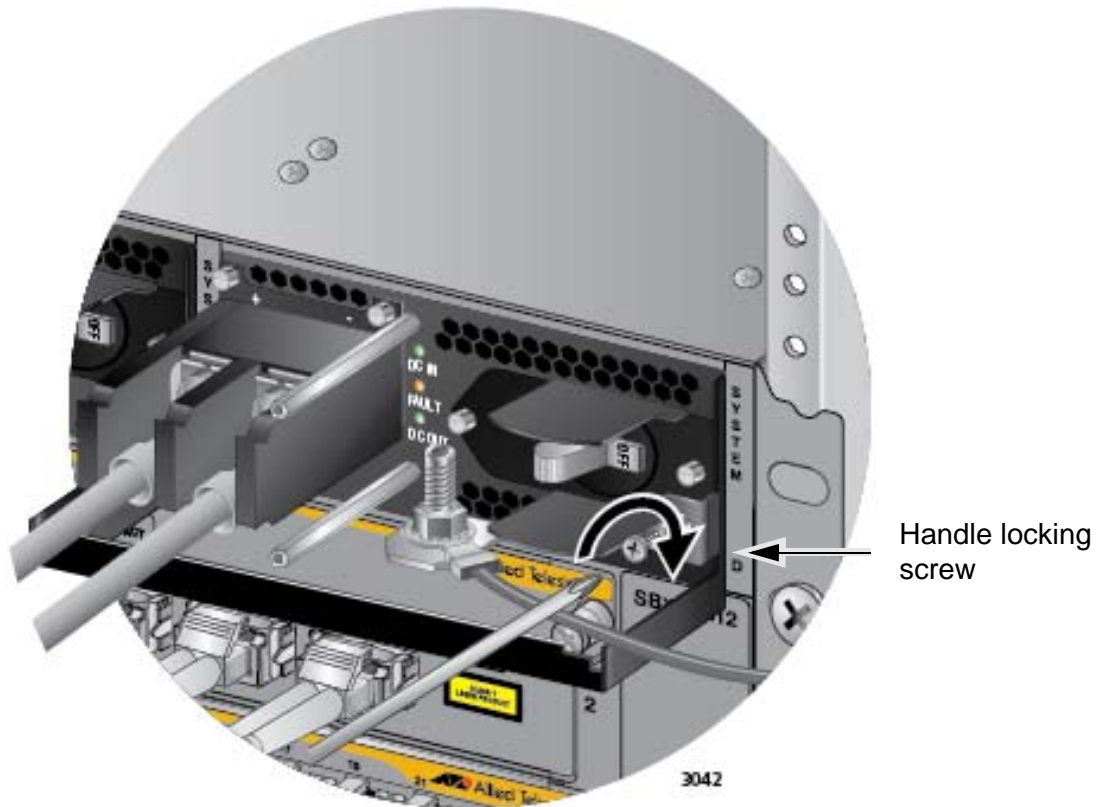

Figure 135. Tightening the Handle Locking Screw

9. Before attaching the power wires from the power supply to the circuit breaker in the wiring closet, check that the circuit breaker is off.
10. Connect the power wires to the circuit breaker.
11. Turn the circuit breaker on.
12. Turn the On/Off switch on the power supply to the On position. See Figure 122 on page 189.
13. Do one of the following:
  - If the chassis has two AT-SBxPWRSYS1 DC Power Supplies, repeat this procedure to power on the second power supply.
  - Otherwise, go to “Monitoring the Initialization Process” on page 206.

## Connecting Bare DC Power Wires

To attach bare lead wires to the positive and negative terminals on the power supply, perform the following procedure:

1. Prepare adequate lengths of two solid or stranded 8 AWG DC power wires by stripping them as shown in Figure 136.

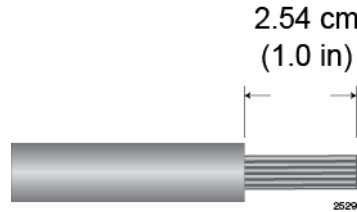

Figure 136. Stripping Solid or Stranded DC Power Wires

2. Use a #1 Phillips-head screwdriver to loosen the two screws on the plastic cover over the positive and negative terminals on the power supply and slide the cover to the right, as shown in Figure 123 on page 190. You may need to lift the locking handle slightly to access the bottom screw.
3. Use a #3 Phillips-head screwdriver to remove the two screws from the positive and negative terminals, as shown in Figure 124 on page 191.
4. Wrap the positive lead wire clockwise around one of the terminal screws and secure the screw and wire to the positive terminal connection on the terminal block with a #3 Phillips-head screwdriver. The positive terminal is on the left.

You may attach the wire to the terminal so that it extends either above or below the terminal block. Figure 137 on page 203 shows the wire above the terminal block. Allied Telesis recommends tightening the screw to 30 to 40 inch-lbs.



Figure 137. Connecting the Positive Wire With Bare Wire

5. Wrap the negative lead wire clockwise around the remaining terminal screw and secure the screw and wire to the negative terminal connection on the terminal block with a #3 Phillips-head screwdriver, as shown in Figure 138 on page 204. The negative terminal is on the right.



Figure 138. Connecting the Negative Lead Wire with Bare Wire

Allied Telesis recommends tightening the screw to 30 to 40 inch-lbs.



**Warning**

Check to see if there are any exposed copper strands coming from the installed wires. When this installation is done correctly there should be no exposed copper wire strands extending from the terminal block. Any exposed wiring can conduct harmful levels of electricity to persons touching the wires. *ES* E12

6. Slide the plastic cover to the left and lightly tighten the two screws with a #1 Phillips-head screwdriver to secure the cover. See Figure 127 on page 194. You might need to lift the locking handle slightly to access the bottom screw.



**Caution**

Do not over tighten the screws or you may crack or break the plastic cover.

7. With a #2 Phillips-head screwdriver, tighten the handle locking screw to secure the power supply to the chassis. See Figure 128 on page 195.
8. Before attaching the power wires from the power supply to the circuit breaker in the wiring closet, check that the circuit breaker is off.
9. Connect the power wires to the circuit breaker.
10. Turn the circuit breaker on.
11. Turn the On/Off switch on the power supply to the On position. See Figure 122 on page 189.
12. Do one of the following:
  - If the chassis has two AT-SBxPWRSYS1 DC Power Supplies, repeat this procedure to power on the second power supply.
  - Otherwise, go to “Monitoring the Initialization Process” on page 206.

## Monitoring the Initialization Process

---

The line and controller cards perform an initialization process whenever you power or reset the chassis. The initialization process takes approximately two minutes to complete. The line cards do not begin to forward traffic from their ports until the process is finished.

The process has two phases:

- ❑ In the first phase, which takes approximately one minute, the controller card loads and initializes its AlliedWare Plus Operating System and, if there are two controller cards in the chassis, set its active or standby state.
- ❑ In the second phase, the Ethernet line cards receive their management software from the active controller card, initialize the software, and configure their parameter settings according to the configurations provided by the active controller card. After this phase, which takes one minute, the line cards begin to forward traffic.

You can monitor the initialization process by viewing either the LEDs on the cards or the messages on the Console port, as explained in the following sections

### Using the LEDs to Monitor the Initialization Process

To monitor the first phase of the initialization process in which the controller card initializes its AlliedWare Plus Operating System and establishes its active master or standby master state, examine the CFC LED in the System Status LEDs on the card. The LED flashes green while the card initializes its management software. When this phase is finished, the card changes the LED to solid green if it is the active master or solid amber if it is the standby master.

To monitor phase 2 in which the line cards initialize and configure their management software, watch the SBx Linecard Status LEDs. There are twelve LEDs (numbered 1 to 12), one for each slot. The LED for a slot flashes green while the corresponding line card initializes its management software and configures its settings in accordance with the settings from the active controller card. The LED changes to solid green when the line card completes the initialization process and begins forwarding traffic.

### Using the Console Port to Monitor the Initialization Process

Another way to monitor the initialization process of the chassis is to connect a terminal or PC with a terminal emulator program to the Console port on the controller card and watch the status messages. If the chassis has two controller cards, you should use the Console port on the controller card in slot 5. (The settings for the terminal or terminal emulator program are found in “Using Local Management to Verify the Chassis” on page 212.) Figure 139 on page 207 and Figure 140 on page 208 illustrate the messages. The controller and line cards are fully initialized and



```
Received event vcs.elected-slave
08:24:44 awplus-5 chassis[1492]: Card has booted as one off boot, SW version
au.

auth, bgpd, cntrd, epsr, exfx, hostd, hsl
imi, imiproxyd, irdpd, lacp, lldpd, loopprot, mstp
nsm, openhpid, ospf6d, ospfd, pdmd, pimd, ripd
ripngd, rmon, sflowd, vrrpd
.
.
.
Received event network.active

Loading configuration file from active CFC, please wait.
.

done!
Received event network.configured

awplus login:
```

Figure 140. Initialization Messages (Continued)



## Chapter 10

# Verifying the Hardware Operations of the Chassis

---

This chapter describes how to verify the operations of the chassis. The chapter contains the following sections:

- “Using the LEDs to Verify the Chassis” on page 210
- “Using Local Management to Verify the Chassis” on page 212

---

**Note**

Allied Telesis recommends using both methods to confirm the initial operations of the chassis, controller cards, and line cards.

---

## Using the LEDs to Verify the Chassis

---

After powering on the chassis for the first time and waiting a minimum of three minutes for the line and controller cards to complete the initialization process, check the operational status of the various hardware components by examining the LEDs, as explained in this procedure:

1. Check the LEDs on the power supplies:
  - ❑ AT-SBxPWRSYS1, AT-SBxPWRSYS2, and AT-SBxPWRPOE1 AC Power Supplies: The power supplies are operating properly when the AC and DC LEDs are solid green and Fault LEDs are off. If there is a problem, refer to “AT-SBxPWRSYS1, AT-SBxPWRSYS2, and AT-SBxPWRPOE1 Power Supplies” on page 216 for troubleshooting suggestions.
  - ❑ AT-SBxPWRSYS1 DC Power Supply: The power supply is operating properly when the DC IN and DC OUT LEDs are solid green and the Fault LED is off. If there is a problem, refer to “AT-SBxPWRSYS1 DC System Power Supply” on page 218 for troubleshooting suggestions.
2. Check the Power LED on the AT-SBxFAN12 module. The module is operating normally when the LED is solid green. If the LED is off, the fan module has a problem or failed. Power off the chassis and contact your Allied Telesis representative for assistance. Do not operate the chassis without a fully operational fan unit.
3. If the chassis has one controller card, check the CFC LED on the card. It should be solid green. If the LED is flashing green, the card is still initializing its AlliedWare Plus Operating System. Wait another minute and check the LED again. If the LED is still flashing green, the card may have encountered a problem that prevents it from completing the initialization process. Power off the chassis and replace the controller card.

---

### Note

If all the LEDs on the controller card are off, they may have been turned off. Try pressing the eco-friendly button on the card to turn them on.

---

4. If the chassis has two controller cards, check the CFC LEDs on both cards. The cards are operating correctly when the LEDs are solid green on one card and solid amber on the other. If both LEDs are flashing green, the controller cards are still completing the initialization process. If the LEDs do not change to solid green and amber after another minute, the cards may have encountered a problem that

prevents them from completing the initialization process. Power off the chassis and replace the cards.

5. To check the status of the Ethernet line cards, inspect the SBx Linecard Status LEDs on the controller card. (If the chassis has two controller cards, you may use the LEDs on either card.) A line card is operating normally when its corresponding LED is solid green. The LED flashes green as the card initializes its management software. If an LED is flashing green after two minutes, the corresponding line card may have a problem and cannot complete the initialization process. For example, the line card in slot 8 of the chassis is operating normally when the SBx Linecard Status, number 8 LED is solid green. For troubleshooting suggestions, refer to “Ethernet Line Cards” on page 220.
6. To check the status of the links of the individual ports on the line cards, inspect the L/A LEDs on the cards. The LEDs should be solid or flashing green on ports that are connected to active network devices. If there is a problem with a link, refer to “Twisted Pair Ports” on page 222 and “Fiber Optic or Twisted Pair Transceivers” on page 226 for troubleshooting suggestions.
7. To check the status of PoE on the ports of the AT-SBx81GP24 Line Card, use the PoE LEDs, shown in Figure 18 on page 42. The LEDs are solid green when ports are delivering power to powered devices on your network. If there is a problem, refer to “Power Over Ethernet” on page 224 for troubleshooting suggestions.

## Using Local Management to Verify the Chassis

---

This section explains how to use the commands in the AlliedWare Plus Operating System on the controller card to confirm the operations of the chassis. The section has the following procedure:

- ❑ “Starting a Local Management Session” on page 212
- ❑ “Entering the AlliedWare Plus Operating System Commands” on page 213

The initial management session of the switch must be a local management session. For instructions on how to configure the chassis for remote management with a Telnet or Secure Shell client, refer to the *Software Reference for SwitchBlade x8100 Series Switches*.

### Starting a Local Management Session

To start a local management session, perform the following procedure:

1. Connect the RJ-45 end of the management card included with the AT-SBx81CFC400 Controller Fabric Card to the Console RS-232 port on the front panel of the AT-SBx81CFC400 Control Card, as shown in Figure 141. If the chassis has two controller cards, you may use the Console RS-232 port on either card to establish a local management session with the chassis.

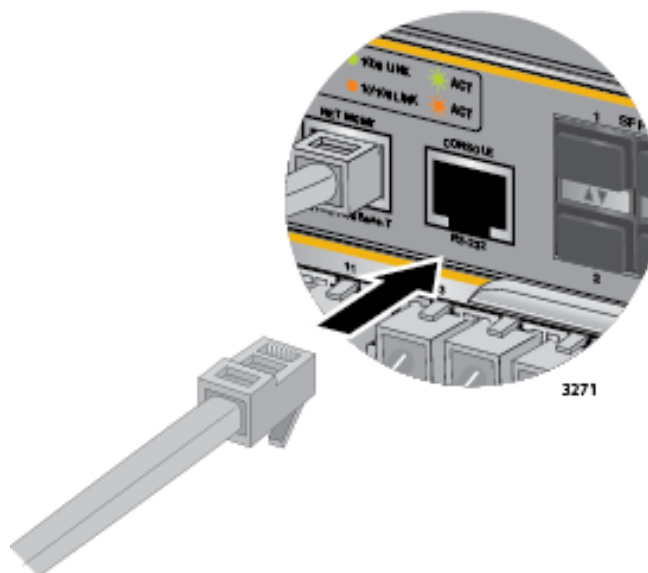

Figure 141. Connecting the Management Cable to the Console RS-232 Port

2. Connect the other end of the cable to an RS-232 port on a terminal or personal computer with a terminal emulation program.

- Configure the VT-100 terminal or terminal emulation program as follows:

- Baud rate: 115,200 bps
- Data bits: 8
- Parity: None
- Stop bits: 1
- Flow controller: None

---

**Note**

The port settings are for a DEC VT100 or ANSI terminal, or an equivalent terminal emulator program.

---

- Press Enter. You are prompted for a user name and password.
- Enter the default user name and password. They are “manager” and “friend” (without the quotes), respectively

---

**Note**

User names and passwords are case sensitive.

---

The local management session starts and the command line interface (CLI) prompt is displayed.

## Entering the AlliedWare Plus Operating System Commands

To confirm the operations of the chassis with the commands in the AlliedWare Plus Operating System, perform the following procedure:

- Enter the SHOW VERSION command in the User Exec or Privileged Exec mode to display the software version number of the management software on the controller card. An example of the command is shown in Figure 142.

```
awplus# show version
AlliedWare Plus (TM) 5.4.5-1
Build name : SBx81CFC400-5.4.5-1.rel ← Software Version Number
Build date : Wed Oct 15 12:13:19 NZDR 2015
Build type : RELEASE
NEW-SNMP SNMP agent software
(c) 1996, 1998-2000 The Regents of the University of California.
All rights reserved;
.
.
.
```

Figure 142. SHOW VERSION Command

2. Compare the version number displayed by the `SHOW VERSION` command with the information in Table 25 on page 82 to confirm that the version of the AlliedWare Plus Operating System on the controller card supports all the hardware components in the chassis. If necessary, update the management software on the controller card.
3. To display the status of the power supplies, fan module, and AT-SBx81CFC400 Controller Fabric Cards, use the `SHOW SYSTEM ENVIRONMENT` command in the User Exec or Privileged Exec mode. The Status column in the display provides the states of the modules. Components are operating normally when they have an “Ok” status.
4. To display the status of the line cards, use the `SHOW CARD` command in the Privileged Exec mode. A line card has a state of “Online” when it is operating normally. An example of the status information is shown in Figure 143.

```
awpl us# show card
```

Slot	Card Type	State
1	AT-SBx81GP24	Online
2	AT-SBx81XS6	Online
3	AT-SBx81GP24	Online
4	AT-SBx81GS24a	Online
5	AT-SBx81CFC400	Online (Active)
6	AT-SBx81CFC400	Online (Standby)
7	AT-SBx81GP24	Online
8	AT-SBx81GS24a	Online
9	AT-SBx81GP24	Online
10	AT-SBx81XS6	Online
11	AT-SBx81GP24	Online
12	AT-SBx81GS24a	Online

Figure 143. SHOW CARD Command

5. To display the states of the individual ports on the Ethernet line cards, use the `SHOW INTERFACE STATUS` command in the Privileged Exec mode.
6. To check the status of PoE on the ports of the AT-SBx81GP24 Line Card, use the `SHOW POWER-INLINE` or `SHOW POWER-INLINE INTERFACE` command in the User Exec or Privileged Exec mode.

For information about the command line interface, refer to the *Software Reference for SwitchBlade x8100 Series Switches* on the Allied Telesis web site.

## Chapter 11

# Troubleshooting

---

This chapter contains information on how to troubleshoot the SwitchBlade x8112 product.

---

**Note**

If you are unable to resolve a hardware problem with the instructions in this chapter, contact Allied Telesis Technical Support for further assistance. Refer to “Contacting Allied Telesis” on page 17 for contact information.

---

The following troubleshooting information is available:

- ❑ “AT-SBxPWRSYS1, AT-SBxPWRSYS2, and AT-SBxPWRPOE1 Power Supplies” on page 216
- ❑ “AT-SBxPWRSYS1 DC System Power Supply” on page 218
- ❑ “Ethernet Line Cards” on page 220
- ❑ “Twisted Pair Ports” on page 222
- ❑ “Power Over Ethernet” on page 224
- ❑ “Fiber Optic or Twisted Pair Transceivers” on page 226
- ❑ “AT-SBx81CFC400 Controller Fabric Card” on page 228
- ❑ “AT-SBxFAN12 Fan Module” on page 229
- ❑ “Local (Console) Management Session” on page 230
- ❑ “Power Supply Interfaces (Opto-couplers)” on page 231

## AT-SBxPWRSYS1, AT-SBxPWRSYS2, and AT-SBxPWRPOE1 Power Supplies

---

The AT-SBxPWRSYS1 and AT-SBxPWRSYS2 AC System Power Supplies and AT-SBxPWRPOE1 PoE Power Supply are operating normally when the AC and DC LEDs are solid green and the Fault LED is off. Possible fault conditions and their solutions are described here:

Fault Condition 1: If the AC LED is off, the power supply is not receiving power, has overheated and been disabled, or has failed and needs to be replaced. Try the following:

- ❑ Verify that there is a power cord connected to the power supply's connector on the back panel of the chassis. For example, if a power supply in slot C does not have power, check for a power cord on connector C on the back panel.
- ❑ Verify that the power cord is securely connected to the chassis and the AC power source.
- ❑ Verify that the AC power has power by connecting another device to it.
- ❑ Verify that the power from the AC power source is within the required levels for your region.
- ❑ If the chassis is still operating, use the `SHOW SYSTEM ENVIRONMENT` command from a local or remote management session to determine if the power supply has overheated and shutdown.

Fault Condition 2: If the AC LED is solid green and the DC LED is off, the power unit is generating insufficient DC power. Replace the power supply.

Fault Condition 3: If the Fault LED is solid amber, try the solutions in Fault Condition 1. If they do not resolve the problem, replace the power supply.

---

### Note

The power supplies are hot swappable in a redundant configuration. This allows the AT-SBx8112 Chassis to continue operating while you exchange power supplies.

---

Fault Condition 4: If the LEDs on the power supply indicate normal operations but the PSU LED on the active master controller card is showing a fault condition, the problem may be with one of the two power supply interfaces (opto-couplers) on the rear panel of the chassis. For troubleshooting suggestions, refer to "Power Supply Interfaces (Opto-couplers)" on page 231.





**Caution**

The power supply interfaces are *not* hot swappable and should only be serviced by an authorized service technician.

---

## AT-SBxPWRSYS1 DC System Power Supply

---

If you suspect a problem with the DC power supply, examine its LEDs. The power supply is operating normally when the DC IN and DC OUT LEDs are solid green and the Fault LED is off. Possible fault conditions and their solutions are described here:

Fault Condition 1: If the DC IN LED is off, the power supply is not receiving power, has overheated and been disabled, or has failed and needs to be replaced. Try the following:

- ❑ Verify that the On/Off switch on the power supply is in the On position.
- ❑ Verify that the DC circuit breaker is on.
- ❑ Verify that the positive and negative power wires are correctly and securely connected to the terminal block on the power supply and circuit breaker.
- ❑ Verify that the DC circuit break has power by attaching another device to it.
- ❑ Verify that the power from the DC circuit break is within the required levels of the power supply. Refer to “Power Specifications” on page 273.
- ❑ If the chassis is still operating, use the SHOW SYSTEM ENVIRONMENT command from a local or remote management session to determine if the power supply has overheated and shutdown.

Fault Condition 2: If the DC IN LED is solid green but the DC OUT LED is off, the power unit is generating insufficient DC power. Replace the power supply.

Fault Condition 3: If the Fault LED is solid amber, try the solutions in Fault Condition 1. If they do not resolve the problem, replace the power supply.

---

### Note

The power supply is hot swappable. If the chassis has two power supplies and one of them fails, you do not have to power off the operational power supply to replace the failed unit.

---

Fault Condition 4: If the LEDs on the power supply indicate normal operations but the PSU LED on the active master control card is off or is showing a fault condition, try the following suggestions:

- ❑ The control card may not be able to detect the DC power supply because it is not running the most recent version of the

management software. For instructions on how to verify the software version on the control card, refer to “Using Local Management to Verify the Chassis” on page 212 and “AlliedWare Plus Software Releases for the Hardware Components” on page 82.

- The problem may be with one of the two power supply interfaces (opto-couplers) on the rear panel of the chassis. For troubleshooting suggestions, refer to “Power Supply Interfaces (Opto-couplers)” on page 231.



**Caution**

The power supply interfaces are *not* hot swappable and should only be serviced by an authorized service technician.

---

## Ethernet Line Cards

---

A quick and easy way to check the overall health of the Ethernet line cards in the chassis is with the SBx STATUS LEDs on the controller card. (If the chassis has two controller cards, you may use the LEDs on either card.) There are twelve LEDs, one for each slot. The LEDs are numbered 1 to 12, just like the slots. The cards in the slots are operating normally when the LEDs are green. The Ethernet line card in slot 8 of the chassis, for example, is operating normally when the SBx STATUS LED 8 on the controller card is solid green.

If you suspect a problem with an Ethernet line card or controller card, try the following:

- ❑ If all the L/A LEDs on the card are off, try pressing the eco-friendly button on the active master controller card to verify that the LEDs on the line cards are on.
- ❑ Check the card's status LED in the SBx STATUS LEDs on the controller card. If the LED is flashing amber, the card is initializing its management software. Wait one to two minutes for the card to complete the process. If the LED does not change to green, try installing the line card in a different slot. If the problem remains, the card cannot complete the initialization process. Try installing the card in another chassis with a different controller card.
- ❑ If the card's status LED in the SBx STATUS LEDs on the controller card is solid amber, the card might not be able to boot up because the controller card does not have its load file and needs to be updated.

Here are some other steps to try:

- ❑ Check that the card is completely installed in the slot and that the front plate is flush with the front of the chassis.
- ❑ Try resetting the card with the REBOOT CARD command. The example of the command restarts the card in slot 2:

```
awpl us# reboot card 2
Reboot card 2 system? (y/n)? y
awpl us#
```

- ❑ Try installing the card in a different slot. If it works in the new slot, the problem is with the previous slot.
- ❑ Try installing the card in a different chassis. If it works in the new chassis, the problem is with the previous chassis. If the problem persists, the problem is with the card.
- ❑ Use the SHOW CARD command to display card status information, as shown in Figure 143 on page 214.

If the problem is with the AT-SBx81XLEM Line Card, verify that the version of the AlliedWare Plus Operating System on the AT-SBx81CFC400 Controller Fabric Card supports the card. The card requires version 5.4.6-1 or later. To determine the version number of the operating system on the controller card, start a management session on the chassis and issue the SHOW SYSTEM command in the Privileged Exec mode. If necessary, update the operating system on the controller card.

## Twisted Pair Ports

---

This section applies to the twisted pair ports on the following devices:

- ❑ AT-SBx81GT24 Line Card
- ❑ AT-SBx81GT40 Line Card
- ❑ AT-SBx81GP24 Line Card
- ❑ AT-SBx81XLEM/XT4 Expansion Module

If a twisted pair port is cabled to a network device but its L/A LED is off, try the following:

- ❑ If all the L/A LEDs on the cards are off, try pressing the eco-friendly button on the active master controller card to verify that the LEDs on the line cards are on.
- ❑ Verify that the network device connected to the port is powered on and operating properly.
- ❑ Check that the twisted pair cable is securely connected to the ports on the line card and the end node.
- ❑ Make sure that the twisted pair cable does not exceed 100 m (328 ft).
- ❑ Verify that the twisted-pair cable is the correct type by referring to the appropriate table in “Cable Requirements” on page 56.
- ❑ Verify that the twisted-pair cable is not faulty by replacing it with a known good cable.
- ❑ Make sure that the operating parameters of the ports on the line card and network device are compatible.

If the L/A LED for a port is on, signalling a link to the network device, but link performance is poor or intermittent, the problem may be from a bad cable. Try replacing the cable.

Another source of poor or intermittent performance on a link can be a speed or duplex mode mismatch between a port and network device. Here are some items to consider when resolving this type of problem:

- ❑ The default speed setting for the ports on the AT-SBx81GT24 and AT-SBx81GP24 Line Cards is Auto-Negotiation. This setting is appropriate for ports connected to network devices that also support Auto-Negotiation.
- ❑ The default speed setting of Auto-Negotiation is not appropriate for ports connected to network devices that do not support Auto-Negotiation and have fixed speeds of 10 or 100 Mbps. For those switch ports, you should disable Auto-Negotiation and set the port's speed manually to match the speeds of the network devices.

- ❑ The ports must be set to Auto-Negotiation, the default setting, to operate at 1000Mbps.
- ❑ The default duplex mode setting for the ports is Auto-Negotiation. This setting is appropriate for ports connected to network devices that also support Auto-Negotiation for duplex modes.
- ❑ The default duplex mode setting of Auto-Negotiation is not appropriate for ports connected to network devices that do not support Auto-Negotiation and have a fixed duplex mode. Disable Auto-Negotiation on those ports and set the duplex modes manually to avoid the possibility of duplex mode mismatches. A switch port using Auto-Negotiation defaults to half-duplex if it detects that the end node is not using Auto-Negotiation, which can result in a mismatch if the end node is operating at a fixed duplex mode of full-duplex.

---

**Note**

The AT-SBx81GT40 Line Card and AT-SBx81XLEM/XT4 Expansion Module do not support half-duplex mode.

---

Yet another source for a poor or intermittent link can be a MDI/MDIX wiring configuration mismatch. The wiring configurations of the ports on the AT-SBx81GT24, AT-SBx81GT40, and AT-SBx81GP24 Line Cards are set automatically with automatic MDIX detection when the ports are operating at 10 or 100 Mbps. (Automatic MDIX detection does not apply to the ports when they are operating at 1000 Mbps.) You may not disable this feature on the ports. For automatic MDIX detection to work successfully, the network device connected to a port must also support the feature. If it does not, a port on the switch defaults to MDIX. This may require the use of a crossover cable. Here are the guidelines to choosing straight-through or crossover cables for the ports:

- ❑ You may use straight-through cables on ports that are connected to network devices that operate at 1000 Mbps.
- ❑ You may use straight-through or crossover cables on ports that are connected to network devices that support automatic MDIX detection and that operate at 10 or 100 Mbps.
- ❑ You *must* use straight-through cables on ports that are connected to network devices that have a fixed wiring configuration of MDI and that operate at 10 or 100 Mbps.
- ❑ You *must* use crossover cables on ports that are connected to network devices that have a fixed wiring configuration of MDIX and that operate at 10 or 100 Mbps.

## Power Over Ethernet

---

This section applies only to the AT-SBx81GP24 Line Card. Each port has two LEDs. The left LED provides port link and activity status and the right LED provides PoE status information. The PoE LED is solid green when a port is delivering power to a powered device (PD). The PoE LED of a port that is not delivering power will be flashing amber, steady amber, or off. If a powered device is not receiving power from a port on the line card, try the following:

- ❑ If all the L/A LEDs on the line cards in the chassis are off, try pressing the eco-friendly button on the active master controller card to turn on the LEDs.
- ❑ Check to be sure that the chassis has at least one AT-SBxPWRPOE1 Power Supply and that the unit is operating properly. The AC and DC LEDs should be solid green and the Fault LED should be off. For troubleshooting suggestions, refer to “AT-SBxPWRSYS1, AT-SBxPWRSYS2, and AT-SBxPWRPOE1 Power Supplies” on page 216.
- ❑ Review the PD’s documentation to confirm that it supports Mode A of the IEEE 802.3at standard. Mode A is one of two modes that define the connector pins that deliver the power from the port on the line card to the PD. In Mode A, the power is carried on pins 1, 2, 3, and 6 on the RJ-45 port, the same pins that carry the network traffic. The second mode, Mode B, defines pins 4, 5, 7, and 8 as the power carriers. The AT-SBx81GP24 Line Card does not support Mode B. Most powered devices are designed to accept power by either mode, but some legacy devices may only support one mode. This can be verified by reviewing the device’s documentation or data sheet. Legacy devices that only support Mode B will not work with this line card.
- ❑ Review the device’s documentation or data sheet to confirm that its power requirements do not exceed 30 W.
- ❑ Verify that you are using the appropriate category of twisted-pair cable by referring to Table 17 on page 57.
- ❑ Try replacing the twisted-pair cable, as explained in “Cabling Guidelines for the Twisted Pair Ports” on page 152.
- ❑ Use the `SHOW POWER-INLINE` command in the management software to determine whether PoE is enabled on the port. The default setting for PoE is enabled.
- ❑ Use the `SHOW POWER-INLINE` command to determine whether the PoE power setting for the port has been reduced from the default setting of 30 W, to a value below the power requirements of the device.
- ❑ Use the `SHOW POWER-INLINE` command to determine whether



the switch has reach its maximum power budget.

- ❑ Try connecting the PD to a port on a different AT-SBx81GP24 Line Card.

## Fiber Optic or Twisted Pair Transceivers

---

This section applies to Ethernet line cards and expansion modules with transceiver slots.

The L/A LEDs for transceiver slots should be solid or flashing green when transceiver ports have links to end nodes. If a transceiver is cabled to an end node but the L/A LED is off, try the following:

- ❑ If all the L/A LEDs on the line cards in the chassis are off, try pressing the eco-friendly button on the active master controller card to turn on the LEDs.
- ❑ Check that the transceiver is firmly inserted into the slot on the line or controller card.
- ❑ Check that both ends of the cable are securely connected to the ports on the transceiver and end node.
- ❑ Verify that the end node is powered on and operating properly.
- ❑ Verify that the switch supports the transceiver. A list of supported transceivers can be found in the SwitchBlade x8112 data sheet on the Allied Telesis web site. You should also check the error log for the following message:

```
port n.n.n doesn't support this module type.
```

The message indicates that the switch does not support the designated transceiver.

---

### Note

The AT-SBx81XLEM/Q2 Module supports revision B of the AT-QSFPSR4 transceiver. It does not support revision A. The revision level of the transceiver is printed on the transceiver label, after the serial number. You can also display it with the `SHOW SYSTEM PLUGGABLE DETAIL` command in the AlliedWare Plus operating system.

---

- ❑ Try replacing the cable.
- ❑ Review the operating specifications of the transceiver and end node to verify that the devices have the same speed and duplex mode.
- ❑ Check that the operating specifications, including wavelength and maximum operating distance, of the transceiver are compatible with the fiber optic port on the end node.
- ❑ Make sure that you are using the appropriate type of fiber optic cable and that the cable length does not exceed the allowed maximum distance. The cable specifications for the transceivers are provided in the installation instructions that ship with the

modules.

- ❑ Use a fiber optic tester to test whether the optical signal is too weak (i.e., sensitivity) or too strong (i.e., maximum input power). The operating specifications of the fiber optic transceivers are shipped with the units.
- ❑ Check the two strands of the fiber optic cable to be sure that the receive fiber connector is connected to the transmit connector on the remote end node, and that the transmit fiber connector is connected to the receive connector on the end node.

## AT-SBx81CFC400 Controller Fabric Card

---

If the chassis has one controller card and the card fails, all network operations stop. The Ethernet line cards stop forwarding all network traffic until the controller card is replaced.

If the chassis has two controller cards and one fails, the Ethernet line cards continue to forward traffic, but the bandwidth of the backplane is reduced, which, depending on the number of Ethernet line cards present and the amount of traffic traversing the backplane, may result in slower network operations.

If the chassis has one controller card, examine the M/S LED on the card. The LED should be solid green. If the LED is flashing amber, the card is initializing its management software. Wait one or two minutes for the card to complete the process and check the LED again. If it has not changed to solid green, the card cannot complete the initialization process. Try moving the controller card to the other controller card slot, slot 5 or 6, to see if it works in a different slot. You might also try connecting a terminal or PC with a terminal emulator program to the Console RS232 port to watch for any error messages.

If the chassis has two controller cards, check the M/S LEDs on both cards. The LEDs should be solid green on one card and solid or flashing amber on the other card. If the LEDs are both flashing amber, they are initializing their management software. Wait one or two minutes for the cards to complete the process and check the LEDs again. If both LEDs are still flashing amber, the cards cannot complete the initialization process. Try replacing the cards.

The controller card has an onboard battery to maintain the date and time when the chassis is powered off or reset. If you manually set the date and time but the card loses the information after you power off or reset the unit, you may have forgotten to remove the battery insulator when you installed the card in the chassis. The insulator is shown in Figure 67 on page 132. The only way to remedy the problem is to remove the controller card from the chassis and remove the battery insulator. If the chassis has only one controller card, removing the card causes the Ethernet line cards to stop forwarding traffic.

## AT-SBxFAN12 Fan Module

---

The AT-SBxFAN12 Fan Module is operating correctly when the POWER LED on the module is solid green. If the LED on the fan module is off, check the FAN LED in the SYS STATUS section on the active master controller card. The LED should be green. If the FAN LED is off or flashing amber, one or more fans in the module are no longer operating properly. You may also view the status of the unit with the SHOW SYSTEM ENVIRONMENT command in the management software.

You may notice changes in the fan speeds. This is normal. The active master controller card automatically adjusts the fan speeds according to the internal temperature of the chassis.

---

**Note**

The AT-SBxFAN12 Fan Module is hot swappable. You do not have to power off the AT-SBx8112 Chassis to replace the module.

---

## Local (Console) Management Session

---

If you are unable to establish a local management session with the switch through the Console RS-232 port on the controller card, do the following:

- ❑ Check to be sure that the RJ-45 serial management cable is securely connected to the Console RS-232 port on the active master controller card and the RS-232 port on the terminal or personal computer.
- ❑ If the chassis has two controller cards, you should be able to use the Console RS-232 port on either card to establish a local management session with the chassis. If you are unsuccessful establishing a session on one of the controller cards, try connecting to the Console RS-232 port on the other card.
- ❑ Check to be sure that the operating parameters on the terminal or the terminal emulation program, if you are using a personal computer, have been set correctly. The default settings for the RJ-45 serial terminal port are located in “Using Local Management to Verify the Chassis” on page 212.
- ❑ Check to be sure that the terminal emulator application is compatible with a VT-100 terminal.

## Power Supply Interfaces (Opto-couplers)

---

The two power supply interfaces in the lower right corner of the rear panel are used by the active master controller card to obtain status information from the power supplies. The interfaces are shown in Figure 9 on page 30.

Each power supply interface supports two power units. The top interface supports the power supplies in slots A and C. The bottom interface supports the supplies in slots B and D.

An interface is operating normally when its Power LED is solid green. The LED of an interface is off if the two corresponding power supply slots are empty or the power supplies are not powered on. For example, the LED for the bottom interface will be off if power supply slots B and D are empty or the power supplies are off.

The network operations of the chassis are not affected if one or both of the interfaces fail. However, the active master controller card changes the PSU LED to flashing amber to signal that it cannot communicate with the power supplies.

---

### Note

The power supply interfaces are *not* hot swappable and can only be serviced by an authorized service technician.

---

If the Power LED on a power supply interface is off, do the following:

1. Check that there are power supplies in the corresponding slots in the front panel and that the power supplies are powered on. (The Power LED on an interface is off when the slots are empty or the power supplies are not powered on.)
2. Inspect the LEDs on the power supplies to check for a fault condition. If there is a fault condition, go to “AT-SBxPWRSYS1, AT-SBxPWRSYS2, and AT-SBxPWRPOE1 Power Supplies” on page 216 for troubleshooting suggestions. If the LEDs indicate the power supplies are operating normally, go to step 3.
3. Check the PSU LED on the active master controller card. If the LED is solid green, the power supplies and interfaces are operating normally. No corrective steps are required. If the PSU LED is solid amber but the LEDs on the power supplies indicate normal operations, there may be a problem with a power supply interface. Contact your Allied Telesis sales representative for assistance.





## Chapter 12

# Replacing Modules

---

This chapter contains procedures on how to replace modules from the unit. The chapter has the following sections:

- ❑ “Replacing the AT-SBxPWRSYS1, AT-SBxPWRSYS2, or AT-SBxPWRPOE1 Power Supply” on page 234
- ❑ “Replacing the AT-SBxPWRSYS1 DC Power Supply” on page 240
- ❑ “Replacing Ethernet Line Cards” on page 251
- ❑ “Replacing Expansion Modules in AT-SBx81XLEM Line Cards” on page 253
- ❑ “Replacing the AT-SBx81CFC400 Controller Fabric Card” on page 259
- ❑ “Replacing the AT-SBxFAN12 Fan Module” on page 261

## Replacing the AT-SBxPWRSYS1, AT-SBxPWRSYS2, or AT-SBxPWRPOE1 Power Supply

---

This section contains the procedure for removing or replacing the AT-SBxPWRSYS1 or AT-SBxPWRSYS2 AC System Power Supply, or the AT-SBxPWRPOE1 PoE Power Supply in the AT-SBx8112 Chassis.

---

**Note**

The illustrations in the procedure show the AT-SBxPWRSYS1 AC System Power Supply from slot D. The procedure is the same for all the power supply slots.

---

---

**Note**

Allied Telesis recommends creating a backup copy of the configuration file in the controller card before removing or replacing a power supply. For instructions, refer to the Software Reference for SwitchBlade x8100 Series Switches on the Allied Telesis web site.

---

---

**Note**

The power supplies are hot swappable.

---



---

**Caution**

When installing the AT-SBxPWRSYS2 Power Supply in an active, operational chassis, you should connect the AC power cord to the chassis before installing the power supply. Attaching the power cord after installing the AT-SBxPWRSYS2 Power Supply might cause the active master controller card to restart its operating system. This can result in a temporary interruption to network operations of the chassis if it has only one controller card. This guideline does not apply to the AT-SBxPWRSYS1 AC or DC Power Supply or AT-SBxPWRPOE1 Power Supply.

---

To remove power supplies from the chassis, perform the following procedure:

1. Disconnect the AC power cord for the power supply from the AC power source and the corresponding AC socket on the back panel of the chassis. The figure in Figure 144 on page 235 shows the removal of the power cord from connector D, which corresponds to slot D on the front panel.



Figure 144. Disconnecting the AC Power Cord from the AC Socket on the Back Panel

2. Lift the locking hand on the power supply. Refer to Figure 145 on page 236.



Figure 145. Lifting the Locking Handle on the Power Supply

3. Carefully pull on the locking handle to slide the power supply from the chassis. Refer to Figure 146 on page 237.



**Warning**

The power supply is heavy. Use both hands to hold the module as you remove it from the chassis.



Figure 146. Removing the Power Supply from the Chassis

4. Do one of the following:
  - To install a new power supply, refer to Chapter 6, “Installing the Power Supplies” on page 107.
  - If you are not installing a new power supply, continue with the rest of this procedure to install a blank slot cover.
5. Place the locking handle on the slot cover in the up position and slide the cover into the empty power supply slot, as shown in Figure 147 on page 238.

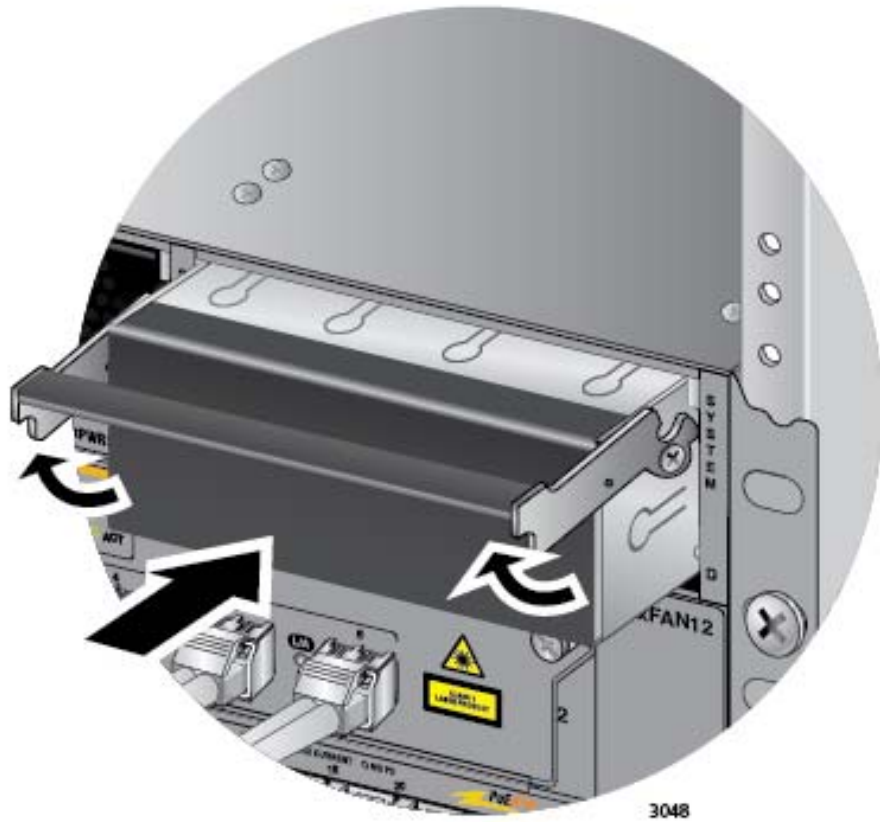

Figure 147. Installing a Blank Power Supply Slot Cover

6. Lower the locking handle to secure the slot cover to the slot. Refer to Figure 148 on page 239.



Figure 148. Lowering the Locking Handle on the Power Supply Slot Cover

## Replacing the AT-SBxPWRSYS1 DC Power Supply

---

To remove an AT-SBxPWRSYS1 DC Power Supply from the chassis, perform the following procedure:

1. Turn off the circuit breaker to the AT-SBxPWRSYS1 DC Power Supply.
2. Turn off the On/Off switch on the front panel of the power supply. Refer to Figure 110 on page 181.
3. Use a #2 screwdriver to loosen the screw on the locking handle. Refer to Figure 149.

---

**Note**

Do not lift the locking handle yet.

---

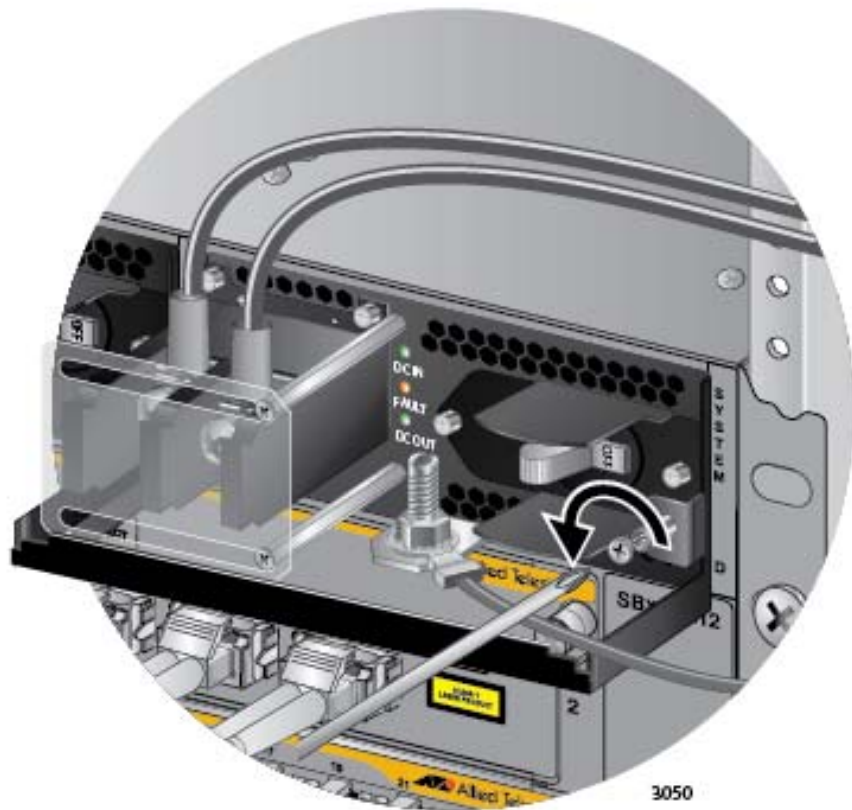

Figure 149. Loosening the Screw on the Locking Handle



**Note**

If the power wires are connected to the terminal block with the right angle terminals, go to step 5.

4. Use a #1 screwdriver to loosen the two screws that secure the plastic cover over the terminal block and slide the cover to the right. You may need to slightly lift the locking handle to access the bottom screw. Refer to Figure 150.

The plastic cover may not be present if you used the right angle terminals to connect the lead wires to the terminal block. If this is the case, you may skip this step.



Figure 150. Opening the Plastic Window over the Terminal Block

5. Use a #3 screwdriver to remove the negative (-) lead wire from the terminal block. The negative lead wire is on the right. Refer to Figure 151 on page 242.

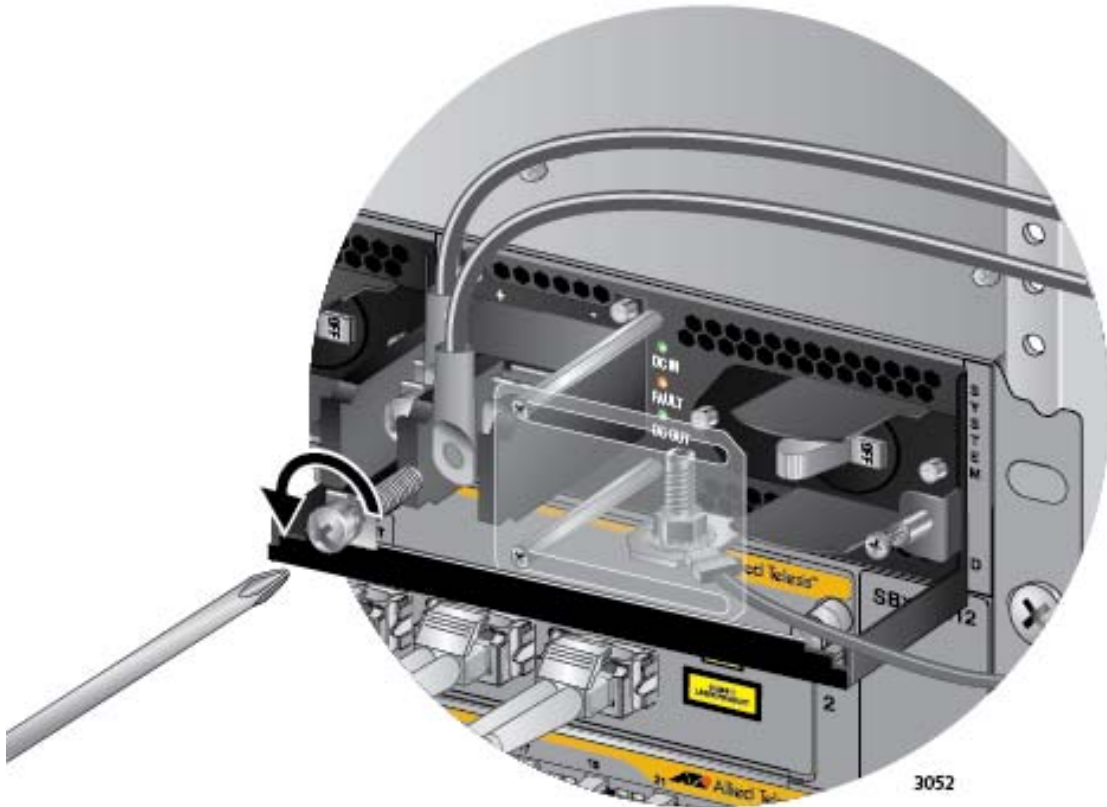

Figure 151. Removing the Negative Lead Wire

6. Use a #3 screwdriver to remove the positive (+) lead wire from the terminal block. Refer to Figure 152 on page 243.



Figure 152. Removing the Positive Lead Wire from the Terminal Block

7. Reinstall the two screws on the negative (-) and positive (+) terminals. Refer to Figure 153 on page 244.



Figure 153. Reinstalling the Screws on the Positive and Negative Terminals

8. Slide the plastic cover to the left and lightly tighten the two screws to secure it in place. Refer to Figure 154 on page 245.



**Caution**

Do not over tighten the screws or you may crack or break the plastic cover.

The plastic cover may not be present if the lead wires were connected to the terminal block with the right angle terminals. If this is the case, you may either skip this step or reinstall the plastic cover on the power supply.



Figure 154. Closing the Plastic Cover

9. Use an 8 mm wrench to remove the grounding wire from the grounding post. Refer to Figure 155 on page 246.

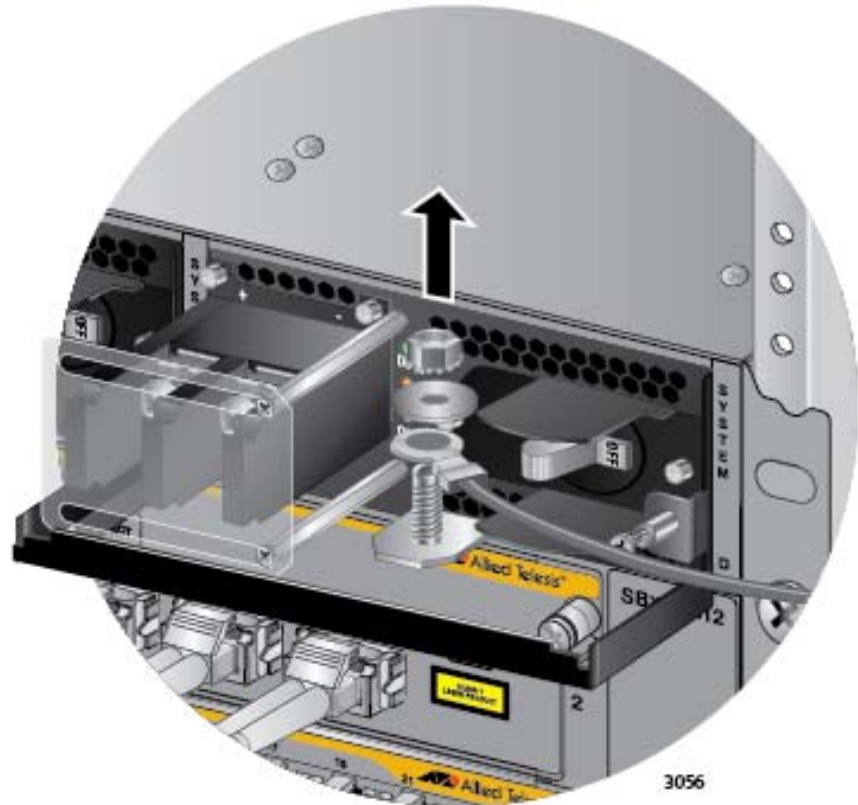

Figure 155. Removing the Grounding Wire

10. Reinstall the nut and washer on the grounding post. Refer to Figure 156 on page 247.

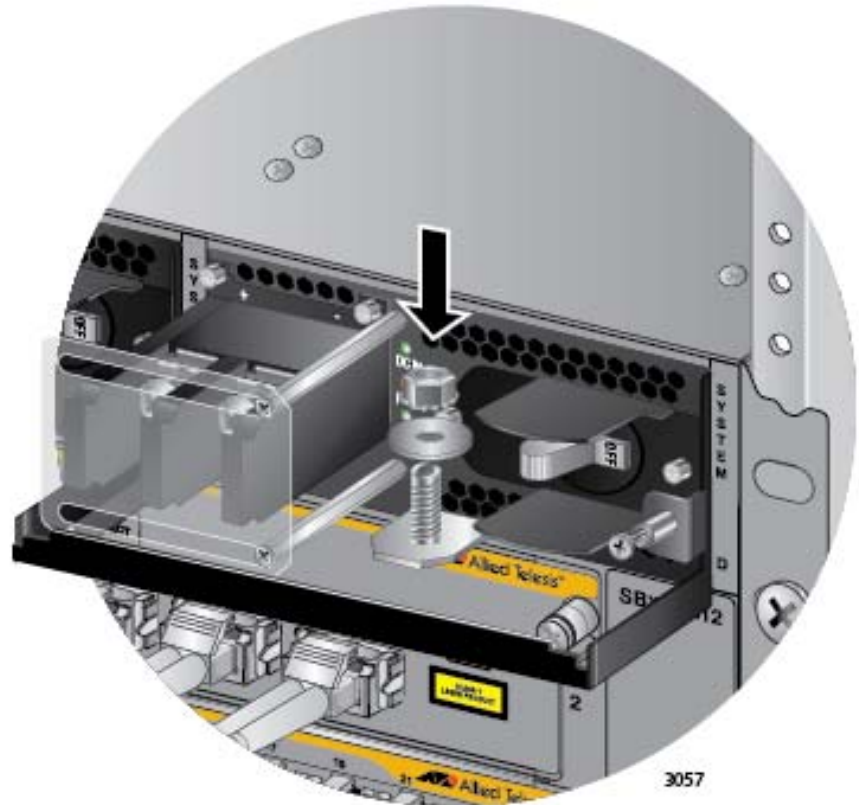

Figure 156. Reinstalling the Nut and Washer on the Grounding Post

11. Lift the locking handle and slide the power supply from the chassis. Refer to Figure 157 on page 248.



**Warning**

The power supply is heavy. Use both hands to hold the module as you remove it from the chassis.

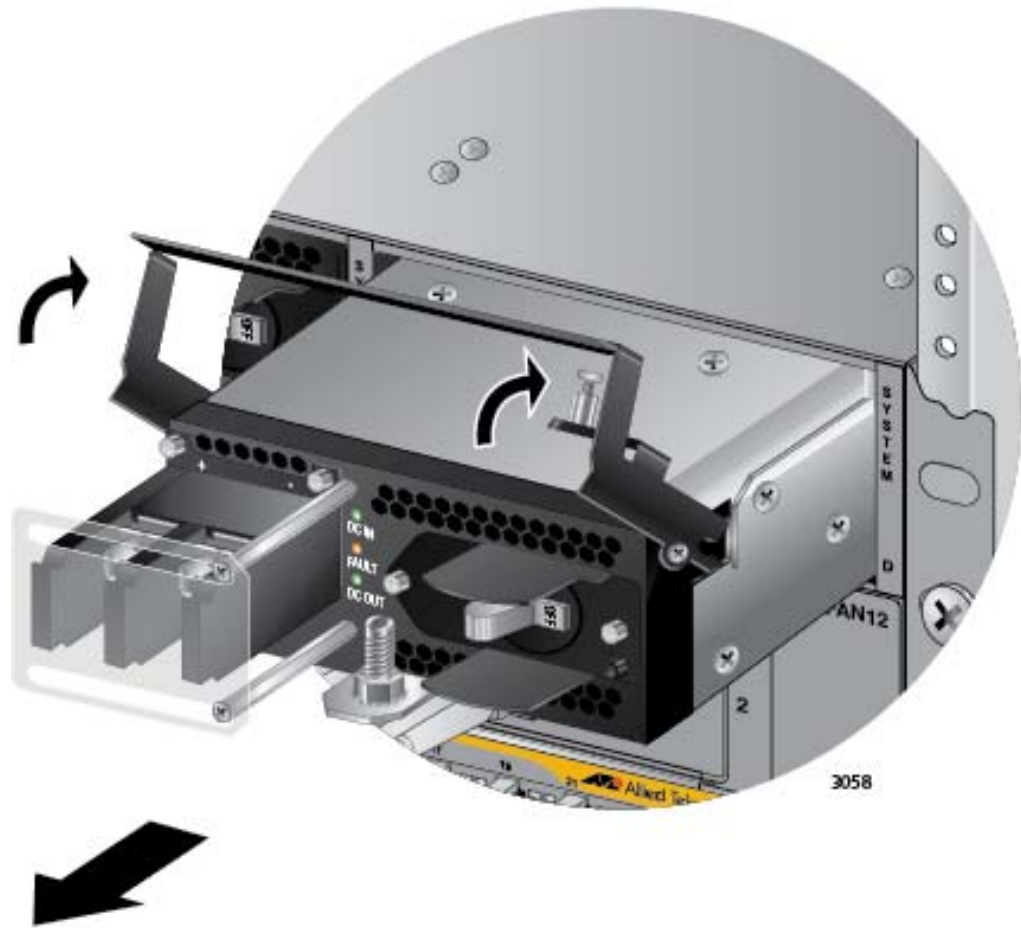

Figure 157. Lifting the Locking Handle and Removing the Power Supply

12. Do one of the following:

- To install a new power supply, refer to Chapter 6, “Installing the Power Supplies” on page 107.
- If you are not installing a new power supply, continue with this procedure to install a blank slot cover.

13. Place the locking handle on the slot cover in the up position and slide the cover into the empty power supply slot. Refer to Figure 158 on page 249.



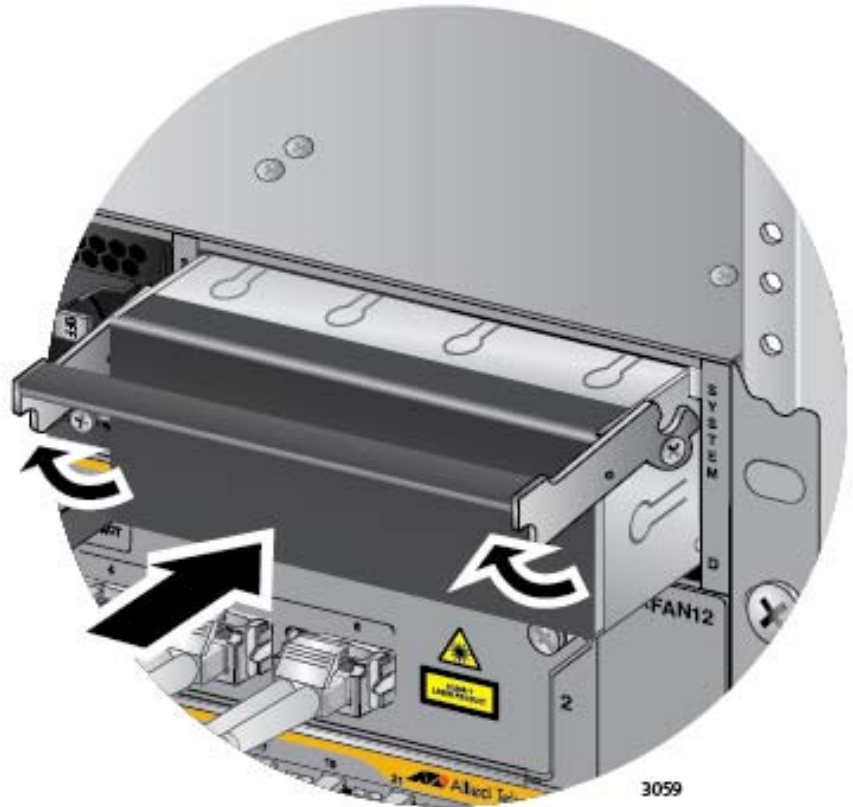

Figure 158. Installing a Blank Power Supply Slot Cover

14. Lower the locking handle to secure the slot cover to the slot. Refer to Figure 159 on page 250.



Figure 159. Lowering the Locking Handle on the Power Supply Slot Cover

## Replacing Ethernet Line Cards

---

This section contains the procedure for replacing Ethernet line cards from the chassis.

---

**Note**

Please review “Guidelines to Handling the Controller and Line Cards” on page 128 before performing this procedure.

---

This procedure requires the following tool:

- #2 Phillips-head screwdriver (not provided)

The Ethernet line cards are hot swappable and can be removed while the chassis is powered on.

To remove an Ethernet line card from the chassis, perform the following procedure:

1. Label and remove the cables from the Ethernet line card.
2. If the line card has fiber optic transceivers, install dust covers on the ports.
3. If the line card has transceivers, label and remove the transceivers.
4. Use a #2 Phillips-head screwdriver to loosen the two screws on the faceplate of the card.
5. Carefully pull on the screws to disconnect the line card from the connector on the backplane.
6. Carefully slide the card from the chassis.

**Caution**

Keep the card level as you slide it out of the chassis. You might damage the components on the top or bottom of the card if you slide it out at an angle. Refer to Figure 63 on page 129.

---

7. Do one of the following:
  - For instructions on how to install the line card in another slot of the chassis or a different chassis, refer to “Installing the Ethernet Line Cards” on page 144.
  - If you do not plan to immediately install another line card in the same slot, you should cover the slot in the chassis with a blank

cover. For instructions, refer to “Installing the Blank Slot Covers” on page 149.

- ❑ If you do not plan to immediately install the card in another chassis, continue with this procedure.
  - ❑ To replace an expansion module in the AT-SBx81XLEM Line Card, go to “Replacing Expansion Modules in AT-SBx81XLEM Line Cards” on page 253.
8. Store the line card in an anti-static bag.
  9. Return the line card to its shipping container.

## Replacing Expansion Modules in AT-SBx81XLEM Line Cards

---

This section contains the procedure for replacing expansion modules in AT-SBx81XLEM Line Cards.

---

**Note**

Please review “Guidelines to Handling the Controller and Line Cards” on page 128 before performing this procedure.

---



---

**Caution**

The expansion modules are not hot-swappable. You must remove the AT-SBx81XLEM Line Card from the chassis to service a module. Installing or replacing a module while the line card is installed in the chassis will damage the devices.

---

This procedure requires the following tools:

- #2 Phillips-head screwdriver (not provided)
- Flat-head screwdriver (not provided)

The illustrations in the procedure show the AT-SBx81XLEM/XS8 expansion module. The procedure is the same for all expansion modules.

To replace an expansion module in the AT-SBx81XLEM Line Card, perform the following procedure:

1. Remove the AT-SBx81XLEM Line Card from the chassis by performing steps 1 to 6 in “Replacing Ethernet Line Cards” on page 251.
2. Place the line card on a level, secure surface.
3. With a Phillips-head screwdriver, remove the two screws that secure the expansion module to the line card. Refer to Figure 160 on page 254.

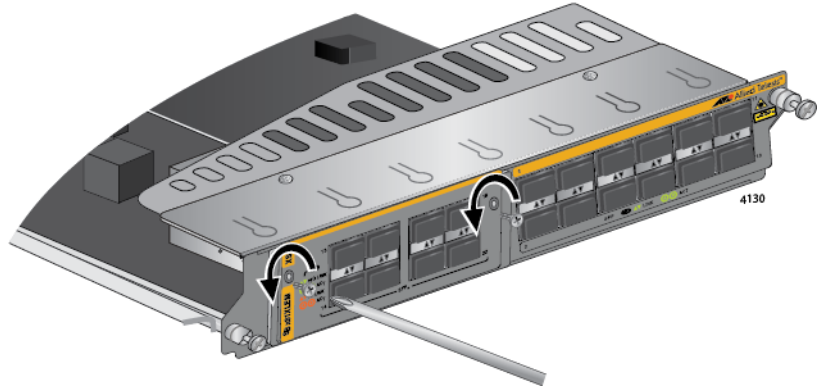

Figure 160. Removing the Screws from the Expansion Module

4. With your thumb and forefinger, pull out the retaining pin on the side of the line card and turn it clockwise one quarter turn until it remains in the retracted position. Refer to Figure 161.

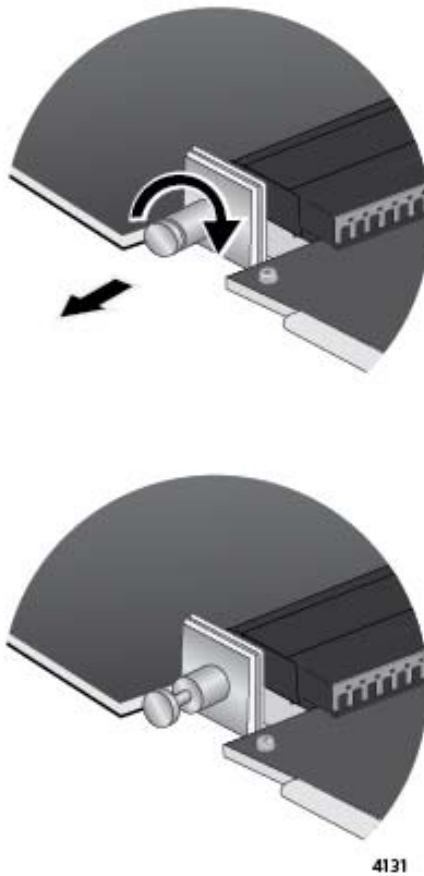

Figure 161. Retracting the Retaining Pin on the AT-SBx81XLEM Line Card

5. Lift the front of the line card and carefully insert the tip of a flathead screwdriver into the slot on the bottom panel of the expansion module. Gently twist the screwdriver to disconnect the module from the connector in the line card. Refer to Figure 162.

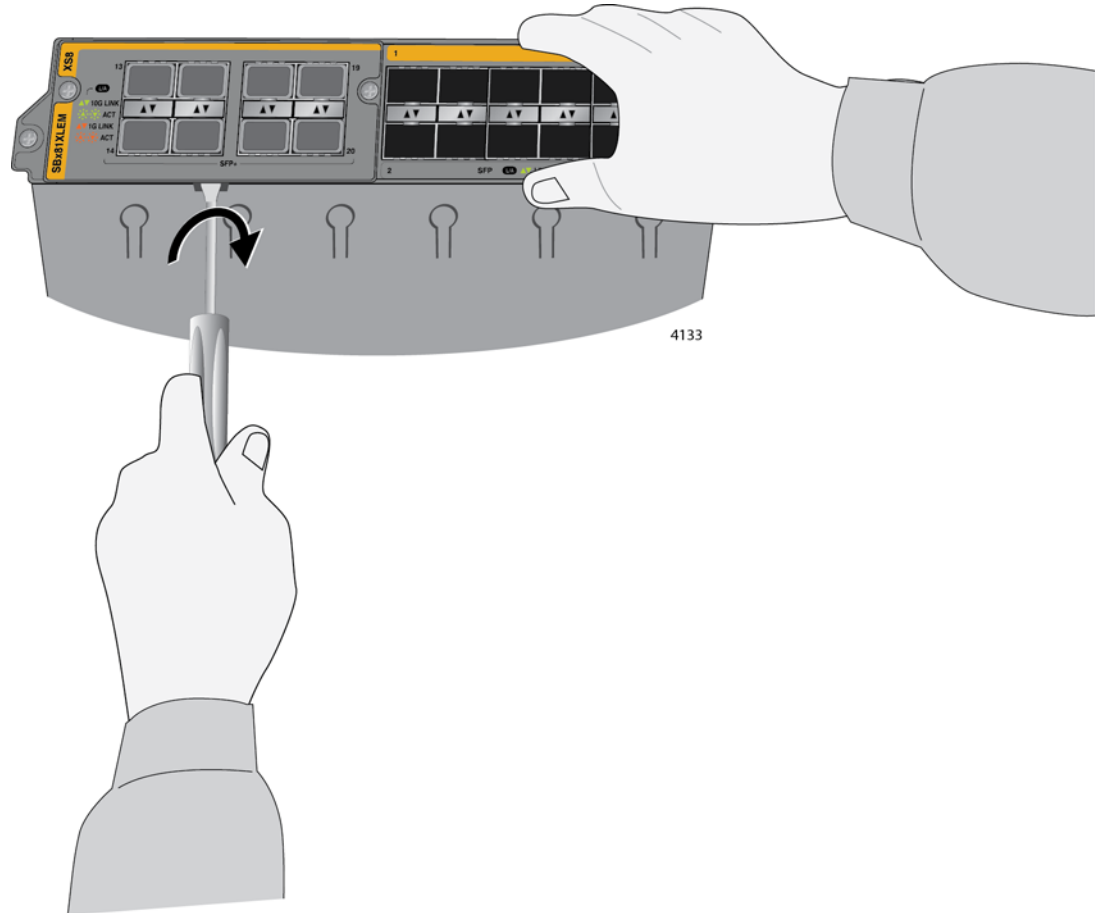

Figure 162. Disconnecting the Expansion Module from the AT-SBx81XLEM Line Card

6. Slide the expansion module from the line card. Refer to Figure 163 on page 256.

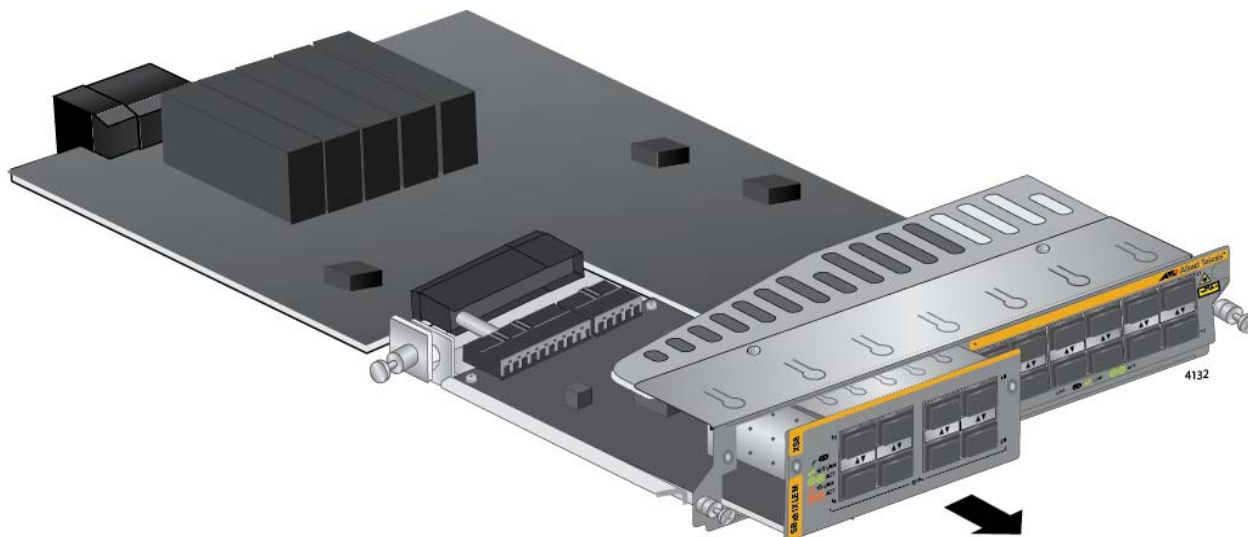

Figure 163. Sliding the Expansion Module from the AT-SBx81XLEM Line Card

7. If you are not installing the expansion module in another AT-SBx81XLEM Line Card, store it in an anti-static bag. Refer to Figure 164.



Figure 164. Storing the Expansion Module in an Anti-static Bag

8. Do one of the following:
  - To install a different expansion module in the line card, go to “Installing Expansion Modules in AT-SBx81XLEM Ethernet Line Cards” on page 136 and start with step 7.
  - To install the line card in the chassis without an expansion module, continue with this procedure.
9. Slide the blank slot cover that comes with the line card into the slot on the card. Refer to Figure 165 on page 257.



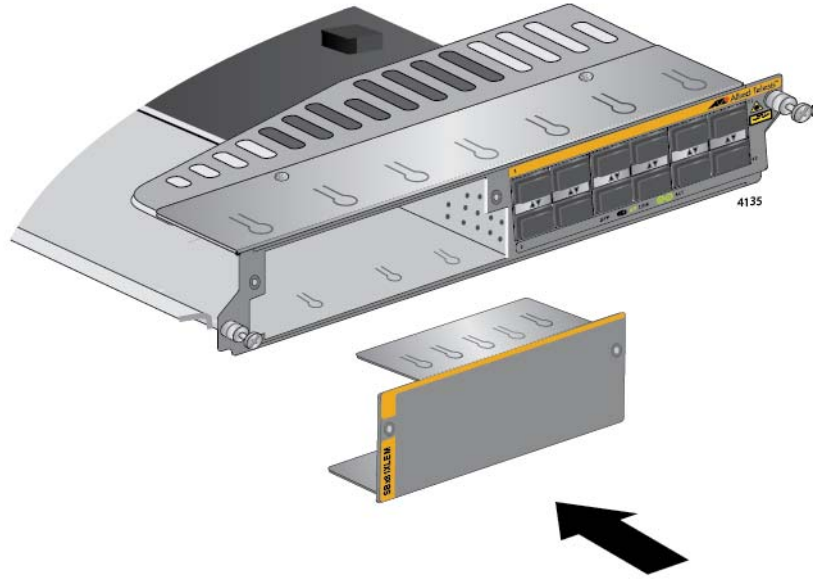

Figure 165. Sliding the Blank Slot Cover into the AT-SBx81XLEM Line Card

10. Secure the blank slot cover to the card with a Phillips-head screwdriver and the two screws removed in step 3. Refer to Figure 166.

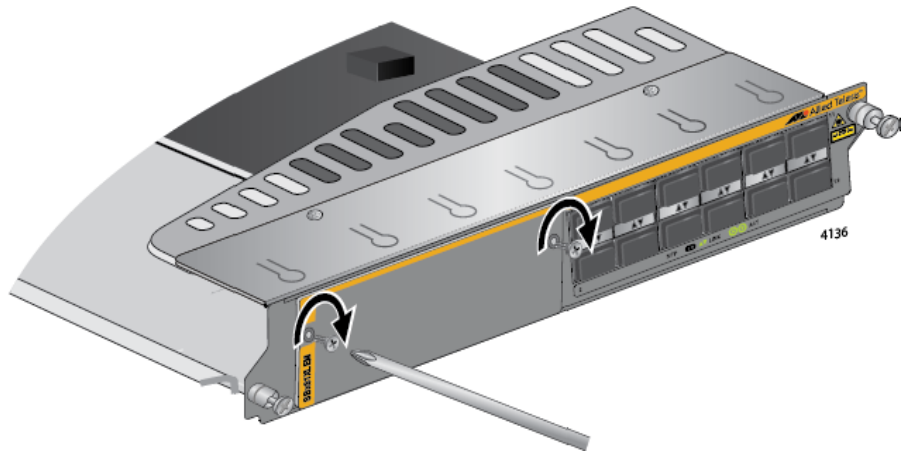

Figure 166. Securing the Blank Slot Cover

11. Turn the retaining pin on the side of the card a quarter turn to release it. Refer to Figure 167 on page 258.

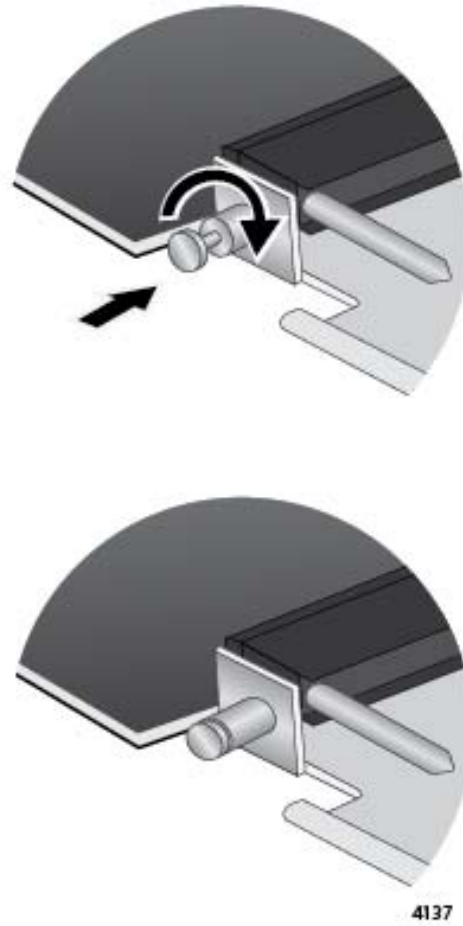

Figure 167. Releasing the Retaining Pin

12. To install the line card back in the chassis, go to “Installing the Ethernet Line Cards” on page 144 and start with step 5.

## Replacing the AT-SBx81CFC400 Controller Fabric Card

---

This section contains the procedure for replacing a controller card from the chassis.

---

**Note**

Please review “Guidelines to Handling the Controller and Line Cards” on page 128 before performing this procedure.

---

This procedure requires the following tool:

- #2 Phillips-head screwdriver (not provided)

The controller card is hot swappable and can be removed while the chassis is powered on.

Here are the general steps if the chassis has only one controller card and that card has failed such that it is no longer responding to management commands and the Ethernet line cards have stopped forwarding traffic:

1. Power off the chassis.
2. Remove the failed controller card. Refer to the instructions in this section.
3. Install the new controller card. You may install the new controller card in the same slot as the failed card or in the other controller card slot. For instructions, refer to “Installing the AT-SBx81CF400 Controller Fabric Card” on page 130.
4. Power on the chassis.
5. Restore the configuration to the Ethernet line and controller cards by uploading the latest archived copy of the configuration file for the chassis to the new controller card. If you do not have an archived copy of the configuration settings of the chassis, restore the configuration manually.

Here are the general steps if the chassis has two controller cards and one of the cards has failed:

1. If the chassis is powered off, power it on.

---

**Note**

You should not replace a controller card in a chassis that has two controller cards while the unit is powered off, especially if you are replacing a failed card in slot 5. If you replace a failed controller card while the chassis is powered off, the Ethernet line cards might lose their configurations if the new controller card is designated as the active card when you power on the chassis.

---

2. Remove the failed controller card. Refer to the instructions in this section.
3. Install the new controller card. For instructions, refer to “Installing the AT-SBx81CF400 Controller Fabric Card” on page 130.

To remove a controller card from the chassis, perform the following procedure:

1. Disconnect the cables from the NET MGMT and Console ports on the controller card.
2. Use a #2 Phillips-head screwdriver to loosen the two screws on the faceplate of the card.
3. Carefully pull out the handles of the faceplate to disconnect the controller card from the connector on the backplane of the chassis.
4. Carefully slide the controller card from the chassis.

**Caution**

Keep the card level as you slide it out of the chassis. You might damage the components on the top or bottom of the card if you slide it out at an angle. Refer to Figure 63 on page 129.

---

5. Do one of the following:
  - For instructions on how to install a new controller card in the chassis, refer to “Installing the AT-SBx81CF400 Controller Fabric Card” on page 130.
  - If you do not plan to immediately install another controller card in the slot, cover the slot with a blank cover. For instructions, refer to “Installing the Blank Slot Covers” on page 149.
  - If you do not plan to immediately install the controller card in another chassis, continue with this procedure.
6. Store the controller card in an anti-static bag.
7. Return the card to its shipping container.

## Replacing the AT-SBxFAN12 Fan Module

---

This section contains the procedures for replacing the AT-SBxFAN12 Fan Module, located in the slot on the right side of the front panel.

**Caution**

Although the fan module is hot swappable and can be replaced while the chassis is powered on, the chassis may overheat if it is operated for more than one or two minutes without a fan module.

---

**Warning**

The fan module has hazardous moving parts. Keep fingers away from moving fan blades.

---

---

**Note**

Only authorized service technicians should replace the fan module.

---

**Caution**

The fan module is heavy. Be sure to use both hands to hold the module as you remove it from the chassis.

---

### Removing the AT-SBxFAN12 Fan Module

To remove the fan module from the chassis, perform the following procedure:

1. If necessary, disconnect or reroute network cables that are blocking access to the fan module.
2. Use a #2 Phillips head screwdriver to loosen the screw at the base of the fan module. Refer to Figure 168 on page 262.

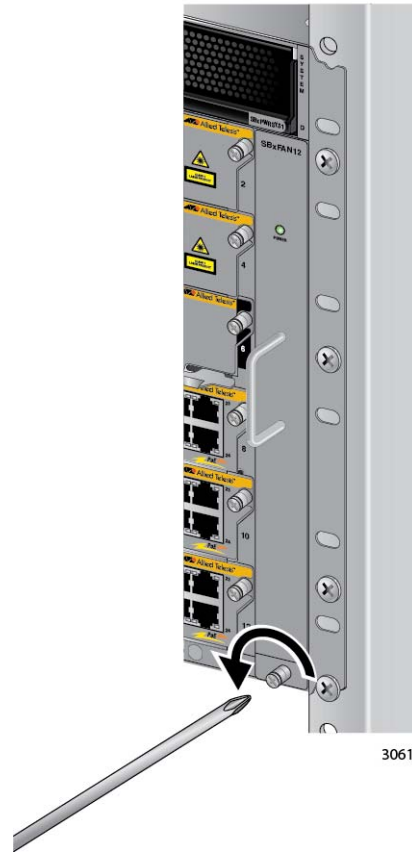

Figure 168. Loosening the Screw on the AT-SBxFAN12 Fan Module

3. Carefully pull on the handle to disconnect the fan module from the connector on the backplane of the chassis. Refer to Figure 169 on page 263.



Figure 169. Loosening the AT-SBxFAN12 Fan Module from the Backplane Connector

4. Slowly pull out the module 51 mm (2 in.). Refer to Figure 170 on page 264.



Figure 170. Withdrawing the AT-SBxFAN12 Fan Module 51 mm (2 In.) from the Chassis

5. Wait ten seconds for the fans to stop.



---

**Warning**

The fan module has hazardous moving parts. Keep fingers away from moving fan blades.

---

6. After the fans have stopped, slide the module from the chassis. Refer to Figure 171 on page 265.



---

**Caution**

The fan module is heavy. Be sure to use both hands to hold it as you remove it from the chassis.

---



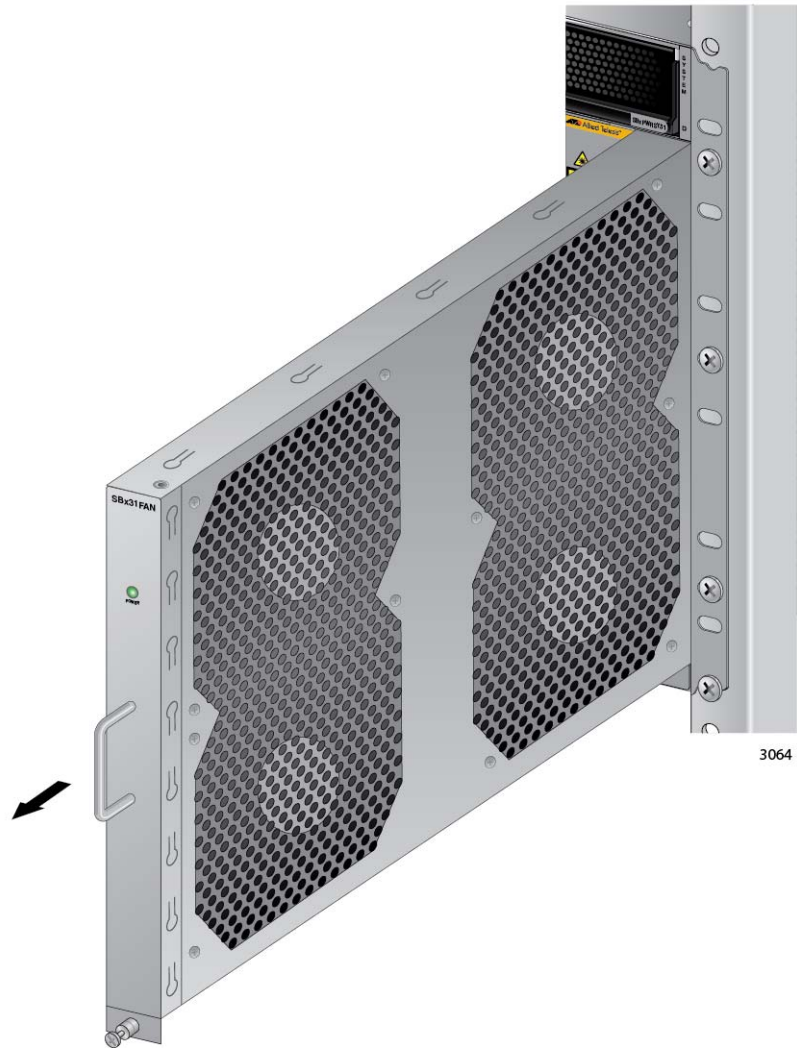

Figure 171. Removing the AT-SBxFAN12 Fan Module from the Chassis

### **Installing a New AT-SBxFAN12 Fan Module**

This procedure assumes that you have already removed the old fan module from the chassis and are continuing directly from the previous procedure, “Removing the AT-SBxFAN12 Fan Module” on page 261. To install the new fan module, perform the following procedure

1. Orient the new module with the LED and module name on top and carefully slide the new module into the slot in the chassis. Refer to Figure 172 on page 266.

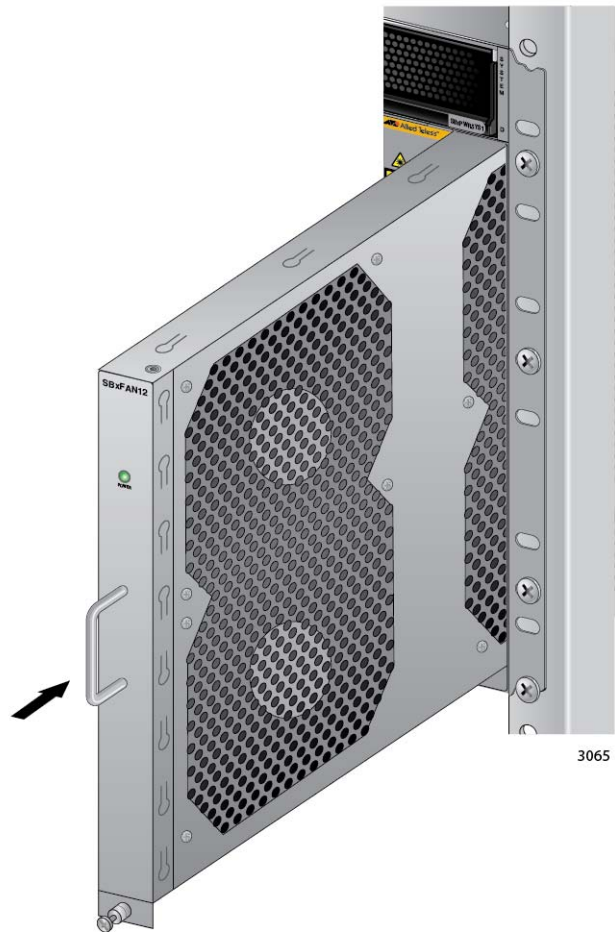

Figure 172. Installing a New AT-SBxFAN12 Fan Module

2. When you feel the fan module make contact with the connector on the backplane, gently push on the top and bottom of the faceplate to seat the module on the connector. Refer to Figure 173 on page 267.



Figure 173. Securing the AT-SBxFAN12 Fan Module on the Backplane Connector

3. With a #2 Phillips-head screwdriver, tighten the screw at the base of the module to secure the module to the chassis. Refer to Figure 174 on page 268.

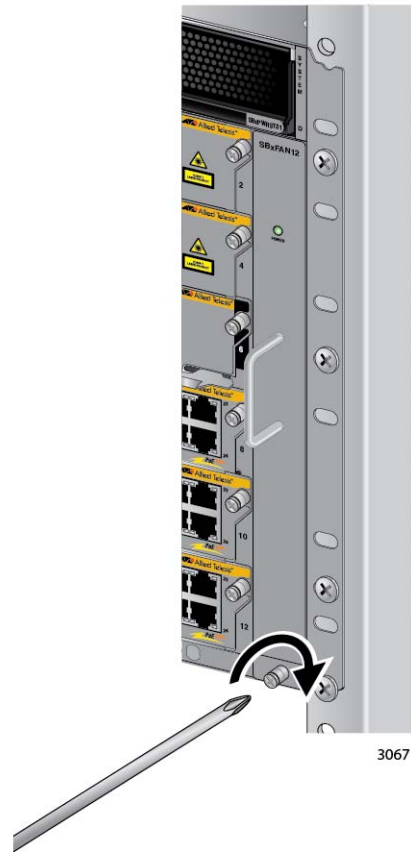

Figure 174. Tightening the Screw on the AT-SBxFAN12 Fan Module

4. Reconnect any network cables you may have disconnected to access the fan module.

## Appendix A

# Technical Specifications

---

This appendix contain the following sections:

- ❑ “Physical Specifications” on page 270
- ❑ “Environmental Specifications” on page 272
- ❑ “Power Specifications” on page 273
- ❑ “Safety and Electromagnetic Emissions Certifications” on page 276
- ❑ “Port Pinouts” on page 277

## Physical Specifications

### Dimensions (W x D x H)

Table 28. Product Dimensions

AT-SBx8112 Chassis	48.03 cm x 38.79 cm x 31.01 cm (18.91 in x 15.27 in x 12.21 in)
AT-SBxPWRSYS1 AC System Power Supply	10.16 cm x 32.21 cm x 4.34 cm (4.00 in x 12.68 in x 1.71 in)
AT-SBxPWRSYS2 AC System Power Supply	10.16 cm x 32.21 cm x 4.34 cm (4.00 in x 12.68 in x 1.71 in)
AT-SBxPWRPOE1 PoE Power Supply	10.16 cm x 32.21 cm x 4.34 cm (4.00 in x 12.68 in x 1.71 in)
AT-SBxPWRSYS1 DC System Power Supply	10.16 cm x 34.2 cm x 4.34 cm (4.00 in x 13.46 in x 1.71 in)
AT-SBxFAN12 Tray Module	2.74 cm x 33.35 cm x 26.04 cm (1.08 in x 13.13 in x 10.25 in)
All Cards AT-SBx81GT24 Line Card AT-SBx81GT40 Line Card AT-SBx81GP24 PoE Line Card AT-SBx81GS24a SFP Line Card AT-SBx81XS6 SFP+ Line Card AT-SBx81XLEM Line Card AT-SBx81CFC400 Controller Fabric Card	20.67 x 31.32 cm x 4.06 cm (8.14 in x 12.33 in x 1.6 in)
AT-SBx81XLEM/Q2 AT-SBx81XLEM/XS8 AT-SBx81XLEM/XT4	9.4 x 16.0 x 3.6 cm (3.7 x 6.3 x 1.4 in.)

### Weight (Kilograms)

Table 29. Product Weights

AT-SBx8112 Chassis	17.77 kg (39.10 lb) with 3 PSU and 10 Line Card blank panels
AT-SBx81GT24 Line Card	0.93 kg (2.05 lb)
AT-SBx81GT40 Line Card	1.04 kg (2.30 lb)
AT-SBx81GP24 PoE Line Card	1.06 kg (2.34 lb)

Table 29. Product Weights (Continued)

AT-SBx81GS24a SFP Line Card	1.06 kg (2.34 lb)
AT-SBx81XS6 SFP+ Line Card	1.06 kg (2.34 lb)
AT-SBx81XLEM Line Card	1.2 kg (2.7 lb)
AT-SBx81XLEM/Q2 Expansion Module	0.2 kg (0.5 lb)
AT-SBx81XLEM/XS8 Expansion Module	0.3 kg (0.65 lb)
AT-SBx81XLEM/XT4 Expansion Module	0.3 kg (0.65 lb)
AT-SBx81CFC400 Controller Fabric Card	1.09 kg (2.40 lb)
AT-SBxPWRSYS1 AC System Power Supply	2.75 kg (6.05 lb) with power cord
AT-SBxPWRSYS2 AC System Power Supply	2.70 kg (6.00 lb) with power cord
AT-SBxPWRPOE1 PoE Power Supply	2.73 kg (6.00 lb) with power cord
AT-SBxPWRSYS1 DC System Power Supply	1.9 kg (4.2 lb)
AT-SBxFAN12 Tray Module	1.82 kg (4.00 lb)

## Environmental Specifications

---

Table 30. Environmental Specifications

Operating Temperature	-0° C to 40° C (32° F to 104° F)
Storage Temperature	-25° C to 70° C (-13° F to 158° F)
Operating Humidity	5% to 90% non-condensing
Storage Humidity	5% to 95% non-condensing
Operating Altitude Range	Up to 3,000 m (9,843 ft)
Acoustic Noise	75.7 dB

---

**Note**

The acoustic noise was measured at 40° C with the following products installed:

---

Table 31. Acoustic Noise Test Components

Product	Quantity
AT-SBx8112 Chassis	1
AT-SBx81CFC400 Controller Fabric Card	2
AT-SBx81GP24 PoE Line Card	5
AT-SBx81XS6 SFP+ Line Card	5
AT-SBxPWRSYS1 AC System Power Supply	2
AT-SBxPWRPOE1 PoE Power Supply	2
AT-SBxFAN12 Tray Module	1



## Power Specifications

---

### AC Voltage, Frequency Requirements (Volts, Hertz)

Table 32. AC Voltage and Frequency Requirements

AT-SBxPWRSYS1 AC Power Supply	100 - 120 / 200 - 240 VAC, 16/8A, 50/60 Hz, (per input)
AT-SBxPWRSYS2 AC Power Supply	100 - 120 / 200 - 240 VAC, 18/8A, 50/60 Hz, (per input)
AT-SBxPWRPOE1 AC Power Supply	100 - 120 / 200 - 240 VAC, 16/8A, 50/60 Hz, (per input)

### DC Voltage Requirements

Table 33. DC Voltage Requirements

AT-SBxPWRSYS1 DC Power Supply	40 - 60V dc (-0% - +20%), 36A (maximum per input)
-------------------------------	---

### Typical power savings in eco-friendly mode (Watts)

Table 34. Typical Power Savings in eco-friendly Mode

AT-SBx81GT24	0.12 W
AT-SBx81GT40	0.79 W
AT-SBx81GP24	0.24 W
AT-SBx81GS24a	0.20 W
AT-SBx81XS6	0.10 W
AT-SBx81XLEM (no expansion module)	0.12 W
AT-SBx81XLEM and AT-SBx81XLEM/Q2	0.17 W
AT-SBx81XLEM and AT-SBx81XLEM/XS8	0.20 W
AT-SBx81XLEM and AT-SBx81XLEM/XT4	0.09 W

**Maximum power consumption (Watts)**

Table 35. Maximum Power Consumption

AT-SBx81GT24	34.4 W
AT-SBx81GT40	53.9 W
AT-SBx81GP24	34.4 W
AT-SBx81GS24a	56.3 W
AT-SBx81XS6	54.8 W
AT-SBx81XLEM (no expansion module)	43.7 W
AT-SBx81XLEM and AT-SBx81XLEM/Q2	64.4 W
AT-SBx81XLEM and AT-SBx81XLEM/XS8	65.1 W
AT-SBx81XLEM and AT-SBx81XLEM/XT4	65.5 W
AT-SBx81CFC400	48.3 W

**Maximum power supply efficiency (based on 100V input voltage)**

Table 36. Maximum Power Efficiency

AT-SBxPWRSYS1 AC	Up to 90%
AT-SBxPWRSYS2 AC	Up to 85%
AT-SBxPWRPOE1 AC	Up to 90%
AT-SBxPWRSYS1 DC	Up to 90%

**Heat dissipation (British Thermal Units/hour)**

Table 37. Heat Dissipation

AT-SBx81GT24	117.39 BTU/hr
AT-SBx81GT40	183.93 BTU/hr
AT-SBx81GP24	117.39 BTU/hr
AT-SBx81GS24a	192.12 BTU/hr

Table 37. Heat Dissipation

AT-SBx81XS6	187.00 BTU/hr
AT-SBx81CFC400	164.82 BTU/hr
AT-SBx81XLEM (no expansion module)	149.19 BTU/hr
AT-SBx81XLEM and AT-SBx81XLEM/Q2	219.80 BTU/hr
AT-SBx81XLEM and AT-SBx81XLEM/XS8	222.15 BTU/hr
AT-SBx81XLEM and AT-SBx81XLEM/XT4	223.42 BTU/hr
AT-SBxPWRSYS1 AC	5118.21 BTU/hr
AT-SBxPWRSYS2 AC	5118.21 BTU/hr
AT-SBxPWRPOE1 AC	5118.21 BTU/hr
AT-SBxPWRSYS1 DC	5118.21 BTU/hr

**Available Power over Ethernet (Watts/port):**

Table 38. Available Power Over Ethernet with One PoE Power Supply

One PoE Power Supply Installed	1200 W @ 56 VDC
IEEE 802.3at Class 4 (30 W /port)	40 ports Maximum
IEEE 802.3af Class 3 (15.4 W /port)	77 ports Maximum
IEEE 802.3af Class 2 (7.3 W /port)	171 ports Maximum
IEEE 802.3af Class 1 (4.0 W /port)	240 ports Maximum

Table 39. Available Power Over Ethernet with Two PoE Power Supplies

Two PoE Power Supply Installed	2400 W @ 56 VDC
IEEE 802.3at Class 4 (30 W /port)	80 ports Maximum
IEEE 802.3af Class 3 (15.4 W /port)	155 ports Maximum
IEEE 802.3af Class 2 (7.3 W /port)	240 ports Maximum
IEEE 802.3af Class 1 (4.0 W /port)	240 ports Maximum

**PoE Mode**

Table 40. PoE Mode on the AT-SBx81GP24 PoE Line Card

IEEE 802.3af / IEEE 802.3at:	Alternative Mode A
------------------------------	--------------------

**Safety and Electromagnetic Emissions Certifications**

---

**Safety and Electromagnetic Emissions:**

Table 41. Safety and Electromagnetic Emissions

EMI/RFI	FCC Class A, EN55022 Class A, EN61000-3-2, EN61000-3-3, CISPR Class A, VCCI Class A, AS/NZS Class A
Immunity	EN55024
Electrical Safety	EN60950-1 (TUV), UL60950-1 (cUL <sub>us</sub> ), EN60825
Safety Agency Approvals	cUL <sub>us</sub> , TUV, C-TICK, CE

## Port Pinouts

This section has the pinouts for the ports on the AT-SBx81GT24, AT-SBx81GT40, and AT-SBx81GP24 Line Cards, and the NET MGMT port on the AT-SBx81CFC400 Controller Fabric Card.

Figure 175 illustrates the pin layouts for RJ-45 and RJ point 5 ports.

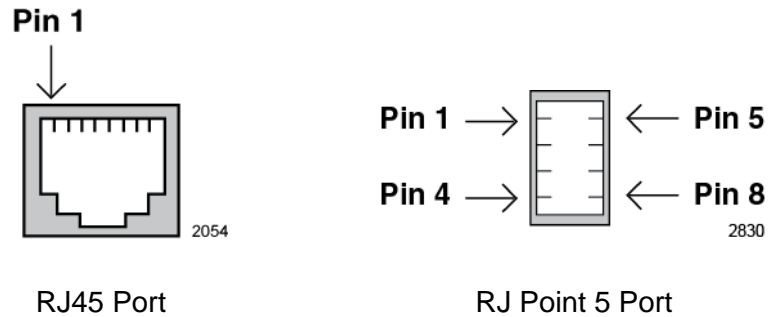

Figure 175. Pin Numbers for RJ-45 and RJ Point 5 Ports (Front View)

Table 42 lists the pin signals when a twisted-pair port is operating in the MDI configuration.

Table 42. MDI Pin Signals (10Base-T or 100Base-TX)

Pin	Signal
1	TX+
2	TX-
3	RX+
6	RX-

Table 43 lists the port pin signals for the MDI-X configuration.

Table 43. MDI-X Pin Signals (10Base-T or 100Base-TX)

Pin	Signal
1	RX+
2	RX-
3	TX+
6	TX-

Table 44 lists the port pin signals for twisted pair ports operating at 1000 Mbps or 10 Gbps.

Table 44. 1000Base-T or 10GBase-T Connector Pinouts

<b>Pin</b>	<b>Pair</b>	<b>Signal</b>
1	1	TX and RX+
2	1	TX and RX-
3	2	TX and RX+
4	3	TX and RX+
5	3	TX and RX-
6	2	TX and RX-
7	4	TX and RX+
8	4	TX and RX-