

IS Series

Industrial Ethernet Layer 2 Switch

IS230-10GP



Installation Guide

Copyright © 2018 Allied Telesis, Inc.

All rights reserved. No part of this publication may be reproduced without prior written permission from Allied Telesis, Inc. Allied Telesis and the Allied Telesis logo are trademarks of Allied Telesis, Incorporated. All other product names, company names, logos or other designations mentioned herein are trademarks or registered trademarks of their respective owners.

Allied Telesis, Inc. reserves the right to make changes in specifications and other information contained in this document without prior written notice. The information provided herein is subject to change without notice. In no event shall Allied Telesis, Inc. be liable for any incidental, special, indirect, or consequential damages whatsoever, including but not limited to lost profits, arising out of or related to this manual or the information contained herein, even if Allied Telesis, Inc. has been advised of, known, or should have known, the possibility of such damages.

Electrical Safety and Emissions Standards

This product meets the following standards:

U.S. Federal Communications Commission
<p>Interference Statement</p> <p>This device complies with part 15 of the FCC Rules. Operation is subject to the following two conditions:</p> <p>(1) This device may not cause harmful interference, and (2) this device must accept any interference received, including interference that may cause undesired operation.</p> <p>This equipment has been tested and found to comply with the limits for a Class A digital device, pursuant to part 15 of the FCC Rules. These limits are designed to provide reasonable protection against harmful interference in a controlled environment, such as a cabinet, hut or telecom closet. This equipment generates, uses and can radiate radio frequency energy and, if not installed and used in accordance with the instruction manual, may cause harmful interference to radio communications. However, there is no guarantee that interference will not occur in a particular installation. If this equipment does cause harmful interference to radio or television reception, which can be determined by turning the equipment off and on, the user is encouraged to try to correct the interference by one or more of the following measures:</p> <ul style="list-style-type: none">- Reorient or relocate the receiving antenna.- Increase the separation between the equipment and receiver.- Connect the equipment into an outlet on a circuit different from that to which the receiver is connected.- Consult the dealer or an experienced radio/TV technician for help. <p>The Federal Communications Commission warns that changes or modifications of the unit not expressly approved by the party responsible for compliance could void the user's authority to operate the equipment and any assurances of safety or performance, and could result in violation of part 15 of the FCC Rules.</p>

Industry Canada
<p>This Class A digital apparatus complies with Canadian ICES-003.</p> <p>Cet appareil numérique de la classe A est conforme à la norme NMB-003 du Canada.</p> <p>This equipment complies with radio frequency exposure limits set forth by Industry Canada for a controlled environment.</p> <p>Cet équipement est conforme aux limites d'exposition aux radiofréquences définies par Industrie Canada pour un environnement contrôlé.</p>

European Union Restriction of the Use of Certain Hazardous Substances (RoHS) in Electrical and Electronic Equipment
<p>This Allied Telesis RoHS-compliant product conforms to the European Union Restriction of the Use of Certain Hazardous Substances (RoHS) in Electrical and Electronic Equipment. Allied Telesis ensures RoHS conformance by requiring supplier Declarations of Conformity, monitoring incoming materials, and maintaining manufacturing process controls.</p>

The regulatory approvals of the product are listed here:

Safety

- IEC/EN/UL60950-1
- CAN/CSA-C22.2 No.60950-1
- UL61010-2-201
- CAN/CSA-C22.2 No.61010-2-201
- EN 61010-2-201

EMI

- FCC part15 Subpart B/ Class A
- ICES-003 Class A
- EN55032 Class A
- CISPR 32 Class A
- VCCI Class A
- AS/NZS CISPR 32 Class A
- EN61000-6-4 Class A

EMS

- IEC 61000-4-2
- IEC 61000-4-3
- IEC 61000-4-4
- IEC 61000-4-5
- IEC 61000-4-6
- IEC 61000-4-8
- EN55024
- EN61000-6-2
- EN50121-4

Shock

- IEC 60068-2-27
- MIL-STD-810G 516.6

Freefall

- IEC 60068-2-31

Vibration

- IEC 60068-2-6
- MIL-STD-810G 514.6

RoHS

- Comply with AT-Doc # 612-001876

**Warning**

In a domestic environment this product may cause radio interference in which case the user may be required to take adequate measures. *⌘* **E84**

**Warning**

Use an EN60825-1 certified optical fiber transceiver. *⌘* **L8**

Translated Safety Statements

Important: The  indicates that a translation of the safety statement is available in a PDF document titled “Translated Safety Statements” on our web site at <http://www.alliedtelesis.com/support>.

Table of Contents

Preface	13
Safety Symbols Used in this Document	14
Contact Allied Telesis	15
Chapter 1: Overview	17
Hardware Components	18
DIN Rail Bracket.....	19
Screw Holes for Wall Brackets	19
Features	20
Twisted-Pair Ports	20
Power Over Ethernet.....	21
SFP Slots	21
Console Port	21
LEDs	21
Power/Alarm Connector	21
MAC Address Tables	22
Management Software	22
Management Methods	22
Installation Options.....	22
Additional Features	22
10/100/1000Base-T Twisted-Pair Ports.....	23
Connector Type.....	23
Speed.....	23
Duplex Mode	23
Maximum Distance.....	24
Cable Requirements	24
Automatic MDIX Detection	24
Port Pinouts.....	24
Power over Ethernet.....	25
PoE Versions	25
Ethernet Cabling for PoE devices	25
Powered Device Classes for PoE and PoE+	26
PoE Connection Guidelines	27
PoE Budget	27
Port Prioritization.....	28
SFP Slots	29
Console Port.....	30
Reset Button.....	31
Grounding Screw.....	32
Power/Alarm Connector	33
Power Supplies	33
P-Fail Alarm Relay Contacts	33
LEDs.....	35
Status LEDs	35
Twisted-Pair Port LEDs	36
SFP Slot LEDs	37
PoE Status LEDs	37
Power Supplies	39

Chapter 2: Begin Installation	41
Review Safety Precautions	42
Ground Connection	43
Power/Alarm Connection	43
Safety Instructions	43
Safety Precautions With Electricity	47
Review Site Requirements	48
Verify Package Contents	50
Chapter 3: Install the Switch	53
DIN Rail Installation	54
Install Switch On Concrete or Masonry Wall or Industrial Panel	56
Chapter 4: Install Twisted-Pair Ports Cables	61
Twisted-Pair Port Cables	62
Install SFP Transceivers and Fiber Cables	63
Chapter 5: Power On Switch	67
Connect Ground Wire	68
Power/Alarm Connector Cables	71
Power/Alarm Connector Wiring	71
Apply Power To Switch	76
Verify Switch Operations	76
Start Local Management Session	77
Chapter 6: Troubleshooting	79
PWR 1 and PWR 2 LEDs	80
Twisted-Pair Ports	81
SFP Slots	82
Power Over Ethernet	83
Appendix A: Technical Specifications	85
Physical Specifications	86
Environmental Specifications	87
Power Specifications	88
Certifications	89
RJ-45 Twisted-Pair Ethernet Port Pinouts	90
RJ-45 Style Serial Console Port Pinouts	92
Power/Alarm Connectors	93
Pin Assignments	93
P-Fail Alarm Contact Rating	93

Figures

Figure 1: Switch Front Panel	18
Figure 2: Switch Top Panel	18
Figure 3: Switch Back Panel Features.....	19
Figure 4: Example of the P-Fail Alarm Relay Circuit	34
Figure 5: Twisted-Pair Port LEDs: Ports 1-10.....	36
Figure 6: SFP LEDs: Ports 9 and 10	37
Figure 7: PoE Status LEDs: Ports 1-8	37
Figure 8: Power/Alarm Connector	40
Figure 9: Power/Alarm Connector on Top of Chassis	43
Figure 10: Pre-installed Components on the Front Panel.....	50
Figure 11: Pre-installed Components on the Top Panel.....	51
Figure 12: Pre-installed DIN Rail Bracket on the Back Panel.....	51
Figure 13: Components in the Accessory Kit.....	52
Figure 14: Orientation of the Switch on a DIN Rail	54
Figure 15: Install Top Slot of DIN Rail Bracket onto DIN Rail.....	54
Figure 16: Install Switch on DIN Rail	55
Figure 17: Remove Din Rail Mounting Bracket.....	57
Figure 18: Install Wall Mount Brackets on the Back of the Switch.....	57
Figure 19: Mark Wall Bracket Hole Locations.....	58
Figure 20: Install Switch Using Wall Brackets	59
Figure 21: Remove the Dust Plug from an SFP Slot	63
Figure 22: Install SFP Transceiver	64
Figure 23: Remove Dust Cover from SFP Transceiver	64
Figure 24: Connect Fiber Optic Cable To SFP Transceiver	65
Figure 25: Strip Grounding Wire	68
Figure 26: Loosen Grounding Screw	69
Figure 27: Wrap Grounding Wire Around Ground Screw	69
Figure 28: Secure Grounding Wire to the Switch	69
Figure 29: Strip Power or Alarm Wire	71
Figure 30: Wrap Wire Strands	72
Figure 31: Remove Power/Alarm Connector	72
Figure 32: Loosen Power/Alarm Connector Wire Retaining Screws	73
Figure 33: Insert Power Supply and Alarm Wires into Power/Alarm Connector.....	73
Figure 34: Verify Wire Installation.....	73
Figure 35: Tighten Wires In Power/Alarm Connector	74
Figure 36: Insert the Power/Alarm Connector	74
Figure 37: Fasten the Power/Alarm Connector to Chassis.....	75
Figure 38: RJ-45 Port Pin Layout (Front View).....	90

Tables

Table 1: Twisted-Pair Cable Requirements	24
Table 2: Maximum Power Levels	25
Table 3: PoE Twisted-Pair Cable Requirements for Powered Devices	26
Table 4: PoE and PoE+ Powered Device Classes	26
Table 5: Maximum Installation Site Temperatures Versus SFP Temperature Ratings	29
Table 6: Status LEDs	35
Table 7: Twisted-Pair Port LEDs: Ports 1-10	36
Table 8: SFP Slot LEDs: Ports 9 and 10	37
Table 9: PoE Status LED Descriptions: Ports 1-8	38
Table 10: Ground Resistivity Recommendations	49
Table 11: Product Dimensions	86
Table 12: Product Weights	86
Table 13: Minimum Cabinet Dimensions	86
Table 14: Environmental Specifications	87
Table 15: Maximum Power Consumptions	88
Table 16: External Power Supply DC Output Specifications	88
Table 17: Heat Dissipation (British Thermal Units/Hour)	88
Table 18: Regulatory Approvals	89
Table 19: Pin Signals for 10 and 100 Mbps	90
Table 20: Pin Signals for 1000 Mbps	91
Table 21: RJ-45 Style Console Port Pin Signals	92
Table 22: Power Connector Pinout Assignments	93

Preface

This guide contains the hardware installation instructions for the IS230-10GP switch. The preface contains the following sections:

- “Safety Symbols Used in this Document” on page 14
- “Contact Allied Telesis” on page 15

Safety Symbols Used in this Document

This document uses the following conventions.

Note

Notes provide additional information.



Caution

Cautions inform you that performing or omitting a specific action may result in equipment damage or loss of data.



Warning

Warnings inform you that performing or omitting a specific action may result in bodily injury.



Warning

Laser warnings inform you that an eye or skin hazard exists due to the presence of a Class 1 laser device.



Warning

Warnings inform you of hot surfaces.

|

Contact Allied Telesis

If you need assistance with this product, you may contact Allied Telesis technical support by going to the Support & Services section of the Allied Telesis web site at **www.alliedtelesis.com/support**. You can find links for the following services on this page:

- ❑ 24/7 Online Support - Enter our interactive support center to search for answers to your questions in our knowledge database, check support tickets, learn about Return Merchandise Authorizations (RMAs), and contact Allied Telesis technical experts.
- ❑ USA and EMEA phone support - Select the phone number that best fits your location and customer type.
- ❑ Hardware warranty information - Learn about Allied Telesis warranties and register your product online.
- ❑ Replacement Services - Submit an RMA request via our interactive support center.
- ❑ Documentation - View the most recent installation guides, user guides, software release notes, white papers and data sheets for your product.
- ❑ Software Updates - Download the latest software releases for your product.

For sales or corporate contact information, go to **www.alliedtelesis.com/purchase** and select your region.

Chapter 1

Overview

This chapter describes the hardware features of the IS230-10GP switch. The sections in the chapter are listed here:

- ❑ “Hardware Components” on page 18
- ❑ “Features” on page 20
- ❑ “10/100/1000Base-T Twisted-Pair Ports” on page 23
- ❑ “Power over Ethernet” on page 25
- ❑ “SFP Slots” on page 29
- ❑ “Console Port” on page 30
- ❑ “Reset Button” on page 31
- ❑ “Grounding Screw” on page 32
- ❑ “Power/Alarm Connector” on page 33
- ❑ “LEDs” on page 35
- ❑ “Power Supplies” on page 39

Hardware Components

The front panel of the switch is shown in Figure 1.

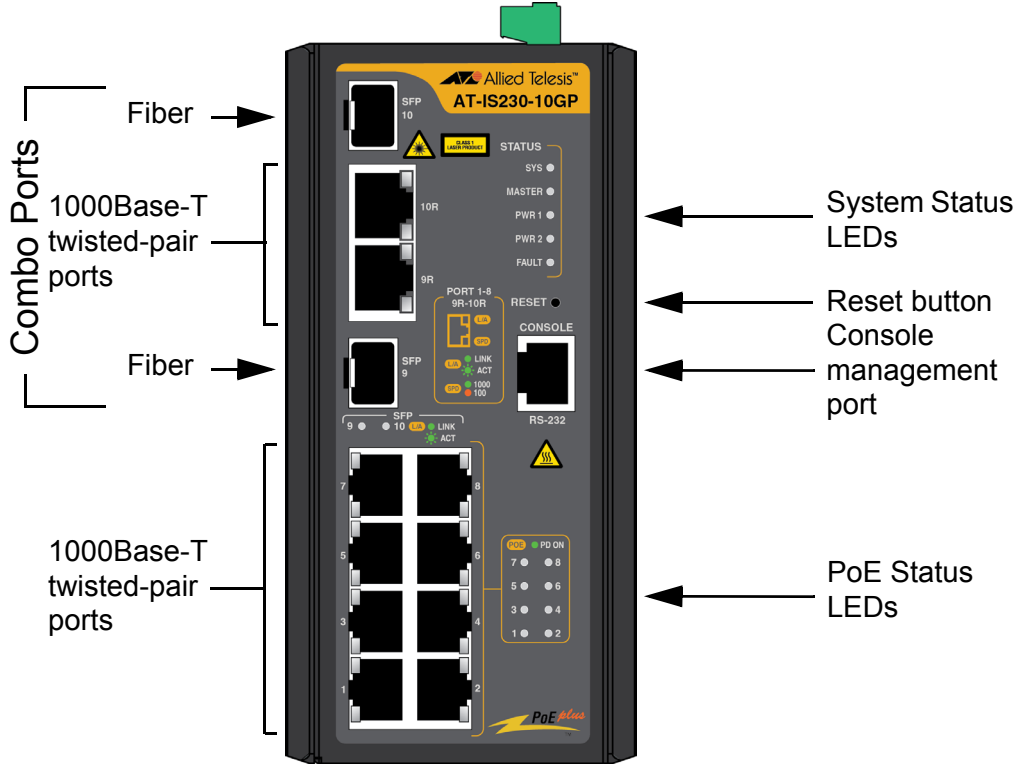

Figure 1. Switch Front Panel

Figure 2 shows the components on the switch top panel.

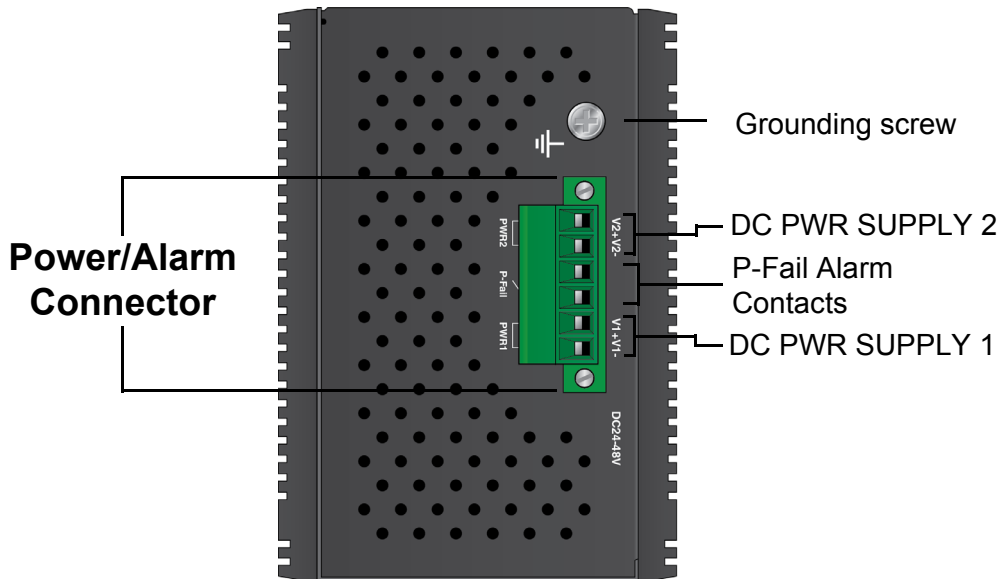

Figure 2. Switch Top Panel

Figure 3 identifies the components on the switch back panel.

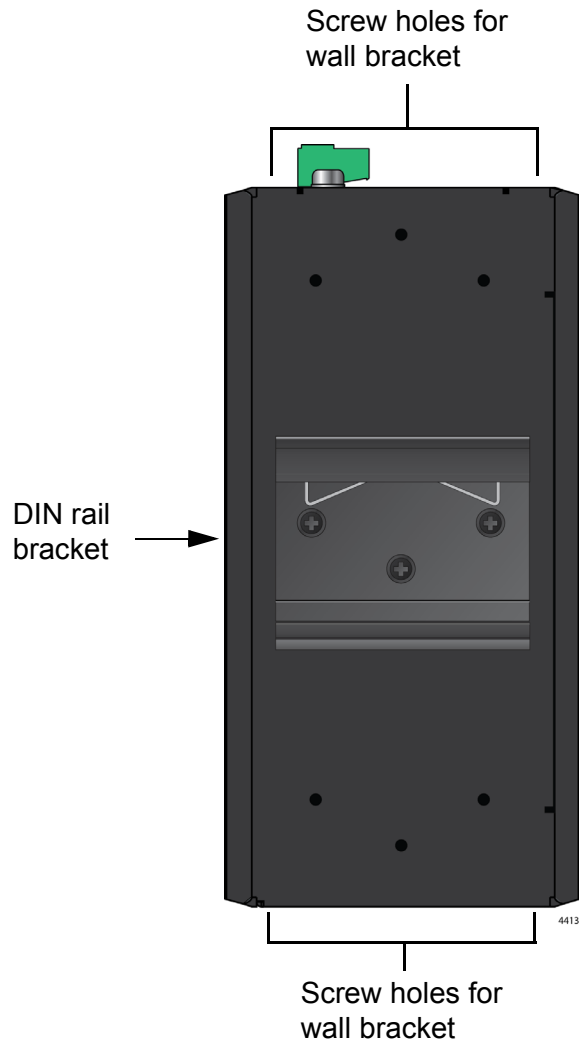

Figure 3. Switch Back Panel Features

DIN Rail Bracket

The switch comes with one DIN rail bracket pre-installed on the back panel. The bracket is compatible with DIN 35x7.5mm rails.

Screw Holes for Wall Brackets

The back panel has six holes for securing the two wall brackets that are included in the accessory kit.

Features

The basic features of the IS230-10GP switch are:

- ❑ “Twisted-Pair Ports”
- ❑ “Power Over Ethernet” on page 21
- ❑ “SFP Slots” on page 21
- ❑ “Console Port” on page 21
- ❑ “LEDs” on page 21
- ❑ “Power/Alarm Connector” on page 21
- ❑ “MAC Address Tables” on page 22
- ❑ “Management Software” on page 22
- ❑ “Management Methods” on page 22
- ❑ “Installation Options” on page 22
- ❑ “Additional Features” on page 22

Twisted-Pair Ports

Here is a summary of the basic features of the 10/100/1000 Mbps twisted-pair ports:

- ❑ 8 each 10/100/1000Base-T/TX RJ-45 Copper ports with IEEE 802.3 af/at PoE
- ❑ 2 each Combo ports 100/1000Base-T/TX RJ-45/SFP (mini-GBIC)
- ❑ X-Ring Pro (ultra high-speed recovery time < 20 ms)
- ❑ RSTP/STP (802.1w/1D)
- ❑ RADIUS Management
- ❑ Auto-MDI/MDIX
- ❑ 100 meters (328 feet) maximum operating distance
- ❑ Jumbo frames from 1518 to 9216 bytes
- ❑ Supports Port Mirroring
- ❑ IEEE 802.1p LANs (VLANs)
- ❑ IEEE 802.1s Multiple Spanning Tree (MSTP)
- ❑ IEEE 802.1x (Port-Based, MD5/TLS/TTLS/PEAP Encryption)
- ❑ IEEE 802.3 10-BASE-T, Ethernet
- ❑ IEEE 802.3u 100-BASE-TX, Fast Ethernet
- ❑ IEEE 802.3ab 1000BASE-T, Gigabit Ethernet
- ❑ IEEE 802.3z 1000BASE-X, Gigabit Ethernet
- ❑ IEEE 802.3x Flow Control
- ❑ IEEE 802.3ad Link Aggregation Control Protocol (LACP)

- ❑ IEEE 802.3az Energy-Efficient Ethernet
 - LPI at 100BASE-TX support
 - LPI at 1000BASE-T support

Power Over Ethernet

Ports 1 to 8 on the IS230-10GP switch offer the following Power over Ethernet features:

- ❑ Ports 1 to 8 support PoE (15 watts) and PoE+ (30 watts)
- ❑ Powered device classes 0 to 4
- ❑ Maximum PoE budget of 120 watts with one or two power supplies
- ❑ Port prioritization
- ❑ Alternative A wiring for PoE or PoE+ devices

SFP Slots

The two SFP combo slots support 100M and 1000M optical module 5 types of transceivers.

Note

SFP transceivers must be purchased separately. Refer to the product data sheet for a list of supported transceivers.

Console Port

One RJ-45 connector supports the console serial management port.

LEDs

The following LEDs are on the front panel:

- ❑ Link/activity and duplex mode LEDs for the twisted-pair ports
- ❑ Link/activity LEDs for the two SFP ports
- ❑ System Status LED
- ❑ Ring Master Active status LED
- ❑ Power supply status LEDs
- ❑ Alarm LED
- ❑ PoE Active status LEDs for the twisted-pair ports 1 through 8

Power/Alarm Connector

The switch has one connector which includes pins for the following functions:

- ❑ Two DC power supply connections
- ❑ P-Fail alarm relay contacts for an external alert device, such as a buzzer or LED, to indicate switch alarms.

MAC Address Tables

Here are the basic features of the MAC address tables:

- Storage capacity up to 8,192 MAC address entries
- Automatic learning and aging
- 300 second default aging time - range from 10 to 630 seconds

Management Software

The switches support the following management software interfaces:

- Command line interface
- Web browser interface

Management Methods

You can manage the switches in the following ways:

- Local management through the Console port
- Remote Telnet or secure shell management
- Remote HTTP or HTTPS web browser management
- SNMPv1, v2c, or v3, Standard MIB, Private MIB

Installation Options

The switches support the following installation options:

- DIN rail installation (compatible with DIN 35x7.5mm rail)
- Concrete or masonry wall or industrial panel

Additional Features

Here are additional features:

- Reset button
- Two DC power supply input connections
- Extended environmental range
- RJ-45 style Console port for local management

10/100/1000Base-T Twisted-Pair Ports

This section describes the following hardware aspects of the twisted-pair ports:

- ❑ “Connector Type”
- ❑ “Speed”
- ❑ “Duplex Mode”
- ❑ “Maximum Distance”
- ❑ “Cable Requirements” on page 24
- ❑ “Automatic MDIX Detection” on page 24
- ❑ “Port Pinouts” on page 24

Connector Type

The twisted-pair ports have 8-pin RJ-45 connectors. The ports use four pins at 10 or 100 Mbps and all eight pins at 1000 Mbps. The pin assignments are listed in Table 19 on page 90 and Table 20 on page 91.

Speed

The ports can operate at 10, 100, or 1000 Mbps. The switch can set the speeds automatically with Auto-Negotiation, the default setting, or you can manually set the speeds with the management software.

Note

Twisted-pair ports must be set to Auto-Negotiation to operate at 1000 Mbps. You cannot manually set twisted-pair ports to 1000 Mbps.

Duplex Mode

The twisted-pair ports can operate in either half- or full-duplex mode at 10 or 100 Mbps. Ports operating at 1000 Mbps can only operate in full-duplex mode. The twisted-pair ports are IEEE 802.3u Auto-Negotiation compliant. The switch can set the duplex modes automatically or you can disable Auto-Negotiation and set the duplex modes manually. Speed and duplex mode settings can be set independently of each other on the ports. For example, the speed of a port can be configured manually while its duplex mode is established through Auto-Negotiation.

Note

Switch ports connected to 10 or 100 Mbps end nodes that do not support Auto-Negotiation should not use Auto-Negotiation to set their speed and duplex mode settings, because duplex mode mismatches might occur. You should disable Auto-Negotiation and set the speed and duplex mode settings manually with the AlliedWare Plus operating system.

Maximum Distance

The ports have a maximum operating distance of 100 meters (328 feet).

Cable Requirements

The cable requirements for the ports on the IS230-10GP switch are listed in Table 1.

Table 1. Twisted-Pair Cable Requirements

Cable Type	10Mbps	100Mbps	1000Mbps
Standard TIA/EIA 568-B-compliant Category 3 shielded or unshielded cabling with 100 ohm impedance and a frequency of 16 MHz.	Yes	Yes	No
Standard TIA/EIA 568-A-compliant Category 5 or TIA/EIA 568-B-compliant Enhanced Category 5 (Cat 5e) shielded or unshielded cabling with 100 ohm impedance and a frequency of 100 MHz.	Yes	Yes	Yes
Standard TIA/EIA 568-B-compliant Category 6 or 6a shielded cabling.	Yes	Yes	Yes

Automatic MDIX Detection

The 10/100/1000 Mbps twisted-pair ports are IEEE 802.3ab compliant, with automatic MDIX detection. This feature automatically configures the ports to MDI or MDI-X depending on the wiring configurations of the end nodes.

Port Pinouts

Refer to Table 19 on page 90 for the pinouts of the twisted-pair ports at 10 or 100 Mbps and to Table 20 on page 91 for the port pinouts at 1000 Mbps.

Power over Ethernet

Ports 1 to 8 on the IS230-10GP switch support Power over Ethernet (PoE). With PoE, the switch can supply electrical power to network devices over the same twisted-pair cables that carry network traffic. The feature can simplify network installation and maintenance because it allows you to use the switch as a central power source for other network devices.

Devices that receive their power over Ethernet cables are called powered devices (PD). Examples of PDs include wireless access points, IP telephones, web cams, and even other Ethernet switches. A PD connected to a port on the IS230-10GP switch receives both network traffic and power over the same twisted-pair cable.

PoE Versions

The IS230-10GP switch supports the following versions of Power over Ethernet:

- ❑ PoE (IEEE 802.3af)
- ❑ PoE+ (802.3at)
- ❑ For PoE and PoE+ devices, power is delivered from the IS230-10GP switch over four of the eight strands using the Alternative A method. With Alternative A, power is delivered on strands 1, 2, 3, and 6, which are the same strands that carry the 10/100Base-TX network traffic.

Note

Alternative B method of delivering PoE power (over strands 4, 5, 7 and 8) is not supported by the IS230-10GP switch.

Table 2 lists the switch ports that support PoE and the maximum power levels. The total available PoE power that the IS230-10GP switch can supply from all the ports combined is 120 Watts.

Table 2. Maximum Power Levels

PoE Version	Switch Ports	Maximum Power Output at Switch Port	Maximum Power at PD
PoE	1 to 8	15.4W	12.95W
PoE+	1 to 8	30.0W	25.5W

Ethernet Cabling for PoE devices

The cable requirements for the PoE twisted-pair ports on the IS230-10GP switch for powered devices are given in Table 3 on page 26. For cable requirements for ports connected to non-PoE devices, refer to Table 1 on page 24.

Table 3. PoE Twisted-Pair Cable Requirements for Powered Devices

Cable Type	10Mbps		100Mbps		1000Mbps	
	PoE	PoE+	PoE	PoE+	PoE	PoE+
Standard TIA/EIA 568-B-compliant Category 3 shielded or unshielded cabling with 100 ohm impedance and a frequency of 16 MHz.	No	No	No	No	No	No
Standard TIA/EIA 568-A-compliant Category 5 shielded or unshielded cabling with 100 ohm impedance and a frequency of 100 MHz.	Yes	No	Yes	No	No	No
Standard TIA/EIA 568-B-compliant Enhanced Category 5 (Cat 5e) shielded or unshielded cabling with 100 ohm impedance and a frequency of 100 MHz.	Yes	Yes	Yes	Yes	Yes	Yes
Standard TIA/EIA 568-B-compliant Category 6 or 6a shielded cabling.	Yes	Yes	Yes	Yes	Yes	Yes

Powered Device Classes for PoE and PoE+

The PoE and PoE+ standards define five powered device classes. The classes are defined by the power requirements of the powered devices. The classes are shown in Table 4. The IS230-10GP switch supports all five classes.

Table 4. PoE and PoE+ Powered Device Classes

Class	Usage	Maximum Power Output at the Switch Port	PD Power Range
0	Default	15.4W	.044W to 12.95W
1	Optional	4.0W	0.44W to 3.84W
2	Optional	7.0W	3.84W to 6.49W
3	Optional	15.4W	6.49W to 12.95W
4	Optional	30.0W	12.95W to 25.5W

PoE Connection Guidelines

Here are guidelines for connecting different types of powered devices (PDs) on the PoE switch ports:

- ❑ PoE or PoE+ devices that comply with the IEEE 802.3af and 802.3at standards support Alternatives A and can be connected to any of the twisted-pair ports 1 - 8.
- ❑ PoE or PoE+ devices that do not comply with the standards and only support Alternative A can also be connected to any of the twisted-pair ports 1 - 8.
- ❑ Non-PoE devices can be connected to any of the twisted-pair ports on the switch. Ports connected to network nodes that are not PDs (that is, devices that receive power from another power source) function as regular Ethernet ports, without power being delivered to the device. The PoE feature remains enabled on the ports but no power is delivered to the devices.

Note

Alternative B method of delivering PoE power (over strands 4, 5, 7 and 8) is not supported.

PoE Budget

The IS230-10GP switch has a PoE budget. This is the total wattage the switch has available for all the powered devices connected to its ports. The maximum possible PoE power available at any one time is 120W. The PoE budget can never be more than that, but it can be less, depending on the maximum power rating of the DC power supply.

The number of powered devices the switch can support at one time depends on the switch's PoE budget and the wattage requirements of the powered devices. As long as the total wattage requirements of all the powered devices is less than the budget of the switch, the switch can supply power to all the devices. If the total wattage requirements exceed the PoE budget, the switch will deny power to one or more devices using a mechanism referred to as port prioritization.

To determine whether the wattage requirements of the PoE devices you plan to connect to the switch exceed its budget, refer to their documentation for their power requirements and add the requirements together. The switch should be able to power all the devices simultaneously as long as the total is below its PoE budget. If the total exceeds the available power budget, you should consider reducing the number of PoE devices so that all the devices receive power.

The switch can handle different power requirements on different ports. This enables you to connect different classes of PoE equipment to the ports on the switch. (See Table 4 on page 26 for the PoE class power ranges.)

Port Prioritization

If the power requirements of the powered devices exceed the switch's power budget, the switch denies power to some ports based on a system called port prioritization. You may use this mechanism to ensure that powered devices critical to the operations of your network are given preferential treatment by the switch in the distribution of power should the demands of the devices exceed the available PoE power capacity. You can configure this feature using the management software.

There are three priority levels:

- Critical
- High
- Low

Ports set to the Critical level, the highest priority level, are guaranteed power before any of the ports assigned to the other two priority levels. Ports assigned to the other priority levels receive power only if all the Critical ports are receiving power. Ports that are connected to your most critical powered devices should be assigned to this level. If there is not enough power to support all the ports set to the Critical priority level, power is provided to the ports in ascending order starting with the lowest port number.

The High level is the second highest level. Ports set to this level receive power only if all the ports set to the Critical level are already receiving power. If there is not enough power to support all of the ports set to the High priority level, power is provided to the ports in ascending order starting with the lowest port number.

The lowest priority level is Low. This is the default setting. Ports set to this level only receive power if all of the ports assigned to the other two levels are already receiving power. As with the other levels, if there is not enough power to support all of the ports set to the Low priority level, power is provided to the ports in ascending order starting with the lowest port number.

Power allocation is dynamic. Ports supplying power to powered devices may cease power transmission if the switch's power budget is at maximum usage and new powered devices, connected to ports with higher priorities, become active.

SFP Slots

The two slots support Ethernet 100/1000Base fiber optic, MSA-compliant SFP transceivers. You can use transceivers to connect switches to other network devices over large distances, build a high-speed backbone network between network devices, or connect high-speed devices, such as servers, to your network.

Refer to the product data sheet for a list of supported Ethernet transceivers.

To protect SFP transceivers from heat-related damage, you should select transceivers whose maximum operating temperatures exceed the anticipated maximum ambient temperature at the switch installation site. Table 5 provides recommendations for SFP maximum operating temperatures for several ambient site temperatures.

Table 5. Maximum Installation Site Temperatures Versus SFP Temperature Ratings

Maximum Ambient Installation Site Temperature	Recommended Maximum SFP Operating Temperature
75° C (167° F)	105° C (221° F)
65° C (149° F)	95° C (203° F)
55° C (131° F)	85° C (185° F)
<=40° C (<=104° F)	70° C (158° F)

Console Port

The Console port is a serial RS-232 port you use to access the management software to configure the features. Management sessions conducted through the Console port are called local management sessions because you have to be at the location of the switch. Local management sessions do not interfere with the network operations of the switch and are not performed over the network. Consequently, the switch does not have to have an IP address for this type of management.

Local management sessions require the following items:

- Terminal or a personal computer with a terminal emulation program
- Management cable (provided in the shipping box)

To establish a local management session with the switch, connect a Terminal or a personal computer with a terminal emulation program to the Console port, which has an RJ-45 style (8P8C) connector, with a management cable.

The Console port has the following settings:

- Default baud rate: 9600 bps (Range is 9600 to 115200 bps)
- Data bits: 8
- Parity: None
- Stop bits: 1
- Flow control: None

Note

These settings are for a DEC VT100 or ANSI terminal, or an equivalent terminal emulation program.

Reset Button

The Reset button resets the switch. You might reset the switch if it is experiencing a problem. The reset button is recessed in the chassis. To press it, use a straightened paper clip or similar object.

The switch behaves as follows:

- ❑ Hold it for 5 sec: The switch software will reboot and return the configuration settings to factory defaults.
- ❑ Hold it for 2 sec: The switch software will reboot and keep the existing configuration settings that have been previously saved.



Caution

The switch does not forward network traffic for approximately one minute while it initializes its management operating system. Some network traffic may be lost.

Note

Unsaved changes to the configuration settings of the switch are discarded when you reset the device.

Grounding Screw

The grounding screw is used to connect the chassis to the earth ground at the installation site. The instructions for connecting the post are provided in the paragraph, "Connect Ground Wire" on page 68.

Note

The switch must be connected to an earth ground. Do not operate the device without an earth ground.

Power/Alarm Connector

The power/alarm connector provides pins for two power supplies and a pair of alarm relay contacts.

Power Supplies

The PWR 1 and PWR 2 connector is for the DC power supplies. You can power the unit with one power supply or two power supplies for power redundancy, which protects the device from power loss in the event a DC power unit fails or loses power.

The switches support the following types of power sources:

- AC/DC rectifiers
- Un-interruptible power supplies

The power supply requirements are described in “Power Supplies” on page 39.

Allied Telesis does not sell or provide power supplies for this product.

Note

This product is intended to be supplied by a UL61010 OR UL61010-2-201 and 60950-1 or 62368-1 Listed DC power source, rated 24-48Vdc, 7A minimum and Tma 75 degree C. If you need further assistance, please contact Allied Telesis for further information.

Le commutateur doit être homologué selon les normes UL61010 ou UL61010-2-201 et UL 60950-1 ou UL62368-1 et alimenté par un courant de sortie de 24-48Vdc, 7A minimum, et température ambiante maximale (Tma) 75 degrés.

P-Fail Alarm Relay Contacts

The power/alarm connector on the top panel of the switch includes two pins for the P-Fail alarm relay contacts. You may connect these contact connections to an external alert device. The switch can use the device to alert you to alarm conditions, such as power supply failures or ports without links. Here are two examples of alert devices:

- LEDs
- Buzzers

The switch does not supply power on the P-Fail alarm relay contacts, which only provide an ON/OFF signal via a dry contact relay. When an alarm occurs, the switch changes the circuit from open (off) to closed (on). The circuit remains closed until the alarm is resolved, at which point the switch automatically opens it again. The processes to resolving alarms can vary.

Power from an external power source is required for an external alert device which is activated when the P-Fail alarm relay contacts are closed. Here are the contact rating specifications for the P-Fail alarm relay:

- ❑ 24VDC maximum
- ❑ 1.0A maximum



Caution

The power supplied to the P-Fail alarm relay contacts must not exceed the above specifications. The contacts can be damaged if these specifications are exceeded.

You can specify the type of Alarm policy that will activate the P-Fail alarm relay contacts when the fault is detected within the IS230-10GP switch management software. Examples of alarm conditions are power supply failures, fiber alarms, and port alarms.

An example of the feature is illustrated in Figure 4. The P-Fail alarm relay contacts are attached to a LED alert device. The alert device is configured such that its LED is off when the circuit is open and on when the circuit is closed.

Now assume you want the switch to close the circuit and activate the LED on the alert device whenever any port on the switch does not have a link to a network device. If the switch detects that a port does not have a link, it changes the circuit from open to closed. The alert device, detecting the change to the circuit, turns the LED on. When the switch detects that all its ports have links again, it opens the circuit, which turns off the LED.

Note

External alarm devices are not available from Allied Telesis.

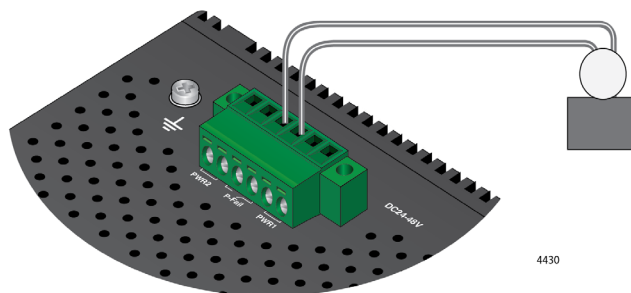

LED
Circuit open - LED off
Circuit closed - LED on

Figure 4. Example of the P-Fail Alarm Relay Circuit

LEDs

The following sections describe the LEDs on the switches:

- “Status LEDs” on page 35
- “Twisted-Pair Port LEDs” on page 36
- “SFP Slot LEDs” on page 37
- “PoE Status LEDs” on page 37

Status LEDs

The status LEDs are defined in Table 6.

Table 6. Status LEDs

LED	State	Description
SYS	Solid Green	System is operating normally
	Off	System is powered down, there is a system crash or an operation is initiating.
MASTER	Solid Green	Active when switch is the Ring Master of an X-Ring configuration
	Off	Switch is not the Ring Master of an X-Ring configuration
PWR 1	Solid Green	The switch is receiving power on the PWR 1 connector contacts and is operating normally.
	Off	The PWR 1 supply is powered down or is not installed.
PWR 2	Solid Green	The switch is receiving power on the PWR 2 connector contacts and is operating normally.
	Off	The PWR 2 supply is powered down or is not installed.
FAULT	Solid Red	Defined major Alarm policy is triggered. See “P-Fail Alarm Relay Contacts” on page 33 for more information.
	Off	System the system is operating normally or is powered OFF.

Twisted-Pair Port LEDs

Twisted-pair ports 1-10 have two LEDs. The LEDs are identified in Figure 5.

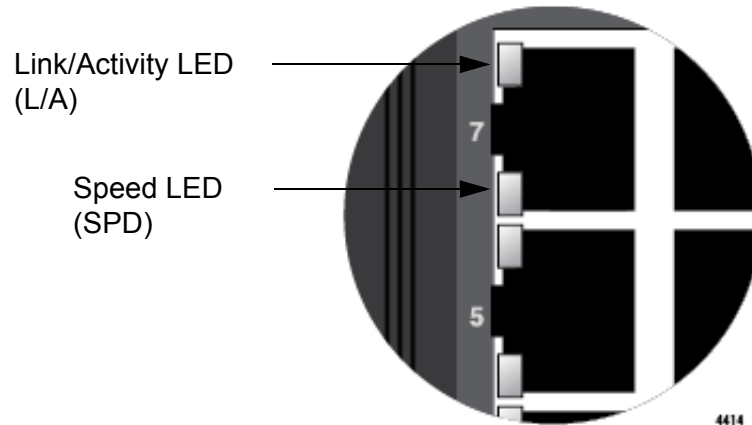

Figure 5. Twisted-Pair Port LEDs: Ports 1-10

The descriptions of the twisted-pair port LEDs are defined in Table 7 on page 36.

Table 7. Twisted-Pair Port LEDs: Ports 1-10

LED	State	Description
LINK/ACT (L/A)	Solid Green	The port has established a link to a network device.
	Flashing Green	The port is transmitting or receiving data.
	Off	The port has not established a link with a network device.
SPEED (SPD)	Solid Green	The port is operating at 1000 Mbps.
	Solid Amber	The port is operating at 100 Mbps.
	Off	The port has not established a link with a network device or the port is operating at 10 Mbps.

SFP Slot LEDs Each SFP slot has one LED. The SFP LEDs for Combo ports 9 and 10 are shown in Figure 6.

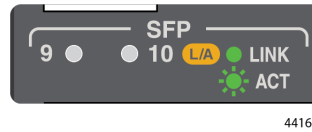

Figure 6. SFP LEDs: Ports 9 and 10

The descriptions of the SFP LEDs are defined in Table 8.

Table 8. SFP Slot LEDs: Ports 9 and 10

State	Description
Solid Green	The port has established a 100Mbps or 1Gbps link to a network device.
Flashing Green	The port is transmitting or receiving network packet traffic at 100Mbps or 1Gbps.
Off	The port has not established a link to a network device.

PoE Status LEDs The PoE Status LEDs for twisted-pair ports 1-8 are shown in Figure 7.

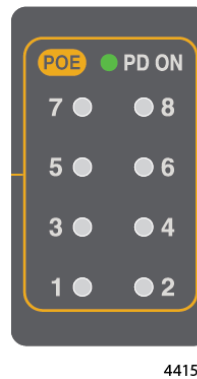

Figure 7. PoE Status LEDs: Ports 1-8

The PoE LED functional descriptions for the twisted-pair ports 1 - 8 are defined in Table 9.

Table 9. PoE Status LED Descriptions: Ports 1-8

LED	State	Description
PoE	Solid Green	PoE is active on the port and is delivering power to a powered device.
	Off	This LED state indicates one of the following conditions: <ul style="list-style-type: none">- The port is connected to a non-PoE device.- The PD is powered off.- PoE is disabled on the port.

Power Supplies

Allied Telesis does not sell power supplies for these products. Power supplies can be purchased from power supply manufacturers.

Note

This product is intended to be supplied by a UL61010 OR UL61010-2-201 and 60950-1 or 62368-1 Listed DC power source, rated 24-48Vdc, 7A minimum and Tma 75 degree C. If you need further assistance, please contact Allied Telesis for further information.

Le commutateur doit être homologué selon les normes UL61010 ou UL61010-2-201 et UL 60950-1 ou UL62368-1 et alimenté par un courant de sortie de 24-48Vdc, 7A minimum, et température ambiante maximale (Tma) 75 degrés.

Here are the power supply requirements for the IS230-10GP switch:

- ❑ DC voltage between 24 and 48 VDC.
Tension continue entre 24 et 48 VDC.
- ❑ The DC power supply must be capable of supplying 7A continuously over the operating temperature range of -40° C to 75° C (-40° F to 167° F).
L'alimentation CC doit être capable de fournir 7A en continu dans la plage de températures de fonctionnement de -40° C à 75° C (-40° F à 167° F).

Note

See “Power Specifications” on page 88 for the DC power supply output requirements.

A single power supply that meets the above requirements can fully power the switch. A second power supply can also be connected for power redundancy.

Power supplies are connected to four of the six terminals on the power/alarm connector on the top panel of the chassis. Refer to Figure 8 on page 40. Each power supply is connected to the switch with two wires, one positive (+) and one negative (-). If you are installing only one power supply to the switch, you may connect it to either the PWR 1 or PWR 2 pins.

Note

See for “Power Connector Pinout Assignments” on page 93 for the pinout function assignments.

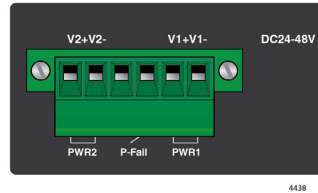

Figure 8. Power/Alarm Connector

Chapter 2

Begin Installation

The chapter contains the following sections:

- “Review Safety Precautions” on page 42
- “Safety Precautions With Electricity” on page 47
- “Review Site Requirements” on page 48
- “Verify Package Contents” on page 50

Review Safety Precautions

Please review the following safety precautions before beginning the installation procedures.

Note

Safety statements that have the  symbol are translated into multiple languages in the *Translated Safety Statements* document at www.alliedtelesis.com/support.



Caution

CAUTION: FOR USE IN A CONTROLLED ENVIRONMENT
ATTENTION: Pour utilisation dans un environnement contrôlé



Warning

Do not block air ventilation holes.
ATTENTION: Ne bloquez pas les ou es de ventilation.



Warning

Use dry cloth for cleaning.
ATTENTION: Utilisez un chiffon sec pour le nettoyage.



Warning

This is open type equipment and should be installed in a suitable enclosure.
ATTENTION: Ceci est un appareil de type ouvert et doit être installé dans une enceinte appropriée.

Ground Connection

Please review this safety information and installation guidelines before installing the ground connection. Refer to “Connect Ground Wire” on page 68 for the installation procedure.



Caution

Before connecting the power, properly ground the device. Lack of a proper grounding setup may result in a safety risk and could be hazardous.

Avant de brancher l'appareil, mettez correctement l'appareil à la terre. L'absence d'une mise à la terre correcte peut entraîner un risque de sécurité et être dangereux.

Power/Alarm Connection

Please review this safety information and installation guidelines before installing the power and alarm wires. Refer to “Power/Alarm Connector Cables” on page 71 for the installation procedure.



Warning

Power cord is used as a disconnection device. To de-energize equipment, disconnect the power cord. ⚡ E3

Le cordon d'alimentation est utilisé en tant que mécanisme de déconnexion. Pour mettre l'équipement hors tension, débrancher le cordon d'alimentation. ⚡ E3

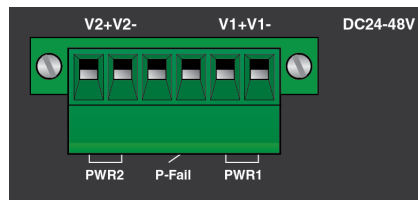

Figure 9. Power/Alarm Connector on Top of Chassis

Safety Instructions

1. The switches can be powered by using SELV +24-48Vdc. All circuits should be connected to a SELV circuit.
2. Make sure the voltage of the power source is correct before connecting the equipment to the power disconnect.
3. If the equipment is not used for a long time, remove it from the power source to avoid damage by transient over voltage.
4. For use in pollution degree 2 environments and indoor use.

5. If the equipment is used in a manner not specified by the manufacturer, the protection provided by the equipment may be impaired.



Warning

Class 1 Laser product. ⚡ L1



Warning

Do not stare into the laser beam. ⚡ L2



Warning

Do not look directly at the fiber optic ends or inspect the cable ends with an optical lens. ⚡ L6



Warning

To prevent electric shock, do not remove the cover. No user-serviceable parts inside. This unit contains hazardous voltages and should only be opened by a trained and qualified technician. To avoid the possibility of electric shock, disconnect electric power to the product before connecting or disconnecting the LAN cables. ⚡ E1



Warning

Do not work on equipment or cables during periods of lightning activity. ⚡ E2



Warning

Power cord is used as a disconnection device. To de-energize equipment, disconnect the power cord. ⚡ E3



Warning

This equipment must be earthed. The ground screw on the unit must be connected to a properly earthed bonding point.

Note

Ground resistance from the building primary bonding point to earth should be less than 5 ohms.

**Caution**

Air flow around the unit and through the cooling fins must not be restricted. E20

Note

All Countries: Install product in accordance with local and National Electrical Codes. E8

**Warning**

Only trained and qualified personnel are allowed to install or replace this equipment. E14

**Caution**

Circuit Overloading: Consideration should be given to the connection of the equipment to the supply circuit and the effect that overloading of circuits might have on overcurrent protection and supply wiring. Appropriate consideration of equipment nameplate ratings should be used when addressing this concern. E21

**Warning**

This unit might have more than one power cord. To reduce the risk of electric shock, disconnect all power cords before servicing the unit. E30

**Warning**

To reduce the risk of electric shock, do not route network cables from PoE ports outside the building that houses this device. E40

**Caution**

The unit does not contain serviceable components. Please return damaged units for servicing. E42

**Warning**

The temperature of an operational SFP or SFP+ transceiver can exceed 70° C (158° F). Exercise caution when handling transceivers with unprotected hands. E43



Caution

An Energy Hazard exists inside this equipment. Do not insert hands or tools into open chassis slots or plugs. ⚡ E44



Warning

This equipment shall be installed in a Restricted Access location. ⚡ E45



Warning

HOT SURFACE, DO NOT TOUCH
ATTENTION: SURFACE CHAUDE, NE PAS TOUCHER.



Warning

Hot surface! The finned surface on the back of the chassis is a heat sink and can become dangerously hot. ⚡ E114



Warning

An operational unit can be hot. Exercise caution when handling with unprotected hands.



Warning

Per NEC section 800.90 all exposed cables, service wires, or drops entering a building must have primary over-voltage protection if they are classified as exposed plants.

Note

The equipment meets EN61000-4-5 Class 3 on the DC inputs and Ethernet ports.



Warning

Allied Telesis does not warrant against lightning or power surges causing damage the device. Such damage will be the responsibility of the equipment owner.

Safety Precautions With Electricity

Please review the following additional safety guidelines before beginning the installation procedure.

- ❑ Disconnect all power by turning off the circuit breakers before installing or removing the device or when working with the power supplies.
- ❑ Do not work alone if potential hazards exist.
- ❑ Never assume that the power is disconnected from a circuit; always check the circuit.
- ❑ Inspect the work area carefully for possible hazards, such as moist floors, ungrounded power extension cables, frayed power cord, or missing safety grounds.

If an electrical accident occurs, proceed as follows:

- ❑ Use caution; do not become a victim yourself.
- ❑ Turn off power to the system.
- ❑ If possible, send another person to get medical aid. Otherwise, access the condition of the victim and then call for help.
- ❑ Determine if the person needs rescue breathing or external cardiac compressions and take appropriate action.

Review Site Requirements

Please observe the following requirements and guidelines when choosing a site for the switch:

- ❑ You can install the switch on a concrete or masonry wall or industrial panel or DIN 35x7.5mm rail.
- ❑ You should not install the switch on a wall or industrial panel that has metal studs. Metal studs may not be strong enough to safely support the device.
- ❑ You should not install the switch only on sheetrock or similar material. Sheetrock is not strong enough to safely support the device.
- ❑ The DC power source should be located near the device and be easily accessible.
- ❑ The site should allow for easy access to the ports on the front of the device, so that you can easily connect and disconnect cables, and view the port LEDs.
- ❑ The site should allow for adequate air flow around and through the cooling fins on the sides of the switch.
- ❑ The site should not expose the device to moisture or water.
- ❑ The site should be a dust-free environment.
- ❑ The site should include dedicated power circuits or power conditioners to supply reliable electrical power to the network devices.
- ❑ If you are installing the device in a wiring or utility box, verify that the enclosure has adequate airflow so that unit does not overheat.
- ❑ Do not place objects on top of the switch.
- ❑ The twisted-pair cabling should not be exposed to sources of electrical noise, such as radio transmitters, broadband amplifiers, power lines, electric motors, and fluorescent lights.
- ❑ The site should allow for the following minimum open spaces around the switch:
 - Four inches under the switch.
 - Eight inches above the switch.
 - Four inches in front of the switch.
 - One inch on the left and right sides of the switch.
- ❑ Before installing the DC power supply, be sure to review the manufacturer's installation guide for rules and restrictions on site requirements, and to follow all guidelines and safety warnings.

- ❑ The switch and DC power source should be installed close to each other so that the DC power cables are kept as short as possible to minimize voltage loss.
- ❑ The switch and power supply should be properly connected to a protective earth ground.
- ❑ The switch and power supply should be individually grounded to the grounding conductor. Do not daisy-chain the ground wires.
- ❑ Powered devices connected to the LAN ports on the switch should be grounded to the same grounding conductor at the service entrance as the switch.
- ❑ LAN ports should have additional lightning protections as specified in 803.3at Section 33.4.1.1.2, Environment B Requirements, when connected to powered devices that are not grounded to the same grounding conductor at the service entrance as the switch.
- ❑ Electromagnetic interference might occur between switches and other devices when multiple switches are powered by a single DC power supply. This can be addressed by installing clamp-on ferrite beads on the DC power cables, between the DC power supply and switches.
- ❑ Recommendations for ground resistivity are given in Table 10.

Table 10. Ground Resistivity Recommendations

Level	Recommendation
Best Practice	<5 ohms
Acceptable	5 to 15 ohms
Marginal	15 to 25 ohms
Non-compliant	>25 ohms

Verify Package Contents

Figure 10 identifies the pre-installed components on the front panel of the switch.

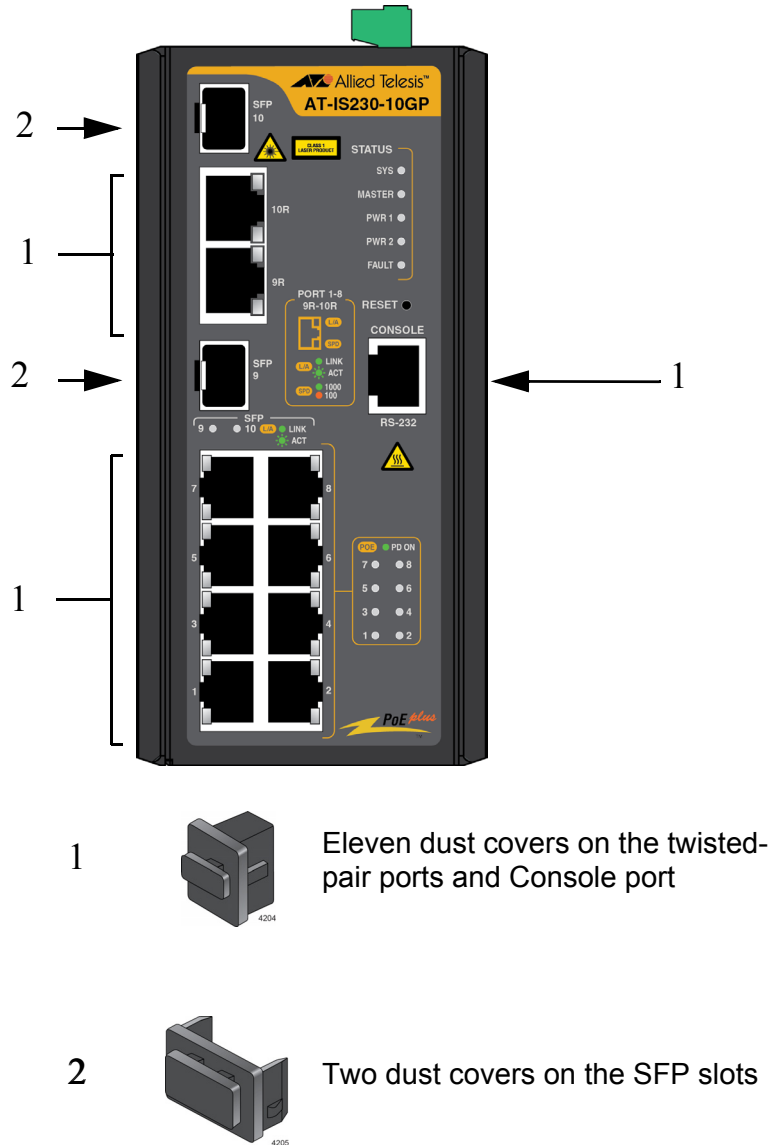

Figure 10. Pre-installed Components on the Front Panel

The Power/Alarm connector and the grounding screw locations are identified in Figure 11.

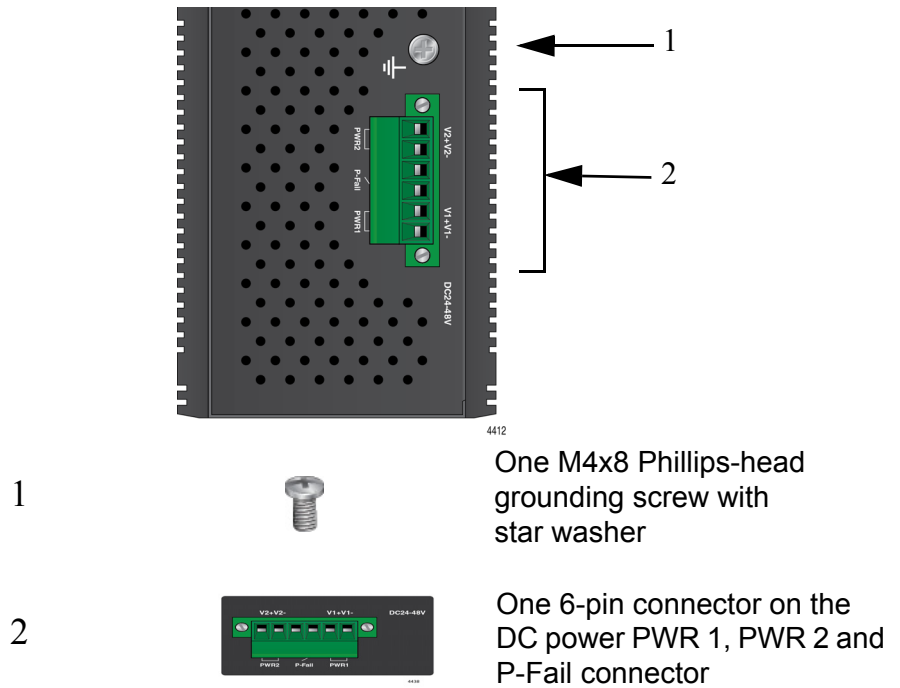

Figure 11. Pre-installed Components on the Top Panel

Figure 12 identifies the pre-installed DIN rail bracket on the back panel.

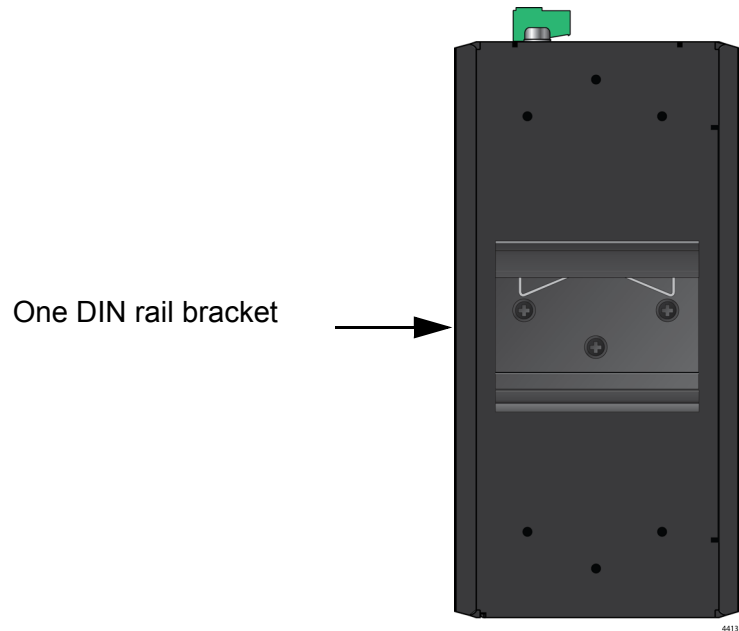

Figure 12. Pre-installed DIN Rail Bracket on the Back Panel

Figure 13 lists the items included in the accessory kit that comes with the switch.

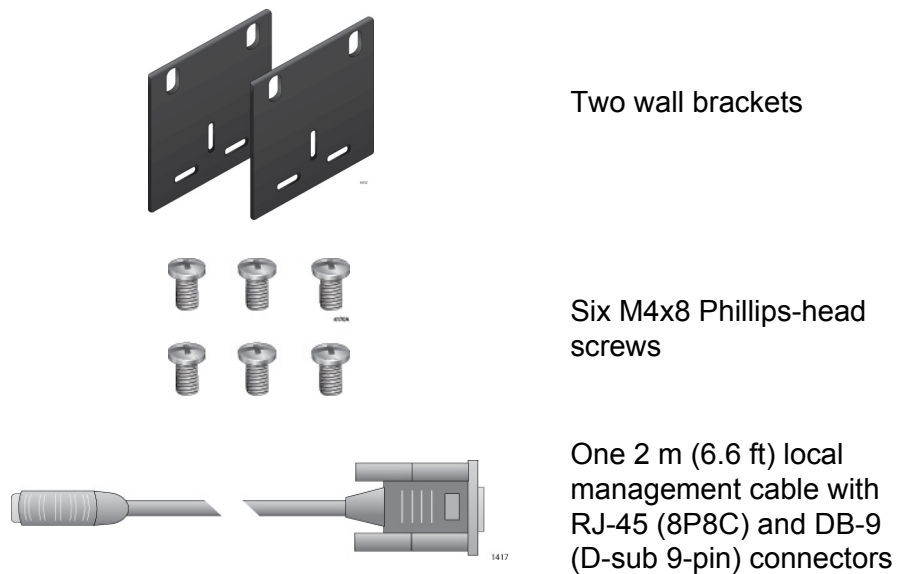

Figure 13. Components in the Accessory Kit

Chapter 3

Install the Switch

The procedures in this chapter are listed here:

- “DIN Rail Installation” on page 54
- “Install Switch On Concrete or Masonry Wall or Industrial Panel” on page 56

DIN Rail Installation

The switch comes with a DIN rail bracket pre-installed on the back panel. The bracket is compatible with a DIN 35x7.5mm rail. The bracket has a spring built into it which holds the bracket in place. Figure 14 shows the proper orientation of the switch on a DIN rail. Do not install the switch horizontally or upside-down.

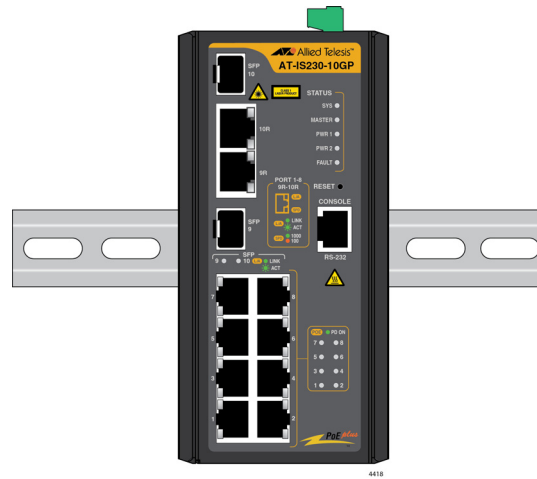

Figure 14. Orientation of the Switch on a DIN Rail

To install the switch on a DIN rail, perform the following procedure:

1. Slide the slot on the top of the DIN rail bracket onto the top edge of the DIN rail. Refer to Figure 15.

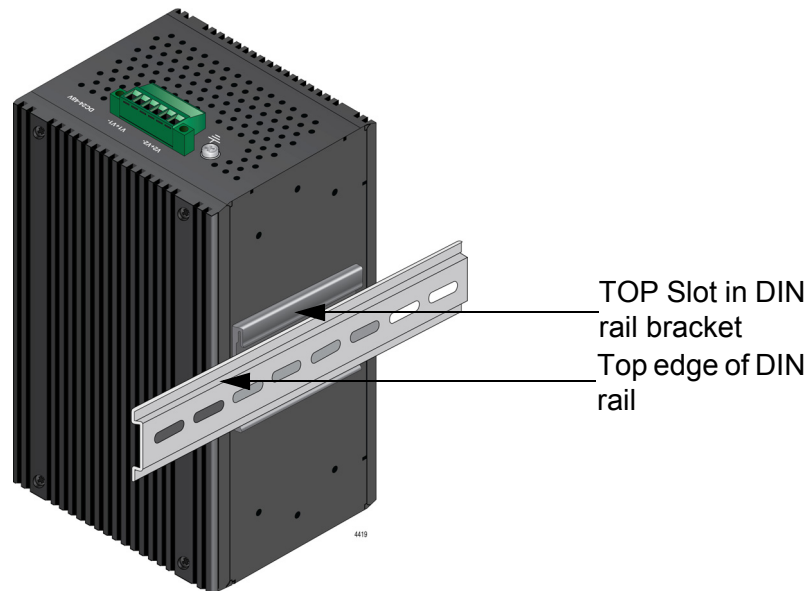

Figure 15. Install Top Slot of DIN Rail Bracket onto DIN Rail

2. Press down (against the spring within the bracket) on the top back edge of the switch until you the bottom edge of the front faceplate of the switch can be pushed back and under the bottom edge of the DIN rail. Release the pressure on the top of the switch until the DIN rail bracket spring securely fastens bracket to the top and bottom of the DIN rail. Refer to Figure 16.

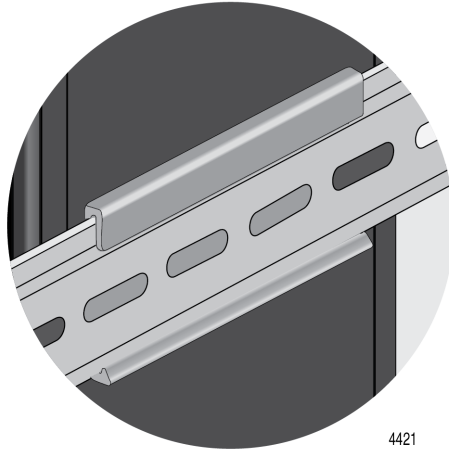

Figure 16. Install Switch on DIN Rail

3. Visually inspect the bracket to verify that the DIN rail is now fitted into the top and bottom slots of the DIN rail bracket.
4. Go to Chapter 4, “Install Twisted-Pair Ports Cables” on page 61.

Install Switch On Concrete or Masonry Wall or Industrial Panel

This section contains instructions on how to install the switch on a concrete or masonry wall or industrial panel.



Warning

The device is heavy. Always ask for assistance before moving or lifting it to avoid injuring yourself or damaging the equipment.



Warning

The device should be installed on a wall or an industrial panel by a qualified building contractor. Serious injury to yourself or others or damage to the equipment may result if it is not properly fastened.

Here are the tools and material required for installing the switch on a concrete or masonry wall or industrial panel:

- Two wall brackets (included with the switch)
- Six bracket screws (included with the switch)
- Four wall screws (not provided)
- Cross-head screwdriver (not provided)
- Drill and 1/4" carbide drill bit (not provided)
- Four anchors and screws (not provided) for attaching the switch to the wall or the panel. The diameter of the screw holes in the wall brackets is 4.5 mm (0.17 in.).

To install the switch on a concrete or masonry wall or industrial panel, perform the following procedure:

1. Place the switch in a table.
2. Remove DIN rail mounting bracket that is factory-installed on the back panel of the switch. Refer to Figure 17 on page 57.

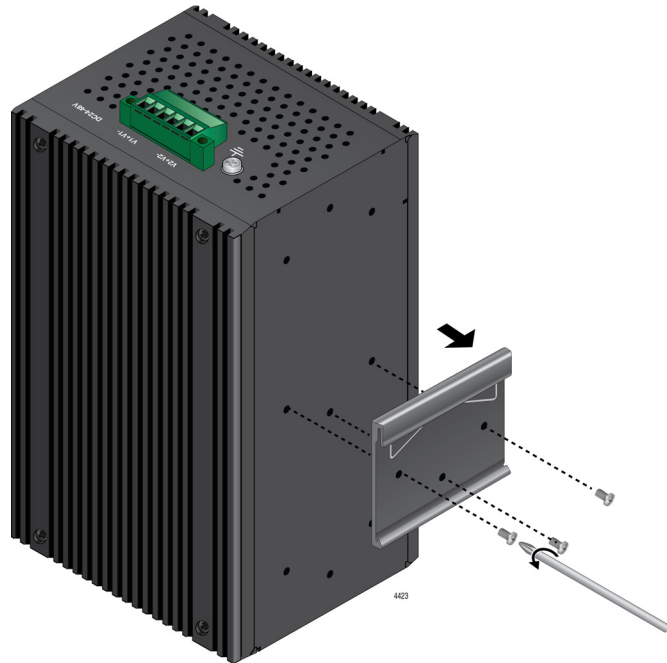

Figure 17. Remove Din Rail Mounting Bracket

3. On the top and bottom of the switch's back panel, align and install the two wall mounting brackets (provided) with the six screws (provided). Refer to Figure 18.

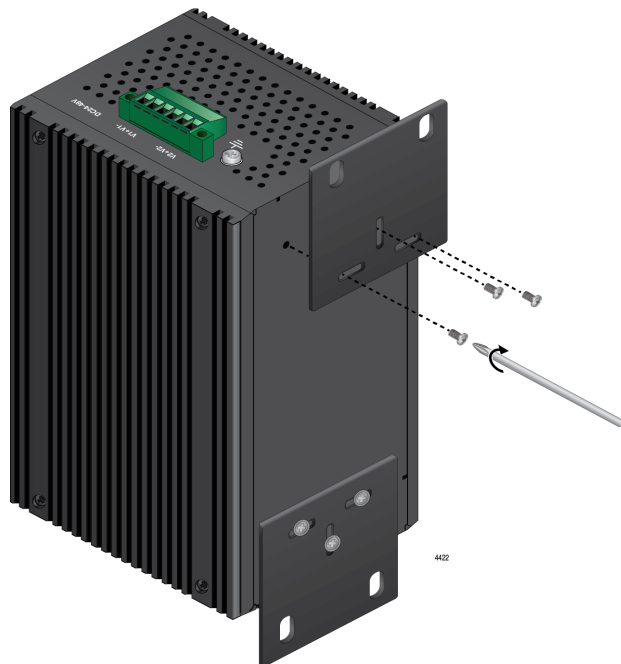

Figure 18. Install Wall Mount Brackets on the Back of the Switch

4. Hold the switch on the concrete or masonry wall or industrial panel at the selected location for the device while you use a pencil or pen to mark the locations of the four screw holes in the two wall brackets. Refer to Figure 19.

Please follow these guidelines as you position the switch on the wall or industrial panel:

- ❑ The switch must be oriented as shown in Figure 19. You may not install the switch horizontally or upside-down.
- ❑ Be sure to leave sufficient space from other devices or walls to allow for adequate air circulation around and through the cooling fins. Refer to “Review Site Requirements” on page 48 for further information.

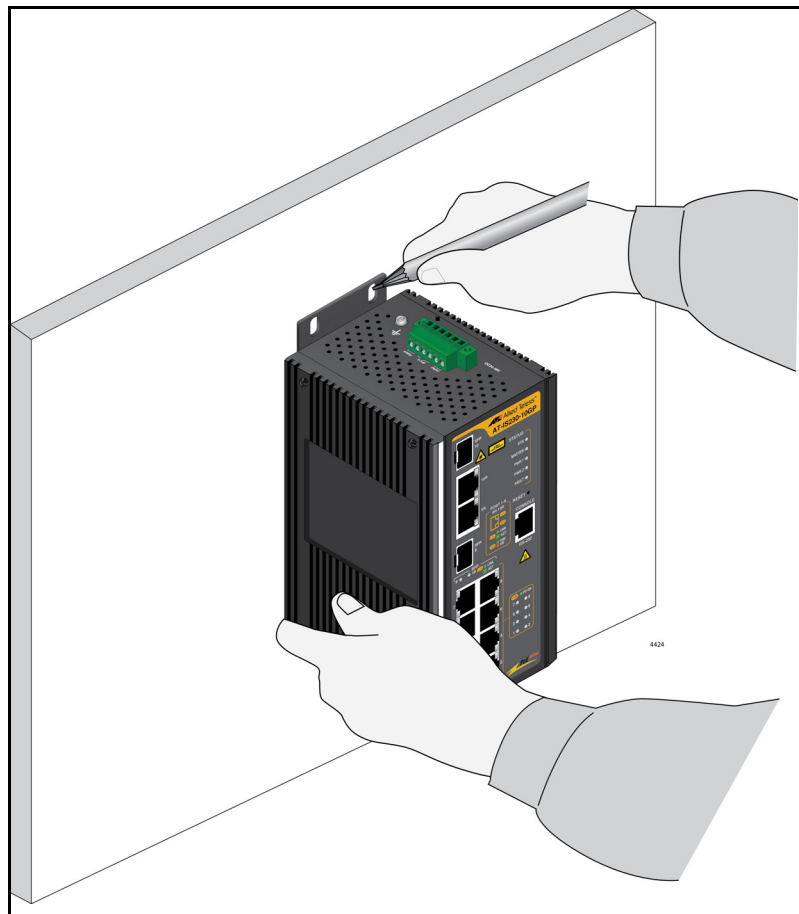

Figure 19. Mark Wall Bracket Hole Locations

5. If you are installing the switch on an industrial panel, skip this step and go to Step 6.

If you are installing the switch on a masonry or concrete wall, perform this step as follows:

- a. Use a drill and 1/4" carbide drill bit to drill the four holes at the locations marked in Step 4. Please review the following guidelines:
 - Prior to drilling, set the drill to hammer and rotation mode. The modes break up the concrete and clean out the hole.
 - Allied Telesis recommends cleaning out the holes with a brush or compressed air.
 - b. Insert anchors (not provided) into the four holes.
 - c. Go to Step 6.
6. Hold the switch at the selected location while you secure it with four screws (not provided). Refer to Figure 20.

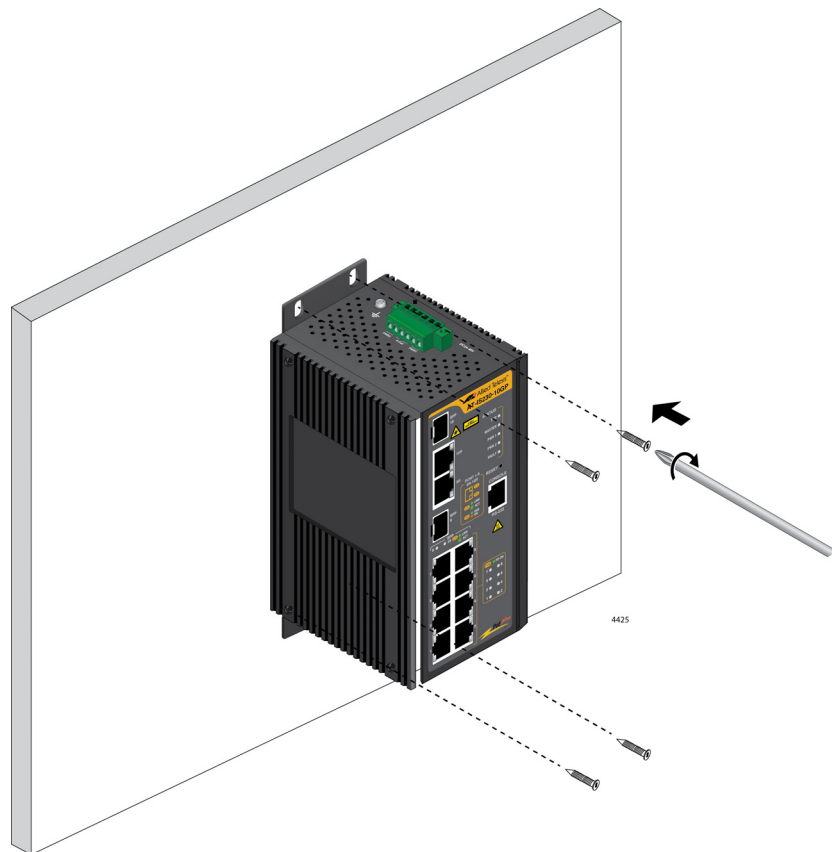

Figure 20. Install Switch Using Wall Brackets

7. Go to Chapter 4, "Install Twisted-Pair Ports Cables" on page 61.

Chapter 4

Install Twisted-Pair Ports Cables

This chapter contains the following procedures:

- “Twisted-Pair Port Cables” on page 62
- “Install SFP Transceivers and Fiber Cables” on page 63

Twisted-Pair Port Cables

Here are the guidelines to cabling the 10/100/1000Base-T twisted-pair ports:

- ❑ The ports have 8-pin RJ45 connectors.
- ❑ The cable specifications for the twisted-pair ports are listed in Table 1 on page 24.
- ❑ The cable specifications for the PoE twisted-pair ports are listed in Table 3 on page 26.
- ❑ The connectors on the cables should fit snugly into the ports, and the tabs should lock the connectors into place.
- ❑ The default setting for PoE on ports 1 to 8 on the IS230-10GP switch is enabled.
- ❑ The 10/100/1000Base-T ports must be set to Auto-Negotiation, the default setting, to operate at 1000Mbps.
- ❑ The default duplex mode setting for the ports is Auto-Negotiation. This setting is appropriate for ports connected to network devices that also support Auto-Negotiation for duplex modes.
- ❑ The default duplex mode setting of Auto-Negotiation is not appropriate for ports connected to network devices that do not support Auto-Negotiation and have a fixed duplex mode. Disable Auto-Negotiation on those ports and set their duplex modes manually to avoid the possibility of duplex mode mismatches. A switch port using Auto-Negotiation defaults to half-duplex if it detects that the end node is not using Auto-Negotiation. This can result in a mismatch if the end node is operating at a fixed duplex mode of full-duplex.
- ❑ The default wiring configuration of the ports is automatic MDIX detection, which configures the MDI/MDIX setting automatically. This setting is appropriate for switch ports that are connected to network devices that also support the feature.

Install SFP Transceivers and Fiber Cables

Please review the following guidelines before installing SFP transceivers:

- ❑ SFP transceivers are hot-swappable. You may install them while the device is powered on.
- ❑ For a list of supported transceivers, refer to the product data sheet.
- ❑ The operational specifications and fiber optic cable requirements of the transceivers are provided in the documents included with the devices.
- ❑ You should install a transceiver before connecting its fiber optic cable.
- ❑ Fiber optic transceivers are dust sensitive. Always keep the plug in the optical bores when a fiber optic cable is not installed, or when you store the transceiver. When you do remove the plug, keep it for future use.
- ❑ Unnecessary removal and insertion of a transceiver can lead to premature failure.
- ❑ Installing or removing a transceiver from a slot in the switch might require slightly more force than typically required with other network equipment. This is because of the design of the SFP cages.



Warning

A transceiver can be damaged by static electricity. Be sure to observe all standard electrostatic discharge (ESD) precautions, such as wearing an antistatic wrist strap, to avoid damaging the device. *ES* E86

The illustrations in the following procedure show a transceiver with a duplex LC connector. The connectors on your transceivers may be different.

To install SFP transceivers in the chassis, perform the following procedure:

1. Remove the dust plug from a transceiver slot. Figure 21 shows the dust plug removed from slot 9.

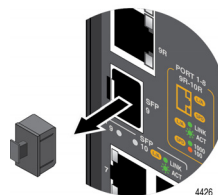

Figure 21. Remove the Dust Plug from an SFP Slot

2. Remove the transceiver from its shipping container and store the packaging material in a safe location.
3. Position the transceiver with its handle on the right and slide it into the slot until it clicks into place. Refer to Figure 22.

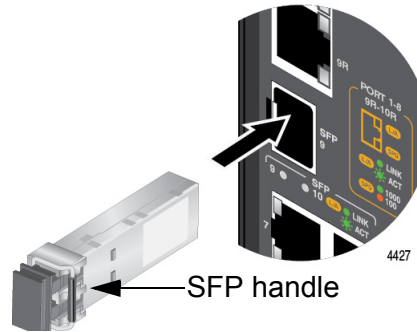

Figure 22. Install SFP Transceiver

Note

If you are ready to attach the fiber optic cable to the transceiver, continue with the next step. Otherwise, repeat steps 1 to 3 to install the remaining transceivers in the switch.

4. Remove the dust cover from the transceiver. Refer to Figure 23.

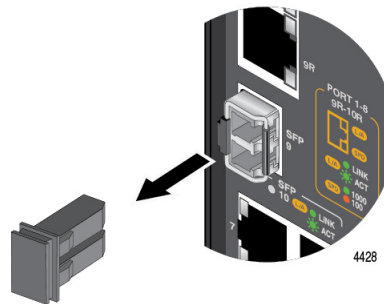

Figure 23. Remove Dust Cover from SFP Transceiver

5. Connect the fiber optic cable to the transceiver. The connector on the cable should fit snugly into the port, and the tab should lock the connector into place. Refer to Figure 24.

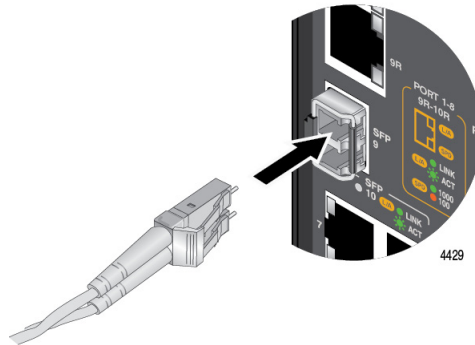

Figure 24. Connect Fiber Optic Cable To SFP Transceiver

6. Repeat this procedure to install and cable the remaining SFP transceivers.
7. Go to Chapter 5, “Power On Switch” on page 67.

Chapter 5

Power On Switch

This chapter contains the following procedures:

- ❑ “Connect Ground Wire” on page 68
- ❑ “Power/Alarm Connector Cables” on page 71
- ❑ “Apply Power To Switch” on page 76
- ❑ “Start Local Management Session” on page 77

Connect Ground Wire

Here are the guidelines for the ground wire:



Warning

Take into consideration the following guidelines before wiring the device.

Attention

Tenez compte des directives suivantes avant de câbler l'appareil.

- ❑ The terminal block (CN1) is suitable for 12-18 AWG (7A). Torque value 7 lb-in.
Le bornier (CN1) est adapté pour 12-18AWG (3,31-0,205mm²).
Valeur de Torgue 7lb-in.
- ❑ The cross sectional area of the earthing conductors should be at least 0.205 mm.
Le min. La section du conducteur de protection doit correspondre au conducteur de puissance dans une plage de 3,31-0,205 mm².
- ❑ The temperature rating of the input connection cable should be higher than 105° C.
La température nominale du câble de connexion d'entrée doit être supérieure à 105° C.



Warning

This equipment must be earthed. The ground screw on the unit must be connected to a properly earthed bonding point.

To connect the grounding wire, perform the following procedure:

1. Strip 2.54cm (1.0 in.) of insulation from the end of the solid grounding wire with a wire insulator stripper. Refer to Figure 25.

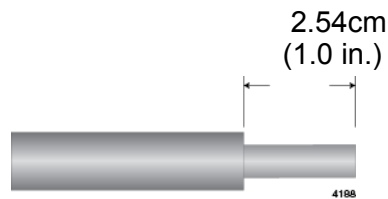

Figure 25. Strip Grounding Wire



Warning

Do not strip more than the recommended amount of wire. Stripping more than the recommended amount can create a safety hazard by leaving exposed wire on the terminal block after installation. *GE* E10

2. Loosen the grounding screw several turns with a #2 Phillips-head screwdriver. Refer to Figure 26 on page 69.

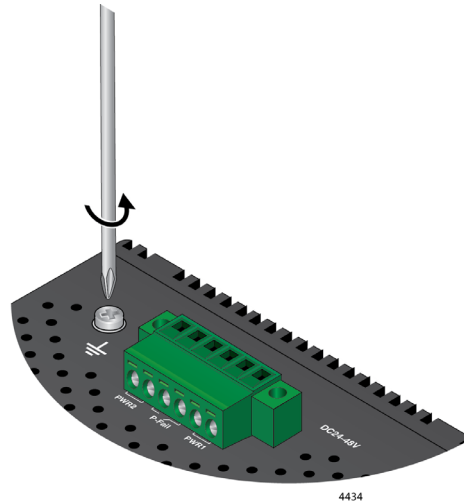

Figure 26. Loosen Grounding Screw

3. Wrap the grounding wire clockwise around the base of the grounding screw beneath the star-lock washer provided. Refer to Figure 27.

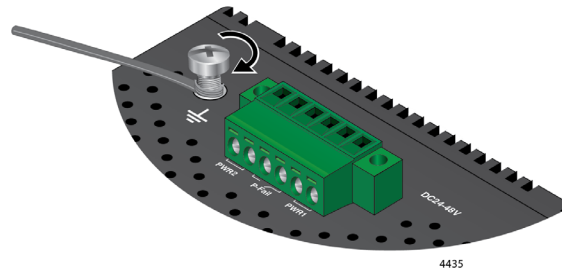

Figure 27. Wrap Grounding Wire Around Ground Screw

4. Tighten the screw clockwise to secure the ground wire to the switch chassis. Refer to Figure 28.

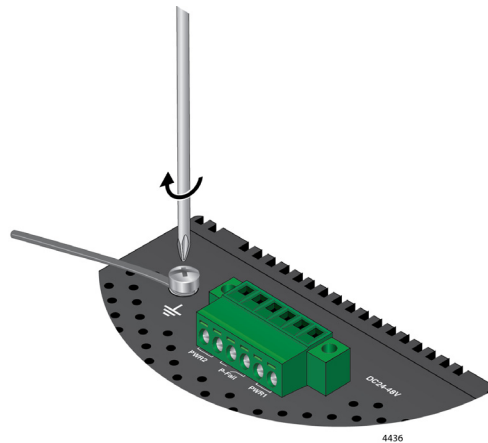

Figure 28. Secure Grounding Wire to the Switch

5. Connect the other end of the ground wire to an earth-ground point at the installation site.
6. Go to “Power/Alarm Connector Cables” on page 71.

Power/Alarm Connector Cables

Here are the materials and tools needed to build the DC power and alarm cables:

- ❑ 12-18 AWG stranded wires.
- ❑ 6-wire connector for the power and alarm cables connections.
- ❑ #1 flat-head screwdriver
- ❑ Wire insulation stripper

Take into consideration the following guidelines before wiring the device:

- ❑ The switches support dual +24-48Vdc power inputs.
- ❑ Tighten wire-clamps to a torque value 7 lb-in. to prevent the DC wires from loosening.
- ❑ The terminal block is suitable for 12-18 AWG (3.31 - 0.205 mm²).
- ❑ P-Fail contacts are provided for switching a closed loop device, such as alarm system, for transmit signals only and do not provide power.



Warning

Power cord is used as a disconnection device. To de-energize equipment, disconnect the power cord. ⚡ E3

Power/Alarm Connector Wiring

To make the two pairs of DC power cables and one pair of wires for the P-Fail alarm relay contacts, perform the following procedure:

1. Strip 6.5mm (0.25 in.) of insulation from the ends of each of power and the alarm wires with a wire insulator stripper. Refer to Figure 29.

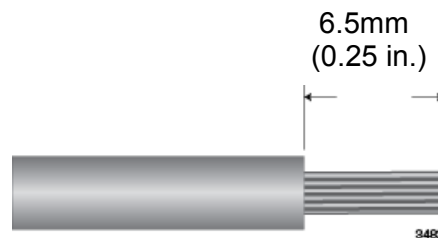

Figure 29. Strip Power or Alarm Wire



Warning

Do not strip more than the recommended amount of wire. Stripping more than the recommended amount can create a safety hazard by leaving exposed wire on the terminal block after installation. ⚡ E10

2. Tightly wrap the wire strands with your finger tips. Refer to Figure 30 on page 72.

This step is to prevent loose strands from touching other wires and causing an electrical short.

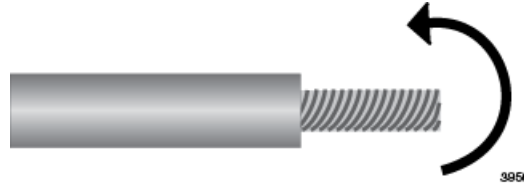

Figure 30. Wrap Wire Strands

Note

Allied Telesis recommends that you also tin the wires with solder as added protection against loose strands. This guide does not provide instructions on how to tin wires.

3. Loosen the two fastening screws on the ends of the Power/Alarm connector . Remove the power/alarm connector from the top panel. Figure 31 shows the removal of this connector.

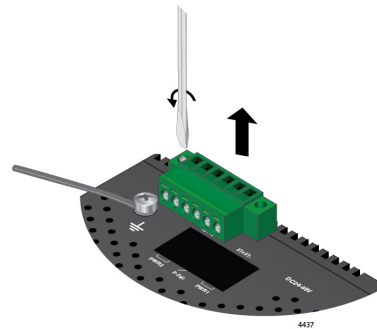

Figure 31. Remove Power/Alarm Connector

- Loosen the wire retaining screws for each of the six wire connections on the power/alarm connector with a #1 screwdriver as shown in Figure 32.

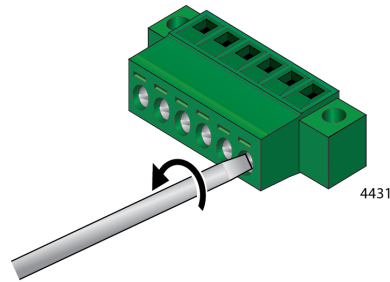

Figure 32. Loosen Power/Alarm Connector Wire Retaining Screws

- Insert the power wires into the wiring slots 1 and 2 (V1+ and V1-) for one power supply. If you are installing the wires for a second power supply, insert them into wiring slots 5 and 6 (V2+ and v2-). Insert the two alarm wires in pins 3 and 4 - there is no polarity for the alarm wires. See for Figure 33 for the insertion of the wires.

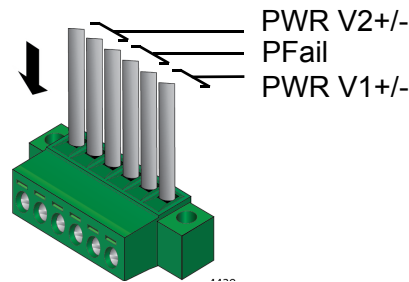

Figure 33. Insert Power Supply and Alarm Wires into Power/Alarm Connector

- After inserting the wires to the connector, verify that there are no exposed wires or loose wire strands. Refer to Figure 34 on page 73.



Warning

Check to see if there are any exposed copper strands coming from the installed wires. When this installation is done correctly there should be no exposed copper wire strands extending from the terminal block. Any exposed wiring can conduct harmful levels of electricity to persons touching the wires. ⚡ E12

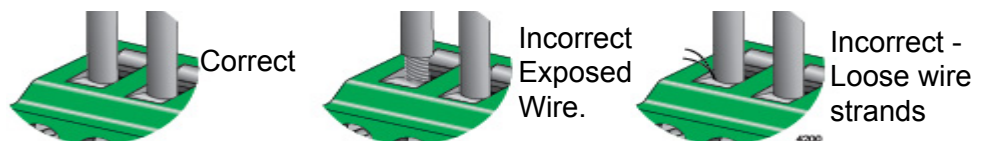

Figure 34. Verify Wire Installation

7. Tighten the retaining screws on the power/alarm connector to secure the wires to a torque value 7 lb-in. Refer to Figure 35.

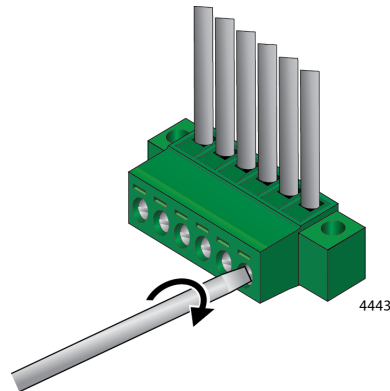

Figure 35. Tighten Wires In Power/Alarm Connector

8. Connect the opposite end of the alarm wires to the external alarm circuit.
9. Verify that the DC power supply is powered off. If there are two DC power supplies, verify that both units are powered off.
10. Connect the opposite ends of the “plus” and “minus” power wires from the power/alarm connector to the first external DC power supply. Refer to the documentation included with the power supply unit for instructions.
11. If you have a second external power supply, connect the second pair of power wires from the power/alarm connector to the second DC power supply. Refer to the documentation included with the power supply unit for instructions.
12. Insert the power/alarm connector into the mating connector on the chassis top panel.

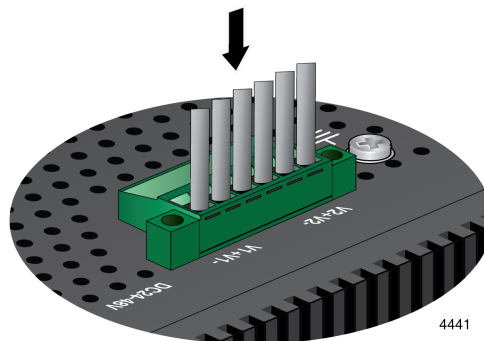

Figure 36. Insert the Power/Alarm Connector

13. Tighten the two connector fastening screws on the ends of the power/ alarm connector to the chassis as shown in Figure 37.

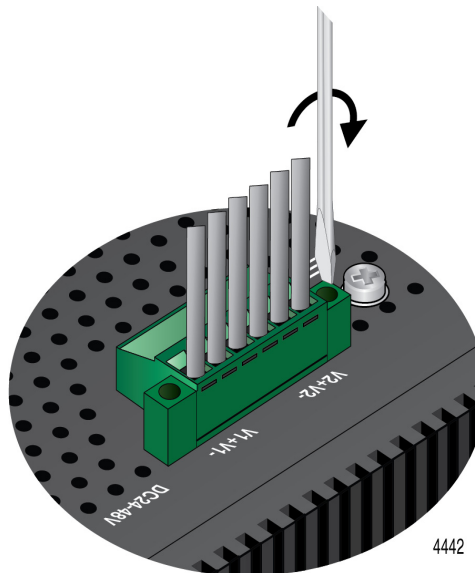

Figure 37. Fasten the Power/Alarm Connector to Chassis

14. After inserting and fastening the power/alarm connector, go to “Apply Power To Switch” on page 76.

Apply Power To Switch

This section contains the procedure for powering on the switch.

To power on the chassis, perform the following procedure:

1. Apply power to the DC power supplies.

Note

The IS230-10GP switch does not have an On/Off switch. To turn the unit OFF, you must turn OFF the power supplies.

2. Wait a minimum of one minute for the switch to initialize its operating system.

Verify Switch Operations

Here are items to check to verify that the switch is operating normally. If there is a problem, refer to Chapter 6, “Troubleshooting” on page 79 for suggestions on how to resolve it.

- The Fault LED should be off.
- One or both PWR 1 and PWR 2 LEDs should be solid green, depending on the number of DC power supplies connected to the unit.
- The LEDs on SFP slots with transceivers connected to active network devices should be solid or flashing green.
- The Link LEDs on twisted-pair ports connected to active network devices should be solid or flashing green or amber. The Link LEDs are identified in Figure 5 on page 36 and Figure 6 on page 37.
- The PoE LEDs should be solid green on ports that are connected to PoE or PoE+ devices. The PoE LEDs are identified in Figure 7 on page 37.

After verifying the operations of the switch, go to “Start Local Management Session” on page 77.

Start Local Management Session

This section contains the procedure for starting a local management session on the switch. Please review the following information before performing the procedure:

- The initial management session with the switch must be a local session.
- Local management sessions are conducted through the Console port on the front panel.
- Local management sessions do not interfere with the network operations of the switch.
- The switch comes with one 2 m (6.6 ft) management cable, with RJ-45 and DB-9 connectors, for local management sessions. Refer to Figure 13 on page 52.
- The switch does not need an IP address for local management sessions.

To start a local management session, perform the following procedure:

1. Connect the RJ-45 connector on your management cable to the Console port on the switch.
2. Connect the other end of the cable to an RS-232 port on a terminal or personal computer with a terminal emulation program.
3. Configure the VT-100 terminal or terminal emulation program as follows:
 - Baud rate: 9600 bps (The baud rate of the Console port is adjustable from 1200 to 115200 bps. The default is 9600 bps.)
 - Data bits: 8
 - Parity: None
 - Stop bits: 1
 - Flow controller: None

Note

The port settings are for a DEC VT100 or ANSI terminal, or an equivalent terminal emulator program.

Note

The baud rate must be set to the default 9600 bps to configure the boot loader.

4. Press Enter. You are prompted for the name and password of the manager account.
5. Enter the user name and password. The default values are “manager” and “friend” (without the quotes), respectively.

Note

User names and passwords are case sensitive.

The switch starts the local management session and displays the following prompt:

awp1us>

This prompt represents the User Exec mode in the command line interface in the switch.

Chapter 6

Troubleshooting

This chapter has suggestions on how to troubleshoot problems with the switch. The sections in the chapter are listed here:

- ❑ “PWR 1 and PWR 2 LEDs” on page 80
- ❑ “Twisted-Pair Ports” on page 81
- ❑ “SFP Slots” on page 82
- ❑ “Power Over Ethernet” on page 83

Note

For further assistance, please contact Allied Telesis Technical Support at www.alliedtelesis.com/support.

PWR 1 and PWR 2 LEDs

Problem: A DC power supply is connected to the switch, but the corresponding PWR 1 or PWR 2 LED on the front panel is off.

Solutions: The unit is not receiving power from the power supply or the power is outside the operating range of the switch. Try the following:

- ❑ Verify that the DC power source is powered on and operating normally.
- ❑ Review the DC power source's documentation to verify that it is compatible with the switch. The power supply requirements for the switch are given in "Power Supplies" on page 39.
- ❑ Verify that the power/alarm connector is fully inserted into the slot in the top panel of the switch.
- ❑ Verify that the DC wires are securely connected to the PWR 1 - PWR 2 connector terminals on the switch and to the DC power supply.
- ❑ Verify that the DC positive and negative wires from the power supplies are connected to the correct connectors on the DC PWR 1 - PWR 2 connector terminals on the switch.
- ❑ Try using a different DC power source.
- ❑ Try replacing the DC power wires.
- ❑ Try connecting the DC power source to a different device to ensure that it is working properly.
- ❑ Test the output voltage from the power source to verify that it is within the operating range of the switch.

Twisted-Pair Ports

Problem: A twisted-pair port on the switch is connected to a network device but the port's LINK/ACT LED is off.

Solutions: The port is unable to establish a link to a network device. Try the following:

- ❑ Verify that the port is connected to the correct twisted-pair cable. This is to eliminate the possibility that the port is connected to the wrong network device which may not be active.
- ❑ Verify that the network device connected to the twisted-pair port is powered on and is operating properly.
- ❑ Verify that the network cable is securely connected to the ports on the switch and remote network device.
- ❑ Try connecting another network device to the twisted-pair port with a different cable. If the twisted-pair port is able to establish a link, then the problem is with the cable or the other network device.
- ❑ Verify that the twisted-pair cable does not exceed 100 meters (328 feet).
- ❑ Verify that you are using the appropriate category of twisted-pair cable. Refer to Table 1 on page 24 and Table 3 on page 26.
- ❑ Use the switch's management software to verify that the port is enabled.
- ❑ If the remote network device is a managed device, use its management firmware to verify that its port is enabled.

Note

A 1000Base connection might require five to ten seconds to establish a link.

Problem: Network performance between a twisted-pair port on the switch and a network device is slow.

Solution: There might be a duplex mode mismatch between the port and the network device. This can occur when a twisted-pair port using Auto-Negotiation is connected to a remote device that has a fixed speed of 10 or 100 Mbps and a fixed duplex mode of full duplex. If this is the cause of the problem, adjust the duplex mode of the port on the network device or switch so that both ports are using the same duplex mode. For the AT-IS230-10GP switch, you have to use the management software to determine the duplex mode settings of the ports.

SFP Slots

Problem: The LINK/ACT LED for an SFP transceiver is off.

Solutions: The fiber optic port on the transceiver cannot establish a link to a network device. Try the following:

- ❑ Verify that the remote network device connected to the fiber optic port is operating properly.
- ❑ Verify that the fiber optic cable is securely connected to the port on the SFP module and to the port on the remote network device.
- ❑ Check that the SFP transceiver is fully inserted in the slot in the switch.
- ❑ Verify that the operating specifications of the fiber optic ports on the transceiver and remote network device are compatible.
- ❑ Verify that the correct type of fiber optic cabling is being used.
- ❑ Verify that the port is connected to the correct fiber optic cable. This is to eliminate the possibility that the port is connected to the wrong remote network device.
- ❑ Try connecting another network device to the fiber optic port using a different cable. If the port is able to establish a link, then the problem is with the cable or with the other network device.
- ❑ Use the switch's management software to verify that the port is enabled.
- ❑ If the remote network device is a managed device, use its management firmware to verify that its port is enabled.
- ❑ Test the attenuation of both directions on the fiber optic cable with a fiber optic tester to determine whether the optical signal is too weak (sensitivity) or too strong (maximum input power).

Power Over Ethernet

Problem: The AT-IS230-10GP switch is not providing power to a PoE or PoE+ device.

Solutions: Try the following:

- ❑ Check that the device's power requirements do not exceed those listed in Table 2 on page 25. The power requirements should be included in the device's documentation or data sheet.
- ❑ Verify that you are using the appropriate category of twisted-pair cable by referring to Table 3 on page 26.
- ❑ Try replacing the twisted-pair cable.
- ❑ Use the management software on the switch to determine whether PoE/PoE+ is enabled on the port. The default setting is enabled.
- ❑ Use the SHOW POWER-INLINE command to determine whether the PoE power setting for the port was reduced to a value below the power requirements of the device.
- ❑ Try connecting the device to a different port on the switch.

Appendix A

Technical Specifications

This appendix contains the following sections:

- “Physical Specifications” on page 86
- “Environmental Specifications” on page 87
- “Power Specifications” on page 88
- “Certifications” on page 89
- “RJ-45 Twisted-Pair Ethernet Port Pinouts” on page 90
- “RJ-45 Style Serial Console Port Pinouts” on page 92
- “Power/Alarm Connectors” on page 93

Physical Specifications

Dimensions

Table 11 lists the dimensions of the products.

Table 11. Product Dimensions

IS230-10GP switch	74 x 105 x 152 mm (W x D x H) (2.91 x 4.13 x 5.98 in.)
-------------------	---

Weights

Table 12 lists the weights of the products.

Table 12. Product Weights

IS230-10GP switch	1.2 Kg (2.65 lb.)
-------------------	-------------------

Cabinet Dimensions

Table 13 provides the minimum cabinet dimensions.

Table 13. Minimum Cabinet Dimensions

Minimum Cabinet Dimensions (W x H x D)	50.8 x 50.8 x 30.5 cm (20.0 x 20.0 x 12.0 in)
---	--

Environmental Specifications

Table 14 lists the environmental specifications of the switches.

Table 14. Environmental Specifications

Operating Temperature Range	-40° C to 75° C (-40° F to 167° F)
Storage Temperature	-40° C to 85° C (-40° F to 185° F)
Operating Humidity	10% to 95% noncondensing
Storage Humidity	10% to 95% noncondensing
Maximum Operating Altitude	3,000 m (9,843 ft)

Power Specifications

Table 15 lists the maximum power consumption values.

Table 15. Maximum Power Consumptions

IS230-10GP switch	168W (Max)
-------------------	------------

Table 16 lists the external power supply DC output specifications.

Table 16. External Power Supply DC Output Specifications

DC Output	24 - 48 VDC, 7.0 A
Operating Temperature Range	-40° C to 75° C (-40° F to 167° F)
Maximum Operating Altitude	3000 m (9,843 ft)

Table 17 lists heat dissipation.

Table 17. Heat Dissipation (British Thermal Units/Hour)

IS230-10GP switch	574.43 BTU/hr
-------------------	---------------

Certifications

The regulatory approvals of the product are listed in Table 18.

Table 18. Regulatory Approvals

Safety	IEC/EN/UL60950-1 CAN/CSA-C22.2 No.60950-1 UL61010-2-201 CAN/CSA-C22.2 No.61010-2-201 EN 61010-2-201
EMI	FCC part15 Subpart B/ Class A ICES-003 Class A EN55032 Class A CISPR 32 Class A VCCI Class A AS/NZS CISPR 32 Class A EN61000-6-4 Class A
EMS	IEC 61000-4-2 IEC 61000-4-3 IEC 61000-4-4 IEC 61000-4-5 IEC 61000-4-6 IEC 61000-4-8 EN55024 EN61000-6-2 EN50121-4
Shock	EN60068-2-27 MIL-STD-810G 516.6
Freefall	IEC 60068-2-31
Vibration	IEC 60068-2-6 MIL-STD-810G 514.6
RoHS	Comply with AT-Doc # 612-001876

RJ-45 Twisted-Pair Ethernet Port Pinouts

Figure 38 identifies pin 1 on an RJ-45 twisted-pair port.

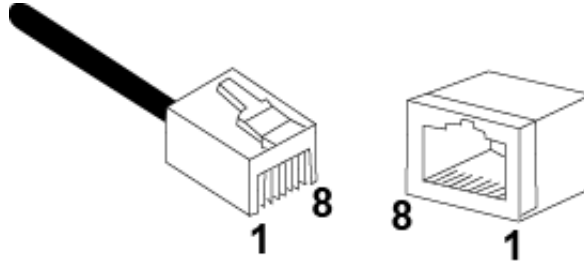

Figure 38. RJ-45 Port Pin Layout (Front View)

Table 19 lists the pin signals for a port when it is operating at 10 or 100 Mbps.

Table 19. Pin Signals for 10 and 100 Mbps

Pin	MDI Signal	MDI-X Signal
1	TX+	RX+
2	TX-	RX-
3	RX+	TX+
4	Not used	Not used
5	Not used	Not used
6	RX-	TX-
7	Not used	Not used
8	Not used	Not used

Table 20 lists the pin signals for a port when it operating at 1000 Mbps.

Table 20. Pin Signals for 1000 Mbps

Pinout	Pair
1	Pair 1 +
2	Pair 1 -
3	Pair 2 +
4	Pair 3 +
5	Pair 3 -
6	Pair 2 -
7	Pair 4 +
8	Pair 4 -

RJ-45 Style Serial Console Port Pinouts

Table 21 lists the pin signals for the RJ-45 style serial Console port.

Table 21. RJ-45 Style Console Port Pin Signals

Pin	Signal
1	Open
2	Open
3	Transmit Data
4	Ground
5	Ground
6	Receive Data
7	Open
8	Ground

Power/Alarm Connectors

Pin Assignments The pinout assignments for the power connector are given in Table 22. For power supply requirements, refer to “Power Supplies” on page 39.

Table 22. Power Connector Pinout Assignments

Assignment	Function
V1 +	PWR Supply 1 V+
V1 -	PWR Supply 1 V-
P-Fail	Alarm fault
P-Fail	Alarm fault
V2 +	PWR Supply 2 V+
V2 -	PWR Supply 2 V-

P-Fail Alarm Contact Rating The contact rating specifications for the P-Fail alarm relay are:

- 24VDC maximum
- 1.0A maximum

