

# CONVERTEON™ Family

## Media Converter Chassis

---

**AT-CV5001**

# Installation Guide

Copyright © 2009 Allied Telesis, Inc.

All rights reserved. No part of this publication may be reproduced without prior written permission from Allied Telesis, Inc.

Allied Telesis, the Allied Telesis logo, and Converteon are trademarks of Allied Telesis, Incorporated. All other product names, company names, logos or other designations mentioned herein are trademarks or registered trademarks of their respective owners.

Allied Telesis, Inc. reserves the right to make changes in specifications and other information contained in this document without prior written notice. The information provided herein is subject to change without notice. In no event shall Allied Telesis, Inc. be liable for any incidental, special, indirect, or consequential damages whatsoever, including but not limited to lost profits, arising out of or related to this manual or the information contained herein, even if Allied Telesis, Inc. has been advised of, known, or should have known, the possibility of such damages.

# Electrical Safety and Emissions Standards

---

This product meets the following standards.

## U.S. Federal Communications Commission

### Radiated Energy

Note: This equipment has been tested and found to comply with the limits for a Class A digital device pursuant to Part 15 of FCC Rules. These limits are designed to provide reasonable protection against harmful interference when the equipment is operated in a commercial environment. This equipment generates, uses, and can radiate radio frequency energy and, if not installed and used in accordance with this instruction manual, may cause harmful interference to radio communications. Operation of this equipment in a residential area is likely to cause harmful interference in which case the user will be required to correct the interference at his own expense.

Note: Modifications or changes not expressly approved of by the manufacturer or the FCC, can void your right to operate this equipment.

## Industry Canada

This Class B digital apparatus complies with Canadian ICES-003.

Cet appareil numérique de la classe A est conforme à la norme NMB-003 du Canada.

RFI Emissions      FCC Class A, EN55022 Class A, EN61000-3-2, EN61000-3-3, VCCI Class A, C-TICK, CE

**Warning:** In a domestic environment this product may cause radio interference in which case the user may be required to take adequate measures.

Immunity            EN55024

Electrical Safety    EN60950 (TUV), UL 60950 (CUL-US)



Laser Safety        EN60825

# Translated Safety Statements

---

**Important:** The  indicates that a translation of the safety statement is available in a PDF document titled “Translated Safety Statements” (613-000990) posted on the Allied Telesis website at [www.alliedtelesis.com](http://www.alliedtelesis.com).

# Contents

---

<b>Preface</b> .....	11
Safety Symbols Used in this Document.....	12
Where to Find Web-based Guides .....	13
Contacting Allied Telesis .....	14
Online Support .....	14
Email and Telephone Support.....	14
Returning Products.....	14
Sales or Corporate Information .....	14
Warranty .....	14
Management Software Updates.....	14
<b>Chapter 1: Overview</b> .....	15
AT-CV5001 Chassis Overview .....	16
Front and Rear Panel Components.....	17
Media Converter Cards.....	18
AT-CV5M02 Management Card .....	19
AT-CV5001AC and AT-CV5001DC Power Supply Modules .....	21
Automatic Fan Speed Control .....	21
Power Supply Alerts and Shutdown .....	22
AT-CV5000 Chassis .....	23
AT-CV5LED Card.....	24
<b>Chapter 2: Installation</b> .....	27
Reviewing the Safety Precautions.....	28
Selecting a Site for the Chassis.....	31
Unpacking the Chassis.....	32
Installing the AT-CV5001 Chassis in a Rack.....	34
Grounding the AT-CV5001 Chassis .....	36
Installing the AT-CV5001AC Power Supply.....	38
Installing the AT-CV5001DC Power Supply .....	43
Installing the Media Converter Line Cards.....	47
Installing the AT-CV5M02 Management Card.....	52
Powering On an AC Powered Chassis.....	57
Powering On a DC Powered Chassis.....	59
<b>Chapter 3: Removing or Replacing Line Cards or Power Supply Modules</b> .....	63
Removing or Replacing Media Converter Line Cards .....	64
Removing or Replacing the AT-CV5001AC Power Supply .....	69
Removing or Replacing the AT-CV5001DC Power Supply .....	73
<b>Chapter 4: Troubleshooting</b> .....	77
<b>Appendix A: Technical Specifications</b> .....	79
Physical Specifications .....	79
Environmental Specifications.....	79
Power Specifications .....	79
AT-CV5001AC Power Supply Module.....	79
AT-CV5001DC Power Supply Module.....	80
Power Supply Module Fuse Specifications.....	80
Safety and Electromagnetic Emissions Certifications.....	80

<b>Appendix B: Cleaning Fiber Optic Connectors</b> .....	81
Using a Cartridge-Type Cleaner .....	82
Using a Swab.....	84

# Figures

---

Figure 1. AT-CV5001 Chassis .....	16
Figure 2. Front Panel .....	17
Figure 3. Rear Panel .....	17
Figure 4. AT-CV5M02 Management Card .....	19
Figure 5. AT-CV5LED Card .....	24
Figure 6. Removing the Feet .....	34
Figure 7. Removing the Feet .....	34
Figure 8. Installing the Brackets .....	35
Figure 9. Mounting the AT-CV5001 Chassis in a 19-inch Equipment Rack .....	35
Figure 10. Connecting the Wire to the Ground Lug .....	36
Figure 11. Removing the Grounding Lug Screws .....	36
Figure 12. Attaching the Grounding Lug to the Chassis .....	37
Figure 13. Removing the Cover from Slot B .....	40
Figure 14. Inserting the AT-CV5001AC Power Supply .....	41
Figure 15. Securing the AT-CV5001AC Power Supply .....	42
Figure 16. Removing the Cover from Slot B .....	44
Figure 17. Inserting the AT-CV5001DC Power Supply .....	45
Figure 18. Securing the AT-CV5001DC Power Supply .....	46
Figure 19. Removing a Blank Slot Cover .....	48
Figure 20. Alignment Guides .....	49
Figure 21. Inserting a Line Card .....	50
Figure 22. Tightening the Captive Screw .....	50
Figure 23. Removing a Slot Cover .....	53
Figure 24. Installing the AT-CV5M02 Management Card .....	55
Figure 25. Tightening the Captive Screw .....	56
Figure 26. Connecting the AC Power Cord .....	57
Figure 27. DC Terminal Block on the AT-CV5001DC Power Supply Module .....	59
Figure 28. Stripped Wire .....	60
Figure 29. Inserting Wires into a DC Terminal Block .....	60
Figure 30. Labeling and Removing the Network Cables .....	64
Figure 31. Installing the Dust Cap .....	65
Figure 32. Removing the SFP Module .....	65
Figure 33. Loosening the Captive Screw .....	66
Figure 34. Removing a Line Card .....	67
Figure 35. Removing the Power Cord from the AT-CV5001AC Power Supply .....	69
Figure 36. Loosening the Captive Screws on the AT-CV5001AC Power Supply .....	70
Figure 37. Removing the AT-CV5001AC Power Supply .....	71
Figure 38. Installing the Slot Cover .....	72
Figure 39. Loosening the Captive Screws on the AT-CV5001AC Power Supply .....	74
Figure 40. Removing the AT-CV5001AC Power Supply .....	75
Figure 41. Installing the Slot Cover .....	76
Figure 42. Ferrule in an SC Connector Plug .....	81
Figure 43. Unclean and Clean Ferrule .....	81
Figure 44. Cartridge Cleaner .....	82
Figure 45. Rubbing the Ferrule Tip on the Cleaning Surface .....	83
Figure 46. Lint-Free and Alcohol-Free Swabs .....	84
Figure 47. Cleaning a Recessed Ferrule .....	84





# Tables

---

Table 1. Safety Symbols ..... 12

Table 2. Status LEDs on the AT-CV5LED Card ..... 24

Table 3. AT-CV5001 Chassis Components ..... 32

Table 4. AT-CV5001AC Power Supply Components ..... 38

Table 5. AT-CV5001DC Power Supply Component ..... 43

Table 6. AT-CV5M02 Management Card Components ..... 54

Table 7. Power Supply Fuse Specifications ..... 80



# Preface

---

This guide contains the installation instructions for the Converteon™ AT-CV5001 Chassis. This preface contains the following sections:



- ❑ “Safety Symbols Used in this Document” on page 12
- ❑ “Where to Find Web-based Guides” on page 13
- ❑ “Contacting Allied Telesis” on page 14

## Safety Symbols Used in this Document

---

This document uses the safety symbols defined in Table 1.

Table 1. Safety Symbols

Symbol	Meaning	Description
	Caution	Performing or omitting a specific action may result in equipment damage or loss of data.
	Warning	Performing or omitting a specific action may result in electrical shock.

## Where to Find Web-based Guides

---

The installation and user guides for all Allied Telesis products are available in portable document format (PDF) from our web site at **[www.alliedtelesis.com](http://www.alliedtelesis.com)**. You can view the documents online or download them onto a local workstation or server.

## Contacting Allied Telesis

---

This section provides Allied Telesis contact information for technical support and for sales and corporate information.

This section provides Allied Telesis contact information for technical support and for sales and corporate information.

### Online Support

You can request technical support online by accessing the Allied Telesis Knowledge Base: [www.alliedtelesis.com/support/kb.aspx](http://www.alliedtelesis.com/support/kb.aspx). You can use the Knowledge Base to submit questions to our technical support staff and review answers to previously asked questions.

### Email and Telephone Support

For Technical Support via email or telephone, refer to the Allied Telesis web site at [www.alliedtelesis.com](http://www.alliedtelesis.com). Select your country from the list on the web site and then select the appropriate tab.

### Returning Products

Products for return or repair must first be assigned a return materials authorization (RMA) number. A product sent to Allied Telesis without an RMA number will be returned to the sender at the sender's expense. For instructions on how to obtain an RMA number, go to the Support section on our web site at [www.alliedtelesis.com](http://www.alliedtelesis.com).

### Sales or Corporate Information

You can contact Allied Telesis for sales or corporate information through our web site at [www.alliedtelesis.com](http://www.alliedtelesis.com).

### Warranty

For hardware warranty information, refer to the Allied Telesis web site at [www.alliedtelesis.com/support/warranty](http://www.alliedtelesis.com/support/warranty).

### Management Software Updates

New releases of the management software for our managed products are available from the following Internet sites:

- Allied Telesis web site: [www.alliedtelesis.com](http://www.alliedtelesis.com)
- Allied Telesis FTP server: <ftp://ftp.alliedtelesis.com>

If the FTP server prompts you to log on, enter "anonymous" as the user name and your email address as the password.

## Chapter 1

# Overview

---

This chapter contains the following sections:

- “AT-CV5001 Chassis Overview” on page 16
- “Front and Rear Panel Components” on page 17
- “Media Converter Cards” on page 18
- “AT-CV5M02 Management Card” on page 19
- “AT-CV5001AC and AT-CV5001DC Power Supply Modules” on page 21
- “AT-CV5000 Chassis” on page 23
- “AT-CV5LED Card” on page 24

## AT-CV5001 Chassis Overview

---

The AT-CV5001 Chassis is a member of the Converteon family of media converter products. The product is used to aggregate large numbers of geographically separate Fast Ethernet or Gigabit Ethernet networks into a central location, over fiber optic cables. The features of the chassis are:

- ❑ Eighteen slots for media converter line cards and the AT-CV5M02 Management Card
- ❑ Two slots for primary and redundant AC or DC power supplies
- ❑ Support for all AT-CV, AT-CM2, and AT-CM3 Series Media Converter Cards, as well as the double-slot AT-CM70S Media Converter Card
- ❑ Support for the AT-CV5M02 Management Card
- ❑ Variable fan speed control
- ❑ Rack-mount or tabletop installation
- ❑ Operations, Administration, and Maintenance (OAM) with the AT-CV5M02 Management Card

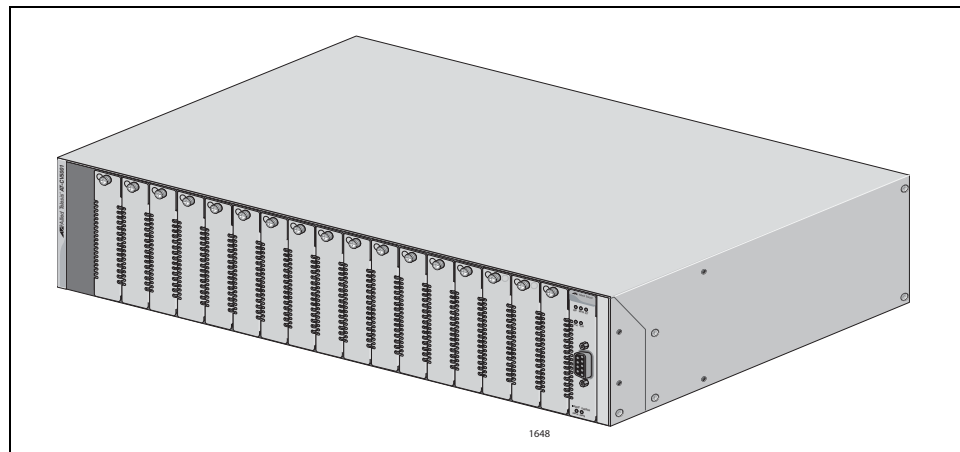

Figure 1. AT-CV5001 Chassis

The chassis supports all the same features as the AT-CV5000 Chassis, including Operations, Administration, and Maintenance (OAM). This feature lets you perform loopback tests between the media converter cards and remote devices, receive notification of power supply problems at remote sites with the dying gasp and the first RPS failure signals, and more. For descriptions of the OAM features, refer to the *AT-S73, AT-S99, and AT-S102 Management Software User's Guide*.

---

**Note**

The chassis does not come with a power supply, Power supplies must be ordered separately.

---



## Front and Rear Panel Components

Figure 2 shows the front panel of the AT-CV5001 Chassis.

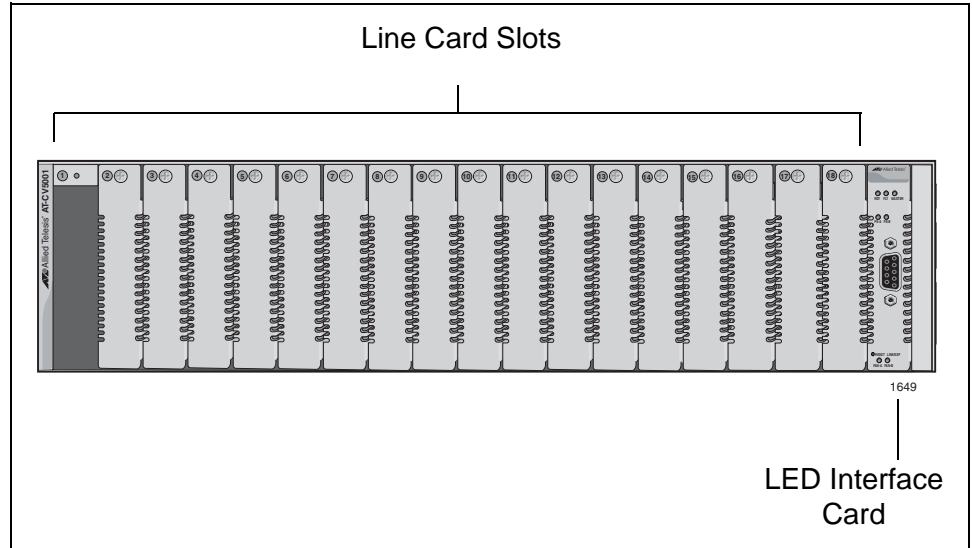

Figure 2. Front Panel

Figure 3 illustrates the rear panel of the chassis.

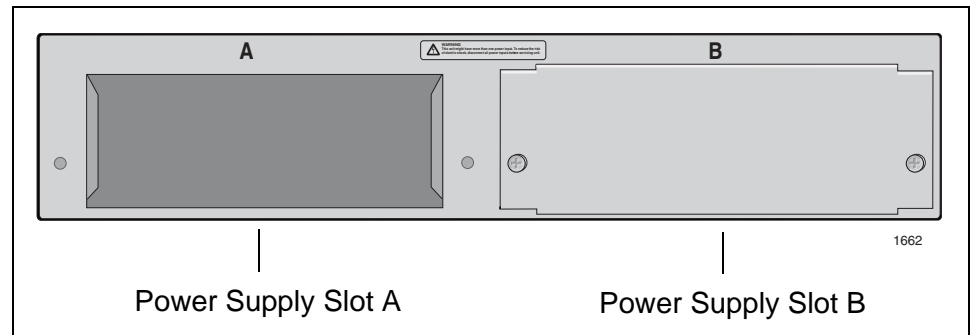

Figure 3. Rear Panel

## Media Converter Cards

---

The chassis supports all the Converteon media converter cards, which include the following:

- ❑ AT-CV Series
- ❑ AT-CM2 Series
- ❑ AT-CM3 Series
- ❑ AT-CM70S Card

The cards can be installed in the chassis in any combination and in any order. For descriptions of the cards, refer to their datasheets on the Allied Telesis web site, their Installation Guides, which are also available on the Allied Telesis web site, or the *AT-S73, AT-S99, and AT-S102 Management Software User's Guide*.

## AT-CV5M02 Management Card

The chassis and the media converter cards are operational as soon as they are installed and powered on, and can be used as unmanaged devices.

If management is desired, you can install the AT-CV5M02 Management Card. This card lets you monitor the operational states of the cards and the chassis, and configure their parameters.

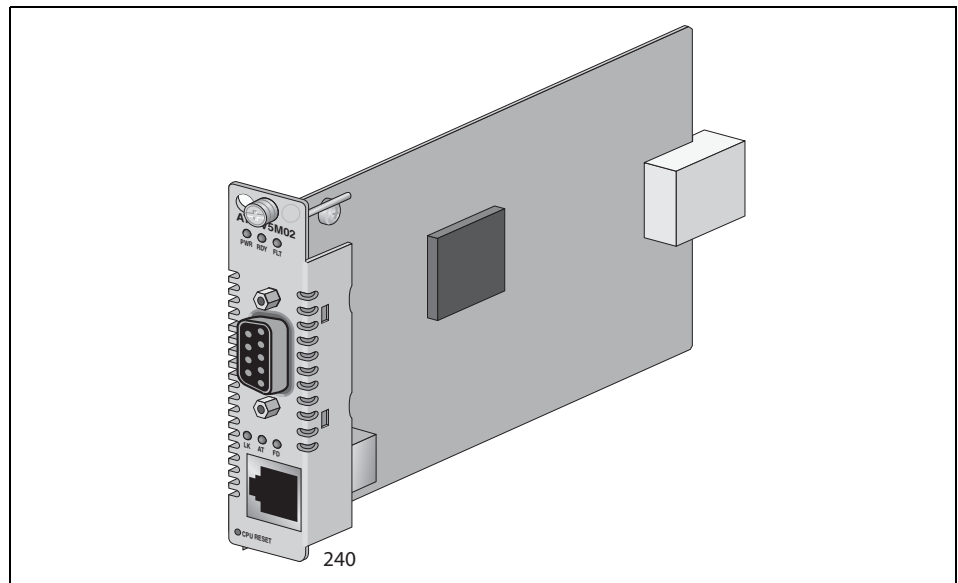

Figure 4. AT-CV5M02 Management Card

Here are the features of the AT-CV5M02 Management Card:

- Local (out-of-band) management through the RS-232 Console port.
- Remote (in-band) management using the card's Telnet server from Telnet clients on your network.
- Remote (in-band) management using a web browser.
- Remote (in-band) management using SNMPv1, SNMPv2c, or SNMPv3.
- Easy-to-use menus and web browser windows.
- Event log for viewing operational messages about the line cards.
- Activity monitor for viewing the event messages in real-time.
- Syslog client for storing the event messages on a syslog server on your network.
- Network Time Protocol (NTP) client for setting the card's date and time from an NTP server on your network or the Internet.

- ❑ Dynamic Host Control Protocol (DHCP) client for assigning the management card's IP address configuration from a BOOTP or DHCP server on your network.
- ❑ Redundant management cards in the AT-CV5001 Chassis.
- ❑ Manual or automatic restoration of previous configurations to the local or remote AT-CM Line Cards.

---

**Note**

For descriptions of the management features, refer to the *Converteon AT-S73, AT-S99 and AT-S102 Management Software User's Guide*, available from the Allied Telesis web site.

---

## AT-CV5001AC and AT-CV5001DC Power Supply Modules

---

The AT-CV5001 Chassis has slots for two power supply modules. The power requirements of the chassis and the media converter line cards can be met with just one power supply. A second power supply can be added for power redundancy.

If the chassis has two power modules, the modules use a load-sharing arrangement in which they both supply power to the media converter line cards. If one of the power supply fails, the second module automatically assumes the role of powering the entire chassis, thus preventing any interruption to the flow of network traffic through the line cards.

There are AC and DC power modules for the chassis. They are:

- ❑ AT-CV5001AC Power Supply Module
- ❑ AT-CV5001DC Power Supply Module

The chassis can have either AC or DC modules, or both AC and DC modules.

The previous AT-CV5000 Chassis had left and right power supply modules. This is not true for the power modules for the AT-CV5001 Chassis. The AT-CV5001AC and AT-CV5001DC Power Supply Modules can be installed in either slot A or slot B in the chassis.

The chassis does not come with a power supply module. Power supply modules must be ordered separately.

### **Automatic Fan Speed Control**

Each power supply module has a single cooling fan that draws air out of the chassis. Air enters the device from the front through the air vents on the faceplates on the slot covers and the media converter cards.

If the chassis has the AT-CV5M02 Management Module, the speed of the fan is automatically adjusted according to the internal temperature of the unit. When operating conditions permit, the speed of the fan is lowered to lessen fan noise, reducing the chance that the unit will be an annoyance to individuals if the device is installed in a public or work area.

The feature works by monitoring the internal temperature of the chassis. If the temperature is below 60° C (140° F), the management card incrementally reduces the speed of the fan over approximately 30 seconds to a minimum speed of 2000 RPM. If the temperature exceeds 60° C, the management card incrementally increases the fan speed over the same time period to approximately 6000 RPM. When the temperature returns below 60° C, the fan speed is again incrementally reduced to 2000 RPM.

## **Power Supply Alerts and Shutdown**

The power supply automatically shuts down if the internal temperature of the chassis exceeds 70 ° C (158° F), and starts again when the temperature returns below 65° C (149° F).

If the speed of the fan in the power supply falls below 2000 RPM or if the fan stops completely, the management card, if present, transmits an SNMP trap and enters a message in the event log, alerting you to the problem.

The management card has two temperature thresholds and sends a trap when either threshold is exceeded. One of the thresholds is adjustable and the other is not. The adjustable threshold is set in the Temperature Threshold Configuration menu in the management software and has a default setting is 60° C (140° F). This is the temperature threshold at which the management card speeds up or slows down the cooling fan in the power supply. If this setting is left unchanged, the management card may send a series of SNMP traps if the operating temperature hovers at that point. To avoid this, you may want to consider raising or lowering this setting. For instructions, refer to the *Converteon AT-S73, AT-S99 and AT-S102 Management Software User's Guide*. Here is the trap for this threshold:

Fan Tray #1/2: Fan Temperature Exceed Limit

The second temperature threshold, which is not adjustable, is 65° C (149° F), five degrees below the temperature at which the power supply automatically shuts down. This temperature threshold alerts you if the power supply is close to shutting down because of a temperature problem. Here is the trap for this threshold:

Temp exceeded 65 deg C in module A/B

## AT-CV5000 Chassis

---

The AT-CV5000 Chassis is the predecessor to the AT-CV5001 Chassis. Both chassis have nearly all the same features. For example, they both support redundant power supplies, redundant management cards, and Operations, Administration, and Maintenance (OAM). They also have the same number of slots for media converter cards. But they do have a few differences. They are:

- ❑ The AT-CV5001 Chassis features automatic fan speed control when a management card is present in the device. This feature is not available on the AT-CV5000 Chassis.
- ❑ The AT-CV5000 Chassis has left and right versions of the AC and DC power supplies. The AT-CV5001AC and AT-CV5001DC Power Supplies for the AT-CV5001 Chassis can fit in either power supply slot in the unit.
- ❑ The AT-CV5000 Chassis has separate fan modules. The fans in the AT-CV5001 Chassis are part of the AT-CV5001AC and AT-CV5001DC Power Supplies.

## AT-CV5LED Card

The AT-CV5001 Chassis comes with the AT-CV5LED Card, shown in Figure 5, installed in slot 19. This card is required in the chassis.

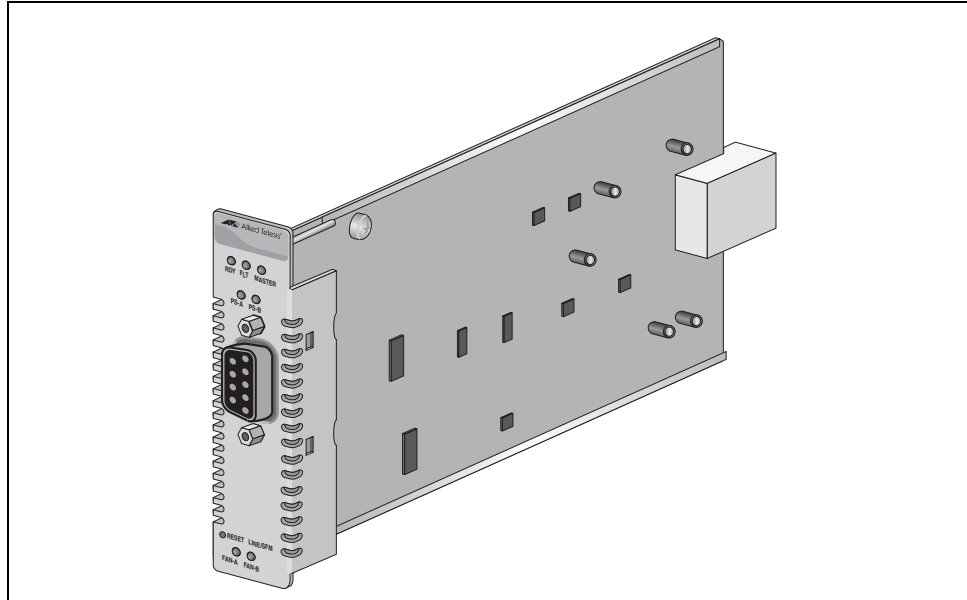

Figure 5. AT-CV5LED Card

### Note

The Console port and the RDY, FLT, and MASTER LEDs on the card are for manufacturing purposes only.

The PS and FAN LEDs reflect the status of the power supplies in the chassis and are described in Table 1.

Table 1. Status LEDs on the AT-CV5LED Card

LED	State	Description
PS-A	Green	The power supply in slot A is operating normally.
	OFF	The power supply in slot A is powered off or has failed. The LED will also be off if the slot is empty or if the input power from the power source is outside the operating range of the power supply module.



Table 1. Status LEDs on the AT-CV5LED Card (Continued)

LED	State	Description
PS-B	Green	The power supply in slot B is operating normally.
	OFF	The power supply in slot B is powered off or has failed. The LED will also be off if the slot is empty or if the input power from the power source is outside the operating range of the power supply module.
FAN-A	Steady Green	The fan in the power supply installed in slot A is operating normally.
	OFF	The power supply in slot A fan has failed, the fan has failed, or the slot is empty.
FAN-B	Steady Green	The fan in the power supply installed in slot B is operating normally.
	OFF	The power supply in slot B fan has failed, the fan has failed, or the slot is empty.

**Note**

The card has a Reset button you can use to reset the AT-CV and AT-CM2 Media Converter Cards in the chassis. The cards initialize their management software. Resetting the line cards may result in the loss of some network traffic. The reset button does not affect the AT-CV5M02 Management Card or the AT-CM3 Media Converter Cards.

The AT-CV5LED Card does not use management software.

**Note**

The AT-CV5LED Card must only be serviced by an Allied Telesis technician. If the card develops a problem, contact Allied Telesis for assistance.



## Chapter 2

# Installation

---

This chapter contains the following installation procedures for the AT-CV5001 Chassis:

- ❑ “Reviewing the Safety Precautions” on page 28
- ❑ “Selecting a Site for the Chassis” on page 31
- ❑ “Unpacking the Chassis” on page 32
- ❑ “Installing the AT-CV5001 Chassis in a Rack” on page 34
- ❑ “Grounding the AT-CV5001 Chassis” on page 36
- ❑ “Installing the AT-CV5001AC Power Supply” on page 38
- ❑ “Installing the AT-CV5001DC Power Supply” on page 43
- ❑ “Installing the Media Converter Line Cards” on page 47
- ❑ “Installing the AT-CV5M02 Management Card” on page 52
- ❑ “Powering On an AC Powered Chassis” on page 57
- ❑ “Powering On a DC Powered Chassis” on page 59

## Reviewing the Safety Precautions

---

Please review the following safety precautions before you begin to install the chassis.

---

### Note

The  indicates that a translation of the safety statement is available in the PDF document titled “Translated Safety Statements” (613-000405) on the Allied Telesis website at [www.alliedtelesis.com](http://www.alliedtelesis.com)

---



**Warning:** Class 1 Laser product.  L1

---



**Warning:** Do not stare into the laser beam.  L2

---



**Warning:** To prevent electric shock, do not remove the cover. No user-serviceable parts inside. This unit contains hazardous voltages and should only be opened by a trained and qualified technician. To avoid the possibility of electric shock, disconnect electric power to the product before connecting or disconnecting the LAN cables.  E1

---



**Warning:** Do not work on equipment or cables during periods of lightning activity.  E2

---



**Warning:** Class I Equipment. This equipment must be earthed. The power plug must be connected to a properly wired earth ground socket outlet. An improperly wired socket outlet could place hazardous voltages on accessible metal parts.  E4

---

Pluggable Equipment. The socket outlet shall be installed near the equipment and shall be easily accessible.  E5

---



**Caution:** Air vents must not be blocked and must have free access to the room ambient air for cooling.  E6

---

**Warning:** Operating Temperature. This product is designed for a maximum ambient temperature of 40° degrees C.  E7

---

All Countries: Install product in accordance with local and National Electrical Codes.  E8

---

---

**Warning:** As a safety precaution, install a circuit breaker with a minimum value of 15 Amps between the equipment and the DC power source.

Always connect the wires to the LAN equipment first before you connect the wires to the circuit breaker. Do not work with HOT feeds to avoid the danger of physical injury from electrical shock. Always be sure that the circuit breaker is in the OFF position before connecting the wires to the breaker. *⌚* E9

---

**Warning:** Do not strip more than the recommended amount of wire. Stripping more than the recommended amount can create a safety hazard by leaving exposed wire on the terminal block after installation. *⌚* E10

---

**Warning:** When installing this equipment, always ensure that the frame ground connection is installed first and disconnected last. *⌚* E11

---

**Warning:** Check to see if there are any exposed copper strands coming from the installed wire. When this installation is done correctly there should be no exposed copper wire strands extending from the terminal block. Any exposed wiring can conduct harmful levels of electricity to persons touching the wires. *⌚* E12

---

This system works with positive grounded or negative grounded DC systems. *⌚* E13

---

**Circuit Overloading:** Consideration should be given to the connection of the equipment to the supply circuit and the effect that overloading of circuits might have on overcurrent protection and supply wiring. Appropriate consideration of equipment nameplate ratings should be used when addressing this concern. *⌚* E21

---

**Warning:** For centralized DC power connection, install only in a restricted access area. *⌚* E23

---

A tray cable is required to connect the power source if the unit is powered by centralized DC power. The tray cable must be a UL listed Type TC tray cable and rated at 600 V and 90 degrees C, with three conductors, minimum 14 AWG. *⌚* E24

---



**Warning:** Mounting of the equipment in the rack should be such that a hazardous condition is not created due to uneven mechanical loading. *⌘* E25

---



**Warning:** Remove all metal jewelry, such as rings and watches, before installing or removing a line card from a powered-on chassis. *⌘* E26

---



**Warning:** This unit might have more than one power source. To reduce the risk of electric shock, disconnect all power sources before servicing the unit. *⌘* E30

---

If installed in a closed or multi-unit rack assembly, the operating ambient temperature of the rack environment may be greater than the room ambient temperature. Therefore, consideration should be given to installing the equipment in an environment compatible with the manufacturer's maximum rated ambient temperature (T<sub>mra</sub>). *⌘* E35

---

**Caution:** Installation of the equipment in a rack should be such that the amount of air flow required for safe operation of the equipment is not compromised. *⌘* E36

---



**Warning:** Reliable earthing of rack-mounted equipment should be maintained. Particular attention should be given to supply connections other than direct connections to the branch circuits (e.g., use of power strips). *⌘* E37

---



**Warning:** Circuit breaker is used as a disconnection device. To de-energize equipment, shut down the circuit breaker and then disconnect the input wire. *⌘* E38

---

## Selecting a Site for the Chassis

---

Observe the following requirements when choosing a site for the chassis:

- ❑ If you plan to install the chassis in an equipment rack, check to be sure that the rack is safely secured and that it will not tip over. Devices in a rack should be installed starting at the bottom, with the heavier devices near the bottom of the rack.
- ❑ The chassis is heavy and requires three people to install it. For the weight and dimensions of the chassis, see “Physical Specifications” on page 79.
- ❑ If you are installing the chassis on a table, be sure that the table is level and secure.
- ❑ The power outlet for the chassis should be located near the unit and should be easily accessible.
- ❑ The site should provide easy access to the ports and connectors on the front and the rear of the chassis, so that you can connect and disconnect cables as well as to view the LEDs.
- ❑ For proper cooling of the chassis, air flow around the unit and through its vents should be unrestricted. Allow 8 inches around the rear of the chassis for proper airflow.
- ❑ Do not place objects on top of the chassis.
- ❑ Do not expose the chassis to moisture or water.
- ❑ Make sure that the site is a dust-free environment.
- ❑ Use dedicated power circuits or power conditioners to supply reliable electrical power to the device.

## Unpacking the Chassis

To unpack the chassis, perform the following procedure:

1. Remove all the components from the shipping package.

---

**Note**

Store the packaging material in a safe location. You must use the original shipping material if you need to return the unit to Allied Telesis.

---

2. Make sure that the following components are included in the package. If any item is missing or damaged, contact your Allied Telesis sales representative for assistance.

Table 2. AT-CV5001 Chassis Components



 <p>A perspective view of the AT-CV5001 chassis, a rectangular metal enclosure with multiple slots on the front panel.</p>	<p>One AT-CV5001 Chassis</p>
 <p>A perspective view of the AT-CV5LED card, a printed circuit board with various components and a connector on the left side.</p>	<p>One pre-installed AT-CV5LED Card in slot 19</p>
 <p>A perspective view of two metal rack-mounting brackets, designed to hold the chassis in a rack.</p>	<p>Two rack-mounting brackets</p>
 <p>A perspective view of eight flathead Phillips screws, arranged in two rows of four.</p>	<p>Eight flathead Phillips rack-mounting bracket screws</p>



Table 2. AT-CV5001 Chassis Components

	<p>One ground lug</p>
	<p>One line card removal tool</p>
	<p>Seventeen preinstalled AT-CV5PNL1 slot covers on the front panel</p>
	<p>One preinstalled power supply slot cover on slot B on the back panel</p>

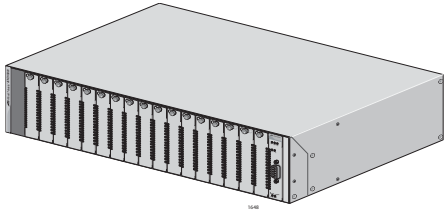
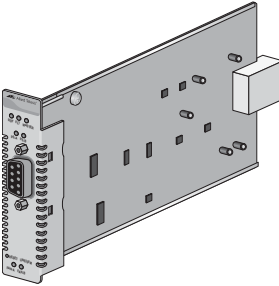
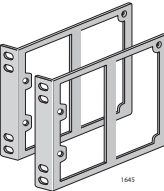
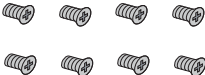
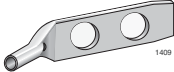
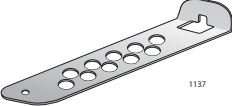
**Note**

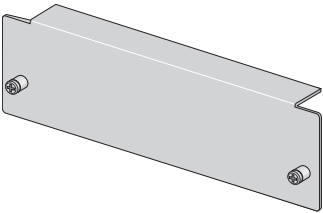
The chassis does not come with a power supply. Power supplies must be ordered separately.

- Place the AT-CV5001 Chassis on a level, secure surface.

## Installing the AT-CV5001 Chassis in a Rack

To install the chassis in a standard 19-inch equipment, perform the following procedure:

1. Turn the chassis over and lay it on its top on a level, secure surface.

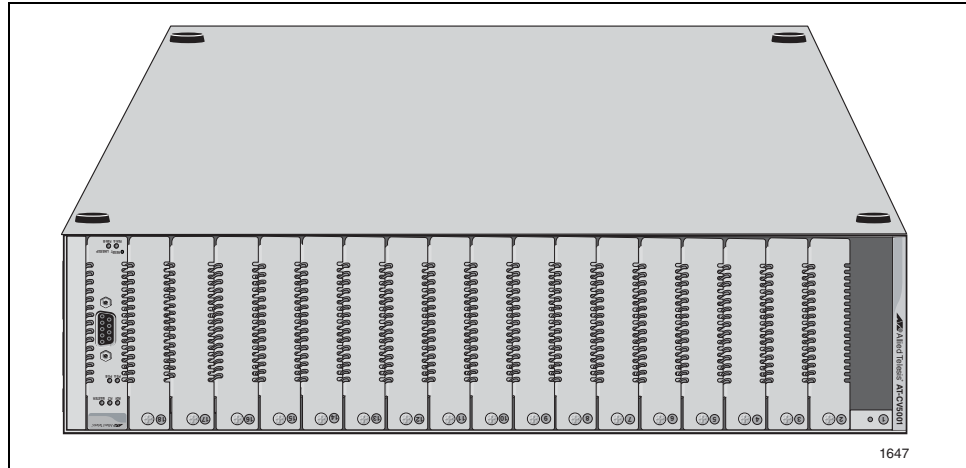

Figure 6. Removing the Feet

2. Using a flat-head screwdriver, pry off the rubber feet from the base of the unit.

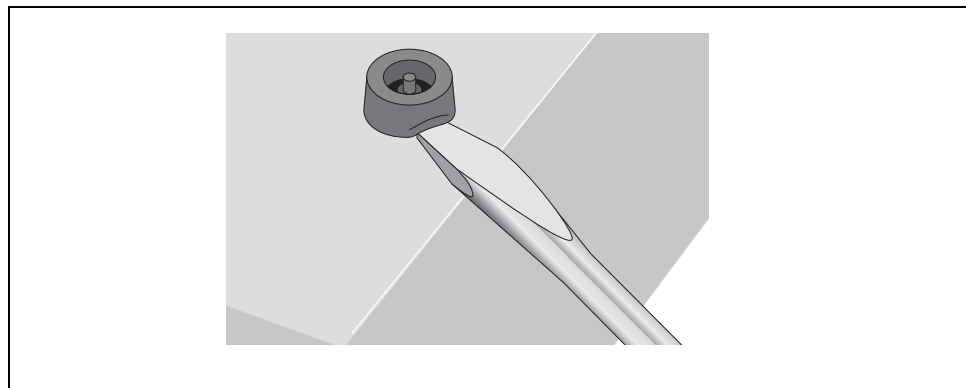

Figure 7. Removing the Feet

3. Turn the chassis right side up on the table.

4. Attach the brackets to the sides of the chassis using four screws (provided) on each side, as shown in Figure 8

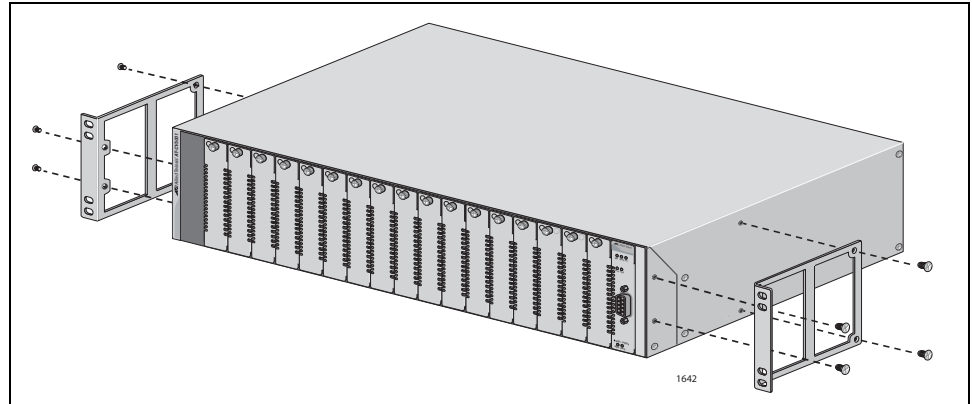

Figure 8. Installing the Brackets

5. Mount the chassis in the equipment rack using appropriate screws (not provided), as shown in Figure 9.



**Caution**

The chassis is heavy. Physical injury may result if you attempt to install the chassis without assistance. Two people should hold the unit while a third person secures it to the rack.

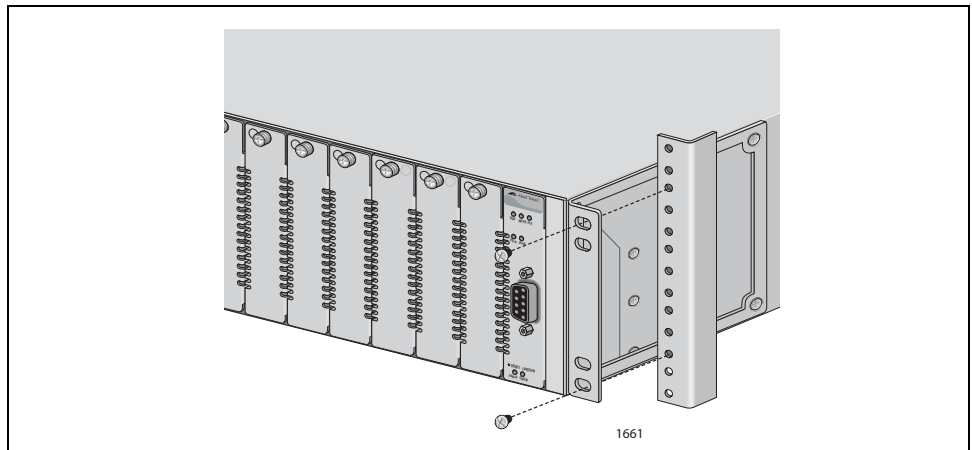

Figure 9. Mounting the AT-CV5001 Chassis in a 19-inch Equipment Rack

## Grounding the AT-CV5001 Chassis

For safe and proper operation, the AT-CV5001 Chassis should be grounded to a ground point in the wiring closet. Grounding the chassis requires the following items:

- ❑ One ground lug
- ❑ One 12 AWG stranded wire or 14 AWG solid wire (not provided)
- ❑ Crimping tool (not provided)
- ❑ Cross-head screwdriver (not provided)



### Warning

When installing this equipment, always ensure that the frame ground connection is installed first and disconnected last. ⚡ E11

To attach the frame ground, perform the following procedure:

1. Use a crimping tool to affix the ground lug to one end of the 12 AWG stranded or 14 AWG solid ground wire, as shown in Figure 10.

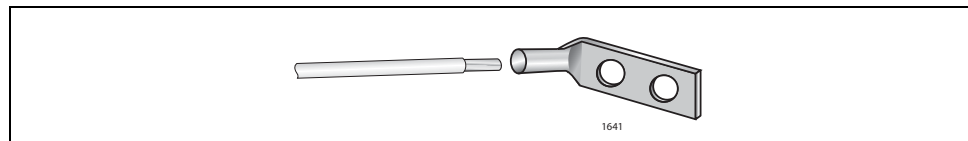

Figure 10. Connecting the Wire to the Ground Lug

2. Remove the two grounding screws from the rear panel of the AT-CV5001 Chassis.

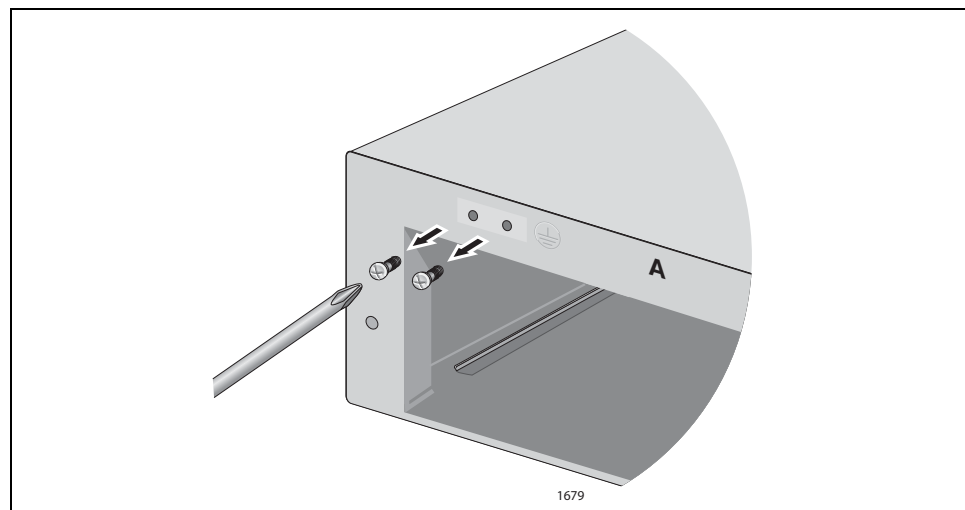

Figure 11. Removing the Grounding Lug Screws

3. Attach the grounding lug to the chassis with the screws removed in the previous step.

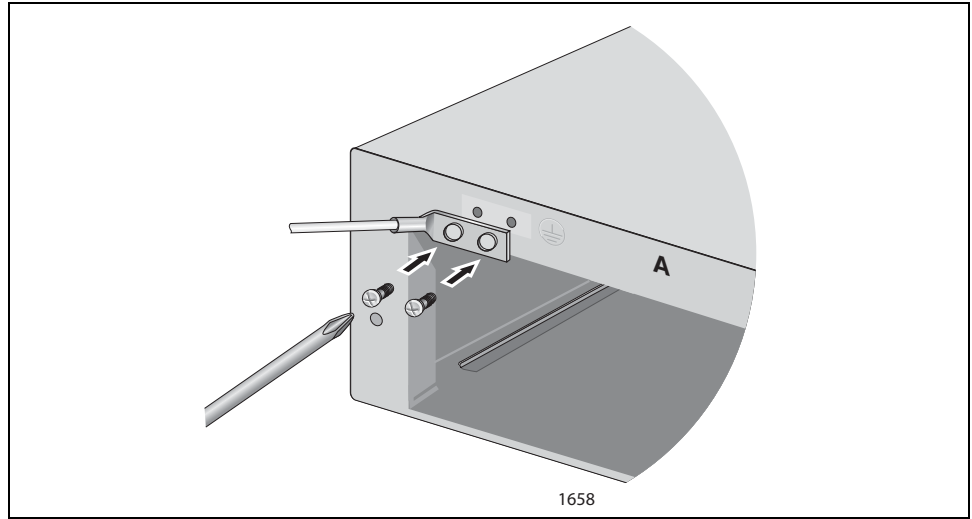

Figure 12. Attaching the Grounding Lug to the Chassis

If you purchased the AT-CV5001AC Power Supply, go to the next procedure. If you purchased the AT-CV5001DC Power Supply, go to “Installing the AT-CV5001DC Power Supply” on page 43.

## Installing the AT-CV5001AC Power Supply

---

The AT-CV5001AC Power Supply can be installed in either power supply slot on the rear panel.

---

**Note**

The AT-CV5001 Chassis can contain two power supplies. The power supplies can be of the same type (AC or DC) or different types (AC and DC).

---

---

**Note**

The power supply module is hot-swappable. If the chassis already has a power supply that is powered on, you do not have to power off the unit to install the new power supply module.

---

To install the AT-CV5001AC Power Supply, perform the following procedure:

1. Remove the AT-CV5001AC Power Supply from its shipping package and store the package in a safe place.

---

**Note**

You must use the original package if you need to return the unit to Allied Telesis.

---

2. Verify the package contents, listed in Table 3.

Table 3. AT-CV5001AC Power Supply Components

	One AT-CV5001AC Power Supply
---	------------------------------

Table 3. AT-CV5001AC Power Supply Components

 <p>The image displays four different power cord connectors, each labeled with a part number. From top to bottom: 1. Part 1694: A three-pronged North American power plug with a tapered, conical shape. 2. Part 1693: A two-pronged European power plug with a cylindrical body and a threaded section. 3. Part 1692: A three-pronged Australian power plug with a cylindrical body and a threaded section. 4. Part 1691: A two-pronged United Kingdom power plug with a rectangular body and a threaded section.</p>	<p>Four regional power cords (North America, Europe, Australia and United Kingdom)</p>
---	--

3. The power supply can be installed in either slot A or slot B. If this is the initial installation and if you are installing just one power supply, Allied Telesis recommends installing the module in slot A because that slot does not have a cover. If you want to install the module in slot B, remove the cover from the slot by loosening the two captive screws with a cross-head screwdriver.

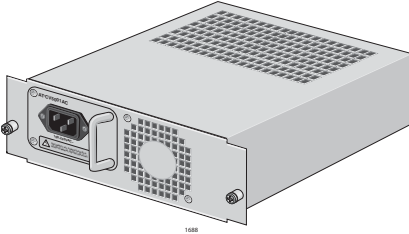
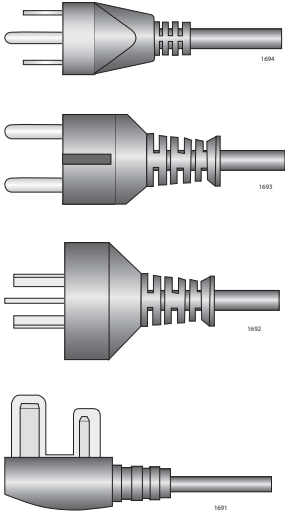
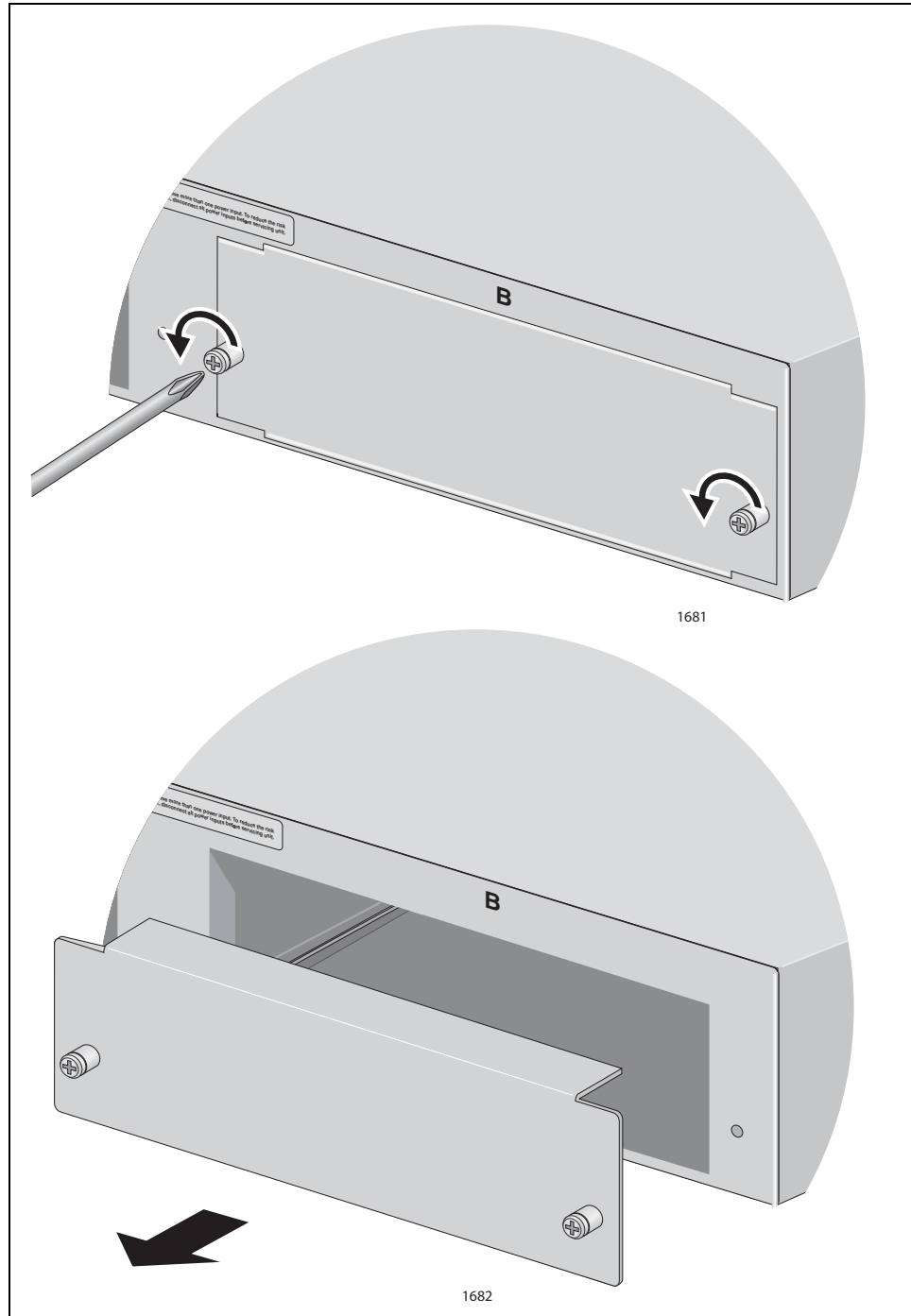

Figure 13. Removing the Cover from Slot B



---

**Note**

Be sure to retain the slot cover and to reinstall it if you remove the power supply from the unit. Open slots hamper the ability of the cooling fan in the remaining power supply to maintain proper air circulation in the chassis.

---

4. Orient the AT-CV5001AC Power Supply as shown in the figure and *gently* slide the module into the slot until it is flush with the front of the chassis.

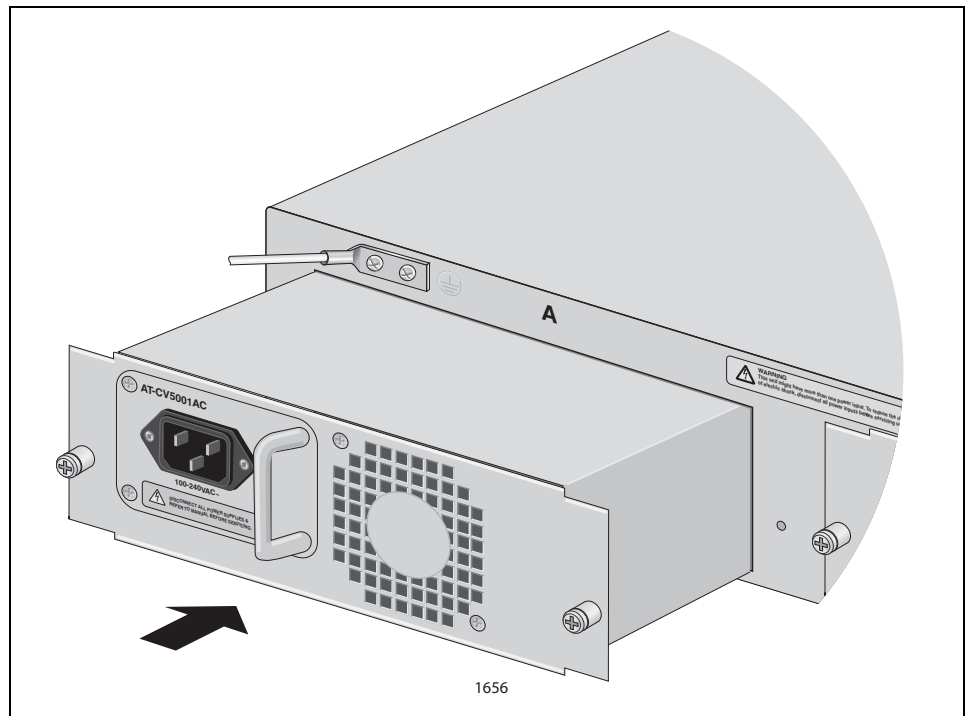

Figure 14. Inserting the AT-CV5001AC Power Supply

---

**Note**

Light pressure may be needed to seat the module on the power and control pins on the backplane inside the chassis. Do not force the module. You might bend the pins. If there is resistance, remove the module and try again.

---

5. Secure the AT-CV5001AC Power Supply to the chassis by tightening the captive screws, as shown in Figure 15.

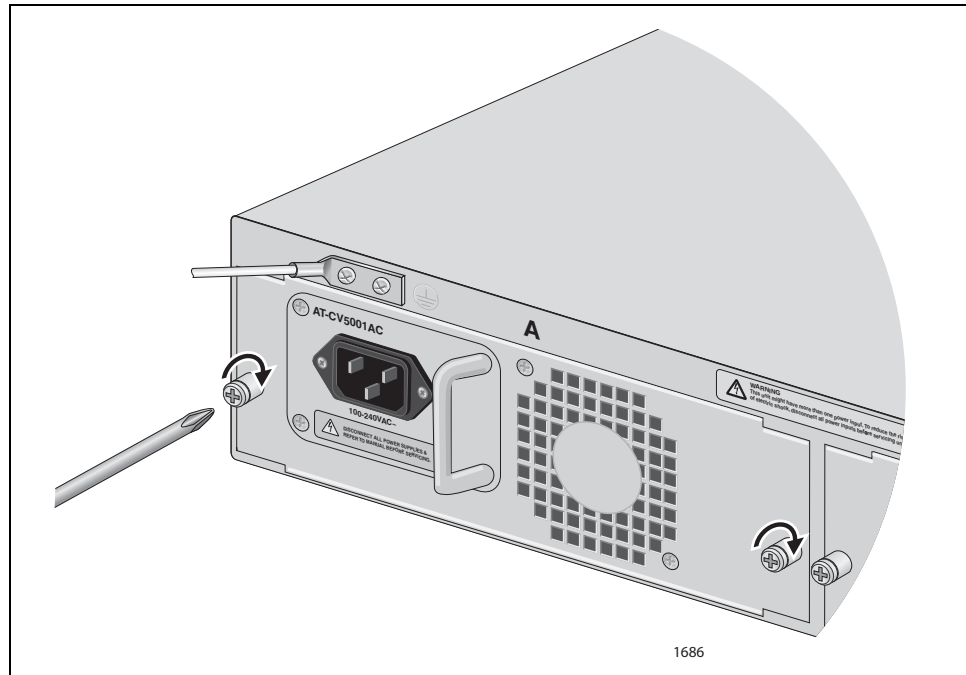

Figure 15. Securing the AT-CV5001AC Power Supply

To install a second AT-CV5001AC Power Supply, repeat this procedure. For information about powering on an AC-powered chassis, refer to “Powering On an AC Powered Chassis” on page 57.

## Installing the AT-CV5001DC Power Supply

The AT-CV5001DC Power Supply can be installed in either slot A or slot B on the rear panel.

---

**Note**

The AT-CV5001 Chassis can contain two power supplies. The power supplies can be of the same type (AC or DC) or different types (AC and DC).

---



---

**Note**

The power supply module is hot-swappable. If the chassis already has a power supply that is powered on, you do not have to power off the unit to install the new power supply module.

---

To install the AT-CV5001DC Power Supply, perform the following procedure:

1. Remove the AT-CV5001DC Power Supply from its shipping package and store the package in a safe place.

---

**Note**

You must use the original package if you need to return the unit to Allied Telesis.

---

2. Verify the package contents.

Table 4. AT-CV5001DC Power Supply Component

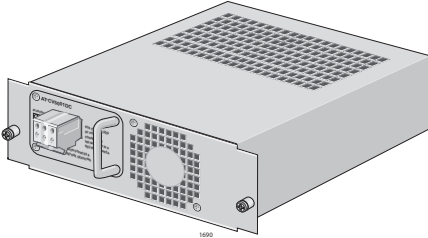
	<p>One AT-CV5001DC Power Supply</p>
---	-------------------------------------

3. The power supply can be installed in either slot A or slot B. If this is the initial installation and if you are installing just one power supply, Allied Telesis recommends installing the module in slot A because that slot does not have a cover. If you want to install the module in slot B, remove the cover from the slot by loosening the two captive screws with a cross-head screwdriver.

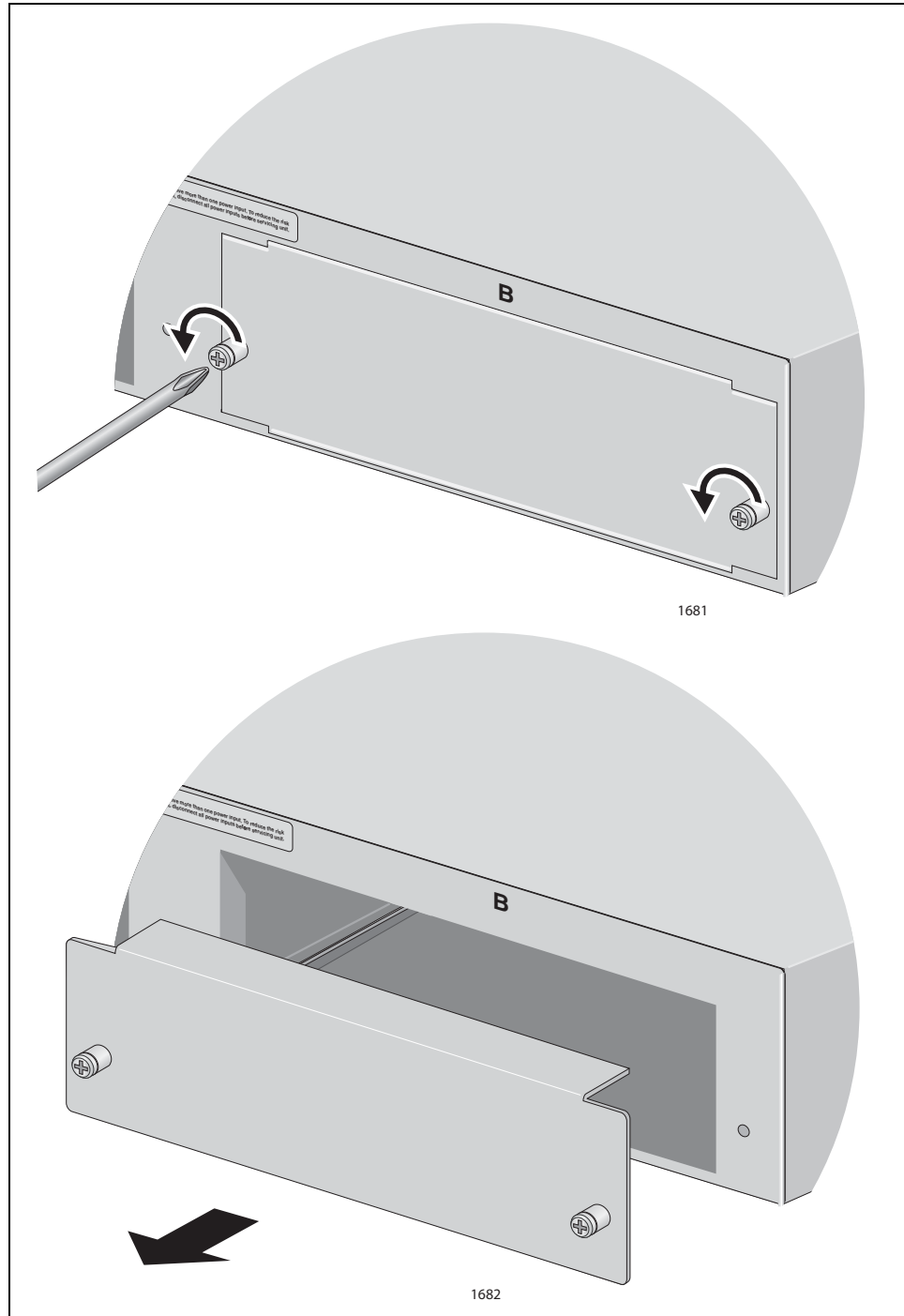

Figure 16. Removing the Cover from Slot B

---

**Note**

Be sure to retain the slot cover and to reinstall it if you ever remove the power supply from the unit. Open slots hamper the ability of the cooling fan in the remaining power supply to maintain proper air circulation in the chassis.

---

4. Orient the AT-CV5001DC Power Supply as shown in the figure and *gently* slide the module into the slot until it is flush with the front of the chassis.

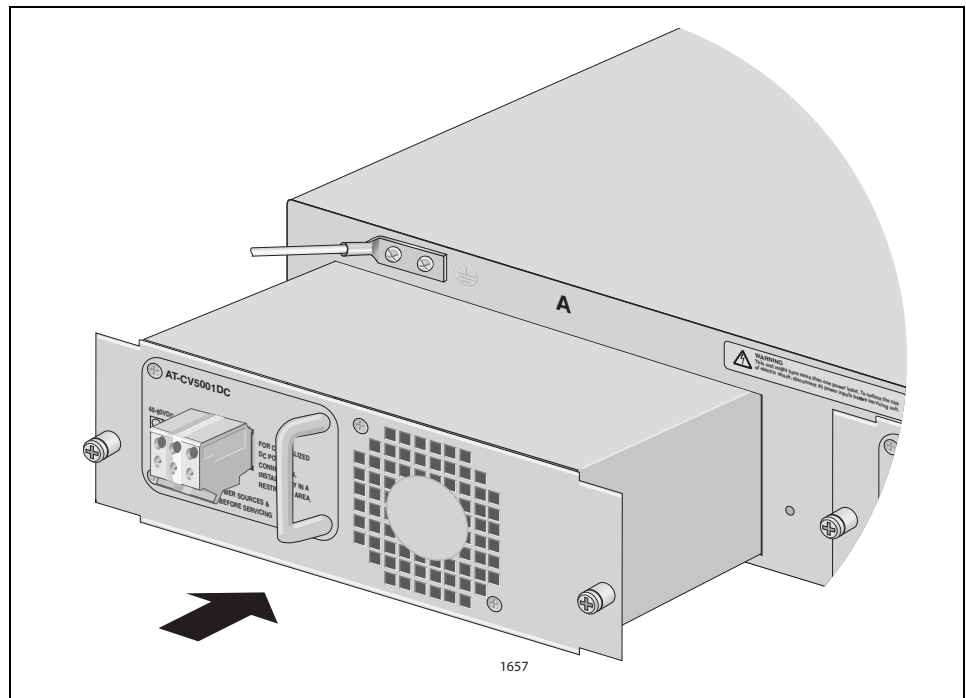

Figure 17. Inserting the AT-CV5001DC Power Supply

---

**Note**

Light pressure may be needed to seat the module on the power and control pins on the backplane inside the chassis. Do not force the module. You might bend the pins. If there is resistance, remove the module and try again.

---

5. Secure the AT-CV5001DC Power Supply to the chassis by tightening the captive screws, as shown in Figure 15.

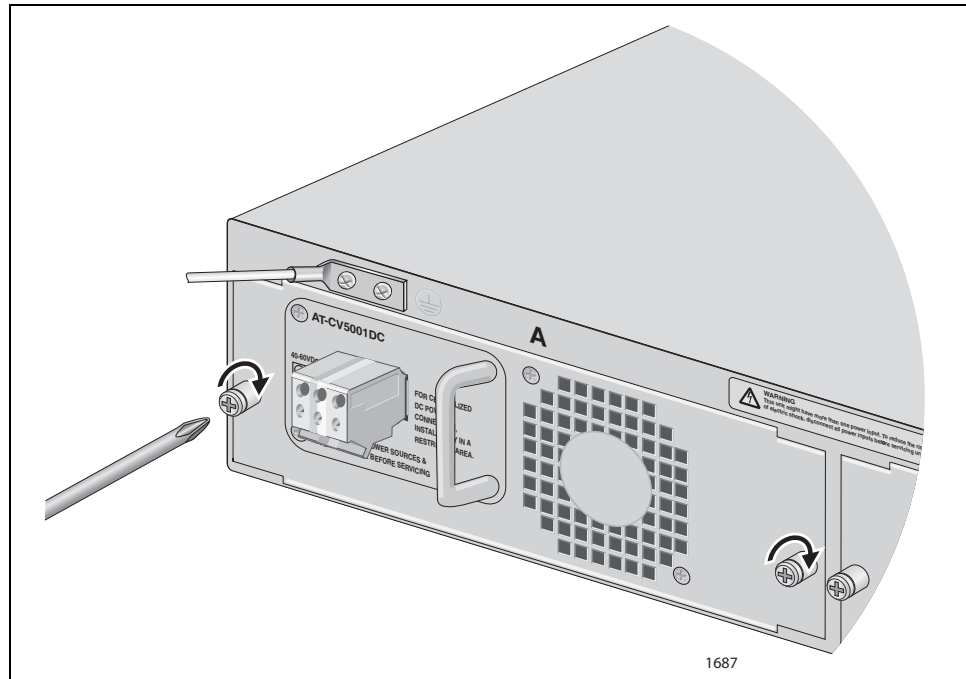

Figure 18. Securing the AT-CV5001DC Power Supply

To install a second AT-CV5001DC Power Supply, repeat this procedure. For information about powering on a DC-powered chassis, refer to “Powering On a DC Powered Chassis” on page 59.

## Installing the Media Converter Line Cards

---

This section contains general instructions on how to install the media converter line cards. For specific instructions, refer to the Installation Guides that come with the cards.



---

**Warning:** Remove all metal jewelry, such as rings and watches, before installing or removing a line card from a powered-on chassis. ⚡ E26

---

---

**Caution** Be sure to observe all standard electrostatic discharge (ESD) precautions, such as wearing an antistatic wrist strap, to avoid damaging the device. A line card can be damaged by static electricity.

---

To install a Converteon line card, perform the following procedure:

1. Remove the Converteon line card from its shipping package and store the package in a safe place.

---

**Note**

You must use the original package if you need to return the unit to Allied Telesis.

---

2. Remove the slot cover from an empty slot in the chassis by loosening the captive screw. The media converter line cards can be installed in any of the slots and in any order. Allied Telesis recommends installing the first line card in slot 1 because that slot does not have a cover. If you are installing the double-slot AT-CM70S Line Card, you must remove two adjacent slot covers.

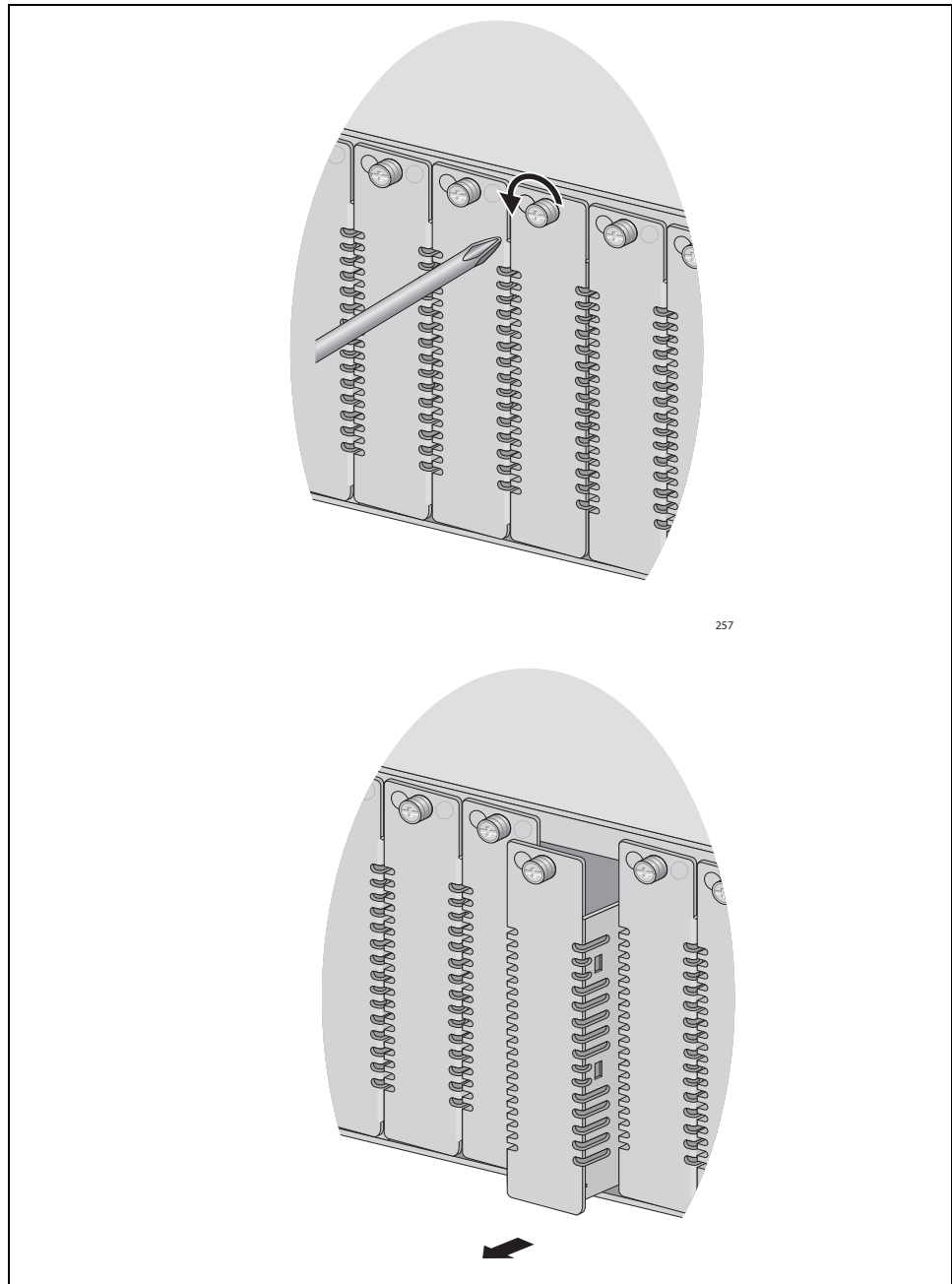

257

Figure 19. Removing a Blank Slot Cover

---

**Note**

Be sure to retain the slot cover and to reinstall it if you remove the media converter line card from the unit. Open slots hamper the ability of the cooling fan in the power supply to maintain proper air circulation in the chassis.

---



3. Set the card's DIP switches to set the operating mode and, in the case of an AT-CV Card, the operating configuration of the 10/100Base-TX twisted pair port. For descriptions of the operating modes, refer to the *AT-S73, AT-S99, and AT-S102 Management Software User's Guide*. For instructions on how to set the DIP switches, refer to Installation Guide that comes with the card.
4. Locate the top and bottom alignment guides inside the line card slots.

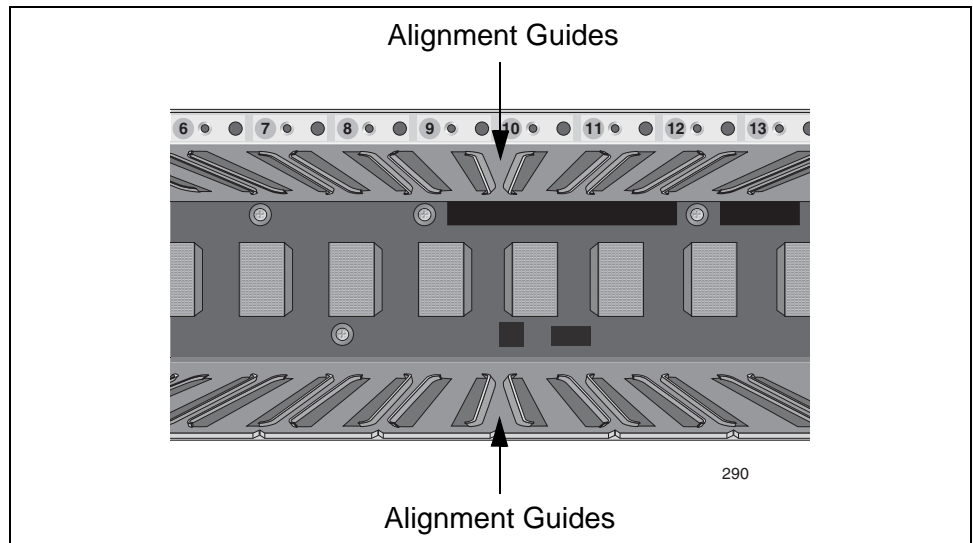

Figure 20. Alignment Guides

5. Align the line card with the top and bottom alignment guides located inside the slot.
6. Slide the line card into the slot, as shown in Figure 21, until the front of the card is flush with the front of the chassis.

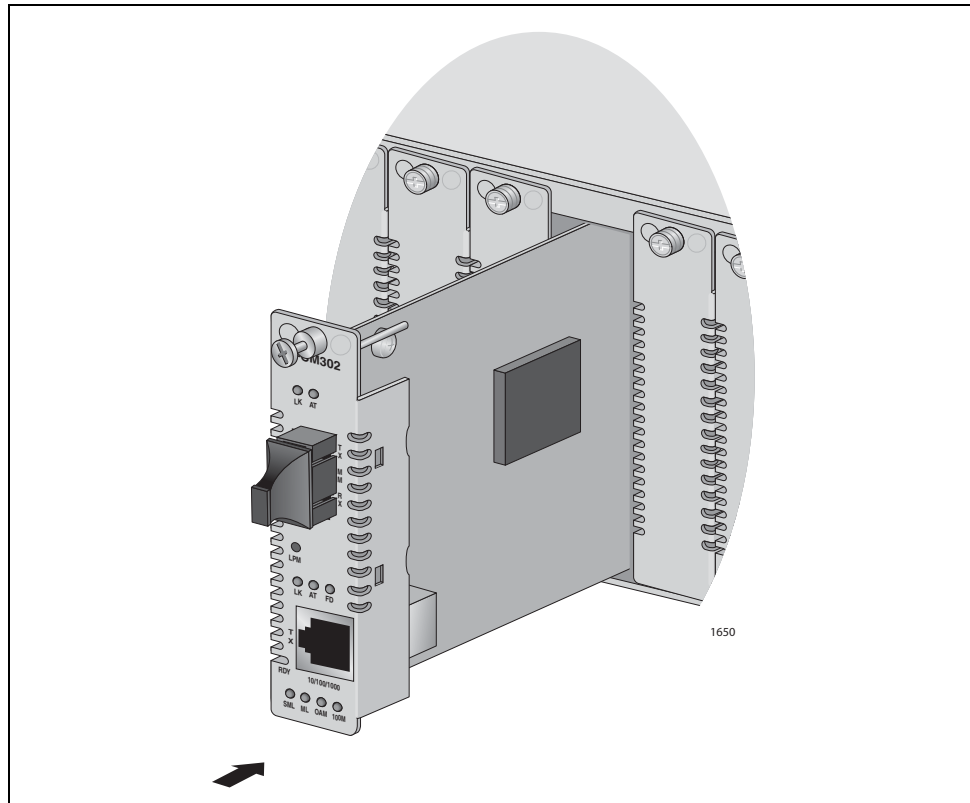

Figure 21. Inserting a Line Card

7. Use a Phillips screwdriver to tighten the captive screw on the card to secure the card to the chassis.

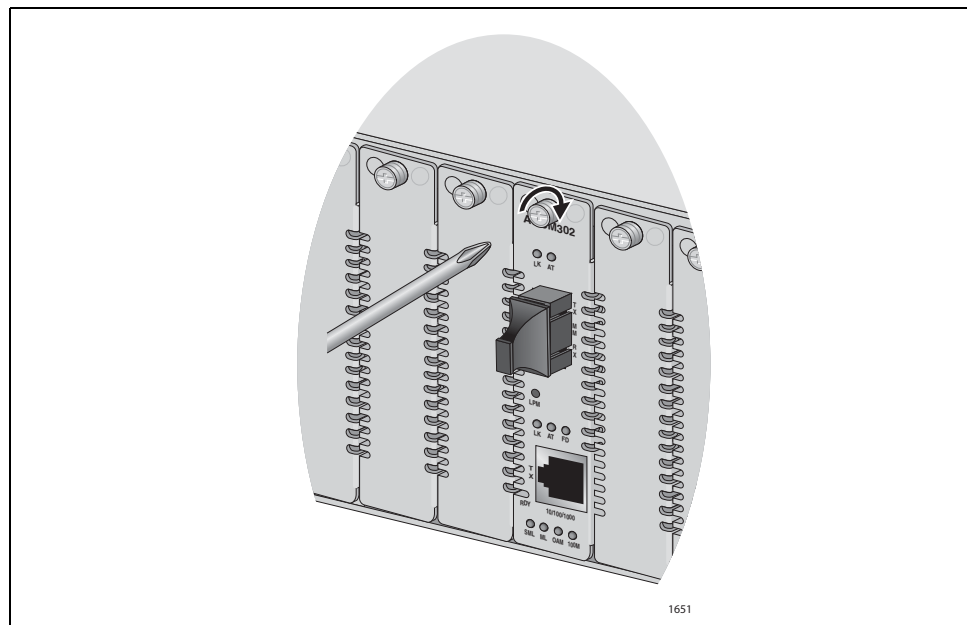

Figure 22. Tightening the Captive Screw

8. Repeat this procedure to install additional line cards.
9. After installing the media converter cards, refer to their Installation Guides for cabling instructions.

## Installing the AT-CV5M02 Management Card

---

This section contains the instructions for installing the AT-CV5M02 Management Card.



**Warning:** Remove all metal jewelry, such as rings and watches, before installing or removing a line card from a powered-on chassis. ⚡ E26

---

**Caution** Be sure to observe all standard electrostatic discharge (ESD) precautions, such as wearing an antistatic wrist strap, to avoid damaging the device. A line card can be damaged by static electricity.

---

**Note**

The AT-CV5001 Chassis does not support the AT-CV5M01 Management Card.

---

To install the AT-CV5M02 Management Card, perform the following procedure:

1. Select a slot in the chassis for the management card. You can install the card in any slot.

---

**Note**

If you are installing a redundant management card into an existing chassis, you should install it while the chassis is powered on. If the chassis is powered off, you should install it in a higher numbered slot than the existing management card. If you install a redundant management card into a lower numbered slot than the existing card while the chassis is powered off, the master configuration file of the new card, which will become the active card, will overwrite the configuration file on the existing card when you power on the chassis. If the auto-copy settings in the new master configuration file is enabled for the chassis slots, the configuration settings of the line cards may change. For further information, refer to *Converteon AT-S73, AT-S99, AT-S102, Management Software User's Guide*.

---

2. Remove the slot cover from an empty slot in the chassis by loosening the captive screw.

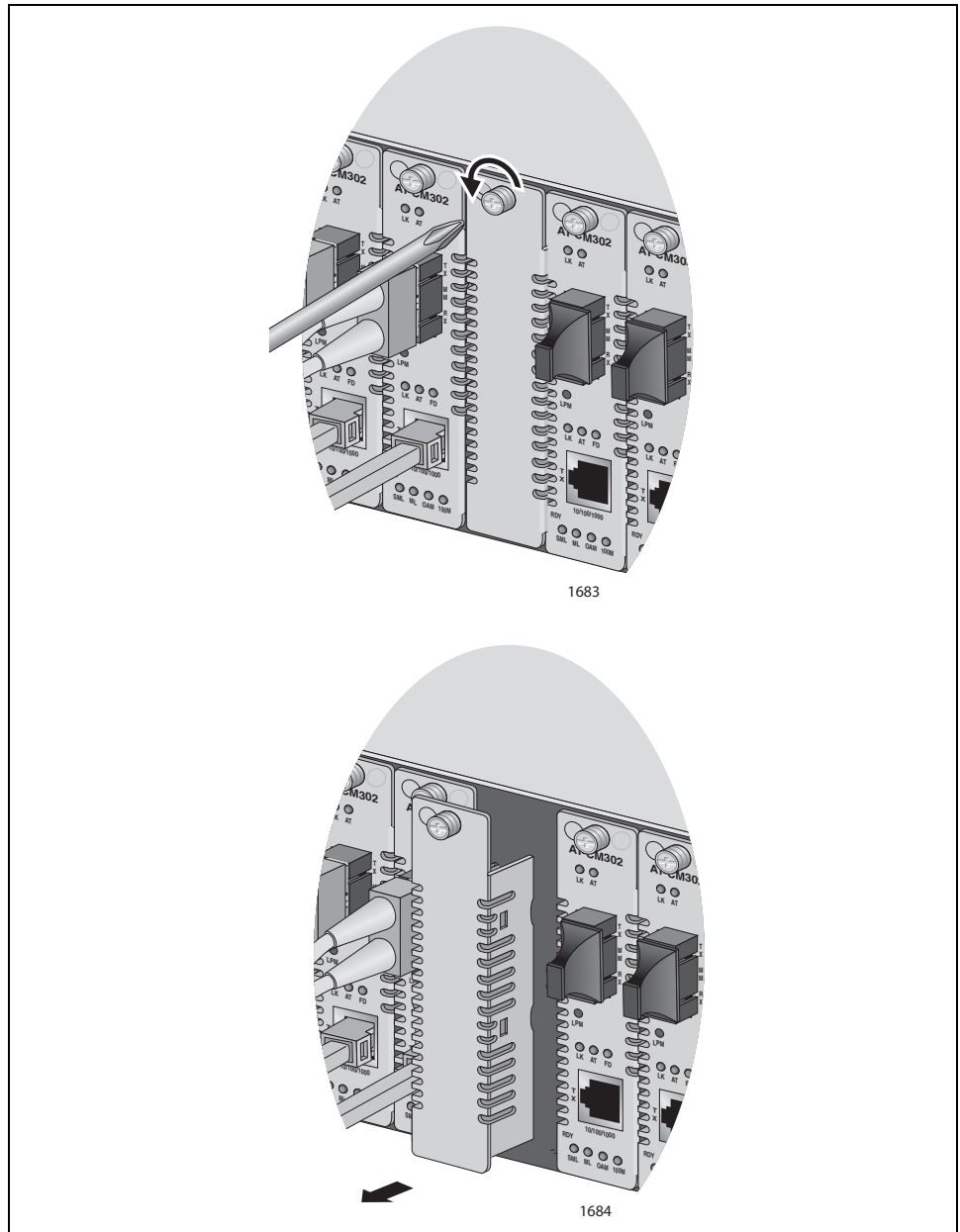

Figure 23. Removing a Slot Cover

**Note**

Be sure to retain the slot cover and to reinstall it if you remove the management card from the unit. Open slots hamper the ability of the cooling fan in the power supply to maintain proper air circulation in the chassis.





1. Remove the AT-CV5M02 Management Card from its shipping package and store the package in a safe place.

**Note**

You must use the original package if you need to return the unit to Allied Telesis.

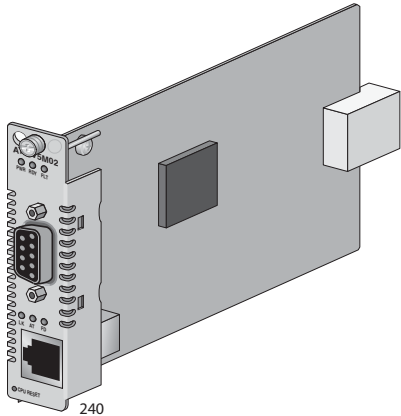
2. Verify the package contents.

Table 5. AT-CV5M02 Management Card Components

 <p>240</p>	<p>One AT-CV5M02 Management Card</p>
 <p>1417</p>	<p>One management cable with DB-9 connectors</p>
 <p>Allied Telesis</p>	<p>One fold-out Management Card Installation Guide</p>
 <p>Allied Telesis DOCUMENTATION 1405</p>	<p>One documentation CD</p>

3. Align the line card with the top and bottom alignment guides for the slot (Figure 20 on page 49).
4. Slide the card into the slot until the front panel of the card is flush with the front of the chassis.

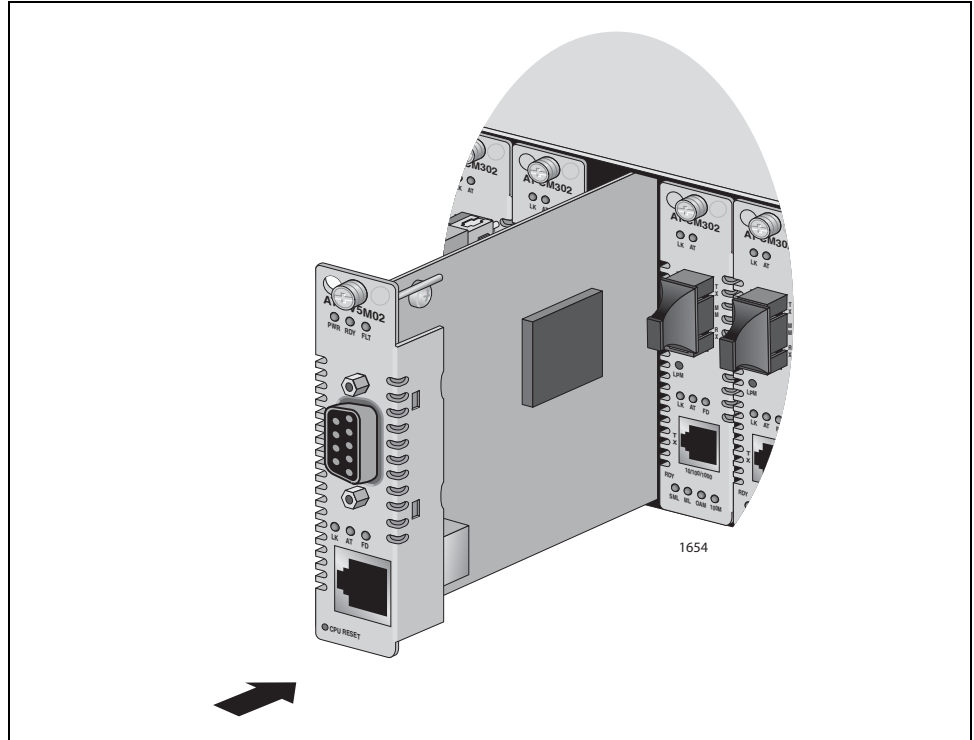

Figure 24. Installing the AT-CV5M02 Management Card

5. Use a Phillips screwdriver to tighten the captive screw to secure the card to the chassis, as shown in Figure 25.

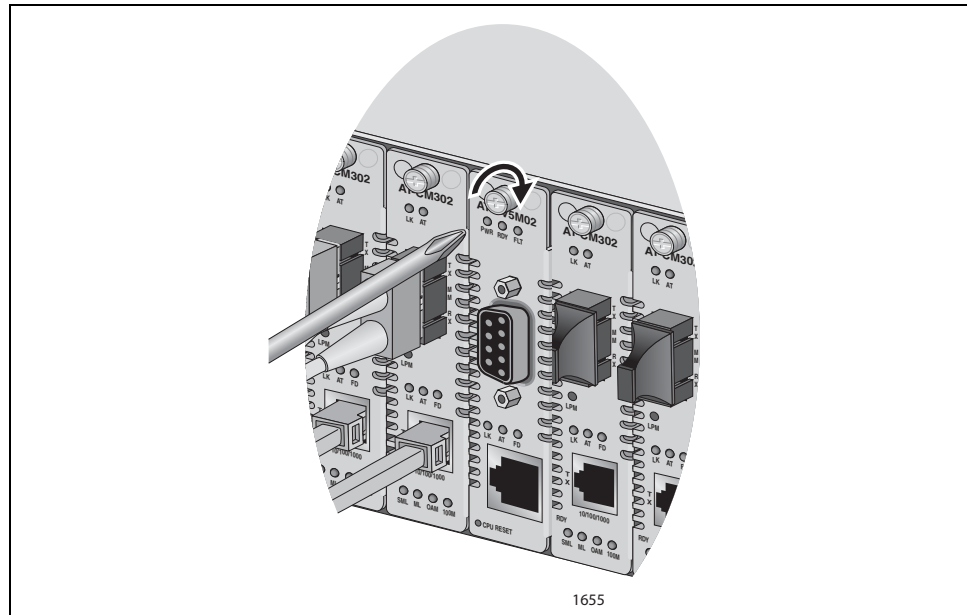

Figure 25. Tightening the Captive Screw

6. If the chassis will have a redundant management card, repeat this procedure to install the second card.
7. After installing the management card, refer to the Management Card Installation Guide for cabling instructions.



## Powering On an AC Powered Chassis

---

This section describes how to power on an AC powered AT-CV5001 Chassis.

To power on an AC powered chassis, perform the following procedure:

1. Select the power cord for your region: North America, United Kingdom, Europe, or Australia.
2. Plug the power cord into the AC power connector on the rear of the chassis, as shown in Figure 26.

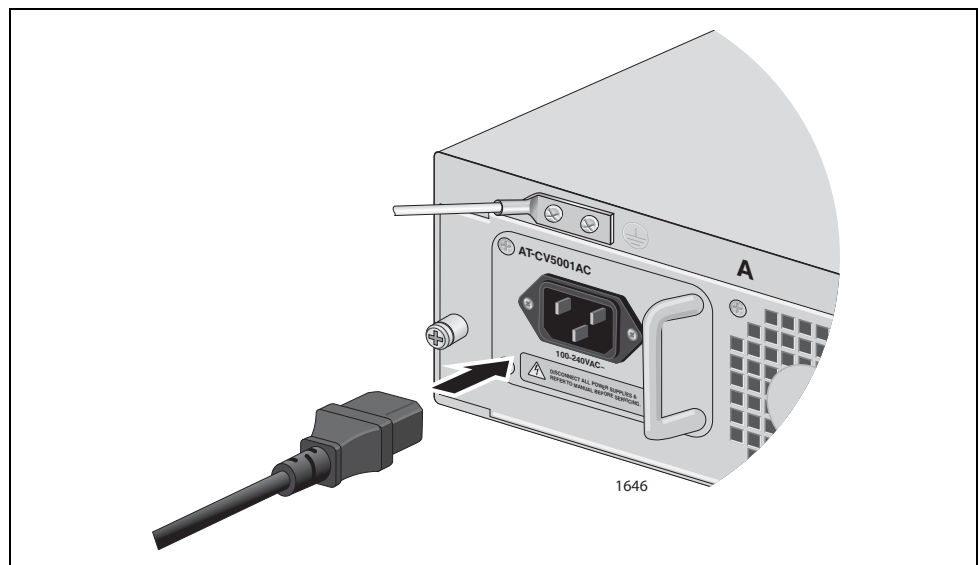

Figure 26. Connecting the AC Power Cord

3. Plug the other end of the power cord to an appropriate power outlet.

If the chassis has two AT-CV5001AC Power Supplies, repeat this procedure to power on the second module.

Refer to “Technical Specifications” on page 79 for the power requirements.

---

**Note**

If the chassis has two power supplies, you can protect the unit from a power circuit failure by connecting the two power supplies to power sources that are operating on different power circuits.

---



**Warning**

This unit might have more than one power source. To reduce the risk of electric shock, disconnect all power cords before servicing the unit. *↻* E30

---



**Warning**

Class I Equipment. This equipment must be earthed. The power plug must be connected to a properly wired earth ground socket outlet. An improperly wired socket outlet could place hazardous voltages on accessible metal parts. *↻* E4

---

4. Check the PS-A, PS-B, FAN-A and FAN-B LEDs on the AT-CV5LED Card in slot 19. The appropriate LEDs should be on. For LED definitions, refer to Table 1, "Status LEDs on the AT-CV5LED Card" on page 24. If an LED is off, refer to "Troubleshooting" on page 77 for instructions.

The chassis is now ready for network operations.

## Powering On a DC Powered Chassis

This section describes how to power on a DC powered AT-CV5001 Chassis. If your chassis is AC powered, see “Powering On an AC Powered Chassis” on page 57. For information on how to install the power supply, refer to “Installing the AT-CV5001DC Power Supply” on page 43.

---

**Warning:** As a safety precaution, install a circuit breaker with a minimum value of 15 Amps between the equipment and the DC power source.

Always connect the wires to the LAN equipment first before you connect the wires to the circuit breaker. Do not work with HOT feeds to avoid the danger of physical injury from electrical shock. Always be sure that the circuit breaker is in the OFF position before connecting the wires to the breaker. *E9*

---

**Warning:** For centralized DC power connection, install only in a restricted access area. *E23*

---

A tray cable is required to connect the power source if the unit is powered by centralized DC power. The tray cable must be a UL listed Type TC tray cable and rated at 600 V and 90 degrees C, with three conductors, minimum 14 AWG. *E24*

1. Power off the DC circuit you plan to use for the chassis.
2. Use the legend next to the terminal block to identify the terminals. The terminals are **positive**, **power supply ground** and **negative**, from right to left.

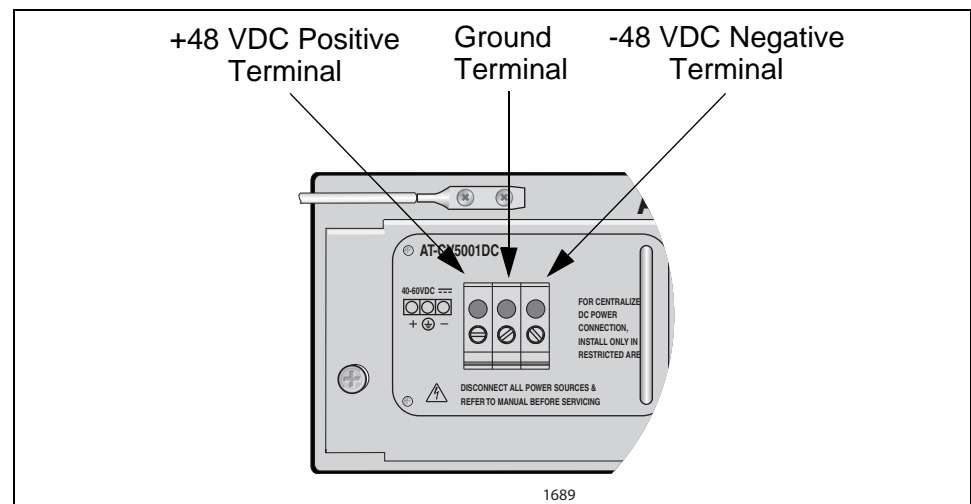

Figure 27. DC Terminal Block on the AT-CV5001DC Power Supply Module

3. With a 14-gauge wire-stripping tool, strip the three wires in the tray cable coming from the DC input power source to  $8\text{mm} \pm 1\text{mm}$  ( $0.31\text{ in.} \pm 0.039\text{ in.}$ ), as shown in Figure 28 on page 60.



**Warning**

Do not strip more than the recommended amount of wire. Stripping more than the recommended amount can create a safety hazard by leaving exposed wire on the terminal block after installation. ⚡ E10

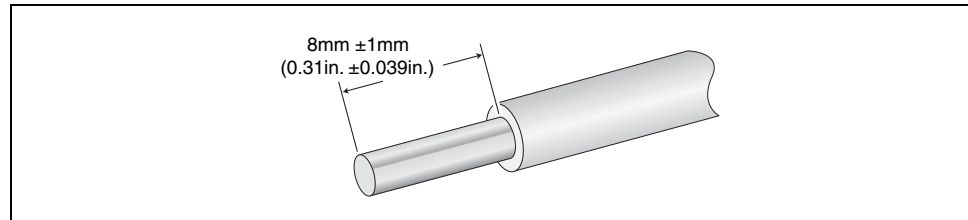

Figure 28. Stripped Wire

4. Insert the power supply ground wire into the middle connector of the DC terminal and tighten the connection with a flathead screwdriver, as shown in Figure 29.



**Warning**

When installing this equipment, always ensure that the power supply ground connection is installed first and disconnected last. ⚡ E11

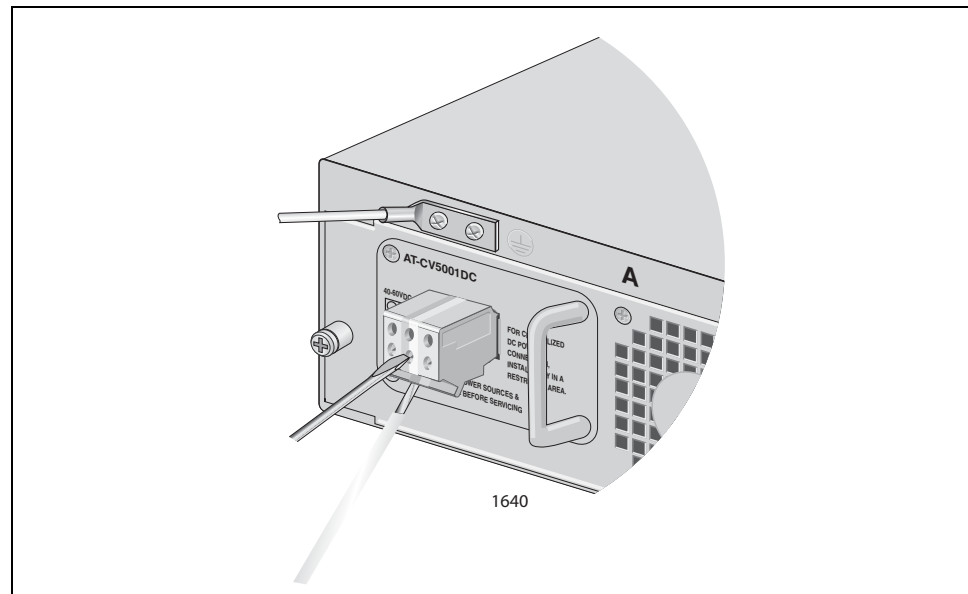

Figure 29. Inserting Wires into a DC Terminal Block

5. Connect the +48 VDC (RTN) feed wire to the terminal block marked + (plus).

6. Connect the -48 VDC feed wire to the terminal block marked - (minus).

---

**Warning:** Check to see if there are any exposed copper strands coming from the installed wires. When this installation is done correctly there should be no exposed copper wire strands extending from the terminal block. Any exposed wiring can conduct harmful levels of electricity to persons touching the wires.

 E12

---

7. Secure the tray cable near the rack framework using multiple cable ties to minimize the chance of the connections being disturbed by casual contact with the wiring. Use at least four cable ties, separated four inches apart. Locate the first one within six inches of the terminal block.

---

This system will work with a positive grounded or negative grounded DC system.  E13

---

8. Verify that the circuit breaker is in the OFF position.
9. Connect the supply-cable wires to the circuit breaker.
10. Energize the circuit breaker.
11. If you installed a second AT-CV5001DC Power Supply, repeat this procedure.

---

**Note**

If the chassis has two power supplies, you can protect the unit from a power circuit failure by connecting the two power supplies to power sources that are operating on different power circuits.

---



---

**Warning**

This unit might have more than one power source. To reduce the risk of electric shock, disconnect all power cords before servicing the unit.  E30

---

12. Check the PS-A, PS-B, FAN-A and FAN-B LEDs on the AT-CV5LED Card in slot 19. The appropriate LEDs should be on. For LED definitions, refer to Table 1, "Status LEDs on the AT-CV5LED Card" on page 24. If an LED is off, refer to "Troubleshooting" on page 77 for instructions.

The chassis is now ready for network operations.



## Chapter 3

# Removing or Replacing Line Cards or Power Supply Modules

---

This chapter contains the following procedures:

- “Removing or Replacing Media Converter Line Cards” on page 64
- “Removing or Replacing the AT-CV5001AC Power Supply” on page 69
- “Removing or Replacing the AT-CV5001DC Power Supply” on page 73

## Removing or Replacing Media Converter Line Cards

All of the Converteon media converter line cards are hot-swappable and can be removed or installed while the chassis is powered on.

To remove or replace a media converter line card, perform the following procedure:



### Caution

Be sure to observe all standard electrostatic discharge (ESD) precautions, such as wearing an antistatic wrist strap, to avoid damaging the device. A line card can be damaged by static electricity.

1. Label and disconnect the network cables from the card.

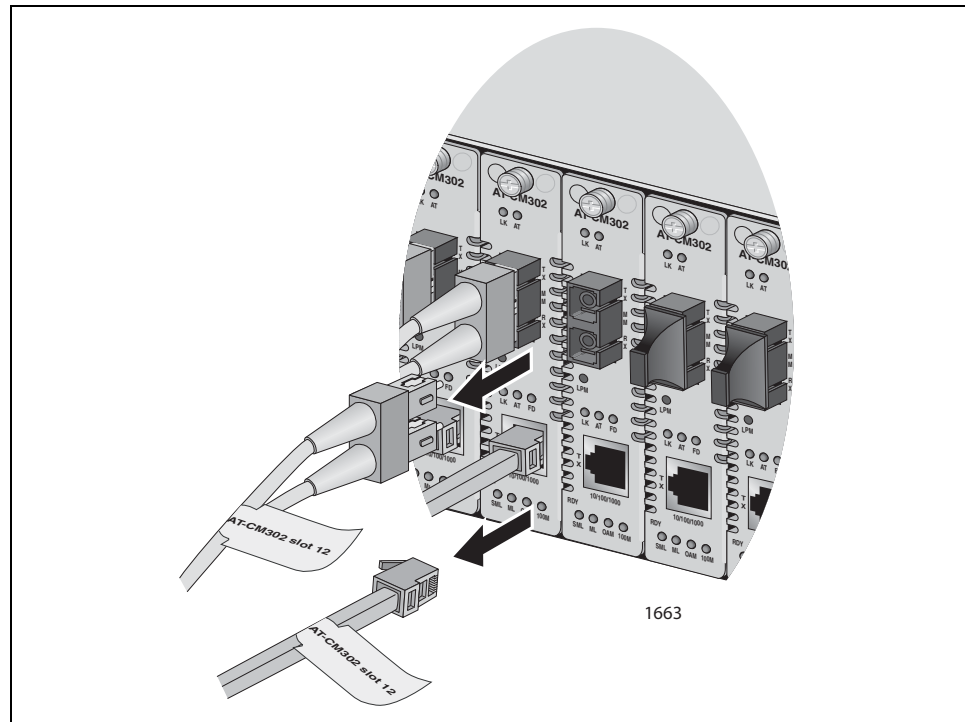

Figure 30. Labeling and Removing the Network Cables



2. Cover the fiber optic port with a dust cap.

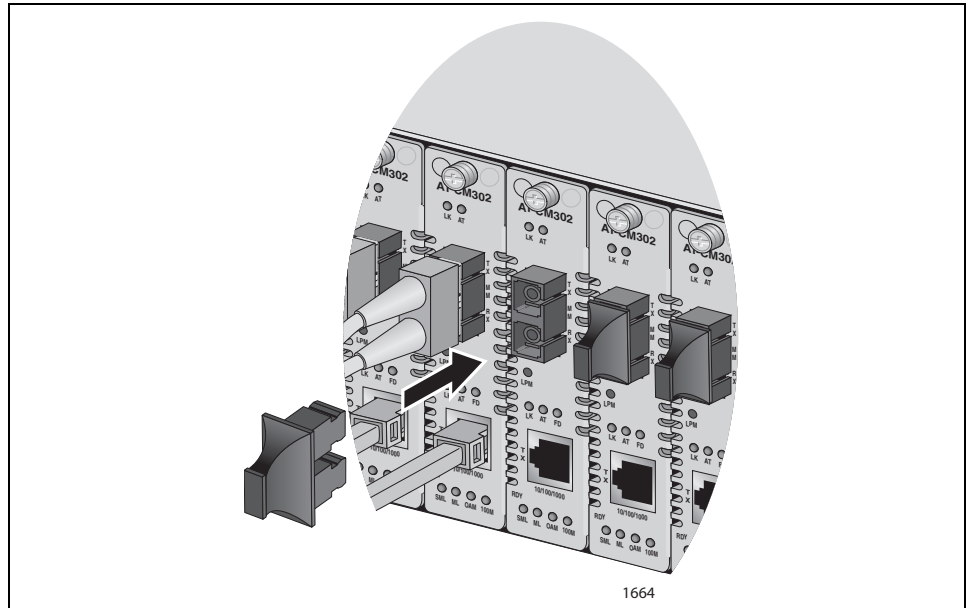

Figure 31. Installing the Dust Cap

3. If the card has an SFP module that needs to be installed in the replacement card, remove the SFP module.

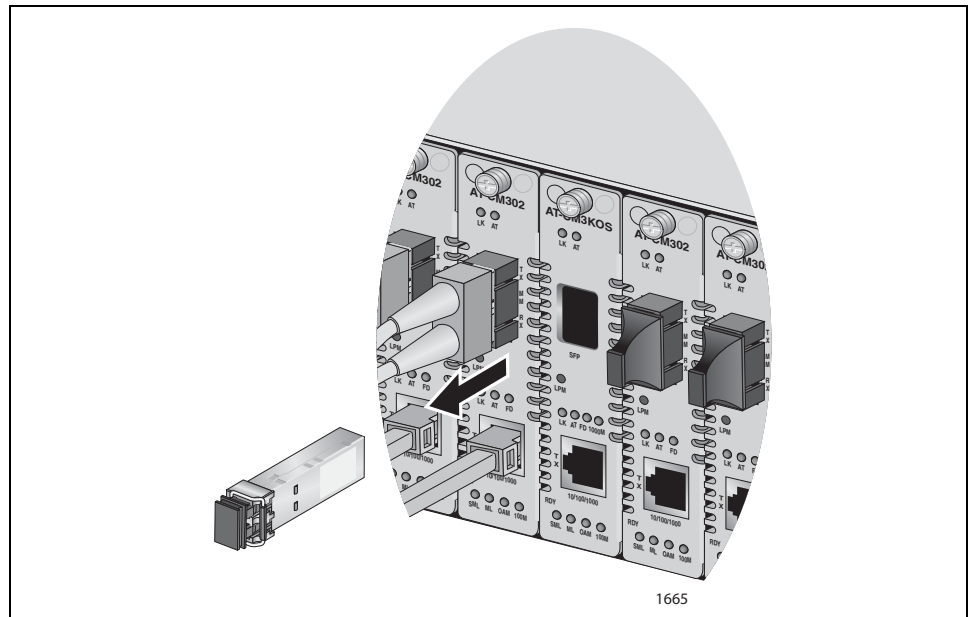

Figure 32. Removing the SFP Module

4. Using a Phillips screwdriver, loosen the captive screw at the top of the line card.

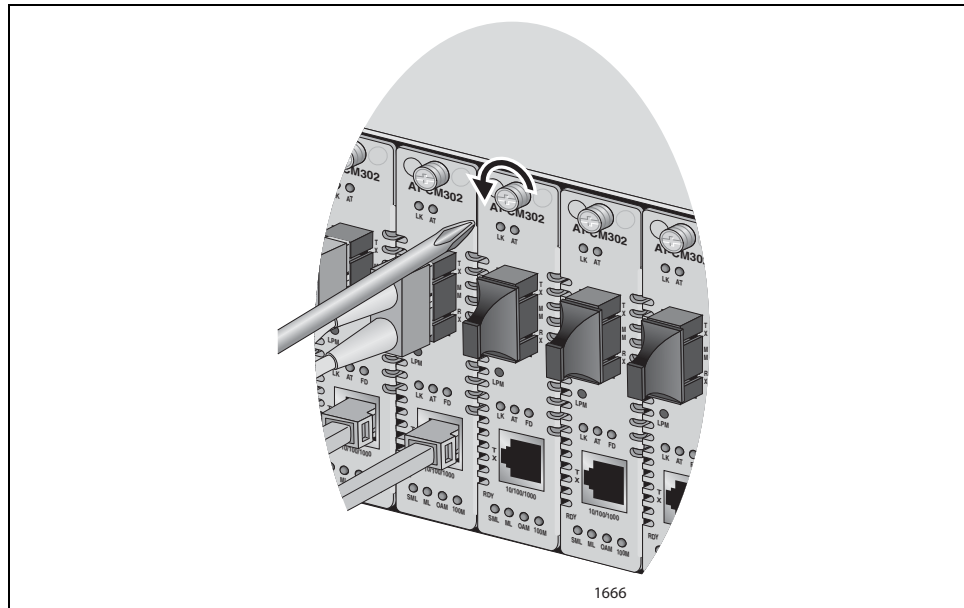

Figure 33. Loosening the Captive Screw

- Hook the slot at the end of the removal tool included with the chassis onto the captive screw at the top of the line card, and pull towards you to remove the card from the chassis, as shown in Figure 34.

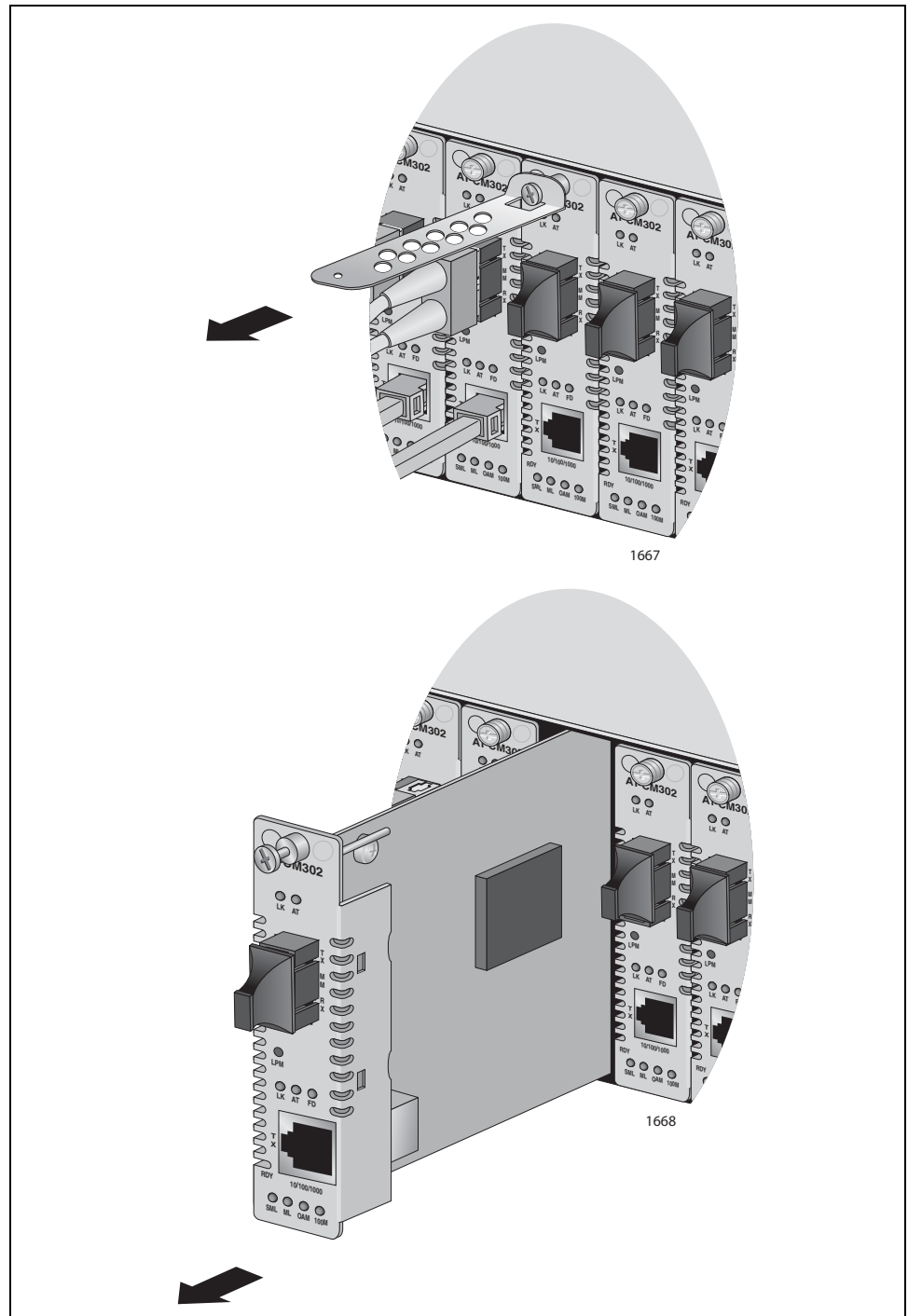
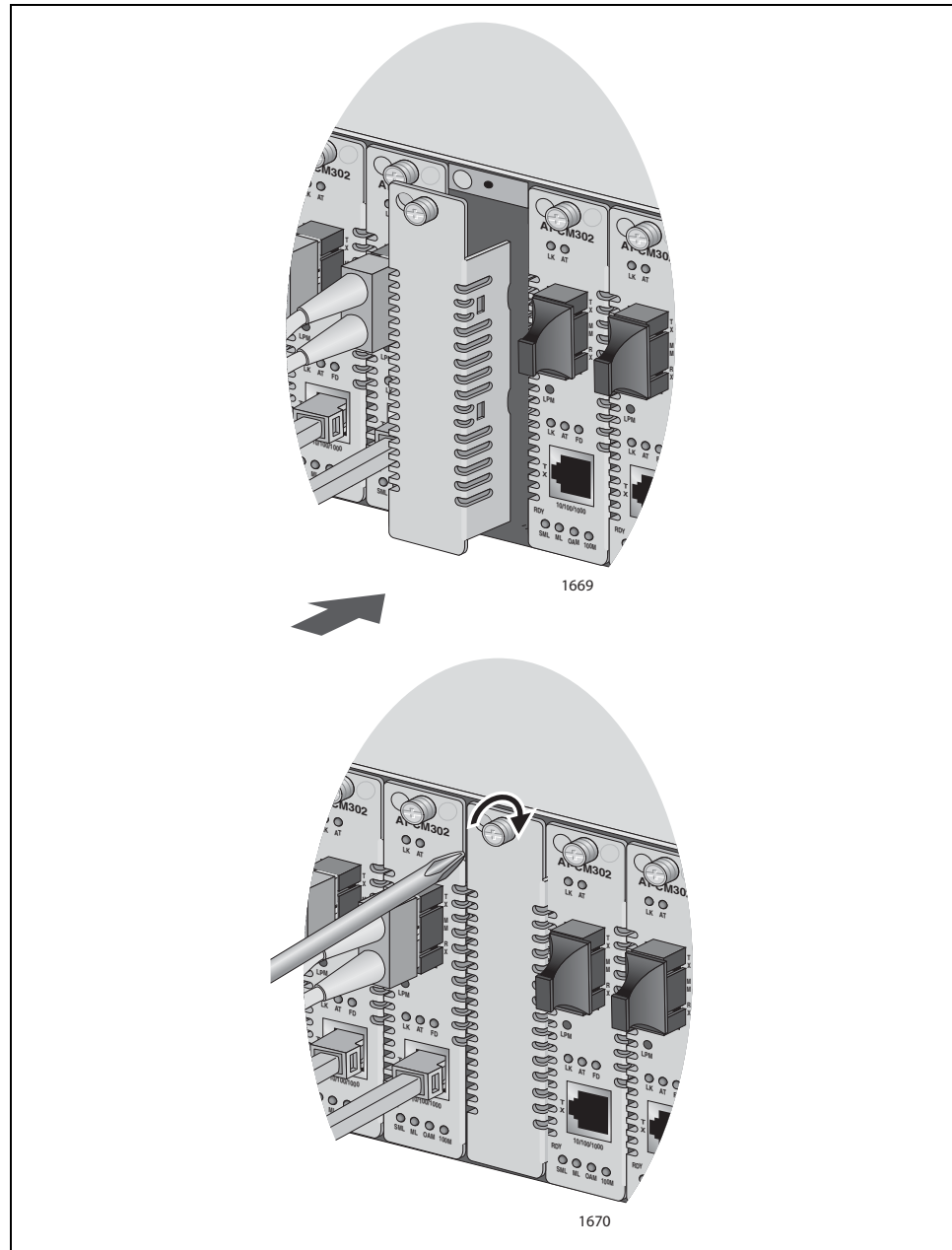

Figure 34. Removing a Line Card

- If you are replacing the card, go to “Installing the Media Converter Line Cards” on page 47 for instructions.

7. If you are not replacing the card, install a blank slot cover in the empty slot and secure it by tightening its captive screw.



**Note**

Do not operate the chassis with open slots. Open slots hamper the ability of the cooling fan in the power supply to maintain proper air circulation in the chassis.

## Removing or Replacing the AT-CV5001AC Power Supply

The AT-CV5001AC Power Supply is hot-swappable. You do not have to power off the chassis to install a second power supply or to replace a failed power supply in a chassis that has two power supplies.

There are two power supply slots. This procedure illustrates slot A. The procedure is the same for slot B.

### Note

The predecessor to the AT-CV5001 Chassis, the AT-CV5000 Chassis, had different power supply modules for the left and right slots. This is not the case for the AT-CV5001AC Power Supply, which can be installed in either power supply slot in the AT-CV5001 Chassis.

To remove or replace the AT-CV5001AC Power Supply, perform the following procedure.

1. Disconnect the power cord from the power source.
2. Disconnect the power cord from the AT-CV5001AC Power Supply.

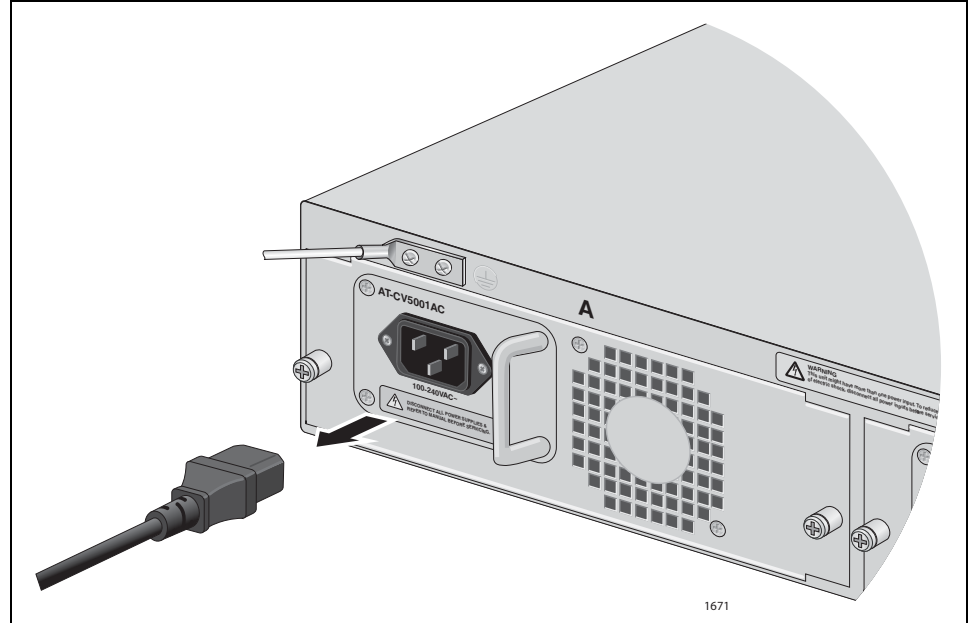

Figure 35. Removing the Power Cord from the AT-CV5001AC Power Supply

3. Using a Phillips screwdriver, loosen the two captive screws on the module.

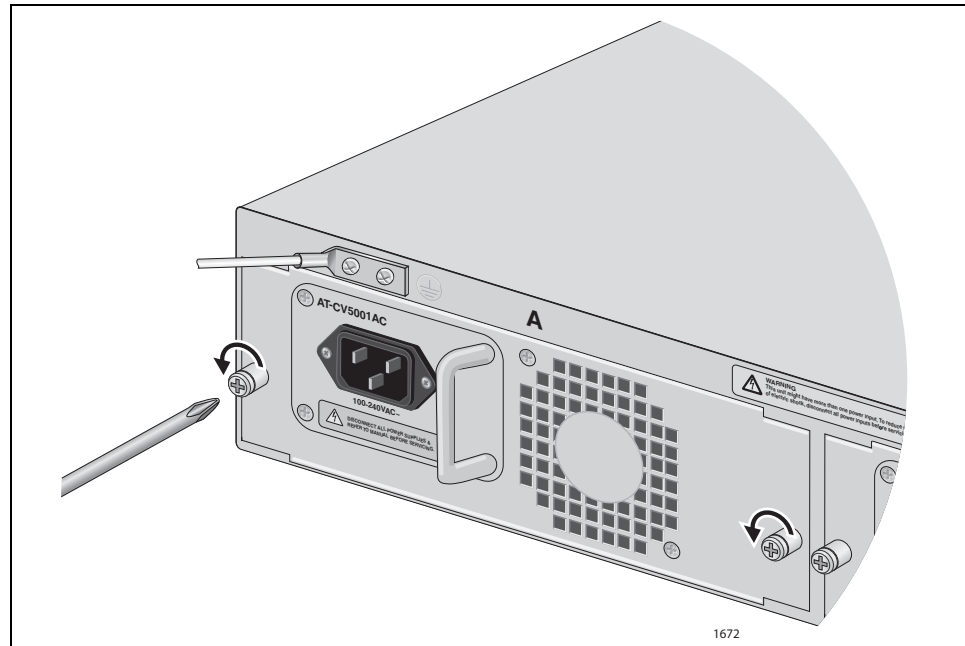

Figure 36. Loosening the Captive Screws on the AT-CV5001AC Power Supply

4. Gently slide the module from the unit.

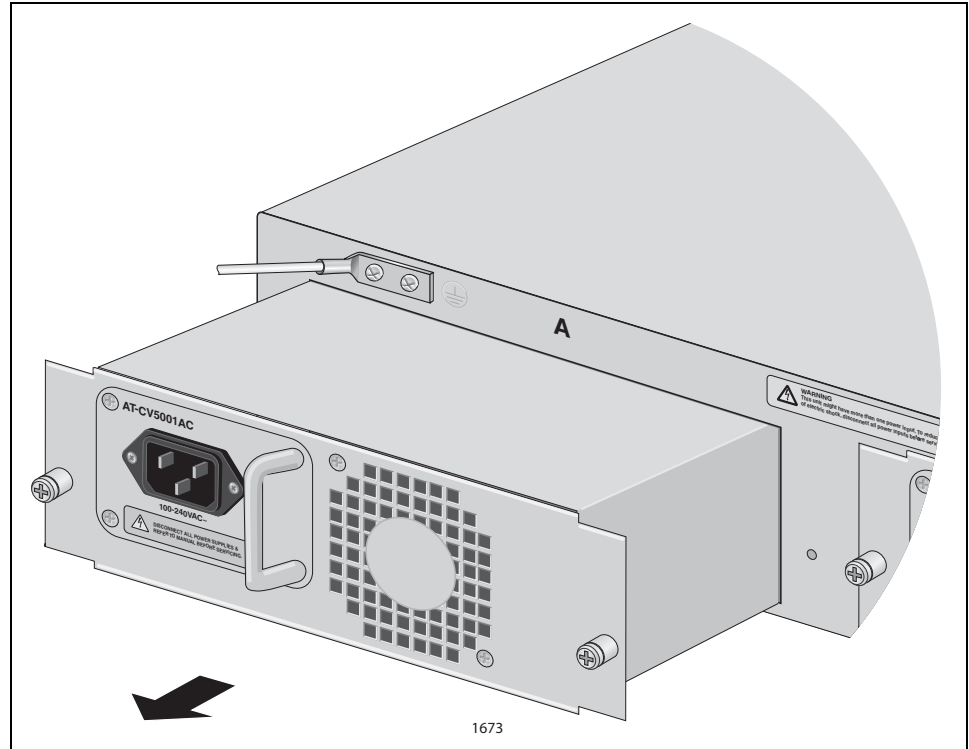

Figure 37. Removing the AT-CV5001AC Power Supply

---

**Note**

Use care when pulling the power supply from the chassis. If you roughly pull the module from the unit, you might bend the power and control pins on the connectors on the backplane.

---

5. To install a new module, refer to “Installing the AT-CV5001AC Power Supply” on page 38.
6. If you are not installing a new module, install the slot cover and secure it to the chassis by tightening the captive screws.

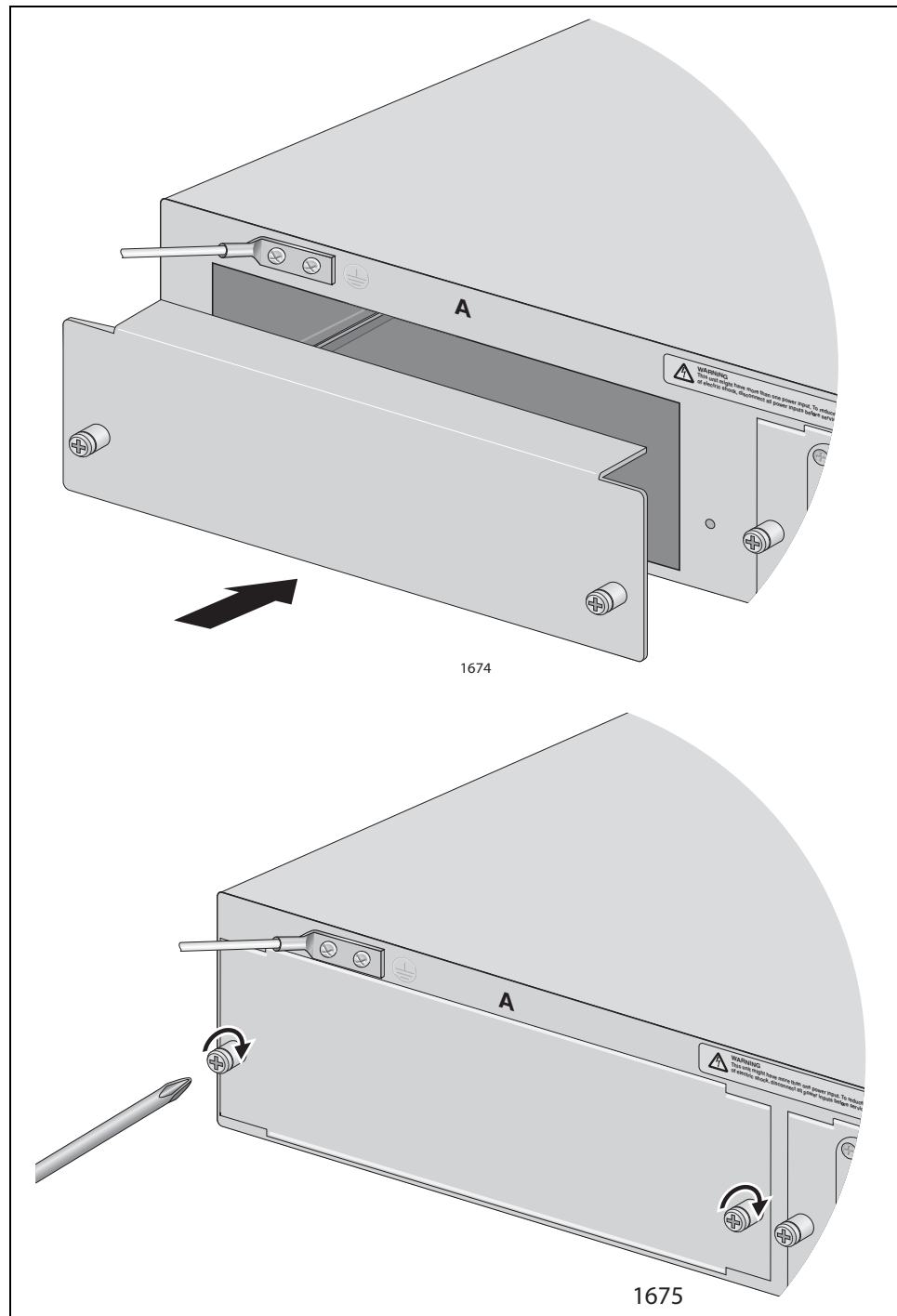

Figure 38. Installing the Slot Cover

**Note**

Do not operate the chassis with open slots. Open slots hamper the ability of the cooling fan in the power supply to maintain proper air circulation in the chassis.



## Removing or Replacing the AT-CV5001DC Power Supply

The AT-CV5001DC Power Supply is hot-swappable. You do not have to power off the chassis to install a second power supply or to replace a failed power supply in a chassis that has two power supplies.

### Note

The predecessor to the AT-CV5001 Chassis, the AT-CV5000 Chassis, had different power supply modules for the left and right slots. This is not the case for this chassis and the AT-CV5001DC Power Supply, which can be installed in either slot.

There are two power supply slots. This procedure illustrates slot A. The procedure is the same for slot B.

To remove or replace the AT-CV5001DC Power Supply, perform the following procedure.

1. Power off the DC circuit to the AT-CV5001DC Power Supply
2. Disconnect the -48 VDC feed wire from the terminal block marked - (minus).

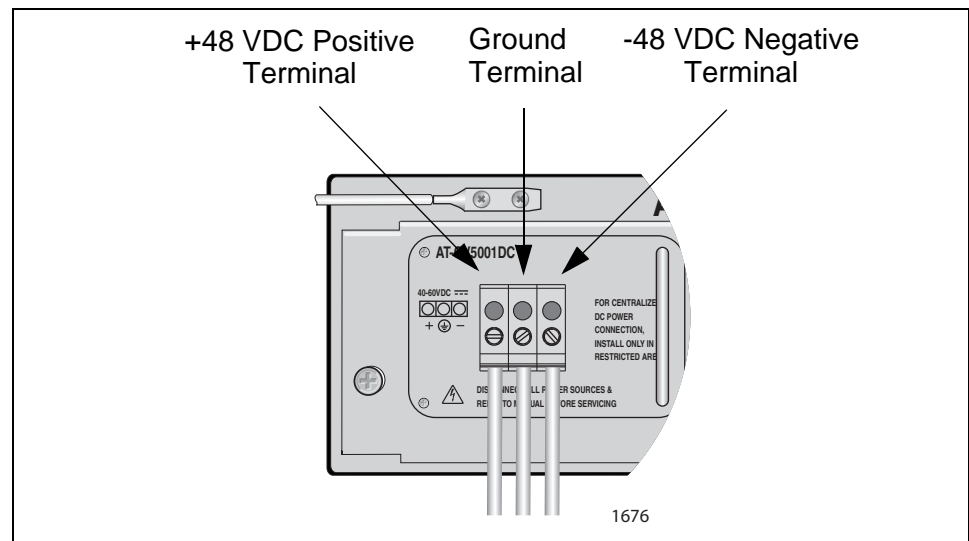

3. Disconnect the +48 VDC (RTN) feed wire from the terminal block marked + (plus).
4. Disconnect the power supply ground wire.



### Warning

When installing this equipment, always ensure that the power supply ground connection is installed first and disconnected last. *E11*

5. Using a Phillips screwdriver, loosen the two captive screws on the module.

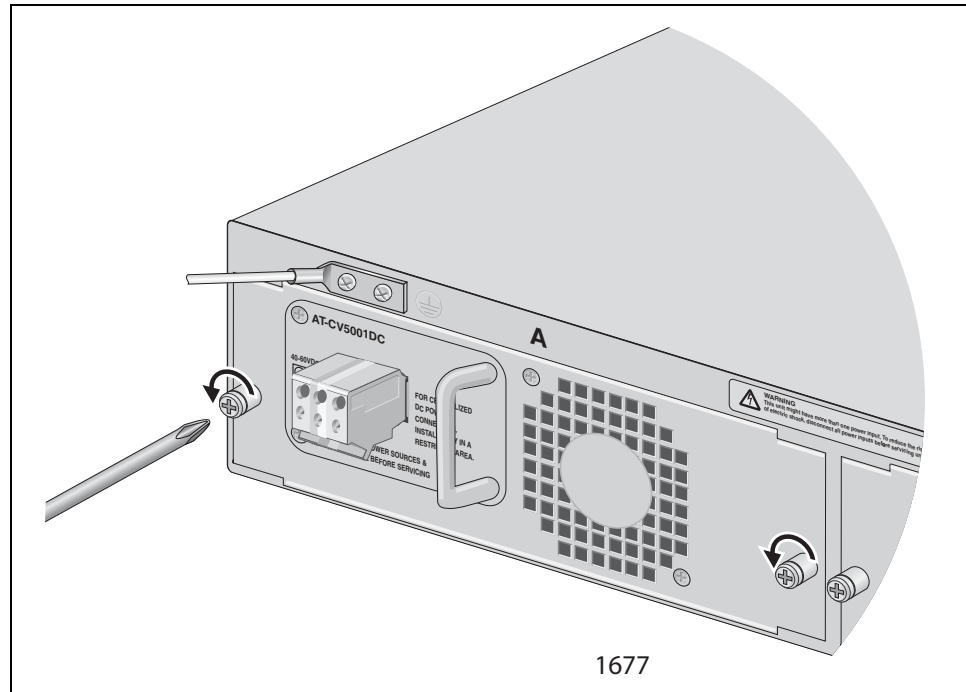

Figure 39. Loosening the Captive Screws on the AT-CV5001AC Power Supply

6. Gently slide the module from the unit.

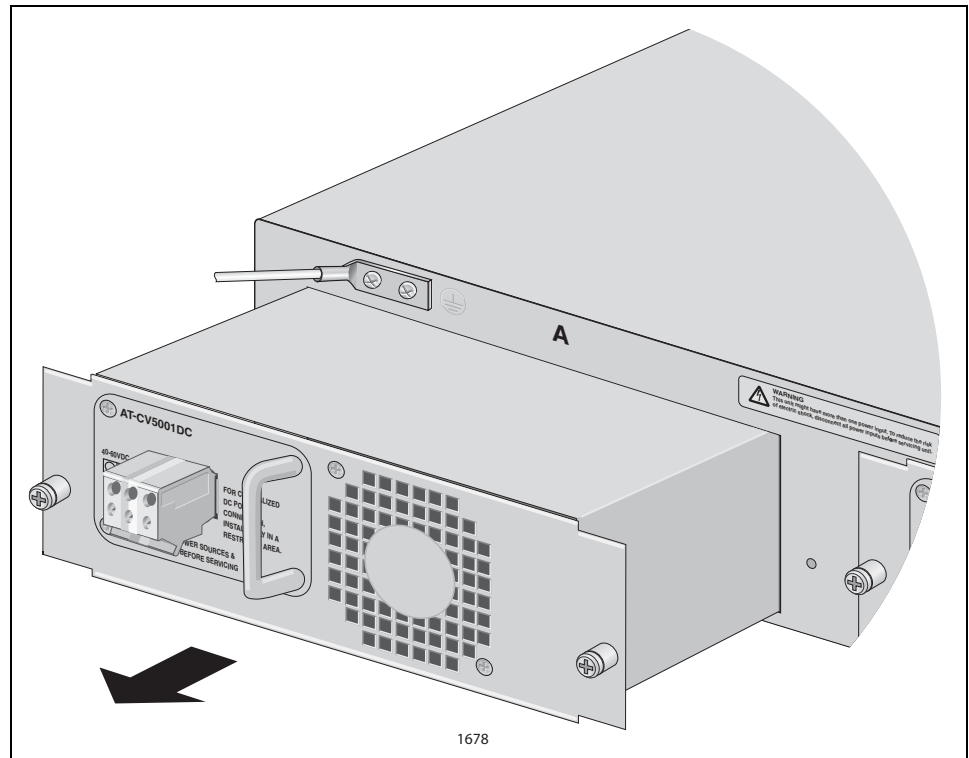

Figure 40. Removing the AT-CV5001AC Power Supply

---

**Note**

Use care when pulling the power supply from the chassis. If you roughly pull the module from the unit, you might bend the power and control pins on the backplane connectors.

---

7. To install a new module, refer to “Installing the AT-CV5001AC Power Supply” on page 38.
8. If you are not installing a new module, install the slot cover and secure it to the chassis by tightening the captive screws.

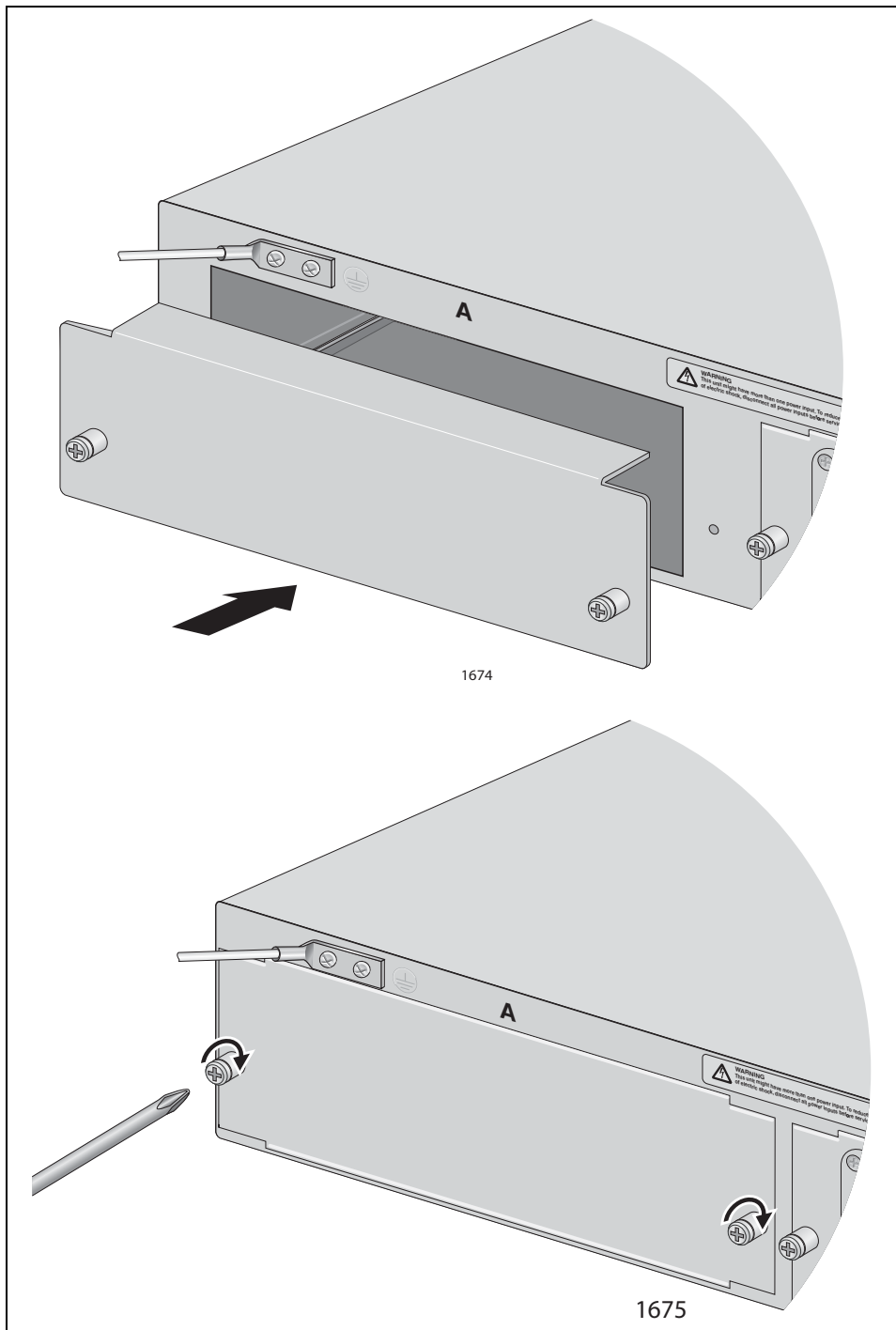

Figure 41. Installing the Slot Cover

**Note**

Do not operate the chassis with open slots. Open slots hamper the ability of the cooling fan in the power supply to maintain proper air circulation in the chassis.

## Chapter 4

# Troubleshooting

---

This chapter contains information on how to troubleshoot the power supply modules in the event a problem occurs.

---

**Note**

If after following the instructions in this chapter you are unable to resolve the problem, contact Allied Telesis Technical Support for assistance. Refer to “Contacting Allied Telesis” on page 14 for contact information.

---

The operational status of a power supply module is displayed on the PS and FAN LEDs on the AT-CV5LED Card installed in slot 19 on the front panel. PS-A and FAN-A LEDs correspond to slot A on the back panel and PS-B and FAN-B LEDs correspond to slot B. If a power supply is operating normally, both the PS LED and the FAN LED will be on. If one or both of them are off, try the following:

- Verify that the module is fully seated in the power supply slot in the chassis.
- Verify that the power cord is firmly connected to the power supply module and the power source.
- Try connecting the power module to another power source, preferably located on a different circuit.
- Verify that the power source is operating properly by plugging a different device into it.
- Verify that the power from the power source meets the operating specifications of the power supply module, listed in “Power Specifications” on page 79.
- Replace the power supply module.



# Appendix A

# Technical Specifications

---

## Physical Specifications

---

Dimensions (W x D x H)	34.25 cm x 44.05 cm x 8.68 cm (13.49 in x 17.35 in x 3.42 in)
Weight:	6.12 kg (13.5 lbs.)
Recommended Minimum Ventilation on All Sides	10 cm (4.0 in)

## Environmental Specifications

---

Operating Temperature:	0° C to 40° C (32° F to 104° F)
Storage Temperature:	-25° C to 70° C (-13°F to 158° F)
Operating Humidity:	5% to 90% non-condensing
Storage Humidity:	5% to 95% non-condensing
Maximum Operating Altitude:	3,000 m (10,000 ft.)
Maximum Storage Altitude:	4,000 m (13,100 ft.)

## Power Specifications

---

<b>AT-CV5001AC Power Supply Module</b>	AC Input Current:	100-240 Vac, 3.0 A 60/50 Hz, 140W maximum
	Dimensions (W x D x H)	21.5 cm x 18.8 cm x 6.5 cm (8.45 in x 7.4 in x 2.55 in)
	Weight:	1.7 kg (3.8 lb.)

**AT-CV5001DC  
Power Supply  
Module**

DC Input Current: 40-60 Vdc  $\overline{=}$ , 6 A, 140W maximum

Dimensions (W x D x H) 21.5 cm x 18.8 cm x 6.5 cm (8.45 in x 7.4 in x 2.55 in)

Weight: 1.7 kg (3.8 lb.)

**Power Supply Module Fuse Specifications**

---

This information is for service personnel only.



**Caution**

For continued protection against risk of fire, replace the fuses only with fuses of the same type and rating.

---

Table 6. Power Supply Fuse Specifications

Designator	Power Supply Module	Location	Rating
F1	AT-CV5001DC Module	Module board. Main input fuse.	125V, 10A
F2	AT-CV5001AC and AT-CV5001DC Modules	Module board. Fan fuse.	125V, 1.5A

**Safety and Electromagnetic Emissions Certifications**

---

EMI: FCC Class A, EN55022 Class A, VCCI Class A, C-TICK, CE

Immunity: EN55024

Safety: UL60950-1 (CUL<sub>US</sub>), EN60950-1 (TUV), CAN/CSA C22.2 No. 60950-1

Laser: EN60825

MTBF: Chassis: 1,840,000 hrs.  
AT-CV5001AC: 180,000 hrs.  
AT-CV5001DC: 190,000 hrs.



## Appendix B

# Cleaning Fiber Optic Connectors

---

The fiber optic connector consists of a fiber optic plug and its adapter. The end of the fiber optic cable is held in the core of the ferrule in the plug. Light signals are transmitted through the core of the fiber. Even minor smudges or dirt on the end face of the fiber, completely invisible to the naked eye, can disrupt light transmission and lead to failure of the component or of the entire system. Therefore, it is of utmost importance to clean all fiber optic connectors before use.

Figure 42 shows the ferrule in an SC connector.

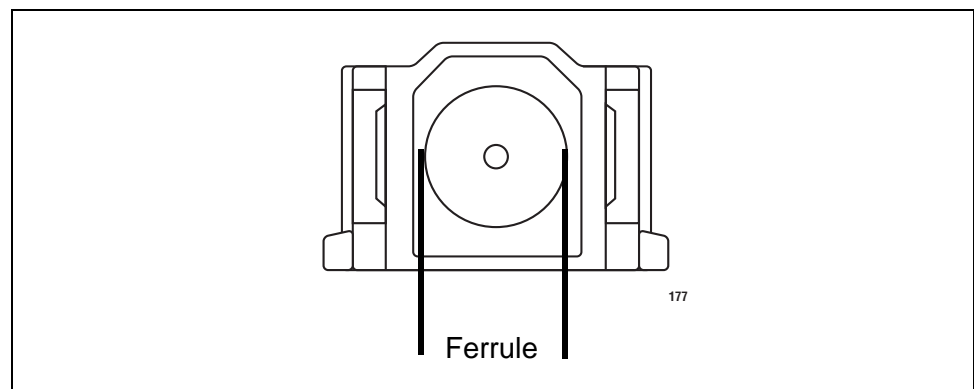

Figure 42. Ferrule in an SC Connector Plug

Figure 43 shows part of the end face of an unclean and clean ferrule.

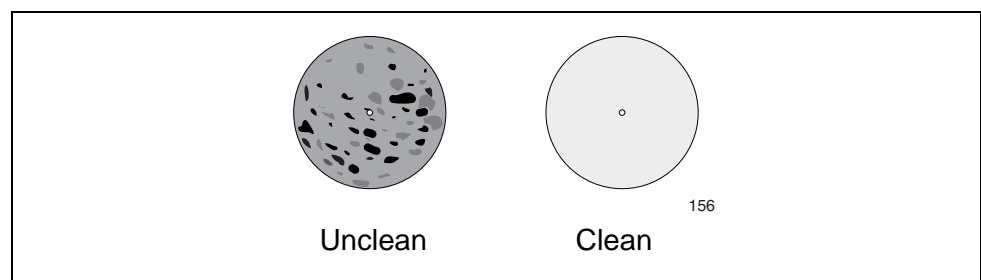

Figure 43. Unclean and Clean Ferrule

This appendix provides the following procedures

- ❑ “Using a Cartridge-Type Cleaner” on page 82
- ❑ “Using a Swab” on page 84

## Using a Cartridge-Type Cleaner

---

Fiber optic cartridge cleaners are available from many vendors and are typically called “cartridge cleaners,” as shown in Figure 44.

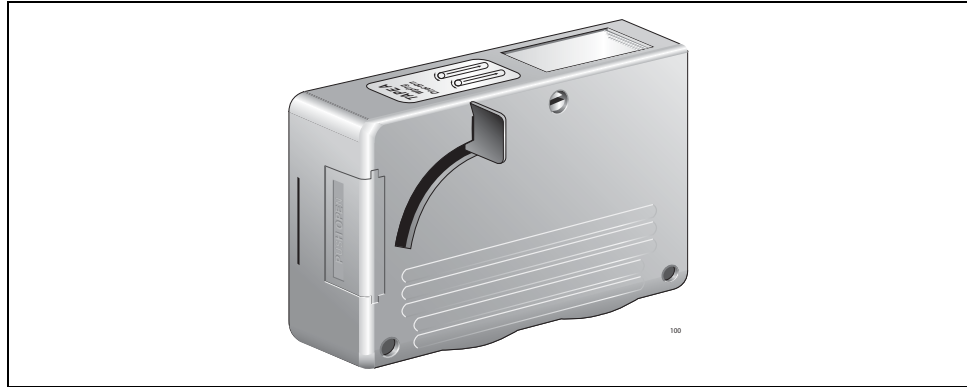

Figure 44. Cartridge Cleaner

---

**Note**

Do not use compressed air or aerosol air to clean a fiber optic connector.

---



**Warning:** Do not stare into the laser beam. ⚠ L2

---



**Warning:** Do not look directly at the fiber optic cable ends or inspect the cable ends with an optical lens. ⚠ E29

---

To clean a fiber optic connector using a cartridge cleaner.

1. With one hand, hold the cartridge cleaner and push the lever on the cleaning cartridge in the direction of the arrow to expose the cleaning surface, as shown in Figure 45 on page 83.
2. Place the ferrule tip on the exposed cleaning surface and rub the ferrule in a downward direction, as shown in Figure 45.

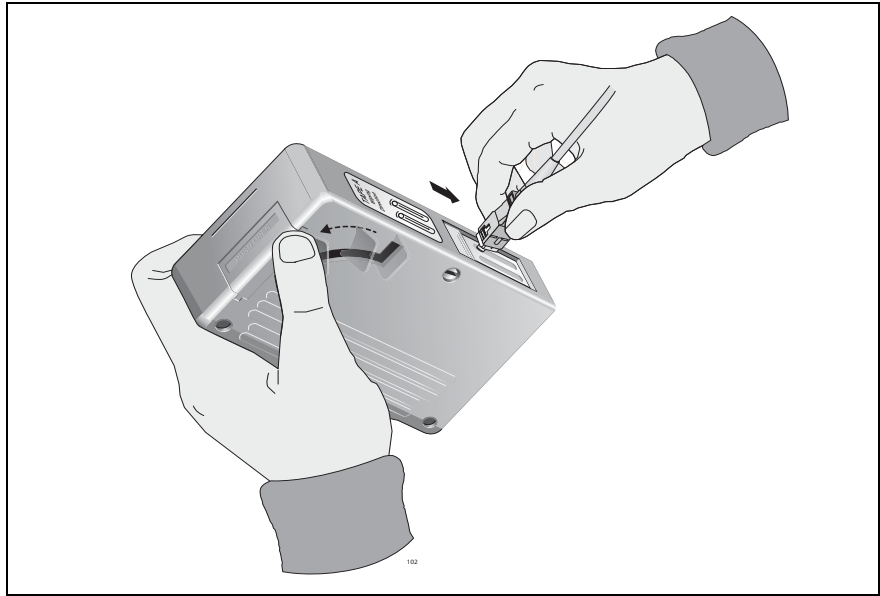

Figure 45. Rubbing the Ferrule Tip on the Cleaning Surface

---

**Note**

Rub the ferrule tip on the cleaning surface in one direction only.

---

3. When you reach the end of the cleaning surface, pick up the ferrule tip, rotate and place it at the top and rub downwards at least 2 times.



---

**Caution**

Failing to pick up the ferrule tip when you reach the bottom of the cleaning surface can result in static electricity that can damage the fiber optic cable.

---

4. If desired, repeat steps 3 and 4.
5. If a fiber inspection scope is available, use the scope to inspect the ferrule end face to make sure that it is clean.
6. Reconnect the cable to the port or protect the ferrule tip with a dust cap.

---

**Note**

Always keep a dust cap on a fiber optic cable when it is not in use.

---



---

**Note**

Do not touch the end face of the ferrule in the connector.

---

## Using a Swab

---

Specially treated swabs (stick cleaners) are available for cleaning inside connector adapters or hard-to-reach ferrule tips. These swabs, often referred to as “lint free” or “alcohol free” swabs, are available from many vendors, as shown in Figure 46. Stick cleaners are available in both 2.5 mm and 1.25 mm sizes for use on SC and MU connectors respectively.

---

**Note**

NEVER use a household cotton swab and/or alcohol to clean a fiber optic connector. This may leave a residue on the ferrule tip.

---

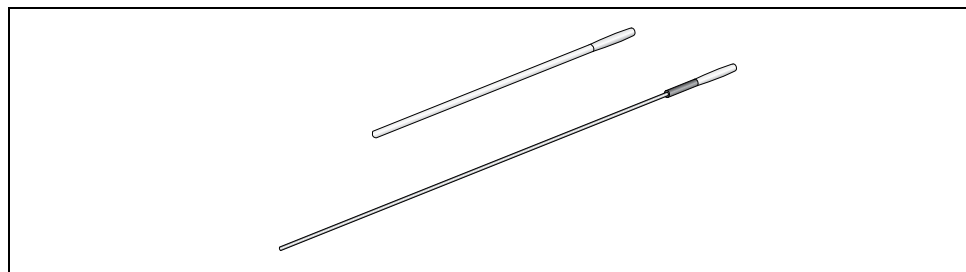

Figure 46. Lint-Free and Alcohol-Free Swabs

---

**Note**

Do not use compressed air or aerosol air to clean a fiber optic connector.

---



**Warning:** Do not stare into the laser beam. ⚠ L2



**Warning:** Do not look directly at the fiber optic cable ends or inspect the cable ends with an optical lens. ⚠ E29

---

To clean a recessed ferrule using a swab.

1. Insert the swab into the adapter as shown in Figure 47 and rub the ferrule tip with the swab.

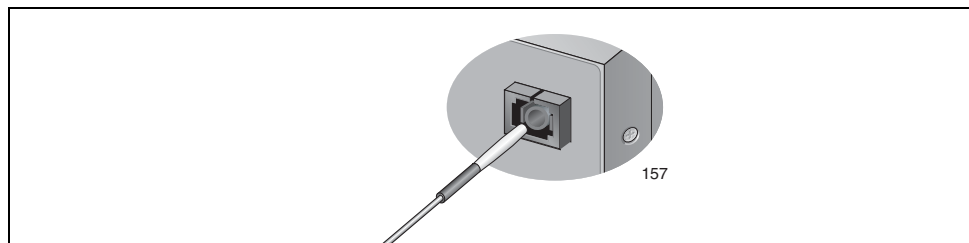

Figure 47. Cleaning a Recessed Ferrule

2. If desired, repeat step 1.
3. If a fiber inspection scope is available, use the scope to inspect the connector to make sure that it is clean and to check for scratches, pits, or other problems that may affect performance.

---

**Note**

Always keep a dust cap on a fiber optic cable when it is not in use.

---

---

**Note**

Do not touch the end face of the ferrule in the connector.

---

