

Replace pre-separation pad Replace separation roller

Pre-separation Pad

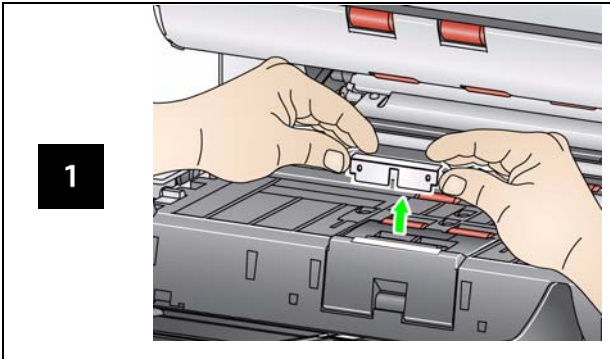

Separation Roller

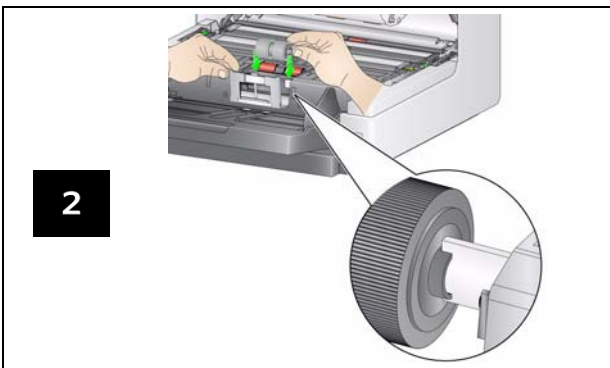
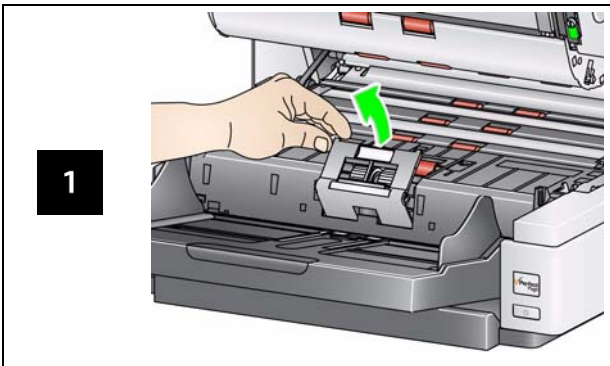

See the User's Guide for feed module replacement procedures..

Supplies and Accessories

CAT No.	Description
832 7538	Feeder Consumables Kit
838 7938	Extra-Large Feeder Consumables Kit
146 2415	Extra-Extra-Large Feeder Consumables Kit
834 8054	Image Guide Set (without Printer)
871 4438	Image Guide Set (with Printer)
808 8239	Flippable Background (without Printer)
800 0853	Flippable Background (with Printer)
896 5519	Staticide Wipes for <i>Kodak</i> Scanners
169 0783	Transport Cleaning Sheets
853 5981	Roller Cleaning Pads
840 5425	Printer Ink Blotters
818 3386	Enhanced Printer Black Cartridge
159 6832	Enhanced Printer Red Cartridge
CAT No.	Accessories
844 5280	Feeder Kit for Ultralightweight Paper
809 6943	Enhanced Printer Accessory
189 4351	<i>Kodak</i> A3 Flatbed Accessory
183 3946	66.04 cm (26 in.) document extender
162 6803	76.2 cm (30 in.) document extender
148 8476	86.36 cm (34 in.) document extender

IMPORTANT:

- ❑ The Roller Cleaning Pad contains sodium lauryl ether sulfate which can cause eye irritation. Refer to the MSDS for more information.
- ❑ Staticide Wipes contain isopropanol which can cause eye irritation and dry skin. Wash your hands with soap and water after performing maintenance procedures. Refer to the Material Safety Data Sheet (MSDS) for more information (www.kodakalaris.com/go/MSDS).

Kodak Alaris Inc.
2400 Mount Read Blvd.
Rochester, NY 14615
A-61656 / Part #5K3537 July, 2014
© 2014 Kodak Alaris Inc. All rights reserved

The Kodak trademark and trade dress are used under license from Eastman Kodak Company



i4000 Plus Series Scanners

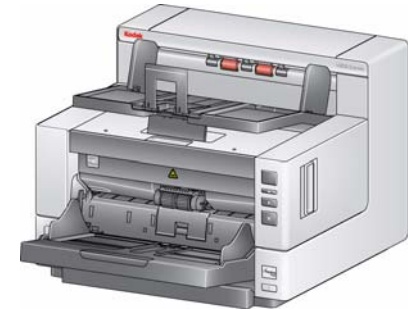

Reference Guide

Kodak Service & Support

www.kodakalaris.com/go/disupport

1.800.822.1414

(US&C only; all other regions, contact your local Kodak Support Center)

When contacting support, have the following available:

- A description of your problem
- Scanner model and serial number
- Computer configuration
- Software application you are using

Codes

Code	LED	Explanation
U1	Red	Check the imaging guides
U2	Red	Ink cartridge missing
U3	Red	Increase document length setting
U4		Future use
U5	Red	Timeout: USB disconnected while scanner was running, etc.
U6	Red	Scanner cover open
U7	Red	<ul style="list-style-type: none"> Too much paper is in the input elevator The feed module is not inserted properly
U8	Red	Multifeed stop
U8	Green flash	Multifeed pause
U9	Red	Document jam or the paper path is blocked
E	Red flash	<ul style="list-style-type: none"> Be sure all cables are connected properly Turn power off and then on again If problem persists, call Service.

Cleaning Frequency Chart

	Procedure	Start of day	Middle of Shift	Start of new shift
1	Vacuum output tray and input areas (input elevator and transport)	x		
2	Clean all rollers; including feed module	x		x
3	Run transport cleaning sheet	x		x
4	Clean imaging guides: basic	x	x	x
	Clean imaging guides: thorough (see <i>User's Guide</i>)	x		x

Cleaning the transport and rollers

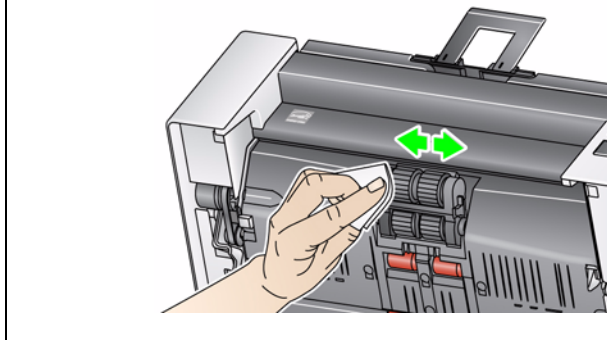
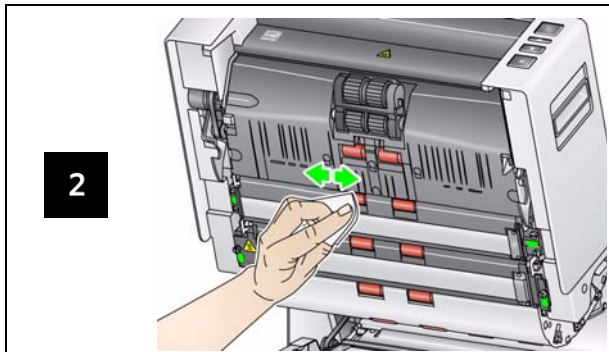
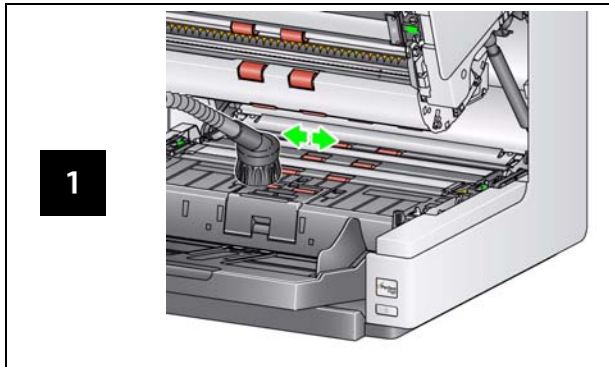

Running a cleaning sheet and cleaning the imaging guides

