



*Airetool*®

TUBE SERVICE TOOLS



# Sales & Service Centers

## Power Tools Sales & Service Centers

### EQUIPMENT GROUP INTERNATIONAL - SOUTH HOUSTON, TX



### EQUIPMENT GROUP INTERNATIONAL - GONZALES, LA



The Airetool® family of tube service tools is one of the most diverse in the heat transfer industry with a broad selection of tube expanders, tube rolling controls, tube cleaners, and re-tubing tools to cover various applications.

## *Airetool*®

### **Tools that perform**

Improving production rates and decreasing cost are critical to the success of today's manufacturer or contractor. The Airetool line of tools are designed and manufactured to perform consistently time after time. When it comes to performance and reliability, there is no doubt as to why manufacturers and contractors around the world have come to rely on the Airetool brand of products.

### **Tools of the highest quality**

When we say our tools are built well, we really mean it. Equipment Group International has brought back the exacting quality that Airetool brand is known for. While manufacturing in the USA to the highest standard.

### **Tools that work with the operator**

It is simple... give an operator a tool that is comfortable to use and the operator will work better. Airetool tool balancing systems do just that, coupled with extending expander or associated tooling life.





# Table of Contents

## Introduction

Warranty, Lubrication, Airetool Products	6
--	---

## Rolling Controls

**7-12**



Introduction	7
Torque Controlled Rolling Motors	8
Models 1762 & 1763 Right-Angle, 1850 Rolling Motors.	9
DAS II Dominator Tube Rolling System	10
DAS II Torque Controller Rolling Motors	11
Adapters & Chucks	12

## Condenser Tube Expander

**13-41**



Introduction	13
Lube-A-Tube Tube Expander Lubricant	16
G-900 Series Tube Expanders	17
G-1300 Series Tube Expanders	18
G-800 Series 3-Roll Tube Expanders	19
G-800 Series 5-Roll Tube Expanders	23
G-1200 Series 3-Roll Tube Expanders - Standard Reach	25
G-1200 Series 3-Roll Tube Expanders - A Reach	29
G-1200 Series 3-Roll Tube Expanders - C Reach	33
G-1200 Series 5-Roll Tube Expanders	37
G-8012 Series Tube Expanders	39
Special Application Tube Expanders	41

## Vernon Hydraulic Tube Expansion

**42-51**



Vernon System Introduction	42
Vernon Type "A" Tube Expanders	44
Vernon Type "S" Tube Expanders	47

## Tube Installation Tools & Heat Exchanger Accessories

**52-64**



GT Series Serrating Tools	52
Flaring, Belling, & Beading Tools, Mandrel Extensions, Universal Joints	54
Pistol Grip Drills & Tube End Facers	55
Tube Hole Gauges, Tube Sheet Hole Brushes, & Tube Guides	56
One & Two Piece Tube Plugs	57
Pop-a-Plugs	59
G-160 Tube Testing tools	60
ATT & AJT Testing tools	62
HydroStatic Test Pumps	64

## Tube Removal Tools

**65-81**





Tube Drifts & Collapsing Tools	65
Chipping Hammers & Rivet Busters	66
Tube Wall Reducing Tools, D-600 Series Pneumatic Drills	67
PIC internal Tube cutters	68
TIC Internal Tube Cutter Motors	69
RCM One Revolution Tube Cutters	70
Tube Pulling Systems, ATP III & PATP III Pumps	71
ATP III Tube Pullers	72
PATP III Tube Pullers	73
ATP III Gripper Kit Components	74
HDP III Tube Pullers & Accessories	75
HDQ III Tube Pullers	76
RAV III Tube Pullers	78
Super Jenny Tube Pulling System	79
JSP Manual Tube Pullers	81







## Pneumatic Tools & Accessories

**82-85**

	Impact Wrenches.....	82
	Pneumatic Grinders.....	84



## Boiler Expanders

**86-99**

	Introduction .....	86
	B-1000 Series Tube Expanders.....	88
	B-2000 Series Tube Expanders.....	89
	B-3000 Series Expanders .....	90
	MS and MPS Short Series Mandrels .....	91
	Boiler Expander and Mandrel Ordering Numbers .....	92
	Boiler Expander Roll Set Ordering Numbers .....	94
	FTE Series Tube Expanders .....	95
	FTF Series Tube Expanders .....	96
	Boiler Tube Expander Accessories .....	97
	Refinery Expanders .....	99









## Tube Cleaners

**100-108**

	Introduction.....	100
	CC Series Condenser Cleaner Systems.....	101
	CC Series Condenser Cleaning.....	102
	CC Series Shaft Components.....	103
	CC Series Drill & Brush Selection Guide, Large Diameter Twist Brushes.....	104
	Brush-Master Brushes.....	106
	Eagle Automatic Tube Cleaning System.....	107
	Overhead Catalyst Cleaners.....	108

## Boiler Tube Cleaners

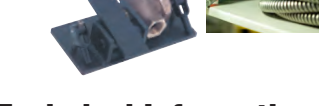
**109-135**

	Tube Cleaners for Straight Tubes .....	109
	Tube Cleaners for Curved Tubes .....	110
	Midget Series Tube Cleaner Selection Guide .....	111
	3000 & 4000 Series Tube Cleaner Selection Guide .....	112
	4000 Series Motors & Components .....	114
	60 & 4000 Series Motors & Components .....	115
	Midget Motors, Water Motors & Components .....	116
	Gas Line Cleaners & Components .....	117
	Type 1 Single Heads & Components.....	118
	Type 2 Single Heads & Components.....	119
	Drill Pipe Selection Chart & 3000 Series Motors.....	120
	Type 3 Single Expansion "P" & "TC" Heads & Components .....	122
	Type 4 "Spring Retraction Type" Forward Swing Arm Heads & Components .....	123
	Type 4 "Clip Type" Forward Swing Arm Heads & Components.....	124
	Type 5 "Clip Type" Self-feeding Wing-Arm Heads & Components .....	125
	Expanding Blade Type Heads & Components .....	127
	Drill Heads & Extensions.....	128
	U-Joints, Flexible Connections, Adapters .....	129
	Foot Valves, Inline Lubricators, & Air Manifolds.....	133
	Armored Left Hand Wire Wound Hose, Swivel Connections.....	134
	Balancers .....	135

## Technical Information

**136-139**

.....	Recommended Cutting Speeds & Special Tables.....	136
-------	--	-----

## Warranty

---

Subject to the terms and conditions hereinafter set forth, Equipment Group International (the company or EGI ) warrants products and parts sold by it, insofar as they are of its own manufacture, against defects of material and workmanship, under use and service in accordance with Company's written instructions, recommendations, and ratings for installation, operating, maintenance, and service of products, for a period of ONE YEAR FROM THE DATE OF SHIPMENT by Company, or any of Company's authorized Distributors.

This warranty is limited to the repair or replacement, as Company may elect, of any defective parts, regarding which, upon discovery of the defects,

the purchaser has given immediate written notice. Installation and transportation costs are not included. Company shall have the option of requiring the return to it of the defective material, transportation prepaid, for inspection.

**COMPANY DOES NOT WARRANT THE MERCHANTABILITY OF ITS PRODUCTS AND DOES NOT MAKE ANY WARRANTY, EXPRESS OR IMPLIED OTHER THAN THE WARRANTY CONTAINED HEREIN, COMPANY HAS NOT AUTHORIZED ANYBODY TO MAKE ANY REPRESENTATION OR WARRANTY OTHER THAN THE WARRANTY CONTAINED HEREIN.**

## Lubrication Products

---

EGI, products are classified as non-hazardous manufactured items, defined in the OSHA 1910.1200 Hazard Communication Standard as "Articles". These products, under conditions of normal use, do not release or cause exposure to a hazardous chemical.

Under normal conditions of use, lubrication products sold separately for or used within these tools should not cause an exposure hazard. Refer to the Material Safety Data Sheet (M.S.D.S.) for Safety and Disposal Information. M.S.D.S. sheets are available upon request from EGI,Ltd.

EGI, Ltd. is also aware of, and complies with,

the provisions of section 611 amendments to the Clean Air Act of 1990. No ozone depleting chemicals have been used in the manufacture of our products.

If you resell or distribute these products, you have the responsibility for ensuring that the Material Safety Data Sheets are provided to the purchaser.

Proper lubrication is essential to the economical operation of pneumatic and electric tools. EGI, Ltd. perform better and their life is extended by using the recommended lubricants. All lubricants that are listed in the accessory section of this catalog have undergone extensive testing and are recommended for use with EGI, Ltd. products.

## Airetool Products and Services

---

Airetool Tube Cleaners and Tube Expanders are used to fabricate and maintain boilers, heat exchangers, condensers and other tubular type equipment. Job proven in a variety of industries, Airetool products serve such facilities as petro chemical plants, oil refineries, nuclear and non-nuclear power plants, paper, sugar and metal mills, air-conditioning servicing and maintenance plants.

Products described in this catalog are representative of the complete Airetool Tube Cleaner and Tube Expander product lines. If a need develops which can not be satisfied by our standard products, please contact your Airetool Distributor, or EGI, Ltd. Sales and Service Center.



**Tools that set the standard**

Outstanding performance, incredible durability, plus the ease of maintenance have made Airetool tube rolling controls the standard which all other manufacturers are measured against.

**Why use torque control when expanding tubes?**

Torque controlled tube rolling increases productivity by achieving the desired tube wall reduction each and every time a tube is expanded. Torque-controlled tube rolling compensates for variations in the tube wall thickness and the tube sheet hole dimensions.

**What is tube wall reduction?**

Tube wall reduction is the percent the tube wall is reduced after the tube OD has contacted the tube sheet ID. The amount of tube wall reduction varies with the tube material, the tube sheet material and the design requirements of the unit. Several factors including pullout strength, tube and tube wall thickness, tube sheet material and thickness, and operating pressure are considered in determining the optimum wall reduction.

**Tube Rolling Set - Up Guide**

Pick five tubes in the vessel to be rolled and complete the work sheet below. It is important that

the measurements used in the set up are actual. Never use averaged dimensions.

**Always Use Engineering Design Specifications for Tube Wall Reduction Percentage**

Satisfactory joints are produced using the above listed percentage of tube wall reduction.

- Step A – Measure tube sheet hole
- Step B – Measure tube OD
- Step C – Calculate clearance (A-B)
- Step D – Measure tube ID
- Step E – Calculate 2x wall thickness (B-D)
- Step F – Calculate 5% wall reduction\* (.05 x E)
- Step G – Calculate finished rolled ID (C+D+F)

After the work sheet is finished, start setting up the torque control motor by test rolling the first of the five tubes. The first test roll must be done with the Airetrol or Electric tube rolling motor set for low torque to avoid over rolling.

Measure the tube ID after rolling the first tube. If more expansion is needed, increase the torque setting on the control and roll the second tube. Check the finished ID. This step may require repeating on tube three, but by the fifth tube you should have achieved your desired finished rolled ID of step G below. The tubes rolled to calibrate the tube wall reduction can now be re-rolled at the correct setting.

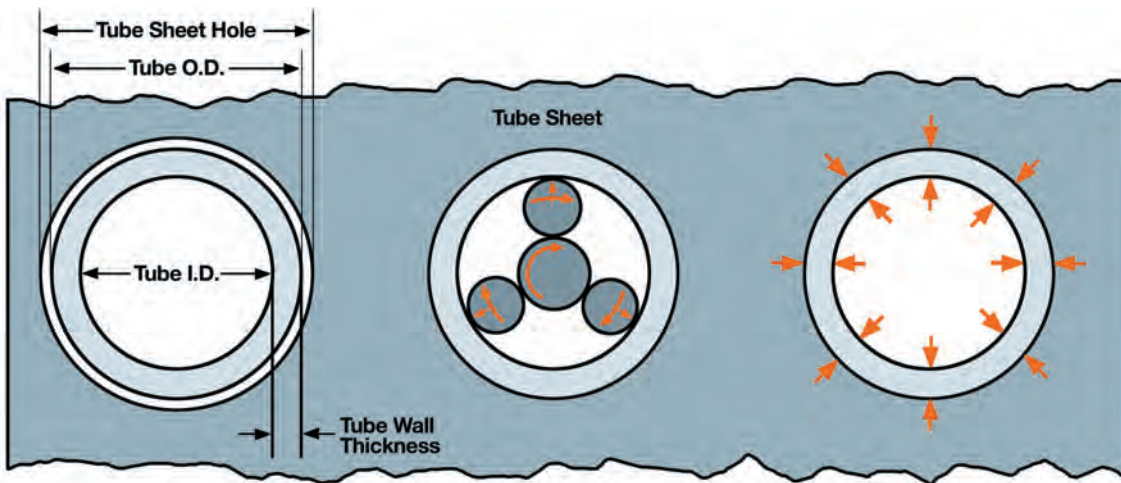

STEP	EXAMPLE	Joint Number				
		1	2	3	4	5
A	Tube Sheet Hole	.760"				
B	- Tube OD	.750"				
C	= Clearance	.010"				
D	Tube ID	.620"				
E	2 x Wall Thickness	.130"				
F	+5% Wall Reduction*	.006"				
G	= Finish Rolled ID	.636"				

\*Example only

# Rolling Controls

Hand-held Torque Controller Rolling Motors



MODEL 720

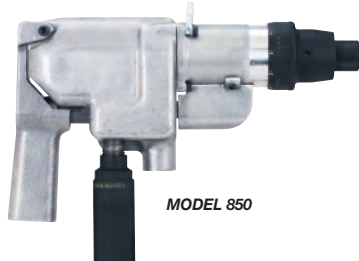

MODEL 850

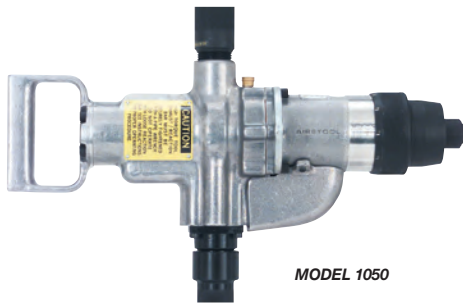

MODEL 1050

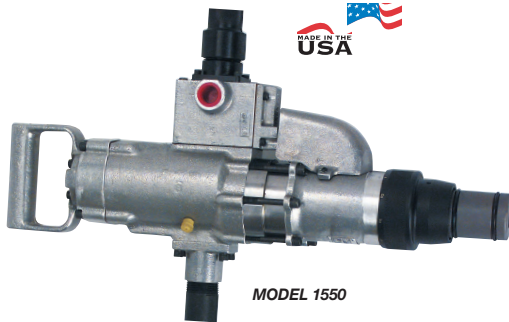

MODEL 1550



## Airetrol Air Driven Rolling Motors

Airetool rolling motors control expansion by the accurate measurement of torque. They automatically stop expanding according to a predetermined setting. Torque control prevents over- and under-expansion of tubes, assures uniformly tightened tube joints, and provides maximum holding strength for individual tubes. All Airetrols include torque sensing cams designed and manufactured specifically for tube expanding applications.

- Strong, lightweight aluminum housings for easier handling and less operator fatigue
- Rugged drive combines precision control and measured torque output
- Simple dial-a-torque adjustment collar for easy set up
- Cushioned shut-off reduces torque reaction
- Quick change chucks to improve productivity

Model Number	Order Number	Speed & Torque @ 90 psig Air Pressure*					Overall Length		Weight		Side to Center		Operating Hose		CFM	Square Drive	Tube Capacities*		Quick Change Chuck (in.)	
		Free Speed	Max. Torque		Min. Torque															
		RPM	in. lbs.	Nm	in. lbs.	Nm	in.	mm	lbs.	Kg	in.	mm	in.	mm	in.	mm	Included	Optional		
720-2500B	8405541	2500	20.0	2.3	2.0	0.23	7.875	198	2.4	1.09	0.813	20.7	3/8	9.5	17	1/4	1/4	6.4	1/4	3/8
720-2500B 3/8	8405561	2500	20.0	2.3	2.0	0.23	7.875	198	2.4	1.09	0.813	20.7	3/8	9.5	17	1/4	1/4	6.4	1/4	3/8
720-1800B	8405383	1800	27.0	3.1	2.0	0.23	7.875	200	2.4	1.09	0.813	20.7	3/8	9.5	17	1/4	3/8	9.5	1/4	3/8
720-1800B 3/8	8405512	1800	27.0	3.1	2.0	0.23	7.875	200	2.4	1.09	0.813	20.7	3/8	9.5	17	1/4	3/8	9.5	1/4	3/8
720-550B	8405391	550	75.0	8.5	2.0	0.23	8.625	219	2.7	1.22	0.813	20.7	3/8	9.5	17	3/8	1/2	12.7	3/8	1/4
850-1250A	8405399	1100	115.0	13.0	22.0	2.49	12.250	311	10.5	4.76	1.438	36.5	1/2	12.7	48	3/8	3/4	19.1	3/8	1/2
850-600A	8405398	500	192.0	21.7	31.0	3.50	12.250	311	10.5	4.76	1.438	36.5	1/2	12.7	48	3/8	1	25.4	3/8, 1/2	-
850-400A	8403500	400	315.0	35.6	43.0	4.85	12.250	311	10.5	4.76	1.438	36.5	1/2	12.7	48	3/8	1	25.4	3/8, 1/2	-

\*Varies depending on tube material, gauge, and tube sheet thickness

Model Number	Order Number	Speed & Torque @ 90 psig Air Pressure*					Overall Length		Weight		Side to Center		Operating Hose		CFM	Square Drive	Tube Capacities*		Quick Change Chuck (in.)	
		Free Speed	Max. Torque		Min. Torque															
		RPM	ft. lbs.	Nm	ft. lbs.	Nm	in.	mm	lbs.	Kg	in.	mm	in.	mm	in.	mm	Included	Optional		
1050-400	8404200	394	22.0	29.8	6.5	8.8	13.625	346	14	6.35	1.938	49.2	3/4"	19.1	68	1/2	1-1/4	31.8	3/8, 1/2	3/4, 1
1050-400 HD	8404201	394	29.5	40.0	7.5	10.2	13.625	346	14	6.35	1.938	49.2	3/4"	19.1	68	1/2	1-1/4	31.8	3/8, 1/2	3/4, 1
1550-900	8404290	756	30.7	41.6	4.7	6.4	18.000	457	27	12.25	1.938	49.2	3/4"	19.1	70	1/2	1-1/2	38.1	3/8, 1/2	3/4, 1
1550-250	8404280	217	100.0	135.5	25.0	33.9	18.000	457	27	12.25	1.938	49.2	3/4"	19.1	56	3/4	2-1/2	63.5	3/4, 1	3/8, 1/2

\*Varies depending on tube material, gauge, and tube sheet thickness



## 1850 Series Torque Control Rolling Motors

Heavy duty torque controlled rolling motor capable of rolling boiler tubes up to 4-1/2" O.D.

- Offers the highest controlled torque of any rolling motor currently available.
- Torque range 320 - 570 ft.lbs.



## 1760 Series Right Angle Torque Control Rolling Motors

These right angle torque control rolling motors are used to roll tubes into drums of package and stationary boilers.

- Heavy duty gear train components for increased durability
- External torque control setting for easy adjustment
- Rotating exhaust deflector and indexing angle head for operator control and comfort
- Modular construction simplifies tool maintenance
- Roll Throttle makes for safe operation in any working position



Model Number	Order Number	Speed & Torque 90 psig Air Pressure*					Overall Length		Weight		Side to Center		Operating Hose		CFM	Square Drive	Tube Capacities*		Chucks (in.)†	
		Free Speed	Maximum Torque		Minimum Torque		in.	mm	lbs.	kg	in.	mm	in.	mm			in.	mm	Incl.	Opt.
		RPM	ft. lbs.	Nm	ft. lbs.	Nm														

### 1850 Series Torque Control Rolling Motors

1850-90	8405315	82	301	408	92	125	13	330	46	20.9	3.375	86	1/2	12.7	60	1	3-1/2	89	3/4, 1	1-1/4, 1-1/2
1850-40	8405314	34	570	772	320	434	15	381	52	23.6	3.625	92.1	1/2	12.7	60	1	4-1/2	114	3/4, 1	1-1/4, 1-1/2

\*Varies depending on tube material, gauge, and tube sheet thickness

Model Number	Order Number	Speed & Torque 90 psig Air Pressure*					Overall Length		Weight		Head Dimensions				Square Drive Size	Tube Capacities*		Chuck Size (in.)†	
		Free Speed	Maximum Torque		Minimum Torque		in.	mm	lbs.	kg	Side to Center		Height Less Square Drive			in.	mm		incl.
		RPM	ft. lbs.	Nm	ft. lbs.	Nm					in.	mm	in.	mm					

### 1760 Series Reversible – Roll Throttle

1763-R-190	8405440	190	140	190	70	95	20.1	530.0	13.0	5.8	1.1	28.0	2.60	65.0	5/8	2.5	63.5	3/4
1763-RS-190	8405442	190	155	210	0	0	19.4	490.0	11.4	5.2	1.1	28.0	2.50	64.0	5/8	2.5	63.5	3/4
1762-R-90	8405444	90	305	413	150	203	21.7	550.0	14.8	6.7	1.5	37.0	2.75	70.0	3/4	4.0	101.5	3/4, 1
1762-RS-90	8405446	90	325	440	0	0	20.1	511.0	13.1	6.0	1.4	37.0	2.8	70.0	3/4	4.0	101.5	3/4, 1

### 1760 Series Reversible – Lever Throttle

1762-L-90	8405448	90	305	413	150	203	21.7	550.0	14.8	6.7	1.5	37.0	2.60	65.0	3/4	4.0	101.5	3/4, 1
-----------	---------	----	-----	-----	-----	-----	------	-------	------	-----	-----	------	------	------	-----	-----	-------	--------

† See page 13 for chuck size chart.

\*Varies depending on tube material, gauge, and tube sheet thickness

Standard Equipment  
 Air Inlet: 1/2" NPT  
 Minimum hose size: 1/2"  
 Splined torque reaction plate and reaction bar included (8567610)

# Rolling Controls

DAS II Rolling Motors

## DAS II Dominator System

The Airetool DAS II Dominator Tube Rolling System was designed to take pneumatic tube rolling technology to the next level using time proven Airetool rolling motors outfitted with on-board pneumatic control logic.

- Fully pneumatic system for fabrication shops and/or field service work
- “Basic” unit works well with tube pulling, tube end facing, and orbital welding equipment
- Greatly enhances the accuracy of tube rolling reducing costly rework of improperly rolled tubes
- Increases expander life (up to 3X) compared to conventional hand-held equipment
- Ergonomic design supports tool weight and torque reaction
- Floor lock holds system in place for stability while rolling tubes
- Right or left hand operation without conversion
- Five foot vertical and horizontal reach
- Available in three different configurations: Basic Unit\*, Standard, Lubricator



DAS II Component	DAS II Dominators		
	Basic Unit*	Standard	With Lube
Base	*	*	*
Tower	*	*	*
Articulating ToolArm	*	*	*
Filter & Lubricator (Tool)		*	*
Airetool Supply Hoses		*	*
Lubricator (Expander)			*

\*The basic positioning unit can be used to support a wide variety of tube service tools including drills, end facers, tube cutting tools, tube pulling rams, and tube cleaning motors

Model Number	Order Number	Movement				Lift Capacity		Operating Pressure		Operating Hose		Allowable Torque	
		Vertical		Horizontal		lbs.	kg	PSI	Bar	in.	mm	ft.-lbs.	Nm
		ft.	m	ft	m								
<b>Automatic Tube Rolling System Less DAS II Airetool</b>													
DAS II Dominator	5526081	5.0	1.5	5.0	1.5	55	25	90	6.2	3/4	19.1	125	169
DAS II Dominator w/lube	5526140	5.0	1.5	5.0	1.5	55	25	90	6.2	3/4	19.1	125	169
<b>Basic Positioning Unit*</b>													
DAS II Dominator Basic Unit	5529158	5.0	1.5	5.0	1.5	55	25	90	6.2	3/4	19.1	125	169





## DAS II Dominator System

The Airetool DAS II Dominator Rolling Motors are designed to deliver power, performance, and durability while providing accurate and repeatable tube expansion.

- Time proven torque control rolling motors with on-board pneumatic control logic
- Simple dial-a-torque adjustment collar for easy set up
- Push-to-start configurations (no suffix) run only when activated, reducing noise and conserving shop air
- Timed Start\* configurations (T suffix) cycle continuously for trigger free tube rolling
- Tool Options include “Cycle Counter” (C suffix) and “Expander Lubricator” (L suffix)



Examples: DAS II 1550 900 TCL is a timed start model with counter & lube

DAS II 850 1250 CL is a push-to-start model with counter & lube

\*Timed Start option will run continuously when the toggle switch is in the “on” position. After the tube is rolled and the tool switches into reverse rotation, an adjustable delay timer is activated. The tool will start running in the forward direction again after the time delay is finished. (Available only on 1050 & 1550 Series.)

Model Number	Order Number	Free Speed	CFM	Maximum Torque		Minimum Torque		Chucks (in.)†	
		RPM		ft. lbs.	Nm	ft. lbs.	Nm	Included	Optional
<b>DAS II Dominator Rolling Motors*</b>									
DAS II 850 1250 Airetrol	8405562	1100	48	9.6	13.0	1.8	2.4	3/8	1/2
DAS II 850 1250 CL Airetrol	8405567	1100	48	9.6	13.0	1.8	2.4	3/8	1/2
DAS II 850 600 Airetrol	8405569	500	48	16.0	21.7	2.6	3.5	3/8, 1/2	-
DAS II 850 600 CL Airetrol	8405578	500	48	16.0	21.7	2.6	3.5	3/8, 1/2	-
DAS II 1050 400 TCL Airetrol	8405594	394	68	29.5	40.0	7.5	10.2	3/8, 1/2	3/4 - 1
DAS II 1550 900 Airetrol	8405563	756	75	30.7	41.6	4.7	6.4	3/8, 1/2	3/4, 1
DAS II 1550 900 CL Airetrol	8405565	756	75	30.7	41.6	4.7	6.4	3/8, 1/2	3/4, 1
DAS II 1550 900 T Airetrol	8405576	756	75	30.7	41.6	4.7	6.4	3/8, 1/2	3/4, 1
DAS II 1550 900 TCL Airetrol	8405580	756	75	30.7	41.6	4.7	6.4	3/8, 1/2	3/4, 1
DAS II 1550 250 Airetrol	8405564	217	75	100.0	135.5	25.0	33.9	3/4, 1	3/8, 1/2
DAS II 1550 250 T Airetrol	8405577	217	75	100.0	135.5	25.0	33.9	3/4, 1	3/8, 1/2
DAS II 1550 250 CL Airetrol	8405568	271	75	100.0	135.5	25.0	33.9	3/4, 1	3/8, 1/2

† 3/8 & 1/2 are QC Chucks (quick change)

\* Configurations

No suffix - Basic Airetrol, push-to-start (PTS)

C suffix - PTS with Counter

L suffix - PTS with Lubricator

T suffix - Timer (continuous cycling, negates PTS, available only on 1050 & 1550 Series)

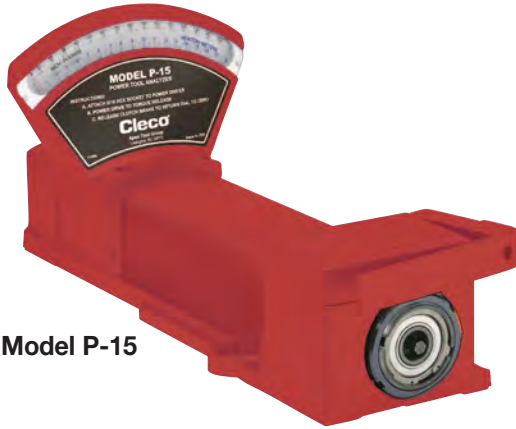

Model P-15

## Model P-15 Torque Analyzer

Use the P-15 analyzer to set a specific torque value on Airetrol rolling controls. The torque analyzers' readings may be used as a standard for the Airetrol's performance providing greater quality control over rolled tube joints.

- Set rolling motor at a specific torque value
- Enhances quality control with torque value consistency
- Time saver with multiple rolling motor applications



Model Number	Order Number	Graduations	Capacity	Height		Width		Length		Weight	
				in.	mm	in.	mm	in.	mm	lb.	kg
<b>P-15 Torque Analyzer</b>											
P-15	810002PT	2 in.-lbs.	5 - 150 in. lbs.	8.0	203.0	5.0	127.0	18.0	457.0	23.0	10.4
MP-15 (metric)	810151	5 cm-kg.	5 - 180 cm-kg	8.0	203.0	5.0	127.0	18.0	457.0	23.0	10.4

General: Drive Size: 5/16" male hex

Optional Equipment: Calibration Kit – 810080

## Analyzer Adapter

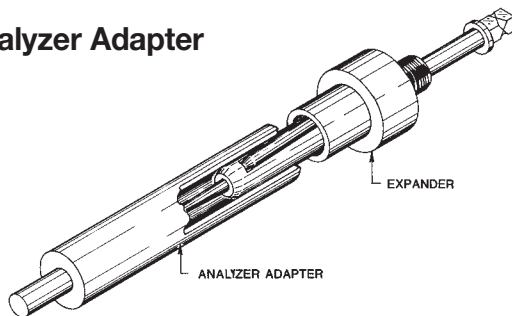

Adapter Number	Order Number	Adapter Used with the Following Expanders
<b>Adapters for P-15 Analyzer</b>		
AD-1	8566501	1201 thru 1203 & 801 thru 803
AD-2	8566503	1205 & 805
AD-3	8566502	1207 thru 1210 & 807 thru 810
AD-4	8567012	1211 thru 1214 & 811 thru 814
AD-5	8566521	1215 thru 1220 & 815 thru 820
AD-6	8566518	1221 thru 1224 & 821 thru 824
AD-7	8566519	1225 thru 1230 & 825 thru 830
AD-8	8566514	1231 thru 1234 & 831 thru 834
AD-9	8566531	1235 thru 1240 & 835 thru 840
AD-8	8566475	1241 thru 1242 & 831 thru 842
AD-10	8566475	1243 thru 1248 & 843 thru 846
AD-11	8566520	1247 thru 1254 & 847 thru 854
AD-12	8566676	1255 thru 1260 & 855 thru 860
AD-13	8567332	1261 thru 1266 & 861 thru 866
AD-14	8566649	1267 thru 1272 & 867 thru 872
AD-15	8567039	1273 thru 1276 & 873 thru 878
AD-16	8567289	1279 thru 1288 & 870 thru 888
AD-17	8567050	1289 thru 1290 & 889 thru 890
AD-18	8567602	1291 thru 1294 & 891 thru 894
AD-19	8567230	1295 thru 1300 & 895 thru 900

For information on AD-0 to AD-08 adapters for P2-B Analyzer, contact technical service.

## Optional and Replacement Chucks

Chuck Description	Order Number	Input Square Drive (in.)	Output Mandrel Square (in.)
<b>720-720S-735S</b>			
720 250 1/4 Chuck	8405334	3/8	1/4
720 375 B 3/8 Chuck ASSY	8405403	3/8	3/8
<b>850</b>			
850 375 QC chuck	8400100	3/8	3/8
850 500 QC chuck	8400200	3/8	1/2
<b>1050-400 1550-900</b>			
1000 375 QC Chuck complete	8400700	1/2	3/8 QC
1000 500 QC Chuck complete	8400800	1/2	1/2 QC
1000 750 Chuck complete	8400900	1/2	3/4
1000 1000 Chuck complete	8404820	1/2	1
<b>1550-250</b>			
QC 1550 500 QC Chuck complete	8405272	3/4	3/8 QC
QC 1550 500 QC Chuck complete	8405271	3/4	1/2 QC
1550 750 Chuck complete	8405259	3/4	3/4
1550 1000 Chuck complete	8405260	3/4	1
<b>999/1850s</b>			
989 750 3/4 square chuck	8404700	1	3/4
989 1000 1" square chuck	8404960	1	1
1850 1250 chuck complete	8405319	1	1-1/4
1850 1500 chuck complete	8405437	1	1-1/2
<b>1752</b>			
1770 110 3/4 chuck complete	8405299	3/4	3/4
1770 110 1 chuck complete	8405300	3/4	1
1770 110 1-1/4 chuck complete	8405400	3/4	1-1/4
<b>1753</b>			
QC 1770 230 1/2 QC chuck complete	8405302	5/8	1/2
1770 230 3/4 chuck complete	8405298	5/8	3/4
1770 230 1 chuck complete	8405306	5/8	1
<b>966s</b>			
850 375 chuck	8400100	3/8	3/8
<b>979s</b>			
939 375 chuck	8400400	5/8 Hex	3/8
939 500 chuck	8400500	5/8 Hex	1/2
939 750 3/4 chuck	8401100	5/8 Hex	3/4

# Airetool®

## The world standard in tube expanders

Airetool heat exchanger and condenser expanders have long been recognized as the standard to which all other brands are measured. The extra time spent manufacturing our expanders results in consistent performance and incredible durability that OEM Heat Exchanger Manufacturers expect.

## Tube Expanders

Tube expanding is the art of cold working the ends of tubes into intimate contact with the metal of the containing tube holes to form a leak proof mechanical seal and/or joint. In other words, it is a mechanical method of establishing a mechanical joint between a tube and a tube hole. Airetool manufactures condensed/heat exchanger expanders, boiler expanders, furnace expanders and many special application expanders.

Tube expanders consist of:

**Mandrel** – A tapered pin through the center of the expander to which the power is attached and when advanced pushes the rolls against the tubes.

**Rolls** – A set of (3 or more) of tapered cylindrical parts which are driven by mandrel and contact the tube wall to be expanded. The taper on the rolls is in the reverse direction and one-half the taper of the mandrel if it is a parallel roll expander.

**Cage** – This is the expander body (or housing) that holds the mandrel and rolls in place. The slots which contain the rolls also provide a feed angle which helps pull the mandrel in to provide expansion of the rolls

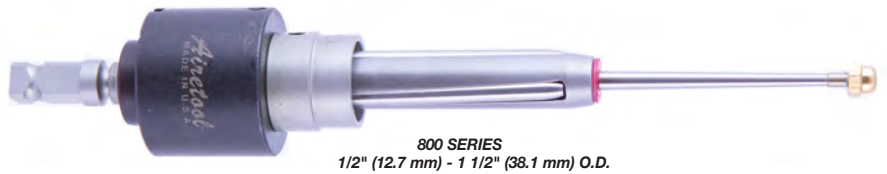

**Mandrel, Rolls and Cage** are the three things common to all expanders. Other parts added further classify the type of expander.

**Thrust Assembly** – This assembly attaches to the cage and allows adjustment of the expanding depth. The thrust collar will remain stationary against the tube sheet or tube end while the cage, mandrel and rolls expand the tube. A thrust assembly is used on condenser/heat exchanger expanders, some furnace expanders and special boiler expanders.



# Heat Exchanger – Condenser Expanders

## Condenser/Heat Exchanger Expanders

Airetool Condenser Heat Exchanger Expanders are self-feeding, parallel rolling, ball bearing thrust expanders. They are available in standard sizes for 1/4" O.D. through 3" O.D. for tube sheets up to 6-3/4" thick. Other sizes and lengths are available upon request. We supply most of the air conditioning manufacturers with expanders up to sixteen feet in length.

### To select the correct tube expander, the following information is required:

- Tube OD
- Tube wall thickness or BWG
- Tube sheet thickness
- Tube material
- Longer reach expanders are available upon request
- Special Conditions, i.e. enhanced tubing, thick tube sheets, double tube sheet, baffle sheets, tubes close to tube sheet channel or other tubes, protrusions, welded tubes, and tube bends close to the tube sheet.

### Setting the tube expander's collar on Primary Tube Sheets

It is very important to set the tube expander's collar in the correct position inside the tube sheet. The expander's roll high point should be positioned ~1/8" (3mm) from the inner side of the tube sheet as shown in the figure below. The purpose for setting the expander's collar this way is to allow for thermal expansion and contraction of the tube while it is in service. If the tube is expanded beyond the tube sheet, thermal expansion and contraction of the tube will cause stress on the tube, which may cause the tube to crack or rupture at the inner tube sheet location. When tightening the set screw on the expander's collar, be sure it is aligned with the cage groove.

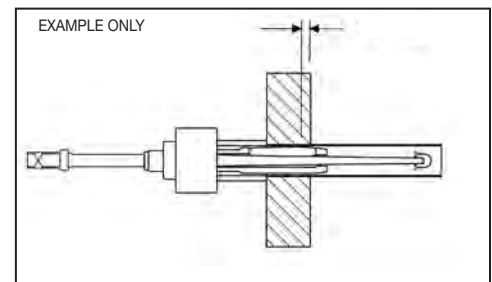

### Double Tube Sheet Applications

In a double tube sheet application additional information is required. The thickness of the outer tube sheet (primary tube sheet) and inner tube sheet (secondary tube sheet) and the distance between the two must be known. When expanding the tube in the primary tube sheet the expanders collar is positioned as in the figure above with an 800 series tube expander. For the secondary tube sheet a 1200 series expander is required with "S" type (double radius) rolls. The "S" type rolls are required to allow the expander to have clearance on each side of the secondary tube sheet as shown in the figure below. The purpose of using "S" type rolls on an inner tube sheet and setting the expander's collar this way is to reduce stresses in the tube due to thermal expansion and contraction of the tube while it is in service.

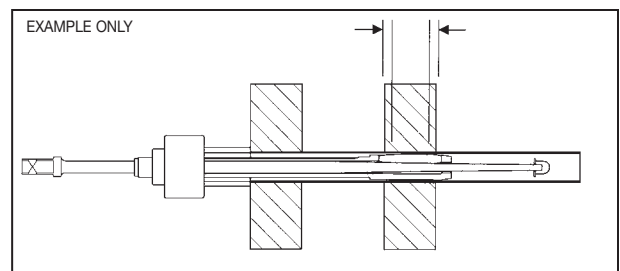

## Five roll expander vs. Three roll expander

Many manufacturers prefer the five-roll expander for applications using tube materials that work to harden quickly such as stainless steel and titanium. The five-roll expander inherently has more contact area with the tube than the three-roll which reduces the amount of work hardening and spring back effect that is common with these tube materials. They are also used in applications with closely spaced tubes having triangular pitch. The thinner the tube walls, 18 BWG (.049"/1.25mm) and thinner, the more apt work hardening is to occur.

## Step Rolling

Step rolling is required when expanding tubes in thick tube sheets. Typically the first expansion is made at the innermost location, away from the inner side of the tube sheet. This is extremely important when rolling the opposite end of the vessel. This allows the tube material to grow in the proper direction towards the operator and keeps the tube from being stressed. After all the tubes have been expanded in this location, adjust the expander's collar to overlap the previously rolled area. Repeat as necessary until the complete thickness of the tube sheet has been expanded. "S" type rolls (double radius) are recommended for step rolling to provide a smooth transition on the I.D. of the tube.

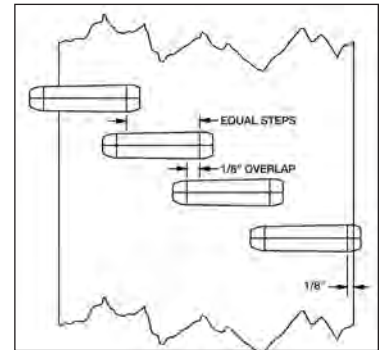

## Care and Maintenance of Tube Expanders

**Tube expanders are precision tools and should be treated as such. The service demanded of them is severe. Therefore, they must be given a reasonable amount of care to ensure satisfactory operation and long life.**

### All Tube Rolling Applications

1. Before using, clean the expander thoroughly to remove any dirt or foreign matter.
2. Check thrust bearing and grease if needed. This should be done daily.
3. Proper lubrication of the expander during the rolling operation is a must in order to keep the rolls and mandrel cool, to extend their life, and to insure uniform tube to tube sheet joints.
4. Inspect rolls and mandrels for scarring or chips regularly and if found, replace them immediately. One small chip in a roll can cause the complete set of rolls and the mandrel to be damaged in a single rolling cycle. Always replace rolls and mandrels at the same time.
5. When the rolling job is complete, wash the expander thoroughly and then oil and grease generously to prevent rusting during storage.

## Lubrication & Cleaning

### Hand-Held Rolling Applications

Depending on the severity of the rolling application, the expander should be washed periodically (every 25-100 tubes) in any commercial solvent. For best expander life, the expander should be left in solvent to cool while a second expander is used to continue rolling.

### DAS Automated Tube Rolling Applications

An optional automatic lubrication system is offered for the automatic tube rolling systems. Hand cleaning is virtually eliminated with the use of the automatic lubricating system as the air pressure that blows the lubrication into the expander to cool it also blows away dirt or foreign matter during each cycle.

# Heat Exchanger – Condenser Expanders

## Flip Collars

All G-800 and G-1200 Series tube expanders are supplied with a flip collar with a 10-32 UNF auto-lube port. The flip collar allows for flush and recessed tube rolling. The standard expander is supplied with a recess of 1/8" (3 mm). Other recess lengths are available. Contact technical service for details.

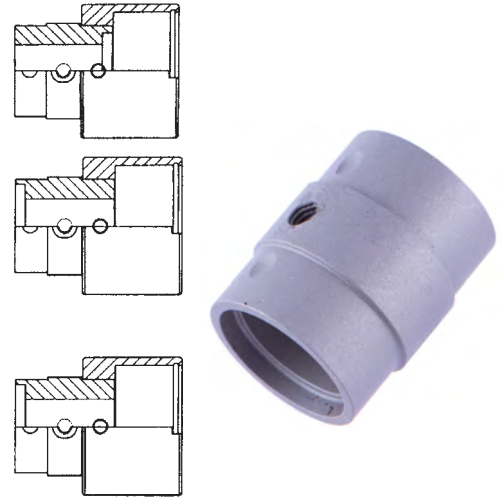

## Fixed Recess Thrust Collars

Fixed recess collars are available for tube projections between 3/16" (4.7mm) to 7/8" (22.2 mm) from the tube sheet for special applications and require a quote from technical service.

## Full Recess Thrust Collars

The full recess collar accommodates tube projections up to 7/8" (22.2 mm) from the tube sheet.

## Adjustable Recess Thrust Collars

The adjustable recess collar accommodates tube projections up to 1/2" (12.7 mm) from the tube sheet.

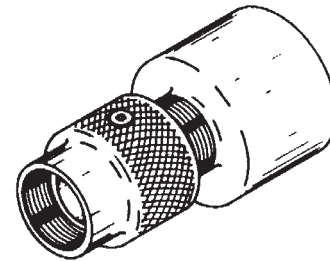

## Thin Wall Thrust Collars

Thin wall thrust collars are recommended when expanding 20 BWG .035" (0.9 mm) or lighter wall tubes. This design limits the possibility of the tube being drawn up inside the thrust collar. Removing the collar's collet allows the expander to be used as a full recess style compensating for various length tube projections from the tube sheet. These collars are application specific and require a quote from technical service.

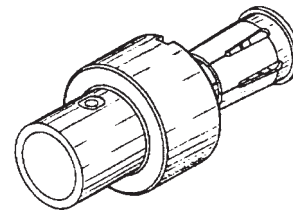

## Small Diameter Thrust Collars

Small diameter thrust collars are recommended for rolling tubes in confined areas, close to tube sheet channels, or if there is interference from adjacent tubes.

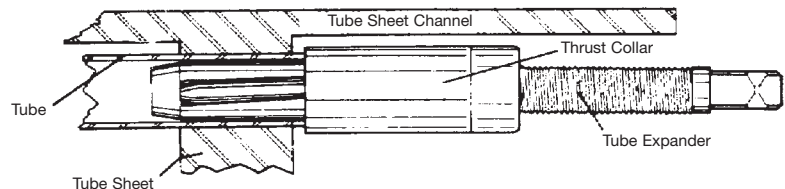

## Tube Expander Lubricant "LUBE-A-TUBE"

- A water soluble lubricant especially compounded for use with tube expanders. It prevents rust and acts as a coolant providing longer life and smoother rolling.
- 5-gallon container: LAT-5 (order number 2981695)





## G-900 Series Expanders

**O.D. Range:**  
**1/4 – 3/8 Inches**  
**6.3 – 9.5 mm**

- Expander with 3/4 in. (19.0 mm) long rolls will accommodate tube sheet thicknesses from 1/4 in. to 3/4 in. (6.3 mm to 19.0 mm)
- Expander with 1-1/4 in. (31.7 mm) long rolls will accommodate tube sheet thicknesses from 3/4 in. to 1-1/4 in. (19.0 mm to 31.7 mm)



NOTE: Information on any size of tube not listed will be furnished upon request.

Tube O.D.		Tube Gauge		Tube I.D.		Tube Sheet Thickness				Min. I.D. Tool Enters		Max. Expan. of Tool		Mandrel No. (Order No.) 1/4 in. Sq. Dr. 6.3 mm	Recommended Controlled Rolling Motors Airetool (Order No.)		
						1/4 in. to 3/4 in. (6.3 mm to 19.0 mm)		3/4 in. to 1-1/4 in. (19.0 mm to 31.7 mm)									
in.	mm	bwg	in.	mm	in.	mm	Tool No. (Order No.)	Roll Set No. (Order No.)	Tool No. (Order No.)	Roll Set No. (Order No.)	in.	mm	in.	mm			
1/4	6.3	18	.049	1.24	.152	3.86	921 (5016710)	921 (5175610)	920 (5016700)	904 (5174800)	.151	3.83	.173	4.39	(921) M-39 (2520300) (920) M-38 (2520100)	720-2500B (8405541)	
		19	.042	1.06	.166	4.21	922 (5016800)	923 (5175700)			.165	4.19	.185	4.70	M-39 (2520300)		
		20	.035	0.88	.180	4.57	923 (5016901)	923 (5175700)			.175	4.44	.200	5.08	M-40 (2520500)		
		21	.032	0.81	.186	4.72	924 (5017000)	924 (5175800)			.180	4.57	.207	5.25	M-40 (2520500)		
		22	.028	0.71	.194	4.92	925 (5017100)	925 (5175900)			.190	4.82	.216	5.48	M-41 (2520700)		
		23	.025	0.63	.200	5.08	926 (5017200)	923 (5175700)			.195	4.95	.222	5.63	M-41 (2520700)		
		24	.022	0.55	.206	5.23	927 (5017300)	924 (5175800)			.201	5.10	.230	5.84	M-41 (2520700)		
		28	.014	0.35	.222	5.63	928 (5017400)	903 (5174700)			.222	5.63	.238	6.04	928 (2161300)		
		29	.013	0.33	.224	5.68					.222	5.63	.238	6.04	928 (2161300)		
		30	.012	0.30	.226	5.74	929 (5519723)	929 (5519757)			.205	5.21	.235	5.99	M-40 (2520500)		
3/8	9.5	14	.083	2.10	.209	5.30	927 (5017300)	924 (5175800)			.201	5.10	.232	5.89	M-41 (2520700)	720-2500B (8405541)	
		15	.072	1.82	.231	5.86	915 (5016410)	903 (5174700)			.230	5.84	.265	6.73	M-42 (2520900)		
		16	.065	1.65	.245	6.22	916* (5016500)	916 (5175600)			.240	6.09	.275	6.98	M-36 (2519700)		
		16	.065	1.65	.245	6.22			916L* (5512156)	916L (5512157)	.240	6.09	.275	6.98	M-36L (2968803)		
		17	.058	1.47	.259	6.57	918 (5016600)	903 (5174700)	920 (5016700)			.255	6.47	.289	7.34		M-38 (2520100)
		18	.049	1.24	.277	7.03	901 (5015200)	903 (5174700)	902 (5015300)	904 (5174800)	.272	6.90	.307	7.79	M-30 (2518400)		
		19	.042	1.06	.291	7.39	903 (5015400)	903 (5174700)	904 (5015500)			.286	7.26	.330	8.38		M-31 (2518700)
		20	.035	0.88	.305	7.74	905 (5015600)	907 (5174900)	906 (5015700)	908 (5175000)	.300	7.62	.334	8.48	M-32 (2518900)		
		21	.032	0.81	.311	7.90	907 (5015800)	907 (5174900)	908 (5015900)			.306	7.77	.340	8.63		M-33 (2519100)
		22	.028	0.71	.319	8.10	909 (5016000)	909 (5175100)	910 (5016100)	910 (5175200)	.314	7.97	.349	8.86	M-34 (2519300)		
		23	.025	0.63	.325	8.25	911 (5016200)	911 (5175300)	912 (5016300)	912 (5175400)	.320	8.12	.357	9.06	M-34 (2519300)		
		24	.022	0.55	.331	8.40	911 (5016200)	911 (5175300)	912 (5016300)			.320	8.12	.357	9.06		M-34 (2519300)

\* This expander has 1" long rolls.

# Condenser Expanders

Selection Guide G-1300 Series Heat Exchanger & Condenser Tube Expanders

## G-1300 Series Expanders

**O.D. Range:**  
**3/8 Inches**  
**9.5 mm**

- Expanders with 3/4 in. (19.0 mm) long rolls will accommodate tube sheet thicknesses of 3/4 in. to 3 in. (19 mm to 76.2 mm)
- Expanders with 1-1/4 in. (31.7 mm) long rolls will accommodate tube sheet thicknesses from 1-1/4 in. to 3-1/2 in. (31.7 mm to 88.9 mm)



NOTE: Information on any size of tube not listed will be furnished upon request.

Tube O.D.		Tube Gauge			Tube I.D.		Tube Sheet Thickness				Min. I.D. Tool Enters		Max. Expan. of Tool		Mandrel No. (Order No.) 1/4 in. Sq. Dr. 6.3 mm	Recommended Rolling Motors (Order No.)
							3/4 in. to 3 in. (19.0 mm to 76.0 mm) *		1-1/4 in. to 3-1/2 in. (31.7 mm to 88.9 mm) *							
in.	mm	bwg	in.	mm	in.	mm	Tool No. (Order No.)	Roll Set No. (Order No.)	Tool No. (Order No.)	Roll Set No. (Order No.)	in.	mm	in.	mm		
3/8	9.5	15	.072	1.82	.231	5.86	1315 (5512183)	1315 (5512184)	1316 (5512185)	1316 (5512180)	.230	5.84	.265	6.73	M-86 (2541400)	720-2500B (8405541)
		16	.065	1.65	.245	6.22	1319 (5512187)	903 (5174700)	1319-L (5512190)	916-L (5512157)	.240	6.09	.275	6.98		
		17	.058	1.47	.259	6.57	1317 (5512191)		1318 (5512192-5)	904 (5174800)	.255	6.47	.289	7.34	M-88 (2541600)	
		18	.049	1.24	.277	7.03	1301 (5055100)		1302 (5055200)						M-80 (2540000)	
		19	.042	1.06	.291	7.39	1303 (5055300)	1304 (5055400)	908 (5175000)	.286	7.26	.320	8.12	M-81 (2540200)		
		20	.035	0.88	.305	7.74	1305 (5055500)	1306 (5055600)						M-82 (2540400)		
		21	.032	0.81	.311	7.90	1307 (5055700)	1308 (5055800)	910 (5175200)	.306	7.77	.340	8.63	M-83 (2540600)		
		22	.028	0.71	.319	8.10	1309 (5055900)	909 (5175100)						1310 (5056000)	M-84 (2540800)	
		23	.025	0.63	.325	8.25	1311 (5056100)	911 (5175300)	1312 (5056200)	912 (5175400)	.320	8.12	.357	9.06		
		24	.022	0.55	.331	8.40										

\* NOTE: Step expanding becomes necessary if the tube sheet thickness exceeds the length of the roll.

## G-800 Series – 3-Roll Expanders

**O.D. Range:**  
**1/2 – 1-1/2 Inches**  
**12.7 – 38.1 mm**

- Expanders with 1-1/2 in. (38.1 mm) long rolls will accommodate tube sheet thicknesses of 1/2 in. to 1-1/2 in. (12.7 mm to 38.1 mm)
- Expanders with 2-1/4 in. (57.1mm) long rolls will accommodate tube sheet thicknesses from 1-1/4 in. to 2-1/4 in. (31.7 mm to 57.1 mm)
- **Reversible Thrust Collar** design allows flush and 1/8 in. recess tube rolling. Collars have lubrication port for use with auto-lube configured ATR and DAS tube rolling systems.



Sizes not listed available upon request.

Tube O.D.		Tube Gauge		Tube I.D.		Tube Sheet Thickness				Min. I.D. Tool Enters		Max. Expan. of Tool		Mandrel Number (Order No.) 3/8 in. Sq. Dr. (9.5 mm)	Recommended Rolling Motors (Order No.)		
						1/2 in. to 1-1/2 in. (12.7 mm to 38.1 mm)		1-1/4 in. to 2-1/4 in. (31.7 mm to 57.1 mm)							Airetrol	Electric	
in.	mm	bwg	in.	mm	in.	mm	Tool No. (Order No.)	Roll Set No. (Order No.)	Tool No. (Order No.)	Roll Set No. (Order No.)	in.	mm	in.	mm			
1/2	12.7	14	.083	2.10	.334	8.48	797 (5005780)	797 (5512194)			.324	8.22	.374	9.49	797 (2131300)	720-550-B (8405391)	
		15	.072	1.82	.356	9.04	799 (5005782)	R-1 (5284800)			.348	8.83	.398	10.10	799 (2131900)		
		16	.065	1.65	.370	9.39	801 (5005800)					.360	9.14	.410	10.41	M-1 (2511800)	720-1800-B-3/8 (8405512)
		17	.058	1.47	.384	9.75	803 (5005900)	R-2 (5285000)			.374	9.49	.424	10.76			
		18	.049	1.24	.402	10.21	805 1/2 (5006000)	R-3 (5285200)			.392	9.95	.447	11.35	M-2 (2512100)		
		20	.035	0.88	.430	10.92	807 1/2 (5525444)	R-4 (5285400)			.420	10.66	.480	12.19	M-3 (2512400)		
5/8	15.8	12	.109	2.76	.407	10.33	805 5/8 (5006001)	R-3 (5285200)			.392	9.95	.447	11.35	M-2 (2512100)	850-600-A (8405398)	
		13	.095	2.41	.435	11.04	807 5/8 (5006100)	R-4 (5285400)			.420	10.66	.480	12.19	M-3 (2512400)		
		14	.083	2.10	.459	11.65	809 (5006200)	R-4 (5285400)	810 (5006300)	R-4-A (5285500)	.449	11.40	.509	12.92	M-4 (2512700)		
		15	.072	1.82	.481	12.21	811 5/8 (5006400)	R-5 (5285800)	812 5/8 (5006500)	R-5-A (5285900)	.471	11.96	.536	13.61	M-5 (2513000)		
		16	.065	1.65	.495	12.57	813 (5006600)	R-6 (5286200)	814 (5006700)	R-6-A (5286300)	.485	12.31	.550	13.97			
		17	.058	1.47	.509	12.92	815 5/8 (5006800)				816 5/8 (5006900)		.499	12.67	.564	14.32	M-6 (2513300)
		18	.049	1.24	.527	13.38	817 5/8 (5007000)	R-7 (5286600)	818 5/8 (5007100)	R-7-A (5286700)	.517	13.13	.582	14.78			
		19	.042	1.06	.541	13.74										850-1250-A (8405399)	
		20	.035	0.88	.555	14.09	819 (5007200)	R-7 (5286600)	820 (5007300)	R-7-A (5286700)	.531	13.48	.596	15.13	M-8 (2513900)		
		21	.032	0.81	.561	14.24											
22	.028	0.71	.569	14.45													



# Condenser Expanders

Selection Guide G-800 Series Heat Exchanger & Condenser Tube Expanders – continued

Tube O.D.		Tube Gauge		Tube I.D.		Tube Sheet Thickness				Min. I.D. Tool Enters		Max. Expan. of Tool		Mandrel Number (Order No.) 3/8 in. Sq. Dr. (9.5 mm)	Recommended Rolling Motors (Order No.)			
						1/2 in. to 1-1/2 in. (12.7 mm to 38.1 mm)		1-1/4 in. to 2-1/4 in. (31.7 mm to 57.1 mm)							Airetrol	Electric		
in.	mm	bwg	in.	mm	in.	mm	Tool No. (Order No.)	Roll Set No. (Order No.)	Tool No. (Order No.)	Roll Set No. (Order No.)	in.	mm	in.	mm				
3/4	19.0	10	.134	3.40	.482	12.24	811 3/4 (5006401)	R-5 (5285800)	812 3/4 (5006501)	R-5-A (5285900)	.471	11.96	.536	13.61	M-5 (2513000)	850-600-A (8405398)		
		11	.120	3.04	.510	12.95	815 3/4 (5006801)	R-6 (5286200)	816 3/4 (5006901)	R-6-A (5286300)	.499	12.67	.564	14.32	M-6 (2513300)			
		12	.109	2.76	.532	13.51	817 3/4 (5007001)	R-7 (5286600)	818 3/4 (5007101)	R-7-A (5286700)	.517	13.13	.582	14.78				
		13	.095	2.41	.560	14.22	821 (5007400)	R-8 (5287000)	822 (5007500)	R-8-A (5287100)	.550	13.97	.615	15.62	M-8 (2513900)			
		14	.083	2.10	.584	14.83	823 (5007600)	R-9 (5287400)	824 (5007700)	R-9-A (5287500)	.574	14.57	.639	16.23				
		15	.072	1.82	.606	15.39	825 3/4 (5007800)	R-10 (5287800)	826 3/4 (5007900)	R-10-A (5287900)	.596	15.13	.661	16.78				
		16	.065	1.65	.620	15.74	827 (5008000)		828 (5008100)		.605	15.36	.685	17.39				
		17	.058	1.47	.634	16.10	829 3/4 (5008200)	R-11 (5288200)	830 3/4 (5008300)	R-11-A (5288300)	.619	15.72	.699	17.75	M-9 (2514200)	850-1250-A (8405399)		
		18	.049	1.24	.652	16.56	831 3/4 (5008400)	R-12 (5288600)	832 3/4 (5008500)	R-12-A (5288700)	.642	16.30	.722	18.33				
		19	.042	1.06	.666	16.91												
		20	.035	0.88	.680	17.27												
		21	.032	0.81	.686	17.42												
22	.028	0.71	.694	17.62														
7/8	22.2	10	.134	3.40	.607	15.41	825 7/8 (5007801)	R-10 (5287800)	826 7/8 (5007901)	R-10-A (5287900)	.596	15.13	.661	16.78	M-8 (2513900)	850-600-A (8405398)		
		11	.120	3.04	.635	16.12	829 7/8 (5008201)	R-11 (5288200)	830 7/8 (5008301)	R-11-A (5288300)	.619	15.72	.699	17.75	M-9 (2514200)			
		12	.109	2.76	.657	16.68	831 7/8 (5008401)	R-12 (5288600)	832 7/8 (5008501)	R-12-A (5288700)	.642	16.30	.722	18.33				
		13	.095	2.41	.685	17.39	833 (5008600)	R-13 (5289000)	834 (5008700)	R-13-A (5289100)	.670	17.01	.750	19.05	M-10 (2514500)			
		14	.083	2.10	.709	18.00	835 (5008800)	R-14 (5289400)	836 (5008900)	R-14-A (5289500)	.685	17.39	.774	19.65	M-11 (2514800)			
		15	.072	1.82	.731	18.56	837 (5009000)	R-15 (5289800)	838 (5009100)	R-15-A (5289900)	.712	18.08	.801	20.34				
		16	.065	1.65	.745	18.92	839 (5009200)		840 (5009300)		.726	18.44	.815	20.70				
		17	.058	1.47	.759	19.27	843 (5009600)	R-16 (5290200)	844 (5009700)	R-16-A (5290300)	.740	18.79	.829	21.05	M-12 (2515100)			850-1250-A (8405399)
		18	.049	1.24	.777	19.73												
1	25.4	8	.165	4.19	.670	17.01	841 (5009400)	R-13 (5289000)	842 (5009500)	R-13-A (5289100)	.655	16.63	.735	18.66	M-9 (2514200)	1050-400 (8404200)		
		9	.148	3.75	.704	17.88	835 (5008800)	R-14 (5289400)	836 (5008900)	R-14-A (5289500)	.685	17.39	.774	19.65	M-11 (2514800)			
		10	.134	3.40	.732	18.59	837 (5009000)	R-15 (5289800)	838 (5009100)	R-15-A (5289900)	.712	18.08	.801	20.34				
		11	.120	3.04	.760	19.30	843 (5009600)	R-16 (5290200)	844 (5009700)	R-16-A (5290300)	.740	18.79	.829	21.05	M-12 (2515100)			
		12	.109	2.76	.782	19.86	845 (5009800)	R-17 (5290600)	846 (5009900)	R-17-A (5290700)	.763	19.38	.852	21.64				
		13	.095	2.41	.810	20.57	847 (5010000)	R-18 (5291000)	848 (5010100)	R-18-A (5291100)	.791	20.09	.880	22.35				
		14	.083	2.10	.834	21.18	849 (5010200)		850 (5010300)		.810	20.57	.909	23.08	M-13 (2515400)			850-600-A (8405398)

# Condenser Expanders

Selection Guide G-800 Series Heat Exchanger & Condenser Tube Expanders – continued



Tube O.D.		Tube Gauge				Tube I.D.		Tube Sheet Thickness				Min. I.D. Tool Enters		Max. Expan. of Tool		Mandrel Number (Order No.) 3/8 in. Sq. Dr. (9.5 mm)	Recommended Rolling Motors (Order No.)	
								1/2 in. to 1-1/2 in. (12.7 mm to 38.1 mm)		1-1/4 in. to 2-1/4 in. (31.7 mm to 57.1 mm)							Airetrol	Electric
in.	mm	bwg	in.	mm	in.	mm	Tool No. (Order No.)	Roll Set No. (Order No.)	Tool No. (Order No.)	Roll Set No. (Order No.)	in.	mm	in.	mm				
1	25.4	15	.072	1.82	.856	21.74	851 (5010400)	R-19 (5291400)	852 (5010500)	R-19-A (5291500)	.837	21.25	.936	23.77	M-13 (2515400)	850-600-A (8405398)	979-C-650/ ATC-900	
		16	.065	1.65	.870	22.09	855 (5010800)	R-21 (5292200)	856 (5010900)	R-21-A (5292300)	.865	21.97	.964	24.48				
		17	.058	1.47	.884	22.45												
		18	.049	1.24	.902	22.91												
		19	.042	1.06	.916	23.26												
		20	.035	0.88	.930	23.62												
1-1/8	28.5	8	.165	4.19	.795	20.19	853 (5010600)	R-20 (5291800)	854 (5010700)	R-20-A (5291900)	.776	19.71	.875	22.22	M-13 (2515400)	979-C-300/ ATC-900		
		9	.148	3.75	.829	21.05	849 (5010200)	R-18 (5291000)	850 (5010300)	R-18-A (5291100)	.810	20.57	.909	23.08				
		10	.134	3.40	.857	21.76	851 (5010400)	R-19 (5291400)	852 (5010500)	R-19-A (5291500)	.837	21.25	.936	23.77				
		11	.102	3.04	.885	22.47	855 (5010800)	R-21 (5292200)	856 (5010900)	R-21-A (5292300)	.865	21.97	.964	24.48				
		12	.109	2.76	.907	23.03	857 (5011000)		858 (5011100)		.883	22.42	.982	24.94	M-14 (2515700) *			
		13	.095	2.41	.935	23.74	859 (5011200)	R-22 (5292600)	860 (5011300)	R-22-A (5292700)	.916	23.26	1.015	25.78	M-15 (2516000) *			
		14	.083	2.10	.959	24.35	861 (5011400)	R-23 (5293000)	862 (5011500)	R-23-A (5293100)	.935	23.74	1.044	26.51				
		15	.072	1.82	.981	24.91	863 (5011600)	R-24 (5293400)	864 (5011700)	R-24-A (5293500)	.962	24.43	1.071	27.20	M-16 (2516300) *			
		16	.065	1.65	.995	25.27	867 (5012000)	R-26 (5294200)	868 (5012100)	R-26-A (5293500)	.990	25.14	1.099	27.91				
		17	.058	1.47	1.009	25.62												
18	.049	1.24	1.027	26.08														
1-1/4	31.7	8	.165	4.19	.920	23.36	865 (5011800)	R-25 (5293800)	866 (5011900)	R-25-A (5293900)	.901	22.88	1.010	25.65	M-15 (2516000) *	979-C-650/ ATC-900		
		9	.148	3.75	.954	24.23	861 (5011400)	R-23 (5293000)	862 (5011500)	R-23-A (5293100)	.935	23.74	1.044	26.51				
		10	.134	3.40	.982	24.94	863 (5011600)	R-24 (5293400)	864 (5011700)	R-24-A (5293500)	.962	24.43	1.071	27.20				
		11	.120	3.04	1.010	25.65	867 (5012000)	R-26 (5294200)	868 (5012100)	R-26-A (5293500)	.990	25.14	1.099	27.91	M-16 (2516300) *			
		12	.109	2.76	1.032	26.21	869 (5012200)	R-27 (5294600)	870 (5012300)	R-27-A (5294700)	1.013	25.73	1.122	28.49				
		13	.095	2.41	1.060	26.92	871 (5012400)	R-28 (5295000)	872 (5012500)	R-28-A (5295100)	1.041	26.44	1.150	29.21	M-17 (2516600) *			
		14	.083	2.10	1.084	27.53	873 (5012600)	R-29 (5295400)	874 (5012700)	R-29-A (5295500)	1.060	26.92	1.169	29.69				
		15	.072	1.82	1.106	28.09	875 (5012800)	R-30 (5295800)	876 (5012900)	R-30-A (5295900)	1.087	27.60	1.196	30.37				
		16	.065	1.65	1.120	28.44	879 (5013200)	R-30 (5295800)	880 (5013300)	R-30-A (5295900)	1.115	28.32	1.224	31.08				
17	.058	1.47	1.134	28.80														
18	.049	1.24	1.152	29.26														

\* 1/2 in. Sq. Dr. (12.7 mm)

# Condenser Expanders

Selection Guide G-800 Series Heat Exchanger & Condenser Tube Expanders – continued

Tube O.D.		Tube Gauge			Tube I.D.		Tube Sheet Thickness				Min. I.D. Tool Enters		Max. Expan. of Tool		Mandrel Number (Order No.) 1/2 in. Sq. Dr. (12.7 mm)	Recommended Rolling Motors (Order No.)	
							1/2 in. to 1-1/2 in. (12.7 mm to 38.1 mm)		1-1/4 in. to 2-1/4 in. (31.7 mm to 57.1 mm)							Airetrol	Electric
in.	mm	bwg	in.	mm	in.	mm	Tool No. (Order No.)	Roll Set No. (Order No.)	Tool No. (Order No.)	Roll Set No. (Order No.)	in.	mm	in.	mm			
1-3/8	34.9	8	.165	4.19	1.045	26.54	877 (5013000)	R-31 (5296200)	878 (5013100)	R-31-A (5296300)	1.026	26.06	1.135	28.82	M-17 (2516600)	1550-250 (8404280)	979-C-210/ ATC-900
		9	.148	3.75	1.079	27.40	873 (5012600)	R-29 (5295400)	874 (5012700)	R-29-A (5295500)	1.060	26.92	1.169	29.69			
		10	.134	3.40	1.107	28.11	875 (5012800)	R-30 (5295800)	876 (5012900)	R-30-A (5295900)	1.087	27.60	1.196	30.37			
		11	.120	3.04	1.135	28.82	879 (5013200)		880 (5013300)		1.115	28.32	1.224	31.08	M-18 (2516900)		
		12	.109	2.76	1.157	29.38	881 (5013400)	R-32 (5296600)	882 (5013500)	R-32-A (5296700)	1.133	28.77	1.242	31.54	M-19 (2517200)	1550-900 (8404290)	979-C-300/ ATC-900
		13	.095	2.41	1.185	30.09	883 (5013600)	R-33 (5297000)	884 (5013700)	R-33-A (5297100)	1.160	29.46	1.275	32.38			
		14	.083	2.10	1.209	30.70	885 (5013800)	R-34 (5297400)	886 (5013900)	R-34-A (5297500)	1.179	29.94	1.294	32.86			
		15	.072	1.82	1.231	31.26											
		16	.065	1.65	1.245	31.62	887 (5014000)	R-35 (5297800)	888 (5014100)	R-35-A (5297900)	1.206	30.63	1.321	33.55	M-20 (2517500)		
1-1/2	38.1	8	.165	4.19	1.170	29.71	889 (5014200)	R-34 (5297400)	890 (5014300)	R-34-A (5297500)	1.145	29.08	1.260	32.00	M-19 (2517200)	1550-250 (8404280)	979-C-210/ ATC-900
		9	.148	3.75	1.204	30.58	885 (5013800)		886 (5013900)		1.177	29.89	1.294	32.86			
		10	.134	3.40	1.232	31.29	887 (5014000)	R-35 (5297800)	888 (5014100)	R-35-A (5297900)	1.206	30.63	1.321	33.55	M-20 (2517500)		
		11	.120	3.04	1.260	32.00	891 (5014400)	R-36 (5298200)	892 (5014500)	R-36-A (5298300)	1.235	31.36	1.350	34.29			
		12	.109	2.76	1.282	32.56	893 (5014600)	R-37 (5298600)	894 (5014700)	R-37-A (5298700)	1.257	31.92	1.372	34.84	M-21 (2517800)	1550-900 (8404290)	979-C-300/ ATC-900
		13	.095	2.41	1.310	33.27	895 (5014800)	R-37 (5298600)	896 (5014900)	R-37-A (5298700)	1.285	32.63	1.400	35.56			
		14	.083	2.10	1.334	33.88											
		15	.072	1.82	1.356	34.44	897 (5015000)	R-38 (5299000)	898 (5015100)	R-38-A (5299100)	1.331	33.80	1.446	36.72			
		16	.065	1.65	1.370	34.79											
		17	.058	1.47	1.384	35.15	899 (5015120)	R-38 (5299000)	900 (5015150)	R-38-A (5299100)	1.331	33.80	1.472	37.38	M-22 (2518100)		
		18	.049	1.24	1.402	35.61											
19	.042	1.06	1.416	35.96													
20	.035	0.88	1.430	36.32													



## G-800 Series – 5-Roll Expanders

**O.D Range:**  
**5/8 – 1-1/2 Inches**  
**15.8 – 38.1 mm**

- Expanders with 1-1/2 in. (38.1 mm) long rolls will accommodate tube sheets from 1/2 in. to 1-1/2 in. (12.7mm to 38.1 mm)
- Expanders with 2-1/4 in. (57.1 mm) long rolls will accommodate tube sheets from 1-1/4 in. to 2-1/4 in. (31.7mm to 57.1 mm)
- **Reversible Thrust Collar** design allows flush and 1/8 in. recess tube rolling. Collars have lubrication port for use with auto-lube configured ATR and DAS tube rolling systems. 20 BWG .035" (0.9 mm).

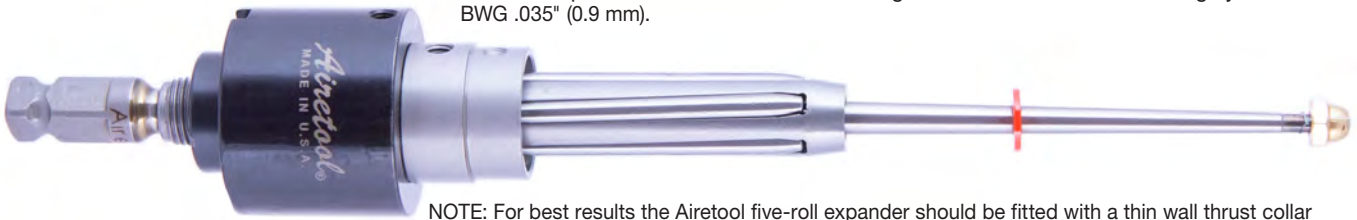

NOTE: For best results the Airetool five-roll expander should be fitted with a thin wall thrust collar when being used to roll tubing with 20 BWG .035" (0.9 mm).

Sizes not listed available upon request.

Tube O.D.		Tube Gauge		Tube I.D.		Tube Sheet Thickness				Min. I.D. Tool Enters		Max. Expan. of Tool		Mandrel Number (Order No.) 3/8 in. Sq. Dr. (9.5 mm)	Recommended Rolling Motors (Order No.)			
						1/2 in. to 1-1/2 in. (12.7 mm to 38.1 mm)		1-1/4 in. to 2-1/4 in. (31.7 mm to 57.1 mm)							Airetool	Electric		
in.	mm	bwg	in.	mm	in.	mm	Tool No. (Order No.)	Roll Set No. (Order No.)	Tool No. (Order No.)	Roll Set No. (Order No.)	in.	mm	in.	mm				
5/8	15.8	17	.058	1.47	.509	12.92	815-5 (5517135)	R-4-5 (5513832)	816-5 (5519516)	R-4-A-5 (5517897PT)	.499	12.67	.564	14.32	M-9 (2514200)	850-1250-A (8405399)		
		18	.049	1.24	.527	13.38	817-5 (5514294)		818-5 (5521051)		.517	13.13	.576	14.63				
		19	.042	1.06	.541	13.74												
		20	.035	0.88	.555	14.09												
		21	.032	0.81	.561	14.24												
		22	.028	0.71	.569	14.45												
3/4	19.0	13	.095	2.41	.560	14.22	821-5 (5513230)	R-5-5 (5513231)	822-5 (5514482)	R-5-A-5 (5518189)	.550	13.97	.615	15.62	M-11 (2514800)	850-600-A (8405398)	979-C-650/ ATC-900	
		14	.083	2.10	.584	14.83	823-5 (5515375)	R-6-5 (5518187)	824-5 (5514171)	R-6-A-5 (5517898)	.574	14.57	.629	15.97	M-12 (2515100)			
		15	.072	1.82	.606	15.39	825-5 (5522104)	R-7-5 (5514393)	826-5 (5518376)	R-7-A-5 (5517899)	.590	14.98	.661	16.78	M-13 (2515400)			
		16	.065	1.65	.620	15.74	827-5 (5513799)		828-5 (5513542)		.605	15.36	.680	17.27				
		17	.058	1.47	.634	16.10												
		18	.049	1.24	.652	16.56												
		19	.042	1.06	.666	16.91												
		20	.035	0.88	.680	17.27												
		21	.032	0.81	.685	17.39												
		22	.028	0.71	.694	17.62												
7/8	22.2	13	.095	2.41	.685	17.39	833-5 (5517076)	R-9-5 (5517888)	834-5 (5514704)	R-9-A-5 (5517900)	.670	17.01	.747	18.97	M-14 (2515700) *	850-600-A (8405398)	979-C-650/ ATC-900	
		14	.083	2.10	.709	18.00	835-5 (5517735)	R-10-5 (5518191)	836-5 (5515680)	R-10-A-5 (5517901)	.685	17.39	.774	19.65	M-15 (2516000) *			
		16	.065	1.65	.745	18.93	839-5 (5518154)	R-11-5 (5517889)	840-5 (5514564)	R-11-A-5 (5517902)	.685	17.39	.750	19.05				
		17	.058	1.47	.759	19.27												
		18	.049	1.24	.777	19.73												

\* 1/2 in. Sq. Dr. (12.7 mm)

# Condenser Expanders

Selection Guide G-800 Type Five-Roll Expanders – continued

Tube O.D.		Tube Gauge		Tube I.D.		Tube Sheet Thickness				Min. I.D. Tool Enters		Max. Expan. of Tool		Mandrel Number (Order No.) 1/2 in. Sq. Dr. (12.7 mm)	Recommended Rolling Motors (Order No.)		
						1/2 in. to 1-1/2 in. (12.7 mm to 38.1 mm)		1-1/4 in. to 2-1/4 in. (31.7 mm to 57.1 mm)							Airetrol	Electric	
in.	mm	bwg	in.	mm	in.	mm	Tool No. (Order No.)	Roll Set No. (Order No.)	Tool No. (Order No.)	Roll Set No. (Order No.)	in.	mm	in.	mm			
7/8	22.2	19	.042	1.06	.791	20.09	845-5 (5513810)	R-11-5 (5517889)	846-5 (5517924)	R-11-A-5 (5517902)	.763	19.38	.851	21.61	M-18 (2516900)	850-1250-A (8405399)	
		20	.035	0.88	.805	20.44											
		21	.032	0.81	.811	20.59											
		22	.028	0.71	.819	20.80											
1	25.4	12	.109	2.76	.782	19.86	845-5 (5513810)	R-11-5 (5517889)	846-5 (5517924)	R-11-A-5 (5517902)	.763	19.38	.852	21.64	M-18 (2516900)	850-600-A (8405398)	979-C-650/ ATC-900
		13	.095	2.41	.810	20.57	847-5 (5513379)	R-13-5 (5513741)	848-5 (5517099)	R-13-A-5 (5517903)	.791	20.09	.880	22.35			
		14	.083	2.10	.834	21.18	849-5 (5514922)	R-12-5 (5517890)	850-5 (5513331)	R-12-A-5 (5515825)	.810	20.57	.909	23.08	M-20 (2517500)		
		15	.072	1.82	.856	21.74	851-5 (5513778)	R-14-5 (5517894)	852-5 (5513330)	R-14-A-5 (5515826)	.837	21.25	.936	23.77			
		16	.065	1.65	.870	22.09											
		17	.058	1.47	.884	22.45	855-5 (5515194)	R-13-5 (5513741)	856-5 (5513745)	R-13-A-5 (5517903)	.865	21.97	.965	24.51	M-21 (2517800)	850-1250-A (8405399)	
		18	.049	1.24	.902	22.91											
		19	.042	1.06	.916	23.26											
		20	.035	0.88	.930	23.62											
		21	.032	0.81	.936	23.77	857-5 (5513825)	R-15-5 (5513833)	858-5 (5515935)	R-15-A-5 (5517907)	.883	22.42	.997	25.32	M-21 (2517800)		
22	.028	0.71	.944	23.97													
1-1/8	28.5	12	.109	2.76	.907	23.03	857-5 (5513825)	R-15-5 (5513833)	858-5 (5515935)	R-15-A-5 (5517907)	.883	22.42	.997	25.32	M-21 (2517800)	1050-400 (8404200)	979-C-300/ ATC-900
		13	.095	2.41	.935	23.74	859-5 (5514397)	R-16-5 (5518056)	860-5 (5513492)	R-16-A-5 (5517904)	.916	23.26	1.000	25.40			
		14	.083	2.10	.959	24.35	861-5 (5513325)	R-17-5 (5517891)	862-5 (5513747)	R-17-A-5 (5517905)	.935	23.74	1.043	26.49			
1-1/4	31.8	15	.072	1.82	1.106	28.09	875-5 (5513884)	R-21-5 (5517887)	876-5 (5519970)	R-21-A-5 (5513291)	1.087	27.60	1.196	30.37	876-5 (2975348)	1050-400 (8404200)	979-C-650/ ATC-900
		16	.065	1.65	1.120	28.44											
		17	.058	1.47	1.134	28.80	879-5 (5513993)	R-21-5 (5517887)	880-5 (5512151)	R-21-A-5 (5513291)	1.115	28.32	1.231	31.26	880-5 (2968789)		
		18	.049	1.24	1.152	29.26											
		19	.042	1.06	1.166	29.61											
		20	.035	0.88	1.180	29.97											
		21	.032	0.81	1.186	30.12											
22	.028	0.71	1.194	30.32													
1-3/8	34.9	12	.109	2.76	1.154	29.31	881-5 (5516001)	R-21-5 (5517887)	882-5 (5514657)	R-21-A-5 (5513291)	1.133	28.77	1.242	31.54	882-5 (2973230)	1550-250 (8404280)	979-C-210/ ATC-900
		14	.083	2.10	1.209	30.70	885-5 (5513252)	R-23-5 (5517892)	886-5 (5515778)	R-23-A-5 (5518192)	1.179	29.94	1.296	32.91			
1-1/2	38.1	17	.058	1.47	1.384	35.15	899-5 (5513850)	R-29-5 (5517893)	900-5 (5517605)	R-29-A-5 (5517906)	1.331	33.80	1.489	37.82	900-5 (2975262)	1550-900 (8404290)	979-C-300/ ATC-900
		18	.049	1.24	1.402	35.61											
		19	.042	1.06	1.416	35.96											
		20	.035	0.88	1.430	36.32											
		21	.032	1	1.436	36.47											
		22	.028	0.71	1.444	36.67											

# Condenser Expanders

Standard Reach G-1200 Series Heat Exchanger & Condenser Tube Expanders



## G-1200 Series – 3-Roll Expander, Standard Reach

**O.D Range:**  
**1/2 – 1-1/2 Inches**  
**12.7 – 38.1 mm**

- Expanders with 1-1/2 in. (38.1 mm) long rolls will accommodate tube sheet thicknesses from 1/2" to 5" (12.7 mm to 127.0 mm)
- Expanders with 2-1/4 in. (57.1 mm) long rolls will accommodate tube sheet thicknesses from 1-1/4" to 5-3/4" (31.7 mm to 146.0 mm)
- Reversible Thrust Collar** design allows flush and 1/8 in. recess tube rolling. Collars have lubrication port for use with auto-lube configured ATR and DAS tube rolling systems.



NOTE: Step expanding becomes necessary if the tube sheet thickness exceeds the length of the roll. Specify "S" Type rolls for step rolling applications.

Sizes not listed available upon request.



Standard Reach						Tube Sheet Thickness				Min. I.D. Tool Enters		Max. Expan. of Tool		Mandrel Number (Order No.) 3/8 in. Sq. Dr. (9.5 mm)	Recommended Rolling Motors (Order No.)			
Tube O.D.		Tube Gauge		Tube I.D.		1/2 in. to 5 in. (12.7 mm to 127.0 mm)		1-1/4 in. to 5-3/4 in. (31.7 mm to 146.0 mm)							Airetrol	Electric		
in.	mm	bwg	in.	mm	in.	mm	Tool No. (Order No.)	Roll Set No. (Order No.)	Tool No. (Order No.)	Roll Set No. (Order No.)	in.	mm	in.	mm				
1/2	12.7	14	.083	2.10	.334	8.48	1197 (5017460)	797 (5512194)			.324	8.22	.374	9.49	1197 (2165300)	720-550-B (8405391)		
		15	.072	1.82	.356	9.04	1199 (5056204)	R-1 (5284800)			.348	8.83	.398	10.10	1199 (2166400)			
		16	.065	1.65	.370	9.39	1201 (5017500)					.360	9.14	.410	10.41		M-51 (2521100)	
		17	.058	1.47	.384	9.75	1203 (5017900)	R-2 (5285000)					.374	9.49	.424	10.76		720-1800-B (8405512)-3/8
		18	.049	1.24	.402	10.21	1205 1/2 (5018300)	R-3 (5285200)					.392	9.95	.447	11.35	M-52 (2522000)	
		20	.035	0.88	.430	10.92	1207 1/2 (5018701)	R-4 (5285400)					.420	10.66	.480	12.19	M-53 (2522900)	
5/8	15.8	12	.109	2.76	.407	10.33	1205 5/8 (5018301)	R-3 (5285200)			.392	9.95	.447	11.35	M-52 (2522000)	850-600-A (8405398)		
		13	.095	2.41	.435	11.04	1207 5/8 (5018700)	R-4 (5285400)			.420	10.66	.480	12.19	M-53 (2522900)			
		14	.083	2.10	.459	11.65	1209 (5019100)		1210 (5019500)	R-4-A (5285500)	.449	11.40	.509	12.92	M-54 (2523800)			
		15	.072	1.82	.481	12.21	1211 5/8 (5019900)	R-5 (5285800)	1212 5/8 (5020300)	R-5-A (5285900)	.471	11.96	.536	13.61	M-55 (2524700)	850-1250-A (8405399)		
		16	.065	1.65	.495	12.57	1213 (5020700)	R-6 (5286200)	1214 (5021100)	R-6-A (5286300)	.485	12.31	.550	13.97				
		17	.058	1.47	.509	12.92	1215 5/8 (5021500)		1216 5/8 (5021900)		.499	12.67	.564	14.32	M-56 (2525600)			
		18	.049	1.24	.527	13.38	1217 5/8 (5022300)	R-7 (5286600)	1218 5/8 (5022700)	R-7-A (5286700)	.517	13.13	.582	14.78				
		19	.042	1.06	.541	13.74												
		20	.035	0.88	.555	14.09										M-58 (2527400)		
		21	.032	0.81	.561	14.24	1219 (5023100)	R-7 (5286600)	1220 (5023500)	R-7-A (5286700)	.531	13.48	.596	15.13				
22	.028	0.71	.569	14.45														

# Condenser Expanders

Standard Reach G-1200 Series Heat Exchanger & Condensor Tube Expanders – continued

Standard Reach						Tube Sheet Thickness				Min. I.D. Tool Enters		Max. Expan. of Tool		Mandrel Number (Order No.) 3/8 in. Sq. Dr. (9.5 mm)	Recommended Rolling Motors (Order No.)		
Tube O.D.		Tube Gauge		Tube I.D.		1/2 in. to 5 in. (12.7 mm to 127.0 mm)		1-1/4 in. to 5-3/4 in. (31.7 mm to 146.0 mm)							Airetrol	Electric	
in.	mm	bwg	in.	mm	in.	mm	Tool No. (Order No.)	Roll Set No. (Order No.)	Tool No. (Order No.)	Roll Set No. (Order No.)	in.	mm	in.	mm			
3/4	19.0	10	.134	3.40	.482	12.24	1211 3/4 (5019901)	R-5 (5285800)	1212 3/4 (5020301)	R-5-A (5285900)	.471	11.96	.536	13.61	M-55 (2524700)	850-600-A (8405398)	979-C-650/ ATC-900
		11	.120	3.04	.510	12.95	1215 3/4 (5021501)	R-6 (5286200)	1216 3/4 (5513251)	R-6-A (5286300)	.499	12.67	.564	14.32	M-56 (2525600)		
		12	.109	2.76	.532	13.51	1217 3/4 (5022301)	R-7 (5286600)	1218 3/4 (5022701)	R-7-A (5286700)	.517	13.13	.582	14.78	M-58 (2527400)		
		13	.095	2.41	.560	14.22	1221 (5023900)	R-8 (5287000)	1222 (5024300)	R-8-A (5287100)	.550	13.97	.615	15.62			
		14	.083	2.10	.584	14.83	1223 (5024700)	R-9 (5287400)	1224 (5025100)	R-9-A (5287500)	.574	14.57	.639	16.23	M-59 (2528300)		
		15	.072	1.82	.606	15.39	1225 3/4 (5025500)	R-10 (5287800)	1226 3/4 (5025900)	R-10-A (5287900)	.596	15.13	.661	16.78			
		16	.065	1.65	.620	15.74	1227 (5026300)		1228 (5026700)			.605	15.36	.685	17.39	850-1250-A (8405399)	
		17	.058	1.47	.634	16.10	1229 3/4 (5027100)	R-11 (5288200)	1230 3/4 (5027500)	R-11-A (5288300)	.619	15.72	.699	17.75			
		18	.049	1.24	.652	16.56					1231 3/4 (5027900)	R-12 (5288600)	1232 3/4 (5028300)	R-12-A (5288700)	.642		16.30
		19	.042	1.06	.666	16.91											
		20	.035	0.88	.680	17.27											
		21	.032	0.81	.686	17.42											
22	.028	0.71	.694	17.62													
7/8	22.2	10	.134	3.40	.607	15.41	1225 7/8 (5025501)	R-10 (5287800)	1226 7/8 (5025901)	R-10-A (5287900)	.596	15.13	.661	16.78	M-58 (2527400)	850-600-A (8405398)	979-C-650/ ATC-900
		11	.120	3.04	.635	16.12	1229 7/8 (5027101)	R-11 (5288200)	1230 7/8 (5027501)	R-11-A (5288300)	.619	15.72	.699	17.75	M-59 (2528300)		
		12	.109	2.76	.657	16.68	1231 7/8 (5027901)	R-12 (5288600)	1232 7/8 (5028301)	R-12-A (5288700)	.642	16.30	.722	18.33	M-60 (2529200)		
		13	.095	2.41	.685	17.39	1233 (5028700)	R-13 (5289000)	1234 (5029100)	R-13-A (5289100)	.670	17.01	.750	19.05			
		14	.083	2.10	.709	18.00	1235 (5029500)	R-14 (5289400)	1236 (5029900)	R-14-A (5289500)	.685	17.39	.774	19.65	M-61 (2530100)		
		15	.072	1.82	.731	18.56	1237 (5030300)	R-15 (5289800)	1238 (5030700)	R-15-A (5289900)	.712	18.08	.801	20.34	M-62 (2531000)		
		16	.065	1.65	.745	18.92	1239 (5031100)		1240 (5031500)			.726	18.44	.815		20.70	
		17	.058	1.47	.759	19.27	1243 (5032700)	R-16 (5290200)	1244 (5033100)	R-16-A (5290300)	.740	18.79	.829	21.05	850-1250-A (8405399)		
18	.049	1.24	.777	19.73													
1	25.4	8	.165	4.19	.670	17.01	1241 (5031900)	R-13 (5289000)	1242 (5032300)	R-13-A (5289100)	.665	16.89	.735	18.66	M-59 (2528300)	1050-400 (8404200)	979-C-300/ ATC-900
		9	.148	3.75	.704	17.88	1235 (5029500)	R-14 (5289400)	1236 (5029900)	R-14-A (5289500)	.685	17.39	.774	19.65	M-61 (2530100)		
		10	.134	3.40	.732	18.59	1237 (5030300)	R-15 (5289800)	1238 (5030700)	R-15-A (5289900)	.712	18.08	.801	20.34	M-62 (2531000)		
		11	.120	3.04	.760	19.30	1243 (5032700)	R-16 (5290200)	1244 (5033100)	R-16-A (5290300)	.740	18.79	.829	21.05			
		12	.109	2.76	.782	19.86	1245 (5033500)	R-17 (5290600)	1246 (5033900)	R-17-A (5290700)	.763	19.38	.852	21.64	850-600-A (8405398)		
		13	.095	2.41	.810	20.57	1247 (5034300)	R-18 (5291000)	1248 (5034700)	R-18-A (5291100)	.791	20.09	.880	22.35			



# Condenser Expanders

Standard Reach G-1200 Series Heat Exchanger & Condenser Tube Expanders – continued



Standard Reach						Tube Sheet Thickness				Min. I.D. Tool Enters		Max. Expan. of Tool		Mandrel Number (Order No.) 3/8 in. Sq. Dr. (9.5 mm)	Recommended Rolling Motors (Order No.)		
Tube O.D.		Tube Gauge		Tube I.D.		1/2 in. to 5 in. (12.7 mm to 127.0 mm)		1-1/4 in. to 5-3/4 in. (31.7 mm to 146.0 mm)							Airetool	Electric	
in.	mm	bwg	in.	mm	in.	mm	Tool No. (Order No.)	Roll Set No. (Order No.)	Tool No. (Order No.)	Roll Set No. (Order No.)	in.	mm	in.	mm			
1	25.4	14	.083	2.10	.834	21.18	1249 (5035100)	R-18 (5291000)	1250 (5035500)	R-18-A (5291100)	.810	20.57	.909	23.08	M-63 (2531900)	850-600-A (8405398)	979-C-300/ATC-900
		15	.072	1.82	.856	21.74	1251 (5035900)	R-19 (5291400)	1252 (5036300)	R-19-A (5291500)	.837	21.25	.936	23.77			
		16	.065	1.65	.870	22.09											
		17	.058	1.47	.884	22.45	1255 (5037500)	R-21 (5292200)	1256 (5037900)	R-21-A (5292300)	.865	21.97	.964	24.48	M-63 (2531900)	850-1250-A (8405399)	979-C-650/ATC-900
		18	.049	1.24	.902	22.91											
		19	.042	1.06	.916	23.26											
		20	.035	0.88	.930	23.62											
1-1/8	28.5	8	.165	4.19	.795	20.19	1253 (5036700)	R-20 (5291800)	1254 (5037100)	R-20-A (5291900)	.776	19.71	.875	22.22	M-63 (2531900)	979-C-300/ATC-900	
		9	.148	3.75	.829	21.05	1249 (5035100)	R-18 (5291000)	1250 (5035500)	R-18-A (5291100)	.810	20.57	.909	23.08			
		10	.134	3.40	.857	21.76	1251 (5035900)	R-19 (5291400)	1252 (5036300)	R-19-A (5291500)	.837	21.25	.936	23.77			
		11	.120	3.04	.885	22.47	1255 (5037500)	R-21 (5292200)	1256 (5037900)	R-21-A (5292300)	.865	21.97	.964	24.48			
		12	.109	2.76	.907	23.03	1257 (5038300)		1258 (5038700)		.883	22.42	.982	24.94	M-64 (2532800) *	1050-400 (8404200)	
		13	.095	2.41	.935	23.74	1259 (5039100)	R-22 (5292600)	1260 (5039500)	R-22-A (5292700)	.916	23.26	1.015	25.78			
		14	.083	2.10	.959	24.35	1261 (5039900)	R-23 (5293000)	1262 (5040300)	R-23-A (5293100)	.935	23.74	1.044	26.51	M-65 (2533700) *	979-C-650/ATC-900	
		15	.072	1.82	.981	24.91	1263 (5040700)	R-24 (5293400)	1264 (5041100)	R-24-A (5293500)	.962	24.43	1.071	27.20			
		16	.065	1.65	.995	25.27	1267 (5042300)	R-26 (5294200)	1268 (5042700)	R-26-A (5294300)	.990	25.14	1.099	27.91	M-66 (2534600) *	979-C-300/ATC-900	
		17	.058	1.47	1.009	25.62											
18	.049	1.24	1.028	26.11													
1-1/4	31.7	8	.165	4.19	.920	23.36	1265 (5041500)	R-25 (5293800)	1266 (5041900)	R-25-A (5293900)	.901	22.88	1.010	25.65	M-65 (2533700) *	1550-250 (8404280)	979-C-300/ATC-900
		9	.148	3.75	.954	24.23	1261 (5039900)	R-23 (5293000)	1262 (5040300)	R-23-A (5293100)	.935	23.74	1.044	26.51			
		10	.134	3.40	.982	24.94	1263 (5040700)	R-24 (5293400)	1264 (5041100)	R-24-A (5293500)	.962	24.43	1.071	27.20			
		11	.120	3.04	1.010	25.65	1267 (5042300)	R-26 (5294200)	1268 (5042700)	R-26-A (5294300)	.990	25.14	1.099	27.91	M-66 (2534600) *	979-C-300/ATC-900	
		12	.109	2.76	1.032	26.21	1269 (5043100)	R-27 (5294600)	1270 (5043500)	R-27-A (5294700)	1.013	25.73	1.122	28.49			
		13	.095	2.41	1.060	26.92	1271 (5043900)	R-28 (5295000)	1272 (5044300)	R-28-A (5295100)	1.041	26.44	1.150	29.21	M-67 (2535500) *	1050-400 (8404200)	979-C-650/ATC-900
		14	.083	2.10	1.084	27.53	1273 (5044700)	R-29 (5295400)	1274 (5045100)	R-29-A (5295500)	1.060	26.92	1.169	29.69			
		15	.072	1.82	1.106	28.09	1275 (5045500)	R-30 (5295800)	1276 (5045900)	R-30-A (5295900)	1.087	27.60	1.196	30.37			
		16	.065	1.65	1.120	28.44											
		17	.058	1.47	1.134	28.80	1279 (5047100)	R-30 (5295800)	1280 (5047500)	R-30-A (5295900)	1.115	28.32	1.224	31.08	M-68 (2536400) *	979-C-650/ATC-900	
18	.049	1.24	1.152	29.26													

\* 1/2 in. Sq. Dr. (12.7 mm)

# Condenser Expanders

Standard Reach G-1200 Series Heat Exchanger & Condenser Tube Expanders – continued

Standard Reach						Tube Sheet Thickness				Min. I.D. Tool Enters		Max. Expan. of Tool		Mandrel Number (Order No.) 1/2 in. Sq. Dr. (12.7 mm)	Recommended Rolling Motors (Order No.)		
Tube O.D.		Tube Gauge		Tube I.D.		1/2 in. to 5 in. (12.7 mm to 127.0 mm)		1-1/4 in. to 5-3/4 in. (31.7 mm to 146.0 mm)							Airetrol	Electric	
in.	mm	bwg	in.	mm	in.	mm	Tool No. (Order No.)	Roll Set No. (Order No.)	Tool No. (Order No.)	Roll Set No. (Order No.)	in.	mm	in.	mm			
1-3/8	34.9	8	.165	4.19	1.045	26.54	1277 (5046300)	R-31 (5296200)	1278 (5046700)	R-31-A (5295900)	1.026	26.04	1.135	28.82	M-67 (2535500)	1550-250 (8404280)	979-C-210/ ATC-900
		9	.148	3.75	1.079	27.40	1273 (5044700)	R-29 (5295400)	1274 (5045100)	R-29-A (5295500)	1.060	26.92	1.169	29.69			
		10	.134	3.40	1.107	28.11	1275 (5045500)	R-30 (5295800)	1276 (5045900)	R-30-A (5295900)	1.087	27.60	1.196	30.37			
		11	.120	3.04	1.135	28.82	1279 (5047100)		1280 (5047500)		1.115	28.32	1.224	31.08	M-68 (2536400)		
		12	.109	2.76	1.157	29.38	1281 (5047900)	R-32 (5295800)	1282 (5048300)	R-32-A (5296700)	1.133	28.77	1.242	31.54			
		13	.095	2.41	1.185	30.09	1283 (5048700)	R-32 (5295800)	1284 (5049100)	R-32-A (5296700)	1.160	29.46	1.275	32.38	M-70 (2538200)	1550-900 (8404290)	979-C-300/ ATC-900
		14	.083	2.10	1.209	30.70	1285 (5049500)	R-34 (5297400)	1286 (5049900)	R-34-A (5297500)	1.179	29.94	1.294	32.86			
		15	.072	1.82	1.231	31.26	1287 (5050300)	R-35 (5297800)	1288 (5050700)	R-35-A (5297900)	1.206	30.63	1.321	33.55			
		16	.065	1.65	1.245	31.62											
1-1/2	38.1	8	.165	4.19	1.170	29.71	1289 (5051100)	R-34 (5297400)	1290 (5051500)	R-34-A (5297500)	1.145	29.08	1.260	32.00	M-69 (2537300)	1550-250 (8404280)	979-C-210/ ATC-900
		9	.148	3.75	1.204	30.58	1285 (5049500)	R-34 (5297400)	1286 (5049900)	R-34-A (5297500)	1.179	29.94	1.294	32.86	M-70 (2538200)		
		10	.134	3.40	1.232	31.29	1287 (5050300)	R-35 (5297800)	1288 (5050700)	R-35-A (5297900)	1.206	30.63	1.321	33.55			
		11	.120	3.04	1.260	32.00	1291 (5051900)	R-36 (5298200)	1292 (5052300)	R-36-A (5298300)	1.235	31.36	1.350	34.29			
		12	.109	2.76	1.282	32.56	1293 (5052700)	R-37 (5298600)	1294 (5053100)	R-37-A (5298700)	1.257	31.92	1.372	34.84			
		13	.095	2.41	1.310	33.27	1295 (5053500)	R-37 (5298600)	1296 (5053900)	R-37-A (5298700)	1.285	32.63	1.400	35.56	M-71 (2539100)	1550-900 (8404290)	979-C-300/ ATC-900
		14	.083	2.10	1.334	33.88											
		15	.072	1.82	1.356	34.44	1297 (5054300)	R-38 (5299000)	1298 (5054700)	R-38-A (5299100)	1.331	33.80	1.446	36.72			
		16	.065	1.65	1.370	34.79											
		17	.058	1.47	1.384	35.15	1299 (5512167)	R-38 (5299000)	1300 (5055075)	R-38-A (5299100)	1.331	33.80	1.472	37.38	M-72 (2539920)		
		18	.049	1.24	1.402	35.61											
		19	.042	1.06	1.416	35.96											
20	.035	0.88	1.430	36.32													

# Condenser Expanders

"A" Reach G-1200 Series Heat Exchanger & Condenser Tube Expanders



## G-1200 Series – 3-Roll Expander, "A" Reach

**O.D Range:**  
1/2 – 1-1/2 Inches  
12.7 – 38.1 mm

- Expanders with 1-1/2 in. (38.1 mm) long rolls will accommodate tube sheet thicknesses from 1-1/4" to 7-3/4" (31.7 mm to 196.8 mm)
- Expanders with 2-1/4 in. (57.1 mm) long rolls will accommodate tube sheet thicknesses from 2" to 8-1/2" (50.8 mm to 215.9 mm)
- **Reversible Thrust Collar** design allows flush and 1/8 in. recess tube rolling



NOTE: Step expanding becomes necessary if the tube sheet thickness exceeds the length of the roll. Specify "S" Type rolls for step rolling applications.

Sizes not listed available upon request.

Tube O.D.		Tube Gauge		Tube I.D.		Tube Sheet Thickness				Min. I.D. Tool Enters		Max. Expan. of Tool		Mandrel Number (Order No.) 3/8 in. Sq. Dr. (9.5 mm)	Recommended Rolling Motors (Order No.)	
						1-1/4 in. to 7-3/4 in. (31.7 mm to 196.8 mm)		2 in. to 8-1/2 in. (50.8 mm to 215.9 mm)							Airetrol	Electric
in.	mm	bwg	in.	mm	in.	mm	Tool No. (Order No.)	Roll Set No. (Order No.)	Tool No. (Order No.)	Roll Set No. (Order No.)	in.	mm	in.	mm		
1/2	12.7	14	.083	2.10	.334	8.48	1197 A (5514943)	797 (5512194)			.324	8.22	.374	9.49	1197-A (2165900)	720-550-B (8405391)
		15	.072	1.82	.356	9.04	1199 A (5515077)	R-1 (5284800)			.348	8.83	.398	10.10	1199 A (2972749)	
		16	.065	1.65	.370	9.39	1201 A (5017600)				.360	9.14	.410	10.41	M-51-A (2521200)	
		17	.058	1.47	.384	9.75	1203 A (5018000)	R-2 (5285000)			.374	9.49	.424	10.76		720-1800-B (8405512)-3/8
		18	.049	1.24	.402	10.21	1205 A (5018400)	R-3 (5285200)			.392	9.95	.447	11.35	M-52-A (2522100)	
		20	.035	0.88	.430	10.92	1207 A (5018800)	R-4 (5285400)			.420	10.66	.480	12.19	M-53-A (2523000)	
5/8	15.8	12	.109	2.76	.407	10.33	1205 A (5018400)	R-3 (5285200)			.392	9.95	.447	11.35	M-52-A (2522100)	850-600-A (8405398)
		13	.095	2.41	.435	11.04	1207 A (5018800)	R-4 (5285400)			.420	10.66	.480	12.19	M-53-A (2523000)	
		14	.083	2.10	.459	11.65	1209 A (5019200)		1210 A (5019600)	R-4-A (5285500)	.449	11.40	.509	12.92	M-54-A (2523900)	
		15	.072	1.82	.481	12.21	1211 A (5020000)	R-5 (5285800)	1212 A (5020400)	R-5-A (5285900)	.471	11.96	.536	13.61	M-55-A (2524800)	850-1250-A (8405399)
		16	.065	1.65	.495	12.57	1213 A (5020800)	R-6 (5286200)	1214 A (5021200)	R-6-A (5286300)	.485	12.31	.550	13.97		
		17	.058	1.47	.509	12.92	1215 A (5021600)		1216 A (5022000)		.499	12.67	.564	14.32	M-56-A (2525700)	
		18	.049	1.24	.527	13.38	1217 A (5022400)	R-7 (5286600)	1218 A (5022800)	R-7-A (5286700)	.517	13.13	.582	14.78		
		19	.042	1.06	.541	13.74										
		20	.035	0.88	.555	14.09										
		21	.032	0.81	.561	14.24										
22	.028	0.71	.569	14.45	1219 A (5023200)	R-7 (5286600)	1220 A (5023600)	R-7-A (5286700)	.531	13.48	.596	15.13	M-58-A (2527500)			

# Condenser Expanders

"A" Reach G-1200 Series Heat Exchanger & Condensor Tube Expanders – continued

"A" Reach						Tube Sheet Thickness				Min. I.D. Tool Enters		Max. Expan. of Tool		Mandrel Number (Order No.) 3/8 in. Sq. Dr. (9.5 mm)	Recommended Rolling Motors (Order No.)		
Tube O.D.		Tube Gauge		Tube I.D.		1-1/4 in. to 7-3/4 in. (31.7 mm to 196.8 mm)		2 in. to 8-1/2 in. (50.8 mm to 215.9 mm)							Airetrol	Electric	
in.	mm	bwg	in.	mm	in.	mm	Tool No. (Order No.)	Roll Set No. (Order No.)	Tool No. (Order No.)	Roll Set No. (Order No.)	in.	mm	in.	mm			
3/4	19.0	10	.134	3.40	.482	12.24	1211 A (5020000)	R-5 (5285800)	1212 A (5020400)	R-5-A (5285900)	.471	11.96	.536	13.61	M-55-A (2524800)	850-600-A (8405398)	979-C-650/ ATC-900
		11	.120	3.04	.510	12.95	1215 A (5021600)	R-6 (5286200)	1216 A (5022000)	R-6-A (5286300)	.499	12.67	.564	14.32	M-56-A (2525700)		
		12	.109	2.76	.532	13.51	1217 A (5022400)	R-7 (5286600)	1218 A (5022800)	R-7-A (5286700)	.517	13.13	.582	14.78	M-58-A (2527500)		
		13	.095	2.41	.560	14.22	1221 A (5024000)	R-8 (5287000)	1222 A (5024400)	R-8-A (5287100)	.550	13.97	.615	15.62			
		14	.083	2.10	.584	14.83	1223 A (5024800)	R-9 (5287400)	1224 A (5025200)	R-9-A (5287500)	.574	14.57	.639	16.23			
		15	.072	1.82	.606	15.39	1225 A (5025600)	R-10 (5287800)	1226 A (5026000)	R-10-A (5287900)	.596	15.13	.661	16.78			
		16	.065	1.65	.620	15.74	1227 A (5026400)		1228 A (5026801)		.605	15.36	.685	17.39			
		17	.058	1.47	.634	16.10	1229 A (5027100)	R-11 (5288200)	1230 A (5027600)	R-11-A (5288300)	.619	15.72	.699	17.75	M-59-A (2528400)	850-1250-A (8405399)	
		18	.049	1.24	.652	16.56											
		19	.042	1.06	.666	16.91											
		20	.035	0.88	.680	17.27											
		21	.032	0.81	.686	17.42											
22	.028	0.71	.694	17.62	1231 A (5028000)	R-12 (5288600)					1232 A (5028400)	R-12-A (5288700)	.642	16.30	.722	18.33	
7/8	22.2	10	.134	3.40	.607	15.41	1225 A (5025600)	R-10 (5287800)	1226 A (5026000)	R-10-A (5287900)	.596	15.13	.661	16.78	M-58-A (2527500)	850-600-A (8405398)	979-C-650/ ATC-900
		11	.120	3.04	.635	16.12	1229 A (5027200)	R-11 (5288200)	1230 A (5027600)	R-11-A (5288300)	.619	15.72	.699	17.75	M-59-A (2528400)		
		12	.109	2.76	.657	16.68	1231 A (5028000)	R-12 (5288600)	1232 A (5028400)	R-12-A (5288700)	.642	16.30	.722	18.33			
		13	.095	2.41	.685	17.39	1233 A (5028800)	R-13 (5289000)	1234 A (5029200)	R-13-A (5289100)	.670	17.01	.750	19.05	M-60-A (2529300)		
		14	.083	2.10	.709	18.00	1235 A (5029600)	R-14 (5289400)	1236 A (5030000)	R-14-A (5289500)	.685	17.39	.774	19.65	M-61-A (2530200)		
		15	.072	1.82	.731	18.56	1237 A (5030400)	R-15 (5289800)	1238 A (5030800)	R-15-A (5289900)	.712	18.08	.801	20.34			
		16	.065	1.65	.745	18.92	1239 A (5031200)		1240 A (5031600)		.726	18.44	.815	20.70	M-62-A (2531100)		
		17	.058	1.47	.759	19.27	1243 A (5032800)	R-16 (5290200)	1244 A (5033200)	R-16-A (5290300)	.740	18.79	.829	21.05			
18	.049	1.24	.777	19.73													
1	25.4	8	.165	4.19	.670	17.01	1241 A (5032000)	R-13 (5289000)	1242 A (5032400)	R-13-A (5289100)	.665	16.89	.735	18.66	M-59-A (2528400)	1050-400 (8404200)	979-C-300/ ATC-900
		9	.148	3.75	.704	17.88	1235 A (5029600)	R-14 (5289400)	1236 A (5030000)	R-14-A (5289500)	.685	17.39	.774	19.65	M-61-A (2530200)		
		10	.134	3.40	.732	18.59	1237 A (5030400)	R-15 (5289800)	1238 A (5030800)	R-15-A (5289900)	.712	18.08	.801	20.34			
		11	.120	3.04	.760	19.30	1243 A (5032800)	R-16 (5290200)	1244 A (5033200)	R-16-A (5290300)	.740	18.79	.829	21.05	M-62-A (2531100)		
		12	.109	2.76	.782	19.86	1245 A (5033600)	R-17 (5290600)	1246 A (5034000)	R-17-A (5290700)	.763	19.38	.852	21.64			
		13	.095	2.41	.810	20.57	1247 A (5034400)	R-18 (5291000)	1248 A (5034800)	R-18-A (5291100)	.791	20.09	.880	22.35			



# Condenser Expanders

"A" Reach G-1200 Series Heat Exchanger & Condenser Tube Expanders – continued



"A" Reach						Tube Sheet Thickness				Min. I.D. Tool Enters		Max. Expan. of Tool		Mandrel Number (Order No.) 3/8 in. Sq. Dr. (9.5 mm)	Recommended Rolling Motors (Order No.)		
Tube O.D.		Tube Gauge		Tube I.D.		1-1/4 in. to 7-3/4 in. (31.7 mm to 196.8 mm)		2 in. to 8-1/2 in. (50.8 mm to 215.9 mm)		in.	mm	in.	mm		Airetrol	Electric	
in.	mm	bwg	in.	mm	in.	mm	Tool No. (Order No.)	Roll Set No. (Order No.)	Tool No. (Order No.)	Roll Set No. (Order No.)							
1	25.4	14	.083	2.10	.834	21.18	1249 A (5035200)	R-18 (5291000)	1250 A (5035600)	R-18-A (5291100)	.810	20.57	.909	23.08	M-63-A (2532000)	850-600-A (8405398)	979-C-300/ ATC-900
		15	.072	1.82	.856	21.74	1251 A (5036000)	R-19 (5291400)	1252 A (5036400)	R-19-A (5291500)	.837	21.25	.936	23.77			
		16	.065	1.65	.870	22.09											
		17	.058	1.47	.884	22.45	1255 A (5037600)	R-21 (5292200)	1256 A (5038000)	R-21-A (5292300)	.865	21.97	.964	24.48	M-63-A (2532000)	850-1250-A (8405399)	979-C-650/ ATC-900
		18	.049	1.24	.902	22.91											
		19	.042	1.06	.916	23.26											
		20	.035	0.88	.930	23.62											
1-1/8	28.5	8	.165	4.19	.795	20.19	1253 A (5036800)	R-20 (5291800)	1254 A (5037200)	R-20-A (5291900)	.776	19.71	.875	22.22	M-63-A (2532000)	1050-400 (8404200)	979-C-300/ ATC-900
		9	.148	3.75	.829	21.05	1249 A (5035200)	R-18 (5291000)	1250 A (5035600)	R-18-A (5291100)	.810	20.57	.909	23.08			
		10	.134	3.40	.857	21.76	1251 A (5036000)	R-19 (5291400)	1252 A (5036400)	R-19-A (5291500)	.837	21.25	.936	23.77			
		11	.120	3.04	.885	22.47	1255 A (5037600)	R-21 (5292200)	1256 A (5038000)	R-21-A (5292300)	.865	21.97	.964	24.48			
		12	.109	2.76	.907	23.03	1257 A (5038300)		1258 A (5038800)		.883	22.42	.982	24.94			
		13	.095	2.41	.935	23.74	1259 A (5039200)	R-22 (5292600)	1260 A (5039600)	R-22-A (5292700)	.916	23.26	1.015	25.78	M-64-A (2532900PT) *	979-C-650/ ATC-900	
		14	.083	2.10	.959	24.35	1261 A (5040000)	R-23 (5293000)	1262 A (5040400)	R-23-A (5293100)	.935	23.74	1.044	26.51	M-65-A (2533800) *		
		15	.072	1.82	.981	24.91	1263 A (5040800)	R-24 (5293400)	1264 A (5041200)	R-24-A (5293500)	.962	24.43	1.071	27.20			
		16	.065	1.65	.995	25.27											
		17	.058	1.47	1.009	25.62	1267 A (5042400)	R-26 (5294200)	1268 A (5042800)	R-26-A (5294300)	.990	25.14	1.099	27.91	M-66-A (2534700) *		
18	.049	1.24	1.028	26.11													
1-1/4	31.7	8	.165	4.19	.920	23.36	1265 A (5041600)	R-25 (5293800)	1266 A (5042000)	R-25-A (5293900)	.901	22.88	1.010	25.65	M-65-A (2533800) *	1550-250 (8404280)	979-C-300/ ATC-900
		9	.148	3.75	.954	24.23	1261 A (5040000)	R-23 (5293000)	1262 A (5040400)	R-23-A (5293100)	.935	23.74	1.044	26.51			
		10	.134	3.40	.982	24.94	1263 A (5040800)	R-24 (5293400)	1264 A (5041200)	R-24-A (5293500)	.962	24.43	1.071	27.20			
		11	.120	3.04	1.010	25.65	1267 A (5042400)	R-26 (5294200)	1268 A (5042800)	R-26-A (5294300)	.990	25.14	1.099	27.91	M-66-A (2534700) *		
		12	.109	2.76	1.032	26.21	1269 A (5043200)	R-27 (5294600)	1270 A (5043600)	R-27-A (5294700)	1.013	25.73	1.122	28.49			
		13	.095	2.41	1.060	26.92	1271 A (5044000)	R-28 (5295000)	1272 A (5044400)	R-28-A (5295100)	1.041	26.44	1.150	29.21	M-67-A (2535600) *	1050-400 (8404200)	979-C-650/ ATC-900
		14	.083	2.10	1.084	27.53	1273 A (5044800)	R-29 (5295400)	1274 A (5045200)	R-29-A (5295500)	1.060	26.92	1.169	29.69			
		15	.072	1.82	1.106	28.09	1275 A (5045600)	R-30 (5295800)	1276 A (5046000)	R-30-A (5295900)	1.087	27.60	1.196	30.37			
		16	.065	1.65	1.120	28.44											
		17	.058	1.47	1.134	28.80	1279 A (5047200)	R-30 (5295800)	1280 A (5047600)	R-30-A (5295900)	1.115	28.32	1.224	31.08	M-68-A (2536500) *		
18	.049	1.24	1.152	29.26													

\* 1/2 in. Sq. Dr. (12.7 mm)

# Condenser Expanders

"A" Reach G-1200 Series Heat Exchanger & Condenser Tube Expanders – continued

"A" Reach							Tube Sheet Thickness				Min. I.D. Tool Enters		Max. Expan. of Tool		Mandrel Number (Order No.) 1/2 in. Sq. Dr. (12.7 mm)	Recommended Rolling Motors (Order No.)	
Tube O.D.		Tube Gauge		Tube I.D.			1-1/4 in. to 7-3/4 in. (31.7 mm to 196.8 mm)		2 in. to 8-1/2 in. (50.8 mm to 215.9 mm)							Airetrol	Electric
in.	mm	bwg	in.	mm	in.	mm	Tool No. (Order No.)	Roll Set No. (Order No.)	Tool No. (Order No.)	Roll Set No. (Order No.)	in.	mm	in.	mm			
1-3/8	34.9	8	.165	4.19	1.045	26.54	1277 A (5046400)	R-31 (5296200)	1278 A (5046800)	R-31-A (5295900)	1.026	26.04	1.135	28.82	M-67-A (2535600)	1550-250 (8404280)	979-C-210/ ATC-900
		9	.148	3.75	1.079	27.40	1273 A (5044800)	R-29 (5295400)	1274 A (5045200)	R-29-A (5295500)	1.060	26.92	1.169	29.69			
		10	.134	3.40	1.107	28.11	1275 A (5045600)	R-30 (5295800)	1276 A (5046000)	R-30-A (5295900)	1.087	27.60	1.196	30.37			
		11	.120	3.04	1.135	28.82	1279 A (5047200)		1280 A (5047600)		1.115	28.32	1.224	31.08	M-68-A (2536500)		
		12	.109	2.76	1.157	29.38	1281 A (5048000)	R-32 (5295800)	1282 A (5048400)	R-32-A (5296700)	1.133	28.77	1.242	31.54	M-70-A (2538300)	1550-900 (8404290)	979-C-300/ ATC-900
		13	.095	2.41	1.185	30.09	1283 A (5048800)	R-32 (5295800)	1284 A (5049200)	R-32-A (5296700)	1.160	29.46	1.275	32.38			
		14	.083	2.10	1.209	30.70	1285 A (5049600)	R-34 (5297400)	1286 A (5050000)	R-34-A (5297500)	1.179	29.94	1.294	32.86			
		15	.072	1.82	1.231	31.26	1287 A (5050400)	R-35 (5297800)	1288 (5050700)	R-35-A (5297900)	1.206	30.63	1.321	33.55			
		16	.065	1.65	1.245	31.62					1.206	30.63	1.321	33.55			
1-1/2	38.1	8	.165	4.19	1.170	29.71	1289 A (5051200)	R-34 (5297400)	1290 A (5051600)	R-34-A (5297500)	1.145	29.08	1.260	32.00	M-69-A (2537300)	1550-250 (8404280)	979-C-210/ ATC-900
		9	.148	3.75	1.204	30.58	1285 A (5049600)	R-34 (5297400)	1286 A (5050000)	R-34-A (5297500)	1.179	29.94	1.294	32.86	M-70-A (2538300)		
		10	.134	3.40	1.232	31.29	1287 A (5050400)	R-35 (5297800)	1288 A (5050800)	R-35-A (5297900)	1.206	30.63	1.321	33.55			
		11	.120	3.04	1.260	32.00	1291 A (5052000)	R-36 (5298200)	1292 A (5052400)	R-36-A (5298300)	1.235	31.36	1.350	34.29			
		12	.109	2.76	1.282	32.56	1293 A (5052800)	R-37 (5298600)	1294 A (5053200)	R-37-A (5298700)	1.257	31.92	1.372	34.84			
		13	.095	2.41	1.310	33.27	1295 A (5053600)	R-37 (5298600)	1296 A (5054000)	R-37-A (5298700)	1.285	32.63	1.400	35.56		M-71-A (2539200)	
		14	.083	2.10	1.334	33.88					1.285	32.63	1.400	35.56			
		15	.072	1.82	1.356	34.44	1297 A (5054400)	R-38 (5299000)	1298 A (5054800)	R-38-A (5299100)	1.331	33.80	1.446	36.72			
		16	.065	1.65	1.370	34.79					1.331	33.80	1.446	36.72			
		17	.058	1.47	1.384	35.15	1299 A (5515074)	R-38 (5299000)	1300 A (5515089)	R-38-A (5299100)	1.331	33.80	1.472	37.38	M-72-A (2980795)	1550-900 (8404290)	979-C-300/ ATC-900
		18	.049	1.24	1.402	35.61											
		19	.042	1.06	1.416	35.96											
20	.035	0.88	1.430	36.32													

# Condenser Expanders

"C" Reach G-1200 Series Heat Exchanger & Condenser Tube Expanders



## G-1200 Series – 3-Roll Expander, "C" Reach

**O.D Range:**  
**1/2 – 1-1/2 Inches**  
**12.7 – 38.1 mm**

- Expanders with 1-1/2 in. (38.1 mm) long rolls will accommodate tube sheet thicknesses from 1-1/2" to 11-3/4" (38.1 mm to 298.4 mm)
- Expanders with 2-1/4 in. (57.1 mm) long rolls will accommodate tube sheet thicknesses from 2-1/4" to 12-1/2" (57.1 mm to 317.5 mm)
- **Reversible Thrust Collar** design allows flush and 1/8 in. recess tube rolling



NOTE: Step expanding becomes necessary if the tube sheet thickness exceeds the length of the roll. Specify "S" Type rolls for step rolling applications.



Sizes not listed available upon request.

"C" Reach						Tube Sheet Thickness				Min. I.D. Tool Enters		Max. Expan. of Tool		Mandrel Number (Order No.) 3/8 in. Sq. Dr. (9.5 mm)	Recommended Rolling Motors (Order No.)					
Tube O.D.		Tube Gauge		Tube I.D.		1-1/2 in. to 11-3/4 in. (38.1 mm to 298.4 mm)		2-1/4 in. to 12-1/2 in. (57.1 mm to 317.5 mm)		in.	mm	in.	mm		Airetrol	Electric				
in.	mm	bwg	in.	mm	in.	mm	Tool No. (Order No.)	Roll Set No. (Order No.)	Tool No. (Order No.)	Roll Set No. (Order No.)										
1/2	12.7	14	.083	2.10	.334	8.48	1197 C (5515076)	797 (5512194)			.324	8.22	.374	9.49	1197 C (2979579)	720-550-B (8405391)				
		15	.072	1.82	.356	9.04	1199 C (5515079)	R-1 (5284800)			.348	8.83	.398	10.10	1199 C (2978730)					
		16	.065	1.65	.370	9.39	1201 C (5017800)				.360	9.14	.410	10.41	M-51-C (2521600)					
		17	.058	1.47	.384	9.75	1203 C (5018200)	R-2 (5285000)			.374	9.49	.424	10.76			720-1800-B (8405512)-3/8			
		18	.049	1.24	.402	10.21	1205 C (5018600)	R-3 (5285200)			.392	9.95	.447	11.35	M-52-C (2522500)					
		20	.035	0.88	.430	10.92	1207 C (5019000)	R-4 (5285400)			.420	10.66	.480	12.19	M-53-C (2523400)					
5/8	15.8	12	.109	2.76	.407	10.33	1205 C (5018600)	R-3 (5285200)			.392	9.95	.447	11.35	M-52-C (2522500)	850-600-A (8405398)				
		13	.095	2.41	.435	11.04	1207 C (5019000)	R-4 (5285400)			.420	10.66	.480	12.19	M-53-C (2523400)					
		14	.083	2.10	.459	11.65	1209 C (5019400)		1210 C (5019800)	R-4-A (5285500)	.449	11.40	.509	12.92	M-54-C (2524300)					
		15	.072	1.82	.481	12.21	1211 C (5020200)	R-5 (5285800)	1212 C (5020600)	R-5-A (5285900)	.471	11.96	.536	13.61	M-55-C (2525200)					
		16	.065	1.65	.495	12.57	1213 C (5021000)	R-6 (5286200)	1214 C (5021400)	R-6-A (5286300)	.485	12.31	.550	13.97						
		17	.058	1.47	.509	12.92	1215 C (5021800)		1216 5/8 C (5022200)			.499	12.67	.564	14.32	M-56-C (2526100)				
		18	.049	1.24	.527	13.38	1217 C (5022600)	R-7 (5286600)	1218 C (5023000)	R-7-A (5286700)	.517	13.13	.582	14.78			850-1250-A (8405399)			
		19	.042	1.06	.541	13.74	1219 C (5023400)	R-7 (5286600)	1220 C (5023800)	R-7-A (5286700)										
		20	.035	0.88	.555	14.09								.531	13.48	.596		15.13	M-58-C (2527900)	
		21	.032	0.81	.561	14.24														
22	.028	0.71	.569	14.45																

# Condenser Expanders

"C" Reach G-1200 Series Heat Exchanger & Condensor Tube Expanders – continued

"C" Reach						Tube Sheet Thickness				Min. I.D. Tool Enters		Max. Expan. of Tool		Mandrel Number (Order No.) 3/8 in. Sq. Dr. (9.5 mm)	Recommended Rolling Motors (Order No.)			
Tube O.D.		Tube Gauge		Tube I.D.		1-1/2 in. to 11-3/4 in. (38.1 mm to 298.4 mm)		2-1/4 in. to 12-1/2 in. (57.1 mm to 317.5 mm)							Airetrol	Electric		
in.	mm	bwg	in.	mm	in.	mm	Tool No. (Order No.)	Roll Set No. (Order No.)	Tool No. (Order No.)	Roll Set No. (Order No.)	in.	mm	in.	mm				
3/4	19.0	10	.134	3.40	.482	12.24	1211 C (5020200)	R-5 (5285800)	1212 C (5020600)	R-5-A (5285900)	.471	11.96	.536	13.61	M-55-C (2525200)	850-600-A (8405398)	979-C-650/ ATC-900	
		11	.120	3.04	.510	12.95	1215 C (5021800)	R-6 (5286200)	1216 3/4 C (5526691PT)	R-6-A (5286300)	.499	12.67	.564	14.32	M-56-C (2526100)			
		12	.109	2.76	.532	13.51	1217 C (5022600)	R-7 (5286600)	1218 C (5023000)	R-7-A (5286700)	.517	13.13	.582	14.78	M-58-C (2527900)			
		13	.095	2.41	.560	14.22	1221 C (5024200)	R-8 (5287000)	1222 C (5024600)	R-8-A (5287100)	.550	13.97	.615	15.62				
		14	.083	2.10	.584	14.83	1223 C (5025000)	R-9 (5287400)	1224 C (5025400)	R-9-A (5287500)	.574	14.57	.639	16.23				
		15	.072	1.82	.606	15.39	1225 C (5025800)	R-10 (5287800)	1226 C (5026200)	R-10-A (5287900)	.596	15.13	.661	16.78				
		16	.065	1.65	.620	15.74	1227 C (5026600)		1228 C (5027000)		.605	15.36	.685	17.39				
		17	.058	1.47	.634	16.10	1229 C (5027400)	R-11 (5288200)	1230 C (5027800)	R-11-A (5288300)	.619	15.72	.699	17.75	M-59-C (2528800)	850-1250-A (8405399)		
		18	.049	1.24	.652	16.56												
		19	.042	1.06	.666	16.91												
		20	.035	0.88	.680	17.27												
		21	.032	0.81	.686	17.42												
22	.028	0.71	.694	17.62	1231 C (5028200)	R-12 (5288600)					1232 C (5028600)	R-12-A (5288700)	.642	16.30			.722	18.33
7/8	22.2	10	.134	3.40	.607	15.41	1225 C (5025800)	R-10 (5287800)	1226 C (5026200)	R-10-A (5287900)	.596	15.13	.661	16.78	M-58-C (2527900)	850-600-A (8405398)	979-C-650/ ATC-900	
		11	.120	3.04	.635	16.12	1229 C (5027400)	R-11 (5288200)	1230 C (5027800)	R-11-A (5288300)	.619	15.72	.699	17.75	M-59-C (2528800)			
		12	.109	2.76	.657	16.68	1231 C (5028200)	R-12 (5288600)	1232 C (5028600)	R-12-A (5288700)	.642	16.30	.722	18.33				
		13	.095	2.41	.685	17.39	1233 C (5029000)	R-13 (5289000)	1234 C (5029400)	R-13-A (5289100)	.670	17.01	.750	19.05	M-60-C (2529700)			
		14	.083	2.10	.709	18.00	1235 C (5029800)	R-14 (5289400)	1236 C (5030200)	R-14-A (5289500)	.685	17.39	.774	19.65	M-61 (2530600)			
		15	.072	1.82	.731	18.56	1237 C (5030600)	R-15 (5289800)	1238 C (5031000)	R-15-A (5289900)	.712	18.08	.801	20.34				
		16	.065	1.65	.745	18.92	1239 C (5031400)		1240 C (5031800)		.726	18.44	.815	20.70	M-62-C (2531500)			
		17	.058	1.47	.759	19.27	1243 C (5033000)	R-16 (5290200)	1244 C (5033400)	R-16-A (5290300)	.740	18.79	.829	21.05				850-1250-A (8405399)
		18	.049	1.24	.777	19.73												
1	25.4	8	.165	4.19	.670	17.01	1241 C (5032200)	R-13 (5289000)	1242 C (5032600PT)	R-13-A (5289100)	.665	16.89	.735	18.66	M-59-C (2528800)	1050-400 (8404200)	979-C-300/ ATC-900	
		9	.148	3.75	.704	17.88	1235 C (5029800)	R-14 (5289400)	1236 C (5030200)	R-14-A (5289500)	.685	17.39	.774	19.65	M-61-C (2530600)			
		10	.134	3.40	.732	18.59	1237 C (5030600)	R-15 (5289800)	1238 C (5031000)	R-15-A (5289900)	.712	18.08	.801	20.34				
		11	.120	3.04	.760	19.30	1243 C (5033000)	R-16 (5290200)	1244 C (5033400)	R-16-A (5290300)	.740	18.79	.829	21.05	M-62-C (2531500)			
		12	.109	2.76	.782	19.86	1245 C (5033800)	R-17 (5290600)	1246 C (5034200)	R-17-A (5290700)	.763	19.38	.852	21.64				
		13	.095	2.41	.810	20.57	1247 C (5034600)	R-18 (5291000)	1248 C (5035000)	R-18-A (5291100)	.791	20.09	.880	22.35				850-600-A (8405398)



# Condenser Expanders

"C" Reach G-1200 Series Heat Exchanger & Condenser Tube Expanders – continued



"C" Reach						Tube Sheet Thickness				Min. I.D. Tool Enters		Max. Expan. of Tool		Mandrel Number (Order No.) 3/8 in. Sq. Dr. (9.5 mm)	Recommended Rolling Motors (Order No.)		
Tube O.D.		Tube Gauge		Tube I.D.		1-1/2 in. to 11-3/4 in. (38.1 mm to 298.4 mm)		2-1/4 in. to 12-1/2 in. (57.1 mm to 317.5 mm)							Airetrol	Electric	
in.	mm	bwg	in.	mm	in.	mm	Tool No. (Order No.)	Roll Set No. (Order No.)	Tool No. (Order No.)	Roll Set No. (Order No.)	in.	mm	in.	mm			
1	25.4	14	.083	2.10	.834	21.18	1249 C (5035400)	R-18 (5291000)	1250 C (5035800)	R-18-A (5291100)	.810	20.57	.909	23.08	M-63-C (2532400)	850-600-A (8405398)	979-C-300/ ATC-900
		15	.072	1.82	.856	21.74	1251 C (5036200)	R-19 (5291400)	1252 C (5036600)	R-19-A (5291500)	.837	21.25	.936	23.77			
		16	.065	1.65	.870	22.09											
		17	.058	1.47	.884	22.45	1255 C (5037800)	R-21 (5292200)	1256 C (5038200)	R-21-A (5292300)	.865	21.97	.964	24.48	M-63-C (2532400)	850-1250-A (8405399)	979-C-650/ ATC-900
		18	.049	1.24	.902	22.91											
		19	.042	1.06	.916	23.26											
		20	.035	0.88	.930	23.62											
1-1/8	28.5	8	.165	4.19	.795	20.19	1253 C (5037000)	R-20 (5291800)	1254 C (5037400)	R-20-A (5291900)	.776	19.71	.875	22.22	M-63-C (2532400)	1050-400 (8404200)	979-C-300/ ATC-900
		9	.148	3.75	.829	21.05	1249 C (5035400)	R-18 (5291000)	1250 C (5035800)	R-18-A (5291100)	.810	20.57	.909	23.08			
		10	.134	3.40	.857	21.76	1251 C (5036200)	R-19 (5291400)	1252 C (5036600)	R-19-A (5291500)	.837	21.25	.936	23.77			
		11	.120	3.04	.885	22.47	1255 C (5037800)	R-21 (5292200)	1256 C (5038200)	R-21-A (5292300)	.865	21.97	.964	24.48			
		12	.109	2.76	.907	23.03	1257 C (5038600)		1258 C (5039000)		.883	22.42	.982	24.94			
		13	.095	2.41	.935	23.74	1259 C (5039400)	R-22 (5292600)	1260 C (5039800)	R-22-A (5292700)	.916	23.26	1.015	25.78	M-64-C (2533300) *	1050-400 (8404200)	979-C-650/ ATC-900
		14	.083	2.10	.959	24.35	1261 C (5040200)	R-23 (5293000)	1262 C (5040600)	R-23-A (5293100)	.935	23.74	1.044	26.51	M-65-C (2534200) *		
		15	.072	1.82	.981	24.91	1263 C (5041000)	R-24 (5293400)	1264 C (5041400)	R-24-A (5293500)	.962	24.43	1.071	27.20			
		16	.065	1.65	.995	25.27											
		17	.058	1.47	1.009	25.62	1267 C (5042600)	R-26 (5294200)	1268 C (5043000)	R-26-A (5294300)	.990	25.14	1.099	27.91	M-66-C (2535100) *		
18	.049	1.24	1.028	26.11													
1-1/4	31.7	8	.165	4.19	.920	23.36	1265 C (5041800)	R-25 (5293800)	1266 C (5042200)	R-25-A (5293900)	.901	22.88	1.010	25.65	M-65-C (2534200) *	1550-250 (8404280)	979-C-300/ ATC-900
		9	.148	3.75	.954	24.23	1261 C (5040200)	R-23 (5293000)	1262 C (5040600)	R-23-A (5293100)	.935	23.74	1.044	26.51			
		10	.134	3.40	.982	24.94	1263 C (5041000)	R-24 (5293400)	1264 C (5041400)	R-24-A (5293500)	.962	24.43	1.071	27.20			
		11	.120	3.04	1.010	25.65	1267 C (5042600)	R-26 (5294200)	1268 C (5043000)	R-26-A (5294300)	.990	25.14	1.099	27.91	M-66-C (2535100) *	1050-400 (0)	979-C-650/ ATC-900
		12	.109	2.76	1.032	26.21	1269 C (5043400)	R-27 (5294600)	1270 C (5043800)	R-27-A (5294700)	1.013	25.73	1.122	28.49			
		13	.095	2.41	1.060	26.92	1271 C (5044200)	R-28 (5295000)	1272 C (5044600)	R-28-A (5295100)	1.041	26.44	1.150	29.21	M-67-C (2536000) *		
		14	.083	2.10	1.084	27.53	1273 C (5045000)	R-29 (5295400)	1274 C (5045400)	R-29-A (5295500)	1.060	26.92	1.169	29.69			
		15	.072	1.82	1.106	28.09	1275 C (5045800)	R-30 (5295800)	1276 C (5046200)	R-30-A (5295900)	1.087	27.60	1.196	30.37			
		16	.065	1.65	1.120	28.44											
		17	.058	1.47	1.134	28.80	1279 C (5047400)		1280 C (5047800)		1.115	28.32	1.224	31.08	M-68-C (2536900) *		
18	.049	1.24	1.152	29.26													

\* 1/2 in. Sq. Dr. (12.7 mm)

# Condenser Expanders

"C" Reach G-1200 Series Heat Exchanger & Condensor Tube Expanders – continued

"C" Reach						Tube Sheet Thickness				Min. I.D. Tool Enters		Max. Expan. of Tool		Mandrel Number (Order No.) 1/2 in. Sq. Dr. (12.7 mm)	Recommended Rolling Motors (Order No.)		
Tube O.D.		Tube Gauge		Tube I.D.		1-1/2 in. to 11-3/4 in. (38.1 mm to 298.4 mm)		2-1/4 in. to 12-1/2 in. (57.1 mm to 317.5 mm)							Airetrol	Electric	
in.	mm	bwg	in.	mm	in.	mm	Tool No. (Order No.)	Roll Set No. (Order No.)	Tool No. (Order No.)	Roll Set No. (Order No.)	in.	mm	in.	mm			
1-3/8	34.9	8	.165	4.19	1.045	26.54	1277 C (5046600)	R-31 (5296200)	1278 C (5047000)	R-31-A (5295900)	1.026	26.04	1.135	28.82	M-67-C (2536000)	1550-250 (8404280)	979-C-210/ ATC-900
		9	.148	3.75	1.079	27.40	1273 C (5045000)	R-29 (5295400)	1274 C (5045400)	R-29-A (5295500)	1.060	26.92	1.169	29.69			
		10	.134	3.40	1.107	28.11	1275 C (5045800)	R-30 (5295800)	1276 C (5046200)	R-30-A (5295900)	1.087	27.60	1.196	30.37			
		11	.120	3.04	1.135	28.82	1279 C (5047400)		1280 C (5047800)		1.115	28.32	1.224	31.08	M-68-C (2536900)		
		12	.109	2.76	1.157	29.38	1281 C (5048200)	R-32 (5295800)	1282 C (5048600)	R-32-A (5296700)	1.133	28.77	1.242	31.54			
		13	.095	2.41	1.185	30.09	1283 C (5049000)	R-32 (5295800)	1284 C (5049400)	R-32-A (5296700)	1.160	29.46	1.275	32.38	M-70-C (2538700)	1550-900 (8404290)	979-C-300/ ATC-900
		14	.083	2.10	1.209	30.70	1285 C (5049800)	R-34 (5297400)	1286 C (5050201PT)	R-34-A (5297500)	1.179	29.94	1.294	32.86			
		15	.072	1.82	1.231	31.26	1287 C (5050600)	R-35 (5297800)	1288 C (5051000)	R-35-A (5297900)	1.206	30.63	1.321	33.55			
		16	.065	1.65	1.245	31.62					1.206	30.63	1.321	33.55			
1-1/2	38.1	8	.165	4.19	1.170	29.71	1289 C (5051400)	R-34 (5297400)	1290 C (5051800)	R-34-A (5297500)	1.145	29.08	1.260	32.00	M-69-C (2537800)	1550-250 (8404280)	979-C-210/ ATC-900
		9	.148	3.75	1.204	30.58	1285 C (5049800)	R-34 (5297400)	1286 C (5050201PT)	R-34-A (5297500)	1.179	29.94	1.294	32.86	M-70-C (2538700)		
		10	.134	3.40	1.232	31.29	1287 C (5050600)	R-35 (5297800)	1288 C (5051000)	R-35-A (5297900)	1.206	30.63	1.321	33.55			
		11	.120	3.04	1.260	32.00	1291 C (5052200)	R-36 (5298200)	1292 C (5052600)	R-36-A (5298300)	1.235	31.36	1.350	34.29			
		12	.109	2.76	1.282	32.56	1293 C (5053000)	R-37 (5298600)	1294 C (5053400)	R-37-A (5298700)	1.257	31.92	1.372	34.84			
		13	.095	2.41	1.310	33.27	1295 C (5053800)	R-37 (5298600)	1296 C (5054200)	R-37-A (5298700)	1.285	32.63	1.400	35.56	M-71-C (2539600)	1550-900 (8404290)	979-C-300/ ATC-900
		14	.083	2.10	1.334	33.88					1.285	32.63	1.400	35.56			
		15	.072	1.82	1.356	34.44	1297 C (5054600)	R-38 (5299000)	1298 C (5055000PT)	R-38-A (5299100)	1.331	33.80	1.446	36.72			
		16	.065	1.65	1.370	34.79					1.331	33.80	1.446	36.72			
		17	.058	1.47	1.384	35.15	1299 C (5513991)	R-38 (5299000)	1300 C (5515091)	R-38-A (5299100)	1.331	33.80	1.472	37.38	M-72-C (2975538)		
		18	.049	1.24	1.402	35.61											
		19	.042	1.06	1.416	35.96											
20	.035	0.88	1.430	36.32													

## G-1200 Series – 5-Roll Expanders

**O.D Range: 5/8 – 1-1/2 Inches 15.8 – 38.1 mm**

- Expanders with 1-1/2 in. (38.1 mm) long rolls will accommodate tube sheet thicknesses as follows:  
 Standard Reach 1/2" to 5" (12.7 mm to 127.0 mm)  
 "A" Reach 1-1/4" to 7-3/4" (31.7 mm to 196.8 mm)  
 "C" Reach 1-1/2" to 11-3/4" (38.1 mm to 298.5 mm)
- Expanders with 2-1/4 in. (57.1 mm) long rolls will accommodate tube sheet thicknesses as follows:  
 Standard Reach 1-1/4" to 5-3/4" (31.7 mm to 146.0 mm)  
 "A" Reach 2" to 8-1/2" (50.8 mm to 215.9 mm)  
 "C" Reach 2-1/4" to 12-1/2" (57.1 mm to 317.5 mm)
- Longer reaches available upon request.
- **Reversible Thrust Collar** design allows flush and 1/8 in. recess tube rolling. Reversible thrust collars on Standard Reach expanders and have lubrication port for use with auto-lube configured ATR and DAS tube rolling systems.



NOTE: Step expanding becomes necessary if the tube sheet thickness exceeds the length of the roll. Specify "S" Type rolls for step rolling applications.



Sizes not listed available upon request.

Standard Reach						Tube Sheet Thickness				Min. I.D. Tool Enters		Max. Expan. of Tool		Mandrel Number (Order No.) 3/8 in. Sq. Dr. (9.5 mm)	Recommended Rolling Motors (Order No.)		
Tube O.D.		Tube Gauge		Tube I.D.		1/2 in. to 5 in. (12.7 mm to 127.0 mm)		1-1/4 in. to 5-3/4 in. (31.7 mm to 146.0 mm)		in.	mm	in.	mm		Airetrol	Electric	
in.	mm	bwg	in.	mm	in.	mm	Tool No. (Order No.)	Roll Set No. (Order No.)	Tool No. (Order No.)	Roll Set No. (Order No.)							
5/8	15.8	17	.058	1.47	.509	12.92	1215-5 (5519905)	R-4-5 (5513832)	1216-5 (5516284)	R-4-A-5 (5517897)	.499	12.67	.564	14.32	M-59 (2528300)	850-1250-A (8405399)	
		18	.049	1.24	.527	13.38	1217-5 (5517561)	R-4-5 (5513832)	1218-5 (5516230)	R-4-A-5 (5517897)	.517	13.13	.576	14.63			
		19	.042	1.06	.541	13.74	1219-5 (5517601)	R-4-5 (5513832)	1220-5 (5515836)	R-4-A-5 (5517897)	.531	13.48	.596	15.13	M-61 (2530100)		
		20	.035	0.88	.555	14.09											
		21	.032	0.81	.561	14.24											
		22	.028	0.71	.569	14.45											
3/4	19.0	13	.095	2.41	.560	14.22	1221-5 (5518046)	R-5-5 (5513231)	1222-5 (5515972)	R-5-A-5 (5518189)	.550	13.97	.615	15.62	M-61 (2530100)	850-600-A (8405398)	979-C-650/ ATC-900
		14	.083	2.10	.584	14.83	1223-5 (5514699)	R-6-5 (5518187)	1224-5 (5513968)	R-6-A-5 (5517898)	.574	14.57	.629	15.97			
		15	.072	1.82	.606	15.39	1225-5 (5515940)	R-7-5 (5514393)	1226-5 (5523014)	R-7-A-5 (5517899)	.590	14.98	.661	16.78	M-62 (2531000)		
		16	.065	1.65	.620	15.74	1227-5 (5514698)	R-7-5 (5514393)	1228-5 (5512230)	R-7-A-5 (5517899)	.605	15.36	.680	17.27	M-63 (2531900)		
		17	.058	1.47	.634	16.10	1229-5 (5515536)	R-8-5 (5515995)	1230-5 (5513536)	R-8-A-5 (5515996)	.619	15.72	.699	17.54			
		18	.049	1.24	.652	16.56	1231-5 (5514862)	R-9-5 (5517888)	1232-5 (5513488)	R-9-A-5 (5517900)	.642	16.30	.729	18.51			
		19	.042	1.06	.666	16.91											
		20	.035	0.88	.680	17.27											
		21	.032	0.81	.686	17.42											
		22	.028	0.71	.694	17.62											
7/8	22.2	13	.095	2.41	.685	17.39	1233-5 (5515915)	R-9-5 (5517888)	1234-5 (5518158)	R-9-A-5 (5517900)	.670	17.01	.747	18.97	M-64 (2532800) *	850-600-A (8405398)	979-C-650/ ATC-900
		14	.083	2.10	.709	18.00	1235-5 (5518682)	R-10-5 (5518191)	1236-5 (5520939)	R-10-A-5 (5517901)	.685	17.39	.774	19.65	M-65 (2533700) *		
		16	.065	1.65	.745	18.92	1239-5 (5525733)	R-11-5 (5517889)	1240-5 (5525734)	R-11-A-5 (5517902)	.685	17.39	.750	19.05	M-67 (2535500) *		
		17	.058	1.47	.759	19.27	1243-5 (5518366)	R-11-5 (5517889)	1244-5 (5521320)	R-11-A-5 (5517902)	.740	18.79	.824	20.92			
		18	.049	1.24	.777	19.73	1245-5 (5525740)	R-11-5 (5517889)	1246-5 (5515924)	R-11-A-5 (5517902)	.763	19.38	.851	21.61			
		19	.042	1.06	.791	20.09											
		20	.035	0.88	.805	20.44											

\* 1/2 in. Sq. Dr. (12.7 mm)

# Condenser Expanders

Selection Guide G-1200 Type Five-Roll Expanders – continued

Standard Reach						Tube Sheet Thickness				Min. I.D. Tool Enters		Max. Expan. of Tool		Mandrel Number (Order No.) 1/2 in. Sq. Dr. (12.7 mm)	Recommended Rolling Motors (Order No.)		
Tube O.D.		Tube Gauge		Tube I.D.		1/2 in. to 5 in. (12.7 mm to 127.0 mm)		1-1/4 in. to 5-3/4 in. (31.7 mm to 146.0 mm)							Airetrol	Electric	
in.	mm	bwg	in.	mm	in.	mm	Tool No. (Order No.)	Roll Set No. (Order No.)	Tool No. (Order No.)	Roll Set No. (Order No.)	in.	mm	in.	mm			
7/8	22.2	21	.032	0.81	.811	20.59	1245-5 (5525740)	R-11-5 (5517889)	1246-5 (5515924)	R-11-A-5 (5517902)	.763	19.38	.851	21.61	M-68 (2536400)	850-1250-A (8405399)	979-C-650/ ATC-900
		22	.028	0.71	.819	20.80											
1	25.4	12	.109	2.76	.782	19.86	1245-5 (5525740)	R-11-5 (5517889)	1246-5 (5515924)	R-11-A-5 (5517902)	.763	19.38	.851	21.61	M-68 (2536400)	850-600-A (8405398)	979-C-650/ ATC-900
		13	.095	2.41	.810	20.57	1247-5 (5516336)	R-13-5 (5513741)	1248-5 (5517558)	R-13-A-5 (5517903)	.791	20.09	.880	22.35			
		14	.083	2.10	.834	21.18	1249-5 (5514121)	R-12-5 (5517890)	1250-5 (5514700)	R-12-A-5 (5515825)	.810	20.57	.909	23.08	M-70 (2538200)		
		15	.072	1.82	.856	21.74	1251-5 (5513797)	R-14-5 (5517894)	1252-5 (5512231)	R-14-A-5 (5515826)	.837	21.25	.936	23.77			
		16	.065	1.65	.870	22.09											
		17	.058	1.47	.884	22.45	1255-5 (5513740)	R-13-5 (5513741)	1256-5 (5513809)	R-13-A-5 (5517903)	.865	21.97	.965	24.51	M-71 (2539100)	850-1250-A (8405399)	
		18	.049	1.24	.902	22.91											
		19	.042	1.06	.916	23.26											
		20	.035	0.88	.930	23.62											
		21	.032	0.81	.936	23.77	1257-5 (5514329)	R-15-5 (5513833)	1258-5 (5513627)	R-15-A-5 (5517907)	.883	22.42	.997	25.32			
22	.028	0.71	.944	23.97													
1-1/8	28.5	12	.109	2.76	.907	23.03	1257-5 (5514329)	R-15-5 (5513833)	1258-5 (5513627)	R-15-A-5 (5517907)	.883	22.42	.997	25.32	M-71 (2539100)	1050-400 (8404200)	979-C-300/ ATC-900
		13	.095	2.41	.935	23.74	1259-5 (5524563)	R-16-5 (5518056)	1260-5 (5525735)	R-16-A-5 (5517904)	.916	23.26	1.000	25.40			
		14	.083	2.10	.959	24.35	1261-5 (5525736)	R-17-5 (5517891)	1262-5 (5514470)	R-17-A-5 (5517905)	.935	23.74	1.043	26.49			
1-1/4	31.8	15	.072	1.82	1.106	28.09	1275-5 (5521923)	R-21-5 (5517887)	1276-5 (5516623)	R-21-A-5 (5513291)	1.087	27.60	1.196	30.37	1276-5 (2982367)	1050-400 (8404200)	979-C-650/ ATC-900
		16	.065	1.65	1.120	28.44											
		17	.058	1.47	1.134	28.80	1279-5 (5525540)	R-21-5 (5517887)	1280-5 (5517875)	R-21-A-5 (5513291)	1.115	28.32	1.231	31.26	1280-5 (2983613)		
		18	.049	1.24	1.152	29.26											
		19	.042	1.06	1.166	29.61											
		20	.035	0.88	1.180	29.97											
		21	.032	0.81	1.186	30.12											
22	.028	0.71	1.194	30.32													
1-3/8	34.9	12	.109	2.76	1.154	29.31	1281-5 (5518823)	R-21-5 (5517887)	1282-5 (5525737)	R-21-A-5 (5513291)	1.133	28.77	1.242	31.54	1282-5 (2986615)	1550-250 (8404280)	979-C-210/ ATC-900
		14	.083	2.10	1.209	30.70	1285-5 (5522166)	R-23-5 (5517982)	1286-5 (5525869)	R-23-A-5 (5518192)	1.179	29.94	1.296	31.91			
1-1/2	38.1	17	.058	1.47	1.384	35.15	1299-5 (5513442)	R-29-5 (5517893)	1300-5 (5514833)	R-29-A-5 (5517906)	1.331	33.80	1.489	37.82	1299-5 (2973869)	1550-900 (8404290)	979-C-300/ ATC-900
		18	.049	1.24	1.402	35.61											
		19	.042	1.06	1.416	35.96											
		20	.035	0.88	1.430	36.32											
		21	.032	0.81	1.436	36.47											
		22	.028	0.71	1.444	36.67											



# Condenser Expanders

G-8012 Series Heat Exchanger & Condenser Tube Expanders

## G-8012 Series

**O.D. Range:**  
**1-3/4 – 4 Inches**  
**44.4 – 76.2 mm**

- Expanders with 2-1/4 in. (57.1mm) long rolls will accommodate tube sheet thicknesses from 1/2 in. to 4 in. (12.7 mm to 101.6 mm)

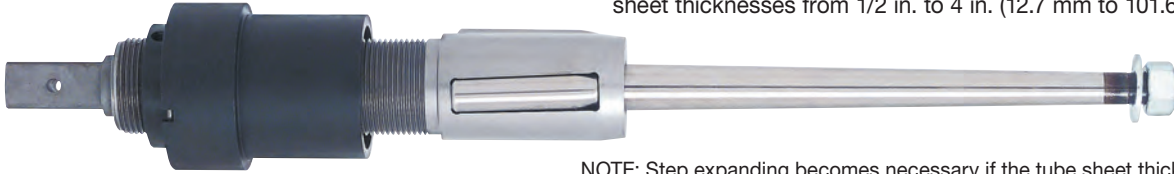

NOTE: Step expanding becomes necessary if the tube sheet thickness exceeds the length of the roll. Specify "S" Type rolls for step expanding applications.

Sizes not listed available upon request.

Tube O.D.		Tube Gauge		Tube I.D.		Tube Sheet Thickness		Min. I.D. Tool Enters		Max. Expan. of Tool		Mandrel No. (Order No.) 3/4 in. Sq. Dr. (19.0 mm)	Recommended Rolling Motors (Order No.)		
						1/2 in. to 4 in. (12.7 mm to 101.6 mm)							Airetrol	Electric	
in.	mm	bwg	in.	mm	in.	mm	Tool No. (Order No.)	Roll Set No. (Order No.)	in.	mm	in.	mm			
1-3/4	44.4	8	.165	4.19	1.420	36.06	8012-1-3/4-8 (5518639)	R-33-A (5297100)	1.368	34.74	1.550	39.37	M-90 (2541900)	1550-250 (8404280)	979-C-210/ ATC-900
		10	.134	3.40	1.482	37.64	8012-1-3/4-10 (5139000)	R-37-A (5298700)	1.420	36.06	1.607	40.81			
		11	.120	3.04	1.510	38.35	8012-1-3/4-11 (5139100)	R-42 (5299400)	1.454	36.93	1.635	41.52			
		12	.109	2.76	1.532	38.91	8012-1-3/4-12 (5139200)	R-44 (5299500)	1.482	37.64	1.657	42.08			
		13	.095	2.41	1.560	39.62	8012-1-3/4-13 (5139300)	R-46 (5299600)	1.510	38.35	1.685	42.79			
		14	.083	2.10	1.584	40.23	8012-1-3/4-14 (5139400)	R-48 (5299700)	1.532	38.91	1.709	43.40			
2	50.8	8	.165	4.19	1.670	42.41	8012-2-8 (5518643)	R-48 (5299700)	1.595	40.51	1.795	45.59	M-91 (2542200)	1550-250 (8404280)	979-C-210/ ATC-900
		10	.134	3.40	1.732	43.99	8012-2-10 (5139500)	R-50 (5299800)	1.640	41.65	1.857	47.16			
		11	.120	3.04	1.760	44.70	8012-2-11 (5139600)	R-52 (5299900)	1.670	42.41	1.885	47.87			
		12	.109	2.76	1.782	45.26	8012-2-12 (5139700)	R-54 (5300000)	1.704	43.28	1.907	48.43			
		13	.095	2.41	1.810	45.97	8012-2-13-18 (5139800)	R-56 (5300100)	1.732	43.99	1.956	49.68			
		14	.083	2.10	1.834	46.58									
		15	.072	1.82	1.856	47.14									
		16	.065	1.65	1.870	47.49									
		17	.058	1.47	1.884	47.85									
18	.049	1.24	1.902	48.31											
2-1/4	57.1	10	.134	3.40	1.982	50.34	8012-2-1/4-10 (5140100)	R-56 (5300100)	1.890	48.00	2.107	53.51	M-92 (2542300)	1550-250 (8404280)	999-C-45/ ATC-900
		11	.120	3.04	2.010	51.05	8012-2-1/4-11 (5140200)	R-58 (5300200)	1.920	48.76	2.135	54.22			
		12	.109	2.76	2.032	51.61	8012-2-1/4-12 (5140300)	R-60 (5300300)	1.954	49.63	2.157	54.78			
		13	.095	2.41	2.060	52.32	8012-2-1/4-13-16 (5140400)	R-62 (5300400)	1.982	50.34	2.185	55.49			
		14	.083	2.10	2.084	52.93									
		15	.072	1.82	2.106	53.49									
16	.065	1.65	2.120	53.84											

# Condenser Expanders

G-8012 Series Heat Exchanger & Condenser Tube Expanders – continued

Tube O.D.		Tube Gauge		Tube I.D.		Tube Sheet Thickness		Min. I.D. Tool Enters		Max. Expan. of Tool		Mandrel No. (Order No.) 3/4 in. Sq. Dr. (19.0 mm)	Recommended Rolling Motors (Order No.)		
						1/2 in. to 4 in. (12.7 mm to 101.6 mm)							Airetrol	Electric	
in.	mm	bwg	in.	mm	in.	mm	Tool No. (Order No.)	Roll Set No. (Order No.)	in.	mm	in.	mm			
2-1/2	63.5	10	.134	3.40	2.232	56.69	8012-2-1/2-10-12 (5139900)	R-64 (5300500)	2.140	54.35	2.407	61.13	M-93 (2542400)	1550-250 (8404280)	999-C-45/ ATC-900
		11	.120	3.04	2.260	57.40									
		12	.109	2.76	2.282	57.96									
		13	.095	2.41	2.310	58.67	8012-2-1/2-13-18 (5140000)	R-64 (5300500)	2.232	56.69	2.450	62.23	M-94 (2542500)		
		14	.083	2.10	2.334	59.28									
		15	.072	1.82	2.356	59.84									
		16	.065	1.65	2.370	60.19									
		17	.058	1.47	2.384	60.55									
		18	.049	1.24	2.402	61.01									
2-3/4	69.8	10	.134	3.40	2.482	63.04	8012-2-3/4-10-16 (5140500)	R-66 (5300700)	2.390	60.70	2.702	68.63	M-96 (2542700)	1850-90 (8405315)	999-C-45/ ATC-900
		11	.120	3.04	2.510	63.75									
		12	.109	2.76	2.532	64.31									
		13	.095	2.41	2.560	65.02									
		14	.083	2.10	2.584	65.63									
		15	.072	1.82	2.606	66.19									
		16	.065	1.65	2.620	66.54									
3	76.2	8	.165	4.19	2.670	67.81	8012-3-8-9 (5512193)	R-67 (5300800)	2.560	65.02	2.829	71.85	M-97 (2968867)	1850-90 (8405315)	999-C-45/ ATC-900
		9	.148	3.75	2.704	68.68									
		10	.134	3.40	2.732	69.39	8012-3-10-18 (5140600)	R-67 (5300800)	2.640	67.05	2.952	74.98	M-96 (25)		
		11	.120	3.04	2.760	70.10									
		12	.109	2.76	2.782	70.66									
		13	.095	2.41	2.810	71.37									
		14	.083	2.10	2.834	71.98									
		15	.072	1.82	2.856	75.54									
		16	.065	1.65	2.870	72.89									
			.058	1.47	2.884	73.25									
		18	.049	1.24	2.902	73.71									



## Linsen Flaring Expander

**O.D. Range:**  
1/4 - 2-5/8 Inches  
6.3 - 66.7mm

These special expanders are designed for making tubing connections without fittings. Using a drill press, lathe, or other power-driven tool, the Linsen expander enlarges the end of the tube leaving a .015" clearance for slip-fit and soldering of another tube of the same size. Can be used on copper, brass, aluminum, and thin steel tubing. Always specify tube gauge when ordering.

- Rolls out tubes smoothly and evenly so it doesn't distort or buckle the tube
- Eliminates extra fittings which saves on installation costs

Expander*	Order Number	Tube O.D.		Cup Length		Shank Diameter (Round)	
		in.	mm	in.	mm	in.	mm
AL 250	5518385	1/4	6.3	.437	11.1	.250	6.35
AL 312	5146300	5/16	7.9	.625	15.87	.250	6.35
AL 375	5146400	3/8	9.5	.625	15.87	.250	6.35
AL 500	5146600	1/2	12.7	.625	15.87	.312	7.92
AL 625	5146800	5/8	15.8	.750	19.05	.312	7.92
AL 750	5146900	3/4	19.0	.750	19.05	.375	9.52
AL 875	5147000	7/8	22.2	.750	19.05	.375	9.52
AL 1000	5146000	1	25.4	1.000	25.40	.500	12.70
AL 1125	5147100	1-1/8	28.5	1.000	25.40	.500	12.70
AL 1250	5147200	1-1/4	31.7	1.000	25.40	.500	12.70
AL 1375	5147300	1-3/8	34.9	1.000	25.40	.500	12.70
AL 1500	5146100	1-1/2	38.1	1.000	25.40	.625	15.87
AL 1625	5147400	1-5/8	41.2	1.000	25.40	.625	15.87
AL 2000	5146200	2	50.8	1.000	25.40	.625	15.87
AL 2125	5512247	2-1/8	53.9	1.000	25.40	.625	15.87
AL 2625	5524547	2-5/8	66.6	1.000	25.40	.562 (Hex)	14.27 (Hex)

\* Other sizes may be available. Contact customer service for details.



## SR Expander\*

The "SR" Short Reach Expanders incorporate a rapid taper on the mandrel that allows full expansion of a tube with minimum travel of the mandrel. The mandrel is retained at the rear of the expander to shorten the mandrel length which allows use near sharp tube bends. These expanders are made to order so application details must be provided ahead of time.

- Compact expander allows operation in confined areas
- Short mandrel length used in "bent tube" applications



## Sugar Mill Evaporator Expanders\*

Fixed roll length special expanders which are either power or hand-driven. Expanders are built precisely to order. Please provide detailed job parameters when inquiring these products.

- Designed for the repair and construction of juice tube evaporators
- Five Roll design to overcome spring back effect of thin wall tubing ensuring tight joints the first time
- Extended version of this expander allows for all tube rolling activities to occur from the top of the unit



## "PST" Pipe Sizing Expander\*

The "PST" Expanders are designed to true pipe ends and enlarge the pipe end diameter in two easy steps, providing the correct clearance between the pipe O.D. and the I.D. of a fitting before making a silver solder or brazed welded joint.

- Portable expanders suitable for field work using hand tools or ratchet wrenches
- Accurate expansion of pipe end using quality hardened parts for greater durability
- Threaded mandrel allows fine adjustment for accurate sizing of the pipe end



## Collins Expander\*

**O.D. Range:**  
1/2 - 4-1/2 Inches  
12.7 - 113.8mm

Collins self-feeding tube expanders are tough, durable, and powerful. These nonparallel rolling, self-feeding expanders are suitable for close quarter tube installation and repair work.

- Compact design works well in thin tube sheet applications
- No setup or adjustments make it quick and easy to use
- Self-contained rolls that won't fall out

\* Please contact your EGI, Ltd sales representative for further information on these products.

# Vernon Hydraulic Tube Expansion

Parallel Pin Tube Expansion



The **Vernon Tube Expanding System** uses a PLC to control all operations. A force transducer transmits pressure for roll torque, and signals cycle completion to retract the mandrel. Consistent RPM throughout the expanding cycle increases production, and the hydraulic system eliminates the need to reverse the expander mandrel. Parallel Pin expanders minimize axial flow of tube material, resulting in a better expanded joint. The Parallel Pin expander is specified by some companies to be used when tube to tube sheet welds are required. This can help reduce the stress on the weld.

The **Vernon Tube Expanding System** is an electrically 5 hp driven hydraulic unit that includes electric motor, two hydraulic pumps, hydraulic controls, and electrical controls in a powder coated cabinet on casters.

## PNEUMATIC BALANCE ARM







## PRECISION POWERHEAD

A single switch starts the cycle and resets for the next cycle. A pause switch allows the operator to stop the cycle at any point and release to continue the cycle. The pneumatic balance arm makes it easy to position the powerhead precisely, ensuring optimal production and quality.



## ELECTRICAL CONTROL PANEL

- "E stop" Button
- "Motor start" Button
- "Lube on" Button
- "Advance cycle" indicator
- "Cycle complete" indicator



## HYDRAULIC CONTROL PANEL

- Roll torque
- Mandrel advance rate
- Mandrel advance force



## DURABLE TOOLING

- Parallel Pin expanders
- Inventory for 1/2"00 to 2"00
- Longer reach expanders available



## ELECTRONIC PAPERLESS RECORDER

- Sets torque roll pressure
- Records pressure & time at completion (At completion of cycle)
- Easy to program





## VERNON "A" TYPE TUBE EXPANDERS

RANGE - TUBE O.D. - 1/2" THRU 1 1/4"

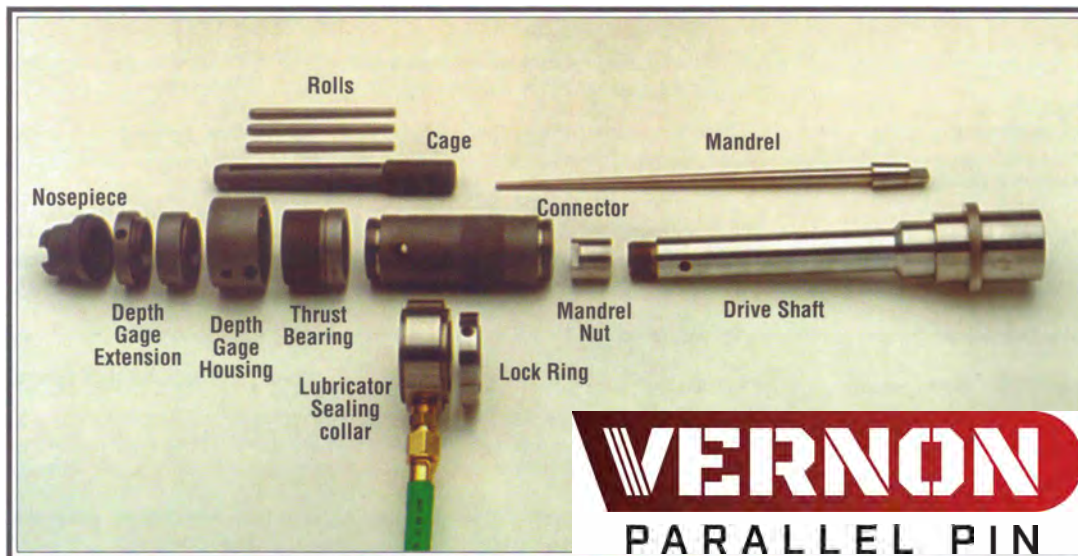

### TOOLING SELECTION GUIDE

TUBE

DEPTH GAGE

O.D.	BWG	I.D. (AVG.) WALL	EFF. ROLL LENGTH	Expander Part No.	Minimum Diameter	Maximum Diameter	Roll Set Part No.	Mandrel Part No.	Housing Part No.	Ext. Piece	Nose Piece
<b>1/2"</b>	17	.384	2-3/16"	5-11A	.374	.424	1/2A	3A	L5	E5	4NPA
	18	.402		4-18A	.387	.450	OA				
	19	.416		4-18A	.387	.450	OA				
<b>5/8"</b>	11	.385	2-3/16"	5-11A	.374	.424	1/2A	3A	L5	E5	5NPA
	12	.407		4-18A	.387	.450	OA				
	13	.435	2-7/8"	5-13A	.422	.502	1A	5A			
	14	.459		5-14A	.452	.515	2A				
	15	.481		5-15A	.462	.525	3A				
	16	.495		5-16A	.472	.537	4A				
	17	.509		5-17A	.488	.551	SA				
	18	.527		5-18A	.512	.575	6A				
	19	.541		5-18A	.512	.575	6A				
	20	.555	3-3/8"	6-13A	.534	.611	9A	6A	L6		
<b>3/4"</b>	10	.482	2-7/8"	5-15A	.462	.525	3A	5A	L5	E6	6NPA
	11	.510		5-17A	.488	.551	SA				
	12	.532		5-18A	.512	.575	6A				

**VERNON "A" TYPE TUBE EXPANDERS**

RANGE - TUBE O.D. - 1/2" THRU 1 1/4"

TUBE		TOOLING SELECTION GUIDE					DEPTH GAGE							
O.D.	BWG	I.D. (AVG.) WALL	EFF. ROLL LENGTH	Expander Part No.	Minimum Diameter	Maximum Diameter	Roll Set Part No.	Mandrel Part No.	Housing Part No.	Ext. Piece	Nose Piece			
<b>3/4"</b>	13	.560	3-3/4"	6-13A	.534	.611	9A	6A	LS	E6	6NPA			
	14	.584		6-14A	.550	.625	10A							
	15	.606		6-15A	.574	.651	11A							
	16	.620		6-16A	.598	.675	12A							
	17	.634		6-17A	.610	.687	9A	8A						
	18	.652		6-18A	.626	.703	10A							
	19	.666		6-18A	.626	.703	10A							
	20	.680		6-20A	.652	.729	11A							
	21	.686		6-20A	.652	.729	11A							
	22	.694		6-20A	.652	.729	11A							
<b>7/8"</b>	9	.579	3-3/4"	6-14A	.550	.625	10A	6A	LS	E6	6NPA			
	10	.607		6-15A	.574	.651	11A	6A						
	11	.635		6-17A	.610	.687	9A	8A						
	12	.657		6-18A	.626	.703	10A	8A						
	13	.685		8-9A	.668	.730	13A	7A						
	14	.709		8-9A	.680	.742	13A							
	15	.731		8-10A	.700	.762	14A							
	16	.745		8-11A	.724	.786	15A							
	17	.759		8-11A	.724	.786	15A							
	18	.777		8-12A	.773	.835	16A							
	19	.791		8-13A	.766	.843	20A	8A						
	20	.805		8-13A	.766	.843	20A							
	21	.811		8-13A	.766	.843	20A							
22	.819	8-14A	.800	.877	18A									
<b>1"</b>	8	.670	3-3/4"	8-8A	.650	.712	12.5A	7A	L8	E6	8NPA			
	9	.704		8-9A	.680	.742	13A							
	10	.732		8-10A	.700	.762	14A							
	11	.760		8-11A	.724	.786	15A							
	12	.782		8-12A	.773	.833	16A							
	13	.810		8-13A	.766	.843	20A	8A						
	14	.834		8-14A	.800	.877	18A							
	15	.856		8-15A	.823	.900	19A	8A						
	16	.870		8-16A	.844	.921	20A	10A				L8	E8	8NPA
	17	.884		8-18A	.869	.921	18A							

# Vernon Hydraulic Tube Expansion

Parallel Pin Tube Expansion

## VERNON "A" TYPE TUBE EXPANDERS

RANGE - TUBE O.D. - 1/2" THRU 1 1/4"

### TUBE

### TOOLING SELECTION GUIDE

### DEPTH GAGE

O.D.	BWG	I.D. (AVG.) WALL	EFF. ROLL LENGTH	Expander Part No.	Minimum Diameter	Maximum Diameter	Roll Set Part No.	Mandrel Part No.	Housing Part No.	Ext. Piece	Nose Piece
1"	18	.902	3-3/4"	8-18A	.881	.953	18A	10A	L8	E8	8NPA
	19	.916		8-18A	.881	.958	18A				
	20	.930		8-20A	.901	.978	19A				
	21	.936		8-20A	.901	.978	19A				
	22	.944		8-20A	.901	.978	19A				
1-1/8"	8	.795	3-3/4"	8-13A	.766	.843	20A	8A	L8	E8	9NPA
	9	.829		8-14A	.800	.877	18A				
	10	.857		8-15A	.823	.900	19A				
	11	.885		8-18A	.869	.921	18A	10A			
	12	.907		8-18A	.881	.958	18A				
	13	.935		10-9A	.923	1.000	21A				
	14	.959		10-9A	.923	1.000	21A				
	15	.981		10-10A	.943	1.020	22A				
	16	.995		10-11A	.975	1.052	23A				
	17	1.009		10-11A	.975	1.052	23A				
18	1.027	10-12A	.999	1.076	24A						
1-1/4"	8	.920	3-3/4"	8-18A	.881	.953	18A	10A	L8	E8	10NPA
	9	.954		10-9A	.923	1.000	21A				
	10	.982		10-10A	.943	1.020	22A				
	11	1.010		10-11A	.975	1.052	23A				
	12	1.032		10-12A	.999	1.076	24A				
	13	1.060		10-14A	1.047	1.124	26A				
	14	1.084		10-14A	1.047	1.124	26A				
	15	1.106		10-16A	1.095	1.172	28A				

Larger sizes available on request.

All take Thrust Bearing LTB -3/4

**VERNON "S" TYPE TUBE EXPANDERS**  
RANGE -TUBE O.D. - 1/2" THRU 2"

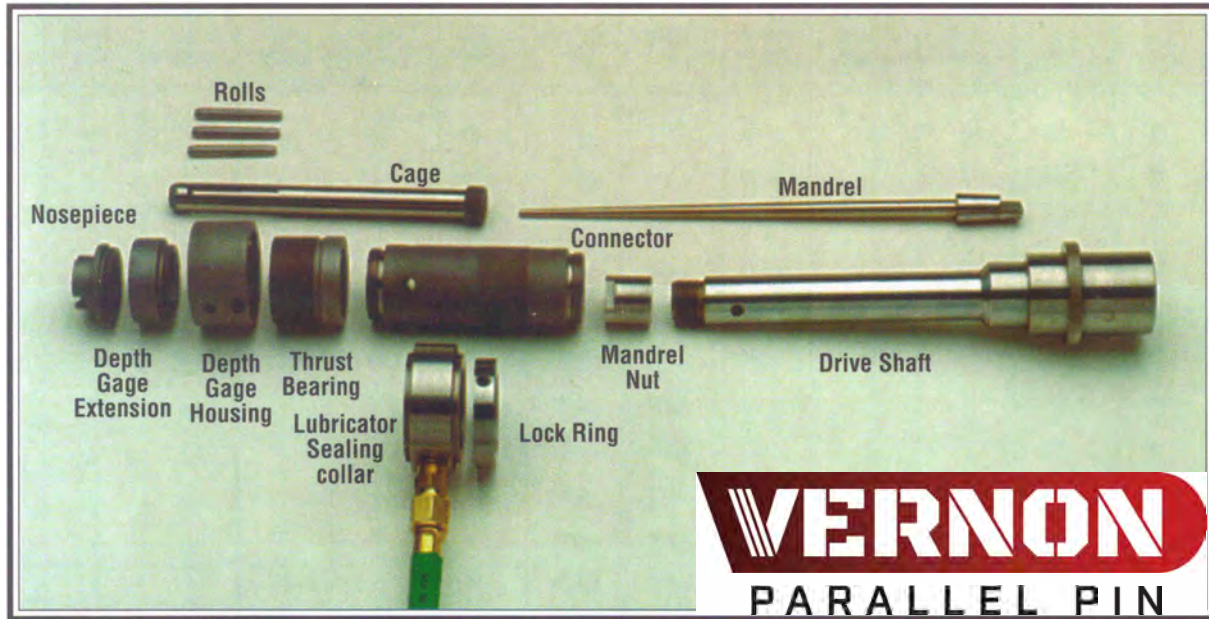

**TUBE**

**TOOLING SELECTION GUIDE**

**DEPTH GAGE**

O.D.	BWG	I.D. (AVG.) WALL	EFFECTIVE MAX ROLL LENGTH	ROLLING DEPTH	Expander Part No.	Minimum Diameter	Maximum Diameter	Roll Set Part No.	Mandrel Part No.	Housing Part No.	Ext. Piece	Nose Piece	Thrust Bearing
<b>1/2"</b>	14	.384	1-1/8"	5"	4-14S	.324	.374	001S	4S	L5	ES	4NP	LTB-3/4
	16	.370			4-16S	.360	.422	1/2S	3S				
	17	.384			5-11S	.373	.435	1/2S					
	18	.402			4-18S	.393	.455	0S					
	19	.418			4-18S	.393	.455	0S					
	20	.430	1-3/16"		5-13S	.426	.485	1A	5S				
<b>5/8"</b>	11	.385	1-1/8"	5"	5-11S	.373	.435	1/2S	3S	L5	E5	5NP	LTB-3/4
	12	.407			5-12S	.393	.455	0S					
	13	.435	1-3/16"		5-13S*	.426	.485	1A	5S				
	14	.459			5-14S	.453	.515	2S					
	15	.481			5-15S	.462	.525	3S					
	16	.495			5-16S	.472	.537	4S					
	17	.509			5-17S	.490	.553	5S					
	18	.527			5-18S	.512	.575	6S					
	*19	.541			5-18S*	.512	.575	6S					
	20	.555	1-7/16"	5-1/2"	6-13S	.534	.611	9S	6S				

\*use 1/2" Connector Extension

# Vernon Hydraulic Tube Expansion

Type "S" Vernon Tooling

## VERNON "S" TYPE TUBE EXPANDERS

RANGE -TUBE O.D. - 1/2" THRU 2"

### TUBE

### TOOLING SELECTION GUIDE

### DEPTH GAGE

O.D.	BWG	I.D. (AVG.) WALL	EFFECTIVE MAX ROLL LENGTH	MAX ROLLING DEPTH	Expander Part No.	Minimum Diameter	Maximum Diameter	Roll Set Part No.	Mandrel Part No.	Housing Part No.	Ext. Piece	Nose Piece	Thrust Bearing
<b>5/8"</b>	21	.561	1-7/16"	5-1/2"	6-13S	.534	.611	9S	6S	LS	E5	5NP	LTB-3/4
	22	.569			6-13S	.534	.611	9S					
<b>3/4"</b>	10	.482	1-3/16"	5"	5-15S	.462	.525	3S	5S	L6	E6	6NP	LTB-3/4
	11	.510			5-17S	.490	.553	5S					
	12	.532			5-18S	.512	.575	6S					
	13	.560	1-7/16"		6-13S	.534	.611	9S	6S				
	14	.584			6-14S	.550	.627	10S					
	15	.606			6-15S	.574	.651	11S					
	16	.620			6-16S	.598	.675	12S					
	17	.634			6-17S	.610	.687	9S	8S				
	18	.652			6-18S	.626	.703	10S					
	19	.666			6-18S	.626	.703	10S					
	20	.680			6-20S	.650	.727	11S					
	21	.686			6-20S	.650	.727	11S					
22	.964			6-20S	.650	.727	11S						
<b>7/8"</b>	9	.579	1-7/16"	5-1/2"	6-14S	.550	.627	10S	6S	L6	E6	7NP	LTB-3/4
	10	.607			6-15S	.574	.651	11S					
	11	.635			6-17S	.610	.687	9S	8S				
	12	.657			6-18S	.626	.703	10S					
	13	.685			8-9S	.668	.730	13S	7S				
	14	.709			8-9S	.680	.742						
	15	.731			8-10S	.700	.762	14S					
	16	.745			8-11S	.724	.787	15S					
	17	.759			8-11S	.724	.787	15S					
	18	.777			8-12S	.773	.835	16S					
	19	.791			8-13S	.766	.843	20S	8S				
	20	.805			8-13S	.766	.843						
21	.811			8-13S	.766	.843							
22	.819			8-14S	.800	.877	18S						
<b>1"</b>	8	.670	1-7/16"	5-1/2"	8-8S	.650	.712	12 1/2 S	7S	L8	E8	8NP	LTB-3/4
	9	.704			8-9S	.680	.742	13S					
	10	.732			8-10S	.700	.762	14S					
	11	.760			8-11S	.724	.787	15S					
	12	.782			8-12S	.773	.835	16S					

Longer reach expanders are available upon request



**VERNON "S" TYPE TUBE EXPANDERS**  
RANGE -TUBE O.D. - 1/2" THRU 2"

TUBE			TOOLING SELECTION GUIDE							DEPTH GAGE			
O.D.	BWG	I.D. (AVG.) WALL	EFFECTIVE ROLL LENGTH	MAX ROLLING DEPTH	Expander Part No.	Minimum Diameter	Maximum Diameter	Roll Set Part No.	Mandrel Part No.	Housing Part No.	Ext. Piece	Nose Piece	Thrust Bearing
1"	13	.810	1-7/16"	5-1/2"	8-13S	.766	.843	20S	8S	L8	E8	8NP	LTB-3/4
	14	.834			8-14S	.800	.877	18S	8S				
	15	.856			8-15S	.823	.900	19S	8S				
	16	.870			8-16S	.844	.921	20S	10S				
	17	.884			8-18S	.869	.946	18S					
	18	.902			8-18S	.881	.958						
	19	.916			8-18S	.881	.958						
	20	.930			8-20S	.901	.978	19S					
	21	.936			8-20S	.901	.978						
	22	.944			8-20S	.901	.978						
	1-1/8"	8			.795	1-7/16"	5-1/2"	8-13S	.766				
9		.829	8-14S	.800	.877			18S	8S				
10		.857	8-15S	.823	.900			19S	8S				
11		.885	8-18S	.869	.946			18S	10S				
12		.907	8-18S	.881	.958								
13		.935	2-1/4"		10-9S	.923	1.000	21S					
14		.959			10-9S	.923	1.000	21S					
15		.981			10-10S	.944	1.017	22S					
16		.995			10-11S	.975	1.052	23S					
17		1.009			10-11S	.975	1.052						
18	1.027	10-12S	.999	1.076	24S								
1-1/4"	8	.920	2-1/4"	5-1/2"	10-9s*	.905	.983	21S	10S	L8	E8	10NP	LTB-3/4"
	9	.959			10-9S	.923	1.000						
	10	.982			10-10S	.944	1.017	22S					
	11	1.010			10-11S	.975	1.052	23S					
	12	1.032			10-12S	.999	1.076	24S					
	13	1.060			10-14S	1.047	1.124	26S					
	14	1.064			10-14S	1.047	1.124						
	15	1.106			10-16S	1.095	1.172	28S					
	16	1.120			10-16S	1.095	1.172						
	17	1.134			10-17S	1.109	1.186	29S					
18	1.152	10-18S	1.127	1.204	30S								
1-3/8"	8	1.045	2-1/4"	5-1/2"	10-12S	.999	1.076	24S	10S	L8	E8	10NP	LTB-3/4"
	9	1.079			10-14S	1.047	1.124	26S					

Longer Reach Expanders available upon request

## VERNON "S" TYPE TUBE EXPANDERS

RANGE -TUBE O.D. - 1/2" THRU 2"

TUBE		TOOLING SELECTION GUIDE										DEPTH GAGE	
O.D.	BWG	I.D. (AVG.) WALL	EFFECTIVE ROLL LENGTH	MAX ROLLING DEPTH	Expander Part No.	Minimum Diameter	Maximum Diameter	Roll Set Part No.	Mandrel Part No.	Housing Part No.	Ext. Piece	Nose Piece	Thrust Bearing
1-3/8"	10	1.107	2-1/8"	5-1/2"	10-16S	1.095	1.172	28S	10S	L8	E8	11NP	LTB-3/4
	11	1.135			10-17S	1.109	1.186	29S					
	12	1.157			10-13S	1.127	1.204	30S					
	13	1.185			12-8S	1.161	1.238	32S					
	14	1.209			12-10S	1.200	1.277	33S					
	15	1.231			12-10S	1.200	1.277	33S					
	16	1.245			12-11S	1.226	1.303	34S					
1-1/2"	8	1.170	2-1/8"	5-1/2"	12-8S	1.161	1.238	32S	10S	L8	E8	12NP	LTB-3/4
	9	1.204			12-8S	1.161	1.238	32S					
	10	1.232			12-10S	1.200	1.277	33S					
	11	1.260			12-11S	1.226	1.303	34S					
	12	1.282			12-12S	1.250	1.327	35S					
	13	1.310			12-13S	1.266	1.343	36S					
	14	1.334			12-14S	1.303	1.380	37S					
	15	1.356			12-15S	1.326	1.403	39S					
	16	1.370			12-16S	1.340	1.417	40S					
	17	1.384			12-16S	1.340	1.417	40S					
	18	1.402			12-18S	1.374	1.451	42S					
	19	1.416			12-18S	1.374	1.451	42S					
	20	1.430			14-9S	1.419	1.579	40S-20	12S				LTB-1
1-5/8"	8	1.295	2-1/8"	5-1/2"	12-13S	1.266	1.343	36S	10S	L8	E13	13NP	LTB-3/4
	9	1.329			12-14S	1.303	1.380	37S					
	10	1.357			12-15S	1.326	1.403	39S					
	11	1.385			12-18S	1.374	1.451	42S					
	12	1.407			12-18S	1.374	1.451						
	13	1.435			14-9S	1.419	1.579	40S-20	12S	L15	E14		LTB-1
	14	1.459			14-9S	1.419	1.579						
	15	1.481			14-9S	1.419	1.579						
16	1.495			14-9S	1.419	1.579							
1-3/4"	9	1.454	2-1/8"	5-1/2"	14-9S	1.419	1.579	40S-20	12S	L15	E14	14NP	LTB-1
	10	1.482			14-9S	1.419	1.579						
	11	1.510			14-11S	1.491	1.651	41S					

\*Longer Reach expanders available upon request

**VERNON "S" TYPE TUBE EXPANDERS**  
RANGE -TUBE O.D. - 1/2" THRU 2"

TUBE		TOOLING SELECTION GUIDE								DEPTH GAGE				
O.D.	BWG	I.D. (AVG.) WALL	EFFECTIVE ROLL LENGTH	MAX ROLLING DEPTH	Expander Part No.	Minimum Diameter	Maximum Diameter	Roll Set Part No.	Mandrel Part No.	Housing Part No.	Ext. Piece	Nose Piece	Thrust Bearing	
1-3/4"	12	1.532	2-1/4"	5-1/2"	14-11S	1.491	1.651	41S	12S	L15	E14	14NP	LTB-1	
	13	1.560			14-11S	1.491	1.651							
	14	1.584			14-11S	1.491	1.651							
	15	1.606			14-16S	1.591	1.751	46S						
	16	1.620			14-16S	1.591	1.751							
1-7/8"	8	1.545	2-1/4"	5-1/2"	14-11S	1.491	1.651	41S	12S	L15	E15	15NP	LTB-1	
	9	1.579			14-11S	1.491	1.651							
	10	1.607			14-16S	1.591	1.751	46S						
	11	1.635			14-16S	1.591	1.751							
	12	1.657			14-16S	1.591	1.751	46S						
	13	1.685			5-1/4"	16-9S	1.635	1.795	49S					
	14	1.709			16-9S	1.635	1.795							
	15	1.731			16-9S	1.635	1.795							
	16	1.745		16-9S	1.635	1.795								
2"	8	1.670	2-1/4"	5-1/4"	16-9S	1.635	1.795	49S	12S	L15	E15	16NP	LTB-1	
	9	1.704			16-9S	1.635	1.795							
	10	1.732			16-9S	1.635	1.795							
	11	1.760			16-11/15S	1.743	1.903	51S						
	12	1.782			16-11/15S	1.743	1.903							
	13	1.810			16-11/15S	1.743	1.903							
	14	1.834			16-11/15S	1.743	1.903							
	15	1.856			16-11/15S	1.743	1.903							
	16	1.870			16-16S	1.841	2.001	56S						
	18				16-18S	1.908	2.068	63S						
	20				16-20S	1.940	2 160	63S						Y

\*Longer reach expanders available upon request

\* Use 1/2" Connector Extension

# Tube Installation Accessories

Heat Exchanger & Condenser Tube Expanders Accessories

## GT Serrating Tools

An innovative line of serrating tools that re-defines grooving technology. The GT Serrating tools efficiently cut grooves in tube sheet holes which increases the strength of the rolled joint between the tube and tube sheet.



### Tube sheet hole application range:

1/2 - 1 in. (12.7 - 25.4mm) I.D.

- Ti coated bits available in SAE and Metric sized groove configurations & shapes
- Serrating Tools available with standard mandrel or mandrels with carbide inserts
- Mandrels with carbide inserts remove burrs left on grooves eliminating an extra de-burring process
- Compact design for extreme rigidity, extended bit life, less run-out and increased accuracy
- Unique through-spindle coolant delivery system provides superior groove quality and unmatched bit life
- Catalog tools have two bit patterns to choose from, all others are special, made to order, and priced on request
- Designed for easy bit replacement which saves time and money
- Depth from face of tube sheet to the back of the second groove is adjustable from 1/2" to 1-1/4" (12,7 - 31,75mm)

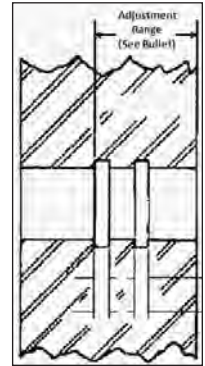

### Complete serrating tool, furnished with carbide insert mandrel, SAE tool bit

Tube Sheet Hole		Inch Tool Number* (Order Number)	Shank	Standard Tool Bit	Optional Tool Bit
in.	mm			1/8 x 1/4 x 1/8"	1/8 x 3/8 x 1/8"
1/2	12.70	GT 500C 3MT (5526083)	3MT	GT 5003 S (2902039)	GT 5003 (2902030)
5/8	15.80	GT 625C 3MT (5525886)	3MT	GT 5003 S (2902039)	GT 5003 (2902030)
3/4	19.05	GT 750C 3MT (5525756)	3MT	GT 7503 S (2901403)	GT 7503 (2900686)
7/8	22.20	GT 875C3MT (5525587)	3MT	GT 7503 S (2901403)	GT 7503 (2900686)
1	25.40	GT 1000C 3MT (5525706)	3MT	GT 7503 S (2901403)	GT 7503 (2900686)
3/4	19.05	GT 750C 1SP (5526137)	1" RD	GT 7503 S (2901403)	GT 7503 (2900686)
1	25.40	GT 1000C 1SP (5526138)	1" RD	GT 7503 S (2901403)	GT 7503 (2900686)

\* Includes "Standard Tool Bit"

### Complete serrating tool, furnished with carbide insert mandrel, Metric tool bit

Tube Sheet Hole		Inch Tool Number* (Order Number)	Shank	Standard Tool Bit	Optional Tool Bit
in.	mm			3 x 6 x 3 mm	3 x 10 x 3 mm
1/2	12.70	GT 1270C 3MT (5526115)	3MT	GT 50 363 (2902091)	GT 50 3103 (2902117)
5/8	15.80	GT 1588C 3MT (5526116)	3MT	GT 50 363 (2902091)	GT 50 3103 (2902117)
3/4	19.05	GT 1905C 3MT (5526117)	3MT	GT 75 363 (2902092)	GT 75 3103 (2902118)
7/8	22.20	GT 2223C 3MT (5526118)	3MT	GT 75 363 (2902092)	GT 75 3103 (2902118)
1	25.40	GT 2540C 3MT (5526119)	3MT	GT 75 363 (2902092)	GT 75 3103 (2902118)
3/4	19.05	GT 1905C 1SP (5526164)	1" RD	GT 75 363 (2902092)	GT 75 3103 (2902118)
1	25.40	GT 2540C 1SP (5526165)	1" RD	GT 75 363 (2902092)	GT 75 3103 (2902118)

\* Includes "Standard Tool Bit"

### Complete serrating tool, furnished with standard mandrel, SAE tool bit

Tube Sheet Hole		Inch Tool Number* (Order Number)	Shank	Standard Tool Bit	Optional Tool Bit
in.	mm			1/8 x 1/4 x 1/8"	1/8 x 3/8 x 1/8"
1/2	12.70	GT 500NC 3MT (5526299)	3MT	GT 5003 S (2902039)	GT 5003 (2902030)
5/8	15.80	GT 625NC 3MT (5526296)	3MT	GT 5003 S (2902039)	GT 5003 (2902030)
3/4	19.05	GT 750NC 3MT (5526297)	3MT	GT 7503 S (2901403)	GT 7503 (2900686)
7/8	22.20	GT 875NC 3MT	3MT	GT 7503 S (2901403)	GT 7503 (2900686)
1	25.40	GT 1000NC 3MT (5526298)	3MT	GT 7503 S (2901403)	GT 7503 (2900686)
3/4	19.05	GT 750NC 1SP	1" RD	GT 7503 S (2901403)	GT 7503 (2900686)
1	25.40	GT 1000NC 1SP	1" RD	GT 7503 S (2901403)	GT 7503 (2900686)

\* Includes "Standard Tool Bit"

### Complete serrating tool, furnished with standard mandrel, Metric tool bit

Tube Sheet Hole		Inch Tool Number* (Order Number)	Shank	Standard Tool Bit	Optional Tool Bit
in.	mm			3 x 6 x 3 mm	3 x 10 x 3 mm
1/2	12.70	GT 1270NC 3MT	3MT	GT 50 363 (2902091)	GT 50 3103 (2902117)
5/8	15.80	GT 1588NC 3MT	3MT	GT 50 363 (2902091)	GT 50 3103 (2902117)
3/4	19.05	GT 1905NC 3MT (526421)	3MT	GT 75 363 (2902092)	GT 75 3103 (2902118)
7/8	22.20	GT 2223NC 3MT (5526305PT)	3MT	GT 75 363 (2902092)	GT 75 3103 (2902118)
1	25.40	GT 2540NC 3MT	3MT	GT 75 363 (2902092)	GT 75 3103 (2902118)
3/4	19.05	GT 1905NC 1SP	1" RD	GT 75 363 (2902092)	GT 75 3103 (2902118)
1	25.40	GT 2540NC 1SP	1" RD	GT 75 363 (2902092)	GT 75 3103 (2902118)

\* Includes "Standard Tool Bit"

### GT Serrating Tool Nomenclature

XX	-	XXXX	-	XX	-	XXX	-	XXX
↓		↓		↓		↓		↓
Tool Series		Tube Sheet Hole Dia.		Mandrel Type		Shank Size		Specials
GT		500 = 1/2"		C = Carbide		3MT = #3 Morse Taper		Longer reach
		625 = 5/8"		NC = Non-carbide		1SP = 1" (25.4mm) Round		
		750 = 3/4"						
		875 = 7/8"						
		1000 = 1"						
		1270 = 12.70mm						
		1588 = 15.88mm						
		1905 = 19.05mm						
		2223 = 22.23mm						
		2540 = 25.40mm						



**Example**  
GT 5003 S  
(2902039)

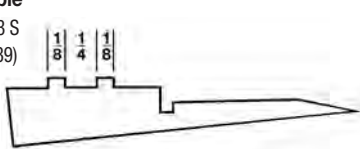



# Tube Installation Accessories

Heat Exchanger & Condenser Tube Expanders Accessories



## Flaring Tools



The Airetool FT-515 –60° flaring tools are designed to flare 1/2 - 1-1/2 inch (12.7 - 38.1mm) OD tubes. Furnished with Type 01 or Type 06 round shanks for use with standard chipping hammers.

Model Number	Ordering Number	Flare Angle	Shank
FT 515 01 Flaring Tool	2470950	60 Degree	-01
FT 515 06 Flaring Tool	2973803	60 Degree	-06

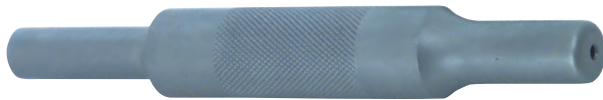

## Belling and Flaring Tools



**Belling tool** – pilot end fits tube I.D. with Type 01 shank. Specify tool OD, gauge, radius in tube sheets.



## Beading Tool



Model Number	Ordering Number	Radius (in.)	Shank Type
12-RM -9-5/32-R-01	2968677	5/32	Type 01
12-RM -9-1/4-R-01	2968676	1/4	(.680" round x 2 3/8" long)

## Sleeve Type Extensions

Designed for use where tubes are close to the shell of the condenser. Small diameter of female end allows access to these tubes.

Sleeve Type Extension Complete	Order Number	Square Drive Size (Male/Female)		Overall Length	
		In.	mm	In.	mm
3/8 x 12	5515758	3/8	9.5	12	305
3/8 x 18	5513774	3/8	9.5	18	457
3/8 x 24	5515759	3/8	9.5	24	610
3/8 x 36	5515761	3/8	9.5	36	915
1/2 x 12	5515733	1/2	12.7	12	305
1/2 x 18	5513775	1/2	12.7	18	457
1/2 x 24	5515734	1/2	12.7	24	610
3/4 x 12	5515735	3/4	19.0	12	305
3/4 x 18	5515736	3/4	19.0	18	457
3/4 x 24	5515737	3/4	19.0	24	610



## Extensions with Quick-Change Chuck



Varying extension lengths are used for hard-to-reach tubes. Quick-change chuck enables operator to change expanders quickly. Specify size of square drive and extension length.

Quick Change Extension Complete	Order Number	Square Drive Size (Male/Female)		Overall Length	
		In.	mm	In.	mm
QC-375-6	5501200	3/8	9.5	6	152
QC-375-8	5501600	3/8	9.5	8	203
QC-375-12	5502000	3/8	9.5	12	305
QC-375-18	5503000	3/8	9.5	18	457
QC-375-24	5504000	3/8	9.5	24	610
QC-375-30	5504500	3/8	9.5	30	762
QC-375-36	5505000	3/8	9.5	36	915
QC-500-12	5507000	1/2	12.7	12	305
QC-500-18	5508000	1/2	12.7	18	457
QC-500-24	5509000	1/2	12.7	24	610
QC-500-30	5510000	1/2	12.7	30	762
QC-500-36	5511000	1/2	12.7	36	915



## Universal Joints and Extensions

Designed for hard-to-reach tubes, the universal joint performs smoothly without binding. Specify size of square drive and extension length.



### Universal Joints

Universal Joint	Order Number	Square Drive Size Female		Overall Length	
		In.	mm	In.	mm
3/8 x 3/8	2115300	3/8	9.5	2.50	64
1/2 x 1/2	2039800	1/2	12.7	2.75	70
3/4 x 3/4	2974913	3/4	19.0	3.50	89

### Universal Extensions

Universal Extensions	Order Number	Square Drive Size Male/Female		Overall Length	
		In.	mm	In.	mm
GP-3/8 x 6	5514896	3/8	9.5	6	152
GP-3/8 x 12	5514898	3/8	9.5	12	305
GP-3/8 x 18	5514899	3/8	9.5	18	457



5150DP-160B



5150DP-800B

## EGI Industrial Drills

Compact, powerful pistol grip drill uses precision machined planetary gears to generate high torque to drill. Handle, exhaust and muffler meet OSHA requirements. Equipped with Jacobs 33BA-1/2 heavy-duty chuck and dead handle.

Specifications	5150DP-400B	5150DP-800B	5150DP-055B	5150DP-160B
Drilling Capacity	1/2"	1/2"	1/2"	1/2"
Free Speed	400 RPM	800 RPM	55 RPM	160 RPM
Spindle Thread	1/2"-20	1/2"-20	1/2"-20	1/2"-20
Rec'd Hose Size	3/8"	3/8"	3/8"	3/8"
Length	8-1/2"	8-1/2"	9-3/4"	9-3/4"
Weight	5.5 lbs.	5.5 lbs.	6.0 lbs.	6.0 lbs.
Air Inlet Thread	3/8"	3/8"	3/8"	3/8"
Avg. Air Cons.	6 cfm	6 cfm	6 cfm	6 cfm



5042

Specifications	5042
Drilling Capacity	1/2"
Free Speed	800 RPM
Spindle Thread	3/8"-24
Rec'd Hose Size	3/8"
Length	7"
Weight	4 lbs.
Air Inlet Thread	1/4"
Avg. Air Cons.	10 cfm

## EGI - 1/2" Heavy-Duty Drill - Reversible

This economic yet rugged 1/2" reversible drill is ideal for drilling, running taps, screws and other fasteners. The 800 RPM gives you the power you need for heavy drilling applications and yet enough speed to make driving applications go faster. Easy to use forward reverse lever is thumb operated for quick action. Comes equipped with Jacobs multicraft 1/2" cap chuck and dead handle to steady the drill and absorb the torque.



## 222 Extra Heavy-Duty Drill/Wood Borer

Features include ball bearing support for long life and efficient operation, a graduated roll throttle for speed control, and durable spur gearing. **Includes breast plate, dead handle and a built-in lubricator standard. Equipped with 1/2" Air Inlet Thread requiring Average Air Consumption of 50 cfm. Recommended hose size of 1/2"**

Motor No.	Free Speed	Drilling	Reaming/ Tapping
222J	1025 RPM	9/16"	3/8"
222K	750 RPM	9/16"	7/16"
222M	350 RPM	7/8"	5/8"



## Tube End Facer

The Airetool TEF Tube End Facer is ideally suited for facing tube ends on heat exchangers and condensers. Tools can also be used to remove welds until they are flush with the tube sheet during tube removal and re-tubing processes.

Tube application range: 3/8 - 2-1/2 in. (9.5 - 63.5mm) O.D.

- Includes full set of free-turning pilots allowing use with several tube gauges
- Adjustable ball bearing thrust collar assures uniform tube facing
- Tube End Facers are equipped with 7/16" hex shank to fit standard drill chucks
- Cutting bits are made from quality tool steel or stainless steel for extended life

Tube O.D.		Tool No. (Order No.)	Gauge	Hex Shank		Spare Bits	
In.	mm			In.	mm	non-ferrous or Carbon Steel	Stainless Steel
3/8	9.5	TEF-375 (5519632)	16-20	5/16	7.9	TEF-376 (2987908)	TEF-376-SS (2991788)
1/2	12.7	TEF-500 (5332415)	16-20	3/8	9.5	TEF-506 (2662531)	TEF-506-SS (2983169)
5/8	15.8	TEF-625 (5332425)	14-18	3/8	9.5	TEF-626 (2662558)	TEF-626-SS (2983170)
3/4	19.0	TEF-750 (5332450)	10-18	3/8	9.5	TEF-756 (2662585)	TEF-756-SS (2983162)
7/8	22.2	TEF-875 (5332460)	14-18	3/8	9.5	TEF-876 (2662603)	TEF-876-SS (2983163)
1	25.4	TEF-1000 (5332475)	10-18	3/8	9.5	TEF-1006 (2662633)	TEF-1006-SS (2983164PT)
1	25.4	TEF-1000 (5526476)	20-24	3/8	9.5	TEF-1006 (2662633)	TEF-1006-SS (2983164PT)
1-1/8	28.5	TEF-1125 (5514016)	12-14	3/8	9.5	TEF-1126 (2975739)	TEF-1126 SS (2990074)
1-1/8	28.5	TEF-1125 (5526477)	20-24	3/8	9.5	TEF-1126 (2975739)	TEF-1126 SS (2990074)
1-1/4	31.7	TEF-1250 (5513801)	12-18	3/8	9.5	TEF-1256 (2968692)	TEF-1256 SS (2987497)
1-1/4	31.7	TEF-1250 (5526478)	20-24	3/8	9.5	TEF-1256 (2968692)	TEF-1256 SS (2987497)
1-1/4	31.7	TEF-1500-SS (5524268PT)	14-18	3/8	9.5	TEF-1256 SS (2987497)	TEF-1256 SS (2987497)
1-1/2	38.1	TEF-1500 (5512103)	12-14	7/16	11.1	TEF-1506 (2968598)	TEF-1506 SS (2990665)
1-3/4	44.4	TEF-1750 (5513605)	12-14	7/16	11.1	TEF-1756 (2974354)	TEF-1756 SS
2	50.8	TEF-2000 (5512102)	12-14	7/16	11.1	TEF-2006 (2968544)	TEF-2006 SS (2991618)
2-1/2	63.5	TEF-2500 (5512202PT)	5-7	3/4	19.0	TEF-2506 (2968963PT)	TEF-2506 SS

A set of even gauge pilots are supplied with tube end facing tools shown above. Other Sizes available. Contact customer service for details.

# Tube Installation Accessories



## Airetool Hole Gauge for Heat Exchanger Tubes

These easy to use inline hole gauges feature three-point contact for self-centering and direct reading scale. All hole gauges furnished with test ring for scale verification. Standard reach tools up to 1" (25.4mm) include carrying case.

**Tube Range: 0.500 - 2.500" O.D. (12.70 - 63.50mm)**

- Graduated scale in 0.002" (.05mm) increments for fast, accurate measurement of tube I.D.
- Each hole gauge also has the range to measure tube sheet holes in next smaller size
- Standard adjustable reach of 6" (152.4mm) and 12" (304.8mm) lengths.



Tube O.D.		Hole Gauge Reach*		Measurement Range	
in.	mm	6" (152.4mm)	12" (304.8mm)	in.	mm
1/2"	12.7	HG-500-6 (5171001)	HG-500-12 (5171100)	.350 - .440	8.89 - 11.18
5/8"	15.8	HG-625-6 (5171200)	HG-625-12 (5171300)	.440 - .545	11.18 - 13.84
3/4"	19.0	HG-750-6 (5171400)	HG-750-12 (5171500)	.550 - .700	13.97 - 17.78
7/8"	22.2	HG-875-6 (5171600)	HG-875-12 (5171700)	.675 - .825	17.15 - 20.96
1"	25.4	HG-1000-6 (5171800)	HG-1000-12 (5171900)	.800 - .950	20.32 - 24.13
1-1/4"	31.7	HG-1250-6 (5172000)	HG-1250-12 (5172100)	.955 - 1.105	24.26 - 28.07
1-3/8"	34.9	HG-1375-6	HG-1375-12 (5521640)	1.060 - 1.220	26.92 - 30.99
1-1/2"	38.1	HG-1500-6 (5518603)	HG-1500-12 (5519614)	1.200 - 1.430	30.48 - 36.22
1-3/4"	44.5	HG-1750-6 (5521886)	HG-1750-12 (5524917)	1.450 - 1.610	36.83 - 40.89
2"	50.8	HG-2000-6 (5521825)	HG-2000-12 (5521143)	1.700 - 1.930	43.18 - 49.02
2-1/2"	63.5	HG-2500-6 (5521098)	HG-2500-12	2.130 - 2.360	54.10 - 59.94

\*Longer reaches available on request



## Airetool (TSHB) Tube Sheet Hole Brush

Tube Sheet Hole Brushes are used to clean and polish the inside surface of the tube sheet holes prior to tube stuffing process.

Model Number	Order Number	Hole Size (in.)	
		in.	mm
TSHB-1/2	1716654	0.500	12.7
TSHB-5/8	1716655	0.625	15.9
TSHB-3/4	1716656	0.750	19.0
TSHB-7/8	1716657	0.875	22.2
TSHB-1	1716658	1.000	25.4
TSHB-1-1/4	1716659	1.250	31.8
TSHB-1-1/2	1717065	1.500	38.1



## Airetool (BTG) Tube Guide

Tube guides have a tapered aluminum pilot with a replaceable nylon brush and are used to guide tubes through tube sheets and support plate holes.

- Nylon brush fits in the tube end, holding pilot firmly in place.
- Speeds "tube stuffing" process which can lower installation costs
- Prevents damage to the tube end reducing rework and scrap materials

Tube O.D.		Gauge	Model Number	Order Number
in.	mm			
1/2"	12.7	16-18	BTG 050 1618 TUBE GUIDE BTG-1	5342004
1/2"	12.7	19-20	BTG 050 1920 TUBE GUIDE BTG-2	5342006
1/2"	12.7	21-23	BTG 050 2123 TUBE GUIDE BTG-2-1/2	5515585
5/8"	15.8	12-13	BTG 062 1213 TUBE GUIDE BTG-3	5342008
5/8"	15.8	14-16	BTG 062 1416 TUBE GUIDE BTG-4	5342010
5/8"	15.8	17-20	BTG 062 1720 TUBE GUIDE BTG-5	5342012
5/8"	15.8	19-22	BTG 060 1922 TUBE GUIDE	5526534PT
5/8"	15.8	22-24	BTG 062 2224 TUBE GUIDE BTG-5-1/2	5512197
3/4"	19	10-12	BTG 075 1012 TUBE GUIDE BTG-6	5342014
3/4"	19	13-16	BTG 075 1316 TUBE GUIDE BTG-7	5342016
3/4"	19	17-20	BTG 075 1720 TUBE GUIDE BTG-8	5342018
3/4"	19	22-24	BTG 075 2224 TUBE GUIDE BTG 8-1/2	5515738
7/8"	22.2	10-12	BTG 087 1012 TUBE GUIDE BTG 9	5342020PT
7/8"	22.2	13-16	BTG 087 1316 TUBE GUIDE BTG-10	5342022
7/8"	22.2	17-20	BTG 087 1720 TUBE GUIDE BTG-11	5342024
7/8"	22.2	21-22	BTG 087 2122 TUBE GUIDE BTG 11-1/2	5342026
1"	25.4	8-9	BTG 100 89 TUBE GUIDE BTG-12-1/2	5516015
1"	25.4	10-12	BTG 100 1012 TUBE GUIDE BTG 12	5342028
1"	25.4	13-16	BTG 100 1316 TUBE GUIDE BTG 13	5342030
1"	25.4	17-20	BTG 100 1720 TUBE GUIDE BTG 14	5342032
1"	25.4	21-23	BTG 100 2123 TUBE GUIDE BTG 14-1/2	5512141
1 - 1/4"	31.8	10-13	BTG 125 1013 TUBE GUIDE BTG 15	5342034
1 - 1/4"	31.8	14-20	BTG 125 1420 TUBE GUIDE BTG 16	5342036
1 - 1/2"	38.1	9-13	BTG 150 913 TUBE GUIDE	5342038
1 - 1/2"	38.1	14-20	BTG 150 1420 TUBE GUIDE	5342040

Other sizes are available upon request. Pilots made of other materials also available. A minimum order quantity of 50 per size applies for special sizes or materials.

## One Piece Tube Plugs

Ideal for sealing leaky tubes in condensers or heat exchangers. Just drive a plug into each end of leaky tube.

Note: The Airetool RCM Series One Revolution Tube Cutter can be used to puncture the tube to ensure that pressure cannot build up in the tube and cause the plugs to loosen or blow out. See page 57 for detailed information on the Airetool RCM Series Tube Cutters. Minimum order quantity 25 pieces.

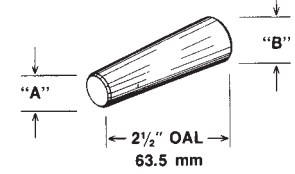

O.D.		Gauge	"A"		"B"		Brass	Steel	316* S.S.	304* S.S.	416* S.S.	Aluminum*	Monel*
in.	mm		in.	mm	in.	mm							
3/8	9.5	15-22	0.176	4.47	0.388	9.86	3751-3	3752-3	3753-3	3754-3	3755-3	3756-3	3757-3
1/2	12.7	11-14	0.176	4.47	0.388	9.86	(2979536)	(2980392)	(2985475)	3754-3	3755-3	3756-3	3757-3
1/2	12.7	15-22	0.301	7.65	0.513	13.03	5001-4	5002-4	5003-4	5004-4	5005-4	5006-4	5007-4
5/8	15.8	11-14	0.301	7.65	0.513	13.03	(2979537)	(2980022)	2981007	2986996	5005-4	5006-4	5007-4
5/8	15.8	15-22	0.426	10.82	0.638	16.20	6251-5	6252-5	6253-5	6254-5	6255-5	6256-5	6257-5
3/4	19	11-14	0.426	10.82	0.638	16.20	(2979231)	(2979232)	2983587	2979413	6255-5	6256-5	2982825
3/4	19	15-22	0.551	14.00	0.763	19.38	7501-6	7502-6	7503-6	7504-6	7505-6	7506-6	7507-6
7/8	22.2	11-14	0.551	14.00	0.763	19.38	(2979233)	(2979234)	2980988	2983589	7505-6	7506-6	2982944
7/8	22.2	15-22	0.676	17.17	0.888	22.56	8751-7	8752-7	8753-7	8754-7	8755-7	8756-7	8757-7
1	25.4	11-14	0.676	17.17	0.888	22.56	(2979235)	(2979236)	2981008	2983590	8755-7	8756-7	8757-7
1	25.4	15-22	0.801	20.35	1.013	25.73	1001-8	1002-8	1003-8	1004-8	1005-8	1006-8	1007-8
1-1/8	28.5	11-14	0.801	20.35	1.013	25.73	(2979237)	(2979238)	2983588	2983591	1005-8	1006-8	1007-8
1-1/8	28.5	15-22	0.926	23.52	1.138	28.90	1121-9	1122-9	1123-9	1124-9	1125-9	1126-9	1127-9
1-1/4	31.7	11-14	0.926	23.52	1.138	28.90	(2989650)	(2979553)	2994101	1124-9	1125-9	1126-9	1127-9
1-1/4	31.7	15-22	1.015	25.78	1.263	32.08	1251-10	1252-10	1253-10	1254-10	1255-10	1256-10	1257-10
1-3/8	34.9	11-14	1.015	25.78	1.263	32.08			2994102	1254-10	1255-10	1256-10	1257-10
1-3/8	34.9	15-22	1.176	29.87	1.388	35.26	1371-11	1372-11	1373-11	1374-11	1375-11	1376-11	1377-11
1-1/2	38.1	11-14	1.176	29.87	1.388	35.26	(2979748)	1373-11	1374-11	1375-11	1376-11	1377-11	1377-11
1-1/2	38.1	15-22	1.301	32.66	1.513	38.93	1501-12	1502-12	1503-13	1504-13	1505-13	1506-13	1507-13
1-1/2	38.1	15-22	1.301	32.66	1.513	38.93		(2991523)					

\* Some items available on quotation basis only

## Two Piece Tube Plugs

For sealing leaky tubes in condensers or heat exchangers. The two piece design has more sealing area and reduces the risk of damaging the tube sheet.

Note: The Airetool One Revolution Tube Cutter is recommended to puncture the tube to ensure that pressure cannot build up in the tube to cause the plug to loosen or blow out. See page 58 for detailed information on the RCM Series Tube Cutters. Minimum order quantity 25 pieces.



Tube Size					Brass Ring and Pin Set		Steel Ring and Pin Set	
O.D.		Gauge	Tube I.D.		Part Number	Order Number	Part Number	Order Number
in.	mm		in.	mm				
5/8	15.8	13	0.435	11.05	TP -6213-B	5523572	TP -6213-S	55233581
5/8	15.8	14	0.459	11.66	TP -6214-B	5522479	TP -6214-S	5520903
5/8	15.8	15	0.481	12.22	TP -6215-B	5523573	TP -6215-S	55233582
5/8	15.8	16	0.495	12.57	TP -6216-B	5520352	TP -6216-S	5519819
5/8	15.8	17	0.509	12.93	TP -6217-B	5523588	TP -6217-S	5523591
5/8	15.8	18	0.527	13.39	TP -6218-B	5519514	TP -6218-S	5520261
5/8	15.8	19	0.541	13.80	TP -6219-B	5520413	TP -6219-S	5523144
5/8	15.8	20	0.555	14.10	TP -6219-B	5520413	TP -6219-S	5523144
5/8	15.8	21	0.561	14.25	TP -6221-B	5520869	TP -6221-S	5523964
5/8	15.8	22	0.569	14.45	TP -6221-B	5520869	TP -6221-S	5523964
3/4	19.0	12	0.532	13.51	TP -6218-B	5519514	TP -6218-S	5520261
3/4	19.0	13	0.650	14.22	TP -6221-B	5520869	TP -6221-S	5523964
3/4	19.0	14	0.584	14.83	TP -7514-B	5519705	TP -7514-S	5520302
3/4	19.0	15	0.606	15.39	TP -7515-B	5520952	TP -7515-S	5520924
3/4	19.0	16	0.620	15.75	TP -7516-B	5519878	TP -7516-S	5519081
3/4	19.0	17	0.634	16.10	TP -7517-B	5520953	TP -7517-S	5521880
3/4	19.0	18	0.652	16.56	TP -7518-B	5519494	TP -7518-S	5519966
3/4	19.0	19	0.666	16.92	TP -7519-B	5518419	TP -7519-S	5523965
3/4	19.0	20	0.680	17.26	TP -7519-B	5518419	TP -7519-S	5523965
3/4	19.0	21	0.686	17.42	TP -7521-B	5519600	TP -7521-S	5523583
3/4	19.0	22	0.694	17.63	TP -7521-B	5519600	TP -7521-S	5523583
7/8	22.2	12	0.657	16.69	TP -7518-B	5519494	TP -7518-S	5519966

Tube Size					Brass Ring and Pin Set		Steel Ring and Pin Set	
O.D.		Gauge	Tube I.D.		Part Number	Order Number	Part Number	Order Number
in.	mm		in.	mm				
7/8	22.2	13	0.685	17.40	TP -7521-B	5519600	TP -7521-S	5523583
7/8	22.2	14	0.709	18.00	TP -8714-B	5522184	TP -8714-S	5521654
7/8	22.2	15	0.731	18.57	TP -8715-B	5523574	TP -8715-S	5523100
7/8	22.2	16	0.754	18.92	TP -8716-B	5522352	TP -8716-S	5522478
7/8	22.2	17	0.759	19.28	TP -8717-B	5523575	TP -8717-S	5522433
7/8	22.2	18	0.777	19.74	TP -8718-B	5520920	TP -8718-S	5519977
7/8	22.2	19	0.791	20.10	TP -8719-B	5523036	TP -8719-S	5523584
7/8	22.2	20	0.805	20.45	TP -8719-B	5523036	TP -8719-S	5523584
7/8	22.2	21	0.811	20.60	TP -8721-B	5523576	TP -8721-S	5520263
7/8	22.2	22	0.819	20.80	TP -8721-B	5523576	TP -8721-S	5520263
1	25.4	12	0.782	19.86	TP -8718-B	5520920	TP -8718-S	5519977
1	25.4	13	0.810	20.57	TP -8721-B	5523576	TP -8721-S	5520263
1	25.4	14	0.834	21.18	TP -1014-B	5521719	TP -1014-S	5520706
1	25.4	15	0.856	21.74	TP -1015-B	5523577	TP -1015-S	5523585
1	25.4	16	0.870	22.10	TP -1016-B	5519515	TP -1016-S	5522890
1	25.4	17	0.884	22.45	TP -1017-B	5522333	TP -1017-S	5523586
1	25.4	18	0.902	22.91	TP -1018-B	5519680	TP -1018-S	5520262
1	25.4	19	0.916	23.27	TP -1019-B	5520903	TP -1019-S	5523587
1	25.4	20	0.930	23.62	TP -1019-B	5520930	TP -1019-S	5523587
1	25.4	21	0.936	23.77	TP -1021-B	5523963	TP -1021-S	5520264
1	25.4	22	0.944	23.98	TP -1021-B	5523963	TP -1021-S	5520264

\*Some items available on quotation basis only



# Pop-A-Plug® CPI/Perma Heat Exchanger & Condenser Tube Plugging System

## Fast, Safe and Reliable Way to Seal Leaking Heat Exchangers & Condensers

Pop-A-Plug® CPI/Perma tube plugs are resistant to thermal cycling and are able to provide a seal that is helium leak tight. Pop-A-Plug® CPI/Perma tube plug installs using a controlled force. This protects against damage to tubesheet ligaments and adjacent tubesheet joints, extending the life of your heat exchanger and reducing total operating cost.

- **Fast** - Simple hydraulic installation significantly reduces turnaround/down time
- **Safe** - Pressure rated to 1,000 PsiG (69 BarG)
- **Reliable** - Provides helium leak tight seal to  $1 \times 10^{-6}$  cc/sec
- Lowest life cycle cost compared to alternative plugging methods
- Permanent solution, engineered for optimal performance throughout the life cycle of the heat exchanger
- Unique breakaway controls installation force for consistent repeatable results
- Eliminates need for welding or explosives
- Standard sizes - 0.472" - 2.067" (11.99mm - 52.50mm), larger sizes available upon request
- Available in - Brass, Carbon Steel, 316 Stainless Steel, 304 Stainless Steel, 4142 Alloy, 70/30 CU/NI, 90/10 CU/NI, Monel, Titanium, Duplex 2205, Chromoly Grade 11, Chromoly Grade 22, additional materials available upon request
- Engineered solution - Fast installation without ligament or roll joint damage
- Designed to be a Through-The-Tube plugging solution. Allows the tube plug to be passed through the length of a straight through-tube heat exchanger and installs in the tubesheet without removing the bundle or far end cover.
- 24/7 Emergency manufacturing service available
- Patented internal & external serrated ring
- Compliant with several QA Systems, including; ANSI N45.2, 10 CFR 50 App. B, and 10 CFR 21

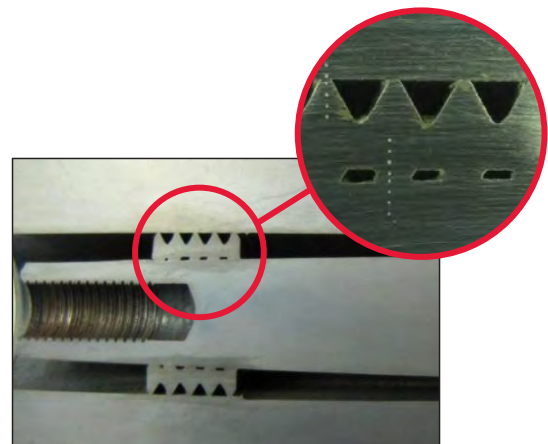
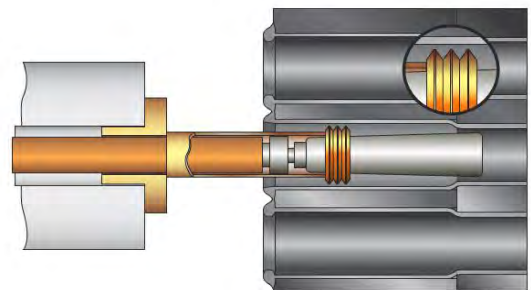

*Multiple points of contact with tube/tubesheet*



**CPI/Perma Plug - Sizing Chart**

Part Number	Tube I.D. Range (inches(mm))	Pin Length (inches(mm))	Brush Kit (hard alloys)	Brush Kit (soft alloys)	Positioner	Pull Rod Assembly	Channel Head Pull Rod Assembly
V-471-Q	0.472 - 0.515 (11.99 - 13.08)	1.630 (41.40)	BSH-471-HT	BSH-471	P-471	PA-471	CPA-471-YY
V-491-Q	0.492 - 0.540 (12.50 - 13.72)	1.670 (42.42)	BSH-491-HT	BSH-491	P-491	PA-491	CPA-491-YY
V-512-Q	0.513 - 0.562 (13.03 - 14.27)	1.590 (40.39)	BSH-512-HT	BSH-512	P-512	PA-512	CPA-512-YY
V-524-Q	0.525 - 0.585 (13.34 - 14.86)	1.280 (32.51)	BSH-524-HT	BSH-524	P-524	PA-524	CPA-524-YY
V-555-Q	0.556 - 0.616 (14.12 - 15.65)	1.400 (35.56)	BSH-555-HT	BSH-555	P-555	PA-555	CPA-555-YY
V-584-Q	0.585 - 0.649 (14.86 - 16.48)	1.320 (33.53)	BSH-584-HT	BSH-584	P-584	PA-584	CPA-584-YY
V-621-Q	0.622 - 0.689 (15.80 - 17.50)	1.570 (39.88)	BSH-621-HT	BSH-621	P-621	PA-621	CPA-621-YY
V-649-Q	0.650 - 0.713 (16.51 - 18.11)	1.320 (33.53)	BSH-649-HT	BSH-649	P-649	PA-649	CPA-649-YY
V-670-Q	0.671 - 0.740 (17.04 - 18.80)	1.660 (42.16)	BSH-670-HT	BSH-670	P-670	PA-670	CPA-670-YY
V-712-Q	0.713 - 0.777 (18.11 - 19.74)	1.320 (33.53)	BSH-712-HT	BSH-712	P-712	PA-712	CPA-712-YY
V-735-Q	0.736 - 0.810 (18.69 - 20.57)	1.680 (42.67)	BSH-735-HT	BSH-735	P-735	PA-735	CPA-735-YY
V-774-Q	0.775 - 0.838 (19.69 - 21.29)	1.320 (33.53)	BSH-774-HT	BSH-774	P-774	PA-774	CPA-774-YY
V-804-Q	0.805 - 0.890 (20.45 - 22.61)	1.700 (43.18)	BSH-804-HT	BSH-804	P-804	PA-804	CPA-804-YY
V-837-Q	0.838 - 0.902 (21.29 - 22.91)	1.320 (33.53)	BSH-837-HT	BSH-837	P-837	PA-837	CPA-837-YY
V-853-Q	0.854 - 0.949 (21.69 - 24.10)	1.720 (43.69)	BSH-853-HT	BSH-853	P-853	PA-853	CPA-853-YY
V-899-Q	0.900 - 0.963 (22.86 - 24.46)	1.320 (33.53)	BSH-899-HT	BSH-899	P-899	PA-899	CPA-899-YY
V-919-Q	0.920 - 1.019 (23.37 - 25.88)	1.760 (44.70)	BSH-919-HT	BSH-919	P-919	PA-919	CPA-919-YY
V-962-Q	0.963 - 1.027 (24.46 - 26.09)	1.320 (33.53)	BSH-962-HT	BSH-962	P-962	PA-962	CPA-962-YY
V-979-Q	0.980 - 1.079 (24.89 - 27.41)	1.820 (46.23)	BSH-979-HT	BSH-979	P-979	PA-979	CPA-979-YY
V-1024-Q	1.025 - 1.088 (26.04 - 27.64)	1.320 (33.53)	BSH-1024-NY	BSH-1024-NY	P-1024	PA-1024	CPA-1024-YY
V-1054-Q	1.055 - 1.154 (26.80 - 29.31)	1.900 (48.26)	BSH-1054-NY	BSH-1054-NY	P-1054	PA-1054	CPA-1054-YY
V-1087-Q	1.088 - 1.152 (27.64 - 29.26)	1.320 (33.53)	BSH-1087-NY	BSH-1087-NY	P-1087	PA-1087	CPA-1087-YY
V-1103-Q	1.104 - 1.203 (28.04 - 30.56)	1.900 (48.26)	BSH-1103-NY	BSH-1103-NY	P-1103	PA-1103	CPA-1103-YY
V-1149-Q	1.150 - 1.213 (29.21 - 30.81)	1.320 (33.53)	BSH-1149-NY	BSH-1149-NY	P-1149	PA-1149	CPA-1149-YY
V-1171-Q	1.172 - 1.270 (29.77 - 32.26)	2.000 (50.80)	BSH-1171-NY	BSH-1171-NY	P-1171	PA-1171	CPA-1171-YY
V-1212-Q	1.213 - 1.336 (30.81 - 33.93)	2.000 (50.80)	BSH-1212-NY	BSH-1212-NY	P-1212	PA-1212	CPA-1212-YY
V-1334-Q	1.335 - 1.458 (33.91-37.03)	2.000 (50.80)	BSH-1334-NY	BSH-1334-NY	P-1334	PA-1334L	CPA-1334L-YY
V-1456-Q	1.457 - 1.579 (37.01-40.11)	2.000 (50.80)	BSH-1456-NY	BSH-1456-NY	P-1456	PA-1456L	CPA-1456L-YY
V-1578-Q	1.579 - 1.701 (40.11-43.21)	2.000 (50.80)	BSH-1578-NY	BSH-1578-NY	P-1578	PA-1578L	CPA-1578L-YY
V-1700-Q	1.701 - 1.823 (43.21-46.30)	2.000 (50.80)	BSHV-1700-NY	BSHV-1700-NY	P-1700	PA-1700L	CPA-1700L-YY
V-1822-Q	1.823 - 1.945 (46.30-49.40)	2.000 (50.80)	BSH-1822-NY	BSH-1822-NY	P-1822	PA-1822L	CPA-1822L-YY
V-1944-Q	1.945 - 2.067 (49.40-52.50)	2.000 (50.80)	BSH-1944-NY	BSH-1944-NY	P-1944	PA-1944L	CPA-1944L-YY

Specifications subject to change without notice. See DC1224 for more information.

**Ordering Information**

Please supply the following information when ordering:

- Tube O.D. and wall thickness; or measured tube I.D.
- Tube material and/or tubesheet material
- Maximum pressure and temperature
- The type of tube-to-tubesheet joint (rolled, welded, etc.)
- Each kit includes a Go/ No-Go Gage for ensuring proper plug size (Brush kits and installation equipment sold separately.)

**Standard Materials**

- The suffix Q in the Part Number column is a plug material designator.
- Replace Q with one of the following: (B) for Brass, (C) for Carbon Steel, (S) for 316 Stainless Steel, (E) for 304 Stainless Steel, (A) for 4142 Alloy, (H) for 70/30 CU/NI, (N) for 90/10 CU/NI, (M) for Monel, (D) for Duplex 2205, (F11) for Chromoly Grade 11, (F22) for Chromoly Grade 22.
- (T) Titanium plugs do not have the same tube I.D. range. Please consult factory for ranges.
- The suffix (YY) in the Pull Rod Assembly column signifies the length, in feet, of the channel head extension. These parts are available in 1, 2, 3, 4, and 6 foot lengths (304.8, 609.6, 914.4, 1219.2 & 1828.8 mm). Add -01, -02, -03, etc. for the respective channel head extension length required.

## NEW! G-160 Tube Testing Tool

### Locate Pinhole Leaks with a Safe & Reliable Leak Detector

Early detection of leaking tubes in heat exchangers, boilers and condensers is essential to avoiding costly downtime. G-160 Tube Testing Tools from EST Group rapidly detect leaks while providing a safer environment for plant personnel. Innovative patent-pending gripper design provides increased operator safety. Operates with compressed air.

#### Features

- Patent-pending gripper design requires less operator force
- Interchangeable Seal & Washer Sets are size specific per tube I.D.
- Ergonomic design with push button activated air injection valve
- Safely test up to ten tubes per minute with less operator fatigue
- Durable corrosion resistant powder coated finish
- Lightweight aluminum construction (1.9lbs./0.9kg. ea.)
- Fully protected gauges - analog & digital available
- Neoprene seals



#### Kit Tube Size Range

- 0.49" - 1.11" (12.4mm - 28.2mm)

*with Optional Support Tube Assemblies*

- 0.28" - 1.81" (7.1mm - 46.0mm)

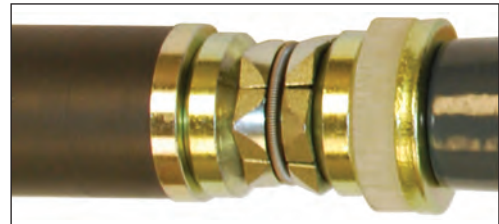

*Patent-pending gripper design*

#### Kit Includes

- Injection & Plugging Tools with analog gauges
- Support Tube Assemblies (GSA-1611 & GSA-1612)
- Wrench & Seal Sizing Gauge
- Impact-resistant Case



*Analog and optional Digital gauges*

<b>GSA-1600 Kit</b>	<b>GSA-1611 Support Tube Assembly</b>	
	Functional Range	0.49" - 0.86" (12.4mm - 21.8mm)
	Available Seal Sizes <i>sold separately, see chart below</i>	GSA-0050-N, GSA-0053-N, GSA-0056-N, GSA-0060-N, GSA-0062-N, GSA-0065-N, GSA-0068-N, GSA-0072-N, GSA-0075-N, GSA-0078-N, GSA-0081-N, GSA-0083-N
	<b>GSA-1612 Support Tube &amp; Gripper Assembly</b>	
	Functional Range	0.86" - 1.11" (21.8mm - 28.2mm)
	Gripper Assembly	GSA-1642
Available Seal Sizes <i>sold separately, see chart below</i>	GSA-0087-N, GSA-0090-N, GSA-0093-N, GSA-0097-N, GSA-0100-N, GSA-0103-N, GSA-0106-N, GSA-0108-N	

Standard kit (GSA-1600) ships with analog gauges - for digital gauges, please order (GSA-1600-D).

<b>Optional Support Tube &amp; Gripper Assemblies</b>	<b>GSA-1610 Support Tube Assembly</b>	
	Functional Range	0.28" - 0.48" (7.1mm - 12.2mm)
	Available Seal Sizes <i>sold separately, see chart below</i>	GSA-0028-N, GSA-0030-N, GSA-0033-N, GSA-0037-N, GSA-0040-N, GSA-0043-N, GSA-0047-N
	<b>GSA-1613 Support Tube &amp; Gripper Assembly</b>	
	Functional Range	1.11" - 1.50" (28.2mm - 38.1mm)
	Gripper Assembly	GSA-1643
	Available Seal Sizes <i>sold separately, see chart below</i>	GSA-0110-N, GSA-0112-N, GSA-0115-N, GSA-0118-N, GSA-0122-N, GSA-0126-NS, GSA-0131-NS, GSA-0134-NS, GSA-0137-NS, GSA-0140-NS, GSA-0143-NS, GSA-0147-NS
	<b>GSA-1614 Support Tube &amp; Gripper Assembly</b>	
	Functional Range	1.49" - 1.81" (37.7mm - 46.0mm)
	Gripper Assembly	GSA-1644
	Available Seal Sizes <i>sold separately, see chart below</i>	GSA-0150-NS, GSA-0153-NS, GSA-0156-NS, GSA-0158-NS, GSA-0162-NS, GSA-0165-NS, GSA-0168-NS, GSA-0173-NS, GSA-0178-NS

### Extended Length Support Tube Assemblies available

1ft - 4ft lengths available for easier testing when a channel head or water box is present, contact EST Group Customer Service for details.

### Neoprene Seal & Washer Set Sizing Chart *(required for above configurations - sold separately)*

Tube OD	1/2"	5/8"	3/4"	7/8"	1"	1 1/8"	1 1/4"	1 3/8"	1-1/2"	1-5/8"	1-3/4"	2"
BWG												
8 - 9	-	0030	0043	0056	0068	0081	0093	0106	0118	0131	0143	0168
10 - 11	-	0037	0047	0062	0072	0087	0097	0112	0122	0137	0147	0173
12 - 13	0028	0040	0053	0065	0078	0090	0103	0115	0128	0140	0153	0178
14 - 15	0033	0047	0056	0072	0083	0097	0110	0122	0134	0147	0158	-
16 - 17	0037	0050	0062	0075	0087	0100	0112	0126	0137	0150	0162	-
18 - 19	0040	0053	0065	0078	0090	0103	0115	0128	0140	0153	0165	-
20 - 24	0043	0056	0068	0081	0093	0106	0118	0131	0143	0156	0168	-

Contact **EGI** Customer Service for seal sizing and part numbers for applications in SWG, metric, or other tube sizes. Alternate seal materials including Viton® available.

Viton® is a registered trademark of DuPont Dow Elastomers.

# Tube Installation Accessories

Joint Testers



AJT-6500 JOINT TESTER

## Joint Testing Tools

The Airetool "AJT" Joint Tester is designed to test for leaks between the tube & the tube sheet on both rolled and welded joints. Easy to use push buttons activate, test and reset the Joint Tester for quick verification. Joint testers comes complete with one manifold assembly and one seal for the tube size ordered. Specify tube O.D. and gauge when ordering.

**Tube Range: 0.625 -1.250" O.D. (15.87 - 31.75mm)**

Air Requirements: 40 -125 PSI (2.7 - 8.5 bar)

- Standard method for testing tube joints providing reliable results
- Fast acting, easy to use tester saves time and reduces labor costs
- Seals are sized specifically for the tube I.D. creating a positive seal

Tube Size		AJT-6500 Joint Tester Assembly	AJT-6500 Joint Tester Replacement Parts		
Tube	BWG	Assembly Number	Seal Description Number (1 Required)	Manifold W/ Square O-Ring	Square O-Ring
5/8"	8-9 10-11 12-13 14-15 16-17	AJT 6500 5/8SP (5525585)	ATT 300 N (2996173) ATT 350 N (2900798) ATT 370 N (2988090) ATT 450 N (2984360) ATT 470 N (2900799)	AJT 6500 5/8SP (2900823)	AJT 16 5/8 (2984663)
	18-19 20-24		ATT 490 N (2984361) ATT 530 N (2984362)		
3/4"	8-9 10-11	AJT 6500 3/4SP (5525586)	ATT 430 N (2995248) ATT 450 N (2984360)	AJT 6500 3/4SP (2900824)	AJT 16 3/4 (2984664)
	12-13 14-15 16-17 18-19 20-24		ATT 490 N (2984361) ATT 530 N (2984362) ATT 570 N (2984363) ATT 610 N (2984364) ATT 650 N (2984365)		
7/8"	8-9 10-11 12-13 14-15 16-17 18-19 20-24	AJT 6500 7/8 (5525567)	ATT 530 N (2984362) ATT 570 N (2984363) ATT 610 N (2984364) ATT 690 N (2984366) ATT 730 N (2900800) ATT 740 N (2984367) ATT 790 N 405 (2984929)	AJT 6500 7/8 (2984358)	AJT 16 7/8 (2984665)
	8-9 10-11 12-13 14-15 16-17 18-19 20-24		ATT 650 N (2984365) ATT 690 N (2984366) ATT 740 N (2984367) ATT 790 N (2984368) AJT 840 N (2984502) AJT 870 N (2900810) AJT 890 N (2984503)		
1"	8-9 10-11 12-13 14-15 16-17 18-19 20-24	AJT 6500 1 (5525568PT)	ATT 790 N 405 (2984933) ATT 840 N (2984369) ATT 870 N (2900801) ATT 940 N (2984492) ATT 980 N (2900802) ATT 990 N (2984671) ATT 1040 N (2984672)	AJT 6500 1 (2984359)	AJT 16 1 (2984666)
	8-9 10-11 12-13 14-15 16-17 18-19 20-24		ATT 890 N (2984370) ATT 940 N (2984492) ATT 990 N (2984671) ATT 1080 N (2900803) ATT 1090 N (2984673) ATT 1100 N (2900804) ATT 1140 N (2984674)		

AJT Joint Tester	Ordering Number
AJT 6500 Joint Tester Kit*	5520175PT
AJT 6500 Gun w/o manifold	2900807

\* Kit consists of: Joint Tester, 6 manifolds (5/8" - 1-1/4"), and 1 ea. ATT470 - ATT1140 seals

AJT 6500 Manifold Assemblies	Ordering Number	Tube I.D. Range	
		in.	mm
AJT 6500 5/8SP	2900823	.280 - .480	7.1 - 12.3
AJT 6500 5/8	2984356	.490 - .830	12.4 - 21.2
AJT 6500 3/4SP	2900824	.280 - .480	7.1 - 12.3
AJT 6500 3/4	2984357	.490 - .830	12.4 - 21.2
AJT 6500 7/8	2984358	.490 - .830	12.4 - 21.2
AJT 6500 1	2984359	.490 - 1.230	12.4 - 31.2
AJT 6500 1 1/8	2984669	.840 - 1.230	21.3 - 31.2
AJT 6500 1 1/4	2984670	.840 - 1.230	21.3 - 31.2



SEAL WITH WASHER



SEAL WITH BACKUP WASHER

## Tube Testing Tools

The advanced design of the Airetool "ATT" Tube Testers enable an operator to test the entire length of the tube between the tube sheets for leaks, merely by pressing a button. Air pressure is induced through the gun causing the seals to expand. Easy to read gauges will display and hold pressure if there are no leaks. The tester comes complete with two #ATT-15-312 support tubes, two #ATT-15-405 support tubes and two seals for the tube size specified. Specify tube O.D. and gauge when ordering.

**Tube Range: 0.625 -1.250" O.D. (15.875 - 31.75mm)**

Air Requirements: 40 -125 PSI (2.7 - 8.5 bar)

- Standard method for testing tubes providing reliable results
- Fast acting, easy to use tester saves time and reduces labor costs
- Seals are sized specifically for the tube I.D. creating a positive seal



ATT-6525 TUBE TESTER

Tube Size		ATT-6525 Tube Tester placement Parts		
Tube in. (mm)	BWG	Tube Seal & Washer (2 required)	Support Tube Seal & Washer (2 required)	Support Tube Assembly*
5/8 (18.5)	8-9	ATT 300 N (2996173)	ATT -500-U (2984659)	ATT-15-125 (2984870)
	10-11	ATT 350 N (2900798)		
	12-13	ATT 370-N (2988090)		
	14-15	ATT 450 N (2984360)		
	16-17	ATT 470 N (2900799)		
	18-19	ATT 490 N (2984361)		
3/4 (19.0)	20-24	ATT 530 N (2984362)	ATT -900-U (2984660)	ATT-15-312 (2984871)
	8-9	ATT 430 N (2995248)		
	10-11	ATT 450 N (2984360)		
	12-13	ATT 490 N (2984361)		
	14-15	ATT 530 N (2984362)		
	16-17	ATT 570 N (2984363)		
7/8 (22.2)	18-19	ATT 610 N (2984364)	ATT-15-312 (2984871)	ATT-15-312 (2984871)
	20-24	ATT 650 N (2984365)		
	8-9	ATT 530 N (2984362)		
	10-11	ATT 570 N (2984363)		
	12-13	ATT 610 N (2984364)		
	14-15	ATT 690 N (2984366)		
1 (25.4)	16-17	ATT 730 N (2900800)	ATT -1250-U (2987062)	ATT-15-312 (2984871)
	18-19	ATT 740 N (2984367)		
	20-24	ATT 790 N 405 (2984929)		
	8-9	ATT 650 N (2984365)		
	10-11	ATT 690 N (2984366)		
	12-13	ATT 740 N (2984367)		
1-1/8 (28.5)	14-15	ATT 790 N (2984368)	ATT -1500-U (2984661)	ATT-15-405 (2984872)
	16-17	ATT 840 N (2984369)		
	18-19	ATT 870 N (2900801)		
	20-24	ATT 890 N (2984370)		
	8-9	ATT 790 N 405 (2984929)		
	10-11	ATT 840 N (2984369)		
1-1/4 (31.7)	12-13	ATT 870 N (2900801)	ATT-15-405 (2984872)	ATT-15-405 (2984872)
	14-15	ATT 940 N (2984492)		
	16-17	ATT 980 N (2900802)		
	18-19	ATT 990 N (2984671)		
	20-24	ATT 1040 N (2984672)		
	8-9	ATT 890 N (2984370)		
1-1/4 (31.7)	10-11	ATT 940 N (2984492)	ATT-15-405 (2984872)	ATT-15-405 (2984872)
	12-13	ATT 990 N (2984671)		
	14-15	ATT-1080 N (2900803)		
	16-17	ATT 1090 N (2984673)		
	18-19	ATT 1100 N (2900804)		
	20-24	ATT 1140 N (2984674)		

\* Support Tube Assembly consists of: Support Tube, Back-up Washer Set, and Locknut

Tube Tester Kit*	Ordering Number	Tube Sizes	
		in.	mm
ATT 6526 Tube Tester Kit 5/8 7/8		5/8 - 7/8	18.5 - 22.2
ATT 6526 Tube Tester Kit 1 1-1/4		1 - 1-1/4	25.4 - 31.7
ATT 6526 Tube Tester Kit 5/8 1-1/4	5520174PT	5/8 - 1-1/4	18.5 - 31.7
ATT 6525 Gun and Support Tube Kit**	5518407PT	5/8 - 1-1/4	18.5 - 31.7

\* Kits include: Guns, standard length Support Tubes, Seals, Washers, and carrying case for range indicated  
 \*\* Includes: Guns and standard length Support Tubes in carrying case

ATT Tube Tester Guns	Ordering Number
ATT 6525 1 Injection Gun	2984876
ATT 6525 2 Plugging Gun	2984877

Support Tube Assemblies	Ordering Number	Support Tube Length		Tube I.D. Range	
		in.	mm	in.	mm
ATT-15-125	2984870	4	101.6		
ATT-15-125-12	2902119	12	304.8	.280 - .480	7.1 - 12.3
ATT-15-125-24	2903223PT	24	609.6		
ATT-15-312	2984871	4	101.6		
ATT-15-312-12	2985236	12	304.8	.490 - .830	12.4 - 21.2
ATT-15-312-24	2985238	24	609.6		
ATT-15-405	2984872	4	101.6		
ATT-15-405-12	2902120	12	304.8	.840 - 1.230	21.3 - 31.2
ATT-15-405-24	2985242	24	609.6		



## Hydrostatic Test Pumps

Hydrostatic Test pumps are a staple in the petro chemical, pipe welding and testing industries. Having been in these industries for more than 25 years, we have perfected the power, pressure, weight and speed ratios of hydrostatic test pumps. Our pumps are USA made here in Houston, Texas. Safety is our number one concern. Only the highest quality components are used in the assembly process of our pumps. We are the originators for the Aluminum box design and two-wheeled cart design. These unique features were a product of listening to our customers over a period of years. The wheeled cart design allows you to maneuver in close quarters and traverse long distances with ease. The box design allows you to stack our pumps where and when applicable. Especially if you have a large rental fleet. Our pumps deliver the reliability and dependability that you expect and deserve when pressure testing pipe and vessels. Every pump is tested prior to departing the factory to ensure it meets our rigid quality control specifications.

### EGI HTP-10K Hydrostatic Test Pump

The HTP-10K was designed with ease and mobility in mind. Bringing up to 10,000 PSI to the job in a wheeled mobile configuration. The large 8" swivel casters allow the operator to bring the pump to the testing area and not have to worry about the terrain or flat tires.



Max. Pressure ..... 9700 PSI  
 Volume @ 100CPM ..... 1.00 GPM  
 Pressure Ratio ..... 97 to 1  
 Max. CFM Req'd ..... .56 CFM  
 Max. Air Req'd ..... 100 PSI

### P-Series Hand Pump

A self-contained and portable hand pump for testing tubes, pipes, and pressure vessels. It is integrated into a 5 gallon attached reservoir which is easily refilled. The pump is hand operated, which eliminates the need for compressed air. With the turn of a knob, the pressure output can be adjusted to either 1,000 PsiG (68.9 BarG), 2,000 PsiG (137.9 BarG), or 3,000 PsiG (206.8 BarG) for the appropriate application. There is also an optional silicone-filled gauge for all weather use and minimal moving parts for durability and longevity. High pressure bleed valve and hose with swivel fitting included.



### P-Series

### P-Series Hand Pump

Model Number	Maximum Outlet Pressure (PsiG(BarG))	Discharge Volume per Stroke (cu in(ml))
PSR-HP-3000	3000 (206.8)	0.73 (11.96)

Length (inches(mm))	Width (inches(mm))	Height (inches(mm))	Approximate Shipping Weight (lbs(kg))
24 (609.6)	7 (177.8)	27 (685.8)	25 (11.34)

## Tube Drifts and Collapsing Tools

For the quick removal of tube stubs from tube sheets.

- For 1/2" - 1" (12.7 - 25.4mm) OD tubes
- Select 01 or 06 style shanks
- 15 style jumbo shanks stocked and available by request
- Standard length is 6". Longer length available upon request.

### Tube Drifts

Tube O.D.		Gauge	Description / Order Number	
in.	mm		-01 Shank	-06 Shank
1/2	12.7	12	TD 500 12 01 (2952840)	TD 500 12 06 (2952890)
1/2	12.7	14	TD 500 14 01 (2953200)	TD 500 14 06 (2953250)
1/2	12.7	16	TD 500 16 01 (2953560)	TD 500 16 06 (2953610)
1/2	12.7	18	TD 500 18 01 (2953920)	TD 500 18 06 (2953970)
1/2	12.7	20	TD 500 20 01 (2972633)	TD 500 20 06 (2979763)
5/8	15.8	10	TD 625 10 01 (2954280)	TD 625 10 06 (2954330)
5/8	15.8	12	TD 625 12 01 (2954640)	TD 625 12 06 (2954690)
5/8	15.8	13	TD 625 13 01 (2954820)	TD 625 13 06 (2954870)
5/8	15.8	14	TD 625 14 01 (2955000)	TD 625 14 06 (2955050)
5/8	15.8	15	TD 625 15 01 (2955180)	TD 625 15 06 (2955230)
5/8	15.8	16	TD 625 16 01 (2955360)	TD 625 16 06 (2955410)
5/8	15.8	17	TD 625 17 01 (2955540)	TD 625 17 06 (2955590)
5/8	15.8	18	TD 625 18 01 (2955720)	TD 625 18 06 (2955770)
5/8	15.8	19	TD 625 19 01 (2972630)	TD 625 19 06 (2979765)
5/8	15.8	20	TD 625 20 01 (2972631)	TD 625 20 06 (2978637)
3/4	19.1	10	TD 750 10 01 (2956080)	TD 750 10 06 (2956130)
3/4	19.1	12	TD 750 12 01 (2956440)	TD 750 12 06 (2956490)
3/4	19.1	13	TD 750 13 01 (2956620)	TD 750 13 06 (2956670)
3/4	19.1	14	TD 750 14 01 (2956800)	TD 750 14 06 (2956850)
3/4	19.1	15	TD 750 15 01 (2956980)	TD 750 15 06 (2957030)
3/4	19.1	16	TD 750 16 01 (2957160)	TD 750 16 06 (2957210)
3/4	19.1	17	TD 750 17 01 (2957340)	TD 750 17 06 (2957390)
3/4	19.1	18	TD 750 18 01 (2957520)	TD 750 18 06 (2957570)
3/4	19.1	19	TD 750 19 01 (2972617)	TD 750 19 06 (2979767)
3/4	19.1	20	TD 750 20 01 (2972618)	TD 750 20 06 (2979768)
7/8	22.2	14	TD 875 14 01 (2958600)	TD 875 14 06 (2958650)
7/8	22.2	15	TD 875 15 01 (29587800)	TD 875 15 06 (2958830)
7/8	22.2	16	TD 875 16 01 (2958960)	TD 875 16 06 (2959010)
7/8	22.2	18	TD 875 18 01 (2959320)	TD 875 18 06 (2959370)
7/8	22.2	20	TD 875 20 01 (2972620)	TD 875 20 06 (2979771)
1	25.4	10	TD 1000 10 01 (2959680)	TD 1000 10 06 (2959730)
1	25.4	12	TD 1000 12 01 (2960040)	TD 1000 12 06 (2960090)
1	25.4	13	TD 1000 13 01 (2960220)	TD 1000 13 06 (2960270)
1	25.4	14	TD 1000 14 01 (2960400)	TD 1000 14 06 (2960450)
1	25.4	15	TD 1000 15 01 (2960580)	TD 1000 15 06 (2960630)
1	25.4	16	TD 1000 16 01 (2960760)	TD 1000 16 06 (2960810)
1	25.4	17	TD 1000 17 01 (2960940)	TD 1000 17 06 (2960990)
1	25.4	18	TD 1000 18 01 (2961120)	TD 1000 18 06 (2961170)
1	25.4	19	TD 1000 19 01 (2972622)	TD 1000 19 06 (2979773)
1	25.4	20	TD 1000 20 01 (2972623)	TD 1000 20 06 (2979774)



TUBE DRIFT



COLLAPSING TOOL



JUMBO SHANK DRIFT



### Collapsing Tools

Tube O.D.		Gauge	Description / Order Number	
in.	mm		-01 Shank	-06 Shank
3/8	9.5	16-22	CT-375-01 (2950000)	CT-375-06 (2980055)
1/2	12.7	16-22	CT-500-01 (2950030)	CT-500-06 (2950080)
5/8	15.8	16-22	CT-625-01 (2950210)	CT-625-06 (2950260)
3/4	19.1	16-22	CT-750-01 (2950390)	CT-750-06 (2950440)
7/8	22.2	16-22	CT-875-01 (2950570)	CT-875-06 (2950620)
1	25.4	16-22	CT-1000-01 (2950750)	CT-1000-06 (2950800)

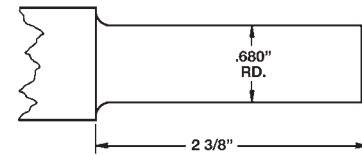

Type No. 01

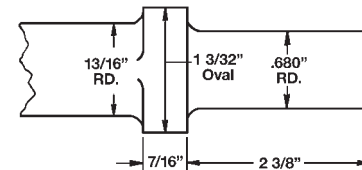

Type No. 06

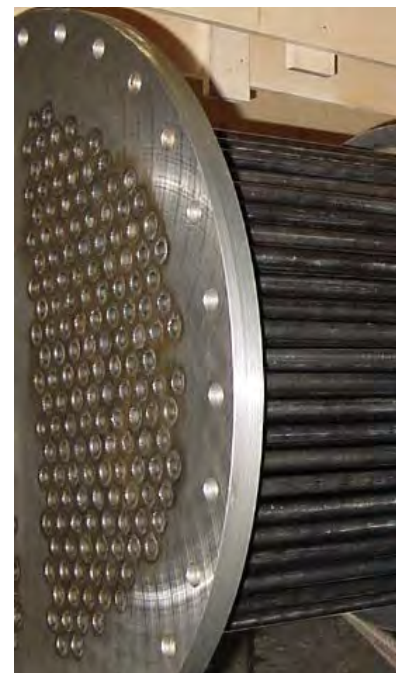

# Tube Removal Tools

Chipping Hammers & Rivet Busters

## Chipping Hammers and Rivet Busters



Beading Chisel



### CH Series Heavy-Duty Chipping Hammers

Four bolt design eliminates handle breakage. Includes chisel retainer and chisel retainer spring. Aluminum handle model available. **Most parts interchangeable with Sullair CH series chipping hammers. Please specify 0.580 hex or 0.680 round shank.**

Specs	Retainer Retainer Spring		
	CH2R/ CH2H	CH3R/ CH3H	CH4R/ CH4H
Blows Per Min.	2300	2100	1700
Stroke	3"	3-3/4"	4-1/4"
Bore	1-1/8"	1-1/8"	1-1/8"
Shank Dia.	0.580H/ 0.680R	0.580H/ 0.680R	0.580H/ 0.680R
Length	14"	15-1/4"	16-1/2"
Weight	17 lbs.	18.5 lbs.	19.5 lbs.
Air Inlet	1/2"	1/2"	1/2"
Avg. Air. Cons.	31 cfm	35 cfm	39 cfm



### CH-ITD Series Inside Trigger Chipping Hammers

Inside trigger design for greater comfort and control. Features include plate valve, vibration spacers, rotating exhaust and replaceable inlet bushings. 4-Bolt design reduces handle breakage. **Please specify 0.580 hex or 0.680 round shank.**

Specs	Retainer Retainer Spring		
	CH2R-ITD/ CH2H-ITD	CH3R-ITD/ CH3H-ITD	CH4R-ITD/ CH4H-ITD
Blows Per Min.	2300	2100	1700
Stroke	3"	3-3/4"	4-1/4"
Bore	1-1/8"	1-1/8"	1-1/8"
Shank Dia.	0.580H/ 0.680R	0.580H/ 0.680R	0.580H/ 0.680R
Length	14-5/8"	16-1/2"	17-1/2"
Weight	17.2 lbs.	18.7 lbs.	19.4 lbs.
Air Inlet	1/2"	1/2"	1/2"
Avg. Air. Cons.	31 cfm	35 cfm	39 cfm

### K2LR-RET/K2LH-RET Chipping Hammer

Smallest line of chippers featuring standard .580 hex or .680 round shank bushing. **Parts interchangeable with Ingersoll-Rand K2L models. Please specify 0.580 hex or 0.680 round shank.**

	Retainer Retainer Spring
1190-1.655	Retainer
1194-2	Retainer Spring
Blows Per Minute	3600
Stroke	1-3/4"
Bore	7/8"
Length	12"
Weight	8 lbs.
Air Inlet Thread	1/4"
Avg. Air Consumption	12 cfm



EG1 133-NEP

EG1 1133-NEP

### EG1 133-NEP EG1 1133-NEP Rivet Buster

Powerful long stroke hammer has the ability to perform all extra heavy-duty demolition applications. Ideal for cutting large rivets, bolts and underground tanks. **Equipped to accept 2000 series jumbo chisels. Model 1133-NEP features a non-ejectable piston.**

Specifications	133-NEP	1133-NEP
Capacity	7/8" Rivets	1"
Bore	1-3/16"	1-3/16"
Piston Stroke	8"	11"
Blows Per Minute	960	850
Length	22"	25"
Weight	30 lbs.	34 lbs.
Shank Diameter	1.5"	1.5"
Air Inlet Thread	3/8"	3/8"



EG1 4181-8-USA-NEP

EG1 4181-USA-NEP

### EG1 4181-8-USA-NEP EG1 4181-USA-NEP Rivet Buster

Ideal for cutting large rivets, concrete demolition, and heavy-duty chipping work in maintenance and construction. Features a Boyer spool valve to deliver smooth power in any operating position. Equipped to accept 2000 series jumbo chisels.

Specifications	4181-8-USA-NEP	4181-USA-NEP
Capacity	7/8" Rivets	1" Rivets
Bore	1-3/16"	1-3/16"
Piston Stroke	8"	11"
Blows Per Minute	1080	720
Length	23"	26"
Weight	31.25 lbs.	34.5 lbs.
Shank Diameter	1.5"	1.5"
Air Inlet Thread	3/8"	3/8"



## Tube Wall Reducing Tools (TWRT)

Tube Wall Reducing Tools are used on heavy gauge tubes in order to reduce the tube wall thickness prior to removing them with a tube drift tool. Available with Morse taper shank.

- Thins tube wall for easier removal with tube drift

Minimum order quantity 3 pieces

Tube O.D.		Tube Gauge	Model	Order Number	Morse Taper*	Tube Sheet Thickness**	
in.	mm					in.	mm
3/8	9.5	16	TWRT-375-16	2980132	#1	2.88	73.03
3/8	9.5	17	TWRT-375-17	2992775	#1	2.88	73.03
3/8	9.5	18	TWRT-375-18	2974712	#1	2.88	73.03
3/8	9.5	20	TWRT-375-20	2978341	#1	2.88	73.03
3/8	9.5	21	TWRT-375-21	2976259	#1	2.88	73.03
3/8	9.5	22	TWRT-375-22	2989963	#1	2.88	73.03
1/2	12.7	17	TWRT-500-17	2677209	#2	2.88	73.03
1/2	12.7	18	TWRT-500-18	2677210	#2	2.88	73.03
1/2	12.7	19	TWRT-500-19	2998102	#2	2.88	73.03
1/2	12.7	20	TWRT-500-20	2982800	#2	2.88	73.03
1/2	12.7	21	TWRT-500-21	2998103	#2	2.88	73.03
1/2	12.7	22	TWRT-500-22	2998104	#2	2.88	73.03
5/8	15.8	12	TWRT-625-12	2677216	#2	3.38	85.73
5/8	15.8	13	TWRT-625-13	2677217	#2	3.38	85.73
5/8	15.8	14	TWRT-625-14	2677218	#2	3.38	85.73
5/8	15.8	15	TWRT-625-15	2677219	#2	3.38	85.73
5/8	15.8	16	TWRT-625-16	2677220	#2	3.38	85.73
5/8	15.8	17	TWRT-625-17	2677221	#2	3.38	85.73
5/8	15.8	18	TWRT-625-18	2677222	#2	3.38	85.73
5/8	15.8	19	TWRT-625-19	2972480	#2	3.38	85.73
5/8	15.8	20	TWRT-625-20	2972479	#2	3.38	85.73
5/8	15.8	21	TWRT-625-21	2984261	#2	3.38	85.73
5/8	15.8	22	TWRT-625-22	2993158	#2	3.38	85.73
3/4	19.1	10	TWRT-750-10	2677226	#2	4.38	111.13
3/4	19.1	11	TWRT-750-11	2677227	#2	4.38	111.13
3/4	19.1	12	TWRT-750-12	2677228	#2	4.38	111.13
3/4	19.1	13	TWRT-750-13	2677229	#2	4.38	111.13
3/4	19.1	14	TWRT-750-14	2677230	#2	4.38	111.13
3/4	19.1	15	TWRT-750-15	2677231	#2	4.38	111.13
3/4	19.1	16	TWRT-750-16	2677232	#2	4.38	111.13
3/4	19.1	17	TWRT-750-17	2677233	#2	4.38	111.13

\* Other shanks styles available on request

\*\*Longer reach available on request

## 600-D Air Drill

Powerful Heavy Duty air drill recommended for use with Airetool serrating tools, push-type tube cutters, and tube wall reducing tools.

- 4.5 Horsepower D-Handle drill provides plenty of power
- Governed motor for consistent cutting speeds
- Reversible support handle for added leverage
- Optional Morse taper adapter makes it universal with tube wall reducing tools, drill bits, and reamers.

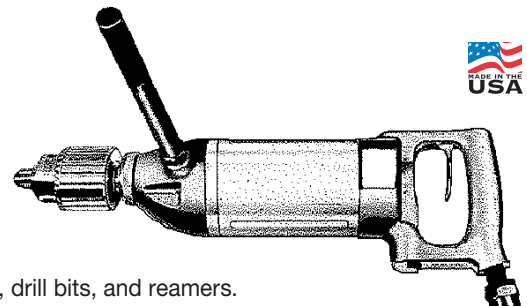

Model	Order Number	Horsepower	Speed	Drill Capacity		Reamer Capacity		Length		Weight		Spindle Thread	Side-to-Center		Air Inlet		Hose Size	
		Hp.	rpm	in.	mm	in.	mm	in.	mm	lbs.	kg		in.	mm	in.	mm	in.	mm
600 D 100	8405289	4.5	100	3/4	19.0	5/8	15.8	18.0	457.0	16.0	7.3	5/8 - 16	1.5	38.1	1/2	12.7	1/2	12.7
600 D 200	6024900	4.5	200	3/4	19.0	5/8	15.8	18.0	457.0	16.0	7.3	5/8 - 16	1.5	38.1	1/2	12.7	1/2	12.7
600 D 265	6025000	4.5	265	3/4	19.0	5/8	15.8	18.0	457.0	16.0	7.3	5/8 - 16	1.5	38.1	1/2	12.7	1/2	12.7
600 D 335	6025100	4.5	335	5/8	15.8	5/8	15.8	18.0	457.0	16.0	7.3	5/8 - 16	1.5	38.1	1/2	12.7	1/2	12.7
600 D 625	6025200	4.5	625	1/2	12.7	7/16	11.1	18.0	457.0	16.0	7.3	5/8 - 16	1.5	38.1	1/2	12.7	1/2	12.7

Stock numbers for Drills with Jacobs Chuck  
Chucks and Morse Taper adapter part numbers



# Tube Removal Tools



## Airetool PIC Internal Tube Cutters

The "PIC" internal tube cutters are an economical solution to low volume tube cutting of various tube materials. Optimum tube cutting performance and tooling life are obtained when the Airetool CF Series cutter feed assist is used to match the cutting speed to the tube material.

**Available for tube sizes  
5/8" - 1-1/4" OD (15.8 - 31.8mm)**

- Two-piece construction allows for quick and easy tool bit replacement.
- Cutter bits are now available with TiN coating, increasing the cutter bit life.
- Airetool PIC tube cutters are sold with a complete set of pilots and two spare tool bit sets
- Larger sizes and longer reaches available upon request.

Tube O.D.		PIC Tube Cutter Reach*			Pilots (incl.)
(in.)	mm	Standard	"A"	"C"	(gauge)
1/2	12.70	PIC 500 (5519733)	PIC 500 A	PIC 500 C	18 - 20
5/8	15.88	PIC 625 (5515553)	PIC 625 A (5515557)	PIC 625 C (5515559)	16 - 20
3/4	19.05	PIC 750 (5515560)	PIC 750 A (5515540)	PIC 750 C (5515514)	14 - 20
7/8	22.22	PIC 875 (5515562)	PIC 875 A (5515564PT)	PIC 875 C (5515566PT)	15 - 20
1	25.4	PIC 1000 (5515567)	PIC 1000 A (5515568)	PIC 1000 C (5515554)	12 - 20
1-1/8	28.57	PIC 1125 (5515820)	PIC 1125 A	PIC 1125 C	14, 16, 18
1-1/4	31.75	PIC 1250 (5518134PT)	PIC 1250 A	PIC 1250 C	14, 16, 18

\* Standard Reach = 1-11/16 to 4-7/16" (43 to 110mm)

"A" Reach = 4-11/16 to 7-7/16" (119 to 189mm)

"C" Reach = 8-3/16 to 10-15/16" (208 to 278mm)

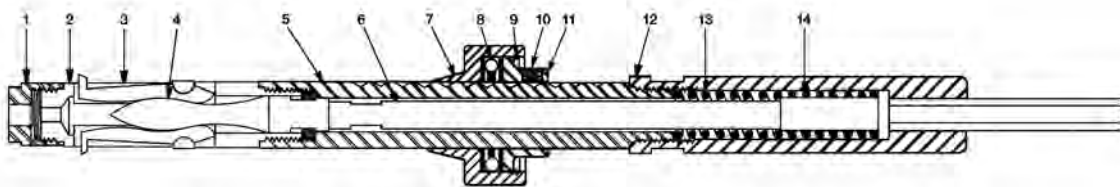

Item Number	Description	5/8" (16mm) 16-20GA	3/4" (19mm) 14-20GA	7/8" (22mm) 16-20GA	1" (25mm) 12-20GA
		Part No. (Order No.)	Part No. (Order No.)	Part No. (Order No.)	Part No. (Order No.)
	Complete PIC Cutter*	PIC-625 (5515553)	PIC-750 (5515560)	PIC-875 (5515562)	PIC-1000 (5515567)
1	Pilot	TTC 6 (2675000)	TTC-6-14 (2668900)	TTC-6-15 (2676400)	TTC-36-12 (2672500)
1	Pilot	TTC-46-18 (2675100)	TTC-6-15 (2669000)	TTC-56-16 (2990534)	TTC-36-13 (2672600)
1	Pilot	TTC-46-19 (2675200)	TTC-6-16 (2669100)	TTC-56-17 (2990535)	TTC-36-14 (2672700)
1	Pilot	TTC-46-20 (2675300)	TTC-6-17 (2669200)	TTC-56-18 (2676500)	TTC-36-15 (2672800)
1	Pilot	TTC 46 22 (2974902)	TTC-6-18 (2669300)	TTC-56-19 (2676600)	TTC-36-16 (2672900)
1	Pilot	TTC 46 23 (2976001)	TTC-6-19 (2669400)	TTC-56-20 (2676700)	TTC-36-17 (2673000)
1	Pilot	TTC 46 24 (2976002)	TTC-6-20 (2669500)		TTC-36-18 (2673100)
1	Pilot				TTC-36-19 (2673200)
1	Pilot				TTC-36-20 (2673300)
2	Body Tip	IC-41 (2979725)	IC-1 (2979306)	IC-51 (2979726)	IC-31 (2979419)
3	Tool Bit* (Non-ferrous)	TTC-43 (5338869)	TTC-3 (5338865)	TTC-53 (5338871)	TTC-33 (5338867)
3	Tool Bit* (Ferrous)	TTC-43-S (5338870)	TTC-3-S (5338866)	TTC-53-S (5338872)	TTC-33-S (5338868)
3	Tool Bit* (Stainless)	TTC-43-SS (5518303)	TTC-3-SS (5517614)	TTC-53-S (5517757)	TTC-33-SS (5516337)
4	Mandrel Tip	IC-44-T (2979724)	IC-4-T (2979308)	IC-34-T (2979409)	IC-34-T (2979409)
5	Body Extension	IC-41X (2979688)	IC-1X (2979672)	IC-51X (2979692)	IC-31X (2979680)
6	Mandrel Extension	IC-4X (2979676)	IC-4X (2979676)	IC-34X (2979684)	IC-34X (2979684)
7	Thrust Body	TTC-47 (2675400)	TTC-7 (2669600)	TTC-57 (2676800)	TTC-37 (2673300)
8	Bearing	TTC-9 (2670000)	TTC-9 (2670000)	TTC-39 (2673800)	TTC-39 (2673800)
9	Thrust Spring	TTC-10 (2670100)	TTC-10 (2670100)	TTC-40 (2673900)	TTC-40 (2673900)
10	Set Screw	10-32X1/4 (8000800)	10-32X1/4 (8000800)	10-32X1/4 (8000800)	10-32X1/4 (8000800)
11	Thrust Nut	TTC-48 (2675700)	TTC-8 (2669900)	TTC-58 (2677100)	TTC-38 (2673700)
12	Spring Housing	PIC-21 (2979752)	PIC-21 (2979752)	PIC-21 (2979752)	PIC-21 (2979752)
13	Spring	PTC-5 (2574180)	PTC-5 (2574180)	PTC-5 (2574180)	PTC-5 (2574180)
14	Driver	PIC-4 (2979751)	PIC-4 (2979751)	PIC-4 (2979751)	PIC-4 (2979751)

\*Standard length listed



## Air Driven Tube Cutter (TIC)

Complete tube cutting system for various tube materials. Five models available in speeds from 100 to 625 rpm for various steel and non-ferrous tube applications.

- Powerful, 4.5 Horsepower motor with D-handle
- Governed motor for consistent cutting speeds
- Positive lever-operated feed of cutter bit
- One mandrel drive adapter works with all sizes of cutters (TTC-30, ordering number 2671400)



RPM	Tube Material	Cutter Complete			
		5/8" O.D.	3/4" O.D.	7/8" O.D.	1" O.D.
<b>Pneumatic Models</b>					
625	Non-ferrous	TIC-625-625 (5515586)	TIC625-750 (5515590)	TIC-625-875 (5515594)	TIC-625-1000 (5515598)
335	Non-ferrous/Ferrous	TIC-350-625 (5515602)	TIC-350-750 (5515606)	TIC-350-875 (5515610)	TIC-350-1000 (5515614)
265	Ferrous-Stainless	TIC-265-625 (5515618)	TIC-265-750 (5515622)	TIC-265-875 (5515626)	TIC-265-1000 (5515630)
200	Ferrous-Stainless	TIC-200-625 (5518909)	TIC-200-750 (5518459)	TIC-200-875 (5522345)	TIC-200-1000 (5519460)
100	Stainless & Titanium	TIC-100-625 (5519526)	TIC-100-750 (5517806)	TIC-100-875 (5522125)	TIC-100-1000 (5518512)
40	Titanium & Inconel	TIC-40-625 (5521860)	TIC-40-750 (5518184)	TIC-40-875	TIC-40-1000

## Cutter Bodies Complete for TIC Models

Several design improvements have been incorporated for maintenance and increased service life

- Shorter and stronger cutter body improves durability and increases bit life
- Cutter body is threaded into body extension for easier bit replacement
- Standard mandrel driver fits all sizes of Airetool tube cutters
- Adjustable reach "IC" cutter bodies:
  - Standard reach 1-11/16" to 4-7/16" (42 - 112mm) shown above
  - "A" reach = 4-11/16" to 7-7/16" (112 - 188mm)
  - "C" reach = 8-3/16" to 10-15/16" (207 - 277mm)
- Larger sizes and longer lengths available upon request.

Description	Tube O.D.			
	5/8" O.D.	3/4" O.D.	7/8" O.D.	1" O.D.

### Tube Cutter body Sub-assemblies for TIC & EIC models

Cutter Body Complete	IC-625 (5515574)	IC-750 (5515577)	IC-875 (5515581)	IC-1000 (5515571)
Tool Bit* (Non-ferrous)	TTC-43 (5338869)	TTC-3 (5338865)	TTC-53 (5338871)	TTC-33 (5338867)
Tool Bit* (Ferrous)	TTC-43-S (5338870)	TTC-3-S (5338866)	TTC-53-S (5338872)	TTC-33-S (5338868)
Tool Bit* (Stainless)	TTC-43-SS (5518303)	TTC-3-SS (5517614)	TTC-53-SS (5517757)	TTC-33-SS (5516337)

\* Tool Bit part numbers above consist of 2 bits each.  
 Tube Cutter Bodies consists of all parts necessary to convert models TIC & EIC to different tube size.

Specify desired reach:  
 Standard Reach 4-7/16" (112.7mm) shown  
 "A" Reach 7-7/16" (188.9mm)  
 "C" Reach 10-15/16" (277.8mm)



# Tube Removal Tools

## RCM One Revolution Tube Cutters

For cutting tubes beyond the tube sheet in heat exchangers, condensers, and boilers. RCM series tube cutters are also an excellent tool for puncturing defective tubes prior to tube plugging. This reduces the risk of pressure buildup in plugged tubes.



- Designed for hand use by employing a ratchet or hand wrench for manual operation
- Available in standard reaches of 6" (152mm) and 10" (254mm)
- Longer reaches are available in 10" increments upon request



Tube O.D.		BWG	Tube I.D.	Tool Reach		Cutting Bit
in.	mm			6" (152.4mm)	10" (254.0mm)	
1/2	12.70	18-19	.400"-.420" 10.2-10.7mm	RCM-105 (5522994)	RCM-105-10 (5523116)	RC-500-2 (2993368)
1/2	12.70	20	.430"-.450" 11.0-11.3mm	RCM-110 (5522929)	RCM-110-10	RC-500-2 (2993368)
5/8	15.88	14	.450"-.470" 11.4-11.9mm	RCM-115 (5522995)	RCM-115-10 (5523118)	RC-625-2 (2993372)
5/8	15.88	15-16	.472"-.510" 12-12.9mm	RCM-120 (5522930)	RCM-120-10 (5523119)	RC-625-2 (2993372)
5/8	15.88	17-18	.500"-.531" 12.7-13.5mm	RCM-130 (5522931)	RCM-130-10 (5523120)	RC-625-2 (2993372)
5/8	15.88	19-20	.531"-.560" 13.5-14.2mm	RCM-135 (5522996)	RCM-135-10 (5523121)	RC-625-2 (2993372)
5/8	15.88	22	.550"-.580" 14.0-14.7mm	RCM-140 (5522932)	RCM-140-10 (5524952)	RC-625-2 (2993372)
3/4	19.05	12-13	.530"-.560" 13.5-14.2mm	RCM-135-3/4 (5523115)	RCM-135-3/4-10 (5526397)	RC-750-2A (2995865)
3/4	19.05	14-15	.580"-.610" 14.7-15.5mm	RCM-150 (5522933)	RCM-150-10 (5523123)	RC-750-2 (2993374)
3/4	19.05	16	.600"-.630" 15.2-16.0mm	RCM-155 (5522997)	RCM-155-10 (5523124)	RC-750-2 (2993374)
3/4	19.05	17-18	.625"-.650" 15.9-16.5mm	RCM-160 (5522934)	RCM-160-10 (5523125)	RC-750-2 (2993374)
3/4	19.05	19-20	.660"-.690" 16.7-17.5mm	RCM-170 (5522935)	RCM-170-10 (5523126PT)	RC-750-2 (2993374)
7/8	22.22	14-15	.700"-.730" 17.8-18.5mm	RCM-180 (5522936)	RCM-180-10 (5523127)	RC-875-2 (2993384)
7/8	22.22	16-17	.740"-.770" 18.8-19.5mm	RCM-190 (5522937)	RCM-190-10 (5523128)	RC-875-2 (2993384)
7/8	22.22	18	.760"-.790" 19.3-20.0mm	RCM-195 (5522998)	RCM-195-10 (5524478)	RC-875-2 (2993384)
7/8	22.22	19-20	.780"-.810" 19.8-20.6mm	RCM-200 (5522938)	RCM-200-10 (5523241PT)	RC-875-2 (2993384)
1	25.40	12	.760"-.790" 19.3-20.0mm	RCM-195 (5522998)	RCM-195-10 (5524478)	RC-875-2 (2993384)
1	25.40	14	.820"-.850" 20.8-21.6mm	RCM-210 (5522939)	RCM-210-10 (5523131)	RC-1000-2 (2993394)
1	25.40	15	.840"-.870" 21.3-22.1mm	RCM-215 (5522999)	RCM-215-10 (5523132)	RC-1000-2 (2993394)
1	25.40	16-17	.860"-.890" 21.8-22.6mm	RCM-220 (5522940)	RCM-220-10 (5523133)	RC-1000-2 (2993394)

Tube O.D.		BWG	Tube I.D.	Tool Reach		Cutting Bit
in.	mm			6" (152.4mm)	10" (254.0mm)	
1	25.40	18-19	.890"-.910" 22.6-23.1mm	RCM-230 (5522941)	RCM-230-10 (5523134)	RC-1000-2 (2993394)
1	25.40	22	.940"-.970" 23.9-24.6mm	RCM-240 (5522942)	RCM-240-10 (5525584)	RC-1000-2 (2993394)
1-1/4	31.75	12	1.020"-1.050" 25.9-26.7mm	RCM-260 (5523000)	RCM-260-10 (5523136)	RC-1250-2 (2993404)
1-1/4	31.75	13-14	1.050"-1.080" 26.7-27.4mm	RCM-270 (5523001)	RCM-270-10 (5523137)	RC-1250-2 (2993404)
1-1/4	31.75	15-16	1.100"-1.130" 27.9-28.7mm	RCM-280 (5523002)	RCM-280-10 (5523138)	RC-1250-2 (2993404)
1-1/4	31.75	17-19	1.130"-1.160" 28.7-29.6mm	RCM-290 (5523003)	RCM-290-10 (5523139)	RC-1250-2 (2993404)
1-3/8	34.93	13-14	1.180"-1.210" 30-30.7mm	RCM-300 (5523709)	RCM-300-10 (5525838)	RC-1500-2 (2993417)
1-1/2	38.10	12-13	1.280"-1.310" 32.5-33.3mm	RCM-330 (5523004)	RCM-330-10 (5523140)	RC-1500-2 (2993417)
1-1/2	38.10	14-15	1.330"-1.360" 33.8-34.5mm	RCM-340 (5523005)	RCM-340-10 (5523005)	RC-1500-2 (2993417)
1-1/2	38.10	16-17	1.360"-1.390" 34.5-35.3mm	RCM-350 (5523006)	RCM-350-10 (5523142)	RC-1500-2 (2993417)
1-1/2	38.10	18-19	1.390"-1.420" 35.3-36.1mm	RCM-360 (5523007)	RCM-360-10 (5523143)	RC-2000-2 (2993427)
2	50.80	12-13	1.770"-1.810" 45.0-46.0mm	RC-2012 (5521677)	RC-2012-10	RC-2000-2 (2993427)
2	50.80	14-15	1.820"-1.860" 46.2-47.2mm	RC-2014 (5521678PT)	RC-2014-10	RC-2000-2 (2993427)
2	50.80	16-17	1.860"-1.900" 46.2-48.2mm	RC-2016 (5521679)	RC-2016-10	RC-2000-2 (2993427)
2	50.80	18-19	1.890"-1.930" 48.0-49.0mm	RC-2018 (5521680)	RC-2018-10	RC-2000-2 (2993427)
2-1/2	63.50	12-13	2.270"-2.310" 57.6mm-58.6	RC-2512 (5521681)	RC-2512-10	RC-2000-2 (2993427)
2-1/2	63.50	14-15	2.320"-2.360" 58.9-60.0mm	RC-2514 (5521682)	RC-2514-10	RC-2000-2 (2993427)
2-1/2	63.50	16-17	2.360"-2.400" 60.0-61.0mm	RC-2516 (5521683)	RC-2516-10	RC-2000-2 (2993427)
2-1/2	63.50	18-19	2.390"-2.430" 60.7-61.7mm	RC-2518 (5521684)	RC-2518-10	RC-2000-2 (2993427)

## Tube Pulling Systems & Pumps

Tube Pulling Systems consist of:

1. Pump Assembly - air/hydraulic or electric/hydraulic (includes hose assembly)
2. Ram Assembly - gripper or spear type
3. Grippers or Spears - Gripper kit / adapter kit with spear / collar with spear (depends on ram selected)

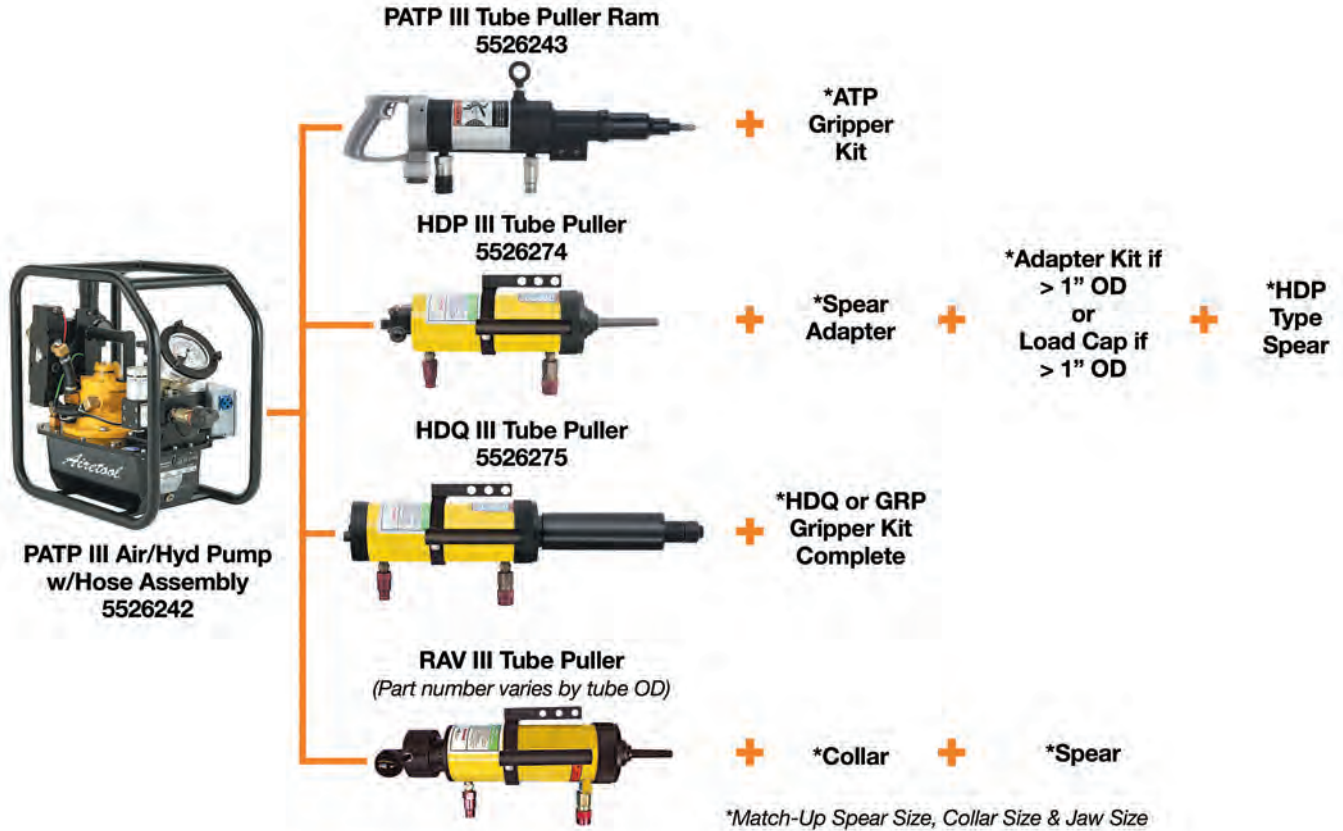

## Tube Pulling Pumps & Accessories

The ATP III & PATP III Pumps are engineered to deliver superior performance and durability. They work in combination with a variety of different tube pulling RAMs.

- Pumps come mounted in a roll cage with casters and large wheels for protection and increased mobility
- Control cables and hydraulic hoses are bundled together for greater safety
- Hydraulic hoses have quick connect fittings for easy attachment to the pump and tube pulling ram

Description	Ordering Number
ATP III Electric/Hydraulic Pump with Hoses, Cord and Pendant	5526244
PATP III Air/Hydraulic Pump with Hose Assembly and Pendant	5526242





# ATP III Tube Pullers

Electric Driven

## ATP III Tube Pullers

Electric/Hydraulic Semi-automatic Tube Pullers For Light & Medium Duty Applications

- The Airetool Model ATP III Tube Pulling Ram develops 13-3/4 tons of pulling power
- Easily remove tubes up to 1 in. O.D. from tube sheets up to 1-1/2 in. thickness\*
- Grippers bite uniformly into the tube I.D. as the piston retracts, pulling the tube from the sheet
- Provides a full 4-3/4 inch total pulling length through a double 2-3/8 inch pull
- Electric switch in the handle of the ram enables the hydraulic pump to operate the ram cylinder
- Puller reverses instantly at the end of the pulling cycle or when the trigger is released

\* Puller capacity of the ATP Ram will vary with tube wall thickness, tube sheet thickness and tube material.



PUMP SHOWN WITHOUT WHEEL ASSEMBLY ATTACHED



ATP-III TUBE PULLING RAM



ATP-9000B HCA HOSE/CORD ASSEMBLY

The following components are required for most common tube pulling applications

Ordering Number	Description
5526244	ATP III Electric/Hydraulic Pump with Hoses, Cord, and Pendant
5526295	ATP III Tube Puller Ram Assembly
5525470PT	ATP 9000B HCA Hose/Cord Assembly
5522513	ATP 9064A 15 Cord Assembly
See page 62	Gripper Kit (tube size specific)

# PATP III Tube Pullers

Air Driven

*Airetool*



PUMP SHOWN WITH WHEEL ASSEMBLY ATTACHED

## PATP III Tube Pullers

Air/Hydraulic Semi-automatic Tube Pullers For Light & Medium Duty Applications

- The Airetool Model PATP III Tube Pulling Ram develops 13-3/4 tons of pulling power
- Easily remove tubes up to 1 in. O.D. from tube sheets up to 1-1/2 in. thickness\*
- Grippers bite uniformly into the tube I.D. as the piston retracts, pulling the tube from the sheet
- Provides a full 4-3/4 inch total pulling length through a double 2-3/8 inch pull
- Electric switch in the handle of the ram enables the hydraulic pump to operate the ram cylinder
- Puller reverses instantly at the end of the pulling cycle or when the trigger is released

\* Puller capacity of the PATP Ram will vary with tube wall thickness, tube sheet thickness and tube material.

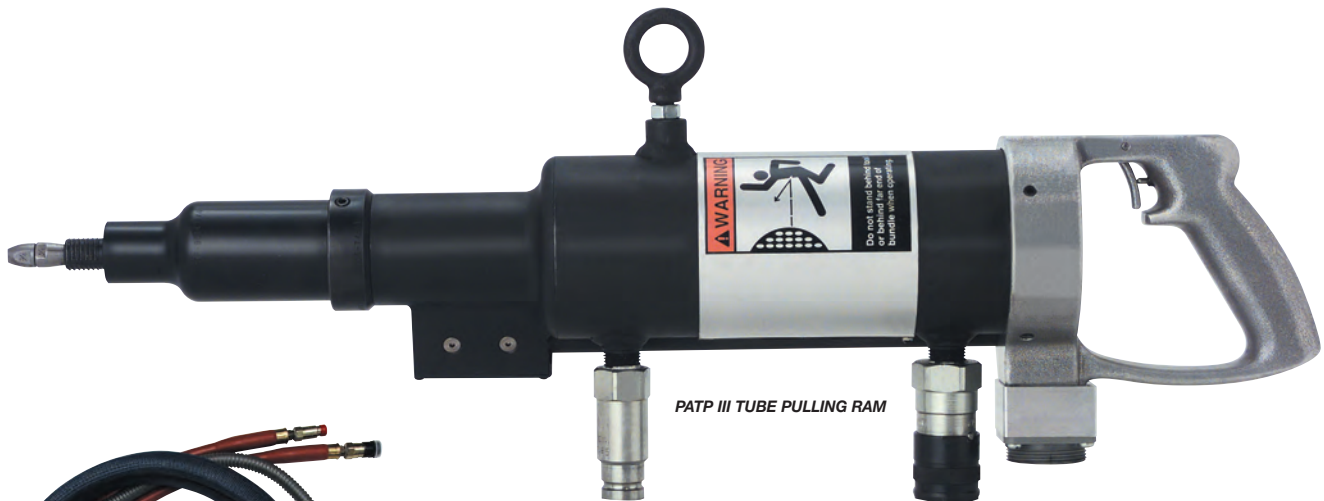

PATP III TUBE PULLING RAM



PATP-9000B HCA HOSE/  
CORD ASSEMBLY



OPTIONAL PENDANT  
ASSEMBLY

The following components are required for most common tube pulling applications

Ordering Number	Description
5526242	PATP III Air/Hydraulic Pump with hose assembly and Pendant
5526243	PATP III Tube Puller Ram Assembly
5524903PT	PATP HT Hose/Tube Assembly
See page 62	Gripper Kit (tube size specific)

Optional pendant for use with HDP III, HDQ III, RAV III and PATP Pumps

Ordering Number	Description
5524904	PATP HDP Pendant Assembly



# ATP III Gripper Kit

## ATP III & PATP III Gripper Kit Components

Features of the ATP III Tube Pulling System Include:

- Free-floating gripper design results in uniform contact on the tube ID for better pulling characteristics and increased durability
- Grippers are segmented, allowing replacement of single gripper segment in the event of tooth breakage
- Grippers bite uniformly into the tube I.D. as the piston retracts, pulling the tube from the sheet
- Grippers are available from 5/8" through 1" accommodating a wide range of tube gages
- Optional 18 in. extension kit provides a useful method of removing hard-to-reach tubes

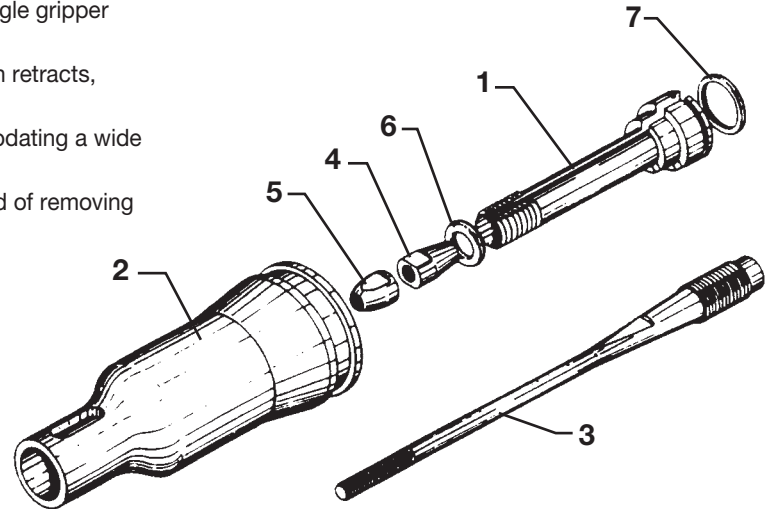

Tube Size (O.D.)		Tube Gauge	Part Number	Gripper Kit* Order Number	1 Gripper Complete** Order Number	2 Nose Bushing	3 Draw Rod	4 Expansion Nut	5 Lock Nut	6 Front O-ring	7 Rear O-ring
in.	mm										
.625	15.9	16-18	ATP-9022-568	5520782	5520793	ATP -9042-5/8 (2991245)	ATP -9034-5/8 (2991237)	ATP -9035-5/8 (2991238)	ATP -9036-5/8 (2991239)	200-9 (3105400)	RTV-65 (3094500)
.625	15.9	20-22	ATP-9022-522	5520783	5520794						
.750	19.1	14-15	ATP-9022-34	5520784	5520795	ATP -9014-3/4 (2991218)	ATP -9015-3/4 (2991224)	ATP -9016-3/4 (2991226)	ATP -9017-3/4 (2991227)	2-113 (3010453)	900-83 (3220900)
.750	19.1	16-18	ATP-9022-368	5520785	5520796						
.750	19.1	20-22	ATP-9022-322	5520786	5520797						
.875	22.2	12-14	ATP-9022-724	5520787	5520798	ATP -9027-7/8 (2991232)	ATP -9037-7/8-1 (2991240)	ATP -9038-7/8-1 (2991241)	ATP -9039-7/8-1 (2991242)	2-113 (3010453)	900-83 (3220900)
.875	22.2	16-18	ATP-9022-768	5520788	5520799						
.875	22.2	20-22	ATP-9022-722	5520789	5520800						
1.000	25.4	12-14	ATP-9022-124	5520790	5520801	ATP -9041-1 (2991244)					
1.000	25.4	16-18	ATP-9022-168	5520791	5520802						
1.000	25.4	20-22	ATP-9022-122	5520792	5520803						

\* Gripper Kit consists of 3 gripper segments, one nose bushing, one draw rod, one expansion nut, one lock nut, and both O-Rings.

\*\* Gripper Complete consists of 3 Gripper Segments and both O-Rings.

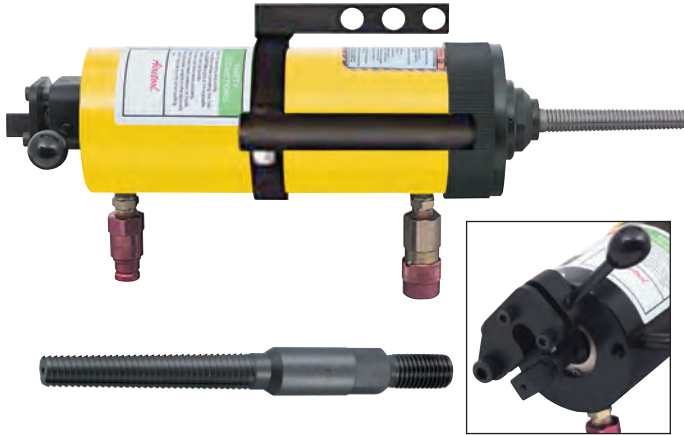

### For Tube Sizes 1/2" thru 1" the following accessories are required:

- HDP 99 3055 3 Spear Adapter (2900051)
- Tube Pulling Spear - refer to the chart below for size selection
- Optional load cap may be required if surrounding tubes are protruding and are closely spaced

### For Tube Sizes 1-1/8" thru 2-1/2" the following accessories are required:

- HDP 99 3055 3 Spear Adapter (2900051)
- HDP 99 Adapter Kit - refer to the chart below for size selection
- Tube Pulling Spear - refer to the chart below for size selection
- 5526274 HDP III Ram Kit includes:  
5526273 Ram, 5526280 Adapter Lock Assembly, and  
2900007 HDP 99 LC 1 Load Cap

### HDP III Tube Pulling Spears

Tube Size			Order Number	Small Diameter End		Large Diameter End		Overall Length	Flat Size
in.	mm	Gauge		in.	mm	in.	mm		
1/2	12.7	20	2983511	0.427	10.8mm	0.499	12.7mm		
5/8	15.8	12-13	2968758	0.402	10.2mm	0.61	15.5mm		
5/8	15.8	14-15	2968759	0.454	11.5mm	0.662	16.8mm		
5/8	15.8	16-17	2968760	0.489	12.4mm	0.625	15.9mm		
5/8	15.8	18-19	2968761	0.521	13.2mm	0.625	15.9mm		
5/8	15.8	20	2979942	0.545	13.8mm	0.62	15.7mm		
3/4	19.0	10	2968759	0.454	11.5mm	0.662	16.8mm		
3/4	19.0	11-13	2968762	0.505	12.8mm	0.713	18.1mm		
3/4	19.0	14-15	2968764	0.597	15.2mm	0.75	19.1mm		
3/4	19.0	16-17	2968765	0.614	15.6mm	0.75	19.1mm	8-3/4"	7/8" HEX
3/4	19.0	18-19	2968766	0.646	16.4mm	0.75	19.1mm	222mm	22.2mm
3/4	19.0	20	2979941	0.67	17.0mm	0.745	18.9mm		
7/8	22.2	14-15	2968769	0.699	17.8mm	0.875	22.2mm		3/4-10 MALE Thread
7/8	22.2	16-17	2968768	0.74	18.8mm	0.948	24.1mm		
7/8	22.2	17-18	2968770	0.755	19.2mm	0.963	24.5mm		
7/8	22.2	20	2983512	0.8	20.3mm	0.874	22.2mm		
1	25.4	9-10	2968769	0.699	17.8mm	0.875	22.2mm		
1	25.4	11	2968770	0.755	19.2mm	0.963	24.5mm		
1	25.4	12-13	2968771	0.777	19.7mm	0.985	25.0mm		
1	25.4	14-15	2968772	0.829	21.1mm	1	25.4mm		
1	25.4	16-17	2968773	0.869	22.1mm	1	25.4mm		
1	25.4	18-20	2968774	0.896	22.8mm	1	25.4mm		
1-1/4	31.7	7-8	2968775	0.856	21.7mm	1.114	28.3mm		
1-1/4	31.7	10-11	2968776	0.977	24.8mm	1.206	30.6mm		
1-1/4	31.7	12-13	2968778	1.027	26.1mm	1.256	31.9mm	5-1/2"	1-1/4" HEX
1-1/4	31.7	14-15	2968780	1.079	27.4mm	1.308	33.2mm	140mm	38.8mm
1-1/4	31.7	16-18	2968781	1.115	28.3mm	1.344	34.1mm		
1-1/2	38.1	10-11	2968782	1.227	31.2mm	1.456	37.0mm		3/4-10 FEMALE Thread
1-1/2	38.1	12-13	2968784	1.277	32.4mm	1.5	38.1mm		
1-1/2	38.1	14	2968786	1.329	33.8mm	1.5	38.1mm		



### HDP III Ram & Accessories

Model Number	Description	Order Number
	HDP III Tube Pulling Ram	5526273
	HDP III ALA Adapter Lock Assembly	5526280
	HDP 99 3055 3 Adapter	2900051
	HDP 99 3055 5 Adapter Extension	2900011
	HDP 99 3055 3 MF Adapter Extension	2900633
	HDP 99 3055 3D Double Pull Adapter	2968857
	HDP 99 LC 1 Load Cap	2900007
	HDP 99 LC 5/8 Load Cap	2900008
	HDP 99 LC 3/4 Load Cap	2900009
	HDP 99 LC 7/8 Load Cap	2900010

### HDP III Adapter Kits

Tube O.D.		Adapter Kit*		Extension Chair	
in.	mm	Model Number	Order Number	Model Number	Order Number
1-1/8 - 1-1/2	28.5 - 38.1	HDP 99 3055 AK 1 1/2	5525287	HDP 99 3055 7 1 1/2 QC	2900001
1-3/4	44.4	HDP 99 3055 AK 1 3/4	5525288	HDP 99 3055 7 1 3/4 QC	2900002PT
2	50.8	HDP 99 3055 AK 2	5525289	HDP 99 3055 7 2 QC	2900003
2-1/2	63.5	HDP 99 3055 AK 2 1/2	5525290	HDP 99 3055 7 2 1/2 QC	2900004PT

\*Kits include: HDP 99 3055 5 Adapter Extension (2900011) and extension chair listed in chart above.



# HDQ III Tube Pullers

## HDQ-III Tube Pullers

- HDQ III Gripper-type tube puller is designed for pulling 1-1/4" thru 1 - 3/4" O.D. tubes in heat exchangers and fire tube boilers using HDQ Gripper Kits (shown below). This gripper-type tube puller makes tube pulling faster and easier. See selection charts below for ordering gripper kits and components for the tube sizes being pulled.

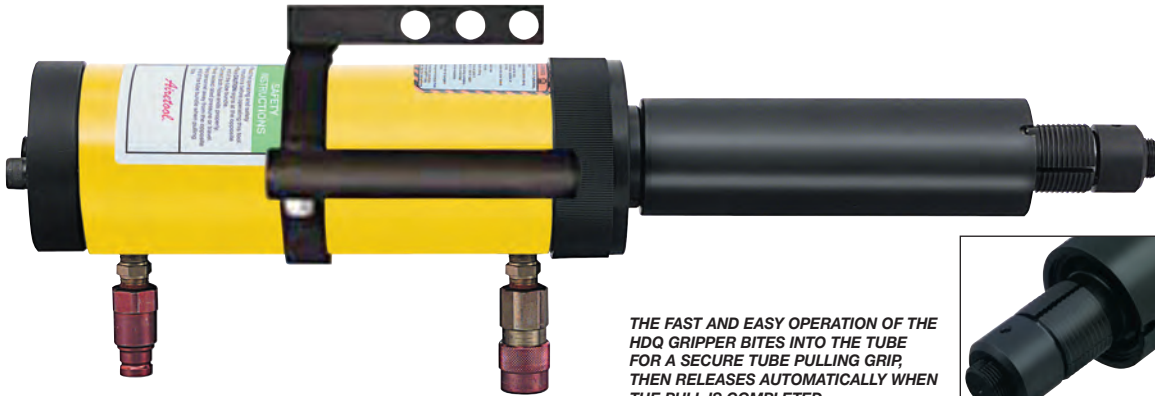

THE FAST AND EASY OPERATION OF THE HDQ GRIPPER BITES INTO THE TUBE FOR A SECURE TUBE PULLING GRIP, THEN RELEASES AUTOMATICALLY WHEN THE PULL IS COMPLETED.

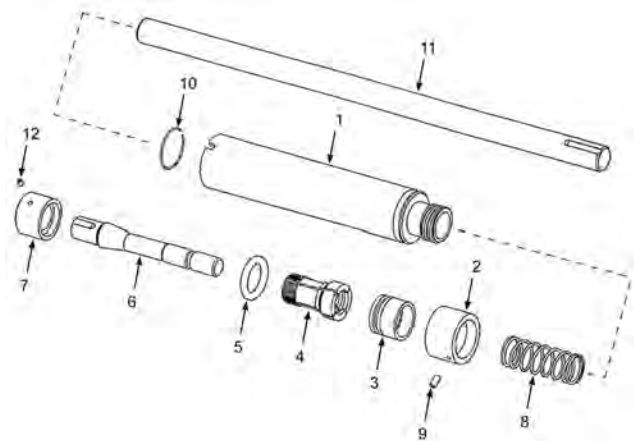

### HDQ III Ram & Accessories

Model Number	Order Number
HDQ III Tube Puller*	5526275PT
HTP III RAM	5526273
HDQ III Adapter Plate	2902631

\* Includes RAM and Adapter Plate

Tube O.D.	Tube Wall BWG	Gripper Kit Complete*	Item Name	HDQ 99 Chair	Position Sleeve	Sleeve Adapter	Gripper	O-Ring	Mandrel	Stop Nut	Spring	Position Sleeve Set Screw	Retainer Ring	Drawbar	Stop Nut Set Screw	
in.	mm		Item Number	1	2	3	4	5	6	7	8	9	10	11	12	
1-1/4	31.7	8-10	HDQ 99 125 8/10 (5525293)	Description	HDQ 99 7 125F QC Chair	HDQ 125 PS	HDQ 125 SA	HDQ 125 1		HDQ 125 M	HDQ 125 1SN	HDQ 31 8	10-32 x 3/16	HDQ 125	HDQ 99 5	10-32 x 3/16
			Order Number	2999993	2985180	2985186	2985168	3094100	2985196	2985191	2985203	8009800	2985357	2900012	8009800	
			Quantity	1	1	1	6	1	1	1	1	1	1	1	1	1
	11-14	HDQ 99 125 11/14 (5525294PT)	Description	HDQ 99 7 125F QC Chair	HDQ 125 PS	HDQ 125 SA	HDQ 125 2	RT V 60	HDQ 125 M	HDQ 125 2SN	HDQ 31 8	10-32 x 3/16	HDQ 125	HDQ 99 5	10-32 x 3/16	
		Order Number	2999993	2985180	2985186	2985169	3094100	2985196	2985192	2985203	8009800	2985357	2900012	8009800		
		Quantity	1	1	1	6	1	1	1	1	1	1	1	1	1	
15-18	HDQ 99 125 15/18 (5525295)	Description	HDQ 99 7 125F QC Chair	HDQ 125 PS	HDQ 125 SA	HDQ 125 3	RT V 60	HDQ 125 M	HDQ 125 3SN	HDQ 31 8	10-32 x 3/16	HDQ 125	HDQ 99 5	10-32 x 3/16		
	Order Number	2999993	2985180	2985186	2988629	3094100	2985196	2988630	2985203	8009800	2985357	2900012	8009800			
	Quantity	1	1	1	6	1	1	1	1	1	1	1	1	1		
1-1/2	38.1	8-12	HDQ 99 150 8/12 (5525296PT)	Description	HDQ 99 7 150F QC Chair	HDQ 150 PS	HDQ 150 SA	HDQ 150 1	2 213	HDQ 150 M	HDQ 150 1SN	HDQ 31 8	10-32 x 3/16	HDQ 150	HDQ 99 5	10 32 x 3/16
			Order Number	2999994	2985181	2985187	2985170	8010303	2985197	2985193	2985203	8009800	2985668	2900012	8009800	
			Quantity	1	1	1	4	1	1	1	1	1	1	1	1	1
	13-18	HDQ 99 150 13/18 (5525297)	Description	HDQ 99 7 150F QC Chair	HDQ 150 PS	HDQ 150 SA	HDQ 150 2	2 213	HDQ 150 M	HDQ 150 2SN	HDQ 31 8	10-32 x 3/16	HDQ 150	HDQ 99 5	10 32 x 3/16	
		Order Number	2999994	2985181	2985187	2985171	8010303	2985197	2985194	2985203	8009800	2985668	2900012	8009800		
		Quantity	1	1	1	4	1	1	1	1	1	1	1	1	1	
1-3/4	44.4	12-18	HDQ 99 175 8/12 (5525298)	Description	HDQ 99 7 175F QC Chair	HDQ 175 PS	HDQ 175 SA	HDQ 175 1	700-30	HDQ 150 M	HDQ 175 1SN	HDQ 31 8	10-32 x 3/16	1 3/8	HDQ 99 5	1/4-20 x 1/4
			Order Number	2999995	2985182	2985189	2985172	3203900	2985197	2985195	2985203	8009800	2349000	2900012	8006600	
			Quantity	1	1	1	4	1	1	1	1	1	1	1	1	1
	13-18	HDQ 99 175 13/18 (5525299)	Description	HDQ 99 7 175F QC Chair	HDQ 175 PS	HDQ 175 SA	HDQ 175 2	2 216	HDQ 150 M	HDQ 175 1SN	HDQ 31 8	10-32 x 3/16	1 3/8	HDQ 99 5	1/4-20 x 1/4	
		Order Number	2999995	2985182	2985189	2985173	8010304	2985197	2985195	2985203	8009800	2349000	2900012	8006600		
		Quantity	1	1	1	4	1	1	1	1	1	1	1	1	1	

## HDQ-III Tube Pullers

- HDQ III Gripper-type tube puller is designed for pulling 2" thru 2-1/2" O.D. tubes in heat exchangers and fire tube boilers using GRP Gripper Kits. This gripper-type tube puller makes tube pulling faster and easier. See selection charts below for ordering gripper kits and components for the tube sizes being pulled.

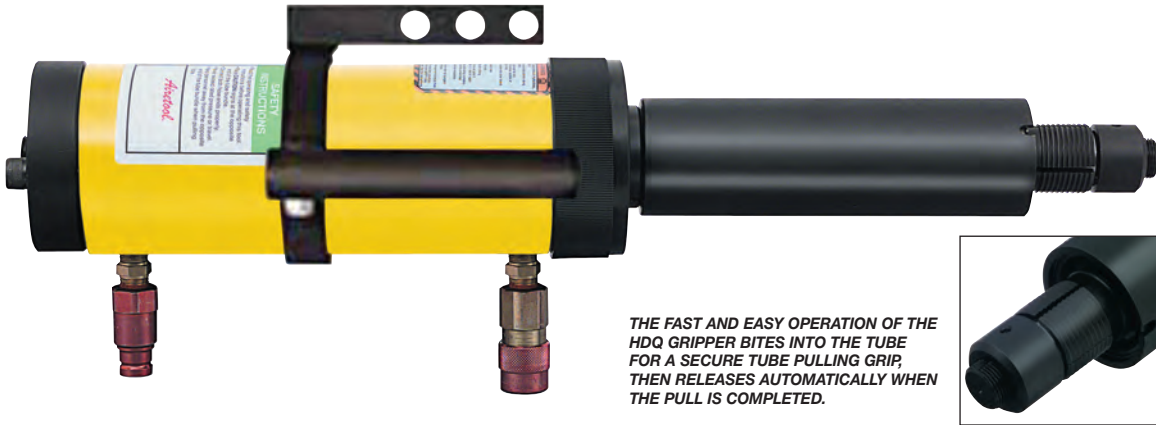

THE FAST AND EASY OPERATION OF THE HDQ GRIPPER BITES INTO THE TUBE FOR A SECURE TUBE PULLING GRIP, THEN RELEASES AUTOMATICALLY WHEN THE PULL IS COMPLETED.

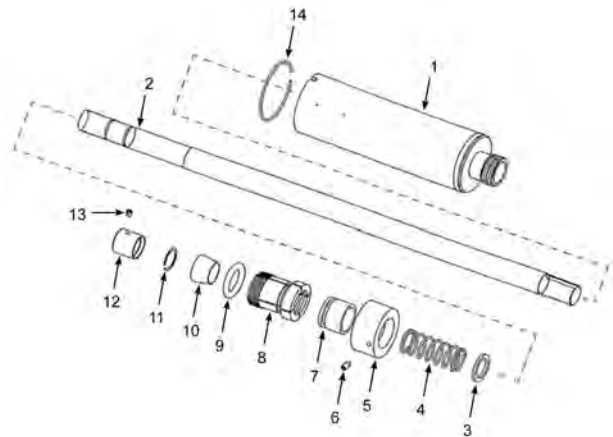

### HDQ III Ram & Accessories

Model Number	Order Number
HDQ III Tube Puller*	5526275PT
HTP III RAM	5526273
HDQ III Adapter Plate	2902631

\* Includes RAM and Adapter Plate

Tube O.D. in. / mm	Tube Wall BWG	Gripper Kit Complete*	Item Name	HDQ 99 Chair	Drawbar	Stop Plate	Spring	Position Sleeve	Socket Set Screw	Sleeve Adapter	Gripper	O-Ring	Cam	Retainer Ring	Stop Nut	Socket Set Screw	Retainer Spring	
			Item Number	1	2	3	4	5	6	7	8	9	10	11	12	13	14	
2	50.8	8-12 GRP 99 200 8/12 (5525300PT)	Description	HDQ 99 7 200F QC Chair	GRP 99 4	GRP 200 STP	GRP 200 SPR	HDQ 200 PS	10-32 x 1/2	GRP 200 SA	GRP 200 1	2 218	GRP 200 CAM	5160 98	GRP 200 SN	1/4-20 X 5/16	1 5/8	
			Order Number	2999996	2900052	2987488	2986930	2985183	8010346	2986932	2987091	8010363	2988791	8010362	2986933	8010335	2350300	
			Quantity	1	1	1	1	1	1	1	4	1	1	1	1	1	1	
	13-18	50.8	GRP 99 200 13/18 (5525301)	Description	HDQ 99 7 200F QC Chair	GRP 99 4	GRP 200 STP	GRP 200 SPR	HDQ 200 PS	10-32 x 1/2	GRP 200 SA	GRP 200 2	2 221	GRP 200 CAM	5160 98	GRP 200 SN	1/4-20 X 5/16	1 5/8
				Order Number	2999996	2900052	2987488	2986930	2985183	8010346	2986932	2987090	8010408	2988791	8010362	2986933	8010335	2350300
				Quantity	1	1	1	1	1	1	1	4	1	1	1	1	1	1
2-1/4	57.1	8-12 GRP 99 225 8/12 (5525302)	Description	HDQ 99 7 225F QC Chair	GRP 99 4	GRP 200 STP	GRP 200 SPR	HDQ 225 PS	10-32 x 1/2	GRP 200 SA	GRP 225 1	2 222	GRP 225 CAM	5160 98	GRP 225 SN	1/4-20 X 5/16	1 5/8	
			Order Number	2999997	2900052	2987488	2986930	2985184	8010346	2986932	2987092	8010409	2986929	8010362	2986934	8010335	2350300	
			Quantity	1	1	1	1	1	1	1	4	1	1	1	1	1	1	
	13-18	57.1	GRP 99 225 13/18 (5525303)	Description	HDQ 99 7 225F QC Chair	GRP 99 4	GRP 200 STP	GRP 200 SPR	HDQ 225 PS	10-32 x 1/2	GRP 200 SA	GRP 225 2	500 23	GRP 225 CAM	5160 98	GRP 225 SN	1/4-20 X 5/16	2
				Order Number	2999997	2900052	2987488	2986930	2985184	8010346	2986932	2987094	3165700	2982929	8010362	2986934	8010335	2005500
				Quantity	1	1	1	1	1	1	1	4	1	1	1	1	1	1
2-1/2	63.5	8-12 GRP 99 250 8/12 (5525304PT)	Description	HDQ 99 7 250F QC Chair	GRP 99 4	GRP 200 STP	GRP 200 SPR	HDQ 250 PS	10-32 x 1/2	GRP 200 SA	GRP 250 1	2 224	GRP 225 CAM	5160 98	GRP 225 SN	1/4-20 X 5/16	1 5/8	
			Order Number	2999998PT	2900052	2987488	2986930	2985185	8010346	2986932	2987095	8010192	2986929	8010362	2986934	8010335	2350300	
			Quantity	1	1	1	1	1	1	1	4	1	1	1	1	1	1	
	13-18	63.5	GRP 99 250 13/18 (5525305)	Description	HDQ 99 7 250F QC Chair	GRP 99 4	GRP 200 STP	GRP 200 SPR	HDQ 250 PS	10-32 x 1/2	GRP 200 SA	GRP 250 2	2 226	GRP 225 CAM	5160 98	GRP 225 SN	1/4-20 X 5/16	2
				Order Number	2999998PT	2900052	2987488	2986930	2985185	8010346	2986932	2987093	2983713	2986929	8010362	2986934	8010335	2005500
				Quantity	1	1	1	1	1	1	1	4	1	1	1	1	1	1

# RAV III Tube Pullers

## RAV III Tube Pullers

- RAV III Semi-Continuous Tube Pulling Ram allows continuous pulling of tubes up to 1" O.D. (25.4mm)
- Tubes over 1" O.D. have a maximum pulling length of 7" (177mm).

To order: Select the desired RAV III Tube Puller Kit, Spear, and Collar. The universal design of this system allows the user to easily change to a different size tube with minimal additional cost.

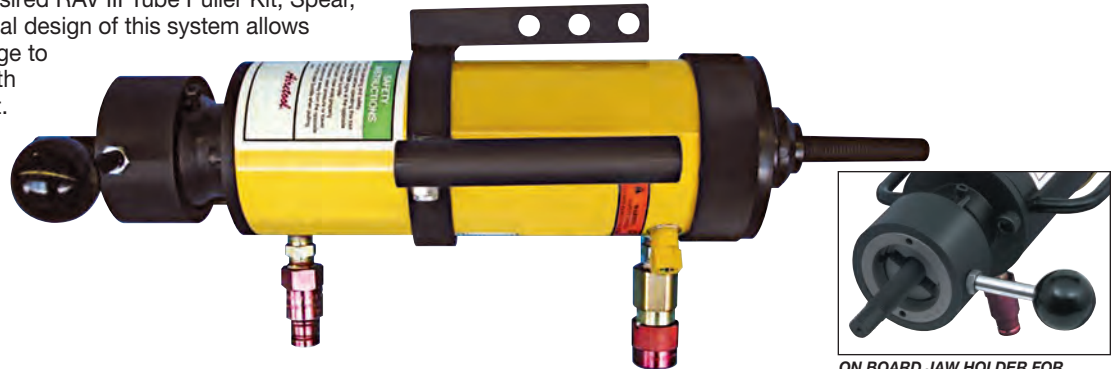

ON BOARD JAW HOLDER FOR SEMI-CONTINUOUS PULLING.

### RAV SPEARS

Description	Order Number	Tube I.D.		Jaw Size		Square Size	
		in.	mm	in.	mm	in.	mm
RAV 99 406 5/8	2900189	.215 - .255	5.5 - 6.5	5/8	15.8	1/2	12.7
RAV 99 407 5/8	2900190	.255 - .295	6.5 - 7.5	5/8	15.8	1/2	12.7
RAV 99 408 5/8	2900191	.295 - .335	7.5 - 8.5	5/8	15.8	1/2	12.7
RAV 99 409 5/8	2900192	.335 - .375	8.5 - 9.5	5/8	15.8	1/2	12.7
RAV 99 410 5/8	2900193	.375 - .415	9.5 - 10.5	5/8	15.8	1/2	12.7
RAV 99 411 5/8	2900194	.415 - .455	10.5 - 11.5	5/8	15.8	1/2	12.7
RAV 99 412 5/8	2900195	.455 - .495	11.5 - 12.5	5/8	15.8	1/2	12.7
RAV 99 413 5/8	2900196	.495 - .535	12.5 - 13.5	5/8	15.8	1/2	12.7
RAV 99 414 5/8	2900197	.535 - .570	13.5 - 14.5	5/8	15.8	1/2	12.7
RAV 99 413 3/4	2900198	.495 - .535	12.5 - 13.5	3/4	19.0	5/8	15.8
RAV 99 414 3/4	2900199	.535 - .570	13.5 - 14.5	3/4	19.0	5/8	15.8
RAV 99 415 3/4	2900200	.570 - .615	14.5 - 15.5	3/4	19.0	5/8	15.8
RAV 99 416 3/4	2900201	.615 - .650	15.5 - 16.5	3/4	19.0	5/8	15.8
RAV 99 417 3/4	2900202	.650 - .695	16.5 - 17.5	3/4	19.0	5/8	15.8
RAV 99 418 3/4	2900203	.695 - .730	17.5 - 18.5	3/4	19.0	5/8	15.8
RAV 99 415 7/8	2900204	.570 - .615	14.5 - 15.5	7/8	22.2	3/4	19.0
RAV 99 416 7/8	2900205	.615 - .650	15.5 - 16.5	7/8	22.2	3/4	19.0
RAV 99 417 7/8	2900206	.650 - .695	16.5 - 17.5	7/8	22.2	3/4	19.0
RAV 99 418 7/8	2900207	.695 - .730	17.5 - 18.5	7/8	22.2	3/4	19.0
RAV 99 419 7/8	2900208	.730 - .770	18.5 - 19.5	7/8	22.2	3/4	19.0
RAV 99 420 7/8	2900209	.770 - .815	19.5 - 20.5	7/8	22.2	3/4	19.0
RAV 99 421 7/8	2900210	.815 - .850	20.5 - 21.5	7/8	22.2	3/4	19.0
RAV 99 419 1	2900211	.730 - .770	18.5 - 19.5	1	25.4	3/4	19.0
RAV 99 420 1	2900212	.770 - .815	19.5 - 20.5	1	25.4	3/4	19.0
RAV 99 421 1	2900213	.815 - .850	20.5 - 21.5	1	25.4	3/4	19.0
RAV 99 422 1	2900214	.850 - .885	21.5 - 22.5	1	25.4	3/4	19.0
RAV 99 423 1	2900215	.885 - .925	22.5 - 23.5	1	25.4	3/4	19.0
RAV 99 424 1	2900216	.925 - .965	23.5 - 24.5	1	25.4	3/4	19.0
RAV 99 425 1	2900217	.965 - 1.005	24.5 - 25.5	1	25.4	3/4	19.0
RAV 99 426 1	2900218	1.005 - 1.045	25.5 - 26.5	1	25.4	3/4	19.0
RAV 99 427 1	2900219	1.045 - 1.085	26.5 - 27.5	1	25.4	3/4	19.0
RAV 99 428 1	2900220	1.085 - 1.125	27.5 - 28.5	1	25.4	3/4	19.0
RAV 99 429 1	2900221	1.125 - 1.160	28.5 - 29.5	1	25.4	3/4	19.0
RAV 99 430 1	2900222	1.160 - 1.200	29.5 - 30.5	1	25.4	3/4	19.0
RAV 99 431 1	2900223	1.200 - 1.240	30.5 - 31.5	1	25.4	3/4	19.0
RAV 99 432 1	2900224	1.240 - 1.280	31.5 - 32.5	1	25.4	3/4	19.0
RAV 99 433 1	2900225	1.280 - 1.320	32.5 - 33.5	1	25.4	3/4	19.0
RAV 99 434 1	2900226	1.320 - 1.360	33.5 - 34.5	1	25.4	3/4	19.0
RAV 99 435 1	2900227	1.360 - 1.400	34.5 - 35.5	1	25.4	3/4	19.0
RAV 99 436 1	2900228	1.400 - 1.440	35.5 - 36.5	1	25.4	3/4	19.0
RAV 99 437 1	2900229	1.440 - 1.475	36.5 - 37.5	1	25.4	3/4	19.0
RAV 99 438 1	2900230	1.475 - 1.515	37.5 - 38.5	1	25.4	3/4	19.0

### RAV III Ram

Model Number	Order Number
HTP III Ram	5526273

### Universal Spears

Description	Model Number	Order Number
RAV Spear, 5/8" I.D., 13-24 BWG	RAV 5/8 13-24	7025691PT
RAV Spear, 3/4" I.D., 12-18 BWG	RAV 3/4 12-18	7025689
RAV Spear, 1" I.D., 9-18 BWG	RAV 1 9-18	7025690
RAV Spear, 1-1/8" I.D., 12-18 BWG	RAV 1 1/8 12-18	7025692

### RAV III Ram Kits & Components

Model Number	Tube O.D.			
	5/8" (15.8mm)	3/4" (19.0mm)	7/8" (22.2mm)	1" (25.4mm)
RAV III Tube Puller Kits* w/ Jaw Holders & Jaws	5526276	5526277	5526278	5526279
RAV III Jaw Holders & Jaws	5526282	5526283		5526286
RAV III Jaw Set (includes 4 springs)	7025595	7025552		7025553

\*RAV III Tube Puller Kits include: RAV III Ram, Jaw Holder Assembly and one set of Jaws



### RAV COLLARS

Tube O.D.		Model Number	Order Number	Collar I.D.		Collar O.D.	
in.	mm			in.	mm	in.	mm
1/2	12.7	RAV 99 316	2900176	0.630	16.0	0.865	22.0
5/8	15.8	RAV 99 319	2900177	0.750	19.0	0.985	25.0
3/4	19.0	RAV 99 323	2900178	0.905	23.0	1.14	29.0
7/8	22.2	RAV 99 326	2900179	1.025	26.0	1.26	32.0
1	25.4	RAV 99 326	2900179	1.025	26.0	1.26	32.0
1-1/8	28.5	RAV 99 332	2900181	1.260	32.0	1.495	38.0
1-1/4	31.7	RAV 99 335	2900182	1.375	35.0	1.61	41.0
1-3/8	34.9	RAV 99 339	2900183	1.530	39.0	1.77	45.0
1-1/2	38.1	RAV 99 345	2900184	1.770	45.0	2.005	51.0
1-3/4	44.4	RAV 99 351	2900185	2.005	51.0	2.24	57.0
2	50.8	RAV 99 358	2900186	2.280	58.0	2.515	64.0



## Super Jenny Semi-Continuous system

- Super Jenny Semi-Continuous Tube Pulling Ram allows continuous pulling of tubes up to 1-1/4" O.D. (31.75 mm)
- Tubes over 1-1/4" O.D. have a maximum pulling length of 7" (177mm).

To order: Select the desired RAV III Tube Puller Kit, Spear, and Collar. The universal design of this system allows the user to easily change to a different size tube with minimal additional cost.

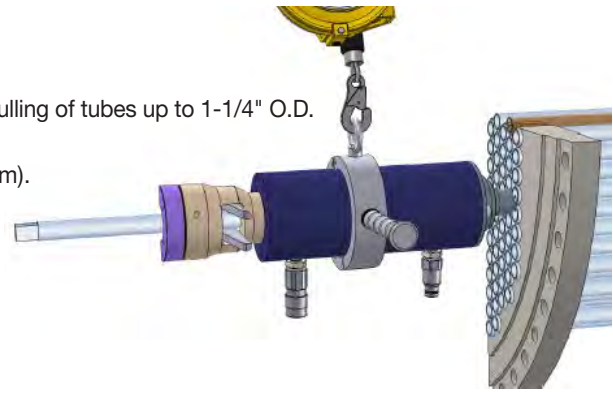

Our "Super Jenny" series of hydraulic semi-automatic Tube pullers, allow the user to continuously pull tubes through heat exchangers and condensers without the use of hammers or winches etc. The key to our system is the OD gripping jaw that will pull the tube as the operator actuates the ram. To release the jaw, the operator simply inserts the jaw release tool and the tube becomes free to be pulled off by hand, or the ram is returned against the tube sheet to take another stroke. All of our pulling heads work in conjunction with our specially designed high flow electric or pneumatic power packs (see page 9 for details). The three different pulling rams allow for the right tool for the job. Pulling capacities range from 10-60 tons making tube removal of 3/8" – 2" OD through the ram a snap. Stubs up to 4" OD can be removed using our chair style tooling. Our smallest ram, the "Mini-Jenny", has been specifically designed for chiller and condenser work. Weighing in at just 18 lbs. (6 kg), this 10-ton capacity ram can pull up to 1" OD tubes. With a 3" stroke, this unit is exceptionally quick, and is ideal for tight access applications. Our 30-ton "Super-Jenny" is the workhorse. Available with either a 3" or 6" stroke, this tool is capable of pulling 5/8" – 1-1/4" tubes continuously. It can even pull up to 3" stubs in specific applications. Our 60-ton "Mega- Jenny" has been designed to pull tubes in the toughest applications. As standard, the unit can thru-pull 1 1/2"-2" tubes. A special adapter is offered as well which will allow the operator to pull smaller diameter tubes with up to 60 tons of pulling force. For example, a tube extraction of 1 1/4" x 10 BWG with a 7" tube sheet was noted to pull at 52 tons of pulling force.

<b>"MINI-JENNY" SPECIFICATIONS</b> (10 ton ram)		
	Imperial	Metric
TUBE OD RANGE (for standard tooling)	5/8" TO 1"	12.7mm to 25.4 mm
PULLING FORCE	10 Tons	
OVERALL LENGTH (w/ nose piece)	15"	380 mm
DIAMETER	3-1/4"	83 mm
WEIGHT	18 lbs.	8 kg
STROKE	3"	76 mm
REQUIRED OIL TYPE	ISO 32 Grade	

<b>"SUPER JENNY" SPECIFICATIONS</b> (30 ton ram)		
	Imperial	Metric
TUBE OD RANGE (for standard tooling)	5/8" TO 1-1/4"	12.7mm to 31.75 mm
PULLING FORCE	30 Tons	
OVERALL LENGTH (w/ nose piece)	17"	430 mm
DIAMETER	5-1/2"	140 mm
WEIGHT	40 lbs	18 kg
STROKE	6"	152 mm
REQUIRED OIL TYPE	ISO 32 Grade	

<b>"MEGA-JENNY" SPECIFICATIONS</b> (60 ton ram)		
	Imperial	Metric
TUBE OD RANGE (for standard tooling)	5/8" TO 2"	12.7mm to 50.8 mm
PULLING FORCE	60 Tons	
OVERALL LENGTH (w/ nose piece)	17"	430 mm
DIAMETER	7 1/2"	191 mm
WEIGHT	75 lbs	34 kg
STROKE	6"	152 mm
REQUIRED OIL TYPE	ISO 32 Grade	

## PUMP SPECIFICATIONS

<b>PUMP SPECIFICATIONS</b>							
PART#	POWER TYPE	HP	MAX PRESSURE		POWER REQUIREMENTS	WEIGHT	
			PSI	Bar		Lbs	Kg
G5773R	Pneumatic	3HP	10,000	700	50 CFM @ 90 PSI	52	23.6
G5173R	Electric	1.5HP	10,000	700	115V/18 amp Single Phase	81	36.7



# Super Jenny Consumables

“SUPER JENNY” Tooling is selected based on two variables the tube outside diameter and the tube wall thickness (or Tube ID).

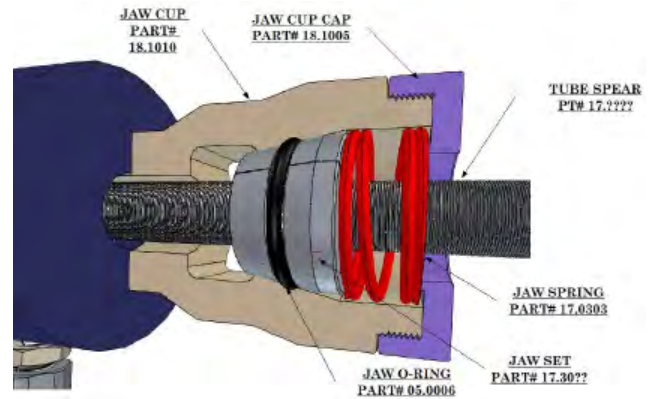

"SUPER JENNY" TOOLING & CONSUMABLES CHART			MINIMUM SPEAR DIAMETER		MAXIMUM SPEAR DIAMETER		MALE SQUARE SIZE	NOSE COLLAR	JAW SETS W/ O-RING
TUBE DIAMETER	WALL THICKNESS	SPEAR PART #	INCH	MM	INCH	MM			
1/2" OD (12.7 mm)	10-12 bwg	17.6000	0.217	5.5	0.319	8.1	1/2"	17.0500	17.3022
	13-16 bwg	17.6001	0.299	7.6	0.402	10.2			
	18-24 bwg	17.6002	0.398	10.1	0.457	11.6			
5/8" OD (15.9 mm)	10-12 bwg	17.6010	0.335	8.5	0.433	11	1/2"	17.0625	17.3032
	13-16 bwg	17.6011	0.433	11	0.535	13.6			
	18-24 bwg	17.6012	0.514	13.05	0.616	15.7			
3/4" OD (19.05mm)	10-12 bwg	17.6020	0.480	12.2	0.583	14.8	5/8"	17.0750	17.3042
	13-16 bwg	17.6021	0.555	14.1	0.657	16.7			
	18-24 bwg	17.6022	0.640	16.25	0.740	18.8			
	13-21 bwg	17.6029	0.555	14.1	0.730	18.5			
7/8" OD (22.2 mm)	10-12 bwg	17.6030	0.604	15.35	0.709	18.0	5/8"	17.0875	17.3047
	13-16 bwg	17.6031	0.683	17.35	0.787	20.0			
	18-24 bwg	17.6032	0.768	19.5	0.870	22.1			
1" OD (25.4 mm)	10-12 bwg	17.6040	0.728	18.5	0.831	21.1	3/4"	17.1000	17.3052
	13-16 bwg	17.6041	0.807	20.5	0.909	23.1			
	18-24 bwg	17.6042	0.890	22.6	0.992	25.2			
	13-21 bwg	17.6043	0.807	20.5	0.972	24.7			
1-1/8" OD (28.58 mm)	10-12 bwg	17.6050	0.858	21.8	0.961	24.4	3/4"	17.1125	17.3062
	13-16 bwg	17.6051	0.937	23.8	1.039	26.4			
	18-24 bwg	17.6052	1.016	25.8	1.118	28.4			
1-1/4" OD (31.75 mm)	10-12 bwg	17.6060	0.980	24.9	1.083	27.5	1"	17.1250	17.3062
	13-16 bwg	17.6061	1.059	26.9	1.161	29.5			
	18-24 bwg	17.6062	1.140	28.95	1.244	31.6			
1-1/2" OD (38.10 mm)	10-12 bwg	17.6070	1.232	31.3	1.335	33.9	1"	17.3212	17.3211
	13-16 bwg	17.6071	1.311	33.3	1.413	35.9			
	18-24 bwg	17.6072	1.390	35.3	1.492	37.9			
1-3/4" OD (44.45 mm)	10-12 bwg	17.6080	1.484	37.7	1.587	40.3	1"	17.3217	17.3216
	13-16 bwg	17.6081	1.563	39.7	1.665	42.3			
	18-24 bwg	17.6082	1.642	41.7	1.744	44.3			
2" OD (50.8 mm)	10-12 bwg	17.6090	1.736	44.1	1.839	46.7	1"	17.3222	17.3221
	13-16 bwg	17.6091	1.815	46.1	1.917	48.7			
	18-24 bwg	17.6092	1.894	48.1	1.996	50.7			

## JSP Manual Tube Pullers

Manual tube puller provides economical method for tube removal

- For tube removal applications ranging from 1/4" to 1-1/2" O.D.
- No external power requirement makes it ideal for field service applications
- Manual operation with a hand wrench make the JSP easy to use
- All components have clearly marked sizes for a quick matching of tool to job
- Components are heat-treated high strength steel for greater durability



O.D.		Gauge	Tube Size				JSP Tube Puller Complete		Spare Spears	
In.	mm		Wall Thickness		I.D.		Model Number	Order Number	Model Number	Order Number
		In.	mm	In.	mm					
1/4	6.35	18	0.049	1.24	0.152	3.86	JSP 250 18	5520136	JSP 1/4 18	2989364
3/8	9.52	16	0.065	1.65	0.245	6.22	JSP 375 16	5520914	JSP 3/8 16	2991563
3/8	9.52	18	0.049	1.24	0.277	7.04	JSP 375 18	5520030	JSP 3/8 18	2989016
3/8	9.52	20	0.035	0.88	0.305	7.75	JSP 375 20	5519932	JSP 3/8 20	2988750
1/2	12.70	14	0.083	2.11	0.334	8.48	JSP 500 14	5519689	JSP 1/2 14	2987297
1/2	12.70	16	0.065	1.65	0.370	9.40	JSP 500 16	5519690	JSP 1/2 16	2986892
1/2	12.70	18	0.049	1.24	0.402	10.21	JSP 500 18	5519070	JSP 1/2 18	2986893
1/2	12.70	20	0.035	0.88	0.430	10.92	JSP 500 20	5519691PT	JSP 1/2 20	2987298
5/8	15.88	14	0.083	2.11	0.459	11.66	JSP 625 14	5519692	JSP 5/8 14	2986894
5/8	15.88	16	0.065	1.65	0.495	12.57	JSP 625 16	5519693	JSP 5/8 16	2986895
5/8	15.88	18	0.049	1.24	0.527	13.39	JSP 625 18	5518868	JSP 5/8 18	2986771
5/8	15.88	20	0.035	0.88	0.555	14.10	JSP 625 20	5519694	JSP 5/8 20	2987182
3/4	19.05	14	0.083	2.11	0.585	14.86	JSP 750 14	5519695	JSP 3/4 14	2986896
3/4	19.05	16	0.065	1.65	0.620	15.75	JSP 750 16	5519696	JSP 3/4 16	2986897
3/4	19.05	18	0.049	1.24	0.652	16.56	JSP 750 18	5518804	JSP 3/4 18	2986364
3/4	19.05	20	0.035	0.88	0.680	17.27	JSP 750 20	5519697	JSP 3/4 20	2986769
7/8	22.22	14	0.083	2.11	0.709	18.01	JSP 875 14	5519698	JSP 7/8 14	2986898
7/8	22.22	16	0.065	1.65	0.745	18.92	JSP 875 16	5519699	JSP 7/8 16	2986899
7/8	22.22	18	0.049	1.24	0.777	19.74	JSP 875 18	5519071	JSP 7/8 18	2986900
7/8	22.22	20	0.035	0.88	0.805	20.45	JSP 875 20	5518700	JSP 7/8 20	2987534
1	25.40	14	0.083	2.11	0.834	21.18	JSP 1000 14	5519701	JSP 1 14	2986901
1	25.40	16	0.065	1.65	0.870	22.10	JSP 1000 16	5519702	JSP 1 16	2986902
1	25.40	18	0.049	1.24	0.902	22.91	JSP 1000 18	5519072	JSP 1 18	2986903
1	25.40	20	0.035	0.88	0.930	23.62	JSP 1000 20	5519703	JSP 1 20	2987209
1	25.40	22-24	0.028-0.022	0.71-0.55	0.944-0.956	23.98-24.30	JSP 1000 22 24	5519926	JSP 1 22 24	2988730
1-1/2	38.10	14	0.083	2.11	1.334	33.88	JSP 1500 14	5526266PT	JSP 1 1/2 14	2989292

Additional sizes are available. Contact technical service for details.

# Impact Wrenches



## Heavy-Duty 1/2" Drive



2705P1

### FEATURES

- Jumbo hammer mechanism
- Steel hammer case
- Pressure-fed mechanism lubrication
- 1/4" NPT inlet

### HEAVY-DUTY 2700 Series

Model	Description	Actuation	Details	Handle	1 min. rpm	1 min. bpm	Max. Torque ft-lb (Nm)	ft-lb (Nm)	lb (kg)	in (mm)	in (mm)	cfm (l/s)	m/s <sup>2</sup> (K <sup>(2)</sup> )
1/2"													
2707P1	1/2" Square	Trigger	Pin	Pistol	8500	1300	450 (610)	40-275 (54-373)	6 (2.72)	6.75 (171)	1.38 (35)	26 (736)	8.7 (0.8)



Titanium hammer case and metal housing stand up to harsh conditions

Reverse bias motor to help remove stubborn bolts

Twin hammer impact mechanism ensures consistent power and minimizes tool vibration

Pressure-fed lubrication mechanism ensures complete coverage throughout the tool

Corrosion-resistant bronze endplates extends the life of the motor



## Super-Duty 3/4"-1 1/2" Drives



2925P1Ti

### FEATURES

- Titanium hammer case
- Corrode-XTM component package
- Twin hammer mechanism
- Choice of balanced or reversed bias motor
- Pressure-fed mechanism lubrication
- Integral muffler
- 3/8" NPT inlet

3942B2Ti



### FEATURES

- Titanium hammer case
- Bronze endplates
- Twin hammer mechanism
- Reverse bias motor
- Pressure-fed mechanism lubrication
- Integral muffler
- 1/2" NPT inlet

3955B2Ti



### FEATURES

- Titanium hammer case
- Bronze endplates
- Twin hammer mechanism
- Reverse bias motor
- Pressure-fed mechanism lubrication
- Integral muffler
- 1/2" NPT inlet

### SUPER-DUTY Series

Model	Description	Actuation	Details	Handle	1 min. rpm	1 min. bpm	Max. Torque ft-lb (Nm)	ft-lb (Nm)	lb (kg)	in (mm)	in (mm)	cfm (l/s)	m/s <sup>2</sup> (K <sup>(2)</sup> )
3/4"-1"													
2925P1Ti	3/4" Square	Trigger	Thru-Hole	Pistol	5200	1050	1450 (1966)	350-1100 (475-1492)	12 (5.44)	8.9 (226)	1.75 (44)	60 (1699)	10.5 (1)
3942B2Ti	1" Square	Inside Trigger	Thru-Hole	D-Handle	5000	850	3250 (4406)	1000-2100 (1356-2848)	22.6 (10.5)	14.3 (362)	2.3 (59)	95 (2690)	16.9 (4.6)
3955B2Ti	1 1/2" Square	Inside Trigger	Thru-Hole	D-Handle	2750	700	5000 (6779)	1600-4150 (2170-5630)	34.6 (15.7)	16.5 (419.1)	2.67 (68)	80 (2266)	20.8 (8.5)



## EXTREME ENVIRONMENT IMPACTS



**750SS**  
**3/4" Impact Wrench**

Offers one of the industry's highest power-to-weight ratio. Featuring a stainless steel hammer case and a twin hammer design for increased durability. Constructed with non-corrosive materials for prolonged field life. 100% Made in the USA.

Square Drive . . . . . 3/4"  
Free Speed . . . . . 4600 RPM  
Max. Torque . . . . . 1700 ft.-lbs.  
Rec'd Hose Size . . . . . 3/8"  
Length . . . . . 9"  
Weight . . . . . 13.5 lbs.  
Air Inlet . . . . . 1/2"  
Avg. Air Consumption . . . . . 58 cfm



**75 ISS**  
**1" Impact Wrench**

Offers one of the industry's highest power-to-weight ratio. Featuring a stainless steel hammer case and a twin hammer design for increased durability. Constructed with non-corrosive materials for prolonged field life. 100% Made in the USA.

Square Drive . . . . . 1"  
Free Speed . . . . . 4600 RPM  
Max. Torque . . . . . 1700 ft.-lbs.  
Rec'd Hose Size . . . . . 3/8"  
Length . . . . . 9"  
Weight . . . . . 13.5 lbs.  
Air Inlet . . . . . 1/2"  
Avg. Air Consumption . . . . . 58 cfm

## Heavy-Duty Impacts

Features a twin hammer clutch for more power per pound, a pressure fed clutch lubrication system, two piece motor housing for easy maintenance, a built-in muffler for low noise and direct drive for fast run down.



**EGI-2940B2**

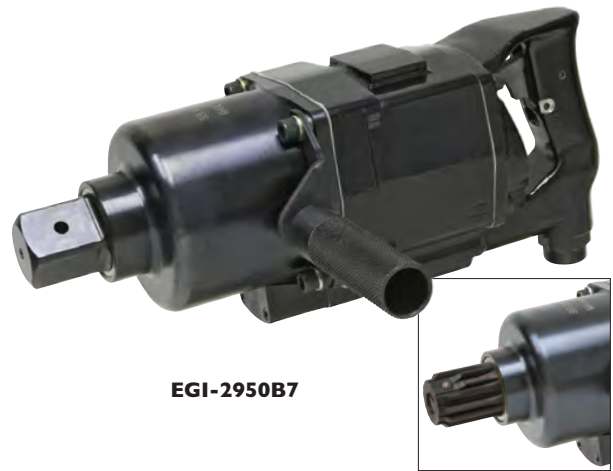

**EGI-2950B7**

Specifications	EGI-2940B2	EGI-2940B1 #5 Spline	EGI-2950B7	EGI 2950B1
Shank Size	1" Sq. Through-Hole	#5 Spline	1-1/2" Sq. Through-Hole	#5 Spline
Handle Type	Inside Trigger	Inside Trigger	Inside Trigger	Inside Trigger
Torque Range	1600-2000 ft.-lbs.	1600-2000 ft.-lbs.	2500-3000 ft.-lbs.	2500-3000 ft.-lbs.
Length	12-13/32"	12-13/32"	14-1/2"	14-1/2"
Weight	22 lbs.	22 lbs.	33 lbs.	33 lbs.
Air Inlet Thread	1/2"	1/2"	1/2"	1/2"
Avg. Air Consumption	58 cfm	58 cfm	70 cfm	70 cfm



## EGI 9524DGF-C4 1/4" Collet Die Grinder – Front Exhaust

Features front exhaust. Heavy-duty steel constructed industrial grinders for the toughest applications. Ideal for foundry, welding, petro chemical, deburring and finishing. Available in 90 degree angle and side exhaust models.

Collet Size.....	1/4"
Maximum HP.....	0.95
Free Speed.....	5500 RPM
Length.....	6.9"
Weight.....	1.9 lbs.
Rec'd Hose Size.....	3/8"
Air Inlet Thread.....	1/4"



EGI-9524DGF-C4

## EGI-G1890IF EGI-G2260IF Die Grinders – Rear Exhaust

Features a hardened alloy steel cylinder and rotor to maintain power while ensuring longer tool life. The rotor housing is milled from a solid bar for precision alignment. Includes a 1/4" Erikson style collet as well as an integrated regulator and two-step safety lever.

Specifications	EGI-G1890IF	EGI-G2260IF
Collet Size	1/4"	1/4"
HP	0.9	0.6
Free Speed	18000	22000
Length	6.5"	6.5"
Weight	1.43 lbs.	1.43 lbs.
Rec'd Hose Size	3/8"	3/8"
Air Inlet Thread	1/4"	1/4"



EGI-G1890IF  
18K Model



EGI-G2260IF  
22K Model

## EGI-9500 Series 9500 Series Grinders

Heavy-duty grinders suitable for a wide range of material removal. The steel housing and high rpm make these grinders tough enough for almost any industry.

**Wheels not included**



EGI-9511AGF-C4



EGI-9511AGS-384T7



EGI-9513EXTAGS-384T1

Specifications	EGI-9511AGF-C4	EGI-9511AGS-384T7	EGI-9511AGS-584T7	EGI-9513EXTAGS-384T1
Capacity	1/4" Collet	4" Type 27 Wheel	4" Type 27 Wheel	4" Type I Wheel
Spindle Thread	—	3/8"-24	3/8"-11	3/8"-24
Maximum HP	0.8	0.8	0.8	0.8
Free Speed	11500 RPM	11500 RPM	11500 RPM	11500 RPM
Head Height	3.25"	3.25"	3.25"	2.3"
Length	7.6"	7.6"	7.6"	9.6"
Weight	3.4 lbs.	3.9 lbs.	3.9 lbs.	3.3 lbs.
Rec'd Hose Size	3/8"	3/8"	3/8"	3/8"
Air Inlet Thread	1/4"	1/4"	1/4"	1/4"

## EGI-1514SG-383CW EGI-1514SG-C4 Extended Grinders

Designed for production grinding of concave and hard to reach surfaces. Features a rugged steel housing and governed air motor with a rotating exhaust deflector. Also available with 4" Type I Guard as well as 9,000, 12,000 and 18,000 RPM.

Specifications	EGI-1514SG-383CW	EGI-1514SG-C4
Capacity	2" Cone or Plug	1"
Termination	3/8"-24 Spindle Thread	1/4" Collet
Maximum HP	1.5	1.5
Free Speed	14000 RPM	14000 RPM
Length	14-3/8"	14-3/8"
Weight	3.5 lbs.	3.5 lbs.
Rec'd Hose Size	3/8"	3/8"
Air Inlet Thread	1/4"	1/4"



EGI-1514SG-383CW



EGI-1514SG-C4



**5667VS**  
**Vertical Grinder**

With Guard

**Wheel not included**

Features include hardened steel motor parts and a high force, corrosion resistant governor to retain optimum grinding efficiency. Ideal for heavy-duty grinding for smoothing, finishing, removing scale, rust and weld splatter, cleaning castings and masonry work. Applications include fabrication shops, refineries, shipyards, steel mills and construction sites.

**Other 3HP Models Available:**

- 9" 5669VS
- 6" Cup Wheel Guard 5666VSC

Capacity .....	7"
Free Speed .....	.6000 RPM
Spindle Thread .....	.5/8"-11
Maximum HP .....	3.00
Height .....	.7-5/8"
Weight .....	9.60 lbs.
Rec'd Hose Size .....	1/2"
Air Inlet Thread .....	1/2"



**6669VS**  
**Vertical Grinder**

With Guard

**Wheel not included**

Features a high force, corrosion resistant governor to retain optimum grinding efficiency and hardened steel motor parts. Provides heavy-duty grinding for smoothing, finishing, removing scale, rust and weld splatter, cleaning castings and masonry work. Ideal for a variety of applications in fabrication shops, refineries, shipyards, steel mills and construction sites.

**Other 4HP Models Available:**

- 7" 6667VS
- 6" Cup Wheel 6666VSC

Capacity .....	9"
Free Speed .....	.6000 RPM
Spindle Thread .....	.5/8"-11
Maximum HP .....	4.00
Height .....	.8-3/16"
Weight .....	10.90 lbs.
Rec'd Hose Size .....	1/2"
Air Inlet Thread .....	1/2"



**Cup Wheel Guard Also Available.**



# Boiler Expanders

## Boiler Expanders

Tube expanding is the art of cold working the ends of tubes into intimate contact with the metal of the containing tube holes to form a leak proof mechanical seal and/or joint. In other words, it is a mechanical method of establishing a mechanical joint between a tube and a tube hole.

Boiler expanders do not include a mandrel when ordered because its possible to obtain them with three different types of mandrels depending on the application.

**Header Mandrel** – This is the longest mandrel that incorporates an extension that allows you to reach through manifolds or header boxes.

**Drum Mandrel** – This mandrel is used when you are expanding inside the boiler drum and can get to the tube at the end.

**Short Series Mandrel Sets** – There are times when the space inside a boiler drum will not allow use of the longer header or drum mandrels. Short series mandrel sets solve this problem by allowing you to expand the tube in multiple steps when space is limited. If you were to take the tapered portion of a header or drum mandrel, cut it in several pieces and add a drive to each section, you would have a short series mandrel set.

**Rolls** – A set of tapered cylindrical parts which are driven by mandrel and contact the tube wall to be expanded. The taper on the rolls is in the reverse direction and one-half the taper of the mandrel if it is a parallel roll expander.

**Flare or Bell Rolls** – This type roll is added to the back of the cage on boiler or furnace expanders to flare the tube end after it has been expanded.

**Cage** – This is the expander body or housing since it holds the mandrel and rolls in place. The slots which contain the rolls also provide a feed angle which helps pull the mandrel in to provide expansion of the rolls.

**Thrust Assembly** – This assembly attaches to the cage and allows adjustment of the expanding depth. The thrust collar will remain stationary against the tube sheet or tube end while the cage, mandrel and rolls expand the tube. A thrust assembly is used on condenser/heat exchanger expanders, some furnace expanders and special boiler expanders.

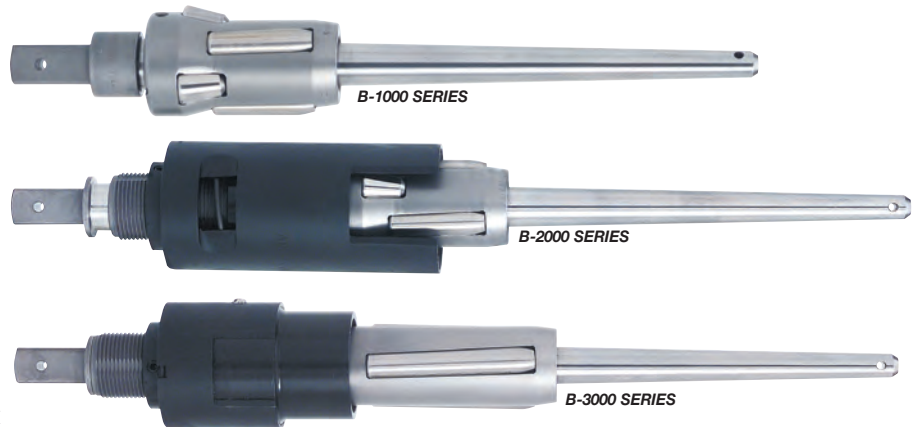

**When selecting a boiler expander, you must know:**

- Tube O.D.
- Tube wall thickness or BWG
- Tube sheet or drum thickness
- Minimum straight section at end of tube
- Drum diameter if less than 18"

This information will allow you to select the proper type boiler expander and mandrels.

**B-1000 Series Boiler Expanders** - The B-1000 series expanders incorporate tube expanding and tube flaring into one tool. They are used when torque control is not desired or where space is limited such as in a small diameter header. Both expanding and flaring rolls are self contained in the cage. The B-1000 series expanders are available for 1 – 4-1/2" O.D. tubes and can accommodate tube sheet thicknesses from 1/2 – 2-3/4". Short series mandrels are also available. A B-1000 series expander can be converted to a B-2000 series by simply adding the thrust mechanism.

**B-2000 Series Boiler Expanders** - The B-2000 series expanders are the same basic expander as the B-1000 series except that they have an exclusive drift thrust assembly that makes torque control possible. The thrust assembly is adjustable and allows accurate positioning of the expander in the tube in relation to the drum for consistent joint expansion on every tube. The B-2000 series expanders are available for 1 – 4-1/4" O.D. tubes and can accommodate tube sheet thicknesses from 1/2 - 2-3/4".

**B-3000 Series Boiler Expanders** - Straight roll expander for non-flare fire tube boiler applications. It can be used in conjunction with Airetool B-1000 or B-2000 flare type expanders in thicker tube sheet applications. The B-3000 expanders are available for 1-1/4 – 4-1/4" O.D. tubes and can accommodate drums up to 5-3/8" thick.

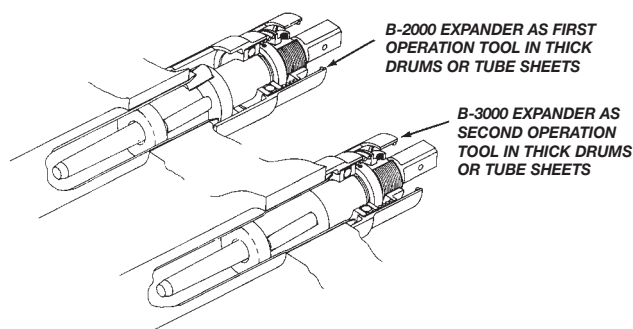

## B-2000 Operation Boiler Tube Expanders B-2000 Series Patented Thrusts Assembly

- Airetool B-2000 Series boiler tube expander with its exclusive drift thrust assembly represents a major advancement in boiler tube expanding. Using a ball bearing, spring loaded drift thrust collar, the B-2000 Series expanders can be accurately positioned in the boiler tube in relation to the drum for consistent joint expansion.
- In operation, the initial positioning of the expander in the tube allows the self-feed rolls to draw the expander into the tube and to engage the flaring rolls at the proper point during the operation. The use of either an electric or air driven torque controlled rolling motor with the B-2000 Series expanders produces more uniform flares and very precise tube wall reduction.
- Accomplishes three unique functions in one operation

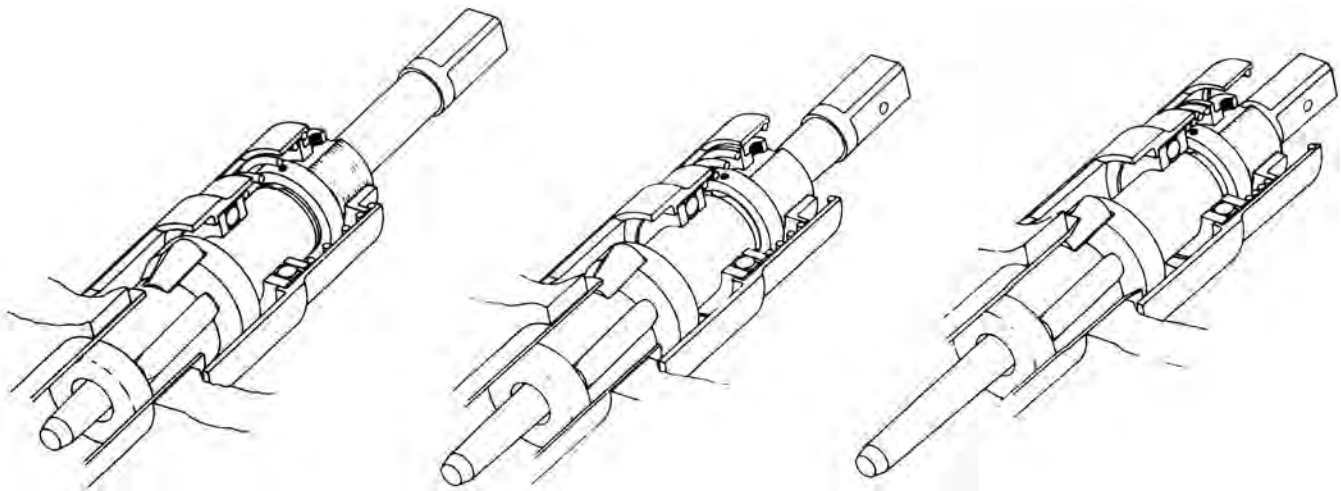

### First

The unique depth adjustable ball bearing drift thrust collar enables the B-2000 Series expander to be positioned into the tube at exactly the same setting every time. Once set, the mandrel is inserted in the expander causing the rolls to be forced outward into contact with the tube I.D., starting the rolling process.

### Second

As the mandrel is rotated, the initial rolling of the straight section takes place. As the mandrel rotation is continued, the drift thrust collar stops the expander at its final operating depth in the tube. During this phase the flaring rolls have also moved into their final depth position.

### Third

Continued mandrel rotation now will allow the straight rolled area to be finished. At this point the amount of torque required is greatly increased. The torque mechanism in the motor measures the torque and when the set torque is reached the motor automatically shuts off. During this phase the expander being held in place by the thrust collar allows the flare rolls to iron out the end of the tube to a smooth and precisely located flare. After shut-off, reversing the motor will back the expander out of the finished tube while at the same time resetting it for the next tube.



# B-1000 Series Boiler Expanders

(Mandrels Sold Separately)

## B-1000 Series Boiler Expanders (Mandrels Sold Separately)

- Tube expanding & tube flaring in one tool combines operations
- Used when torque control is not desired or when space is limited
- Self contained rolls keep tool components together
- Convertible to B-2000 series



B-1000 Series: x = Tube Sheet Thickness

Refer to the Expander Table: Replace the X with the appropriate number

X	Tube Sheet Thickness		"A" Dimension		"B" Dimension	
	in.	mm	in.	mm	in.	mm
3	1/2 - 3/4	12.7 - 19.05	1-7/16	36.5	1-1/16	26.9
5	7/8 - 1-1/4	22.2 - 31.7	1-15/16	49.2	1-9/16	39.6
7	1-3/8 - 1-3/4	34.9 - 44.4	2-7/16	61.9	2-1/16	52.3
9	1-7/8 - 2-1/4	47.6 - 57.1	2-15/16	74.6	2-9/16	65.0
11	2-3/8 - 2-3/4	60.3 - 69.8	3-7/16	87.3	3-1/16	77.7

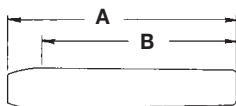

SHORT SERIES MANDRELS

Expander Number*	Tube Size				Expander							
	O.D.	Gauge	O.D.	Gauge	Expansion Range		Straight Roll Set*	Complete Roll Set*	Mandrel Options			
					in.	mm			Long Mandrel		Square Drive	Short Mandrel **
								Number	Length			
B-1079-x	1	13-14			0.787-0.921	20.0-23.4	079-x-RS	079-x-FS	83-MP	9-13/32"	1/2	-----
B-1083-x	1	15-16			0.827-0.961	21.0-24.4	083-x-RS	083-x-FS	83-MP	9-13/32"	1/2	-----
B-1087-x	1-1/4	7			0.866-1.004	22.0-25.5	087-x-RS	087-x-FS	91-MP	9-13/32"	1/2	-----
B-1091-x	1-1/4	8-9			0.906-1.043	23.0-26.5	095-x-RS	095-x-FS	91-MP	9-13/32"	1/2	-----
B-1095-x	1-1/4	10			0.945-1.105	24.0-28.1	095-x-RS	095-x-FS	99-MP	10-1/16"	1/2	-----
B-1099-x	1-1/4	11-13			0.984-1.142	25.0-29.0	099-x-RS	099-x-FS	99-MP	10-1/16"	1/2	-----
B-1103-x	1-1/4	14-15			1.024-1.181	26.0-30.0	103-x-RS	103-x-FS	99-MP	10-1/16"	1/2	-----
B-1111-x	1-1/4	16			1.105-1.299	28.1-33.0	111-x-RS	111-x-FS	118-MP	11-11/16"	3/4	MPS-1,2,3
B-1118-x	1-1/2	10-12			1.221-1.378	31.0-35.0	118-x-RS	118-x-FS	118-MP	11-11/16"	3/4	MPS-1,2,3
B-1126-x	1-1/2	13-16			1.300-1.496	33.0-38.0	126-x-RS	126-x-FS	126-MP	12-15/64"	3/4	MPS-2,3,4
B-1134-x	1-3/4	8-9	2	3	1.379-1.575	35.0-40.0	126-x-RS	126-x-FS	134-MP	12-23/32"	3/4	MPS-2,3,4
B-1142-x	1-3/4	10-12	2	4-5	1.457-1.673	37.0-42.5	142-x-RS	142-x-FS	150-MP	12-27/32"	3/4	MPS-3,4,5
B-1150-x	1-3/4	13-16	2	6	1.536-1.752	39.0-44.5	150-x-RS	150-x-FS	150-MP	12-27/32"	3/4	MPS-3,4,5
B-1158-x	2	7-9	2-1/4	3	1.615-1.850	41.0-47.0	158-x-RS	158-x-FS	174-MP	13-27/32"	3/4	MPS-4,5,6,7,8
B-1166-x	2	10-12	2-1/4	4-5	1.693-1.929	43.0-49.0	166-x-RS	166-x-FS	174-MP	13-27/32"	3/4	MPS-4,5,6,7,8
B-1174-x	2	13-16	2-1/4	6	1.722-2.027	45.0-51.5	174-x-RS	174-x-FS	174-MP	13-27/32"	3/4	MPS-4,5,6,7,8
B-1181-x	2	16	2-1/2	3	1.851-2.126	47.0-54.0	181-x-RS	181-x-FS	197-MP	16-15/64"	1	MPS-7,8,9,10,11
B-1189-x	2-1/4	10-13	2-1/2	4-5	1.930-2.205	49.0-56.0	174-x-RS	174-x-FS	197-MP	16-15/64"	1	MPS-7,8,9,10,11
B-1197-x	2-1/4	14-16	2-1/2	6	2.009-2.362	51.0-60.0	205-x-RS	205-x-FS	197-MP	16-15/64"	1	MPS-6,7,8,9,10,11
B-1205-x	2-1/2	7-10			2.087-2.441	53.0-62.0	205-x-RS	205-x-FS	221-MP	16-15/64"	1	MPS-7,8,9,10,11,12
B-1213-x	2-1/2	11-13	3	2	2.116-2.520	55.0-64.0	213-x-RS	213-x-FS	221-MP	16-15/64"	1	MPS-7,8,9,10,11,12
B-1221-x	2-1/2	14-16			2.245-2.598	57.0-66.0	221-x-RS	221-x-FS	221-MP	16-15/64"	1	MPS-7,8,9,10,11,12
B-1229-x	2-3/4	7-9			2.323-2.677	59.0-68.0	221-x-RS	221-x-FS	244-MP	16-3/8"	1	MPS-8,9,10,11,12,13
B-1237-x	2-3/4	10-12			2.402-2.756	61.0-70.0	237-x-RS	237-x-FS	244-MP	16-3/8"	1	MPS-8,9,10,11,12,13
B-1244-x	2-3/4	13-16			2.481-2.835	63.0-72.0	252-x-RS	252-x-FS	244-MP	16-3/8"	1	MPS-8,9,10,11,12,13
B-1252-x	3	7-8			2.560-2.913	65.0-74.0	252-x-RS	252-x-FS	268-MP	15-25/32"	1	MPS-10,11,12,13,14
B-1260-x	3	10-12			2.638-2.992	67.-076.0	260-x-RS	260-x-FS	268-MP	15-25/32"	1	MPS-10,11,12,13,14
B-1268-x	3	13-14			2.717-3.071	69.0-78.0	268-x-RS	268-x-FS	268-MP	15-25/32"	1	MPS-10,11,12,13,14
B-1276-x	3	15-16			2.796-3.150	71.0-80.0	276-x-RS	276-x-FS	300-MP	16-1/4"	1	MPS-12,13,14,15,16
B-1284-x	3-1/4	7-11			2.874-3.228	73.0-82.0	284-x-RS	284-x-FS	300-MP	16-1/4"	1	MPS-12,13,14,15,16
B-1292-x	3-1/4	12-14			2.953-3.307	75.0-84.0	292-x-RS	292-x-FS	300-MP	16-1/4"	1	MPS-12,13,14,15,16
B-1300-x	3-1/4	15-16	3-1/2	7-9	3.032-3.386	77.0-86.0	315-x-RS	315-x-FS	300-MP	16-1/4"	1	MPS-12,13,14,15,16
B-1308-x	3-1/2	10-12			3.111-3.465	79.0-88.0	284-x-RS	284-x-FS	347-MP	18-7/32"	1	MPS-15,16,17,18,19
B-1315-x	3-1/2	13-15			3.190-3.622	81.0-92.0	315-x-RS	315-x-FS	347-MP	18-7/32"	1	MPS-14,15,16,17,18,19
B-1323-x	3-1/2	16	3-3/4	7-8	3.268-3.701	83.0-94.0	323-x-RS	323-x-FS	347-MP	18-7/32"	1	MPS-14,15,16,17,18,19
B-1331-x	3-3/4	9-12			3.347-3.780	95.0-96.0	331-x-RS	331-x-FS	347-MP	18-7/32"	1	MPS-14,15,16,17,18,19
B-1339-x	3-3/4	13-16			3.426-3.858	87.0-98.0	355-x-RS	355-x-FS	347-MP	18-7/32"	1	MPS-14,15,16,17,18,19
B-1347-x	4	7-8			3.505-3.937	89.0-100.0	363-x-RS	363-x-FS	347-MP	18-7/32"	1	MPS-14,15,16,17,18,19
B-1355-x	4	9-12			3.583-4.016	91.0-102.0	355-x-RS	355-x-FS	394-MP	18-17/64"	1	MPS-17,18,19,20,21
B-1363-x	4	13-15			3.662-4.094	93.0-104.0	363-x-RS	363-x-FS	394-MP	18-17/64"	1	MPS-17,18,19,20,21
B-1370-x	4	16	4-1/4	7-8	3.741-4.173	95.0-106.0	370-x-RS	370-x-FS	394-MP	18-17/64"	1	MPS-17,18,19,20,21
B-1378-x	4-1/4	9-11			3.820-4.252	97.0-108.0	378-x-RS	378-x-FS	394-MP	18-17/64"	1	MPS-17,18,19,20,21
B-1386-x	4-1/4	12-16			3.898-4.331	99.0-110.0	386-x-RS	386-x-FS	394-MP	18-17/64"	1	MPS-17,18,19,20,21
B-1394-x	4-1/2	7-14			3.997-4.407	101.5-111.9	394-x-RS	394-x-FS	394-MP	18-17/64"	1	MPS-17,18,19,20,21

\*x Signifies tube sheet thickness

\*\* Note: Short Mandrel lengths: MPS-1 thru MPS-10 = 7" (177.8mm), MPS-11 thru MPS-16 = 8" (203.2mm), MPS-17 thru MPS-21 = 9" (228.1mm)



# B-2000 Series Boiler Expanders

(Mandrels Sold Separately)



## B-2000 Series Boiler Expanders (Mandrels Sold Separately)

- Incorporates exclusive drift thrust collar
- Adjustable positioning provides consistent joint expansion every time

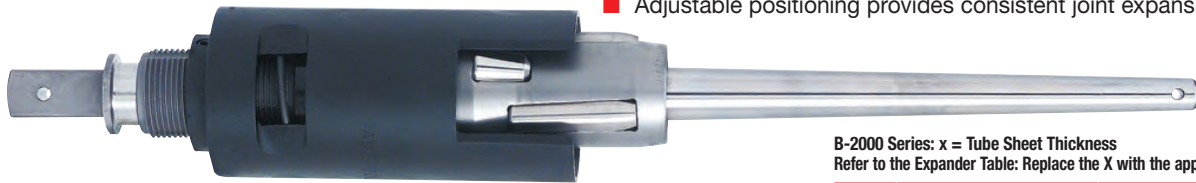

SHORT SERIES MANDRELS

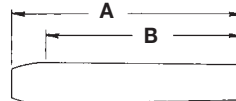

B-2000 Series: x = Tube Sheet Thickness  
Refer to the Expander Table: Replace the X with the appropriate number

X	Tube Sheet Thickness		"A" Dimension		"B" Dimension	
	in.	mm	in.	mm	in.	mm
3	1/2 - 3/4	12.7 - 19.05	1-7/16	36.5	1-1/16	26.9
5	7/8 - 1-1/4	22.2 - 31.7	1-15/16	49.2	1-9/16	39.6
7	1-3/8 - 1-3/4	34.9 - 44.4	2-7/16	61.9	2-1/16	52.3
9	1-7/8 - 2-1/4	47.6 - 57.1	2-15/16	74.6	2-9/16	65.0
11	2-3/8 - 2-3/4	60.3 - 69.8	3-7/16	87.3	3-1/16	77.7

Expander Number*	Tube Size				Expander							
	O.D.	Gauge	O.D.	Gauge	Expansion Range		Straight Roll Set*	Complete Roll Set*	Mandrel Options			
					in.	mm			Long Mandrel		Square Drive	Short Mandrel **
									Number	Length		
B-1079-x	1	13-14			0.787-0.921	20.0-23.4	079-x-RS	079-x-FS	83-MP	9-13/32"	1/2	-----
B-2083-x	1	15-16			0.827-0.961	21.0-24.4	083-x-RS	083-x-FS	83-M	13-27/32"	1/2	-----
B-2087-x	1-1/4	7			0.866-1.004	22.0-25.5	087-x-RS	087-x-FS	91-M	13-27/32"	1/2	-----
B-2091-x	1-1/4	8-9			0.906-1.043	23.0-26.5	095-x-RS	095-x-FS	91-M	13-27/32"	1/2	-----
B-2095-x	1-1/4	10			0.945-1.105	24.0-28.1	095-x-RS	095-x-FS	99-M	14-3/8"	1/2	-----
B-2099-x	1-1/4	11-13			0.984-1.142	25.0-29.0	099-x-RS	099-x-FS	99-M	14-3/8"	1/2	-----
B-2103-x	1-1/4	14-15			1.024-1.181	26.0-30.0	103-x-RS	103-x-FS	99-M	14-3/8"	1/2	-----
B-2111-x	1-1/4	16			1.105-1.299	28.1-33.0	111-x-RS	111-x-FS	118-M	15-27/32"	3/4	MS-1,2,3
B-2118-x	1-1/2	10-12			1.221-1.378	31.0-35.0	118-x-RS	118-x-FS	118-M	15-27/32"	3/4	MS-1,2,3
B-2126-x	1-1/2	13-16			1.300-1.496	33.0-38.0	126-x-RS	126-x-FS	126-M	16-31/64"	3/4	MS-2,3,4
B-2134-x	1-3/4	8-9	2	3	1.379-1.575	35.0-40.0	126-x-RS	126-x-FS	134-M	16-31/64"	3/4	MS-2,3,4
B-2142-x	1-3/4	10-12	2	4-5	1.457-1.673	37.0-42.5	142-x-RS	142-x-FS	150-M	17-3/32"	3/4	MS-3,4,5
B-2150-x	1-3/4	13-16	2	6	1.536-1.752	39.0-44.5	150-x-RS	150-x-FS	150-M	17-3/32"	3/4	MS-3,4,5
B-2158-x	2	7-9	2-1/4	3	1.615-1.850	41.0-47.0	158-x-RS	158-x-FS	174-M	18-3/32"	3/4	MS-4,5,6,7,8
B-2166-x	2	10-12	2-1/4	4-5	1.693-1.929	43.0-49.0	166-x-RS	166-x-FS	174-M	18-3/32"	3/4	MS-4,5,6,7,8
B-2174-x	2	13-16	2-1/4	6	1.722-2.027	45.0-51.5	174-x-RS	174-x-FS	174-M	18-3/32"	3/4	MS-4,5,6,7,8
B-2181-x	2	16	2-1/2	3	1.851-2.126	47.0-54.0	181-x-RS	181-x-FS	197-M	20-15/32"	1	MS-7,8,9,10,11
B-2189-x	2-1/4	10-13	2-1/2	4-5	1.930-2.205	49.0-56.0	174-x-RS	174-x-FS	197-M	20-15/32"	1	MS-7,8,9,10,11
B-2197-x	2-1/4	14-16	2-1/2	6	2.009-2.362	51.0-60.0	205-x-RS	205-x-FS	197-M	20-15/32"	1	MS-6,7,8,9,10,11
B-2205-x	2-1/2	7-10			2.087-2.441	53.0-62.0	205-x-RS	205-x-FS	221-M	20-21/32"	1	MS-7,8,9,10,11,12
B-2213-x	2-1/2	11-13	3	2	2.116-2.520	55.0-64.0	213-x-RS	213-x-FS	221-M	20-21/32"	1	MS-7,8,9,10,11,12
B-2221-x	2-1/2	14-16			2.245-2.598	57.0-66.0	221-x-RS	221-x-FS	221-M	20-21/32"	1	MS-7,8,9,10,11,12
B-2229-x	2-3/4	7-9			2.323-2.677	59.0-68.0	221-x-RS	221-x-FS	244-M	20-1/2"	1	MS-8,9,10,11,12,13
B-2237-x	2-3/4	10-12			2.402-2.756	61.0-70.0	237-x-RS	237-x-FS	244-M	20-1/2"	1	MS-8,9,10,11,12,13
B-2244-x	2-3/4	13-16			2.481-2.835	63.0-72.0	252-x-RS	252-x-FS	244-M	20-1/2"	1	MS-8,9,10,11,12,13
B-2252-x	3	7-8			2.560-2.913	65.0-74.0	252-x-RS	252-x-FS	268-M	20-1/64"	1	MS-10,11,12,13,14
B-2260-x	3	10-12			2.638-2.992	67.-076.0	260-x-RS	260-x-FS	268-M	20-1/64"	1	MS-10,11,12,13,14
B-2268-x	3	13-14			2.717-3.071	69.0-78.0	268-x-RS	268-x-FS	268-M	20-1/64"	1	MS-10,11,12,13,14
B-2276-x	3	15-16			2.796-3.150	71.0-80.0	276-x-RS	276-x-FS	300-M	20-1/2"	1	MS-12,13,14,15,16
B-2284-x	3-1/4	7-11			2.874-3.228	73.0-82.0	284-x-RS	284-x-FS	300-M	20-1/2"	1	MS-12,13,14,15,16
B-2292-x	3-1/4	12-14			2.953-3.307	75.0-84.0	292-x-RS	292-x-FS	300-M	20-1/2"	1	MS-12,13,14,15,16
B-2300-x	3-1/4	15-16	3-1/2	7-9	3.032-3.386	77.0-86.0	315-x-RS	315-x-FS	300-M	20-1/2"	1	MS-12,13,14,15,16
B-2308-x	3-1/2	10-12			3.111-3.465	79.0-88.0	284-x-RS	284-x-FS	347-M	22-15/32"	1	MS-15,16,17,18,19
B-2315-x	3-1/2	13-15			3.190-3.622	81.0-92.0	315-x-RS	315-x-FS	347-M	22-15/32"	1	MS-14,15,16,17,18,19
B-2323-x	3-1/2	16	3-3/4	7-8	3.268-3.701	83.0-94.0	323-x-RS	323-x-FS	347-M	22-15/32"	1	MS-14,15,16,17,18,19
B-2331-x	3-3/4	9-12			3.347-3.780	95.0-96.0	331-x-RS	331-x-FS	347-M	22-15/32"	1	MS-14,15,16,17,18,19
B-2339-x	3-3/4	13-16			3.426-3.858	87.0-98.0	355-x-RS	355-x-FS	347-M	22-15/32"	1	MS-14,15,16,17,18,19
B-2347-x	4	7-8			3.505-3.937	89.0-100.0	363-x-RS	363-x-FS	347-M	22-15/32"	1	MS-14,15,16,17,18,19
B-2355-x	4	9-12			3.583-4.016	91.0-102.0	355-x-RS	355-x-FS	394-M	22-33/64"	1	MS-17,18,19,20,21
B-2363-x	4	13-15			3.662-4.094	93.0-104.0	363-x-RS	363-x-FS	394-M	22-33/64"	1	MS-17,18,19,20,21
B-2370-x	4	16	4-1/4	7-8	3.741-4.173	95.0-106.0	370-x-RS	370-x-FS	394-M	22-33/64"	1	MS-17,18,19,20,21
B-2378-x	4-1/4	9-11			3.820-4.252	97.0-108.0	378-x-RS	378-x-FS	394-M	22-33/64"	1	MS-17,18,19,20,21
B-2386-x	4-1/4	12-16			3.898-4.331	99.0-110.0	386-x-RS	386-x-FS	394-M	22-33/64"	1	MS-17,18,19,20,21
B-2394-x	4-1/2	7-14			3.997-4.407	101.5-111.9	394-x-RS	394-x-FS	394-M	22-33/64"	1	MS-17,18,19,20,21

\*x Signifies tube sheet thickness

\*\* Note: Short Mandrel lengths: MPS-1 thru MPS-10 = 7" (177.8mm), MPS-11 thru MPS-16 = 8" (203.2mm), MPS-17 thru MPS-21 = 9" (228.1mm)

# B-3000 Series Boiler Expanders

(Mandrels Sold Separately)

## B-3000 Series Boiler Expanders (Mandrels Sold Separately)

- Straight roll expander for non-flare tube rolling
- Use in conjunction with B-1000 & B-2000 expanders for thicker tube sheet applications
- Convertible to B-2000 series



B-3000 Series: x = Tube Sheet Thickness  
Refer to the Expander Table: Replace the X with the appropriate number

X	Tube Sheet Thickness		"A" Dimension		"B" Dimension	
	in.	mm	in.	mm	in.	mm
7	1/2 - 4-3/8	12.7 - 111.1	2-7/16	61.9	2-1/16	52.3
11	1-1/2 - 5-3/8	38.1 - 136.5	3-7/16	87.3	3-1/16	77.7

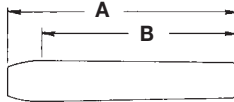

SHORT SERIES MANDRELS

Expander Number*	Tube Size				Expander						
	O.D.	Gauge	O.D.	Gauge	Expansion Range		Straight Roll Set*	Mandrel Options			
					in.	mm		Long Mandrel		Square Drive	Short Mandrels **
							Number	Length			
B-3111-7	1-1/4	16			1.105-1.299	28.1-33.0	111-x-RS	118-M	15-27/32"	3/4	MS-1,2,3
B-3118-7	1-1/2	10-12			1.221-1.378	31.0-35.0	118-x-RS	118-M	15-27/32"	3/4	MS-1,2,3
B-3126-7	1-1/2	13-16			1.300-1.496	33.0-38.0	126-x-RS	126-M	16-31/64"	3/4	MS-2,3,4
B-3134-x	1-3/4	8-9	2	3	1.379-1.575	35.0-40.0	126-x-RS	134-M	16-31/64"	3/4	MS-2,3,4
B-3142-x	1-3/4	10-12	2	4-5	1.457-1.673	37.0-42.5	142-x-RS	150-M	17-3/32"	3/4	MS-3,4,5
B-3150-x	1-3/4	13-16	2	6	1.536-1.752	39.0-44.5	150-x-RS	150-M	17-3/32"	3/4	MS-3,4,5
B-3158-x	2	7-9	2-1/4	3	1.615-1.850	41.0-47.0	158-x-RS	174-M	18-3/32"	3/4	MS-4,5,6,7,8
B-3166-x	2	10-12	2-1/4	4-5	1.693-1.929	43.0-49.0	166-x-RS	174-M	18-3/32"	3/4	MS-4,5,6,7,8
B-3174-x	2	13-16	2-1/4	6	1.722-2.027	45.0-51.5	174-x-RS	174-M	18-3/32"	3/4	MS-4,5,6,7,8
B-3181-x	2	16	2-1/2	3	1.851-2.126	47.0-54.0	181-x-RS	197-M	20-15/32"	1	MS-7,8,9,10,11
B-3189-x	2-1/4	10-13	2-1/2	4-5	1.930-2.205	49.0-56.0	174-x-RS	197-M	20-15/32"	1	MS-7,8,9,10,11
B-3197-x	2-1/4	14-16	2-1/2	6	2.009-2.362	51.0-60.0	205-x-RS	197-M	20-15/32"	1	MS-6,7,8,9,10,11
B-3205-x	2-1/2	7-10			2.087-2.441	53.0-62.0	205-x-RS	221-M	20-21/32"	1	MS-7,8,9,10,11,12
B-3213-x	2-1/2	11-13	3	2	2.116-2.520	55.0-64.0	213-x-RS	221-M	20-21/32"	1	MS-7,8,9,10,11,12
B-3221-x	2-1/2	14-16			2.245-2.598	57.0-66.0	221-x-RS	221-M	20-21/32"	1	MS-7,8,9,10,11,12
B-3229-x	2-3/4	7-9			2.323-2.677	59.0-68.0	221-x-RS	244-M	20-1/2"	1	MS-8,9,10,11,12,13
B-3237-x	2-3/4	10-12			2.402-2.756	61.0-70.0	237-x-RS	244-M	20-1/2"	1	MS-8,9,10,11,12,13
B-3244-x	2-3/4	13-16			2.481-2.835	63.0-72.0	252-x-RS	244-M	20-1/2"	1	MS-8,9,10,11,12,13
B-3252-x	3	7-8			2.560-2.913	65.0-74.0	252-x-RS	268-M	20-1/64"	1	MS-10,11,12,13,14
B-3260-x	3	10-12			2.638-2.992	67.0-76.0	260-x-RS	268-M	20-1/64"	1	MS-10,11,12,13,14
B-3268-x	3	13-14			2.717-3.071	69.0-78.0	268-x-RS	268-M	20-1/64"	1	MS-10,11,12,13,14
B-3276-x	3	15-16			2.796-3.150	71.0-80.0	276-x-RS	300-M	20-1/2"	1	MS-12,13,14,15,16
B-3284-x	3-1/4	7-11			2.874-3.228	73.0-82.0	284-x-RS	300-M	20-1/2"	1	MS-12,13,14,15,16
B-3292-x	3-1/4	12-14			2.953-3.307	75.0-84.0	292-x-RS	300-M	20-1/2"	1	MS-12,13,14,15,16
B-3300-x	3-1/4	15-16	3-1/2	7-9	3.032-3.386	77.0-86.0	315-x-RS	300-M	20-1/2"	1	MS-12,13,14,15,16
B-3308-x	3-1/2	10-12			3.111-3.465	79.0-88.0	284-x-RS	347-M	22-15/32"	1	MS-15,16,17,18,19
B-3315-x	3-1/2	13-15			3.190-3.622	81.0-92.0	315-x-RS	347-M	22-15/32"	1	MS-14,15,16,17,18,19
B-3323-x	3-1/2	16	3-3/4	7-8	3.268-3.701	83.0-94.0	323-x-RS	347-M	22-15/32"	1	MS-14,15,16,17,18,19
B-3331-x	3-3/4	9-12			3.347-3.780	95.0-96.0	331-x-RS	347-M	22-15/32"	1	MS-14,15,16,17,18,19
B-3339-x	3-3/4	13-16			3.426-3.858	87.0-98.0	355-x-RS	347-M	22-15/32"	1	MS-14,15,16,17,18,19
B-3347-x	4	7-8			3.505-3.937	89.0-100.0	363-x-RS	347-M	22-15/32"	1	MS-14,15,16,17,18,19
B-3355-x	4	9-12			3.583-4.016	91.0-102.0	355-x-RS	394-M	22-33/64"	1	MS-17,18,19,20,21
B-3363-x	4	13-15			3.662-4.094	93.0-104.0	363-x-RS	394-M	22-33/64"	1	MS-17,18,19,20,21
B-3370-x	4	16	4-1/4	7-8	3.741-4.173	95.0-106.0	370-x-RS	394-M	22-33/64"	1	MS-17,18,19,20,21
B-3378-x	4-1/4	9-11			3.820-4.252	97.0-108.0	378-x-RS	394-M	22-33/64"	1	MS-17,18,19,20,21
B-3386-x	4-1/4	12-16			3.898-4.331	99.0-110.0	386-x-RS	394-M	22-33/64"	1	MS-17,18,19,20,21
B-3394-x	4-1/2	7-14			3.997-4.407	101.5-111.9	394-x-RS	394-M	22-33/64"	1	MS-17,18,19,20,21

\*x Signifies tube sheet thickness

\*\* Note: Short Mandrel lengths: MPS-1 thru MPS-10 = 7" (177.8mm), MPS-11 thru MPS-16 = 8" (203.2mm), MPS-17 thru MPS-21 = 9" (228.1mm)

Expander	Units	Expansion Range		MS & MPS	Expansion Range		MS & MPS	Expansion Range		MS & MPS	Expansion Range		MS & MPS	Expansion Range		MS & MPS	Expansion Range		MS & MPS	Expansion Range			
		Min	Max		Min	Max		Min	Max		Min	Max		Min	Max		Min	Max		Min	Max	Min	Max
B - X111	in. mm	1.102 28.0	1.299 33.0	#1	1.102 28.0	1.183 30.0	#2	1.124 28.5	1.234 31.3	#3	1.189 30.2	1.299 33.0											
B - X118	in. mm	1.181 30.0	1.378 35.0	#1	1.181 30.0	1.262 32.1	#2	1.203 30.6	1.313 33.4	#3	1.268 32.2	1.378 35.0											
B - X126	in. mm	1.26 32.0	1.496 38.0	#2	1.26 32.0	1.366 34.7	#3	1.342 34.1	1.431 36.3	#4	1.407 35.7	1.496 38.0											
B - X134	in. mm	1.339 34.0	1.575 40.0	#3	1.339 34.0	1.432 36.4	#4	1.407 35.7	1.497 38.0	#5	1.485 37.7	1.575 40.0											
B - X142	in. mm	1.417 36.0	1.673 42.5	#3	1.417 36.0	1.489 37.8	#4	1.486 37.7	1.554 39.5	#5	1.564 39.7	1.632 41.5	#6	1.605 40.8	1.673 42.5								
B - X150	in. mm	1.496 38.0	1.752 44.5	#3	1.496 38.0	1.568 39.8	#4	1.565 39.7	1.633 41.5	#5	1.643 41.7	1.711 43.5	#6	1.684 42.8	1.752 44.5								
B - X158	in. mm	1.575 40.0	1.85 47.0	#4	1.575 40.0	1.613 41.0	#5	1.622 41.2	1.691 43.0	#6	1.663 42.3	1.732 44.0	#7	1.722 43.7	1.791 45.5	#8	1.781 45.2	1.85 47.0					
B - X166	in. mm	1.654 42.0	1.929 49.0	#4	1.654 42.0	1.692 43.0	#5	1.701 43.2	1.77 45.0	#6	1.742 44.3	1.811 46.0	#7	1.801 45.8	1.807 47.5	#8	1.86 47.3	1.929 49.0					
B - X174	in. mm	1.732 44.0	2.027 51.5	#4	1.732 44.0	1.79 45.5	#5	1.799 45.7	1.868 47.4	#6	1.84 46.7	1.909 48.5	#7	1.899 48.2	1.968 50.0	#8	1.958 49.7	2.027 51.5					
B - X181	in. mm	1.811 46.0	2.126 54.0	#7	1.811 46.0	1.889 48.0	#8	1.88 47.7	1.948 49.5	#9	1.938 49.2	2.006 51.0	#10	1.993 50.6	2.061 52.3	#11	2.017 51.2	2.126 54.0					
B - X189	in. mm	1.89 48.0	2.205 56.0	#7	1.89 48.0	1.968 50.0	#8	1.958 49.7	2.027 51.5	#9	2.016 51.2	2.085 53.0	#10	2.071 52.6	2.14 54.4	#11	2.095 53.2	2.205 56.0					
B - X197	in. mm	1.969 50.0	2.362 60.0	#6	1.969 50.0	2.066 52.5	#7	2.057 52.2	2.125 54.0	#8	2.116 53.7	2.184 55.5	#9	2.174 55.2	2.242 56.9	#10	2.229 56.6	2.297 58.3	#11	2.253 57.2	2.362 60.0	2.253 57.2	2.362 60.0
B - X205	in. mm	2.047 52.0	2.441 62.0	#7	2.047 52.0	2.126 54.0	#8	2.116 53.7	2.185 55.5	#9	2.174 55.2	2.243 57.0	#10	2.229 56.6	2.298 58.4	#11	2.253 57.2	2.363 60.0	#12	2.331 59.2	2.441 62.0	2.331 59.2	2.441 62.0
B - X213	in. mm	2.126 54.0	2.52 64.0	#7	2.126 54.0	2.205 56.0	#8	2.197 55.8	2.264 57.5	#9	2.255 57.3	2.322 59.0	#10	2.31 58.7	2.377 60.4	#11	2.334 59.3	2.442 62.0	#12	2.412 61.3	2.52 64.0	2.412 61.3	2.52 64.0
B - X221	in. mm	2.205 56.0	2.598 66.0	#7	2.205 56.0	2.283 58.0	#8	2.274 57.8	2.342 59.5	#9	2.332 59.2	2.4 61.0	#10	2.387 60.6	2.455 62.4	#11	2.411 61.2	2.52 64.0	#12	2.489 63.2	2.598 66.0	2.489 63.2	2.598 66.0
B - X229	in. mm	2.283 58.0	2.677 68.0	#8	2.283 58.0	2.342 59.5	#9	2.331 59.2	2.4 61.0	#10	2.386 60.6	2.455 62.4	#11	2.41 61.2	2.52 64.0	#12	2.488 63.2	2.598 66.0	#13	2.567 65.2	2.677 68.0	2.567 65.2	2.677 68.0
B - X237	in. mm	2.362 60.0	2.756 70.0	#8	2.362 60.0	2.421 61.5	#9	2.41 61.2	2.479 63.0	#10	2.465 62.6	2.534 64.4	#11	2.489 63.2	2.599 66.0	#12	2.567 65.2	2.677 68.0	#13	2.646 67.2	2.756 70.0	2.646 67.2	2.756 70.0
B - X244	in. mm	2.441 62.0	2.835 72.0	#8	2.441 62.0	2.5 63.5	#9	2.489 63.2	2.558 65.0	#10	2.544 64.6	2.61 66.4	#11	2.568 65.2	2.678 68.0	#12	2.646 67.2	2.756 70.0	#13	2.725 69.2	2.835 72.0	2.725 69.2	2.835 72.0
B - X252	in. mm	2.52 64.0	2.913 74.0	#10	2.52 64.0	2.612 66.3	#11	2.568 65.2	2.667 68.0	#12	2.646 67.2	2.755 70.0	#13	2.725 69.2	2.834 72.0	#14	2.804 71.2	2.913 74.0	#15	2.883 73.2	2.992 76.0	2.883 73.2	2.992 76.0
B - X260	in. mm	2.598 66.0	2.992 76.0	#10	2.598 66.0	2.691 68.4	#11	2.647 67.2	2.756 70.0	#12	2.725 69.2	2.834 72.0	#13	2.804 71.2	2.913 74.0	#14	2.883 73.2	2.992 76.0	#15	3.071 75.2			
B - X268	in. mm	2.667 68.0	3.071 78.0	#10	2.667 68.0	2.77 70.4	#11	2.725 69.2	2.835 72.0	#12	2.803 71.2	2.913 74.0	#13	2.882 73.2	2.992 76.0	#14	2.961 75.2	3.071 78.0	#15				
B - X276	in. mm	2.756 70.0	3.15 80.0	#12	2.756 70.0	2.887 73.3	#13	2.857 72.6	2.966 75.3	#14	2.936 74.6	3.045 77.3	#15	2.988 75.9	3.097 78.7	#16	3.041 77.2	3.15 80.0	#17				
B - X284	in. mm	2.835 72.0	3.228 82.0	#12	2.835 72.0	2.965 75.3	#13	2.935 74.5	3.044 77.3	#14	3.014 76.5	3.123 79.3	#15	3.066 77.9	3.175 80.6	#16	3.119 79.2	3.228 82.0	#17				
B - X292	in. mm	2.913 74.0	3.307 84.0	#12	2.913 74.0	3.044 77.3	#13	3.014 76.5	3.123 79.3	#14	3.093 78.6	3.202 81.3	#15	3.15 79.9	3.25 82.7	#16	3.198 81.2	3.307 84.0	#17				
B - X300	in. mm	2.992 76.0	3.386 86.0	#12	2.992 76.0	3.123 79.3	#13	3.094 78.6	3.202 81.3	#14	3.173 80.6	3.281 83.3	#15	3.225 81.9	3.333 84.7	#16	3.278 83.3	3.386 86.0	#17				
B - X308	in. mm	3.071 78.0	3.465 88.0	#15	3.071 78.0	3.177 80.7	#16	3.119 79.2	3.23 82.0	#17	3.151 80.0	3.304 83.9	#18	3.231 82.1	3.384 86.0	#19	3.312 84.1	3.465 88.0	#20				
B - X315	in. mm	3.15 80.0	3.622 92.0	#14	3.15 80.0	3.282 83.4	#15	3.225 81.9	3.334 84.7	#16	3.278 83.3	3.387 86.0	#17	3.31 84.1	3.461 87.9	#18	3.39 86.1	3.541 89.9	#19	3.471 88.2	3.622 92.0	3.471 88.2	3.622 92.0
B - X323	in. mm	3.228 82.0	3.701 94.0	#14	3.228 82.0	3.361 85.4	#15	3.304 83.9	3.413 86.7	#16	3.357 85.3	3.466 88.0	#17	3.389 86.1	3.54 89.9	#18	3.469 88.1	3.62 91.9	#19	3.55 90.2	3.701 94.0	3.55 90.2	3.701 94.0
B - X331	in. mm	3.307 84.0	3.78 96.0	#14	3.307 84.0	3.44 87.4	#15	3.383 85.9	3.492 88.7	#16	3.436 87.3	3.545 90.0	#17	3.468 88.1	3.619 91.9	#18	3.548 90.1	3.699 94.0	#19	3.629 92.2	3.78 96.0	3.629 92.2	3.78 96.0
B - X339	in. mm	3.386 86.0	3.858 98.0	#14	3.386 86.0	3.518 89.4	#15	3.461 87.9	3.57 90.7	#16	3.514 89.2	3.623 92.0	#17	3.546 90.1	3.697 93.9	#18	3.626 92.1	3.777 95.9	#19	3.707 94.1	3.858 98.0	3.707 94.1	3.858 98.0
B - X347	in. mm	3.465 88.0	3.937 100.0	#14	3.465 88.0	3.597 91.4	#15	3.539 89.9	3.649 92.7	#16	3.592 91.2	3.702 94.0	#17	3.624 92.0	3.776 95.9	#18	3.704 94.1	3.856 97.9	#19	3.785 96.1	3.937 100.0	3.785 96.1	3.937 100.0
B - X355	in. mm	3.543 90.0	4.016 102.0	#17	3.543 90.0	3.696 93.9	#18	3.626 92.1	3.776 95.9	#19	3.707 94.1	3.857 98.0	#20	3.786 96.2	3.936 100.0	#21	3.866 98.2	4.016 102.0	#22				
B - X363	in. mm	3.622 92.0	4.094 104.0	#17	3.622 92.0	3.774 95.9	#18	3.704 94.1	3.854 97.9	#19	3.785 96.1	3.935 99.9	#20	3.863 98.1	4.014 102.0	#21	3.944 100.2	4.094 104.0	#22				
B - X370	in. mm	3.701 94.0	4.173 106.0	#17	3.701 94.0	3.853 97.9	#18	3.782 96.1	3.933 99.9	#19	3.863 98.1	4.014 102.0	#20	3.942 100.1	4.093 104.0	#21	4.022 102.1	4.173 106.0	#22				
B - X378	in. mm	3.78 96.0	4.252 108.0	#17	3.78 96.0	3.932 99.9	#18	3.862 98.1	4.012 101.9	#19	3.934 98.1	4.093 104.0	#20	4.022 102.1	4.172 106.0	#21	4.102 104.2	4.252 108.0	#22				
B - X386	in. mm	3.858 98.0	4.331 110.0	#17	3.858 98.0	4.011 101.9	#18	3.94 100.0	4.091 103.9	#19	4.012 101.9	4.17 106.0	#20	4.1 104.1	4.251 108.0	#21	4.18 106.1	4.331 110.0	#22				
B - X394	in. mm	3.937 100.0	4.407 111.9	#17	3.937 100.0	4.087 103.8	#18	4.018 102.1	4.167 105.8	#19	4.099 104.1	4.248 107.9	#20	4.178 106.1	4.327 109.9	#21	4.258 108.2	4.4 111.9	#22				

Mandrel Lengths		
Mandrel Number	B-1000	B-2000 & B-3000
	MPS	MS
1 - 10	7.000" (177.8mm)	12.188" (309.6mm)
11 - 16	8.000" (203.2mm)	13.188" (335.0mm)
17 - 21	9.000" (228.1mm)	14.188" (360.0mm)

# Boiler Expanders

## B-1000 & B-2000 Series Boiler Expanders Material Descriptions & Ordering Numbers

Material Description	Material Number	Material Description	Material Number	Material Description	Material Number	Material Description	Material Number	Material Description	Material Number
B-1079-3	5522190	B-1150-3	5522796	B-1244-3		B-1339-3		B-2095-3	
B-1079-5		B-1150-5	5522197	B-1244-5		B-1339-5		B-2095-5	5521961
B-1079-7		B-1150-7	5521883	B-1244-7	5522181	B-1339-7		B-2095-7	
B-1079-9		B-1150-9	5521888	B-1244-9	5522842	B-1339-9		B-2095-9	
B-1079-11		B-1150-11	5521862	B-1244-11	5521952	B-1339-11	5522540	B-2095-11	
B-1083-3		B-1158-3	5521933PT	B-1252-3	5521953	B-1347-3	5526391	B-2099-3	
B-1083-5	5523808	B-1158-5	5521934	B-1252-5	5522327	B-1347-5		B-2099-5	
B-1083-7		B-1158-7	5521935	B-1252-7	5522477	B-1347-7	5522180	B-2099-7	
B-1083-9		B-1158-9	5521845	B-1252-9	5521954	B-1347-9		B-2099-9	
B-1083-11		B-1158-11	5521910	B-1252-11	5522320PT	B-1347-11	5523722	B-2099-11	
B-1087-3	5523735	B-1166-3	5521936	B-1260-3	5521955	B-1355-3		B-2103-3	
B-1087-5	5525513	B-1166-5	5521937	B-1260-5	5522094	B-1355-5		B-2103-5	5522411
B-1087-7		B-1166-7	5521938	B-1260-7	5522095	B-1355-7	5525944	B-2103-7	
B-1087-9		B-1166-9	5521939	B-1260-9	5522096	B-1355-9	5524221	B-2103-9	
B-1087-11		B-1166-11	5521940	B-1260-11	5522097	B-1355-11		B-2103-11	
B-1091-3		B-1174-3	5521941	B-1268-3		B-1363-3	5522062	B-2111-3	
B-1091-5		B-1174-5	5521942PT	B-1268-5	5521957	B-1363-5		B-2111-5	
B-1091-7		B-1174-7	5521943	B-1268-7		B-1363-7		B-2111-7	
B-1091-9		B-1174-9	5521944	B-1268-9		B-1363-9		B-2111-9	
B-1091-11		B-1174-11	5521945	B-1268-11		B-1363-11		B-2111-11	
B-1095-3		B-1181-3	5522017	B-1276-3	5523191	B-1370-3		B-2118-3	5521963
B-1095-5	5521927	B-1181-5	5522149	B-1276-5	5523270	B-1370-5		B-2118-5	
B-1095-7		B-1181-7	5522868	B-1276-7	5524555	B-1370-7		B-2118-7	
B-1095-9		B-1181-9	5522783	B-1276-9		B-1370-9		B-2118-9	
B-1095-11		B-1181-11	5522205PT	B-1276-11		B-1370-11		B-2118-11	
B-1099-3		B-1189-3	5525255	B-1284-3	5522173	B-1378-3		B-2126-3	5525355PT
B-1099-5	5525463	B-1189-5	5522393	B-1284-5	5521958	B-1378-5		B-2126-5	
B-1099-7	5525386	B-1189-7	5522179	B-1284-7		B-1378-7		B-2126-7	5524532PT
B-1099-9		B-1189-9	5522782	B-1284-9		B-1378-9		B-2126-9	
B-1099-11		B-1189-11	5523948	B-1284-11	5525545	B-1378-11		B-2126-11	
B-1103-3	5525904	B-1197-3	5525999	B-1292-3		B-1386-3		B-2134-3	
B-1103-5		B-1197-5		B-1292-5		B-1386-5		B-2134-5	
B-1103-7		B-1197-7	5522178	B-1292-7		B-1386-7		B-2134-7	5523729
B-1103-9		B-1197-9		B-1292-9	5525084	B-1386-9		B-2134-9	
B-1103-11		B-1197-11	5522223	B-1292-11		B-1386-11		B-2134-11	
B-1111-3	5522195	B-1205-3	5522426	B-1300-3		B-1394-3	5525605	B-2142-3	
B-1111-5	5521928	B-1205-5	5521946	B-1300-5	5523696PT	B-1394-5	5526042	B-2142-5	5523064
B-1111-7	5522147	B-1205-7	5521947	B-1300-7		B-1394-7		B-2142-7	5522063
B-1111-9	5526051	B-1205-9	5521948	B-1300-9		B-1394-9	5524597	B-2142-9	5521965
B-1111-11		B-1205-11	5521949	B-1300-11		B-1394-11	5525385	B-2142-11	5521966
B-1118-3	5521929	B-1213-3	5521950	B-1308-3	5523571	B-2079-3		B-2150-3	
B-1118-5	5522360	B-1213-5	5521951PT	B-1308-5	5524747	B-2079-5		B-2150-5	5522167
B-1118-7		B-1213-7	5522175	B-1308-7		B-2079-7		B-2150-7	5521967
B-1118-9		B-1213-9	5522146	B-1308-9		B-2079-9		B-2150-9	5521968
B-1118-11		B-1213-11	5522092	B-1308-11	5523694	B-2079-11		B-2150-11	5521902
B-1126-3	5522795	B-1221-3	5521889	B-1315-3		B-2083-3		B-2158-3	
B-1126-5		B-1221-5	5522313	B-1315-5		B-2083-5		B-2158-5	5521971
B-1126-7	5522204	B-1221-7		B-1315-7		B-2083-7		B-2158-7	5521972
B-1126-9		B-1221-9		B-1315-9		B-2083-9		B-2158-9	5521973
B-1126-11		B-1221-11		B-1315-11		B-2083-11		B-2158-11	5521974
B-1134-3	5526046	B-1229-3	5526082	B-1323-3		B-2087-3		B-2166-3	5521975PT
B-1134-5	5521930	B-1229-5		B-1323-5		B-2087-5		B-2166-5	5521897
B-1134-7	5524036	B-1229-7		B-1323-7	5525891	B-2087-7		B-2166-7	5521977
B-1134-9	5521846	B-1229-9		B-1323-9		B-2087-9		B-2166-9	5521978
B-1134-11		B-1229-11		B-1323-11		B-2087-11		B-2166-11	5521979
B-1142-3	5522196	B-1237-3		B-1331-3		B-2091-3		B-2174-3	5521892
B-1142-5	5522391	B-1237-5	5526020	B-1331-5		B-2091-5		B-2174-5	5521981
B-1142-7	5522423	B-1237-7		B-1331-7		B-2091-7		B-2174-7	5521982
B-1142-9	5521931	B-1237-9		B-1331-9		B-2091-9		B-2174-9	5521983
B-1142-11	5521932	B-1237-11	5523711	B-1331-11	5525198	B-2091-11		B-2174-11	5521984

## B-2000, B-3000 Series Boiler Expanders & Mandrel Material Descriptions & Ordering Numbers

Material Description	Material Number	Material Description	Material Number	Material Description	Material Number	Material Description	Material Number	Material Description	Material Number
B-2181-3		B-2276-3		B-2370-3		B-3276-11	5523194	83-M	
B-2181-5		B-2276-5	5523087	B-2370-5		B-3284-7	5523026	91-M	2995063
B-2181-7		B-2276-7		B-2370-7		B-3284-11		99-M	2995057
B-2181-9	5523784	B-2276-9		B-2370-9		B-3292-7	5524448	118-M	2993819
B-2181-11	5523785	B-2276-11		B-2370-11		B-3292-11		126-M	2993820
B-2189-3	5522452	B-2284-3		B-2378-3		B-3300-7	5526349	134-M	2902805
B-2189-5		B-2284-5		B-2378-5		B-3300-11		150-M	2993821
B-2189-7		B-2284-7		B-2378-7		B-3308-7		174-M	2993545
B-2189-9		B-2284-9	5525237	B-2378-9		B-3308-11		197-M	2994636
B-2189-11		B-2284-11		B-2378-11		B-3315-7	5523710	221-M	2993822
B-2197-3	5525873	B-2292-3		B-2386-3		B-3315-11		244-M	2993823
B-2197-5		B-2292-5		B-2386-5		B-3323-7	5523763	268-M	2993824
B-2197-7		B-2292-7		B-2386-7		B-3323-11		300-M	2994303
B-2197-9		B-2292-9		B-2386-9		B-3331-7	5523220	347-M	2994235
B-2197-11		B-2292-11		B-2386-11		B-3331-11	5525197	394-M	2994208
B-2205-3		B-2300-3		B-2394-3	5526218	B-3339-7			
B-2205-5		B-2300-5		B-2394-5		B-3339-11	5522269		
B-2205-7	5521986	B-2300-7		B-2394-7		B-3347-7	5522319	83-MP	2993831
B-2205-9	5521987	B-2300-9		B-2394-9		B-3347-11	5523311PT	91-MP	2995080
B-2205-11	5521988	B-2300-11		B-2394-11	5525608	B-3355-7	5524218	99-MP	2993832
B-2213-3	5521989	B-2308-3	5525607	B-3111-7	5522000	B-3355-11		118-MP	2993833
B-2213-5	5521990	B-2308-5		B-3118-7	5522001	B-3363-7	5522111	126-MP	2994714
B-2213-7	5522498	B-2308-7		B-3126-7	5522002PT	B-3363-11		134-MP	2994065
B-2213-9	5522499	B-2308-9		B-3134-7	5522206	B-3370-7	5522020	150-MP	2993834
B-2213-11	5522200	B-2308-11	5526011	B-3134-11		B-3370-11		174-MP	2993835
B-2221-3	5521991	B-2315-3		B-3142-7	5522003	B-3378-7		197-MP	2994196
B-2221-5	5522812	B-2315-5		B-3142-11	5522004	B-3378-11	5526556PT	221-MP	2993836
B-2221-7		B-2315-7		B-3150-7	5522005	B-3386-7		244-MP	2993837
B-2221-9		B-2315-9		B-3150-11	5521861	B-3386-11		268-MP	2993838
B-2221-11		B-2315-11		B-3158-7	5522006	B-3394-7	5522427	300-MP	2994133
B-2229-3		B-2323-3	5525510	B-3158-11	5522007	B-3394-11	5524626	347-MP	2994675
B-2229-5		B-2323-5	5525498	B-3166-7	5522008			394-MP	2994321
B-2229-7		B-2323-7		B-3166-11	5522009				
B-2229-9	5525606	B-2323-9		B-3174-7	5521692				
B-2229-11		B-2323-11	5523775	B-3174-11	5522010			MPS-1	2994289
B-2237-3		B-2331-3		B-3181-7	5522918			MPS-2	2994290
B-2237-5		B-2331-5		B-3181-11				MPS-3	2994070
B-2237-7		B-2331-7	5525050	B-3189-7				MPS-4	2994071
B-2237-9		B-2331-9		B-3189-11	5523691			MPS-5	2994072
B-2237-11	5524444PT	B-2331-11		B-3197-7	5522318PT			MPS-6	2994073
B-2244-3		B-2339-3		B-3197-11	5522032			MPS-7	2994074
B-2244-5		B-2339-5		B-3205-7	5522011PT			MPS-8	2994075
B-2244-7		B-2339-7		B-3205-11	5522012			MPS-9	2994192
B-2244-9		B-2339-9		B-3213-7	5522260			MPS-10	2994193
B-2244-11	5521992	B-2339-11	5522544	B-3213-11	5522121			MPS-11	2994194
B-2252-3		B-2347-3		B-3221-7	5522098			MPS-12	2994293
B-2252-5		B-2347-5		B-3221-11	5522099			MPS-13	2994294
B-2252-7	5523089	B-2347-7	5523730	B-3229-7	5522869			MPS-14	2994295
B-2252-9	5521994	B-2347-9		B-3229-11	5525863			MPS-15	2994296
B-2252-11	5522293	B-2347-11	5522240	B-3237-7	5522013			MPS-16	2994297
B-2260-3	5521995	B-2355-3		B-3237-11	5522014			MPS-17	2994298
B-2260-5	5523357PT	B-2355-5		B-3244-7	5522787			MPS-18	2994299
B-2260-7	5524223	B-2355-7	5524219	B-3244-11	5522425			MPS-19	2994300
B-2260-9	5525158	B-2355-9		B-3252-7	5521893			MPS-20	2994301
B-2260-11	5522294	B-2355-11		B-3252-11	5522015			MPS-21	2994302
B-2268-3		B-2363-3		B-3260-7	5521894				
B-2268-5		B-2363-5		B-3260-11	5522292				
B-2268-7		B-2363-7		B-3268-7	5524157				
B-2268-9		B-2363-9		B-3268-11	5523193				
B-2268-11		B-2363-11		B-3276-7	5522407PT				



# Boiler Expanders

## Roll Set Material Descriptions & Ordering Numbers

Material Description	Material Number	Material Description	Material Number	Material Description	Material Number	Material Description	Material Number	Material Description	Material Number	Material Description	Material Number
079-3-FS		103-9-RS		158-7-FS	5522373	221-3-RS		276-11-FS	5525382PT	355-7-RS	5524220
079-3-RS	5523172	103-11-FS		158-7-RS	5522225	221-5-FS	5522054	276-11-RS	5525381	355-9-FS	5524222PT
079-5-FS	5525164	103-11-RS		158-9-FS	5521848	221-5-RS		284-3-FS	5523578	355-9-RS	
079-5-RS		111-3-FS		158-9-RS	5522519	221-7-FS	5522055	284-3-RS		355-11-FS	5523010PT
079-7-FS	5526561PT	111-3-RS		158-11-FS	5522048PT	221-7-RS	5523687	284-5-FS	5522873	355-11-RS	5523011
079-7-RS		111-5-FS	5522312PT	158-11-RS	5521911	221-9-FS		284-5-RS	5523246	363-3-FS	5526393
079-9-FS		111-5-RS		166-3-FS	5522348	221-9-RS		284-7-FS		363-3-RS	5526392
079-9-RS		111-7-FS	5524554	166-3-RS	5523155	221-11-FS	5522056	284-7-RS	5523415	363-5-FS	
079-11-FS		111-7-RS	5522493	166-5-FS	5522049	221-11-RS	5522150	284-9-FS		363-5-RS	
079-11-RS		111-9-FS		166-5-RS	5522064	237-3-FS	5523599	284-9-RS		363-7-FS	5522182
083-3-FS	5523046	111-9-RS		166-7-FS	5522027	237-3-RS		284-11-FS	5523695	363-7-RS	5523024
083-3-RS		111-11-FS		166-7-RS	5522531	237-5-FS	5526021	284-11-RS		363-9-FS	
083-5-FS		111-11-RS		166-9-FS	5522036	237-5-RS		292-3-FS		363-9-RS	
083-5-RS		118-3-FS	5522786	166-9-RS	5522779	237-7-FS	5523399	292-3-RS		363-11-FS	5523309
083-7-FS	5526562PT	118-3-RS	5526018	166-11-FS	5522037	237-7-RS	5523818	292-5-RS		363-11-RS	5523310
083-7-RS		118-5-FS	5522361	166-11-RS	5522126	237-9-FS	5522144	292-5-RS		370-3-FS	
083-9-FS		118-5-RS		174-3-FS	5523113	237-9-RS		292-7-FS		370-3-RS	
083-9-RS		118-7-FS	5522814	174-3-RS	5523950	237-11-FS	5522142	292-7-RS	5524449	370-5-FS	
083-11-FS		118-7-RS	5522828	174-5-FS	5522051	237-11-RS	5522141	292-9-FS		370-5-RS	
083-11-RS		118-9-FS		174-5-RS	5525683PT	252-3-FS	5524791	292-9-RS		370-7-FS	
087-3-FS		118-9-RS	5523453	174-7-FS	5522050	252-3-RS		292-11-FS		370-7-RS	5522441
087-3-RS		118-11-FS		174-7-RS	5522271	252-5-FS	5522328	292-11-RS		370-9-FS	
087-5-FS		118-11-RS		174-9-FS	5522270	252-5-RS		315-3-FS		370-9-RS	
087-5-RS		126-3-FS	5522792PT	174-9-RS	5522992	252-7-FS	5522183	315-3-RS		370-11-FS	
087-7-FS		126-3-RS	5525356	174-11-FS	5522052	252-7-RS	5522436	315-5-FS	5523697PT	370-11-RS	
087-7-RS		126-5-FS	5522876	174-11-RS	5523215	252-9-FS	5522848	315-5-RS		378-3-FS	
087-9-FS		126-5-RS		181-3-FS	5524738	252-9-RS	5524331	315-7-FS		378-3-RS	
087-9-RS		126-7-FS	5523731	181-3-RS		252-11-FS	5522038	315-7-RS	5523762	378-5-FS	
087-11-FS		126-7-RS	5522989	181-5-FS	5522369	252-11-RS	5522087	315-9-FS		378-5-RS	
087-11-RS		126-9-FS	5521849	181-5-RS		260-3-FS	5523152	315-9-RS		378-7-FS	
095-3-FS	5522322	126-9-RS	5525691	181-7-FS	5522164	260-3-RS		315-11-FS		378-7-RS	
095-3-RS		126-11-FS	5525168	181-7-RS	5522913	260-5-FS	5522057PT	315-11-RS		378-9-FS	
095-5-FS	5522412	126-11-RS	5524958PT	181-9-FS	5522849	260-5-RS		323-3-FS		378-9-RS	
095-5-RS		142-3-FS		181-9-RS		260-7-FS	5522058	323-3-RS		378-11-FS	
095-7-FS		142-3-RS		181-11-FS	5523786	260-7-RS	5522911	323-5-FS	5525499	378-11-RS	5526557PT
095-7-RS		142-5-FS	5522392	181-11-RS	5522850	260-9-FS	5522059	323-5-RS	5525500	386-3-FS	
095-9-FS		142-5-RS	5525911PT	205-3-FS	5522867	260-9-RS		323-7-FS		386-3-RS	
095-9-RS		142-7-FS	5522066PT	205-3-RS		260-11-FS	5522060	323-7-RS	5523764	386-5-FS	
095-11-FS		142-7-RS	5522065	205-5-FS	5522395	260-11-RS	5522481	323-9-FS		386-5-RS	
095-11-RS		142-9-FS	5521850	205-5-RS	5522529	268-3-FS		323-9-RS		386-7-FS	
099-3-FS		142-9-RS	5522947	205-7-FS	5522177	268-3-RS		323-11-FS	5523776	386-7-RS	
099-3-RS		142-11-FS	5522235	205-7-RS	5522317	268-5-FS	5522370	323-11-RS	5522031	386-9-FS	
099-5-FS	5526003	142-11-RS	5522028	205-9-FS	5522316	268-5-RS	5522895	331-3-FS	5522893	386-9-RS	
099-5-RS		150-3-FS	5522813	205-9-RS		268-7-FS	5525323	331-3-RS		386-11-FS	
099-7-FS		150-3-RS		205-11-FS	5522221	268-7-RS	5525876	331-5-FS		386-11-RS	
099-7-RS		150-5-FS	5522781	205-11-RS	5522033	268-9-FS		331-5-RS		394-3-FS	
099-9-FS		150-5-RS	5524531	213-3-FS	5522339	268-9-RS		331-7-FS		394-3-RS	5526219
099-9-RS		150-7-FS	5521884	213-3-RS	5523777	268-11-FS	5522061	331-7-RS	5523221	394-5-FS	5523360
099-11-FS		150-7-RS	5522086	213-5-FS	5522805	268-11-RS	5521976	331-9-FS		394-5-RS	
099-11-RS		150-9-FS	5521891	213-5-RS	5522530	276-3-FS	5524737	331-9-RS		394-7-FS	
103-3-FS		150-9-RS	5522518	213-7-FS	5522176	276-3-RS		331-11-FS	5525200	394-7-RS	
103-3-RS	5526024	150-11-FS	5521864	213-7-RS	5522315	276-5-FS	5523091	331-11-RS	5525199	394-9-FS	
103-5-FS	5522390	150-11-RS	5521863	213-9-FS	5522314	276-5-RS		355-3-FS		394-9-RS	
103-5-RS		158-3-FS	5522238	213-9-RS		276-7-FS	5523092PT	355-3-RS		394-11-FS	
103-7-FS		158-3-RS		213-11-FS	5522053	276-7-RS	5524323	355-5-FS	5522483	394-11-RS	
103-7-RS		158-5-FS	5522302	213-11-RS	5522155	276-9-FS		355-5-RS			
103-9-FS		158-5-RS	5523693	221-3-FS		276-9-RS		355-7-FS	5523090		

## FTE Series Firetube Boiler Tube Expanders

Airetool product engineers have designed an economical, yet durable Firetube boiler tube expander for non-flaring (FTE) applications with 3/8" to 1" thick tube sheets. This unique design increases the expansion range for a given expander and includes a metal roll retainer that keeps the rolls in the expander's cage when the mandrel is removed. Mandrels are sold separately with choices based on application and space limitations.

Available for 2", 2-1/2" and 3" O.D. Tubes with 10-14 gauge tube walls. The FTE Series are excellent tube expanders for expanding air heater tubes in power utility boilers.

- Flip collar accommodates different tube sheet thicknesses
- 3-roll design expands and seals tubes in round or oval tube sheet holes
- Increased expansion range means less inventory and lower operating costs
- Ball bearing thrust collar allows torque controlled tube rolling
- Short mandrels for use in limited space applications

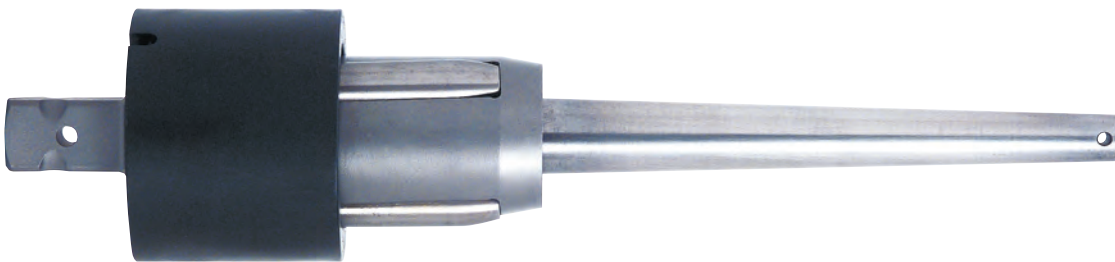

### FTE Series Expanders

Expander		Tube Size			Expansion Range w/ Drum Mandrel		Drum Mandrel		Mandrel Square		Mandrel Length	
Model No.	Order No.	in.	mm	Gauge	in.	mm	Model No.	Order No.	in.	mm	in.	mm
FTE 200	5523811	2	50.8	10-14	1.656 - 1.940	42.1 - 49.2	FTE-200-M	2997688	3/4	19.0	11.75	298.5
FTE 250	5523812	2-1/2	63.5	10-14	2.125 - 2.440	53.9 - 61.9	FTE-250-M	2997689	1	25.4	12.13	308.0
FTE 300	5523813	3	76.2	10-14	2.565 - 2.940	65.0 - 74.6	FTE-300-M	2997690	1	25.4	13.13	333.4

### Short Mandrels for FTE Expanders

Expander		Expansion Range w/ Drum Mandrel	
Model No.	Order No.	in.	mm
FTE 200 SM1	2997994	1.656 - 1.780	42.1 - 45.2
FTE 200 SM2	2997995	1.730 - 1.854	44.0 - 47.1
FTE 200 SM3	2997996	1.820 - 1.940	46.3 - 49.2
FTE 250 SM1	2997997	2.125 - 2.265	53.9 - 57.5
FTE 250 SM2	2997998	2.205 - 2.353	56.0 - 59.7
FTE 250 SM3	2997999	2.290 - 2.440	58.2 - 62.0
FTE 300 SM1	2998000	2.565 - 2.730	65.1 - 69.3
FTE 300 SM2	2998001	2.660 - 2.835	67.6 - 72.0
FTE 300 SM3	2998002	2.770 - 2.940	70.3 - 74.6

### FTE Replacement Roll Sets

Expander		Tube Size	
Model No.	Order No.	in.	mm
FTE-200-RS	5524570	2	50.8
FTE-250-RS	5524571	2-1/2	63.5
FTE-300-RS	5524572	3	76.2

# Boiler Expanders

## FTF Series Firetube Boiler Flaring Tube Expanders

The FTF series expanders complement the FTE series boiler expanders but include tube flaring capabilities. This design incorporates a thrust collar for torque controlled tube rolling, roll retainers, and offset flare rolls.

Available in tube sizes of 2", 2-1/2" and 3" O.D. and 10-14 gauge wall thickness for tube sheets of 3/8" - 1" thick. Mandrels are sold separately with choices based on application and space limitations

- 3-roll design expands and seals tubes in round or oval tube sheet holes
- Offset flare rolls eliminate ridges produced by competitive models
- Metal roll retainers keep the rolls in tool when mandrel is removed
- Increased expansion range: Accommodates more tube sizes, reducing inventory cost
- Thrust collar: Provides uniform flared tube ends
- Short mandrel options for use in limited space applications

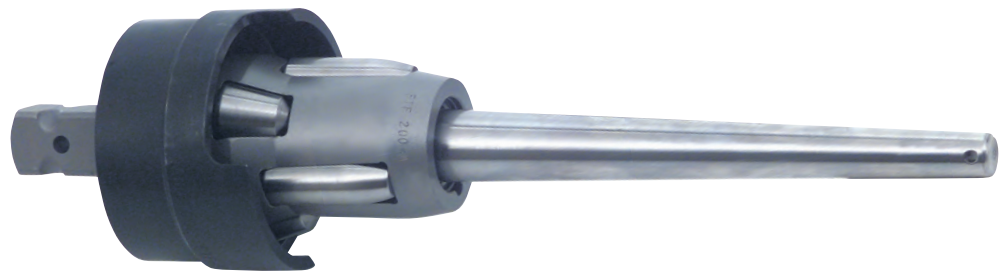

### FTF Series Expanders

Expander		Tube Size			Tube Sheet Thickness		Expansion Range w/ Drum Mandrel		Drum Mandrel		Mandrel Square		Mandrel Length	
Model No.	Order No.	in.	mm	Gauge	in.	mm	in.	mm	Model No.	Order No.	in.	mm	in.	mm

#### Tube Sheet Thickness 3/8 - 5/8" (9.5 - 15.8mm)

FTF 200 A	5524470	2	50.8	10-14	3/8 - 5/8	9.5 - 16.0	1.656 - 1.940	42.1 - 49.2	FTE-200-M	2997688	3/4	19.0	11.75	298.5
FTF 250 A	5524472	2-1/2	63.5	10-14	3/4 - 1	19.0 - 25.0	2.125 - 2.440	53.9 - 61.9	FTE-250-M	2997689	1	25.4	12.13	308.0
FTF 300 A	5524474	3	76.2	10-14	3/8 - 5/8	9.5 - 16.0	2.565 - 2.940	65.0 - 74.6	FTE-300-M	2997690	1	25.4	13.13	333.4

#### Tube Sheet Thickness 3/4 - 1" (19.05 - 25.48mm)

FTF 200 B	5524471	2	50.8	10-14	3/4 - 1	19.0 - 25.0	1.656 - 1.940	42.1 - 49.2	FTE-200-M	2997688	3/4	19.0	11.75	298.5
FTF 250 B	5524473	2-1/2	63.5	10-14	3/8 - 5/8	9.5 - 16.0	2.125 - 2.440	53.9 - 61.9	FTE-250-M	2997689	1	25.4	12.13	308.0
FTF 300 B	5524475	3	76.2	10-14	3/4 - 1	19.0 - 25.0	2.565 - 2.940	65.0 - 74.6	FTE-300-M	2997690	1	25.4	13.13	333.4

### Short Mandrels

Expander		Expansion Range w/ Drum Mandrel	
Model No.	Order No.	in.	mm
FTE 200 SM1	2997994	1.656 - 1.780	42.1 - 45.2
FTE 200 SM2	2997995	1.730 - 1.854	44.0 - 47.1
FTE 200 SM3	2997996	1.820 - 1.940	46.3 - 49.2
FTE 250 SM1	2997997	2.125 - 2.265	53.9 - 57.5
FTE 250 SM2	2997998	2.205 - 2.353	56.0 - 59.7
FTE 250 SM3	2997999	2.290 - 2.440	58.2 - 62.0
FTE 300 SM1	2998000	2.565 - 2.730	65.1 - 69.3
FTE 300 SM2	2998001	2.660 - 2.835	67.6 - 72.0
FTE 300 SM3	2998002	2.770 - 2.940	70.3 - 74.6
FTF 300 B FS	5524638	3	76.2

### FTF Replacement Roll Sets

Expander		Tube Size	
Model No.	Order No.	in.	mm

#### Tube Sheet Thickness 3/8 - 5/8" (9.5 - 15.8mm)

FTF 200 A FS	5524633	2	50.8
FTF 250 A FS	5524635	2-1/2	63.5
FTF 300 A FS	5524637	3	76.2

#### Tube Sheet Thickness 3/4 - 1" (19.05 - 25.48mm)

FTF 200 B FS	5524634	2	50.8
FTF 250 B FS	5524636	2-1/2	63.5
FTF 300 B FS	5524638	3	76.2

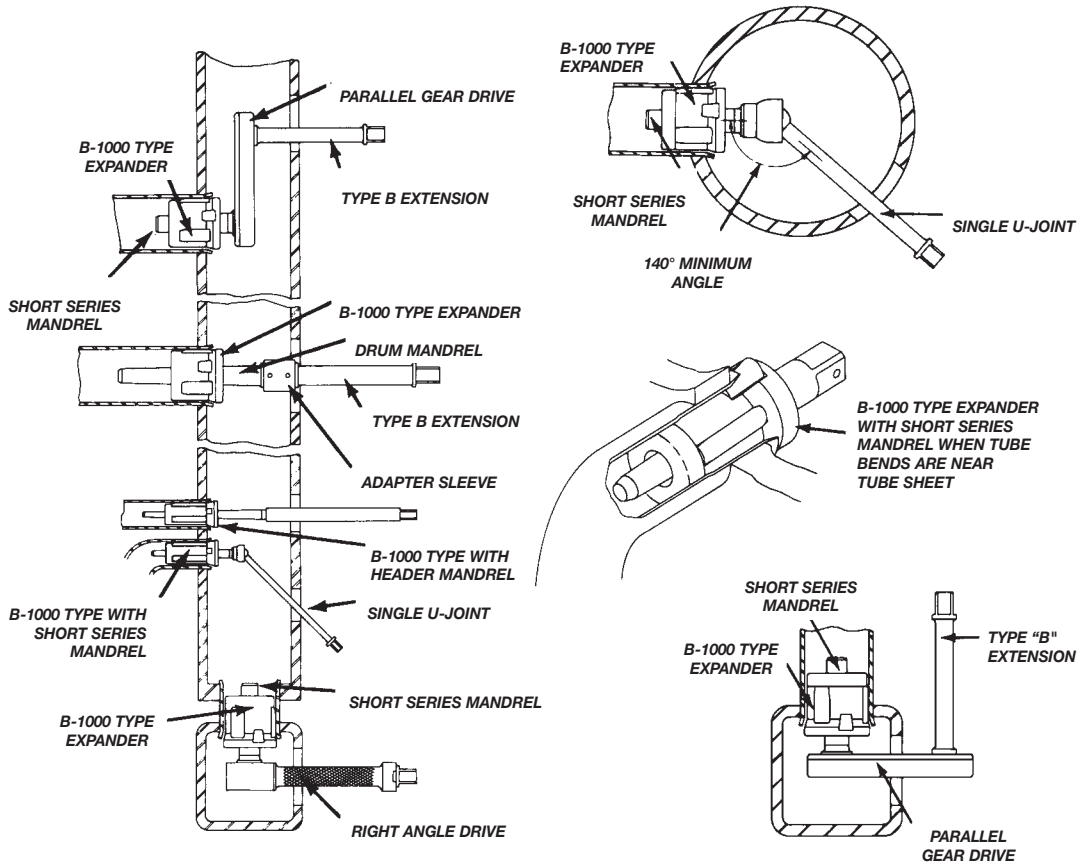

## Ratchet Wrenches

Close-action ratchet wrenches designed for use with boiler expanders, universal joints, and extensions when air or electric power sources are unavailable.

Model Number	Order Number	Female Square Drive		Overall Length		Weight	
		in.	mm	in.	mm	lbs.	Kg
21 3/8	2021700	3/8	9.5	7.0	177.8	1.0	0.45
21 1/2	2021600	1/2	12.7	7.0	177.8	1.0	0.45
23 1/2	2023000	1/2	12.7	13.0	330.2	3.75	1.70
24 3/4	2023900	3/4	19.0	15.0	381.0	6.0	2.73
24 1	2023800	1	25.4	15.0	381.0	6.0	2.73



## Adapter Sleeve



Model Number	Order Number	Female Square Drive		Weight	
		in.	mm	lbs.	Kg
3/8 X 3/8	2113900	3/8	9.5	0.25	0.11
1/2 X 1/2	2038850	1/2	12.7	0.50	0.23
3/4 X 3/4	2113400	3/4	19.0	1.25	0.57
1 X 1	2001900	1	25.4	1.75	0.80

## Universal Joint



Universal Joint	Order Number	Female Square Size		Overall Length	
		in.	mm	in.	mm
3/8 x 3/8	2115300	3/8	9.5	2.50	64
1/2 x 1/2	2039800	1/2	12.7	2.75	70
3/4 x 3/4	2974913	3/4	19.0	3.50	89

# Boiler Tube Expander Accessories

## Right Angle Gear Drive and Parallel Gear Drive

Precision gear drives provide the means to expand tubes in close, hard-to-reach places.



RIGHT ANGLE GEAR DRIVE



PARALLEL GEAR DRIVE



### Right Angle Gear Drives

Order Number	Model Number	Housing Size		Drive Square Drive		Driven Square Drive		Overall Length		Housing Dimensions & Weight								Round hole Tool Enters	
		in.	mm	in.	mm	in.	mm	in.	mm	Width		Thickness		Length		Weight		in.	mm
										in.	mm	in.	mm	in.	mm	lbs.	Kg		
5169900	RA 100	0.50	12.7	1/2	12.7	1/2	12.7	10.0	254.0	2.25	57.2	1.37	34.8	3.25	82.6	3.75	1.70	3.25	82.6
5170000	RA 101	0.50	12.7	1/2	12.7	3/4	19.0	10.0	254.0	2.25	57.2	1.37	34.8	3.25	82.6	3.75	1.70	3.25	82.6
5170100	RA 102	0.50	12.7	3/4	19.0	3/4	19.0	10.0	254.0	2.25	57.2	1.37	34.8	3.25	82.6	3.75	1.70	3.25	82.6
5170500	RA 106	0.75	19.0	3/4	19.0	3/4	19.0	11.4	289.6	2.75	69.9	1.87	47.5	4.00	101.6	7.50	3.41	4.00	101.6
5170900	RA 110	1.00	25.4	1	25.4	1	25.4	12.9	327.7	3.25	82.6	1.87	47.5	4.50	114.3	9.00	4.09	4.25	108.0

### Parallel Gear Drives

Order Number	Model Number	Female Square Drive		Distance between Square Centers		Housing Dimensions & Weight							
		in.	mm	in.	mm	Width		Thickness		Length		Weight	
						in.	mm	in.	mm	in.	mm	lbs.	Kg
5169400	P 200	1/2	12.7	6	716.9	2.00	50.8	1.31	33.3	8.50	215.9	5.50	2.50
5169500	P 201	5/8	15.8	6	716.9	2.00	50.8	1.31	33.3	8.50	215.9	5.50	2.50
5169600	P 202	3/4	19.0	6	716.9	2.75	69.9	1.31	33.3	9.25	235.0	8.25	3.75
5169700	P 203	7/8	22.2	6	716.9	2.75	69.9	1.31	33.3	9.25	235.0	8.25	3.75
5169800	P 204	1	25.4	6	716.9	2.75	69.9	1.31	33.3	9.25	235.0	8.25	3.75

## Universal Joints



SINGLE UNIVERSAL JOINT



DOUBLE UNIVERSAL JOINT



Order Number	Drive Socket		Male Square Drive		Overall Length		Weight	
	in.	mm	in.	mm	in.	mm	lbs.	Kg

### Single Universal Joint

5343500	3/8	9.5	3/8	9.5	9	228.6	.50	.23
5343600	3/8	9.5	3/8	9.5	12	203.2	.62	.28
5342800	1/2	12.7	1/2	12.7	9	225.6	.62	.28
5342900	1/2	12.7	1/2	12.7	12	203.2	.75	.34
5343000	1/2	12.7	1/2	12.7	16	406.4	1.00	.45
5343100	1/2	12.7	1/2	12.7	20	508.0	2.12	.96
5343200	3/4	19.0	3/4	19.0	12	203.2	4.24	1.93
5343300	3/4	19.0	3/4	19.0	16	106.4	2.75	1.25
5343400	3/4	19.0	3/4	19.0	20	508.0	3.25	1.48
5342500	1	25.4	1	25.4	12	203.2	4.00	1.82
5342600	1	25.4	1	25.4	16	406.4	4.75	2.16
5342700	1	25.4	1	25.4	20	508.0	5.50	2.50

### Double Universal Joint

5342400	3/8	9.5	3/8	9.5	3.50	88.9	.75	0.34
5342200	1/2	12.7	1/2	12.7	3.75	95.3	.88	0.40
5342300	3/4	19.0	3/4	19.0	4.75	120.7	2.00	0.91
5342100	1	25.4	1	25.4	6.69	169.9	4.50	2.05

## Extensions



EXTENSION TYPE A



EXTENSION TYPE B



Size of Square		Type	Ordering Number	O.A.L. Length		Weight	
in.	mm			in.	mm	lbs.	Kg
3/8	9.5	A	2114500	4.0	101.6	0.25	0.11
			2114600	6.0	152.4	0.38	0.17
			2114700	8.0	203.2	0.50	0.23
1/2	12.7		2037000	4.0	101.6	0.25	0.11
			2037100	6.0	152.4	0.50	0.23
			2037200	8.0	203.2	0.63	0.28
3/4	19.0		2111200	4.0	101.6	0.63	0.28
			2111300	6.0	152.4	1.00	0.45
			211400	8.0	203.2	1.50	0.68
1	25.4		2002100	4.0	101.6	1.25	0.57
			2002200	6.0	152.4	2.00	0.91
			2002400	8.0	203.2	2.75	1.25
3/8	9.5	2114800	10.0	254	0.38	0.17	
		2973293	12.0	304.8	0.50	0.23	
		2115100	20.0	508	0.75	0.34	
1/2	12.7	2037400	10.0	254	0.50	0.23	
		2037800	12.0	304.8	0.63	0.28	
		2038800	20.0	508.4	4.00	1.82	
3/4	19.0	2111800	10.0	254	1.56	0.71	
		5112200	12.0	304.8	1.63	0.74	
		2113300	20.0	508.4	2.56	1.17	
1	25.4	2003200	12.0	304.8	2.88	1.31	
		2004300	20.0	508.4	4.50	2.05	



## Tube Expanders for Refinery Fittings

Airetool refinery fitting tube expanders are self-feeding, with five expanding rolls which produce uniform tube expansion and tightness throughout the full thickness of the tube fitting. Contact customer service for ordering details.



*G-100 COMPLETE WITH IRONING OUT ATTACHMENT AND THRUST.*



*G-200 COMPLETE WITH IRONING OUT ATTACHMENT, WITHOUT THRUST.*



*G-300 WITH THRUST AND WITHOUT IRONING OUT ATTACHMENT.*



*G-400 WITHOUT THRUST OR IRONING OUT ATTACHMENT.*



*G-500 WITH THRUST AND IRONING OUT ATTACHMENT, WITHOUT FLARING ROLLS.*



*G-600 WITH THRUST ONLY AND WITHOUT FLARING ROLLS.*

# Tube Cleaners Introduction

## Clean tubes mean lower fuel costs.

All piping, heat exchangers, condensers, chillers, and boiler tubes accumulate scale over various periods of use. This scale decreases flow and retards heat transfer. This consequently increases fuel consumption which lowers overall efficiency.

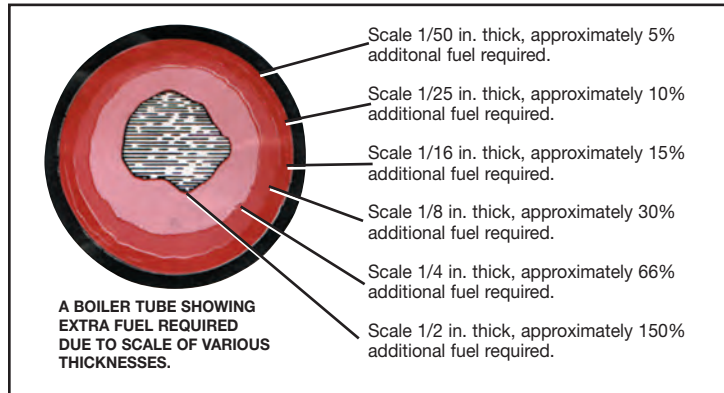

For selecting the proper Airetool tube cleaner components the following information is required:

- Tube ID
- Tube length
- Type of deposit
- Thickness of deposit
- Straight or curved tube
- If curved, the minimum bend radius (see charts)

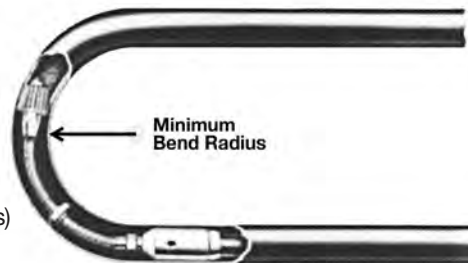

Rigid shaft cleaning systems for straight tubes in heat exchangers and condensers are shown on pages 85-89.

Flexible shaft cleaning systems for straight and curves tubes in condensers, chillers, evaporators and other tubular heat transfer apparatus are shown on pages 90-91.

Refer to the overview of motors and cleaning heads based on tube scale thickness and composition on pages 92 (straight tubes) and 93 (curved tubes), then use the selection guide on pages 94-97 that match boiler tube cleaning motors and heads together.

Note: Operating hoses are not included with boiler tube cleaners. It is always recommended to use an in-line lubricator and foot valve when operating the Airetool boiler tube cleaners. See page 117 for more information on these accessories.

## Boiler tube cleaner applications include:

- Oil field drill pipe renewal
- Natural gas line renewal
- Aluminum smelter siphon tube cleaning
- Catalyst cleaners
- Process line cleaning
- Sugar Refinery Transfer line cleaning

# Tube Cleaners

Heat Exchanger & Condenser Cleaning Systems



## System Components

### Motors

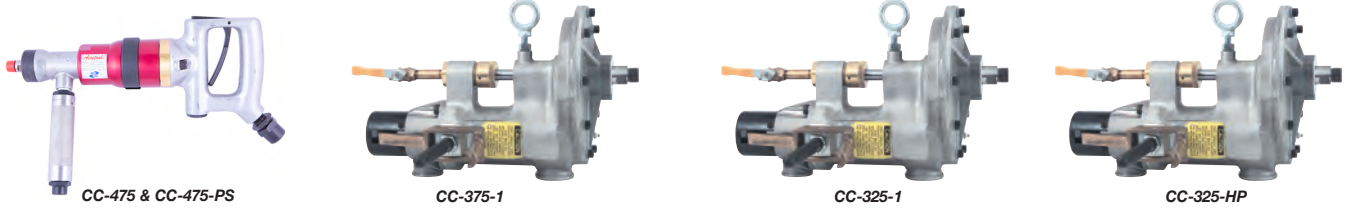

### Shafts

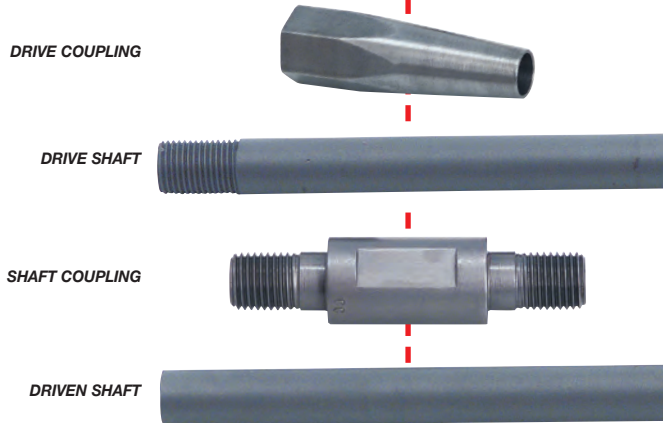

### Drills and Brushes

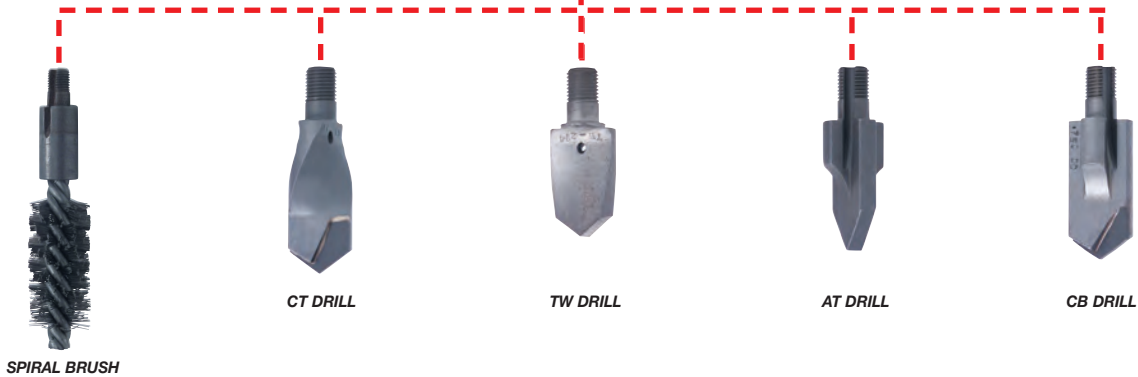

## Complete Cleaning Systems

- Complete cleaners consist of an air motor with integral water feed valve couplings; up to 22 ft. of shafting with necessary couplings (please specify shaft length required); motor shaft wrench and an extra set of motor blades.
- The CC 475 Cleaner Complete includes two drills of any type or size up to 1", three spiral brushes up to 1" and 15 feet of 3/8 inch water hose.
- The CC 475-PS Cleaner Complete includes two drills of any type or size up to 1-1/2", three spiral brushes up to 1-1/2" and 15 feet of 3/8 inch water hose.
- CC-375-1, 325-1 & 325-HP: Includes Ball bearing trolley and rope block.

Model Number	Order Number
<b>Lightweight Condenser Cleaners Complete</b>	
CC-475	4105601
CC-475-PS	4105602
<b>Geared Drive Cleaners Complete</b>	
CC-375-1	
CC-325-1	4105603
CC-325-HP	4105604PT
<b>15 feet of 3/8 inch Water Hose</b>	
Water Hose	4105082
<b>Water Feed Attachment</b>	
WF-100	4098700

# Tube Cleaners

Heat Exchanger & Condenser Cleaning Systems

## Cleaning Motors

### Clean Tubes Equal Higher Operating Efficiencies

Airetool lightweight condenser & geared drive cleaners make it easy to maintain your industrial process at a high level of efficiency by providing cleaning motors that are both powerful and durable.



CC-475 & CC-475-PS

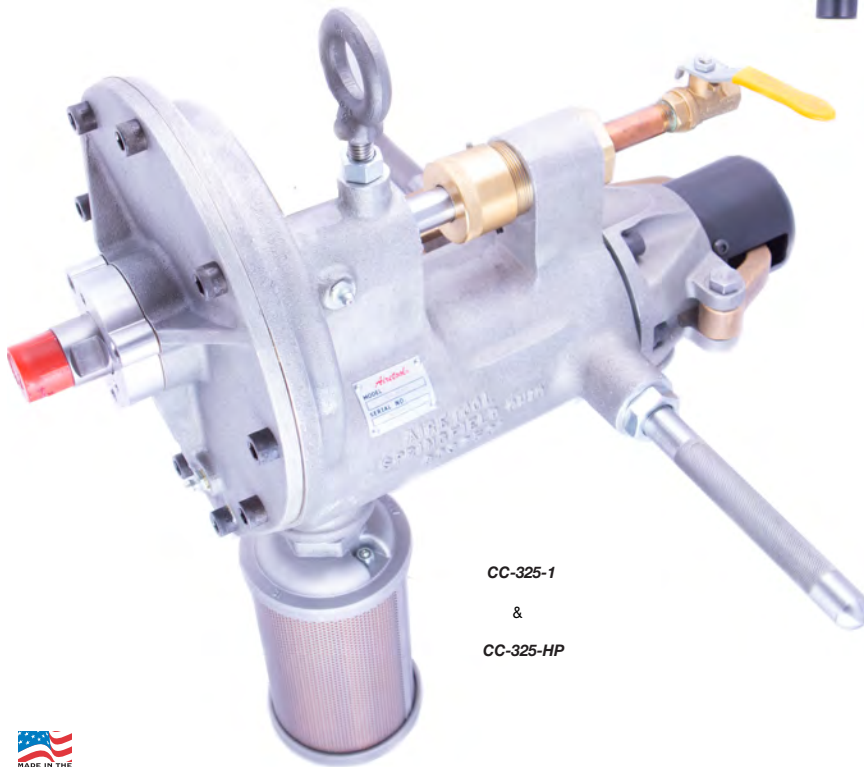

CC-325-1  
&  
CC-325-HP



Model Number	Order Number	Range.5	RPM	Weight		Length		Air Inlet	Operating Air Pressure		Water Inlet	Max. Water Pressure	
				lbs.	Kg	in.	mm	NPT	PSI	kg/cm2	NPT	PSI	kg/cm2
<b>Lightweight Condenser Cleaners</b>													
CC-475	4090900	up to 1 in. (25.4 mm) ID Tubes	3800	10	4.53	15-3/4	400.0	1/2	90-100	6-7	3/8	100	7
CC-475-PS	4105343	up to 1-1/2 in. (38.1 mm) ID Tubes	2300	10	4.53	15-3/4	400.0	1/2	90-100	6-7	3/8	100	7
<b>Geared Drive Cleaners*</b>													
CC-375-1	4090700	up to 1-3/4 in. (44.4 mm) ID Tubes	1200	38	17.20	19	482.6	1	90-100	6-7	3/8	100	7
CC-325-1	4090600	up to 2 in. (50.8 mm) ID Tubes	800	42	19.00	19	482.6	1	90-100	6-7	3/8	100	7
CC-325-HP	4104821	up to 2 in. (50.8 mm) ID Tubes	800	44	19.90	19	482.6	1	90-100	6-7	1/2	5000	350

\* Water hose not included.

## Shaft Components

Shafting components connect the motor to the drill head or brush.

- Drive Shafts & Driven Shafts come in standard lengths of five and ten foot
- Other lengths available on request

DRIVE COUPLING



DRIVE SHAFT

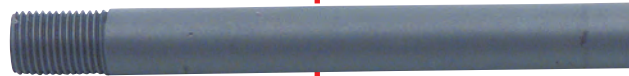

SHAFT COUPLING



DRIVEN SHAFT

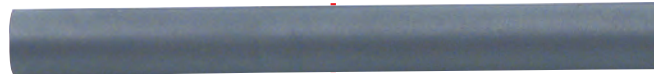

Tube I.D.		Shaft Diameter		Drive Coupling For CC-475 CC-475-PS & WF-100	Drive Coupling Thread	Drive Coupling For CC-375-1 CC-325-1 & CC-325-HP	Drive Coupling Thread	Drive Shaft Length*		Drive Shaft Thread	Shaft Coupling	Shaft Coupling Thread	Driven Shaft Length*		Driven Shaft Thread
in.	mm	in.	mm					5 ft.	10 ft.				5 ft.	10 ft.	
.291-.358	7.39-9.09	1/4	6.35	AT-337-A (1201100)	5/8" NF X 1/4" NF	—	—	CC-336-5 (1717133)	CC-336-10 (1717151)	1/4" NFM X 10-32 F	CC-334 (1232800)	10-32M	CC-335-5 (1717132)	CC-335-10 (1717150)	10-32 F X 10-32 F
.359-.420	9.09-10.67	5/16	7.94	AT-333-A (1201000)	5/8" NF X 5/16" NF	AT-333 (1200900)	1" NF X 5/16" NF	CC-332-5 (1717135)	CC-332-10 (1717153)	5/16" NFM X 1/4" NFF	CC-330 (1232500)	1/4" NFM	CC-331-5 (1717134)	CC-331-10 (1717152)	1/4" NFF X 1/4" NFF
.421-.483	10.67-12.27	3/8	9.52	AT-321-A (1200700)	5/8" NF X 3/8" NF	AT-352 (1201300)	1" NF X 3/8" NF	CC-324-5 (1717137)	CC-324-10 (1717155)	3/8" NFM X 1/4" NFF	CC-322 (1231900)	1/4" NFM	CC-323-5 (1717136)	CC-323-10 (1717154)	1/4" NFF X 1/4" NFF
.484-.608	12.27-15.44	7/16	11.11	AT-313-A (1200300)	5/8" NF X 7/16" NF	AT-353 (1201400)	1" NF X 7/16" NF	CC-316-5 (1717139)	CC-316-10 (1717157)	7/16" NFM X 5/16" NFF	CC-314 (1230800)	5/16" NFM	CC-315-5 (1717138)	CC-315-10 (1717156)	5/16" NFF X 5/16" NFF
.609-.831	15.44-21.11	1/2	12.7	AT-309-A (1200100PT)	5/8" NF X 1/2" NF	AT-359 (1201900)	1" NF X 1/2" NF	CC-312-5 (1717141)	CC-312-10 (1717159)	1/2" NFM X 3/8" NFF	CC-310 (1230400)	3/8" NFM	CC-311-5 (1717140)	CC-311-10 (1717158)	3/8" NFF X 3/8" NFF
.832-1.055	21.11-28.80	5/8	15.88	AT-301-A (1199100)	5/8" NF X 5/8" NF	AT-351 (1201200)	1" NF X 5/8" NF	CC-304-5 (1717144)	CC-304-10 (1717163)	5/8" NFM X 3/8" NFF	CC-302 (1229500)	3/8" NFM	CC-303-5 (1717143)	CC-303-10 (1717162)	3/8" NFF X 3/8" NFF
1.056-1.561	28.80-39.65	3/4	19.05	AT-317-A (1200500)	5/8" NF X 3/4" NF	AT-357 (1201800)	1" NF X 3/4" NF	CC-320-5 (1717146)	CC-320-10 (1717165)	3/4" NFM X 7/16" NFF	CC-318 (1231400)	7/16" NFM	CC-319-5 (1717145)	CC-319-10 (1717164)	7/16" NFF X 7/16" NFF
1.562-2.374	39.65-60.30	1	25.4	AT-325-A (1200800)	5/8" NF X 1" NF	AT-354 (1201500)	1" NF X 1" NF	CC-328-5 (1717148)	CC-328-10 (1717167)	1" NFM X 7/16" NFF	CC-326 (1232200)	7/16" NFM	CC-327-5 (1717147)	CC-327-10 (1717166)	7/16" NFF X 7/16" NFF

\* Standard lengths available upon request



# Tube Cleaners

Heat Exchanger & Condenser Cleaning Systems

## Drills and Brushes

Airetool drills are designed especially to prevent damage to the tube I.D., and are available in a variety of shapes to remove all types of scale deposits. Passages in the drill shaft enable flushing fluid to reach the drill cutting edge. Larger sizes available on request.

- Type "AT" - standard drill for medium deposits
- Type "CB" - standard drill ("AT" style) for medium deposits with carbide insert for better durability
- Type "CB-xxx-HP" - high pressure drills provide better flushing power when used with the CC-325-HP motor
- Type "TW" - standard twist drill for thick deposits
- Type "CT" - standard twist drill ("TW" style) for thick deposits with carbide insert for better durability
- Wire Brushes are for light deposits



Minimum order quantities may apply.

Tube I.D.		Diameter of Drill or Brush		Stud Thread	AT (Standard) Drills	CB (Carbide) Drills	CB (Carbide) "HP" Drills*	CT (Carbide Twist) Drills	TW (Twist) Drills	Wire Brush
in.	mm	in.	mm		Model (Order No.)	Model (Order No.)	Model (Order No.)	Model (Order No.)	Model (Order No.)	Model (Order No.)
.291-.306	7.39-7.77	0.281	7.14	10-32 UNC	AT-199 (1192200)	CB-199 (1220400)	-	-	-	199-B (1020412)
.306-.321	7.77-8.15	0.296	7.52	10-32 UNC	AT-199-5 (1192300)	CB-199-5 (1220500)	-	-	-	199-5-B (1020415)
.322-.337	8.18-8.56	0.312	7.92	10-32 UNC	AT-200 (1192400)	CB-200 (1715666)	-	-	-	200-B (1020460)
.338-.353	8.51-8.97	0.328	8.33	10-32 UNC	AT-200-5 (1192500)	CB-200-5 (1220600)	-	-	-	200-5-B (1020450)
.359-.389	9.12-9.88	0.343	8.71	1/4" UNF	AT-201 (1192600)	CB-201 (1220700)	-	-	TW-201 (1311400PT)	201-B (1020500)
.390-.420	9.91-10.67	0.375	9.52	1/4" UNF	AT-202 (1192700)	CB-202 (1220800)	-	-	TW-202 (1311500)	202-B (1020600)
.421-.452	10.69-11.48	0.406	10.31	1/4" UNF	AT-203 (1192800)	CB-203 (1220900)	-	-	TW-203 (1311600)	203-B (1020700PT)
.452-.483	11.48-12.27	0.437	11.10	1/4" UNF	AT-204 (1192900)	CB-204 (1221000)	-	-	TW-204 (1311700)	204-B (1020800)
.484-.514	12.29-13.06	0.468	11.89	5/16" UNF	AT-205 (1193000)	CB-205 (1221100)	CB-205-HP (1715190)	CT-205 (1241600)	TW-205 (1311800)	205-B (1020900)
.515-.545	13.08-13.84	0.500	12.7	5/16" UNF	AT-206 (1193100)	CB-206 (1221200)	CB-206-HP (1715565)	CT-206 (1241700)	TW-206 (1311900)	206-B (1021000)
.546-.577	13.87-14.66	0.531	13.49	5/16" UNF	AT-207 (1193200)	CB-207 (1221300)	CB-207-HP (1715561)	CT-207 (1241800)	TW-207 (1312000)	207-B (1021201)
.578-.608	14.68-15.44	0.562	14.27	5/16" UNF	AT-208 (1193300)	CB-208 (1221400)	CB-208-HP (1715566)	CT-208 (1241900)	TW-208 (1312100)	208-B (1021400)
.578-.608	14.68-15.44	0.562	14.27	3/8" UNF	AT-108 (1192000)	CB-108 (1220300)	CB-108-HP (1715567PT)	CT-108 (1241100)	TW-108 (1311300)	108-B (1021500)
.609-.639	15.47-16.23	0.593	15.06	3/8" UNF	AT-209 (1193400)	CB-209 (1221500)	CB-209-HP (1715562)	CT-209 (1242000)	TW-209 (1312200)	209-B (1021600)
.640-.675	16.26-17.15	0.625	15.88	3/8" UNF	AT-210 (1193500)	CB-210 (1221600)	CB-210-HP (1715568)	CT-210 (1242100)	TW-210 (1312300PT)	210-B (1021810)
.676-.706	17.17-17.93	0.656	16.66	3/8" UNF	AT-211 (1193600)	CB-211 (1221700)	CB-211-HP (1716249)	CT-211 (1242200)	TW-211 (1312400)	211-B (1022001)
.707-.737	17.96-18.72	0.687	17.45	3/8" UNF	AT-212 (1193700)	CB-212 (1221800)	CB-212-HP (1715569PT)	CT-212 (1242300)	TW-212 (1312500)	212-B (1022100)

\* "HP" Style drills are used for more aggressive cleaning with CC-325-HP cleaning motor

## Drills and Brushes (continued)

Tube I.D.		Diameter of Drill or Brush		Stud Thread	AT (Standard) Drills	CB (Carbide) Drills	CB (Carbide) "HP" Drills*	CT (Carbide Twist) Drills	TW (Twist) Drills	Wire Brush
in.	mm	in.	mm		Model (Order No.)	Model (Order No.)	Model (Order No.)	Model (Order No.)	Model (Order No.)	Model (Order No.)
.738-.769	18.75-19.53	0.718	18.24	3/8" UNF	AT-213 (1193800)	CB-213 (1221900)	CB-213-HP (1715570PT)	CT-213 (1242400)	TW-213 (1312600)	213-B (1022500)
.770-.800	19.56-20.32	0.750	19.05	3/8" UNF	AT-214 (1193900)	CB-214 (1222000)	CB-214-HP (1715571)	CT-214 (1242500)	TW-214 (1312700)	214-B (1022700)
.801-.831	20.35-21.11	0.781	19.84	3/8" UNF	AT-215 (1194000)	CB-215 (1222100)	CB-215-HP (1715859)	CT-215 (1242600)	TW-215 (1312800)	215-B (1022802)
.832-.862	21.13-21.89	0.812	20.62	3/8" UNF	AT-216 (1194100)	CB-216 (1222200)	CB-216-HP (1715572)	CT-216 (1242700)	TW-216 (1312900)	216-B (1022900)
.863-.894	21.92-22.71	0.843	21.41	3/8" UNF	AT-217 (1194200)	CB-217 (1222300)	CB-217-HP (1715573)	CT-217 (1242800PT)	TW-217 (1313000)	217-B (1023000)
.895-.925	22.73-23.50	0.875	22.23	3/8" UNF	AT-218 (1194300)	CB-218 (1222400)	CB-218-HP (1715950)	CT-218 (1242900)	TW-218 (1313100)	218-B (1023100)
.926-.956	23.52-24.28	0.906	23.01	3/8" UNF	AT-219 (1194400)	CB-219 (1222500)	CB-219-HP (1715730PT)	CT-219 (1243000)	TW-219 (1313200)	219-B (1023200)
.957-.987	24.31-25.07	0.937	23.80	3/8" UNF	AT-220 (1194500)	CB-220 (1222600)	CB-220-HP (1716142PT)	CT-220 (1243100)	TW-220 (1313300)	220-B (1023304)
.998-1.024	25.35-26.01	0.968	24.59	3/8" UNF	AT-221 (1194600)	CB-221 (1222700)	CB-221-HP (1716434)	CT-221 (1243200PT)	TW-221 (1313400)	221-B (1023400)
1.025-1.055	26.04-26.80	1.000	25.40	3/8" UNF	AT-222 (1194700)	CB-222 (1222800)	CB-222-HP (1716223)	CT-222 (1243300PT)	TW-222 (1313500)	222-B (1023600)
1.056-1.086	26.82-27.58	1.031	26.19	7/16" UNF	AT-223 (1194800)	CB-223 (1223000PT)	-	CT-223 (1243400)	TW-223 (1313600)	223-B (1023700)
1.087-1.117	27.61-28.37	1.062	26.97	7/16" UNF	AT-224 (1194900)	CB-224 (1223000PT)	-	CT-224 (1243500)	TW-224 (1313700)	224-B (1023800)
1.118-1.149	28.40-29.18	1.093	27.76	7/16" UNF	AT-225 (1195000)	CB-225 (1223100)	-	CT-225 (1243600)	TW-225 (1313800)	225-B (1023900)
1.150-1.180	29.21-29.97	1.125	28.58	7/16" UNF	AT-226 (1195100)	CB-226 (1223200)	-	CT-226 (1243700)	TW-226 (1313900)	226-B (1024001PT)
1.181-1.211	30.00-30.76	1.156	29.36	7/16" UNF	AT-227 (1195200)	CB-227 (1223300)	-	CT-227 (1243800)	TW-227 (1314000)	227-B (1024100)
1.212-1.242	30.78-31.55	1.187	30.15	7/16" UNF	AT-228 (1195300)	CB-228 (1223400)	-	CT-228 (1243900)	TW-228 (1314100)	228-B (1024200)
1.243-1.280	31.57-32.51	1.218	30.94	7/16" UNF	AT-229 (1195400)	CB-229 (1223500)	-	CT-229 (1244000)	TW-229 (1314200)	229-B (1024300)

\* "HP" Style drills are used for more aggressive cleaning with CC-325-HP cleaning motor

## Large Diameter Twist Brushes (LDTB)

■ Brush should be sized 1/8" -3/16" smaller than the nominal tube I.D. for best results.



Diameter		Model Number	Order Number	Stud Thread
in.	mm			
1.50	38.1	LDTB 1500	1003700	5/8 NC
1.62	41.2	LDTB 1625	1004500	5/8 NC
1.75	44.4	LDTB 1750	1004300	5/8 NC
1.87	47.6	LDTB 1875	1004600PT	5/8 NC
2.00	50.8	LDTB 2000	1004900	5/8 NC
2.12	53.9	LDTB 2125	1005800PT	5/8 NC
2.25	57.1	LDTB 2250	1005700PT	5/8 NC

Diameter		Model Number	Order Number	Stud Thread
in.	mm			
2.50	63.5	LDTB 2500	1005401	5/8 NC
2.75	69.8	LDTB 2750	1005900	5/8 NC
3.00	76.2	LDTB 3000	1006500	5/8 NC
3.25	82.5	LDTB 3250	1007100	5/8 NC
3.50	88.9	LDTB 3500	1006900	5/8 NC
3.75	95.2	LDTB 3750	1007200	5/8 NC
4.00	101.6	LDTB 4000	1007300	5/8 NC

# Condenser Cleaners

Brush-Master Tube Cleaners



## Brushmaster Brushes

### Super 2D Brushes

Airetool Super 2D Brushes are for cleaning internally enhanced tubing. The brush is constructed from material that out-cleans and out-wears other tube brushes. Super 2 D Brushes have two cleaning diameters to assure all surfaces are being cleaned. These brushes are recommended for removing soft and light scale deposits.

### Super Brushes

Super Brushes are for cleaning smooth bore tubing. They are made from the same long-lasting material as the Super 2D Brush. The longer brush cleaning surface reduces the tube cleaning time. They are recommended for removing soft and light scale deposits.

Part Number	Order Number	Tube Inside Diameter	
		in.	mm
<b>Super 2 D Brush</b>			
SCB-750	2996773	.500-.700	12.7-17.8
SCB-1000	2996774	.700-.950	17.8-24.1
<b>Super Brush</b>			
SB-750	2996555	.437-.700	11.1-14.2
SB-1000	2996556	.625-1.000	15.8-17.5
SB-1250	2996557	1.000-1.200	19.0-25.4

## Nylon, Brass and Stainless Steel Brushes

Nylon, brass and stainless steel brushes are available in brush diameters .250" - 1.000" (6.3-25.4mm) in 1/16" (1.6mm) increments. Select the brush size equal to or one size smaller than the I.D. of the tubes to be cleaned.

Minimum order quantity 12 pieces

Brush Diameter		Brush Material		
in.	mm	Nylon	Brass	Stainless Steel
1/4	6.35	N-250 (2996528)	B-250 (2996515)	SS-250 (2996541)
5/16	7.92	N-312 (2996529)	B-312 (2996516)	SS-312 (2996542)
3/8	9.52	N-375 (2996530)	B-375 (2996517)	SS-375 (2996543)
7/16	11.10	N-437 (2996531)	B-437 (2996518)	SS-437 (2996544)
1/2	12.70	N-500 (2996532)	B-500 (2996519)	SS-500 (2996545)
9/16	14.27	N-562 (2996533)	B-562 (2996520)	SS-562 (2996546)
5/8	15.88	N-625 (2996534)	B-625 (2996521)	SS-625 (2996547)
11/16	17.48	N-687 (2996535)	B-687 (2996522)	SS-687 (2996548)
3/4	19.05	N-750 (2996536)	B-750 (2996523)	SS-750 (2996549)
13/16	20.62	N-812 (2996537)	B-812 (2996524)	SS-812 (2996550)
7/8	22.22	N-875 (2996538)	B-875 (2996525)	SS-875 (2996551)
15/16	23.82	N-937 (2996539)	B-937 (2996526)	SS-937 (2996552)
1	25.40	N-1000 (2996540)	B-1000 (2996527)	SS-1000 (2996553)

## The Eagle Automatic Tube Cleaner

The EAGLE Tube Cleaner is a new design, unique in the international marketplace, which is capable of drilling or brushing tubes of all lengths up to 2" diameter. The EAGLE is safety engineered and operates on air and water power. The simplicity of the EAGLE allows for a one person operation and even casual labor can be quickly trained.

The EAGLE Tube Cleaner is more than a drill, it is a complete tube cleaning system. With a single machine, tube diameters up to 2" OD and lengths of up to 31' can be cleaned in either vertical or horizontal positions with channel heads in place. Simple conversions ensure that the machine is optimally configured for every type of bundle. The EAGLE requires less manpower and results in faster maintenance than other methods. It is considerably faster and more effective than hand-drilling or hydro-blasting.

Heat transfer efficiency up to 95% is typical and one customer has reported the restoration of 100% heat transfer efficiency. There is no type of fouling which the EAGLE cannot handle.

The EAGLE has many features never before available on tube cleaners. A unique water pressure control allows the operator to slow the forward speed of the drill while maintaining maximum water pressure for flushing action through the drill bit; a very important feature for certain types of fouling. For safety, a special torque absorption mount protects the machine, the bundle, and the operator from damage or injury, should the drill bit bind up in drilling on unusually difficult jobs.

- Many features gained through actual field experience make the EAGLE the leader in the field
- The EAGLE Tube Cleaner is the result of years of experience defouling some of the most difficult heat exchanger applications



Stock Number	Description
000014-___-3	EAGLE Tube Cleaner with 3/8" drill rod for Horizontal or Vertical application
000015-___-3	EAGLE Tube Cleaner with 1/2" drill rod for Horizontal or Vertical application
000021-___-3	EAGLE Tube Cleaner with 3/8" drill rod for Vertical only application
000022-___-3	EAGLE Tube Cleaner with 1/2" drill rod for Vertical only application

Middle Value for tube length in feet to be cleaned

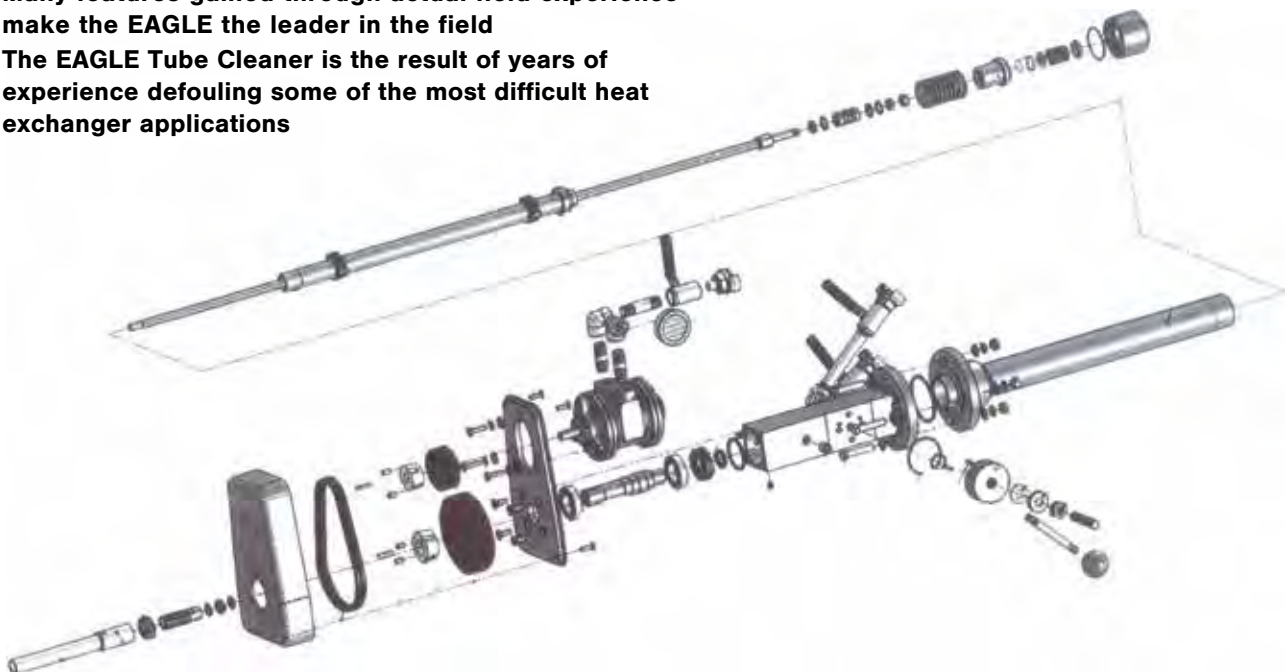



# Overhead Catalyst Cleaners

## Overhead Catalyst Cleaners

Overhead catalyst cleaner systems are specifically designed for the safe removal of spent catalyst from the top of the reactor tower. The system collects the catalyst carried by the exhaust air and discharges the spent catalyst into any suitable container.

- Helps eliminate the danger of catalyst contacting the operator
- Uses high-powered, high-performance air motor to remove catalyst quickly and efficiently
- Cleaner systems are available for tubes from 1-3/16" up to 5" diameter (I.D.)
- Specify tube size and gauge when ordering



### Cleaner Complete example (See picture at right)

Model Number	Ordering Number	Description	Quantity
OHC-250 2000 3162	4104981	Cleaner Complete* (~85 lbs.)	1
1806	1049100	SPARE MOTOR BLADES	4
OHC 2501	1284700	MAIN CLEANER BODY	1
FC 200 1 7/8	1245180	FC TYPE DRILL BIT - 1-7/8" DIA.	1
OHC 2507	1285300	DUST SEAL ASSEMBLY	1
OHC 2509 1 3/4	1285800	OHC TYPE DRILL BIT - 1-3/4" DIA.	2
OHC 2510	1286100	DUST SEAL GASKET	3
OHC 2511	1286200	RENEWABLE PILOT	1
WRENCH 5/8	14-0810	SHAFT WRENCH - 5/8"	1
3162	4075800	AIR MOTOR	1
OHC 2508 3/4	4105113	OPERATING HOSE & COUPLINGS - 50FT	1
OHC 2502	4105368	DISPOSAL TUBE ASSEMBLY	1

\* Cleaner Complete includes three drill bits, three extra dust seal gaskets, a spare set of motor blades, and motor shaft wrench(s)



## FC-2000-3162

Shown below (1 5/8-2)

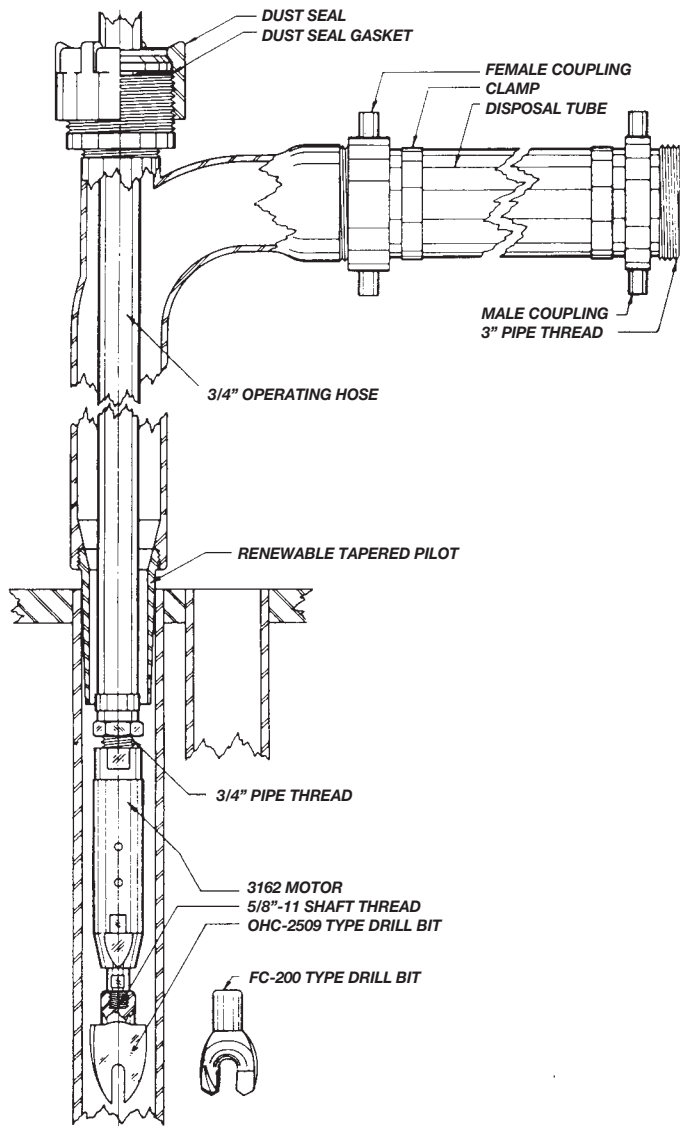

### Catalyst Cleaner Bits

Model Number	Order Number	Description
FC-200-1 1/4 5/8NC	1716980PT	Drill Bit - 1-1/4" Diameter
FC-200-1 3/8	1245160	Drill Bit - 1-3/8" Diameter
FC-200-1 1/2 9/16NC	1245153	Drill Bit - 1-1/2" Diameter
FC-200-1 5/8 9/16NC	1245175	Drill Bit - 1-5/8" Diameter
FC-200-1 5/8 5/8NC	1716622	Drill Bit - 1-5/8" Diameter
FC-200-1 3/4 5/8NC	1245155	Drill Bit - 1-3/4" Diameter
FC-200-1 7/8 5/8NC	1245180	Drill Bit - 1-7/8" Diameter
FC 200 1 15/16 5/8NC	1716521	Drill Bit - 1-15/16" Diameter
FC 200 1 23/32 5/8NC	1716542	Drill Bit - 1-23/32" Diameter
FC 200 2 1/2 7/8NC	1715100	Drill Bit - 2-1/2" Diameter
OHC-2509-1 5/8	1285900	Drill Bit - 1-5/8" Diameter
OHC-2509-1 3/4	1285800	Drill Bit - 1-3/4" Diameter
OHC-2509-1 7/8	1286000	Drill Bit - 1-7/8" Diameter

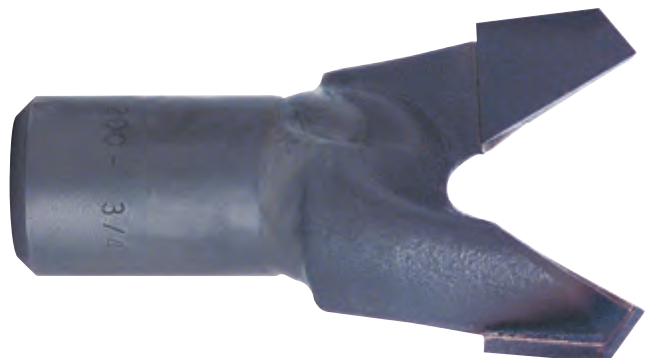



# Boiler Tube Cleaners

Tube Cleaners for Straight Tubes

*Airetool*

## Complete series of motors and heads available for tube sizes 1/2" to 1-3/8" (12.7 to 34.9 mm) I.D.

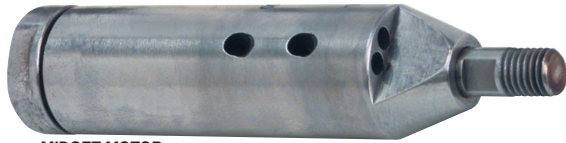

**MIDGET MOTOR  
WITH OPTIONAL HEADS**

Complete cleaner consists of: air motor with extra set of blades; shaft wrench; metal box; choice of single unit cutter head with four extra cutters and two extra cutter pins. If a Type 2 head (30 series) is ordered, one extra flexible connection is furnished. If expanding blade head is ordered, one extra set of blades is furnished.

For operating hose (not included) refer to page 116.



**Drill Head with Universal Joint**  
Range: 1/2 in. (12.7 mm) - 1-3/8 in. (34.9 mm)  
Deposit: heavy-medium to soft



**Single Unit Head with Universal Joint**  
Range: 1/2 in. (12.7 mm) - 1-3/8 in. (34.9 mm)  
Deposit: light-hard to medium



**Expanding Blade Cutter Head**  
Range: 1/2 in. (12.7 mm) - 4-1/2 in. (114.3 mm)  
Deposit: light-hard to medium

## Complete series of motors and heads available for tube sizes 1-1/2" to 13-3/4" (12.7 to 336.5mm) I.D.



**3000 SERIES MOTOR  
WITH OPTIONAL HEADS**

Complete cleaner consists of: air motor with extra set of blades; shaft wrench; choice of cutter head with two extra sets of cutters and cutter pins; universal joint with two extra pins; two drills. If single unit head is ordered, four extra sets of cutters are furnished. If arm-type head is ordered, one extra set of arm pins is furnished.

For operating hose (not included) refer to page 116.

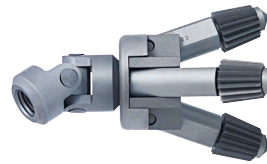

**TYPE-4 Forward Swing Head**  
Range: 1-3/4 in. (44.4 mm) - 4 1/4 in. (120.6 mm)  
Self feeding  
Deposit: 1/2 in. (12.7 mm) thick-soft to medium



**TYPE-5 Wing Arm Head**  
Range: 1-3/4 in. (44.4 mm) - 13 1/4 in. (336.5 mm)  
Self feeding  
Deposit: 1/2 in. (12.7 mm) thick-hard to medium



**TYPE-3 P-Type Head**  
Range: 2-1/4 in. (57.1 mm) - 7 in. (177.8 mm) Self feeding  
Deposit: 3/8 in. (9.5 mm) thick-hard to medium



**Drill Head with Universal Joint**  
Range: 1-1/2 in. (38.1 mm) - 11 in. (279.4 mm)  
Deposit: 3/4 in. (19.0 mm) thick-medium to hard and plugged tubes

# Boiler Tube Cleaners

Tube Cleaners for Curved Tubes

Complete series of motors and heads available for tube sizes 13/16" to 2-1/8" (20.6 to 53.9 mm) I.D.



MIDGET MOTOR WITH OPTIONAL HEADS

Complete cleaner consists of: air motor with extra set of blades; shaft wrench; metal box; choice of single unit cutter head with four extra cutters and two extra cutter pins; universal joint with two extra pins; two drills. If single unit head is ordered, four extra cutters are furnished.

For operating hose (not included) refer to page 116.



Drill Head with Universal Joint  
Range: 1-1/2 in. (38.1 mm) - 2-1/8 in. (53.9 mm)  
Deposit: light-hard to medium



**TYPE-1 "40" SERIES**  
Single Unit Head with Universal Joint  
Range: 1/2 in. (12.7 mm) - 2-1/8 in. (53.9 mm)  
Deposit: light-medium to hard



**TYPE-2 "30" SERIES**  
Single Unit Head with Flexible Shaft  
Range: 1/2 in. (12.7 mm) - 2-1/8 in. (53.9 mm)  
Deposit: light-medium to hard

Complete series of motors and heads available for tube sizes 1-1/2" to 13-1/4" (38.1 to 336.5 mm) I.D.



4000 SERIES MOTOR WITH OPTIONAL HEADS

Complete cleaner consists of: air motor with extra set of blades; shaft wrench; choice of cutter head with two extra sets of cutters and cutter pins; universal joint with two extra pins; two drills. If single unit head is ordered, four extra sets of cutters are furnished. If arm-type head is ordered, one extra set of arm pins is furnished.

For operating hose (not included) refer to page 116.



Drill Head with Universal Joint  
Range: 1-1/2 in. (38.1 mm) - 11 in. (279.4 mm)  
Deposit: 1/2 in. (12.7 mm) - thick-hard to medium

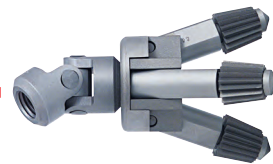

**TYPE-4**  
Forward Swing with Universal Joint  
Range: 1-3/4 in. (44.4 mm) - 4-3/4 in. (120.6 mm)  
Deposit: 1/2 in. (12.7 mm) - thick-soft to medium

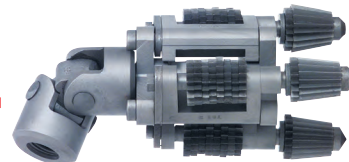

**TYPE-5**  
Wing Arm Head with Universal Joint  
Range: 1-3/4 in. (44.4 mm) - 13-1/4 in. (336.5 mm)  
Self feeding  
Deposit: 1/2 in. (12.7 mm) - thick-hard to medium

# Boiler Tube Cleaners

Selection Guide

## Midget Tube Cleaners – Curved and Straight

Range: 1/2 to 1-3/4 in.  
12.7 to 44.4 mm

Complete cleaner consists of: air motor with extra set of blades; shaft wrench; metal box; choice of single unit cutter head with four extra cutters and two extra cutter pins. If a Type 2 head (30 series) is ordered, one extra flexible connection is furnished. If expanding blade head is ordered, one extra set of blades is furnished. For operating hose (not included) refer to page 116.

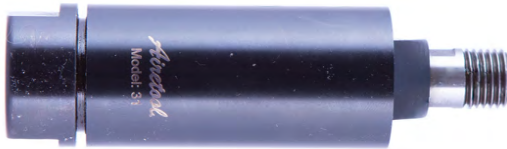

MIDGET MOTOR



Use for straight tubes.  
 Use for curved tubes.

Tube I.D.		Minimum Tube Centerline Radius		Motor Number	Motor O.D.		Rotor Thread	Air Coupling Pipe Tap (in.)	Hose Size		Heads Available			Drill*	Universal	Flexible
in.	mm	in.	mm		in.	mm			in.	mm	Universal Type 1	Flexible Type 2	Blade Type 8			
1/2	12.7	Straight		24	15/32	11.9	10-32	18-20	3/16	4.7	2440	2430	2480	MD-1	2451	2461
5/8	15.8	Straight		30	37/64	14.6	1/4 NF	1/8	1/4	6.3	3040	3030	3080	MD-2	PA-3051	X-6461
3/4	19.0	Straight		27	11/16	17.4	1/4 NF	1/8	1/4	6.3	2740	2730	2780	MD-3	PA-3051	X-6461
13/16	20.6	5.0	126.0	X-64	11/16	17.4	1/4 NF	1/4	1/4	6.3	X-6440	X-6430	-	MD-3	6451	X-6461
7/8	22.2	Straight		29	25/32	19.8	3/8 NF	1/4	3/8	9.5	2940	2930	2980	MD-4	2651-A	-
27/32	21.4	Straight		29	25/32	19.8	3/8 NF	1/4	3/8	9.5	2940	2930	2980	MD-4	2651-A	-
1	25.4	Straight		26	29/32	23.0	3/8 NF	3/8	3/8	9.5	2640	2630	6180	MD-4	2651-A	-
1-1/32	26.1	5.0	127.0	X-61	7/8	22.2	5/16 NF	1/4	1/4	6.3	X-6140	X-6130	-	MD-3	6151-C	X-6161
1-1/8	28.5	Straight		31	1-1/32	26.1	7/16 NF	3/8	3/8	9.5	3140	3130	3180	MD-5	3151	X-6361
1-1/4	31.7	Straight		X-63-A	1-1/16	26.9	3/8 NF	3/8	3/8	9.5	X-6340	X-6330	6380	MD-5	6651	X-6361
1-1/4	31.7	6.0	152.4	X-63	1-1/16	26.9	3/8 NF	3/8	3/8	9.5	X-6340	X-6330	-	MD-5	6651	X-6361
1-3/8	34.9	Straight		X-65-A	1-3/16	30.1	3/8 NF	3/8	3/8	9.5	X-6540	X-6530	6580	0	6651	X-6661
1-1/2	38.1	6.0	152.4	X-65	1-3/16	30.1	3/8 NF	3/8	3/8	9.5	X-6540	X-6530	-	MD-5	6651	X-6661
1-5/8	41.2	24.0	609.6	4200	1-1/2	38.1	5/8 NC	1/2	1/2	12.7	4140	4130	-	1	4151	4161
1-3/4	44.4	6.0	152.4	X-66	1-5/16	33.3	3/8 NF	3/8	3/8	9.5	X-6640	X-6630	-	0	6651	X-6661
1-3/4	44.4	15.0	381.0	4200	1-1/2	38.1	5/8 NC	1/2	1/2	12.7	4140	4130	-	1	4151	4161

Some items are available on a quotation basis only.

\* Drill must be used with Universal Joint or flexible connection.

# Boiler Tube Cleaners

## Selection Guide

### 3000 and 4000 Series Tube Cleaners – Curved and Straight

Range: 1-1/2 to 13-1/4 in.  
38.1 to 336.5 mm

Complete cleaner consists of: air motor with extra set of blades; shaft wrench; choice of cutter head with two extra sets of cutters and cutter pins; universal joint with two extra pins; two drills. If single unit head is ordered, four extra sets of cutters are furnished. If arm-type head is ordered, an extra set of arm pins is furnished.

For operating hose (not included) refer to page 116 .



- Use for straight tubes.
- Use for curved tubes.

Tube I.D.		Minimum Tube Centerline Radius		Motor Number	Motor O.D.		Rotor Thread	Air Coupling Pipe Tap (in.)	Hose Size		Heads Available				Universal Joint	Drill*
in.	mm	in.	mm		in.	mm			in.	in.	mm	Single Expansion Type 3	Forward Swing Type 4	Single Unit		
												Type 2	Type 1			
1-1/2	38.1	Straight		3150	1-3/8	34.9	9/16 NC	1/2	1/2	12.7	TC-14	-	-	1740	31551	0
1-5/8	41.2	Straight		3162	1-1/2	38.1	5/8 NC	3/4	1/2	12.7	TC-11	-	1840	1940	4151	1
1-3/4	44.4	Straight		3175	1-5/8	41.2	5/8 NC	3/4	1/2	12.7	TC-11	-	1840	1940	4151	1
1-7/8	47.6	Straight		3187	1-3/4	44.4	5/8 NC	3/4	3/4	19.0	TC-17-PY	-	2340	4140	4151	1
2	50.8	Straight		3200	1-7/8	47.6	5/8 NC	3/4	3/4	19.0	TC-16	-	2340	4140	4151	1
2	50.8	15.0	381.0	4225	1-3/4	44.4	5/8 NC	1/2	1/2	12.7	-	-	4130	4140	4151	1
2-1/8	53.9	Straight		3212	2	50.8	5/8 NC	3/4	3/4	19.0	TC-13-PY	2340	-	4140	4151	4
2-1/8	53.9	15.0	381.0	4225	1-3/4	44.4	5/8 NC	1/2	1/2	12.7	-	-	4130	4140	4151	1
2-1/4	57.1	Straight		3225	2-1/8	53.9	3/4 NC	3/4	3/4	19.0	P-15-PY	4470-A	-	-	2151	4
2-1/4	57.1	15.0	381.0	4250	1-7/8	47.6	5/8 NC	1/2	1/2	12.7	-	4470	-	-	4151	4
2-5/16	58.7	12.0	304.8	4250	1-7/8	47.6	5/8 NC	1/2	1/2	12.7	-	4470	-	-	4151	4
2-3/8	60.3	Straight		3225	2-1/8	53.9	3/4 NC	1	1	25.4	P-9-S	4470-A	-	-	2151	4
2-1/2	63.5	Straight		3250	2-5/16	58.7	7/8 NC	1	1	25.4	P-9	4470-B	-	-	21451	4
2-1/2	63.5	15.0	381.0	4250	1-7/8	47.6	5/8 NC	1/2	1/2	12.7	-	-	4470	-	4151	4

Some items are available on a quotation basis only.

\* Drill must be used with Universal Joint or flexible connection.

# Boiler Tube Cleaners

Selection Guide



Tube I.D.		Minimum Tube Centerline Radius		Motor Number	Motor O.D.		Rotor Thread	Air Coupling Pipe Tap (in.)	Hose Size		Heads Available			Universal Joint	Drill*
											Single Expansion Type 3	Wing Arm Type 5	Forward Swing Type 4		
in.	mm	in.	mm		in.	mm	in.		in.	mm					
2-5/8	66.6	Straight		3262	2-1/2	63.5	7/8 NC	1	1	25.4	P-7	2060	4470-A	21451	4
2-5/8	66.6	24	609.6	4300	2-1/4	57.1	3/4 NC	1	3/4	19.0	-	3360	3370	3551	5
2-3/4	69.8	Straight		3275	2-5/8	66.6	7/8 NC	1	1	25.4	P-7	2060	3370-A	651	5
2-3/4	69.8	12	304.8	4300	-1/4	57.1	3/4 NC	1	3/4	19.0	-	3360	3370	3551	5
2-7/8	73.0	Straight		3275	2-5/8	66.6	7/8 NC	1	1	25.4	P-6-A	1060	-	651	5
2-7/8	7.03	28	711.2	4325	2-1/2	63.5	3/4 NC	1	3/4	19.0	-	3560	3270	3551	5
3	76.2	Straight		3300	2-13/16	71.4	1 NF	1	1	25.4	P-6	1060	-	21051	5
3	76.2	16	406.4	4300	2-1/2	63.5	3/4 NC	1	3/4	19.0	-	3560	3270	3551	5
3	76.2	12	304.8	4300	2-1/4	57.1	3/4 NC	1	3/4	19.0	-	3560	3270	3551	5
3-1/16	77.7	Straight		3300	2-13/16	71.4	1 NF	1	1	25.4	P-6	1060	-	21051	5
3-1/8	79.3	Straight		3312	2-15/16	74.6	1 NF	1	1	25.4	P-5	1060	-	1151	6
3-3/16	80.9	Straight		3318	3	76.2	1 NF	1	1	25.4	P-5	1060	-	1151	6
3-1/4	82.5	Straight		3318	3	76.2	1 NF	1	1	25.4	P-5	1060	-	1151	6
3-1/4	82.5	16	406.4	4350	2-3/4	69.8	7/8 NC	1	1	25.4	-	3560	970-B	651	5
3-3/8	85.7	Straight		3318	3	76.2	1 NF	1	1	25.4	P-5	960	-	1151	6
3-12	88.9	Straight		3350	3-5/16	84.1	1-1/8 NF	1	1	25.4	P-4	760	-	20751	6
3-1/2	88.9	20	508	4350	2-3/4	69.8	7/8 NC	1	1	25.4	-	4760	770-B	551	6
3-5/8	92.0	Straight		3350	3-5/16	84.1	1-1/8 NF	1	1	25.4	P-3	760	-	20751	6
3-3/4	95.2	Straight		3350	3-5/16	84.1	1-1/8 NF	1	1	25.4	P-3	760	-	20751	6
3-7/8	98.4	Straight		3350	3-5/16	84.1	1-1/8 NF	1	1	25.4	P-3	760	-	20751	6
4	101.6	Straight		3400	3-3/4	95.2	1-1/8 NF	1	1	25.4	P-2	760	-	20751	6
4	101.6	15	381	4450	3-1/8	79.3	7/8 NC	1	1	25.4	-	4760	770-B	551	6
4-1/8	104.7	Straight		3400	3-3/4	95.2	1-1/8 NF	1	1	25.4	P-2	760	-	20751	6
4-1/4	107.9	Straight		3400	3-3/4	95.2	1-1/8 NF	1	1	25.4	P-1	5060-AS	-	20751	6
4-1/4	107.9	36	91.4	4450	3-1/8	79.3	7/8 NC	1	1	25.4	-	4760	870-B	551	6
4-3/8	111.1	Straight		3400	3-3/4	95.2	1-1/8 NF	1	1	25.4	P-1	5060-AS	-	20751	6
4-1/2	114.3	Straight		3400	3-3/4	95.2	1-1/8 NF	1	1	25.4	P-0	5060-AS	-	20751	6
4-1/2	114.3	15	381	4450	3-1/8	79.3	7/8 NC	1	1	25.4	-	4760	870-B	551	6
4-1/2	114.3	24	609.6	4450	3-1/8	79.3	7/8 NC	1	1	25.4	-	4760	870-B	551	6
4-3/4	120.6	Straight		3400	3-3/4	95.2	1-1/8 NF	1	1	25.4	P-10	5060-AS	-	20751	6
4-13/16	122.2	18	457.2	4481	3-3/4	95.2	1-1/8 NF	1	1	25.4	-	5060-A	-	5051	6
5	127.0	Straight		3500	4-3/4	120.6	1-3/8 NF	1-1/4	1-1/4	31.8	TC-19-H-S	35260	-	21251-E	6
5	127.0	24	609.6	4481	3-3/4	95.2	1-1/8 NF	1	1-1/4	31.8	TC-19-H-S	35260	-	5051	6

Some items are available on a quotation basis only.  
 \* Drill must be used with Universal Joint or flexible connection.



# 4000 Series Motors

## 4000 Series Motors

4000 series motors, components and (ordering numbers)

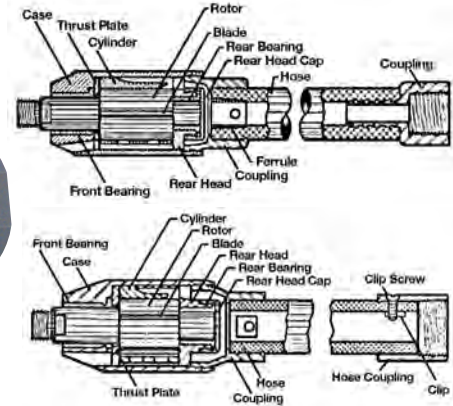

Motor Number	Motor O.D.	Tube I.D.	Case	Cylinder	Rear Head	Machine Coupling	Rotor	Blades (Qty.)	Thrust Plate	Front Bearing	Rear Bearing	Rear Head Cap	Front Dowel	Rear Dowel	Tail Hose Assembly*	Shaft Wrench	Rotor Thread	Hose Size
4250 (4080300)	1-7/8"	2-1/4 X 15R 2-15/16 X 12R 2-1/2 X 15R	42501 (1162700)	42502 (1162900)	42503 (1163000)	42504 (1163100)	42505 (1163700)	4406 (4) (1081300)	2307 (1053800)	4408 (1081400)	42509 (1163800)	4413 (1081500)	32011 (1142000)	42512 (1163900)	Line A Below	5/8" (14-0810)	5/8" N.C.	1/2"
4300 (4080500)	2-1/4"	2-5/8 X 24R 2-3/4 X 12R	43001 (1164400)	43002 (1164800)	43003 (1164900)	43004 (1165000)	43005 (1165500)	3306 (5) (1072600)	3307 (1072700)	3308 (1072800)	32009 (1141900)	3213 (1071300)	43011 (1165700)	43012 (1165800)	Line B Below	3/4" (14-0812)	3/4" N.C.	3/4"
4325 (4080700)	2-1/2"	2-7/8 X 28R 3 X 16R	43251 (1166800)	43252 (1167000)	43253 (1167100)	43254 (1167200)	43255 (1167900)	3206 (5) (1071100)	3207 (1071200)	3308 (1072800)	32009 (1141900)	3213 (1071300)	43211 (1166600)	43212 (1166700)	Line B Below	3/4" (14-0812)	3/4" N.C.	3/4"
4350 (4080800)	2-3/4"	3-1/4 X 16R 3-1/2 X 20R	43501 (1168100)	43502 (1168200)	43503 (1168300)	43504 (1168400)	43505 (1168800)	3706 (5) (1077900)	3307 (1078000)	3708 (1078100)	32759 (1146700)	213 (1022300PT)	32311 (1143900)	43512 (1168900)	Line B Below	7/8" (14-0814)	7/8" N.C.	1"
4450 (4081100)	3-1/8"	4 X 15R	44501 (1169800)	44502 (1170200)	44503 (1170300)	44504 (1170400)	44505 (1170600)	4706 (5) (1082900)	507 (1026400)	4708 (1083000PT)	33009 (1147500)	713 (1030700)	33212 (1148300)	44512 (1170700)	Line B Below	7/8" (14-0814)	7/8" N.C.	1"
4481 (4081400)	3-3/4"	4-13/16 X 18R	44811 (1170800)	44812 (1170900)	34003 (1151200)	34004 (1151300)	44815 (1171100)	5006 (5) (1083700)	34007 (1151800)	5008 (1083800)	33009 (1147500)	713 (1030700)	33212 (1148300)	44512 (1170700)	Not Req'd	1-1/8" (3241800)	1-1/8" N.C.	1"
4600 (4081800)	5"	5-3/4 X 72R 6 X 26R	46001 (1171900)	44812 (1170900)	34003 (1151200)	34004 (1151300)	44815 (1171100)	5006 (5) (1083700)	34007 (1151800)	5008 (1083800)	33009 (1147500)	713 (1030700)	33212 (1148300)	44512 (1170700)	Not Req'd	1-1/8" (3241800)	1-1/8" N.C.	1"

\*Includes Machine Coupling

Motors are supplied with ribs or rib cage for tube/pipe sizes larger than 6" ID.

Line Number	Tap Size	Tail Hose	Hose Coupling	Clip	Screw	Ferrule
A	1/2"	4415 (1081600)	4116 (1079000)	-	-	4418 (1081700)
B	1"	3315 (1072900)	3316 (1073100PT)	3317 (1073200)	3318 (8010065)	-

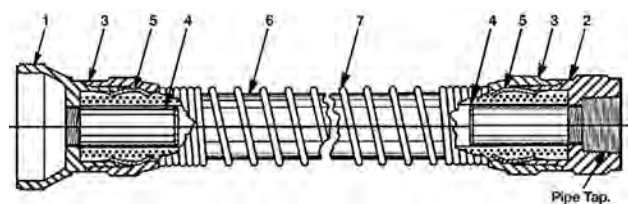

## Accessory Heavy Duty Screw Type Tail Hose Assemblies with Wire Inserted Hose and Spring Protector for 4000 Series Motors

Tail Hose Assembly	Used With Motor Assembly									
		Machine Coupling	Hose Coupling	Hose Pipe Tap	Compression Nut	Compression Ferrule	Compression Sleeve	Hose	Spring	
		Detail #	1	2	-	3	4	5	6	7
425019 HD (4092100)	4250	42504 KB (1716866)	425016 (1186900)	1/2"	42504 C (1163300)	42504 D (1163400)	42504 E (1163500)	425015 (1186800)	425017 (1186950)	
430019 HD (4092200)	4300	43004 B (1165000)	432516 (1187300)	3/4"	43254 C (1167400)	43254 D (1167500)	43254 E (1167600)	432515 K (1187250)	43254 K (1167700)	
432519 HD (4092350)	4325	43254 KB (1167800)	432516 (1187300)	3/4"	43254 C (1167400)	43254 D (1167500)	43254 E (1167600)	432515 K (1187250)	43254 K (1167700)	
435019 HD (4092400)	4350	43504 B (1168500)	435016 (1187600PT)	1"	43504 C (1168600)	43254 D (1167500)	43254 E (1167600)	432515 K (1187250)	43254 K (1167700)	
445019 HD (4092500)	4450	44504 B (1170500)	435016 (1187600PT)	1"	43504 C (1168600)	43254 D (1167500)	43254 E (1167600)	432515 K (1187250)	43254 K (1167700)	
460019 HD (4092501)	4600	46004 B (1171950)	460016 (1188010)	1"	46004 C (1171960)	46004 D (1171970)	46004 E (1171980)	460015 K (1188020)	46004 K (1717471)	

## 60 & 4000 Series Motors

60 & 4000 series motors, components and (ordering numbers)

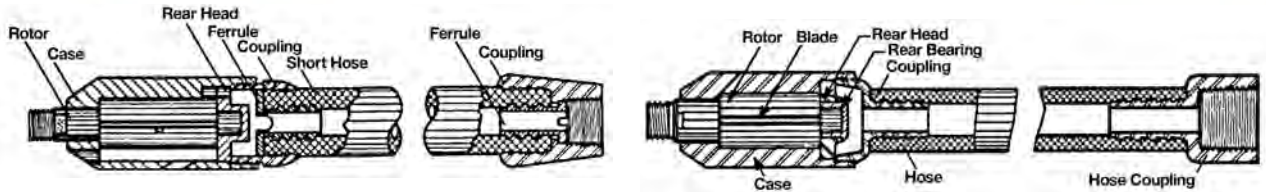

Motor Number	Motor O.D.	Tube I.D. (Radius)	Case	Rear Head w/ Bearing	Machine Coupling	Rotor	Blades (4 req.)	Rear Bearing	Rear Dowel (Qty.)	Tail Hose	Tail Hose Coupling	Tail hose Assembly	Front Ferrule	Rear Ferrule	Shaft Wrench	Rotor Thread	Hose Size
X 64 (4090200)	1 1/16"	13/16" (5")	X 6401 (1334800)	X 6403 (1334900)	X 6404 (1335000)	X 6405 (1335200)	X 6406 (1335300)	-	X 6412 (2) (1335400)	X 6415 (1335500)	X 6416 (1335600)	X 6419	X 6417 (1335700)	X 6418 (1335800)	3/16" (3240200)	1/4" N.F.	1/4"
X 61 (4089900)	7/8"	1-1/32" (5")	X 6101 (1331200)	X 6103 (1331300)	X 6104 (1331400)	X 6105 (1331600)	X 6106 (1331700)	-	X 6112 (2) (1331800)	X 6115 (1331900)	X 6116 (1332000)	X 6119	X 6117 (1332100PT)	X 6118 (1332200)	1/4" (14-0804)	5/16" N.F.	1/4"
X 63 (4090000)	1-1/16"	1-1/4" (6")	X 6301 (1333300)	X 6303 (1333400)	X 6304 (1333500)	X 6305 (1333700)	X 6306 (1333800)	-	X 6312 (2) (1334000)	X 6315 (1334100)	X 6316 (1334200)	X 6319	X 6317 (1334300)	X 6318 (1334400)	5/16" (14-0805)	3/8" N.F.	3/8"
X 65 (4090300)	1-3/16"	1-1/2" (6")	X 6501 (1336300PT)	X 6503 (1336400)	X 6504 (1336500)	X 6505 (1336700)	X 6506 (1336800)	-	X 6312 (2) (1334000)	X 6315 (1334100)	X 6316 (1334200)	X 6519	X 6317 (1334300)	X 6318 (1334400)	5/16" (14-0805)	3/8" N.F.	3/8"
X 66 (4090500)	1-5/16"	1-3/4" (6")	X 6601 (1337300)	X 6603 (1337400)	X 6604 (1337500)	X 6605 (1337700)	X 6606 (1337800)	-	X 6312 (2) (1334000)	X 6315 (1334100)	X 6316 (1334200)	X 6619	X 6617 (1337900)	X 6318 (1334400)	3/8" (2902629)	3/8" N.F.	3/8"
4200 (4080000)	1-1/2"	1-5/8" (24") 1-3/4" (15")	42001 G (1161300)	42003 (1161500)	42004 (1161600)	42005 (1161800)	4106 (1078800)	42009 (1162100)	42012 (1162200)	4115 (1078900)	4116 (1079000)	42019 (4091500)	1 AJ243 (1716170)	1 AJ243 (1716170)	5/8" (14-0810)	5/8" N.C.	1/2"
4225 (4080100)	1-3/4"	2" (15")	42251 G (1162500)	42003 (1161500)	42004 (1161600)	42005 (1161800)	4106 (1078800)	42009 (1162100)	42012 (1162200)	4115 (1078900)	4116 (1079000)	42019 (4091500)	1 AJ243 (1716170)	1 AJ243 (1716170)	5/8" (14-0810)	5/8" N.C.	1/2"



# Midget Motors

## Midget Motors

For 1/2" - 1-3/8" I.D. tubes

Straight tube midget motors, components and (ordering numbers)

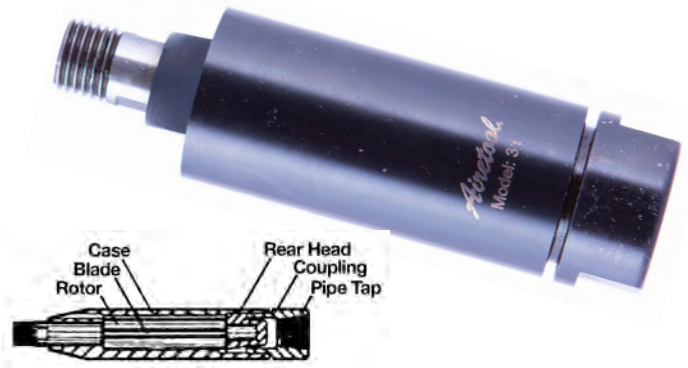
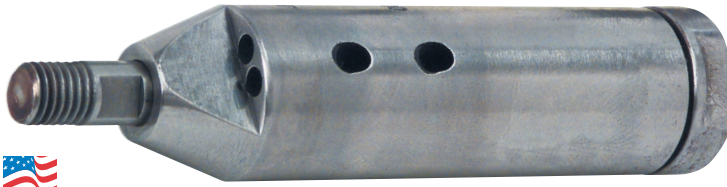

Motor Number	Motor O.D.	Tube I.D.	Case	Rear Head	Machine Coupling	Rotor	Rotor Blade (Qty.)	Dowel pin (Qty.)	Shaft Wrench	Rotor Thread	Air Hose
24 (4074900)	15/32"	1/2"	X 2401 (1056400)	2403 (1056500)	2404 (1056600)	2405 (1056700)	2406 (4) (1056800)	2412 (1056900)	5/32" (3240100)	10-32	3/16"
30 (4075400)	37/64"	5/8"	X 3001 (1067100)	X 3003 (1067300)	X 3004 (1067400)	X 2705 (1063000)	2706 (4) (1063100)	3012 (1067500)	3/16" (3240200)	1/4" N.F.	1/4"
27 (4075100)	11/16"	3/4"	X 2701 (1062600)	X 2703 (1062800)	2704 (1062900PT)	X 2705 (1063000)	2706 (4) (1063100)	3012 (1067500)	3/16" (3240200)	1/4" N.F.	1/4"
29 A (4075310)	25/32"	7/8"	2901 A (1064901)	2903 A (1065001)	2904 (1065100)	2605 (1060800PT)	2606 (4) (1060900)	X 6112 (1331800)	5/16" (14-0805)	3/8" N.F.	3/8"
26 (4075000)	29/32"	1"	2601 G (1060500)	2603 (1060600)	2604 (1060700)	2605 (1060800PT)	2606 (4) (1060900)	X 6312 (1334000)	5/16" (14-0805)	3/8" N.F.	3/8"
31 (4075600)	1-1/32"	1-1/8"	3101 (1069800)	3103 (1069900)	3104 (1070000)	3105 (1070100)	3106 (4) (1070200PT)	3111 (1070300)	5/16" (2902629)	3/8" N.F.	3/8"
X 63 A (4090100)	1-1/16"	1-1/4"	X 6301 (1333300)	X 6303 (1333400)	X 6304 A (1333600)	X 6305 (1333700)	X 6306 (4) (1333800)	X 6312 (2) (1334000)	5/16" (14-0805)	3/8" N.F.	3/8"
X 65 A (4060400)	1-3/16"	1-3/8"	X 6501 (1336300PT)	X 6503 (1336400)	X 6504 A (1336600)	X 6505 (1336700)	X 6506 (4) (1336800)	X 6312 (2) (1334000)	5/16" (14-0805)	3/8" N.F.	3/8"

## Water Driven Motors

For 2" and 3-3/4" I.D. tubes

Water driven motors are used only in the overhead cleaning of vertical catalyst tubes.

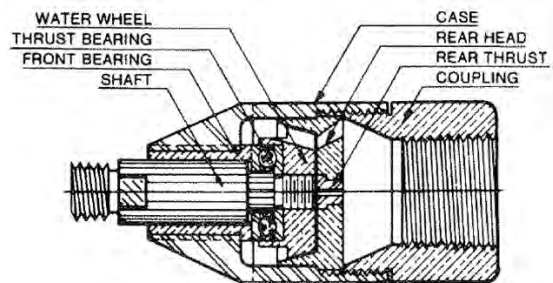
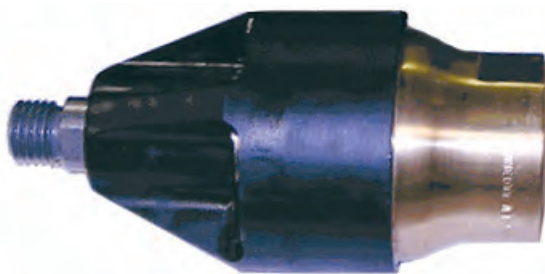

Model Number	Motor O.D.	Tube I.D.	Case	Water Wheel	Rear Head	Machine Coupling	Pipe Tap	Shaft	Thrust Bearing	Front Bearing	Rear Thrust	Shaft Wrench	Shaft Thread	Hose
W-7 (4088200)	3-1/2"	3-3/4"	W 701 (1319300)	W 702 (1319400PT)	W 703 (1319500)	W 10704 (1326000)	1-1/2"	W 905 (1319900)	W 907 (1320000)	W 908 (1320100)	W 910 (1320200)	7/8" (14-0814)	7/8" N.C.	1-1/2"
W-16-A (4089200)	1-11/16"	2"	W 1601 A (1323300)	W 1602 (1323400)	W 1603 A (1323600)	W 1604 A (1323800)	3/4"	W 1605 (1323900)	W 1607 (1324000)	W 1608 (1324100)	W 1610 (1324200)	5/8" (14-0810)	5/8" N.C.	3/4"

\* Other sizes available. Contact customer service for details

## Gas Line Cleaners

**Range: 3/4 to 1-1/2 in.  
19.05 to 38.10 mm**

Used successfully by gas utilities for cleaning old service lines before inserting new plastic and copper tubing. The thorough cleaning action of the barrel-shaped cutter head assures the removal of material that could cut or rupture the renewal tubing.

- Renews gas service lines instead of replacing them
- Complete kit consists of: motor, with an extra set of blades; head; lubricator; wire wound hose; spare cutters and a metal carrying case
- Other sizes available on request

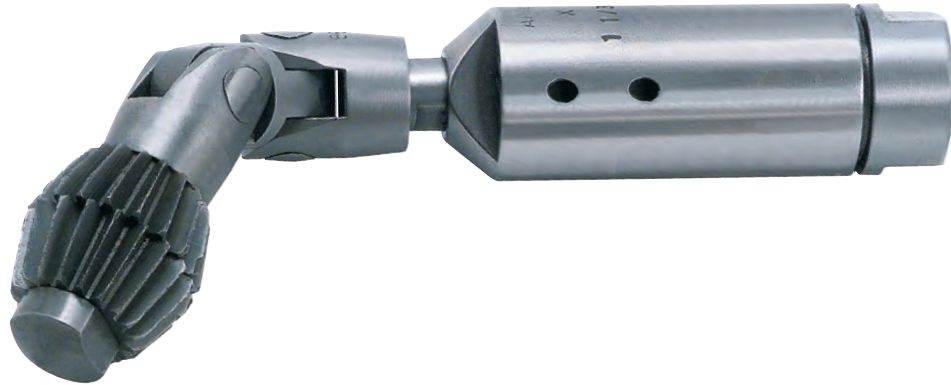

Cleaner Complete	Order Number	Pipe I.D.		Motor Assembly		Motor Diameter		Head Assembly		Air Inlet		Hose Size		Hose Length	
		in.	mm	Model	Order No.	in.	mm	Model	Order No.	in.	mm	in.	mm	ft	M
27 GLC 50	4105416	3/4	19.05	27	4075100	11/16	17.46	2740 S	4104802	1/4	6.35	1/4	6.35	50	15.24
X 64 GLC 50		1	25.4	X 64	4090200	11/16	17.46	2640 S		1/4	6.35	1/4	6.35	50	15.24
X 61 GLC 50		1-1/8	28.58	X 61	4089900	7/8	22.23	3140 S		1/4	6.35	1/4	6.35	50	15.24
X 63 A GLC 25	4105354	1-1/4	31.7	X 63 A	4090100	1-1/16	26.9	6340 S	4104903	3/8	9.5	3/8	9.5	25	7.62
X 63 A GLC 50	4105355	1-1/4	31.7	X 63 A	4090100	1-1/16	26.9	6340 S	4104903	3/8	9.5	3/8	9.5	50	15.24
X 65 GLC 25	4105573	1-1/2	38.1	X 65	4090300	1-3/16	30.16	6340 S	4104903	3/8	9.5	3/8	9.5	25	7.62
X 65 A GLC 25	4104724	1-1/2	38.1	X 65 A	4090400	1-3/16	30.1	1740 S		3/8	9.5	3/8	9.5	25	7.62
X 65 A GLC 50	4105359	1-1/2	38.1	X 65 A	4090400	1-3/16	30.1	1740 S		3/8	9.5	3/8	9.5	50	15.24

\* Other sizes may be available. Contact customer service for details



# Type 1 - Single Unit Heads

## 1/2" - 2-1/4" I.D. "Series 40"

Single unit heads, components and (ordering numbers)

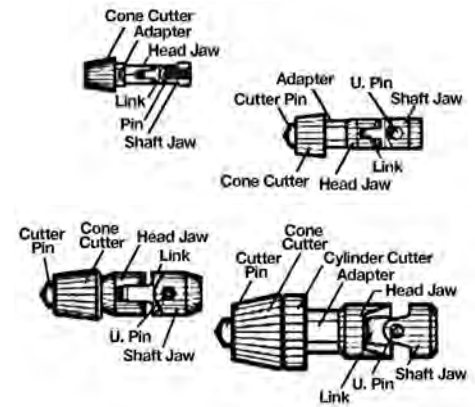
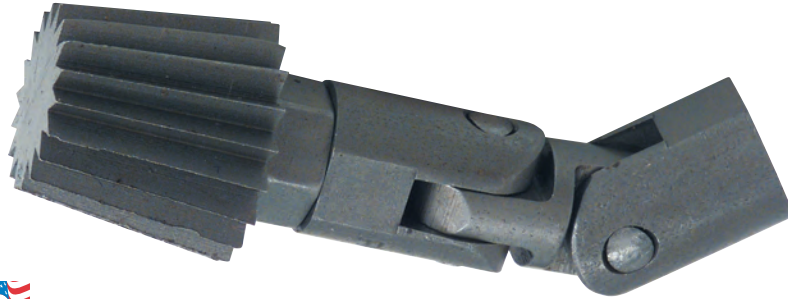

Head Number	Tube I.D.	Universal Joint	Shaft Jaw Tap	Adapter	Cutter Pin	Cone Cutter (qty.)	Cylinder Cutter
2440 (4051800)	1/2"	2451 (4094800)	10-32	2443 (1057000)	-	2487 S (1058400)	-
3040 (4053200)	5/8" 11/16"	PA 3051 (4098200)	1/4" N.F.	2734 (1063300)	-	3037 (10681000)	-
2740 (4052400)	3/4" 13/16"	PA 3051 (4098200)	1/4" N.F.	2734 (1063300)	-	C 3 (1212500)	-
2740 S (4104802PT)	3/4" 13/16"	6451 (4096500)	1/4" N.F.	-	2944 (1065900)	2947 S (2) (1066100PT)	-
X 6440 (4074400)	13/16"	6451 (4096500)	1/4" N.F.	-	2944 (1065900)	2947 (1066000)	-
2940 (4052800)	27/32" 7/8"	2651 (4094900)	3/8" N.F.	2943 (1065800)	2944 (1065900)	2947 (1066000)	-
2640 (4052100)	1"	2651 (4094900)	3/8" N.F.	2643 (1061200)	2644 (1061400)	337 (1025700)	-
X 6140 (4074000PT)	1-1/32"	6151 (4096100PT)	5/16" N.F.	-	2644 (1061400)	337 (1025700)	-
3140 (4053800)	1-1/8"	6651 (4096700)	7/16" N.F.	-	3144 A (1070500)	2837 (1064600)	-
X 6340 (4074200)	1-1/4"	6651 (4096700)	3/8" N.F.	-	2544 S (1059400)	947 (1038700)	-
12240 (4059200)	1-1/4" 1-1/2"	3151 (4095000)	7/16" N.F.	-	2544 S (1059400)	947 (1038700)	-
X 6540 (4074600)	1-3/8"	6651 (4096700)	3/8" N.F.	-	2544 S (1059400)	6547 (1097600)	-
1740 (4050500)	1-1/2"	31551 (4097500)	9/16" N.F.	1743 (1047801)	2844 (1064800)	1097 (1043100)	1088 (1042800)
1940 (4051000)	1-5/8"	4151 (4095600)	5/8" N.C.	1943 (1051400)	1944 (1051500)	797 (1034500)	788 (1034300)
X 6640 (4074800)	1-3/4"	6651 (4096700)	3/8" N.F.	-	2544 S (1059400)	897 B (1038300)	-
4140 (4054900)	1-5/8" 2"	4151 (4095600)	5/8" N.C.	1943 (1051400)	1944 (1051500)	897 B (1038300)	888 B (1037700)
4440 C (4055300)	2-1/4"	4151 (4095600)	5/8" N.C.	1943 (1051400)	1944 (1051500)	897 (1038100)	888 (1037600)



# Type 2 Single Unit Heads



## 1/2" - 2-1/8" I.D. "Series 30"

Single unit heads, components and (ordering numbers)

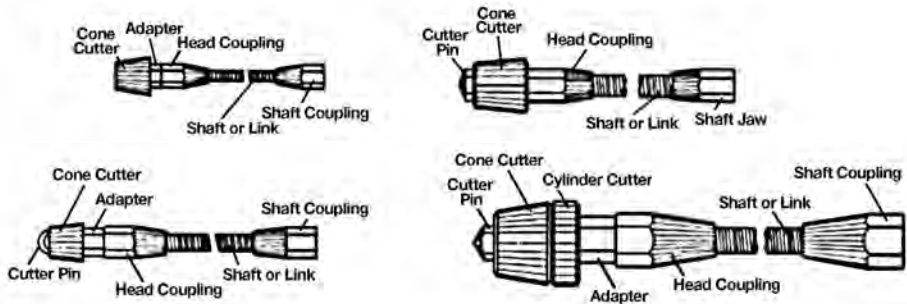

Head Number	Tube I.D.	Flex Connection	Shaft Cpl. Tap	Head Cpl. Tap	Adapter	Cutter Pin	Cone Cutter	Cylinder Cutter	Length	Diameter
2430 (4051700)	1/2"	2461 A (4035500)	10-32	10-32	2443 (1057000)	-	2487 S (1058400)	-	4"	3/16"
3030 (4053100)	5/8"	X 6461 A (4046200)	1/4" N.F.	1/4" N.F.	2734 (1063300)	-	3037 (1068100)	-	4"	3/16"
2730 (4052300)	3/4"	X 6461 A (4046200)	1/4" N.F.	1/4" N.F.	2734 (1063300)	-	C 3 (1212500)	-	4"	3/16"
X 6430 (4074300)	13/16"	X 6461 A (4046200)	1/4" N.F.	1/4" N.F.	-	2944 (1065900)	2947 (1066000)	-	4"	3/16"
2930 (4052700)	7/8"	2961 A (4036500)	3/8" N.F.	3/8" N.F.	2943 (1065800)	2944 (1065900)	2947 (1066000)	-	4-1/2"	1/4"
12130	1"	12161 A (4038300)	5/16" N.F.	5/16" N.F.	-	2644 (1061400)	337 (1025700)	-	4-1/2"	1/4"
2630 (4052000)	1"	2661 A (4036200)	3/8" N.F.	5/16" N.F.	-	2644 (1061400)	337 (1025700)	-	4-1/2"	1/4"
X 6130 (4073900)	1-1/32"	X 6161 A (4045000)	5/16" N.F.	5/16" N.F.	-	2644 (1061400)	337 (1025700)	-	4"	3-16
3130 (4053700)	1-1/8"	X 6361 A (4045600)	7/16" N.F.	3/8" N.F.	-	3144 A (1070500)	2837 (1064600)	-	4-1/2"	1/4"
X 6330 (4074100)	1-1/4"	X 6361 A (4045600)	3/8" N.F.	7/16" N.F.	-	2544 S (1059400)	947 (1038700)	-	4-1/2"	1/4"
X 6530 (4074500)	1-1/2"	X 6661 A (4046800)	3/8" N.F.	7/16" N.F.	-	2544 S (1059400)	6547 (1097600)	-	6-1/2"	3/8"
X 6630 (4074700)	1-3/4"	X 6661 A (4046800)	3/8" N.F.	7/16" N.F.	-	2544 S (1059400)	797 (1034500)	-	6-1/2"	3/8"
4130 (4054800)	1-5/8" 2-1/8"	4161 A (4037100)	5/8" N.C.	5/8" N.C.	1943 (1051400)	1944 (1051500)	897 B (1038300)	888 B (1037700)	7"	1/2"

### Drill Pipe Recommendation Chart

Size	Connection	Weight	Grade	TJ ID	Tube ID	Motor	Spring Head	Finger Head	Lance
2-3/8"	2-3/8"IF/NC26	6.65#	S-135	1.750"	1.815"	3150	SRA-1470	1840	1/2"
2-7/8"	2-7/8" HTPAC	10.40#	E-75	1.500"	2.151"	3150	SRA-1470	NA	1/2"
2-7/8"	2-7/8" HTPAC	10.40#	S-135	1.500"	2.151"	3150	SRA-1470	NA	1/2"
2-7/8"	2-7/8" HTPAC	10.40#	G-105	1.500"	2.151"	3150	SRA-1470	NA	1/2"
2-7/8"	2-3/8HTSLH90	10.40#	S-135	1.975"	2.151"	3150	SRA-1470	NA	1/2"
2-7/8"	HT-26	10.40#	S-135	1.750"	2.151"	3150	SRA-1470	NA	1/2"
2-7/8"	NC26 2-3/8 IFSH	10.40#	X-95	1.500"	2.151"	3150	SRA-1470	NA	1/2"
2-7/8"	NC26 2-3/8 IFSH	10.40#	S135	1.500"	2.151"	3150	SRA-1470	NA	1/2"
2-7/8"	2-7/8" AOH	10.40#	S-135	2.156"	2.151"	3200	SRA-1870	NA	3/4"
2-7/8"	2-7/8"IF NC31	10.40#	E-75	2.125"	2.151"	3200	SRA-1870	NA	3/4"
2-7/8"	2-7/8" AOH	10.40#	X-95	2.156"	2.151"	3200	SRA-1870	NA	3/4"
2-7/8"	2-7/8"IF NC31	10.40#	S-135	2.000"	2.151"	3200	SRA-1870	NA	3/4"
3-1/2"	3-1/2"IF NC38	13.30#	E-75	2.688"	2.764"	3250	SRA-3370	3370	1"
3-1/2"	3-1/2"IF NC38	13.30#	X-95	2.688"	2.764"	3250	SRA-3370	3370	1"
3-1/2"	3-1/2"IF NC38	13.30#	XD-105	2.563"	2.764"	3250	SRA-3370	3370	1"
3-1/2"	3-1/2"IF NC38	13.30#	S-135	2.563"	2.764"	3250	SRA-3370	3370	1"
3-1/2"	3-1/2" HT-38	13.30#	S-135	2.563"	2.764"	3250	SRA-3370	3370	1"
3-1/2"	3-1/2" XT-38	13.30#	S-135	2.563"	2.764"	3250	SRA-3370	3370	1"
3-1/2"	3-1/2"IF NC38	15.50#	X-95	2.563"	2.602"	3250	SRA-3370	3370	1"
3-1/2"	3-1/2"IF NC38	15.50#	XD-105	2.563"	2.602"	3250	SRA-3370	3370	1"
3-1/2"	3-1/2"IF NC38	15.50#	S-135	2.563"	2.602"	3250	SRA-3370	3370	1"
3-1/2"	NC-38	15.50#	S-135	2.563"	2.602"	3250	SRA-3370	3370	1"
3-1/2"	XT-38	13.30#	S-135	2.563"	2.602"	3250	SRA-3370	3370	1"
4"	XT-39	14.00#	S-135	2.688"	3.340"	3250	SRA-3270	3270	1"
4"	XT-39	15.70#	XD-105	2.688"	3.340"	3250	SRA-3270	3270	1"
4"	4" FH NC40	14.00#	S-135	2.688"	3.340"	3250	SRA-3270	3270	1"
4"	HT-40	14.00#	S-135	2.688"	3.340"	3250	SRA-3270	3270	1"
4"	XT-39	14.00#	S-135	2.813"	3.340"	3250	SRA-3270	3270	1"
4"	XT-M 38	14.00#	S-135	2.688"	3.340"	3250	SRA-3270	3270	1"
4-1/2"	4-1/2"XH NC46	16.60#	S-135	3.000"	3.826"	3275	SRA-970	970	1"
4-1/2"	4-1/2"XH NC46	20.00#	S-135	3.000"	3.640"	3275	SRA-970	970	1"
5"	4-1/2"IF NC50	19.50#	S-135	3.250"	4.276"	3300	SRA-770	770	1"
5"	XT-50	19.50#	S-136	3.750"	4.276"	3300	SRA-770	770	1"
5"	4-1/2"IF NC50	25.60#	S-135	3.250"	4.000"	3300	SRA-770	770	1"
5-1/2"	5-1/2" FH	21.90#	S-135	3.500"	4.778"	3350	SRA-5770	770 SA	1"
5-1/2"	5-1/2" FH	24.70#	S-135	3.000"	4.670"	3350	SRA-5770	770 SA	1"
5-7/8"	XT-57	23.40#	S-135	4.250"	5.153"	3400	SRA-5770	770 SA	1"
5-7/8"	XT-57	26.30#	S-135	4.250"	5.045"	3400	SRA-5770	770 SA	1"
5-7/8"	CTM57	28.70#	S-135	4.250"	4.875"	3400	SRA-5770	770 SA	1"

## 3000 Series Motors

3000 series straight motors, components and (ordering numbers)



All Motors include Shaft Wrench

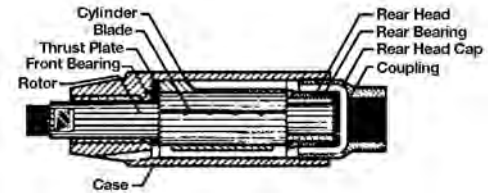

Motor Number	Motor O.D.	Tube I.D.	Case	Cylinder	Rear Head	Machine Coupling	Rotor	Blades (Qty.)	Thrust Plate	Front Bearing	Rear Bearing	Rear Head Cap	Front Dowel	Rear Dowel	Shaft Wrench	Rotor Thread	Hose Size
3150 (4075700)	1-3/8"	1-1/2"	31501 (1138900)	31502 (1139000)	31503 (1139100)	31504 (1139200)	31505 (1139300)	1806 (4) (1049100PT)	1707 (1047500)	X 1708 (1330400)	31509 (1139400)	-	31511 (1139500)	31512 (1139600)	9/16" (14-0809)	9/16" N.C.	1/2"
3162 (4075800)	1-1/2"	1-5/8"	31621 (1139900)	31622 (1140000)	31623 (1140100)	31624 (1140200)	31625 (1140300)	1806 (4) (1049100PT)	1807 (1049200)	X 1808 (1330500PT)	31629 (1140500)	-	31511 (1139500)	31512 (1139600)	5/8" (14-0810)	5/8" N.C.	1/2"
3175 (4075900)	1-5/8"	1-3/4"	31751 (1140600)	31622 (1140000)	31623 (1140100)	31624 (1140200)	31625 (1140300)	1806 (4) (1049100PT)	1807 (1049200)	X 1808 (1330500PT)	31629 (1140500)	-	31511 (1139500)	31512 (1139600)	5/8" (14-0810)	5/8" N.C.	1/2"
3187 (4076000)	1-3/4"	1-7/8"	31871 (1140900)	31872 (1141000)	31873 (1141100)	31874 (1141200)	31875 (1141300PT)	2306 (4) (1053700)	22307 C (1138800)	2208 (1053100)	32129 (1142900)	-	31811 (1140700)	31812 (1140800)	5/8" (14-0810)	5/8" N.C.	3/4"
3200 (4076100)	1-7/8"	2"	32001 (1141400PT)	32002 (1141500)	32003 (1141600)	32004 (1141700)	32005 (1141800)	2306 (4) (1053700)	2307 (1053800)	2208 (1053100)	32009 (1141900)	3213 (1071300)	31811 (1140700)	32012 (1715981)	5/8" (14-0810)	5/8" N.C.	3/4"
3212 (4076200)	2"	2-1/8"	32121 (1142200)	32122 (1142400)	32123 (1142500)	32124 (1142600)	32125 (1142700)	21606 (4) (1135800)	21607 (1135900)	2208 (1053100)	32129 (1142900)	4413 (1081500)	32011 (1142000)	32112 (1142100)	5/8" (14-0810)	5/8" N.C.	3/4"
3225 (4076300)	2-1/8"	2-1/4"	32251 (1143000)	32252 (1143200)	32253 (1143300)	32254 (1143400)	32255 (1143700)	21506 (5) (1134300)	1507 (1045800)	1408 (1045500)	32009 (1141900)	3213 (1071300)	32011 (1142000)	32112 (1142100)	3/4" (14-0812)	3/4" N.C.	3/4"
3250 (4076500)	2-5/16"	2-1/2"	32501 (1144600)	32502 (1144800)	32503 (1144900)	32504 (1145000)	32505 (1145100)	21406 (5) (1133000)	21407 (1133100)	21408 (1133200)	32009 (1141900)	3213 (1071300)	32511 (1145200)	32512 (1145300)	7/8" (14-0814)	7/8" N.C.	1"
3262 (4076600)	2-1/2"	2-5/8"	32621 (1145600)	32622 (1145800)	32623 (1145900)	32624 (1146000)	32755 (1146600)	21306 (5) (1131700)	21907 (1137700)	1008 (1040700)	32759 (1146700)	213 (1022300PT)	32611 (1145400)	32612 (1145500)	7/8" (14-0814)	7/8" N.C.	1"
3275 (4076700)	2-5/8"	2-3/4"	32751 (1146100)	32752 (1146300)	32753 (1146400)	32754 (1146500)	32755 (1146600)	21306 (5) (1131700)	21307 (1131800)	1008 (1040700)	32759 (1146700)	213 (1022300PT)	32611 (1145400)	32612 (1145500)	7/8" (14-0814)	7/8" N.C.	1"
3300 (4076900)	2-13/16"	3"	33001 (1146900)	33002 (1147000)	33003 (1147100)	33004 (1147200)	33005 (1147400)	21006 (5) (1121500)	21007 (1121600)	1108 (1043400)	33009 (1147500)	713 (1030700)	32611 (1145400)	32612 (1145500)	1" (3241600)	1" N.F.	1"
3318 (4077200)	3"	3-3/16"	33181 (1148100)	33252 (1148600)	33253 (1148700)	33254 (1148800)	33255 (1149000)	20706 (5) (1116200)	20907 (1119300)	1108 (1043400)	33009 (1147500)	713 (1030700)	33211 (1148200)	33212 (1148300)	1" (3241600)	1" N.F.	1"
3350 (4077500)	3-5/16"	3-5/8"	33501 (1149200)	33502 (1149500PT)	33503 (1149600PT)	33504 (1149700)	33505 (1149900)	20706 (5) (1116200)	20707 (1116300)	20708 (1116400)	33009 (1147500)	713 (1030700)	33211 (1148200)	33212 (1148300)	1-1/8" (3241800)	1-1/8" N.F.	1"
3400 (4077900)	3-3/4"	4"	34001 (1150800)	34002 (1151100)	34003 (1151200)	34004 (1151300)	34005 (1151600)	20706 (5) (1116200)	34007 (1151800)	20708 (1116400)	33009 (1147500)	713 (1030700)	33211 (1148200)	33212 (1148300)	1-1/8" (3241800)	1-1/8" N.F.	1"
3500 (4078500)	4-3/4"	5"	35001 (1153100)	35502 (1155300)	35503 (1155400)	35504 (1155500)	35505 (1155800)	21206 (5) (1125300)	35507 (1155900)	21208 (1125400)	33009 (1147500)	713 (1030700)	33211 (1148200)	33212 (1148300)	1-3/8" (3241900)	1-3/8" N.F.	1"
3600 (4078900)	5-3/4"	6"	36001 (1156100)	35502 (1155300)	35503 (1155400)	35504 (1155500)	35505 (1155800)	21206 (5) (1125300)	35507 (1155900)	21208 (1125400)	33009 (1147500)	713 (1030700)	33211 (1148200)	33212 (1148300)	1-3/8" (3241900)	1-3/8" N.F.	1"

Motors for tube/pipe sizes larger than 5" ID are supplied with ribs or rib cage to center the motor in tube or pipe being cleaned.

# Type 3 - Single Expansion "P" & "TC" Heads

## 1-1/2" - 7" I.D. for Straight Tubes and Drill Pipe

Single expansion heads, components and (order numbers)

- "PY" heads developed specifically for the rigorous conditions found in Pipe Yard applications
- "PY" heads have larger diameter front ends and stronger coupling studs that increase durability

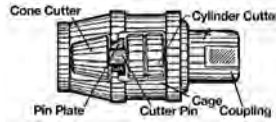

Head Number	Tube I.D.	Closed	Expands To	Cage	Pin Plate	Head Coupling	Tap Coupling	Cutter Pin (qty.)	Cone Cutter (qty.)	Cylinder Cutter (qty.)
TC 14 (4072000)	1-1/2"	1-3/8"	1-23/32"	1781 (1048300)	-	1783 (1048500)	9/16"	1584 (1), 1884 (1) (1046600) (1051100PT)	1787 (1) (1048600)	1788 (2) (1048800)
TC 11 (4071500)	1-3/4"	1-5/8"	2"	1881 (1050700)	-	1883 (1051000)	5/8"	1584 (1), 1884 (1) (1046600) (1051100PT)	1587 (1) (1046700)	1588 (2) (1047000)
TC 17 PY (4105583)	1-7/8"	1-11/16"	2"	2281 T C 17 PY (1717018)	-	2383 (1055400)	5/8"	1584 PY (3) (1716989)	2287 (3) (1053400)	2288 (6) (1053500)
TC 16 PY (4105566)	2"	1-13/16"	2-3/16"	2381 PY (1716988)	-	2383 (1055400)	5/8"	1584 PY (3) (1716989)	1787 (3) (1048600)	1788 (6) (1048800)
TC 13 PY (4105569)	2-1/8"	1-5/16"	2-5/16"	2381 A PY (1716995)	-	2383 (1055400)	5/8"	1584 PY (3) (1716989)	1787 (3) (1048600)	1788 (6) (1048800)
P 15 PY (4105570)	2-1/4"	2-1/16"	2-7/16"	P 1591 PY (1716997)	P 1592 (1294400)	183 (1019900)	3/4"	2484 PY (3) (1716998)	2487 (3) (1058200)	2488 (6) (1717384)
P 9 S (4070300)	2-3/8"	2-3/16"	2-11/16"	P 991 S (1292700)	P 992 S (1293400)	183 (1019900)	3/4"	2484 (3) (1057900)	C 52 (3) (1217500PT)	C 76 (6) (1218400)
P 9 PY (4105567)	2-1/2"	2-1/4"	2-13/16"	P 991 PY (1716990)	P 992 (1293300)	183 (1019900)	3/4"	1584 PY (3) (1716989)	1587 (3) (1046700)	1588 (6) (1047000)
P 8 (4069400)	2-5/8"	2-9/16"	2-7/8"	P 891 (1291800)	P 892 (1292300)	21483 (1133700)	7/8"	184 (3) (1020300)	1087 (3) (1042700)	1088 (6) (1042800)
P 7 (4068900)	2-3/4"	2-9/16"	2-15/16"	P 791	P 792	983 S (1039800)	7/8"	184 (3) (1020300)	1087 (3) (1042700)	1088 (6) (1042800)
P 6 A PY (4105591)	3"	2-11/16"	3-1/8"	P 691 A PY (1717032)	P 692 A (1290700)	983 S (1039800)	7/8"	184 PY (3) (1717033)	1087 (3) (1042700)	1088 (6) (1042800)
P 6 (4068400)	3-1/8"	2-13/16"	3-1/4"	P 691 AY	P 692 (1290600)	983 S (1039800)	7/8"	184 (3) (1020300)	1087 (3) (1042700)	1088 (6) (1042800)
P 5 (4067400)	3-1/4"	3-1/16"	3-9/16"	P 591 (1289100)	P 592 (1289600)	983 S (1039800)	7/8"	184 (3) (1020300)	987 (3) (1040000)	988 (6) (1040100PT)
P 4 (4066900PT)	3-1/2"	3-3/16"	3-13/16"	P 491 (1288500PT)	P 492 (1289000)	883 D (1036100)	7/8"	884 (3) (1036700)	787 (3) (1034200)	788 (6) (1034300)
P 3 (4066400)	3-3/4"	3-9/16"	4-3/16"	P 391 (1287900)	P 392 (1288300)	883 F (1036400)	7/8"	884 (3) (1036700)	887 B (3) (1037300)	888 B (6) (1037700)
P 2 (4065900)	4"	3-3/4"	4-1/2"	P 291 (1287100)	P 292 (1287700)	883 F (1036400)	7/8"	884 (3) (1036700)	887 (3) (1037100)	888 (6) (1037600)
P 1	4-1/4"	3-13/16"	4-3/4"	P 191	P 192	883 F (1036400)	1 1/8"	884 P (3) (1036800)	887 (3) (1037100)	888 (6) (1037600)
P 0	4-1/2"	4-1/8"	4-15/16"	P 091 (1286300)	P 092 (1286600)	883 F (1036400)	1 1/8"	884 P (3) (1036800)	887 B (3) (1037300)	888 B (6) (1037700)
P 10 (4070800)	4-3/4"	4-3/8"	4-15/16"	P 1091 (1293500)	P 1092 (1293800)	883 F (1036400)	1 1/8"	884 P (3) (1036800)	887 (3) (1037100)	888 (6) (1037600)
TC 19 H S	5"	4-1/2"	5-9/16"	1991 H S	-	21283	1 3/8"	884 P (3) (1036800)	1287 (3) (1044300)	1288 (9) (1044400)
TC 19 S	5-1/4"	4-7/8"	5-15/16"	1991 S	-	8293 (1111010)	1 3/8"	884 P (4) (1036800)	1287 (4) (1044300)	1288 (12) (1044400)
TC 20 S (4073200)	6"	5-1/2"	6-1/2"	2091 S (1052800)	-	8293 (1111010)	1 3/8"	884 P (4) (1036800)	1287 (4) (1044300)	1288 (12) (1044400)
TC 21 S	6-1/4"	5-3/4"	6-3/4"	2191 S	-	8293 (1111010)	1 3/8"	884 P (4) (1036800)	11887 (4)	11888 (12)
TC 22 S	6-1/2"	6"	7-1/16"	2291 S	-	8293 (1111010)	1 3/8"	884 P (4) (1036800)	11887 (4)	11888 (12)
TC 23 S	6-3/4"	6-1/4"	7-5/16"	2391 S	-	8293 (1111010)	1 3/8"	2484 S (4) (1058100)	8287 (4)	8288 (12)
TC 24 S	7"	6-1/2"	7-9/16"	2491 S	-	8293 (1111010)	1 3/8"	2484 S (4) (1058100)	8287 (4)	8288 (12)



# Type 4 - SRA Spring Retracting Arm Heads



## 1-1/2" - 4-3/4" I.D. for Straight Tubes, Bent Tubes, and Drill Pipe

Forward swing arm heads, components and (ordering numbers)

Recommended spare parts: cone cutters and cutter pins, cutter arms and arm pins.

- Developed specifically for Drill Pipe applications to protect box end threads
- The "SRA" arms are held closed until air is applied which allows for easy insertion into the box end of drill pipe, especially when used with automated cleaning equipment

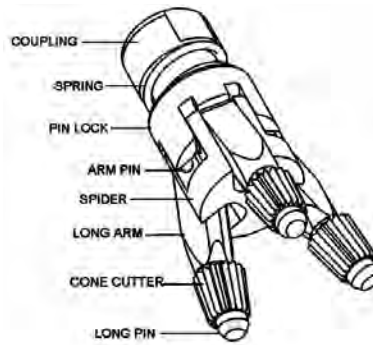
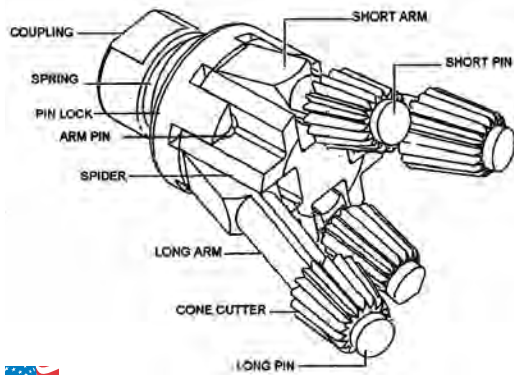

Head Number	Tube I.D.	Closed	Expands To	Spider	Fig.	Long Arm (qty.)	Short Arm (qty.)	Head Coupling	Coupling Tap	Long Cutter Pin (qty.)	Short Cutter Pin (qty.)	Arm Pin (qty.)	Pin Lock (qty.)	Cone Cutter (qty.)	Star Cutter (qty.)	Spring	Universal Joint	No. of Arms
SRA 1470 9/16 (4105691PT)	1-1/2"	1-3/8"	2-3/8"	1471 (1717450PT)	1	1472 (3) (1717451PT)	-	SRA 1473 9/16 (1717452PT)	9/16"	1474 (3) (1717453PT)	-	1475 (3) (1717454PT)	SRA 1476 (1717455PT)	2947 (3) (1066000)	-	SRA 1479 (1717449PT)	-	3
SRA 1870 5/8 (4105684PT)	2"	1-7/8"	2-7/8"	1871 (1050300PT)	1	4472 (3) (1082300)	-	SRA 1873 (1717447PT)	5/8"	4474 (3) (1082400)	-	4475 (3) (1082500)	SRA 1876 (1717448PT)	C 19 (3) (1214100)	-	SRA 1879 (1717448PT)	-	3
SRA 4470 3/4 (4105679)	2-5/16"	2"	3-1/2"	4471 (1082200)	1	4472 (3) (1082300)	-	SRA 4473 3/4 (1717435)	3/4"	4474 (3) (1082400)	-	4475 (3) (1082500)	SRA 4476 (1717434)	C 19 (3) (1214100)	-	SRA 4479 (1717436)	-	3
SRA 3370 7/8 (4105678)	2-3/4"	2-1/4"	3-7/8"	3371 (1075500)	1	3372 (3) (1075600)	-	SRA 3373 7/8 (1717432)	7/8"	3374 (3) (1075700)	-	3375 (3) (1075800)	SRA 3376 (1717431)	637 (3) (1028800)	-	SRA 3379 (171433)	-	3
SRA 3270 7/8 (4105681)	3"	2-1/2"	4"	3271 (1071700)	1	3472 (2) (1076100)	3272 (2) (1071800)	SRA 3373 7/8 (1717432)	7/8"	3474 (2) (1076200)	3274 (2) (1071900)	3275 (4) (1072000)	SRA 3276 (1717444)	1047 (2) (1041700)	2837 (2) (1064600)	SRA 3379 (171433)	-	4
SRA 3270 UJK (4105694PT)	3"	2-1/2"	4"	3271 (1071700)	2	3472 (2) (1076100)	3272 (2) (1071800)	SRA 3273U (1717456PT)	7/8"	3474 (2) (1076200)	3274 (2) (1071900)	3275 (4) (1072000)	SRA 3276 (1717444)	1047 (2) (1041700)	2837 (2) (1064600)	SRA 3379 (171433)	651 KNF (4094150PT)	4
SRA 970 7/8 (4105680)	3-1/4"	2-3/4"	4-1/4"	971 (1039000)	1	972 (2) (1039100)	972 A (2) (1039200)	SRA 973 7/8 (1717442)	7/8"	974 (2) (1039300)	974 A (2) (1039400)	975 (4) (1039500)	SRA 976 (1717441)	637 (4) (1028800)	-	SRA 3379 (1717433)	-	4
SRA 770 7/8 (4105677PT)	3-1/2"	3"	4-7/8"	771 (1033000)	1	772 (2) (1033200)	772 A (2) (1033300)	SRA 773 7/8 (1717429)	7/8"	774 (2) (1033500)	774 A (2) (1033600)	775 (4) (1033800)	SRA 776 (1717428)	747 (4) (1031700)	-	SRA 779 (1717430)	-	4
SRA 5770 7/8 (4105683PT)	4-3/4"	2-3/4"	5-1/2"	771 (1033000)	1	772 S (4) (1033400)	-	SRA 773 7/8 (1717429)	7/8"	774 S (4) (1033700)	-	775 (4) (1033800)	SRA 776 (1717428)	747 (4) (1031700)	-	SRA 779 (1717430)	-	4



# Type 4 - Forward Swing Arm Heads

## 1-3/4" - 4-3/4" I.D. for Straight Tubes, Bent Tubes and Drill Pipe

Forward swing arm heads, components and (ordering numbers)

Recommended spare parts: cone cutters and cutter pins, cutter arms and arm pins.

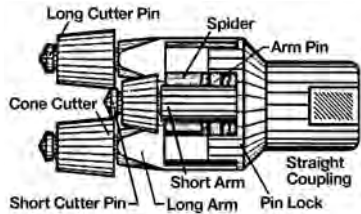

Figure 1 Shown with head coupling for straight tubes.

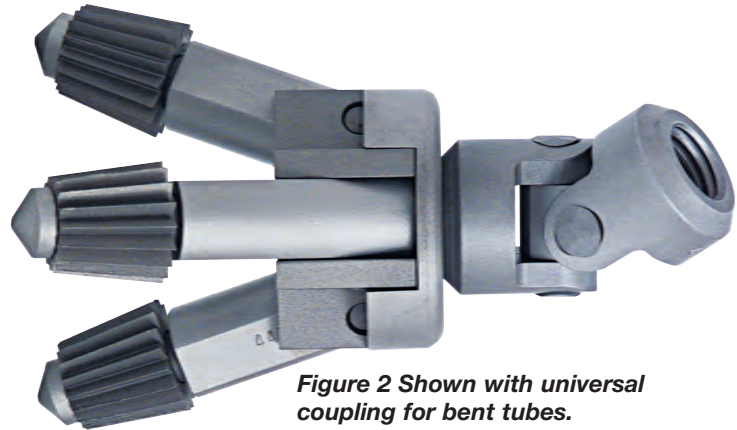

Figure 2 Shown with universal coupling for bent tubes.



Head Number	Tube I.D.	Closed	Expands To	Spider	Figure	Long Arm (qty.)	Short Arm (qty.)	Head Cpl.	Cpl. Tap	Long Cutter Pin (qty.)	Short Cutter Pin (qty.)	Arm Pin (qty.)	Pin Lock (qty.)	Cone Cutter (qty.)	Star Cutter (qty.)	No. of Arms
1840 (4050700)	1-3/4"	1-1/2"	2-1/8"	1841 (1049800)	1	1842 (1) (1049900)	1842 A (1) (1050000)	-	5/8" N.C.	1834 (1) (1049600)	1834 A (1) (1049700)	1845 (2) (1050100PT)	1846 (1050202)	337 (2) (1025700)	338 (3) (1025905)	2
1840 B (4050800)	2-1/4"	1-1/2"	2-1/8"	1841 (1049800)	2	1842 (1) (1049900)	1842 A (1) (1050000)	MM 66 (1279200)	5/8" N.C.	1834 (1) (1049600)	1834 A (1) (1049700)	1845 (2) (1050100PT)	1846 (1050202)	337 (2) (1025700)	338 (3) (1025905)	2
2340 (4051400)	2"	1-7/8"	3"	2341 (1054000)	1	1832 (1) (1049400PT)	1832 A (1) (1049500PT)	-	5/8" N.C.	1834 (1) (1049600)	1834 A (1) (1049700)	2345 (2) (1054300)	2346 (1054400)	337 (2) (1025700)	338 (3) (1025905)	2
4440 (4052000)	2"	1-7/8"	3"	2341 (1054000)	2	1832 (1) (1049400PT)	1832 A (1) (1049500PT)	MM 66 (1279200)	5/8" N.C.	1834 (1) (1049600)	1834 A (1) (1049700)	2345 (2) (1054300)	2346 (1054400)	337 (2) (1025700)	338 (3) (1025905)	2
4470 (4055400)	2-5/16"	2"	3-7/8"	4471 (1082200)	2	4472 (3) (1082300)	-	MM 66 (1279200)	5/8" N.C.	4474 (3) (1082400)	-	4475 (3) (1082500)	4476 (1082600)	C 19 (3) (1214100)	-	3
4470 A (4055500)	2-5/16"	2"	3-7/8"	4471 (1082200)	1	4472 (3) (1082300)	-	2383 B (1055600)	3/4" N.C.	4474 (3) (1082400)	-	4475 (3) (1082500)	4476 (1082600)	C 19 (3) (1214100)	-	3
3370 (4054400)	2-1/4"	2-1/4"	3-5/8"	3371 (1075500)	2	3372 (3) (1075600)	-	3551 (4095400)	3/4" N.C.	3374 (3) (1075700)	-	3375 (3) (1075800)	3376 (1075900)	637 (3) (1028800)	-	3
3370 A (4054500)	2-3/4"	2-1/4"	3-5/8"	3371 (1075500)	1	3372 (3) (1075600)	-	2043 7/8 (1052600)	7/8" N.C.	3374 (3) (1075700)	-	3375 (3) (1075800)	3376 (1075900)	637 (3) (1028800)	-	3
3270 (4054000)	3"	2-1/2"	4"	3271 (1071700)	2	3472 (2) (1076100)	3272 (2) (1071800)	3551 (4095400)	7/8" N.C.	3474 (2) (1076200)	3274 (2) (1071900)	3275 (2) (1072000)	3276 (1072200)	1047 (2) (1041700)	2837 (2) (1064600)	4
3270 A 7/8 (4054100)	3"	2-1/2"	4"	3271 (1071700)	1	3472 (2) (1076100)	3272 (2) (1071800)	2043 7/8 (1052600)	7/8" N.C.	3474 (2) (1076200)	3274 (2) (1071900)	3275 (2) (1072000)	3276 (1072200)	1047 (2) (1041700)	2837 (2) (1064600)	4
970 (4049900)	3-1/4"	2-3/4"	4-7/8"	971 (1039000)	1	972 (2) (1039100)	972 A (2) (1039200)	543 7/8 (1027300)	7/8" N.C.	974 (2) (1039300)	974 A (2) (1039400)	975 (4) (1039500)	976 (4) (1039600)	637 (4) (1028800)	-	4
970 B (4050000)	3-1/4"	2-3/4"	4-7/8"	971 (1039000)	2	972 (2) (1039100)	972 A (2) (1039200)	551 (4094000)	7/8" N.C.	974 (2) (1039300)	974 A (2) (1039400)	975 (4) (1039500)	976 (4) (1039600)	637 (4) (1028800)	-	4
770 (4048700)	3-1/2"	3"	4-3/4"	771 (1033000)	1	772 (2) (1033200)	772 A (2) (1033300)	873 A (1035400)	7/8" N.C.	774 (2) (1033500PT)	774 A (2) (1033600)	775 (4) (1033800)	776 (1033900)	747 (4) (1031700)	-	4
770 B (4048800)	3-1/2"	3"	4-3/4"	771 (1033000)	2	772 (2) (1033200)	772 A (2) (1033300)	1151 (4094400)	7/8" N.C.	774 (2) (1033500PT)	774 A (2) (1033600)	775 (4) (1033800)	776 (1033900)	747 (4) (1031700)	-	4
870 (4049300)	3-1/4 - 4"	3-3/8"	5-1/8"	871	1	772 (2) (1033200)	772 A (2) (1033300)	873 A (1035400)	7/8" N.C.	774 (2) (1033500PT)	774 A (2) (1033600)	875 (4)	876	747 (4) (1031700)	-	4
870 B (4049400)	3-1/4 - 4"	3-3/8"	5-1/8"	871	2	772 (2) (1033200)	772 A (2) (1033300)	1151 (4094400)	7/8" N.C.	774 (2) (1033500PT)	774 A (2) (1033600)	875 (4)	876	747 (4) (1031700)	-	4
770 SA (4049000)	4-3/4"	2-3/4"	5-1/2"	771 S (1033100)	1	772 S (4) (1033400)	-	543 7/8 (1027300)	7/8" N.C.	774 S (4) (1033700)	-	775 (4) (1033800)	776 S (4) (1034000)	747 (4) (1031700)	-	4
770 S	4-3/4"	2-1/4"	5-1/2"	771 S (1033100)	2	772 S (4) (1033400)	-	551 (4094000)	7/8" N.C.	774 S (4) (1033700)	-	775 (4) (1033800)	776 S (4) (1034000)	747 (4) (1031700)	-	4

# Type 5 - "Self Feed" Clip Type Wing Arm Heads



## 1-3/4" - 9" I.D. for Curved Tubes and Pipe

Wing arm heads, components and (ordering numbers)

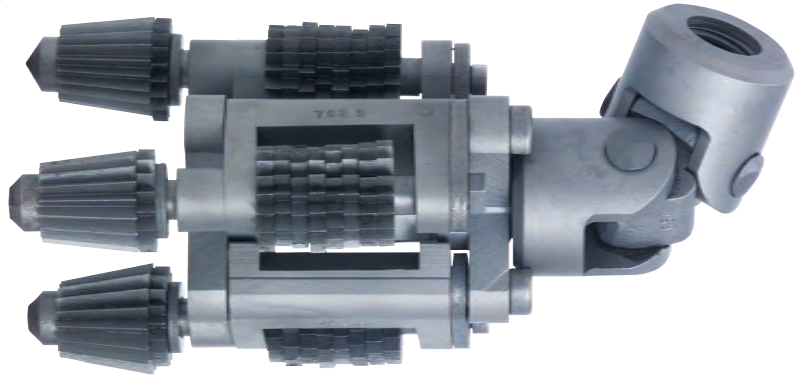
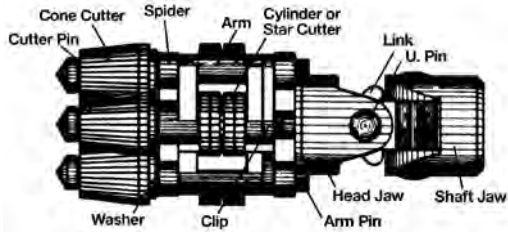

Head Number	Tube I.D.	Closed	Expand To	Spider	Arm (qty.)	Universal Coupling	Coupling Plate	Coupling Tap	Cutter Pin (qty.)	Arm Pin (qty.)	Clip (qty.)	Cone Cutter	Cylinder Cutter (qty.)	Washer (qty.)
11740 C (4058910)	2"	1-1/2"	2-1/8"	11741 (1113900)	11742 (2) (1114000)	4151 W (4095700)	-	5/8" N.C.	11744 (2) (1114700)	11745 (2) (1114800)	-	11747 (2) (1114900)	11748 (8) (1115000)	-
3060 C	2-1/4"	1-15/16"	2-5/8"	3061	3062 S (3)	4151 (4095600)	-	5/8" N.C.	3364 (3) (1075200)	3365 (3) (1075300)	3068 (3)	3047 (3)	3048 (3)	-
3360 (4054300)	2-5/8"	2-1/4"	3"	3361 (1074900)	3362 S (3) (1075100)	3333 (4095100PT)	-	3/4" N.C.	3364 (3) (1075200)	3365 (3) (1075300)	3368 (3) (1075400)	337 (3) (1025700)	338 (15) (1025905)	339 (3) (1026000)
3560 3/4 (4105128)	2-7/8"	2-5/8"	3-3/4"	1061 (1042000)	1062 S (3) (1042200)	3532 3/4 (4095300)	-	3/4" N.C.	1064 (3) (1042300)	1065 (3) (1042400)	1068 (3) (1042500)	1047 (3) (1041700)	1048 (15) (1041800)	-
3560 7/8 (4054700)	3-3/8"	2-5/8"	3-3/4"	1061 (1042000)	1062 S (3) (1042200)	3531 7/8 (4095200)	-	7/8" N.C.	1064 (3) (1042300)	1065 (3) (1042400)	1068 (3) (1042500)	1047 (3) (1041700)	1048 (15) (1041800)	-
960 C (4049800)	3-1/2"	3-1/8"	4-1/4"	961 (1038900)	762 S (3) (1032800PT)	551 (4094000)	-	7/8" N.C.	35264 (3) (1154900)	765 (3) (1032900)	35268 (3) (1155100)	947 (3) (1038700)	948 (27) (1038800)	749 (3) (1031900PT)
760 C (4048600)	3-3/4"	3-1/4"	4-1/2"	761 (1032600)	762 S (3) (1032800PT)	1151 (4094400)	-	7/8" N.C.	35264 (3) (1154900)	765 (3) (1032900)	35268 (3) (1155100)	747 (3) (1031700)	748 (24) (1031802)	749 (3) (1031900PT)
760 C 1-1/8 (4048620PT)	3-3/4"	3-1/4"	4-1/2"	761 (1032600)	762 S (3) (1032800PT)	5051 E (4104884)	-	1-1/8" N.F.	35264 (3) (1154900)	765 (3) (1032900)	35268 (3) (1155100)	747 (3) (1031700)	748 (24) (1031802)	749 (3) (1031900PT)
5060 A (4056300)	4-13/16"	3-7/8"	5-5/8"	5061 A (1086900)	562 S (3) (1027900)	5051 E (4104884)	5043 A (1085400)	1-1/8" N.F.	564 (3) (1028000)	565 (3) (1028100)	568 (3) (1028200)	747 (3) (1031700)	748 (24) (1031802)	749 (3) (1031900PT)
35260 C	5-1/4"	4-1/2"	6"	35261	35262 S (4) (1154800)	5051 H (4096000)	35243 A	1-1/8" N.F.	35264 (4) (1154900)	35265 (4) (1155000)	35268 (4) (1155100)	271 (4) (1025400)	C 79 (12) (1218700)	749 (4) (1031900PT)
36060 C (4061600)	6"	5-3/8"	7-1/8"	36041 (1156200)	36562 S (4) (1158200)	5051 H (4096000)	36043 A (1156400)	1-1/8" N.F.	36564 (4) (1158300)	36545 (4) (1157900)	36546 (4) (1158000)	37697 (4) (1160200)	37688 (12) (1160100)	36549 (4) (1158100)
36560 C (4061800)	6-1/2"	5-7/8"	7-5/8"	36541 C (1157200)	36562 S (4) (1158200)	5051 H (4096000)	36543 AC (1157500)	1-1/8" N.F.	36564 (4) (1158300)	36545 (4) (1157900)	36546 (4) (1158000)	37697 (4) (1160200)	37288 (12) (1160100)	36549 (4) (1158100)
37260 C	7-1/4"	6-1/4"	8"	37241	36562 S (4) (1158200)	21251 A (4097200)	37243 A	1-3/8" N.F.	36564 (4) (1158300)	36545 (4) (1157900)	36546 (4) (1158000)	37697 (4) (1160200)	37288 (12) (1160100)	36549 (4) (1158100)
37660 C	7-5/8"	6-1/2"	8-1/2"	37641	36562 S (5) (1158200)	21251 A (4097200)	37643 A	1-3/8" N.F.	36564 (5) (1158300)	36545 (5) (1157900)	36546 (5) (1158000)	37697 (5) (1160200)	37288 (15) (1160100)	36549 (5) (1158100)
38760 C	8-1/4"	7-1/2"	9-1/2"	38741	36562 S (5) (1158200)	21251 A (4097200)	38743 A	1-3/8" N.F.	36564 (5) (1158300)	36545 (5) (1157900)	36546 (5) (1158000)	37697 (5) (1160200)	37288 (15) (1160100)	36549 (5) (1158100)

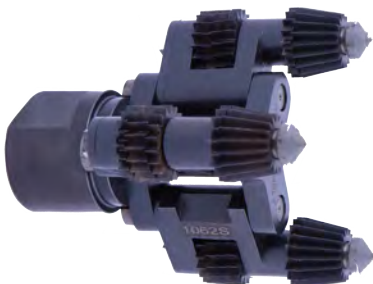

# Type 5 - "Self Feed" Clip Type Wing Arm Heads

1-3/4" - 8-3/4" I.D. for Straight Tubes and Pipe

Wing arm heads, components and (ordering numbers)

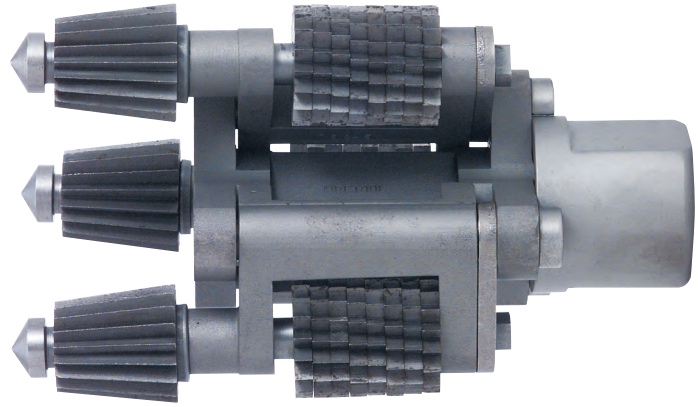
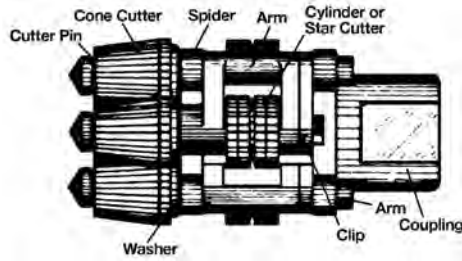

Head Number	Tube I.D.	Closed	Expands To	Spider	Arm (Qty.)	Coupling	Coupling Plate	Coupling Tap	Cutter Pin (qty.)	Arm Pin (qty.)	Clip (qty.)	Cone Cutter (qty.)	Cylinder Cutter (qty.)	Washer (qty.)
11740 (4058900)	1-3/4"	1-1/2"	2-1/8"	11741 (1113900)	11742 (2) (1114000)	11743 B (1114400)	-	5/8" N.C.	11744 (2) (1114700)	11745 (2) (1114800)	-	11747 (2) (1114900)	11748 (8) (1115000)	-
3060 5/8 (4053400)	2-3/8"	1-15/16"	2-5/8"	3061 (1069100)	3062 S (3) (1069300)	3043 (1068500)	-	5/8" N.C.	3364 (3) (1075200)	3365 (3) (1075300)	3068 (3) (1069400)	3047 (3) (1068900)	3048 (3) (1069000)	-
3060 3/4 (4053401)	2-3/8"	1-15/16"	2-5/8"	3061 (1069100)	3062 S (3) (1069300)	3043 3/4 (1068700)	-	3/4" N.C.	3364 (3) (1075200)	3365 (3) (1075300)	3068 (3) (1069400)	3047 (3) (1068900)	3048 (3) (1069000)	-
2060 3/4 (4051300)	2-1/2"	2-1/4"	3"	3361 (1074900)	3362 S (3) (1075100)	2043 3/4 (1052400)	-	3/4" N.C.	3364 (3) (1075200)	3365 (3) (1075300)	3368 (3) (1075400)	337 (3) (1025700)	338 (15) (1025905)	339 (3) (1026000)
2060 7/8 (4051301)	2-1/2"	2-1/4"	3"	3361 (1074900)	3362 S (3) (1075100)	2043 7/8 (1052600)	-	7/8" N.C.	3364 (3) (1075200)	3365 (3) (1075300)	3368 (3) (1075400)	337 (3) (1025700)	338 (15) (1025905)	339 (3) (1026000)
1060 3/4NC (4010201)	3"	2-5/8"	3-3/4"	1061 (1042000)	1062 S (3) (1042200)	1033 3/4 (1041000)	-	3/4" N.C.	1064 (3) (1042300)	1065 (3) (1042400)	1068 (3) (1042500)	1047 (3) (1041700)	1048 (15) (1041800)	-
1060 7/8THD (4105640)	3"	2-5/8"	3-3/4"	1061 (1042000)	1062 S (3) (1042200)	1033 7/8 (1041100)	-	7/8" N.C.	1064 (3) (1042300)	1065 (3) (1042400)	1068 (3) (1042500)	1047 (3) (1041700)	1048 (15) (1041800)	-
1060 1NF (4050202)	3"	2-5/8"	3-3/4"	1061 (1042000)	1062 S (3) (1042200)	1033 1 (1040900PT)	-	1" N.C.	1064 (3) (1042300)	1065 (3) (1042400)	1068 (3) (1042500)	1047 (3) (1041700)	1048 (15) (1041800)	-
960 (4049700)	3-1/4"	3-1/8"	4-1/8"	961 (1038900)	762 S (3) (1032800)	543 7/8 (1027300)	-	7/8" N.C.	35264 (3) (1154900)	765 (3) (1032900)	35268 (3) (1155100)	947 (3) (1038700)	948 (27) (1038800)	749 (3) (1031900PT)
760 1 (4048500)	3-1/2"	3-1/4"	4-1/2"	761 (1032600)	762 S (3) (1032800)	743 1 (1031200)	-	1" N.F.	35264 (3) (1154900)	765 (3) (1032900)	35268 (3) (1155100)	747 (3) (1031700)	748 (24) (1031802)	749 (3) (1031900PT)
760 1 1/8 (4048501)	3-1/2"	3-1/4"	4-1/2"	761 (1032600)	762 S (3) (1032800)	743 1 1/8 (1716210)	-	1-1/8" N.F.	35264 (3) (1154900)	765 (3) (1032900)	35268 (3) (1155100)	747 (3) (1031700)	748 (24) (1031802)	749 (3) (1031900PT)
5060 AS (4056400)	4-1/2"	3-7/8"	5-5/8"	5061 A (1086900)	562 S (3) (1027900)	843 (1034900)	5043 A	1-1/8" N.F.	564 (3) (1028000)	565 (3) (1028100)	568 (3) (1028200)	747 (3) (1031700)	748 (24) (1031802)	749 (3) (1031900PT)
35260	5-1/4"	4-1/2"	6"	35261	35262 S (4) (1158200)	35243	35243 A	1-3/8" N.F.	35264 (4) (1154900)	35265 (4) (1155000)	35268 (4) (1155100)	271 (4) (1025400)	C 79 (12) (1218700)	749 (4) (1031900PT)
36060 1-1/8	6"	5-3/8"	7-1/8"	36041 (1156200)	36562 S (4) (1158200)	36043	-	1-1/8" N.F.	36564 (4) (1158300)	36545 (4) (1157900)	36546 (4) (1158000)	37297 (4) (1159200)	37688 (12) (1160100)	36549 (4) (1158100)
36060 1-3/8	6"	5-3/8"	7-1/8"	36041 (1156200)	36562 S (4) (1158200)	36043	-	1-3/8" N.F.	36564 (4) (1158300)	36545 (4) (1157900)	36546 (4) (1158000)	37297 (4) (1159200)	37688 (12) (1160100)	36549 (4) (1158100)
36560 1 1/8 (4061701)	6-1/2"	5-7/8"	7-5/8"	36541 C (1157200)	36562 S (4) (1158200)	35243 B (1154200)	36543 AC (1157500)	1-1/8" N.F.	36564 (4) (1158300)	36545 (4) (1157900)	36546 (4) (1158000)	37297 (4) (1159200)	37288 (12) (1159100)	36549 (4) (1158100)
37260	7-1/4"	6-1/4"	8"	37241	36562 S (4) (1158200)	8293 (1111010)	37243 A	1-3/8" N.F.	36564 (4) (1158300)	36545 (4) (1157900)	36546 (4) (1158000)	37297 (4) (1159200)	37288 (12) (1159100)	36549 (4) (1158100)
37660	7-5/8"	6-1/2"	8-1/2"	37641	36562 S (4) (1158200)	8293 (1111010)	37643 A	1-3/8" N.F.	36564 (5) (1158300)	36545 (5) (1157900)	36546 (5) (1158000)	37697 (5) (1160200)	37288 (15) (1159100)	36549 (5) (1158100)
38760 (4062500)	8-3/4"	7-1/2"	9-1/2"	38741 (1160500)	36562 S (4) (1158200)	8293 (1111010)	38743 A (1160600)	1-3/8" N.F.	36564 (5) (1158300)	36545 (5) (1157900)	36546 (5) (1158000)	37697 (5) (1160200)	37688 (15) (1160100)	36549 (5) (1158100)

## Expanding Blade Type Head

Tube I.D. range 1/2" thru 4-1/2"

When ordering specify the motor number and the motors shaft thread size.

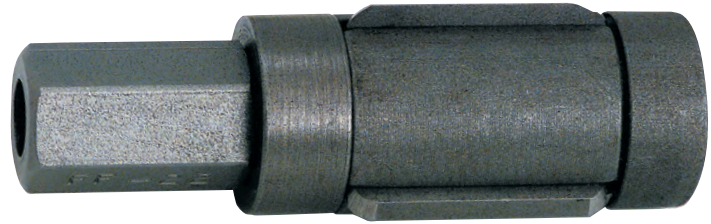

Head Number	Tube I.D.	Minimum Diameter	Maximum Diameter	Stud Size	Blade Body	Rear Retainer	Blade Set	Blade (qty.)	Coupling	Coupling Tap
2840	1/2"	29/64"	37/64"	10-32	2481 (1057700)	2483 (1057800)	2487 (4000250)	2487 (4) (1058300)	FF 1010 (1249800)	10-32
3080 (4053600)	5/8"	9/16"	11/16"	1/4" N.F.	3081 (1069500)	3083 (1069600)	3087 (4000290PT)	3087 (3) (1069700)	FF 22 (1245700)	1/4" N.F.
2780 (4052500)	3/4"	11/16"	13/16"	1/4" N.F.	2781 (1063800)	2783 (1063900)	2787 (4000270)	27878 (3) (1064000)	FF 22 (1245700)	1/4" N.F.
6480 (4057200)	13/16"	3/4"	7/8"	5/16" N.C.	2981 (1066400)	2983 (1066500)	6487 (4000330)	6487 (3) (1095800)	FF 312 (1248600)	1/4" N.F.
2980 (4052900)	7/8"	25/32"	29/32"	5/16" N.C.	2981 (1066400)	2983 (1066500)	2987 (4000280)	2987 (3) (1066600)	FF 3137 (1250500)	3/8" N.F.
6180 (4056700)	1"	7/8"	1-3/32"	5/16" N.C.	6181 (1089900)	6183 (1090000)	6187 (4000310PT)	6187 (4) (1090100)	FF3137 (1250500)	3/8" N.F.
2680 (4052200)	1"	15/16"	1-5/32"	5/16" N.C.	6181 (1089900)	6183 (1090000)	2687 (4000260PT)	2687 (4) (1062500)	FF3137 (1250500)	3/8" N.F.
3180 7/16 NF (4053900PT)	1-1/8"	1-1/32"	1-1/4"	5/16" N.C.	3181 (1070700)	3183 (1070800)	3187 (4000300)	3187 (4) (1070900)	FF 314 (1248700PT)	7/16" N.F.
6380 3/8 (4057000)	1-1/4"	1-5/32"	1-3/8"	5/16" N.C.	3181 (1070700)	3183 (1070800)	6387 (4000320PT)	6387 (4) (1092400)	FF3137 (1250500)	3/8" N.F.
6580 3/8 NF (4057400PT)	1-3/8"	1-9/32"	1-1/2"	5/16" N.C.	3181 (1070700)	3183 (1070800)	6587 (4000340)	6587 (4) (1098100PT)	FF3137 (1250500)	3/8" N.F.
6580 7/16 NF (4057401PT)	1-3/8"	1-9/32"	1-1/2"	5/16" N.C.	3181 (1070700)	3183 (1070800)	6587 (4000340)	6587 (4) (1098100PT)	FF314 (1250500)	7/16" N.F.
1780 (4050600PT)	1-1/2"	1-3/8"	1-11/16"	9/16" N.C.	1781 (1048200PT)	1783 (1048400PT)	1787 (4000200)	1787 (4) (1048700)	FF 5656 (1250900PT)	9/16" N.C.
1880 (4050900PT)	1-5/8"	1-1/2"	1-13/16"	5/8" N.C.	1881 (1050600PT)	1883 (1050900PT)	1887 (4000210PT)	1887 (4) (1051200PT)	FF 66 (1247000)	5/8" N.C.
1980 (4051100PT)	1-3/4"	1-5/8"	1-15/16"	5/8" N.C.	1881 (1050600PT)	1883 (1050900PT)	1987 (4000250PT)	1987 (4) (1051700PT)	FF 66 (1247000)	5/8" N.C.
2380 C (4051600PT)	1-7/8"	1-3/4"	2-1/16"	5/8" N.C.	1881 (1050600PT)	1883 (1050900PT)	2387 C (4000240PT)	2387 C (4) (1055900PT)	FF 66 (1247000)	5/8" N.C.
2380 (4051500PT)	2"	1-7/8"	2-3/16"	5/8" N.C.	2381 (1054700PT)	2383 (1055750PT)	2387 (4000230)	2387 (4) (1055800PT)	FF 66 (1247000)	5/8" N.C.
21680 S (4061000PT)	2-1/8"	1-3/4"	2-1/4"	5/8" N.C.	21681 S (1136100PT)	21683 S (1136200PT)	21587 (4000400)	21587 (4) (1135100PT)	FF 66 (1247000)	5/8" N.C.
21580	2-1/4"	1-7/8"	2-3/8"	3/4" N.C.	21581	21583	21587 (4000400)	21587 (4) (1135100PT)	FF 77 (1247500)	3/4" N.C.
21480 (4060800)	2-1/2"	2-1/8"	2-5/8"	3/4" N.C.	21481 (1133500)	21483 (1133600)	21587 (4000400)	21587 (4) (1135100PT)	FF 78 (1247700)	7/8" N.C.
21380	2-3/4"	2-3/8"	2-15/16"	7/8" N.C.	21381	21383	21087 (4000390)	21087 (6) (1123300PT)	FF 88	7/8" N.C.
21080 (4059700PT)	3"	2-5/8"	3-5/16"	1" N.F.	21081 (1122000PT)	21083 (1122900PT)	21087 (4000390)	21087 (6) (1123300PT)	FF 11 (1245300PT)	1" N.F.
20980	3-1/4"	2-7/8"	3-3/8"	1" N.F.	20781 (1116600)	20783 (1116700)	20987	20987 (6)	FF 11 (1245300PT)	1" N.F.
20780	3-1/2"	3-1/8"	3-5/8"	1" N.F.	20781 (1116600)	20783 (1116700)	20787 (4000350)	20787 (6) (1116800)	FF 111 (1248200)	1-1/8" N.F.
20880	4"	3-5/8"	4-1/8"	1" N.F.	20781 (1116600)	20783 (1116700)	20887 (4000360)	20887 (6) (1118100)	FF 111 (1248200)	1-1/8" N.F.
20880 H	4-1/2"	4-1/8"	4-5/8"	1" N.F.	20781 (1116600)	20783 (1116700)	20887 H	20887 H (6)	FF 111 (1248200)	1-1/8" N.F.



# Drill Heads

## Drill Heads

Tube I.D. range 1/2" thru 3-1/4"

- Airetool drill heads are made from alloy steel For strength and durability
- Drills can be used with extensions (below) for larger tube I.D.'s as required

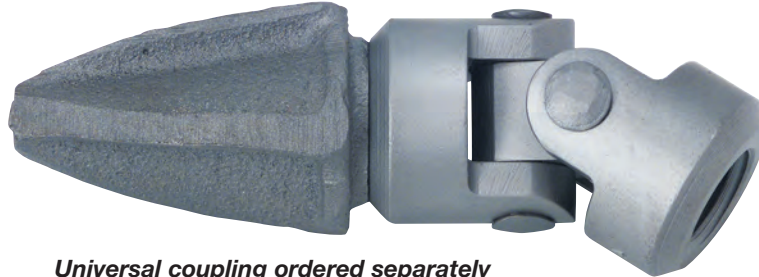

Universal coupling ordered separately

Tube I.D.	Drill Number	Order Number	Hard Surfaced	Hard Surfaced Order Number	Drill O.D.	Stud Thread Size	Number of Flutes	Weight (Lbs.)
1/2"	MD-1	1267500	-NA	-	7/16"	10-32	3	0.01
5/8"	MD-2	1267600	-NA	-	1/2"	1/4" N.F.	3	0.02
11/16" - 13/16"	MD-3	1267700	-NA	-	5/8"	1/4" N.F.	3	0.03
7/8" - 1 1/8"	MD-4	1267800	-NA	-	5/8"	5/16" N.F.	3	0.05
1 1/8" - 1 1/4"	MD-5	1267900	-NA	-	13/16"	7/16" N.F.	3	0.06
1 3/8" - 1 3/4"	00	1000500	00-S		1 1/16"	7/16" N.F.	4	0.20
1 1/2"	0	1000300	0-S		1 5/16"	1/2" N.C.	4	0.25
1 5/8" - 2 1/4"	1	1003100	1-S	1004800	1 3/8"	5/8" N.C.	4	0.30
2 1/4" - 2 3/4"	4	1007400	4-S	1007900	1 3/4"	5/8" N.C.	4	0.50
2 1/4" - 2 3/4"	16		16-S	1011702	1 11/16"	5/8" N.C.	5	0.60
2 1/4" - 3 1/4"	5	1008000	5-S	1008500	2 3/8"	3/4" N.C.	5	1.06
3 1/4" - 4"	6-3/4	1716299	6-3/4-S		2 5/8"	3/4" N.C.	5	1.60
3 1/4" - 4"	6	1008700	6-S	1009100	2 5/8"	7/8" N.C.	5	1.60
4" - 4 1/2"	7	1009500	7-S	1009500	2 3/4"	7/8" N.C.	5	2.00
4 1/2" - 9"	8	1009600	8-S	1009901	3 5/16"	1" N.F.	6	2.60
*9" - 11"	21	1012900	21-S	1013100	4 5/8"	1 1/8" N.F.	6	5.50
11" - 12"	13	1010902	13-S	1011013	5 3/4"	1 1/8" N.F.	6	7.00

## Drill Extensions - Male to Female

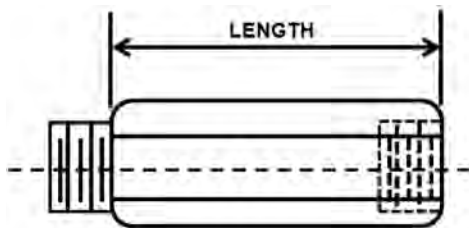

Thread Description	7/8" N.C. Male x 7/8" N.C. Female		1" N.C. Male x 1" N.C. Female		1-1/8" N.C. Male x 1-1/8" N.C. Female	
	Model No.	Order No.	Model No.	Order No.	Model No.	Order No.
Length (in.)						
1.50	756					
2.00	756 A	1032100PT	5056	1086100	21256	1129300
2.50	756 B	1032201PT				
3.00	756 C	1032300PT	5056 A	1086200	21256 A	1129400
4.00	756 D	1032400PT	5056 B	1086300	21256 B	1129500
5.00			5056 C	1086400	21256 C	1129600
6.00			5056 D	1086500	21256 D	1129700
7.00			5056 E	1086600	21256 E	1129800
8.00	756 H	1032500PT	5056 F	1086700	21256 F	1129900



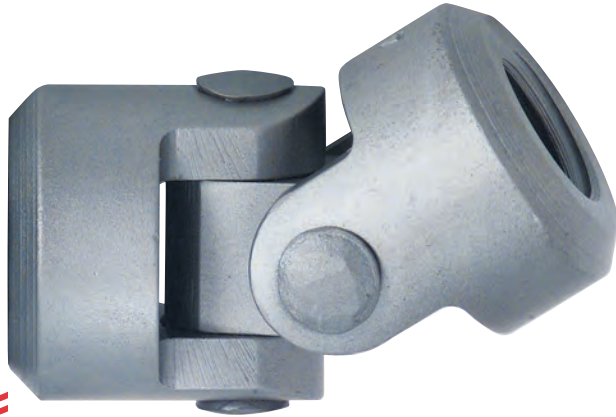

## 10-32 thru 7/8" N.C. thread combinations

■ For adapting cleaning heads to cleaning motors  
U-joints, components and ordering numbers



Universal Jont No.	Shaft Jaw	Head Jaw	Link	Pin (2 req.)	U-Joint O.D. (in.)	Overall Length (in.)	Thread Size	Cleaner Kits Used On
2451 (4094800)	2452 (1057100)	2452 (1057100)	2454 (1057200)	2455 (1057300)	0.312	1.25	10-32 x 10-32	24
PA 3051 (4098200)	PA 3052 (1294500)	PA 3052 (1294500)	PA 3054 (1294600)	PA 3055 (1294700)	.437 (.375 Hex)	1.375	1/4" x 1/4" N.F. N.F.	27, 27 A, 30, 30 A
6451 (4096500)	6453 V (1094800)	6453 V (1094800)	6454 V (1095100)	6455 V (1095200)	0.500	1.687	1/4" x 1/4" N.F. N.F.	X 64
6451 B	6453 V (1094800)	6457 V (1095300)	6454 V (1095100)	6455 V (1095200)			1/4" x 5/16" N.F. N.C.	X 64
6151 C (4096300)	6452 V (1094600)	6453 V (1094800)	6454 V (1095100)	6455 V (1095200)			5/16" x 1/4" N.F. N.F.	X 60, X 61
6151 (4096100PT)	6452 V (1094600)	6452 V (1094600)	6454 V (1095100)	6455 V (1095200)			5/16" x 5/16" N.F. N.F.	X 61
6151 B (4096200)	6452 V (1094600)	6457 V (1095300)	6454 V (1095100)	6455 V (1095200)			5/16" x 5/16" N.F. N.C.	X 61
2651 (4094900)	2652 (1061700PT)	2652 (1061700PT)	2654 (1061900)	2655 (1062000)			0.625	1.593
6351 B (4096400)	6652 (1100100)	6657	6654 (1100300)	6655 (1100400)	0.750	2.125	3/8" x 5/16" N.F. N.C.	X 63
6651 B (4096800)	6652 (1100100)	6658 (1100700)	6654 (1100300)	6655 (1100400)			3/8" x 7/16" N.F. N.C.	X 65, X 66
6651 (4096700)	6652 (1100100)	6653 (1100200)	6654 (1100300)	6655 (1100400)			3/8" x 7/16" N.F. N.F.	31, X 63, X 65, X 66
3151 (4095000)	6653 (1100200)	6653 (1100200)	6654 (1100300)	6655 (1100400)			7/16" x 7/16" N.F. N.F.	31
31551 (4097500)	4153 (1079700)	4157 (1080200)	4154 (1079900)	4155 (1080100)	1.125	2.062	9/16" x 1/2" N.C. N.C.	3150
4151 W (4095700)	4152 (1079600)	4153 (1079700)	4154 (1079900)	4155 (1080100)			5/8" x 1/2" N.C. N.C.	11740 C
4151 (4095600)	4152 (1079600)	4152 (1079600)	4154 (1079900)	4155 (1080100)			5/8" x 5/8" N.C. N.C.	3162, 3175, 3187, 3200, 3212 4200, 4225, 4237, 4250, 4275
3333 (4095100PT)	3552 (1076800)	3332 (1074000)	3554 (1077500)	3555 (1077700)	1.500	2.75	3/4" x 3/4" N.C. N.C.	3360 Head
3532 (4095300)	3552 (1076800)	3533 (1076500)	3554 (1077500)	3555 (1077700)	1.593		3/4" x 3/4" N.C. N.C.	3540, 3560 Head 3/4 N.C. Rotor Thread
3531 (4095200)	3557 (1077800)	3533 (1076500)	3554 (1077500)	3555 (1077700)			7/8" x 3/4" N.C. N.C.	3540, 3560 Head 7/8 N.C. Rotor Thread

# U-Joints

## 5/8" N.C. thru 1-38" N.F. thread combinations

■ For adapting cleaning heads to cleaning motors

U-joints, components and ordering numbers

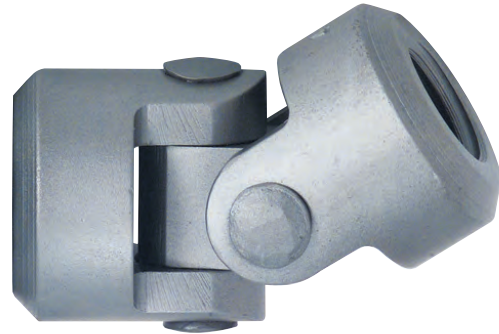

Universal Jont No.	Shaft Jaw	Head Jaw	Link	Pin (2 req.)	U-Joint O.D. (in.)	Overall Length (in.)	Thread Size	Cleaner Kits Used On
2251 (4094700)	3553 (1077400)	3553 (1077400)	3554 (1077500)	3555 (1077700)	1.500	2.750	5/8" x 5/8" N.C. N.C.	
2151 (4094600)	3552 (1076800)	3553 (1077400)	3554 (1077500)	3555 (1077700)			3/4" x 5/8" N.C. N.C.	3225, 3237
3551 (4095400)	3552 (1076800)	3552 (1076800)	3554 (1077500)	3555 (1077700)			3/4" x 3/4" N.C. N.C.	4300, 4300 A, 4325
3551 A (1076800)	3552 (1076800)	3552 (1076800)	3554 A (1077500)	3555 (1077700)		3/4" x 3/4" N.C. N.C.	15 Deg. Restricterd	
1551 (1029900)	253 (1029900)	1553 (1046500)	654 (1029900)	255 (1025310PT)	1.625	3.437	3/4" x 5/8" N.C. N.C.	
251 (1029900)	253 (1029900)	253 (1029900)	654 (1029900)	255 (1025310PT)			3/4" x 3/4" N.C. N.C.	
21451 (4097400)	21452 (1133400)	1553 (1046500)	654 (1029900)	255 (1025310PT)			7/8" x 5/8" N.C. N.C.	3250, 3262
651 H (4094300)	653 (1029600PT)	653 (1029600PT)	654 (1029900)	655 (1030200)	1.750	3.218	3/4" x 3/4" N.C. N.C.	
651 (4094100)	652 (1029400)	653 (1029600PT)	654 (1029900)	655 (1030200)			7/8" x 3/4" N.C. N.C.	3275, 3287, 4350
651 A (1029400)	652 (1029400)	653 (1029600PT)	654 A (1029900)	655 (1030200)			7/8" x 3/4" N.C. N.C.	15 Deg. Restricterd
551 (4094000)	652 (1029400)	652 (1029400)	654 (1029900)	655 (1030200)			7/8" x 7/8" N.C. N.C.	4400, 4425, 4450, 4450 A
21051 (4097000)	1152 (1043600)	21053 (1121900)	1154 (1044100)	1155 (1044200)	1.937	3.687	1" x 3/4" N.F. N.C.	3300, 3306
1151 (4094400)	1152 (1043600)	1153 (1044000)	1154 (1044100)	1155 (1044200)			1" x 7/8" N.F. N.C.	3312, 3318, 3325, 3337
20751 (4096900)	5052 (1085600PT)	1153 (1044000)	1154 (1044100)	5055 (1086000) 1155 (1044200)	2.250	4.062	1-1/8" x 7/8" N.F. N.C.	3350 through 3475
5051 (4095800)	5052 (1085600PT)	5057 (1086800)	1154 (1044100)	5055 (1086000)			1-1/8" x 7/8" N.F. N.C.	4481, 4500, 4537
5051 E (1085600PT)	5052 (1085600PT)	5053 (1086800)	1154 (1044100)	5055 (1086000)			1-1/8" x 1" N.F. N.F.	4575, 4600, 4650, 4712, 4762
5051 H (4096000)	5052 (1085600PT)	5052 (1085600PT)	1154 (1044100)	5055 (1086000)			1-1/8" x 1-1/8" N.F. N.F.	
21251 H (4097300)	21252 (1128500)	21257 (1130100)	21254 (1128800)	21255 (1129000)	2.437	5.312	1-3/8" x 1" N.F. N.F.	3500 through 3900
21251 (4097100)	21252 (1128500)	21253 (1128700)	21254 (1128800)	21255 (1129000)			1-3/8" x 1-1/8" N.F. N.F.	3975 through 31325
21251 A (4097200)	21252 (1128500)	21252 (1128500)	21254 (1128800)	21255 (1129000)			1-3/8" x 1-3/8" N.F. N.F.	

## Flexible Connections

Use for connecting cleaning head to motor when cleaning tubes with short radius bends. Flexible connectors come complete with female/Female couplings in lengths from 4 - 14 inches (102 - 356mm)

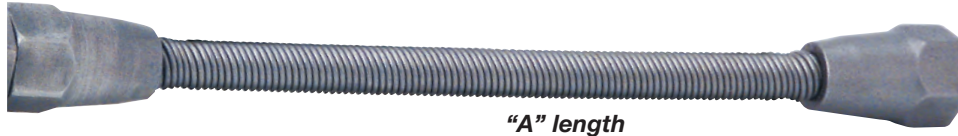

Part Number	Order Number	Thread Size	Core Diameter	Cleaner Motor Options	Type "A"		Type "C"	
					Approx. Length (in.)	Wt.	Approx. Length (in.)	Wt.
2461 A	4035500	10-32 X 10-32	3/16"	24	4.00	.06#	13.00	.20#
2461 C	4035700	10-32 X 10-32		24				
X 6461 C	4046400	1/4 N.F. X 1/4 N.F.		30,27, X64				
X 6462		1/4 N.F. X 5/16 N.C.		27, X64				
X 6161 A	4045000	5/16 N.F. X 5/16 N.F.		X61				
X 6161 C	4045200	5/16 N.F. X 5/16 N.F.		X61				
2661 A	4036200	3/8 N.F. X 5/16 N.F.	1/4"	26	4.50	.18#	.40#	
2961 A	4036500	3/8 N.F. X 3/8 N.F.		29				
X 6361 A	4045600	3/8 N.F. X 7/16 N.F.		X63,31				
3161 C	4037000	7/16 N.F. X 5/16 N.C.		31				
X 6661 A	4046800	3/8 N.F. X 7/16 N.F.	3/8"	X65, X66	6.50	.25#	.45#	
X 6662 A	4047200	3/8 N.F. X 7/16 N.C.		X65, X66				
2561 A	4035800	7/16 N.F. X 7/16 N.F.	1/2"		6.50	.5#	1.0#	
4161 A	4037100	5/8 N.C. X 5/8 N.C.		3175, 4225				
4162 A	4037500	5/8 N.C. X 9/16 N.C. Male		4200, 4225, 4250				
4163 C	4038200	5/8 N.C. X 7/16 N.C.		4200				
31561		9/16 N.C. X 1/2 N.C.		3150				
43061 C	4042800	3/4 N.C. X 3/4 N.C.	5/8"	4300, 4325	14.00	1.5#		
43062 C	4043100	3/4 N.C. X 9/16 N.C. Male		3225, 4300, 4325				
32261 C	4039500	3/4 N.C. X 5/8 N.C.		3225				
42562		5/8 N.C. X 9/16 N.C. Male	3/4"	3200, 4250	Not Available	2.6#		
43561 C	4043400	7/8 N.C. X 3/4 N.C.		4350, 3250				
44061		7/8 N.C. X 7/8 N.C.		4350, 4450				
44062 C	4044300	7/8 N.C. X 7/8 N.C. Male		4450				
43562		7/8 N.C. X 9/16 N.C. Male	1"	3250, 4350	3.1#			
33063 C	4040400	1 N.F. X 7/8 N.C.		3300				
33561 C	4040700	1-1/8 N.F. X 1-1/8 N.F.		3350, 3400, 4600				
33562		1-1/8 N.F. X 1 N.F.		3350, 3400, 4600				
44861 C	4044600	1-1/8 N.F. X 7/8 N.C.		3350, 3400, 4600				
44862		1-1/8 N.F. X 7/8 N.C. Male		3350, 3400, 4600				
35061		1-3/8 N.F. X 1 N.F.		3500 and up				
35062	4041400	1-3/8 N.F. X 1- 1/8 N.F.		3500 and up				
35063		1-3/8 N.F. X 1-3/8 N.F. Male		3500 and up				

# Adapters

These adapters are used to configure motors and heads in special applications where the standard Airetool offering does not match up on thread sizes.

Female X Female



Part Number	Female X Female
FF 1 0	10-32 X 10-32
FF 1031	10-32 X 5/16 N.C.
FF 22	1/4 N.F. X 1/4 N.F.
FF 231	1/4 N.F. X 5/16 N.F.
FF 237	1/4 N.F. X 3/8 N.F.
FF 312	5/16 N.C. X 1/4 N.F.
FF 3131	5/16 N.C. X 5/16 N.F.
FF3137	5/16 N.C. X 3/8 N.F.
FF314	5/16 N.C. X 7/16 N.F.
FF 374	3/8 N.F. X 7/16 N.C.
FF 374 F	3/8 N.F. X 7/16 N.F.
FF 376	3/8 N.C. X 5/8 N.C.
FF 437	7/16 N.C. X 3/8 N.C.
FF 45	7/16 N.F. X 1/2 N.C.
FF 456	7/16 N.F. X 9/16 N.C.
FF 46	7/16 N.F. X 5/8 N.C.
FF 47	7/16 N.C. X 3/4 N.C.
FF 54	1/2 N.F. X 7/16 N.C.
FF 56	1/2 N.F. X 5/8 N.C.
FF 56 F	1/2 N.F. X 5/8 N.F.
FF 564	9/16 N.C. X 7/16 N.C.
FF 5656	9/16 N.C. X 9/16 N.C.
FF 566	9/16 N.C. X 5/8 N.C.
FF 567	9/16 N.C. X 3/4 N.C.
FF 637	5/8 N.C. X 3/8 N.F.
FF 64	5/8 N.C. X 7/16 N.C.
FF 65	5/8 N.C. X 1/2 N.C.
FF 66	5/8 N.C. X 5/8 N.C.
FF 66 F	5/8 N.C. X 5/8 N.F.
FF 67	5/8 N.C. X 3/4 N.C.
FF 68	5/8 N.C. X 7/8 N.C.
FF 77	3/4 N.C. X 3/4 N.C.
FF 78	3/4 N.C. X 7/8 N.C.
FF 856	7/8 N.C. X 9/16 N.C.
FF 86	7/8 N.C. X 5/8 N.F.
FF 88	7/8 N.C. X 7/8 N.C.
FF 81	7/8 N.C. X 1 N.F.
FF 16	1 N.F. X 5/8 N.C.
FF 17	1 N.F. X 3/4 N.C.
FF 11	1 N.F. X 1 N.F.
FF 111	1 N.F. X 1-1/8 N.F.
FF 118	1-1/8 N.F. X 7/8 N.C.
FF 1111	1-1/8 N.F. X 1-1/8 N.F.

Male X Male

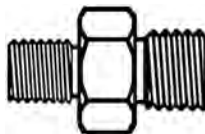

Part Number	Male X Male
2443	10-32 X 10-32
MM 1031	10-32 X 5/16 N.F.
MM 250	1/4 N.F. X 1/4 N.F.
2734	1/4 N.F. X 5/16 N.C.
MM 24	1/4 N.F. X 7/16 N.F.
MM 3034	5/16 N.F. X 1/4 N.F.
MM 3131	5/16 N.C. X 5/16 N.C.
MM 3131 F	5/16 N.C. X 5/16 N.F.
MM 3137	5/16 N.F. X 3/8 N.F.
MM 3737	3/8 N.C. X 3/8 N.C.
MM 3737 F	3/8 N.F. X 3/8 N.F.
MM 374	3/8 N.C. X 7/16 N.C.
MM 374 F	3/8 N.F. X 7/16 N.F.
MM 437	7/16 N.C. X 3/8 N.F.
MM 44	7/16 N.F. X 7/16 N.F.
MM 456	7/16 N.F. X 9/16 N.C.
MM 46	7/16 N.F. X 5/8 N.C.
MM 5056	1/2 N.C. X 9/16 N.C.
MM 56	1/2 N.C. X 5/8 N.C.
MM 564	9/16 N.C. X 7/16 N.C.
MM 5650	9/16 N.C. X 1/2 N.F.
MM 5656	9/16 N.C. X 9/16 N.C.
MM 566	9/16 N.C. X 5/8 N.C.
MM 567	9/16 N.C. X 3/4 N.C.
MM 568	9/16 N.C. X 7/8 N.C.
MM 561	9/16 N.C. X 1 N.F.
MM 66	5/8 N.C. X 5/8 N.C.
MM 67	5/8 N.C. X 3/4 N.C.
MM 68	5/8 N.C. X 7/8 N.C.
MM 77	3/4 N.C. X 3/4 N.C.
MM 78	3/4 N.C. X 7/8 N.C.
MM 88	7/8 N.C. X 7/8 N.C.
MM 81	7/8 N.C. X 1 N.C.
MM 11	1 N.F. X 1 N.F.
MM 112	1 N.F. X 1-1/8 N.F.
MM 1111	1-1/8 N.F. X 1-1/8 N.F.
MM 1313	1-3/8 N.F. X 1-3/8 N.F.

Male X Female

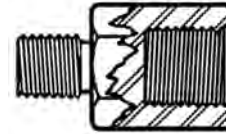

Part Number	Male X Female
MF 22	1/4 N.C. X 1/4 N.F.
MF 231	1/4 N.F. X 5/16 N.C.
MF 231	F 1/4 N.F. X 5/16 N.F.
MF 312	5/16 N.C. X 1/4 N.F.
MF 312 F	5/16 N.F. X 1/4 N.F.
MF 3131	5/16 N.C. X 5/16 N.F.
MF 3131 F	5/16 N.F. X 5/16 N.C.
MF 314	5/16 N.C. X 7/16 N.F.
MF 314 F	5/16 N.F. X 7/16 N.F.
2943	3/8 N.F. X 1/4 N.F.
MF 3731	3/8 N.F. X 5/16 N.C.
MF 3731 F	3/8 N.F. X 5/16 N.F.
2643	3/8 N.F. X 5/16 N.F.
MF 3737	3/8 N.C. X 3/8 N.F.
MF 374	3/8 N.C. X 7/16 N.C.
MF 374 F	3/8 N.F. X 7/16 N.F.
MF 431	7/16 N.C. X 5/16 N.C.
MF 431 F	7/16 N.F. X 5/16 N.F.
MF 433	7/16 N.C. X 3/8 N.C.
MF 4343	7/16 N.C. X 7/16 N.F.
MF 435	7/16 N.C. X 1/2 N.C.
MF 435 F	7/16 N.F. X 1/2 N.C.
MF 436	7/16 N.C. X 5/8 N.C.
MF 436 F	7/16 N.F. X 5/8 N.C.
MF 531	1/2 N.F. X 5/16 N.F.
1743	1/2 N.C. X 3/8 N.C.
MF 543	1/2 N.C. X 7/16 N.C.
MF 543 F	1/2 N.F. X 7/16 N.C.
MF 56	1/2 N.C. X 5/8 N.C.
MF 56 F	1/2 N.F. X 5/8 N.C.
MF 57	1/2 N.C. X 3/4 N.C.
MF 563	9/16 N.C. X 3/8 N.C.
MF 565	9/16 N.C. X 1/2 N.C.
MF 566	9/16 N.C. X 5/8 N.C.
MF 567	9/16 N.C. X 3/4 N.C.
MF 568	9/16 N.C. X 7/8 N.C.
MF 561	9/16 N.C. X 1 N.F.
MF 631	5/8 N.C. X 5/16 N.C.
MF 637	5/8 N.C. X 3/8 N.C.
1943	5/8 N.C. X 7/16 N.F.
MF 65	5/8 N.C. X 1/2 N.F.
MF 656	5/8 N.C. X 9/16 N.C.
MF 68	5/8 N.C. X 7/8 N.C.
MF 743	3/4 N.C. X 7/16 N.F.
MF 743 F	3/4 N.F. X 7/16 N.C.
MF 76	3/4 N.C. X 5/8 N.C.
MF 71	3/4 N.C. X 1 N.C.
MF 711	3/4 N.C. X 1-1/8 N.F.
MF 86	7/8 N.C. X 5/8 N.C.
MF 86	F 7/8 N.C. X 5/8 N.F.
MF 87	7/8 N.C. X 3/4 N.C.
MF 81	7/8 N.C. X 1 N.F.
MF 811	7/8 N.C. X 1-1/8 N.F.
MF 813	7/8 N.C. X 1-3/8 N.F.
MF 16	1 N.F. X 5/8 N.F.
MF 18	1 N.F. X 7/8 N.C.
MF 1111	1 N.F. X 1-1/8 N.F.
MF 1113	1-1/8 N.F. X 1-3/8 N.F.
MF 138	1-3/8 N.F. X 7/8 N.C.
MF 1311	1-3/8 N.F. X 1-3/8 N.F.

**Model FV-100 Foot Valve**

For quick control of air when cleaning tubes. Has LOCK ON-EASY OFF feature. Easily secured to working platform or most convenient location.

Model Number	Order Number	Length		Width		Height		NPT	Weight	
		in.	mm	in.	mm	in.	mm	in.	Lbs.	kg
FV-100	4035310	10	254	6.5	165.1	4	101.6	1	12	5.45

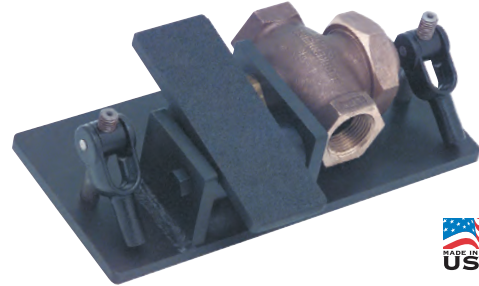

**In-Line Lubricator**

Lubricator stays connected to the tool. Internal adjustment of lubrication rate.

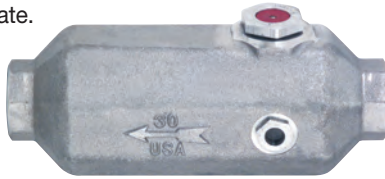

Ordering Number	Hose Size	Lubricator	Bowl Capacity
3067800	1/2 NPT	#0	1/6 pt (7 cl)
3067900	3/4 NPT	#1	1/3 pt (15 cl)
3068000	3/4 NPT	#2	1/2 pt (23 cl)
3068100	1 NPT	#3	1 pt (47 cl)

**HV-TWIN-PAK**

**Air Distribution Manifold**

The HiVis Twin-PAK is an air delivery system that allows two operators to run tools simultaneously from one air supply. The portable design delivers clean and lubricated air in the most confined spaces. The built in S7F filter is unique because it removes 100% of visible moisture from your air supply and automatically purges water before tool operation is affected. The internal oiler has an 11oz capacity to make this unit virtually maintenance free. An overflow safety valve will shut air off to both tools in the event of a hose breaking or being severed. The Twin-PAK is also convenient to stack to make storage easy.



Height ..... 15"  
 Length ..... 28-1/2"  
 Depth ..... 10"  
 Weight ..... 31 lbs

**HiVis Manifolds**

Eliminate the clutter and run just one hose to your worksite and then connect up to four or eight pneumatic tools at once. Equipped with a gauge to monitor working pressure and a 200 psi pressure release valve to prevent excess pressure build up. Top and bottom brackets allow for easy stacking or mounting to skids or other surfaces. Connect or stack multiple manifolds to handle the busiest worksites.



HV-5G-4P

Model	Number of 3/4" Outlets	Capacity	Working Pressure	Test Pressure	Inlet Size	Tank Diameter	Width with Fittings	Height	Length	Weight
HV-5G-4P	4	5 gal	200 psi	300 psi	1"	10"	22-1/2"	14-1/2"	20"	36 lbs
HV-15G-8P	8	15 gal	200 psi	300 psi	2"	12"	22-1/2"	16-1/2"	44"	72 lbs



# Accessories

## Armored Left Hand Wire Wound Hose

Airetool® armored hoses are the toughest available on the market. Providing the wear resistance and toughness needed to last in the harshest of applications.

- Wire Braided Hydraulic rated hose 1,200 PSI
- Tightly wound outer "D" shaped wire guard
- Crimped fixed fitting at work end of hose
- Crimped swivel fitting at supply end of hose



## Air Hose Selection Guide

Note: Standard "WB-LHWW" braid hose has one layer wire braid and a left hand wire wound outside hose protector.

Hose Size (in.)	Working Pressure PSI	Length ft.		Model Number	Order Number	Air Coupling Pipe Tap Size (in.)	Wire Wound (W/W) Not Wire Wound (N/WW)	Hose OD (over wire)		
		ft.	M					in.	mm	
<b>Air Motor – 25</b>										
3/16	250	25	7.62	3/16" -25 ft.-250	4105071	18-20	N/WW	0.437	11.11	
3/16	250	50	15.24	3/16" -50 ft.-250	4105072	18-20	N/WW	0.437	11.11	
<b>Air Motors – 27, 27A, 30, 30A</b>										
1/4	225	25	7.62	1/4" -25 ft.-225	4105075	1/8	N/WW	0.531	13.49	
1/4	225	50	15.24	1/4" -50 ft.-225	4105076	1/8	N/WW	0.531	13.49	
<b>Air Motors – X-64, X-61</b>										
1/4	225	25	7.62	1/4" -25 ft.-225	4105073	1/4	N/WW	0.531	13.49	
1/4	225	50	15.24	1/4" -50 ft.-225	4105074	1/4	N/WW	0.531	13.49	
<b>Air Motor – 29</b>										
3/8	205	25	7.62	3/8" -25 ft.-205	4105083	1/4	N/WW	0.687	17.46	
3/8	205	50	15.24	3/8" -50 ft.-205	4105084	1/4	N/WW	0.687	17.46	
<b>Air Motors – 26, 31</b>										
3/8	205	25	7.62	3/8" -25 ft.	4105088	3/8	N/WW	0.687	17.46	
3/8	205	50	15.24	3/8" -50 ft.	4105089	3/8	N/WW	0.687	17.46	
<b>Air Motors – X-63, X-63A, X-65, X-65A, X-66</b>										
3/8	625	25	7.62	3/8" -25 ft.-WB-LHWW	1717371	3/8	Left hand W/W	0.875	22.22	
3/8	625	50	15.24	3/8" -50 ft.-WB-LHWW	1717372	3/8	Left hand W/W	0.875	22.22	
<b>Air Motors – 3150, 3175, 4200, 4225, 4250</b>										
1/2	625	25	7.62	1/2" -25 ft.-WB-LHWW	1717373	1/2	Left hand W/W	1.000	25.4	
1/2	625	50	15.24	1/2" -50 ft.-WB-LHWW	1717374	1/2	Left hand W/W	1.000	25.4	
<b>Air Motors – 3162, 3187, 3200, 3225, 3212, 4300, 4325</b>										
3/4	625	25	7.62	3/4" -25 ft.-WB-LHWW	1717375	3/4	Left hand W/W	1.250	31.75	
3/4	625	50	15.24	3/4" -50 ft.-WB-LHWW	1717376	3/4	Left hand W/W	1.250	31.75	
<b>All other air motors</b>										
1	625	25	7.62	1" -25 ft.-WB-LHWW	1717377	1	Left hand W/W	1.625	41.28	
1	625	50	15.24	1" -50 ft.-WB-LHWW	1717378	1	Left hand W/W	1.625	41.28	

## Swivel Connections

Extreme Service Duty designed for 3500 and larger cleaning motors available in 1" & 1-1/4"NPT pipe thread

Ordering Number	Description	Thread Size
4091300	SC 100 Swivel	1" NPT
4091400	SC 125 Swivel	1-1/4" NPT



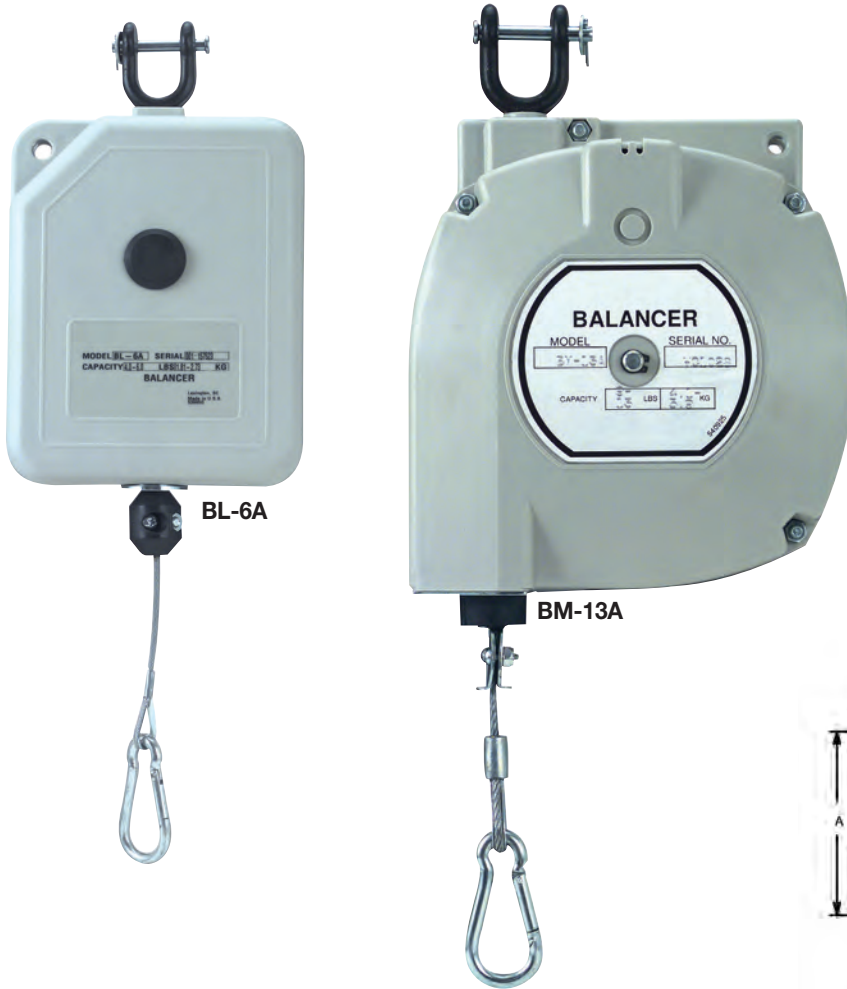

**Ergonomic Tool Balancers**

Capacity

1 - 45 lbs.

0.5 - 20.5 kg

- External tension adjustment
- 360° Swivel
- Retracting in-line cable

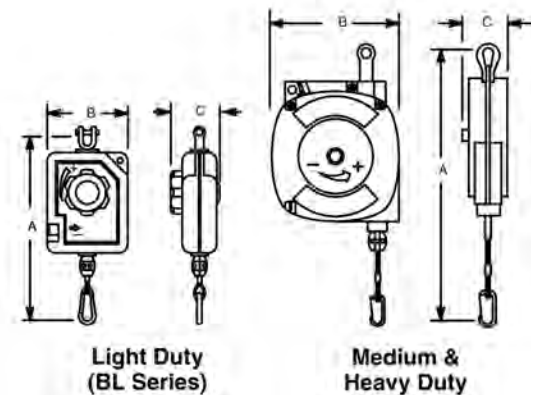

Model Number	Lock Feature	Capacity		"A"		"B"		"C"		Weight	
		lbs.	kg	in.	mm	in.	mm	in.	mm	lbs.	kg

**Light Duty – 5.2 ft. (1.6m) Cable Travel**

BL-2A	–	2.0-1.0	0.9-0.5	10.4	263	4.0	102	2.2	56	1.1	0.5
BL-4A	–	4.0-2.0	1.8-0.9	10.4	263	4.0	102	2.2	56	1.1	0.5

**Light Duty – 6.7 ft. (2.0m) Cable Travel**

BL-6A	–	6.0-4.0	2.7-1.8	12.9	327	5.5	140	3.1	79	3.3	1.5
BLL-6A	Ratchet	6.0-4.0	2.7-1.8	12.9	327	5.5	140	3.1	79	3.3	1.5
BL-8A	–	8.0-6.0	3.6-2.7	12.9	327	5.5	140	3.1	79	3.3	1.5
BLL-8A	Ratchet	8.0-6.0	3.6-2.7	12.9	327	5.5	140	3.1	79	3.3	1.5

**Medium Duty – 6.6ft. (2.0m) Cable Travel**

BM-13A	Non-Locking	13-9.0	5.9-4.1	13.8	350	6.9	175	4.5	114	9.0	4.1
BM-13A	Lock/Release	13-9.0	5.9-4.1	13.8	350	6.9	175	4.5	114	9.0	4.1
BM-18A	Non-Locking	18-13	8.2-5.9	13.8	350	6.9	175	4.5	114	9.0	4.1

**Medium Duty – 6.0ft. (1.8m) Cable Travel**

BM-25A	Automatic	25-18	11.4-8.2	20.7	527	7.8	197	6.6	169	19.0	8.6
BM-35A	Automatic	35-25	15.9-11.4	20.7	527	7.8	197	6.6	169	19.0	8.6
BM-45A	Automatic	45-35	20.5-15.9	20.7	527	7.8	197	6.6	169	19.0	8.6

# Technical Information

## Cutting Speeds

### Speed, Feed & Power

Please use the chart below as a guide only. Many variables contribute to the optimum parameters for each application. These variables include: particular material characteristics, cutter design, cutter sharpness, airline pressure and flow capacity and cutter lubrication.

All portable drilling tools have limited power and thrust. In most cases, holes over 1/2 inch diameter cannot be produced at machine tool rates. Feed rates and/or speeds are reduced. Consult EGI, Ltd for advise on particular applications.

### For best results with your drilling system:

1. Maintain lubricated air to the tool with pressure of 90 psig *while the tool is running.*
2. Use high quality cutters.
3. Replace cutters when point dulls – hole diameter generally increases, cycle times lengthen (*except positive feed*) and hole finish worsens.
4. Whenever possible, provide lubricant mist to the drill point.
5. Insure there is an adequate flow path for drill chips (*swarf*).
6. Utilize fixtures that are secure and rigid.
7. Assure that accessory items are sized correctly and working properly.
8. Train operating personnel in the proper use of the tool.
9. **Please consult the machinery handbook for optimum cutting feeds and speeds.**

Material	Function	Drill Diameter						
		1/8	3/16	1/4	5/16	3/8	7/16	1/2
		.125	.188	.250	.313	.375	.437	.500
Aluminum (300 SFM)	Speed (RPM)	9000	6000	4600	3600	3000	2600	2300
	Feed Rate (IPR)	.002	.003	.004	.004	.004	.004	.004
	Power (HP)	.2	.3	.6	1.0	1.5	1.8	2.0
Mild Steel (90 SFM)	Speed (RPM)	2700	1800	1300	1100	900	750	650
	Feed Rate (IPR)	.005	.005	.005	.006	.006	.006	.006
	Power (HP)	.2	.3	.6	1.0	1.5	1.8	2.0
High Strength Steel Stainless Steel (30 SFM)	Speed (RPM)	900	600	450	375	300	250	220
	Feed Rate (IPR)	.001	.001	.001	.001	.001	.001	.001
	Power (HP)	.2	.3	.6	1.0	1.5	1.8	2.0
Titanium/Inconel (20 SFM)	Speed (RPM)	600	400	300	250	200	175	150
	Feed Rate (IPR)	.002	.003	.003	.003	.004	.004	.005
	Power (HP)	.2	.3	.6	1.0	1.5	1.8	2.0

### Composites

Graphite, kevlar, fiberglass, and other composite materials vary widely. Fiber, resin, processing method and type of cutting tool all affect the optimum drilling speed and feedrate. Little power or thrust is normally required, but controlled feedrates at the proper speed is mandatory. Carbide or diamond cutting tools are required. Contact your material supplier or experiment with an NC Drilling Machine.

**Stacks of Various Materials** Use the lowest speed and feedrate of the materials in the stack. Peck feed drilling is best.

A. Peck Drilling permits higher drilling speeds    B. Carbide cutting tools (when applicable) permits higher drilling speeds    C. Oil hole cutting tools permit higher drilling speeds.

### Speed (RPM)

Describes the number of revolutions of the spindle per unit of time.

Example: Revolutions per minute=RPM

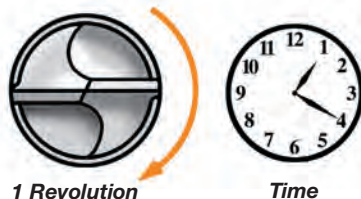

$$\text{Speed} = \text{Revolution} \div \text{Time}$$

### Surface Speed (SFM)

Describes the velocity (*speed*) of the **outside** of the drill bit.

Example: 30 surface feet per minute (30 SFM)

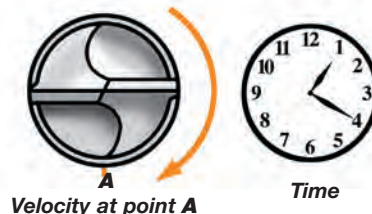

$$\text{Surface Speed} = \text{Distance} \div \text{Time (rotational)}$$

### Feed Rate (IPR)

Describes the distance the spindle travels during each revolution.

Example: 0.002 inches per revolution = .002 IPR

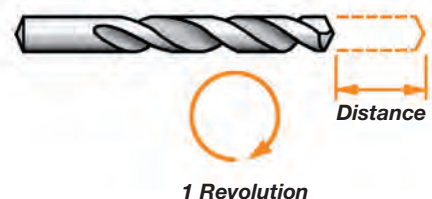

$$\text{Feed Rate} = \text{Distance} \div \text{Revolution}$$

## Recommended Cutting Speeds for Tube Cutters and Tube Facers

The recommended cutting speeds in this chart are based on published speeds and feeds. A slower RPM may be necessary depending on tube material analysis and hardness. Proper lubrication must be used.

Tube Material	Tube O.D.									
	1/4"	3/8"	1/2"	5/8"	3/4"	7/8"	1"	1-1/4"	1-1/2"	2"
Aluminum (500 FPM)	7500 rpm	5000 rpm	3800 rpm	3000 rpm	2500 rpm	2200 rpm	1900 rpm	1500 rpm	1275 rpm	950 rpm
Brass (300 FPM)	4600 rpm	3050 rpm	2300 rpm	1825 rpm	1625 rpm	1300 rpm	1150 rpm	925 rpm	750 rpm	575 rpm
Copper (250 FPM)	3825 rpm	2550 rpm	1900 rpm	1525 rpm	1275 rpm	1100 rpm	950 rpm	750 rpm	625 rpm	500 rpm
Carbon Steel (FPM)	2150 rpm	1425 rpm	1075 rpm	850 rpm	700 rpm	625 rpm	525 rpm	425 rpm	350 rpm	275 rpm
Stainless Steel (65 FPM)	1000 rpm	660 rpm	500 rpm	400 rpm	330 rpm	285 rpm	250 rpm	200 rpm	165 rpm	125 rpm
Titanium (30 FPM)	450 rpm	300 rpm	230 rpm	185 rpm	155 rpm	130 rpm	115 rpm	95 rpm	75 rpm	60 rpm
Inconel (20 FPM)	305 rpm	205 rpm	155 rpm	125 rpm	100 rpm	90 rpm	75 rpm	60 rpm	50 rpm	40 rpm

## Special Tables

### Airetool Boiler Cleaner Motor Air Consumption Chart

Proper air supply and lubrication are imperative for proper operation of the Airetool boiler tube cleaner motors. 90 psi should be maintained at motor during operation for best cleaning results. Motor requires 20 to 30 drops of oil per minute.

#### Boiler Cleaner Motor – Air Consumption C.F.M.

Motor Number	Pressure		
	60 Lbs.	80 Lbs.	100 Lbs.
3500	176	196	255
3450	174	194	248
3400	174	194	248
3350	155	178	207
3318	137	159	203
3312	129	149	200
3300	129	149	200
3275	127	147	172
3262	95	109	132
3250	93	106	127
3225	86	95	115
3212	79	87	103
3187	65	72	90
3175	57	69	86
3150	51	60	74
X-65-A	20	23	27
X-63-A	18	21	23
31	21	23	26
26	21	27	30
29	21	27	30

Motor Number	Pressure		
	60 Lbs.	80 Lbs.	100 Lbs.
27A	09	10	11
27	09	10	11
30A	09	10	11
30	09	10	11
24	08	09	10
4600	119	134	149
4481	119	134	149
4450	76	85	93
4400	61	66	74
4350	61	66	74
4325	58	64	72
4300	57	63	71
4250	55	61	69
4225	33	37	41
4200	33	37	41
X-66	22	25	29
X-65	20	23	27
X-63	18	21	23
X-61	12	14	16
X-64	10	11	12

### Decimal Equivalents

Decimal Equivalents															
in.	Dec.	in.	Dec.	in.	Dec.	in.	Dec.	in.	Dec.	in.	Dec.	in.	Dec.	in.	Dec.
1/64	.016	9/64	.141	17/64	.266	25/64	.391	33/64	.516	41/64	.641	49/64	.766	57/64	.891
1/32	.031	5/32	.156	9/32	.281	13/32	.406	17/32	.531	21/32	.656	25/32	.781	29/32	.906
3/64	.047	11/64	.172	19/64	.297	27/64	.422	35/64	.547	43/64	.672	51/64	.797	59/64	.922
1/16	.063	3/16	.188	5/16	.313	7/16	.438	9/16	.563	11/16	.688	13/16	.813	15/16	.938
5/64	.078	13/64	.203	21/64	.328	29/64	.453	37/64	.578	45/64	.703	53/64	.828	61/64	.953
3/32	.094	7/32	.219	11/32	.344	15/32	.469	19/32	.594	23/32	.719	27/32	.844	31/32	.969
7/64	.109	15/64	.234	23/64	.359	31/64	.484	39/64	.609	47/64	.734	55/64	.859	63/64	.984
1/8	.125	1/4	.250	3/8	.375	1/2	.500	5/8	.625	3/4	.750	7/8	.875	1	1.000

# Special Tables

## Tube Sizes – Birmingham Wire Gauges

OD of Tube (in.)	Birmingham Wire Gauge												
	00-.380	0-.340	1-.300	2-.284	3-.259	4-.238	5-.220	6-.203	7-.180	8-.165	9-.148	10-.134	11-.120
1/4													
3/8													
5/8													
3/4												.482	.510
7/8												.607	.635
1										.670	.704	.732	.760
1-1/4										.920	.954	.982	1.010
1-1/2										1.170	1.204	1.232	1.260
1-3/4							1.310	1.344	1.390	1.420	1.454	1.482	1.510
2						1.524	1.560	1.594	1.640	1.670	1.704	1.732	1.760
2-1/4	1.490	1.570	1.650	1.682	1.732	1.774	1.810	1.844	1.890	1.920	1.954	1.982	2.010
2-1/2	1.740	1.820	1.900	1.932	1.982	2.024	2.050	2.094	2.140	2.170	2.204	2.232	2.260
2-3/4	1.990	2.070	2.150	2.182	2.232	2.274	2.310	2.344	2.390	2.420	2.454	2.842	2.510
3	2.240	2.320	2.400	2.432	2.482	2.524	2.560	2.594	2.640	2.570	2.704	2.732	2.760
3-1/4	2.490	2.570	2.650	2.682	2.732	2.774	2.810	2.844	2.890	2.920	2.854	2.982	3.010
3-1/2	2.740	2.820	2.900	2.932	2.982	3.024	3.060	3.094	3.140	3.170	3.204	3.232	3.260
3-3/4	2.990	3.070	3.150	3.182	3.232	3.274	3.310	3.344	3.390	3.420	3.454	3.482	3.510
4	3.240	3.320	3.400	3.432	3.482	3.524	3.560	3.594	3.640	3.670	3.704	3.732	3.760
4-1/4	3.490	3.570	3.650	3.682	3.732	3.774	3.810	3.844	3.890	3.920	3.954	3.982	4.010
4-1/2	3.740	3.820	3.900	3.932	3.982	4.024	4.060	4.094	4.140	4.170	4.204	2.232	4.260
4-3/4	3.990	4.070	4.150	4.182	4.232	4.274	4.310	4.344	4.390	4.420	4.454	4.482	4.510
5	4.240	4.320	4.400	4.432	4.482	4.524	4.560	4.594	4.640	4.670	4.704	4.732	4.760
5-1/4	4.490	4.570	4.650	4.682	4.732	4.774	4.810	4.844	4.890	4.920	4.954	4.982	5.010

OD of Tube (in.)	Birmingham Wire Gauge												
	12-.109	13-.095	14-.083	15-.072	16-.065	17-.058	18-.049	19-.042	20-.035	21-.032	22-.028	23-.025	24-.022
1/4							.152	.166	.180	.186	.194	.200	.206
3/8			.209	.231	.245	.259	.277	.291	.305	.311	.319	.325	.331
1/2		.310	.334	.356	.370	.384	.402	.416	.430	.436	.444	.450	.456
5/8	.407	.435	.459	.481	.495	.509	.527	.541	.555	.561	.569	.575	.581
3/4	.532	.560	.584	.606	.620	.634	.652	.666	.680	.686	.694	.700	.706
7/8	.657	.685	.709	.731	.745	.759	.777	.791	.805	.811	.819	.825	.831
1	.782	.810	.834	.856	.870	.884	.902	.916	.930	.936	.944	.950	.956
1-1/4	1.032	1.060	1.084	1.106	1.120	1.134	1.152	1.166	1.180	1.186	1.194	1.200	1.206
1-1/2	1.282	1.310	1.334	1.356	1.370	1.384	1.402	1.416	1.430	1.436	1.444	1.450	1.456
1-3/4	1.532	1.560	1.584	1.606	1.620	1.634	1.652	1.666	1.680	1.686	1.694	1.700	1.706
2	1.782	1.810	1.834	1.856	1.870	1.884	1.902	1.916	1.930	1.935	1.944	1.950	1.956
2-1/4	2.032	2.060	2.084	2.106	2.120	2.134	2.151						
2-1/2	2.282	2.310	2.334	2.356	2.370	2.384	2.402						
2-3/4	2.532	2.560	2.584	2.606	2.620	2.634	2.652						
3	2.782	2.810	2.834	2.856	2.870	2.884	2.902						
3-1/4	3.032	3.060	3.084	3.106	3.120	3.134	3.151						
3-1/2	3.282	3.310	3.334	3.356	3.370	3.384	3.401						
3-3/4	3.532	3.560	3.584	3.606	3.620	3.634	3.652						
4	3.782	3.810	3.834	3.856	3.870	3.884	3.902						
4-1/4	4.032	4.060	4.084	4.106	4.120	4.134	4.152						
4-1/2	4.282	4.310	4.344	4.356	4.370	4.384	4.402						
4-3/4	4.532	4.560	4.584	4.606	4.620	4.634	4.652						
5	4.782	4.810	4.834	4.856	4.870	4.884	4.902						
5-1/4	5.032	5.060	5.084	5.106	5.120	5.134	5.152						



Nominal Pipe Size (in.)	Outside Diameter (in.)	Schedule Number							
		Nominal Wall Thickness Inches / Nominal Inside Diameter Inches (ID)							
		40	ID	80	ID	120	ID	160	ID
1/8	.405	.068	.269	.095	.215				
1/4	.540	.088	.364	.119	.302				
3/8	.675	.091	.493	.126	.423				
1/2	.840	.109	.622	.147	.546			.187	.466
3/4	1.050	.113	.824	.154	.742			.218	.614
1	1.315	.133	1.049	.179	.957			.250	.815
1-1/4	1.660	.140	1.380	.191	1.278			.250	1.160
1-1/2	1.900	.145	1.610	.200	1.500			.281	1.338
2	2.375	.154	2.067	.218	1.939			.343	1.689
2-1/2	2.875	.203	2.469	.276	2.323			.375	2.125
3	3.500	.216	3.068	.300	2.900			.437	2.626
3-1/2	4.000	.226	3.548	.318	3.364				
4	4.500	.237	4.026	.337	3.826	.437	3.626	.531	3.438
5	5.563	.258	5.047	.375	4.813	.500	4.563	.625	4.313
6	6.625	.280	6.065	.432	5.761	.562	5.501	.718	5.189
8	8.625	.322	7.981	.500	7.625	.718	7.189	.906	6.813
10	10.750	.365	10.020	.593	9.564	.843	9.064	1.125	8.500
12	12.750	.406	11.938	.687	11.378	1.000	10.750	1.312	10.126

### Thread Designations

Size		NC	NF
in.	mm		
10 -32	4.8	-	10-32 UNF
1/4	6.4	1/4-20 UNC	1/4-28 UNF
5/16	7.9	5/16-18 UNC	5/16-24 UNF
3/8	9.5	3/8-16 UNC	3/8-24 UNF
7/16	11.1	7/16-14 UNC	7/16-20 UNF
1/2	12.7	1/2-13 UNC	1/2-20 UNF
9/16	14.3	9/16-12 UNC	9/16-18 UNF
5/8	15.9	5/8-11 UNC	5/8-18 UNF
3/4	19.1	3/4-10 UNC	3/4-16 UNF
7/8	22.2	7/8-9 UNC	7/8-14 UNF
1	25.4	1-8 UNC	1-14 UNS
1-1/8	28.6	1-1/8-7 UNC	1-1/8-12 UNF
1-3/8	34.9	1-3/8-16 UNC	1-3/8-12 UNF

### Metric Table Conversions

Fractional Inch	Decimal Inch	Millimeter	Fractional Inch	Decimal Inch	Millimeter	Fractional Inch	Decimal Inch	Millimeter
1/64	.016	0.40	23/64	.359	9.13	45/64	.703	17.86
1/32	.031	0.79	3/8	.375	9.53	23/32	.719	18.26
3/64	.047	1.19	25/64	.391	9.92	47/64	.734	18.65
1/16	.063	1.59	13/32	.406	10.32	3/4	.750	19.05
5/64	.078	1.98	27/64	.422	10.72	49/64	.766	19.45
3/32	.094	2.38	7/16	.438	11.11	25/32	.781	19.84
7/64	.109	2.78	29/64	.453	11.51	51/64	.797	20.24
1/8	.125	3.18	15/32	.469	11.10	13/16	.813	20.64
9/64	.141	3.57	31/64	.484	12.30	53/64	.828	21.03
5/32	.156	3.97	1/2	.500	12.70	27/32	.844	21.43
11/64	.172	4.36	33/64	.516	13.10	55/64	.860	21.83
3/16	.188	4.76	17/32	.531	13.50	7/8	.875	22.23
13/64	.203	5.16	35/64	.547	13.89	57/64	.891	22.62
7/32	.219	5.56	9/16	.563	14.29	29/32	.906	23.02
15/64	.234	5.95	37/64	.578	14.68	59/64	.922	23.42
1/4	.250	6.35	19/32	.594	15.08	61/64	.953	24.21
17/64	.266	6.75	39/64	.609	15.48	31/32	.969	24.61
9/32	.282	7.14	5/8	.625	15.88	63/64	.984	25.00
19/64	.297	7.54	41/64	.641	16.27	1	1.000	25.40
5/16	.313	7.94	21/32	.656	16.67	2	2.000	50.80
21/64	.328	8.33	43/64	.672	17.07	3	3.000	76.20
11/32	.344	8.73	11/16	.688	17.46			

## POWER TOOLS SALES & SERVICE CENTERS

Please note that all locations may not service all products.  
Contact the nearest EGI, Ltd Sales & Service Center for the appropriate facility to handle your service requirements.

### NORTH AMERICA

#### Houston, TX

**EGI, Ltd.**

**812 Utah Street**

**South Houston, TX 77587**

Phone: +1 (713) 944-2775

Fax: +1 (713) 944-2891

Email: [sales@equipmentgroup.com](mailto:sales@equipmentgroup.com)

[www.equipmentgroup.com](http://www.equipmentgroup.com)



Sales Center



Service Center

#### Gonzales, LA

**EGI, Ltd.**

**2910 South Ruby St.**

**Gonzales, LA 70737**

Phone: +1 (225) 647-4004

Fax: +1 (225) 647-4024

Email: [sales@equipmentgroup.com](mailto:sales@equipmentgroup.com)

[www.equipmentgroup.com](http://www.equipmentgroup.com)



Sales Center



Service Center

#### New York, NY

**EGI, Ltd.**

**Brooklyn, NY**

Phone: +1 (929) 236-4200

Email: [esteban@equipmentgroup.com](mailto:esteban@equipmentgroup.com)

[www.equipmentgroup.com](http://www.equipmentgroup.com)



International Sales Office



*Airetool*®  
Tools that Work Since 1928