



TESEO®

ALUMINIUM PIPEWORK FLUID POWER DISTRIBUTION SYSTEMS



Square thinking
outside
the box

INDEX

COMPANY PROFILE	Page	3
Teseo commercial network.....	Page	5
HBS - Hollow bar system	Page	16
Hollow bar.....	Page	20
Accessories.....	Page	21
NPT Accessories.....	Page	34
AP - Aluminium pipework	Page	38
Hollow bar.....	Page	42
Accessories.....	Page	43
NPT Accessories.....	Page	54
AP - Multifluid 25 bar	Page	56
ATS - Air track supply	Page	62
Accessories.....	Page	65
SAB - Swinging arm bracket	Page	70
Accessories.....	Page	72
WBA - Workbench for assembly	Page	74
Accessories.....	Page	76
MAT - Modular air trolley	Page	79
AM - Aluminium manifold	Page	81
DT - Drilling tool	Page	82
Manual pipe bender	Page	83
CA - Commercial Accessories	Page	85
Technical Sheet	Page	90
HBS-AP Assembling instructions	Page	93

LEGEND

A	mm	Height, dimension
B	mm	Width, dimension
C	mm	Distance
D - d	mm	Diameter
E	mm	Hexagon, wrench
F	Kg - Nm	Force
G	"	Gas thread (BSP or NPT)
I - i	mm	Distance between slots
J x	cm ⁴	Moment of inertia along x
J y	cm ⁴	Moment of inertia along y
L	mm	Length
N°	_	Code number
n°	_	Quantity number
P	g	Weight
R	mm	Radius
S	mm	Thickness
T	-	Threaded hole
V	dm ³	Inside volume
α°	°	Angle
	Only on request - check availability

HBS Hollow bar system	Swinging arm bracket SAB
AP Aluminium pipework	Modular air trolley MAT
POW Powered aluminium pipework	Workbench for assembly WBA
ATS Air track supply	All systems SYS

IMPORTANT

The drawings contained in the catalogue are typical and not binding. Teseo Srl are continuously improving products and features and reserves the right to modify design and dimensions at any time.

WARNING!

For the correct application of all Teseo products carefully read the technical data in this catalogue and on our website www.teseoair.com. Thoroughly read the instruction manual before carrying out the installation.

TESEO HISTORY

Teseo SRL was founded in 1988 and initially worked within the textile industry as an industrial supplier and engineering consultants.

During this period they discovered several problems linked to many factory's compressed air distribution systems. The traditional pipework distribution systems, such as Black and Galvanised steel, had many limitations and restrictions for the distribution of Compressed Air such as low flow rates, high pressure drop, corrosion, fluid contamination and major difficulties in modifying the installations.

As a solution to solve these problems, Teseo began to design and develop a modular aluminium pipework system for the distribution of compressed air. In the early 90's Teseo were the first company to successfully develop and bring to market a Modular Aluminium Pipework System specifically designed for the distribution of Compressed Air and other fluids.

Combining the features of a structural profile together with the full flow of a pipe, Teseo achieved one of the most innovative systems for fluid power distribution.

Modern high tech designs, easy to use and flexible were the main features to claim everyone's attention. Afterwards energy efficiency, thanks to the low friction coefficient of the inner surface of the pipes, became an additional advantage compared to the traditional piping systems.

Teseo were pioneers in this new market sector, modular aluminium systems for the distribution of inert gases. There was immediately an excellent feedback from en-



gineering consultants, installers and end users thanks to the wide range of the diameters (from ½" up to 4" - 12mm to 110 mm internal diameter!) and ease of installation, Teseo soon became the worldwide reference for Compressed Air modular aluminium pipework systems.

Today Teseo is a modern and dynamic company with an active and motivated sales and management team. Our Technical department have a passion for continuously improving and developing our existing range of products, forward thinking and striving to develop new ranges to meet our customers' future needs and requirements.



WHY BUY A TESEO SYSTEM



The choice of a Teseo modern modular piping system in aluminium eliminates the hidden costs of a compressed air system. Such costs are constantly increasing during the entire lifetime of your distribution system. Typical hidden costs eliminated or reduced by Teseo aluminium piping are:

- **Costs for air leaks.** The patented clamping and sealing concept of our piping system eliminates leaks, a major problem in many compressed air systems, Teseo pipework systems saves energy normally wasted in such systems.
- **Costs of air treatment,** in-line Filters, maintenance, repairing machines and tools. Aluminium is not affected by rusting or corrosion, so inside Teseo piping air is always as clean as after the treatment done at the source. This guarantees a longer life to the equipment connected.
- **Costs for downtime and labour for each modification.** A Teseo pipework network is easy to modify and to extend. As a compressed air system inside the factory, adding a new branch line or point of use drop takes few minutes to be operative. These can also be added live using our hot tap.
- **Costs for the low flow rate and high pressure drop.** High precision aluminium extruded profiles of Teseo piping have a smooth inner surface. The friction of air flowing through the tubing is considerably lower than in a conventional rough steel or black steel pipe. Such a feature can be easily translated into less pressure drop and extra flow with the same electric power supply consumption. Contact our sales representative or website to get more information.



TESEO
Systems

TRADITIONAL
Systems

-  Hidden costs (Air quality, modifications, low efficiency and air leaks)
-  Labour costs
-  Material costs

HIGH TECH DESIGN

LIGHT WEIGHT

HEAVY DUTY PROFILES AND ACCESSORIES

100% METAL PIPES & FITTING

100% RECYCLABLE ALUMINIUM

ENERGY SAVING

SAFE AND RELIABLE



SALES NET

Today compressed air is widely used in many different industrial fields, applications range from textile to precision engineering, to automotive and pharmaceutical industry. Through complete plants or simple manifolds, the distribution of compressed air is used in every kind of production activity as service or machine. Aluminium is now the preferred choice for the inert gas distribution among the out dated technology of galvanised steel or welded steel. Due to the growing interest in aluminium solutions, Teseo has developed its own commercial network.

Teseo is managing its products through a national and international network of distributors and qualified installers providing them with a technical and commercial quality support.



ENGINEERING OFFICES AND CONSULTING

Constantly involved in new projects, engineering consultants and engineering offices are working with Teseo to specify and promote fluid power distribution with modular aluminium systems through sizing and technical specifications of complete industrial plants.

BRANCHES AND DISTRIBUTORS

Teseo are constantly improving its own commercial network through branches and distributors to grant the best products and services to suit the needs of our customers (installers, resellers, end users).

Our worldwide net of Teseo contacts is all directed to the customer's satisfaction offering technical assistance and fast delivery from their warehouse.

ITALY:

TESEO SRL
VIA DEGLI OLEANDRI, 1
25015 DESENZANO DEL GARDA
BRESCIA
Tel. +39 030 9150411
Fax +39 030 9150419

SPAIN:

TESEO IBERICA AP, S.L.
POL.IND.SEGLE XX C/GALICIA,114
08223 TERRASSA - BARCELONA
Tel. +34 93 7834730
Fax +34 93 7834538

GERMANY:

TESEO DEUTSCHLAND GMBH
BLEICHSTR. 47
56249 HERSCHBACH
Tel. +49 2626 923225
Fax +49 2626 349255

NETHERLANDS:

TESEO NEDERLAND B.V.
GEERDINKSERF, 19
7722 AZ DALFSEN
Tel. +31 529 435983
Fax +31 529 435984

UNITED KINGDOM:

TESEO UK
UNIT 2, HOUSE 5
LYNDERSWOOD FARM, LYNDERSWOOD LANE
BRAINTREE, ESSEX CM77 8JT
Tel. +44 08701 672150
Fax +44 08701 672151

CANADA:

TESEO CANADA
4420, BOULEVARD INDUSTRIEL
J1L 2S8 SHERBROOKE, QUÉBEC
Tel. +1 819 823 2179
Fax +1 819 562 2274

FLUID POWER IN THE FACTORY AND ON MACHINERY

Bypass and manifolds for the assembly and installation of compressed air equipment.



Distribution pipework in aluminium for compressed air, nitrogen, vacuum and other inert gases, from 12mm to 110 mm internal diameter.



Drops to the point of use, fast and easy to install or modify.

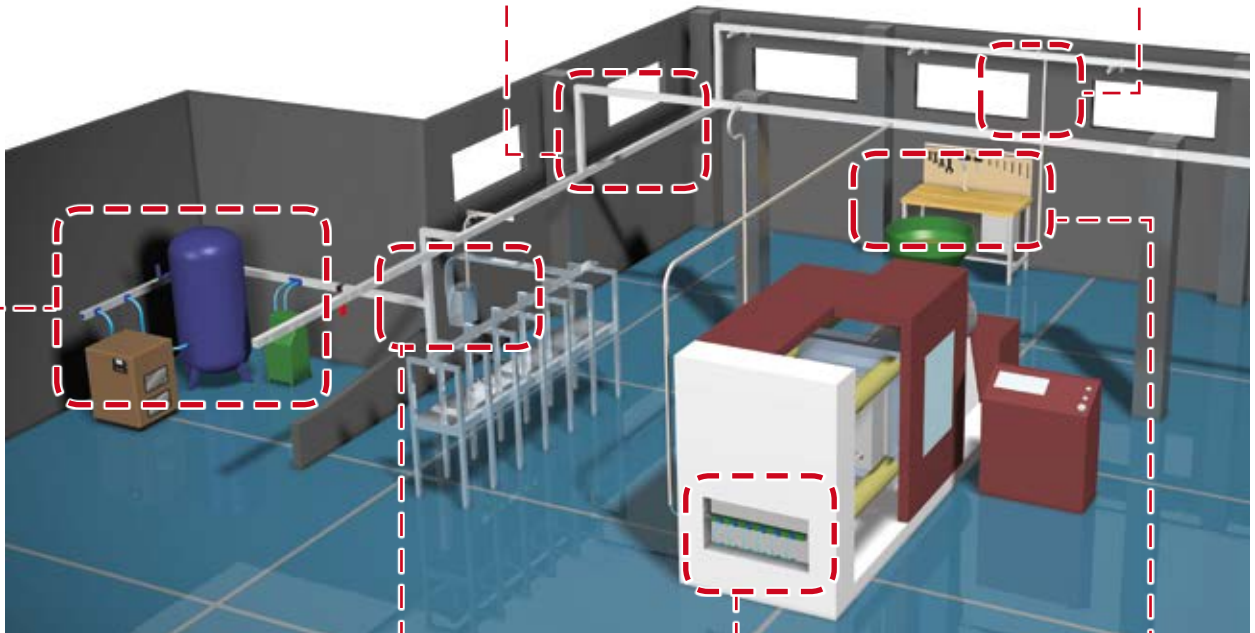

Distribution manifolds integrated on pneumatic control panels for automation.



Modular distribution manifolds on machines or automatic lines.



Feeding lines for pneumatic tools along walls or work benches.

ERGONOMIC SOLUTIONS FOR PNEUMATIC TOOLS

Modular track and trolleys on ATS aluminium rail for compressed air and electrical distribution.



Pressurized SAB pivoting arms in aluminium for feeding tools, covering a wide working radius.



Swinging SAB arms on benches, to support and feed pneumatic tools.

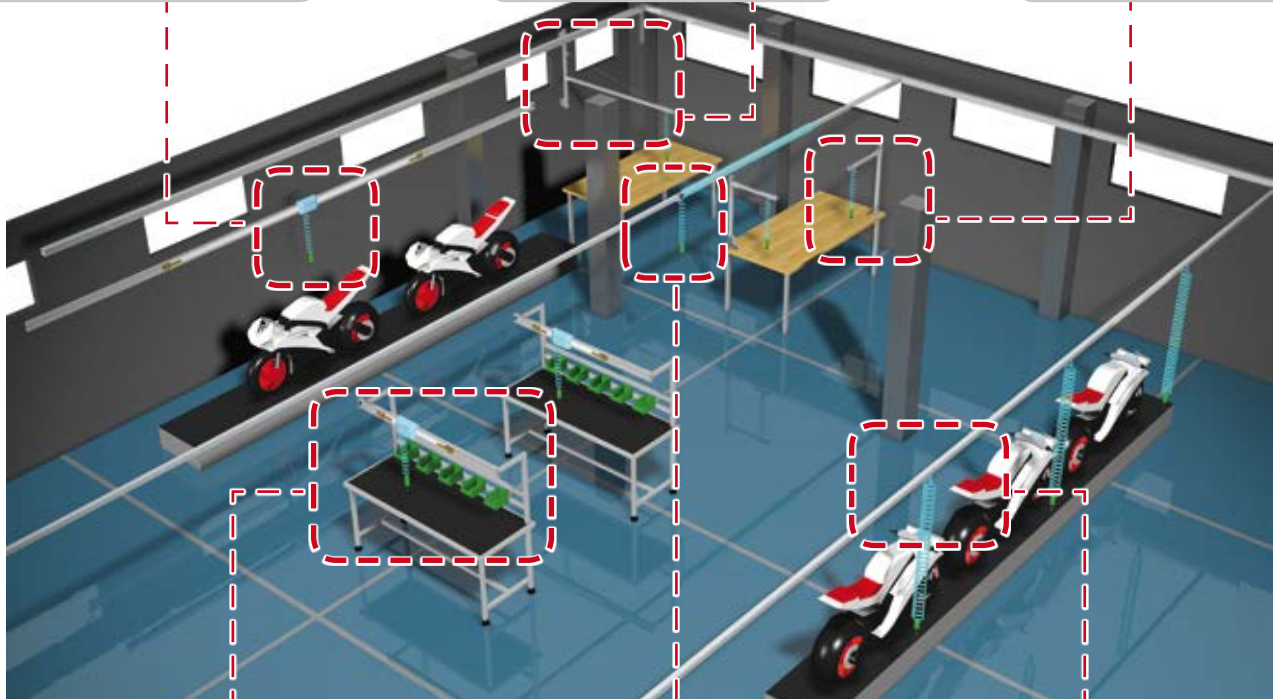

Workbenches for assembly, operated with pneumatic and electrical tools.



MAT Trolley running overhead on the aluminium pipework supporting and feeding pneumatic tools



Assembly and production lines built in Teseo aluminium profiles and glider pads

NATIONAL AND INTERNATIONAL TRADE FAIRS

Trade fairs remain the main means to release new technological trends and news developed by the manufacturers.

As the pioneer of the first modular aluminium piping for fluid power distribution, Teseo has attended many of the most relevant worldwide trade shows achieving worldwide recognition.

During the main fluid power shows, Teseo has received many awards and certificates for innovation, benefits and features of its fluid power distribution system.



PRESS RELEASE

Since the beginning Teseo has invested in communication on technical reviews dedicated to pneumatic and to technical trade magazines, either with advertisements or with press release about applications.

Thanks to the job done in the past, the Teseo brand is now clearly and strongly identified with the concepts of quality, reliability and modularity. With coverage and presence in the most prestigious and well-known worldwide publications.



www.teseoair.com

SOME ON-LINE SERVICES

- @ Area dedicated to products, where you can run advanced searches for components or check their correct coding, and technical data and view explanatory drawings.
- @ Area dedicated to our virtual press office: editorials on our brand and products promotions, like trade fairs reports and publications on specific magazines all over the world.
- @ Area dedicated to case histories and different applications of our products.
- @ Area dedicated to product news, past, present and future significant events.
- @ Dedicated on-line forms are available, fill in to ask for customized products, ask for a quote, place an order or to assemble simple components with more complex ones.
- @ Register on-line and communicate with all of the Teseo departments.
- @ Free design software is available on line in order to size your own plant with Teseo's Aluminium pipework system.
- @ Simple on line software is available to order Teseo parts and fittings, by using a simple and intuitive form.
- @ A complete converter of units of measurement is also available on line.

It is possible to download this Catalogue and many other documents in Acrobat ® PDF format.

AWARDS



WINNER 2007



FINALIST 2006



FINALIST 2006



FINALIST 2006



WINNER 2006



WINNER 2001



WINNER 2000



WINNER 1999



WINNER 1996



WINNER 1992

FROM DESIGN TO THE INSTALLATION

Teseo supports its own partners and customers through the designing and sizing of air lines, the development of customized solutions for machines and production lines. Consulting on standards, information and technical training for installers, assistance during the installation and testing of the system.

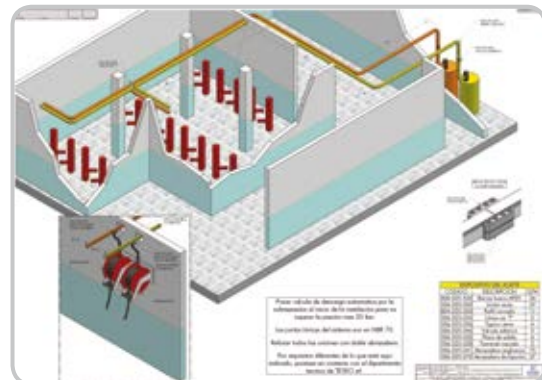
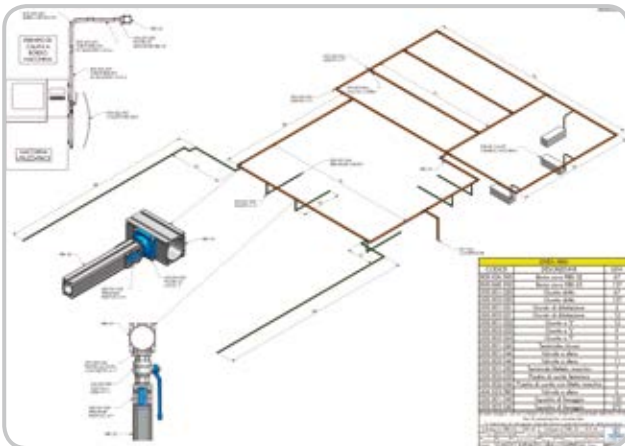
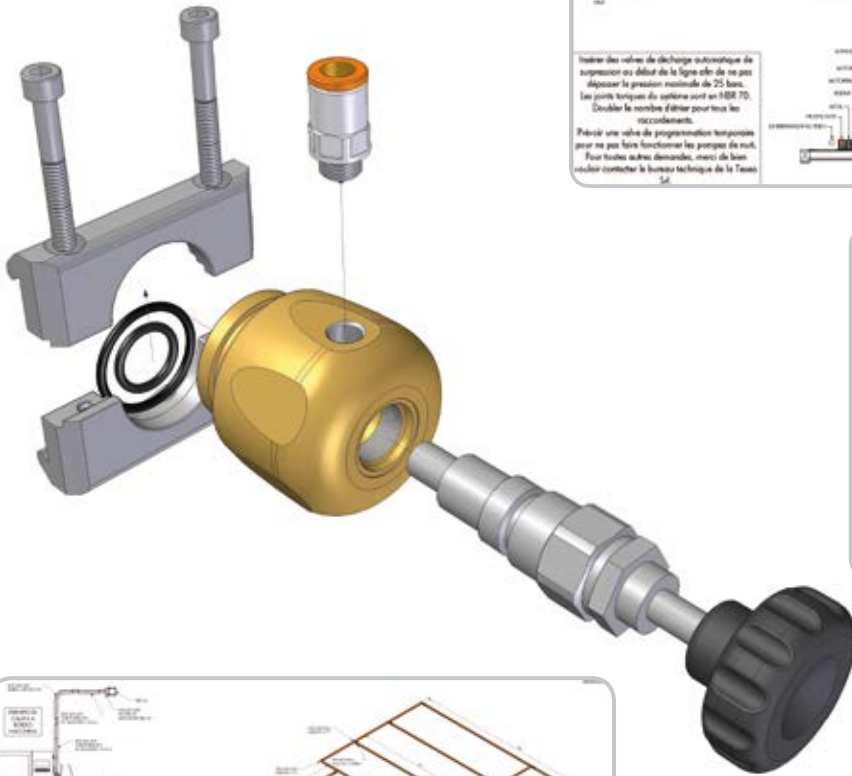
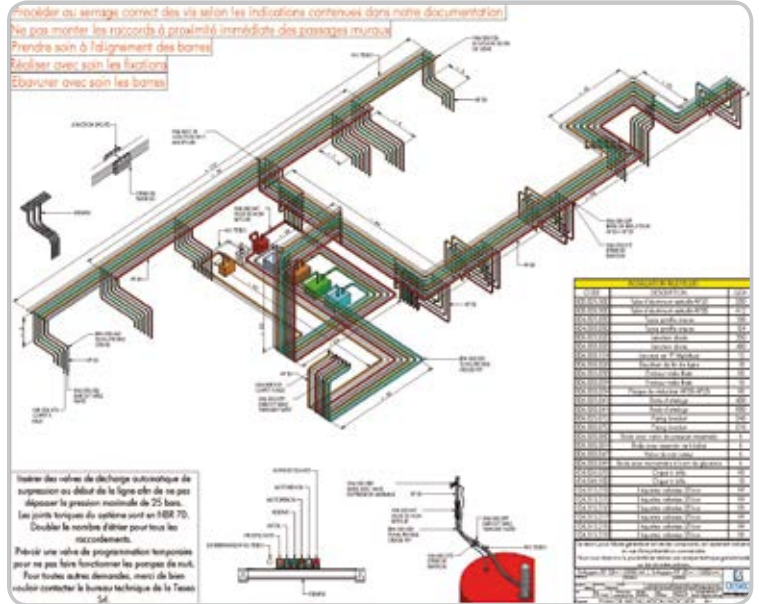

ITALIAN DESIGN AS A VALUE

At Teseo we design and project using the most modern three-dimensional CAD system combined with flexible and expedient methods.

We face each project searching for innovation, considering the environmental and ergonomic impacts. Moreover, we try to make the most of the DESIGN, by optimizing the production process and by assuring quality and functionality.

We co-operate with external offices, with university departments but most of all with our customers. They help us and drive our innovation by discussing their necessities and experiences.

Each patent requires a lot of technical work, for the carrying out of the technical patented drawings, for the evaluation of the precedence, for the compilation of our technical requests from the reference institute, and afterwards for the maintenance and the legal protection of our rights and our customers.

The Certification and the homologation of our products are essential for us, the engagement in collaborating with certification institutes is constant as we prefer, even if we are sure about quality and safety of our production, to get approvals in a serious and open way. Teseo designs according to the standards UNI ISO for planning as UNI 4820, UNI 5456 and others.

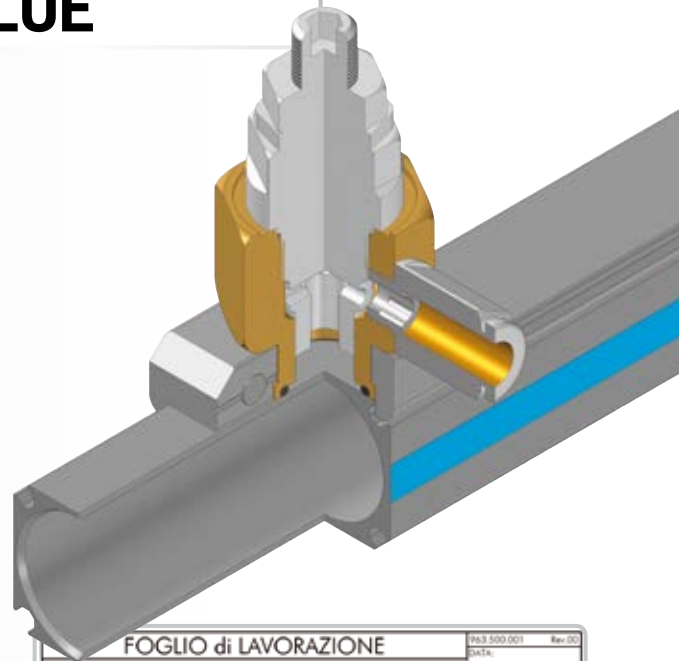

FOGLIO di LAVORAZIONE						96.3.500.001	Rev.00
DATA:							
CANTINOTTO							
TEMPO TECNICO I.F.Z.							
TEMPO TECNICO TOT.							
TEMPO IMPIEGATO							
ADDETTO MONTAGGIO							
RESPONSABILE							
FORNITORE							
Pos.	Codice	Descrizione	Qnt.	Materiale	Peso		
1	134.001.000	PISTONELLA ATTORNITORE	2	Acc. acciaio	0,17 g		
2	122.006.010	PIRE T.C.F. M6 x 10	2	Acc. inox 316	4,18 g	NOTE:	
3	122.006.010	PIRE T.C.F. M6 x 10	4	Acc. inox 316	8,36 g		
4	211.001.000	SUMMATORIOME OMA 020403	1	M6 x 10	0,73 g		
5	211.001.000	SUMMATORIOME OMA 020403	2	M6 x 10	0,73 g		
6	134.001.000	PISTONELLA ATTORNITORE	1	Acc. inox 316	0,17 g		
7	122.006.010	PIRE T.C.F. M6 x 10	2	Acc. inox 316	4,18 g		
8	122.006.010	PIRE T.C.F. M6 x 10	2	Acc. inox 316	4,18 g		
9	122.006.010	PIRE T.C.F. M6 x 10	2	Acc. inox 316	4,18 g		
10	122.006.010	PIRE T.C.F. M6 x 10	2	Acc. inox 316	4,18 g		
OPERAZIONE						ATTREZZATURE	TEMPO
10 PREPARA IL MATERIALE DAL MAGAZZINO							
20 PREPARAZIONE UN CAMPIONE DA FAR CORRERE A VOCE							
30 CONTROLLA ACCOPPIAMENTO STAFFE 30 E MANICOTTO 30							
40 APPLICA ETICHETTA 40 SU STAFFE 30							
50 MONTA VITE 50 SU TRAVERSI 10 INFIANDO STAFFA 30							
60 INCASTRATA OR 18 x 9 CON GRANDE DI VITE 18 x 9						111.003.100	
70 MONTARE O-RING 140 SU MANICOTTO 10 NELL'APPPOSITA SEDE PIANA							
80 MONTARE O-RING 150 SU MANICOTTO 10 NELLE SEDE SUL CANOTTO							
90 INCANTARE VITE 10 SU TRAVERSI 10 INFIANDO MANICOTTO 10							
100 INCASTRARE NEL SACCHETTO 101 VITE 18 x 9							
110 INCASTRARE ETICHETTA CODICE E BIANCA							
120 QUANDO IL BANCO DI LAVORO E SATURO INVIARE 30 GRUPPI ALLA VOLTA NEL SACCHETTO 101 030.500							
130 DEPOSITARE IL MAGAZZINO							
140 DEPOSITARE IN AREA MATERIALE IN LAVORAZIONE							
150 CONDIZIONA IL SEGUENTE FOGLIO A RIF.							
160 RIF. INGIUNGE I DATI DELLA PRODUZIONE NEL GESTIONALE							
170 FINE CONTROLLA I GRUPPI INCASTRATI							
180 FINE DEPOSITA IL MATERIALE NELL'AREA MAT. COMP. COMPONENTI FINITI							
NOTE: LA FAS CON # NEL CASO DI FORNITORI ESTERNI TENGONO GESTIRE DIRETTAMENTE DA RFI I BOG							
337.88 g							
11/09/2008							
Cognome: PIASTRA DI RIDUZIONE Ø32 I 36						003.002.037	
						 WWW.TESEOCOM.COM	

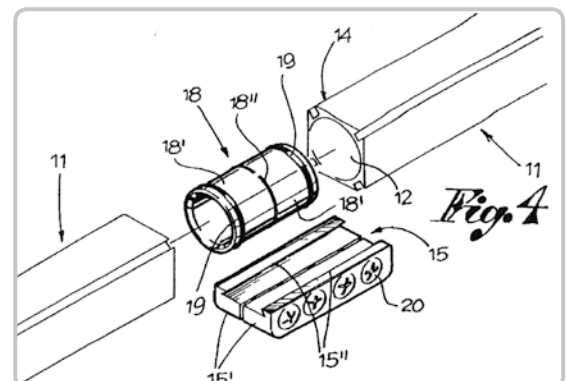

PATENTS

A patent is at the origin of Teseo design philosophy and we are constantly searching for new patented solutions.

Our patents are issued to protect the creativeness of our technical staff and the reliance of our distribution network together with all our customers who are looking for innovation and quality of the products purchased.

At Teseo we consider that the patents are vitally important, and are the only distinguishing marks of the innovative inventors and manufacturers.

Today our R & D Technical office, are managing various patents registered in different countries and developing new patented products also for Design. To make our philosophy more clearly identified and original, Teseo has registered its own trade mark Worldwide.



CERTIFICATION

The Design, production and Quality management is certified according to the standard UNI en ISO 9001. SGS, the most famous certification institute, analyses and approves our management system, with an annual audit for the checking of the level and its improvement.

Teseo components are tested in our internal test department and also through external certified structures SIT, ISPEL, UNI or institutes such as SGS, TUV, TSSA and others.

Our quality management department collaborates with external qualified and experienced consultants in our industrial field.

Teseo components are manufactured with quality raw materials according to standard ISO: UNI en 755-2, UNI EN 755-3, UNI EN 515, UNI EN 573-3, UNI EN 1706, UNI 5931, UNI EN 1461, UNI EN 3601 and others.

Teseo components are tested according to various procedures; The TUV institute checked an assembly of the HBS, testing it to cyclical pressurization; The AQM society tested the principal components of the AP range up to 120 bars with a range of temperature from -20°C to +130°C; the SGS institute certified that the AP system succeeded with the failure test pressure at 160 bars.

The University of Torino independently tests and measures the flow rates of our piping while the Brescia university is co-operating with specific technical consultants.

The calibration tools used in Teseo are regularly tested and certified by MG.

Teseo pipework systems are in compliance with the US standards ANSI B31.3 and B31.9. Approved by the Certification Bodies of the different provinces of Canada

Teseo pipework systems are designed, manufactured and tested according to the safety requirements of the European Standard 97/23/CE (PED).

Kiwa has determined that the quality management system of Teseo Srl meets the requirements of Annex III, E1 of the Pressure Equipment Directive 97/23/CE.



QUALITY

Teseo carries out inspection of all aspects of production to guarantee the suitability of its products. All parts are checked, not only at the manufacturing process but also during all the different assembly processes.

Each item is clearly identified by a product sheet with all the checks to be done according to the critical features of the products and its sizing using a plan sampling according to the standard UNI ISO 2859 that enables us to define a LQA chosen through 1.5, 2.5 and 6.5.



We carry out the quality check of the material by using the sampling frame in accordance with UNI ISO 2859. For each drawing there is a specific check sheet.

In each item sheet there is a list with the checks to be done, according to the criticality of the dimension we settle check coefficient "LQA" (acceptable quality limit). To be chosen among 1.5, 2.5 and 6.5.



Teseo's pipework system undergoes 10 functional, dimensional and aesthetical checks during all the production and packaging processes.

Teseo works with a product traceability process, where specified. This procedure allows Teseo to verify all the documentation in case of a non conformity and to point out the possible faults in the production process. Such procedure enables us to follow up the quality of our products with suppliers.

Further, we have planned preventive checks and settings of our measurement instruments. Written procedures were defined in order to regulate the setting's modalities and their frequency. Such procedures have been set for all those instruments and devices which can affect the safety and the quality of our production.



100% MADE IN ITALY

Teseo co-operates with the main Italian societies, always dedicated in any situation, to the highest levels of quality standards to get the best quality product in each step of its manufacturing process.

Teseo provides to the selection and the follow-up of each supplier based upon the certifications of the manufacturers, a study about relation price/quality, the importance of the supplier on the market, the control declaration sheet about the product, the availability and the modularity, the availability to supply in emergency conditions.

The calibrated pipework is extruded by highly efficient Italian extrusion companies. During the past years, they have succeeded in granting high precision production levels reducing non conformity reports close to zero.

Furthermore, Teseo have succeeded in strengthening business relations with the most Technically advanced manufacturing factories in Italy, they have invested in purchasing machine tools which are in the forefront to manufacture components increasing quality and reliability.

Teseo has a production department for the assembly of the components, where highly qualified staff is used to deal with several components, and are constantly up-dated on a technical and quality basis.

This department is managed according to the same quality management system Teseo uses for all our external suppliers.



HBS HOLLOW BAR SYSTEM

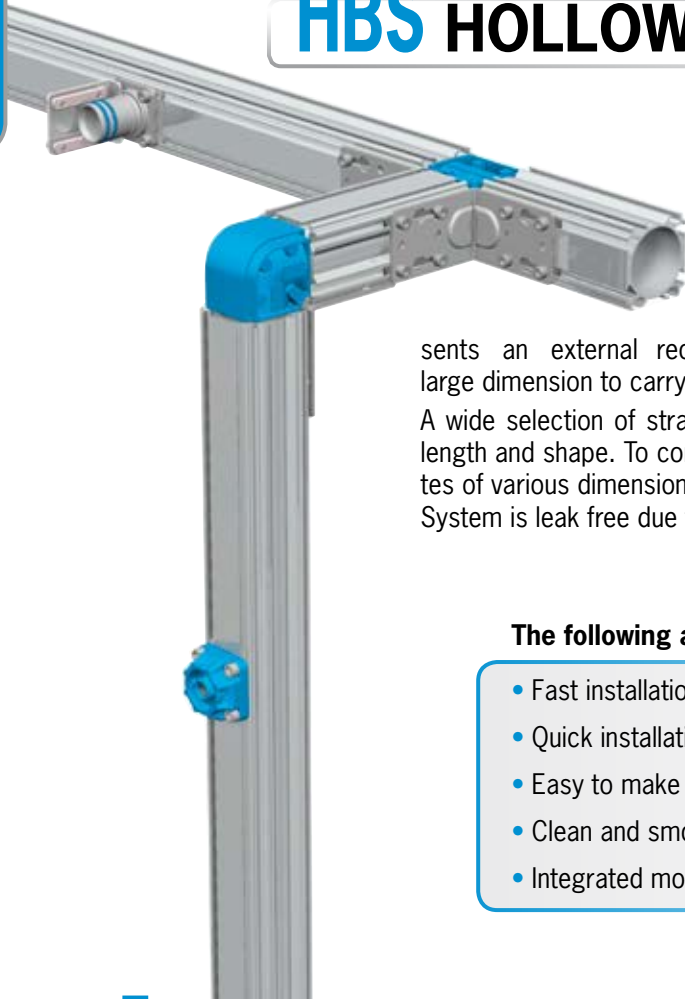

The great innovation of this unique system lies in the methods and means to add lines of compressed air and other fluids under pressure. The system is mainly composed of an extruded aluminium bar, which presents an external rectangular section with tee slots and an internal bore of large dimension to carry a considerable flow of compressed air.

A wide selection of straight joints, T or I joints allows for airlines of whatever length and shape. To complete the equipment we supply a number of outlet plates of various dimensions and shapes. The Teseo Modular aluminium Pipework System is leak free due to positive o-ring seals.

The following advantages stand out:

- Fast installation.
- Quick installation of additional outlets.
- Easy to make changes and add new branch lines.
- Clean and smooth inner and outer surfaces.
- Integrated modular system

EASY TO ASSEMBLE

DEBURRING



MOUNTING

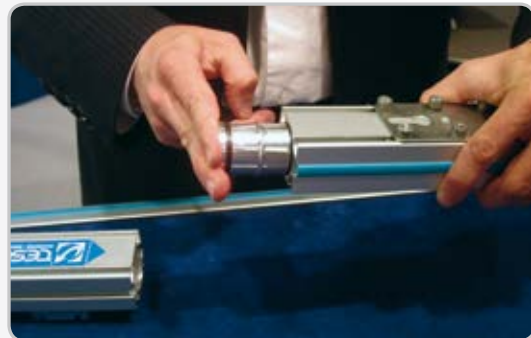

ASSEMBLING



TIGHTENING



BLUE DESIGN

The new generation of the blue in **TESEO** is the result of the modification and the improvement of all the TESEO systems.

Our continuous R & D into **Energy Saving** together with a high regard for the **Design** ruled our technical choices. We studied the internal passages and the thicknesses to increase the flow rates through our tubing.

Double seats for the O-rings and high quality NBR **Blue O-Rings**, manufactured for Teseo, are applied to all the connections for high quality sealing.

Ergonomics of the complete system has been improved thanks to optimization of the shapes and weights. Precision manufacturing carried out on many components improves the outer finishing and removes the die-casting defects.

Outlet plates have been re-designed with new moulds, to improve quality and accuracy.

The blocking parts have been analyzed and improved.

The implementation of accessories and components is continuous.

Teseo are sourcing **New certifications** and international compatibility.



Indicative diagram for the choice of the HBS diameter according to compressor installed max power.

Compressor power kW	HBS	Indicative flow rate (L 30 m - 6 bar - Δp 3%) NI/min
19	25	2.900
36	32	5.400
110	50	16.400
195	63	29.200
350	80	53.000
785	110	117.500

Dipartimento
di Meccanica
Politecnico di Torino



Indicative diagrams of compressed air flow rates and related pressure drops in a line 30 m long (20°C - 1013 mbar).

The data used has been provided by the UNIVERSITY OF TURIN. See online software (page 9)

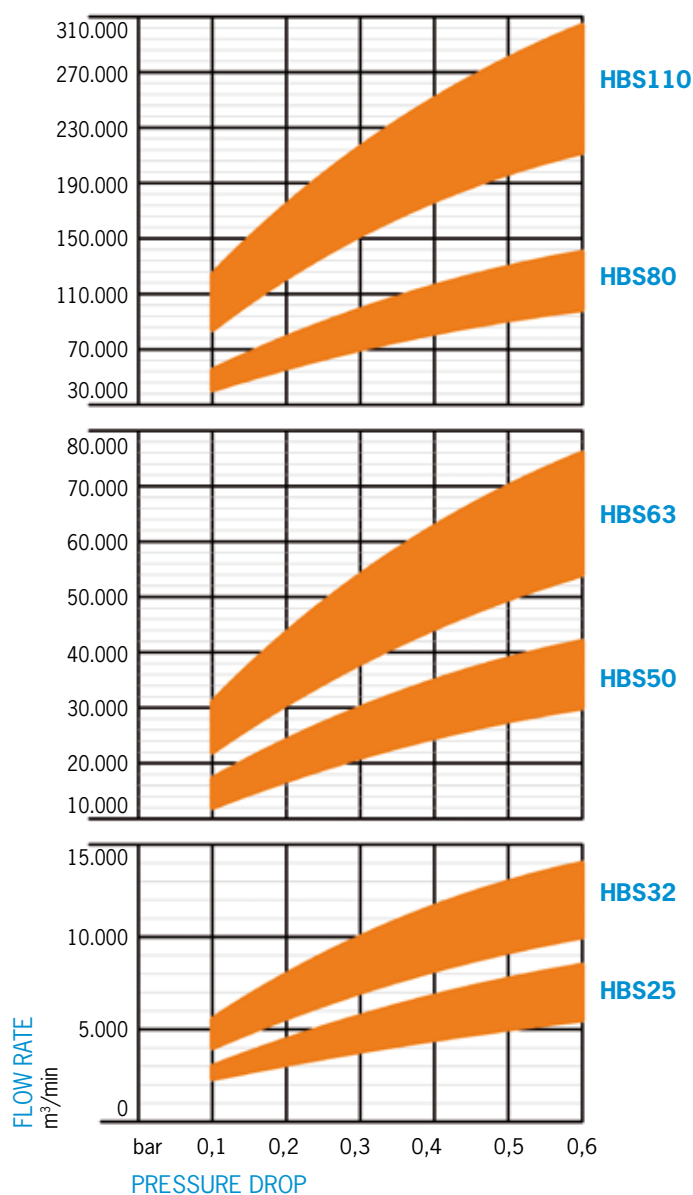

AIR PRESSURE: 6 → 12 bar
0,6 → 1,2 MPa
87 → 174 psi

TECHNICAL CHARACTERISTICS

Extruded Aluminium	Alloy EN AW-6060 UNI EN 573-3:1996
International designations	ANSI 6060 - DIN1748/1: AlMgSi 0,5 BS 6060
Chemical composition	Si: 0,45 - Mg: 0,45 - Fe: 0,3
Heat treatment	Aging T5 o T6
Surface treatment (upon request)	Chemical silver anodization
Specific weight, density	Kg/dm³ 2,71
Electrical conductivity	% IACS 53
Thermal Conductivity	W/m·K 200
Specific heat.....	J/Kg·K 96
Coefficient of expansion.....	mm/m °C 0,024
Tensile strength.....	Kg/mm² 24
Yield strength.....	Kg/mm² 20
Modulus of elasticity	Kg/mm² 6.700
Brinell hardness	HB 70÷80
Melting range.....	°C 600-650
O-ring material	NBR 70
Operating temperature.....	°C -20/+120
Screw material	Steel class 8.8
Screw driving torque	Nm 10÷13,5 (90÷120 Inch Lbs)
Outlet thread	BSP or NPT
Terminal thread	BSP or NPT
Max operating pressure	15 bar - 1,5 MPa - 217 psi
Failure test pressure	56 bar - 5,6 MPa - 813 psi

Compatibility with fluids

Compressed air, Vacuum, Argon, Nitrogen, Carbon dioxide, Mineral oil*, Synthetic oil*, Other fluids*.

WARNING!

Teseo components are intended only to uses for which they have been specifically designed by the manufacturer and patent holder. This does not absolve the professional user to refrain from checking technical compatibility and current project of your application. Our technical department is at your disposal for evaluations, analysis of special use, to design and eventually implement specific components and assemblies. Teseo company is not responsible for any damage caused by improper, erroneous, unreasonable and product incompatibilities with applications not specified by the catalog.

*For further information, please apply to Teseo Srl Technical Office.

PROFILES SECTION OVER VIEW

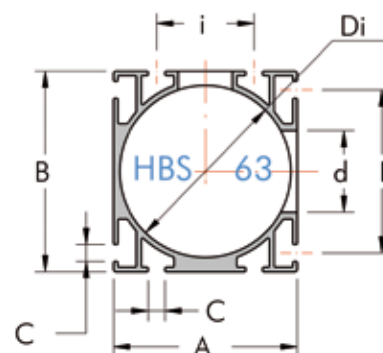
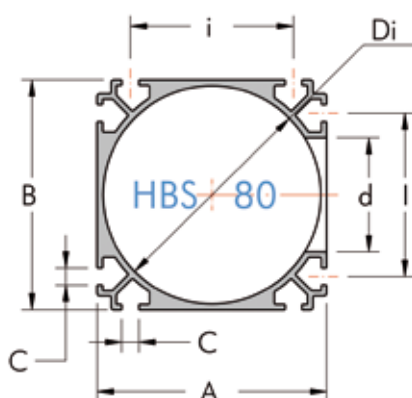
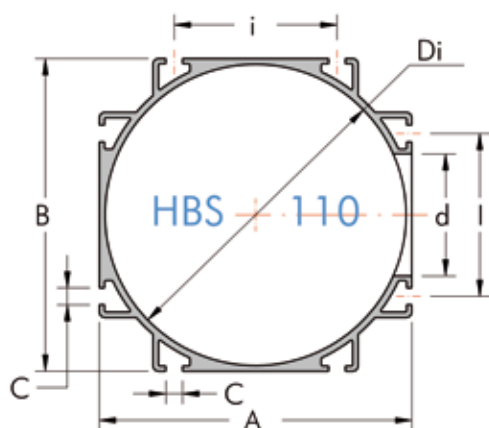
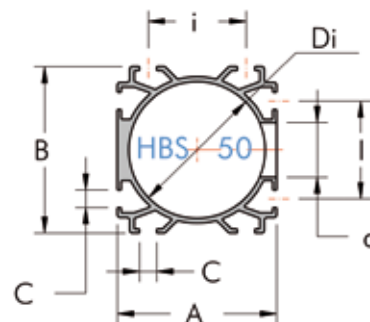
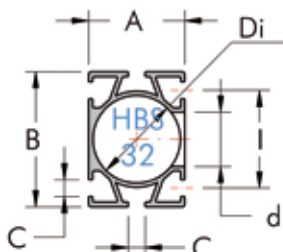
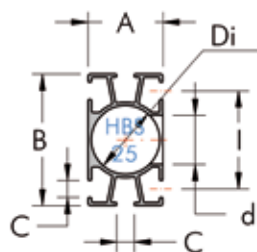

SIZE DIMENSIONS

Name	Dimensions							Max hole	Inner volume	Weight	Moment of inertia		Section area
	Di mm	A mm	B mm	l mm	i mm	C mm	d mm				V l/m	P g/m	
HBS25	25	28	49	36	-	6,2	18	0,5	800	6,70	2,90	5	
HBS32	32	36	50	36	-	6,2	20	0,8	1150	11,90	6,60	8	
HBS50	50	60	60	36	36	6,2	20	2,0	1800	25,00	31,50	20	
HBS63	63	68	74	60	36	6,2	20/30	3,1	2770	74,20	58,80	31	
HBS80	80	85	85	60	60	6,2	42	5,0	3300	120,00	120,00	50	
HBS110	110	115	115	60	60	6,2	43	9,5	4200	265,00	265,00	95	

NATURAL ALUMINIUM EXTRUDED PIPE

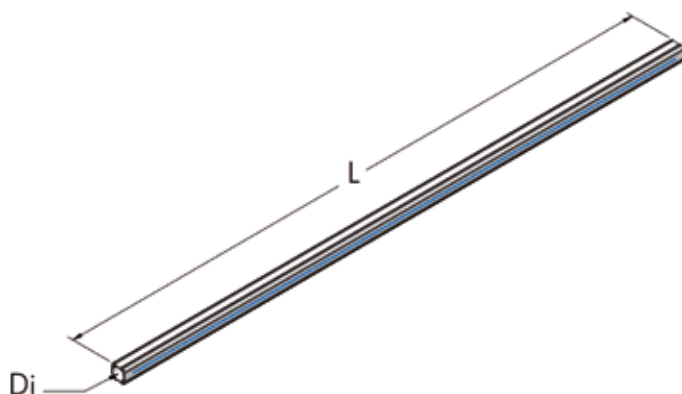

Di mm	L m	Part. no.	P Kg	n°	
25	5	800 028 500	4,0	32	
32	5	800 036 500	5,7	24	
50	5	800 060 500	9,0	16	
63	5	800 068 500	13,8	12	
80	5	800 085 500	16,7	8	
110	5	800 114 500	21,0	4	

Di mm	L m	Part. no.	P Kg	n°	
25	2,5	800 028 250	2,0	32	
32	2,5	800 036 250	2,9	24	
50	2,5	800 060 250	4,5	16	
63	2,5	800 068 250	6,9	12	
80	2,5	800 085 250	8,3	8	
110	2,5	800 114 250	10,5	4	

ANODIZED ALUMINIUM EXTRUDED PIPE

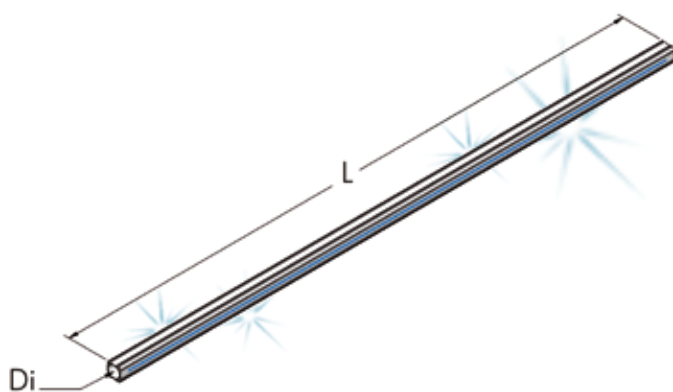

Di mm	L m	Part. no.	P Kg	n°	
25	5	801 028 500	4,0	32	
32	5	801 036 500	6,3	24	
50	5	801 060 500	9,5	16	
63	5	801 068 500	14,0	12	
80	5	801 085 500	17,0	8	
110	5	801 114 500	21,3	4	

Di mm	L m	Part. no.	P Kg	n°	
25	2,5	801 028 250	2,0	32	
32	2,5	801 036 250	3,1	24	
50	2,5	801 060 250	4,7	16	
63	2,5	801 068 250	7,0	12	
80	2,5	801 085 250	8,5	8	
110	2,5	801 114 250	10,6	4	

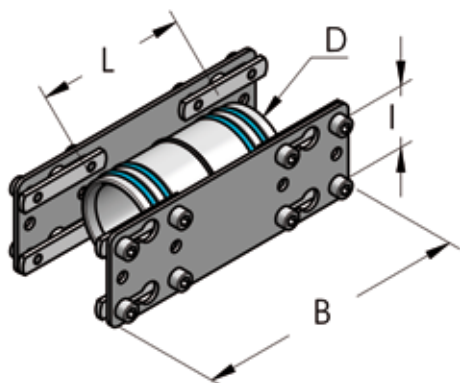
STRAIGHT JOINT, COMPLETE

D mm	I mm	L mm	B mm	Part. no.	P g	 n°
25*	36	50	120	003 000 020	180	20
32*	36	65	120	003 001 020	200	20
50	36	90	160	003 002 020	570	10
63	36-60	106	160	003 003 020	770	10
80	60	130	160	003 004 020	950	10
110	60	180	230	003 005 020	2000	5

* It is suggested to the user, if the application makes it necessary, the implementation with the components:
711 048 120 + 725 010 056 + 212 006 008 (Page 31 and 32)

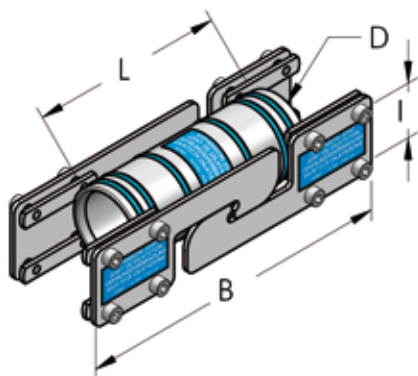
SLIDING JOINT, COMPLETE

D mm	I mm	L mm	B mm	Part. no.	P g	 n°
25	36	75	200	003 000 021	420	10
32	36	95	200	003 001 021	450	10
50	36	130	200	003 002 021	780	10
63	60	150	200	003 003 021	1000	5
80	60	180	200	003 004 021	1400	5
110	60	280	280	003 005 021	2500	5

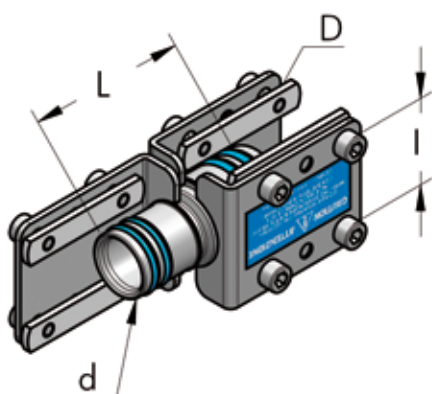
REDUCTION JOINT STRAIGHT, COMPLETE

D mm	d mm	L mm	I mm	Part. no.	P g	 n°
32	25	66	36	003 001 049	270	10
50	32	88	36	003 002 049	621	10
63	50	105	36	003 003 049	777	5
80	63	125	60	003 004 049	1470	5
110	80	280	60	003 005 049	3000	2

L JOINT, COMPLETE

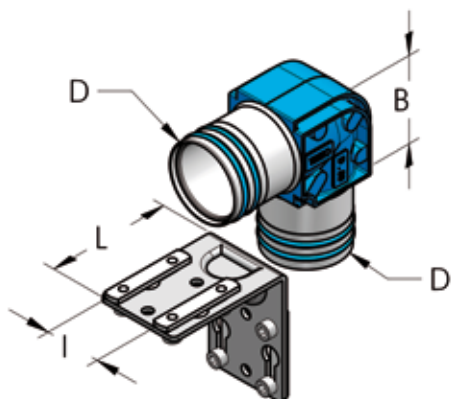

D mm	I mm	L mm	B mm	Part. no.	P g	n°
25	36	60	30	003 000 022	240	20
32	36	60	42	003 001 022	280	20
50	36	80	60	003 002 022	530	10
63	36-60	80	75	003 003 022	1400	10
80	60	80	85	003 004 022	2600	10
110	60	110	165	003 005 022	3000	5

T JOINT, COMPLETE

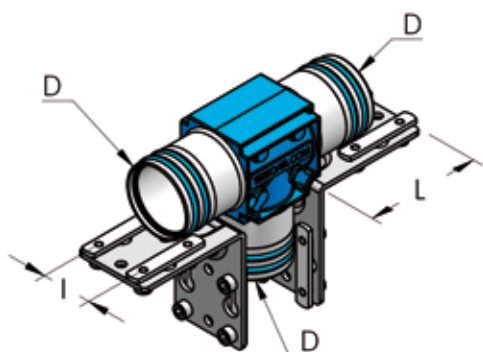

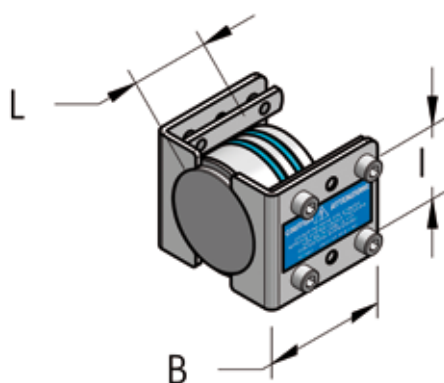

D mm	I mm	L mm	B mm	Part. no.	P g	n°
25	36	60	30	003 000 024	400	10
32	36	60	50	003 001 024	430	10
50	36	80	60	003 002 024	820	10
63	36-60	80	75	003 003 024	2100	10
80	60	80	85	003 004 024	3500	5
110/80	60	110	230	003 005 023	3900	2
110	60	110	230	003 005 024	4000	2

CLOSED TERMINAL, COMPLETE

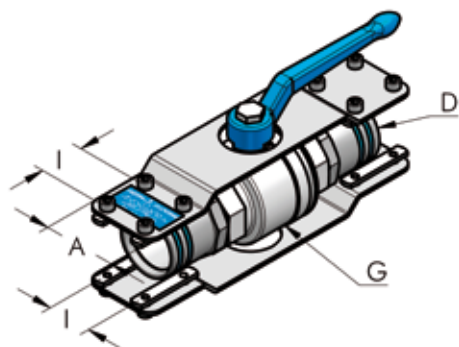

D mm	I mm	L mm	B mm	Part. no.	P g	n°
25	36	29	60	003 000 026	120	20
32	36	32	60	003 001 026	120	20
50	36	40	60	003 002 026	430	10
63	60	40	60	003 003 026	700	10
80	60	66	80	003 004 026	1350	5
110	60	150	110	003 005 026	2000	2

BALL VALVE, COMPLETE

D mm	G	I mm	A mm	Part. no.	P g	 n°
25	3/4" - BSP	36	50	003 000 046	630	10
32	1" - BSP	36	50	003 001 046	1120	10
50	1 1/2" - BSP	36	60	003 002 046	2050	10
63	2" - BSP	36	60	003 003 046	3360	10
80	2 1/2" - BSP	60	72	003 004 046	5300	5
110	4" - BSP	60	78	003 005 046	12600	2

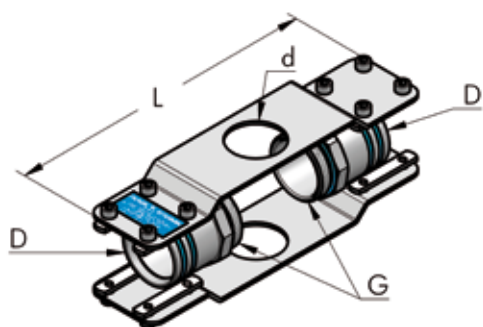
KIT FOR BALL VALVE

D mm	G	L mm	d mm	Part. no.	P g	 n°
25	3/4" - BSP	220	30	003 000 047	340	10
32	1" - BSP	220	30	003 001 047	650	10
50	1 1/2" - BSP	250	42	003 002 047	740	10
63	2" - BSP	250	42	003 003 047	910	10
80	2 1/2" - BSP	-	-	003 004 047	1400	5

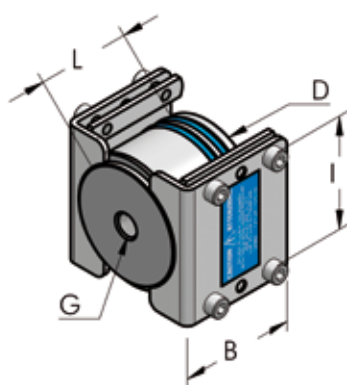
TERMINAL WITH THREADED HOLE, COMPLETE

D mm	G	L mm	B mm	I mm	Part. no.	P g	 n°
25	1/4" - BSP	28	60	36	003 000 025	114	20
32	1/4" - BSP	32	60	36	003 001 025	130	20
32	1/2" - BSP	32	60	36	003 001 031	128	20
50	1/4" - BSP	40	60	36	003 002 025	440	20
50	1/2" - BSP	50	60	36	003 002 029	430	20
63	1/4" - BSP	50	60	60	003 003 025	656	20
80	1/4" - BSP	66	80	60	003 004 025	1300	20
80	1/2" - BSP	66	80	60	003 004 029	1300	20
110	3/8" - BSP	150	110	60	003 005 025	2000	2

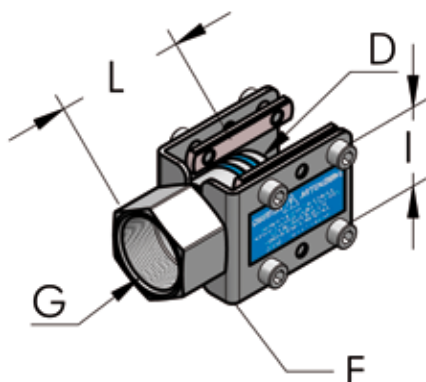
TERMINAL THREADED FEMALE, COMPLETE

D mm	G	E mm	L mm	I mm	Part. no.	P g	n°
25	3/4" - BSP	30	45	36	003 000 027	120	20
32	1" - BSP	36	60	36	003 001 027	140	20
50	1 1/2" - BSP	52	70	36	003 002 028	340	20
63	1 1/2" - BSP	65	72	60	003 003 028	440	10
80	1" - BSP	-	66	60	003 004 027	1300	20
80	2" - BSP	82	95	60	003 004 028	920	10
110	2 1/2" - BSP	115	150	60	003 005 028	2000	2

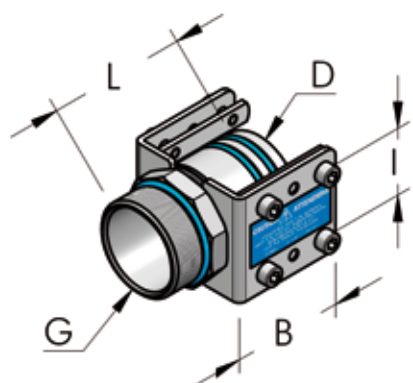
NIPPLE THREADED MALE, COMPLETE



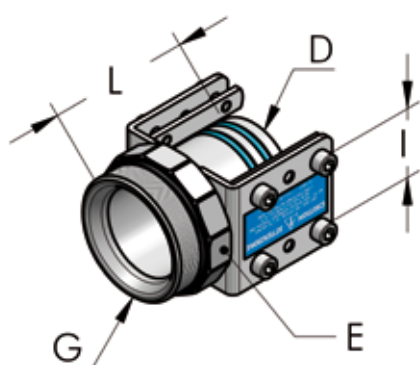



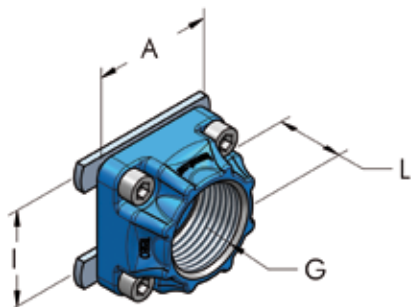

D mm	G	L mm	B mm	I mm	Part. no.	P g	n°
25	3/4" - BSP	47	60	36	003 000 029	110	20
32	1" - BSP	55	60	36	003 001 030	230	20
50	1 1/2" - BSP	76	60	36	003 002 030	330	20
63	2" - BSP	80	60	60	003 003 030	430	10
80	2 1/2" - BSP	100	80	60	003 004 030	650	10

TERMINAL THREADED MALE, COMPLETE

D mm	G	L mm	E mm	I mm	Part. no.	P g	n°
25	1" - BSP	45	36	36	003 000 030	130	20
32	1 1/4" - BSP	61	50	36	003 001 029	190	20
50	2" - BSP	75	65	36	003 002 031	440	20
63	2 1/2" - BSP	90	82	60	003 003 031	600	10
80	3" - BSP	110	90	60	003 004 031	830	10
110	4" - BSP	152	115	60	003 005 031	1500	5







FEMALE OUTLET PLATE, COMPLETE

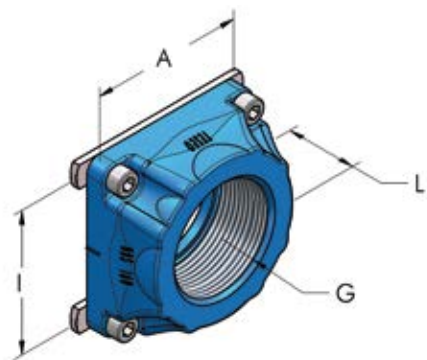

I mm	G	A mm	L mm	Part. no.	P g	n°	
36	1/8" - BSP	50	25	003 001 032	80	20	
36	1/4" - BSP	50	25	003 001 033	80	20	
36	3/8" - BSP	50	25	003 001 034	80	20	
36	1/2" - BSP	50	25	003 002 033	110	20	
36	3/4" - BSP	50	25	003 002 034	105	20	
36	1" - BSP	50	25	003 002 035	90	20	







FEMALE OUTLET PLATE, COMPLETE

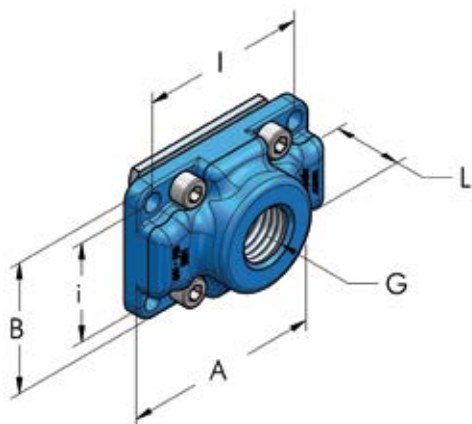

I mm	G	A mm	L mm	Part. no.	P g	n°	
60	1/2" - BSP	72	30	003 003 033	250	10	
60	3/4" - BSP	72	30	003 003 034	220	20	
60	1" - BSP	72	30	003 003 035	200	10	
60	1 1/2" - BSP	72	30	003 003 036	150	10	
60	1 1/4" - BSP	72	30	003 003 038	175	10	
60	2" - BSP	72	30	003 003 039	193	10	

MODULAR OUTLET PLATE



I mm	i mm	G	A mm	B mm	L mm	Part. no.	P g	n°	
60	36	1/8" - BSP	72	48	25	003 360 030	140	10	
60	36	1/4" - BSP	72	48	25	003 360 031	137	10	
60	36	3/8" - BSP	72	48	25	003 360 032	133	10	
60	36	1/2" - BSP	72	48	25	003 360 033	129	10	
60	36	3/4" - BSP	72	48	25	003 360 034	125	10	
60	36	1" - BSP	72	48	25	003 360 035	120	10	

MALE OUTLET PLATE, COMPLETE

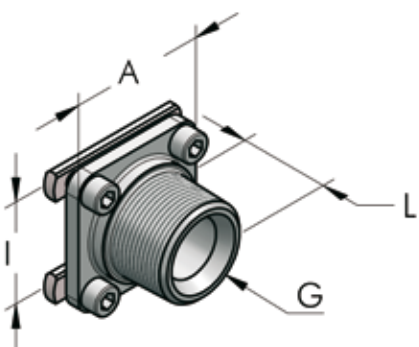

I mm	G	A mm	L mm	Part. no.	P g	n°	
36	1" - BSP	48	32	003 002 036	120	20	
60	2" - BSP	70	49	003 004 036	600	10	

FEMALE MULTIPLE OUTLET PLATE, COMPLETE

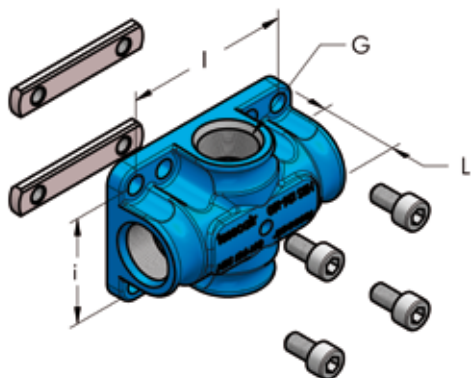

I mm	i mm	Holes	G	L mm	Part. no.	P g	n°	
36	36	2	1/4" - BSP	24	003 001 036	120	20	
36	36	2	3/8" - BSP	24	003 001 037	115	20	
36	36	4	1/4" - BSP	24	003 001 038	110	20	
36	36	4	3/8" - BSP	24	003 001 039	100	20	
60	36	4	1/4" - BSP	30	003 360 054	190	10	
60	36	4	3/8" - BSP	30	003 360 056	175	10	
60	36	4	1/2" - BSP	30	003 360 058	150	10	
60	36	2	1/2" - BSP	30	003 360 059	160	10	

REDUCTION PLATE, COMPLETE

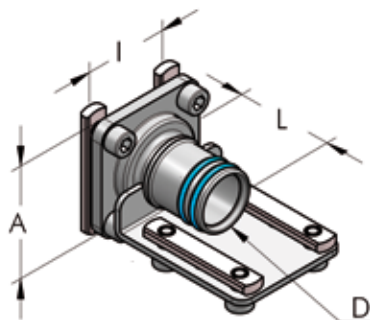

D mm	I mm	A mm	L mm	Part. no.	P g	n°	
25	36	48	40	003 000 037	190	20	
32	36	48	44	003 002 037	200	20	
50	60	70	60	003 003 037	530	10	
63	60	70	72	003 004 037	610	10	

CONDENSATE LEVEL SPY HOLE

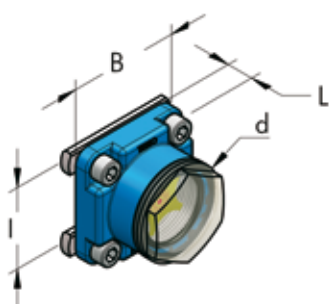

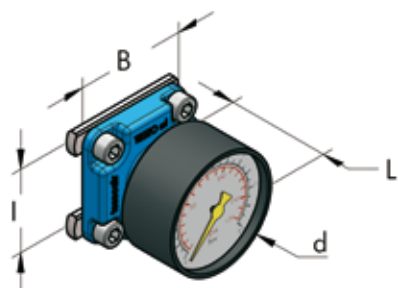

I mm	d mm	L mm	B mm	Part. no.	P g	n°	
36	40	10	48	003 001 044	100	20	
60	40	12	72	003 003 044	180	10	

MANOMETER, COMPLETE

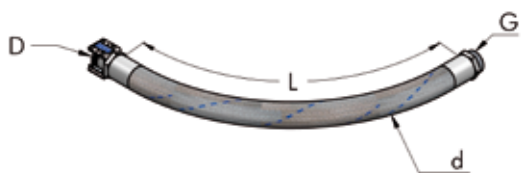

I mm	d mm	L mm	B mm	Part. no.	P g	n°	
36	50	45	48	003 001 048	144	10	
60	50	55	72	003 003 048	205	10	

FLEXIBLE PIPE FOR CONNECTION TO COMPRESSOR

D mm	G	L mm	d mm	Part. no.	P g	 n°
25	1" - BSP	1000	37	003 000 058	1700	20
32	1"1/4 - BSP	1000	44	003 001 058	2200	20
50	2" - BSP	1000	65	003 002 058	4000	20
63	2"1/2 - BSP	1300	77	003 003 058	4700	20
80	3" - BSP	1600	90	003 004 058	5800	20

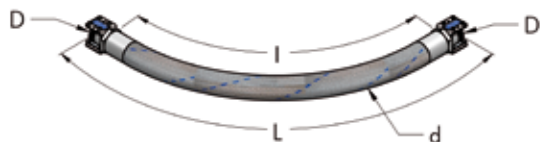
FLEXIBLE JOINT FOR HBS-HBS CONNECTION

D mm	d mm	L mm	I mm	Part. no.	P g	 n°
25	37	1000	1050	003 000 059	1900	10
32	44	1000	1080	003 001 059	2400	10
50	65	1000	1100	003 002 059	4300	10
63	77	1300	1450	003 003 059	5000	10
80	90	1600	1800	003 004 059	6300	10

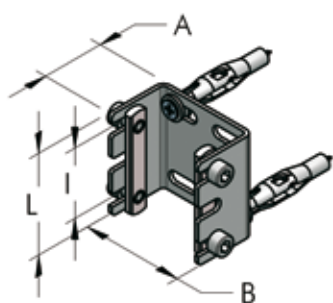
U BRACKET, COMPLETE

I mm	B mm	L mm	A mm	Part. no.	P g	 n°
36	50	52	30	003 000 040	140	20

For HBS 25 Only

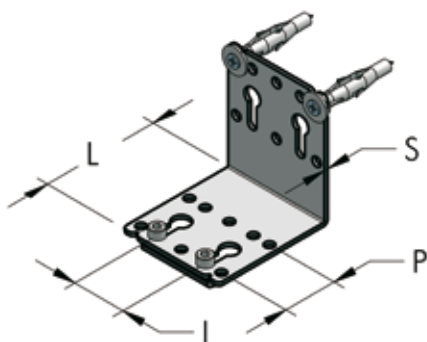
L PLATE, COMPLETE

I mm	P mm	L mm	S mm	Part. no.	P g	 n°
36	36	60	2	003 001 040	100	20
36-60	36	80	3	003 003 040	260	20
36-60	36-60	140	3,5	003 004 040	430	20

HANGING BRACKET

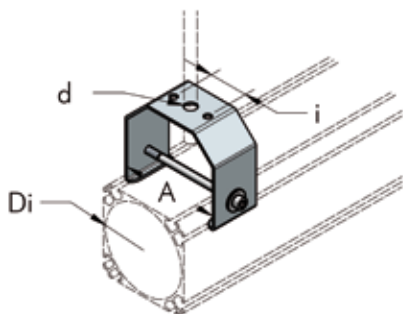

Di mm	A mm	d mm	i mm	Part. no.	P g	n°
63	68	11	36	003 003 073	395	10
80	85	11	36	003 004 073	391	10
110	115	11	36	003 005 073	481	10

SUPPORT BRACKET, COMPLETE

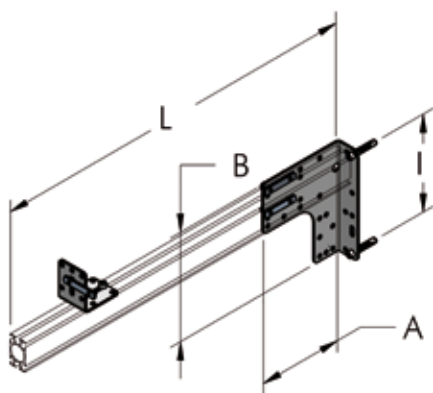

A mm	B mm	I mm	L mm	Part. no.	P g	n°
130	170	140	600	003 001 070	1300	10
130	170	140	*	003 001 071	360	10

*without bar

ADHESIVE COLOUR STICKERS



L mm	Colour	Part. no.	P g	n°
310	Blue RAL 5015	104 025 150	29	11
310	Brown RAL 8003	104 028 316	29	11
310	Grey RAL 7000	104 028 317	29	11
310	Red RAL 3020	104 028 318	29	11
310	Yellow RAL 1028	104 028 319	29	11
310	Green RAL 6029	104 028 315	29	11

DEMO SUIT-CASE

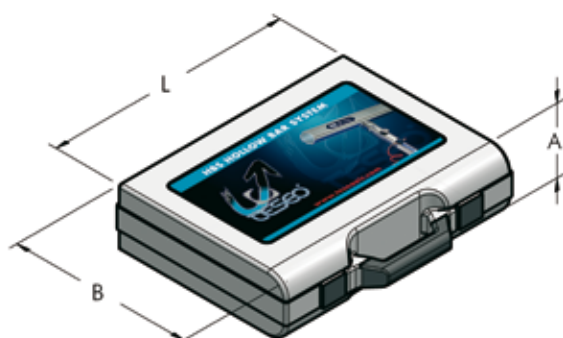

A mm	B mm	L mm	Configuration	Part. no.	P g	n°
130	380	490	22 HBS parts	003 001 090	4500	1

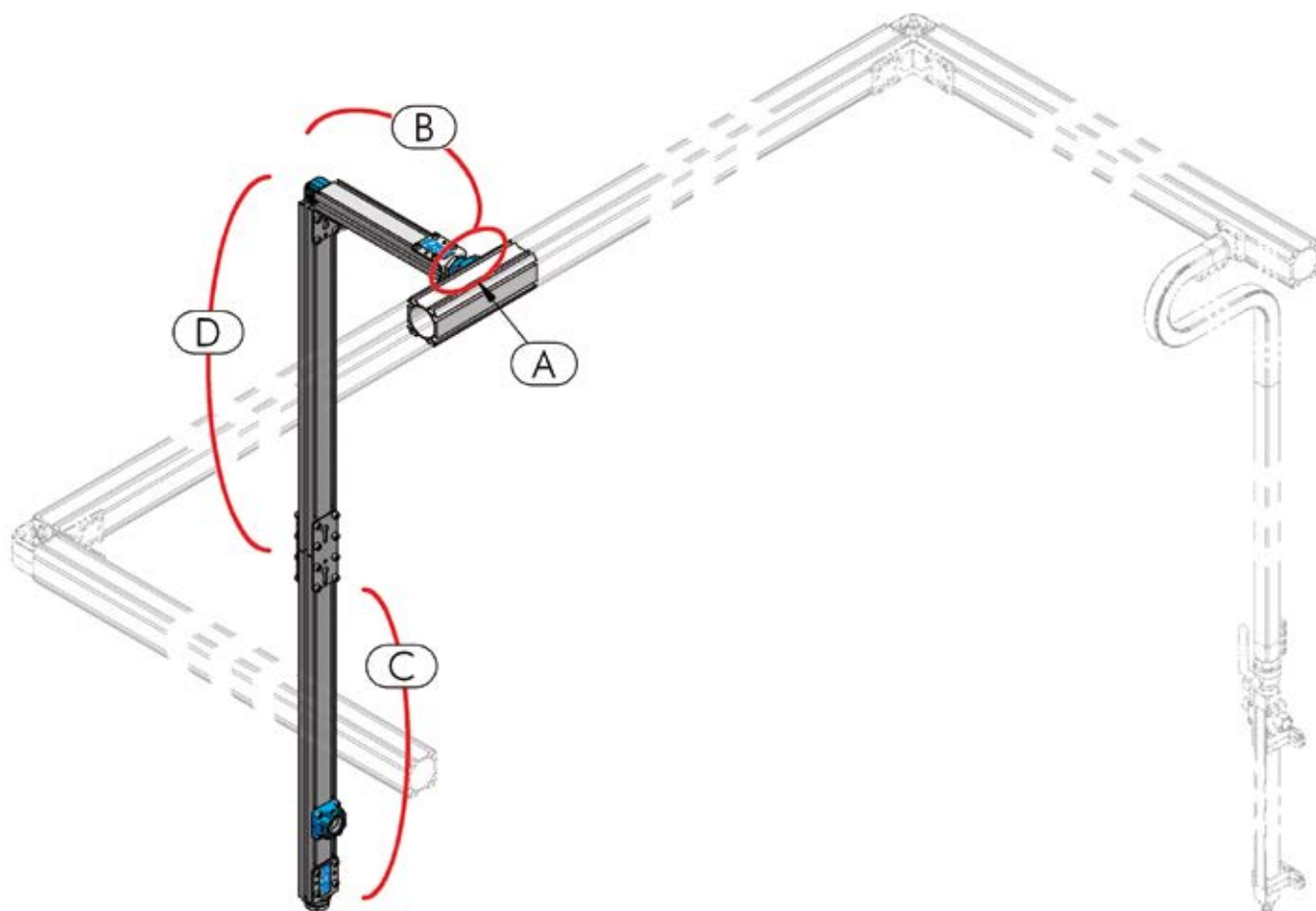

CREATE YOUR DROP COLUMN

- A - Confirm the characteristics of your main line and of the secondary lines that derive from it, to define a components list.
- B - Study the route from the main line that the secondary lines have to take and choose the components and pipework needed.
- C - Define the types of end of line attachments required and choose the appropriate components.
- D - Verify the pipework's route from B to C and choose the quantity of pipework and the components needed

A	HBS pages 24-25-26-30
	AP pages 50
B	HBS pages 20-22-27
	AP pages 42-43-46-51-52
C	HBS pages 20-21-22-23-24-25-26-27-30
	AP pages 43-44-45-46-47-51
D	HBS pages 20-21-30
	AP pages 42-43

REDUCTION PLATE FOR D14 COLUMN, COMPLETE

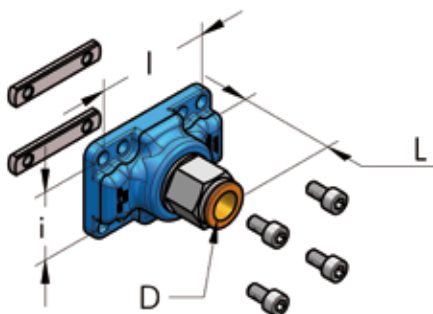

I mm	i mm	D mm	L mm	Part. no.	P g	n°	
36	36	14	50	003 001 134	160	20	
60	60	14	55	003 003 134	300	20	
60	36	14	55	003 360 134	170	20	

3 OUTLET BLOCK FOR COLUMN DROP D14, COMPLETE

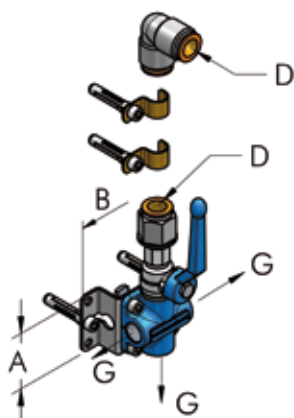

D mm	G	A mm	B mm	Part. no.	P g	n°	
14	3/8" - BSP	48	85	003 001 068	500	20	
14	1/2" - BSP	48	85	003 002 068	520	20	

STRAIGHT PIPE FOR COLUMN DROP D14

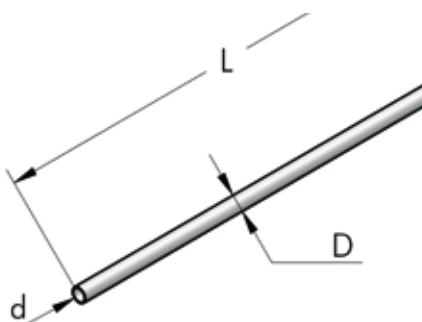

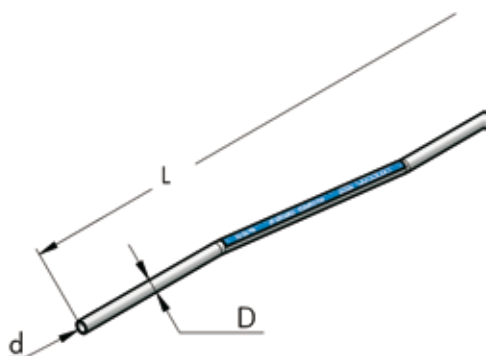

D mm	d mm	L m	Part. no.	P g	n°	
14	12	1	425 014 100	106	20	
14	12	5	425 014 500	530	20	

BENT PIPE FOR COLUMN DROP D14

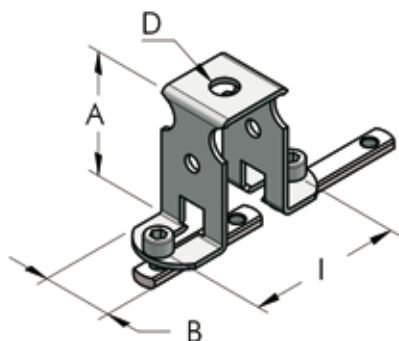

D mm	d mm	L m	Part. no.	P g	n°	
14	12	5	804 014 500	535	20	

HANGING BRACKET, COMPLETE

I mm	A mm	B mm	D mm	Part. no.	P g	 n°
36-60	50	28	10	003 001 074	100	20

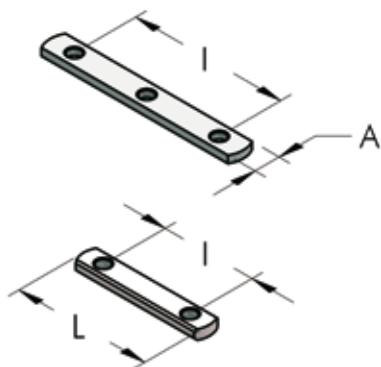
SMALL PLATE WITH M6 HOLES

I mm	A mm	L mm	holes	Part. no.	P g	 n°
36	10	56	2	725 010 056	12	100
60	10	80	2	725 010 080	23	50
60	10	78	3	725 010 081	22	50

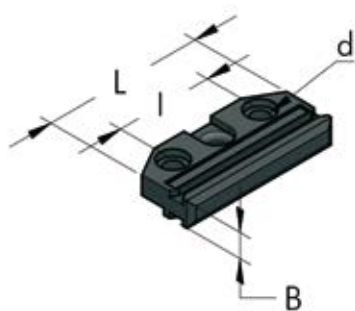
INSULATING BLOCK

d mm	L mm	I mm	B mm	Part. no.	P g	 n°
6	60	36	10	003 001 075	26	20

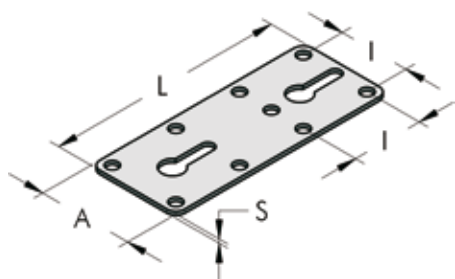
STRAIGHT PLATE, IN GALVANIZED STEEL

A mm	L mm	I mm	S mm	Part. no.	P g	 n°
48	120	36	2	711 048 120	80	20
54	160	36	2,5	711 056 160	146	20
72	160	36-60	2,5	711 072 160	201	20
78	240	36-60	3,5	711 078 230	422	20

L PLATE, IN GALVANIZED STEEL

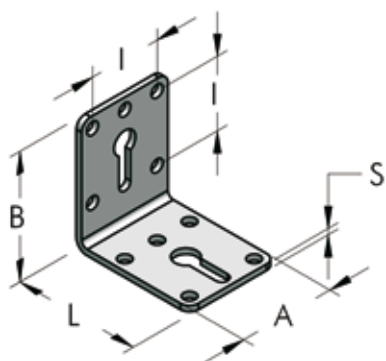

A mm	B mm	L mm	I mm	S mm	Part. no.	P g	n°
48	60	60	36	2	721 048 060	77	20
54	80	80	36	2,5	732 056 080	148	20
72	80	80	36-60	3	732 072 090	245	20
78	94	140	36-60	3,5	732 078 140	420	20

FIXING BRACKET, IN GALVANIZED STEEL

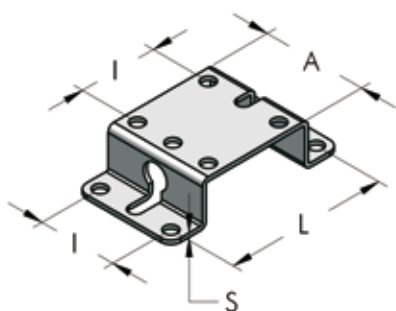

A mm	L mm	I mm	S mm	Part. no.	P g	n°
48	72	36	2	735 048 120	78	20

O-RING SEAL IN NBR70

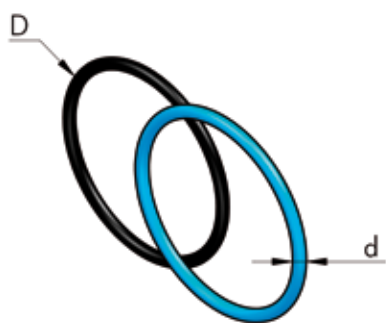

D mm	d mm	Cod. AS-BS	Part. no.	P g	n°
25	1,78	2081-019	271 020 002	0,4	100
25	2	0210-02	271 021 002	0,5	100
29	3	0230-03	271 023 003	0,7	100
32	2,62	3106-121	271 027 003	0,7	100
32	3	0260-03	271 026 003	0,8	100
50	2,62	3175-132	271 044 003	1	100
50	3	0440-03	271 043 003	1,3	100
63	2,62	3225-140	271 057 003	1,2	100
63	3	0560-03	271 056 003	1,5	100
80	3	0720-03	271 072 003	2,2	100
80	2,62	3287-150	271 073 003	1,5	100
110	3,53	4387-241	271 101 004	4	100

ALLEN SCREW, IN GALVANIZED STEEL

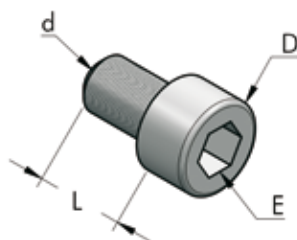

d mm	L mm	D mm	E mm	Part. no.	P g	n°
M6	8	10	5	212 006 008	4,2	100
M6	10	10	5	212 006 010	4,5	100
M6	12	10	5	212 006 012	4,8	100
M6	14	10	5	212 006 014	5,0	100
M6	18	10	5	212 006 018	5,8	100

BASIC TOOLS BOX

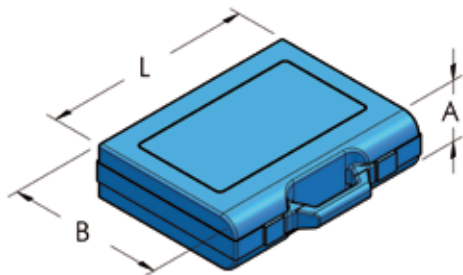

A mm	B mm	L mm	Part. no.	P g	 n°
50	190	240	003 001 092	700	1

DRILLING JIG

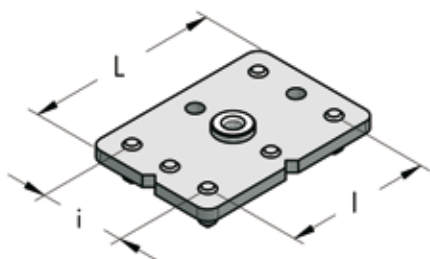

l mm	i mm	L mm	Part. no.	P g	 n°
60	36	80	911 036 060	190	1

TUBES TO HOLD SMALL PLATE IN POSITION

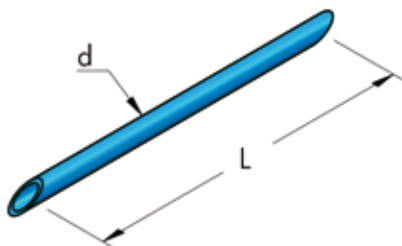

d mm	L mm	Mat	Part. no.	P g	 n°
8	150	PVC	421 006 015	5	10

VASELINE GREASE



Part. no.	P g	 n°
111 003 100	850	20
111 003 010	100	20

PTFE BLUE GREASE

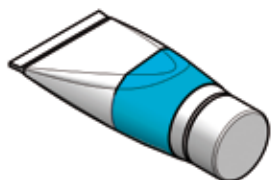

Part. no.	P g	 n°
114 003 005	50	20

TERMINAL WITH THREADED HOLE, COMPLETE

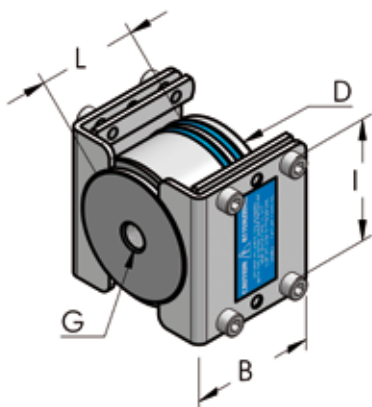

D mm	G	L mm	B mm	I mm	Part. no.	P g	n°	
25	1/4" - NPT	22	60	36	003 000 425	114	20	
32	1/4" - NPT	25	60	36	003 001 425	130	20	
32	1/2" - NPT	25	60	36	003 001 431	128	20	
50	1/4" - NPT	40	60	36	003 002 425	440	20	
50	1/2" - NPT	40	60	36	003 002 429	430	20	
63	1/4" - NPT	50	60	60	003 003 425	656	20	
80	1/4" - NPT	66	80	60	003 004 425	1300	20	
80	1/2" - NPT	66	80	60	003 004 429	1300	20	
110	3/8" - NPT	203	110	60	003 005 425	2000	20	

TERMINAL THREADED FEMALE, COMPLETE

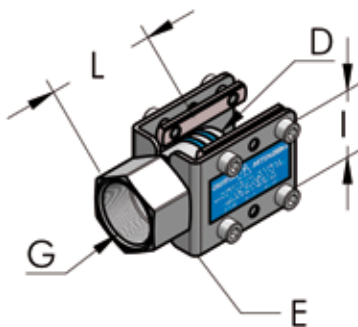

D mm	G	E mm	L mm	I mm	Part. no.	P g	n°	
25	3/4" - NPT	30	40	36	003 000 427	120	20	
32	1" - NPT	36	50	36	003 001 427	140	20	
50	1 1/2" - NPT	52	70	36	003 002 428	340	20	
63	1 1/2" - NPT	65	75	60	003 003 428	440	10	
80	1" - NPT	-	66	60	003 004 427	920	20	
80	2" - NPT	82	95	60	003 004 428	920	10	
110	2 1/2" - NPT	115	150	60	003 005 428	2000	20	

NIPPLE THREADED MALE, COMPLETE

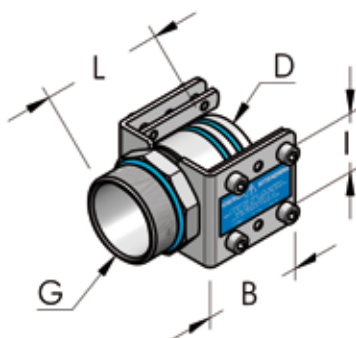

D mm	G	L mm	B mm	I mm	Part. no.	P g	n°	
25	3/4" - NPT	36	60	36	003 000 429	110	20	
32	1" - NPT	44	60	36	003 001 430	230	20	
50	1 1/2" - NPT	75	60	36	003 002 430	330	20	
63	2" - NPT	80	60	60	003 003 430	430	10	
80	2 1/2" - NPT	102	80	60	003 004 430	650	10	

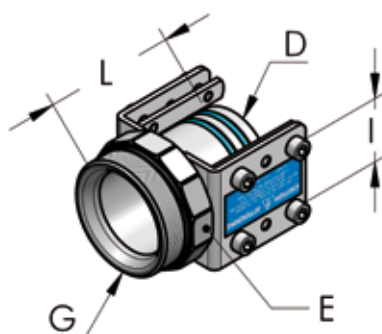

TERMINAL THREADED MALE, COMPLETE



D mm	G	L mm	E mm	I mm	Part. no.	P g	n°	
25	1" - NPT	40	36	36	003 000 430	130	20	
32	1 1/4" - NPT	52	50	36	003 001 429	190	20	
50	2" - NPT	75	65	36	003 002 431	440	20	
63	2 1/2" - NPT	90	82	60	003 003 431	600	10	
80	3" - NPT	120	90	60	003 004 431	830	10	
110	4" - NPT	150	115	60	003 005 431	1500	20	

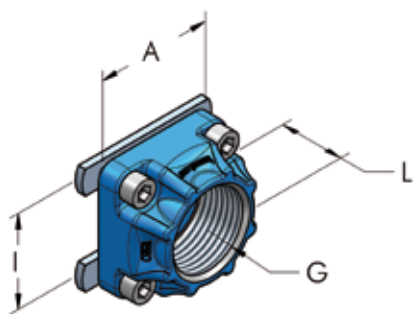





FEMALE OUTLET PLATE, COMPLETE

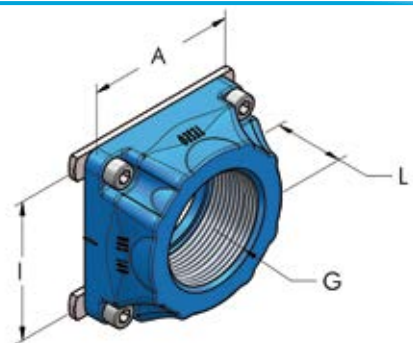

I mm	G	A mm	L mm	Part. no.	P g	n°	
36	1/8" - NPT	50	25	003 001 432	80	20	
36	1/4" - NPT	50	25	003 001 433	80	20	
36	3/8" - NPT	50	25	003 001 434	80	20	
36	1/2" - NPT	50	25	003 002 433	110	20	
36	3/4" - NPT	50	25	003 002 434	105	20	
36	1" - NPT	50	25	003 002 435	90	20	



FEMALE OUTLET PLATE, COMPLETE



I mm	G	A mm	L mm	Part. no.	P g	n°	
60	1/2" - NPT	70	30	003 003 433	250	10	
60	3/4" - NPT	72	30	003 003 434	220	20	
60	1" - NPT	72	30	003 003 435	200	10	
60	1 1/2" - NPT	72	30	003 003 436	150	10	
60	1 1/4" - NPT	72	30	003 003 438	175	10	
60	2" - NPT	72	30	003 003 439	193	10	

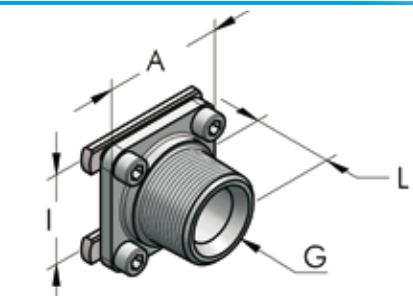



MALE OUTLET PLATE, COMPLETE

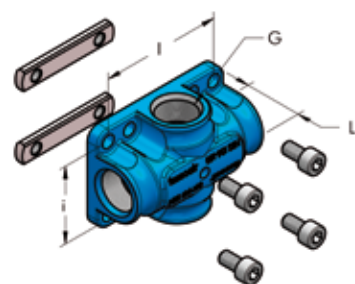

I mm	G	A mm	L mm	Part. no.	P g	n°	
36	1" - NPT	48	36	003 002 436	120	20	
60	2" - NPT	70	49	003 004 436	600	10	







FEMALE MULTIPLE OUTLETS PLATE, COMPLETE

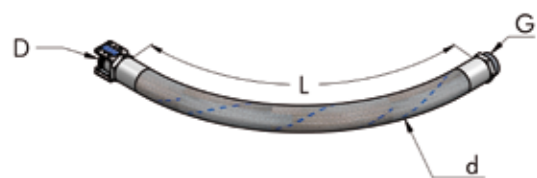

I mm	holes	G	L mm	Part. no.	P g	n°	
36	2	1/4" - NPT	24	003 001 436	120	20	
36	2	3/8" - NPT	24	003 001 437	115	20	
36	4	1/4" - NPT	24	003 001 438	110	20	
36	4	3/8" - NPT	24	003 001 439	100	20	

FLEXIBLE PIPE FOR CONNECTION TO COMPRESSOR



D mm	G	L mm	d mm	Part. no.	P g	n°	
25	1" - NPT	1000	37	003 000 458	1700	20	
32	1 1/4" - NPT	1000	44	003 001 458	2200	20	
50	2" - NPT	1000	65	003 002 458	4000	20	
63	2 1/2" - NPT	1300	77	003 003 458	4700	20	
80	3" - NPT	1600	90	003 004 458	5800	20	

COMPRESSED AIR AND FLUIDS PIPING SYSTEMS



MODULAR MANIFOLDS INTEGRATED ON MACHINES

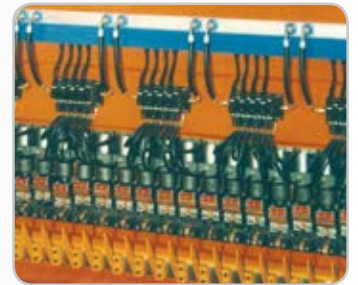

ASSEMBLY AND PRODUCTION LINES





AP MODULAR PIPING SYSTEM

This product patented by Teseo is the result of years of research and experience in installing thousands of distribution systems made up of aluminium profiles all over the world. AP is suitable for compressed air distribution lines or for main line drops.

The following advantages stand out:

- Easy and quick to assemble, no special tools required, it can be assembled without special skills.
- Its simple section is symmetric and can be used on all the sides. Easy to cut and bend.
- Equipped with numerous accessories which are designed of simple modular elements compatible both with the present HBS system and steel pipes with "Gas" BSP or NPT threads.
- A very competitive price, thanks to the quick mounting, AP is more convenient than a traditional piping system.

EASY TO ASSEMBLE

DEBURRING



MOUNTING



ASSEMBLING



TIGHTENING

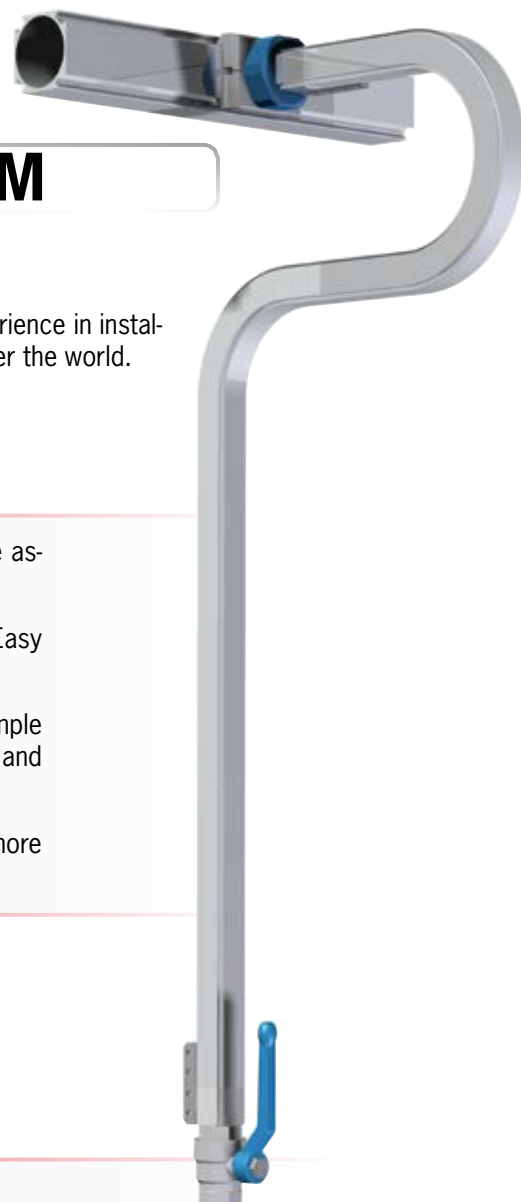

BLUE DESIGN

The new generation of “blue” in **TESEO** is the result of the modification and the improvement of all the Teseo systems. Our continuous research into **Energy Saving** together with a high regard for the **Design** ruled our technical choices. We studied the internal passages and the thicknesses to increase the flow rate.

Double seats for the O-rings and high quality NBR **Blue O-Rings**, manufactured for Teseo, are applied to all the connections for a better sealing.

Ergonomics of the complete system has been improved thanks to optimization of the shapes and weights. Precision manufacturing carried out on many components improves the outer finishing and removes the die-casting defects.

Outlet plates plates have been re designed with new moulds, to improve quality and accuracy. The blocking parts have been analyzed and improved.

The implementation of accessories and components is continuous.

Teseo are sourcing **New certifications** and international confirmation.



Indicative diagram for the choice of the AP diameter according to compressor installed max power

Compressor power	AP	Indicative flow rate (L 30m - 6 bar - Δp 3%)
kW		l/min
11	22	1.650
19	28	2.900
67	45	10.000
110	54	16.400
195	68	29.200



Indicative diagrams of compressed air flow rates and related pressure drops in a line 30 m long (20°C - 1013 mbar). The data used has been provided by the POLYTECHNIC INSTITUTE OF TURIN.

See online software (page 9)

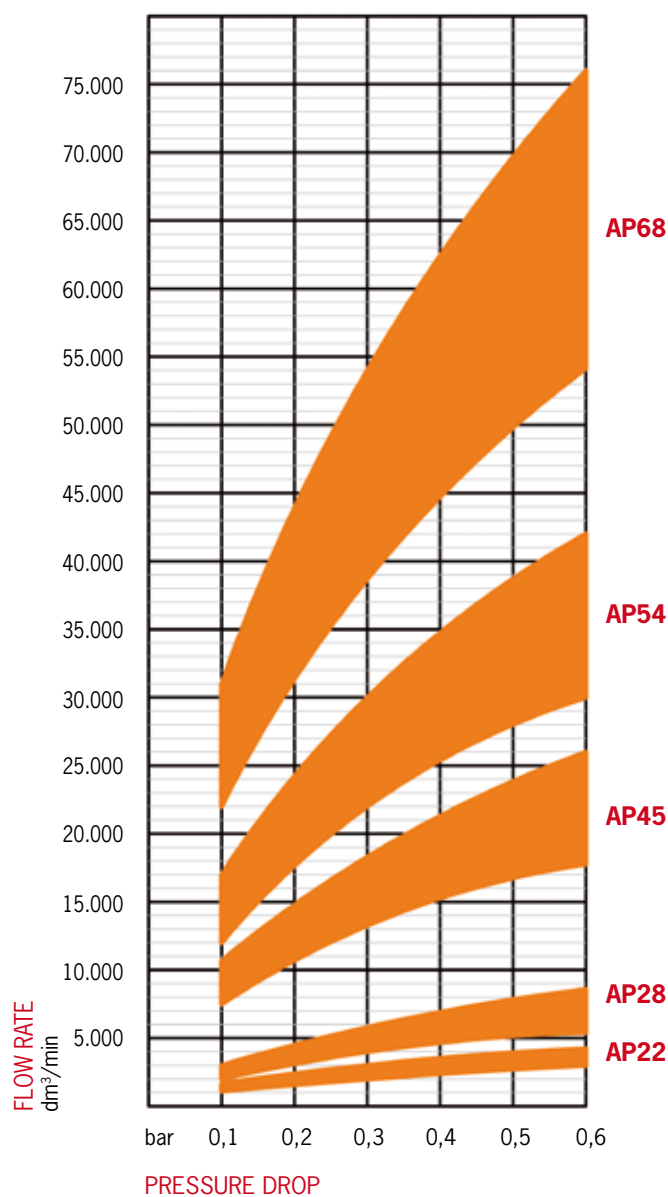

AIR PRESSURE: 6 → 12 bar
0,6 → 1,2 MPa
87 → 174 psi

TECHNICAL CHARACTERISTICS

Extruded Aluminium.....	Alloy EN AW 6060 UNI EN 573-3:1996
International designations.....	ANSI 6060 - DIN 1748/1: AlmNsl 0,5 BS 6060
Chemical composition.....	Si: 0,45% - Mg: 0,45% - Fe: 0,3%
Heat treatment.....	Aging T5 o T6
Surface treatment (upon request)	Chemical silver anodization
Specific weight, density	Kg/dm³ 2,71
Electrical conductivity	% IACS 53
Thermal Conductivity	W/m.K 200
Specific heat.....	J/Kg.K 96
Coefficient of expansion.....	mm/m °C 0,024
Tensile strength.....	Kg/mm² 24
Yield strength.....	Kg/mm² 20
Modulus of elasticity.....	Kg/mm² 6.700
Brinell hardness	HB 70÷80
Melting range	°C 600-650
O-ring material	NBR 70
Operating temperature	°C -20/+120
Screw material	Steel Class 8.8
M5 Screw driving torque.....	10 N·m (90 Inch·Lbs) ± 10%
M6 Screw driving torque.....	14 N·m (120 Inch·Lbs) ± 10%
Outlet thread.....	BSP or NPT
Terminal thread	BSP or NPT
Max operating pressure	15 bar - 1,5 MPa - 217 psi
Powering multfluid, max operating pressure.....	25 bar - 2,5 MPa - 362 psi
Failure test pressure.....	80 bar - 8 MPa - 1160 psi

Compatibility with fluids

Compressed air, Vacuum, Argon, Nitrogen, Carbon dioxide, Mineral oil*, Synthetic oil*, Other fluids*

WARNING!

Teseo components are intended only to uses for which they have been specifically designed by the manufacturer and patent holder. This does not absolve the professional user to refrain from checking technical compatibility and current project of your application. Our technical department is at your disposal for evaluations, analysis of special use, to design and eventually implement specific components and assemblies. Teseo company is not responsible for any damage caused by improper, erroneous, unreasonable and product incompatibilities with applications not specified by the catalog.

*For further information, please apply to Teseo Srl Technical Office.

PROFILES SECTION OVER VIEW

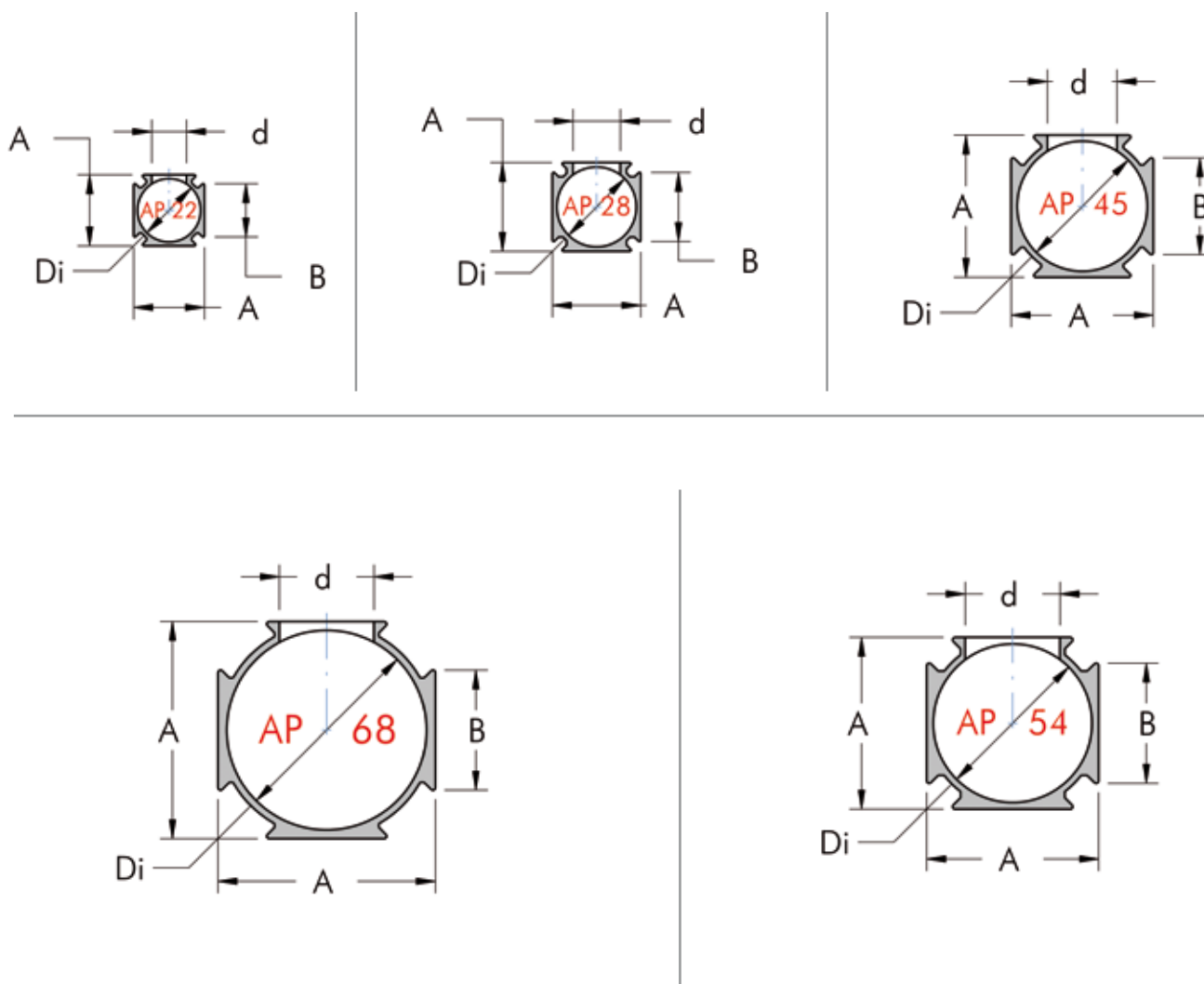

AP

SIZE DIMENSIONS





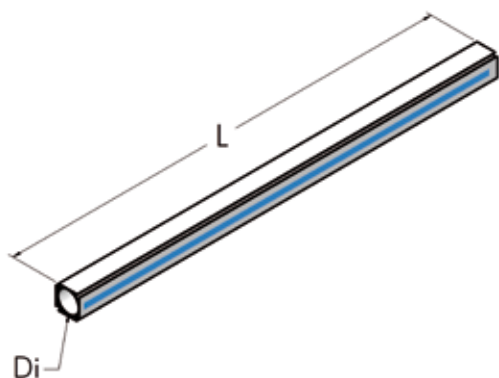

Name	Dimensions				Max hole	Weight	Moment of inertia		Inner volume
	Di mm	A mm	B mm	d mm			Jx cm ⁴	Jy cm ⁴	
AP22	20	22,4	16,4	11	370	0,90	0,90	0,32	
AP28	25	28	21,5	15	590	2,20	2,20	0,5	
AP45	40	45	31	22	1170	11,00	11,00	1,3	
AP54	50	55	38	30	1690	23,70	23,70	2	
AP68	63	69	38	30	2080	44,10	44,10	3,1	

NATURAL ALUMINIUM EXTRUDED PIPE

POW









Di mm	L m	Part. no.	P kg	 n°	
20	5	800 020 500	1,9	100	
25	5	800 025 500	3	64	
40	5	800 040 500	5,8	36	
50	5	800 050 500	8,4	16	
63	5	800 063 500	10,4	16	

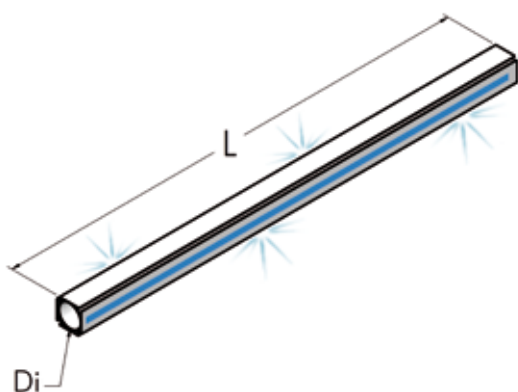





Di mm	L m	Part. no.	P kg	 n°	
20	2,5	800 020 250	0,95	100	
25	2,5	800 025 250	1,5	64	
40	2,5	800 040 250	2,9	36	
50	2,5	800 050 250	4,2	16	
63	2,5	800 063 250	5,2	16	

ANODIZED ALUMINIUM EXTRUDED PIPE

POW





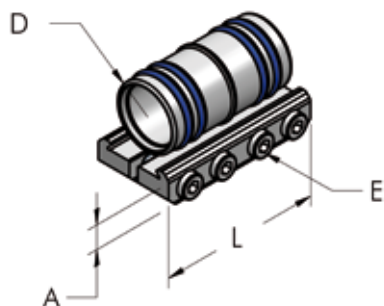

Di mm	L m	Part. no.	P kg	 n°	
20	5	801 020 500	1,9	100	
25	5	801 025 500	3	64	
40	5	801 040 500	5,8	36	
50	5	801 050 500	8,4	16	
63	5	801 063 500	10,4	16	

Di mm	L m	Part. no.	P kg	 n°	
20	2,5	801 020 250	0,95	100	
25	2,5	801 025 250	1,5	64	
40	2,5	801 040 250	2,9	36	
50	2,5	801 050 250	4,2	16	
63	2,5	801 063 250	5,2	16	

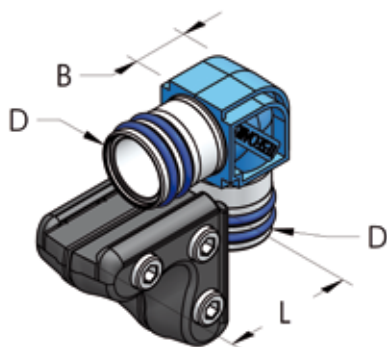



STRAIGHT JOINT, COMPLETE**POW**

D mm	L mm	A mm	E mm	Part. no.	P g	 n°
20	46	9	4	006 020 020	39	10
25	60	10	4	006 025 020	86	10
40	80	12	5	006 040 020	200	10
50	150	12	5	006 050 020	395	10
63	150	12	5	006 063 020	480	10

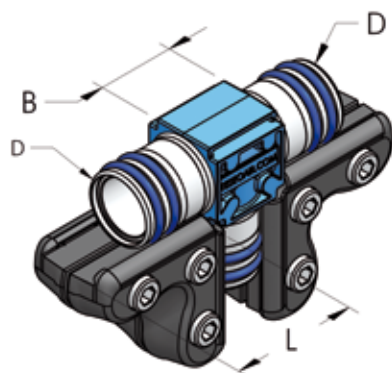
L JOINT, COMPLETE

D mm	L mm	B mm	Part. no.	P g	 n°
20	40	22	006 020 022	90	10
25	50	30	006 025 022	135	10
40	75	100	006 040 022	430	10 
50	100	57	006 050 022	780	10 
63	100	72	006 063 022	910	10 

T JOINT, COMPLETE

D mm	L mm	B mm	Part. no.	P g	 n°
20	40	24	006 020 024	150	10
25	50	30	006 025 024	240	10
40	75	160	006 040 024	730	10 
50	100	60	006 050 024	1325	10 
63	100	76	006 063 024	1530	10 

CLOSED TERMINAL, COMPLETE

POW

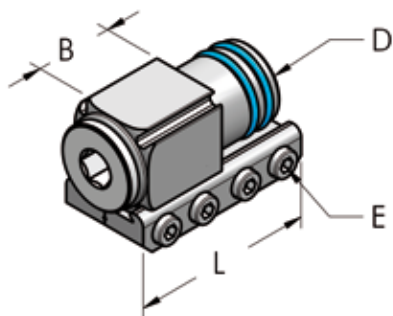

D mm	L mm	E mm	B mm	Part. no.	P g	n°	
20	46	4	24	006 020 026	70	10	
25	60	4	28	006 025 026	125	10	
40	80	5	35	006 040 026	300	10	
50	150	5	75	006 050 026	710	10	
63	90	5	-	006 063 026	700	10	

TERMINAL WITH THREADED HOLE, COMPLETE

POW

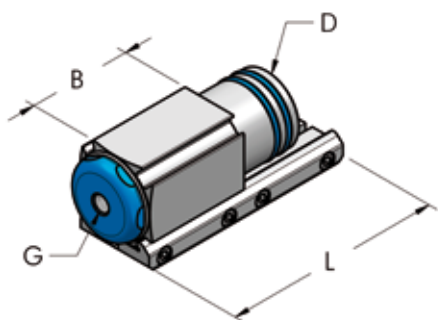

D mm	G	L mm	B mm	Part. no.	P g	n°	
40	1/8" - BSP	80	35	006 040 015	295	10	
40	3/8" - BSP	80	35	006 040 016	290	10	
40	1/2" - BSP	80	35	006 040 017	280	10	
40	3/4" - BSP	80	35	006 040 018	270	10	
40	1/4" - BSP	80	35	006 040 025	260	10	
50	1/8" - BSP	150	75	006 050 015	705	10	
50	1/2" - BSP	150	75	006 050 017	690	10	
50	3/4" - BSP	150	75	006 050 018	670	10	
50	1" - BSP	150	75	006 050 019	655	10	
50	1/4" - BSP	150	75	006 050 025	700	10	
63	1/4" - BSP	90	-	006 063 025	660	10	

TERMINAL THREADED FEMALE, COMPLETE

POW

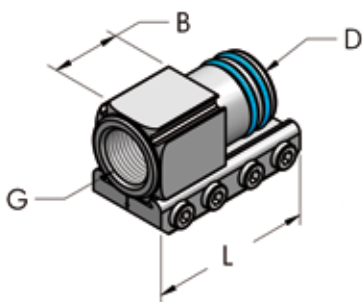



D mm	G	L mm	B mm	Part. no.	P g	n°	
20	3/8" - BSP	46	24	006 020 028	54	10	
25	1/2" - BSP	60	28	006 025 028	105	10	
40	1" - BSP	80	35	006 040 027	260	10	
50	1"1/4" - BSP	150	75	006 050 027	615	10	
50	1"1/2" - BSP	150	75	006 050 028	565	10	
63	1"1/2" - BSP	90	20	006 063 028	430	10	

TERMINAL THREADED MALE, COMPLETE

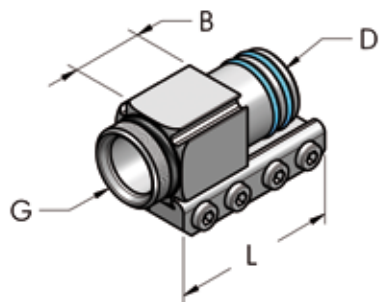
POW





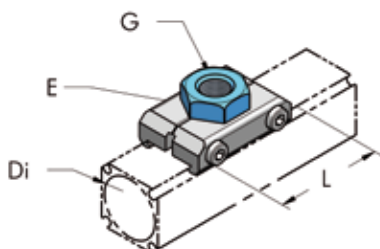

D mm	G	L mm	B mm	Part. no.	P g	 n°	
20	1/2" - BSP	46	24	006 020 030	57	10	
25	3/4" - BSP	60	28	006 025 030	110	10	
40	1 1/4" - BSP	80	35	006 040 029	245	10	
50	1 1/2" - BSP	150	75	006 050 029	655	10	
63	2" - BSP	90	12	006 063 030	390	10	
63	2 1/2" - BSP	90	13	006 063 031	450	10	

FEMALE OUTLET PLATE, COMPLETE

POW





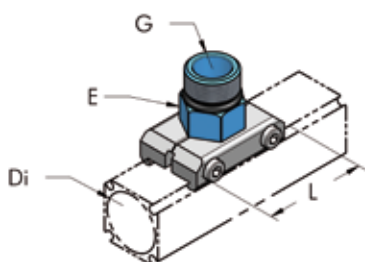

Di mm	G	L mm	E mm	Part. no.	P g	 n°	
20	1/4" - BSP	46	22	006 020 033	36	10	
20	3/8" - BSP	46	22	006 020 034	40	10	
25	1/4" - BSP	46	22	006 025 033	37	10	
25	3/8" - BSP	46	22	006 025 034	46	10	
25	1/2" - BSP	46	30	006 025 035	55	10	
40	1/8" - BSP	70	36	006 040 032	148	10	
40	1/4" - BSP	70	36	006 040 033	140	10	
40	3/8" - BSP	70	36	006 040 034	135	10	
40	1/2" - BSP	70	36	006 040 035	130	10	
40	3/4" - BSP	70	36	006 040 036	120	10	
50/63	1/4" - BSP	74	50	006 050 033	195	10	
50/63	1/2" - BSP	74	50	006 050 034	190	10	
50/63	3/4" - BSP	74	50	006 050 035	215	10	
50/63	1" - BSP	74	50	006 050 036	195	10	

MALE OUTLET PLATE, COMPLETE

POW



Di mm	G	L mm	E mm	Part. no.	P g	 n°	
20	3/8" - BSP	46	22	006 020 063	36	10	
25	1/2" - BSP	46	22	006 025 064	49	10	
40	1/2" - BSP	70	36	006 040 062	135	10	
40	3/4" - BSP	70	36	006 040 063	140	10	
40	1" - BSP	70	36	006 040 064	140	10	
50/63	3/4" - BSP	74	50	006 050 063	190	10	
50/63	1" - BSP	74	50	006 050 064	185	10	
50/63	1 1/4" - BSP	74	50	006 050 065	190	10	
50/63	1 1/2" - BSP	74	50	006 050 066	195	10	

OUTLET PLATE WITH QUICKFIT, COMPLETE

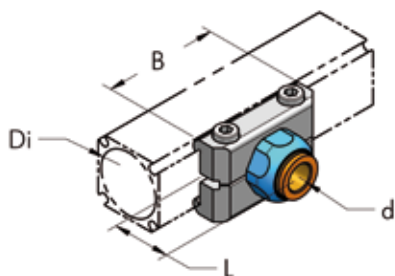

Di mm	d mm	B mm	L mm	Part. no.	P g	n°	
20	8	46	23	006 020 084	112	10	
20	10	46	26	006 020 085	190	10	
25	8	46	23	006 025 084	235	10	
25	10	46	23	006 025 085	246	10	
40	10	70	23	006 040 085	318	10	
40	12	70	26	006 040 086	370	10	

REDUCTION PLATE, COMPLETE

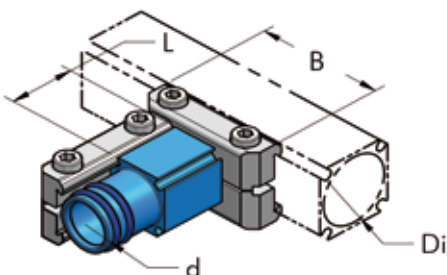

Di mm	d mm	B mm	L mm	Part. no.	P g	n°	
25	20	46	24	006 020 039	112	10	
40	20	70	24	006 040 037	190	10	
40	25	70	28	006 040 038	235	10	
50/63	40	74	35	006 040 039	370	10	
50/63	20	74	35	006 050 038	318	10	
50/63	25	74	60	006 050 039	370	10	

FLEXIBLE PIPE FOR CONNECTION TO COMPRESSOR FOR COMPRESSED AIR (15 BAR)

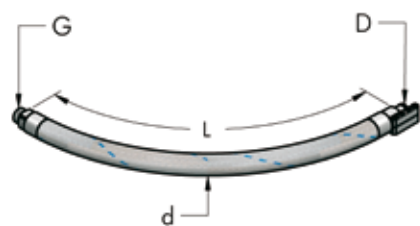





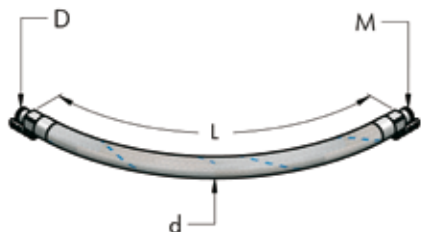

D mm	G	L mm	d mm	Part. no.	P g	n°	
20	1/2" - BSP	700	30	006 020 058	500	1	
25	3/4" - BSP	700	35	006 025 058	750	1	
40	1 1/4" - BSP	1000	50	006 040 058	3000	1	
50	2" - BSP	1000	65	006 050 058	4075	1	
63	2 1/2" - BSP	1300	77	006 063 058	4700	1	

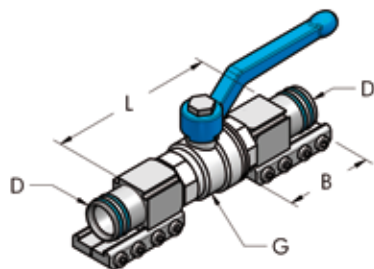
FLEXIBLE JOINT FOR AP-AP CONNECTION FOR COMPRESSED AIR (15 BAR)



D mm	M mm	L mm	d mm	Part. no.	P g	n°	
20	20	700	30	006 020 059	510	1	
25	25	700	35	006 025 059	830	1	
40	40	1000	50	006 040 059	3050	1	
50	50	1000	65	006 050 059	4300	1	
63	63	1300	77	006 063 059	5000	1	

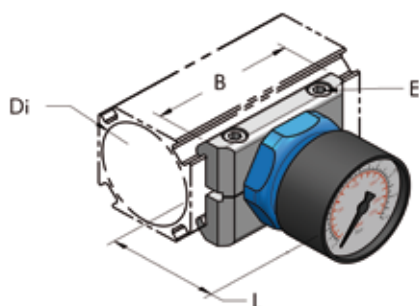

BALL VALVE, COMPLETE

D mm	G	L mm	B mm	Part. no.	P g	 n°	
20	1/2" - BSP	100	46	006 020 046	290	10	
25	3/4" - BSP	118	56	006 025 046	500	10	
40	1"1/4" - BSP	150	70	006 040 046	1250	10	
50	1"1/2" - BSP	245	150	006 050 046	2450	10	
63	2" - BSP	150	90	006 063 046	3300	10	

MANOMETER, COMPLETE

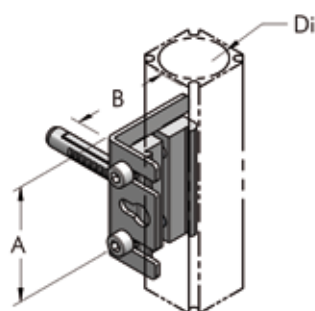
Di mm	L mm	B mm	E mm	Part. no.	P g	 n°	
20	58	46	4	006 020 048	70	10	
25	52	56	4	006 025 048	75	10	
40	58	70	5	006 040 048	174	10	
50/63	58	74	5	006 050 048	230	10	

L PLATE, COMPLETE**POW**

Di mm	d mm	A mm	B mm	Part. no.	P g	 n°	
20	8	50	40	006 020 040	70	10	
25	8	50	40	006 025 040	75	10	
40	8	80	60	006 040 040	140	10	
50/63	8	80	60	006 050 040	160	10	

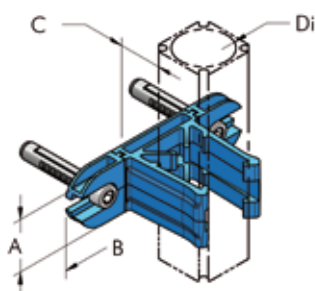
SNAP CLAMP, COMPLETE**POW**

Di mm	A mm	B mm	C mm	Part. no.	P g	 n°	
20	20	70	20	006 020 041	17	10	
25	25	88	17	006 025 041	25	10	
40	40	135	43	006 040 041	175	10	
50	50	150	40	006 050 041	213	10	

SNAP CLAMP

POW

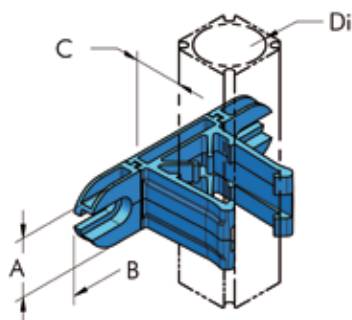

Di mm	A mm	B mm	C mm	Part. no.	P g	n°	
20	20	70	20	006 020 042	17	10	
25	25	88	17	006 025 042	25	10	
40	40	135	43	006 040 042	140	10	
50	50	150	40	006 050 042	174	10	

HANGING BRACKET

POW

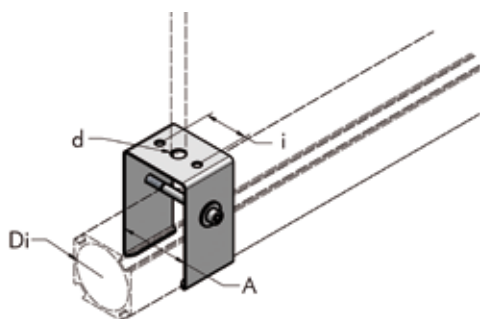

Di mm	A mm	d mm	i mm	Part. no.	P g	n°	
40	45	11	30	006 040 073	274	10	
50	55	11	36	006 050 073	302	10	
63	69	11	36	006 063 073	323	10	

SUPPORT BRACKET, COMPLETE

POW

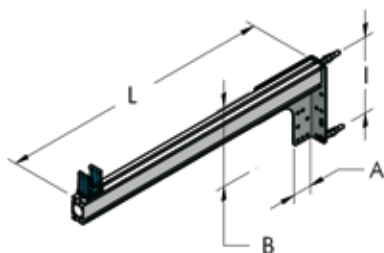

A mm	B mm	L mm	I mm	Part. no.	P g	n°	
136	174	600	140	006 020 070	1300	10	
136	174	600	140	006 025 070	1300	10	
136	174	600	140	006 040 070	1400	10	
136	174	600	140	006 050 070	1450	10	
136	174	600	140	006 063 070	1400	10	

L PLATE IN GALVANIZED STEEL

POW

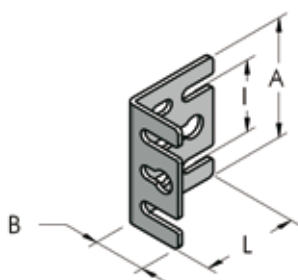

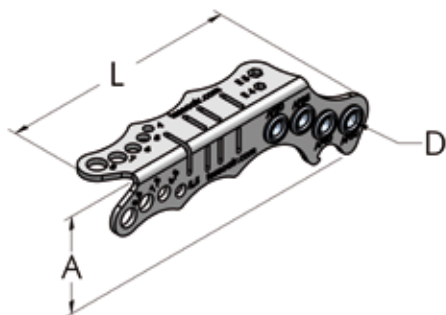

A mm	B mm	I mm	L mm	Part. no.	P g	n°	
50	25	30	40	732 020 050	37	10	
66	35	50	47	732 066 080	60	10	

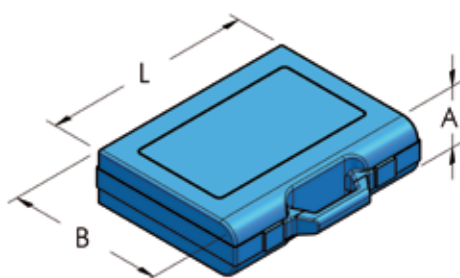

DRILLING JIG AP**POW**

A mm	D mm	L mm	Part. no.	P g	 n°
45	6	136	911 020 050	90	1

BASIC TOOLS BOX

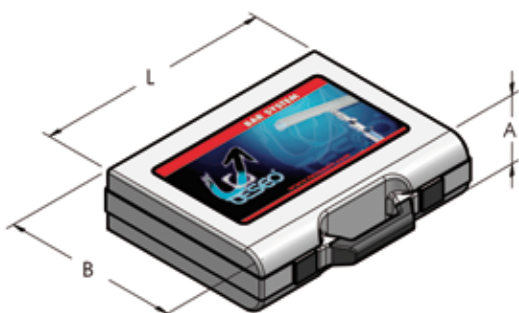
A mm	B mm	L mm	Part. no.	P g	 n°
50	190	240	006 020 092	600	1 

DEMO SUIT-CASE

A mm	B mm	L mm	Part. no.	P g	 n°
80	340	440	006 020 090	3700	1 

VASELINE GREASE**POW**

Part. no.	P g	 n°
111 003 100	850	20
111 003 010	100	20

PTFE BLUE GREASE**POW**

Part. no.	P g	 n°
114 003 005	50	20 

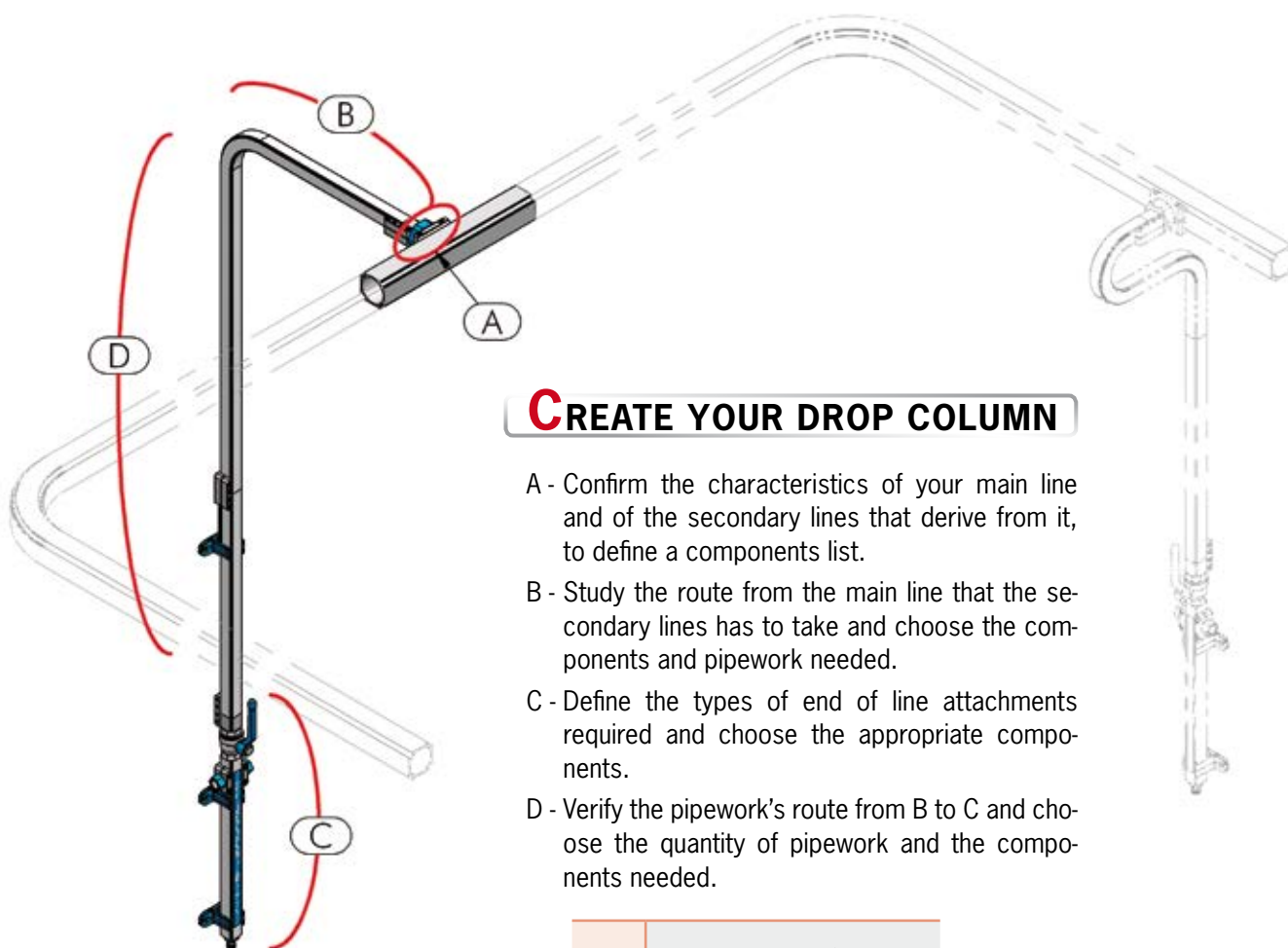

CREATE YOUR DROP COLUMN

- A - Confirm the characteristics of your main line and of the secondary lines that derive from it, to define a components list.
- B - Study the route from the main line that the secondary lines has to take and choose the components and pipework needed.
- C - Define the types of end of line attachments required and choose the appropriate components.
- D - Verify the pipework's route from B to C and choose the quantity of pipework and the components needed.

A	pages 45-46-51
B	pages 42-43-46-51-52
C	pages 42-43-44-45-47-51
D	pages 42-43

REDUCTION PLATE HBS - AP, COMPLETE

HBS

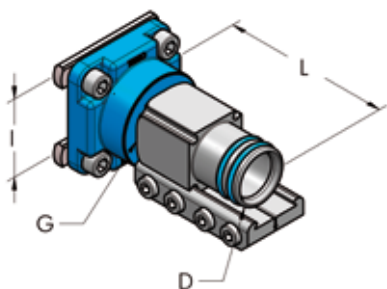

D mm	G	I mm	L mm	Part. no.	P g	n°	
20	1/2" - BSP	36	49	006 020 037	180	1	
20	1/2" - BSP	60	54	006 020 038	190	1	
25	3/4" - BSP	36	49	006 025 037	310	1	
25	3/4" - BSP	60	54	006 025 038	340	1	
40	1"1/4 - BSP	60	70	006 040 060	750	1	
50	1"1/2 - BSP	60	105	006 050 037	820	1	
63	-	60	72	006 063 037	800	1	

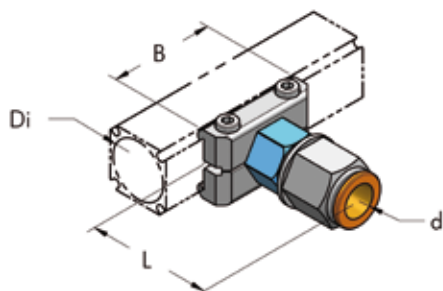
OUTLET PLATE WITH D14 QUICKFIT, COMPLETE

Di mm	d mm	B mm	L mm	Part. no.	P g	n°
20	14	46	51	006 020 134	95	20
25	14	56	52	006 025 134	100	20
40	14	70	50	006 040 134	190	20
50/63	14	74	50	006 050 134	240	20

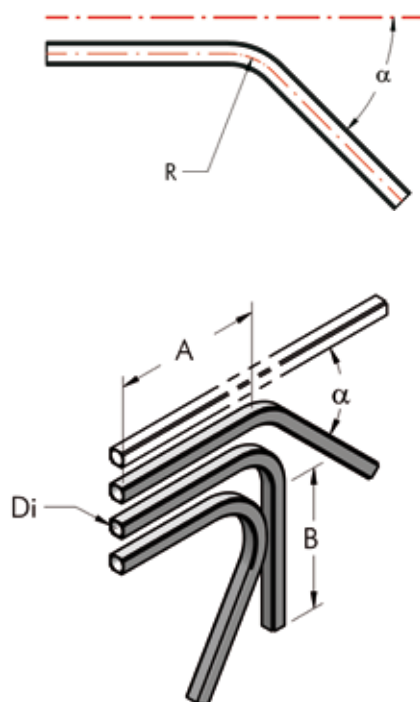
SPECIAL ANGLE CURVED PIPE**POW**

Di mm	A mm	B mm	R mm	α°	Part. no.	P Kg	n°
20	220	240	77	30	804 020 047	0,2	5
20	220	220	77	45	804 020 048	0,2	5
20	220	200	77	60	804 020 049	0,2	5
20	160	180	77	120	804 020 057	0,2	5
20	160	160	77	135	804 020 058	0,2	5
20	160	140	77	150	804 020 059	0,2	5
25	220	240	77	30	804 025 047	0,3	5
25	220	220	77	45	804 025 048	0,3	5
25	220	200	77	60	804 025 049	0,3	5
25	160	180	77	120	804 025 057	0,3	5
25	160	160	77	135	804 025 058	0,3	5
25	160	140	77	150	804 025 059	0,3	5
40	190	230	150	30	804 040 047	0,7	5
40	190	190	150	45	804 040 048	0,7	5
40	190	150	150	60	804 040 049	0,7	5
50	190	230	150	30	804 050 047	1	5
50	190	190	150	45	804 050 048	1	5
50	190	150	150	60	804 050 049	1	5
63	220	310	150	30	804 063 047	1,3	2
63	220	280	150	45	804 063 048	1,3	2
63	220	250	150	60	804 063 049	1,3	2

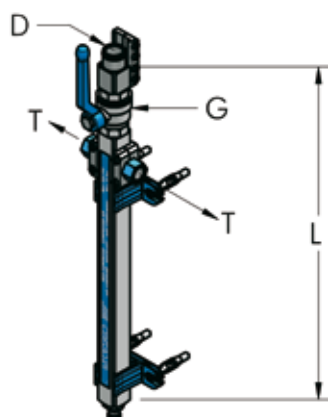
DROP COLUMN MANIFOLD COMPLETE WITH ACCESSORIES

D mm	L mm	G	T	Part. no.	P g	n°
20	440	1/2" - BSP	3/8" - BSP	006 020 055	680	1
25	440	3/4" - BSP	3/8" - BSP	006 025 055	1060	1

90° CURVED PIPE

POW

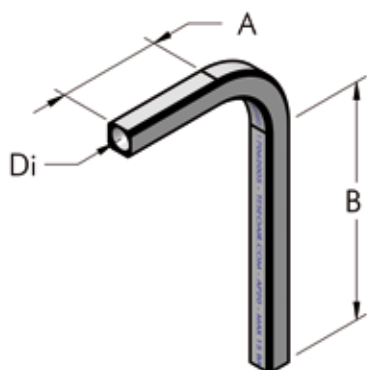

Di mm	A mm	B mm	R mm	Part. no.	P Kg	n°	
20	80	300	77	804 020 050	0,2	5	
20	310	570	77	804 020 100	0,4	5	
20	370	2010	77	804 020 250	0,9	5	
25	115	250	77	804 025 050	0,3	5	
25	310	570	77	804 025 100	0,6	5	
25	370	2010	77	804 025 250	1,5	5	
40	135	255	150	804 040 050	1	5	
50	135	255	150	804 050 050	1,05	5	
63	150	240	150	804 063 050	1,3	5	

180° CURVED PIPE

POW

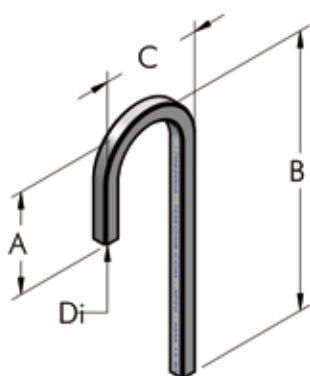

Di mm	A mm	B mm	C mm	Part. no.	P Kg	n°	
20	190	310	176	804 020 060	0,25	5	
20	180	1250	176	804 020 149	0,55	5	
25	200	490	182	804 025 060	0,4	5	
25	200	1240	182	804 025 149	0,9	5	

180°-90° CURVED PIPE

POW

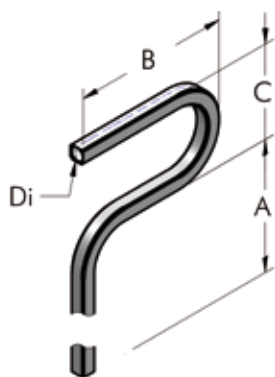

Di mm	A mm	B mm	C mm	R mm	Part. no.	P Kg	n°	
20	1375	296	176	77	804 020 148	0,95	5	
25	1370	302	182	77	804 025 148	1,5	5	

4 HOLES FEMALE OUTLET PLATE, COMPLETE

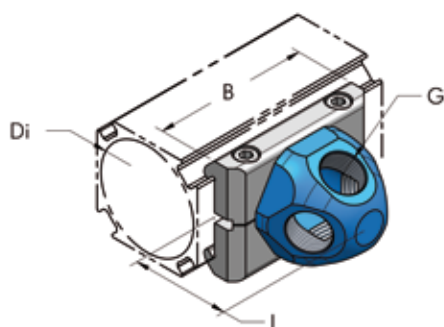

Di mm	B mm	L mm	G	Part. no.	P g	n°	
50/63	74	47	3/8" - BSP	006 050 053	200	10	
50/63	74	47	1/2" - BSP	006 050 054	190	10	

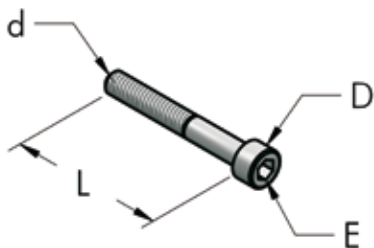
ALLEN SCREW, IN GALVANIZED STEEL

d mm	L mm	D mm	E mm	Part. no.	P g	n°
M5	20	8,5	4	212 005 020	4	20
M5	25	8,5	4	212 005 025	5	20
M6	35	10	5	212 006 035	10	20
M6	45	10	5	212 006 045	14	20

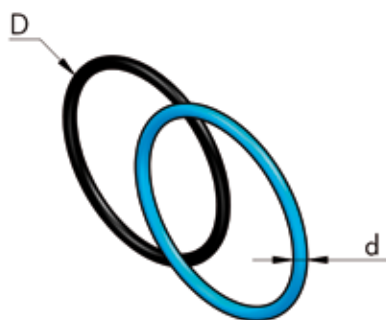
O-RING SEAL IN NBR70

D mm	d mm	Code AS/BS NORM	Part. no.	P g	n°
16	1,78	2050 - 014	271 012 002	0,1	10
16	2	0120 - 02	271 013 002	0,2	100
20	1,78	2062 - 014	271 016 002	0,15	10
20	2	0160 - 02	271 017 002	0,2	100
25	1,78	2081 - 019	271 020 002	0,22	10
25	2	0210 - 02	271 021 002	0,8	100
25	2,62	3087 - 118	271 022 003	0,5	100
36	3	0300 - 03	271 031 003	0,9	100
40	3	0350 - 03	271 035 003	1,1	10
50	2,62	3175 - 132	271 044 003	1	10
50	3	0440 - 03	271 043 003	1,3	100

15 BAR ADHESIVE COLOUR STICKERS

HBS

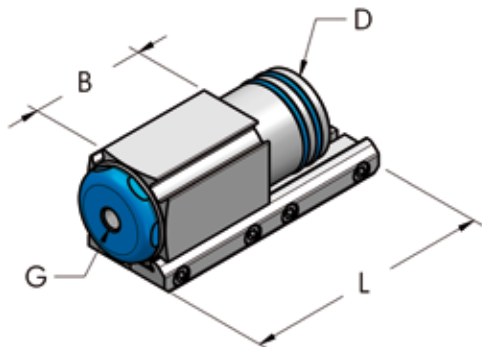

L mm	B mm	Colour	Part. no.	P g	n°
310	15	Blue RAL 5015	104 015 310	29	11
310	15	Green RAL 6029	104 015 315	29	11
310	15	Brown RAL 8003	104 015 316	29	11
310	15	Grey RAL 7000	104 015 317	29	11
310	15	Red RAL 3020	104 015 318	29	11
310	15	Yellow RAL 1028	104 015 319	29	11
310	28	Blue RAL 5015	104 025 150	29	11
310	28	Green RAL 6029	104 028 315	29	11
310	28	Brown RAL 8003	104 028 316	29	11
310	28	Grey RAL 7000	104 028 317	29	11
310	28	Red RAL 3020	104 028 318	29	11
310	28	Yellow RAL 1028	104 028 319	29	11

TERMINAL WITH THREADED HOLE, COMPLETE
POW

D mm	G	L mm	B mm	Part. no.	P g	n°	
40	1/8" - NPT	80	35	006 040 415	295	10	
40	3/8" - NPT	80	35	006 040 416	290	10	
40	1/2" - NPT	80	35	006 040 417	280	10	
40	3/4" - NPT	80	35	006 040 418	270	10	
40	1/4" - NPT	80	35	006 040 425	260	10	
50	1/8" - NPT	150	75	006 050 415	705	10	
50	1/2" - NPT	150	75	006 050 417	690	10	
50	3/4" - NPT	150	75	006 050 418	670	10	
50	1" - NPT	150	75	006 050 419	655	10	
50	1/4" - NPT	150	75	006 050 425	700	10	
63	1/4" - NPT	90	-	006 063 425	660	10	

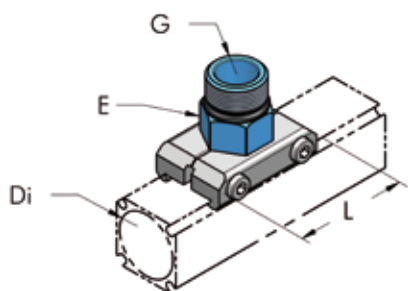
MALE OUTLET PLATE, COMPLETE
POW

Di mm	G	L mm	E mm	Part. no.	P g	n°	
20	3/8" - NPT	46	22	006 020 463	36	10	
25	1/2" - NPT	46	22	006 025 464	49	10	
40	1/2" - NPT	70	36	006 040 462	135	10	
40	3/4" - NPT	70	36	006 040 463	140	10	
40	1" - NPT	70	36	006 040 464	140	10	
50/63	3/4" - NPT	74	50	006 050 463	190	10	
50/63	1" - NPT	74	50	006 050 464	185	10	
50/63	1 1/4" - NPT	74	50	006 050 465	190	10	
50/63	1 1/2" - NPT	74	50	006 050 466	195	10	

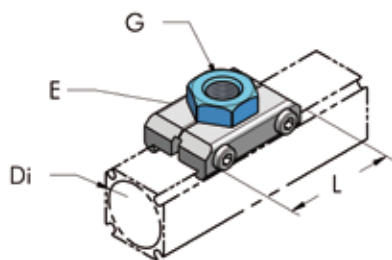
FEMALE OUTLET PLATE, COMPLETE
POW

Di mm	G	L mm	E mm	Part. no.	P g	n°	
20	1/4" - NPT	46	22	006 020 433	36	10	
20	3/8" - NPT	46	22	006 020 434	40	10	
25	1/4" - NPT	46	22	006 025 433	37	10	
25	3/8" - NPT	46	22	006 025 434	46	10	
25	1/2" - NPT	46	30	006 025 435	55	10	
40	1/8" - NPT	70	36	006 040 432	148	10	
40	1/4" - NPT	70	36	006 040 433	140	10	
40	3/8" - NPT	70	36	006 040 434	135	10	
40	1/2" - NPT	70	36	006 040 435	130	10	
40	3/4" - NPT	70	36	006 040 436	120	10	
50/63	1/4" - NPT	74	50	006 050 433	195	10	
50/63	1/2" - NPT	74	50	006 050 434	190	10	
50/63	3/4" - NPT	74	50	006 050 435	215	10	
50/63	1" - NPT	74	50	006 050 436	195	10	

TERMINAL THREADED FEMALE, COMPLETE

POW

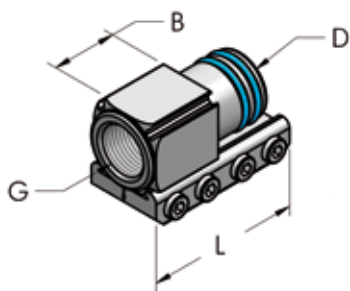

D mm	G	L mm	B mm	Part. no.	P g		n°
20	3/8" - NPT	46	24	006 020 428	54		10
25	1/2" - NPT	60	28	006 025 428	105		10
40	1" - NPT	80	35	006 040 427	260		10
50	1"1/4" - NPT	150	75	006 050 427	615		10
50	1"1/2" - NPT	150	75	006 050 428	565		10
63	1"1/2" - NPT	90	20	006 063 428	430		10

TERMINAL THREADED MALE, COMPLETE

POW

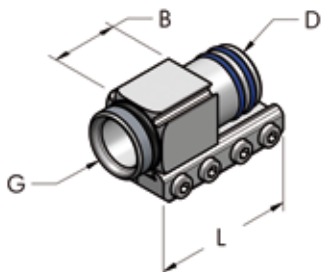

D mm	G	L mm	B mm	Part. no.	P g		n°
20	1/2" - NPT	46	24	006 020 430	57		10
25	3/4" - NPT	60	28	006 025 430	110		10
40	1"1/4" - NPT	80	35	006 040 429	245		10
50	1"1/2" - NPT	150	75	006 050 429	655		10
63	2" - NPT	90	12	006 063 430	390		10
63	2"1/2" - NPT	90	13	006 063 431	450		10

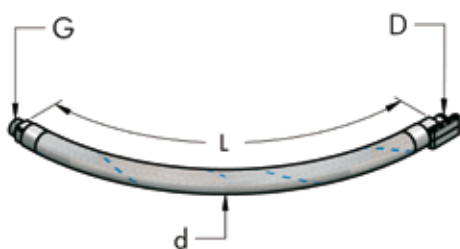
FLEXIBLE PIPE FOR CONNECTION TO COMPRESSOR FOR COMPRESSED AIR (15 BAR)

D mm	G	L mm	d mm	Part. no.	P g		n°
20	1/2" - NPT	700	30	006 020 458	500		1
25	3/4" - NPT	700	35	006 025 458	750		1
40	1"1/4" - NPT	1000	50	006 040 458	3000		1
50	2" - NPT	1000	65	006 050 458	4075		1
63	2"1/2" - NPT	1300	77	006 063 458	4700		1

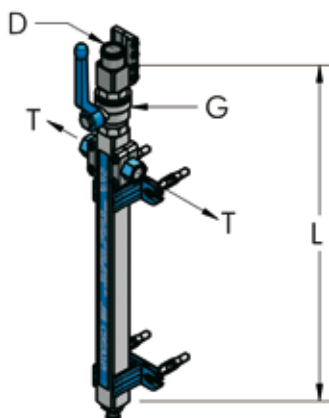
DROP COLUMN MANIFOLD COMPLETE WITH ACCESSORIES

D mm	L mm	G	T	Part. no.	P g		n°
20	440	1/2" - BSP	3/8" - NPT	006 020 455	680		1
25	440	3/4" - BSP	3/8" - NPT	006 025 455	1060		1

AP

NPT COMPONENTS

MULTIFLUID 25 BAR

USE OF AP MULTIFLUID AT 25 BARS (360 PSI)

The patented AP system is suitable for inert gases and fluids.

By doubling the clamping brackets of every single joint and terminal of the system, the product can be used at a working pressure of up to 25 bar (360 psi).

The increase of the working pressure enables the transportation of incompressible fluids, such as mineral and synthetic oil, cooling and lubricating fluids.

For such a specific application a series of dedicated accessories are available, such as safety relief valves, manometers and expansion tanks, illustrated in the following pages.

Kiwa has determined that the quality management system of Teseo Srl meets the requirements of Annex III, E1 of the Pressure Equipment Directive 97/23/CE.





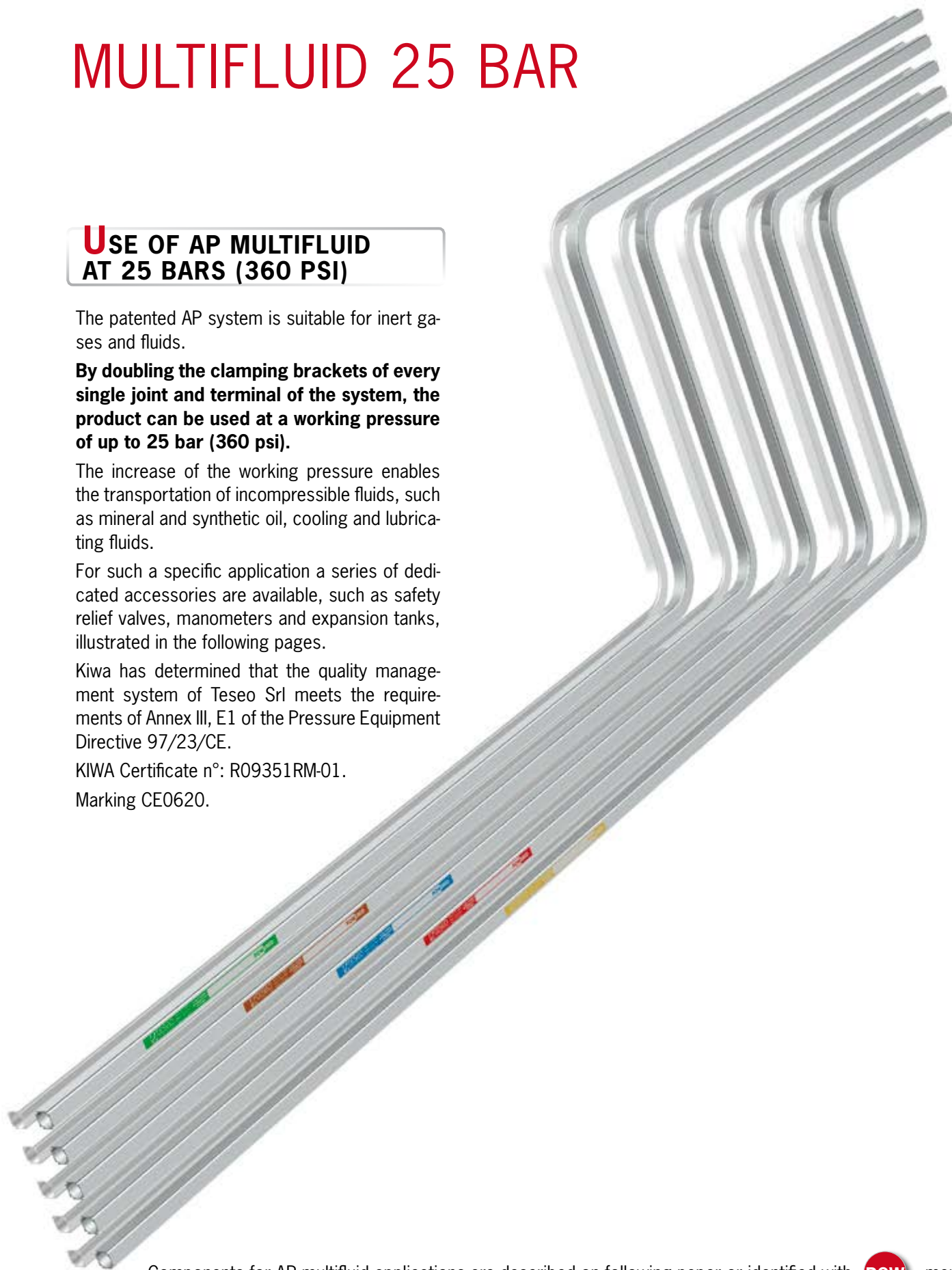

KIWA Certificate n°: R09351RM-01.

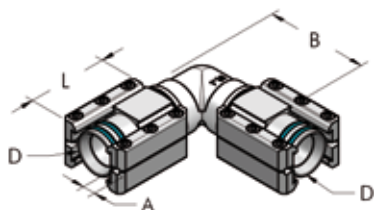
Marking CE0620.







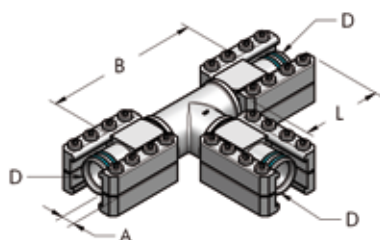

Components for AP multifluid applications are described on following paper or identified with  mark





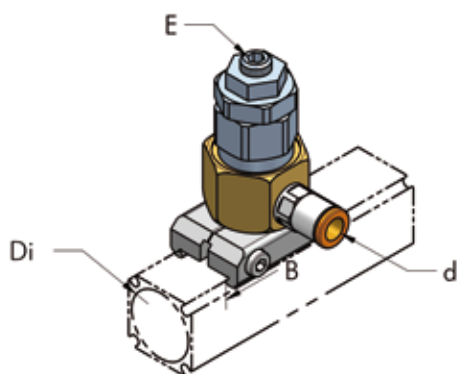

MULTIFLUID L JOINT, COMPLETE

D mm	L mm	A mm	B mm	Part. no.	P g	 n°	
20	46	9	50	006 020 122	214	10	
25	60	10	65	006 025 122	330	10	
40	80	12	100	006 040 122	640	10	
50	150	12	150	006 050 122	1500	10	

MULTIFLUID T JOINT, COMPLETE

D mm	L mm	A mm	B mm	Part. no.	P g	 n°	
20	46	9	100	006 020 124	270	10	
25	60	10	130	006 025 124	425	10	
40	80	12	160	006 040 124	890	10	
50	150	12	245	006 050 124	2100	10	

OUTLET PLATE WITH PRESSURE VALVE, COMPLETE

Di mm	d mm	B mm	E mm	A mm	Part. no.	P g	 n°	
20	8	46	5	65	006 020 080	48	10	
25	8	56	5	65	006 025 080	50	10	
40	8	70	5	65	006 040 080	220	10	
50	8	74	5	65	006 050 080	300	10	

OUTLET PLATE FOR EXPANSION TANK, COMPLETE

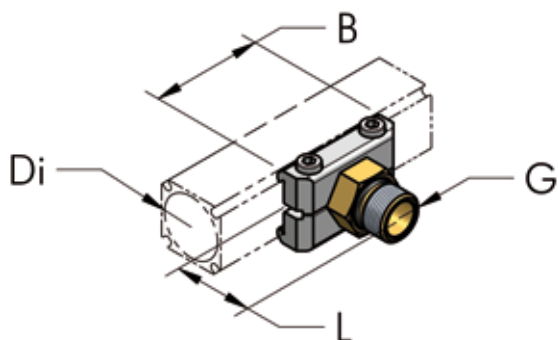

Di mm	G	L mm	B mm	Part. no.	P g	
20	M18 x 1,5	32	46	006 020 081	45	
25	M18 x 1,5	33	46	006 025 081	71	
40	M18 x 1,5	36	70	006 040 081	136	
50/63	M18 x 1,5	36	74	006 050 081	197	

NON-RETURN VALVE, COMPLETE

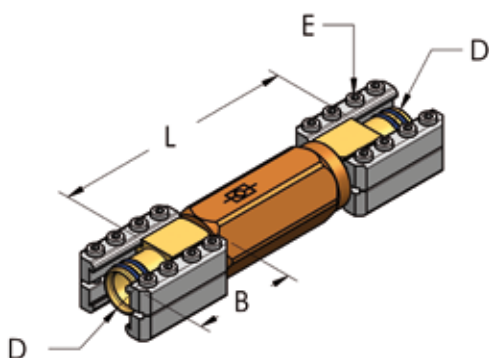





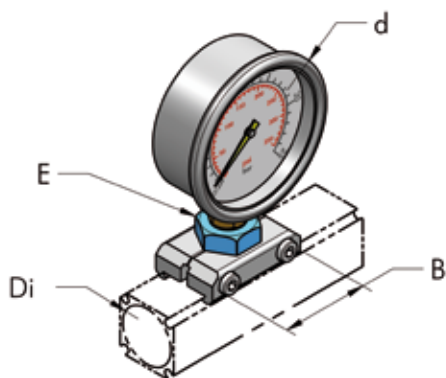

D mm	L mm	B mm	E mm	Part. no.	P Kg	n°	
20	130	46	4	006 020 047	0,35	1	
25	145	60	4	006 025 047	0,82	1	
40	210	80	5	006 040 047	2,2	1	
50	300	150	5	006 050 047	3,4	1	

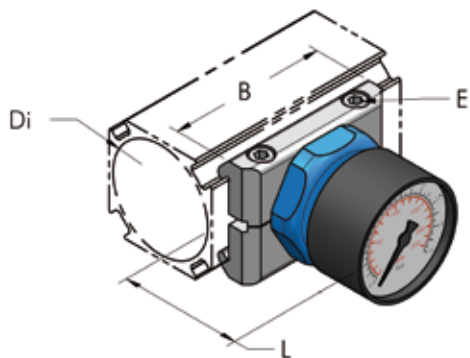
GLYCERYNE MANOMETER, COMPLETE







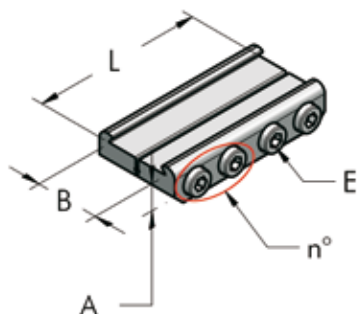

Di mm	d mm	B mm	E mm	Part. no.	P g	n°	
20	70	46	22	006 020 049	240	10	
25	70	56	22	006 025 049	250	10	
40	70	70	36	006 040 049	345	10	
50	70	74	50	006 050 049	400	10	



VACUUM MANOMETER, COMPLETE

Di mm	L mm	E mm	B mm	Part. no.	P g	 n°	
20	60	4	46	006 020 348	70	10	
25	60	4	56	006 025 348	75	10	
40	60	5	70	006 040 348	174	10	
50/63	60	5	74	006 050 348	230	10	

CONNECTION CLAMP, COMPLETE

A mm	B mm	E mm	L mm	n°	Part. no.	P g	 n°	
9	20	4	46	2	006 020 072	32	10	
10	25	4	60	4	006 025 072	60	10	
12	40	5	80	3	006 040 072	120	10	
12	50/63	5	150	4	006 050 072	285	10	

25 BAR ADHESIVE COLOUR STICKERS

L mm	B mm	Colour	Part. no.	P g	 n°	
310	15	Blue RAL 5015	104 515 310	29	11	
310	15	Green RAL 6029	104 515 315	29	11	
310	15	Brown RAL 8003	104 515 316	29	11	
310	15	Grey RAL 7000	104 515 317	29	11	
310	15	Red RAL 3020	104 515 318	29	11	
310	15	Yellow RAL 1028	104 515 319	29	11	
310	28	Blue RAL 5015	104 525 150	29	11	
310	28	Green RAL 6029	104 528 315	29	11	
310	28	Brown RAL 8003	104 528 316	29	11	
310	28	Grey RAL 7000	104 528 317	29	11	
310	28	Red RAL 3020	104 528 318	29	11	
310	28	Yellow RAL 1028	104 528 319	29	11	

COMPRESSED AIR AND FLUIDS PIPING SYSTEMS

AP



MODULAR MANIFOLDS INTEGRATED ON MACHINES

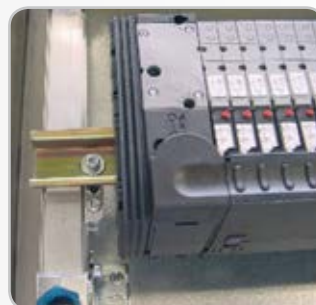



AP

ATS AIR TRACK SUPPLY

This unique track and trolley system is produced by Teseo srl. It has been designed to support tooling and to provide compressed air, fluids and electrical supply to any point along the track.

A.T.S. is manufactured from a modular extruded aluminium track which can be secured to a wall or any suitable structure, the trolley runs along the track with minimal effort, supporting tooling and providing power right to the point of use. Additional options can be supplied on the trolley.

The benefits are:

- no trailing hoses to impair operator movements;
- trolley allows total flexibility of use anywhere along the track;
- supported tools improve operator comfort.



Technical specifications

- Extruded anodized aluminium rail.
- Trolley runs on roller bearings.
- Supply tube: 8 mm (1/4").
- Operating pressure: 8 bar (117 psi).
- Electric current: 240v ac
- Approximate load on trolley: 30 kg (66 lb).
- Cable: 3G-2,5 mm² C/47

The systems are delivered in a preassembled kit, packed in a stout cardboard box 3 m long (10 ft. ap-prox.) containing all its units already preassembled, along with the fixing brackets and the instructions.





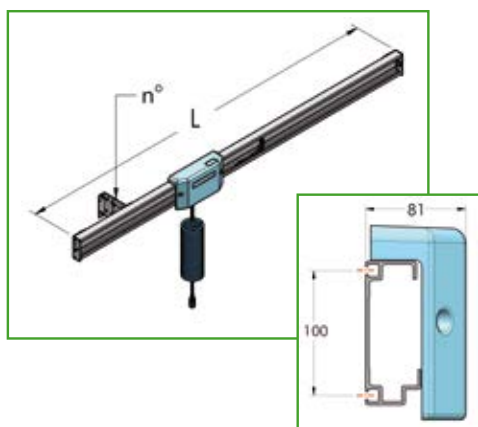

On the trolley there are one 1/4" outlet and one hook.

The following parts are to be ordered separately:

- accessories, special supports: see page 65;
- assembling tools;
- Transport and installation at the customer's factory.









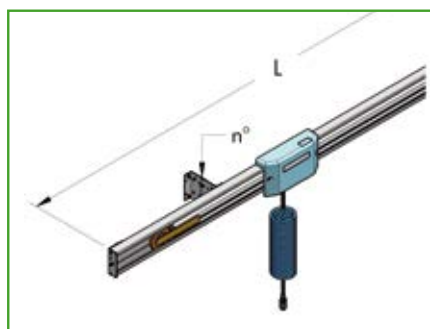







PNEUMATIC ATS, WITH CHAIN



L m	Part. no.	Brackets n°	P Kg	 n°	
1,5	001 003 001	2	10	1	
2	001 003 002	2	11	1	
2,5	001 003 081	2	12	1	
3	001 003 003	2	13	1	
4	001 003 004	4	15	1	

PNEUMATIC ATS, WITH BAR



L m	Part. no.	Brackets n°	P Kg	 n°	
5	001 003 005	4	20	1	
6	001 003 006	4	23	1	
7	001 003 007	4	25	1	
8	001 003 008	4	27	1	
9	001 003 009	6	30	1	
10	001 003 010	6	33	1	
11	001 003 011	6	35	1	
12	001 003 012	6	37	1	
13	001 003 013	8	40	1	
14	001 003 014	8	42	1	
15	001 003 015	8	44	1	
16	001 003 016	8	47	1	
17	001 003 017	10	49	1	
18	001 003 018	10	51	1	

ATS WITH ELECTRIC FEED

This system has a compressed air feed and is equipped with a single phase electric feed. An output on the trolley is provided with a three-pole terminal board and an input on one side of the rail with a box and safety clamp. The other features are the same as the standard model.

PNEUMATIC AND ELECTRIC ATS, WITH CHAIN

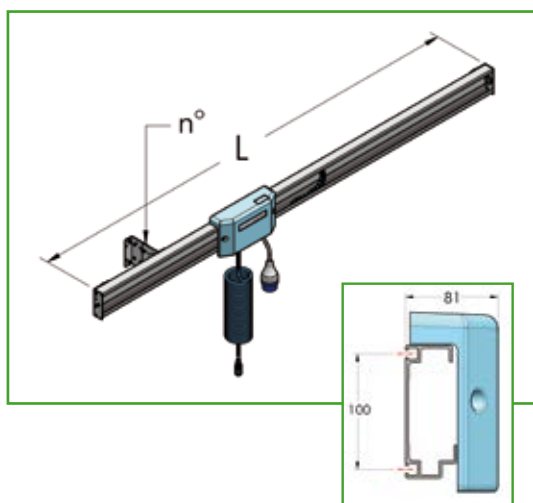

L m	Part. no.	Brackets n°	P Kg	n°	
1,5	001 004 001	2	13	1	
2	001 004 002	2	14	1	
2,5	001 004 081	2	15	1	
3	001 004 003	2	16	1	
4	001 004 004	4	18	1	

PNEUMATIC AND ELECTRIC ATS, WITH BAR

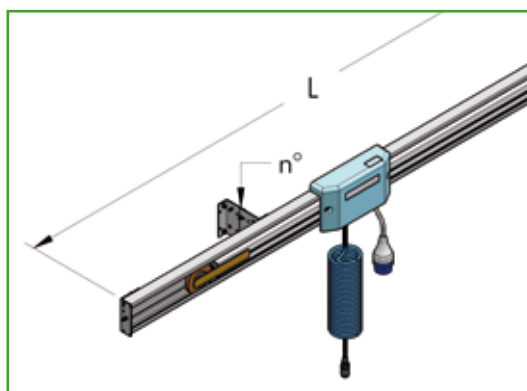





L m	Part. no.	Brackets n°	P Kg	n°	
5	001 004 005	4	24	1	
6	001 004 006	4	28	1	
7	001 004 007	4	31	1	
8	001 004 008	4	34	1	
9	001 004 009	6	36	1	
10	001 004 010	6	41	1	
11	001 004 011	6	44	1	
12	001 004 012	6	46	1	

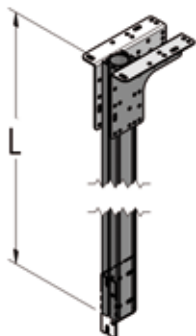

WALL OR CEILING SUPPORT

MAT





L m	Part. no.	P Kg	n°	
0,5	001 003 060	1,6	10	
1	001 003 061	2,5	10	
2	001 003 062	3,8	10	

ADDITIONAL OUTLET BLOCK

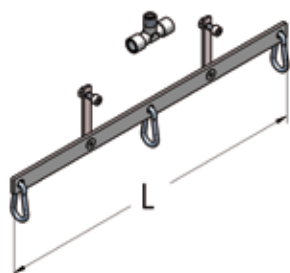
G	Part. no.	P g	n°	
1/4" - BSP	001 003 068	150	10	



3 ATTACHMENT TOOLING SUPPORT

L mm	Part. no.	P g	n°	
400	001 003 069	290	1	

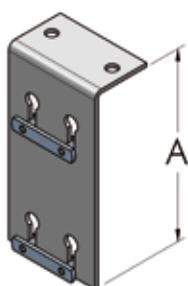

SPECIAL FIXING BRACKET

MAT

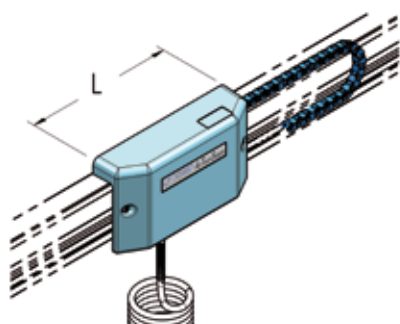

A mm	Part. no.	P g	n°	
160	001 005 036	400	20	



ADDITIONAL TROLLEY*

L mm	Part. no.	P Kg	n°	
270	001 003 067	1,7	1	

* Only on standard A.T.S. of 2, 3, 4 m



PLASTIC CHAIN



L m	Part. no.	P g	 n°	
1	336 011 100	70	1	



HOSE



L m	Part. no.	P g	 n°	
1	421 008 100	40	1	

HOSE-CHAIN SET





L* m	Part. no.	P g	 n°	
1,5-4	001 002 040	-	1	

*Specify ATS length







ROPE-HOSE SET







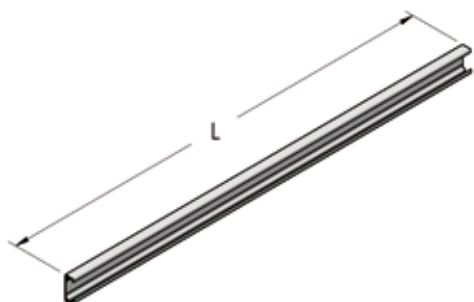

L* m	Part. no.	P g	 n°	
5-18	001 002 024	-	1	

*Specify ATS length



ANODIZED RAIL

L m	Part. no.	P Kg	 n°	
1	801 115 100	1,8	1	
1,5	801 115 150	2,6	1	
2	801 115 200	3,5	1	
2,5	801 115 250	4,4	1	
3	801 115 300	5,3	1	

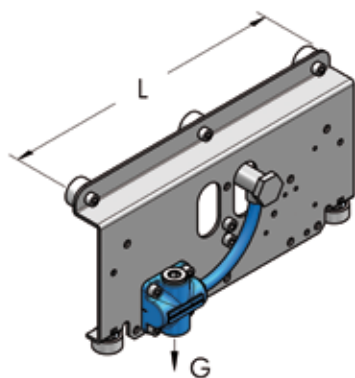

PUNCHED RAIL

L m	Part. no.	P Kg	 n°	
1,5	802 115 150	2,6	1	
2	802 115 200	3,7	1	
2,5	802 115 250	4,4	1	
3	802 115 300	5,3	1	

STANDARD TROLLEY SET

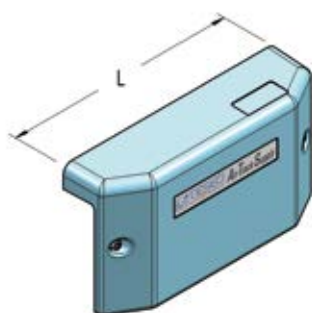
L mm	G	Part. no.	P g	 n°	
270	1/4" - BSP	001 003 020	1450	1	

STANDARD ATS PLASTIC COVER SET

L mm	Part. no.	P g	 n°	
270	001 003 022	185	1	

ATS TRACK JOINT SET

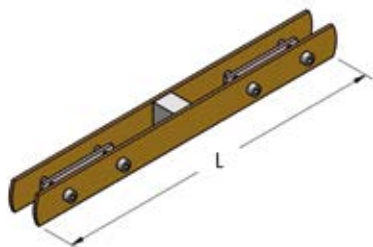

L mm	Part. no.	P g	n°	
220	001 002 028	540	1	

PULLEYS SET

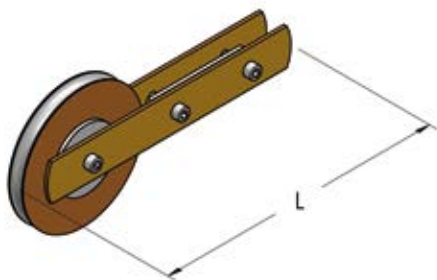

L mm	Part. no.	P g	n°	
250	001 002 026	1600	2	

ATS TRACK TERMINALS SET

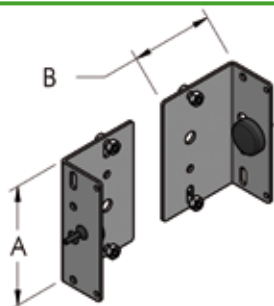

A mm	B mm	Part. no.	P g	n°	
115	80	001 002 034	555	1	

STANDARD FIXING BRACKETS SET

MAT

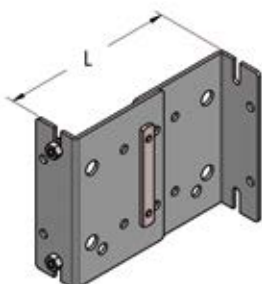

L mm	Part. no.	P g	n°	
125-135	001 003 036	550	1	

DOUBLE JOINING PLATES SET (2)

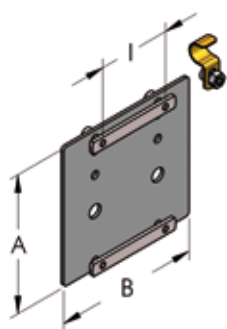

B mm	A mm	I mm	Part. no.	P g	n°	
120	115	60	001 003 030	650	1	

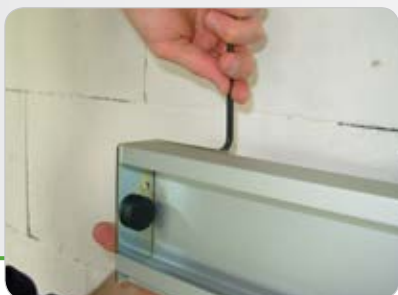

ATS

SAB SWINGING ARM BRACKET

The swinging arm for feeding and supporting compressed air pneumatic tools can be used over a large semi circular working area.

It consists of a horizontal bar fixed on a hollow pivot revolving on self-lubricating bearings, with gaskets for the compressed air seal.

The pivot is supported by two brackets attached to the wall with expansion dowels. For extra movement along the length of the SAB, an ATS system can be fitted.





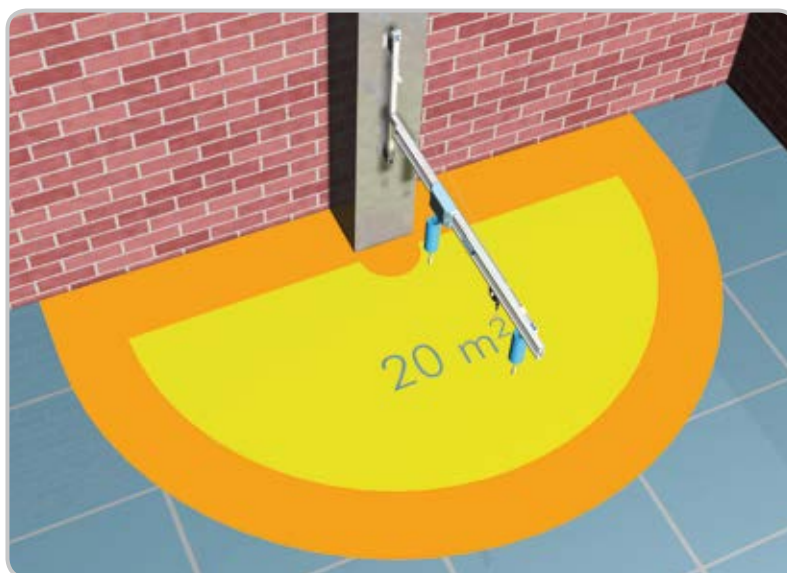

The sketch below shows an integrated solution obtained fixing a 3 m A.T.S. on a 3 m S.A.B.

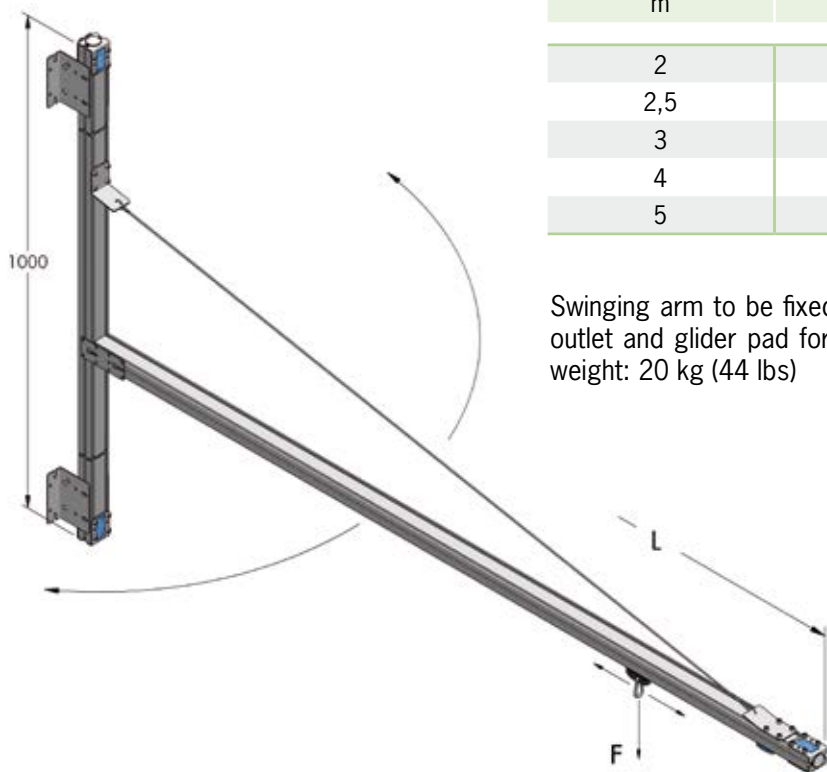
SAB



Picture above shows a 3m ATS combined with 3m SAB.



SAB - WALL VERSION

L m	Part. no.	P Kg	 n°	
2	002 001 200	11	1	
2,5	002 001 250	11,5	1	
3	002 001 300	12	1	
4	002 001 400	13	1	
5	002 001 500	14,5	1	

Swinging arm to be fixed to the wall complete with fixing dowels, 3/8" outlet and glider pad for tool balancer attachment. Maximum bearable weight: 20 kg (44 lbs)

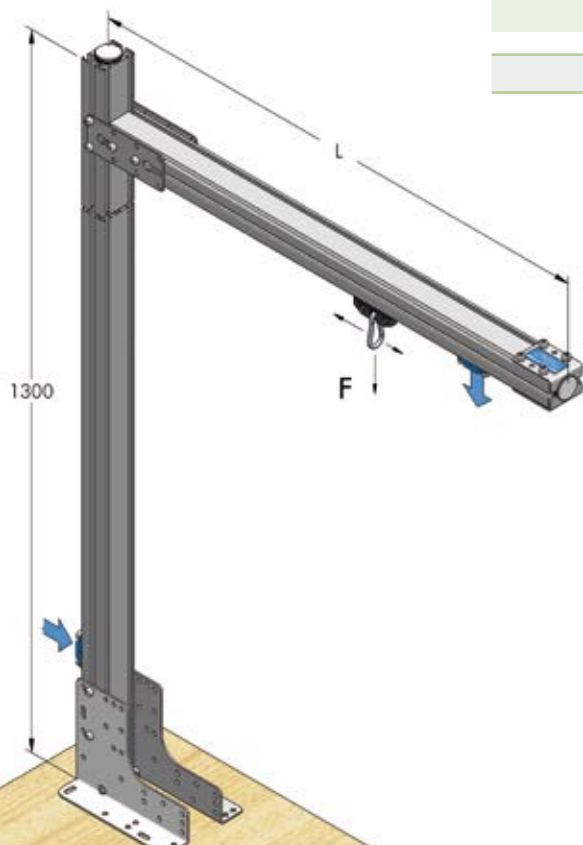
SAB

SAB - BENCH VERSION

L m	Part. no.	P Kg	 n°	
0,7	002 002 070	5,5	1	

Swinging arm to be fixed to the bench, complete with fixing screws, 3/8" outlet plate and glider pad for tool attachment. Maximum bearable weight: 20 kg (44 lbs)

ADDITIONAL GLIDER PAD

HBS

MAT



L mm	Part. no.	P g	n°
60	002 001 040	20	20

ADDITIONAL OUTLET PLATE

HBS

MAT



G	l mm	Part. no.	P g	n°
3/8" - BSP	36	003 001 934	80	20

PLATES FOR FIXING ATS ON SAB

HBS

ATS

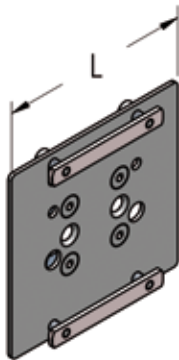

L mm	Part. no.	P g	n°
120	002 001 042	350	20

NYLON PIPE WITH QUICK FITTINGS

SYS



L m	Part. no.	P g	n°
5	001 003 065	400	10

Max operating temperature 60 °C at 8 bar

SAB INSTALLATION



SAB



WBA WORKBENCH FOR ASSEMBLY

The workbench is specially equipped for assembly work using pneumatic tools. It is constructed with a stout extruded aluminium frame which supports the A.T.S. system. The A.T.S. system consists of a rail on which a trolley runs freely. The trolley has an air outlet and a spring catch.

One of the two upright supports of the bench frame is pressurized acting as both a reservoir and a delivery tube.

To complete the system we supply height adjustable feet and cross bars with shelves to which parts bins can be hooked. The whole frame is supplied, partially assembled, in a stout cardboard box. The supply of the simple bench frame represents a valid alternative to the complete bench.

It must be fixed to the customer's existing workbench by means of proper feed.



Technical Characteristics:





- Anodized aluminium frame
- Table dimensions: 75x150 or 200 cm
- Height from ground: 85-95 cm
- Height of trolley from ground: 220 cm
- Compressed air outlet: 1/4"
- Compressed air inlet: 3/8"

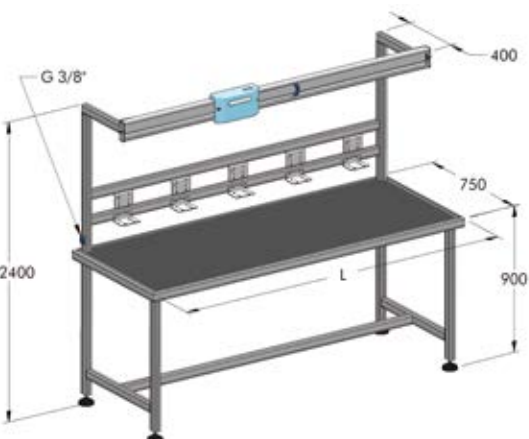

WBA - WORKBENCH FOR ASSEMBLY





Complete assembly bench with A.T.S. brackets and adjustable feet. Accessories and packaging excluded.



L m	Part. no.	P Kg	 n°	
1,5	004 001 150	77	1	
2	004 001 200	87	1	

WITH ELECTRIC FEED





As above, adding cable on trolley

L m	Part. no.	P Kg	 n°	
1,5	004 003 150	78	1	
2	004 003 200	88	1	

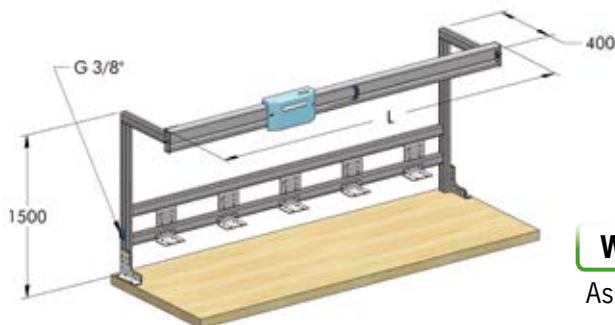
WBA - FRAME FOR BENCH





Complete frame for existing bench



L m	Part. no.	P Kg	 n°	
1,5	004 011 150	24	1	
2	004 011 200	26	1	

WITH ELECTRIC FEED

As above, adding cable on trolley

L m	Part. no.	P Kg	 n°	
1,5	004 013 150	25	1	
2	004 013 200	27	1	

NEON LAMP SYSTEM COMPLETE

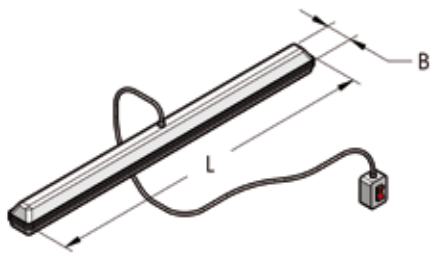

B mm	L m	Part. no.	P Kg	n°	
120	1,30	004 001 072	3,4	1	

BLUE PVC STRIP

HBS MAT

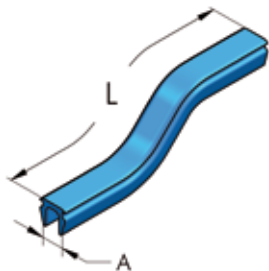

A mm	L m	Part. no.	P g	n°	
6,2	1	874 006 100	34	100	

RIGHT "L" PLATE

SYS

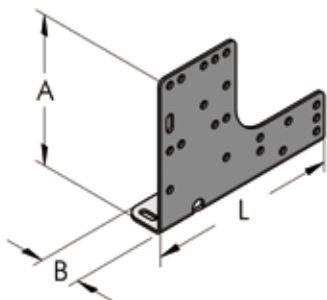

A mm	B mm	L mm	Part. no.	P g	n°	
130	36	174	732 174 130	400	20	

LEFT "L" PLATE

SYS

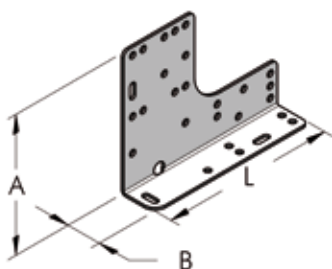

A mm	B mm	L mm	Part. no.	P g	n°	
130	36	174	732 174 131	400	20	

SMOOTHED PLATE

HBS SYS

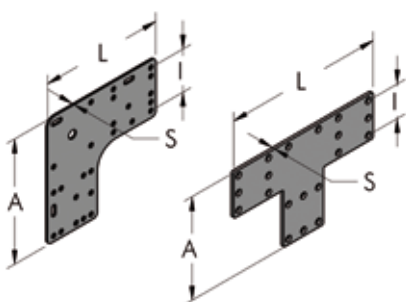

	A mm	I mm	L mm	S mm	Part. no.	P g	n°	
L	174	36-60	174	2,5	711 174 174	400	20	
	108	36	108	3	711 108 108	174	20	
T	174	36-60	268	2,5	711 174 268	546	10	
	108	36	168	3	711 108 168	236	20	

HBS

MAT

BRACKET

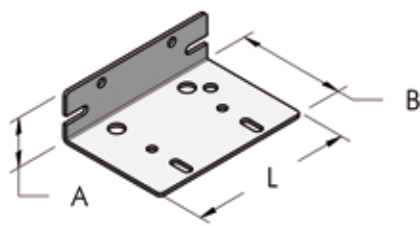

A mm	B mm	L mm	Part. no.	P g	n°
36	80	120	732 120 115	260	20



HBS

BENCH "L" PLATE

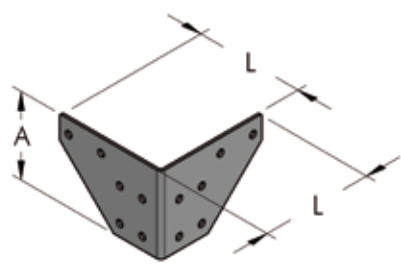

A mm	L mm	Part. no.	P g	n°
85	110	732 085 220	280	20



FOOT, COMPLETE

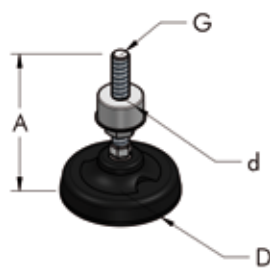

D mm	A mm	G mm	d mm	Part. no.	P g	n°
80	93	M12	32	004 001 070	320	10



PLUG FOR FOOT

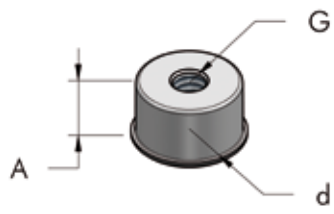

d mm	A mm	G mm	Part. no.	P g	n°
32	30	M12	512 032 030	115	20



PVC PLASTIC COVER FOR BENCHES

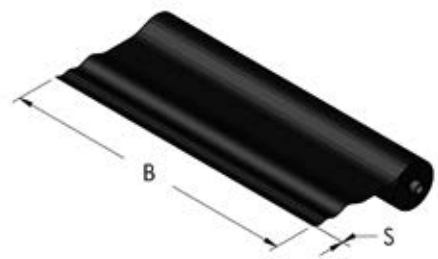

S mm	B cm	Part. no.	P kg/m ²	n°
2	200	151 002 200	2	2



WBA

SERVICE BENCH COMPLETE (IN CARDBOARD BOX, TO BE ASSEMBLED)

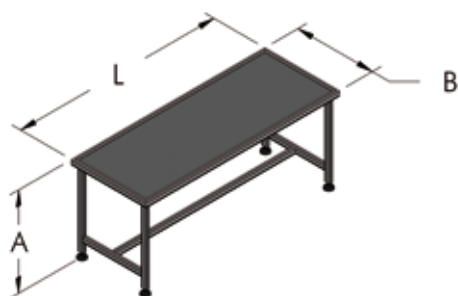

A cm	B cm	L cm	Part. no.	P Kg	n°	
90	75	150	004 021 150	30	1	↗
90	75	200	004 021 200	31	1	↗

CUSTOMIZED STRUCTURES

Teseo's technical department is able to design, quote and manufacture structures and work benches able to match customer's requirements. Besides supplying bespoke solutions, Teseo includes the quality and knowledge of its products.

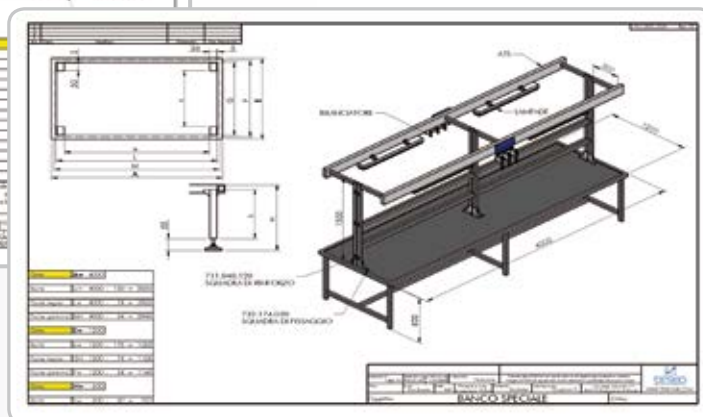
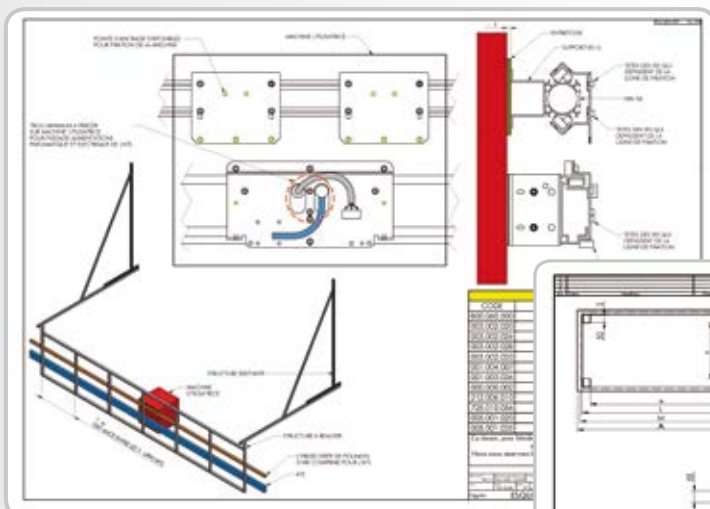
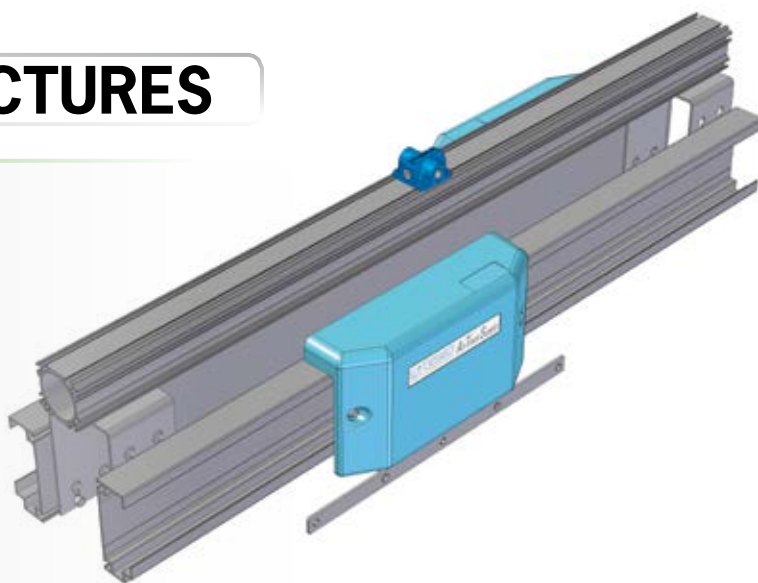

MAT MODULAR AIR TROLLEY

The trolley on hollow bar is equipped with 6 ball bearing wheels running on HBS 50 profile.

The hollow bar has a double function: track for the trolley and conduit for compressed air.

This trolley is recommended for high flow and heavy loads (max 40 kg)

Typical the application on assembly lines of car plants.

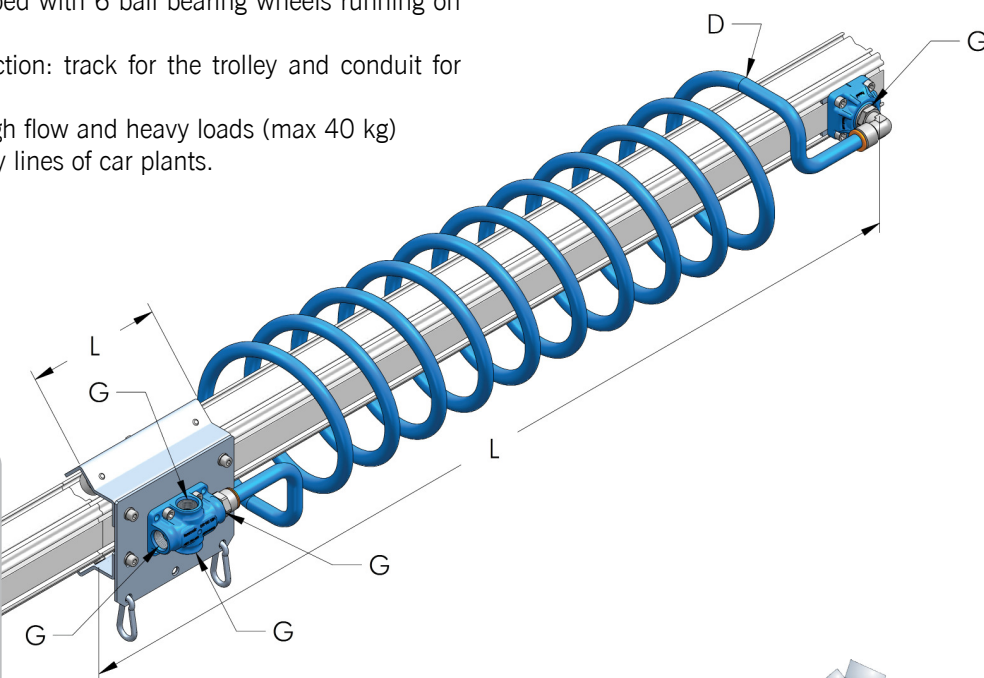
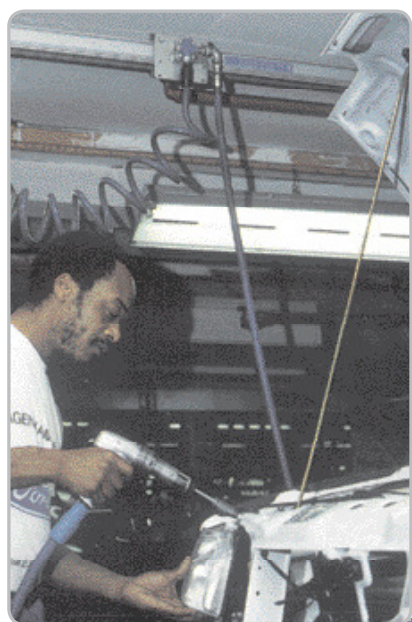

	D mm	G	L mm	Part no.	P g	 n°
Trolley	-	1/2" BSP	150	005 001 020	1400	1
Hose	14	1/2" BSP	4500	005 001 065	1000	1
Hollow bar	50	-	5000	801 060 500	9500	1
Glider pad	26	-	60	002 001 040	20	1

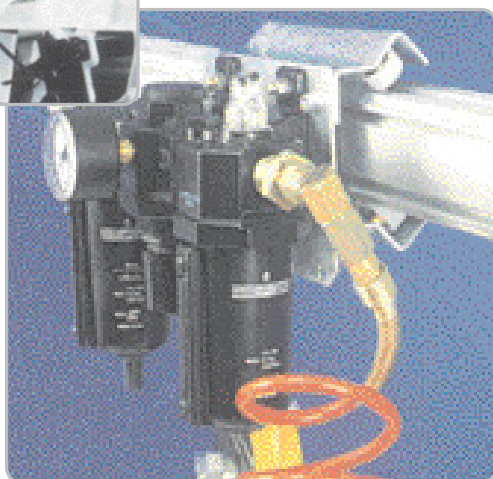

WARNING !

Maximum static load applied to the hook 30 kg ($T_{min} -20^{\circ}C$ $T_{max} +80^{\circ}C$)

SUPPORT "L" PLATE

HBS

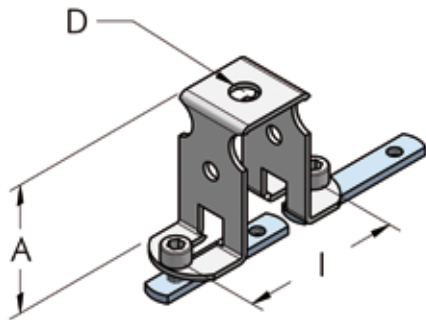

A mm	I mm	D mm	Part. no.	P g	n°
50	36-60	6,5	003 001 074	100	10

HANGING SUPPORT PLATE

HBS

ATS

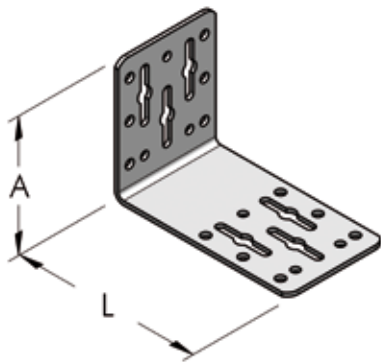

A mm	L mm	Part. no.	P g	n°
94	140	732 078 140	420	20

STROKE END STOP

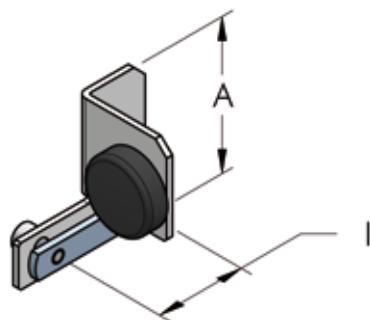

A mm	I mm	Part. no.	P g	n°
60	36	005 001 035	80	20

BALL BEARING WHEEL

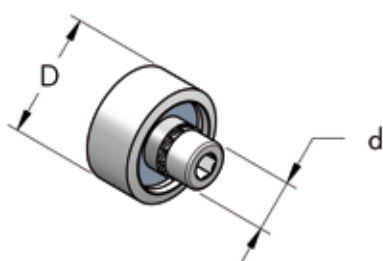

D mm	d mm	Part. no.	P g	n°
24	6	005 001 043	22	20

AM ALUMINIUM MANIFOLD

AM is a revolutionary manifold for the distribution of compressed air and other fluids under pressure (drinking water, oil, inert gases and vacuum Δ).

AM is particularly suitable to be mounted onto automatic machines to feed the different servomechanisms or onto injection or die-casting presses to cool moulds.

AM is assembled by means of the Teseo HBS components and bars.

The following drawings show an example of an assembled manifold with its parts.

1

Choose the bar diameter and cut to size



2

Mark positions and sign the centres

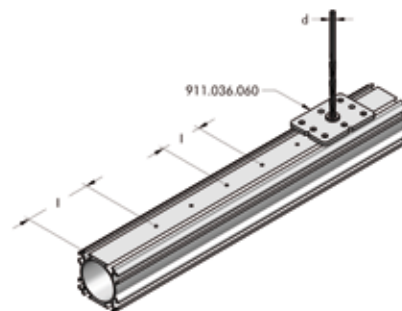

3

Drill holes in the bar

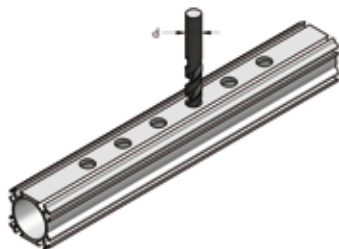

4

4. Choose required outlet plates



5

5. Choose the appropriate terminals

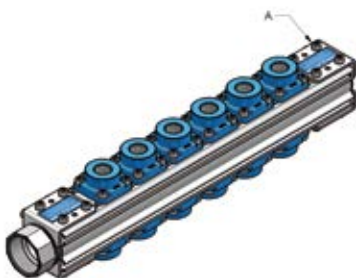

6

Choose the appropriate fixing brackets



For chemical compatibility and further details contact TESEO srl technical dept.

PROPOSAL

The technical office of Teseo srl can design bespoke manifolds at the request of the customer and supply them already assembly. The manifolds can be manufactured with both systems, HBS and AP.

DT DRILLING TOOL

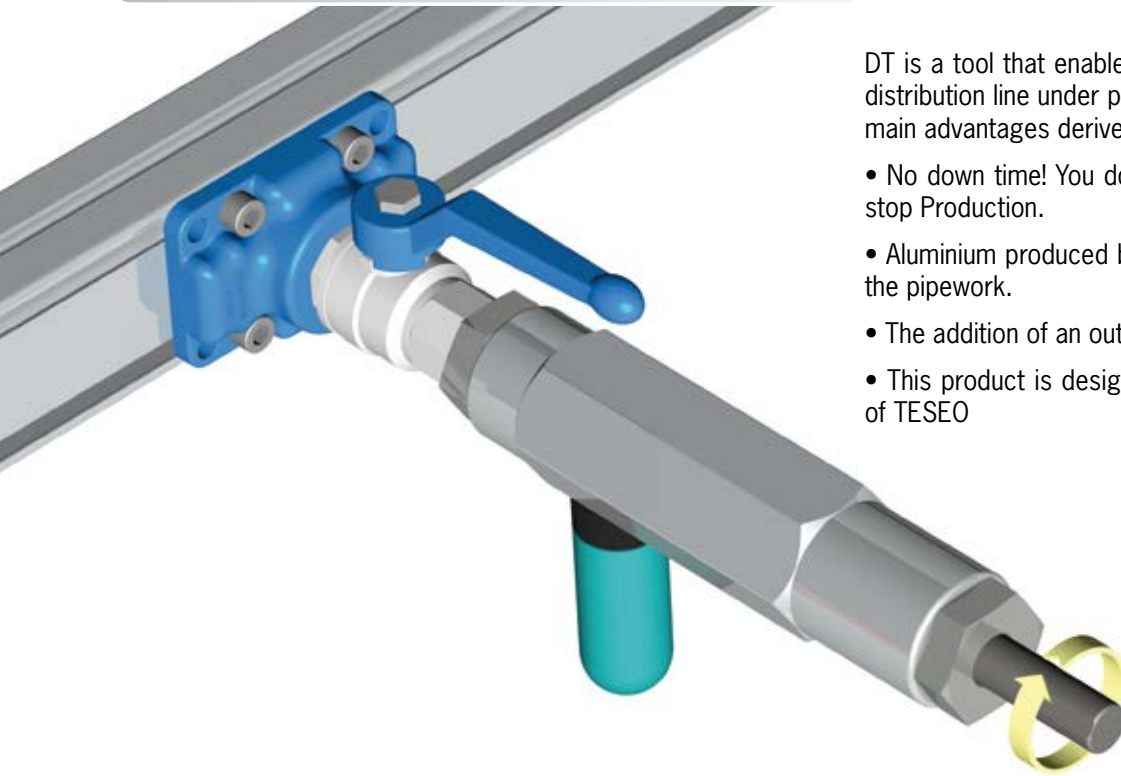



DT is a tool that enables you to drill the compressed air distribution line under pressure with ease and safety. The main advantages derived from the use of DT:

- No down time! You don't have to empty the system or stop Production.
- Aluminium produced by drilling does not penetrate into the pipework.
- The addition of an outlet plate is easy and safe
- This product is designed for the HBS and AP systems of TESEO

OUTLET PLATE

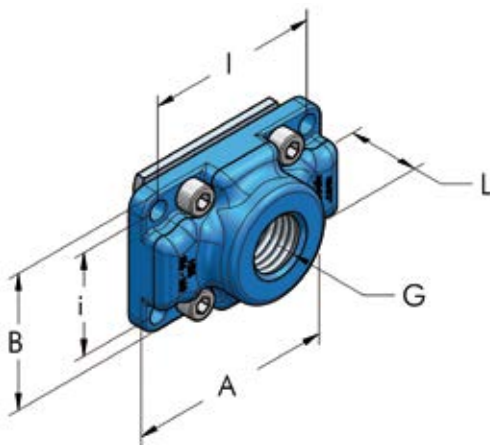
HBS



I mm	i mm	G	A mm	B mm	L mm	Part. no.	P g	 n°
36	36	1/2" - BSP	48	48	25	003 002 033	110	20
36	36	3/4" - BSP	48	48	25	003 002 034	105	20
60	60	1/2" - BSP	72	72	30	003 003 033	250	20
60	60	3/4" - BSP	72	72	30	003 003 034	220	20
60	36	1/2" - BSP	72	48	25	003 360 033	129	10
60	36	3/4" - BSP	72	48	25	003 360 034	125	10

DRILLING TOOL

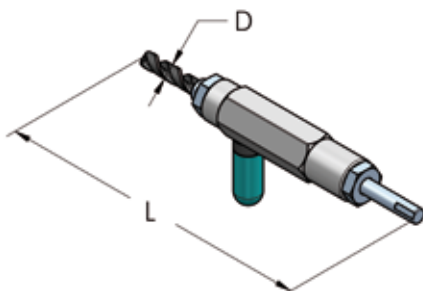

D mm	G	L mm	Part. no.	P g	 n°
13	1/2" - BSP	320	005 004 021	750	1
19	3/4" - BSP	335	005 004 026	840	1

DT

PIPE BENDER **CENT80**

We thought about a new tool that could solve quickly and economically all the bending needs in your installations.

Practical, lightweight and portable, CENT80 is the new tool that allows the manual execution of all the bends up to 180°, straight on site.



Supported products



AP28



AP22



14mm



10mm

MANUAL PIPE BENDER

AP

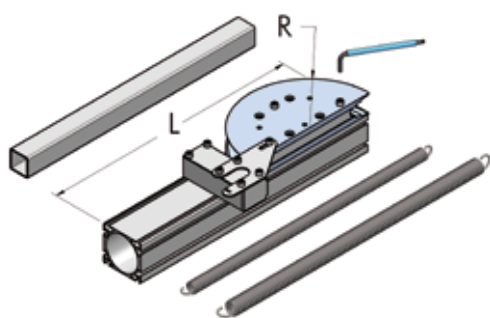

Di mm	R mm	L mm	Part. no.	 n°
8	65	450	005 006 020	1
12	88			
20	100			
25	115			

CENT80 is ideal for quickly creating bends on pipework installations, anywhere you are.

On site it is possible to secure it with a robust bench vice or, with a couple of clamps, vertically on a standard bench, on the floor of the truck, on the forks of the forklift, CENT80 will follow you anywhere.



APPLICATIONS

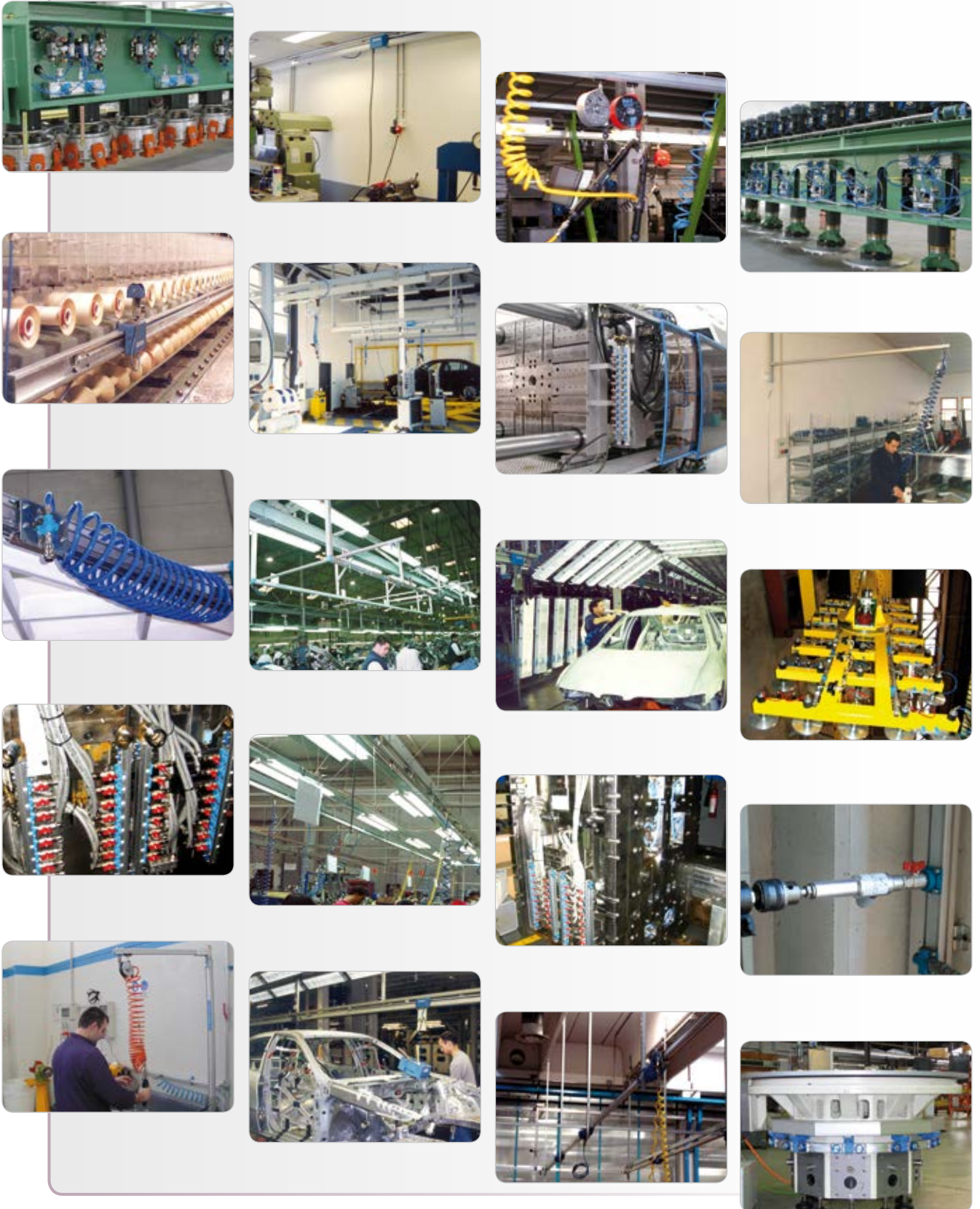



THREADED STRAIGHT PUSH FITTING

HBS

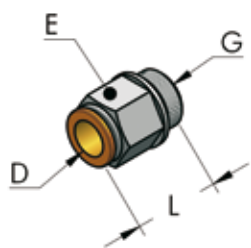
AP





D mm	G	L mm	E mm	Part. no.	P g	n°	
14	3/8" - BSP	36	22	413 017 036	46	20	
14	1/2" - BSP	34	22	413 021 034	47	20	

STRAIGHT PUSH FITTING

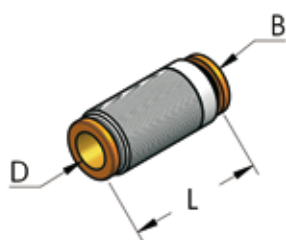
HBS







D mm	B mm	L mm	Part. no.	P g	n°	
14	20	48	413 014 048	62	20	

L PUSH FITTING

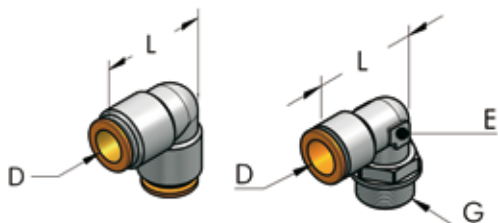
HBS

AP





D mm	G	L mm	E mm	Part. no.	P g	n°	
14	-	35	-	414 014 035	77	20	
14	1/2" - BSP	35	18	414 021 035	88	20	

T PUSH FITTING

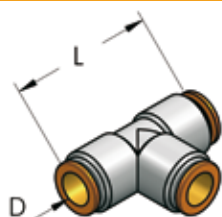
HBS





D mm	L mm	Part. no.	P g	n°	
14	70	414 014 070	110	20	

AIR REGULATION UNIT

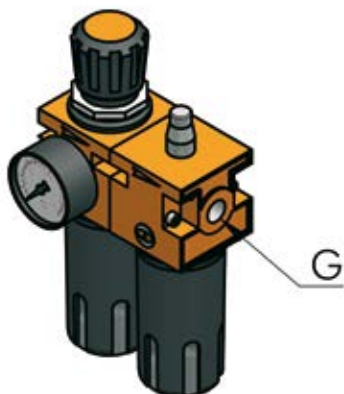
SYS



G	Configuration	Part. no.	P g	n°	
3/8" - BSP	Pressure regulator, filter, manometer	003 001 060	1200	10	
3/8" - BSP	Regulator, filter, lubricator, manometer	003 001 062	2000	10	

M/F NIPPLE WITH TAPERED THREAD

SYS

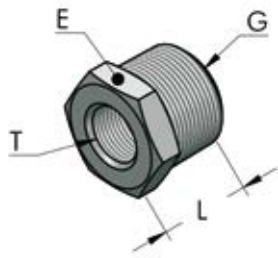

G	T	L mm	E mm	Part. no.	P g	n°	
1/2" - BSP	1/4" - BSP	16	24	417 021 016	31	20	

THREADED PLUG, WITH SEAL

SYS

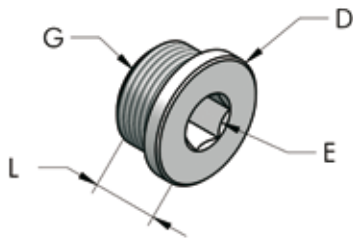

G	D mm	L mm	E mm	Part. no.	P g	n°	
1/4" - BSP	18	11	6	418 014 011	10	20	
3/8" - BSP	21	13	8	418 017 013	20	20	
1/2" - BSP	26	15	10	418 021 015	32	20	

FEMALE FLANGE EN 1092-100

HBS

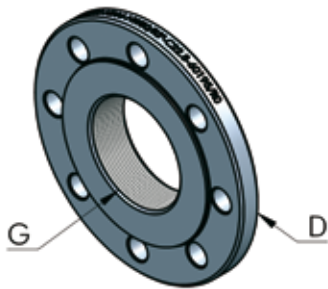

D mm	G	holes	Part. no.	P g	n°	
200	3" - BSP	8	436 085 035	3800	10	
220	4" - BSP	8	436 114 040	5000	10	

M/M THREADED NIPPLE

SYS

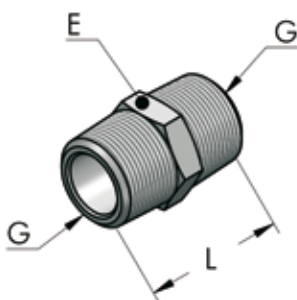





G	L mm	E mm	Part. no.	P g	n°	
3/8" - BSP	28	17	417 017 028	26	20	
1/2" - BSP	35	22	417 021 033	44	20	
3/4" - BSP	40	27	417 026 040	78	20	
1" - BSP	34	34	417 033 034	221	20	
1 1/2" - BSP	60	55	417 048 060	290	20	

CONDENSATE DRAIN

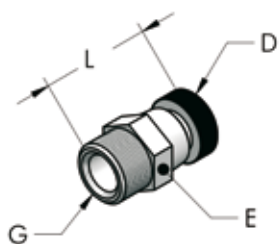
HBS

AP



G	D mm	L mm	E mm	Part. no.	P g	n°	
1/4" - BSP	13	26	14	435 014 035	20	10	
3/8" - BSP	14	27	17	435 017 024	30	10	







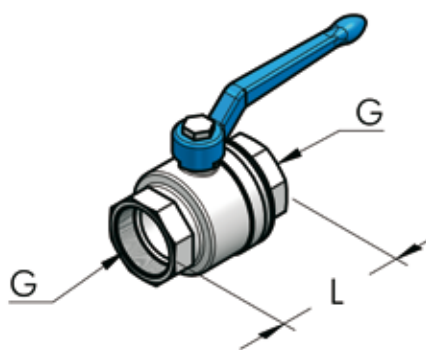

F/F BALL VALVE

HBS

AP

POW



G	L mm	Part. no.	P g	n°	
1/2" - BSP	50	434 021 050	170	10	
3/4" - BSP	68	434 026 070	300	10	
1" - BSP	80	434 033 080	420	10	
1"1/4 - BSP	90	434 042 080	670	10	
1"1/2 - BSP	100	434 048 100	990	10	
2" - BSP	115	434 060 120	1600	10	
2"1/2 - BSP	150	434 075 150	3550	10	





M/F BALL VALVE

HBS

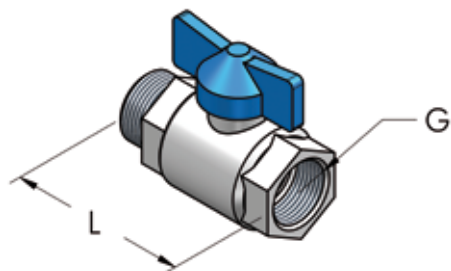
AP

POW



L mm	G	Part. no.	P g	n°	
55	3/8" - BSP	434 010 055	150	10	
67	1/2" - BSP	434 021 067	210	10	
82	3/4" - BSP	434 026 075	360	10	

BALANCER FOR TOOL ATTACHMENT



ATS

WBA

SAB

HBS



F Kg	Part. no.	P g	n°	
0,4 ÷ 1	001 003 072	500	1	
1 ÷ 2	001 003 073	500	1	

DEBURRING TOOL

SYS

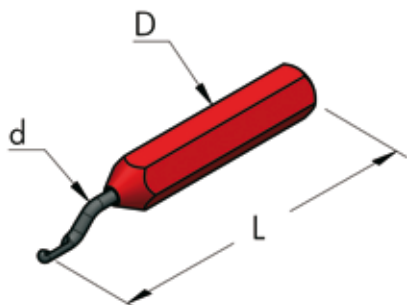

d mm	D mm	L mm	Part. no.	P g	n°	
3	14	150	909 012 130	55	10	
3	Spare blade		909 003 047	3	10	

ALLEN SPANNER

SYS

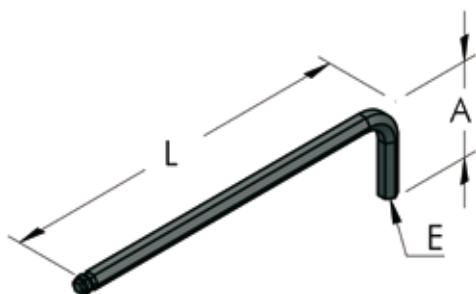

E mm	A mm	L mm	Part. no.	P g	n°	
5	34	140	901 130 005	30	10	

ALLEN SCREW DRIVER

AP

POW

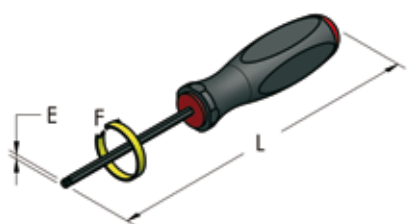

E mm	L mm	F	Part. no.	P g	n°	
4	200	6-10	901 170 004	40	1	
5	220	6-14	901 190 005	75	1	

DRILLING TOOL

SYS

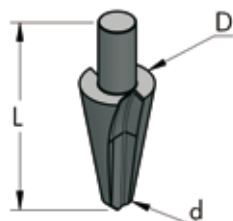



D mm	d mm	L mm	Part. no.	P g	n°	
20	8	62	922 020 062	46	1	

HBS

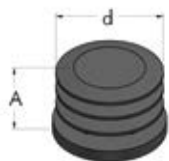
SMALL PLASTIC FOOT





d mm	A mm	Part. no.	P g	n°	
25	20	293 025 022	8	20	
32	25	293 032 025	10	20	

WBA

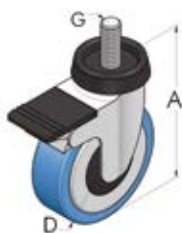
SMALL WHEEL





A mm	d mm	G mm	Part. no.	P g	n°	
110	80	M12	381 080 104	380	10	

SYS

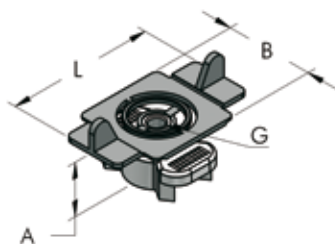
HEXAGONAL NUT M6 FOR HILTI SYSTEM





L mm	B mm	A mm	G mm	Part. no.	P g	n°	
50	30	15	M6	233 006 034	22	50	

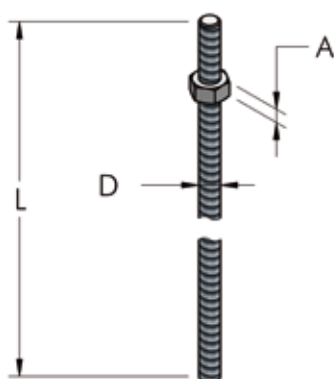

SYS

HEXAGONAL NUT



D mm	A mm	Part. no.	P g	n°	
M6	5	230 006 005	2,5	20	



HANGING TIE ROD

D mm	L m	Part. no.	P g	n°	
M6	1	226 006 100	200	10	

SYS

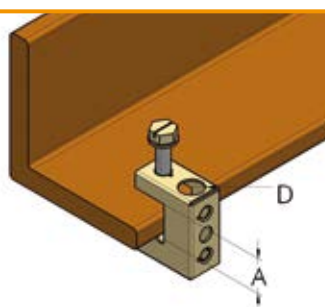
BUCKLE



D mm	A mm	Part. N°	P g	n°	
10	18	294 010 018	25	20	

TESEO PIPING SYSTEMS APPROXIMATE FLOW RATES

Based upon independent data provided by the university of Torino (I), mechanical Department, research Contract n° 1089/97.

PRESSURE DROP			FLOW RATE in l/min								
Working pressure (bar)	$\Delta p = P_i - P_u$ about 3%	L (m)	Ø 14	AP22	AP28 e HBS25	HBS32	AP45	AP54 e HBS50	AP68 e HBS63	HBS80	HBS110
2	0,07	30	160	600	1.000	1.900	3.600	5.900	10.500	19.000	42.300
4	0,12	30	300	1.100	2.000	3.600	6.650	10.900	19.500	35.400	78.500
6	0,18	30	460	1.650	2.900	5.400	10.000	16.400	29.200	53.000	117.500
8	0,25	30	628	2.300	4.000	7.300	13.500	22.700	39.700	72.200	160.000
10	0,30	30	650	2.700	4.800	9.000	16.800	27.200	48.500	88.000	195.000

Flow rates in this char are calculated with 3% pressure drop from inlet pressure. Length of pipe is 30 metres.

WE EAT THEM ALL!



Comparing nominal diameters with the competitors, the flow rate of our piping is physically larger. The blue lines are small, they fit in ours. **MAKE THE RIGHT CHOICE!**

APPROXIMATE CHART FOR CHOOSING TESEO PIPING DIAMETER - HBS SYSTEM

Flow rate in			LENGTH (in meters)									
m ³ /h	l/min	cfm	20	50	100	200	300	400	500	1000	1500	2000
21	350	12	25	25	25	25	25	25	25	25	25	25
30	500	18	25	25	25	25	25	25	25	25	25	25
42	700	25	25	25	25	25	25	25	25	25	25	32
54	900	32	25	25	25	25	25	25	25	25	32	32
66	1100	39	25	25	25	25	25	25	25	32	32	32
90	1500	53	25	25	25	25	25	25	32	32	50	50
120	2000	71	25	25	25	25	32	32	32	50	50	50
150	2500	88	25	25	25	32	32	32	50	50	50	50
216	3600	127	25	25	32	32	50	50	50	50	50	50
360	6000	212	25	32	50	50	50	50	50	50	50	63
540	9000	318	32	50	50	50	50	63	63	63	80	80
690	11500	406	32	50	50	50	63	63	63	80	80	80
780	13000	459	50	50	50	63	63	63	80	80	80	110
900	15000	530	50	50	50	63	63	80	80	80	110	110
1260	21000	742	50	50	63	80	80	80	80	110	110	110
1620	27000	954	50	63	63	80	80	110	110	110	110	#110
2100	35000	1236	50	63	80	80	110	110	110	110	#110	#110
3000	50000	1766	63	80	80	110	110	110	110	#110	#110	#110
3360	56000	1978	63	80	110	110	110	110	#110	#110	#110	#110
3720	62000	2190	63	80	110	110	110	#110	#110	#110	#110	#110
4800	80000	2825	80	110	110	110	#110	#110	#110	#110	#110	#110
5880	98000	3461	80	110	110	#110	#110	#110	#110	#110	#110	#110
6720	112000	3955	80	110	#110	#110	#110	#110	#110	#110	#110	#110
9600	160000	5650	110	110	#110	#110	#110	#110	#110	#110	#110	#110
12000	200000	7063	110	#110	#110	#110	#110	#110	#110	#110	#110	#110
15000	250000	8829	110	#110	#110	#110	#110	#110	#110	#110	#110	#110

This chart indicates Teseo piping diameters calculated at 8 bars pressure and 5% pressure drop from inlet pressure.
#110 = indicates pressure drop over 5%

APPROXIMATE CHART FOR CHOOSING TESEO PIPING DIAMETER - AP SYSTEM

Flow rate in			LENGTH (in meters)									
m ³ /h	l/min	cfm	20	50	100	200	300	400	500	1000	1500	2000
21	350	12	22	22	22	22	22	22	22	22	22	22
30	500	18	22	22	22	22	22	22	22	22	28	28
42	700	25	22	22	22	22	22	22	22	28	28	45
54	900	32	22	22	22	22	22	28	28	28	45	45
66	1100	39	22	22	22	22	28	28	28	45	45	45
90	1500	53	22	22	22	28	28	28	45	45	45	45
120	2000	71	22	22	28	28	45	45	45	45	45	45
150	2500	88	22	28	28	45	45	45	45	45	45	54
216	3600	127	28	28	45	45	45	45	45	54	54	54
360	6000	212	28	45	45	45	45	54	54	54	54	68
540	9000	318	45	45	45	54	54	68	68	68	#68	#68
690	11500	406	45	45	54	54	68	68	68	#68	#68	#68
780	13000	459	45	45	54	68	68	68	#68	#68	#68	#68
900	15000	530	45	54	54	68	68	#68	#68	#68	#68	#68
1260	21000	742	45	54	68	#68	#68	#68	#68	#68	#68	#68
1620	27000	954	54	68	68	#68	#68	#68	#68	#68	#68	#68
2100	35000	1236	54	68	#68	#68	#68	#68	#68	#68	#68	#68
3000	50000	1766	68	#68	#68	#68	#68	#68	#68	#68	#68	#68
3360	56000	1978	68	#68	#68	#68	#68	#68	#68	#68	#68	#68
3720	62000	2190	68	#68	#68	#68	#68	#68	#68	#68	#68	#68

This chart indicates Teseo piping diameters calculated at 8 bars pressure and 5% pressure drop from inlet pressure.
#68 = indicates pressure drop over 5%

RESISTANCE TO CHEMICAL AGENTS

MATERIAL	ALUMINIUM (AL)	O-RING SEALS	NYLON	NICKEL- PLATED BRASS	97/23/CE
GAS					
Compressed air	A	A	A	A	K
Vacuum	A	A	A	A	K
Nitrogen	A	A	A	A	K
Carbon dioxide	A	A	A	A	K
Argon	A	A	A	A	K
Argon - Nitrogen Mixture	A	A	A	A	K
Argon-Carbon Dioxide Mixture	A	A	A	A	K
Oxygen	D	C	A	A	
Dry Chlorine	A	D	D	C	
Sulphidric Acid	A	D	A	C	
Dry Sulphur Dioxide	A	D	C	A	
ORGANIC AND CHEMICAL COMPOUNDS					
Mineral engine oil	A	A	B	A	K
Synthetic motor oil	A	A	B	A	K
Exhausted engine oil	A	A	B	A	K
Oil emulsion 3% for metalworking	A	A	A	A	K
Oil emulsion 8% for metalworking	A	A	A	A	K
Glycol	A	A	B	A	K
Glycol and water mixture	A	A	A	A	K
Windscreen washing fluid	B	D	B	D	
Ammonia solution	A	B	B	C	
Methyl alcohol	B	B	B	C	
Vinilic glue	A	A	A	A	
Ethanol	A	A	B	A	K
Formalin	A	A	B	A	K
Acetone	A	D	A	A	K
Aniline	C	D	C	A	
Potassium bicarbonate	D	B	B	A	
Potassium permanganate	A	B	D	A	
Benzene	A	D	B	A	
Gasoline	A	B	B	A	K
Diesel fuel	A	A	B	A	K
ACIDS					
Citric acid	B	A	B	C	
Boric acid	B	A	B	C	
Acetic acid	B	C	D	C	
Cloridric acid	C	D	D	D	
Oleic acid	B	C	B	D	
Nitric acid	C	D	D	C	
Tartaric acid	A	A	B	C	K
Phosphoric acid	D	D	D	D	
Sulfuric acid	D	D	D	D	

Legend: A = Very good; B = Good; C = Low; D = Poor; K= KIWA PED

Attention: the content of this table is based upon customer's inquiries forwarded by customers during past 20 years. It is always recommended to evaluate the PED 97/23 directive and consider norms and laws applicable.

PED = 97/23/CE, annexe III, E1 compliant - CE 0620 - KIWA.

In the eventually of any doubt, please contact Teseco's Technical Office.

CONDITIONS FOR THE TRANSPORTATION OF WATER IN THE HBS SYSTEM

The HBS product by Teseco is suitable to carry water provided that the following conditions are respected

1. Softened water is to be avoided because of its richness in sodium ions.
2. The acidity must range between pH5 and pH8.
3. The maximum content of chlorine ions must not exceed 2000 mg/L.
4. Iron (Fe), nickel (ni), lead (pb) and Tin (Sn) must not be present.
5. The maximum Copper (Cu) content should be not exceed 0,05 mg/L; the maximum Mercury (Hg) content should not exceed 0,005 mg/L.
6. Aluminium must not be in direct contact with iron or Copper. aluminium and iron must be insulated by galvanization while aluminium and Copper must be insulated with plastic or inert organic matter.
7. Oxygen, Carbon Dioxide and ammonia ions, dissolved in water do not cause corrosive effects.
8. Water with solution of emulsion oil for the cooling of machinery does not cause any problems.
9. We recommend electrical earth bonding of our pipework systems in order to avoid any stray currents
10. We recommend the use of ANODIZED bars

In the event of any doubt, please contact Teseco's Technical office.

Source: AQM, technical services S-I-NAL Accredited (UNI CEI EN 45001).

HBS-AP ASSEMBLING INSTRUCTIONS

1. INTRODUCTION

- 1.1. This manual is very easy to consult and we recommend reading it before starting work, bearing in mind the regulations in your country.
- 1.2. Pay attention to the instructions identified by the mark **ATTENTION**.
- 1.3. The HBS and AP ranges of products from TESEO are suitable for the distribution of compressed air, nitrogen, vacuum and inert gases.
- 1.4. For any application with **water** distribution, please check our sheet on page 92. For other **fluids** it is necessary to know their exact composition and to check if they are compatible with the HBS and AP system; in case of any doubt, please contact the technical department of TESEO.
- 1.5. **ATTENTION: TESEO is not responsible for problems due to failure to follow the instructions contained in within this manual.**

2. TOOLS AND FIXTURES

- 2.1. The **tools required** to install even a small system are: one Allen wrench for 4 and 5 mm slots, one de-burring tool or one scraper, neutral grease, one drill bit and one drilling machine, one hacksaw, some small tubes for placing the small plates, one tape measure.
- 2.2. The **tools suggested** for fast and safe work are: one pair of adjustable pliers, one battery screwdriver, one drilling jig, one chop saw with metal circular blade, one stepped cone cutter or cone cutter, one PTFE tape or sealing band, one torque wrench, one level or one plumb line, one bench on wheels.
- 2.3. Close attention should be paid to safety. To this purpose, scaffolding, helmets, harnesses, gloves and protective glasses must be used by all personnel.
- 2.4. **ATTENTION: follow the regulations concerning safety at work presently in force in your country.**

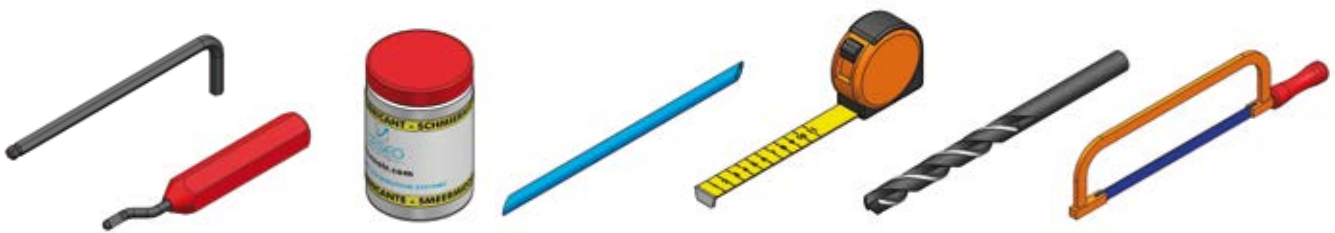

3. PREPARATION

- 3.1. **Cutting:** this can be done by hand, using a hacksaw provided that the blade has been lubricated with vaseline or other oils, as aluminium is a material which could clog the tool. When making many cuts, we suggest using a circular chop saw with metal cutting blade.
- 3.2. **Deburring:** after cutting the pipe, it is necessary to remove the sharp edges using a de-burring tool. This operation is required to avoid any damage to the o-ring and to make easier the connection.

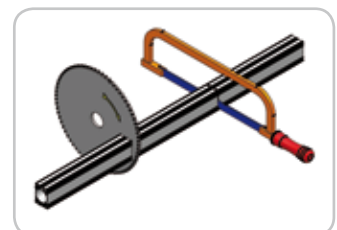
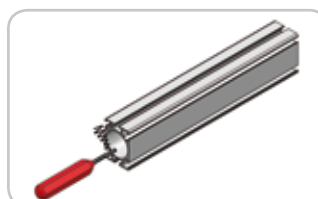

3.3. **Lubrication:** in order to make it easier to insert joint, lubricate the inner surface of the hollow bar, in order to avoid any damage to the O ring.

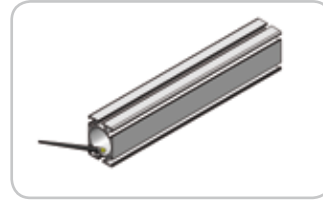

3.4. **Drilling:** during the drilling operation, it is required to have the pilot hole in the centre of the pipe. Please use a drilling jig.

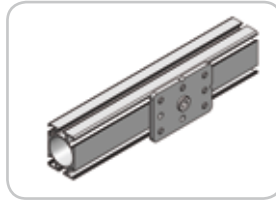

The maximum diameter of the smoothed hole must not exceed the recommended diameter. Please see the table.

HBS	 Ø 25	 Ø 32	 Ø 50	 Ø 63	 Ø 80	 Ø 110
AP	 Ø 20	 Ø 25	 Ø 40	 Ø 50	 Ø 63	

The following tools can be used: a drill, a coned drill, a counter bore, a hole saw.

3.5. **Hole de-burring:** on outlet plates we recommend de-burring a maximum 1mm around the hole in order not to damage the o ring seal.

3.6. **ATTENTION: Wear protective glasses and gloves during cutting and drilling. Flying chips could cause injury to eyes and hands.**



4. HBS SYSTEM ASSEMBLY OPERATIONS

4.1. **Insertion of small plates:** the small plates can be inserted into the slot in the bar at any point. Straighten and secure them by means of sharpened small tubes.

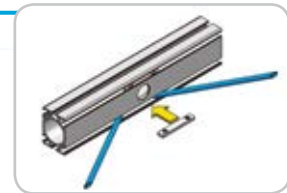

4.2. **Joint insertion:** to make it easier, first insert the plates and the small plates with loose screws into the slots, then insert the joint and connect the second bar. Now position the plates half-way on each side and tighten the screws.



4.3. **How to tighten the screws:** The screws must be tightened but be careful not to tear the thread. The torque of the m6 screws should be between a minimum of 10 N·m (91 inch-lbs) and a maximum of 13.5 N·m (120 inch-lbs).

4.4. **“L” and “T” Joint** have to be fixed using specific fixing plates. They allow you to fix pipes on two sides. Should you need to connect HBS 25 piping, using an “L” joint on the narrow side, it is required to cut 6 mm on each corner.

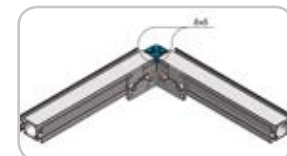

4.5. **Expansion of the line:** for lines with a straight section longer than 50 meters, we suggest mounting a sliding joint every 30 to 40 meters. This will make any future dismantling easier. The two fixing plates have to be assembled in the middle of the available space.



4.6. **ATTENTION: check that all the screws are tightened at the end of each pipe connection and when securing them be careful not to tear the thread.**

5. AP SYSTEM ASSEMBLY OPERATIONS

- 5.1. **Clamping brackets installation:** insert one side of the clamping bracket in the groove of the profile, push both clamping brackets to touch the profiles and tighten the screws.
 - 5.2. **Joints:** introduce the joint into one pipe, then connect the second pipe, position the clamping bracket equally so that it is clamping both pipes or fitting and half the other and finally tighten the screws.
 - 5.3. **Screws tightening:** Screws must be tightened properly but not excessively, to avoid stripping the threads. The recommended tightening torque for M5 screws is between 9 N·m and 11 N·m maximum. For M6 screws the minimum is 13 N·m and the maximum 15 N·m.
- 5.4. ATTENTION:** once completed the assembly of every joint, double check the screws correct blockage and be sure that no threads are damaged for excessive tightening.



6. INSTALLATION

- 6.1. **How to trace the distribution line:** trace a horizontal line at the chosen height by means of a stretched plumb line. With the TESEO system you do not need to give the inclination to collect the condensate as the up-column and the down-column are already equipped at the bottom with a collection and a drain valve.
- 6.2. **How to secure the pipework:** The pipework can be supported by several types of ceiling or wall mounted fixing plates and brackets. The recommended distance between these fixing brackets is 2 to 4 meters, depending on the weight of the distributed fluid.

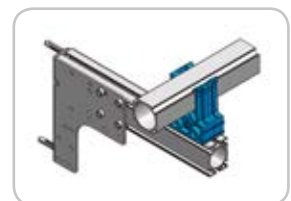
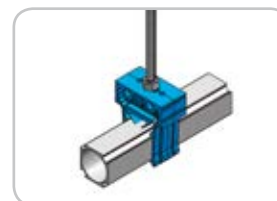
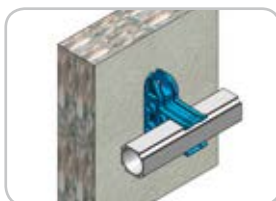
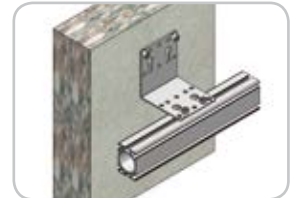
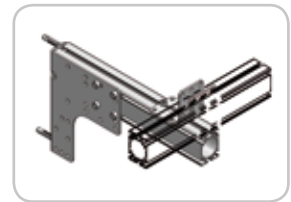
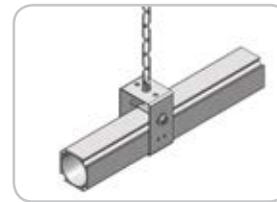
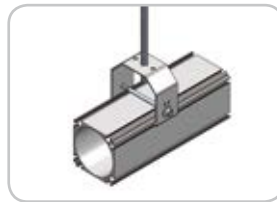
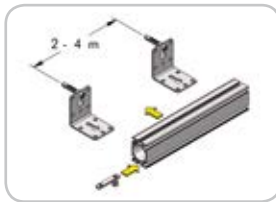

- 6.3. **Isolation valves:** ball valves must be mounted both at the beginning of the line and at the beginning of the branches of the main line. Mount a pressure gauge at the beginning of the main line and a safety valve on the air receiver.
- 6.4. **Take-offs: for the down tubes:** to prevent any impurities fouling the bottom of the hollow bar, we recommend fitting the outlet plates on the sides of the hollow bar.
- 6.5. **Flexible pipe:** its use is recommended in order to isolate the installation from the vibrations of the compressor.
- 6.6. **Earthing:** it is recommended in case of stray electrical currents.
- 6.7. **ATTENTION:** wear a safety helmet, harnesses and use scaffolding in compliance with the law before tracing and installing the line, as these operations are usually carried out at a dangerous height.



7. GENERAL TEST AND INSPECTION

- 7.1. **Inspect** every part of the system and check that no screw is loose, that all joints are properly in place and all brackets are properly secured.
- 7.2. Check that the **service valve** placed between the compressor room and the line is closed.
- 7.3. Start the compressor and fill the tank up to the maximum pressure. If a compressor is not available, use nitrogen tanks and/or small portable compressors.
- 7.4. Open the valve and fill the system up to 1 bar approx. (15 psi); close the valve and check that no leaks are detected in the system.
- 7.5. **Increase the pressure** of the system slowly until you reach the maximum pressure. Keep this pressure for about 1 hour. Test the system when the pressure is 1.5 times higher than the working pressure.
- 7.6. Inspect the system again and check that no leaks or other unusual deformations are visible in the joints.
- 7.7. **Empty** the system.
- 7.8. **ATTENTION: testing and inspection must be carried out only when no one is present in the working area. Wear a safety helmet and protective glasses when inspecting the system. Please follow all safety precautions.**

8. REPAIRS AND MODIFICATIONS

- 8.1. Modifications to the system are quick and easy. We suggest preparing all tools in advance, next to the area where modifications are to be made. By doing so, the downtime of the line is minimized.
- 8.2. If a leak is detected in the system, consult the following table where the most common causes and corresponding remedies are described.
- 8.3. In the case of faulty pieces manufactured by TESEO, please contact our technical department.
- 8.4. **ATTENTION: release pressure from the area of the system to be modified before carrying out repairs, maintenance or modifications. Isolate the area and inform people about maintenance operations.**

CAUSE OF THE LEAK

CORRECTIVE ACTION (REMEDIAL)

O ring seal damage due to incorrect installation, or defective.	Replace the O ring seal.
Fitting or outlet plate threads damaged.	Seal with a Teflon band or replace the faulty piece.
The drilled hole on the bar is too big or misaligned.	Replace the faulty section of the hollow bar.
Extrusion blowholes into the hollow bar.	Replace the defective part.
Misaligned mounting of the joint in the corresponding bar seats.	Disassemble the joint and realign the bars.
Defects in the seat of o ring of "I" and "T" joints.	Replace faulty joint.

INSTALLATION OF FLEXIBLE PIPES

1. CONNECTION TO MACHINE

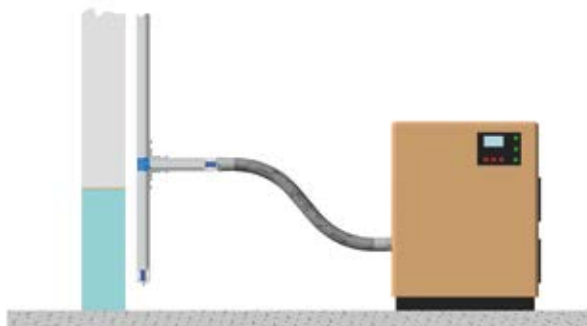

We recommend that the compressor is connected with a flexible pipe to absorb the vibrations due to the machine on every installation.

2. OBSTACLES

We remind you that to avoid any distortion, the bend radiuses of the flexible rubber pipes must not be too sharp to avoid damage it, the flexible pipe mustn't be forced against the obstacle.

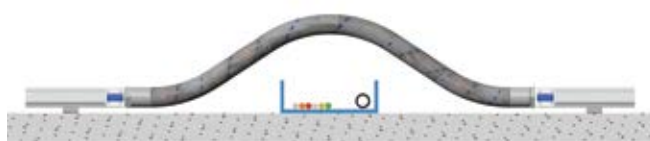

3. CHANGES IN HEIGHT

Hoses can be useful when the changing of level is lower or equal than the encumbrance of two L Joints; However it is recommended when the vertical side of the line can't be fixed.

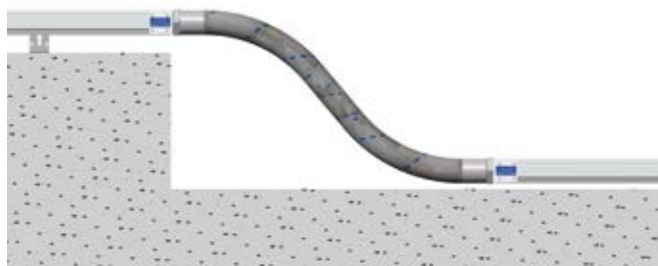

4. SPECIAL ANGLES

It is useful too when the horizontal angle of the line can't be achieved with others components from our catalogue; however it remains possible to use terminals threaded together from steel components (not recommended) from retail trade.



5. CURVING AT 180°

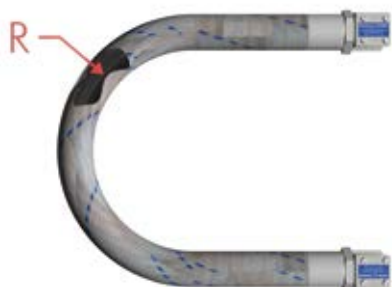

Flex Pipe	HBS25	HBS32	HBS50	HBS63	HBS80
Min Radius mm	100	130	200	270	340
Flex Pipe	AP22	AP28	AP45	AP54	AP68
Min Radius mm	90	100	150	200	270

Material	EPDM
Temperature	-30°C ÷ +70°C
Available for special request	

COMPRESSED AIR IS EXPENSIVE: DON'T WASTE IT!

Good tips for new investment

MAKE THE RIGHT CHOICE

You may change your compressor or dryer in future, but your compressed air piping is a fixed utility in your plant.

USE QUALITY PRODUCTS

Original quality piping system will assure reliable performance and expected safety standards in your factory.

CHOOSE THE RIGHT SIZE

The right engineering & sizing of the system is fundamental to save energy, potentially more than any other practice.

INSTALL A LEAK FREE SYSTEM

Modular systems with positive seals will perform better than any threaded conventional tubing.

DON'T FOCUS ON INITIAL COST

The cost of components is only a small part of the total investment. Choose systems with the lowest cost of ownership!

COMPRESSED AIR LIFETIME COSTS

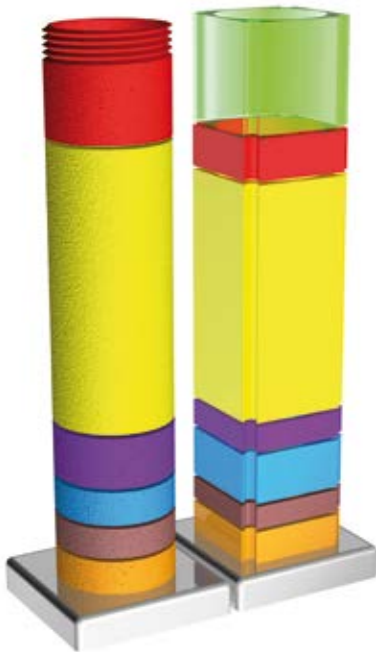

- **MONEY SAVED:** saving due to correct sizing and engineering, optimised working pressure and choice of high quality product.
- **LEAKAGE:** cost of air leaks and inappropriate use of compressed air during the lifetime of the system.
- **ELECTRICITY:** cost of electricity to feed the air compressor.
- **INSTALLATION:** cost of labour for installing the system, for extensions and modifications, for ordinary maintenance.
- **MATERIAL:** cost of pipes and fittings for assembling the system.
- **MAINTENANCE:** cost for running ordinary maintenance of the machines generating compressed air.
- **GENERATION:** cost of machines for generating compressed air (including compressor, receiver, dryer, filters).

Some good general practices...

Prevent and reduce leaks

In a conventional piping system leaks may waste 20-40% of your compressed air. Routinely check your system for leaks.

Reduce air pressure

Reducing the pressure in your system of 1 bar (15 psi) will lead to 7% saving on your annual energy consumption.

Feed compressors with cool air

With 3°C cooler intake air, compressor will save 1% energy to reach the desired working pressure.

Avoid inappropriate use

Check the efficiency of compressed air used for cooling, agitating, mixing or inflating in your factory.

**Contact our technical department for a first quick check-up of your system.
We will help you to focus on the analysis and intervention by giving an assessment of costs and waste.**

DATA FOR PLANT

Agent: Installer:
 Retailer: End user:

Fill in at least 4 fields below to develop the new project:

units Flow rate
 units Teseo diameter
 units Maximum pressure drop
 units Absolute starting pressure
 units Length of the considered network

For complex multi-diameter do sketch on the next page by adding all the notes you want

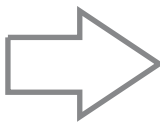

Refine your project:

Compressor/s Power

c1 Units c2 Units c3 Units c4 Units c5 Units

Area consumption

z1 Units z2 Units z3 Units z4 Units z5 Units

units Coincidence factor

Type of thread:

BSP

NPT

Drop column*

Diameter:..... Quantity:.....

Diameter:..... Quantity:.....

Diameter:..... Quantity:.....

Already have an installation? With these few data we tell you how much it costs!
 And on the purchase of a new plant Teseo calculate the payback!

Product installed: Total development:
 Age of the installation: Ø Pipe:
 Daily working hours: % Losses hypothesized:
 Labor cost: Cost of electricity

In what language do you wish the project to be developed:

Italian

English

German

Spanish

When you want the project:

If you have additional information, you can write them on the next page,
 more information allow us to better develop your project.

* Or create your drop column using the instructions on page 29 (HBS system) and page 50 (AP system).

For any special product that you have to realize contact the technical department Teseo Italy.

NOTES:

DRAFT:

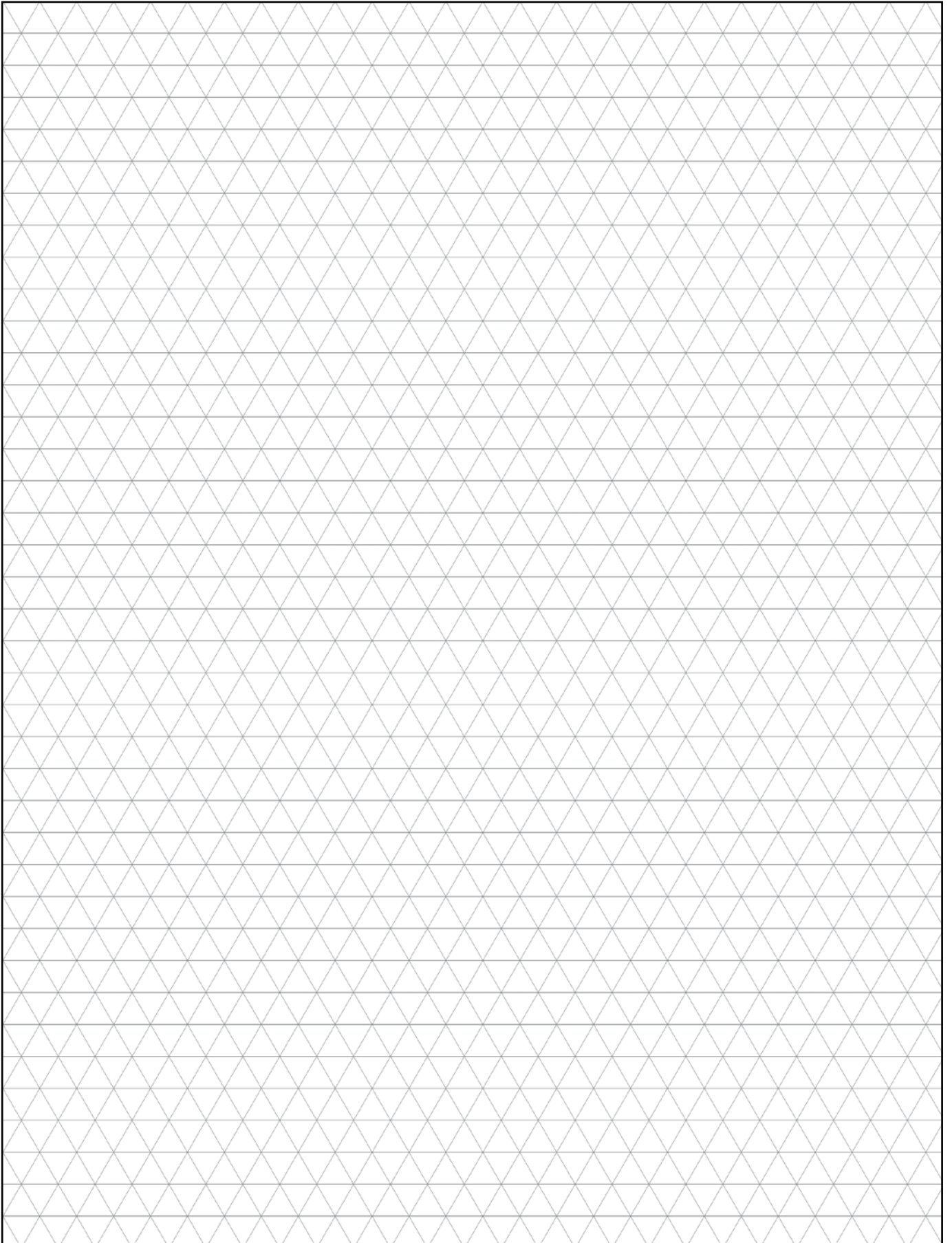

AGGIORNAMENTI

EN: UPDATES

DE: NOTIZEN

FR: NOTES

ES: ACTUALIZACIONES

NL: OPMERKINGEN



PL: AKTUALIZACJE

RU: ОБНОВЛЕНИЯ

GIUNTO A CROCE PER HBS, COMPLETO

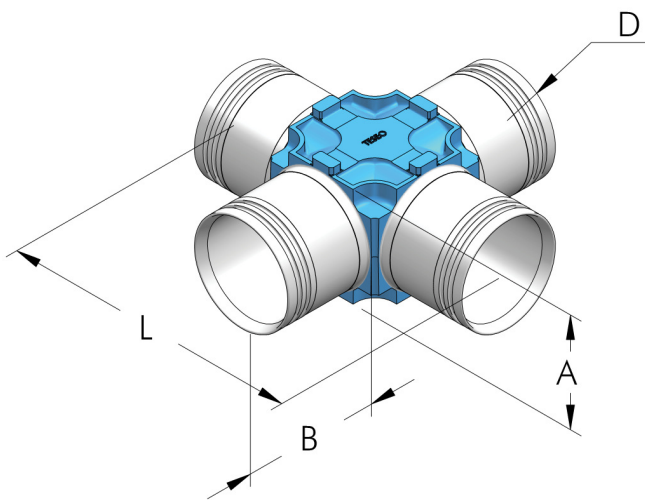
HBS



D mm	A mm	L mm	B mm	Codice N°	P kg	
80	83	260	60	003 004 045	4,6	
110	114	306	90	003 005 045	5,6	

EN: CROSS JOINT FOR HBS

DE: KREUZVERBINDER FÜR HBS

FR: JONCTION EN CROIX POUR HBS

ES: UNIÓN EN CRUZ PARA HBS

NL: HBS KRUIS KOPPELING



PL: ŁĄCZNIK KRZYŻAKOWY - HBS

RU: КРЕСТООБРАЗНАЯ МУФТА ДЛЯ HBS

GIUNTO A 45° PER HBS

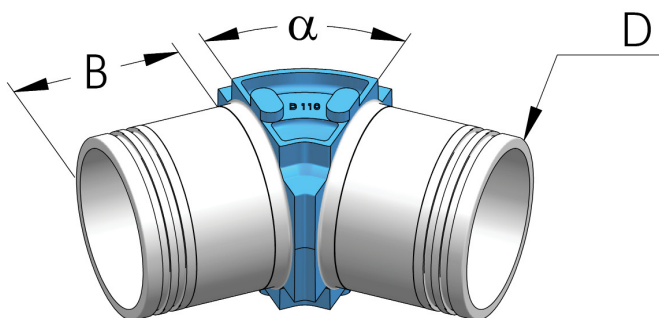
HBS



D mm	α °	B mm	Codice N°	P kg	
80	45	60	003 004 051	2,4	
110	45	90	003 005 051	3,2	

EN: 45° JOINT HBS

DE: 45° VERBINDUNG HBS

FR: JUNCTION 45° HBS

ES: UNIÓN 45° HBS

NL: 45° KOPPELING HBS

PL: KOLANKO 45° - HBS

RU: МУФТА ПОД 45° HBS

AGGIORNAMENTI

EN: UPDATES

DE: NOTIZEN

FR: NOTES

ES: ACTUALIZACIONES

NL: OPMERKINGEN

PL: AKTUALIZACJE

RU: ОБНОВЛЕНИЯ

TERMINALE A FLANGIA PER HBS

HBS

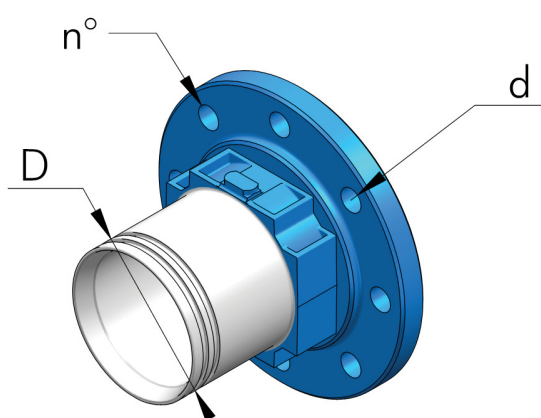

D mm	d mm	Norma	n° fori	Codice N°	P kg	
80	18	UNI-EN 1092	4	003 004 050	2,4	↗
100	18	UNI-EN 1092	8	003 005 050	3,3	↗
100	19	ASME 150lb	8	003 005 450	3,4	↗

EN: FLANGED ADAPTER FOR HBS

DE: ENDSTÜCK MIT FLANSCH FÜR HBS

FR: EMBOUT HBS AVEC BRIDE

ES: TERMINAL HBS CON BRIDA

NL: EINDSTOP MET FLENS

PL: PRZYŁĄCZE KOŁNIERZOWE - HBS

RU: ФЛАНЦЕВЫЙ ТЕРМИНАЛ ДЛЯ HBS

GUARNIZIONE PIANA PER FLANGE

HBS

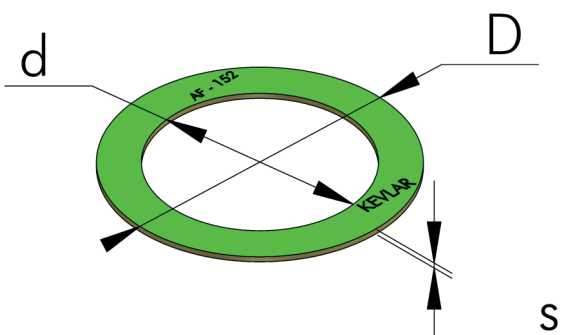

D mm	d mm	DN	S mm	Codice N°	P g	
142	90	80	2	274 089 002	33	↗
160	116	100	3	274 116 003	56	↗

EN: FLAT SEAL FOR FLANGES

DE: FLACHDICHTUNG FÜR FLANSCH

FR: JOINT PLAT POUR BRIDES

ES: JUNTA PLANAS PARA BRIDAS

NL: VLAKKE PAKKING VOOR FLENZEN

PL: USZCZELKA POD KOŁNIERZ - HBS

RU: ПЛОСКАЯ УПЛОТНИТЕЛЬНАЯ ПРОКЛАДКА ДЛЯ ФЛАНЦЕВ

AGGIORNAMENTI

EN: UPDATES

DE: NOTIZEN

FR: NOTES

ES: ACTUALIZACIONES

NL: OPMERKINGEN



PL: AKTUALIZACJE

RU: ОБНОВЛЕНИЯ

PROFILO IN PVC MORBIDO COLORE BLU

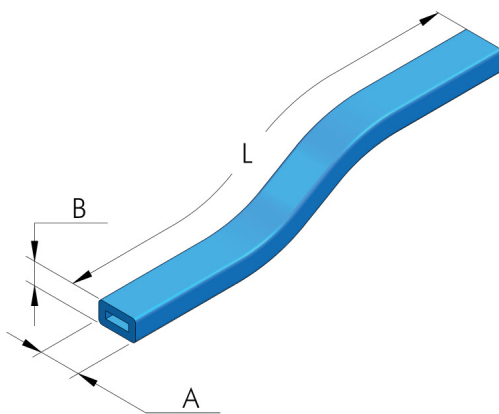
AP



AP	L m	A mm	B mm	Codice N°	P g	
45/54	1	10	5,8	874 010 100	58	
68	1	21	4,6	874 021 100	116	

EN: BLUE PVC STRIP FOR AP

DE: BLAUE PROFILHAUS PVC FÜR AP

FR: BLEU PROFIL EN PVC POUR AP

ES: PERFIL DE PVC AZUL PARA AP45

NL: BLAUW PVC PROFIEL VOOR AP

PL: PROFIL Z PCV - NIEBIESKI

RU: ПРОФИЛЬ ИЗ СИНЕГО ПВХ

MINI VALIGIA DEMO AP

AP

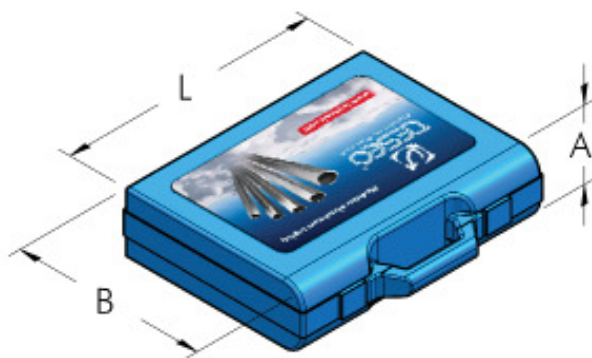

A mm	B mm	L mm	Codice N°	P g	
50	190	240	006 020 091	550	

EN: AP MINI DEMO CASE

DE: AP MINI DEMO-KOFFER

FR: PETITE MALETTE DE DEMONSTRATION AP

ES: MINI MALETA DEMO AP

NL: AP MINI DEMO KOFFER

PL: WALIZKA DEMONSTRACYJNA - MINI

RU: AP МИНИ-ДЕМО СЛУЧАЙ

MINI IMPIANTO ARIA COMPRESSA AP22 - 10 m

AP

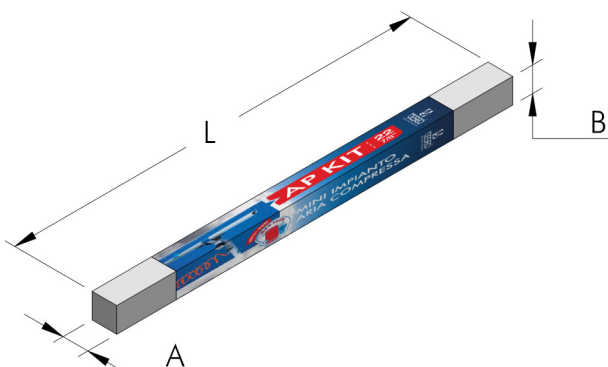

A mm	B mm	L m	Codice N°	P kg	
125	125	2	006 022 102	5,6	

EN: MINI COMPRESSED AIR SYSTEM AP22 - 10 m

DE: MINI DRUCKLUFTSYSTEM AP22 - 10 m

FR: MINI SYSTEME D'AIR COMPRIME AP22 - 10 m

ES: MINI SISTEMA DE AIRE COMPRIMIDO AP22 - 10 m

NL: MINI PERSLUCHTSYSTEEM AP22 - 10 m

PL: MINI ZESTAW DO SPRĘŻONEGO POWIETRZA - 10M

RU: МИНИ-СИСТЕМА ДЛЯ СЖАТОГО ВОЗДУХА AP22 - 10M

AGGIORNAMENTI

EN: UPDATES

DE: NOTIZEN

FR: NOTES

ES: ACTUALIZACIONES

NL: OPMERKINGEN

PL: AKTUALIZACJE

RU: ОБНОВЛЕНИЯ

STAFFA DI AGGANCIAMENTO A BLINDO (ZUCCHINI)

SYS

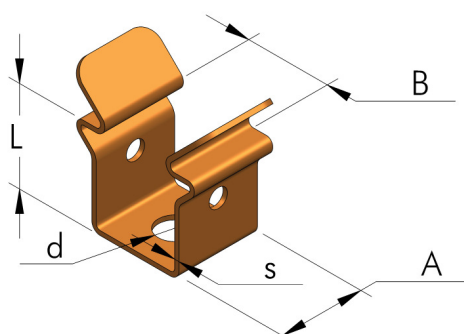

L mm	B mm	A mm	d mm	S mm	Codice N°	P g	
20	22	18	7,5	1	292 022 020	20	

EN: SNAP CLAMP FOR ELECTRIC BUSBAR (ZUCCHINI)

DE: BEFESTIGUNGSKLEMME FÜR SCHIENENVERTEILER (ZUCCHINI)

FR: ÉQUERRE D'ACCROCHAGE À BARRE BLINDO (ZUCCHINI)

ES: BRIDA DE ENGANCHE A BARRA HUECA (ZUCCHINI)

NL: KOPPELINGSBEUGEL OP BUSBAR (ZUCCHINI)

PL: KLAMRA ZACISKOWA DLA SZYN ELEKTRYCZNYCH (ZUCCHINI)

RU: СКОБА КРЕПЛЕНИЯ К ШИНОПРОВОДУ (ZUCCHINI)

VITE AUTOFILETTANTE 5x38

SYS

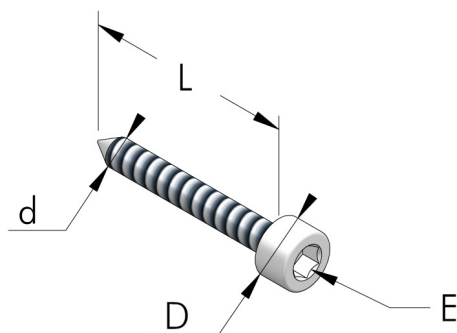

L mm	D mm	d mm	E mm	Codice N°	P g	
38	10	5	5	206 005 038	5,7	

EN: ALLEN SCREW 5x38

DE: ZYLINDERSCHRAUBE 5x38

FR: VIS A TÊTE CYLINDRIQUE 5x38

ES: TORNILLO CON CABEZAL CILINDRICO 5x38

NL: ZELFTAPPENDE SCHROEF 5X38

PL: ŚRUBA IMBUSOWA 5X38

RU: ВИНТ-САМОРЕЗ 5X38

TASSELLO AD ESPANSIONE SX8

SYS

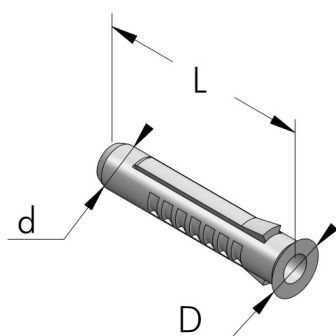

L mm	D mm	d mm	Codice N°	P g	
40	10	7,6	208 008 040	1,5	

EN: PLUG SX8

DE: DÜBEL SX8

FR: CHEVILLE SX8

ES: TACO PLÁSTICO SX8

NL: EXPANSIEPLUG SX8

PL: KOŁEK ROZPOROWY SX8

RU: ДЮБЕЛЬ SX8

IRELAND
ireland@teseoair.com

DEUTSCHLAND
www.teseoair.de
deutschland@teseoair.com

IBERICA
www.teseoiberica.eu
www.teseoiberica.com
teseo@teseoiberica.com

UNITED STATES
www.teseo.us
www.teseoair.us

TESEO
www.teseoair.com
www.teseoair.it
teseo@teseoair.com

NEDERLAND
www.teseonederland.eu
nederland@teseoair.com

MEXICO
www.teseo.com.mx

UNITED KINGDOM
www.teseouk.eu
uk@teseoair.com

CANADA
www.teseo.ca
canada@teseoair.com

COLOMBIA
www.teseo.co
colombia@teseoair.com

FRANCE
www.teseo.fr
france@teseoair.com

EN

COD. 995 518 014 - Pubbl: GIUGNO 2014



TESEO[®]

**Teseo srl - Via degli Oleandri, 1
25015 Desenzano del Garda (BS) - Italy
Tel. +39 030 9150411 - Fax +39 030 9150419
www.teseoair.com - teseo@teseoair.com**



Graphics: ALYKE' COMUNICAZIONE - TESEO TECHNICAL DEPT