

# HK™ Horizontal Ceiling Mounted A/C's (1 to 15 Tons)

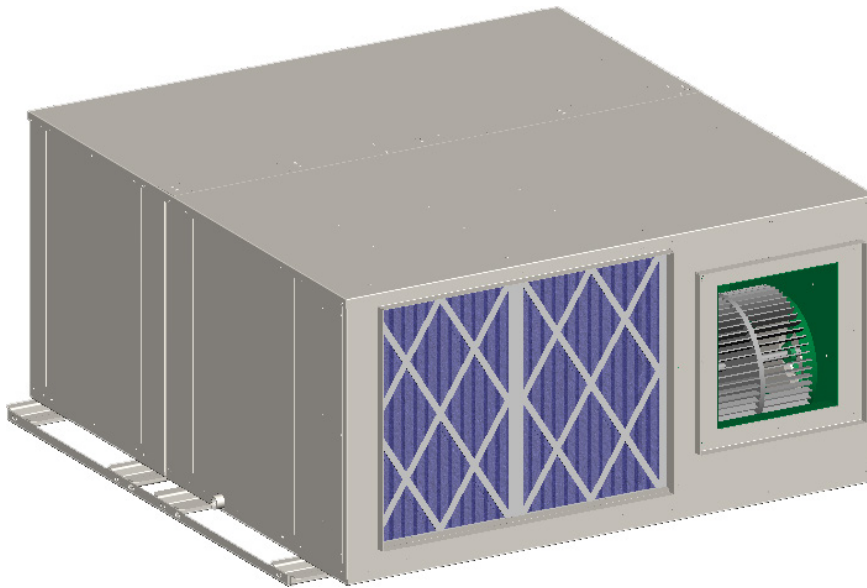

**1 to 15 Tons**  
**Ducted, High-Static**

## Features & Benefits

- 1 to 15 Ton Capacities
- Comfort Applications
  - General Office Spaces
  - Conference Rooms
  - Restaurants / Retail Stores
- Precision Applications
  - Computer / Server Rooms
  - Telecom Rooms
  - Labs / Hospitals
- Ducted, Same-Face, Straight-Thru & 90° Air Patterns
- DX Air, Water & Glycol Cooled, Chilled Water & Free-Cooling
- Total Temp & Humidity Control
  - Optional Steam Humidifier
  - Optional Heat/Reheat via Electric, Hot Gas, Hot Water, Steam or Heat Pump
- Microprocessor Controls & More!

**AboveAir**  
TECHNOLOGIES



HK™ above-the-ceiling a/c's (Engineering Manual, HKS-LE30.0)

**AboveAir™** ceiling mounted air conditioners are the space saving environmental control solution to your comfort and precision cooling needs. Available in a wide variety of cooling methods and cabinet configurations including a full range of options, **AboveAir™** ceiling A/C's are a step above!

- ☑ R410a Refrigerant
- ☑ Hidden above-the-ceiling installation
- ☑ Space saving air pattern options
- ☑ Variety of cooling methods
- ☑ Self-contained & split systems
- ☑ Flexible options and accessories
- ☑ Energy efficient operation
- ☑ Low sound operation

## Contents

<b>Introduction</b> .....	2
<b>Features and Benefits</b> .....	3
<b>Performance Data</b>	
DX Air Cooled, 1-5 Tons.....	4-5
DX Air Cooled, 6-15 Tons.....	6-7
DX Water Cooled, 1-5 Tons .....	8
DX Water Cooled, 6-15 Tons .....	9
DX Glycol Cooled, 1-5 Tons.....	10
DX Glycol Cooled, 6-15 Tons.....	11
Chilled Water Air Handlers, 1-15 Tons .....	12
Hot Water & Steam Heat.....	13
<b>Electrical Data</b> .....	14-23
<b>Guide Specifications</b> .....	24-31
<b>Dimensional Data</b> .....	32-38
<b>Model Nomenclature</b> .....	39
<b>Approximate Unit Weights (lbs)</b> .....	39

## Air Cooled

**AAC/P-( )**  
DX - Air Cooled  
Self-Contained

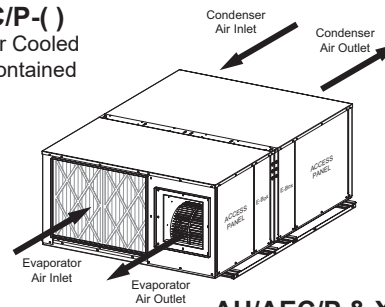

**AH/AEC/P & XCU/XCX-( )**  
DX - Air Cooled Split with Centrifugal  
Blower Indoor / Outdoor Remote Con-  
densing Unit & Condensers

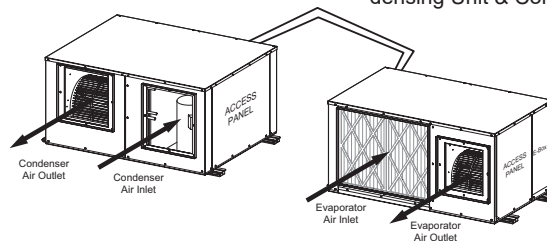

**AH/AEC/P & XPU/XP1-( )**  
DX - Air Cooled Split with Propel-  
ler Fan Outdoor Remote Condens-  
ing Unit & Condensers

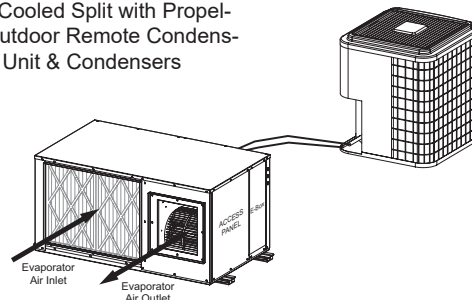

## Water/Glycol Cooled (plus Free-Cooling)

**AWC/P & AGC/P-( )**  
DX - Water/Glycol  
Cooled Self-Contained  
(split available)

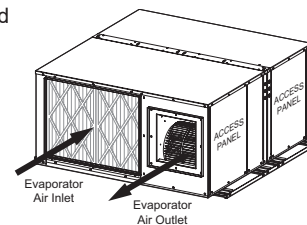

## Chilled Water Systems

**ACC/P-( )**  
Chilled Water  
Air Handling Units

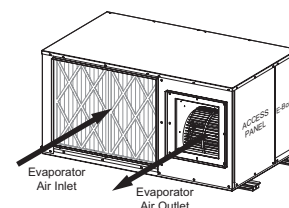

# FEATURES & BENEFITS

**AboveAir™** ducted high static belt-driven ceiling mounted air conditioners can be configured for various applications:

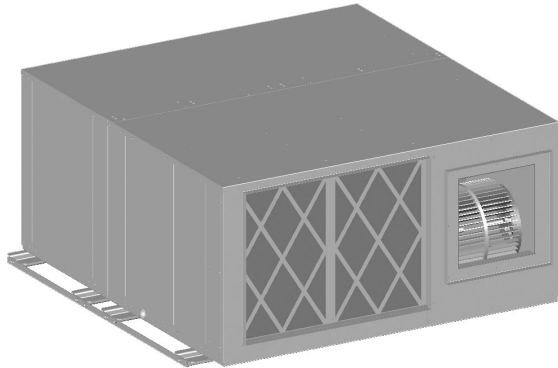

## Packaged & Split Systems

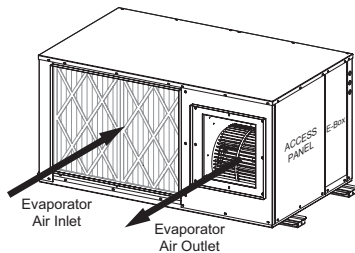

### Ducted Same-Face

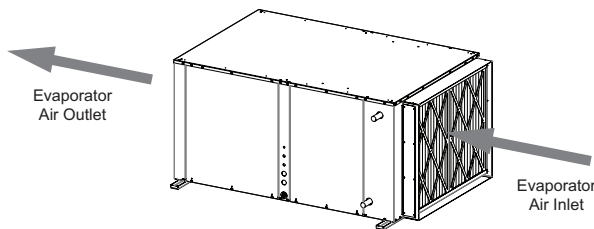

### Ducted Straight-Thru

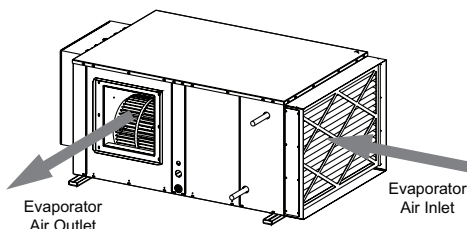

### Ducted 90° / Right-Angle

### Select Options:

- Digital Heat/Cool Thermostats
- Temp & Humid Microprocessor Controls with Alarms and Optional BMS Communications
- Steam Canister Humidifier
- Heating Mode with Electric, Hot Water, Steam or Heat Pump Heating
- Dehumidification Mode with Reheat
- High Efficiency Air Filtration
- Low Ambient Head Pressure Control
- 2 & 3-way 150 psig or 350 psig Water/Glycol Cooled Regulating Valves
- High Static Belt-Drive Blowers (up to 2" ESP)
- Hot Gas Bypass
- Free-Cooling: Air Side & Water/Glycol Side Economizer Systems

### Select Accessories:

- Condensate Pumps
- Main Power Electrical Disconnects
- Firestats
- Smoke Detectors
- Remote Water-Leak Detectors
- Compressor Sound Jackets
- Hanging Vibration Isolators
- Glycol Pump Packages & Drycoolers
- ... and more!



# DX - Air Cooled, (HK1™, 1-5 Tons) - Performance Data

		1.0 Ton	1.5 Tons	2.0 Tons	3.0 Tons	4.0 Tons	5.0 Tons	
<b>AIR COOLED DX</b>  <b>Std CFM</b>	<b>Nominal Size</b>							
	<b>ComfortCool™ Model</b>	<b>AAC/AEC/AHC-012</b>	<b>AAC/AEC/AHC-018</b>	<b>AAC/AEC/AHC-024</b>	<b>AAC/AEC/AHC-036</b>	<b>AAC/AEC/AHC-048</b>	<b>AAC/AEC/AHC-060</b>	
	<b>80°F DB / 67°F WB, 50% RH</b>							
	Total	BTUH	14,500	20,300	27,800	40,700	53,700	67,700
	Sensible	BTUH	10,300	14,600	20,400	30,100	40,000	50,200
	<b>75°F DB / 62.5°F WB, 50% RH</b>							
	Total	BTUH	13,300	18,600	25,500	37,400	49,400	62,300
	Sensible	BTUH	10,100	14,300	20,000	29,600	39,300	49,300
	<b>72°F DB / 60°F WB, 50% RH</b>							
	Total	BTUH	12,700	17,700	24,400	35,800	47,100	59,600
	Sensible	BTUH	9,900	14,000	19,900	29,000	38,900	48,300
	<b>AIR COOLED DX</b>  <b>OPT CFM</b>	<b>PrecisionCool™ Model</b>	<b>AAP/AEP/AHP-012</b>	<b>AAP/AEP/AHP-018</b>	<b>AAP/AEP/AHP-024</b>	<b>AAP/AEP/AHP-036</b>	<b>AAP/AEP/AHP-048</b>	<b>AAP/AEP/AHP-060</b>
<b>80°F DB / 67°F WB, 50% RH</b>								
Total		BTUH	15,000	20,900	28,800	42,000	56,600	69,700
Sensible		BTUH	11,400	16,200	23,200	33,600	48,600	56,100
<b>75°F DB / 62.5°F WB, 50% RH</b>								
Total		BTUH	13,800	19,200	26,500	38,900	52,200	64,700
Sensible		BTUH	11,300	16,000	22,900	33,500	48,000	55,800
<b>72°F DB / 60°F WB, 50% RH</b>								
Total		BTUH	13,200	18,500	25,400	37,100	49,900	61,800
Sensible		BTUH	11,200	16,000	22,500	32,800	47,000	54,700

### GENERAL SHARED DATA

<b>ALL DX MODELS</b>	<b>Electric Heat and/or Reheat (Factory Installed) - BTUH include standard evaporator motor heat, (Optional)</b>							
	Capacity	BTUH	17,675	17,675	18,245	36,490	36,490	37,635
		KW	5.2	5.2	5.3	10.7	10.7	11.0
	Stages	NO	1	1	1	1	1	1
	Type	TXT	Fin-Tube	Fin-Tube	Fin-Tube	Fin-Tube	Fin-Tube	Fin-Tube
	<b>Hot Gas Reheat - (Optional)</b>							
	Capacity	BTUH	10,110	14,140	19,380	28,430	37,550	47,350
	<b>Hot Water &amp; Steam Heating - (Optional)</b>							
	Capacity	See Page 13 for Complete Hot Water & Steam Heating Coil Performance Data						
	<b>Steam Canister Humidifier - (Optional)</b>							
	Steam Capacity	LBS/HR	5	5	5	5	10	10
	Power Input	KW	1.79	1.79	1.79	1.79	3.4	3.4
	<b>Evaporator Blower / Motor - Belt Drive, DWDI Centrifugal</b>							
	Std Airflow Rate	CFM	400	600	800	1,200	1,600	2,000
	Std Blower Motor	HP	1/3	1/3	1/2	3/4	3/4	1
	Opt Airflow Rate	CFM	500	750	1,000	1,500	2,250	2,500
	Opt Blower Motor	HP	1/3	1/3	1/2	3/4	1	1-1/2
	E.S.P.	IN WG	0.75	0.75	0.75	0.75	0.75	0.75
	Blower Diameter	IN	10 X 8	10 X 8	10 X 8	10 X 8	12 X 9	12 X 9
	<b>Evaporator Coil - Aluminum Fin, Copper Tube</b>							
	Rows	NO	3	3	4	4	4	4
	Face Area	FT²	2.0	2.0	2.9	2.9	5.1	5.1
	<b>Filters - 30% Dust Spot Efficient</b>							
	(Qty.) Nom. Size	(NO) IN	(1) 18 x 24 x 2	(1) 18 x 24 x 2	(1) 18 x 24 x 2	(1) 18 x 24 x 2	(2) 16 x 24 x 2	(2) 16 x 24 x 2
<b>Compressor - Heat Pump Duty Hermetic</b>								
Type	TXT	Scroll	Scroll	Scroll	Scroll	Scroll	Scroll	
(Qty.) Horsepower	(NO) HP	(1) 1.25	(1) 1.5	(1) 2.0	(1) 3.0	(1) 4.0	(1) 5.0	
<b>Connection Sizes</b>								
Condensate Drain	FPT IN	3/4	3/4	3/4	3/4	3/4	3/4	
Humidifier Inlet	IN OD	1/4	1/4	1/4	1/4	1/4	1/4	

# DX - Air Cooled, (HK1™, 1-5 Tons) - Performance Data

## Heat Rejection Data

Nominal Size Model Size	1.0 Ton 012	1.5 Tons 018	2.0 Tons 024	3.0 Tons 036	4.0 Tons 048	5.0 Tons 060
----------------------------	----------------	-----------------	-----------------	-----------------	-----------------	-----------------

### DX - AIR COOLED CONDENSER DATA

**AIR  
COOLED  
DX**

Indoor, Remote Centrifugal Blower Air Cooled Condenser & Condensing Unit Data - (XCU & XCX Models)							
Remote Condensing Unit Model	XCU-012	XCU-018	XCU-024	XCU-036	XCU-048	XCU-060	
Remote Condenser Model	XCX-012	XCX-018	XCX-024	XCX-036	XCX-048	XCX-060	
Airflow Rate	CFM	1,000	1,200	1,400	2,000	2,500	3,250
	IN ESP	0.5	0.5	0.5	0.5	0.5	0.5
Blower Motor	HP	1/2	3/4	3/4	1	1-1/2	2
Blower Diameter	IN	10 x 8	10 x 8	10 x 8	12 x 9	15 x 10	15 x 10
Blower Type		BD - Centrifugal	BD - Centrifugal	BD - Centrifugal	BD - Centrifugal	BD - Centrifugal	BD - Centrifugal
Coil Face Area	FT <sup>2</sup>	2.5	2.5	4.1	4.1	6.5	6.5
Rows	NO	4	4	4	4	4	4
Outdoor, Remote Propeller Fan Air Cooled Condensing Units & Condensers - (XPU & XP1 models)							
Remote Condensing Unit Model	XPU-012	XPU-018	XPU-024	XPU-036	XPU-048	XPU-060	
Remote Condenser Model	XP1-012	XP1-018	XP1-024	XP1-036	XP1-048	XP1-060	
Airflow Rate	CFM	1,792	2,218	2,218	3,167	3,365	3,365
	IN ESP	Free Discharge	Free Discharge	Free Discharge	Free Discharge	Free Discharge	Free Discharge
Fan Motor	(NO) HP	(1) 1/12	(1) 1/10	(1) 1/10	(1) 1/5	(1) 1/4	(1) 1/4
Fan Type		DD - Propeller	DD - Propeller	DD - Propeller	DD - Propeller	DD - Propeller	DD - Propeller
Coil Face Area	FT <sup>2</sup>	8.4	8.4	9.8	17.25	19.4	15.09
Rows	NO	1	1	1	1	1	2

## Connection Data

Nominal Size Model Size	1.0 Ton 012	1.5 Tons 018	2.0 Tons 024	3.0 Tons 036	4.0 Tons 048	5.0 Tons 060
----------------------------	----------------	-----------------	-----------------	-----------------	-----------------	-----------------

### DX - AIR COOLED REFRIGERANT (R407C & R410a) CONNECTION DATA

**AIR  
COOLED**

DX Split Air Handling Units & Indoor, Centrifugal Blower Remote Air Cooled Condensing Units - (AHC/P & XCU models)							
Liquid Line	OD IN	(1) 3/8	(1) 3/8	(1) 3/8	(1) 3/8	(1) 3/8	(1) 3/8
Suction Line	OD IN	(1) 3/4	(1) 3/4	(1) 3/4	(1) 3/4	(1) 7/8	(1) 7/8
DX Split Evaporators & Indoor Remote Centrifugal Air Cooled Condensers - (AEC/P & XCX models)							
Liquid Line	OD IN	(1) 3/8	(1) 3/8	(1) 3/8	(1) 3/8	(1) 3/8	(1) 3/8
Hot Gas Line	OD IN	(1) 1/2	(1) 1/2	(1) 1/2	(1) 1/2	(1) 5/8	(1) 5/8
Outdoor, Propeller Fan Remote Air Cooled Condensers & Condensing Units - (XP1 w/ Liquid & Hot Gas Lines and XPU w/ Liquid & Suction Lines)							
Liquid Line	OD IN	(1) 3/8	(1) 3/8	(1) 3/8	(1) 3/8	(1) 3/8	(1) 3/8
Suction or Hot Gas Line	OD IN	(1) 3/4	(1) 3/4	(1) 3/4	(1) 7/8	(1) 7/8	(1) 7/8

**Note:** DX Split systems ship from the factory with a dry-nitrogen holding charge and sweat (copper) connections ready for field R410a refrigerant charging.

# DX - Air Cooled, (6-15 Tons HK) - Performance Data

Nominal Size		6.0 Tons	8.0 Tons	10.0 Tons	12.0 Tons	15.0 Tons	
<b>AIR COOLED DX  STD CFM</b>	<b>ComfortCool™ Model</b>	<b>AAC, AEC &amp; AHC-072</b>	<b>AAC, AEC &amp; AHC-096</b>	<b>AAC, AEC &amp; AHC-120</b>	<b>AAC, AEC &amp; AHC-144</b>	<b>AAC, AEC &amp; AHC-180</b>	
	<b>80°F DB / 67°F WB, 50% RH</b>						
	Total	BTUH	82,700	104,600	132,100	156,600	199,700
	Sensible	BTUH	61,500	79,100	98,400	116,100	145,700
	<b>75°F DB / 62.5°F WB, 50% RH</b>						
	Total	BTUH	75,900	96,300	121,600	143,900	182,400
	Sensible	BTUH	60,500	77,900	96,800	114,200	143,300
	<b>72°F DB / 60°F WB, 50% RH</b>						
	Total	BTUH	72,800	91,900	116,000	137,200	173,800
	Sensible	BTUH	60,000	76,300	94,900	111,900	140,400
	<b>AIR COOLED DX  OPT CFM</b>	<b>PrecisionCool™ Model</b>	<b>AAP, AEP &amp; AHP-072</b>	<b>AAP, AEP &amp; AHP-096</b>	<b>AAP, AEP &amp; AHP-120</b>	<b>AAP, AEP &amp; AHP-144</b>	<b>AAP, AEP &amp; AHP-180</b>
		<b>80°F DB / 67°F WB, 50% RH</b>					
Total		BTUH	85,700	107,800	136,000	159,900	199,700
Sensible		BTUH	69,800	88,400	110,000	123,900	145,700
<b>75°F DB / 62.5°F WB, 50% RH</b>							
Total		BTUH	79,000	99,900	125,400	146,600	182,400
Sensible		BTUH	68,400	87,700	108,000	122,400	143,300
<b>72°F DB / 60°F WB, 50% RH</b>							
Total		BTUH	75,500	95,400	120,100	139,800	173,800
Sensible		BTUH	67,000	85,800	107,200	119,800	140,400

### GENERAL SHARED DATA

<b>ALL DX MODELS</b>	<b>Electric Heat and/or Reheat (Factory Installed) - includes standard evaporator motor heat, (Optional)</b>						
	Capacity	BTUH	37,635	55,880	58,175	79,855	79,855
		KW	11.0	16.4	17.0	23.4	23.4
	Stages	NO	1	2	2	2	2
	Type	TXT	Fin-Tube	Fin-Tube	Fin-Tube	Fin-Tube	Fin-Tube
	<b>Hot Gas Reheat - (Optional)</b>						
	Capacity	BTUH	30,360	38,520	48,640	57,560	72,960
	<b>Hot Water &amp; Steam Heating - (Optional)</b>						
	Capacity	See Page 13 for Complete Hot Water & Steam Heating Coil Performance Data					
	<b>Steam Canister Humidifier - (Optional)</b>						
	Steam Canister	LBS/HR	10	15	15	15	15
	Power Input	KW	3.4	5.1	5.1	5.1	5.1
	<b>Evaporator Blower / Motor - Belt Drive, DWDI Centrifugal</b>						
	Std Airflow Rate	CFM	2,400	3,200	4,000	4,800	5,500
	Std Blower Motor	HP	1-1/2	2	3	5	5
	Opt Airflow Rate	CFM	3,000	3,800	5,000	5,500	5,500
	Opt Blower Motor	HP	2	3	5	5	5
	E.S.P.	IN WG	0.75	0.75	0.75	0.75	0.75
	Blower Diameter	IN	12 X 9	12 X 9	15 X 10	15 X 10	15 X 10
	<b>Evaporator Coil - Aluminum Fin, Copper Tube</b>						
	Rows	NO	5	4	4	4	4
	Face Area	FT²	5.1	8.6	8.6	11.8	11.8
	<b>Filters - 30% Dust Spot Efficient</b>						
	(Qty.) Nom. Size	(NO) IN	(2) 16 x 24 x 2	(3) 16 x 25 x 2	(3) 16 x 25 x 2	(4) 16 x 24 x 2	(4) 16 x 24 x 2
	<b>Compressor - Heat Pump Duty Scroll</b>						
	(Qty.) Horsepower	(NO) HP	(2) 3.0	(2) 4.0	(2) 5.0	(2) 6.0	(2) 7.5
	<b>Connection Sizes</b>						
	Condensate Drain	FPT IN	3/4	3/4	3/4	3/4	3/4
Humidifier Inlet	IN OD	1/4	1/4	1/4	1/4	1/4	

# DX - Air Cooled, (6-15 Tons HK) - Performance Data

## Heat Rejection Data

Nominal Size Model Size	6.0 Tons 072D	8.0 Tons 096D	10.0 Tons 120D	12.0 Tons 144D	15.0 Tons 180D
----------------------------	------------------	------------------	-------------------	-------------------	-------------------

### DX - AIR COOLED CONDENSER DATA

**AIR COOLED DX**

Packaged or Split, Indoor (Optional Outdoor), Centrifugal Blower Air Cooled Condensing Unit Data - (AAC/P & XCU Models)						
Model	TXT	AAC/P, XCU-072D	AAC/P, XCU-096D	AAC/P, XCU-120D	AAC/P, XCU-144D	AAC/P, XCU-180D
Airflow Rate	CFM	3,800	4,500	6,000	7,500	7,500
	IN ESP	1.0	1.0	1.0	1.0	1.0
Blower Motor	HP	2	3	5	7-1/2	7-1/2
Blower Diameter	IN	15 x 10	15 x 10	15 x 15	15 x 15	15 x 15
Blower Type	TXT	Centrifugal	Centrifugal	Centrifugal	Centrifugal	Centrifugal
Coil Face Area	FT <sup>2</sup>	6.5	6.5	9.7	9.7	13.8
Rows	NO	5	5	6	6	6
Outdoor, Propeller Fan Remote Air Cooled Condenser & Condensing Units - (XP4 & XPU models)						
Model	TXT	XP4/XPU-072D	XP4/XPU-096D	XP4/XPU-120D	XP4/XPU-144D	XP4/XPU-180D
Airflow Rate	(NO) CFM	8,000	10,000	10,000	12,000	12,000
	IN ESP	Free Discharge	Free Discharge	Free Discharge	Free Discharge	Free Discharge
Fan Motor	(NO) HP	(4) 1/4	(4) 1/4	(4) 1/4	(4) 1/4	(4) 1/4
Fan Type	TXT	Propeller	Propeller	Propeller	Propeller	Propeller

## Connection Data

Nominal Size Model Size	6.0 Tons 072D	8.0 Tons 096D	10.0 Tons 120D	12.0 Tons 144D	15.0 Tons 180D
----------------------------	------------------	------------------	-------------------	-------------------	-------------------

### DX - AIR COOLED REFRIGERANT CONNECTION DATA

**AIR COOLED**

DX Air Handling Units & Indoor, Centrifugal Blower Remote Air Cooled Condensing Units - (AHC/P & XCU models)						
Liquid Line	OD IN	(2) 3/8	(2) 3/8	(2) 1/2	(2) 1/2	(2) 1/2
Suction Line	OD IN	(2) 3/4	(2) 7/8	(2) 7/8	(2) 7/8	(2) 1-1/8
Type	TXT	Copper Sweat	Copper Sweat	Copper Sweat	Copper Sweat	Copper Sweat
DX Split Evaporators & Indoor Remote Centrifugal Air Cooled Condensers - (AEC/P & XCX models)						
Liquid Line	OD IN	(2) 3/8	(2) 3/8	(2) 1/2	(2) 1/2	(2) 1/2
Hot Gas Line	OD IN	(2) 1/2	(2) 5/8	(2) 7/8	(2) 7/8	(2) 7/8
Type	TXT	Copper Sweat	Copper Sweat	Copper Sweat	Copper Sweat	Copper Sweat
Outdoor, Propeller Fan Remote Air Cooled Condensers - (XP4 models)						
Model	TXT	XP4-072D	XP4-096D	XP4-120D	XP4-144D	XP4-180D
Liquid Line	OD IN	(2) 3/8	(2) 3/8	(2) 1/2	(2) 1/2	(2) 1/2
Hot Gas Line	OD IN	(2) 1/2	(2) 5/8	(2) 7/8	(2) 7/8	(2) 7/8
Type	TXT	Copper Sweat	Copper Sweat	Copper Sweat	Copper Sweat	Copper Sweat
Outdoor, Propeller Fan Remote Air Cooled Condensing Units - (XPU models)						
Model	TXT	XPU-072D	XPU-096D	XPU-120D	XPU-144D	XPU-180D
Liquid Line	OD IN	(2) 3/8	(2) 3/8	(2) 1/2	(2) 1/2	(2) 1/2
Suction Line	OD IN	(2) 3/4	(2) 7/8	(2) 7/8	(2) 7/8	(2) 1-1/8
Type	TXT	Copper Sweat	Copper Sweat	Copper Sweat	Copper Sweat	Copper Sweat

**Note:** DX Split systems ship from the factory with a dry-nitrogen holding charge and sweat (copper) connections ready for field refrigerant (R410a) charging.

# DX - Water Cooled, (1-5 Tons HK) - Performance Data

**WATER  
COOLED  
DX  
  
STD  
CFM**

Nominal Size		1.0 Ton	1.5 Tons	2.0 Tons	3.0 Tons	4.0 Tons	5.0 Tons
<b>ComfortCool™ Model</b>		<b>AWC-012</b>	<b>AWC-018</b>	<b>AWC-024</b>	<b>AWC-036</b>	<b>AWC-048</b>	<b>AWC-060</b>
<b>80°F DB / 67°F WB, 50% RH</b>							
Total	BTUH	15,400	21,000	29,500	43,300	56,900	71,700
Sensible	BTUH	10,700	15,000	21,200	31,200	41,400	51,900
<b>75°F DB / 62.5°F WB, 50% RH</b>							
Total	BTUH	14,200	19,300	27,100	39,800	52,400	66,300
Sensible	BTUH	10,500	14,700	20,800	30,700	40,700	51,300
<b>72°F DB / 60°F WB, 50% RH</b>							
Total	BTUH	13,500	18,400	25,900	38,000	50,000	63,400
Sensible	BTUH	10,300	14,400	20,400	30,100	39,900	50,300
<b>PrecisionCool™ Model</b>		<b>AWP-012</b>	<b>AWP-018</b>	<b>AWP-024</b>	<b>AWP-036</b>	<b>AWP-048</b>	<b>AWP-060</b>
<b>80°F DB / 67°F WB, 50% RH</b>							
Total	BTUH	16,000	21,700	30,500	44,800	60,100	74,100
Sensible	BTUH	11,800	16,600	23,700	34,700	50,000	57,900
<b>75°F DB / 62.5°F WB, 50% RH</b>							
Total	BTUH	14,600	19,900	28,200	41,100	55,500	68,500
Sensible	BTUH	11,500	16,200	23,600	34,200	49,300	57,200
<b>72°F DB / 60°F WB, 50% RH</b>							
Total	BTUH	13,900	18,900	27,000	39,600	53,000	65,900
Sensible	BTUH	11,400	16,000	23,200	34,000	48,300	56,900

**WATER  
COOLED  
DX  
  
OPT  
CFM**

## GENERAL SHARED DATA

<b>Electric Heat and/or Reheat (Factory Installed) - BTUH include standard evaporator motor heat, (Optional)</b>							
Capacity	BTUH (KW)	17,675 (5.2)	17,675 (5.2)	18,245 (5.3)	36,490 (10.7)	36,490 (10.7)	37,635 (11.0)
Stages	NO	1	1	1	1	1	1
<b>Hot Water &amp; Steam Heating - (Optional)</b>							
Capacity	See Page 13 for Complete Hot Water & Steam Heating Coil Performance Data						
<b>Steam Canister Humidifier - (Optional)</b>							
Steam Capacity	LBS/HR	5	5	5	5	10	10
Power Input	KW	1.79	1.79	1.79	1.79	3.4	3.4
<b>Evaporator Blower / Motor - Belt Drive, DWDI Centrifugal</b>							
Std Airflow Rate	CFM	400	600	800	1,200	1,600	2,000
Std Blower Motor	HP	1/3	1/3	1/2	3/4	3/4	1
Opt Airflow Rate	CFM	500	750	1,000	1,500	2,250	2,500
Opt Blower Motor	HP	1/3	1/3	1/2	3/4	1	1-1/2
E.S.P.	IN WG	0.75	0.75	0.75	0.75	0.75	0.75
Blower Diameter	IN	10 X 8	10 X 8	10 X 8	10 X 8	12 X 9	12 X 9
<b>Evaporator Coil - Aluminum Fin, Copper Tube</b>							
Rows	NO	3	3	4	4	4	4
Face Area	FT <sup>2</sup>	2.0	2.0	2.9	2.9	5.1	5.1
<b>Filters - 30% Dust Spot Efficient</b>							
(Qty.) Nom. Size	(NO) IN	(1) 18 x 24 x 2	(1) 18 x 24 x 2	(1) 18 x 24 x 2	(1) 18 x 24 x 2	(2) 16 x 24 x 2	(2) 16 x 24 x 2
<b>Compressor - Heat Pump Duty Hermetic</b>							
Type	TXT	Scroll	Scroll	Scroll	Scroll	Scroll	Scroll
(Qty.) Horsepower	(NO) HP	(1) 1.0	(1) 1.5	(1) 2.0	(1) 3.0	(1) 4.0	(1) 5.0
<b>Water Cooled Condenser Data - 85°F EWT / 95°F LWT, 0% glycol solution (rated at 80°F DB/67°F WB EAT, Opt Evap CFM)</b>							
Total Heat of Rej.	BTUH	19,045	25,900	35,900	52,855	71,100	88,150
Flow Rate	GPM	3.8	5.2	7.2	10.6	14.2	17.6
Water Press Drop	FT WG	11.3	12.2	15.0	20.0	18.4	29.9
Condenser Type	TXT	Coaxial	Coaxial	Coaxial	Coaxial	Coaxial	Coaxial
Water Reg. Valve	2-Way, 150 psig - factory installed, (3-way & High Pressure Valves are Optional)						
<b>Connection Data</b>							
Water IN/OUT	IN OD	5/8	5/8	7/8	7/8	1-1/8	1-1/8
Condensate Drain	FPT IN	3/4	3/4	3/4	3/4	3/4	3/4
Humidifier Inlet	IN OD	1/4	1/4	1/4	1/4	1/4	1/4



# DX - Water Cooled, (6-15 Tons HK) - Performance Data

Nominal Size		6.0 Tons	8.0 Tons	10.0 Tons	12.0 Tons	15.0 Tons	
<b>ComfortCool™ Model</b>		<b>AWC-072D</b>	<b>AWC-096D</b>	<b>AWC-120D</b>	<b>AWC-144D</b>	<b>AWC-180D</b>	
<b>WATER COOLED DX  STD CFM</b>	<b>80°F DB / 67°F WB, 50% RH</b>						
	Total	BTUH	87,900	111,000	140,100	166,300	212,200
	Sensible	BTUH	63,700	81,600	101,900	120,000	150,900
	<b>75°F DB / 62.5°F WB, 50% RH</b>						
	Total	BTUH	80,800	102,100	129,500	153,300	194,200
	Sensible	BTUH	62,700	80,600	100,500	118,600	148,900
	<b>72°F DB / 60°F WB, 50% RH</b>						
	Total	BTUH	77,100	97,600	123,800	146,400	185,300
	Sensible	BTUH	61,600	79,100	98,700	116,400	146,100
	<b>PrecisionCool™ Model</b>		<b>AWP-072</b>	<b>AWP-096</b>	<b>AWP-120</b>	<b>AWP-144</b>	<b>AWP-180</b>
	<b>WATER COOLED DX  OPT CFM</b>	<b>80°F DB / 67°F WB, 50% RH</b>					
		Total	BTUH	90,700	114,400	144,900	170,100
Sensible		BTUH	71,200	91,500	113,100	128,300	150,900
<b>75°F DB / 62.5°F WB, 50% RH</b>							
Total		BTUH	84,200	106,100	133,500	156,600	194,200
Sensible		BTUH	71,000	90,900	111,900	126,700	148,900
<b>72°F DB / 60°F WB, 50% RH</b>							
Total		BTUH	80,600	101,500	127,800	149,300	185,300
Sensible		BTUH	69,500	88,900	109,800	124,400	146,100

### GENERAL SHARED DATA

<b>WATER COOLED DX</b>	<b>Electric Heat and/or Reheat (Fin-Tube, Factory Installed) - BTUH include standard evaporator motor heat, (Optional)</b>						
	Capacity	BTUH (KW)	37,635 (11.0)	55,880 (16.4)	58,175 (17.0)	79,855 (23.4)	79,855 (23.4)
	Stages	NO	1	2	2	2	2
	<b>Hot Water &amp; Steam Heating - (Optional)</b>						
	Capacity	See Page 13 for Complete Hot Water & Steam Heating Coil Performance Data					
	<b>Steam Canister Humidifier - (Optional)</b>						
	Steam Canister	LBS/HR	10	15	15	15	15
	Power Input	KW	3.4	5.1	5.1	5.1	5.1
	<b>Evaporator Blower / Motor - Belt Drive, DWDI Centrifugal</b>						
	Std Airflow Rate	CFM	2,400	3,200	4,000	4,800	5,500
	Std Blower Motor	HP	1.5	2	3	5	5
	<i>Opt Airflow Rate</i>	<i>CFM</i>	<i>3,000</i>	<i>3,800</i>	<i>5,000</i>	<i>5,500</i>	<i>5,500</i>
	<i>Opt Blower Motor</i>	<i>HP</i>	<i>2</i>	<i>3</i>	<i>5</i>	<i>5</i>	<i>5</i>
	E.S.P.	IN WG	0.75	0.75	0.75	0.75	0.75
	Blower Diameter	IN	12 X 9	12 X 9	15 X 10	15 X 10	15 X 10
	<b>Evaporator Coil - Aluminum Fin, Copper Tube</b>						
	Rows	NO	5	4	4	4	4
	Face Area	FT²	5.1	8.6	8.6	11.8	11.8
	<b>Filters - 30% Dust Spot Efficient</b>						
	(Qty.) Nom. Size	(NO) IN	(2) 16 x 24 x 2	(3) 16 x 25 x 2	(3) 16 x 25 x 2	(4) 16 x 24 x 2	(4) 16 x 24 x 2
	<b>Compressors - Heat Pump Duty Hermetic</b>						
	Type	TXT	Scroll	Scroll	Scroll	Scroll	Scroll
	(Qty.) Horsepower	(NO) HP	(2) 3.0	(2) 4.0	(2) 5.0	(2) 6.0	(2) 7.5
	<b>Water Cooled Condenser Data - 85°F EWT / 95°F LWT, 0% glycol solution (rated at 80°F DB/67°F WB EAT, Opt Evap CFM)</b>						
	Total Heat of Rej.	BTUH	106,800	13,590	172,875	203,550	255,200
	Flow Rate	GPM	21.4	27.1	34.6	40.7	51.0
	Water Press Drop	FT WG	20.3	16.7	29.9	14.5	19.5
	Condenser Type	TXT	Coaxial	Coaxial	Coaxial	Coaxial	Coaxial
	Water Reg. Valve	2-Way, 150 psig - factory installed, (3-way & High Pressure Valves are Optional)					
	<b>Connection Sizes</b>						
Water IN/OUT	OD	1-1/8	1-1/8	1-3/8	1-3/8	1-5/8	
Condensate Drain	FPT IN	3/4	3/4	3/4	3/4	3/4	
Humidifier Inlet	IN OD	1/4	1/4	1/4	1/4	1/4	

### Performance Data

# DX - Glycol Cooled, (1-5 Tons HK) - Performance Data

**GLYCOL  
COOLED  
DX  
  
STD  
CFM**

Nominal Size		1.0 Ton	1.5 Tons	2.0 Tons	3.0 Tons	4.0 Tons	5.0 Tons
<b>ComfortCool™ Model</b>		<b>AGC-012</b>	<b>AGC-018</b>	<b>AGC-024</b>	<b>AGC-036</b>	<b>AGC-048</b>	<b>AGC-060</b>
<b>80°F DB / 67°F WB, 50% RH</b>							
Total	BTUH	14,200	19,400	27,200	39,800	52,600	66,200
Sensible	BTUH	10,100	14,300	20,100	29,700	39,500	49,500
<b>75°F DB / 62.5°F WB, 50% RH</b>							
Total	BTUH	13,000	17,800	24,900	36,600	48,200	60,800
Sensible	BTUH	9,900	14,000	19,800	29,100	38,900	48,600
<b>72°F DB / 60°F WB, 50% RH</b>							
Total	BTUH	12,400	17,000	23,900	34,800	46,200	57,800
Sensible	BTUH	9,700	13,700	19,700	28,600	38,600	47,700

**GLYCOL  
COOLED  
DX  
  
OPT  
CFM**

<b>PrecisionCool™ Model</b>		<b>AGP-012</b>	<b>AGP-018</b>	<b>AGP-024</b>	<b>AGP-036</b>	<b>AGP-048</b>	<b>AGP-060</b>
<b>80°F DB / 67°F WB, 50% RH</b>							
Total	BTUH	14,700	20,000	28,200	41,000	55,400	68,200
Sensible	BTUH	11,200	15,800	22,900	33,200	48,200	55,400
<b>75°F DB / 62.5°F WB, 50% RH</b>							
Total	BTUH	13,600	18,600	25,900	38,000	51,100	63,200
Sensible	BTUH	11,300	16,000	22,700	33,100	47,500	55,100
<b>72°F DB / 60°F WB, 50% RH</b>							
Total	BTUH	12,900	17,700	24,700	36,300	48,800	60,300
Sensible	BTUH	11,100	15,600	22,300	32,400	46,500	54,000

### GENERAL SHARED DATA

**GLYCOL  
COOLED  
DX**

<b>Electric Heat and/or Reheat (Fin-Tube, Factory Installed) - BTUH include standard evaporator motor heat, (Optional)</b>							
Capacity	BTUH (KW)	17,675 (5.2)	17,675 (5.2)	18,245 (5.3)	36,490 (10.7)	36,490 (10.7)	37,635 (11.0)
Stages	NO	1	1	1	1	1	1
<b>Hot Water &amp; Steam Heating - (Optional)</b>							
Capacity	See Page 13 for Complete Hot Water & Steam Heating Coil Performance Data						
<b>Steam Canister Humidifier - (Optional)</b>							
Steam Capacity	LBS/HR	5	5	5	5	10	10
Power Input	KW	1.79	1.79	1.79	1.79	3.4	3.4
<b>Evaporator Blower / Motor - Belt Drive, DWDI Centrifugal</b>							
Std Airflow Rate	CFM	400	600	800	1,200	1,600	2,000
Std Blower Motor	HP	1/3	1/3	1/2	3/4	3/4	1
Opt Airflow Rate	CFM	500	750	1,000	1,500	2,250	2,500
Opt Blower Motor	HP	1/3	1/3	1/2	3/4	1	1-1/2
E.S.P.	IN WG	0.75	0.75	0.75	0.75	0.75	0.75
Blower Diameter	IN	10 X 8	10 X 8	10 X 8	10 X 8	12 X 9	12 X 9
<b>Evaporator Coil - Aluminum Fin, Copper Tube</b>							
Rows	NO	3	3	4	4	4	4
Face Area	FT <sup>2</sup>	2.0	2.0	2.9	2.9	5.1	5.1
<b>Filters - 30% Dust Spot Efficient</b>							
(Qty.) Nom. Size	(NO) IN	(1) 18 x 24 x 2	(1) 18 x 24 x 2	(1) 18 x 24 x 2	(1) 18 x 24 x 2	(2) 16 x 24 x 2	(2) 16 x 24 x 2
<b>Compressor - Heat Pump Duty Hermetic</b>							
Type	TXT	Scroll	Scroll	Scroll	Scroll	Scroll	Scroll
(Qty.) Horsepower	(NO) HP	(1) 1.0	(1) 1.5	(1) 2.0	(1) 3.0	(1) 4.0	(1) 5.0
<b>Glycol Cooled Condenser Data - 110°F EGT / 120°F LGT, 40% Ethylene Glycol solution (rated at 80°F DB/67°F WB EAT, Opt Evap CFM)</b>							
Total Heat of Rej.	BTUH	18,690	25,510	35,120	51,410	69,310	85,470
Flow Rate	GPM	4.1	5.6	7.8	14.4	15.4	18.9
Glycol Press Drop	FT WG	10.8	11.8	14.3	18.9	17.7	28.4
Condenser Type	TXT	Coaxial	Coaxial	Coaxial	Coaxial	Coaxial	Coaxial
Glycol Reg. Valve	2-Way, 150 psig - factory installed, (3-way & High Pressure Valves are Optional)						
<b>Connection Data</b>							
Glycol IN/OUT	OD	5/8	5/8	7/8	7/8	1-1/8	1-1/8
Condensate Drain	FPT IN	3/4	3/4	3/4	3/4	3/4	3/4
Humidifier Inlet	IN OD	1/4	1/4	1/4	1/4	1/4	1/4

# DX - Glycol Cooled, (6-15 Tons HK) - Performance Data

	Nominal Size	6.0 Tons	8.0 Tons	10.0 Tons	12.0 Tons	15.0 Tons	
<b>GLYCOL COOLED DX</b>  <b>STD CFM</b>	<b>ComfortCool™ Model</b>	<b>AGC-072D</b>	<b>AGC-096D</b>	<b>AGC-120D</b>	<b>AGC-144D</b>	<b>AGC-180D</b>	
	<b>80°F DB / 67°F WB, 50% RH</b>						
	Total	BTUH	80,900	102,400	129,200	153,100	189,500
	Sensible	BTUH	60,800	78,200	97,200	114,700	141,900
	<b>75°F DB / 62.5°F WB, 50% RH</b>						
	Total	BTUH	74,600	94,200	118,600	140,300	173,500
	Sensible	BTUH	60,400	76,900	95,400	112,400	139,100
	<b>72°F DB / 60°F WB, 50% RH</b>						
	Total	BTUH	71,200	89,900	112,900	133,800	165,200
	Sensible	BTUH	59,200	75,300	93,700	110,400	136,100
	<b>GLYCOL COOLED DX</b>  <b>OPT CFM</b>	<b>PrecisionCool™ Model</b>	<b>AGP-072</b>	<b>AGP-096</b>	<b>AGP-120</b>	<b>AGP-144</b>	<b>AGP-180</b>
		<b>80°F DB / 67°F WB, 50% RH</b>					
Total		BTUH	83,900	106,100	133,000	156,200	189,500
Sensible		BTUH	68,800	88,600	108,700	122,800	141,900
<b>75°F DB / 62.5°F WB, 50% RH</b>							
Total		BTUH	77,300	97,700	122,800	142,900	173,500
Sensible		BTUH	67,700	86,700	108,100	120,600	139,100
<b>72°F DB / 60°F WB, 50% RH</b>							
Total		BTUH	73,900	93,100	117,000	136,200	165,200
Sensible		BTUH	66,400	84,800	105,900	118,200	136,100

### GENERAL SHARED DATA

<b>GLYCOL COOLED DX</b>	<b>Electric Heat and/or Reheat (Fin-Tube, Factory Installed) - BTUH include standard evaporator motor heat, (Optional)</b>						
	Capacity	BTUH (KW)	37,635 (11.0)	55,880 (16.4)	58,175 (17.0)	79,855 (23.4)	79,855 (23.4)
	Stages	NO	1	2	2	2	2
	<b>Hot Water &amp; Steam Heating - (Optional)</b>						
	Capacity	See Page 13 for Complete Hot Water & Steam Heating Coil Performance Data					
	<b>Steam Canister Humidifier - (Optional)</b>						
	Steam Canister	LBS/HR	10	15	15	15	15
	Power Input	KW	3.4	5.1	5.1	5.1	5.1
	<b>Evaporator Blower / Motor - Belt Drive, DWDI Centrifugal</b>						
	Std Airflow Rate	CFM	2,400	3,200	4,000	4,800	5,500
	Std Blower Motor	HP	1.5	2	3	5	5
	<i>Opt Airflow Rate</i>	<i>CFM</i>	<i>3,000</i>	<i>3,800</i>	<i>5,000</i>	<i>5,500</i>	<i>5,500</i>
	<i>Opt Blower Motor</i>	<i>HP</i>	<i>2</i>	<i>3</i>	<i>5</i>	<i>5</i>	<i>5</i>
	E.S.P.	IN WG	0.75	0.75	0.75	0.75	0.75
	Blower Diameter	IN	12 X 9	12 X 9	15 X 10	15 X 10	15 X 10
	<b>Evaporator Coil - Aluminum Fin, Copper Tube</b>						
	Rows	NO	5	4	4	4	4
	Face Area	FT <sup>2</sup>	5.1	8.6	8.6	11.8	11.8
	<b>Filters - 30% Dust Spot Efficient</b>						
	(Qty.) Nom. Size	(NO) IN	(2) 16 x 24 x 2	(3) 16 x 25 x 2	(3) 16 x 25 x 2	(4) 16 x 24 x 2	(4) 16 x 24 x 2
	<b>Compressors - Heat Pump Duty Hermetic</b>						
	Type	TXT	Scroll	Scroll	Scroll	Scroll	Scroll
	(Qty.) Horsepower	(NO) HP	(2) 3.0	(2) 4.0	(2) 5.0	(2) 6.2	(2) 7.5
	<b>Glycol Cooled Condenser Data - 110°F EGT/120°F LGT, 40% EG solution (rated at 80°F DB/67°F WB EAT, Opt Evap CFM)</b>						
	Total Heat of Rej.	BTUH	104,590	132,550	167,550	198,740	247,500
	Flow Rate	GPM	23.1	29.3	37.1	44.0	54.8
	Glycol Press Drop	FT WG	19.4	16.0	27.4	13.6	18.3
	Condenser Type	TXT	Coaxial	Coaxial	Coaxial	Coaxial	Coaxial
	Glycol Reg. Valve	2-Way, 150 psig - factory installed, (3-way & High Pressure Valves are Optional)					
	<b>Connection Sizes</b>						
Glycol IN/OUT	IN OD	1-1/8	1-1/8	1-3/8	1-3/8	1-5/8	
Condensate Drain	FPT IN	3/4	3/4	3/4	3/4	3/4	
Humidifier Inlet	IN OD	1/4	1/4	1/4	1/4	1/4	

# Chilled Water Systems, (1-15 Tons HK) - Performance Data

Nominal Unit Size		1.0 Ton	1.5 Tons	2.0 Tons	3.0 Tons	4.0 Tons	5.0 Tons	6.0 Tons	8.0 Tons	10.0 Tons	12.0 Tons	15.0 Tons
<b>Cooling Capacity - BTUH @ 45°F EWT, 0% Glycol Solution</b>												
<b>STD CFM, ComfortCool™</b>		<b>ACC-012</b>	<b>ACC-018</b>	<b>ACC-024</b>	<b>ACC-036</b>	<b>ACC-048</b>	<b>ACC-060</b>	<b>ACC-072</b>	<b>ACC-096</b>	<b>ACC-120</b>	<b>ACC-144</b>	<b>ACC-180</b>
<b>80°F DB / 67°F WB, 50% RH</b>												
Total	BTUH	13,300	18,300	29,800	40,300	58,600	69,100	91,700	111,500	127,500	149,600	211,300
Sensible	BTUH	9,600	13,500	20,800	29,000	41,000	49,200	63,500	79,600	93,600	110,100	146,800
<b>75°F DB / 62.5°F WB, 50% RH</b>												
Total	BTUH	10,500	14,500	23,400	31,800	46,000	54,400	72,000	88,200	101,300	118,800	166,500
Sensible	BTUH	8,800	12,400	18,900	26,500	37,300	45,000	57,600	72,900	86,200	101,400	133,500
<b>72°F DB / 60°F WB, 50% RH</b>												
Total	BTUH	9,100	12,600	20,100	27,500	39,500	46,900	61,800	76,200	87,800	103,000	143,300
Sensible	BTUH	8,200	11,700	17,600	24,800	34,800	42,100	53,700	68,200	81,000	95,300	124,500
Flow Rate	GPM	2.5	3.5	6.0	8.0	12.0	14.0	18.0	22.5	24.0	30.0	40.0
Coil Press. Drop	FT H2O	1.9	3.4	3.4	5.6	3.4	4.4	8.7	12.8	4.4	6.5	17.4

<b>OPT CFM, PrecisionCool™</b>		<b>ACP-012</b>	<b>ACP-018</b>	<b>ACP-024</b>	<b>ACP-036</b>	<b>ACP-048</b>	<b>ACP-060</b>	<b>ACP-072</b>	<b>ACP-096</b>	<b>ACP-120</b>	<b>ACP-144</b>	<b>ACP-180</b>
<b>80°F DB / 67°F WB, 50% RH</b>												
Total	BTUH	15,900	21,300	35,200	47,100	74,800	80,100	106,400	120,400	151,900	166,600	211,300
Sensible	BTUH	11,600	16,000	25,000	34,600	54,000	58,500	75,600	89,200	112,900	123,400	146,800
<b>75°F DB / 62.5°F WB, 50% RH</b>												
Total	BTUH	12,600	17,000	27,700	37,400	59,100	63,500	84,100	96,400	121,000	132,500	166,500
Sensible	BTUH	10,600	14,800	22,800	31,900	49,500	53,800	69,100	82,600	104,300	113,900	133,500
<b>72°F DB / 60°F WB, 50% RH</b>												
Total	BTUH	10,900	14,700	23,900	32,400	51,000	55,000	72,500	84,100	105,200	115,200	143,300
Sensible	BTUH	10,000	14,000	21,300	29,900	46,300	50,500	64,600	77,800	98,200	107,200	124,500
Flow Rate	GPM	3.0	4	7	9.5	15.0	16.0	21.0	24.0	30.0	36.0	40.0
Coil Press. Drop	FT H2O	2.6	4.3	4.4	7.6	5.0	5.6	11.3	14.3	6.5	8.9	17.4

<b>Chilled Water Coil / Valve - Aluminum Fin, Copper Tube</b>												
Rows	NO	3	3	4	4	4	4	4	4	4	4	6
Face Area	FT²	2.0	2.0	2.8	2.8	4.9	4.9	4.9	8.6	8.6	11.8	11.8
Standard Valve	BTUH	2-way, 300 psig - field installed (3-way Valves are Optional)										

## GENERAL SHARED DATA

<b>Electric Heat and/or Reheat (Factory Installed) - includes standard evaporator motor heat, (Optional)</b>												
Capacity	BTUH	17,675	17,675	18,245	36,490	36,490	37,635	37,635	55,880	58,175	79,855	79,855
	KW	5.2	5.2	5.3	10.7	10.7	11.0	11.0	16.4	17.0	23.4	23.4
Stages	NO	1	1	1	1	1	1	1	2	2	2	2
Type	TXT	Fin-Tube	Fin-Tube	Fin-Tube	Fin-Tube	Fin-Tube	Fin-Tube	Fin-Tube	Fin-Tube	Fin-Tube	Fin-Tube	Fin-Tube

<b>Hot Water &amp; Steam Heating - (Optional)</b>												
Capacity	See Page 13 for Complete Hot Water & Steam Heating Coil Performance Data											

<b>Steam Canister Humidifier - (Optional)</b>												
Steam Canister	LBS/HR	5	5	5	5	10	10	10	15	15	15	15
Power Input	KW	1.79	1.79	1.79	1.79	3.4	3.4	3.4	5.1	5.1	5.1	5.1

<b>Evaporator Blower / Motor - Belt Drive, DWDI Centrifugal</b>												
Std Airflow Rate	CFM	400	600	900	1,200	1,600	2,000	2,400	3,200	4,000	4,800	5,500
Std Blower Motor	HP	1/2	1/2	1/2	3/4	3/4	1	1-1/2	2	3	5	5
Opt Airflow Rate	CFM	500	750	1,000	1,500	2,250	2,500	3,000	3,800	5,000	5,500	5,500
Opt Blower Motor	HP	1/2	1/2	1/2	3/4	1	1-1/2	2	3	5	5	5
E.S.P.	IN WG	0.75	0.75	0.75	0.75	0.75	0.75	0.75	0.75	0.75	0.75	0.75
Fan Diameter	IN	10 X 8	10 X 8	10 X 8	10 X 8	12 X 9	12 X 9	12 X 9	12 X 9	15 X 10	15 X 10	15 X 10

<b>Filters - 2", 30% Dust Spot Efficient</b>												
(Qty.) Nom. Size	(NO) IN	(1) 18x24	(1) 18x24	(1) 18x24	(1) 18x24	(2) 16x24	(2) 16x24	(2) 16x24	(3) 16x25	(3) 16x25	(4) 16x24	(4) 16x24

<b>Connection Sizes - Copper</b>												
Chilled Water	IN OD	5/8	5/8	7/8	7/8	1-1/8	1-1/8	1-1/8	1-3/8	1-3/8	1-5/8	1-5/8
Condensate Drain	FPT IN	3/4	3/4	3/4	3/4	3/4	3/4	3/4	3/4	3/4	3/4	3/4
Humidifier Inlet	IN OD	1/4	1/4	1/4	1/4	1/4	1/4	1/4	1/4	1/4	1/4	1/4

# Hot Water & Steam Heating Coils, (HK) - Performance Data

## HOT WATER HEATING COIL

Nominal Unit Size	1.0 Ton	1.5 Tons	2.0 Tons	3.0 Tons	4.0 Tons	5.0 Tons	6.0 Tons	8.0 Tons	10.0 Tons	12.0 Tons	15.0 Tons	
<b>Hot Water Heating Coil - @ 180°F EWT / 160 LWT, 70°F EAT, (Optional)</b>												
<b>ComfortCool™ Model</b>	<b>A_C-012</b>	<b>A_C-018</b>	<b>A_C-024</b>	<b>A_C-036</b>	<b>A_C-048</b>	<b>A_C-060</b>	<b>A_C-072</b>	<b>A_C-096</b>	<b>A_C-120</b>	<b>A_C-144</b>	<b>A_C-180</b>	
Std Airflow Rate	CFM	400	600	900	1,200	1,600	2,000	2,400	3,200	4,000	4,800	5,500
Heating Capacity	BTUH	19,310	25,250	36,060	46,290	67,750	78,440	87,510	102,290	150,950	167,280	180,750
Flow Rate	GPM	1.8	2.4	3.5	4.5	6.6	7.6	8.5	10.1	16.0	17.3	18.7
Fluid Press. Drop	FT H2O	1.7	2.8	2.5	3.8	2.8	3.6	4.3	5.8	4.0	4.5	5.2
LAT	°F DB	108.2	103.4	107.4	102.2	105.6	102.8	100.6	97.2	103.9	101.3	99.5
<b>PrecisionCool™ Model</b>	<b>A_P-012</b>	<b>A_P-018</b>	<b>A_P-024</b>	<b>A_P-036</b>	<b>A_P-048</b>	<b>A_P-060</b>	<b>A_P-072</b>	<b>A_P-096</b>	<b>A_P-120</b>	<b>A_P-144</b>	<b>A_P-180</b>	
Opt Airflow Rate	CFM	500	750	1,000	1,500	2,250	2,500	3,000	3,800	5,000	5,500	5,500
Heating Capacity	BTUH	22,470	28,810	41,680	52,850	83,570	89,580	98,620	112,480	171,650	180,750	180,750
Flow Rate	GPM	2.1	2.7	4.0	5.1	8.1	8.7	9.7	11.2	18.0	18.7	18.7
Fluid Press. Drop	FT H2O	2.2	3.4	3.1	4.8	4.0	4.5	5.4	7.0	4.9	5.2	5.2
LAT	°F DB	105.5	100.7	104.5	99.5	101.3	100.1	97.9	95.3	100.8	99.5	99.5
<b>Hot Water Heating Coil Physical Data</b>												
Rows	NO	1	1	1	1	1	1	1	1	1	1	1
Face Area	FT²	2.0	2.0	2.8	2.8	4.9	4.9	4.9	8.6	8.6	11.8	11.8
HW IN/OUT	IN OD	5/8	5/8	5/8	5/8	7/8	7/8	7/8	1-1/8	1-1/8	1-1/8	1-1/8
Standard Valve	TXT	2-way - field installed (3-way valves are optional)										

## STEAM HEATING COIL

Nominal Unit Size	1.0 Ton	1.5 Tons	2.0 Tons	3.0 Tons	4.0 Tons	5.0 Tons	6.0 Tons	8.0 Tons	10.0 Tons	12.0 Tons	15.0 Tons	
<b>Steam Heating Coil - @ 5 PSIG (227.1°F) Supply Steam, 70°F EAT, (Optional)</b>												
<b>ComfortCool™ Model</b>	<b>A_C-012</b>	<b>A_C-018</b>	<b>A_C-024</b>	<b>A_C-036</b>	<b>A_C-048</b>	<b>A_C-060</b>	<b>A_C-072</b>	<b>A_C-096</b>	<b>A_C-120</b>	<b>A_C-144</b>	<b>A_C-180</b>	
Std Airflow Rate	CFM	400	600	800	1,200	1,600	2,000	2,400	3,200	4,000	4,800	5,500
Heating Capacity	BTUH	29,840	37,760	53,360	66,700	100,300	113,230	124,450	143,250	213,640	234,270	250,280
Condensate	LB/HR	31	39	56	69	104	118	130	149	223	244	113
Steam Pr. Drop	FT H2O	0.1	0.1	0.1	0.1	0.1	0.1	0.1	0.1	0.1	0.1	0.1
LAT	°F DB	139.8	128.9	132.4	122.0	128.6	122.9	118.5	111.9	119.9	115.6	112.6
<b>PrecisionCool™ Model</b>	<b>A_P-012</b>	<b>A_P-018</b>	<b>A_P-024</b>	<b>A_P-036</b>	<b>A_P-048</b>	<b>A_P-060</b>	<b>A_P-072</b>	<b>A_P-096</b>	<b>A_P-120</b>	<b>A_P-144</b>	<b>A_P-180</b>	
Opt Airflow Rate	CFM	500	750	1,000	1,500	2,250	2,500	3,000	3,800	5,000	5,500	5,500
Heating Capacity	BTUH	34,050	42,620	60,480	74,770	120,410	127,040	138,920	155,030	239,020	250,280	250,280
Condensate	LB/HR	35	44	63	78	125	132	145	162	249	113	113
Steam Pr. Drop	FT H2O	0.1	0.1	0.1	0.1	0.1	0.1	0.1	0.1	0.1	0.1	0.1
LAT	°F DB	133.7	123.1	126.6	116.6	120.0	117.5	113.3	108.2	114.7	112.6	112.6
<b>Steam Heating Coil Physical Data</b>												
Rows	NO	1	1	1	1	1	1	1	1	1	1	1
Face Area	FT²	2.0	2.0	2.8	2.8	4.9	4.9	4.9	8.6	8.6	11.8	11.8
STM IN/OUT	IN OD	5/8	5/8	5/8	5/8	7/8	7/8	7/8	1-1/8	1-1/8	1-1/8	1-1/8
Standard Valve	TXT	2-way - field installed (3-way valves are optional) - Steam Specialties by Others										

# Electrical Data (Standard CFM) - Air Cooled, Self-Contained

## STANDARD CFM, DX-Air Cooled Self-Contained, 1 to 3 Tons

MODEL	AAC-012S-				AAC-018S-				AAC-024S-				AAC-036S-			
Power Supply	208/1/60	277/1/60	208/3/60	460/3/60	208/1/60	277/1/60	208/3/60	460/3/60	208/1/60	277/1/60	208/3/60	460/3/60	208/1/60	277/1/60	208/3/60	460/3/60
<b>Cooling Only (or Cooling with Hot Gas Reheat, Hot Water or Steam Reheat/Heat)</b>																
FLA	16.4	12.7	----	----	21.3	16.0	----	----	22.1	17.9	13.5	7.7	29.7	24.9	20.6	9.6
MCA	18.7	14.4	----	----	24.5	18.4	----	----	25.3	20.6	15.6	9.0	34.2	28.9	24.0	11.1
MOP	25	20	----	----	35	25	----	----	35	30	20	15	50	40	35	15
<b>with Electric Heat (No Electric Reheat or Humidifier)</b>																
FLA	27.4	20.6	----	----	27.4	20.6	----	----	28.2	21.2	15.9	7.7	53.4	40.1	31.0	14.2
MCA	34.2	25.7	----	----	34.2	25.7	----	----	35.2	26.5	19.9	9.1	66.7	50.1	38.7	17.7
MOP	35	30	----	----	35	30	----	----	40	30	20	15	70	60	40	20
<b>with Electric Reheat/Heat (No Humidifier)</b>																
FLA	40.5	30.7	----	----	45.4	34.1	----	----	46.2	36.0	27.4	14.0	77.9	61.1	48.4	22.1
MCA	48.8	37.0	----	----	54.6	37.1	----	----	55.4	43.2	32.9	16.9	94.5	74.1	58.7	26.8
MOP	50	40	----	----	60	40	----	----	60	45	35	20	100	80	60	30
<b>with Humidifier with or without Hot Gas Reheat, Hot Water/Steam Reheat/Heat (No Electric Reheat/Heat)</b>																
FLA	24.6	18.9	----	----	29.5	22.2	----	----	30.3	24.1	21.7	11.4	37.9	31.1	28.8	13.3
MCA	26.9	20.6	----	----	32.7	24.6	----	----	33.5	26.8	23.8	12.7	42.4	35.1	32.2	14.8
MOP	35	25	----	----	45	30	----	----	45	35	30	15	60	50	45	20
<b>with Electric Heat (No Electric Reheat) &amp; Humidifier</b>																
FLA	35.6	26.8	----	----	35.6	26.8	----	----	36.4	27.4	24.1	11.4	61.6	46.3	39.2	17.9
MCA	42.4	31.9	----	----	42.4	31.9	----	----	43.4	32.7	28.1	12.8	74.9	56.3	46.9	21.4
MOP	45	35	----	----	45	35	----	----	45	35	30	15	80	60	50	25
<b>with Electric Reheat/Heat &amp; Humidifier</b>																
FLA	40.5	30.7	----	----	45.4	34.1	----	----	46.2	36.0	27.4	14.0	77.9	61.1	48.4	22.1
MCA	48.8	37.0	----	----	54.6	41.0	----	----	55.4	43.2	32.9	16.9	94.5	74.1	58.7	26.8
MOP	50	40	----	----	60	45	----	----	60	45	35	20	100	80	60	30

## STANDARD CFM, DX-Air Cooled Self-Contained, 6 to 15 Tons

MODEL	AAC-048S-		AAC-060S-		AAC-072D-		AAC-0096D-		AAC-120D-		AAC-144D-		AAC-180D-	
Power Supply	208/3/60	460/3/60	208/3/60	460/3/60	208/3/60	460/3/60	208/3/60	460/3/60	208/3/60	460/3/60	208/3/60	460/3/60	208/3/60	460/3/60
<b>Cooling Only (or Cooling with Hot Gas Reheat, Hot Water or Steam Reheat/Heat)</b>														
FLA	23.1	10.7	26.5	13.3	25.9	12.3	45.1	20.7	53.1	26.3	77.6	38.0	81.2	40.0
MCA	26.7	12.3	30.4	15.2	42.8	19.7	48.8	22.3	57.1	28.3	83.4	40.8	87.5	43.0
MOP	40	15	45	20	50	25	60	25	70	35	100	50	110	50
<b>with Electric Heat (No Electric Reheat or Humidifier)</b>														
FLA	31.0	14.2	31.7	14.6	33.3	15.4	48.6	22.4	53.1	26.3	77.6	38.0	81.2	40.0
MCA	38.7	17.7	39.7	18.2	42.8	19.7	60.8	28.0	63.7	29.2	85.3	40.8	87.5	43.0
MOP	40	20	45	20	50	25	70	30	70	35	100	50	110	50
<b>with Electric Reheat/Heat (No Humidifier)</b>														
FLA	50.9	23.3	54.3	25.8	53.7	24.8	86.9	39.6	94.9	45.2	133.2	63.2	136.8	65.1
MCA	61.5	28.1	65.1	30.9	77.5	35.4	100.9	45.9	109.2	51.8	152.9	72.3	157.0	74.4
MOP	70	30	70	35	80	40	110	50	110	60	175	80	175	80
<b>with Humidifier with or without Hot Gas Reheat, Hot Water/Steam Reheat/Heat (No Electric Reheat/Heat)</b>														
FLA	39.5	18.1	42.9	20.7	40.1	18.7	59.3	27.1	67.3	32.7	91.8	44.4	95.4	46.4
MCA	43.1	19.7	46.8	22.6	57.0	26.1	63.0	28.7	71.3	34.7	97.6	47.2	101.7	49.4
MOP	50	25	60	30	70	30	70	35	80	40	110	50	125	60
<b>with Electric Heat (No Electric Reheat) &amp; Humidifier</b>														
FLA	47.4	21.6	48.1	22.0	47.5	21.8	62.8	28.8	67.3	32.7	91.8	44.4	95.4	46.4
MCA	55.1	25.1	56.1	25.6	57.0	26.1	75.0	34.4	77.9	35.6	99.5	47.2	101.7	49.4
MOP	60	30	60	30	70	30	80	35	80	40	110	50	125	60
<b>with Electric Reheat/Heat &amp; Humidifier</b>														
FLA	50.9	23.3	54.3	25.8	53.7	24.8	86.9	39.6	94.9	45.2	133.2	63.2	136.8	65.1
MCA	61.5	28.1	65.1	30.9	77.5	35.4	100.9	45.9	109.2	51.8	152.9	72.3	157.0	74.4
MOP	70	30	70	35	80	40	110	50	110	60	175	80	175	80

**Notes:**

- 1) FLA = Full Load Amps; MCA = Min Circuit Amps; MOP = Max Overcurrent Protection
- 2) 277V available via field installed step-down transformer.

# Electrical Data (Optional CFM) - Air Cooled, Self-Contained

## OPTIONAL CFM, DX-Air Cooled Self-Contained, 1 to 3 Tons

MODEL	AAP-012S-				AAP-018S-				AAP-024S-				AAP-036S-			
Power Supply	208/1/60	277/1/60	208/3/60	460/3/60	208/1/60	277/1/60	208/3/60	460/3/60	208/1/60	277/1/60	208/3/60	460/3/60	208/1/60	277/1/60	208/3/60	460/3/60
<b>Cooling Only (or Cooling with Hot Gas Reheat, Hot Water or Steam Reheat/Heat)</b>																
FLA	#REF!	12.7	----	----	21.3	16.0	----	----	22.1	17.9	13.5	7.7	29.7	24.9	20.6	9.6
MCA	18.7	14.4	----	----	24.5	18.4	----	----	25.3	20.6	15.6	9.0	34.2	28.9	24.0	11.1
MOP	25	20	----	----	35	25	----	----	35	30	20	15	50	40	35	15
<b>with Electric Heat (No Electric Reheat or Humidifier)</b>																
FLA	27.4	20.6	----	----	27.4	20.6	----	----	28.2	21.2	15.9	7.7	53.4	40.1	31.0	14.2
MCA	34.2	25.7	----	----	34.2	25.7	----	----	35.2	26.5	19.9	9.1	66.7	50.1	38.7	17.7
MOP	35	30	----	----	35	30	----	----	40	30	20	15	70	60	40	20
<b>with Electric Reheat/Heat (No Humidifier)</b>																
FLA	40.5	30.7	----	----	45.4	34.1	----	----	46.2	36.0	27.4	14.0	77.9	61.1	48.4	22.1
MCA	48.8	37.0	----	----	54.6	37.1	----	----	55.4	43.2	32.9	16.9	94.5	74.1	58.7	26.8
MOP	50	40	----	----	60	40	----	----	60	45	35	20	100	80	60	30
<b>with Humidifier with or without Hot Gas Reheat, Hot Water/Steam Reheat/Heat (No Electric Reheat/Heat)</b>																
FLA	24.6	18.9	----	----	29.5	22.2	----	----	30.3	24.1	21.7	11.4	37.9	31.1	28.8	13.3
MCA	26.9	20.6	----	----	32.7	24.6	----	----	33.5	26.8	23.8	12.7	42.4	35.1	32.2	14.8
MOP	35	25	----	----	45	30	----	----	45	35	30	15	60	50	45	20
<b>with Electric Heat (No Electric Reheat) &amp; Humidifier</b>																
FLA	35.6	26.8	----	----	35.6	26.8	----	----	36.4	27.4	24.1	11.4	61.6	46.3	39.2	17.9
MCA	42.4	31.9	----	----	42.4	31.9	----	----	43.4	32.7	28.1	12.8	74.9	56.3	46.9	21.4
MOP	45	35	----	----	45	35	----	----	45	35	30	15	80	60	50	25
<b>with Electric Reheat/Heat &amp; Humidifier</b>																
FLA	40.5	30.7	----	----	45.4	34.1	----	----	46.2	36.0	27.4	14.0	77.9	61.1	48.4	22.1
MCA	48.8	37.0	----	----	54.6	41.0	----	----	55.4	43.2	32.9	16.9	94.5	74.1	58.7	26.8
MOP	50	40	----	----	60	45	----	----	60	45	35	20	100	80	60	30

## OPTIONAL CFM, DX-Air Cooled Self-Contained, 6 to 15 Tons

MODEL	AAP-048S-		AAP-060S-		AAP-072D-		AAP-0096D-		AAP-120D-		AAP-144D-		AAP-180D-	
Power Supply	208/3/60	460/3/60	208/3/60	460/3/60	208/3/60	460/3/60	208/3/60	460/3/60	208/3/60	460/3/60	208/3/60	460/3/60	208/3/60	460/3/60
<b>Cooling Only (or Cooling with Hot Gas Reheat, Hot Water or Steam Reheat/Heat)</b>														
FLA	23.8	11.1	28.0	14.1	27.3	13.0	47.5	21.7	56.5	28.1	77.6	38.0	81.2	40.0
MCA	27.5	12.7	31.9	16.0	44.2	20.4	51.1	23.3	60.4	30.1	83.4	40.8	87.5	43.0
MOP	40	15	45	20	50	25	60	25	70	35	100	50	110	50
<b>with Electric Heat (No Electric Reheat or Humidifier)</b>														
FLA	31.7	14.6	33.3	15.4	34.7	16.1	51.0	23.4	56.5	28.1	77.6	38.0	81.2	40.0
MCA	39.7	18.2	41.6	19.2	44.2	20.4	63.7	29.2	67.9	31.5	85.3	40.8	87.5	43.0
MOP	40	20	45	20	50	25	70	30	70	35	100	50	110	50
<b>with Electric Reheat/Heat (No Humidifier)</b>														
FLA	51.7	23.7	55.8	26.6	55.1	25.5	89.2	40.6	98.2	47.0	133.2	63.2	136.8	65.1
MCA	62.2	28.5	66.7	31.7	79.0	36.1	103.3	46.9	112.5	53.6	152.9	72.3	157.0	74.4
MOP	70	30	70	35	80	40	110	50	125	60	175	80	175	80
<b>with Humidifier with or without Hot Gas Reheat, Hot Water/Steam Reheat/Heat (No Electric Reheat/Heat)</b>														
FLA	40.2	18.5	44.4	21.5	41.5	19.4	61.7	28.1	70.7	34.5	91.8	44.4	95.4	46.4
MCA	43.9	20.1	48.3	23.4	58.4	26.8	65.3	29.7	74.6	36.5	97.6	47.2	101.7	49.4
MOP	50	25	60	30	70	30	70	35	90	40	110	50	125	60
<b>with Electric Heat (No Electric Reheat) &amp; Humidifier</b>														
FLA	48.1	22.0	49.7	22.8	48.9	22.5	65.2	29.8	70.7	34.5	91.8	44.4	95.4	46.4
MCA	56.1	25.6	58.0	26.6	58.4	26.8	77.9	35.6	82.1	37.9	99.5	47.2	101.7	49.4
MOP	60	30	60	30	70	30	80	40	90	40	110	50	125	60
<b>with Electric Reheat/Heat &amp; Humidifier</b>														
FLA	51.7	23.7	55.8	26.6	55.1	25.5	89.2	40.6	98.2	47.0	133.2	63.2	136.8	65.1
MCA	62.2	28.5	66.7	31.7	79.0	36.1	103.3	46.9	112.5	53.6	152.9	72.3	157.0	74.4
MOP	70	30	70	35	80	40	110	50	125	60	175	80	175	80

**Notes:**

- 1) FLA = Full Load Amps; MCA = Min Circuit Amps; MOP = Max Overcurrent Protection
- 2) 277V available via field installed step-down transformer.

# Electrical Data (Std CFM) - DX Split Evap & Self-Contained W/G

## STD CFM, DX - Split Evap & Water/Glycol Cooled Self-Contained, 1 to 3 Tons

MODEL	AEC / AWC / AGC-012S-				AEC / AWC / AGC-018S-				AEC / AWC / AGC-024S-				AEC / AWC / AGC-036S-			
Power Supply	208/1/60	277/1/60	208/3/60	460/3/60	208/1/60	277/1/60	208/3/60	460/3/60	208/1/60	277/1/60	208/3/60	460/3/60	208/1/60	277/1/60	208/3/60	460/3/60
<b>Cooling Only (or Cooling with Hot Gas Reheat, Hot Water or Steam Reheat/Heat)</b>																
FLA	12.3	9.6	----	----	16.1	12.1	----	----	16.9	14.0	10.3	6.1	23.1	19.9	16.7	7.6
MCA	14.6	11.4	----	----	19.3	14.5	----	----	20.1	16.7	12.4	7.4	27.6	23.9	20.1	9.1
MOP	20	15	----	----	30	20	----	----	30	25	20	15	45	35	30	15
<b>with Electric Heat (No Electric Reheat or Humidifier)</b>																
FLA	27.4	20.6	----	----	27.4	20.6	----	----	28.2	21.2	15.9	7.3	53.4	40.1	31.0	14.2
MCA	34.2	25.7	----	----	34.2	25.7	----	----	35.2	26.5	19.9	9.1	66.7	50.1	38.7	17.7
MOP	35	30	----	----	35	30	----	----	40	30	20	15	70	60	40	20
<b>with Electric Reheat/Heat (No Humidifier)</b>																
FLA	36.4	27.7	----	----	40.2	30.2	----	----	41.0	32.1	24.2	12.4	71.3	56.1	44.5	20.1
MCA	44.7	34.0	----	----	49.4	37.1	----	----	50.2	39.3	29.8	15.3	87.9	69.2	54.8	24.8
MOP	45	35	----	----	50	40	----	----	60	45	30	20	90	70	60	25
<b>with Humidifier with or without Hot Gas Reheat, Hot Water/Steam Reheat/Heat (No Electric Reheat/Heat)</b>																
FLA	20.5	15.8	----	----	24.3	18.3	----	----	25.1	20.2	18.5	9.8	31.3	26.1	24.9	11.3
MCA	22.8	17.6	----	----	27.5	20.7	----	----	28.3	22.9	20.6	11.1	35.8	30.1	28.3	12.8
MOP	30	20	----	----	40	30	----	----	40	30	25	15	50	45	40	15
<b>with Electric Heat (No Electric Reheat) &amp; Humidifier</b>																
FLA	35.6	26.8	----	----	35.6	26.8	----	----	36.4	27.4	24.1	11.0	61.6	46.3	39.2	17.9
MCA	42.4	31.9	----	----	42.4	31.9	----	----	43.4	32.7	28.1	12.8	74.9	56.3	46.9	21.4
MOP	45	35	----	----	45	35	----	----	45	35	30	15	80	60	50	25
<b>with Electric Reheat/Heat &amp; Humidifier</b>																
FLA	36.4	27.7	----	----	40.2	30.2	----	----	41.0	32.1	24.2	12.4	71.3	56.1	44.5	20.1
MCA	44.7	34.0	----	----	49.4	37.1	----	----	50.2	39.3	29.8	15.3	87.9	69.2	54.8	24.8
MOP	45	35	----	----	50	40	----	----	60	45	30	20	90	70	60	25

## STD CFM, DX - Split Evap & Water/Glycol Cooled Self-Contained, 4 to 15 Tons

MODEL	AEC/AWC/AGC-048S-		AEC/AWC/AGC-060S-		AEC/AWC/AGC-072D-		AEC/AWC/AGC-0096D-		AEC/AWC/AGC-120D-		AEC/AWC/AGC-144D-		AEC/AWC/AGC-180D-	
Power Supply	208/3/60	460/3/60	208/3/60	460/3/60	208/3/60	460/3/60	208/3/60	460/3/60	208/3/60	460/3/60	208/3/60	460/3/60	208/3/60	460/3/60
<b>Cooling Only (or Cooling with Hot Gas Reheat, Hot Water or Steam Reheat/Heat)</b>														
FLA	17.6	7.9	19.6	9.8	19.0	8.8	35.9	16.2	40.5	20.0	59.0	28.7	62.6	30.7
MCA	21.3	9.5	23.5	11.7	35.9	16.2	39.5	17.8	44.5	22.0	64.8	31.5	68.9	33.7
MOP	35	15	35	15	45	20	50	20	60	25	80	40	90	45
<b>with Electric Heat (No Electric Reheat or Humidifier)</b>														
FLA	31.0	14.2	31.7	14.6	33.3	15.4	48.6	22.4	51.0	23.4	68.2	31.5	68.2	31.5
MCA	38.7	17.7	39.7	18.2	41.6	19.2	60.8	28.0	63.7	29.2	85.3	39.3	85.3	39.3
MOP	40	20	40	20	45	20	70	30	70	30	90	40	90	45
<b>with Electric Reheat/Heat (No Humidifier)</b>														
FLA	45.4	20.5	47.4	22.3	46.8	21.3	77.6	35.1	82.3	38.9	114.6	53.9	118.2	55.8
MCA	56.0	25.3	58.2	27.4	70.6	31.9	91.6	41.4	96.6	45.5	134.3	63.0	138.4	65.1
MOP	60	30	60	30	80	35	100	45	100	50	150	70	150	70
<b>with Humidifier with or without Hot Gas Reheat, Hot Water/Steam Reheat/Heat (No Electric Reheat/Heat)</b>														
FLA	34.0	15.3	36.0	17.2	33.2	15.2	50.1	22.6	54.7	26.4	73.2	35.1	76.8	37.1
MCA	37.7	16.9	39.9	19.1	50.1	22.6	53.7	24.2	58.7	28.4	79.0	37.9	83.1	40.1
MOP	50	20	50	25	60	25	60	30	70	35	100	45	100	50
<b>with Electric Heat (No Electric Reheat) &amp; Humidifier</b>														
FLA	47.4	21.6	48.1	22.0	47.5	21.8	62.8	28.8	65.2	29.8	82.4	37.9	82.4	37.9
MCA	55.1	25.1	56.1	25.6	55.8	25.6	75.0	34.4	77.9	35.6	99.5	45.7	99.5	45.7
MOP	60	30	60	30	60	30	80	35	80	40	100	50	100	50
<b>with Electric Reheat/Heat &amp; Humidifier</b>														
FLA	47.4	21.6	48.1	22.3	47.5	21.8	77.6	35.1	82.3	38.9	114.6	53.9	118.2	55.8
MCA	56.0	25.3	58.2	27.4	70.6	31.9	91.6	41.4	96.6	45.5	134.3	63.0	138.4	65.1
MOP	60	30	60	30	80	35	100	45	100	50	150	70	150	70

**Notes:**

- 1) FLA = Full Load Amps; MCA = Min Circuit Amps; MOP = Max Overcurrent Protection (Max Fuse Size)
- 2) 277/1/60 systems may require factory provided field installed step-down transformer.
- 3) ---- Consult local AboveAir Sales Representative for non-cataloged system power supply information.



# Electrical Data (Opt CFM) - DX Split Evap & Self-Contained W/G

## STD CFM, DX - Split Evap & Water/Glycol Cooled Self-Contained, 1 to 3 Tons

MODEL	AEP / AWP / AGP-012S_				AEP / AWP / AGP-018S_				AEP / AWP / AGP-024S_				AEP / AWP / AGP-036S_			
Power Supply	208/1/60	277/1/60	208/3/60	460/3/60	208/1/60	277/1/60	208/3/60	460/3/60	208/1/60	277/1/60	208/3/60	460/3/60	208/1/60	277/1/60	208/3/60	460/3/60
<b>Cooling Only (or Cooling with Hot Gas Reheat, Hot Water or Steam Reheat/Heat)</b>																
FLA	12.3	9.6	----	----	16.1	12.1	----	----	16.9	14.0	10.3	6.1	23.1	19.9	16.7	7.6
MCA	14.6	11.4	----	----	19.3	14.5	----	----	20.1	16.7	12.4	7.4	27.6	23.9	20.1	9.1
MOP	20	15	----	----	30	20	----	----	30	25	20	15	45	35	30	15
<b>with Electric Heat (No Electric Reheat or Humidifier)</b>																
FLA	27.4	20.6	----	----	27.4	20.6	----	----	28.2	21.2	15.9	7.3	53.4	40.1	31.0	14.2
MCA	34.2	25.7	----	----	34.2	25.7	----	----	35.2	26.5	19.9	9.1	66.7	50.1	38.7	17.7
MOP	35	30	----	----	35	30	----	----	40	30	20	15	70	60	40	20
<b>with Electric Reheat/Heat (No Humidifier)</b>																
FLA	36.4	27.7	----	----	40.2	30.2	----	----	41.0	32.1	24.2	12.4	71.3	56.1	44.5	20.1
MCA	44.7	34.0	----	----	49.4	37.1	----	----	50.2	39.3	29.8	15.3	87.9	69.2	54.8	24.8
MOP	45	35	----	----	50	40	----	----	60	45	30	20	90	70	60	25
<b>with Humidifier with or without Hot Gas Reheat, Hot Water/Steam Reheat/Heat (No Electric Reheat/Heat)</b>																
FLA	20.5	15.8	----	----	24.3	18.3	----	----	25.1	20.2	18.5	9.8	31.3	26.1	24.9	11.3
MCA	22.8	17.6	----	----	27.5	20.7	----	----	28.3	22.9	20.6	11.1	35.8	30.1	28.3	12.8
MOP	30	20	----	----	40	30	----	----	40	30	25	15	50	45	40	15
<b>with Electric Heat (No Electric Reheat) &amp; Humidifier</b>																
FLA	35.6	26.8	----	----	35.6	26.8	----	----	36.4	27.4	24.1	11.0	61.6	46.3	39.2	17.9
MCA	42.4	31.9	----	----	42.4	31.9	----	----	43.4	32.7	28.1	12.8	74.9	56.3	46.9	21.4
MOP	45	35	----	----	45	35	----	----	45	35	30	15	80	60	50	25
<b>with Electric Reheat/Heat &amp; Humidifier</b>																
FLA	36.4	27.7	----	----	40.2	30.2	----	----	41.0	32.1	24.2	12.4	71.3	56.1	44.5	20.1
MCA	44.7	34.0	----	----	49.4	37.1	----	----	50.2	39.3	29.8	15.3	87.9	69.2	54.8	24.8
MOP	45	35	----	----	50	40	----	----	60	45	30	20	90	70	60	25

## OPT CFM, DX - Split Evap & Water/Glycol Cooled Self-Contained, 4 to 15 Tons

MODEL	AEP/AWP/AGP-048S_		AEP/AWP/AGP-060S_		AEP/AWP/AGP-072D_		AEP/AWP/AGP-0096D_		AEP/AWP/AGP-120D_		AEP/AWP/AGP-144D_		AEP/AWP/AGP-180D_	
Power Supply	208/3/60	460/3/60	208/3/60	460/3/60	208/3/60	460/3/60	208/3/60	460/3/60	208/3/60	460/3/60	208/3/60	460/3/60	208/3/60	460/3/60
<b>Cooling Only (or Cooling with Hot Gas Reheat, Hot Water or Steam Reheat/Heat)</b>														
FLA	18.4	8.3	21.1	10.6	20.4	9.5	38.2	17.2	43.9	21.8	59.0	28.7	62.6	30.7
MCA	22.0	9.9	25.0	12.5	37.3	16.9	41.9	18.8	47.8	23.8	64.8	31.5	68.9	33.7
MOP	35	15	40	20	50	20	50	25	60	30	80	40	90	45
<b>with Electric Heat (No Electric Reheat or Humidifier)</b>														
FLA	31.7	14.6	33.3	15.4	34.7	16.1	51.0	23.4	54.3	25.2	68.2	31.5	68.2	31.5
MCA	39.7	18.2	41.6	19.2	43.4	20.1	63.7	29.2	67.9	31.5	85.3	39.3	85.3	39.3
MOP	40	20	45	20	50	25	70	30	70	35	90	40	90	45
<b>with Electric Reheat/Heat (No Humidifier)</b>														
FLA	46.2	20.9	48.9	23.1	48.2	22.0	80.0	36.1	85.6	40.7	114.6	53.9	118.2	55.8
MCA	56.8	25.7	59.8	28.2	72.1	32.6	94.0	42.4	99.9	47.3	134.3	63.0	138.4	65.1
MOP	60	30	60	30	80	35	100	45	100	50	150	70	150	70
<b>with Humidifier with or without Hot Gas Reheat, Hot Water/Steam Reheat/Heat (No Electric Reheat/Heat)</b>														
FLA	34.8	15.7	37.5	18.0	34.6	15.9	52.4	23.6	58.1	28.2	73.2	35.1	76.8	37.1
MCA	38.4	17.3	41.4	19.9	51.5	23.3	56.1	25.2	62.0	30.2	79.0	37.9	83.1	40.1
MOP	50	20	50	25	60	25	70	30	70	35	100	45	100	50
<b>with Electric Heat (No Electric Reheat) &amp; Humidifier</b>														
FLA	48.1	22.0	49.7	22.8	48.9	22.5	65.2	29.8	68.5	31.6	82.4	37.9	82.4	37.9
MCA	56.1	25.6	58.0	26.6	57.6	26.5	77.9	35.6	82.1	37.9	99.5	45.7	99.5	45.7
MOP	60	30	60	30	60	30	80	40	90	40	100	50	100	50
<b>with Electric Reheat/Heat &amp; Humidifier</b>														
FLA	48.1	22.0	49.7	23.1	48.9	22.5	80.0	36.1	85.6	40.7	114.6	53.9	118.2	55.8
MCA	56.8	25.7	59.8	28.2	72.1	32.6	94.0	42.4	99.9	47.3	134.3	63.0	138.4	65.1
MOP	60	30	60	30	80	35	100	45	100	50	150	70	150	70

**Notes:**

- 1) FLA = Full Load Amps; MCA = Min Circuit Amps; MOP = Max Overcurrent Protection (Max Fuse Size)
- 2) 277/1/60 systems may require factory provided field installed step-down transformer.
- 3) ---- Consult local AboveAir Sales Representative for non-cataloged system power supply information.

# Electrical Data (Standard CFM) - DX & CW Air Handling Units

## STANDARD CFM, DX-Split & Chilled Water Air Handling Evaps, 1 to 3 Tons

MODEL	ACC & AHC-012_				ACC & AHC-018_				ACC & AHC-024_				ACC & AHC-036_			
Power Supply	208/1/60	277/1/60	208/3/60	460/3/60	208/1/60	277/1/60	208/3/60	460/3/60	208/1/60	277/1/60	208/3/60	460/3/60	208/1/60	277/1/60	208/3/60	460/3/60
<b>Cooling Only (or Cooling with Hot Gas Reheat, Hot Water or Steam Reheat/Heat)</b>																
FLA	3.3	2.5	1.2	0.6	3.3	2.5	1.2	0.6	4.1	3.1	2.0	1.0	5.2	3.9	3.1	1.6
MCA	4.1	3.1	1.5	0.8	4.1	3.1	1.5	0.8	5.1	3.8	2.5	1.3	6.5	4.9	3.9	2.0
MOP	15	15	15	15	15	15	15	15	15	15	15	15	15	15	15	15
<b>with Electric Heat (No Electric Reheat or Humidifier)</b>																
FLA	27.4	20.6	15.1	6.9	27.4	20.6	15.1	6.9	28.2	21.2	15.9	7.3	53.4	40.1	31.0	14.2
MCA	34.2	25.7	18.8	8.6	34.2	25.7	18.8	8.6	35.2	26.5	19.9	9.1	66.7	50.1	38.7	17.7
MOP	35	30	20	15	35	30	20	15	40	30	20	15	70	60	40	20
<b>with Electric Reheat/Heat (No Humidifier)</b>																
FLA	27.4	20.6	15.1	6.9	27.4	20.6	15.1	6.9	28.2	21.2	15.9	7.3	53.4	40.1	31.0	14.2
MCA	34.2	25.7	18.8	8.6	34.2	25.7	18.8	8.6	35.2	26.5	19.9	9.1	66.7	50.1	38.7	17.7
MOP	35	30	20	15	35	30	20	15	40	30	20	15	70	60	40	20
<b>with Humidifier with or without Hot Gas Reheat, Hot Water/Steam Reheat/Heat (No Electric Reheat/Heat)</b>																
FLA	11.5	8.7	9.4	4.3	11.5	8.7	9.4	4.3	12.3	9.3	10.2	4.7	13.4	10.1	11.3	5.3
MCA	12.3	9.3	9.7	4.5	12.3	9.3	9.7	4.5	13.3	10.0	10.7	5.0	14.7	11.1	12.1	5.7
MOP	15	15	15	15	15	15	15	15	15	15	15	15	15	15	15	15
<b>with Electric Heat (No Electric Reheat) &amp; Humidifier</b>																
FLA	35.6	26.8	23.3	10.6	35.6	26.8	23.3	10.6	36.4	27.4	24.1	11.0	61.6	46.3	39.2	17.9
MCA	42.4	31.9	27.0	12.3	42.4	31.9	27.0	12.3	43.4	32.7	28.1	12.8	74.9	56.3	46.9	21.4
MOP	45	35	30	15	45	35	30	15	45	35	30	15	80	60	50	25
<b>with Electric Reheat/Heat &amp; Humidifier</b>																
FLA	35.6	26.8	23.3	10.6	35.6	26.8	23.3	10.6	36.4	27.4	24.1	11.0	61.6	46.3	39.2	17.9
MCA	42.4	31.9	27.0	12.3	42.4	31.9	27.0	12.3	43.4	32.7	28.1	12.8	74.9	56.3	46.9	21.4
MOP	45	35	30	15	45	35	30	15	45	35	30	15	80	60	50	25

## STANDARD CFM, DX-Split & Chilled Water Air Handling Evaps, 6 to 15 Tons

MODEL	ACC & AHC-048_		ACC & AHC-060_		ACC & AHC-072_		ACC & AHC-0096_		ACC & AHC-120_		ACC & AHC-144_		ACC & AHC-180_	
Power Supply	208/3/60	460/3/60	208/3/60	460/3/60	208/3/60	460/3/60	208/3/60	460/3/60	208/3/60	460/3/60	208/3/60	460/3/60	208/3/60	460/3/60
<b>Cooling Only (or Cooling with Hot Gas Reheat, Hot Water or Steam Reheat/Heat)</b>														
FLA	3.1	1.6	3.9	2.0	5.4	2.8	6.9	3.5	9.3	4.5	12.6	6.3	12.6	6.3
MCA	3.9	2.0	4.9	2.5	6.8	3.5	8.6	4.4	11.6	5.6	15.8	7.9	15.8	7.9
MOP	15	15	15	15	15	15	15	15	20	15	25	15	25	15
<b>with Electric Heat (No Electric Reheat or Humidifier)</b>														
FLA	31.0	14.2	31.7	14.6	33.3	15.4	48.6	22.4	51.0	23.4	68.2	31.5	68.2	31.5
MCA	38.7	17.7	39.7	18.2	41.6	19.2	60.8	28.0	63.7	29.2	85.3	39.3	85.3	39.3
MOP	40	20	40	20	45	20	70	30	70	30	90	40	90	40
<b>with Electric Reheat/Heat (No Humidifier)</b>														
FLA	31.0	14.2	31.7	14.6	33.3	15.4	48.6	22.4	51.0	23.4	68.2	31.5	68.2	31.5
MCA	38.7	17.7	39.7	18.2	41.6	19.2	60.8	28.0	63.7	29.2	85.3	39.3	85.3	39.3
MOP	40	20	40	20	45	20	70	30	70	30	90	40	90	40
<b>with Humidifier with or without Hot Gas Reheat, Hot Water/Steam Reheat/Heat (No Electric Reheat/Heat)</b>														
FLA	19.5	9.0	20.3	9.4	19.6	9.2	21.1	9.9	23.5	10.9	26.8	12.7	26.8	12.7
MCA	20.3	9.4	21.3	9.9	21.0	9.9	22.8	10.8	25.8	12.0	30.0	14.3	30.0	14.3
MOP	25	15	25	15	25	15	25	15	35	15	40	20	40	20
<b>with Electric Heat (No Electric Reheat) &amp; Humidifier</b>														
FLA	47.4	21.6	48.1	22.0	47.5	21.8	62.8	28.8	65.2	29.8	82.4	37.9	82.4	37.9
MCA	55.1	25.1	56.1	25.6	55.8	25.6	75.0	34.4	77.9	35.6	99.5	45.7	99.5	45.7
MOP	60	30	60	30	60	30	80	35	80	40	100	50	100	50
<b>with Electric Reheat/Heat &amp; Humidifier</b>														
FLA	47.4	21.6	48.1	22.0	47.5	21.8	62.8	28.8	65.2	29.8	82.4	37.9	82.4	37.9
MCA	55.1	25.1	56.1	25.6	55.8	25.6	75.0	34.4	77.9	35.6	99.5	45.7	99.5	45.7
MOP	60	30	60	30	60	30	80	35	80	40	100	50	100	50

**Notes:**

- 1) FLA = Full Load Amps; MCA = Min Circuit Amps; MOP = Max Overcurrent Protection (Max Fuse Size)
- 2) - - - - Consult local AboveAir Sales Representative for non-cataloged system power supply information.

# Electrical Data (Optional CFM) - DX & CW Air Handling Units

## OPTIONAL CFM, DX-Split & Chilled Water Air Handling Evaps, 1 to 3 Tons

MODEL	ACP & AHP-012-__				ACP & AHP-018-__				ACP & AHP-024-__				ACP & AHP-036-__			
	208/1/60	277/1/60	208/3/60	460/3/60	208/1/60	277/1/60	208/3/60	460/3/60	208/1/60	277/1/60	208/3/60	460/3/60	208/1/60	277/1/60	208/3/60	460/3/60
<b>Cooling Only (or Cooling with Hot Gas Reheat, Hot Water or Steam Reheat/Heat)</b>																
FLA	3.3	2.5	1.2	0.6	3.3	2.5	1.2	0.6	4.1	3.1	2.0	1.0	5.2	3.9	3.1	1.6
MCA	4.1	3.1	1.5	0.8	4.1	3.1	1.5	0.8	5.1	3.8	2.5	1.3	6.5	4.9	3.9	2.0
MOP	15	15	15	15	15	15	15	15	15	15	15	15	15	15	15	15
<b>with Electric Heat (No Electric Reheat or Humidifier)</b>																
FLA	27.4	20.6	15.1	6.9	27.4	20.6	15.1	6.9	28.2	21.2	15.9	7.3	53.4	40.1	31.0	14.2
MCA	34.2	25.7	18.8	8.6	34.2	25.7	18.8	8.6	35.2	26.5	19.9	9.1	66.7	50.1	38.7	17.7
MOP	35	30	20	15	35	30	20	15	40	30	20	15	70	60	40	20
<b>with Electric Reheat/Heat (No Humidifier)</b>																
FLA	27.4	20.6	15.1	6.9	27.4	20.6	15.1	6.9	28.2	21.2	15.9	7.3	53.4	40.1	31.0	14.2
MCA	34.2	25.7	18.8	8.6	34.2	25.7	18.8	8.6	35.2	26.5	19.9	9.1	66.7	50.1	38.7	17.7
MOP	35	30	20	15	35	30	20	15	40	30	20	15	70	60	40	20
<b>with Humidifier with or without Hot Gas Reheat, Hot Water/Steam Reheat/Heat (No Electric Reheat/Heat)</b>																
FLA	11.5	8.7	9.4	4.3	11.5	8.7	9.4	4.3	12.3	9.3	10.2	4.7	13.4	10.1	11.3	5.3
MCA	12.3	9.3	9.7	4.5	12.3	9.3	9.7	4.5	13.3	10.0	10.7	5.0	14.7	11.1	12.1	5.7
MOP	15	15	15	15	15	15	15	15	15	15	15	15	15	15	15	15
<b>with Electric Heat (No Electric Reheat) &amp; Humidifier</b>																
FLA	35.6	26.8	23.3	10.6	35.6	26.8	23.3	10.6	36.4	27.4	24.1	11.0	61.6	46.3	39.2	17.9
MCA	42.4	31.9	27.0	12.3	42.4	31.9	27.0	12.3	43.4	32.7	28.1	12.8	74.9	56.3	46.9	21.4
MOP	45	35	30	15	45	35	30	15	45	35	30	15	80	60	50	25
<b>with Electric Reheat/Heat &amp; Humidifier</b>																
FLA	35.6	26.8	23.3	10.6	35.6	26.8	23.3	10.6	36.4	27.4	24.1	11.0	61.6	46.3	39.2	17.9
MCA	42.4	31.9	27.0	12.3	42.4	31.9	27.0	12.3	43.4	32.7	28.1	12.8	74.9	56.3	46.9	21.4
MOP	45	35	30	15	45	35	30	15	45	35	30	15	80	60	50	25

## OPTIONAL CFM, DX-Split & Chilled Water Air Handling Evaps, 6 to 15 Tons

MODEL	ACP & AHP-048-__		ACP & AHP-060-__		ACP & AHP-072-__		ACP & AHP-0096-__		ACP & AHP-120-__		ACP & AHP-144-__		ACP & AHP-180-__	
	208/3/60	460/3/60	208/3/60	460/3/60	208/3/60	460/3/60	208/3/60	460/3/60	208/3/60	460/3/60	208/3/60	460/3/60	208/3/60	460/3/60
<b>Cooling Only (or Cooling with Hot Gas Reheat, Hot Water or Steam Reheat/Heat)</b>														
FLA	3.9	2.0	5.4	2.8	6.9	3.5	9.3	4.5	12.6	6.3	12.6	6.3	12.6	6.3
MCA	4.9	2.5	6.8	3.5	8.6	4.4	11.6	5.6	15.8	7.9	15.8	7.9	15.8	7.9
MOP	15	15	15	15	15	15	20	15	25	15	25	15	25	15
<b>with Electric Heat (No Electric Reheat or Humidifier)</b>														
FLA	31.7	14.6	33.3	15.4	34.7	16.1	51.0	23.4	54.3	25.2	68.2	31.5	68.2	31.5
MCA	39.7	18.2	41.6	19.2	43.4	20.1	63.7	29.2	67.9	31.5	85.3	39.3	85.3	39.3
MOP	40	20	45	20	45	25	70	30	70	35	90	40	90	40
<b>with Electric Reheat/Heat (No Humidifier)</b>														
FLA	31.7	14.6	33.3	15.4	34.7	16.1	51.0	23.4	54.3	25.2	68.2	31.5	68.2	31.5
MCA	39.7	18.2	41.6	19.2	43.4	20.1	63.7	29.2	67.9	31.5	85.3	39.3	85.3	39.3
MOP	40	20	45	20	45	25	70	30	70	35	90	40	90	40
<b>with Humidifier with or without Hot Gas Reheat, Hot Water/Steam Reheat/Heat (No Electric Reheat/Heat)</b>														
FLA	20.3	9.4	21.8	10.2	21.1	9.9	23.5	10.9	26.8	12.7	26.8	12.7	26.8	12.7
MCA	21.3	9.9	23.2	10.9	22.8	10.8	25.8	12.0	30.0	14.3	30.0	14.3	30.0	14.3
MOP	25	15	25	15	25	15	35	15	40	20	40	20	40	20
<b>with Electric Heat (No Electric Reheat) &amp; Humidifier</b>														
FLA	48.1	22.0	49.7	22.8	48.9	22.5	65.2	29.8	68.5	31.6	82.4	37.9	82.4	37.9
MCA	56.1	25.6	58.0	26.6	57.6	26.5	77.9	35.6	82.1	37.9	99.5	45.7	99.5	45.7
MOP	60	30	60	30	60	30	80	40	90	40	100	50	100	50
<b>with Electric Reheat/Heat &amp; Humidifier</b>														
FLA	48.1	22.0	49.7	22.8	48.9	22.5	65.2	29.8	68.5	31.6	82.4	37.9	82.4	37.9
MCA	56.1	25.6	58.0	26.6	57.6	26.5	77.9	35.6	82.1	37.9	99.5	45.7	99.5	45.7
MOP	60	30	60	30	60	30	80	40	90	40	100	50	100	50

**Notes:**

- 1) FLA = Full Load Amps; MCA = Min Circuit Amps; MOP = Max Overcurrent Protection (Max Fuse Size)
- 2) - - - - Consult local AboveAir Sales Representative for non-cataloged system power supply information.

## DX - AIR COOLED, REMOTE CONDENSERS & CONDENSING UNITS

Unit Size (Tons)	Condenser / Cond Unit Model	Main Power Supply	Type	Compressor (Fixed Speed)				Cond Fan Motor				Unit Nameplate Data		
				Qty.	RLA	LRA	Type	Qty.	HP (kW)	FLA	Type	FLA	MCA	MOP
1.0 Ton	XP1-012S-1*	208/1/60	Outdoor Pad/Roof Mtd	---	---	---	---	1	1/6 (0.12)	1.1	PSC	1.1	1.4	15
	XP1-012S-7*	277/1/60	Outdoor Pad/Roof Mtd	---	---	---	---	1	1/6 (0.12)	0.8	PSC	0.8	1.0	15
	XPU-012S-1*	277/1/60	Outdoor Pad/Roof Mtd	1	9.0	48.0	Scroll	1	1/6 (0.12)	1.1	PSC	10.1	12.3	20
	XPU-012S-7*	277/1/60	Outdoor Pad/Roof Mtd	1	7.1	43.0	Scroll	1	1/6 (0.12)	0.8	PSC	7.9	9.7	15
	XCX-012S-1*	277/1/60	Indoor Ceiling Mtd	---	---	---	---	1	1/2	4.1	AC	4.1	5.1	15
	XCX-012S-7*	277/1/60	Indoor Ceiling Mtd	---	---	---	---	1	1/2	3.1	AC	3.1	3.8	15
	XCU-012S-1*	277/1/60	Indoor Ceiling Mtd	1	9.0	48.0	Scroll	1	1/2	4.1	AC	13.1	15.3	20
	XCU-012S-7*	277/1/60	Indoor Ceiling Mtd	1	7.1	43.0	Scroll	1	1/2	3.1	AC	10.2	12.0	15
1.5 Ton	XP1-018S-1*	208/1/60	Outdoor Pad/Roof Mtd	---	---	---	---	1	1/6 (0.12)	1.1	PSC	1.1	1.4	15
	XP1-018S-7*	277/1/60	Outdoor Pad/Roof Mtd	---	---	---	---	1	1/6 (0.12)	0.8	PSC	0.8	1.0	15
	XPU-018S-1*	277/1/60	Outdoor Pad/Roof Mtd	1	12.8	58.3	Scroll	1	1/6 (0.12)	1.1	PSC	13.9	17.1	25
	XPU-018S-7*	277/1/60	Outdoor Pad/Roof Mtd	1	9.6	54.0	Scroll	1	1/6 (0.12)	0.8	PSC	10.4	12.8	20
	XCX-018S-1*	277/1/60	Indoor Ceiling Mtd	---	---	---	---	1	3/4	5.2	AC	5.2	6.5	15
	XCX-018S-7*	277/1/60	Indoor Ceiling Mtd	---	---	---	---	1	3/4	3.9	AC	3.9	4.9	15
	XCU-018S-1*	277/1/60	Indoor Ceiling Mtd	1	12.8	58.3	Scroll	1	3/4	5.2	AC	18.0	21.2	30
	XCU-018S-7*	277/1/60	Indoor Ceiling Mtd	1	9.6	54.0	Scroll	1	3/4	3.9	AC	13.5	15.9	25
2.0 Ton	XP1-024S-1*	208/1/60	Outdoor Pad/Roof Mtd	---	---	---	---	1	1/6 (0.12)	1.1	PSC	1.1	1.4	15
	XP1-024S-7*	277/1/60	Outdoor Pad/Roof Mtd	---	---	---	---	1	1/6 (0.12)	0.8	PSC	0.8	1.0	15
	XP1-024S-3*	208/3/60	---	---	---	---	---	---	---	---	---	---	---	---
	XP1-024S-8*	460/1/60	Outdoor Pad/Roof Mtd	---	---	---	---	1	1/4 (0.19)	1.0	PSC	1.0	1.3	15
	XPU-024S-1*	208/1/60	Outdoor Pad/Roof Mtd	1	12.8	64.0	Scroll	1	1/6 (0.12)	1.1	PSC	13.9	17.1	25
	XPU-024S-7*	277/1/60	Outdoor Pad/Roof Mtd	1	10.9	60.0	Scroll	1	1/6 (0.12)	0.8	PSC	11.7	14.4	25
	XPU-024S-3*	208/3/60	Outdoor Pad/Roof Mtd	1	8.3	58.0	Scroll	1	1/6 (0.12)	1.1	PSC	9.4	11.5	15
	XPU-024S-4*	460/3/60	Outdoor Pad/Roof Mtd	1	5.1	28.0	Scroll	1	1/4 (0.19)	1.0	PSC	6.1	7.4	15
	XCX-024S-1*	208/1/60	Indoor Ceiling Mtd	---	---	---	---	1	3/4	5.2	AC	5.2	6.5	15
	XCX-024S-7*	277/1/60	Indoor Ceiling Mtd	---	---	---	---	1	3/4	3.9	AC	3.9	4.9	15
	XCX-024S-3*	208/3/60	Indoor Ceiling Mtd	---	---	---	---	1	3/4	3.1	AC	3.1	3.9	15
	XCX-024S-8*	460/1/60	Indoor Ceiling Mtd	---	---	---	---	1	3/4	1.6	AC	1.6	2.0	15
	XCU-024S-1*	208/1/60	Indoor Ceiling Mtd	1	12.8	64.0	Scroll	1	3/4	5.2	AC	18.0	21.2	30
	XCU-024S-7*	277/1/60	Indoor Ceiling Mtd	1	10.9	60.0	Scroll	1	3/4	3.9	AC	14.8	17.5	25
	XCU-024S-3*	208/3/60	Indoor Ceiling Mtd	1	8.3	58.0	Scroll	1	3/4	3.1	AC	11.5	13.6	20
	XCU-024S-4*	460/3/60	Indoor Ceiling Mtd	1	5.1	28.0	Scroll	1	3/4	1.6	AC	6.7	8.0	15

**Notes:**

- 1) FLA = Full Load Amps; MCA = Min Circuit Amps; MOP = Max Overcurrent Protection (Max Fuse Size)
- 2) --- Consult local AboveAir Sales Representative for non-cataloged system power supply information.

## DX - AIR COOLED, REMOTE CONDENSERS & CONDENSING UNITS

Unit Size (Tons)	Condenser / Cond Unit Model	Main Power Supply	Type	Compressor (Fixed Speed)				Cond Fan Motor				Unit Nameplate Data		
				Qty.	RLA	LRA	Type	Qty.	HP (kW)	FLA	Type	FLA	MCA	MOP
<b>3.0 Ton</b>	XP1-036S-1*	208/1/60	Outdoor Pad/Roof Mtd	---	---	---	---	1		2.0	PSC	2.0	2.5	15
	XP1-036S-7*	277/1/60	Outdoor Pad/Roof Mtd	---	---	---	---	1	1/4 (0.19)	1.5	PSC	1.5	1.9	15
	XP1-036S-3*	208/3/60	---	---	---	---	---	---	---	---	---	---	---	---
	XP1-036S-8*	460/1/60	Outdoor Pad/Roof Mtd	---	---	---	---	1	1/4 (0.19)	1.0	PSC	1.0	1.3	15
	XPU-036S-1*	208/1/60	Outdoor Pad/Roof Mtd	1	17.9	112.0	Scroll	1	1/4 (0.19)	2.0	PSC	19.9	24.4	40
	XPU-036S-7*	277/1/60	Outdoor Pad/Roof Mtd	1	16.0	87.0	Scroll	1	1/4 (0.19)	1.5	PSC	17.5	21.5	35
	XPU-036S-3*	208/3/60	Outdoor Pad/Roof Mtd	1	13.5	88.0	Scroll	1	1/4 (0.19)	2.0	PSC	15.5	18.9	30
	XPU-036S-4*	460/3/60	Outdoor Pad/Roof Mtd	1	6.0	44.0	Scroll	1	1/4 (0.19)	1.0	PSC	7.0	8.5	15
	XCX-036S-1*	208/1/60	Indoor Ceiling Mtd	---	---	---	---	1	1	6.6	AC	6.6	8.3	15
	XCX-036S-7*	277/1/60	Indoor Ceiling Mtd	---	---	---	---	1	1	5.0	AC	5.0	6.2	15
	XCX-036S-3*	208/3/60	Indoor Ceiling Mtd	---	---	---	---	1	1	3.9	AC	3.9	4.9	15
	XCX-036S-8*	460/1/60	Indoor Ceiling Mtd	---	---	---	---	1	1	2.0	AC	2.0	2.5	15
	XCU-036S-1*	208/1/60	Indoor Ceiling Mtd	1	17.9	112.0	Scroll	1	1	6.6	AC	24.5	29.0	45
	XCU-036S-7*	277/1/60	Indoor Ceiling Mtd	1	16.0	87.0	Scroll	1	1	5.0	AC	21.0	25.0	40
XCU-036S-3*	208/3/60	Indoor Ceiling Mtd	1	13.5	88.0	Scroll	1	1	3.9	AC	17.4	20.8	30	
XCU-036S-4*	460/3/60	Indoor Ceiling Mtd	1	6.0	44.0	Scroll	1	1	2.0	AC	8.0	9.5	15	
<b>4.0 Ton</b>	XP1-048S-1*	208/1/60	Outdoor Pad/Roof Mtd	---	---	---	---	1	1/4 (0.19)	2.0	AC	2.0	2.5	15
	XP1-048S-7*	277/1/60	Outdoor Pad/Roof Mtd	---	---	---	---	1	1/4 (0.19)	1.5	AC	1.5	1.9	15
	XP1-048S-3*	208/3/60	---	---	---	---	---	---	---	---	---	---	---	---
	XP1-048S-8*	460/1/60	Outdoor Pad/Roof Mtd	---	---	---	---	1	1/4 (0.19)	1.0	AC	1.0	1.3	15
	XPU-048S-1*	208/1/60	Outdoor Pad/Roof Mtd	1	19.9	109.0	Scroll	1	1/4 (0.19)	2.0	AC	21.9	26.8	45
	XPU-048S-7*	277/1/60	Outdoor Pad/Roof Mtd	1	14.9	81.8	Scroll	1	1/4 (0.19)	1.5	AC	16.4	20.2	35
	XPU-048S-3*	208/3/60	Outdoor Pad/Roof Mtd	1	13.1	83.1	Scroll	1	1/4 (0.19)	2.0	AC	15.1	18.4	30
	XPU-048S-4*	460/3/60	Outdoor Pad/Roof Mtd	1	6.1	41.0	Scroll	1	1/4 (0.19)	1.0	AC	7.1	8.6	15
	XCX-048S-1*	208/1/60	Indoor Ceiling Mtd	---	---	---	---	1	1-1/2 (1.12)	7.5	AC	7.5	9.4	15
	XCX-048S-7*	277/1/60	Indoor Ceiling Mtd	---	---	---	---	1	1-1/2 (1.12)	5.6	AC	5.6	7.0	15
	XCX-048S-3*	208/3/60	Indoor Ceiling Mtd	---	---	---	---	1	1-1/2 (1.12)	5.4	AC	5.4	6.8	15
	XCX-048S-4*	460/3/60	Indoor Ceiling Mtd	---	---	---	---	1	1-1/2 (1.12)	2.8	AC	2.8	3.5	15
	XCU-048S-1*	208/1/60	Indoor Ceiling Mtd	1	26.4	134.0	Scroll	1	1-1/2 (1.12)	7.5	AC	33.9	40.5	60
	XCU-048S-7*	277/1/60	Indoor Ceiling Mtd	1	19.9	130.0	Scroll	1	1-1/2 (1.12)	5.6	AC	25.5	30.5	50
XCU-048S-3*	208/3/60	Indoor Ceiling Mtd	1	16.0	110.0	Scroll	1	1-1/2 (1.12)	5.4	AC	21.4	25.4	40	
XCU-048S-4*	460/3/60	Indoor Ceiling Mtd	1	7.8	52.0	Scroll	1	1-1/2 (1.12)	2.8	AC	10.6	12.5	20	
<b>5.0 Ton</b>	XP1-060S-1*	208/1/60	Outdoor Pad/Roof Mtd	---	---	---	---	1	1/4 (0.19)	2.0	AC	2.0	2.5	15
	XP1-060S-7*	277/1/60	Outdoor Pad/Roof Mtd	---	---	---	---	1	1/4 (0.19)	1.5	AC	1.5	1.9	15
	XP1-060S-3*	208/3/60	---	---	---	---	---	---	---	---	---	---	---	---
	XP1-060S-8*	460/1/60	Outdoor Pad/Roof Mtd	---	---	---	---	1	1/4 (0.19)	1.0	AC	1.0	1.3	15
	XPU-060S-1*	208/1/60	Outdoor Pad/Roof Mtd	1	26.4	134.0	Scroll	1	1/4 (0.19)	2.0	AC	28.4	35.0	60
	XPU-060S-7*	277/1/60	Outdoor Pad/Roof Mtd	1	19.8	100.6	Scroll	1	1/4 (0.19)	1.5	AC	21.3	26.3	45
	XPU-060S-3*	208/3/60	Outdoor Pad/Roof Mtd	1	16.0	110.0	Scroll	1	1/4 (0.19)	2.0	AC	18.0	22.0	35
	XPU-060S-4*	460/3/60	Outdoor Pad/Roof Mtd	1	7.8	52.0	Scroll	1	1/4 (0.19)	1.0	AC	8.8	10.7	15
	XCX-060S-3*	208/3/60	Indoor Ceiling Mtd	---	---	---	---	1	2 (1.49)	6.9	AC	6.9	8.6	15
	XCX-060S-4*	460/3/60	Indoor Ceiling Mtd	---	---	---	---	1	2 (1.49)	3.5	AC	3.5	4.4	15
	XCU-060S-3*	208/3/60	Indoor Ceiling Mtd	1	15.6	110.0	Scroll	1	2 (1.49)	6.9	AC	22.5	26.5	40
	XCU-060S-4*	460/3/60	Indoor Ceiling Mtd	1	7.8	52.0	Scroll	1	2 (1.49)	3.5	AC	11.3	13.2	20

**Notes:**

- 1) FLA = Full Load Amps; MCA = Min Circuit Amps; MOP = Max Overcurrent Protection (Max Fuse Size)
- 2) --- Consult local AboveAir Sales Representative for non-cataloged system power supply information.

## DX - AIR COOLED, REMOTE CONDENSERS & CONDENSING UNITS

Unit Size (Tons)	Condenser / Cond Unit Model	Main Power Supply	Type	Compressor (Fixed Speed)				Cond Fan Motor				Unit Nameplate Data		
				Qty.	RLA	LRA	Type	Qty.	HP (kW)	FLA	Type	FLA	MCA	MOP
6.0 Ton	XP1-072S-1*	208/1/60	Outdoor Pad/Roof Mtd	---	---	---	---	1	1 (0.75)	6.4	AC	6.4	8.0	15
	XP1-072S-7*	277/1/60	Outdoor Pad/Roof Mtd	---	---	---	---	1	1 (0.75)	4.8	AC	4.8	6.0	15
	XP1-072S-3*	208/3/60	---	---	---	---	---	---	---	---	---	---	---	---
	XP1-072S-8*	460/1/60	Outdoor Pad/Roof Mtd	---	---	---	---	1	1 (0.75)	3.2	AC	3.2	4.0	15
	XP4-072D-1*	208/1/60	Outdoor Pad/Roof Mtd	---	---	---	---	4	1/4 (0.19)	2.0	AC	8.0	9.0	15
	XP4-072D-7*	277/1/60	Outdoor Pad/Roof Mtd	---	---	---	---	4	1/4 (0.19)	1.5	AC	6.0	6.8	15
	XP4-072D-3*	208/3/60	---	---	---	---	---	---	---	---	---	---	---	---
	XP4-072D-8*	460/1/60	Outdoor Pad/Roof Mtd	---	---	---	---	4	1/4 (0.19)	1.0	AC	4.0	4.5	15
	XPU-072S-3*	208/3/60	Outdoor Pad/Roof Mtd	1	23.2	164.0	Scroll	1	1 (0.75)	6.4	AC	29.6	35.4	50
	XPU-072S-4*	460/3/60	Outdoor Pad/Roof Mtd	1	11.2	75.0	Scroll	1	1 (0.75)	4.2	AC	15.4	18.2	25
	XPU-072D-3*	208/3/60	Outdoor Pad/Roof Mtd	2	13.5	88.0	Scroll	4	1/4 (0.19)	2.0	AC	35.1	38.4	50
	XPU-072D-4*	460/3/60	Outdoor Pad/Roof Mtd	2	6.0	44.0	Scroll	4	1/4 (0.19)	1.0	AC	15.9	17.4	20
	XCX-072D-3*	208/3/60	Indoor Ceiling Mtd	---	---	---	---	1	2 (1.49)	6.9	AC	6.9	8.6	15
	XCX-072D-4*	460/3/60	Indoor Ceiling Mtd	---	---	---	---	1	2 (1.49)	3.5	AC	3.5	4.4	15
	XCU-072D-3*	208/3/60	Indoor Ceiling Mtd	2	13.5	88.0	Scroll	1	2 (1.49)	6.9	AC	34.0	37.3	50
	XCU-072D-4*	460/3/60	Indoor Ceiling Mtd	2	6.0	44.0	Scroll	1	2 (1.49)	3.5	AC	15.4	16.9	20
8.0 Ton	XP1-096S-1*	208/1/60	Outdoor Pad/Roof Mtd	---	---	---	---	1	1 (0.75)	6.4	AC	6.4	8.0	15
	XP1-096S-7*	277/1/60	Outdoor Pad/Roof Mtd	---	---	---	---	1	1 (0.75)	4.8	AC	4.8	6.0	15
	XP1-096S-3*	208/3/60	---	---	---	---	---	---	---	---	---	---	---	---
	XP1-096S-8*	460/1/60	Outdoor Pad/Roof Mtd	---	---	---	---	1	1 (0.75)	3.2	AC	3.2	4.0	15
	XP4-096D-1*	208/1/60	Outdoor Pad/Roof Mtd	---	---	---	---	4	1/4 (0.19)	2.0	AC	8.0	9.0	15
	XP4-096D-7*	277/1/60	Outdoor Pad/Roof Mtd	---	---	---	---	4	1/4 (0.19)	1.5	AC	6.0	6.8	15
	XP4-096D-3*	208/3/60	---	---	---	---	---	---	---	---	---	---	---	---
	XP4-096D-8*	460/1/60	Outdoor Pad/Roof Mtd	---	---	---	---	4	1/4 (0.19)	1.0	AC	4.0	4.5	15
	XPU-096S-3*	208/3/60	Outdoor Pad/Roof Mtd	1	25.0	164.0	Scroll	1	1 (0.75)	6.4	AC	31.4	37.7	60
	XPU-096S-4*	460/3/60	Outdoor Pad/Roof Mtd	1	12.2	100.0	Scroll	1	1 (0.75)	4.2	AC	16.4	19.4	30
	XPU-096D-3*	208/3/60	Outdoor Pad/Roof Mtd	2	13.1	83.1	Scroll	4	1/4 (0.19)	2.0	AC	34.2	37.5	50
	XPU-096D-4*	460/3/60	Outdoor Pad/Roof Mtd	2	6.1	41.0	Scroll	4	1/4 (0.19)	1.0	AC	16.2	17.7	20
	XCX-096D-3*	208/3/60	Indoor Ceiling Mtd	---	---	---	---	1	3 (2.24)	9.3	AC	9.3	11.6	20
	XCX-096D-4*	460/3/60	Indoor Ceiling Mtd	---	---	---	---	1	3 (2.24)	4.5	AC	4.5	5.6	15
	XCU-096D-3*	208/3/60	Indoor Ceiling Mtd	2	13.1	83.1	Scroll	1	3 (2.24)	9.3	AC	35.5	38.8	50
	XCU-096D-4*	460/3/60	Indoor Ceiling Mtd	2	6.1	41.0	Scroll	1	3 (2.24)	4.5	AC	16.7	18.2	20

**Notes:**

- 1) FLA = Full Load Amps; MCA = Min Circuit Amps; MOP = Max Overcurrent Protection (Max Fuse Size)
- 2) 277/1/60 systems may require factory provided field installed step-down transformer.
- 3) The above unit electrical data is reflective of the standard performance data and standard options as shown in this manual.
- 4) ---- Consult local AboveAir Sales Representative for non-cataloged system power supply information.

## DX - AIR COOLED, REMOTE CONDENSERS & CONDENSING UNITS

Unit Size (Tons)	Condenser / Cond Unit Model	Main Power Supply	Type	Compressor (Fixed Speed)				Cond Fan Motor				Unit Nameplate Data		
				Qty.	RLA	LRA	Type	Qty.	HP (kW)	FLA	Type	FLA	MCA	MOP
10.0 Ton	XP1-120S-1*	208/1/60	Outdoor Pad/Roof Mtd	---	---	---	---	1	1 (0.75)	6.4	AC	6.4	8.0	15
	XP1-120S-7*	277/1/60	Outdoor Pad/Roof Mtd	---	---	---	---	1	1 (0.75)	4.8	AC	4.8	6.0	15
	XP1-120S-3*	208/3/60	---	---	---	---	---	---	---	---	---	---	---	---
	XP1-120S-8*	460/1/60	Outdoor Pad/Roof Mtd	---	---	---	---	1	1 (0.75)	3.2	AC	3.2	4.0	15
	XP4-120D-1*	208/1/60	Outdoor Pad/Roof Mtd	---	---	---	---	4	1/4 (0.19)	2.0	AC	8.0	9.0	15
	XP4-120D-7*	277/1/60	Outdoor Pad/Roof Mtd	---	---	---	---	4	1/4 (0.19)	1.5	AC	6.0	6.8	15
	XP4-120D-3*	208/3/60	---	---	---	---	---	---	---	---	---	---	---	---
	XP4-120D-8*	460/1/60	Outdoor Pad/Roof Mtd	---	---	---	---	4	1/4 (0.19)	1.0	AC	4.0	4.5	15
	XPU-120S-3*	208/3/60	Outdoor Pad/Roof Mtd	1	16.7	114.0	Scroll	1	1 (0.75)	6.4	AC	23.1	27.2	40
	XPU-120S-4*	460/3/60	Outdoor Pad/Roof Mtd	1	12.2	80.0	Scroll	1	1 (0.75)	4.2	AC	16.4	19.4	30
	XPU-120D-3*	208/3/60	Outdoor Pad/Roof Mtd	2	15.6	110.0	Scroll	4	1/4 (0.19)	2.0	AC	39.3	43.2	50
	XPU-120D-4*	460/3/60	Outdoor Pad/Roof Mtd	2	7.8	52.0	Scroll	4	1/4 (0.19)	1.0	AC	19.5	21.5	25
	XCX-120D-3*	208/3/60	Indoor Ceiling Mtd	---	---	---	---	1	5 (3.73)	12.6	AC	12.6	15.8	25
	XCX-120D-4*	460/3/60	Indoor Ceiling Mtd	---	---	---	---	1	5 (3.73)	6.3	AC	6.3	7.9	15
	XCU-120D-3*	208/3/60	Indoor Ceiling Mtd	2	15.6	110.0	Scroll	1	5 (3.73)	12.6	AC	43.9	47.8	60
	XCU-120D-4*	460/3/60	Indoor Ceiling Mtd	2	7.8	52.0	Scroll	1	5 (3.73)	6.3	AC	21.8	23.8	30
12.0 Ton	XP4-144D-1*	208/1/60	Outdoor Pad/Roof Mtd	---	---	---	---	4	1/4 (0.19)	2.0	AC	8.0	9.0	15
	XP4-144D-7*	277/1/60	Outdoor Pad/Roof Mtd	---	---	---	---	4	1/4 (0.19)	1.5	AC	6.0	6.8	15
	XP4-144D-3*	208/3/60	---	---	---	---	---	---	---	---	---	---	---	---
	XP4-144D-8*	460/1/60	Outdoor Pad/Roof Mtd	---	---	---	---	4	1/4 (0.19)	1.0	AC	4.0	4.5	15
	XPU-144D-3*	208/3/60	Outdoor Pad/Roof Mtd	2	23.2	164.0	Scroll	4	1/4 (0.19)	2.0	AC	54.4	60.2	80
	XPU-144D-4*	460/3/60	Outdoor Pad/Roof Mtd	2	11.2	75.0	Scroll	4	1/4 (0.19)	1.0	AC	26.4	29.2	40
	XCX-144D-3*	208/3/60	Indoor Ceiling Mtd	---	---	---	---	1	7-1/2 (5.59)	18.6	AC	18.6	23.3	40
	XCX-144D-4*	460/3/60	Indoor Ceiling Mtd	---	---	---	---	1	7-1/2 (5.59)	9.3	AC	9.3	11.6	20
	XCU-144D-3*	208/3/60	Indoor Ceiling Mtd	2	23.2	164.0	Scroll	1	7-1/2 (5.59)	18.6	AC	65.0	70.8	90
	XCU-144D-4*	460/3/60	Indoor Ceiling Mtd	2	11.2	75.0	Scroll	1	7-1/2 (5.59)	9.3	AC	31.7	34.5	45
15.0 Ton	XP4-180D-1*	208/1/60	Outdoor Pad/Roof Mtd	---	---	---	---	4	1/4 (0.19)	2.0	AC	8.0	9.0	15
	XP4-180D-7*	277/1/60	Outdoor Pad/Roof Mtd	---	---	---	---	4	1/4 (0.19)	1.5	AC	6.0	6.8	15
	XP4-180D-3*	208/3/60	---	---	---	---	---	---	---	---	---	---	---	---
	XP4-180D-8*	460/1/60	Outdoor Pad/Roof Mtd	---	---	---	---	4	1/4 (0.19)	1.0	AC	4.0	4.5	15
	XPU-180D-3*	208/3/60	Outdoor Pad/Roof Mtd	2	25.0	164.0	Scroll	4	1/4 (0.19)	2.0	AC	58.0	64.3	80
	XPU-180D-4*	460/3/60	Outdoor Pad/Roof Mtd	2	12.2	100.0	Scroll	4	1/4 (0.19)	1.0	AC	28.4	31.4	40
	XCX-180D-3*	208/3/60	Indoor Ceiling Mtd	---	---	---	---	1	7-1/2 (5.59)	18.6	AC	18.6	23.3	40
	XCX-180D-4*	460/3/60	Indoor Ceiling Mtd	---	---	---	---	1	7-1/2 (5.59)	9.3	AC	9.3	11.6	20
	XCU-180D-3*	208/3/60	Indoor Ceiling Mtd	2	25.0	164.0	Scroll	1	7-1/2 (5.59)	18.6	AC	68.6	74.9	90
	XCU-180D-4*	460/3/60	Indoor Ceiling Mtd	2	12.2	100.0	Scroll	1	7-1/2 (5.59)	9.3	AC	33.7	36.7	45

**Notes:**

- 1) FLA = Full Load Amps; MCA = Min Circuit Amps; MOP = Max Overcurrent Protection (Max Fuse Size)
- 2) 277/1/60 systems may require factory provided field installed step-down transformer.
- 3) The above unit electrical data is reflective of the standard performance data and standard options as shown in this manual.
- 4) --- Consult local AboveAir Sales Representative for non-cataloged system power supply information.

## 1.0 General

### ☑ 1.1 Summary

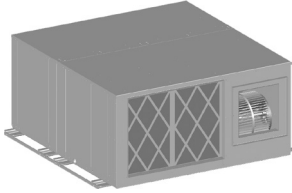

These specifications describe the requirements for a horizontal ceiling mounted air conditioner. The system shall be designed to control space temperature and humidity.

The air conditioning manufacturer shall design and furnish all equipment in the quantities and configurations shown on the project plans and specifications.

The system shall be provided by Above-Air Technologies in Frederick, Maryland, USA. The system shall be listed by Intertek (ETL Semko), Inc. to conform with UL Std 1995 and be certified to CAN/CSA Std C22.2 No. 236 (Control No. 3091370). The system shall be NYC MEA230-06-E and Chicago Code Approved. The system model number shall be \_\_\_\_\_.

### ☑ 1.2 Design Requirements

The system shall be an AboveAir HK-Horizontal™ brand factory assembled and tested. Evaporator sections shall be designed for above the drop-ceiling installation. Remote condensing unit sections shall be designed for either outdoor or indoor above the drop-ceiling installation.

Evaporators and indoor remote condensing unit sections shall be designed for ducted same-face air distribution.

The system shall have a total cooling capacity of \_\_\_\_\_ BTU/H, and a sensible cooling capacity of \_\_\_\_\_ BTU/H, based on an entering air condition of \_\_\_\_\_ °F DB, and \_\_\_\_\_ °F WB, \_\_\_\_\_ % RH.

The evaporator section shall be designed for \_\_\_\_\_ Volt, \_\_\_\_\_ Phase, \_\_\_\_\_ Hertz main power supply. The remote condensing unit section (if applicable) shall be designed for \_\_\_\_\_ Volt, \_\_\_\_\_ Phase, \_\_\_\_\_ Hertz main power supply.

### ☑ 1.3 Submittals

Submittals shall be provided after manufacturer's receipt of a written purchase order and shall include: Detailed Perform-

mance and Electrical Data; Guide Specifications; and Dimensional Drawings.

### ☑ 1.4 Quality Assurance

The system shall be factory tested prior to shipment. Testing shall include, but shall not be limited to: system and component operational and functional testing; electrical "HiPot" insulation test; refrigerant and water piping circuit pressuring testing per UL 1995 Safety Standard for Heating and Cooling Equipment. The system shall be designed and manufactured according to world class quality standards.

## 2.0 Products

### ☑ 2.1 Standard Features / All Systems

#### ☑ 2.1.1 Cabinet

The cabinet chassis and access panels shall be constructed of heavy gauge galvanized steel. Cabinet access panels shall rest in recessed pockets designed for minimum air leakage. The cabinet and access panels shall be lined with 2 lb/ft<sup>2</sup> high density sound and thermal insulation conforming to NFPA 90A and 90B.

#### ☑ 2.1.2 Component Access

The unit shall be serviceable within the ceiling through large side access panels.

#### ☑ 2.1.3 Electrical System

##### General:

The electrical system shall conform to National Electric Code (NEC) requirements according to UL 1995. The control circuit shall be a 24 VAC low voltage circuit.

The electrical system shall include, but not be limited to the following factory installed items: 24 VAC control transformer; terminal connections; grounding lug; overload protection; and starter/contactors for blower motor, compressor, humidifier and electric heater stage (if applicable).

**Packaged Systems:** (single point power) Self-Contained systems shall be designed for single point main power connection.

**Split DX Systems:** (separate power) Split systems shall require separate main power supplies to the evaporator and condensing unit sections. The evaporator and condensing unit sections shall be

electrically interlocked by a field wired 24 volt control signal.

### Overflow Safety Float:

The system shall be provided with a factory installed float type condensate pan overflow safety switch. The circuit shall be designed to shut down all system water producing operations in the event of an overflow condition.

### ☑ 2.1.4 Air Distribution

The system air distribution shall be configured for a draw-through air pattern to provide even air distribution and maximum coil performance.

#### ☑ 2.1.4.1 Evaporator Blower/Motor

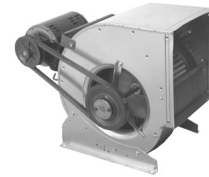

The evaporator blower assembly shall be designed for \_\_\_\_\_ CFM @ \_\_\_\_\_ inches external static pressure (e.s.p.)

The blower shall be the belt-driven centrifugal type, double width double inlet (DWDI), and statically and dynamically balanced to a minimum vibration level. The shaft shall be heavy duty steel with self-aligning ball bearings sized for an average 100,000 hours of service life.

The blower motor shall be \_\_\_\_\_ Hp at 1725 RPM (or 3450 RPM) and mounted on an adjustable base. Belts shall be sized for 200% of the motor horsepower rating. Motors shall have overload protection and a minimum NEMA service factor of 1.15.

#### ☑ 2.1.4.2 Air Patterns

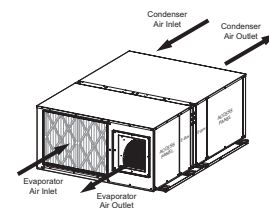

##### ☐ 2.1.4.2.1 Ducted Same-Face

The system shall be designed for ducted same-face evaporator (and/or indoor condenser) air pattern. Air inlet and outlet connections shall include factory provided turned-out duct flanges for each of field duct connection.

*(Note-1: Reverse/Mirror-Image Air Patterns are optionally available. Please consult your local sales representative for specification details.)*



## □ 2.1.4.2.2 Ducted Straight-Thru

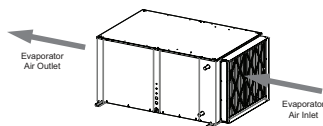

The system shall be designed for ducted straight-thru evaporator air pattern. Air inlet and outlet connections shall include factory provided turned-out duct flanges for each of field duct connection.

## □ 2.1.4.2.3 Ducted 90°/Right-Angle

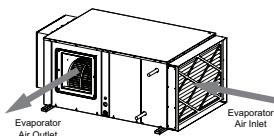

The system shall be designed for ducted 90°/Right-Angle evaporator air pattern. Air inlet and outlet connections shall include factory provided turned-out duct flanges for each of field duct connection.

## ☑ 2.1.4.3 Air Filtration

The filter(s) shall be 2 inch thick pleated and rated for 30% dust spot efficiency (based on ASHRAE 52.1). The filter(s) shall be serviceable through a side access panel without shutting down the system.

## □ 2.2 Direct Expansion Systems

### □ 2.2.1 DX - Evaporator Coils



The DX evaporator coil shall be constructed of copper tubes and aluminum fins. The system shall be designed for a draw-through air pattern for maximum heat transfer. Coil end-plates shall be hot dipped galvanized. The evaporator coil shall be mounted in an insulated stainless steel condensate drain pan.

### □ 2.2.2 Compressors



Each compressor shall be the high efficiency, low sound power scroll type. Each compressor shall be mounted on

vibration isolators. Each compressor shall be complete with reversible positive oil pump, charging and service ports, internal spring isolation, and discharge gas vibration eliminator.

## □ 2.2.3 DX - Refrigeration Circuits



Each refrigeration circuit shall be pre-piped with refrigerant copper tubing. The refrigeration system shall include, but not be limited to: expansion valve with external equalizer; sight glass; refrigerant filter-drier; schrader service valves and high & low refrigerant pressure safety switches.

## ☑ 2.3 Standard Features / Individual Systems

### □ 2.3.1 DX - Air Cooled Systems

#### □ 2.3.1.1 DX - Air Cooled (Self-Contained Systems) AAC/AAP-( )

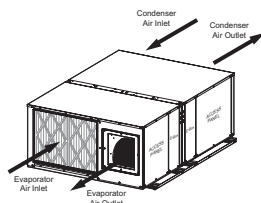

The system shall be a self-contained, ceiling mounted air conditioner with factory mounted integral dx air cooled condensing unit with belt-driven centrifugal blower. The condensing unit shall be sized for full heat of rejection at 95°F ambient and be capable of operation to \_\_\_ °F low ambient air temperature

The system shall require only single point main power supply and ship from the factory with a full operating refrigerant charge (1-8 Ton units). AAC/P-012/096 models shall ship from the factory as one-piece units, while AAC/P-120/180 models shall ship split from the factory and require field packaged unit assembly and refrigerant charging.

*(Note-1: Select 0°F Low Ambient Damper option or -30°F Flooded Condenser low ambient head pressure control as application requires - see options for more detail.)*

#### □ 2.3.1.2 DX - Air Cooled Split (Air Handler & Indoor Remote Condensing Unit) AHC/AHP-( ) & XCU-( )

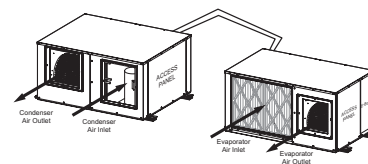

The system shall be a split configuration with indoor ceiling mounted dx air handling unit and remote indoor (optional outdoor) air cooled belt-driven centrifugal blower condensing unit. The compressor(s) shall be located in the condensing unit. The condensing unit shall be sized for full heat of rejection at 95°F ambient and be capable of operation to \_\_\_ °F low ambient air temperature.

The system shall factory tested prior to shipment. The air handling and condensing unit sections shall ship separately from the factory with a dry-nitrogen holding charge for field sweat (copper) connection and refrigerant charging.

#### □ 2.3.1.3 DX - Air Cooled Split (Air Handling & Outdoor Remote Condensing Units) AHC/AAP-( ) & XPU-( )

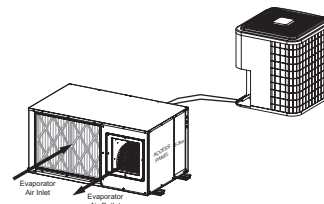

The system shall be a split configuration with indoor ceiling mounted dx air handling unit and a remote outdoor air cooled propeller fan condensing unit for each refrigerant circuit. Each compressor shall be located in the condensing unit. The condensing unit shall be sized for full heat of rejection at 95°F ambient and be capable of operation to \_\_\_ °F low ambient air temperature.

The system shall factory tested prior to shipment. The air handling and condensing unit sections shall ship separately from the factory with a dry-nitrogen holding charge for field sweat (copper) connection and refrigerant charging.

*(Note-1: Select 0°F Fan Cycling, -20°F Fan Speed or -30°F Flooded Condenser low ambient head pressure control as application requires - see options for more details.)*

**□ 2.3.1.4 DX - Air Cooled Split**  
(Split Evap & Outdoor Remote Condenser)  
AEC/AEP-( ) & XP1 or XP2-( )

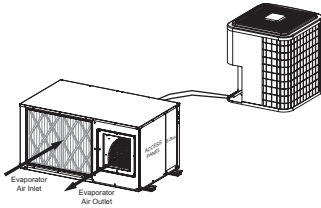

The system shall be a split configuration with indoor ceiling mounted dx evaporator and outdoor dx air cooled propeller fan remote condenser. The compressor shall be located in the indoor evaporator section. The condenser shall be sized for full heat of rejection at 95°F ambient and be capable of operation to \_\_\_ °F low ambient air temperature.

The system shall be refrigerant charged and run tested at the factory prior to shipment. The evaporator and condenser sections shall ship separately with a dry-nitrogen charge ready for field refrigerant charging.

*(Note-1: See 2.4.1 pg 12 Low Amb. Options.)*

**□ 2.3.1.6 DX - Air Cooled Split**  
(Split Evap & Outdoor Remote Condenser)  
AEC/AEP-( ) & XCX-( )

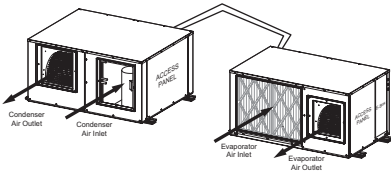

The system shall be a split configuration with indoor ceiling mounted dx evaporator and indoor dx air cooled belt-driven centrifugal blower remote condenser. The compressor shall be located in the indoor evaporator section. The condenser shall be sized for full heat of rejection at 95°F ambient and be capable of operation to \_\_\_ °F low ambient air temperature.

The system shall be refrigerant charged and run tested at the factory prior to shipment. The evaporator and condenser sections shall ship separately with a dry-nitrogen charge ready for field refrigerant charging.

*(Note-1: See 2.4.1 pg 12 Low Amb. Options.)*

**□ 2.3.1.7 DX - Air Cooled Remote Condensing Unit**  
(Indoor/Outdoor Centrifugal Blower Configuration)  
XCU-( ) Only

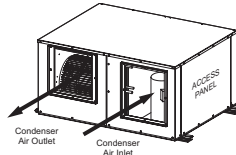

The system shall be a indoor horizontal ceiling mounted (optional outdoor) remote air cooled belt-driven centrifugal blower condensing unit. The remote condensing unit shall include, but not be limited to: condenser coil; centrifugal belt-driven blower and blower motor; compressor; sight glass; refrigerant filter-drier; shraeder service valves; high & low refrigerant pressure switches; grounding lug; 24 Vac control transformer; individual blower motor and compressor starters/contactors; and terminal strip.

The condensing unit shall be sized for full heat of rejection at 95°F ambient and be capable of operation to \_\_\_ °F low ambient air temperature.

The condensing unit shall ship from the factory with a dry-nitrogen holding charge for field sweat (copper) connection and refrigerant charging.

*(Note-1: Select 0°F Low Ambient Damper option or -30°F Flooded Condenser low ambient head pressure control as applications requires - see options for more detail.)*

**□ 2.3.2 DX - Air Handling Unit**  
AHC/AHP-( ) Only

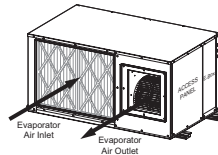

The system shall be a split indoor horizontal ceiling mounted dx air handling unit designed for field connection to the specified remote condensing unit (*air, water or glycol cooled*). The air handling unit shall include, but not be limited to: evaporator coil; centrifugal belt-driven blower and blower motor; thermal expansion valve, shraeder service valves; grounding lug; 24 Vac control transformer; individual blower motor, humidifier, heater starters/contactors (if applicable); and terminal strip.

The air handling unit shall ship from the factory with a dry-nitrogen holding charge for field sweat (copper) connection and refrigerant charging.

**□ 2.3.3 DX - Water Cooled Systems**

**□ 2.3.3.1 DX - Water Cooled**  
(Self-Contained Systems)  
AWC / AWP-( )

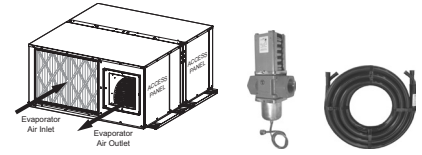

The system shall be a self-contained, ceiling mounted air conditioner with integral dx water cooled condensing unit. Each refrigerant circuit shall include a water cooled coaxial (or SS brazed-plate) condenser and factory installed head pressure controlling 2-way water regulating valve rated for 150 psi w.w.p. The water cooled condenser shall be designed to provide the total required system heat of rejection at 85°F entering water temperature and 95°F leaving water temperature. Source water shall be provided by a remote water source (*by others*).

All models sizes shall ship from the factory as a one-piece unit as standard. The system shall require only single point main power supply and ship from the factory with a full operating refrigerant charge.

*(Note: Higher pressure and 3-way valves are optionally available, see option 2.4.2.)*

**□ 2.3.3.2 DX - Water Cooled Split**  
(Air Handling & Remote Condensing Unit)  
AHC/AHP-( ) & XWU-( )

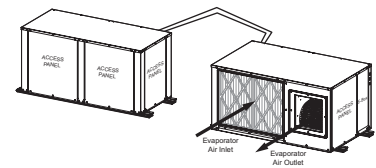

The system shall be a split configuration with indoor ceiling mounted dx air handling unit and remote indoor (*optional outdoor*) water cooled condensing unit. The compressor(s) shall be located in the condensing unit.

Each refrigerant circuit shall include a water cooled coaxial (or SS brazed-plate) condenser and factory installed head pressure controlling 2-way water regulating valve rated for 150 psi w.w.p. The water cooled condenser shall be designed to provide the total required system heat of rejection at 85°F entering water temperature and 95°F leaving water temperature. Source water shall be provided by a remote water source (*by others*).

The system shall factory tested prior to shipment. The air handling and condensing unit sections shall ship separately from the factory with a dry-nitrogen holding charge for field sweat (copper) connection and refrigerant charging.

*(Note-1: Higher pressure and 3-way valves are optionally available, see option 2.4.2.)*

### □ 2.3.3.3 DX - Water Cooled (Remote Condensing Units) XWU-( ) Only

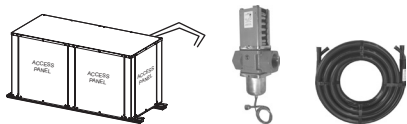

The system shall be an indoor horizontal ceiling mounted (optional outdoor) remote water cooled condensing unit. The remote condensing unit shall include, but not be limited to: compressor; water cooled coaxial (or SS brazed-plate) condenser; factory installed 2-way water regulating valve rated for 150 psi w.w.p.; sight glass; refrigerant filter-drier; shraeder service valves; high & low refrigerant pressure switches; grounding lug; 24 Vac control transformer; individual compressor starters/contactors; and terminal strip.

The water cooled condenser shall be designed to provide the total required system heat of rejection at 85°F entering water temperature and 95°F leaving water temperature. Source water shall be provided by a remote water source (by others).

The condensing unit shall ship from the factory with a dry-nitrogen holding charge for field sweat (copper) connection and refrigerant charging.

*(Note: Higher pressure and 3-way valves are optionally available, see option 2.4.2.)*

### □ 2.3.4 DX - Glycol Cooled Systems

#### □ 2.3.4.1 DX - Glycol Cooled (Self-Contained Systems) AGC / AGP-( )

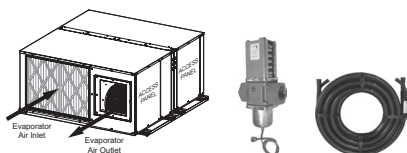

The system shall be a self-contained, ceiling mounted air conditioner with integral dx glycol cooled condensing unit. Each refrigerant circuit shall include a glycol cooled coaxial (or SS brazed-plate) condenser and factory installed head pressure controlling 2-way glycol

regulating valve rated for 150 psi w.w.p. The condenser shall be designed to provide the total required system heat of rejection at 110°F entering glycol temperature and 120°F leaving glycol temperature based on 40% ethylene glycol solution. Source glycol shall be provided by a remote glycol drycooler source (see AboveAir Technologies' FluidCool™ drycoolers).

All models sizes shall ship from the factory as a one-piece unit as standard. The system shall require only single point main power supply and ship from the factory with a full operating refrigerant charge.

*(Note: Higher pressure and 3-way valves are optionally available, see option 2.4.2.)*

#### □ 2.3.4.2 DX - Glycol Cooled Split (Air Handling & Remote Condensing Unit) AHC/AHP-( ) & XGU-( )

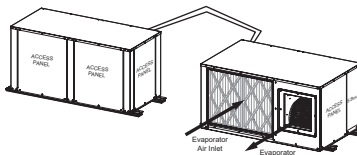

The system shall be a split configuration with indoor ceiling mounted dx air handling unit and remote indoor (optional outdoor) glycol cooled condensing unit. The compressor(s) shall be located in the condensing unit.

Each refrigerant circuit shall include a glycol cooled coaxial (or SS brazed-plate) condenser and factory installed head pressure controlling 2-way glycol regulating valve rated for 150 psi w.w.p. The glycol cooled condenser shall be designed to provide the total required system heat of rejection at 110°F entering glycol temperature and 120°F leaving glycol temperature based on 40% ethylene glycol solution. Source glycol shall be provided by a remote glycol drycooler source (see AboveAir Technologies' FluidCool™ drycoolers).

The system shall factory tested prior to shipment. The air handling and condensing unit sections shall ship separately from the factory with a dry-nitrogen holding charge for field sweat (copper) connection and refrigerant charging.

*(Note-1: Higher pressure and 3-way valves are optionally available, see option 2.4.2.)*

#### □ 2.3.4.3 DX - Glycol Cooled (Remote Condensing Units) XGU-( ) Only

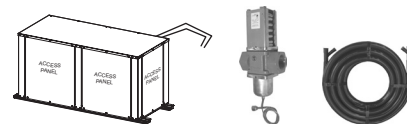

The system shall be an indoor horizontal ceiling mounted (optional outdoor) remote glycol cooled condensing unit. The remote condensing unit shall include, but not be limited to: compressor; glycol cooled coaxial (or SS brazed-plate) condenser; factory installed 2-way water regulating valve rated for 150 psi w.w.p.; sight glass; refrigerant filter-drier; shraeder service valves; high & low refrigerant pressure switches; grounding lug; 24 Vac control transformer; individual compressor starters/contactors; and terminal strip.

The glycol cooled condenser shall be designed to provide the total required system heat of rejection at 110°F entering glycol temperature and 120°F leaving glycol temperature based on 40% ethylene glycol solution. Source glycol shall be provided by a remote glycol drycooler source (see AboveAir Technologies' FluidCool™ drycoolers).

The condensing unit shall ship from the factory with a dry-nitrogen holding charge for field sweat (copper) connection and refrigerant charging.

*(Note: Higher pressure and 3-way valves are optionally available, see option 2.4.2.)*

#### □ 2.3.4.4 Glycol Pump Packages & Drycoolers FC-( ) / PA-( )



Glycol condenser source shall be provided by a FluidCool™ brand remote air cooled glycol drycooler and Pump-All™ brand pump package.

The glycol drycooler shall be the outdoor mounted propeller fan type complete with factory installed aquastat fan cycling controls, motor starters with overload protection and non-fused disconnect switch.

The glycol pump package shall be a (single or dual) pump package designed for outdoor installation complete with individual pump motor starters. Dual glycol pump packages shall be provided

with manual lead-lag switch and field installed flow switch for automatic switchover to backup pump upon loss of flow.

An expansion tank and automatic air purger-vent shall be factory provided for field installation.

The drycooler shall provide \_\_\_\_\_ BTUH total heat rejection at a flow rate of \_\_\_\_\_ GPM with \_\_\_\_\_ °F EGT and \_\_\_\_\_ °F LGT at \_\_\_\_\_ °F ambient air temperature. Each pump shall be \_\_\_\_\_ Hp and shall be sized to provide \_\_\_\_\_ GPM @ \_\_\_\_\_ Ft. w.g. total system head. The glycol solution shall be \_\_\_\_\_ % (ethylene or propylene) by volume.

The drycooler and pump package shall be designed for \_\_\_\_\_ Volt, \_\_\_\_\_ Phase, \_\_\_\_\_ Hertz main power supply.

*(Note: See AboveAir Technologies' Fluid-Cool™ indoor & outdoor glycol drycooler and PumpAll™ glycol pump packages engineering manuals for more information.)*

## □ 2.3.5 Chilled Water Systems ACC/ACP(-)

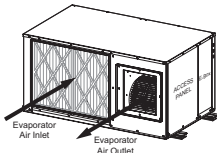

The system shall be a chilled water air handling unit with chilled water cooling coil and chilled water control valve.

The chilled water cooling coil shall be constructed of copper tubes and aluminum fins. The system shall be designed for a draw-through air pattern for maximum heat transfer. Coil end-plates shall be hot dipped galvanized. The cooling coil shall be mounted in an insulated stainless steel condensate drain pan.

Chilled water flow shall be controlled by a factory installed slowly opening and closing 2-way motorized valve rated for a maximum 300 psig w.w.g.

*(Note: 3-way and higher pressure valves are optionally available.)*

## 2.4 Options

### □ 2.4.1 Air Cooled Condenser - Low Ambient Control

#### □ 2.4.1.1 0°F Ambient - Fan Cycling (XP1, XP2 & XPU Models)

Fan cycling controls shall be factory installed to the direct drive condenser fan

to allow for low ambient operation to 0°F.

#### □ 2.4.1.2 -20°F Ambient - Variable Speed Fan (XCU, XP1/2 & XPU)

Variable fan speed head pressure controls (JCI P266 DD or BD VFD66 / VFD) shall be factory installed to allow for low ambient operation to -20°F. Compressor cold start time delay relay and crankcase heater shall be factory installed with the -20°F low ambient control feature.

#### □ 2.4.1.3 -30°F Flooded Condenser (All Condensing/er Models)

A flooded condenser system shall be provided to allow for low ambient condenser operation to -30°F. The flooded system shall include a factory installed liquid refrigerant receiver and modulating head pressure control valve. Compressor cold start time delay relay and crankcase heater shall be factory installed with the -30°F low ambient control feature.

### □ 2.4.2 DX - Water/Glycol Cooled Reg. Valves



- 2-Way, 150 psig Reg. Valve
- 3-Way, 150 psig Reg. Valve
- 2-Way, 350 psig Reg. Valve
- 3-Way, 350 psig Reg. Valve

System head pressure shall be controlled by a factory provided \_\_\_-way water / glycol regulating valve rated for \_\_\_ psig w.w.p.

## 2.4.2 CONTROL OPTIONS

#### □ 2.4.2.1 DT-201, 202 & 203™ - Digital H/C Thermostat (7-day programmable)



A remote wall or unit mounted deluxe 7-day programmable heat pump ready thermostat with digital display shall be factory provided for field installation. The thermostat shall include FAN AUTO-ON, AUTO-COOL-OFF-HEAT-EM (emergen-

cy heat), SET and PROG/MAN selector switches.

*(Note: 201 = 1-Stg H/C; 202 = 2-Stg H/C; 203 = 3-Stg H/2-Stg C.)*

#### □ 2.4.2.2 MC-2000™, Advanced Microprocessor T/H Controller w/ Alarms



The system shall be provided with a MC-2000™ advanced microprocessor based temperature and humidity controller with alarms.

#### Select Features/Benefits:

- 4x20 Character Liquid Crystal Alpha-numerical Display
- User Configurable
- Run-Time Hours
- Current Unit Mode Status
- Alarm Status
- Digital & Analog Inputs / Outputs
- Temperature Anticipation
- Remote Stop / Start Contact
- Summary Alarm Contact
- Automatic or Manual (selectable) Restart After Power Loss
- Sequential Load After Restart
- Recovery Delay
- Compressor Short Cycle Timers
- Cold Start Time Delay
- Security Password Access
- Self-Diagnostics
- Service Mode

#### Unit Status Display

The control system shall display current unit functions and room status (if applicable):

- Current Dry Bulb Temp Set Point
- Current Relative Humidity Set Point
- System ON/OFF
- Cooling
- Heating
- Humidifying
- Dehumidifying
- Reheating
- Actual Room DB Temperature
- Actual Room Relative Humidity

#### Alarm Conditions:

Alarm conditions activate an audible and visual indicator plus close a summary alarm dry contact connection. The control system shall alert to the following alarm conditions (if applicable):

- High Temperature
- Low Temperature
- High Humidity
- Low Humidity
- High Head Press
- Smoke Detection
- Firestat
- Leak Detection

- Sensor Failure
- Sensor Failure
- Summary Failure
- Loss of Power
- Loss of Air Flow
- Dirty Filter

## Digital & Analog Control Inputs / Outputs:

The control system shall be capable of both digital (ON/OFF) and analog (proportional integral, PI) input and output control.

## Select MC-2000 Options:

- Multi-Unit N+1 Sequencing
- BMS Communications Interface:
  - ModBus RS485 Serial Connection
  - BACnet over MS/TP (RS485 Serial)
  - BACnet Over IP (Ethernet / EIA485)

## 2.4.3 HEAT / REHEAT OPTIONS

### 2.4.3.1 Electric Reheat/Heat

#### 2.4.3.1.1 Electric Heat and/or Reheat *(factory installed)*

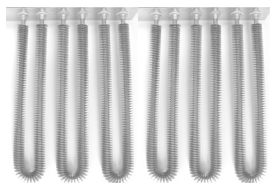

An electric heating system shall be factory installed to provide:

- Electric Heat Only during heat mode
- Electric Reheat to offset sensible cooling during the dehumidification mode and to provide heating during heat mode.

Heater elements shall be the low-watt density finned-tubular type. The heater shall be complete with individual heater stage starter/contact and overheat safeties. Systems incorporating factory installed electric heaters shall require only single point power to the main unit power distribution. The electric heat shall have a capacity of \_\_\_\_\_ BTU/H and a KW rating of \_\_\_\_ KW, controlled in \_\_\_\_ stages.

#### 2.4.3.1.2 Electric Duct Heater *(Large KW Requirements)*



An electric duct mounted heater shall be factory provided for field installation. The

duct heater shall be configured for:

- Electric Heat Only during heat mode
- Electric Reheat to offset sensible cooling during the dehumidification mode and to provide heating during heat mode.

The duct heater shall be the open wire nichrome element type complete with magnetic de-energizing contactors, differential air pressure switch, 24V Class-II control transformer, disc type automatic & manual reset thermal cutouts, door-interlock non-fused disconnect switch, over heat safeties, hinged lid and 1" duct insulation allowance. The control panel shall be position on the left as a standard.

The duct heater shall require a separate main power supply from the unit. The electric heat shall have a capacity of \_\_\_\_\_ BTUH and a KW rating of \_\_\_\_ KW, controlled in \_\_\_\_ stages. The duct heater dimensions shall be configured for a duct that is \_\_\_\_ " Wide X \_\_\_\_ " High with a 1" allowance for duct insulation.

#### 2.4.3.1.3 SCR Fired Heat/Re-heat

*(Requires MC-2000™)*

The electric heat/reheat shall be controlled through a "zero firing" silicon control rectifier (SCR) with an extruded aluminum heat sink and solid state logic system to provide close dry bulb temperature control of the leaving conditioned air temperature. The electric heat shall have a capacity of \_\_\_\_\_ BTUH and a KW rating of \_\_\_\_ KW.

### 2.4.3.3 Steam Heat

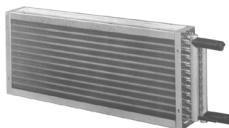

A Steam Heating system shall be factory provided. The steam heating system shall be complete a factory installed aluminum fin, copper tube steam coil and field installed 2-way motorized steam rated control valve. Steam piping specialties shall be field provided. Steam shall be provided by a remote source at the specified temperature and pressure. The steam heating system shall have a rated capacity of \_\_\_\_\_ BTUH @ \_\_\_\_ psig saturated steam.

### 2.4.3.4 Hot Water Heat

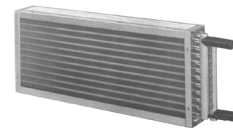

A Hot Water Heating system shall be factory provided. The hot water heating system shall be complete a factory installed aluminum fin, copper tube hot water coil and field installed 2-way motorized hot water control valve. Hot water shall be provided by a remote source at the specified flow rate and temperature. The hot water heating system shall have a rated capacity of \_\_\_\_\_ BTUH @ \_\_\_\_\_ GPM, \_\_\_\_\_ °F EWT.

### 2.4.3.5 Heat Pump Option

The system shall include a factory installed heat pump heating cycle including 4-way reversing valve, suction-line accumulator, automatic defrost cycle (air source hp) and remote wall mounted heat pump temperature controller with auxiliary heating control capability. The heat pump mode heating capacity shall be \_\_\_\_\_ BTUH.

### 2.4.4 Steam Humidification



An electrode steam canister type humidification system shall be factory installed within the air conditioning system. The humidifier shall be complete with disposable canister, steam distributor, fill and drain valve, air gap, automatic flush cycle, manual humidity output adjustment and field installed remote wall mounted humidistat. The humidifier shall have a maximum output capacity of \_\_\_\_\_ lbs/hr.

*(Note: Remote wall mounted humidistat is not required with MC-1000™ or MC-2000™ combination temp & humid control option.)*

## 2.5 Accessories

### 2.5.1 Condensate Pump



A condensate pump shall be factory provided for field installation. The conden-

sate pump shall be provided with dual internal float switches: one for pump operation initiation and the other for pump reservoir overflow safety. The condensate pump shall require a separate main power supply.

*(Note: Condensate pumps can be powered through A/C unit main power via Optional "Condensate Pump Fused Powered Terminal Connection".)*

## □ 2.5.2 Hot Gas Bypass Systems

### □ 2.5.2.1 Hot Gas Bypass To Evaporator Inlet *(HG Line Required on Splits)*



Each refrigerant circuit shall be provided with a factory installed hot gas (discharge) bypass valve. The hot gas bypass valve shall be designed to supply hot gas to evaporator inlet as required to provide coil freeze-protection and capacity modulation under low load conditions.

*(Note: 3<sup>rd</sup> Line - Each circuit of a Split DX system with compressor located in condensing unit shall require a field installed copper hot gas bypass refrigerant line between the evaporator and condensing unit sections.)*

### □ 2.5.2.2 Hot Gas Bypass To Suction Line with Quench Valve *(XPU-XCU & XWU-XGU Remote Condensing Units 3<sup>rd</sup> Line Not Required!)*



Each refrigerant circuit of the Split DX system shall be provided with a factory installed hot gas bypass system to include: hot gas (discharge) bypass and desuperheating quench. The hot gas bypass system shall be designed to supply hot gas and liquid refrigerant to the suction line as required to provide coil freeze-protection and capacity modulation under low load conditions. All hot gas bypass components shall be factory installed and shall not require additional field refrigerant lines on split DX systems.

## □ 2.5.3 Suction-Line Accumulators



Each refrigerant circuit shall be provided with a factory installed Suction-Line Accumulator to prevent liquid slugging of the compressor and excessive refrigerant dilution of the compressor oil during low load conditions. The accumulator shall return refrigerant and oil to the compressor at a sufficient rate to maintain both system operating efficiency and proper oil level. The accumulators shall be wrapped with a 1/2" closed-cell neoprene insulation to prevent sweating.

## □ 2.5.4 Main Power, Non-Fused Disconnect



A main power non-fused disconnect shall be factory provided for field installation. The disconnect shall be NEMA rated for indoor or outdoor installation as required.

## □ 2.5.5 Firestat



A Firestat shall be factory provided for field installation in the return air duct and wired to the A/C unit electrical control panel. The Firestat shall shut-down all A/C system operations upon sensing a high return air temperature condition.

## □ 2.5.6 Smoke Detector



A Smoke Detector shall be factory provided for field installation in the return air duct and wired to the A/C unit electrical control panel. The Smoke Detector shall shut-down all A/C system operations upon activation.

## □ 2.5.7 Remote Water-Leak Detector

A remote water-leak detector shall be factory provided for field installation. The remote water-leak detector shall be wired to shut down all A/C unit water producing functions upon sensing a water leak.

## □ 2.5.8 Flow Switch - Water/Glycol Condenser

A factory installed flow switch shall shut-down / lockout compressor operation prior to the high refrigerant pressure switch alarm upon sensing a loss or low dx condenser water/glycol flow. A flow switch alarm shall be indicated both via MC-2000 microprocessor display and auxiliary dry-contact terminal connection.

## □ 2.5.9 Low Entering Condenser Water / Glycol Kit to 45°F EWT/EGT

A low enter condenser water/glycol kit shall be provided with liquid refrigerant receiver, compressor crankcase heater and insulated wrapped coaxial condenser and unit internal condenser water/glycol piping. The Low EWT/EGT kit shall allow for continued winter A/C operation when condenser source water/glycol drops below 65°F (down to 45°F).

## □ 2.5.10 VAV Supply Air Control *(VFD w/ Modulating HGBP)*



*VFD Control*

The system shall be designed for Variable Air Volume (VAV) application. A factory installed evaporator blower motor Variable Frequency Drive (VFD) with Proportional-Integral (PI) capabilities shall be provided to automatically vary system evaporator air volume based on a signal from the factory provided field installed static air pressure transducer. The A/C system shall be designed to maintain a constant leaving air temperature based on user adjustable set point temperature (eg.: 55°F DB). A/C system cooling capacity shall modulate via a factory installed modulating (0-10 Vdc) hot gas bypass on the primary or lead refrigerant circuit. A field installed supply air temperature sensor shall provide input value signal to the MC-2000 micro-processor controller for automatic modulating control of the

hot gas bypass valve. Dual compressor/circuit systems shall also include a factory installed snap-acting type pressure regulating hot gas bypass system for capacity modulation and evaporator freeze-protection on the cir-2.

**2.5.11 DX Water/Glycol Cooled with Free Cooling Cycle**  
AWP / AGP-( )-FE

The system shall include a factory installed water/glycol free cooling cycle complete with economizer cooling coil, aquastat, automatic control logic and field installed 3-way control valve. The FE coil shall be capable of providing rated sensible capacity without compressor operation when entering water/glycol fluid temperatures are 45°F or below.

*(Note: 2-way DX/FE valve configurations are optionally available.)*

**2.5.12 Air Side Economizer**  
All Model Types

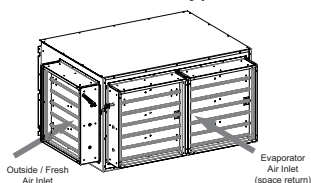

The system shall be provided with an Air-Side Economizer to include factory provided and field installed air side economizer mixing box and controls per the following sequence of control:

On a call for cooling by the indoor space thermostat, the indoor fan and the economizer shall be energized. The outdoor air control shall determine whether the outdoor air is suitable for “free/economizer-cooling”. If the outdoor air is suitable, mechanical cooling shall be locked out by the outdoor enthalpy control. The motor actuator shall be energized, operating the outdoor air and the return air dampers. The motor actuator shall be regulated by the mixed air sensor to maintain proper discharge air temperature.

When outdoor air is not suitable for “free/economizer-cooling”, the Economizer shall be locked out and the outdoor air damper shall maintain minimum position while the indoor fan is operating. Upon unit shutdown or power loss, the spring return motor actuator shall close the outdoor air damper.

The Economizer shall be automatically locked out during the heat mode (if appl.).

The Air Side Economizer shall include: prewired modulating spring return motor actuator, compressor lockout, minimum position potentiometer, outdoor air control (enthalpy), mixed air sensor, multi-tap transformer and damper linkage.

The Air-Side Economizer and Controls shall ship separately from the unit for field installation.

**2.5.13 Hanging / Mounting Isolators**

**Rubber/Cork Anti-Vibration Pads:**



Each indoor horizontal ceiling mounted A/C shall be provided with a set of quantity four (4"x4"x7/8") Rubber/Cork Anti-Vibration Pad vibration mounting isolators.

**Hanging Spring Isolators**



Each horizontal ceiling mounted section shall be provided with spring vibration hanging isolators sized for the total distributive weight of the unit.

**2.5.14 Hose Kits - Automatic**



Condenser water/glycol hose kits shall be factory provided by the heat pump manufacturer. Each kit shall include the piping specialties necessary to ensure a proper installation: a Hays 2500 Series Mesurflo Automatic Flow Control Valve, along with two 36" flexible hoses, ball valves on the return and supply sides with P/T Ports and includes high flow “Y-ball” strainers for sizes 1/2"-2" and a manual air vent on the return. Hose materials shall be reinforced, bonded,

EPDM rubber with a temperature rating of 32°F to 225°F with a working pressure of 400 psig. Minimum burst pressure shall be four (4) times the working pressure at maximum rated temperature. Hose material shall be stainless steel braid over an EPDM liner. Strainers shall be Y-Ball type configuration with a stainless steel 20 mesh screen that is easily accessible for cleaning without disconnecting the hoses.

**2.5.15 Compressor Sound Jacket**



Each compressor shall be provided with a factory installed compressor sound jacket with snap closure system for ease of removal and reinstallation. Sound jackets shall have a noise reduction coefficient (NRC) of 85 per ASTM and C-423 and a sound transmission lost (STC) of 11 per ASTM E-90.

## DX - Air Cooled, Self-Contained

Models: AAC & AAP-012 thru 180

**2-Side Access:**

18"-24" on Left & Right Sides!

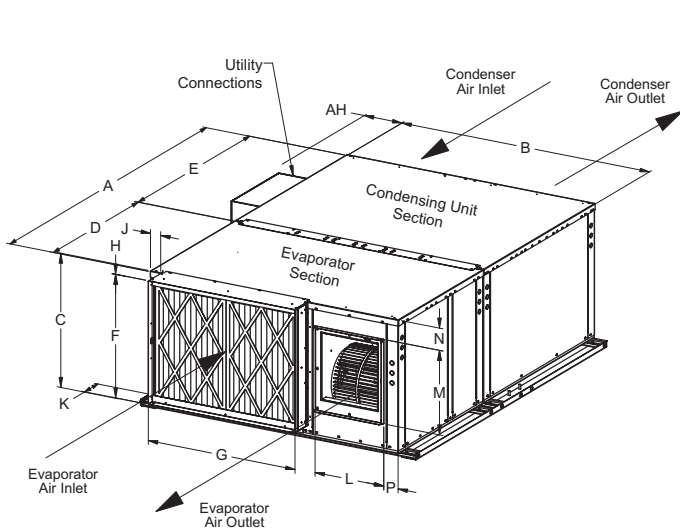

**Front / Right / Top**  
(Evaporator End)

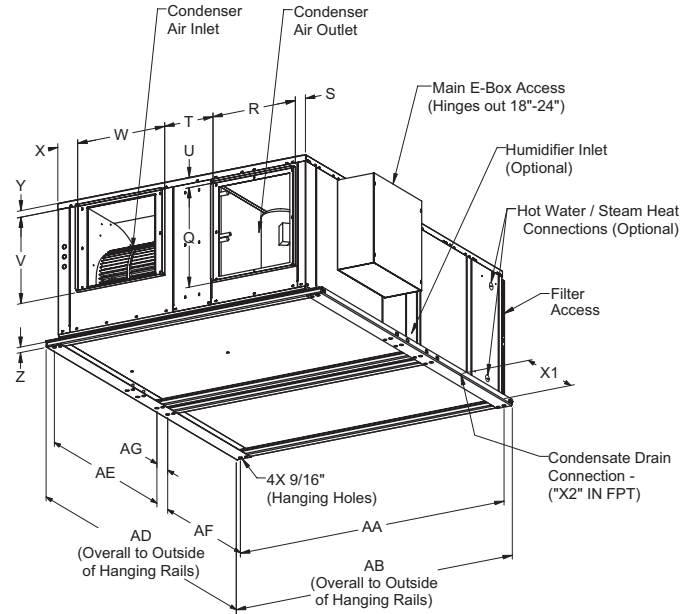

**Rear / Left / Bottom**  
(Condensing Unit End)

Dimensions (Inches)													
AAC-( )-SF Cabinet Size	A	B	C	D	E	F		H	J	K		L	M
						Evap Air Inlet Conns.	G			2" Filter	2" Pre / 4" Pst		
012, 018, 024, 030 & 036	59.17	44	22	25	34	20.85	22	0	2.76	5	9.22	14	14
048, 060 & 072	74.17	54	27	32	42	24.88	32	0	2.33	5	9.22	15	17
096 & 120	96.17	74	29.5	38	58	27	46.88	0	2.89	5	9.22	18	20
144 & 180	108.17	82	36	40	68	35.25	50	0	3.95	5.2	9.42	18	20
AAC-( )-SF Cabinet Size	N	P	Q	R	S	T	U	V	W	X	Y	Z	
			Cond Air Inlet Conns.					Cond Air Outlet Conns.					
012, 018, 024, 030 & 036	2.49	3.5	16	16	2.5	7.13	2	16	16	2.38	0.81	1.11	
048, 060 & 072	4.47	3.13	20	18	2.19	10.5	2.06	17.38	19	4.31	1.3	1.11	
096 & 120	2.74	3.5	24	30	2.59	10.68	2	18.25	23	7.72	2.99	1.11	
144 & 180	8.62	6	31	34	2.63	14.25	1.69	18.25	23	8.13	9.49	1.11	
AAC-( )-SF Cabinet Size	AA	AB	AD	AE	AF	AG	X1	X2	AH				
							(Condensate Drain)		(E-Box Depth)				
012, 018, 024, 030 & 036	47.5	50.21	57.11	30.63	21.13	3.8	12.5	3/4" FPT	8" Max				
048, 060 & 072	57.5	60.21	71.86	38.75	27.5	4.05	16	3/4" FPT	8" Max				
096 & 120	77.5	80.21	93.17	53.25	33.63	4.73	19	3/4" FPT	N/A	Note-2			
144 & 180	85.5	88.21	106.42	63.25	35.25	4.92	20	1" FPT	N/A	Note-2			

- Notes
- 1) AAC-144 & 180 Model Packaged Air Cooled - Ships in Two Sections for Shipping & Rigging Purposes. Field packaged unit assembly kit included loose ... requires field electrical wiring, refrigerant piping and R410a refrigerant charging.
  - 2) AAC-096 thru 180 Model Cabinet Main E-Box is located internal to the Condensing Unit Section ... External Hinged E-Box is not required on these physical size cabinets.
  - 3) Air-Source Heat Pump Option shall be provided with a Stainless Steel Condenser Coil Drain Pan which Requires Field Drain Connection for Defrost Cycle Water Drainage.



## DX Split, Horizontal Air Handling Units

Models: AHC & AHP-012 thru 180

### 2-Side Access Std

(MC Micro reqs. Rear Access):

18"-24" on Left & Right Sides!

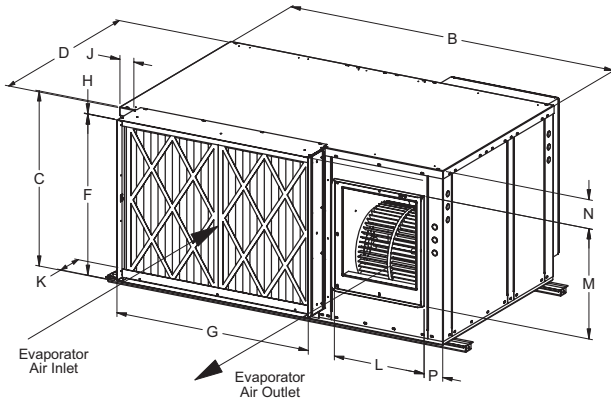

Front / Right / Top

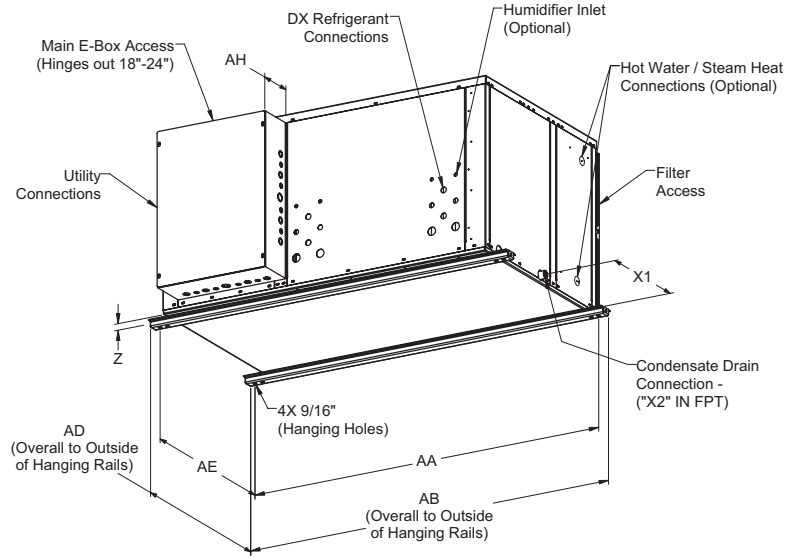

Rear / Left / Bottom

Dimensions (Inches)											
AHC(-)-SF Cabinet Size	B	C	D	F	G	H	J	K		L	M
				Evap Air Inlet Conns.				2" Filter	2" Pre / 4" Pst	Evap Air Outlet Conns.	
012, 018, 024, 030 & 036	44	22	25	20.85	22	0	2.76	5	9.22	14	14
048, 060 & 072	54	27	32	24.88	32	0	2.33	5	9.22	15	17
096 & 120	74	29.5	38	27	46.88	0	2.89	5	9.22	18	20
144 & 180	82	36	40	35.25	50	0	3.95	5.2	9.42	18	20
AHC(-)-SF Cabinet Size	N	P	Z	AA	AB	AD	AF	X1	X2	AH	
								(Condensate Drain)		(E-Box Depth)	
012, 018, 024, 030 & 036	2.49	3.5	1	47.5	50	22.69	21.13	12.5	3/4" FPT	8" Max	
048, 060 & 072	4.47	3.13	1	57.5	60	29.06	27.5	16	3/4" FPT	8" Max	
096 & 120	2.74	3.5	1	77.5	80	35.19	33.63	19	3/4" FPT	8" Max	
144 & 180	8.62	6	1	85.5	88	38.25	35.25	20	1" FPT	8" Max	

## DX - Air Cooled, Indoor Horizontal Centrifugal Blower, Remote Condensing Units

Models: XCU-012 thru 180

### 2-Side Access:

18"-24" on Left & Right Sides!

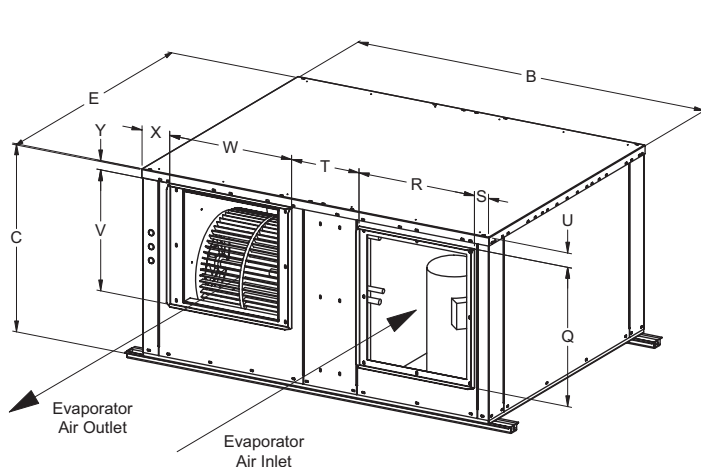

Front / Right / Top

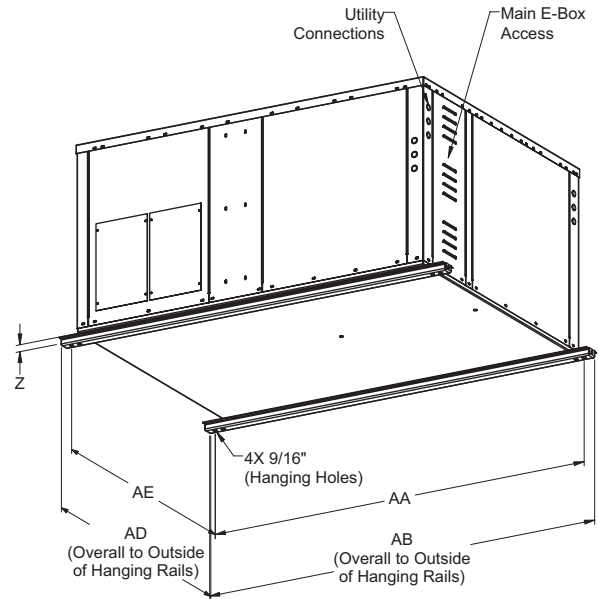

Rear / Left / Bottom

Dimensions (Inches)									
XCU/XCX(-)-SF Cabinet Size	B	C	E	Q	R	S	T	U	
				Cond Air Inlet Conns.					
012, 018, 024, 030 & 036	44	22	34	16	16	2.5	7.13	2	
048, 060 & 072	54	27	42	20	18	2.19	10.5	2.06	
096 & 120	74	29.5	58	24	30	2.59	10.68	2	
144 & 180	82	36	68	31	34	2.63	14.25	1.69	
XCU/XCX(-)-SF Cabinet Size	V	W	X	Y	Z	AA	AB	AD	AE
	Cond Air Outlet Conns.								
012, 018, 024, 030 & 036	16	16	2.38	0.81	1	47.5	50.21	57.11	30.63
048, 060 & 072	17.38	19	4.31	1.3	1	57.5	60.21	71.86	38.75
096 & 120	18.25	23	7.72	2.99	1	77.5	80.21	93.17	53.25
144 & 180	18.25	23	8.13	9.49	1	85.5	88.21	106.42	63.25

### Notes

1) Air-Source Heat Pump Option shall be provided with a Stainless Steel Condenser Coil Drain Pan which Requires Field Drain Connection for Defrost Cycle Water Drainage.

## 1-10 Tons (Single Circuit), Outdoor, DX - Air Cooled Propeller Fan, Remote Condensing Units & Condensers Models: XPU & XP1-012S thru 120S

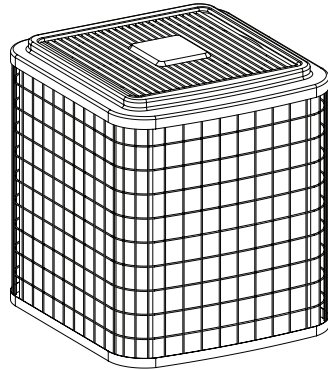

FRONT / LEFT / TOP

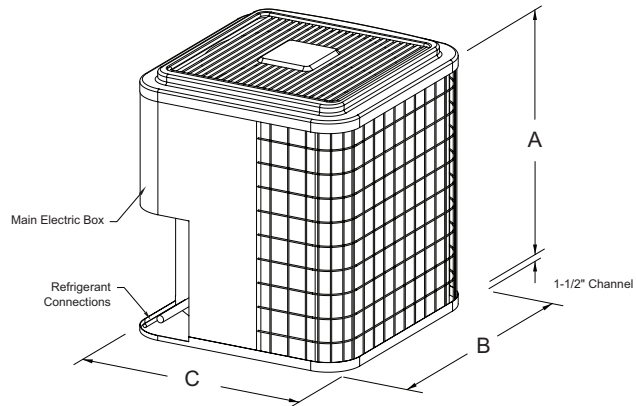

REAR / LEFT / TOP

XPU & XP1(-) Model Size	Dimensions		
	A	B	C
XPU & XP1-012S	24-13/16"	23-1/8"	23-1/8"
XPU & XP1-018S	25"	25-3/4"	25-3/4"
XPU & XP1-024S	28-11/16"	23-1/8"	23-1/8"
XPU & XP1-030S	31-3/16"	25-3/4"	25-3/4"

XPU & XP1(-) Model Size	Dimensions		
	A	B	C
XPU & XP1-036S	32-5/16"	31-3/16"	31-3/16"
XPU & XP1-048S	35-3/4"	31-3/16"	31-3/16"
XPU & XP1-060S	28-15/16"	31-3/16"	31-3/16"
XPU & XP1-072S, 096S & 120S	41-1/2"	35-1/2"	35-1/2"

## 6-15 Tons (Dual Circuit), Outdoor, DX - Air Cooled Propeller Fan, Remote Condensing Units & Condensers Models: XPU & XP4-072D thru 180D

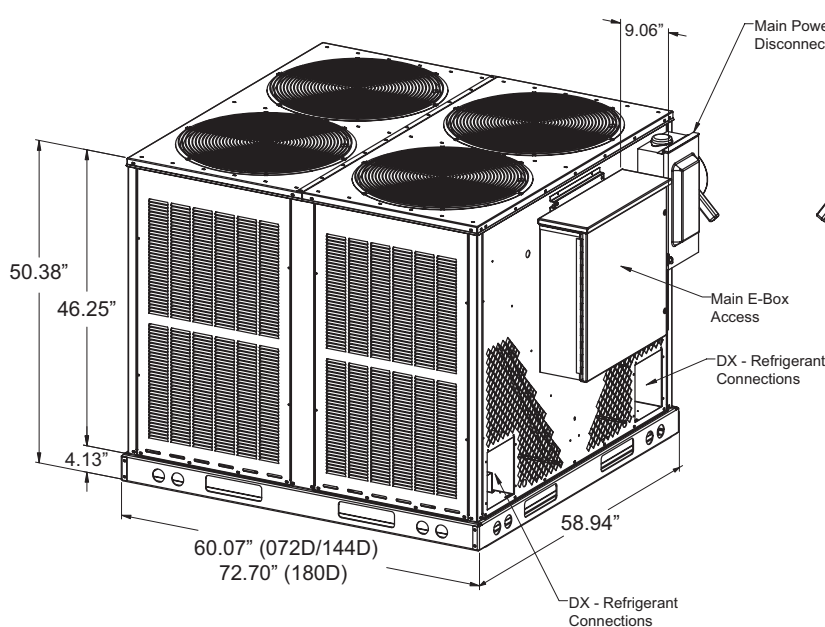

Front / Right / Top

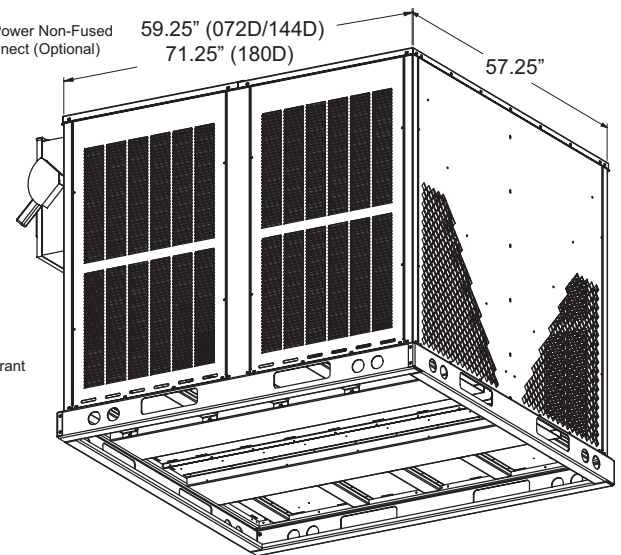

Rear / Left / Bottom

# DX - Split DX Evap & Water/Glycol Self-Contained

Model: AEC/AEP, AWC/AWP & AGC/AGP-012 thru 180

(Also AWC/AWP & AGP/AGP-012/180-\_-FE Free-Cooling Economizer)

**3-Side Access:**

18"-24" on Rear, Left & Right Sides!

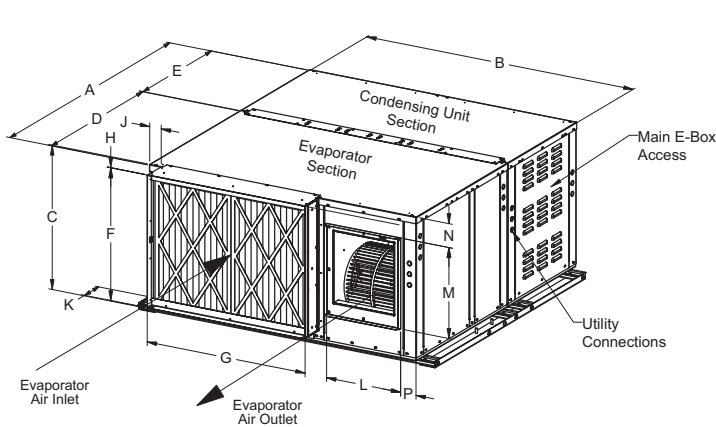

**Front / Right / Top**  
(Evaporator End)

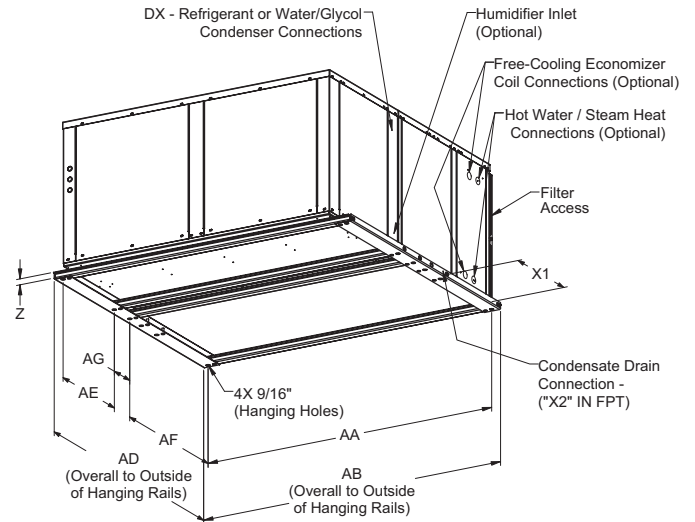

**Rear / Left / Bottom**  
(Condensing Unit End)

Dimensions (Inches)													
AEC, AWC, AGC-( )-SF Cabinet Size	A	B	C	D	E	F	G	H	J	K		L	M
						Evap Air Inlet Conns.				2" Filter	2" Pre / 4" Pst		
012, 018, 024, 030 & 036	45.17	44	22	25	20	20.85	22	0	2.76	5	9.22	14	14
048, 060 & 072	56.17	54	27	32	24	24.88	32	0	2.33	5	9.22	15	17
096 & 120	62.17	74	29.5	38	24	27	46.88	0	2.89	5	9.22	18	20
144 & 180	64.17	82	36	40	24	35.25	50	0	3.95	5.2	9.42	18	20
AEC, AWC, AGC-( )-SF Cabinet Size	N	P	Z	AA	AB	AD	AE	AF	AG	X1	X2	(Condensate Drain)	
012, 018, 024, 030 & 036	2.49	3.5	1.11	47.5	50.21	43.3	17	21.13	3.61	3/4" FPT	8" Max		
048, 060 & 072	4.47	3.13	1.11	57.5	60.21	52.48	18	27.5	5.42	3/4" FPT	8" Max		
096 & 120	2.74	3.5	1.11	77.5	80.21	60.05	21	33.63	3.86	3/4" FPT	N/A <sup>Note-2</sup>		
144 & 180	8.62	6	1.11	85.5	88.21	63.3	21	35.25	4.05	1" FPT	N/A <sup>Note-2</sup>		

## DX - Water/Glycol Cooled, Indoor Horizontal, Remote Condensing Units

Models: XWU & XGU-012 thru 180

### 3-Side Access:

18"-24" on Front, Right & Left Sides!

### Standard Cabinet "Right-Side" Piping Connections

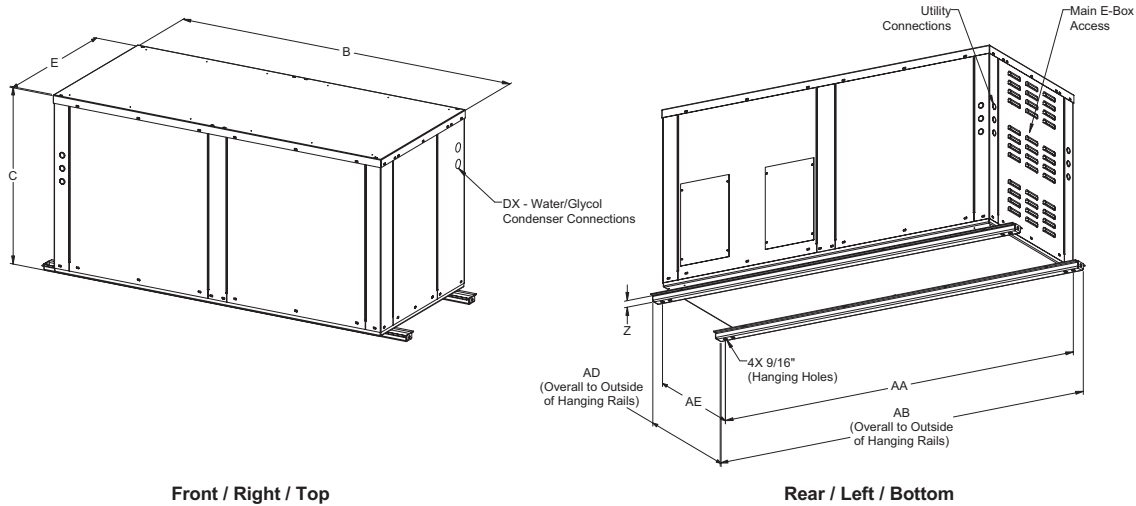

### Optional Cabinet "Left-Side" Piping Connections

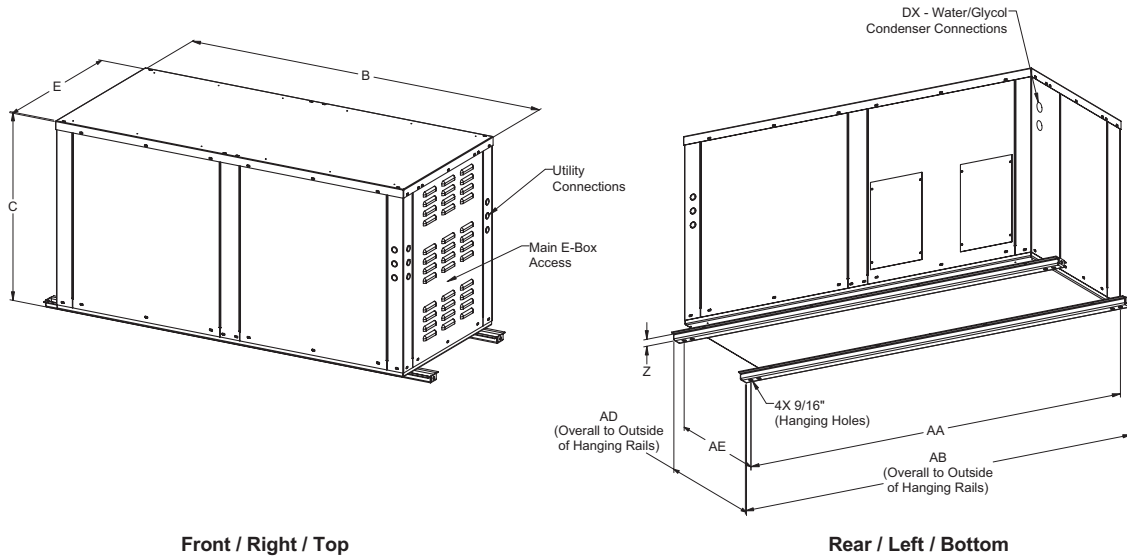

Dimensions (Inches)								
XWU/XGU-( )-STD Cabinet Size	B	C	E	Z	AA	AB	AD	AE
012, 018, 024, 030 & 036	44	22	20	1	47.5	50.21	18.56	17
048, 060 & 072	54	27	24	1	57.5	60.21	19.56	18
096 & 120	74	29.5	24	1	77.5	80.21	22.56	21
144 & 180	82	36	24	1	85.5	88.21	24	21

## Chilled Water, Horizontal Air Handling Units

Models: ACC & ACP-012 thru 180

**2-Side Access Std**  
 (MC Micro reqs. Rear Access):  
 18"-24" on Left & Right Sides!

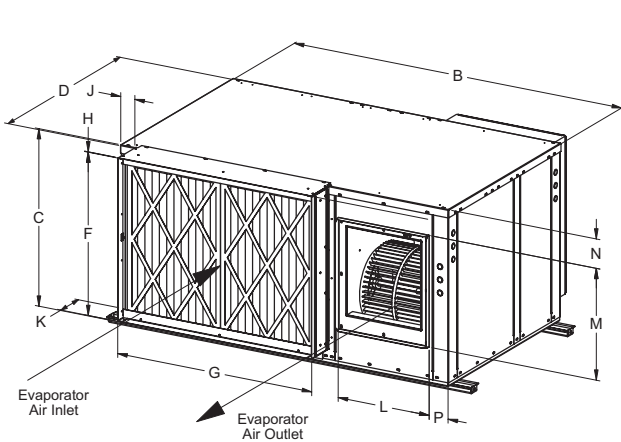

Front / Right / Top

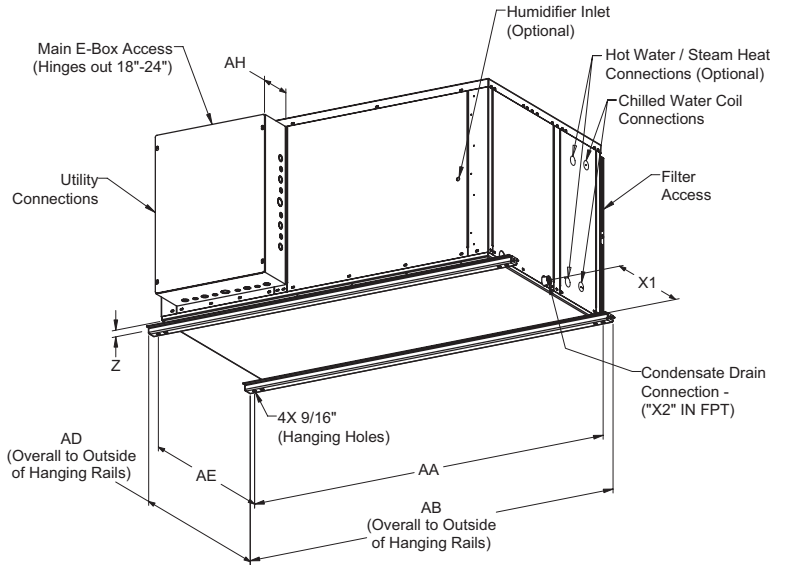

Rear / Left / Bottom

Dimensions (Inches)											
ACC-( )-SF Cabinet Size	B	C	D	F	G	H	J	K		L	M
				Evap Air Inlet Conns.				2" Filter	2" Pre / 4" Pst	Evap Air Outlet Conns.	
012, 018, 024, 030 & 036	44	22	25	20.85	22	0	2.76	5	9.22	14	14
048, 060 & 072	54	27	32	24.88	32	0	2.33	5	9.22	15	17
096 & 120	74	29.5	38	27	46.88	0	2.89	5	9.22	18	20
144 & 180	82	36	40	35.25	50	0	3.95	5.2	9.42	18	20
ACC-( )-SF Cabinet Size	N	P	Z	AA	AB	AD	AF	X1	X2	AH	
								(Condensate Drain)		(E-Box Depth)	
012, 018, 024, 030 & 036	2.49	3.5	1	47.5	50	22.69	21.13	12.5	3/4" FPT	8" Max	
048, 060 & 072	4.47	3.13	1	57.5	60	29.06	27.5	16	3/4" FPT	8" Max	
096 & 120	2.74	3.5	1	77.5	80	35.19	33.63	19	3/4" FPT	8" Max	
144 & 180	8.62	6	1	85.5	88	38.25	35.25	20	1" FPT	8" Max	

## Model Nomenclature

### Packaged Systems & Split Evaporators

<b>A</b>	<b>G</b>	<b>C - 120</b>	<b>D - 4 - E1</b>	<b>H - FE - 00</b>
<b>a</b>	<b>b</b>	<b>c - d</b>	<b>e - f - g</b>	<b>h - i - j</b>

- a: **A** - AboveAir™ Horizontal HK Series
- b: **A** - DX, Air Cooled  
**C** - Chilled Water  
**E** - DX, Evaporator with Compressor  
**G** - DX, Glycol Cooled  
**H** - DX, Air Handling Unit  
**W** - DX, Water Cooled
- c: **C** - Cabinet Generation Series
- d: **D** - Dual Circuit/Compressor DX System
- e: **012** = 1 Ton; **018** = 1.5 Tons; **024** = 2.0 Tons; **030** = 2.5 Tons;  
**036** = 3.0 Tons; **048** = 4.0 Tons; **060** = 5.0 Tons; **072** = 6.0 Tons;  
**096** = 8.0 Tons; **120** = 10.0 Tons; **144** = 12.0 Tons; **180** = 15.0 Tons
- f: **1** - 208-230V / 1 Ph / 60 Hz  
**3** - 208-230V / 3 Ph / 60 Hz  
**4** - 460-480V / 3 Ph / 60 Hz  
**5** - 575V / 3 Ph / 60 Hz  
**7** - 277V / 1 Ph / 60 Hz
- g: **00** - No Heat  
**E1** - Electric Heat 1-Stage  
**E2** - Electric Heat 2-Stages  
**ES** - SCR Fired Electric Heat  
**HE** - Heat Pump with Auxiliary Electric Heat  
**HG** - Hot Gas Reheat  
**HP** - Heat Pump w/o Auxiliary Electric Heat  
**HW** - Hot Water Heat  
**ES** - SCR Fired Electric Heat  
**ST** - Steam Heat
- h: **0** - No Humidifier  
**H** - Electrode Canister Humidifier
- i: **00** - No Economizer  
**AE** - Air Side Economizer  
**DC** - Dual Cool / Alternate Water Source  
**FE** - Water/Glycol Side Free Cooling Economizer
- j: **00** - None  
**OA** - 100% Outside-Air System

### Remote Condensing Units

<b>X</b>	<b>C</b>	<b>U - 120</b>	<b>D - 4 - 00 - 00</b>
<b>a</b>	<b>b</b>	<b>c - d</b>	<b>e - f - g - h</b>

- a: **X** - Remote Condenser or Condensing Unit (wrap-around coil type)  
**W** - Remote Condenser or Condensing Unit (slab coil type)
- b: **C** - DX, Air Cooled, Centrifugal Blower Type  
**G** - DX, Glycol Cooled  
**P** - DX, Air Cooled, Propeller Fan Type  
**W** - DX, Water Cooled
- c: **U** - Outdoor DX Condensing Unit  
**X** - Indoor DX Condenser  
**1** - Single-Circuit Condenser  
**2** - Dual-Circuit Condenser
- d: **D** - Dual Circuit/Compressor DX System
- e: **012** = 1 Ton; **018** = 1.5 Tons; **024** = 2.0 Tons; **036** = 3.0 Tons;  
**048** = 4.0 Tons; **060** = 5.0 Tons; **072** = 6.0 Tons; **090** = 7.5 Tons;  
**096** = 8.0 Tons; **120** = 10.0 Tons; **144** = 12.0 Tons; **180** = 15.0 Tons
- f: **1** - 208-230V / 1 Ph / 60 Hz  
**3** - 208-230V / 3 Ph / 60 Hz  
**4** - 460-480V / 3 Ph / 60 Hz  
**5** - 575V / 3 Ph / 60 Hz  
**7** - 277V / 1 Ph / 60 Hz
- g: **00** - None  
**HP** - Heat Pump Option
- h: **00** - None  
**OA** - 100% Outside-Air System
- i: **A** - Indoor Mounted  
**B** - Outdoor Mounted

## Approximate Shipping Weights (lbs.)

UNIT SIZE	MODEL TYPE													
	AAC/P			AHC/P	XCU	XPU	XP1	AEC	AWC/P & AGC/P			AWC/P & AGC/P-FE	XWU & XGU	ACC & ACP
	Evap	Cond	Packaged System						Evap	Cond	Packaged System			
<b>012</b>	235	325	570	235	325	130	85	420	235	195	440	455	195	240
<b>018</b>	235	345	590	235	345	135	90	440	235	215	460	475	215	240
<b>024</b>	250	355	610	250	355	135	90	450	250	215	470	495	215	245
<b>036</b>	250	360	620	250	360	140	100	460	250	225	480	505	225	245
<b>048</b>	340	475	820	340	475	200	140	620	340	290	640	680	290	340
<b>060</b>	340	515	865	340	515	210	145	655	340	325	675	715	325	340
<b>072</b>	370	585	960	370	585	1,035	885	695	370	375	745	795	375	360
<b>096</b>	385	590	985	385	590	1,045	885	755	385	400	795	845	400	370
<b>120</b>	550	895	1,475	550	895	1,050	885	1,060	550	535	1,105	1,175	535	550
<b>144</b>	560	940	1,515	560	940	1,200	955	1,100	560	570	1,145	1,215	570	550
<b>180</b>	560	940	1,515	560	940	1,200	955	1,115	560	580	1,155	1,225	580	550

**Notes:**

1) AAC/P-012/120 systems ship from the factory as a 1-piece, packaged unit as a standard. AAC/P-144/180 systems ship from the factory split for freight & field rigging purposes.

# Innovative HVAC Solutions

## Outdoor-Air Units - IAQ Make-Up Air



**RT-OA Rooftop DOAS**  
(3 to 72 Tons)

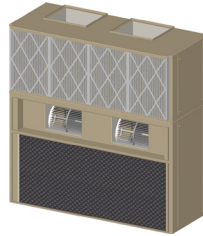

**VK-OA Vertical Floor Mtd**  
(1 to 30 Tons)

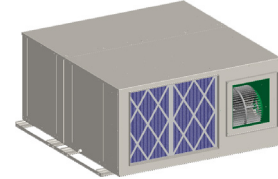

**HK-OA Horizontal Ceiling Mtd**  
(1 to 30 Tons)

## MissionCritical Units - Precision A/C's



**SC-2x4 SpotCool  
Ceiling Mounted A/C's**  
(1 to 3 Tons)

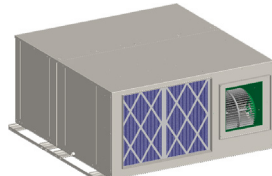

**HK Horizontal High-Static  
Ceiling Mounted A/C's**  
(1 to 30 Tons)



**MC Vertical Floor Mtd A/C's  
Up-Flow & Down-Flow**  
(1 to 30 Tons)

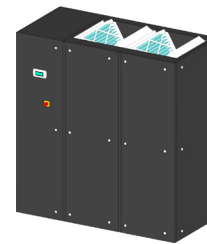

**FC Floor-Console Mtd A/C's  
Up-Flow & Down-Flow**  
(1 to 5 Tons)

## Comfort Units - A/C's & Water Source Heat Pumps



**SC-2x4 SpotCool  
Ceiling Mtd A/C's**  
(1 to 3 Tons)

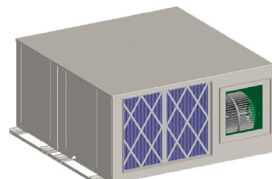

**HK Horizontal Packaged  
& Split Ceiling Mtd A/C's**  
(1 to 30 Tons)

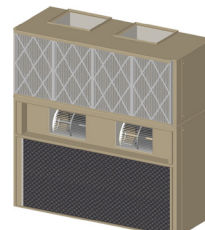

**VK Vertical Packaged &  
Split Floor Mtd A/C's**  
(1 to 30 Tons)

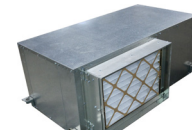

**M3-HP Horizontal & Vertical  
Water Source Heat Pumps**  
(0.5 to 30 Tons)

## Remote Heat Rejection Units

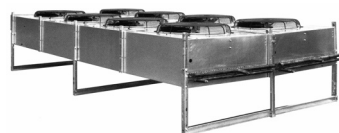

**Remote Air Cooled  
Condensers, Condensing Units &  
Glycol Drycoolers**  
(1 to 180 Tons of THR)

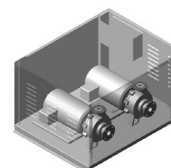

**Single, Dual & Triplex  
Glycol Pump Packages**  
(1/2 to 50 HP)