

# **Research Conference Proceedings**

## **Southern Region**



**Held in conjunction with the meeting of the**  
**Southern Association of Agriculture**  
**Scientists (SAAS)**



**Hosted by**  
**Murray State University**  
Hutson School of Agriculture  
**University of Kentucky**  
College of Agriculture, Food, and Environment

**Mobile, Alabama**

**February, 2017**

**SOUTHERN REGION CONFERENCE**  
**AMERICAN ASSOCIATION FOR AGRICULTURE EDUCATION**

**February 5-7, Mobile, Alabama**

**Mobile Convention Center**

**Southern Association of Agricultural Scientists (SAAS) Agricultural Education Division Officers**

President and Conference Chair: Brian Parr, Murray State University

Past President: J.C. Bunch, University of Florida

**American Association of Agricultural Education (AAAE) Southern Region Officers**

President: Brian Myers, University of Florida

Vice President/President Elect: J.C. Bunch, University of Florida

Secretary: Andrew Thoron, University of Florida

**Manuscript Reviewers for 2017 AAAE Southern Region Research Conference**

The AAAE Southern Region members express their sincere gratitude to the following AAAE colleagues who served as reviewers for the 2017 AAAE Southern Region Research Conference.

Antoine Alston	Frank Flanders	Brian Myers
James Anderson II	Jim Flowers	Michael Newman
Matt Baker	Curt Friedel	Ed Osborne
Kirby Barrick	Nick Furhman	Travis Park
Joey Blackburn	Donna Graham	Brian Parr
Todd Brashears	Amy Harder	Tobin Redwine
Gary Briers	Julie Harlin	Shane Robinson
Tom Broyles	Jay Jayaratne	Eric Rubenstein
Jackie Bruce	Don Johnson	Donna Westfall-Rudd
JC Bunch	David Jones	Rick Rudd
James Christiansen	Eric Kaufman	Kate Shoulders
Steven Chumbley	Mark Kistler	Chris Stripling
Barry Croom	Alexa Lamm	Robert Strong
Tiffany Drape	David Lawver	Stacy Vincent
Don Edgar	Laura Lemons	George Wardlow
Leslie Edgar	James Lindner	Wendy Warner
Kirk Edney	OP McCubbins	Elizabeth Wilson
Craig Edwards	Gary Moore	Meghan Wood
Chris Estep	Tim Murphy	

## **SESSION A**

- Toward a Contemporary Model of Teaching and Learning [7-23](#)  
*Kevin Curry Jr., John Tummons, Karen Vines, Kasee Smith,  
Tyson Sorenson*
- Power of Statistical Tests Used to Address Nonresponse Error in the [24-36](#)  
Journal of Agricultural Education  
*Donald M. Johnson, Catherine W. Shoulders*
- Extension's Role in Saving Citrus: Entering the Genetic Modification [37-51](#)  
Science Conversation  
*Taylor K. Ruth, Alexa J. Lamm, Joy N. Rumble*

## **SESSION B**

- Perceptions of African-American Students on Pursuing Agricultural [52-66](#)  
and Natural Resources Careers: Voices from an 1862 Land-grant  
Institution  
*Courtney P. Brown, Shelly Sitton, M. Craig Edwards, Nicholas R. Brown*
- An Exploration of Behavioral Change Through an Educational [67-82](#)  
Intervention  
*Alex K. Tingle, Stacy K. Vincent, Kang Namkoong, Joan Mazur,  
Morgan Schafbuch, Jennifer Watson*
- Using the Theory of Planned Behavior to Understand Extension [83-99](#)  
Client's Water Conservation Intentions  
*Anil Kumar Chaudhary, Laura A. Warner, Alexa J. Lamm, Glenn D. Israel,  
Joy N. Rumble, Randall A. Cantrell*

## **SESSION C**

- Agriscience Education Through Inquiry-based Learning: Investigating [100-115](#)  
Factors that Influence the Science Competence of Hispanic Middle

School Students

- Peter Skelton, J. Joey Blackburn, Kristin S. Stair, Natalie Levy*  
Exploring How Pedagogical Strategies Change Student Perceptions of Writing Apprehension [116-132](#)
- Laura M. Gorham, Courtney Meyers, Sinclair Dobelbower*  
Investigating the Motivational Changes of Pre-service Agricultural Education Teachers During a Six-Week Project Based Learning Experience [133-149](#)
- F. Richie Roberts, J. Shane Robinson*

**SESSION D**

- Imaging Service-Learning in The Agricultural Education Magazine from 1929 to 2009: Implications for the Method's Reframing and Use [150-170](#)
- Richie Roberts, M. Craig Edwards*
- Evidence for Recruitment Appeals to Students of Color in the National Teach Ag Campaign: An Exploratory Media Content Analysis [171-184](#)
- Sarah E. LaRose, Lisa K. Lundy*
- Needs Assessments for School-Based Agricultural Education Teachers: A Review of Literature [185-198](#)
- Catherine A. DiBenedetto, Victoria Willis*

**SESSION E**

- An Integration of Outdoor Classrooms into Schools: A Synthesis of Literature [199-216](#)
- H. Lillian Goldsmith, Eric D. Rubenstein*
- Comparative Analysis of Student Taught Science or Agriscience: Results on State Standardized Science Assessment [217-234](#)
- Anna J. Warner, Andrew C. Thoron, Glenn D. Israel*
- Administrative Perceptions of an Agriculture Dual Enrollment Program [235-250](#)
- Dr. Steven "Boot" Chumbley, Dr. J. Chris Haynes, Mark Hainline*

## **SESSION F**

A National Look at How Experience Influences Engagement in  
Water Conservation [251-267](#)

*Pei-wen Huang, Alexa J. Lamm*

Using the Situational Theory of Problem Solving to Guide National  
Extension Programming with High Water Users [268-281](#)

*Alexa J. Lamm, Laura A. Warner, Lisa K. Lundy,  
Jyothi Swaroop Bommidi*

Partnering with the Government: Can Extension Capitalize on how  
Political Affiliation and Perception of Government Impacts Water  
Conservation? [282-297](#)

*Brandon McKee, Pei-wen Huang, Alexa Lamm*

## **SESSION G**

Effects of an Applied Workshop on Teacher Self-Efficacy and Intent  
to Teach Hydraulics [298-307](#)

*Donald M. Johnson, George W. Wardlow*

A Description of Agriculture Teachers' Selections of Preferred  
Teaching Partners Based on Attire and Physical Attributes [308-320](#)

*Catherine W. Shoulders, Hailey R. Gates*

## **SESSION H:**

Designing an International Experience Program for [State] 4-H Members [321-330](#)

*Sheli E. Danjean, Melissa Carter, J.C. Bunch*

Agricultural Students' Affective Perceptions of Cost, Expectancy, and  
Value in the Context of Short-Term Study Abroad Programs: Applying  
Expectancy-Value-Cost Models [331-346](#)

*Brandon M. Raczkoski, J. Shane Robinson, M. Craig Edwards, Marshall A. Baker*

**SESSION I:**

Thinking Critically about how Agriculture and Natural Resource Opinion [347-360](#)

Leaders Communicate

*J. Brianne Bird, Alexa J. Lamm, Lisa K. Lundy*

Examining the Critical Moments in Information Processing of Water [361-374](#)

Conservation Videos within Young Farmers and Ranchers: A

Psychophysiological Analysis

*Laura M. Gorham, R. Glenn Cummins, Kyle C. Gilliam, Matt Baker,*

*Scott Burris, Erica Irlbeck*

## **Toward a Contemporary Model of Teaching and Learning**

Kevin Curry Jr.  
John Tummons  
Karen Vines, Kasee Smith  
Tyson Sorenson

### **Abstract**

*Agricultural education was built upon well-defined models of teaching and learning. These models have driven the underlying philosophy for what an agricultural educator should do, and how they should behave in both classroom and non-formal educational settings. While the models of teaching and learning used in agricultural education have remained essentially unchanged since their inception, the landscape of education, schools, and modern students have changed dramatically. This philosophical paper was written to examine and summarize current models of teaching and learning used in agricultural and extension education preparation programs, and highlight important issues to be considered if the profession determines an updated model for teaching and learning could better benefit today's learners.*

### **Introduction**

Agricultural education plays an important role in bridging the gap between the general public and scientists working to solve the current and emerging challenges of our time (Roberts, Harder, & Brashears, 2016). Therefore, a critical need exists for educators who can effectively teach and help learners understand key principles and skills in agriculture and natural resources. But what is effective teaching? What are the characteristics of effective teachers? What frameworks exist in agricultural education to guide effective teaching and learning? What frameworks for effective teaching and learning are best suited for today's 21st century agriculture students? The purpose of this paper is to examine these critical questions.

Teaching is a difficult and complicated task; in order for learning to occur, the teacher must simultaneously attend to the content, teaching and learning activities, the needs of the learners, and critical tasks (Darling-Hammond et al., 2008). Teachers must negotiate a careful balance between the needs of the curriculum and the needs of the student (Dewey, 1902). Teaching has been described as an art and a science (Marzano, 2007). Teachers bring unique skills and experiences to their classrooms: the teaching strategies successfully implemented by one teacher may not work for another teacher (Bransford, Darling-Hammond, & Lepage, 2005). Further, an effective strategy today may not work tomorrow or with other students. Simply put, the construct of "teacher effectiveness" is an important, yet tangled and unstable construct deeply intertwined with the learners, the school, the community, and the teacher (Darling-Hammond, Amrein-Beardsley, Haertel, & Rothstein, 2012). However, researchers have identified the teacher as the most important variable in learning outcomes; an effective teacher is able to facilitate student knowledge gains despite a myriad of environmental and contextual factors which can limit learning (Bransford et al., 2005).

At the postsecondary level, agricultural education departments prepare teachers of agriculture for employment in a variety of educational contexts (Barrick & Garton, 2010). Agricultural education programs build teaching capacity within learners through structured and sequenced coursework, field experiences, and internships focused on general knowledge, technical content knowledge, pedagogical knowledge, and pedagogical content knowledge (Roberts & Kitchel, 2010). According to Bransford et al. (2005), specific goals of teacher preparation programs include: providing subject matter knowledge and experiences, developing teaching skills needed to provide productive learning experiences for a diverse set of students, and fostering a professional commitment from teachers to help every child succeed.

Behaviorist approaches to teaching and learning dominated teacher preparation programs during the first half of 20<sup>th</sup> century educational research (Schunk, 2004). From a behavioral perspective, teacher preparation programs prepare agricultural educators by identifying the problems of teaching, then practicing and reinforcing predetermined techniques or behaviors as a form of stimulus-response, clinical decision-making (Grossman, 2005). Behaviorists focus on what learners can *do*; teaching in the behavioral paradigm involves teachers modifying the learning environment to elicit desired responses from learners (Schunk, 2004). Early behaviorist teaching pedagogy was based upon four principles:

1. Form habits: Do not expect habits to create themselves
2. Beware of forming habits which must be broken later
3. Do not form two or more habits when one habit will do as well
4. Other things being equal, have a habit formed in the way it is to be used

(Thorndike, 1912, pp. 173-174)

Teacher preparation programs must consider the readiness level of novice educators and scaffold experiences to enable students to develop critical skills and abilities (Darling-Hammond et. al., 2005). Developmentally appropriate shaping activities, such as microteaching, allows preservice teachers to isolate and practice specific teaching behaviors to lay a foundation for further teacher development (Gage, 1978). In the 1970's, educational researchers renewed their attempts to explain the relationship(s) between teacher process (behavioral) variables and product (student achievement) variables. In their meta-analysis of teacher research, Rosenshine and Furst (1971) identified five teacher factors most often associated with student learning: clarity, variability, enthusiasm, task-oriented or business-like behavior, and student opportunity to learn the criterion material. Behavioral paradigms regarding teaching and learning are still relevant today in teacher preparation programs, as more states adopt behavioral based performance assessments and portfolios to evaluate both preservice and inservice teachers (CAEP, 2016; Darling-Hammond et.al., 2005; SCALE, 2016).

Teacher effectiveness research is complex and not without its detractors. Perhaps the most direct criticism of Rosenshine and Furst comes from Cruickshank (1976), who suggested effective teaching behaviors are both content and context specific, inferring effective teaching cannot be described for all situations by one list of behaviors. Other criticisms of process-type effectiveness models are an underlying assumption that greater quantity of behaviors always equates to better teaching and a low correlation between selected behaviors and student outcomes (Doyle, 1977). Finally, effective teacher behaviors, as defined by Rosenshine and Furst



(1971), focus on the teaching event, ignoring other important teacher behaviors which can impact student learning.

Within departments of agricultural education, Rosenshine and Furst (1971) has served as a foundational framework for preparing preservice agriculture teachers (Phipps, Osborne, Dyer, & Ball, 2008; Torres & Whittington, 2016). However, agricultural education has changed; effective teacher behaviors alone may not reflect the needs of our profession in today's broader vision of agricultural education. Indeed, the top ranked research question for the 2016 AAAE research agenda solicits the methods effective in preparing people to solve complex, interdisciplinary problems (Roberts et al., 2016). While some teacher educators have argued effective teaching behaviors transcend contextual differences between classrooms (Cruickshank, 1976; Darling-Hammond & Snyder, 2000), the research agenda is testament to the fact that today's graduate must prepare the modern learner to be proficient in significantly different challenges than preservice agriculture teachers graduating 50 years ago.

### **Problem Statement**

The Information Age has fundamentally transformed teaching and learning in agriculture. Today's beginning agricultural educators enter a workplace where learners have always had access to the world's information at their fingertips; students do not need experts to access the information they seek (Beetham & Sharpe, 2013). Today's agricultural educators face unique and complex challenges including competing expectations, changing societal needs, funding, and accountability (Ball & Cohen, 1999). Secondary agriculture teachers enter a climate of high-stakes testing where they are scrutinized through ever-increasing systems of observation and evaluation, and are expected to immediately perform at an expert level or risk losing their jobs (Darling-Hammond, 2015). Extension educators are challenged to help communities address complex challenges in their educational role that crosses multiple societal demographics (Davis & Sulaiman, 2014).

### **Purpose**

The American Association for Agricultural Education (AAAE) published a statement regarding teacher preparation in agriculture through the National Standards for Teacher Education in Agriculture (AAAE, 2001). Standard one in the framework states:

The design, implementation, and evaluation of an agricultural education teacher preparation program reflect a *dynamic* conceptual framework, grounded in experience-based knowledge developed with input valued by all stakeholders. The conceptual framework establishes the vision for the agricultural education teacher preparation program to prepare teachers to work effectively in schools. (AAAE, 2001. p. 1).

In the 15 years since this framework was adopted, departments of agricultural education have changed in two dramatic ways: widespread movement from colleges of education to colleges of agriculture, and a broadening of their educational mission to include Extension education, agricultural leadership, and communication. The move of teacher preparation programs from colleges of education to colleges of agriculture evidences a need for agricultural

education to be well grounded in the content area and further suggests there is sufficient contrast to other teacher preparatory programs that a distinct model of teaching and learning is warranted. Although one could argue the human brain learns the same in all environments, the authors contend the diversity of our environments in agricultural education require that teaching be adapted to provide for the greatest potential learning outcomes based on clientele needs. Clientele in Cooperative Extension or community development programs, for example, represent all age groups who have different objectives for learning than secondary students. Graduates of agricultural education programs intending to work in these fields need to must have a vast toolkit in order to be flexible in meeting the individualized needs of their learners.

One overarching purpose of this philosophical examination is to highlight the independent frameworks of effective teaching and learning presented in the literature, and in doing so, critically evaluate the current models used to prepare the 21<sup>st</sup> century agriculture education students for their careers. More precisely, how can we advance the agricultural education profession forward to adopt a more contemporary model of effective teaching and learning that is inclusive of the needs of all learners in the discipline?

### **Theorizing Effective Teaching and Learning in School-Based Agricultural Education**

Although effective teaching has been examined since the inception of formalized education, conceptualizing what it entails has been an elusive concept. Cooper and McIntyre (1996) summarized the struggle in their examination of effective teaching, stating:

The history of research on classroom teaching has thus been one of gradually developing understanding of its complexity and the blind alleys which await those who are too ready to make assumptions about the nature of teaching or of effective teaching (p. 2).

Attempting to define effective teaching relies on the examination of variables related to individual students, individual teachers, and individual schools. There is no universally agreed upon definition of effective teaching, rather, it is a concept examined through the lens of each teaching paradigm, content area, and application. Still, the challenge of defining universal variables relating across disciplines, formal and informal teaching settings, and to a wide variety of students to help strengthen all instruction has been taken on by academics (Reigeluth, 1985).

In the late 1950's and early 1960's several research initiatives were attempted to define the factors that could contribute to effective teaching strategies (Abeasi & Reigeluth, 1985). Bloom (1956) worked specifically in developing the levels of educational taxonomy related to deepening student knowledge. Carroll (1963) developed a model that outlined the importance of student and school factors related to effective learning. The five classes of variables (aptitude, opportunity to learn, ability to understand, quality of instructional events, and perseverance) are presented to account for variations in levels of student achievement.

Other researchers examined the importance of teacher factors related to effective teaching. One of the seminal pieces of work on examining effective teaching was the meta-analysis conducted by Barak Rosenshine and Norma Furst (1969). Their examination of the

factors most often associated with quality teaching yielded eleven different characteristics of effective teachers. The analysis of the variables led them to conclude “the best results were obtained on the first five variables” (Rosenshine & Furst, 1971, p. 42). These five variables are described in Table 1.

Table 1. *Characteristics of Effective Teachers (Rosenshine & Furst, 1971)*

Characteristic	Description
Clarity	Effective teachers can clearly communicate abstract concepts
Variability	The ability to use variety in teaching methods, learning modes, and delivery strategies
Enthusiasm	Excitement about students, subject, and the profession of teaching
Task-Oriented and/or Business-like Behaviors	Exhibits business-like behaviors
Student Opportunity to Learn Criterion Materials	Gears instruction and assessments to predefined learning outcomes

Newcomb, McCracken, Warmbrod & Whittington (2004) isolated sixteen principles of teaching and learning within five general constructs specific to the agricultural education profession. The five constructs included: organization and structure of subject matter, motivation, rewards and reinforcement, techniques of teaching, and transfer of learning. Situated in the textbook for many undergraduate preservice teacher education institutions, these principles have served as a popular effective teaching framework in recent years. The individual principles describe the behaviors of teachers and the conditions necessary for student learning.

Educational researchers continue to work toward an outline of the student, teacher, and school factors that play a role in the larger landscape of effective teaching and learning. Reid and Johnston (1999) analyzed effective teaching behaviors and developed a list which included approachability, clarity, depth of knowledge, interaction, interest, and organization. Other examinations of effective teaching factors have substantiated the claims related to the influence of the ability to interact with students, content knowledge, and ability to employ instructional strategies on teacher effectiveness (Young & Shaw, 1999). Darling- Hammond and colleagues outlined important teacher characteristics that guide teacher development of effective teaching behaviors (Darling- Hammond, Hammerness, Grossman, Rust, & Schulman, 2005).

The sum of the body of work related to effective teaching comes from an examination of two main categories of teacher effectiveness: who a teacher is, and what a teacher does. Rosenshine and Furst (1969, 1971) sought to identify the intrinsic characteristics helping teachers be successful and thus is an example of research that examined who a teacher is. Darling-Hammond (2000) is the modern equivalent of the examination of who a teacher is, as her topical research has been focused on identifying the personality and behavioral traits which can lead to success in the classroom, teacher retention, and student learning. Darling-Hammond's work has included analyses of multiple successful teaching meta-analyses. These analyses have yielded information related to the importance of teachers having structured procedural instruction (Darling-Hammond, 2000), high levels of content matter preparation (Darling-Hammond, 2005), and a strong focus on metacognition related to teaching skills (Darling-Hammond, 2005). Both the seminal (Rosenshine & Furst, 1969, 1971) and modern (Darling-Hammond, 2000, 2005) works on teacher effectiveness have focused on determining the personal characteristics of effective teachers. These factors are used extensively in teacher preparation programs to enhance preservice learning. By developing the personal characteristics of teaching, preservice teachers are able to connect with students, build relationships, and act as professionals.

The second category of effective teaching research concerns the importance of factors related to what an effective teacher does as part of their daily activities. Reflective of this focus are the teacher evaluation instruments imposed on teachers that assesses what a teacher is doing from a methodological sense throughout the lesson. EdTPA, today's most frequently used preservice teacher certification assessment, outlines fifteen research-based teacher behaviors for which teacher candidates must demonstrate proficiency in order to earn initial teacher certification. Representative among them are: "lesson planning for understanding," "monitoring and supporting student learning," and "uses analysis of what students know and are able to do to guide instruction" (Smith, Baker, Hattie, & Bond, 2008; SCALE, 2016b).

Gangé (1965) developed a model which combined teacher characteristics and components of instruction required for successful student instruction, as shown in Figure 1. The model includes components related to the specific learning outcomes desired for a lesson, the conditions of learning, and the prescriptive events of instruction Gangé believed were required for effective teaching to occur. By focusing on learning outcomes, Gangé (1965) claimed that "appropriate decisions regarding instructional method and assessment could be made" (p. 215). The conditions of learning were considered to include both school and classroom climate, including the attitudes and personal behaviors of the teacher. Finally, the nine events of instruction were the sequential items recommended by Gangé as an outline for lesson delivery.

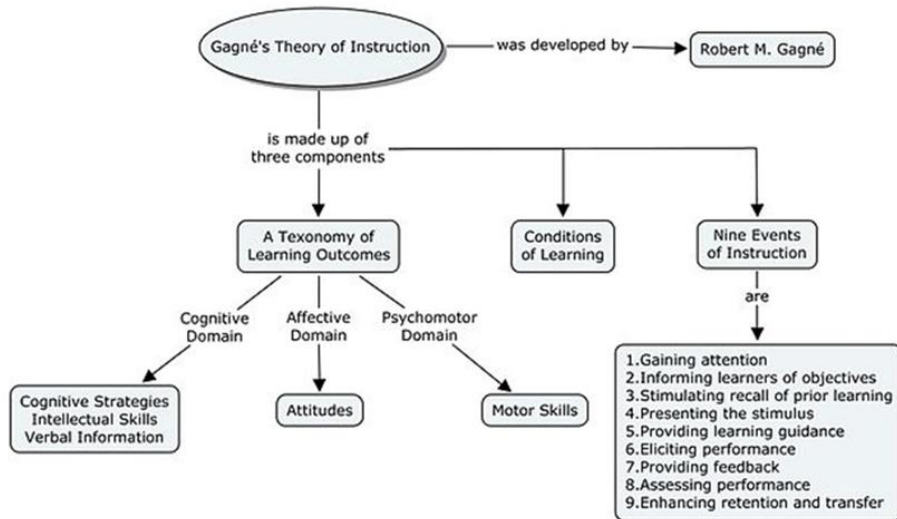

Figure 1. Gagné's (1965) Theory of Instruction

Duncan and Biddles (1974), created a model based on the work of Mitzel (1960), which depicted an even more complex view of the multiple variables included in effective teaching. These variables include those related to the teacher, student variables, learning environment variables, and outcome variables, as shown in Figure 2. Like Gagné (1965) and Carol (1963), the Duncan and Biddles (1974) model illustrates a broader perspective of teaching and learning beyond the precise focus of teacher effectiveness. The presage variables describe the litany of demographics, experiences, and characteristics that influence teacher behavior in the classroom. When combined with the description of what influences student behavior in the classroom, the model provides valuable context to the effective teaching characteristics espoused by Rosenshine and Furst (1971).

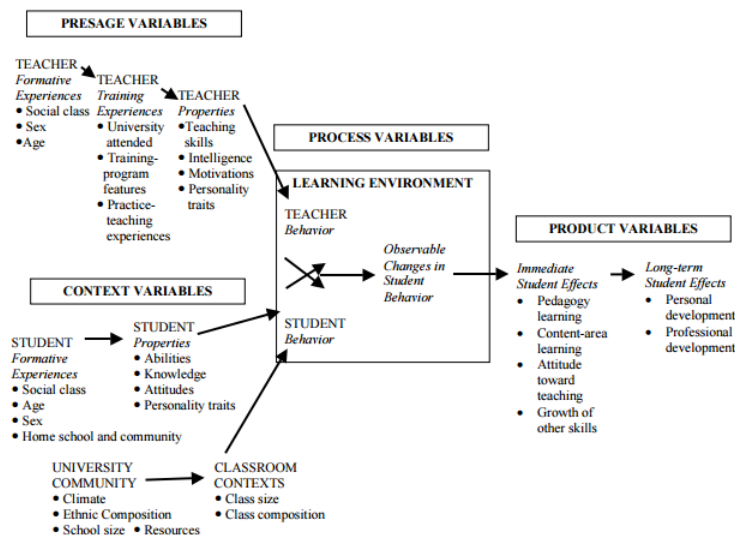

Figure 2. Duncan & Biddles (1974) Model of Teaching and Learning

The examination of theories related to effective teaching provide background for examining current strategies for effective teaching in agricultural education. What learning outcomes should teachers be working toward? What conditions, both personally and environmentally, should agricultural educators foster in their classrooms? What instructional events should be incorporated into agricultural education lesson delivery? The goal of the remainder of our examination is to determine the current status of effective teaching literature as it relates to multiple models of effective teaching.

### **Theories of Effective Teaching and Learning for Cooperative Extension**

Agricultural education is not limited to a formal classroom setting. Although commonly referred to as nonformal education, a wide range of teaching methodologies are used in Cooperative Extension, largely dependent on the audience and educational objectives. Experiential approaches through on-farm demonstrations were one of the earliest methods employed as agents worked with farmers to solve challenges associated with crop and livestock production (Seevers & Graham, 2012). Teaching youth how to produce crops using the latest technology to produce maximum yields or how to provide families with access to healthy food in all seasons was the primary focus of the corn and canning clubs from which 4-H originated (Sutphin & Hillison, 1999). Their parents, serving as interested observers, often adopted the successful techniques demonstrated by their children (Seevers & Graham, 2012).

Cooperative Extension has long found its theoretical basis in Roger's theory of diffusion of innovations (Franz, Piercy, Donaldson, Richard, & Westbrook, 2010). Original demonstrations were intended to encourage early adopters to make use of innovations in agriculture and home management to pave the way for others to accept improved practices (Rogers, 2010). Moreover the voluntary, self-directed, problem solving nature of adult audiences emphasizes andragogical approaches (Knowles, 1980). Andragogy focuses on characteristics of adult learners and emphasizes learning rather than teaching. The role of the teacher is that of facilitator rather than the deliverer of education. The responsibility for education is shared between the educator and learner. Previous experience of the learner is an important consideration in determining the most effective method of educational delivery with experiential and participatory approaches being most effective.

In defining teaching, Knowles (1980) identifies five "implications for practice" associated with andragogical approaches to education. The first relates to creating a learning climate in which the adult learner feels respected. The second is to allow the learner to identify their own needs as opposed to the teacher prescribing needs. The third involves the learner in the development of the educational experience. The fourth implication defines the source of education as a learning experience in which discovery of the learner is the educational gain. Finally, in andragogy, the evaluation of learning is best done by the learner (Knowles, 1980). Knowles goes on to suggest that children begin to move toward self-direction and continue on that path from an early age so that andragogical approaches may be appropriate for both youth and adults. His sense is that using an andragogical approach with youth teaches them to learn and emphasizes lifelong learning. The emphasis on facilitation and guidance suggests that as an educator, the Extension professional must place greater emphasis on the learners rather than strictly emphasizing content transmission.

Further, the role of teaching is fundamentally different in Extension than it is in other education contexts. Extension operates on logic models for program planning that encompasses processes from needs assessment through program evaluation (Seevers & Graham, 2012; University of Wisconsin - Extension, 2014). Educational activities are developed to achieve desired outcomes for specific audiences related to an overarching program. While effective teaching is an important attribute of extension professionals, a survey of extension directors and administrators (Hibberd, Blomeke & Lillard, 2013) instead highlights the emphasis on program planning. Participants in the study prioritized attributes of extension professionals such as “conducts a needs assessment”, and “develops partnerships” higher than more explicit aspects of an effective teacher such as “uses technology to enhance learning” and “matches teaching strategies to educational material”. These findings exemplify how models of teaching and learning in extension education are targeted less towards what makes agents effective teachers, and more to the needs of the learner.

### **Effective Teaching**

Public Law 107-110, better known as “No Child Left Behind”, had profound impacts on school-based education. In an attempt to increase performance and establish greater accountability, a key component of the legislation required newly hired teachers to be “highly qualified” (No Child Left Behind Act, 2001). The law defines highly qualified teachers as those who: (1) fulfill their state’s licensing requirements, (2) obtain a bachelor’s degree or higher, and (3) demonstrate competence in the subject matter they teach (No Child Left Behind Act, 2001). The “highly qualified” designation still persists today, and is representative of the underlying notion that effective teachers have extensive pre-service training. Even so, states operate independently in clarifying the precise requirements needed for licensure.

A scan for nationwide policy, revealed no national standards or guidelines for teaching effectiveness. Rather, each state implements its own policies that govern teacher evaluation. The National Council on Teacher Quality publishes an annual summary of educational laws, and in their 2015 report, they found a concerning pattern emerging across states with performance-based teacher evaluation systems: nearly all teachers are identified as effective or highly effective (Doherty & Jacobs, 2015). When implemented correctly, the report argues that performance-based evaluations can be useful tools, encouraging effective instruction and valuing highly effective teachers. Delaware, Florida, and Louisiana lead the nation in connecting the dots between teacher evaluations and effective teaching.

Insight into the value placed on different aspects of effective teaching can be found in previous work on teacher perceptions. Preservice teachers identified “student-centered”, “effective classroom and behavior manager”, and “competent instructor” as the top three characteristics of an effective teacher (Minor, Onwuegbuzie, Witcher, & James, 2002). Similarly, with perspectives from preservice-, novice-, and experienced teachers, Walls, Nardi, von Minden, and Hoffman (2002) outlined effective teaching behaviors into five categories: emotional enrollment, teacher skill, teacher motivation, student participation, and rules and

grades. In their analysis they presented each category with opposing behaviors of the effective and the ineffective teacher. For example, in the category of student participation, effective teachers “had lots of hands-on activities” while ineffective teachers “discouraged students from asking questions”.

Viewed from the wider lens, however, effective teaching is reflective of the broader paradigm of teaching and learning. Situated in a student-centered model, effective teaching may be qualified very differently when compared to a teacher-centered model. Likewise if an educator, school, district, or state employs a constructivist mindset when developing curriculum, they may identify effective teaching behaviors in a different way than those with a behaviorist approach. To identify the balance point, the argument could be made that the ideal model of teaching and learning is a simple equation: Student Learning = Effective teaching. As Banta (2010) describes, “faculty must change their principle focus from what they are teaching to what their students are learning.” The shift of emphasis in this example is subtle, but profound. Rather than belaboring the point of what teachers should do, if we pivot to improving student learning outcomes, would effective teaching happen as a result?

In many programs, Rosenshine and Furst (1971) is the basis for effective teaching characteristics. However, one must ask if the findings from Rosenshine and Furst are still relevant in today’s agricultural education classroom as a framework for effective teaching? Do more current frameworks exist that more fully explain and predict teaching and learning in the 21<sup>st</sup> century agricultural education classroom? Within agricultural education, some have prescribed common performance areas as key indicators of effective teaching while others have prescribed characteristics of effective teaching to include categories within an agricultural program and personal qualities.

Two unique studies have tackled the task of identifying perceptions of effective teaching in agricultural education. First, Miller, Kahler, and Rheault (1989) identified five performance areas with effective agriculture teachers: productive teaching behavior; organized and structured class management; positive interpersonal relationships; completing professional responsibilities; and personal characteristics behavior. They described productive teaching behavior as: developing lifelike situations for students, utilizing learning activities that meet the learning objectives, motivating students to learn, and seeking continued improvement. They also described personal behavior characteristics as: humor, patience, enthusiasm, confidence, and ability to cope with changes in the teaching environment. The second examination, by Roberts and Dyer (2004), categorized effective agriculture teachers in areas of instruction, FFA, SAE, community relations, marketing, professional growth/professionalism, program planning/management, and personal qualities. Among those personal qualities, they found the “most effective” agriculture teachers to be those that cared for students, were motivated, enthusiastic, self-confident, had an understanding and supportive spouse/family, were honest, moral, and ethical, open-minded, well-organized, and resourceful.

Although insightful, these agricultural education studies are not sufficient as frameworks for effective teaching and learning because they do not empirically demonstrate an increase in student learning. Furthermore, there is little evidence to suggest these characteristics apply to the variety of agriculture programs and disciplines within agricultural education. Finally, these



studies highlight the core argument of this paper: for decade’s agricultural education has focused solely on the teacher in terms of defining effective teaching characteristics with little regard for student learning as an empirical measurement.

Put simply, the measure of effective teaching should be student learning. Contrary to this point, the emphasis in agricultural education at all levels seems to be dominated by the “what” and “how” of teaching with little regard for student outcomes. If we are training teachers to develop learners, the time may have come to grapple with our current models of teaching and learning. A critical examination could reveal areas for modification which allow more emphasis on student learning and the ability to generate empirical results reflective of the change.

### Modern Assessment of Effective Teaching

In recent decades, there has been a stronger emphasis placed on student learning as the indicator of effective teaching outside of the agricultural education discipline. Spurred along by standardized assessments and teacher accountability, this emphasis on student learning has changed frameworks on teaching and learning. Evidence of this shift can be found in EdTPA’s “Effective Teaching Cycle” (SCALE, 2016a), depicted in Figure 3. The EdTPA is an assessment of teacher candidates used by teacher preparation programs to measure performance during the student teaching experience. To date, there are 38 states implementing EdTPA in some way (AACTE, 2016). Teacher candidates are required to record segments of their teaching, and provide commentary that addresses specific aspects of planning, instruction, and assessment, all centered on student learning. Further, the evaluation rubrics for all commentaries specify the need to assess teacher impact on student learning. With more states and agricultural education departments adopting EdTPA as a requirement in the teacher credentialing process, it is worth examining whether the EdTPA’s model of effective teaching (implemented at the end of the degree) is consistent with the models and teachings put forth in the course offerings prior to the student teaching experience. Is the EdTPA’s student centered model reflective of the models of teaching and learning pre-service programs espouse?

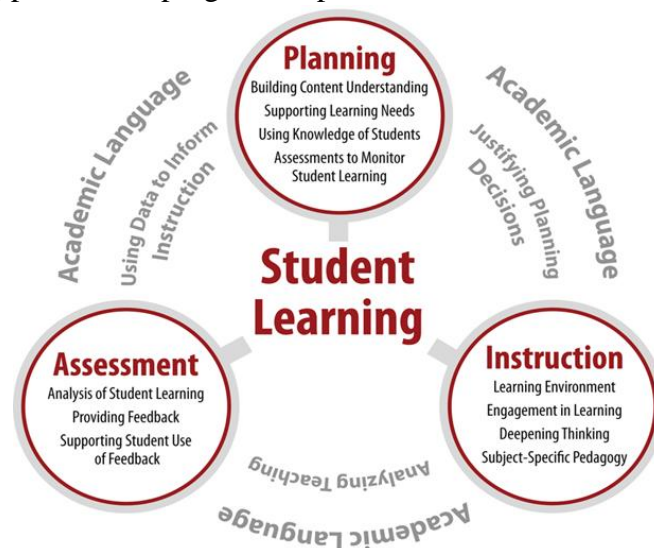

Figure 3. EdTPA's Effective Teaching Cycle (SCALE, 2016a)

## Conclusions and Recommendations

After review of the theoretical models, the primary finding of this study indicates there is a differing focus for the various models of teaching and learning. The most commonly used seminal work on teaching and learning (Rosenshine & Furst, 1971), and the majority of studies conducted in the agricultural education discipline, are focused on teaching, more specifically, teacher behaviors. Other models (e.g., Carrol, 1963; Duncan & Biddle, 1974; Gangé, 1965; and EdTPA, 2016) are focused on student outcomes with a proclivity toward the *learning* half of teaching and learning. Likewise, if we look to our colleagues in extension education, we find evidence of learner-centered philosophies (andragogy) as the source of an effective teaching and learning model.

In many ways the agricultural education profession has already shifted, albeit informally, from the strictly defined pedagogical approach. The three component model of FFA, SAE and classroom/laboratory instruction expresses a learner-centered mindset. Indeed, the National FFA Organization is a student led organization (Jenkins & Kitchell, 2009) devoted to the premier leadership, personal growth, and career success of members. SAE programs are best implemented when they are designed by students with specific goals in mind (Jenkins & Kitchell, 2009). Further, experiential learning serves as a foundation for agricultural education (Roberts, 2006) where instructional practices in classrooms commonly utilize hands-on contextual approaches geared toward the needs of students. Secondary agriculture programs already implement learner-centered approaches in the three component model; our overarching model of teaching and learning should embody the same philosophy.

It is recommended the agricultural education profession investigate the creation and adoption of a formal model of teaching and learning. A contemporary model of teaching and learning would provide clarity and consistency to our teacher preparation programs. The model should be inclusive of not only the characteristics and behaviors of effective teachers, but the context variables that are influential in the learning process, and the processes in place to measure student outcomes. Although we have much to learn from the theoretical models of teaching and learning presented in this review, the nuances of the agricultural education profession demands a distinct model of teaching and learning tailored to factors that make us unique from other educational disciplines.

## References

- Abeasi, K., & Reigeluth, C. M. (1985). Group Discussions as an effective method of instruction. *Syracuse University Guides, School of Education*.
- American Association for Agricultural Education (2001). *National Standards for Teacher Education in Agriculture*. Retrieved from: <http://aaaeonline.org/Resources/Documents/National%20Standards%20for%20Teacher%20Education.pdf>
- American Association of Colleges for Teacher Education (AACTE) (2016). *Participation Map*. Retrieved from: <http://edtpa.aacte.org/state-policy>
- Ball, D., & Cohen, D. (1999). Developing practice, developing practitioners: Toward a practice-based theory of professional education. In L. Darling-Hammond & G. Sykes (Eds.), *Teaching as the learning profession: Handbook of policy and practice* (pp. 3-32). San Francisco, CA: Jossey-Bass.
- Banta, T. W. (2010). Impact of addressing accountability demands in the United States. *Quality in Higher Education*, 16(2), 181-183. doi:10.1081/13538322.2010.485742
- Barrick, R. K. & Garton, B. L. (2010). Frameworks for agriculture teacher preparation. In Torres, R. M., Kitchel, T. J., & Ball, A.L. *Preparing and advancing teachers in Agricultural Education*. Columbus, OH: Curriculum Materials Service, The Ohio State University.
- Beetham, H., & Sharpe, R. (2013). *Rethinking pedagogy for a digital age: Designing for 21st century learning*. Routledge.
- Bloom, B. S. (1956). Taxonomy of educational objectives. Vol. 1: Cognitive domain. *New York: McKay*, 20-24.
- Bransford, J., Darling-Hammond, L., & LePage, P. (2005). Introduction. In Darling-Hammond, L. & Bransford, J. *Preparing teachers for a changing world: What teachers should learn and be able to do*. San Francisco, CA: Josey-Bass.
- CAEP. (2016). *Council for Accreditation for the Educator Preparation: Accreditation and Program Review*. Retrieved from: <http://www.caepnet.org/accreditation/caep-accreditation/caep-accreditation-resources>
- Carroll, J. B. (1963). A model of school learning. *Teachers College Record*, 64, 723-733.
- Cooper, P., & McIntyre, D. (1996). *Effective teaching and learning: Teachers' and students' perspectives*. McGraw-Hill Education London, UK.
- Cruickshank, D.R. (1976). Synthesis of selected research on teacher effects: *Journal of Teacher Education*. 27(1), 57-60.

- Darling-Hammond, L. (2015). Can value added add value to teacher evaluation?. *Educational Researcher*, 44(2), 132-137.
- Darling-Hammond, L. (2000). Teacher quality and student achievement: A review of state policy evidence. *Educational Policy Analysis Archives*, 8(1), 1-42.
- Darling-Hammond, L., Amrein-Beardsley, A., Haertel, E., & Rothstein, J. (2012). Evaluating teacher evaluation. *The Phi Delta Kappan*, 93(6). pp. 8-15.
- Darling-Hammond, L., Barron, B., Pearson, P. D., Schoenfeld, A. H., & Elizabeth, K. (2008). *Powerful Learning: What We Know About Teaching for Understanding*.
- Darling-Hammond, L., Hammerness, K., with Grossman, P., Rust, F., & Schulman, L. (2005). The Design of Teacher Education Programs. In L. Darling-Hammond & J. Bransford (Eds.), *Preparation of teachers for a changing world: What teachers should learn and be able to do* (390-441). San Francisco, CA: Josey-Bass
- Darling-Hammond, L., & Snyder, J. (2000). Authentic assessment of teaching in context. *Teaching and Teacher Education*, 16(5), 523-545.
- Davis, K., & Sulaiman, R. V. (2014). The new extensionist: Role and capacities to strengthen extension and advisory services. *Journal of International Agricultural and Extension Education* 21(3). doi: 10.5191/jiaee.2014.21301
- Dewey, J. (1902). *The child and the curriculum*. Chicago: University of Chicago Press.
- Doherty, K. M., Jacobs, S. (2015). *State of the states: Evaluating teaching, leading and learning*. National Council of Teacher Quality.
- Doyle, W. (1977). Paradigms for research on teacher effectiveness. *Review of research in education*, 5, 163-198.
- Dunkin, M. J., & Biddle, B. J. (1974). *The study of teaching*. New York: Holt, Rinehart, and Winston.
- EdTPA. (2016) *About edTPA*. Retrieved from:  
[http://www.edtpa.com/PageView.aspx?f=GEN\\_AboutEdTPA.html](http://www.edtpa.com/PageView.aspx?f=GEN_AboutEdTPA.html)
- Franz, N., Piercy, F., Donaldson, J., Richard, R., & Westbrook, J. (2010). How farmers learn: Implications for agricultural educators. *Journal of Rural Social Sciences*, 25(1), 37-59.
- Gage, N. L. (1978). *The scientific basis of the art of teaching*. New York: Teachers College Press
- Gagné, R. (1965). *The conditions of learning*. New York, NY: Holt, Rinehart and Winston, Inc.

- Grossman, P. (2005). Research on the pedagogical approaches in teacher education. In M. Cochran-Smith and K. Zeichner (Eds.), *Report of the AERA Panel on Research and Teacher Education*. Washington, D.C.: American Educational Research Association Consensus Panel on Teacher Education.
- Hibberd, C., Blomeke, C., & Lillard, A. (2013, June 20). Skills and attributes of 21st century Extension professionals [Webinar]. Retrieved from <https://connect.extension.iastate.edu/p9qxc1vehka/?launcher=false&fcsContent=true&pbMode=normal>
- Jenkins III, C. C., & Kitchel, T. (2009). Identifying Quality Indicators of SAE and FFA: A Delphi Approach. *Journal of Agricultural Education*, 50(3), 33-42.
- Knowles, M. (1980). What is Andragogy? *The modern practice of adult education: From pedagogy to andragogy*. Englewoods Cliff, NJ: Cambridge Adult Education.
- Marzano, R. J. (2007). *The art and science of teaching: A comprehensive framework for effective instruction*. Ascd.
- Merriam, S. B., Caffarella, R. S., & Baumgartner, L. M. (2007). Traditional Learning Theories Learning in adulthood (3rd ed., pp. 275-297). San Francisco, CA: Jossey-Bass.
- Miller, W. W., Kahler, A. A., & Rheault, K. (1989). Profile of the effective vocational agriculture teacher. *Journal of agricultural education*, 30(2), 33-40. DOI: 10.5032/jae.1989.02033
- Minor, L. C., Onwuegbuzie, A. J., Witcher, A. E., & James, T. L. (2002). Preservice teachers' educational beliefs and their perceptions of characteristics of effective teachers. *The Journal of Educational Research*, 96(2), 116-127.
- Mitzel, H. E. (1960). *Teacher effectiveness*. In C. W. Harris (Ed.), *Encyclopedia of Educational Research* (Third Edition). New York: Macmillan.
- Newcomb, L. H., McCracken, J. D., Warmbrod, J. R., & Whittington, M. S. (2004). *Methods of teaching agriculture* (3rd ed.). Upper Saddle River, NJ: Pearson Prentice Hall.
- No Child Left Behind Act of 2001, 20 U.S.C. § 6319 (2002).
- Phipps, L. J., Osborne, E. W., Dyer, J. E., & Ball, A. L. (2008). *Handbook on agricultural education in public schools*. Clifton Park, NY: Thompson Learning.
- Reid, D. J., & Johnston, M. (1999). Improving teaching in higher education: Student and teacher perspectives. *Educational Studies*, 25(3), 269-281.

- Roberts, T. G. (2006). A philosophical examination of experiential learning theory for agricultural educators. *Journal of Agricultural Education* 47(1). 17-29. doi: 10.5032/jae.2006.01017
- Roberts, T. G., & Dyer, J. E. (2004). Characteristics of effective agriculture teachers. *Journal of Agricultural Education*, 45,(4), 82-95. DOI: 10.5032/jae.2004.04082
- Roberts, T. G., Harder, A., & Brashears, M. T. (Eds). (2016). American Association for Agricultural Education national research agenda: 2016-2020. Gainesville, FL: Department of Agricultural Education and Communication.
- Roberts, T. G., & Kitchel, T. J. (2010). Designing professional knowledge, curriculum, and instruction. In Torres, R. M., Kitchel, T. J., & Ball, A.L. *Preparing and advancing teachers in Agricultural Education*. Columbus, OH: Curriculum Materials Service, The Ohio State University.
- Rogers, E. M. (2010). *Diffusion of innovations*. Simon and Schuster.
- Rosenshine, B., & Furst, N. (1969). The effects of tutoring upon pupil achievement: A research review. Washington, D.C.: Office of Education. (ERIC Document Reproduction Service No. ED 064 462)
- Rosenshine, B. and M. Furst. (1971). Research on teacher performance criteria. In B.O. Smith (Ed.). *Research in teaching education*. pp. 27-72. Englewood Cliffs, NJ: Prentice Hall
- Stanford Center for Assessment, Learning, and Equity (SCALE). (2016a). *edTPA Agricultural Education Assessment Handbook*. Palo Alto, CA: Author.
- Stanford Center for Assessment, Learning, and Equity (SCALE) (2016b). *Review of research on teacher education: edTPA task dimensions and rubric constructs*. Stanford Center for Assessment, Learning, and Equality. Retrieved from: [https://secure.aacte.org/apps/rl/res\\_get.php?fid=1705&ref=edtpa](https://secure.aacte.org/apps/rl/res_get.php?fid=1705&ref=edtpa)
- Seevers, B., & Graham, D. (2012). *Education through Cooperative Extension* (3rd ed.). Fayetteville, AR: University of Arkansas.
- Smith, T., W., Baker, W., Hattie, J., & Bond, L. (2008). A validity study of the certification system of the National Board for Professional Teaching Standards. In L. C. Ingvarson and J. Hattie (Eds.), *Assessing teachers for professional certification: The first decade of the National Board for Professional Teaching Standards* (pp. 345–380). Amsterdam, the Netherlands: Elsevier Press.
- Sutphin, C. M., & Hillison, J. (1999). History of Extension work in Virginia prior to Smith-Lever. *Journal of Extension*, 37(6).
- Thorndike, E. L. (1912). *Education: A first book*. New York: Macmillan

Torres, R. M., & Whittington, M. S. (May, 2016). Foundational texts for Teacher Education. In *AAAE Teacher Education Caucus*. Symposium conducted at the meeting of the American Association for Agricultural Education, Kansas City, MO

University of Wisconsin - Extension. (2014). *Logic Model*. Program Development and Evaluation. Retrieved from <http://www.uwex.edu/ces/pdande/evaluation/evallogicmodel.html>

Walls, R. T., Nardi, A. H., von Minden, A. M., & Hoffman, N. (2002). The characteristics of effective and ineffective teachers. *Teacher education quarterly*, 29(1), 39-48.

Young, S., & Shaw, D. G. (1999). Profiles of effective college and university teachers. *Journal of Higher Education* 70(6), 670-686.

## **Power of Statistical Tests Used to Address Nonresponse Error in the *Journal of Agricultural Education***

Donald M. Johnson, University of Arkansas  
Catherine W. Shoulders, University of Arkansas

### **Abstract**

As members of a profession committed to the dissemination of rigorous research pertaining to agricultural education, authors publishing in the *Journal of Agricultural Education (JAE)* must seek methods to evaluate and, when necessary, improve their research methods. The purpose of this study was to describe how authors of manuscripts published in *JAE* between 2006 and 2015 tested for nonresponse error. Results indicated that none of the studies' tests had acceptable power to detect small effect sizes, 14.3% had acceptable power to detect medium effect sizes, and 43% of the studies' tests did not have acceptable power to detect large effect sizes. These findings suggest that while authors frequently find no difference between respondents and others (late respondents, nonrespondents, or the population), the tests used to detect these differences are often not powerful enough to do so, leading to higher than acceptable risk for Type II error and overgeneralization of findings. Using the theory of planned behavior as a framework, we highlight these findings to spur change within the profession's expectations of reporting statistical power when testing for nonresponse error and offer a primer to improve researchers' perceived behavioral control over reporting power. We also offer specific suggestions for conducting and reporting the results of tests for nonresponse bias.

### **Introduction**

According to the *Journal of Agricultural Education's (JAE)* philosophy and policies, the journal exists to provide a vehicle for the wide dissemination of "results of research...in agricultural education" (AAAE, n.d., para. 1). The journal's policies related to article retraction suggest that research articles published within the journal are assumed to be of high rigor. This assumption is supported by the manuscript's review process, which asks reviewers to evaluate manuscripts based on rigor, including the completeness and correctness of the study's methods and procedures. The value of quality research has also been established by experienced reviewers, who stated, "Quality research contributes to the body of knowledge...Manuscripts that fail to adequately demonstrate these characteristics are not useful" (Roberts, Barrick, Dooley, Kelsey, Ravin, & Wingenbach, 2011, p. 1-2).

The American Association for Agricultural Education (AAAE), which is the parent organization for the *JAE*, has suggested the reporting of effect sizes for statistical significance in quantitative data analysis as an aspect of maintaining rigor (AAAE, 2016), as they "enable researchers to judge the practical significance of quantitative research results" (Kotrlik, Williams, & Jabor, 2011, p. 132). This requirement of AAAE research conference submissions echoes the APA's value of effect sizes, as the 2009 guidelines note, "it's almost always necessary to include some measure of effect size in the Results section" (p. 34). According to the Neyman-Person method of statistical inference, the effect size displays the degree to which an alternate hypothesis ( $H_1$ ), which states there is a difference in the mean of a particular characteristic between two or more groups within a population, is different from the null hypothesis ( $H_0$ ), which states there is no



difference in the mean of a particular characteristic between two or more groups within a population (Cohen, 1992). While effect sizes for each statistical test are reported on continuous scales that range upward from zero, with an effect size of zero being equal to the  $H_0$ , Cohen (1988) proposed operational definitions of small, medium, and large effect sizes for each scale which allow researchers to compare effect sizes between studies using different statistical tests. According to Cohen (1992), these definitions were created so that:

Medium [effect sizes] represent an effect likely to be visible to the naked eye of the careful observer. (It has since been noted in effect size surveys that it approximates the average size of observed effects in various fields.) I set small [effect size] to be noticeably smaller than medium but not so small as to be trivial, and I set large [effect size] to be the same distance above medium as small was below it. (p. 156)

Cohen's operational definitions of effect size have been widely adopted for general use across disciplines (Cohen, 1992), including within the discipline of agricultural education (Kotrlik et al., 2011).

However, the ability of a researcher to detect a small, medium, or large effect size, which is termed statistical power, depends on the sample sizes of the groups from which the statistical test was calculated. The power of a significance test can determine whether a researcher is able to find a small, medium, or large effect size that exists within a population, or whether that researcher is more likely than not to miss that effect and instead commit Type II error. Because population sizes in agricultural education vary, it is possible that some researchers fail to obtain sufficient power to detect differences between groups. While committing Type II error leads to more conservative findings and conclusions when determining the impact of treatments that could influence future practices, Type II error can lead to particularly concerning results when used to mitigate nonresponse error. Nonresponse error, which results from failing to include in the sample participants whose responses are representative of all members of a population (Lindner, Murphy, & Briers, 2001), may occur when less than 100% of an appropriately acquired sample responds. If nonrespondents differ from respondents on variables relevant to the survey, generalizing the findings directly from the respondents to the population results in biased estimates of population parameters. According to Reio (2007), the extent of this nonresponse bias can be calculated as:

$$\text{Nonresponse bias} = \text{Proportion of Nonrespondents} (M_{\text{respondents}} - M_{\text{nonrespondents}})$$

Two important insights can be derived from the formula for nonresponse bias. First, a high response rate is not an entirely adequate protection against nonresponse bias if large differences exist between respondents and nonrespondents (Martin, 2004). Second, a low response rate may provide an unbiased estimate of the population parameters if there is little or no difference between respondents and nonrespondents (Martin, 2004). For example, in a survey with an 80% response rate (proportion of nonrespondents = .20) and a mean of 4.50 (on a 1 to 5 scale) for respondents and a mean (although unknown) of 1.50 for nonrespondents, the nonresponse bias is equal to -0.60, resulting in an actual population mean of 3.90, not the biased estimate of 4.50. Conversely, in a survey with a 20% response rate (proportion of nonrespondents = .80) and a mean of 4.50 for respondents and a mean of 4.40 (although, again, unknown) for

nonrespondents, the nonresponse bias is equal to -0.08, and the sample mean for respondents is a relatively unbiased estimate of the population mean of 4.42, despite the low response rate.

Methods to address potential nonresponse bias include comparing respondents to the population on appropriate characteristics, comparing respondents to nonrespondents on specific known characteristics, comparing early to late respondents, and gaining access to nonrespondents in a manner known as “double dipping” (Miller & Smith, 1983). Roberts et al. cited nonresponse as a common threat to research within *JAE* (2011), and because of the numerous methods available to address nonresponse error, stressed that authors “account for non-response error and...select methodologies based on best practices in the social sciences, not on perceived ease” (p. 3). Lindner et al. (2001) determined that of the 114 manuscripts that attempted to control for nonresponse error published in *JAE* between 1990 and 1999, 75.4% did not find any difference between respondents and nonrespondents (which could have been represented by late respondents).

The AAEA membership has previously established the value of examining the procedures used in conducting research, with frequently cited publications recommending authors devote time to improving their knowledge and abilities within research methods (Lindner et al., 2001; Miller & Smith, 1983; Roberts et al., 2011). Cohen (1992) has identified power as a weak area within social science research and noted that while “there is no controversy among methodologists about the importance for power analysis...It is not at all clear why researchers continue to ignore power analysis” (p. 155). Because of the varied sample sizes used within agricultural education research and the frequency with which response rates total less than 100%, the ability for researchers to confidently and accurately report differences between respondents and nonrespondents with acceptable power must be established.

### **Theoretical Framework**

This study examined the power of statistical methods used to test for nonresponse error within manuscripts published in *JAE* between 2005 and 2016 using the theory of planned behavior as a framework. The theory of planned behavior states that an individual’s behavior is a result of his or her intention to perform the behavior, which is influenced by his or her attitude toward the behavior, the subjective norm regarding the behavior, and the individual’s perceived control over the behavior (Figure 1) (Ajzen, 1991).

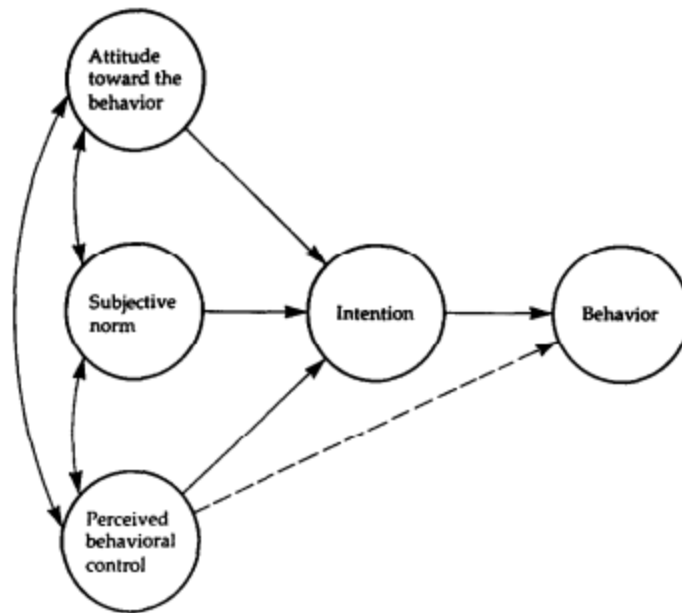

Figure 1. Theory of Planned Behavior (Ajzen, 1991).

A person’s intention to perform a behavior indicates “how hard [her or she is] willing to try, how much of an effort they are planning to exert, in order to perform the behavior” (Ajzen, 1991, p. 181). Intention is shaped by an individual’s perceptions regarding his or her ability to perform the behavior, namely “the ease or difficulty of performing the behavior” (Ajzen, 1991, p. 183). Individuals who are confident in their ability to perform a behavior are likely to put more effort in to performing that behavior; similarly, improving a person’s perceived behavioral control and therefore their behavioral intentions regarding a particular behavior can be increased by increasing available resources or knowledge or reducing unfamiliar elements within the behavioral situation (Ajzen, 1991). Attitude toward a behavior “refers to the degree to which a person has a favorable or unfavorable evaluation or appraisal of the behavior in question (Ajzen, 1991, p. 188). This construct, along with the subjective norms regarding the behavior, which refer to the “perceived social pressure to perform or not perform the behavior” (Ajzen, 1991, p. 188) can combine with perceived behavioral control to determine an individual’s intention to perform a behavior.

Within the context of this study, we use the theory of planned behavior to posit factors which would increase researchers’ likelihood to report power during analysis of differences between respondents and nonrespondents. Because of the previously established value AAAE members place on quality research, we assume researchers hold positive attitudes regarding performing statistical tests with appropriate effect sizes which accurately identify differences within the population (in other words, the researchers would rather not commit Type II error if their actions could reduce its likelihood in occurring). Cohen (1992) has noted an absence of establishing power in a variety of social science disciplines, and posits that reasons for its omission may be due to “the low level of consciousness about effect size” (p. 155) or perhaps “researchers find it too complicated, or do not have at hand...reference material for power analysis” (p. 156). These potential barriers reduce researchers’ perceived behavioral control in calculating and reporting power when testing for nonresponse error. And, as Cohen (1992) mentioned, because few

researchers are reporting power calculations within their manuscripts, there is little expectation or pressure from the research society to do so. The theory of planned behavior suggests that by shifting the subjective norm to include an expectation of power reporting (as has occurred following the publication of previous manuscripts examining research procedures within the profession [Lindner et al., 2001]), and by improving researchers' perceived behavioral control in reporting power calculations via reducing unfamiliar aspects of the concept, researchers' intentions, and ultimately, their behaviors, regarding the reporting of power during tests for nonresponse error can be altered.

### **Conceptual Framework**

To offer readers a framework for the concept of statistical power (Camp, 2001) and reduce any knowledge-related barriers (Ajzen, 1991) to considering power when reporting results of tests used to address nonresponse error, we offer a primer and example. When researchers attempt to determine the differences between two groups of people within a population via samples of individuals from those groups, they are attempting to extrapolate the results from those two samples to the larger population. Therefore, a group that is not representative of the population will be unable to produce results representative of the entire population, particularly if the variable of interest is linked to a characteristic within the group. We will explain this concept using an example wherein a researcher is comparing those that responded and those that did not respond to a survey inquiring about respondents' heart rates. It is possible that nonrespondents were not as healthy as respondents, and were therefore unable to summon the energy to respond to the survey. Had they responded, their responses to the survey about their heart rates would have likely been different than responses from those that were healthy enough to respond. Without comparing respondents to nonrespondents in some way, the researcher would not be able to determine whether the responses received were likely to be representative of the population. When comparing respondents to nonrespondents, the researcher certainly hopes to detect differences between the two groups, should a difference be present. Failing to determine a difference between the two groups would lead the researcher to commit Type II error and lead readers to believe the respondents were characteristic of the entire population when in fact they were not. Type II error in comparing respondents to nonrespondents leads to overgeneralization of findings to a population not represented by the sample. Cohen (1988, 1992) established that research with a 20% chance of committing Type II error is acceptable, which has been a widely adopted standard across disciplines (Field, 2009).

Differences between groups can occur at different levels of magnitude. In our example, the difference between heart rates of healthy respondents and those that did not respond because they were ailing in health would be much smaller than the difference between heart rates of healthy respondents and those that did not respond because they were dead. Further, the difference between respondents and those that did not respond because they were busy doing physical activities would likely be even smaller. The magnitude of the difference on a variable within the population is the effect size, and as Cohen (1988, 1992) has established, the effect size can be small (healthy respondents to physically active nonrespondents), medium (healthy respondents to unwell nonrespondents) and large (healthy respondents to dead nonrespondents). A statistical test's ability to detect these effect sizes is known as power, and is the opposite of Type II error.

Because an acceptable Type II error risk is .20, the minimum acceptable power is 1 - .20, or .80 (Cohen, 1998; 1992; Field, 2009).

While researchers hope to have at least an 80% chance of detecting a difference present between respondents and nonrespondents and only a 20% chance of missing that difference, their ability to do so depends on the sample sizes they use to compare groups. Smaller effect sizes are less apparent than larger effect sizes, and therefore require larger sample sizes for detection. Smaller sample sizes reduce the researcher’s ability to detect a difference, thus reducing power and increasing the risk of Type II error. Power also depends on the statistical test used, as effect size calculations differ by test, and on the significance criterion ( $\alpha$  [alpha level]). While the standard alpha level for social science research is .05, .10 can be used in “circumstances in which a less rigorous standard for rejection is desired” (Cohen, 1992, p. 156). Cohen has established appropriate sample sizes required in order to have an 80% chance of detecting effect sizes of each magnitude and at each alpha level and for each statistical test. Table 1 displays Cohen’s recommended sample sizes per group for tests comparing two means, as two-tailed *t*-tests are most commonly used when comparing respondents to nonrespondents or early respondents to late respondents (Table 1).

Table 1

*N per group for small, medium, and large effect sizes for two-tailed t-tests at power = .80 for  $\alpha = .01, .05, \text{ and } .10$  (Cohen, 1992, p. 158)*

			$\alpha$					
			.05			.10		
	.01		Sm	Med	Lg	Sm	Med	Lg
<b>Sm</b>	Med	Lg	393	64	26	310	50	20
<b>586</b>	95	38						

To illustrate the importance of sample size in the power of tests of significance, we will refer back to our example. To determine the heartrate differences between respondents and nonrespondents, a researcher may use a two-tailed independent samples *t*-test. If, among the population, the researcher anticipates a medium effect size (in our example, a medium effect size was representative of nonrespondents being those in poor health), he or she must have data from 64 respondents and 64 nonrespondents in order to have an 80% chance of finding a difference at the .05 level. If, with 64 cases per group, *t* is not significant, either the actual population effect size is smaller than .50 (a medium effect size for *t*-tests, [Cohen, 1992]), or a Type II error has been committed (of which there is a 20% chance). Illustrating the extreme, we will point out the case if the researcher had fewer than 26 cases per group, at which point he or she would have a less than 80% chance of even detecting the difference in heartrate between the living and deceased (a large effect size,  $\geq .80$ ).

The risk for committing a Type II error in tests of nonresponse error within agricultural education research may be higher than the accepted 20%, as sample sizes used to address nonresponse error can be as small as 10% of the responding sample (Miller & Smith, 1983). Lindner, et al. (2001) found that response rates for studies within *JAE* between 1990 and 1999 ranged from 28% to 100%, with the average being 81.6%. Nearly 70% of studies had a response rate of less than 100%, establishing the need to test for nonresponse error (Lindner et al., 2001). In the Lindner et al. (2001) study, nonresponse error was addressed by comparing early to late

respondents in 31.3% of the studies, by double dipping with a sample of nonrespondents in 18.7% of the studies, by comparing respondents and nonrespondents on characteristics known *a priori* in 2.3% of the studies, and by comparison between respondents and the population on characteristics known *a priori* in 0.9% of the studies. Nearly 47% of the studies with less than a 100% response rate did not attempt to test for nonresponse error.

### **Purpose and Objectives**

The purpose of this study was to describe how authors of manuscripts published in *JAE* between 2006 and 2015 tested for nonresponse error. To achieve this purpose, we developed the following objectives:

1. to describe methods used to test for nonresponse error in manuscripts published in *JAE*;
2. to describe references cited in support of authors' method of testing for nonresponse bias;
3. to describe the frequency with which manuscripts included data and methodological details required to allow readers to conduct *post hoc* power analyses of the authors' statistical tests for testing for nonresponse bias; and
4. to determine the power of tests used in testing for nonresponse error within manuscripts published in *JAE*.

### **Methods**

This descriptive study examined all 127 articles published in the *JAE* between 2006 and 2015, inclusive, where authors reported an attempt to test for nonresponse error. In four articles, the researchers reported unsuccessful attempts to follow-up with nonrespondents and cautioned readers not to generalize beyond the respondents; these articles were included only in the analyses of the methods used to test for nonresponse bias and references cited (objectives 1 and 2). Four articles reported surveys conducted with two populations where efforts were made to test for nonresponse error with each population. For objectives 3 and 4, each test for nonresponse bias was considered as a unit of analysis ( $N = 127$ ).

Articles were identified by manually examining all 526 articles published in the *JAE* between 2006 and 2015. A standardized coding sheet was developed and used to guide data collection from each article, with the following information collected: (a) article identification number, (b) response rate(s), (c) method(s) of testing for nonresponse bias (as described by Lindner et al., 2001), (d) reference(s) cited in support of method(s) used, (e) variable(s) used in statistical comparison(s), (f) statistical test(s) used, (g) test alpha level, (h) expected effect size, (i) sample size for each group, (j) obtained test statistic or *p*-value, (k) whether or not a statistically significant difference was found, and (l) whether statistical power was reported. The title page and the methods section of each identified manuscript were printed and keyed to the identification number on the coding sheet to allow verification of all data. All article coding was completed by one researcher. The second researcher used the same coding sheet to examine a random sample of 13 (10.2%) articles and a 100% agreement was achieved all items coded, providing evidence of the consistency and reliability of the data coding process.

In order for a reader to calculate statistical power *post hoc*, the author must report specific statistical data in the article: (a) the statistical test(s) used, (b) the number of subjects in each

comparison group, (c) the alpha level of the statistical test(s), and (d) the effect size of the difference anticipated in the population (Faul, Erdfelder, Lang, & Buchner, 2007). For this study, in cases where the authors reported the statistical tests(s) used and the number of subjects in each comparison group but did not report the alpha level, the customary alpha level of .05 was assumed. Additionally, in cases where the authors did not report the anticipated effect size, the standard small, medium, and large values offered by Cohen (1992) were assumed in order to allow for any possible researcher effect size expectations to be examined. This resulted in 35 (27.6%) tests of nonresponse bias where statistical power could be calculated *post hoc*. G\*Power Version 3.1.9.2 (Faul et al., 2007) software was used to calculate statistical power and results were confirmed by comparison with Cohen's (1988) power tables.

## Findings

Objective 1 sought to describe methods used to test for nonresponse error in manuscripts published in *JAE* (Table 2). The majority compared early to late respondents (74%,  $n = 97$ ), while double-dipping with nonrespondents was the second-most frequent method. Comparing respondents to a known population, regressing days to respond, and using multiple methods were each employed to a lesser degree.

Table 2

*Methods used to Test for Nonresponse Bias in Articles Published in the Journal of Agricultural Education, 2006 - 2015*

Method	<i>f</i>	%
Compared early to late respondents	97	74.0
Followed up with a sample of nonrespondents	20 <sup>a</sup>	15.3
Compared respondents to population on characteristics known <i>a priori</i>	8	6.1
Regressed days-to-respond on selected variables	3	2.3
Compared early to late respondents AND followed up with a sample of nonrespondents	4	3.0

*Note.* Based on 131 tests reported in 127 articles.

<sup>a</sup>Includes four (4) cases where attempts to follow up with nonrespondents were unsuccessful.

The use of these methods was supported with literature from within and outside of the discipline (Table 3). Lindner et al.'s 2001 manuscript, which was published in *JAE* and proposed three protocols for handling nonresponse issues, was cited most frequently. A manuscript by Miller and Smith (1983), which outlines nonresponse methods and was cited by Lindner et al., was cited in approximately one-third of the manuscripts. Various editions of *Introduction to Research in Education*, by Ary, et al. (1996, 2014) were also cited with some frequency. Almost 10% of articles did not cite any reference in support of their methods for testing nonresponse bias.

Table 3

*References Cited to Support Methods used to Test for Nonresponse Bias in Articles Published in the Journal of Agricultural Education, 2006 - 2015*

Reference Cited	<i>f</i>	% <sup>a</sup>
Lindner, Murphey, & Briers, 2001	76	58.0
Miller & Smith, 1983	45	34.4
Ary, et al. (various editions and co-authors)	13	9.9
Other	10	7.6
None	13	9.9

<sup>a</sup>Percentages total more than 100% because some authors cited multiple sources.

Authors included in their manuscripts various degrees of detail regarding how those methods of testing for nonresponse bias were carried out (Table 4). Less than half of the manuscripts detailed the specific variables on which groups were compared. Slightly more than half of the manuscripts included which statistical test was used in comparing groups, while slightly less than half listed the number of respondents within each comparison group. Less than 20% of manuscripts reported the alpha level of the statistical test or the obtained test statistic or its associated probability. None of the articles stated the statistical power of the test or the expected effect size. Nearly 92% ( $n = 113$ ) of the statistical tests found no difference between groups when testing for nonresponse bias.

Table 4

*Details of Analysis in Tests for Nonresponse Bias Reported in Articles Published in the Journal of Agricultural Education, 2006 - 2015*

Detail of Analyses	Reported in Article	
	<i>f</i>	% <sup>a</sup>
1. Specific variable(s) used for comparison	57	44.9
2. Statistical test used in comparison	66	52.0
3. Alpha level of test(s) <sup>b</sup>	25	19.7
4. Number of respondents in comparison group 1	61	48.0
5. Number of respondents in comparison group 2	59	48.5
6. Expected effect size	0	0.0
7. Test statistic or associated probability	22	17.3
8. Statistical power of test	0 <sup>c</sup>	0.0

<sup>a</sup>Percentages are based on 127 tests for nonresponse bias reported in 123 articles. <sup>b</sup>Where alpha levels and effect sizes were not reported, we assumed the customary alpha level of .05 and analyzed data for effect sizes of small, medium, and large values (Cohen, 1992) in order to allow for any possible researcher expectations to be examined. <sup>c</sup>In four analyses, authors reported a concern about the statistical power of their test, but did not provide the actual power coefficient.

None of the articles contained all the information necessary for a reader to calculate the statistical power of tests of nonresponse bias. However, again, by assuming an alpha level of .05 and using the small, medium, and large effect sizes specified by Cohen (1988), *post hoc* power analysis could be conducted for 35 (27.6%) tests. None of these tests achieved the acceptable power of .80 at the small effect size, five (14.3%) achieved power of .80 at the medium effect



size, and 20 (57%) achieved power of .80 at the large effect size. The average likelihood these tests would detect a small effect size was 15% (Table 5). Manuscripts had a mean power of .57 at the medium effect size, meaning that, on average, the odds of a manuscript accurately detecting a medium effect size was slightly greater than 50/50. The average manuscript power at the large effect size was .86, which exceeds the minimum acceptable threshold of .80.

Table 5

*Post Hoc Analyses of the Statistical Power for Tests of Nonresponse Bias (n = 35) Reported in the Journal of Agricultural Education, 2006 - 2015*

Effect Size <sup>a</sup>	Statistical Power			
	<i>M</i>	<i>SD</i>	Median	<i>IQ</i> <sub>range</sub>
Small ( <i>d</i> = 0.20)	.15	.07	.13	.05
Medium ( <i>d</i> = 0.50)	.57	.21	.56	.23
Large ( <i>d</i> = 0.80)	.86	.15	.92	.15

<sup>a</sup>Descriptors based on Cohen (1988).

### Conclusions/Implications/Recommendations

Fifteen years after Lindner et al. (2001) published results that stated 46% of *JAE* manuscripts did not attempt to test for nonresponse error and provided recommendations for doing so, the state of professional practice in agricultural education research has improved to the point where controlling for nonresponse error is an essential component of manuscript quality (Roberts et al., 2011). As Ajzen (1991) posited, by altering the social norms to include an expectation of testing for nonresponse error and offering familiar methods for doing so, researchers began including tests for nonresponse error in their manuscript writing behaviors more frequently. However, as Cohen (1992) lamented with regard to the work of social scientists in general, authors publishing within *JAE* omitted the subject of power from their statistical calculations. None of the articles published between 2006 and 2015 stated the statistical power of their tests, although 92% of them stated no difference was found (a statement that can only be made with 80% accuracy if the power  $\geq$  .80). Less than one-third of the manuscripts included sufficient detail for the reader to calculate the power of the test used even when assuming the test alpha level and using standard effect sizes.

When power was calculated, we found that none of the manuscripts were able to detect small effect sizes, which were those that are smaller than medium, but not trivial (Cohen, 1992). Eighty-five percent of the manuscripts were unable to detect medium effect sizes, which are those that are observable to the trained eye (Cohen, 1992); in our previously used example, medium effect size was likened to that of the heart rates between healthy individuals and physically unwell individuals. Close to half of the manuscripts were unable to detect even large effect sizes (such as the difference in heart rate between alive and deceased individuals), leading to a very likely chance that the lack of differences found between respondents and others could have actually been the result of Type II error. The dissemination of these findings offer a catalyst to alter the profession's subjective norm regarding the reporting of power when testing for nonresponse error (Ajzen, 1991), as researchers seek to fulfill the expectations of their peers by minimizing their risk for committing Type II error. In order to increase researchers' perceived behavioral control in calculating and reporting power, and in reducing Type II error, we propose several recommended practices when testing for nonresponse error (Ajzen, 1991).

When conducting tests for nonresponse bias, researchers should prioritize statistical power over the employment of previously used methods as they determine appropriate sample sizes for groups of nonrespondents or late respondents. While Miller and Smith (1983) recommended sampling 10-20% of nonrespondents, indiscriminate use of this method without consideration of the number of nonrespondents provides no guarantee with regard to power, and therefore with regard to protecting against Type II error.

We also recommend that researchers determine and report the power of their test(s) of nonresponse bias in order to inform the reader of the risk of Type II error. Researchers should include necessary components for the reader to calculate power on his or her own, including the statistical test used, the number of respondents in each group, the alpha level used, and the anticipated effect size. While no published rule exists on the methods for anticipating effect sizes within a population, we recommend researchers cite justification from the existing literature base for their estimates whenever available. The following may serve as an example for reporting the results of tests for nonresponse bias:

To test for nonresponse bias, early respondents (those responding prior to the third mailing,  $n = 102$ ) were compared to late respondents ( $n = 59$ ), on the variable 'commitment to teaching as a career', using a two-tailed independent  $t$ -test at the .05 alpha level; the power of the test was .85 for a medium effect (*Cohen's*  $d = 0.50$  [Cohen, 1988]). There was no significant difference between early ( $M = 4.43$ ,  $SD = 0.82$ ) and late ( $M = 4.34$ ,  $SD = 0.87$ ) respondents,  $t(157) = 0.65$ ;  $p = .52$ . Thus, the findings were generalized to the population (Miller & Smith, 1983; Linder et al., 2001).

We believe researchers should be more open to the possibility that respondents and nonrespondents are different in meaningful ways and that nonresponse bias is a threat to generalizability until we have sufficient evidence to the contrary. Subjects who do not respond to a survey (or respond late) already differ from those who do respond (or respond early) in at least one dimension. Despite this difference, we traditionally assume respondents and nonrespondents are not different and then require overwhelming evidence ( $p < .05$ ) of this difference before we are willing to acknowledge the possibility of nonresponse bias. Researchers are accustomed to assuming no difference exists between groups until proven otherwise ( $H_0$ ) when hypothesis testing in order to yield conservative results and avoid mistakenly generalizing results beyond the sample. However, this same assumption, when testing nonresponse bias, actually yields less conservative results (finding no difference where there is one yields to overgeneralization of the study's results). Therefore, we recommend researchers not reflexively use the .05 alpha level in testing for nonresponse bias. When selecting an alpha level, researchers directly control the probability of committing a Type I error and indirectly the probability of committing a Type II error (Mitchell & Jolley, 2010). In introductory research methods courses, many of us were taught that, instead of blindly following convention, we should base our alpha level on the relative consequences of committing a Type I versus a Type II error. In testing for nonresponse bias, a Type I error incorrectly leads researchers to limit their findings, conclusion, and recommendations to the respondents. Conversely, a Type II error incorrectly leads researchers to generalize from the respondents to the population when this generalization is not appropriate. We argue that, given the state of the science in agricultural education research, Type I errors are

generally less consequential than Type II errors in this specific instance and recommend use of less conservative alpha levels (.10 or .15) in tests of nonresponse bias (Cohen, 1988).

Finally, when tests with acceptable power yield statistically significant differences between groups or when acceptable power is not attainable, researchers should caution readers against generalizing results beyond the sample of respondents to prevent overgeneralization the findings. Studies yielding valid results of interest to the profession from a specific groups of respondents, regardless of their generalizability, can add to the body of knowledge and assist researchers as they design and conduct research. Stated differently, researchers within agricultural education should accept the proposition that meaningful results appropriately limited to only the respondents are more valuable than results inappropriately generalized to the population.

The results of this study confirm Cohen's (1992) concerns about omitting consideration of power when employing statistical tests. While the recommendations made align with those made by Cohen (1988, 1992), change in the societal norms regarding testing for nonresponse error and the inclusion of power calculations within *JAE* is in the hands of the profession's members. As Lindner, et al. (2001) stated, "the profession will verify or refute the utility of the methods proposed here" (p. 52). Regardless of the behavioral change produced, any examination into the utility of these recommendations will continue to further the profession's commitment to improvement in research methods (Lindner et al., 2001; Miller & Smith, 1983; Roberts at al., 2011).

### Literature Cited

- AAAE. (n.d.) JAE philosophy. *The American Association for Agricultural Education*. Retrieved from <http://jae-online.org/index.php/philosophy>.
- AAAE. (2016). AAEE Manuscript Submission Guide. Retrieved from <http://aaaeonline.org>.
- Ajzen, I. (1991). The theory of planned behavior. *Organizational Behavior and Human Decision Processes*, 50, 179-211.
- Ary, D., Jacobs, L., & Razavieh, A. (1996). *Introduction to research in education* (5th ed.). Fort Worth, TX: Holt, Rinehard, & Winston, Inc.
- Ary, D., Jacobs, L.C., Sorenson, C. K., & Walker, D. (2014). *Introduction to research in education* (9th ed.). Belmont, CA: Cengage Learning.
- Camp, W. G. (2001). Formulating and evaluating theoretical frameworks for career and technical education. *Career and technical education research*, 26(1), 1-5.
- Cohen, J. (1988). *Statistical power analysis for the behavioral sciences* (2nd ed.). Hillsdale, NJ: Erlbaum.
- Cohen, J. (1992). A power primer. *Psychological Bulletin*, 112(1), 155-159.

- Faul, F., Erdfelder, E., Lang, A.-G., & Buchner, A. (2007). G\*Power 3: A flexible statistical power analysis program for the social, behavioral, and biomedical sciences. *Behavior Research Methods*, 39, 175-191.
- Field, A. (2009). *Discovering statistics using SPSS*. (3rd ed.). Thousand Oaks, CA: SAGE Publications.
- Kotrlík, J. W., Williams, H. A., & Jabor, M. K. (2011). Reporting and interpreting effect size in quantitative agricultural education research. *Journal of Agricultural Education*, 52(1), 132-142. doi: 10.5032/jae.2011.01132
- Lindner, J. R., Murphy, T. H., & Briers, G. E. (2001). Handling nonresponse in social science research. *Journal of Agricultural Education*, 42(4), 43-53. Doi: 10.5032/jae.2001.04043
- Martin, E. (2004). Presidential address: Unfinished business. *Public Opinion Quarterly*, 68(3), 439-450. doi: 10.1093/poq/nfh020
- Miller, L. E., & Smith, K. L. (1983). Handling nonresponse issues. *Journal of Extension*, 21(5), 45-50.
- Mitchell, M. L., & Jolley, J. M. (2010). *Research design explained* (7th ed.). Independence, KY: Wadsworth Centage Learning.
- Reio, Jr., T. G. (2007). Survey nonresponse bias in social science research. *New Horizons in Adult Education and Human Resource Development*, 21(1/2), 48-51.
- Roberts, T. G., Barrick, R. K., Dooley, K. E., Kelsey, K. D., Raven, M. R., & Wingenbach, G. J. (2011). Enhancing the quality of manuscripts submitted to the *Journal of Agricultural Education*: Perceptions of experienced reviewers. *Journal of Agricultural Education*, 52(3), 1-5. doi: 10.5032/jae.2011.03001

## **Extension's Role in Saving Citrus: Entering the Genetic Modification Science Conversation**

Taylor K. Ruth, University of Florida  
Alexa J. Lamm, University of Florida  
Joy N. Rumble, University of Florida

### **Abstract**

Extension agents across the nation will need to facilitate difficult conversations with the public if genetic modification (GM) science is used to combat citrus greening disease. This study used the innovation characteristics described by Rogers to explore if using GM science as a solution to citrus greening had diffused amongst US residents. An online survey was completed by 1,051 respondents across the US. Respondents were then classified into geographic regions. Demographic differences amongst respondents from the regions were identified however respondents from all regions had neutral perceptions of GM science's compatibility, trialability, complexity, and observability. All regions aside from the West agreed there was a relative advantage to using GM science; the West neither agreed nor disagreed. The Midwest was the only region with half of respondents agreeing they would consume GM citrus. All diffusion characteristics aside from observability were predictors of GM citrus consumption, and the Midwest was less likely to consume GM products when compared to the Northeast. Recommendations are offered for how extension agents can develop educational programming tailored to the needs of their regions to aid consumers in making educated decisions about GM citrus in the future.

### **Introduction**

Extension agents are often referred to as "change agents" and help communities adapt to a variety of issues (Peek et al., 2015). Extension is not only tasked with educating the public (Benge, Harder, & Carter, 2011) but engaging the public to help solve complex problems (Warner, Hinrichs, Schneyer, & Joyce, 1998). These problems are not always simple, and extension agents have been asked by university and public leaders to facilitate conversations with the public about contentious and controversial topics (Patton & Blaine, 2001; Welch & Braunworth, 2010).

One of the most complicated topics extension agents communicate about is conventional versus nonconventional agriculture (Martin, 2016) and includes discussions about genetically modified (GM) crops (U.S. Department of Agriculture [USDA], 2015). In the past, extension agents have felt unprepared to foster conversations with the public about GM science and have expressed concern about providing the public with balanced information (Brown, Kiernan, Smith, Highes, 2003). A recent meta-analysis concluded that GM crops posed no harm to human health (National Academy of Sciences, 2016; Nicolia, Manzo, Veronesi, & Rosellini, 2014), yet consumers have historically expressed suspicion of the technology (Senauer, 2013) and have been unsure about its associated risks and benefits (Ruth & Rumble, 2016). President Obama signed a law in August of 2016 that mandated food containing GM ingredients be labeled (Popken, 2016), which will likely drive more conversations amongst the public on the topic. To complicate matters, people living in different areas may hold varying agricultural values and require tailored extension education programs (Martin, 2016).

GM science may be a topic of debate, but it may be the only way to save the citrus industry as it battles citrus greening, a disease destroying the US citrus industry with no current solution. Citrus greening, or Huanglongbing (HLB) is caused by a bacterium spread by a small insect called the Asian citrus psyllid (UF/IFAS Citrus Extension, 2016a). The disease affects the entire tree and causes the fruit to taste bitter (UF/IFAS Citrus Extension, 2016b). There is no cure for citrus greening and no management practices that would be affordable for farmers (Singerman & Useche, 2016). Production dropped by over 100 million boxes in Florida during the 2014 season, and farmers reported 80% of their trees have been infected with HLB (Singerman & Useche, 2016). This disease could be the end of the \$9 billion orange industry in Florida (Voosen, 2014). Researchers have already used GM science to create trees resistant to citrus canker, another major citrus disease, and have been using similar strategies to test greening resistant trees as well (Allen, 2016). Scientists are optimistic that GM science will be used to create citrus greening resistant trees in the near future (Allen, 2016). Experts in the industry expect that GM citrus trees could be the solution to the problem, but only if consumers are willing to purchase and drink GM orange juice (Voosen, 2014).

Citrus production is not limited to Florida alone, with California and Texas as the two other major citrus producing states in the US (USDA, 2016b). Citrus greening had reached all three citrus producing states by 2014 (Harrell, 2014). While the disease has the potential to devastate citrus producing communities, consumers across the US will be affected if a solution is not found. Consumption of orange juice is expected to increase, yet customers may not be able to find or purchase it if citrus greening continues to decrease orange production (USDA-Foreign Agricultural Services [FAS], 2016).

With GM science as a viable solution to the disease, extension agents will need to learn how to facilitate potentially difficult conversations between researchers, growers, and consumers. Extension agents' concerns about balancing facts and values regarding GM science (Brown et al., 2002) will need to be addressed before proper educational programming can be developed.

Even though citrus is primarily grown in three states, orange juice is consumed across the nation. As a national problem, extension agents need to be able to recognize how different regions of the US view GM science as a solution to citrus greening. Differences in newspaper coverage of GM science has been identified between regional areas of the US (Crawley, 2007), and the differences may be reflective in residents' attitude toward the technology. Variations in political ideology across the nation could also lead to differing degrees of acceptance of GM science. In accordance with Priority 2 of the National Research Agenda (Roberts, Harders, & Brashears, 2016), the purpose of this study was to explore the diffusion of the idea of using GM science amongst US residents as a solution to citrus greening in different regions of the US.

### **Theoretical Framework**

Diffusion of innovations theory provided the framework for this study. Rogers (2003) described an innovation as a type of idea or practice that a group or person would consider new. The adoption of the innovation is dependent upon its perceived relative advantage, compatibility, complexity, trialability, and observability. The relative advantage of the innovation only has to be perceived by the person/group as being better than an alternative and does not have to be concrete (Rogers, 2003). How well the innovation aligns with the adopters' social norms and

values is its compatibility. Complexity describes how easy or difficult it is to understand the innovation, and trialability is how easily it can be tested. The final characteristic, observability, describes how well potential adopters can view others using the innovation. Innovations high in relative advantage, compatibility, trialability, and observability but low in complexity will diffuse the quickest through a group (Rogers, 2003). Additionally, people who guide others' behaviors through social interactions, or opinion leaders, influence the rate of adoption for an innovation. After an opinion leader shares his or her experience with the innovation, the diffusion typically increases through the group (Rogers, 2003).

Extension has explored the diffusion of GM science amongst farmers (Perterson, Cassman, & Cantrell, 2002), but there have been few studies examining the diffusion of GM science amongst consumers. Weick and Walchi (2002) used the theory to explore diffusion of GM science with the public. The researchers concluded the relative advantage of GM crops provided benefits to farmers, but consumers viewed GM crops as having health, ethical, and environmental disadvantages compared to non-GM crops (Weick & Walchi, 2002). However, GM science was found to align more with American values when compared to Europeans, which made the innovation moderate in compatibility. Distinction between traditional, selective breeding of crops and genetic engineering has increased the complexity of understanding GM crops for the consumer (Weick & Walchi, 2002). While there are plenty of opportunities for consumers to purchase and try GM food, many of the GM products on the market do not directly benefit consumers. Consumers may have eaten GM food and not realized it, which lowered the trialability. Similarly, consumers were unable to observe the benefits of others using GM food due the lack of direct benefits, which also lowered observability (Weick & Walchi, 2002).

Klerk and Sweeney (2007) researched the effect of knowledge on perceptions of risk and adoption of GM food. The researchers concluded that for perceptions of relative advantage to increase, consumers would have to possess more positive attitudes toward the innovations than they did at the time. Rumble et al. (2016) looked specifically at the diffusion of GM science to combat citrus greening amongst undergraduate students in a citrus growing state. Relative advantage was the only diffusion characteristic viewed positively by the students; however, compatibility was the only characteristic predictive of students' likelihood of consuming GM citrus. Rumble et al. (2016) suggested research should be conducted on consumers nationwide to determine if the millennial generation differs in their attitudes toward GM science and purchasing behavior when compared to the average consumer. This research explored what US consumers believe about the diffusion of GM science, specifically examining perceptions of diffusion characteristics, and determine if differences exist in different regions of the US.

The U.S. Census Bureau (2015) divided the country into four main regions: Northeast, South, Midwest, and West. The southern region includes Florida, Georgia, South Carolina, North Carolina, Virginia, West Virginia, Maryland, Delaware, Kentucky, Tennessee, Alabama, Mississippi, Arkansas, Louisiana, Oklahoma, and Texas. The southern region of the US has over one-third of the farms in the US and is known for growing high yields of cotton and fruits (USDA, 2000). In 2012, 94% of cotton fields were GM (USDA, 2016a). Maine, New Hampshire, Vermont, Massachusetts, Connecticut, Rhode Island, New York, New Jersey, and Pennsylvania are all considered Northeastern states. This is the most populous region of the US, but accounts for 15% of US farms and 9% of the total cropland. Midwestern states have more cropland than any other area, the largest farms, and grow mostly cash grains (USDA, 2000),

which include corn and soybeans. Eighty-five percent of corn acres and 75% of soybean acres in the US have been planted with GM crops (Fernandez-Cornejo, Wechsler, Livingston, & Mitchell, 2014). North Dakota, South Dakota, Nebraska, Kansas, Montana, Iowa, Missouri, Wisconsin, Illinois, Michigan, Indiana, and Ohio are all considered Midwestern states. Western region agriculture includes high production of fruits and more non-family farms than any other regions; however, this region has the least amount of cropland (USDA, 2000). Western states are Washington, Oregon, Idaho, Montana, Wyoming, Colorado, Utah, Arizona, New Mexico, Nevada, and California. The final US region is the Pacific region and includes Alaska and Hawaii. Alaska is not known for growing GM crops, but approximately 75% of the Papaya in Hawaii were developed with GM science to stop the spread of a virus that was devastating the islands (Callis, 2013).

### **Purpose and Objectives**

The purpose of this research was to explore the diffusion of GM science as a potential solution to citrus greening amongst different regions of the US so extension programs can be developed applicable to discussing GM science. The following research objectives guided this study:

RO1: Describes respondents in the Southern, Northeastern, Midwestern, and Western regions of the US.

RO2: Describe different regions' perceptions of GM science's diffusion characteristics.

RO3: Explore differences in regions' perceptions of GM science's diffusion characteristics.

RO4: Explore differences in regions' likelihood to consume GM citrus products.

RO5: Determine how US region, relative advantage, compatibility, complexity, observability, and trialability predict likelihood to consume GM citrus products.

### **Methodology**

An online survey instrument was used to collect the data for this study. The population of interest was US residents, 18 years and older. Qualtrics, an online public opinion research company, distributed the instrument to a non-probability sample of an opt-in panel. The survey was distributed to 1,751 potential respondent in all 50 states in the US. To ensure that responses were received from each state, quota sampling procedures were used at the beginning of the instrument. Additionally, two attention filters were used in the survey to ensure respondents were thoughtfully considering the questions. There were 1,051 respondents who met the quota requirements and passed the attention filters, which resulted in a 60% participation rate. Post-stratification weighting procedures were used to increase the generalizability of the research. The respondents were weighted on sex, race, and age to align with the 2010 National Census. Weighting procedures can lessen the effects of non-probability sampling, such as exclusion, non-participation, and selection bias, and provide representation sometimes better than probability sampling (Baker et al., 2015).



Although this research was part of a greater study, six constructs in addition to demographic questions were analyzed to fulfill the purpose. All questions were researcher-developed. Demographic questions included age, sex, income, education, race (check all that apply), ethnicity, and political affiliation.

Semantic differential and Likert-type scales were used to collect respondents' perceptions of GM science's diffusion characteristics. Relative advantage, compatibility, and trialability were measured with Likert-type scales that ranged from 1 = *strongly disagree*, 2 = *disagree*, 3 = *neither agree nor disagree*, 4 = *agree*, and 5 = *strongly agree*. Relative advantage used eight items, which were averaged, to create the construct. Higher scores represented agreement that GM science offered a relative advantage. The items included statements like "GM science increases the amount of food a farmer can grow" and "GM science enhances the taste of food."

Compatibility was measured with a six-item scale that asked respondents how GM science aligned with their personal values and beliefs. Negatively framed statements like "Overall, GM science does more harm than good" were reverse coded so that a five indicated respondents agreed GM science was compatible. The items were averaged to make the construct.

Trialability used five statements like "food products that result from plants made with GM science are easy to try" and "if given the opportunity, I would try food products that result from plants made with GM science." Each statement was coded so that five indicated agreement that food made by GM science could be tried and one indicated disagreement. The construct was measured by averaging the five items. Real limits were created to aid in the interpretation of the results (Colwell & Carter, 2012). Relative advantage, compatibility, and trialability used the following real limits: 1.00 – 1.49 = *strongly disagree*, 1.50 – 2.49 = *disagree*, 2.50 – 3.49 = *neither agree nor disagree*, 3.50 – 4.49 = *agree*, 4.50 – 5.00 = *strongly agree*.

Five-point, semantic differential scales measured respondents' perceptions of complexity and observability. Negative adjectives, such as "complex" and "invisible," were assigned a one and positive adjectives, like "simple" and "visible" were assigned a five. The complexity construct included six pairs of adjectives and observability included six pairs too. Both constructs were created by averaging the items in each scale.

To determine if the idea of GM science had diffused amongst respondents, the final question asked their likelihood of consuming fruit or juice grown on a GM tree. A five-point Likert-type scale with the following labels was used to answer the question: 1 = *extremely unlikely*, 2 = *unlikely*, 3 = *neither likely nor unlikely*, 4 = *likely* and 5 = *extremely likely*. The question was recoded into a dichotomous variable to use as the dependent variable in a logistic regression. Respondents were coded as likely to consume GM citrus products if they selected likely or extremely likely to consume the fruit, and were coded as not likely to consume GM citrus products if they selected the alternatives.

A panel of experts reviewed the survey prior to distribution to account for the validity of the instrument. The panel included an associate professor with expertise in survey design, an assistant professor who specializes in food production and the Associate Director for the Center for Public Issues Education at the University of Florida. After receiving IRB approval from the

University of Florida, a pilot test confirmed that all constructs, except one, were reliable at an alpha level of at least 0.7 (Field, 2013). Initially, trialability had a Cronbach’s  $\alpha$  of .67. After removal of one item in the construct, reliability increased to .76. In order to avoid a history effect, the survey was only open for two days (Ary, Jacobs, & Sorensen, 2010).

Regions of the US were created following the US census guide. For objectives one and two, simple descriptive statistics were used to analyze the results. Objective three was fulfilled by using an ANOVA and a *post hoc* test. Because of unequal groups sizes in the regions, Tukey-HSD was used to determine individual differences between regions. Descriptive statistics and Chi-square analysis were used to explore objective four. Finally logistic regression was used to fulfill objective five. The regions were recoded as dummy variables, and the Northeast was treated as the control because it had the largest sample size (Field, 2013).

## Results

### Description of Respondents

The demographics of the respondents can be seen in Table 1. The largest proportion of respondents in the South and Midwest were between the ages of 45 and 64. The largest age group in the Northeast and West was 25 to 44. The Northeast and Midwest were also the only regions where the majority of respondents were women. All four regions had similar education characteristics, but the Northeast had more respondents earning \$150,000 or more annually compared to other regions. Nearly a quarter of respondents in the Northeastern and Western regions identified themselves as Hispanic. The west also had the highest proportion of respondents whose race was categorized as other and smallest proportion of white respondents. The largest political affiliations in the Midwest and West were independent, while almost half of the Northeast respondents and one-third of Southern respondents were democrats.

Table 1

#### *Description of Respondents*

	South <i>n</i> = 253 %	Northeast <i>n</i> = 317 %	Midwest <i>n</i> = 254 %	West <i>n</i> = 227 %
Age				
18-24	12	11	12	10
25-44	33	43	28	41
45-64	37	29	38	34
65+	18	18	23	16
Gender				
Female	49	57	51	46
Male	52	43	49	54
Education				
High School or less	17	14	14	20
Some College	30	22	30	26
2-year College Degree	14	11	8	13

4-year College Degree	27	35	32	27
Graduate or Professional School	12	19	16	15
Income				
\$25,000 >	16	15	23	16
\$25,000 -\$49,999	25	18	33	28
\$50,000 -\$74,999	22	10	19	20
\$75,000 -\$149,999	34	35	20	32
\$150,000 or more	4	14	6	4
Race				
White	84	80	82	69
African American	14	16	11	11
Other	3	6	8	24
Hispanic	3	24	4	26
Political Affiliation				
Republican	30	16	16	22
Democrat	36	50	33	36
Independent	32	31	41	37
Other	2	3	2	5

### Regional Perceptions of Diffusion Characteristics

The South, Northeast, and Midwest respondents agreed that GM science had a relative advantage, but the West neither agreed nor disagreed about the relative advantage (Table 2). All four regions neither agreed nor disagreed about the compatibility or trialability of GM science. Additionally, all regions indicated that GM science was average in complexity and observability.

Table 2

#### *Description of Regions' Perceptions of GM Science Relative Advantage, Compatibility, Complexity, Observability, and Trialability*

	South <i>n</i> = 253 <i>M</i> ( <i>SD</i> )	Northeast <i>n</i> = 317 <i>M</i> ( <i>SD</i> )	Midwest <i>n</i> = 254 <i>M</i> ( <i>SD</i> )	West <i>n</i> = 227 <i>M</i> ( <i>SD</i> )
Relative Advantage	3.58 (0.76)	3.62 (0.69)	3.61 (0.71)	3.49 (0.75)
Compatibility	3.22 (0.74)	3.30 (0.73)	3.26 (0.67)	3.18 (0.46)
Complexity	2.65 (0.75)	2.77 (0.79)	2.61 (0.79)	2.61 (0.74)
Observability	2.89 (1.09)	2.67 (0.95)	2.56 (0.95)	2.59 (0.91)
Trialability	3.32 (0.80)	3.47 (0.72)	3.27 (0.65)	3.25 (0.84)

### Differences Regional Perceptions of Diffusion Characteristics

ANOVAs between the regions and the diffusion characteristics were not statistically significant for relative advantage and compatibility. However, statistically significant associations were identified between region and complexity ( $F(3, 1046) = 2.97, p = .03$ ), observability ( $F(3,$

1046) = 5.37,  $p < .01$ ), and trialability ( $F(3, 1046) = 4.82, p < .01$ ). *Post hoc* tests identified the Northeast viewing GM science as more complex compared to the Midwest, and the South viewing GM science as more observable than the Midwest and West. Additionally, the Northeast viewed trialability as greater than the Midwest or West (Table 3). There were no other statistically significant differences between regions.

Table 3

*Follow-up Tukey-HSD between Regions and Diffusion Characteristics*

	<i>I</i>	<i>J</i>	<i>Mean Difference (I-J)</i>	<i>p</i>
<u>Complexity</u>	Northeast	South	.13	.21
		Midwest	.17	.05*
		West	.16	.08
<u>Observability</u>	South	Midwest	.31	.00**
		Northeast	.20	.07
		West	.29	.00**
<u>Trialability</u>	Northeast	South	.15	.08
		Midwest	.20	.01**
		West	.21	.00**

Note. \* $p < .05$ , \*\*  $p < .01$

**Likelihood to Consume GM Citrus by Region**

The majority of respondents in each region indicated they were not likely to consume GM citrus products (Table 4). The only exception was the Midwestern respondents were split on whether or not they would consume GE citrus products. A chi-square between region and likelihood to consume GM citrus was not statistically significant, which indicated region of origin did not impact likelihood to consume GM citrus ( $X^2(3) = 6.12, p = .11$ ).

Table 4

*Respondents Likely to Consume GM Citrus Products*

	<i>n</i>	<i>%</i>
South	253	39
Northeast	317	46
Midwest	254	50
West	227	43

**Predicting Likelihood to Consume GM Citrus**

The logistic regression model was statistically significant ( $X^2(8) = 414.82, p < .00$ ) and could account for approximately 43.7% ( $pseudo-R^2 = .437$ ) of the variance in likelihood of consuming GM citrus products. Compared to the Northeast, Midwest respondents were less likely to consume GM citrus products. Relative advantage, compatibility, complexity, and trialability were all statistically significant predictors of likelihood to consume GM citrus, but observability

was not. As the relative advantage of GM science increases by one, the log odds of consumers likely to consume GM citrus products increases by 3.24. Additionally, as compatibility, complexity, and trialability increase by one, the log odds of likelihood of consuming GM citrus products increases by 1.98, 1.43, and 2.20 respectively. A full description of the results can be seen in Table 5.

Table 5

*Likelihood of Consuming GM Citrus*

	<i>b</i>	<i>Log Odds</i>	<i>p</i>
Midwest	-.53	.59	.01**
South	.21	1.24	.33
West	-.30	.74	.16
Relative Advantage	1.18	3.24	.00**
Compatibility	.70	1.98	.00**
Complexity	.36	1.43	.00**
Trialability	.79	2.20	.00**
Observability	.02	1.02	.83

Note. \*\*  $p < .01$

### Conclusions & Implications

With GM science as one of the few viable solutions to citrus greening, this research sought to examine the diffusion of the idea of GM science in different US regions to assist in developing extension programs that help producers communicate with consumers about GM science use in citrus production. Respondents in all four regions, South, Northeast, Midwest, and West, had neutral perceptions of the compatibility, complexity, trialability, and observability of GM science. This finding is reflective of consumers being unsure about the associated risks and benefits of GM science (Ruth & Rumble, 2016). Additionally, observability and trialability have been difficult for consumers to identify (Wieck & Walchi, 2002), which may explain the neutral perceptions. Similar to what was found by Rumble et al. (2016) respondents did positively perceive the relative advantage of GM science in the South, Northeast, and Midwest, but Western region respondents were neutral about the advantages. Based on Rogers (2003) description of the diffusion characteristics, the idea of GM science has likely diffused throughout the public more so in the South, Northeast, and Midwest compared to the West. However, the neutral perceptions of the diffusion characteristics aside from relative advantage indicated the technology has not yet been fully adopted by the public. While statistical associations were noted between the regions for the complexity, observability, and trialability of GM science, the large standard deviation for the scores indicated that practical differences were not present. Although these regions have varying types of agricultural production (USDA, 2000), political climates, and news coverage of GM science (Crawley, 2007), the residents shared similar views toward the technology.

Regardless of region, the majority of respondents indicated they were not likely to consume GM citrus, which could be devastating to the citrus industry if GM science were to be used to combat citrus greening. The regions with the highest percent of respondents reporting they would not consume GM citrus were the South and West. These regions include Florida, Texas, and California – the top three citrus producing states in the country (USDA, 2016b). This evidence indicates a possible disconnect between the consumers in these areas and understanding the severity of citrus greening in their communities and on their state economy. Since GM food will be labeled in the near future (Popken, 2016), consumers will be alerted if their citrus is GM and less likely to purchase it. If producers are able to save their groves with GM science but unable to sell their product, the industry will remain in distress.

Even though the South, Northeast, Midwest, and West had similar perceptions toward GM science and likelihood to consume GM citrus products, living in the Midwest was predictive of likelihood to consume the GM fruit. Compared to the Northeast, Midwest consumers were a little more than half as likely to consume GM citrus. This finding was supported by Midwest respondents viewing GM science as more complex and harder to try compared to the Northeast respondents. Viewing the diffusion characteristics in this way indicate diffusion of the idea of GM science would be less in the Midwest compared to the Northeast (Rogers, 2003), and was supported by the regression model. The Midwest produces the highest yields of GM crops, like corn and soy, in the US (USDA, 2000). The Midwest residents may be more exposed to controversial discussions about use of GM science, which makes them less likely to consume a GM product compared to the Northeast, where GM crops are not typically grown. An alternative explanation could be that citrus is not grown in the Midwest, and the residents do not see the connection or need for producing GM citrus.

Positive perceptions of relative advantage, compatibility, trialability, and complexity also increased odds of the likelihood of consuming GM citrus products. This finding differed from previous studies with college students where only compatibility was predictive of consumption (Rumble et al., 2016). This difference could be due to different values between college students and the general public. In addition, regional location was included in the analysis and may be accounting for variance in the model that was not accounted for in the study conducted by Rumble et al. (2016). Positive perceptions of relative advantage increased the odds of consumption by more than three, making it the strongest predictor, which was consistent with previous literature (Klerk & Sweeney, 2007). These findings supported the diffusion of innovations theory (Rogers, 2003) and GM science being viewed as an innovation.

### **Recommendations**

If GM science is used as a solution for citrus greening, extension agents will need to facilitate difficult conversations in the future to address the issue. Most of the diffusion characteristics were viewed neutrally, which means polarized attitudes have yet to form for or against the technology. However, consumers were not likely to consume citrus produced using GM science, which is alarming. Consumers likely have questions or concerns about GM science, which is why their attitudes were mostly neutral. Extension can serve the role as liaison between researchers and the public (Patton & Blaine, 2001; Welch & Braunworth, 2010) to address these concerns and provide people with relevant information about GM science to form educated opinions.

Limited differences in regional perceptions of GM science were identified, but citrus producing regions of the US had the highest proportion of respondents reporting they would not be likely to consume GM citrus products. In these areas in particular, extension agents should create educational and awareness campaigns that highlight the importance of citrus in these communities and the effect of citrus greening on local farmers. Consumers may be uninformed about citrus greening, which could create a disconnect for why their citrus would be GM in the first place. Similarly, extension agents in the Midwest could also work on educating residents about citrus greening. They were less likely to consume GM citrus products than the Northeast, and increasing the personal relevance of citrus greening could help consumers make educated purchasing decisions. One way to emphasize relevance would be explaining that as the disease continues to spread, orange juice prices will increase.

Relative advantage, compatibility, complexity, and trialability were all predictors of likelihood of consuming GM citrus. Extension programs should focus on these four areas to provide the public with appropriate information to make purchasing decisions in the future. To address relative advantage, extension agents could present information about citrus greening and potential solutions to the problem so consumers can better understand how and why GM science would be used in citrus. Inviting opinion leaders in communities to tour orange groves affected by citrus greening is another way to demonstrate the potential need for GM science in the citrus industry. By inviting opinion leaders specifically, the information can be shared with a broad audience that the public would view credible (Rogers, 2003).

Compatibility with GM science can be addressed through forum style discussions about the technology. Providing people a safe space to express their concerns about the use of GM science and have their questions answered by university researchers and local farmers would allow extension agents to discuss more than just the science. Discussing concerns based on values and beliefs would allow people to make informed decisions about the compatibility of GM science. Concerns about complexity could also be discussed at these types of events. Small, informal discussions with scientists at local coffee shops or diners are one way to encourage discussion and lessen the complexity related to GM science. These strategies could ease extension agents' concerns about balancing consumers' worries related to both values and facts (Brown et al., 2002).

Trialability of GM science may be difficult for consumers to recognize they are participating in (Weick & Walchi, 2002), and extension agents should consider providing opportunities for people to try and reflect upon eating GM food. Hosting lunch and learns could help people identify what foods have been developed with GM science and recognize what GM food they are exposed to on a daily basis. Additionally, if GM science is used with citrus in the future, extension agents will need to proactively provide opportunities for consumers to try the fruit. Focusing on increasing trialability with opinion leaders would also help to increase the rate of adoption for GM citrus (Rogers, 2003).

Future research could utilize qualitative methods to gather deeper insight into people's perceptions and knowledge of GM science and their likelihood to consume GM citrus. This study measured behavioral intent to consume GM citrus, but providing respondents with the

opportunity to try GM citrus (and telling them it was not GM after the study if the products are not on the market yet) would give researchers a better idea of people's behavior related to GM citrus consumption. Another research possibility includes hosting a science café or discussion about GM science and collecting information about knowledge and perceptions of the technology. This information could provide extension agents with guidance for program development around GM science. With the passing of the labelling law for GM food, another potential line of research would be to see if consumers notice the label and how that affects their purchasing behaviors.

While this survey used post-stratification weighting to lessen the effects of non-probability sampling, simple random sampling of the US population would help increase the generalizability of the study. This study was also confined to US residents alone. Replicating the survey in other citrus producing countries, or to countries the US exports citrus to, could provide valuable insight into cultural differences in perceptions of GM science. While differences in perceptions were not found between the identified regions in the study, analyzing perceptions of GM science between citrus producing states and non-citrus producing states could yield different results.

### References

- Ary, D., Jacobs, L. C., & Sorensen, C. (2010). *Introduction to research in education* (8<sup>th</sup> ed). United Kingdom: Wadsworth Cengage Learning.
- Allen, G. (2016, December 4). After a sour decade, Florida citrus may be near a comeback. *NPR*. Retrieved from [http://www.npr.org/sections/thesalt/2016/12/04/503183540/after-a-sour-decade-florida-citrus-may-be-near-a-comeback?utm\\_source=npr\\_newsletter&utm\\_medium=email&utm\\_content=20161205&utm\\_campaign=npr\\_email\\_a\\_friend&utm\\_term=storyshare](http://www.npr.org/sections/thesalt/2016/12/04/503183540/after-a-sour-decade-florida-citrus-may-be-near-a-comeback?utm_source=npr_newsletter&utm_medium=email&utm_content=20161205&utm_campaign=npr_email_a_friend&utm_term=storyshare)
- Baker, R., Brick, J., Bates, N., Battaglia, M., Couper, M., Dever, J., ... Tourangeau, R. (2013). Summary report of the aapor task force on non-probability sampling. *Journal of Survey Statistics and Methodology*, 1(2), 90-143. [doi:10.1093/jssam/smt008](https://doi.org/10.1093/jssam/smt008)
- Benge, M., Harder, A., & Carter, H. (2011) Necessary pre-entry competencies as perceived by Florida Extension agents. *Journal of Extension*, 49(5), 1-11. Retrieved from <http://www.joe.org/joe/2011october/a2.php>
- Brown, J. L., Kiernan, N. E., Smith, E. S., & Hughes, L. (2003). County agent views about facilitating public education and discussion of genetic engineering use in agriculture. *Journal of Extension*, 41(6), 6RIB5. Retrieved from <http://www.joe.org/joe/2003december/rb5.php>
- Callis, T. (2013, June 10). Papaya: A GMO success story. *Hawaii Tribune Herald*. Retrieved from <http://hawaiitribune-herald.com/sections/news/local-news/papaya-gmo-success-story.html>
- Colwell, S, & Carter, E. (2012). *Introduction to statistics for social sciences + connect w/etext*. Retrieved



from [highered.mheducation.com/sites/dl/free/.../coL35220\\_ch02\\_036\\_073\\_final.pdf](http://highered.mheducation.com/sites/dl/free/.../coL35220_ch02_036_073_final.pdf)

- Crawley, C. E. (2007). Localized debates of agricultural biotechnology in community newspapers: A quantitative content analysis of media frames and sources. *Science Communication*, 28(3), 314-346. doi:10.1177/1075547006298253
- Fernandez-Cornejo, J., Wechsler, S., Livingston, M., & Mitchell, L. (2014). *Genetically engineered crops in the United States* (Report No. 162). Retrieved from U.S. Dept. of Agriculture, Economic Research Service website: <http://www.ers.usda.gov/media/1282246/err162.pdf>
- Field, A. (2013). *Discovering statistics using IBM SPSS statistics* (4th ed.). Thousand Oaks, CA: SAGE.
- Harrell, C. (2014). Fighting citrus greening. *Thrive*. Retrieved from <http://www.syngenta-us.com/thrive/production/citrus-siege.html>
- Klerck, D., & Sweeney, J. C. (2007). The effect of knowledge types on consumer-perceived risk and adoption of genetically modified foods. *Psychology & Marketing*, 24(2), 171-193. Retrieved from <http://onlinelibrary.wiley.com/doi/10.1002/mar.20157/epdf>
- Martin, M. J. (2016). The polarization of agriculture: The evolving context of extension work. *Journal of Extension*, 54(2), 2COM1. Retrieved from <http://www.joe.org/joe/2016april/comm1.php>
- National Academy of Sciences. (2016). *Genetically engineered crops: Experiences and prospects*. Retrieved from <http://www.nap.edu/catalog/23395/genetically-engineered-crops-experiences-and-prospects>
- Nicolia, A., Manzo, A., Veronesi, F., & Rosellini, D. (2014). An overview of the last 10 years of genetically engineered crop safety research. *Critical Reviews in Biotechnology*, 34(1), 77-88. doi:10.3109/07388551.2013.823595
- Patton, D. B., & Blaine, T. W. (2001). Public issues education: Exploring Extension's role. *Journal of Extension*, 39(4), 1-5. Retrieved from <http://www.joe.org/joe/2001august/a2.php>
- Peek, G. G., Sanders, L. D., Shideler, D., Ferrell, S. L., Penn, C. J., & Halihan, T. (2015). Framing a public issue for extension: Challenges in oil and gas activity. *Journal of Extension*, 53(5), 5FEA1. Retrieved from <http://www.joe.org/joe/2015october/a1.php>
- Peterson, J. M., Cassman, K. G., & Cantrell, R. (2002). Changes in cultural practices of farmers in southeast Nebraska as a result of their adoption of transgenic crops. *Journal of Extension*, 40(1), 1FEA5. Retrieved from <http://www.joe.org/joe/2002february/a5.php>
- Popken, B. (2016, August 1). Obama signs controversial GMO food label law. *NBC News*. Retrieved from <http://www.nbcnews.com/business/consumer/obama-signs-controversial-gmo-food-label-law-n620796>

- Roberts, T. G., Harder, A., & Brashears, M. T. (Eds). (2016). *American Association for Agricultural Education national research agenda: 2016-2020*. Gainesville, FL: Department of Agricultural Education and Communication.
- Rogers, E.M. (2003). *Diffusion of innovations* (5th ed.). New York: Free Press.
- Rumble, J. N., Ruth, T. K., Owens, C. T., Lamm, A. J., Taylor, M. R., & Ellis, J. D. (2016). *Undergraduate student thoughts on using the science of genetic modification as a solution to citrus greening*. Paper presented at the 2016 Southern Region American Association for Agricultural Education Conference, San Antonio, TX.
- Ruth, T. K., & Rumble, J. N. (2016). *Influence of persuasive communication of Florida consumers' attitude toward genetically modified food*. Paper presented at the Southern Region American Association for Agricultural Communication Conference, 2016, San Antonio, TX.
- Senauer, B. (2013, August). *Considering the mandatory labeling of genetically engineered foods in the U.S.* University of Minnesota, Food Policy Research Center. Retrieved from <http://www.foodpolicy.umn.edu/policy-summaries-andanalyses/ge-labeling/index.htm>
- Singerman, A., & Useche, P. (2016). *Impact of citrus greening on citrus operations in Florida (FE983)*. Retrieved from UF/IFAS website: <http://edis.ifas.ufl.edu/fe983>
- UF/IFAS Citrus Extension. (2016a, August 1). *Citrus greening (Huanglongbing)*. Retrieved from <http://www.crec.ifas.ufl.edu/extension/greening/index.shtml>
- UF/IFAS Citrus Extension. (2016b, August 1). *Symptoms*. Retrieved from <http://www.crec.ifas.ufl.edu/extension/greening/symptoms.shtml>
- U.S. Census Bureau (2015). *Census regions and divisions of the United States*. Retrieved from [https://www.census.gov/geo/reference/gtc/gtc\\_census\\_divreg.html](https://www.census.gov/geo/reference/gtc/gtc_census_divreg.html)
- U.S. Department of Agriculture. (2000). *Farm resource regions*. Retrieved from [http://www.ers.usda.gov/media/926929/aib-760\\_002.pdf](http://www.ers.usda.gov/media/926929/aib-760_002.pdf)
- U.S. Department of Agriculture. (2015). *USDA coexistence fact sheets - Conventional farming*. Retrieved from <http://www.usda.gov/documents/coexistence-conventional-farming-factsheet.pdf>
- U.S. Department of Agriculture. (2016a, February 8). *Biotechnology frequently asked questions (FAQs)*. Retrieved from <http://www.usda.gov/wps/portal/usda/usdahome?navid=AGRICULTURE&contentid=BiotechnologyFAQs.xml>
- U.S. Department of Agriculture. (2016b, June 10). *Oranges: Production map by state*. Retrieved from [https://www.nass.usda.gov/Charts\\_and\\_Maps/Citrus\\_Fruits/orgmap.php](https://www.nass.usda.gov/Charts_and_Maps/Citrus_Fruits/orgmap.php)

- U.S. Department of Agriculture - Foreign Agricultural Services. (2016). *Citrus: World market trade*. Retrieved from <http://apps.fas.usda.gov/psdonline/circulars/citrus.pdf>
- Voosen, P. (2014, September 13). Can genetic engineering save the Florida orange? *National Geographic*. Retrieved from <http://news.nationalgeographic.com/news/2014/09/140914-florida-orange-citrus-greening-gmo-environment-science/>
- Warner, M. E., Hinrichs, C., Schneyer, J., & Joyce, L. (1998). From knowledge extended to knowledge created: Challenges for a new Extension paradigm. *Journal of Extension*, 36(4), 1-5. Retrieved from <http://www.joe.org/joe/1998august/rb1.php>
- Weick, C. W., & Walchli, S. B. (2002). Genetically engineered crops and foods: Back to the basics of technology diffusion. *Technology in Society*, 24, 265-283. doi:10.1016/S0160-791X(02)00008-8
- Welch, T., & Braunworth, W. S. (2010). Education in the face of controversy: When water and politics mix. *Journal of Extension*, 48(3), 1-9. Retrieved from <http://www.joe.org/joe/2010june/a1.php>

## **Perceptions of African-American Students on Pursuing Agricultural and Natural Resources Careers: Voices from an 1862 Land-grant Institution**

Courtney P. Brown, Langston University  
Shelly Sitton, Oklahoma State University  
M. Craig Edwards, Oklahoma State University  
Nicholas R. Brown, Jenks Public School

### ***Abstract***

*This phenomenological study examined the lived experiences of nine African-American students pursuing an agricultural and natural resources (ANR) degree at an 1862 land-grant institution. Individual interviews were conducted, and participants were asked about their experiences studying ANR. Six themes were found based on of the participants' perceptions. The participants perceived African-American history in regard to slavery and its aftermath affected the number of African-Americans pursuing careers in ANR today. The participants also shared experiences and influences that motivated them to pursue careers in ANR and persist toward their related goals. Learning the motivations of the African-American undergraduate students choosing ANR majors helped expose layers of nuance and complexity comprising the phenomenon. The results revealed areas in which additional research should be conducted to help promote more racial diversity in the ANR sector, including preparation through university degree programs.*

### **Introduction/Review of Literature**

During the several decades after the Reconstruction Era in the United States (Browne, 2003), nearly one million African-American farmers owned an estimated 15 million acres of land (Grant, Wood, & Wright, 2012). At that time, African-Americans represented more than 13% of all farmers nationwide (Browne, 2003). Beginning in 1920, the number has declined by 98% due to economic struggles, racial discrimination, and land loss (Wood & Gilbert, 2000). Although “African American farmers are historically important contributors to agriculture in the United States” (Balvanz et al., 2011, p. 68), today, African-Americans involved in agriculture represent a very small percentage of the total. Balvanz et al. (2011) suggested several causes:

African Americans face[d] institutional and social discrimination. The deleterious effects of discriminatory practices continue to be barriers to maintaining the family farm.

Discriminatory lending is associated with farmland loss, such that the number of African American farmers in the United States has been falling at a much higher rate than that of White farmers. (p. 68)

Many advocates recognize African-American farmers face specific barriers and started organizations to address their needs, including groups whose purpose is to expose inner-city, African-American youth to the agricultural industry (Grant et al., 2012). Collaborations among 1890 land-grant colleges, The Black Farmers and Agriculturalists Association, and other organizations are pursued to help educate African-Americans about their agricultural history and the importance of keeping agriculture alive in the African-American community (Moon, 2007).

### **Life for African-Americans after Slavery**

The conclusion of the American Civil War marked the end of legal slavery in the United States, and the number of African-American farmers increased, reaching its peak in the early 1900s (Browne, 2003). The promise made to African-Americans at slavery's end was that *40 acres and a mule* were to be given to freed slaves (Gates, 2013). However, when President Andrew Johnson came into office following Abraham Lincoln's assassination in 1865, he terminated most small-farm initiatives for freed slaves, preventing this promise from materializing the way it was intended (Gates, 2013). The alternative result for many was tenant farming or sharecropping (Moon, 2007). The system of sharecropping kept many African-Americans in constant debt to land owners, and their acquired land was often substantially fewer acres as compared to White neighbors (Brown et al., 1994). The earnings of most African-American sharecroppers were inadequate to sustain a comfortable way of life (Hornsby, 2010).

Nonetheless, the peak of land ownership among African-Americans was during the early 1900s (Browne, 2003), and, at that time, land ownership was a symbol of hope for many (Merem, 2006). Across an 80-year span, however, their land ownership dropped from 15 million acres to slightly more than two million (Browne, 2003). Many African-American farmers did not receive sufficient information to capitalize on government programs designed to help them (Merem, 2006). According to Merem (2006), lack of knowledge on farm policies and programs created more financial issues. He also found "the current institutional set up overseeing agricultural land use and rural affairs favored big corporate farms over small family farms associated with Black farmers" (Merem, 2006, p. 98). Many African-American farmers also expressed experiencing discrimination from the USDA: "The common complaint was that Black farmers had been purposely driven into bankruptcy through discriminatory procedures of the Farm Service Agency and the local farmer committees that approved USDA entry" (Browne, 2003, p. 145). With most African-American farmers averaging around 65 years of age, today's lack of representation of African-American youth in production agriculture is apparent (USDA, 2007); less than 1% of African-American farmers are under 25 years of age (Merem, 2006).

In 1872, Senator Justin Smith Morrill presented a bill in Congress that would become The Second Morrill Act (Neyland, 1990). This Act finally passed in 1890, 28 years after the original Morrill Land-Grant College Act had become law; it allowed for the creation of state colleges for Black students who would study agriculture and mechanic arts (Kerr, 1987). After the end of slavery, however, some resistance existed among freed African-Americans whether to study agriculture (Moon, 2007). For example, when African-Americans were provided an opportunity to pursue an education and establish institutions, a debate ensued about whether to create a curriculum to continue to develop practical skills and trades or a program of study stressing the liberal arts and humanities (Moon, 2007). This issue continued after enactment of the Second Morrill Act. The idea of attending an institution dedicated to the study of agriculture did not appeal to many African-Americans. The horrors of the past seemed to still linger and "their history of exploitation during slavery and slavery's aftermath had taken the dignity and respect out of agricultural and mechanical occupational pursuits" (Neyland, 1990, p. 21).

Another trend that occurred during the 1890s was that many African-Americans moved from the rural countryside to the city (Harris, 1992). This migration influenced more African-Americans to leave agricultural jobs and gravitate toward industrial work (Harris, 1992). "From 1910 to

1920, more than half a million African Americans left the South, with the largest numbers migrating in a three-year span, 1916-19, in what has been called the Great Migration” (Harris, 1992, p. 36). Not only did many African-Americans leave the rural South for a more industrialized North, they also moved to cities in the South (Harris, 1992). During this time, a few influential African-American thought leaders emerged to help the efforts of promoting agriculture among their people (Ownby, 2003). Booker T. Washington was one such individual who led the development of Tuskegee Normal and Industrial School, now Tuskegee University, a historically Black university with strong agricultural roots (Croom, 2007; Croom & Alston, 2009; Ownby, 2003). Contrary to some African-American leaders, Washington “believed all Black southerners needed to know how to work on a farm. He idealized the skills of subsistence farming and urged people to use them to escape poverty” (Ownby, 2003, p. 34).

Shortly after the *Great Migration*, an organization was created to promote agriculture among young Black males: New Farmers of America (NFA) was founded in 1935 (National FFA Organization, 2013). The NFA “was an organization of Negro farm boys studying vocational agriculture in the public schools throughout 18 states in the eastern and southern United States” (Wakefield & Talbert, 2003, p. 95). NFA reached its peak of active membership in 1963 with 58,132 members (National FFA Organization, 2013). The purported *merger* of the NFA with the Future Farmers of America (FFA) occurred in 1965 (Wakefield & Talbert, 2003). NFA was a prosperous organization before the merger (Wakefield & Talbert, 2003), and it contributed more than 50,000 students to the FFA membership roll in 1965. In 2013, however, 579,678 members comprised the National FFA Organization and only 8% were African-American (National FFA Organization, 2013). To evaluate the merger’s effects, Wakefield and Talbert (2003) interviewed former NFA members. Their study’s participants said involvement in NFA contributed to them developing leadership skills but observed that few African-Americans held leadership positions in FFA after the merger. Participants also said they perceived this lack of leadership led to poor morale among Black FFA members following the merger (Wakefield & Talbert, 2003).

### **African Americans in Higher Education including Agriculture and Natural Resources**

In 2000, African-Americans represented roughly 11% of the total enrollment of higher education institutions in the United States (Burns, 2006). However, “[u]nderrepresented minorities tend to struggle to find instructors, classmates and programs with which they feel a connection” (Anderson II, 2006, p. 11); Vincent, Henry, and Anderson II (2012) concurred. With African-Americans representing 13% of the nation’s population, universities have developed recruitment strategies to increase the number of African-Americans in higher education (Burns, 2006) with limited success. From 2002 to 2005, a slight decline occurred in the enrollment of African-American undergraduate students studying for degrees in agricultural and natural resources [ANR] (Burns, 2006, p. 10).

Dr. Charles Magee, professor and director of biological and agricultural systems engineering at Florida A&M University, expressed the idea that if African-Americans saw more images of themselves on agricultural products they may be more eager to learn about the industry and its career opportunities (Morgan, 2000). “If our children could look at Carver’s face on a jar of peanut butter, they would start saying ‘I want to be like George and not just be like Mike [, i.e., Michael Jordan]’” (Morgan, 2000, p. 24). Morgan (2000) spoke with Dr. Annie King, an

associate dean in the College of Agricultural and Environmental Sciences at the University of California-Davis, to explore her thoughts on the lack of African-American representation in agricultural programs. Dr. King shared:

I was taught by my parents, who had been sharecroppers, that working on the land or with products from the land was an honorable profession. . . . But many parents and grandparents today tell young men and women about the great hardship associated with slavery or they speak about dirty, hard work with low pay, or even the loss of family-owned farms. (Morgan, 2000, p. 23)

Brown (1993) conducted a study to investigate the core reasons why African-American youth do not seem to show much interest in agriculture. He concluded some of the contributing factors were home life, school-related, and the importance of education in general (Brown, 1993). Brown (1993) found most African-American students avoid agriculture programs because of the misconception that only farm and other production-related jobs are available in the industry (Brown, 1993). He concluded many of the high school participants had little or no knowledge of agriculture or the careers available in the agriculture industry (Brown, 1993). Talbert and Larke (1995) also found that African-American students enrolled in secondary agriscience in Texas had less of a rural background and held more negative attitudes about agriculture than White students. Nevertheless, some African-Americans continue to aspire for careers in ANR. Examining the *lived experiences* of African-American students who chose to pursue ANR career preparation by earning university degrees may provide insight about this phenomenon.

### **Theoretical Lens: Expectancy Value Theory**

Expectancy value (E-V) theory can provide a basis for examining what individuals expect regarding success associated with actions and how that would add to their accomplishment behaviors. Persistence, task choice, and performance are influenced by expectancies and values, which are impacted by how individuals perceive their proficiencies and the difficulties associated with various tasks as well as their personal self-schema and goals (Wigfield & Eccles, 2002). The satisfaction a person experiences from performing a task or the personal interest he/she has in a subject area is its *intrinsic value* (Wigfield & Eccles, 2002). When individuals create current and future goals, how well those goals relate to a task is defined as the *utility value*. The negative parts of performing a task are considered the *costs* (Wigfield & Eccles, 2002). Participants' views on studying for careers leading to employment in the ANR sectors were interpreted through E-V theory: What made the students decide to pursue a career in an area where they are a minority and, historically, as a race, faced numerous hardships? A phenomenological approach was an appropriate method for studying their views.

### **Study's Purpose and Research Questions**

This study sought to examine the *lived experiences* of African-American students who attended an 1862 land-grant institution during the 2013-2014 academic year. Two research questions guided this study: a) How did the students' experiences influence their choices of college majors and related career objectives? b) What was the *essence* of the students' lived experiences?

### **Methods and Procedures**

Phenomenology emphasizes lived experience and interpretation (Merriam, 2009). The phenomenological approach allows researchers to examine human experiences from the perspective of the study's subjects (Creswell, 1994). "The task of the phenomenologist, then, is to depict the essences or basic structure of experience" (Merriam, 2009, p. 25). In such studies, what emerges is the phenomenon's *consciousness* (Moustakas, 1994), and the primary concern of the researcher is to expose the firsthand experience of an individual from his or her perspectives (Lester, 2005). Moustakas (1994) explained the concept of a phenomenon: "The very appearance of something makes it a phenomenon. The challenge is to explicate the phenomenon in terms of its constituents and possible meanings, thus discerning the features of consciousness and arriving at an understanding of the essences . . ." (p. 49). An *essence* is the brief description that stems from the phenomenon's textural and structural description (Creswell, 2013). It summarizes the individuals' shared experiences by reducing that to the essentials (Creswell, 2013). Moreover, the transcendental phenomenological approach used in this study included *Epoche*, i.e., the researcher "engage[d] in disciplined and systematic efforts to set aside prejudgments regarding the phenomenon being investigated" (Moustakas, 1994, p. 22).

### **Study Population and Participants**

The target population of this study was African-American students between the ages of 18 and 25 who attended Oklahoma State University (OSU) and studied in the College of Agricultural Sciences and Natural Resources (CASNR) during the 2013-2014 academic year. Of the 2,720 students studying in CASNR, 46 were African-American, including graduate and undergraduate students (CASNR, 2014). After soliciting subjects through electronic mail messages and snowball sampling (Creswell, 2013), nine undergraduate African-American students were recruited.

*Ricky*, an 18-year-old freshman male from a rural area in the South, was majoring in landscape architecture. Although drawn to nature and the outdoors, he had no early exposure to agriculture as no family members or friends were involved in the industry. *Taylor*, a 19-year-old freshman female from a metropolitan area in the South, was majoring in animal science with a pre-vet concentration. Being raised around animals, mostly dogs, sparked her love for animals; however, she did not have family members or friends in agriculture. *Kasey*, a 19-year-old sophomore female from a metropolitan area in the South, was majoring in animal science. She grew up a block away from a downtown area, but her grandfather owned a farm she visited.

*Kenny*, a 21-year-old senior male from a metropolitan suburb in the South, was majoring in agribusiness. His first exposure to agriculture was spending some summers on his grandfather's small family farm. *Eddie*, a 20-year-old freshman male from a metropolitan area in the South, was majoring in agribusiness. He spent three years in an inner-city high school and his senior year in a suburban high school. Eddie was exposed to agriculture at a young age by his grandmother, who raised livestock. *Cassie*, a 19-year-old freshman female from an urban area in the South, was majoring in animal science with a pre-vet concentration. She was introduced to agriculture in ninth grade when she joined FFA and began agricultural education courses; some of her relatives were involved in agriculture.



*Derek*, a 20-year-old freshman male from an urban area in the South, was a freshman majoring in animal science. His agricultural involvement began during his sophomore year in high school when his desire to ride horses connected him with a horse rancher. He began learning and working for the rancher, became FFA president, and did horse judging, livestock judging, and parliamentary procedure. *Destiny*, a 19-year-old freshman female from an urban area in the South, was majoring in animal science with a pre-vet concentration. Although having a love for animals and regularly attending rodeos, she did not have family in agriculture. *Robert*, a 20-year-old male from a southeastern state, was a junior majoring in agricultural education. He grew up on his family farm where his adoptive White parents taught him the importance of agriculture.

## **Data Collection and Analysis**

Face-to-face interviews lasting approximately 60 minutes were held with each participant (Creswell, 1994). The interviews included semi-structured, open-ended questions, which allowed the flexibility to follow emerging ideas (Merriam, 2009). The questions – prepared and emergent – explored the study’s phenomenon and encouraged the participants to reveal their personal experiences and related meanings (Moustakas, 1994). The interviews were recorded with an *iPhone* using the downloadable, digital recording application *Audio Memos*. Each was transcribed using *Express Scribe*, a transcription software. When the transcripts were created, each participant was given a pseudonym to protect his or her identity. After transcription of the data in Microsoft Word, participants were sent their transcripts via an electronic mail message and given five days to respond with clarifications, i.e., member-checking (Lincoln & Guba, 1985). The changes received were applied to the transcripts.

Data were analyzed by using Moustakas’ (1994) modification of the Van Kaam Method through which the lead researcher reviewed each transcript and familiarized herself with the participants and their experiences by creating lists and preliminary groups (Moustakas, 1994). The participants’ thoughts and emotions about their experiences were equally highlighted, i.e., *horizontalization* (Moustakas, 1994). Atlas.ti.v. 7 was used to create codes for the significant statements emerging from the transcripts. From the nine participants, 146 significant statements were found under 35 codes, and six themes emerged. Each theme was substantiated through rich descriptions (Lincoln & Guba, 1985); direct quotes from the participants were identified to support the six emergent themes.

## **Ethical Considerations**

Tracy’s (2010) *eight big-tent criteria* were followed to ensure the study represented high-quality qualitative research, including worthy topic, rich rigor, sincerity, credibility, resonance, significant contribution, ethical, and meaningful coherence. According to Tracy (2010), studies that explore little-known phenomena are often more interesting. With the small numbers of African-Americans choosing to pursue ANR careers, the phenomenon of African-American students who chose to prepare for such was *worthy of study*.

“A richly rigorous qualitative scholar is also better equipped to make smart choices about samples and contexts that are appropriate or well poised to study specific issues” (Tracy, 2010, p. 841). To ensure *rich rigor*, Tracy (2010) suggested researchers ask themselves four questions:

Are there enough data to support significant claims? Did the researcher spend enough time to gather interesting and significant data? Is the context or sample appropriate given the goals of the study? Did the researcher use appropriate procedures in terms of field note style, interviewing practices, and analysis procedures? (p. 841)

These questions were asked by the lead researcher during the study.

Maintaining a sense of *sincerity* is critical in qualitative research and can be reached by the investigator being honest, self-reflexive, and transparent (Tracy, 2010). The lead researcher practiced *self-reflexivity* by journaling her feelings and thoughts, which aided in bracketing such and decreased the likelihood of biases influencing her interpretations (Moustakas, 1994). When research is trustworthy and reliable, this builds its *credibility* (Tracy, 2010). Tracy (2010) stated credibility “is achieved through thick description, triangulation or crystallization, and multivocality and partiality” (p. 843), which this study included. *Meaningful coherence* is achieved by researchers connecting their theoretical framework and situational goals with data collection and analysis procedures (Tracy, 2010). The researchers’ interpretations, as derived from the study’s findings, reflect this criterion.

### ***Reflexivity***

The lead researcher is an African-American female who grew up in a mostly rural suburb near Memphis, Tennessee. Her father was reared by his grandparents on a small family farm near Jackson, Tennessee, and her mother visited her grandparents’ small farm in Medon, Tennessee almost every summer. Roughly 70 acres of land existed between the two farms, which produced cotton, corn, black-eyed peas, and other fruits and vegetables. They also raised hogs, chickens, beef, and dairy cattle. Her father studied agriculture in high school and was an active member of his FFA chapter. The most exposure the lead researcher had to agriculture growing up were the stories her parents told about life on the families’ acquired land after slavery. She gained an interest in agriculture in college, after she had her first hands-on farming experiences. She earned a BS degree in agriculture with a concentration in agriscience and a minor in communication arts from Austin Peay State University. During the study, she was pursuing a MS degree in agricultural communications. Noticing she was one of the only, if not the only, African-American in her degree programs at two universities sparked her research interest. This study includes two limitations: a) the results may be transferrable but should not be generalized; b) the potential for bias existed on the part of the lead researcher but she closely monitored potential biases to reduce the likelihood of such affecting the results.

### **Findings/Results**

Six themes emerged from analysis of the study’s data. The themes are presented with supporting quotes derived from the study’s participants.

#### **Theme 1: Positive Experiences that Encouraged Participants to Pursue ANR as a Career.**

Kasey shared her experiences growing up on her family farm in Texas and how it influenced her choice to join the agricultural industry. She said:

It was actually really fun, because I got to milk a cow for the first time and then I was like, ‘I really want to do this when I grow up,’ so that’s kind of when I was like I want to

be a vet, because I was hoping to administer medication to the cows. And we found out that a cow was pregnant, so I got to watch her give birth when the time came. So, I was like this is kind of where I want to be when I get older.

Kenny described his experience at OSU and how an advisor encouraged him to change his major: . . . I actually went to the AG business [department], . . . and just kind of spoke with some of the advisors there, and my advisor now . . . he actually really is the one who influenced me to go ahead and make the switch.

Ricky discussed the role an African-American in the ANR sector played in his decision to pursue a career in landscape architecture. He said:

Because I was trying to choose between [becoming] a pharmacist and a landscape architect. I found out that, I guess I could say my idol, Eddie George, he's a famous Ohio State football player and he also became a landscape architect, so I was like, oh that's cool, so I might as well do that.

Cassie stressed the encouragement she received from her high school agriculture teacher and how that influenced her to get involved in agriculture. She explained:

. . . my AG advisor, she was very [influential], because she was the one who pushed me to be better than what I was. . . . with big shows I've gotten second place, I've gotten grand champion at major shows, and so that really helped me out. And then, with just that enjoyment, that love for, my new love for agriculture that I just wanted to continue it on, not stop it in high school. I just wanted to go with it.

## **Theme 2: The Desire for African-American Students to Create Change Strengthened their Commitment to Pursue ANR Degrees.**

Participants were motivated to pursue agriculturally related degrees because of their perceptions of the lack of African-Americans in the industry. Taylor shared the change she hoped to see in veterinary science: "After going to all the vets in my neighborhood, there's nothing but White vets. . . . I just feel there's something that we need to change."

Robert described a similar experience in regard to teaching agricultural education. He said:

. . . the year I graduated high school we did some research and there was only two African-American agriculture teachers in the entire state of Oklahoma. And I was appalled at the findings . . . . And that was the first thing that really got me wanting to become an agriculture education teacher teaching high school students.

Participants also shared how they perceived African-Americans could make a difference by pursuing careers in agriculture and its allied fields. Kenny described why:

. . . the career opportunities are definitely growing. You're going to need AG, and with the world population booming you know the jobs are going to come so you got to transition Black people in the mindset of you know this is where the world's going . . . try to find those jobs and try to make a difference in AG because we're definitely capable.

Kenny also described how it would be a positive result for African-Americans to use ANR as a platform to make a difference globally. He said:

It'd just be cool to see Black people stand up and actually make a difference on a global scale. And AG definitely has the capabilities of impacting the world . . . actually making the effort to change things and make things better would really, really, be really cool.

Several students also mentioned wanting to join the industry because it was *something different* from what many American-Africans do for careers. Derek shared his view:

. . . if I could continue on aiming to be successful and even though . . . not many African-Americans are involved in this, I figured I wanted to be different. . . . So, my goal was to make a change and make a difference.

Robert stressed it was time for African-Americans to make an impression in the industry. He said: "Through my eyes it is important that we as African-Americans make our mark. . . . we need to step up to the plate, so to speak, and take part, make our mark."

### **Theme 3: Historical Hurts and Lack of Encouragement Contribute to the Low Number of African-Americans in ANR.**

All participants were asked: "Why aren't more African-Americans pursuing agricultural careers?" In response, the struggle of *forgetting the past arose*. Destiny expressed that the history of slavery in the United States affects African-Americans' decisions to join the industry. She said: "May be like the older generations like their parents or grandparents, maybe they kind of see how if they work on farms it's kind of like the slavery days." Another perspective explained was the view of being a minority in the industry. Destiny indicated many African-Americans may perceive they do not have a place in ANR, where their numbers are small, but if exposed to it early they may not have this perception. She elaborated: ". . . if they're younger . . . and don't have to worry about any kind of racism or anything like that. They could just go with it."

A repeated viewpoint was African-Americans are more drawn to the sports and entertainment industries than ANR. Eddie expressed they are drawn to what is seen on television, i.e., Blacks excelling in athletics and in entertainment: "They watch BET a lot, they might watch ESPN . . . but they don't have lot of . . . commercials about the actual food that we eat."

Kasey described how people, including African-Americans, emulate what they see:

. . . people are inspired by other people . . . people always want to be rappers and basketball players . . . they see them every day. But you never really see anyone in the AG industry so you're just like I don't think I can make it, why try . . . .

The participants also perceived the low number of African-Americans involved in ANR had much to do with lack of encouragement from the industry and the government. Derek said: "I feel people aren't going out to the right people. The AG industry, they're going more out to the White people, and that's not good at all." Robert elaborated further: ". . . the government needs to put . . . more emphasis on encouraging minorities in the field of agriculture."

Another factor participants saw as a contributor to the lack of African-Americans is little exposure to or knowledge of what the industry has to offer. Kasey discussed how her experience in agriculture helped her become aware she had an interest in the field. She stated:

. . . how would you know that you want that to be your major. See if I never would've

had that farm or if I never would've went to the livestock show, I wouldn't be the least interested in cows, or horses, or dogs, or anything [involving agriculture].

Eddie expounded on this point: "There's many [AG] jobs you can do, you can have from AG. It's just learning and then knowing what AG can provide for you." Kenny agreed that many African-Americans are not willing to join the industry because they may have misconceptions about its opportunities. He said: ". . . you're not just going to be on a farm. You know there's other things you can do[, including] food, fiber, energy and all kind[s] of other things."

#### **Theme 4: Giving Back, Promotion, and Early Exposure for African-American Youth can Increase their Involvement in ANR.**

Kenny suggested implementing programs in high schools that expose African-Americans to the importance of ANR. He explained his position:

You know once you . . . have access to it you can actually see this is what I can do and this is where I can go with it. So if you were able to put programs in place . . . for historically Black high schools or whatever and actually had people speak on AG and make them realize that there's not just farming then you could definitely see a change.

Kasey discussed the importance of successful African-Americans in ANR encouraging African-American youth to pursue careers in the sector. She said:

We have to be outspoken about our success, not like bragging about it, but just showing our younger people that they can do it too. . . . if we got here you can get here. It may be hard but nothing is easy. . . . when people succeed in their field other people will follow.

Taylor stated: "I think we just need to have more older people, Black African-Americans, that succeed[ed] and went to college to come out and tell Black kids that all because your Black doesn't mean that you can't succeed into anything." Destiny added:

. . . if they see how much the country depends on agriculture and food, . . . [we] don't really think about where it comes from; we just go to the store and buy it. And so, like if they kind of see the process behind what needs to be done maybe that would get them interested, like maybe they'd want to help, help out the world.

#### **Theme 5: Effects of Positive Experiences while involved in ANR.**

Kenny described enjoying the time he had with classmates and the support he received from them. He said: "I've been learning as I go but I've really enjoyed a lot of it. I'm learning new stuff honestly every day from going to classes and hearing people talk. My classmates have been really supportive." Taylor shared her experience with other students: "But all the students in my animal science class are really, really nice. They're not like the racist type or looking at me in a funny way or anything like that." Ricky also discussed the camaraderie he experienced in his program. He said: "But everybody treats you like a family here at [OSU], same with the AG Program, especially with my program, . . . [landscape] architecture because it's not that many of us." Cassie shared how joining FFA in high school helped her get on the right path:

. . . for a while there like I was going on the wrong path, and then FFA said 'hey if you're going to be something you know you're going to have to do it, you're going to have to be something better than what you're doing,' so that helped me out a lot.

Derek described how being involved in agriculture had helped prepare him for life. He said: “AG taught me a lot of life qualities. I had a lot of new connections and everything.” Derek also indicated joining the ANR industry could potentially help African-Americans gain more confidence. He further stated: “African-Americans are going to be a lot more noticeable in the agriculture industry and also they also can . . . feel more greater about themselves than now.” Cassie shared Derek’s view about being a part of the industry as a minority. She said: “I feel empowered. I don’t know if that’s right, but I feel empowered.”

Cassie also shared her family’s excitement when told she would pursue a degree in agriculture. She said: “My African-American side of the family is not really into AG, and so they were really excited that I was in anything that was kind of scientific.” Cassie’s grandmother was elated: “My grandmother was really excited that I got involved into agriculture because it’s something out of the norm for our family and so she was excited that I branched and did something I really liked.”

### **Theme 6: Negative Perceptions Experienced while involved in ANR.**

The participants also shared some negative perceptions. Destiny discussed the overwhelming experience of joining an unfamiliar program:

It’s been pretty overwhelming because I’ve never been in the AG field and then all the kids here, like half the kids in my class have grown up on farms so they know what it’s like and they already have experience from childhood.

Derek had negative experiences regarding his African-American friends and family members after becoming involved in agriculture. He stated: “I kind of lost a few friendships from my Black friends because of being involved in the agriculture industry.” Participants also discussed the lack of connection they perceived as a minority in ANR. Ricky shared his experience: “You don’t really have anybody to run to sometimes,” and “[y]ou don’t have anybody to relate to.”

Eddie described the lack of connections he experienced being the only African-American in some of his courses. He stated:

So it’s just a different feeling. I wouldn’t say like for me being comfortable to where I understand cause a lot of people express something in different ways that I don’t understand. And just being that one person, everybody looks at you differently. They have a higher standard for you. . . .

Robert addressed the adversity he faced being an African-American in agriculture by sharing how he used the negativity as more motivation to reach his goals. He stated:

And the fact that I’m African-American, it did make it harder because a lot of people was like you can’t do that because you’re African-American. Well the way I see it, that just means I have to work harder to get to where I need to be, to where I want to be.

Taylor also discussed how some White peers viewed her when she entered an agricultural class:

And there’s a lot of issues, you know, some of my classes I’m the only Black person in there but, you know, there[’s] some people that’s nice but there’s some people that’s just like why is she here and all this other stuff.

Kasey shared her initial shock of attending a similar class: “It’s a little bit of culture shock. I just

never been around this environment. I mean I like it, but I don't really fit in.”

### **Conclusions, Implications, and Recommendations**

Experiences of the nine study participants overlapped and intertwined. The experiences they shared, such as growing up on a farm, being exposed to agriculture by family members, teachers, or other mentors, and realizing not many African-Americans are present in the sector, encouraged them to pursue career preparation in ANR. They also revealed what it meant to be an African-American studying in an ANR undergraduate degree program. Participants shared that, at times, it was challenging facing an industry where not many people with whom they were studying and someday would likely work could relate and connect with them. Several participants expressed feelings of being a minority when entering their classrooms or joining an organization such as FFA, but they were encouraged by the support received from classmates, advisors, and other mentors. In addition, participants voiced their desires to make a difference in the world through agriculture, food, and related fields, which kept them persistent in trying to reach their career goals. Their passions were integrated with the ANR sector and they hoped to share that with other African-American youth. The fact the participants had *gone against the grain* and were preparing to join the agricultural industry, although they may have faced many challenges, including feelings of exclusion or judgment, formed the study's *essence*. Their desire to make a difference is what motivated them to remain persistent (Wigfield & Eccles, 2002) along with intentions of encouraging other African-Americans to pursue studies and careers in ANR. Regarding why so few African-Americans are involved in the industry, most participants revealed views on the lingering effects of slavery, the hardships of ancestors who worked in agriculture, and the promotion of successful African-Americans in the entertainment industry and in athletics. Morgan (2000) also concluded the older generation telling African-American youth about the hardships associated with working in agriculture may negatively affect their pursuit of related careers. In addition, some participants said they did not perceive the industry sufficiently promoted the opportunities available to African-Americans. Seeing African-Americans who chose careers in ANR may encourage more African-American youth to pursue related degrees. Industry and higher education officials, therefore, should publicize and promote the successes of African-Americans working in agriculture and its allied sectors.

The participants' desires to create change was a significant finding. Most wanted to pursue ANR careers because the industry is *different*, along with the idea of making a difference in the world by working in it. Participants expressed they perceived the rewards, i.e., their *expectancy value*, of staying involved in the industry outweighed the negativity experienced. This finding supports the study's theoretical lens, as explained by E-V theory, suggesting choices are influenced by perceptions of expectancies and values, which are determined by how individuals view the difficulties associated with achieving their goals (Wigfield & Eccles 2002).

Future research should examine the lives of African-American students positively affected by participation in ANR education along with older African-Americans who succeeded in the industry to explore how they overcame adversity. Researchers should also conduct a qualitative study, perhaps with focus groups, to explore differences between African-American students who chose to pursue ANR studies versus those who select other majors. Such a study may provide more understanding about why the number of African-Americans in ANR remains low.

Some participants experienced feeling unconnected to their White peers and being the subject of negative perceptions. Wakefield and Talbert (2003) also saw this view when studying the NFA merger with FFA. The lack of leadership roles held by African-Americans after the merger lowered the morale of Black students, which resulted in a loss of connection to agriculture as perceived by their informants (Wakefield & Talbert, 2003). Institutions should ensure faculty and staff members are equipped with the behaviors needed to serve a racially diverse audience. If instructors are well prepared to help students transition into an environment in which they feel alone, sensitive mentors may be able to make their experiences less uncomfortable and more inclusive (Anderson II, 2006). We should continue to explore the views of African-Americans and learn more about what motivates them to participate in ANR. Understanding their experiences may help encourage a new generation of such youth to pursue related careers.



## References

- Anderson II, J. C. (2006, March & April). Insights for recruiting underrepresented individuals into careers in agriculture, food, and natural resources. *The Agricultural Education Magazine*, 78(5), 11-13.
- Balvanz, P., Barlow, M. L., Lewis, L. M., Samuel, K., Owens, W., Parker, D. L. . . ., & Ammerman, A. (2011). The next generation, that's why we continue to do what we do: African American farmers speak about experiences with land ownership and loss in North Carolina. *Journal of Agriculture, Food Systems, and Community Development*, 1(3), 67-88.
- Brown, S. L. (1993). *African-American high school students' perceptions toward agriculture and careers in agriculture*. (Unpublished doctoral dissertation.) Ames: Iowa State University Digital Repository. Retrieved from <http://lib.dr.iastate.edu/cgi/viewcontent.cgi?article=11405&context=rtld>
- Browne, W. P. (2003). Benign public policies, malignant consequences, and the demise of African American agriculture. In R. D. Hurt (Ed.), *African American life in the rural South 1900-1950* (pp. 129-151). Columbia, MO: The Curators of the University of Missouri.
- Burns, M. J. (2006). *Factors influencing the college choice of African-American students admitted to the college of agriculture, food and natural resources*. (Unpublished master's thesis). Retrieved from <http://argo.library.okstate.edu/login?url=http://search.proquest.com.argo.library.okstate.edu/docview/60344536?accountid=4117>
- College of Agricultural Sciences and Natural Resources (CASNR). (2014). *Present student body*. Author. Retrieved from <https://irim.okstate.edu/sites/default/files/StudentProfile/2013/pdf/2013psb.pdf>
- Creswell, J. W. (1994). *Research design: Qualitative & quantitative approaches*. Thousand Oaks, CA: Sage Publications, Inc.
- Creswell, J. W. (2013). *Qualitative inquiry & research design: Choosing among five approaches* (3rd ed.). Thousand Oaks, CA: Sage Publications, Inc.
- Croom, D. B. (2007). Agricultural education at the Tuskegee Normal and Industrial School. *Journal of Agricultural Education*, 48(2), 13-22. doi:10.5032/jae.2007.02013
- Croom, D. B., & Alston, A. (2009). The problem of agricultural and industrial education for African-Americans: A historical inquiry. *Journal of Agricultural Education*, 50(3), 1-10. doi:10.5032/jae.2009.03001

- Gates Jr., H. L. (2013). *The African Americans: Many rivers to cross. 100 amazing facts about the Negro, the truth behind '40 acres and a mule.'* Public Broadcasting Service, WNET. Retrieved from <http://www.pbs.org/wnet/african-americans-many-rivers-to-cross/history/the-truth-behind-40-acres-and-a-mule/>
- Grant, G. R., Wood, S. D., & Wright, W. J. (2012). Black farmers united: The struggle against power and principalities, *The Journal of Pan African Studies*. 5(1), 3-22.
- Harris Jr., R. L. (1992). *Teaching African-American history* (1992 revised ed.). United States of America: American Historical Association.
- Hornsby Jr., A. (2010). *African Americans in the post-emancipation South: The outsiders' view*. Lanham, MD: University Press of America, Inc.
- Kerr, N. A. (1987). *The legacy: A centennial history of the state agricultural experiment stations 1887-1987*. Columbia: Missouri Agricultural Experiment Station, University of Missouri.
- Lester, S. (2005). An introduction to phenomenological research. Author. Retrieved from [https://www.academia.edu/1936094/An\\_introduction\\_to\\_phenomenological\\_research](https://www.academia.edu/1936094/An_introduction_to_phenomenological_research)
- Lincoln, Y. S., & Guba, E. (1985). *Naturalistic inquiry*. Newbury Park, CA: Sage Publications.
- Merem, E. (2006). The loss of agricultural land among Black farmers. *Western Journal of Black Studies*, 30(2), 89-102.
- Merriam, S. B. (2009). *Qualitative research: A guide to design and implementation*. San Francisco, CA: Jossey-Bass.
- Moon, F. F. (2007). *Blacks in agriculture*. Unpublished manuscript, Tennessee State University, Nashville.
- Morgan, J. (2000). African Americans & agriculture. *Black Issues in Higher Education*, 17(8), 20-29.
- Moustakas, C. (1994). *Phenomenological research methods*. Thousand Oaks, CA: Sage Publications, Inc.
- National FFA Organization. (2013). *National FFA online*. Author. Retrieved from [www.ffa.org](http://www.ffa.org)
- Neyland, L. W. (1990). *Historically Black land-grant institutions and the development of agriculture and home economics 1890-1990*. Tallahassee: Florida A&M University Foundation, Inc.
- Ownby, T. A. (2003). A crude and raw past: Work, folklife, and anti-agrarianism in twentieth-century African American autobiography. In R. D. Hurt (Ed.), *African American life in*

- the rural south 1900-1950* (pp. 27-53). Columbia: The Curators of the University of Missouri.
- Talbert, B. A., & Larke Jr., A. (1995). Factors influencing minority and non-minority students to enroll in an introductory agriscience course in Texas. *Journal of Agricultural Education*, 36(1), 38-45. doi:10.5032/jae.1995.01038
- Tracy, S. J. (2010). Qualitative quality: Eight “big-tent” criteria for excellent qualitative research. *Qualitative Inquiry*, 16(10), 837-851. doi:10.1177/1077800410383121
- United States Department of Agriculture (USDA). (2007). *2007 census of agriculture*. Author. Retrieved from <http://www.agcensus.usda.gov/Publications/2007/index.php>
- Vincent, S. K., Henry, A. L., & Anderson II, J. C. (2012). College major choice for students of color: Toward a model of recruitment for the agricultural education profession. *Journal of Agricultural Education*, 53(4), 187-200. doi:10.5032/jae.2012.04187
- Wakefield, D. B., & Talbert, B. A. (2003). A historical narrative on the impact of the New Farmers of America (NFA) on selected past members. *Journal of Agricultural Education*, 44(1), 95-104. doi:10.5032/jae.2003.01095
- Wigfield, A., & Eccles, J. S. (Eds.). (2002). *Development of achievement motivation*. London, UK: Academic Press.
- Wood, S. D., & Gilbert, J. (2000). Returning African American farmers to the land: Recent trends and a policy rationale. *Review of Black Political Economy*, 27(4), 43-64.

## **An Exploration of Behavioral Change Through an Educational Intervention**

Mr. Alexander Tingle, University of Kentucky

Dr. Stacy Vincent, University of Kentucky

Dr. Joan Mazur, University of Kentucky

Ms. Morgan Schafbuch, University of Kentucky

Ms. Jennifer Watson, Southeast Center for Agricultural Safety and Injury Prevention

Dr. Kang Namkoong, University of Kentucky

### **Abstract**

*Seeking to reverse hazardous practices developed through Apprenticeship of Observation theory, the researchers explored secondary agriculture youth behavior following their engagement in a four-part intervention. Utilizing a qualitative research design over a five-year period, the researchers interviewed 63 secondary students from 15 schools in three states within the Appalachia region of the United States. Findings revealed that the project led to intention and behavior changes. Barriers were discovered in how some students' behavior failed to change. Through the lens of the Theory of Learned Behavior, a model is presented that highlights an approach to changing behavior and possibly combatting the lack of behavioral change. From the findings it is recommended that educators further engage in the delivery of instruction, which follows the four-part intervention to assist in changing student attitudes and perceived behavioral control.*

### **Introduction**

Agriculture remains one of the most dangerous careers in the United States (CDC, 2014). This ranking is largely imparted due to the high number of tractor rollover deaths and injuries that occur every year (CDC, 2014). According to Swenson (2004), there are roughly 130 deaths annually from tractor rollovers. According to the CDC (2014), only 59% of the nation's tractors have rollover protection systems (ROPS) installed. This places the remaining tractor operators at an increased risk of injury or death if involved in a tractor rollover accident.

According to Elkind (1993), many farm families acknowledge the risks associated with agriculture, but continue to believe that the industry is appropriate for children. In comparison to other industries, children working with their families in agriculture are not subject to the same child labor laws that are enforced by commercial trades (Marlenga, Berg, Linneman, Brison & Pickett, 2007). It is reported that nearly 113 people, 20 years old or younger die each year from agricultural related accidents (CDC, 2014). However, tractors with both a ROPS and seatbelt

installed, when correctly used by the operator, rarely lead to serious injury when overturned (Hoy, 2009). Even though there is a high risk of injury and death from tractor rollovers, many farmers believe that they can avoid or prevent tractor accidents (Ambe, Bruening, & Murphy, 1994). Given these statements, it is proposed that utilizing an educational intervention to change student behavior could be much more impactful.

### **Need for the Study**

Given the high risk for tractor related injuries and death among farm youth, there is a need for an educational based program that focuses on behavioral change related to tractor safety. Many studies have shown that behavioral change can be accomplished through an educational program (Beckman & Smith, 2008; Hungerford & Volk, 1990; Shultz, 1999; Zelezny, 1999). However, it has been discussed that solely knowledge-based programs have little effect on actually changing the behaviors of learners (Finger, 1994; Kaiser & Furher, 2003; Nolet, 2009; Stern, 2000). Yet, one line of thought states that educational programs seeking behavioral change must include cognitive, social, psychomotor and emotional dimensions to truly change the behaviors of learners (Boone & Boone, 2005). Because of this, Mabie and Baker (1996) propose the use of experiential learning due to its ability to develop a deeper understanding of concepts. Another study found that behavioral changes were more likely to occur in traditional classrooms due to the fact traditional classrooms provide longer exposure to content with typically younger learners (Zelezny, 1999).

Beckman & Smith (2008) conducted a study that yielded positive results of behavior change in regards to dietary and nutritional concepts. The combination of both “passive” curriculum and experiential learning resulted in measurable behavioral change (Beckman & Smith, 2008). This study served as a platform for the researchers’ own attempt of behavioral change in regards to tractor safety within a traditional agriculture classroom setting.

### **Theoretical Framework**

This study utilized the Theory of Planned Behavior (TPB) (Ajzen, 1991) to combat negative behaviors acquired through the Apprenticeship of Observation (Lortie, 1975). The Apprenticeship of Observation is most commonly referenced in teacher education and explains how individuals revert to observed behaviors when encountering new situations (Lortie, 1975). In this study, the students have typically received no formal safety training regarding tractors and have only observed the safety practices of their parents, grandparents or employers. Because of this, it is thought that these individuals will mimic those same behaviors and therefore put themselves at a higher risk of death and injury when operating tractors.

In an effort to change these behaviors for both the current students and future generations, the Theory of Planned Behavior was implemented in an attempt to reverse these learned negative behaviors. The TPB is an expansion of Ajzen’s original Theory of Reasoned Action (TRA) (Marcoux & Shope, 1997). Much like the TRA, the TPB explains that an individual’s intentions are the main factor contributing to the behavior they actually conduct (Ajzen, 1991). The intention of the individual is influenced by three modules, which are attitudes towards the behaviors; the subjective norms regarding the behavior; and perceived behavioral control as expressed through Figure 1 (Ajzen, 1991).

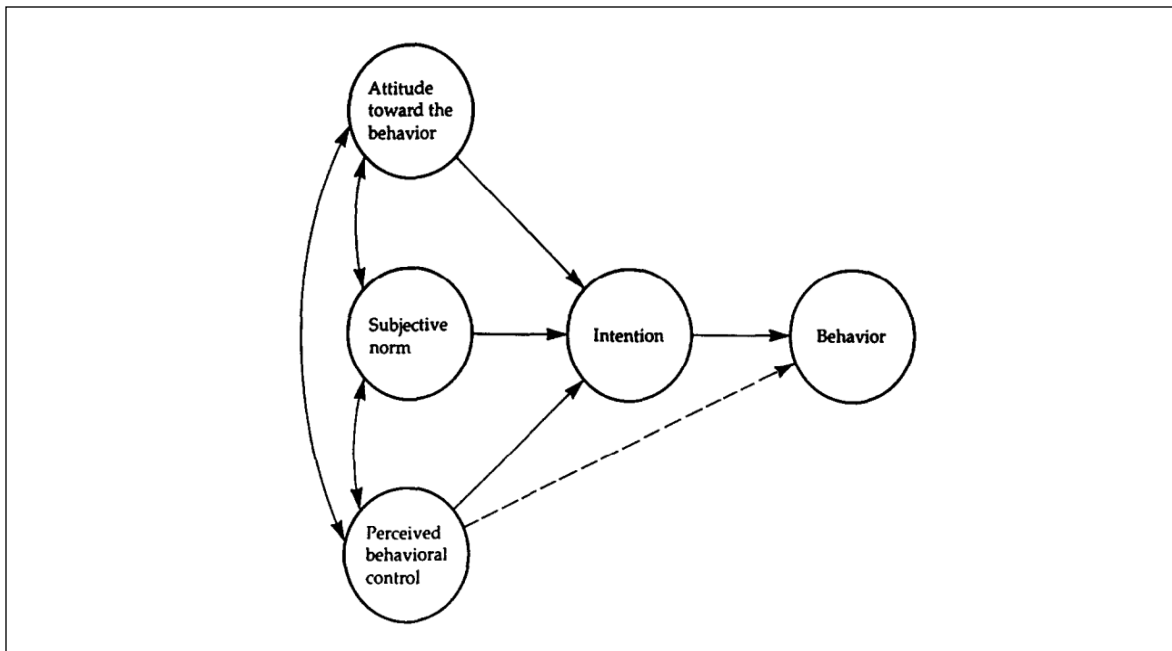

*Figure 3- Theory of Planned Behavior (Ajzen, 1991)*

Ajzen (1991) explains that if an individual has a positive attitude, supportive subjective norms, and a strong sense of behavioral control, they are then more likely to have strong intentions and will most often complete the behavior. However, if there is negativity or weakness in any of the three contributing factors it may result in weak intentions and thus not completing the behavior. Similar combinations of negative intention factors are believed to influence the negative safety behaviors carried out by the students.

### **Purpose**

The purpose of this qualitative study was to understand the factors influencing a student's behavioral change through a tractor safety educational intervention. The study sought to answer the following questions.

- 1) Did the students' attitudes, subjective norms and perceived behavioral control change throughout the duration of the educational intervention?
- 2) Did students report positive intentions of changing their behavior in regards to tractor safety?

### **Methods**

This qualitative case study consisted of implementing a tractor safety educational intervention to high school students enrolled in agricultural education courses across three states in the Appalachian region of the Southeast over a five year period. The intervention took place in

secondary agriculture courses taught by full time agricultural teachers. The intervention utilized a four-part model with a goal of changing student behavior in regards to tractor safety and rollover prevention. The four-part model consisted of an interactive curriculum with a focus on youth involvement and engaged learning; teacher training in the establishment of youth-adult partnerships; an experiential learning exercise that consists of the construction of a NIOSH approved tractor safety device; and the connection of youth to community through student recruitment and selection of farmers in need of such safety devices. The delivery of the curriculum expanded over two to three weeks in each participating classroom and consisted of many standards-based lessons that applied both literary and mathematical components. At the conclusion of the four-part model implementation, the researchers met with the students and allowed each to expand on their lived experiences during the implementation process.

### Population and Sample

This study focused on the southern Appalachian region of the United States. According to Cole (2007) this region of the country has a higher percentage of poverty and smaller acreage farms where many late model tractors without safety features are used due to the economic benefit of not purchasing new equipment. The study consisted of 15 schools in Kentucky, Tennessee and North Carolina over a two-year academic calendar. These particular schools were selected based upon their high quality teachers, high poverty index score, rugged terrain, and population demographics. Of the 15 schools, 437 students participated and 63 were interviewed at the conclusion of the intervention. The 63 were selected because of their involvement throughout the entirety of the four-part curriculum intervention.

Semi-structured interviews were conducted to collect qualitative data that followed an interview guide written by the research team and designed through the theories of Apprenticeship of Observation (Lortie, 1975), Theory of Learned Behavior (Ajzen, 1991), and Youth-Adult Partnerships (Mitra, 2008). Prior to the interview, the Office of Research Integrity approved the use of human subjects. Students who completed all parts of the intervention were placed into focus groups of 3-5 participants. The aim of the interview was to determine the students' perceived attitudes and behaviors toward safe farm practices around a tractor both before and after completing the project.

### Data Analysis

Following the interview, all students were provided alias names and the conversations were transcribed. Initially, open coding was used to identify factors affecting the students' attitude, subjective norms, and perceived behavioral control in regards to ROPS and tractor safety. After this, axial coding was utilized to develop themes and understand the underlying factors during the educational intervention that led to, if any, change in behavior. These sub themes were compiled and make up the findings of this research.

### Trustworthiness

Trustworthiness is the level at which the findings of the study accurately represent the respondents (Dooley, 2007). According to Gall, Gall, & Borg (2009), triangulation can reduce the risk that conclusions contain systemic bias or reflect the limitations of a specific data collection method. This study used a triangulation method posit by Denzin (2009) named which analyzes

data collected from the initial application, interviews, and reflective journals to validate conclusions.

All precautions were taken to prevent biased answers during the interviews with students. However, it quickly became apparent during one interview that the amount of students per focus group could potentially affect the way other students wanted to be perceived by the interviewers. During these instances, the interviewers attempted to avoid status issues, but bias may have still occurred. All bias were identified and bracketed (Denzin, 2009).

The interviews consisted of a moderating researcher as well as a co-research evaluator who sat behind the focus group and listened for comments that reflected behavioral change, recorded mannerisms used to further express points being made, identified biases made during the research process, and assisted the moderating researcher in the research process. Such indicators of behavioral change were represented through student attitudes and opinions towards ROPS both prior to and after their exposure to the intervention. The researchers also listened for student comments on immediate safety changes and personal plans for addressing tractor safety in the future.

## **Findings**

After reviewing and analyzing the data collected through student interviews three major themes were arranged and are followed by several sub themes. Of the three major themes, the initial theme explains the factors controlling student behavior prior to their exposure of the educational intervention. The remaining two major themes represent the overall behavioral change outcomes in relation to the educational intervention and the following sub themes help identify the contributing factors influencing the students' behavior.

### *Theme 1: Factors influencing student behavior prior to the educational intervention*

The first major theme identified the students' behaviors prior to completing the educational intervention. The major theme outlines three factors that influenced the students' behavior prior to taking the class. These factors were the students' attitudes, subjective norms and perceived behavioral control. These factors, or the lack there of, were identified as being responsible for the early behaviors of the students.

#### *Subtheme A: Beginning attitudes towards/ knowledge of tractor safety*

Nearly every student admitted to having little knowledge of rollover protective systems or poor attitudes towards them prior to taking the class. Many of these students also admitted to operating tractors without such safety devices, but explained that they rarely thought of the dangers associated with them before the intervention. When asked if there was ever any hesitation to get on a tractor without ROPS before the class, students answered as follows:

“No, not really. I didn't know the dangers of getting on it at the time.”- Alex

“No. That tractor has been there since I was little and I've been driving it since I was little.”- Jordan

“No. I'll drive anything.”- Morgan



### Subtheme B: *Beginning subjective norms*

Many of the students were exposed to negative subjective norms prior to the intervention in regards to tractor safety. It was a common theme that tractor safety was taught by their parents, grandparents and employers with a blanket statement of “go slow” or “just be safe”, as reported by several students. Several students also acknowledged that many farmers in their community did not operate tractors with ROPS and it was “just common in the area”. These subjective norms are represented in the following student responses:

“I mean it’s usually papaw that I’m with on the tractor, but I mean we’re always safe. We don’t do anything not safe, you know what I’m saying?”- Marshal

“Just always be careful. Don’t drive it [tractor] in a ditch.”- Stephan

“There is probably only a select few tractors that I’ve ever seen with a ROPS on it, and that’s probably one of them [ROPS built in class]. It’s pretty common around here.”- Justin

### Subtheme C: *Beginning perception of behavioral control*

Many students expressed having little to no perceived control over their behavior. In other words, even if they did know the safety benefits of ROPS, it was beyond their ability to purchase such a system for their own tractor(s). This lack of perceived behavioral control is expressed through the following student answer:

“We’ve got Deere’s and they don’t have plans for them. I mean I guess I could buy one, but that is a lot of money.” – Kyle

Given these outlined factors above, it was concluded that prior to participating in this educational intervention, nearly every student had factors contributing to weak intentions and in return did not lead to the students executing positive behaviors in regards to tractor safety.

### Theme 2: *Change in behavior*

The second major theme found within the data is that of behavioral change from students. This theme is broad and requires subthemes to explain the process. Behavioral change was documented by the students expressed intentions to carry out the new behaviors in the future. In addition to this question, the students were also asked how they planned to discuss and educate their children in the future and how that differed from what they had been exposed to. In regards to the first research question, of the 63 interviewed students, three- fourths expressed changes in intent and behavior. Students who did express behavioral change highlighted how they planned to carry out their intentions and how they would differ their children’s exposure to farm safety and equipment. Several of the students that indicated changed behavior answered the researcher’s questions with the following comments:

“Honestly, I think before [intervention] I would let my kids get on the tractor without rollover bars because I didn’t realize the dangers or how dangerous a tractor is before.”- Chad

“I had no idea. Before then, yeah, I wouldn’t have cared, but now I say one has to be on it...”- Mark

After further analyzing the data, two subsets of intention factors emerged that led to behavioral change from this educational intervention. The first subset resulted in the intervention changing the attitudes, subjective norms, and perceived behavioral control of the students. The

second behavior changing subset created positive attitudes and strengthened perceived control, but had little effect on the subjective norms that the students are exposed too. Both of these subsets were successful in changing the behaviors of students.

#### Subtheme A: *Change in attitude*

Beginning with the change in attitude presented in both subsets, both the curriculum and teacher were cited by the students to have been a changing agent. The curriculum presented many statistics of deaths and injuries related to tractor rollover accidents. Many teachers also went beyond the provided curriculum and showed news clips and rollover fatality videos to their students. The combination of these stimuli appeared to have the biggest influence on changing the student's attitudes towards tractor rollover safety. This is highlighted by the following student responses:

“He [teacher] showed us how important the CROPS was. You know, he showed us videos of these, of like how much accidents happen with people that have CROPS and don't have CROPS and the fatalities between the two. He showed us all that so we understood it real good... And if you don't wear your seat belt it's [ROPS] basically ineffective. I never thought about that and I never wore a seatbelt on a tractor.”- Brad

“... The safety part mostly because we watched videos and how much people die just in agriculture accidents and rolling over. So yeah, I mean I had heard it all my life, but until I saw what all could happen, it didn't really click.”- Jordan

“He [teacher] made me understand it [tractor safety] better than I did before... I've never thought about wearing a seatbelt on a tractor till he went into detail about it. Honestly, because the ones I have rode I've never worn a seatbelt.”- Bryan

“He showed us videos and how it stopped it.” – Allison

“Just showing videos and stuff. Like he pulled up a bunch of videos on YouTube and then one day he showed us a bunch of statistics and stuff and all that. And then he [teacher] told some personal stories from his hometown where people had been killed in rollovers without [ROPS]. – Tim

#### Subtheme B: *Changes in subjective norms*

The second intention factor leading to change were the subjective norms that the students were exposed to. Again, as stated previously, the majority of the students were exposed to negative subjective norms prior to the intervention meaning that many farmers, including their parents and employers, did not emphasize or use rollover protection systems on their tractors. Of all the parts of the intervention, the subjective norms were the hardest to combat. Of the students who showed behavioral changes, nearly half reported the intervention impacting their subjective norms while the other half did not. Never the less, both groups, despite their subjective norms being changed, still showed changes in behavior. The change in subjective norm was in part noted by the student's willingness to recognize the lack of ROPS on local tractors and the perceptions of putting them on other vehicles. Several of the student's change of subjective norms are as follows:

“Oh yeah, they are all around this place [tractors without ROPS]. They should probably get one.” – Josh

“Yeah, I'd put one [ROPS] on my lawnmower if I could.”- Keith

“Oh yeah. We built- they build a go-kart out in the shop and I was pulling it with a little Kubota lawn tractor and we were over there joking like ‘oh, we need to build a rollover bar for that’.”- Alex

Students that did not indicate a change in subjective norms had occurred provided responses that seemed hesitant that massive change in their community would occur. For example, many of the students understood the benefits of ROPS and later indicated their desire to change their behavior, but seemed to be hung on the fact that their community and the older generation would not change their “head strong” ways. This was reflected in the following student responses:

“... I work for him. It’s supposed to be on some Ford tractor. Ah, but he’s like talking to that brick wall right there. You never know what you’re going to get out of him.” – Kameron

“You’ve got to think about it more and I’d probably get one. But ah...”- Tyler

“The only time you ever think about it is after somebody gets hurt because it’s so common [tractors without ROPS in the community]. – Howard

#### Subtheme C: *Change in behavioral control*

Lastly, of the two subsets of intention factors that led to behavioral change, the perceived ability of control was vital to behavioral change success. The perceived control essentially means that the students have the confidence to take the actions need to carry out positive behaviors. With respect to tractor safety, this meant that the students a) felt confident they could build their own ROPS b) could talk to their family, neighbors and employers about tractor safety, c) Could overcome financial burdens to purchase/ build ROPS. Both subsets to produce behavior change did in increase student’s perceived ability of control. This is further explained through the following responses.

“Yeah I could build one [ROPS]. Yeah, I mean especially if I was working for somebody and they had a Ford or Massey or something. I’d talk to them about it because it could save my life or his.”- David

“Yeah, if I was working for somebody and they didn’t have it I’d defiantly bring it up and tell them...” – John

“But I have talked to him [neighbor] and told him we can get him one if he’d be willing to pay for it and he’s thinking about it.”- Luke

“I would mention. I’m planning on mentioning it to my aunt’s dad here around Christmas time because that’s when I’ll finally be around him.”- Mitchel

The three previously explained factors identified from the data answer for our initial research question. We sought to understand if the students’ attitudes, subjective norms and perceived behavioral control were changed through the duration of the educational intervention. The above factors and student responses answered the question by showing specific examples of student changes towards positive attitudes, subjective norms and perceived behavioral control that were derived from their experience with the intervention. The positive changes created during the intervention led to strong intentions and ultimately behavioral change.

### Theme 3: No Change in Behavior

As the third major theme, a particular culture of student participants did not show signs of behavioral changes at the conclusion of the intervention. After coding and organizing the data, it was clear that the students who did not provide evidence of changed behavior also had little, to no, change in their subjective norms or perceived ability to control the factors that promote the behaviors. It appears that the students' perception to change behavior is the biggest factor in changing their intention and thus changing their behavior and answering our final research question. This is drawn from the fact that several of the students that did change their behaviors were also lacking change in subjective norms. The only differing factor is their perceived ability to control.

The lack of perceived ability to control the behavior was found to be the "affordability factor". Many of the students that did not change their behavior explained that they felt comfortable in their ability to construct a ROPS at home. However, in combination with the area subjective norms, many of the students did not feel that they could afford ROPS or should even consider investing in them. This is indicated by the following student responses.

"Whether you have a ROPS on it or not you still need to be careful because it's not going to protect you from everything. I mean accidents can happen at any time with or without the ROPS on it. I mean, even if you've got the ROPS on it and you're not wearing your seat belt you can still die. It's just that chance." - Mark

"No not really. I mean it's a pretty common thing around here. You know, not everybody can afford a new tractor with the ROPS on them. So, I mean it's a common thing around here and no one ever pays attention to it." - Ashton

### **Conclusion, Implications and Limitations**

The study utilized a four-part educational intervention in order to positively change safety behaviors, acquired through years of observation (Lortie, 1975), within high school students enrolled in secondary agricultural education programs throughout three different states. In some situations, the poor behaviors developed from the Apprenticeship of Observation theory were reversed immediately following the intervention. Data collected from this study provides evidence that the four-part educational intervention strengthens and/or positively changes student intentions, which are indicators for behavioral change. Furthermore, qualitative data collected aligns with Ajzen's Theory of Planned Behavior (1991) as the intervention targeted the three factors influencing intention and successfully addressed them. The intervention was able to alter and create positive attitudes towards the newly learned behaviors regarding tractor safety across the board. However, in some cases, external factors limited the ability of the four-part model to alter individual intention factors throughout the duration of the intervention. For example, limited financial resources and the cost of ROPS were cited as factors in the lack of change of certain student's perceived behavioral control. Such interference from external factors led to the occurrence of students not indicating positive intentions and thus having no change in their overall behavior. Yet, students could experience combinations of change or no change in intention factors, but still portray strong intentions leading to change in behavior. This study provided evidence that the four-part intervention could fail to change a student's subjective norms, but still record strong intentions and behavioral change. Nevertheless, the findings suggest that both student attitudes

and perceived behavioral control must be altered through the intervention or positive intentions will not be reported.

Based upon the findings, it is recommended that educators utilize the Theory of Youth/Adult Partnerships (Camino, 2000) to place an emphasis on creating positive student attitudes and increasing student perceived behavioral control towards the desired behavior through curriculum and experiential learning activities. The findings show that behavioral change can still be achieved even when students' subjective norms were not altered. Because of this, when the students' attitude and perceived behavioral control were changed, it led to stronger intentions and changed behavior towards tractor safety. Student attitude's and perceived behavioral control can be altered through youth adult partnerships, curriculum and experiential learning (Camino, 2005). Although steps should be taken to create positive subjective norms, this may be harder for a teacher to combat due to his or her limited control of a students' home and work experiences.

It is imperative that teachers spend more time thoroughly teaching the curriculum before advancing to the experiential learning component in order for behavioral change to occur. Although the experiential learning project is an important part of the intervention and strengthens the students' perceived behavioral control, the participants imply that the curriculum is an equally important part and should not be passed over as a disconnect begins to occur in regards to relevance. Teachers who scantily covered the curriculum and dove straight into the experiential learning project achieved a lower level of behavioral change among their students upon the conclusion of the intervention.

Of the students interviewed, those with the highest indicators of behavioral change were taught by teachers that believed in the desired behaviors and brought in local sources such as first responders to explain tractor related accidents and tragedies that had happened within their community. These teachers also added locally derived videos and news stories to the curriculum to solidify the need for such safety devices in the students' opinion. In addition, the teachers were better able to relate the content to their students, thus creating more positive attitudes towards the new behavior and ultimately achieving a higher level of indicated behavioral change. Thus, it is recommended that the curriculum writers include more localized and relatable factors to better engage students and increase the rate of positive attitude creation. Additionally, the need for teachers to exhibit a genuinely positive attitude towards the desired behavior and go beyond the established curriculum to bring more localized content into the classroom is crucial for evidence of behavioral change.

During future implementations of this intervention it is recommended that a teacher professional development event be held prior to teaching of the curriculum. Such professional development events will solidify the need for the behavioral change within the teacher, clarify the curriculum and create a network for the teachers to utilize throughout the duration of the intervention. Additionally, it is recommend that methods of student communication between intervention sites be enhanced through the creation of a social media app.

Future researchers should also address the potential bias generated through the use of focus groups. Although not perceived to have significantly affected the findings of this study, the characteristics and qualities of both the research and subjects could generate status bias that should

be better addressed. More specifically, it is recommended that future agricultural safety behavioral change research use smaller focus groups with students of similar gender, occupation and agricultural experience to better reduce status related bias.

Discussions

The transcriptions were coded through the lens of the Theory of Planned Behavior (Ajzen, 1991). From the findings, the researchers designed a model, (see Figure 2), which illustrates the factors, or themes, that arose from this study. The concept explains the factors influencing student behavior both prior to and during the educational intervention. It then explains the two possible outcomes and the factors contributing to make them so.

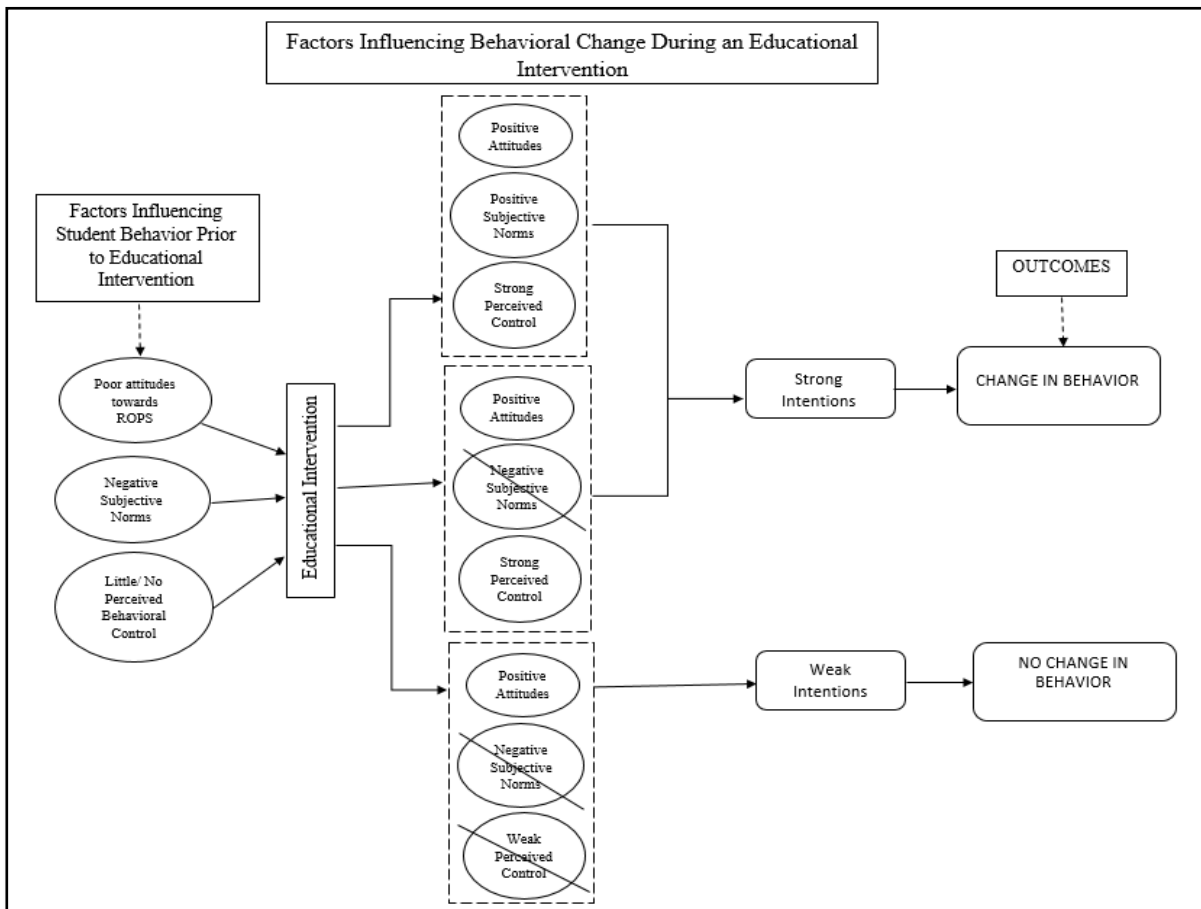

*Figure 4: Factors influencing behavior prior to the intervention*

The model illustrates how a student's attitudes, subjective norms, and perceived behavioral control could be altered through the researchers' educational intervention. After an exhaustive review of the student interview transcripts, the researchers found a commonality of both negative intentions and behaviors regarding tractor safety prior to their exposure of the intervention, as seen on the far left of the model. As the model progresses to the right, the combinations of student intention factors that were altered throughout this intervention is explained.

The first combination exemplifies that the intervention generated positive attitudes, positive subjective norms and strong perceptions of behavioral control for some students. Similarly to Alzen's (1991) theory, the second combination the intervention was able to generate created positive attitudes and strengthen perceived control, but was unable to influence students' subjective norms regarding tractor safety, as illustrated in the model. Although this combination only altered two of the three intention factors, the participants still indicated strong intentions and demonstrated behavioral change. The final combination of intention factors outlined in the model explains the creation of positive attitudes without the students' subjective norms and perceived behavior control being altered. Because this final combination was unable to address two of the three behavioral intention factors, the combination led to weak intentions and ultimately no change in behavior.

The proposed visual conceptualizes the factors from the study that effected behavioral change, or lack thereof, resulting from the educational intervention. Practitioners and researchers can use the proposed model in future pursuits of behavioral change.

In a study of similar fashion, it is recommended that in future interventions, educators should reference the model to assist with the understanding of how a curriculum design, youth-adult partnerships, community connection and experiential learning component should target each intention factor necessary to assist in changing a students' behavior. This visual concept can also be referenced to trouble shoot future educational interventions while evaluating their success of behavioral change. The concept explains the possible combinations that lead to behavioral change and can assist in diagnosing the missing dimensions when such interventions are unsuccessful.

The model outlines three possible combinations of intention factors, but fails to further investigate and pinpoint the exact cause that altered, or failed to alter, each factor. Little attention was given to teacher characteristics and what role that plays in a learner's willingness to change behavior. Future research that analyzes the teacher characteristics within the behavior change of the students would further assist the model's design. Furthermore, research should build upon this study and examine the teacher pedagogical strategies that lead to the influence of behavioral change within a variety of classroom settings that do not reflect that of the current study.

## References

- Ajzen, I. (1991). The theory of planned behavior. *Organizational Behavior and Human Decision Processes*, 50(2), 179-211.
- Ajzen, I., & Driver, B. L. (1992). Application of the theory of planned behavior to leisure choice. *Journal of Leisure Research*, 24(3), 207-224.
- Beck, L., & Ajzen, I. (1991). Predicting dishonest actions using the theory of planned behavior. *Journal of Research in Personality*, 25(3), 285-301.
- Ambe, F., Bruening, T. H., & Murphy, D. J. (1994). Tractor operator's perceptions of farm tractor safety issues and implications to agricultural and extension education. *Journal of Agricultural Education*, 35(4), 67-73. doi: 10.5032/jae.1994.04067
- Beckman, L. L., & Smith, C. (2008). An evaluation of inner-city youth garden program participants' dietary behavior and garden and nutrition knowledge. *Journal of Agricultural Education*, 49(4), 11-24. doi: 10.5032/jae.2008.04011
- Boone, H. N., & Boone, D. A. (2005). ABC's of behavioral objectives: Putting them to work for evaluation. *Journal of Extension*, 43(5).
- Camino, L. A. (2000). Youth-adult partnerships: Entering new territory in community work and research. *Applied Developmental Science*, 4(1), 11-20.
- Camino, L. (2005). Pitfalls and promising practices of youth–adult partnerships: An evaluator's reflections. *Journal of Community Psychology*, 33(1), 75-85.
- Centers for Disease Control and Prevention, National Institute for Occupational Health and Safety. (2014). *Agricultural Safety*. Retrieved from <http://www.cdc.gov/niosh/topics/aginjury/>
- Cole, H. P. (2007). Next steps to reduce agricultural tractor overturn fatal and non-fatal injuries. *Journal of Agricultural Safety and Health*, 13(4), 347-348. doi: 10.13031/2013.23927
- Denzin, N. K. (2009) *The Research Act: A Theoretical Introduction to Sociological Methods*. New Brunswick, NJ: Aldine Transaction Company.
- Denzin, N. K., & Lincoln, Y. S. (Eds.). (2005) *Handbook of qualitative research*. Thousand Oaks, CA: Sage Publications
- Dooley, K. E. (2007). Viewing agricultural education research through a qualitative lens. *Journal of Agricultural Education*, 48(4), 32-42. doi: 10.5032/jae.2007.04032



- Dudas, R. A., Bundy, D. G., Miller, M. R., & Barone, M. (2011). Can teaching medical students to investigate medication errors change their attitudes towards patient safety. *BMJ Quality & Safety*, bmjqs-2010.
- Elkind, P. D. (1993). Correspondence between knowledge, attitudes, and behavior in farm health and safety practices. *Journal of Safety Research*, 24(3), 171-179. doi:10.1016/0022-4375(93)90028-L
- Finger, M. (1994). From knowledge to action? Exploring the relationships between environmental experiences, learning, and behavior. *Journal of social issues*, 50(3), 141-160. doi: 10.1111/j.1540-4560.1994.tb02424.x
- Frisk, E., & Larson, K. L. (2011). Educating for sustainability: Competencies & practices for transformative action. *Journal of Sustainability Education*, 2, 1-20. Retrieved from <http://www.jsedimensions.org/wordpress/wp-content/uploads/2011/03/FriskLarson2011.pdf>
- Gall, J. P., Gall, M. D., & Borg, W. R. (2009). *Applying Educational Research: A Practical Guide* (6<sup>th</sup> Edition). Boston, MA: Pearson Education, Inc.
- Gordon, J. C. (2002). Beyond knowledge: guidelines for effective health promotion messages. *Journal of Extension*, 40(6), 1-6.
- Hoy, R. M. (2009). Farm tractor rollover protection: Why simply getting rollover protective structures installed on all tractors is not sufficient. *Journal of Agricultural Safety and Health*, 15(1), 3-4, doi: 10.13031/2013.25418
- Hungerford, H. R., & Volk, T. L. (1990). Changing learner behavior through environmental education. *The Journal of Environmental Education*, 21(3), 8-21. doi:10.1080/00958964.1990.10753743
- Kaiser, F. G., & Fuhrer, U. (2003). Ecological behavior's dependency on different forms of knowledge. *Applied Psychology*, 52(4), 598-613. doi: 10.1111/1464-0597.00153
- Knobloch, N. A. (2003). Is experiential learning authentic. *Journal of Agricultural Education*, 44(4), 22-34. doi:10.5032/jae.2003.04022
- Lorig, K. R., & Holman, H. R. (2003). Self-management education: history, definition, outcomes, and mechanisms. *Annals of Behavioral Medicine*, 26(1), 1-7. doi: 10.1207/S15324796ABM2601\_01
- Lortie, D. C. (1975). *School teacher: A sociological inquiry*. Chicago: University of Chicago Press.

- Mabie, R., & Baker, M. (1996). A comparison of experiential instructional strategies upon the science process skills of urban elementary students. *Journal of Agricultural Education*, 37(2), 1-7. doi: 10.5032/jae.1996.02001
- Marlenga, B., Berg, R. L., Linneman, J. G., Brison, R. J., & Pickett, W. (2007). Changing the child labor laws for agriculture: impact on injury. *American Journal of Public Health*, 97(2), 276-282. doi: 10.2105/AJPH.2005.078923
- Marcoux, B. C., & Shope, J. T. (1997). Application of the theory of planned behavior to adolescent use and misuse of alcohol. *Health Education Research*, 12(3), 323-331. doi: 10.1093/her/12.3.323
- Maxwell, J. A. (2012). *Qualitative research design: An interactive approach* (3<sup>rd</sup> Edition). Thousand Oaks, CA: Sage Publications.
- Mitra, D. L. (2008). *Student voice in school reform: Building youth-adult partnerships that strengthen schools and empower youth*. SUNY Press.
- Monroe, M. C. (2003). Two avenues for encouraging conservation behaviors. *Human Ecology Review*, 10(2), 113-125.
- Morgan, D. L. (2007). Paradigms lost and pragmatism regained methodological implications of combining qualitative and quantitative methods. *Journal of Mixed Methods Research*, 1(1), 48-76. doi: 10.1177/2345678906292462
- Nolet, V. (2009). Preparing sustainability-literate teachers. *The Teachers College Record*, 111(2), 409-442.
- Pratt, C., & Bowman, S. (2008). Principles of effective behavior change: Application to extension family educational programming. *Journal of Extension*, 46(5).
- Schultz, P. W. (1999). Changing behavior with normative feedback interventions: A field experiment on curbside recycling. *Basic and Applied Social Psychology*, 21(1), 25-36. doi:10.1207/s15324834basp2101\_3
- Senge, P. M. (2000). The academy as learning community: Contradiction in terms or realizable future. *Leading academic change: Essential Roles for Department Chairs*, 275-300.
- Shakarian, D. C. (1995). Beyond lecture: Active learning strategies that work. *Journal of Physical Education, Recreation & Dance*, 66(5), 21-24.
- Simmons, B. & Volk, T. (2002). Conversations with environmental educators: A Conversation with Harold Hungerford. *Journal of Environmental Education*, 34(1), 5-8. doi:10.1080/00958960209603475

- Sterling , S. (2001). *Sustainable Education: Re-visiting Learning and Change*. Schumacher Briefings No. 6 Green Books Ltd.
- Stern, P. (2000). Toward a coherent theory of environmentally significant behavior. *Journal of Social Issues*, 56(3), 407-424. doi: 10.1111/0022-4537.00175
- Swenson, E. (2004). National Agricultural Tractor Safety Initiative.
- Zelezny, L. C. (1999). Educational interventions that improve environmental behaviors: A meta-analysis. *The Journal of Environmental Education*, 31(1), 5-14.  
doi:10.1080/00958969909598627

## **Using the Theory of Planned Behavior to Understand Extension Client's Water Conservation Intentions**

Anil Kumar Chaudhary, University of Florida

Laura A. Warner, University of Florida

Alexa J. Lamm, University of Florida

Glenn D. Israel, University of Florida

Joy N. Rumble, University of Florida

Randall A. Cantrell, University of Florida

### **Abstract**

Water scarcity is one of the most critical complex issues of the present time; Extension professionals can play a role in addressing this problem by helping home landscape irrigation users to conserve water. This study used survey research to examine the relationship between several variables, including attitudes, subjective norms, perceived behavioral control, personal norms, demographic factors, and past behaviors, on intention to use good irrigation practices among Florida home landscape irrigation users ( $N = 1,063$ ). The final hierarchical linear regression model explained 39% of the variance in intentions to engage in good landscape irrigation practices. Subjective norms had a strong influence on intention to engage in landscape water conservation, and past behaviors and personal norms also improved the prediction. Extension professionals should incorporate subjective norms into water conservation programs by emphasizing somewhat invisible conservation behaviors to improve perceptions of peers' practices. When personal norms were strong, the subjective norms were slightly less important. Residents who feel a personal obligation to conserve water may be more open to information related to water conservation, and they may be more likely to act, even in the absence of social support. Finally, Extension professionals should consider the audience's past behaviors to design programs that are compatible with actions Extension clients are likely to take.

### **Introduction**

Only three percent of the earth's total water is fresh and of that only a small portion is available for human use (Feldman, 2012). Water supply is threatened by a growing population, climate change, and increasing water pollution (Adams et al., 2013; Wolters, 2014), and by 2050 almost one-third of all U.S. counties will encounter water scarcity issues (Spencer & Altman 2010). Water's role in society is pivotal, and it serves multiple purposes, including agricultural needs, recreation, industry, and public health (Lamm, Lamm, & Carter, 2015).

Florida has seen an increase in its population by 580 percent (16.03 million) with in a time span of 60 years (1950 to 2010) due to its pristine beaches and attractive residential landscapes (Marella, 2014). Many Florida residents embrace a culture of aesthetically pleasing landscapes, investing substantial resources to maintain them (Baum, Dukes, & Miller, 2005). Florida residents consume nearly 71% of their total public supply water through landscape irrigation (Baum et al., 2005; Haley et al., 2007). To maintain their culturally-important lush landscapes, Florida residents use thousands of gallons of fresh water per watering cycle via automatic irrigation systems, often using more water than is needed (Baum et al., 2005; Haley, Dukes, & Miller, 2007). This consumption, driven by the desire for aesthetically-pleasing

landscapes among a rapidly-growing, urbanizing population, has increased the withdrawal of water by 465 percent (12,334 Mgal/day) just in 60 years (1950 to 2010), and this has contributed to scarcity of water in Florida (Marella, 2014). Water issues have recently become more contentious in Florida (Lamm et al., 2015).

Addressing landscape irrigation water use and conservation can be extremely difficult because of the diversity of the end users as well as their irrigation systems (Kjelgren, Rupp, & Kilgren, 2000). However, there are numerous water conservation practices and technologies available to home irrigation users. Some of the available water conservation options include converting from high water to low-water use landscapes or using alternative sources of water, such as recycled water (Kjelgren et al., 2000). Residents can also use technologies such as rain shutoff devices or soil moisture sensors to ensure water is not applied to the landscape when it is not needed (St. Hilaire et al., 2008). To encourage conservation, Extension professionals who focus on water issues need to understand personal and social factors that influence residents' intentions to adopt water conservation behaviors and technologies (Gregory & Di Leo, 2003; Huang, Lamm, & Dukes, 2016).

### **Theoretical Framework**

This study was guided by the Theory of Planned Behavior (TPB) (Ajzen, 1988). TPB explains that individual behavior is predicted by behavioral intentions, or the motivation to perform a behavior. Stronger intention to perform a specific behavior corresponds to greater likelihood that the behavior will be performed (Ajzen, 1991). Intentions are predicted by attitude toward the behavior, perceived approval of the behavior by others (subjective norms), and the perceived control an individual has over the performance of the behavior (perceived behavioral control) (Ajzen, 1988, 1991). The TPB has been successfully used to predict behaviors such as residential water conservation (Clark & Finley, 2007; Lam, 2006), environmental practices (Harland, Staats, & Wilke, 1999), driving violations (Parker, Manstead, & Stradling, 1995), and engagement in preventive dental care and cancer evaluations (McCaul et al., 1993). The power of attitudes, subjective norms, and perceived behavioral control to predict behavioral intentions varies across different contexts and behaviors (Ajzen, 1991).

Attitude toward water conservation refers to the degree to which a resident has a positive or negative evaluation of water conservation behaviors (Ajzen, 1991; Armitage & Conner, 2001; Trumbo & O'Keefe, 2001). Willis et al. (2011) found that residents who had very positive water conservation and environmental attitudes saved more water than those with only moderately positive attitudes. Lam (1999) found that positive attitudes toward limiting use of water among Taiwanese government employees was a significant predictor of their water conservation intentions and ultimately water conservation behavior. Similarly, Clark and Finley (2007) found that attitude toward water conservation was significantly and positively correlated with water conservation intentions among household water users.

Subjective norms are the general social pressure perceived by an individual to perform or not perform a specific behavior such as conserving water (Ajzen, 1988; 1991; Trumbo & O'Keefe, 2001). Subjective norms are conceptualized as perceived approval or expectations of water conservation behavior felt externally (Ajzen, 1988; Armitage & Conner, 2001; Trumbo & O'Keefe, 2001). Schultz et al. (2007) found that positive subjective norms promoted energy use

reductions among individual households. Similarly, Goldstein, Cialdini, and Griskevicius (2008) found an appeal to subjective norms increased towel reuse among hotel guests.

Perceived behavioral control is perceived capability to engage in a specific behavior such as water conservation (Ajzen, 1988; Armitage & Conner, 2001; Trumbo & O'Keefe, 2001). Parker et al. (1992) found motorists with lower perceived behavioral control over aberrant driving behaviors (e.g., speeding) were more likely to commit driving violations. In a meta-analysis of TPB factors, Godin and Kok (1996) found that perceived behavioral control explained 13% of the variation in behavioral intentions and 12% additional variation in actual behaviors. In another meta-analysis, Armitage and Conner (2001) found that perceived behavioral control increased prediction of behavior intentions by 6%. In summary, several studies have demonstrated significant effects of the TPB core variables (attitudes, subjective norms, and perceived behavioral control) on individuals' intentions to conserve water (Clark & Finley, 2007; Lam, 1999, 2006; Trumbo & O'Keefe, 2001).

### **Extending the Theory of Planned Behavior**

Ajzen (1991) confirmed that the TPB is "open to the inclusion of additional predictors if it can be shown that they capture a significant proportion of the variance in intention or behavior after the theory's current variables have been taken into account" (199). Researchers have found incorporating additional variables along with the core TPB variables (attitude, subjective norms, and perceived behavioral control) can increase this model's predictive power (Armitage & Conner, 2001). The following is a discussion of selected extra variables that have been tested along with the standard TPB model.

#### *Psychological and Environmental Factors*

Researchers have reported incorporating psychological and environmental factors into the TPB core variables improves the understanding water conservation behaviors (Clark & Finley, 2007; Lam, 1999, 2006; Trumbo & O'Keefe, 2001). Lam (1999) added perceived moral obligation and perceived water rights to the TPB variables to predict Taiwan residents' intentions to conserve water in general and specifically to install water-saving appliances. This model explained a 41% variation in intentions to conserve water and 24% variation in actual installation of water-saving appliances (Lam, 1999). By incorporating environmental values, information-seeking efforts, and socio-demographic variables along with core TPB variables, Trumbo and O'Keefe (2001) explained an additional 27% of the variation in behavioral intentions to conserve water among three communities in California and Nevada, USA. In a study among residents of Blagoevgrad, Bulgaria, Clark and Finley (2007) added "sociodemographics, environmental attitudes, information possession, and concern over future water shortages" (p. 618) to the standard TPB variables and the resulting model explained 27.2% of the variation in residents' intentions to conserve water.

#### *Personal Norms*

Personal norms are the perceived commitment an individual feels toward internal values, and they are experienced as personal obligations to engage in a certain behavior such as water conservation (Schwartz, 1977). Personal norms are different from attitudes as "attitudinal concepts refer to evaluations based on material, social, and/or psychological payoffs, [while]

personal norms focus exclusively on the evaluation of acts in terms of their moral worth to the self” (Schwartz & Howard, 1984, p. 245). Harland et al. (1999) found adding a personal norm variable to the three core TPB variables increased the proportion of variance explained in five pro-environmental behavioral intentions (e.g., installing energy-saving light bulbs) and four self-reported measures of environmentally supportive behaviors (e.g., turning off faucet). It is well documented that adding personal norms to TPB can explain many behaviors such as drinking skim milk (Raats, Shepherd, & Sparks 1995), avoiding driving violations (Parker et al., 1995), engaging in pro-environmental behaviors (Harland et al., 1999). However, personal norms have not been studied in the context of landscape water conservation behaviors.

### *Demographic Factors*

Demographic factors may reveal further insights into whether people engage in environmental behaviors (Stern, 2000). For example, both Dietz, Stern, and Guagnano (1998) and Lam (2006) found that females exhibited more pro-environmental behavior. In a review of 12 studies, Lam and Chao (2003) found females had greater intentions to demonstrate pro-environmental behavior. However, Clark and Finley (2007) reported sex had no effect in their study on water conservation behaviors. Age has been reported to both positively and inversely explain pro-environmental behaviors (Dietz et al., 1998; Klineberg, McKeever, & Rothenbach, 1998; Theodori & Luloff, 2002), yet some studies have found no relationship between age and intentions to conserve water (Lam, 2006; Trumbo & O’Keefe, 2001). Mixed findings for the effect of age could be explained by a possible non-linear relationship between age and behavioral intentions (Wiernik, Dilchert, & Ones, 2016). Income is considered an important demographic factor that can explain pro-environmental or water conservation behavior (de Oliver, 1999; Lam, 2006; Trumbo & O’Keefe, 2001). According to Trumbo and O’Keefe (2001), lower-income residents show greater intentions to conserve water. Hamburg, Haque, and Everitt (1997) found that people who recycled had greater income levels, were younger, and more educated than people who did not. Variance explained while assessing TPB influence on landscape water conservation intentions could be more meaningful when controlling for demographic variables.

### *Past Behavior*

The effect of past behaviors stands out among the variables that have been used to increase the predictive power of attitude on behavior (Fielding et al., 2012; Gregory & Di Leo, 2003; Ouellette & Wood, 1998). Past behavior can directly influence an individual’s future behaviors with limited mediating effects from attitudes, future intentions, norms, and perceived behavioral control (Ouellette & Wood, 1998). Past behaviors have also been shown to both positively and negatively influence the development of an individual’s attitude toward a specific behavior (Aarts et al., 1998).

The addition of variables to the TPB, such as psychological and environmental factors (perceived moral obligation, environmental values), demographic variables (sex, age and income), personal norms, and past behaviors such as water conservation can increase the power to predict intentions to conserve water. Despite the literature demonstrating the applicability of the TPB to water conservation behaviors, this model has not been fully applied to landscape water conservation behaviors, and research has not considered the addition of personal norms, past behaviors, and demographics to intentions to engage in good landscape irrigation practices.

## Purpose and Research Questions

The purpose of this study was to assess residents' landscape water conservation behavioral intentions using TPB constructs, assuming strong intentions are good predictors of actual landscape water conservation behaviors (Ajzen, 1991). This research aligns with research priority 7 of the American Association for Agricultural Education National Research Agenda, *Addressing Complex Problems* (Roberts, Harder, & Brashears, 2016). This research addresses the complex issue of water conservation by examining residents' behavioral intentions to conserve water to inform impactful Extension programs. The research questions were:

- How well can the TPB core variables (attitude, perceived behavioral control, and subjective norm) predict Florida residents' intentions to engage in good landscape irrigation practices?
- Does the addition of personal norms, past water conservation behaviors, and demographics to core TPB variables improve the prediction for Florida residents' intentions to engage in good landscape irrigation practices?

## Methodology

This cross-sectional study was part of a larger study conducted to examine Florida residents' landscape water conservation practices and perceptions. The target population was Florida residents who use landscape irrigation because this group has the potential to conserve substantial amounts of water by adopting good irrigation practices (Authors, 2016). Participants were required to be at least 18 years of age; Florida residents; have lawn or landscape; have an irrigation system; and have responsibility for controlling their irrigation. We used a web-based survey sampling company to recruit a purposive sample ( $N = 1,063$ ). We used non-probability sampling because landscape irrigation use is not systematically documented and therefore random sampling was not possible. Though the findings are restricted to the participants, non-probability samples have value and can generate results comparable to or sometimes better than probability samples, especially when there is no specific sampling frame of the target population (Abate, 1998; Twyman, 2008; Vavreck & Rivers, 2008; Baker et al., 2013). During a preliminary pilot test, we attempted to recruit individuals to match Florida census data and found that the target population differed from the overall state population (Warner, Rumble, Martin, Lamm, & Cantrell, 2015). Among 2,829 potential respondents who received an invitation, 98 chose not to participate. Of the 2,731 respondents who agreed to participate, 1,683 met the four screening criteria, indicating that they belonged to the target population, and were therefore eligible to complete the survey. We incorporated quality control questions to ensure respondents' attention and maintain integrity of data (Lavrakas, 2008). Those who did not respond as instructed were not permitted to proceed with the survey, which reduced the overall completion rate. Out of 1,683 eligible respondents a total of 1,063 responses were considered complete for the purpose of data analysis, for a participation rate of 63.16% (Baker et al., 2016).

We assessed variation in behavioral intention to engage in good landscape irrigation practices using the TPB model. The dependent variable, behavioral intention to engage in good landscape irrigation practices, was calculated using the mean score of twelve statements which were each measured on a five-point Likert-type scale where -2 = *very unlikely*, -1 = *unlikely*, 0 = *undecided*, 1 = *likely*, 2 = *very likely* to engage in specific future water conservation behaviors. These statements were selected from best water conservation irrigation practice



recommendations by Florida Friendly Landscaping Program, a major Florida Cooperative Extension initiative that promotes residential landscape water conservation. Respondents who selected *not applicable* ( $n = 228$ ) for one or more of the twelve practices were excluded from further analysis. We asked respondents to indicate how likely or unlikely they were to engage in the following good landscape irrigation practices in future: *Eliminate irrigated areas in my landscape; Turn off zone(s) or capped irrigation heads for established woody plants; Convert turfgrass areas to landscaped beds; Replace high water plants with drought tolerant plants; Replace high volume irrigated areas with low volume irrigation; Install smart irrigation controls (such as soil moisture sensors (SMS) or an evapotranspiration device (ET)) so irrigation won't turn on when it isn't needed; Calibrate my sprinklers; Use a rain gauge to monitor rainfall for reducing/skipping irrigation; Use a rain barrel or cistern; Use different irrigation zones/zone run times based on plants' irrigation needs; Seasonally adjust irrigation times; and Follow watering restrictions.*

The survey instrument incorporated the term *good irrigation practices*, which was considered to be understood by the Florida general public as conserving water because Florida has a high percentage of water conscious people due to high awareness of water issues, extensive water conservation programming, and numerous landscape water conservation options (Authors, 2016). Following Ajzen (1988), we quantified attitude using the mean score of six items each measured on a five-point semantic differential scale. There was one main statement: *implementing good irrigation practice is*, which participants completed using six different five-point semantic scales (-2 to 2): *good to bad, important to unimportant, wise to foolish, beneficial to harmful, positive to negative, and necessary to unnecessary*. We quantified subjective norms using the mean score of five statements measured on a five-point Likert type scale (-2 = *strongly disagree*, -1 = *disagree*, 0 = *undecided*, 1 = *agree*, 2 = *strongly agree*). The statements were: *the people who are important to me would approve if I reduced my landscape's impact on water resources; the people that I am close to think I should encourage others to protect our water resources; it is expected that I will manage my landscape using the smallest amount of water possible; the people whose opinions I value expect that I will minimize my personal impact on local water resources; and the people that I am close to would approve if I explored ways to reduce my impact on water resources.*

We calculated perceived behavioral control using the mean score of five items measured on a five-point semantic differential scale. There was one main statement: *implementing good irrigation practice is*, which was completed using five different five-point semantic scales (-2 to 2): *possible for me to not possible for me; easy for me to not easy for me; in my control to not in my control; up to me to not up to me; and practical for me to not practical for me*. We measured personal norms, past water conservation behaviors, and demographics in addition to the core TPB variables. We quantified personal norms using the mean score of five statements measured on a five-point Likert type scale (-2 = *strongly disagree*, -1 = *disagree*, 0 = *undecided*, 1 = *agree*, 2 = *strongly agree*). The statements were: *I feel a personal obligation to explore ways to reduce my landscape's impact on water resources; it is important to manage my landscape using the smallest amount of water possible; it is important to encourage my friends and family to protect our water resources; I feel a personal obligation to minimize my personal impact on local water resources; and I should be responsible for doing whatever I can to protect water resources.*

We measured past water conservation behaviors using five statements alongside a dichotomous response (1 = *no*, 2 = *yes*) with *unsure* option. The statements were: *I have low-water consuming plant materials in my yard; I use recycled waste water to irrigate my lawn/landscape; I use high efficiency sprinklers; I use drip (micro) irrigation; and I use a rain sensor to turn off irrigation when it is not needed.* For analysis purposes, past water conservation behaviors were dummy coded with a base as not engaging in the water conservation behavior (0) and remaining as engaging in the water conservation behavior (1). We excluded respondents who indicated that they were *unsure* ( $n = 399$ ) for one or more of the five practices from further analysis. We created the past water conservation behavior index by summing five statements and therefore the index could range from zero to five. Demographics included sex, age, and total family income from all sources before taxes. We dummy coded the sex variable as 1 = *male*, 0 = *female*. We measured age on a continuous scale calculated based on respondents' year of birth. We measured family income through five income categories (1 = *less than \$49,999*, 2 = *\$50,000 to \$74,999*, 3 = *\$75,000 to \$149,999*, 4 = *\$150,000 to \$249,999*, and 5 = *\$250,000 or more*) and treated income as a continuous variable for data analysis following Trumbo and O'Keefe (2001).

We used an expert panel to establish the instrument's face and content validity. We selected experts for the panel based on proficiency in survey methodology, water conservation outreach programming, and water conservation practices and technologies. The study was approved by the [University] Institutional Review Board. Once the face and content validity were established, we pilot-tested the instrument. We calculated post-hoc reliability for the pilot test using Cronbach's alpha and deemed it satisfactory at 0.80 or greater (Cohen, 1988) for all items. We made no major changes to the instrument based on the pilot test. Following the full study, we calculated post-hoc reliability on the final instrument using Cronbach's alpha and found it to be satisfactory for all components [attitude (0.89), perceived behavioral control (0.89), personal norms (0.90), social norms (0.88), and behavioral intentions (0.87)].

We analyzed data using SPSS (version 22.0; IBM Corp., Armonk, NY). We used means and standard deviations to describe the data and hierarchical linear regression to assess the effect of components of TPB variables. In hierarchical linear regression, we regressed the behavioral intention to engage in good landscape irrigation practices against the set of independent variables. In the first block (model 1) of hierarchical regression, we entered all core TPB variables- *attitude, subjective norm and perceived behavioral control*, then we added the *personal norms* variable to create the second block (model 2). In the third block (model 3) we entered *past water conservation behavior*. In the final block (model 4), we added all three demographic variables (*sex, age, and family income*). Prior to analysis, we examined the data and found it satisfied all assumptions of hierarchical linear regression regarding multi-collinearity, independence of residuals, homoscedasticity, linearity, and normally distributed errors.

## Results

Out of 1,063 responses, 535 were included in the final analysis. The sample had slightly more females (52%), the average age was 50.1 years, and 66.9% of respondents earned between \$50,000 and \$149,000 per year. The percentage of females in our sample was equivalent to percentage of females in Florida (51.1%) in 2014, but sample respondents earned more income compared to median Florida household (\$47,212) income in 2014 (USCB, n. d.). Respondents' behavioral intentions to engage in good landscape irrigation practices in the future ranged between undecided and likely on a five-point scale (1 = *very unlikely* to 5 = *very likely*). Using

the real limits of the five-point scale, the majority of respondents had strong perceived norms (personal and subjective), had positive attitudes toward good landscape irrigation practices, and indicated they had perceived control over water conservation (Table 1). On average, respondents' past engagement in water conservation behaviors ranged from one to four behaviors with five being the maximum (Table 1).

Table 1  
*Descriptive Statistics of Behavioral Intentions, Theory of Planned Behavior and Demographic Variables (n = 535) for Good Landscape Irrigation Practices of Residents*

Predictor	<i>M</i>	<i>SD</i>
Behavioral intentions <sup>a</sup>	0.82	0.74
Age	50.11	15.90
Past water conservation behavior <sup>b</sup>	2.50	1.36
Personal norm <sup>c</sup>	1.26	0.64
Subjective norm <sup>c</sup>	0.96	0.78
Attitude <sup>d</sup>	1.72	0.49
Perceived behavioral control <sup>e</sup>	1.47	0.62

*Note.* <sup>a</sup>Five-point scale (-2 = very unlikely to 2 = very likely); <sup>b</sup>Summed score of engagement in five water conservation practices ranging from zero = does not engage to 5 = engages in all five practices; <sup>c</sup>Five-point scale (-2 is weak perceived norm and 2 is strong perceived norm); <sup>d</sup>Five-point semantic differential scales (-2 is negative attitude and 2 is positive attitude); <sup>e</sup>Five-point semantic differential scales (-2 is no perceived behavioral control and 2 is high perceived behavioral control)

All four models were significant predictors of intentions to engage in good landscape irrigation practices (Table 2). The results of hierarchical linear regression indicated that each block added significantly to the overall model. The final model with all variables had an  $R^2 = 0.388$ , revealing the overall model explained 39% of the variance in intentions to engage in good landscape irrigation practices.

Table 2  
*Hierarchical Linear Regression Models in a Study of Good Landscape Irrigation Practices of Florida Residents Examining Effect of Demographic Variables, Past Water Use Behavior, Personal Norms, and Theory of Planned Behavior Variables on Intentions to Conserve Water (n = 535)*

Predictor	$R^2$	$R^2$ change	<i>F</i>	<i>p</i>
Model 1	0.251	0.251	7.12	< 0.001
Model 2	0.278	0.028	32.64	< 0.001
Model 3	0.370	0.092	31.58	< 0.001
Model 4	0.388	0.017	41.64	< 0.001

The first block included the three core TPB variables, out of which subjective norms and perceived behavioral control significantly explained intentions to engage in good landscape irrigation practices. Attitude did not significantly explain intentions to engage in good landscape irrigation practices. The hierarchical regression standardized beta coefficients for TPB variables

indicated that residents with higher subjective norms and perceived behavioral control had higher intentions to engage in good landscape irrigation practices (Table 3). The largest effect size was for subjective norms, which individually explained 13% variation, followed by perceived behavioral control, which explained 1.9% variation in intentions. Overall, model 1 explained 25.1% variation in intentions with core TPB variables (subjective norms, attitudes, and perceived behavioral control) only. This is substantially higher than the 10-18% variation in intentions to conserve water explained by the TPB core variables reported by others (Clark & Finley, 2007; Lam, 2006; Trumbo & O'Keefe, 2001).

Table 3

*Demographic Variables, Past Water Use Behavior, Personal Norms, and Theory of Planned Behavior Variables in Hierarchical Linear Regression Analysis of Florida Residents (n = 535)*

Predictor	Model 1 ( $\beta$ )	Model 2 ( $\beta$ )	Model 3 ( $\beta$ )	Model 4 ( $\beta$ )	$R^2$ change
Subjective norm	0.40**	0.25**	0.21**	0.18**	0.130
Attitude	0.02	-0.03	-0.01	-0.01	0.001
Perceived behavioral control	0.17**	0.15**	0.11**	0.14**	0.019
Personal norm		0.24**	0.19**	0.18**	0.028
Past water conservation behavior			0.32**	0.33**	0.092
Sex (male)				-0.07*	0.004
Age				-0.11**	0.010
Family income				0.01	0

Note. \* $p \leq 0.05$  \*\* $p \leq 0.01$ , reported  $\beta$  are standardized regression coefficients

The second block added the personal norms variable, and this model significantly explained intentions to engage in good landscape irrigation practices. The addition of personal norms increased the  $R^2$  by .028, meaning that when TPB variables were controlled, personal norms explained 2.8% of the variation in intentions to engage in good landscape irrigation practices (Table 2). This 2.8% increase in explained variation solely by personal norms demonstrates its effect size. When the subjective norm variable was removed from first block, the variance explained in behavioral intentions to engage in good landscape irrigation practices by personal norms was similar (12.4%) to subjective norm. This shows that when only one norm variable (subjective norm or personal norm) is used in the full model, the effect on intent is comparable. This effect is similar to findings of Harland et al. (1999), who reported that additions of personal norms to standard TPB explained an additional 3 to 7% variation in behavioral intentions to engage in environmentally responsible behaviors. The third block added the past landscape water conservation behavior variable to block two, and in this model the added variable significantly explained intentions to engage in good landscape irrigation practices. The addition of the third block increased the  $R^2$  by 9.2%, meaning that when TPB and personal norm variables were controlled, past water conservation behaviors alone explained 9.2% of the variation in intentions to engage in good landscape irrigation practices (Table 2). Because past water conservation behavior was significant with a positive beta, we interpreted this to mean that residents who were engaged in good landscape irrigation practices in the past are more likely to do so in the future.

In the fourth and final block, which included Florida residents' demographic characteristics, only age and sex significantly explained residents' intentions to engage in good

landscape irrigation practices. Family income was a non-significant predictor. The negative beta for age indicates that as age increases, engagement in good landscape irrigation practices decreases. In terms of effect size, the age variable explained more of the variance (1.1%) in behavioral intentions compared to other demographic variables. This finding is consistent with those of Dietz et al. (1998) and Hamburg et al. (1997). The negative beta for sex indicates that males are less likely to conserve water, and this finding is consistent with others who reported higher pro-environmental behavior among females (Clark & Finley, 2007; Lam, 2006; Lam & Chao, 2003). The addition of demographic variables in the final block increased the overall  $R^2$  by 1.7%, meaning that as core TPB variables, personal norms, and past water conservation behaviors were controlled, demographics explained 1.7% of the variation in the intentions to engage in good landscape irrigation practices. This finding is consistent with Clark and Finley (2007), who found that among their measured demographic variables only age, education, residence type, and presence of a garden significantly related to intentions to conserve water. Our findings are inconsistent with those of Trumbo and O'Keefe (2001) who reported that only income explained the intentions to conserve water among several demographic characteristics. The non-significant income variable may be explained by the higher overall income among study participants compared to the Florida population overall. Overall, addition of personal norms, past water conservation behaviors, and demographics to core TPB variables improved the prediction by explaining an additional 13.7% variance in Florida residents' behavioral intentions to engage in good landscape irrigation practices.

### **Conclusions and Recommendations**

The results of the current study indicated the presence of positive overall dispositions toward landscape water conservation. The addition of past water conservation behaviors and personal norms to the core TPB variables significantly improved the explanation for intentions to conserve water. Only a few researchers have incorporated past water conservation behaviors into the standard TPB model, and the current study was the first to apply them to landscape water conservation. In Trumbo and O'Keefe's (2001) study, past behaviors were non-significant in explaining the intentions of residents to conserve water. The current study revealed that the past water conservation behavior variable is significant, and we agree with others who have asserted that residents who conserved water in the past are likely to conserve water in the future (Aarts et al., 1998; Fielding et al., 2012; Gregory & Di Leo, 2003; Ouellette & Wood, 1998). Thus, it would behoove water conservation outreach professionals to carefully consider residents' past behaviors when developing new water conservation programs. To increase the adoption of water conservation behaviors, Extension professionals are encouraged to reinforce the behaviors they want people to continue doing by specifically targeting and providing support for people who engaged in landscape water conservation in the past. This may be especially important among people who have engaged in landscape water conservation but have discontinued these practices. Further, Extension professionals should Different outreach strategies may need to be used for residents who have not previously engaged in landscape water conservation.

Personal norms have previously been studied along with TPB variables to explain behaviors (Harland et al., 1999; Parker et al., 1995), and this study explored whether personal norms explained landscape water conservation behaviors. Several conclusions were drawn from this element. First, the addition of personal norms significantly predicted water conservation behaviors when controlling for TPB core variables, and personal norms uniquely explained an

additional 2.8% variation in behavioral intentions. This reveals that the influence of residents' moral consideration on water conservation behavioral intentions is not fully captured by the TPB core variables. Second, the decrease in the unique contribution made by subjective norms on behavioral intentions (exhibited by decrease in standardized regression coefficient) reveals that personal norms increase the TPB's conceptual clarity. An adjustment to subjective norms while controlling personal norms reveals the actual influence of non-internalized norms (Schwartz, 1977).

Additionally, we concluded that when personal norms are strong then subjective norms are slightly less important. This finding can be used to promote conservation behaviors in communities where social support is low. Residents who feel a personal obligation to conserve water may be more open to information related to water conservation, and they may be more likely to act, even in the absence of social support. Extension professionals should therefore include personal norms in their working agenda. For example, if a large group of residents in the target audience perceive personal obligation to conserve water (personal norm), then Extension professionals can help to translate this personal norm into a broader social norm to promote water conservation practices and technologies. Extension professionals can translate water conserving personal norms into social norms by making demonstration at the lawns of community volunteers lawns that how slight changes in water use behavior (skipping irrigation twice a week) can save a great amount of water. In settings where personal norms are low, Extension professionals should develop strategies to increase the personal sense of obligation to engage in landscape water conservation practices.

Excluding attitude, the TPB core variables (subjective norms and perceived behavioral control) significantly predicted intentions to conserve water. Although residents indicated overall positive water conservation attitudes, the effect of the attitude variable on intent was non-significant. There was likely a ceiling effect with attitudes toward the water conservation behavior (high mean attitude score and low variability) that may have affected the utility of the measure as a predictor of intentions. Recent water crises and increased publicity of water issues both nationally and in Florida might have heightened awareness of and increased attitude toward water conservation, therefore stronger positive attitude might not impact behavioral intentions to conserve water. Additionally, because the survey focused on landscape water conservation, it is possible that social desirability bias was present (Krumpal, 2013). Because subjective norms and perceived behavioral control do explain behavioral intentions, we recommend that Extension professionals consider these characteristics first when planning programs to encourage landscape water conservation. When the target audience's subjective norms or perceived behavioral control are low, Extension professionals need to develop strategies to increase these characteristics. To increase perceived behavioral control, Extension professionals should provide opportunities to increase the skills needed to adopt and maintain technologies such as irrigation timers and soil moisture sensors. For example, hands-on skill building activities can be incorporated into educational programs to increase perceived behavioral control.

Among the significant TPB variables, the influence of subjective norms on variance in behavioral intentions was almost seven times greater than perceived behavioral control. This finding emphasizes the critical importance of positive support to engage in landscape water conservation within a social system. This support might exist in the form of encouragement and expectations communicated directly or indirectly by peers, neighbors, friends, and family

members. As subjective norms are recognized as an effective strategy to promote behavior change among target audiences (Kumar Chaudhary & Warner, 2015; McKenzie-Mohr, 2011), we recommend that Extension professionals develop strategies to increase individuals' awareness of their peers' engagement in landscape water conservation practices (McKenzie-Mohr, 2011). For example, educational materials could provide a clear distinction regarding how many people in a target audience are already engaging in a specific desired behavior in comparison to their neighbors. A new norm for water conservation also can be encouraged in the community by collaborating with local leaders to adopt and promote water conservation behaviors (Blaine et al., 2012). As conservation behaviors often are unseen (Kim, Hong, & Magerko, 2009), it would be helpful to provide opportunities for those who engage in landscape water conservation practices to share their experiences and demonstrate technologies in order to increase the perceived norm.

Extension professionals should identify factors that lead to low perceived behavioral control, such as site-specific barriers to the adoption of landscape water conservation practices or lack of required skill, and develop strategies to address them. Perceived behavioral control can be increased by helping people gain skills needed to adopt specific water conservation technologies and practices. This might be done by helping people learn how to use specific irrigation technologies and by developing clear resources and making them available online through videos or fact sheets. Extension professionals can demonstrate landscape water conservation behaviors such as installing rain barrels (Ott, Monaghan, Israel, Gouldthorpe, & Wilber, 2015), which can reduce perceptions that these technologies are difficult to use (Trumbo & O'Keefe, 2001). Perceived behavioral control can also be increased by removing residents' perceived barriers to adoption. For example, if residents associate conservation with prohibitive costs and expensive technologies, Extension professionals can reduce this barrier by educating residents on the potential financial savings that might result from saving water or by emphasizing less costly water conservation options. For example, skipping a week of irrigation can save significant amounts of water with no expense (Haley et al., 2007).

Overall, the current study confirmed that landscape water conservation behavioral intentions can be explained by the TPB model with a specific and important population that uses and makes decisions about landscape irrigation and ultimately has the opportunity to conserve substantial amounts of water. The TPB core variables explained substantially higher (25.1%) variation in landscape water conservation behavioral intentions compared to other studies (Clark & Finley, 2007; Lam, 2006; Trumbo & O'Keefe, 2001), which indicates that TPB is useful for understanding behaviors performed outside the home, and specifically landscape water conservation behaviors. The addition of personal norms and past water conservation behavior variables is beneficial and provides a better overall prediction of intent to conserve water (Clark & Finley, 2007; Lam, 1999, 2006; Trumbo & O'Keefe, 2001). Past water conservation behaviors enhance the TPB prediction model, which reveals the importance of deeply understanding the target audience's existing and past practices. Extension professionals should conduct thorough needs assessments and encourage people to use technologies and practices on a trial basis to increase the likelihood that certain water conservation behaviors will be used in the future. Subjective norms strongly guide water conservation behaviors, but they may not be absolutely required, because the influence of subjective norms on water conservation behaviors is reduced when personal norms are strong.

This study is a preliminary examination of the addition of these variables with a purposive sample. In the case of behaviors such as landscape water conservation, which are often invisible, further research is needed to better understand what factors link intentions and actual water conservation behaviors. To better explain landscape water conservation behaviors among Florida residents, future research should utilize a random sample of the target population and incorporate variables such as homeowners' association membership, whether the lawn is maintained by a professional landscaping company, residents' environmental values, and the amount of water bills along with core TPB variables.

## References

- Aarts, H., Verplanken, B., & van Knippenberg, A. (1998). Predicting behavior from actions in the past: Repeated decision making or a matter of habit? *Journal of Applied Social Psychology, 28*, 1356–1375. doi:10.1111/j.1559-1816.1998.tb01681.x
- Abate, T. (1998). *Accuracy of online surveys may make phone polls obsolete*. The San Francisco Chronicle, D1.
- Adams, D. C., Allen, D., Borisova, T., Boellstorff, D. E., Smolen, M. D., & Mahler R. L. (2013). The influence of water attitudes, perceptions, and learning preferences on water-conserving actions. *Natural Sciences Education, 42*(1), 114–122. Retrieved from <https://dl.sciencesocieties.org/publications/nse/abstracts/42/1/114>
- Ajzen, I. (1988). *Attitudes, personality and behavior*. Milton Keynes: Open University Press.
- Ajzen, I. (1991). The theory of planned behavior. *Organizational Behavior and Human Decision Processes, 50*(2), 179–211. doi:10.1016/0749-5978(91)90020-T
- Armitage, C. J., and M. Conner, M. (2001). Efficacy of the theory of planned behavior: A meta-analytic review. *British Journal of Social Psychology, 40*(4), 471–499. doi:10.1348/014466601164939
- Baker, R., Brick, J. M., Bates, N. A., Battaglia, M., Couper, M. P., Dever, J. A., & Tourangeau, R. (2013). *Report of the AAPOR task force on non-probability sampling*. [http://www.aapor.org/AAPORKentico/AAPOR\\_Main/media/MainSiteFiles/NPS\\_TF\\_Report\\_Final\\_7\\_revised\\_FNL\\_6\\_22\\_13.pdf](http://www.aapor.org/AAPORKentico/AAPOR_Main/media/MainSiteFiles/NPS_TF_Report_Final_7_revised_FNL_6_22_13.pdf) (accessed 20 June 2015)
- Baker, R., Brick, J. M., Keeter, S., Biemer, P., Kennedy, C., Kreuter, F., Mercer, A., & Terhanian, G. (2016). *Evaluating survey quality in today's complex environment*. Retrieved from [http://www.aapor.org/AAPOR\\_Main/media/MainSiteFiles/AAPOR\\_Reassessing\\_Survey\\_Methods\\_Report\\_Final.pdf](http://www.aapor.org/AAPOR_Main/media/MainSiteFiles/AAPOR_Reassessing_Survey_Methods_Report_Final.pdf)
- Baum, M. C., Dukes, M. D., & Miller, G. L. (2005). Analysis of residential irrigation distribution uniformity. *Journal of Irrigation and Drainage Engineering, 131*(4), 336–341. doi:10.1061/(ASCE)0733-9437(2005)131:4(336)



- Blaine, T. W., Clayton, S., Robbins, P., & Grewal, P. S. (2012). Homeowner attitudes and practices towards residential landscape management in Ohio, USA. *Environmental Management*, *50*(2), 257–271. doi: 10.1007/s00267-012-9874-x
- Clark, W. A., & Finley, J. C. (2007). Determinants of water conservation intention in Blagoevgrad, Bulgaria. *Society and Natural Resources*, *20*(7), 613–627. doi:10.1080/08941920701216552
- Cohen, J. (1988). *Statistical power analysis for the behavioral sciences* (2nd ed.). Hillsdale, NJ: Lawrence Erlbaum Associates.
- de Oliver, M. (1999). Attitudes and inaction: A case study of the manifest demographics of urban water conservation. *Environment and Behavior*, *31*, 372–394. doi:10.1177/00139169921972155
- Dietz, T., Stern, P. C., & Guagnano, G. A. (1998). Social structural and social psychological bases of environmental concern. *Environment and Behavior*, *30*, 450–71. doi:10.1177/001391659803000402
- Feldman, D. L. (2012). *Water*. Malden, MA: Polity Press.
- Fielding, K. S., Russell, S., Spinks, A., & Mankad, A. (2012). Determinants of household water conservation: The role of demographic, infrastructure, behavior, and psychosocial variables. *Water Resources Research*, *48*, W10510. doi:10.1029/2012WR012398
- Godin, G., & Kok, G. (1996). The theory of planned behavior: A review of its applications to health-related behaviors. *American Journal of Health Promotion*, *11*, 87–98. doi:10.4278/0890-1171-11.2.87
- Goldstein, N. J., Cialdini, R. B., & Griskevicius, V. (2008). A room with a viewpoint: Using social norms to motivate environmental conservation in hotels. *Journal of Consumer Research*, *35*(3), 472–482. doi:10.1086/586910
- Gregory, G., & Di Leo, M. (2003). Repeated behavior and environmental psychology: The role of personal involvement and habit formation in explaining water consumption. *Journal of Applied Social Psychology*, *33*(6), 1261–1296. doi:10.1111/j.1559-1816.2003.tb01949.x
- Haley, M. B., Dukes, M. D., & Miller, G. L. (2007). Residential irrigation water use in Central Florida. *Journal of Irrigation and Drainage Engineering*, *133*(5), 427–434. doi:10.1061/(ASCE)0733-9437(2007)133:5(427)
- Hamburg, K. T., Haque, C E., & Everitt, J. C. (1997). Municipal waste recycling in Brandon, Manitoba: Determinants of participatory behavior. *Canadian Geographer*, *41*, 149–65. doi:10.1111/j.1541-0064.1997.tb01155.x
- Harland, P., Staats, H., & Wilke, H. A. (1999). Explaining proenvironmental intention and behavior by personal norms and the theory of planned behavior. *Journal of Applied Social Psychology*, *29*(12), 2505–2528. doi:10.1111/j.1559-1816.1999.tb00123.x

- Huang, P. W., Lamm, A. J., & Dukes, M. D. (2016). Informing extension program development through audience segmentation: Targeting high water users. *Journal of Agricultural Education*, 57(2), 60-74. doi: 10.5032/jae.2016.02060
- Kim, T., Hong, H., & Magerko, B. (2009). Coralog: Use-aware visualization connecting human micro-activities to environmental change. *Proceedings of the 27th international conference on human factors in computing systems, Boston, USA*, 4303–4308.
- Kjelgren, R., Rupp, L., & Kilgren, D. (2000). Water conservation in urban landscapes. *HortScience*, 35(6), 1037–1040. Retrieved from <http://hortsci.ashspublications.org/content/35/6/1037>.
- Klineberg, S., McKeever, M., & Rothenbach, B. (1998). Demographic predictors of environmental concern: It does make a difference how it's measured. *Social Science Quarterly*, 79(4), 735–753. Retrieved from [www.jstor.org/stable/42863844](http://www.jstor.org/stable/42863844)
- Krumpal, I. (2013). Determinants of social desirability bias in sensitive surveys: A literature review. *Quality & Quantity*, 47, 2025–2047. doi:10.1007/s11135-011-9640-9
- Kumar Chaudhary, A., & Warner, L. A. (2015). Promoting behavior change using social norms: Applying a community based social marketing tool to extension programming. *Journal of Extension*, 53(3). Retrieved from <https://joe.org/joe/2015june/tt4.php>
- Lamm, K. W., Lamm, A. J., & Carter, H. S. (2015). Bridging water issue knowledge gaps between the general public and opinion leaders. *Journal of Agricultural Education*, 56(3), 146–161. doi:10.5032/jae.2015.03146
- Lam, S. P. (1999). Predicting intentions to conserve water from the theory of planned behavior, perceived moral obligation, and perceived water right. *Journal of Applied Social Psychology*, 29(5), 1058–1071. doi:10.1111/j.1559-1816.1999.tb00140.x
- Lam, S. P. (2006). Predicting intention to save water: theory of planned behavior, response efficacy, vulnerability, and perceived efficiency of alternative solutions. *Journal of Applied Social Psychology*, 36(11), 2803–2824. doi:10.1111/j.0021-9029.2006.00129.x
- Lam, S. P., & Chao, Y. (2003). December. *Factors influencing college students and the public's green consumption behavior: A meta-analysis*. Paper presented at the 13th Conference on Environmental Management and Urban Development, Kaohsiung, Taiwan, Republic of China.
- Lavrakas, P. J. (Ed.). (2008). *Encyclopedia of survey research methods*. Thousand Oaks, CA: Sage Publications, Inc.
- McCaul, K. D., Sandgren, A. K., O'Neill, H. K., & Hinsz, V. B. (1993). The value of the theory of planned behavior, perceived control, and self-efficacy expectations for predicting health-protective behaviors. *Basic and Applied Social Psychology*, 14, 231–252. doi:10.1207/s15324834basp1402\_7
- Marella, R. (2014). *Water withdrawals, use, and trends in Florida, 2010*. U.S. Geological Survey. Retrieved from <http://pubs.usgs.gov/sir/2014/5088/pdf/sir2014-5088.pdf>

- McKenzie-Mohr, D. (2011). *Fostering sustainable behavior* (3rd ed.). Canada: New Society Publishers.
- Ott, E., Monaghan, P., Israel, G. D., Gouldthorpe, J., & Wilber, W. (2015). Rain barrel owners as a piece of the water conservation puzzle: Segmenting extension audiences using their landscape water conservation practices. *Journal of Extension*, *53*(2). Retrieved from <https://joe.org/joe/2015april/rb5.php>
- Ouellette, J. A., & Wood, W. (1998). Habit and intention in everyday life: The multiple processes by which past behavior predicts future behavior. *Psychological Bulletin*, *124*(1), 54–74. doi:10.1037/0033-2909.124.1.54
- Parker, D., Manstead, A. S., Stradling, S. G., Reason, J. T., & Baxter, J. S. (1992). Intention to commit driving violations: An application of the theory of planned behavior. *Journal of Applied Psychology*, *77*(1), 94–101. doi:10.1037/0021-9010.77.1.94
- Parker, D., Manstead, A. S. & Stradling, S. G. (1995). Extending the theory of planned behaviour: The role of personal norm. *British Journal of Social Psychology*, *34*(2), 127–138. doi:10.1111/j.2044-8309.1995.tb01053.x
- Raats, M. M., Shepherd, R., & Sparks, P. (1995). Including moral dimensions of choice within the structure of the theory of planned behavior. *Journal of Applied Social Psychology*, *25*, 484–494. doi:10.1111/j.1559-1816.1995.tb01763.x
- Roberts, T. G., Harder, A., & Brashears, M. T. (Eds.). (2016). *American Association for Agricultural Education national research agenda: 2016-2020*. Gainesville, FL: Department of Agricultural Education and Communication.
- Schultz, P. W., Nolan, J. M., Cialdini, R. B., Goldstein, N. J., & Griskevicius, V. (2007). The constructive, destructive, and reconstructive power of social norms. *Psychological Science*, *18*(5), 429–434. doi:10.1111/j.1467-9280.2007.01917.x
- Schwartz, S. H. (1977). Normative influences on altruism. In L. Berkowitz (Ed.), *Advances in experimental social psychology* (Vol. 10, pp. 22 1–279). New York, NY: Academic.
- Schwartz, S. H., & Howard, J. A. (1984). Internalized values as moderators of altruism. In E. Staub, D. Bar-Tal, J. Karylowski, & J. Reykowski (Eds.), *Development and maintenance of prosocial behavior* (pp. 229–255). New York, NY Plenum.
- Spencer, T., & Altman, P. (2010). *Climate change, water, and risk: Current water demands are not sustainable*. Natural Resources Defense Council, Washington, DC. Retrieved from <http://www.nrdc.org/globalWarming/watersustainability/files/WaterRisk.pdf>
- Stern, P. C. (2000). Toward a coherent theory of environmentally significant behavior. *Journal of Social Issues*, *56*, 407–424. doi:10.1111/0022-4537.00175
- St. Hilaire, R., Arnold, M. A., Devitt, D. A., Hurd, B. H., Lesikar, B. J., Lohr, V. I., Martin, C. A., McDonald, G. V., Morris, R. L., Pittenger, D. R., Shaw, D. A., Wilkerson, D. C., & Zoldoske, D. F. (2008). Efficient water use in residential urban landscapes. *HortScience* *43*(7), 2081–2092. Retrieved from <http://hortsci.ashspublications.org/content/43/7/2081>

- Theodori, G., & Luloff, A. (2002). Position on environmental issues and engagement in proenvironmental behavior. *Society and Natural Resources*, 15, 471–482. doi:10.1080/08941920290069128
- Trumbo, C. W., & O'Keefe, G. J. (2001). Intention to conserve water: Environmental values, planned behavior, and information effects. A comparison of three communities sharing a watershed. *Society and Natural Resources*, 14(10), 889–899. doi:10.1080/089419201753242797
- Twyman, J. (2008). Getting it right: Yougov and online survey research in Britain. *Journal of Elections, Public Opinions and Parties*, 18, 343–354. doi:10.1080/17457280802305169
- United States Census Bureau (USCB). n. d. *Quick facts*. Retrieved from <https://www.census.gov/quickfacts/table/PST045215/12>
- Vavreck, L., & Rivers, D. (2008). The 2006 cooperative congressional election study. *Journal of Elections, Public Opinion and Parties*, 18(4), 355–366. doi:10.1080/17457280802305177
- Warner, L. A., Rumble, J., Martin, E., Lamm, A. J., & Cantrell, R. (2015). The effect of strategic message selection on residents' intent to conserve water in the landscape. *Journal of Agricultural Education*, 56(4), 59-74. doi: 10.5032/jae.2015.04059
- [Authors]. (2016)
- Wiernik, B. M., Dilchert, S., & Ones, D. S. (2016). Age and employee green behaviors: A meta-analysis. *Frontiers in Psychology*, 7, 1–15. doi:10.3389/fpsyg.2016.00194
- Willis, R. M., Stewart, R. A., Panuwatwanich, K., Williams, P. R., & Hollingsworth, A. L. (2011). Quantifying the influence of environmental and water conservation attitudes on household end use water consumption. *Journal of Environmental Management*, 92(8), 1996–2009. doi:10.1016/j.jenvman.2011.03.023
- Wolters, E. A. (2014). Attitude–behavior consistency in household water consumption. *The Social Science Journal*, 51(3), 455–463. doi:10.1016/j.soscij.2013.10.003

## **Agriscience education through inquiry-based learning: Investigating factors that influence the science competence of Hispanic middle school students**

Peter Skelton, New Mexico State University  
J. Joey Blackburn, Louisiana State University  
Kristin S. Stair, Louisiana State University  
Natalie Levy, Louisiana State University

### **Abstract**

*Inquiry-based teaching methods have been found to enhance students' abilities to understand the process of scientific inquiry. The purpose of this study was to determine if middle school students taught through an inquiry-based teaching approach consisting of scientific skill development, scientific knowledge, and scientific reasoning were more likely to meet their respective science grade level expectation. Participants consisted of predominantly Hispanic sixth and eighth grade students enrolled in school enrichment programs through the MMSAEEC. Inquiry-based instruction was integrated within science classes using lessons in soil pH and water quality. Overall, sixth grade students scored highest on items related to science skill, while the eighth grade students scored highest on the science knowledge portion of the instrument. Regarding the sixth grade students, science reasoning and science skill were found to be significant predictors of grade level expectation, while science skill was significant for the eighth grade data. It is recommended that teachers incorporate inquiry-based learning strategies into their classrooms to encourage students to ask questions and refine their ability to think critically and solve problems. Further research is needed to clarify the role of science comprehension and the associated sub-dimensions with the ability to predict grade level expectation.*

### **Introduction**

According to a report published by the National Science Board (NSB) (2015), upwards of 26 million workers, from sub-baccalaureate through doctoral level, are employed in jobs that require significant knowledge in the science, technology, engineering, and math (STEM) fields. This represents nearly one-fifth of all jobs in the United States (NSR, 2015). Additionally, a 17% increase in STEM employment opportunities has been projected by the year 2020 (White House Initiative on Educational Excellence for Hispanics (WHIEE) (n.d.). Currently, there is a shortage of qualified employees for current STEM positions and not enough students are pursuing education in STEM to provide an adequate workforce to meet future growth in the field (WHIEE, n.d.). Even more alarming is the lack of representation of minorities in STEM (National Science and Technology Council, 2013). Clearly, it is imperative to build student interest in STEM fields in a way that will encourage the eventual pursuit of a STEM career.

Research has indicated attitudes and interest of students as young as middle school aged can be positively influenced by the integration of STEM (Wyss, Heulskamp, & Siebert, 2012). This integration has been especially important as a method of developing student engagement in the science fields (National Academy of Sciences, National Academy of Engineering, and Institute

of Medicine, 2007). Science, in particular, often disengages students with scientific concepts that fail to connect to their daily lives (Diaz & King, 2007). As an alternative, educational reform has suggested a more hands-on approach to science integration to engage students in active learning, problem solving, and exploration (Satchwell & Loepp, 2002). Career and Technical Education (CTE) programs, such as agricultural education, can enable students to learn science skills by embedding content in authentic contexts (Conroy & Walker, 2000; Pearson, Young, & Richardson, 2013; Roberts & Ball, 2009; Roegge & Russel, 1990; Zirkle, 2004). Additionally, teaching science in context further develops students' critical thinking and problem solving skills (Phipps, Osborne, Dyer, & Ball, 2008; Myers, 2004; Thoron & Myers, 2011; Thoron & Myers, 2012).

Inquiry-based teaching methods have also been found to enhance a student's ability to conduct experiments and help them gain a better understanding of the process of scientific inquiry (NRC, 2007). Inquiry-based instruction is rooted within the constructivism paradigm popularized by educational philosophers such as Piaget, Vygotsky, and Dewey (Doolittle & Camp, 1999). In fact, Dewey (1910/1997) outlined steps of reflective thinking, which align very closely to the scientific methods utilized in modern inquiry-based learning. Effective inquiry-based learning is derived from scientific thinking and realistic problem solving and its flexible approach allows teachers to modify the structure of lessons based on particular educational goals (NRC, 2000). As a student-centered approach to learning, inquiry-based instruction begins with students' current knowledge, then proceeds with instructor support in developing knowledge of scientific inquiry (NRC, 2000). This differs from traditional teaching methods that focus on the teacher as an expert (NRC, 2000; Parr & Edwards, 2004). Problem-solving and higher-order thinking skills are enhanced when students are encouraged to expand their knowledge through active engagement and reflection (NRC, 2000; Von Secker & Lissitz, 1999).

Following the NRC's (2000) publication on the scientific inquiry teaching method, the prominence of inquiry-based science instruction increased in an effort to reform science education in the U.S. (Thoron & Meyers, 2011). Inquiry-based methods align well with CTE and agricultural education courses as these subjects have been shown to be an innovative means for improving core content achievement by allowing students to apply these concepts to real-world situations (Parr, Edwards, & Leising, 2008; Pearson, Young, & Richardson, 2013; Young, Edwards, & Leising, 2008; Thoron & Meyers, 2011). Thoron and Meyers (2011) conducted a quasi-experimental study to determine the effects of an inquiry-based approach versus a subject matter approach on high school students' achievement in agriscience instruction. This study found that students who were taught using the inquiry-based teaching method scored higher on content knowledge assessments than students taught using the subject matter approach (Thoron & Meyers, 2011).

Teachers should purposefully select methodologies when integrating STEM content into the context of agriculture (Baker, Brown, Blackburn, & Robinson, 2014). When successfully implemented in the classroom, inquiry-based teaching can lead to an authentic learning experience that encourages students to think critically (Parr & Edwards, 2004; Thoron, Meyers & Abrams, 2011). However, successful inquiry-based teaching requires adequate professional

development and teacher training (Thoron et al., 2011; Thoron and Meyers, 2011). Teacher in-service programs, such as the National Agriscience Teacher Ambassador Academy (NATAA), teach educators to utilize pedagogy that encourages students to engage in scientific thought, conduct detailed observations, and ask open-ended questions (Thoron et al., 2011). Thoron et al. (2011) interviewed NATAA teacher participants after they received inquiry-based instructional training to gain a deeper understanding about their perceptions of implementing these techniques into their classrooms. They found that implementing inquiry-based instruction in the classroom was an individual process for each teacher and that inquiry-based instruction was a more rewarding teaching method, despite increased lesson preparation time (Thoron et al., 2011). Additionally, focus group respondents indicated the use of inquiry-based teaching methods helped the teachers form positive associations with other instructors and administrators. Overall, this method was regarded as an asset to agriscience teachers, especially when combined with adequate preservice training and professional development, that allowed them implement this strategy in their classrooms (Thoron et al., 2011).

The Memorial Middle School Agricultural Extension and Education Center (MMSAEEC) in Las Vegas, NM is an agriscience education program developed by the New Mexico State University (NMSU) Cooperative Extension Service in partnership with the public school system to integrate inquiry-based and experiential learning methods into the classroom (Skelton & Seevers, 2010; Skelton, Seevers, Dormody, & Hodnett, 2012; Skelton, Stair, Dormody, & Vanleeuwen, 2014). The mission of this sixth through eighth grade STEM education program is to prepare students to think critically about complex concepts and become aware of careers in the STEM fields (Skelton & Seevers, 2010; Skelton et al., 2012; Skelton et al., 2014). The program employs the skills of a NMSU faculty member to deliver instruction, conduct classroom based experimental studies, plan field trips, and provide demonstrations (Skelton & Seevers, 2010; Skelton et al., 2012; Skelton et al., 2014). The MMSAEEC seeks to achieve its mission through contextualized instruction and hands-on learning within the subjects of agriculture and natural resources (Skelton & Seevers, 2010; Skelton et al., 2012; Skelton et al., 2014).

Studies by Skelton, Dormody, & Lewis (In Press) and Skelton et al. (2014) have been conducted to measure the science achievement and comprehension of middle school students participating in the MMSAEEC program. Skelton et al. (2014) conducted a quasi-experimental study to determine if there was a difference in student achievement in science, as well as agriculture and natural resources. This study also analyzed differences in student interest in STEM careers between the MMSAEEC program and two comparison middle schools. Student achievement in science, and agriculture and natural resources was determined from New Mexico standardized test scores. A comparison of performance on the science standardized test indicated that the MMSAEEC students' overall test scores were higher than the comparison schools in overall science comprehension, as well as the sub-dimensions of science and people, scientific investigations, and physical science. However, the life science and earth science sub-dimension scores were not significantly different (Skelton et al., 2014). Overall, MMSAEEC students had improved performance and higher scores; however, interest in STEM careers was not significantly different between the groups. In fact, all students indicated a similarly strong

interest; however, the MMSAEEC students were twice as likely to be interested in agricultural careers (Skelton et al., 2014).

One important factor of the MMSAEEC program is the demographics of the students involved. Overall, 88% of students in the program are Hispanic, a demographic that is underrepresented in STEM (Lopez et al., 2005). Hispanics represent nearly 20% of the U.S. population, however they represent less than two percent of the total STEM workforce (WHIEE, n.d, n.d.). Although Hispanics in New Mexico have not traditionally been considered a minority within the state, the overall Hispanic community in the U.S. is a minority group that has shown a lack of educational attainment. The drop-out rate for Hispanic students, age 25 years or less, is 27% and is attributed to issues such as language barriers, needing to work to supplement their family's income, and a lack of family support for education (Gasbarra & Johnson, 2008).

There is also a socioeconomic trend within the Hispanic community in which 23% of the population lives below the poverty level, with an average family income of \$34,396 (Lopez et al., 2005) However, as the population of Hispanics is projected to increase in the U.S., their buying power and their overall economic contribution is projected to increase (Lopez et al., 2005). It will be important to increase engagement in STEM careers through education that also prepares Hispanic students for employment (Gasbarra & Johnson, 2008; Lopez et al., 2005).

The shortage of Hispanics in STEM and science related fields has been associated with several factors, including (a) the methods that are used to teach science in schools, (b) the lack of qualified instructors teaching these subjects, and (c) under-funded schools that are deficient in proper supplies to effectively teach these subjects (Gasbarra & Johnson, 2008). There is a need for Hispanic students to have access to more hands-on STEM education that can provide better access to education for this community (Gasbarra & Johnson, 2008). In order develop interest in STEM careers, alternative methods of teaching science may be necessary to reach diverse populations and actively engage learners.

### **Conceptual Framework**

Experiential and inquiry-based learning programs employ a process by which knowledge is created through experience (Kolb, 1984). Through this process, experiential learning creates an environment for students to carry out investigations in a real-world context. According to Kolb (1984), effective engagement in curriculum requires: (a) concrete experience; (b) reflective observation; (c) abstract conceptualization; and (d) active experimentation. The conceptual framework for this study is developed from the interaction of these four principles through a model of application involving scientific knowledge, scientific skills, and scientific reasoning developed by Skelton et al. (2012) (see Figure 1). The interconnection of all three concepts forms a broader contextual understanding and improves comprehension in science content (Skelton et al., 2012).



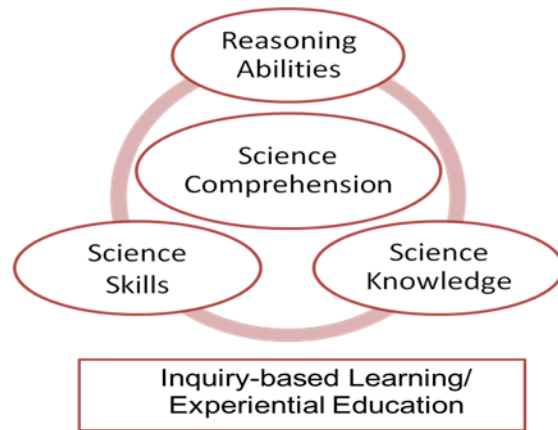

Figure 1. A conceptual model for improving science comprehension (Skelton et al., 2012).

The content of the program is based on the New Mexico public school grade level expectation (GLE), STEM curriculum, as well as the 4-H Science, Engineering, and Technology curriculum (Skelton & Seevers, 2010). The teaching methods used within this program are based on a conceptual model consisting of inquiry-based activities and the experiential learning process (Skelton et al., 2012; Skelton et al., 2014). The combination of inquiry and experiential learning provides an opportunity for higher level thinking skills to be developed and be retained by students (Skelton et al., 2014). The process model begins with science skill and/or knowledge development or acquisition, and proceeds to higher order thinking skills that allow students to demonstrate mastery of the content and then form scientific conclusions (Skelton et al., 2012).

The purpose of this research aligns closely with the AAAE National Research Agenda, specifically Research Priority Area 3: Sufficient Scientific and Professional Workforce that Addresses the Challenges of the 21st Century as well as Research Area Priority Area 4: Meaningful, Engaged Learning in All Environments (Roberts, Harder, & Brashears, 2016). Deepening our understanding of how core content integration influences the achievement of minority students enrolled in agricultural education programs can assist the profession in meeting the demand for a scientifically prepared workforce that is well represented by all ethnic and racial groups.

### **Purpose and Objectives**

The purpose of this study was to determine if middle school students taught via an inquiry-based teaching approach consisting of scientific skill development, scientific knowledge and scientific reasoning, were more likely to meet their respective science grade level expectation (GLE). The following research objectives guided the statistical analyses of the study:

1. Determine the level of science comprehension (i.e., science knowledge, science skill, and science reasoning) by grade level.
2. Determine whether science comprehension subdimension scores (i.e., science knowledge, science skill, and science reasoning) can predict if students are more likely to meet their respective science GLE.

## Methodology

### Research Design

This study represents data collected as part of a larger study (Skelton et al., In Press). Participants in this study consisted of six classes of 6th grade students and five classes of 8th grade students enrolled in school enrichment programs through the MMSAEEC. Students in 6th grade received enrichment as part of their earth science curriculum which consisted of soil pH. Students in 8th grade received programming targeted at analyzing water chemistry. These topic areas fit within the New Mexico standardized science curriculum and were identified as ideal areas for inquiry-based teaching. MMSAEEC programs are designed as educational enhancements, similar to 4-H school enrichment programs, and are delivered through the traditional classroom. Broadly, the experiments examined the relationships between plant growth and soil pH (6th grade) and plant growth and water quality (8th grade). Researchers spent the first week teaching basic principles and applications for testing pH of solutions (i.e., litmus paper, pH paper, meters) and water chemistry (i.e., dissolved oxygen, pH, total dissolved solids, nitrate, ammonia-nitrogen, phosphorous, electrical conductivity, and chlorine). During this process, content was introduced, techniques were demonstrated, and students practiced collecting data. Then, using a guided-inquiry approach, students were provided with a problem to investigate and the materials necessary to carry out the investigation. In teams of 3, the students developed hypotheses and devised their own procedures to test their hypotheses. Following their procedures, the students designed conducted their own experiments. Upon completion of the experiments, they were required to explain the problem, their hypothesis, procedures utilized, and present conclusions to their classmates (Skelton et al., In Press).

In order to measure science comprehension, an instrument was developed that reflected the New Mexico agriculture, food, and natural resource content and performance standards. Pre-test and post-test assessments were designed to measure change in scientific knowledge, science skill development, and scientific reasoning ability (see Table 1). Skelton et al. (In Press) offers an in-depth discussion of the pre-test and post-test differences. Overall science comprehension was determined as a result of each program treatment through the aggregation of the sub-dimension scores. For each grade level, a researcher-created instrument, consisting of nine multiple-choice items, was developed with three questions measuring each sub-dimension. A panel of experts established face and content validity of the instruments. The panel make no recommendations, therefore the instrument was utilized as presented.

Table 1

*Pretest Scores of Students Enrolled In MMSAEEC (Skelton et al., In Press)*

Grade Level	<i>M</i>	<i>SD</i>
Sixth Grade ( <i>n</i> = 88)		
Science Knowledge	0.75	0.75
Science Skill	1.82	0.88

Science Reasoning	1.06	0.79
Science Comprehension Total	3.62	1.57
Eighth Grade ( <i>n</i> = 43)		
Science Knowledge	1.86	0.86
Science Skill	0.98	0.87
Science Reasoning	1.23	0.84
Science Comprehension Total	4.07	1.88

*Note.* Categories of knowledge, skill, and reasoning comprised of three items each.

Regarding the sixth grade students, 77 (87.50%) were of Hispanic origin and 41 (46.59%) were female. A total of 36 (83.72%) of the eighth grade students were of Hispanic origin and 19 (44.18%) were female. Additionally, student Measure of Academic Proficiency and Progress (MAPP) scores were obtained from Las Vegas City Schools to determine if students were at or below their respective GLE (see Table 2). The MAPP is administered three times per year to track students' academic progression. For this study, the students' mid-year test data was utilized, as it was administered during the same time of year as the study's intervention.

Table 2

*Personal Characteristics and Grade Level Expectations of Students Participating in MMSAEEC (Skelton et al., In Press)*

Grade Level	<i>F</i>	%
Sixth Grade ( <i>n</i> = 88)		
Hispanic Origin	77	87.50
Gender (Female)	41	46.59
At Grade Level Expectation	36	40.90
Below Grade Level Expectation	52	59.10
Eighth Grade ( <i>n</i> = 43)		
Hispanic Origin	36	83.72
Gender (Female)	19	44.18
At Grade Level Expectation	29	67.40
Below Grade Level Expectation	14	32.60

## Data Analysis

Data associated with objective one were analyzed via descriptive statistics, specifically the mean, standard deviation, and percentage. Logistic regression was utilized to meet the needs of objective two. Logistic regression is appropriate when the outcome variable is categorical in nature (Field, 2009). Specifically related to this study, the outcome variable was whether or not the students met their respective GLE. Due to the exploratory nature of this study, the alpha level utilized to determine statistical significance was set a 0.10. Nagelkerke's  $R^2$  was employed

to determine the practical significance of the regression model. The value of Nagelkerke's  $R^2$  ranges between zero and one, making its interpretation similar to the classical  $R^2$  utilized to measure effect size in multiple regression (Field, 2009; Nagelkerke, 1991).

### Findings

Objective one of this study sought to determine overall science comprehension of students after participating in an inquiry-based science program. Sixth grade students had an overall science comprehension mean of 6.35 (SD = 1.52) out of a possible nine items (see Table 3). The highest mean was in the area of science skill (M = 2.48; SD = 0.66). The lowest mean was for science reasoning (M = 1.76; SD = 0.71).

Table 3

*Performance on the Science Comprehension Examination Post-Test for 6th Grade (n = 88)*

Test Category	M	%	SD
Science Knowledge	2.11	70.33	0.82
Science Skill	2.48	82.67	0.66
Science Reasoning	1.76	58.67	0.71
Science Comprehension Total	6.35	70.56	1.52

*Note.* Categories of knowledge, skill, and reasoning comprised of three items each.

Regarding performance of the eighth grade students, the overall mean of science comprehension was 6.05 (SD = 1.59) out of a possible nine items (see Table 4). The highest mean was in the area of science knowledge (M = 2.37; SD = 0.76) and the lowest was science reasoning (M = 1.74; SD = 0.79).

Table 4

*Performance on the Science Comprehension Examination Post-Test for 8th Grade (n = 88)*

Test Category	M	%	SD
Science Knowledge	2.37	79.00	0.76
Science Skill	1.93	64.33	0.94
Science Reasoning	1.74	58.00	0.79
Total	6.05	67.22	1.59

*Note.* Categories of knowledge, skill, and reasoning comprised of three items each.

Objective Two sought to determine if science comprehension sub-scores could predict science GLE. Prior to employing logistic regression, the Hosmer and Lemshow Goodness of Fit (HLGF) Test was calculated to determine how well the model fits the data. Table 5 lists the results of the HLGF by grade level. Regarding the sixth grade data, the HLGF was determined not to be statistically significant, indicating the model fit the data well (see Table 5). Similarly, the HLGF

was calculated prior to analyzing data associated with the eighth grade students. The HLGf for this group was determined to not be statistically significant (see Table 6).

Table 5

*Results of the Hosmer and Lemeshow Goodness of Fit Test for 6<sup>th</sup> Grade*

	$\chi^2$	<i>df</i>	<i>p</i>
Step 1 – 6th Grade	4.54	7	0.72
Step 1 – 8th Grade	6.87	8	0.55

The regression model associated with the sixth grade data predicted 70.5% of the cases correctly versus 59.1% predicted in the initial constant model. Nagelkerke’s  $R^2$  was calculated to determine the significance of the overall model. Specifically, Nagelkerke’s  $R^2$  was 0.36 for the data associated with the sixth grade students. Science knowledge was determined to not be statistically significant ( $p = 0.45$ ). Both science skill ( $Wald = 3.11$ ;  $p = 0.08$ ) and science reasoning ( $Wald = 10.84$ ;  $p = 0.00$ ) were determined to be statistically significant at the  $\alpha = 0.10$  level (see Table 6). The science skill and science reasoning odds ratios were 2.38 and 4.17, respectively.

Table 6

*Logistic Regression of 6th Grade Test Areas on Grade Level Expectation*

Variable	<i>B</i>	<i>SE</i>	<i>Wald</i>	<i>df</i>	<i>p</i>	<i>Odds Ratio</i>
Science Knowledge Score	0.26	0.34	0.58	1	0.45	1.29
Science Skill Score	0.87	0.49	3.11	1	0.08	2.38
Science Reasoning Score	1.43	0.43	10.84	1	0.00	4.17

*Note.*  $\alpha = .10$

The regression model associated with the eighth grade data predicted 74.4% of the cases correctly versus 67.4% in the initial constant model (see Table 7). Nagelkerke’s  $R^2$  was calculated to be 0.25 for the overall model. Science skill was the only sub-score determined to be statistically significant ( $Wald = 6.05$ ;  $p = 0.01$ ) at the  $\alpha = 0.10$  level. The science skill odds ratio was 3.20.

Table 7

*Logistic Regression of 8th Grade Test Areas on Grade Level Expectation*

Variable	<i>B</i>	<i>SE</i>	<i>Wald</i>	<i>df</i>	<i>p</i>	<i>Odds Ratio</i>
Science Knowledge Score	-.045	0.53	0.70	1	0.40	0.64
Science Skill Score	1.16	0.47	6.05	1	0.01	3.20
Science Reasoning Score	-.064	0.53	1.46	1	0.23	2.30

*Note.*  $\alpha = .10$

## **Discussion and Implications**

Objective one sought to determine the level of science comprehension by grade level. Regarding the sixth grade students, there was a 31.5% increase in the number of correct items on the post-test instruments (Skelton et al., In Press). Eight-grade students completing the water chemistry unit demonstrated a 40.79% increase in the items they answered correctly (Skelton et al., In Press). The overall score on the 9-item science comprehension instrument could be considered low average (i.e., roughly 70% correct) for both sixth and eighth grade students. The sixth grade students performed best on items related to science skill, while the eighth grade students scored highest on the science knowledge portion of the instrument (Skelton et al., In Press). Results from this study indicate that the inquiry-based methods used in this program were beneficial to overall science comprehension of both grade levels. This is consistent with several prior studies that have investigated the merits of inquiry-based learning (Parr et al., 2008; Pearson et al., 2013; Young et al., 2008; Thoron & Meyers, 2011).

The purpose of objective two was to determine if the science comprehension sub-dimensions (i.e., science knowledge, science skill, and science reasoning) could predict whether students would meet their respective GLE, as measured by the MAPP. Regarding the sixth grade students, science skill and science reasoning were found to be statistically significant predictors. Per analysis of the odds ratios of these sub-dimensions, it was determined that the higher students scored, the more likely they were to meet their GLE. Science knowledge was not a significant predictor of GLE of the sixth grade students.

Regarding the eight-grade students, science skill was found to be a statistically significant predictor. Analysis of the odds ratio indicated that as scores in the science skill sub-dimension increased students were more likely to meet their GLE. The sub-dimensions of science knowledge and science reasoning were not significant predictors for this group of students.

In both the 6th grade program and the 8th grade program, over 85% of students were identified as being Hispanic and over 45% of the students were female (Skelton et al., In Press). An increase in science comprehension, especially for students that are typically identified as underrepresented in the science field is an important finding (National Research Council, 2007; Barron, 2003). Active learning has been recognized as being one of the most influential factors to student success, being even more impactful than student background and previous academic performance (Barron & Darling-Hammond, 2008). Identifying specific ways that inquiry-based learning can be used help all learners advance in science fields can not only be beneficial for students, but would assist in the development of professional development, pre-service teacher education, and in-service opportunities.

## **Recommendations**

Active learning and engagement in hands-on learning strategies have been identified as effective methods of science instruction (Rutherford & Ahlgren, 1990; Barron & Darling-Hammond, 2008). Results from this research demonstrate that inquiry based learning strategies benefit students and it is recommended that teachers should incorporate inquiry-based learning strategies

as a regular part of their classroom instruction. However, integration can be a challenge, particularly because teachers may not have received formal training in how to incorporate inquiry-based learning within the agriscience classroom (Linn, Slotta & Baumgartner, 2000). Because successful inquiry-based learning requires extensive student support and teacher training, adequate planning is crucial for successful integration (Rosenfeld & Rosenfeld, 1998).

Guskey's Model of Teacher Change (2002) describes successful professional development as being a complex process that requires more than just individual training sessions. This model describes ideal professional development as having four key stages: (a) learning about the professional development topic in depth; (b) putting the professional development to practice; (c) determining how students learn as a result of the change in teaching methods; and (d) addressing any change in behavior that results from implementation. Professional development in inquiry-based learning cannot stop after introducing the concept, but rather, should allow teachers to learn about the topic, implement inquiry-based learning and then analyze how inquiry-based learning can impact their classroom. The MMSAEEC program should be utilized to teach agriculture teachers across New Mexico to better incorporate inquiry-based and experiential learning. Studies that actively analyze inquiry-based learning in programs, such as this one, may be helpful for teachers to learn about inquiry-based teaching strategies and better understand how to incorporate this teaching method into their content.

Because agriscience is often known for the experiential nature of its programs (Achieve, Inc., 2015), actively including hands-on and inquiry-based learning strategies may be an excellent opportunity for agriscience and science teachers to develop partnerships that can benefit both teachers and students. Through active partnerships, teachers can provide opportunities for students to better understand scientific principles within the context of agriculture. Similar partnerships have been discussed related to the integration of mathematics in to agricultural education (Parr et al., 2008; Young et al., 2008). Pearson et al. (2013) partnered science and CTE teachers together to develop a community of practice whereby they developed curriculum maps and ensured each lesson was science enhanced. Utilizing these types of partnerships could create stronger collegial relationships and ensure students receive the most accurate, up-to-date science content delivered in the context of CTE.

Regarding future research, further investigation is warranted into the predictive power of the science comprehension subdimensions. This exploratory study utilized a small sample and liberal alpha value in determining significance; therefore, future studies should utilize large samples of students and utilize a more conservative alpha value to determine statistical significance. It is also recommended that future experimental research should be conducted to determine precisely how inquiry-based learning influences student science comprehension. Within the MMSAEEC, future studies should include a delayed post-test to understand the long-term effects of this educational model. While this study analyzed science knowledge within a small aspect of science education, larger studies that address more aspects of science and CTE would be beneficial to teacher education programs. Additionally, other models of inquiry-based education should be studied to identify which methods are most effectively integrated within agriscience programs.

It is also recommended that in addition to studying the overall benefits of inquiry-based learning on student achievement, specific aspects of science integration should be examined. The ability to generate accurate hypotheses, for example, has been connected to the development of efficient and effective problems solvers (Blackburn & Robinson, 2016; Johnassen, 2000). In MMSAEEC and other similar program models, a better understanding of student achievement in areas such as these could help to increase understanding of student success in STEM programs.

Lastly, specific research should be conducted to more closely examine inquiry-based learning models on students from diverse backgrounds. Programs such as MMSAEEC that work with a large number of students from traditionally underrepresented populations can provide unique opportunities to study both student achievement and student interest in STEM. Longitudinal research, in particular, should be conducted to determine if programs like these do increase the number of diverse students that enter the STEM workforce. In a study conducted by Oakes (1990), three factors were determined to be necessary for underrepresented students to pursue careers in science: (a) students' opportunities to learn science and math; (b) their achievement in science and math; and (c) the students' decisions to pursue careers in these areas. The MMSAEEC model as designed by Skelton et al. (In Press) provides opportunities within each of these three areas, therefore, this program and similar models should be investigated to determine the long term impact of successful student achievement in science and math, student interest in these areas, and their decision to eventually pursue careers in these fields.



## References

- Achieve, Inc. (2015). Building a strong relationship between competency based pathways and Career and Technical Education. Retrieved: <https://careertech.org/sites/default/files/CTE-CompetencyBasedPathways.pdf>
- Barron, B. (2003). When smart groups fail. *Journal of the Learning Sciences*, 12(3), 307–359. doi: 10.1207/S15327809JLS1203\_1
- Barron, B., & Darling-Hammond, L. (2008). Teaching for Meaningful Learning: A review of research on inquiry-based and cooperative learning. Retrieved from <http://www.edutopia.org/pdfs/edutopia-teaching-for-meaningful-learning.pdf>
- Baker, M. A., Brown, N. R., Blackburn, J. J., & Robinson, J. S. (2014). Determining the effects that the order of abstraction and type of reflection have on content knowledge when teaching experientially: An exploratory experiment. *Journal of Agricultural Education*, 55(2), 106–119. doi: 10.5032/jae.2014.02106
- Blackburn, J. J., & Robinson, J. S. (2016). Determining the effects of cognitive style, problem complexity, and hypothesis generation on the problem solving ability of school-based agricultural education students. *Journal of Agricultural Education*, 57(2), 46–59. doi: 10.5032/jae.2016.02046
- Skelton, P., Dormody, T., & Lewis, M. (In Press). Examining the effects of an extension youth science center on underserved middle school student science comprehension. *Journal of Extension*.
- Conroy, C. A., & Walker, N. J. (2000). An examination of integration of academic and vocational subject matter in the aquaculture classroom. *Journal of Agricultural Education*, 41(2), 54–64. doi: 10.5032/jae.2000.02054
- Dewey, J. (1910/1997). *How we think*. Mineola, NY: Dover Publications.
- Diaz, D., & King, P. (2007). Adapting a post-secondary STEM instructional model to K-5 mathematics instruction. *Proceedings of the 2007 American Society of Engineering Education Conference*. [http://icee.usm.edu/icee/conferences/asee2007/papers/3069\\_ADAPTING\\_A\\_POST\\_SEC\\_ONDARY\\_STEM\\_INSTRUCTI.pdf](http://icee.usm.edu/icee/conferences/asee2007/papers/3069_ADAPTING_A_POST_SEC_ONDARY_STEM_INSTRUCTI.pdf).
- Doolittle, P. E., & Camp, W. G (1999). Constructivism: The career and technical education perspective. *Journal of Vocational and Technical Education*, 16(1). Retrieved from <https://ejournals.lib.vt.edu/index.php/JCTE/article/view/647/692>
- Field, A. P. (2009). *Discovering statistics using SPSS (third edition)*. London: Sage publications
- Gasbarra, P. & Johnson, J. (2008). *Out before the game begins: Hispanic leaders talk about what's needed to bring more Hispanic youngsters into science, technology, and math professions*. Retrieved from <http://www.publicagenda.org/files/pdf/outbefore.PDF>

- Guskey, T. R. (2002). Professional development and teacher change. *Teachers and Teaching: Theory and Practice*, 8(3/4), 381–391. doi: 10.1080/135406002100000512
- Jonassen, D. H. (2000). Toward a design theory of problem solving. *Educational Technology Research and Development*, 48(4), 63–85. Retrieved from <http://link.springer.com/article/10.1007%2F02300500?LI=true#page-1>
- Kolb, D. A. 1984. *Experiential learning: Experience as the source of learning and development*. New Jersey: Prentice-Hall.
- Linn, M.C., Slotta, J.D., & Baumgartner, E. (2000). Teaching high school science in the information age: A review of courses and technology for inquiry-based learning. Santa Monica, CA: Milken Family Foundation. Retrieved from <http://www.mff.org>
- Lopez, R. R., Lopez, A., Wilkins, R. N., Torres, C. C., Valdez, R., Teer, J. G., & Bowser, G. (2005). Changing Hispanic demographics: Challenges in natural resource management. *Wildlife Society Bulletin*, 33(2), 553–564. doi: 10.2193/0091-7648(2005)33[553:CHDCIN]2.0.CO;2
- Myers, B. E. (2004). Effects of investigative laboratory integration on student content knowledge and science process skill achievement across learning styles (Unpublished doctoral dissertation). University of Florida, Gainesville, FL.
- Nagelkerke, N. J. D. (1991). A note on a general definition of the coefficient of determination. *Biometrika*, 78, 691–692.
- National Academy of Sciences, National Academy of Engineering, and Institute of Medicine. (2007). *Rising above the gathering storm: Energizing and employing America for a brighter economic future*. Washington, DC: The National Academies Press.
- National Research Council (2000). *Inquiry and the National Science Education Standards: A guide for teaching and learning*. Washington, DC: National Academy Press.
- National Research Council (2007). *Taking science to school: Learning and teaching science in grades K-8*. Washington, DC: National Academy Press.
- National Science Board (2015). *Revisiting the STEM workforce: A companion to the science and engineering indicators 2014* (Report No. NSB-2015-10). Arlington, VA: National Science Board.
- National Science and Technology Council (2013). *Federal science, technology, engineering, and mathematics (STEM) education 5-year strategic plan*. Retrieved from [https://www.whitehouse.gov/sites/default/files/microsites/ostp/stem\\_stratplan\\_2013.pdf](https://www.whitehouse.gov/sites/default/files/microsites/ostp/stem_stratplan_2013.pdf)

- Oakes, J. (1990). *Lost talent: The under-participation of women, minorities, and disabled persons in science* (Report No. R-3774-NSF/RC). Santa Monica, CA: The Rand Corporation.
- Parr, B., & Edwards, M. C. (2004). Inquiry-based instruction in secondary agricultural education: Problem solving - An old friend revisited. *Journal of Agricultural Education*, 45(4), 106–117. doi: 10.5032/jae.2004.04106
- Parr, B. A., Edwards, M. C., & Leising, J. G. (2008). Does a curriculum integration intervention to improve the mathematics achievement of students diminish their acquisition of technical competence? An experimental study in agricultural mechanics. *Journal of Agricultural Education*, 49(1), 61–71. doi: 10.5032/jae.2008.01061
- Pearson, D., Young, R. B., & Richardson, G. B. (2013). Exploring the technical expression of academic knowledge: The science-in-CTE pilot study. *Journal of Agricultural Education*, 54(4), 162–179. doi:10.5032/jae.2013.04162
- Phipps, L. J., Osborne, E. W., Dyer, J. D., & Ball, A. L. (2008). *Handbook on agricultural education in public schools* (6th ed.). New York, NY: Thomson Delmar Learning.
- Roberts, T. G., & Ball, A. L. (2009). Secondary agricultural science as content and context for teaching. *Journal of Agricultural Education*, 50(1), 81–91. doi: 10.5032/jae.2009.01081
- Roberts, T. G., Harder, A., & Brashears, M. T. (Eds). (2016). *American Association for Agricultural Education national research agenda: 2016-2020*. Gainesville, FL: Department of Agricultural Education and Communication.
- Roegge, C. A. & Russel, E. B. (1990). Teaching applied biology in secondary agriculture: Effects on student achievement and attitudes. *Journal of Agricultural Education*, 31(1), 27–31. doi: 10.5032/jae.1990.01027
- Rosenfeld, M., & Rosenfeld, S. (1998). *Understanding the “surprises” in PBL: An exploration into the learning styles of teachers and their students*. Paper presented at the European Association for Research in Learning and Instruction (EARLI), Sweden.
- Rutherford, J. F., & Ahlgren, A. (1990). *Science for all Americans* (Report No. 2061). New York: Oxford University Press.
- Sahin, A. (2015). *A practice-based Model of STEM teaching. STEM Students on the Stage (SOS)*. Sense Publishers: Netherlands.
- Satchwell, R. E., and Loepp, F. L. (2002). Designing and Implementing an Integrated Mathematics, Science, and Technology Curriculum for the Middle School. *Journal of Industrial Teacher Education*, 39(3). Retrieved from <http://scholar.lib.vt.edu/ejournals/JITE/v39n3/satchwell.html>

- Skelton, P., & Seevers, B. (2010). A new extension model: The Memorial Middle School Agricultural Extension and Education Center. *Journal of Extension*, 48(6), 1–4.
- Skelton, P., Seevers, B., Dormody, T., & Hodnett, F. (2012). A conceptual process model for improving youth science comprehension. *Journal of Extension*, 50(3), 1–4.
- Skelton, P., Stair, K. S., Dormody, T., & Vanleeuwen, D. (2014). Determining the science, agriculture and natural resources, and youth leadership outcomes for students participating in an innovative middle school agriscience program. *Journal of Agricultural Education*, 55(4), 53–71. doi: 10.5032/jae.2014.04053
- Thoron, A. C., & Myers, B. E. (2011). Effects of inquiry-based agriscience instruction on student achievement. *Journal of Agricultural Education*, 52(4), 175–187. doi:10.5032/jae.2011.04175
- Thoron, A. C., & Myers, B. E. (2012). Effects of inquiry-based agriscience instruction on student scientific reasoning. *Journal of Agricultural Education*, 53(4), 156–170. doi: 10.5032/jae.2012.04156
- Thoron, A. C., Myers, B. E., & Abrams, K. (2011). Inquiry-based instruction: How is it utilized, accepted, and accessed in schools with National Agriscience Teacher Ambassadors? *Journal of Agricultural Education*, 52(1), 96–106. doi:10.5032/jae.2011.01096
- Von Secker, C. E., & Lissitz, R. W. (1999). Estimating the impact of instructional practice on student achievement in science. *Journal of Research in Science Teaching*, 36(10), 1110–1126. doi: 10.1002/(SICI)1098-2736(199912)36:10<1110::AID-TEA4>3.0.CO;2-T
- White House Initiative on Educational Excellence for Hispanics (n.d.). *Hispanics and STEM education fact sheet*. Retrieved from <http://sites.ed.gov/hispanic-initiative/files/2014/04/WHIEEH-STEM-Factsheet.pdf>
- Wyss, V. L., Heulskamp, D., Siebert, C. J. (2012). Increasing middle school student interest in STEM careers with videos of scientists. *International Journal of Environmental & Science Education*, 7(4), 501–522. Retrieved from <http://files.eric.ed.gov/fulltext/EJ997137.pdf>
- Young, R. B., Edwards, M. C., Leising, J. G. (2008). Effects of a math-enhanced curriculum and instructional approach on students' achievement in mathematics: A year-long experimental study in agricultural power and technology. *Journal of Southern Agricultural Education Research*, 58(1). Retrieved from <http://www.jsaer.org/pdf/Vol58/58-01-004.pdf>
- Zirkle, C. (2004). Integrating academic and occupational skills across the curriculum. *Techniques*, 79(6), 24–26. Retrieved from <http://acte.hodgsonconsult.com/content.aspx?id=5790>

## **Exploring How Pedagogical Strategies Change Student Perceptions of Writing Apprehension**

Laura M. Gorham, Texas Tech University  
Courtney Meyers, Texas Tech University  
Sinclair Dobelbower, Texas Tech University

### **Abstract**

*Writing skills are imperative for students in any career; however, many students have acknowledged avoiding courses that emphasize writing. These same students fail to learn proper mechanics during their post-secondary education. Writing intensive courses have served as a place where students have the opportunity to improve confidence, minimize avoidance-like attitudes, and improve writing techniques. Prior literature has found a relationship between self-efficacy and writing apprehension, additionally research has suggested how pedagogical strategies can be used to improve self-efficacy. This study sought to explore how the implementation of pedagogical activities changes self-efficacy and the student's level of writing apprehension. A qualitative research design allowed for a thick description of the students' perceptions and reactions to pedagogical activities. The findings suggested pedagogical practices and the role of the instructor played important roles to improve student confidence in writing. Specifically, practicing writing, opportunities to edit and reflect, following a guide, and writing about what matters may be used in courses to improve confidence and writing skills. Additionally, the instructor should provide constructive criticism and serve as a coach during the learning process. In order to improve writing curriculum and student confidence toward writing, instructors should incorporate these recommendations into their curriculum. The researchers also suggest conducting additional research to determine the role of writing apprehension within the college classroom.*

### **Introduction and Literature Review**

Although written communication skills have been found to be imperative in any field a college graduate chooses, many college students avoid courses that focus on writing skills, and thus fail to learn proper mechanics during their post-secondary education (Belkin, 2015; Leef, 2013). Popular press authors have indicated employers are frustrated with their recent graduates' lack of writing skills (Anderson, 2014; Selingo, 2012), and some have suggested college-level instructors must make student learning of writing skills a higher priority (Leef, 2013). Similarly, research in the realm of agricultural education and communications has discussed the need for agricultural education and communications graduates to have well-developed writing skills (Ahrens, Meyers, Irlbeck, Burris, & Roach, 2016; Davis & Jayaratne, 2015; Irlbeck & Akers, 2009; Morgan, 2010). Graduates within the agricultural sciences must be able to clearly, correctly, and articulately express themselves as they enter graduate school and the professional workplace setting (Lindner, Murphy, Wingenbach, & Kelsey, 2004).

Historically, agricultural communications programs, instructors, and faculty have emphasized writing skills (Ahrens et al., 2016). Additionally, with a growing need for sophisticated written communications skills, instructors across the agricultural sciences have incorporated writing intensive assignments (Trojan, Meyers, & Hudson, *in press*). Although instructors stress the need for students to improve writing skills, students have shown writing apprehension, or avoidance-

like attitudes toward writing, causing them to not take writing courses seriously (Ahrens et al., 2016; Daly & Miller, 1975). In fact, writing apprehension is one of the main factors that affects student's motivation and confidence when writing. High writing apprehension also leads students to avoid the learning process (Daly & Miller, 1975; Daly, 1978).

Writing apprehension, a term coined by Daly and Miller (1975), describes the interaction between attitudes toward writing and an individual's motivations, confidence, and skills to complete a written task. Writing apprehension occurs when an individual tends to avoid situations they perceive to demand writing and some form of evaluation (Daly, 1978). Daly (1978) explained that although students need some apprehension to be careful and attentive writers, high and low levels of writing apprehension have been found to be a barrier in the development of a student's written communication skills (Faris, Golen, & Lynch, 1999). Apprehension is scored on a continuum from 26 to 130 with a mean of 75. Individuals with a score between 60 and 90 do not show a significantly unusual level of writing apprehension and tend to have the best motivation while writing. However, those with high writing apprehension tend to write with poor mechanics (grammar, spelling, and punctuation) and tone. Although those with low writing apprehension tend to not fear the writing process, these individuals may exhibit a lack of motivation to complete writing assignments and may be unmotivated to check their work for grammar, spelling, and punctuation errors (Daly, 1978). Although students may fear a writing task, the importance of learning these imperative writing skills is crucial to students' career success (Leggette & Homeyer, 2015). In order to continue to improve writing curriculum in agricultural education and communications, faculty and instructors must understand the students' fears and attitudes toward writing (Leggette & Jarvis, 2015) and identify techniques to help students overcome these fears.

Writing intensive courses have served as places where students are able to improve their confidence and writing techniques (Leggette, McKim, & Dunsford, 2013; Trojan et al., *in press*). These courses are dependent upon teachers who develop effective pedagogical strategies and coach or train students to develop writing skills (Leggette, 2015; Trojan et al., *in press*). According to Hudd, Sardi, and Lopriore (2013), writing instructors perform two roles in the writing intensive course: 1) to act as coaches who help students to guide discovery, creativity, and critical thinking, and 2) to act as teachers who help students understand the proper writing components and standards of grammar, spelling, and punctuation. However, the teaching of writing is time consuming and many students fail at writing because the instructors do not provide enough time or effort to coach students through the learning process (Bean, 2011; Leggette, 2015). Instructors must be able to "help their students during the development stages of the writing process" (Leggette, 2015 p. 104) by providing a varied amount of "assignments, resources, reaction, and instruction" (p. 107).

### **Theoretical Framework**

The concept of self-efficacy, a component of social cognitive theory, was used as a framework to explain how pedagogical strategies and the role of the instructor contributed to a change in writing apprehension throughout the duration of a one-semester writing intensive course. According to Bandura (2012), social cognitive theory explains how "human functioning is a product of the interplay of intrapersonal influences, the behavior individuals engage in, and the environmental forces that impinge upon them" (p. 11). This theory has been used to describe

how an instructor should begin to understand the motivation of the student by exploring the student's interpersonal experiences, behavior, and environment. Bandura (1995) noted a major component of social cognitive theory was self-efficacy, or internal disposition. This concept explained how "beliefs people hold about their abilities and about the outcome of their efforts powerfully influence the ways in which they will behave" (Pajares & Johnson, 1994, p. 313). The premise of social cognitive theory reflects how someone's behavior, or motivation toward an action, was shaped by their beliefs in their capabilities (Bandura, 1986; Pajares & Johnson, 1994). Writing apprehension has also been used to judge a person's competence as he thinks about or performs a writing task and to identify a person's general self-esteem level when performing a writing task (Daly & Wilson, 1983; Gorham & Meyers, *in press*). Further, Pajares and Johnson (1994) found writing apprehension had a strong relationship with self-efficacy. Because self-efficacy is used to describe an individual's beliefs about their capabilities, the more a student fears or has apprehension toward writing, the more likely the student will not have confidence in his or her capabilities as a writer (Gorham & Meyers, *in press*; Pajares & Johnson, 1994; Trojan et al., *in press*).

Prior research has suggested students' writing apprehension level can be influenced by increasing self-efficacy (Gorham & Meyers, *in press*; Martinez, Kock, & Cass, 2011; Matoti & Shumba, 2011; Pajares, 2003). Further, teaching strategies and the role of the instructor have been proven to affect students' ability to be effective writers (Leggette, 2015). Because writing self-efficacy beliefs and writing performances are related, the researchers sought to identify how an individual's level of self-efficacy may be influenced by the four factors of self-efficacy that influence confidence through teaching strategies and instructor characteristics in a writing intensive course: performance accomplishments, verbal persuasion, vicarious experience, and psychological states (Bandura, 1977).

Performance accomplishments refer to the personal mastery of a specific task (Bandura, 1977). Similar to other skills, learning to write properly requires repeated practice for a long duration of time (Trojan et al., *in press*; Kellogg & Raulerson, 2007; Leggette et al., 2013). Courses involving a writing intensive component allow students to complete multiple assignments and the opportunity to improve their writing skills (Gorham & Meyers, *in press*; Trojan et al., *in press*). Within these courses, students may immerse themselves in a writing-rich environment (Leggette & Homeyer, 2015). These courses provide opportunities for both small in-class writing assignments as well as larger out-of-class assignments to be evaluated (Leggette & Homeyer, 2015). In addition to providing opportunities to practice writing, these courses also provide places where teachers can push effective writing strategies to higher quality levels. Therefore, continuous practice and multiple assignments may allow individuals to increase their self-efficacy with the completion of these successful tasks and assignments.

While repeatedly gaining success with a task may help to increase self-efficacy, verbal persuasion is another factor that helps students gain confidence in their writing abilities. Verbal persuasion refers to feedback that proves to individuals they had the knowledge and abilities to achieve a task at hand (Bandura, 1977). When an instructor uses verbal persuasion, it gives the students the information they need to improve on a task such as written or verbal feedback on an assignment (Margolis & McCabe, 2006). Instructors should provide students with positive feedback on their writing performance several times during the course as it is pivotal in helping

improve students' writing competency (Kellogg & Raulerson, 2007; Leggette et al., 2013; Pajares & Johnson, 1994). Continuous feedback throughout the semester gives the students the opportunity to "learn from their mistakes and improve on the next assignment" (Leggette & Homeyer, 2015, p. 119). Although instructor feedback is pivotal to success, "feedback may be given by the students themselves if the right conditions exist" (Leggette et al., 2013, p. 2). Further, instructors have used writing intensive assignments to help train students to become better writers (Gorham & Meyers, *in press*). Because writing is "more than rules," and is a complex procedure, writing must be evaluated through continuous assessment and critical feedback (Leggette et al., 2013, p. 2). As Pajares (2003) stated, "positive persuasions may work to encourage and empower; negative persuasions can work to defeat and weaken self-beliefs" (p. 140). By providing positive feedback and support, students may feel the motivation to complete a task at hand (Crumbo, 1999) while also learning and improving their techniques (Leggette et al., 2013).

Vicarious experiences can be used to increase self-efficacy to show a successful model of completing a task. Bandura (1977) explained, "seeing others perform threatening activities without adverse consequences can generate expectations in observers that they too will improve if they intensify and persist in their efforts" (p. 197). Writing intensive courses have served as a place where students may observe others performing tasks (Pajares, 2003) such as peer review sessions and examples. As a student views others completing a task, the student will make social comparisons, which "can be powerful influences on developing self-perceptions of competence" (Pajares, 2003, p. 140). One method teachers have used to teach writing is to provide clearly articulated examples of written tasks (Leggette & Homeyer, 2015). However, examples can hinder students' creative thinking. To overcome lack of creativity, teachers can provide guidance by assigning readings of well-written documents, providing rubrics that address project requirements, and encouraging outlines that help students structure their assignments (Leggette & Homeyer, 2015). Additionally, repetitious project building tasks where students develop a larger project throughout the semester by combining different writing assignments may allow students to develop "their own thoughts and ideas while reflecting on their own thinking" (Leggette & Homeyer, 2015, p. 119).

Efficacy beliefs have been connected to physiological states such as anxiety and stress (Pajares, 2003). In order to decrease anxiety, students must be given the chance to increase self-belief in themselves (Kellogg & Raulerson, 2007). Writing is an emotional and psychological process just as much as a cognitive activity (McLeod, 1987). Self-confidence may be increased through Masche's (2013) self-reflection. In Masche's (2013) model, conversations and self-reflections were used to help students believe they have the power and capability to be a successful. In these self-reflections, students must be given adequate time to allow for both "mental and emotional engagement in the recent experience (Kolb, 1984; Proudman, 1992). During this time, students must be encouraged to make holistic pictures or generalizations about their learning that can then be applied to their lives (Meyers & Arnold, 2015) and future writing endeavors. Leggette et al. (2013) also found that self-reflection and evaluation is a "valuable learning tool that could enhance student's performance, attitudes, and self-efficacy" (p. 3). Because self-reflection pertaining to assignments allow students to self-identify and recognize what needs to be improved, students who then assess their own work may be better able to identify and correct mistakes before submitting assignments (Leggette et al., 2013). Additionally, self-reflection



forces students to understand what attributes are necessary for higher quality writing materials (Andrade, 2008; Leggette et al., 2013).

### **Purpose & Research Questions**

Both academics and employers have suggested college students need to improve their writing skills. As agricultural educators, faculty and instructors must find ways to develop a sufficient scientific and professional workforce that addresses the challenges of the 21<sup>st</sup> century (Roberts, Harder, & Brashears, 2016) and sophisticated writing skills in students are necessary to do so. Prior research has suggested writing apprehension is a major factor contributing to student avoidance to learn writing skills (Daly & Wilson, 1983). However, writing apprehension may be diminished and skills may be improved by increasing the students' self-efficacy (Pajares & Johnson, 1994). Further, in one writing intensive course, Gorham and Meyers (*in press*) found many students lessened their writing apprehension. Based upon the need to improve self-efficacy to change writing apprehension, the purpose of this study was to explore how the factors of self-efficacy influence student perceptions of writing apprehension in a writing intensive course at Texas Tech University. The following research questions were used to achieve the purpose:

RQ1: What pedagogical strategies helped students gain confidence and motivation toward writing?

RQ2: What was the role of the instructor in helping to change students' perceptions and attitude toward writing?

### **Methods**

Qualitative methodology has often been used to understand complex phenomenon such as attitudes and behaviors toward completing tasks, because this approach allows researchers to derive thick descriptions of a scenario or situation (Erlandson, Harris, Skipper, & Allen, 1993). In this study, the researchers examined student self-reflections to understand the participants' experiences in a writing intensive course and to understand how specific course activities impacted students' perceptions of writing apprehension. A case study of students enrolled in a required writing course at Texas Tech University for the College of Agricultural Sciences and Natural Resources allowed the researchers to investigate a "phenomenon within its real-life context" (Merriam, 1998, p. 21). The population for this study was students enrolled in the scientific writing course, and a sample of 92 students enrolled in the Spring 2015 semester was selected for this study. This population was selected because students enrolled in a previous semester had expressed fear and avoidance-like attitudes to completing written assignments, and this particular sample was chosen as the researcher had access to students in several majors with varying levels of writing apprehension. Student majors were animal science, crop and soil science, horticulture or turf grass science, agricultural education, and agricultural and applied economics majors. The majority of students were freshmen or sophomores.

To determine writing apprehension scores, students were asked to take Daly and Miller's (1975) writing apprehension test at the beginning (week 1) and end of the semester (week 15) to determine their writing apprehension scores. Student WA scores were disseminated to students after the completion of both the pre-test and post-test. Gorham and Meyers (*in press*) found a significant difference between pre-test and post-test scores and students demonstrated an improvement in writing apprehension throughout the semester.

At three points during the semester, students completed self-reflections about their experiences in the course. In each of the reflections, students commented on instructional techniques, writing projects, and changes in writing apprehension. Merriam (1998) discussed documents as the “umbrella term to refer to a wide range of written, visual, and physical material relevant to the study at hand” (p. 112). The documents were gathered and analyzed in order to understand how different factors of self-efficacy affected student perceptions of writing. Table 2 provides the prompts students answered in their reflections.

Table 2  
*Writing Reflection Prompts*

Writing Reflection	Date of Reflection	Number of Reflections	Prompt
Reflection 1	Week 5	81	Describe how your confidence toward writing has changed throughout the semester, so far.
Reflection 2	Week 10	76	Describe how your motivation toward writing has changed throughout the semester. What factors have helped to change your writing apprehension?
Reflection 3	Week 16	78	Describe how course assignments, in-class activities, feedback on grading, self-reflection assignments, or other aspects of the course have changed your confidence and/or motivation toward writing.

*Note:* Number of reflections differs due to student attendance during that particular class day.

Because self-reflections were assigned as course assignments, the students received a grade if they responded and were required to provide their name. After a grade was assigned, pseudonyms were used prior to data analysis to protect the student’s identity and minimize researcher bias because the main researcher was the instructor of the course. These pseudonyms are used in the manuscript to verify that the quotations are from many students.

To demonstrate trustworthiness of the data collection, the researchers used data triangulation via the collection of three self-reflections to improve the credibility of the study (Guion, Diehl, & McDonald, 2011). Additionally, this research was part of a larger study that also included interviews, observations, questionnaires, and other self-reflections, which provided validity checks across the data sources (Lincoln & Guba, 1990). The self-reflections were analyzed independently and are the only data sources reported in the manuscript. Peer debriefing was used to develop quality reflection questions (Erlandson et al., 1993). Although students were not given a page limit or minimum length, they were asked to write in complete sentences and paragraphs to develop thick descriptions to demonstrate transferability, or the degree in which the findings can be translated to another setting, situation, or participants (Erlandson et al., 1993).

The student reflections were analyzed using thematic analysis via open and axial coding for specific themes (Glaser & Strauss, 1967). The lead researcher, a doctoral student in agricultural communications who was also the course instructor, analyzed the data after final grades were assigned. Throughout the study, the researcher documented a “running account of the process of

inquiry” in an audit trail (Erlandson et al., 1993, p. 34). The audit trail detailed theme formation, document organization, and researcher notes. An additional researcher approved the questions for self-reflection and confirmed the themes that emerged from the data analysis process (Erlandson et al., 1993). Texas Tech’s Institutional Review Board approved the procedures for this study before data collection.

## Findings

### **RQ1: What pedagogical practices helped students gain confidence and motivation toward writing?**

Thematic analysis of student self-reflections revealed the following pedagogical strategies changed students’ writing apprehension throughout the semester: *good practice makes perfect*, *opportunities to edit*, *opportunities to reflect*, *following a guide*, and *write about what matters*.

**Good practice makes perfect.** The students discussed how multiple writing tasks and assignments during the semester helped them become more comfortable or confident with the writing techniques. Michaela explained how writing more often makes her more at ease with the process. She said, “I think I am more comfortable writing because we have been writing so often for this class” (Michaela, Reflection 1). Vivian discussed how she has been able to improve her writing skills through practice. She said, “I definitely feel a lot more confident. I think this class has given me a lot of opportunity to practice” (Vivian, Reflection 2). Seth discussed, “With multiple writing assignments, I have had more opportunities to improve my writing” (Seth, Reflection 2). Casey revealed that completing several writing assignments helped him improve his writing skills:

Having multiple writing assignments and continuously having feedback returned back with it. I can better myself. The first one I was really nervous about when we turned and talked about our writing apprehension, but as things go on it continuously gets better. I think I can do this I can do better. I can ace this. I know how to do it. It is almost a muscle memory similarly to a sport. Like in basketball you shoot muscle memory for free throws and it’s I feel it is just as long as you can keep doing it over and over again it will work out. (Casey, Reflection 2)

In the third reflection, it became more apparent that students felt multiple writing assignments helped them perfect their writing. Cory discussed how it helped him practice his writing when he said, “[Feedback] impacted it greatly through practice makes perfect. Though I still have more improvement, repetition and getting feedback had a huge effect on my skills and techniques” (Cory, Reflection 3). Vivian also stated, “I think my attitude toward writing changed throughout the course. Practice does make me feel more confident about writing” (Vivian, Reflection 3).

Students also discussed how in-class activities helped to engage their interest and give them experience before completing larger assignments. Cory explained, “I’m a big fan of class activities because it actually helps engage my interest even further” (Cory, Reflection 1). Jared discussed how the in-class activities help to give him more experience when he said, “The activities are helpful because it gives me more experiences to write” (Jared, Reflection 1).

Although the majority of the students stated how continuous practice helped them to improve their writing, some students explained how it made them more fearful of writing. “I am a little more afraid to write because I am noticing a lot more errors than previously found. I’m taking two writing intensive courses, so all the assignments are piling up on me” (Omar, Reflection 2).

**Opportunities to Edit.** The theme of peer editing emerged in the final reflection. The students expressed how editing peer assignments helped them to understand the mistakes of others, which helped them to recognize their own mistakes. David explained, “The peer reviews gave me an opportunity to edit others work which allowed me to eventually begin correcting my mistakes” (David, Reflection 3). Houston explained how peer edits helped him to realize his mistakes before turning in his papers when he said, “My favorite part of this course was peer editing. This helped me know what I need to work on to get a better grade next time” (Houston, Reflection 3). However, as stated by Austin, the peer review experience depends upon the quality of the peer reviewer, “Sometimes peers do not give enough feedback on your work” (Austin, Reflection 2).

**Opportunities to Reflect.** At various points during the semester, students were asked to spend one minute reflecting upon their grade and feedback on some of their returned assignments. Terri explained how she thought the one-minute papers were the perfect time for her to reflect on what she was learning. “The reflections [one-minute papers] allow me to reflect on what I am learning and to ensure I understand it” (Terri, Reflection 2). Shelby discussed how it made her think about her assignments in detail when she said, “I think the reflections help a lot because it lets me sit and think about the grade I got and why” (Selby, Reflection 1). One student, Mariela, stated it prompted more writing, “I feel that I may enjoy writing a lot more than I did before. I actually started a journal just to write” (Mariela, Reflection 1). In the third reflection, Michaela showed more confidence, “I think by doing reflections on my writing, I have got more comfortable having my writing reviewed and edited” (Michaela, Reflection 3). One student explained how she did not find value in reflecting, “I don’t think I put to much thought into the reflections. So, I don’t think that they raised or lowered my score by any means. I just wrote something down” (Amy, Reflection 2).

**Following a Guide.** Writing examples helped them to understand what is expected of them when completing assignments. Cory explained how examples help him improve his writing. “It [examples] has helped me a bunch because I have been able to use them to better my writing” (Cory, Reflection 2). Savannah reflected, “The examples are the best assistance in creating a good paper” (Savannah, Reflection 2). London discussed how examples have helped him to check if his assignments were correct. “I believe my writing apprehension has gone down a little due to the detailed rubrics and examples, which made it easier to check if I am formatting and writing the correct way” (London, Reflection 1). Carly explained how writing was made easier: “Writing is still not my favorite thing in the world. It has been made easier because we have guidelines and examples. If I could always have those writing would not be that bad” (Carly, Reflection 1).

In the third reflection, the idea of organization techniques, or laying out assignments in an organizational manner, was expressed as a tool that helped students understand how to complete an assignment in separate steps. For example, students were provided an outline of the information that should be included in a cover letter. Brandyn explained, “The organizational

techniques helped me organize my papers to keep my writing and formatting in order” (Brandyn, Reflection 3). Dylan reflected about how it helped him write in a more methodical fashion when he said, “Instead of looking at it as a whole paper, I break it down into sections” (Dylan, Reflection 3). Vivian expressed how organizing the material into steps helps to make a project less stressful when she said, “The step-by-step building the big project. I really like having my project into broken into smaller pieces to work on and then they all come together at the end. It is really helpful and less stressful” (Vivian, Reflection 3). Further, Alexis said, “Smaller assignments leading to bigger ones helped to curb my anxiety toward a project” (Alexis, Reflection 3).

**Write About What Matters.** Students explained how their interest in the subject matter or the topic at hand increased their motivation and decreased their fear toward completing the writing task. “My motivation toward writing has increased due to the research paper because it is something I am passionate about. Allow us to write more about what we are passionate about” (Tate, Reflection 2). Richard explained that picking their topics was interesting. “I like writing about things I am interested in that is more motivation than an English class writing about Romeo and Juliet” (Richard, Reflection 2). In Richard’s second reflection he said, “I enjoy writing for a purpose not just, writing to write” (Richard, Reflection 1). Similarly, Kelsey explained, “Allowing me to write about my own topic will be a huge help when it comes tdown to writing my paper” (Kelsey, Reflection 2).

Students expressed how business-writing assignments helped to prepare them for their careers. Nick explained how the assignments were useful to preparing him for the workplace:

Assignments that were gone over in the class helped me to realize my writing lows and correct them for future endeavors. I will use what I learned in course assignments to better my writing in the workplace. Clearly, professionalism is an essential there [in the workplace] and this class helped me in that aspect. (Nick, Reflection 3).

Kelsey stated how writing projects that are similar to what she will use in her career helped her to become less apprehensive. She said, “my writing apprehension has changed somewhat because it has become easier for me to write professionally for future references and employers” (Kelsey, Reflection 1).

### **RQ2: What was the role of the instructor in helping to change student’s attitude toward writing?**

Analysis of the reflections revealed that the instructor played a role in helping the students diminish their writing apprehension throughout the semester. The following instructor practices helped to change self-efficacy and writing apprehension: *nothing but the truth and instructor as a coach*.

**Nothing but the Truth.** Throughout the semester, the majority of students reflected about how feedback made an impact on their writing apprehension. Students discussed how constructive criticism of positive and negative aspects of their writing helped them to improve. Further, students indicated that feedback helped to increase their confidence in writing. Macee said, “She said, “I was fairly confident about my writing before and have gained more confidence after seeing feedback. I am pleased with the feedback I have had on my work” (Macee, Reflection 2).

Savannah suggested feedback improved her assignments, “Feedback has helped me because it helps me know what I need to change and gives me confidence in my writing” (Savannah, Reflection 1). Taylor simply explained, “I feel as though the feedback in this class has been the biggest factor in improving my writing apprehension” (Taylor, Reflection 1). Carly stated, “Because I was super self conscious of my writing, I always put it off because I didn’t want others to read it or be judged by it. But now, I do the writing assignments right away because I like the feedback” (Carly, Reflection 3).

Students discussed how constructive feedback was necessary to understand the material. Cassidy said constructive criticism helps to make her aware of mistakes when she said, “Continue giving feedback, both positive and negative, on the assignments. The feedback helps enforce good habits and gives a nudge in the right direction on the bad ones” (Cassidy, Reflection 2). Brady discussed, “Having all this feedback has helped me to understand the material better by showing what to do/what not to do, and how to fix anything” (Brady, Reflection 2). Brandon discussed how it helps him to learn through his mistakes when he said, “Keep offering praise for positive aspects of assignments and harsh criticism when necessary. Everyone learns through mistakes, but we must be aware of these mistakes” (Brandon, Reflection 2). In the third reflection, Kelsey explained, “The biggest impact on my writing apprehension in this class was feedback when my work was graded. It made it easy for me to see exactly what I needed to work on” (Kelsey, Reflection 3). Further, Trevor explained how feedback must be clear for the student to understand, “Sometimes I would like to have more explanation of what I did wrong on the paper and what I have done well. I would like it to be more critical.” Amy also explained how at first feedback hurt her feelings,

At first, it [feedback] made kind of upset in a way because I put a lot of effort into this type of project because it is something that I will use – resume and cover letter – Especially since I took it to the writing center and still had a lot of marks on my paper. (Amy, Reflection 2)

**Instructor as Coach.** Another dominant theme was the idea of the instructor motivating the students. Students explained how instructor motivation impacts motivation and confidence toward writing. Lynn explained how talking through assignments improved her understanding. “The instructor and TAs have helped me to understand the material very well. This motivates me to do better work.” (Lynn, Reflection 2). Nick discussed how it helped him when the instructor went over the assignments. “Y’all do a great job of talking through the assignments which is really helpful when completing them” (Nick, Reflection 2).

Another thing the instructor did was create a classroom environment that improved motivation. “[My] favorite part would be the classroom environment. I liked how we are given the opportunity to freely ask questions and speak out our thoughts” (Cynthia, Reflection 3). Vivian also explained how an approachable instructor made it easier to ask questions and to discuss her issues, “It is easy to ask questions and discuss my issues” (Vivian, Reflection 3). Macee said, “The lectures and PowerPoint’s were very helpful to see how things should be done and determine what is correct and what is incorrect in writing” (Macee, Reflection 3).

Terri reflected on how the instructor in another course caused her to have writing apprehension:

I have had several different professors. This one [professor] is big into research and the way he comes off is a little scary. He makes me scared to death to write, and I don't know what he is looking for. Others are like, "Have fun with it. We want you to enjoy this, and we want you to be able to use this knowledge to help you go further in your career and studies." (Terri, Reflection 3).

Similarly, Casey explained how instructors play a role in his writing apprehension:

Because of my first English course, where I probably had the hardest professor that I have had throughout my career. I ended up with a C, and I barely got that C. It was just frustrating! What's wrong with it? That's why my writing apprehension is so high is because of that class and that teacher. (Casey, Reflection 2)

### **Conclusion and Discussion**

Post-secondary scholars and employers alike have discussed the need for college graduates to be proficient in their writing skills when they enter the workforce (Belkin, 2015; Leef, 2013). Although instructors in college classrooms may stress the importance of writing in future careers, students may still show a lack of motivation or confidence to write (Leef, 2013). Writing apprehension, or the level of fear and the lack of confidence toward writing, has been characterized as a major factor influencing student motivation to master their writing skills (Daly & Miller, 1975). Teaching strategies and the role of the instructor have also been found to impact the effectiveness of students to learn writing skills in the classroom (Leggette, 2015). The researchers explored how specific components of self-efficacy (performance accomplishments, verbal persuasion, vicarious experience, and psychological states) helped to minimize writing apprehension and increase confidence in writing skills through the use of pedagogical strategies and the instructor interventions.

During and at the end of the course, the students reflected upon how classroom strategies influenced their writing apprehension. The emergent themes of *good practice makes perfect*, *opportunities to edit*, *opportunities to reflect*, *following a guide*, and *write about what matters* provided implications regarding what strategies make students better writers. These themes are similar to what other researchers have identified as strategies that can be used in the classroom to impact writing apprehension (Kellogg & Raulerson, 2007; Martinez et al., 2011; Matoti & Shumba, 2011; Pajares, 2007). The instructor was also identified to play a key role in providing guidance to students when enrolled in a writing intensive course through the emergent themes of *nothing but the truth* and *instructor as a coach*.

When compared to the four factors of self-efficacy, each of the themes could be placed in a specific area of self-efficacy: performance accomplishments (*good practice makes perfect*), verbal persuasion (*nothing but the truth*, *opportunities to edit*), psychological states (*opportunities to reflect*, *write about what matters*, *instructor as a cheerleader*), and vicarious experience (*following a guide*). The ability to complete multiple assignments during the semester helped improve student's confidence toward writing. Similar to prior literature, continuous practice allows students to use their writing skills, learn from their mistakes, and perform with a higher quality (Leggette, 2015). When the instructor provides verbal persuasion such as constructive criticism and allows students the opportunity to edit their work and the work of others, students are given the information they need to improve upon tasks and skills (Margolis

& McCabe, 2006). The findings of this study suggested when detailed feedback is given multiple times throughout the semester, the students know exactly what needs to be fixed, how to fix it, and how to use the information in later assignments (Leggette et al., 2013; Pajares & Johnson, 1994). The process of modeling was also recognized in the student comments regarding the instructor providing detailed outlines and rubrics as well as reading assignments to share examples of the type of assignments to be completed. Although Legette and Homeyer (2015) indicated too many examples may inhibit creativity in writing as students may feel constrained to the work of others, the examples and outlines provided guides of prior completed work, while outlines and rubrics provided questions to promote thoughts and ideas when writing. Additionally, the students suggested the self-reflection and peer review activities enabled evaluation of their own work as well as the work of others. By understanding how their work and the work of others could be improved, the students invested mental and emotional engagement in a recent experience, and the students were encouraged to generalize about their own learning (Leggette et al., 2013; Meyers & Arnold, 2016). Additionally, the emergent theme of the *instructor as a coach* provided students with encouragement to believe they have the capability to be successful writers. Students also addressed that if the instructor inhibited their confidence, they would not perform well in a course nor would they be confident in their writing.

Prior research has provided evidence that students' writing apprehension level can be changed by increasing self-efficacy. Similar to the results of other studies (Leggette, 2015), the writing intensive course may facilitate improvement in writing skills and attitude toward writing. Findings from this study revealed unique and practical information for educators when planning courses focused on improving students' writing. When classroom strategies are designed to increase a student's confidence in a task, the student is able to become aware of how his or her writing techniques have changed during a semester. Although students expressed they were fearful of feedback on writing assignments at the beginning of the course, they learned constructive criticism helped them notice and correct their mistakes. Additionally, when the students were able to write on topics that interested them, they provided more detail and attention to their assignments.

Students from a variety of disciplines need to be trained to write correctly because it is imperative for graduate education and the workplace (Lindner et al., 2004). Teachers and instructors should use the results of this study to recognize writing apprehension does exist in undergraduate students. To change students' writing apprehension, teachers should focus on developing curriculum structured to increase confidence and motivation toward writing. The results of this study provide recommendations to improve student confidence such as continuous feedback, multiple take home and in class assignments, self-reflection activities, and one-minute papers. Because prior research suggested reflection activities encourage critical and active thinking (Leggette et al., 2013; Meyers & Arnold, 2015), instructors should implement activities that allow students to reflect upon their writing skills. Future research in the realm of writing apprehension should focus on understanding the role of writing apprehension in other courses. Research should seek to understand how writing apprehension is affected when the identified pedagogical strategies are not implemented. The findings from this study were limited to one writing intensive course; therefore, future research should explore the role of writing apprehension at a national or state level on student perceptions of writing. This study could also



identify how the role of the instructor changes a student's perceptions of writing and ability to complete writing tasks to a high degree of quality.

## References

- Ahrens, C. A., Meyers, C., Irlbeck, E., Burriss, S., Roach, D. (2016). Exploring agricultural communications students' perceptions of communication apprehension and writing apprehension in the classroom. *Journal of Agricultural Education*, 57(2), 119-133. doi: 10.5032/jae.2016.02119
- Anderson, P. (2014). *Technical communication: A reader centered approach* (8th ed.). Boston, MA: Wadsworth.
- Andrade, H. (2008). Self-assessment through rubrics. *Educational Leadership*, 65(4), 60-63.
- Bandura, A. (1977). Self-efficacy: Toward a unifying theory of behavior change. *Psychological Review*, 84(2), 191-215.
- Bandura, A. (1986). *Social foundations of thought and action: A social cognitive theory*. Englewood Cliffs, NJ: Prentice Hall.
- Bandura, A. (1995). *Self-efficacy in changing societies*. New York, NY: Cambridge University Press.
- Bandura, A. (2012). On the functional properties of perceived self-efficacy revisited. *Journal of Management*, 38(1), 9-44. doi: 10.1177/0149206311410606
- Bean, J. (2011). Backward design: Towards an effective model of staff development in writing in the disciplines. In M. Deane, & P. O'Neil. (Eds.) *Writing in the Disciplines*. (p. 215 – 235). United Kingdom: Palgrave MacMillan.
- Belkin, D. (2015, January 16). Test finds college graduates lack skills for white collar jobs. *The Wall Street Journal*. Retrieved from <http://www.wjm.com/articles/test-finds-many-students-ill-prepared-to-enter-work-force-1421423744>.
- Crumbo, G. B. (1999). Writing apprehension and the effects of "I think I can, I think I can." *Dissertation Abstracts International Section B*, 60(3), 1297.
- Daly, J. A. (1978). Writing apprehension and writing competency. *The Journal of Education Research*, 72(1), 10-14. 10.1080/00220671.1978.10885110
- Daly, J. A., & Miller, M. D. (1975). The empirical development of an instrument to measure writing apprehension. *Research in the Teaching of English*, 9(3), 242- 249. Retrieved from: <http://www.jstor.org/stable/40170632>
- Daly, J. A., & Wilson, D. A. (1983). Writing apprehension, self-esteem, and personality. *Research in the Teaching of English*, 17(4), 327-341. Retrieved from: <http://www.jstor.org/stable/40170968>

- Davis, J. R., & Jayaratne, K. S. (2015). In-service Training Needs of Agriculture Teachers for Preparing Them to Be Effective in the 21st Century. *Journal of Agricultural Education*, 56(4), 47-58. doi: 10.5032/jae.2015.04047
- Faris, K. A., Golen, S. P., & Lynch, D. H. (1999). Writing apprehension in beginning accounting majors. *Business Communication Quarterly*, 62(2), 9-22. doi: 10.1177/108056999906200203
- Erlandson, D., Harris, E., Skipper, B. & Allen, S. (1993). *Doing naturalistic inquiry: A guide to methods*. Newbury Park, CA: Sage Publications.
- Glaser, B. G. & Strauss, A. L. (1967). *The discovery of grounded theory: Strategies for qualitative research*. Chicago, IL: Aldine Publishing Company.
- Gorham, L. M., & Meyers, C. (in press). Evaluating change in students' writing apprehension scores in a writing intensive course: A pre-test, post-test design. *Journal of Agricultural Education*.
- Guion, L. A., Diehl, D. C., & McDonald, D. (2011) Triangulation: Establishing the validity of qualitative studies (FCS6014). Gainesville: University of Florida Institute of Food and Agricultural Sciences. Retrieved from <http://edistt.ifas.ufl.edu/pdf/files/FY/FY39400.pdf>
- Hudd, S. S., Sardi, L. M., & Lopriore, M. T. (2013). Sociologists as Writing Instructors Teaching Students to Think, Teaching an Emerging Skill, or Both?. *Teaching Sociology*, 41(1), 32-45. doi:10.1177/0092055X12458049
- Irlbeck, E. G., & Akers, C. (2009). Employers' perceptions of recent agricultural communications graduates' workplace habits and communications skills. *Journal of Agricultural Education*, 50(4), 63-71. doi 10.5032/jae.2009.04063.
- Kellogg, R. T. & Raulerson, B. A. III. (2007). Improving the writing skills of college students. *Psychonomic Bulletin & Review*, 14(2), 237-242. 10.3758/BF03194058
- Kolb, D. A. (1984). *Experiential learning: Experience as the source of/earning and development*. Englewood Cliffs, NJ: Prentice-Hall.
- Leef, G. (2013, December 11). For 100K, you would think college graduates could write. *Forbes Magazine* [Online]. Retrieved from <http://www.forbes.com/sites/georgeleef/2013/12/11/for-100k-you-would-at-least-think-that-college-grads-could-write/>
- Leggette, H. R. (2015). Faculty define the role of writing in the social sciences of agriculture. *NACTA Journal*, 59(2), 104-110.
- Leggette, H. R., & Homeyer, M. (2015). Understanding students' experiences in writing-intensive courses. *NACTA Journal*, 59(2), 116 - 121.

- Leggette, H. R., & Jarvis, H. (2015). How students develop skill and identity in an agricultural communications writing course. *Journal of Applied Communications*, 99(1), 38-51.
- Leggette, H. R., McKim, B. R., & Dunsford, D. (2013). A case study of using electronic self-assessment rubrics in a core curriculum writing course. *NACTA Journal*, 57(2), 2-10.
- Lincoln, Y. S., & Guba, E. G. (1990). Judging the quality of case study reports. *International Journal of Qualitative Studies in Education*, 3(1), 53-59.
- Lindner, J. R., Murphy, T. H., Wingenbach, G. J., & Kelsey, K. D. (2004). Written communication competencies: Strengths and weaknesses of agricultural education graduate students. *NACTA Journal*, 48(4), 31-38.
- Margolis, H., & McCabe, P. P. (2006). Improving self-efficacy and motivation what to do, what to say. *Intervention in school and clinic*, 41(4), 218-227. doi: 10.1177/10534512060410040401
- Martinez, C. T., Kock, N., & Cass, J. (2011). Pain and pleasure in short essay writing: Factors predicting university students' writing anxiety and writing self- efficacy. *Journal of Adolescent & Adult Literacy*, 54(5), 351-360. doi: 10.1598/JAAL.54.5.5
- Masclé, D. D. (2013). Writing self-efficacy and written communication skills. *Business Communication Quarterly*, 76(2), 216-225. doi: 10.1177/1080569913480234
- Matoti, S., & Shumba, A. (2011). Assessing the writing efficacy of post-graduate students a university of technology in South Africa. *Journal of Social Sciences: Interdisciplinary Reflection of Contemporary Society*, 29(2), 109-118.
- McLeod, S. H. (1987). Defining writing across the curriculum. *WPA: Writing Administration*, 11(1-2), 19-24.
- Merriam, S. B. (1998). *Qualitative research and case study applications in education*. Jossey-Bass. San Francisco, CA
- Meyers, C. A., & Arnold, S. (2016). Student expectations and reflections of a study away course experience to Washington, D. C. *Journal of Applied Communications*, 100(2), 86-99.
- Morgan, A. C. (2010). Competencies needed by agricultural communication graduates: An industry perspective. *Journal of Applied Communications*, 94(1-2), 19-32.
- Pajares, F. (2003). Self-efficacy beliefs, motivation, and achievement in writing: A review of the literature. *Reading & Writing Quarterly*, 19(2), 139-158. doi: 10.1080/10573560390143085

- Pajares, F., & Johnson, M. T. (1994). Confidence and competence in writing: The role of self-efficacy, outcome expectancy, and apprehension. *Research in the Teaching of English*, 28(3), 313-331. Retrieved from <http://www.jstor.org/stable/40171341?origin=JSTOR-pdf>
- Proudman, B. (1992). Experiential education as emotionally-engaged learning. *Journal of Experiential Education*, 15, 19-23.
- Roberts, T. G., Harder, A., & Brashears, M. T. (Eds). (2016). *American Association for Agricultural Education national research agenda: 2016-2020*. Gainesville, FL: Department of Agricultural Education and Communication.
- Selingo, J. (2012, September 12). Skills gap? Employers and colleges point fingers at each other. *The Chronicle of Higher Education*. Retrieved from <http://chronicle.com/blogs/next/2012/09/12/skills-gap-employers-and-colleges-point-fingers-at-each-other/>
- Trojan, S., Meyers, C., & Hudson, N. (in press). Incorporating writing-intensive assignments in an animal science production course. *NACTA Journal*.

## **Investigating the Motivational Changes of Pre-service Agricultural Education Teachers During a Six-Week Project-Based Learning Experience**

F. Richie Roberts, Oklahoma State University  
J. Shane Robinson, Oklahoma State University

### **Abstract**

*The Planning the Community Program in Agricultural Education course exists to provide pre-service teachers in agricultural education with experiences in FFA and SAE. As such, pre-service teachers embarked on a six-week project-based learning experience in Spring 2016 in which they raised a pen of broilers from a one-day old chick to harvest ready (42 days). The broilers were used as the context to learn about data management and Supervised Agricultural Experiences (SAEs). In this case study, we examined pre-service teachers' motivation regarding their self-reported beliefs and perspectives for participating in the six-week project-based learning experience. As a result of the study, three themes emerged: (a) initial self-ambition, (b) achievement stagnation, and (c) stabilized self-concept. Students began the project with high motivation and excitement. However, toward the midway point of the project, students' motivation waned, due to monotony and challenges. Finally, during the last two weeks, pre-service teachers' motivation stabilized, as their self-concepts and reflection abilities matured. The study holds important implications for how teacher educators in agricultural education should design and deliver future project-based learning experiences regarding students' motivational processes. Specifically, this study indicates that, although student motivation may fluctuate at various stages, it is developed and sustained in a successive manner over time.*

### **Introduction**

Agricultural education exists, as a discipline, to enable students to learn valuable life skills necessary for employment in various sectors of the agricultural industry through rich, experiential learning opportunities (Baker, Robinson, & Kolb, 2012). However, creating such opportunities, where students are expected to apply their knowledge and skills in various contexts, can be a difficult yet imperative task (Arnold, Warner, & Osborne, 2006). To be deemed effective, agricultural education teachers are expected to be quality classroom instructors, have a solid understanding of and be able to advise students in the FFA program, and operate, maintain, and utilize all school-based laboratories (Roberts & Dyer, 2004) by providing rich experiences across the comprehensive agricultural education model (Baker et al., 2012).

Agricultural education teachers face a myriad of challenges regarding their professional role. Among them is a lack of student motivation for learning or experiencing agriculture (Boone & Boone, 2009). Fewer people than ever before rely on farming as their livelihood (Environmental Protection Agency, 2012). As people have become further removed from the family farm (Sayers, 2011), so too has their basic knowledge about (Jones, Robinson, & Edwards, 2014; Wingenbach, McIntosh White, Degenhart, Pannkuk, & Kujawski, 2007), and motivation and appreciation for agriculture, food, fiber, and natural resources (Boone & Boone, 2009; Dyer & Breja, 2003; Stair, Warner, & Moore, 2012).

Sadly, today's college students know very little about agriculture. Colbath and Morrish (2010) revealed that incoming freshmen students enrolled at a higher education institution in central Texas failed (54%) a basic agricultural literacy test, where 70% was deemed *acceptable*. Unfortunately, students majoring in agriculture do not fare much better. In a study of the entire freshmen body at Oklahoma State University, it was found that students in the College of Agricultural Sciences and Natural Resources possessed barely a passing grade (61%) on a similar 100-point test regarding their knowledge of basic agricultural concepts (Jones et al., 2014). This lack of basic knowledge has implications for pre-service agricultural education teachers, as they come to the university with a dearth of rich, lived experiences in agriculture. It becomes the role of teacher preparation programs and educators to provide the adequate human capital, such as knowledge and experiences, pre-service teachers need before entering the profession (Mundt, 1991; Robinson & Baker, 2013).

Fortunately, teacher preparation programs of agriculture exist to provide coursework and experiences that enable students to learn technical agricultural skills and improve their confidence to teach them (Leiby, Robinson, & Key, 2013). Kennel (2009) stated, "because teachers are the single most important influence on student achievement, teacher education programs need to provide learning experiences for pre-service educators to impact their confidence to teach pertinent subject matter . . . ." (p. 2). One such area of need is supervised agricultural experience (SAEs) programs (Rubenstein, Thoron, & Estepp, 2014).

Rubenstein et al. (2014) stated,

Since its inception, school-based agricultural education in the United States has utilized the home project method, later known as a supervised agricultural experience program (SAE), as a way to provide students with contextual, hands-on learning experiences outside of class that complement classroom learning. (p. 72)

Although SAEs are a fundamental component of the agricultural education program (Croom, 2008; Ramsey & Edwards, 2012) and have been since Stimson's Farm Project Method was introduced in the early 1900s (Boone, Doerfert, & Elliot, 1987), teachers spend the least amount of time teaching students about them in comparison to other aspects of their job (Robinson, Krysher, Haynes, & Edwards, 2010; Terry & Briers, 2010). Therefore, a decline in student participation in SAEs at the secondary level exists (Croom, 2008). Although the reasons for the decline are largely unknown (Bird, Martin, & Simonsen, 2013), it could be due to teachers' lack of knowledge regarding SAEs (Lewis, Rayfield, & Moore, 2012).

It is widely recognized that, although agricultural education consists of a balanced and integrated three-circle model including classroom and laboratory instruction, FFA, and SAE (Phipps, Osborne, Dyer, & Ball, 1988), the SAE component appears to be the weakest among the three (Croom, 2008; Rubenstein et al., 2014; Wilson & Moore, 2007). In addition to being the weakest component, Dyer and Breja (2003) revealed that SAEs actually serve as "obstacles" to recruiting students into agricultural education programs (p. 84).

Part of the reason SAE participation has decreased over time is due to historical issues. Stimson's vision of SAE "became in actuality a mission statement of agricultural education.

Many teachers soon realized, however, that education in agriculture must encompass more than only one home project, and initiated broader SAE programs . . . .” (Dyer & Osborne, 1995, p. 6). The Vocational Act of 1963 was intended to improve the broader aspect of what constituted an SAE. However, it came with unintended consequences and “de-emphasize[d] the need for SAE programs” (Dyer & Osborne, 1995, p. 7), which had a negative impact on SAE activity in the US (Boone, Doerfert, & Elliot, 1987). The decrease in students’ SAE participation eventually had a ripple effect, resulting in teachers being less experienced in and knowledgeable about teaching SAEs (Dyer & Osborne, 1995).

To increase participation, teachers have tried to motivate and encourage students to participate in SAEs through extrinsic rewards (Bird et al., 2013). Specifically, teachers use FFA awards as the motivation to participate in quality SAEs (Wilson & Moore, 2007). However, the spirit of SAEs may be more intrinsic than extrinsic for students in secondary programs (Bird et al., 2013).

Motivation can be impacted by the types of experiences students have (Baker, Robinson, & Terry, 2015). Kolb (1984) recognized the need for establishing concrete learning experiences in which students reflected, drew conclusions, and then retried their new ideas for experiencing a novel situation. It is important that an expert be present to guide the novice learner through a novel learning experience (Kolb, 1984).

Teacher educators should provide the expert guidance to pre-service teachers regarding the skills and experiences they need to be successful in the classroom (Stair et al., 2012). Teachers have indicated that ensuring SAE quality and effectiveness is one of the most important and difficult tasks associated with teaching school-based agriculture (Dyer & Osborne, 1995; Ramsey & Edwards, 2012; Robinson & Haynes, 2011; Rubenstein et al., 2014). Therefore, including SAEs in teacher preparation programs is imperative (McLean & Camp, 2000). Further, “teacher preparation programs in agriculture [should] provide authentic, relevant instruction to preservice teachers on developing, implementing, maintaining, sustaining, evaluating, and supervising an SAE program” (Rubenstein et al., 2014, p. 72). For SAEs to be relevant, viable, and impactful for secondary students, teachers must be well equipped, as they play an integral role in the development and delivery of student SAEs (Rubenstein & Thoron, 2015). Given the importance that motivation plays in shaping quality SAEs (Bird et al., 2013), a need existed to understand how pre-service teachers experienced motivation as they engaged in experiences designed to enhance their instructional knowledge and skills to facilitate SAEs.

### **Theoretical Framework**

Through our analytic procedures, we decided Maehr’s and Zuscho’s (2009) achievement goal theory (AGT) served as the most appropriate theoretical lens to describe how pre-service agricultural education students experienced motivation during a six-week SAE project focused on raising broilers. Although scholars have theorized the link between motivation and learning from multiple perspectives (Schunk, 2016), AGT emphasizes the importance that *motivational processes* play in students’ learning experiences. Motivational processes affect the way students acquire, transfer, and use new knowledge and skills (Dweck, 1986). Further, AGT scholars (Senko et al., 2013; Senko & Hulleman, 2013) conceptualize motivational processes as the *goal-directed behaviors* students’ exhibit over time. Goal-directed behaviors involve social cognitive



processes such as motives, strivings, achievements, concerns, and action. As a consequence, Maehr and Zuscho (2009) argued that motivation should be examined in terms of students' shifting perspectives, beliefs, and behaviors throughout the *life* of learning activities.

Therefore, we discerned motivation through students' self-reported beliefs and perspectives regarding their goal-directed behaviors. For example, we analyzed how participants articulated their choice to engage in particular activities, quality of engagement, performance, and resolve. In other words, we used this *a posteriori* theoretical lens to make sense of the *motivational shifts* participants experienced during their six-week broiler project. However, AGT also positioned us to consider the role that *cultural* and *individual* factors might have played in shaping the motivational processes of participants. For example, through the lens of AGT, we analyzed the influence that factors such as the culture of learning activities, individual tasks, and as well as the laboratory environment might have played in affecting students' motivation. Therefore, AGT served as underlying theoretical scaffolding to which the study's findings are anchored.

### **Theoretical Perspective, Purpose, and Rationale**

From this study's early conception, we nested our decisions in Koro-Ljungberg's, Yendol-Hoppy's, Smith's, and Hayes' (2009) position that qualitative researchers' philosophical perspective and methodological choices should be aligned. Therefore, we grounded this study in the worldview of *constructionism* (Crotty, 1998). Constructionists consider knowledge to be “. . . contingent upon human practices, being constructed in and out of interaction between human beings and the world, and developed and transmitted within an essentially social context” (p. 42). Grounded in this perspective, we developed the purpose of this study, which was to describe how pre-service agricultural education teachers experienced motivation during a project-based learning assignment that used broilers as a context for teaching data management (i.e., record keeping) and SAE concepts. Consequently, we also were positioned to address Priority 4 of the National Research Agenda, which calls for “meaningful, engaged learning in all environments” (Roberts, Harder, & Brashears, 2016, p. 37). Next, we will outline the background of this study.

### **Background of the Study**

*Planning the Community Program in Agricultural Education* is the second in a sequence of courses taken by agricultural education students at Oklahoma State University. Per the 2016-2017 Oklahoma State University Course Catalog, the *Planning the Community Program in Agricultural Education* course exists to help students improve their human capital regarding their “FFA chapter advisement, planning and managing the instructional program, [and] identification and completion of records and reports required to be a teacher of agricultural education in Oklahoma” (p. 199). The course is designed to assist and equip students with the tools needed to conduct quality SAE programs at the secondary level. The aim of this course is to allow students to gain a theoretical and practical understanding of the FFA and SAE components of agricultural education's integrated three-circle model. In Spring 2016, the course's lead instructor introduced record keeping and SAE concepts through a project-based learning approach. Through this project, 34 pre-service teachers partnered to care for approximately 200 one-day-old broilers over a six-week period. As an additional requirement for the course, students designed broiler experiments, tested interventions, collected and maintained accurate records, and rotated between student and advisory roles to gain insight into facilitating such experiences.

Specifically, each student was provided “five (5) broilers to raise and collect data for the last six weeks of the semester” (Name, 2016, p. 5). Students were paired with a partner, so as to have 10 birds between them, to design an experiment and role-play the teacher and student during the project’s duration.

To assist pre-service teachers with making learning connections, they were required to submit weekly reflections, photos, and data collection records. Further, the pre-service teachers were required to create and deliver a final presentation of their experience to their peers. In the design of this project, our personal beliefs about teaching and learning influenced its conceptualization. Therefore, to be transparent about our influences, the reflexivity section details our position in the design, collection, and analysis of data associated with this study.

### **Reflexivity**

It is crucial for qualitative researchers to reveal the biases and perspectives influencing their decision-making (Patton, 2002). As a consequence, we constructed the following reflexivity statement as a way to promote *honesty* and *sincerity* before offering an interpretation of the study’s findings (Lincoln & Guba, 1985).

*Both researchers were involved directly with the course under investigation. For example, the lead researcher is a doctoral student in agricultural education and was a teaching assistant for the course. The second author is a Professor at Oklahoma State University and served as the course’s lead instructor. It also is important to note that both researchers are former school-based, agricultural education (SBAE) instructors in Oklahoma. Because we consider Oklahoma traditional in regard to agricultural production, we also held biases concerning the importance of using animals as a context for teaching and learning. This bias influenced our decision to use poultry (i.e., broilers) to facilitate the teaching of record keeping and SAEs for this project-based learning assignment.*

Given these experiences and perspectives, we recognize our influences on this study. However, we attempted to mitigate our biases whenever possible. Consequently, the following section outlines our methodological decisions, analytic moves, and discoveries as we sought to understand this phenomenon.

### **Methodology**

We chose to ground this study, methodologically, in Stake’s (1995) instrumental case study approach. Due to its roots in the interpretivist paradigm (Stake, 1995), this choice allowed us to bring our theoretical and methodological decisions into philosophical alignment (Koro-Ljungberg et al., 2009). For example, instrumental case studies can offer rich understandings into bounded systems (Stake, 1995). However, this qualitative approach’s strength lies in the context-rich description of *specific issues* that may have transferability to similar circumstances (Creswell, 2013; Stake, 1995).

In this study, *time* and the *unit of analysis* bounded the case. For example, we limited the

project-based learning assignment to a six-week period and analyzed data for only one particular laboratory section of the course. Our reason for bounding this case during this time period is because the broilers are typically harvested at Oklahoma State University after 42 days (Name, personal communication, January 17, 2016). We offer a deeper insight into participant characteristics and selection criteria next.

## **Participants**

Each participant ( $n = 14$ ) was enrolled in Laboratory Section 001 of the *Planning the Community Program in Agricultural Education* course at Oklahoma State University in Spring 2016. Our decision to mobilize data from this particular *unit of analysis* was threefold: (a) it was the largest laboratory section, (b) it reflected student demographics best, and (c) the lead researcher was immersed in all of the section's major activities throughout the duration of the project. As a consequence, we purposefully selected (Patton, 2002) seven female and seven male pre-service agricultural education teachers from this bounded system.

## **Data Sources and Analysis**

In this study, we collected multiple sources of data to triangulate findings. For example, written reflections, student photographs, record keeping submissions, field observations, summative presentation materials, and video of participants' final presentations all furnished sources of data. Analysis was an ongoing process as we began to engage data sources (Saldaña, 2015). To make sense of our analytic work, we used memoing techniques to mobilize findings, empirical assertions, and analytic shortcomings. Because data becomes fragmented in qualitative analysis, we followed Saldaña's (2015) recommendations to continually return to the data corpus to minimize misrepresentations, thus improving the transferability of the findings.

Data were analyzed using the constant comparative method (Corbin & Strauss, 2015). Both hand coding and NVivo® qualitative analysis software were used to explore and manage the data. To initiate analysis through the constant comparative method, we used Saldaña's (2012) coding suggestions consisting of the following techniques: (a) open, (b) axial, and (c) selective. Through two distinct rounds of open coding and multiple coders, we identified initial codes (Saldaña, 2012). Then, we scrutinized the relationships of the open codes in the axial coding phase. When analyzing these relationships, we considered the study's context and the consequences of reducing data units into particular categories through a negotiation phase (Patton, 2002). Ultimately, the resulting product was used to develop evidentiary warrants (Corbin & Strauss, 2015). To mobilize the evidentiary warrants, we reengaged the data through selective coding (Saldaña, 2012). The use of selective coding allowed us to develop an analytic story line that we chose to narrate through the three themes (Saldaña, 2015).

## **Rigor and Trustworthiness**

Before offering our interpretation of the findings, it is important to discuss our strategies for building *rigor* and *trustworthiness* into this investigation. From this study's inception, we allowed Lincoln's and Guba's (1985) four standards of qualitative quality – credibility, transferability, dependability, and confirmability – to drive our ethical decision-making. Strategies for upholding each standard are outlined below.

*Credibility* refers to the production of trustworthy findings (Lincoln & Guba, 1985). We addressed credibility in this study through three major strategies: (a) persistent observations, (b) triangulation of data sources, and (c) peer debriefing sessions. We also stressed the importance of the study's findings in providing meaning to other contexts, or *transferability*. To accomplish this, we provided a rich description of the setting and participants while also being frank about the limitations of this study. The third standard, *dependability*, represents the stability of the investigation. We emphasized dependability in three major ways: (a) only collecting data that connected to the purpose of this study, (b) clearly describing each researchers' role in the study, and (c) outlining the philosophical paradigms influencing this investigation's design. Finally, the extent to which the study's findings could be linked to data, or *confirmability*, was addressed through using direct quotes from participants and regularly comparing claims against relevant data sources. Through our efforts to uphold standards for rigor and trustworthiness, we gained confidence in our interpretations of this investigation's findings.

## Findings

Through our analysis of the data, three processes emerged that describe how participants experienced motivation in the project-based learning assignment under investigation. Using Maehr's and Zuscho's (2009) AGT as theoretical lens, we narrated the processes through three themes: (a) *initial self-ambition*, (b) *achievement stagnation*, and (c) *stabilized self-concept*. The processes provide new insights into the role that motivational shifts can play in shaping learning outcomes for pre-service agricultural education teachers. Using relevant examples from the data, each theme seeks to distinguish how participants experienced these *motivational processes* throughout the six-week broiler project, which provided a context for teaching record keeping and SAE concepts.

### Initial Self-Ambition

Through the lens of AGT, individual goals and ambitions could serve as powerful motivators (Maehr & Zuscho, 2009). In accordance, participants in this study articulated the *ambitions* they held regarding the broiler project were connected largely to building their professional capacity. Typically, participants expressed these sentiments in the *early stages* of the project. For example, Participant 11 revealed his ambition was to gain a deeper understanding of teaching the scientific method in the context of agriculture. In his first journal entry, he wrote:

I feel like there a lot of valuable things that can be learned and taught by doing this assignment. For example, you can learn to teach the scientific method and the importance of being consistent and responsible. The scientific method is crucial in the agriculture industry.

Meanwhile, Participant 13's early goal was to hone her pedagogical skills to keep students engaged in laboratory settings. She explained, "This type of project is one that most students will be excited and motivated to complete." On the other hand, Participant 7 saw value in the project due to its focus on animals. He explained, "The livestock side of teaching Ag is something I'm excited for, yet nervous for at the same time." Consequently, his ambition was to gain more knowledge about facilitating such experiences for his future students.

In the project's introduction, participants also were optimistic about learning to facilitate record keeping for SAEs. In the first week, many pre-service teachers expressed their ambitions to gain proficiency in this particular technical area through the project. For instance, Participant 4 found this element of the project "thrilling and exciting." Several participants even submitted photos after week # 1 that depicted elements of the record keeping process (see Figure 1).

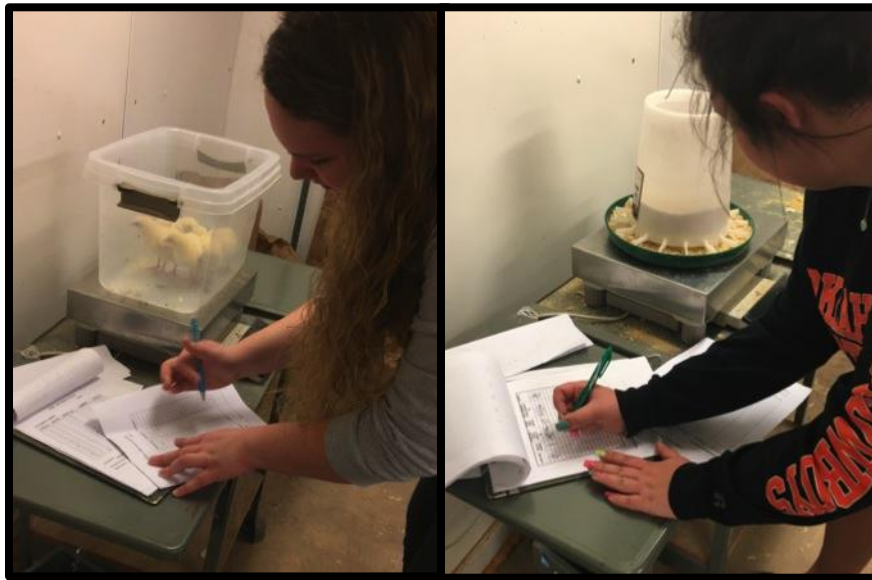

*Figure 1.* Participant 1's (Left) and Participant 2's (Right) photo submission from week # 1 of the broiler project. Photos depict pre-service agricultural education teachers in various phases of the record keeping process.

In the first theme, we outlined the *initial self-ambitions* experienced by participants in the broiler project. This motivational process appeared to be manifested through the pre-service teachers' early goals and ambitions to gain proficiency in various pedagogical and content-specific areas, such as animal husbandry and record keeping. However, as participants gained experience and competence with the broilers, these positive views often became stagnated, as achievement appeared to stall.

### **Achievement Stagnation**

After several weeks of caring for the broilers, participants appeared to lose sight of their initial ambitions. Further, their motivation for the project seemed to become *disconnected, narrow, and stagnant*. AGT scholars (Huang, 2011; Linnenbrink-Garcia, 2012; Putwain, Larkin, & Sander, 2013) argued that *stagnation* occurs as individual challenges and concerns begin to overpower learners' goals and expectations. For instance, Participant 2 did not perceive growth in her abilities; consequently, she struggled to make sense of how to engage her future students in similar projects. She explained:

I feel that I am satisfactory. I myself am a little tuned out from this project. This project to me is the same routine. I feel I can't engage students if I myself am not engaged. This particular project isn't something I have found passion in and until I find that spark I

don't really know how excited I will really be. I feel maybe it will be more interesting as the project goes on but right now I have no clue how to engage my students.

Other participants articulated their struggles with staying motivated were due to the demanding and monotonous tasks associated with the project. For example, Participant 10 explained, "keeping motivated can be a hard task." Similarly, Participant 9 voiced that he experienced "little growth" during this phase of the project. Interestingly, participants' photo submissions also appeared to lack a sense of motivational and skill development. For example, in photo submissions for week # 3 several participants submitted photos illustrating their unwillingness to test new boundaries and work toward achieving their initial goals for the project. Instead, their submissions depicted rudimentary skills, such as weighing broilers (see Figure 2).



Figure 2. Participant 4's (Left), Participant 11's (Center), and Participant 12's (Right) photo submissions from week # 3 of the broiler project. Photos depict participants' weighing broilers – a low-level skill for this phase of the project.

The second theme, *achievement stagnation*, demonstrated a substantial shift in participants' motivational schemes. For instance, they seemed to lose sight of the importance of their early ambitions as they engaged in monotonous and tedious activities associated with the broiler project. This motivational disengagement also appeared to influence their learning outcomes, as numerous participants refrained from making important pedagogical and content knowledge connections.

### **Stabilized Self-Concept**

Over the final weeks of the project, students began to encounter more complex problems. For example, in the project, many of the participants faced issues such as "sickness" (Participant 12), "disease" (Participant 6), "irregular growth patterns" (Participant 8), and the "death" of one or more of their broilers (Participant's 7, 10, and 14). Interestingly, after confronting these difficulties, participants began to articulate more *complex, integrated, and stable* perspectives. In this regard, AGT conjectures that as learners persist through the trials of learning activities, their motivation often stabilizes as they begin to *make meaning* of how these difficulties helped them

to grow and mature (Maehr & Zuscho, 2009). The maturation of one's self-perspective, therefore, holds substantial implications for the study of motivation.

In the literature, Schunk (2016) defined *self-concept* as the self-perspectives individuals hold of themselves. As a consequence, one's self-concept is formed by the confidence a person maintains as a result of his or her experiences (Shunk, 2016). In this study, participants' self-concept appeared to stabilize in the later stages of the broiler project. This factor also appeared to positively influence the pre-service teachers' motivation to gain quality professional benefits from the assignment.

For example, as the broiler project came to a conclusion, we asked the pre-service teachers to reflect deeply on their professional growth and development. To facilitate this process, we required each student to develop and deliver a final presentation (Name, 2016). Through this process, participants seemed to *make sense* of their experience, which also appeared to help them crystallize their beliefs about the role the project had in shaping their pedagogical and technical development. We captured the final presentations and resulting discussions on video; therefore, we were able to use these moments of explanation, clarification, and co-construction of knowledge as important data points in this study.

In students' final evaluation of their learning, they seemed to make important connections in regard to the value the broiler experience might provide as they transitioned into teaching in a real-world laboratory setting. Participant 3 explained,

Towards the end we became more comfortable with the project and began to learn what needed to be done to help out the animals and make their life easier day-by-day. For example, we had to move the feeders up and down. This is part of the learning process and will help us solve problems when we are in the real world as ag teachers.

Other participants perceived they had matured professionally through the project as well. For example, they espoused they could "provide recommendations" to future students (Participant's 10 and 14), "plan successful laboratory experiences" (Participant's 8 and 9), overcome "unexpected challenges" (Participant's 2 and 5), and "manage students" in a laboratory setting (Participant's 4 and 6) better than they could before engaging in the experience. Therefore, the final theme detailed how the pre-service teachers in agricultural education began to move beyond the motivational stagnation experienced in the mid-stages of the broiler project. Further, by confronting complex issues and reflecting deeply on their experiences, numerous participants' *self-concept* seemed to stabilize in the project's final stages, which encouraged positive professional growth.

## **Conclusions**

In this study, we sought to describe how pre-service teachers in agricultural education at Oklahoma State University experienced motivation during a project-based learning assignment that used broilers as a context for teaching concepts related to data management and SAEs. By interpreting the findings through the theoretical lens of Maehr's and Zuscho's (2009) AGT, three themes emerged: (a) initial self-ambition, (b) achievement stagnation, and (c) stabilized self-concept. The themes represent the motivational processes participants underwent during the six-

week broiler project. To situate these findings in the literature, conclusions are provided for each process.

The first theme, *initial self-ambition*, illuminated the importance of participants' early goals and expectations regarding the broiler assignment, which mainly seemed to reflect their desire for professional growth and development. For example, participants articulated enthusiasm to enhance their knowledge and skills about facilitating the *scientific method*, *livestock projects*, as well as *record keeping* for SAEs. These early ambitions appeared to drive the motivational processes experienced by participants. As a consequence, we conclude that identifying participants' individual self-ambitions is central to understanding how motivational shifts might occur at the individual level during project-based learning assignments. Although this literature on motivation and learning supports this finding (Dweck, 1986; Maehr & Zuscho, 2009), scant evidence exists in the context of agricultural education.

In the mid-stages of the broiler project, pre-service teachers seemed to experience *achievement stagnation*. For instance, participants reported the *challenges*, *demands*, and *monotony* of certain tasks associated with the assignment caused them to lose sight of its intents and purposes. As a result, participants' course submissions also appeared to lack a sense of pedagogical and content-specific growth. Existing evidence across disciplines suggests that challenges in learning endeavors may result in students lacking the motivation needed to attain their educational and professional goals (Huang, 2011; Senko et al., 2013). However, findings from this investigation hold new insights for the motivation literature by providing a basis for how *contextual*, *emotive*, and *visceral* dimensions of learning might affect students' motivation.

The final theme demonstrated how participants' motivation appeared to *stabilize* in the latter phases of the assignment. This stabilization seemed to occur through the maturation of participants' self-concept through reflective strategies that required participants to consider how they grew professionally during the project. The view that *reflection* serves as a crucial element of learning process is situated firmly in the agricultural education literature (Baker, Brown, Blackburn, & Robinson, 2014; Epler, Drape, Broyles, & Rudd, 2013; Lambert, Sorenson, & Elliot, 2014). However, the notion that reflection may be used as a technique to stabilize the self-concept of pre-service teachers has not been addressed explicitly.

### **Discussion, Implications, and Recommendations**

Recently, the construct of motivation appears to have been operationalized as a quantitative variable in the agricultural education literature (Baker et al., 2015; Chumbley, Haynes, & Stofer, 2015; Roberts, Terry, Brown, & Ramsey, 2016). However, by approaching this study from the qualitative paradigm, this study's findings hold important implications for agricultural education in regard to future research, theory, and practice.

First, existing research in agricultural education largely attempts to measure students' changes in motivation using pre-determined outcomes through treatments that are both short-term and novel in design (Baker et al., 2015; Chumbley et al., 2015; Roberts et al., 2016). However, by using an emergent design that was more longitudinal in nature, this study's findings illuminated three existing motivational processes while also providing empirical evidence of a theorized,



sequential relationship among them. Additional research is needed to explore the parameters of this relationship and whether more nuanced motivational processes need to be *discovered* and more evocatively *defined*. Researchers exploring the motivation of pre-service teachers also should consider the findings to examine whether the motivational process identified might influence the design, collection of data, and resulting outcomes of their studies.

The three motivational processes also warrant future research. For example, *initial self-ambitions* appeared to influence the major motivational shifts experienced by participants. Consequently, future work should attempt to identify pre-service teachers' goals and expectations more extensively as they engage in project-based learning throughout teacher preparation training. Additional research is needed to explore the *stagnation* participants experienced in regard to achievement. In this case, *monotony* and the *demands* associated with the project seemed to have influenced participants' motivation negatively. To this point, we recommend that future investigations test various interventions throughout project-based learning assignments to determine whether learners' motivation could be maintained at a more consistent level. Finally, although the agricultural education literature is rife with evidence concerning the importance of reflection (Baker et al., 2014; Epler et al., 2013; Lambert et al., 2014), more research is needed to identify the types of reflective strategies that might be most useful in assisting pre-service teachers' self-concept to *stabilize*.

In this investigation, we used Maehr's and Zuscho's (2009) AGT as an *a posteriori* lens to make meaning of the study's emergent findings. Therefore, we allowed AGT to assist in organizing our understanding of how participants experienced motivation during the broiler project. As a result, we were able to more intimately grasp and explain each motivational process. Nevertheless, we believe the study's findings could offer a crucial expansion to AGT. For example, participants in this study appeared to experience the motivational processes in a successive manner. Consequently, more theory-building efforts should be undertaken to generate a clearer conceptual explanation for how AGT might unfold in praxis.

In an era where less people are exposed to agriculture (Environmental Protection Agency, 2012; Jones et al., 2014; Sayers, 2011; Wingenbach et al., 2007), this course was focused on providing concrete experiences in which students could participate and reflect over time (Kolb, 1984). However, providing such experiences came with a *cost*. The broiler project under investigation required *time*, *money*, and *human capital* to be successful. In practice, therefore, university officials should deeply consider whether they are willing to dedicate the time and resources necessary to ensure that students gain a quality learning experience. We also recommend that practitioners consider whether broilers might be the most appropriate context to facilitate learning the principles of data management (i.e., record keeping) and SAEs. For example, perhaps a horticulture project could be a more cost-effective and less controversial alternative given the rise of animal advocacy legislation in recent years. Moving forward, we recommend that university officials consider the *motivational processes* identified in this study in the design and delivery of project-based learning assignments for pre-service teachers in agricultural education. By integrating strategies to promote consistent motivational behaviors purposefully, perhaps greater learning outcomes can be achieved.

## References

- Arnold, S., Warner, W. J., & Osborne, E. W. (2006). Experiential learning in secondary agricultural education classrooms. *Journal of Southern Agricultural Education Research*, 56(1), 30–39. Retrieved from <http://www.jsaer.org/pdf/Vol56/56-01-030.pdf>
- Baker, M. A., Brown, N. R., Blackburn, J. J., & Robinson, J. S. (2014). Determining the effects that the order of abstraction and type of reflection have on content knowledge when teaching experientially: An exploratory experiment. *Journal of Agricultural Education*, 55(2), 106-119. doi:10.5032/jae.2014.02106
- Baker, M. A., Robinson, J. S., & Kolb, D. A. (2012). Aligning Kolb's experiential learning theory with a comprehensive agricultural education model. *Journal of Agricultural Education*, 53(4), 1–16. doi:10.5032/jae.2012.04001
- Baker, M. A., Robinson, J. S., & Terry, Jr., R. (2015). The effects of an experiential approach of an experiential approach to learning on student motivation. Proceeding from the 2015 American Association for Agricultural Education Conference. San Antonio, TX.
- Bird, W. A., Martin, M. J., & Simonsen, J. C. (2013). Student motivation for involvement in supervised agricultural experiences: An historical perspective. *Journal of Agricultural Education*, 54(1), 31–46. doi:10.5032/jae.2013.01031
- Boone, H. N., Doerfert, D. L., & Elliot, J. (1987). Supervised occupational experience programs: History, philosophy, current status, and future implications. *Journal of American Association of Teacher Educators in Agriculture*, 28(4), 57–64. doi:10.5032/jaatea.1987.04057
- Boone, H. N. Jr., & Boone, D. A. (2009). An assessment of problems faced by high school agricultural education teachers. *Journal of Agricultural Education*, 50(1), 21–32. doi:10.5032/jae.2009.01021
- Colbath, S. A., & Morrish, D. G. (2010). What do college freshmen know about agriculture? An evaluation of agricultural literacy. *NACTA Journal*, 54(4), 1–15.
- Corbin, J., & Strauss, A. (2015). *Basics of qualitative research: Techniques and procedures for developing grounded theory* (4th ed.). Thousand Oaks, CA: Sage.
- Chumbley, S. B., Haynes, J. C., & Stofer, K. A. (2015). A measure of students' motivation to learn science through agricultural STEM emphasis. *Journal of Agricultural Education*. 56(4). 107-122. doi:10.5032/jae.2015.04107
- Creswell, J. W. (2013). *Qualitative inquiry and research design: Choosing among the five approaches* (3rd ed.). Thousand Oaks, CA: Sage.

- Croom, D. B. (2008). The development of the integrated three-component model of agricultural education. *Journal of Agricultural Education*, 49(1), 110–120. doi:10.5032/jae.2008.01110
- Crotty, M. (1998). *The foundations of social research: Meaning and perspective in the research process*. Thousand Oaks, CA: Sage.
- Dweck, C. S. (1986). Motivational processes affecting learning. *American Psychologist*, 41(10), 1040-1048. doi:10.1037/0003-066X.41.10.1040
- Dyer, J. E., & Breja, L. M. (2003). Problems in recruiting students into agricultural education programs: A Delphi study of agriculture teacher perceptions. *Journal of Agricultural Education*, 44(2), 75–85. doi:10.5032/jae.2003.02075
- Dyer, J. E., & Osborne, E. W. (1995). Participation in supervised agricultural experience programs: A synthesis of research. *Journal of Agricultural Education*, 36(1), 6–14. doi:10.5032/jae.1995.01006
- Environmental Protection Agency (2012). *Demographics*. Author. Retrieved from <http://www.epa.gov/agriculture/ag101/demographics.html>
- Epler, C. M., Drape, T. A., Broyles, T. W., & Rudd, R. D. (2013). The influence of collaborative reflection and think-aloud protocols on pre-service teachers' reflection: A mixed methods approach. *Journal of Agricultural Education*, 54(1), 47-59. doi:10.5032/jae.2013.01047
- Huang, C. (2011). Achievement goals and achievement emotions: A meta-analysis. *Educational Psychology Review*, 23(1), 359– 388. doi:10.1007/s10648-011-9155-x
- Jones, C., Robinson, J. S., & Edwards, M. C. (2014). An assessment of the agricultural literacy of incoming freshmen at a land-grant university: Implications and opportunities for agricultural educators. *Proceedings of the 2014 Southern Region AAAE Conference, Dallas, TX*. Retrieved from [http://aaaeonline.org/uploads/allconferences/1-31-2014\\_59\\_2014\\_SAERC\\_Proceedings.pdf](http://aaaeonline.org/uploads/allconferences/1-31-2014_59_2014_SAERC_Proceedings.pdf)
- Kennel, E. G. (2009). *A study of pre-service agricultural education students: Knowledge of horticulture and self-efficacy to teach horticulture*. Unpublished master's thesis, Oklahoma State University, Stillwater, OK.
- Kolb, D. A. (1984). *Experiential learning: Experience as the source of learning and development*. Upper Saddle River, NJ: Prentice Hall.
- Koro-Ljungberg, M., Yendol-Hoppey, D., Smith, J. J., & Hayes, S. B. (2009). (E)pistemological awareness, instantiation of methods, and uninformed methodological ambiguity in qualitative research projects. *Educational Researcher*, 38(9), 687-699. doi:10.3102/0013189X09351980

- Lambert, M. D., Sorensen, T. J., & Elliott, K. M. (2014). A comparison and analysis of preservice teachers' oral and written reflections. *Journal of Agricultural Education, 55*(4), 85-99. doi:10.5032/jae.2014.04085
- Leiby, B. L., Robinson, J. S., & Key, J. P. (2013). Assessing the impact of a semester-long course in agricultural mechanics on pre-service agricultural education teachers' importance, confidence, and knowledge of welding. *Journal of Agricultural Education, 54*(1), 179–192. doi:10.5032/jae.2013.01179
- Lewis, L. J., Rayfield, J., & Moore, L. L. (2012). Supervised agricultural experience: An examination of student knowledge and participation. *Journal of Agricultural Education, 53*(4), 70–84. doi:10.5032/jae.2012.04070
- Lincoln, Y. S., & Guba, E. G. (1985). *Naturalistic inquiry*. Newbury Park, CA: Sage Publications.
- Linnenbrink-Garcia, L., Middleton, M. J., Ciani, K. D., Easter, M. A., O’Keefe, P. A., & Zusho, A. (2012). The strength of the relation between performance-approach and performance-avoidance goal orientations: Theoretical, methodological, and instructional implications. *Educational Psychologist, 47*(1), 281– 301. doi:10.1080/00461520.2012.722515
- Maehr, M. L., & Zusho, A. (2009). Achievement goal theory: Past, present, and future. In K. R. Wentzel & A. Wigfield (Eds.), *Handbook of motivation at school* (Vol. 1, pp. 77– 104). New York, NY: Taylor & Francis.
- McLean, R. C., & Camp, W. G. (2000). An examination of selected preservice agricultural teacher education programs in the United States. *Journal of Agricultural Education, 41*(2), 25–35. doi:10.5032/jae.2000.02025
- Mundt, J. (1991). The induction year – A naturalistic study of beginning secondary teachers of agriculture in Idaho. *Journal of Agricultural Education, 32*(1), 18–23. doi:10.5032/jae.1991.04070
- Patton, M. (2002). *Qualitative research and evaluation methods* (3rd ed.). Thousand Oaks, CA: Sage.
- Phipps, L. J., Osborne, E. W., Dyer, J. E., & Ball, A. (2008). *Handbook on agricultural education in public schools* (6th ed.). Clifton Park, NY: Thomson Delmar Learning.
- Putwain, D. W., Larkin, D., & Sander, P. (2013). A reciprocal model of achievement goals and learning related emotions in the first year of undergraduate study. *Contemporary Educational Psychology, 38*(1), 361– 374. doi:10.1016/j.cedpsych.2013.07.003
- Ramsey, J. W., & Edwards, M. C. (2012). Entry-level technical skills that teachers expected students to learn through supervised agricultural experiences (SAEs): A modified Delphi study. *Journal of Agricultural Education, 53*(3), 42–55. doi:10.5032/jae.2012.03042

- Roberts, T. G., & Dyer, J. E. (2004). Characteristics of effective agriculture teachers. *Journal of Agricultural Education*, 45(4), 82–95. doi:10.5032/jae.2004.04082
- Roberts, T. G., Harder, A., & Brashears, M. T. (Eds). (2016). *American Association for Agricultural Education national research agenda: 2016-2020*. Gainesville, FL: Department of Agricultural Education and Communication, University of Florida.
- Roberts, R., Terry, Jr., R., Brown, N. R., & Ramsey, J. W. (2016). Students' motivations, value, and decision to participate in service-learning at the National FFA Days of Service. *Journal of Agricultural Education*, 57(2), 187–202. doi:10.5032/jae.2016.02187
- Robinson, J. S. (2016). *AGED 3202 – Planning the Community Program in Agricultural Education, Course syllabus* [Class handout]. Department of Agriculture, Oklahoma State University, Stillwater, OK.
- Robinson, J. S., & Baker, M. A. (2013). The effect of human capital on principals' decisions to interview candidates in agricultural education: Implications for pre-service teachers. *Journal of Agricultural Education*, 54(1), 140–152. doi:10.5032/jae.2013.01140
- Robinson, J. S., & Haynes, J. C. (2011). Value and expectations of supervised agricultural experiences as expressed by agriculture instructors in Oklahoma who were alternatively certified: A qualitative study. *Journal of Agricultural Education*, 52(2), 47–57. doi:10.5032/jae/2011.02047.
- Robinson, J. S., Krysher, S., Haynes, J. C., & Edwards, M. C. (2010). How Oklahoma State University students spent their time student teaching in agricultural education: A fall versus spring semester comparison with implications for teacher education. *Journal of Agricultural Education*, 51(4), 142–153. doi:10.5032/jae/2010.04142.
- Rubenstein, E. D., & Thoron, A. C. (2015). Supervised agricultural experience programs: An examination of committed teachers and student-centered programs. *Journal of Agricultural Education*, 56(4), 75–89. doi:10.5032/jae.2015.04075
- Rubenstein, E. D., Thoron, A. C., & Estep, C. M. (2014). Perceived self-efficacy of preservice agriculture teachers toward specific SAE competencies. *Journal of Agricultural Education*, 55(4), 72–84. doi:10.5032/jae.2014.04072
- Saldaña, J. (2012). *The coding manual for qualitative researcher* (3rd ed.). Thousand Oaks, CA: Sage.
- Saldaña, J. (2015). *Thinking qualitatively: Methods of mind*. Thousand Oaks, CA: Sage.
- Sayers, I. (2011). New approaches to feeding the world's population. *International Trade Forum* 3, 30–33.

- Schunk, D. (2016). *Learning theories: An educational perspective* (7th ed.). Boston, MA: Pearson.
- Senko, C., Durik, A. M., Patel, L., Lovejoy, C. M., Valentiner, D., & Stang, M. (2013). Achievement goal effects on performance under low versus high challenge conditions. *Learning & Instruction, 23*(1), 60– 68. doi:10.1016/j.learninstruc.2012.05.006
- Senko, C., & Hulleman, C. S. (2013). The role of goal attainment expectancies in achievement goal pursuit. *Journal of Educational Psychology, 105*(1), 504-521. doi:10.1037/a0031136
- Smith, K. L., & Rayfield, J. (2016). An early historical examination of the educational intent of supervised agricultural experiences (SAEs) and project-based learning in agricultural education. *Journal of Agricultural Education, 57*(2), 146–160. doi:10.5032/jae.2016.02146
- Stair, K. S., Warner, W. J., & Moore, G. E. (2012). Identifying concerns of preservice and in-service teachers in agricultural education. *Journal of Agricultural Education, 53*(2), 153–164. doi:10.5032/jae.2012.02153
- Stake, R. E. (1995). *The art of case study research*. Thousand Oaks, CA: Sage Publications, Inc.
- Oklahoma State University. 2016-2017 University Catalog.
- Terry, R., Jr., & Briers, G. E. (2010). Roles of the secondary agriculture teacher. In R.M. Torres, T. Kitchel, & A.L. Ball (Eds.), *Preparing and advancing teachers in agricultural education*, (pp. 86–99). Columbus, OH: Curriculum Material Services.
- Wilson, E. B., & Moore, G. E. (2007). Exploring the paradox of supervised agricultural experience programs in agricultural education. *Journal of Agricultural Education, 48*(4), 82–92. doi:10.5032/jae.2007.040982
- Wingenbach, G. J., McIntosh White, J., Degenhart, S., Pannkuk, T., & Kujawski, J. (2007). Pre-service teachers' knowledge and teaching comfort levels for agricultural science and technology. *Journal of Agricultural Education, 48*(2), 114–126. doi:10.5032/jae.2007.02114

## Imaging Service-Learning in *The Agricultural Education Magazine* from 1929 to 2009: Implications for the Method's Reframing and Use

Richie Roberts, Oklahoma State University  
M. Craig Edwards, Oklahoma State University

### Abstract

*Service-learning's (SL) discourse is written as a story of victory, achievement, and transformation in school-based, agricultural education (SBAE). The institutional, monetary, and human resources dedicated to improving both learning and communities through SL are significant. Little work, however, has been put forth to examine this victory narrative's underlying assumptions and implications. Therefore, the purpose of this historical investigation was to explore how SL was imaged in The Agricultural Education Magazine (The Magazine) from 1929 to 2009. Through the analysis of data, SL's imaging in The Magazine appears to have been positioned through three distinct lenses: (a) cultural, (b) pedagogical, and (c) political. In culturally imaged SL, actors emphasized the importance of shaping young adolescents into productive citizens to meet the demands of society and culture. Meanwhile, the pedagogical lens emerged in response to calls for improved instructional effectiveness; consequently, practitioners and scholars outlined how SL could be used to enhance students' academic achievement. The final lens, political, arose as a way to address equity, race, and privilege in agricultural education. Based on these conclusions, we offer implications and recommendations that may help reframe SL to respond to contemporary issues and trends in SBAE.*

### Introduction

During the past two decades, service-learning (SL) appears to have been *depicted* as an instructional method with the potential to transform schools, local communities, and even the world (Butin, 2015). By merging classrooms and communities, theory and practice, and cognitive and affective dimensions, SL can seemingly reshape the realities of education by addressing local problems through engaging students in real-world, service-based opportunities. To that aim, Butin (2007) defined SL as “the linkage of academic work with community-based engagement within a framework of respect, reciprocity, relevance, and reflection” (p. 177). The SL literature teems with promises and stories of its transformative benefits (Clayton, Bringle, Senior, & Morrison, 2010). SL seems to speak to noble aspirations, such as duty and honor, which many perceive are missing in society (Billig & Welsh, 2004). Often these possibilities are narrated as *victory narratives* – constructed to illuminate what SL *could* achieve in regard to diversity and pluralism (Gilbride-Brown, 2008). And, in many ways, SL has achieved these aims. For instance, more than 1,100 U.S. higher education institutions are now members of Campus Compact, a national coalition committed to SL; further, over 100,000 K-12 schools report using SL to engage students every year (Campus Compact, 2016).

SL was established as a *strategic instructional method* with the potential to shift students' theoretical orientations and worldviews. To accomplish this, SL challenges the static conception of teaching and learning (Jones & Abes, 2004). For example, teachers, students, and community members become *partners* in the learning process and are freed from many of the hierarchical

structures present in education (Green, 2003). As a result, SL may shatter current educational labels such as *student* and *teacher* by calling into question the roots of knowledge, power, and identity (Swaminathan, 2007). The practice of SL, therefore, encourages practitioners to *work against norms* in education by embracing a captivating, often local, and impactful practice.

SL's promise also appears to have seeped into the philosophical foundation of agricultural education (Roberts & Edwards, 2015). A foundation operationalized by an integrated three-circle model consisting of classroom/laboratory instruction, FFA, and Supervised Agricultural Experience (SAE), i.e., its "philosophical tenet" (Croom, 2008, p. 110). However, Roberts and Edwards (2015) proposed that SL could be the instructional tool SBAE instructors use to provide more impactful experiences manifested "through and between [the] programmatic dimensions" of the model (p. 227). Evidence increasingly demonstrates SBAE may be using SL for this purpose. For example, in 2007 the National FFA Organization adopted a SL initiative to better achieve the FFA motto (Slavkin & Sebastian, 2013). This change introduced service-based programs such as the *Living to Serve* and *Food for All* initiatives so SL would become more visible in FFA (Slavkin & Sebastian, 2013). More recent, the *agricultural service-learning* SAE also gained acceptance as a distinct SAE category (National FFA Organization, 2014). Through these shifts, SL is positioned to become a powerful instructional tool for unifying SBAE students' learning experiences. Arguably, a *victory narrative* for this instructional method has emerged in SBAE. However, SL also has a darker side. Critics argue this method is simply "curricular fluff" that obscures essential elements of the learning process (Kiely, 2005, p. 5). For example, although the goal of SL is to connect learning and service through reflective strategies, too often this is not the case (Clark, 2003; Flower, 1997). Devoid of apparent curricular influences and reflective activities, SL at best becomes an *act of volunteerism* and at worst as a way to meet *service requirements* for graduation (Flower, 1997). Another critique of SL is that students begin to view the individuals served as *others* because they may appear weak or needy – a view which often contradicts the self-constructed identities of many young adults (Clark, 2003). The literature's limited view of SL may also result from variant conceptual and theoretical views. For instance, Giles and Eyster (1994) suggested SL has roots in both Addams' (1910) concept of *noblesse oblige* and Dewey's (1938) theory of learning.

Addams (1910) argued individuals of privilege have a responsibility to help those less privileged – a view subsumed by many contemporary practitioners of SL. Moreover, Dewey (1938) maintained schools should reflect communal life and prepare students to become productive members of a democratic society. Dewey (1938) posited these aims could be achieved by developing impactful learning experiences that allow students to work through relevant societal problems. Therefore, these two theoretical cornerstones seem to influence how teachers, students, and community partners operationalize SL. However, Jones and Abes (2004) contended when SL is conceptualized as a way to help the needy, many students fail to recognize how their own power and privilege shape such experiences. Moreover, too much focus may be placed on producing quality citizens while silencing the roles of curriculum and learning (Henry, 2005). Conversely, when SL is positioned from a purely *experiential* view, emphasis is placed on the learning outcomes of students while ignoring features such as agency, community, and epistemological development (Jones, Gilbride-Brown, & Gasiorski, 2005).

Despite SL's critiques, its discourse in SBAE is written as a story of victory, achievement, and transformation. And, as a result, the institutional, monetary, and human resources dedicated to



improving both learning and communities through SL are significant. For instance, Roberts' and Edwards' (2015) historical investigation of the origins of SL noted the method has been used in SBAE at pivotal moments to address "local problems and help[ed] to rejuvenate a sense of community" (p. 226). Little work, however, has examined this victory narrative's underlying assumptions and implications. Such as *Who has conveyed this story over time? What were the terms? Who benefitted? and What were the consequences?* By peeling back the layers of SL's *historical imaging*, perhaps SBAE can get to the core of its theory and practice.

By using the term *imaging*, we refer to the conceptualizations practitioners and scholars use to explain and depict a phenomenon (Koro-Ljungberg, 2016). Imaging is used to help individuals construct a conceptual understanding of abstract ideas and provides scaffolding for meaning-making. It can also shape how individuals speak of a phenomenon as they move through context-bound environments. As a consequence, imaging can promote a narrow view while ignoring its many complexities. Therefore, imaging may influence how SL is operationalized, categorized, or even silenced in SBAE. A critical analysis of the pictorial and textual imaging of SL was warranted to assist the discipline in recognizing how normative traditions influence practice. This study was positioned to investigate the historical imaging of SL in *The Agricultural Education Magazine (The Magazine)* by examining the "tangled and complex" context in which the imaging was situated (Salevouris & Furay, 2015, p. 43). It is important to note, however, that SL has been "identified by a variety of names" throughout SBAE's history (Roberts & Edwards, 2015, p. 226). Mindful of that inconsistency, we did not disregard data sources if they used the different words to describe the method considering the term *service-learning* was not introduced until 1967 (Marks, 1973). Instead, we included all of *The Magazine's* displays of service-based learning as the historical record for analysis.

### **Purpose, Significance, and Research Question**

This study's purpose was to explore how SL was imaged in *The Magazine* from 1929 to 2009. Specifically, this *working of the past* sought to illuminate how SBAE used depictions of SL to remember. And through this remembering, how the imaging of SL may construct our current understanding of this method while also shaping its future representations. As a consequence, this study may hold valuable implications for research and practice. For example, by understanding the motives underlying the ways in which SL was imaged, perhaps new conceptual and theoretical progress could be made regarding its implications for learning and related outcomes. Findings may also provide valuable insight into existing conceptualizations of SL influencing its practice in SBAE. By critiquing SL's historical depiction, we can begin to question its underlying assumptions and modify behaviors, as needed. The current study also sought to address Research Priority 5 of the American Association for Agricultural Education's National Research Agenda, which calls for evaluation of delivery methods in agricultural education to ensure their effectiveness (Roberts, Harder, & Brashears, 2016). This research question framed the study: *How was SL imaged in The Magazine from 1929 to 2009?*

### **Methodology**

We used historical research methods to guide this investigation. Historical research allows researchers to critique the roles of society and ideology on dominant discourses throughout

history (Salevouris & Furay, 2015). This approach does not discriminate among sources of data; for instance, interviews, historical documents, visual artifacts, and video may be used to reconstruct the historical storyline for a phenomenon or issue (Salevouris & Furay, 2015); in the present study, the imaging of SL. This method also offers a broad framework to critique the socially and historically influenced narratives of individuals, groups, institutions, disciplines, and paradigms (Linde, 2009). In this form of research, it is assumed the historical record is something individuals create and therefore researchers must carefully analyze artifacts from multiple lenses, especially in regard to *continuity*, *change*, and *multiple causalities* (Salevouris & Furay, 2015). Therefore, we placed a particular emphasis on the multiple ways context, society, and philosophical viewpoints may have influenced the imaging of SL.

By following Salevouris' and Furay's (2015) recommendations by which we (a) developed the research question, (b) collected data, (c) analyzed artifacts, and (d) constructed an integrative social critique of the issue. However, their suggestions are not linear in design; instead, we used such as anchor points while interacting with the methodology through a constellation of decisions, quandaries, and discoveries. An in-depth discussion of this process is offered in the procedures section. It is important to note that in the study's early conceptualization, standards for rigor and trustworthiness were built into its design (Lincoln & Guba, 1985). For example, we offered context-rich descriptions while also being explicit about our uncertainties and biases to achieve *credibility* (Lincoln & Guba, 1985). We also kept a thorough audit trail of artifacts and our analytic procedures to promote *confirmability*. In regard to *dependability*, we emphasized the coherence of data sources by only collecting artifacts connected to the study's purpose (Lincoln & Guba, 1985). However, due to the historical nature of this investigation, *transferability* was more difficult to achieve. As such, we were cautious to only engage data sources likely to be deemed *useful* by others interested in SL in the context of SBAE. Overall, Lincoln's and Guba's (1985) recommendations largely shaped how we collected and analyzed the study's data.

## Procedures

In our initial review of *The Magazine*, we noted many authors appeared to depict SL as a *best practice* for both teaching and learning. Through this engagement with the bounded source we formulated an initial research question: *What did SL mean to agricultural education's discourse?* Our working assumption was that SL's imaging evolved over time. Therefore, we began to question *why* artifacts depicted in *The Magazine* were represented in particular ways. After questioning these factors, we reformulated our research question, i.e., *How was SL imaged in The Magazine from 1929 to 2009?* Published articles, photographs, and captions were key sources used to construct the study's analytic storyline. We grounded our use of these artifacts in Enns' and Martins' (2015) justification for using *The Magazine* as a source of data. For example, Enns and Martin (2015) provided three rationales for how *The Magazine* can serve as a quality historical source: (a) the magazine has maintained an open submission process for scholars and teachers from its inception; (b) the source usually features accompanying visuals with its articles; and (c) it has maintained broad readership among agricultural educators. Because of our emphasis on the depiction of SL in SBAE, we worked *within and against* common conceptions of SL by using this bounded source of data over an 81-year period.

Due to the vast number of articles published during the scope of this study, data collection and

analysis was a recursive process over a five-month time span. Therefore, analysis was ongoing as we engaged artifacts in individual issues of *The Magazine*. During this period, we followed Enns’ and Martins’ (2015) procedures in which we bracketed volumes by decade. During this time, we also read through each issue of the magazine, identified artifacts, and constructed analytic memos to capture the general substance and spirit of each source (Saldaña, 2015). In total, we collected 264 artifacts – including articles, photographs, and captions – published in *The Magazine* from 1929 to 2009. Because *The Magazine* was bracketed by decade, we did not pursue artifacts appearing after 2009 to avoid an incomplete period of analysis.

In general, authors and photographs were clearly identified in *The Magazine*; therefore, we could preserve important layers of nuance, detail, and context as the discursive storyline began to thicken. We then conducted two distinct *reads of the data* (Salevouris & Furay, 2015). In our first reading we sought to illuminate the general meaning of each artifact to understand the message communicated. Next, our second reading involved critiquing the social and historical features of power, privilege, and culturally influenced ideology represented by each artifact. To accomplish this, we drew on Holley’s and Colyar’s (2009) concept of *focalization*. Focalization calls for researchers to use “the point of view from which the events unfold or the location from which the actors and characters are viewed” (Holley & Colyar, 2009, p. 681). Using focalization, we began to shift our analytic lens between “internal and external points of view” (Holley & Colyar, 2009, p. 682), which produced codes from a range of different perspectives. Then, to reduce the data, we scrutinized artifacts using thematic analysis (Riessman, 2008). To weave the narrative together, we followed Saldaña’s (2015) recommendation to apply analytic memoing to mobilize empirical assertions and propositions. Ultimately, three empirically saturated themes – cultural, pedagogical, and political – emerged. To situate this imaging, the findings section presents our social critique while illuminating implicit discourses existing in the pages of *The Magazine*. Table 1 outlines the artifacts analyzed by decade and theme.

Table 1  
*Artifacts from The Agricultural Education Magazine (1929 – 2009)*

Year(s)	Volume(s)	Frequency of Artifacts by Theme			
		Cultural	Pedagogical	Political	Subtotal
1929	1	3	0	0	3
1930 – 1939	2 – 10	11	6	0	17
1940 – 1949	11 – 20	35	9	1	45
1950 – 1959	21 – 30	32	15	3	50
1960 – 1969	31 – 40	10	4	5	19
1970 – 1979	41 – 50	19	7	5	31
1980 – 1989	51 – 60	13	20	6	39
1990 – 1999	61 – 70	8	11	4	23
2000 – 2009	71 – 81	5	29	3	37

Year(s)	Volume(s)	Frequency of Artifacts by Theme			
		Cultural	Pedagogical	Political	Subtotal
<b>Total</b>	<b>81</b>	<b>136</b>	<b>101</b>	<b>27</b>	<b>264</b>

### Findings

Through the analysis of data, three distinct lenses of SL emerged: (a) cultural, (b) pedagogical, and (c) political. The lenses illuminate how the agricultural education discipline chose to *portray* SL in *The Magazine*. They do not tell SL's complete story, rather the themes offer an important glimpse into the complexities of its imaging in SBAE over an 81-year period. The findings section, therefore, strives to draw distinctions among the three lenses of SL appearing in *The Magazine*. Each theme is also knit together by a common thread of *motive*, which is woven throughout our *integrative social critique* of the findings (Saleavouris & Furay, 2015).

#### A Cultural Lens

Through culturally imaged depictions, the practice of SL appeared to be focused on shaping young adolescents into productive citizens based on societal demands. As a result, instruction was attuned to foster social sensitivity to promote a cooperative, mutually beneficial society. Through this lens, the motive to employ SL appeared to stem from a desire to create *moral citizens* prepared to address longstanding societal divisions.

Just before the financial crash of Wall Street in 1929, SBAE instructors recognized the need to engage students in their communities (Ekstrom, 1929; Hamlin, 1929; Mobley, 1929). At the time, SBAE instructors emphasized that moral education should saturate all aspects of the curriculum (Ekstrom, 1929; Mobley, 1929). In response, state agricultural education staff in Georgia responded by initiating *community improvement contests* to imbue a spirit of service in students (Hamlin, 1929). This statewide initiative motivated students to use the skills developed through agricultural education to *rethink* their roles as citizens to make a positive difference in communities. Hamlin (1929) summarized the outcomes:

A summary of all the reports made by the schools [showed] . . . that the boys in the contest built 87 poultry houses and 144 hog-houses. . . . boys set out 3,982 shrubs and 4,744 fruit and nut trees. They built and repaired 3,868 terraces; built 1,946 rods of fence; sowed 2,102 acres to legumes; turned under 848 acres of cover crops. Two hundred ninety-three of the boys treated their planting for disease and 918 inoculated legume seed. In 49 homes running water was installed in kitchens; 29 homes were screened, and 25 sanitary toilets were built. (p. 13)

On first glance, Hamlin (1929) appeared to communicate the outcomes of a competition-based, service initiative. However, when questioning the *context* and *terms* surrounding the development of this excerpt, it is important to situate the report in its historical context. The report appeared only 12 years after the United States entered World War I (Urban & Wagoner, 2014). And the war effort had a profound influence on schooling during that period. Teachers and students actively supported the war effort through civic engagement and activities such as the *Student Army Training Corps* (Taft, 1974). As a consequence, a *cultural* expectation was that education should produce loyal citizens prepared to do their part in society. Therefore, Hamlin's

(1929) *motive* to publish could be interpreted as an attempt to document that agricultural educators were *doing their part* to fulfill cultural expectations. This cultural influence continued well into the 1940s, as agricultural education students continued to use their knowledge and skills to contribute to home front efforts supporting the nation's involvement in World War II [WW II] (Cunningham, 1942; James, 1944; LeBeau, 1942; Peeler, 1943; Potter, 1943; Walters, 1945; Woodlin, 1943). Students grew victory gardens and animals, collected milk and eggs, canned fruits and vegetables, recycled and repurposed scrap metal, fundraised to purchase war bonds, established local cooperatives, and used metal and fabrication skills to construct canneries and other buildings dedicated to the war effort (Cunningham, 1942; James, 1944; LeBeau, 1942; Peeler, 1943; Potter, 1943; Walters, 1945; Woodlin, 1943). For instance, SBAE students from North Carolina used their skills to assist at a poultry processing plant as part of the war effort (see Figure 1).



Figure 1. (Left) FFA boys help feed the Army. Reprinted with permission from “Developing a Community War Program” by W. C. James, 1944, *The Agricultural Education Magazine*, 16(7), p. 131. (Right) BOAC activities. Reprinted with permission from “Stories in Pictures” by R. J. Reynolds, 1981, *The Agricultural Education Magazine*, 53(9), p. 24.

Across this theme's storied terrain, expectations for civic engagement appeared to continue to influence SBAE's curriculum well into the next several decades (Bach, 1954; Bachman, 1981; Calhoun, 1957; Cummings, 1957; Daniel, 1986; Edman, 1953; Garrison, 1979; Grey, 1957; Jewell, 1979; Menoher, 1957; Ogles, 1950). This discovery was surprising considering progressive approaches, such as SL, came under attack during the period (Ravitch, 2010). For example, Bestor (1952) issued a damaging blow against progressive educators by declaring their pedagogical techniques were *anti-intellectual* and could even *harm the schooling of children*. Moreover, with the Soviet Union's launch of the *Sputnik* satellite in 1957, progressive educational approaches began to diminish due to the United States' renewed commitment to science and mathematics in public schools (Zimmerman, 2002). The discursive patterns in *The Magazine* painted a much different picture of this era for SBAE, however. In fact, 50 artifacts were mobilized for analysis from this decade (see Table 1). For example, Grey (1957) highlighted SBAE students from Bremond, Texas who created a monument to promote their program while also enhancing the community's appearance. Given *The Magazine's* strong evidence contradicting the dominant discourse of progressive education's decline in this era, it is important to reflect on the philosophical tenets of SBAE. As such, we revisited the artifacts and noted a majority of the activities highlighted had a strong focus on students applying principles of science, technology, engineering, and mathematics (Calhoun, 1957; Cummings, 1957; Grey, 1957; Walters, 1951), or in today's parlance, STEM. Therefore, perhaps SL was used as a way to

uphold the traditions of SBAE programs while also responding to *cultural* shifts calling for more attention to subjects such as mathematics and science. By 1971, however, progressive approaches began to regain momentum in U.S. public education (Urban & Wagoner, 2014).

Influenced by the words *living to serve* appearing in the National FFA Organization's motto, SBAE's *culture* began to evolve with the introduction of a new program, Building our American Communities [BOAC] (Reese, 2003). BOAC offered a broad framework for SBAE instructors to incorporate service-oriented projects into their curriculum (Bachman, 1981; Daniel, 1986; Garrison, 1979; Jewell, 1979; Reynolds, 1981). Projects emerging from BOAC were wide-ranging. For example, *The Magazine* highlighted activities involving students participating in the application of chemical fertilizer for community members, service through turf and grass management efforts, as well as the construction of outdoor classrooms and community parks [see Figure 1] (Bachman, 1981; Daniel, 1986; Garrison, 1979). The influence of BOAC on agricultural education programs should not be understated. The program appeared to influence the culture of SBAE well into the 1990s until it was replaced by new service initiatives such as Food for America and the youth mentoring program, Partners in Active Learning Support (PALS). If the first SL theme is conceptualized through a cultural lens, a range of activities appear to have shaped its imaging in *The Magazine*. However, no single cultural influence could be identified; instead, the motives behind SL's use appeared to have ebbed and flowed with dominant societal and cultural trends. Nevertheless, at this lens's core was the *concept or ideal of producing engaged citizens* (Adams & Clark, 2009; Daniel, 1986; Edman, 1953).

### ***A Pedagogical Lens***

The second theme, *pedagogical*, first emerged in *The Magazine* in the 1940s (Cook, 1947; Deems, 1947; Evans, 1945; Harper, 1949; Naugher, 1946). The motive underlying this conceptualization appeared to be improving the systematic delivery of SL as a method of instruction. Contributors, therefore, clarified how to align service activities with the curricular aims of SBAE to enrich student learning. Similar to the previous theme, SBAE programs across the United States created initiatives calibrated to assist with the nation's WW II efforts. However, many of the efforts were sustained after the war, especially in regard to school canneries and agricultural mechanics programs (Deems, 1947; Evans, 1945; Naugher, 1946). Although the motives for these programs seemed to be culturally influenced, some key actors recognized a need to outline the *learning value* associated with the activities for both students and community members while also offering suggestions for improvement (Clements, 1945; Deems, 1947; Naugher, 1946). Evans (1945) explained how a WW II community cannery initiative led by the Halfway, Oregon program opened her eyes to new methods and techniques.

When our School Community Cannery was first proposed, some of us were 'Doubting Thomases.' We were so used to the old way of canning over a hot stove that we could not accept the new and better way until it had been tried. *Our vision was impaired but now we see the light* [emphasis added]. (Evans, 1945, p. 144)

At the close of the 1940s and beginning of the 1950s, educational reformers began to emphasize a philosophical commitment to *life adjustment curriculum* (Fraser, 2014). The intent of this new curricular emphasis was to enhance the lives of people and improve society through educational training to bolster the personal knowledge and skills of individuals so they could thrive in an

evolving society (Fraser, 2014). Although this educational movement was not broadly implemented throughout American public schooling (Urban & Wagoner, 2014), it appears the philosophy may have influenced aspects of SBAE. For example, in this period, contributors to *The Magazine* emphasized the instructional aspects of SL in the hope of improving its outcomes for students and communities (Edmon, 1953; Roy & Dale, 1960; Scott, 1947; Sutphin, 1979). In this regard, Agan (1954) posed critical questions for agricultural educators to consider when emphasizing citizenship development through students' cooperative, service-based activities. In addition, Urban (1966) stressed the need for instruction *before* students engaged in a "chore service" (p. 152) for local farmers to ensure they experienced impactful learning outcomes. As a result, students were more likely to learn basic skills before implementing such in a service setting. In accord, Sutphin (1979) encouraged agricultural educators to negotiate students' learning objectives with community cooperators to ensure expectations adequately aligned with the local context. Through this increasingly critical view of the method, contributors were stressing the need for *academic rigor* when using SL while also aspiring to improve society.

As SBAE progressed into the 1980s, it faced many new challenges. With publication of the report *A Nation at Risk* also came declining enrollments and the discipline faced increased scrutiny to place more emphasis on academic content and the associated *learning value* of agricultural education courses (McKim, Balschweid, Velez, & Lambert, 2016). Therefore, contributors to *The Magazine* began to feature approaches emphasizing student learning across all three domains of agricultural education's three-circle model, and strategies for improving the delivery of SL appeared to gain popularity during the next several decades. In particular, Lelle (1991), Connors (1992), and Jones and Rayfield (2009) asserted SBAE students could use SL as a way to fulfill their SAE requirements. Moreover, Tarpley (2003) argued SL should be infused into SBAE via FFA chapters' programs of activities (see Figure 2). Other contributors to *The Magazine* (Swan, 2006; Woods, 2002) stressed the need for *reflection* to connect students' learning across SBAE's programmatic dimensions.



*Figure 2.* Service-learning as a component of a FFA chapter's program of activities. Reprinted with permission from "Service-learning for Pre-service Teachers" by R. Tarpley, 2003, *The Agricultural Education Magazine*, 75(5), p. 27.

Although the pedagogical lens did not surface in *The Magazine* until the 1940s, it is presumed to have played an important role in shaping SL's imaging and practice in SBAE. By offering insight into the delivery of SL, the authors provided teachers guidance about effectively using the learning method as they navigated the social and cultural trends influencing their programs.

## A Political Lens

The final theme, a *political* imaging of SL, emerged as a way to embolden the voices of disempowered individuals and marginalized populations in agricultural education (Downey, 1985; Flowers, 1946; Hickson, 1950; Kortesmaki, 1970; Ortiz, 1968; Phillips & Dormody, 1993; Rees & Iverson, 1993; Smith-Wong & Baker, 1994). Through this conceptualization, the motive emanating the use of SL was to enable students to confront issues and problems associated with the imbalances of power in society while also harnessing the resources necessary to enact social change. Although SL is often depicted as a harmonious learning method promoting charitable values, when viewed from a political lens, it can demand *respect*, *reciprocity*, and *agency* for students and community members. This view holds the potential to promote social justice through action while explicitly working to bring about change. Framing SL from a political stance seems to have been depicted first in *The Magazine* during the 1940s. For example, Flowers (1946) highlighted a vocational agriculture teacher from Alamo, Tennessee who was troubled by the poor living conditions of African-Americans in his community. He explained:

This young Negro teacher was sincerely disturbed by the low living standard in which his people were existing, and he resolved to do all in his power to help them improve their conditions. With the help of his supervisors, his plans were drawn, problem by problem, to include the use of county, state, and government agencies. (p. 95; see Figure 3)

As a result, vocational agriculture students were able to assist their community by applying their agricultural mechanics, horticulture, marketing, and communications skills through a community-wide effort aimed at improving the living conditions of African-Americans. During the next several decades, glimpses of politically framed SL were found in *The Magazine*. For instance, contributors depicted SL efforts designed to help African-Americans, homeless youth, the mentally and physically disabled, as well as marginalized populations in developing countries (Byram, 1965; Cicchetti, 1975; Donahoo, 1953; Hickson, 1950; Hopkins, 1982; Kortesmaki, 1970; Ortiz, 1968).

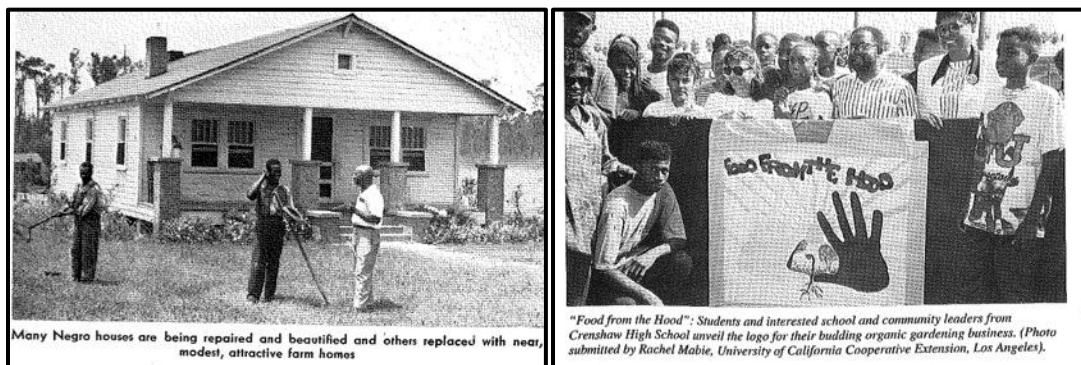

Figure 3. (Left) Politically framed service-learning in 1946. Reprinted with permission from “Negro Project for Rural Housing in Alamo, Tennessee” by W. A. Flowers, 1946, *The Agricultural Education Magazine*, 19(5), p. 95. (Right) Food from the hood. Reprinted with permission from “From Fallow to Fertile: Regenerating Inner City Resources” by K. Smith-Wong and M. Baker, 1994, *The Agricultural Education Magazine*, 66(10), p. 6.



Despite the persistence of racial and social discrimination, SL in SBAE continued to bring attention to these problems, especially in regard to race and poverty. Smith-Wong and Baker (1994) articulated how urban, African-American students in Los Angeles used a service-oriented entrepreneurship program to address local inequities. The program, *Food from the Hood*, facilitated students growing a variety of crops and marketing their produce at farmers' markets in and around Los Angeles (see Figure 3). *Food from the Hood* also provided sustenance for the underprivileged because the students donated a portion of their crop to the homeless. Smith-Wong and Baker (1994) explained: "Under a student mandate, students gave 25% of the produce to the homeless. By the end of the year the group had earned \$1,500. The money was used to help send three student participants to college" (p. 6).

The data demonstrated when SL was examined through the political lens, teachers, students, and community members often questioned or challenged the public's framing of these issues. To accomplish this, many SL projects sought to create a *space* in which students could begin to comprehend the importance of fairness and achieving equality for all citizens (Flowers, 1946; Kortessmaki, 1970; Rees & Iverson, 1993; Smith-Wong & Baker, 1994).

### Conclusions and Implications

Practitioners and scholars have used *The Magazine* as a venue for advancing important *cultural*, *pedagogical*, and *politically* driven messages through the use of SL in SBAE. Many contributors throughout *The Magazine's* history depicted the method as noble, fulfilling, and deeply impactful. As a result, *The Magazine* contributed to SL's *victory narrative* in SBAE by communicating a *promise of transformation* for students, teachers, and communities. Three lenses emerged as SBAE responded to emerging trends in American society. For example, in response to societal issues such as the Great Depression and WW II, SL was depicted as a way students could use their learning to contribute to societal needs (Cunningham, 1942; Ekstrom, 1929; Woodlin, 1943). This lens emphasized the impact of the *service* being provided. Artifacts positioned from the cultural lens perspective often reported the effects students' service had on their local communities (Daniel, 1986; Grey, 1957; Hamlin, 1929). Therefore, this finding supports Roberts' and Edwards' (2015) claim that SL in SBAE "ha[s] been instrumental in solving local problems and helping to rejuvenate a sense of community" (p. 226).

The pedagogical lens seemed to gain prominence in *The Magazine* in response to increased calls for academic rigor and accountability in K-12 education. For instance, in light of the report *A Nation at Risk* and declining enrollment trends, many educators began to discontinue progressive educational approaches to accommodate more curricular room for science and mathematics (Fraser, 2014; McKim et al., 2016; Urban & Wagoner, 2014). However, *instead of rejecting SL*, contributors to *The Magazine* appeared to demonstrate that *space* existed for learning *and* service in the context of local communities (Connors, 1992; Fear, 1987; Lelle, 1991; Nelson, 1994; Pearson, 1984). Articles viewed through the pedagogical lens focused on *best practices* involving the method to improve student learning (Jones & Rayfield, 2009; Nelson, 1994; Swan, 2006). As a result, SL was imaged as a way students could develop through classroom instruction, SAE projects, and FFA activities by more firmly connecting their learning to service opportunities in local communities (Connors, 1992).

Based on the data analyzed, the political lens appeared to emerge as tensions associated with the

*civil rights movement* began to pervade U.S. society. It spoke to the importance associated with helping students understand the social impacts of *inequality, racism, and privilege* (Byram, 1965; Donahoo, 1953; Hopkins, 1982; Kortesmaki, 1970). Therefore, politically positioned SL was a method of instruction that reframed relations of power while also questioning the status quo. For example, imaging of marginalized students in *The Magazine* was often framed from a perspective of endorsing tolerance of different cultures, bringing attention to those students' struggles, or calling for change by championing for improved resources (Downey, 1985; Flowers, 1946; Kortesmaki, 1970; Smith-Wong & Baker, 1994).

## Recommendations and Discussion

By questioning the imaging of SL in *The Magazine*, possibilities for future practice and *research* become clearer. First, we must more deeply understand the outcomes and consequences associated with *doing* SL. This study highlighted three distinct ways SL was imaged. However, more research is needed to understand the micro-politics, attitudes, and practices of teachers, students, and community members as they engage in SL. For example, how can the framing of SL endeavors influence aspects of *voice, assessment, and learning* in SBAE? Moreover, how are teachers', students', and stakeholders' views on social norms, such as diversity and inclusion, shaped by SL experiences when examined through the different lenses?

From our analysis of the data, SL's discourse formed a rich narrative. More effort, however, is needed to understand how this discourse *works as a storyline* in agricultural education. For example, how does SL's imaging shape the ways practitioners *talk, conceptualize, and practice* the method today? Future research should also explore the consequences of positioning SL endeavors through one lens instead of another. To this point, if a teacher champions SL as a way to promote *citizenship*, the carried assumptions and implications will likely differ from a SL activity with *academic learning* as its primary aim. We recommend professional development opportunities be created to assist practitioners with understanding how the unique framing of SL may *support and limit* its outcomes. In practice, SL can be difficult and time-consuming to implement (Banerjee & Hausafus, 2007; Kaye, 2010). It takes considerable resources and planning before students *may* begin to have impactful SL experiences. Therefore, by examining educators' motives perhaps their use of SL can be augmented to increase the likelihood of achieving the learning objectives. That warrants additional research questions: Are the motives purely outcome driven? Are they culturally or politically charged? Are they recognition based? Could instructors' decisions to use SL as a method of instruction be rooted in deeper ontological and epistemological beliefs? And, do practitioners perceive the resources dedicated to SL activities are worth the cost? By exploring these questions, perhaps teachers' capacities for delivering more impactful, engaging, and high-gain SL experiences can be improved.

By examining how SL has been imaged in *The Magazine*, we now understand better *where we have been* and can begin to advance more theoretical and conceptual discussions. Because *motives* appear to influence SL's imaging, we argue more attention should be placed on the role *social processes* play in shaping SL's practice and resulting outcomes. By more deeply understanding the "production and reproduction of relationships between people and things, and people and practice" (Sheehy & Leander, 2004, p. 95), we theorize new, thought-provoking possibilities may exist. For example, perhaps SL could be *reframed* to serve as a more powerful

complement to SBAE. Recent literature suggests agricultural education has taken a *critical turn* by questioning the influence of gender, race, power, and ideology (Enns & Martin, 2015; Kelsey, 2007; Martin & Kitchel, 2013, 2015). These investigations have led to increased calls for exploring inclusive approaches that may create a more equitable and inviting socio-cultural climate in SBAE. Perhaps SL could serve as a mechanism for facilitating such change.

## References

- Adams, C., & Clark, J. (2009). The big picture. *The Agricultural Education Magazine*, 81(5), 5-8. Retrieved from [http://www.naae.org/profdevelopment/magazine/archive\\_issues/Volume81/2009\\_03-04.pdf](http://www.naae.org/profdevelopment/magazine/archive_issues/Volume81/2009_03-04.pdf)
- Addams, J. (1910). *Twenty years at Hull-House*. New York, NY: Macmillan.
- Agan, R. J. (1954). Preparing for citizenship through cooperative activities. *The Agricultural Education Magazine*, 27(2), 28. Retrieved from [http://www.naae.org/profdevelopment/magazine/archive\\_issues/Volume27/v27i2.pdf](http://www.naae.org/profdevelopment/magazine/archive_issues/Volume27/v27i2.pdf)
- Bach, I. E. (1954). Vo-ag provides experience in citizenship. *The Agricultural Education Magazine*, 27(2), 32. Retrieved from [http://www.naae.org/profdevelopment/magazine/archive\\_issues/Volume27/v27i2.pdf](http://www.naae.org/profdevelopment/magazine/archive_issues/Volume27/v27i2.pdf)
- Bachman, K. C. (1981). BOAC programs at work. *The Agricultural Education Magazine*, 53(11), 23. Retrieved from [http://www.naae.org/profdevelopment/magazine/archive\\_issues/Volume53/v53i11.pdf](http://www.naae.org/profdevelopment/magazine/archive_issues/Volume53/v53i11.pdf)
- Banerjee, M., & Hausafus, C. O. (2007). Faculty use of service-learning: Perceptions, motivations, and impediments for the human sciences. *Michigan Journal of Community Service Learning*, 14(1), 32-45. Retrieved from <http://hdl.handle.net/2027/spo.3239521.0014.103>
- Bestor, A. E. (1952). Life-adjustment education: A critique. *Bulletin of the American Association of University Professors (1915-1955)*, 38(3), 413-441. doi:10.2307/40220906
- Billig, S., & Welch, M. (2004). *New perspectives in service-learning: Research to advance the field*. Greenwich, CT: Information Age Publishing.
- Butin, D. W. (2007). Justice-learning: Service-learning as justice-oriented education. *Equity and Excellence in Education*, 40(2), 177-183. doi:10.1080/10665680701246492

- Butin, D. W. (2015). Dreaming of justice: Critical service-learning and the need to wake up. *Theory to Practice*, 54(1), 5-10. doi:10.1080/00405841.2015.977646
- Byram, H. M. (1965). Agricultural education in Central America and Panama. *The Agricultural Education Magazine*, 37(11), 276. Retrieved from [http://www.naae.org/profdevelopment/magazine/archive\\_issues/Volume37/v37i11.pdf](http://www.naae.org/profdevelopment/magazine/archive_issues/Volume37/v37i11.pdf)
- Calhoun, C. (1957). School and community activities a part of an effective program. *The Agricultural Education Magazine*, 30(6), 137. Retrieved from [http://www.naae.org/profdevelopment/magazine/archive\\_issues/Volume30/v30i6.pdf](http://www.naae.org/profdevelopment/magazine/archive_issues/Volume30/v30i6.pdf)
- Campus Compact. (2016). Presidents' declaration on the civic responsibility of higher education. Author. Retrieved from <http://www.compact.org/presidential/declaration.html>
- Cicchetti, R. (1975). Working with the handicapped. *The Agricultural Education Magazine*, 47(11), 247. Retrieved from [http://www.naae.org/profdevelopment/magazine/archive\\_issues/Volume47/v47i11.pdf](http://www.naae.org/profdevelopment/magazine/archive_issues/Volume47/v47i11.pdf)
- Clark, C. (2003). Unfolding narratives of service learning: Reflections on teaching, literacy, and positioning in service relationships. *Journal of Adolescent and Adult Literacy*, 46(4), 288–297. Retrieved from <http://www.jstor.org/stable/40013587>
- Clayton, P. H., Bringle, R. G., Senor, B., Huq, J., & Morrison, M. (2010). Differentiating and assessing relationships in service-learning and civic engagement: Exploitative, transactional, or transformational. *Michigan Journal of Community Service Learning*, 16(2), 5-22. Retrieved from <http://hdl.handle.net/2027/spo.3239521.0016.201>
- Clements, D. M. (1945). Responsibility of vocational education in the postwar world. *The Agricultural Education Magazine*, 17(8), 145. Retrieved from [http://www.naae.org/profdevelopment/magazine/archive\\_issues/Volume17/v17i8.pdf](http://www.naae.org/profdevelopment/magazine/archive_issues/Volume17/v17i8.pdf)
- Connors, J. (1992) Volunteerism as SAE. *The Agricultural Education Magazine*, 65(6), 18-19. Retrieved from [http://www.naae.org/profdevelopment/magazine/archive\\_issues/Volume65/v65i6.pdf](http://www.naae.org/profdevelopment/magazine/archive_issues/Volume65/v65i6.pdf)
- Cook, G. C. (1947). Evaluating outcomes of instruction in school community canneries. *The Agricultural Education Magazine*, 20(4), 70-71. Retrieved from [http://www.naae.org/profdevelopment/magazine/archive\\_issues/Volume20/v20i4.pdf](http://www.naae.org/profdevelopment/magazine/archive_issues/Volume20/v20i4.pdf)
- Croom, D. B. (2008). Development of the integrated three-component model of agricultural education. *Journal of Agricultural Education*, 49(1), 110. doi:10.5032/jae.2008.01110
- Cummings, J. C. (1957). Community service activities. *The Agricultural Education Magazine*, 30(6), 130-131. Retrieved from [http://www.naae.org/profdevelopment/magazine/archive\\_issues/Volume30/v30i6.pdf](http://www.naae.org/profdevelopment/magazine/archive_issues/Volume30/v30i6.pdf)
- Cunningham, R. L. (1942) Future farmers and the war effort. *The Agricultural Education*

- Magazine*, 15(5), 97. Retrieved from  
[http://www.naae.org/profdevelopment/magazine/archive\\_issues/Volume15/v15i5.pdf](http://www.naae.org/profdevelopment/magazine/archive_issues/Volume15/v15i5.pdf)
- Donahoo, A. W. (1953). Point four aids Bolivian Andean rural community. *The Agricultural Education Magazine*, 26(6), 132-133. Retrieved from  
[http://www.naae.org/profdevelopment/magazine/archive\\_issues/Volume26/v26i6.pdf](http://www.naae.org/profdevelopment/magazine/archive_issues/Volume26/v26i6.pdf)
- Daniel, D. (1986). Stories in pictures. *The Agricultural Education Magazine*, 59(2), 24. Retrieved from  
[http://www.naae.org/profdevelopment/magazine/archive\\_issues/Volume59/v59i2.pdf](http://www.naae.org/profdevelopment/magazine/archive_issues/Volume59/v59i2.pdf)
- Deems, H. W. (1947). Give the improvement project more time and attention. *The Agricultural Education Magazine*, 20(4), 74. Retrieved from  
[http://www.naae.org/profdevelopment/magazine/archive\\_issues/Volume20/v20i4.pdf](http://www.naae.org/profdevelopment/magazine/archive_issues/Volume20/v20i4.pdf)
- Dewey, J. (1938). *Experience and education*. New York, NY: Collier Books.
- Downey, R. S. (1985). Teaching the disadvantaged and the handicapped. *The Agricultural Education Magazine*, 57(8), 5-7. Retrieved from  
[http://www.naae.org/profdevelopment/magazine/archive\\_issues/Volume57/v57i8.pdf](http://www.naae.org/profdevelopment/magazine/archive_issues/Volume57/v57i8.pdf)
- Edmon, V. (1953). Community service through FFA. *The Agricultural Education Magazine*, 26(2), 43. Retrieved from  
[http://www.naae.org/profdevelopment/magazine/archive\\_issues/Volume26/v26i2.pdf](http://www.naae.org/profdevelopment/magazine/archive_issues/Volume26/v26i2.pdf)
- Ekstrom, G. F. (1929). Teaching cooperation thru cooperation. *The Agricultural Education Magazine*, 1(5), 6. Retrieved from  
[http://www.naae.org/profdevelopment/magazine/archive\\_issues/Volume1/v1i5.pdf](http://www.naae.org/profdevelopment/magazine/archive_issues/Volume1/v1i5.pdf)
- Enns, K. J., & Martin, M. J. (2015). Gendering agricultural education: A study of historical pictures of women in the agricultural education magazine. *Journal of Agricultural Education*, 56(3), 69-89. doi:10.5032/jae.2015.03069
- Evans, W. W. (1945). How the school serves our community. *The Agricultural Education Magazine*, 17(8), 144. Retrieved from  
[http://www.naae.org/profdevelopment/magazine/archive\\_issues/Volume17/v17i8.pdf](http://www.naae.org/profdevelopment/magazine/archive_issues/Volume17/v17i8.pdf)
- Fear, R. (1987). Student activities through community involvement. *The Agricultural Education Magazine*, 60(5), 8. Retrieved from  
[http://www.naae.org/profdevelopment/magazine/archive\\_issues/Volume60/v60i5.pdf](http://www.naae.org/profdevelopment/magazine/archive_issues/Volume60/v60i5.pdf)
- Flower, L. (1997). Partners in inquiry: A logic for community outreach. In L. Adler-Kassner, R. Crooks, & A. Watters (Eds.), *Writing the community: Concepts and models for service-learning in composition* (pp. 95–118). Sterling, VA: Stylus Publishing.
- Flowers, W. A. (1946). Negro project for rural housing in Alamo, Tennessee. *The Agricultural Education Magazine*, 19(5), 95. Retrieved from

- [http://www.naae.org/profdevelopment/magazine/archive\\_issues/Volume19/v19i5.pdf](http://www.naae.org/profdevelopment/magazine/archive_issues/Volume19/v19i5.pdf)
- Fraser, J. W. (2014). *The school in the United States: A documentary history* (3rd ed.). New York, NY: Routledge.
- Garrison, J. M. (1979). Community service spraying. *The Agricultural Education Magazine*, 52(6), 137. Retrieved from [http://www.naae.org/profdevelopment/magazine/archive\\_issues/Volume52/v52i6.pdf](http://www.naae.org/profdevelopment/magazine/archive_issues/Volume52/v52i6.pdf)
- Gilbride-Brown, J. K. (2008). (E)racing service-learning as critical pedagogy: Race matters (Doctoral dissertation). Retrieved from [http://rave.ohiolink.edu/etdc/view?acc\\_num=osu1226014242](http://rave.ohiolink.edu/etdc/view?acc_num=osu1226014242)
- Giles, D. E., & Eyler, J. (1994). The theoretical roots of service-learning in John Dewey: Toward a theory of service-learning. *Michigan Journal of Community Service Learning*, 1(1), 77-85. Retrieved from <http://hdl.handle.net/2027/spo.3239521.0001.109>
- Green, A. E. (2003). Difficult stories: Service-learning, race, class, and whiteness. *College Composition and Communication*, 55(2), 276-301. doi:10.2307/3594218
- Grey, J. D. (1957). Stories in pictures. *The Agricultural Education Magazine*, 30(2), 48. Retrieved from [http://www.naae.org/profdevelopment/magazine/archive\\_issues/Volume30/v30i2.pdf](http://www.naae.org/profdevelopment/magazine/archive_issues/Volume30/v30i2.pdf)
- Hamlin, L. (1929). Georgia community improvement contest closes. *The Agricultural Education Magazine*, 1(7), 13. Retrieved from [http://www.naae.org/profdevelopment/magazine/archive\\_issues/Volume1/v1i7.pdf](http://www.naae.org/profdevelopment/magazine/archive_issues/Volume1/v1i7.pdf)
- Harper, J. (1949). Community service and farming programs. *The Agricultural Education Magazine*, 22(4), 88. Retrieved from [http://www.naae.org/profdevelopment/magazine/archive\\_issues/Volume22/v22i4.pdf](http://www.naae.org/profdevelopment/magazine/archive_issues/Volume22/v22i4.pdf)
- Henry, S. E. (2005). "I can never turn my back on that:" Liminality and the impact of class on service-learning experience. In D. W. Butin's (Ed.), *Service-learning in higher education* (pp. 3-24). New York, NY: Palgrave Macmillan.
- Hickson, W. F. (1950). A year round food supply is one of the needs of farm families. *The Agricultural Education Magazine*, 23(2), 36. Retrieved from [http://www.naae.org/profdevelopment/magazine/archive\\_issues/Volume23/v23i2.pdf](http://www.naae.org/profdevelopment/magazine/archive_issues/Volume23/v23i2.pdf)
- Holley, K. A., & Colyar, J. (2009). Rethinking texts: Narrative and the construction of qualitative research. *Educational Researcher*, 38(1), 680-686. doi:10.3102/0013189X09351979
- Hopkins, J. (1982). Teaching horticulture to handicapped students in urban areas. *The Agricultural Education Magazine*, 55(1), 8-9. Retrieved from [http://www.naae.org/profdevelopment/magazine/archive\\_issues/Volume55/v55i1.pdf](http://www.naae.org/profdevelopment/magazine/archive_issues/Volume55/v55i1.pdf)

- James, W. C. (1944). Developing a community war program. *The Agricultural Education Magazine*, 16(7), 131. Retrieved from [http://www.naae.org/profdevelopment/magazine/archive\\_issues/Volume16/v16i7.pdf](http://www.naae.org/profdevelopment/magazine/archive_issues/Volume16/v16i7.pdf)
- Jewell, L. R. (1979). Effective teaching – community oriented. *The Agricultural Education Magazine*, 52(3), 56-57. Retrieved from [http://www.naae.org/profdevelopment/magazine/archive\\_issues/Volume52/v52i3.pdf](http://www.naae.org/profdevelopment/magazine/archive_issues/Volume52/v52i3.pdf)
- Jones, D., & Rayfield, J. (2009). Agricultural service-learning as an SAE: A model for community development. *The Agricultural Education Magazine*, 81(5), 9-10. Retrieved from [http://www.naae.org/profdevelopment/magazine/archive\\_issues/Volume81/2009\\_03\\_04.pdf](http://www.naae.org/profdevelopment/magazine/archive_issues/Volume81/2009_03_04.pdf)
- Jones, S., Gilbride-Brown, J., & Gasiorski, A. (2005). Getting inside the “underside” of service-learning: Student resistance and possibilities. In D. W. Butin’s (Ed.), *Service-learning in higher education* (pp. 3-24). New York, NY: Palgrave Macmillan.
- Jones, S. R., & Abes, E. S. (2004). Enduring influences of service-learning on college students’ identity development. *Journal of College Student Development*, 45(2), 149-166. doi: 10.1353/csd.2004.0023
- Kaye, C. B. (2010). *The complete guide to service learning: Proven, practical ways to engage students in civic responsibility, academic curriculum, & social action* (2nd ed.). New York, NY: Free Spirit Publishing.
- Kelsey, K. D. (2007). Overcoming gender bias with self-efficacy: A case study of women agricultural education and pre-service teachers. *Journal of Agricultural Education*, 48(1), 52-63. doi:10.5032/jae.2007.01052
- Kiely, R. (2005). A transformative learning model for service-learning: A longitudinal case study. *Michigan Journal of Community Service Learning*, 12(1), 5-22. Retrieved from <http://hdl.handle.net/2027/spo.3239521.0012.101>
- Koro-Ljungberg, M. (2016). *Reconceptualizing qualitative research: Methodologies without methodology*. Thousand Oaks, CA: Sage.
- Kortesmaki, W. J. (1970). Stories in pictures. *The Agricultural Education Magazine*, 42(8), 212. Retrieved from [http://www.naae.org/profdevelopment/magazine/archive\\_issues/Volume42/v42i8.pdf](http://www.naae.org/profdevelopment/magazine/archive_issues/Volume42/v42i8.pdf)
- LeBeau, O. R. (1942). How teachers of vocational agriculture can contribute to the war and post-war planning. *The Agricultural Education Magazine*, 14(11), 204-205. Retrieved from [http://www.naae.org/profdevelopment/magazine/archive\\_issues/Volume14/v14i11.pdf](http://www.naae.org/profdevelopment/magazine/archive_issues/Volume14/v14i11.pdf)
- Lelle, M. A. (1991). Expanding the mission: Supervised experience in community development. *The Agricultural Education Magazine*, 63(11), 12. Retrieved from

[http://www.naae.org/profdevelopment/magazine/archive\\_issues/Volume63/Vol63\\_No11.PDF](http://www.naae.org/profdevelopment/magazine/archive_issues/Volume63/Vol63_No11.PDF)

- Lincoln, Y. S., & Guba, E. G. (1985). *Naturalistic inquiry*. Newbury Park, CA: Sage Publications.
- Linde, C. (2009). *Working the past: Narrative and institutional memory*. Oxford, England: Oxford University Press.
- Marks, J. L. (1973). *1973 Southern Regional Education Board fact book*. Atlanta, GA: Southern Regional Education Board Press.
- Martin, M. J., & Kitchel, T. (2013). Agrarianism: An ideology of the National FFA Organization. *Journal of Agricultural Education*, 54(3), 28-40. doi:10.5032/jae.2013.03028
- Martin, M. J., & Kitchel, T. (2015). Critical theory view of the National FFA Convention. *Journal of Agricultural Education*, 56(2), 122-127. doi:10.5032/jae.2015.02122
- McKim, A. J., Balschweid, M. A., Velez, J. J., & Lambert, M. D. (2016). Agricultural education: A philosophical review of science and society. (*American Association for Agricultural Education [AAAE] 43rd Annual Conference, May 17 – 20, Kansas City, MO, USA.*)
- Menoher, O. (1957). Stimulate interest in vocational agriculture by taking part in community activities. *The Agricultural Education Magazine*, 30(6), 135-136. Retrieved from [http://www.naae.org/profdevelopment/magazine/archive\\_issues/Volume30/v30i6.pdf](http://www.naae.org/profdevelopment/magazine/archive_issues/Volume30/v30i6.pdf)
- Mobley, M. D. (1929). A community cotton project. *The Agricultural Education Magazine*, 1(5), 8. Retrieved from [http://www.naae.org/profdevelopment/magazine/archive\\_issues/Volume1/v1i5.pdf](http://www.naae.org/profdevelopment/magazine/archive_issues/Volume1/v1i5.pdf)
- National FFA Organization. (2014). Three circle service (FFA officer 2 officer series). Indianapolis, IN: National FFA Organization. Retrieved from <http://www.youtube.com/watch?v=50NLLofrQFQ>
- Naugher, R. E. (1946). Improving the program of instruction in school-community canneries. *The Agricultural Education Magazine*, 18(8), 148-149. Retrieved from [http://www.naae.org/profdevelopment/magazine/archive\\_issues/Volume18/v18i8.pdf](http://www.naae.org/profdevelopment/magazine/archive_issues/Volume18/v18i8.pdf)
- Nelson, C. L. (1994). Responsible environmental teaching in a threatened community. *The Agricultural Education Magazine*, 67(6), 7-8. Retrieved from [http://www.naae.org/profdevelopment/magazine/archive\\_issues/Volume67/v67i6.pdf](http://www.naae.org/profdevelopment/magazine/archive_issues/Volume67/v67i6.pdf)
- Ogles, O. M. (1950). Mobilizing the community in a conservation program. *The Agricultural Education Magazine*, 23(2), 29. Retrieved from [http://www.naae.org/profdevelopment/magazine/archive\\_issues/Volume23/v23i2.pdf](http://www.naae.org/profdevelopment/magazine/archive_issues/Volume23/v23i2.pdf)



- Ortiz, E. (1968). Greenhouse and nursery program for the mentally retarded. *The Agricultural Education Magazine*, 41(3), 71. Retrieved from [http://www.naae.org/profdevelopment/magazine/archive\\_issues/Volume41/v41i3.pdf](http://www.naae.org/profdevelopment/magazine/archive_issues/Volume41/v41i3.pdf)
- Pearson, C. (1984). Laboratory SOEP: What are the options? *The Agricultural Education Magazine*, 56(10), 5-7. Retrieved from [http://www.naae.org/profdevelopment/magazine/archive\\_issues/Volume56/v56i10.pdf](http://www.naae.org/profdevelopment/magazine/archive_issues/Volume56/v56i10.pdf)
- Peeler, R. J. (1943). North Carolina FFA gets results. *The Agricultural Education Magazine*, 16(6), 115. Retrieved from [http://www.naae.org/profdevelopment/magazine/archive\\_issues/Volume16/v16i6.pdf](http://www.naae.org/profdevelopment/magazine/archive_issues/Volume16/v16i6.pdf)
- Phillips, L., & Dormody, T. (1993). Agricultural education for the mentally handicapped. *The Agricultural Education Magazine*, 65(9), 14-15. Retrieved from [http://www.naae.org/profdevelopment/magazine/archive\\_issues/Volume65/v65i9.pdf](http://www.naae.org/profdevelopment/magazine/archive_issues/Volume65/v65i9.pdf)
- Potter, H. C. (1943). Methods of correlating wartime instruction with farm labor needs. *The Agricultural Education Magazine*, 16(2), 26. Retrieved from [http://www.naae.org/profdevelopment/magazine/archive\\_issues/Volume16/v16i2.pdf](http://www.naae.org/profdevelopment/magazine/archive_issues/Volume16/v16i2.pdf)
- Ravitch, D. (2010). *The death and life of the great American school system: How test and choice are undermining education*. New York City, NY: Basic Books.
- Rees, F., & Iverson, M. (1993). Horticulture therapy. *The Agricultural Education Magazine*, 65(9), 10-11. Retrieved from [http://www.naae.org/profdevelopment/magazine/archive\\_issues/Volume65/v65i9.pdf](http://www.naae.org/profdevelopment/magazine/archive_issues/Volume65/v65i9.pdf)
- Reese, S. (2003). Career and technical student organizations: Building our future. *Techniques: Connecting Education and Careers*, 78(2), 18-23. Retrieved from <http://eric.ed.gov/?id=EJ660456>
- Reynolds, R. J. (1981). Stories in pictures. *The Agricultural Education Magazine*, 53(9), 24. Retrieved from [http://www.naae.org/profdevelopment/magazine/archive\\_issues/Volume53/v53i9.pdf](http://www.naae.org/profdevelopment/magazine/archive_issues/Volume53/v53i9.pdf)
- Riessman, C. K. (2008). *Narrative methods for the human sciences*. Thousand Oaks, CA: Sage.
- Roberts, R., & Edwards, M. C. (2015). Service-learning's ongoing journey as a method of instruction: Implications for school-based agricultural education. *Journal of Agricultural Education*, 56(2), 217-233. doi:10.5032/jae.2015.02217
- Roberts, T. G., Harder, A., & Brashears, M. T. (Eds.). (2016). *American Association for Agricultural Education national research agenda: 2016-2020*. Gainesville, FL: Department of Agricultural Education and Communication, University of Florida.

- Roy, P., & Dale, S. (1960). Vo-ag leadership in community development. *The Agricultural Education Magazine*, 33(4), 94-95. Retrieved from [http://www.naae.org/profdevelopment/magazine/archive\\_issues/Volume33/v33i4.pdf](http://www.naae.org/profdevelopment/magazine/archive_issues/Volume33/v33i4.pdf)
- Saldaña, J. (2015). *Thinking qualitatively: Methods of mind*. Thousand Oaks, CA: Sage.
- Salevouris, M. J., & Furay, C. (2015). *The methods and skills of history: A practical guide* (4th ed.). Malden, MA: John Wiley and Sons, Inc.
- Scott, M. J. (1947). Community study serves as basis for improved program. *The Agricultural Education Magazine*, 19(8), 145. Retrieved from [http://www.naae.org/profdevelopment/magazine/archive\\_issues/Volume19/v19i8.pdf](http://www.naae.org/profdevelopment/magazine/archive_issues/Volume19/v19i8.pdf)
- Sheehy, M., & Leander, K. M. (2004). Introduction. In K. M. Leander & M. Sheehy (Eds.) *Spatializing literacy research and practice* (pp. 1–13). New York, NY: Peter Lang.
- Slavkin, M., & Sebastian, S. (2013, September/October). Living to serve: National FFA Organization and service-learning. *The Agricultural Education Magazine*, 86(2), 14-17. Retrieved from [http://www.naae.org/profdevelopment/magazine/archive\\_issues/Volume86/2013\\_09-10.pdf](http://www.naae.org/profdevelopment/magazine/archive_issues/Volume86/2013_09-10.pdf)
- Smith-Wong, K., & Baker, M. (1994). From fallow to fertile: Regenerating inner city resources. *The Agricultural Education Magazine*, 66(10), 5-7. Retrieved from [http://www.naae.org/profdevelopment/magazine/archive\\_issues/Volume66/v66i10.pdf](http://www.naae.org/profdevelopment/magazine/archive_issues/Volume66/v66i10.pdf)
- Sutphin, D. (1979). Community involvement and the instructional program. *The Agricultural Education Magazine*, 52(4), 80-81. Retrieved from [http://www.naae.org/profdevelopment/magazine/archive\\_issues/Volume52/v52i4.pdf](http://www.naae.org/profdevelopment/magazine/archive_issues/Volume52/v52i4.pdf)
- Swaminathan, R. (2007). Educating for the real world: The hidden curriculum of community service-learning. *Equity and Excellence in Education*, 40(2), 134-143. doi:10.1080/10665680701246450
- Swan, B. G. (2006). Motivating students through service-learning. *The Agricultural Education Magazine*, 78(4), 23-24. Retrieved from [http://www.naae.org/profdevelopment/magazine/archive\\_issues/Volume78/v78i4.pdf](http://www.naae.org/profdevelopment/magazine/archive_issues/Volume78/v78i4.pdf)
- Taft, P. (1974). *United they teach: The story of the united federation of teachers*. Washington, DC: Nash Publications.
- Tarpley, R. S. (2003). Service-learning for preservice agriculture teachers, *The Agricultural Education Magazine*, 75(5), 26-27. Retrieved from [http://www.naae.org/profdevelopment/magazine/archive\\_issues/Volume75/v75i5.pdf](http://www.naae.org/profdevelopment/magazine/archive_issues/Volume75/v75i5.pdf)
- Urban, W. J. (1966). Work experience for boys – service for farmers. *The Agricultural Education Magazine*, 38(7), 152-153. Retrieved from

- [http://www.naae.org/profdevelopment/magazine/archive\\_issues/Volume38/v38i7.pdf](http://www.naae.org/profdevelopment/magazine/archive_issues/Volume38/v38i7.pdf)
- Urban, W. J., & Wagoner, J. L. (2014). *American education: A history* (5th ed.). New York, NY: Routledge.
- Walters, T. G. (1945). Community food processing in Georgia. *The Agricultural Education Magazine*, 17(7), 130. Retrieved from [http://www.naae.org/profdevelopment/magazine/archive\\_issues/Volume17/v17i7.pdf](http://www.naae.org/profdevelopment/magazine/archive_issues/Volume17/v17i7.pdf)
- Walters, T. G. (1951). Community canning centers. *The Agricultural Education Magazine*, 23(11), 251. Retrieved from [http://www.naae.org/profdevelopment/magazine/archive\\_issues/Volume23/v23i11.pdf](http://www.naae.org/profdevelopment/magazine/archive_issues/Volume23/v23i11.pdf)
- Woodlin, R. J. (1943). FFA chapter grows poultry and buys bonds. *The Agricultural Education Magazine*, 15(10), 198. Retrieved from [http://www.naae.org/profdevelopment/magazine/archive\\_issues/Volume15/v15i10.pdf](http://www.naae.org/profdevelopment/magazine/archive_issues/Volume15/v15i10.pdf)
- Woods, M. (2002). Research on service learning. *The Agricultural Education Magazine*, 75(2), 24-25. Retrieved from [http://www.naae.org/profdevelopment/magazine/archive\\_issues/Volume75/v75i2.pdf](http://www.naae.org/profdevelopment/magazine/archive_issues/Volume75/v75i2.pdf)
- Zimmerman, J. (2002). *Whose America? Culture wars in the public schools*. Cambridge, MA: Harvard University Press.

## **Evidence for Recruitment Appeals to Students of Color in the National Teach Ag Campaign: An Exploratory Media Content Analysis**

Sarah E. LaRose, University of Florida  
Lisa K. Lundy, University of Florida

### **Abstract**

Using framing theory as a guide, this study aims to describe the observed trends found in annual reports of the National Teach Ag Campaign through a qualitative content analysis for evidence of recruitment appeals targeting students of color to pursue a career in agricultural education. Using the constant comparative method, the researchers describe depictions of themes found in the annual reports of the National Teach Ag Campaign which demonstrate appeals to students of color as outlined by the Vincent et al. (2012) conceptual model for recruiting students of color into agricultural education, as well as the presence of underrepresented populations as depicted by annual reports of the National Teach Ag Campaign. The results of the data analysis can be broadly categorized into three major categories: (1) Formatting changes, (2) Visual representation of people of color, and (3) Evidence of appeals to inducements and influences proposed by Vincent et al. (2012).

### **Introduction**

Agricultural education is a profession that faces many challenges, but it has chiefly faced a continual shortage of qualified teachers prepared to run agricultural education programs across the country. This is not a new problem, with there being a reported teacher shortage since almost the inception of formalized, government-funded school-based agricultural education nearly 100 years ago (Camp, Broyles, & Skelton, 2000). Various studies have been performed over the years to identify factors that influence student choice to enter the profession of agricultural education (Calvin & Pense, 2013; Lawver & Torres, 2011; Hillison & Hagee, 1982; Juergenson, 1964) in the hopes of identifying best practices and boosting the supply of agricultural education instructors nationwide. Various recruitment methods have been used to promote the profession to prospective agriculture teachers, and most recently, the National Association of Agricultural Educators (NAAE) established the National Teach Ag Campaign in 2009 to specifically address the shortage of prospective educators entering the profession. The present study aims to describe the observed trends found in annual reports of the National Teach Ag Campaign related to appeals to students of color through a qualitative content analysis using framing theory to guide the study.

Initially, agricultural education was delivered to rural, White, male students, but eventually expanded to be offered to Black male students, followed by female students and students of all ethnicities. The teaching workforce over the years has also been predominantly White males, but has shifted to include more female teachers recently. In the 2011-2012 school year, about 82% of all public school teachers were non-Hispanic White, 7% were non-Hispanic Black, and 8% were Hispanic (Goldring, Gray, & Bitterman, 2013). This contrasts greatly with the 2012 student enrollment demographic percentages at 51% White, 24% Hispanic, and 16% Black,

demonstrating a gap between the cultural background or diversity of teachers and the students enrolled in their classes. The agricultural education profession also mirrors the disproportionate demographics of teachers, with the 2010 National Supply and Demand Study finding that approximately 68% of all reporting teachers as White, non-Hispanic, 28% unknown ethnicity, 1.5% African American, and 1.2% Hispanic (Kantrovich, 2010). Of the 742 license-eligible agriculture education program completers in 2015, 92% reported as White, non-Hispanic, 5% as Hispanic/Latino, 2% American Indian/Alaskan, and fewer than 1% as African American/Black, further emphasizing the lack of ethnic diversity in potential agriculture teachers (Foster, Lawver, & Smith, 2014).

Previous literature points to a continued need for an increased emphasis on cultural diversity and gender representation in agricultural education (LaVergne, Larke, Jr., Elbert, & Jones, 2011; LaVergne, Jones, Larke, Jr., & Elbert, 2012; Talbert & Edwin, 2010; Vincent, Kirby, Deeds, & Faulkner, 2014, Warren & Alston, 2007) as well as the need for an increasingly multicultural teaching workforce (Albert Shanker Institute, 2015). At the secondary level, Talbert and Larke (1995) emphasized the importance of utilizing minority agriculture professionals in the classroom and FFA activities as well as depicting minorities in instructional materials, and further recommend that “Efforts should be conducted to recruit more minorities into agriscience teaching” (p. 38), suggesting students would better relate to a role model of the same ethnicity. Vincent, Henry, and Anderson (2012) emphasized that “an understanding of the disparity between the cultural representation among students and teachers in American public schools is significant because the cultural background of individuals in power positions has been demonstrated to matter” (p. 188). Thus, in order to reach the increasingly diverse student population, it is important that the teaching workforce become more diverse.

Currently, limited research specifically within agricultural education has addressed the recruitment of agricultural education teachers in underrepresented populations. In order to address this gap, Vincent et al. (2012) proposed a conceptual model for recruiting students of color into agricultural education, constructed from the results of their study. Ten students of Latino and Black heritage in agricultural education were recruited and participated in a nine-question semi-structured focus group interview regarding the motivating factors behind why they selected agricultural education as their future profession. The results of their interviews contributed to the design of the proposed conceptual model.

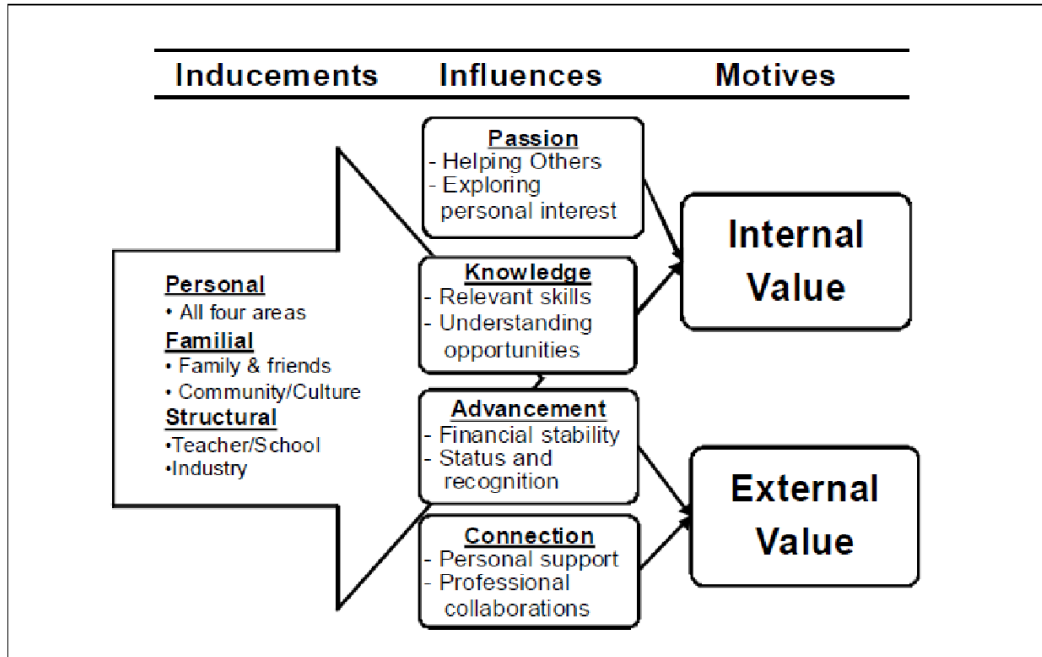

Figure 1. Conceptual model for recruiting students of color into agricultural education (Vincent, Henry, & Anderson, 2012).

In addition to identifying factors influencing the internal and external motivation for students of color to pursue a career in agricultural education, focus group participants also stated that damaging images of agriculture continue to exist in communities of color. According to Vincent et al., “When asked to explain the images of agriculture that the participants had prior to selecting agricultural education, they mentioned phrases such as farming, manual labor, lack of (ethnic or racial) diversity, harvesting crops, and slavery. Participants noted that agricultural education must address these images if the goal is to recruit more students into teaching” (2012, p. 193).

### Literature Review

This study is grounded in framing theory. According to Hallahan (2009), “framing is conceptually connected to the underlying psychological processes that people use to examine information, to make judgements, and to draw inferences about the world around them” (p. 206). Thus, framing involves the construction of an individual’s reality, and can be manipulated through imagery, text, word choice, juxtaposition of text and imagery, or what material is selected to be highlighted on display. What an organization chooses to highlight is deemed to be important, whereas what is not chosen to be highlighted may be inferred by recipients as not important. Because people see the world from multiple perspectives, these constructed realities will vary according to how they infer the framed messages. Thus, framing plays a central role in marketing and public relations.

Framing operates through two cognitive mechanisms: 1) contextual cues, and 2) priming (Hallahan, 2009). Contextual cues are those which are prompted by the components of the actual message, whereas priming is a process through which specific previous memories or

schemas are triggered to decode a message. Marketing and public relations specialists can take advantage of these mechanisms by actively planning to stimulate or prime the audience through specific context clues in their broadcasted messages. Hallahan (2009) posits that there are seven different factors or “models” which are framed in public relations messages: situations, attributes, choices, actions, issues, responsibility, and news. Marketing efforts of the Teach Ag Campaign can capitalize upon principles of framing theory to help guide their endeavor to recruit and retain high quality, diverse agriculture teachers.

Recruiting people of color into various professions is not a new theme in the United States. In a 1991 literature review of issues related to recruitment and retention of underrepresented racial/ethnic students in higher education sponsored by the National Association of College Admission Counselors, it was found that research related to these issues had occurred as early as 1971. Consequently, this subject has been extensively studied. In 1989, the American Association of Colleges for Teacher Education published “Recruiting Minority Teachers: A Practical Guide” which served as a resource for recruiting students in high school, college, and from non-traditional sources. Most recently, the Education Alliance at Brown University published a comprehensive report titled “Minority Teacher Recruitment, Development, and Retention” in which effective recruitment strategies are studied (Torres, Santos, Peck, & Cortes, 2004). Studies have sought to identify factors which influence minorities to enroll in higher education, select teaching as a career, agriculture as a career, and factors which inhibit these decisions. Other research has broken down the minority population into specific demographics to study, such as Native Americans, Latinos, or African Americans/Blacks, as it is dangerous to lump all populations together since the lived experience of each culture is uniquely different from one another.

The agricultural education profession has dedicated research to identifying what motivates students to select agricultural education as a career, difficulties faced by beginning teachers, and retention of agriculture teachers. Diversity is an issue largely studied at the high school level, though there is some recent research which seeks to increase the diversity of ethnicity in post-secondary agricultural education majors. Studies have also sought to identify the impact of diversity training on agriculture teachers’ perceptions of diversity within the high school setting.

Oliver and Brown (1988) identified six principles of recruitment of minority students to higher education: (1) Recruitment efforts involve the primary populace of the university, (2) Recruitment efforts should not exclusively or primarily dependent on active minority participation, (3) Recruitment efforts should purposively encourage connections within the social networks of the minority students recruited, (4) There should be a diverse array of activities available within the program, (5) Active service programs should be incorporated into minority recruitment programs, and (6) In order to facilitate success of recruitment efforts, there must also be an actively addressed retention plan.

With the changing demographics of the student population in the United States, it is important to address the demographics of the teacher population. Coupled with the demand for a qualified teaching force in agricultural education, it is necessary to recruit prospective agriculture teachers from a variety of ethnic backgrounds. A primary avenue through which the agricultural education profession actively recruits is the National Teach Ag Campaign. In order to

understand if current teacher recruitment efforts address the specific hallmarks of recruiting students of color, it is necessary to evaluate these materials.

In order to help address the above outlined needs, the purpose of this study is to explore annual reports of the National Teach Ag Campaign for evidence of recruitment efforts targeting students of color to pursue a career in agricultural education. The following objectives guided the study:

1. To describe specific themes found in the annual reports of the National Teach Ag Campaign which demonstrate appeals to students of color as outlined by the Vincent et al. (2012) conceptual model for recruiting students of color into agricultural education.
2. To describe the presence of underrepresented populations as depicted by annual reports of the National Teach Ag Campaign.

### **Methodology**

The materials evaluated were selected through a convenience purposive sample. In order to identify overall recurring themes arising from the National Teach Ag Campaign, the sample was limited to the Annual Reports posted on the National Teach Ag website ([www.naae.org/teachag](http://www.naae.org/teachag)). There were a total of five reports evaluated including the 2010-2011, 2012, 2013, 2014, and 2015 reports. Annual reports ranged in length from 15 pages to 54 pages for a grand total of 145 pages evaluated from the five years of available reports. Copies of the PDF files were downloaded and evaluated on an electronic tablet to allow the researchers to magnify full color photos.

The data was collected via a qualitative media content analysis using the constant comparative method proposed by Glaser (1965) in which the researcher inductively develops theory through comparing observed phenomena to previously observed phenomena. Qualitative media content analysis is a type of content analysis that is a systematic way to study media and propaganda since it evaluates the dynamic between the text/media and potential audiences on the premise that these audiences may interpret the meaning of the images differently (Macnamara, 2005). According to Glaser (1965, p. 439), the constant comparative method consists of four stages:

- (1) Comparing incidents applicable to each category,
- (2) Integrating categories and their properties,
- (3) Delimiting the theory, and
- (4) Writing the theory.

In this method, the researcher initially codes observations in the phenomena and then they are to write memos regarding their observations and then pause for reflective thought, taking as much time as needed to carefully consider the findings and how they relate to each other, finding common themes that emerge. Each of the five Teach Ag Campaign Annual Reports were evaluated in this method. Initial rounds of observation noted the total page length, total number of photos, total number of graphics, as well as a description of the content and layout of each page. Subsequent rounds of observation evaluated the data for presence of visual aids that included people of color, as well as appeals to the inducements and influences proposed by Vincent et al. (2012), eventually emerging as themes found in the reports.

### **Results**



The results of the data analysis can be broadly categorized into three major categories: (1) Formatting changes, (2) Visual representation of minority populations, and (3) Evidence of appeals to inducements and influences proposed by Vincent et al. (2012).

### *Formatting Changes*

The National Teach Ag Campaign was established in 2009 by the National Association of Agricultural Educators (NAAE) to help address the shortage of agriculture teachers in the United States. Initially, it was staffed by only two people: Ellen Thompson, Coordinator, and Julie Fritsch, NAAE Communications/Marketing Coordinator, and was sponsored by three different donors. The first annual report was not completed until the 2010-2011 year. At 54 pages in length it is by far the longest of the five available annual reports, consisting primarily of descriptions of each of the initiatives, including sample grant applications and award letters, as well as twenty-four pages of news articles from around the country that feature stories about activities associated with the National Teach Ag Campaign.

The initial Teach AG logo features a green handprint with an obscured thumbprint, situated behind large bold text “TEACH AG.” In subsequent reports, this logo retains the original feel but has been edited to provide a cleaner professional look as well as ensuring that the entire handprint is visible. See Figure 2 for an illustration of the change in these logos. This improvement in the quality of the graphics is consistently evident in the entire report, and the following report from 2012 appears to demonstrate a more united “brand” of the Teach Ag Campaign.



*Figure 2.* Changes observed in the official Teach Ag Campaign Logo.

In addition to improved graphics, the annual reports also changed the way in which they summarized data. The first report included sample copies of all documents utilized to promote the campaign, including a copy of a poster that was mailed to agriculture teachers around the country. More recent reports do not have an entire page dedicated to the poster as earlier reports do, but instead show small images of various recruitment materials and resources. The most recent report, 2015, actually changes the format of the whole report from a mailed book-like report to a calendar that can be used for the 2016-2017 year. The top half of the calendar is used

to broadcast information about the campaign while the bottom half includes a calendar with important agricultural education-related dates highlighted. Furthermore, beginning with the 2013 report, sponsor advertisements are included. The CHS Foundation has advertised in the campaign each year since 2013, and Growth Energy (American Ethanol) has advertised since 2014. The newest report also includes testimonials from current college students regarding the impact that the Teach Ag Campaign has had.

*Visual representation of people of color*

While coding observations of the annual reports, the researchers recorded descriptions of included photos, as well as the themes represented by the photos. These visual objects can take on multiple meanings, connotations, and cultural significance depending on the perspective of the viewer (Perloff, 2014). The researchers also documented the total number of photos and graphic icons present in each report. These totals can be seen in Table 1.

Report Year	Total # Pages	Total # Photos	Total # Graphic Icons	# Images People of Color Present
2010-2011	54	11	20	1 (single image of “Urban Ag Teacher” on Poster)
2012	20	16	104	3 (all urban middle school students)
2013	32	59	104	10 (first educators and preservice teachers depicted)
2014	24	68	73	2 (students in promotional materials & CHS advertisement)
2015	15	66	95	11 (Ambassadors, students, award recipients)
Totals	145	220	396	27

*Table 1.* Quantity and use of visual objects in National Teach Ag Campaign Annual Reports.

The number of images depicting people who appear to be persons of color were not very frequent, as only 27 images of the 220 total photographs demonstrated this characteristic (12%). Not only did these images not occur very frequently, but when they did, people of color were often portrayed exclusively as urban middle school students, even appearing on the cover of the 2012 annual report. Students in these images were photographed as members of a class that National Teach Ag Ambassadors were teaching as part of their outreach in Washington D.C. Images such as these appear throughout the report. In the 2013 report, another one of these photos (Figure 3) is presented with the following quote: “Each year, the National Teach Ag Campaign selects the nation’s most outstanding agricultural education majors to represent the profession as National Teach Ag Ambassadors” (p. 18). The juxtaposition of this text in

combination with the frequency in which this same image is repeated (White female preservice teacher presenting to Black youth) consistently presents the image of White teachers and Black students.



Figure 3. Images of Teach Ag Ambassadors teaching minority youth.

In the 2011 report, the only person of color depicted appears on a promotional poster, as a Black female teacher. She is dressed in a lab coat and surrounded by equipment indicative that she teaches a science-based subject, and behind her is a cityscape skyline. Next to her is a White male teacher, seemingly representing the countryside, as he is surrounded by tools, a barn, and is holding a piglet and welding mask. See Figure 4 for an illustration of this image.



Figure 4. 2011 National Teach Ag Poster.

Despite being depicted as an educator in the very first annual report (2011), people of color do not appear as educators again until the 2013 report. It seems in 2013 there was a greater push for diversity and inclusion, as the National Teach Ag Day was hosted by North Carolina Agricultural and Technical University, an historically black 1890 Land Grant University. During this event, a “Diversity and Inclusion Dialogue” was held, but seems to be the only one of its kind mentioned in any of the annual reports. The photo taken of the participants in this event is the first to appear in this series of annual reports that depicts people of color as teacher educators and preservice educators.

It is curious that out of the entire series of reports, only one student of Asian ancestry is depicted, being present in an advertisement for American Ethanol, one of the sponsors of the Teach Ag Campaign. The populations of color which are most consistently represented in visual imagery selected by the campaign include Black or Latino persons. The vast majority of images depict White preservice teachers, teacher educators, middle or high school students, or stakeholders. Most frequently appearing in these images are college-age White females, who consistently comprise the majority of the National Teach Ag Ambassadors. In 2013, all twelve collegiate National Teach Ag Ambassadors were White females. This is reflective of the profession, as in the 2015 National Supply and Demand Study, it was found that 67% of license-eligible program completers were female (Foster et al., 2015). Thus, not only were people of color underrepresented in the images of preservice teachers, but so were males. The most recent annual report (2015) does depict male students of color as being National Teach Ag Ambassadors.

In addition to photos, the National Teach Ag Campaign uses a variety of graphic icons. Most of these are related to the Teach Ag handprint logo, social media, or agriculture-related objects, but in 2013 an icon which seems to evoke a sense of mentoring, appeared in the reports. It depicts two people facing away from the viewer, with one person’s hand on the others’ shoulder. This icon appears multiple times throughout the Teach Ag literature for the remainder of the reports. The hands of the “mentor” in the image are depicted as flesh tone for a White person each time the icon appears. See Figure 5 for an illustration of this icon.



*Figure 5.* Teach Ag “Mentor” Icon.

Finally, the annual reports since 2013 feature advertisement from program sponsors CHS Foundation, DuPont Pioneer, and Growth Energy (American Ethanol). CHS Foundation leads

their advertisements with the phrase “Investing in the future of rural America” flanked with large color photographs of White FFA members, students, and farmers.

*Evidence of appeals to inducements and influences proposed by Vincent et al. (2012)*

Four major factors influenced students of color to select agricultural education as a major in the Vincent et al. (2012) study: Passion, knowledge, advancement, and connection. Furthermore, three factors were identified as inducements to select agricultural education or to stray away: Personal, family, and structural factors. When these factors were presented in a positive light, students of color were more likely to select agricultural education as a major, whereas when they were negative, students elected to avoid agricultural education. For example, if a student had an agricultural instructor while in high school that they greatly admired and identified with, they were induced into selecting agricultural education as a major. Likewise, if they had a negative experience with an agricultural instructor, then they were induced to not select agricultural education as a major. Throughout the review of the annual reports in the present study, the researchers sought to identify recruitment efforts which aligned with these proposed influences and inducements.

Each of the annual reports cited Teach Ag representatives attending the national conference of the collegiate student organization, Minorities in Agriculture and Natural Resources and Related Sciences (MANRRS) to present workshops and speeches. In 2013, the National Teach Ag Campaign sent representatives to the Latinos in Agriculture Conference, although this appears to be the only year in which this occurred. Furthermore, the wording of the campaign mission statement and goal were revised to include the word “diverse” in 2014. The current mission statement is as follows:

To raise AWARENESS of the need to RECRUIT and RETAIN high quality and diverse AGRICULTURE TEACHERS, ENCOURAGE others to consider a career teaching agriculture, and CELEBRATE the POSITIVE CONTRIBUTIONS that agriculture teachers make in their schools and communities.

It is interesting that the word “diverse” is not in all caps as other keywords are. However, when looking at the goal of the campaign, which was also established in 2014, the word “diverse” is capitalized:

To ENSURE an ABUNDANT SUPPLY of HIGH QUALITY and DIVERSE agriculture teachers who will INSPIRE the next generation of LEADERS, PROBLEM SOLVERS, and AGRICULTURALISTS.

Later, the word “ENTREPRENEURS” was added before “and AGRICULTURALISTS.”

It is difficult to discern particular themes related to Vincent et al.’s (2012) influences in earlier versions of the annual reports. However, in 2015, the report content shifted to include example Tweets, quotes from agriculture teachers, and testimonials from college students involved with the National Teach Ag Campaign. An analysis of these quotes reveals connections to the factors of Passion, Knowledge, and Connection.

## Conclusion

There are limitations for this study. Qualitative research is inherently biased as the researcher interprets the sample being studied through their own lenses and world view. Macnamara (2005) emphasizes that although qualitative content analyses “can conform to the scientific method and produce reliable findings...[it] is difficult and maybe impossible to do with scientific reliability” (p. 5). The researchers recognize that along with this bias are various power dynamics at play as well. The researchers are of White, non-Hispanic ethnicity and realize that their life experiences differ from others, which might influence how they interpret the information gleaned through this content analysis. Furthermore, this also impacts the replicability of the study, as other researchers performing the same systematic exploration of the content might identify different themes. Additionally, this study assumed that the annual reports evaluated provided a comprehensive overview of all recruitment efforts of the National Teach Ag Campaign, and that the ways in which students of minority backgrounds were recruited were specifically addressed in the reports. The results of the study also assume that through the constant comparative method that the researcher is able to glean accurate overarching themes.

The National Teach Ag Campaign is a relatively new initiative in the long history of agricultural education, having only existed for the past five years. In the early stages of inception, the annual reports focused on promoting events which created visibility for the campaign, rather than highlighting the impact that a career in agricultural education has on students. Now that the campaign has increased sponsorship from an initial three donors to a current four donors, more opportunities are available for students to become involved with the campaign at various levels. Since 2012, a panel of twelve National Teach Ag Ambassadors has been selected to represent the campaign in various parts of the country. Most recently, the 2015 cohort of ambassadors was assigned to groups of students who signed up expressing interest in Teach Ag at National FFA Convention. The ambassadors are tasked with mentoring these students throughout the year after National Convention has ended. Personal support and connections has been highlighted by students of color as a desirable influence on selecting agricultural education as a career.

It is evident that the Teach Ag Campaign has prioritized a commitment to recruiting a more diverse teaching workforce as evidenced by the changes made to their mission statement, goals, and images presented in more recent annual reports. Although many of the images depicted in the annual reports do not show wide racial diversity, there is a slight trend towards including persons of more ethnicities in these images in more recent reports. It has been suggested by previous research (Talbert & Larke, 1995) that students may relate more to teachers of a similar ethnicity, and framing theory posits that the manner in which messages are framed “limits or defines the message’s meaning by shaping the inferences that individuals make about the message” (Hallahan, 2009, p.207). By framing visual imagery coupled with reinforcing messages appealing to student passion, opportunity to gain knowledge, opportunity for advancement, and connections to aid in personal and professional support, the Teach Ag Campaign can have a powerful influence over the ways in which students perceive the potential career of teaching agriculture. It will be necessary for the marketing team with the campaign to continue to reevaluate what promotional materials they choose to create so as to appeal to different demographics and work toward their goal of recruiting and retaining a diverse, high quality workforce of agriculture teachers.

Due to the drastic difference between the teachers of minority background working as educators and the amount of students of minority backgrounds, it is imperative to increase recruitment efforts. Identifying what the current efforts of the National Teach Ag Campaign are can help guide the campaign's impact on future recruitment efforts, and help the campaign meet its goal of ensuring "an abundant supply of high quality and diverse agriculture teachers who will inspire the next generation of leaders, problem solvers, entrepreneurs, and agriculturalists" (Teach Ag Annual Report, 2015, p. 14).

## References

- Albert Shanker Institute. (2015). *The State of Teacher Diversity in American Education*. Retrieved from <https://assets.documentcloud.org/documents/2426481/the-state-of-teacher-diversity.pdf>
- American Association of Colleges for Teacher Education. (1989). *Recruiting Minority Teachers: A Practical Guide*. Washington, D.C.: AACTE Publications.
- Calvin, J. & Pense, S. L. (2013). Barriers and Solutions to Recruitment Strategies of Students into Post-Secondary Agricultural Education Programs: A Focus Group Approach. *Journal of Agricultural Education*, 54(4), 45-57.
- Camp, W. G., Broyles, T., & Skelton, N. S. (2000). *A national study of the supply and demand for teachers of agricultural education in 1999-2001*. Blacksburg, VA: Virginia Polytechnic Institute and State University.
- Foster, D. D., Lawver, R. G., & Smith, A. R. (2015). *National Agricultural Education Supply and Demand study, 2015 Executive Summary*. Retrieved from The American Association for Agricultural Education Website: [http://aaaeonline.org/resources/Documents/NSD%20Summary\\_2015.pdf](http://aaaeonline.org/resources/Documents/NSD%20Summary_2015.pdf)
- Glaser, B. G. (1965). The constant comparative method of qualitative analysis. *Social Problems*, 12(4), 436-445.



- Goldring, R., Gray, L., and Bitterman, A. (2013). *Characteristics of Public and Private Elementary and Secondary School Teachers in the United States: Results From the 2011–12 Schools and Staffing Survey* (NCES 2013-314). U.S. Department of Education. Washington, DC: National Center for Education Statistics. Retrieved [6/1/16] from <http://nces.ed.gov/pubsearch>.
- Hallahan, K. (2009). Seven models of framing: Implications for public relations. *Journal of Public Relations Research*, 11(3), 205-242.
- Hillison, J. & Hagee, G. (1982). Sixteen Theorems of Successful Recruitment Activities for Departments of Agricultural Education. *Journal of Agricultural Education*, 23(1), 3-8.
- Juergenson, E. M. (1964). Providing an Adequate Supply of Teachers. *Journal of the American Association of Teacher Educators in Agriculture*, 4(1), 8-10.
- Juergenson, E. M. (1964). A New Look at Recruitment. *Journal of the American Association of Teacher Educators in Agriculture*, 5(1), 15-16.
- Kantrovich, A. J. (2010). *The 36<sup>th</sup> volume of a national study of the supply and demand for teachers of agricultural education 2006-2009*. West Olive, MI: Michigan State University. American Association for Agricultural Education.
- Kena, G., Musu-Gillette, L., Robinson, J., Wang, X., Rathbun, A., Zhang, J., Wilkinson-Flicker, S., Barner, A., and Dunlop Velez, E. (2015). *The Condition of Education 2015* (NCES 2015-144). U.S. Department of Education, National Center for Education Statistics. Washington, DC. Retrieved [6/1/16] from <http://nces.ed.gov/pubsearch>.
- LaVergne, D. D., Larke, Jr., A., Elbert, C. D., & Jones, W. A. (2011). The benefits and barriers toward diversity inclusion regarding agricultural science teachers in Texas secondary agricultural education programs. *Journal of Agricultural Education*, 52(21), 140-150.
- LaVergne, D. D., Jones, W. A., Larke, Jr., A., & Elbert, C. D. (2012). The effect of teacher demographic and personal characteristics on perceptions of diversity inclusion in agricultural education programs. *Journal of Agricultural Education*, 53(3), 84-97.
- Lawver, R. G. & Torres, R. M. (2011). Determinants of Pre-Service Students' Choice to Teach Secondary Agricultural Education. *Journal of Agricultural Education*, 52(1), 61-71.
- Lee, C. (1991). *Achieving diversity: Issues in the recruitment and retention of underrepresented racial/ethnic students in higher education: A review of the literature*. United States of America: National Association of College Admission Counselors.
- Macnamara, J. (2005). Media content analysis: Its uses, benefits and Best Practice Methodology. *Asia Pacific Public Relations Journal*, 6(1), 1-34.



- Oliver, J. & Brown, L. B. (1988). College and university minority recruitment: Barriers, recruitment principles, and design guidelines. *Journal of College Student Development*, 29(1), 40-47.
- Perloff, R. M. (2014). *The Dynamics of Persuasion: Communications and Attitudes in the 21<sup>st</sup> Century* (5<sup>th</sup> ed.). New York, NY: Routledge.
- Talbert, B. A. & Edwin, J. (2010). Preparation of agricultural education students to work with diverse populations. *Journal of Agricultural Education*, 49(1), 51-60.
- Talbert, A. B., & Larke, A. (1995). Factors influencing minority and non-minority students to enroll in an introductory agriscience course in Texas. *Journal of Agricultural Education*, 36(1), 38-45.
- Torres, J., Santos, J., Peck, N. L., & Cortes, L. (2004). *Minority teacher recruitment, development, and retention*. Providence, RI: Brown University.
- Vincent, S. K., Henry, A. L., & Anderson II, J. C. (2012). College Major Choice for Students of Color: Toward a Model of Recruitment for the Agricultural Education Profession. *Journal of Agricultural Education*, 53(4), 187-200.
- Vincent, S. K., Kirby, A. T., Deeds, J. P., & Faulkner, P. E. (2014). The evaluation of multicultural teaching concerns among pre-service teachers in the South. *Journal of Agricultural Education*, 55(1), 152-166.
- Warren, C. K. & Alston, A. J. (2007). An analysis of diversity inclusion in North Carolina secondary agricultural education programs. *Journal of Agricultural Education*, 32(1), 7-12.

## **Needs Assessments for School-Based Agricultural Education Teachers: A Review of Literature**

Catherine A. DiBenedetto, Clemson University  
Victoria Willis, Clemson University

### **Abstract**

*School-based agricultural education (SBAE) programs have become more diverse with the ever changing and growing agriculture industry. Agricultural education teachers are challenged with expanding their knowledge and competencies in order to effectively teach and design successful SBAE programs. Needs assessments aid in providing knowledge as to which competency areas should be focused on to better equip teachers with adequate knowledge, experiences, resources and materials. To better understand how agricultural education teacher's needs have changed or remained the same throughout three decades, this review of literature of 17 studies provided insight into teacher needs assessments throughout the 1980's, 1990's, and 2000's. While some competencies experienced inconsistent results, there were several competencies produced overwhelming cohesive results. Findings indicated FFA Program Management as a consistent need of agricultural education teachers throughout all three decades. Public relations and use of computers and technology in the classroom were consistent during the 1990's and 2000's. The review of literature revealed less emphasis was needed in professional development in the area of technical skills related to the AFNR career pathways. A variation of needs between experienced and beginning teachers has existed throughout the decades. Recommendations included continuing to administer needs assessments to a variety of agricultural educational teachers throughout the nation with a cohesive and consistent instrument to assist teacher educators, the National FFA Organization, and NAAE with designing in-service professional development opportunities for a wider variety of agricultural education teachers.*

Keywords: school-based agricultural education; agricultural education teachers; teacher needs assessments; in-service needs; in-service professional development; teaching competencies

### **Introduction and Conceptual Framework**

Many teachers may believe that their skills or knowledge are inadequate for providing students with the necessary skills to face the demanding world (Sorensen, Tarpley, & Warnick, 2010). In-service needs assessments serve as a beneficial tool to discover the needs and competencies of teachers within agricultural education. Historically, one of the main roles of university agricultural education programs has been the identification of pertinent topics for in-service training of agriculture instructors (Edwards & Briers, 1999). Agriculture is a diverse and ever changing industry, which can make it challenging for agricultural education teachers to stay current in their knowledge base. Due to the diversity of activities and the enormous amount of content taught within the realm of agricultural education, most instructors require some form of in-service on a regular basis to be able to cope with the demands of the profession (Sorensen et al., 2010). Consistent and timely in-service needs assessments can be of great use to assist in determining which topics should be covered when designing in-service professional development for agricultural education teachers. In-service professional development providers should periodically monitor the needs of beginning teachers, as they change over time, and provide assistance based upon current needs (Birkenholz & Harbstreit, 1987). Agriculture teachers have been willing to

learn and have requested in-service education to improve the quality of their teaching. Regardless of certification method, teachers have had a continuing desire and need for in-service training to ensure their skills will remain current (Barrick, Ladewig, & Hedges, 1983). Evaluating the results of in-service needs assessments from varying states, level of teacher experience, and background can expand the knowledge base on how teachers' needs for professional development can be more efficiently addressed. Trends and differences within teacher in-service needs assessments should be observed to determine the types of in-service that will be provided to agricultural education teachers in the future (Layfield & Dobbins, 2002).

According to the National Agriculture Education Teacher Supply and Demand Executive Summary there were 1,028 open agricultural education teaching positions in 2015 and concerns for teacher retention during a time of unease with supply and demand issues (Foster, Lawver, Smith & Thompson, 2016). Determining the competencies needed for the agriculture and natural resource workforce and the competencies needed to effectively educate students in these areas supported the need to analyze teacher needs assessments across three decades, 1983-2010. Priority 3 of the NRA of the AAAE calls for, "Sufficient Scientific and Professional Workforce that Addresses the Challenges of the 21<sup>st</sup> Century." Priority 3 described, "Utilizing research to draw a connection between the impact of our academic programs and student preparedness and success is essential for survival and sustainability of agricultural leadership, education, and extension education, but also for agricultural communication (Roberts, Harder & Brashears, 2016)." Current literature suggests considering needs assessment research on a national scope to determine common needs (Layfield & Dobbins, 2002). An increase in timely and relevant participation in needs assessment studies will prove to be beneficial in identifying trends in order to determine the focus of agricultural education and provide improved preparation for educators (Duncan, Ricketts, Peake, & Uessler, 2006).

### **Purpose & Objectives**

The purpose of this study was to conduct a review of literature to describe agricultural education teacher needs assessments over the past three decades and determine recommendations for conducting timely needs assessments to determine current teacher in-service needs. This purpose was supported by the following objectives: 1) Describe the similarities and differences among agricultural education teacher needs assessments throughout the decades; 2) Determine how in-service opportunities for current agricultural education teachers can be improved upon.

### **Methods & Procedures**

To accomplish the purpose of this study, a review of literature was conducted on literature pertinent to agricultural education teacher needs assessments. The reviewed literature was gathered from the *Journal of Agricultural Education* and the *Journal of Career and Technical Education*. Reviewed literature was separated by decade and compared with studies within each decade as well as outside of the study's decade. Each article was evaluated for its suitability and relevance to the present literature review. Given the number of studies that have been conducted on the topic of teacher needs assessments, a meta-analytical approach was used for this study (Newton & Rudestam, 1999). A form of meta-analysis was conducted by including the results of studies conducted across nine states within a thirty year period. Conflicting findings existed in the literature regarding teacher's needs for in-service. In total, 17 (N=17) studies were identified

and used as a part of this literature review from 1983-2010.

## Review of Literature

**Research Within the 1980's:** Barrick et al. (1983) recognized teacher in-service needs by identifying the importance of, relative knowledge of, and relative ability to provide application of specific technical agriculture topics. The Barrick et al. (1983) study did not provide data as to the specific subject areas teachers responded to through the survey instrument. The study confirmed the need for a combination of two or more rankings to be considered to form conclusions regarding in-service education needs (Barrick et al., 1983). Newman and Johnson (1994) supported the conclusion of basing in-service needs on two or more rankings, as rankings of the units based on the mean weighted discrepancy scores appeared to be quite different from rankings of the units based solely on importance or competence (Newman & Johnson, 1994).

As agricultural education teachers progressed in their careers, in-service needs also progressed, as experience, knowledge, and resources became more readily available or depleted. Claycomb and Petty's (1983) study aimed to determine the perceived needs of teachers at varying times throughout the individual's career. The study determined the needs of teachers at specific stages in their career by utilizing survey methodology. The "Beginning Teachers' Needs Questionnaire" was developed and divided into nine areas.

All perceived needs categories changed rankings of perceived needs based upon subject's surveyed answers, except for FFA and Program Development and Planning. The need for other subject areas decreased over the years, likely due to exposure and gaining experience in the subject areas. One of the most drastic changes found in the study was in Program Administration, as it was rated highest for all pre-service teachers and lowest for all teachers with one year of experience. Human relations also experienced some differences in rankings from pre-service to experienced teachers. Human Relations was ranked lowest of all by pre-service, but was the second highest in-service need for experienced teachers.

The need for assistance in human relations and program administration outweighed technical expertise during the first year of teaching. In Garton and Chung's (1996;1997) studies, technical agriculture knowledge and skill competencies were ranked lower in priority when compared to competencies in areas of instruction, program planning, development, evaluation, and program administration. According to Claycomb and Petty (1983), many agriculture teachers graduate from preparation programs with a lack of necessary technical agriculture knowledge required in order to be successful teachers (Claycomb & Petty, 1983). In Joerger's (2002) study, technical agriculture was revealed as the lowest ranked in-service need; program design and management ranked first with teaching and classroom management, leadership and SAE development following (Joerger, 2002). In Roberts and Dyer's (2004) study, Technical Agriculture was ranked next to last for perceived in-service needs by traditionally and alternatively certified teachers (Roberts and Dyer, 2004). This data concludes that technical agriculture competence was not as much a factor in the success of a beginning teacher as were the other professional competencies (Garton & Chung, 1996).

Organizing, conducting, and maintaining of adult/young farmer programs was ranked as a high priority by pre-service teachers, however teachers with one year of experience perceived little

assistance as needed in this area. Claycomb and Petty's (1983) findings highlighted the fact that needs for first year teachers were not necessarily the same as second year teachers and concluded that in-service needs of beginning teachers changed over time (Claycomb & Petty, 1983). In-service needs of agricultural education teachers should be assessed and prioritized on a continual basis (Birkenholz & Harbstreet, 1987, Claycomb & Petty, 1983).

Birkenholz and Harbstreet (1987) identified the in-service needs of beginning agricultural teachers in Missouri by prioritizing beginning teachers in-service needs, identifying relationships which may have existed between perceived in-service needs and employment situational characteristics of beginning agricultural teachers, and by identifying activities which beginning teachers would have liked to have added or eliminated from their job responsibilities. The items ranked as most needed included: using a microcomputer in the classroom, developing skills in agribusiness and electricity, training contest teams, and assisting students with SOEP records. Items ranked as least needed for in-service included: operating audiovisual equipment, participating in vocational agriculture and other professional education activities, planning and conducting field trips, participating in civic organizations, completing reports for local administrators, and teaching day classes.

In Birkenholz and Harbstreet's study (1987), completing reports for local administration as an in-service need was ranked as below the 4.0 level, which indicated a non-need (Birkenholz & Harbstreet, 1987). However, Claycomb and Petty (1983) found Program Administration, which included local and state forms and reports, was ranked highest for all pre-service teachers and lowest for all teachers with one year of experience (Claycomb & Petty, 1983). Other research concluded that an in-service need for completing reports for local and state administration existed (Garton & Chung 1996; Joerger, 2002; Layfield & Dobbins, 2002).

Birkenholz's (1987) study revealed that sixty-six of the seventy-five in-service items produced responses from both extremes of the nine-point scale, which indicated a wide variation among the in-service priorities of respondents while displaying a lack of consensus among beginning vocational agricultural teachers. The Barrick et al. (1983) study indicated a wide variation among the in-service priorities of respondents and the ranking of the topics varied significantly in a majority of aspects (Barrick et al., 1983).

**Articles within the 1990's:** Newman and Johnson's (1994) study identified and assessed in-service education needs of teachers who taught pilot agriscience courses in Mississippi and determined their need for additional instructional materials. In review of data from teacher perceptions of importance of and personal competence in units from agriscience courses, it was observed that teachers who ranked units lower in importance also ranked their competence level as average. Does a lower competence level in teacher's abilities influence the teacher's responses to the unit importance ranking? Teacher's unfamiliarity with technology and its capabilities were a contributing factor in the lack of technology acceptance (Garton & Chung, 1996).

Introduction to Agriscience and Agriscience I courses expressed an in-service need in biotechnology, computer technology, and mechanical technology. Additional materials requested for Introduction to Agriscience included computer and mechanical technology. Additional materials requested for the Agriscience I course included biotechnology, computers, and

mechanical technology. Units listed as having a perceived need for in-service correlated with the additional materials requested in almost every material needs category (Newman & Johnson, 1994). The most pressing needs for in-service education included biotechnology, computers, and mechanical/physical technology. Many other research studies conducted on in-service needs have expressed a need for technology/computer use in the classroom (Birkenholz & Harbstreet, 1987; Dormondy & Torres, 2002; Edwards & Briers, 1999; Garton & Chung; 1996, Joerger, 2002; 1996; Kotrlik, Redmann, Harrison & Handley, 2000; Layfield & Dobbins, 2002; Newman & Johnson, 1994; Roberts & Dyer, 2004; Ruhland & Bremer, 2001). Joerger's (2002) study revealed using computers in teaching as a professional competency teachers felt most skilled in, which contrasts the research presented in which computer technology was ranked as a high priority in-service need by teachers (Joerger, 2002). Roberts and Dyer's (2004) study showed that the majority of traditional and alternative certified teachers had a high need for in-service training in using computer technology and computer applications (Roberts & Dyer, 2004). According to Kotrlik, et al. (2000), in-service training was especially critical in the area of information technology because technology had changed rapidly and many experienced teachers may have had very limited or no training in this area (Kotrlik et al., 2000).

Garton and Chung's (1996) study aimed to identify and prioritize the in-service needs of beginning agriculture teachers in Missouri. The study consisted of first and second year beginning agriculture teachers and members of the Joint State Staff in Agricultural Education, which included teacher educators and state supervisors. Twelve of the fifty professional competencies as perceived by beginning teachers, received a mean weighted discrepancy score greater than 4.0, which indicated a greater need for in-service training. The twelve competencies with mean weighted discrepancy scores greater than 4.0 were: completing reports for local/state administrators, motivating students to learn, preparing FFA degree applications, developing an effective public relations program, preparing proficiency award applications, teaching agriscience (integrating science and agriculture, utilizing a local advisory committee, developing SAE opportunities for students, using computers in classroom teaching, supervising students' SAE programs, teaching using experiments, and conducting local FFA chapter activities. Ten of the fifty professional competencies as perceived by beginning teachers, received a mean weighted discrepancy score less than 2.0, which indicated less of a need for in-service were: teaching knowledge and skills in agricultural construction, teaching about and agriculture's relationship with the environment, teaching knowledge and skills in the plant sciences, conducting parent/teacher conferences, using multimedia equipment in teaching, implementing VIMS in the local program, planning and conducting student field trips, developing knowledge and skills in the animal sciences, teaching knowledge and skills in soils and soil management, and teaching equine science. Aligned with Garton and Chung's (1996) in-service least needed rankings, several other studies also ranked planning and conducting field trips as a lowest in-service need (Birkenholz & Harbstreet, 1987; Layfield & Dobbins, 2002). Layfield & Dobbins (2002) ranked plant science, parent teacher conferences, animal science, soils management and equine science as lowest priority in-service needs, aligning with Garton and Chung's (1996) study.

An overlap between the in-service needs teachers ranked and the in-service needs Joint State Staff ranked occurred for: effective public relations, utilizing local advisory committee, and motivating students to learn. An overlap between the lowest ranked in-service needs teachers

categorized and the in-service needs Joint State Staff ranked included: conducting/planning field trips and teaching equine science. Similarities between Joint State Staff high in-service needs and high in-service needs from other research studies overlapped as well. Birkenholz and Harbstreet (1987), Newman and Johnson (1994), and Sorensen et al. (2010) expressed a need for assistance in agriculture mechanics and Joint State Staff ranked repairing and reconditioning agriculture mechanics tools and equipment as a high in-service need. Layfield & Dobbins (2002) study ranked adult programs as a high in-service need and Joint State Staff ranked conducting an adult program as a high in-service need as well. Some differences between Garton and Chung's (1996) in-service needs and other research was also observed. Joint State Staff ranked managing student behavior problems as a high in-service need for beginning teachers whereas Layfield & Dobbins (2002) ranked managing student behavior problems as a least preferred competency for experienced teachers. Joint State Staff ranked preparing agriculture contest teams as a low in-service need, however other research ranked preparing contest teams as a high in-service need (Birkenholz & Harbstreet, 1987; Joerger, 2002). According to Garton and Chung's (1996) study, the professional competency with the greatest need for in-service education, as perceived by beginning teachers was for completing reports for local and state administrators, which has supported the conclusions of previous research as a needed priority area of in-service professional development (Claycomb & Petty, 1983; Layfield & Dobbins, 2002; Mundt & Connors, 1999; Roberts & Dyer, 2004).

Mundt and Connors (1999) study identified challenges associated with the first years of teaching agriculture. The top seven categories rated as very important included: managing the overall activities of the local FFA chapter, balancing professional and personal responsibilities and maintaining personal motivation and a positive outlook, building the support of faculty, counselors, and administrators within the school system, recruiting and motivating students in agricultural education, using proper classroom management strategies and dealing with student discipline problems, building support from parents, organizations, and adult groups within the community, and properly managing time, completing paperwork, and meeting required deadlines. Three of the eight categories were in relation to time management. Time management tips were also listed as a teacher professional development need by Roberts and Dyer's (2004).

Mundt and Connors (1999) ranked motivating students in agricultural education and using proper classroom management strategies and dealing with student discipline problems as an important in-service need. Student discipline and motivating students has been reoccurring as an in-service need in several other studies. Duncan et al. (2006) and Joerger (2002) ranked motivating students to learn and managing student behavior problems as a high in-service need (Duncan et al, 2006, Joerger, 2002). Garton and Chung (1996) ranked motivating students to learn as a high in-service need, while Joint State Staff in the study also ranked managing student behavior problems as a high in-service need (Garton & Chung, 1996). One of Edwards and Briers (1999) high ranking competencies included, "motivating student learning and improving achievement" (Edwards & Briers, 1999). Layfield and Dobbins ranked managing student behavior problems as a low priority in-service need among experienced teachers, however beginning teachers did not mention managing student problems in their in-service needs (Layfield & Dobbins, 2002).

Edwards and Briers (1999) study purpose was to compare the rankings of in-service needs as determined by direct assessment to a ranking based on a mean weighted discrepancy score. Four

competencies in Edwards and Briers (1999) study were related to facilitating positive public image. Portraying a positive image of the agricultural education program and utilizing effective public relations has been a recurring in-service need in previous research. Mundt and Connors (1999) ranked building support from parents, organizations, and adult groups within the community as an important in-service need (Mundt & Connors, 1999). Under the category, management and planning, building the image of agriculture programs, and having a working relationship with local media were ranked as teacher needs in Roberts and Dyer's (2004) study. Creating strategic partnerships and having a marketing program were competencies both listed as low at the time of graduation and current status for agricultural education teachers according to Dormondy and Torres' (2002) study. An in-service need for developing an effective public relations program for experienced teachers was revealed in several other studies (Duncan et al., 2006; Garton & Chung, 1996; Layfield & Dobbins, 2002; Roberts & Dyer, 2004). Developing support for an effective public relations program should be further researched as a priority need.

**Articles Within the 2000's:** Kotrlik, et al. (2000) study aimed to determine the information technology related in-service needs of Louisiana agriscience teachers. Agriscience teachers were found to value information technology, but did not have appropriate general and software specific knowledge. Knowledge, skill level, and availability of training and technology have been key factors in implementing information technology into the school systems. According to Kotrlik, et al. (2000) no recent study had been conducted of the information technology needs of agriscience or vocational teachers. As mentioned previously, many other in-service research studies concluded that computer and technology use in the classroom was ranked as a high in-service need. Data revealed that agriscience teachers placed a high value on information technology by strongly agreeing that teachers should know how to use computers and that teachers and students should have computers available for instruction. When determining general information technology knowledge and skill possessed by Louisiana agriscience teachers, teachers did not rank themselves above average on any of the technology that has been available for the last decade and ranked themselves average or below average in all software areas. Teachers have placed less confidence in information technology training offered by universities, as universities have not offered information technology training desired by teachers, and most have resorted to self-directed learning.

Ruhland and Bremer's (2001) study focused on examining the professional development needs of novice secondary career and technical education teachers to determine if career and technical education teachers who entered the profession through alternative certification routes had different needs than those of traditionally prepared teachers. Often, state, district, and building administrators rather than teachers make professional development decisions. Offering in-service needs to teachers should be done in an organized and effective manner that will result in an improved knowledge and competency of a skill or subject area. Ruhland and Bremer (2001) mentioned that current professional development opportunities were often unfocused, fragmented, low-intensity activities that lead to no significant change in teaching practices. Respondents named three areas that would help improve their practice as a teacher in the coming years; the most frequent answers included: peer coaching and networking, up-to-date technology and computer skills, and workshops or instruction on topics including curriculum development and special populations.



Layfield and Dobbin's (2002) study focused on the needs of beginning and experienced agriculture teachers in South Carolina. The top ten competencies in need by experienced agriculture teachers included: using computers in the classroom and teaching, preparing FFA degree applications, preparing proficiency award applications, using multimedia equipment in teaching, teaching record keeping skills, developing an effective public relations program, developing SAE opportunities for students, completing reports for local/state/federal accountability, organizing a local Young Farmer Agribusiness program, and developing local adult education programs. The top ten in-service needs of beginning agriculture teachers proved to be similar to the needs of experienced teachers, as five of the ten competencies overlapped, including: 1) developing local adult education programs, 2) developing SAE opportunities for students, 3) preparing FFA degree applications, 4) completing reports for local, state, and federal accountability, and 5) preparing proficiency award applications. The top ten in-service needs of beginning teachers included: 1) utilizing a local advisory committee, 2) developing local adult education programs, 3) organizing fund-raising activities for the local FFA chapter, 4) preparing agriculture/FFA contest teams, 5) developing SAE opportunities for students, 6) preparing FFA degree applications, 7) developing performance based assessment instruments, 8) completing reports for local/state/federal accountability, 9) preparing proficiency award applications, and 10) supervising students' SAE programs. Six of the top ten competencies for in-service reported by beginning agriculture teachers overlapped with the Garton and Chung (1996) study. Both groups of teachers reported an in-service need for utilizing a local advisory committee, developing SAE opportunities for students, preparing FFA degree applications, completing reports for local/state/federal accountability, preparing proficiency award applications, and supervising student's SAE programs (Garton & Chung, 1996). The ten least preferred competency needs for in-service reported by experienced teachers included: assessing and evaluating student performance, teaching skills and knowledge in plant sciences, managing student behavior problems, teaching skills/knowledge in soils and soil management, organizing fundraising activities for the local FFA chapter, relations with teachers and administration, knowledge and skills in animal sciences, planning banquets, conducting parent/teacher conferences, and planning and conducting student field trips. The ten least preferred competencies for beginning teachers included: teaching agriscience (integrating science and agriculture), planning banquets, conducting parent/teacher conferences, teaching knowledge/skills in small animal care, locating and selecting student references and materials, teaching knowledge and skills in plant sciences, teaching agricultural mechanics skills, developing knowledge and skills in the animal sciences, planning and conducting student field trips, and teaching equine science. An overlap of five least preferred competencies occurred between experienced and beginning teachers, which included: planning banquets, conducting parent/teacher conferences, teaching skills/knowledge in plant sciences, developing knowledge/skills in animal sciences, and planning/conducting field trips.

Joerger's (2002) study revealed that teachers have difficulty locating adequate teaching materials, however, Dobbins and Layfield's (2002) study revealed that beginning teachers ranked locating and selecting student references and materials as a lower priority in-service need (Joerger, 2002). The areas of teaching knowledge and skills in plant sciences, developing knowledge and skills in animal sciences, conducting parent/teacher conferences, and planning and conducting student field trips were indicated as lower priority needs for in-service in Layfield and Dobbin's (2002) study, as well as Garton and Chung's (1996) study.

Within the Layfield and Dobbin's study, preparing FFA degree applications, organizing FFA fundraisers, and supervising SAE programs were mentioned as high priority in-service needs. FFA management and advising has surfaced as a high priority in-service need across many other studies (Birkenholz & Harbstreit, 1987; Duncan et al., 2006; Edwards and Briers, 2000; Garton & Chung, 1996; Joerger, 2002; Layfield & Dobbins, 2002; Mundt & Connors, 1999; Roberts & Dyer, 2004; Sorensen, et al., 2010). Joerger's (2002) study revealed a high in-service need for FFA related categories, as preparing FFA degree and proficiency award applications, utilizing local FFA Alumni or Young Farmer affiliates, supervising student SAEPs, preparing agriculture/FFA career development teams, and conducting local FFA activities were all mentioned (Joerger, 2002). Managing the overall activities of the local FFA chapter was a top preparation need according to Mundt and Connor's (1999) study. Preparing FFA degree applications and proficiency applications occurred as a high priority in-service need in several studies (Duncan et al., 2006; Garton & Chung, 1996; Joerger, 2002; Layfield & Dobbins, 2002; Roberts & Dyer, 2004; Sorensen, et al., 2010).

Joerger's (2002) study focused on identifying the common and unique in-service needs of year 2000 and 2001 cohorts of beginning agricultural education teachers who had completed one semester of teaching. Teachers ranked the perceived importance, competence, and in-service needs within the categories of teaching and classroom management, leadership and SAEP development, technical agriculture, and program design and management. The 2001 teacher cohort indicated it was somewhat important, and the 2000 cohort believed it was of little importance to organize and conduct adult education programs. Conducting an adult education program was also ranked as a lowest pre-service and in-service need in Duncan et al. (2006) study. A difference was observed, as data from Layfield and Dobbin's (2002) study indicated developing adult education programs as a high priority perceived in-service need for both beginning and experienced teachers (Layfield & Dobbins, 2002). The highest ranking in-service needs for this study included: managing student behavior, motivating students to learn, providing guidance for post-secondary education needs, and providing career exploration activities (Layfield & Dobbins, 2002). Joerger's (2002) 2001 cohort listed soils management and knowledge as the third highest ranking in-service education need, whereas Layfield and Dobbin's (2002) experienced teachers ranked soils management and knowledge as a least preferred need. Garton and Chung's (1996) study as well as Duncan et al. (2006) study also ranked soils and soils management as a least preferred need.

Dormondy and Torres' (2002) study determined perceptions among New Mexico State University pre-service agricultural education program graduates from 1990 to 2001 who were currently teaching agriculture and their attainment of teacher competencies and professional development activities which influenced their growth since graduation. Of the 28 statements, teacher's perceived low competency in using computer technology in the classroom, therefore this became a high priority inservice need. The lack of improvement of computer competency from time of graduation to current teacher status supported computer technology as a needed area for in-service professional development.

Elbert and Bagget's (2003) study identified the competencies perceived as needed by secondary level agricultural teachers in Pennsylvania to help them become more effective while working with disabled students. Areas where teachers felt the least competent included: completing

individual vocational education plans and individual education plans. According to the study, secondary agricultural education teachers need additional training to become more knowledgeable with laws that apply to special needs students (Elbert & Bagget, 2003). Teaching special needs students was not brought up in many of the other research studies, however, in the Sorensen et al. (2010) study, teaching disabled students was one of the top three competencies in which teachers had the least mean perceived ability. Duncan et al. (2006) study listed teaching learning disabled students as an in-service need in the category of Teaching and Learning.

Roberts and Dyer's (2004) study examined the in-service needs of alternatively certified agriculture teachers versus the needs of traditionally certified agriculture teachers. The greatest needs for traditionally certified teachers for in-service training under the FFA and SAE Supervision category included preparing proficiency award applications, preparing for career development events, and developing SAE opportunities for students. In the Instruction and Curriculum category, the greatest in-service need of alternative and traditional teachers was in changing the curriculum to meet the needs in technology. The traditionally certified teachers program management and planning category indicated a high need for writing grant proposals for external funding, building the image of agriculture programs and courses, recruiting and retaining quality students and establishing a working relationship with local media. Alternatively certified teachers also indicated a high need for in-service in writing grant proposals for external funding, building the image of agriculture programs and courses, and recruiting and retaining quality students. Traditionally certified teachers indicated a high level of need for in-service within the teacher professional development category, for managing and reducing work-related stress, time management tips and techniques, and professional growth and development. Alternatively certified teachers indicated a need for training in managing and reducing work-related stress and time management tips and techniques. Traditionally certified teachers expressed higher levels of in-service need than did alternatively certified teachers in six of the nine individual items that composed this construct (Roberts & Dyer, 2004).

Duncan et al. (2006) study analyzed Georgia agriculture teachers' perceived importance of, and competence in, a variety of professional agricultural teaching competencies to identify their in-service needs. The five highest rated pre-service/in-service preparation needs for Specific/Technical Areas included: integrating current advances in agriculture technology into the curriculum, teaching skills and concepts in small animal care and veterinary technology, teaching skills and concepts in animal biotechnology, and teaching skills and concepts in aquaculture. Teaching skills and concepts in soils and soil management, and animal science were the lowest ranked needs as perceived by the teachers. Highest ranking needs in Teaching and Learning Category included: motivating students to learn, teaching students to think critically and creatively, managing student behavior problems, and teaching learning disabled students. Planning and conducting fieldtrips and conducting adult program were the lowest ranked pre-service/in-service needs as perceived by the teachers.

Sorensen et al. (2010) study identified and prioritized the in-service needs of agriculture teachers in the state of Utah. The top six competencies in which in-service was needed included: utilizing the community in providing opportunities for students, developing SAE opportunities for all students, preparing FFA proficiency award applications, planning and implementing student recruitment activities, teaching learning disabled students, and making repairs to equipment and

tools. The lowest six competencies with the least in-service need included: how to set up a meeting room, conducting parent/teacher conferences, explaining the history and organization of FFA, explaining FFA degree areas, explaining proper dress/characteristics of a good FFA leader, and planning/organizing a FFA meeting. Conducting parent/teacher conferences was found as a low priority need for in-service in several other studies (Birkenholz & Harbstreit, 1987; Garton & Chung, 1997; Layfield & Dobbins, 2002). Planning and organizing FFA fundraisers and planning FFA banquets were also found in the least preferred in-service needs of experienced South Carolina teachers (Layfield & Dobbins, 2002). Organizing fundraising activities ranked as the third highest in-service need for South Carolina beginning teachers, which indicated a difference between in-service needs according to beginning and experienced teachers (Layfield & Dobbins, 2002). Several other research studies also ranked developing SAE opportunities for students as a high in-service need (Duncan et al., 2006; Garton & Chung, 1996; Layfield & Dobbins, 2002; Roberts & Dyer, 2004).

### **Findings**

Administering teacher needs assessments can prove to be a valuable tool to collect teacher input and determine priority area needs for in-service teacher professional development. This review of literature found through three decades of research that competency levels and priority areas of needs are diverse and somewhat inconsistent depending on the level of teaching experience (pre-service, novice, or experienced/senior teachers) and type of teacher certification (traditional or alternatively certified teachers). A contrast in needs was found among the competency areas, some of which included: completing reports and forms, managing student behavior problems, preparing contest teams, locating adequate teaching materials, and conducting adult education programs (Barrick et al., 1983; Birkenholz & Harbstreit, 1987; Claycomb & Petty, 1983; Garton & Chung, 1996; Joerger, 2002; Layfield & Dobbins, 2002).

While some competencies experienced inconsistent results, there were several competencies which had an overwhelmingly cohesive response. Technical agriculture competence was found to be not as much of a factor in teacher success, as program design and management and other categories related to managing the FFA component of the SBAE program (Claycomb & Petty, 1983; Garton & Chung, 1996; Joerger, 2002; Roberts & Dyer, 2004). Technology and computer use in the classroom was also a major competency area in which a majority of the data over two decades collectively agreed a priority need for in-service professional development existed. Teachers have requested computers as an additional material required for the teaching of agriscience courses and have noted not having appropriate general and software specific knowledge in information technology (Kotrlik et al., 2000; Newman & Johnson, 1994).

Portraying a positive image of the agricultural education program and utilizing effective public relations served as another competency which received cohesive agreement as a priority area in-service need (Dormondy & Torres, 2002; Duncan et al., 2006; Edwards & Briers, 1999; Garton & Chung, 1996; Layfield & Dobbins, 2002; Mundt & Connors, 1999; Roberts & Dyer, 2004). Another priority in-service need which received high perceived need for in-service professional development was FFA management and advising, particularly in the area of preparing FFA degree and proficiency award applications (Birkenholz & Harbstreit, 1987; Duncan et al., 2006; Edwards & Briers, 1999; Garton & Chung, 1996; Joerger, 2002; Layfield & Dobbins, 2002; Mundt & Connors, 1999; Roberts & Dyer, 2004; Sorensen et al., 2010). Providing special

education services may be an emerging priority need for agricultural education and career and technical education teachers (Duncan et al., 2006; Elbert & Bagget, 2003).

### **Conclusions, Implications, and Recommendations**

As a result of this review of literature across three decades of studies which conducted needs assessments for agricultural education teachers, it was determined that competencies in the areas of, technology and computer use in the classroom, developing a public relations program and support for the program, and FFA management and advising are categories of high priority for in-service needs. In-service teacher professional development opportunities should further emphasize these specified areas while honing in on specific skills needed by teachers such as time management, managing student discipline, and encouraging student motivation. Less emphasis should be placed on technical agriculture skills. Overarching themes occurred among the decades in reference to needs assessment competencies. Inconsistency among respondents answers for needs assessments categories were found in all three decades, with a difference between beginning and experienced teachers emerging. Technology use in the classroom emerged as an in-service need throughout the 1990 and 2000's literature, completing reports for administration and FFA management and advising surfaced as an in-service need in all three decades, and knowledge in teaching special needs students emerged in the 2000's.

The *National Research Agenda: American Association for Agricultural Education's Research Priority Areas for 2016-2020* indicated the need to provide a sufficient scientific and professional workforce to address the challenges of the 21<sup>st</sup> century. Through identifying common needs for agriculture teachers, the professional workforce will be better equipped to educate and prepare future agriculture leaders. It should be noted that professional development needs have varied dependent upon the types and experience level of the teachers. It is therefore recommended that a variety of professional development opportunities be designed and provided for agricultural education teachers dependent upon their level of experience. The National Association of Agricultural Educators (NAAE) has already begun to conduct in-service training at various levels of experience for agricultural education teachers. We recommend continuation and focused expansion of these types of teacher professional development programs.

Further teacher needs assessments studies should be conducted on a continual basis, taking into account the variation between experienced and beginning teachers. Identifying national trends in agricultural education will prove beneficial to determine the direction of the program and further address in-service needs as the number of states with timely and relevant needs assessment data increases (Duncan et al., 2006). Open communication between teacher education programs, teacher educators, school administration and teachers should occur in order to determine, design, and provide relevant in-service opportunities while also identifying national trends among in-service needs assessments. Although many of the instruments used to gather data in the studies conducted over the three decades were similar, there was little consistency and many discrepancies among the factors included for data collection. We recommend development of a cohesive and consistent instrument to be utilized nationwide to assist in better determining the professional development needs for a variety of agricultural education teachers which should include pre-service, novice, experienced, traditional and alternatively certified teachers.

## References

- Barrick, K.R., Ladewig, H.W., & Hedges, L.E. (1983). Development of a systematic approach to identifying technical in-service needs of teachers. *The Journal of American Association of Teacher Educators in Agriculture*, 24(1), 13-19.
- Birkenholz, R.J., & Harbstreit, S.R. (1987). Analysis of the in-service needs of beginning Vocational agriculture teachers. *The Journal of the American Association of Teacher Educators in Agriculture*, 28(1), 41-49
- Claycomb, D.M., & Petty, G.C. (1983). A three year longitudinal study of the perceived needs for assistance as ranked by vocational agriculture instructors. *Journal of the American Association of Teachers in Agriculture*, 24(4), 28-33.
- Dormondy, T.J., & Torres, R.M. (2002). A follow-up study of agricultural education program graduates on teaching competencies. *Journal of Agricultural Education*, 43(4), 33-45.
- Duncan, D.W., Ricketts, J.C., Peake, J.B., & Uessler, J. (2006). Teacher preparation of Georgia agriculture teachers. *Journal of Agricultural Education*, 47(2), 24-35.
- Edwards, M.C., & Briers, G.E. (1999). Assessing the in-service needs of entry-phase agriculture teachers in Texas: A discrepancy model versus direct assessment. *Journal of Agricultural Education*, 40(3), 40-49.
- Elbert, C.D. & C.D. Baggett. (2003). Teacher competence for working with disabled students perceived by secondary level agricultural instructors in Pennsylvania. *Journal of Agricultural Education*, 44(1), 105-115.
- Foster, Lawver, Smith & Thompson. (2016). National Agricultural Education Supply and Demand Study 2015 Executive Summary. Retrieved from: [aaaeonline.org/Teacher-Supply-And-Demand](http://aaaeonline.org/Teacher-Supply-And-Demand).
- Garton, B.L. & Chung, N. (1996). The in-service needs of beginning teachers of agriculture as perceived by beginning teachers, teacher educators, and state supervisors. *Journal of Agricultural Education*, 37(3), 52-58.
- Garton, B.L., & Chung, N. (1997). An assessment of the in-service needs of beginning teachers of agriculture using two assessment models. *Journal of Agricultural Education*, 38(3), 51-58.
- Joerger, R.M. (2002). A comparison of the in-service education needs of two cohorts of beginning Minnesota agricultural education teachers. *Journal of Agricultural Education*, 43(3), 11-24.
- Kotrlik, J.W., Redmann, D.H., Harrison, B.C., & Handley, C.S. (2000). Information

technology related professional development needs of Louisiana agriscience teachers. *Journal of Agricultural Education*, 41(1), 18-29.

Layfield, K. D., & Dobbins, T.R. (2002). In-service needs and perceived competencies of South Carolina agricultural educators. *Journal of Agricultural Education*, 43(4), 46-55.

Mundt, J.P., & Connors, J.J. (1999). Problems and challenges associated with the first years of teaching agriculture: A framework for preservice and in-service education. *Journal of Agricultural Education*, 40(1), 38-48.

Newman, M.E. & Johnson, D.M. (1994). In-service education needs of teachers of pilot agriscience courses in Mississippi. *Journal of Agricultural Education*, 35(1), 54-60.

Newton, R. R., & Rudestam, K. E. (1999). *Your statistical consultant*. Thousand Oaks, CA: Sage.

Roberts, T.G. & Dyer, J.E. (2004). In-service needs of traditionally and alternatively certified agriculture teachers. *Journal of Agricultural Education*, 45(4), 47-70.

Roberts, T.G., Harder, A., & Brashears, M.T. (Eds). (2016). *American Association for Agricultural Education national research agenda: 2016-2020*. Gainesville, FL: Department of Agricultural Education and Communication.

Ruhland, S.K. & C.D. Bremer. (2001). Professional development needs of novice career and technical education teachers. *Journal of Career and Technical Education*.

Sorensen, T.J., Tarpley, R.S., & Warnick, B.K. In-service needs of Utah agriculture teachers. (2010). *Journal of Agricultural Education*, 51(3), 1-11.

# INTEGRATION OF OUTDOOR CLASSROOMS INTO SCHOOLS

H. Lillian Goldsmith, University of Georgia

Eric D. Rubenstein, University of Georgia

## Abstract

*Since 1990, environmental education (EE) has become more integrated into K-12 education through EE programs. A synthesis of research identified overall themes, outcomes, benefits, and challenges surrounding research integrating outdoor learning into mandatory curriculum. Most research on outdoor classroom focuses on student development, attitude, and knowledge changes along with teachers' factors for adaptation. Students engaged in outdoor learning have more positive attitudes toward school, feel more responsibility and ownership over school work, demonstrate improved confidence and self-esteem, and improved achievement in testing. More research should be conducted surrounding students daily student behavior and achievement after participating in outdoor classroom learning.*

Keywords: Outdoor classrooms, student achievement, experiential education, outdoor learning

## Introduction

Environmental education (EE) was established to foster awareness and concern, not only for environmental issues but also for economic, social, political, and ecological issues in urban and rural areas (Unesco-Unep, 1978; United Nations Educational, Scientific and Cultural Organization, 1975). In 1990, the United States Environmental Protection Agency created the National Environmental Education Act that set up training, fellowships, awards and grants for environmental education professionals and youth, and the National Environmental Education Training Foundation (United States Environmental Protection Agency, 1990). The United States Environmental Protection Agency reinforced that “environmental education does not advocate a particular viewpoint or course of action. Rather, environmental education teaches individuals how to weigh various sides of an issue through critical thinking and it enhances their own problem-solving and decision making skills” (United States Environmental Protection Agency, 2015), para. 3).

Since 1990, EE has become more integrated into K-12 education through programs which integrate mandatory school curriculum into complimentary environmental lesson plans (Project Learning Tree, 2015; Project WET, 2015), provide educators with clear guidelines and assessment tools, and encourage environmental literacy (North American Association for Environmental Education, 2010). Environmental literacy has been measured based on: 1.



knowledge of natural and human systems, 2. inquiry skills, 3. skills for decision and action, and 4. personal responsibility (Berkowitz, Archie, & Simmons, 1997). Environmental literacy measurements provides educators and researchers with a reputable way to measure effects of outdoor education.

Priest (1986) defined outdoor education as an “experiential process of learning by doing, which takes place primarily through exposure to the out-of-doors” (p. 13). Outdoor learning engages students in all three learning domains including the cognitive, affective, and psychomotor to increase environmental literacy (Barnett et al., 2006; Bogner, 2002; Carrier, 2009; Chawla, 2007; Dillon et al., 2006; Priest, 1986). According to current research, outdoor classrooms encouraged students’ positive environmental knowledge, attitudes, development, and academic performance (Änggård, 2010; Ballantyne & Packer, 2009; Bogner, 2002; Chambers & Radbourne, 2014; Dennis, Wells, & Bishop, 2014; Dillon et al., 2006; Eick, 2012; Rios & Brewer, 2014). Researchers must understand the overall relationship between outdoor learning, development, education, and the role that outdoor learning facilitates in this relationship. Comparing the findings from current studies about outdoor learning would assist in the evaluation of the utility of outdoor classrooms for teachers, impacts on student learning, and would appraise the current research base to identify reoccurring themes and knowledge gaps.

## **Literature Review**

Education in the United States has shifted specifically towards meeting higher standards in science, technology, engineering, and math (STEM) over the past 10 years (United States Department of Education, 2015). Teachers who have taught applied lessons in outdoor settings observed better retention of material, beneficial behavioral changes in students, and higher achievement on standardized tests (Ghent, Trauth-Nare, Dell, & Haines, 2014; Lieberman & Hoody, 1998; Rios & Brewer, 2014; Weise, 2012; Wirth & Rosenow, 2012). Further, experiential and sensory learning techniques were used in outdoor EE to engage students in holistic learning (Wirth & Rosenow, 2012).

Students’ experiment and learn from their own experiences, which have been encouraged and developed through interdisciplinary, integrated, hands-on, and sensory-based learning experiences (Änggård, 2010; Dillon et al., 2006; National Research Council (NRC), 2010; Wirth & Rosenow, 2012). Successful outdoor education included teaching through interdisciplinary curriculum and the experiential learning process using methods such as observing nature, conducting experiments, and exploring natural surroundings (Änggård, 2010; Dillon et al., 2006; Eick, 2012; NRC, 2010; Priest, 1986; Rios & Brewer, 2014; Wirth & Rosenow, 2012). To increase the likelihood that long-term impacts will be displayed in behavior, attitudes, knowledge, skills and cognitive changes, teachers should increase students’ exposure to EE (Stern, Powell, & Ardoin, 2008). However, many teachers reported they were unable to utilize outdoor EE due to the inability to acquire the resources, space, along with financial or administrative support (Ernst, 2007; Mirka, 1973).

The overall impact of outdoor classrooms on students learning and development has not yet been synthesized as a whole. Comparing the characteristics of outdoor learning settings,

teaching techniques, and student outcomes in education studies would not only help evaluate the value of existing literature but also identify the current trends, knowledge gaps, and areas of overlap. Therefore, this study aimed to synthesize the existing literature base to identify current trends and knowledge gaps.

### Purpose

The purpose of this research was to identify the overall themes, benefits, and challenges surrounding research on integrating outdoor learning into mandatory curriculum. The research questions that guided this study were:

1. What are the main themes and outcomes relating to research surrounding outdoor environmental education?
2. What are the benefits and challenges of integration outdoor environmental education into standard classroom curriculum?

### Methods

A synthesis of peer reviewed articles pertaining to outdoor classrooms and outdoor education was conducted. Articles were first identified by reviewing the table of contents within mainstream EE journals that included *The Journal of Environmental Education*, *Environmental Education Research*, and *Applied Environmental Education and Communication*. Articles (n=64) were identified using keywords “outdoor classroom”, “outdoor education”, and “outdoor classroom effects”. The search was later expanded to the University library portal and Google Scholar using the same key words. Studies were considered for review if outdoor classrooms were included in the focus of the research as a study variable. Studies that met these criteria were evaluated for main outcomes and findings. Sixty four articles were identified, but only fifty four met the required review criteria for outdoor classrooms.

All articles were carefully reviewed and an annotated bibliography was created. The main focus points from each article were recorded and then examined and grouped into the following codes: achievement, knowledge, teaching methods, classroom management, child development, behavior, attitudes, and family and community learning. Coding definitions can be found in Table 1. Articles that addressed multiple codes were placed and addressed in each code accordingly.

Table 1

*Code and sub-code definitions, amount of articles identified in each code*

Code and Sub-code	Definition	# Articles Identified
<b>Teaching Methods</b>	Successful methods and practices used in facilitating learning in outdoor classrooms	33
Factors of using outdoor classrooms	Barriers to using outdoor classrooms, characteristics of successful outdoor classrooms	12

Teacher based	Methods for teacher planning, curriculum development, assessment, and training	17
Student based	Student led activities, programs, exploration, and learning by doing	6
Environment Based	Experience of environment facilitated learning, impact of outdoor settings	12

Code and Sub-code	Definition	# Articles Identified
<b>Management and Development</b>	Effects of outdoor classrooms on classroom management and child development	13
Student behavior, engagement, and concept of self	Impact of outdoor classroom on students classroom behavior, level of engagement, and students confidence level, comfort, and/or self-esteem	9
Play	Outdoor classrooms and natural areas used as a venue to impact imaginative, social, and physical play	6
Code and Sub-code	Definition	# Articles Identified
Standardized Testing	Impact measured by student performance on standardized testing	6
Environmental Knowledge	Impact measured by environmental knowledge as defined by environmental literacy including knowledge of natural and human systems, inquiry skills, skills for decision and action, and personal responsibility(Berkowitz, Archie, & Simmons, 1997)	6
Other Knowledge	Impact measured by students gain on a specific subject or application but did not measure for environmental knowledge as a whole i.e.) species, water cycle, climate change, communication, garden knowledge	11
<b>Behavior and Attitudes</b>	Observed changed in student behaviors and attitudes after participation in outdoor classrooms	20
Length of program and other factors	Impact of length of program and other factors on changes in student behaviors and attitudes	6
Environmental attitude and stewardship	Change of students environmental attitude and stewardship defined as a care to protect or conserve the environment	19

### **Trustworthiness & Rigor**

Lincoln and Guba (1985) stated that qualitative research must ensure the credibility, transferability, dependability, and confirmability of the research. To ensure credibility, researchers used thick descriptions in the reporting of data. The researchers utilized peer debriefing, prolonged engagement, and triangulation of sources. During the data analysis process, one of the researchers analyzed the data and met with the other researcher to conduct peer-debriefing sessions to ensure the credibility of the data analysis process. A methodological journal was utilized to address the dependability and confirmability of the study (Lincoln & Guba, 1985). The methodological journal was utilized to describe the methodological decisions made by the researchers throughout the study.

### **Subjectivity Statement**

The primary researcher received an undergraduate degree in natural resources conservation with a focus on environmental education and is currently pursuing a Master's degree in agriculture and environmental education. The second researcher is an assistant professor in agriculture education and received formal preparation in agriculture education at both an undergraduate and graduate level. During their teaching career the second researcher has utilized environmental education to enhance the agriculture curriculum.

## **Findings**

### **Environmental Education Limiting Factors**

**Factors influencing use of outdoor classrooms.** Successful outdoor classroom programs maintained the following characteristics 1.) financially self-sufficient, 2.) physically isolated from the school due to the nature of outdoor field classes, 3.) teachers were visible and active in the school, and 4.) classrooms were supported from a broad network of allies (Sharpe & Breunig, 2009). However, studies that included challenges or factors that restrained teachers from using outdoor classrooms were more prominent. The main barriers for using outdoor classrooms as reported by teachers include: transportation, teacher ability, funding, state testing, planning time, safety/liability, and access (Barnett et al., 2006; Comishin, Dymont, Potter, & Russell, 2004; Dillon et al., 2006; Ernst, 2007; Ernst, 2009; Ernst, 2012; Ernst & Tornabene, 2012; Ernst, 2014; Mirka, 1973).

Simmons (1998) also found that teachers perceived different risks and challenges for teaching in natural areas. Risk is often present in outdoor classrooms, however overly nervous teachers can diminish the positive effects of outdoor learning (Stan & Humberstone, 2011). Along with risk, another inherent aspect of outdoor learning is the physical conditions of the environment which can present a different set of risks. Physical conditions (weather) should be taken into account when planning activities along with assessing the students learning throughout the outdoor lesson (Moncrieff, 2012). Teachers reported that they would feel more comfortable teaching and could teach well in outdoor settings if training was offered (Simmons, 1998). Additionally, pre-service teachers who were trained and practiced teaching outdoors felt more comfortable in integrating outdoor experiences into the curriculum (Bennett & Heafner, 2004)

**Teacher needs for implementation.** Teachers in Switzerland have stated that using outdoor classrooms allowed teachers to integrate material, children to explore the surrounding environment, and increased the overall environmental literacy of the students (Lindemann-Matthies, 2011). Teachers' passion and ability to teach in the outdoors can positively and negatively affect a student's learning in the outdoors (Martin, 2003). Another study used on-site training to accommodate the busy schedule of teachers and for teachers to obtain hands on experience (Kenney, Militana, & Donohue, 2003). Hands-on training allowed teachers to become familiar with equipment and obtain direct feedback (Moseley, Huss, & Utley, 2010).

Successful teachers in outdoor classrooms develop curriculum that links outdoor and formal classroom lessons and uses the environment as a context for learning (Chambers & Radbourne, 2014; Eick, 2012). Teachers and administrators report that using the environment in teaching increased their enthusiasm and commitment toward teaching (Lieberman & Hoody, 1998). Teaching outdoors also resulted in better working relationships with students and colleagues, provided more opportunities to explore new subject matter than traditional, discipline-based teaching, and allowed for more frequent occasions to use innovated instructional strategies (Lieberman & Hoody, 1998).

Students aged 8-17 reported field investigation, story, and drama as the most successful learning tools used in one outdoor learning experience (Ballantyne & Packer, 2009). Another study concluded that active learning activities such as leaf rubbing or hiking with a ranger resulted in long term retention of the material presented (Farmer, Knapp, & Benton, 2007). Ballantyne and Packer (2002; 2009) found worksheets and teacher presentations to be the least effective and most unenjoyable for students. At another school, teachers developed backpack lessons (Weise, 2012). Teachers could check out a backpack which included all the materials and curriculum needed to teach a lesson in the established outdoor classroom (Weise, 2012). Furthermore, teachers can also take advantage of the many resources offered through the state, national, and worldwide network (Wirth & Rosenow, 2012). Positive effects on student learning have also been found when teachers prepare students for the outdoor learning experience with pre-experience activities and reinforce the concepts learned with post-experience activities (Smith-Sebasto & Cavern, 2006; Stern, et al., 2008).

**Student based.** Outdoor classrooms often take the shape of student led activities and exploration. Students have reported that field investigation, story time, drama, hiking, and seeing plants and wildlife as the most enjoyable and effective activities in outdoor learning (Ballantyne, & Packer, 2009; Farmer, Knapp, & Benton, 2007), which encouraged students to explore nature using all of their senses (Änggård, 2010). Exploration of the surrounding

environment while engaging all of the students senses has been facilitated by play based activities and child led programs in successful English Forest Schools and Danish Udeskoles which immerse children in outdoor learning every day for a majority, if not the entire day (Waite, Bølling, & Bentsen, 2015). Further, student led learning gardens have been established in the United States with teachers supporting the learning through integrated curriculum (Kozak & McCreight, 2013; Ruiz-Gallardo, Verde, & Valdés, 2013). Students in these programs planned, planted, tended, and harvested the garden in which teachers supported them by providing curriculum related assignments such as measuring plant growth, gathering harvest data, calculating the area of the garden, and/or writing garden reports (Kozak & McCreight, 2013; Ruiz-Gallardo et al., 2013).

**Environment based.** The most impactful outdoor classrooms integrate student and environment based learning. Outdoor classrooms can be located anywhere outdoors but are especially efficient when located near a school, such as in the playground, a nearby park, forest, river, or pond (NRC, 2010). The outdoor setting enriches classroom lessons and provides meaningful background knowledge and experiences to facilitate learning (Chambers & Radbourne, 2014; Rios & Brewer, 2014). Ballantyne and Packer (2009) introduced a new pedagogy for experiential learning that incorporated learning by doing, being in the environment, real life experience, sensory engagement, and local context. The authors concluded that the greatest benefits will be obtained from the use of experiential learning instructional strategies in natural environments. English, Swedish, and Danish outdoor learning programs focused on experiential, child led, learning primarily in the outdoors (Änggård, 2010; Waite et al., 2015). These outdoor learning programs demonstrated the positive health, cognitive, and physical development effects possible with successful outdoor instruction. The pedagogy used in English, Swedish, and Danish outdoor learning programs parallel with that proposed by Ballantyne & Packer (2009) where positive effects on children's health, cognitive, and physical development were noted (Änggård, 2010; Waite et al., 2015). In the United States, garden based learning (Kozak & McCreight, 2013; Miller, 2007; Ruiz-Gallardo et al., 2013) and school yard learning through state and nationwide projects (Kenney et al., 2003; Martin, 2003) have been shown to be extremely effective in deepening students comprehension of standard curriculum by creating a relevant, hands-on, outdoor experience.

## **Management and Development**

**Student behavior, engagement, and concept of self.** Students who were engaged in curriculum that integrated outdoor learning displayed improved behavior in and out of the classroom (Chambers & Radbourne, 2014). Teachers also noticed that being in outdoor classrooms allowed for positive behavior and cooperation along with longer student engagement, and more space for movement resulting in less conflict (Dennis et al., 2014; Rios & Brewer, 2014). Learning on school grounds resulted in greater confidence, stronger motivation towards learning, and a greater sense of belonging and responsibility (Dillon et al., 2006). Greenspaces and natural areas helped decrease the severity of attention disorders (Taylor & Kuo, 2006; Wirth & Rosenow, 2012). Chawla (2007) found that children are most engaged when the environmental features were responsive and gave immediate feedback to the child's actions. In a study where "at-risk" secondary education students were placed in a garden-based learning environment, the students showed improved attitudes towards school, higher participation rates,

felt responsibility for work, increased self-esteem, and self-confidence (Ruiz-Gallardo et al., 2013).

**Student venues for play and development of social, cognitive, physical, and emotional domains.** Outdoor, natural environments provide a wider variety of play behaviors for children (Dennis et al., 2014). Established outdoor schools in England, Denmark, and Sweden emphasize allow and encourage students to conduct experiments, engage in imaginary play, develop motor skills by playing with loose material such as sticks and leaves, and learn to manage both positive and negative emotions (Änggård, 2010; Waite et al., 2015). Outdoor spaces have been found to encourage creative play that stimulates positive cognitive, social, and emotional development (Kellert, 2002; Malone & Tranter, 2003; Taylor & Kuo, 2006; Wirth & Rosenow, 2012).

## **Knowledge and Assessment**

**Standardized testing.** Positive correlations between standardized testing scores and/or classroom performance and the use of outdoor classrooms has been recorded throughout the literature base (Eick, 2012; Ghent et al., 2014; Lieberman & Hoody, 1998; Rios & Brewer, 2014; Ruiz-Gallardo et al., 2013; Taylor & Kuo, 2006). Eick (2012) used outdoor classroom lessons to meet curriculum standards in a third grade classroom which resulted in increased achievement in the state literacy standardized test. Chambers and Radbourne (2014) reported that students who participated in curriculum that integrated learning in the environment showed higher scores on standardized testing and better ability to apply knowledge and skills across multiple contexts. In a national study in the United States, researchers found that students enrolled in programs that used the environment as the integrating content had significantly better performance on standardized testing in reading, writing, math, science, and social studies (Lieberman & Hoody, 1998).

Another study focused on the influence of a green school initiative which integrated environmental education and hands on field learning into the curriculum on student achievement on Maryland standardized tests (Ghent et al., 2014). Students enrolled in schools with the green school initiative had significantly higher test scores on all content area assessments, except biology (Ghent et al., 2014). A study of “at-risk” students enrolled in a garden based learning program led to decreased rates of dropout and failure rates and a progressively increasing amount of successful students who more frequently passed classes and graduated from high school (Ruiz-Gallardo et al., 2013). In a 14 week environmental education curriculum integration program for fourth and fifth graders, the researchers found that male students scored significantly higher from exposure to outdoor learning (Carrier, 2009). Carrier (2009) showed that both boys and girls increased performance after the outdoor learning program; however, it was argued that boys may have benefited more from the active outdoor learning experiences. Whereas girls showed higher comfort in traditional classrooms, boys and girls shared similar comfort in the outdoor classroom (Carrier, 2009).

**Environmental knowledge.** Students in both elementary and secondary schools have reported looking forward to learning about and experiencing the environment when taking trips to an outdoor area and have gained environmental knowledge after their experience (Ballantyne & Packer, 2002). Outdoor field based studies in a Boston public school system revealed that after participating in the yearlong program, students had a better understanding of science methodology, science as an authority, and a positive ecological mindset, along with having a significantly higher desire “to be a scientist” (Barnett et al., 2006). Curriculum that integrated learning in the environment has been found to heighten students’ ethic of care for the environment along with increasing environmental literacy and ecological understanding (Chambers & Radbourne, 2014). In a group of fourth graders, students who were exposed to a field trip to a National Park were able to retain and explain general content along with ecological and environmental knowledge presented during the trip both immediately after and a year after the trip (Farmer et al., 2007). Another study of fourth and fifth grade students who were exposed to outdoor learning experiences in their school yard displayed significantly higher environmental knowledge and comfort levels (Martin, 2003).

**Other knowledge.** Studies used pre- and post-tests to examine knowledge gains towards a specific topic. Studies often included a long term retention test. One study created a pre- and post-test to quantify the effects of an outdoor classroom in regard to small animals such as insects and invertebrates (Drissner, Hans-Martin, Rinderknecht, & Hille, 2013). The authors found that the students who were exposed to the experiential outdoor learning had greater understanding and fewer misconceptions towards the animals (Drissner et al., 2013). A similar study analyzed the effect of outdoor education on retained knowledge of plants and also found that participant’s knowledge significantly increased in the immediate post and retention test three months later when exposed to outdoor education (Fancovicova & Prokop, 2011). Further, Randler et. al (2005) displayed a similar trend in knowledge gain in finding significant gains in knowledge toward amphibians for students exposed to an outdoor aspect in an amphibian conservation program for elementary school students. Powell and Wells (2002) measured knowledge gain from different types of experiential lessons and found no significant differences. The authors argued that since all lessons were experiential on different levels, any experiential lesson was found to be effective (Powell & Wells, 2002). Sellmann and Bogner (2013) also found a significant increase in knowledge scores from students exposed to an outdoor learning program in a botanical garden.

Studies also used qualitative methods such as interviews and observation to obtain data. Chambers and Radbourne (2014) observed increased ability to interact with the environment and communicate the experience through multiple communication methods, along with improvement in students inferring and making connections. Elementary students engaged in a school garden showed a deep knowledge and understanding of the garden facilitated by the students implementing and taking responsibility for the garden (Kozak & McCreight, 2013). In a similar account, elementary students were exposed to hands-on applications of math, science, and language by participating in gardening activities (Miller, 2007). An outdoor classroom provided a place for students to learn naturally, better retained the information, allowed teachers to meet standards of learning and provided an area for the community after school hours to use for reaction, reflection, and extra family learning (Weise, 2012). By allowing extra after school hours, knowledge learned by students was often shared between students and families



developing a multigenerational education from the presence of the outdoor classroom (Weise, 2012).

## Behavior and Attitudes

**Length of program and other factors.** Longer programs with more exposure to the outdoors have been found to be more likely to foster positive environmental behavior and attitudes (Bogner, 1998; Powers, 2004; Smith-Sebasto & Cavern, 2006; Stern et al., 2008). Bogner (1998) found that a five day program created a more positive environmental behavior than one day program. Along with longer exposure pre- and post-activities prior to and following the program also created a more positive impact on environmental behavior and attitudes (Smith-Sebasto & Cavern, 2006; Stern et al., 2008). In another study, Powers (2004) found that there was no significant change in knowledge gained from a one day versus a five day outdoor field experience. Studies on the differences in boys and girls in outdoor learning environments found that girls displayed more positive changes in attitude and behavior than boys (Carrier, 2009; Martin, 2003).

Recently, behavior and attitudes has been seen as a main outcome of outdoor learning. Researchers gather primarily self-reported data through two main methods including quantitative pre- and post- surveys or questionnaires. Additionally, qualitative observation, interviews, and analysis of student work to measure outcomes. The self-reported behaviors and attitudes and pre-/post- test methods as shown in Table 3, have been heavily favored in current research.

Table 3  
*Methods for researching student attitudes and behavior*

Author, Year	Self-Reported Behavior	Self-Reported Attitudes	Observer Reported Student Attitudes (Teacher/Administrator)	Observation/Interview	Pre/Post Test
Ballantyne & Packer, 2002	x	x			x
Ballantyne & Packer, 2009	x	x		x	
Barnett, Lord, Strauss, Rosca, Landford, & Deni, 2006		x			x
Bogner, 1998	x	x			x
Bogner, 2002		x			x
Carrier, 2009	x	x			x
Chambers & Radbourne, 2014		x		x	
Dettman-Easler & Pease, 1999		x			x

Drissner, Hease, Rinderknecht & Hille, 2013		x			x
Fančovičová & Prokop, 2011		x			x
Farmer, Knapp & Benton, 2007	x	x		x	
Kenney, Militana & Donohue, 2003			x	x	
Martin, 2003	x	x			x
Miller, 2007				x	
Powers, 2004		x			x
Smith-Sebasto & Cavern, 2006		x			x
Stern, Powell, & Ardoin, 2008	x	x			x

**Environmental attitude and stewardship.** Other literature reviews have found the current research base to reveal that outdoor learning and field visits improve students' positive attitudes toward the environment (Dillon et al., 2006; Rios & Brewer, 2014). Student participation in outdoor learning improved students' attitude toward school (Ruiz-Gallardo et al., 2013) and increases students' desire to pursue a career in the scientific field (Barnett et al., 2006). In adolescent students, hands-on science involvement stimulated more positive environmental attitudes along with creating a significant response to human dominance and altering nature (Bogner, 2002). Students' attitudes towards wildlife (Dettmann-Easler & Pease, 1999), small invertebrates (Drissner et al., 2013), and plants (Fancovicova & Prokop, 2011) increased significantly compared to an indoor class after being exposed to outdoor learning programs. Along with showing greater awareness towards the environment, involvement in outdoor learning resulted in an ethic of care for the environment (Chambers & Radbourne, 2014) and overall positive environmental attitudes in elementary students (Kenney et al., 2003; Miller, 2007)

**Environmental behavior.** Although there was only a small amount of literature that examines outdoor learning effects on behavior changes, the findings so far have been promising. One study found that students reported having more positive behavior in natural areas and changing household practices such as amount of shampoo used, recycling, and water conservation after being exposed to a nature based educational field trip (Ballantyne & Packer, 2002). A similar study found that outdoor learning field trips fostered positive environmental behaviors and attitudes such as negativity towards littering, along with carpooling and riding bikes instead of driving (Farmer et al., 2007). Moreover, Ballantyne & Packer (2009) found that students' capacity and willingness to act responsibly toward the environment increased after exposure to outdoor learning.

### Conclusion/Implications

Teachers' main barriers to using outdoor settings for teaching are lack of funding and lack of teacher knowledge or skills in teaching outdoors although teachers have identified natural settings as conducive for instruction (Ernst, 2007; Ernst, 2009; Ernst, 2012; Ernst & Tornabene,

2012; Ernst, 2014; Mirka, 1973; Simmons, 1998). However, teachers use of outdoor classrooms resulted in positive effects on achievement, standardized testing focus, attention span, application of knowledge gained to other contexts and improved classroom behavior (Änggård, 2010; Ballantyne & Packer, 2002; Barnett et al., 2006; Bogner, 1998; Chambers & Radbourne, 2014; Comishin et al., 2004; Drissner et al., 2013; Eick, 2012; Ghent et al., 2014; Lieberman & Hoody, 1998; Rios & Brewer, 2014).

Students engaged in outdoor learning have more positive attitudes toward school, feel more responsibility and ownership over school work, and demonstrate improved confidence and self-esteem (Barnett et al., 2006; Eick, 2012; Kozak & McCreight, 2013; Ruiz-Gallardo et al., 2013). During lesson planning, curriculum should be developed to integrate standards of learning in order to capitalize on the positive impacts of outdoor learning. Therefore, teacher preparation programs must continue to prepare preservice teachers and environmental educators to properly use outdoor classrooms. Outdoor learning settings provide a venue for young children to play and learn along with developing in physical, cognitive, affective, and emotional domains at all levels of development (Änggård, 2010; Kellert, 2002; Miller, 2007; Wells, 2000; Wirth & Rosenow, 2012). Early childhood teachers especially, should make use of extra cognitive, physical, social, and emotional stimulation that outdoor classrooms provide to promote child development. Outdoor classrooms allow students to develop positive environmental behavior and attitudes that include an ethic of care and stewardship for the environment (Ballantyne & Packer, 2002; Ballantyne & Packer, 2009; Bogner, 2002; Dettmann-Easler & Pease, 1999; Farmer et al., 2007).

There were gaps in the literature identified by this study. Teaching techniques in outdoor settings are inherently different than in a formal classroom, yet the differences are rarely found in the literature base. Further, outdoor educator characteristics and traits have not been explored. Although preservice teacher trainings have been explored by a few studies, the research surrounding training preservice teachers and professional development is incomplete. Finally, current literature focuses on the outputs of outdoor programs. However, there lacks a literature base on the overall inputs of successful programs that could be replicated.

### **Recommendations**

Further investigation needs to be done in outdoor learning programs. Therefore, the researchers propose the following recommendations for future practitioners to consider:

1. Early childhood educators should use outdoor classrooms as an arena for extra stimulation in a child's cognitive, physical, social, and emotional development.
2. Expose students to the outdoors regularly, explore with all senses, create experiences that provide context and application of the material presented, and provide pre- and post-activities to reinforce gains made in the outdoor classroom.
3. Agriculture educators should take advantage of the resources and training available both locally and nationally.
4. Agriculture educators must understand that there is an inherent risk associated with learning outdoors which must be addressed and managed for; however, the risk should not prevent

teachers from discouraging students to explore and experiment in natural settings within reason.

5. Agriculture educators in classroom settings should work to further integrate outdoor education into mandatory curriculum.

The authors propose the following recommendations for university faculty:

1. Offer teacher preparation and professional development so preservice teachers are prepared to offer students with hands on, engaging, outdoor learning upon entering the workforce in both formal and non-formal teaching.
2. Develop a standard outdoor teacher training with best practices to enhance student engagement, learning, and risk management.

Finally, the authors propose the following recommendations for researchers to:

1. Further studies in student achievement and knowledge, especially with implications for standardized testing, should be continued.
2. Continue to study outdoor learning effects on behavior. This can be observed in daily life through actions such as recycling behavior, water conservation as well as classroom behavior changes.
3. Future studies should focus on other outdoor learning input, overall program structure, and educator characteristics.
4. Future studies should complement the current literature base with observation, interviews, and/or focus groups for richer data to further understand the implications and outcomes of outdoor classrooms.
5. Child development in outdoor learning settings should also be pursued to create teacher best practices based on the student's current stage of development.

## References

- Änggård, E. (2010). Making use of "nature" in an outdoor preschool: Classroom, home and fairyland. *Children Youth and Environments*, 20(1), 4-25.
- Ballantyne, R., & Packer, J. (2002). Nature-based excursions: School students' perceptions of learning in natural environments. *International Research in Geographical and Environmental Education*, 11(3), 218-236.
- Ballantyne, R., & Packer, J. (2009). Introducing a fifth pedagogy: Experience-based strategies for facilitating learning in natural environments. *Environmental Education Research*, 15(2), 243-262.
- Barnett, M., Lord, C., Strauss, E., Rosca, C., Langford, H., Chavez, D., & Deni, L. (2006). Using the urban environment to engage youths in urban ecology field studies. *Journal of Environmental Education*, 37(2;2), 3-11.

- Bennett, K. R., & Heafner, T. L. (2004). Having a field day with environmental education. *Applied Environmental Education and Communication*, 3(2), 89-100.
- Berkowitz, A. R., Archie, M., & Simmons, D. (1997). Defining environmental literacy: A call for action. *Bulletin of the Ecological Society of America*, (2), 170-172.
- Bogner, F. X. (1998). The influence of short-term outdoor ecology education on long term-variables of environmental perspective. *Journal of Environmental Education*, 29(4), 17.
- Bogner, F. X. (2002). The influence of a residential outdoor education programme to pupil's environmental perception. *European Journal of Psychology of Education*, 17(1), 19-34.
- Carrier, S. J. (2009). Environmental education in the schoolyard: Learning styles and gender. *Journal of Environmental Education*, 40(3), 2-12.
- Chambers, J. M., & Radbourne, C. (2014). Teaching critical literacy skills through the natural environment "as" text. *Applied Environmental Education and Communication*, 13(2), 120-127.
- Chawla, L. (2007). *Childhood experiences associated with care for the natural world: A theoretical framework for empirical results*. Colorado University. doi:10.7721/chilyoutenvi.17.4.0144
- Comishin, K., Dymont, J. E., Potter, T. G., & Russell, C. L. (2004). The development and implementation of outdoor-based secondary school integrated programs. *Applied Environmental Education and Communication*, 3(1), 47-53.
- Dennis, S. F., Wells, A., & Bishop, C. (2014). *A post-occupancy study of nature-based outdoor classrooms in early childhood education*. Colorado University. doi:10.7721/chilyoutenvi.24.2.0035
- Dettmann-Easler, D., & Pease, J. L. (1999). Evaluating the effectiveness of residential environmental education programs in fostering positive attitudes toward wildlife. *Journal of Environmental Education*, 31(1), 33.
- Dillon, J., Rickinson, M., Teamey, K., Morris, M., Choi, M. Y., Sanders, D., & Benefield, P. (2006). The value of outdoor learning: Evidence from research in the UK and elsewhere. *School Science Review*, 87(320), 107.
- Drissner, J., Hans-Martin, H., Rinderknecht, A., & Hille, K. (2013). Effective environmental education through half-day teaching programmes outside school. *ISRN Education*, doi:10.1155/2013/503214
- Eick, C. (2012). Use of the outdoor classroom and nature-study to support science and literacy learning: A narrative case study of a third-grade classroom. *Journal of Science Teacher Education*, 23(7), 789-803. doi:10.1007/s10972-011-9236-1

- Ernst, J. (2007). Factors associated with K-12 teachers' use of environment-based education. *Journal of Environmental Education*, 38(3), 15-32.
- Ernst, J. (2009). Influences on US middle school teachers' use of environment-based education. *Environmental Education Research*, 15(1), 71-92. doi:10.1080/13504620802710599
- Ernst, J. (2012). Influences on and obstacles to K-12 administrators' support for environment-based education. *Journal of Environmental Education*, 43(2), 73-92. doi:10.1080/00958964.2011.602759
- Ernst, J. (2014). Early childhood educators' use of natural outdoor settings as learning environments: An exploratory study of beliefs, practices, and barriers. *Environmental Education Research*, 20(6), 735-752. doi:10.1080/13504622.2013.833596
- Ernst, J., & Tornabene, L. (2012). Preservice early childhood educators' perceptions of outdoor settings as learning environments. *Environmental Education Research*, 18(5), 643-664. doi:10.1080/13504622.2011.640749
- Fancovicova, J., & Prokop, P. (2011). Plants have a chance: Outdoor educational programmes alter students' knowledge and attitudes towards plants. *Environmental Education Research*, 17(4), 537-551.
- Farmer, J., Knapp, D., & Benton, G. M. (2007). An elementary school environmental education field trip: Long-term effects on ecological and environmental knowledge and attitude development. *Journal of Environmental Education*, 38(3), 33-42.
- Feldman, R. S. (2012). Theoretical perspectives and research. In J. Mosher (Ed.), *Child development* (6th ed., pp. 19-49) Pearson Education, Inc.
- Ghent, C., Trauth-Nare, A., Dell, K., & Haines, S. (2014). The influence of a statewide green school initiative on student achievement in K-12 classrooms. *Applied Environmental Education and Communication*, 13(4), 250-260.
- Kellert, S. R. (2002). Experiencing nature: Affective, cognitive, and evaluative development in children. In P. H. J. Kahn, S. R. Kellert, P. H. J. (. Kahn & S. R. (. Kellert (Eds.), (pp. 117-151). Cambridge, MA, US: MIT Press.
- Kenney, J. L., Militana, H. P., & Donohue, M. H. (2003). Helping teachers to use their school's backyard as an outdoor classroom: A report on the watershed learning center program. *Journal of Environmental Education*, 35(1), 18-26.
- Kozak, M. S., & McCreight, J. (2013). We grew it!: Enrichment through gardening in elementary school. *Applied Environmental Education & Communication*, 12(1), 29-37. doi:10.1080/1533015X.2013.795833

- Lieberman, G. A., & Hoody, L. L. (1998). Closing the Achievement Gap: Using the Environment as an Integrating Context for Learning. Results of a Nationwide Study.
- Lincoln, Y., & Guba, E. (1985). *Naturalistic inquiry*. Newbury Park, California: SAGE Publications.
- Lindemann-Matthies, P. (2011). Swiss elementary school teachers' attitudes toward forest education. *Journal of Environmental Education*, 42(3), 152-167. doi:10.1080/00958964.2010.523737
- Malone, K., & Tranter, P. J. (2003). School grounds as sites for learning: Making the most of environmental opportunities. *Environmental Education Research*, 9(3), 283.
- Martin, S. C. (1999). The influence of outdoor school yard experiences on elementary students' environmental knowledge, attitudes, behaviors, and comfort levels. *Journal of Elementary Science Education*, 15(2), 51-63.
- Miller, D. L. (2007). The seeds of learning: Young children develop important skills through their gardening activities at a midwestern early education program. *Applied Environmental Education and Communication*, 6(1), 49-66.
- Mirka, G. (1973). Factors which influence elementary teachers' use of outdoor classrooms. *Journal of Environmental Education*, 1(4), 31-33.
- Moncrieff, D. (2012). Interactive learning and assessment for learning (AfL) in the outdoor classroom. *Environmental Education*, 100, 20-21.
- Moseley, C., Huss, J., & Utley, J. (2010). Assessing K-12 teachers' personal environmental education teaching efficacy and outcome expectancy. *Applied Environmental Education and Communication*, 9(1), 5-17.
- National Research Council (NRC). (2010). *Surrounded by science: Learning science in informal environments*. Washington, D.C.: National Academies Press.
- North American Association for Environmental Education. (2010). *Excellence in environmental education: Guidelines for learning (K-12)*. Washington, D.C.: North American Association for Environmental Education.
- Powell, K., & Wells, M. (2002). The effectiveness of three experimental teaching approaches on student science learning in fifth-grade public school classrooms. *The Journal of Environmental Education*, 33(2), 33-38. doi:10.1080/00958960209600806
- Powers, A. L. (2004). Evaluation of one- and two-day forestry field programs for elementary school children. *Applied Environmental Education and Communication*, 3(1), 39-46.

- Priest, S. (1986). Redefining outdoor education: A matter of many relationships. *The Journal of Environmental Education*, 17(3), 13-15. doi:10.1080/00958964.1986.9941413
- Project Learning Tree. (2015). Who we are. Retrieved from <https://www.plt.org/who-we-are>
- Project WET. (2015). What we do. Retrieved from <http://www.projectwet.org/what-we-do>
- Randler, C., Ilg, A., & Kern, J. (2005). Cognitive and emotional evaluation of an amphibian conservation program for elementary school students. *Journal of Environmental Education*, 37(1), 43-52.
- Rios, J. M., & Brewer, J. (2014). Outdoor education and science achievement. *Applied Environmental Education and Communication*, 13(4), 234-240.
- Ruiz-Gallardo, J., Verde, A., & Valdés, A. (2013). Garden-based learning: An experience with “At risk” secondary education students. *Journal of Environmental Education*, 44(4), 252. doi:10.1080/00958964.2013.786669
- Sellmann, D., & Bogner, F. X. (2013). Climate change education: Quantitatively assessing the impact of a botanical garden as an informal learning environment. *Environmental Education Research*, 19(4), 415-429. doi:10.1080/13504622.2012.700696
- Sharpe, E., & Breunig, M. (2009). Sustaining environmental pedagogy in times of educational conservatism: A case study of integrated curriculum programs. *Environmental Education Research*, 15(3), 299-313.
- Simatwa, E. M. (2010). Piaget's theory of intellectual development and its implication for instructional management at pre-secondary school level. *Educational Research and Reviews*, 5(7), 366-371.
- Simmons, D. (1998). Using natural settings for environmental education: Perceived benefits and barriers. *Journal of Environmental Education*, 29(3), 23.
- Smith-Sebasto, N., & Cavern, L. (2006). Effects of pre-and post-trip activities associated with a residential environmental education experience on students' attitudes toward the environment. *The Journal of Environmental Education*, 37(4), 3-17.
- Stan, I., & Humberstone, B. (2011). An ethnography of the outdoor classroom--how teachers manage risk in the outdoors. *Ethnography and Education*, 6(2), 213-228.
- Stern, M. J., Powell, R. B., & Ardoin, N. M. (2008). What difference does it make? Assessing outcomes from participation in a residential environmental education program. *Journal of Environmental Education*, 39(4), 31-43.
- Taylor, A. F., & Kuo, F. E. (2006). Is contact with nature important for healthy child development? state of the evidence. In C. Spencer, M. Blades, C. (. Spencer & M. (. Blades



(Eds.), (pp. 124-158). New York, NY, US: Cambridge University Press.  
doi:10.1017/CBO9780511521232.009

Unesco-Unep. (1978). The tbilisi declaration. *Connect*, 3(1), 1-8.

United Nations Educational, Scientific and Cultural Organization. (1975). *"The belgrade charter": Framework for environmental education*. Nature Study.

United States Department of Education (US DOE). (2015). *Science, technology, engineering and math: Education for global leadership*. Retrieved from <http://www.ed.gov/stem>

United States Environmental Protection Agency. (1990). *National environmental education act*. United States:

United States Environmental Protection Agency. (2015). What is environmental education? Retrieved from <http://www.epa.gov/education/what-environmental-education>

Waite, S., Bølling, M., & Bentsen, P. (2015). Comparing apples and pears?: A conceptual framework for understanding forms of outdoor learning through comparison of English forest schools and Danish udeskole. *Environmental Education Research*, , 1-25.

Weise, L. (2012). Get 'em outside. *Science & Children*, 49(7), 36-40.

Wells, N. M. (2000). AT HOME WITH NATURE: Effects of "greenness" on children's cognitive functioning. *Environment & Behavior*, 32(6), 775.

Wirth, S., & Rosenow, N. (2012). Supporting whole-child learning in nature-filled outdoor classrooms. *YC: Young Children*, 67(1), 42-48.

## **Comparative Analysis of Students Taught Science or Agriscience: Results on State Standardized Science Assessment**

Anna J. Warner, University of Florida  
Andrew C. Thoron, University of Florida  
Glenn D. Israel, University of Florida

### **Abstract**

*Since standardized test scores are utilized for evaluation and policy decisions, educators are searching for research-proven ways to increase scores. Agricultural education has been recognized for increasing student achievement of scientific concepts. This study used contextualized learning and status attainment theories in a descriptive logistical regression research design to determine if student enrollment in a high school level Agriscience Foundations course for science credit during the 8th grade year was associated with state science achievement test scores. The study supported the status attainment theory by identifying demographic variables which distinguished the hierarchy of enrollment and achievement. Additionally, students enrolled in agricultural foundations performed higher than students enrolled in basic science and equivalent to slightly lower than students in advanced science, indicating the important role agriscience classes can play in science achievement.*

### **Introduction**

Current trends in Science, Technology, Engineering, & Mathematics (STEM) education signify a nation implementing major efforts to improve science learning. Further, the science community supports the United States' desire to strengthen science education in public schools in order to prepare a scientifically skilled, 21<sup>st</sup> century workforce and maintain a competitive edge in the global economy (Bybee & Fuchs, 2006). Calls for science literacy and science reform (National Research Council [NRC], 2005) reveal a change in teaching methodology that shifts focus from conceptual to procedural understandings (Duggan & Gott, 2010) and the need for students to learn through experience in a context (NRC, 2000). Dewey (1916) stated that science is justified by its relationship in connecting problems and solutions with needs of society. In other words, science in schools is best taught in a context and should solve current societal issues. Agricultural education provides a context for student learning of science (True, 1969) while authentic, agriculturally-based problems provide societal issues to be investigated.

The United States education system relies greatly on measuring student achievement through standardized testing in order to set educational policy and practices despite the debate surrounding the validity and meaning of such test scores (Israel & Beaulieu, 2004). Although the implementation of higher standards and testing is designed to increase student achievement, slight to no progress has been reported, and American students continue to perform below the international average (Florida Department of Education [FDOE], 2015a; Israel & Beaulieu, 2004; United States Department of Education [USDE], 2012). According to the Program for International Student Assessment (PISA), American students are scoring below the international average in science (USDE, 2012). In 2012, the United States ranked 28 out of 65 in science literacy. Florida students scored lower than the international and national students. However, that National Center for Educational Statistics (NCES) identified agriculture as one of five

Career and Technology Education (CTE) concentrators which scored higher on the National Assessment of Education Progress (NEAP) science test (Levesque, Wun, & Green, 2010).

In 1988, Florida began using the Florida Comprehensive Assessment Test (FCAT) to assess the implementation of higher standards known as the Sunshine State Standards by measuring students' mathematic, reading, science, and writing achievement (FDOE, 2015a). Student FCAT scores are ranked into 5 levels (FDOE, 2009; FDOE, 2015a; FDOE, 2015b; FDOE, 2015d). Score level descriptions are as follows: Level 1 "little success with the content on the FCAT," Level 2 "limited success with the content on the FCAT," Level 3 "partial success with the content on the FCAT," Level 4 "success with the content on the FCAT by answering most questions correctly, except for the most challenging questions," and Level 5 "success with the content on the FCAT by answering most questions correctly" (FDOE, 2009). Students must score at Level 3 to pass these assessments (FDOE, 2009; FDOE, 2015b; FDOE, 2015d).

The current educational environment treats student achievement on standardized tests as "the 'currency' for school officials" (Israel, Myers, Lamm, & Galindo-Gonzalez, 2012, p. 15). Standardized test scores impact school accountability and evaluation (NRC, 1999; Theriot & Kotrlik, 2009); school funding (Hamilton, Stecher, & Klein, 2002); student tracking, placement, promotion, and graduation (Hamilton et al., 2002; NRC, 1999; Theriot & Kotrlik, 2009); teacher evaluations (NRC, 1999); evaluation of the U.S. education system (NRC, 1999); and creation of educational policies (Israel & Beaulieu, 2004). In order to address the diverse implications of student achievement, researchers must continue to investigate all factors impacting student achievement. Priority five of the National Research Agenda for agricultural education focuses on "efficient and effective Agricultural Education programs" (Roberts, Harder, & Brashears, 2016, p. 41). This study specifically contributes to answering research priority question four, "how do school-based agricultural education programs contribute to CTE and broader educational initiatives?" (p. 43).

### **Theoretical Framework**

Two theories which guide this study are contextualized learning (Buriak, McNurlen, & Harper, 1996; Dworkin, 1959; Fosnot, 1996; Haury & Rillero, 1994) and status attainment (Duncan, Featherman, & Duncan, 1972; Wilson & Portes, 1975). Contextualized learning stems from constructivism, the idea that "learners construct their own knowledge from experience" (Doolittle & Camp, 1999, p. 25). This theory stresses the importance of providing authentic examples and experiences for learners to inquire and create their own meaning, models, concepts, and strategies (Dworkin, 1959; Fosnot, 1996; Haury & Rillero, 1994). Buriak, McNurlen, and Harper (1996) underscore the role of offering various contexts for pupils to learn how to apply their knowledge in diverse settings. Agricultural education provides a context for students to develop their learning of scientific and mathematical concepts applied to agriculture, supporting the transfer of their learning to different situations (Conroy, Trumbull, & Johnson 1999).

According to the status attainment theory, socioeconomic background, innate ability, and mediating factors, such as aspirations, determine an individual's position in educational hierarchies (Wilson & Portes, 1975). Over forty years of research has provided evidence which supports socioeconomic status, race, ethnicity and other background variables as variables which

strongly influence educational achievement (Darling-Hammond, 2000; Haller & Porter, 1973; Israel et al., 2012; Portes & MacLeod, 1996; Wilson & Portes, 1975). Israel et al. reinforced the relevance of status attainment theory based on the significant role of student-level variables in higher linear modeling. Agricultural education offers an opportunity for students to experience contextualized learning of scientific principles within the field of agriculture and has the potential of increasing student achievement. However, the role of student-level variables on student achievement cannot be overlooked.

### **Review of Literature**

Although CTE subjects are not tested on state, national, and international standardized tests, CTE courses contribute to student success in academic areas (Chiasson & Burnett, 2001; Conroy et al., 1999; Israel et al., 2012; Meeder & Suddreth, 2012; Nolin & Parr, 2013; Phipps, Osborne, Dyer, & Ball, 2008; Skelton, Stair, Dormody, & Vanleeuwen; Stripling & Roberts, 2012). Historically, science and mathematics have been integral principles of agricultural education (Conroy et al.). Since the 1980s, the Carl Perkins Act has mandated CTE programs to integrate core academic content into coursework which has made CTE a model for teaching academic and transferable skills required for career success (Meeder & Suddreth, 2012). Myers and Dyer (2004) confirmed the continued expectations of agriscience teachers to “integrate curriculum that addresses standards in science, mathematics, and other content areas” (p. 44).

Florida Department of Education has recognized Agriscience Foundations as a science credit which can count towards high school graduation (K-20 Education Code, 2011), and research supports this decision (Chiasson & Burnett, 2001; Connors & Elliot, 1995; Conroy et al., 1999; Israel, et al., 2012; Stripling & Roberts, 2012). Research has shown students who were engaged in agricultural education had improved science achievement. Students have reported higher performance in mathematics and science because of enrollment in an aquaculture course (Conroy & Walker, 1998). Chiasson and Burnette (2001) found that agriscience students in Louisiana performed significantly higher on the science portion of the graduate exit examination than their non-agriscience counterparts. Additionally, the agricultural students performed significantly higher on scientific method, biology, and earth science sub-scales and equivalent on the physics subscale. Chemistry was the only subscale where agriscience students scored lower than non-agriscience students. Skelton et al. (2014) found similar results when comparing middle school students attending an agricultural and natural resources focused middle school with a comparison middle school. Students who were taught science integrated with agricultural and leadership skills performed higher on overall science achievement scores and on four of the five sub-dimensions including scientific investigation, physical science, earth science, and science and people. However, Despain, North, Warnick, and Baggaley (2016) found students taking agricultural biology in place of biology, as a science credit, in Utah high schools performed lower on the state end-of-course core biology exams.

When investigating how the type of CTE coursework and the CTE occupational cluster impacted student performance on science standardized test scores, Israel et al. (2012) found that agricultural CTE students performed slightly lower than students in health CTE programs and somewhat lower than students in STEM CTE programs, but higher than students in education CTE programs. However, the researchers noted that agricultural and health students scored similarly and just slightly below STEM students when controlled for student and school factors.

## **Variables Impacting Student Achievement Test Scores**

Israel and Beaulieu (2004) identified several variables which were significant predictors of the math, reading, and math/reading composite scores for 8<sup>th</sup> grade students. Student variables having a positive relationship on scores included: being classified as gifted, higher average grade composite, completed Algebra 1, student engagement in class, and hours doing homework. Student variables having a negative relationship on scores included: black or Hispanic ethnic groups, being female, being regarded as a disruptive student, and students with attendance issues. The researchers also identified variables in the following categories which also served as predictors: resources, family social capital structure, family social capital process, school social capital structure, school social capital process, community social capital structure, and community social capital process. The authors stated, “the contextual aspects of school and community structure mediated the influence of family social capital, student ability, and background on student achievement” (p.283). Israel, et al. (2012) proposed a conceptual model defining student and school structure variables impacting CTE student outcomes on science achievement tests. Student factors included age, gender, race/ethnicity, gifted status, and home language. School attributes included enrollment and composition, disciplinary environment, community location, average science achievement, curriculum quality and funding, and the learning process. The learning process included the dynamics of CTE involvement, CTE specialization, and college prep coursework.

Although researchers have investigated factors which impact student achievement on 8<sup>th</sup> grade standardized tests (Israel & Beaulieu, 2004) and several researchers have investigated the impact of agricultural coursework on student achievement on standardized tests at the high school level (Chiasson & Burnett, 2001; Connors & Elliot, 1995; Conroy et al., 1999; Israel, et al., 2012; Stripling & Roberts, 2012; Theriot & Kotrlik, 2009; Thoron & Myers, 2011), a gap in the literature exists when investigating the impact of agricultural coursework on student achievement tests at the middle school level.

### **Purpose of the Study**

Educators, administrators, and policy makers are consistently striving to increase student achievement. The purpose of this study was to determine if student enrollment in a high school level Agriscience Foundations course for science credit during the 8<sup>th</sup> grade year was associated with the FCAT scores of 8<sup>th</sup> grade students. The following objectives guided the study:

1. Describe the characteristics of the populations of Agriscience Foundations students, Basic Physical Science students, and Advanced Physical Science students.
2. Determine if students enrolled in the Agriscience Foundations course as a science credit score higher on FCAT science tests than those students enrolled in basic science and advanced science courses.
3. Ascertain what factors impacted students’ achievement on FCAT tests.
4. Analyze how the course taken for science credit impacted science FCAT achievement scores.

## **Methodology**

A quantitative, descriptive logistical regression research design was utilized. Logistical regression was selected as it allowed for the use of categorical data provided by the data set to predict categorical outcomes of the dependent variables (Agresti & Finlay, 1997; Fields, 2013).

### **Population**

The population of interest for this study is 8<sup>th</sup> grade students in the state of Florida. At the time of the study, only one county school system in the state was teaching the high school Agriscience Foundations curriculum to 8<sup>th</sup> grade students providing a convenience sample of this population. Since a convenience sample was utilized, randomization was compromised (Agresti & Finlay, 1997). Additionally, this sample is likely to provide an undercoverage of the population by not adequately representing certain groups. This sample will prohibit the generalizability of the results to beyond those students included in the study.

The analysis was based on FCAT test data provided by a north central county school district in Florida. The data set included data for 1129 8<sup>th</sup> grade students enrolled in one of the four county middle schools offering an agricultural course for science credit in 8<sup>th</sup> grade during the 2013-2014 school year. Middle schools in the county not offering agricultural programs were excluded from the data set.

FCAT achievement levels for previous and most recent FCAT tests in reading, math and science as well as writing scores were provided by the data set. The data set also included the course taken as science credit, the teacher for that course, proficiency levels for reading writing, math, and science, attendance data, and semester and final grades for the course. In addition, demographic variables included gender, age, ethnicity, status of free and reduced lunch, homelessness, migrant, exceptionalities, 504 Section, ESE testing accommodations, and student first language other than English.

### **Dependent Variable**

The FCAT achievement levels in science served as dependent variables for the study. The rigorous alignment of test items to content standards provide validity to these tests (Israel et al., 2012). Additionally, the Florida Department of Education has conducted an instructional validity study aimed at demonstrating that “any student who is seeking a regular high school diploma has been given the opportunity to learn the content measured by each required assessment” (FDOE, 2011, p. 2). In order to perform binary logistical regression, the researcher coded FCAT score categories in to pass/fail categories. Students must score a 3 or higher to be considered at grade level and pass the exam (FDOE, 2015d). Students scoring at level 1 or 2 were assigned to the fail category; students scoring a 3-5 were assigned to the pass category.

### **Independent Variable**

The independent variable was the course students took for science credit during their 8<sup>th</sup> grade year. Students had the option of enrolling in Agriscience Foundations, a high school level introductory agricultural course; M/J Physical Science, the basic level science course; or M/J Physical Science Advanced, a more advanced science course. All three courses integrate, “laboratory investigations that include scientific inquiry, research, measurement, problem solving, emerging technologies, tools and equipment, as well as, experimental quality, and safety

procedures” (FDOE, 2015c, p. 1; Florida State University [FSU], 2015a, p. 1; FSU 2015b, p. 1). While the basic and advanced levels covered the same content, higher level objectives were utilized in the advanced class requiring higher level thinking (P. Nobel’s, personal communication, April 15, 2016). The Agriscience Foundations course teaches all biological, physical, and environmental principles as well as scientific and research concepts through the context of agriculture in addition to developing competencies in the following areas: agricultural history and the global impact of agriculture, career opportunities, agriscience safety, principles of leadership, agribusiness, employability, and human relations skills (FDOE, 2015c). In addition to the CTE benchmarks, the student performance standards for the course also outlines Florida Standards for grades 09-10 in reading, writing, and mathematical practices for technical content.

### **Control Variables**

From the literature and the data set provided, a set of control variables were developed. The control variables included gender, race-ethnicity, total days absent, free and reduced lunch status, student grade, and school (Israel & Beaulieu, 2004; Israel et al., 2012; Theriot & Kotrlik, 2009). The researchers chose to use the following variables for the justification provided. Course level designations were assigned to reflect the courses offered. Advanced and basic level science courses were designated to better reflect the different levels of content covered and to make a better comparison to the Agriscience Foundations course which was considered a high school level course. Final grade in course taken for science credit was selected as a variable to reflect student performance. To condense Ethnicity and Race categories from those reported, the researcher analyzed the categories to find acceptable groupings. Since Asian students reflected a small portion of the sample, they were condensed into a category with White students because literature noted that these races tend to outperform African-American and Latino students on achievement tests (Israel & Beaulieu, 2004; Lareau, 2002; Steele & Aronson, 1998). Black and Hispanic students were individual categories due to the large percentage of the sample they reflect. Multi-racial and American Indian/Alaskan Native created the Other category which accounted for a small percentage of the total sample. Free and Reduced Lunch Status was selected as a measure of socioeconomic status. Total Days Absent was chosen to represent student attendance. Total Days Out of School Suspension and Total Days in School suspension were selected as measures of disruptive behavior. Student Age provided a way to control for students who had been held back or promoted a grade.

To analyze the categorical independent variables, dummy coding was used and reference categories for each categorical variable were purposefully selected. Agriscience Foundations was used as the reference category to align with research objectives. Final letter grade B, White/Asian, Males, and Not Eligible for free and reduced lunch were used as the reference category because those categories represented the largest proportion of the sample.

### **Data Analysis**

IBM SPSS Statistics version 22 was utilized to analyze data. Multiple imputation was utilized to impute values for missing FCAT score levels. Shafer and Graham (2002) recommend using multiple imputation to handle missing data when data is missing at random. Descriptive statistics were used to address objective one and two. For objective one, frequencies were utilized to describe the characteristics of the populations of Agriscience Foundations students, Basic Physical Science students, and Advanced Physical Science students. Using the imputed data set, frequencies were analyzed determine the distribution of FCAT scores for agriscience,

basic science, and advanced science students for objective two. Additionally, crosstabs were examined for the control variables of school and race/ethnicity.

Binary logistical regression was completed to address objectives three and four. Logistic regression allows the use of continuous and categorical data to predict a categorical dependent variable (Agresti & Finlay, 1997; Fields, 2013). Binary logistic regression specifically predicts membership of two particular group outcomes, in this case pass or fail groups of the FCAT exam. The hierarchical method was utilized to construct a model with appropriate goodness of fit scores based on the Hosmer and Lemeshow Test for each of the FCAT tests (Fields, 2013). This model was created by entering known predictors which impact student achievement scores from the literature into block one, variables of interest (i.e. course taken for science credit and final grade in science credit course) in block two, and additional student control variables into additional blocks. The model was adjusted by removing insignificant predicting factors until finding a model with the best goodness of fit and predictability statistics. Once an appropriate model was formed, it was verified with the forced entry method (Fields, 2013).

The Nagelkerke  $R^2$  statistic was chosen to represent the amount of variance explained by the model. Since the Cox Snell  $R^2$  never reaches its theoretical maximum of 1, Fields (2013) recommends using the Nagelkerke  $R^2$  which has been adjusted to overcome that shortcoming. Correlations were checked to identify the possibility of suppressor variables. Odds ratios were reported for easier interpretation of the data over the Beta coefficient (Agresti & Finlay, 1997; Fields, 2013). The American Psychological Association (2010) recommends the use of standardized reports of effect size in addition to original units. Standardized Beta scores were calculated using an Excel<sup>®</sup> Spreadsheet following the procedure outlined by King (2007) in Appendix A. “Variables having larger standardized beta weights (in absolute value) are considered to be stronger predictors in the equation” (King, 2007, p. 3).

## Results

Objective one aimed to describe the characteristics of the populations of Agriscience Foundations students, Basic Physical Science students, and Advanced Physical Science students. Table 1 shows the distribution of course selection and student attributes. The Basic Physical Science population had the highest percentage of students who qualified for free lunch (68.4%). The Advanced Physical Science course was not offered in School A or School C. The Agriscience Foundations population had a larger percentage of females (56.9%), White, Non-Hispanic students (70.2%), and students not eligible for free or reduced lunches (33.5%), and a lower percentage of Black, Non-Hispanic students (8%).

Table 1  
Distribution of course selection and student attributes.

Variable	Agriscience Foundations ( <i>n</i> = 1128)	Basic Physical Sci. ( <i>n</i> = 5112)	Advanced Physical Sci. ( <i>n</i> = 528)
Male (%)	43.1	54.8	58.0
Age (%)			
13	13.3	14.3	23.9
14	78.2	61.7	67.0
15	8.0	21.6	9.1
16	0.5	2.3	0.0



Race-ethnicity (%)			
White, Non-Hispanic	70.2	49.9	48.9
Black, Non-Hispanic	8.0	20.7	18.2
Hispanic	17.6	20.5	23.9
Asian, Pacific Islander	1.1	2.2	0.0
Multiracial, Non-Hispanic	2.7	6.3	8.0
American Indian/ Alaskan Native	0.5	0.4	1.1
Receive Testing Accommodation (%)	10.1	17.6	12.5
Total Days Absent $\mu$ (sd)	9.1(10.6)	12.4(11.2)	8.3(7.2)
Free and Reduced Lunch Status (%)			
Free Lunch	53.2	68.4	59.1
Reduced Lunch	13.3	8.8	14.8
Not Eligible	33.5	22.8	26.1
School (%)			
School A	37.2	17.0	0.0
School B	11.7	17.7	35.2
School C	22.9	31.0	0.0
School D	28.8	34.3	64.8

Objective two intended to determine if students enrolled in the Agriscience Foundations course as a science credit scored higher on FCAT tests than those students enrolled in a basic or advanced science course. Table 2 shows the frequency distributions of FCAT Science score levels for 8<sup>th</sup> grade students in agriscience, basic science, and advanced science courses. A significant association was found between Science FCAT score levels and course taken for science credit. Over two-thirds of students in basic science earned a 1 or 2 on the FCAT Science test. Almost 57% of students in Agriscience Foundations and 59.1% of students in advanced science scored at level 3. Only 0.3% of basic science students, 3.2% of agriscience students, and 3.4% of advanced science students scored at score level 5.

Table 2.

Distribution of FCAT Science Scores for 8<sup>th</sup> Grade Agriscience, Basic Science, and Advanced Science Students.

FCAT Test	Score Level	Agriscience (1128)	Basic Science (5094)	Advanced Science (528)
FCAT Science <sub>A</sub>	1	3.2%	28.2%	0.0%
	2	27.1%	40.4%	13.6%
	3	56.9%	28.1%	59.1%
	4	9.6%	3.0%	23.9%
	5	3.2%	0.3%	3.4%
Total		100.0%	100.0%	100.0%

Note. (n)

<sub>A</sub>  $\chi^2 = 1320.31$ ,  $df = 8$ ,  $p = <0.01$   $N = 6743$

A higher percentage of students enrolled in Agriscience Foundations earned a passing score of 3 or higher than those who enrolled in basic science. Significant Pearson Chi-Square tests indicate a significant association between the course taken and FCAT score levels. Crosstabs were run to identify significant associations between courses taken, FCAT scores, and the control variables of school (Table 3) and ethnicity (Table 4). Significant associations were found between FCAT score level for agriscience, basic science, and advanced science students based on school and race/ethnicity. Students enrolled in Agriscience foundations consistently did better than basic science students across all schools and race/ethnicity groups.

Table 3  
Distribution of Science FCAT Score Level Controlling for School.

Score Level	School A (%)		School B (%)		School C (%)			School D (%)			
	Ag	Basic Sci	Ag	Basic Sci	Ag	Basic Sci	Adv. Sci	Ag	Basic Sci	Adv. Sci.	
1	4.3	32.5	0.0	21.7	4.5	25.2	0.0	3.8	33.4	0.0	
2	28.6	41.5	14.0	31.2	36.4	47.0	6.5	32.1	44.5	17.5	
3	60.0	24.6	60.5	40.7	50.0	23.2	64.5	52.8	21.2	56.1	
4	5.7	0.8	18.6	5.8	9.1	4.6	29.0	7.5	0.7	21.1	
5	1.4	0.6	0	0.6	0.0	0.0	0.0	3.8	0.1	5.3	
Total	100.0	100.0	100.0	100.0	100.0	100.0	100.0	100.0	100.0	100.0	
		$X^2 = 238.53$ df = 4 p = <0.01 N = 1287		$X^2 = 203.93$ df = 4 p = <0.01 N = 1821		$X^2 = 331.79$ df = 4 p = <0.01 N = 1224			$X^2 = 769.57$ df = 4 p = <0.01 N = 2411		

Note. School A and School C do not offer Advanced Science.

Table 4  
Distribution of Science FCAT Score Level Controlling for Ethnicity.

Score Level	White/Asian (%)			Black (%)			Hispanic (%)			Other (%)				
	Ag	Basic Sci.	Adv. Sci.	Ag	Basic Sci.	Adv. Sci.	Ag	Basic Sci.	Adv. Sci.	Ag	Basic Sci.	Adv. Sci.		
1	3.0	23.9	0.0	6.7	41.6	0.0	0	27.6	0.0	0.0	21.4	0.0		
2	25.4	39.1	9.3	26.7	39.8	18.8	36.4	45.2	19.0	16.7	37.0	12.5		
3	59.7	32.1	60.5	60.0	17.3	56.3	42.4	25.3	61.9	66.7	39.6	50.0		
4	9.7	4.4	25.6	0.0	1.1	25.0	12.1	1.7	14.3	16.7	1.8	37.5		
5	2.2	0.5	4.7	6.7	0.1	0.0	6.1	0.2	4.8	0.0	0.3	0.0		
Total	100.0	100.0	100.0	100.0	100.0	100.0	100.0	100.0	100.0	100.0	100.0	100.0		
			$X^2 = 6.37.79$ , df = 8 p = <0.01, N = 3710			$X^2 = 430.64$ , df = 8 p = <0.01, N = 1241			$X^2 = 275.72$ , df = 8 p = <0.01, N = 1367			$X^2 = 116.44$ , df = 8 p = <0.01, N = 425		

Objective three proposed to ascertain what factors impacted students' achievement on the science FCAT test. Objective 4 targeted to analyze how the level of the course taken impacted FCAT science achievement scores. A binary logistic regression model was analyzed to address these objectives. The model created to predict the odds of passing the Science FCAT was statistically significant as denoted by the omnibus test ( $X^2 = 1871.26$ , df = 6, p = <0.01). The Hosmer Lemeshow Test determined that the model was a good fit ( $X^2 = 6.68$ , df = 6, p = 0.33). The Nagelkerke R square was 0.33 designating the logistic combination of all the independent

variables in the final model predicted 33% of the variance in odds of passing the Science FCAT. The model predicted 73.5% correctly, a 15.7% increase over the intercept only model.

Table 5 displays the results of the Science FCAT model. The model included the variables of course taken for science credit and final letter grade in the course taken for science credit. Other control variables identified in the methods were tested but found to be insignificant predictors. The odds ratios reported represent the probability of success over the probability of failure on the FCAT Science test when all other factors in the model are controlled.

Students had statistically significant lower odds of passing if they were enrolled in basic science by a factor of 0.42 and statistically significant higher odds of passing if they were enrolled in advanced science by a factor of 4.45, when compared to student enrolled in agriscience courses. Final grade in the course taken for science credit also had a statistically significant association with the odds of passing the Science FCAT test. Students scoring an A in their course taken for science credit increased their odds of passing, compared to students who earned a B by a factor of 2.97. Students scoring a C lowered their odds of passing by a factor of 0.30 when compared to students earning a B. Students earning a D also lowered their odds of passing by a factor of 0.43 when compared to students earning a B. Student earning an F lowered their odds of passing as well by a factor of 0.07 when compared to students earning a B. Correlations were checked to identify the possibility of suppressor variables; while there were significant correlations, all coefficients were below  $r = 0.51$  and did not indicate a strong effect size (Ferguson, 2009). Earning an A or C had the largest standardized Beta scores followed closely by advanced science course, and then by basic science course.

Table 5  
Predictive Ability of the Variables in the Science FCAT Model

<i>Variable in the Model</i>	<i>B</i>	<i>Standardize B</i>	<i>Wald</i>	<i>df</i>	<i>p</i>	<i>Odds Ratio</i>
Course taken for Science Credit <sup>A</sup>						
Basic Science	-0.86	-0.09	119.72	1	<0.01	0.42
Advanced Science	1.49	0.10	95.49	1	<0.01	4.45
Course						
Final Letter Grade in Science Course <sup>B</sup>						
A	1.09	0.12	255.03	1	<0.01	2.97
C	-1.19	-0.12	202.96	1	<0.01	0.30
D	-0.84	-0.05	39.12	1	<0.01	0.43
F	-2.68	-0.09	38.39	1	<0.01	0.07
Constant	0.214		7.489	1	<0.01	1.24

<sup>A</sup> Reference category is Agriscience Foundations

<sup>B</sup> Reference category is B

### Conclusions and Recommendations

**Objective 1: Describe the characteristics of the populations of Agriscience Foundations students, Basic Physical Science students, and Advanced Physical Science students.** The populations of the three courses taken for science credit differed based upon demographic and independent variables. Notable differences in the characteristics of the population include age, race, total days absent, free and reduced lunch, and schools. The basic science course included many more students who were 15-16 years old. Since most students are 14 years old when they enter high school, this may suggest more students who are retained a grade are in basic science.

The Agriscience Foundations course had 70.2% (n = 792) White/Asian students, which was 21.3% higher than advanced science and 22.3% higher than basic science. The agriscience course was also made up of 56.9% female students.

These findings lend support to the status attainment theory's claim that demographic variables contribute to determining hierarchy within educational environments. (Duncan, Featherman, & Duncan, 1972; Wilson & Portes, 1975). This theory offers insight to other research on the diversity of the agriscience classroom and reinforces the need for agriscience programs to do a better job of recruiting diverse students so the population characteristics of the school are mimicked in the agriscience classrooms as recommended by Torres, Kitchel, and Ball (2010). The basic science course had the highest mean score of total days absent ( $\mu$  12.4,  $sd$  = 11.2). The increase in missed time at school could contribute to the lower achievement scores of students in this category as noted by Lamdin (1996). Following this recommendation, resources should be directed to improving student attendance. Additionally, basic science had the most students qualifying for free lunches indicating this population is from a lower social economic status. Neither School A nor School C offered an advanced science course. Since students enrolled in Agriscience Foundations courses had better odds of passing the FCAT tests than students in basic science course, students should be encouraged to take Agriscience Foundations when advanced science courses are not offered in the school.

**Objective 2: Determine if students enrolled in the Agriscience Foundations course as a science credit score higher on the FCAT science test than those students enrolled in a science course.** Contrary to the results reported by Despain et al. (2016), both of the crosstabs had significant chi-squared statistics indicating a statistically significant association between the FCAT score level and course taken for science credit. Both agriscience and advanced science students scored higher than basic science students who accounted for 75% of the sample; however, over two-thirds of students scored at a 3 or lower. Less than 4% of students in all of the course options scored at level 5. The results of the score distributions for the FCAT science test indicate that this test should be re-evaluated for instructional validity and adjustments should be made to the test or curriculum to address the shortcomings found. Overall, the results from objective 2 indicate that agriscience students scored higher than basic science students and equivalent to slightly lower than advanced science students on the FCAT science test.

**Objective 3: Ascertain what factors impacted student's achievement on FCAT tests.** The model was tested with other predictive factors; however, this is the only model which resulted in acceptable goodness of fit statistics as determined by the Hosmer Lemeshow Test. This may suggest that the material covered in these science classes are more powerfully associated with the material covered on the FCAT Science test than any of the control variables. However, it is important to note that this was the test that had over two thirds of students score at a level 3 or lower. The fact that so many students scored in the lower levels of this test may mask the effects of the control variables in this model. The researchers strongly recommend a review of this test and the curricular material to address these findings. Of the 6 statistically significant predictors, two had practically significant odds ratios as determined by (Ferguson, 2009). Advanced science had a strong effect size and A had a moderate effect size. Based on the standardized Beta scores, all 6 factors met the required effect size for practically significant results. Earning a C had the largest effect on lowering the odds of group membership in the Science FCAT pass group, while enrolling earning and A had the largest effect on increasing the odds of passing.

**Objective 4: Analyze how the level of the course taken impacted FCAT achievement scores.** All of the models indicated students enrolled in Agriscience Foundations had higher odds of passing the FCAT science test compared to students enrolled in basic science when all other variables were controlled. Additionally, when crosstabs were analyzed, it was evident agriscience students scored at a higher level across all score levels than basic science students. This finding supports the findings of Chiasson and Burnett (2001), Conroy et al. (1999), Israel, et al. (2012), Nolin and Parr (2013), Stripling and Roberts (2012), and Theriot and Kotrlík (2009); students in CTE, specifically agricultural education programs, have higher science achievement scores. The findings suggest the Agriscience Foundations course does a better job teaching students the science skills they need to be successful in 8<sup>th</sup> grade. Schools should consider the impacts of enrollment in Agriscience Foundations on student achievement, and offer more students the opportunity to take Agriscience Foundations as an alternative to basic science in 8<sup>th</sup> grade. Additional research is needed to determine why students in these courses are better prepared. Is it because of learning the content in the context of agriculture (Conroy et al., 1999; FDOE, 2015c), the use of different teaching methods (Freeman, Eddy, McDonough, Smith, Okoroafor, Jordt, & Wenderoth, 2014; Thoron & Myers, 2011), the students' motivation and engagement level (Young, 2013), the level of inquiry used (Jiang & McComas, 2015), amount of time student is engaged in learning (Witt, Ulmer, Burris, Brachears, & Burley, 2014), teacher-student interactions (Allen, Gregory, Mikami, Lun, Hamre, & Pianta, 2013), teacher knowledge of scientific concepts (Sadler, Sonnert, Coyle, Cook-Smith, & Miller, 2013), or some other factors.

The regression models indicated students in advanced science had greater odds of passing the FCAT science test. Agriscience teachers should collaborate with advanced science teachers to determine strategies used in the advanced science courses which could be integrated in Agriscience Foundations to further increase the success of students. As Patricia Nobles (personal communication, April 15, 2016) indicated, the major difference between the basic and advanced level science courses was higher order learning objectives. Researchers should analyze learning objectives in the advanced science course and the Agriscience Foundations course to determine if differences exist within the level of thinking required by the objectives.

### **Recommendations for Future Research**

Continued research in this area is recommended. Additional insight on the objectives of this study could be provided by obtaining additional information on this data set in order to analyze the impact of other predictor variables as outlined by Israel and Beaulieu (2004). Darling-Hammond (2000) found that teacher quality variables, such as preparation and certification, more strongly predicted student outcomes on achievement tests than did student demographic variables. The impact of teacher characteristics should be further explored. Creating a hierarchical linear model to analyze nested data of school and teacher characteristics would provide a more thorough and precise understanding of factors affecting student achievement scores without violating the assumptions of independence (Fields, 2013).

In order to generalize the findings of this study, random sampling of Florida middle schools would be required. Additionally, this study should be replicated to analyze the new Florida Assessments Standard tests. Similar studies in other states should be conducted to see if results are similar with their state tests. If the agriscience curriculum is associated with higher scores and increased odds of passing the achievement tests in middle schools, more studies like

this study and Nolin and Parr (2013) should be conducted to analyze the relationships of agricultural curricula and achievement scores at the high school level. Finally, researchers should identify better measures of student engagement and disruptive behaviors to include in the models.

## References

- Agresti, A., & Finlay, B. (1997). *Statistical Methods for the Social Sciences*. Upper Saddle River, NJ: Prentice Hall.
- Allen, J., Gregory, A., Mikami, A., Lun, J., Hamre, R., & Pianta, R. (2013). Observing the effective teacher-student interactions in secondary school classrooms: Predicting student achievement with Classroom Assessment Scoring System – Secondary. *School Psychology Review*, 42(1), 76-98.
- American Psychological Association (APA). (2010). *Publication manual of the American Psychological Association*. Washington D.C.: American Psychological Association.
- Buriak, P., McNurlen, B., & Harper, J. G. (1996). Toward a scientific basis for the craft of teaching. *Journal of Agricultural Education*, 37(4), 23-35. doi: 10.5032/jae.1996.04023
- Bybee, R. W., & Fuchs, B. (2006). Preparing the 21<sup>st</sup> century workforce: A new reform in science and technology education. *Journal of Research in Science Teaching*, 43(4), 349-352. doi:10.1002/tea.20147
- Chiasson, T. C., & Burnett, M. F. (2001). The influence of enrollment in agriscience courses on the science achievement of high school students. *Journal of Agricultural Education*, 42(1), 61-71. doi: 10.5032/jae.2001.01061
- Connors, J. J., & Elliot, J. F. (1995). The influence of agriscience and natural resources curriculum on students' science achievement scores. *Journal of Agricultural Education*, 36(3), 57-63. doi: 10.5032/jae.1995.03057
- Conroy, C. A., Trumbull, D. J., & Johnson, D. (1999). *Agriculture as a rich context for teaching and learning, and for learning mathematics and science to prepare for the workforce of the 21<sup>st</sup> century*. Paper presented at the Transitions from Childhood to the Workforce Teaching and Learning Conference, Ithaca, NY.
- Conroy, C., & Walker, N. (1998). *National Aquaculture Curriculum Evaluation Phase II Final Report*. Ithaca, NY: Cornell University
- Darling-Hammond, L. (2000). Teacher quality and student achievement. *Education Policy Analysis Archives*, 8(1), 1-44. doi: 10.14507/epaa.v8n1.2000
- Despain, D., North, T., Warnick, B. K., and Baggaley, J. Biology in the agriculture classroom: A descriptive comparative study. *Journal of Agricultural Education*, 57(1), 194-211. doi: 10.5032/jae.2016.01194
- Dewey, J. (1916). *Democracy in Education*. New York Macmillan.
- Dolittle, P. E., & Camp, W. G. (1999). Constructivism: The career and technical education perspective. *Journal of Vocational and Technical Education*, 16(1), 23-46.

- Duggan, S., & Gott, R. (2010). What sort of science education do we really need? *International Journal of Science Education*, 24(7), 661-679. doi:10.1080/09500690110110133
- Duncan, O. D., Featherman, D. L., & Duncan, B. (1972). *Socioeconomic background and achievement*. New York, NY: Seminar Press.
- Dworkin, M. S. (1959). *Dewey on education*. NY: Teachers College Press.
- Ferguson, C. J. (2009). An effect size primer: A guide for clinicians and researchers. *Professional Psychology: Research and Practice*, 40(5), 532-538. doi: 10.1037/a0015808
- Fields, A. (2013). *Discovering Statistics Using IBM SPSS Statistics*. Thousand Oaks, CA: Sage Publications.
- Florida Department of Education (FDOE). (2009). *Understanding FCAT Reports: 2009*. Retrieved from <http://www.fldoe.org/>
- Florida, Department of Education (FDOE). (2011). *2011 Instructional Validity Study*. Retrieved from [http://www.fasa.net/upload\\_documents/2011-08-19-FFF\\_2011InstructionalValidityFCAT20EOCAAlignmentStudyFI.pdf](http://www.fasa.net/upload_documents/2011-08-19-FFF_2011InstructionalValidityFCAT20EOCAAlignmentStudyFI.pdf)
- Florida Department of Education (FDOE). (2015a). *FCAT*. Retrieved from <http://www.fldoe.org/accountability/assessments/k-12-student-assessment/history-of-fls-statewide-assessment/fcat/>
- Florida Department of Education (FDOE). (2015b). *FCAT 2.0 and Florida EOC assessments achievement levels*. Retrieved from <http://www.fldoe.org/>
- Florida Department of Education (FDOE). (2015c). *Student Performance Standards: Agriscience Foundations 1*. Retrieved from <http://www.fldoe.org/academics/career-adult-edu/career-tech-edu/curriculum-frameworks/2016-17-frameworks/agriculture-food-natural-resources.stml>
- Florida Department of Education (FDOE). (2015d). *Understanding FCAT 2.0 Reports: Spring 2014*. Retrieved from <http://www.fldoe.org/>
- Florida State University. (2015a). *CPALMS: M/J Physical Science (#2003010)*. Retrieved from <http://www.cpalms.org/Public/PreviewCourse/Preview/13126>
- Florida State University. (2015b). *CPALMS: M/J Physical Science, Advanced (#2003020)*. Retrieved from <http://www.cpalms.org/Public/PreviewCourse/Preview/13127>
- Fosnot, C. T. (1996). *Constructivism: Theory, perspectives, ad practice*. New York, NY: Teachers College Press.
- Freeman, S., Eddy, S. L., McDonough, M., Smith, M. K., Okoroafor, N. J., Jordt, H., & Wenderoth, M. P. (2014). Active learning increases student performances in science, engineering, and mathematics. *PNAS*, 111(23), 8410-8415. Doi: 10.1073/pnas.1319030111



- Hamilton, L. S., Stecher, B. M., & Klein, S. P. (2002). *Making sense of test-based accountability in education*. Santa Monica, CA: Rand.
- Haller, A. O., & Portes, A. (1973). Status attainment process. *Sociology of Education*, 46, 51-91.
- Haury, D. L., & Rillero, P. (1994). *Perspectives of hands-on science teaching*. North Central Regional Education Laboratory. Retrieved from <http://www.ncrel.org/sdrs/areas/issues/content/contareas/science/eric/eric-toc.htm>
- Israel, G. D., & Beaulieu, L. J. (2004). Laying the foundation for employment: The Role of social capital in educational achievement. *The Review of Regional Studies*, 34(3), 260-287.
- Israel, G. D., Myers, B. E., Lamm, A. J., & Galindo-Gonzalez, S. (2012). CTE students and science achievement: Does type of coursework and occupational cluster matter? *Career and Technical Education Research*, 37(1), p. 3-20. doi: 10.5328/cter37.1.3
- Jiang, F., & McComas, W. F. (2015). The effects of inquiry teaching on student science achievement and attitudes: Evidence from propensity score analysis of PISA data. *International Journal of Science Education*, 37(3), 554-576. doi: 10.1080/09500693.2014.1000426
- K-20 Education Code, 48 Flo. Stat. § 1003-43 (2011).
- King, J. E. (2007, February). *Standardized coefficients in logistical regression*. Paper presented at the meeting of the Southwest Educational Research Association, San Antonio, Texas.
- Lamdin, D. J. (1996). Evidence of student attendance as an independent variable in education production functions. *The Journal of Educational Research*, 89(3), 155-162. doi:10.1080/00220671.1996.9941321
- Lareau, A. (2002) Invisible inequality: Social class and childrearing in black families and white families. *American Sociological Review*, 67, 747-776.
- Levesque, K., Wun, J., & Green, C. (2010). Science achievement and occupational career/technical education course taking in high school: The class of 2005. Retrieved from <http://nces.ed.gov/pubs2010/2010021.pdf>
- Meeder, H., & Suddreth, T. (2012). *Common core state standards and Career and Technical Education: Bridging the divide between college and career readiness*. Retrieved from Achieve, Inc. website: <http://www.achieve.org/CCSS-CTE-BridgingtheDivide>
- Myers, B. E., & Dyer, J. E. (2004). Agriculture teacher education programs: A synthesis of the literature. *Journal of Agricultural Education*, 45(3), 44-52. doi: 10.5032/jae.1998.02027
- National Research Council (NRC). (1999). *High stakes testing for tracking, promotion, and graduation*. Washington, DC: National Academies Press.

- National Research Council (2000). *Inquiry and the National Science Education Standards: A guide for teaching and learning*. Washington, D.C.: National Academy Press.
- National Research Council (2005). *How Students Learn: Science in the classroom*. Washington, D.C.: National Academy Press.
- Nolin, J. B., & Parr, B. (2013). Utilization of a high stakes high school graduation exam to assess the impact of agricultural education: A measure of curriculum integration. *Journal of Agricultural Education*, 54(3), 41-53. doi: 10.5032/jae.2013.03041
- Phipps, L. J., Osborne, E. W., Dyer, J. E., & Ball, A. L. (2008). *Handbook on agricultural education in public schools*. (6<sup>th</sup> ed.) Clifton Park, NY: Delmar Learning
- Portes, A., & MacLeod, D. (1996). Educational progress of children of immigrants: The roles of class, ethnicity, and school context. *Sociology of Education*, 69(4), 255-275.
- Roberts, T. G., Harder, A., & Brashears, M. T. (Eds.). (2016). American Association for Agricultural Education national research agenda: 2016-2020. Gainesville, FL: Department of Agricultural Education and Communication.
- Sadler, P. M., Sonnert, G., Coyle, H. P., Cook-Smith, N., & Miller, J. L. (2013). The influence of teachers' knowledge on student learning in middle school physical science classrooms. *American Educational Research Journal*, 50(5), 1020-1049. doi: 10.3102/0002831213477680
- Schafer, J. L., & Graham, J. W. (2002). Missing data: Our view of the state of the art. *Psychological Methods*, 7(2), 147-177.
- Skelton, P., Stair, K. S., Dormody, T., & Vanleeuwen, D. (2014). Determining the science, agriculture and natural resource, and youth leadership outcomes for students participating in a innovative middle school agriscience program. *Journal of Agricultural Education*, 55(4). 53-71. doi: 10.5032/jae.2014.04053
- Steele, C., & Aronson, J. (1998). Stereotype threat and the test performance of successful African Americans. In Jencks, C., & Philips, M. (Eds.), *The Black-white test score gap* (pp. 401-427). Washington, DC: The Brookings Institution Press.
- Stripling, C. T., & Roberts, T. G. (2012). Florida preservice agricultural education teachers' mathematics ability and efficacy. *Journal of Agricultural Education*, 53(1), 109-122. doi: 10.5032/jae.2012.01109
- Theriot, P. J., & Kotrlik, J. W. (2009). Effects of enrollment in agriscience on students' performance in science on the high school graduation test. *Journal of Agricultural Education*, 50(4), 72-85. doi: 10.5032/jae.2009.04072

- Thoron, A. C., & Myers, B. E. (2011). Effects of inquiry-based agriscience instruction on student achievement. *Journal of Agricultural Education*, 52(4), 175-187. doi: 10.5032/jae.2009.04072
- Torres, R. M., Kitchel, T., & Ball, A. L. (Ed.) (2010). *Preparing and advancing teachers in agricultural education*. Columbus, OH: Curriculum Material Service, The Ohio State University.
- True, A. C. (1969). *A History of Agricultural Education in the United States*. New York, NY: Arno Press.
- United States Department of Education, Institute of Education Sciences, National Center for Education Statistics. (2012). *The Condition of Education 2012* (NCES Publication No. 2012-045). Retrieved from <http://nces.ed.gov/pubsearch/pubsinfo.asp?pubid=2012045>
- United States Department of Education, The National Commission on Mathematics and Science. (2000). *Before It's Too Late: A Report to the Nation from The National Commission on Mathematics and Science Teaching for the 21st Century*. Retrieved from <http://www.nationalmathandscience.org/resources/reports-and-studies?page=2>
- Wilson, K. L., & Portes, A. (1975). The educational attainment process: Results from a national sample. *American Journal of Sociology*, 81(2), 343-363.
- Witt, P. A., Ulmer, J. D., Burris, S., Brashears, T., & Burley, H. A comparison of student engaged time in agriculture instruction. *Journal of Agricultural Education*, 55(2), 16-32. doi: 10.5032/jae.2014.02016
- Young, A. (2013). *Engagement and motivation in learning: Perspectives of middle school agricultural education students* (Master's thesis). Retrieved from University of Florida Digital Collections.

## **Administrator Perceptions of an Agriculture Dual Enrollment Program**

**Dr. Steven “Boot” Chumbley, Texas A&M University-Kingsville**

**Dr. J. Chris Haynes, University of Wyoming**

**Mark Hainline, Texas Tech University**

### **Abstract**

*Student enrollment in colleges of agriculture is on the decline. A shortage of qualified candidates adequately prepared via a rigorous curriculum, standards and assessment practices exists, further increasing the lack of alignment between secondary and higher education. Dual enrollment courses can increase college preparation for future graduates and help students succeed. Dual enrollment allows high school students to take courses while dually enrolled in corresponding college work. The Concerns Based Adoption Model frameworks for levels of use and stages of concern guided this study. The dual enrollment program was found to have a positive impact on students taking more rigorous courses and gaining a more in-depth knowledge of agriculture. Administrators indicated this program helped in establishing higher standards in coursework, enhancing campus prestige and the reputation of the agriculture program. Administrators saw that the program benefited in preparing students for what college is “really like”. Research focused on the pedagogical approaches of how dual enrollment offerings benefit the creation of future high quality dual credit courses.*

### **Introduction**

It is a commonly held feeling among educators that there is a lack of alignment in curriculum, standards and assessments between high school and higher education (Bailey, Hughes & Karp, 2002; Barnett & Hughes, 2010). Almost, annually 60% of first-year college students discover that, while fully eligible to attend college, they are not academically ready for postsecondary studies (National Center for Public Policy and Higher Education, 2009). This problem is exacerbated with minorities and students from low socioeconomic backgrounds (Balfanz & Legters, 2004). To be successful in college, secondary students must have appropriate academic content preparation, learn academic behaviors, cognitive strategies such as analytic thinking, and be able to understand college culture (Zeidenburg & Bailey, 2009). This has in turn affected the agriculture industry as there continues to be a shortage of qualified graduates for jobs within the United States (Goecker, Smith, Smith & Goetz, 2010). One reason for this shortage could be contributed to decline in student enrollment in agriculture majors (Baker, Settle, Chiarelli, & Irani, 2013).

An innovative program which can help to increase college preparation for future graduates is the agriculture dual enrollment program. While dual enrollment/dual credit courses have been in use for many years, agriculture based dual enrollment programs are not as prevalent, especially at the university level in comparison to the junior college level. Dual enrollment courses allow high school students to enroll synchronously in their usual high school courses and a corresponding college course (Estación, Cotner, D'Souza, Smith, & Borman, 2011). Courses can be offered as a

face-to-face/online hybrid where students participate in lab activities through their high school courses, but complete assessments (i.e. tests and quizzes) online from the university instructor. Referred to as blended learning (Barnett & Stamm, 2010), this model has a high probability of success because instructors deliver the same rigorous college content while considering the pedagogical strategies that may be better at engaging secondary students (Karp, Bailey, Hughes & Fermin, 2005).

Previous studies have shown that an administrators support of dual enrollment is key to success of the program (Adelman, 2006; Farrace, 2008). In Michigan, state school administrators have worked with legislators to ease the road to college course attainment through dual enrollment (Cavanagh, 2011). In Colorado, administrator support for dual enrollment rose after community colleges starting offering courses via distance through interactive video chat (Gertge, 2004). School leaders at rural schools have been quick to adopt dual enrollment courses, many times because coordinating boards that grade schools on dual credit participation (Andrews, 2001; Karp, Calcagno, Hughes, Jeong & Bailey, 2008). Krueger (2006) found that dual enrollment program improved relationships between high schools and colleges, enhanced K-12 efficiency and reduced college remediation. Student participation in a dual enrollment program has also showed to have an impact on students' decisions of college majors (Morrison, 2008).

Kim and Bragg (2008) found that students who took dual credit courses had statistically significant, positive relationships between college readiness in reading and writing with articulated credit hours (i.e., hours that are actually accepted by a college). Findings of Bailey et al. (2002) indicated that seniors enrolled in six credits of dual credit courses per semester, demonstrated improved college readiness and were more likely to graduate from college on time than were seniors not enrolled in dual credit courses. Dual enrollment has also been shown to benefit underrepresented and underachieving students as well as students enrolled in career and technology education programs (Bailey, Hughes & Karp, 2005).

Studies by Adelman (2006) and Swanson (2008) found momentum to completion an important factor in a student's quest to obtain a college degree. When students choose not to enroll in postsecondary education right after high school, they do not generate sufficient academic momentum, potentially leading to failure to obtain a college degree. Researchers discovered students currently taking, or have previously taken dual enrollment courses, show increased academic momentum (Barnett & Hughes, 2010). Additionally, previous findings indicated students who participate in dual enrollment enhance their chances for college admission. Participating in dual enrollment has the propensity to create circumstances by which students are reluctant to give up credits earned. These students are perhaps more likely to experience a sense of achievement in their initial college credit classes, and, therefore, enter post-secondary education without delay after high school to a greater degree than non-participants (Morrison, 2008).

Critics of dual enrollment warn about students enrolling in courses prior to being ready. Mead (2009) postulated that students who take courses too young or before they are ready may end up becoming discouraged against college in the future. The study's review of literature has shown that other concerns exist that must be addressed for a program to be successful. These include: providing strong support systems from both secondary and university students (Barnett & Stamm, 2010), provide appropriate dual course sequencing (Karp, 2006) and modeling courses

that prepares students for career success while maintaining high academic standards (Adelman, 2006).

This study addresses the National Research Agenda's Priority Area 5: Efficient and effective agricultural education programs (Doerfert, 2011). This agenda states, "Agricultural education has the obligation to show that its curriculum can be used to meet the academic challenges of today's school system while preparing students for a career in the agricultural industry" (Doerfert, 2011, p. 26).

### **Agriculture Dual Enrollment Program Model**

The State of New Mexico School Grading Accountability system requires that all students must have taken at least one dual credit/dual enrollment course or Advanced Placement (AP) class to fulfill the requirements for graduation (New Mexico Public Education Department, 2013). Those classes that were dual credit must have been completed successfully with a grade of "C" or better. In the 2013-2014 school year, 79% of students met this criterion. It was also found that 41% of the students limited themselves to only taking one college course during their high school career. Established relationships with school leaders, teachers, and students can lead to increased enrollment and success of students in dual enrollment programs. Offering more diversity in course selections in the area of agriculture sciences will also help to recruit and retain students in this high need area (Bailey, Hughes & Karp, 2005).

The strategic plan of this program relies on four specific goals for the overall program: access, accountability, affordability, and student success (Eastern New Mexico University Factbook, 2015). These courses are offered at no cost to the school or student and are paid for by the state. School administrators, secondary teachers, and university faculty must be in agreement on the courses offered and in what format they will be taught. A memo of understanding (MOU) is kept on file with the high school, college, and the state public education department. Teachers must be deemed qualified by the university faculty who most often require a minimum of a master's degree. Students must be at least a junior in classification and in good academic standing (minimum 2.5 GPA).

Currently Eastern New Mexico University offers six different agriculture dual enrollment courses. These courses include introduction to animal science, dairy science, introduction to horticulture, introduction to metal fabrication, rural buildings construction, and principles of engines and power units. The 18 hours of dual enrollment courses offered all apply directly to majors in agricultural science. Courses are offered in three different formats: fully online through the university instructor, as a hybrid online/face-to-face model with the university faculty offering online content and the secondary teacher leading lab activities; and solely by the high school teacher serving as a university adjunct instructor. It has been found that programs with the hybrid course model have a high probability of success because instructors deliver the same rigorous college content while considering the pedagogical strategies that may be better for engaging secondary students (Picciano & Seaman, 2009).

To ensure program rigor, university instructors and secondary teachers work together to make sure students are performing their own work and put forth the required effort. Student

assessments are developed by the university instructor and are completed online through the university blackboard system. This increases student accountability and upholds the high standards and rigor of the university. Even though, strengths and benefits of the program have been identified, areas that merit program improvement exist as well. The dual enrollment program, agriculture course offerings and how those courses are offered is continually changing and adapting to best serve the needs of the students, secondary schools, and the university. This research will assist program leaders in addressing all of these needs and making the necessary pedagogical, program and course content changes.

### **Conceptual Framework**

This research was guided by the Concerns-Based Adoption Model (CBAM) (Hall & Hord, 2006), a conceptual framework which describes, explains and predicts probable educator concerns and behaviors throughout a change process. The CBAM forms the analytic lens for this research and has been associated with investigation of participant responses in 'top-down' situations. In this case, the CBAM is applied to the change process of administrators who supervise schools that are implementing and have students enrolling in the agriculture dual enrollment program. This model was originally based on research that showed beginning educators went through developmental stages and expressed predictable concerns at each stage as they learned to implement an innovative program (Hall & Hord, 2001). The model was later adapted to measure concerns teachers and school leaders expressed as they learned to use new practices and the extent to which they actually implemented the innovative educational methods.

Today's educational systems involve numerous individuals responsible for facilitating change. These facilitators need a means of assessing the needs of the individuals with whom they work so that the most appropriate and timely assistance can be given. Drawing initially from the work of Francis Fuller (1969), the Concerns Based Adoption Model was developed by researchers at the University of Texas at Austin in the early 1980s. The model is built on the premise that change is a process, not an event, and as individuals navigate their way through the process they encounter not only a number of affective 'stages of concern' but they also progress through different 'levels of use' (Hall & Hord, 1987, 2006). Two important kinds of assessment information CBAM provides are: Concerns of the individual about whatever new programs, products, or ideas (innovations) are being offered, delivered, or implemented and individuals' knowledge of and how they use these innovations. The particular focus of this study was on administrators' stages of concern and levels of use components of that model.

The CBAM is a framework that describes the perceptions and motivations school leaders might have about a change in curriculum and/or instructional practices at different points in its implementation (Sweeny, 2003). Hall and Hord (2006) described multiple stages that an educator goes through towards program adoption. At Stage 0, "Awareness", they have little knowledge about or interest in the change. At Stage 1, "Informational", interest is peaked at learning more about the innovation. During Stage 2, "Personal", concerns about how the innovation relates to the individual develop. Stage 3, "Management", is reached with experimentation and implementation; at this point, concerns intensify around the logistics and new behaviors associated with putting the change into practice. At Stage 4, "Consequence", looks at concerns about the effect of the innovation on the students. Stage 5, "Collaboration",

reflects school leader (administrator and counselor) interest in coordinating with others in using the innovation. Stage 6, “Refocusing”, involves thinking about making major modifications in the use of the innovation, or perhaps replacing it with something else (Hall & Hord, 2006).

The CBAM Levels of Use focuses on general patterns of behaviors as educators prepare to use, begin to use, and gain experience implementing a classroom change (Hall & Hord, 1987, 2006). Level 0, “Nonuse”, reflects a state in which there is little knowledge of the change and no plans for its implementation. Level I, “Orientation”, when decisions are made to seek more information about the change, but the school have not made any attempts at implementation yet. Level II, “Preparation”, the educator is actively preparing to put the change into practice, but has not actually begun to implement it in the classroom. Level III, “Mechanical”, begins the change and implementation. Level IV, “Routine”, has been reached when the educator is comfortable with the change and not planning to amend how it is used. Most administrators settle in at a Routine level of use. Some, however, may actively assess the impact of the innovation on their students and initiate changes in the innovation or their use of it on this basis.

The CBAM is helpful not only in understanding the change process, but in designing change strategies. An effective change strategy is one that helps teachers through the stages, addressing the seven concerns more or less in sequence (Anderson, 1997). For example, skipping the stage of personal concern, or not giving teachers enough time to work through it makes successful change more difficult. Different concerns always interact and are operationalized by users at different points throughout the process.

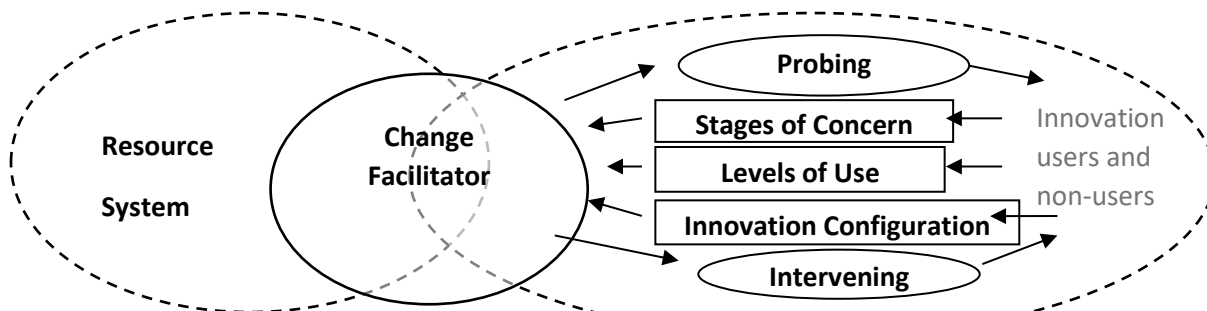

Figure 1. Concerns Based Adoption Model by Hall & Hord (2006)

### Purpose/Objectives

Results from this study can contribute to a better understanding of the agriculture dual enrollment program secondary administrators, their opinions of course offerings, and the overall agriculture dual enrollment program. The purpose of this study was to understand school administrators’ perceptions of the New Mexico agriculture dual enrollment program impact on the secondary school and students. A total of four research objectives guided this study:

1. Determine administrators’ perceptions of the impact of the agriculture dual enrollment program to areas of student success.



2. Evaluate administrators' perceptions of impact the agriculture dual enrollment program has on secondary agriculture educators.
3. Evaluate administrators' perceptions of how the agriculture dual enrollment program's presence on a campus influences counselors.
4. Determine administrators' perceptions of the overall benefit of the agriculture dual enrollment program to the secondary school campuses.

## Methods

This research employed a descriptive study with open ended questions. These research methods sought to overcome weaknesses of a single method (Johnson & Onwuegbuzie, 2004). After IRB approval and individual participant agreement to participate, collection of data began. The sample population for this study was all New Mexico administrators who supervised schools which were offering the agricultural dual enrollment courses on their campus ( $N = 34$ ) of the 90 schools with agricultural programs in the state. Researchers received a response rate of 88% ( $n = 24$ ). To assess non-response error, a comparison of early and late responders was conducted, which revealed no significant ( $p < .05$ ) differences. Based on this information, the researcher concluded the findings could be generalized to the population (Lindner, Murphy & Briars, 2001). Although potential exists to transfer this to other settings, the findings of this study are limited to the participants of this study's results in the state of New Mexico.

Quantitative data was collected in relation to teacher's perceptions on the cost and benefits of the dual enrollment program. Campus principals were asked to rank the impact of the dual enrollment course offerings on a five point Likert type scale (1= *strongly disagree* to 5= *strongly agree*). The rating was on the dual credit course offering in relation to areas of student success, impacts on the high school teacher, guidance counselor and secondary school campus as a whole. Participants were asked open ended questions relating to the impacts on students, teachers, the school as a whole, and their overall opinion of the agriculture dual enrollment program. The instrument used for this study was a modified version of the Teacher Dual Enrollment Impact Survey, developed by the National Association for Concurrent Enrollment Partnerships (NAECP, 2012). It was modified to assess the administrators' opinions versus teacher opinions.

The NACEP is a professional organization with over 200 postsecondary members across the United States. Per NACEP guidelines, none of the essential questions were deleted or modified other than specifying course focus (in this case agricultural science). The validity of this instrument has been established through testing and usage across the country (NACEP, 2011). Chief academic officers at the institution were also given a chance to review drafts of the survey to ensure instrument validity. The reliability of the instrument resulted in a Cronbach's Alpha score of .957 post-hoc evaluation.

Open-ended responses were solicited to investigate program participants' experiences because this method allowed researchers to understand how people "make sense of their world" (VanMaanen, 1979). Hall and Hord (1987) indicated researchers may use open-ended concerns statements to assess stages of concern. For example, the school leaders' knowledge of the

innovation grows in the process of implementing the innovation and this may raise or lower personal concerns. This technique, which involves written responses to open-ended prompts, has been used in various research projects on instructional innovation (Newlove & Hall, 1976). A survey with the open-ended prompt is given to school leaders or teachers who are implementing a particular intervention. Open-ended written statements of concerns are not dependent on face-to-face interaction between consultants and consultees, and also provide a written record of teachers' concerns. Conversely, the written statements are time-consuming to complete and analyze, and some responses will be too brief to be accurately classified into the appropriate stage (Hall & Hord, 1987; 2001)

Questions were asked at the end of each likert-type scale. These were reviewed by the researchers and the data analyzed using the constant comparative method (Glaser & Strauss, 1967). This employed unitizing and categorizing of the data. The constant comparative method allowed the researchers to repeatedly compare the responses with previous responses in an attempt to discover new relationships (Dye, Schatz, Rosenberg, & Coleman, 2000). Following the unitizing of the data, the data were coded as part of an audit trail to ensure confirmability (Erlandson, Harris, Skipper & Allen, 1993). The units of data were sorted into emergent categories of participant perceptions.

The researchers used measures of credibility to validate the study. Credibility relates to the level of confidence in the researchers, study design and findings to accurately represent the data (Ary, Jacobs & Sorenson, 2010). Credibility was established through member checks and peer debriefing. Participants were purposely selected for this study based upon their experience supervising programs that were participating in the agriculture dual enrollment program. The average number of years that participants had experience with the dual enrollment program was 4.5 years. Although potential exists to transfer this to other settings, the findings of this study are limited to the participants of this study's results in the state of New Mexico.

## Findings

**Objective one:** Determine administrators' perceptions of the impact of the agriculture dual enrollment program to areas of student success. Table one illustrates the administrators' perception of dual enrollment on student success.

Table 1

*Administrators' Perceptions of the Agriculture Dual Enrollment Program to Student Success*

Prompt	<i>M</i>	<i>Mode</i>	<i>SD</i>
Continued rigorous learning into their senior year	3.88	4	1.03
Chose to take courses on campus	3.86	5	1.46
Gained an in depth knowledge of agriculture	3.83	4	1.05
Have enrolled in academically challenging courses	3.71	4	1.20
Developed effective time management skills	3.67	4	1.29
Developed an understanding of their academic skill	3.67	4	1.04

Gained an appreciation for the challenge of college	3.63	4	1.06
Developed effective study habits	3.58	4	1.06
Developed realistic college expectations	3.58	4	1.02
Considered, for the first time, going to college	3.38	3	1.31

*Note.* 1 = strongly disagree, 5 = strongly agree

Overall administrators had mixed feelings on the impact of agricultural dual enrollment on student success with an overall mean of 3.69 ( $SD = 1.15$ ). Administrators perceived the largest impact of the program on students' success in regard to continuing rigorous learning into their senior year ( $M = 3.88, SD = 1.03$ ), staying on campus to get college credit ( $M = 3.86, SD = 1.05$ ), and gaining an in-depth knowledge of agriculture ( $M = 3.83, SD = 1.05$ ). Participants were also asked the open ended question, "What is the single greatest impact agricultural dual enrollment courses have had on your students?" They responded that involvement in the program led to more students getting involved in more rigorous courses, more students were attending college, they saw more momentum built towards interest in college, graduating more students, and gave high school agricultural students the opportunity to start college early. Several commented on the benefit of this program because they get free college credit. Selected administrator comments include:

*"They learn better study habits and get a taste of what higher education will demand."*

*"It saves them time and money"*

*"This gives students the opportunity to determine whether they can be successful at the next level."*

*"Due to the availability of dual enrollment courses, our school has sent more graduated students in to post-secondary institutions."*

**Objective two:** Evaluate administrators' perceptions of impact the agriculture dual enrollment program has on secondary agriculture educators. Table two provides detail on these findings.

Table 2

Prompt	<i>M</i>	<i>Mode</i>	<i>SD</i>
Was supported by the dual university liaison	3.71	4	1.08
Increased critical thinking skills taught in courses	3.63	4	1.06
Developed better understanding of college expectations	3.63	4	1.06
Established higher standards for student work	3.50	4	1.06
Was more connected with their discipline	3.46	4	1.06
Found dual content useful in non-dual courses	3.46	4	0.93
Learned about new ideas in their discipline	3.42	4	1.02

Have been energized as a teacher	3.38	3	1.06
Found the job more satisfying	3.29	4	1.04
Learned new instructional strategies	3.25	3	1.26
Taken leadership positions within the school	3.00	3	0.98
Have been released from other school duties	2.89	3	0.93
Found it more difficult to fulfill other responsibilities	2.54	2	1.06

Note. 1 = strongly disagree, 5 = strongly agree

Findings indicated school administrators felt mostly neutral about the impact of an agricultural dual enrollment program on the agricultural science teachers, with a mean score of 3.32 ( $SD = 1.05$ ). The highest mean scores were found in the areas of positive relationships with university dual liaisons ( $M = 3.71, SD = 1.08$ ), a visible increase of critical thinking taught by teachers ( $M = 3.63, SD = 1.06$ ) and teachers having a better understanding of college expectations ( $M = 3.63, SD = 1.06$ ). Administrators did not feel that the program took teachers away from other responsibilities, nor made it more difficult for them to do their job.

When asked, “What is the single greatest impact dual enrollment has had on your teachers?”, the majority of administrators reported on teachers’ willingness to increase course rigor. Some administrators also cited teachers’ aligning courses to college expectations, a more positive attitude and developing working relationships with university faculty.

**Objective three:** Evaluate administrators’ perceptions of how the agriculture dual enrollment program’s presence on a campus influences counselors. Table three details how teachers recognized this program impacted school counselors’ decisions.

Table 3

*Perceived Impact of the Dual Enrollment Program in Relation to School Counselors*

Prompt	<i>M</i>	<i>Mode</i>	<i>SD</i>
Changed the way they present college options to students	3.79	4	1.06
Perceived more students as capable of higher levels of academic achievement	3.50	4	1.02
Developed a better understanding of skills students need to succeed in college	3.46	4	1.06
Increased their knowledge of current college requirements	3.38	4	1.06
Enrolled more students in my agriculture science class	3.33	4	1.30

Note. 1 = strongly disagree, 5 = strongly agree

Administrators were found to have a neutral perception of the impact dual enrollment had on school counselors. The highest mean scores were found within the area of how the school counselor “presents college options to students using dual enrollment” ( $M = 3.79, SD = 1.06$ ).

Administrators did not feel that counselors enrolled more students in agricultural courses because of the dual enrollment program ( $M = 3.33$ ,  $SD = 1.30$ ).

**Objective four:** Determine administrators’ perceptions of the overall benefit of the agriculture dual enrollment program to the secondary school campuses. These findings are presented within table four.

Table 4

*Perceived Benefit of Agriculture Dual Enrollment to the Overall Secondary Campus*

Prompt	<i>M</i>	<i>Mode</i>	<i>SD</i>
Progressed in meeting school goal of offering rigorous courses	4.00	4	1.06
Demonstrated to parents that their students are doing challenging work	3.88	4	1.04
Enhanced campus prestige and academic reputation	3.67	4	1.27
Offers requisite courses for agriculture dual enrollment that are appropriate	3.63	4	1.06
Raised expectations for student performance	3.42	4	1.06

*Note.* 1 = strongly disagree, 5 = strongly agree

Overall administrators agreed dual enrollment brought rigorous courses to their campuses ( $M = 4.00$ ,  $SD = 1.06$ ) and demonstrated to stakeholders that students were performing well within challenging courses ( $M = 3.88$ ,  $SD = 1.04$ ). When answering the question, “What is the single greatest impact the agricultural dual enrollment program has had on your school?”, administrators felt that the dual enrollment program positively affected students having the chance to receive college courses for free, better prepared students for college success, increased university/secondary campus collaboration and the program has helped the school in meeting state dual credit requirements. Some opened answer responses include:

*“Our students have an edge on their educational goals once reaching college.”*

*“Students and teachers have access to courses that will provide a foundation of learning for a lifetime.”*

*“Students are graduating at a higher percentage than other schools based on the large number of students being enrolled in dual credit courses.”*

*“Has provided a taste of what students can expect once they get to college.”*

*“Great program and very beneficial to our school and district.”*

*“Allowed us to provide a wide variety of classes to our students regardless of our rural and small demographics.”*

The final question of the survey was an open response asking, “What are some challenges that you have seen from your involvement with the agriculture dual enrollment program?”. Some administrators felt that the school should get more credit on its state accountability grading because of dual enrollment participation. Some reflections from this statement include:

*“While parents love it, some students may not be able to handle the rigor of these courses.”*

*“The benefits of the program outweigh the challenges.”*

*“Perhaps a few onsite courses as well as online courses?”*

*“We would like to see dual credit courses offered in our Navajo Language and focus on issues specifically facing our agriculture issues.”*

### **Conclusions**

The researchers found that overall, administrators perceived that the agriculture dual enrollment program had a positive impact on students, teachers, and the secondary campus. Specifically, administrators were mostly positive regarding the increased rigor of coursework and the depth of knowledge in agriculture topics as influenced by the inclusion of dual enrollment curriculum, which is similar to findings by Hughes (2010). Similar to findings outlined by Young, Slate, Moore, and Barnes (2014), administrators were positive regarding the opportunity for students to earn college credit without having to leave the high school campus, resulting in less travel time and decreased costs for transportation. Furthermore, administrators cited the opportunity to participate in college courses before high school graduation translated into more recent graduates enrolling in post-secondary education. An increase in critical thinking skills taught in courses as well as providing opportunities for students to develop a better understanding of college expectations were cited as positive impacts on the school as a whole as a result of the changes implemented by the secondary teachers who taught the dual enrollment courses. This positive impact to the campus is a major component of change adoption within the CBAM (Hall & Hord, 2001). The administrator’s comments backed up these findings as well as provided more detail on how the teachers were impacted in these areas.

Interestingly, administrators had more positive perceptions regarding the impact of dual enrollment courses in relation to school counselors than agricultural education teachers had been found to have. This difference could be attributed to the varying degrees of contact the administrators have with counselors versus the agricultural education teachers. Most notably, as a result of the opportunities provided by dual enrollment courses, the administrators perceived a change in how school counselors presented college options to students. As well, after having an opportunity to view how students responded to the challenging curriculum, the counselors were perceived to have higher expectations of the students who enrolled in the courses. Contrary to the perceptions of dual enrollment teachers regarding the impact of the program on school counselors, the beliefs of the administrators tended to fall into the mid-levels of use, *informational* and *orientation*, respectively. By addressing the mid-stages of concern related to

*informational* and *orientation*, the researcher can successfully reach the later stages of *collaboration*. As the school counselors advance through the various stages outlined in the CBAM, they would eventually become adopters and advocates of the agriculture dual enrollment program.

### **Recommendations for Practice**

Dual enrollment program directors are encouraged to develop and present a professional development workshop for school administrators to increase their level of understanding, which can be used as a stepping stone to increase the level of understanding and adoption of the school counselors of the agriculture dual enrollment program. This was important, as the level of counselors' support was the construct that had the lowest average scores perceived by administrators. Using the CBAM, counselors need to be better informed through appropriate professional development, which, from a leadership standpoint, may be best implemented by school administrators before they can advance further along the spectrums for levels of concern and levels of use. Being part of a larger study involving agriculture science teachers and school counselors, recommended practices will include how all of these school officials can work collegially towards the improvement of the dual enrollment program. As noted within CBAM, an organization does not change until the individuals within it change (Hall & Hord, 2006). Additionally, it is recommended that professional development be provided to secondary educators that serve as "adjunct" faculty to the university. Researchers (Picciano & Seaman, 2009) suggested that dual enrollment courses offered from a hybrid model have a higher probability of success than do those offered strictly through the university, necessitating the need for training of those that serve in an adjunct capacity. Moreover, it is further recommended that an increase in training among secondary faculty would increase enrollment and concomitantly the success of those students enrolled in dual enrollment courses.

### **Recommendations for Research**

The researchers will continue studying the barriers and influences of administrators' adoption of the agricultural dual enrollment courses, guided by the CBAM. As this is a part of a larger study involving teachers and counselors, results should be further studied and compared. Research focused on the pedagogical approaches of course offerings both from the university instructor and the secondary agricultural science teacher and administrators' perspectives would benefit the creation of higher quality dual enrollment courses. It is suggested that researchers continue studying the benefit of students' participation in the dual enrollment program on college entrance and success in higher education. Research should also be conducted regarding career paths of the high school students taking courses. After taking dual enrollment courses, does it influence their decision to major in agriculture? To develop a program that is available to a wide range of learners, while maintaining high standards for course accountability, more research should be performed on how well these programs address the needs of school leaders and communities. The researchers suggest further comparisons of the program perceptions of school administrators, counselors, teachers and students be completed to additionally gauge their perceived levels of use and stages of concern in regard to the agricultural dual enrollment program.

## Resources

- Adelman, C. (2006) *The toolbox revisited: Paths to degree completion from high school through college*. Washington, DC: U.S. Department of Education, Office of Vocational Education.
- Anderson, S. E. (1997). Understanding teacher change: Revisiting the concerns based adoption model. *Curriculum Inquiry*, 27, 331-367.
- Andrews, H. A. (2001) *The dual credit phenomenon! Challenging secondary school students across 50 states*. Stillwater, OK: New Forums Press.
- Ary, D., Jacobs, L. C., & Sorenson. (2010). *Introduction to research in education* (8th ed.) Belmont, CA: Thomson Wadsworth.
- Bailey, T. R., Hughes, K. L., & Karp, M. (2002). What role can dual enrollment programs play in easing the transition between high school and postsecondary education? Washington, DC: Preparing for America's Future: The High School Symposium. Retrieved from ERIC database. (ED465090)
- Bailey, T. R., Hughes, K., & Karp, M. M. (2005). *What role can dual enrollment programs play in easing the transition between high school and postsecondary education?* Washington, DC: Office of Vocational and Adult Education, U.S. Department of Education (U.S. Department of Education Publication No. ED-99-CO-0160)
- Baker, L. M., Settle, Q., Chiarelli, C., & Irani, T. (2013). Recruiting strategically: Increasing enrollment in academic programs of agriculture. *Journal of Agricultural Education* 54 (3), 54-66. doi: 10.503/jae.2013.03054
- Balfanz, R., & Legters, N. (2004). Locating the dropout crisis: Which high schools produce the nation's dropouts? Where are they located? Who attends them? Report 70. Center for Research on the Education of Students Placed at Risk, CRESPAT. Retrieved from <http://www.csos.jhu.edu/crespar/techReports/Report70.pdf>
- Barnett, E., & Hughes, K. (2010). *Issue brief: Community college and high school partnerships*. New York, NY: Community College Research Center, Columbia University. Retrieved from ERIC database. (ED512397)
- Barnett, E., & Stamm, L. (2010). *Dual enrollment: A strategy for educational advancement of all students*. Retrieved from [www.blackboardinstitute.com/pdf/Bbinstitute\\_DualEnrollment](http://www.blackboardinstitute.com/pdf/Bbinstitute_DualEnrollment)
- Cavanagh, S. (2011). Public school choice pushed in Michigan. *Education Week*, 31(A), 1-2. Retrieved from <http://www.edweek.org/ew/toc/2011/09/21/index.html>
- Doerfert, D. L. (Ed.) (2011). *National research agenda: American Association for Agricultural Education's research priority areas for 2011-2015*. Lubbock, TX: Texas Tech University, Department of Agricultural Education and Communications.



- Dye, J. F., Schatz, I. M., Rosenberg, B. A., & Coleman, S. T. (2000). Constant comparison method: A kaleidoscope of data. *The Qualitative Report*, 4(1/2). Retrieved from [www.nova.edu/ssss/QR/QR4/dye.html](http://www.nova.edu/ssss/QR/QR4/dye.html)
- Erlandson, D. A., Harris, E. L., Skipper, B. L., & Allen, S. D. (1993). *Doing naturalistic inquiry*. Newbury Park, CA: SAGE.
- Estación, A., Cotner, B. A., D'Souza, S., Smith, C. S., & Borman, K. M. (2011). *Who enrolls in dual enrollment and other acceleration programs in Florida high schools? Issues & answers*. REL 2012-No. 119. Regional Educational Laboratory Southeast. (ED526313)
- Farrace, R. (2008). Double duty: A conversation with Pamela Drake and Scott Nielson. *Principal Leadership*, 8(8), 22-26. Retrieved from <http://eric.ed.gov/?id=EJ789933>
- Fuller, F. F. (1969). Concerns of teachers: A developmental conceptualization. *American Educational Research Journal*, 6(2), 207–226. doi:10.3102/00028312006002207
- Gertge, P. A. (2004). Analyses of dual credit in rural eastern Colorado (doctoral dissertation). Retrieved from ProQuest Dissertation & Theses (3160092).
- Goecker, A. D., Smith, P. G., Smith, E. & Goetz, R. (2010). *Employment opportunities for college graduates in food, renewable energy and their environment: United States, 2011-2015*.
- Hall, G. E., & Hord, S. M. (1987). *Change in schools: Facilitating the process*. Albany, NY: State University of New York Press.
- Hall, G. E., & Hord, S. M. (2001). *Implementing change: Patterns, principles, and potholes*. Boston, MA: Allyn and Bacon.
- Hall, G. E., & Hord, S. M. (2006). *Implementing change: Patterns, principles, and potholes*. Boston, MA: Allyn and Bacon.
- Johnson, R. B., & Onwuegbuzie, A. J. (2004). Mixed methods research: A research paradigm whose time has come. *Educational Researcher*, 33(7), 14-26. doi: 10.3102/0013189x033007014
- Karp, M. M. (2007). *Learning about the role of college student through dual enrollment participation*. CCRC Working Paper No. 7. New York: Community College Research Center, Teachers College, Columbia University.
- Karp, M. M., Bailey, T., Hughes, K., & Fermin, B. (2005). Update to state dual enrollment policies: Addressing access and quality. Washington, DC. U.S. Department of Education: Office of Adult and Vocational Education.

- Karp, M. M., Calcagno, J. C., Hughes, K. L., Jeong, D., & Bailey, T. R. (2007). *The postsecondary achievement of participants in dual enrollment: An analysis of student outcomes in two states*. Community College Research Center, Columbia University.
- Kim, J., & Bragg, D. D. (2008). The impact of dual and articulated credit on college readiness and retention in four community colleges. *Career and Technical Education Research*, 33(2), 133-158. doi: <http://dx.doi.org/10.5328/CTER33.2.133>
- Krueger, C. (2006). Dual enrollment: Policy issues confronting state policymakers. Policy Brief. Denver, CO: Education Commission of The States. Retrieved from ERIC database (ED493711).
- Lindner, J. R., Murphy, T. H., & Briers, G. E. (2001) Handling nonresponse in social science research. *Journal of Agricultural Education*, 42(4), 43-52. doi: 10.5032/jae.2001.04043
- Mead, R. A. (2009) *A comparison of the enrollment and academic success of dual credit and non-dual credit students* (unpublished doctoral dissertation). Iowa State University, Ames, IA.
- Morrison, M. C. (2008). *The benefits of acceleration-baccalaureate advantages*. Mason City, IA: North Iowa Area Community College.
- National Association of Concurrent Enrollment Partnerships (2011). Retrieved from <http://www.nacep.org/research-policy/legislation-policy/>
- National Center for Education Statistics (2011) *The Condition of Education 2011*. Washington, DC: U.S. Department of Education
- Newlove, B. W., & Hall, G. E. (1976). *A manual for assessing open-ended statements of concern about the innovation* (Report No. 3029). Austin, TX: The University of Texas at Austin, Research and Development Center for Teacher Education. (ERIC Document Reproduction Service No. ED 144 207).
- Picciano, A.G. & Seaman, J. (2009). *K-12 Online Learning: A 2008 Follow-Up of the Survey of U.S. School District Administrators*. Needham, MA: The Sloan Consortium.
- New Mexico Public Education Department (2013). Retrieved from <http://www.ped.state.NewMexico.us/dualcredit/>
- Swanson, J. (2008). An analysis of the impact of high school dual enrollment course participation on post-secondary academic success, persistence and degree completion. *Dissertation Abstracts International: Section A. Humanities and Social Sciences*, AAT 3323472.
- Sweeny, B. (2003). *CBAM: A model of the people development process*. Retrieved from <http://www.mentoring-association.org/membersonly/CBAM.html>

- Van Maanen, J. (1979). Reclaiming qualitative methods for organizational research: A preface. *Administrative science quarterly*, 24(4), 520-526. doi: 10.2307/2392358
- Young, R. D., Slate, J. R., Moore, G. W., & Barnes, W. (2014). Dual credit and non-dual credit college students: Differences in GPAs after the second semester. *Journal of Education and Human Development*, 3(2), 203-230. Retrieved from [http://jehdnet.com/journals/jehd/Vol\\_3\\_No\\_2\\_June\\_2014/11.pdf](http://jehdnet.com/journals/jehd/Vol_3_No_2_June_2014/11.pdf)
- Zeidenberg, M., & Bailey, T. (2009). Human resource development and career and technical education in American community colleges. Paper presented at the Asia-Pacific Economic Cooperation (APEC) Human Resources Development Group Meeting, Chicago, IL. Retrieved from ERIC database. (ED509712).

## **A National Look at How Experience Influences Engagement in Water Conservation**

Pei-wen Huang, University of Florida  
Alexa J. Lamm, University of Florida

### **Abstract**

*Extension educators have diligently educated the general public about water conservation. Incorporating audiences' personal experience into educational programming is recommended as an approach to effectively enhance audiences' adoption of water conservation practices. To ensure the impact on the audiences and environment, understanding the differences in issues audiences are concerned and audiences' behavioral pattern is needed. This study examined the regional differences in how U.S. residents' experiences with water issues related to their engagement and intention to engage in water conservation in order to facilitate the development of Extension educational programming in different regions. An online survey was administered to collect responses from U.S. residents in this descriptive and correlational study. Respondents' water issues experience, water use behaviors, water conservation practice application, and willingness to act on water conservation were measured. Regional differences in how experience were associated with water use behaviors, water conservation practices application, and willingness to act were found. Extension educators should be aware of such regional differences when developing water conservation educational programs and provide recommendations tailored to regional audiences' needs and interests. By doing so, audiences' adoption of water conservation practices is expected to increase.*

### **Introduction**

Experience is an important component in both formal and non-formal educational settings (Huang & Lamm, 2015; Knowles, Holton, & Swanson, 2005; Kolb, 1984; Rubenstein & Thoron, 2014). In the realm of environmental education, previous experience has been found to influence perceptions, awareness of, and motivations to learn about environmental conservation (Brasier et al., 2011; Fuss, Bornkessel, Mattern, & Stamminger, 2011). Water issues are recurrently identified as one of the largest issues facing the country (United States Environmental Protection Agency [USEPA], 2015a) and the world (Roberts, Harder, & Brashears, 2016). Cooperative Extension, an organization “[providing] non-formal education and learning activities to people throughout the country” (National Institute of Food and Agriculture [NIFA], 2016, para. 1), has been actively involved in water conservation education. To maximize the impact education can have on an audiences' behavior change regarding water conservation, Extension has targeted specific audiences that have personal experiences with water issues along with incorporating simulated personal experiences into educational programming for those that do not (Singletary & Daniels, 2004; Pratt & Bowman, 2008). By simulating personal experiences into educational programming, participants can directly see the relevance of water issues to their daily lives, resulting in a higher tendency to take environmental protection action, such as conserving water resources (Huang & Lamm, 2015; Laughlin et al., 2004).

Individuals tend to respond and react to issues more directly linked to their lives, such as daily water demand, than those with loose linkages and uncertainties, such as climate change (Haasnoot, Middelkoop, Van Beek, & Van Deursen, 2011). However, residents in different states

interact with water differently depending on their life styles and the water issues they face. For example, in California water is limited due to drought and is paired with a high level of demand for water by the agricultural industry (USEPA, 2015b). In Florida, population growth, climate change, and residents' reliance on groundwater for lush landscapes has put pressure on water resources (USEPA, 2013a). Residents of Maryland are actively engaged in water sports and fishing, but the Chesapeake Bay area is facing water quality issues due to nutrient pollution (USEPA, 2013b; USEPA, 2016) and residents in the Great Lakes area are known for their active fishing but industrial water use in the area has resulted in water quality issues and contamination of fish populations (USEPA, 2015c). These differences in experience and exposure to water issues are expected to influence individuals' attitudes and behaviors regarding water protection (Borisova, Smolen, Boellstorff, McFarland, & Adams, 2013; Mahler et al., 2010; Shaw, Hazel, Bardon, & Jayaratne, 2012).

While individuals' environmental perceptions and behaviors may be influenced by their personal experiences (Gifford & Nilsson, 2014), additional understanding of how this influences their engagement in water conservation may help Extension educators develop educational programs relevant to their audiences' needs (Huang, Lamm, & Dukes, 2016). By providing relevant and practical advice, Extension educators can effectively enhance their audiences' acceptance and adoption of water conservation behaviors (Wagner & Kuhns, 2013) fulfilling the first research priority of the National Research Agenda: "public and policy maker understanding of agriculture and natural resources" (Roberts et al., 2016, p. 13). Extension educators can use the findings to facilitate and strengthen the development of future water conservation educational programs targeting the general public to realize greater impact.

### **Theoretical Framework**

This study was driven by the theory of cognitive dissonance (Festinger, 1957). This theory describes the situation when an individual has more than one cognition, such as knowledge, opinions, beliefs, values, and attitudes, conflicting with one and another (Festinger, 1957). A conflict between cognitions can lead to an uncomfortable feeling that the individual would want to minimize the discrepancy between cognitions or avoid situations that may increase the discrepancy (Festinger, 1957). Cognitive dissonance may occur due to past experience. When a later cognition is related to, but inconsistent with, past experience, individuals will be motivated to change the dissonant situation to a consonant one (Festinger, 1957). Cognitive dissonance may have different magnitudes depending on the importance or relevance to one's personal values, and/or the level of dissonant to consonant elements (Festinger, 1957). The higher the dissonance magnitude is, the more likely individuals are to change their situation (Festinger, 1957).

Cognitive dissonance has been frequently used to explain individuals' behavioral decision and cognition related to environmental conservation. Thøgersen (2004) examined consumers' performance of different environmentally responsible behaviors and found patterns of both consistent and inconsistent environmentally responsible behaviors. While consumers preferred to behave in a consistent manner, some may choose to remain their inconsistent behaviors because they subjectively perceived the cost to change the behavior exceeded the value to conserve environment (Thøgersen, 2004). Similarly, the study of Whitmarsh and O'Neill (2010) revealed cognitive dissonance between individuals' pro-environmental behaviors and self-identity related to their environmental value may lead to behavioral change. While individuals' past behavior

was associated with their self-identity, they tended to engage in pro-environmental behaviors to remain consistency in past behaviors (Whitmarsh & O'Neill, 2010).

Individuals gain experience through past behaviors (Whitmarsh & O'Neill, 2010), therefore their gained experience is paired with later information which may result in behavioral change or denial of behavioral change. Individuals who have experienced water issues and learned about water conservation have a high potential for adopting water conservation practices and behaviors (Fielding et al., 2013; Nieswiadomy, 1992). However, without continuous experience with water issues, individuals may gradually lose the connection between water conservation behaviors and water issues over time and discontinue their engagement in water conservation behaviors (Fielding et al., 2013).

Huang and Lamm (2015) found individuals' past experience with water issues can influence their perception of water. Fielding et al. (2013) and Harriden (2013) found keeping a "Water Diary" was an approach that made individuals stay aware of how they use water and motivated them to conserve water. Wolfe (2012) found decision-making regarding engaging in water conservation was influenced by knowledge and experience with water and water issues. Individuals who perceived water conservation efforts should be behavior-driven and possessed knowledge and experience with water and water issues tended to adopt water conservation practices, as well as feel personally responsible for water conservation. On the other hand, individuals who perceived water conservation efforts should be technology-driven and possessed knowledge and experience with water and water issues tended to not adopt water conservation practices, as well as feel personally responsible for water conservation (Wolfe, 2012).

Empirical studies have shown cognitive dissonance, when properly used, may influence individuals' perception and create behavioral change toward engaging in water conservation. Further examination of how water-related experiences influence engagement in water conservation differently based on the water issues facing different areas is needed. Recommendations and guidance can be provided to the nationwide Extension system to effectively communicate with audiences and increase engagement in water conservation (Huang & Lamm, 2015; Monz, Cole, Leung, & Marion, 2010).

### **Purpose and Objectives**

The purpose of this study was to examine if regional differences existed in how U.S. residents' experiences with water issues related to their engagement in water use behaviors, application of water conservation practices, and willingness to act on water conservation in order to guide and facilitate future Extension programming. The objectives were to:

1. Describe U.S. residents' experiences with water issues, engagement in water use behaviors, application of water conservation practices, and willingness to act on water conservation by regions;
2. Identify regional differences in U.S. residents' experiences with water issues, engagement in water use behaviors, application of water conservation practices, and willingness to act on water conservation; and
3. Examine the relationships between U.S. residents' experiences with water issues, engagement in water use behaviors, application of water conservation practices, and

willingness to act on water conservation by regions.

### Methods

This study was descriptive and correlational using an online survey developed by researchers to examine U.S. residents' experiences with water issues and opinions about water conservation. The survey instrument was developed based on the 2012 RBC Canadian Water Attitudes Study (Patterson, 2012). The survey was administered electronically by collaborating with a public opinion survey research company to recruit respondents representative of the U.S. general public aged 18 years or older. Data were collected using a non-probability opt-in sampling technique.

The instrument was distributed to 2,948 U.S. residents with 1,050 complete responses received after quotas and manipulation checks were passed, resulting in a 36% participation rate. Non-probability opt-in sampling techniques have been widely used in public opinion research with data adjustment approaches recommended to strengthen the representativeness of the results (Baker et al., 2013). In this study, post-stratification weighting methods (Kalton & Flores-Cervantes, 2003) were used to overcome non-participation bias, selection, and exclusion limitations (Baker et al., 2013). Data were weighted based on the 2010 U.S. Census of age, sex, and race/ethnicity (Kalton & Flores-Cervantes, 2003). Data analysis, including descriptive statistics and correlational analysis, was conducted using SPSS<sup>®</sup> 24.0.

Experience with water issues was measured by asking respondents to indicate if they have experienced any of the five listed water issues within the past year. "*I have not experienced any of these*" was also provided as the sixth option. One point was assigned to respondents for each issue they indicated they had experienced. The overall points were summed to create the index score of water issue experience ranging from zero to five.

The respondents were then asked three sets of questions regarding their water use behaviors, application of water conservation practices, and willingness to act on water conservation. Respondents' water use behaviors were measured using a five-point Likert-type scale ranging from 1 = *Never*, 2 = *Almost Never*, 3 = *Sometimes*, 4 = *Almost Every Time*, 5 = *Every Time* with seven statements. *Does Not Apply* was also included as an option respondents could choose, and responses of *Does Not Apply* were transformed as missing values. The index score of water use behaviors was calculated by averaging the seven items and found reliable ( $\alpha = .86$ ).

To measure respondents' application of water conservation practices, six statements on a three-point scale of -1 = *No*, 0 = *Not Sure*, 1 = *Yes* was used. The index score of water conservation practice application was created by averaging the scores to the six items. In terms of willingness to act on water conservation, 20 statements were used on a five-point Likert-type scale ranging from 1 = *Very Unlikely*, 2 = *Unlikely*, 3 = *Undecided*, 4 = *Likely*, 5 = *Very Likely*. *Not Applicable* was an available option in the willingness to act questions, and responses of *Not Applicable* were transformed as missing values. The index score of willingness to act was calculated *a priori* by averaging the 20 items and found reliable ( $\alpha = .87$ ). Lastly, respondents' demographics were collected by questions asking their sex, race, ethnicity, and age.

The instrument was validated by a panel of experts specializing in water quality issues, public opinion research, and survey design. The panel of experts included the Chief Executive Officer of the Florida Nursery, Growers and Landscape Association, an Extension specialist in water

economics and policy, the Director of the Center for Landscape Conservation and Ecology, the Director of University of Florida Water Institute, the Director and associate director of Center for Public Issues Education, and an assistant professor specializing in agricultural communication.

The demographics were displayed in Table 1. In the Midwest, Northeast, and South, female respondents were more prevalent than male respondents, while male respondents were more prevalent than female respondents in the West. The majority of respondents were Non-Hispanic Caucasian/White in all regions. As for age, the majority of respondents were aged between 30-59 in the Midwest and South, 20-49 in the Northeast, and 20-59 in the West.

Table 1  
*Demographics*

	Frequency (%)			
	Midwest (n = 240)	Northeast (n = 236)	South (n = 364)	West (n = 210)
<i>Sex</i>				
Female	59.4	54.5	56.1	29.6
Male	40.6	45.5	43.9	70.4
<i>Race (Non-Hispanic)</i>				
African American	11.9	6.8	14.9	10.9
Asian	1.3	3.4	4.9	11.3
Caucasian/White	73.0	75.0	64.9	54.4
Native American	1.0	.7	.6	.4
Other	2.5	1.9	1.5	.5
<i>Hispanic Ethnicity</i>	10.3	12.3	13.2	22.5
<i>Age</i>				
20-29	11.4	22.5	17.4	22.5
30-39	16.8	14.8	21.3	12.7
40-49	19.3	19.7	19.7	14.5
50-59	20.3	18.2	18.4	13.9
60-69	13.4	14.0	12.2	10.1
70-79	8.5	5.5	7.7	6.2
80 and older	10.3	5.2	3.3	20.1

## Results

### Experiences with Water Issues

Respondents were asked to indicate their water issues experiences (Table 2). More than 60% of the respondents had not experienced any listed water issues in the past year regardless of regions. The water issue that most respondents had experienced was “Closed rivers, lakes or springs due to poor water quality” in the Midwest and West, “Closed beaches due to red tide/poor water quality” in the Northeast, and “Poor quality of drinking water at home” in the South. Significant differences among regions were found across two water issues: “Closed rivers, lakes or springs due to poor water quality” ( $\chi^2(3) = 11.22, p = .01$ ) and “Poor quality of drinking water at home” ( $\chi^2(3) = 8.82, p = .03$ ).



Table 2  
*Experiences with Water Issues by Regions*

Water Issues	Frequency of Water Issue Experiences (%)				$\chi^2$	<i>p</i>
	Midwest ( <i>n</i> = 240)	Northeast ( <i>n</i> = 236)	South ( <i>n</i> = 364)	West ( <i>n</i> = 210)		
Closed rivers, lakes or springs due to poor water quality	19.3	10.7	10.8	11.8	11.22	.01**
Poor quality of drinking water at home	12.7	13.7	19.3	11.4	8.82	.03*
Closed beaches due to red tide/poor water quality	11.6	19.2	13.2	11.5	7.53	.06
Closed rivers, lakes or springs due to low water levels	5.4	6.9	10.2	10.3	6.24	.10
Prohibitions on eating fish you have caught	13.8	10.8	8.4	9.4	4.47	.22
I have not experienced any of these	58.4	58.9	61.8	64.7	2.50	.48

Note. \*\**p* < .01; \**p* < .05.

### Engagement in Water Use Behaviors

Respondents' engagement in water use behaviors was examined using seven listed items (Table 3). Among all regions, "I allow used motor oil to run down a storm drain" was the behavior with most respondents indicated they never or almost never perform, followed by "I hose down my driveway" in the Midwest, "I allow oil from cooking to run down the drain" in the Northeast and South, and "I let my sprinklers run when it has rained or is raining" in the West. Significant regional differences were found in engagement in all the listed water use behaviors.

### Application of Water Conservation Practices

Respondents were asked whether they have applied six water conservation practices (Table 4). Low-flow shower heads and water-efficient toilets were the two conservation practices the most respondents have applied in all regions. However, significant regional differences also existed in respondents' application of water conservation practices. "I have low-flow shower heads installed in my home" ( $\chi^2(3) = 22.67, p = .00$ ), "I have water-efficient toilets installed in my home" ( $\chi^2(3) = 17.06, p = .00$ ), and "I have low-water consuming plant materials in my yard" ( $\chi^2(3) = 14.46, p = .00$ ) were the three items found with significant regional differences.

### Willingness to Act on Water Conservation

Twenty water conservation-related behaviors/activities were used to measure respondents' willingness to act (Table 5). Respondents in the Midwest, Northeast, and South indicated the highest likelihood of conserving water through only running their washing machine when it was full and responsibly disposing of hazardous materials, while those in the West through

responsibly disposing of hazardous materials and voting to support water conservation programs. When comparing the regions, significant differences were found in 10 out of 20 water conservation-related behaviors/activities.

Table 3  
*Water Use Behavior Engagement by Regions*

Water Use Behavior	Frequency of Water Issue Experiences (%)												$\chi^2$	<i>p</i>
	Never/Almost Never				Sometimes				Almost Every Time/Every Time					
	M	N	S	W	M	N	S	W	M	N	S	W		
I leave the water running in the kitchen when washing and/or rinsing dishes	47.3	43.2	54.5	45.6	29.4	25.5	31.2	22.9	19.3	29.3	12.9	28.1	55.33	.00**
I allow soapy water to run down a storm drain	61.0	54.2	54.9	51.5	9.5	13.1	12.4	14.2	10.2	11.7	15.9	20.8	45.30	.00**
I hose down my driveway	65.7	60.3	59.2	57.6	10.1	14.5	11.6	15.7	3.8	3.2	13.1	5.3	36.23	.00**
I let my sprinklers run when rain is predicted in the forecast	64.5	59.7	66.8	59.2	2.2	3.7	5.0	9.7	4.7	5.7	3.9	7.0	35.64	.00**
I let my sprinklers run when it has rained or is raining	65.0	59.6	70.1	63.2	.4	5.7	1.7	7.2	6.0	4.0	3.1	3.4	32.06	.01**
I allow oil from cooking to run down the drain	64.4	65.2	70.3	57.9	20.4	21.8	20.7	20.2	10.7	10.4	7.3	16.3	28.62	.02*
I allow used motor oil to run down a storm drain	78.6	73.1	80.8	72.4	1.3	2.2	2.9	1.5	2.2	5.2	2.9	6.4	26.98	.03*

*Note.* \*\**p* < .01; \**p* < .05; Respondents were allowed to select *Does Not Apply*, and the *Does Not Apply* responses are not included in the table. M = *Midwest*, N = *Northeast*, S = *South*, W = *West*.

Table 4  
*Water Conservation Practice Application by Regions*

Water Conservation Practice	Frequency of Water Conservation Practice Application (%)												$\chi^2$	<i>p</i>
	No				Unsure				Yes					
	M	N	S	W	M	N	S	W	M	N	S	W		
I have low-flow shower heads installed in my home	37.6	41.5	37.9	29.8	21.2	18.6	19.3	8.9	41.3	39.9	42.8	61.3	30.75	.00**
I have water-efficient toilets installed in my home	40.6	36.1	37.1	30.6	14.4	16.9	18.8	8.5	45.0	47.1	44.0	61.0	21.79	.00**
I have low-water consuming	48.2	53.7	53.1	46.3	21.9	22.0	16.0	13.0	29.9	24.3	30.9	40.7	19.93	.00**

plant materials in my yard															
I use rain barrels to collect water for use in my garden/lawn	81.2	74.9	81.2	85.4	2.3	6.0	3.4	2.4	16.5	19.1	15.4	12.2	11.03	.09	
I have donated money at least once in the past five years to a nonprofit that works to provide access to drinking water in another country	80.5	74.2	82.1	79.1	4.8	8.9	5.3	4.2	14.7	16.9	12.5	16.7	8.81	.18	
I use recycled wastewater to irrigate my lawn/landscape	74.6	74.0	75.5	78.3	9.7	10.5	5.9	6.5	15.7	15.5	18.6	15.1	7.17	.31	

Note. \*\* $p < .01$ ; M = Midwest, N = Northeast, S = South, W = West.

Table 5  
Willingness to Act on Water Conservation by Regions

Willingness to Act	Frequency of Willingness to Act (%)												$\chi^2$	$p$
	Very Unlikely/Unlikely				Undecided				Likely/Very Likely					
	M	N	S	W	M	N	S	W	M	N	S	W		
Vote to support water conservation programs	2.4	6.1	4.9	9.6	23.8	20.7	16.5	6.3	70.3	69.3	72.7	83.1	72.45	.00**
Join a water conservation organization	40.1	43.7	41.9	51.4	35.0	28.2	30.4	17.9	20.8	22.8	22.2	25.9	49.81	.00**
Reduce use of pesticides if your landscape quality would decrease	7.0	6.7	8.1	6.6	12.9	14.9	18.5	9.7	44.5	45.9	52.0	48.5	43.14	.00**
Reduce use of fertilizer if your landscape quality would decrease	10.1	7.6	7.5	5.5	17.2	15.9	18.6	12.5	41.5	43.5	51.3	44.4	42.11	.00**
Support water restrictions issued by my local government	6.7	5.5	7.6	13.9	22.5	16.6	19.0	10.2	61.6	72.1	68.6	73.6	41.94	.00**
Only run the dishwasher when it is full	4.7	2.5	4.7	10.8	4.5	3.9	7.2	3.5	64.7	64.2	66.4	67.9	39.54	.00**

Responsibly dispose of hazardous materials	1.0	2.9	2.2	2.1	6.0	9.8	8.5	3.9	81.5	71.6	78.8	83.3	36.69	.00**
Buy a specialty license plate that supports water protection efforts	59.8	56.3	56.5	59.8	20.2	18.6	19.3	13.2	12.3	15.2	18.3	21.7	33.76	.00**
Reduce your use of natural resources	9.7	10.4	14.1	13.5	28.2	25.7	20.7	16.1	57.7	55.6	59.5	68.9	31.97	.01**
Avoid purchasing plants that require a lot of watering	9.1	9.8	7.9	7.2	20.0	19.6	15.9	20.6	56.9	54.9	63.8	66.3	31.82	.01**
Volunteer for a stream clean up or wetland restoration event	43.9	35.8	40.7	47.3	21.4	32.0	27.6	28.6	25.5	24.9	23.8	20.3	24.25	.06
Keep a timer in the bathroom to help you take a shorter shower	53.6	47.8	50.2	54.4	19.6	20.7	23.8	12.3	19.8	24.9	21.4	29.8	21.87	.11
Only water your lawn in the morning or evening	4.3	3.7	7.1	5.2	9.3	12.2	8.2	12.3	51.0	49.6	56.9	56.7	21.63	.12
Use biodegradable cleaning products	14.3	15.3	17.1	18.2	23.5	26.1	22.8	16.4	60.9	55.5	55.9	62.8	21.48	.12
Vote for candidates who support water conservation	2.7	4.5	5.3	4.4	23.5	26.3	24.5	23.1	70.0	65.6	64.4	68.3	20.60	.15
Donate to an organization that protects water	32.0	29.4	34.0	42.2	27.0	29.1	27.2	23.2	34.9	35.0	33.3	27.4	18.50	.24
Only run the washing machine when it is full	9.2	5.5	7.3	6.1	7.3	4.2	6.7	5.9	79.9	85.7	83.5	82.2	15.67	.40
Sweep patios and sidewalks instead of hosing them down	5.0	4.7	5.4	5.9	8.6	6.8	6.9	4.7	65.4	64.7	73.2	68.4	15.32	.43
Visit springs, lakes, state parks, etc., to learn about water issues	17.7	24.9	22.8	23.8	27.2	26.0	27.5	29.8	48.8	43.9	44.3	42.5	13.77	.54
Reduce the number of times a week you water your lawn	7.5	4.0	5.8	5.4	8.3	7.3	10.4	5.9	49.4	53.7	52.5	51.8	13.30	.58

Note. \*\* $p < .01$ ; Respondents were allowed to select *Not Applicable*, and the *Not Applicable* responses are not included in the table. M = Midwest, N = Northeast, S = South, W = West.

## Relationships among Variables

The relationships among water issue experience, water use behaviors, water conservation practice application, and willingness to act on water conservation by regions were examined (Table 6). To describe the relationships, Davis' (1971) convention was used with  $.01 \geq R \geq .09 =$  *Negligible*,  $.10 \geq R \geq .29 =$  *Low*,  $.30 \geq R \geq .49 =$  *Moderate*,  $.50 \geq R \geq .69 =$  *Substantial*,  $R \geq .70 =$  *Very Strong*. In the Midwest, low to moderate relationships were found among some variables: respondents who had experienced more water issues tended to performed more listed water use behaviors, apply more water conservation practices, and more willing to act on water conservation behaviors/activities; respondents who had performed more listed water use behaviors tended to apply more water conservation practices. In the Northeast, experience showed low to moderate relationships with water use behaviors, water conservation practice application, and willingness to act, while a substantial relationship was found between water use behavior and water conservation practice application. As for respondents in the South, low to moderate relationships were found between experience and water use behavior, experience and water conservation practice application, experience and willingness to act, and water use behavior and water conservation practice application. Lastly, in the West, relationships were in low magnitudes between experience and water use behavior, experience and water conservation practice application, and water use behaviors and water conservation practice application; but the relationship between water use behaviors and willingness to act was in a substantial magnitude.

Table 6

*Relationships among Water Issue Experience, Water Use Behaviors, Water Conservation Practice Application, and Willingness to Act on Water Conservation by Regions*

Region	Constructs	1. Experience	2. Water Use Behaviors	3. Water Conservation Practice Application	4. Willingness to Act
		<i>r</i>	<i>r</i>	<i>r</i>	<i>r</i>
Midwest	1	1.00			
	2	.15	1.00		
	3	.25	-.09	1.00	
	4	.10	.47	.02	1.00
Northeast	1	1.00			
	2	.21	1.00		
	3	.40	.10	1.00	
	4	.28	.58	.03	1.00
South	1	1.00			
	2	.18	1.00		
	3	.36	.07	1.00	
	4	.10	.47	-.07	1.00
West	1	1.00			
	2	.19	1.00		
	3	.19	-.21	1.00	
	4	.07	.56	.07	1.00

## Conclusion and Implications

The key findings of this study aligned with the studies of Borisova et al. (2013), Mahler et al. (2010), Shaw et al. (2012), and Whitmarsh and O'Neill (2010) that individuals' application of water conservation practices and intention to conserve water may be associated with their experience of water issues and experience gained through performing certain water use behaviors, and such associations differed by region. In this study, individuals who had experienced more water issues tended to be more likely to apply water conservation practices (in all regions) and more willing to conserve water in the future (in the Midwest, Northeast, and South). Such findings were similar to the studies of Fielding et al. (2013) and Nieswiadomy (1992) that experience with water issues can make individuals more aware of water issues and water conservation. Interestingly, in this study, when experience with water issues increased, individuals tended to perform more water-consuming behaviors in all regions. This finding conflicted with the studies of Fielding et al. (2013) and Nieswiadomy (1992) but to a certain level resonated with Thøgersen's (2004) study that individuals' environmental responsible behaviors might be inconsistent with individuals' value to conserve environment. Note that in this study the water use behaviors listed were all water-consuming behaviors. Such a finding reflected a situation that the general public may have difficulty to relate their water use behaviors to their water issue experiences, or the general public may outvalue some other factors, such as time and effort, to their value to conserve water when making their water user behavior decision.

This study revealed that the levels of association between experience with water issues, negative water use behaviors, application of water conservation practices, and willingness to act differed by region. Such a finding implies individuals living in different regions may have different levels of awareness of how water can be conserved to protect water resources and alleviate water issues that influence their lives. Individuals with more water issue experience tended to conserve water to ensure their behaviors and experience are cognitively consonant (Festinger, 1957). Therefore, Extension educators can target cognitive dissonance existing between audiences' experience and behaviors about water conservation to strengthen the effectiveness of the educational programs.

Additionally, this study showed similar findings to Haasnoot et al. (2011), Huang and Lamm (2015), and Laughlin et al. (2004) that individuals tend to respond to issues with higher personal relevancy. For example, respondents in the Midwest and Northeast, who are known to be active in water sports and fishing, were more responsive to water quality issues in rivers, lakes, springs, and beaches, while respondents in the West who are known to be intensively influenced by drought were relatively more responsive to the water quantity issue. This study also revealed individuals were less likely to conserve water during routine household cleaning. Such a finding also resonates with Thøgersen's (2004) study and implies that individuals may see conserving water during routine household cleaning activities as behaviors with higher cost, such as labor.

Similar to Huang et al. (2016), more respondents applied water conservation practices related to personal hygiene, which are highly relevant to their daily life, than practices related to landscaping use and donation, which are less relevant to their daily life. Given the majority of respondents in all regions indicated they are willing to vote and support water conservation-related programs and candidates supporting water conservation, such a finding implies the general public may expect the involvement of authority in water conservation to make greater

impact to the issue. Overall, the findings of this study revealed directions Extension educators can focus on to strengthen their efforts on water conservation.

### **Recommendations**

Extension educators have taken various steps to ensure the impact of water conservation on the sustainability of water resources, such as providing face-to-face educational programs to audiences (e.g., workshops, site visiting), collaborating with local, state, and federal governments, and conducting research to optimize the effectiveness of educational or technical impact on the audiences and the environment (NIFA, 2016). This study provides insight into how national Extension should reframe existing or develop new water conservation educational programs with improved effectiveness and persuasiveness to audiences in different regions of the country.

Given that respondents of this study showed how personal relevancy of certain water issues, water use behaviors, and water conservation practice application may influence their responses by regions, Extension educators should be aware of such regional differences. When developing water conservation educational programs, the content should be relevant to local water issues, and recommendations of water conservation practices should be provided with the ones the audiences tend to adopt. For example, Extension educators serving in the South should draw audiences' attention to water conservation by initiating communication about drinking water quality issues and discussing household water use behaviors that may degrade water quality (e.g., allowing soapy water to run down a storm drain), as well as providing water conservation practices guides that are relevant and easy to adopt to alleviate the drinking water quality issue (e.g., to vote and support water conservation programs and water restrictions issued by local government and reduce fertilizer and pesticide uses for landscaping maintenance). Extension educators serving in the West should take a different route by initiating conversation about water scarcity in local water resources, discussing household water use behaviors that may increase water consumption (e.g., leaving the water running when washing dishes), and providing recommendations on water conservation practices to mitigate water shortage issues (e.g., to vote to support water conservation programs and only run the washing machine when it is full).

Extension educators should enhance audiences' awareness of how their water use behaviors and engagement in water conservation may influence water resources and their life. Extension educators in each region should be aware of how audiences in their region respond to their experience with water issues regarding their water conservation engagement. Although experience with water issues is suggested to be an effective trigger to encourage individuals' engagement in water conservation (Singletary & Daniels, 2004; Pratt & Bowman, 2008), audiences in different regions may respond to their water issue experience with different levels of water use and water conservation engagement and intention to conserve water. At program development stage, Extension educators should be aware if the references and recommendations are applicable and relevant to their region of service.

While Extension educators are aware of the regional differences in audiences' cognition and behavior regarding water conservation, Extension educators working with audiences at county or state levels are recommended to conduct similar studies on their local audiences to ensure the water conservation program can be developed tailored to audiences' need and interest. Future



research is also recommended to be conducted to verify how the effectiveness and impact of Extension water conservation programs are improved by implementing the recommendations of this study. By understanding audiences' cognition and behavior to develop water conservation educational program, increased public engagement in water conservation can be expected.

## References

- Baker, R., Brick, J. M., Bates, N. A., Battaglia, M., Couper, M. P., Dever, J. A.,... Tourangeau, R. (2013). *Report of the AAPOR task force on non-probability sampling*. American Association for Public Opinion Research. Retrieved from <http://www.aapor.org/AM/Template.cfm?Section=Reports1&Template=/CM/ContentDisplay.cfm&ContentID=5963>
- Borisova, T., Smolen, M., Boellstorff, D. E., McFarland, M. L., & Adams, D. (2013). Public preferences for water resource topics and information sources in the Southern United States. *Journal of Extension, 51*(2). Retrieved from <http://www.joe.org/joe/2013april/rb6.php>
- Brasier, K. J., Filteau, M. R., McLaughlin, D. K., Jacquet, J., Stedman, R. C., Kelsey, T. W., & Goetz, S. J. (2011). Residents' perceptions of community and environmental impacts from development of natural gas in the marcellus shale: A comparison of Pennsylvania and New York cases. *Journal of Rural Social Sciences, 26*(1), 32-61.
- Davis, J. A. (1971). *Elementary survey analysis*. Englewood Cliffs, NJ: Prentice-Hall.
- Festinger, L. (1957). *A theory of cognitive dissonance*. Evanston, IL: Row, Peterson.
- Fielding, K. S., Spinks, A., Russell, S., McCrea, R., Stewart, R., & Gardner, J. (2013). An experimental test of voluntary strategies to promote urban water demand management. *Journal of Environmental Management, 114*, 343-351. doi: 10.1016/j.jenvman.2012.10.027
- Fuss, N., Bornkessel, S., Mattern, T., & Stamminger, R. (2011). Are resource savings in manual dishwashing possible? Consumers applying Best Practice Tips. *International Journal of Consumer Studies, 35*(2), 194-200. doi: 10.1111/j.1470-6431.2010.00972.x
- Gifford, R., & Nilsson, A. (2014). Personal and social factors that influence pro-environmental concern and behaviour: A review. *International Journal of Psychology, 49*(3), 141-157. doi: 10.1002/ijop.12034
- Haasnoot, M., Middelkoop, H., Van Beek, E., & Van Deursen, W. P. A. (2011). A method to develop sustainable water management strategies for an uncertain future. *Sustainable Development, 19*(6), 369-381. doi: 10.1002/sd.438
- Harriden, K. (2013). Water Diaries: generate intra-household water use data—generate water use behaviour change. *Journal of Water Sanitation and Hygiene for Development, 3*(1), 70-80. doi: 10.2166/washdev.2013.015

- Huang, P., & Lamm, A. J. (2015). Impact of experience and participation in Extension programming on perceptions of water quality issues. *Journal of International Agricultural and Extension Education*, 22(3). doi: 10.5191/jiaee.2015.22303
- Huang, P., Lamm, A. J., & Dukes, M. (2016). Informing extension program development through audience segmentation: Targeting high water users. *Journal of Agricultural Education*, 57(2), 60–74. doi: 10.5032/jae.2016.02060
- Kalton, G., & Flores-Cervantes, I. (2003). Weighting methods. *Journal of Official Statistics*, 19(2), 81-97.
- Knowles, M. S., Holton, E. F., & Swanson, R. A. (2005). *The adult learner: The definitive classic in adult education and human resource development*. San Diego, CA: Elsevier Inc.
- Kolb, D. A. (1984). *Experiential learning: Experience as the source of learning and development*. New Jersey: Prentice-Hall.
- Laughlin, K., Szogi, A., Burris, F., Mahler, R. L., Loeffelman, K., Steele, V., & Alderson, L. (2004). Enhancing public understanding of water resources issues: A community-based short-course for the Pacific Northwest. *Journal of Extension*, 42(4). Retrieved from <http://www.joe.org/joe/2004august/a4.php>
- Mahler, R. L., Gamroth, M., Pearson, P., Sorensen, F., Barber, M. E., & Simmons, R. (2010). Information sources, learning opportunities, and priority water issues in the Pacific Northwest. *Journal of Extension*, 48(2). Retrieved from <http://www.joe.org/joe/2010april/rb2.php>
- Monz, C. A., Cole, D. N., Leung, Y. F., & Marion, J. L. (2010). Sustaining visitor use in protected areas: Future opportunities in recreation ecology research based on the USA experience. *Environmental Management*, 45(3), 551-562. doi: 10.1007/s00267-009-9406-5
- National Institute of Food and Agriculture. (2016). *Extension*. Retrieved from <https://nifa.usda.gov/extension>
- Nieswiadomy, M. L. (1992). Estimating urban residential water demand: Effects of price structure, conservation, and education. *Water Resources Research*, 28(3), 609-615.
- Patterson, L. (2012). *2012 RBC Canadian water attitudes study*. RBC Blue Water Project. Retrieved from <http://www.rbc.com/community-sustainability/environment/rbc-blue-water/index.html>
- Pratt, C., & Bowman, S. (2008). Principles of effective behavior change: Application to extension family educational programming. *Journal of Extension*, 46(5). Retrieved from <http://www.joe.org/joe/2008october/a2.php>

- Roberts, T. G., Harder, A., & Brashears, M. T. (Eds). (2016). *American Association for Agricultural Education national research agenda: 2016-2020*. Gainesville, FL: Department of Agricultural Education and Communication. Retrieved from [http://aaaeonline.org/resources/Documents/AAAE\\_National\\_Research\\_Agenda\\_2016-2020.pdf](http://aaaeonline.org/resources/Documents/AAAE_National_Research_Agenda_2016-2020.pdf)
- Rubenstein, E. D., & Thoron, A. C. (2014). Successful Supervised Agricultural Experience Programs as Defined by American FFA Degree Star Finalists. *Journal of Agricultural Education*, 55(3), 162-174. doi: 10.5032/jae.2014.03162
- Shaw, J., Hazel, D., Bardon, R., & Jayaratne, K. S. U. (2009). Landowners' knowledge, attitude, and aspirations towards woody biomass markets in North Carolina. *Journal of Extension*, 50(4). Retrieved from <http://www.joe.org/joe/2012august/a9.php>
- Singletary, L., & Daniels, S. E. (2004). Assessing the impacts of collaborative-based extension programs to address natural resource conflicts. *Proceedings of the 20th Annual Conference of the Association for International Agricultural and Extension Education (AIAEE), May 23-29, 2004*, Dublin, Ireland. 802-812.
- Thøgersen, J. (2004). A cognitive dissonance interpretation of consistencies and inconsistencies in environmentally responsible behavior. *Journal of Environmental Psychology*, 24(1), 93-103. doi: 10.1016/S0272-4944(03)00039-2
- United States Environmental Protection Agency. (2013a). *Saving water in Florida*. Retrieved from [https://www3.epa.gov/watersense/docs/florida\\_state\\_fact\\_sheet\\_508.pdf](https://www3.epa.gov/watersense/docs/florida_state_fact_sheet_508.pdf)
- United States Environmental Protection Agency. (2013b). *Saving water in Maryland*. Retrieved from [https://www3.epa.gov/watersense/docs/maryland\\_state\\_fact\\_sheet\\_508.pdf](https://www3.epa.gov/watersense/docs/maryland_state_fact_sheet_508.pdf)
- United States Environmental Protection Agency. (2015a). *Region 5 Agriculture: Partnerships*. Retrieved from <https://archive.epa.gov/region5/agriculture/web/html/partnerships.html>
- United States Environmental Protection Agency. (2015b). *Saving water in California*. Retrieved from [https://www3.epa.gov/watersense/docs/california\\_state\\_fact\\_sheet.pdf](https://www3.epa.gov/watersense/docs/california_state_fact_sheet.pdf)
- United States Environmental Protection Agency. (2015c). *Contaminated sediment in the Great Lakes*. Retrieved from <https://www.epa.gov/greatlakes/contaminated-sediment-great-lakes>
- United States Environmental Protection Agency. (2016). *Chesapeake Bay*. Retrieved from <https://www.epa.gov/nutrient-policy-data/chesapeake-bay>
- Wagner, K., & Kuhns, M. (2013). Meeting horticulture clientele interests in an urban setting: A needs assessment for reduced pesticide and pollinator education in the greater Salt Lake area. *Journal of the NACAA*, 6(1). Retrieved from <http://www.nacaa.com/journal/index.php?jid=221>

- Whitmarsh, L., & O'Neill, S. (2010). Green identity, green living? The role of pro-environmental self-identity in determining consistency across diverse pro-environmental behaviours. *Journal of Environmental Psychology*, *30*(3), 305-314. doi: 10.1016/j.jenvp.2010.01.003
- Wolfe, S. E. (2012). Water cognition and cognitive affective mapping: Identifying priority clusters within a Canadian water efficiency community. *Water Resources Management*, *26*(10), 2991-3004. doi: 10.1007/s11269-012-0061-x

## **Using the Situational Theory of Problem Solving to Guide National Extension Programming with High Water Users**

Alexa J. Lamm, University of Florida  
Laura A. Warner, University of Florida  
Lisa K. Lundy, University of Florida  
Jyothi Swaroop Bommidi, University of Florida

### **Abstract**

Extension professionals have been conducting water conservation programs across the nation, recognizing the need to conserve water as one of the top issues facing the U.S. Research has shown the number of people that will be exposed to water scarcity will steadily increase, yet a large portion of the U.S. population uses an exhorbinant amount of water in their home landscape. This research uses the Situational Theory of Problem Solving in an attempt to further understand why and how high water users (residents that control their home landscape irrigation systems) across the U.S. recognize water as an issue and choose to communicate about water conservation. The findings revealed high water users recognize water use as an issue but exhibit a low level of involvement in solving the issue. In addition, as their perceived level of involvement increases, they are less likely to communicate about it revealing a sense of cognitive dissonance and discomfort with their behavior to the point they would rather not discuss it. Recommendations include encouraging extension professionals to work at the community level to discuss community conservation effects, utilize existing clientele to develop a sense of involvement among their circles of influence and encourage the use of social media techniques to distribute information and further their reach.

### **Introduction**

Water is critical to society as so much of daily human life is fully dependent upon its availability. An impressive "1.35 billion jobs (42% of the world's total active workforce) are likely to be heavily water dependent" (United National World Water Assessment Programme, 2016, p. 37). The United States consumes a lot of water; at 2,842 cubic meters per capita per year, it has the third largest water consumption footprint among countries around the world with populations larger than five million (Hoekstra & Mekonnen, 2012). From 2014 to 2060, the United States population is projected to increased from 319 million to 417 million residents (Colby & Ortman, 2015). Gosling and Arnell (2016) found the number of people exposed to water scarcity as a result of population growth by 2020 will be 58 million in the United States alone.

With an increasing dependence on water, more scarcity and population growth, water utilization for recreational-landscape irrigation must be monitored and reduced. In several parts of the U. S., where lush landscapes are sought after year round, water used in landscapes is much higher than that used for domestic or commercial purposes, which may be detrimental in the long run. For example, landscape irrigation for California's homes and businesses accounts for for 50% or more of the total water used (Mayer, DeOreo, Hayden, Davis, Caldwell, & Miller, 2009). Similarly, landscape irrigation using a programmed sprinkler in Florida has been found to account for just more than half (50.8%) of a household's water consumption (Endter-Wada,

Kurtzman, Keenan, Kjelgren, & Neal, 2008). In some places, such as Scottsdale, Arizona and Denver, Colorado, analyses of irrigation practices have revealed outdoor water use accounting for more than 60% of a household's water consumption (DeOreo, Mayer, Dziegielewski, & Kiefer, 2016). Not only are these large amounts, but may reflect more water being used than the plants' actual need (Endter-Wada et al., 2008; Kjelgren, Rupp & Kilgren, 2000).

Water withdrawals for recreational-landscape irrigation in Florida has been increasing since 2005 (Marella, 2013; Marella, 2014). Individuals who have in-ground irrigations systems, use outside landscaping companies to manage their lawns, have a higher than average annual household income, and are not readily engaged in water conservation have been labeled as high water users (Huang, Lamm, & Dukes, 2016). High water users are a prime target population for extension professionals trying to reduce water consumption because they have the ability to reduce water use in a way that is not detrimental to their personal health or well being.

High water users have been found to schedule their irrigations systems outside of best management practices developed by the land grant university preferring to set their irrigation systems and then forget about them (Huang et al., 2016). Warner, Lamm, Rumble, Martin, and Cantrell (2016) analyzed high water users by clustering them based on specific behavioral or perceived notions and found that the majority are water considerate, meaning they are somewhat engaged in conservations practices but are not active water conservers and have room to improve. In addition, Warner et al. (2016) found 19% of high waters users are unconcerned about their water use and unlikely to modify practices to conserve water in their landscape.

Researchers have noted that "Extension must begin to use approaches that go beyond knowledge transfer and deliberately motivate behavior change" (Monaghan, Ott, Wilber, Gouldthorpe, & Racevskis, 2013, p. 3) especially when it comes to education about water use. One approach is to present water conservation as a problem and examine how people then address the problem to determine their motivations (Grunig, 1997). By understanding motivation, and its connection to increasing communication, extension professionals can begin to change how people think about water as a problem, are motivated to change and then communicate about that change to create a resounding effect. Research using this approach aligns with research priority area seven of the National Research Agenda which seeks to identify how extension programs can address complex interdisciplinary issues such as water conservation (Roberts, Harder, & Brashears, 2016).

### **Theoretical Framework**

The situational theory of problem solving and its theoretical predecessor, the theory of publics, are both rooted in the writings of John Dewey who wrote about human thought and inquiry as a process pursuant to solving a problem (Dewey, 1910). James Grunig first introduced the situational theory of publics in 1966 as a theory to explain how individuals communicate and make decisions. The theory evolved to offer an explanation for the identification of publics of organizations (Grunig, 1997). The situational theory has been used to identify and understand publics, including being used to explain and predict public opinion (Grunig, 2003).

The theory of publics employs three variables to explain and predict individual communication behavior: problem recognition, level of involvement and constraint recognition (Kim & Grunig,

2011). The theory of publics also has two dependent variables that distinguish active and passive communication behavior in how individuals go about acquiring information: information seeking and processing. Researchers have used the theory of publics to predict which publics are more likely to communicate actively about various issues (Aldoory & Sha, 2006). The key implication for extension professionals is the ability to avoid targeting costly communication messages to inactive or less active publics who are unlikely to attend to these messages (Grunig, 1989; Grunig & Hunt, 1984). Agricultural education researchers have used the theory of publics to examine high water users based on their problem recognition that plentiful water is important, their level of involvement in water conservation behaviors, and their constraint recognition related to homeowner's association membership and association requirements to abide by water restrictions (Lamm, Lundy, Warner & Lamm, 2016).

The situational theory of problem solving (STOPS) expands upon the dependent variables related to information acquisition in the theory of publics and adds dependent variables for information selection and information transmission (Kim & Grunig, 2011). According to Kim and Grunig (2011, p. 122), "people selectively invest their communicative and cognitive resources in a problem only when they perceive the effort to be necessary and relevant." STOPS extends the communicative behaviors involved in problem solving, underscoring that when people seek and find helpful information they tend to share that information with others faced with the same problem (Kim & Grunig, 2011). While STOPS has been used in a number of behavior change communications contexts, it has not been applied to strategies to encourage landscape water conservation behaviors.

Grunig (1997) defined problem recognition as occurring when "people detect that something should be done about a situation and stop to think about what to do" (p. 10). In their study of home irrigation users, Warner et al. (2016) discovered that those who were most involved in home landscape practices were also those who assigned the highest level of importance to water issues. Following a campus-wide outreach program evaluation, Lim, Greenwood, & Jiang (2015) reported that problem recognition surrounding watershed protection was a key factor explaining students' information seeking and sharing about the issue.

Involvement recognition refers to an individual's perception the he/she is connected with a problem. Higher levels of perceived involvement are typically associated with more active information seeking (Grunig, 1976). While personal involvement comes from the field of psychology, constraint recognition comes from economics and management science (Kim & Grunig, 2011). Constraint recognition occurs when "people perceive that there are obstacles in a situation that limit their ability to do anything about the situation" (Grunig, 1997, p. 10). A lack of perceived constraints, often referred to as self efficacy or perceived behavioral control, has been positively related to environmental behaviors such as conserving water (Trumbo & O'Keefe, 2005). Referent criterion are previous experiences and/or knowledge that influence how individuals approach problem solving (Kim & Grunig, 2011). In a study on communication among undergraduates, Burch (2014) found that problem recognition, involvement recognition, and constraint recognition explained nearly half of the variance in situational motivation surrounding climate change. Of these variables, involvement recognition was the only significant and unique contributor (Burch, 2014).

These independent variables produce varying levels of situational motivation in problem solving. The level of motivation leads individuals to various communicative actions in the problem solving process. These actions have been categorized as acquisition, selection and transmission (Kim & Grunig, 2011). The general postulate of STOPS is that “the more one commits to problem resolution, the more one become *acquisitive* of information pertaining to the problem, *selective* in dealing with the information, and *transmissive* in giving it to others” (Kim & Grunig, 2011, p. 125).

Kim and Grunig’s (2011) model includes an active and a passive communication behavior for each of the following categories: information acquisition (seeking and attending), information selection (forefending and permitting), and information transmission (forwarding and sharing). For our study, active and passive communication behaviors were difficult to distinguish, so we chose to operationalize information acquisition, information selection and information transmission as singular independent variables. We adapted Kim and Grunig’s (2011) model to reflect this modification (Figure 1).

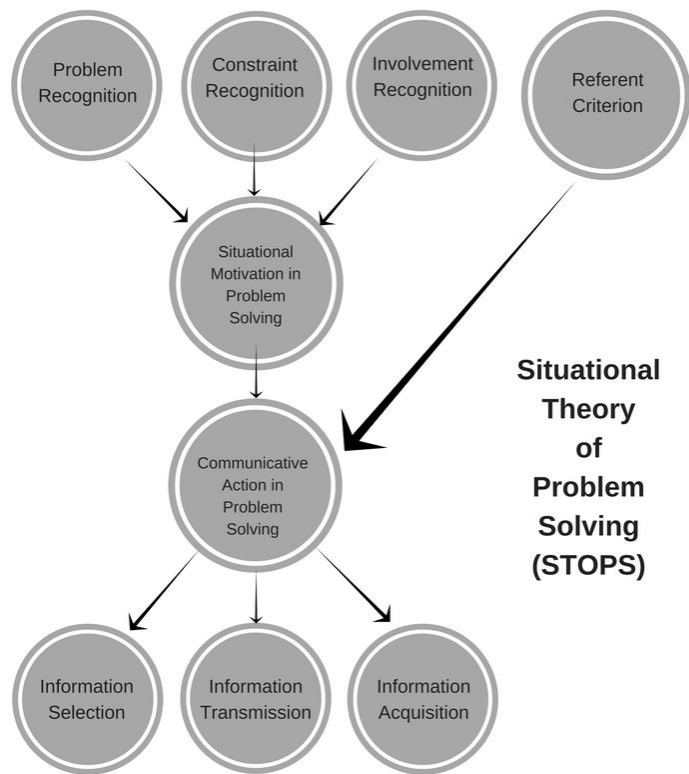

Figure 1. Situational theory of problem solving (adapted from Kim & Grunig, 2011)

### Purpose and Objectives

The purpose of this study was to gain a deeper understanding of high water users across the U.S. by determining how their situational motivation to solve water issues impacted their communicative action related to water use. This will aid extension professionals in developing impactful programs that result in enhanced adoption of water conservation behaviors among this important audience. The study was guided by the following objectives:



1. Identify high water users' situational motivation to solve water issues in the form of problem recognition, constraint recognition and perceived level of involvement.
2. Identify high water users' communicative action related to water use in the form of information selection, transmission and acquisition.
3. Determine if high water users' situational motivation to solve water issues predicted their communicative action related to water use.

## Methods

### Participants

The population for this study was high water users nationwide who had decision-making control over their landscape irrigation. We targeted individuals who had control over their landscape irrigation because this audience is most able to personally impact their outdoor water use (Warner et al., 2016). We used purposive sampling as it was the best possible way to reach a national audience of people who use and control the irrigation in the home landscape. Although purposive sampling limits the generalizability of findings, in some situations it is considered the best way to make estimations about a population when random sampling is not possible (Baker et al., 2013).

Screening questions were used to ensure that respondents were at least 18 years of age, had a lawn or landscaping, and an irrigation system they controlled. Using an online survey research company, we invited 3,140 people to participate in the study. Of these, 2,448 belonged to the study population. We used quality control questions to discard responses from any participants who were not paying attention to the questions and answering accurately. Following data collection there were 1,052 completed surveys, or a 43% completion rate. Demographic information revealed that the average respondent was 40 years of age. More than half of respondents were white (83.7%;  $n = 881$ ), female (51.4%;  $n = 541$ ), and owned their home (83.9%;  $n = 883$ ). The states most represented by the panel included California (21.2%;  $n = 223$ ), Florida (12.5%;  $n = 132$ ), Texas (6.9%;  $n = 73$ ), and New York (4.5%;  $n = 47$ ).

### Instrumentation and Data Collection

We developed an instrument to achieve the study's specific objectives. We employed an expert panel specializing in water conservation extension education, survey methodology, and agricultural engineering to ensure content and face validity of the instrument. Following expert panel review, the instrument was pilot tested with individuals who were not included in the full study. The instrument was distributed electronically. Prior to data collection, the study was approved by the University of Florida Institutional Review Board (Protocol #2015-U-1102).

We developed six scales to measure variables corresponding to the research objectives: problem recognition, constraint recognition, involvement recognition, information selection, information transmission, and information acquisition. The reliability of the study variables was tested *post hoc* using Cronbach's alpha and was considered appropriate (Santos, 1999) for problem recognition (.71), constraint recognition (.71), involvement recognition (.84), information selection (.84), information transmission (.89), and information acquisition (.76).

Problem recognition was measured by asking respondents to complete the phrase *In regards to water conservation, I believe* by selecting one of five points between each of five bipolar paired statements. Responses included pairs such as *water conservation is needed, water conservation is not needed* and *water availability is not an issue, water availability is an issue*. Response could range from a one (low problem recognition) to five (highest problem recognition), with incremental values assigned for the points between. We created a problem recognition index from the average mean score of the five responses.

Constraint recognition was measured by asking respondents to complete the phrase *In regards to water conservation, I feel* by selecting one of five points between each of five bipolar paired statements. Some of the paired responses included *there are things that prevent me from conserving water, there is nothing that prevents me from conserving water* and *I have no control over my water conservation practices, I have complete control over my water conservation practices*. Responses ranged from one (low constraint recognition) to five (high constraint recognition), and a constraint recognition index was created using the average mean score of the five responses.

Involvement recognition was measured by asking respondents to complete the phrase *In regards to water conservation, I think* by selecting one of five points between each of five bipolar paired statements such as *if I conserve water it only effects me, if I conserve water it effects everyone* and *my actions help save water resources, my actions do not help save water resources*. Responses ranged from one (low involvement recognition) to five (high involvement recognition). An involvement recognition index was created using the average mean score of the five responses.

Information acquisition was measured by asking respondents to complete the phrase *When receiving information about water* with five statements along a Likert-type scale (1 = *strongly disagree*, 2 = *disagree*, 3 = *neither disagree nor agree*, 4 = *agree*, 5 = *strongly agree*). Examples of the statements include *I like to gather as much information as possible* and *the more information sources, the better my knowledge*. Responses ranged from one (low information acquisition) to five (high information acquisition). Information selection was measured using the same phrase and Likert scale with statements such as *I look for the source of the information* and *the source of information is most important*. Responses ranged from one (low information selectivity) to five (high information selectivity). Information acquisition and information selection indexes were created using the average mean score of each set of five responses, respectively.

Information transmission was measured using six questions each with bipolar pairs of responses with five points between. These items included statements such as *overall, in your discussions with friends and colleagues, regarding issues surrounding water are you* which was completed by selecting a response point between *not used as a source of advice* and *often used as a source of advice*. Responses could range from one (weak source of information) to five (strong source of information), and the average mean score of the six items was calculated to create an information transmission index.

## Data Analysis

Study objectives one and two were examined by calculating the means for each of the six indexes. Multiple linear regression and hierarchical regression were used to achieve study objective three. All data for the study were analyzed using quantitative methods with SPSS 22.0.

## Results

### Situational Motivation

Situational motivation was measured in the form of problem recognition, constraint recognition and perceived level of involvement in water issues. An index was created for each using the average of respondent reactions to five statements (Table 1). Respondents reported the highest level of problem recognition and the lowest level of perceived level of involvement indicating they realize water issues are a problem but do not feel personally involved in the issue.

Table 1  
*Situational Motivation Indexes*

	<i>M</i>	<i>SD</i>
Problem Recognition	4.14	.73
Constraint Recognition	3.89	.74
Perceived Level of Involvement	1.98	.85

Note. Scale: 1 = *Low*, 5 = *High*.

### Communicative Action

Communicative action was measured in the form of information selection, transmission and acquisition related to water use. An index was created for each using the average of respondent reactions (Table 2). Respondents reported the highest level of information selection and the lowest level of information transmission indicating they do select information related to water use but are not transmitting that information to others at the same level.

Table 2  
*Communicative Action Indexes*

	<i>M</i>	<i>SD</i>
Information Selection	4.07	.69
Information Transmission	3.20	1.00
Information Acquisition	3.63	.72

Note. Scale: 1 = *Low*, 5 = *High*.

### Situational Motivation Predicting Communicative Action

A series of hierarchical regression models were conducted utilizing the three components of situational motivation (problem recognition, constraint recognition and perceived level of involvement) as the independent variables and the three components of communicative action (information selection, transmission and acquisition) as the dependent variables. In each of the

models, problem recognition was introduced first, followed by constraint recognition and finally perceived level of involvement to determine individual and collective effect.

Problem recognition had a significant positive effect on information selection until perceived level of involvement was introduced into the model when it became the only significant predictor (Table 3). In addition, perceived level of involvement was a negative predictor of information selection indicating that as perceived level of involvement increased, information selection around water use decreased. The overall model was significant, and Model 3 did have a more significant effect than the previous models, indicating all three variables should be included. However, the variance the variables accounted for was low so the findings should be interpreted with caution (Table 4).

Table 3  
*Hierarchical regression of communicative action on situational motivation*

	Model 1	Model 2	Model 3
<i>Information Selection</i>			
Problem Recognition	.12**	.10**	.05
Constraint Recognition		.06	.01
Perceived Level of Involvement			-.11**
<i>Information Transmission</i>			
Problem Recognition	.20**	.15**	.04
Constraint Recognition		.16**	.04
Perceived Level of Involvement			-.23**
<i>Information Acquisition</i>			
Problem Recognition	.09**	.05	-.03
Constraint Recognition		.11**	.02
Perceived Level of Involvement			-.19**

Note. \*\* $p < .01$ .

Table 4  
*Hierarchical regression of communicative action on situational motivation*

Variable Entered	Adjusted $R^2$	$R^2$ Change	F Change	Sig. of Change
<i>Information Selection</i>				
Problem Recognition	.015	.015	16.38	.00
Problem Recognition and Constraint Recognition	.017	.003	3.64	.06
Problem Recognition and Constraint Recognition, and Perceived Level of Involvement	.026	.010	10.71	.00
<i>Information Transmission</i>				
Problem Recognition	.022	.022	23.46	.00

Problem Recognition and Constraint Recognition	.031	.011	12.17	.00
Problem Recognition and Constraint Recognition, and Perceived Level of Involvement	.050	.022	24.57	.00
<i>Information Acquisition</i>				
Problem Recognition	.010	.01	8.96	.00
Problem Recognition and Constraint Recognition	.020	.01	11.98	.00
Problem Recognition and Constraint Recognition, and Perceived Level of Involvement	.040	.03	29.59	.00

Problem recognition had a positive significant effect on information transmission until perceived level of involvement was introduced into the model when it became the only significant predictor (Table 3). Constraint recognition was also a significant positive predictor of information transmission until perceived level of involvement was entered into the model. At this point, it also became non-significant. Perceived level of involvement was a negative predictor of information transmission indicating that as perceived level of involvement increased, information transmission around water use decreased. Similar to information selection, this overall model was significant, and Model 3 had a more significant effect than the previous models indicating all three variables should be included. Once again, the variance the variables accounted for was low so the findings have limited interpretability (Table 4).

Finally, problem recognition was a significant positive predictor of information acquisition when it was in the model by itself. However, once constraint recognition was entered into the model, problem recognition became non-significant and constraint recognition was a significant positive predictor (Table 3). However, when perceived level of involvement was entered into the model, both problem recognition and constraint recognition became non-significant. Once again, perceived level of involvement was the only significant predictor of information acquisition and it was negative indicating that as perceived level of involvement increased information acquisition around water use decreased. The overall model was significant with Model 3 having the most significant effect indicating all three variables should be included. Again, the effect size is small and therefore should be interpreted with caution (Table 4).

### Conclusions

This study completed the first step necessary to examine the potential application of STOPS to landscape water conservation practices to assist extension professionals in making choices about how they educate high water users. Looking at the descriptive results of situational motivation, the low perceived level of involvement and high level of problem recognition among respondents revealed a disconnect between high water users' behaviors and their connection to water conservation. Given the magnitude and complexity of water issues, it is possible high water users feel their landscape irrigation does not affect the problem or that changes at the

household level would not make a difference. It also may be that high water users value the aesthetics they receive from a lush, green landscape over their concern for the environment which agrees with the findings from Warner et al. (2016).

Reviewing the results regarding communicative action revealed high water users were selecting information about water but were less active in sharing it with others. Perceived level of involvement was a significant negative predictor of information transmission indicating that the more the high water users felt they were involved the less they talked about it. Perhaps this is cognitive dissonance (Festinger, 1957) in action, where high water users know they are not doing the environmentally conscious thing but are doing it anyway which makes them uncomfortable speaking with others about it and aligns with the findings of Huang et al. (2016) when they studied high water users in Florida. In fact, level of involvement was the only significant predictor in all three regression models, and had a negative effect, indicating this is having influence in all of their communicative actions.

Given the low amount of variance the predictors account for, the findings from the regression models should be used with caution. Although situational motivation variables are predictors of communicative action as predicted by Kim and Grunig (2011), in the case of high water users there are other variables at play that may be better descriptors of why and how they are communicating (or not communicating) about water issues.

### **Implications and Recommendations**

Overall, the findings from this research imply there are many obstacles extension professionals face when trying to get high water users to engage in water conservation. To begin overcoming these obstacles, extension professionals should place an emphasis on getting high water users to understand the connection between their landscape practices and water issues. By targeting programs on a community scale, scenarios can be developed to demonstrate the impact multiple households can have when they take action together. For example, an extension professional might access real water use data from a utility company within a neighborhood and share the potential water savings that would be realized if every household installed, or properly managed, smart irrigation controls.

Conservation behaviors are strongly influenced by social norms, or the perceptions of what one's peers do and expect (Ajzen, 1991; Warner, Rumble, Martin, Lamm, & Cantrell, 2015). Since high water users were not engaging in sharing information about water, there may be a perception that their peers are not engaged in water conservation or that conservation is unpopular. Extension professionals should encourage extension audiences to share water information and conservation strategies within their spheres of social influence. Perhaps extension professionals could create blogs that their audiences could then guest blog for and share within their social media circles to have further impact. By activating opinion leadership power (Lamm, Lamm, & Carter, 2015) the perception that others do not share their belief can be reduced.

Problem recognition becoming non-significant when constraint recognition was incorporated into the model implies a perceived inability to act on a problem that may be preventing high water users from taking action. Extension professionals should consider this finding and ensure

programming is focused on making landscape water conservation practices easy and practical. The complexities of landscape irrigation systems may be keeping high water users from altering their landscaping practices to ensure sprinklers are not running when it is raining or rain is predicted in the forecast. Extension professionals could develop and provide simple, short YouTube videos showing how to effectively manage these seemingly complex technologies, reducing the perception of constraint. Again, extension professionals could encourage those in attendance at their trainings to share the tools through their own social media channels, and within their neighborhoods, to increase their reach.

Theoretically, the findings revealed the influence of situational motivation on communicative action, in the case of water conservation within the high water user audience, is limited. Future research should explore the use of the theory as it relates to water conservation with the general public and even compare it to high water users to see if situational motivation has more of an effect. In addition, the role of cognitive dissonance should be further examined within this audience. If cognitive dissonance is playing a role, extension professionals will find it hard to communicate with this audience that can have the most positive influence on water conservation (Huang et al., 2016).

Operationally, additional research could be conducted to examine the influence of distributing social media to this audience in the form of videos to reduce perceptions of complexity and/or the suggested blogs from extension program participants. The role of opinion leadership within groups of high water users could also be powerful and should be examined to see if it has an effect on increasing perceived level of involvement. Despite its limitations, this research takes a first step at examining the effects of motivation on communicative action and provides a launch pad for further exploration within this space as we seek to improve extension educational practice.

## References

- Ajzen, I. (1991). The theory of planned behavior. *Organizational Behavior and Human Decision Making Processes*, 50, 179-211.
- Aldoory, L., & Sha, B. L. (2006). Elaborations of the situational theory of publics for more effective application to public relations scholarship and practice. In E. L. Toth (Ed.), *The future of excellence in public relations and communication management*. Mahwah, NJ: Erlbaum.
- Baker, R., Brick, J. M., Bates, N. A., Battaglia, M., Couper, M. P., Dever, J. A., & Tourangeau, R. (2013). *Report of the AAPOR task force on non-probability sampling*. Retrieved from [http://www.aapor.org/AAPORKentico/AAPOR\\_Main/media/MainSiteFiles/NPS\\_TF\\_Report\\_Final\\_7\\_revised\\_FNL\\_6\\_22\\_13.pdf](http://www.aapor.org/AAPORKentico/AAPOR_Main/media/MainSiteFiles/NPS_TF_Report_Final_7_revised_FNL_6_22_13.pdf)
- Burch, M. E. (2014). *Climate change, situational theory of problem solving, and issue framing effects* (Master's thesis). Retrieved from <http://scholarcommons.usf.edu/etd/5449/>.
- Colby, S. L., & Ortman, J. M. (2014). *Projections of the size and composition of the US Popula-*

- tion: 2014 to 2060. Current Population Reports, P25-1143. Washington, DC: U. S. Census Bureau. Retrieved from <http://www.census.gov/content/dam/Census/library/publications/2015/demo/p25-1143.pdf>
- DeOreo, W. B., Mayer, P., Dziegielewski, B., & Kiefer, J. (2016). *Residential end uses of water, version 2*. Denver, CO: Water Research Foundation.
- Dewey, J. (1910). *How we think*. Boston: D. C. Heath.
- Endter-Wada, J., Kurtzman, J., Keenan, S. P., Kjelgren, R. K., & Neale, C. M. U. (2008), Situational waste in landscape watering: Residential and business water use in an urban Utah community. *Journal of the American Water Resources Association*, 44, 902–920. doi:10.1111/j.1752-1688.2008.00190.x
- Festinger, L. (1957). *A theory of cognitive dissonance*. Evanston, IL: Row Peterson.
- Gosling, S. N. & Arnell, N. W. (2016). The impacts of climate change on river flood risk at the global scale. *Climatic Change*, 134(3), 387-401. doi:10.1007/s10584-014-1084-5
- Grunig, J. E. (1976). Communication behaviors in decision and nondecision situations. *Journalism Quarterly*, 53, 232–263.
- Grunig, J. E. (1989). Publics, audiences and market segments: Models of receivers of campaign messages. In C. T. Salmon (Ed.), *Information campaigns: Managing the process of social change* (pp. 197–226). Newbury Park, CA: Sage.
- Grunig, J. E. (1997). A situational theory of publics: Conceptual history, recent challenges and new research. In D. Moss, T. MacManus, & D. Verčič (Eds.), *Public relations research: An international perspective* (pp. 3–46). London: ITB Press.
- Grunig, J. E. (2003). Constructing public relations theory and practice. In B. Dervin & S. Chaffee, with L. Foreman-Wernet (Eds.), *Communication, another kind of horse race: Essays honoring Richard F. Carter* (pp. 85–115). Cresskill, NJ: Hampton Press.
- Grunig, J. E., & Hunt, T. (1984). *Managing public relations*. New York: Holt, Rinehart and Winston.
- Hoekstra, A. Y., & Mekonnen, M. M. (2012). The water footprint of humanity. *Proceedings of the National Academy of Sciences of the United States of America*, 109(9), 3232–3237. doi:10.1073/pnas.1109936109
- Huang, P., Lamm, A. J., & Dukes, M. (2016). Informing extension program development through audience segmentation: Targeting high water users. *Journal of Agricultural Education*, 57(2), 75-89. doi: 10.5032/jae.2016.02075
- Kim, J. N., & Grunig, J. E. (2011). Situational theory of problem solving. *Journal of*



*Communication*, 61, 120-149. doi:10.1111/j.1460-2466.2010.01529.x

- Kjelgren, R., Rupp, L., & Kilgren, D. (2000). Water conservation in urban landscapes. *HortScience*, 35(6), 1037–1040. Retrieved from <http://hortsci.ashspublications.org/content/35/6/1037>
- Lamm, K. W., Lamm, A. J., & Carter, H. (2015). Bridging water issue knowledge gaps between the general public and opinion leaders. *Journal of Agricultural Education*, 56(3), 146-161. DOI: 10.5032/jae.2015.03146
- Lamm, A. J., Lundy, L. K., Warner, L. A., & Lamm, K. W. (2016). Associating importance with behavior: Providing direction for water conservation communication. *Journal of Applied Communications*, in press.
- Lim, J. S., Greenwood, C. A., & Jiang, H. (2015). The situational public engagement model in a municipal watershed protection program: information seeking, information sharing, and the use of organizational and social media. *Journal of Public Affairs*, 16(3), 231–244. doi:10.1002/pa.1583
- Marella, R. L. (2013). *Water use in Florida, 2005 and trends 1950-2005*. U.S. Geological Survey. Retrieved from <http://pubs.usgs.gov/fs/2008/3080/>
- Marella, R. L., (2014). *Water withdrawals, use, and trends in Florida, 2010*. U.S. Geological Survey Scientific Investigations Report 2014–5088, 59. Retrieved from <http://dx.doi.org/10.3133/sir20145088>. ISSN 2328–0328
- Mayer, P., DeOreo, W., Hayden, M., Davis, R., Caldwell, E., & Miller, T. (2009). *Evaluation of california weather-based “smart” irrigation controller programs*. Retrieved from [http://davisengineering.com/reports/Evaluation\\_of\\_California\\_Smart\\_Controller\\_Programs\\_-\\_Final\\_Report.pdf](http://davisengineering.com/reports/Evaluation_of_California_Smart_Controller_Programs_-_Final_Report.pdf)
- Monaghan, P., Ott, E., Wilber, W., Gouldthorpe, J., & Racevskis, L. (2013). Defining audience segments for extension programming using reported water conservation practices. *Journal of Extension*, 51(6). Retrieved from <http://www.joe.org/joe/2013december/a8.php>
- Roberts, T. G., Harder, A., & Brashears, M. T. (Eds). (2016). *American Association for Agricultural Education national research agenda: 2016-2020*. Gainesville, FL: Department of Agricultural Education and Communication.
- Santos, J. R. A. (1999). Cronbach's alpha: A tool for assessing the reliability of scales. *Journal of Extension*, 37(2), Article 2TOT3. Retrieved from <http://www.joe.org/joe/1999april/tt3.php>.
- Trumbo, C., & O'Keefe, G. (2005). Intention to conserve water: environmental values, planned behavior and information effects. A comparison of three communities sharing a

watershed. *Society & Natural Resources: An International Journal*, 18, 573-585.  
doi:10.1080/08941920590948002.

United National World Water Assessment Programme. (2016). *The United Nations world water development report 2016: Water and jobs*. Paris, UNESCO. Retrieved from <http://unesdoc.unesco.org/images/0024/002439/243938e.pdf>

Warner, L. A., Lamm, A. J., Rumble, J. N., Martin, E., & Cantrell, R. (2016). Classifying residents who use landscape irrigation: Implications for encouraging water conservation behavior. *Environmental Management*, 58(2), 238–253. doi:10.1007/s00267-016-0706-2.

Warner, L. A., Rumble, J. N., Martin, E., Lamm, A. J., & Cantrell, R. (2015). The effect of strategic message selection on residents' intent to conserve water in the landscape. *Journal of Agricultural Education*, 56(4), 59-74. doi:10.5032/jae.2015.0405

## **Partnering with the Government: Can Extension Capitalize on how Political Affiliation and Perception of Government Impacts Water Conservation?**

Brandon McKee, University of Florida  
Pei-wen Huang PhD., University of Florida  
Alexa Lamm PhD., University of Florida

### **Abstract**

Extension, being a local, state and federally funded program has a natural partnership with government agencies at all three levels, however these partnerships could be built upon and targeted at specific audiences for greater effect if more is known about how government influences public perception. The government has recognized the need for increased public engagement in water conservation to ensure the sustainability of water resources for future generations and taken action through incentive programs and regulations. Political affiliation is known to influence public perception of government initiatives, which may impact levels of intention and engagement in water conservation. This study explored how US residents responded to positive and negative governmental influences on water conservation practices using an online survey. The findings revealed significant differences in the water conservation activities respondents are currently engaged in, as well as future intentions, depend upon political affiliation. Additionally, intention can be predicted by political affiliation and positive government perceptions. By examining the dissonance created by respondents' engagement and intention to take water conservation action, guidance can be provided to extension educators on how to collaborate with government agencies to develop and implement programs and policies that encourage or enforce engagement in water conservation behaviors.

### **Introduction**

Extension educators have played an important role connecting local needs with research and then providing assessments of established programs (Terry & Osborne, 2015). The role of Extension educators is to provide the public with knowledge based on research, so the public will make informed decisions on local and national issues. Water conservation is one of the pinnacle issues that must be addressed by Extension educators (Lamm, Lamm, & Carter, 2015; Huang & Lamm, 2015a; Huang & Lamm, 2015b; Huang, Lamm & Dukes, 2016). Increases in agricultural production, irrigation, recreation, industry, and power generation have been leading to increased water scarcity as the population continues to grow (Adams et al., 2013; Hoekstra, Mekonnen, Chapagain, Mathews, & Richter, 2012, Huang et al., 2016). Today's Extension educators play a significant role in understanding public perceptions and assist in the implementation of water conservation practices. This role can be effectively filled by programs and messages that encourage water conservation efforts (Warner, Lamm, Rumble, Martin, & Cantrell, 2016). Since local, state and federal funding largely funds extension, partnerships with government agencies including local public officials, water management district personnel and state regulatory agencies should be natural. However, engagement between Extension educators and their government partners has been limited due to a lack of understanding in how they can support one another.

Domestic water use has been an issue of discussion driving the development of government water policies and strategies (Babel, Gupta, & Pradhan, 2007). Conservation practices are largely encouraged through policies and associated programs and activities. These government-supported programs and activities can be perceived as positive or negative by the public and have varying degrees of success (Gneezy, Meier, & Rey-Biel, 2011). According to Manner and Gowdy (2010), policy design that takes advantage of a person's intrinsic motivation for conservation may be more effective than policy that is strict and imprisons the public.

Government policymakers have tried many types of motivators to encourage adoption of efficient conservation practices and technologies, which meet national environmental performance targets (Higgins, McNamera, & Foliente, 2014). These motivators include incentives such as rebates, tax breaks, and other fiscal instruments (Higgins et al., 2014). Government policymakers have supported programs and activities that increase water application efficiencies, including the encouragement of installing more efficient irrigation systems, applying converting practices, and introducing market mechanisms (Boelens & Vos, 2012). On the other side, a study conducted on negative incentives showed that negative framing could create a more motivated population (Goldsmith & Dhar, 2013). However, negative incentives have been studied far less and are used less often than rewards and positive incentives (Promberger, Brown, Ashcroft, & Marteau, 2011).

Political affiliation and polarization have been studied extensively, but few studies have been conducted that examine the relationships between political parties and areas that exist outside of the political arena (Coffey & Joseph, 2012). Coffey and Joseph (2012) found that political affiliation can extend into the populations' personal, social, and economic choices. In fact, strong relationships between political affiliation and conservation efforts had been found (DuPont & Bateman, 2012). According to Costa and Kahn (2013), political liberals were more likely to receive notification about their electricity usage than political conservatives. These notifications can encourage energy conservation within the population. Additionally, an individual's psychological value regarding conservation can be connected to a person's political ideology (Gromet, Kunreuther, & Larrick, 2012). Gromet et al. (2012) found the more conservative individuals were, the less psychological value they placed on environmental conservation. This may be due to the pattern that occurs between a party's social cue and endorsement which effects voters' behaviors (Lau & Redlawsk, 2001).

Pressure on water resources from a growing population will increase future costs for conserving water, such as rationing of water for agricultural use, recreation, the public and will require the installation of new (potentially expensive) technologies (Olmstead & Stavins, 2009; Phelps, Carrasco, Webb, Koh, & Pascual 2013). With future conservation costs increasing and few policy measures being taken to ensure water conservation, more effective motivators and incentives need to be created to preserve water. Therefore, understanding the full effect of how to enact positive and negative governmental influences to encourage the greatest conservation is needed. Extension educators can then work with policy makers and government partners to develop policy and educational programs that utilize cognitive influences on water conservation (Leal, Rumble, & Lamm, 2015). By understanding public perception of water use and knowing the most efficient government support that encourages engagement in water conservation, Extension educators can encourage policymakers to create policies that work.

This study sought to address two research priorities of the National Research Agenda (Roberts, Harder, & Brashears, 2016), “public and policy maker understanding of agriculture and natural resources” (p. 13) and “addressing complex problems” (p. 57). Extension educators need to understand the relationships between political affiliation and perception of governmental influence, as well as their effect on public engagement in water conservation, so they can more appropriately work with and support government action. Perhaps this could even lead to the development of policies that support and promote water conservation (Higgins et al., 2014).

### **Theoretical Framework**

This study applied the theory of cognitive dissonance (Festinger, 1957) to identify the relationships between positive and negative perceptions of governmental influence and water conservation, as well as examine how political affiliations connects and influences these perceptions. Cognitive dissonance theory was proposed by Festinger (1957) and has made a significant mark on the field of social psychology (Metin & Camgoz, 2011). Metin and Camgoz (2011) explained that cognitive dissonance theory proposes “when people experience psychological discomfort (dissonance), they strive to reduce it through either changing behaviors and cognitions or adding new cognitive elements” (p. 131). The reward for the change in behavior would be to live in agreement with others with their own beliefs. The theory was built on the notion that individuals strive for consistency and therefore, inconsistencies lead to dissonance that must be dealt with. Jarcho, Berkman, and Lieberman (2011) explained that decision-making is a part of daily life and these decisions often include choices between outcomes, which appear equally attractive. To compensate for their decision and the unchosen alternative, “people will adjust their attitudes to support their decision by increasing their preference for the selected option, decreasing their preference for the rejected option” (Jarcho et al., 2011, p. 460). An example of cognitive dissonance was given by Vining and Ebreo (2002): an individual who performs pro-environmental behavior, such as water conservation currently leaves the water on while brushing teeth and washing dishes. In order to resolve the negative emotion and the dissonance created between the individual’s conflicting viewpoints, the individual will align their actions by reducing their water waste. This can be an effective tool for Extension educators when attempting to inform the public about water conservation.

A study conducted by Kantola, Syme, and Campbell (1984) focused on cognitive dissonance and energy conservation behavior by monitoring an Australian Population. The participants experienced cognitive dissonance when the participants consumed higher amounts of energy than they indicated on their willingness to save energy. The observation was then made that the randomly assigned group which received a letter that they were over-users of energy, would significantly reduce their energy usage in the post-trial follow ups. Stone and Fernandez (2008) described the observation as, “inducing dissonance by making homeowners aware of a discrepancy between their pro-conservation attitude and past conservation behavior did seem to motivate them to alter their conservation behavior above and beyond the other influence strategies” (p. 1030).

Thøgerson (2004) performed a cognitive dissonance study on the consistencies and inconsistencies in environmentally responsible behaviors. The findings of this study recognized

that most people desire to respond consistently by identifying respondents' environmentally relevant behaviors and performance norms. Thøgerson (2004) resolved,

Behavioral inconsistency threatens the individual's self-perception as a morally reliable person only if he or she holds moral norms of some strength for this type of behavior. Hence, for individuals who have no or only weak moral norms for environmentally relevant behaviors it matters little if they perceive their behavior in this domain to be inconsistent. However, for individuals with strong moral norms the desire to avoid cognitive dissonance creates a drive to behave consistently. (p. 95)

Thøgerson's (2004) study provided evidence that in order for the population to become more environmentally sustainable, their actions should become more consistent with the norms. Cognitive dissonance within individuals would drive their conservation behaviors to be more consistent with their perceived conservation responsibility and develop strong moral norms towards water sustainability.

Between 2001 and 2010, a study on governmental influence was conducted regarding the conservation of the Brazilian Amazon area (Nolte, Agrawal, Silvius, & Soares-Filho, 2013). The study was performed under the pretext that the Amazon was managed under different government regime, and the different approaches had led to some debates on which approach was the most effective one. Nolte et al. (2013) asserted the most effective approach was reliant upon two other main factors: the level of deforestation pressure that the area had been exposed to and the intensity of governmental enforcement. The locations observed were categorized into sustainable use and strictly protected areas. The proponents of strict conservation continued to argue that ending resource extraction and equipping enforcement techniques should be a more effective way in ensuring conservation than an inclusionary approach. However, other contributors continued the argument that indigenous people have intrinsic need to protect their livelihood and that this incentive would be far superior to any other incentives given from a governmental agency. Nolte et al. (2013) concluded that both strictly protected and sustainable use areas substantially reduced deforestation rates inside the Amazon, but strictly protected areas were more consistent with conservation efforts.

The theory of cognitive dissonance provides an explanation for the inconsistencies created between current actions and future intentions of water conservation and governmental influence (Thogerson, 2004). Therefore, the inconsistencies that will be noted in this study can be used as tools by policymakers and extension educators to inform public water use, such as the study conducted on energy use by Kantola et al, (1984). This study examined the impact a strict government may have on public water conservation action versus one that offers incentives and is perceived by the public as supportive of taking personal action without enforcement.

### **Purpose and Objectives**

The purpose of this study was to determine how US residents' perception of government and political affiliations influenced current water conservation actions and willingness to act towards water conservation. The research objectives for this study were to:

1. Describe the current water conservation actions, willingness to act towards water conservation, and perceptions of government influence on water conservation.
2. Determine if differences in political affiliation impacted perceptions of government, current action, and willingness to act towards water conservation.
3. Determine if political affiliation and perception of government predicted current action and willingness to act towards water conservation.

## Methodology

A quantitative study using an online survey design was conducted to explore how individuals' intention to conserve water can be predicted by their political affiliation and perception of government influence on water conservation. The survey instrument was researcher-developed based on the 2012 RBC Canadian Water Attitudes Study (Patterson, 2012) and the Government Style Questionnaire (Green-Demer, Blanchard, Pelletier, & Béland, 1994). To accomplish the objectives, three sections of the instrument were used: perceptions of government, the water conservation activities respondents are currently engaged in, and respondents' willingness to act on water conservation-related activities. Prior to data collection, the developed instrument was reviewed by a panel of experts specializing in water issues, public opinion research, and survey design to ensure face and content validity. The panel of experts included the Chief Executive Officer of [Association], an Extension specialist in water economics and policy, the Director of the [Center], the Director of the [Institute], the Associate Director of the [Center], and an assistant professor specializing in agricultural communication.

Once the instrument was reviewed, a pilot test was conducted with 50 respondent's representative of the target population to confirm reliability of the constructs. All were found reliable with Cronbach's alpha levels greater than .80. The survey was then distributed nationwide to respondents aged 18 or older by collaborating with a public opinion survey research company. Data were collected using a non-probability opt-in sampling method. A total of 2,703 respondents were invited to respond to the survey. Quotas were set *a priori* as well as attention filters integrated. If a respondent did not fill a quota or failed an attention filter they were dismissed and their response was not recorded resulting in 1,050 complete responses and a participation rate of 42%. Since the use of a non-probability data collection method can lead to selection, exclusion, and non-participation biases, post-stratification weighting methods were applied to ensure the responses were representative of the population of interest (Baker et al., 2013; Kalton & Flores-Cervantes, 2003). Data were weighted by respondents' residential state, age, gender, and race/ethnicity according to the 2010 U.S. Census. Descriptive statistics were used for objective one, ANOVAs for objective two and linear regression for objective three.

The respondents were first asked to indicate their perceptions of government using four negative perception statements and three positive perception statements on a five-point Likert-type scale ranging from 1 = *Strongly Disagree*, 2 = *Disagree*, 3 = *Neither agree nor disagree*, 4 = *Agree*, or 5 = *Strongly Agree*. The index scores were calculated by averaging the scores of the four negative perception statements and the three positive perception statements. Both indices were found reliable with Cronbach's  $\alpha$  of .77 (negative) and .93 (positive). Respondents' water conservation activities they currently engaged in were measured by asking respondents to indicate how often they performed seven actions on a five-point Likert-type scale ranging from 1

= *Never*, 2 = *Almost Never*, 3 = *Sometimes*, 4 = *Almost Every Time*, 5 = *Every Time*. Respondents were able to select *Does Not Apply*. The responses of *Does Not Apply* were transformed as missing values when analyzing data. The construct of water conservation activities was found reliable ( $\alpha = .71$ ) using an index score created by averaging the seven items. Respondents' willingness to act toward water conservation was measured by asking how likely respondents were to engage in 20 activities in the future on a five-point Likert-type scale ranging from 1 = *Very Unlikely*, 2 = *Unlikely*, 3 = *Undecided*, 4 = *Likely*, 5 = *Very Likely*. *Not Applicable* was also included as an option in the willingness to act questions. The responses of *Not Applicable* were also transformed as missing values. The measurement of willingness to act was found reliable ( $\alpha = .93$ ) by creating the index score, which was calculated by averaging the 20 items. Lastly, respondents were asked a set of demographic questions including sex, race, ethnicity, age, region of residency, education level, income level, and political affiliation.

The respondents were 51% female and 49% male. The majority of the respondents were white (67%), while the rest of the respondents were 12% Black, 5% Asian or Pacific Islander, 1% Native American, 1% were multiracial, and 14% identified as other type of race. Fifteen percent of the respondents considered themselves to be Hispanic. Thirty-five percent of the respondents were between the age of 20 and 39 years old, 37 % were between 40 and 59 years old, and 28% were over 60 years of age. More respondents lived in the South (35%) compared to those living in the Midwest (23%), Northeast (22%), and West (20%). In terms of education level, 2% of the respondents had less than a 12<sup>th</sup> grade education, 22% had a high school education or General Education Development certificate, 25% had some college education without a degree, 13% had a 2-year college degree, 26% had a 4-year degree, and 13% had a graduate or professional degree. The respondents reported their political affiliation as: 26% Republicans, 38% Democrats, 26% Independents, and 10% non-affiliated. For income levels, 22% of the respondents had an income level of less than \$24,999, 29% had an income level between \$25,000 and \$49,999, 24% had an income level between \$50,000 and \$74,999, 21% had an income level between \$75,000 and \$149,999, and 4% made more than \$150,000.

## Results

### Perceptions of Government

Respondents were asked to indicate their perceptions of government using seven provided statements. The perception statements were divided into two categories: negative government perception (Table 1) and positive government perception (Table 2). Within the negative government perception statements, 40% of respondents agreed or strongly agreed the government imposes its environmental strategies on them. However, 36% of the respondents disagreed or strongly disagreed the government is trying to force them to adopt environmental behaviors. Of the positive government perception statements, 62% of the respondents agreed or strongly agreed they have the choice to participate in the environmental programs established by the government; 16% disagreed or strongly disagreed with the statement that "The government gives me the freedom to make my own decisions in regards to the environment."

Table 1

*Negative Government Perceptions (N =1050)*



	Strongly Disagree	Disagree	Neither Agree nor Disagree %	Agree	Strongly Agree
I feel the government wants to make me feel guilty when I do nothing for the environment	12.2	23.1	27.2	24.5	13.1
I feel the government imposes its environmental strategies on us	8.1	21.1	30.2	27.4	13.0
I feel that the government is trying to force me to adopt environmental behaviors	11.6	24.6	28.7	23.9	12.1
I think the government puts a lot of pressure on people to adopt environmentally-conscious behaviors	7.7	21.8	28.8	31.0	10.8

Table 2  
*Positive Government Perception (N=1050)*

	Strongly Disagree	Disagree	Neither Agree nor Disagree %	Agree	Strongly Agree
I feel I have the choice to participate in the environmental programs established by the government	4.6	7.5	26.4	46.5	15.0
I feel I have the choice to use the strategies provided by the government in order to help the environment	4.8	7.7	31.8	42.6	13.1
The government gives me the freedom to make my own decisions in regards to the environment	5.9	10.3	29.6	43.0	11.2

### **Current Water Conservation Activities**

Respondents were asked about how often they participated in six water conservation practices (Table 3). “I allow used motor oil to run down a storm drain” was the practice with the highest percentage of the respondents indicating they never or almost never participate in (93%). However, only 50% of respondents reported they never or almost never leave the water running in the kitchen while washing and/or rinsing dishes.

Table 3  
*Water Conservation Activities*

		Never	Almost Never	Some- times %	Almost Every Time	Every Time
	<i>N</i>					
I allow used motor oil to run down a storm drain.	874	88.6	4.0	2.5	2.8	2.1
I let my sprinklers run when rain is predicted in the forecast.	773	70.9	15.1	6.9	5.0	2.1
I hose down my driveway to wash it.	861	60.4	17.8	16.8	3.1	2.0
I allow soapy water to run down a storm drain.	868	53.2	15.8	14.6	78.2	8.3
I allow oil from cooking to run down the drain.	1017	50.4	17.2	21.4	7.6	3.3
I leave the water running in the kitchen when washing and/or rinsing dishes.	1024	30.4	19.4	28.7	13.7	7.8

### Willingness to Act

Respondents were asked the likelihood of participating in 20 water conservation practices (Table 4). Over 89% of respondents identified they were likely or very likely to responsibly dispose of hazardous materials ( $n = 826$ ). The activity with the most respondents identified they were unlikely or very unlikely to participate in was buying a specialty license plate that supports water protection efforts ( $n = 605$ , 62 %).

Table 4  
*Willingness to Act on Water Conservation*

	<i>N</i>	Very Unlikely	Unlikely	Un- decided %	Likely	Very Likely
Only run the dishwasher when it is full	802	3.7	3.5	6.7	16.5	69.6
Responsibly dispose of hazardous materials	924	1.4	.8	8.4	21.2	68.2
Only run the washing machine when it is full	1010	3.6	3.7	6.5	22.3	63.9
Sweep patios and sidewalks instead of hosing them down	848	4.3	2.0	8.6	26.7	58.4
Reduce the number of times a week you water your lawn	695	5.5	3.0	12.7	24.8	54.0
Only water your lawn in the morning or evening	731	5.9	1.6	14.8	26.6	51.1
Support water restrictions issued by my local government	993	4.1	4.6	18.7	30.3	42.3
Avoid purchasing plants that require a lot of watering	921	4.1	5.6	21.1	31.0	38.2

Reduce use of pesticides if your landscape quality would decrease	738	4.2	6.1	20.9	33.3	35.5
Vote to support water conservation programs	1009	2.8	3.0	18.0	42.3	33.9
Reduce use of fertilizer if your landscape quality would decrease	738	3.8	7.3	23.5	33.6	31.8
Vote for candidates who support water conservation	1002	3.1	1.5	25.8	39.2	30.4
Reduce your use of natural resources	995	4.8	8.1	23.8	34.9	28.3
Use biodegradable cleaning products	1018	9.6	6.9	23.3	35.0	25.3
Visit springs, lakes, state parks, etc., to learn about water issues	995	10.9	12.7	29.2	27.9	19.3
Donate to an organization that protects water	984	21.7	14.9	28.7	24.0	10.7
Volunteer for a stream clean up or wetland restoration event	973	29.0	15.9	29.4	16.4	9.2
Keep a timer in the bathroom to help you take a shorter shower	993	29.9	24.3	20.9	15.8	9.2
Join a water conservation organization	997	23.2	22.9	29.9	16.0	7.9
Buy a specialty license plate that supports water protection efforts	976	40.0	21.9	19.8	13.0	5.3

Note. *N* for each item varies based on the option to select Does not apply that was coded as missing data.

### Impact of Political Affiliation on Perceptions, Current Activities and Willingness to Act

Impact of political affiliation on perceptions, current activities, and willingness to act regarding water conservation were examined (Table 5). Respondents neither agreed nor disagreed that the government imposes values upon them ( $M = 3.52$ ;  $SD = .83$ ). Respondents slightly more agreed the government is supportive of whatever the public's actions may be ( $M = 3.78$ ;  $SD = .71$ ). Current Activities had a mean of 4.02 which indicated participants' actions aligned with the listed activities almost every time ( $SD = .56$ ). Willingness to Act had a mean of 3.92 revealing the public was likely to have intentions to conserve water in the future ( $SD = .68$ ).

Table 5  
*Descriptive Statistics of the Variables of Interest*

Variables	<i>N</i>	<i>M</i>	<i>SD</i>
Negative Government Perception <sup>a</sup>	1050	3.52	.83
Positive Government Perception <sup>a</sup>	1050	3.78	.71
Current Activities <sup>b</sup>	659	4.02	.56
Willingness to Act <sup>c</sup>	476	3.92	.68

Note. <sup>a</sup>Scale: 1 = *Strongly Disagree*, 2 = *Disagree*, 3 = *Neither Disagree nor Agree*, 4 = *Agree*, and 5 = *Strongly Agree*; <sup>b</sup>Scale: 1 = *Never*, 2 = *Almost Never*, 3 = *Sometimes*, 4 = *Almost Every Time*, and 5 = *Every Time*; <sup>c</sup>Scale: 1 = *Very Unlikely*, 2 = *Unlikely*, 3 = *Undecided*, 4 = *Likely*, 5 = *Very Likely*.

An analysis of variance was conducted to determine if differences in the indices existed based on political affiliation (Table 6). Statistically significant differences were found between political affiliation and negative government perception ( $F(1, 670) = 2.933, p = .09$ ) and between political affiliation and positive government perception ( $F(1,670) = 26.594, p = .00$ ). Post-hoc tests were conducted between the political affiliation groups and the result showed compared to Democrats, Republicans tend to have a more negative government perceptions, whereas Democrats tend to have more positive government perceptions than Republicans. Statistically significant differences between political affiliation and current activities were not found, however, a difference between political affiliation and willingness to act was found to be statistically significant ( $F(1,316) = 20.768, p = .00$ ). The post-hoc tests revealed Democrats scored higher on the willingness to act than Republicans. Table 6 was composed using a dummy variable for Republicans (0) and for Democrats (1) in order to test the countries most influential political parties.

Table 6  
*Mean Comparison of Political Affiliation in Different Variables*

Political Affiliation Groups	Variables											
	Negative Government			Positive Government			Current Activities			Willingness to Act		
	<i>N</i>	<i>M</i>	<i>SD</i>	<i>N</i>	<i>M</i>	<i>SD</i>	<i>N</i>	<i>M</i>	<i>SD</i>	<i>N</i>	<i>M</i>	<i>SD</i>
Republican	276	3.91	.63	276	3.41	.89	170	4.00	.54	129	3.56	.72
Democrat	397	4.00	.66	397	3.74	.75	255	4.04	.60	189	3.94	.74

### Predicting Current Activities and Willingness to Act

Two linear regression models were run to determine if political affiliation and perception of government were predictors of current activity engagement and willingness to act. The results are presented in Table 7. The first model using current activities as the dependent variable was significant and revealed current activities can be predicted by positive government perception but neither negative government perception nor political affiliation. The model shows that as an individuals' perception of the government becomes more positive the less likely they are to engage in water conservation activities ( $b = -.12, p = .01$ ), however, the effect size was small explaining only 2% of the variation. The second model using willingness to act as the dependent variable revealed political affiliation, negative government perception and positive government perception were all significant predictors of willingness to act and accounted for 52% of the variance.

Table 7  
*Predictors of Current Water Conservation Activity Engagement and Willingness to Act in the Future to Conserve Water*

Variable	Current Activities ( $R^2 = .02$ )		Willingness to Act ( $R^2 = .52$ )	
	<i>b</i>	<i>p</i>	<i>b</i>	<i>p</i>
Political Affiliation - Democrat	.01	.93	.19	.03*
Negative Government Perception	.1	.09	.63	.00**

Positive Government Perception	-.12	.01**	.21	.00**
--------------------------------	------	-------	-----	-------

*Note.* Political affiliation was dummy coded with Democrat entered into the model as a 1 versus being Republican as a 0. \* $p < .05$ ; \*\* $p < .01$ .

### Conclusion and Implications

The findings revealed the existence of dissonance between current actions and future intentions with willingness to act in the future predicted by perception of government support and enforcement along with political affiliation, but current actions hardly impacted at all. Looking at the descriptive results, the public failed to align their intended water conservation actions with their desired positive government perception. Goldsmith et al. (2013) indicated that using negative framing could motivate the population towards a desired outcome. However, this study revealed negative framing would only be effective on activities the public is willing to do in the future rather than on their reported current activities. Such findings imply that Extension educators should be focusing on an individual's willingness to act rather than their current activities. It also implies extension professionals should partner with government agencies to develop enforcement policy and regulation, as well as incentive programs, as an effective tool to get people to engage in the activities they claim they are willing to participate in the future.

The finding that revealed public current activities and willingness to act in the future were both predicted by positive government perception implies individuals' intentions are to conserve water without enforcement and strict guidelines set in place by the government. Thogerson (2004) asserted that behavioral inconsistencies can threaten individuals' self-perception, and when individuals are confronted with such inconsistencies they will work to align their actions and beliefs. The findings of this study align with Thogerson's (2004) beliefs in that the water conservation activities individuals were currently participating in were inconsistent with their intention to participate in water conservation activities in the future. This conflict can be identified as a cognitive dissonance (Festinger, 1957) and can drive behavior change.

Although few studies have been conducted to explore the influences of political affiliation (Coffey et al., 2012), this study added to the conversation by examining the influence of political affiliation on water conservation. Previous research revealed liberals were more likely to conserve energy by finding out about their over-usage (Costa et al., 2013). In this study Democrats were found to be more willing to act in the future towards water conservation than Republicans. Additionally, Republicans had a stronger negative government perception than Democrats who had a greater positive government perception. This finding implies that Republicans may respond to negative impositions by the government while Democrats may have a stronger response to positive government influence. Extension educators working within communities that have a more liberal or conservative bent should be aware of these differences and work with their government partners to develop restrictions in more conservative areas and provide incentive programs in more liberal areas.

### Recommendations

With conservation costs increasing and new regulation being developed to ensure water protection, the need for effective governmental policies is imperative. Extension has a place at the table when working with government partners in the development of these policies since they

are working directly with the public and can offer the most understanding of their target population. Based on the results of this study, it is evident that dissonance exists between current actions and willingness to act regarding water conservation. Intention to engage in water conservation efforts may be influenced by the feeling that participation in water conservation practices are optional, but that the public also needs strong government influence to increase conservation (Nolte et al., 2013). Effective extension educators and policymakers should be aware of this cognitive dissonance that can be used to drive participation in water conservation (Terry & Osborne, 2015).

Extension educators need to work with decision makers to leverage this effect. For example, working collaboratively to assist local governments in developing campaigns that use notifications of overuse, communicating about this over use, offering educational opportunities, and possibly implementing fines for overuse may encourage water conservation (Kantola et al., 1984). Extension education programs could be built in to this campaign where home visits or trainings at central neighborhood locations are offered by Extension educators to discuss water conservation activities in conjunction with notifications (Warner et al., 2015). This way the dissonance created by the notifications would encourage participation in Extension programs that could lead to further action.

Extension educators should also open communication channels with the public to provide feedback about why strict government enforcement can be a vital tool in water conservation (Costa et al., 2013). Given political affiliation influences perception of government enforcement, and this perception influences future willingness to engage in water conservation efforts, Extension educators should target their communication methods based on their communities political leaning (Gromet et al., 2012). For example, since Republicans are more inclined to react to increases in negative government perception, the programs should be implemented with appropriate amounts of pressure to encourage conservation from Republicans. Moreover, Extension educators should be aware of policymakers' political affiliation so that when they are working with them they can enhance communication effectiveness (Terry & Osborne, 2015).

Future studies are recommended based on the findings of this study. Researchers should examine public attitudes and perceptions of available government programs and policies related to water conservation, as well as explore specific government programs and policies that should be implemented to further increase public engagement in water conservation (Higgins et al., 2014). Specific water conservation programs and policies, as well as specific practices could then be identified as either negative (restricted) government influence or positive (unrestricted) government influence. Future studies should also be conducted to explore the magnitude of variance between current actions and future intentions (Wicklund & Brehm, 1976). Researchers should also consider examining the impacts party social cues and endorsements may have on conservation policy (Lau et al., 2001) to confirm if current participation in water conservation truly aligns with political affiliation and examine the strength of that relationship.

## References

- Adams, D. C., Allen, D., Borisova, T., Boellstorff, D. E., Smolen, M. D., & Mahler, R. L. (2013). The influence of water attitudes, perceptions, and learning preferences on water-conserving actions. *Natural Sciences Education*, 42(1), 114-122. doi:10.4195/nse.2012.0027
- Babel, M. S., Gupta, A. D., & Pradhan, P. (2007). A multivariate econometric approach for domestic water demand modeling: an application to Kathmandu, Nepal. *Water Resources Management*, 21(3), 573-589. doi: 10.1007/s11269-006-9030-6
- Baker, R., Brick, J. M., Bates, N. A., Battaglia, M., Couper, M. P., Dever, J. A.,... Tourangeau, R. (2013). *Report of the AAPOR task force on non-probability sampling*. American Association for Public Opinion Research. Retrieved from <http://www.aapor.org/AM/Template.cfm?Section=Reports1&Template=/CM/ContentDisplay.cfm&ContentID=5963>
- Boelens, R., & Vos, J. (2012). The danger of naturalizing water policy concepts: Water productivity and efficiency discourses from field irrigation to virtual water trade. *Agricultural Water Management*, 108, 16-26. doi: 10.1016/j.agwat.2011.06.013
- Coffey, D. J., & Joseph, P. H. (2012). A polarized environment: the effect of partisanship and ideological values on individual recycling and conservation behavior. *American Behavioral Scientist*, 0002764212463362. 10.1177/0002764212463362
- Costa, D. L., & Kahn, M. E. (2013). Energy conservation “nudges” and environmentalist ideology: Evidence from a randomized residential electricity field experiment. *Journal of the European Economic Association*, 11(3), 680-702. doi: 10.1111/jeea.12011
- Dupont, D. P., & Bateman, I. J. (2012). Political affiliation and willingness to pay: An examination of the nature of benefits and means of provision. *Ecological Economics*, 75, 43-51. doi: 10.1016/j.ecolecon.2012.01.012
- Festinger, L. (1957). *A theory of cognitive dissonance*. Evanston, IL: Row, Peterson.
- Gneezy, U., Meier, S., & Rey-Biel, P. (2011). When and why incentives (don't) work to modify behavior. *The Journal of Economic Perspectives*, 25(4), 191-209. doi: 10.1257/089533011798394550
- Goldsmith, K., & Dhar, R. (2013). Negativity bias and task motivation: Testing the effectiveness of positively versus negatively framed incentives. *Journal of Experimental Psychology: Applied*, 19(4), 358. doi: 10.1037/a0034415
- Green-Demer, I., Blanchard, C., Pelletier, L. G., & Béland, A. (1994). *Perception of government environmental strategies by the citizens: The government style questionnaire (GSQ)*.

(Research Paper No. 13). Ottawa: University of Ottawa Institute for Research on Environment and Economy.

- Gromet, D. M., Kunreuther, H., & Larrick, R. P. (2013). Political ideology affects energy-efficiency attitudes and choices. *Proceedings of the National Academy of Sciences*, *110*(23), 9314-9319. doi: 10.1073/pnas.1218453110
- Higgins, A., McNamara, C., & Foliente, G. (2014). Modelling future uptake of solar photovoltaics and water heaters under different government incentives. *Technological Forecasting and Social Change*, *83*, 142-155. doi: 10.1016/j.techfore.2013.07.006
- Hoekstra, A. Y., Mekonnen, M. M., Chapagain, A. K., Mathews, R. E., & Richter, B. D. (2012). Global monthly water scarcity: Blue water footprints versus blue water availability. *PLoS One*, *7*(2), e32688. doi: 10.1371/journal.pone.0032688
- Huang, P., & Lamm, A. J. (2015a). Impact of experience and participation in Extension programming on perceptions of water quality issues. *Journal of International Agricultural and Extension Education*, *22*(3). Doi:10.5191/jiaee.2015.22303
- Huang, P., & Lamm, A. J. (2015b). Understanding public engagement in water conservation behaviors and knowledge of water policy: Promising hints for Extension. *Journal of Extension*, *53*(6). Retrieved from <http://www.joe.org/joe/2015december/rb1.php>
- Huang, P., Lamm, A. J., & Dukes, M. (2016). Informing extension program development through audience segmentation: Targeting high water users. *Journal of Agricultural Education*, *57*(2), 75-89. doi: 10.5032/jae.2016.02075
- Jarcho, J. M., Berkman, E. T., & Lieberman, M. D. (2011). The neural basis of rationalization: cognitive dissonance reduction during decision-making. *Social Cognitive and Affective Neuroscience*, *6*(4), 460-467. doi: 10.1093/scan/nsq054
- Kalton, G., & Flores-Cervantes, I. (2003). Weighting methods. *Journal of Official Statistics*, *19*(2), 81-97.
- Kantola, S. J., Syme, G. J., & Campbell, N. A. (1984). Cognitive dissonance and energy conservation. *Journal of Applied Psychology*, *69*(3), 416. doi: 10.1037/0021-9010.69.3.416
- Lamm, K. W., Lamm, A. J., & Carter, H. (2015). Bridging water issue knowledge gaps between the general public and opinion leaders. *Journal of Agricultural Education*, *56*(3), 146-161. DOI: 10.5032/jae.2015.03146
- Lau, R., & Redlawsk, D. (2001). Advantages and disadvantages of cognitive heuristics in political decision making. *American Journal of Political Science*, *45*(4), 951-971. Retrieved from <http://www.jstor.org/stable/2669334>



- Leal, A., Rumble, J. N., & Lamm, A. J. (2015). Setting the agenda: Exploring Florida residents' perceptions of water quality and quantity issues. *Journal of Applied Communications*, 99(3), 53-68.
- Manner, M., & Gowdy, J. (2010). The evolution of social and moral behavior: Evolutionary insights for public policy. *Ecological Economics*, 69(4), 753-761. doi: 10.1016/j.ecolecon.2008.04.021
- Metin, I., & Camgoz, S. M. (2011). The advances in the history of cognitive dissonance theory. *International Journal of Humanities and Social Science*, 1(6), 131-136.
- Nolte, C., Agrawal, A., Silvius, K. M., & Soares-Filho, B. S. (2013). Governance regime and location influence avoided deforestation success of protected areas in the Brazilian Amazon. *Proceedings of the National Academy of Sciences*, 110(13), 4956-4961. doi: 10.1073/pnas.1214786110
- Olmstead, S. M., & Stavins, R. N. (2009). Comparing price and nonprice approaches to urban water conservation. *Water Resources Research*, 45(4). doi: 10.1029/2008WR007227
- Patterson, L. (2012). *2012 RBC Canadian water attitudes study*. RBC Blue Water Project. Retrieved from <http://www.rbc.com/community-sustainability/environment/rbc-blue-water/index.html>
- Phelps, J., Carrasco, L. R., Webb, E. L., Koh, L. P., & Pascual, U. (2013). Agricultural intensification escalates future conservation costs. *Proceedings of the National Academy of Sciences*, 110(19), 7601-7606. doi: 10.1073/pnas.1220070110
- Promberger, M., Brown, R. C., Ashcroft, R. E., & Marteau, T. M. (2011). Acceptability of financial incentives to improve health outcomes in UK and US samples. *Journal of Medical Ethics*, 37(11), 682-687. doi:10.1136/jme.2010.039347
- Roberts, T. G., Harder, A., & Brashears, M. T. (Eds). (2016). *American Association for Agricultural Education national research agenda: 2016-2020*. Gainesville, FL: Department of Agricultural Education and Communication. Retrieved from [http://aaaeonline.org/resources/Documents/AAAE\\_National\\_Research\\_Agenda\\_2016-2020.pdf](http://aaaeonline.org/resources/Documents/AAAE_National_Research_Agenda_2016-2020.pdf)
- Stone, J., & Fernandez, N. C. (2008). To practice what we preach: The use of hypocrisy and cognitive dissonance to motivate behavior change. *Social and Personality Psychology Compass*, 2(2), 1024-1051. doi: 10.1111/j.1751-9004.2008.00088.x
- Terry, B. D., & Osborne, E. (2015). Fundamental dimensions and essential elements of exemplary local Extension units. *Journal of Agricultural Education*, 56(2), 43-63. doi: 10.5032/jae.2015.02043

- Thøgersen, J. (2004). A cognitive dissonance interpretation of consistencies and inconsistencies in environmentally responsible behavior. *Journal of Environmental Psychology, 24*(1), 93-103. doi: 10.1016/S0272-4944(03)00039-2
- Warner, L. A., Rumble, J., Martin, E., Lamm, A. J., & Cantrell, R. (2015). The effect of strategic message selection on residents' intent to conserve water in the landscape. *Journal of Agricultural Education, 56*(4), 59-74. doi: 10.5032/jae.2015.04059
- Wicklund, R. A., & Brehm, J. W. (1976). *Perspectives on cognitive dissonance*. Hillsdale, NJ: Psychology Press.

# Effects of an Applied Workshop on Teacher Self-Efficacy and Intent to Teach Hydraulics

Donald M. Johnson, University of Arkansas  
George W. Wardlow, University of Arkansas

## Abstract

*Agricultural mechanics is an important component of school-based agricultural education programs, yet many university agricultural education programs lack the necessary facilities, personnel, and available credit hours to adequately prepare preservice teachers in basic agricultural technologies, much less more advanced technologies. This study investigated the effects of a one-day applied hydraulics workshop on teachers' (n = 22) self-efficacy and intent to teach hydraulics. Prior to the workshop, a majority of teachers had a negative perception of their understanding of hydraulic concepts and their ability to effectively teach hydraulics. Upon completion of the workshop, a majority of respondents had positive perceptions of their understanding of hydraulics concepts and their ability to effectively teach hydraulics. Teachers' participation in the workshop resulted in a statistically significant ( $p < .001$ ) overall increase in self-perceived understanding and ability to teach hydraulics; the Cohen's  $d$  of 1.65 indicated workshop participation had a large effect on teachers' perceptions. In addition, the percentage of teachers indicating they planned to teach hydraulics in one or more courses increased from 36.4% prior to the workshop to 87.3% after the workshop.*

## Introduction and Theoretical Framework

Agricultural mechanics is an important component of a majority of high school agricultural education programs (McCubbins, Anderson, Paulsen, & Well, 2016). In order to effectively teach agricultural mechanics, teachers must possess appropriate content and pedagogical knowledge and skills (National Board for Professional Teaching Standards [NBPTS], 2014). However, while agricultural mechanics remains a core component of the secondary program, agricultural mechanics coursework required by university teacher education programs has steadily declined in recent decades (Blackburn, Robinson, & Fields, 2015). In a national study, Burris, Robinson, and Terry (2005) determined the modal requirement for coursework in agricultural mechanics was five to eight semester credit hours.

How can high school teachers of agriculture, who are expected to include instruction in agricultural mechanics in their programs, attain knowledge and skills in this curricular area? Intensive workshops on various mechanical technologies may be the most efficient way to increase teachers' knowledge, skills and self-efficacy for teaching agricultural technology after they have completed their teacher education programs and are employed as educators (Paulsen, Han, Humke, & Ohde, 2014).

## Theoretical Framework

Success at achieving a task is determined, in part, by one's self-perceptions of their ability to achieve the task. This perception is one's self-efficacy. Kirk (2016, para 1) explained that self-efficacy is commonly defined as the belief that an individual has in their capabilities to achieve a goal. Success is based, in part, on an individual's belief in their own abilities. Bandura (1986)

defined self-efficacy as a person's judgement of his or her capability "to organize and execute courses of action required to attain designated types of performances" (p. 391). In this context, teacher self-efficacy can be defined as "teachers' individual beliefs about their own abilities to successfully perform specific teaching and learning related tasks within the context of their own classrooms" (Dellinger, Bobbett, Olivier, & Ellett, 2008, p. 751).

Kirk (2016) described four sources of self-efficacy. These include: mastery experiences based on successful hands-on practice, vicarious experiences based on observation of others' successes, verbal persuasion which utilizes encouragement of an individual, and emotional state which centers on positive beliefs in one's ability versus anxiety over possible failure. According to Bandura (1986), mastery experiences and vicarious experiences are the two strongest influences on self-efficacy.

How can teachers provide opportunities that enhance self-efficacy of students to learn? One would logically deduce that teachers themselves must first have positive levels of self-efficacy regarding their subject matter. Teacher efficacy or a teacher's confidence in their ability to promote student learning was discussed as early as 1976 (Armor et al., 1976). Jerald (2007) noted that teachers with a stronger sense of efficacy: tend to exhibit greater levels of planning and organization; are more open to new ideas and are more willing to experiment with new methods to better meet the needs of their students; are more persistent and resilient when things do not go smoothly; are less critical of students when they make errors; and are less inclined to refer a difficult student to special education. Each of these teacher attributes is associated with learning. Thus, teachers of agricultural mechanical technologies must have knowledge of those technologies in order to teach effectively. Exposure to agricultural technologies, either through coursework or experiential learning, is declining in college teacher preparation programs. Further, the nature of agriculture technologies continues to evolve, necessitating teachers to be updated periodically. In-service teacher workshops are an effective means to deliver technical updating (Paulsen, Han, Humke, & Ohde, 2014).

## **Workshop Description**

A one-day, intensive workshop was developed and conducted in June 2016 to provide technical content and pedagogical approaches to teaching hydraulics in Arkansas agricultural education programs. In designing the workshop, the researchers were cognizant of the fact that most participating teachers would not have access to hydraulic trainers, test benches, and similar equipment in their schools. Thus, while hydraulic trainers were used for parts of the workshop, emphasis was placed on developing and modeling low-cost activities teachers could actually use in their classrooms.

After a brief welcome and orientation, the workshop instructor presented a brief (20 minute) illustrated lecture providing an orientation to hydraulic power transmission; basic principles such as Pascal's Law and force, pressure, area relationships; hydraulic system components, systems and schematics; and safety. A hydraulic wood splitter circuit animation was used to demonstrate component functions, symbols, and fluid flow when extending and retracting the cylinder and attached splitting wedge.

After the lecture teachers were divided into six groups of three or four to complete a modified version of the hydraulic bottle jack activity described by Kirk, Fravel, and Massey (2012). The groups disassembled the bottle jacks and identified the reservoir, pumping piston and cylinder, check valves, lift piston and cylinder, flow control valve, and pressure relief valve. Once teachers had discussed these components and understood how they worked together as a system, the teachers used printed hydraulic symbols and color-coded wires (red for high-pressure lines and green for low-pressure lines) to develop a schematic that described the jack's operation (Figure 1). Teachers next measured the diameters and calculated the areas of the pumping and lift pistons and calculated the jack's theoretical hydraulic multiplication of force and the fluid pressure at maximum lift capacity (4-tons). A group discussion on use of this activity with high school students was conducted after teachers reassembled the jacks.

Next, teachers were taken to the lab and the workshop instructor provided an overview of the hydraulic trainers, their components, operation, and safety. After the orientation, one-half of the teachers remained in the lab and worked in groups of two or three per trainer to build and operate the first five (of 10) common hydraulic circuits. These circuits incorporated different directional control valves (open-center, closed-center and tandem-center), actuators (hydraulic motors and cylinders), pressure valves (sequencing and pressure reducing), a hydraulic accumulator, and measurement devices (pressure gauges and flow meters). Figure 2 shows the schematic for an example circuit.

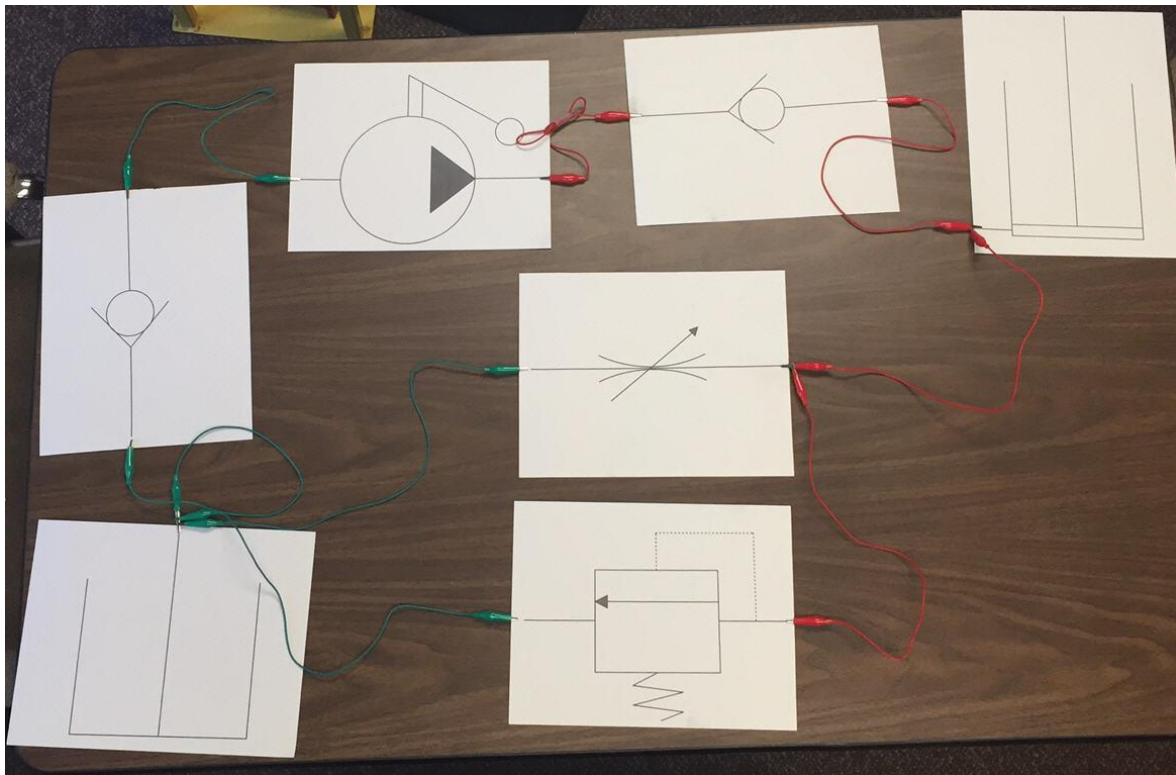

**Figure 1.** Example hydraulic bottle jack circuit schematic created during workshop.

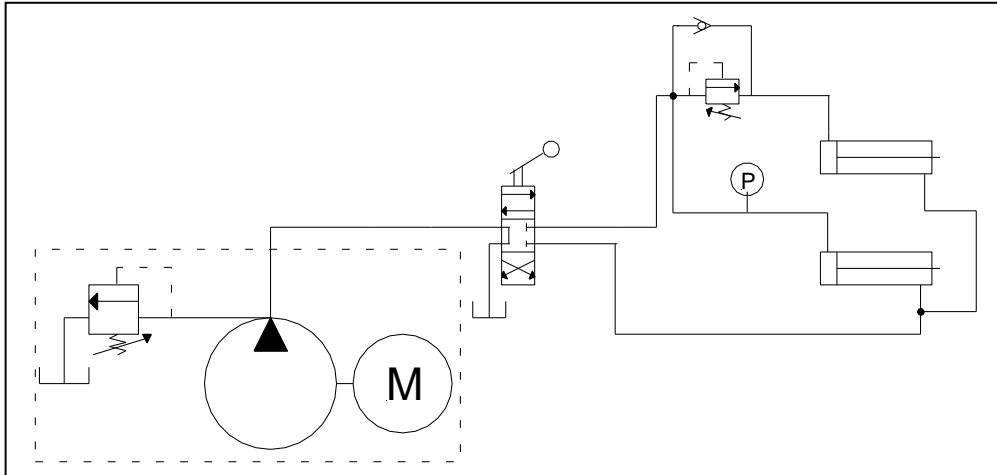

**Figure 2.** Example workshop hydraulic circuit with pressure-sequenced cylinders.

While the first group of teachers were building and operating circuits on the trainers, the other group of teachers went into a classroom and worked in groups of two or three to “build” the same hydraulic circuits using hydraulic symbol cards and color-coded wires. Teachers then used the constructed circuit schematics to visualize and explain the operation of each circuit.

After each group had constructed the first five circuits (either on the trainer or using the cards), the groups were reversed and the original lab groups used the cards to construct and discuss the circuits just built in the lab while the original classroom groups built and operated the first five circuits on the trainers. This same rotation process was then used as the groups built the remaining circuits using both the cards and the trainers.

The workshop concluded with a discussion and question and answer session. The primary focus was on technical questions and on how to incorporate hands-on hydraulics instruction into high school agriculture classes using low-cost methods such as the hydraulic symbol cards and the hydraulic bottle jack activity. Each teacher received a printed copy of all workshop materials, including slides, activities, and hydraulic symbol templates.

### **Purpose and Objectives**

The purpose of this study was to evaluate the effects of a one-day applied hydraulics workshop on teachers’ self-efficacy and intent to teach hydraulics. Specific objectives were to:

1. Determine teachers’ self-efficacy and intent to teach hydraulics before and after completing a hydraulics inservice workshop; and
2. Determine the effects of workshop completion on teachers’ self-efficacy and intent to teach hydraulics.

## Methods

A two-day agricultural technology inservice workshop for secondary school agriculture teachers was held on the University of Arkansas campus in June 2016. The first day was devoted to agricultural hydraulics and the second day was devoted to tungsten inert-gas (TIG) welding. Teachers were free to participate in one or both workshop sessions, with each session scheduled for six hours of instruction.

The target population for this study was the 26 Arkansas high school agriculture teachers who self-selected to attend the agricultural hydraulics workshop session. Evaluation data for the hydraulics workshop were collected at the beginning of the second day from the participating teachers who returned for the TIG welding session ( $n = 23$ ); 22 (84.6%) teachers provided usable evaluation responses. The research protocol was approved as exempt by the university institutional review board.

The evaluation instrument contained 10 statements about teaching hydraulics and incorporated a retrospective pretest (Rockwell & Kohn, 1989) and a traditional posttest. Each participant responded twice to each item, indicating their level of agreement (strongly disagree, disagree, agree, or strongly agree) both before and after completion of the hydraulics workshop. According to Gouldthorpe and Israel (2013), retrospective pretests ask respondents to recall their perceptions prior to engaging in the treatment at the same time they evaluate their perceptions after completing the treatment. Gouldthorpe and Israel specifically recommended use of retrospective pretests when measuring attitude changes in short-duration educational workshops. An example evaluation item is shown in Figure 3.

BEFORE the Workshop (circle your response)				Statement	AFTER the Workshop (circle your response)			
SD	D	A	SA	I find it difficult to explain to students how hydraulics work.	SD	D	A	SA

**Figure 3.** Example item showing retrospective pretest and posttest response modes.

The instrument was based, in part, on selected items from the teaching self-efficacy construct of the Science Teaching Efficacy Beliefs Instrument (STEBI; Enochs & Riggs, 1990). Items were modified for use in this study by replacing the word “science” with “hydraulics”. Paulsen, Han, Humke, and Odhe (2014) used a modified version of the full STEBI to measure changes in teacher self-efficacy for teaching renewable energy as a result of workshop participation. A panel of three researchers with expertise in technical education and evaluation methods examined the instrument and judged it to possess face and content validity. Cronbach’s alpha reliability estimates of .91 (pretest) and .77 (posttest) were obtained *post hoc*.

The participants in this workshop were considered to be a time and place sample representative of the population of future workshop participants (Oliver & Hinkle, 1982). Data were analyzed using descriptive and inferential statistics.

## Results

In retrospectively evaluating their ability and intent to teach hydraulics before completing the workshop (Table 1), a majority of teachers agreed or strongly agreed their level of knowledge prevented them from teaching about hydraulics (54.6%), found it difficult to explain how hydraulics work (54.6%), could not teach hydraulics as well as they did other subjects (77.3%), would not want their principal to evaluate them when teaching hydraulics (59.1%), and lacked sufficient equipment and supplies to teach hydraulics (64.7%). Somewhat contradictorily, a slight majority of respondents either agreed or strongly agreed they were able to answer student questions about hydraulics (52.3%) and possessed the hands-on skills necessary for teaching hydraulics (54.5%). A minority of respondents agreed or strongly agreed they knew how to effectively teach hydraulics (40.1%) or planned to teach hydraulics in one or more classes next year (36.4%).

In evaluating their ability and intent to teach hydraulics after completion of the workshop (Table 1), a majority of respondents disagreed or strongly disagreed their level of knowledge prevented them from teaching about hydraulics (95.4%), found it difficult to explain how hydraulics work (86.4%), could not teach hydraulics as well as they did other subjects (59.2%), would not want their principal to evaluate them when teaching hydraulics (68.2%), and lacked sufficient equipment and supplies to teach hydraulics (63.7%). Consistent with these increased levels of confidence, virtually all participants felt they were able to answer student questions about hydraulics (95.4%) and possessed the hands-on skills necessary for teaching hydraulics (100%). Upon completion of the workshop, approximately 90% of participants agreed or strongly agreed they knew how to teach hydraulics effectively (88.6%) and planned to teach hydraulics in one or more classes next year (90.9%).

To determine the change in agreement with individual statements regarding their ability to teach hydraulics as a result of the workshop, responses were dichotomized as either disagree (strongly disagree and disagree) or agree (agree and strongly agree) and *Fisher's exact test* probabilities were calculated to determine if there were significant ( $p < .05$ ) associations between workshop completion and changes in teachers' self-efficacy and intent to teach hydraulics (Table 1). The results indicated completion of the workshop was associated with increases in perceived ability to teach hydraulics for 9 of the 10 statements; the level of agreement with the statement regarding the lack of equipment and supplies did not significantly change as a result of the workshop.

To further examine the overall effects of the workshop on teacher perceptions of their ability to teach hydraulics, negatively worded items were reverse-coded and pretest and posttest responses to the 10 items were summed (using the original four-point scale) and averaged to develop measures of hydraulics teaching self-efficacy before and after the workshop. As shown in Table 2, the mean teacher self-efficacy score before the workshop fell near the exact mid-point of the 1 to 4 scale, indicating teachers were uncertain of their ability to teach hydraulics. After the workshop, teacher self-efficacy for teaching hydraulics was positive and this difference was statistically significant. The calculated *Cohen's d* of 1.65 indicates the workshop had a large effect on teacher self-efficacy (Cohen, 1988).



Table 1

*Teachers' Level of Agreement with Selected Statements about Teaching Hydraulics Before and After Workshop Completion*

Evaluation Statement	Before Workshop ( <i>n</i> = 22)				After Workshop ( <i>n</i> = 22)				Fisher's Exact <i>p</i> <sup>a</sup>
	<i>SD</i> %	<i>D</i> %	<i>A</i> %	<i>SA</i> %	<i>SD</i> %	<i>D</i> %	<i>A</i> %	<i>SA</i> %	
I understand hydraulics well enough to be effective in teaching students about it.	9.1	36.4	50.0	4.6	0.0	0.0	68.2	31.8	.001
I find it difficult to explain to students how hydraulics work.	13.6	31.8	54.6	0.0	27.3	59.1	9.1	4.6	.009
I know how to teach effectively about hydraulics.	0.0	59.1	36.4	4.6	4.6	6.8	65.9	22.7	.002
I am able to answer students' questions about hydraulics.	4.6	43.2	47.7	4.6	0.0	4.6	72.7	22.7	.002
Even when I try very hard, I don't teach hydraulics as well as I do most subjects.	4.6	18.2	77.3	0.0	4.6	54.6	36.4	4.6	.009
I have the necessary hands-on skills to teach about hydraulics.	4.6	40.9	45.4	9.1	0.0	0.0	72.7	27.3	.005
Given a choice, I would not invite my principal to evaluate my teaching of hydraulics.	18.2	22.7	59.1	0.0	27.3	43.2	25.0	4.6	.040
I will teach about hydraulics in one or more classes next year.	9.1	54.6	27.3	9.1	4.6	4.6	63.6	27.3	.000
The lack of equipment and supplies will prevent me from teaching about hydraulics.	9.1	27.3	55.6	9.1	9.1	54.6	27.3	9.1	.082
My level of knowledge will prevent me from teaching about hydraulics.	13.6	31.8	54.6	0.0	22.7	72.7	4.6	0.0	.001

<sup>a</sup>Responses were collapsed into two categories, disagree (combination of strongly disagree and disagree) and agree (combination of agree and strongly agree), prior to analyses.

Table 2

Teachers' Overall Self-Efficacy about Teaching Hydraulics Before and After Workshop Completion

	<i>n</i>	<i>M</i>	<i>SD</i>	<i>t</i>	<i>p</i>
Before Workshop	22	2.48	0.54	7.74	<.001
After Workshop	22	3.04	0.37		

Note. Cohen's *d* = 1.65.

### Conclusions and Recommendations

Before completing the workshop, a majority of teachers agreed that their level of knowledge prevented them from teaching about hydraulics. However, statistical analyses indicated that completion of the workshop significantly increased participants' perceived knowledge of hydraulics principles and practices. Further, a majority of respondents indicated that their new level of knowledge would not prevent them from teaching about hydraulics and a majority planned to teach hydraulics in one or more classes the next year. Analyses also indicated that participation in the workshop significantly increased teachers' self-efficacy to teach hydraulics.

Given the importance of agricultural mechanics in the high school curriculum (McCubbins et al., 2016) and concerns about the limited agricultural mechanics coursework for preservice agriculture teachers (Burriss, 2005), the results of this study document the viability of inservice workshops as a mechanism for providing current teachers with the skills, knowledge and self-efficacy necessary to teach important agricultural technologies (NBPST, 2014). Thus, these results support the findings of Paulsen et al. (2014) concerning the effects of workshop participation on teachers' self-efficacy and intent to teach new technologies.

If success at learning is affected by peoples' self-perceptions of their abilities to learn and this self-efficacy is derived, in part, from participation in mastery experiences based on successful hands-on practice including experiencing positive beliefs in one's ability versus anxiety over possible failure (Kirk, 2016), then individuals learn best when they have opportunity to practice applications of new knowledge to achieve some level of mastery. For teachers to be effective at supporting positive student learning, they must master the subject matter and have a positive self-efficacy about it. This study indicates that a hands-on workshop for teachers increased their self-efficacy and intent to teach hydraulics. A follow-up contact will be made with participating teachers to determine if they acted on their stated intent to teach hydraulics.

As University teacher education programs offer fewer courses and experiences in agricultural mechanical technologies each year, even as this subject area remains a significant component of high school agriculture programs, how can high school teachers of agriculture attain and maintain levels of knowledge and skills appropriate to teach it? One or two day intensive workshops appear to be an effective method of supporting teachers in their attempt to teach technologies they did not have the opportunity to study as preservice teachers.

The agricultural education department at the University of Arkansas has offered intensive technology-oriented workshops for teachers each summer for several years. The results of this study suggest these workshops are an effective method of encouraging and enabling teachers to incorporate advanced agricultural mechanics instruction into their local programs. As competition for university and state resources increase, results of studies such as this should be widely shared with client groups and budgetary decision makers.

### References

- Armor, D., Conroy-Oseguera, P., Cox M., King, N., McDonnell, L., Pascal, A. Pauly, E., & Zellman, G. (1976). Analysis of the school preferred reading programs in selected Los Angeles minority schools. (REPORT NO. R-2007-LAUDS). Santa Monica, CA: Rand Corporation. (ERIC Document Reproduction Service No. 130 243).
- Bandura, A. (1986). *Social foundations of thought and action: A social cognitive theory*. Englewood Cliffs, NJ: Prentice-Hall.
- Blackburn, J. J., Robinson, J. S., & Field, H. (2015). Preservice agriculture teachers' perceived levels of readiness in an agricultural mechanics course. *Journal of Agricultural Education*, 56(1), 172-187. doi: 10.5032/jae.2015.01172
- Burris, S., Robinson, J. S., & Terry Jr., R. (2005). Preparation of preservice teachers in agricultural mechanics. *Journal of Agricultural Education*, 46(3), 23-34. doi: 10.5032/jae.2005.03023
- Byrd, A. P., Anderson, R. G., Paulsen, T. H., & Shultz, M. J. (2015). Does the number of post-secondary agricultural mechanics courses completed affect teacher competence? *Journal of Agricultural Education*, 56(1), 20-31. doi: 10.5032/jae.2015.01020
- Cohen, J. (1988). *Statistical power analysis for the behavioral sciences* (2<sup>nd</sup> ed.). Hillsdale, NJ: Erlbaum.
- Enochs, L. G., & Riggs, I. M. (1990). Further development of an elementary science teaching efficacy belief instrument: a preservice elementary scale. *School Science and Mathematics*, 90(8), 694-706. doi: 10.1111/j.1949-8594.1990.tb12048.x
- Gouldthorpe, J. L., & Israel, G. D. (2013). *Capturing change: comparing pretest-posttest and retrospective evaluation methods*. Publication WC135, University of Florida Cooperative Extension Service. Retrieved from <http://edis.ifas.ufl.edu/wc135>
- Jerald, C. D. (2007). *Believing and achieving*. Washington, D.C.: Center for Comprehensive School Reform and Improvement. Retrieved from <http://files.eric.ed.gov/fulltext/ED495708.pdf>
- Kirk, K. (2016). Self-Efficacy: Helping students believe in themselves. In *On the Cutting Edge - Strong Undergraduate Geoscience Teaching*. Retrieved from <http://serc.carleton.edu/NAGTWorkshops/affective/efficacy.html>

- Kirk, K. R., Fravel, P. M., & Massey, H. F. (2012). Use of the hydraulic bottle jack for instruction in fluid power transfer fundamentals. *Proceedings of the 2012 Annual National Agricultural Mechanics Professional Development Conference, 31*, 41-54.
- McCubbins, O. P., Anderson, R. G., Paulsen, T. H., & Wells, T. (2016). Teacher-perceived adequacy of tools and equipment available to teach agricultural mechanics. *Journal of Agricultural Education, 57*(3), 223-236. doi:10.5032/jae.2016.03223
- National Board for Professional Teaching Standards. (2014). *What Teachers Should Know and Be Able to Do*. Retrieved from <http://www.nbpts.org/five-core-propositions>
- Oliver, J. D., & Hinkle, D. E. (1982). Occupational education research: selecting statistical procedures. *Journal of Studies in Technical Careers, 4*(3), 199-209.
- Paulsen, T.H., Han, G., Humke, S. J., & Ohde, N. R. (2014). Teacher self-efficacy as a result of an agriculture-based renewable energy professional development workshop. *Journal of Agricultural Systems, Technology, and Management, 25*(2014), 44-60. Retrieved from <http://jastm.org/index.php/jastm/article/view/29/44>
- Rockwell, S. K., & Kohn, H. (1989). Post-then-pre evaluation: measuring behavior more accurately. *Journal of Extension, 27*(2). Retrieved from <https://joe.org/joe/1989summer/a5.php>

# **A Description of Agriculture Teachers' Selections of Preferred Teaching Partners Based on Attire and Physical Attributes**

Catherine W. Shoulders, University of Arkansas

Hailey R. Gates, University of Arkansas

## **Abstract**

*Whether we are aware of it or not, our age, gender, and clothes can speak for us before we have even said a word. In this study, we asked agriculture teachers attending the National FFA Convention to select teaching partners based on their attire and physical attributes. Participants reported on their gender, age, and NAAE region, then were asked to select from eight images of confederates the one they most preferred to hire for their existing agriculture program. Results indicated that participants selected teaching partners dressed in more formal and more informal attire with similar frequency, but selected male teaching partners more frequently than female teaching partners. Small associations were revealed between participants' gender and the confederates' age, participants' NAAE region and confederates' gender, and the participants' gender and confederates' gender.*

## **Introduction**

Teachers throughout the public education system make choices in an effort to display a desired culture and setting within their classrooms. One of the first decisions made daily by teachers is in regard to their clothing; the sartorial choices of teachers of all subjects play a role in the impressions others form about them, the classes they teach, and the schools in which they work (Freeburg & Workman, 2009). Whether intentionally or unintentionally, clothing communicates cultural traditions, roles and authority, and social status (Damhorst, 1990; Damhorst, Miller-Spillman, & Michelman, 2005; Gordon, Tengler, & Infante, 1982).

School based agriculture teachers are members of a unique profession due to their varied responsibilities and teaching environments (Phipps, Osborne, Dyer, & Ball, 2008). Agriculture teachers may find themselves in the classroom, the greenhouse, and the county fairgrounds all within the course of one day (Terry & Briers, 2010). Shoulders and Myers (2012) found 16 different agricultural laboratories in which teachers instruct students, many of which require teachers to engage in physical work and come in contact with debris, potentially hazardous conditions, and weather and outdoor elements, as these laboratories mimic realistic work settings (Hyslop-Margison, 2000). Amid their unique teaching environments, agriculture teachers are still expected to serve as participating members of their schools' professional communities (Terry & Briers, 2010), which requires that agriculture teachers share in at least some aspects of the professional identities of other teachers (Darling-Hammond & Bransford, 2005). One of the aspects that indicate teachers' professional identities is their chosen attire (Moore & Hofman, 1988).

Because the responsibilities and work environments of teachers not teaching agricultural subjects can differ from those who do teach agricultural subjects, others' expectations of teachers, including what they wear when working, may differ as well. However, the role of their attire in shaping others' impressions of them and their programs is very similar. Gordon (2010) found that 94% of career and technical education supervisors believed that "attire does affect the professionalism of secondary teachers" (p. 55). The differences between the roles and settings of

agriculture and non-agriculture teachers (and potential differences in sartorial choices of agriculture and non-agriculture teachers based on these differing roles and settings), paired with the similar influence attire has on how these teachers are viewed by others, led Gorman (2010) to call for research regarding career and technical education teachers' attire and its influence on others' impressions of them and their programs.

Approximately 3,443 school based agriculture programs across the nation employ multiple agriculture teachers (J. B. Bledsoe, personal communication, September 30, 2016), suggesting their individual attire both influences teachers' impressions of one another, and influences others' perceptions of both the individual teachers and the collective agriculture program (Damhorst et al., 2005; Freeburg & Workman, 2009). Serving as one another's coworkers, the professional identities of teachers within multi-teacher agriculture programs play a vital role in the program's social environment (Schneider, 1987). Further, teachers choose whether to welcome others in to their social environments, work or otherwise, based on how they perceive the new-comer's wardrobe choices (Damhorst, et al., 2005). Because both the culture of the multi-teacher agriculture program and the impression others get of the program depend on the ability for the agriculture teachers to participate in a shared professional community, and teachers' initial willingness to participate in that shared professional community is influenced by the sartorial choices of the other agriculture teachers, research is needed to investigate how teachers perceive the attire of other agriculture teachers working within the same agriculture program.

### **Theoretical Framework**

The theoretical framework of this study is based on the expectancy violations theory (EVT) (Burgoon, 1993) and its role on teachers' participation within shared professional communities (Darling-Hammond & Bransford, 2005). Expectancy violations theory asserts that cultural norms establish expected interpersonal communication patterns, and that violations to these expectations draw attention due to their novelty (Dunbar & Segrin, 2012). Violations can be viewed positively or negatively, and shape how individuals perceive other aspects of the individual's message. For example, Morris, Gorham, Cohen, & Huffman (1996) found that college students viewed instructors wearing professional attire as more competent than more informally dressed instructors, while Gille-Knauf & Mittag (2008) found that provocatively dressed female undergraduates in female-dominated majors were viewed as less intelligent than their more conservatively dressed counterparts.

Expectancy violations theory requires that societal norms are established; alternative actions are only in violation of expectations of those expectations are established. Societal norms for teacher attire have been established with the United States. The majority of school dress codes specifically prohibit attire that would be considered inappropriate for the roles of the educator, and while an exact definition of inappropriate dress has not been agreed upon, media materials have labeled casual attire, articles that are sexually revealing, or attire that violates conventional norms as inappropriate for teachers (Workman & Freeburg, 2010).

One of the six commonplaces shared by all professions, including that of the teacher, is "the development of a professional community that aggregates and shares knowledge and develops professional standards" (Shulman, 1998, p. 516). Participation within the shared professional community requires the sharing of teachers' professional identities (Dillabough, 1999). While no uniform definition of professional identity exists, it generally refers to the constantly evolving

views of teachers' concepts of self and roles as teachers (Biejaard, Meijer, & Verloop, 2004). Volkmann and Anderson (1998) described professional identity as "a complex and dynamic equilibrium where professional self-image is balanced with a variety of roles teachers feel that they have to play" (Biejaard et al., 2004, p. 113). Teachers' "images of self strongly determine the way teachers teach, the way they develop as teachers, and their attitudes toward educational changes (Biejaard et al., 2004, p. 108). Professional identity is also shaped by how teachers are portrayed in society and societal expectations regarding teachers' behavior (Tickle, 2000), as well as by interactions with peers and other professionals (Dillabough, 1999). Researchers generally agree that multiple versions of personal, professional, and institutional sub-identity can conflict or align with one another as they evolve through self-reflection and social interaction (Biejaard et al., 2004; Dillabough, 1999; Mishler, 1999; Roberts, 2000); Mishler (1999) likened one's professional identity to a chorus of voices rather than one voice. As those sub-identities evolve to align to a greater degree, the chorus becomes more harmonious (Biejaard et al., 2004).

As teachers interact with their professional communities, their professional identities are displayed to one another via all manners of interpersonal communication (Schneider, 1987). However, in order for these networks to be beneficial, there is a primitive need for acceptance amongst the members, and wardrobe choice plays a substantial role in that social process (Damhorst et al., 2005). The ease with which teachers interact within these professional communities relies on their perceptions of one another's alignment with or violations from their own expectations of the agriculture teacher, which are largely shaped by society. With regard to teacher attire, Workman and Freeburg (2010) summarized the tenets of EVT and professional identity by stating, "Theoretically, dress can express role embracement or role distance" (p. 10). Therefore, according to EVT and its role within the professional identity of teachers, agriculture teachers whose attire aligns with the expectations of teacher attire or whose attire violates those expectations in a positively viewed manner should find themselves more easily welcomed into the professional community of the multi-teacher agriculture program.

### **Conceptual Framework**

Teachers' sartorial choices make up part of their professional identities (Schneider, 1987), but those choices are also influenced by other aspects of their identities, such as age (Biejaard, Verloop, & Vermunt, 2000), gender (Prakash, 1992; Stokburger-Sauer & Teichmann, 2011), and community expectations (Duffee & Aikenhead, 1992). Biejaard et al. (2000) found that older, experienced teachers viewed their own professional identities as different from their original professional identities as younger, beginning teachers. The role of clothing in expressing one's professional identity remains constant throughout one's career; however, how individuals use clothing to mediate between the social world and the ageing body (Twigg, 2007). According to Twigg (2007), "At an individual level, people come to recognize their own ageing through changes in bodily appearance, and these changes are reflected, or resisted, in clothing choices" (p. 290). As the baby boomer generation ages, it leaves in the teaching profession a workforce with an average age of 43 years (Goldring, Gray, & Bitterman, 2013), which influences the ways in which the sartorial choices of those entering the profession are viewed by established communities of older teachers.

Studies from decades past, when the nation's agricultural education jobs were largely dominated by men (Kelsey, 2006), reported that men were less interested in clothing, spent less money on clothing, and were less involved in shopping for clothing than women (Frith & Gleeson, 2004).

Craik (1994) stated that men made their sartorial choices based on comfort and fit rather than on style. However, shifts toward a greater focus on style in menswear (Frith & Gleeson, 2004) and the increase of women being employed as agriculture teachers (Whittington & Raven, 1995) suggest that clothing choices may be more heavily considered by today's agriculture teachers than they were in the past. Generally, females have been shown to define their identity in accordance with their environment and through interaction with other individuals while men generally show an individualistic character of autonomy and independence (Stokburger-Sauer & Teichmann, 2011, p. 890). While these positions suggest that women may be more apt to consider how his or her sartorial choices will influence their interactions with others, studies focusing on human attraction have found that while women do use clothing as a way of displaying physical beauty, men use clothing to display economic achievement (Griskevicius et al., 2007).

Numerous studies have displayed the influences of sartorial choices on a variety of variables in academic settings. Dunbar and Segrin (2012) and Butler and Roesel (1991) found that formally dressed high school teachers were perceived as more credible by students than those who dressed informally. However, that same formal attire has also led to decreased perceptions of likability and approachability (Morris et al., 1996). However, Hayden, Loftin, Howard, and Shoulders (2016) found that students held agriculture teachers to different standards with regard to attire and posited that "agriculture students' expectations of agriculture teachers differ from their expectations of traditional teachers, causing them to view the agriculture teacher dressed in the attire expected for a traditional teacher as a violation of their expectations" (p. 337). Their findings aligned with others from research in physical education, which led researchers to recommend clothing that aligns with the occupational characteristics and skills expected of a leader within that occupation (Gordon, 2010). These conflicting expectations between the social norms of teacher attire and the occupational attributes expected of the agriculture teacher must be explored in order to ascertain how clothing influences teacher's success within the professional culture of the school based agriculture program.

### **Purpose**

The purpose of this study was to describe the association between agriculture teachers' demographic attributes and their selection of preferred teaching partners based on attire. The following objectives guided the study:

1. Describe participants' genders, ages, geographic locations, and community types.
2. Describe the frequency with which participants selected teaching partners displaying specific demographic characteristics and types of attire.
3. Describe the associations between participants' demographic characteristics and the demographic characteristics of their selections of preferred teaching partners.
4. Describe the associations between participants' demographic characteristics and the attire of their selections of preferred teaching partners.

### **Methods**

This study used a correlational design to describe the relationship between agriculture teachers' demographic characteristics and their selections of preferred teaching partners. We collected data over a two-day period using via a convenience sample at the 2015 National FFA Convention exposition. The exposition features booths and exhibits from universities, companies, and



organizations across the nation, and draws the attendance of “thousands of [FFA] advisors (National FFA Organization, 2016, para. 1). Teachers were recruited as they passed the study booth, which was located in a central area of the exposition center. Once their roles as current agriculture teachers were confirmed, participants were each given a response form on which they indicated their gender, age, and zip code. Participants were asked to complete the response form and then were verbally given a scenario in which they were able to hire an additional agriculture teacher for their current program. On the table in front of the participants, boxes presenting images of the potential teaching partners were displayed. Participants were instructed to view each of the potential teaching partners and place their response forms in the box displaying the teacher they would prefer to work with in their agriculture program. Following the procedures of Morris et al. (1996), we displayed headless images of trained confederates of different ages (20s and 40s) and genders (male and female) dressed in two categories of attire. Sartorial categories included business casual (dress shirt or blouse, dress slacks or skirt, dress shoes), or casual (polo shirt or plain shirt, jeans or khakis, and boots or shoes) (Morris et al., 1996) (see Table 1). Attire categories were evaluated for validity by an expert in apparel merchandizing.

Table 1  
*Teacher Confederates and Their Attire*

<b>Photograph Identification</b>	<b>Gender</b>	<b>Age</b>	<b>Attire</b>
<b>A</b>	Female	20s	Casual
<b>B</b>	Male	40s	Business Casual
<b>C</b>	Female	40s	Casual
<b>D</b>	Male	20s	Casual
<b>E</b>	Female	40s	Business Casual
<b>F</b>	Male	20s	Business Casual
<b>G</b>	Female	20s	Business Casual
<b>H</b>	Male	40s	Casual

Each confederate was instructed to maintain a neutral stance. Images of confederates were displayed on white backgrounds for consistency. Boxes on which confederates’ images were displayed were opaque with small holes for response submissions, preventing participants from viewing other participants’ selections. (see Figure 1).



Figure 1. Participants selected their preferred teacher by placing their response forms in the corresponding box.

Data was analyzed using SPSS v. 22. Participants' demographic characteristics and selections of preferred teachers were analyzed via descriptive statistics, including means, standard deviations, and frequencies. Rural-Urban Continuum Codes were utilized to identify the community type of each respondents' provided zip code (United States Department of Agriculture, 2012). While 9 community types are recognized by the Rural-Urban Continuum Codes, for ease of analysis, we condensed codes to indicate urban (codes 1-3), micropolitan (codes 4-6), and rural (codes 7-9). The magnitude of any relationships between participants' characteristics and their selections were analyzed using Cramer's V ( $\phi_c$ ), which measures "the strength of association between two categorical variables" (Field, 2006, p. 695). While Cramer's V is calculated following chi-square analysis, which tests for statistical significance of an association between categorical variables (Field, 2006), the convenience sample used for this study limits findings to the sample. Inferential statistics such as the chi-square analysis are inappropriate when findings are not intended to be generalized to a larger population; therefore, results of the chi-square analyses are not reported. Results of each Cramer's V were interpreted using Cohen's (1988) guidelines, wherein small effect sizes are those of 0.1, medium effect sizes are those of 0.3, and large effect sizes are those of 0.5.

## Results

The first objective sought to describe participants' genders, ages, geographic locations, and community types (Table 2). Responses were received from 400 agriculture teachers during the two-day data collection period.

Table 2  
*Participants' Demographics*

Characteristic	<i>f</i>	%
Gender		
male	262	65.5
female	138	34.5
Age		
20-29	115	28.8
30-39	129	32.3
40-49	98	24.5
50-59	56	14.0
≥60	12	3.0
NAAE Region		
I	39	9.8
II	84	21.0
III	74	18.5
IV	123	30.8
V	52	13.0
VI	26	6.5
Community Type		
Urban	146	36.5
Micro	75	18.8
Rural	173	43.3

Nearly two-thirds (65.5%) of participants were male, while 61% were under 40 years of age. All six regions of the National Association of Agricultural Educators (NAAE) was represented, with Region IV being represented to the greatest degree (30.8%) and Region VI being represented to the least degree (6.5%). Teachers most frequently taught in rural communities (43.3%) and least frequently taught in micropolitans (18.8%).

The second objective sought to describe the frequency with which participants selected teaching partners displaying specific demographic characteristics and types of attire. Male teachers were selected by 75.8% of all participants ( $n = 303$ ), while females were only selected by 24.3% of participants ( $n = 97$ ). Younger (those appearing to be in their twenties) teachers were selected by 62.8% of the respondents ( $n = 251$ ), while older teachers (those appearing to be in their forties) were selected by 37.3% of the respondents ( $n = 149$ ). Nearly half (48.5%) of the participants selected teaching partners wearing business casual attire ( $n = 194$ ), while 51.5% of the participants selected teaching partners wearing casual attire ( $n = 206$ ). The most frequently selected teacher was the younger male dressed in casual attire ( $n = 89$ ), while the least frequently selected teacher was the older female dressed in casual attire ( $n = 3$ ). It should be noted that tall male confederates were selected more frequently than female confederates (Table 3).

Table 3  
*Confederates selected as preferred teaching partners*

<b>Confederate</b>	<b><i>f</i></b>	<b>%</b>
<b>Younger, male, casual</b>	89	22.3
<b>Older, male, business casual</b>	75	18.8
<b>Younger, male, business casual</b>	73	18.3
<b>Older, male, casual</b>	66	16.5
<b>Younger, female, casual</b>	48	12.0
<b>Younger, female, business casual</b>	41	10.3
<b>Older, female, business casual</b>	5	1.3
<b>Older, female, casual</b>	3	0.8

The third objective sought to describe the associations between participants' demographic characteristics and the demographic characteristics of their selections of preferred teaching partners (Table 4).

Table 4  
*Strength of Associations Between Participant and Selected Confederate Variables*

<b>Association</b>	<b><math>\phi_c</math></b>	<b>Interpretation (Cohen, 1988)</b>
<b>Participant Gender*Confederate Age</b>	.146	Small
<b>Participant NAAE Region*Confederate Gender</b>	.112	Small
<b>Participant Gender*Confederate Gender</b>	.105	Small
<b>Participant NAAE Region*Confederate Age</b>	.097	Negligible
<b>Participant Age*Confederate Age</b>	.089	Negligible
<b>Participant Age*Confederate Gender</b>	.075	Negligible
<b>Participant Community*Confederate Gender</b>	.069	Negligible
<b>Participant Community*Confederate Age</b>	.044	Negligible

The gender of participants was associated with the selected confederates' age and gender to a small degree. Seventy-three percent of the female participants chose younger confederates, while 58% of the male participants chose younger confederates. Seventy-nine percent of the male participants ( $n = 207$ ) and 70% of the female participants ( $n = 42$ ) selected male confederates. A small association was also found between the NAAE region in which the participants' taught and the gender of their selected teachers (Table 5). Male teachers were chosen by the majority of respondents in all NAAE regions.

Table 5  
*Frequency of Selection of Male Teaching Partners by Participants' NAAE Region*

Participants' NAAE Region	<i>f</i>	%
<b>I</b>	29	74.4
<b>II</b>	68	88.3
<b>III</b>	50	67.6
<b>IV</b>	91	74.0
<b>V</b>	38	73.1
<b>VI</b>	21	80.8

The fourth objective sought to describe the associations between participants' demographic characteristics and the attire of their selections of preferred teaching partners. Cramer's V scores indicated negligible relationships between participants' gender and the attire of their selected teaching partners ( $\phi_c = .062$ ), participants' age and the attire of their selected teaching partners ( $\phi_c = .021$ ), and participants' community type and the attire of their selected teaching partners ( $\phi_c = .064$ ).

Males selected confederates dressed in business casual attire 50.8% of the time ( $n = 133$ ), while females selected confederates dressed in business casual attire 43.5% of the time ( $n = 60$ ). Between 47% and 48.5% of participants under 29 years of age, between 30 and 49 years of age, and aged 50 and over selected confederates dressed in business casual attire. Urban participants selected teaching partners dressed in business casual attire 52.7% of the time ( $n = 77$ ), while similarly dressed confederates were selected by metropolitan participants 43.4% of the time ( $n = 33$ ) and by rural participants 46.33% of the time ( $n = 81$ ). A small relationship was found between the NAAE region in which participants taught and the attire of their selected teaching partners ( $\phi_c = .114$ ) (Table 6).

Table 6  
*Frequency of Selection of Teaching Partners Dressed in Business Casual Attire by Participants' NAAE Region*

Participants' NAAE Region	<i>f</i>	%
<b>I</b>	17	43.6
<b>II</b>	39	46.4
<b>III</b>	32	43.2
<b>IV</b>	69	56.1
<b>V</b>	21	42.0
<b>VI</b>	11	42.3

Teachers from Region IV selected confederates dressed in business casual attire at least 10% more than any other region. Teachers from Region V selected these more professionally dressed confederates least frequently.

### **Conclusions/Implications/Recommendations**

Results from this study yielded an overwhelming preference for male teachers; 75.8% of participants selected male confederates. While more male participants than female participants selected male teaching partners, over half of both genders preferred male teaching partners. The profession of school-based agricultural education used to be dominated by males, but shifts in recent decades has led to growth in the number of females employed as agriculture teachers (Whittington & Raven, 1995). With preservice teacher programs reporting a female demographic of up to 64% (Foster, Lawver, & Smith, 2015), further research must be conducted to better understand why both male and female agriculture teachers within this sample prefer to work alongside a male. The tenets of EVT may suggest that males align more with society's expectations of the agriculture teacher, as has been seen historically (Kelsey, 2006; Whittington & Raven, 1995).

Additionally, a small relationship was found between participant gender and confederate age, with female participants selecting younger confederates at a higher rate than their male counterparts. This relationship was stronger than that between participant age and confederate age. As the nation continues to experience a shortage of agriculture teachers and seeks ways to recruit more high school graduates to enroll in postsecondary agricultural education programs, recruiters can assure younger graduates of the ease with which they can integrate into professional communities who are eager to welcome them. However, further research should be conducted to explore reasons for female participants' preference of younger teachers more than their male counterparts, as mid-career moves are common among millennials (Arthur & Rousseau, 1996). Perhaps females feel the tension of holding employment within a traditionally male-dominated profession, and perceive younger teaching partners as more accepting of their roles as leaders in the agriculture program. While we offer this as a possible hypothesis, qualitative research could provide a more thorough investigation of this phenomenon.

When given the opportunity to select a teaching partner from a selection of older and younger male and female confederates dressed in business casual or casual attire, little difference was seen between selection of confederates based on clothing; slightly over half of the participants (51.5%) selected teachers dressed in casual attire, while slightly under half (48.5%) selected teachers dressed in business casual attire. This 3% difference implies that when selecting between teaching partners that were dressed in business casual and casual attire, respondents as a whole did not value one style over another to any substantial degree. Similar results regarding teachers' credibility based on clothing by Dunbar and Segrin (2012) concluded that there was no significant difference between teachers who dressed moderately and those who dressed formally. However, business casual and casual attire are only two styles of clothing, and they fall toward the center of the continuum of clothings' level of professionalism. Further research should be conducted to determine whether teachers value these two more moderate styles of clothing over those more casual or more professional, as was seen from students in Hayden et al.'s (2016) study.

Every teacher, regardless of subject taught, has the ability to portray their professional identity through their daily sartorial choices. Simmons echoed this point, stating, “Without question, dress sends a strong message about who teachers are as individuals and as professionals” (1996, p. 298). This study provided a glimpse into the expectation of attire and physical attributes that agriculture teachers hold of their teaching partners. While teachers should be encouraged to consider attire when both developing their professional identities as preservice teachers and as they seek to display that identity to others when teaching, this study holds greater value in providing a starting point for future research in how agriculture teachers shape their own professional identities, and how those identities interact with others’ identities to shape their agriculture programs.

### References

- Arthur, M. B., & Rousseau, D. M. (1996). *The boundaryless career*. Oxford University Press.
- Biejaard, D., Meijer, P. C., & Verloop, N. (2004). Reconsidering research on teachers’ professional identity. *Teaching and Teacher Education, 20*, 107-128.
- Biejaard, D., Verloop, N., & Vermunt, J. D. (2000). Teachers’ perceptions of professional identity: An exploratory study from a personal knowledge perspective. *Teaching and Teacher Education, 16*, 749-764.
- Burgoon, J. K. (1993). Interpersonal expectations, expectancy violations, and emotional communication. *Journal of Language and Social Psychology, 12*(1-2), 30-48.
- Butler, S., & Roesel, K. (1991). Students’ perceptions of male teachers: Effects of teachers’ dress and students’ characteristics. *Perceptual and Motor Skills, 73*(3), 943-951.
- Cohen, J. (1988). *Statistical power analysis for the behavioral sciences* (2<sup>nd</sup> ed.). Hillsdale, NJ: Lawrence Erlbaum Associates.
- Craik, I. (1994). *The face of fashion: Cultural studies in fashion*. New York, NY: Routledge.
- Damhorst, M. (1990). In search of a common thread: Classification of information communicated through dress. *Clothing and Textiles Research Journal, 8*(2), 1-12.
- Damhorst, M. L., Miller-Spillman, K., Michelman, S. (2005). *The meanings of dress*. (2<sup>nd</sup> ed.) New York, NY: Fairchild.
- Darling-Hammond, L. & Bransford, J. (Eds.). (2005). *Preparing teachers for a changing world*. San Francisco, CA: Jossey Bass.
- Dillabough, J. A. (1999). Gender politics and conceptions of the modern teacher: Women, identity and professionalism. *British Journal of Sociology of Education, 20*(3), 373-394.

- Dunbar, N., & Segrin, C. (2012). Clothing and teacher credibility: An application of expectancy violations theory. *ISRN Education*, 2012, 1-12. doi: 10.5402/2012/140517
- Duffee, L., & Aikenhead, G. (1992). Curriculum change, student evaluation, and teachers practical knowledge. *Science Education*, 76, 493-506.
- Field, A. (2006). *Discovering statistics using IBM SPSS Statistics*. (4<sup>th</sup> ed.). Thousand Oaks, CA: SAGE.
- Foster, D. D., Lawver, R. G., & Smith, A. R. (2015). National agricultural education supply & demand study. Retrieved from <http://www.naae.org/teachag/NSD%20ES%20Final%20March%202015%20.pdf>.
- Freeburg, B. W., & Workman, J. E. (2009). A method to identify and validate social norms related to dress. *Clothing and Textiles Research Journal*, 28(1). doi: 10.1177/0887302X08327452
- Frith, H., & Gleeson, K. (2004). Clothing and embodiment: Men managing body image and appearance. *Psychology of Men & Masculinity*, 5(1), 40-48. doi: 10.1037/1524-9220.5.1.40
- Gille-Knauf, T. R., & Mittag, R. M. (2008). Smart and sexy? Major and clothing's influence on perceptions of intelligence. *UW-L Journal of Undergraduate Research*, 11. Retrieved from [https://www.uwlax.edu/urc/jur-online/PDF/2008/gille-knauf\\_mittag.pdf](https://www.uwlax.edu/urc/jur-online/PDF/2008/gille-knauf_mittag.pdf).
- Goldring, R. Gray, L., & Bitterman, A. (2013). *Characteristics of public and private elementary and secondary school teachers in the United States* (NCES Report No. 2013-314). Retrieved from the National Center for Education Statistics website: <http://files.eric.ed.gov/fulltext/ED544178.pdf>.
- Gordon, H. (2010). Career and technical education administrators' perceptions of secondary teachers' attire as indicated by selected professional attributes. *Journal of Career and Technical Education*, 25(1) 47-61.
- Gordon, W. I., Tengler, C. D., & Infante, D. A. (1982). Women's clothing perceptions as predictors of dress at work, job satisfaction, and career advancement. *Southern Speech Communication Journal*, 47, 422-434.
- Griskevicius, V., Tybur, J.M., Sundie, J.M., Cialdini, R.B., Miller, G.F., Kenrick, D.T. Blatant benevolence and conspicuous consumption: When romantic motives elicit strategic costly signals. *Journal of Personality and Social Psychology*, 93(1), 85-102.
- Hayden, A., Loftin, A., Howard, C., Shoulders, C. W. (2016). What not to wear: an exploration of how attire shapes high school students' perceptions of agriculture. [Abstract]. *American Association of Agricultural Education*, 335-338.

- Hyslop-Margison, E. J. (2000). The market economy discourse on education: Interpretation, impact, and resistance. *Alberta Journal of Educational Research*, 46(3). Retrieved from <http://ajer.journalhosting.ucalgary.ca/index.php/ajer/article/view/212>.
- Kelsey, K. D. (2006). A case study of women's experiences in a preservice teacher preparation program. *Journal of Agricultural Education*, 47(4), 123. doi: 10.5032/jae.2006.04123
- Mishler, E. G. (1999). *Storylines: Craft artists' narratives of identity*. Cambridge, MA: Harvard University Press.
- Moore, M., & Hofman, J. E. (1988). Professional identity in institutions of higher learning in Israel. *Higher Education*, 17(1). 69-79.
- Morris, T., Gorham, J., Cohen, S., & Huffman, D. (1996). Fashion in the classroom: Effects of attire on student perceptions of instructors in college classes. *Communication Education*, 45(2), 135-148.
- National FFA Organization. (2016). Exhibit in Indianapolis: Why exhibit. Retrieved from <https://www.ffa.org/events/conventionandexpo/expo>.
- Phipps, L. J., Osborne, E. W., Dyer, J. E., & Ball, A. (2008). *Handbook on agricultural education in public schools*. Clifton Park, NY: Thompson Delmar Learning.
- Prakash, V. Sex roles and advertising preferences. *Journal of Advertising Research*, 32(3), 43-52.
- Schneider, B. (1987). The people make the place. *Personnel Psychology*, 40(3), 437-453.
- Shoulders, C. W., & Myers, B. E. (2012). Teachers' use of agricultural laboratories in secondary agricultural education. *Journal of Agricultural Education*, 53(2), 124-138. doi: 10.5032/jae.212.02124
- Shulman, L. (1998). Theory, practice and the education of professionals. *The Elementary School Journal*, 98(5), 511-526.
- Simmons, B. J. (1996). Teachers should dress for success. *The Clearing House*, 69(5), 297-298.
- Stokburger-Sauer, N. E., & Teichmann, K. (2011). Is luxury just a female thing? The role of gender in luxury brand consumption. *Journal of Business Research*, 66, 889-896. doi: 10.1016/j.jbusres.2011.12.007
- Terry, R. & Briers, G. E. (2010). Roles of the secondary agriculture teacher. In R. M. Torres, T. Kitchel, & A. L. Ball (Eds.), *Preparing and advancing teachers in agricultural education* (pp. 87-98) Columbus, OH: The Ohio State University.
- Tickle, L. (2000). *Sources of the self: The making of the modern identity*. Cambridge, MA:



Harvard University Press.

Twigg, J. (2007). Clothing, age and the body: A critical review. *Ageing & Society*, 27, 285-305. doi: 10.1017/S0144686X06005794

United States Department of Agriculture, Economic Research Service [USDA-ERS]. (2012). Identifying nine rural definitions. Retrieved from <http://www.ers.usda.gov/data-products/rural-definitions/data-documentation-and-methods.aspx>.

Volkman, M. J., & Anderson, M. A. (1998). Creating professional identity: Dilemmas and metaphors of a first-year chemistry teacher. *Science Education*, 82(3), 293-310.

Whittington, S. M., & Raven, M. R. (1995). Learning and teaching styles of student teachers in the northwest. *Journal of Agricultural Education*, 36(4), 10-17. doi: 10/5032/jae.1995.04010

Workman, J. E., & Freeburg, B. W. (2010). Teacher dress codes in employee handbooks: An analysis. *Journal of Family and Consumer Sciences*, 102(3), 9.

## Designing an International Experience Program for Louisiana 4-H Members

Shelli E. Danjean, Louisiana State University

Melissa Cater, Louisiana State University

J.C. Bunch, University of Florida

### Abstract

*As the U.S agriculture sector is now more globally interdependent than before, the mission of U.S Cooperative Extension has evolved to include an international component. Moreover, international awareness has been identified as an integral component of appropriate Extension outreach services and activities. In order to develop a global perspective among students from an early age, the U.S CEP has worked to establish international exchange programs (IEPs), such as the International 4-H Youth Exchange Program and States' 4-H International Exchange Program, in some states. The purpose of this descriptive study was to identify the perceptions and preferences held by Louisiana 4-H members toward participation in an IEP. 4-H members perceived IEPs as at least somewhat important, and they preferred to participate in a short-term IEP during the 11th grade or post high school. As such, recommendations for practice include gearing IEP recruitment toward 4-H members in the 9th and 10th grades. Moreover, they preferred this program to be held during the summer months in Europe or Australia/New Zealand. Considering the wide array of possible IEP locations, future research should examine the specific characteristics of Europe or Australia/New Zealand that appeal to 4-H members. A study of this nature may aid Extension personnel in attracting 4-H members to IEPs in other locations. Important activities to include in the IEP design included courses related to their career interest and acquiring hands-on experience. However, 4-H members did not perceive staying with a host family as important. As 4-H exchange programs are often designed to include host families, this study should be conducted with 4-H members in other states to assess whether this finding is specific to 4-H members in this study, or if it represents a national trend that warrants reexamination of the overall design of international 4-H programs employed by U.S CEP.*

Keywords: 4-H members, international experience program (IEP), program design

### Introduction

As a result of globalization, local and global realities have become intertwined (Baker & LeTendre, 2005; Lechner & Boli, 2015). While globalization may not directly and exclusively determine local circumstance, Lechner & Boli (2015) maintained that world societies continue to integrate as individuals become conscious of their participation in global networks and how those networks are influenced by global forces. Moreover, even if national members are not yet aware of the larger structures in place, “their everyday lives are nevertheless embedded in a global culture that transcends their village, town or country, and that becomes part of individual and collective identities” (Lechner & Boli, 2015, p. 2). Reflective of this common knowledge and collective identities across regions, is the emergence of international institutions in all areas

of human activity (Lechner & Boli, 2015). While education may be viewed by some as being solely a national undertaking, Baker and LeTendre (2005) maintained that this image is largely inaccurate. In reality, globalization has altered the fabric of education and demanded the integration of a global aspect into the curricula (Baker & LeTendre, 2005; USDE, 2012).

As the U.S agriculture sector is now more globally interdependent than before (Lewis & Gibson, 2008), agricultural and Extension education must be modeled to meet the demands of a globalized world and prepare clientele for participating as members of a global society (Akpan & Martin, 1996; Ludwig & McGirr, 2003). Regarding the role of U.S Cooperative Extension, Ludwig (2001) noted that Extension's mission will continue to be influenced by internationalization. Additionally, Etling, Reaman and Sawi (1993) maintained that Extension faculty and personnel must be cognizant of the relationship between Extension's mission and the international issues at hand. Moreover, the National Association of State Universities and Land Grant Colleges (NASULGC) put forth the rationale for including international awareness as an integral component of appropriate Extension outreach services and activities (NASULGC, 2004). As such, Extension educators need not only recognize the role of Extension in the international arena, but they must put forth significant efforts to incorporate an international component into their programming (Bates, 2006; Ludwig, 1995).

International cooperation has been largely considered a facilitator of internationalization among institutions and organizations (Arnold, Davis, & Corliss, 2014; Boyd et al., 2001; Odell, Williams, Lawrence, Gartin, & Smith, 2002; USDE, 2012). The U.S. Cooperative Extension Program (CEP) has worked to internationalize programming by way of establishing partnerships with international organizations to conduct overseas development projects, and employ 4-H youth outbound exchange programs and programs to host international guests (Ludwig & McGirr, 2003; Major & Miller, 2012). International experience programs (IEPs), such as the International 4-H Youth Exchange Program (IFYE) and States' 4-H International Exchange Program, have been established in some states as a means of developing a global perspective among 4-H members early on in their educational experience (Boyd et al., 2001; Ingram, Smith-Hollins, & Radhakrishna, 2009; Odell et al., 2002). Prior research supports the notion that IEPs supplement the overall internationalization of Extension, as well as offer a variety of benefits to 4-H members who participate. In prior studies, 4-H members who participated in an IEP (a) demonstrated a more developed global perspective and awareness of world issues, (b) developed greater levels of self-confidence and awareness of self-purpose, (c) were more willing to immerse themselves in another culture, as well as able to do so with greater ease, (d) had a greater interest in pursuing an internationally focused career and (e) continued to travel internationally following their initial IEP participation (Arnold et al., 2014; Boyd et al., 2001; Ingram et al., 2009; Odell et al., 2002). Additionally, as youth have been acknowledged as having the ability to evoke change within their surrounding community (Major & Miller, 2012; Olberding & Olberding, 2010), enhancing youth's global perspective could produce a ripple effect of international awareness and acceptance among family, friends, and community (Boyd et al., 2001; Olberding & Olberding, 2010). In a study by Boyd et al. (2001), 4-H youth who participated in an IEP reported that they believed their family and friends gained global awareness as a result of their participation in the program. Moreover, Boyd et al. (2001) conducted a survey with the family and friends of the IEP participants and found that the close

persons of the 4-H IEP participants not only perceived the IEP as being beneficial to the 4-H member, but also perceived it as being indirectly beneficial to them personally.

While much of the existing literature has examined the outcomes and possible benefits of IEPs for 4-H members, little research has been conducted to examine the IEP perceptions and participation preferences held by 4-H members. If such programs are to be successful, they must be developed to appeal to the target population (Ivy, 2008). In a study conducted to examine IEP destination choices as part of a marketing strategy, Kavakas (2013) found the IEP itself and the skills and experiences gained while participating were important marketing components. Moreover, the attractiveness of a country was among the most important elements influencing students' IEP destination choice (Kavakas, 2013). As such, identifying which countries and activities are most appealing and important to Louisiana 4-H members can aid Extension personnel in developing marketable IEPs for 4-H members. Lastly, the logistical considerations associated with an IEP can influence students' participation. Logistical considerations, such as time of year to participate, duration of program, and academic level for participating (Bunch, Blackburn, Danjean, Stair, Blanchard, 2015; Danjean, Bunch, & Blackburn, 2015) may influence 4-H members' decision to participate in a particular IEP. Prior studies to examine these preferences have been conducted among college student populations, but not among 4-H members. As such, this study was conducted to examine 4-H members' IEP perceptions and participation preferences as part of the initial phase in implementing an IEP for 4-H youth in Louisiana.

### **Purpose and Objectives**

This study was conducted as part of a larger study. The purpose of this descriptive study was to examine the perceptions and preferences held by 4-H members toward participation in an international experience program. The following objectives guided this study:

1. Describe 4-H members' perceptions of the importance of participating in an IEP.
2. Describe 4-H members' IEP logistical preferences including time of year to participate, program length, and academic level during which to participate in an IEP.
3. Describe 4-H members' preference of location(s) as destinations for an IEP.
4. Describe 4-H members' IEP design preferences in terms of importance of inclusion of select activities as part of the IEP.

### **Methods**

#### **Population and Sample**

The target population for this study ( $N = 789$ ) consisted of all 4-H members who attended a three-day summer conference at Louisiana State University. Completed instruments were collected from 628 of the 789 4-H members in attendance, which yielded an 80% response rate. Most the 4-H respondents were white ( $f = 485$ ; 77.2%) females ( $f = 389$ ; 61.9%) with an average age of 15 ( $SD = 1.54$ ) and an academic grade level ranging from 7 to 12. Additionally, most the 4-H respondents grew up on a farm or in a rural area ( $f = 269$ ; 42.8%) and were not fluent in a language other than English ( $f = 552$ ; 87.9%).

## **Instrumentation**

Items were modified from questionnaires by Bunch, Lamm, Israel, and Edwards (2013) and Reiger (n.d) to develop an instrument to assess 4-H members' IEP participation preferences (Blinded authors, in press). To ensure face and content validity, an expert panel with collective proficiencies in 4-H youth development, international program development, and instrument development reviewed the questionnaire. The panel deemed the instrument acceptable.

For the purpose of this study, only four sections of the instrument were used. The first section of the instrument was designed to measure 4-H members' perceived level of importance concerning participation in an IEP. In this section, responses were measured using a four-point Likert-type scale (1 = *not at all important*, 2 = *not very important*, 3 = *somewhat important*, and 4 = *very important*). The second section of the instrument was designed to measure 4-H youth members' logistical preferences for participating in an IEP, including (a) time of year to participate, (b) program length, and (c) academic level during which to participate (see table 2 for response categories). The third section was used to identify 4-H youth members' preference of select location(s) as possible destinations for an an IEP. In this section, participants were asked to rate the appeal of nine locations on a four-point Likert-scale (1 = *not at all appealing*, 2 = *somewhat unappealing*, 3 = *somewhat appealing*, 4 = *very appealing*). The fourth section of the instrument was utilized to identify 4-H members' IEP design preferences. In this section, participants were asked to indicate the importance of the inclusion of select activities as part of an IEP (i.e., in-field lectures/labs, participating in field research, acquiring hands-on experience and skills, etc.). Responses were measured using a four-point Likert-type scale (1 = *not at all important*, 2 = *somewhat unimportant*, 3 = *somewhat important*, and 4 = *very important*). Lastly, demographic items were used to describe the personal and educational characteristics of the population sample.

## **Data Collection**

The 4-H youth educators were given a data collection packet that included (a) data collection protocol, (b) hard copy instruments, (c) participants right to refuse protocol, (d) instructions on returning instruments to the researchers, and (e) a distribution checklist. The 4-H youth educators distributed hard copy questionnaires to 4-H youth participants during the final evening of the three-day summer conference and returned the completed instruments to the researchers. Parental consent for participation in this study was collected as part of the program enrollment process.

## **Data Analysis**

Data were analyzed using descriptive statistics. Nominal and ordinal data were analyzed using frequencies and percentages for objective two, while interval level data were computed using means and standard deviations for objectives one, three, and four.

## Findings

### Objective 1: Perceived importance of participating in an IEP

Objective one sought to describe 4-H members' perceived importance of participating in an IEP. More than 75% of the 4-H members perceived participating in an IEP as *somewhat important* ( $f = 287$ ; 45.7%) or *very important* ( $f = 230$ ; 36.6%). The remaining participants perceived IEPs as *not very important* ( $f = 58$ ; 9.2%) or *not important* ( $f = 53$ ; 8.4%).

### Objective 2: IEP logistical preferences

Objective two sought to describe 4-H members' preferences pertaining to the logistical factors associated with participating in an IEP. The specific factors examined included preferred academic level during which to participate in an IEP, time of year, and program length. More 4-H members identified the 11th grade ( $f = 139$ ; 22.7%) or post high school/in college ( $f = 118$ ; 19.3%) as the most suitable academic level during which to participate in an IEP, while fewer preferred to participate in an IEP during 12th grade ( $f = 77$ ; 12.6%) or 8th grade ( $f = 65$ ; 10.4%). Regarding time of year, more 4-H members ( $f = 246$ ; 39.7%) identified summer as the preferred time of year to participate in an IEP. Regarding IEP duration, more 4-H members identified 1-2 weeks ( $f = 219$ ; 35.2%) or 3-4 weeks ( $f = 209$ ; 33.6%) as the preferred length of an IEP, while the fewest 4-H members ( $f = 110$ ; 17.7%) preferred to participate in a 5-6 weeklong IEP. Lastly, some 4-H members ( $f = 84$ ; 13.5%) selected *none* as the ideal duration of an IEP (see Table =1).

Table 1.

*4-H Youth Members' Logistical Preferences for Participating in an IEP (N = 628)*

Variable	<i>f</i>	%
<b>Participation Preference: Academic Level<sup>a</sup></b>		
11th grade	139	22.7
Post high school/in college	118	19.3
9th grade	111	18.1
10th grade	102	16.7
12th grade	77	12.6
8th grade	65	10.6
<b>Participation Preference: Time of Year<sup>b</sup></b>		
Summer	246	39.7
Fall semester	202	32.6
Spring semester	171	27.6
<b>Participation Preference: Length of Program<sup>c</sup></b>		
1-2 weeks	219	35.2
3-4 weeks	209	33.6
5-6 weeks	110	17.7
None	84	13.5

*Note.*

<sup>a</sup> Responses missing from 16 study participants for this item

<sup>b</sup> Responses missing from 9 study participants for this item

<sup>c</sup> Responses missing from 6 study participants for this item

### Objective 3: IEP location preferences

Objective three was established to identify 4-H members' preferred location(s) as destinations for an IEP. In all, seven of the select locations were perceived by 4-H members as *somewhat appealing*, and three were perceived as *somewhat unappealing*. The locations with the highest means were Europe ( $M = 3.32$ ;  $SD = .99$ ) and Australia or New Zealand ( $M = 3.20$ ;  $SD = 1.04$ ). The locations with the lowest means were Asia (mainland) ( $M = 2.43$ ;  $SD = 1.07$ ), Southeast Asia ( $M = 2.39$ ;  $SD = 1.09$ ), and Africa ( $M = 2.28$ ;  $SD = 1.14$ ) (See Table 2).

Table 2.

*4-H Members' Perception of Appeal for Select IEP Locations*

Locations	<i>N</i>	<i>M</i>	<i>SD</i>	Interpretation
Europe	617	3.32	.99	Somewhat appealing
Australia or New Zealand	612	3.20	1.04	Somewhat appealing
North America	610	2.88	1.14	Somewhat appealing
South America	613	2.84	1.07	Somewhat appealing
South Pacific	618	2.79	1.07	Somewhat appealing
Central America	606	2.76	1.09	Somewhat appealing
India	596	2.60	1.12	Somewhat appealing
Asia (mainland)	612	2.43	1.07	Somewhat unappealing
Southeast Asia	614	2.39	1.09	Somewhat unappealing
Africa	618	2.28	1.14	Somewhat unappealing

*Note.* Real Limits – 1.00 to 1.49 = *Not at all appealing*; 1.50 to 2.49 = *Somewhat unappealing*; 2.50 to 3.49 = *Somewhat appealing*; and 3.50 to 4.00 = *Very Appealing*.

### Objective 4: IEP design preferences

Objective four sought to describe 4-H members' IEP design preferences in terms of the importance of inclusion of select activities and experiences while participating in an IEP. All activities were perceived by 4-H members as being *somewhat important* components to include in an IEP. The activities with the highest means were taking courses related to your career interests ( $M = 3.40$ ;  $SD = .89$ ), acquiring hands-on experience and skills ( $M = 3.37$ ;  $SD = .89$ ), learning about a different culture ( $M = 3.27$ ;  $SD = .91$ ), and free time to do what you want ( $M = 3.27$ ;  $SD = .93$ ). The activities with the lowest means were staying with a host family ( $M = 2.86$ ;  $SD = .1.00$ ), in-field lectures and labs ( $M = 2.78$ ;  $SD = 1.03$ ), and attending non-credit courses at foreign universities ( $M = 2.56$ ;  $SD = .95$ ) (see Table 3).

Table 3.

*4-H Members' Perception of Importance for IEP Design Components*

Activities	<i>N</i>	<i>M</i>	<i>SD</i>	Interpretation
Taking courses related to your career interests	612	3.40	.89	Somewhat important
Acquiring hands-on experience and skills	618	3.37	.89	Somewhat important

Learning about a different culture	621	3.27	.91	Somewhat important
Free time to do what you want	617	3.27	.93	Somewhat important
Traveling in a country	620	3.24	.92	Somewhat important
Sightseeing	619	3.23	.94	Somewhat important
Socializing with citizens of host country	618	3.22	.96	Somewhat important
Working one-on-one with professors and students	618	3.15	.97	Somewhat important
Speaking and learning host country language	614	3.15	.92	Somewhat important
Participating in field research	614	3.09	.94	Somewhat important
Staying with a host family	617	2.86	1.00	Somewhat important
In-field lectures and labs	620	2.78	1.03	Somewhat important
Attending non-credit courses at foreign universities	608	2.56	.95	Somewhat important

*Note.* Real Limits: 1.00 to 1.49 = *Not at all important*; 1.50 to 2.49 = *Somewhat unimportant*; 2.50 to 3.49 = *Somewhat important*; 3.50 to 4.00 = *Very important*.

## Conclusions

More than three-fourths of the Louisiana 4-H members who participated in this study perceived IEPs as at least somewhat important. If 4-H members were to participate in an IEP, they preferred to participate in a short-term IEP held during the summer of the 11th grade or post high school/in college. Additionally, they preferred that this IEP be located in either Europe or Australia/New Zealand. Regarding important activities to include in the design of an IEP, 4-H members identified all activities as at least somewhat important. The activities 4-H members perceived as most important were those that allowed them to take courses related to their career interest, acquire hands-on experience and skills, learn about a different culture, and have free time to do what they want. The IEP components 4-H members considered least important were staying with a host family, engaging in in-field lectures and labs, and attending non-credit courses at a foreign university.

As a census survey design was employed in this study, the results cannot be generalized beyond the scope of the population of the study. However, when considered alongside the prior literature, the findings of this study may provide some implications for agricultural and Extension faculty and personnel in Louisiana, as well as offer directions for future research and practice. Moreover, the trends observed in this study contribute to the limited body of literature pertaining to international programming for 4-H youth. Discussion of key conclusions, as well as recommendations for future research and practice, are provided in following section.

## Discussion and Recommendations

Based on the findings of this study, IEPs designed for 4-H members in Louisiana should be short-term programs (duration of no more than four weeks) held during the summer. This recommendation is further supported by findings in prior research conducted with other student populations. Bunch et al. (2015) and Danjean et al. (2015) examined the IEP participation preferences of College of Agriculture students and found that the majority of students preferred to participate in a short-term IEP held during the summer. Additionally, a nation-wide study



conducted by the Institute of International Education (2015) revealed that more students participated in short-term IEPs in the 2013-2014 academic year than traditional, long-term programs. While most of the 4-H members preferred to participate in a short-term IEP, it should be noted that some selected “none” as the ideal length of an IEP. This finding may indicate that some 4-H members in this study lack interest in participating in an IEP, regardless of the attributes of the program. As such, future research should be conducted to identify other variables that may influence 4-H members interest in participating in an IEP.

When designing IEPs for 4-H members, Extension personnel should also consider the location of the program. In a study conducted with College of Agriculture students, Van Hoof and Verbeeten (2005) found students were more motivated to participate in an IEP when they perceived the location to be appealing. Based on the findings of this study, IEPs designed for 4-H members in Louisiana should be located in either Europe or Australia/New Zealand. Prior studies conducted with other student populations have also identified these locations as the IEP destinations most appealing to students (Bunch et al., 2015; Danjean et al., 2015; IEE, 2015). However, considering the wide array of alternative IEP destinations, it could be beneficial to conduct future research to identify characteristics of Europe and Australia/New Zealand 4-H members find appealing. A study of this nature may aid Extension personnel in attracting 4-H members to IEPs in other locations that share similar characteristics.

Regarding the design of an IEP, Louisiana 4-H members perceived taking courses related to their career interests and gaining hands on experience as the most important activities to include in the design of an IEP. This finding is consistent with prior studies conducted with other student populations, in which students reported being more motivated to participate in an IEP if they perceived the IEP as being beneficial and relevant to their future careers (Briers, Shinn, & Nguyen, 2010; Van Hoof & Verbeeten, 2005). As such, it could be beneficial to conduct research to examine the career interests of 4-H members prior to designing an IEP. In practice, IEP information distributed to 4-H members should highlight the career benefits and opportunities for hand-on experience. As most Louisiana 4-H members identified the 11th grade as the most suitable academic level for participating in an IEP, this information should be distributed to 4-H members as early as the 9th and 10th grade. Introducing 4-H members to IEPs prior to the 11th grade may increase the likelihood they will actually participate later in their high school careers. Moreover, it could be beneficial to introduce 9th and 10th grade 4-H members and their families to opportunities to host international exchange students. Arnold et al. (2014) conducted a qualitative study with 4-H international participants, in which seven of ten participants reported having hosted an international exchange student prior to their own international experience. Moreover, participants who hosted an international student reported that hosting an international student influence profoundly their desire to participate in an IEP themselves (Arnold et al., 2014). Additionally, as post high school/in college was the second most preferred academic level for participating in an IEP, it could be beneficial for Louisiana Extension personnel to partner with local universities in their internationalization efforts.

Lastly, future research should be conducted to examine why 4-H members perceived staying with a host family as the least important activity to include in the design of an IEP. Traditionally, international 4-H programs employed by U.S. CEP have been designed to send 4-H members to live with foreign host families. Moreover, in a study by Arnold et al. (2014), 4-H

IEP participants reported that being exposed to the culture and daily rituals of the host family was the most important component of their exchange experience. Living with a host family allowed greater immersion into the culture, which resulted in a deeper reflection among participants regarding the limitations of their own global perspective (Arnold et al., 2014). However, the findings of this study indicate that a host family design may not be best suited for 4-H members in Louisiana. As such, future research should be conducted with 4-H members in other states to assess whether this finding is specific to the population of this study, or if this finding represents a national trend among 4-H members that warrants reexamination of the overall design of international 4-H programs employed by the U.S CEP.

## References

- Akpan, M., & Martin, R. A. (1996). Perceptions and activities of agricultural education professors in U.S institutions of higher education regarding internationalization of the agricultural education curriculum. *Journal of International Agricultural and Extension Education*, 3(2), 63–71.
- Arnold, M., Davis, J., & Corliss, A. (2014). From 4-H international youth exchange to global citizen: Common pathways of ten past program participants. *Journal of Youth Development*, 9(2), 85–98.
- Authors. (2016). [Instrument development quantitative responses]. Unpublished raw data.
- Baker, D. P., & LeTendre, G. K. (2005). *National differences, global similarities: World culture and the future of schooling*. Stanford, CA: Stanford University Press.
- Bates, R. M. (2006). Jumpstart your international Extension experience with farmer-to farmer. *Journal of Extension* [On-line], 44(6), Article 6IAW1, Retrieved from <http://www.joe.org/joe/2006december/iw1.php>
- Boyd, B. L., Giebler, C., Hince, M., Liu, Y., Mehta, N., Rash, C., ... Yanta, Y. (2001). Does study abroad make a difference? An impact assessment of the international 4-H youth exchange program. *Journal of Extension*, 39(5), 1–7.
- Briers, G. E., Shinn, G. C., & Nguyen, A. N. (2010). Through students' eyes: Perceptions and aspirations of college of agriculture and life science students regarding international education experiences. *Journal of International Agricultural and Extension Education*, (17)2, 5–20. doi: 10.5191/jiaee.2010.17201
- Bunch, J. C., Blackburn, J. J., Danjean, S. E., Stair, K. E., & Blanchard, L. D. (2015). Examining Louisiana State University College of Agriculture students' perceived motivators and barriers to participation in international experiences. *Journal of International Agricultural and Extension Education*, 22(3), 69–82. doi: 10.5191/jiaee.2015.22305
- Bunch, J. C., Lamm, A. J., Israel, G. D., & Edwards, C. M. (2013). Assessing the motivators and barriers influencing undergraduate student choices to participate in international experiences. *Journal of Agricultural Education*, 54(2), 217–231. doi: 10.5032/jae.2013.02217
- Danjean, S. E., Bunch, J. C., Blackburn, J. J. (2015). Examining the motivations and barriers influencing the decisions of Louisiana State University College of Agriculture freshmen to participate in international experiences. *Journal of International Agricultural and Extension Education*, 22(1), 49–62. doi: 10.5191/jiaee.2015.22104

- Etling, A., Reaman, K. K., El Sawi, G. (1993). Overcoming barriers to a global outlook in 4-H. *Journal of Extension*, 31(2). Retrieved from <http://www.joe.org/joe/1993summer/intl2.php>
- Ingram, P. D., Smith-Hollins, C., & Radhakrishna, R. (2009). Impact of yearlong 4-H Japanese internship experience on United States participants. *Journal of International Agricultural and Extension Education*, 16(1), 15–30.
- Institute of International Education (IEE). (2015). *Open doors report fast facts*. Retrieved from <http://www.iie.org/Research-and-Publications/Open-Doors/Data/US-Study-Abroad/Duration-of-Study-Abroad/2008-14>
- Ivy, J. (2008). A new higher education marketing mix: The 7Ps for MBA marketing. *International Journal of Education Management*, 22(4), 288–299. doi: 10.1108/09513540810875635
- Kavakas, D. (2013). Students as consumers: Identifying study abroad destination choice influences for marketing purposes. *American College of Thessaloniki*. Retrieved from [http://www.aieaworld.org/assets/docs/Listserv\\_Summaries/studentsasconsumers.pdf](http://www.aieaworld.org/assets/docs/Listserv_Summaries/studentsasconsumers.pdf)
- Lechner, F. J., & Boli, J. (Eds). (2015). *The globalization reader*. John Wiley & Sons.
- Ludwig, B.G. (1995). What characterizes an internationalized U.S. Extension system? *Journal of International Agricultural and Extension Education*, 2(2), 28–34
- Ludwig, B. G. (2001). Two decades of progress in globalizing U.S. Extension systems. *Journal of International Agricultural and Extension Education*, 8(2), 15–22.
- Ludwig, B. G., & McGirr, M. J. (2003). Globalizing Extension – A national initiative for U.S. land grant universities. *Proceedings of the 19th Annual Conference of the Association for International Agricultural and Extension Education, Raleigh, NC*, 401–411.
- Major, J., & Miller, R. (2012). Global 4-H network: Laying the groundwork for Extension opportunities. *Journal of Extension*, 50(6), 6FEA3.
- National Association of State Universities and Land-Grant Colleges (NASULGC) Task Force on International Education. (2004). A call to leadership: The presidential role in internationalizing the university. Retrieved from <http://www.aplu.org/NetCommunity/Document.Doc?id=340>
- Odell, K. S., Williams, M. E., Lawrence, L. D., Gartin, S. A., Smith, D. K. (2002). Evaluation of the International 4-H Youth Exchange (IFYE) Program. *Journal of International Agricultural and Extension Education*, 9(1), 57–64.
- Olberding, J. C. & Olberding, D. J. (2010). “Ripple effects” in youth peacebuilding and exchange programs: Measuring impacts beyond direct participants. *International Studies Perspectives*, 11, 75–91.
- Rieger, M. (n.d.). *University of Florida College of Agricultural and Life Sciences study abroad interest survey*. Unpublished manuscript, University of Florida.
- U.S. Department of Education (USDE). (2012). *Succeeding globally through international education engagement*. Washington, DC: USDE
- Van Hoof, H. B., & Verbeeten, M. J. (2005). Wine is for drinking, water is for washing: Student opinions about international exchange programs. *Journal of Studies in International Education*, 9(1), 42–61. doi: 10.1177/1028315304271480

# **Agricultural Students' Affective Perceptions of Cost, Expectancy, and Value in the Context of Short-Term Study Abroad Courses: Applying Expectancy-Value-Cost Models**

Brandon M. Raczkoski, Oklahoma State University  
J. Shane Robinson, Oklahoma State University  
M. Craig Edwards, Oklahoma State University  
Marshall A. Baker, Oklahoma State University

## **Abstract**

*To date, agricultural students' motivations in regard to study abroad courses using expectancy-value-cost models have not been incorporated into study abroad research as a potential factor influencing their choice to participate. Moreover, affective domains have received little attention in motivation research. If taken together, are researchers able to forecast students' intent to participate in study abroad programs? The purpose of this study was to identify undergraduate and graduate students' perceived affective conceptualizations of their motivations to participate in short-term study abroad programs. A descriptive-correlational research design was used in combination with modified versions of the Self and Task Perceptions Instrument (STPI), Expectancy-Value-Cost Questionnaire, and Social Cognitive Theory items. The authors posited that expectancy, value, self-efficacy, and cost would influence students' motivations to enroll in a short-term study abroad course before graduation. Overall, agricultural students were found to have somewhat strong motivation to study abroad. Intrinsic value and expectancy- and ability-related beliefs were found to be the greatest motivational factors. Students were least motivated by outside effort cost and self-efficacy. Task effort cost and location lived when growing up were weakly and negatively correlated. Outside effort cost, however, had a strong, positive relationship to students' intentions to study abroad.*

## **Introduction**

As agricultural systems become increasingly globalized (Bobbitt & Akers, 2013), employers in the agricultural and natural resources sectors have expressed the need for employees with interpersonal communication and leadership skills (Crawford, Lang, Fink, Dalton, & Fielitz, 2011; Harder et al., 2015) as well as a "good grasp on issues and events that affect things throughout the world" (Irani, Place, & Friedel, 2006, p. 28). In 2003, Begley and Boyd opined that a global mindset is a function of an individual, and not socially embedded within the culture of an organization. To this end, "an understanding of agriculture's history and current economic, social, and environmental significance, both domestically and internationally, is important for all Americans" (Doerfert, 2011, p. 11).

Over the years, substantial literature has demonstrated the merits associated with international experiences (Goldstein & Kim, 2006), including cross-cultural skills and global awareness (Harder et al., 2015; Kitsantas, 2004), increased geopolitical concern (Carlson & Widaman, 1988), and decreased ethnocentrism (Anderson, Hubbard, & Lawton, 2015). Further, researchers have assessed agricultural students' perceptions of interests, barriers, and benefits associated with international experiences (Bunch, Lamm, Israel, & Edwards, 2013; Chang et al., 2013; Place, Irani, Friedel, & Lundy, 2004).

Empirical research suggested expected outcomes of international education for college students are typified by an impacted career trajectory (Orahood, Kruze, & Pearson, 2004) and perceived impact on employability (Briers, Shinn, & Nguyen, 2010; Teichler & Janson, 2007). Short-term study abroad courses in the College of Agricultural Sciences and Natural Resources (CASNR) at Oklahoma State University (OSU) offer students such experiences. These courses provide students with opportunities to develop skills employers' value, while learning "a diverse overview of [a] nation's agriculture, history, and modern culture" through agriculturally focused, service-learning projects (Short-Term Study Abroad Programs, 2016, para 2).

A comparative analysis of global study abroad data revealed U.S. student participation is considerably lower than in other developed nations (Organization for Economic Co-operation and Development [OECD], 2011). To address this deficiency, the 2005 Lincoln Commission report set a goal of having 1 million U.S. students study abroad by 2017 (Durban, 2006). As a result, U.S. student participation in study abroad programs increased substantially. According to the Institute of International Education [IIE] (2014), the number of U.S. students studying abroad more than doubled during the last decade. During 2013-2014, approximately 304,467 American students studied abroad, a 5% increase from the year prior (IIE, 2015). Yet, the number of college students with agricultural majors participating in study abroad courses remains insufficient in contrast to participation rates of students from other colleges within institutions of higher learning (IIE, 2015).

These findings, notwithstanding, limited inquiries have been undertaken to measure students' motivations for participating in short-term study abroad courses or experiences. What is more, little is known about how *expectancy*, *value* (Eccles & Wigfield, 2002), and *cost* (Flake, Barron, Hulleman, McCoach, & Welsh, 2015) motivate students to participate in such programs.

## **Theoretical Framework**

### **Expectancy-Value of Achievement Motivation**

This study was framed using a combination of the expectancy-value theory of achievement motivation (Eccles et al., 2000), cost (Barron & Hulleman, 2015), and social cognition (Eccles & Wigfield, 2002). According to Wigfield, Tonks, and Klauda (2009), expectancy and value, as psychological constructs, were defined by the theorists Kurt Lewin and Edward Tolman. However, the first mathematical expectancy-value model was developed by John William Atkinson (1957, 1964) in an attempt "to explain different kinds of achievement-related behaviors, such as striving for success, choice among achievement tasks, and persistence" (Wigfield et al., 2009, p. 55). Isaac et al. (2001) indicated the model suggests individuals feel motivated when "the personal expenditure of effort will result in an acceptable level of performance, the performance level achieved will result in a specific outcome for the person, and the outcome attained is personally valued" (p. 215).

Within the expectancy-value model, the major outcome component is *achievement-related choices* (Eccles et al., 2000). Achievement-related choices predicated expectancies for success and subjective-task value. Subjective-task value, defined broadly, is the motivation behind an

individual's actions. According to Eccles and Wigfield (1995), "task value [should] be conceptualized in terms of four major components: "attainment value (importance), intrinsic value (interest), utility value (usefulness), and cost" (p. 216).

Attainment value [is] representing the importance of doing well on a task in terms of one's self-schema and core personal values, [i]ntrinsic or value is the inherent enjoyment or pleasure one gets from engaging in an activity, [u]tility value is the value a task acquires because it is instrumental in reaching a variety of long- and short-term goals, [and] cost is what is lost, given up, or suffered as a consequence if engaging in a particular activity. (Eccles & Wigfield, 1995, p. 216)

Moreover, these variables influenced subjective-task value and expectancy-related beliefs directly (Eccles et al., 1983). They were operationalized as a set of beliefs about expected ability and expectancies for success (Gao & Xiang, 2008), which include perceived competence, perceived difficulty of tasks, individuals' goals and self-schema, the cultural milieu, and memories of achievement-related activities (Wigfield et al., 2009).

In college students' motivations to study abroad, subjective-task value was found to affect achievement-related choices (Sánchez, Fornerino, & Zhang, 2006). Other studies determined that students' perceived motivations, barriers, interests, and benefits to study abroad cannot be generalized across all college students, therefore, demonstrating these specific aspects of the phenomenon are not universal (Bunch et al., 2013; Hackney, Boggs, & Borozan, 2012).

### **Expectancy-Value-Cost Model of Motivation**

Barron and Hulleman (2015) proposed making cost a major component of expectancy-value models of achievement motivation. The *cost*, i.e., *task effort cost*, *outside effort cost*, *loss of valued alternatives* (LOVA), and *emotional cost*, of engaging in an activity influences motivation (Barron & Hulleman, 2015; Flake et al., 2015). In previous empirical motivation research, the theorized sub-component of cost in expectancy-value models often has been neglected or ignored altogether. However, cost has received increased attention in regard to "its importance in capturing motivational dynamics that complement expectancy and value components" (Barron & Hulleman, 2015, p. 1).

As such, we utilized a comprehensive model of expectancy-value of achievement motivation, which included four *cost* dimensions. An important distinction to be made when measuring cost is to pay special attention to the wording of items so such is perceived to surpass a critical threshold, and the activity is viewed as overwhelming. For example, "[t]o be [as a] perceived cost, it must be perceived negatively by the respondent" (Barron & Hulleman, 2015, p. 16). Flake et al. (2015) operationally defined each cost dimension.

Task effort cost[s] [are] negative appraisals of time, effort, or amount of work put forth to engage in the task, [o]utside effort cost[s] [involved] negative appraisals of time, effort, or amount of work put forth for task other than the task of interest, [l]oss of valued alternatives cost [included] a negative appraisal of what is given up as a result of engaging in the task of interest, and [e]motional cost [included] negative appraisals of a psychological state that results from exerting effort for the task. (p. 237)

The application of a combined expectancy-value theory of achievement motivation and expectancy-value-cost model of motivation in the context of CASNR students at OSU can expand our knowledge of their perceptions of expectancy, value, and cost regarding short-term study abroad courses or experiences.

### Social Cognitive Theory

As noted by Eccles and Wigfield (2002), a need exists to integrate expectancy theories and social cognitive theories to form a comprehensive model of individuals' perceptions of ability and expectancies for success. Taken together, this study examined CASNR students' personal characteristics as related to their perceived affective motivations, i.e., expectancies for success, subjective-task value, cost, and self-efficacy, for short-term study abroad courses or experiences as influences on success associated with such programs. In other words, regarding these theoretical propositions, what motivates students to participate in study abroad programs?

Figure 1 is a comprehensive model indicating individual student's motivations to study abroad. As depicted, the four root constructs of students' motivations are task effort cost, loss of valued alternatives cost, emotional cost, and outside effort cost.

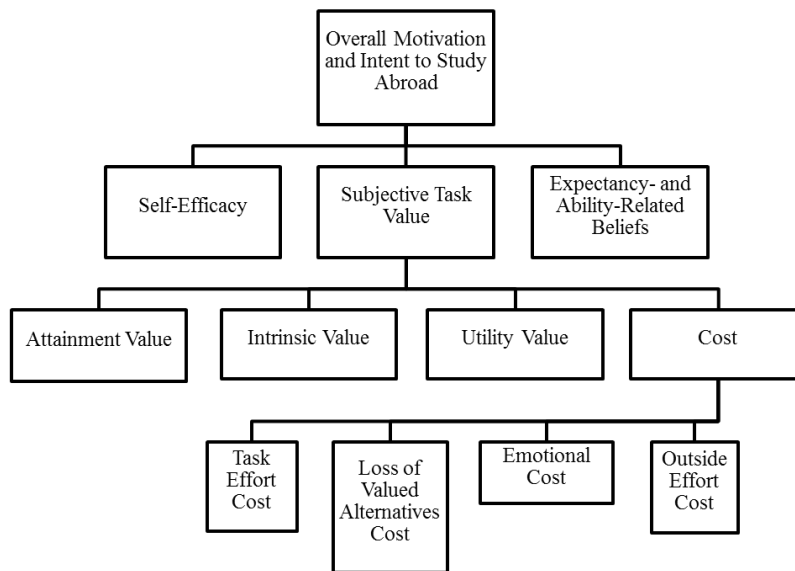

Figure 1. A Comprehensive Model of Individuals' Motivations to Study Abroad.

### Purpose of the Study

The purpose of this study was to identify undergraduate and graduate students' forecasted conceptualizations, prior to a *direct experience*, of their motivations to enroll in a short-term study abroad course or experience before graduation. Further, this study sought to determine whether students' personal characteristics significantly correlated ( $p < .05$ ) with these motivational factors. To these ends, we posited OSU CASNR students' perceived motivations, i.e., expectancy, value, cost, and self-efficacy, and their personal characteristics would explain

why they choose to participate in short-term study abroad courses or experiences. This study aligned with Priority 4 – Meaningful, Engaged Learning in All Environments (Doerfert, 2011). Four objectives guided this study.

- 1) Describe the personal characteristics of Oklahoma State University students who are CASNR majors;
- 2) Determine the perceived affective factors that motivate students in the CASNR at Oklahoma State University to enroll in short-term study abroad courses;
- 3) Describe the relationships between students' perceived affective motivations to participate in study abroad courses and their selected personal characteristics; and
- 4) Describe the relationships between perceived affective factors that motivate students to participate in study abroad courses and overall motivation and intent to enroll in such prior to being graduated.

### Methods and Procedures

This descriptive-correlational study included all students in the College of Agricultural Sciences and Natural Resources at Oklahoma State University during the fall semester of 2016 ( $N = 2,978$ ). Students with previous short-term study abroad experience were excluded from the analysis. The questionnaire used in this study was distributed online using Qualtrics Survey Software in accordance with Dillman's, Smyth's, and Christian's (2009) method for Internet surveys. In all, 529 students responded to the questionnaire for a response rate of 18%. However, after the exclusion of incomplete questionnaires and individuals with prior short-term study abroad experience, the usable responses were reduced to 219 (7%).

To determine whether responses were generalizable to the population, nonresponse error was addressed by comparing respondents' personal characteristics to data from CASNR at OSU. No statistically significant differences ( $p > .05$ ) were found between respondents and the general student population of CASNR. Therefore, we concluded our sample was representative of the OSU CASNR population. Researchers also assessed *early* ( $n = 123$ ) and *late* ( $n = 96$ ) respondents to assess nonresponse error (Lindner, Murphy, & Briers, 2001; Miller & Smith 1983). There were no statistically significant differences found between early and late respondents in the variables used for the study.

The 38-item instrument used in this study was a modified version of the Self and Task Perception Instrument [STPI] (Eccles & Wigfield, 1995), with reliable post hoc Cronbach's alpha scores ranging from .78 (utility value) to .87 (ability- and expectancy-related beliefs); the Expectancy-Value-Cost Questionnaire (Flake et al., 2015), with reliable post hoc Cronbach's alpha scores ranging from .78 (task effort cost) to .90 (outside effort cost); and items from the Social Cognitive Theory (Bandura, 1986; Bobbitt & Akers, 2013), with a modest post hoc Cronbach's alpha score of .64 (Warmbrod, 2014). An expert panel at Oklahoma State University reviewed the questionnaire for face and content validity in regard to the study's purpose and objectives. Correlation coefficients were used to examine the relationships between expectancy, value, cost, and self-efficacy (Franekel et al., 2012). Magnitudes of correlations were used to assess the correlation coefficients in this study (Davis, 1971).



Respondents were presented a series of concepts measuring their motivation to participate in a study abroad course or experience, e.g., *A short-term study abroad course or experience will be fun*. All items were presented in random order, and each included a 5-point summated rating scale ranging from 1 = *Completely Disagree*, 2 = *Somewhat Disagree*, 3 = *Neither*, 4 = *Somewhat Agree*, and 5 = *Completely Agree* (Warmbrod, 2014). Costs and self-efficacy items were negatively worded on the questionnaire and reverse coded for analysis.

For an overview of study abroad courses offered at Oklahoma State University in CASNR, Table 1 was included. In the summer of 2016, eight short-term study abroad courses were offered, with eight different participating faculty members (see Table 1). The length of experiences ranged in duration from 10 to 17 days, including courses in landscape architecture, agricultural economics, horticulture, and animal science, to name a few. The longest duration for a study abroad trip was 17 days in China. The most expensive trip was Guatemala at \$340 per day, and the least expensive trip was Central Europe at \$119 per day (see Table 1).

Table 1

*CASNR's Short-Term Study Abroad Courses Offered during the Summer of 2016*

Location	Dates	Duration (in days)	Est. Fees & Tuition (\$)	Est. Average Cost per Day (\$)
China	May 12-28	17	\$2,400	\$141
New Zealand	May 10-22	13	\$3,650	\$281
Ghana	May 20-29	10	\$2,350	\$235
Guatemala	May 20-29	10	\$3,400	\$340
Central Europe	May 23-June 7	16	\$1,900	\$119
Ireland	June 15-28	14	\$3,695	\$264
Thailand	July 9-23	15	\$3,400	\$227
Peru	July 28-August 10	14	\$3,225	\$230

## Findings

Objective one was to describe the personal characteristics of Oklahoma State University students who were CASNR majors. Participants self-reported to be mostly White (73.5%), female (70.3%), undergraduate students (see Table 2). Of the participants, nearly one-third indicated they grew up on a farm or ranch ( $f = 72$ , 32.9%), with only 19 (8.7%) growing up in a downtown area in the city or town. More than three-fourths indicated they were neither transfer students ( $f = 165$ , 75.3%), nor fluent in another language ( $f = 170$ , 77.6%; see Table 2).

Table 2

*CASNR Students' Personal Characteristics*

Variable	<i>f</i>	%
Gender		
Female	154	70.3
Male	63	28.8

Not reported	2	0.9
<b>Educational Status</b>		
Freshman	64	29.2
Sophomore	42	19.2
Junior	39	17.8
Senior	33	15.1
Master's	25	11.4
Doctoral	12	5.5
Not reported	4	1.8
<b>Location where you were raised</b>		
Farm/Ranch	72	32.9
Rural, not farm	56	25.6
Subdivision in or near town or city	69	31.5
Downtown area in city or town	19	8.7
Not reported	3	1.4
<b>Ethnicity</b>		
Asian American	5	2.3
Black or African American	12	5.5
Native American/Alaskan Native	28	12.8
Non-Hispanic, White	161	73.5
Hawaiian	0	0.0
Hispanic	11	5.0
International Student	20	9.1
<b>Grade Point Average</b>		
4.0 or higher	41	18.7
3.99 to 3.50	69	31.5
3.49 to 3.00	48	21.9
2.99 to 2.50	17	7.8
2.49 or less	7	3.2
Not reported	37	16.9
<b>Fluent in another language</b>		
Yes	46	21.0
No	170	77.6
Not reported	3	1.4
<b>Transfer student</b>		
Yes	52	23.7
No	165	75.3
Not reported	2	0.9

---

Objective two was to determine the perceived affective factors that motivate students in CASNR at Oklahoma State University to enroll in a short-term study abroad course. Cost, i.e., task effort cost, emotional cost, LOVA, and outside effort cost, and self-efficacy items were worded negatively on the questionnaire and reverse coded for analysis. It was found the largest motivational factors to participate in short-term study abroad courses or experiences were intrinsic value ( $M = 4.20$ ,  $SD = 0.69$ ) and expectancy- and ability-related beliefs ( $M = 4.10$ ,  $SD = 0.65$ ; see Table 3). Self-efficacy ( $M = 2.83$ ,  $SD = 0.82$ ) was the lowest motivator for students

to participate in such programs. A summated mean score for motivational constructs also is presented in Table 3. Students had a summated mean score of 32.73 out of 45 regarding their motivation to participate in short-term study abroad courses or experiences.

Table 3

*Motivational Construct Means*

Construct	<i>M</i>	<i>SD</i>
Intrinsic Value*	4.20	0.69
Expectancy Beliefs*	4.10	0.65
Emotional Cost**	3.82	0.91
Task Effort Cost**	3.74	0.91
Attainment Value*	3.65	0.79
Utility Value*	3.63	0.72
LOVA**	3.51	0.97
Outside Effort Cost**	3.25	1.09
Self-Efficacy**	2.83	0.82
Summated	32.73	7.55

*Note.* \* = positively worded items; \*\* = negatively worded items; 1 = *Completely Disagree*, 2 = *Somewhat Disagree*, 3 = *Neither*, 4 = *Somewhat Agree*, 5 = *Completely Agree*; LOVA = loss of valued alternatives.

Objective three was to describe the relationships between students' perceived affective motivations to participate in study abroad courses or experiences and their selected personal characteristics. Bivariate correlation analysis revealed education status and outside effort cost ( $r = -.21$ ) correlated weakly and negatively. Task effort cost ( $r = -.27$ ), expectancy- and ability-related beliefs ( $r = -.16$ ), and self-efficacy ( $r = -.16$ ) and location lived when growing up correlated weakly and negatively. Age and outside effort cost ( $r = -.17$ ) also were weakly and negatively correlated (see Table 4).

Table 4

*Spearman's Rho Correlations between Selected Ordinal Variables and Motivational Factors*

Constructs	Education status	Location growing up	Median household income	GPA	Age
Intrinsic Value	.03	-.05	-.02	.00	.10
Expectancy Beliefs	.04	-.16*	.02	.04	.07
Emotional Cost	.09	-.10	-.02	.07	.08
Task Effort Cost	-.12	-.27**	.06	-.01	-.12
Attainment Value	-.06	-.10	.02	-.06	.06
Utility Value	-.11	-.03	.11	-.05	-.01
LOVA	.01	-.08	.08	-.01	.00

Outside Effort Cost	-.21**	-.12	.09	-.06	-.17*
Self-Efficacy	.06	-.16*	.09	.01	.04

*Note.* Magnitude:  $.01 \geq r \geq .09$  = Negligible,  $.10 \geq r \geq .29$  = Low,  $.30 \geq r \geq .49$  = Moderate,  $.50 \geq r \geq .69$  = Substantial,  $r \geq .70$  = Very Strong (Davis, 1971).  
\* $p < .05$ ; \*\* $p < .01$ .

The point-biserial coefficient correlation revealed the top motivational factors by gender, fluency in another language, and transfer student status (see Table 5). Intrinsic value and gender ( $r = .14$ ) were weakly and positively correlated; while self-efficacy ( $r = -.14$ ) was weakly and negatively correlated. Task effort cost and fluency in another language ( $r = .14$ ) were weakly and positively correlated (see Table 5).

Table 5

*Point-biserial Correlations between Dichotomous Variables and Motivational Factors*

Constructs	Gender	Fluency in another language	Transfer student
Intrinsic Value	.14*	-.07	.04
Expectancy Beliefs	.10	.01	.02
Emotional Cost	-.08	.00	.07
Task Effort Cost	.00	.14*	.11
Attainment Value	.05	.03	-.03
Utility Value	.08	-.09	.00
LOVA	.01	.00	-.02
Outside Effort Cost	-.07	.01	.04
Self-Efficacy	-.14*	.05	.07

*Note.* Magnitude:  $.01 \geq r \geq .09$  = Negligible,  $.10 \geq r \geq .29$  = Low,  $.30 \geq r \geq .49$  = Moderate,  $.50 \geq r \geq .69$  = Substantial,  $r \geq .70$  = Very Strong (Davis, 1971).  
\* $p < .05$ .

Objective four was to describe the relationships between perceived affective factors that motivate students to participate in study abroad programs' and overall perceived motivation and intent, e.g., *I will be motivated to enroll in a credit-bearing short-term study abroad course or experience prior to being graduated.* Each factor had a moderate to strong correlation to students' overall intent to study abroad prior to being graduated. Outside effort cost ( $r = .60$ ) had a strong, positive correlation to students' intent to study abroad. Self-Efficacy had a weak, positive correlation with intent to study abroad ( $r = .15$ ; see Table 6).

Table 6

*Spearman's Rho Correlations between Motivational Factors and Intent to Study Abroad*

Construct	Overall Intent to Study Abroad
-----------	--------------------------------

	<i>r</i>
Intrinsic Value	.54**
Expectancy and Ability Beliefs	.51**
Emotional Cost	.38**
Task Effort Cost	.46**
Attainment Value	.44**
Utility Value	.56**
Loss of Valued Alternatives Cost	.51**
Outside Effort Cost	.60**
Self-Efficacy	.15*

*Note.* Magnitude:  $.01 \geq r \geq .09$  = Negligible,  $.10 \geq r \geq .29$  = Low,  $.30 \geq r \geq .49$  = Moderate,  $.50 \geq r \geq .69$  = Substantial,  $r \geq .70$  = Very Strong (Davis, 1971).

\* $p < .05$ ; \*\* $p < .01$ .

### Conclusions

The purpose of this study was to identify OSU CASNR undergraduate and graduate students' perceived affective conceptualizations of their motivations to participate in short-term study abroad courses or experiences, particularly motivational factors that correlated with personal characteristics and overall motivation and intent to enroll in a study abroad course before graduation. In this study, we asked students to forecast their motivations. Those affective appraisals potentially could be different than retrospective and real time appraisals, and caution should be taken when generalizing the findings of this study beyond the affective conceptualization of students' motivations to enroll in a short-term study abroad course or experience.

Items related to expectancy-value, expectancy-value-cost, and Social Cognitive Theory were adapted to be written in future tense and used to measure a series of concepts in regard to participation in short-term study abroad courses or experiences. The empirical structure of expectancy, value, self-efficacy, and cost remained relatively consistent with previous research (Bobbitt & Akers, 2013; Eccles & Wigfield, 1995; Flake et al., 2015). However, similar to Flake et al. (2015), we gained "substantive insights as to how cost manifests differentially in different situations" (p. 243), and how cost interacts with expectancy, value, and self-efficacy among a new population. Nearly three-quarters of the sample identified as White, female, undergraduate students. Approximately one-third of the participants indicated growing up on a ranch or farm, with less than one tenth growing up downtown or near a city or town. The largest proportions of participants were undergraduates, although distributions existed amongst all grade levels, including graduate students.

The findings showed the largest affective appraisals of motivation to study abroad were intrinsic value ( $M = 4.20$ ,  $SD = 0.69$ ) and expectancy- and ability-related beliefs ( $M = 4.10$ ,  $SD = 0.65$ ; see Table 3). Self-efficacy ( $M = 2.83$ ,  $SD = 0.82$ ) and outside effort cost ( $M = 3.25$ ,  $SD = 1.09$ ) were the least motivational constructs (see Table 3). This runs counter to the notion individuals tend to overestimate their ability prior to performing a task (Bandura, 1986). Moreover,

students' perceived outside effort cost to be the next lowest influence on their motivation. That is, perceived positive affective appraisals of time and effort put forth for tasks other than enrolling in a short-term study abroad course was the least motivational cost factor, as viewed by students. To that end, the Millennial Generation prefers multi-tasking, which includes the tendency to bore easily (Johnson & Lopes, 2008).

When analyzing the relationships between students' motivations and personal characteristics, the strongest relationship existed between task effort cost and location lived when growing up ( $r = -.27$ ). Spearman's rho correlation indicated a weak, negative, and statistically significant ( $p < .01$ ) relationship between the variables. Where a student lives while growing up negatively influences the perceived time, effort, and amount of work necessary to enroll in a short-term study abroad course or experience.

As expected, the measures of cost were moderately and strongly correlated. These findings were consistent with previous research (Flake et al., 2015). To that end, differential relationships were observed between expectancy and value and cost items. After recoding the negatively worded cost items, measures of cost were moderately and positively correlated to expectancy and value, while expectancy and value were moderately and positively correlated to students' intent to enroll in a short-term study abroad course before graduation. We observed outside effort cost was more related to students' motivations to study abroad ( $r = .60$ ) than any other motivational factor. This raises the question of how outside demands influence students' intent to study abroad. Further, of the motivational constructs studied, self-efficacy was least related to students' intent to study abroad ( $r = .15$ ). Self-efficacy was the least effective influence on motivation, which raises questions regarding its integration into the expectancy-value theory of achievement motivation framework (Eccles & Wigfield, 2002).

### **Implications and Recommendations**

Despite advances in the field of motivation, this attention has often "overemphasized rational, cognitive processes in motivation, at the expense of affective and other processes" (Eccles & Wigfield, 2002, p. 127). Moreover, "cognitive models cannot adequately capture conceptual change" (Eccles & Wigfield, 2002). Apart from attribution theory, affective domains have received minimal attention in motivation research (Eccles & Wigfield, 2002). This study investigated affective domains in the context of agricultural students' motivations to study abroad. The low self-efficacy of agricultural students in their motivation to study abroad should be an indicator of decreasing enrollment rates in study abroad courses. Therefore, it is recommended that researchers, instructors, and administrators focus on investigating other ways to encourage students to enroll and participate in such learning experiences.

Although this research has its limitations, the findings of the study hold important implications for administrators and faculty members on pedagogical approaches appropriate for implementing and facilitating high-value international learning experiences. Emphasis should be placed on designing international learning experiences that appeal to students' expectancies, values, and conceptualizations about various costs as well as to potential employers.

Moreover, in previous studies, students were asked about *costs* relative to when they were engaged in a task (Flake et al., 2015). In the current study, students were asked to *anticipate their motivations to engage in a task*, i.e., enrolling in a short-term study abroad course or experience before graduation. These findings are theoretically and conceptually distinct from students' retrospective and real time appraisals of motivations to enroll in a study abroad course, including implications for how motivation to study abroad changes not overtime, but through different stages of task engagement, i.e., before, during, and after, *concrete experiences*. Therefore, rich, in-depth qualitative research is needed to identify the themes and understand the differences students experience throughout the stages of engaging in study abroad courses or experiences more fully (Flake et al., 2015). In addition, examination of the psychometric properties of the scales used in the current study is warranted.

It is also recommended students' motivations be investigated during and after a short-term study abroad course or experience, i.e., a longitudinal study following a group of students through the stages of task engagement. In addition, researchers should investigate students' motivations to study abroad by geographic setting, distance, language, and financial cost.

Finally, at Oklahoma State University, students are required to take an international dimension (ID) course during their program to graduate (Moriba & Edwards, 2011). Students can achieve their ID credit in two ways, either through enrolling in one of many 16-week, on-campus courses, or through participating in one of the eight study abroad courses, as depicted in Table 1. Therefore, further research should be conducted to identify and describe the ID component at this institution and other ID dimension courses at other higher education institutions. Focus should be placed on identifying the expected outcomes and comparing students' motivations regarding the various offerings.

## Discussion

As the world population continues to expand and becomes more globalized, it is imperative students be able to navigate it effectively. To do so, students need opportunities to explore and learn about the world. The ID courses at Oklahoma State University exist to provide experiences in which students can gain international awareness and competence. Yet, regardless of the programming in effect, students must be motivated to participate. How can faculty and administrators make study abroad courses or experiences more attractive for students? The findings of this study point to *outside effort cost* as the most significant prohibitor to students' desires to study abroad. In all, students appear to be motivated to study abroad. However, the perception of students is that such programs compete with their outside influences, i.e., personal time, effort, and work, making them less of a realistic option for participation. Further, the type of home environment in which students were raised, i.e., farm versus city, appears to have an impact on whether or not students choose to study abroad. More research is needed to determine how these perceptions can be offset and overcome.

## References

- Anderson, P. H., Hubbard, A., & Lawton, L. (2015). Student motivation to study abroad and their intercultural development. *Frontiers: The Interdisciplinary Journal of Study Abroad*, 26(Fall), 39–52. Retrieved from <http://ir.stthomas.edu/cgi/viewcontent.cgi?article=1022&context=ocbmgmtpub>
- Atkinson, J. W. (1957). Motivational determinants of risk-taking behavior. *Psychological Review*, 64(6), 359–372. doi:10.1037/h0043445
- Atkinson, J. W. (1964). *An introduction to motivation*. Princeton, NJ: Van Nostrand.
- Bandura, A. (1986). *Social foundations of thought and action: A social cognitive theory*. Englewood Cliffs, NJ: Prentice Hall.
- Barron, K. E., & Hulleman, C. S. (2015). Expectancy-value-cost model of motivation. *Psychology*, 84, 261–271. Retrieved from [https://www.researchgate.net/profile/Chris\\_Hulleman/publication/265965932\\_Expectancy-Value-Cost\\_Model\\_of\\_Motivation/links/542214600cf26120b7a010a8.pdf](https://www.researchgate.net/profile/Chris_Hulleman/publication/265965932_Expectancy-Value-Cost_Model_of_Motivation/links/542214600cf26120b7a010a8.pdf)
- Begley, T. M., & Boyd, D. P. (2003). The need for a corporate global mind-set. *Sloan Management Review*, 45(Winter), 25–32. Retrieved from <http://search.proquest.com/docview/224963743?pq-origsite=gscholar>
- Bobbitt, R., & Akers, C. (2013). Going global: Study abroad intentions of agriculture and natural resource students. *NACTA Journal*, 57(3a), 21–27. Retrieved from <http://search.proquest.com/docview/1445180862/fulltextPDF/87862F61B0A24CA6PQ/1?accountid=4117>
- Briers, G. E., Shinn, G. C., & Nguyen, A. N. (2010). Through students' eyes: Perceptions and aspirations of college of agriculture and life science students regarding international educational experiences. *Journal of International Agricultural and Extension Education*, 17(2), 5–20. doi:10.5191/jiaee.2010.17201
- Bunch, J. C., Lamm, A. J., Israel, G. D., & Edwards, M. C. (2013). Assessing the motivators and barriers influencing undergraduate students' choices to participate in international experiences. *Journal of Agricultural Education*, 54(2), 217–231. doi:10.5032/jae.2013.02217
- Carlson, J. S., & Widaman, K. F. (1988). The effects of study abroad during college on attitudes toward other cultures. *International Journal of Intercultural Relations*, 12(1), 1–17. doi:10.1016/0147-1767(88)90003-X
- Chang, C. W., Pratt, O., Bielecki, C., Balinas, M., McGucken, A., Rutherford, T., & Wingenbach, G. (2013). Agriculture students' interests, preferences, barriers and



- perceived benefits of international educational experiences. *NACTA Journal*, 57(3a), 97–103. Retrieved from <http://search.proquest.com/docview/1445180869?pqorigsite=gscholar>
- Crawford, P., Lang, S., Fink, W., Dalton, R., & Fielitz, L. (2011). Comparative analysis of soft skills: What is important for new graduates. *Michigan State University and the University Industry Consortium*, 1–24. Retrieved from <https://ag.purdue.edu/oap/career/Documents/2012%20Soft%20Skills%20Survey%202011%20Crawford%20Lang%20Fink%20Dalton%20Fielitz.pdf>.
- Davis, J. (1971). *Elementary survey analysis*. Englewood Cliffs, NJ: Prentice Hall.
- Dillman, D., Smyth, J., & Christian, L. (2009). *Internet, mail, and mixed-mode surveys: The tailored design method*. New York, NY: Wiley.
- Di Pietro, G. (2013). Do study abroad programs enhance the employability of graduates? *Institute for the Study of Labor (IZA)*, 1–27. Retrieved from <http://ftp.iza.org/dp7675.pdf>
- Doerfert, D. L. (Ed.) (2011). *National Research Agenda: American Association for Agricultural Education's research priority areas for 2011-2015*. Lubbock, TX: Texas Tech University, Department of Agricultural Education and Communications. Retrieved from <http://aaaeonline.org/resources/Documents/AAAE%20National%20Research%20Agenda.pdf>
- Durbin, R. J. (2006). The Lincoln Commission and the future of study abroad. *International Educator*, 15(1), 4–6. Retrieved from [http://www.nafsa.org/\\_/File/\\_/InternationalEducator/FrontlinesJanFeb.pdf](http://www.nafsa.org/_/File/_/InternationalEducator/FrontlinesJanFeb.pdf)
- Eccles, J. S., Adler, T. F., Futterman, R., Goff, S. B., Kaczala, C. M., & Meece, J. (1983). Expectancies, values and academic behaviors. In J. T. Spence (Ed.), *Achievement and achievement motives*. (75–146). San Francisco, CA: W. H. Freeman.
- Eccles, J. S., & Wigfield, A. (1995). In the mind of the actor: The structure of adolescents' achievement task values and expectancy-related beliefs. *Personality and Social Psychology Bulletin*, 21(3), 215–225. doi:10.1177/0146167295213003
- Eccles, J. S., & Wigfield, A. (2002). Motivational beliefs, values, and goals. *Annual Review of Psychology*, 53(1), 109–132. doi:10.1146/annurev.psych.53.100901.135153
- Flake, J. K., Barron, K. E., Hulleman, C., McCoach, B. D., & Welsh, M. E. (2015). Measuring cost: The forgotten component of expectancy-value theory. *Contemporary Educational Psychology*, 41, 232–244. doi:10.1016/j.cedpsych.2015.03.002
- Fraenkel, J. R., Wallen, N. E., & Hyun, H. H. (2012). *How to design and evaluate research in education* (8th ed.). New York, NY: McGraw-Hill.

- Gao, Z., & Xiang, P. (2008). College students' motivation toward weight training: An application of expectancy-value model. *Journal of Teaching in Physical Education*, 27(1), 399–415. Retrieved from <http://search.proquest.com/docview/215880355/fulltextPDF?accountid=4117>
- Goldstein, S. B., & Kim, R. I. (2006). Predictors of US college students' participation in study abroad programs: A longitudinal study. *International Journal of Intercultural Relations*, 30(4), 507–521. doi:10.1016/j.ijintrel.2005.10.001
- Hackney, K., Boggs, D., & Borozan, A. (2012). An empirical study of student willingness to study abroad. *Journal of Teaching in International Business*, 23(2), 123–144. doi:10.1080/08975930.2012.718705
- Harder, A., Andenoro, A., Roberts, T. G., Stedman, N., Newberry III, M., Parker, S. J., & Rodriguez, M. T. (2015). Does study abroad increase employability? *NACTA Journal*, 59(1), 41–48. Retrieved from <http://search.proquest.com/docview/1660304976?pq-origsite=gscholar>
- Institute of International Education. (2014). *Open doors 2014 fast facts*. Author. Retrieved from <http://www.iie.org/Researchand-Publications/~media/Files/Corporate/Open-Doors/Fast-Facts/Fast%20Facts%202010.ashx>
- Irani, T., Place, N. T., & Friedel, C. (2006). Beliefs, attitudes, perceptions, and barriers toward international involvement among college of agriculture and life science students. *Journal of International Agricultural and Extension Education*, 13(2), 27–37. Retrieved from [https://www.aiaee.org/attachments/155\\_Irani,-Vol-13.2-3.pdf](https://www.aiaee.org/attachments/155_Irani,-Vol-13.2-3.pdf)
- Isaac, R. G., Zerbe, W. J., & Pitt, D. C. (2001). Leadership and motivation: The effective application of expectancy theory. *Journal of Managerial Issues*, 13(2), 212–226. Retrieved from <http://www.jstor.org/stable/40604345>
- Johnson, J. A., & Lopes, J. (2008). The intergenerational workforce revisited. *Organization Development Journal*, 20(1), 31–36. Retrieved from <http://search.proquest.com/docview/197999345?accountid=4117>
- Kitsantas, A. (2004). Studying abroad: The role of college students' goals on the development of cross-cultural skills and global understanding. *College Student Journal*, 38(3), 441-452. Retrieved from <http://web.a.ebscohost.com/ehost/detail/detail?sid=4d0c6ee0-cfcb-4824-9b3f5b3e0bf00fcb%40sessionmgr4006&vid=0&hid=4106&bdata=JnNpdGU9ZWwhvc3QtbG12ZQ%3d%3d#AN=14669496&db=aph>
- Lindner, J. R., Murphy, T. H., & Briers, G. E. (2001). Handling nonresponse in social research. *Journal of Agricultural Education*, 42(4), 43-53. doi:10.5032/jae.2001.04043
- Miller, L. E., & Smith, K. L. (1983). Handling nonresponse issues. *Journal of Extension*, 21(5), 45-50. Retrieved from: <http://www.joe.org/joe/1983september/83-5-a7.pdf>

- Moriba, M., & Edwards, M. C. (2011). Investigating the international awareness of students meeting their international dimension requirement through course offerings in the college of agriculture at Oklahoma State University. *Proceedings of the 27th Annual Conference of the Association for International Agricultural and Extension Education*, Windhoek, Namibia, 67–68. doi:10.5191/jiaee.2011.18204
- Orahood, T., Kruze, L., & Pearson, D. E. (2004). The impact of study abroad on business students' career goals. *Frontiers: The Interdisciplinary Journal of Study Abroad*, 10(7), 117–130. Retrieved from <http://files.eric.ed.gov/fulltext/EJ891452.pdf>
- Organization for Economic Co-operation and Development. (2014). *Education at a glance 2011: Highlights*. OECD Publishing. Retrieved from <http://www.iese.org/Research-and-Publications/Open-Doors/Data/Fast-Facts>
- Place, N. P., Irani, T., Friedel, C., & Lundy, L. (2004). Beliefs, attitudes, perceptions and predictors of international involvement among college of agricultural and like science students. In *AIAEE 20th Annual Conference Proceedings*, Dublin, Ireland. 284–294. Retrieved from <https://www.aiaee.org/attachments/article/1141/103.pdf>
- Sánchez, C. M., Fornerino, M., & Zhang, M. (2006). Motivations and the intent to study abroad among US, French, and Chinese students. *Journal of Teaching in International Business*, 18(1), 27–52. doi:10.1300/J066v18n01\_03
- Short-Term Study Abroad Programs. (2016, December 9). Retrieved from <http://internationalagprograms.okstate.edu/short-term-study-abroad>
- Teichler, U., & Janson, K. (2007). The professional value of temporary study in another European country: Employment and work of former ERASMUS students, *Journal of Studies in International Education*, 11(3-4), 486–495. Retrieved from <http://jsi.sagepub.com/content/11/3-4/486.full.pdf>
- Warmbrod, J. R. (2014). Reporting and interpreting scores derived from Likert-type scales. *Journal of Agricultural Education*, 55(5), 30–47. doi:10.5032/jae.2014.05030
- Wigfield, A., & Eccles, J. S. (2000). Expectancy–value theory of achievement motivation. *Contemporary Educational Psychology*, 25(1), 68–81. doi:10.1006/ceps.1999.1015
- Wigfield, A., Tonks, S., & Klauda, S. L. (2009). Expectancy-value theory. In K. Wentzel & A. Wigfield (Eds.), *Handbook of motivation at school* (pp. 55–75). New York, NY: Routledge.

# **Thinking Critically about how Agriculture and Natural Resource Opinion Leaders Communicate**

J. Brianne Bird, Alexa J. Lamm, Lisa K. Lundy  
University of Florida

## **Abstract**

In order to address the complex challenges facing the agricultural and natural resource industry, extension educators must collaborate with opinion leaders. Extension educators can use the assistance of opinion leaders in program design and implementation in order to best meet the needs of stakeholders and the public. Collaboration between extension educators and opinion leaders is more easily conducted when each party understands one another's cognitive style and communication channel preference. This study explored the relationship between opinion leader critical thinking style among three contextual issue groups in agriculture and natural resources and preferred communication preferences used by extension educators. The three contextual issue groups included opinion leaders from the areas of water, food safety, and genetic modification (GM). Researchers used the University of Florida Critical Thinking Inventory (UFCTI) to measure critical thinking style of 300 respondents in Florida. Each of the contextual issue groups preferred engagement with information as their preferred critical thinking style. Among the contextual issue groups, significant differences were identified between the water and food safety groups in the information seeking UFCTI score and the GM and food safety groups in the information engagement score. The preferred method of receiving information overall was visiting a website.

## **Introduction**

Historically, the work of extension professionals was characterized as individualistic due to the flat organizational structure of the Cooperative Extension Service (Bruce & Carter, 1967). Working as individuals, extension professionals have always been asked to do less with more. They are provided only minimal resources and have to find ways to best communicate with stakeholders while dealing with organizational limitations (Bruce & Carter, 1967). Part of this is being constantly confronted with transdisciplinary issues and expected to come up with solutions to satisfy both industry leaders and the public. In present times, extension professionals are expected to collaborate with professionals from different issue areas to help create solutions to transdisciplinary issues (Braverman, Franz, & Rennekamp, 2012). Although a collaborative work environment is a change from the historic individualistic nature of extension, extension professionals are still expected to meet stakeholder needs with very limited resources (Braverman, Franz, & Rennekamp, 2012; Bruce & Carter, 1967).

The complex challenges the agricultural and natural resource industry are facing have been classified into five areas: space, agricultural production, natural resource management, energy consumption, and climate change (Andenoro, Baker, Stedman, & Weeks, 2016). The impending population of 9.2 billion by 2050 has contributed to the complexity of problems the agriculture and natural resource industry are facing (Food and Agriculture Organization of the United Nations, 2009). Priority seven of the national research agenda has called for researchers to identify more methods of providing the public with opportunities to seek information and engage in activities focused on developing the next generation of leaders able to address these complex challenges (Andenoro et al., 2016).

In order to best communicate with target audiences and conserve resources, extension professionals must collaborate with opinion leaders in the complex challenge areas (Lamm, Lamm & Carter, 2015; Lamm, Lamm & Carter, 2014; Taylor & Lamm, 2016). Opinion leaders provide a powerful means of communicating innovative ideas to the public (Valente & Davis, 1999). To begin with, opinion leaders can use their heightened credibility with the target audience to convey messages developed by extension professionals (Lamm et al., 2015; Valente & Davis, 1999; Valente & Pumpuang, 2007). In addition, opinion leaders are able to act as role models for the programs being implemented while communicating feedback from their communities to extension professionals. In the same way, one of the more beneficial outcomes of enlisting the assistance of opinion leaders is their value as a recurrent implementer of the program or idea even after the extension professional is no longer leading program implementation (Valente & Pumpuang, 2007). When extension professionals properly collaborate with opinion leaders, it allows for an environment which fosters more innovative solutions which individually might not have been possible (Andenoro et al., 2016; Gokhale, 1995; Lamm et al., 2014). This partnership will allow extension professionals to optimize the use of their resources (Taylor & Lamm, 2016).

Extension professionals must also collaborate with opinion leaders to create attitude shifts that lead to positive behavior changes in order to sustain the unprecedented global population in the future (Andenoro et al., 2016). With this in mind, extension professionals must work to best understand the preferred communication channels of opinion leaders and their followership. A method to better understand the thought processes and preferred communication channels of opinion leaders is through the assessment of individual critical thinking style (Gorham, Lamm, & Rumble, 2014; Lamm, 2015a). Without a proper assessment of critical thinking styles among group members working towards a common goal, communication is likely to be more difficult which in turn will prolong decision-making and solution identification (Lamm, 2015e). In a study by Gay, Terry, and Lamm (2015) critical thinking styles were measured in order to best align programming with the needs of extension volunteers. Gay et al. (2015) highlighted the effectiveness of applying the results of critical thinking style assessments to volunteer training by both enhancing the volunteer's retention of the program information, as well as encouraging the retention of volunteer involvement by increasing perceived confidence in tasks involved with service. By assessing critical thinking style, extension professionals can gain a better understanding of how to properly communicate messages to opinion leaders that enhance their ability to make correct inferences and deduce conclusions from data, heighten their awareness of biased messages disseminated from unaccredited sources, and improve leadership development (Lamm, 2015b; Pascarella & Terenzini, 1991).

## Conceptual Foundation

The conceptual foundation for this study incorporated the use of both the principles of critical thinking style and the theory of opinion leadership. The classification of critical thinking style falls on a continuum ranging from engagement to seeking information (Lamm, 2015c). An individual who is classified as one who seeks information is also known as a “seeker.” A seeker is one who is open to the opinions of others and actively seeks to increase their knowledge through objective decision-making (Lamm & Irani, 2011; Lamm, 2015c). A seeker recognizes every problem as complex and investigates every aspect of the issue often finding more than one solution. Seekers will actively seek the truth to a statement, even if the statement contradicts the individual’s own opinion or belief (Lamm, 2015c). On the other end of the continuum, an individual who practices engagement with others in order to critically think is also known as an “engager.” Engagers easily communicate their reasoning processes to others when approaching a decision or solution (Lamm, 2015c). Engagers are aware of their environment and tend to look for opportunities to use more hands on and collaborative approaches to reasoning and problem solving for situations in which they feel a higher level of perceived competence (Lamm, 2015c; 2015d). Verbal reflections among group members with an engagement critical thinking style will encourage the application of the information being communicated (Lamm, 2015d).

Commonly researched in the areas of public opinion and communication, the theory of opinion leadership describes the process by which an individual with social influence identifies messages communicated to him/her and relays the messages to the groups of people within his/her realm of influence in a way that causes behavioral change (Aral, 2011; Rogers & Cartano, 1962; Schafer & Taddicken, 2015). Opinion leadership is categorized as a two-step communication process where an opinion leader receives a message and decides whether or not to disseminate the information to his/her group of influence (Lazarfeld, Berelson, & Gaudet, 1948). Rogers and Cartano (1962) define opinion leaders as those who are sought out by others for advice and information. Expanding on the idea, Aral (2011) defined an opinion leader as an individual with social influence who can elicit behavioral change within a network as opposed to just being connected to a network and relaying a message. For example, behavioral change could be illustrated by an opinion leader advocating for a new product or idea to gain social acceptance among his/her network (Aral, 2011).

Three facets of opinion leadership commonly referred to in the literature include a description of the opinion leaders themselves in terms of how they are identified, the relationship between opinion leaders and their network, and which communication channels are preferred and selected by opinion leaders (Schafer & Taddicken, 2015). Opinion leaders have been identified as those who are able to reach the “less active sections of the population” using social influence and interpersonal communication strategies (Rogers & Cartano, 1962, p. 436). The social relationship referred to in opinion leadership is illustrated by the idea of an interconnected network of individuals interacting through multiple outlets of communication guided by social influence (Aral, 2011; Rogers & Cartano, 1962). Additionally, opinion leaders tend to engage with their networks in a way that coordinates understanding of a product or idea. For example, an opinion leader might connect the new idea or product to existing social norms in order to gain more rapid acceptance (Rogers, 2003). In terms of preferred communication channels, opinion

leaders seek more impersonal and technically accurate sources of information (Rogers & Cartano, 1962).

The literature supports a strong connection between information seeking and communication behaviors and opinion leadership (Arndt, 1972). The tendency of opinion leaders to engage and connect new ideas to preexisting social norms to increase understanding reflects the engaging critical thinking style, whereas the tendency to seek more impersonal and technically accurate sources of information is associated with the characteristics of an information seeking critical thinking style (Lamm & Irani, 2011). In addition, the presence of monomorphic tendencies are more common among opinion leaders. Opinion leaders described as monomorphic only show social influence on a single topic (Rogers & Cartano, 1962). This tendency is similar to the engagement critical thinking style, as engagers look for circumstances where they can actively collaborate with other individuals on topics where they have high levels of perceived competence (Lamm & Irani, 2011). In regards to issues involving individuals with social influence on a single topic in the agriculture and natural resources fields, opinion leaders have been characteristically described as less optimistic and less likely to take risks (Lamm et al., 2014). Likelihood to take risks has been observed as a reflection of the engagement critical thinking style due to the reservations of engagers to act on circumstances when perceived competence is low within a topic area (Lamm & Irani, 2011).

Based on the critical thinking style literature, group members working together towards a common vision are more likely to collaborate when attributes such as communication channel preference and critical thinking style are similar (Kirton, 2003; Lamm, 2015e). Although the process of decision-making might be slowed, groups of individuals with different viewpoints can benefit from the opportunity to incorporate the perspectives of others into their own perspective resulting in a solution that maximizes outreach efforts (Cole, 1985). In the same way, extension professionals can benefit from collaborating with opinion leaders to create an environment which fosters the maximization of outreach efforts to the public to address complex issues facing agriculture and natural resources.

### **Purpose and Objectives**

The purpose of this study was to explore the relationship between opinion leaders' critical thinking style and communication channel preferences and if those relationships varied depending upon expression of opinion leadership within diverse agriculture and natural resource contextual issue areas. The objectives for this study were to:

1. Identify and describe opinion leaders emerging from the general public within three agriculture and natural resource contextual issues areas: water, food safety, and genetic modification (GM).
2. Identify opinion leaders' critical thinking styles within the three agriculture and natural resource contextual issues areas: water, food safety, and GM.
3. Determine if differences in critical thinking styles existed among those expressing opinion leadership within the within the three issues areas: water, food safety, and GM.

4. Identify the preferred communication channels among those expressing opinion leadership within the three contextual issues areas, and if preferred communication varied depending upon critical thinking style.

## **Methods**

In order to reach the objectives, this descriptive study used non-probability opt-in sampling procedures to reach the target audience of [State] residents age 18 or older. Respondents in the study completed an online questionnaire which assessed self-reported critical thinking style, opinion leadership within one of the three contextual areas (water, food safety, or GM), and communication channel preferences. The three contextual issue areas were selected in order to identify and compare critical thinking style and communication channel preferences among opinion leaders representing different contextual issue areas. A panel of experts were used to validate the survey instrument.

Each of the respondents within the three contextual issue areas took one of two surveys: a water-focused survey and a food-focused survey (that included questions about both food safety and GM). The water survey was sent to 1,192 individuals with 749 responses received resulting in a participation rate of 63%. The food survey (which included questions about both GM and food safety) was sent to 770 individuals with 524 responses received resulting in a participation rate of 68%. The 524 responses to the food survey were then processed and weighted based on the population's demographics. After eliminating respondents that failed manipulation checks the sample included 450 individuals. After finalizing responses to the food survey, the respondents were divided into two separate data sets. One data set represented the respondents' answers from the food safety portion of the survey, and the other data set represented the respondents' answers from the GM portion of the survey. The three data sets (water, food safety and GM) were then combined to contain all 1,649 respondents representing responses within the three contextual issue areas.

Opinion leaders were then identified. A series of questions adapted from a previously established instrument (Childers, 1986) were used to identify level of leadership within each of the three context areas. The scale requested the respondent indicate their perceptions of six statements on a five-point semantic differential scale. The statements included: the amount of people he/she told about [the contextual issue], how often the respondent talked to their friends and colleagues about [the contextual issue], the likelihood of the respondent telling peers about new developments of a [contextual issue] versus peers telling the respondent, how much information the respondent gives his/her friends regarding the [contextual issue], how often the respondent is asked by his/her circle of friends about the [contextual issue], and how often the respondent is used as a source of advice on the [contextual issue]. Responses to the six items were averaged to create an overall opinion leadership score within the contextual area. Reliability analysis was run resulting in a Cronbach alpha coefficient of .89. A score of one reflected a low level of opinion leadership whereas a score of five reflected a high level of opinion leadership. The  $z$  score of the opinion leadership index score was then calculated. Respondents with a  $z$  score of one, based on their index score indicating they were one standard deviation or more above the mean, were identified as opinion leaders and used in further data analysis.



The 300 opinion leaders identified in this study were then categorized based on the contextual issue area represented by the online survey they took. The water group included 115 opinion leaders, the food safety group included 124 respondents, and the GM group included 61 respondents. Of the 300 opinion leaders, 38% were male and 62% were female. In regards to race, 1.3% self-identified as American Indian or Alaska Native, 3.0% self-identified as black or African American, 4.7% self-identified as Asian or Pacific Islander, 83.7% self-identified as white, and 2.3% self-identified as other. Respondents ranged in age from 19 to 81. Age was broken down into four generations including traditionalists (ages 71 to 85), baby boomers (ages 52 to 70), generation X (ages 36 to 51), and millennials (ages 18 to 35) to provide a more general comparison of the groups (Hammill, 2005). Results were analyzed using the Statistical Package for the Social Sciences<sup>®</sup> (SPSS) version 22.

In order to measure critical thinking style, the University of Florida Critical Thinking Inventory (UFCTI) was used (Lamm & Irani, 2011). The UFCTI requests respondents indicate their level of agreement with 20 statements on a five-point Likert-type scale that ranges from 1 = *Strongly Disagree*, 2 = *Disagree*, 3 = *Neither Agree nor Disagree*, 4 = *Agree*, 5 = *Strongly Agree* (Lamm & Irani, 2011). An overall seeking information score is assigned based on responses to 13 items with an overall seeking information score that can range from 13 to 65. An overall engagement score is assigned based on responses to seven items with an overall engagement score that can range from seven to 35. To calculate the overall UFCTI score, the engagement item scores are transposed, summed and multiplied by 1.866 (Lamm & Irani, 2011). The new engagement score is then added to the seeking information score to result in the overall UFCTI score. The overall UFCTI score is then examined on a continuum with scores that can range from 27 to 130 and is used to categorize critical thinking disposition between engaging to seeking information. An overall score of 26 to 78.4 categorized an individual's critical thinking style as an engager, whereas an overall score of 78.5 to 130 categorized an individual's critical thinking style as a seeker (Lamm & Irani, 2011). Reliability was calculated *ex post facto* with the overall UFCTI resulting in a Cronbach's *a* of .94, the engager construct a Cronbach's *a* of .87, and the seeker construct a Cronbach's *a* of .90.

Respondents were presented with 11 statements to identify their communication channel preferences. They were asked to check all that applied from the following list: reading printed fact sheets, bulletins, or brochures; visiting a website; attending a short course or workshop; watching a demonstration or display; reading a newspaper article or series; watching television coverage; attending a one-time volunteer activity; getting trained for a regular volunteer position; attending a fair or festival; watching a video; and attending a seminar or conference.

Data was analyzed using SPSS version 22.0. The data was analyzed descriptively, then chi-square analysis were conducted to identify significant differences between communication channel preference and issue group. Finally, a series of ANOVAs were conducted to identify significant differences in critical thinking styles among the opinion leaders within the three contextual issue areas. A significance level of  $p \leq .05$  was identified *a priori*.

### **Results Identify and describe water, food safety and GM opinion leaders**

An analysis of the three groups revealed the majority of the overall opinion leaders were female. Among the three groups, the water group identified as 67% ( $n = 77$ ) female, the food safety

group identified as 59% ( $n = 73$ ) female, and the GM group identified as 59% ( $n = 36$ ) female. The average age for each of the three groups was 43 for the water group ( $M = 42.8$ ,  $SD = 16.7$ ), 42 for the food safety group ( $M = 42.1$ ,  $SD = 14.8$ ), and 42 for the GM group ( $M = 41.9$ ,  $SD = 14.5$ ). The range of ages for each of the three groups was between 19 and 81 for the water group, and between 19 and 74 for both the food safety and GM groups.

In regards to ethnicity 15% ( $n = 17$ ) of the respondents in water group, 22% ( $n = 27$ ) of the respondents from the food safety group, and 23% ( $n = 14$ ) of the respondents from the GM group identified themselves as Hispanic/Latino(a)/Chicano(a). When examining race for the three groups, the majority of each of the groups identified themselves as white. Among the three groups, the water group identified as 77% ( $n = 89$ ) white, the food safety group identified as 85% ( $n = 105$ ) white, and the GM group identified as 84% ( $n = 51$ ) white. A complete description of the demographic characteristics for each of the three groups can be found in Table 1.

Table 1

*Demographical Breakdown of Water, Food Safety, and GM Issue Groups*

Demographic Variable	Water ( $n = 115$ ) %	Food Safety ( $n = 124$ ) %	GM ( $n = 61$ ) %
<b>Age</b>			
18 to 35	43	40	38
36 to 51	20	30	36
52 to 70	31	27	25
71 to 85	6	3	1
<b>Ethnicity</b>			
Hispanic/Latino(a) Chicano(a)	15	22	23
<b>Race</b>			
White	77	85	84
Black or African American	13	5	2
Asian or Pacific Islander	4	6	8
Native American or Alaskan Native	1	1	2
Other	5	3	4
<b>Sex</b>			
Male	33	41	41
Female	67	59	59

**Identify water, food safety and GM opinion leaders' critical thinking styles**

Overall the opinion leaders' UFCTI scores ranged from 67.5 to 91.2 ( $M = 77.5$ ,  $SD = 6.58$ ). In addition, the overall seeking score was 55.3 ( $SD = 6.15$ ), and the mean engagement score was 54.8 ( $SD = 6.58$ ). The three issue groups were also evaluated individually to address individual descriptive statistics reflecting the seeking information, engaging, and overall UFCTI scores. The water group's overall UFCTI score was 77.9 ( $SD = 3.28$ ), which classified this group as the

engagement thinking style. The water group's overall UFCTI score was the closest score to the information seeking critical thinking style category when compared to the other two groups. The food safety group's overall UFCTI score was 77.5 ( $SD = 3.85$ ). The GM group's overall UFCTI score was 76.9 ( $SD = 3.54$ ), which classified this group as having the strongest affinity towards the engaging critical thinking style when compared to the other two groups. A complete description of the critical thinking style scores for each of the three groups can be found in Table 2.

Table 2

*Critical Thinking Styles of Water, Food Safety, and GM Opinion Leaders*

Critical Thinking Style	Water ( $n = 115$ )		Food Safety ( $n = 124$ )		GM ( $n = 61$ )	
	<i>M</i>	<i>SD</i>	<i>M</i>	<i>SD</i>	<i>M</i>	<i>SD</i>
Overall UFCTI Score	77.9	3.28	77.5	3.85	76.9	3.54
Seeker Score	56.2	6.25	54.2	5.9	56.1	6.22
Engager Score	55.3	6.92	53.6	6.4	56.2	5.98

**Determine if differences in critical thinking styles existed among water, food safety and GM opinion leaders**

In order to identify if significant differences in critical thinking styles existed between issue groups, a one-way ANOVA was conducted. Although there were no significant differences in the overall UFCTI between groups, there were significant differences in seeking information and engaging scores ( $p = .02$  and  $p = .03$ , respectively). A *post hoc* test was conducted to identify where the differences between groups existed (Table 3). A significant difference was found between the water and food safety groups in reference to the seeking information critical thinking style score ( $MD = 2.01$ ,  $p = .03$ ). A significant difference was also identified between the GM and food safety groups in the engagement critical thinking style score ( $MD = 2.58$ ).

Table 3

*Significant Differences in Critical Thinking Style among Water, Food Safety, and GM Opinion Leaders*

Issue Group Comparison		<i>p</i>	<i>MD</i>	<i>SE</i>
Seeker Score	Water Food Safety	.034*	2.01	.06
	GM	1.00		0.79
Engager Score	Food Safety GM	.12	-1.95	0.95
	Food Safety Water	.16	1.63	0.84
	GM Water	1.00	0.95	1.03
	GM Food Safety	.04*	2.58	1.02

Note. \* $p < .05$

### Identify the preferred communication channels of water, food safety and GM opinion leaders

Each respondent was asked to indicate which type(s) of communication method he/she would be interested in participating in to learn more about the issue topic under discussion (i.e. water, food safety, and GM). Descriptive statistics were run to calculate how many individuals from each group indicated they would take part in a specific communication method. A chi-square analysis was conducted to identify any significant differences between issue groups and communication channel preferences (Table 4). The results revealed there were significant differences between the issue groups and the communication channel preferences for looking at a demonstration or display, taking part in a one-time volunteer activity, and attending a fair or festival (Table 4).

Table 4

*Communication Channel Preferences of Water, Food Safety, and GM Opinion Leaders*

	Water ( $n = 115$ )	Food Safety ( $n = 124$ )	GM ( $n = 61$ )	$X^2$	$p$
	%	%	%		
Attend a fair or festival	37	8	10	37	.00*
Take part in a one-time volunteer activity	32	17	20	8.3	.02*
Look at a demonstration or display	30	15	16	9.1	.01*
Watch a video	50	36	34	5.7	.06
Watch TV coverage	65	54	49	5.1	.08
Attend a seminar or conference	22	15	23	2.2	.33
Get trained for a regular volunteer position	19	15	15	1.1	.59
Attend a short course or workshop	29	24	25	.71	.70
Read printed fact sheets, bulletins, or brochures	46	48	52	.65	.72
Read a newspaper article or series	45	42	39	.61	.74
Visit a website	77	77	80	.39	.82

Note. \* $p < .05$

### Conclusions

The results from the study supported the preexisting literature regarding common tendencies of opinion leaders. First, the data revealed the majority of the opinion leaders were white women ranging in age from 18 to 50 years old. The overall critical thinking score for the three groups

collectively classified the sample as engager ( $M = 77.5$ ). This finding supports the notion that women exhibit strengths when networking found in the literature (Madsen, 2012; Mayer, 2001).

When examining the three issue groups separately, differences were identified among overall critical thinking styles. Although all three issue groups were classified as engagers, there were some subtle differences in the level of engagement among groups. These differences might exist due to the reasoning behind individual involvement with an issue topic. For example, water issue opinion leaders could be serving in this capacity for environmentally-conscious reasons, which could elicit behavior closer on the continuum to information seeking, compared to the other two issue groups. As stated by Lamm and Irani (2011), information seeking behavior describes individuals who prefer to think about information they sought out on their own. Thus, environmentally-conscious behavior could be subject change based on the new information released from accredited sources (Gorham, Lamm, & Rumble, 2014).

Food safety opinion leaders may show signs of information seeking behavior based on the frequency with which new information concerning health concerns regarding food safety practices emerges. In this instance, individuals might seek information to find the true answer, even if it contradicts an individual's belief is categorized as information seeking critical thinking style (Lamm & Irani, 2011). The GM opinion leaders had the strongest engager tendencies. This finding aligns with previous literature on the subject. In a study by Ruth (2015), consumers' change in attitude was correlated with the message's source. Wunderlich and Gatto's (2015) study on consumer perceptions of GM products also supported this notion adding that most consumers utilize more interactive media and news outlets to find information on the topic of GM. The use of interactive information retrieval could be categorized as using an engagement critical thinking style (Lamm & Irani, 2011).

Furthermore, significant differences were identified among the opinion leaders depending upon the issue within the individual seeking and engagement critical thinking style scores. The significant difference identified between the water and food safety groups in information seeking scores could be attributed to the tendency of individuals involved in food safety issue groups to engage in behaviors that reflect ideas they feel personally competent in. For example, individuals who engage in opinion leadership of food safety that perceive a high level of competence may not be inclined to seek out additional information that could contrast existing behaviors (GentryVan Laanen & Nies, 1995; Roy, Francis, Shaw, & Rajagopal, 2016). However, information communicated through a means of engagement can create attitude and behavioral change in regards to food safety (Gentry-Van Laanen & Nies, 1995; Roy, Shaw, & Rajagopal, 2016). Another significant difference was between the GM and food safety opinion leaders and their engagement critical thinking style score. This difference was supported by the literature in reference to the prevalence of engagement with information behaviors leaders utilize when communicating with their followership about GM issues (Ruth, 2015; Wunderlich & Gatto, 2015).

After analyzing the communication channel preferences among opinion leaders in the three contextual issue groups, some significant differences existed. The water contextual issue group identified that looking at a demonstration or display, taking part in a one-time volunteering activity, and attending a festival were some of the highest ranked preferred communication channel preferences. The water group's affinity for these communication channels resulted in

significant differences when compared to the other two contextual issue groups. These communication channels were ranked highest among the water issues category. The literature also supports the tendency for environmentally conscious individuals to participate in workshops and events to establish meaningful interpersonal connections within the community (Diehl, Swenson & Wente, 2012).

### **Implications and Recommendations**

The findings from this study provide implications for how extension professionals should communicate with opinion leaders within issue areas. In terms of addressing complex problems facing the agriculture and natural resource industry, extension professionals need to effectively communicate with individuals from different disciplinary backgrounds in order to come up with more creative solutions (Andenoro et al., 2016). By understanding critical thinking styles, and associated communication channel preferences, extension professionals can more effectively collaborate with opinion leaders to disseminate important information regarding complex issues to the general public (Lamm, 2015e). Opinion leaders expressing the engagement critical thinking style exhibit a high level of competence, therefore enhancing face-to-face communication between them and extension professionals could improve the likelihood of increasing their level of opinion leadership engagement resulting in a continuous cycle of twoway communication with their followership (Deci & Ryan, 2008; Lamm & Irani, 2011; Rogers, 2003). This continuous cycle could then enable extension programming to become a recurring social norm even after the extension professional is not directly affiliated with the program. The recurrence of the extension program without the need for direct contact with an extension professional will assist in resource conservation for Extension as a whole.

In addition, since this study found most opinion leaders within these important issue areas are women, extension programs should be made to appeal to women. Further research into when women are inclined to meet, the settings they prefer, and the type of learning opportunities they want to engage in could enhance this cause. Since the web was the most preferred communication channel, research examining the style of web-based content preferred by women, critical thinking style, and by topical issue would be helpful in creating materials best suited to the communication preferences of opinion leaders no matter the issue being addressed.

Since most of the opinion leaders were more inclined to engage when thinking critically, web materials including discussion boards or interactive webinars would be helpful to extension professionals when disseminating important information regarding complex issues. For information seeking styles, creating websites providing information regarding different perspectives of the same issue type, and including reflective questions, might be helpful. Additional research might investigate the communication preferences and critical thinking styles of the followership of the opinion leaders within each issue group. This assessment could allow researchers to assess significant differences between opinion leaders and their followership. This information would enable extension professionals to provide recommendations to improve communication techniques between opinion leaders and their followership, increasing the ability for extension to reach an even larger target audience.

## References

- Andenoro, A. C., Baker, M., Stedman, N. L. P., & Weeks, P. P. (2016). Research priority seven: Addressing complex problems. In T. G. Roberts, A. Harder, & M. T. Brashears (Eds.), *American Association for Agricultural Education national research agenda: 2016-2020* (pp. 57-62). Gainesville, FL: Department of Agricultural Education and Communication.
- Aral, S. (2011). Identifying social influence: A comment on opinion leadership and social contagion in new product diffusion. *Marketing Science, 30*(2), 217-223. doi: 10.1287/mksc.1100.0596
- Arndt, J. (1972). Intrafamilial homogeneity for perceived risk and opinion leadership. *Journal of Advertising, 1*(1), 40-47. doi: 10.1080/00913367.1972.10672472
- Braverman, M. T., Franz, N. K., & Rennekamp, R. A. (2012). Extension's evolving alignment of programs serving families and youth: Organizational change and its implications. *Journal of Extension, 50*(6). Retrieved from <http://www.joe.org/joe/2012december/a1.php>
- Bruce, R. L., & Carter, G. L. (1967). Administrative climate. *Journal of Extension, 5*(1), 7-14. Retrieved from <http://www.joe.org/joe/1967spring/1967-1-a1.pdf>
- Childers, T. L. (1986). Assessment of the psychometric properties of an opinion leadership scale. *Journal of Marketing Research, 23*(2), 184-188.
- Cole, M. (1985). The zone of proximal development: Where culture and cognition create each other. In J. V. Wertsch (Ed.), *Culture, communication, and cognition: Vygotskian perspectives* (pp. 146-161). New York, NY: Cambridge University Press.
- Deci, E. L., & Ryan, R. M. (2008). Self-determination theory: A macrotheory of human motivation, development, and health. *Canadian Psychology, 49*(3), 182-185. doi: 10.1037//a0012801
- Deihl, D. C., Swenson, S. E., Wente, J. N. (2012). Evaluation of a sustainable Green Living Expo event: Attendee's reports of satisfaction, learning, and behavior change. *Journal of Extension, 50*(3). Retrieved from <http://www.joe.org/joe/2012june/a8.php>
- Food and Agriculture Organization of the United Nations (FAO). (2009). *How to feed the world in 2050*. Retrieved from [http://www.fao.org/fileadmin/templates/wsfs/docs/expert\\_paper/How\\_to\\_Feed\\_the\\_World\\_in\\_2050.pdf](http://www.fao.org/fileadmin/templates/wsfs/docs/expert_paper/How_to_Feed_the_World_in_2050.pdf).
- Gay, K. D., Terry, B., & Lamm, A. J. (2015). Identifying critical thinking styles to enhance volunteer development. *Journal of Extension, 53*(6). Retrieved from <http://www.joe.org/joe/2015december/tt2.php>
- Gokhale, A. A. (1995). Collaborative learning enhances critical thinking. *Journal of Technology Education, 7*(1), 22-30. Retrieved from <https://scholar.lib.vt.edu/ejournals/JTE/v7n1/gokhale.jte-v7n1.html>

- Gorham, L. M., Lamm, A. J., & Rumble, J. N. (2014). The critical target audience: Communicating water conservation behaviors to critical thinking styles. *Journal of Applied Communications*, 98(4), 42–55. Retrieved from [http://journalofappliedcommunications.org/images/stories/issues/2014/jac\\_v98\\_n4\\_article4.pdf](http://journalofappliedcommunications.org/images/stories/issues/2014/jac_v98_n4_article4.pdf)
- Hammill, G. (2005). Mixing and managing four generations of employees. *FDU Magazine*, 12(2). Retrieved from <http://www.fdu.edu/newspubs/magazine/05ws/generations.htm>
- Kirton, M. J. (2003). *Adaption-Innovation: In the context of diversity and change*. New York, NY: Routledge.
- Lamm, A. J. (2015a). *Integrating critical thinking into extension programming #1: Critical thinking defined* (AEC544). Gainesville: University of Florida Institute of Food and Agricultural Sciences. Retrieved from <http://www.edis.ifas.ufl.edu/wc206>
- Lamm, A. J. (2015b). *Integrating critical thinking into extension programming #2: Developing critical thinking skills* (AEC545). Retrieved from <http://www.edis.ifas.ufl.edu/wc207>
- Lamm, A. J. (2015c). *Integrating critical thinking into extension programming #3: Critical thinking style* (AEC546). Retrieved from <http://www.edis.ifas.ufl.edu/wc208>
- Lamm, A. J. (2015d). *Integrating critical thinking into extension programming #4: Measuring critical thinking styles using the UFCTI* (AEC547). Retrieved from <http://www.edis.ifas.ufl.edu/wc209>
- Lamm, A. J. (2015e). *Integrating critical thinking into extension programming #5: Using critical thinking styles to enhance team work* (AEC548). Retrieved from <http://www.edis.ifas.ufl.edu/wc210>
- Lamm, A. J., & Irani, T. (2011). *UFCTI manual*. Gainesville, FL: University of Florida.
- Lamm, K. W., Lamm, A. J., & Carter, H. (2015). Bridging water issue knowledge gaps between the general public and opinion leaders. *Journal of Agricultural Education*, 56(3), 146161. DOI: 10.5032/jae.2015.03146
- Lamm, K. W., Lamm, A. J., & Carter, H. S. (2014). Opinion leadership development: Context and audience characteristics count. *Journal of Agricultural Education*, 55(2), 91-105. doi: 10.5032/jae.2014.02091
- Lazarsfeld, P., Berelson, B., & Gaudet, H. (1948). *The people's choice* (2nd ed.). New York, NY: Columbia University Press
- Madsen, S. R. (2012). Women and leadership in higher education: Current realities, challenges, and future directions. *Advances in Developing Human Resources*, 14(2). doi: 10.1177/1523422311436299
- Mayer, L. C. (2001). Predictors of women's success in achieving senior-level administrative positions in CSREES. *Journal of Extension*, 39(2). Retrieved from <http://www.joe.org/joe/2001april/rb6.php>



- National Agricultural Library: USDA. (n.d.). *Farm demographics: Introduction to farm demographics*. Retrieved from <http://www.start2farm.gov/usda/knowledge>
- Pascarella, E., & Terenzini, P. (1991). *How college affects students: Findings and insights from twenty years of research*. San Francisco, CA: Jossey Bass.
- Rogers, E. M. (2003). *Diffusion of innovations* (5th ed.). New York, NY: Free Press.
- Rogers, E. M., & Cartano, D. G. (1962). Methods of measuring opinion leadership. *The Public Opinion Quarterly*, 26(3), 435-441. Retrieved from <http://www.jstor.org/stable/2747233>
- Ruth, T. K. (2015). *The influence of persuasive communication on Florida consumers' change in attitude and change in risk perception of genetically modified food* (Masters thesis). Retrieved from University of Florida Libraries Catalog. UF034054040
- Schafer, M. S., & Taddicken, M. (2015). Opinion leadership revisited: A classical concept in a changing media environment. *International Journal of Communication*, 9, 956-959.
- Taylor, M. R., & Lamm, A. J. (2016, February). *Identifying the needs of opinion leaders to encourage widespread adoption of water conservation and protection*. Paper presented at the American Association for Agricultural Education Southern Region Conference, San Antonio, TX.
- Valente, T. W., & Davis, R. L. (1999). Accelerating the diffusion of innovations using opinion leaders. *The Annals of the American Academy of Political and Social Science*, 566(1), 556-567. Retrieved from <http://www.jstor.org/stable/1048842>
- Valente, T. W., & Pumpuang, P. (2007). Identifying opinion leaders to promote behavior change. *Health Education and Behavior*, 34(6), 881-896. Retrieved from <http://heb.sagepub.com/content/34/6/881.full.pdf+html>
- Wunderlich, S., & Gatto, K. A. (2015). Consumer perception of genetically modified organisms and sources of information. *Advances in Nutrition*, 6(1), 841-851. doi: 10.3945/an.115.008870

## **Examining the Critical Moments in Information Processing of Water Conservation Videos within Young Farmers and Ranchers: A Psychophysiological Analysis**

Laura M. Gorham, Texas Tech University  
R. Glenn Cummins, Texas Tech University  
Kyle C. Gilliam, Texas Tech University  
Matt Baker, Texas Tech University  
Scott Burris, Texas Tech University  
Erica Irlbeck, Texas Tech University

### **Abstract**

*Discussions on water conservation and how to conserve and provide enough water has become one of the most highly debated issues in modern society. Agricultural irrigation plays a key role in the water quantity levels in rural communities, and farmers and ranchers have previously supported water conservation practices. However, many of these same producers are conflicted between conserving water for future generations or maximizing profits for short-term yield to cover the increasing costs of annual operations and debt service. Although many Extension efforts have engaged the public in understanding of behavior and attitudes toward water conservation, limited research has been focused on understanding how agriculturalists respond to water conservation messages. Theories of information processing have connected increased cognitive resource allocation and cognitive processing may lend itself to stronger attitudes and a stronger likelihood of behavioral intent and action. The goal of this study was to employ an innovative measurement approach – the use of a psychophysiological measure (e.g., heart rate) to determine what message components elicited increased information processing during exposure to two water conservation videos. The results of this study provides key information to educators and communicators designing messages targeting farmer and rancher attitudes of water conservation. Farmers and ranchers allocated more attention to sections of the video that provided scientific evidence, specifically on screen graphics and narrated statistics. Because attention allocation has been associated with information processing, the findings from this study provide unique evidence showing where in a media stimulus farmers and ranchers allocate attention.*

### **Introduction and Literature Review**

Globally, water is a crucial aspect of human survival impacting modern industry, recreation, and the agricultural food system (Watkins, 2009). Although water may cover more than 70% of the planet, less than three percent is freshwater that may be used for drinking (Adler, 2007). However, both non-recreational and recreational activities used to support modern society have negatively impacted the quantity of water available (Haung, Lamm, & Dukes, 2016). In an effort to preserve naturally occurring freshwater, discussions on how to conserve and provide enough water has become one of the most highly debated issues in modern society (Levy & Sidel, 2011).

Increases in water use are due to a growing population who needs more water than ever before to sustain themselves (Bartlett, 1999; Flint, 2004). According to Flint (2004), water demand in the United States has more than doubled since the 1950's and is expected to continue to increase as the world population grows to more than 9 billion by the year 2050. Although residential and

industrial water demands play a key role in urban and suburban environments, water demand is primarily used for agricultural irrigation in rural areas (Huang et al., 2016).

The context of this research was in the Southern Great Plains in an arid to semi-arid environment. In 2007, Allen, Baker, Segarra, and Brown reported that irrigated landscapes in these climatic areas were often fragile and stressed due to declining water quality and quantity and that efficiencies in irrigation (often exceeding 95% for drip systems) resulted in more water usage as new cropping systems were added.

According to West, Johnson, Kellison, Brown, & Pate (2015), some of the most conservation-oriented farmers in the Southern Great Plains experienced a 25% decline in aquifer volume compared to a 2003 baseline measure, and that “close to one-half of that decline occurred during 2011 and 2012, two years of severe drought and high water extraction” (p. 4). Texas High Plains farmers are also facing state-mandated pumping restrictions. As of January 1, 2015, Texas House Bill 1763 required that regional water districts adopt conservation measures. The regional underground district adopted a “Desired Future Condition” of 50% of the 2010 saturated thickness remaining in the aquifer in 50 years and placed a new rule on the amount of water that can be extracted to 18” per contiguous acre. Regional producers realize that the next drought will include these new pumping restrictions. Hence, growers and municipalities alike have a sense of urgency for interventions, which will reduce aquifer depletion where 95% of the aquifer extraction is to support the region’s \$5B agricultural economy.

Prior research has shown farmers and ranchers have been found to have positive attitudes toward water conservation practices and programs (Durst, Meyers, Irlbeck, & Ritz, 2016). However, these same farmers also have indicated neutrality when asked if they had intentions of participating in water conservation practices (Durst et al., 2016). Durst et al.’s (2016) study on farmer and producers’ perceptions on water conservation had similar results in terms of consumer water conservation perceptions to Huang et al. (2015) and Gorham, Lamm, and Rumble (2014) studies.

Many farmers and ranchers understand the need for engaging in water conservation behaviors; however, many are unable to maximize participation in water conservation activities due to a variety of reasons. These reasons range from changing weather patterns, the need to maximize production due to increasing costs and debt service obligations, and/or land tenure issues. Because persuasion theories suggest that the higher the level of information processing, the higher the level of attitude change during a persuasive message (Petty & Cacioppo, 1986), a useful first step in crafting tailored messages that will achieve strategic communication goals is to identify specific message elements or techniques that elicit increased information processing. By identifying such passages that yield increased information processing in response to educational videos that persuade receivers to participate in conservation behaviors, agriculturalists can develop higher quality messaging.

Prior research has addressed the ideas of strategic communications (i.e., targeting audiences and tailoring messages) as an effective means to communicate about water conservation practices with the public. For example, Huang et al. (2016) recommended message tailoring, or developing communication and education programs that are relevant to the specific needs and behavioral patterns of high-water users. Gorham et al. (2014) identified how critical thinking

style or the way individual's think about and seek out information had a moderate relationship with water conservation intentions. Similarly, the role of salient and tailored messages to encourage water conservation behaviors has provided evidence that such messaging can encourage individuals to participate in environmentally responsible behavior (Warner, Rumble, Martin, Lamm, & Cantrell 2015). When making information salient for consumers to participate in behaviors, or frame a message, communicators select aspects of information "to promote a particular problem, definition, casual interpretation, moral evaluation, and/or treatment recommendation" (Entman, 1993, p. 52).

Message features or attributes refer to aspects of communication that produce a greater effect on affective, cognitive, and behavioral processes that impact persuasion (Shen & Bigsby, 2013). The goal of the persuasive messages is to have the receiver think and behave in a specific way or to find information as truthful (Petty & Cacioppo, 1986; Shen & Bigsby, 2013). Specifically, the aspects of message construction have influenced how receivers find information to be true (Shen & Bigsby, 2013; Warner et al., 2015). Within persuasion literature, researchers have found two types of message features impacting decision-making are statistical evidence, which "presents statistics such as frequencies and percentages to support the claim, or testimonial evidence, which "uses a person's personal experience, eye-witness account or personal opinion to support a claim" (Shen & Bigsby, 2013, p. 22). In Allen and Preiss' (1977) meta-analysis, statistical evidence has been found to be more persuasive than testimonial evidence. However, Warner et al. (2015) discovered messages resonating with an individual's social and personal beliefs were more effective in persuading someone to participate in conservation behaviors in consumer-based research with water conservation messages.

Studies have shown how tailored message frames are crucial to achieving strategic communication goals to encourage an audience segment to engage in water conservation (Gorham et al., 2014; Huang et al., 2016; Warner et al., 2015). However, these studies only allow the researchers to understand an individual's overall or global response to a communication material after they have viewed it, and they disregard the dynamic nature of messages or how they unfold over time. Moreover, post-test assessment fails to reveal the dynamic nature of individual response to various parts of a message over time. Theories of information processing suggest higher levels of information processing lead to higher levels of change in attitude and behavioral intent (Petty & Cacioppo, 1986). Drawing upon theories of information processing during message consumption, this study employs a psychophysiological, or a biometric measurement tool (e.g., heartrate as a proxy for cognitive resource allocation), to understand how specific message attributes or components of a message create higher levels of information processing in response to water conservation videos.

### **Conceptual Framework**

In order for a communications message to have an effect on attitude or behavioral intention, it must be processed by an individual (Lang & Ewoldsen, 2010). Information processing has been conceptualized as the idea of how an individual attends to, makes sense of, and remembers information contained in a message (Geiger & Newhagen, 1993; Lang, 2000). In theories regarding information processing of persuasive messages to encourage behaviors, such as the Elaboration Likelihood Model, higher central-route processing refers to higher levels of information processing of a persuasive message (Petty & Cacioppo, 1986). Such central

processing of a message is privileged, as it leads to stronger memory for the message, attitude, and behavior change. As researchers look to understanding what parts of water conservation messages create more significant changes in attitude and behavior, researchers must determine what cognitive processes occurred that resulted in the desired attitude change (Lang & Ewoldsen, 2010).

During message consumption, information processing is automatic, and the individual will undergo sub-conscious cognitive and emotional processing of messages (Lang, 2000; Potter & Bolls, 2012). The use of psychophysiological measures of viewer response allows researchers to investigate the sub-conscious processing by continuously monitoring and recording “changes in the activity of physiological system caused by psychological input” (Ravaja, 2004, p. 193). This approach differs from typical measurement approaches that rely on qualitative or quantitative self-report in that such responses are subject to various biases and represent a less “pure” measurement of how viewers automatically respond during message consumption. Put another way, self-report data are viewed as “offline” responses; whereas, psychophysiological measures are “online” responses collected during the act of message consumption. Moreover, specific responses may be pinpointed to precise elements within the message to reveal key message components. Theoretical advances in cognitive psychology and media psychology have provided connections to yoke specific types of physiological response with various constructs of cognitive resource allocation (i.e. attention) and their impact on information processing (Potter & Bolls, 2012; Ravaja, 2004).

**Attention.** Attention to an external stimulus such as a media message has been conceptualized as the “allocation of limited mental resources to a specific stimuli” (Ravaja, 2004, p. 197). Within psychophysiology, this increase in resource allocation or attention is indexed by cardiac deceleration, or a decrease in heart rate (Potter & Bolls, 2012). Furthermore, this allocation of cognitive resources may occur both in a controlled and uncontrolled fashion. For example, uncontrolled responses may be “orienting responses” to novel stimuli or the introduction of something in one’s sensory environment. Within media messages, such responses may be elicited by structural elements such as cuts, edits, or the introduction of onscreen graphics (Lang, Potter, Bolls, & Kawahara, 1999; Lang, Potter, & Grabe, 2003). In contrast, controlled attention allocation may result when viewers find information particularly salient or high in motivational relevance (Ravaja, 2004). Additionally, these measures may provide evidence of attention allocation that is complementary, and even sometimes, contradictory to self-report data (Ravaja, 2004). In both types of response, the individual prepares for greater information uptake, and these increases in attention allocation have been shown to relate to increased memory for elements of a message (Bolls, Muehling, & Yoon, 2003).

By continuously tracking these measures of viewers’ allocation of resources to a message, researchers can empirically examine processing of information without relying on self-report (Ravaja, 2004). Furthermore, these psychophysiological measures have the unique ability to detect changes in information processing throughout the duration of media consumption and allows researchers to understand how processing changes over time (Potter & Bolls, 2012). Lastly, measurement of resource allocation through psychophysiological measures allows comparisons with more traditional self-report measures to reveal consistencies or discrepancies between the two. Sometimes, By adopting these tools to understand what elements of a message

elicit increased attention within specific audiences, agricultural educators and communicators can develop messages targeted to increasing information processing to influence behavior intentions and attitude change.

### **Purpose and Research Questions**

Supporting Research Priority 7 of the AAAE National Research Agenda (Roberts, Harder, & Brashears, 2016), the goal of this study was to employ an innovative measurement approach—the use of psychophysiology as a transdisciplinary approach to solving the complex problem of sustainable water management—to determine what message attributes or components elicit increased information processing during exposure to two water conservation videos. To fulfill the purpose, the following research questions were addressed:

RQ<sub>1</sub>: What were the differences between the participant's cognitive resource allocation between the two videos?

RQ<sub>2</sub>: What message attributes created higher levels of cognitive resource allocation in the scientific evidence and testimonial videos?

RQ<sub>3</sub>: What were the differences in self-reported message elaboration between the two videos?

### **Methods**

#### **Design**

To address these research questions, an experiment was conducted where participants viewed two videos focusing on water, drought, and agriculture while the psychophysiological measure of heart rate for cognitive resource allocation was continuously recorded. A 2 (message appeal: testimonial vs. scientific evidence) X 80 (3-second time periods) within-subjects design was used to evaluate the role of information processing during stimulus exposure in a laboratory setting. Within this research approach, within-subjects designs are frequently employed to control for individual differences in resting or baseline heart rate (Potter & Bolls, 2014).

#### **Independent Variable**

**Treatment Variable.** The persuasive strategy employed by a message has the potential to elicit differences in message elaboration by inviting either central or peripheral processing of message content (Shen & Bigsby, 2013). Based upon prior research, two messages employing distinct message appeals while discussing water and drought impacts in the Southwestern United States were employed. One video was a human-interest or testimonial video outlining farmer/rancher personal experience, or testimonial evidence, of the effect of drought in an area geographically proximal to the research location. The second treatment was a scientific evidence-based video focused on presentation of statistics and percentages to conserve water. Both videos were edited to be four minutes in duration. Presentation order of the videos was counterbalanced across participants to guard against order effects (Ary, Jacobs, & Sorenson, & Walker, 2013).

#### **Dependent Variable**

**Resource Allocation.** Attention has been conceptualized as greater allocation of cognitive resources to encoding a message into the participant's memory. It has been operationalized through cardiac deceleration (i.e., lower heart rate) via online measurement during message consumption (Potter & Bolls, 2012). Throughout an orienting response to a specific message attribute, Ravaja (2004) explains, "increased cardiac parasympathetic activity causes the heart to slow down and is associated with information intake, attention, and approach behavior" (p. 201).

To answer research question one and two, heart rate was recorded as time between R-spikes in the QRS pattern in electrocardiogram waveform and transformed for ease of interpretation into heart rate in beats per minute. Heart rate data were resampled offline into 80 three-second time intervals. Lastly, heart rate values were transformed into change scores from a baseline or resting state to control for individual differences in physiological response. Baseline measures of heart rate were assessed for five seconds before onset of each message.

**Elaboration.** Cognitive elaboration of a message's features occur when individuals think critically and evaluates the content and features of a stimulus. In order to determine the level of elaboration on each message, or research question three, the researchers utilized Reynolds' (1997) self-report elaboration scale. After viewing each message, participants were asked to indicate their level of agreement with 12 items that were paired with 5-point Likert-type response scales (1 = *Strongly Disagree*, 5 = *Strongly Agree*). Sample items included "While watching I was exerting a good deal of cognitive effort" and "While watching the message, I was deep in thought about the message." Responses were internally consistent (Cronbach's  $\alpha = .84$ ), and they were summed and averaged to create an elaboration measure in response to each message.

### **Participants**

For the purpose of this study, twenty male beginning farmers and ranchers from the Lubbock, Texas area were recruited for this study. Participants were provided a \$100 gift card to Tractor Supply Company as an incentive. The beginning farmers and ranchers were selected as individuals who had recently completed, or were close to completing, a college degree program in an agricultural college at a large university. Physiology data were deleted for three participants due to high levels of noise artifacts from participant movement, yielding a sample of 17 for analysis.

### **Procedure and Protocol**

After participants signed Texas Tech University Institutional Review Board approved consent forms, the psychophysiological measures of heart rate were collected via a bioamplifier module data acquisition system connected to a desktop computer running AcqKnowledge version 4.21. The AcqKnowledge software allows researchers to control the data acquisition process and extract the data offline after collection. The participants were seated in a comfortable chair locked in a reclining position and were asked to view two stimulus clips on a 40-inch flat panel television monitor approximately four feet away. Instructions and stimuli were presented on the television monitor through MediaLab stimulus presentation software. Heart rate, the physiological indicator of cognitive resource allocation, was recorded from the electrocardiogram (ECG) waveform obtained from the AcqKnowledge software during exposure to each stimulus. To record ECG, three AG/AGCL electrodes were placed on the participants (ground electrode placed on the wrist, positive and negative referenced recording electrodes placed on the forearms), and signals from the electrodes were transmitted to ECG100C bioamplifier module, and then to the data collection program (AcqKnowledge).

### **Data Analysis**

To perform data analysis, participant data were converted into change scores for each psychophysiological measure (Potter & Bolls, 2012). Calculations were computed by subtracting

heart rate from the mean baseline. Baseline data were collected 5 seconds prior to each stimulus to represent the participant's resting heart rate prior to message onset. Data were resampled offline into 3-second segments. A repeated measures ANOVA was conducted in SPSS version 22.0 to answer RQ1. To determine the message attributes that created higher levels of cognitive resource allocation (RQ2), the researchers created an average for each participant response per 3-second segment. Next, z-score computations were completed in SPSS version 22.0 and were plotted on a graph in Excel. Potter and Bolls (2012) discussed cognitive resource allocation occurs when heart rate decreases. Visual inspections of peaks more than 1.0 standard deviations below the baseline identified attention allocation to message attributes over time. Afterward, the researchers conducted a repeated measures ANOVA to determine the significance of the changes in heart rate (RQ2). A paired sample t-tests was also used to determine differences in self-perceived elaboration between the treatment videos (RQ3).

## Results

### **RQ1: What were the differences between participants' cognitive resource allocation between the two videos?**

This research question sought to identify if any difference appeared in overall resource allocation between the two videos. A repeated-measures ANOVA was conducted where message type (2) and time period (80) served as within-subjects factors and heartrate change from baseline served as the repeated dependent measure. This test failed to find an overall effect of message type,  $F(1, 16) = .20, p > .05$ . Thus, no global difference was observed in terms of resource allocation.

### **RQ2: What message attributes created higher levels of cognitive resource allocation?**

In this research question, the researchers sought to identify moments within the message that led to increased cognitive resource allocation. To identify these moments, mean heart rate change scores for each time segment were standardized to z-scores. These z-scores were then plotted and visually inspected to identify unique moments within each message when mean standardized heart rate change scores fell below 1.0 standard deviation from the series mean of zero. As such, these represent periods indicative of increased resource allocation (i.e., decreases in heart rate).

### **Scientific Evidence Video**

Visual inspection of the standardized heart rate change data provided evidence of five critical moments within the scientific evidence video where heart rate deceleration suggested increased levels of cognitive resource allocation (see Figure 1).



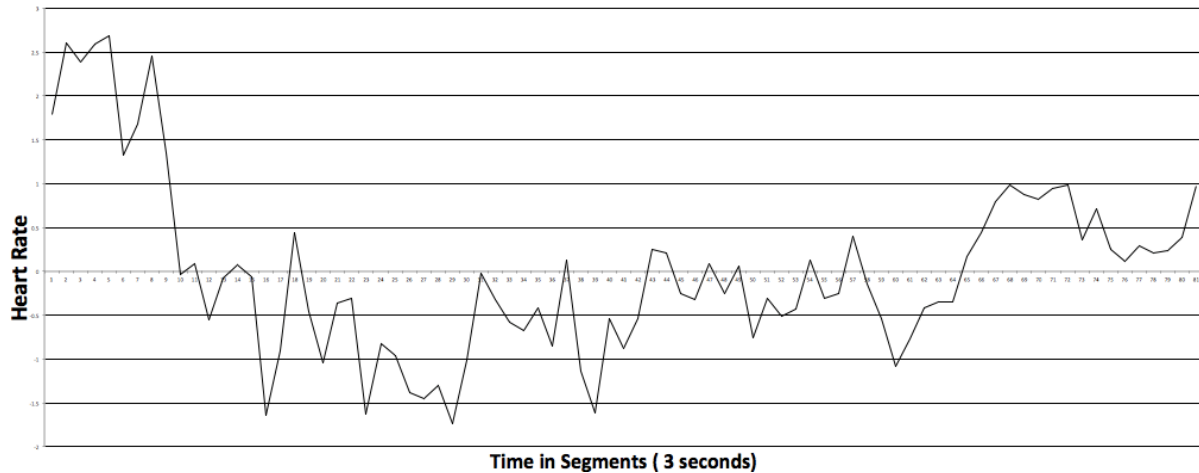



Figure 1. Standardized heart rate change over time during scientific evidence video.

Table 1 provides a description of the video during the critical moments. To verify the decrease in heart rate change during each of these segments, data for each period were subjected to repeated-measures ANOVAs where time period served as the within-subjects variable and the change score measurements for each specified period served as the repeated dependent measure. The first test examining heart rate deceleration during time segment 16 found a significant decrease in heart rate,  $F(1, 16) = 19.99, p < .001, \eta^2_p = .56$ . Similarly, a critical moment occurred at segment 23 to 30 which discussed agricultural irrigation had a statistically significant difference from baseline,  $F(8, 128) = 6.67, p < .001, \eta^2_p = .29$ . Third, the discussion on the period of drought for segment 38-41 also led to a statistically significant decrease in heart rate from baseline,  $F(4, 64) = 9.87, p < .001, \eta^2_p = .38$ . Lastly, the animated graphic explaining aquifer recharge at time period 60 also elicited a significant decrease in heart rate from baseline,  $F(1, 16) = 20.18, p < .001, \eta^2_p = .56$ . In sum, these passages all represent moments within the four-minute video where participants exhibited significant increases in allocation of cognitive resources to the message.

Table 1  
Description of Scientific Evidence Video Critical Moments

Segment	Imagery	Narration
16		“The Ogallala Aquifer, also known as the High Plains Aquifer, is a ground water storage reservoir that stretches 174,000 mi <sup>2</sup> underneath parts of eight states from South Dakota to Texas.”
20		“Today’s irrigation technologies is able to pump out water that has been in the aquifer for hundred for thousands of years in just a matter of minutes.”

23-30



“A rate that far outpaces the rate that nature can replenish it - threatening the over sustainability of the aquifer and for agriculture.”

38-41



“This area as well as others, you are now in a period of exceptional drought.”

60



“In Western Kansas, it can take one year to recharge the aquifer by less than an inch.”

Note: Segment numbers refer to three-second segments within each video.

### Testimonial Video

A similar visual inspection of the data provided evidence of three moments within the testimonial video where heart rate deceleration suggested significant levels of cognitive resource allocation (standardized heart rate change scores more than 1.0 standard deviations away below the series mean).

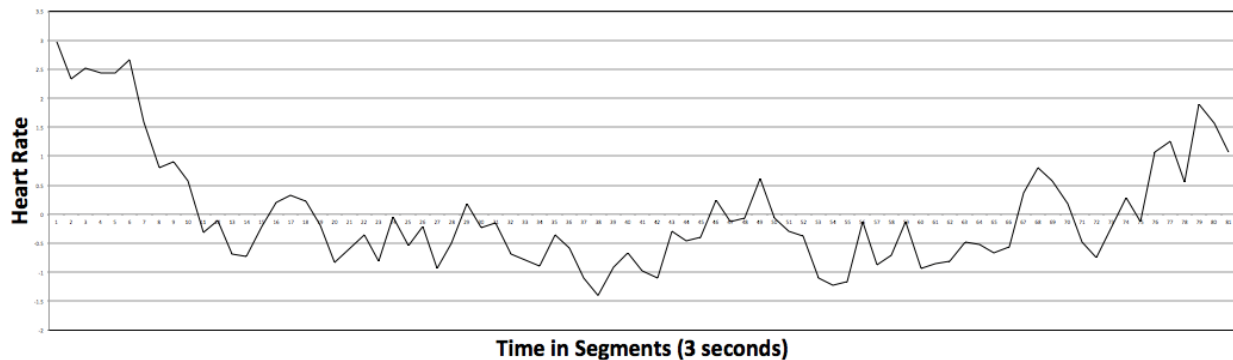





Figure 2. Standardized heart rate change over time during testimonial video.

Table 2 provides a description of the video during the critical moments. A repeated-measures ANOVA examining heart rate change from baseline within those segments revealed that scores were significantly lower during that period,  $F(4, 64) = 11.64, p < .001, \eta^2_p = .42$ . Next, a discussion of corn not doing well in the heat within segments 41-42 likewise elicited significant decrease in heart rate from baseline,  $F(2, 32) = 10.31, p < .001, \eta^2_p = .39$ . The third and final critical moment was within segments 53-55,  $F(3, 48) = 10.62, p < .001, \eta^2_p = .40$ . In sum, the testimonial video elicited fewer passages where participants exhibited increased attention allocation.

Table 2

#### Description of Testimonial Video Critical Moments

Segment	Imagery	Narration
---------	---------	-----------

37-39		“We wear two hats. We use our farming hat to raise the feed source, and we use our cowboy or cattleman’s hat to raise our cattle on our pasture land.”
41-42		“Corn does not do well in the heat. So that’s a problem right there.”
53-55		“Cattle numbers are down. Cow Herds are gong down. Thus, we are losing Cargill’s, packing plants, there aren’t enough cattle to keep them open.”

Note: Segment Numbers refer to three-second segments of video

### RQ3: What were the differences in self-reported message elaboration between the two videos?

To answer the final research question, a paired-samples *t* test was conducted to compare responses to the self-report measure of message elaboration in response to the two videos. That test revealed that the difference in message elaboration approached statistical significance,  $t(20) = 1.84, p = .06, \text{Cohen's } d = .41$ . Participants reported greater elaboration in response to the testimonial message ( $M = 4.28, SD = .41$ ) compared to the scientific evidence message ( $M = 4.10, SD = .30$ ). Although the test statistic did not reach the level of statistical significance, the associated effect size suggests that the observed effect was moderate. Thus, the failure to reach significance may be a function of the small sample of beginning farmers and ranchers employed in the design (Hoyle, 1999).

### Discussion and Recommendation

This study assessed the role of information processing as a function of message type. The researchers examined the influence of two message types (scientific evidence and testimonial) of water conservation videos on the physiological process of attention and the self-report measure of elaboration. The results of this study indicated the video providing greater levels of scientific evidence had a higher level of cognitive resource allocation because the scientific video had more frequent heart rate deceleration during critical moments throughout the video.

Specifically, research question two explored which facets of the two videos elicited attention. The results for the scientific evidence video indicated media features, such as cuts, edits or the introduction of on screen graphics, elicited orienting responses that result in increased attention allocation (Lang et al., 1999; Lang et al., 2003). Similarly, orienting responses were documented with message features depicting on-screen graphics in the scientific evidence video. Additionally, information, in segments 13 and 77, included to scientists referring to statistics depicting the impact of drought and the necessity for water conservation to elicit an attention response.

Although the scientific evidence video provided evidence of higher attention allocation during exposure to specific video features, the testimonial video caused participants to allocate attention to information related to their current occupation. For example, in the testimonial video, the participants had an orienting response, as observed by a decreased heart rate, when the narrator discussed issues regarding management practices, temperature impacting cattle efficiency, and the loss of jobs in production plants. As discussed by Warner et al. (2015), issues impacting the participants personally have elicited a higher level of persuasive effectiveness, or a higher level of information processing, due to messages with personal or social congruence. The researchers concluded visual media pertaining to life on the farm resulted in personal similarity, which caused an attentional response.

Global responses to the messages were reported through self-report elaboration scale used in research question three. Although the paired samples *t* test was approaching significance, the moderate effect size indicated the participants had a greater elaboration during the testimonial message. This result suggested cognitive processing was higher for the testimonial; however, psychological measures provided evidence that the scientific message invited more frequent resource allocation. Perhaps this finding was a result of the scientific message that was more demanding of limited resources, while the testimonial invited more rumination with easier to process information. This finding is representative of online (i.e. physiological and biometric measurements) versus offline (i.e. self report) measures of response. The offline response is a more contemplative response that references a more cumulative representation of how the individual provided cognitive resource allocation; whereas, the online response is raw and immediate to the specific message features in the videos.

Because message frames are crucial to strategic communication goals (Gorham et al. 2014; Huang et al., 2016; Warner et al., 2015), understanding which aspects of message construction and the message appeal that impact information processing are crucial to improving farmer and rancher water conservation practices. Not only does information processing lead to memory recall, but it also leads to higher levels of attitude formation and behavioral intention in the case of persuasive messaging (Petty & Cacioppo, 1986). The results of this study suggest communication with farmers and ranchers about water conservation may be different than strategic communication to target the general public about water conservation.

When targeting farmers and/or ranchers with messages, educators and communicators should focus on incorporating scientific evidence to promote information processing. The results of this study indicated farmers and ranchers allocate attention via cognitive resource allocation to scientific evidence. At the same time, inferences to personal relevance and messages congruent with aspects of farming resulted in increased cognitive resource allocation provided minimal evidence to attention allocation. Extension and communications practitioners and faculty should use this information to apply and combine scientific evidence with a small amount of discussion of testimonial content to improve information processing to partake in water conservation behaviors. Similarly, within an educational setting, this study's results show educators and communicators should include more emphasis on statistics and facts related to reasons to implement water conservation tactics embedded within video graphics into curriculum. For example, the findings suggested attention allocation to on screen graphics representing facts and statistics as well as references to the participants' current occupation and community news

elicited a higher attention response. Therefore, when creating messages, and education programming, practitioners should implement these types of elements into their educational and communication materials.

Further, research should explore the impact of message features in information processing and provide connections to attitude or behavioral intentions. As shown in this study, physiological measures provide agricultural social sciences with the ability to pinpoint how specific message features impact message processing. This knowledge should be used in experimental methods to explore how facets of information such as topic, message features, and number of arguments, effect how individual's perceive information, process information, and develop an attitude toward such information.

## References

- Adler, R. W. (2007). Freshwater. In J. C. Dernbach (Ed.). *Stumbling Toward Sustainability* (197-225). Washington D.C.: Environmental Law Institute.
- Allen, M., & Preiss, R. W. (1997). Comparing the persuasiveness of narrative and statistical evidence using meta-analysis. *Communication Research Reports*, 14(2), 125-131. doi 10.1080/08824099709388654
- Allen, V., Baker, M., Segarra, E., & Brown, P. (2007). Integrated systems in dry climates. *Agronomy Journal*, 99(2), 346-360. doi 10.2134/agronj2006.0148
- Ary, D., Jacobs, L. C., Sorensen, C., & Walker, D. (2013). *Introduction to Research in Education* (9<sup>th</sup> ed.). Belmont, CA: Wadsworth.
- Bartlett, A. A. (1999). Colorado's population problem. *Population Press*, 5(6): 8-9
- Bolls, P.D., Muehling, D.D., & Yoon, K. (2003). The effects of television commercial pacing on viewers' attention and memory. *Journal of Marketing Communications*, 9, 17-28.
- Durst, L., Meyers, C. A., Irlbeck, E. I., & Ritz, R. (2016). *Adoption of Water Conservation Practices in Irrigation Management: An Application of the Theory of Planned Behavior in the Texas High Plains*. Paper presented at the Western Regional Conference, Tucson: AZ.
- Entman, R. M. (1993). Framing: Toward clarification of a fractured paradigm. *Journal of communication*, 43(4), 51-58. doi: 10.1111/j.1460-2466.1993.tb01304.x
- Flint, W. R. (2004). The sustainable development of water resources. *Journal of Contemporary Water Research and Education*, 127(1), 6. Retrieved from [http://www.eeeee.net/sd\\_water\\_resources.pdf](http://www.eeeee.net/sd_water_resources.pdf)
- Geiger, S., & Newhagen, J. (1993). Revealing the black box: Information processing and media effects. *Journal of Communication*, 43(4), 42-50.
- Gorham, L. M., Lamm, A., J., & Rumble, J. N. (2014). The critical target audience: Communicating water conservation behaviors to critical thinking styles. *Journal of Applied Communications*, 98(4), 42-55. Retrieved from [http://journalofappliedcommunications.org/images/stories/issues/2014/jac\\_v98\\_n4\\_article4.pdf](http://journalofappliedcommunications.org/images/stories/issues/2014/jac_v98_n4_article4.pdf)
- Huang, P., Lamm, A. J., & Dukes, M. D. (2016). Informing extension program development through audience segmentation: Targeting high water users. *Journal of Agricultural Education*, 57(2), 60-74. doi: 10.5032/jae.2016.02060
- Hoyle, R.H. (1999). *Statistical strategies for small sample research*. Thousand Oaks, CA: Sage.
- Konikow, L.F. (2013). Groundwater depletion in the United States (1900–2008). *U.S. Geological Survey (Scientific Investigations Report 2013–5079)*. Retrieved from <http://pubs.usgs.gov/sir/2013/5079>.
- Lang, A. (2000). The limited capacity model of mediated message processing. *Journal of communication*, 50(1), 46-70. doi: 10.1111/j.1460-2466.2000.tb02833.x
- Lang, A., Bolls, P., Potter, R.F., & Kawahara, K. (1999) The effects of production pacing and arousing content on the information processing of television messages. *Journal of Broadcasting & Electronic Media*, 43, 451-475.
- Lang, A., & Ewoldsen, D. (2010). Beyond effects: Conceptualizing communication as dynamic, complex, nonlinear, and fundamental. In S. Allan (Ed.). *Rethinking communication: Keywords in communication research* (pp. 237-256). New York: Peter Lang.

- Lang, A., Potter, D., & Grabe, M.E. (2003). Making news memorable: Applying theory to the production of local television news. *Journal of Broadcasting & Electronic Media*, 47, 113-123.
- Levy, B. S., & Sidel, V. W. (2011). Water rights and water fights: preventing and resolving conflicts before they boil over. *American journal of public health*, 101(5), 778-780. doi: 10.2105/AJPH.2010.194670
- Olmstead, S. M., & Stavins, R. N. (2009). Comparing price and non-price approaches to urban water conservation. *Water Resources Research*, 45(4), W04301.
- Petty, R.E., & Cacioppo, J.T. (1986). *Communication and persuasion: Central and peripheral routes to attitude change*. New York: Springer/Verlag.
- Potter, R. F., & Bolls, P. (2012). *Psychophysiological measurement and meaning: Cognitive and emotional processing of media*. Routledge.
- Ravaja, N. (2004). Contributions of psychophysiology to media research: Review and recommendations. *Media Psychology*, 6(2), 193-235. doi 10.1207/s1532785xmep0602\_4
- U.S. Department of Agriculture, Natural Resources Conservation Service. (n.d.). NRCS conservation programs: Environmental Quality Incentives Program (EQIP). Retrieved from [http://www.nrcs.usda.gov/Internet/NRCS\\_RCA/reports/fb08\\_cp\\_eqip.html#contracts](http://www.nrcs.usda.gov/Internet/NRCS_RCA/reports/fb08_cp_eqip.html#contracts)
- Reynolds, R. A. (1997). A validation test of a message elaboration measure. *Communication Research Reports*, 14(3), 269-278. doi 10.1080/08824099709388670
- Roberts, T. G., Harder, A., & Brashears, M. T. (Eds). (2016). *American Association for Agricultural Education national research agenda: 2016-2020*. Gainesville, FL: Department of Agricultural Education and Communication.
- Shen, L., & Bigsby, E. (2013). The effects of message features: Content, structure, and style. In J.P. Dillard & L. Shen (eds.), *The Sage Handbook of Persuasion: Developments in Theory and Practice* (pp. 20-35). Thousand Oaks, CA: Sage.
- Warner, L. A., Rumble, J., Martin, E., Lamm, A. J., & Cantrell, R. (2015). The Effect of Strategic Message Selection on Residents' Intent to Conserve Water in the Landscape. *Journal of Agricultural Education*. 56(4). 59 - 74. doi: 10.5032/jae.2015.04059
- Water sense. (2013). *Environmental Protection Agency*. Retrieved from [http://www.epa.gov/WaterSense/about\\_us/index.html](http://www.epa.gov/WaterSense/about_us/index.html)
- Watkins, K. (2009). Human development report 2006: Beyond scarcity: Power, poverty, and the global water crisis. *United Nations Development Programme*. Retrieved from <http://dspace.cigilibrary.org/jspui/handle/123456789/20135>
- West, C., Johnson, P., Kellison, R., Brown, P., & Pate, J. (2015). *An integrated approach to water conservation for agriculture in the Texas Southern High Plains. Final Report Phase 1 of Texas Alliance for Water Conservation*.