

Recruitment - extra pages of opportunities

ELECTRONICS WORLD

INCORPORATING WIRELESS WORLD

OCTOBER 1998 £2.45

Austria Asch. 68.00
Denmark DKr. 69.00
Germany DM 18.00
Greece Dra. 1300.00
Holland Dfl. 12.50
Italy L. 9000.00
Malta Lm. 1.65
IR £3.30
Singapore S\$7.50
Spain Pts. 900
USA \$6.50

A REED BUSINESS PUBLICATION
SOR DISTRIBUTION

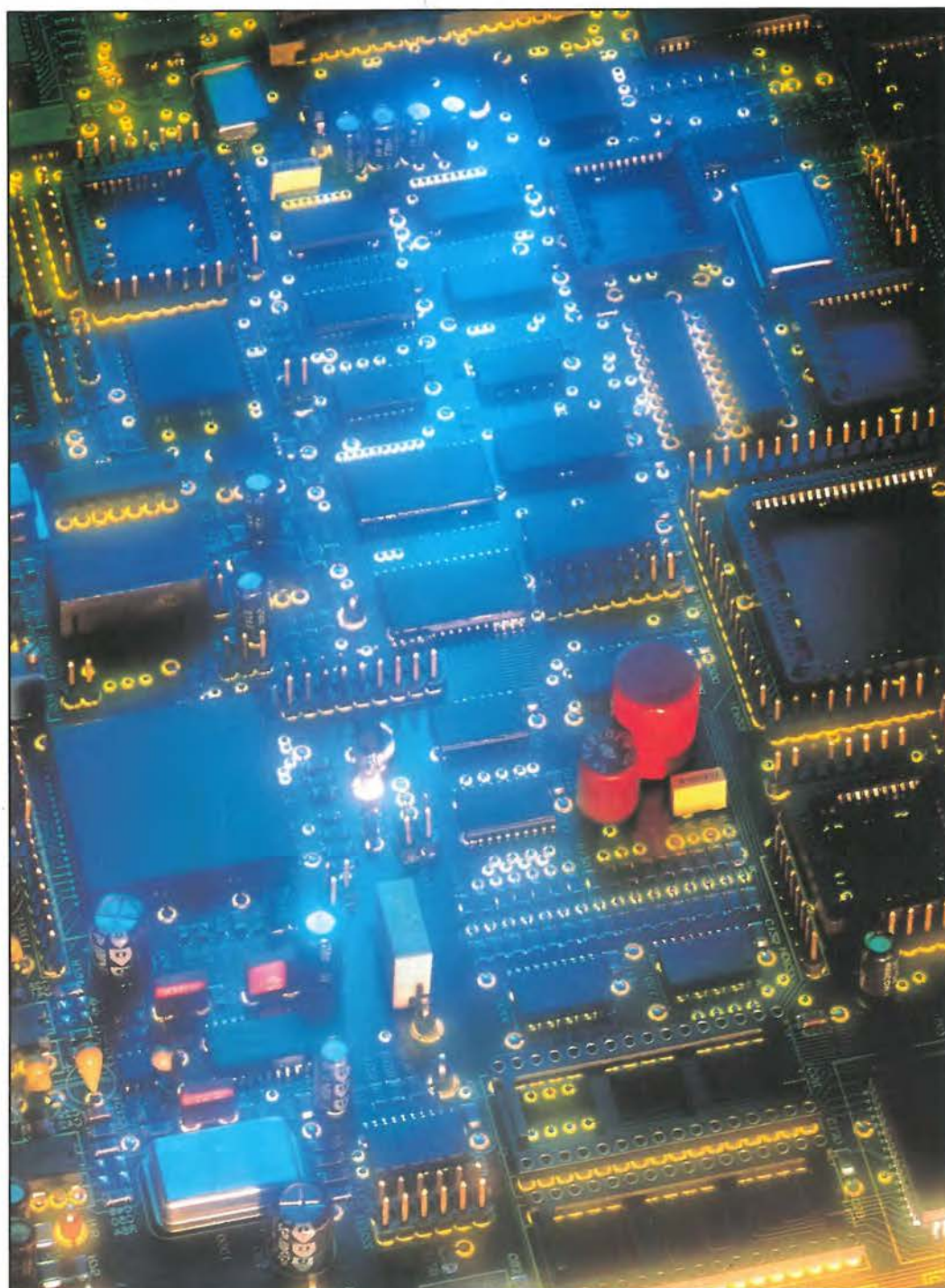

**Designing
with
saturation**

**Exclusive:
earliest tv
recordings**

**Improving the
stereo image**

**Linearising
techniques**

**Telemetry via
mobile phone**

**Simple
50-950MHz
synthesiser**

**Patenting
demystified**

Fourteen Circuit Ideas - page 870



9 770959 833042

Power distribution system combines aesthetics and versatility

The DB2000 modular power distribution system offers a stylish and flexible mains-power solution for office-based applications such as computer workstations, dealing desks, high-technology office furniture and LAN racking.



Modules are available with up to 15 standard BS1363 sockets and can be specified in horizontal or vertical configurations, with a single switch and/or fuse for each module or for each individual socket. In addition, there is a wide range of support modules to protect against earth leakage, overcurrents and mains transients.

Power may be fed from other modules or direct from the mains supply through re-wireable or pre-wired ST18 connectors.

Designed for safe and easy installation, the DB2000 modules incorporate a sliding shutter/locking mechanism which

serves as a lock when the Wieland connector is inserted and as a safety shutter when the connector is removed.

The DB2000 system enables users to quickly configure a customised power distribution system, which can easily be altered at a later date to accommodate changing requirements.

CIRCLE NO. 101 ON REPLY CARD

200W switch-mode PSU for datacomms

Byfleet-based Safety Power Group has introduced a switch-mode power supply specifically designed for use in modular data-communications systems.

Known as the 48FS200-121, this high-reliability 200W PSU accepts input voltages in the range 42-72VDC and provides a single output of +5V at 40A. Its high MTBF figure of 100,000 hours is backed by a 2-year guarantee as standard.

Key features of the 48FS200-121 include convection cooling, reverse protection and undervoltage protection on the inputs, POWER OK and OUTPUT OK signals on the outputs, and a power-sharing facility that makes the PSU suitable for n+1 redundancy designs and 'hot' insertion/removal applications.

Mounted on a 4U x 9TE panel, the power supply carries a CE mark and complies with all relevant European standards for safety and EMC, including EN60950,



EN55022, EN61000 and IEC801-5. In addition, it is designed to meet the BTNR 2511 in-rush specification.

Equipped with H15 DIN connectors as standard, the 48FS200-121 can also be fitted with additional accessories such as handles, mains switches, LEDs and test points. Operating temperature range is specified as 0 to 70°C, derating by 2.5%/°C above 55°C.

CIRCLE NO. 102 ON REPLY CARD

New 250W power supply features compact design

The new FL250 switch-mode power supply, available exclusively from the Safety Power Group, uses double-sided plated-through-hole PCB technology to achieve a low profile of just 43mm, thereby providing equipment designers with a valuable space-saving opportunity.



Manufactured in the UK by Ferrus Power, the FL250 is CE marked and carries all the necessary international safety approvals, including EN60950 and UL1950, as well as meeting the requirements of the EN55022 Class B, FCC Class B and CISPR 22 Class B standards for electromagnetic interference.

This new 250W power supply is available with single outputs of 5V @ 50A, 12-15V @ 17A, 24-28V @ 9A or 48V @ 5.2A or a choice of four multiple-output configurations.

CIRCLE NO. 103 ON REPLY CARD



150W PSU features universal input

Available from the Safety Power Group is a versatile 150W switch-mode power supply that offers a universal input and a wide choice of single or multiple outputs, making it suitable for use in applications.

Manufactured in the UK by Ferrus Power the FW150 is designed to comply with the EN55022-B, EN61000-4 and IEC801-5 electromagnetic interference standards, as well as the EN60950, UL1950 and CSA22.2 No. 950 safety standards.

The power supply can be specified with single outputs of 5V @ 30A, 12-15V @ 13A, 24-28V @ 6.5A or 48V @ 3.2A, all of which feature remote-sense capability and power-fail signals. Alternatively, four multiple-output configurations are available.

All versions feature a 90-264V universal input, together with 24/48V DC input and overcurrent protection facilities.

The FW150 comes complete with a 2-year guarantee as standard.

CIRCLE NO. 104 ON REPLY CARD

750W SMPSU for telecoms applications



Now available exclusively from Safety Power Group is the FR750 switch-mode power supply - a 750W unit that offers a wide range of single or multiple outputs and an array of advanced features that make it ideal for use in telecommunications applications.

The FR750 can be specified with single outputs of 5V @ 120A, 12-15V @ 56A, 24-28V @ 28A or 48V @ 16A or any one of six multiple-output configurations. Multiple-output versions achieve an MTBF of 80,000 hours, and for single outputs this figure rises to 120,000 hours.

Providing facilities such as current sharing, remote sensing, adjustable 'Power OK' signals, programming outputs and 24/48V DC input capability, the new power supply can be tailored to meet the requirements of most telecommunications systems.

The FR750 carries a CE mark and complies with all relevant European standards for EMC and safety, including EN55022, EN61000, IEC801 and EN60950.

Housed in a chassis-mounting enclosure, the PSU is equipped with screw and stud terminals and is supplied with a 2-year guarantee.

CIRCLE NO. 105 ON REPLY CARD

Special Offers From DELTA δ



- The smallest and lightest bench power supplies available
- Only 1.8kgms model ES 030-5
- Programming and monitoring (standard), RS 232 (optional)
- 19" rack mounting (optional)
- EN 60950 IEC 61010 EN 500811/EN50082 & CE Approved.

ES 030-5 0-30V 0-5A £324.00*

ES 030-10 030V 0-10A £599.00*

SM 7020D 0-35V 0-20A Auto Ranging 35-70V 0-10A £895.00*

SM 30-45 0-30V 0-45A £1,199.00*

Prices subject to VAT and Carriage *

- Master/Slave Operation
- Battery Charging
- 19" rack mounting
- MTBF 500,000 hours
- To 18kWatts Power Systems.

Choose from over 50 different models



'your partners in power'

Safety Power Group Ltd,
15 Wintersells Business Park,
Byfleet, Surrey KT14 7LF,
Tel 01932 336025 Fax 01932 336550
www.safetypower.co.uk/delta

Ring today for your 36 page catalogue.

CIRCLE NO. 106 ON REPLY CARD

Contents

811 COMMENT

Borrow, learn then leave.

813 NEWS

- "No thanks" to new EMC rules
- Mobile phones may soon answer back
- Engineers' pay deals still falling
- Phone health case goes before judge
- Polymer batteries nearer
- Voice analysis detects one too many

818 STAKE A CLAIM

Down-to-Earth answers to frequently asked questions regarding patenting issues.

Special offer voucher details - turn to page 820

823 RESTORING BAIRD'S IMAGE

For the first time, **Donald McLean** reveals detailed new information from the world's earliest recordings of television.

830 IMPROVE YOUR IMAGE

Richard Brice looks at the stereo image from play back and recording perspectives.

838 TELEMETRY VIA MOBILE PHONE

Heikki Kalliola's simple interface allows you to control items in any remote location that can receive mobile phone signals.

842 DESIGNING WITH SATURATION

Bryan Hart investigates the characteristics of transistors in saturation to help you produce better switches.

847 SPEAKERS' CORNER

To get the most from a loudspeaker, you need to know a little about the physics of moving masses, explains **John Watkinson**.

850 SHAPING UP

Although usually a nuisance, non-linearity can be a useful design tool. **Ian Hickman** looks at a selection of ideas involving non-linearity and suggests uses for them.

855 HANDS ON INTERNET

Cyril Bateman has found new humidity sensing circuits on the Net, together with information on recovering signals swamped in noise.

859 LETTERS

Harmonic workout, What Microsoft monopoly? EMC regulations versus the real world, Light gates, Tap it again, Cold junction comments, Wire with Litz, Filament failure, Crossover comments.

867 SYNTHESISED 50-950MHz SOURCE

Programmable via ttl logic levels, **Nick Wheeler's** 50 to 950MHz signal generator is simple since it revolves around a highly integrated crystal-based synthesiser chip.

870 CIRCUIT IDEAS EXTRA

- Low-battery voltage detector
- Oscilloscope deflection amplifier
- Digital programming of capacitance
- Test ignition coil and plugs
- Simple parallel-to-serial
- Binary adder has analogue output
- Circuit board tester
- Audio amplifier power-up muting
- Ac spike suppressor
- Bidirectional RS-485 repeater
- Split supply from a single battery
- Temperature-controlled heatsink fan
- Single-chip watchdog timer
- Oscillator has low phase noise

879 NEW PRODUCTS

Over forty new product outlines, presented by **Phil Darrington**.

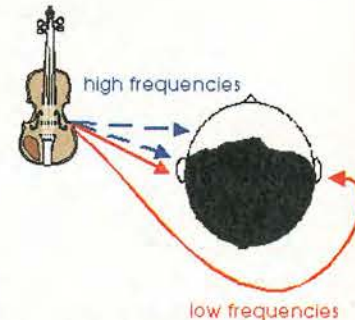

Views on how to get the best stereo image are changing. See page 830.

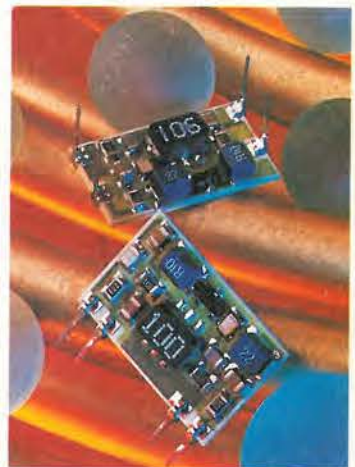

What's is it? This - and well over forty other recently introduced items - are featured in New Products starting on page 879.

Using image-recovery techniques, **Don McLean** has revealed television pictures recorded on disc as early as the twenties, page 823.



November ISSUE ON SALE 8 October

WINRADIO



**More choice:
external WINRADIO arrives!**

WINRADIO now brings you a complete choice in computer controlled radio scanning and reception.

With either the internal or external versions, you can couple all the power of the latest Windows PCs (not just the fraction that you can squeeze down an RS232 connection) to the latest synthesised receiver design techniques, and you'll get the ultimate in wide range, all mode programmable radio reception.

New external WINRADIO™ (WR1000e and WR1500e) provide complete comms systems connecting either via the basic RS232 - or with an optional PCMCIA adapter, for high speed control. Power from existing 12v supplies, or our optional NiMH rechargeable 12v battery pack.

Use WINRADIO scanning PC comms receiver systems for...

Broadcast · Media monitoring · Professional & amateur radio communications · Scanning · Spot frequency & whole spectrum monitoring · Instrumentation Surveillance (and recording)

If you still want the ultimate receiver-in-a-PC with full DSP, then you need the WR3000-DSP with its hardware for real-time recording, signal conditioning and decoding applications. (This is available as an ISA card only).



VisiTune™ spectrum tuning display



Your choice of virtual front panel



The DSP applet provided with the WR3000 spectrum monitor ISA card (£995+VAT) allows continuous control of audio bandwidth and other signal conditioning functions

Model No	WR-1000	WR-1500
Construction	WR-1000i/WR-1500i - Internal full length ISA cards WR-1000e/WR-1500e - external RS232/PCMCIA (optional)	
Frequency range	0.5-1300 MHz	0.15-1500 MHz
Modes	AM,SSB/CW,FM-N,FM-W	AM,LSB,USB,CW,FM-N,FM-W
Tuning step size	100 Hz (5 Hz BFO)	100 Hz (10 Hz for SSB and CW)
IF bandwidths	6 kHz (AM/SSB), 17 kHz (FM-N) 270 kHz (FM-W)	2.5 kHz(SSB/CW), 9 kHz (AM) 17 kHz (FM-N) 270 kHz (FM-W)
Receiver type	PLL-based triple-conv. superhet	
Scanning speed	10 ch/sec (AM), 50 ch/sec (FM)	
Audio output on card	200mW	200mW
Max on one motherboard	8 cards	8 cards
Dynamic range	65 dB	75 dB
IF shift (passband tuning)	no	±2 kHz
DSP in hardware	no	no
IRQ required	no	no
Spectrum Scope	yes	yes
Visitune	yes	yes
Published software API	yes	yes
Internal ISA cards	£299 inc vat	£399 inc vat
External units	£389 inc vat	£449 inc vat
PCMCIA adapter (external)	£30 with 'e' series unit, otherwise: £69 inc.	
PPS NiMH 12v battery pack & charger:	£79 with 'e' series unit, otherwise: £139	

Digital Suite Software

1. WEFAX / HF Fax
2. Packet Radio for HF and VHF
3. Aircraft Addressing and Reporting System (ACARS)
4. Audio Oscilloscope, real time Spectrum Analyzer with calibration cursors
5. Squelch-controlled AF Recorder and Playback
6. DTMF, CTSS decode and analyse

(requires SoundBlaster 16 compatible sound card)

For your free info pack and software emulation demo disk contact Broadercasting Communication Systems

http://www.broadercasting.com
email: info@broadercasting.co.uk

FREEPHONE: 0800 0746 263
Fax: 01245 287057

Unit B, Chelford Court, Robjohns Road, Widford Industrial Estate, Chelmsford, Essex CM1 3AG



EOE WINRADIO and VisiTune are trademarks of WINRADIO Communications

CIRCLE NO. 110 ON REPLY CARD

EDITOR

Martin Eccles
0181 652 3128

CONSULTANTS

Ian Hickman
Philip Darrington
Frank Ogden

EDITORIAL ADMINISTRATION

Jackie Lowe
0181-652 3614

E-MAIL ORDERS

jackie.lowe@rbi.co.uk

ADVERTISEMENT MANAGER

Richard Napier
0181-652 3620

DISPLAY SALES EXECUTIVE

Joannah Cox
0181-652 3620

ADVERTISING PRODUCTION

0181-652 3620

PUBLISHER

Mick Elliott

EDITORIAL FAX

0181-652 8111

CLASSIFIED FAX

0181-652 8938

NEWSTRADE ENQUIRIES

0171 261 7704

ISSN 0959-8332

SUBSCRIPTION HOTLINE

01622 778000

SUBSCRIPTION QUERIES

rbp.subscriptions@rbi.co.uk
Tel 01444 445566
Fax 01444 445447

For a full listing of
RBI magazines:
http://www.reedbusiness.com



Borrow, learn then leave

It's much harder being a student today than it was twenty five years ago. Not that standards have changed significantly; the reason for this state of affairs is money.

Students in the seventies had none of the financial problems that confront students of today. The reduction of the maintenance grant to almost nothing and the introduction of an additional tuition free of £1000 a year causes even more grief and hardship. Yes, student loans are available, and it's easy to accumulate a debt of several thousand pounds on graduation - to be paid back once the graduate goes into employment.

But starting a working life with a debt as large as this is a daunting prospect. What happens if the graduate should choose to get married to another graduate - which is more often the case than not? The combined debt could easily exceed £12000. And the couple will probably want to buy a house, which means securing a £50000 mortgage. Rather than me.

Furthermore, what if an electronics graduate wants to do postgraduate study? Fortunately, studentships for Master's degree are not means tested - but they only last a year. Then of course, some will want to a Ph.D. This means another two or three years - or even more. By this time newly qualified electronics engineers with their B.Eng., M.Sc. and Ph.D. will have accumulated a very disturbing debt before they even find a job.

What is the starting salary in Britain for an electronics engineer with a Ph.D? £18000 to £20000 tops. Doesn't sound too bad except for the fact the student may have accumulated a sizeable debt before work begins. Then they look at jobs in the USA. The starting salary for a design engineer in Silicon Valley is around \$60,000 - which is much more attractive.

But what about the debt that the newly qualified engineer amassed as a student? Simple, once you're in the States and you have no



intention of returning to the UK to live, you forget it. Start with a clean slate and a salary of \$60000 - almost twice the amount that could be earned in the UK.

Sadly though, the country that paid for the engineer's education is left with the debt and gains nothing from the engineer's future contributions as a designer.

Will we see a new brain drain of British engineering talent to the USA? Is it happening now? Will it happen in the future? Can you blame the students? And what measures should be taken to prevent the USA siphoning off our most able designers?

In the sixties and seventies, every student had a means-tested grant to live on, which covered accommodation, books and living expenses. Although not excessive, it was certainly adequate and there was no need for any student to accumulate a large overdraft.

One solution is to have Undergraduate Engineering Studentships, or UESs, which does the same as the previous grant system by covering the living costs and fees for students on electronics degree courses. On graduation, students would not have a debt hanging around their necks and would probably be less inclined to emigrate to the USA.

But even this scheme will have difficulties; which degree courses should have UESs attached to them? If only some universities get UESs, what happens to the others? Will it mean mass unemployment

for electronics lecturers? Very few students would choose an electronics degree course without a UES. And who should decide which universities get UESs?

Should the IEE decide by accrediting degree programmes? I think not. Since the IEE's goal posts for membership shift periodically, this institute is not in the best position to judge.

Don't forget that engineering degrees are considerably more difficult and intellectually demanding than softer options. We need to encourage our young people to take up electronics in preference to fluffy subjects.

Every British born student who is accepted onto a Single Honours degree - B.Sc. or B.Eng. - in electronics or electronics engineering in a British university should be funded for the full duration of the programme. Unless this happens, the shortage of electronics design engineers will be even more acute in the future than it is at present.

Dr Allen Brown

● Nick Prentice, on finishing his education, set up his own business. Doing well, and then to put his venture on a firmer footing, he went to the TSB to open a business account. Nick says he was refused such an account on the grounds that he has not finished paying off his student loan. Does anyone have any similar stories? Ed.

Electronics World is published monthly. By post, current issue £2.45, back issues (if available) £3.00. Orders, payments and general correspondence to **L333, Electronics World, Quadrant House, The Quadrant, Sutton, Surrey SM2 5AS.** Tel: 892984 REED BP G. Cheques should be made payable to Reed Business Information Ltd

Newstrade: Distributed by Marketforce (UK) Ltd, 247 Tottenham Court Road London W1P 0AU 0171 261-5108.

Subscriptions: Quadrant Subscription Services, Oakfield House Perrymount Road, Haywards Heath, Sussex RH16 3DH. Telephone 01444 445566. Please notify change of address.

Subscription rates 1 year UK £34.00 2 years £54.00 3 years £68.00. Europe/Eu 1 year £49.00 2 years £78.00 3 years £98.00 ROW 1 year £59.00 2 years £94.00 3 years £119

Overseas advertising agents: France and Belgium: Pierre Mussard, 18-20 Place de la Madeleine, Paris 75008. United States of America: Ray Barnes, Reed Business Publishing Ltd, 475 Park Avenue South, 2nd Fl New York, NY 10016 Tel: (212) 679 8888 Fax: (212) 679 9455

USA mailing agents: Mercury Airfreight International Ltd, 10(b) Englehard Ave, Avenel NJ 07001. Periodicals Postage Paid at Rahway NJ Postmaster. Send address changes to above.

Printed by BPCC Magazines (Carlisle) Ltd, Newtown Trading Estate Carlisle, Cumbria, CA2 7NR

Typeset by JJ Typographics Ltd, Unit 4, Baron Court, Chandlers Way, Temple Farm Industrial Estate, Southend-on-Sea, Essex SS2 5SE © Reed Business Information Ltd 1997 ISSN 0959 8332

OLSON

THE IEC 320 CONNECTION



UP DATE

Companies say "no thanks" to SLIM EMC rules

A UK trade association is lobbying the European Commission (EC) against changing the EMC directive, a move that would herald more expense for hard pressed electronics firms.

Gambica, representing the instrumentation, control and automation industry, argues that changes should not be made to the regulations just for the sake of it.

Proposed changes are part of the EC's SLIM initiative. SLIM aims to simplify product legislation and give all directives a common format.

"SLIM aims to simplify regulations

so they're not oppressive and detrimental to companies' effectiveness," said Ian Clasper, senior executive at Gambica.

However, in the EMC directive's case, changes so soon after introduction would mean even more expense for UK companies.

"We like SLIM and the idea of reducing the regulations, but in terms of the EMC directive we don't want it changed at this time," Clasper said.

John Whaley, general manager of test house SGS, agrees: "The EMC directive is complicated, but the reality is that everyone has come to

terms with that complication, and it should not be radically changed."

Clasper maintains that the EMC directive has already been costly for European companies. "Why change it without justification?" he asks.

Clasper believes the only justification for SLIM, and a far better use of its time, is harmonising standards across the world.

"The EC should not change the EMC directive. It should take account of international trade and try to harmonise the standards worldwide," he said.

Richard Ball, *Electronics Weekly*

Mobile phone may soon answer back

Speech recognition and text-to-speech technologies will be added to mobile phones from Ericsson next year.

The Swedish telecoms giant has licensed the technology from Belgian speech company Lernout & Hauspie.

"There will be a couple of products coming out with speech recognition next year," said Jan Ahrenbring, v-p of marketing and communication at Ericsson Mobile Communications.

Initially only on high-end mobile phones, the features will include voice recognition instead of push button dialling and the ability for the phone to turn E-mails and messages into speech.

Hands-free operation is a desirable option, especially when the mobile is used in cars.

For the mobile to synthesise a voice to read back E-mails and messages is easier than reading the text of a long message from a mobile phone's small display.

"A speech user interface is ideal to address these challenges," said Jerry Calabrese, president of L&H's core technology division.

To keep down the amount of processing power and memory for these features, Ericsson has also licensed L&H's speech compression technology.

"This is because all speech recognition technology takes a lot of space," said Ahrenbring.

The three technologies - speech recognition, text to speech and

compression - were also licensed by Motorola earlier this year.

The company could use the systems in mobile phones and other products such as handheld computers.

Richard Ball



Only 1 in 4 companies mention 2000 Bug

Three quarters of companies make no mention of tackling the Millennium date problem in their annual reports, according to a survey of 400 companies. The survey, by analysts Company Reporting, found that those who do flag it up seem over-optimistic about the results of their efforts.

Engineers' pay deals are still falling

Pay settlements in the engineering sector have fallen for the third consecutive month. According to the latest figures from the Engineering Employers' Federation, the average settlement level to the end of June fell to 3.5 per cent, down from 3.6 per cent for the previous three months.

Phone health case goes before the judge

A court action intent on forcing mobile phones to carry health warning labels has been adjourned until September.

The private action by Roger Coghill of Coghill Research Labs, a bio-electromagnetics laboratory, is against a local mobile phone distributor for allegedly contravening the 1987 Consumer Protection Act. Coghill started the action after Trading Standards declined to pursue it. "Someone, somewhere has to do something," said Coghill.

He wants labels fitted which warn that prolonged continuous use of a mobile phone, in excess of 20 minutes, may endanger health. "What I'm trying to say is there is serious scientific concern that there's a problem with mobile phones," said Coghill. "What is coming out is the possibility that they're not safe if used for a long time."

There have been several recent mobile phone health scares including reports of short term memory loss and damage to unborn babies.

BUY DIRECT!

CIRCLE NO. 111 ON REPLY CARD

VISA MasterCard SWITCH

24 HOUR DELIVERY SERVICE
MASTERCARD AND VISA
CREDIT CARDS ACCEPTED

ISO 9002 REGISTERED FIRM
GB 1907

OLSON ELECTRONICS LIMITED

OLSON HOUSE, 490 HONEY POT LANE,
STANMORE, MIDDLESEX HA7 1JX
TEL: 0181-905 7273 FAX: 0181-952 1232

Electronics sector is still buoyant

The electronics sector is avoiding the recession currently affecting UK manufacturing, according to a report from Oxford Economic Forecasting.

It predicts the electronics sector will grow by 2.5 per cent in 1998 despite manufacturing firms having to contend with a 'seriously overvalued' exchange rate and the effects of the Asian crisis.

The report stresses that not all the manufacturers' woes are due to

market forces. It criticises manufacturers' productivity performance over the last few years, describing it as appalling.

In particular it highlights the limited investment by UK firms - including electronics one - in new equipment over the last few years. "Although unit labour costs - a measure of productivity - fell in the electronics sector in 1997, it had two poor years in 95 and 96," said report author Alan Wilson.

The overall outlook for manufacturing is pretty gloomy, claims Wilson. "There are no signs of an upturn; all the indicators are pointing down."

The Confederation of British Industry (CBI) has also reported that export orders last month fell at the fastest rate for 12 years. "UK manufacturers are clearly running into considerable difficulties," said Andrew Buxton, chairman of the CBI's economic affairs committee.

An arresting development

A language translator from Belgian firm Lernout & Hauspie is being used in the fight against international organised crime.

Europe's new crime enforcement agency - Europol - is using the T1 translator to overcome the problems of multi-lingual communications.

Documents in any major European language are translated in seconds to another language.

The system is being trialled in Spain. Information on drug trafficking is translated into English and distributed to other drug enforcement officers around Europe.

"In the fight against drugs, speed is often key to a successful operation. We can now translate between English and Spanish and vice-versa in seconds. This is a considerable benefit," said Klaus Schmidt, Europol's project coordinator.

Is V-chip necessary?

An industry television group has questioned the need for the V-chip to control access to violent or sexually explicit TV programmes in the UK.

The group - made up of the BBC, the ITC and the Broadcasting Standards Commission - said that broadcasters should give clear guidance about TV violence instead of relying on electronic devices.

"The V-chip and other electronic gate-keeping devices offer only an inadequate quick fix solution to the problem of regulating violent content on television," reported the group. It also suggested that any use of electronic methods for regulating TV viewing should be carefully assessed following their introduction into the UK.

SVGA flat-panel chips

National Semiconductor announced what it claims is the industry's first SVGA/UXGA compliant chipset for next generation, high resolution flat panel monitors. The DS90C387 and DS90CF388 LDI chips are based on National's low voltage differential signaling technology.

Reconditioned pcs going for a song

ICL is targeting small businesses and home users with pcs as cheap as £200. The pcs are part of a recycling scheme ICL is offering its large customers, in which unwanted desktop and notebook pcs are reconditioned and sold to the public through a chain of dealers. The pcs range from a sub 50MHz 486 for £199 to £348 for a Pentium clocked above 100MHz. For nearest dealer ring 01925 435431.

Spot the difference... Signum Technologies of Cheltenham has developed a way of marking digital images to enable tampering to be detected. "The marks are undetectable to the eye," said company technical director David Hilton. "This is different from digital fingerprinting which makes visible changes."

Called VeriData, the product authenticates an image by adjusting a quarter of the image's pixels by ± 1 bit. This not only allows

alterations to be detected but adds a number to the image which can be used to identify where the image was authenticated. Digital fingerprinting, as provided by Signum and others, is a more robust process used for copyrighting. This uses bigger changes to add identification marks that can survive compression and photocopying. VeriData is aimed at digital images used in court, and is also applicable to digital sound recordings.



Microsoft Internet Explorer

File Edit View Go Favorites Help

Back Forward Stop Refresh Home Search Favorites History Channels Print Font Edit

Address http://www.tiepie.nl

PLUG IN AND MEASURE

8-12 bit
200kHz-50MHz
100mVolt-1200Volt

STORAGE OSCILLOSCOPE
SPECTRUM ANALYZER
VOLTMETER
TRANSIENT RECORDER

TiePie introduces the HANDYSCOPE 2

A powerful 12 bit virtual measuring instrument for the PC

The HANDYSCOPE 2, connected to the parallel printer port of the PC and controlled by very user friendly software under Windows or DOS, gives everybody the possibility to measure within a few minutes. The philosophy of the HANDYSCOPE 2 is:

"PLUG IN AND MEASURE"

Because of the good hardware specs (two channels, 12 bit, 200 kHz sampling on both channels simultaneously, 32 KWord memory, 0.1 to 80 volt full scale, 0.2% absolute accuracy, software controlled AC/DC switch) and the very complete software (oscilloscope, voltmeter, transient recorder and spectrum analyzer) the HANDYSCOPE 2 is the best PC controlled measuring instrument in its category.

The four integrated virtual instruments give lots of possibilities for performing good measurements and making clear documentation. The software for the HANDYSCOPE 2 is suitable for Windows 3.1 and Windows 95. There is also software available for DOS 3.1 and higher.

A key point of the Windows software is the quick and easy control of the instruments. This is done by using:

- the speed button bar. Gives direct access to most settings.
- the mouse. Place the cursor on an object and press the right mouse button for the corresponding settings menu.

- menus. All settings can be changed using the menus.

Some quick examples:
The voltage axis can be set using a drag and drop principle. Both the gain and the position can be changed in an easy way. The time axis is controlled using a scalable scroll bar. With this scroll bar the measured signal (10 to 32K samples) can be zoomed live in and out.

The pre and post trigger moment is displayed graphically and can be adjusted by means of the mouse. For triggering a graphical WYSIWYG trigger symbol is available. This symbol indicates the trigger mode, slope and level. These can be adjusted with the mouse.

The oscilloscope has an AUTO DISK function with which unexpected disturbances can be captured. When the instrument is set up for the disturbance, the AUTO DISK function can be started. Each time the disturbance occurs, it is measured and the measured data is stored on disk. When pre samples are selected, both samples before and after the moment of disturbance are stored.

The spectrum analyzer is capable to calculate an 8K spectrum and disposes of 6 window functions. Because of this higher harmonics can be measured well (e.g. for power line analysis and audio analysis).

The voltmeter has 6 fully configurable settings. 11 different values can be measured and these values can be displayed in 16 different ways. This results in an easy way of reading the requested values. Besides this, for each display a bar graph is available.

When slowly changing events (like temperature or pressure) have to be measured, the transient recorder is the solution. The time between two samples can be set from 0.01 sec to 500 sec, so it is easy to measure events that last up to almost 200 days.

The extensive possibilities of the cursors in the oscilloscope, the transient recorder and the spectrum analyzer can be used to analyze the measured signal. Besides the standard measurements, also True RMS, Peak-Peak, Mean, Max and Min values of the measured signal are available.

To document the measured signal three features is provided for. For common documentation three lines of text are available. These lines are printed on every print out. They can be used e.g. for the company name and address. For measurement specific documentation 240 characters text can be added to the measurement. Also "text balloons" are available, which can be placed within the measurement. These balloons can be configured to your own demands.

For printing both black and white printers and color printers are supported. Exporting data can be done in ASCII (SCV) so the data can be read in a

spreadsheet program. All instrument settings are stored in a SET file. By reading a SET file, the instrument is configured completely and measuring can start at once. Each data file is accompanied by a settings file. The data file contains the measured values (ASCII or binary) and the settings file contains the settings of the instrument. The settings file is in ASCII and can be read easily by other programs.

Other TiePie measuring instruments are: HS508 (50MHz-8bit), TP112 (1MHz-12bit), TP208 (20MHz-8bit) and TP508 (50MHz-8bit).

Convince yourself and download the demo software from our web page: <http://www.tiepie.nl>. When you have questions and / or remarks, contact us via e-mail: support@tiepie.nl

Total Package:
The HANDYSCOPE 2 is delivered with two 1.1/1.10 switchable oscilloscope probe's, a user manual, Windows and DOS software. The price of the HANDYSCOPE 2 is £299.00 excl. VAT.

TiePie engineering (UK), 28 Stephenson Road, Industrial Estate, St Ives, Cambridgeshire, PE17 4WJ, UK
Tel: 01480-460028; Fax: 01480-460340

TiePie engineering (NL)
Koperslagersstraat 37
8601 WL SNEEK
The Netherlands
Tel: +31 515 415 416
Fax +31 515 418 819

814

ELECTRONICS WORLD October 1998

CIRCLE NO. 112 ON REPLY CARD

Power amplifier circuit boards

£42 per pair fully inclusive or £25 each

Professionally designed and manufactured printed circuit boards for Giovanni Stochino's no compromise 100W power amp are available to buy.

These high-quality fibre-glass reinforced circuit boards are designed for Giovanni Stochino's fast, low-distortion 100W power amplifier described in the August 1998 issue. Layout of the double-sided, silk screened and solder masked boards has been verified and approved by Giovanni.

This offer is for the pcbs only. The layout does not accommodate the power supply scheme shown in the article. Note that a copy of the article and a few designers' notes are included with each purchase, but you will need some knowledge of electronics and thermal management in order to successfully implement this design.

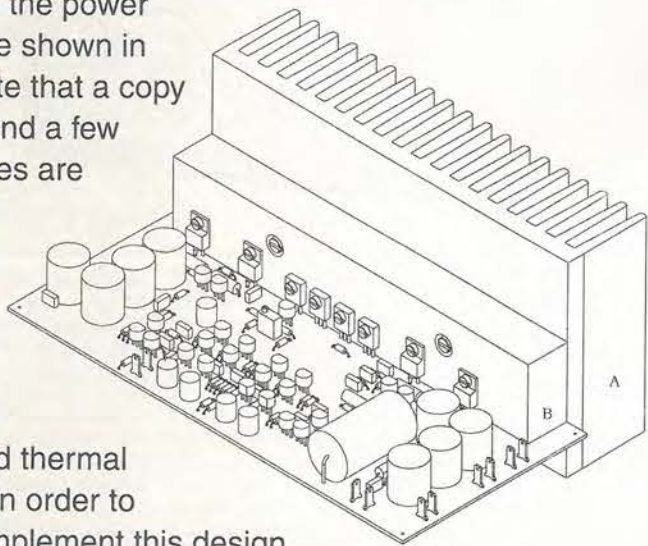

Giovanni's high-performance power amplifier mounted on its heat sink.

Please send me ___ pcbs @ £25 each or £42 a pair.
I enclose my cheque for £ ____
Please debit my credit card for £ ____
Card type MasterCard/Visa.
Card number _____ Expiry date ____/____

Signature _____

Name _____
Address _____

Tel _____

Cheques made payable to Reed Business Information.
Post to: PCB Offer, Electronics World, Quadrant House, The Quadrant, Sutton, Surrey, SM2 5AS. Please allow 28 days for delivery.

Specifications

Power into 8Ω load 100W
Small-signal bandwidth before the output filter 20Hz (-0.1dB), 1.3MHz (-3dB)
Unity gain frequency before the output filter 22MHz
Output noise (BW=80kHz, input terminated with 50Ω) 42µV rms
Measured output offset voltage +32mV

Distortion performance

V _{out} pk-pk	1kHz	20kHz
5	0.0030%	0.0043%
10	0.0028%	0.0047%
20	0.0023%	0.0061%
40	0.0028%	0.0110%
80	0.0026%	0.0170%

Slew rate

Positive slew-rate +320V/µs
Negative slew-rate -300V/µs

Disagreement looms over next digital TV standard

Set-top box manufacturer Pace Micro Technology is predicting the end for the European DAVIC cable modem standard, with a US-developed system taking a lead.

The UK's largest cable company, Cable & Wireless Communications has ordered 100000 set-top boxes which will use the multimedia cable network system (MCNS) rather than DAVIC, the European digital video broadcast (DVB) standard. Other European cable companies are following suit, said Pace.

"We would love to have backed a European standard, but we're a

commercial company and we have to back a viable standard," said Andy Trott, director of engineering for networks at Pace.

Trefor Hooker, marketing manager of operating system supplier Microware, has the opposing view. "I would actually disagree. DVB has been going considerably longer than MCNS in the US," said Hooker.

"Lots of people are implementing the DVB specification worldwide. There are working solutions today," Hooker said. Microware supplies the OS for a DVB set-top box sold in Hong Kong.

Pace claims that silicon conforming to DAVIC is not yet in large scale production. Even when it is released, no one is sure whether the devices will actually work together.

"There isn't an interoperability testing lab available," said Trott, whereas MCNS has had such a lab since September 1997.

"Manufacturers using DAVIC are relying on the silicon working first time," he said.

"It's very simple, and not many people like to hear it, but DAVIC is just not available," summed up Trott.

Richard Ball

Polymer batteries pass test phase

Lithium Technology of Pennsylvania has finished testing its lithium-ion polymer battery for portable computers.

"We have been developing this battery with a notebook computer maker," said company president David Cade. "I can't say which one but it's in the top ten."

Lithium-ion polymer batteries are entirely solid state, having no liquid electrolyte inside. They can be made extremely thin - less than 0.5mm - and with a high energy density.

These attributes make them suitable for notebooks, laptops and mobile phones.

High internal resistance, leading

to poor current delivery has been a characteristic of lithium polymer cells.

"We have no problems at all with this," said Cade. "We use carbon fibre webs in our batteries, which give us all kinds of advantages in structure, conductivity and pulse discharge rates."

Using these webs, said Cade, also simplified manufacturing.

"It allows us to use low cost coating techniques developed for the paper industry," he said.

Cade is cautious about predicting a date for commercial manufacture: "To be safe I would say we will go into production early next year."

Electronics driver info goes ahead

The government is to press ahead with electronic driver information and control networks as part of its drive to cut further road building. Transport minister John Reid announced a major cutback in the roads programme last week and an expansion of the use of automatic incident detection systems. He said more use is to be made of automatic traffic monitoring systems and computerised traffic models to provide information to improve traffic management. Such techniques have been effective in the Midlands and the government's White Paper, A New Deal for Trunk Roads in England, foresees a major expansion of such technology as a means of cutting congestion.

Voice analysis detects one too many

Doing the decent thing and nicking someone's car keys to stop them driving home drunk could become a thing of the past if Samsung gets its way.

It has applied for a patent covering an in-car anti-drink driving device which uses voice analysis.

The potential driver speaks to the car's computer as they prepare to drive away. A parameter extractor in the computer generates a "linear prediction coefficient-cepstrum coefficient after producing a linear prediction coefficient by taking an auto-correlation" - according to the patent - on the incoming voice signal.

It compares this coefficient with a parameter extracted when the driver was sober. If the coefficients match, the person can drive away, if not, they can't.

Presumably the concept could be extended as an anti-theft measure by preventing people with unfamiliar voices

driving the car away.

Samsung does not say whether it has a working prototype.

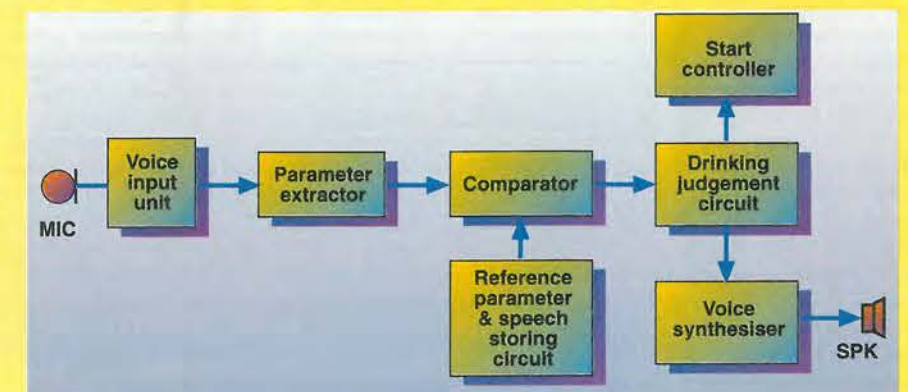

The Chartered Institute of Patent Agents, a professional body similar to the IEE in electronic engineering, has put together a guide to answer some of the most frequently asked questions from budding inventors.

The Chartered Institute of Patent Agents
Tel: 0171 405 9450
Web page: <http://www.cipa.org.uk>

Stake a claim

"You can't patent an idea."
You can't patent abstract ideas, such as a mathematical formula, but a patent can give protection broad enough to cover the concept or principle behind a new technological effect or product.

"Patenting is expensive."
Worldwide protection may eventually cost a lot of money, but an initial British 'provisional' patent application is relatively inexpensive and creates an option for filing overseas for 12 months. It is important to bear in mind the costs spent in realising the invention, those necessary to develop it commercially and the likely returns when the product is marketed.

"It is better to rely on secrecy than to patent?"
For some inventions, such as complex recipes, it might be better to keep the details to yourself than to tell everyone about them in a patent. However, most inventions can't be kept secret. Before long someone will find out the details, the invention will no longer be new, and patent protection will not then be available.

"Inventions are protected automatically by copyright"
Copyright only protects 'works' which are artistic, literary, musical, etc. Most technical inventions can



Mr inventor... Sir Clive Sinclair is an inventor's phenomenon. Since 1972 he has amazed and infuriated the British public and industry-watchers alike. From the first pocket calculator, via the first genuine home computer to the bizarre C5 electric bicycle.

only be protected by patent, not copyright.

"Protection is possible by posting details to yourself or your bank manager"
This is certainly useful to prove an invention has been made by a particular date, but it provides no protection at all. For this to be achieved a patent application must be filed and then the application must be granted.

"When you get a patent, you can't afford to enforce it"

A full scale court action can cost a fortune – for both sides. There are examples of private individuals suing large companies, in some cases with legal aid. In practice most companies don't waste time and money going to court and will often prefer to take a licence or reach some other agreement.

"Large manufacturers will steal your invention and ignore your patent"
If the invention is any good, the manufacturer will want to buy your patent, so that it can be used and competitors kept at bay. The invention might be stolen, but the patent could be enforced.

"You can't stop them taking your ideas in Taiwan"
As countries become more developed, it becomes more in their interest to respect patent rights. If protection is not obtained in countries such as Taiwan, others there can lawfully use the invention, but import into a country where you have a patent could be prevented.

"Can I do it myself?"
Of course you can – if you have the spare time to find out about all the procedures – and the British Patent Office is very helpful in explaining the various official requirements.

US Constitution and the World treaty on fair trade (GATT).
This is one area where international cooperation really works. Countries have been bringing their laws into line and agreeing treaties for a long time. One of the most important treaties on international patenting, which includes almost all countries, has been operating since the 19th Century. The European Patent Office opened for business in Munich in 1978, and at the same time the World Intellectual Property Office in Geneva started accepting International patent applications.
So, patents are important – for business, for the country, for the world.

Patents in a global framework

Patents are granted for new inventions and give their owners the right to stop anyone else from making or using that invention for a limited period.
British inventors have had the right to patent protection for their inventions since as far back as the 17th Century and earlier.
In the past, some countries, such as China – and even the Netherlands – tried doing without patents but soon found that this was not a good idea.
Now virtually every country in the world has a patent system; and the right to protection for inventions is enshrined in many important national and international laws and agreements such as the Declaration of Human Rights, the

Be realistic...

"If you have a patent, you can stop everyone using your invention"
This may be difficult to realise in practice. A balance of licensing some and preventing others may produce a greater commercial return.

"Invent a better mousetrap and the world will beat a path to your door"
Manufacturers are undoubtedly cautious before incurring the often considerable expense required to develop and market a new product. Inventors have to become salesmen once their inventions are made!

"Confidentiality may be better until you know whether it is worth patenting"
It is possible to approach manufacturers under a cloak of confidentiality to see if they are interested in the invention, this does not prevent you patenting later if they are interested, but it is difficult to prevent ideas leaking out. Also, some manufacturers refuse to consider ideas in confidence, because it puts them in an awkward position if they are already working secretly on the same idea. Manufacturers usually prefer to consider patent protection

already applied for when dealing with inventors. The conflicting aspects are best discussed with your patent agent.

"If your invention is taken up, you will get a lot of money"
Hopefully this will be true, but there is never any guarantee that the product will sell well. Proper advice is needed as to the kind of deal to do with a manufacturer, and this also should be discussed with your patent agent.

"If your invention is really good, a manufacturer will buy it up to keep it secret"
Patent applications are published at an early stage, and then there is no possibility of secrecy any more. To keep it secret the manufacturer would have to buy your invention at a very early stage and then withdraw the application before publication. The manufacturer could then be stuck with an expensive lack of protection, if someone else came up with the same idea, or if the idea leaked out. In practice, there is no evidence of inventions being suppressed, and logically this is unlikely to be in any manufacturer's long term interests.

However, the value of a patent depends critically on the wording used, and professional assistance and expertise can make all the difference between a valuable patent and a worthless piece of paper.

"You can't trust patent agents"
Inventors are understandably – and indeed should be – wary of telling strangers about their ideas. Even so, patent agents are bound by professional regulations controlled

by Royal Charter and have a total duty to respect confidentiality, their work is critically based on this. ■

The Alternative Oscilloscope

Pico Technology provides an alternative to costly, bulky, and complicated oscilloscopes. Our range of virtual instrumentation enables your PC to perform as an oscilloscope, spectrum analyser and digital multimeter.

- ▼ Upto 100 MS/s sampling and 50 MHz spectrum analysis
- ▼ A fraction of the price of comparable benchtop DSOs
- ▼ Simple Windows based user interface

The **practical** alternative
Connection to a PC gives virtual instruments the edge over traditional

"...the most powerful, flexible test equipment in my lab."

oscilloscopes: the ability to print and save waveforms is just one example. Advanced trigger modes, such as save to disk on trigger, make tracking down elusive intermittent faults easy. Combining several instruments into one small unit means it is lighter and more portable. When used with a notebook computer, field engineers can carry a complete electronics lab in their PC.

The **simple** alternative
Virtual instruments eradicate the need for bewildering arrays of switches and dials associated with traditional 'benchtop' scopes. The units are supplied with PicoScope for Windows software. Controlled using the standard Windows interface, the software is easy to use with full on line help. Installation is easy and no configuration is required; simply plug into the parallel port and it is ready to go. We provide a two year guarantee and free technical support via phone, fax or E-mail.

The **low cost** alternative
The Pico range of PC based oscilloscopes work with your PC – anything from a dustbin-ready 8086 to the latest pentium. The PicoScope software utilises your monitor to display data. This gives you a larger, clearer display than any scope, at a fraction of the price. The savings don't stop there: All those expensive upgrades needed for traditional oscilloscopes: such as FFT maths, disk drives and printers are already built into your computer. The PC has made computing affordable, now Pico has made test equipment affordable too.

FROM £59

Seeing is understanding

Call for a FREE demo disk or visit our web site.

Fax: (0)1954 211880 Tel: (0)1954 211716

E-mail: post@picotech.co.uk <http://www.picotech.com>

Broadway House 149-151 St Neots Road Hardwick Cambridge CB3 7CJ UK

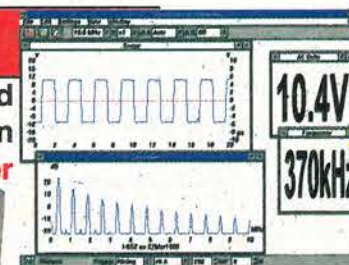

CIRCLE NO.117 ON REPLY CARD

Develop RISC microcontroller systems simply and cheaply

AVR Professional Microcontroller Starter System

This is a comprehensive suite of development tools for Atmel's AVR RISC microcontroller family. It has everything you need to get a project up and running quickly. Both the programmer and evaluation module supplied support 8, 20 and 40-pin



dual-in-line devices from the AVR 'classic' family as standard.

The Integrated Development Environment (IDE) allows you to produce programs in either AVR Assembler or AVR BASIC and then compile them to produce a suitable format for simulation and programming into a 'real' AVR device.

In-system programming via the cable supplied can be performed without removing the device from the evaluation module - true ISP. You can also fast parallel program devices in the programmer ZIF socket.

Working BASIC example programs are included. The programmer and BASIC compiler can be upgraded to support larger memory devices such as the new ATmega AVR family.

Features

- Parallel and in-system programming (ISP) of Atmel 'classic' AVR RISC microcontroller family
- Evaluation module features 8/20/40 pin microcontroller sockets, LEDs, switches, serial communications and more.
- Integrated Development Environment, or IDE, includes Editor, BASIC Compiler for programs to 1Kbytes, Macro Assembler & Software Simulator.
- Programmer/Evaluation module connects to COM Port
- Meridian for Windows 3.11, 95 or NT - Programmer Interface Software
- Field upgradeable programmer firmware
- Connecting cables and power supply adaptor
- CE compliant

Support: Atmel AVR (90S) Microcontroller Family • AT90S1200, AT90S1200A, AT90S2323, AT90S2343, AT90S2313, AT90S4414, AT90S8515 • A chargeable upgrade to support in-system programming (ISP) of the new Atmel ATmega family is now available.

The voucher on the front of this magazine entitles you to 25% discount off the list price - a saving of over £30 - until 31 October 1998. Normal selling price £131.54, i.e. £99+carriage+VAT.

Equinox Technologies UK Ltd, 3 Atlas Court, St. Georges Square, Bolton, BL1 2HB England, Tel: +44 (0) 1204 529000, Fax: +44 (0) 1204 535555 E-mail: sales@equinox-tech.com

Save 50% - only £61.69*

* inclusive price using the Voucher. Normal selling price £123.38.

The IdeaFactory PRO from Quickroute

Drag and drop your innovations

The IdeaFactory is a brand new amazing interactive simulation and modelling tool that goes beyond traditional circuit simulation. It includes multimedia sound and graphics, mathematics, 2D and 3D graph plotting, chart recorders, data import and export, animation - and more.

Creating models is easy. Just drag and drop objects from the toolbar and link them up with the automatic wiring tool. The IdeaFactory models animate in front of your eyes, and you can interact with sliders, switches, keypads etc in real time. Whether its creating animated computer games, complex logic circuits, mathematical models, exploring signal processing, or data analysis and display, The IdeaFactory PRO will bring your ideas to life.

The IdeaFactory PRO gives lets you work with logic gates, LEDs, 7-segment displays, switches, sliders, mathematical modules like plus, minus, multiply, divide, sin, cos, exp, power, 1/x, summation, integration, differentiation, etc., 3D graphs, instruments and more....

The IdeaFactory PRO requires a minimum of a 386 based PC with 4Mbyte RAM, Windows 3.1, 95, 98 or NT, and mouse. A WAV file compatible sound card is optional.

Quickroute Systems Ltd, Regent House, Heaton Lane, Stockport, SK4 1BS, UK. Alternatively phone 0161 476 0202 or fax 0161 476 0505 or email hyperlink mail to :sales@quicksys.demon.co.uk

THE IdeaFactory

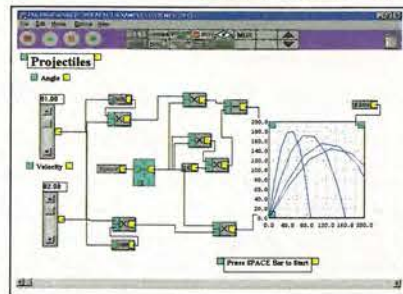

IdeaFactory PRO modelling a projectile. Adjust the velocity and angle sliders and watch the projectile path plotted on the graph in.

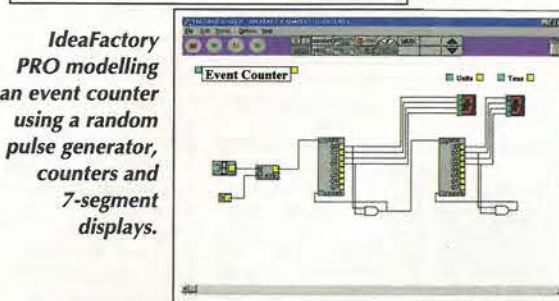

IdeaFactory PRO modelling an event counter using a random pulse generator, counters and 7-segment displays.

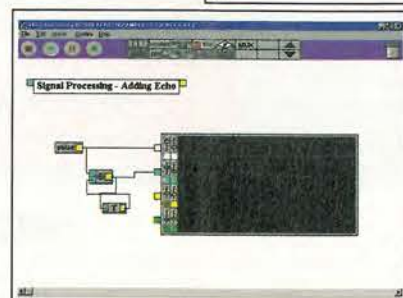

The IdeaFactory PRO modelling an 'echo' signal processor using a mixer and a delay line. Pulses are echoed and displayed in the 'real time' bar chart recorder.

The best of Newnes for *Electronics World* readers

Claim £5 off any two Newnes Marston's Circuit Manuals and Newnes Ian Hickman books using the voucher on the cover of this magazine.

Newnes books by Ray Marston include:

Audio IC User's Handbook. Including pre and power amps, processing circuits and power supplies ed. 2 1997, 272 pages £19.99.

Modern CMOS Circuits Manual 2nd edition. Detailed description of over 120 modern ICs and their applications. 1995 192 pages £14.99.

Power Control Circuits Manual. In-depth look at electronic power control from basics to AC power control data and modern house wiring. 1997, 240 pages £14.99.

Modern TTL Circuits Manual. Covers leading high-speed general purpose range - the 74 series, and shows how to make TTL work for you. 224 pages £14.99.

Optoelectronics Circuits Manual. Short on mathematics but crammed with practical circuits. 192 pages £14.99.

Instrumentation and Test Gear Circuits Manual. Almost 500 outstandingly useful practical circuits: the modern electronics laboratory handbook. 400 pages £14.99.

Security Electronics Circuits Manual. A vast range of ideas and designs, covering the whole range of security applications. 1998 192 pages £14.99

Ian Hickman's Newnes books include: Practical Radio Frequency Handbook 2nd edition. The practical design handbook, now includes a chapter on EMC. 1997 320 pages £19.99.

Analog and RF Circuits. Collected works on topics such as RF amps, oscillator design and filters 1998 320 pages £25.

Analog Electronics. Analog circuitry explained, with latest developments and techniques. 300 pages £19.99.

Oscilloscopes 4th edition. How to use them, how they work: the practical book. 1995 272 pages £17.99.

Digital Storage Oscilloscopes. Practical information about the latest equipment. 1996 208 pages £25.

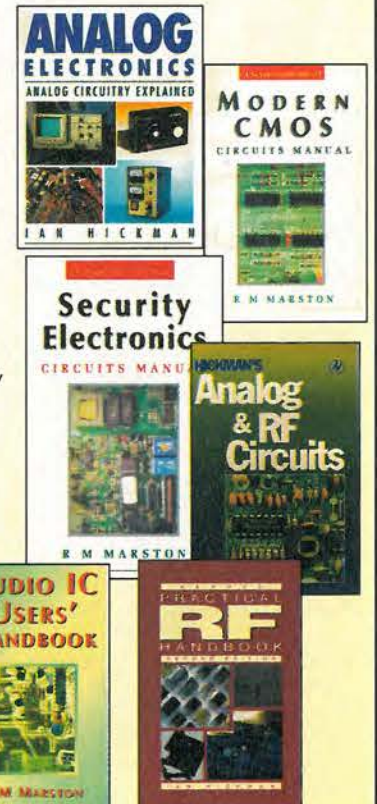

Newnes, Linacre House, Jordan Hill, Oxford OX2 8DP, e-mail sales@bhein.rel.co.uk. See our Web site at <http://www.bh.com>.

30% discount for EW readers on a hand held digital multimeter



Features
3.5 digit 44 range dmm
AC and DC voltage and current
Resistance and capacitance
Diode, continuity and Hfe
Frequency to 20MHz
Logic test
Auto power off, data & peak hold
Overload protection
Input warning beeper
Gold plated switch contacts
Protective rubber holster

Vann Draper is offering over 30% discount to readers of *Electronics World* on a professional quality hand held multimeter.

The LP310 is normally priced at £69.33 but for readers is just £49 fully inclusive of VAT and delivery.

The meter is supplied ready to use complete with test leads, rubber holster, battery, instructions and a 12 month guarantee.

Key Specifications

DC volts	: 200m, 2V, 20V, 200V, 1000V basic accuracy 0.25%
AC volts	: 200m, 2V, 20V, 200V, 750V basic accuracy 1.2%
DC current	: 200uA, 2mA, 20mA, 200mA, 2A, 10A
AC current	: 200uA, 2mA, 20mA, 200mA, 2A, 10A
Resistance	: 200, 2k, 20, 2000, 2M, 20M, 2000M
Capacitance	: 2nF, 20nF, 200nF, 2uF, 20uF
Frequency	: 2kHz, 20kHz, 200kHz, 2MHz, 20MHz auto ranging
Size and weight	: 200 x 95 x 55mm, 500g (with holster)



Vann Draper Electronics Ltd
The test & measurement specialists
www.vanndraper.co.uk

WINRADIO

Save £50.00 when you buy the WR1000i using the voucher on the front cover of this magazine. Normal price £299.00, discount price £249.

WinRADIO combines the performance of a comms receiver with the control power of a Windows-based pc.

WinRADIO creates a new concept in radio communications. Using the keyboard or a mouse, WinRADIO is operated exactly like a professional radio scanner – with the same controls and displays you would only find on high-quality equipment.

Why WinRADIO?

A virtual front panel gives the receiver a greater flexibility, greater number and sophistication of functions, practically unlimited memory capacity, and the ability to customise the receiver for special applications, which would be difficult to achieve within the constraints of the fixed control panel of a traditional scanner.

WinRADIO can have different personalities depending on the user's applications and preferences. New functions – for example spectrum displays or frequency databases, can be easily added and integrated with the receiver operating interface.

A number of independent receivers can be controlled by a single PC. This is very useful if you need to monitor several channels simultaneously.

The WinRADIO receiver card plugs into a slot in the motherboard of your IBM compatible computer. The card contains a micro-processor controlled, sensitive wide-band receiver, with connectors for an antenna and an external speaker or headphones.

What is included?

The WinRADIO package contains the receiver card, software, handbook and a start-up indoor antenna.

For more information on this product please see our advert in October issue of Electronics World or look at our web-site <http://www.broadercasting.co.uk>

Broadercasting Communication Systems, Chelford Court
Widford Industrial Estate, Chelmsford, Essex, CM1 3AG
Tel: 0800 0746 263, fax: 01245 287057 e-mail
info@broadercasting.co.uk

System Requirements
IBM compatible PC with 486 CPU or higher, Windows 3.1, 95 or NT. 4MB of RAM minimum, vacant slot for 16-bit ISA card. Speaker or headphones with standard 3.5mm plug.

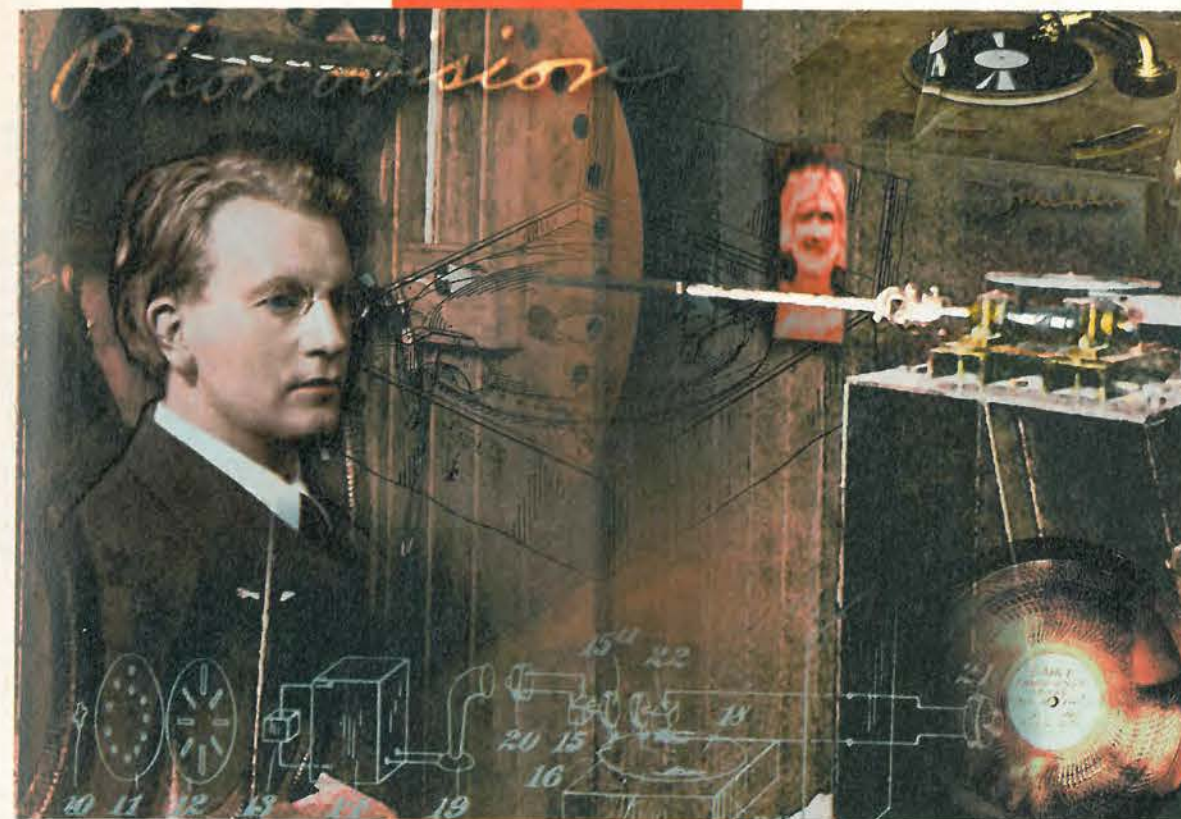

Restoring Baird's image

For the first time, **Don McLean** reveals detailed new information from the world's earliest recordings of television.

John Logie Baird recorded television images in his laboratory in London soon after giving the world's first demonstration of television. This was well before television broadcasting began.¹

Baird made the recordings with a view to developing a mass-market videodisc player. But he did not succeed, primarily due to distortion during recording.

Studying the signal and its faults yields the first detailed information on Baird's equipment and the problems that he encountered. Correcting the faults gives us the first television images from the dawn of television.

The first video disc

Baird's television 'standard' of the late twenties comprised only 30 lines per

picture shown at 12.5 pictures per second. The bandwidth was narrow enough for the signal to be handled like audio.

Baird used this to attempt a means of capturing television images onto audio wax cylinders and discs, Fig. 1. He called this process 'Phonovision'.

His 1926 patent² described the basic idea of simultaneously recording vision and sound signals. In 1928, he filed for a patent³ on the 'Phonovisor'. Had it been successful, the Phonovisor would have been the world's first consumer videodisc in a combined playback and display system. Its extreme simplicity of construction would also have made it low cost.

We know from the work described here that the duration of a disc with vision and sound could have been only

a minute or so. This would have been sufficient for a music video similar – in marketing terms at least – to the *TelDec* system of the seventies and cd video singles of the eighties.

Baird's videodisc system never became a product⁴ despite the experiments being heavily promoted. Bizarrely, Baird did demonstrate the *sound* of the vision signal. He declared⁵ that he could recognise something about the subject from listening to the vision signal. Very likely, he only did this to suggest that he was making progress.

First sightings

In June 1928, Baird reported that he had managed to see a "crude smudgy" rendition on playback but that it was "more of a curiosity".⁶ By 1931,

Donald F McLean
B.Sc(Hons) CEng FIEE

FM Embedded Controllers at a ground breaking price!

WEB SITE
<http://www.cms.uk.com>



£95 each
PER 100 UNITS

The range of 'FM-Controllers' provide most of the features required for embedded control at a very low cost

FEATURES FM-200 Controller

- ◆ 68K Micro-Controller 14 MHz clock
- ◆ 512 Kbytes Flash EEPROM
- ◆ 512 Kbytes SRAM Battery Backed
- ◆ 2 RS232 Serial Ports
- ◆ 1 RS232/RS485 Serial Port
- ◆ Real Time Calendar Clock (Y2K Compliant)
- ◆ Watchdog & Power fail detect
- ◆ 10 Digital I/O Lines
- ◆ 2-16 bit Counter/Timers
- ◆ I²C Bus or M-Bus
- ◆ Expansion Bus
- ◆ Size 100x80 mm

OTHER FEATURES

- ◆ Up/Download removable card for data logging and/or re-programming
- ◆ STE I/O Bus, 68000 and PC Interface
- ◆ Designed, Manufactured and supported in the UK

OPTIONAL EXTRAS

Additional extra features to the FM 200

- ◆ LCD Port Graphics or Alphanumeric
- ◆ Key Pad Port 64 Keys 8x8
- ◆ 8 Channels 8 bit analogue in
- ◆ 2 Channels 8 bit analogue out
- ◆ 8 Channels 13 bit analogue in
- ◆ Up to 32 Digital I/O Channels
- ◆ Up to 8 Mbytes of SRAM Battery Backed
- ◆ Up to 512 Kbytes of Flash EEPROM
- ◆ 1 Mbyte EPROM Space



CAMBRIDGE
MICROPROCESSOR
SYSTEMS LIMITED

Units 17-18, Zone D, Chelmsford Road Industrial Estate, Great Dunmow,
Essex UK CM6 1XG Tel: +44 (0) 1371 875644 Fax: +44 (0) 1371 876077

DEVELOPMENT

The PC Starter Pack provides the quickest method to get your application up and running

Operating System

- ◆ Real Time Multi Tasking
- ◆ Unlimited copy licence

Languages

- ◆ 'C', Modula-2 and Assembler
- ◆ Full libraries & device drivers provided

Expansion

- ◆ Easy to expand to a wide range of peripheral and I/O cards

Support

- ◆ Free unlimited telephone, FAX, email and Internet support

Custom Design

- ◆ CMS will design and manufacture to customers requirements



Fig. 1. The Phonovision discs all resemble 25cm (10in) diameter single-sided 78rev/min 'shellac' audio discs. A distinguishing feature is the radial structure caused by Baird's synchronous recording method.



Fig. 2. Most Phonovision discs have a dated 'Columbia Graphophone Company TEST RECORD' label. This one is from the earliest known recording of television, featuring a rather wooden performance by 'Stookie Bill'.

reports were still describing Phonovision as a "scientific curiosity".⁷ From then on, Phonovision dropped out of the news.

In all that time, Baird never demonstrated pictures from the discs, most likely due to their poor quality.

Table 1. Details of all known Baird Phonovision discs.

Reference No.	Date	Content discovered after restoration
SWT515-4	20 Sep 1927	operator's hand and 'Stookie Bill'
RWT620-4	10 Jan 1928	over-modulated recording of 'Wally' Fowlkes' head
RWT620-6	10 Jan 1928	'Wally' Fowlkes' head in motion (marred by amplifier oscillation)
RWT620-11	10 Jan 1928	'Wally' Fowlkes' head in motion
RWT115-3	28 Mar 1928	Baird's temp, Miss Mabel Pounsford - head and shoulders

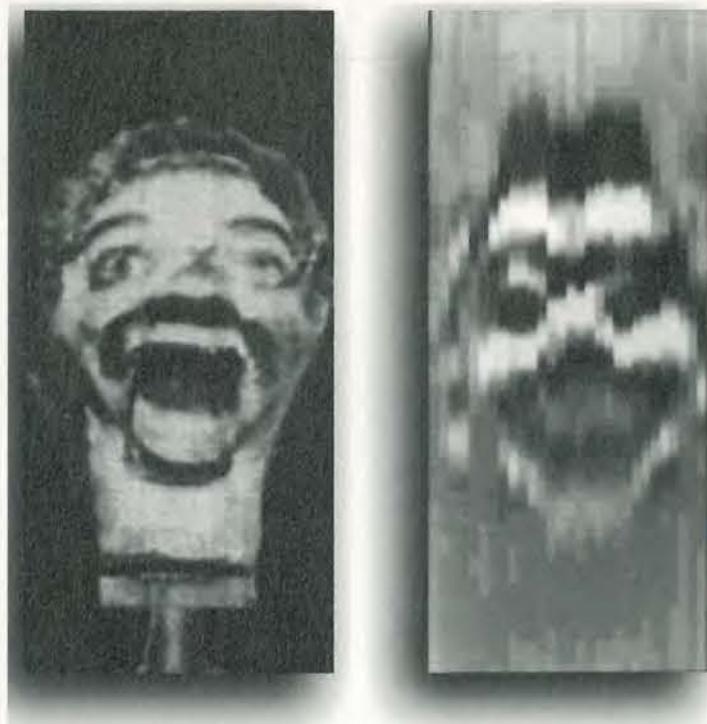

Fig. 3. Instead of live performers, Baird often used a ventriloquist's dummy head in his experiments as a test subject. He had several such heads - all called 'Stookie Bill'. The photograph on the left is a different model from that restored from the 1927 recording on the right. The vertical line shearing is caused by errors in constructing the scanning disc, cf Fig. 4.

This is supported by the various attempts over the years since then to view pictures from the discs. Analogue filtering and oscilloscope displays showed that the recorded quality was too poor to give any recognisable imagery. But by using a computer to capture, store, analyse and process the raw signal, I have managed to restore the recordings.

The recorded quality of Phonovision is so poor that Baird could not have seen the images at the quality presented here. These experimental images fall far short of studio quality. They should not be considered as typical of Baird's and the BBC's subsequent 30-line broadcasts.

Never intended for public appraisal, the discs are merely a snapshot view of his experimental period on a subject he himself deemed unsuccessful.

The re-discovery of Phonovision
Attention on Baird's other achievements and the great strides in electron-

ic television technology passed Phonovision by. For decades, the discs were spread around the country, until the work described here brought them together and subsequently their historic value was recognised.

After many years of searching, there are today only five different vision-only recordings from Baird's experiments. They are listed in the panel.

Some of the discs have a Columbia Graphophone Company Test Record label, Fig. 2, indicating Columbia had been engaged in cutting and pressing the discs. Each disc has a reference number for the session and take, consistent with Columbia Graphophone Company practice, Table 1.

The house of Ben Clapp, Baird's first engineer, was bombed in the Second World War destroying all but one of his collection of Phonovision discs.⁸ The surviving disc, SWT515-4, is the earliest-known recording of television in the world made in September 1927 - a mere twenty months after Baird's

historical first demonstration.

This disc contains a test signal - a simple white bar or edge - and one of Baird's dummy heads Fig. 3. It is a doubly-historic disc: it was also one of a few that Baird used to transmit test signals from Ben Clapp's house in Coulsdon to New York in late 1927⁹ for the Transatlantic Television experiments. Given both the distortions on the disc and its slow frame rate, it was probably used only as a readily identifiable sound to test reception.

The 'Wally' recordings of January 1928 are the earliest of a living face. The name 'Wally' is scratched on the disc surface and the image has a close resemblance to Wally Fowlkes - one of Baird's laboratory assistants.¹⁰

On the discs, the subject turns his head from profile to full face and looks up and down, Fig. 4. When he moves his head towards and away from the camera, the effect is as if there is a vertical sheet of light immediately in front of the camera.

A picture of a Phonovision disc in a July 1928 magazine is in fact the same disc as RWT115-3 dated 28 March 1928, Fig. 5, supporting the validity of the dates written on the disc labels. No one knew who "Miss Pounsford" was until an appeal on Channel 4 in 1993 over the restored pictures brought success.

This was now Mabel Pounsford, a temporary secretary to Baird in the twenties, Fig. 6:

Signal capture. The first step in

restoration is to capture the raw video signal into the computer. Recorded directly onto the disc without modulation, the video signal is played back from a conventional record deck and sampled into the computer using ideally a clock extracted from the turntable rotation.

Analogue pre-processing corrects for the disc cutter's frequency characteristic (Blumlein¹¹) and phase response. The digitised signal is stored in a disc file for analysis and correction.

Processing the signal. Analysing the video signal reveals features common to all five Phonovision discs. Every disc has exactly three 30-line tv frames, i.e. 90 lines, per revolution without either separate or combined¹² audio soundtrack.

There are no embedded synchronisation pulses. The 30-line system did not support them, relying on video content for line synchronisation and manual adjustment for frame sync. The principal idea behind Phonovision was not to rely on synchronisation from the video signal but to link the camera physically with the record platter to give an exact number of frames on each revolution of the disc. Baird obviously understood the problems caused by playback variation.

Timebase distortion. This mechanical linkage gave rise to the most serious problem plaguing the Phonovision discs - fluctuation in speed. Ironically,

Baird was developing Phonovision to get round that very problem. Whereas live broadcasts would give as steady a picture as the camera generating it, a recording would be subject to minor random speed changes that would ruin a sync-less television picture.

There are three separate types of timebase distortion.

Offsets in the start of certain lines, but constant from frame to frame, Figs 3 and 4. This distortion caused by errors in positioning the lenses on the Nipkow scanning disc. A slight circumferential error - radial errors do not show up - would give rise to an early or late start to a line.

The maximum error is 3% of line



Fig. 4. From the January 1928 session, this is Wally Fowlkes, one of Baird's assistants and commonly televised as a test subject. The name 'Wally' was scratched on the disc surface.

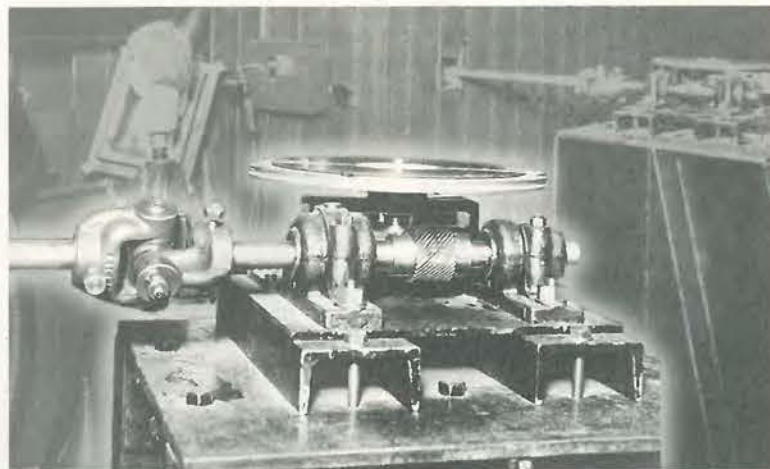

Fig. 6. Mabel Pounsford is pictured on the left many years after her short spell as a temp to Baird. The label on the disc incorrectly says "Woman smoking a cigarette". The 'cigarette' is, in fact, her chin suffering massive timebase distortion. Restoration converts her to a non-smoker (right).



Fig. 5. Proof of the discs' ages comes from a photograph from July 1928 from which the signature "Miss Pounsford" and the serial number "RWT115-3" can be read. The current Phonovision disc dated 28 March 1928, bottom left, has identical markings.

Fig. 7. This composite photograph shows the main Phonovision transport with helical gear assembly and universal joint coupling. A major component of the timebase distortion can be attributed to such a coupling.



length for line 11, indicating a 0.4° error in its position. For a 150cm-diameter Nipkow disc, this amounts to a 4mm offset error in drilling the hole for the 6cm wide lens. Notably this pattern of offsets is common to the September 1927 and January 1928 recordings indicating the same scanning disc was used for both sessions.

Low frequency variation in timebase at frequencies up to the frame rate. The effect is worse in the September 1927 recording, improves by January 1928 and is absent from the March 1928 recording. This indicates where Baird was focusing his effort.

The slow variation suggests a flexible coupling, most likely at the motor driving the Nipkow disc. A spectral analysis of the timebase errors shows an unusually high content at the second harmonic of the tv frame rate 180° phase-shifted to the fundamental.

An off-axis universal joint coupling such as in Fig. 7 would give such a result. A bent or misaligned drive shaft would give the same effect.

High frequency variation within frame. Present only on the March 1928 recording, the pattern establishes in the first few seconds and then remains static throughout. As the pattern is at the tv frame rate, this is likely to be the result of mechanical reso-

nance in the coupling between the Nipkow disc and the gearing assembly.

The lack of low-frequency variation apparent in the earlier discs indicates Baird had moved to a hard mechanical linkage between Nipkow disc and recording deck. This is undoubtedly the reason for this resonance.

Restoring the timebase

The absence of any synchronising information in the video signal means that correction has to rely on video content. With no low frequencies and limited video bandwidth, the Phonovision signal resembles a modulated sine wave. This makes the restoration of the timebase a complex process.

Over the years I have developed a hybrid solution based on several multi-pass algorithms using variants on auto-correlation.¹³ The parameters for the algorithms are tuned to the Phonovision session on which the disc was made.

Recording speed. To make these recordings, Baird dropped his tv frame rate from 12.5 per second to around 4 per second to give about 80rev/min at the disc cutting equipment. The Columbia engineers probably dictated this rate.

Three clues support this. The first is a sequence of 11 frames in which the

subject turns from face-on to the right and then to the left, Fig. 8. This speed is unnatural at Baird's standard of 12.5 frames per second.

The second clue is the absence of low frequencies. Recording at 80rev/min would give a line frequency of only 120Hz with may contribute to this effect.

The third clue is that the quality of the recording groove is excellent, suggesting a recording speed of 78 to 80rev/min.¹⁴

In his laboratory, Baird would have had extreme difficulties seeing any picture at this low frame rate, as his display had no persistence.

Signal problems

The discs all suffer from lack of video bandwidth. Given that these discs were professionally recorded, this is a real surprise.

Fortunately on the earliest recording there is a bright bar or edge whose impulse response allows us to make an estimate of the system's bandwidth. The signal is reasonably flat within 1dB only between 250Hz and 1200Hz at 78rev/min.

It may be that, as shown on his 1926 patent, Baird used a microphone in front of a loudspeaker rather than a direct connection. The Columbia engineers may well have insisted on some such arrangement. That the disc-cutter has managed to record the mechanical rumble from the Nipkow disc but not the low video frequencies shows that the low frequencies were lost before recording.

Image processing. The unusual nature of the video amplitude distortion required me to develop a custom suite of image processing tools. Digital filtering tackled the frequency and phase errors while a time-domain image tracking algorithm reduced image noise.

Drop-outs and clicks were removed by a new algorithm based on statistical comparison of adjacent lines and frames. The restored images were re-sampled onto an arc-scan grid to sim-

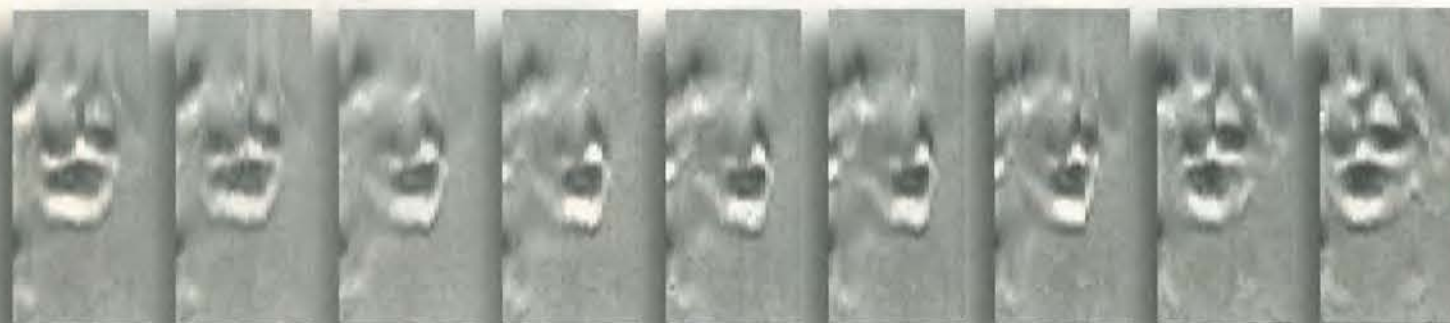

Fig. 8. A series of consecutive 30-line frames showing Miss Ponsford turning her head from side-to-side. The movement is too rapid for the Baird 'standard' 12.5 frames per second. This is one of the clues that the Phonovision discs were recorded at a much lower frame rate.

ulate the contemporary display method. Ideally the images shown here should be tinted the orangey-red of neon – the variable light source used for display.

Sound and vision. At the start of each of the three discs recorded in January 1928, a rumbling sound drops logarithmically in pitch over several seconds. The profile of the drop is identical for a high-pitched shriek associated with the video content, Fig. 9. Notably though, the video signal maintains constant pitch throughout this period. This is a great piece of evidence telling us several things.

The shriek dropping in pitch is a sound external to the platter: the platter is coming up to speed and hence the sound appears to fall in pitch. That the video stays at constant pitch tells us that, for the January 1928 session, the Nipkow disc and record platter are mechanically linked.

A rumble at TV frame rate also drops in pitch. This is the sound of the Nipkow disc turning. The shriek is most likely Baird's video amplifier bursting into oscillation.

Analysing the graph tells us that the disc-cutter was started when the Nipkow disc had reached 20% of final speed after just over two rotations. In the following six rotations, it had achieved 50% speed and after a further 24 rotations had reached 90% of maximum speed of around four rotations per second.

Knowing the mass of the Nipkow disc, we could estimate the torque force of Baird's main drive motor.

How Baird recorded Phonovision

A few pictures exist from publications of 1928 of Baird's Phonovision recording studio. By extracting common features in each of the pictures, I have built a computer 3D model for the laboratory.

The Phonovision disc on the turntable gives the absolute reference for dimensions. The lessons learned from the discs support the model and suggest that the studio portrayed could well have been used to make or even replay the Phonovision discs.

Underneath the record platter is a helical-gear assembly that transfers the rotation of the drive-shaft to the turntable, Figs 7, 10, 12. Measuring the relative diameters of the gear parts from the photographs gives a ratio of 3:1. For every three turns of the drive shaft, there is one revolution of the record platter. This matches what we see with the Phonovision discs.

These discs all have 90 lines per revolution, so each revolution is exactly three frames. If the shaft were directly

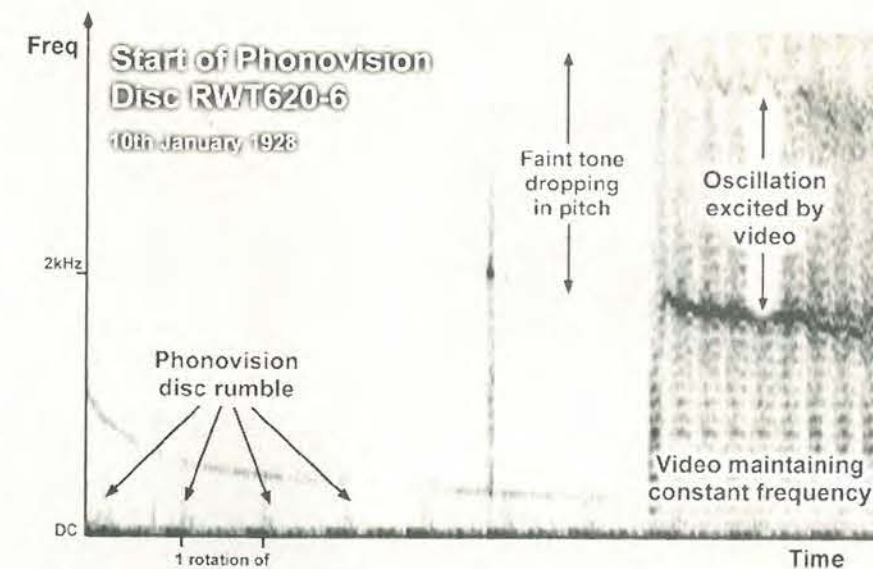

Fig. 9. A sonogram of the start of a January 1928 recording provides evidence that the scanning disc and Phonovision turntable were mechanically linked. In addition, Baird's video amplifier in oscillation – evident from the central black line – gives us the acceleration profile of his camera disc.

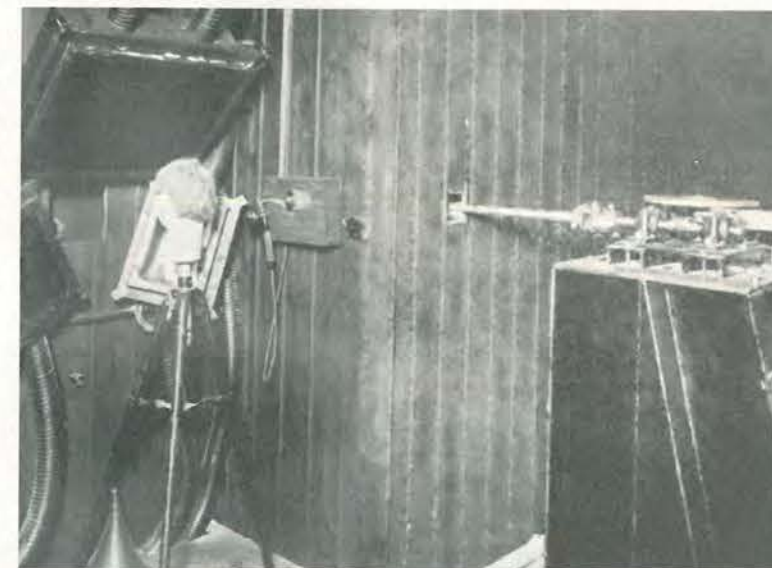

Fig. 10. This rarely seen enhanced view shows – for the first time – the same scanning equipment being used for Phonovision, on the right, and Baird's experiments in near-infra-red light which he called "Noctovision," shown on the left. Often misunderstood and overstated, Noctovision merely exploited the extended red-end response of his photo-sensor.

coupled to the scanning disc, then you would expect exactly three frames per revolution. Following the direction of rotation of the record platter through the gears, Fig. 12, the shaft entering the wall rotates clockwise.

On the left of the picture, Figs 10, 11, 12, a ventriloquist's dummy head faces an aperture under blacked-out lights. In the aperture, parts of two lenses are visible, Figs 10, 12. From the computer model, for a 64cm (25in) radius Nipkow disc, the apertures would be just over 13cm (5in) apart,

which is what we see on the picture.

When the disc was spinning, the lenses moved from bottom to top. This, and the drive shaft coming out to the Phonovision equipment just 64cm (25in) away, is consistent with a single Nipkow disc centred on the drive shaft.

The overall Nipkow disc would be around 1.5m (5 feet) in diameter. Although we already knew that Baird built large Nipkow discs, this is the first evidence of their use in his pioneering work¹⁵.

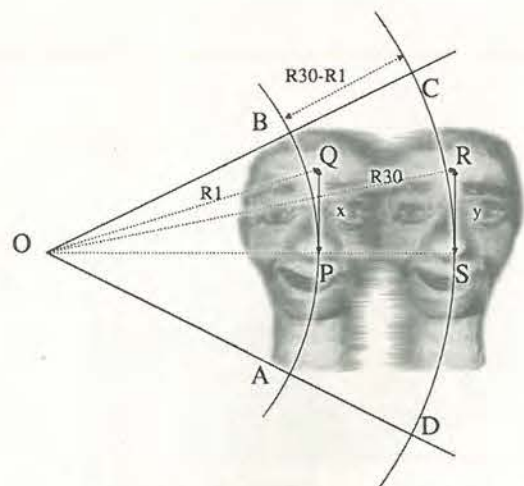

Fig. 13. By measuring the proportional height of a fixed-size object – the centre-line of 'Stookie Bill' – across all lines, we can calculate the image aspect ratio from the unique geometry of arc-scanning.

Arc scanning and aspect ratio

Part way through the earliest Phonovision disc of 'Stookie Bill' – Baird's ventriloquist's dummy head – a hand rocks the head from side to side across all lines in the picture. This good fortune allowed me to use the fixed height of the head to determine whether the camera system was a Nipkow disc or a mirror drum.

A mirror drum generates an image with straight lines whereas a Nipkow disc scans each line in an arc. For the Nipkow disc, an object of constant height moving across the field of view takes proportionately more of the line length the closer it is to the centre of rotation, Fig. 13.

Using the centre line of 'Stookie Bill', I measured the proportion of line length across all possible positions and then plotted on a graph. The geometry

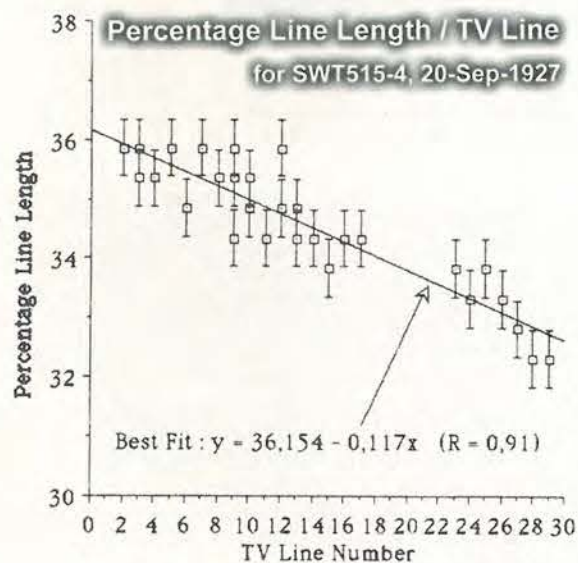

of arc-scanning allows the aspect ratio of the image to be calculated.¹⁶

Aspect ratio from arc-scanning. In Fig. 13, ABCD represents the scanned area on the Nipkow disc with angle AOB being $2\pi/30$ – assuming a single spiral per revolution. AB and CD are the paths followed by lines 1 and 30 respectively. For small angles, the object heights at these extremes are:

$$\frac{x}{R_1} = \sin f$$

$$\frac{y}{R_{30}} = \sin g$$

where f is angle POQ, or $F_1 \times 2\pi/30$, g is angle SOR, or $F_{30} \times 2\pi/30$ and F_1 and F_{30} are the fractions of line length for the respective lines derived from the regression analysis, Fig. 14.

For constant object height across the frame, $x=y$, and you can combine the equations to derive an expression for the width, W , of the image:

$$W = R_{30} - R_1 = R_1(a-1) = -R_{30}(1/a-1)$$

where $a = \sin f / \sin g$. Now, the raster height can be expressed by the arc-length, H ,

$$H_1 = R_1 \times 2\pi/30$$

$$H_{30} = R_{30} \times 2\pi/30$$

Aspect ratio AR is defined as the ratio of height to width of the scanned area, or the average of the instantaneous aspect ratio values on lines 1 and 30.

$$AR = -\pi \times ((1+a)/(1-a))/30$$

Using $F_1=0.36037$ and $F_{30}=0.32644$ from Fig. 14 gives $AR=2.12:1$

Taking into account the action of rocking the head, the calculated aspect ratio is 2.12 in mid-frame, within 10% of the actual 2.33 ratio, i.e. 7 vertical to 3 horizontal.

Early standard.

There is one departure from the subse-

quent Baird standard for 30-line television: the first line in the frame was innermost on the disc on the Phonovision discs whereas the standard called for the first line to be the outermost. With Miss Pounsford's hair parting determining scanning direction, Baird's camera used for Phonovision scanned the frame of the scene from left to right rather than the Baird standard of from right to left.

The 'standard' though is for the broadcast period that started in 1929. Baird's television standards had been migrating over the years: his first demonstration in January 1926 had been on 32 lines¹⁷. With the Phonovision discs we have evidence of early use of the 30-line system with only minor differences from the subsequent broadcast standard.

The Phonovisor

Intended as a mass-market replay device, the Phonovisor was stunningly simple in concept. By mounting the disc turntable of a conventional gramophone onto a Nipkow disc, synchronised playback of pictures through the Nipkow disc would be assured without recourse to electronics or complex mechanics, Fig. 15.

The practicalities however make it a challenge, despite the problems in making Phonovision discs.

There is a trade-off between replay rate, number of frames per revolution and displayed picture size. A Phonovisor used to view Phonovision needed a playback speed of 250rev/min to give a Baird television standard picture.

Not only is needle replay not practical at this speed, but the recording is less than a minute long. The viewable picture height on a Baird Nipkow disc is the arc-length between adjacent holes.

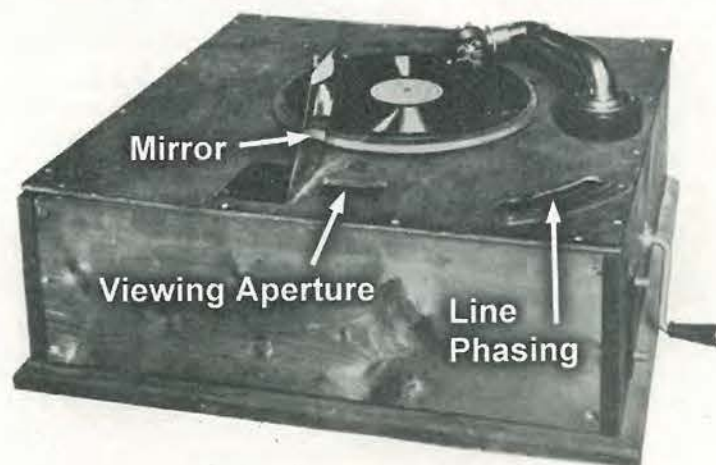

Fig. 15. Mock-up of Baird's Phonovisor showing what he intended to manufacture. Note that the pick-up is mounted backwards. The lever on the right may be either for lining up the image on replay or more simply for adjusting speed.

On a Phonovisor with a 50cm disc, like Fig. 15, the image would be about 17mm by 7mm. It would be proportionately smaller the more frames per revolution.

In summary

Starting from simply the pattern and content of a vision signal cut onto a handful of audio test discs, I have been able to reveal an astonishing amount of detailed new information from these historic pioneering days of television.

The main achievement has been the restoration of what I believe are the world's earliest recordings of televi-

sion. Television pictures captured in Baird's laboratory in the twenties must be rated among the most important of television's short history.

While the restoration work reveals the latent images, analysis of the content and the corrections applied reveals a wealth of hard facts about Baird's experiments. We now know what type of camera Baird was using, how well it was built, how fast it accelerated to speed, what departures there were to his television standard – even the type of lighting in the studio.

Most importantly, we can now truly appreciate the difficulties he encoun-

tered in trying to bring this invention to practicality.

Baird himself summed it up. "...I had a gramophone record made of... (the vision signal) and I found that... I could reproduce the original scene. A number of these records were made... but the quality was so poor that there seemed no hope of competing with the cinematograph."¹⁸

Finally, I would like to mention that I am indebted to Ray Herbert, ex-employee of Baird and now the Baird Company historian, for his support over the years. ■



Fig. 11. A stereo anaglyph, requiring red-blue spectacles, of the computer reconstruction of Baird's laboratory, cf Fig. 10.

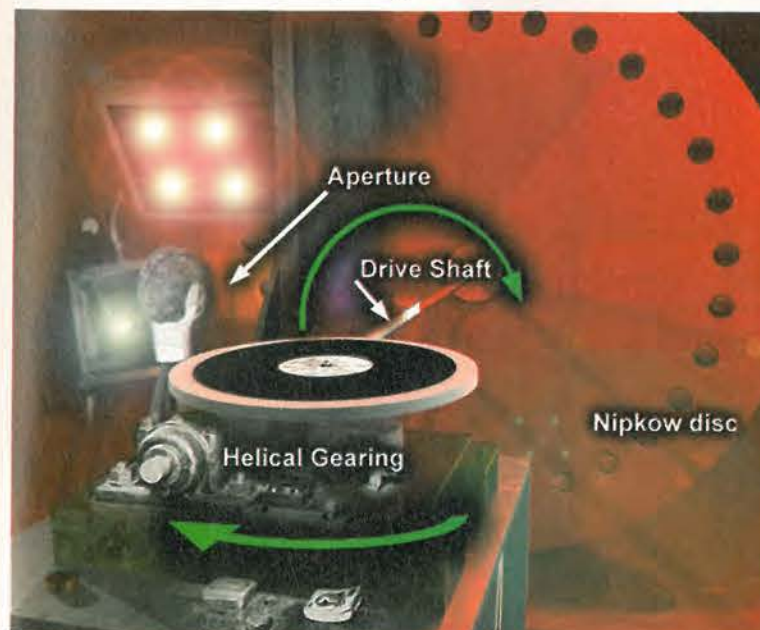
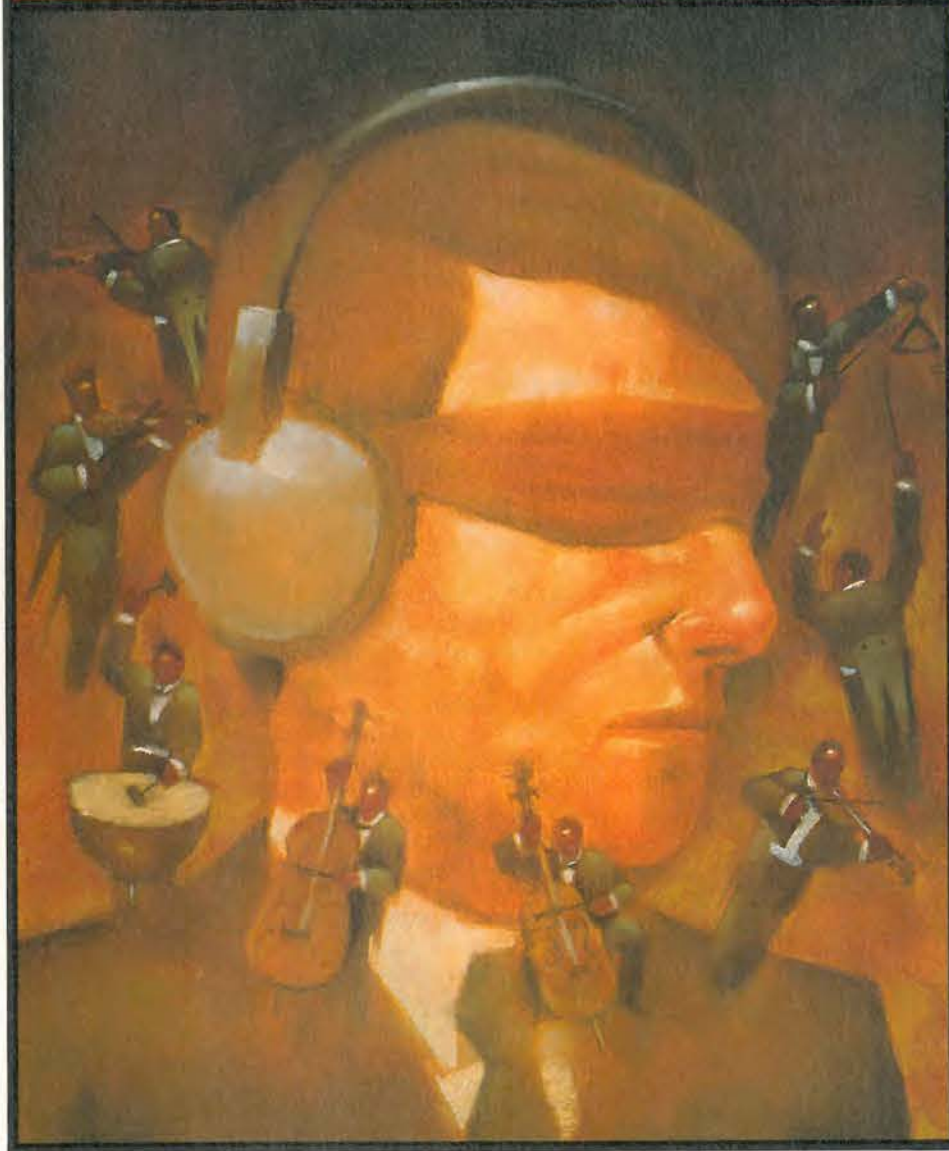

Fig. 12. Knowing the direction of rotation of the turntable from the discs, and following this action through the helical gears, Fig. 7, you can see that the drive-shaft rotated clockwise as it entered the wall. Behind the wall is the most likely arrangement of a large diameter Nipkow scanning disc.

References

1. McLean, D F, 'Dawn of Television,' *Electronics World*, September 1998.
2. British Patent No 289104, applied for 15 October 1926.
3. British Patent No 324049, applied for 10 October 1928.
4. The Major Radiovision disc of 1934/5 was not 'Phonovision' but a commercial venture by Plew and was sold as a test disc for aligning 30-line displays.
5. Baird, J L, 'Sermons, Soap and Television', Royal Television Society, 1988.
6. Baird, J L, Report of the 1st General Meeting, *Television*, June 1928, p. 14.
7. Moseley & Barton Chapple, *Television – Today and Tomorrow*, 2nd edition, 1931.
8. Clapp, B, Personal Communication, 1983.
9. Log of G2KZ, 7 October 1928, courtesy R M Herbert 1998.
10. Baird, J L, 'Sermons, Soap and Television' refers to Wally Fowlkes being used as the subject for these experiments.
11. Levin, E, Personal Communication 1996
12. British Patent No 289104, *ibid*.
13. McLean, D F, 'Using a Micro to Process 30-line Baird TV Recordings', *Wireless World*, October 1983.
14. Levin, E, *ibid*, 1996.
15. Herbert, R M. Personal Communication 1998.
16. McLean D F, 'The Recovery of Phonovision', IEE 3rd International Conf on Image Processing and its Applications, July 1989, pp. 300-304.
17. Herbert, RM, *ibid*, 1998.
18. Baird, Margaret, 'Television Baird', HAUM 1973, p. 65.

Improve your image



Now that stereo audio designers have all but eliminated crosstalk, Richard Brice explains why they shouldn't have. Richard also builds on Blumlein's work, presenting an improved stereo microphone technique, in this first article based on his new book.

Electronics plays two roles in the art-form we call music. Traditionally, its role is regarded as the conduit and its aspiration, the unimpeachable conveyor of music.

Many articles have appeared in these pages which discuss this role; the quest for the ever-more 'perfect' audio amplifier for example. But I'd like to take a different approach which takes a look at the creative role for electronics. Scrutinised from this perspective, what is in my view a rather moribund debate takes on a new vitality.

A perfect example of this more open-minded approach, concerns improvements to conventional stereophony. This article concentrates on just two techniques which aim to improve conventional stereo recording techniques;

- an unusual stereo microphone arrangement
- a very simple idea for improving two-loudspeaker stereophonic image quality.

A better image

Postponing the microphone technique until later, let's first look at a system which uses an apparently 'distorting' crosstalk signal to improve stereo quality. The irony here illustrates well the enlightened approach mentioned above.

For years, the reduction of left-right crosstalk has been a primary aim of recording system designers and one of the 'triumphs' of digital audio mooted as its elimination. But we now know that there are beneficial effects of controlled left-right channel crosstalk. So, the effects of this 'distortion' have been misunderstood and the deleterious results from its elimination in digital systems similarly mistaken.

It is possible that this has nurtured much of the debate surrounding the subjective differences between analogue and digital recording systems. It also explains many of the apparent 'shortcomings' of digital recording. In order to see why, we have to take a quick look at our ability to localise - i.e. determine the direction of - sounds in space.

How we locate sounds

Consider the situation in Fig. 1, where an experimental subject is presented with a source of steady sound located at some distance from the side of the head. The two most important cues the brain uses to determine the direction of a sound are due to the physical nature of sound and its propagation through the atmosphere and around solid objects. Two reliable observations can be made:

- at all frequencies, there is a delay between the sound reaching the near ear and the further ear,
- at high frequencies, the relative loudness of a sound at the two ears is different since the nearer ear receives a louder signal compared with the remote ear.

It can be demonstrated that both effects aid the nervous system in its judgement as to the location of a sound source. At high frequencies, the head casts an effective acoustic 'shadow.' This shadow acts like a low-pass filter and attenuates high frequencies arriving at the far ear. In this way, it enables the nervous system to make use of intensity differences to determine direction.

At low frequencies, sound diffracts and bends around the head to reach the far ear virtually unimpeded. So, in the absence of intensity-type directional cues, the nervous system compares the relative delay of the signals at each ear. This effect is termed interaural delay difference.

In the case of steady-state sounds or pure tones, the delay manifests itself as a phase difference between the signals arriving at either ear. But, of course, this phase difference is only useful at low frequencies. Above about 500Hz, the distance between the ears is more than one wavelength.

The idea that sound localisation is based upon interaural time differences at low frequencies and interaural intensity differences at high frequencies has been called 'duplex theory' and it originates with Lord Rayleigh at the turn of the century.

Two-loudspeaker stereophony

Consider the 'classic' stereo arrangement, Fig. 2. A moment's thought will probably lead you to some fairly

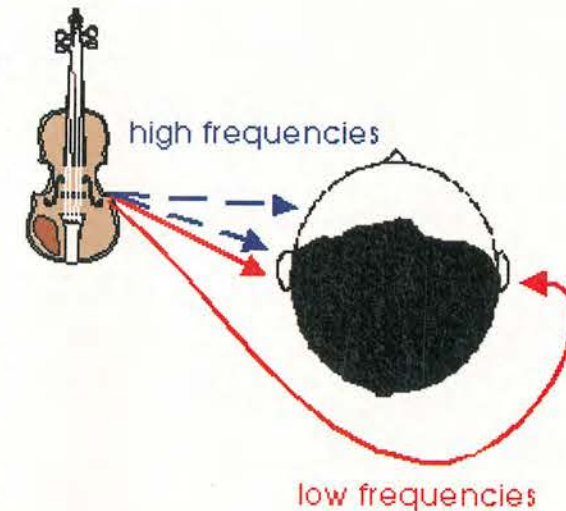

Fig. 1. Two key cues that the brain uses to locate sound sources are the difference in time taken to reach each ear and, at high frequencies, the intensity of sound reaching each ear.

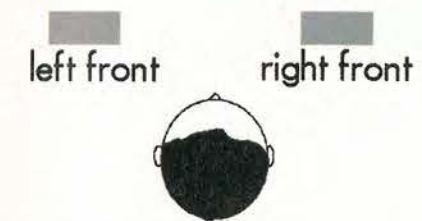

Fig. 2. It is easy to understand how the classic stereo arrangement works with high frequencies, but what about the lower frequencies, where the sound can diffract around the head and reach the other ear?

obvious conclusions: if all the sound comes out of the left loudspeaker, the listener will clearly experience the sound from the left. Similarly with the right.

If both loudspeakers reproduce identical sounds at identical intensity, it is reasonable to assume that the listener's brain will conclude the existence of a 'phantom' sound, coming from directly in front. This is because, in nature, that situation will result in the sound at both ears being identical. And indeed it does; as experiments have confirmed.¹

More surprisingly, proportionally varied interchannel signal intensities result in a continuum of perceived 'phantom' image positions between the loudspeakers. And the system works as well for high frequency sounds as for low frequency ones. But how?

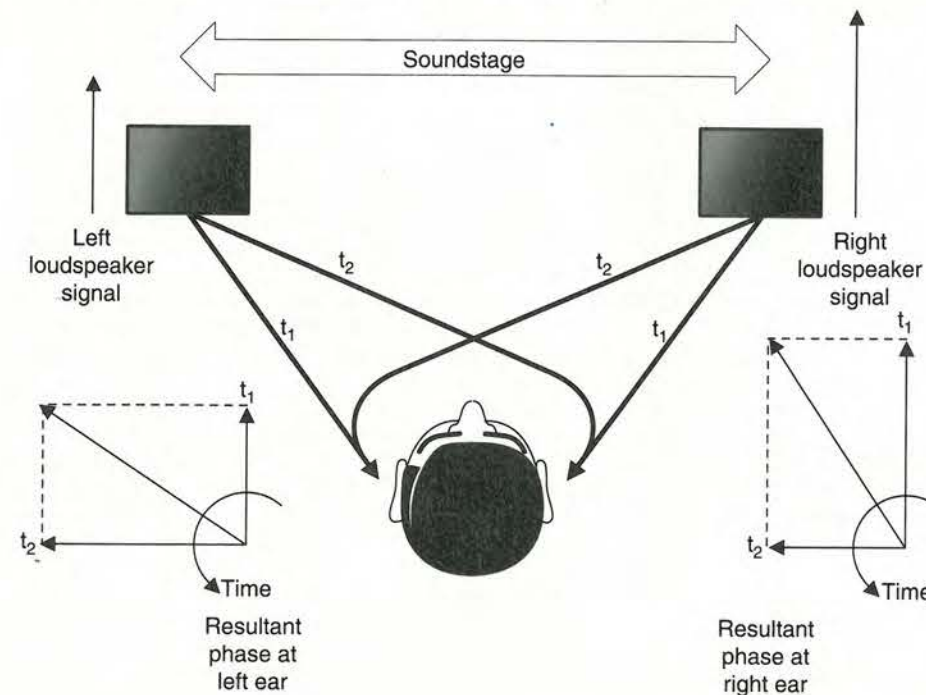

Fig. 3. While it is immediately obvious that left/right channel intensity differences result in high-frequency inter-aural intensity differences when listening to a stereo loudspeaker system, it is far from obvious that these same level differences do, in fact, translate into low-frequency interaural phase differences as well.

While it is fairly obvious that inter-channel intensity differences will reliably result in the appropriate inter-aural intensity differences at high-frequencies, what about at low-frequencies? Here, the sound can diffract around the head and reach the other ear. Where does the necessary low-frequency time-delay component come from?

Well, when two spaced loudspeakers produce identically phased low-frequency sounds at different intensities, the sound-waves from both loudspeakers travel the different distances to both ears and arrive at either ear at different times.

Figure 3 illustrates the principle. The louder signal travels the shorter distance to the right ear and the longer distance to the left ear. But the quieter signal travels the shorter distance to the left ear and the longer distance to the right ear.

The result is that the sounds add vectorially to the same intensity but with a different phase at each ear. Our brain interprets this phase information in terms of interaural delay. This means that stereophonic reproduction from loudspeakers requires only that stereo information be carried by inter-channel intensity difference.

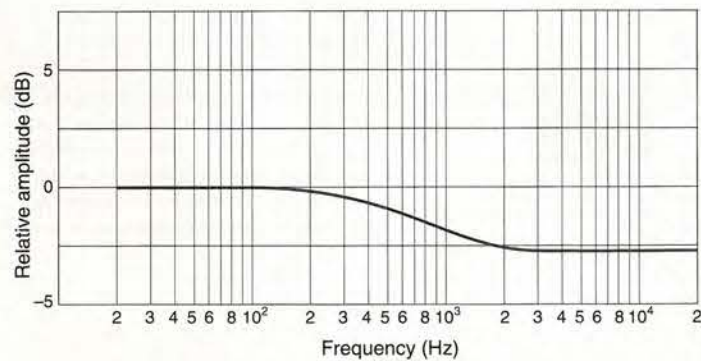
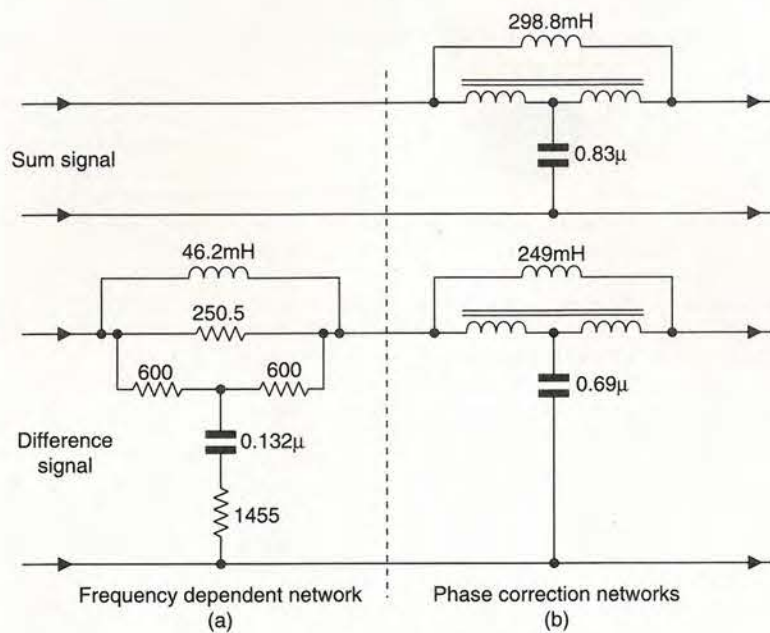
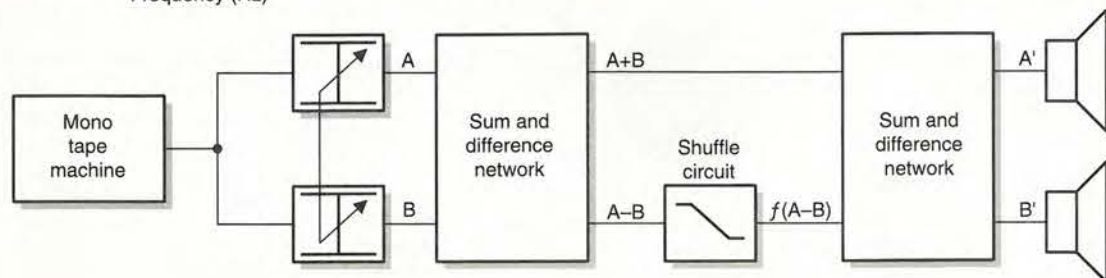

Fig. 4. Practical shuffler circuit and its implementation in the difference channel.



Confused literature...

Despite a huge body of confused literature to the contrary, there is no requirement to encode interchannel delay difference. If this were not the case, the pan control, which the sound engineer uses to 'steer' instruments into position in the stereo sound-stage would not be the simple potentiometer control shown in Fig. 4.

You might think that it is incredibly fortunate that a given interchannel intensity ratio, leading to a particular interaural intensity ratio at high frequencies, causes an exactly appropriate interaural phase difference at low frequencies. It would be incredibly fortunate – if it were true.

For a given interchannel intensity difference, the direction of the perceived auditory event is further from a central point between the loudspeakers when a high-frequency signal is reproduced than when a low frequency is reproduced. Since music is itself a wideband signal, when two-loudspeakers reproduce a stereo image from an interchannel intensity derived stereo music signal, the high frequency components of each instrument or voice will subtend a greater angle at the listening position, than will the low-frequency components.

In fact the stereo image will be 'smeared.' There exists an analogy with chromatic aberration in a lens. This problem was appreciated even in the very early days of research on interchannel intensity related stereophony and, through the years, a number of different solutions have been proposed.

The shuffler

In his original stereo patent application, Blumlein mentioned that it was possible to control the width of a stereo image. He explained that this could be done by matrixing the left and right signal channels into a sum and difference signal pair and controlling the gain of the difference channel prior to re-matrixing back to the normal left and right signals.

Blumlein further suggested that, to alter the stereo image width in a frequency dependent fashion, all that was needed was a filter with the appropriate characteristics to be inserted in this difference channel. After his untimely death, the post-war team working at EMI on a practical stereo system and attempting to cure this frequency dependent 'smearing' of the stereo picture implemented just such an arrangement and introduced a low-pass filter into the difference channel.²

Figure 4 is an illustration of their practical Shuffler circuit – as they termed it – and its implementation in the difference channel. Unfortunately this circuit was found to introduce distortion and tonal colouring and was eventually abandoned.

Other derivatives of the Shuffler have appeared using operational amplifier techniques. But the act of matrixing, filtering and re-matrixing is fraught with problems. This is because it is necessary to introduce compensating delays in the sum channel. These must exactly match the frequency dependent delay caused by the filters in the difference channel if comb filter colouration effects are to be avoided.

Moreover, the signal manipulation performed by the Shuffler must be very carefully defined and the EMI team did not have the benefit of more modern psychological

Have you got the *capacity* to resist this *inducement*?

12 ISSUES free

ELECTRONICS WORLD
INCORPORATING WIRELESS WORLD

not, as they invariably suppose, due to digital taking something mysteriously away. It is due to the analogue equipment adding beneficial high-frequency crosstalk distortion.

This hf crosstalk technique is exploited in the *Francinstien* range of stereophonic image enhancement systems.

In blind listening tests conducted with 'expert' audiences of musicians and recording engineers using material specially recorded for the experiment, preference for *Francinstien* enhanced signals was overwhelmingly significant.⁵

These tests were scored using classic questionnaire type Likert scales, but room was also given for comments and typical observations included, "more air" and "more space" around each instrument. This is typical of my experience of listeners' reactions to the process.

Commercial units are illustrated in Fig. 6. The schematic is given in Fig. 7. The *Francinstien* technique is especially useful because of its wide application. It can be used to improve all pre-existing stereo recordings and may thereby be left in-circuit all the time.

Improved microphone technique

In commercial classical music recordings, it's theoretically possible to 'mike-up' every instrument in an orchestra and then – with electronic panning – create a stereo picture of the orchestra. But this is usually not done for several reasons.

Firstly, the technique is costly and complicated. Secondly often it is simply not practicable. The fact that a multi-miked stereo technique would not work for a recording of the dawn chorus goes without saying. Finally, this 'multi-miked' technique has rarely found favour when it has been tried. Critics, musicians and audiophiles all agree that it fails to provide as faithful a representation of the real orchestral experience.

For these reasons, recordings of real sound fields depend almost exclusively on the application of simple, or 'purist' microphone techniques where the majority of the signal that

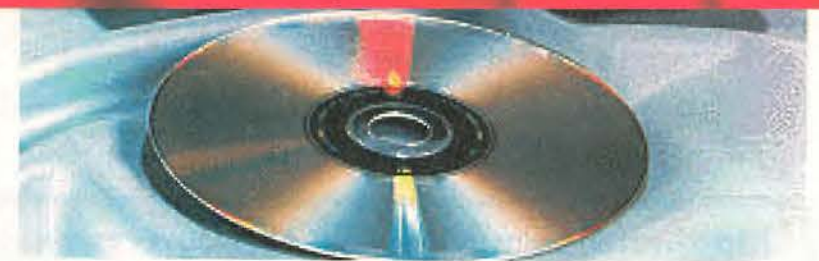

Fig. 6. Stereophonic image enhancement products incorporating beneficial hf crosstalk.

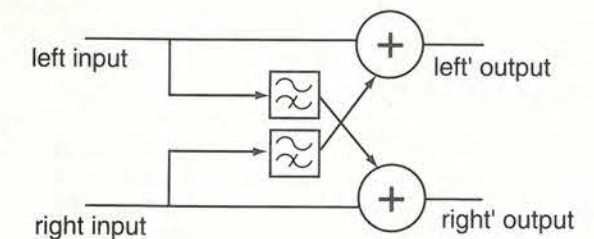

Fig. 7. Outline diagram of the stereo image enhancement circuit used in the products of Fig. 6.

goes on to the master tape at a classical recording session is derived from just two microphones.

Surprisingly, there are no fixed rules as to how these main microphones should be arranged, although a number of popular deployments have evolved over the years.

The way that the microphones are arranged achieves a certain character of sound. Often it betrays a 'house style'. For instance Deutsche Grammophon currently use two pressure-zone microphones taped to huge sheets of Perspex. Essentially, this arrangement is essentially the same as wide spaced omni-directional microphones much beloved by American recording institutions.

Subscribe to **Electronics World** for 3 years but pay for just 2!

Please enter my subscription for:
(tick one of the following)

	UK	Europe	Rest of World	
1 year	<input type="checkbox"/> £34	<input type="checkbox"/> £49	<input type="checkbox"/> £59	
2 years	<input type="checkbox"/> £54	<input type="checkbox"/> £78	<input type="checkbox"/> £94	SAVE 20%
3 years	<input type="checkbox"/> £68	<input type="checkbox"/> £98	<input type="checkbox"/> £119	1 year FREE!

In every monthly issue

- Detailed circuit diagrams
- New product reviews
- Informative design-oriented explanations
- CAE software
- and more

Full money back guarantee

If you're not completely satisfied with **Electronics World** within the first 60 days we'll refund your money in full - no questions asked.

Please allow 28 days for delivery of your first issue.

Please tick here if you do not wish to receive direct marketing promotions from other relevant companies.

Three ways to pay

1 I enclose a cheque for £ _____ made payable to **Electronics World**.

2 Please charge my Visa/Mastercard/American Express/Diners Club (please delete as appropriate)

Card Number

Expiry date /

Signed _____ Date _____

3 Please invoice me/my company. Purchase Order No. _____

Name _____

Job Title _____ Company _____

Address _____

Tel. No. _____

Company VAT registration number _____

Return your completed form to:
Electronics World Subscriptions, FREEPOST RCC 2619,
PO Box 302, HAYWARDS HEATH, UK, RH16 3BR 087

Credit Card Orders
Tel: +44 (0) 1444 445566 (quoting code 087)

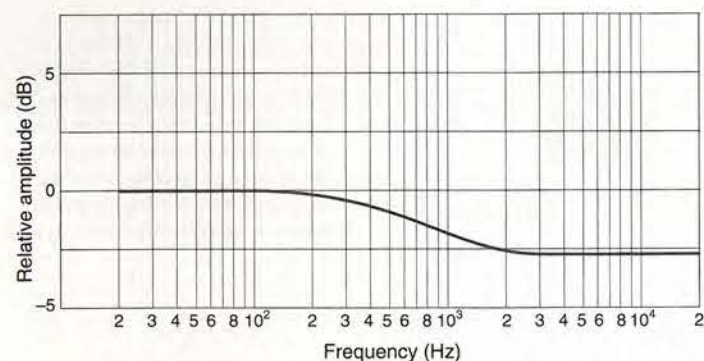
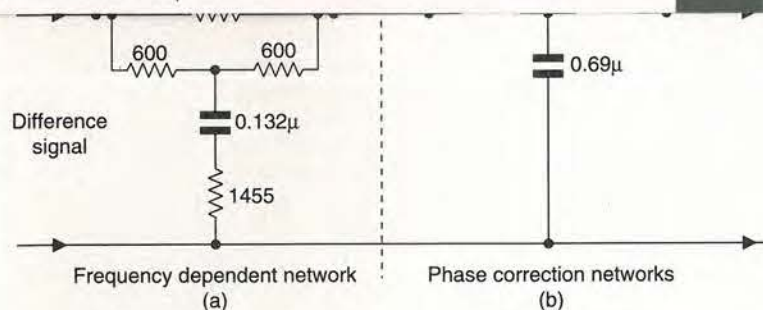
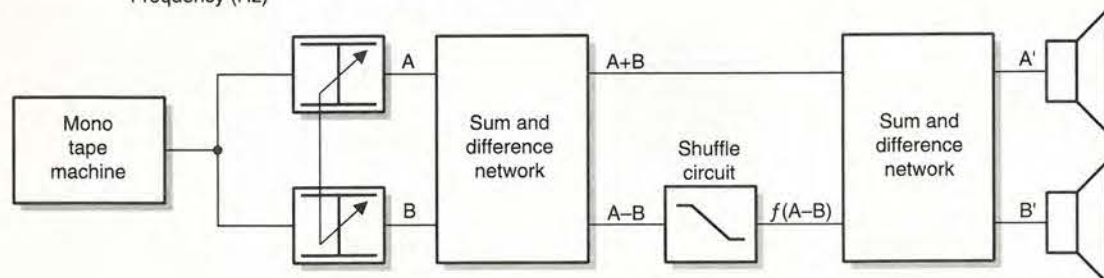

Fig. 4. Practical shuffler circuit and its implementation in the difference channel.



matrixing back to the normal left and right signals. Blumlein further suggested that, to alter the stereo image width in a frequency dependent fashion, all that was needed was a filter with the appropriate characteristics to be inserted in this difference channel. After his untimely death, the post-war team working at EMI on a practical stereo system and attempting to cure this frequency dependent 'smearing' of the stereo picture implemented just such an arrangement and introduced a low-pass filter into the difference channel.² Figure 4 is an illustration of their practical Shuffler circuit - as they termed it - and its implementation in the difference channel. Unfortunately this circuit was found to introduce distortion and tonal colouring and was eventually abandoned. Other derivatives of the Shuffler have appeared using operational amplifier techniques. But the act of matrixing, filtering and re-matrixing is fraught with problems. This is because it is necessary to introduce compensating delays in the sum channel. These must exactly match the frequency dependent delay caused by the filters in the difference channel if comb filter colouration effects are to be avoided. Moreover, the signal manipulation performed by the Shuffler must be very carefully defined and the EMI team did not have the benefit of more modern psychological

research into the signal manipulation required to bring about stereo-image improvement.

Edeko

Remember, it's a fundamental characteristic of the blurring problem that the brain perceives the high-frequency intensity derived image as generally wider than the low-frequency, delay-derived image. With this in mind Dr Edeko³ conceived of a way of solving the problem acoustically and therefore of side-stepping the problems which beset electronic solutions.

Edeko suggested a specially designed loudspeaker arrangement, Fig. 5. In this arrangement, the angle between the high-frequency loudspeaker drive-units subtended a smaller angle at the listening position than the mid-range drive-units. In turn, the mid-range drivers subtended a smaller angle than the low frequency units.

This device, coupled with precise designs of electrical crossover network, enabled the image width to be manipulated with respect to frequency.

Sharper images using crosstalk

There is a much simpler technique which may be used to narrow a stereo image at high frequencies and that is by the application of periodic interchannel crosstalk.⁴

Distortion mechanisms in reproduction from vinyl and other analogue media are predominantly hf crosstalk caused by electrical or mechanical negative reactances. Interestingly, investigations reveal that these distortions may be similar to those required to bring about an improvement in the realism of the reproduced stereo image.

This suggests that there may be something in the hi-fi cognoscenti's preference for vinyl over cd and for many recording musicians' preference for analogue recording over the, apparently better, digital alternative. But the reason is not, as they invariably suppose, due to digital taking something mysteriously away. It is due to the analogue equipment adding beneficial high-frequency crosstalk distortion.

This hf crosstalk technique is exploited in the *Francinstien* range of stereophonic image enhancement systems.

In blind listening tests conducted with 'expert' audiences of musicians and recording engineers using material specially recorded for the experiment, preference for *Francinstien* enhanced signals was overwhelmingly significant.⁵

These tests were scored using classic questionnaire type Likert scales, but room was also given for comments and typical observations included, "more air" and "more space" around each instrument. This is typical of my experience of listeners' reactions to the process.

Commercial units are illustrated in Fig. 6. The schematic is given in Fig. 7. The *Francinstien* technique is especially useful because of its wide application. It can be used to improve all pre-existing stereo recordings and may thereby be left in-circuit all the time.

Improved microphone technique

In commercial classical music recordings, it's theoretically possible to 'mike-up' every instrument in an orchestra and then - with electronic panning - create a stereo picture of the orchestra. But this is usually not done for several reasons.

Firstly, the technique is costly and complicated. Secondly often it is simply not practicable. The fact that a multi-miked stereo technique would not work for a recording of the dawn chorus goes without saying. Finally, this 'multi-miked' technique has rarely found favour when it has been tried. Critics, musicians and audiophiles all agree that it fails to provide as faithful a representation of the real orchestral experience.

For these reasons, recordings of real sound fields depend almost exclusively on the application of simple, or 'purist' microphone techniques where the majority of the signal that

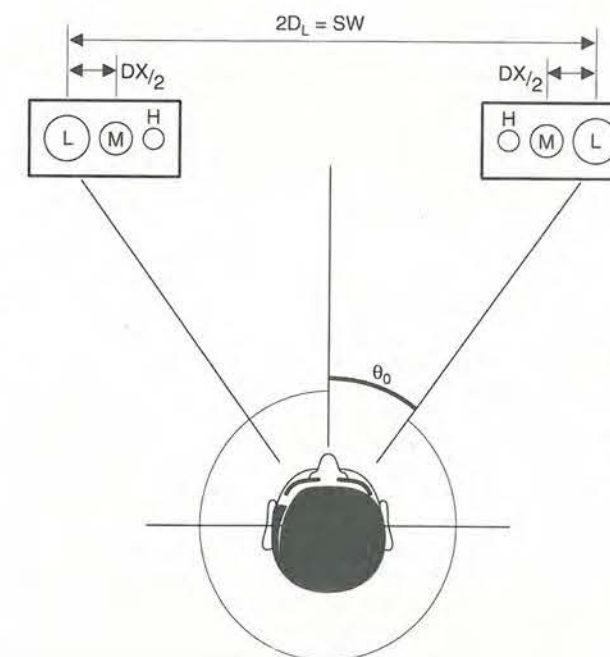

Fig. 5. Edeko (1988) suggested a specially designed loudspeaker arrangement.



Fig. 6. Stereophonic image enhancement products incorporating beneficial hf crosstalk.

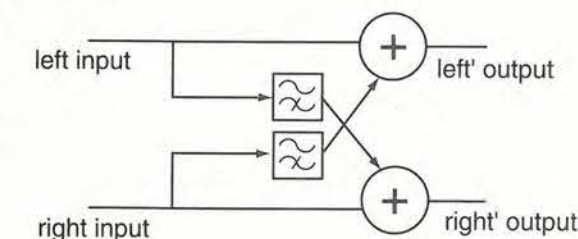

Fig. 7. Outline diagram of the stereo image enhancement circuit used in the products of Fig. 6.

goes on to the master tape at a classical recording session is derived from just two microphones.

Surprisingly, there are no fixed rules as to how these main microphones should be arranged, although a number of popular deployments have evolved over the years.

The way that the microphones are arranged achieves a certain character of sound. Often it betrays a 'house style'. For instance Deutsche Grammophon currently use two pressure-zone microphones taped to huge sheets of Perspex. Essentially, this arrangement is essentially the same as wide spaced omni-directional microphones much beloved by American recording institutions.

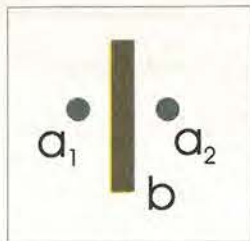

Fig. 8. In Blumlein's patent, two pressure microphones a_1 and a_2 are mounted either side of block of wood b . This wooden baffle provides the high-frequency intensity differences at the microphones in the same way as the human head affects the ears.

British record companies have developed their own arrangements too, while the BBC has stuck almost exclusively to coincident crossed pairs until relatively recently.

This part of the article describes a microphone technique which re-creates the original work by Blumlein with modern signal processing. In controlled recording and listening tests with musician-engineers, the system was preferred to other microphone techniques.⁵

It is possible this is as a result of the system recording extra directional cues over and above those coded in conventional amplitude derived stereophony.⁶

Blumlein's stereo

What makes Blumlein's 1933 patent relating to stereo⁷ so important is his originality in realising the principle, as explained above, that interchannel intensity differences alone produce both high-frequency interaural intensity differences and low-frequency interaural phase differences when listening with loudspeakers.

Intriguingly, Blumlein regarded the principle of pan-potted stereo as trivial. It seems that even in 1933, the principle of positioning a pre-recorded single mono sound-signal by means of stereo as trivial. It seems that even in 1933, the principle of positioning a pre-recorded single mono sound-signal by means of stereo as trivial.

The technological problem Blumlein set out to solve was how to 'capture' the sound field; so that directional information was encoded solely as intensity difference.

Blumlein noted that a crossed pair of velocity microphones mounted at 45° to the centre of the stereo image has the technological advantage that a pure intensity-derived stereo signal may be obtained from such a configuration without the use of electrical matrixing.

His instinct proved right because this has become one of the standard arrangements for the acquisition of intensity coded stereophony. This is so to such an extent that the configuration has become associated exclusively with his name. It is often referred to as the 'Blumlein-pair', an eponymous, and somewhat incorrect label.

In fact, the greater part of Blumlein's patent is concerned with a primitive 'dummy-head', or quasi-binaural, stereophonic microphone arrangement in which,

"...two pressure microphones a_1 and a_2 [are] mounted on opposite sides of a block of wood or baffle b which serves to provide the high frequency intensity differences at the microphones in the same way as the human head operates upon the ears..." (Fig. 8).

Blumlein noted that, when listened to with headphones, the direct output from the microphones produced an excellent stereo effect. But, when replayed through loudspeakers, the stereo effect was very disappointing.

The transformation Blumlein required was the translation of low-frequency, inter-microphone phase differences into inter-channel intensity differences. He proposed the following technique:

"The outputs from the two microphones are taken to suitably arranged network circuits which convert the two primary channels into two secondary channels which may be called the summation and difference channels arranged so that the current flowing in the summation channel will represent the mean of the currents flowing in the two original channels, while the current flowing into the difference channel will represent half the difference of the currents in the original channels... Assuming the original currents differ in phase only, the current in the difference channel will be $\pi/2$ different in phase from the current in the summation channel. This difference current is passed through two resistances in series between which is a condenser which forms a shunt arm. The voltage across this condenser will be in phase with that in the summation channel. By passing the current in the summation channel through a plain resistive attenuation network comprised of resistances a voltage is obtained which remains in phase with the voltage across the condenser in the difference channel. The voltages are then combined and re-separated by [another] sum and difference process... so as to produce two final channels. The voltage in the first final channel will be the sum of these voltages and the second final channel will be the difference between these voltages. Since these voltages were in phase the two final channels will be in phase but will differ in magnitude."

Blumlein's comments on the perpendicularity of the sum and difference vectors are far from obvious. But consider Fig. 9.

A modern practical implementation

The circuit described below is designed so that maximum stereo obliquity is achieved when the inter-microphone delay is 500µs. Other calibrations are possible *mutatis mutandis*. Table 1 tabulates the phase-angle which 500µs represents at various frequencies.

Consider the 30Hz case. The circuit operates by first deriving the sum and difference of the phasor (vector) quantities derived from the primary left and right channels, i.e. let,

$$V_1=(0,1)$$

and,

$$V_2=(\sin 5.4^\circ, \cos 5.4^\circ)=(0.1, 0.996)$$

$$V_{sum}=V_1+V_2=(0.1, 1.996)$$

which has a magnitude of 2.

$$V_{diff}=V_1-V_2=(-0.1, 0.004)$$

has a magnitude of 0.1. So, at 30Hz, the difference channel is 20 times, or 26dB, smaller than sum channel's signal.

Now consider the situation at 300Hz, where

$$V_2=(\sin 54^\circ, \cos 54^\circ)=(0.81, 0.59)$$

$$V_{sum}=(0.81, 1.59), \text{ magnitude}=1.78$$

$$V_{diff}=(-0.81, -0.41), \text{ magnitude}=0.9.$$

At 300Hz the signal is approximately 2 times smaller, i.e. 6dB, compared with the signal in the sum channel.

Now 300Hz is nearly three octaves away from 30Hz and the

gain difference is 20dB, demonstrating that the signal in the difference channel rises by 6dB/octave. This confirms Blumlein's statement that, "for a given obliquity of sound the phase difference is approximately proportional to frequency, representing a fixed time delay between sound arriving at the two ears."

Looking now at the circuit diagram for the binaural to summation stereophony transcoder illustrated in Fig. 10, consider the role of the integrator circuit implemented around IC_{3a}.

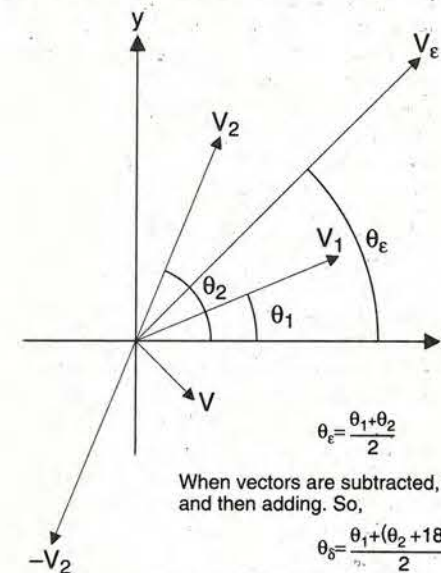

Fig. 9. Provided the magnitude of two vectors remains identical, the sum vector and difference are always perpendicular, as shown.

When vectors are subtracted, it's like adding 180° and then adding. So,

$$\theta_\epsilon = \frac{\theta_1 + \theta_2}{2}$$

Which is the same as saying,

$$\theta_\delta = \frac{\theta_1 + \theta_2}{2} + 90^\circ$$

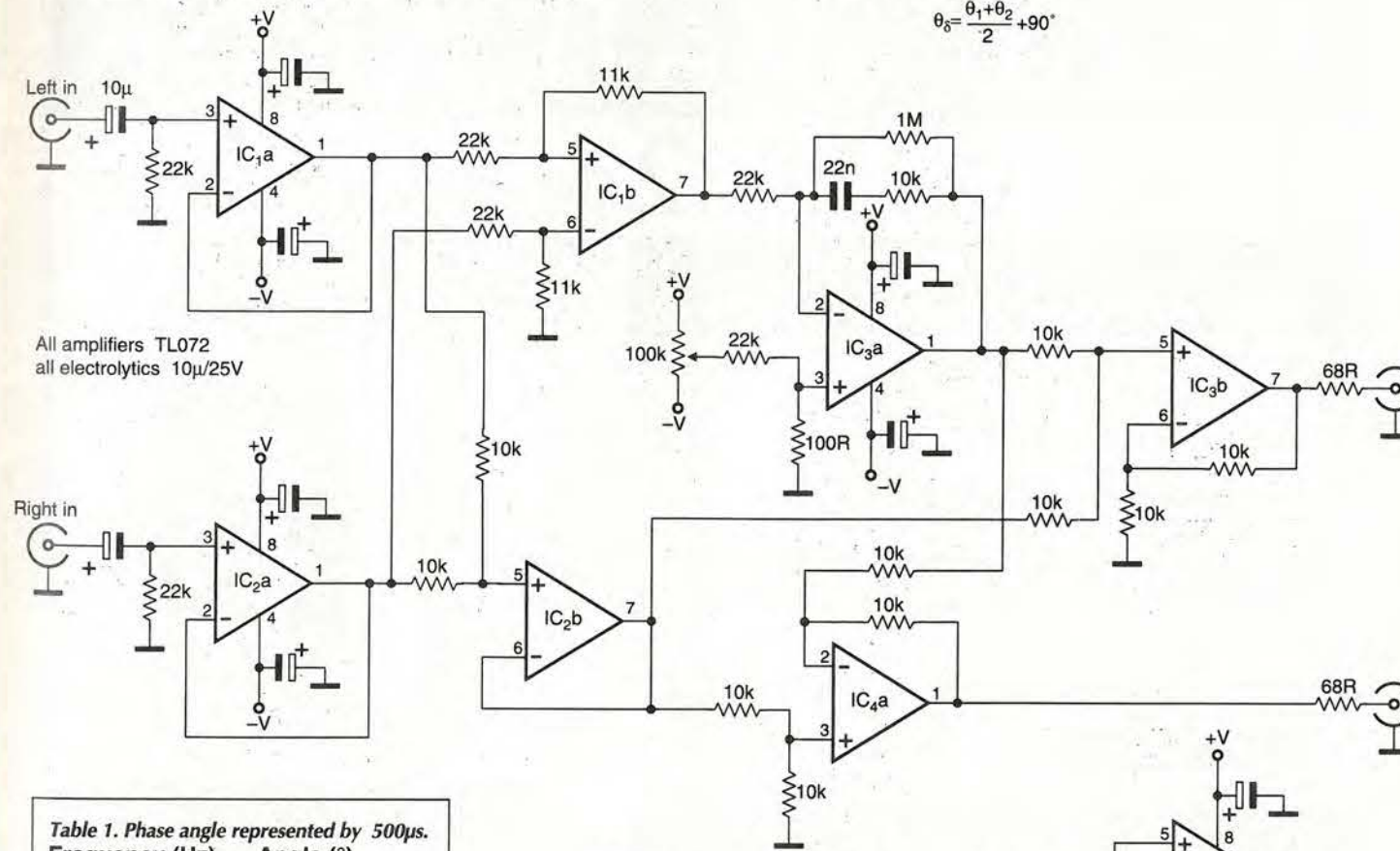

All amplifiers TL072
all electrolytics 10µ/25V

Frequency (Hz)	Angle (°)
30	5.4
60	10.8
300	54
1k	180

Fig. 10. Circuit schematic for the binaural to summation stereophony transcoder.

Multimedia and Virtual Reality Engineering

by Richard Brice, Director, Electric Perception Ltd

This is a complete technical guide to multimedia and virtual reality and includes a Hypertext edition of the book with added audio and graphics on CD. It covers Hardware, software, video and never before published 3D audio techniques,

"...a complete practical introduction to virtual reality and multimedia for those who wish to build systems" Booknews

Richard's book covers the foundations and engineering needed to design and construct projects incorporating video, audio and textural elements and including the use of the latest hardware, to create an artificial world for education, information or entertainment. Production and authoring platforms are described, computer animation and hypertext are covered, but

those looking for pages of software listings and computerspeak will be disappointed. This book is about the nuts and bolts: sound and video cards, head mounted displays,

CrystalEyes glasses, other 3D glasses for entertainment, audio and video production, and realistic auditory and visual stimulation including stereoscopy. The creation of Cyberspace, and strategies to

achieve a complete Cyberatmosphere are presented. Three-dimensional sound generation and video techniques which have never previously been published are revealed. This is the handbook for anyone working in the industry, or hoping to enter it. It also provides a guide for those hoping to 'cross-fertilise' the industry, coming from audio, video, computing or engineering backgrounds.

Inclusive hardback price: £27.50 UK, 29.50 Europe, £32 ROW

To order by post, send a cheque or postal order to Jackie Lowe at Electronics World, Quadrant House, The Quadrant, Sutton, Surrey SM2 5AS. Please make your cheque payable to Reed Business Information. Alternatively, fax full credit card details to 0181 652 8111, e-mail jackie.lowe@rbi.co.uk. Allow 28 days for delivery ISBN: 0 7506 2987 8

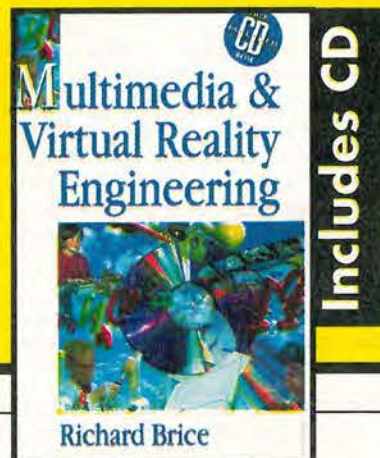

The role of this circuit is twofold. It has to rotate the difference phasor by 90° – and thus align it with the axis of the phasor in the sum channel. It also has to provide the gain/frequency characteristic to compensate for the rising characteristic of the signal in the difference channel.

These requirements could be achieved with a simple integrator. But at frequencies above 1000Hz, it is necessary to return the circuit to a straightforward matrix arrangement. This is because the circuit needs to transmit the high frequency differences obtained due to the baffling effect of the block of wood directly into the stereo channels.

The straightforward matrix is implemented by returning the gain and phase characteristic of the integrator-amplifier to 0dB and 0° phase-shift at high frequencies. This is the function of the 10kΩ resistor in series with the 22nF integrator capacitor.

Note that the actual circuit returns to 180° phase shift at high frequencies – ie. not 0°; this is a detail which is compensated for in the following sum and difference arrangement.

Making modifications

Clearly all the above calculations could be made for other microphone spacings. For instance consider the situation in which two omnidirectional mics spaced 2m apart are used as a stereo pick-up arrangement.

With this geometry, 30Hz would produce nearly 22° of phase shift between the two microphones for a 30° obliquity. This would require a magnitude sum phasor with a value

of 1.97 and a magnitude difference phasor of 0.39. In other words, an integrator with a gain of 5 is needed.

The gain at high frequency would once again need to fall to unity. At first this seems impossible because it requires the stand-off resistor in the feedback limb to remain 10kΩ as drawn in Fig. 10. A little more thought reveals that the transition region must begin at a commensurately lower frequency for a widely spaced microphone system. This is because phase ambiguities of more than 180° will arise at lower frequencies. As a result, all that needs to be scaled is the capacitor, revealing that there is a continuum of possibilities of different microphone spacings and translation circuit values.

References

1. Blauert, J. (1983) Spatial Hearing MIT Press
2. Brittain, F.H. and Leakey, D.M. (1956) Two-channel stereophonic sound systems Wireless World Vol 62 No. 5, 206-210
3. Edeko, F.O. Improving stereophonic image sharpness Electronics and Wireless World Vol 94 No. 1623 (Jan 1988)
4. Brice, R. (1998) Music Engineering. Newnes
5. Private correspondence (with F. Rumsey)
6. Brice, R. (1997) Multimedia and Virtual Reality Engineering. Newnes
7. Blumlein, A. British Patent 394,325 June 14th 1933

The *Francinstien* range of stereophonic image enhancement systems mentioned in the article is developed by Perfect Pitch Music Ltd, Tel., +33 1 47 23 54 02.

The Headphone Amplifier Box
Balanced or unbalanced microphone or line input to headphone output
Professional portable units operating from an internal PP3 battery or external mains adaptor



- * Precision transformerless balanced input
- * Bridged headphones output drive
- * Sensitivity selectable over a wide range of input levels
- * Low noise and distortion
- * High common mode rejection
- * Loop through facility
- * Extensive RFI protection

The Balance Box (precision mic/line amplifier) –
The Phantom Power Box – **The OneStop** DIN rail mounting radio frequency interference filter and voltage transient protector for voltage and current loop process signal lines

Conford Electronics Conford Liphook Hants GU30 7QW
Information line 01428 751469 Fax 751223
E-mail contact@confordelec.co.uk
Web <http://www.confordelec.co.uk/catalogue/>

CIRCLE NO.120 ON REPLY CARD

ADVANCED ACTIVE AERIAL



The aerial consists of an outdoor head unit with a control and power unit and offers exceptional intermodulation performance: SOIP +90dBm, TOIP +55dBm. For the first time this permits full use of an active system around the lf and mf broadcast bands where products found are only those radiated from transmitter sites.

- General purpose professional reception 4kHz-30MHz.
- –10dB gain, field strength in volts/metre to 50 Ohms.
- Preselector and attenuators allow full dynamic range to be realised on practical receivers and spectrum analysers.
- Noise – 150dBm in 1Hz. Clipping 16 volts/metre. Also 50 volts/metre version.

- ★ Broadcast Monitor Receiver 150kHz-30MHz.
- ★ Stabilizer and Frequency Shifters for Howl Reduction
- ★ Stereo Variable Emphasis Limiter 3
- ★ 10-Outlet Distribution Amplifier 4
- ★ PPM10 In-vision PPM and chart recorder
- ★ Twin Twin PPM Rack and Box Units.
- ★ PPM5 hybrid, PPM9 microprocessor and PPM8 IEC/DIN –50/+6dB drives and meter movements
- ★ Broadcast Stereo Coders

SURREY ELECTRONICS LTD
The Forge, Lucks Green, Cranleigh, Surrey GU6 7BG.
Telephone: 01483 275997. Fax: 276477.

CIRCLE NO.121 ON REPLY CARD

CROWNHILL ASSOCIATES LIMITED

The Old Bakery, New Barns Road,
Ely Cambs. CB4 7PW
Tel: +44 (0)1353 666709 Fax: +44 (0) 1353 666710

Low cost professional quality Smart Card Systems

CHIPDRIVE EXTERN

Intelligent programmer for Smart Cards using the International Standard T=0 or T=1 protocols also Memory and Secure Memory using I²C, 2-wire & 3-wire interfaces
Supplied with software to read and write to most popular secure smart cards, inc GSM, PAY PHONE and ACCESS CONTROL cards.
T=0 or T=1 @ 3.579MHz
RS232 @ 9600 -11500 bps
Internal Supply/Ni-MH
Size: 100x70x80 mm Weight 660 Gram
Supplied with **CardServer** API for easy development of SmartCard Applications using Visual Basic, Delphi or C++
Supplied with Sample Memory cards & Secure Smart cards
CE compliant



Chip Drive Intern

3.5" floppy bay version of the CHIPDRIVE.
Applications are available to provide SmartCard controlled access of data on Hard drives or "PC-LOCK", to control access to the whole PC Fully Compatible **TOOLBOX** for systems development.



Most popular smart cards are plastic, the size of a credit card, with an embedded microprocessor containing an operating system and erasable non-volatile memory. Physical protection against unauthorized tampering with the card is provided through the following scheme: The microprocessor and memory are created as a single chip. This insures there are no data paths that can be monitored or probed. This chip is connected to a thin circuit board and encapsulated with an epoxy. The "module" is then glued within a well milled into the plastic card. This prohibits physical access to the microprocessor and provides a more durable medium than magnetic stripe cards.

NEW CHIPDRIVE -micro

Fully Compatible with **TOOLBOX** for application development. Featuring the same functionality as Chip Drive Extern but in a small neat low cost package, similar in size to a smart card.



Chipdrive Developer Kit
micro, sample cards and Toolbox
£99.95 + P&P + VAT

<http://www.towitoko.co.uk>
<http://www.crownhill.co.uk>
<http://edsim.cambs.net>



Driver and application software is available for the CHIPDRIVE family of terminals including the command set DLL for Windows 3.11/95NT, easy to use 16 and 32 Bit DLLs with just one function call to the "CardServer", a powerful Background task which relieves the application programmer from device and card administration. Featuring automatic protocol and card type detection. Allowing several applications to access one terminal dependent on the type of card inserted.
£29.95 + £5 P&P + VAT

The microprocessor operates under control of a "built in" program called an operating system. A serial interface - which make it impossible to access the memory directly - is employed to communicate with the card. An ISO (International Standards Organisation) protocol is used to exchange commands and data with the card. Finally, Holograms, signature stripes, photos, etc can be applied to card for additional security. And the card can be custom printed with your artwork. Crownhill can supply OPEN ARCHITECTURE cards, that will allow you the end user to create your own operating system, to control access to the EEPROM memory of up to 64Kbits (8Kbytes) in size. Crownhill have off the shelf operating systems for Control access, Electronic purse and Portable Document applications. Others can be written to your specification.

SMARTCARDS Available from Stock:
GemPlus, Atmel, Xicor, Siemens, SGS Crownhill and more...
SLE4442, 4432, 4418, 4428, 4404, AT88SCxxx, AT24c01-16.
GPM103, GFM1K, 2K, 4K, GPM416 Phone Cards, Loyalty Cards

THE SMARTEST SOLUTION
Crownhill can offer a broad range of smart cards from just £1.00 and Smart Card sockets for just £1.45 each. PIC Microchip based Smart Cards now available at just £3.50 each... **DEVELOP YOUR OWN SMART CARD!** Crownhill can supply over 150 different types of IC from more than 12 silicon suppliers, which can all be incorporated into smart card format. Some cards are available from stock, most are manufactured to the customers' specification

CIRCLE NO.122 ON REPLY CARD

NOW AVAILABLE RANGER 2

The Complete, Integrated Schematic & PCB Layout Package

- Windows Ranger 2**
For Windows 95 & NT
• New Hierarchical Circuit
• Split Devices • Gate & Pin Swap
• New Edit Devices in Circuit
• Copper Fill • Power Planes
• Autorouter • Back Annotation
£250
- Ranger 2 Outputs:**
Full Windows Outputs
Plus - HP-GL
Gerber
NC Drill
AutoCad DXF
- Windows Ranger 2 with Specetra SP2**
Ranger & Specetra Autorouter provide the most cost effective PCB Design system available. A powerful, intuitive system at an outstanding price!
£600
- Windows Ranger 2 Upgrade**
Upgrade your existing PCB Package to Windows Ranger 2.
£150
- SPECIAL OFFER Ranger 2 Lite £35** (Prices exc VAT/P&P)

Demo Software -download from <http://biz.ukonline.co.uk/seetrax>
Call 01730 260062
Fax 01730 267273
Old Buriton Limeworks, Kiln Lane,
Buriton, Petersfield, Hants. GU31 5SJ

for Windows 95™
Demo Software - available from our Web Address



SEETRAX
Advanced Systems & Technology for PCB Manufacture

CIRCLE NO.119 ON REPLY CARD

TELEMETRY via mobile phone

Heikki Kalliola uses a remote mobile phone to find out the temperature in his holiday cottage and turn the heating on if need be.

This telemetry solution makes use of a mobile phone and has two main benefits. It works in places where there are no telephone lines and it needs no approvals, since it requires no modifications to the telephone system. I have applied this design to control the temperature of a holiday cottage far away in the countryside. It incorporates a talking thermometer design of mine described in an article called 'Thermometer answers back' published in the July/August 1996 issue.

Prior to setting off to the country house, I can find out what the temperature there is and switch the heating on if need be.

How it works...

Ringing sound of the telephone is caught by the microphone, amplified and converted to pulses, Figs 1,2. When the total number of pulses reaches the number dictated by counter IC₁₁, relay RY₁ activates solenoid S, the plunger of which answers the phone call.

Releasing RY₁ resets the counter and turns on the closing circuit, IC₁₀, preventing the solenoid from reacting for a couple of minutes while control commands are received.

Control is performed via dtmf, or dual-tone multiple-frequency, codes keyed from the calling phone. Tones are caught by the microphone, amplified and directed to the dtmf receiver, IC₃ and further to four digit register IC_{4,5}.

When a new digit is keyed, the previous ones shift forward. So in the diagram, the last entered digit is in the left register. Digits are converted from binary to decimal via IC_{6,9}. The controlling command comprises four digits, the first three forming the security code and the fourth being the function code. The valid security code can be changed any time with switches S_{1,3}.

When a valid four digit command has been received, the output determined by the function code is activated. With the settings shown in Fig. 2, the command '4721' triggers the thermometer to talk via delay circuit IC₁₂.

Delay is there to give the mobile phone user time to put handset back to the ear after keying the code. Command '4722' turns on an output, which I use for switching the heating. More outputs can be implemented if needed.

Output is turned off by any keying anything other than a valid control command, i.e. security code plus function code. As a result, this circuit does not allow simultaneous control

Fig. 1. Basically, the circuit listens for a call, answers it and then waits for a specific sequence of four digits. The first three digits are for security, the fourth contains command information.

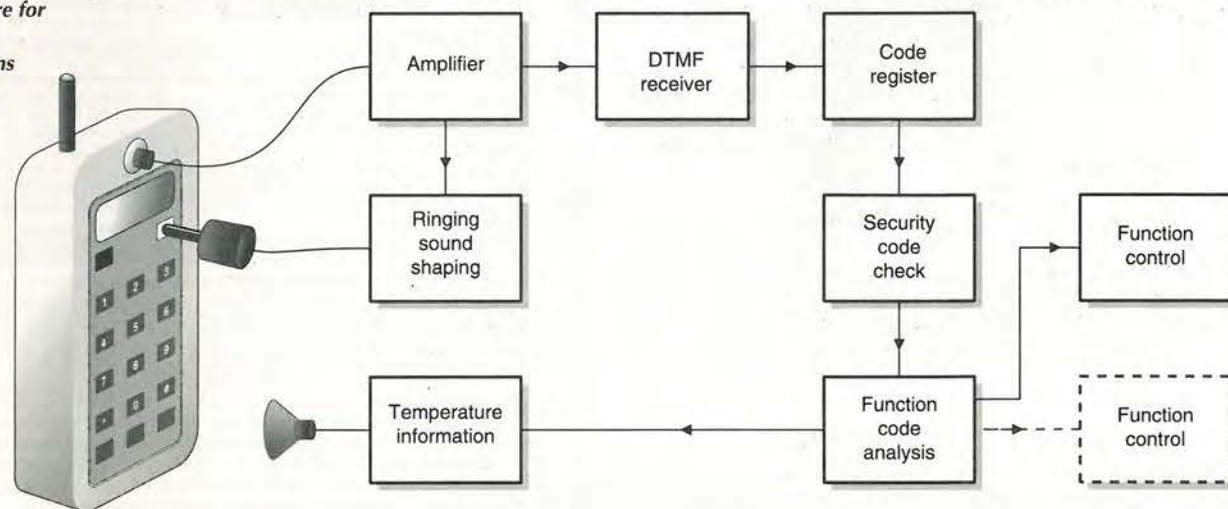

of outputs independently from each other. If you turn on one channel, it turns off another which possibly has been on. A more flexible arrangement would be easy to produce using a microcontroller.

Operational aspects

The microphone is best located near the earpiece of the phone, where the dtmf codes are received.

Sensitivity of the amplifier is adjusted via R₆. Do not set the sensitive higher than it needs to be since noise could then make the solenoid operate when it shouldn't.

The solenoid is fixed in front of the answering button, which is normally a green handset symbol. It is important not to set any legitimate numbers for the phone, otherwise disturbing noise from the environment could make the solenoid call that number.

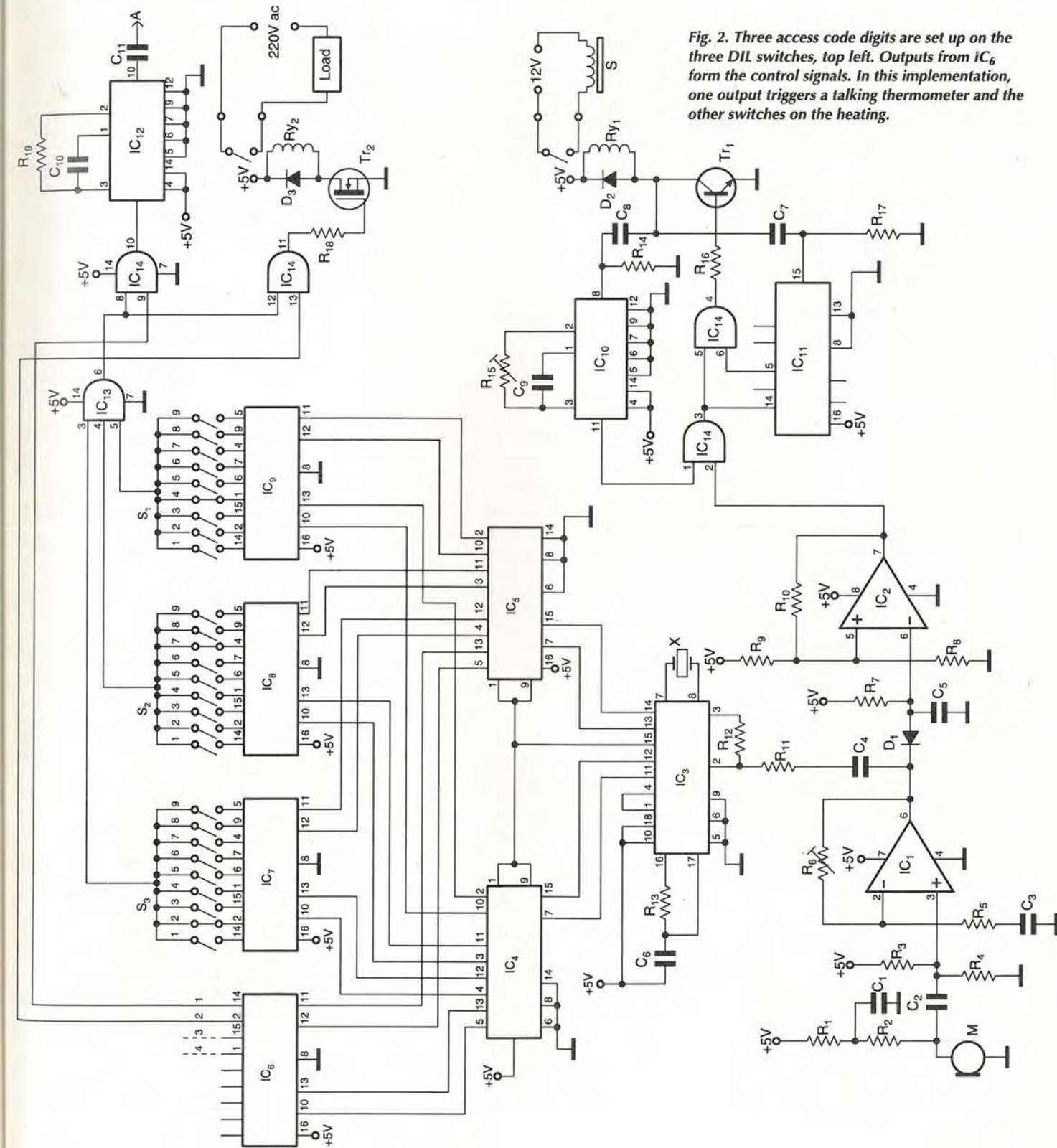

Fig. 2. Three access code digits are set up on the three DIL switches, top left. Outputs from IC₆ form the control signals. In this implementation, one output triggers a talking thermometer and the other switches on the heating.

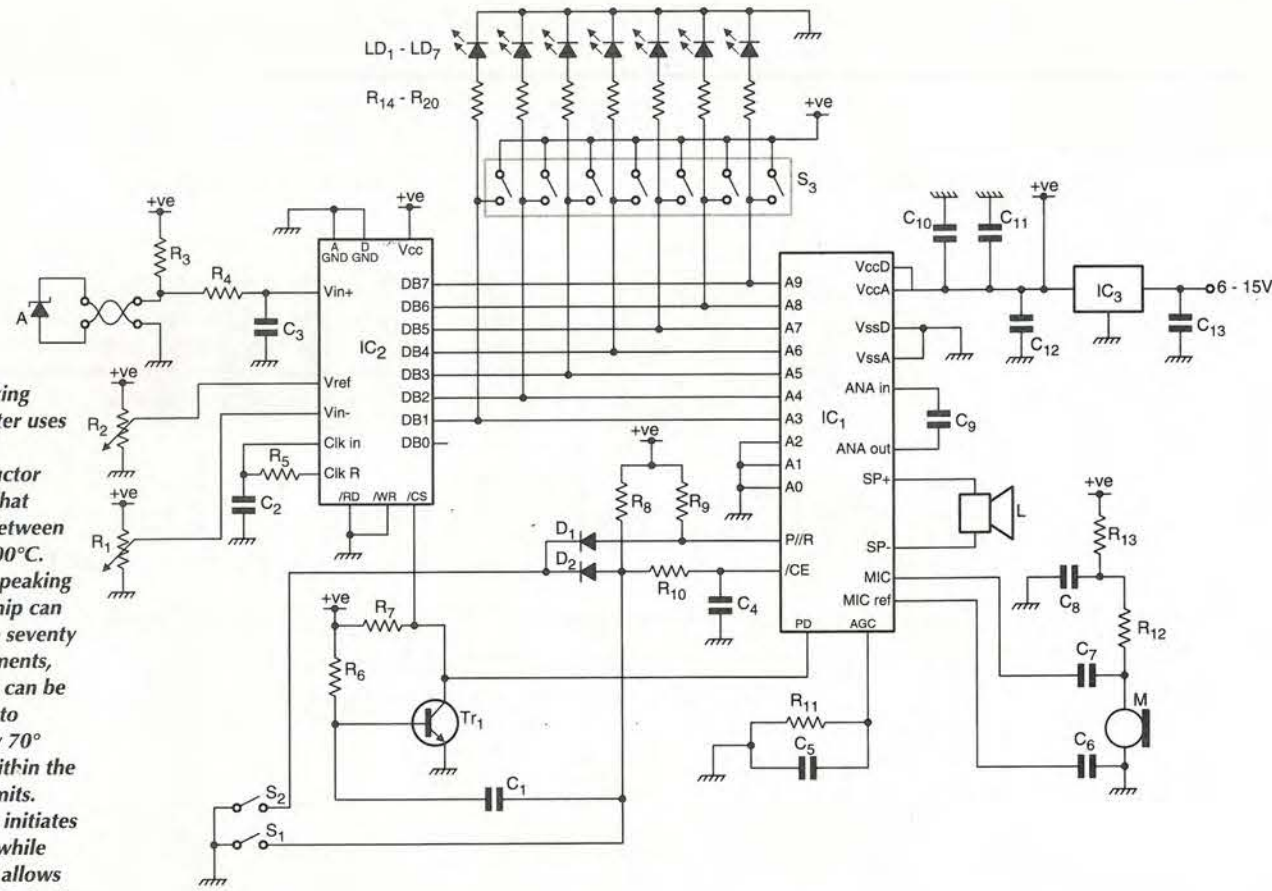

Fig. 3. Talking thermometer uses a National Semiconductor sensor IC that operates between -40 and 100°C. Since the speaking memory chip can store up to seventy announcements, the system can be calibrated to handle any 70° window within the sensor's limits. Pushing S₁ initiates playback, while holding S₂ allows recording. Point A of the main circuit connects to S₁.

The number of ringing sounds to activate the solenoid is determined by which output pin of counter IC₁₁ is connected to gate IC₁₄. It is better not to let the phone answer too early to prevent solenoid activating before the telephone is ready. It sounds also more natural to the user if the phone rings a few times before answering.

Note that in this circuit the functions are mutually exclusive. If for example the heating is turned on and you send a command to the interface to listen to the temperature, the heating will turn off and stay off until re-activated.

Note also that keying anything other than the right four digit code will turn off a function that was on. This could be a useful security feature. If the correct codes are forgotten

or lost, it is still possible for anyone knowing the phone number to turn off a function.

If the device is to be used in critical applications like heating, additional security controls like thermostat, timer switch, etc., should be installed. These are needed to make sure that no damage is caused in case of phone connection disturbance or a user forgetting to turn off the device.

The circuit does not contain feedback to the user verifying whether the requested function has actually been performed. Such a feature could be added by constructing a voice signal to the connecting relay.

In my application, verification is automatic, since the temperature message is verification itself. In addition, relay RY₂ is noisy enough to be audible over the phone.

Parts list

Resistors (0.25W)

- R₁ 330
- R₂ 1.5k
- R_{3,4} 47k
- R₅ 1k
- R₆ 5M trimmer
- R₇ 5.6M
- R_{8,13} 380k
- R₉ 470k
- R₁₀ 3.3M
- R₁₁ 10k
- R_{12,19} 100k
- R_{14,17} 33k
- R₁₅ 1M trimmer
- R_{16,18} 2.2k

Capacitors (16V)

- C_{1,9} 47µF
- C₂ 0.47µF
- C₃ 1µF
- C_{4,6-8} 100nF
- C₅ 200nF
- C_{10,11} 6.8µF

Semiconductors

- IC₁ LF357
- IC₂ TL072
- IC₃ 8870
- IC_{4,5} 4015
- IC₆₋₉ 4028
- IC_{10,12} 4047
- IC₁₁ 4017
- IC₁₃ 4073
- IC₁₄ 4081

- Tr₁ 2N2222
- Tr₂ IRFZ34
- D₁₋₃ 1N4001

Other

- M Electret microphone
- RY₁ DIL-relay (5V)
- RY₂ Relay (5V, contacts 10A, 220V)
- SW₁₋₃ DIL-switch (9 contacts)
- X 3.579545Mhz crystal
- S Solenoid 12V (eg. RS 347-652)

We make our programmers work harder

FEATURES

- ◆ Supports EPROMs, EEPROMs, Flash, Serial PROMs, BPROMs, PSDs, PALs, GALs, PEELs, MACH, MAX, EPLDs, and over 200 Microcontrollers including 87C48/51, 89C51/52, PIC, MC705/711, ST6, Z86, COP etc.
- ◆ Hands free programming so you can produce batches of the same chip without pressing a key
- ◆ Correct programming and verification at 1.8, 2.7, 3.3 and 5V
- ◆ Serial number mode supports date/time stamping, unique IDs
- ◆ Progress indicator shows number of devices programmed
- ◆ No adapters required for DIL parts upto 48-pins. Universal adapters for 44-pin PLCC, 44-pin PSOP and 48-pin TSOP parts
- ◆ Programmes and verifies Intel 28F400 in under 15 seconds
- ◆ Connects to parallel port - no PC cards needed
- ◆ Tests 7400, 4000, DRAM and SRAM
- ◆ Mains or battery operation
- ◆ FREE software device support upgrades via bulletin board and www



NEW Windows '95™ Software provides the best user interface on the market

NEW - Hands free programming

Programming Speeds the fastest in the business: 28F008 in 29 sec

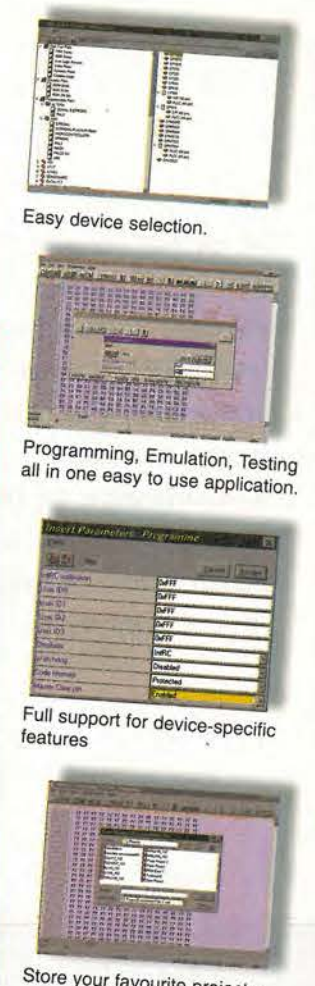

Easy device selection.

Programming, Emulation, Testing all in one easy to use application.

Full support for device-specific features

Store your favourite projects...

48-pin Universal Programmer STILL ONLY

£695



SPEEDMASTER GLV32 £695

LV40 PORTABLE £995

PROGRAMMER MODELS AND PRICES					
SINGLE SOCKET PROGRAMMER		EMULATOR OPTIONS		GANG PROGRAMMERS	
FOR ALL PC BASED PROGRAMMERS					
MICROMASTER LV48	48-pin universal programmer	£695	LVECEMUL8	128kx8 ROM/RAM emulator with modify on the fly feature Upgradable to 512x8	£125
SPEEDMASTER/MICROMASTER	40-pin programmer range (see website or call for model details)	FROM £395	LVECEMUL16	128x16 ROM/RAM emulator with modify on the fly feature Upgradable to 512x16	£195
EPMASTER LV	40-pin EPROM/Flash programmer	£295			
LV40 PORTABLE	As Micromaster LV, plus completely portable with built in keypad and LCD display.	£995			
			SPEEDMASTER GLV32	8-way 32-pin EPROM/Flash Gang/Set programmer	£695
			SPEEDMASTER GLVCOP	8-way 40-pin gang programmer for National Semiconductor COP micros	£1500
			SOCKET ADAPTERS	Full range of adapters for PLCC, SOIC, TSOP, PSOP etc...	FROM £65

All prices exclude VAT and delivery

See for yourself - download a demo from our Website at www.icetech.com
ORDER NOW - ALL PRODUCTS IN STOCK. CREDIT CARD ORDERS: 01226 767404



For a copy of our catalogue giving full details of programmers, emulators, erasers and adapters, call, fax or e-mail us. You can also access our BBS or Home page. All our products are in stock now for next day delivery - call our credit card hotline now.

ICE Technology Ltd. Penistone Court, Sheffield Road, Penistone, Sheffield, UK S36 6HP
 Tel: +44 (0)1226 767404 Fax: +44 (0)1226 370434 BBS: +44 (0)1226 761181 (14400,8N1)
 Web: www.icetech.com Email: sales@icetech.com



In order to get the best out of a switching design involving transistors that saturate, you need to have a sound knowledge of the characteristics of saturation. Bryan Hart illustrates why.

Designing with saturation

In science and engineering generally, the word 'saturation' indicates some limiting condition such as the state of magnetisation of an iron-cored transformer. With the bipolar junction transistor, or bjt, 'saturation' is commonly describes one operating state – the 'on' condition of the device used as a switch.

What, precisely though, is meant by saturation in that case? For the circuit design engineer the treatment of the topic in the literature is not, in my view, as clear and informative as it could be. For example, the saturation region has been described variously as that '...below the knee of the collector characteristics' and '...where the collector characteristics merge'.

Consider Figs 1 & 2, which are photographs of the collector characteristics of a general purpose low power silicon bipolar junction transistor, namely a ZTX300, in the vicinity of the origin. Superimposed on Fig. 1, by double exposure, is another curve dealt with later. Figure 2 shows the same characteristics as Fig. 1 but with an expanded horizontal scale.

It is apparent that there is no unique 'knee point'. Furthermore, although the curves appear to converge to a single point, they do not 'merge' in the sense of combining to form a single trace.

This article is intended to clarify the meaning of saturation. Also, in the case of common-emitter switch – i.e. 'inverter' – design, the article will justify its representation by a simplified dc equivalent circuit based on information given on manufacturers' data sheets.

To do this it is necessary first to review a general dc model of the bipolar transistor that gives a good first-order description of device performance.

The BJT dc model

A low-power silicon n-p-n transistor, symbolised in Fig. 3a), is chosen for discussion because of its predominance in design work. Bear in mind that the remarks made concerning it are equally valid for a p-n-p transistor if

the directions of currents and the polarities of bias voltages are reversed.

The bipolar junction transistor model of Fig. 3b) is a 'transport' version¹ of the classic model proposed by J. J. Ebers and J. L. Moll.² Diodes D_E and D_C , which are assumed to have ideal exponential I - V characteristics, refer respectively to the base-emitter and base-collector junctions. As each diode may be either forward or reverse biased independently of the other, there are four possible operating modes, or regions.

These regions are indicated on the mode-map of Fig. 4. It is apparent that in three of them the dc model reduces to a simpler form. Thus, in the normal-active mode, used in analogue applications, D_C is reverse biased and the collector current may be regarded as dependent upon either the current in D_E or upon the potential difference across it. In the reverse-active mode the bipolar transistor works 'backwards'. This mode is not normally used.

Uses of saturation

The saturation mode, together with the cut-off mode, is used in switching circuits. In the model considered, saturation is defined unambiguously as that mode for which D_E and D_C both conduct.

Figure 4 applies whatever the configuration employed. Figure 5 is an interpretation of it in the I_C , V_{CE} plane. It shows that the saturation region comprises two sub-regions. In the first quadrant, where I_C is greater than zero, it is bounded by the lines $V_{CE}=0$ and $V_{BC}=0$, i.e., $V_{CE}=V_{BE}$.

The near-vertical trace towards the centre of Fig. 1 shows this boundary line. It was obtained by strapping together the collector and base leads of the device. The boundaries in the third quadrant, where $I_C < 0$, are set by the lines $V_{CE}=0$, $V_{BE}=0$.

In saturation, I_C and I_B in Fig. 3b) are given by the following equations, in which the sec-

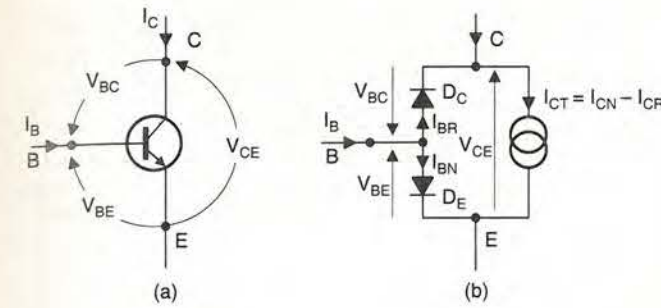

ond subscripts, N and R, refer to 'normal' and 'reverse' respectively.

$$I_C = I_{CT} - I_{BR} = I_{CN} - I_{CR} - I_{BR} \quad (1)$$

and,

$$I_B = I_{BN} + I_{BR} \quad (2)$$

where,

$$I_{CN} = I_S \{ \exp(V_{BE}/V_T) - 1 \} \quad (3)$$

$$I_{CR} = I_S \{ \exp(V_{BC}/V_T) - 1 \} \quad (4)$$

$$I_{BN} = I_{CN} / \beta_N \quad (5)$$

$$I_{BR} = I_{CR} / \beta_R \quad (6)$$

In these equations, I_S is a parameter that is dependent upon device geometry – emitter area and base width – and base doping profile. It is constant at a fixed temperature.

Parameter V_T is the 'thermal voltage' kT/q , k being Boltzmann's constant, or $1.38 \times 10^{-23} \text{ J/K}$, T the Absolute Temperature in kelvins ($^{\circ}\text{C} + 273$) and q is the magnitude of the electronic charge in coulombs, or $1.602 \times 10^{-19} \text{ C}$.

Throughout this article, V_T is taken as 25mV, its approximate value at room temperature, 290K.

The parameter β_N is the common-emitter current gain, i.e. the ratio I_C/I_B with the bipolar transistor in the normal-active mode and $V_{BC}=0$: it is taken as, being independent of I_C and T . A similar definition applies to β_R .

In the normal-active mode $I_{CR}=0$ and $I_C \approx I_{CN} = \beta_N I_B$.

The collector current results from all those electrons from the emitter that reach the base-collector junction and are swept across it by the field existing there. In saturation $\beta_N I_B$ exceeds the maximum current that the external circuit is able to supply. Regarding charge carrier flow within the device, there is a 'bottleneck' condition.

As the base-collector junction is not permitted a carrier flow corresponding to $I_C = \beta_N I_B$, the only way to achieve a balance is by the junction becoming forward biased. Then electrons not only arrive at the junction from the emitter but are also injected back from the collector region into the base, i.e. I_{CR} is greater than zero.

Voltage V_{BC} increases till the net flow corresponds to the current allowed by the external circuit. In that case V_{CE} , now known as $V_{CE(sat)}$, is the difference between V_{BE} and V_{BC} and is, consequently, less than either.

A bipolar transistor in saturation may be

Fig. 3. Symbolic representation of an n-p-n transistor, a). On the right, b) is a dc model for a).

Fig. 4. Mode-map for dc operation.

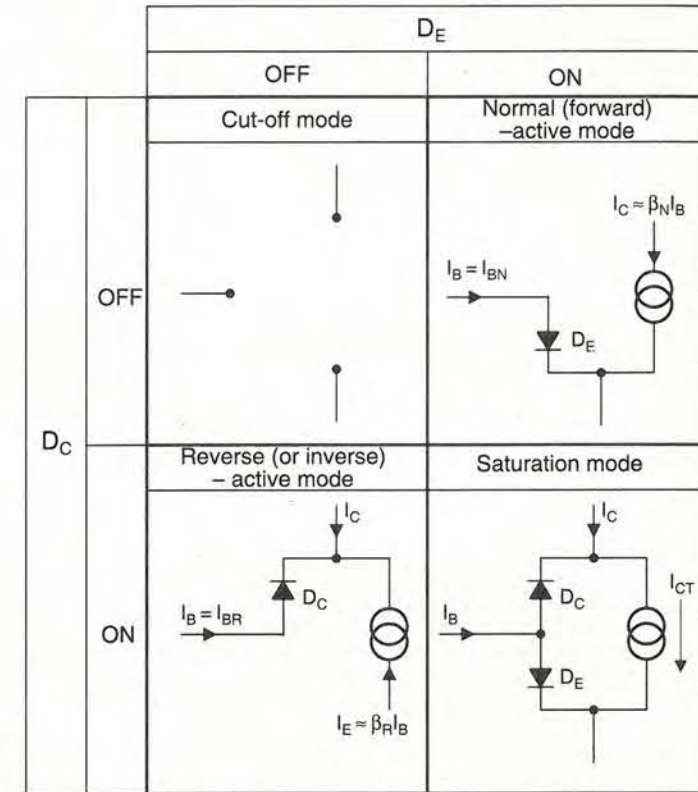

viewed as comprising two transistors, each working at the edge of saturation, i.e. $V_{BC}=0$, connected in inverse parallel.

Squirting sand

In mechanics, a crude analogy that shows the difference between the normal-active and saturation regions is provided by a nozzle squirting particles of sand at a wire mesh located a short distance from the nozzle in a plane at right angles to it.

If the mesh is extremely coarse almost all the sand particles pass through it but if the mesh is fine some particles bounce back. In this analogy, sand particles play the part of electrons, the nozzle the injecting emitter and the mesh the biased base-collector junction.

There is, incidentally, a direct link between the model of Fig. 3b) and the physical electronics of bipolar transistor operation. The link is that each of the currents defined earlier can be associated with a minority carrier charge pattern in each of the quasi-neutral regions E, B, C of the transistor.

A study of that link is rewarding for the added physical insight it offers but I will not pursue it here because this article is concerned primarily with the circuit representation of the saturated state.

In the next section, I show that Fig. 3b) can be reduced to a simpler form in the case of the inverter configuration widely used in interface circuit design. Then, in a final section, Fig. 3b) is used to demystify the operation of a standard ttl input stage and of a precision switch.

The saturated bipolar inverter

Figure 6 shows a common-emitter switch

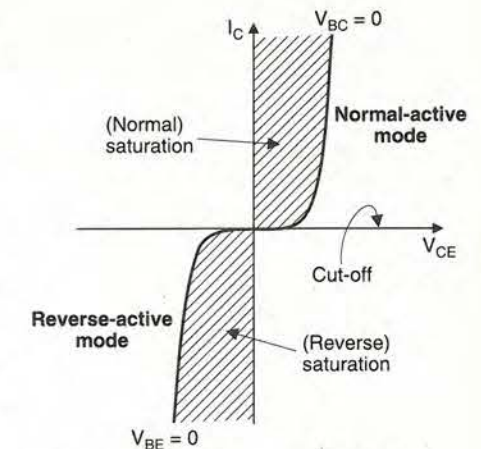

Fig. 5. Plot for I_C - V_{CE} corresponding to Fig. 4.

using a silicon bipolar transistor. When Q_1 is saturated its V_{CE} is not zero. As a result, Q_2 can only be cut off in the sense defined in the mode-map classification of Fig. 4. That means that D_E is off if its base is connected to the junction point of a resistive potential divider network connected between the collector of Q_1 and a negative supply rail.

Since a negative rail is not used here, it is necessary to establish a relaxed practical criterion for the off condition with single rail circuits. A suitable criterion, discussed elsewhere³ is that Q_2 may be regarded as off if its V_{BE} is less than 0.4V. This is compatible with the upper limit for a logic '0' output voltage with standard ttl.

In Figure 7, the load-line construction for Q_1 illustrates this requirement. Operating point P must lie not only to the left of the boundary

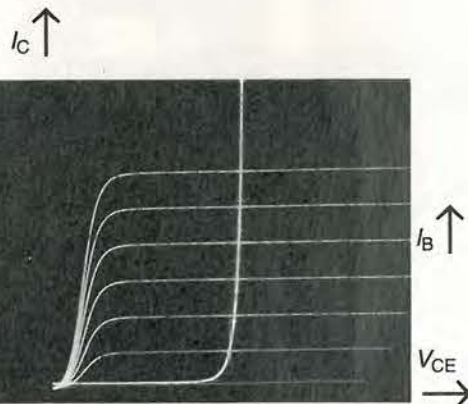

Fig. 1. Collector characteristics of a ZTX300. Scales: vertical, 0.2mA/div; horizontal, 0.1V/div.

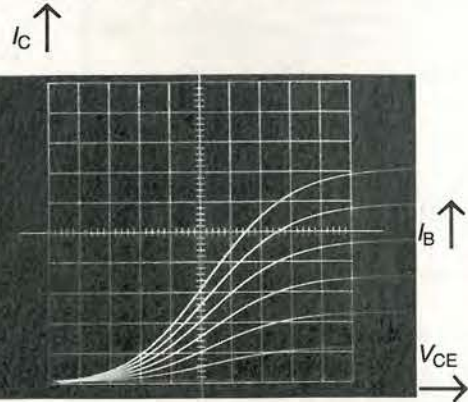

Fig. 2. Detail of Fig. 1 near the origin. Scales: vertical, 0.2mA/div; horizontal 20mV/div.

line $V_{BC}=0$ but also in the region to the left of the line $V_{CE}=0.4V$.

Under normal conditions $V_{CC} \gg V_{CE(sat)}$, so we know that $I_{C1} = V_{CC}/R_C$ but how to choose I_{B1} to ensure that $V_{CE(sat)} \leq 0.4V$? To answer that question you need to return to equations (1) to (6). With the usual conditions of saturation, $V_{BE}, V_{BC} \gg V_T$ so you can ignore the unity terms in comparison with the exponential terms.

Now,

$$V_{CE(sat)} = (V_{BE} - V_{BC}) = V_T \log_e(I_{CN}/I_{CR}) \quad (7a)$$

Expressing I_{CN}, I_{CR} as functions of I_B, I_C gives,

$$V_{CE(sat)} = V_T \log_e X \quad (7b)$$

where,

$$X = \frac{I_C + \beta_R + 1}{\beta_R \left[1 - \left(\frac{I_C}{\beta_N I_B} \right) \right]} \quad (7c)$$

In particular, for $I_C=0$,

$$V_{CE(sat)} = V_T \log_e \{ 1 + (1/\beta_R) \} \quad (8)$$

'Offset' voltage

Apart from its use in the last section of this article, the $V_{CE(sat)}$ given by equation (8) deserves brief mention in another context.

Known as the 'offset' voltage, it denotes the common point of intersection of the collector characteristics. This is an important parameter of the bipolar transistor when used as a 'chopper' for microvolt level analogue signals. However, since the advent of field-effect transistors, which have no such inherent offset voltage, interest in bipolar transistor choppers

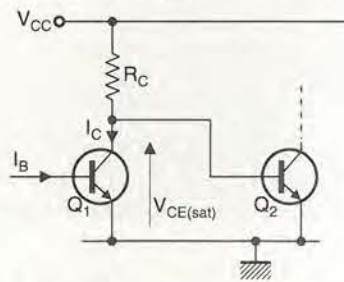

Fig. 6. Basic bipolar junction transistor inverter stage.

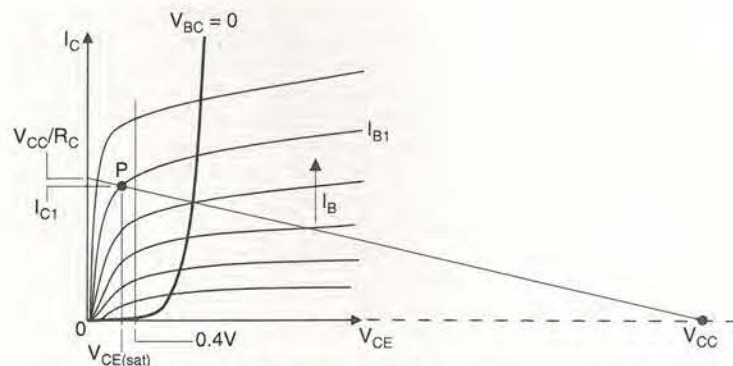

Fig. 7. Load-line construction for Fig. 6.

has declined so that topic will not be discussed further.

From equation (7a) you can calculate I_B for a given I_C and $V_{CE(sat)}$, if β_N and β_R are known. However, β_R is not usually specified on data sheets for discrete devices. Unfortunately, it is important in determining $V_{CE(sat)}$, as shown by the curves of Fig. 8. The choice $\beta_N=100$ is representative of modern devices and errs on the 'safe' side: larger values of β_N merely cause the curves to move slightly nearer the horizontal axis.

Implicit in equation (7a) is the fact that $V_{CE(sat)}$ is constant with change in I_C if (I_C/I_B) is fixed. Figures 9, 10 are pictorial interpretations of this.

The particular value of I_C/I_B necessary to guarantee a specified $V_{CE(sat)}$ is often denoted by the parameter $\beta_{(sat)}$, the 'beta in saturation'. Some writers use β_F , the subscript referring to the fact that we are 'forcing' the device to saturate. However, the subscript F is also used in describing the 'forward' active mode so there is a risk of confusion if that is used.

The parameter β_R is under the control of the device designer and largely determined by the ratio of emitter junction area to collector junction area. A 'large' ratio means a large β_R but also increased emitter capacitance, which can adversely affect switching times.

A theoretical value for the saturation voltage temperature coefficient, $TCV_{CE(sat)}$, can be found as follows. Assuming that β_N, β_R are independent of T , or have only a weak dependence on it, and that I_C/I_B is constant, $\log_e X$ in equation (7b) can be taken as temperature invariant.

Then, differentiation gives,

$$TCV_{CE(sat)} = V_{CE(sat)}/T \quad (9)$$

For $V_{CE(sat)}=300mV$ and $T=300K$ this gives a rule-of-thumb temperature coefficient of $+1mV/^\circ C$.

In the normal active mode V_{BE} decreases by about $2mV/^\circ C$ at fixed I_C . So how does the $+1mV/^\circ C$ arise? The answer is that, with fixed I_C/I_B , $V_{BE(sat)}$ and $V_{BC(sat)}$ both decrease with T but $V_{BC(sat)}$ decreases by more than the former.

The curves of Figs 1, 2 appear to validate Fig. 10. In the normal-active mode the curves

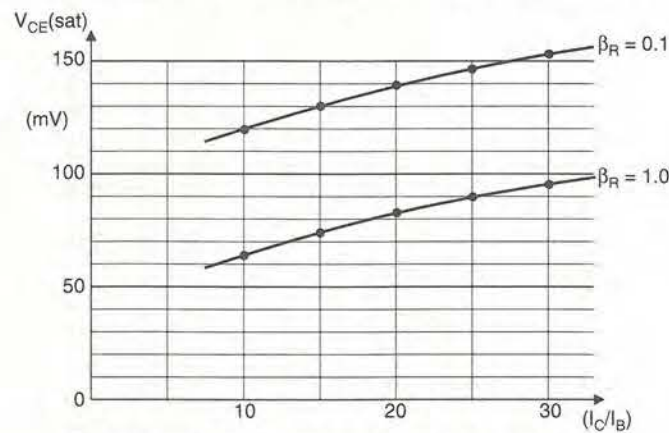

Fig. 8. Plots based on equation (7a) of the text. $\beta_N=100$.

for consecutive values of I_B are equally spaced in I_C . This is true also in saturation, but the spacing reduces with $V_{CE(sat)}$.

Testing the idea

A direct experimental test of the applicability of Figs 9, 10 to practical devices can be made using the circuit of Fig. 11, which is connected to a curve tracer. This is only a basic set-up, suitable for rapid visual checks. More refined developments of it permit accurate measurements to be made on a sweep basis or by a point-by-point plot.

Transistors Q_{P1}, Q_{P2} , connected in the grounded-base configuration, operate in the normal-active mode and supply I_B, I_C , respectively, to the bipolar transistor under test, or T.U.T.

If you assume that Q_{P1} and Q_{P2} have the same value of emitter-base drop, V_{EB} , and a common value for grounded-base current gain α_p , which is approximately unity, then,

$$I_C = \frac{\alpha_p (V_{CC} - V_{EB} - V_B)}{R_1} \quad (10)$$

and,

$$\frac{I_C}{I_B} = \frac{R_2}{R_1} \quad (11)$$

The supply rail V_{CC} , obtained from the curve tracer, is a full-wave-rectified sinusoidal waveform having a zero-volt baseline and an adjustable amplitude, so $I_C=I_B=0$ for $V_{CC} < (V_{EB} + V_B) \approx 2V$ and $I_C \approx V_{CC}$ for $V_{CC} \gg 2V$.

Table 1 gives the switch settings used to obtain Fig. 12, which applies to the same T.U.T. as that used in Figs 1, 2.

In Fig. 12 there is a baseline corresponding to a V_{CE} of 0 and there are three traces obtained with a $V_{CC(peak)}$ of 100V so, for the top and middle traces, $I_{C(max)}$ is around 10mA and for the bottom trace, $I_{B(max)}$ is around 0.5mA.

The traces are not quite parallel to the horizontal axis for two reasons. First, β_N and β_R are not constant, as assumed. They decrease at low and high currents. However, this makes no difference to the form of the model or the applicability of equation (7b), which predicts an increase in $V_{CE(sat)}$ at low currents owing to this effect.

Secondly, the bulk or extrinsic resistances

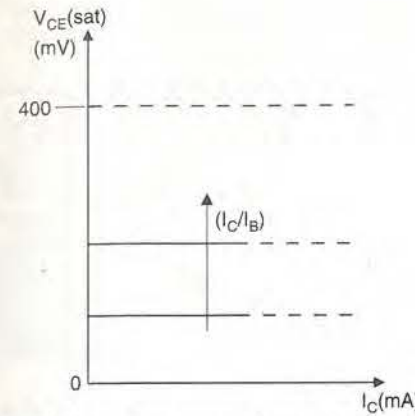

Fig. 9. Idealised saturation characteristics.

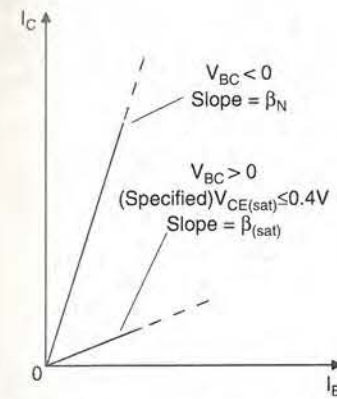

Fig. 10. Current transfer characteristics for Fig. 9.

r_{CX}, r_{EX} , of the collector and emitter regions, respectively, have been neglected. When these are added to the model, equation (7b) is modified to,

$$V_{CE(sat)} = V_T \log_e X + [I_C r_{CX} + (I_C + I_B) r_{EX}] \quad (12)$$

The bracketed term accounts for the positive slope on the traces. By virtue of device doping and geometry, r_{CX} is much greater than r_{EX} so the slope is mainly due to r_{CX} . This parameter depends on the process technology used in the manufacture of the bipolar transistor. The device designer has some control over it though, and it is possible to have an r_{CX} value of less than 10Ω for bipolar transistors intended for saturated switching circuits. The two parameters r_{CX} and β_R govern the choice of specified $V_{CE(sat)}$ for a given I_C/I_B .

Relating theory to practice

To see how this discussion relates to manufacturers' data sheets, consider the well established BC108.⁴ The first part of saturation specification reads: $V_{CE(sat)} < 250mV$ and $V_{BE(sat)} = 700mV$ (typ) for $I_C = 10mA$ and $I_B = 0.5mA$.

It is implicit that this $V_{CE(sat)}$ is a maximum value that includes the effect of the bracketed term in equation (12): it will be less for I_C values of less than 10mA.

The relevant saturation characteristic has the general shape and location of curve (i) in Fig. 13. We err on the side of safety in a 'worst-

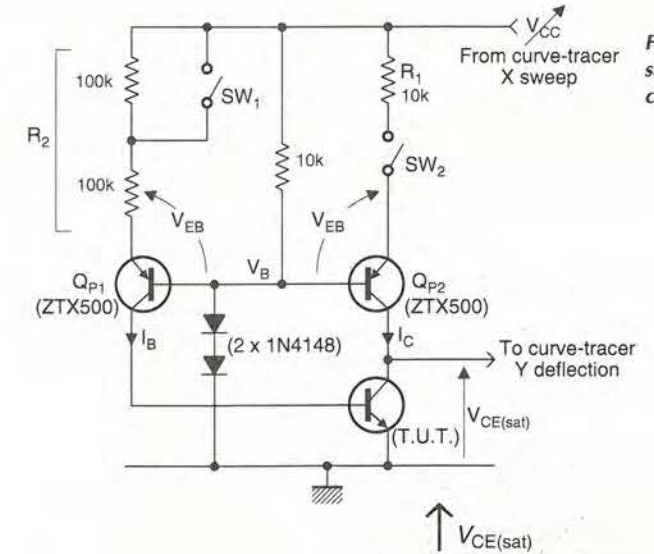

Fig. 11. Test circuit for saturation characteristics.

Fig. 12. Test results: $V_{CE(sat)}$ versus I_C for a ZTX300 transistor. Vertical scale: $20mV/div$. $I_{C(max)}$ for top and middle trace, $\approx 10mA$, $I_{B(max)}$ for bottom trace, $\approx 0.5mA$.

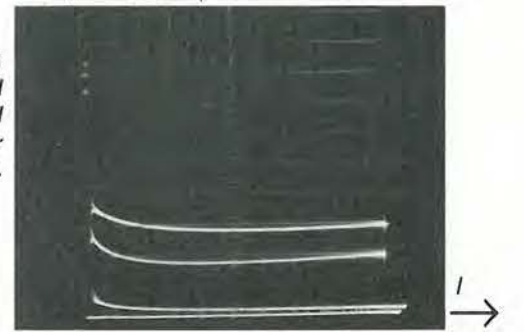

Table 1. Experimental test options for Fig. 11.

Trace	Display	I_C/I_B	SW ₁	SW ₂	
Top	$V_{CE(sat)}$ vs I_C	20	X	•	$I_{C(max)} \approx 10mA$
Middle	$V_{CE(sat)}$ vs I_C	10	•	•	
Bottom	$V_{CE(sat)}$ vs I_B	0	•	X	$I_{B(max)} \approx 0.5mA$

• = closed X = open

case' circuit design philosophy by assuming, instead, that the saturation characteristic is represented by curve (ii).

This is a line parallel to the horizontal axis that passes through the specification point. The ratio (I_C/I_B) associated with it is taken to be that of curve (i) and in this case is represented by the parameter $\beta_{(sat)}$ introduced earlier.

In making the curve-substitution we are imagining the BC108 to be replaced by a 'well-behaved' device that has $r_{CX}=r_{EX}=0$ and constant β_N, β_R .

Up to this point I have not considered $V_{BE(sat)}$. Equations (1) to (6) show that this increases with I_C , for fixed I_C/I_B . Nevertheless, you can assume that $V_{BE(sat)}$ is constant because in a well-designed circuit it has only a second-order effect in setting I_B . Only a typical value is given for this parameter so, allowing an extra 100mV, a reasonable value for this 'constant' $V_{BE(sat)}$ is 800mV.

A simplified dc equivalent circuit for the BC108, that follows from our discussion, is shown in Fig. 14. As an example of its use,

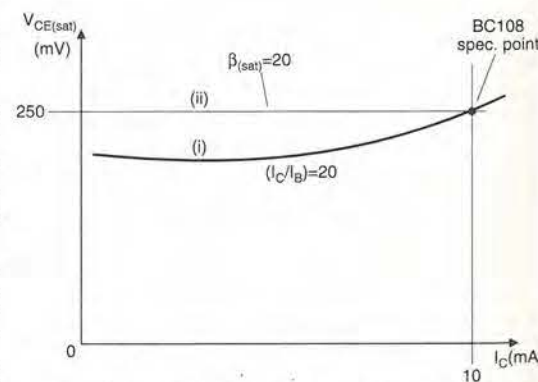

Fig. 13. Saturation characteristic for BC108: actual shape (i) and assumed characteristic, (ii).

refer back to Fig. 6 and suppose that I_B is supplied via a resistor R_B connected between the base of Q_1 and the V_{CC} rail. For the usual case $V_{CC} \gg V_{BE(sat)}, V_{CE(sat)}$, the limit set on R_B is given by,

$$R_B \leq 20R_C \quad (13)$$

Equation (13) applies to the design of conventional collector-base coupled monostable and astable circuits using the BC108. The second part of the BC108 specification applies to a higher current range where $V_{CE(sat)}$ is less than 600mV and $V_{BE(sat)}$ is typically 900mV for a collector current of 100mA and base current of 5mA.

This is directly applicable to the design of some interface circuits, for example, those for driving a relay coil, the winding of a motor or

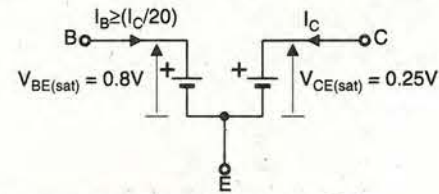

Fig. 14. Simplified saturation model for BC108, for $I_C=10mA$.

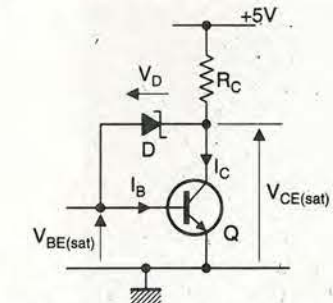

Fig. 15. Inverter stage with Schottky-diode clamping.

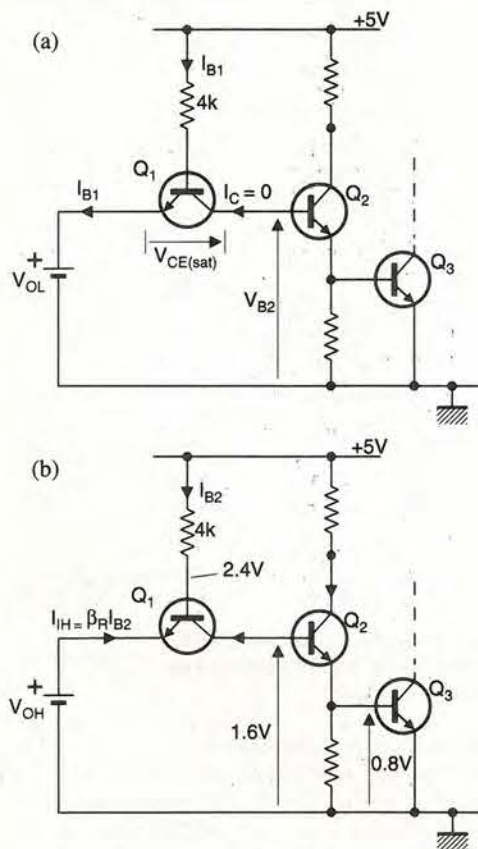

Fig. 16. Standard ttl input stage, simplified: Input level, a) '0', b) '1'.

a number of leds. However, it would be unrealistic to take $V_{CE(sat)}$ as 600mV if you wanted to operate at, say, 15mA - i.e., outside the 10mA range previously considered.

A reasonable approach then would be to estimate $r_{CX}+r_{EX}$, find the potential difference across it due to 5mA, and add that to the worst-case $V_{CE(sat)}$ at a collector current of 10mA.

Clearly, $(r_{CX}+r_{EX}) \times 100mA$ is less than 600mV so $r_{CX}+r_{EX}$ is less than 6Ω and the estimated value at 15mA would be 280mV.

To conclude this section, consider the well-known Schottky-diode base-collector clamping scheme of Fig. 15. By inspection,

$$V_{CE(sat)} = V_{BE(sat)} - V_D \quad (14)$$

The bipolar transistor is prevented from becoming deeply saturated because V_D , at around 0.35V, is significantly less than the V_{BC} that would exist in D's absence. This results in improved dynamic performance, because of the reduction in excess minority carrier charge stored in the base of Q, but this is at the price of a higher $V_{CE(sat)}$.

The calculation of $V_{CE(sat)}$ and its spread is not simple. This is because it requires a knowledge of the I-V characteristic of D as well as the parameter $V_{BE(sat)}$, which is not closely specified.

Other saturating circuits.

Figures 16, 17 show two circuits for which the simplified model of Fig. 14 is not appropriate because they do not use straightforward inverter stages. It is necessary to go back to the full model of Fig. 3b).

Figure 16a) indicates the input circuit conditions existing in a standard ttl stage when the input voltage is at a logic zero level. Figure 16b) illustrates the conditions for a logic-one level.

The input transistor, Q_1 , is shown as having only one emitter. This simplifies the analysis without invalidating its general applicability.

In Fig. 16a), transistor Q_1 is saturated and Q_2, Q_3 are cut off. In this condition $I_C=0$ and $V_{CE(sat)}$ is given by equation (8) because the extrinsic voltage drop $I_B r_{EX}$ is negligible, at around a millivolt, in comparison with the logarithmic term.

To hold Q_2 off V_{B2} needs to be less than 0.6V. As a result, a design constraint is,

$$V_T \log_e \{1 + (1/\beta_R)\} + V_{OL} < 0.6V \quad (15)$$

In Fig. 16(b), Q_2 and Q_3 are saturated and Q_1 operates in the reverse-active mode if V_{OH}

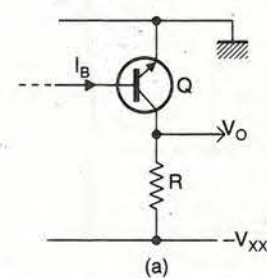

Fig. 17. A precision voltage switch: a) Circuit; b) Simplified representation for $V_O=0V$.

exceeds the base voltage of Q_1 . Taking a conducting junction drop as 0.8V this means that V_{OH} is more than 2.4 V.

The logic one level input current, I_{IH} , is then given by,

$$I_{IH} = \beta_R I_{B2} \quad (16)$$

To reduce gate input loading for a logic one input, choosing an I_{IH} value of less than 40μA when, as here, I_{B2} is 0.65mA implies that β_R is around 0.06.

This satisfies equation (15) and is achievable in practice if the emitter area of Q_1 is suitably scaled down with respect to that of the collector.

From what I have said previously, it might seem impossible to meet the condition $V_{CE(sat)}=0$ with a bipolar switch. That is true for an ordinary inverter stage. However, by putting $X=1$ in equation (7), you find that it is possible to have a $V_{CE(sat)}$ of 0 if you operate with a collector current less than 0, i.e., in the reverse-saturation mode.

Figure 17a) outlines a precision voltage switch that exploits this possibility. With no base current, Q is off and $V_O=-V_{XX}$. For finite base current, it follows from equation (7a) that $V_{CE(sat)}=0$ and $V_O=0$ if $I_{CN}=I_{CR}$.

$$I_B = I_{BN} + I_{BR} \quad (17)$$

$$I_B = I_{CR} \{ (1/\beta_N) + (1/\beta_R) \} \quad (18)$$

$$I_{CR}/\beta_R = V_{XX}/R \quad (19)$$

$$I_B = \frac{V_{XX}}{R} \left(1 + \frac{\beta_R}{\beta_N} \right) \quad (20)$$

Fig. 17b) shows an equivalent circuit for $V_O=0V$. From a circuit viewpoint, Q behaves merely as a couple of 'catching' diodes, D_E and D_C , with balancing voltage drops.

References

- Getreu, I, 'Modelling the Bipolar Transistor', Tektronix Inc, 1976, pp. 15-20.
- Ebers, JJ, and Moll, JL, 'Large-Signal Behaviour of Junction Transistors', Proc. IRE, Vol. 42 pp. 1761-1772, Dec 1954.
- Hart, BL, 'Introduction to Analogue Electronics', Arnold 1997, pp. 238-239.
- Data Sheets for the BC107-109, Philips, 1993.

SPEAKERS' CORNER

Sound reproduction depends totally on microphones and loudspeakers containing parts that move in sympathy with the audio waveform. To build accurate loudspeakers, you need to know a little about the physics of moving masses, explains John Watkinson.

Isaac Newton explained that a mass would remain at rest or travel at constant velocity unless some net force acted upon it. If such a force acts, the result is an acceleration where $F=ma$.

Figure 1 shows a mass supported on a spring. This configuration is found widely in loudspeakers because all diaphragms need compliant support to keep them in place yet allow vibration. An ideal spring produces a restoring force which is proportional to the displacement.

The constant of proportionality is called the stiffness, which is the reciprocal of the compliance. When such a system is displaced and released, the displacement performs a sinusoidal function called simple harmonic motion or shm.

When more energy is put in to the system, it oscillates at the same frequency but the amplitude has to increase so that the restoring force can be greater.

Eventually the resonance of a mass on a spring dies away. The faster energy is taken out of the system, the greater the rate of decay. Any mechanism which removes energy from a resonant system is called damping. In a loudspeaker this could come from losses in the spider, the surround, or from electromagnetic damping in the coil. Acoustic radiation also extracts energy.

The motion of a rigid body can be completely determined by the mass, the stiffness and the damping factor. As audio signals contain a wide range of frequencies, it is important to consider what happens when resonant systems are excited by them.

Audio excitement

Figure 2 shows the displacement, velocity and acceleration of a mass, stiffness, damping system. This system is excited by a constant amplitude sinusoidal force acting on the mass at various frequencies.

Below resonance, the frequency of excitation is low and little force is needed to accelerate the mass. The force needed to deflect the spring is greater and so the system is said to be stiffness controlled. The amplitude is independent of frequency, described as constant amplitude operation, and so the velocity rises at 6dB/octave towards resonance.

Above resonance, the inertia of the mass is greater than the stiffness of the spring and the system is said to be mass controlled. With a constant force there is constant acceleration, yet as frequency rises there is less time for the acceleration to act. Thus velocity is inversely proportional to frequency which in engineering terminology is -6dB/octave.

The radiating ability of the diaphragm is proportional to velocity,

i.e. it rises at 6dB/octave. The frequency response in this region is flat because the two slopes cancel. Mass control is commonly found in loudspeakers for this reason.

It will be clear that the behaviour just noted has a direct parallel in the behaviour of an electronic damped tuned circuit consisting of an inductor, a capacitor and a resistor and the mathematics of both are one and the same. By converting mechanical parameters into electrical parameters the behaviour of a mechanism can be analysed as if it were an electronic circuit. This is particularly common way of modelling loudspeakers.

Cone acceleration

In mass controlled loudspeakers we are interested in the cone acceleration. You will see from Fig. 2 that far above resonance the acceleration is in phase with the input signal, which is the desired result. However, as frequency falls the phase response deteriorates to 90° at resonance and a phase reversal below. The rate of

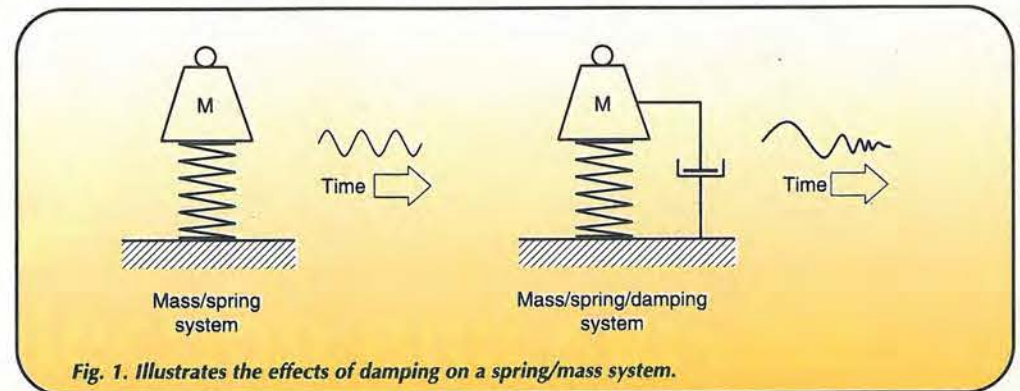

Fig. 1. Illustrates the effects of damping on a spring/mass system.

LOW COST Embedded Control

...with extra BYTE!

Low cost Embedded Control Control Systems Custom Design Micro-Controllers Logic Controllers Data Loggers Analogue & Digital I/O

CAMBRIDGE MICRO PROCESSOR SYSTEMS LIMITED

Units 17-18, Zone 'D', Chelmsford Road Industrial Estate, Great Dunmow, Essex UK CM6 1XG
Tel: +44 (0) 1371 875644 Fax: +44 (0) 1371 876077

<http://www.cms.uk.com>

CIRCLE NO.124 ON REPLY CARD

CONTROL & ROBOTICS from Milford Instruments

BASIC Stamps-

- Re-Programmable
- BASIC language
- RS232 Serial ports
- 8 or 16 I/O lines
- SPI/DTMF
- Fast development

Serial LCDs

- RS232 Serial interface
- 2x16 to 4x40
- Simple 3-pin connection
- Integral Keypad option
- Large Numerics option
- Driver chips available for OEM use

3-Axis Machine

- Stamp 2 based
- Drills PCBs
- 3-Axis movement
- Stepper drive
- 4 thou resolution
- Win 3.1 software

Servo Controller

- Control up to 8 servos
- RS232 Commands

Scenix

- Fastest 8-bit micro
- 50MIPS
- Flash Eprom
- 18/28 pins
- PIC16C5x pin replacement

Robotics

- Humanoid
- 5-Axis Arm
- Walking Insect

IR Decoder

- Uses any remote
- 7 digital outputs
- Toggle/momentary
- Re-Programmable

Milford Instruments 01977 683665 www.milinst.demon.co.uk

CIRCLE NO.125 ON REPLY CARD

AUDIO DESIGN

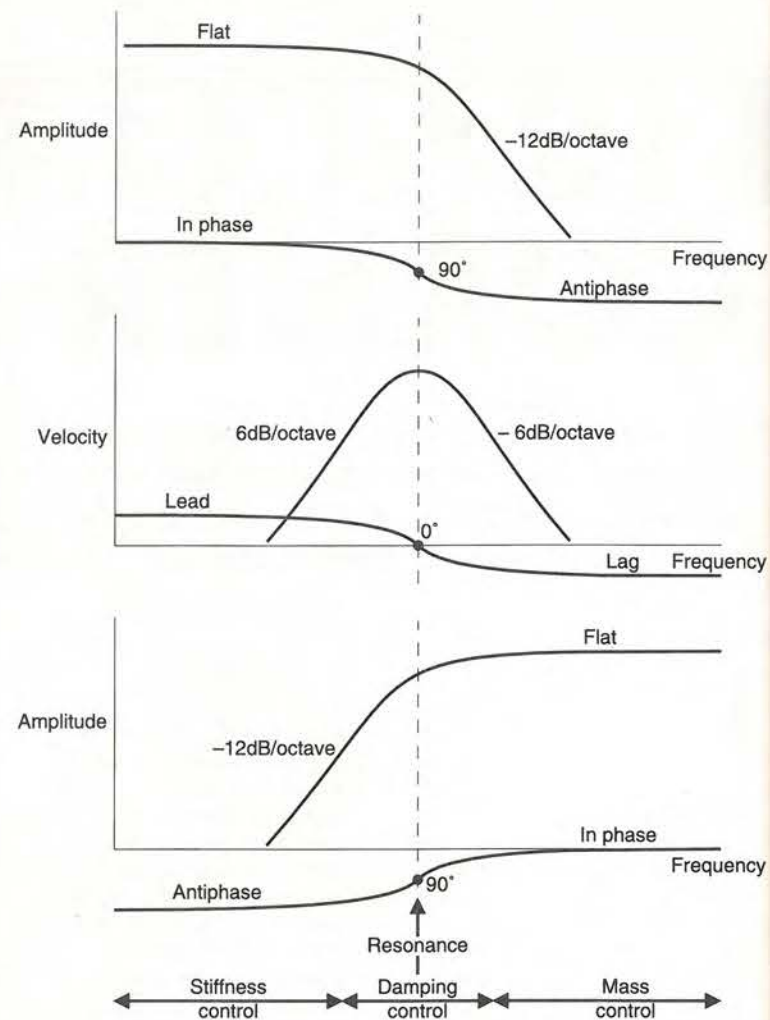

Fig. 2. Displacement, velocity and acceleration curves of a mass-stiffness-damping system assuming sinusoidal excitation force acting on the mass.

phase change in the vicinity of resonance is a function of the damping.

The phase reversal around the fundamental resonance means that a simple loudspeaker cannot reproduce the input waveform at low frequencies. Even if the resonance is set below the useful audio band, it will be clear from Fig. 2 that the effects of the varying phase response are present well into the band. These effects are audible as a footprint which gives a loudspeaker a characteristic "sound" which it should not have.

One direct consequence of the phase lag is that the acoustic centre of the loudspeaker moves backwards as resonance is traversed. The sound source appears at a distance which is a function of frequency. To the best of my knowledge genuine sound sources don't have this attribute so the loudspeaker must be creating an artifact.

Changes to the damping factor around resonance can be heard. A

lightly damped system produces plenty of low frequencies but suffers hangover. A well damped system lacks lf but reproduces transients well. Clearly both are wrong, we are just changing the nature of the artifact rather than eliminating it.

Every loudspeaker designer has seen the electrical equivalent circuit which models the behaviour of a loudspeaker. But few make the connection that an unwanted mechanical resonance or phase change can be suppressed by incorporating at some point a suitable electronic circuit designed to have the opposite characteristic. Units like this don't just sound better, they sound more like the original which is the only useful criterion.

Yet again the same conclusion is reached: only active speakers can go beyond fundamental quality restrictions of passive technology. Until loudspeaker design ceases to be a subset of carpentry there is little prospect of widespread change. ■

17000 NEW products with our semiconductor supplement

MAPLIN
ELECTRONICS

the key to better selection and service

Telephone 01702 554000 with your enquiry PLEASE QUOTE PRIORITY CODE MA078





Although usually a nuisance, non-linearity can be a useful design tool. Various non-linear shaping techniques, giving a 'bendy' transfer characteristic, have been invented. Ian Hickman looks at a selection of ideas, and suggests uses for them.

Shaping up

Linearity is a highly prized quality in most electronic circuits. More often than not, the output of an amplifier for example needs to be a highly faithful replica of the input. This is especially so in audio amplifiers.

Another example of the need for linearity is waveform generators. Unlike amplifiers, generators have no input, but some types are asked to produce a very linear output.

Just how this has been achieved over the years is described in reference 1.

Intentional non-linearity

But in some applications, a non-linear amplifier or waveform generator may be required. Often, the intention is to cancel the non-linearity of the output of a sensor, or the transfer function of some other device, by subjecting it to a non-linearity of the opposite sense. Thus a 'bendy' law can be linearised by an amplifier with a transfer curve that bends the other way.

Obtaining a characteristic which is non-linear but smooth is not easy. There should of course be no discontinuities in

the curve, but also there should be no discontinuities in its gradient – first differential or slope.

Ideally also there should be no discontinuities in the curve's second differential or radius of curvature, perhaps even no discontinuities in the rate of change of radius of curvature, i.e. the third differential.

But for some applications, all of this can go by the board, and a piecewise linear approximation be near enough.

Figure 1 outlines a clumsy – but effective – approximate square-law circuit I applied in a psophometer – a true-rms reading audio noise-measuring telephone voltmeter. This was used in an instrument designed for a Post Office contract back in the sixties, long before the appearance of rms-to-dc converter ICs such as the AD536.

The square-law circuit was followed by an IC 'ideal rectifier' stage and the resultant dc smoothed by the inertia of the moving coil indicating instrument. The square root function was looked after by a suitable non-linear scale on the meter.

In Fig. 1, the diodes and associated resistors of various val-

ues implement a piecewise approximation to a square-law current versus voltage characteristic in the first and third quadrants. The fairly soft takeover, as each diode clamped further voltage drop across its parallel resistor, resulted in a smoothish curve.

Of course the diode forward voltage drops – which set the 'breakpoints' of the piecewise approximation – will vary by about 0.4%/°C. Consequently, there must have been some temperature compensation included somewhere, and fortunately the required operating temperature range was really rather mild.

Fixing the breakpoints

A more sophisticated piecewise linear approximation has been described, where the diodes defining the breakpoints are included within the feedback loops of op-amps. This renders the breakpoints completely independent of temperature.² The arrangement is shown in Fig. 2.

At each of the breakpoints, a defined change of slope of the transfer characteristics is obtained. By setting the position of the breakpoints, and the change of slope at each, a given curve can be closely matched. Clearly, the more breakpoints, the closer the match that is possible.

The breakpoints V occur at the following voltages, and beyond each breakpoint the slope S takes the value indicated:

$$V_1 = 15(R_4/R_5) \quad S_1 = R_0/R_1$$

$$V_n = 15(R_4/R_n) \quad S_n = R_0/R_1 + R_0/R_2 + \dots + R_0/R_n$$

while the slope is zero up to V₁.

Getting rid of the corners

I recently wanted a circuit which provided a smoothly curved response, without discrete breakpoints inherent in a circuit such as Fig. 2. After some experimentation, such an arrangement was arrived at, incidentally not involving lots of op-amps and diodes.

It seemed that as a diode provides a non-linear relation between forward voltage and current, it should be possible to use this to provide a circuit with a non-linear response. Both diodes and – more particularly – transistors have frequently been used to provide a logarithmic response, but that was not what was wanted in this case.

The first version dreamed up is shown in Fig. 3. The voltage -V is in the few hundreds of millivolts range, and is strategically chosen so that the diode is just conducting slightly. If the voltage fed to the non-inverting input is zero, i.e. R₁=0Ω, then the inverting input is a virtual earth.

The diode therefore has no effect, other than demanding a positive offset at the output. This supplies the current that the diode sinks, and the circuit works as a normal inverting amplifier, apart from the offset. Figure 4, upper trace, shows the output when the input is a triangular wave – a nice linear response.

If R₁ is finite, feeding a small portion of the input waveform to the non-inverting input, the inverting input is no longer a virtual earth. The feedback will do what ever is necessary to force the voltage at the inverting input to follow that at the non-inverting input. In this way, the same small portion of the input waveform appears also across the diode.

The current the diode sinks is therefore now a function of the input waveform, and what was previously a constant offset at the output is now variable.

With a positive-going input, the diode will sink more current, so less current is sunk by the feedback resistor R₄, resulting in a smaller negative going output. Conversely, with a negative going input, the diode sinks less current and a larger positive going output voltage – and current through R₄ – is necessary to balance the current through R₃.

The result is a distorted triangle wave, the slope of which

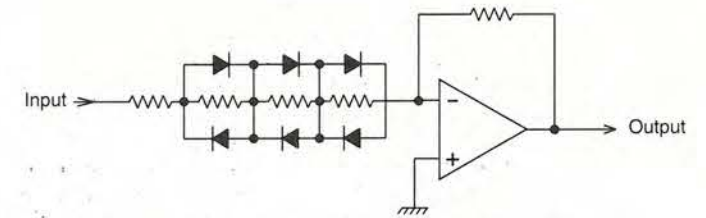

Fig. 1. A circuit giving an output voltage, on each half cycle of the input, of the same polarity as the input but of magnitude equal to the input squared. Used in the sixties as part of the rms response of a psophometer.

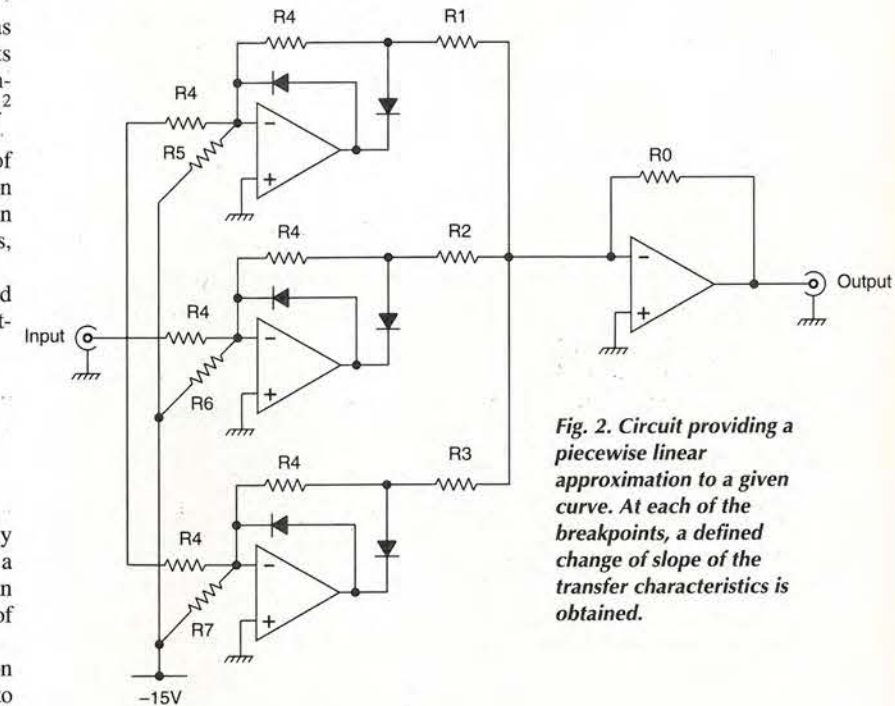

Fig. 2. Circuit providing a piecewise linear approximation to a given curve. At each of the breakpoints, a defined change of slope of the transfer characteristics is obtained.

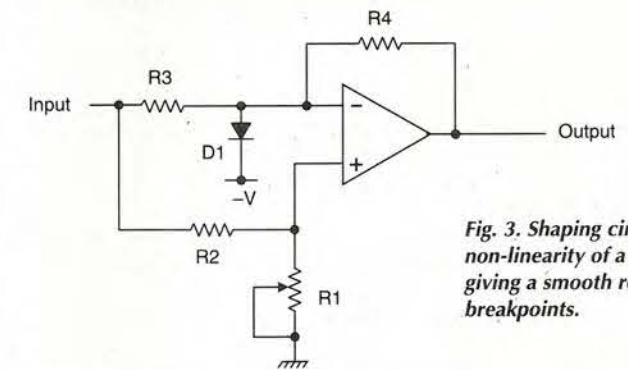

Fig. 3. Shaping circuit using the non-linearity of a single diode, giving a smooth response free of breakpoints.

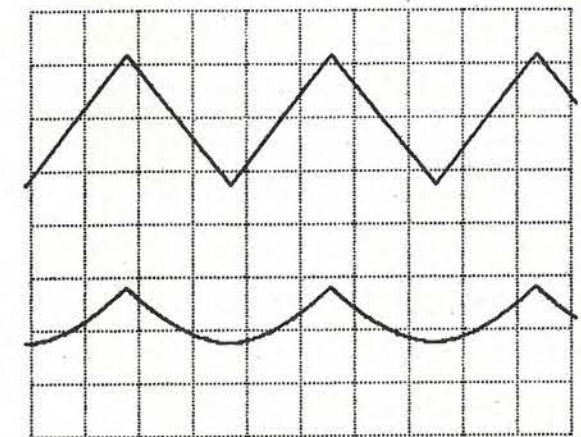

Fig. 4a) upper trace; with R₁ in Fig. 3 shorted, the output with a triangular wave input is undistorted as shown. b) lower trace; with the two potentiometers in Fig. 5 suitably adjusted, the peaks of the waveform are exaggerated, and the troughs compressed.

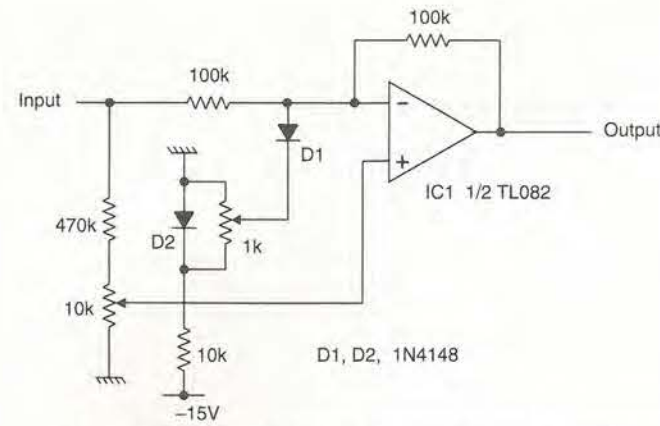

Fig. 5. Circuit with temperature compensating diode added, and showing component values.

Fig. 6a) upper trace; if the signal applied to the non-inverting input is larger, and the diode forward bias lower, only the negative going peaks of the output are affected.
b) lower trace; if the diode bias is now increased, the negative peaks are not merely compressed, but actually inverted.

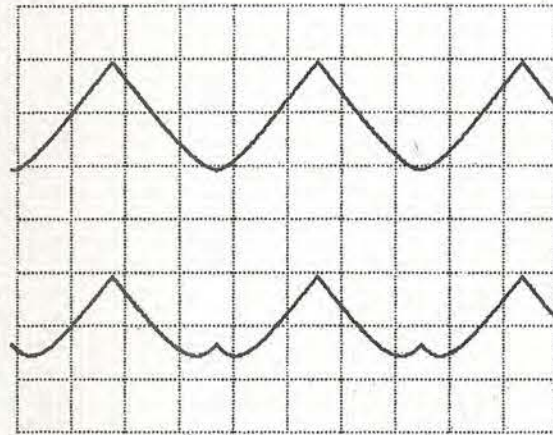

Fig. 7a) upper trace; if the diode forward bias is increased sufficiently, the circuit becomes a perfect frequency doubler.
b) lower trace; if the amplitude at the non-inverting input is now increased, what were previously the negative peaks are now more positive than the erstwhile positive peaks themselves.

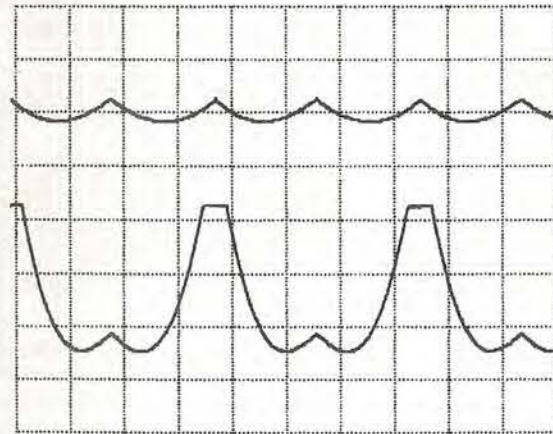
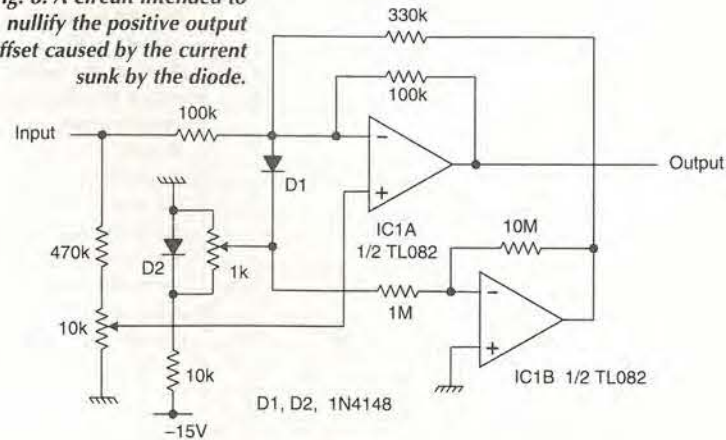

Fig. 8. A circuit intended to nullify the positive output offset caused by the current sunk by the diode.



nevertheless varies smoothly everywhere, as shown in Fig. 4, lower trace. The positive-going peaks are exaggerated, and the negative-going peaks compressed. The degree of this intentional distortion is adjustable, by means of the voltage applied to the cathode of the diode and the amplitude of the fraction of the input signal applied to the non-inverting input.

How does temperature affect it?

The forward voltage drop of the diode will of course vary slightly with temperature. This was undesirable for the application I had in mind for the circuit.

So some compensation was provided, to stabilise the response shown in Fig. 4 against ambient variations. This was achieved with the use of another diode, as shown in the practical circuit of Fig. 5. The two diodes were mounted side by side, touching, and a temperature test run.

When the ambient temperature was raised from 20°C to 30°C, there was a 1V shift in the dc level of the output, but its 5V peak to peak amplitude and degree of shaping showed very little change.

While the compensation would be nowhere near adequate for instrumentation on an arctic expedition, for the intended application in a laboratory environment it was adequate, as the application required that the waveform was ac coupled.

An intriguing circuit

Before going on to apply the circuit, its performance was investigated further. It turns out to have interesting properties, with other possible uses, when set up differently.

The voltage applied to the cathode of the diode, and the fraction of the input applied to the non-inverting input interact to provide a number of different modes of operation.

If the voltage at the cathode is rather low, and the amplitude applied to the non-inverting input larger than used when recording the performance shown in Fig. 4, the diode will cut off completely on negative going excursions at the input. So positive peaks at the output will be unaffected, with just some compression of the negative peaks, as shown in Fig. 6a).

If now the diode forward bias be increased, the negative peaks are not merely compressed, but actually inverted, Fig. 6b). The reason is that as the current through the diode increases, its slope resistance becomes lower and lower. Thus the inverting input is almost shorted to ground, and the circuit tends toward non-inverting operation.

If the process is carried further, the inverted negative peaks of Fig. 6b) rise up until they reach the same level as the positive peaks. At this point, the circuit becomes an ideal squarer, as shown in Fig. 7a). Later, this is shown even more dramatically in the upper trace of Fig. 10. There, a 440Hz sinewave - i.e. concert pitch A above middle C, is doubled to a very respectable 880Hz sinewave an octave higher, lower trace.

Push the circuit a little further, as in Fig. 7b), and the diode clamps the inverting input hard on the positive peaks of the input. The circuit now becomes non-inverting, with large positive output peaks coinciding with the positive peaks of the input. These peaks hit the positive supply rail in the example shown.

In Figs 4, 6 and 7, the oscilloscope was externally triggered from the input triangle-wave generator. So you can see by comparing Figs 6 and 7, that the large peaks in Fig. 7b) correspond with the inverted negative peaks in Fig. 6b).

Compensating the offset...

The two potentiometers in Fig. 5 jointly set the degree of shaping achieved. But as I mentioned earlier, adjusting the diode bias has an additional effect: it introduces a positive offset into the output voltage, of magnitude varying with its setting.

This offset is clearly inconvenient, although once the

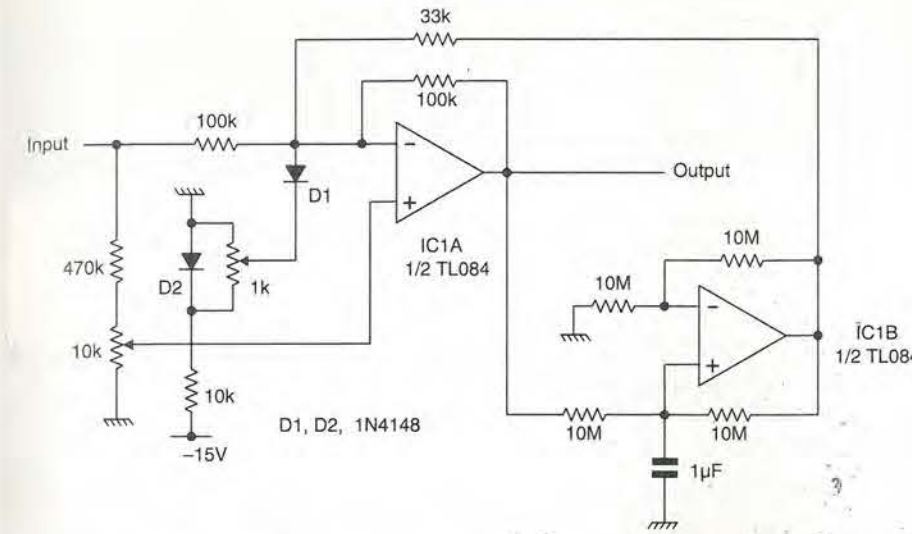

Fig. 9. A more effective offset cancellation scheme using a de Boo non-inverting integrator.

Fig. 10. A 440Hz sinewave input, upper trace (5V/div., 1ms/div.), applied to the circuit of Fig. 9, is doubled to give a an 880Hz sinewave output, lower trace (1V/div., 1ms/div.).

desired degree of shaping has been achieved, it can be removed. The simplest way of doing this is to connect a resistor of suitable value from the anode of the diode to the positive supply rail. This resistor now provides the standing current sunk by the diode, so that when the input signal is at zero volts, so is the output.

While effective, this compensation can only be achieved once the potentiometer settings are determined. It would be convenient if adjustments did not change the offset, better still if it did not introduce an offset at all.

Figure 8 shows a modification that goes some way towards this. Another op-amp picks off the negative voltage at the cathode of the diode, and applies a positive voltage to a resistor, forcing a current into the inverting junction.

If this current equals that sunk by the diode, there is no output offset, but in practice, some variation of offset with potentiometer settings remains.

...with a de Boo integrator

While the compensation provided by the additional circuitry in Fig. 8 is only approximate, it proved useful in setting up.

An improved arrangement is shown in Fig. 9. This uses a non-inverting 'de Boo' integrator to monitor the long term average voltage at the output of IC₁. This is compared with a zero volts reference - ground - by virtue of the resistor to ground at the inverting input of the integrator IC₂.

If the average IC₁ output voltage tries to go positive, the integrator injects a compensating current of exactly the right amount at the inverting input of IC₁. This provides the standing current sunk by the diode, leaving the mean voltage of the output waveform ground-centred.

The time constant of the integrator is more than adequate to ensure that it has no effect on IC₁'s output waveshape. When either potentiometer is adjusted, a temporary offset is caused, but the output voltage trace slides gently back into the ground-centred position over a period of a few seconds.

The arrangement completely negates the offset shift with temperature described earlier.

Could be useful...

Interesting though this circuit is to experiment with, it was nevertheless developed with a particular serious application in mind - an application where a discrete breakpoint approach definitely shows its limitations. This is the linearisation of a voltage controlled oscillator tuned by means of a varactor.

At first, the reverse capacitance of a varactor diode decreases rapidly with increasing reverse voltage. This decrease

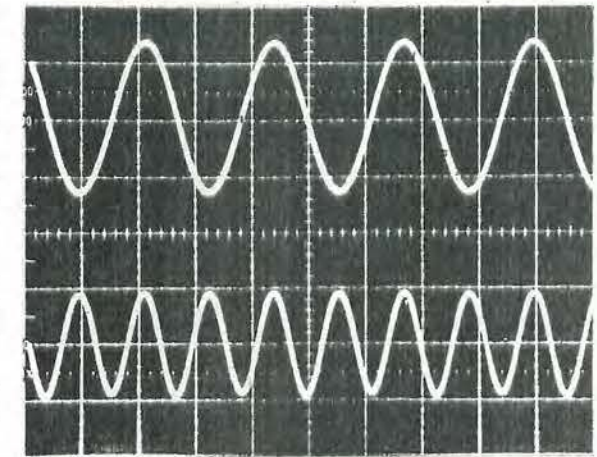

slows down though as the voltage increases further.

Various laws have been proposed to describe the capacitance/reverse-voltage law, but the exact nature for any given varactor depends on the particular doping profile of the semiconductor junction region.

Whatever the law, a linear sawtooth frequency sweep requires distortion of a linear sawtooth tuning voltage waveform. The peak of the waveform, which more negatively biases the diode, needs stretching out to make it more peaky. At the same time, the other half of the sawtooth, where the reverse bias is at its minimum, needs compressing or gently squashing.

This is a function which the circuit described above accomplishes elegantly, without any slope discontinuities or breakpoints. I intend to try incorporating it in a special purpose frequency sweep circuit in the near future.

The two potentiometers provide a continuous range of non-linear laws, and with luck, one pair of potentiometer settings should just do the job.

References

- Hickman, I, 'Sweeping back', *Electronics World* May 1998 pp. 385-390.
- 'Op. Amp. Applications Handbook,' *Electronic Design* Vol. 17 No 11 24 May 1969.

MARCONI TF 2019A

Synthesised Signal Generators
80Hz to 1040Mhz AM/FM, Memories, LCD
A REAL Anchor Special ONLY £750

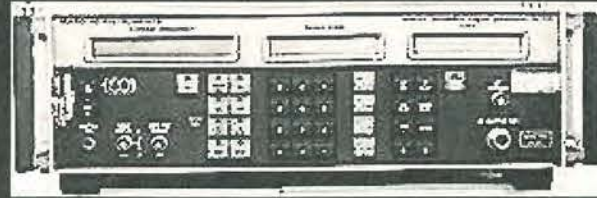
**Frequency Counters**

Racal Dana 9903/4
7 segment 30Mhz £24
Racal Dana 9916
8 segment 520Mhz £65
Racal Dana 9918
9 segment 560Mhz £75
HP 5314A
7 segment 100Mhz £50

Signal Generators

Marconi TF2019A 10Hz to 1040Mhz Synthesised NOW ONLY £750
HP 8640A
To 512Mhz NOW ONLY £245
HP 8683A
2.3-6.5 GHz AM/FM NOW ONLY £499

Marconi TF2015
10-520Mhz NOW ONLY £95
Marconi TF2171 Synchronizer for 2015 NOW ONLY £95
BOTH TF2015 and TF2171
ONLY £180

Conference Equipment

Elite OHP's
Choice of 4 types from ONLY £35
UNICOL
Stands Choice from ONLY £45
KODAK SAV1030
Carousel Slide Proj ONLY £175
KODAK EKTAPRO 3000
Carousel Slide Projectors NOW ONLY £225

Video Equipment

Panasonic AG6200
VHS ONLY £125
Panasonic AG6810
HiFi Duplication machines
VHS NOW ONLY £150
SONY VO5630
Low Band Umatic ONLY £225
PANASONIC AG6100
VHS Players ONLY £100
JVC TM22EK
Pal/Secam Colour Monitors
NOW ONLY £125
JVC TM90PSN
Triple Std Colour Minotor Pal/Secam/NTSC NOW ONLY £175

Computer Monitors

Choice of 16 VGA/SVGA 14", 15", 17"
First come first served.
Any size . . . ONLY £45

Audio Equipment

Sonifex
Cartridge Decks Only £75
Studer
A810 R-R, choice of 5
Just arrived and untested at present
so only £225
Studer B67 R-R Choice of 2 as above,
so only £225
Marantz
Cassette decks. Choice of 2 - Only £45

Spares and Repairs

STUDER/ASC Broadcast/Studio
CD Players ONLY £65
REVOX B67 R-R PSU fault
Nice Unit Only £165

Oscilloscopes

HP 1741A 100Mhz Storage Dual
Time base only £350
TEK 465B 100Mhz Dual Trace/
Timebase Now Only £295
TEK 465M scope as 465B but built only
for Military. Only £350
TEK 475 200Mhz Dual Trace/Timebase
Now Only £395
TEK 2445A 150Mhz Four Trace/2 Time base
Digital with Cursors, etc.
Now Only £995
TEK 2465 300Mhz Four Trace/2 timebase
Now Only £1250

IWATSU SS-5711 100Mhz
Four Trace Dual Time base
Now Only £345

Philips PM 3217 50Mhz
Dual Trace Dual timebase
Now Only £275

Hameg 1005 100Mhz
Dual Trace/Timebase
Now Only £295

GOULD OS1100A 30Mhz
Dual Trace/Timebase
Now Only £95

GOULD OS300 20Mhz
Dual Trace Only £150

NICOLET 2090-111
1Mhz Digital Scope, Cursor ctrl
Now Only £150

**GOULD OS3600 with
DM3010 DMM fitted,** 60Mhz
Dual Trace, Dual Timebase
Now Only £350

TEK T922R 20Mhz
Dual Trace, Single Timebase
Only £225

Miscellaneous

EIP 451
Microwave Pulse Counter
To 18Ghz, Auto sweep.
Variable sample rate. £350.
GIGA Pulse internal counter
2-8Ghz Only £150

FARNELL AMM
Auto Modulation Meters
110Khz to 2.5Ghz
NOW ONLY £195

FARNELL SSG 520
Synthesised Signal Generator
10Mhz - 520Mhz AM-FM-Sinad
ONLY £425

FARNELL TTS620
Transmitter Test Set which
Matches SSG 520 (above)
ONLY £425
BOTH SSG520 and TTS520
For ONLY £795

AVO Model 8 Mk 5/Mk 6
Multimeters . . . THE Standard
ONLY £85

THIS MONTH'S SPECIALS

MARCONI TF2966B Radio Comms
Test sets
To 1000Mhz NOW ONLY £4,000

PHILIPS PM3382
Digital/Analog
CombiScopes
100Mhz/20MS/s Complete
As New.
ONLY £950

MARCONI TF 6960B
RF Power Meters
c/w 6910 RF head,
10Mhz-20Ghz LCD display
NOW ONLY £450

NEW EQUIPMENT

DTA20 Oscilloscope 20Mhz
Twin trace incl probes ONLY £225

DTA40 Oscilloscope 40Mhz
Twin Trace incl probes ONLY £299

DTS40 Oscilloscope 40Mhz
Digital Storage twin channel
Cursors + readouts
Incl. Probes. ONLY £399

DSM3850A Multiscope
Digital Scope, Multimeter,
Logic anal in one box,
5" LCD panel. Incl case
ONLY £399

AMM256 Automatic Mod Meter
1.5Mhz to 2Ghz, LCD
IEEE488 ONLY £495

SCG50 Synth Clock Gen.
To 50Mhz, LED display
ONLY £125

TTS520 Transmitter Test Set
10Mhz to 520Mhz, Freq, Power
Mod and more. ONLY £750

Black Star Meteor 100 Counters
With fitted TXO option to 100Mhz
REDUCED NOW - ONLY £50

SCOPE PROBES
X1/X10 switchable to 100Mhz
Complete with adaptors
ONLY £9.95

ANCHOR SUPPLIES LTD

The Cattle Market Depot
Nottingham NG2 3GY, UK

Tel: (0115) 986 4902

Fax: (0115) 986 4667

<http://www.anchor-supplies.ltd.uk>
sales@anchor-supplies.ltd.uk

MAIL ORDER A PLEASURE

Also at
Peasehill Road, Ripley, Derby

All prices are EX VAT and Carriage

Hands-on Internet

Cyril's found new humidity sensing information on the Net, together with details on recovering signals swamped in noise. But first, an update on operating systems, bugs and year 2000 problems.

Following the collapse of the eleventh hour discussions between the DoJ and Microsoft, Windows 98 was shipped to oems on Monday 18 May and released for general sale on 25 June.

The DoJ and some twenty states have now taken further legal action and the Microsoft trial date has been set for 8 September. Reported in *pcweek*¹ number two at Microsoft Steve Ballmer has been officially appointed its President. Bill Gates remains Chairman/CEO and now plans to devote much of his time to product development.

Cinet has published an interim test review² of the shrink-wrap version of Windows 98, with recommendations and performance expectations, aimed at six typical user levels. Using hardware ranging from 486DX/66 to a Pentium II clocked at 400MHz, they find Windows 98 from 6% to 23% slower than Windows 95 without Explorer, but 9% faster than Windows 95 with it.

While NT4 offers a relatively restricted choice of hardware drivers, NT5 will offer a wide choice, similar to Windows 98. The second beta of NT5 is now due and product release is due next year. Since many electronic design software developers are already promoting NT as their preferred long term engineering software platform, which system should one now choose?

If, like me, you are still running OS/2, Win3.1 or Windows for Workgroups, and have older hardware, then upgrading to Windows 98 seems the logical choice. If you are already running the latest version of Windows 95 with the OSR2.1

upgrade, your operating system choice is less clear-cut.

Windows 98 offers two significant benefits. If you have run out of interrupts, then its support for the USB port is particularly attractive.* This port allows 'hot' plugging of external peripherals. W98's 'Fat32' file system improves hard disc utilisation. Interested readers will find more background information to aid their choice by referring to the CINET³ and Chicago Tribune⁴ articles.

Bugs...

A major trojan horse bug has been revealed in three of the most popular e-mail programs. Researchers at a Finnish University discovered the bug while performing security testing on Windows NT. Eudora apparently is not affected, but Microsoft has already posted patches for its Outlook 98 and Outlook Express programs. Netscape Mail version 4.x and above for Windows was also vulnerable and a patch for this will be provided.⁵ It seems earlier versions are not affected, Fig. 1.

Discovered while testing Windows NT, this bug is a software fault. As a result, Windows 95 and Windows 98 operating systems running these same e-mail applications are also affected.

The bug affects the way e-mail clients handle file attachments with

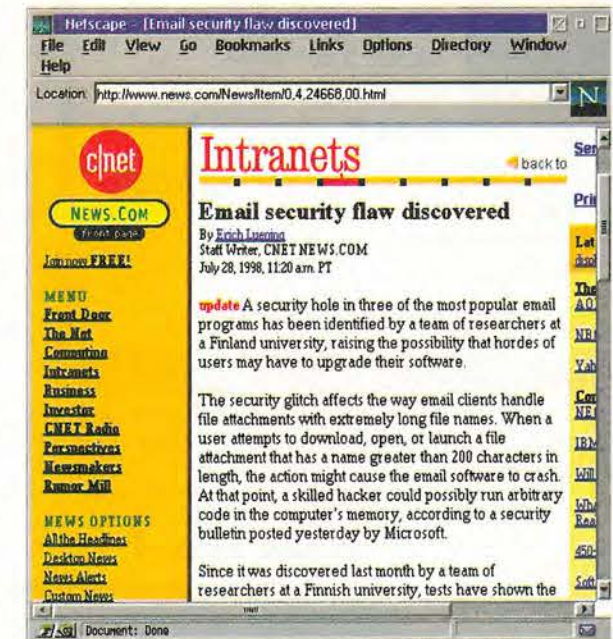

Fig. 1. If you use Outlook98, Outlook Express or Netscape Mail v 4 and receive E-mails with attached files, your computer could be at risk.

extremely long file names. The e-mail 'tags' containing the names of attached files put no limit on the length of file names which can be used. This means that they could contain the entire code for a hidden rogue application.⁶

Server and workstation versions of

*The latest oem version of Windows 95 has universal serial bus support too. I believe this to be the fourth release of 95 - Ed.



Fig. 2. Potentially serious – even for a stand-alone NT system with Internet access and all NT networked systems.

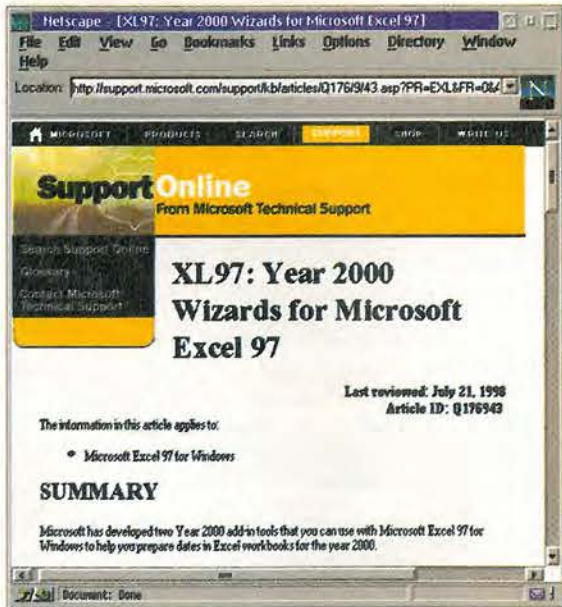

Fig. 3. Incorrect handling of dates – especially when using two digits for the year – can have undesired effects in the next century.

Windows NT 4.0 and 3.51 operating systems have a security flaw which allows an ordinary network user, and possibly via internet access, to impersonate a system administrator. Reported by News.Com,⁷ Mark Edwards of the NTSecurity Web page said "its probably one of the top five or six bugs for Windows NT". Suitable program code, if executed through a seat on an NT network, seeks out the highest system-level authority it can find for its user. This program gets the network to grant the user 'debug-level' rights. That user is then able to impersonate the system administrator, Fig. 2.

2000 problems, or more
According to Microsoft, Windows 98 is year 2000 compliant for two digit years, provided two files have been updated. The first file, Date Time Picker, or comctl32.dll, is common to all systems. Download and install file '401comupd.exe' from msdownload.⁸ The second update varies according to which internet Web browser you use. Microsoft Wallet which is involved with internet credit card transactions, needs updating to parse two digit year entries correctly.⁹

A recent update to the Microsoft Knowledge Base, article Q176943 for Excel 97,¹⁰ offers two add-in tools or wizards for year 2000 compatibility. You can use within Excel 97 to help you prepare any dates used, Fig. 3. The Year 2000 Download Site,¹¹ conveniently offers direct links to download patches for all the Microsoft operating systems discussed in this and the earlier articles, together with many other useful links and articles.

New humidity notes
Temperature is easily measured electronically, but humidity has always been rather more difficult to ascertain. Over the years various

methods based on the temperature difference between wet and dry thermometers, or change in length of pieces of catgut have been traditionally used.

A recent application note from Philips Passive Components,¹² available from their Web site as 'moisture.pdf', describes two simple circuits which enable electronic control or measurement of humidity.

The sensor used is a specially constructed polymer film capacitor using very thin, air-permeable gold electrodes. Change of humidity causes the capacitor's dielectric constant to change almost linearly from its nominal 122pF at 43% humidity, at room temperature.

Usable from 10% to 90% humidity and from -25 to 85°C, its 0.4 ± 0.5pF capacitance change/%relative humidity, permits accurate humidity measurement using simple circuits. Two Philips examples are shown. The simpler bistable IC-based circuit Fig. 4 can be battery powered while the larger circuit incorporates a linearising network for improved accuracy, Fig. 5.

Both circuits need calibrating for humidity, a task easily performed by suspending the sensor inside an airtight container holding a saturated solution of a known salt at 25°C. The Philips application note includes a list of suitable salts, permitting calibration over the range 11.3% to more than 90% relative humidity, together with full instructions.

Back from the noise
Extracting a very small low level signal submerged in very much larger amplitude noise is a difficult task. Analog Devices¹³ illustrates a 'lock-in' amplifier acting as a synchronous detector and narrow band filter.

The company's AD630 balanced modulator/demodulator integrated

circuit is used to recover a 400Hz carrier modulated by a 0.1Hz sine wave, which was swamped by a 100dB larger amplitude, band limited and clipped white noise source. This combination of signals was chosen to simulate the wanted signal from a chopped radiation detector, buried by background and detector noise.

The AD630 is basically a precision op amp with two independent differential input stages, with a precision comparator able to quickly select which input channel is active. Its -100dB of crosstalk between the two input stages, facilitates synchronous recovery of these buried signals, Fig. 6.

The oscillogram clearly shows how this simple circuit can be extremely effective when used as a lock-in low frequency amplifier, to recover a wanted signal, Fig. 7.

The simple test circuits illustrated are usable at considerably higher frequencies, when additional low-pass filtering of the output would aid in rejecting wider bandwidth interference.

Simulation

In the July issue I described how many simulation and design software packages were upgrading to support only Windows 95 or Windows NT. One exception, the popular Micro-Cap simulator¹⁴ was recently upgraded as Micro-Cap V version 2.0.

Micro-Cap V is a 32bit analogue/digital simulator with an intuitive user interface and more than 10000 pre-modelled library parts. Micro-Cap V however, still supports all Windows operating systems. For those of you wanting to evaluate this simulator, a working but free of charge, 1.75Mbyte demo version can be downloaded from the Spectrum Software Web site.

Fig. 6. Based on the Analog Devices AD630 modem chip, this synchronous detector can extract a wanted signal buried in noise.

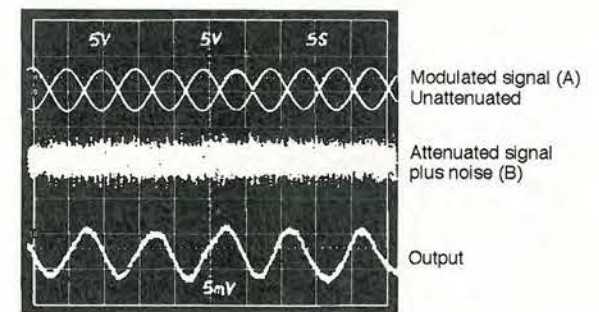
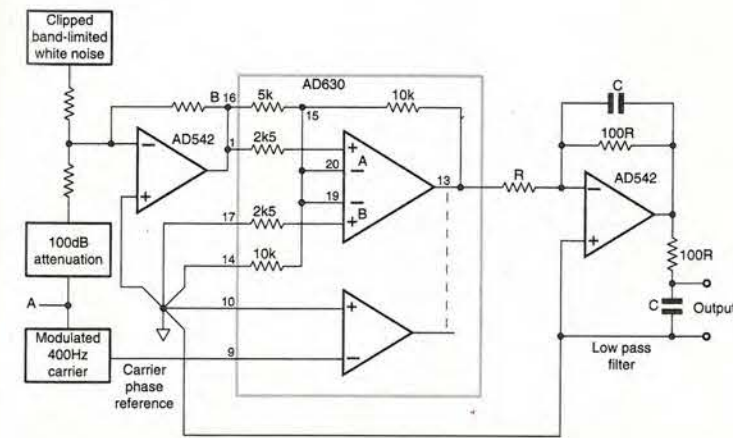

Fig. 7. The lower trace shows the wanted signal has been successfully recovered from the very noisy middle trace.

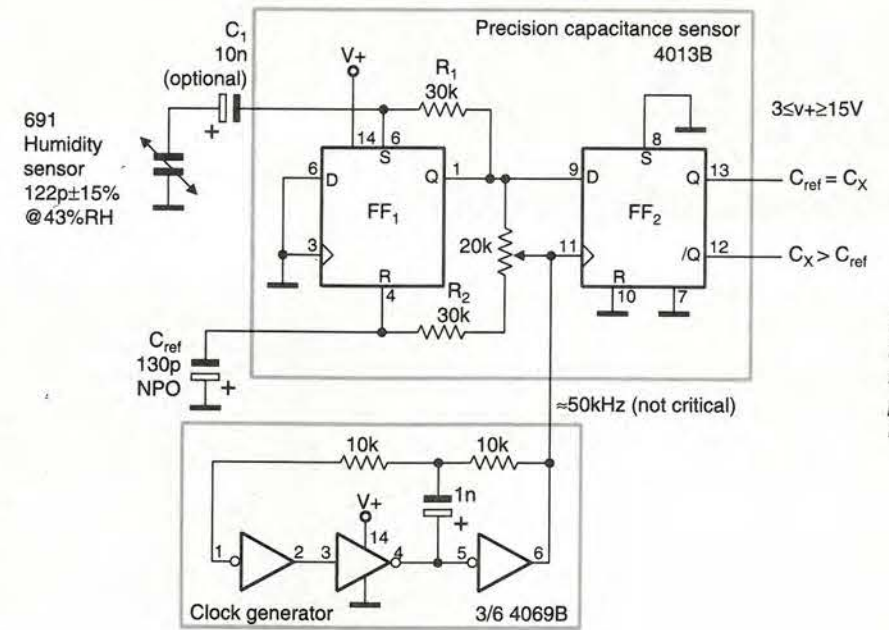

Fig. 4. The basis of a simple and portable hygrometer.

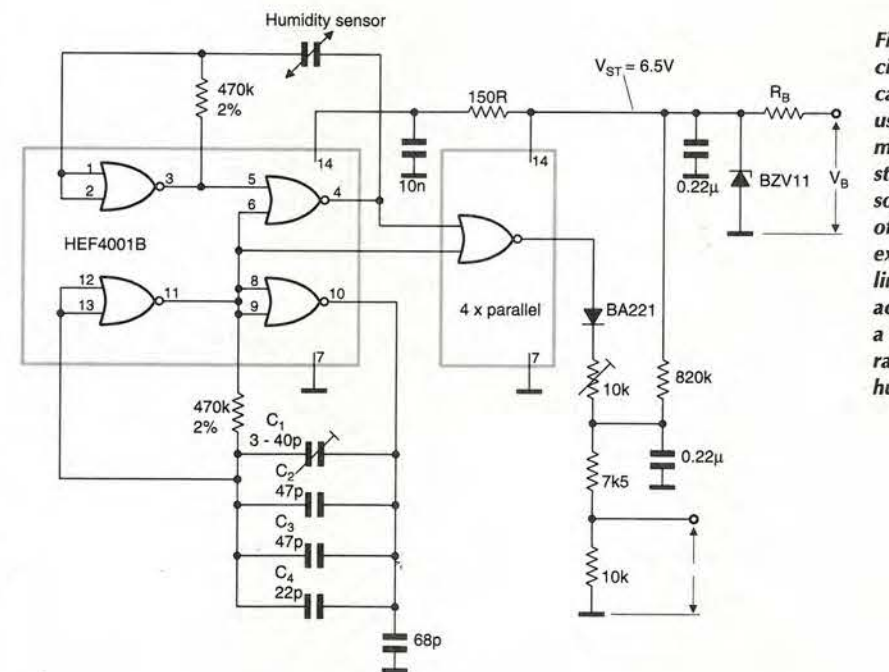

Fig. 5. This circuit when calibrated using two or more standard salt solutions, offers excellent linearity and accuracy over a very wide range of humidity.

Where to surf

1. Ballmer named Microsoft president.
2. Windows 98.
3. USB: is your pc connected.
4. Living off the FAT32 of the land.
5. E-mail security flaw discovered.
6. E-mail Hole Exposes Computers.
7. Serious NT bug emerges.
8. Common Controls Library Patch.
9. Windows 98.
10. XL97: Year 2000 Wizards for Excel 97.
11. Year 2000 Download Page.
12. Philips Passive Components - Moisture.Pdf
13. Analog Devices Inc. - AD630.
14. Spectrum-Software.

- <http://www.zdnet.com/pcweek/news/0720/2/mball.html>
<http://www.cnet.com/Content/Features/Special/Win98>
<http://www.cnet.com/Content/Reports/Trends/USB/ss02.html>
<http://cgi.chicago.tribune.com.tech/columns/0,1710,1,00.html>
<http://www.news.com/News/Item/0,4,24668,00.html>
<http://www.wired.com/news/news/technology/story/14034.html>
<http://www.news.com/News/Item/0,4,24643,00.html>
<http://www.microsoft.com/msdownload/ieplatform/ie/comctrl.asp>
<http://www.microsoft.com/ithome/topics/year2k/product/win98.htm>
<http://support.microsoft.com/support/kb/articles/Q176/9/43.asp>
http://www.spiral.lu/lil/projets/an2000/y2k_Download.html
<http://www.passives.comp.philips.com/pdf/moisture.pdf>
<http://www.analog.com/pdf/ad630.pdf>
<http://www.spectrum-soft.com>

Telnet

Tel: 01203 650702

Quality second-user test & measurement equipment

Hewlett Packard

8920A R/F Comms Test (various options) £4995
8922 BGH G.S.M. Test £POA

Rohde & Schwartz

CM5 54 Radio Comms service monitor (0.4 to 1000MHz) £6250
CMTA94 GSM Radio Comms Analyser £7500

Schlumberger - Stabilock

4031 Radio comms test (0.4 to 10.00MHz) £4995
4040 'High accuracy' Radio comms test £2995

Wandel & Goltermann

PFJ-8 Error & jitter test set £12500 (All options fitted)
PCM4 PCM Channel measurement set £POA

Marconi

2305 Modulation Meter £1995
2041 Low noise signal generator (10KHz - 2.7GHz) £7500

Racal

6111 GSM test sets £POA
Rohde & Schwartz CMD55 Digital Radiocomms Test set £12000

OSCILLOSCOPES

Beckman 9020 - 20MHz - Dual channel £150
Gould 4074 - 100MHz - 4 channel D.S.O. with Printer £2400
Hewlett Packard 54100D - 1GHz Digitizing £1500
Hewlett Packard 54200A - 50MHz Digitizing £500
Hewlett Packard 54201A - 300MHz Digitizing £1250
Hitachi V152/V12/V222/V302B/V302F/V353F/V550B/V650F from £125
Hitachi VI 100A - 100MHz - 4 channel £1000
Intron 2020 - 20MHz - Dual channel D.S.O. (new) £450
Iwatsu SS 5710/SS 5702 - from £125
Kikusui COS 5100 - 100MHz - Dual channel £350
Lectroy 9450A - 300MHz/400 MS/s D.S.O. 2 channel £2250
Meguro MSO 1270A - 20MHz - D.S.O. (new) £450
Philips 3055 - 50MHz - Dual channel £450
Philips PM 3335 - 50MHz - D.S.O. Dual channel £1200
Philips 3295A - 400MHz - Dual channel £1750
Panasonic VP574 I A - 100MHz D.S.O. Dual channel £1750
Tektronix 455 - 50MHz - Dual channel £275
Tektronix 465 - 100MHz - Dual channel £350
Tektronix 464/466 - 100MHz - (with AN. storage) £350
Tektronix 475/475A - 200MHz/250MHz - from £450
Tektronix 468 - 100MHz - D.S.O. £650
Tektronix 2213/2215 - 60MHz - Dual channel £350
Tektronix 2220 - 60MHz - Dual channel D.S.O. £1250
Tektronix 2225 - 50MHz - Dual channel £395
Tektronix 2235 - 100MHz - Dual channel £600
Tektronix 2221 - 60MHz - Dual channel D.S.O. £1250
Tektronix 2245A - 100MHz - 4 channel £900
Tektronix 2440 - 300MHz/500 MS/s D.S.O. £3750
Tektronix 2445A - 150MHz - 4 channel £1250
Tektronix 2445 - 150MHz - 4 channel + DMM £1200
Tektronix TAS 475 - 100MHz - 4 channel £995
Tektronix 7000 Series (100MHz to 500MHz) from £200

SPECTRUM ANALYSERS

Ando AC 821 1 - 1.7GHz £2250
Avcom PSA-65A - 2 to 1000MHz £850
Anritsu MS 62B - 50Hz to 1700MHz £2500
Anritsu MS 610B 10KHz - 2GHz £4750
Advantest/TAKEDA RIKEN - 4132 - 100KHz - 1000MHz £2500

Marconi

Radio Communications Test Sets



2955 £2250
2955A £2500
2958 (TACS) £2750
2960 (TACS + Band III) £2750
2960A (TACS) £2950
2955B £4000
with 2960B added £4250



Fax 01203 650 773

Hewlett Packard 3561A - Dynamic Signal Analyser £4750
Hewlett Packard 3562A Dual channel dynamic signal analyser 64µHz - 100KHz £6250
Hewlett Packard 3585A - 20Hz to 40MHz £4500
Hewlett Packard 8591A - 9KHz - 1.8GHz with tracking generator, option 10 £6500
Hewlett Packard 8505A - 1.3GHz - Network Analyser £1995
Hewlett Packard 8753A - 3GHz - Network Analyser £6000
Hewlett Packard 8753B + 85047A - 6GHz - Network Analyser 6GHz 5 parameter test set £12000
Hewlett Packard 8756A/8757A Scaler Network Analyser from £1000
IFR A7550 - 10KHz-1GHz - Portable £2950
Meguro - MSA 4901 - 30MHz - Spec.Analyser £850
Meguro - MSA 4912 - 1 MHz - 1GHz Spec.Analyser £1250
Tektronix 495P Spec analyser prog. - 1.8GHz £5000
Tektronix 469P - 1KHz to 1.8GHz £4500
Wiltron 6409 - 10-2000MHz R/F Analyser £2000

MISCELLANEOUS

IFR 1200S - Radio comms test set £2995
GN ELM1 EPR31 - PCM Signalling Recorder £3000
HP 339A Distortion measuring set £1500
HP 3488A - Switch/Control unit £650
HP4279A - 1MHz - C-V meter £4500
HP 436A Power meter + lead + sensor various available from £995
HP 435A + 435B Power meters from £200
HP 8656A Synthesised signal generator £1500
HP 8656B Synthesised signal generator £2750
HP 8657A - Signal generator 100KHz - 1040MHz £3250
HP 37900D - Signalling test set £5000
HP 5385A - 1 GHz Frequency counter £750
HP 8901B - Modulation Analyser £4000
HP 8903E - Distortion Analyser £2000
Marconi 2610 True RMS Voltmeter £700
Philips PM 5193 Synthesised Function Gen 50MHz £1500
Philips 5515 - TN - Colour TV pattern generator £1500
Leader 3216 Signal generator 100KHz - 140MHz - AM/FM/CW with built in FM stereo modulator (as new) a snip at £995
Tektronix 1502 - TDR cable tester £900
Tektronix 1751 PAL Waveform/Vector Monitor £2200
Wiltron 6747A-20 - 10MHz-20GHz - Swept Frequency Synthesiser £6000

LETTERS

Letters to "Electronics World" Quadrant House, The Quadrant, Sutton, Surrey, SM2 5AS

Understanding capacitors

Many thanks for Cyril Bateman's articles on capacitors. The pitfalls of misusing the multitude of different types are often overlooked.

I was particularly glad to see Cyril restating the manufacturers recommendation to use 1Ω/volt of series resistance when using tantalum electrolytics to decouple power rails. Many engineers ignore this and I have seen the resulting holes burned in the pcb by short circuit capacitors - especially on pc motherboard +5V rails which can easily supply 20A of current.

Manufacturers supply fused devices for this application but very few engineers realise why they are necessary and opt for the cheaper unfused alternative.

One thing I would disagree with is Cyril's statement about aluminium oxide being a semiconductor. Having worked for many years in the thick film hybrid industry, which relies on alumina substrates, I can assure him that this is definitely not the case.

I think that Cyril is confusing ionic conduction in liquid electrolytes with hole/electron conduction in solid semiconductors. Both give rise to rectifying effects and threshold voltages around 1V but they are not the same thing. Semiconductor diodes do not generate gas when conducting in the forward direction!

The manganese dioxide in

tantalum capacitors is a semiconductor but that is a different story.

Chris Green
Bream
Gloucestershire

Filament failure

With reference to Ian Hickman's useful article 'The Protection Racket,' I think there is a bit more to what happens during the failure of a hot filament during warm up.

Firstly, consider an incandescent lamp or a directly heated filament in a valve. An efficient lamp design must prevent too much heat leaking from the incandescent filament. The filament is therefore rather poorly supported and is vulnerable to magnetic forces.

Many lamps use a coiled or a coiled-coil format, which may perhaps increase the magnetic effect. A mechanical shock is caused by the pulse of inrush current and the mechanical forces produced are significant in relation to the mechanical strength of the filament.

So a common failure mode is simply that the filament breaks rather than melts. Quite often though, the breakage leads to a loose end of the broken filament touching the wire on the other side of the circuit, causing finally an exciting meltdown.

As a second example, consider an indirectly-heated cathode in a thermionic valve. In the heyday of thermionic valves it was a commonly stated belief that the tendency for the heater to fail at the

German satellites

To answer Andrew Emmerson's query in your August issue, the German project that I mentioned in my 1945 article referred to the ideas which Dr Werner von Braun and his colleagues were fond of discussing while they were developing the V2 missile, viz. multi-stage rockets, and their extension to artificial satellites.

This was one of Himmler's excuses for arresting von Braun on the not altogether inaccurate grounds that he was more interested in reaching the Moon than London!

Even in 1945 the idea of artificial satellites was an old one, but not until the advent of television was its most important commercial application obvious.

Sir Arthur C Clarke CBE
Sri Lanka

time of switch on was 'because the cold heater has a low resistance which allows an excessive inrush current which then overheats the heater'.

This is self contradictory. If its cold it isn't overheating and if it is hot there is no excessive current. A more satisfactory explanation is as follows.

The cathode is heated to make it hot enough to emit electrons, but with as little power as possible. Therefore the thermal leakage paths are minimised.

The most notable path is via the connecting straps which are always remarkably thin, whether the ends of the heater itself or a separate strap. This thinness appears most obvious at the weld to the more substantial wire that connects eventually to the external pin.

The useful part of the heater is tucked inside the cathode cylinder. It has considerable thermal inertia and so can not heat anywhere nearly so rapidly as the

little connecting straps.

As you switch on, there is usually a very evident bright light from these straps. They usually become almost as incandescent as a lamp. During that brief period, the bulk of the heater is still very cool in comparison so that the total circuit resistance is small and the inrush current large.

Not surprisingly a failure due to melting virtually always occurs at the straps and never the heater proper - unless of course there was a serious flaw in its manufacture.

Finally though, as Ian Hickman implies, there must also be an effect of sudden thermal changes, resulting in changing mechanical stresses. I wonder if any reader who designed such devices and therefore has more specialist knowledge, would be kind enough to offer some further comments on the subject.

Bob Pearson
Bourne
Lincolnshire

Gain-stage comments

I found the article 'Gain Stage Investigations' by John Linsley Hood difficult to reconcile with my own amplifier philosophy and investigations. After careful consideration I offer the following comments.

On page 579, the amplifier stages are consistently shown without a Miller dominant pole capacitor, although this normally determines the open-loop gain of an amplifier at a given frequency. It is not clear if this is a deliberate avoidance of the normal transconductance-transresistance configuration.

In reality, Miller capacitance is always present - even if it is just the

Are your ears flat?

Regarding the letter on hearing non-linearities in the June issue, for several years I have been incorporating the circuit shown for a passive 'presence' volume control into my audio systems. It came from an SGS-Fairchild design note dated 1968.

I have found it moderately useful when listening to music at low volume through loudspeakers; however when using headphones, the effect is quite dramatic.

Use of the normal volume control causes the sound to go 'thin', but if the presence control is used to reduce the volume, the effect is to bundle the sound source up and transport it off into the distance.

Alan Frobisher
Ely

Cambridgeshire

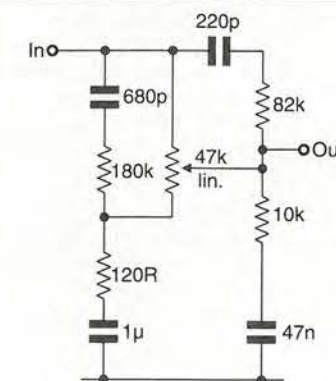

Simple loudness control has a dramatic effect when used with headphones.

All equipment is used - with 30 days guarantee.
Add carriage and VAT to all goods.
Telnet, 8 Cavans Way, Binley Industrial Estate,
Coventry CV3 2SF.

Tel: 01203 650702
Fax: 01203 650 773

a bicycle spoke vibrate on the edge of your desk, but with a piece of Litz wire this will not work.

Secondly, the smaller the variable air capacitor the better. Large, thick air capacitor plates are poor. It is essential that critical equipment is cushioned well with foam rubber or something similar.

It is clear that the supply ripple requirements are very high – at least 0.01%. Supply ICs can achieve this, but ultimate care must be taken to make the best possible ground connection to supply ICs.

Wim de Ruyter
Oudkarspel
The Netherlands

Radiation answers

In the May 1998 issue, an article called 'Versatile radiation meter' appeared on pages 402-406.

Having been involved with a few nuclear in-reactor measurements and the consequent radiation controls etc I was puzzled by the motivation of the above paper. In it, the potential production of gamma radiation by high voltage flashes is hypothesised.

This is very improbable in a standard environment, unless very high voltage flashes were produced in-vacuo by means of very special triggering or by break down of the device.

In any case it is practically impossible to arrive at gamma rays.

These are generally produced by decay of radioactive elements, other nuclear reaction, or by the 'synchrotron radiation.'

As I recall, the range of wavelength involved are 0.005 to 1.4 Å for γ-rays and 0.1-100 Å for x-rays.

As an example, one of the shortest x-ray wavelengths, at 0.137 Å, comes from 83Bi, which is equivalent to about 90keV. This does not mean that this emission is excited by only 90keV, since this is the 're-entry' energy of the emitting electron.

To excite this deep orbit of the Bi atom, however, all the other electrons need to be pulled away first, for example by a suitable bombardment by other high-energy electrons. This explains the very high energy needed.

To produce shorter wavelengths than x-rays it is necessary to interact with the nucleus of atoms: a task that a simple discharge cannot perform.

X-ray production is also improbable since during normal discharges that are not in a vacuum, it is only possible to excite the more external electrons of the element involved, for example platinum discharge electrodes, or/and the surrounding gas. At best, this gives rise to short ultra-violet radiation.

This does not mean that precautions are useless, since in high-voltage vacuum devices like post

accelerated cathode-ray tubes, very high voltage rectifiers, transmitting tubes etc, some x-rays can be generated. But these are 'soft' x-rays and therefore easily screened off.

Because of the potential danger, measurement is necessary to evaluate each case. But measurement is not easy. I was puzzled by the choice of Geiger-Müller counters as measuring devices, since they are neither particularly sensitive nor reliable. This is one of the oldest radiation measuring devices.

For this purpose, specialised solid state devices were available twenty years ago, albeit costly. I imagine that several more are commercialised now.

Of the long-established devices, the ionisation chamber would have been a better choice, and it would have simplified the associated electronics.

In the early days, the design was somewhat difficult as electrometers and large amplification were needed to pick up the tiny currents produced by the ionisation chamber. Today the design should be easier.

This ionisation chamber has the added bonus that it can be self made with simple means.

As found by the author of the article, 'sources' of radiation to test the apparatus are infrequent. As noted in the article, the gas

mantle is one since thorium dioxide – a naturally radioactive element – is one of its components. Luminous watches are lit by a low energy emitter, which cannot penetrate outside.

Another natural source is granite, which often contains small quantities of uranium. But you have to search for a good sample, or find information on where uranium-bearing granite is sited.

Calibrated sources can be obtained from specialised laboratories, but they are probably available only to professionals. If uncalibrated, therefore, such an instrument will be measuring an unknown amount of radiation in all cases. In addition, its directivity will be uncertain, making all the guesses very unrealistic.

Having said that, I appreciated the interesting design of the electronics.

Dr G. Imarisio
Menton
France

Pot luck

Regarding 'Pot problems' in the July letters column, the value of both the volume and balance controls on the *Leak 70* amplifier is 20kΩ log, not 20Ω. I have a copy of the circuit diagram.

S M Jacovides
London

What Microsoft monopoly?

I read the Comment on page 539 of the July edition with some surprise. One could easily assume from the tone of this piece that the author had a distinct bias against Microsoft Corporation in general, and Windows in particular.

There is no monopoly in the operating system market: the availability and continued development of OS/2, Mac OS, Linux, etc bears testament to this. The perceived monopoly of Windows stems from a variety of sources, viz:

- In the late seventies and early eighties a plethora of incompatible systems existed. Then IBM came along with its pc. The excellent marketing ploy of licensing the technology to system designers meant that the IBM pc rapidly became accepted as a standard as industry adopted the new IBM product.

IBM then contracted Microsoft to develop an operating system for its new baby. Thus came PC-DOS, and the clone-builders version, MS-DOS. The IBM/Microsoft tie-up is where the seeds of Microsoft's success were sown.

- Interest in GUI technology, started by Xerox in the US, led to the production of the Mac, and a curious product from Microsoft called Presentation Manager for DOS – a direct GUI spin-off from the new OS Microsoft was developing for IBM.

- The marketing ploy backfired, to some extent a victim of its own success. Now most pc users have a pc-clone, mostly running Windows. Users of genuine IBM machines generally use OS/2.

- The marketing success of the pc in its various forms is the opposite of the situation with the Macintosh. Visual styling and the doubtful technical advantages of an OS built as a GUI from the ground up were of no consequence to the vast numbers of pc users, who could switch to a GUI without having to buy a new machine.

This situation was made worse by the initially poor availability of business software for the Mac. Add to this the reputation of the Mac as being 'good for desk-top publishing and graphics', and you have a high-tech machine that no word-processor or spreadsheet user wanted.

Of course, this software has always been available for the Mac, but the dtp image coupled with the already vast developer effort in the pc world meant that the best business software was always available first for the pc, then 'ported' to the Mac. Naturally, most business users used pcs.

My point with all this is that technical excellence is no basis for the successful marketing of computers. People buy whatever is marketed best.

Does anybody remember the Video 2000 system from Philips? This system was far better in terms of technology and performance than either VHS or Betamax, but was let down by poor marketing.

It is pointless also to wish that the computer industry had been 'well regulated'. If this had been the case, we would all most likely still be using CP/M as the various industry members squabbled over which way was best. The type of regulation mentioned would result only in creativity stifled by the dead hand of a committee.

It is inevitable that progress results in standardisation – the factors at work in the computer industry are many and complex, but at the end of the day, it is still a customer – led industry and we have only ourselves to blame.

How could government create legislation to force developers to create applications at the same price? Different platforms present different technical difficulties to the developer. Isn't it only fair for software companies to levy charges based on technical difficulties, and also on customer demand?

Software that every one wants is always cheaper than niche software. A legislative approach like this could only result in one thing – vast increases in software prices for everyone, is this really a better situation than a so called monopoly?

Anyway, what about Sun's Java OS? This is written in the nearest thing to Esperanto for computers as it will run on any machine that has a Java Virtual Machine (JVM) byte-code interpreter.

Obviously the JVM is platform specific, but other than that code written in Java will run on any platform without modification. Perhaps this is the real way forward.

Keith W Saxon
St Helens Lancashire

PROTEUS

Schematic Capture

NEW Version IV

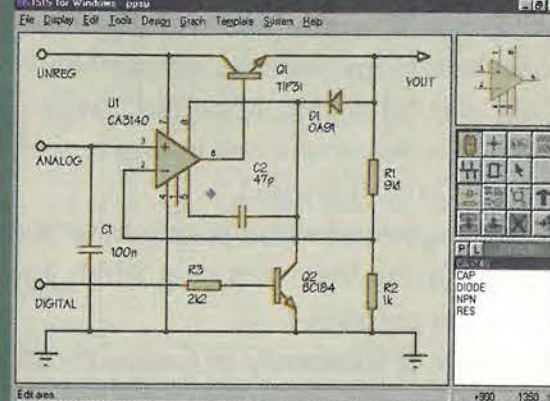

- Produces attractive schematics like you see in the magazines.
- Netlist, Parts List & ERC reports.
- Hierarchical Design.
- Full support for buses including bus pins.
- Extensive component/model libraries.
- Advanced Property Management.
- Seamless integration with simulation and PCB design.

Simulation

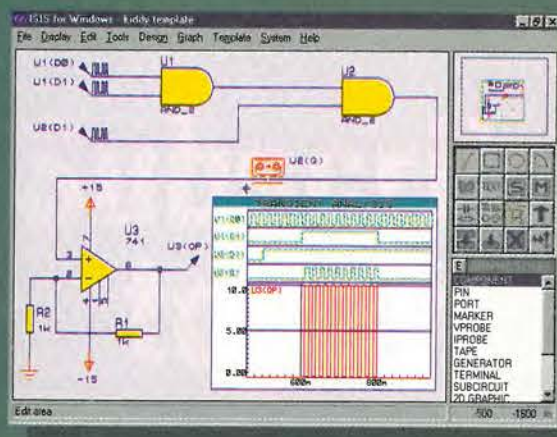

- Non-Linear & Linear Analogue Simulation.
- Event driven Digital Simulation with modelling language.
- Partitioned simulation of large designs with multiple analogue & digital sections.
- Graphs displayed directly on the schematic.

The IVth Generation

New Features

- Component Auto-Placer
- Pinswap/Gateswap Optimizer
- Background Regeneration of Power Planes
- Enhanced Autorouting with Tidy Pass
- Full Control of Schematic Appearance
- Extensive New Component Libraries

Available in 5 levels - prices from £295 to £1875 + VAT.
Call now for further information & upgrade prices.

PCB Design

NEW Version IV

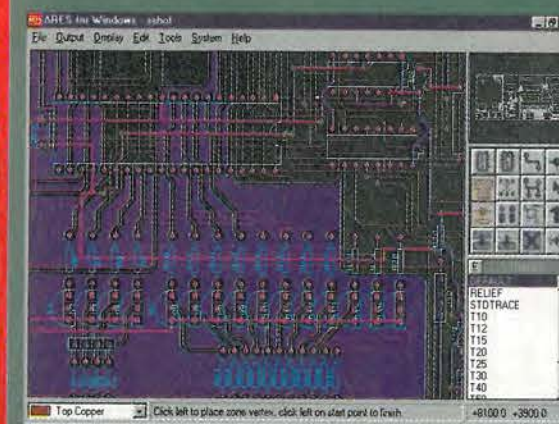

- Automatic Component Placement.
- Rip-Up & Retry Autorouter with tidy pass.
- Pinswap/Gateswap Optimizer & Backannotation.
- 32 bit high resolution database.
- Full DRC and Connectivity Checking.
- Shape based gridless power planes.
- Gerber and DXF Import capability.

"PROTEUS is particularly good

with its rip-up-and-retry autorouter"
EWW January 1997

Write, phone or fax for your free demo disk, or ask about our full evaluation kit.
Tel: 01756 753440. Fax: 01756 752857. EMAIL: info@labcenter.co.uk
53-55 Main St, Grassington, BD23 5AA. WWW: <http://www.labcenter.co.uk>

Labcenter
Electronics

Fully interactive demo versions available for download from our WWW site.
Call for educational, multi-user and dealer pricing - new dealers always wanted.
Prices exclude VAT and delivery. All manufacturer's trademarks acknowledged.

Dictionary of Communications Technology

new edition

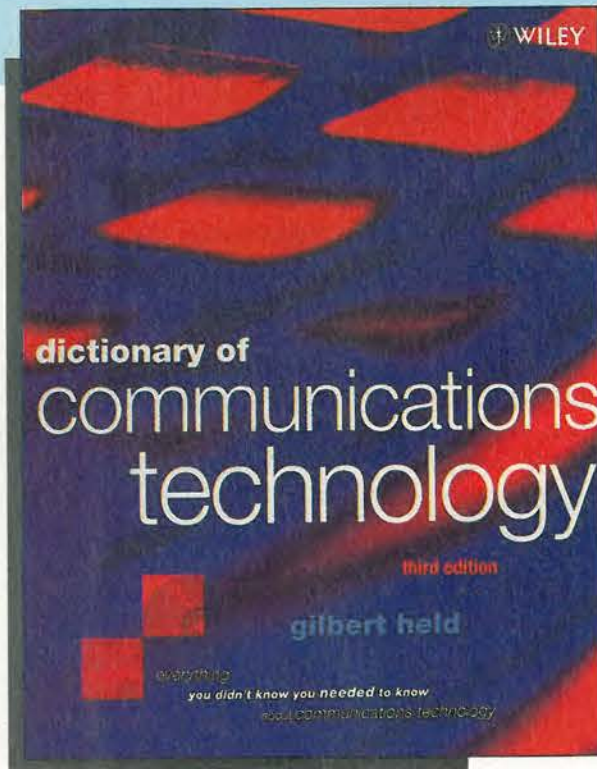

With over 9000 entries and 250 illustrations, this book is an invaluable reference work for anyone involved with electronics and communications. Dictionary of Communications Technology provides comprehensive coverage of data and communications and has entries on PC lans, the Internet, communications testing and client-server applications - in 500 pages.

Over 20 major companies helped prepare the Dictionary of Communications Technology, including AT&T, IBM and Digital Equipment Corporation.

Gilbert Held, author of Dictionary of Communications Technology, is an internationally author who has used his enormous expertise to make this work one of the most comprehensive sources of telecommunications information.

UK Price: £38.95 Europe £42.95 ROW £46.95

**** Price includes delivery and package ****

Fax your order to 0181 6528111 or post to Room L333, Quadrant House, The Quadrant, Sutton, Surrey, SM2 5AS

Please supply the following title:

Dictionary of Communications Technology

Total _____

Name _____

Address _____

Postcode _____ Telephone _____

Method of payment (please circle)

Access/Mastercard/Visa/Cheque/PO

Cheques should be made payable to Reed Business Information

Credit card no. _____

Card expiry date _____

Signed _____

Please allow up to 28 days for delivery

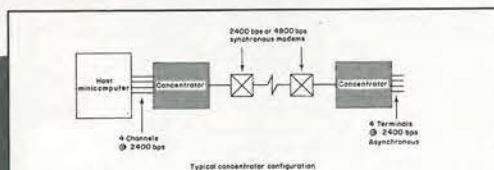

Typical concentrator configuration

concentration An off-site network monitoring service marketed by Timeplex, Inc. of Woodcliff Lake, NJ.

concatenation 1. The linking of transmission channels or subnetworks end to end. 2. The linking of blocks of user data or protocol transmissions. 3. In fiber optic technology, the interconnection of two or more fibers into one continuous length.

concentration Collection of data at an intermediate point from several low- and medium-speed lines for transmission across one high-speed line.

concentrator A device used to divide a data channel into two or more channels of average lower speed, dynamically allocating space according to the demand in order to maximize data throughput at all times. Also known as **terminal concentrator**.

conditioned circuit A circuit that has been electrically altered to obtain the desired characteristics for voice and data transmission. The reader is referred to the entries C-1 through C-8 and D-1 and D-2 for specific information on C-level and D-level conditioning.

conditioned loop A loop that has conditioning equipment, usually equalizers, attached to obtain a desired line characteristic, to facilitate voice or data transmission.

conditioning The "tuning" or addition of equipment to improve the transmission characteristics or quality of a leased voice-grade line so that it meets specifications for data transmission. (See figure below.)

modem pooling A feature of a PBX and other communications products that permits subscribers to be automatically or manually connected to a group of shared or "pooled" modems.

modem sharing unit A device that splits a signal among a cluster of terminals and allows them to share one modem.

modem substitution switch An external option that allows you to reroute your data through a "hot" spare (a modem that is already powered up) in the event of the original modem failure.

moderator A participant who is in charge of a conference. A moderator is responsible for keeping the discussion on track, for alleviating fights, and for similar functions.

MODES Discrete optical waves that can propagate in optical waveguides. Whereas, in a single-mode fiber, only one mode, the fundamental mode, can propagate. There are several hundred modes in a multimode fiber which differ in field pattern and propagation velocity (multimode dispersion). The upper limit to the number of modes is determined by the core diameter and numerical aperture of the waveguide.

Modified Chemical Vapor Deposition An AT&T Bell Laboratories-patented process that uses high temperatures to speed the manufacture of large quantities of fiber lightguide. The glass is made by allowing hot vapors to form a coating inside a tube of heated silica, which is later drawn into fiber. Temperatures reach 4000 degrees F. (The melting point of steel is 2800 degrees F.)

Modified Final Judgment (MFJ) The 1982 Federal Court ruling that determined the rules governing the divestiture of the Bell Operating Companies from AT&T and other antitrust and deregulation issues. Preceded over by Judge Harold Greener, as was the AT&T Antitrust settlement which the MFJ modified. Judge Greener continues his involvement in collecting and interpreting the provisions of this settlement.

modular distribution accessories A term used to reference splitters, modular adapters and modular

modem, multipoint A device that combines a multiplexer and a modem allowing two or more DTEs to be connected to the same line. Also split stream modem.

modem, quick turnaround A modem with minimal turnaround time when the line is used in a half-duplex mode. Also Quick Poll (QP), Fast Poll (FP),

modem, short haul Description of both line drivers and limited distance modems.

modem, wideband A modem designed to operate at speeds greater than those used with high-speed modems, such as 19.2 or 36 Kbps. Wideband modems will not operate over voice-grade circuits but require a wideband circuit.

Modem-7 Communications software program supporting the public-domain, X-modem, error correcting file transfer protocol. This version of the X-modem has multiple transfer capability.

modem connect The name used in DNA for that class of communications links governed by industry standards for modem connection.

modem eliminator A device used to connect a local terminal and a computer port in lieu of the pair of modems that they would expect to connect to; allows DTE-to-DTE data and control signal connections otherwise not easily achieved by standard cables or connectors. Modified cables (consumer cables) or connectors (adapters) can also perform this function.

modem operation characteristics See page 270.

modem, quick turnaround A modem with minimal turnaround time when the line is used in a half-duplex mode. Also Quick Poll (QP), Fast Poll (FP),

modem, short haul Description of both line drivers and limited distance modems.

modem, wideband A modem designed to operate at speeds greater than those used with high-speed modems, such as 19.2 or 36 Kbps. Wideband modems will not operate over voice-grade circuits but require a wideband circuit.

Modem-7 Communications software program supporting the public-domain, X-modem, error correcting file transfer protocol. This version of the X-modem has multiple transfer capability.

modem connect The name used in DNA for that class of communications links governed by industry standards for modem connection.

modem eliminator A device used to connect a local terminal and a computer port in lieu of the pair of modems that they would expect to connect to; allows DTE-to-DTE data and control signal connections otherwise not easily achieved by standard cables or connectors. Modified cables (consumer cables) or connectors (adapters) can also perform this function.

modem operation characteristics See page 270.

ELECTRONICS WORLD
INCORPORATING WIRELESS WORLD

READER INFORMATION SERVICE

For more information about any of the products or services in this issue of **ELECTRONICS WORLD**, simply ring the relevant enquiry number. Enquiry numbers may be found at the bottom of each individual advertisement.

101	102	103	104	105	106	107	108	109	110	111
112	113	114	115	116	117	118	119	120	121	122
123	124	125	126	127	128	129	130	131	132	133
134	135	136	137	138	139	140	141	142	143	144
145	146	147	148	149	150					

					500	501	502	503	504	
505	506	507	508	509	510	511	512	513	514	515
516	517	518	519	520	521	522	523	524	525	526
527	528	529	530	531	532	533	534	535	536	537
538	539	540	541	542	543	544	545	546	547	548
549	550	551	552	553	554	555	556	557	558	559
560	561	562	563	564	565	566	567	568	569	570
571	572	573	574	575	576	577	578	579	580	581
582	583	584	585	586	587	588	589	590	591	592
593	594	595	596	597	598	599	600			

Name _____
 Job title _____
 Company Address _____
 Telephone _____ OCT1998
 Only tick here if you do not wish to receive direct marketing promotions from other companies.

Newsagent order form

Pass this order form to your newsagent to ensure you don't miss the next issue of *EW*.

To
 (name of Newsagent)

Please reserve me the November issue of *Electronics World* and continue to order every month's issue until further notice

Name.....

Address.....

Thank you

Subscribe today!

Guarantee your own personal copy each month

Save on a 2 year subscription

ELECTRONICS WORLD
INCORPORATING WIRELESS WORLD

Subscribe today!

Guarantee your own personal copy each month

Save on a 2 year subscription

ELECTRONICS WORLD
INCORPORATING WIRELESS WORLD

Postage will be paid by licensee

Do not affix postage stamps if posted in Gt Britain, Channel Islands, N Ireland or the Isle of Man.

211

Business Reply Service
Licence No. CY711

ELECTRONICS WORLD
Reader Information Service
Reed Business Information
Oakfield House
Perrymount Road
Haywards Heath
Sussex RH16 3BR

SEE OVER!

ELECTRONICS WORLD

INCORPORATING WIRELESS WORLD

SUBSCRIPTION CARD

Please enter my subscription to ELECTRONICS WORLD. I enclose Cheque/Eurocheque to the value of £ _____ made payable to **Reed Business Information**
Please charge my Mastercard/Visa/Amex account

With £ _____ Expiry Date _____

Signature _____

Name _____

Job Title _____

Address _____

Postcode _____

Tel: _____ Country _____

SUBSCRIPTION RATES

UK 1 year £34
UK 2 years £54
Student rate(proof required)£21.30

Airmail

Europe 1 year £49
Europe 2 years £78
Rest of the world 1 year £59
Rest of the world 2 years £94
Surface mail 1 year £39

Post to:

ELECTRONICS WORLD
P.O. Box 302
Haywards Heath,
West Sussex RH16 3DH UK.

CREDIT CARD HOTLINE

Tel: +44 01444 445566
Fax: +44 01444 445447

Please tick here if you do not wish to receive direct marketing-promotion from other companies

ELECTRONICS WORLD

INCORPORATING WIRELESS WORLD

SUBSCRIPTION CARD

Please enter my subscription to ELECTRONICS WORLD. I enclose Cheque/Eurocheque to the value of £ _____ made payable to **Reed Business Information**
Please charge my Mastercard/Visa/Amex account

With £ _____ Expiry Date _____

Signature _____

Name _____

Job Title _____

Address _____

Postcode _____

Tel: _____ Country _____

SUBSCRIPTION RATES

UK 1 year £34
UK 2 years £54
Student rate(proof required)£21.30

Airmail

Europe 1 year £49
Europe 2 years £78
Rest of the world 1 year £59
Rest of the world 2 years £94
Surface mail 1 year £39

Post to:

ELECTRONICS WORLD
P.O. Box 302
Haywards Heath,
West Sussex RH16 3DH UK.

CREDIT CARD HOTLINE

Tel: +44 01444 445566
Fax: +44 01444 445447

Please tick here if you do not wish to receive direct marketing-promotion from other companies

Those Engineers Ltd



Spicycle™

CIRCLE NO.132 ON REPLY CARD

Soon the whole world will be on Spicycles!

To gain a head start, jump onto the latest in electronic engineering CAD from the author of SpiceAge.

- Schematic editing - publication quality images
- Analogue + mixed mode digital simulation with extended SPICE-like functions
- PCB layout with high definition visuals
- TrueType fonts
- Back annotation of schematic from simulator
- Simulate directly from the schematic AND the PCB for the ultimate in design checking
- Library includes electronic + mechanical engineering behavioural devices
- Upgrade path for existing customers
- 12 months maintenance included (limited introductory offer)

Please contact Charles Clarke at Those Engineers Ltd, 31 Birkbeck Road, LONDON NW7 4BP.

Tel +44 (0) 181 906 0155

FAX +44 (0) 181 906 0960

e-mail Those_Engineers@compuserve.com

web http://www.spiceage.com

KOMPASS CD-PLUS 1998

The essential source for business information

- 57,000 companies on a single CD
- 41,000 products and services
- 18 search criteria



Indispensible for:

- cost-effective purchasing
- generating new business
- market research
- financial, credit and sales planning

With Downloading, Printing and Networking Functions

NEW for 1998! All of the UK's top 5,000 companies

To try out this CD FREE simply fill in the coupon and post it back today to:

Reed Business Information.

Windsor Court, East Grinstead House, East Grinstead, West Sussex RH19 1XD.

or fax it on 01342-335747

Please send me a FREE trial copy of Kompass CD-Plus NOW

Title _____ Initial: _____ Surname: _____

Job Title: _____ E-mail: _____

Company: _____

Address: _____

Post Code: _____

Nature of Business: _____

Tel No: _____ Fax No: _____



CIRCLE NO.133 ON REPLY CARD

October 1998 ELECTRONICS WORLD



HATELY ANTENNA TECHNOLOGY

1 Kenfield Place, ABERDEEN AB15 7UW Scotland, U.K.

Tel/Fax: +44 (0) 1224 316 004

CROSSED FIELD ANTENNA AUDIBLE IN UK ON MW

Following a recent technical survey in Egypt it is now evident that the signals provided by the 22kW Tanta CFA are the strongest and clearest programme audible in the Cairo area on Medium Wave. In fact the Ground Plane CFA in the centre of the Nile Delta is audible both day and night in Cyprus (480km to the north) and at Khartoum (600km overland to the south). The quality is remarkable, many listeners reporting "sounds like an FM station". Why this is so is not yet understood but may be due to the source being so small.

As technical comparisons between the CFA and conventional mast antennas six or ten times taller are still on-going, on some days the 22kW from Tanta is put to another antenna as a check, thus the signal heard at every distance may be weaker.

At night time one can easily hear it on 864kHz in the UK, if on the CFA. It is distinguishable as a male Arabic speaker reciting. The other two stations on the channel are on masts and said to be 200kW at Sofia Bulgaria, and 500kW at Moscow and are completely overwhelmed on the nights when the CFA is in use. We at this address will welcome reports and endeavour to confirm with a colour photograph of the Tanta GP Crossed Field Antenna. Please comment on fading and sound quality.

We are marketing new Variants of the CFA for transmitting and reception, and are applying for a new patent on the most remarkable development found, Viz: a double loop antenna. These aerials are only 1% of a wavelength in diameter and when mounted horizontally, emit and capture omnidirectional waves with horizontal polarisation. Signals are of course 3 to 6dB down on a dipole since there is 2.6dB gain over an isotrope and 3dB gain by ground reflection for all dipoles.

AMATEUR BAND ANTENNAS OF THE NEW MONOBAND VARIANT:-

CFL 3.6 diam 67cm (2ft 6in) £75 inc VAT and postage,
CFL 7 £60 inc, CFL 14 £44 inc, CFL 50 diam 10cm (4in) £40 inc.

Test antenna can be made for any freq. for agreed deposit.

Telephone or fax.

Proprietor: Maurice C Hately, M Sc FIEE Chartered Electrical Engineer (GM3HAT)

CIRCLE NO.134 ON REPLY CARD

M&B RADIO (LEEDS)

THE NORTH'S LEADING USED TEST EQUIPMENT DEALER

OSCILLOSCOPES	HP 3310B 0.0005 Hz-5 MHz function generator	£200	HP 3761A error detector	£200
HP 1420D 100 MHz 2 channel digitising (27 channels logic state triggering)	HP 3200B 10 MHz-500 MHz oscillator	£300	HP 3754A selective level meter	£200
HP 1740A 100 MHz 2 channel	ADREY 741A 100 KHz-4 GHz Cpt 01	£1,800	HP 3702B/3705 IF/BIB Receiver +3710A/3716A IF/BIB transmitter	£400
TEKTRONIX 7903/7A26 a2/7B80 100 MHz 4 channel	ADREY 2330A 200 Hz-1 MHz synthesised source	£1,195	HP 3586C 50 Hz-32.5 MHz selective level meter	£500
TEKTRONIX 7603/7A18A a2/7B37A 4 channel	THURLBY T319 10 MHz DDS function generator	£500	HP 3581A 1 Hz-50 KHz selective voltmeter w/ new	£1,500
TEKTRONIX 7A26 200 MHz 2 channel unit (boxed new + manual)	THURLBY TG220 2 MHz sweep function generator	£200	HP 3488A 5.5 digit multimeter/auto cal (LCD)	£400
TEKTRONIX 2445A 100 MHz 4 channel (NEW)	TEKTRONIX 2901 sine mark generator	£200	HP 3455A 6.5 digit bench multimeter	£495
TEKTRONIX 2445 100 MHz 4 channel GP-IB	MARCONI TF2302 10 KHz-1000 MHz signal generator	£1,800	HP 3437A 3.5 digit high speed system voltmeter	£300
TEKTRONIX 2246A 100 MHz 4 channel auto-cal	MARCONI TF2018 80 KHz-520 MHz signal generator	£1,800	HP 1400B 100 MHz 4 channel oscilloscope	£1,995
TEKTRONIX 2245 100 MHz 4 channel (NEW)	MARCONI TF2017 10 KHz-1024 MHz signal generator	£250	HP 415B/8461A/8464A1 1700A 10 MHz-18 GHz (new/HP casemanual)	£500
TEKTRONIX 2235 100 MHz 2 channel	MARCONI TF2016 10 KHz-120 MHz (200 TF2016A)	£250	HP 415A/8462A/100 KHz-4 GHz RF power meter	£1,000
TEKTRONIX 2230 100 MHz 2 channel digital storage	MARCONI TF2015 10 MHz-520 MHz	£250	HP 400 E 10 Hz-10 MHz AC voltmeter	£95
TEKTRONIX 2225 50 MHz 2 channel	FARNEL 55G520 10 MHz-520 MHz synthesised	£325	HP 331A distortion analyser	£1,000
TEKTRONIX 2220 60 MHz 2 channel digital storage	FLUKE 6811A 10 Hz-1 MHz synthesised signal generator	£1,000	HP 105B quartz oscillator	£200
TEKTRONIX 2215 60 MHz 2 channel	RHOODES & SCHWARTZ APN62 0.1 Hz-160 KHz LF gen. (new)	£2,000	HP R332 series 8 controller	£250
TEKTRONIX 7504 4 slot mainframe	GIGA GRI 1011A 12 GHz-18 GHz pulse generator	£400	LINIFLEX FI-2 HF receiver	£195
TEKTRONIX 475A 250 MHz 2 channel	PHILIPS PM5190 1 MHz-2 MHz LF synthesiser (new)	£400	MARCONI 6593A VSWR indicator	£4,000
TEKTRONIX 468 100 MHz 2 channel digital storage	WAVETEK 193 20 MHz sweep modulation generator	£400	MARCONI TF2389 RF communications test set	£4,000
TEKTRONIX 466 100 MHz 2 channel	WAVETEK 192 20 MHz sweep modulation generator	£175	MARCONI TF2387 data communications monitor	£750
TEKTRONIX 465 100 MHz 2 channel opt GS	SAVROSA MA 38 10 Hz-100 KHz	£175	MARCONI TF2386 programmable interface unit	£600
TEKTRONIX 434 25 MHz 2 channel storage	TEST EQUIPMENT		MARCONI TF2385 mod master 50 KHz-2.3 GHz	£2,000
PHILIPS PM 3110 60 MHz digital storage	ANRITSU MS9091 3 GHz error detector	£950	MARCONI TF2384 RF power meter	£150
PHILIPS PM 3263X 100 MHz delay/levers	ANRITSU MS9091C voltmeter monitor (boxed new with manuals)	£750	NARDA 3044B-20 3.7 GHz-8 GHz 20dB directional coupler (new)	£150
PHILIPS PM 3217 50 MHz 2 channel	AVO C71460 valve tester + info	£150	NARDA 3004-10 4-10 GHz 10dB directional coupler	£100
PHILIPS PM 3057 50 MHz 2 channel	BALL EFRATOM MRT-H rubidium frequency standard	£4,000	RACAL RA177 20 MHz receiver	£350
PHILIPS PM 3055 50 MHz 2 channel	BRD 8922 5000V 50 Ohm coaxial resistor	£500	RACAL RA17U 30 MHz valve receiver	£150
PHILIPS PM 2217 100 MHz 4 channel with cursors	BRD 8321 100V 30dB attenuator	£200	RACAL DANA 9921 10 Hz-100 MHz frequency counter	£295
PHILIPS PM 2215 100 MHz 4 channel	BRD 8320 300V 30dB attenuator	£200	RACAL DANA 9919 10 Hz-100 MHz frequency counter	£295
PHILIPS PM 3057 50 MHz 2 channel	BRD 8321 100V 30dB attenuator	£200	RACAL DANA 9918 10 Hz-100 MHz frequency counter	£295
NICOLET 4094/4562/F43 digital scope	BROOKDEAL 9412A 12MHz sensitive detector	£1,000	RACAL DANA 9916 10 Hz-520 MHz frequency counter	£95
HITACHI W 1100 100 MHz 4 channel with cursors	BRUEL & KJAEER 2515 vibration analyser (AS NEW)	£3,000	RACAL DANA 9915 10 Hz-520 MHz frequency counter	£95
GOULD 4035 20 MHz digital storage + remote keypad	BRUEL & KJAEER 1973 sine generator	£1,250	RACAL DANA 9914 10 Hz-200 MHz frequency counter	£85
GOULD 054000 10 MHz digital storage 2 channel	BRUEL & KJAEER 2636 measuring amplifier	£2,000	RACAL DANA 9908 10 Hz-1100 MHz universal counter timer	£400
GOULD 1401 20 MHz digital storage 2 channel	BRUEL & KJAEER 2971 phase meter	£400	RACAL DANA 9906 50 MHz universal counter timer	£75
GOULD 1421 20 MHz digital storage 2 channel	DATRON 1845 universal digital multimeter	£400	RACAL DANA 9301A true RMS RF millivoltmeter	£400
GOULD 05330 20 MHz 2 channel	EIP 548A 10 Hz-26.5 GHz microwave counter	£2,000	RACAL DANA 9300 RMS voltmeter (New Instrument)	£200
GOULD 05100A 30 MHz 2 channel DIL timebase	EIP 331 12.5 GHz autocal microwave counter	£250	RACAL 9341M LCR distabridge	£395
GOULD 05150B 15 MHz 2 channel	FARNEL PDA3502A dual power supply 0-35V 2 amp	£400	RACAL 9308 1.5 MHz-2000 MHz automatic modulation meter	£350
SPECTRUM ANALYSERS	FARNELL RB103035 electronic load	£100	RACAL DANA 9999 10 Hz-100 MHz nanosecond counter	£595
TEKTRONIX 494P 10 KHz-1800 MHz	FARNELL TSV70 power supply 0-70V 0.10 amp	£350	RACAL DANA 1991 10 Hz-160 MHz universal counter timer 9 digit	£395
TEKTRONIX 494P 10 KHz-21 GHz (1 year Cal & warranty)	FARNELL LT36-2 2x 0-30V 2 amp	£195	RACAL DANA 6000 microprocessing digital voltmeter	£250
TEKTRONIX 492P 10 KHz-21 GHz OPT 001/002/003	FLUKE 5270 200V 30dB attenuator	£2,750	REDIFON RA500 100 Hz-30 MHz receivers	£400
TAKEEDA RIKEN TR41 72 400 Hz-1800 MHz spectrum/network analyser	FLUKE 5200A AC calibrator	£2,000	RF MICROSYSTEMS INC ANTRC-176 VHF/UHF KAL filters	£400
ANRITSU MS618A 10 KHz-2 GHz spectrum analyser	FLUKE 8550A diurnal RF multimeter	£750	RHOODES & SCHWARTZ GAN82 IFR analyser	£400
HP CALAN 3010R sweep/ingress analyser	FLUKE 5400B direct volts calibrator	£4,950	RSCYLLON 6048 selective level meter	£400
HP 8902A audio analyser	FLUKE 5350A precision power amp	£2,750	SAYRUSA AMR 7702 digital transmission analyser (new)	£500
HP 8550A 10 MHz-5 GHz spectrum analyser	FLUKE 5200A AC calibrator	£2,000	SIEMENS D1108 200 KHz-50 MHz level meter	£350
HP 8551B/1821 10 MHz-21 GHz	FLUKE 5320B DC calibrator	£1,25	SIEMENS W1108 200 KHz-30 MHz level meter	£350
HP 8552B 100 KHz-1.500 MHz analyser + mainframe	FLUKE 3320B prog constant current/voltage calibrator	£450	TEKTRONIX A6902A isolator	£450
HP 8557A 100 KHz-350 MHz analyser + mainframe	HP 59403A VHF/UHF common carrier interface	£1,25	TEKTRONIX T1410 1.5 GHz video generator	£1,500
HP 8407A/B812B network analyser 0.1-110 MHz	HP 11700A down converter	£195	TEKTRONIX 521A vector scopes	£300
HP 1451A 0.2 Hz-25.5 KHz dual channel signal analyser	HP 11645B 150 MHz-18 GHz modulator	£500	TEKTRONIX 145 pul gen lock test signal generator	£1,500
HP 1417B/8523B/8555A 10 MHz-18 GHz	HP 11582A attenuator set DC-18 GHz	£300	THURLBY 1503 13 GHz frequency counter	£145
HP 1417B/8523B/8554B 10 MHz-250 MHz	HP 8970A noise figure meter	£3,500	WAVETEK 1018A log lin RF peak power meter DC-26 GHz	£1,000
HP 1407B/8523B/8553B 10 MHz-110 MHz	HP 8750A storage normaliser	£300	WAYNE KERR AMP125 auto modulation meter	£750
MARCONI 2380/2382 100 Hz-400 MHz	FLUKE B508A vector voltmeter	£2,250	W & G DL45 data line analyser	£POA
MARCONI TF2370 10 Hz-110 MHz digital storage	HP 8474A RF power meter calibrator	£235	W & G DL15 data line analyser	£POA
SECULAR GENERATORS	HP 6448A DC power supply 0-600V/0-1.5 amp	£730	W & G SP19 50 Hz-35 MHz level measuring set	£500
HP 8954A DC-600 KHz multfunction synthesiser	HP 8291A DC power supply 0-40V/0-5 amp	£165	W & G SP31 200 Hz-620 KHz level meter	£750
HP 8681D 2.3 GHz-13 GHz OPT 001/003 solid state generator (as new)	HP 6263A DC power supply 0-30V/10 amp	£250		
HP 8654A 100 KHz-960 MHz signal generator	HP 5370B universal time interval counter	£750		
HP 8640A 20 Hz-512 MHz signal generator	HP 5348A 1.5 MHz-26.5 GHz counter/SSA/SS64+B sensors	£2,000		
HP 8620C/86430 5.5 GHz synthesiser	HP 5342A 500 MHz-18 GHz microwave frequency meter	£900		
HP 8620C/8641A 3.2-6.5 GHz sweeper	HP 5335A universal systems counter high stability OPT	£600		
HP 8620C/86200A 10-1300 MHz sweeper	HP 5180A waveform recorder	£750		
HP 8620C/86230B 18 GHz-4.2 GHz sweeper	HP 5087A distribution amplifier (new)	£300		
HP 8620C sweeper mainframe (as new)	HP 5006A signature analyser 4500 HP 5005A signature multimeter	£200		
HP 8065B 0.3 Hz-20 MHz pulse generator	HP 4954A protocol analyser + HP 18135A opt	£2,000		
HP 3314B 10 Hz-21 MHz synthesiser/level meter				
HP 3320A frequency synthesiser 0.1 Hz-13 MHz				
HP 3314A 0.01 Hz-19.99 MHz function/waveform monitor				
HP 3312A 0.1 Hz-13 MHz function generator				

ALL PRICES PLUS VAT AND CARRIAGE ● ALL EQUIPMENT SUPPLIED WITH 30 DAYS WARRANTY
86 Bishopgate Street, Leeds LS1 4BB
Tel: (0113) 2435649 Fax: (0113) 2426881

Visit our Web site
<http://www.mb-radio.co.uk>
 e-mail info@mb-radio.co.uk

CIRCLE NO. 135 ON REPLY CARD

Easy-PC

Electronics CAD for Windows 95, 98 and NT

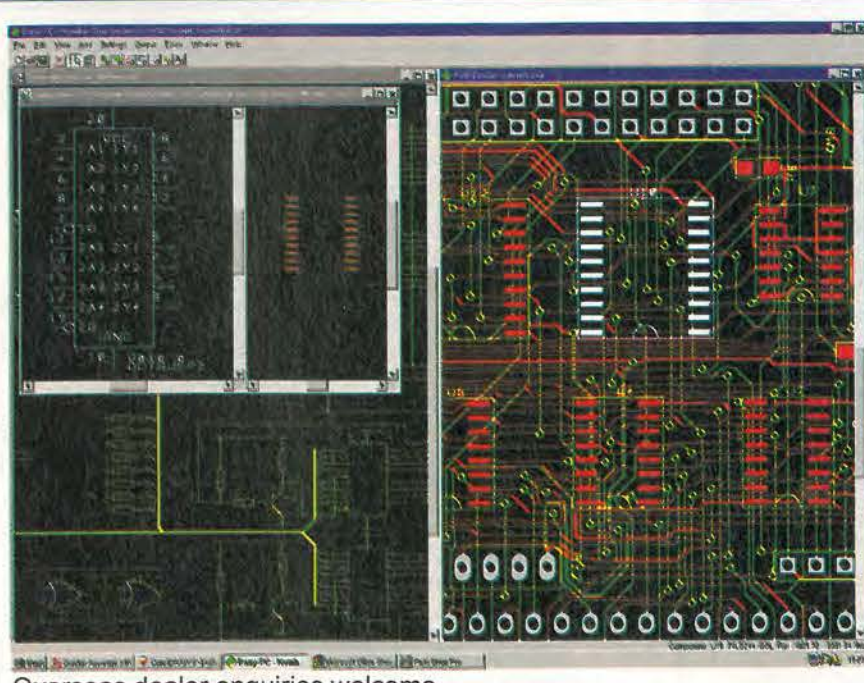

- True Windows graphical user interface
- Multi-sheet Schematics - Projects.
- Full links to our Analogue, Digital and Electromagnetic Simulators.
- Impressive, high speed, gridless, shape-based autorouter options.
- Design rule and connectivity checks.
- Full Windows outputs.
- Gerber, Excellon and DXF outputs.
- Free technical support! No dongles or maintenance contracts.
- Trade up allowance from other products.
- New internet level version available.
- New demo available - please call!

Number One Systems
 Ref: WW, Harding Way, St. Ives, Cambridgeshire, PE17 4WR, United Kingdom
 Tel: 01480 461778 Fax: 01480 494042
 International: +44 1480 461778/494042
 email: sales@numberone.com
<http://www.numberone.com>

CIRCLE NO. 136 ON REPLY CARD

Synthesised 50-950MHz source

Programmable via ttl logic levels, Nick Wheeler's 50 to 950MHz signal generator is simple since it revolves around a highly integrated crystal-controlled synthesiser chip.

This design uses the Synergy SY89430V synthesiser to provide any crystal-referenced frequency from 50MHz to 950MHz.

Using a 16MHz crystal, the frequency can be selected in 2MHz steps. Internal frequency division by 1, 2, 4 or 8 can be selected, providing reduced coverage in smaller steps. Any crystal in the range 6.26MHz to 25MHz can be used. The SY89430V is specified up to 950MHz, but the three samples I have had work up to 1008MHz at least, but not consistently.

These parts use emitter-coupled logic, or ecl, but the programming inputs operate at 3.3V or 5.0V logic levels. While I have described a free-standing source capable of driving a 50Ω load this circuit can clearly be integrated into any logic system, as a clock for example.

Using the 89430 synthesiser
 A phase-locked loop operates at 2MHz, derived from a 16MHz crystal. This controls the frequency of a voltage-controlled oscillator which has an operating range from 400MHz up to the specified 950MHz.

As I mentioned earlier, this part may extend above 1GHz, but this is not guaranteed. A 9-bit ttl-level word M_{0,8} sets the modulus, M, of a frequency divider in the range 250-510. With a 16MHz crystal the voltage-controlled oscillator is held at 2xM (MHz).

Output frequency of the device is then determined by the 2-bit word N(1,0), also at ttl level. Table 1 shows the effect of varying N(1,0). Values on M(8,0) and N(1,0) are read into the appropriate internal registers by a low-high transition of /PLOAD.

In my version of the circuit, I tie /PLOAD, on pin 7, to ground via 4.7kΩ and a normally closed press-button switch.

Table 1. SY89430's four output ranges are selected via logic levels on N₀ and N₁.

N ₁	N ₀	Div. ratio	Range (MHz)	Step (MHz)
1	1	1	400 to >950	2
0	0	2	240 to >500	1
0	1	4	120 to >250	0.5
1	0	8	<50 to >120	0.25

When this switch is operated the internal pull-up resistor takes /PLOAD high.

I have found that after setting in a frequency change, using this for a few moments ensures that the internal registers are set properly. The latches of the register inputs are specified as being transparent when /PLOAD is low.

No difficulty will be experienced if the output frequency is monitored as I suggest. The circuit does, however, sometimes misbehave by locking onto a wrong frequency if M settings outside the range 250-510 are applied.

Bearing in mind that the voltage-controlled oscillator runs at 2xM (MHz), settings in accordance with the table below do, however, invariably work.

There is a lower-frequency version of this part, the

Fig. 1. Complete programmable signal source for 50-950MHz with 50Ω output. The ecl synthesiser chip at the heart of the circuit has three power supply inputs, each fed via a separate 5V regulator.

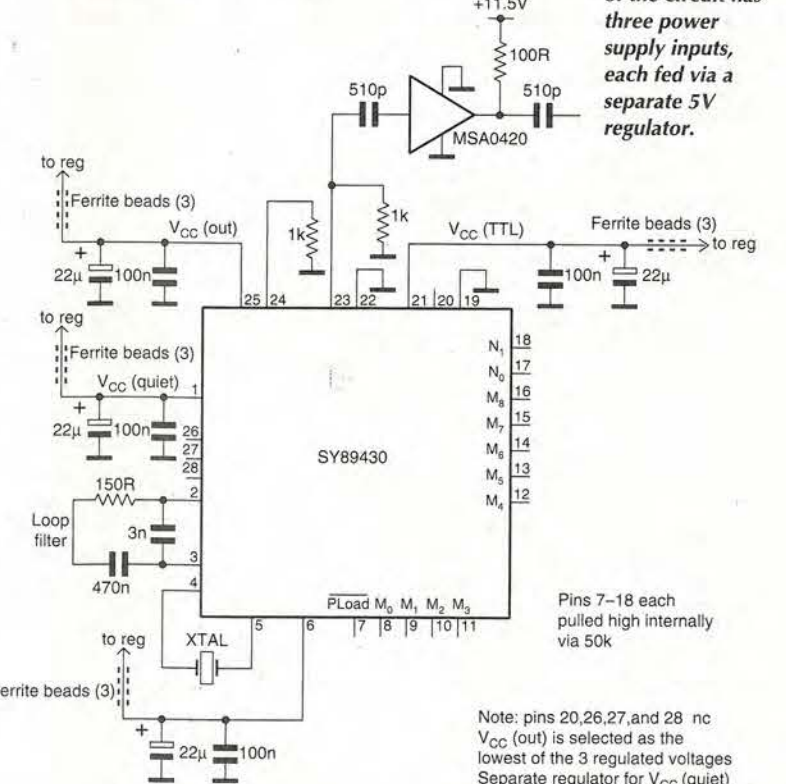

Note: pins 20, 26, 27, and 28 are V_{cc} (out) is selected as the lowest of the 3 regulated voltages. Separate regulator for V_{cc} (quiet)

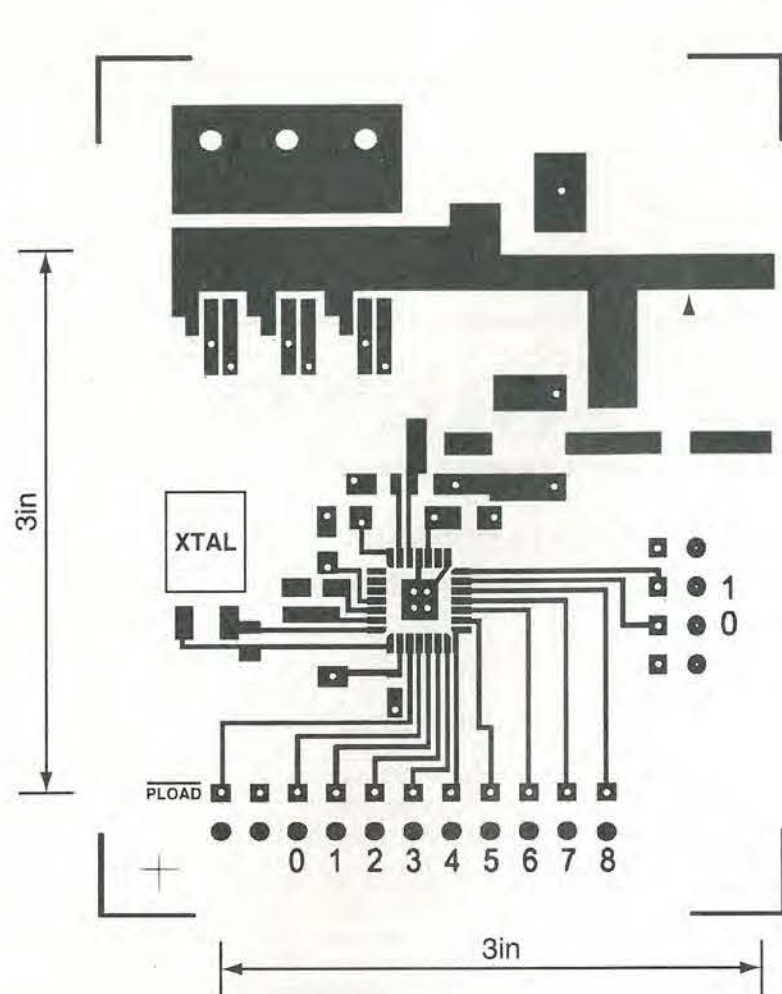

Fig. 2. Layout of the signal source is critical; this one works. The small circular dots are 1mm holes while the three holes at top left are 3mm. 15 circular blobs, right and bottom, are guides for drilling 2 mm holes. The board is connected by ribbon cable to the selector. The strands of cable pass through these holes for strain relief.

Using plccs

Plastic leaded chip carriers, or plccs, are becoming increasingly the format of choice for moderately complex ICs, i.e., those having 20-84 leads. The square design minimises the length of the connections between the actual chip and the output terminals.

Plastic leaded chip carrier parts can be mounted directly on the circuit board, using one of the many smd technologies. The big advantage of plcc technology, for development or experimental work, is that excellent smd sockets are available. These enable costly parts to be retrieved without difficulty for re-use.

Manufacturers data, such as reference 4, specify the dimensions of the necessary solder pads. But these dimensions really relate to the design of the screen-printing of solder paste for volume production. It is perfectly feasible to assemble sockets such as the 28-way RS203-9448 – as used for this design – by hand, using a fine-tipped iron and surface-mounting solder paste.

The small plastic square at the base of the socket should be removed to make access easier. This square is attached at its corners by thin plastic spokes. The material is quite soft and can be cut with a scalpel, care

being taken not to deform the solder tabs.

Also take care not to deform the socket from squareness while doing this. Soldering is made much easier if a modified design of pad is used. Figure 3 shows such a pad for the 28-way part. Dimensions for other parts can be found in the RS Catalogue.

Essentially, the pads are extended inwards by about 1mm. This provides a small area of copper to which the solder paste can be applied using a hypodermic syringe and a coarse needle. Solder paste usually comes with a thin plastic nozzle, but I find these nozzles a trifle clumsy. Note the bevelling of the corner pads.

The use of sockets creates a 'no-go' area of 0.7in square for the 28-way part. Inside this square, no parts, such as decoupling capacitors, can be mounted. When laying out the circuit, I find it convenient to mark out this square with a hairline trace. Such a trace disappears in the etching process.

I make my transparencies using a colour printer. If the trace is in blue, it is effectively transparent to the ultra-violet used for the photographic process.

Note that plcc sockets are also available for through-hole techniques. They have an array of through-pins on a 0.1in grid. But surface mounting is virtually essential for designs of this sort.

SY89429V. This is guaranteed up to 400MHz and has a divide-by-16 range selected by N(1,1).

Phase-locked loops require a filter for stability, and the three components of this are shown in Fig. 1.

The selected-frequency outputs are at ecl levels and have to be properly terminated. In this case, since the layout is very compact, a simple 1k Ω to ground is sufficient. One of the outputs is buffered by an MSA-0420 MMIC to give an output of at least 1V pk-pk when terminated in 50 Ω . The MSA-0420 is a premium-grade part. Cheaper types are available.

All the remaining external parts relate to power supplies which are carefully decoupled. The supply to Pin 25 must be lower than that to pins 6 and 21.

Supply to the vco, pin 1, is separate and should be as noise-free as possible, since noise on this line is translated into frequency jitter. The requirements are met by having three separate 7805 regulators, that for pin 25 being selected as having the lowest output voltage.

Synergy parts with a 'V' part-number suffix will work with V_{CC} down to 3.3V, but I have not tried them.

Implementing the design

Circuits operating at 1GHz can be based on double-sided GRP boards such as G10. This is fortunate, since Teflon-based board is both costly and difficult to work with.

I used conventional photo-etching techniques for my prototype. These involved no more than a modest pc-compatible, Windows 95, a low-cost package called Serif Draw Plus 2 and a suitable ultra-violet exposure box.

No specialised equipment was necessary. The artwork I developed is reproduced as Fig. 2. One side of the board is a continuous ground plane and is not illustrated.

Tidy layout is achieved by distributing V_{CC} from the three regulators on the underside of the board. vias are created at the appropriate points using Vero pins, small areas being etched to insulate these.

If the board is to be manually prototyped, these holes can be counter-bored on the groundplane side. This avoids the need for etching on the groundplane side and also the need for registration.

The numerous earth points on the parts side are connected to the groundplane using track pins such as Maplin FL82D. Each lead from the via at each regulator output threads three

ferrite beads. There is a 22 μ F tantalum capacitor at each via adjacent to the four V_{CC} inputs to the synthesiser, on the groundplane side of the board.

The SY89430V comes in plcc and soic options. I chose the former. A note on using plcc format appears in the panel entitled 'Using plccs.' Essential decoupling components, mounted as close to the IC as the socket will allow, are 1206-format 0.1 μ F parts. Their earthy ends are on pads grounded via pins to the ground plane.

The three loop-filter components are also located as close in as possible. Pins 23 and 24 are grounded through 1k Ω as close in as possible, too. The square inside the plcc footprint provides ground, via four through pins in parallel, for pins 19 and 22.

Loading data serially

Pins 20, 26, 27 and 28 support a facility for serially loading the programming data and for some test functions. These are not used and should be left open.

The broad 0.11in traces associated with the MMIC are, on the 0.0625in board used, 50 Ω striplines. An SMA jack is mounted on the pcb and this is connected via a length of RG405 semi-rigid co-axial cable to a jack mounted on the front panel. Including mains power supply, the whole instrument fits into a die-cast box 190 by 110 by 60mm.

The modulus M(8,0) is selected by nine small toggle switches and N(1,0) by a four-position rotary switch.

The power supply is conventional. An LM317, thermally coupled via an insulating washer to the diecast case, is set to provide 11.5V for the MMIC. This is reduced to 5V by the three regulators mentioned above.

Control and application

A feature of ttl programming inputs on Synergy ecl parts is that they are normally tied either high or low internally via resistors in the region of 50k Ω . In the case of the SY89430 they are tied high. They can be forced low by grounding them through 4.7k Ω or less.

The simplest method of programming this part is by a dual-in-line switch to set the 'M' and 'N' inputs low as required. Some people can effortlessly do binary to decimal conversions in their head. I cannot, so I use a prescaler² and frequency meter to check the settings. This is less of a chore than doing the calculation, and gives one confidence that no mistake has been made.

The fact that the modulus is set by a 9-bit word makes such approaches as using bcd thumbwheel switches and an eeprom to decode them into a proper form, impracticable except at prohibitive cost. I have also built a system using three cascaded LS193 up/down counters which can either be incremented or decremented one count at a time or clocked at a slew rate.

Parallel outputs from the counters form the modulus word, and leds on each line indicate the selection. This however involves ten ICs. And, naturally, the indication is a binary number.

The output is specified as a square wave of 45%-55% duty ratio, but of course on my 100MHz oscilloscope, even at the lowest specified selectable frequency using a 16MHz crystal looks very much like a sine wave.

Rise and fall times are specified as 300-800ps. Setting the frequency to an arbitrarily-chosen 53.5MHz yielded harmonics detectable on my home-made spectrum analyser³ right up to 850MHz.

The oscillator circuit calls for a series-resonant crystal. If a crystal calibrated for parallel resonance is used, it will work just as well, but the frequency will be slightly low.

Assuming my frequency meter is accurate, a selected frequency of 125MHz measures out at 124.941MHz. This

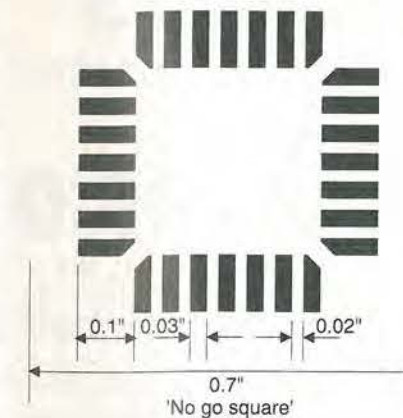

Fig. 3. Dimensions of the plcc pad.

Designer deal

Electronics World readers wanting to experiment with this design can obtain the pcb, plcc socket and SY89430 at the special fully inclusive price of £38.95. This is an exclusive reader offer – the normal package selling price would be £70. For overseas readers, the inclusive price is £35.50 (no VAT).

Note that the package includes data sheets, design notes and other useful information on high-speed circuit layout. Please send your cheque to Nic Houslip at NJ Houslip Ltd, 16 Swinbrook Way, Shirley, Solihull B90 3LZ. Tel. 0121 733 8033, fax, 0121 733 7772, e-mail nic_houslip@compuserve.

is 472ppm low. In many applications though, such an error is irrelevant.

I set the frequency to several quiet points in the vhf broadcast band. A suitable receiver was fully quieted at a distance of several metres. There was no perceptible noise. I think this proves that there is no jitter in the phase-locked loop.

The synthesiser IC consumes just under a watt at 5V. It gets quite hot. A 24-hour soak test at an ambient temperature of 20°C led to a final air temperature inside the box of 40°C.

Operating outside the limits

Guaranteed frequency limits for the SY89430V are 50MHz to 950MHz. These are readily achieved.

At the lower limit, which is obtained in the divide-by-eight mode, the waveform is a fair approximation to a square wave. Lower values of M can be selected, operation down to 48MHz being possible. However, frequencies as low as this are easily generated by other means.

I have found that 973MHz is the highest frequency at which this part can consistently be asked to operate, although I have sometimes achieved 1008MHz.

In summary

The simplicity and low parts-count of this useful signal source are attributable to the use of emitter-coupled logic. ■

References

1. Synergy Semiconductors' Information Pack, Europe Sales, Synergy Semiconductor, 16 Swinbrook Way, Shirley, Solihull, West Midlands. B90 3LZ. Tel 0121-733-8033.
2. Wheeler, N, 'Gigahertz Prescaler,' *Electronics World*, Sep. 1996.
3. Wheeler, N, 'Spectrum analysis on the cheap,' *Electronics World*, March 1992.
4. Motorola, 'High Performance ECL Data' (DL140/D Rev 4).

Technical support

The circuit and much useful application data is fully set out in reference 1, which can be obtained gratis from Synergy.¹ The company has a Website on <http://www.synergyssemi.com>.

The specialised parts for this design are not currently available in small quantities from any usual suppliers.

CIRCUIT IDEAS

Over £600 for a circuit idea?

New awards scheme for circuit ideas

- Every circuit idea published in *Electronics World* receives £35.
- The pick of the month circuit idea receives a Pico Technology ADC42 – worth over £90 – in addition to £35.
- Once every six months, Pico Technology and *Electronics World* will select the best circuit idea published during the period and award the winner a Pico Technology ADC200-50 – worth £586.

How to submit your ideas

The best ideas are the ones that save readers time or money, or that solve a problem in a better or more elegant way than existing circuits. We will also consider the odd solution looking for a problem – if it has a degree of ingenuity.

Your submission will be judged on its originality. This means that the idea should certainly not have been published before. Useful modifications to existing circuits will be considered though – provided that they are original.

Don't forget to say why you think your idea is worthy. We can accept anything from clear hand writing and hand-drawn circuits on the back of an envelope. Type written text is better. But it helps us if the idea is on disk in a popular pc or Mac format. Include an ascii file and hard-copy drawing as a safety net and please label the disk with as much information as you can.

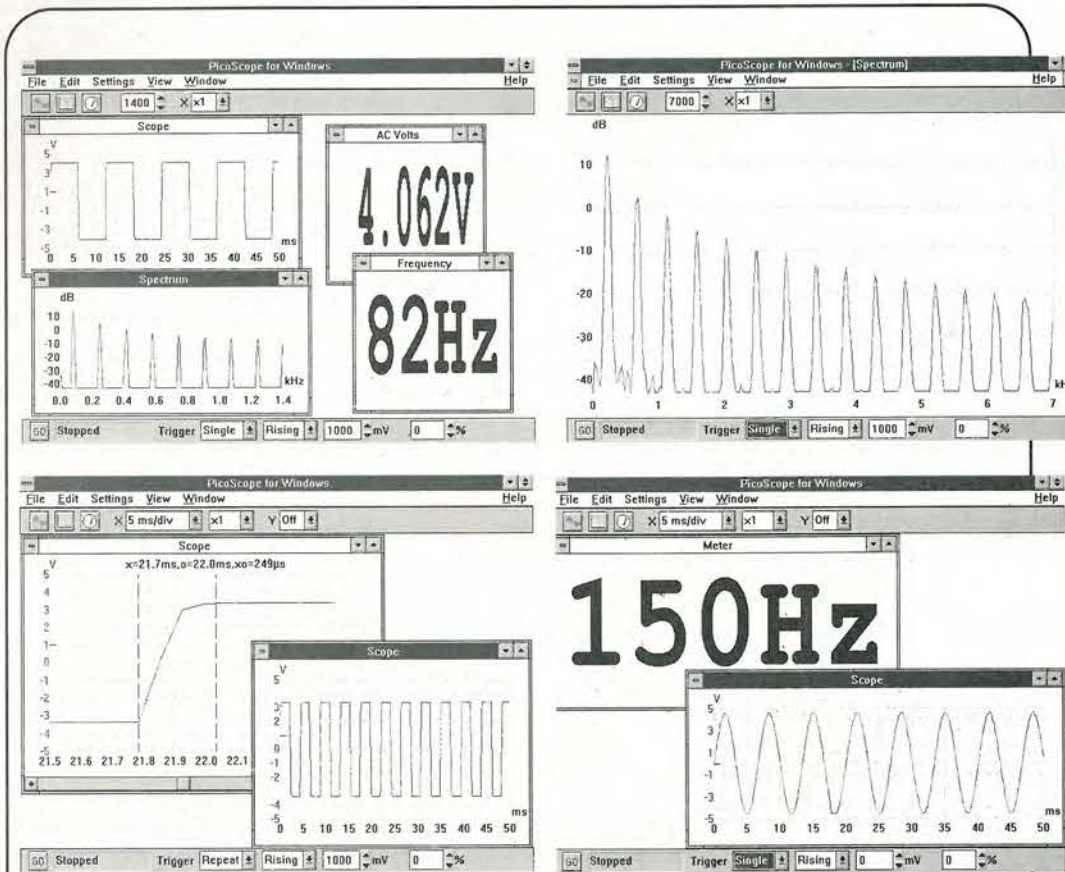

Turn your PC into a high-performance virtual instrument in return for a circuit idea.

The ADC200-50 is a dual-channel 50MHz digital storage oscilloscope, a 25MHz spectrum analyser and a multimeter. Interfacing to a pc via its parallel port, ADC200-50 also offers non-volatile storage and hard-copy facilities. Windows and DOS virtual instrument software is included.

ADC42 is a low-cost, high-resolution a-to-d converter sampling to 12 bits at 20ksample/s. This single-channel converter benefits from all the instrumentation features of the ADC200-50.

Low-battery voltage detector draws a mere 0.3µA

ADC42 Winner

While low-voltage detectors are worthwhile for many battery-powered devices, it is not helpful to have the detector hogging more than its share of current and thereby reducing battery life. This one draws less than 0.3µA.

The circuit shows a 3V lithium battery output being monitored by a Panasonic MN1381G, the output of which is normally high, forcing IC_{1B} to stay high. If the battery voltage falls below the threshold of 2.5V, the 1381 output goes low and allows IC_{1B} to oscillate with a 5s period. Each negative-going edge of the oscillator output is differentiated

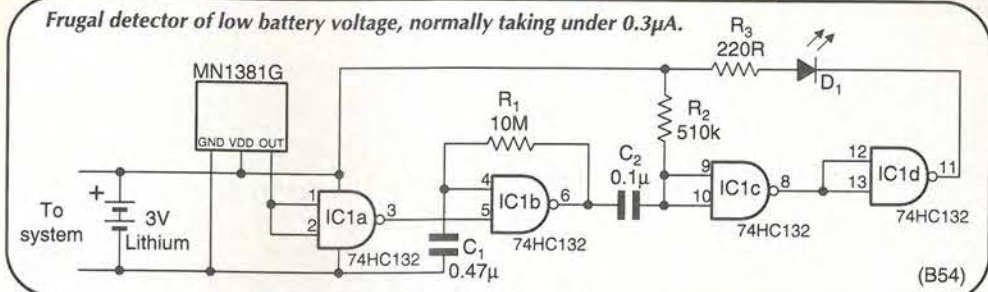

in C₂R₂ and the output at IC_{1D} drives the led. As an example of the effect on a typical circuit, a device designed to use a 500mAh lithium battery for 24 hours per day for two years will have its

battery life reduced by about 1%.
Yongping Xia
 Torrance
 California
 USA
 B54

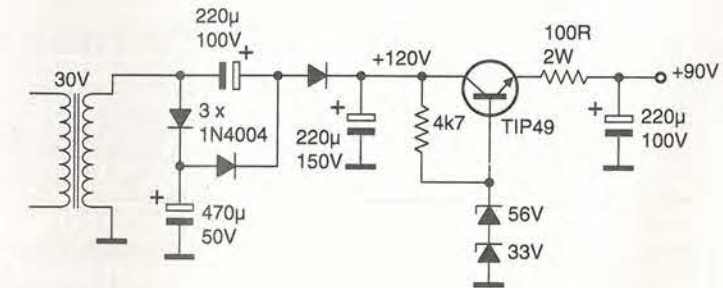
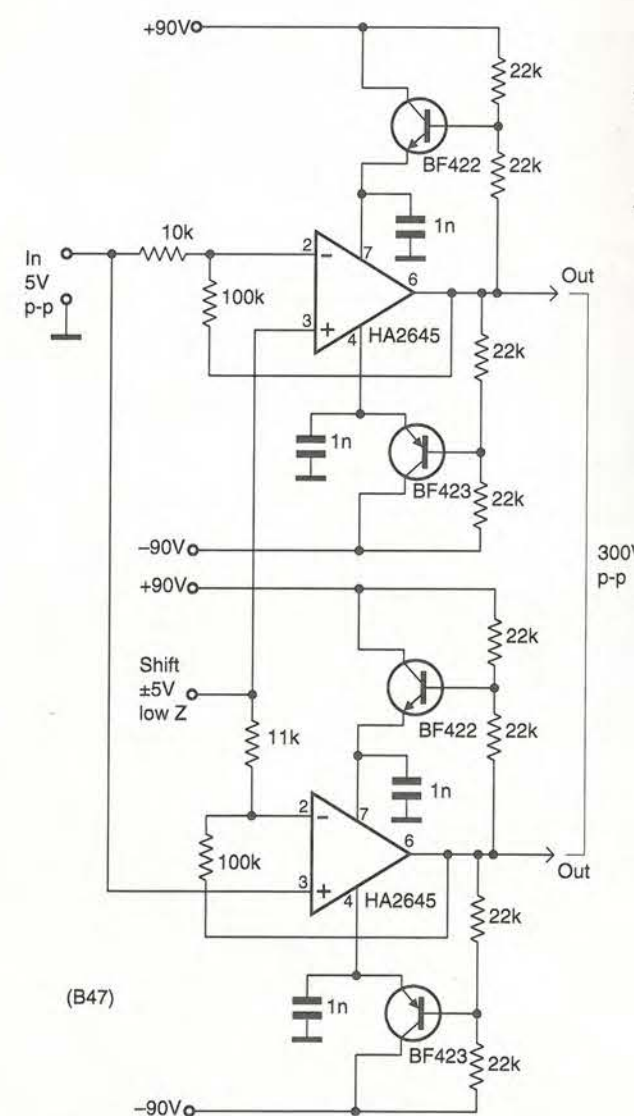

With suitable supplies, this deflection amplifier puts out up to 300V pk-pk at low frequencies.

Oscilloscope deflection amplifier

Depending on the supply rails used, this simple, linear and versatile amplifier will produce up to 300Vpk-pk at low frequencies, having a gain of 20 from a 15Vpk-pk input.

The Harris HA-2645 is probably the best choice in this circuit. Current drain is ±15mA from 90V stabilised rails, obtained from 30V windings and positive and negative voltage triplers and a series transistor with a zener reference. The 100Ω, 2W resistor protects the transistor during short-duration faults. Only one positive supply is shown, the negative using a 2SB546

Frank van Vloten
 Gillitts
 KZN
 South Africa
 B47

Further reading
 Burr Brown. Designing with op-amps. McGraw-Hill.

ADC200 Winner

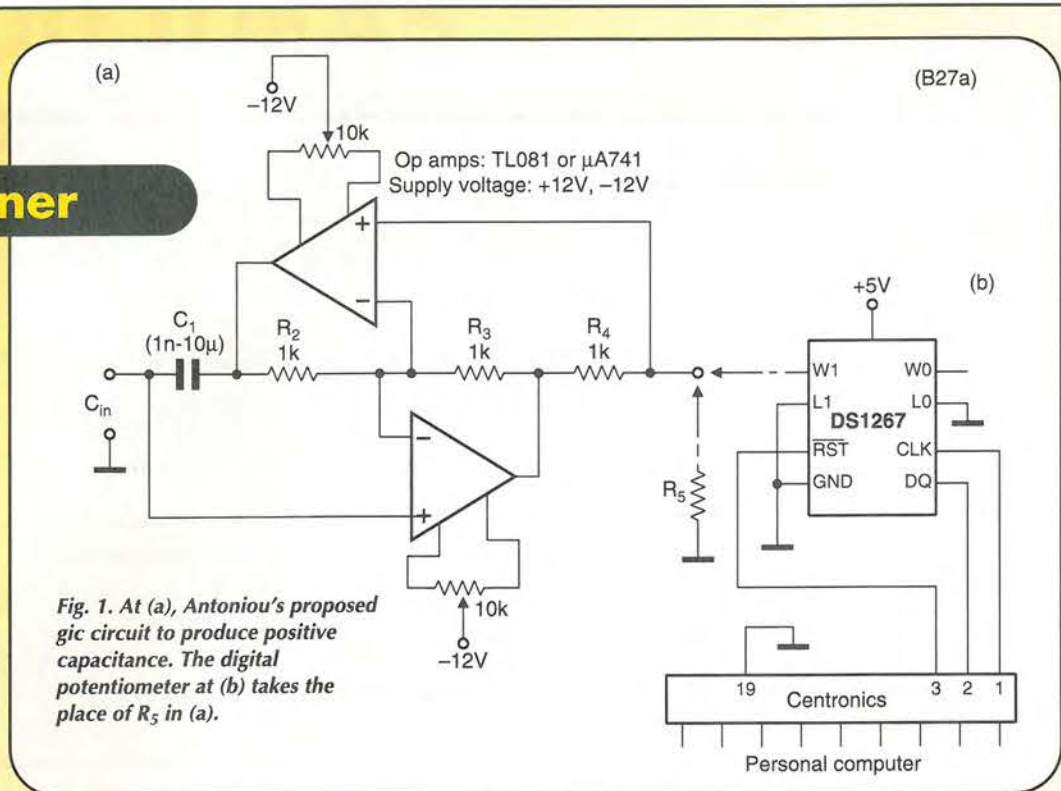

Fig. 1. At (a), Antoniou's proposed circuit to produce positive capacitance. The digital potentiometer at (b) takes the place of R_5 in (a).

Digital programming of capacitance

Variable capacitance proposed by Dunn¹ and a development described as bipolar programmable capacitance by A R Al-Ali and M T Abuelma'atti² are highly sensitive. The arrangement described here, using the generalised impedance converter circuit by Antoniou³, produces a positive capacitance with a sensitivity of unity.

In the circuit of Fig. 1, input capacitance is determined by

$$C_{in} = C_1 R_2 R_4 / R_3 R_5$$

(1)

Half of the dual digital potentiometer DS1267/50k Ω simulates R_5 , control being applied over three wires \RST, DQ and CLK from a pc, the resulting resistance in ohms between pins W_1 and L_1 being calculated by

$$R_5 = N(50000/256) + 300$$

in which N is an integer between zero and 256 placed in the DS1267 register by the pc. Figure 2 shows the theoretical result; the largest value obtained was 2000pF.

Using both halves of the DS1267, the circuit may be used to tune biquad filters, the resonant frequency of which is,

$$\omega_0 \Rightarrow 1/\sqrt{C_a C_b R_a R_b}$$

and

$$Q \Rightarrow \sqrt{C_a / C_b R_a R_b}$$

C_a and C_b being connected to W_0/L_0 and W_1/L_1 respectively. If C_a/C_b is kept constant, ω_0 may be varied while Q remains constant.

Lech Tomawski
University of Silesia
Katowice
Poland
B27

References

- Dunn, J. 'Vary capacitance to positive or negative,' *Electronic Design*, Vol.5, 1991, p. 113.
- Al-Ali, AR and Abuelma'atti, MT, 'Bipolar programmable capacitor,' *Electronics World and Wireless World*, July, 1995, p. 602.
- Antoniou, A, 'Realisation of gyrators using operational amplifiers,' *Proc. IEEE*, vol. 116, 1969, p. 1838.

Fig. 2. Effective input capacitance for varying values of C_1 against the value of R_5 and the digital input to the DA1267 from the pc.

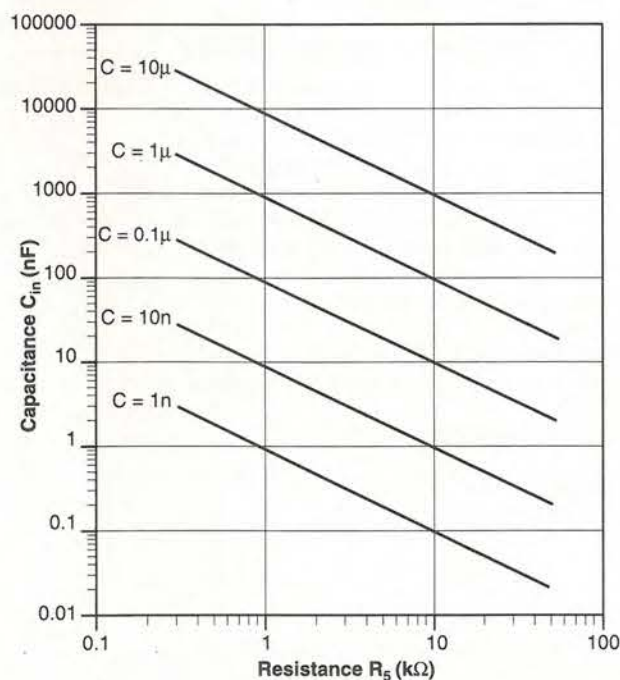

electronicsWEEKLY

HyperACTIVE

CONNECT WITH THE UK'S

NO. 1 READ FOR ELECTRONICS

PROFESSIONALS ON THE

INTERNET

Electronics Weekly HyperACTIVE is more than just a magazine on the Web. Check out the site and you'll see why thousands of electronics professionals around the world regularly log on to www.electronicweekly.co.uk/

For **News** HyperACTIVE's Daily News Service brings you the latest news in the industry - as it breaks. For **Jobs** HyperACTIVE has the largest and most varied collection of jobs available in the electronics market. Now we bring you the improved **Jobs and Careers** service with a whole range of new and exciting features.

All this plus, the **latest technology**, market information, toolkit's, a searchable archive, and loads more....

Don't miss out.

Point your browser at <http://www.electronicweekly.co.uk/> register now (it's free)

SPONSORED BY



ADVERTISER INFORMATION: 0181 652 3639 OR E-MAIL: richardnapier@rbi.co.uk

Testing ignition coil and plugs

To remove them from one's list of suspects, this circuit will test both ignition coil and sparking plugs outside the car.

When S₁ connects the mains, C₁ charges through the variable chain, eventually causing Tr₁ to conduct, whereupon the relay operates, contact A closes and the capacitor discharges rapidly, deactivating the relay. The outcome is that the relay opens and closes its contacts at high speed.

As contact B opens, the field of the ignition coil collapses and generates the high voltage for the spark. Adjustment of the variable resistor varies the spark rate.

The two rectifiers avoid loading of the relay circuit by the ignition coil.

Rupen Chanda
Madras
India
B55

Establish the health or otherwise of an ignition system without flattening your battery.

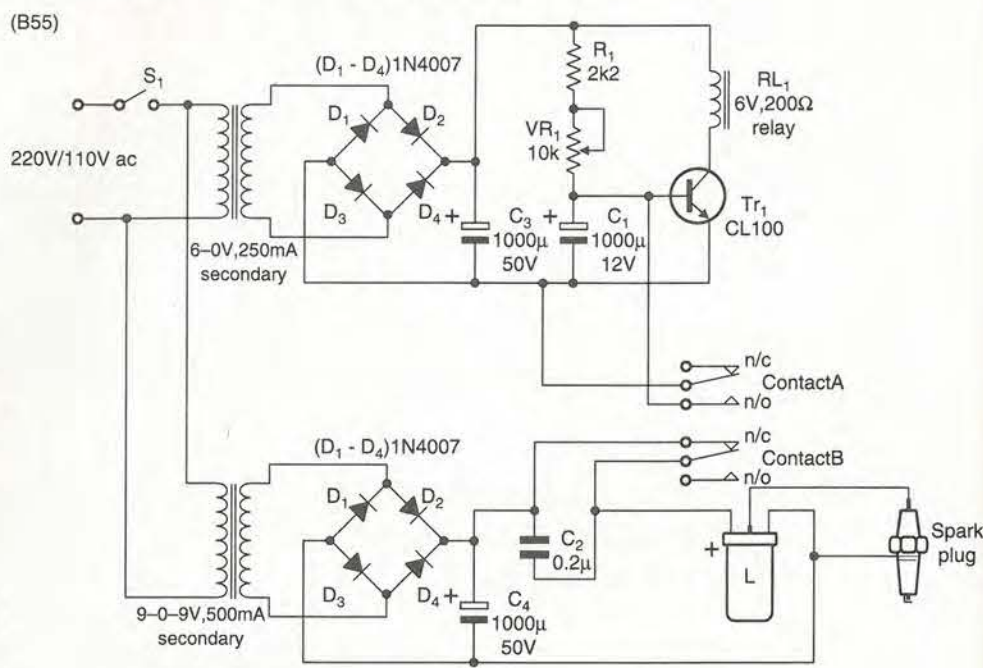

Nine year index - new update

Hard copies and floppy-disk databases both available

Whether as a PC data base or as hard copy, SoftCopy can supply a complete index of *Electronics World* articles going back over the past nine years.

The computerised index of *Electronics World* magazine covers the nine years from 1988 to 1996, volumes 94 to 102 inclusive is available now. It contains almost 2000 references to articles, circuit ideas and applications - including a synopsis for each.

The EW index data base is easy to use and very fast. It runs on any IBM or compatible PC with 512k ram and a hard disk.

The disk-based index price is still only £20 inclusive. Please specify whether you need 5.25in, 3.5in DD or 3.5in HD format. Existing users can obtain an upgrade for £15 by quoting their serial number with their order.

Photo copies of *Electronics World* articles from back issues are available at a flat rate of £3.50 per article, £1 per circuit idea, excluding postage.

Hard copy *Electronics World* index Indexes on paper for volumes 100, 101, and 102 are available at £2 each, excluding postage.

TABLE OF CONTENTS	
Applications Applications by description Applications by part numbers Company addresses Author Index Books Circuit Ideas Information Subject Index Analogue Design Audio Avionics Broadcast Communications Components Computing Consumer Electronics Control Electronics Digital & DSP Design History Networks & Telematics	The <i>Electronics World</i> SoftIndex runs from January 1988 to May 1998 and contains references to 1300 articles and 800 circuit ideas. There is a separate author index with full cross references. Reprints can be obtained for all the articles in this index - see the information section for more details. For up to date information about <i>Electronics World</i> see our website at http://www.softcopy.co.uk . <input type="button" value="Search"/> <input type="button" value="Report"/> <input type="button" value="Note"/> <input type="button" value="About"/> <input type="button" value="Exit"/>

Ordering details

The EW index data base price of £20 includes UK postage and VAT. Add an extra £1 for overseas EC orders or £5 for non-EC overseas orders

Postal charges on hard copy indexes and on photocopies are 50p UK, £1 for the rest of the EC or £2 worldwide.

For enquires about photocopies etc please send a sae to SoftCopy Ltd at the address below.

Send your orders to SoftCopy Ltd, 1 Vineries Close, Cheltenham GL53 0NU

Cheques payable to SoftCopy Ltd
Allow 28 days for delivery

**e-mail at SoftCopy@compuserve.com.
tel 01242 241455**

SMALL SELECTION ONLY LISTED - EXPORT TRADE AND QUANTITY DISCOUNTS - RING US FOR YOUR REQUIREMENTS WHICH MAY BE IN STOCK

HP New Colour Spectrum Analysers
 HP141T+8552B IF + 8553B RF -1KHz-110Mc/s - £700.
 HP141T+8552B IF + 8554B RF -100KHz-1250M - £900.
 HP141T+8552B IF + 8556A RF -20Hz-300KHz - £700.
 HP141T+8552B IF + 8555A 10 Mc/s-18GHz - £1200.
 HP8443A Tracking Gen Counter 100KHz-110Mc/s - £200.
 HP8445B Tracking Preselector DC to 18GHz - £250.
 HP8444A Tracking Generator • 5-1300Mc/s - £450.
 HP8444A OPT 059 Tracking Gen • 5-1500Mc/s - £650.
 HP35601A Spectrum Anz Interface - £500.
 HP4953A Protocol Anz - £400.
 HP8970A Noise Figure Meter + 346B Noise Head - £3k.
 HP8755A Scalar Network Anz PI - £250 + MF 180C - Heads 11664 Extra - £150 each.
 HP8903A Audio Anz - £1000.
 HP8656A 100KHz - 990 Mc/s, S/G AM-FM - £1000.
 HP3709B Constellation ANZ £1.5k.
 HP11715A AM-FM Test Source - £500.
FARNELL TVS70MKII PU 0-70V 10 amps - £150.
FARNELL PSG 520 S/G 10 Mc/s AM-FM - £150.
TEK 475 Oscilloscopes 200Mc/s - £300.
TEK 475A Oscilloscopes 250Mc/s - £350.
MARCONI 6500 Network Scaler Anz - £500. Heads available to 40GHz many types in stock.
HP3580A 5Hz-50KHz Spectrum ANZ £750 - £1000.
HP3582A .02Hz to 25.6KHz Spectrum ANZ £1.5k.
TEK 7L5 - L3 - Opt 25 Tracking Gen - £900.
TEK 7L12 - 100KHz-1800Mc/s - £1000.
TEK 7L18 - 1.5-60GHz - £1000.
Mixers are available for the above ANZs to 60GHz.
HP8673D Signal Generator .05-25.6GHz - £15k.
Systron Donner 1618B Microwave AM FM Synthesizer 50Mc/s - 18GHz £2k.
ADRET 3310A FX Synthesizer 300Hz - 60Mc/s - £600.
HP Plotters 7470A - 7475A. Up to £250.
HP3730A + 3737A Down Converter Oscillator 3.5 - 6.5GHz.
Marconi Microwave Amps 491-492-493-494-495 - 1GHz -12.4GHz- £250 each.
HP6034A System Power Supply 0-60V 0-10A - £500.
HP6131C Digital Voltage Source + -100V/Amp.
HP3779A Primary Multiplex Analyser - £200 qty.
HP3779C Primary Multiplex Analyser - £300 qty.
HP5316A Universal Counter A+B.
HP8901A Modulation Meter AM-FM - £1000.
Marconi TF2374 Zero Loss Probe - £200.
Marconi TF2305 Modulation Meter - £1000.
Racal/Dana 2101 Microwave Counter - 10Hz-20GHz - with book as new £2k.
Racal/Dana 1250-1261 Universal Switch Controller + 200Mc/s PI Cards.
Racal/Dana 9303 True RMS Levelmeter + Head - £450.
IEEE Interface - £500.
TEKA6902A also A6902B Isolator - £300-£400.
TEKFG5010 Programmable Function Genr 20Mc/s - £600.
TEK2465 300 Mc/s Oscilloscope - £2k + Probes - £150.
TEK CT-5 High Current Transformer Probe - £250.
TEK J16 Digital Photometer + J6523-2 Luminance Probe - £300.
HP745A+746A AC Calibrator - £600.
Marconi TF2008 - AM-FM signal generator - also sweeper - 10Kc/s - 510Mc/s - from £250 - tested to £400 as new with manual - probe kit in wooden carrying box.
HP Frequency comb generator type 8406 - £400.
HP Sweep Oscillators type 8690 A+B + plug-ins from 20Mc/s to 18GHz also 18-40GHz.
HP Network Analyser type 8407A + 8412A + 8601A - 100Kc/s - 110Mc/s - £500 - £1000.
HP Amplifier type 8447A - 1-400Mc/s £200 - HP8447A Dual - £300.
HP Frequency Counter type 5340A - 18GHz £800.
HP 8410-A-B-C Network Analyser 110Mc/s to 12 GHz or 18 GHz - plus most other units and displays used in this set-up- 8411a-8412-8413-8414-8418-8740-8741-8742-8743-8746-8650. From £1000.
Racal/Dana 9301A-9302 RF millivoltmeter - 1.5-2GHz - qty in stock £250-£400.
Racal/Dana Modulation Meter Type 9009-9008 - 8Mc/s - 1.5GHz - £150/£250.
Marconi RCL Bridge type TF2700 - £150.
Marconi/Saunders Signal Sources type - 605B-6070A-6055A-6059A-6057A-6056 - £250-£350. 400Mc/s to 18GHz.
Marconi Microwave 6600A 1 sweep osc., mainframe with 6650PI - 18-26.5 GHz or 6651 PI - 26.5-40GHz-£750 or PI only £600. MF only £250.
Tektronix Plug-ins 7A13-7A14-7A18-7A24-7A26-7A11-7M11-7S11-7D10-7S12-S1-S2-S6-S52-PG506-SC504-SG502-SG503-SG504-DC503-DC508-DB501-WR501-DM501A-FG501A-TG501-PG502-DC505A-FG504-7B80 - 85 - 7B92A.
Gould J3B test oscillator + manual - £150.
Tektronix Mainframes - 7603-7623A-7613-7704A-7844-7904-TM501-TM503-TM506-7904A-7834-7623-7633-7844-7854-7104.
Marconi 6155A Signal Source-1 to 2GHz - LED - £400.
Barr & Stroud Variable filter EF3 0.1Hz-100Kc/s + high pass + low pass - £150.
Racal/Dana 9300 RMS voltmeter - £250.
HP 8750A storage normalizer - £400 with lead + S.A. or N, A Interface. Board fitted.
TEKTRONIX - 7S14-7T11-7S11-7S12-S1-S2-S39-S47-S51-S52-S53-7M11.
Marconi mod meters type TF2304 - £250.
Systron Donner counter type 6054B - 20Mc/s - 24GHz - LED readout - £1k.

Farnell electronic load type RB1030-35 - £350.
 Racal/Dana counters-99904-9905-9906-9915-9916-9917-9921-50Mc/s-3GHz - £100 - £450 - all fitted with FX standards.
 HP180TR, HP181T, HP182T mainframes £300 - £500.
 Marconi 6700A sweep oscillator - 18GHz PIs available.
Racal/Dana VLF frequency standard equipment. Tracer receiver type 900A + difference meter type 527E + rubidium standard type 9475 - £2750.
HP432A-435A or B-436A-power meters + powerheads to 60GHz - £150 - £1750 - spare heads.
HP8614A signal gen 800Mc/s - 2.4GHz, new colour - £400.
HP8616A signal gen 1.8GHz - 4.5GHz, new colour £400.
HP3336A or B syn level generator - £500 - £600.
HP3586A or C selective level meter - £500.
HP8683D S/G microwave 2.3-13GHz-opt 001 - 003 - £1k.
HP8640B S/G AM-FM 512Mc/s or 1024Mc/s. Opt 001 or 002 or 003 - £800-£1250.
HP86222B Sweep PI -01-2.4GHz + ATT £1000-£1250.
HP86290A Sweep PI-2 - 18GHz - £1000 - £1250.
HP86 Series PIs in stock - splitplan from 10Mc/s - 18.6GHz - £250 - £1k.
HP8620C Mainframe - £250. IEEE.
HP8615A Programmable signal source - 1MHz - 50Mc/s - opt 002-£1k.
HP8601A Sweep generator .1-110Mc/s £300.
HP8349A Microwave Amp 2 - 20GHz Solid state - £1500.
HP1980B Oscilloscope measurement system - £300.
HP3455/3456A Digital voltmeter - £400.
HP5370A Universal time interval counter - £1k.
HP5335A Universal counter - 200Mc/s-£500.
HP5328A Universal counter - 500Mc/s - £250.
HP6034A Power supply -0.60V-0.10 amps - £500.
HP3710A 3715A-3716A-3702B-3703B-3705A-3711A-3791B-3712A-3793B microwave link analyser.
HP3552A Transmission test set - £350.
HP3763A Error detector - £500.
HP3764A Digital transmission analyser - £800.
HP3770A Amp delay distortion analyser - £400.
HP3770B - £450.
HP3780A Pattern generator detector - £400.
HP3781A Pattern generator - £400.
HP3782A Error detector - £400.
TEKTRONIX 577 Curve tracer + adaptors - £900.
TEKTRONIX 1502/1503 TDR cable test set - £400.
Racal 1991-1992-1998 - 1300Mc/s counters - £400-£900.
Fluke 80K-40 high voltage probe in case - BN - £50-£75.
HP4545 microwave 18GHz counter - £1200.
Fluke 510A AC ref standard - 400Hz-£200.
Fluke 355A DC voltage standard - £300.
Wiltron 610D Sweep Gen + 6124C PI-4-8GHz-£400.
Wiltron 610D Sweep Generator +61084D PI - 1Mc/s - 1500Mc/s £500 - 10 Mc/s - 18GHz - £1000.
HP8699B Sweep PI YIG oscillator .01 - 4GHz - £300. 8690B MF-£250. Both £500.
Dummy Loads & Power at up to 2.5 kilowatts FX up to 18GHz - microwave parts new and ex equip - relays - attenuators - switches - waveguides - Yigs - SMA - APC7 plugs - adaptors etc. qty. in stock.
B&K items in stock - ask for list.
Power Supplies Heavy duty + bench in stock - Farnell - HP - Weir - Thurlby - Racal etc. Ask for list. Large quantity in stock, all types to 400 amp - 100kV.
Marconi 2955 Radio Test set - £1800.
Marconi 2955 + 2959 Tacs radio test set - £2000.
Marconi 2955R Radio test set - £2000.
Marconi TF2015 S/G 10Mc/s - 520Mc/s AM/FM - £100.
Marconi TF2016A S/G 10Kc/s-120Mc/s. AM/FM - £100.
Marconi TF2171 Digital synchronizer for 2015/2016 - £50.
Marconi TF2017 S/G .01-1024Mc/s. AM/FM. High grade - low noise - LED readout. - £1k.
Marconi TF2018 S/G 80Kc/s-520Mc/s. AM/FM - £600.
Marconi TF2018A S/G 80Kc/s-520Mc/s. AM/FM - £800.
Marconi TF2019 S/G 80Kc/s-1040Mc/s. AM/FM - £1000.
Marconi TF2019A S/G 80Kc/s-1040Mc/s. AM/FM - £1250.
Marconi TF2022E S/G 10Kc/s-1.01GHz. AM/FM - £1250.
Marconi TF2022E As above but as new + Cal cert - £1500.
Marconi TF6311 Microwave Sweep S/G 10Mc/s - 20GHz c/w TF6501 amplitude Anz. plus heads 10Kc/s-20GHz. Heads available to 40GHz - £4000.
Farnell S/G ESG1000 10Hz-1000Mc/s. AM/FM - £800.
IFR 1200S Communications radio test set - £2500.
TF2370 Spectrum Anz's 30Hz-110Mc/s. Large qty to clear as received from Gov - all sold as is from pile complete or add £100 for basic testing and adjustment. Callers preferred - Pick your own from over sixty units.
A. Early Model - Grey - Rear horizontal alloy cooling fins - qty of 5 - £750 lot - singly - £200.
B. Late Model - Grey-Vertical alloy cooling fins - £300.
Marconi TK2373 Extender to 1.25GHz - £300 - £400.
HP3325A Synthesized function generator - £1000 - £1500.
HP3325B Synthesized function generator - £2500.
HP8405A Vector voltmeter - late colour - £400.
HP8508A Vector voltmeter - £2500.
HP8505A Network Anz 500KHz-1.3GHz - £1000.
HP8505A + 8502A or 8503A test sets- £1200 - £1500.
HP8505A + 8502A or 8503A + 8501A normalizer - £1750-£2000.
HP8557A .01Mc/s-350Mc/s - 8558B 0.1-1500Mc/s - 8559A .01-21GHz 180T or 180C-D-T £500 - £2000.
TEK492 Spectrum Anz-OPT 2-50Kc/s-21GHz - £2.5k.
TEK492P S.A. opt 1-2-3-50 Kc/s - 21GHz £4k.
TEK495 S.A. 100Hz - 1.8GHz - £3k.
TEKTRONIX - HP Oscilloscopes - 100Mc/s-465-465B-1740-1741 etc - £300 - qty in stock.
Phillips 3217 50Mc/s oscilloscopes - £150-£250.
Phillips 3296 350Mc/s IR remote oscilloscope - £750.

NEW REVISED LOW PRICES FOR OLDER EQUIPMENT

ITEMS BOUGHT FROM HM GOVERNMENT BEING SURPLUS. PRICE IS EX WORKS. SAE FOR ENQUIRIES. PHONE FOR APPOINTMENT OR FOR DEMONSTRATION OF ANY ITEMS. AVAILABILITY OR PRICE CHANGE. VAT AND CARRIAGE EXTRA. ITEMS MARKED TESTED HAVE 30 DAY WARRANTY. WANTED: TEST EQUIPMENT-VALVES-PLUGS AND SOCKETS-SYNCRS-TRANSMITTING AND RECEIVING EQUIPMENT ETC.

Johns Radio, Whitehall Works, 84 Whitehall Road East, Birkenshaw, Bradford BD11 2ER. Tel: (01274) 684007. Fax: 651160

Simple parallel-to-serial conversion

Eight-bit parallel data is converted to one start bit, one stop-bit RS232 form by this interface. It can be a part of any programmable logic device, epld, fpga, etc., and it can be used to allow a pc to read eight parallel lines via one of its com ports.

Other than setting the bit rate, no initialisation is needed. The bit rate is equal to one clock period. Bit rate divisor

List. Programming the pc's com port bit-rate setting in turbo C.

```
output (0x2FB,131) ;/*2F8 for baud setting */.
output (0x2F8,0xXX) ;/* LSB byte of divisor*/.
output (0x2F9,0xXX) ;/* MSB byte of divisor*/.
output (0x2FB,3) ;/* 2F8 for transmission*/.
```

'B' can also be used to setting the bit rate divisor on the pc using 1843200/(16B).

It is possible to program the pc for any bit rate by putting the corresponding divisor value in 16-bit format using statements in turbo-C as given in the List for COM1.

Data transmission starts on the first leading edge clock after the leading edge of LD, which can be further controlled by pc or some other control. The pc reads the data via the statement, inport (0x2F8):

The timing diagram shows output for decimal 6 and 85 at D7...0-

Vijayan Pillai
Kerala
India
B29

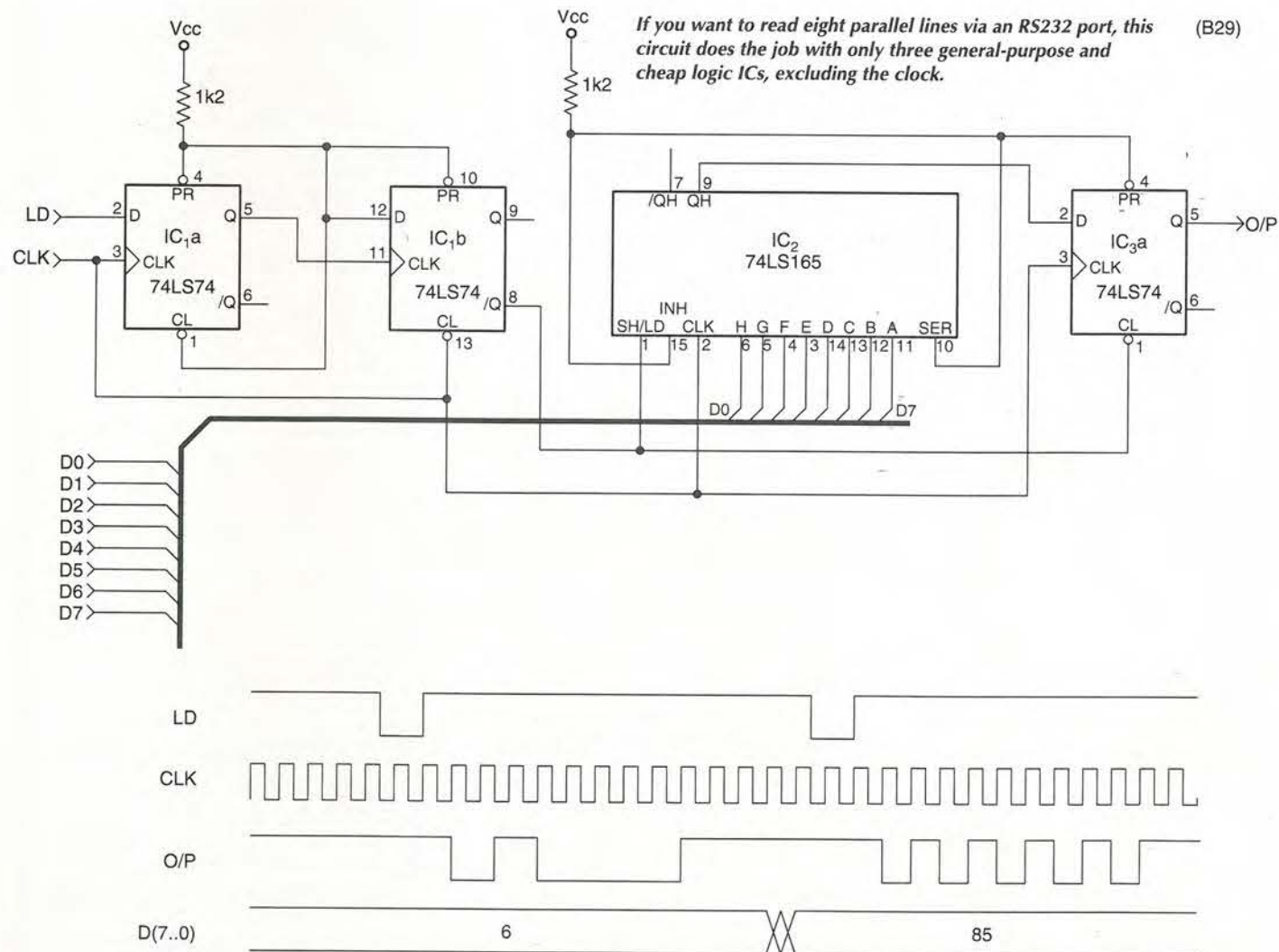

If you want to read eight parallel lines via an RS232 port, this circuit does the job with only three general-purpose and cheap logic ICs, excluding the clock.

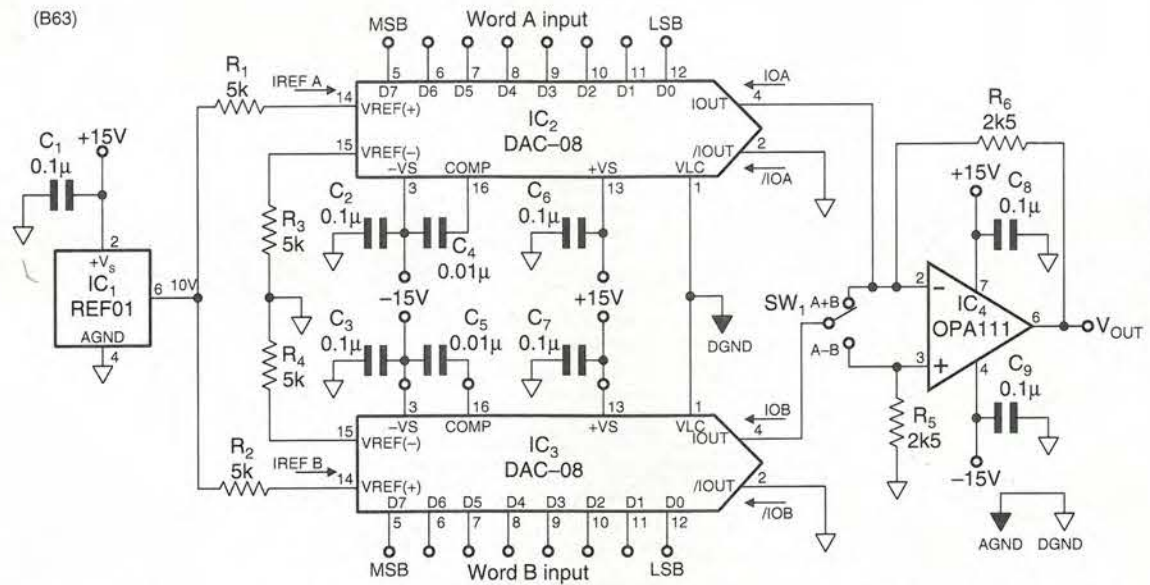

Neither digital ics nor their power supply are required in this analogue-output binary adder and subtractor.

Binary adder and subtractor gives analogue output

To obtain an analogue output from the algebraic addition or subtraction of two digital inputs the usual method involves the use of several digital ics followed by a digital-to-analogue converter.

The eight-bit circuit shown totally eliminates digital ics and their power supply; it needs only four ics and the output is delayed only by the 85ns settling time of the d-to-a converter and that of the op-amp.

A 10V reference provides current for both multiplying d-to-a converters, so that

$$I_{refA} = 10/R_1 = 2\text{mA},$$

and similarly for I_{refB} .

Output currents of the converters $I_{oA/B}$ are controlled by the binary inputs to the converters and the reference currents, so that

$$I_{oA} = I_{refA}(N_A/2^n),$$

where n is the number of bits in the binary word and N_A lies between 0 and $2^n - 1$, depending on the input word.

Setting switch S_1 to its position (A+B) gives the expression for output voltage,

$$V_{out(A+B)} = I_{oA} \times R_6 + I_{oB} \times R_6 \\ = I_{refA} \times (N_A/2^n) \times R_6 + I_{refB} \times (N_B/2^n) \times R_6.$$

With the switch in the A-B position, the above becomes a subtraction, assuming that $R_5 = R_6$.

For the values $I_{refA/B} = 2\text{mA}$, $R_5/6 = 2.5\text{k}\Omega$ and $n = 8$,

$$V_{out(A+B \text{ or } A-B)} \\ = 2 \times 2.5(N_A \pm N_B)/2^n \\ = 5/256(N_A \pm N_B)/2^n.$$

V Manoharan

Naval Physical & Oceanographic Laboratory
Kochi
India
B63

Circuit board tester

This little circuit indicates the basic integrity of a 5V printed board, detecting 0V, 5V and floating parts.

If the probe is floating, as it would be on a broken track, then both leds barely light up, since there is no current to drive the transistors, but if the probe touches 0V or 5V one or other lights. I have not tried it, but it may be that a digital signal would light them in proportion to the mark:space ratio.

The circuit is cheap enough to incorporate on a board permanently for fault finding.

John Farbrother
Walsall
Staffordshire
B64

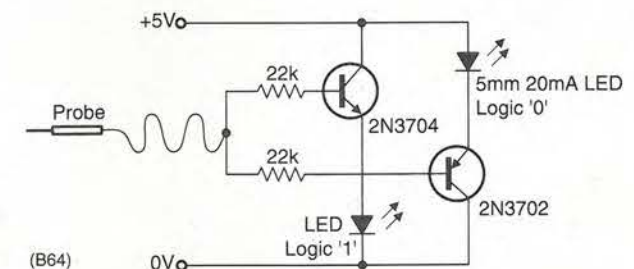

They don't often come much simpler than this. A circuit to detect 0V, 5V or a broken track.

More circuit ideas on page 884

Surplus always wanted for cash!

THE ORIGINAL SURPLUS WONDERLAND!

THIS MONTH'S SELECTION FROM OUR VAST EVER CHANGING STOCKS

Surplus always wanted for cash!

THE AMAZING TELEBOX

Converts your colour monitor into a QUALITY COLOUR TV!!



TV SOUND & VIDEO TUNER
CABLE COMPATIBLE

The TELEBOX is an attractive fully cased mains powered unit, containing all electronics ready to plug into a host of video monitors made by makers such as MICROVITEC, ATARI, SANYO, SONY, COMMODORE, PHILIPS, TATUNG, AMSTRAD etc. The composite video output will also plug directly into most video recorders, allowing reception of TV channels not normally receivable on most television receivers* (TELEBOX MB). Push button controls on the front panel allow reception of 8 fully tuneable 'off air' UHF colour television channels. TELEBOX MB covers virtually all television frequencies VHF and UHF including the HYPERBAND as used by most cable TV operators. A composite video output is located on the rear panel for direct connection to most makes of monitor or desktop computer video systems. For complete compatibility - even for monitors with audio sound - an integral 4 watt audio amplifier and low level Hi Fi audio output are provided as standard.

TELEBOX ST for composite video input type monitors £36.95
TELEBOX STL as ST but fitted with integral speaker £39.50
TELEBOX MB Multiband VHF/UHF/Cable/Hyperband tuner £69.95
For overseas PAL versions state 5.5 or 6 mHz sound specification.
*For cable / hyperband signal reception TELEBOX MB should be connected to a cable type service. Shipping on all Teleboxes, code (B)

NEW State of the art PAL (UK spec) UHF TV tuner module with composite 1V pp video and NICAM hi fi stereo sound outputs. Micro electronics all on one small PCB only 73 x 160 x 52 mm enable full software control via a simple 2 wire link to any IBM type computer. Supplied complete with simple working program and documentation. Requires +12V & +5V DC to operate. BRAND NEW - Order as MY00. Only £49.95 code (B)

FLOPPY DISK DRIVES 2 1/2" - 14"

Massive purchases of standard 5 1/4" and 3 1/2" drives enables us to present prime product at industry beating low prices! All units (unless stated) are BRAND NEW or removed from often brand new equipment and are fully tested, aligned and shipped to you with a full 90 day guarantee. Call for over 2000 unlisted drives for spares or repair.

- 3 1/2" Panasonic JU363/4 720K or equivalent RFE £24.95(B)
- 3 1/2" Mitsubishi MF355C-L 1.4 Meg. Laptops only £25.95(B)
- 3 1/2" Mitsubishi MF355C-D 1.4 Meg. Non laptop £18.95(B)
- 5 1/4" Teac FD-55GFR 1.2 Meg (for IBM pc's) RFE £18.95(B)
- 5 1/4" Teac FD-55F-03-U 720K 40/80 (for BBC's etc) RFE £29.95(B)
- 5 1/4" BRAND NEW Mitsubishi MF501B 360K £22.95(B)
- Table top case with integral PSU for HH 5 1/4" Floppy or HD £29.95(B)
- 8" Shugart 800/801 8" SS refurbished & tested £210.00(E)
- 8" Shugart 810 8" SS HH Brand New £195.00(E)
- 8" Shugart 851 8" double sided refurbished & tested £280.00(E)
- 8" Mitsubishi M2894-83 double sided NEW £295.00(E)
- 8" Mitsubishi M2896-63-02U DS slimline NEW £295.00(E)
- Dual 8" cased drives with integral power supply 2 Mb £499.00(E)

HARD DISK DRIVES

- 2 1/2" TOSHIBA (19 mm H) MK2101MAN 2.16 Gb. New £199.00
- 2 1/2" TOSH (12.5 mm H) MK1002MAV 1.1 Gb laptop. New £115.00
- 2 1/2" to 3 1/2" conversion kit for PC's, complete with connectors £12.95
- 3 1/2" FUJII FK-309-26 20mb MFM I/F RFE £59.95
- 3 1/2" CONNER CP3024 20 mb IDE I/F (or equiv.) RFE £59.95
- 3 1/2" CONNER CP3044 40mb IDE I/F (or equiv.) RFE £69.00
- 3 1/2" RODIME RO3057S 45mb SCSI I/F (Mac & Acorn) £89.00
- 3 1/2" QUANTUM UM 400 Prodrive 42mb SCSI I/F, New RFE £49.00
- 3 1/2" WESTERN DIGITAL 850mb IDE I/F New £185.00
- 5 1/4" MINISCRIIBE 3425 20mb MFM I/F (or equiv.) RFE £49.95
- 5 1/4" SEAGATE ST-238R 30 mb RLL I/F Refurb £69.95
- 5 1/4" CDC 94205-51 40mb HH MFM I/F RFE tested £69.95
- 5 1/4" HP 97548 85 Mb SCSI RFE tested £99.00
- 5 1/4" HP C3010 2 Gbyte SCSI differential RFE tested £195.00
- 8" NEC D2246 85 Mb SMD interface. New £199.00
- 8" FUJITSU M2322K 160Mb SMD I/F RFE tested £195.00
- 8" FUJITSU M2392K 2 Gb SMD I/F RFE tested £345.00
- Many other drives in stock - Shipping on all drives is code (D)

TEST EQUIPMENT & SPECIAL INTEREST ITEMS

- MITLS. FA3445ETKL 14" Industrial spec SVGA monitors £245
- IKW to 400 kW - 400 Hz 3 phase power sources - ex stock EPOA
- IBM 8230 Type 1, Token ring base unit driver £760
- Wayne Kerr RA200 Audio frequency response analyser £2500
- IBM 53F5501 Token Ring ICS 20 port lobe modules £750
- IBM MAU Token ring distribution panel 8228-23-5050N £95
- AIM 501 Low distortion Oscillator 9Hz to 330KHz, IEEE £550
- ALLGON 8360.11805-1880 MHz hybrid power combiners £250
- Trend DSA 274 Data Analyser with G703(2M) 64 V £EPOA
- Marconi 6310 Programmable to 2 to 22 GHz sweep generator £6500
- Marconi 2022C 10KHz-1GHz RF signal generator £1550
- Marconi 2030 opt 03 10KHz-1.3 GHz signal generator, New £5150
- HP1650B Logic Analyser £3750
- HP3781A Pattern generator & HP3782A Error Detector EPOA
- HP6621A Dual Programmable GPIB PSU 0-7 V 160 watts £1800
- HP6284 Rack mount variable 0-20V @ 20A metered PSU £675
- HP54121A DC to 22 GHz four channel test set EPOA
- HP8130A opt 020 300 MHz pulse generator, GPIB etc £8500
- HP A1, A0 8 pen HPGL high speed drum plotters - from £950
- EG-G Brookdeal 95035C Precision lock in amp EPOA
- View Eng. Mod 1200 computerised inspection system EPOA
- Sony DXC-3000A High quality CCD colour TV camera £1100
- Keithley 590 CV capacitor / voltage analyser EPOA
- Racal ICR40 dual 40 channel voice recorder system £3750
- Fiskers 45KVA 3 ph On Line UPS - New batteries £9500
- ICI R5030U34 Cleanline ultrasonic cleaning system EPOA
- Mann Tally MT645 High speed line printer £2200
- Intel SBC 486/133SE Multibus 486 system, 8Mb Ram £945
- Siemens K4400 64Kb to 140Mb demux analyser £2950

IC's - TRANSISTORS - DIODES

OBSELETE - SHORT SUPPLY - BULK

6,000,000 items EX STOCK

For MAJOR SAVINGS - CALL OR SEE OUR WEBSITE

VIDEO MONITOR SPECIALS

One of the highest specification monitors you will ever see - At this price - Don't miss it!!

Mitsubishi FA3415ETKL 14" SVGA Multisync colour monitor with fine 0.28 dot pitch tube and resolution of 1024 x 768. A variety of inputs allows connection to a host of computers including IBM PC's in CGA, EGA, VGA & SVGA modes, BBC, COMMODORE (including Amiga 1200), ARCHIMEDES and APPLE. Many features: Etched faceplate, text switching and LOW RADIATION MPR specification. Fully guaranteed, supplied in EXCEL-

LENT little used condition. Tilt & Swivel Base £4.75 Order as MITS-SVGA

VGA cable for IBM PC Included. £119

External cables for other types of computers CALL

As New - Ex Demo

17" 0.28 SVGA Mitsubishi Diamond Pro monitors Full multisync etc. Full 90 day guarantee. £325.00 (E)

Just in - Microvitec 20" VGA (800 x 600 res.) colour monitors. Good SH condition - from £299 - CALL for info

PHILIPS HCS35 (same style as CM8833) attractively styled 14" colour monitor with both RGB and standard composite 15.625 KHz video inputs via SCART socket and separate phono jacks. Integral audio power amp and speaker for all audio visual uses. Will connect direct to Amiga and Atari BBC computers. Ideal for all video monitoring / security applications with direct connection to most colour cameras. High quality with many features such as front concealed flap controls, VCR correction button etc. Good used condition - fully tested - guaranteed Dimensions: W14" x H12 3/4" x 15 1/4" D.

PHILIPS HCS31 Ultra compact 9" colour video monitor with standard composite 15.625 KHz video input via SCART socket. Ideal for all monitoring / security applications. High quality, ex-equipment fully tested & guaranteed (possible minor screen bums). In attractive square black plastic case measuring W10" x H10" x 13 1/2" D. 240 V AC mains powered. Only £79.00 (D)

KME 10" 15M10009 high definition colour monitors with 0.28" dot pitch. Superb clarity and modern styling. Operates from any 15.625 kHz sync RGB video source, with RGB analog and composite sync such as Atari, Commodore Amiga, Acorn Archimedes & BBC. Measures only 13 1/2" x 12" x 11". Good used condition. Only £125 (E)

20" 22" and 26" AV SPECIALS

Superbly made UK manufacture. PIL all solid state colour monitors, complete with composite video & optional sound input. Attractive teak style case. Perfect for Schools, Shops, Disco, Clubs, etc. In EXCELLENT little used condition with full 90 day guarantee.

20"....£135 22"....£155 26"....£185 (F)

DC POWER SUPPLIES

Virtually every type of power supply you can imagine. Over 10,000 Power Supplies Ex Stock. Call or see our web site.

LOW COST PC'S

Always over 1000 PC's from stock. 1000's of spares and accessories. Call or see our web site for info.

- Intel SBC 486/125C08 Enhanced Modulus (MSA) NEW £1450
- Zeta 3220-05 A0 4 pen HPGL fast drum plotters £1150
- Nikon HF-X-11 (Ephiphot) exposure control unit £1450
- Motrola VME Bus Boards & Components List. SAE / CALL EPOA
- Title O-18 vdc linear, metered 30 amp bench PSU. New £550
- Fujitsu M3041R 600 LPM printer with network interface £1950
- Fujitsu M3041D 600 LPM printer with network interface £1950
- Parkin Elmer 299B Infrared spectrophotometer £500
- Parkin Elmer 597 Infrared spectrophotometer £3500
- VG Electronics 1035 TELETEXT Decoding Margin Meter £3750
- LightBand 60 output high spec 2u rack mount video VDA's £495
- Sekonic SD 150H 18 channel digital Hybrid chart recorder £1995
- Taylor Hobson Tallysurf amplifier / recorder £750
- ADC SB200 Carbon dioxide gas detector / monitor £1450
- System Video 1152 PAL waveform monitor £485
- ANRITSU 9654A Optical DC-2.5Gb/w waveform monitor £5,650
- ANRITSU MS9001B1 0.6-1.7 uM optical spectrum analyser EPOA
- ANRITSU ML93A optical power meter £990
- ANRITSU Fibre optic characterisitic test set EPOA
- VISION ENGINEERING T33 Dynascopic microscope £1850
- R&S FT03 Dual sound unit £775
- R&S SBUF-E1 Vision modulator £775
- WILTRON 6630B 12.4 / 20GHz RF sweep generator £1250
- TEK 2445 150 MHz 2 trace oscilloscope £1250
- TEK 2465 300 MHz 300 MHz oscilloscope rack mount £1955
- TEK 1502 Portable TRM (time domain reflectometer) £600
- PHILIPS PW1730/10 66KV XRAY generator & accessories EPOA
- CLAUDE LYONS 12A 240V single phase auto. volt. regs £325
- CLAUDE LYONS 100A 240/415V 3 phase auto. volt. regs £2900

19" RACK CABINETS

Superb quality 6 foot 40U

Virtually New, Ultra Smart

Less than Half Price!

Top quality 19" rack cabinets made in UK by Optima Enclosures Ltd. Units feature designer, smoked acrylic lockable front door, full height lockable half louvered back door and louvered removable side panels. Fully adjustable internal fixing struts, ready punched for any configuration of equipment mounting plus ready mounted integral 12 way 13 amp socket switched mains distribution strip make these racks some of the most versatile we have ever sold. Racks may be stacked side by side and therefore require only two side panels to stand singly or in multiple bays. Overall dimensions are: 77 1/2" H x 32 1/2" D x 22" W. Order as:

OPT Rack 1 Complete with removable side panels. £345.00 (G)
OPT Rack 2 Rack. Less side panels. £245.00 (G)

Over 1000 racks, shelves, accessories 19" 22" & 24" wide 3 to 46 U high. Available from stock !!

32U - High Quality - All steel RakCab

Made by Eurocraft Enclosures Ltd to the highest possible spec, rack features all steel construction with removable side, front and back doors. Front and back doors are hinged for easy access and all are lockable with five secure 5 lever barrel locks. The front door is constructed of double walled steel with a 'designer style' smoked acrylic front panel to enable status indicators to be seen through the panel, yet remain unobtrusive. Internally the rack features fully slotted reinforced vertical fixing members to take the heaviest of 19" rack equipment. The two movable vertical fixing struts (extras available) are pre punched for standard 'cage nuts'. A mains distribution panel internally mounted to the bottom rear, provides 8 x IEC 3 pin Euro sockets and 1 x 13 amp 3 pin switched utility socket. Overall ventilation is provided by fully louvered back door and double skinned top section with top and side louvers. The top panel may be removed for fitting of integral fans to the sub plate etc. Other features include: fitted castors and floor levelers, prepunched utility panel at lower rear for cable / connector access etc. Supplied in excellent, slightly used condition with keys. Colour Royal blue. External dimensions mm=1625H x 635D x 603 W. (64" H x 25" D x 23 1/2" W)

Sold at LESS than a third of makers price !!

A superb buy at only £245.00 (G) 42U version of the above only £345 - CALL

BATTERY SCOOP - 50% off !!

A special bulk purchase from a cancelled export order brings you the most amazing savings on these ultra high spec 12v DC 14 Ah rechargeable batteries. Made by Hawker Energy Ltd, type SBS15 featuring pure lead plates which offer a far superior shelf & guaranteed 15 year service life. Fully BT & BS6290 approved. Supplied BRAND NEW and boxed. Dimensions 200 wide, 137 high, 77 deep. M6 bolt terminals. Fully guaranteed. Current makers price over £70 each!

Our Price £35 each (c) or 4 for £99 (D)

RELAYS - 200,000 FROM STOCK

Save ££££'s by choosing your next relay from our Massive stocks covering types such as - Military, Octal, Cradle, Hermetically Sealed, Contactors, Time Delay, Reed, Mercury Wetted, Solid State, Printed Circuit Mounting, CALL US WITH YOUR NEEDS. Many obsolete types from stock. Save ££££'s

LOW COST RAM & CPU'S

INTEL 'ABOVE' Memory Expansion Board. Full length PC-XT and PC-AT compatible card with 2 Mbytes of memory on board. Card is fully selectable for Expanded or Extended (286 processor and above) memory. Full data and driver disks supplied. RFE. Fully tested and guaranteed. Windows compatible. £59.95

Half length 8 bit memory upgrade cards for PC AT XT expands memory either 256k or 512k in 64k steps. May also be used to fill in RAM above 640k DOS limit. Complete with data. Order as: XT RAM UG. 256k. £34.95 or 512k £39.95

SIMM SPECIALS
1 MB x 9 SIMM 9 chip 120ns Only £8.50
1 MB x 9 SIMM 3 chip 80 ns £10.50 or 70ns £11.95
1 MB x 9 SIMM 9 chip 80 ns £10.50 or 70ns £11.75
1 MB 70 ns 72 pin SIMM - with parity. Only £35.00
INTEL 486-DX33 CPU £19.95 INTEL 486-DX66 CPU £59.00

FULL RANGE OF CO-PROCESSORS EX STOCK - CALL FOR EXT
MOTOROLA 25 Mhz 68040 (XC68040RC25M) CPU'S £59.00 shipping charges for RAM / CPU upgrades is code B

SOFTWARE SPECIALS

NT4 WorkStation, complete with service pack 3 and licence - OEM packaged. Special Price ONLY £99.00

Microsoft - Windows for Workgroups 3.11 & DOS 6.22. Supplied on 3 1/2" disks with licence & concise documentation. £39.95
DOS 5.0 on 3 1/2" disks with concise books cw QBasic. £14.95
Wordperfect 6 for DOS supplied on 3 1/2" disks with manual £24.95 shipping charges for software is code B

NEW PRODUCTS CLASSIFIED

Please quote "Electronics World" when seeking further information

PASSIVE AND ACTIVE COMPONENTS

Connectors and cabling

Optical connectors. Connectors, pigtaills and assemblies by AMP exhibit very low insertion and return losses, so reducing the cost of 1310nm and 1550nm catv installations; the SC-APC range, the initials meaning Subscriber Connector - Angled Physical Contact, shows an insertion loss of less than 0.4dB random maximum. There are 8" and 9" SC-APC assemblies, the former providing a return loss of 65dB, that of the 9" type being 70dB, the figures being the same for both wavelengths.

All the connectors and assemblies are available to take cables of 0.9mm to 3mm. AMP. Tel., 0181 954 2356; fax, 0181 9547467.

Enq no 501

Audio d-to-a converter. Asahi Kasei's AK4350 is a low-power delta-sigma converter meant for use in portable audio equipment. Sampling rate is 8-50kHz and there is a post filter and single-ended output buffer. The multi-bit $\Delta\Sigma$ technique is responsible for a dynamic range of 90dB and there is a 20kHz x8 finite impulse response interpolator with a ripple of ± 0.06 dB; stop-band attenuation is 43dB. Soft mute is provided on-chip.

AMP. Tel., 0181 954 2356; fax, 0181 9547467. Enq no 501

Ferrite designers' kit.

Samples of more than 150 different forms of ferrite core are contained in the Fair-Rite Omni Kit, which provides a rapid solution to many problems of interference on signal lines. There are slugs and beads, flat and round cable suppression cores, connector suppression plates, multi-aperture types, discs, toroids and bobbins. A point to note is that, should you become carried away and use up all the samples of any of the types, they will be replaced free.

Schaffner EMC Ltd. Tel., 0118 977 0070; fax, 0118 9792969. Enq no 507

Discrete active devices

500mW in SOT323. Zetex claims to have the first high-performance bipolar transistors in the SOT323 package. Super323 n-p-n and p-n-p devices in the ZUMT range handle 1.5A continuously and exhibit a $V_{CE(sat)}$ of 0.18V for a 1A collector current and 10mA of base drive. A full range of components in this package will include rf, avalanche, medium-power and switching transistors.

Zetex plc. Tel., 0161 622 4422; fax, 0161 622 4420; web, www.zetex.com. Enq no 505

Hardware

Fan mounts. SRS has a new range of subrack front panels in 3U and 6U heights and 21HP, 42HP and 84HP widths. The panels are designed to take one, two or four 90mm fans (3U) or double the number in the 6U versions, a blanking plate being available to cover unused positions. There are also intake panels punched with ventilation slots, which may be fitted with filters. In addition, a 3U fan tray takes up to three equally spaced fans.

SRS Products plc. Tel., 01279 635500; fax, 01279 451220. Enq no 509

Switching DIN connectors. 96-way DIN connectors by Elco keep 10 of the phosphor-bronze contacts closed in the normal state to maintain contact and allow daisy-chain signalling across a VME bus when a card is not in position. When a card is inserted, its pins open the contacts, the card operates and maintains bus integrity. Connectors are rated at 350V dc/ac peak and 3A; minimum lifetime being 400 insertions and extractions.

Hawnt Electronics Ltd. Tel., 0121 7843355; fax, 0121 783 1657; web, sales@hawnt.co.uk. Enq no 502

Data converters

Audio d-to-a converter. Asahi Kasei's AK4350 is a low-power delta-sigma converter meant for use in portable audio equipment. Sampling rate is 8-50kHz and there is a post filter and single-ended output buffer. The multi-bit $\Delta\Sigma$ technique is responsible for a dynamic range of 90dB and there is a 20kHz x8 finite impulse response interpolator with a ripple of ± 0.06 dB; stop-band attenuation is 43dB. Soft mute is provided on-chip.

AMP. Tel., 0181 954 2356; fax, 0181 9547467. Enq no 501



Displays

High-contrast, 15in monitor.

Panasonic's PanaSync S50 15in crt monitor uses a new type of phosphor layer of Crystal Pigment Phosphor and the company's own screen coat A-AGRAS. The result is claimed to be a reduction in reflections and sharper images, since the ambient light is "trapped" in the layer. Resolution is 1280 by 1024, refreshed at 75Hz, but 1024 by 768 is recommended for the 15in size. The display supports VESA DDC1/2B standards for Plug-and-Play working and, unusually, there is a degauss button.

Panasonic UK Ltd. Tel., 0500 404041; web, www.panasonic.co.uk. Enq no 506

Filters

Feedthrough filters. SFNO feedthrough electromagnetic interference filters by Syfer screw into place and have a diameter of 3.6mm, so that the mounting pitch is only 3.8mm. Available in values from 10pF to 10nF, their voltage rating is 500V and temperature range -55°C to 125°C.

Syfer Technology Ltd. Tel., 01603 629721; fax, 01603 665001. Enq no 508

Hardware

Fan mounts. SRS has a new range of subrack front panels in 3U and 6U heights and 21HP, 42HP and 84HP widths. The panels are designed to take one, two or four 90mm fans (3U) or double the number in the 6U versions, a blanking plate being available to cover unused positions. There are also intake panels punched with ventilation slots, which may be fitted with filters. In addition, a 3U fan tray takes up to three equally spaced fans.

SRS Products plc. Tel., 01279 635500; fax, 01279 451220. Enq no 509

Solderless connectors.

Cinch C/IN: APSE connectors use a new compression method of making and retaining contact which needs no solder, provides a dense array of contacts, is useful into the gigahertz range of frequencies and, having a path length of about 0.8mm, offers a small propagation delay and low inductance of under 1nH. Stacking height is 0.8mm and the connectors are suitable for use in ic array sockets.

Surtech Distribution Ltd. Tel., 01256 840055; fax, 01256 479785. Enq no 503

Polyester enclosures.

New enclosures by Briticent are made from a blend of reinforced polyester and glass fibre for use at temperatures between -30°C and 120°C. They are rated to IP65, are resistant to impact and much lighter than equivalent steel types and come in sizes from 300x250x140mm to 800x600x300mm. Doors open through 180°, left or right, on concealed stainless steel hinges. A number of accessories are offered, including a modular chassis; DIN-rail and base plate mounting is provided as standard.

Ensto Briticent International. Tel., 01425 474617; fax, 01425 471595. Enq no 510

Anti-emi gaskets.

Low-profile, beryllium copper gaskets, ECP 632/636, have no-sag fingers to eliminate shearing, the size allowing the gaskets to be used where narrow gaps are to be filled with a low closing force. Widths are 11.4mm and 15.2mm, strips are up to 4.06m long and the fingers are 2.54mm wide on a 3.18mm pitch. Attenuation is up to 100dB and mounting is by double-sided adhesive transfer tape.

TBA Industrial Products Ltd. Tel., 01706 47718; fax, 01706 46170. Enq no 511

DISTEL on the web !! - Over 16,000,000 items from stock - www.distel.co.uk



ALL MAIL & OFFICES
Open Mon - Fri 9.00 - 5.30
Dept WW, 32 Biggin Way
Upper Norwood
London SE19 3XF

NEW DISTEL®
Visit our web site
www.distel.co.uk
email admin@distel.co.uk

ALL ENQUIRIES
0181 679 4414
FAX 0181 679 1927



All prices for UK Mainland. UK customers add 17.5% VAT to TOTAL order amount. Minimum order £10. Bona Fide account orders accepted from Government, Schools, Universities and Local Authorities - minimum account order £50. Cheques over £100 are subject to 10 working days clearance. Carriage charges (A)=£3.00, (A1)=£4.00, (B)=£5.50, (C)=£6.50, (D)=£12.00, (E)=£15.00, (F)=£18.00, (G)=CALL. Allow approx 6 days for shipping - faster CALL. All goods supplied to our Standard Conditions of Sale and unless stated guaranteed for 90 days. All guarantees on a return to base basis. All rights reserved to change prices / specifications without prior notice. Orders subject to stock. Discounts for volume. Top CASH prices paid for surplus goods. All trademarks, tradenames etc acknowledged. © Display Electronics 1998. E & O.E. 06/98

Please quote "Electronics World" when seeking further information

Linear integrated circuits

Surface-mounted op-amp. The NJM2125F op-amp from the New Japan Radio Company is a single-supply design working from 2.7V to 20V at 1mA. It slews at 1.2V/ μ s and is contained in an extremely small MTP5 package.

Young-ECC Electronics. Tel., 01628 810727; fax, 01628 810807.

Logic

"Fastest" 2.5V buffers. Fairchild's VCX group of 2.5V CMOS logic devices now includes the 74VCX16827/162827 20-bit buffers which, in common with the rest of the family, are specified to work on 1.8V, 2.5V and 3.6V supplies; noise and emi generated by elements in this family are less than 0.8V on a 3.3V supply and the 162827 has internal 26 Ω resistors to reduce ringing. Both the new devices are in the 56-lead TSSOP package.

Fairchild Semiconductor Corporation. Tel., 01793 856811; fax, 01793 856858; web, www.fairchildsemi.com.

Enq no 513

Wireless cctv. VideoWave VTX1394 transmitter and VRX1394 receiver from Low Power Radio Solutions provide secure transmission of CCIR Pal video signals with a range of up to 760m using a 1/4-wave whip; range may be increased to 1km or 2km with more exotic antennas. Several transmitters may be accessed from a single receiver and the transmission is secured by scrambling. Current consumption is 600mA from 12V dc and the units are type approved to MPT1349 for the UK at 1394MHz. Fm channel bandwidth is 10MHz and output power adjustable up to 500mW.

Low Power Radio Solutions Ltd. Tel., 01993 709418; fax, 01993 708575.

Enq no 527



Materials

Thermally conductive insulator. Kool-Pads K177 and K228 by Warth are in soft, compliant material providing an alternative to mica washers and grease, the grease not being needed. The material is silicone rubber coated onto a layer of woven glass fibre and will not crack, age or suffer contamination. The pads are available with adhesive or non-adhesive coating and have a thermal resistance of 0.45 or 0.5°C/W, breakdown voltage of 3.5 or 4.5kV and work at temperatures between -60°C and 180°C.

Thickness is 0.177mm or 0.228mm. Warth International Ltd. Tel., 01342 315044; fax, 01342 312969; web, www.warth.co.uk.

Enq no 514

Microprocessors and controllers

8051 with lcd controller. New to the Siemens C500 family of 8-bit microcontrollers is the C505L, said to be the first 8051 to possess a liquid-crystal display controller. The chip is compatible with 80C51/2 controllers and provides 32Kbyte of otp memory, 256Byte of ram, 256byte of xram, an async./sync. serial interface and a 10-bit, 6 μ s a-to-d converter. Instruction cycle time at 20MHz is 300ns; an integrated clock works in power-down mode, the chip drawing 50 μ A at 3V in this state.

Siemens plc. Tel., 0990 550500; fax, 01344 396721.

Enq no 515

Mixed-signal ics

Speech synthesiser. Oki's MSM9831 single-chip synthesiser is claimed to be the smallest available. It uses a non-linear, 8-bit pulse-code modulation algorithm to give equivalent sound quality to that from a 10-bit straight pcm and samples at 4-16kHz. Voice quality and playback time are both selectable, 31 channels providing up to 11s at 4kHz. A serial interface has allowed the use of only eight pins, which makes the device suitable for use in equipment such as cameras and portable CD players. Voltage rail needed is 2-5.5V.

Oki Semiconductor (UK) Ltd. Tel., 01753 516577; fax, 01753 517195.

Enq no 516

Digital pot/comparator chip. Two digitally controlled potentiometers, each driving an analogue voltage comparator, are contained in Xicor's X9448, which is expected to find application in voltage threshold measurement and in automatic test. The outcome of the arrangement is that external voltages are compared with the "wiper" voltages, latches setting outputs high or low. Wiper position is determined by registers containing data supplied over a two-wire serial bus.

Xicor Ltd. Tel., 01933 700544; fax, 01933 700533; e-mail, xicor-uk@xicor.com

Enq no 517

Microwave components

Programmable sources. When connected to the parallel port of a 386 or higher pc running Windows 3.1 or higher, ANS Series microwave sources from Atlantic Microwave may be programmed to cover a half-octave frequency range in 100kHz steps, software to perform this function being supplied. The source's memory is non-volatile and the units may be used without the pc control, once programmed. Output is +7dBm with -60dBc spurious and -35dBc harmonics, an internal crystal reference maintaining stability at ± 2 ppm from 0°C to 50°C.

Atlantic Microwave Ltd. Tel., 01376 550220; fax, 01376 552145.

Enq no 518

Optical devices

Optical sensing heads. Two sensing heads by Matsushita are for use with UZF1/3 amplifiers and are for the detection of glass and silicon in industry. The UZFRL41 is only 4mm square and has a convergent sensing range of 8mm for transparent objects such as glass boards, only the nearest being detected. UZFRL42 was designed for use with reflective silicon wafers at 2mm range.

Matsushita Automation Controls Ltd. Tel., 01908 231555; fax, 01908 231599; e-mail, info@macuk.co.uk;

web, www.mac-europe.com.

Enq no 519

Oscillators

1 in 10¹¹ crystal oscillators. Carrying a claim to be the world's most stable crystal oscillators, the CPO-1 series from CEPE (now part of C-MAC) stay within ± 1 part in 10¹¹ over a -20°C to 60°C range, being designed for use as master clocks in SDH/Sonet fixed-line switching and in satellite navigation base stations. Stability can only be matched by atomic clocks at up to twice the price and short-term statistical variance (1-100s at 5MHz) of ± 1 in 10¹³ is better than that from an atomic clock. Crystals are SC-cut types with their flattest temperature versus frequency characteristic at the oven temperature. Frequencies available are 2-10MHz or 13MHz for less demanding requirements and, in crystals resonating at 9MHz and above, a special mounting method reduces shock-induced frequency variation. Power consumption from 12, 15 or 24V is 2.4W when steady.

C-MAC Quartz Crystals Ltd. Tel., 01279 626626; fax, 01279 454825.

Enq no 520

Passive components

Power chokes and inductors. API Delevan's LP Series of inductors are only 2.4mm in height and are produced in values from 4.7nH to 1 μ H in tolerances down to $\pm 1\%$. Operating temperature is -55°C to 90°C. There is also a range of radial-lead chokes for use in switched-mode power supplies. The 3443 Series covers the range 1 μ H-15000 μ H at currents of 0.26A-17.8A; dc resistance 0.005-21.9 Ω . A catalogue for both



types of device is available. Mercator. Tel., 01493 334000; fax, 01493 334050.

Enq no 521

Power semiconductors

Tempcomp. audio power Darlington. Darlington power transistors in Allegro's SAP Series are provided with temperature compensation on the chip to obtain very fast response; idling current is stable in the presence of temperature changes. These are audio power devices in n-p-n or p-n-p form rated at 80W, 100W and 150W and 10A, 12A and 15A.

Allegro Microsystems Inc. Tel., 01932 253355; fax, 01932 246622; web, www.allegromicro.com

Enq no 522

Protection devices

Resettable fuses. PolySwitch RGE is a range of Raychem resettable fuses which now includes several new devices, current coverage now being 3A to 14A to replace larger, slower, higher-resistance devices at higher currents. Trip times are, for example, 5s to 10s for the 4A type and 40s to 30A in the 14A fuse. The fuses are around one-third the size of older types, the 4A version being 8.9mm x 11.9mm.

Raychem Ltd. Tel., 0800 968626 (free); fax, 0800 968627; web, www.Raychem.com.

Enq no 523

Switches and relays

Miniature signal relay. Model G5V-1 sealed signal relay by Omron is an extremely small device for communications and general switching use. It takes up less than 1 cubic centimetre and uses 150mW, the spdt contacts handling 1-2mA at up to 125Vac/60Vdc. Impulse withstand voltage is 1.5kV in accordance with FCC part 68.

Onboard Electronics Ltd. Tel., 01256 818222; fax, 01256 840610; e-mail, onboardelectronics@compuserve.com

Enq no 524

Transducers and sensors

Pressure transducer. Model 210-90-050-XX is a miniature, flush-mounted transducer by Paine Corporation that is only 32mm long and which is meant for use where frequent flushing or cleaning is needed or when the medium is a thick slurry. Output is 1mV/V and temperature rating 135°C. Amplified types are also available to give 0-5V output for pressures of 0-500lb/in² to 0-10000lb/in².

Endevco UK Ltd. Tel., 01763 261311; fax, 01763 261120; e-mail, sales@endevco.co.uk.

Enq no 525

Telemetry receiver. A synthesised receiver module by Wood & Douglas is crystal-controlled and frequency-selectable by a serial interface. The board-mounted, nickel-silver SR500 module stores frequencies in non-volatile memory and an optional parallel interface permits the selection of eight programmed channels. SR500 is ETSI and MPT approved and is available now in the 430-470MHz band; versions for the 130-185MHz and 860-880MHz bands will follow. Switching bandwidth is 8MHz, channel spacing 12.5, 20 or 25kHz, channel switching time under 50ms and the outputs are analogue or digital.

Wood and Douglas Ltd. Tel., 0118 981 1444; fax, 0118 981 1567; e-mail, info@woodanddougles.co.uk; web, www.woodanddougles.co.uk.

Enq no 531



Please quote "Electronics World" when seeking further information

Wafer thermostat.

Now available in the UK, the Airpax Series 5003 thermostat is a sealed, wafer-type thermal measuring a mere 0.25in deep and weighing 2.3g. It is a bimetallic type with a positive, reinforced snap action with rapid thermal response. Ratings are 3A and 240V ac and operating temperature may be set between 1.6°C and 163°C with narrow or standard switching differentials. The thermostats are UL recognised and CSA certified.

EAO Ltd. Tel., 01444 236000; fax, 01444 236641; e-mail, uksales@eao.com; web, www.eao-group.com

Enq no 526

EQUIPMENT

Power supplies

Dual-output dc-dc converter. 30W dual-output converters in the Calnex CS Series are designed for use in 5V logic systems with disk storage, the 5/12V outputs handling 5V microprocessors and driving hard disks or CD-roms; the 12V output is rated for 4A surge for rapid startup of large drives. Input range is 9-36V for the 24D5.12CS and 20-72V for the 48D5.12CS models, the 5V output being rated at 3A and the 12V output at 1.3A, with load regulation, cross and line regulation and noise 120mVpk-pk. There is short-circuit protection by current limit and thermal shutdown. An output trim facility provides $\pm 10\%$ variation.

Calnex Electronics Ltd. Tel., 01525 373178; fax, 01525 851319; e-mail, calnex@btinternet.com; web, www.calnex.co.uk.

Enq no 529

Production test equipment

Screen-printing inspection. DEK Printing Machines offers DEK 2Di, a set of inspection tools to monitor screen printing processes. It is built into the printing machine and looks for stencil blockage and smearing on the bottom of the stencil, tests for paste on the pad, and paste alignment with the pad, and bridging between pads. Each inspection site is of 4mm x 4mm and there may be over 200 sites per board. Depending on the error level, the machine may stop or give a warning or, in closed-loop control, will start the stencil-cleaning cycle. As the company points out, it is better to get it right before printing than to find bad print later.

DEK Printing Machines Ltd. Tel., 01305 760760; fax, 01305 760123; web, www.dek.com.

Enq no 530

Radio systems

Am transmitter. RF Solutions' miniature am transmitter is meant for security, car alarms and data-capture use at fixed frequencies of 315, 418 or 433MHz, sending data up to 4kHz at a range of 70m. It accepts data

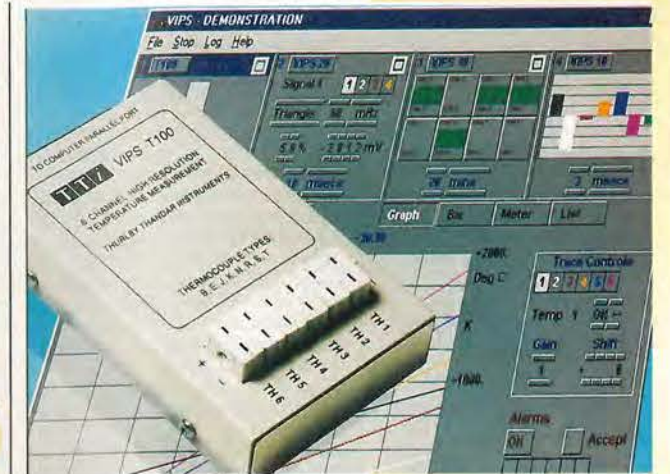

from a microcontroller, encoder or any CMOS/ttl source with no need for extra circuitry. Current needed is 4mA from a 2-14V supply and the device measures 18 x 11mm in sil or dil form. The company's range of receivers will work with this transmitter.

RF Solutions Ltd. Tel., 01273 488880; fax, 01273 480661; e-mail, icepic@pavilion.co.uk; web, www.rf-solutions.co.uk.

Enq no 532

Test and measurement

Video inspection. Standard specification of Cambridge Technology's complete video inspection system includes a 1-50x zoom lens, a high-resolution camera, an A6 video/digital printer, a precision stand and colour monitor, options being a 50/500x zoom lens and digital image archiving.

Cambridge Technology Systems. Tel., 01223 892020; fax, 01223 894385.

Enq no 533

Signal-conditioning for recorder.

Signal conditioning for voltage, current, pulse and strain-gauge inputs is provided by a range of modules for Yokogawa's DR230, a fast, multi-channel data-acquisition and recording instrument. The modules expand the instrument's capacity to 300 channels for inputs up to 500m away, one of the modules being a dedicated ac voltage and current input. A further module conditions inputs from thermocouples and resistive temperature detectors. Records are printed on 250mm wide charts in analogue and digital form and may be saved on an internal floppy disk. Computer interfaces are provided as options.

Martron Instruments Ltd. Tel., 01494 459200; fax, 01494 535002; e-mail, info@martron.co.uk; web, www.martron.co.uk

Enq no 535

I/Q modulation generator. Modulation generator AMIQ and its associated WiniQSIM software constitute a response to the need for

Temperature module. Newest in the range of virtual instrument pods from TTI is the VIPS-T100 16-bit-resolution temperature measurement module for thermocouples, operating from a pc's parallel port, which also provides the power. Six connectors take thermocouples of types B, E, J, K, N, R, S or T, different types being mixed on the same unit; the inputs may also be used to measure voltage down to 1 μ V. Four units may be used together to give up to 24 channels. Windows software provides display and control, the display showing the data in the form of meters, graphs, charts and listings, the inputs being scaled and offset for each channel and channel names provided. DLL drivers are available.

Thurby Thandar Instruments Ltd. Tel., 01480 412451; fax, 01480 450409.

Enq no 534

test equipment in the presence of an increased use of I/Q modulation in communications. AMIQ is a dual-channel instrument, designed as a 100MHz I/Q source with a 4Msample memory and 14-bit amplitude resolution - a performance required for the generation of signals for digital systems such as wide-band code-division multiplex access (w-cdma). An automatic amplitude/offset alignment process greatly reduces error vector, which has previously been very difficult to achieve. When combined with the software, the equipment provides, for example, up to 512 multi-carrier signals, cdma signals with selectable coded channels and a data editor to create any tdma frame configuration.

Rohde & Schwarz UK Ltd. Tel., 01252 811377; fax, 01252 811447; web, www.rsd.de/UK.

Enq no 536

£300, 20MHz oscilloscope. For less than £300, Feedback offers the

Please quote "Electronics World" when seeking further information

CS-4125 20MHz, dual-channel oscilloscope, which is principally intended for use in education. It is particularly simple in operation and the instrument meets all relevant safety standards. Sensitivity is 1mV/division to 5V/division and the -3dB bandwidth 20MHz at sensitivities over 2mV/div. (5MHz below). Fastest sweep at x10 expansion is 20ns/div. The 150mm tube has an internal graticule and its accelerating voltage is 2kV. **Feedback Test and Measurement.** Tel., 01892 653322; fax, 01892 663719; e-mail, feedback@fdbk.demon.co.uk; web, www.fbk.com/Enq no 537

COMPUTER AND DATA HANDLING

Computers
Multimedia single-board computer. Graphics, video and audio are all within the range of Blue Chip's *Pentium PC* has up to 64Mb of dram, 512Kb L2 cache memory and, for diskless operation, the option of plug-in flash from 2Mb to 72Mb and up to 512Kb of dram. The board uses Pentium processors to P200MMX and the PCI Local bus svga video and its 1Mb of memory drives 3.3V and 5V 24-bit tft and dstn lcds. It has four serial ports, dual USB ports a parallel port and PCI-based Ethernet controller, in addition to hard and floppy drives. **Blue Chip Technology.** Tel., 01829 772000; fax, 01829 772001; e-mail, sales@bluechiptechnology.co.uk; web, www.bluechiptechnology.co.uk. **Enq no 538**

PCMCMIA line transformers. APC has a group of very thin ISDN 5 line transformers for mounting on PCMCMIA cards. The height of the transformers is 2.54mm and they take up one side of the board, leaving the other free for circuitry. First available are APC48201/2/3, all of which contain dual S transformers for transmit and receive in one 24 x 14.88 x 2.54mm package. Turns ratios available are 1:1, 1:2 and 1:2.5. **Advanced Power Components Ltd.** Tel., 01634 290588; fax, 01634 290591; web, www.apcisdn.com. **Enq no 551**

Computer board-level products
68040 cpu. *BVME4500* by BVM is a VMEbus module using a 33MHz 68040 processor and, having much in common with the rest of BVM's processor family, allows portable applications between them. It comes in a 3U form and is also made in an extended-temperature version. A choice of memory is offered, all dual-ported to the bus. There is 2Mbyte of 32-bit-wide non-volatile sram and 2Mbyte of 32-bit boot-sector flash eprom. Two extra modules expand memory to 16Mbyte of flash and 96Mbyte of dram. Boot-sector flash may be remotely programmed from the bus. Two RS232 ports and a 32-bit dma-driven, 10BaseT Ethernet port are on-board with connections on the front panel. **BVM Ltd.,** Tel., 01489 780144; fax, 01489 783 589; e-mail, sales@bvmltd.co.uk; web, www.bvmltd.co.uk. **Enq no 539**

Data acquisition
Odyssey acquisition card. Nicolet has introduced an additional card for the *Odyssey* data-acquisition mainframe. *OD-200* combines the functions of transient recorder, data-logger and oscilloscope, using 10Msamples digitisers for transient recording and so achieving 100 times the transient capture speed of the original card, the *OD-100*. There are four channels, each with a 14-bit, 10Msamples/a-to-d converter, trigger circuitry and 5MHz filtered differential amplifiers. As a transient recorder, the card will stream data at up to 1Msamples/s to a 4Gbyte or 9Gbyte hard disk, additionally providing XY and fast Fourier, as well as ordinary X/Y displays. **Nicolet Technologies Ltd.** Tel., 01908 225630; fax, 01908 225633; e-mail, Nicolet_Technologies_Ltd@msn.com **Enq no 540**

Data communications
Single-chip bert. Vitesse's *VSC8109* contains all necessary bit error rate tester functions in the one ic. It is for use in 2.5Gb/s and 10Gb/s Sonet/SDH test systems, generating and comparing 16-bit 155/622Mb/s pseudorandom binary sequences. Used with multiplexers and demultiplexers, the device makes a simple serial tester, also providing serial test in wavelength division multiplex systems. Sequence lengths with up to 2³¹ permutations are supported and the comparator has a 16-bit error accumulator with overflow. **Strategic Test and Measurement Systems Ltd.** Tel., 01203 323160; fax, 01203 323161; e-mail, info@strategic-test.com; web, www.strategic-test.com. **Enq no 544**

Broadband Technology 2000 Ltd. Tel., 01494 474800; fax, 01494 443100; e-mail, 100616.3040@compuserve.com. **Enq no 541**

Interfaces
GPIB meets FireWire. National Instruments has a new interface that connects computers equipped with an IEEE1394 'FireWire' port to GPIB instruments. With the *GPIB-1394*, up to 14 programmable GPIB-based engineering or scientific instruments can be integrated with computers equipped with an IEEE1394 interface quickly and easily. The *1394* is compatible with industry-standard instrumentation software such as LabVIEW, LabWindows/CVI, and ComponentWorks for Visual Basic. **National Instruments.** Tel., 01635 523545; fax, (01635) 523154, e-mail: info.uk@natinst.com. **Enq no 542**

Mass storage
Combined rewritable optical and CD-ROM drive. Panasonic's *LF-1097 SCSI-2-compatible* drive is a combined 650Mbyte PD rewritable optical disc drive and 24x CD-rom drive that gives better performance than rewritable CD-roms but will still play CDs, the one drive serving both purposes. Seagate's *Backup Exec* software is supplied with the drive, which is also compatible with the company's DVD-ram drives and with dos 6.0. Windows 3.1, 95 and NT 3.51, OS/2 Warp 3.0 and higher, and for Unix with Sun Solaris, and SCO OpenServer. **Panasonic.** Tel., 0800 444220. **Enq no 543**

Software
Displaying physical changes in workplaces. *DIAdem-Insight* by GFS mB of Aachen is a new feature of the *DIAdem* data acquisition, analysis and graphics software that displays changes in a test item by means of animation. For example, it will show as colour changes or as physical displacements the effects of heat, vibration resonances or loading on a structure or machine during a measurement, the display being saved for further use or for transmission elsewhere. The cursor may be scrolled through the measurement data to indicate the exact occurrence of an event. **Strategic Test and Measurement Systems Ltd.** Tel., 01203 323160; fax, 01203 323161; e-mail, info@strategic-test.com; web, www.strategic-test.com. **Enq no 544**

Pcb design. Accel announces three developments to its printed-board design software. *Signal Integrity*, which was developed with Incases GmbH, provides accurate simulation of reflection and crosstalk effects on pcb layouts and is intended mainly for use in the design of digital circuitry working at 20MHz and above or low-voltage circuitry vulnerable to noise. **Accel Gerber** by Advanced CAM Technologies, assists in the translation of designs to the

manufacturing stage, while *Dr Spice* and *Dr Spice 2000* are for the simulation of analogue and mixed-signal designs, the free library containing more than 20000 parts. **Britcomp Sales Ltd.** Tel., 01372 362111; fax, 01372 362333; e-mail sales@britcomp.com. **Enq no 545**

Field strength calculation. Version 3.02 of *Wandel & Goltermann's EFC-400* simulation software for 0-500kHz electric and magnetic fields now has automated display management. Clicking the mouse will produce printed forms for documenting and display and a dialogue box assists in navigating the system. The software simulates hv overhead lines, buried cables, substations, etc., and a data archive supplies pylons and other power lines to the simulation, after which actual background field strengths and various frequencies from different sources can be taken into account. **Wandel & Goltermann GmbH.** Tel., 0049 7121 8616 16; fax, 0049 7121 8613 33; e-mail, info@wago.de; web, www.wg.com **Enq no 546**

Flothern v.2 for Windows NT. *Flothern v.2*, *Flomerics* thermal analysis software is now available for use with Windows NT. This facility simulates air flow and heat dissipated by components and systems to assist in the identification and solution of overheating problems. New in version 2 are a new graphical interface that presents a cad-like appearance; three windows to provide an overall view, geometry creation and 3-D graphics, the windows being interactive; thermal models of common parts such as fans and heat sinks; a radiation model; and interpretation and simplification of imports from other software. **Flomerics Ltd.** Tel., 0181 941 8810; fax, 0181 9418730; e-mail flomerics@flomerics.co.uk; web, www.flomerics.com. **Enq no 547**

Mathcad extended. Extension packs and electronic books are introduced by Mathsoft to provide extra functions for *Mathcad 7*. *Mathcad 7* extensions include one containing numerical recipes for differential equations, optimisation and data modelling, based on the Cambridge University Press book *Numerical Recipes in C* by Press et al. For image processing, there is a pack to assist in smoothing, crisping, edge detection, erosion and dilation on colour and greyscale images and, for signal processing, there is a pack to provide over 60 functions in acoustic, optical, digital or analogue operations. The electronic reference books are on electrical engineering (Hicks), mechanical engineering (Roark) and civil engineering (also Roark). **Adept Scientific Micro Systems Ltd.** Tel., 01462 480055; fax, 01462 480213; e-mail, info@adeptsience.co.uk; web, www.adeptsience.co.uk. **Enq no 548**

TELFORD ELECTRONICS

Old Officers Mess, Hoo Farm, Humbers Lane
Horton, Telford, Shropshire TF6 6DJ, UK
Phone: (00 44) 01952 605451 Fax: (00 44) 01952 677978
e-mail: telfordelectronics@telford2.demon.co.uk
Carriage: £10+VAT @ 17.5% to be added to all UK orders
Overseas orders welcome - Please call

**ALL OUR EQUIPMENT HAS A 30 DAY GUARANTEE
(EXCEPT CLEARANCE ITEMS WHICH ARE SOLD AS-IS)**

MICROWAVE	
JFW Stepped Attenuators 0-8dB in 2dB steps DC-20GHz 155.00	
JFW Stepped Attenuators 0-10dB in 1dB Steps DC-20GHz 155.00	
HP5342A 18GHz Frequency Counter 800.00	
HP8405 Vector Voltmeter 2250.00	
HP8502A Transmission/Reflection Test Set 500kHz-1.3GHz 7750.00	
HP8743B Reflection Transmission Test Unit 2-12.4GHz 3200.00	
Maury Microwave Sliding Termination up to 20GHz 8500.00	
HP11720A Pulse Modulator 2-18GHz 7720.00	
HP11722A Sensor Module 6800.00	
HP11691D Directional Coupler 5600.00	
HP11692D Directional Coupler 5700.00	
HP335D 120dB Attenuator DC-15GHz 2300.00	
HP3488A Switch Control Unit 3800.00	
Wiltron 560 Scaler Analyzer c/w Detectors & SWR Bridge £1500.00	
Semi Rigid Co-Axial Cable Type: UT141/A 0-20GHz EPOA	
3 Metre Lengths Discount qty: 100pcs-E500.00 £10.00	
PRICE EACH LENGTH £1.00	
Continental Microwave Transmitter Control VML-TR440 1/1 £750.00	
Digital Microwave 12GHz TX/RX (NEW) £1200.00	
HP 752A Directional Coupler 3dB £150.00	
HP X352A Variable Attenuator 0-50dB 8.2-12.4GHz £120.00	
HP11720A Pulse Modulator 2-18GHz £720.00	
HP11722A Sensor Module £600.00	
HP3304A Programmable Attenuator 18GHz 0-11dB £175.00	
HP3305A Programmable Attenuator 18GHz 0-110dB £175.00	
HP3320A Attenuator 11dB £250.00	
HP3320B Attenuator 21dB £250.00	
HP3322A Attenuator 120dB £250.00	
HP332B Frequency Meter £200.00	
HP356A Frequency Meter 3.7-12.4GHz £200.00	
HP5411A 2GHz S/S Test Set £560.00	
HP8405A Vector Voltmeter £250.00	
HP8410B £200.00	
HP8414A £175.00	

DATA/TELECOMS	
Anritsu MS334A PCM Error Detector £120.00	
BT (Fulcrum) T1020 Network Transmission Performance Analyzer £500.00	
Cushman CE24 FX Selection Level Meter £400.00	
DataLab DL 1000 Programmable Transient Recorder £250.00	
GW Elm EPR31 PCM Signalling Recorder £520.00	
HP 1350A Graphics Translator £200.00	
HP1631D Logic Analyser £850.00	
HP3336A Synthesized Level Generator £1300.00	

OSCILLOSCOPES	
Tektronix TAS455 60MHz Dual Channel Oscilloscope £600.00	
Goudi 1802 Digital Storage Oscilloscope 20MHz £1250.00	
Goudi DS2052 Digital Oscilloscope £1750.00	
Hitachi VD6015 Digital Storage Oscilloscope £300.00	
Hitachi VC222 20MHz Oscilloscope £225.00	
Iso-Tech ISR640 40MHz £200.00	
Philips PM3340 20Hz Digital £3000.00	
Philips PM3305 35MHz £250.00	
Philips PM3325A 60MHz DSO £1000.00	
Philips PM3262 100MHz £300.00	
Philips PM3352A 50MHz Storage £300.00	
Tek 2215 60MHz £300.00	
Tek 2225 50MHz £350.00	
Tek 2235 60MHz £500.00	
Tek 2245 100MHz £500.00	
Tek 475 200MHz £350.00	
Tek SC502 15MHz £300.00	

AA 950mAH	
CR1216 1.2AH £2.29	
C 2AH with solder tags £2.60	
D (H-P) 2.1AH £4.95	
D 4AH with solder tags £4.95	
PP3 8.4V 110mAH £1.55	
1/2AA with solder tags £1.55	
Sub C with solder tags £2.50	
AAA (H-P) 180mAH £2.95	
1/3 AA with tags (GhalpCTV) £1.95	
Nickel Metal Hydride AA cells high capacity with no memory. If charged at 100ma and discharged at 250ma or less 1300mAH capacity (lower capacity for high discharge rates) £2.95	
Special offers please check for availability stick of 4 4.2 x 16mm nicad batteries 171mmx16mm dia with red & black leads 4. 95	
5 button cell 6V 280mAH battery with wires (Narta Sx25Dk) £2.45	
Ordinal 866 battery pack 12v 1.60AH contains 10 sub C cells with solder tags the size most commonly used in cordless screwdrivers and drills 22 dia x 42mm tall it is easy to crack open and was manufactured in 1994, £8.77 each or £110.50 per box of 14 BCI box 190x106x50mm with slots to house a pcb the lid contains an edge connector (12 way 8mm pitch) and screw terminals to connect in wires and 5 slide in cable blanks £2.95	
7segment common anode led display 12mm £0.45	
GaAs FET low leakage current S873 112.95 each 0.95	
10+ £7.95 100+ BC547A transistor 20 for £1.00	
SL952 UHF limiting amplifier LC 16 surface mounting package with data sheet £1.95	
DC-DC converter Reliability model V12P5 12v in 5v 200ma out 300v input to output isolation with data 0.45 each or pack of 10 £39.50 Airpac AR2903-C large stepping motor 14v 7.5 step 270nm 68mm dia body 6.3mm shaft £8.95 or £200.00 for a box of 30	
Polyester capacitors box type 22.5mm lead pitch 0.9uF 250vdc 18p each 14p 100+ 9p 1000+ 1uf 250vdc 20p each 150p 100+ 10p 1000+ Polypropylene 1uf 400vdc (Wena MKP10) 27.5mm pitch 33x29x17mm case 75p each 60p 100+ Philips 123 series solid aluminium axial leads 33uF 10v & 2.2uF 40v 40p each 25p 100+ Solid carbon resistors very low inductance ideal for RF circuits 270ohm 2W 50ohm 2W 25p each 15p each 100+ we have a range of 0.25w 0.5w 1w and 2w solid carbon resistors please send SAE for list MX1801 Digital multimeter 17 ranges 1000vdc 750vac 2Mohm 200mA transistor Hfe 5v and 1.5v battery test £9.95	
Hand held ultrasonic remote control £3.95	
CV2486 gas relay 30 x 10mm dia with 3 wire terminals will also work as a neon light 20p each or £3.50 per 100 Verbatim R300NH Shrink tape commonly used on nc machines and printing presses etc. it looks like a normal cassette with a slot cut out of the top £4.95 each (£3.75 100+) Hostatic compound tube 0.095 HV3-2405-E5 5-24v 50mA regulator ic 1R-26vdc input 8 pin DIL package 0.349 each (100+ 2.25)	

All products advertised are new and unused unless otherwise stated. Wide range of CMOS TTL 74HC 74F Linear Transistors kits rechargeable batteries, capacitors, tools etc always in stock. Please add £1.95 towards P&P (orders from the Scottish Highlands, Northern Ireland, Isle of Man, Isle of Wight and overseas may be subject to higher P&P for heavy items). VAT included in all prices.

JPG Electronics 276-278 Chatsworth Road Chesterfield S40 2BH
Mastercard/Visa Orders (01246) 211202 Fax 550959
Callers welcome 9:30am to 5:30pm Monday to Saturday

Tek 468 100MHz DSO £500.00		HP809A 10Hz-200MHz £450.00	
HP171A 100MHz £300.00		HP815A 1Hz-50MHz Pulse £450.00	
HP1742 100MHz £275.00		HP815A Programmable Signal Source £1200.00	
Fluke 92B Oscilloscope Meter 60MHz £450.00		HP8620C + HP8622B 0.01-2.4GHz Sweeper £1200.00	
		HP8642M 0.1-2100MHz £12500.00	
		HP8667A 0.1-1040MHz £3500.00	
		HP8684B 5-4-12.5GHz £1950.00	
		Marconi 2019A 80kHz-1040MHz £1450.00	
		Marconi 2022 10KHz-1GHz £300.00	
		Marconi 6057 Signal Source 5-5-8.5GHz £200.00	
		Marconi 6059A 12-18GHz Signal Source £200.00	
		Racal 9053 Two Tons £120.00	
		Syrston Donner 170Z Audio-1GHz £600.00	
		Tektronix 50A 0.001-240MHz £350.00	
		Farnell Tyco: 8025 0-60V 0-25A Metered - brand New. £400.00	
		General Radio 1265A DC Power Supply 0-400V 0-5A £475.00	
		Farnell TSV70 MK2 Stabilised Power Supply £180.00	
		Farnell 30/100 30V 10A £700.00	
		Power Ten Systems Power Supply 0-30V 0-60A £300.00	
		Powerline Type: LAB510 0-30V 0-10A £175.00	
		Powerline Type: LAB532 5V-5A + 15V 0-5A -15V 0-5A 0-30v-2A £200.00	

POWER SUPPLIES	
Farnell PDA3502A 0-35V 0-2A £160.00	
HP6634A Systems DC Power Supply 0-100V 0-1A 100W £800.00	
HP6634A Systems DC Power Supply 0-35V 0-15A £800.00	
HP6248 0-20V 0-20A £250.00	
HP5181G DC Current Source 0-100V 0-250mA £300.00	
Powerline Electronics 0-70V 0-10A £175.00	
Farnell Tyco: 8025 0-60V 0-25A Metered - brand New. £400.00	
General Radio 1265A DC Power Supply 0-400V 0-5A £475.00	
Farnell TSV70 MK2 Stabilised Power Supply £180.00	
Farnell 30/100 30V 10A £700.00	
Power Ten Systems Power Supply 0-30V 0-60A £300.00	
Powerline Type: LAB510 0-30V 0-10A £175.00	
Powerline Type: LAB532 5V-5A + 15V 0-5A -15V 0-5A 0-30v-2A £200.00	

SIGNAL ANALYZERS	
HP8903B Audio Analyser £2500.00	
HP3728A Noise & Interface Test Set EPOA	
HP3561A Dynamics Signal Analyser £6000.00	
HP890A Vector Analyser £5000.00	
Takeda Riken TR4172 Spectrum/Network Analyser 1.8GHz EPOA	
HP8901A Modulation Analyser £1500.00	
HP370A Universal Counter/Timer £850.00	
Philips PM6680 High Resolution Programmable Timer/Counter option C fitted £1350.00	
Philips PM6685 Timer/Counter £300.00	
Philips PM6695 Option C fitted Timer/Counter £1650.00	
Marconi 2355 Test Set £1200.00	
Advanced TR432 Spectrum Analyser 1GHz £1500.00	
B&K 2033 Signal Analyser £2000.00	
B&K 2636 Measuring Amplifier £4000.00	
B&K 5935 Dual Microphone Supply £650.00	
HP1827 + HP8556B Spectrum Analyser 100kHz-1.5GHz £1200.00	
HP334A Distortion Analyser £250.00	
HP339A Distortion Measuring Set £1200.00	
HP3580A 25kHz Spectrum Analyser £600.00	
Marconi 2305 Modulation Meter £2000.00	
Marconi 2382 + 2380 400MHz Spectrum Analyser £3500.00	
Marconi TR201 True RMS Voltmeter £500.00	
Marconi TR203 True RMS Voltmeter £500.00	
R&S LIRE RMS Voltmeter £800.00	
R&S ZPV + ES Plug-in 3-2GHz £1800.00	
R&S CM552 Comms. Service Monitor £500.00	
Tektronix DA484 Programmable Distortion Analyser £700.00	

SIGNAL GENERATORS	
Arel T1008 300kHz-650MHz £700.00	
Cushman CE12 Two Tone Generator £150.00	
Farnell DS02 Synthesized 0.1MHz-110KHz £185.00	
Fluke 4311A 12-18GHz £50.00	
Fluke 6010A 10Hz-11MHz Synthesized £175.00	
HP11710B Down Converter (HP8640B) £275.00	
HP144 Pulse Generator 100V 2A £1200.00	
HP3325A Synthesized Generator 1Hz-21MHz £1250.00	
HP450A Oscillator 10Hz-1MHz £125.00	
HP854A Test Oscillator 10MHz £225.00	
HP8005B 0.3Hz-10MHz £300.00	

MISCELLANEOUS	
I. L. X. LIGHTWAVE EQUIPMENT LD159018 Temperature Controller PDA842A Photo Diode Amplifier LDX3742 Laser Diode Controller LDX3207B Precision Current Source Anritsu MW920A OTDR + MH951A 850nm Plug-in + MH952A 1300nm Plug-in SM Fibre Splice Preparation Kit Cassir Optical Cable Fault Locator Type: OF-108L Rack Precision Type: DB2900 Single Mode Variable Attenuator Schlumberger Type: S17780 OTDR + S17782 Plug-in Solomat MP4000 Matrix Processor c/w Software, Portable multichannel, datalogger, alarm monitor, battery/ mains Operated Kane-May KM403 Air Velocity 0-30 in metres-per-second Air Temperature (C) -30 to +200C. Battery Operated. Portlow MK11: Portable diagonal beam flowmeter. Made by: Micronics Bacharach: Combustion Analyser/Environmental monitor Type: 300SX Kane-May Combustion Analyser Type: 9004 Kane-May: Temperature Sensor Type: 1204 c/w 8004 Temperature & humidity sensor. GGA-28 Therm-Anomometer + KM01 Infratec Casella: Aerosol Monitoring System Type: AMS950 Ranges: 0-20mg/m 0-200mg/m CEL Instruments: Precision Integrating Impulse Meter Type: CEL 493 c/w: CEL 296 Octave & third octave scan filter set + CEL 2842 Calibrator Haffmann SWMS Flow Meter CEL 281 + 281 Keypad + Programmable Noise Dosimeter Neotronics Explot 75 Amblog + Charger. Portable atmosphere monitor.	

PRINTERS	
HP2252A/D Thinkjet Printer HPiB £35.00	
HP7550A Plotter £250.00	
HP Draft Master RX £500.00	

CIRCLE NO. 140 ON REPLY CARD

LANGREX SUPPLIES LTD
DISTRIBUTORS OF ELECTRONIC VALVES
TUBES AND SEMICONDUCTORS AND I.C.S. **181 884**
PHONE 0181 684 1166 1 MAYO ROAD • CROYDON • SURREY CR0 2QP 3056
24 HOUR EXPRESS MAIL ORDER SERVICE ON STOCK ITEMS
email: langrex@aol.com

AZ31	2.00	KT66 China	10.00	524GT	3.00	6V8G	8.00
6A05	2.00	KT88 China	12.00	6AC5	2.00	6V8GT	5.00
CL33	10.00	N7B	8.00	6AF5	20.00	6V8GT	3.00
E8BCC	8.50	OA2	3.00	6AF57G	7.50	6XSGT	3.00
E180F	3.50	OB2	3.00	6AU5GT	4.00	12A17	3.00
E610F	20.00	OC3	3.00	6AU6	2.00	12A17	3.50
EABCB0	2.00	OD3	3.00	6AV8A	4.00	12AX7	5.00
EB91	1.50	PCF80	2.00	6BA4	22.00	12AX7A	7.50

Holding off application of power to a muting relay during the switching on and off of an audio amplifier avoids noisy – and sometimes expensive – transients.

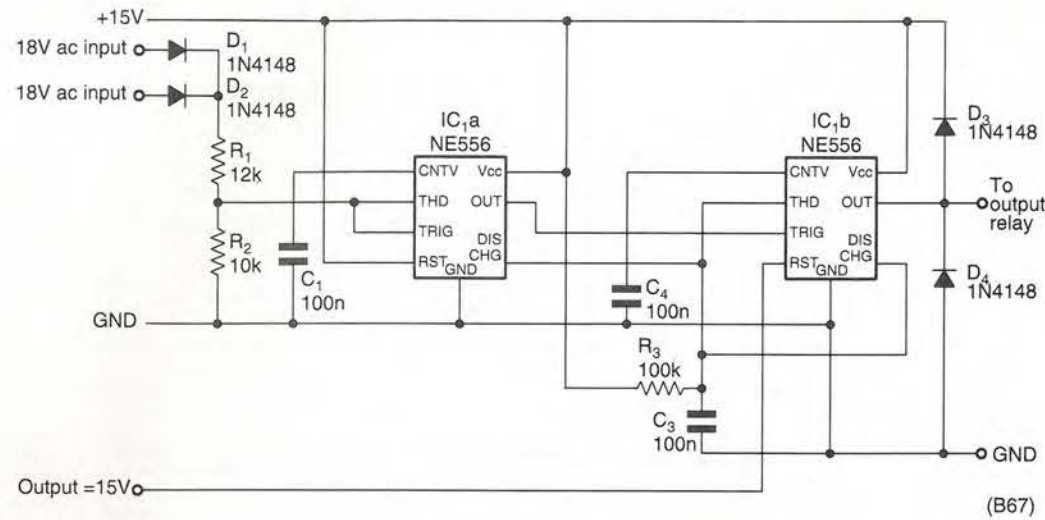

Muting an audio amplifier during power switching

To avoid clicks, bangs and possible speaker troubles when switching the power to an audio amplifier, it is advisable to reduce the resulting transients or to isolate them; this circuit isolates them by means of a relay in a muting circuit, as used in the design by R. Williamson (*EW*, December 1995). The NE556 dual timer's left-hand half is used to convert the rectified and voltage-divided ac input to a rectangular wave, its output trigger-

ing the other half, which is a monostable to drive the relay. Each time the squarer emits a trigger, it also discharges the timing capacitor of the monostable, C_3 , the output going high and activating the relay after the power supply has had time to reach its operating levels. At switch-off, the ac is removed before the supply rail capacitors discharge. Ac disappears and C_3 charges up completely, so that the output goes low and the relay is de-

activated. The relay is therefore always turned off during the application or removal of the ac supply. To ensure that the relay is not switched on at the same time as the amplifier, a 15V signal obtained from a schmitt trigger in the power supply holds the monostable off until the supply is established. **Bernard Van den Abeele**
Evergem
Belgium
B67

Ac spike suppressor

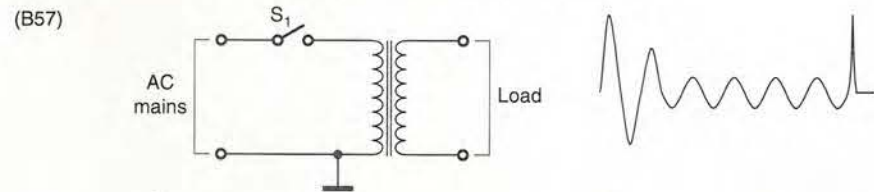

Fig. 1. Switching on a transformer causes spikes due to leakage inductance and inter-winding capacitance.

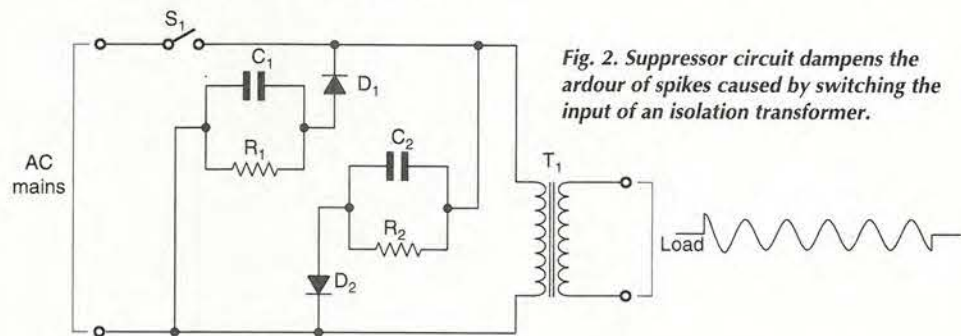

Fig. 2. Suppressor circuit dampens the ardour of spikes caused by switching the input of an isolation transformer.

Switching power to a circuit on the primary side of an isolation transformer has a tendency to cause switching spikes, due to the existence of leakage inductance and inter-winding capacitance. Figure 1 shows the familiar gruesome result. The arrangement of Fig. 2 stops all that, as shown in the waveform diagram. Depending in which half-cycle of the mains waveform the power is switched, $D_{1/2}$ conducts and $C_{1/2}$ absorbs the extra energy, discharging through the resistor. Diodes are fast-acting types and must be able to handle peak current for a short time. Select component values to take account of leakage inductance, winding capacitance and load. **Vijayan Pillai**
Npol
Kochi Kerala
India
B57

Bidirectional RS-485 repeater

To be inserted in long lines or to allow radial lines in a star arrangement to be isolated from the others, each being terminated, this repeater shows which line is receiving data and opens the other line to forward the data.

A line not transmitting is inactive, its state being logic one. Both drivers are disabled and both receivers enabled. If no driver is active in the line, resistors R_3 keep it at one.

If line A goes to zero, the receiver in IC_1 detects the level. Output pin R is taken to IC_2 input pin D, IC_2 being activated at pin DE by gate IC_3 and imposing a zero on line B. Reception on line B is disabled at pin /RE. This state of affairs lasts while the zero level remains on Line A.

When line A goes to one again, line B is driven to one and is disabled. Nevertheless, R_1C_1 has to be shorter after a time R_1C_1 , overriding the

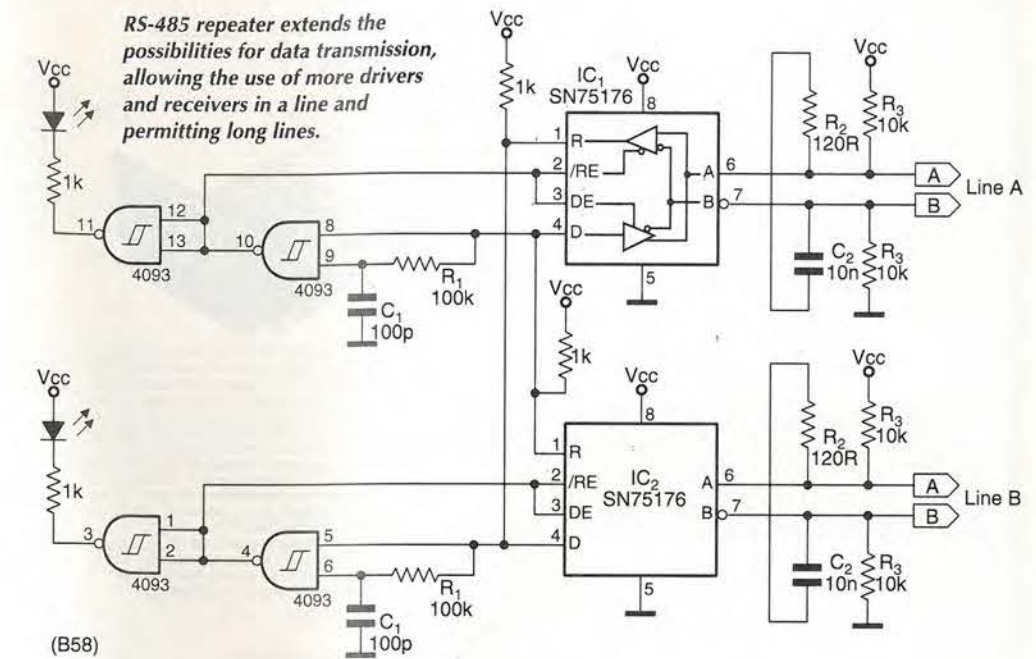

effect of the resistors R_3 . The time constant of terminating components R_2C_2 should be shorter than that of R_1C_1 to allow C_2 to charge by the driver before the driver is disabled. Nevertheless, R_1C_1 has to be shorter than the time of one bit.

The circuit has operated at 9600baud and should go to 100kbaud. **Albert Pijuan**
Girona
Catalonia
Spain
B58

Split supply from a single battery

From the one battery, this circuit arrangement produces symmetrical positive and negative outputs equal to the battery voltage and is protected against short circuits.

The 741 op-amp operates as a 1kHz square-wave generator and is, at switch-on, supplied with $V_{batt}/2$ to each supply pin by way of the two diodes. When the op-amp starts to oscillate, its output drives the transistors, their outputs being superimposed on the battery voltage and the op-amp now receiving double its steady-state supply.

The increased voltages are taken as the output after smoothing by the two 47µF capacitors. If required, the square wave is available as an output and, if symmetry of the square wave needs adjustment, the 47kΩ resistors on the op-amp input can be replaced by a potentiometer.

In the event of an excessive demand from the load, the oscillator stops and output current is reduced.

Efficiency is about 85% with a 12V

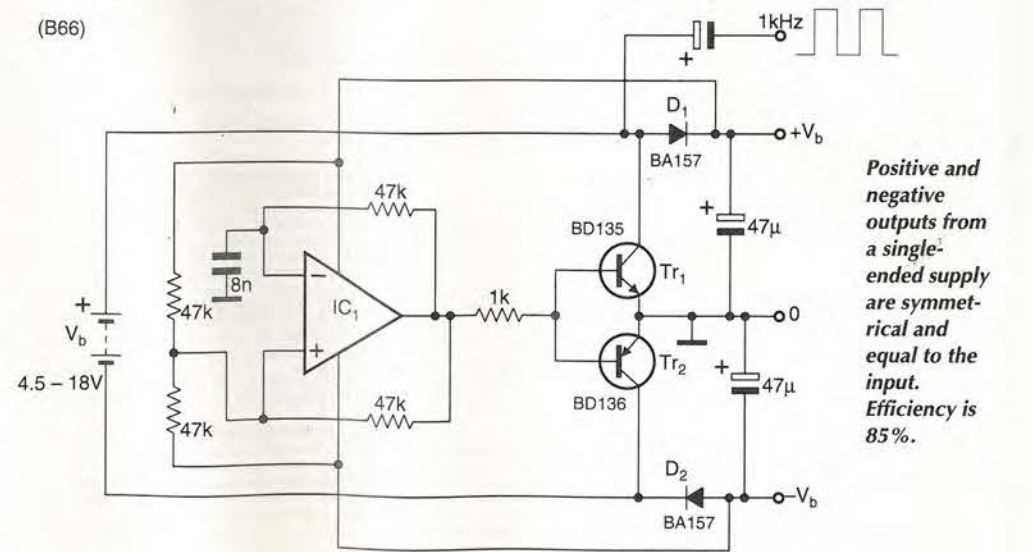

supply and the maximum operating frequency is about 20kHz; above that, faster diodes will be needed. Higher powers could be achieved with low on-resistance mosfets and Schottky

diodes. **Edward Reszke**
Wroclaw
Poland
B66

Positive and negative outputs from a single-ended supply are symmetrical and equal to the input. Efficiency is 85%.

HART

The Home of *Hi-Finesse*. Its not what you do, its HOW you do it that counts!

Hart Audio Kits and factory assembled units use the unique combination of circuit designs by the renowned John Linsley Hood, the very best audiophile components, and our own engineering expertise, to give you unbeatable performance and unbelievable value for money.

We have always led the field for easy home construction to professional standards, even in the sixties we were using easily assembled printed circuits when Heathkit in America were still using tagboards! Many years of experience and innovation, going back to the early Dinsdale and Bailey classics gives us incomparable design background in the needs of the home constructor. This simply means that building a Hart kit is a real pleasure, resulting in a piece of equipment that not only saves you money but you will be proud to own.

Why not buy the reprints and construction manual for the kit you are interested in to see how easy it is to build your own equipment the HART way. The FULL cost can be credited against your subsequent kit purchase.

SHUNT FEEDBACK PICKUP PREAMPLIFIER



If you want the very best sound out of vinyl discs then you need our high quality preamplifier with Shunt Feedback equalisation. The K1450 also has an advanced front end, specially optimised for low impedance moving coil cartridges as well as moving magnet types. Selected discrete components are used throughout for ultimate sound quality. The combination of John Linsley Hood design, high quality components and an advanced double sided printed circuit board layout make this a product at the leading edge of technology that you will be proud to own. A recent review in "Gramophone" magazine endorsing this view. Bought in kit form our step by step instructions it is very easy and satisfying to assemble, or you can buy a factory assembled version if you wish.

This magnificent kit, comes complete with all parts ready to assemble inside the fully finished 228 x 134 x 63mm case. Comes with full, easy to follow, instructions as well as the Hart Guide to PCB Construction, we even throw in enough Hart Audiograde Silver Solder to construct your kit!

K1450 Complete Kit £116.58
K1450SA Audiophile Kit £138.94
A1450SA Factory assembled Audiophile unit £188.94

"CHIARA" HEADPHONE AMPLIFIER.



Highest quality, purpose designed, 'single ended' class 'A' headphone amplifier for 'stand alone' use or to supplement those many power amplifiers that do not have a headphone facility. Easy installation with special signal link-through feature, the unit uses our 'Andante' Ultra High Quality power supply.

Housed in the neat, black finished, Hart minibox it features the wide frequency response, low-distortion and 'musicality' that one associates with designs from the renowned John Linsley Hood. Volume and balance controls are Alps "Blue Velvet" components. Very easy to build, or available factory assembled, the kit has very detailed instructions, and comes with Hart audiograde silver solder. A valuable personal listening option and an attractive and harmonious addition to any hifi system.

K2100 Complete Standard Kit £112.50
K2100SA 'Series Audiophile' Kit with selected audiophile components £115.46
A2100SA 'Series Audiophile', Factory Assembled £115.46
CM2100 Construction Manual £2.50

"Andante" Linear Technology AUDIOPHILE POWER SUPPLIES

The HART "Andante" series power supplies are specially designed for exacting audio use requiring absolute minimum noise, low hum field and total freedom from mechanical noise.

Utilising linear technology throughout for smoothness and musicality makes it the perfect partner for the above units, or any equipment requiring fully stabilised $\pm 15V$ supplies.

There are two versions, K3550 has $2 \pm 15V$ supplies and a single $15V$ for relays etc. K3565 is identical in appearance and has one $\pm 15V$. Both are in cases to match our "Chiara" Headphone Amplifier and our K1450 "Shunt Feedback" Pickup preamp.

K3550 Full Supply with all outputs £94.75
K3565 Power Supply for K1450 or K2100 £84.42
A3550 Factory Assembled Full Supply £147.25

SPEAKER DESIGN SOFTWARE.

VISATON "Speaker Pro 6" is a complete speaker design program for use on IBM machines. Covers cabinet and crossover design and contains a full expandable database of drive units. Earning a "most recommendable" accolade it tests this program is ideal for the professional speaker builder or serious audiophile.

0303 Speaker Pro 6, 3.5" Disk £45.51

SPEAKER DAMPING MATERIALS

Polyester Wool and Pure Lambs Wool both have optimal damping properties and are pleasant to handle. Standard 125g bag is sufficient for 20 litres enclosure volume.

5070 Polyester Wool, 125g £3.20
5069 Pure Lambs Wool, 125g £6.73

SPECIAL OFFER! SOLENOID CONTROLLED FRONT LOAD CASSETTE DECK SFL800

High quality (0.08%W&F) cassette mechanism with capability of using standard or downstream monitor R/P head. Offers all standard facilities under remote, logic or software control. The control requirements are so simple that for many applications not needing all functions manual switches will suffice. Power requirements are also simple with 12v solenoids and 12v speed controlled Motor, total power requirement being under 300mA. Logic control and wiring circuits are included free with each deck.

SFL800 Deck with Standard stereo head £29.50
SFL800D Fitted with High Quality Downstream monitor head, £44.90 (The Head alone is normally over £60!)

HART TECHNICAL BOOKSHELF

Try us for: Bigger Range of Books, Better Prices, NO "28 Day Wait"

New Titles:

"A BEGINNER'S GUIDE TO TUBE AUDIO DESIGN" Bruce Rozenblit. A practical book that does exactly what its title says and takes a modern look at valve amplifier construction. 132pp. ISBN 1-88280-13-3 £18.20
"HIGH PERFORMANCE LOUDSPEAKERS" Edn.5. Martin Colloms. Latest edition, just out. A really in-depth coverage of the whole World of speakers and high quality sound reproduction, but entirely readable in style. Just reviewed in "HiFi World". 478pp. ISBN 0-4719-7089-1 £24.95
"AUDIO ELECTRONICS" John Linsley Hood £19.95
"THE ART OF LINEAR ELECTRONICS" John Linsley Hood. 1994 £19.95
"THE ART OF ELECTRONICS" Horowitz & Hill £35.00
"DIGITAL AUDIO AND COMPACT DISC TECHNOLOGY" 3rd. Edn. 0-240 51397 5 £19.95
"INTRODUCING DIGITAL AUDIO CD, DAT AND SAMPLING" ISBN 1870775 22 8 £7.95
"ACTIVE FILTER COOKBOOK" Don Lancaster £19.95
"THE ART OF SOLDERING" 0-85935-324-3 0 £3.95
"TOWERS' INTERNATIONAL TRANSISTOR SELECTOR" 0-572-01062-1 £19.95
"AUDIO" F.A. Wilson. BP111 £3.95
"HOW TO USE OSCILLOSCOPES & OTHER TEST EQUIPMENT" R.A. Penfold. BP267 £3.50
"THE HART PRINTED CIRCUIT BOARD CONSTRUCTION GUIDE" £2.50
"A SIMPLE CLASS A AMPLIFIER" J.L.Linsley Hood M.I.E.E. 1969. RLH12 £2.75
"CLASS-A POWER" Single Ended 15W Amp. J.L.Linsley Hood M.I.E.E. 1996. RLH13 £2.50

LOUDSPEAKERS; THE WHY AND HOW OF GOOD REPRODUCTION. G. Briggs. 1949. £8.95
"THE LOUDSPEAKER DESIGN COOKBOOK" Vance Dickason. (5th Edn.) £23.95
"ELECTROSTATIC LOUDSPEAKER DESIGN AND CONSTRUCTION" Ronald Wagner BKT6 £15.95
"THE ELECTROSTATIC LOUDSPEAKER DESIGN COOKBOOK" Roger P. Sanders. 1995 £24.95
"BULLOCK ON BOXES" Bullock & White £10.95
"AN INTRODUCTION TO LOUDSPEAKERS & ENCLOSURE DESIGN" V. Capel. BP256 £3.95
"LOUDSPEAKERS FOR MUSICIANS" BP297 £3.95
"THEORY & DESIGN OF LOUDSPEAKER ENCLOSURES" J.E. Benson £21.95
"QUICK & EASY TRANSMISSION LINE SPEAKER DESIGN" Larry D. Sharp £8.95
"THE COUPLED CAVITY HANDBOOK" David Purton £4.90
"VISATON. HOME HI FI CATALOGUE." Full Specifications and Thiele Small Data on all Drive Units £4.50
"VISATON. CAR HI FI CATALOGUE." In car guide £3.50
"VISATON. CABINET PROPOSALS" Book 1. In GERMAN £6.50
"VISATON. CABINET PROPOSALS" Book 2. In GERMAN £6.50
"SPEAKER PRO 6." VISATON Cabinet Design Software. £45.51
"SPEAKER PRO 6." Demo Version with drive unit database £9.28

"VALVE AMPLIFIERS" Morgan Jones. 1995/6 £24.50
"THE VTL BOOK" David Manley 1994. BKVT1 £17.95
"MULLARD TUBE CIRCUITS FOR AUDIO AMPLIFIERS BKAA27" £11.95
"THE WILLIAMSON AMPLIFIER." 0-9524-1918-4 £6.95
"AN APPROACH TO AUDIO FREQUENCY AMPLIFIER DESIGN." GEC 1957 £17.95
"AUDIO ANTHOLOGIES, articles from Audio Engineering. Six volumes covering the days when audio was young and valves were king! BKAA31 to 6. All £12.95 each
"THE RADIO TRON DESIGNERS HANDBOOK" (CD) £49.00
"PRINCIPLES OF ELECTRON TUBES" H.D. Reich PH.D. £25.95
"POWER AMP PROJECTS" Anthology. 1970-1989. £15.50
"WORLD TUBE DIRECTORY" 1996-7 Sourcebook of valve related products £5.95
Fuller descriptions of the contents of all our books is given in our full catalogue, price £4.50

Postage on all books, unless starred, is only £2 per book, maximum £4.50 for any number, any size. Starred items are heavy books costing £3.50 to send.

Don't forget No waiting at HART! All listed books are normally in stock. Just ring with your Credit Card Number for instant despatch!

Fuller Details of ALL kits are given in our List, FREE on request.

'AUDIO DESIGN' 80 WATT POWER AMPLIFIER.



This fantastic John Linsley Hood designed amplifier is the flagship of our range, and the ideal powerhouse for your ultimate hifi system. This kit is your way to get £K performance at bargain basement prices. Unique design features such as fully FET stabilised power supplies give this amplifier World Class performance with startling clarity and transparency of sound, allied to the famous HART quality components and ease of construction.

Standard model comes with a versatile passive front-end giving 3 switched inputs, with ALPS precision "Blue Velvet" low-noise volume and balance controls, no need for an external preamp. Construction is very simple and enjoyable with all the difficult work done for you, even the wiring is pre-terminated, ready for instant use! All versions are available with Standard components or specially selected Super Audiophile components and Gold Plated speaker terminals and all are also available factory assembled.

K1100 Complete STANDARD Stereo Amplifier Kit, £415.21
K1100S Complete SLAVE Amplifier Kit, £353.62
K1100M Complete MONOBLOC Amplifier Kit, £271.20
RLH11 Reprints of latest Amplifier articles £1.80
K1100CM Construction Manual with full parts lists £5.50

ALPS "Blue Velvet" PRECISION AUDIO CONTROLS.



Now you can throw out those noisy ill-matched carbon pots and replace with the famous Hart exclusive ALPS "Blue Velvet" range components only used selectively in the very top flight of World class amplifiers. The improvement in track accuracy and matching really is incredible, giving better tonal balance between channels and rock solid image stability. Motorised versions have 5v DC motor.

MANUAL POTENTIOMETERS

2-Gang 100K Lin. £15.67
2-Gang 10K, 50K or 100K Log. £16.40
2-Gang 10K Special Balance, zero crosstalk and zero centre loss. £17.48

MOTORISED POTENTIOMETERS

2-Gang 20K Log Volume Control £26.20
2-Gang 10K RD Special Balance, zero crosstalk and less than 10% loss in centre position £26.98

TOROIDAL MAINS & OUTPUT TRANSFORMERS for EL34, 32W VALVE AMPLIFIER

Special set of toroidal transformers, 2 output & 1 mains for the "Hot Audio Power" valve amplifier design described in the Oct. 1995 issue of "Wireless World". Total Wt 4.8Kg. Special price for the set. £99. Post £8
RJM11. Photocopies of the Article by Jeff Macaulay. £2

PRECISION Triple Purpose TEST CASSETTE TC1D.

Are you sure your tape recorder is set up to give its best? Our latest triple purpose test cassette checks the three most important tape parameters without test equipment. Ideal when fitting new heads. A professional quality, digitally mastered test tape at a price anyone can afford.

Test Cassette TC1D. Our price only £9.99

Send for Your FREE copy of our LISTS

WILMSLOW AUDIO Tel. 01455 286603 Fax. 01455 286605

All Prices include UK/EC VAT.



CIRCLE NO. 143 ON REPLY CARD

Temperature-controlled heatsink fan

If the TIP127 transistor is mounted on the back of a component that requires cooling, its V_{be} variation with temperature controls power to the 12V, 80mm square fan, from 3.2V at 16°C to 13.2V at 43°C.

Set the fan voltage to 5V dc, so that the fan just runs with both transistors at ambient temperature. There is a slight inertia, caused by a tracking delay, but the circuit is effective and quiet enough to be used with a Class B amplifier at low levels.

G S Maynard
Newtownabbey
Co. Antrim
Northern Ireland
B70

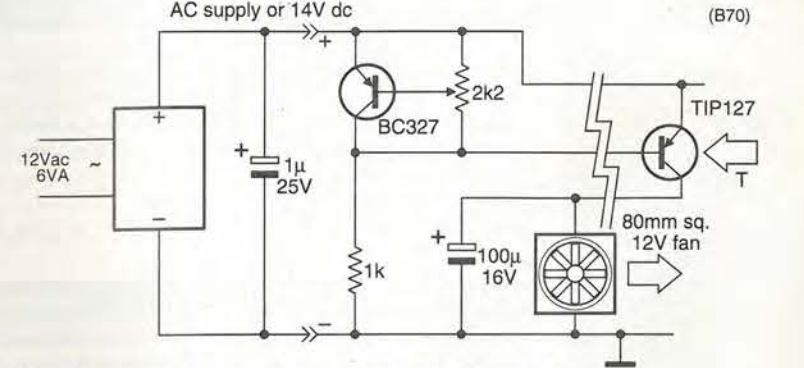

Simple automatic temperature control uses the change in base-emitter voltage of a transistor to control fan voltage.

Single-chip watchdog timer

Since the watchdog timer I had decided to use was not available, this circuit took its place. It is, in fact, cheaper and the reset signal's timing may be varied by changing the value of one capacitor.

If the microprocessor does not send a refresh signal to the timer, the second bistable device produces a 2.5ms positive-going pulse every 580ms. When the supply is applied, the circuit provides an initial reset pulse.

Recognition of the refresh input is by its rising edge, which is more reliable than a dependence on level.

Cristóbal Rueda Guerrero
Malaga
Spain
B59

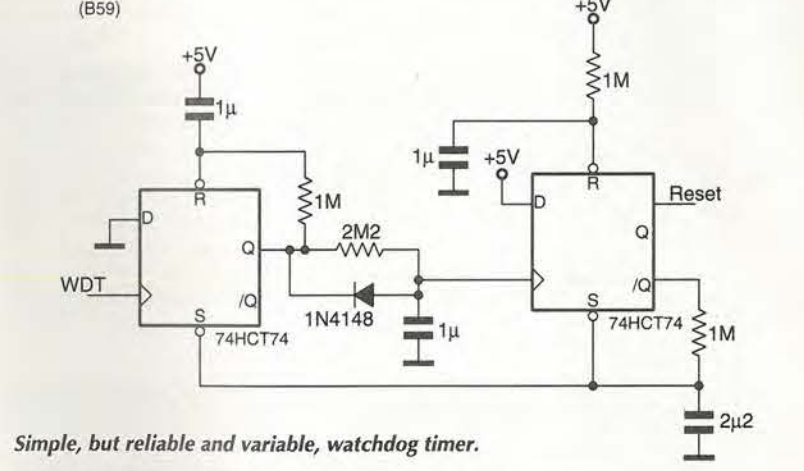

Simple, but reliable and variable, watchdog timer.

Oscillator has low phase noise

This oscillator covers the 3-7.5MHz range and exhibits low phase noise.

Amplification is low - just over unity - to inhibit 1/f noise, which would cross-modulate the signal amplitude, causing associated fm. Adjustable damping maintains the effect over a wide tuning range to provide less than 1dB flatness over an octave. Even harmonics from the isolation amplifier extend the usable range to about 30MHz.

The 5uH coil is tapped 1/6 from the ground end and the output from the amplifier common emitter provides a dc indication of signal amplitude.

Wim de Ruyter
Oudkarspel
Netherlands
B45

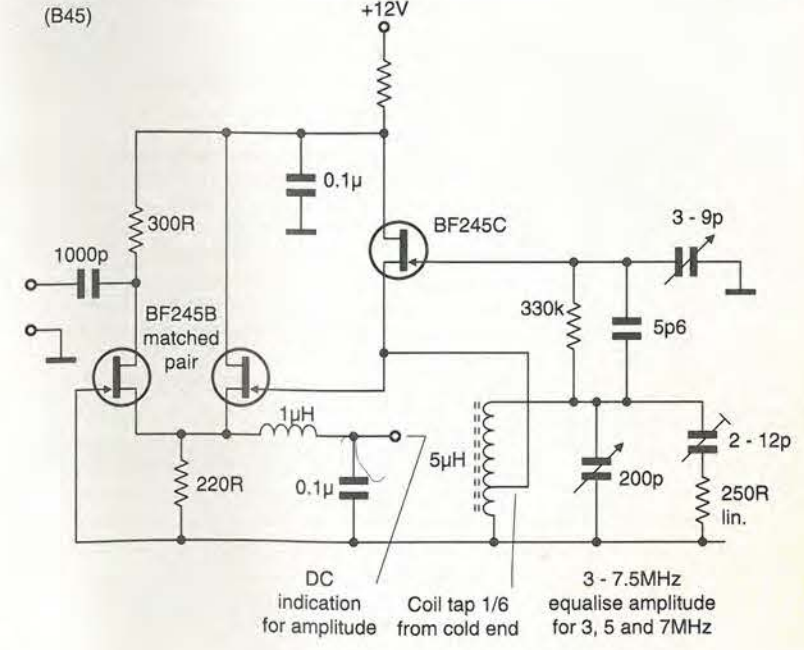

Low phase-noise oscillator may be used up to 30MHz.



Project ~ Design ~ Support

SOFTWARE TEAM LEADER - Surrey to £40k

Our client requires a seasoned Team Leader to work on a new mobile comms joint venture project. You will be responsible for co-ordinating the development of all embedded software and should therefore have a strong background in software development in 'C' and asm. Quote WW9808-79
Contact Rachel Evans on 0117 905 5028 or Email: rachele@mdm.co.uk

RF DESIGN ENGINEER - London to £40k

This position offers the opportunity for an experienced designer of RF instrumentation for mobile communications applications, to lead a team of multi-disciplined engineers on several new development projects. You will need several years experience of RF design to 2GHz and the determination to drive a project through to completion. Quote WW9804-31
Contact Rachel Evans on 0117 905 5028 or Email: rachele@mdm.co.uk

APPLICATIONS ENGINEER - N. Wilts to £38k

This company is a leading provider of software solutions to the telecoms industry world-wide. They are looking for a specialist with strong software skills in RT embedded design, C++, OO development, UML or OMT to provide support to the sales department. The role will include product support, presentations, consultancy and customer training. If you are looking for a more customer orientated role.....this is it! Quote WW9807-56
Contact Deana Lawrence on 0117 905 5028 or Email: deana@mdm.co.uk

PRINCIPAL DESIGN ENGINEER - Gwent to £35k+

This role will involve the design of analogue and digital circuits for military telecommunications projects. Our client is seeking a Senior Engineer with a strong background in a similar environment to lead a team of Junior Engineers on some of the most advanced projects being undertaken. Quote WW9807-15
Contact Rachel Evans on 0117 905 5028 or Email: rachele@mdm.co.uk

DEVELOPMENT & INSTALLATION ENGINEER - Cambs to £30k

This role will involve you in all aspects of a project from the development work to installation of antenna control products for world class satcoms applications. You will be involved in the planning and management of retrofit projects world-wide, writing specs and documentation and providing support to engineers and customers. Quote WW9805-154
Contact Deana Lawrence on 0117 905 5028 or Email: deana@mdm.co.uk

RF TEST ENGINEER - Hants to £18k

A young dynamic individual is required by this leading research company to undertake systems and sub-systems tests on radio communications projects. Qualified to HNC standard you will need several years experience of network/spectrum analysers and an understanding of calibration procedures for RF measurements. Quote WW9808-59
Contact Rachel Evans on 0117 905 5028 or Email: rachele@mdm.co.uk

TYPE APPROVALS ENGINEERS - Surrey £16k - £25k

Get your head around something different!...join a world leader in obtaining GSM type approvals, regulatory testing and confidence work for mobile cellular radio products. Qualified to degree/HND standard you should have a minimum of 2 years hands on experience of cellular radio GSM/PCN type approval and testing. Quote WW9808-39
Contact Rachel Evans on 0117 905 5028 or Email: rachele@mdm.co.uk

QA ENGINEER - South West to £25k

One of the world's leading suppliers of communications test systems is looking for a QA person to join a team of multi-disciplined engineers working on remote test systems on clients sites. You should have excellent qualifications and several years experience in QA, ideally in telecoms and a knowledge of installation and commissioning of systems. Quote WW9808-02
Contact Deana Lawrence on 0117 905 5028 or Email: deana@mdm.co.uk

ELECTRONICS ENGINEER - Newport to £24k

This role will involve you in the development of advanced scientific and industrial instrumentation, designing analogue and digital electronics for video products. It will also encompass documentation, cct layouts, supplier and sub-contractor liaison and test verification. Degree qualified, you should have good CAD design skills and a knowledge of principles of engineering and mathematics. Quote WW9808-70
Contact Deana Lawrence on 0117 905 5028 or Email: deana@mdm.co.uk

BUSINESS DEVELOPMENT ENGINEER - South West to £24k

Our client has an excellent opportunity for an individual to move into a marketing orientated role. This position would suit either a raw graduate with an out-going nature or a Telecoms Design Engineer who has a few years experience and enjoys the customer contact. Quote WW9808-03
Contact Deana Lawrence on 0117 905 5028 or Email: deana@mdm.co.uk

PROJECT ENGINEER - Newport to £28k

Our client is seeking an exceptional individual to take responsibility for project management and design of highly complex scientific and industrial instrumentation. A flexible engineer, you should have a broad based electronics background, ideally use to working on projects employing embedded processors, FPGAs and high performance A to D interfaces. Quote WW9806-69
Contact Deana Lawrence on 0117 905 5028 or Email: deana@mdm.co.uk

PROJECT MANAGER - Cambs to £30k

Our client is looking for a hands-on Project Manager to take control of an antenna control project for a major client. Ideally you will have experience of managing development and installation projects with overall responsibility for planning, budgets and milestones. As this will be a small team, you should expect to be involved in test documentation and commissioning of the systems. Quote WW9808-76
Contact Deana Lawrence on 0117 905 5028 or Email: deana@mdm.co.uk

mdm recruitment
Kings House, 14 Orchard Street, Bristol BS1 5EH
Tel: 0117 905 5028 Fax: 0117 905 5108
Email: mdm@dircon.co.uk

For more vacancies visit our website <http://www.mdm.co.uk>



Systems ~ Design ~ Support

RADIO SYSTEMS ENGINEERS - UK/WORLD to £35k

If radio networks are where you're at, these are without doubt some of the finest opportunities around. You'll be liaising at all levels, internally and externally, devising radio communications solutions. A relevant mix of skills is required with experience in dealing with utilities/emergency services etc. an advantage. Quote WW9708-92
Contact Mark Wheeler on 01666 511311 or Email: markw@mdm.co.uk

RF DESIGN ENGINEERS - Bristol to £40k

Involved in projects that seem to go on forever? Stuck in a corner working on the bit the boss says you have to do? Yes? Then your salvation is at hand with this fast growing Radio Systems Design House where your talents can be truly realised. Accomplished design skills up to 2GHz in receivers, mixers and PA's ideal. Quote WW9707-56
Contact Mark Wheeler on 01666 511311 or Email: markw@mdm.co.uk

RF IC DESIGN ENGINEERS - Bristol to £45k

Make a mark for yourself and be the first IC Designer in this established and fast growing Radio Systems Design House. You'll be working alongside a very fine multidisciplinary team of Engineers involved in some of the most stimulating projects around. Good hands on skills are required including experience up to 2GHz together with some good ideas. Quote WW9712-17
Contact Mark Wheeler on 01666 511311 or Email: markw@mdm.co.uk

RF/MICROWAVE DESIGN ENGINEERS - Beds to £38k

No such thing as the boredom factor with this company since they work in areas as diverse as cellular radio, mobile data, satellite communications and navigation to name but a few. Your design experience probably lies somewhere in the 100MHz to 100GHz region, either in solid state design or more plumbing related areas!! Be the best you can be. Quote WW9808-77
Contact Mark Wheeler on 01666 511311 or Email: markw@mdm.co.uk

RF DESIGN ENGINEER - Hereford to £35k

Fancy the chance to get in on the ground floor of a small growing business? Not only will your role be to design parts of IF infrastructure for microwave applications to 2GHz, but also the opportunity to liaise with clients to define their requirements. Hence, this is a good chance to broaden your horizons and build your business skills. Genesis CAD useful. Quote WW9808-17
Contact Mark Wheeler on 01666 511311 or Email: markw@mdm.co.uk

SOFTWARE ENGINEER - Hampshire to £45k

The first thing that you need is C/C++ experience. Add in some Yourdon or other structured methodology and preferably some radio or telecommunications work environment and you're likely to have the right ingredients for these challenging roles. This Software House offers some fine challenges in mobile communications and T&M - and they'll pay you for your worth. Quote WW9805-157
Contact Mark Wheeler on 01666 511311 or Email: markw@mdm.co.uk

SNR BUYER - Wilts to £27k

Our Client is a world leader in the design and manufacture of innovative products for domestic applications. They have several requirements for specialist buyers to cover electronics components, R&D, production and commodities procurement. You will need a strong track record and a proven ability to negotiate with suppliers and undertake long term contracts. Quote WW9806-50
Contact Malcolm Masters on 01666 511311 or Email: malcolm@mdm.co.uk

COMMISSIONING ENGINEER - West Country to £20k

Working on the installation of highly complex handling systems, you will be involved in the site installation and commissioning of brand new, innovative systems utilising the very latest technological advances.....that means lots of troubleshooting and plenty of overtime!!! If you enjoy a challenge, call today! Quote WW9808-78
Contact Malcolm Masters on 01666 511311 or Email: malcolm@mdm.co.uk

TEST ENGINEER - Bristol to £20k

As one of the country's leading suppliers of microwave components and sub-systems, our client has a reputation for providing quality products. To help maintain this, they are seeking an Engineer to work on high and low power GaAs fet amps from DC to 40 GHz. It is essential that you have excellent problem solving skills and experience in amplifier/stub tuning. Quote WW9807-12
Contact Malcolm Masters on 01666 511311 or Email: malcolm@mdm.co.uk

EMC ENGINEER - Surrey to £20k

A great opportunity to join one of the world's leading specialists in EMC carrying out RF and non ionising radiation hazard surveys on clients' sites and applied EMC research. You should be qualified to HNC standard and have experience of RF measurements, ideally gained on site surveys. Mobility and a clean driving licence essential. Quote WW9808-38
Contact Malcolm Masters on 01666 511311 or Email: malcolm@mdm.co.uk

BENCH TECHNICIANS - Notts £10-£22k

Component level expertise? Board level diagnosis? Shiny new technical qualification? This leading cellular maintenance organisation wants you!! You don't have to have communications product experience (although it would help), but you'll be keen to keep abreast of the latest technology. All this in a positive, friendly environment too! Quote WW9703-37
Contact Mark Wheeler on 01666 511311 or Email: markw@mdm.co.uk

BENCH/FIELD ENGINEER - Manchester to £17k

A nice service job working in a vibrant city is on offer here. This established company offers a broad spread of work encompassing everything from cellular phones to complex PMR systems. Your component level skills should be radio related and you will have a relevant technical qualification. Coronation Street fans will be given preference (only joking). Quote WW9710-03
Contact Mark Wheeler on 01666 511311 or Email: markw@mdm.co.uk

mdm recruitment
Brinkworth House, Brinkworth, Nr Swindon SN15 5DF
Tel: 01666 511311 Fax: 01666 511308
Email: recruitment@mdm.co.uk

For more vacancies visit our website <http://www.mdm.co.uk>

Hardware

PROJECT MGR/SNR HW ENGINEER

SLOUGH £30K+++
New position for a Senior Engineer with circa 8 years or more experience of hands-on or team management within a commercial electronics company and preferably with Datacomms or Telecomms background.
You will be responsible for a small multi-disciplined team of Engineers, project management and play a key role in hands-on design of Datacommunications products from initial specification through to customer acceptance.
Your experience should include a good grounding in digital hardware, comms (E1, kilostream, G.703, X21, RS²³², ISDN), FPGA/PLD's, management or management potential! **Ref: AL552EWD**

AUTOMOTIVE

MIDLANDS £18-30K
New development projects with one of Britain's most respected manufacturers of automotive, avionic and transport electronic systems.
We are currently looking to recruit a couple of Hardware Engineers with experience of Digital and Analogue Electronics (with possibly an Automotive background - but not essential) to join a project based team working on ABS/Traction Control, Innovative Radar based Cruise Control or Power Control solutions.
Interested? Please give me a call or send through a current CV quoting... **Ref: AL499EWD**

POWER SUPPLY/ANALOGUE

Kent	S.M.P.S	£20-30K+
Cambs	Analogue, Audio	to £35K
M.Wales	Power Supply, Drives	£open
Suffolk	S.M.P.S 2yrs+	to £25K
Norfolk	S.M.P.S, custom design	to £30K
Wilt	A.C. Power Control	£28K
Swindon	S.M.P.S, DC/DC Comms	£28K
S.Coast	S.M.P.S, Defence co.	£30K
Reading	High Power, FET, IGBT	£neg
S.Wales	PS.U., Analogue, R&D	£28K
Dorset	3 phase, PS.U., design	£30K
Telford	PS.U.s, Analogue, TVs	£28K

Ref: AL550EWD

ASIC/FPGA DESIGNERS

S.COAST £18-40K+ RELOC.
Major recruitment within the Hardware/IC Division of this "multi-national blue chip" company who are primarily focused within the Space Industry.
You will join a dedicated team of Engineers responsible for ASIC/FPGA design (to 200K gates) using RTL VHDL coding and VHDL simulation.
Your experience should include a good digital hardware base with preferably FPGA or ASIC design experience. Interested? **Ref: AL535EWD**

Contact - Andrew Langridge

RF/Comms

RF DESIGN ENGINEER

WEST YORKS £20-30K
A company who research, design and manufacture broadband microwave components and subsystems for use in the defence and civil areas require RF Design Engineers.
You will be responsible for systems and circuit design and will, therefore, require experience in Rx/Tx design, LNA's, filters and designing for production.
Degree qualified or equivalent with 2 years+ design experience. Relocation package available. **Ref: AJ95EWD**

RF TEST TECHNICIAN

BERKS/M4 CORRIDOR £NEG
A company who research, develop and manufacture products and systems for Communications and Surveillance applications require an RF Test and Repair Technician.
You will be responsible for RF testing including noise measurement, switching isolation and gain from VLF to SHF, fault-finding and repair, ATE testing, software loading, writing of test schedules and design/assembly of simple test jigs.
ONC qualified or equivalent with 3 years experience in an RF system maintenance division required. **Ref: AJB9EWD**

TELECOMMS CONSULTANTS

EAST ANGLIA UPTO £50K
A company who provide solutions for operating companies and equipment manufacturers within the Telecommunications market require contract or permanent Telecomms Consultants.
You will need to be flexible as travel to customer sites is expected and have experience in any of the following: general telecomms or datacomms, IN, routing and transmission, switching, ISDN, network management systems and signalling. **Ref: AJ93EWD**

RF ENGINEER - DEFENCE

BERKS £21-28K
A company who lead the way in Telecommunications Services and Defence Electronics globally require an RF Engineer.
Working within the Product Business Division you will be responsible for designing RF circuits for tactical radios from concept to production, liaising with a variety of Departments eg. Prototype Services, Drawing Office and Production.
Degree qualified in a relevant discipline with 2 years experience in designing RF circuits with experience in particular of Radio Receiver and Design Principles and UHF/VF RF circuits. **Ref: AJ90EWD**

Contact - Alison Jones

R&D/Test Dev.

PRODUCT DEV ENGINEER - REMOTE LOW POWER RF SYSTEMS

A company responsible for the design/development of remote monitoring products require a Product Development Engineer. You will be responsible for the conceptualisation of a customer or market requirement, and communicate these ideas into a working product. You will liaise with other R&D teams on new product development. You will be required to work on your own initiative and project manage several product developments.
HNC/HND Electronics, general electronic design, low power RF systems, understanding of RF propagation, design tools - ORCAD etc, digital systems. **Ref: PS31EWD**

TEST DEVELOPMENT SPECIALIST - GPS BASED

SOUTH EAST ££25-30K
An innovative company responsible for the Development of RF solutions that are used primarily for GPS purposes require a test Development Specialist.
You will be responsible for liaison with R&D and Product teams on DFT/Testability issues, you will introduce form concept to full integration Test Solutions and all relevant documentation. You will investigate new methods of test for hi-volume products, will introduce test plans and strategies for all New Products.
HNC/HND Electronics, 2-4 years experience in Test Development, experience in a variety of systems - HPBASIC, LabWindows/CVI, ATE systems, IEEE-488/GPIB Rack & Stack based. **Ref: PS0027EWD**

SENIOR IC DESIGNER - SET TOP/NC'S - MPEG ETC

SOUTH EAST ££30-35K
A company who are responsible for the design/development of Network Computers, Set Top Boxes and Audio/Video systems require a Senior IC Designer.
You will be responsible for IC development for a range of hi-tech consumer and industrial electronics, and for component development from conception through to full development. You will liaise with other Engineering Teams and customers on product developments. You will take a key role in project managing most product developments.
HND/Degree Electronics, IC development background, VHDL/Verilog, Synopsys and Cadence tools, development work should cover A/V systems, understanding of MPEG/JPEG standards, Set Top Box/Interactive products. **Ref: PS0033EWD**

Contact - Peter Starling

Armed Forces

(EX & CURRENT)



Vacancies in large Multi-nationals and Defence companies now.

Phone **John Dawson** now to see if you fit the bill.

Positions include:

TELECOMMS SYSTEMS ENGINEER

NEWPORT £NEG
Security Clearance needed. For fixed and deployable military comms systems. The job holder will provide telecomms expertise and product knowledge to support current and future tactical comms systems. Involved in customer liaison, technical bids and system architecture Electronics/Telecomms background with experience in some of the following voice, data and/or packet transmission with multiplexing, switching and fibre optics. **Ref: JD/EWD01**



- * RF Test Engineer £Neg Corby
- * Test & Weapons Engineer £Neg Somerset
- * Systems Engineer £Neg Surrey
- exp in Naval Command & Control Systems pref.
- * Field Service Tech £14.5-16.5K Manchester
- exp in Radio Test Equipment
- * Weapons Product Manager £Neg Bedford
- * Comms Engineer £Neg Surrey
- exp in ground-ground/ground-air comms
- * ILS Engineers £20-35K South East

Contact - John Dawson

£45K

&

CONTRACT

Superb opportunities for ENGINEERS

* RF

* MICROWAVE

* ANTENNA

* RADIO SYSTEMS

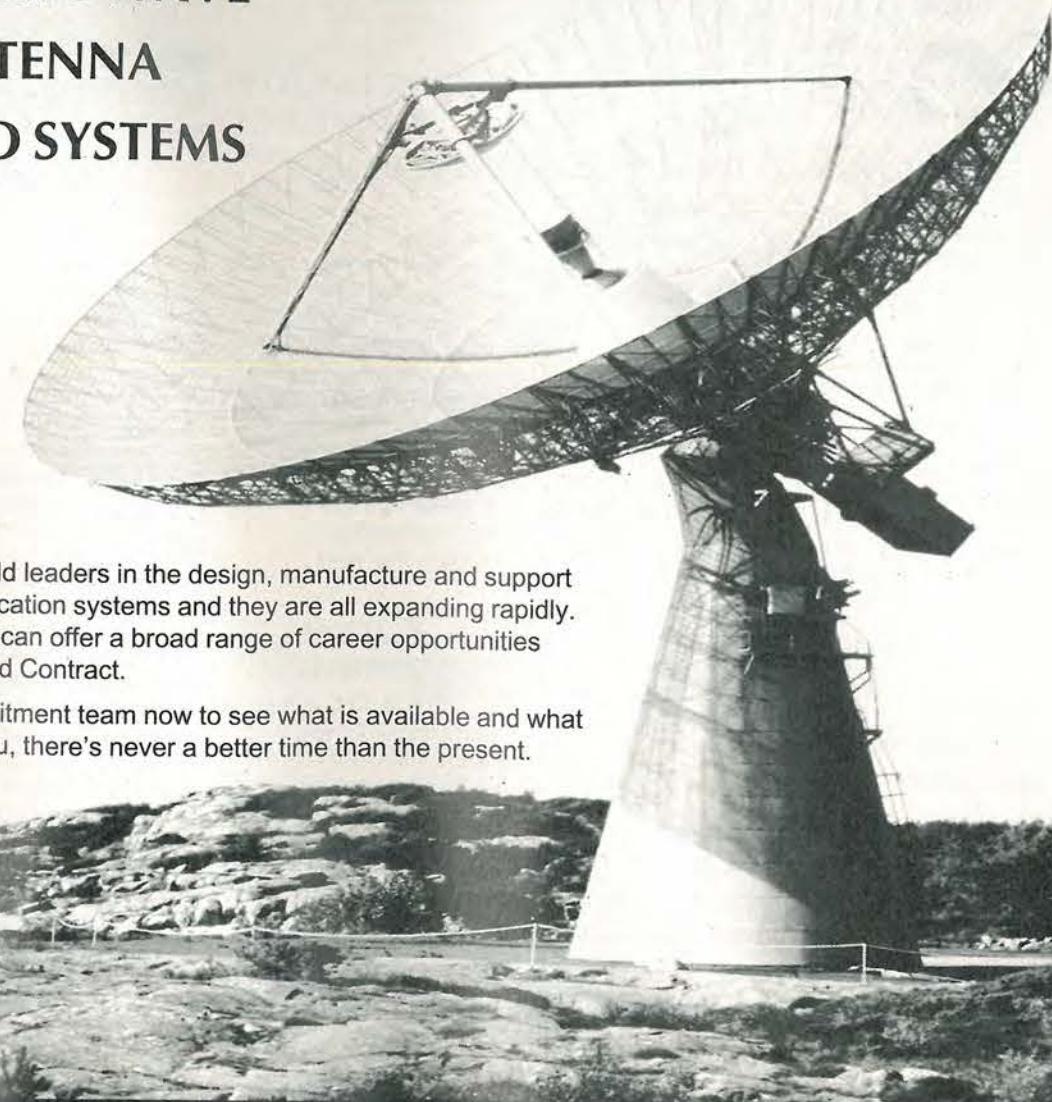

Our clients are world leaders in the design, manufacture and support of mobile communication systems and they are all expanding rapidly. Consequently they can offer a broad range of career opportunities both Permanent and Contract.

Call the STS Recruitment team now to see what is available and what it could mean to you, there's never a better time than the present.

For latest vacancies:



<http://www.stsrecruit.com>



Ref:WW/9829



Precisely the right people

STS Recruitment

Radley House
8 St Cross Road
Winchester
Hampshire
SO23 9HX

Telephone: 01962 869478

Home: 01962 715530

Fax: 01962 841982

Email: sts@tcp.co.uk

Solution

Technical Recruitment Specialists

SOFTWARE ● HARDWARE

RF DESIGN ENGINEER

Wilts £25k to 40k + Benefits

Due to the continued expansion of this well known company who design, develop and manufacture telecommunications equipment we are now looking to recruit experienced RF Designers. You should have at least 2 years experience of RF Design and development with a leading commercial company. Your designs should include Rx, TX, Synthesisers, LNA's to frequency ranges 2 Ghz, however higher frequency ranges will be considered. You should also be familiar with various design tools such as EEsof, Touchstone, Libra and Pspice.

Excellent future career prospects are available for experienced engineers.

DESIGN/APPLICATIONS ENGINEER

Crystal Oscillators Glasgow £25k+

This company has an annual revenue of \$500 million, a worldwide staff of 5,500, with 500 of these in Scotland. They pride themselves as having the broadest range of radio frequency products in the industry. They now seek an Engineer with commercial 'know how' to undertake Project Management of new designs (involving close liaison with the Chicago design centre), Application Engineering, working closely with customers and sales and marketing.

You should be a competent design engineer with at least 5 years experience with a good understanding of customer requirements and be an excellent communicator.

SALES PROFESSIONALS – RF COMPONENTS

Various Locations £Excellent +Bens

We have a broad base of clients both OEM's and Distributors operating in all applications areas of RF Component Sales (Comms, Military, Aerospace etc). If you are currently working in this arena as either an internal/external sales person we are interested in talking to you. Your product portfolio is likely to include some of the following: RF/Microwave IC's, VCO's, Synthesisers, Amplifiers, Antenna's, Cabling Systems and Interconnection Products. We are also interested in talking to people with an RF Test/Analyses equipment background. Contact: Andy Raymond

CONSULTANTS – RF DESIGN (Radio Products)

Herts £30k to 53k

Top class consultancy firm is looking to recruit several top class RF Design Engineers who can offer exceptional Design and Development skills. Your background should cover some of the following, GSM, DECT, PMR, CT1/2, CDMA with particular RF design experience in RF Amplifiers, Mixers and Synthesisers in the 400 Mhz to 1.8 GHz range. To be considered for the Consultant positions it is vital that you have a good degree (2:1 or 1st) and have the ability to develop and maintain client relationships.

RF TEST & TUNING ENGINEERS

Bucks £Negotiable

A leader in their field company are looking to recruit several Test and Tuning Engineers. Responsibilities will be to test and tune Mast Head Amplifiers to ensure the receiving and transmitting frequencies conform to required customer specification (1 to 2 GHz). The right candidate should have experience in the use of Vector Network Analysers, Signal Generators and Power Meters. Call Simon Allder.

RF/MICROWAVE TEST ENGINEERS

Bucks, Beds £16k to 22k

Several companies in the northern home counties are looking to recruit RF/Microwave test engineers who have at least 1 years experience to work in test and development of RF products for telecoms and other coms related products such as cellular phones, base station equipment and network products. You will need previous experience of test to component level up to 20 GHz using spectrum analysers, oscilloscopes, meters etc. Other useful skills would include, circuit design skills, test skills in the VHF, UHF, LF and MHz ranges and project management. Call Simon Allder.

RF TEST ENGINEER

Herts £27k to 30k

This Automotive and electronics company are looking to recruit RF Test Engineers. The ideal candidate must be HNC/HND qualified in relevant discipline, good knowledge of analogue, digital, RF circuitry and automatic test principles and test techniques. Understanding of the following software languages: HP/HT BASIC, C, C++. Call Simon Allder.

SOFTWARE ● HARDWARE

TALENTED DESIGNERS!

Electro-mech Various locations £20-£40k

Are you a talented Designer with a background in mechanical design? Are you currently in a job which you feel is taking you nowhere? Or are you just interested in finding out a bit more about what opportunities there are out there for you? In either case we would like to hear from you. We have lots of high quality client companies who are looking for good, creative Designers – using ProEngineer, SDRC, Autocad, Catia, Unigraphics and others! Opportunities genuinely exist in a number of market areas including telecomms, audio, power supply, automotive, aerospace. Don't wait any longer – make the decision to further your career today!

RF DESIGN ENGINEERS

Wiltshire £20k to £40k

This highly successful company has placed its GSM centre of excellence in the UK and is investing not only in the technology but also in highly skilled technical engineers. You will be responsible for the design and development of various RF products including Synthesisers, Receivers, Transmitters and control loops for the next generation of base station equipment. You should have experience of simulation using HP EEsof with previous experience of designing RF products within the communications.

RF DESIGN ENGINEER

Hants/Surrey £22k to £37k

Degree qualified engineers with 2-8 years relevant RF circuit design experience are required to work for this world leader in the design and development of GSM, PCN and Satellite communications products. You should have a high level of experience in designing Receivers, Synthesisers LNA's and Transmitters up to 2 GHz and have experience in designing products for high volume manufacturing. You should also be willing to work at the bench testing designs.

RF DESIGN ENGINEER

Herts/Cambs £Exceptional

This superb company is looking for several highly experienced RF Design Engineers who have extensive experience of RF Design and Development in the HF and VHF (50 to 200 MHz) spectrum. You should have solid experience in the design of low cost Rx/Tx, LNA's, Mixers, VCO's Synthesisers, PA's and Filters taking the relevant ETSI standards into consideration. Any experience of UHF would be highly beneficial.

YOUNG RF DESIGN ENGINEER

Wilts to £30k + bonuses

This household name, with a diverse product range, requires a talented young RF Design Engineer at their UK design centre working on designs for a variety of mobile communication applications. You will be a practical 'hands on' engineer with experience of LNA's, transmitters and receivers together with RF modelling tools. Working under pressure to tight timescales you should be capable of working on your own initiative, whilst supporting other team members.

RF DESIGN ENGINEERS

Cambs, M3 & M4 £Superb

The current Telecommunications market is providing excellent opportunities for RF Design Engineers at all levels. Due to the demand for experienced design engineers we currently have over twenty positions covering various technologies and of course locations. In short the requirements are for RF Design Engineers with hands-on experience of Receivers, Transmitters, Synthesisers, LNA's and Filters. Frequency ranges are typical of the telecoms market usually to 2GHz. Technology areas of interest are CDMA, GSM and PCN in either a mobile phones or base stations. Other relevant product areas include modern design and digital radio. You should be well versed in CAD/CAE tools such as HP EEsof, Touchstone and PSPICE to name a few. Salary levels on offer depend on experience gained but for engineers with 1-3 years £25-£30k and 3 years + £30-45k.

RF DESIGN ENGINEERS

Herts/Cambs £18k to 45k

Very well respected company involved in the design and development of many of today's high tech communications products is looking to recruit RF Engineers who have an excellent track record in the design of innovative Radio/Mobile communications products. You will need a good degree coupled with solid experience of GSM, PMR, CDMA, RF design including Amplifiers, Mixers, Synthesisers to 1.8 GHz. You should also have good experience of simulation packages such as HP EEsof or Touchstone.

IC DESIGNERS

Hants to £40k

This newly established group offers this opportunity to work in a small organisation environment and yet be part of a large international company which has been a highly respected household name for many years. They now seek several talented IC design engineers at various levels of seniority. The main skills areas they wish to recruit in are RF IC design and digital CMOS IC design. Experience of high level design tools will be required and any mobile comms or broadcast experience will be useful. This company is looking to recruit individuals who wish to further their skills and be highly rewarded for their efforts ensuring that they have the status they deserve.

RF CIRCUIT/IC DESIGN/APPLICATIONS

UK/USA £Excellent

As a recognised leader within the world of RF components this client offers an excellent opportunity to become part of a team of design engineers within a commercial organisation. You will be designing/supporting products for a variety of RF application, but primarily mobile communications. You will need at least 2 years experience of RF design at board or IC level. You will have the opportunity to work in the UK (Berkshire) or the USA (California). Excellent salaries are available for successful candidates. Contact Steve Davis.

Contact:
Kari Myring
(Software)
Steve Davis
Simon Allder
(Production and Test)

Solution
The Tower House
High Street
Aylesbury
Bucks
HP20 1SQ

Tel:
01296 336036
Fax:
01296 336037
Email:
SolutionTechnical
@MSN.COM



OPERATING & SERVICE MANUALS

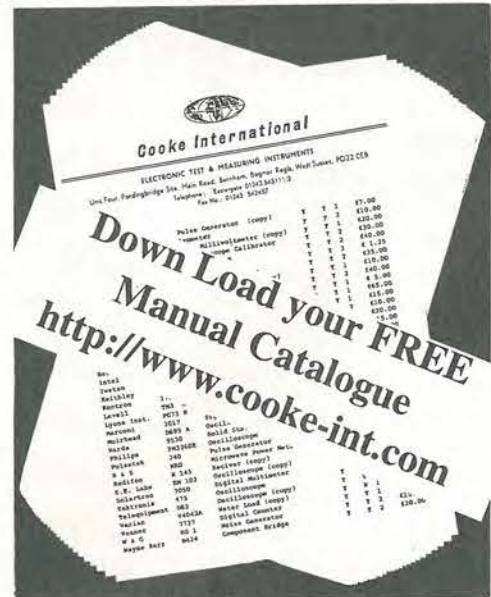

CONTACT
Cooke International
 Unit Four, Fordingbridge Site, Barnham,
 Bognor Regis, West Sussex, PO22 0HD, U.K.
 Tel: (+44)01243 545111/2 Fax: (+44)01243 542457
 Web: <http://www.cooke-int.com>
 E-mail: info@cooke-int.com

CIRCLE NO. 144 ON REPLY CARD



SUPPLIER OF QUALITY USED TEST INSTRUMENTS



DOWN LOAD your FREE
Stock Catalogue
<http://www.cooke-int.com>

CONTACT
Cooke International
 Unit Four, Fordingbridge Site, Barnham,
 Bognor Regis, West Sussex, PO22 0HD, U.K.
 Tel: (+44)01243 545111/2 Fax: (+44)01243 542457
 Web: <http://www.cooke-int.com>
 E-mail: info@cooke-int.com

CIRCLE NO. 145 ON REPLY CARD

CLASSIFIED

Tel: 0181 652 3620

Fax 0181 652 8938

ARTICLES FOR SALE

19" Rack Enclosures
 New and Used most sizes
 16U to 50U side and rear panels
 mains distribution 19" Panel mounts
 optima eurocraft. Prices from £45 +vat
M&B Radio
 86 Bishopsgate Street Leeds LS1 4BB
 Tel. 0113 2702114 Fax. 0113 2426881

PHILIPS 5390S
1GHz RF SYNTHESIZER
WITH SERVICE MANUAL
£1099 + VAT
 100KHz to 1020MHz, -127dBm to +13dBm
 Unique video modulation + sound at
 4.5/5.5/6.0MHz, int or ext AM (to 1.02GHz) or FM
 (to 340MHz)
 RF sweep - 8 settings memories - IEEE interface
Anode Laboratories Ltd
 Tel: 01353 649412 Fax: 01353 648128

ADVANTEST TR4131, 4GHz Spectrum
 Analyser £2,995.00, Anritsu ML522, 300-
 1000MHz Measuring Rx £2,995.00, Racal 1795
 Rx £795.00, Eddystone 1650, 10KHz-30MHz Rx
 £995.00, W.J. 340A-6, 1-900KHz Rx £395.00,
 W.J. 373A-10, .5-30MHz Rx £395.00, W.J.
 RS111-1B-39, 30-1000MHz Rx £995.00, W.J.
 9477, Demodulator £795.00, Tel/Fax: 01908-
 365726 or Email: phil@two-way.demon.co.uk

UNUSED TMS77C82NL any quantity con-
 sidered. Tel: 0181 930 0943. Fax: 0181 933 2996.

RF DESIGN SERVICES
 All aspects of RF
 hardware development
 considered from
 concept to production.

WATERBEACH ELECTRONICS
TEL: 01223 862550
FAX: 01223 440853

ELECTRONIC CIRCUIT SIMULATOR
PROGRAM FOR PCs. Calculates gain, phase
 and impedances. Provides graphical output. Many
 circuit examples. £10. Montgomery 01753
 643384.

WANTED PART-TIME MICROCHIP PIC
PROGRAMMER, to work on one-off
 interesting projects. Contact Simon on: 01784
 457953 (Staines). Email: teces@globalnet.co.uk

DISPOSAL SALE of PTFE/FEP s/plate
 equipment, wires and multicore cables, mixed
 specs, colours and sizes. Tel: 01772 435858.

COMPUTER UPS. 1KVA 240V including two
 12V 24Ah batteries in fair condition. Tel Bristol
 0117 9793883.

ARTICLES WANTED

VALVES, etc, WANTED
 Most types considered but especially KT88, PX4/PX25, KT66, KT77, EL34,
 EL37, ECC83. Valves must be UK manufacture to achieve top prices. £220
 paid for working quad stereo system (II + II + 22).
COURTEOUS, PROFESSIONAL SERVICE
 Ask for a free copy of our wanted List.
BILLINGTON EXPORT LTD., Billingshurst, Sussex RH14 9EZ
 Tel: 01403 784961 Fax: 01403 783519
 Email: billingtonexportltd@btinternet.com
 VISITORS PLEASE PHONE FOR APPOINTMENT

★★ WANTED ★★
 Test equipment,
 Electronic Scrap, Valves,
 Transmitters/Receivers,
 Factory and Warehouse
 Clearance.
 Confidentiality Assured.
TELFORD
ELECTRONICS
 Phone: 01952 605451
 Fax: 01952 677978

TOP PRICES PAID
 For all your valves,
 tubes, semi conductors
 and IC's.
Langrex
Supplies
Limited
 1 Mayo Road, Croydon
 Surrey CR0 2QP
 TEL: 0181 684 1166
 FAX: 0181 684 3056

ADVERTISERS' INDEX

ANCHOR SUPPLIES	854	MILFORD INSTRUMENTS	848
CMS	822 & 848	NUMBER ONE SYSTEMS	866
CONFORD ELECTRONICS	837	OLSON ELECTRONICS	812
CROWNHILL	837	PICO	819
DATAMAN	OBC	PS CONSULTANTS	810
DISPLAY ELECTRONICS	878	QUICKROUTE	861
EQUINOX TECHNOLOGY	IBC	RALFE ELECTRONICS	896
HATELY ANTENNA	865	SAFETY POWER	IFC
ICE TECHNOLOGY	841	SEETRAX	836
JOHNS RADIO	875	STEWART OF READING	861
JPG ELECTRONICS	883	SURREY ELECTRONICS	837
LABCENTER ELECTRONICS	863	TELFORD ELECTRONICS	883
LANGREX	865	TELNET	858
M & B RADIO	866	THOSE ENGINEERS	865
MAPLIN	849	TIE PIE	815
		WILMSLOW	886

APPOINTMENTS



BBC Research and Development

Kingswood Warren, Tadworth, Surrey.
 Research and Development Department provides engineering R&D for the BBC.
 Working with partners in the UK and Europe, we are currently undertaking
 projects in all areas of broadcasting including digital television, digital radio and
 multimedia projects. To contribute to our progress in these areas, we seek
 two highly creative individuals who are ready to take their knowledge and
 skills to new levels.
 Spectrum Planning Group is a team of about thirty professional engineers who
 handle all matters relating to the provision of radio spectrum to new services,
 protection of existing services, effects on non-broadcast services, national and
 international co-ordination, and providing outline designs for new transmitters.

Research & Development Engineer

Salary in the range: £22,000 - £28,000 according to experience.
 You will be contributing to the successful launch of the BBC's terrestrial digital
 television and digital radio services, carrying out research, software development
 and practical measurements to refine and update the planning processes, an area
 which has increased greatly with the move into new OFDM-based digital
 transmission systems.
 Holding a good honours degree in Electronics, Physics, Computer Sciences or a
 closely related subject, you should have broadcast engineering experience,
 preferably in an R&D capacity. An effective communicator who can lead and
 motivate support staff, you'll be a good team player and be ready to make a
 significant contribution to our continuing success.
 Initially the work is in Spectrum Planning Group, but in the future you may be
 required to work in any of the other groups in the Department: Studio,
 Multimedia & Networking, Transmission Systems and System Design.
Ref. 28878/AS

Service Planning Engineer

Salary in the range: £17,500 - £23,000 according to experience.
 The work will involve site tests for proposed new transmitting stations and
 surveys of the coverage of existing ones, as well as work at Kingswood,
 calibrating and setting up equipment in vehicles.
 You must be qualified to Higher National Certificate, Higher TEC or equivalent
 standard in the field of Electronic/Electrical Engineering, Physics or Computer
 Sciences, have good knowledge of radio-frequency measurement techniques and
 possess a valid UK driving licence. You should have experience of using a
 personal computer and a basic understanding of radio propagation.
 You will receive training in the use of survey vehicles and equipment, including
 our helicopter-borne transmitter survey system, and you will then be required
 to work individually or as part of a small team. Although based at Kingswood
 Warren, you must be prepared to travel and work for periods anywhere in the
 UK, and this may include weekend working. **Ref. 28879/AS**
 We are located in attractive surroundings in Kingswood, Surrey, with staff restaurant
 and club facilities. Further information on BBC Research & Development and our
 work can be obtained from our web site at <http://www.bbc.co.uk/rd>
 For further details and an application form, please contact
BBC Recruitment Services (quoting appropriate ref.) by September
 21st on 0181-740 0005, Minicom 0181-225 9878. Alternatively, send a
 postcard to **BBC Recruitment Services, PO Box 7000, London W12 8GJ**,
 or e-mail recserv@bbc.co.uk quoting ref. and giving your full name and
 address. Application forms to be returned by September 24th.
 You can also see this vacancy on [http://www.bbc.co.uk/jobs/](http://www.bbc.co.uk/jobs/e28878.shtml)
[e28878.shtml](http://www.bbc.co.uk/jobs/e28878.shtml) and apply online from our world wide web site.



Working for equality of opportunity

Contact Joannah Cox on
0181 652 3620

ELECTRONICUPDATE

A regular advertising feature enabling readers to obtain more information on companies' products or services.

T & M EQUIPMENT



ADVANTEST TR9407 ft spectrum analyser to 1MHz PRICED TO CLEAR*	E1500
ANRITSU MES18A pcm error-rate test set 1kbit/sec-150 Mbit/sec* PTC*	E500
ANRITSU MES20B digital transmission analyser	E4000
ANRITSU MLS3A optical power meter with MA96A power sensor (0.75-1.8µm)	E1000
ANRITSU MN95D fibre-optic attenuator 0-85db	E250
BRADLEY 192 oscilloscope calibrator PTC*	E250
CHASE LFR1000 interference measuring receiver 9kHz-150kHz PTC*	E200
DATRON 1061 voltmeter, PTC*	E250
DRANETZ 626-PA-8006 ac neutral monitor, c/w TR2018 clamp	E250
EIP 575 source locking frequency counter 18GHz GPIB option	E1500
FLANN MICROWAVE Z7072 frequency meter 73-113GHz	E275
FLANN precision rotary waveguide attenuator 20110 0-60db 18-26GHz	E750
FLANN precision rotary waveguide attenuator 22110 0-70db 26-40GHz	E750
IFR A-7550 1GHz portable spectrum analyser with receiver options AM/FM/SSB	E3000
IFR A-7550 spectrum analyser 1GHz with tracking generator option PTC*	E2500
KEITHLEY 192 programmable digital multimeter	E400
MAURA MICROWAVE 8650E TNC-calibration kit	E1500
NARDA dual directional coupler 1-4GHz	E200
NARDA 3020A dual directional coupler 500-1000MHz	E350
PHILIPS PMS193 synthesized function generator 0.1MHz-50MHz	E2000
PHILIPS PMS580 I.F. modulator (PAL 1)/PMS582 UHF-converter PTC*	E100
PHILIPS PMS580 I.F. modulator (PAL 1) PTC*	E100
RACAL-DANA 9008 modulation meter	E350
RACAL-DANA 1995 option 01, 200MHz universal counter/timer PTC*	E500

ralfe electronics exclusively professional T&M ©

• 36 Eastcote Lane • South Harrow • Middx HA2 8DB • England •
TEL (+44) 0181-422 3593 • FAX (+44) 0181-423 4009

EST
45
YRS



DISTRIBUZIONE E ASSISTENZA, ITALY: TLC RADIO, ROMA (06) 871 90254

RHODE & SCHWARZ UDS 5, 5.5-digit multimeter IEEE	E650
RHODE & SCHWARZ URE rms digit voltmeter IEEE	E750
SCHLUMBERGER 1254 4-channel frequency response analyser	E3500
SCHLUMBERGER 4922 radio code analyser	E250
SCHLUMBERGER SRTG-GA62 selective call test set	E250
SYSTRON DONNER 8041A 100MHz 8-digit frequency counter IEEE	E250
TAU-TRON MN302/MB302N bert transmitter/receiver PTC*	E250
TEXSCAN 1503 sweep generator 450-950MHz PTC*	E100
WANDEL & GOLTERMANN PF2 error ratio measuring set	E400
WANDEL & GOLTERMANN DLM-Z0 data circuit test set	E250
WANDEL & GOLTERMANN PCM3 telephone channel test set	E500
WANDEL & GOLTERMANN SPM31 level meter PTC*	E500
WANDEL & GOLTERMANN WM30 level tracer	E500
WANDEL & GOLTERMANN PF4 bit error reate tester (BNS11/01, Opt 00.01)	E2000
WAVETEK 23 synthesized function generator 0.01Hz-12MHz	E1000
WAVETEK 1080 sweep generator 1-1000MHz	E1250
WAYNE KERR 3220 20A bias unit (for 3245 inductance analyser)	E1250
WAYNE KERR SR268 source and detector	E250
WILTRON 560A scalar analyser PTC*	E350
WILTRON 6637 sweeper generator 2-18GHz (option 03)	E2000
WILTRON 6659A sweep generator 10MHz-26.5GHz	E3000
(options 01/10/13)	E3000
WILTRON 6640B sweep generator 26.5-40GHz (options 03)	E3500

NB items marked 'PTC*' are 'priced to clear' and have been significantly reduced in price as we need the space. Working, no accessories, no guarantees but 7-day right to refuse.

HEWLETT PACKARD

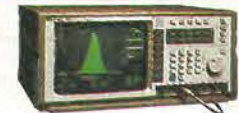

1640B serial data generator	E500
346A noise source	E350
10715A digital interferometer	E1000
3336A synthesizer/level generator	E2000
3235A switch/test unit	E1000
11857D 7mm test port cables	E500
33320G/33322G programmable attenuators 4GHz, with driver 11713A	E650
As above but 18GHz set	E1000
3552A transmission test set	E500
3561A dynamics signal analyser	E5000
3586A selective level meter	E1250
E3615A bench power supply	E175
37900D signalling test set with 2 x 37915A interface cards	E5500
4948A /04) in-service TIM set	E500
4093B protocol tester base (PT300)	E3000
435B/8481A microwave power meter	E500
436A digital power meter	E650
437B digital power meter	E750
8018A serial data generator	E1000
5334B frequency counter, option 060	E1000
83411C lightwave receiver 100/1550nm	E1750
83440C lightwave detector 20GHz 1300nm/1550nm	E2000
8350A sweeper mainframe/86290B 2-18GHz plug-in	E3000
83572B sweeper plug-in unit (for 8350B) 26.5-40GHz	E7500
8590A 1.8GHz spectrum analyser	E2500
86222A/8620C 10MHz-2.4GHz sweep generator system	E1500
8672A synthesized signal generator Z-18GHz	E6500
8903B audio analyser E2500 - (specify your own filter requirements-add £200 for each filter)	E1500
J2215A FDDI portable multimode test set	E1500

All equipment sold calibration-checked by independent laboratories and carries un-conditional refund and 90-day guarantees. FOR EXCLUSIVE ACCESS TO OUR COMPLETE STOCK INVENTORY AND SPECIAL BARGAIN DISPOSAL PLEASE CHECK OUR WEBSITE www.ralfe-electronics.co.uk

ISO9002 ACCREDITED STOCKIST MEASUREMENT & TEST EQUIPMENT

CIRCLE NO.146 ON REPLY CARD

The Affordable Solution for 8051 & AVR™ Microcontroller Support Tools

DISTRIBUTORS FOR



IAR Microcontroller Development Tools

C-Compilers, Assemblers, Simulators

8051, Atmel AVR, Hitachi H8

MICRO-PRO DEVICE PROGRAMMER

The complete programming solution!

Supports:

MICROCONTROLLERS
Atmel 89C, 89S, 90S(AVR),
Generic 87C, Dallas 87C520
FLASH MEMORY
Atmel 29C, 49F
SERIAL/PARALLEL EEPROM
Atmel 24C, 25C, 59C, 93C, 28C
CONFIGURATORS
Atmel 17C, Xilinx XC17

Not all devices may be supported within each family.

NOW SUPPLIED WITH LIBRARIES FOR...

Only... £124.95

Order Code: MPW-PLUS



PROFESSIONAL AVR™ MICROCONTROLLER STARTER SYSTEM

System Contents

- Combined Serial & Parallel Device Programmer
- Evaluation module for 8, 20 & 40-pin DIL devices
- In-System Programming (ISP) Cable
- Integrated Windows™ Development Environment
- AVR™ Basic LITE (1k bytes code) Compiler
- AVR™ Assembler
- Mains Power Supply Adaptor
- PC Serial Cable (Connects to PC COM Port)
- Atmel CD-ROM Datbook
- One AT90S1200 DIL Microcontroller



Figure 1

Order Code: AVR2-ST

Only... £99.95

WRITE IN BASIC RUN IN A FLASH

AVR™ BASIC

- Compiled BASIC generates tight AVR™ machine code
- Not a Run-Time Interpreter; NO code overhead!
- Target speeds comparable with assembler
- Breaks the cost barrier for small projects
- Ideal for educational, hobbyist and professional use

Order Codes:
AVR-BAS-LITE
AVR-BAS-8K

Only... £24.95

and £149.95

FLASH 8051 Professional Starter System

System Contents

- Combined Serial & Parallel Device Programmer
- Evaluation module for 20 & 40-pin DIL devices
- In-System Programming (ISP) Cable
- Keil PK51-2K Integrated Windows™ Development Environment (2K code limit). Includes C-Compiler, Macro Assembler, Linker, Hex Creator, Editor & Simulator
- Mains Power Supply Adaptor
- PC Serial Cable
- Atmel CD-ROM Datbook
- One AT89S8252 40-pin DIL Microcontroller

System layout shown in Fig 1 above

Order Code: EQ-8051-ST1

Only... £124.95

KEIL SOFTWARE THE ULTIMATE 8051 TOOL SET



µVision
Integrated Development Environment for Windows™

- Optimising Ansi-C Compiler
- Macro Assembler
- Linker
- Software Simulator
- Integrated Editor
- Hex Creator

Starter Systems supplied with 2K Toolset & Development Systems supplied with 8K Toolset are available for Atmel, Dallas, Siemens, Temic 8051 microcontroller derivatives

For sales tel: +44 (0) 1204 529000, fax: +44 (0) 1204 535555, e-mail: sales@equinox-tech.com, Web Site: www.equinox-tech.com

EQUINOX DISTRIBUTORS: AUSTRALIA Farnell +61 2 9645 8888 AUSTRIA Farnell +43 0660 87 75 BELGIUM Alcom Electronics NvSa +32 3 227 36 47 BRAZIL Hasteck +55 11 522 1799 Anacom +55 11 453 5588 DENMARK Farnell +45 44 53 66 44 EIRE Farnell +353 1 8309277 FINLAND Farnell +358 9 3455 400 FRANCE Farnell +33 474 65 94 66 NEWTEK +31 4687 2200 GERMANY Elektronik Laden +49 52 32 81 71 Farnell +49 89 61 39 39 Inetek GmbH +49 7321 93850, MSC Vertriebs GmbH +49 08 9945532 12 GREECE Microlec +30 1 5395042 4 HONG KONG Farnell 800 968 280 (HK Direct Toll Free) ITALY Farnell +44 113 231 1311 Gnflo Italian Technology +39 51 89 20 52, Newtek Italia +39 2 33 10 53 08 MALAYSIA Farnell +60 3 773 8000 NETHERLANDS Alcom Electronics BV +31 10 4519533 Antratek +31 10 450 4949 Farnell +31 30 241 2323 NEW ZEALAND Farnell +64 9 357 0646 NORWAY ACTE NC +47 63898900 Jakob Hatteland Electronic AS +47 53763000 PORTUGAL Anatomic +35 119 371 834 Farnell +44 113 289 0040 SINGAPORE Farnell +65 788 0200 SPAIN Anatomic SA +34 1 366 01 59 Farnell +44 113 231 0447 SWEDEN ACTE NC +46 8 445 28 70 Farnell +46 8 730 50 00 SWITZERLAND Anatek Ag +41 41 748 32 41 Farnell +41 204 64 64 UNITED KINGDOM Abacus Polar +44 1204 202025 Farnell +44 113 263 6311 Rapid Electronics +44 1206 751166 Quarndon Electronics +44 1332 332651 USA Hitools Inc +1 408 298 9077 Newark Electronics +1 800 718 1997, Peachtree Technology +1 770 888 4002 Pioneer Standard +1 888 832 3976

Equinox reserves the right to change prices & specifications of any of the above products without prior notice. E&OE. All prices are exclusive of VAT & carriage. AVR™ is a trademark of the Atmel Corporation

CIRCLE NO. 107 ON REPLY CARD

New From National Instruments Free Software Showcase CD-Rom



The Free Software Showcase CD, from National Instruments, provides engineers and scientists with extensive information and demonstration versions of industry-leading application software for measurement and automation applications, such as LabView™, LabWindows™/CVI, Lookout™, HiQ™ and more. Now in standard HTML format, Software Showcase delivers an easy-to-use interface and direct access to information via the internet.

Call National Instruments for your FREE copy on:
01635 523545

CIRCLE NO.147 ON REPLY CARD

CABLING SOLUTIONS FROM THE LCD EXPERTS



Trident Microsystems' new LVDS system, provides the cabling solution to overcome all the problems associated with driving Digital TFT over long distances.

Trident's new LVDS system now allows for digital drive of up to 20 metres in length.

For further details call Trident today
Tel: 01737 780790
Fax: 01737 771908

CIRCLE NO.149 ON REPLY CARD



LCR & IMPEDANCE METERS

The 3522 LCR HiTESTER and 3531 Z HiTESTER together provide a wide range of test frequencies. The 3522 offers DC and a range from 1mHz to 100kHz and the 3531 covers the range from 42Hz to 5MHz. Test conditions can now come closer to a component's operating conditions. The high basic accuracy of ±0.08%, combined with ease of use and low price give these impedance meters characteristics.

TELONIC INSTRUMENTS LTD

Tel: 0118 9786911
Fax: 0118 9792338

CIRCLE NO.148 ON REPLY CARD



INDUSTRIAL COMPUTER PRODUCTS

The latest ICP catalogue featuring a comprehensive range of CPU boards and enclosures, complete with price list, is now available from Wordsworth.

Further details from:
Wordsworth
Tel: 01732 861000

CIRCLE NO.150 ON REPLY CARD



The Embedded Solutions Company
3 Atlas House St Georges Square Bolton BL1 2HB England



[TRUTH
OR
ILLUSION?]

the world's most powerful portable programmers

CE



Dataman S4

[Analysis]

- Programs 8 and 16-bit EPROMs, EEPROMs, PEROMs, 5 and 12V FLASH, Boot-Block FLASH, PICs, 8751 Microcontrollers and more.
- EPROM emulation as standard!
- Rechargeable battery power for total portability.
- All-in price includes emulation leads, AC charger, PC software, spare library ROM, user-friendly manual.
- Supplied fully charged and ready to use.

S4 GAL Module

[Analysis]

- Programs wide range of 20 and 24 pin logic devices from the major GAL vendors.
- Supports JEDEC files from all popular compilers.

Dataman-48LV

[Analysis]

- Plugs straight into your parallel port of PC or laptop.
- Programs and verifies at 2, 2.7, 3, 3.3 and 5 V
- True no-adaptor programming right up to 48-pin DIL devices.
- Free universal 44-pin PLCC adaptor.
- Built-in world standard PSU – for go-anywhere programming.
- Package adaptors for TSOP, PSOP, QFP, SOIC and PLCC.
- Optional EPROM emulator.

Support

[Analysis]

- 3 year parts and labour guarantee.
- Windows/DOS software included.
- Free software updates via BBS/Internet.
- Free technical support for life.
- Next day delivery – always in stock.
- Dedicated UK supplier, established 1978.

Truth — Claim Verified

[Recommended Action]

Secure for own use without delay. Order via credit card hotline – phone today, use tomorrow. Alternatively, request more detailed information on these and other market-leading programming solutions.

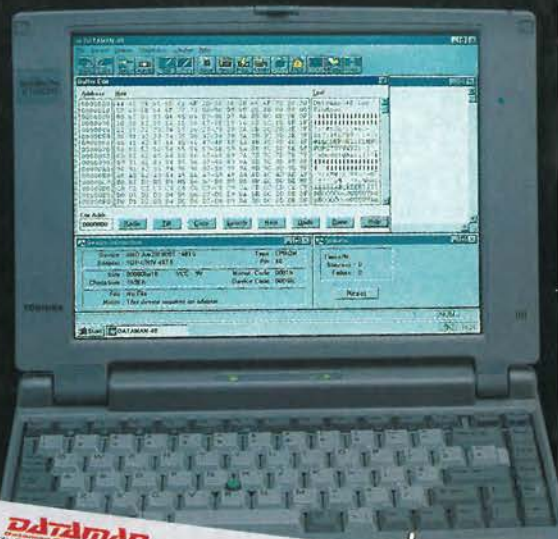

NEW MODEL



£795 PLUS VAT

3
YEAR
GUARANTEE

DATAMAN

Dataman Programmers Ltd, Station Road, Maiden Newton, Dorchester, Dorset, DT2 0AE, UK
Telephone +44/0 1300 320719 Fax +44/0 1300 321012
BBS +44/0 1300 321095 (24hr) Modem V.34M.FCV.32bis
Home page: <http://www.dataman.com>
FTP: <ftp://ftp.dataman.com> Email: sales@dataman.com

hotline
01300 320719



Orders received by 4pm will normally be despatched same day.
Order today, get it tomorrow!

Money-back 30-day Trial

Try the Dataman S4 or Dataman-48LV without obligation for 30 days. If you do not agree that these truly are the most powerful portable programmers you can buy, simply return your Dataman product within 30 days for a full refund.

CIRCLE NO. 109 ON REPLY CARD