

MARCH 1985 95p

Australia \$1.75
New Zealand \$1.95
Malaysia \$4.95

ISSN 0141-0857

Practical Wireless

THE RADIO MAGAZINE

March 1985
Practical
WIRELESS
DATACARD

HF Band Beacons

Frequency (MHz)	Call Sign	Location	
10 144	OK0WZY	W. Germany	
14 100	CT38*	Funchal, Azores	
14 100	UA30G*	Isle of Man	
14 100	KH6D/B*	Honolulu, Hawaii	
14 100	OH29*	Spain	
14 100	WSWA/B*	St. Paul, Alaska	
14 100	ZS6N/B*	New Zealand	
14 100	4U1UN/B*	USSR	
14 100	4X6TU/B*	New Zealand	
28 175	VE3TIN	Canada	
28 202	ZS5HF	South Africa	
28 202	ON1GI	Ontario, Canada	
28 205	MA15Y	Malaysia	
28 207	9A30P	Yugoslavia	
28 210	FO30N	France	
28 215	UR355	USSR	
28 217	VE3T	Canada	
28 217	VE3T	Canada	
28 220	5B3	USA	
28 222	28 225	28 228	28 230
28 235	VP2	Virgin Islands	
28 237	LASTEN	Osaka, Japan	
28 237	ZS3HL	Transvaal, S. Africa	
28 240	DM6CA	Cape Town, S. Africa	
28 242	ZS1CTB	Bahran	
28 242	9A30C	Yugoslavia	
28 245	221ANB	Butawayo	

KEY

- Region 1
- Other regions
- USA
- Amateur Service Allocation Basis
- Primary
- Secondary

* Because of the small band allocation that the IARU Region 1 has agreed used for Morse and other narrow-band width transmission modes such as RTTY

** See licence schedule for modes currently allowed

IPC Magazine 1985.

HF BAND PLANS

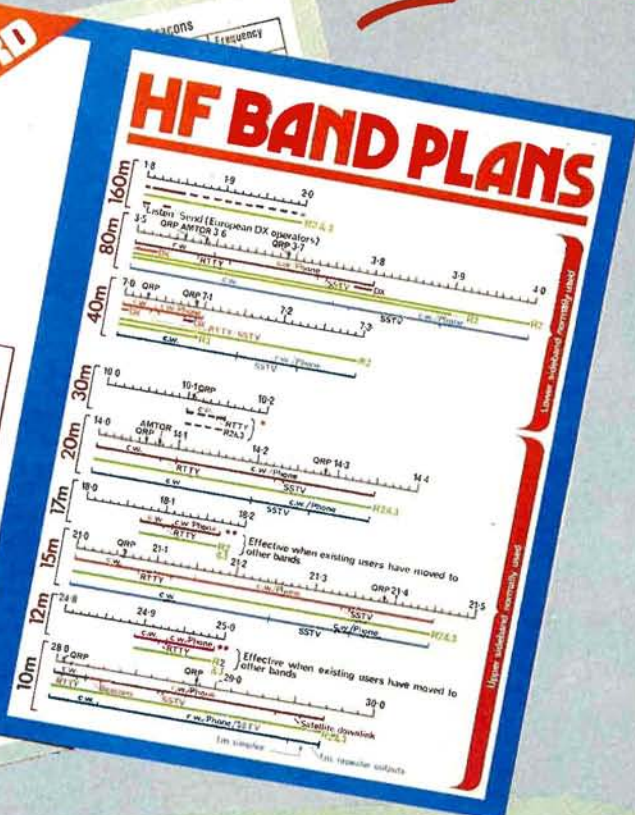

A 12-Element Yagi for 430 MHz

Modifying the AR-2001



Practical ATV Techniques

ANTEX

a world of soldering

Tomorrows Soldering Technology Today.

ANTEX has a worldwide reputation for quality & service & for many years has been one of the best known & most popular names in soldering. Always at the forefront of technology, ANTEX is continually researching new and better ways of achieving more accurate, reliable, and cost effective soldering. On ANTEX Soldering Irons, the advanced design of the interface between the element & the bit allows more efficient heat transfer to the bit and improved stability of the temperature at the point of contact with the work. Indeed, experiments have shown that an XS25 watt iron can be used for tasks where a 40 watt iron would normally have been required.

ANTEX Soldering Irons exhibit exceptionally low leakage currents & hence are suitable for use on Static Sensitive Devices. Sophisticated temperature controlled soldering units have recently been added to the ANTEX range.



SK5 Soldering Kit



ST4 Stand



TCSU1 Soldering Unit

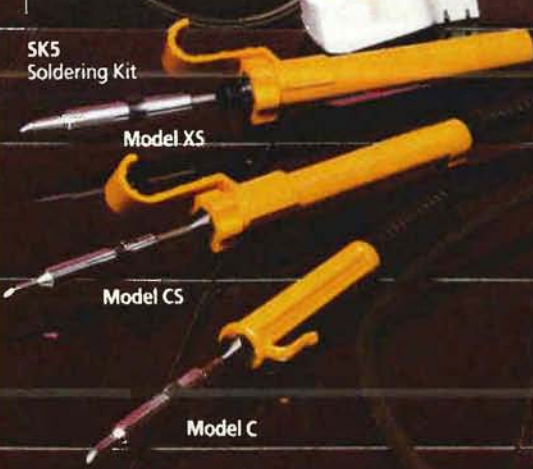

Model XS

Model CS

Model C



TCSU-D Temperature-Controlled Soldering Unit

Model C
- 15 Watts. Available for 250, 220, 115, 100, 50 or 24 volts.

Model XS
- 25 Watts. Available for 240, 220, 115, 100, 50, 24 or 12 volts.

Model XS-BP
- 25 Watts. 240 volts, fitted with British Plug.

ST4 Stand
To suit all irons

SK5 Soldering Kit. Contains model CS 240v Iron, an ST4 Stand and solder.

SK6 Soldering Kit. Contains model XS240v Iron, an ST4 Stand and solder.

SK5-BP and SK6-BP Soldering Kits as above with British Plug.

Model CS
- 17 Watts. Available for 240, 220, 115, 100, 50, 24 or 12 volts.

Model CS-BP
- 17 Watts. 240 volts, fitted with British Plug.

TCSU1
- Very robust temperature controlled Soldering Unit, with a choice of 30 Watt (CSTC) or 40 Watt (XSTC) miniature irons. Range 65°C to 470°C Accuracy ± 5°C

www.americanradiohistory.com

TCSU-D
Elegant Temperature Controlled Soldering Unit with 50 W Iron (XSD) and built around FERRANTI custom-made ULA. Range Ambient to 450°C. Accuracy ± 5°C. Zero crossing switching. Detachable sponge

ANTEX Made in England
ANTEX (Electronics) Ltd. Tel: 0732 667377 Telex: 45296
 Mayflower House, Plymouth, Devon.
 Please send literature, price list and my nearest stockist to:

Name _____ Address _____ Telephone _____



Practical Wireless

FOR THE **Radio** ENTHUSIAST ...

FREE WITH THIS ISSUE!
HF BANDPLAN DATACARD

MARCH 1985 VOL. 61 NO. 3 ISSUE 936

Contents

Staff

- 22** **Modifying the AR2001**
P. J. Turner G8TSY
- 24** **Multiple Choice**
Practice Questions for the RAE
- 28** **Vertical Antenna for 7MHz**
Stan Crabtree G3OXC
- 30** **12-element Yagi for 430MHz**
Dave Powis G4HUP
- 34** **Radio Wave Propagation—3**
F. C. Judd G2BCX
- 38** **PW Review**
Yaesu FT-203R 2m Hand-held
- 40** **Practical ATV Techniques—1**
Allan Latham G8CMQ
- 44** **Introducing Short-wave Listening—2**
Charles Molloy
- 51** **Valved Communications Receivers—2**
The R1155 by *Chas. E. Miller*
- 54** **Kindly Note**
PW Teme-4—February 1985
PW Triambic Keyer—February 1985

Regulars

- | | | |
|------------------|---------------|--------------|
| 79 Advert Index | 46 Letters | 18 PW RUIS |
| 33 Benny | 19 News | 17 Services |
| 48 Club News | 39 Next Month | 37 Swap Spot |
| 17 Comment | 55 On the Air | |
| 50 Did You Know? | 27 Products | |

EDITORIAL OFFICES

Practical Wireless
Westover House
West Quay Road
Poole, Dorset BH15 1JG
☎ Poole 671191

Geoff Arnold T.Eng FSERT, G3GSR
Editor

Dick Ganderton C.Eng., MIERE, GBVFN
Assistant Editor

Steve Hunt
Art Editor

John Fell G8MCP
Technical Editor

Alan Martin G8ZPW
News & Production Editor

Elaine Howard G4LFM
Technical Sub-Editor

Rob Mackie
Technical Artist

Kathy Moore
Secretary

ADVERTISEMENT OFFICES

Practical Wireless
King's Reach Tower
Stamford Street
London SE1 9LS
Telex: 915748 MAGDIV-G

Dennis Brough
Advertisement Manager
☎ 01-261 6636
☎ 01-261 6872

Roger Hall G4TNT (Sam)
Ad. Sales Executive
☎ 01-261 6807

Claire Gerrish
Secretary
☎ 01-261 6636

Barbara Blake
Classified Supervisor
☎ 01-261 5897

Ian Sweeney
Make-up & Copy
☎ 01-261 6570

COPYRIGHT © IPC Magazines Limited 1985 Copyright in all drawings, photographs and articles published in *Practical Wireless* is fully protected and reproduction or imitation in whole or in part is expressly forbidden. All reasonable precautions are taken by *Practical Wireless* to ensure that the advice and data given to our readers are reliable. We cannot however guarantee it and we cannot accept legal responsibility for it. Prices are those current as we go to press.

LOWE SHOPS

Whenever you enter a **LOWE ELECTRONICS** shop, be it Glasgow, Darlington, Cambridge, Cardiff, London or here at Matlock, then you can be certain that, along with a courteous welcome, you will receive straightforward advice. Advice given, not with the intention of "making" a sale, but the sort which is given freely by one radio amateur to another. Of course, if you decide to purchase then you have the knowledge that **LOWE ELECTRONICS** are the company that set the standard for amateur radio after-sales service. The shops are open Tuesday to Friday from 9.00 to 5.30 pm, Saturday from 9.00 to 5.00 pm and close for lunch each day from 12.30 till 1.30pm.

In **Glasgow** the **LOWE ELECTRONICS** shop (the telephone number is 041-945 2626) is managed by Sim GM3SAN. Its address is 4/5 Queen Margaret's Road, off Queen Margaret's Drive. That's the right turn off Great Western Road at the Botanical Gardens' traffic lights. Street parking is available outside the shop and afterwards the Botanical gardens are well worth a visit...

In the **North East** the **LOWE ELECTRONICS** shop is found in the delightful market town of Darlington (the telephone number is 0325 486121) and is managed by Don G3GEA. The shop's address is 56 North Road, Darlington. That is on the A167 Durham Road out of town. A huge free car park across the road, a large supermarket and bistro restaurant combine to make a visit to Darlington a pleasure for the whole family.

Cambridge, not only a University town but the location of a **LOWE ELECTRONICS** shop managed by Tony G4NBS. The address is 162 High Street, Chesterton, Cambridge (the telephone number is 0223 311230). From the A45 just to the north of Cambridge turn off into the town on the A1039, past the science park and turn left at the first roundabout, signposted Chesterton. After passing a children's playground on your left turn left again (between the shops) into Green End Road. Very quickly, and without you noticing it, Green End Road becomes High Street. Easy and free street parking is available outside the shop.

For **South Wales**, the **LOWE ELECTRONICS** shop is located in Cardiff. Managed by Richard GW4NAD, who hails from Penarth, the shop (the telephone number is 0222 464154) is within the premises (on the first floor) of South Wales Carpets, Clifton Street, Cardiff. Clifton Street is easily found, being a left turn off Newport Road just before the Infirmary. Once in Clifton Street, South Wales Carpets is the modern red brick building at the end of the street on the right hand side. Enter the shop, follow the arrows past the carpets, up the stairs and the "Emporium" awaits you. Free street parking is available outside the shop.

LOWE ELECTRONICS London shop is located at 223/225 Field End Road, Eastcote, Middlesex (the telephone number is 01-429 3256). The new shop, managed by Andy G4DHQ is easily found, being part of Eastcote tube station buildings and as such being on the Metropolitan and Piccadilly lines (approximately 30 minutes from Baker Street main junction). For the motorist, we are only about 10 minutes' driving time from the M40, A40, North Circular Road (at Hanger Lane) and the new M25 junction at Denham. Immediately behind the shop is a large car park where you can currently park for the day for 20p. There is also free street parking outside the shop.

Although not a shop there is on the South Coast a source of good advice and equipment - John G3JYG. His address is 16 Harvard Road, Ringmer, Lewes, Sussex. (telephone 0273 812071). An evening or weekend telephone call will put you in touch with John.

Finally, here in **Matlock**, David G4KFN is in charge. Located in an area of scenic beauty a visit to the shop can combine amateur radio with an outing for the whole family. May I suggest a meal in one of the town's inexpensive restaurants or a picnic on the hill tops followed by a spell of portable operation.

not even a mouse, could hide behind a TRIO TH21E.....

I am not for one moment suggesting that current hand-helds should be photographed with an elephant but I have heard many amateurs refer to their existing hand-helds as "bricks". That the TH21E could not be called. In fact I am tempted to say it is the rig that not even a mouse could hide behind. Over the past fourteen years I have watched amateur radio equipment develop from cumbersome to perfection. I remember John, G3PCY, showing me the first TR2400 and our mutual amazement at how TRIO could put so much radio in such a small package. Later developments produced the TR2500 and its 70 centimetre version, the TR3500 and left me in no doubt that TRIO would soon produce a compact inside pocket transceiver. At the same time it became apparent that a simpler rig with performance would have great appeal. That transceiver is the TH21E and being typically TRIO is

right first time. Size is not the most important feature, it's just the way the transceiver feels when picked up, impossible to put down. I am not going to give its dimensions, I will just say that it is hand sized, the true inside pocket transceiver. As an owner and with the rig always on your person the hobby of amateur radio expands to an all day event. **Never miss a contact, never miss a friend.**

A similar transceiver is available for 70 centimetres, the TH41E. Having the same features including reverse repeater the TH41E is just the rig that newcomers to the hobby have been looking for. Around the country are many 70 centimetre repeaters and what has been needed for some time has been a low cost FM rig that everyone could afford. The TH41E from TRIO is that transceiver and many amateurs are discovering the 70 centimetre band with one.

First of all the Pocketfone, now the TH41E.

1 watt output in high power position, 150 mW in low position.

Full coverage of the 2 metre amateur band from 144 to 146 MHz. (TH41E covers from 430 to 440 MHz.)

Frequency selection by simple thumbwheel switches.

Full repeater facilities including reverse repeater.

The rig comes complete with nicad pack and charger.

TH21E £179.48 inc VAT
TH41E £199.00 inc VAT



LOWE ELECTRONICS

Chesterfield Road, Matlock, Derbyshire. DE4 5LE.
Telephone 0629 2817, 2430, 4057, 4995. Telex 377482.
(Delivery of stock items normally by return of post)



the TRIO two metre base station, the TS711E.

Several weeks have passed since I took delivery of my own TRIO TS711E. The Japanese home market model has returned whence it came and I am using the version designed specifically for the UK market. The rig is perfection epitomised. For today's two metre operator any base station with less facilities and performance than the TS711E would be far from acceptable. The TS711E's receiver performance in sensitivity and in its ability to reject unwanted adjacent signals is outstanding. I'm not talking about test equipment figures though undoubtedly these will soon be published. My own on air operating with the rig has enabled me to hear what I previously couldn't.

The transceiver covers the 2 metre band from 144 to 146 MHz in FM, USB, LSB and CW modes. When switched to the auto position the rig correctly selects mode according to frequency, a great advantage to the blind operator. Simple up/down frequency shift is provided both on the transceiver front panel and microphone.

IF shift is available, an essential when considering today's crowded 2 metre band. For more penetrating transmitted audio when working DX speech processing can also be switched in.

The TS711E has two separate VFO's and forty channels of memory. Each memory remembers frequency, operating mode, simplex or repeater shift and whether or not a tone burst is to be included. Frequencies stored in memory can be readily transferred to either VFO A or B. The VFO can be either free running as for SSB or CW operation or electrically switched to a "click" stop where it changes frequency in 12.5 or 5 kHz steps. The two VFO's can quickly be put on the same frequency, an aid when checking the position of a strong adjacent signal with one VFO whilst remaining on your operating frequency with the other.

Frequency scan on VFO can be either between or outside user set limits. On memory the transceiver can either scan the entire memory contents or be instructed to look at those frequencies of a particular mode. The TS711E has a timed hold on an occupied channel.

Both priority channel and the immediate recall of your local net frequency are possible with the TS711E.

For those with failing sight or a blind operator the TS711E is a dream come true, not only is the operating mode identified by the appropriate CW letter sent in tone (F for FM, U for upper side band etc.), other rigs just beep but, when fitted with the VS1 optional board, a digitally encoded girls voice will announce both frequency and where applicable, whether the rig is switched to repeater shift.

TS711E 2 metres £792.15 carr £7.00
TS811E 70 cmtes £898.00 carr £7.00



DCS (digital code squelch) explained.

For many years amateurs up and down the country have used net frequencies. A particular channel which a group have used to keep in touch, not at the exclusion of general listening but when working in the shack. It was possible to pick an obscure frequency and for nobody other than those in the "net" to appear. Today, with many stations on the band that way of operating a net channel does not work. It is impossible in the more densely populated areas to find a frequency that will remain unused for many minutes. Those who have good locations have an even greater problem.

With the DCS system TRIO have introduced a simple method of providing a quiet net channel. The latest generation of TRIO transceivers, the handheld TR2600E and TR3600E, the mobile TM211E and TM411E and the base station TS711E and TS811E all have as standard DCS. DCS or digital code squelch to give its full name uses digitally coded information to open the squelch on a programmed receiver. The transceiver sends, both at the beginning and end of the transmission your code. If the transceiver belonging to your friend is programmed with the same code and of course you are on the same frequency then you will open his squelch and be heard. If you transmit without the code then he will not hear you. The code takes the form of a 5 digit digitally coded data string. By using 5 digits 100,000 different combinations are possible. The various rigs each have different capacities of code storage, the handheld TR2600E/TR3600E can each retain three codes whilst the TS711E/TS811E base stations can each hold up to ten. The great advantage of the TRIO system over previous designs is that the DCS system is an integral part of the equipment and as such is simplicity itself to use. Being part of the rig the system uses the keyboard to impart the information and the display to visually confirm your entry.

In addition the DCS system will hold and transmit in decimal ASCII code the operators call sign. The information is included in the data string. Call signs to a maximum of 6 digits may be stored. By using the optional CD10 call sign unit the incoming data is decoded and visually displayed. Not only that, the CD10 will store the call signs of the last twenty stations that called you, assuming they have the facility.

The transceivers will also tell you if you have been called in your absence. The TR2600E/TR3600E have a yellow led which illuminates when the rig is activated. The base station TS711E/TS811E have a call alarm which beeps until cancelled.

Of course, if you want to get really sophisticated then the base station transceivers will handle group calls. If your TS711E/TS811E is called, not necessarily on the code on which the equipment is set, the transceiver will first check if that particular code is one of the ten stored and whether it is active. The term "active" means that although ten codes are stored each needs individually switching on otherwise it will be treated as not being there. If the particular code has been activated then the squelch will open and your rig will automatically move to the new incoming code so that you may reply. Of course, if it didn't then you wouldn't know which code had been used and would be unable to reply. Unbelievable!

The DCS system is not complicated, that's just my description. What I do advise is that before buying a new rig, check whether it has DCS, best of all pop into a LOWE shop and see the system for yourself.

Please beware of KEWOOD equipment with DCL. This is a totally different system and is only for the Japanese home market. DCL enables your rig to do all the above but also look together with the transceiver it is working for a clear channel, the rigs doing this by themselves without you doing a thing. It may be all right in Japan where there are no 2 metre repeaters and there exists a different style of operating but I am sure you will agree that here it is totally unworkable.

LOWE ELECTRONICS

Chesterfield Road, Matlock, Derbyshire. DE4 5LE.

Telephone 0629 2817, 2430, 4057, 4995. Telex 377482.

(Delivery of stock items normally by return of post)





South Midlands

* FREE FINANCE • 2 YEAR GUARANTEE
BRANCHES AT: SOUTHAMPTON, LEEDS, CHESTER

'YAESU' FOR H.F. EQUIPMENT — 'SMC' AT YOUR SERVICE



FRG8800

SPECIFICATION

FREQUENCY COVERAGE:

150KHz-29.999MHz
118MHz-173.999MHz*

FREQUENCY RESOLUTION:

100Hz (Digital Readout)

FREQUENCY STABILITY:

<±300Hz in 30 mins after 1 min on <50Hz
in 30 mins after warm up

MODES OF RECEPTION:

AM, CW, FM, NB, SSB (LSB/USB) A3E,
A1A, G3E, J3E

SELECTIVITY:

SSB/CW (J3E/A1A):
2.7KHz @ -6dB, 8.0KHz @ -50dB

FM (G3E) narrow:

12.5KHz @ -6dB, 30KHz @ -40dB

AM (A3E/H3E) (standard/narrow):

6.0KHz @ -6dB, 15KHz @ -50dB
2.7KHz @ -6dB, 8KHz @ -50dB

SENSITIVITY:

SSB/CW (J3E/A1A) @ 10dB S + N/N:
<0.4uV into 50 ohms, 1.50-30MHz
<3.0uV into 500 ohms, 0.15-1.6MHz
<1.0uV into 50 ohms, 118-174MHz*

FM (G3E) @ 20dB S + N/N

<1.0uV into 50 ohms, 1.60-30MHz

<2.0uV into 50 ohms, 118-174MHz*

AM (A3E) @ 10dB S + N/N:

<4.0uV into 50 ohms, 1.60-30MHz

<3.0uV into 500 ohms, 0.15-1.6MHz

<10uV into 50 ohms, 118-174MHz*

SQUELCH SENSITIVITY:

SSB/CW (J3E/A1A):

<2uV, 1.60-30.0MHz

<4uV, 118-174MHz*

FM(G3E):

<0.5uV, 1.6-30.0MHz

<1.0uV, 118-174MHz*

AM (A3E):

<2uV, 1.60-30.0MHz

<4uV, 118-174MHz*

AUDIO OUTPUT:

1.4W in 8 ohms internal @ 10% T.H.D.

4-16 ohms external speaker/phones

Constant level line output (recorder)

POWER REQUIREMENTS:

100/120 220/240V @ 50/60Hz

35VA Rx, 5VA standby

12V DC (nominal)*

1A Rx, 0.020A standby

DIMENSIONS (Ex/Inc. projections)

335/350 W, 120/130 H, 235/270D, mm

Weight 6.1/6.3Kg (w/o, c/w VHF unit)

*OPTIONAL UNIT

General Coverage

Continuous coverage from 150KHz to 30MHz. Two speed spin tuned VFO plus keyboard plus computer interface control.

All mode

The FRG8800 demodulates SSB (USB & LSB) CW, AM (Wide and Narrow) and FM narrow as standard. This, complemented by an all mode squelch, produces the most practical receiver available. The FM narrow is useful for 10M, CB and for VHF with the optional VHF convertor.

Memory

The FRG8800 comes fully equipped with twelve memories programmed and scanned at the touch of a single button. Any of the memory channels will accept a frequency within the whole range of the receiver including the VHF range (with the optional VHF unit). The mode is also stored in the memory eliminating the need for inconvenient manual mode change, when hopping from one memory to the next.

Selectivity & Sensitivity

Four filters are fitted as standard (SSB/CW, AM, AM-NAR and FM NAR) with bandwidths chosen for optimum performance, these combined with switchable AGC and variable tone control provides maximum enjoyment despite today's crowded bands.

High input sensitivities are obtained by the latest in RF stages, making the most of inefficient aeriels and difficult locations, and a continuously variable RF attenuator control overcomes problems encountered with very powerful stations.

LCD Display

The back-lit green LCD display incorporates easy to read "any angle" 10mm digits. A twelve function display indicates the transceiver's status at a glance. It includes memory channel number, mode, and frequency to a resolution of 100Hz. Also included is a two dimensional LCD, graphical SIMPO and 'S' meter, which is conventionally calibrated at 1-5 and 0-9, +20dB, +40dB, +60dB respectively.

Keyboard

A 12 button keyboard is fitted as standard allowing quick accurate changes of frequency and band, (MHz and KHz programmed individually). The keyboard also has nine control buttons to allow rapid changes from memory to VFO, memory to memory and VFO to memory. Memory channels can also be recalled at the turn of a knob, ideal for storing calling/working channels or broadcast reception.

The keyboard is complemented by an opto-coupled, two speed, VFO drive, fast for rapid tuning of a band or slow for accurately tuning in a signal. In addition a fine tune control compensates for drift in the received signal. The dial can be electronically locked preventing accidental change in frequency.

Clock/timer

Dual accurate 12 hour clocks, with AM/PM indicators are ideal for log keeping (GMT/Local). The clock uses the main digital display and features full back-up facilities in the event of a mains failure or disconnection. The timer can activate the receiver or tape recorder via the relay contacts provided. A snooze facility allows up to 59 minutes of listening.

VHF Convertor (optional)

The FRV8800, extends coverage to include 118-174MHz all within the main frame, thereby allowing monitoring of: PMR, marine and air bands, as well as 2M.

The FRG8800 is operated as before via the keyboard or VFO, and the memory still holds any frequency and mode. The actual VHF frequency is displayed on the main LCD to a resolution of 100Hz.

Worldwide

At 6.1Kg (excluding convertor) the FRG8800 is ideal for taking on any trip. The power supply is easily adjustable from 240-220 VAC to 110-120V, 50/60Hz mains and 12V DC operation is available as an option.

SMC STOCK CARRYING AGENTS WITH DEMONSTRATION FACILITIES

JOHN DOYLE, TRANSWORLD COMMS, NEATH (0639) 52374 DAY

(0639) 2942 EVE JOHN STRINGER, SMC, NORTHERN IRELAND (0247) 464875

SMC SERVICE

Free Securitor delivery on major equipment
Access and Barclaycard over the phone.
Biggest branch agent and dealer network.
Securitor 'B' Service contract at £5.00
Biggest stockist of amateur equipment.
Same day despatch wherever possible.

FREE FINANCE

*On many regular priced items SMC offers.
Free Finance for invoice balance over £120.
20% down and the balance over 6 months or
50% down and the balance over a year.
You pay no more than the cash price!
Details of eligible items available on request.

GUARANTEE

Importer warranty on Yaesu Musen products.
Aby staffed and equipped Service Department.
Daily contact with the Yaesu Musen factory.
Tens of thousands of spares and test equipment.
Twenty-five years of professional experience.
• 2 Year warranty on regular priced Yaesu products.

Communications Ltd.

SEE, MAIN DISTRIBUTOR FACTORY BACKED

BUCKLEY, STOKE, GRIMSBY, JERSEY, EDINBURGH, N. IRELAND.



YAESU FOR VHF EQUIPMENT — 'SMC' YOUR SUPPLIER

NEW FT209R/FT709R HAND HELDS

KEYBOARD ENTRY — SCANNING COMPREHENSIVE LCD DISPLAY

Two 4 bit CPU's. 10 memories (independent Tx & Rx) reverse/simplex (either) by single key touch, scanning; manual-auto band (full or partial) — memory, clear-busy, skip-select, programmable power save system (10 selectable dwell times). Large LCD 1/4" Digits + 10 special functions, "any angle". Meter; S/battery condition, VOX. 65x34x169mm.

INCREDIBLE

FT209R (1.8W)	c/w FBA5, YHA14A, CSC10 etc	£209.00
FT209R (2.7W)	c/w FNB3, YHA14, CSC10 etc	£239.00
FT209R (3.7W)	c/w FNB4, YHA14, CSC11 etc	£249.00
FT209RH (2.3W)	c/w FBA5, YHA14, CSC10 etc	£229.00
FT209RH (3.7W)	c/w FNB3, YHA14, CSC10 etc	£259.00
FT209RH (5.0W)	c/w FNB4, YHA14, CSC11 etc	£269.00
CSC10	Soft case (FBA5, FNB3 fitting).....	£6.90
CSC11	Soft case (FNB4 fitting).....	£7.65

For general accessories see FT203R list.
FNB5, FNB3, FNB4, YH2, MH12A2b, SMC8.9AA, NC15, MMB21

NEW FT203R & FT703R HANDHELDS

"THUMBWHEEL" TINY HANDHELD

Ultra compact 65W x 34D x 153Hmm, synthesised handheld. Computer aided design and component insertion with chip capacitors and resistors has produced this modern marvel: 2.5W RF (10.8V) (3.5W RF (12V)). It has VOX (for use with YH-2 lightweight headset, and built in 'S'/PO meter. Supplied with tone burst, helical and appropriate case.

FT203R	c/w FBA5, CSC6 etc	£155.00
FT203R	c/w FNB3, CSC6 etc	£185.00
FT203R	c/w FNB4, CSC7 etc	£190.00
FBA5	7.29V Cell case only (6x'AA')	£6.50
FNB3	10.8V NiCad Pack (425MAH)	£35.00
FNB4	12.0V NiCad Pack (500MAH)	£40.00
CSC6	Soft case (FBA5 or FNB3 fitting).....	£5.75
CSC7	Soft case (FNB4 fitting).....	£6.90
YH2	Headphone/Microphone option.....	£29.90
MH-12A 2b	Speaker/Microphone option.....	£14.55
MMB21	Mobile mounting bracket.....	£7.65
SMC8.9AA	Charger (slow) 13A style	£8.45
NC15	Charger (quick) and Power Unit.....	£57.50

FT2700RH — TWO-IN-ONE

The ultimate 2M and 70cms FM radio based on Yaesu's new die-cast aluminium chassis, allowing 25W output on both bands. Two 4-bit CPU's allow simple operation of the dual VFO's 10 channel memory, with back up. Dual: receiver front ends, local synthesisers, IF's and transmitter RF stages gives full duplex capability. Comprehensive scanning facilities allow continuous or skip scanning between memory channels in the same band, combined with a MHz switch for changing from one band to another. Large green LCD gives aesthetically pleasing and easy to read display of transceiver operating status incl. memory and reverse repeater at a glance. The PO/S meter is a distinctive two colour graphical LCD incorporated into the main display.



FT2700RH	Tx/Rx, 2M/70cms, 25W/25W, Full Duplex	£520.00
FT2SYNTH	Voice Synthesiser Module	£21.45
OMT2700RH	Owners Manual	£2.65

FT270R/RH — LARGE ON OUTPUT

FT270R/RH is a 2M FM Transceiver based on a unique diecast aluminium heatsink with ducting which allows a continuous 45W output (RH model). The R model is rated at 25W output. The LCD display uses large 5mm digits allowing easy reading of all transceiver functions. Dual 4-bit microprocessors allows quick operation of dual VFO's, ten memories and scanning. Upper and lower band scanning limits can be set as well as monitoring priority memory channel. Optional voice synthesiser is available to give an audible indication of frequency, at the touch of a button.



FT270R	Transceiver 2M, FM, 25W synthesised	£325.00
FT270RH	Transceiver 2M, FM, 45W synthesised	£380.00
FT2SYNTH	Voice Synthesiser Module	£21.45
OMT270R	Owners Manual	£2.65

FT757GX THE BIGGEST SELLER

Every item normally sold as an extra is provided as standard, including AM and FM modes, a 600Hz narrow CW filter, iambic keyer with dot-dash memory, 25KHz marker generator, IF shift and width filters, effective noise blanker and AF speech processor ... all at no extra charge.

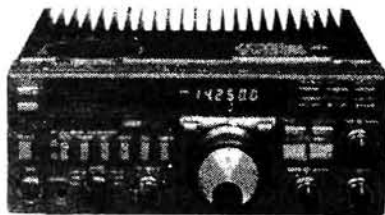

FT757GX	Transceiver General Coverage RX.....	£759.00
FC757AT	Automatic antenna tuner	£249.00
FP757GX	Switch mode PSU (50pc duty)	£140.00
FP757HD	Heavy duty PSU (100pc duty)	£179.00
FIF80	Computer interface for PC8001 NEC.....	£106.20
FIF65	Computer interface for Apple II.....	£54.80
FIF232C	Computer interface RS232C	£58.65

FT77 THE IDEAL MOBILE

Employing all the latest engineering and manufacturing techniques the FT77 is intended to offer the essential modern operating features in the most economical, reliable and compact HF transceiver available.



FT77	8 Band Rx/Tx 100W output	£479.00
FT77S	8 Band Rx/Tx 10W output	£449.00
FP700	Matching AC PSU	£146.00
FC700	Matching antenna tuner	£105.00
FV700DM	Digital VFO unit.....	£209.00
MKT77	Marker unit	£10.75
FMUT77	FM unit.....	£28.35
AMUT77	AM unit	£23.75

LEEDS SMC (Leeds) 257 Otley Road, Leeds 16, Yorkshire Leeds (0532) 782326 9.30 Mon-Sat	CHESTERFIELD SMC (Jack Tweedy) Ltd 102 High Street New Whittington, Chesterfield Chest. (0246) 453340 9.5.30 Tues Sat	BUCKLEY SMC (TMP) Unit 27, Pinfold Lane Buckley, Chwyd Buckley (0244) 549563 10-5 Tues-Fri 10-4 Sat	STOKE SMC (Stoke) 76 High Street Talkie Pits, Stoke Kidsgrove (07816) 72644 9.5-30 Mon Sat	GRIMSBY SMC (Grimsb) 247A Freeman Street Grimsb, Lincs Grimsb (0472) 59388 9.30-5.30 Mon-Sat	JERSEY SMC (Jersey) 1 Belmont Gardens St. Helier, Jersey Jersey (0634) 77067 9-5 pm Mon-Sat Closed Wed	EDINBURGH SMC Scotcomm 23 Morton Street Edinburgh EH15 2HN Tel 031-657 2430 10-5 Tues-Fri, 9-4 Sat	N IRELAND SMC N. Ireland 10 Ward Avenue Bangor County Down 0247 464875
--	--	--	--	--	---	--	--

Southampton Showroom open 9.5-30 pm Monday to Friday, 9-1 pm Saturday.

HEAD OFFICE S.M. HOUSE, RUMBRIDGE STREET, TOTTON, SOUTHAMPTON, SO4 4DP, ENGLAND.
& MAIL ORDER Tel: (0703) 867333. Telex: 477351 SMCOMM G. Telegram: "Aerial" Southampton



4,000

WORLD-WIDE USERS

Isn't it about time you switched to Icom?

IC-751

The IC-751 could be called the flagship of the ICOM range as it features 32 memory channels, full HF receive capability, digital speech synthesizer, computer control and power-supply options. The 751 is fully compatible with ICOM auto units such as the AT-500 and IC-2KL. The IC-751 now has a remote push-button frequency selector pad.

Standard features include: a speech processor, switchable choice of J-FET pre-amp or 20dB pin diode attenuator and two VFO's, marker, 4 variable tuning rates, pass band tuning, notch, variable noise blanker, monitor switch, direct feed mixer in the front end, full break-in on CW and AMTOR compatibility.

The first IF is 70.045 MHz. Any XIT and RIT adjustment is shown on the display. The transmitter features high reliability 2SC2904 transistors in a low IMD (-32dB@100W) full 100% duty cycle. For more detailed information on this excellent set, please get in touch with us.



IC-290D/290E



290D is the state of the art 2 meter mobile, it has 5 memories and VFO's to store your favourite repeaters and priority channel to check your most important frequency automatically. Programmable offsets are included for odd repeater splits, tuning is 5KHz or 1KHz.

The squelch on SSB silently scans for signals, while VFO's with equalising capability mark your signal frequency with the touch of a button. Other features include: RIT, 1 KHz or 100Hz tuning/CW sidetone, AGC slow or fast in SSB and CW, Noise blanker to suppress pulse type noises on SSB/CW.

You can scan the whole band between VFO's/scan memories and VFO's. Adjustable scan rate 144 to 146 MHz remote tuning with IC-HM10 and HM11 microphones. Di frequency display, Hi/Low power switch. Optional Nicad battery system allows retention of memory.

Special Offers for 1985: 25 watt IC-290D reduced to £469 and the 10 watt IC-290E reduced to £359. The 70cm version IC-290E is reduced to £529. Take advantage of this money saving offer.

* AT THE LAST COUNT





RAEDEK ELECTRONICS

102 PRIORY ROAD, SCRIBERS LANE, HALL GREEN, BIRMINGHAM B28 0TB

TEL: 021-474 6000

TELEX: 311033 CHACOM/G Attn: CROSAL

R.F. POWER TRANSISTORS - Many other types available

VALVES - National, Varian, Mullard, RCA, ITT ...

2N3375	11.30	2SC1011	5.38	2SC1945	2.61	MRF221	12.05	MRF517	3.50	SD1143	9.45	6A4	17.50	EL34	3.50	5 500A	225.00	6BQ5	1.80	6GJ7	1.85
2N3553	2.00	2SC1070	1.15	2SC1946	18.75	MRF229	3.50	MRF620	18.00	SD1143-1	10.00	6BE6	14.00	EL36	2.30	5AR4	2.50	6BR8A	2.55	6GK6	1.35
2N3632	12.50	2SC1096L	0.90	2SC1946A	16.50	MRF231	12.36	MRF644	25.70	SD1144-1	2.50	6E0F	13.10	EL38	4.95	5A5A4	2.50	6BX6	2.75	6GW8	1.30
2N3733	13.20	2SC1096M	0.90	2SC1947	9.88	MRF232	13.50	MRF646	26.10	SD1158	7.95	6E0L	12.95	EL81	10.95	5B254M	24.00	6BZ6	2.50	6GX6	3.30
2N3866	1.20	2SC1117	1.50	2SC1955	7.20	MRF233	14.30	MRF648	30.85	SD1201	7.35	6E1CC	3.20	EL83	11.30	5C22	128.00	6C4	1.85	6GY6	3.00
2N3929	11.26	2SC1120	7.50	2SC1966	11.00	MRF234	16.00	MRF750	6.50	SD1202	7.50	6E8CC	3.90	EL84	2.95	5CX1500A	595.00	6CA4	1.65	6H6	3.00
2N3927	11.82	2SC1121	24.00	2SC1967	15.00	MRF237	9.70	MRF646	46.00	SD1212-4	6.00	6E9F	9.25	EL86	2.80	5D22	76.00	6CA7	3.50	6H6A	2.50
2N4416	0.75	2SC1122	18.00	2SC1968	17.50	MRF238	12.60	MRF901	2.75	SD1212-7	4.00	6E9CC	8.50	EL91	9.10	5R4	6.00	6CB6A	1.90	6H8	3.05
2N4427	1.20	2SC1162B	0.90	2SC1968A	22.00	MRF239	20.00	MRF904	2.95	SD1214	8.70	6E2CC	6.50	EL92	6.50	5R4GYA/B	3.75	6CB8	1.90	6H8E	4.00
2N5090	13.50	2SC1165	6.95	2SC1969	3.50	MRF240	24.50	MRF911	2.50	SD1216	11.00	6E30L	23.50	EL93	2.80	5R4WGB	17.90	6C67	2.25	6HF5	3.85
2N5109	2.25	2SC1169	4.85	2SC1970	11.00	MRF241	35.00	MRF915	22.50	SD1219	18.00	6E30P	6.50	EL94	6.50	5R7B	6.00	6CH6	9.95	6HG5	1.95
2N5160	4.80	2SC1176	14.00	2SC1971	4.00	MRF245	30.00	MRF916	30.00	SD1219-4	16.00	6E30C	7.90	EL95	6.00	5A4GB	2.50	6C13	2.30	6HG8	2.50
2N5190	1.50	2SC1177	9.43	2SC1972	11.00	MRF247	30.10	MRF917	43.00	SD1220-1	9.50	6E50T	7.90	EL99	6.75	5U1P	40.00	6C16	10.95	6HS8	3.95
2N5589	6.00	2SC1178	18.00	2SC1978	7.50	MRF260	5.50	MRF904	2.00	SD1222-5	11.00	6E91	2.95	EL803	9.95	5V4G4	2.75	6C8E	6.00	6HZ6	2.75
2N5590	8.50	2SC1208D	0.64	2SC2001	0.45	MRF264	11.00	SD1005	8.20	SD1222-STUD	13.00	6EBC1	1.90	EL803S	9.95	5Z6GT	1.90	6C16	3.30	6J5	3.15
2N5591	8.50	2SC1213A	0.40	2SC2006	0.75	MRF305	42.00	SD1006	2.10	SD1224-2	11.00	6E9F9	1.50	EL821	9.95	6AH6	3.50	6C8E	2.30	6J5GT	2.95
2N5643	13.00	2SC1213C	4.00	2SC2053	0.80	MRF316	55.00	SD1012-3	10.00	SD1229-F1	10.95	6E98	1.85	EM84	2.00	6AJ8	2.50	6C96	4.95	6J6	2.20
2N5913	2.50	2SC1239	1.42	2SC2087	36.00	MRF317	73.00	SD1013-4	10.50	SD1229-F1	10.95	6ECC2	2.50	EN32	16.25	6AK5	2.75	6C06	2.20	6JA8	4.00
2N5945	10.90	2SC1241	1.50	2SC2099	15.00	MRF321	35.00	SD1013	10.00	SD1229-STUD	11.00	6ECC4	12.10	EN91	2.80	6AK5W	2.75	6C04W	6.50	6J6A	4.00
2N5946	15.63	2SC1251	10.00	2SC2100	24.00	MRF323	35.00	SD1014-6	10.50	SD1244-6	12.75	6ECC7	3.70	EN92	3.30	6AK6	1.95	6C05W	1.95	6J8A	4.20
2N6080	8.00	2SC1260	1.11	2SC2103	18.00	MRF326	63.00	SD1015	17.50	SD1244-6	12.75	6ECC1	1.80	EZ35	1.85	6AL5	1.95	6C05	3.80	6J8CA	3.50
2N6081	8.75	2SC1303	5.00	2SC2105	15.00	MRF327	70.00	SD1018-6	13.00	SD1256	6.95	6ECC2	1.80	EZ41	2.45	6ALS	1.80	6C07	3.00	6J8C	4.95
2N6082	9.00	2SC1306	1.00	2SC2116	1.60	MRF329	58.06	SD1019	23.10	SD1262	15.00	6ECC3	1.60	EZ80	1.95	6AM5	9.10	6C25	3.15	6J8GA	3.85
2N6083	12.00	2SC1307	1.50	2SC2118	9.00	MRF412	18.51	SD1019-5	23.10	SD1270	3.75	6ECC5	2.20	EZ81	1.65	6AM6	2.95	6D8A	2.30	6JH8	6.25
2N6084	13.20	2SC1311	0.40	2SC2221	5.50	MRF421	36.85	SD1020	1.50	SD1272	10.95	6ECC8	2.00	EZ90	2.00	6AN8A	2.70	6D0C	2.45	6JH6	2.20
2N6084	13.20	2SC1311E	0.40	2SC2223	0.50	MRF422	42.00	SD1024	16.10	SD1272-2	10.95	6ECC9	3.00	PL025	1.65	6A05A	1.95	6D0C5	1.50	6JH8E	3.95
2N6095	8.50	2SC1314	25.00	2SC2237	16.00	MRF426	23.00	SD1076	18.50	SD1278	13.75	6ECC189	2.10	PL509	5.50	6A05W	1.90	6D07	2.00	6J5CC	3.95
2N6255	3.45	2SC1318	0.40	2SC2281	13.00	MRF427A	21.00	SD1077	1.60	SD1278-1	13.75	6ECC80	2.20	PL519	5.75	6A08	2.20	6D06	3.95	6K6GT	2.75
2SC730	2.70	2SC1368B	1.00	2SC2283	9.00	MRF428	57.00	SD1078	26.50	SD1285	12.75	6ECC86	2.50	QV002-6	19.50	6AR5	12.90	6D75	2.30	12AT6	1.70
2SC731	3.55	2SC1363B	0.50	2SC2287	11.00	MRF428A	75.00	SD1080	1.55	SD1300	1.25	6ECP801	1.85	QV003-10	6.50	6AS5	5.50	6D0W4B	4.20	12AT7	1.60
2SC732	0.25	2SC1429	1.35	2SC2293	12.50	MRF433	16.71	SD1080-6	7.50	SD1303	2.50	6ECP81	2.50	QV017-50	12.00	6ASTG	7.20	6E5	2.40	12AL6	2.00
2SC741	2.50	2SC1509	6.00	2SC2290	27.50	MRF498A	14.95	SD1080-7	7.50	SD1316	21.00	6ECL2	3.60	QV03 12	4.50	6AUGT	6.80	6E8A	2.45	12AU7A	1.60
2SC821	6.60	2SC1546	0.45	2SC2347	0.30	MRF450	11.90	SD1088	26.00	SD1317	8.00	6ECL3	2.50	4CX250B (EIM)	6A06A	2.55	6E85	1.65	12AV6	2.00	
2SC828	0.30	2SC1568	0.45	2SC2389	2.00	MRF453	14.00	SD1089	28.50	SD1405	21.00	6ECL6	3.90	AMPJ	49.00	6AV5	2.55	6E87	2.75	12AX7	1.60
2SC828B	0.25	2SC1583	5.00	2SC2390A	18.00	MRF453A	14.00	SD1089	40.10	SD1407	27.50	6E40	8.50	4CX250B (NAT)	6A06A	2.65	6EJ7	2.00	12AX7WA	4.80	
2SC890	8.50	2SC1822	0.33	2SC2393	12.50	MRF454	21.00	SD1115-2	7.50	SD1407MP	55.00	6E90	2.75	4CX250A (EIM)	6A05A	1.90	6E8A	4.15	12B4A	2.80	
2SC891	18.00	2SC1623	0.30	2SC2395	15.00	MRF454A	24.00	SD1115-7	2.10	SD1410	21.00	6E95	4.70	4CX350A (EIM)	6B8A	1.90	6E77	2.85	12B6A	2.00	
2SC900	0.87	2SC1688	19.80	2SC2407	1.00	MRF455	16.00	SD1127	2.50	SD1410-1	21.00	6E96	2.60	4CX350A (AMP)	6B8E	1.90	6E7V	2.85	12B6A	3.00	
2SC900F	0.87	2SC1674	0.25	2SC2420	18.00	MRF455A	21.00	SD1131	3.25	SD1410	21.00	6E99	2.95	4CX350A (AMP)	6B8H	2.00	6E86	2.00	12B7A	4.80	
2SC908	4.50	2SC1675	0.20	2SC2494	16.00	MRF456	19.95	SD1132	9.50	SD1412	36.00	6E91	2.95	4CX350A (AMP)	6B8J	2.00	6E88	16.50	12B7A	2.65	
2SC911A	18.00	2SC1678	1.40	2SC2509	6.00	MRF466	24.50	SD1133-1	10.00	SD1412-3	24.00	6E92	2.20	4CX350A	6B8K	4.15	6E89	2.25	12B8E	2.00	
2SC945	0.21	2SC1729	18.00	2SC2531	1.30	MRF472	4.40	SD1134-1	2.50	SD1413	10.00	6E93	1.60	4CX1500A	6B8L	68.50	6E95	2.25	805	42.00	
2SC945H	0.21	2SC1730	0.25	2SC2538	1.10	MRF475	2.20	SD1134-2	10.00	SD1414	36.00	6E94	1.80	4CX1500B	6B8L	68.50	6E95	2.25	805	42.00	
2SC952	0.60	2SC1740Q	0.20	2SC2539	15.00	MRF476	2.25	SD1134-8	10.00	SD1416	33.00	6E95	2.70	4CX10000	6B8L	1.45	6E95	2.80	807	2.90	
2SC982	0.30	2SC1765	7.75	2SC2540	24.95	MRF477	12.50	SD1134-STUD	7.10	SD1418	30.00	6E98	2.75	4021	57.00	6B8L	1.45	6E95	2.30	810	50.00
2SC994	2.50	2SC1815Y	0.28	2SC2545E	12.50	MRF492	27.50	SD1135	10.25	SD1421	36.00	6E98A	2.00	4022	64.75	6B8M	30.95	6E98	2.10	811A	14.90
2SC998	4.17	2SC1906	0.33	MRF497	18.50	SD1135-3	12.00	SD1428	24.00	SD1428	30.00	6E98A	2.00	4PR60C	250.00	6B8M	3.60	6E98A	1.90	812A	19.90
2SC1001	9.90	2SC1907	0.30	MRF212	12.00	MRF515	2.60	SD1136	11.70	SD1429	15.98	6E99	1.90	4X150A	42.50	6E98B	2.45	6E98A	3.00	813 (NAT)	28.50

TERMS: C.O.W. POSTAGE/PACKING: Add £1 to order under £50 value. VAT: All prices are excluding VAT please add 15% to order and postage. GUARANTEE: All goods are of current production and sold with the manufacturer's warranty. ENQUIRIES: Are welcomed for other types/brands of valves. Please send SAE. Normally stock items are shipped by return post.

Master Electronics - Microprocessors - Now! The Practical Way!

- Electronics - Microprocessors - Computer Technology is the career and hobby of the future. We can train you at home in a simple, practical and interesting way.
- Recognise and handle all current electronic components and 'chips'.
- Carry out full programme of experimental work on electronic computer circuits including modern digital technology.
- Build an oscilloscope and master circuit diagram.
- Testing and servicing radio - T.V. - hi-fi and all types of electronic/computer/industrial equipment.

by SEEING and DOING

New Job? New Career? New Hobby?

SEND THIS COUPON NOW.

FREE! COLOUR BROCHURE
Please send your brochure without any obligation!

OR TELEPHONE US 062 887 2598
OR TELEX 22758 (24 HR SERVICE)

I am interested in ELECTRONICS
 MICROPROCESSORS
 RADIO AMATEUR LICENCE
 CITY & GUILDS EXAMS

Other Subjects _____

NAME _____
ADDRESS _____
P/W/S _____

British National Radio & Electronics School P.O. Box 7, Taignton, Devon, TQ 14 0HS

ALTRON

CHOICE OF PROFESSIONALS

COMPACT LATTICE TOWERS and SLIMLINE TUBULAR MASTS

TELESCOPIC-TILT/OVER, FIXED-MOBILE FROM 6m UP TO 36m

Suitable for a wide range of civil and military applications such as:

- RADIO COMMUNICATION SURVEILLANCE & CCTV
- METEOROLOGICAL MONITORING
- AMATEUR RADIO
- AERO & MARINE NAV AIDS
- FLOODLIGHTING, ETC.

Purpose designed using 4.5m and 3m section modules for low retracted heights and cost effective shipment. Engineered to B.S.I. Standards and hot dip galvanized to BS729 for protection. Wind loads are based on B.S.C.P.3. Chap V. PT2, 1972 for wind speeds up to 100 mph/160 kph.

RELIABILITY QUALITY KNOW HOW

WE DESIGN, WE MAKE, WE SELL DIRECT

PRICES RANGE FROM £253.00 incl. VAT. & UK DELIVERY SAE FOR MORE DETAILS, PLEASE

Allweld Engineering
Factory 6, 232 Selsdon Road,
South Croydon, Surrey, CR2 6PL, G.B.
Tel: 01-680 2995 (24 hr) 01-681 6734.



Doesn't he
look
happier?



AMATEUR RADIO EXCHANGE LTD

Now that
we are
married!



SX 400

Undoubtedly the world leader in scanning receivers from 25MHz-520MHz - AM-FM continuous cover. **£595**



AR2001

General coverage UHF/VHF scanner - AM-FM - with memory frequency cover 25-550MHz. **£359.**



RE 2000E

VHF/UHF SCANNER
Airband plus low-band, high-band and UHF AM and FM. **£258.**



CENTURY-21D

The bargain of the year! HF synthesised receiver 500kc-30MHz. Digital readout - Good sensitivity and selectivity. **£169**



ICOM IC-R71

What more can be said about this receiver that has not been said already - the choice of the experts. **£695.**

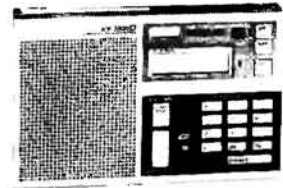

SONY 7600D

When it comes to portability, this little receiver is tops - fits into a briefcase or even a handbag. Scans - memory & bands. HF & VHF. CW, AM & SSB. **£179.**

AND NOW THREE NEW MODELS



FRG8800

The latest from Yaesu. A great receiver using all the latest technology available. 150KHz to 30MHz. AM wide-narrow-SSB FM wide-narrow VHF option. **£PHONE.**



FT2700R

The long awaited dual band VHF/UHF transceiver with full duplex operation. Phone for more details.

All prices inc. VAT



HX2000E

An excellent hand-held scanner
60- 80MHz
118-136MHz
138-174MHz
436-490MHz
490-525MHz
AM/FM
5-10-12½Kc steps
£269

PRICES CORRECT AT TIME OF GOING TO PRESS
ALL OFFERS SUBJECT TO AVAILABILITY
WE CANNOT POSSIBLY LIST EVERY SINGLE
ITEM WE STOCK. BUT WE DO CARRY ALL THE
WELL-KNOWN BRANDS INCLUDING:

ALINCO
BNOS
DIAMOND
JAYBEAM
T.E.T.
DRAE
ICS
WRASSE
TONNA
HI-MOUND
AKD
SMC
MICROWAVE MODULES
MUTEK
TONO

Rotators and VHF amps
Power supplies and VHF amps
antennas

AMTOR
slow scan
antennas
keys
wavemeters
HS antennas



PLUS
BRENDA'S
COFFEE

RTTY/CW/AMTOR
CONFIDENTIAL FREQUENCY LIST
PHONE FOR BEST PRICES FOR
CASH, OR CHEQUE ON NEW AND
SECONDHAND

CLOSED - Mondays
OPEN - TUES, WED, THURS,
FRI 9.30-5.30. SAT 9.30-5.00.

LONDON:
373 UXBRIDGE ROAD,
ACTON,
LONDON W3 9RH
Tel: 01-992 5765/6

NORTHERN:
38 BRIDGE STREET,
EARLESTOWN, NEWTON LE WILLOWS,
MERSEYSIDE WA12 9BA.
Tel: 092 52 29881



more on your wavelength

NEW

DRAE SLOW SCAN TELEVISION RECEIVER



Delivery of stock items despatched within 24 hrs.

Provides an affordable entry to the exciting world of SSTV

• £189 (Inc VAT) for a complete receive unit

- Simple upgrade to full transceiver with plug in TX module (available soon)
- Latest design all on a single PTH Glass Fibre PCB.
- Receives European and US standard transmissions. Add a new dimension to your H.F. receiver with a DRAE Slow Scan Television Receiver. Simply connect between any receiver and a standard television or video monitor to watch slow scan pictures from all over the world. Previously the preserve of a devoted few the DRAE SSTV receiver brings Slow Scan within the reach of the average amateur. Available from Stock at time of going to Press.

Prices		
VHF WAVEMETER	£27.50	SSTV Receiver £189.00
MORSE TUTOR	£52.00	24 A Power Supply £110.00
3 WAY VHF SWITCH (SO239)	£15.40	12 A Power Supply £79.50
3 WAY UHF SWITCH (N Type)	£19.90	6 A Power Supply £53.50
2 Metre Preset ATU	£11.80	4 A Power Supply £34.00

Prices and Details of Commercial Power Supplies+DC/DC Converters on request

DAVTREND LTD. Sanderson Centre, Lees Lane, Gosport, Hampshire PO12 3UL Telephone 0705 520141

BRITISH MADE

DRAE

COMMUNICATION CENTRE OF THE NORTH

The largest range of communications equipment available in the North. Full range of receivers, transceivers, antennas, power supplies, meters. Ali tubing - wall brackets etc.

We are the original amateur radio suppliers in the North West with 20 years experience in all types of equipment.

We are the only official TRIO stockists in the North West. Full range of equipment on display. Guaranteed after sales service.

RECEIVERS

TRIO R600 Solid State Receiver	£285.00
TRIO R2000 Solid State Receiver	£456.00
JRC NRD515 Receiver	£965.00
YAESU FRG7700 Receiver	£385.00
Wide Band Scanning Receiver AR2001, 25-550 MHz	£365.00
R532 Airband Receiver	£186.00
Yaesu FRG8800 Receiver	£525.00

Please send SAE for full information and up-to-date prices as these fluctuate to change in sterling rates. For the caller a wide range of Aluminium Tubing, Clamps, etc. at competitive prices, i.e. 12' x 2" Ali Tubing £9.00.

Full range of RSGB and ARRL publications in stock.

Part Exchanges welcome. Second hand lists daily.

Send S.A.E. for details of any equipment.

HP terms. Access/Barclaycard facilities.

Open 6 days a week. 24 Hour Mail Order Service.

Phone 0942-676790.

STEPHENS JAMES LTD.
47 WARRINGTON ROAD,
LEIGH, LANCS. WN7 3EA.

Amcomm of London

LOOK! BEAT THE PILE UP WITH NO HANDS AND THE HEIL BM10

A NEW and UNIQUE NO HANDS Headset/Boom Microphone weighing in at a super light 8oz.

The Heil BM10 is a VERY SPECIAL unit designed to a specification from some of the WORLD'S LEADING contest and DX operators.

The microphone *element is the SPECTACULAR Heil HC4 with a specially TAILORED RESPONSE to help you push through the pile up. The headpieces are soft, comfortable and have a high "CLOSE OUT" of external noises. The whole unit is HIGHLY VERSATILE allowing removal or adjustment of the headpieces or microphone to suit the OPERATOR'S NEEDS yet it remains ROBUST enough to meet the RIGOROUS demands of PROLONGED use.

The Heil BM10 CAN DO MUCH FOR YOU, TRY IT, HANDS OFF STYLE, RELAX, SIT RIGHT BACK, CUT THROUGH THE PILE UP AND WATCH YOUR CONTEST SCORE SOAR.



PRICE HEIL BM10 £65:00 inc VAT & Carr.

*Adaptor required for Icom equipment.

Goods will be despatched by return



Amcomm

SERVICES LTD.,

194 NORTHOLT ROAD, SOUTH HARROW,
MIDDX. HA2 0EN, ENGLAND. (Opp. South
Harrow Underground Station)
TEL: 01-422 9585, TELEX: 24263



THE CQ CENTRE

LONDON'S NEWEST AND BRIGHTEST EMPORIUM FREE PARKING OUTSIDE
10 Merton Park Parade, Kingston Road (Junction of Merton Hall Road),
London SW19 Telephone: 01-543 5150/4212



THE SHIRKERS
PAUL
G4HXZ
AND
PAUL
G1JJW

LATEST MET ANTENNAS. 70cms (432-58) This 5 ele beam can be back mounted so there is no need to use a non-metallic mast, it has a gain of 9.2dBd, is only 0.7m long and weighs just 0.4kg. **Only £19.95**

CONFIDENTIAL FREQUENCY LIST - now in stock (includes RTTY frequencies) **£13.50**

INDOOR ACTIVE ANTENNA: This indoor telescopic antenna has been designed for flat dwellers etc. It covers all H.F. bands and eliminates the need for outdoor aerials. (requires a PP3 9V battery). **£28.50**

CW - THE EASY WAY: Get a G4HXZ morse tape (including two simulated Amateur Licence tests) and a Hi-Mound telegraphy key (HK 706/7). **Pair £23.00**

MORSE OSCILLATOR: Our morse oscillator has variable tone and volume controls, a built-in key-in button and a 3.5mm jack socket on the back for your own key. **Only £14.45**

DE LUXE VERSION: As above but also with a headphone socket and l.e.d. for silent practice and peace for the family. **Only £17.45**

ALL PRICES INCLUDE P.&P.

23CM CONVERTER: Just plug in your antenna and TV. Tune to Channel 36 (approx.) and you are away. **£36.50**

G5RV 10-80M, full size **£16.00**
(Type) 10-80M, half size **£15.00**

HB9CV for 70cms.
Mail Order price. **Each £11.00.**

SLIM JIMS: 2m or 70cms.
Mail Order price. **Each £9.50.**

LASHING KITS - RAWLPLUGS
TK BRACKETS AVAILABLE.

Power Splitters now in stock

As the country's largest second-hand dealers, we are very keen to purchase second-hand equipment.

Part exchanges welcomed - Anything considered.

MON.-FRI. 10.00-6.00 SAT. 9.30-4.30. Goods normally despatched within 3-4 days.

Credit available through SHEPHERD FINANCE. Ask for written details.



Just Some of our Success Stories...

-POWER SUPPLIES



-LINEARS

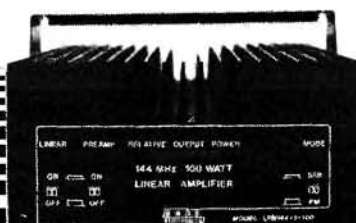

-NICADS & CHARGERS

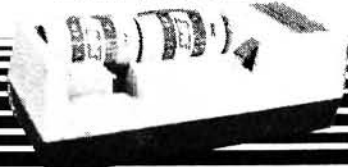

HIGHEST QUALITY, SUPERBLY CONSTRUCTED

"A" series power supplies

- Continuous rated output
- Over voltage crow bar
- Over current protection
- Fully R.F. protected
- Large current meters

13.8V. 6amps - 12/6A£52.90
13.8V. 12amps - 12/12A£95.45
13.8V. 25amps - 12/25A£138.00
13.8V. 40amps - 12/40A£276.00



Goods normally despatched by return.
• ALL PRICES INCLUDE V.A.T.

B.N.O.S.
ELECTRONICS

B.N.O.S. Electronics Ltd. (Dept PW)
Bigods Hall Great Dunmow
Essex CM6 3BE Tel: (0371) 4677

Incorporating over 40 years' design expertise made to highest engineering standards utilising highly regarded Mosfets and GaAs FETS.

LINEAR PART NUMBERING SYSTEM

LINEAR PREAMP RF METER 144-3-100 OUTPUT POWER

LINEAR AMPLIFIER 144-3-100 INPUT POWER

FREQUENCY (BAND)

ZM Range

LPM 144-1-100	£172.50
LPM 144-3-100	£172.50
LPM 144-10-100	£149.50
LPM 144-25-160	£207.00
LPM 144-3-180	£235.75
LPM 144-10-180	£235.75
L 144-1-100	£143.75
L 144-3-100	£143.75
L 144-10-100	£120.75
L 144-25-160	£178.25
L 144-3-180	£207.00
L 144-10-180	£207.00

70 cms.

LPM 432-1-50	£184.00
LPM 432-3-50	£184.00
LPM 432-10-50	£155.25

NICADS

Format	Cap. (AH)	Height (mm)	Diam. (mm)	Prices	1-9	10-24	25-99
AAA	0.18	45.0	10.51	1.47	1.39	1.32	
1/2AA*	0.10	17.4	14.7	1.38	1.31	1.24	
1/2AA*	0.225	25.0	14.7	1.04	0.99	0.94	
AA	0.50	49.5	14.7	1.08	1.02	0.96	
AA*	0.50	49.5	14.7	1.14	1.08	1.02	
NEW AA (SUPER)	0.60	49.5	14.7	1.18	1.12	1.08	
1/2A*	0.45	28.0	17.2	1.18	1.12	1.08	
RR*	1.20	42.1	22.6	1.86	1.76	1.66	
C	2.20	49.7	25.9	2.85	2.70	2.56	
D (SUB)	1.20	60.5	33.5	2.85	2.70	2.56	
D	4.00	60.5	33.5	5.06	4.80	4.56	
D*	4.00	60.5	33.5	5.10	4.84	4.60	
F*	7.00	94.0	33.5	7.36	6.98	6.62	
SF*	10.00	91.3	41.7	POA	POA	POA	
PP3	0.11	49x26.5x17.5	4.52	4.29	4.07	4.07	
PP9	1.2	81x52x66	POA	POA	POA	POA	

* DENOTES SOLDER TAGS FITTED

AC. 1 SAFT MAZDA AA CHARGER, CHARGES 1 to 4 AA CELLS - £5.75
PC. 3 SAFT MAZDA PP3 CHARGER, CHARGES 1 or 2 PP3 CELLS - £5.75
MC. 4 JECKSON MULTICHARGER, CHARGES 2 or 4 AA, C or D CELLS £7.00
MC. 6 SAFT MAZDA MULTICHARGER, CHARGES 1 to 4 AA, C or D CELLS, or 1 or 2 PP3 CELLS £8.75

CARRIAGE FREE ON ALL MAINLAND UK ORDERS OVER £5 - THOSE UNDER PLEASE ADD 60p AVAILABLE DIRECT FROM MANY U.K. AGENTS AND AT MOST RALLIES AND EXHIBITIONS



Mail order & shops:

441 PRINCES ROAD, DARTFORD, KENT DA1 1RB
Telephone: (0322) 91454

ORDERING INFORMATION: P/P 50p on orders less than £20 in value otherwise post free. All components full spec & guaranteed. Discounts available on orders over £50 — phone for details. For unlisted components phone for price. Goods normally despatched by return post.

NEW CATALOGUE NOW AVAILABLE CONTAINING THOUSANDS OF LINES MANY ILLUSTRATED

This incredible volume contains everything required by the home constructor, amateur radio and CB user and computer enthusiast.

We think the semiconductor section contains more types than have ever been offered to the hobbyist.

Sections are headed as follows:

Aerials, Amplifiers, Audio Accessories, Batteries, Boxes, Bulbs, Capacitors, Crystals, Car Components, Car Audio, CB & Ham Equipment, Computer Connectors, Fuseware, Hardware, Headphones, Knobs, Lamps, Leads, Loudspeakers, Microphones, Meters, OPTO, PCB, Resistors, Semiconductors, Special Effect Equipment, Switches, Power Supplies, Test Equipment, Tools, Transformers, Wound Components.

In addition to listed items we continue to provide a procurement service for obsolete and difficult to obtain types.

How many suppliers do you have at the moment that offer a service like this?

Please fill in coupon below and send with £1.25. Print clearly as coupon is used as address label.

Catalogue contains £2.50 discount order form — You make a profit straight away.

NAME

ADDRESS

POSTCODE

WOOD & DOUGLAS

Why not start 1985 on a new band?
We can now offer the following packages
for 24cms FMTV.

- | | | |
|---------------------|--|------|
| 1. Receive Package | (VIDIF Kit — 1250DC50 Boxed) | £105 |
| | (VIDIF Ass — 1250DC50 Boxed) | £120 |
| 2. Receive Package | (VIDIF Kit — TVMOD1 Kit — 1250DC50 Boxed) | £110 |
| | (VIDIF Ass — TVMOD1 Ass — 1250DC50 Boxed) | £126 |
| 3. Transmit Package | Kit (UFM01 — 70LIN3/LT — 70FM10 — WDV400/1200 Boxed) | £130 |
| | Ass (UFM01 — 70LIN3/LT — 70FM10 — WDV400/1200 Boxed) | £130 |

The above prices are inclusive of VAT but exclusive of £1.50 postage. Please allow maximum of 28 days delivery for boxed items. No additional discount available for the purchase of more than one package. Please contact our sales staff for further information.

The demand for boxes, connectors etc. to make a professional finish on our pre-amp/linear combinations has encouraged our release of the following hardware packs:—
Typical contents: Diecast Box, Heatsink, Switches, LED's, Cable etc.

- | | | |
|--------------------------|--------------------|--------|
| 1. 2M LINEAR/PRE-AMP 25W | (BNC Connectors) | £14.95 |
| 2M LINEAR/PRE-AMP 25W | (SO239 Connectors) | £14.25 |
| 2. 2M LINEAR/PRE-AMP 10W | (BNC Connectors) | £13.95 |
| 2M LINEAR/PRE-AMP 10W | (SO239 Connectors) | £13.25 |
| 3. 144LIN25B KIT | (BNC Connectors) | £13.75 |
| 144LIN25B KIT | (SO239 Connectors) | £12.80 |
| 4. 70LIN10 KIT | (BNC Connectors) | £13.75 |
| 70LIN10 KIT | (SO239 Connectors) | £12.80 |

For further details on these Hardware packages please contact our sales staff on the above telephone number. Prices are inclusive of VAT but exclusive of £1.50 carriage.

While every endeavour is being made to hold prices on our products due to the fluctuating dollar/pound exchange rate we can not guarantee to hold some component prices. In particular RF Power components such as 'SD' part numbers will be affected. Please check current prices with our sales staff before ordering replacement parts.

Further details on our product range will gladly be forwarded on receipt of large size SAE. Technical help is available by phone during normal office hours. Kits are usually available by return of post but please allow 28 days for unforeseen delays. Please add 75 pence to your total order for postage and handling. Credit card orders are gladly accepted, please give us a call.

ANYONE CAN SELL A KIT ... REPUTATION SELLS OURS

UNIT 13, YOUNGS INDUSTRIAL ESTATE
ALDERMASTON, READING RG7 4PQ
Tel: 07356 71444 Tx: 848702



AUDIO FILTERS MODELS FL2, FL3, FL2/A

Model FL3 represents the ultimate in audio filters for SSB and CW. Connected in series with the loudspeaker, it gives variable extra selectivity better than a whole bank of expensive crystal filters. In addition it contains an automatic notch filter which can remove a "tuner-upper" all by itself. Model FL2 is exactly the same but without the auto-notch. Any existing or new FL2 can be up-graded to an FL3 by adding Model FL2/A converters on kit, which is a stand-alone auto-notch unit. Datong filters frequently allow continued copy when otherwise a QSO would have to be abandoned.

Prices: FL2 £89.70, FL3 £129.37, FL2/A £39.67

ACTIVE RECEIVING ANTENNAS

Datong active antennas are ideal for modern broadband communications receiver — especially where space is limited.

- highly sensitive (comparable to full-size dipoles).
- Broad and coverage (below 200 kHz to over 30 MHz).
- needs no tuning, matching or other adjustments.
- two versions AD270 for indoor mounting or AD370 (illustrated) for outdoor use
- very compact, only 3 metres overall length. ● professional performance standards.

Prices: Mod-1 AD270 (indoor use only) £51.75 Both prices include mains power unit. Model AD370 (for outdoor use) £69.00

MORSE TUTOR

The uniquely effective method of improving and maintaining Morse Code proficiency. Effectiveness proven by thousands of users world-wide.

- Practise anywhere, anytime at your convenience.
- Generates a random stream of perfect Morse in five character groups
- D70's unique "DELAY" control allows you to learn each character with its correct high speed sound. Start with a long delay between each character and as you improve reduce the delay. The speed within each character always remains as set on the independent "SPEED" control.
- Features long life battery operation compact size, built-in loudspeaker plus personal earpiece

Price: £56.35

Our full catalogue plus further details of any product are available free on request. All prices include VAT and postage and packing. Goods normally despatched within 3 days subject to availability.

DATONG ELECTRONICS LIMITED
write to dept. P.W.
Spence Mills, Mill Lane
Bramley, Leeds LS13 3HE
England
Tel (0532) 552461

HP FACILITIES AVAILABLE



EAST LONDON HAM STORE WHERE YOUR POCKET COUNTS

PROMPT MAIL ORDER



FREE DELIVERY ON ALL RIGS: Phone us last for best prices

 SX400 £595 INCLUDING FREE DISCONE ANTENNA	 £365 AOR 2001 INCLUDING FREE DISCONE ANTENNA	 ICOM R71 £699 INCLUDING DATONG AD270 ACTIVE ANTENNA	<p>ICOM R71 SPECIAL OFFER FOR ONE MONTH ONLY £699 inc. ARA 30 ACTIVE ANTENNA * * * * * RS 2000 £450 INCLUDING DATONG AD 270 ACTIVE ANTENNA ALSO AVAILABLE THE DC 10 VHF CONVERTOR IF BOUGHT WITH ABOVE - £15</p>
 ICOM IC271E £699 INCLUDING 9XY TONNA OR SWEDISH BRASS MORSE KEY OR PS25 INTERNAL POWER SUPPLY	 ICOM IC751 £1239 INCLUDING SWR200 METER OR 5 BAND TRAPPED VERTICAL ANTENNA WITH RADIAL KIT	 ICOM IC745 £898 INCLUDING SWEDISH BRASS MORSE KEY OR BASS MIKE	 <p>ICOM ICO2E OR ICO4E + FREE SPEAKER MIKE AT £259 ICO2E £269 ICO4E + ALL ICOM ACCESSORIES IN STOCK</p>
 TW4000 £510 INCLUDING DIAWA DUAL BAND ANTENNA + GUTTER MOUNT OR VS1	 TR9130 £445	 FT726 + 70cm ± SATELLITE INC. FREE 9XY + 19XY TONNA + SWEDISH MORSE KEY	 FT757GX+FC757+FP757HD INCLUDING 5 BAND VERTICAL + SWEDISH BRASS MORSE KEY

Communications Terminal New Tonno 777 Tx/Rx, use it with any Micro with RS232. AMTOR/RTTY/CW. For £399.
Also Tonno Q5000 AMTOR/RTTY/CW/Keyboard + 5" Monitor. P.O.A.
Also many others in stock.

 Swedish Key £58.00	 METER WITH PEP/AVERAGE 10-20-100-200W. SWC200 £80	 TS 71E FOR E775 INC. 9XY TONNA OR SWEDISH MORSE KEY	 <p>TH21 ONE OF THE MOST POWERFUL, NEATEST AND SMALLEST 2M PORTABLES. £175</p> <p>TR2600 INCLUDING DIGITAL CODE SQUELCH £270</p>
--	--	---	--

dressler - ara 30 - active antenna
 200 kHz . . . 40 MHz

Professional electronic circuitry with very wide dynamic range. Meets professional demands both in electronics and mechanical ruggedness. 120 cm long glassfibre rod. Circuit is built into waterproof 2,5 mm thick aluminium tube. Ideal for commercial and swl-receiving systems.



£85

KENWOOD TRIO TM201A SPECIAL OFFER
£295.19
 FOR ONE MONTH ONLY **£265.00**



VHF POWER AMP.

D200 2MTR. 300w F.M. 550w SSB **£625**
 D200S 2MTR. 400-500w 1Kw. D.C. in **£725**
 D70 70cms 325w F.M. 500w SSB **£725**
NEW MODEL DUE TO ARRIVE
 1296 MWZ. 1w-in-10w out.

MAST HEAD PRE-AMPS GAAS FET
 POWER HANDLING UP TO 1KW
 -7 to -9dB NOISE
 15 to 19dB GAIN
 0-2dB INSERTION LOSS



EVV200 GAAS 2MTR 750W SSB **£75**
 EVV2000 GAAS 2MTR. 1KW SSB **£90**
 EVRPS receive 2MTR. only **£45**
 EVRPS receive 70cm. **£48**
 EVV700 GAAS 70cm. 500W SSB **£80**
 EVV70 GAAS 70cm. 100W **£50**
 EVV2 GAAS 2MTR. 100W **£50**
 VV200VOX GAAS 2MTR. 250W SSB **£80**
 INTERFACE **£21**
 DRESSLER ASA12 Mast Head Coaxial 2 in 1 out Switch with 'N' Connector **£21**
 1Hz-1GHz 1KW. PEP 0.15dB Insertion Loss **£43**

GAREX THE SCANNER SPECIALISTS

J.I.L. SX-200-N - THE SUPERIOR SCANNER

- ★ The choice of the professionals
 - ★ AM + FM all bands
 - ★ Wide coverage: 26-88, 108-180, 380-514MHz
 - ★ 16 memories ★ Positive action keyboard
 - ★ Proven reliability ★ 12v DC & 230v AC
 - ★ S-meter & 96-108MHz converter available
- £299**

REVCO RS-2000-E - THE VERSATILE SCANNER

- ★ 70 memories ★ AM + FM all bands
 - ★ Cover: 60-180, 380-520MHz
 - ★ Search & store of active channels
 - ★ All the usual search & scan functions
 - ★ 12v DC & 230v AC operation
 - ★ Counts activity of selected channel
- £259**

J.I.L. SX-400 - THE PROFESSIONAL SCANNER

- ★ Covers 26-520MHz (no gaps)
 - ★ AM + FM (manual, automatic or programmable)
 - ★ **Computer interfacing for limitless memory, remote control & data logging**
 - ★ Switchable channel spacing & I.F. bandwidths
 - ★ I.F. output terminals (10.7MHz & 455KHz)
 - ★ Specifications set by the professionals
- PHONE FOR LATEST PRICE**

Regulated mains adaptor for SX-400 **£29.50**
 SX232 (RS232 interface) now available **£224.25**

★ REVCO NE ★

A superb quality 16 element, all British made VHF/UHF broadband fixed station aerial from Revco. Ideally suited to all scanners and other VHF/UHF Receivers
Covers 50-500MHz PRICE £27.45 inc

ASK FOR OUR LIST OF SECONDHAND SCANNER BARGAINS

★ SPECIAL OFFER ★

CENTURY 21D communications receiver. 0.5 to 30MHz. CW, USB, LSB, AM & FM. Digital readout. Provisions for an external speaker and headphones. An excellent performer for only **£199**

CRYSTALS FOR NR-56, SR-9, SR-11, TM-56B. We have a range of 2m & VHF Marine band crystals for these receivers at **£3.00** each (+20p post per order). Please phone to check stock.

RESISTOR KITS a top selling line for many years. E12 series, 5% carbon film, 10w to 1m, 61 values, general purpose rating 1/4W or 1/2W (state which).

- Starter pack 5 each value (305 pieces) **£3.10**
- Standard pack 10 each value (610 pieces) **£5.55**
- Mixed pack, 5 each 1/4W + 1/2W (610 pieces) **£5.55**
- Giant pack, 25 each value (1525 pieces) **£13.60**

DC/DC TRANSISTORISED INVERTERS 12V input, 400V 200mA rectified and fully smoothed output **£9.50**

This unit is a chassis section cut from used R/T equipment, tidied, fully wired & tested. Free-standing but no luxuries like cabinet. 24v version - same price. SAE for details.

SPECIAL OFFER discontinued line 12 or 24v to 380v inverter. £5

We have in stock a very large range of spare parts for **PYE RADIOTELEPHONES**. Models include Olympic, Westminster, Whitehall, Europa, Mascots and PF70 Series. Parts also available for Cambridge, Vanguard etc. etc.

SAE FOR FREE EXTENSIVE LIST

GAREX FM DETECTOR and squelch conversion for Pye R/T equipment Ready Assembled, full instructions. Tailor-made, easy-fit design, replaces existing squelch board, with minimum of modifications. For AM Cambridge **£6.30**; for Vanguard AM25B (Valve RX) **£6.10**; for Transistor Vanguard AM25T **£6.95**.

MAIN DISTRIBUTOR OF REVCO PRODUCTS

PRICES INCLUDE UK P&P and 15% VAT

Goods normally despatched by return

GAREX ELECTRONICS

7 NORVIC ROAD, MARSWORTH, TRING, HERTS, HP23 4LS

Phone 0296 668684. Callers by appointment only

Phone now for details of our interest free credit



"Run more than ten tasks on a ZX81-FORTH ROM?"

Sure! More than 10 tasks simultaneously and, in some cases, up to 300 times faster! That's what replacing the basic ROM with the new FORTH does for the ZX81 - and more!

The brains behind the breakthrough belong to David Husband, and he's building Skywave Software on the strength of it. Already orders are flooding in and it's easy to see why.

The ZX81-FORTH ROM gives you a totally new system. In addition to multi-tasking and split screen window capability, you can also edit a program while three or four others are executing, schedule tasks to run from 50 times a second to once a year, and with a further modification switch between FORTH and BASIC whenever you like.

Return of post subject to availability.

The ZX81-FORTH ROM gives you a normal keyboard with a 64 character buffer and repeat, it supports the 16k, 32k, 64k RAM packs, it is fig-FORTH compatible and it supports the ZX printer.

The price, too, is almost unbelievable. As a "fit it yourself Eprom", complete with manual, it's just £25 + VAT.

Add £3 p&p UK (£6 Europe, £12 outside Europe) and send your order to the address below.



David Husband
 73 Curzon Road, Bournemouth,
 BH1 4PW, ENGLAND.
 Tel: (0202) 302385.
 International +44 202 302385.

COMMUNICATION RECEIVER

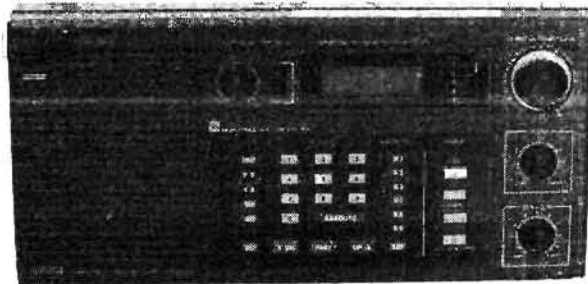

uniden MODEL CR-2021

A compact communications receiver with full professional specifications and facilities.

- FULL FREQUENCY COVERAGE OF 150KHz to 29.999MHz and 78 to 108MHz.
- MAXIMUM SENSITIVITY ON AM/SSB/CW, also FM, with NARROW/WIDE FILTER.
- MEMORY FOR ANY 6 AM/SSB and 6 FM FREQUENCIES, plus AUTOMATIC SCANNING BETWEEN ANY TWO FREQUENCIES.
- KEYBOARD ENTRY OF FREQUENCY SHOWN ON LCD DISPLAY.
- EXTERNAL SOCKETS FOR AERIAL, EARTH, HEADPHONES and LOUDSPEAKER.
- OPERATION FROM INTERNAL BATTERIES, 12V DC, or 240V AC.
- ONLY £189.75 inc VAT and P&P.

Please allow 7-14 days for delivery

LECMAR ELECTRONICS

Vectis Yard, Cowes, Isle of Wight
 Tel: (0983) 293996

DEALER ENQUIRIES INVITED

BARCLAYCARD ACCESS

BI-PAK BARGAINS

HIGH QUALITY MODULES FOR STEREO, MONO & OTHER AUDIO EQUIPMENT

O/N/O	POWER R.M.S.	MAX SUP. VOLTAGE	PRICE
AL 30A	10 Watts	30V	£4.95
AL 60	25 Watts	30-50V	£5.92
AL 80	35 Watts	40-60V	£6.75
AL 120	50 Watts	50-70V	£15.22
AL 250	125 Watts	50-80V	£20.60

O/N/O	AC Input	Price
SPM 120/45	40-48V	£8.05
SPM 120/55	50-55V	£8.05
SPM 120/65	60-65V	£8.05

O/N/O	Price
MM 100	£14.75
MM 100G	£14.75

O/N/O	Price
MPA30	£4.29

Monographic Equaliser
GE 100 MKII 10 Channel OUR PRICE ONLY £20.00

Full Specifications and Data available on request. Please send self-addressed envelope.

OPTO 7-Segment Displays

Brand new 1st Quality
LITRONIX DL 707R 14-pin

Red 0.3" Common Anode Display 0-9 with right hand decimal point. TTL compatible 5v DC Supply. Data supplied.

	5 pieces	£3	(60p each)
IN	10 pieces	£5	(50p each)
PACKS	50 pieces	£20	(40p each)
OF	100 pieces	£35	(35p each)
	1,000 pieces	£300	(30p each)

**THE MORE YOU BUY
THE LESS YOU PAY**

BI-PAK'S OPTO SPECIAL

A selection of large and small sized LED's in various shapes, sizes & colours, together with 7 Segment Displays both anode & cathode plus photo transistors emitters and detectors. Cadmium Cell ORP12 and Germ. photo transistor OCP71 included. In all a total of 25 Opto pieces valued over

£12 Normal Price
Order No. VP57
Our Super Value
Price Just
£5.00

DIGITAL VOLT METER MODULE

3 x 7 segment displays Bass Circuit. 0-2v+ instructions provided to extend voltage & current ranges. Operating voltage 9/12v. Typ Power Consumption 50mA.

O/N/O. VP99 **Once only price**
£9.95

SINGLE SIDED FIBREGLASS BOARD

Order No	Pieces	Size	Sq. Ins.	Price
FB1	4	9 x 2 1/4"	100	£1.50
FB2	3	11 x 3"	100	£1.50
FB3	4	13 x 3"	156	£2.00

DOUBLE SIDED FIBREGLASS BOARD

FB4	2	14 x 4	110	£2.00
-----	---	--------	-----	-------

EDGE CONNECTORS

2 x 5 way .1 Pitch Edge Connector (Gold)
(O/N/O AMP163279) 2) £1.20 each. £50 per 50 off

PICK-UP COIL

Large telephone pick-up coil for high sensitivity. Suchon pad to stick to telephone. 90cm lead to 3.5 jack plug. Con. nets direct to cassette recorder. Dims: 32mm(dia) x 17mm(body) 36mm(dia) sucker. O/N/O. YP87 **£1.00**

VALUE PACKS

Pak No	Qty	Description	Price
VP1	300	Assorted Resistors Mixed Types	£1.00
VP2	300	Carbon Resistors 1/4-1/2 Watt Pre-Formed	£1.00
VP3	200	1/4 Watt Min Carbon Resistors Mixed	£1.00
VP4	200	1/2 Watt Resistors 100 ohm-1M Mixed	£1.00
VP5	200	Assorted Capacitors All Types	£1.00
VP6	200	Ceramic Caps Miniature - Mixed	£1.00
VP7	100	Mixed Ceramic Discs. 50pf - 015pf	£1.00
VP8	100	Mixed Ceramic Discs. 50pf - 015pf	£1.00
VP9	100	Assorted Polyester/Polystyrene Caps	£1.00
VP10	60	C280 Type Caps Metal Foil Mixed	£1.00
VP11	50	Electrolytics - All Sorts	£1.00
VP12	60	Bead Type Polystyrene Min Caps	£1.00
VP13	50	Silver Mica Caps Ass. 56pf - 150pf	£1.00
VP14	50	Silver Mica Caps Ass. 180pf - 4700pf	£1.00
VP15	25	01uF 250V Min. layer metallised Polyester Capacitors	£1.00
VP16	50	Wirewound Res. 9V (avg) Ass. 1 ohm - 12K	£1.00
VP17	50	Metres PVC Covered Single Strand Wire Mixed Colours	£1.00
VP18	30	Metres PVC Covered Multi Strand Wire Mixed Colours	£1.00
VP19	40	Metres PVC Single/Multi Strand Hook Up Wire Mixed	£1.00
VP20	6	Rocker Switches 5 Amp 240v	£1.00
VP21	15	2in. high bright RED LEDs in plastic encapsulation-Large area light source	£1.00
VP22	200	Sq. Inches Total, Copper Clad Board Mixed Sizes	£1.00
VP23	20	Assorted Slider Pots Mixed Values	£1.00
VP24	10	Slider Pots. 40 mm 22K 5 x Log 5 x Lin	£1.00
VP25	10	Slider Pots. 40 mm 47K 5 x Log. 5 x Lin	£1.00
VP26	15	Small .125" Red LED'S	£1.00
VP27	15	Large .2" Red LED'S	£1.00
VP28	10	Rectangular .2" Red LED'S	£1.00
VP29	30	Ass. Zener Diodes 250mW - 2W Mixed Vts. Coded	£1.00
VP30	10	Ass. 10W Zener Diodes Mixed Vts. Coded	£1.00
VP31	10	5 Amp SCR'S TO-66 50-400V Coded	£1.00
VP32	20	3 Amp SCR'S TO-66 Up To 400v Uncoded	£1.00
VP33	200	Sil. Diodes Switching Like 1N4148 DO-35	£1.00
VP34	200	Sil. Diodes Gen Purpose Like OA200/BAX13/16	£1.00
VP35	1	1 Amp 1N4000 Series Sil. Diodes Uncoded All Good	£1.00
VP36	8	Black Instrument Type Knobs With Pointer 1/4" Dia	£1.00
VP37	10	Black Heatsinks To Fit TO 3, TO-220 Ready Drilled	£1.00
VP38	4	Power-Fin Heatsinks 2 x 10-3.2 x TO-66 Size	£1.00
VP39	4	Power-Fin Heatsinks 2 x 10-3.2 x TO-66 Size	£1.00
VP40	50	BC107/8 Type NPN Transistors Good Gen. Purpose Uncoded	£1.00
VP41	50	BC177/8 Type PNP Transistors Good Gen. Purpose Uncoded	£1.00
VP42	10	Silicon Power Trans. Similar 2N3055 Uncoded	£1.00
VP43	10	Precision Resistors. 2-1% tol.	£1.00
VP44	10	1N4002 Sil. Rects 1A 100v preformed typical	£1.00
VP45	4	40A Power Rectifiers Silicon TO48 300PIV	£1.00
VP46	5	BY187 12KV Sil. Diodes in carriers 2.5mA	£1.00
VP47	4	100K 1in. Multi-turn pots ideal var cap tuning	£1.00
VP48	10	Assorted pots. inc. Dual & Switched types	£1.00
VP49	25	Solid Tantalum Caps. Mixed Values	£1.00

OPTICALLY COUPLED MODULES

1 pair SD1/131 Consisting 1 x LS600 Silicon Light Sensor & 1 x Matched Gallium Arsenide Light Source - Type TIL23, on ready mounted fibre glass board. Including Data. Ideal Alarm projects etc. O/N/O VP147.

BI-PAK Price ONLY £0.60 pr.

LED DISPLAYS

VP130	6	RED 7 Seg. CC 14mm x 7.5mm RDP FND353	£2.00
VP131	4	GREEN 7 Seg. CA 6" LDP XAN6520	£2.00
VP132	5	RED 7 Seg. CC 6" LDP XAN6940	£2.00
VP133	6	RED Over-flow 6" 3 x CA 3 x CC 6630/50	£2.00
VP134	5	GREEN Over-flow 6" CA XAN6530	£2.00
VP135	5	RED 7 Seg. CA 3" XAN3061	£2.00
VP136	3	DUAL RED 7 Seg. 5" CA DL527 DPR	£2.00
VP137	3	DUAL RED 7 Seg. 5" CA DL727 DPR	£2.00
VP138	20	Assorted LED Displays - Our mix with Data	£5.00

RDP = Right Hand Decimal Point CC = Common Cathode
LDP = Left Hand Decimal Point CA = Common Anode

ANTENNA SWITCH 2 and 3 WAY

Co-axial switch for one transceiver to two antennae or one antenna to two transceivers. Dims: 66 x 55 x 32mm (Body). O/N/O. VP 113 **£4.50**

As above but 3-way. O/N/O. VP 114 **£4.75**

HIGH PASS FILTER/SUPPRESSOR

CB/TV. High pass filter. Reduces unwanted signals picked up by antenna. Dims: 45 x 25 x 17mm. O/N/O. VP 115 **45p**

Designed to reduce harmonics on the VHS and TV band. Cut-off frequency: 30MHz. V.S.W.R.: Less than 1.2 to 1. Impedance loss: -0.2dB @ 27MHz. Impedance: 50 ohms. Dims: 80 x 55 x 40mm. O/N/O. VP 116 **£2.75**

LOW PASS FILTER

Designed to reduce harmonics on the VHS and TV band. Cut-off frequency: 30MHz. V.S.W.R.: Less than 1.2 to 1. Impedance loss: -0.2dB @ 27MHz. Impedance: 50 ohms. Dims: 80 x 55 x 40mm. O/N/O. VP 116 **£2.75**

IC BARGAINS

40 Assorted TTL CMOS INTEGRATED CIRCUITS 74 Series & CD4000 Series All new Gates Flip-Flops - MSI etc. GREAT VALUE Data Book & Sheets included. 40 Pieces (Our Mix) **£4.00** O/N/O. VP40

TRANSISTOR PACKS

VP150	20	BC183B Sil. Trans. NPN 30v 200mA Hfe240+ TO92	£1.00
VP151	25	BC171B Sil. Trans. NPN 45v 100mA Hfe240+ TO92	£1.00
VP152	15	T1S90 Sil. Trans. NPN 40v 400mA Hfe100+ TO92	£1.00
VP153	15	T1S91 Sil. Trans. PNP 40v 400mA Hfe100+ TO92	£1.00
VP154	15	MPSA56 Sil. Trans. PNP 80v 800mA Hfe50+ TO92	£1.00
VP155	20	BF595 Sil. Trans. NPN eqvt. BF184 H.F. TO92	£1.00
VP156	20	BF495 Sil. Trans. NPN eqvt. BF173 H.F. TO92	£1.00
VP157	15	ZTX500 Series Sil. Trans. PNP Plastic	£1.00
VP158	15	ZTX107 Sil. Trans. NPN eqvt. BC107 Plastic	£1.00
VP159	15	ZTX108 Sil. Trans. NPN eqvt. BC108 Plastic	£1.00
VP160	20	E5024 Sil. Trans. PNP eqvt. BC214L TO92	£1.00
VP161	25	BC183L Sil. Trans. NPN 30v 200mA TO92	£1.00
VP162	5	SJE5451 Sil. Power Trans. NPN 80v 4A Hfe20+	£1.00
VP163	2	NP/NPN pairs Sil. Power Trans. like SJE5451	£1.00
VP164	4	2N6289 Sil. Power Trans. NPN 40v 40w 7A Hfe30+	£1.00
VP165	6	BFT33 NPN Sil. Trans. 80v 5A Hfe50-200 TO39	£1.00
VP166	5	BFT34 NPN Sil. Trans. 100v 5A Hfe50-200 TO39	£1.00
VP167	1	BUY9C NPN TO3 VCB 500 10A 100w Hfe15+	£1.00
VP168	10	BC478 eqvt. BCY71 PNP Sil. Trans. TO18	£1.00
VP169	10	BXS21 eqvt. BC394 NPN Sil. Trans. 80v 50mA TO18	£1.00
VP170	10	Assorted Power Trans. NP/NPN Coded & Data	£1.00
VP171	10	BF355 NPN TO-39 Sil. Trans. eqvt. BF258 225v 100mA	£1.00
VP172	10	SM1502 PNP TO39 Sil. Trans. 100v 100mA Hfe100+	£1.00

TRANSISTORS

100 Silicon NPN Transistors. All Perfect. Coded Mixed. Types With Data And Eqvt. Sheet No Rejects. Fantastic Value. O/N/O. BP38 **£3.00**

The best known Power Transmitter in the world 2N3055 NPN 115V. Our Bi-Pak Special Offer Price. 100 off **£3.50** 50 off **£1.60** 100 off **£3.00**

100 Silicon PNP Transistors. All Perfect. Coded. Mixed. Types With Data and Eqvt. Sheet. No Rejects. Real Value. O/N/O. 8P39 **£3.00**

BD312 COMPLIMENTARY PNP POWER TRANSISTORS TO 2N3055. Equivalent MJ2955 BD312 TO3. Special Price **£0.70 each. 10 off £6.50**

SEMICONDUCTORS FROM AROUND THE WORLD

100 A collection of Transistors, Diodes, Rectifiers & Bridges, SCR's, Triacs, I.C.s & Opto's all of which are current every day useable devices. Guaranteed Value Over £10 Normal Retail Price. Data etc. in every pack. Order No. VP56 **Our Price £4.00**

TRANSISTOR CLEARANCE

100 All Sorts Transistors. A mixed bag NPN-PPN Silicon & Germ. Mainly Uncoded You To Sort Pack includes instructions for making Simple Transistor Tester, Super Value. Order No. VP60 **£1.00**

150 De-soldered Silicon Transistors from boards 10mm leads all good. O/N/O. VP173 **£1.00**

TECASBOTY

THE ELECTRONIC COMPONENTS AND SEMICONDUCTOR BARGAIN OF THE YEAR!

This collection of Components and Semiconductors for the hobbyist is probably the most value-packed selection ever offered, it consists of Resistors, carbon and wirewound of various values. Capacitors: All types, sorts and sizes including electrolytics Potentiometers - single, dual, slider and preset. Switches, Fuses, Heatsinks, Wire, P.C.B. Board, Plugs, Sockets etc., PLUS a selection of Semiconductors for everyday use in popular Hobby Projects. These include: SCR's, Diodes, Rectifiers, Triacs & Bridges as well as a first class mix of Transistors and I.C.'s. In all, we estimate the value of this in current retail catalogues to be over £25! So, help yourself to a great surprise and order a Box TODAY - ONLY AT BI-PAK. Remember, stocks are limited so hurry! You can call us on 0920 3182/3442 and order with your Barclaycard or Access Card - 24hr Answerphone Service NOW. Order No. VP 85.

just **£7.00**

ANTENNA COUPLER

Transceiver/car radio antenna coupler. With co-axial cables. One co-axial terminates in antenna plug and the other in PL259 plug. Dims: 67 x 46 x 30mm. O/N/O. VP 117 **£2.00**



PRECISION MORSE KEYS

Well designed beginners key. Fully adjustable. Dims: Base 82mm x 45mm. O/N/O. VP 122. **£1.85**

ELECTRONIC SIREN 12v DC

Red plastic case with adjustable fixing bracket. Emits high-pitched wailing note of varying pitch - 100 cycles per minute. Dims: 90mm(dia) 60mm(depth) Power: 12v DC **Our Price: £5.50**



POWER SUPPLY OUR PRICE £3.75

Power supply fits directly into 13amp socket. Fused for safety. Polarity reversing socket. Voltage switch. Lead with multi plug input - 240v AC 50Hz Output - 3 4.5 6 7.5 9 & 12v DC. Rating 300ma MW88.

TAPE RECORDER SWITCH

Unit to control motor of tape recorder. 1.8m cord and 2.5mm plug attached. On/Off switch. Dims: 55 x 20 x 20mm. O/N/O. VP 127 **£1.00**

(LEARN A LINGO) PILLLOW SPEAKER

Slim under pillow unit. 80ohms 2" speaker. 1.5m lead with 3.5mm mono jack plug. Black. Dims: 65(dia) x 17mm. O/N/O. VP 88 **£1.25**



BI-PAK

Send your orders to Dept PW3 BI-PAK PO BOX 6 WARE, HERTS
SHOP AT 3 BALDOCK ST. WARE, HERTS
TERMS CASH WITH ORDER. SAME DAY DESPATCH. ACCESS,
BARCLAYCARD ALSO ACCEPTED. TEL. (0920) 3182. GIRO 388 7006
ADD 15% VAT AND £1.00 PER ORDER POSTAGE AND PACKING



Use your credit card Ring us on Ware 3182 NOW and get your order even faster. Goods normally sent 2nd Class Mail. Remember you must add VAT at 15% to your order. Total Postage add £1.00 per Total order.

Amcomm of London

INTEREST FREE HIRE PURCHASE ON MANY ITEMS

01-422 9585 FOR FAST DELIVERY

2 YEAR GUARANTEE ON MANY PRODUCTS

HF TRANSCEIVERS

YAESU FT 980	1475:00
ICOM IC 751	1239:00
TRIO TS 930S	1150:00
YAESU FT 757GX	719:00
TRIO TS 430S	739:00
ICOM IC 745	898:00
YAESU FT 77	479:00

All accessories available for above.
Carriage and VAT included.

2M TRANSCEIVERS FM

YAESU FT 230R 25w mobile	269:00
ICOM IC 27E 25w mobile	359:00
TRIO TM201A 25w mobile	269:00
YAESU FT 208R H/Held 3w	239:00
YAESU FT 209R H/Held 5w	209:00
ICOM IC2E H/Held	199:00
ICOM IC02E H/Held keyboard	259:00
FDK Multi 725x 25w mobile	239:00
YAESU FT 290R	Phone

Carriage and VAT included.

2M TRANSCEIVERS MULTIMODE

YAESU FT 726R 2M/70cms/6M/HF Basic	769:00
ICOM IC 271E 25w base stn	625:00
ICOM IC 271H 100w base stn	799:00
TRIO TR 9130 25w mobile	449:00
MULTI 750XX 20w mobile	349:00

Carriage and VAT included.

70CM TRANSCEIVERS

YAESU FT 790R Multimode portable	299:00
YAESU FT 703 H/Held	T.B.A.
YAESU FT 709 H/Held	T.B.A.
ICOM IC 4E H/Held	259:00
TRIO TW4000A 70/2M mobile	469:00
MICRO 7 3 channel 70cms H/Held	99:00

Carriage and VAT included.

HF/VHF RECEIVERS

YAESU FRG 7700 RECEIVER	385:00
ICOM IC R70	539:00
ICOM IC R71	629:00
TRIO R2000	429:00
TRIO R600	259:00
AR 2001 25/550Mhz	399:00
NRD 515	965:00

Carriage and VAT included

AR 2001 Receiver 25/500 MHz



£339:00 inc VAT

add £3:50 carriage

ANTENNA COUPLERS

THP HC200 1.8-30MHz 20w pep	82:95
THP HC400L 1.8-30MHz 350w pep	149:00
THP HC2000 1.8-30MHz 25w pep	T.B.A.
AMTECH 300B 1.8-30MHz 300w pep	54:00
ICOM IC AT500 AUTOMATIC	399:00
ICOM IC AT1000 AUTOMATIC	Phone
YAESU FC 757 AUTOMATIC	245:00
YAESU FC 102 WARC 2Kw	Phone
WELZ AC38 1.8-30MHz	73:95

VAT included. Amtech 300B 1.50 others £6 Securicor.

Prices correct going to press, E. & O.E.

TELEGRAPH ACCESSORIES

Hi Mound Keys

HK 708 Hand Key with base	13:67
HK 707 Hand Key with base and dust cover	14:48
HK 706 Hand Key with base and dust cover	15:60
HK 702 Key with marble base and dust cover	29:65
MK 704 Dual lever paddle, no base	12:76
MK 705 Dual lever paddle marble base	23:78
COK-2 Practice oscillator	7:99
Swedish Brass	49:00
KENPRO Iambic Electronic Keyer KP100	79:00
KENPRO Iambic Memory Keyer	169:00
DAIWA DK210 Electronic Keyer	50:00

VAT included. Add £1 carriage per item.

HEIL ACCESSORIES

HEIL HC3 Microphone Element	22:85
HEIL HC5 Microphone Element (Icom SM5/6)	25:40
HEIL HM 5 Desk Microphone (300Hz-3KHz) cardoid fwd	59:00
HEIL SS2 SPEAKER... see page 10	65:00
HEIL EQ300 Mic Equaliser	65:00
HEIL BM10 80Z HEADSET/BOOM MIC	65:00

Carriage and VAT included.



SWR/POWER METER

WELZ SP200 1Kw	82:00
WELZ SP300 1Kw	115:00
WELZ SP400 150w	82:00
WELZ SP15M 200w	41:00
WELZ SP250 2Kw	57:75
TOYO TM1X 3.5 150MHz 120w	18:80
TOYO T430 145/430MHz thru line watt meter 120w	44:65
TOYO T435 145/435MHz thru line watt meter 200w	49:35

VAT included. Add £2 per item carriage.

VHF LINEAR AMPLIFIERS

THP HL30V 0.5-3w in 30w out	39:99
THP HL82V 10w in 85w out	144:50
THP HL110V 10w in 110w out	179:95
THP HL160V 10w in 160w out	244:52
THP HL160V 25w in 160w out	209:73
MML 144/30LS	75:00
MML 144/50S	92:00
MML 144/100S	149:95
MML 144/100HS	149:95
MML 144/100LS	169:95
MML 144/200S	245:00

UHF LINEAR AMPLIFIERS

MML 432/30L	139:95
MML 432/50	129:95
MML 432/100	245:00
THP HL20U 1-3w in 20w out	77:99
THP HL45U 10w in 45w out	152:77
THP HL90U 10w in 90w out	268:59
ALINCO ELH250C	114:95

B.N.O.S. complete range also in stock.

VAT included. Add £2 per item carriage.

CLOSED MONDAY
HOURS: 10:00 - 5:30

Goods normally despatched by return.



Amcomm

SERVICES LTD., 194 NORTHOLT ROAD, SOUTH

HARROW, MIDDX. HA2 0EN. ENGLAND. (Opp. South Harrow Underground Station)

TEL: 01-422 9585. TELEX: 24263



Morse for Class B's

The recent announcement (reported in the "Stop Press" item on page 45 of our February issue) of a one-year trial of c.w. operating privileges for Class B Licence-holders marks the fulfilment of a long campaign for on-air Morse practice facilities. Although it is only a trial period, I cannot imagine anything happening during that year which might cause the DTI to decide that the change should not be made permanent.

The question which it does raise in my mind, though, is whether this will spell death to the idea of a Novice Licence in the UK. The argument for and against such a licence has raged in recent years, with wildly conflicting reports of the demand from aspiring amateurs, and of the attitude of those who are already licensed. Among those who are in favour, there are vastly different ideas of what form a Novice Licence might take. Phone only, c.w. only, c.w. and phone; all h.f. bands, some h.f. bands, the 28MHz band only, 144MHz only, 430MHz only, all v.h.f./u.h.f.; power limit 5W, 10W, 50W, 400W—these are just some of the suggestions that have been made to me.

Obviously there's no way of satisfying all these demands, but that's really only the beginning of the problem. What about the 26 122 Class A and 27 095 Class B licence-holders? (October 1984 figures.) Many of them feel strongly that providing an "easy" way to an amateur transmitting licence—especially one that allows operation on the h.f. bands, would be an insult to them in the hard work that they put into studying for their exams. Trying to slot a new Novice Licence with an acceptable format into an existing

structure of a "full" (Class A) and a "technicians" (Class B) grade without upsetting either has always struck me as an impossible task.

The new Morse operating privileges will, of course, be no help to enthusiasts who have trouble understanding the technical side of the RAE syllabus, but for those who find the Morse a problem, with no local amateurs to practise with, it will undoubtedly be the answer to a prayer.

Some of those Class B licence-holders who will benefit from this move will have no interest whatever in h.f. operation. They will simply want the benefit of using Morse at speeds below 12 w.p.m. for weak-signal communication modes such as moonbounce (e.m.e.) on v.h.f./u.h.f. No matter—it's all part of the essential self-training aspect of amateur radio.

As a parting thought, what about the idea of allowing Class B's using c.w. onto the exclusive c.w. portion of the 28MHz band (28.0–28.2MHz under the Region 1 HF Band Plan). Though it wouldn't give them too much scope at the present phase of the sunspot cycle, it would certainly increase occupancy of a very under-used band.

Geoff Arnold

QUERIES

While we will always try to assist readers in difficulties with a *Practical Wireless* project, we cannot offer advice on modifications to our designs, nor on commercial radio, TV or electronic equipment. Please address your letters to the Editor, "Practical Wireless", Westover House, West Quay Road, Poole, Dorset BH15 1JG, giving a clear description of the problem and enclosing a stamped self-addressed envelope. Only one project per letter please.

Components for our projects are usually available from advertisers. For more difficult items, a source will be suggested in the "Buying Guide" box included in each constructional article.

PROJECT COST

The approximate cost quoted in each constructional article includes the box or case used for the prototype. For some projects the type of case may be critical; if so this will be mentioned in the Buying Guide.

INSURANCE

Turn to the "News" pages for details of the PW Radio Users Insurance Scheme, exclusive to our readers.

CONSTRUCTION RATING

Each constructional project will in future be given a rating, to guide readers as to its complexity:

Beginner

A project that can be tackled by a beginner who is able to identify components and handle a soldering iron fairly competently. Generally this category will be used for simple projects, but sometimes for more complicated ones of wide appeal. In this case, construction and wiring will be dealt with in some detail.

Intermediate

A project likely to appeal to a wide range of constructors, and requiring only basic test equipment to complete any tests and adjustments. A fair degree of experience in building electronic or radio projects is assumed.

Advanced

A project likely to appeal to an experienced constructor, and often requiring access to workshop facilities and test equipment for construction, testing and alignment. Constructional information will generally be limited to the more critical aspects of the project. Definitely not recommended for a beginner to tackle on his own.

SUBSCRIPTIONS

Subscriptions are available at £13 per annum to UK addresses and £14 overseas, from "Practical Wireless" Subscription Department, Room 2816, King's Reach Tower, Stamford Street, London SE1 9LS. Airmail rates for overseas subscriptions can be quoted on request.

BACK NUMBERS AND BINDERS

Limited stocks of some recent issues of *PW* are available at £1 each, including post and packing to addresses at home and overseas.

Binders are available (Price £5.50 to UK addresses, £5.75 overseas, including post and packing) each accommodating one volume of *PW*. Please state the year and volume number for which the binder is required.

Send your orders to **Post Sales Department, IPC Magazines Ltd., Lavington House, 25 Lavington Street, London SE1 0PF**. All prices include VAT where appropriate.

Please make cheques, postal orders, etc., payable to IPC Magazines Limited.

PW RADIO USERS INSURANCE SCHEME



Practical Wireless Radio Users Insurance Scheme was devised by Registered Insurance Brokers B. A. LAYMOND & PARTNERS LIMITED following consultation with PRACTICAL WIRELESS to formulate an exclusive scheme designed to meet the needs and requirements of: Amateur Radio Enthusiasts ● CB Radio Users ● Taxi Companies and Fleet Users with Radio Telephones. A copy of the Policy can be inspected at the offices of B. A. Laymond & Partners Ltd., or of Practical Wireless in Poole.



SPECIAL FEATURES

- All Risks Cover ● "New Lamps for Old" Cover (as defined in policy) ● Index Linked Cover to combat inflation ● Includes Personal Liability cover against damages payments of up to £500000 to members of the public ● Licence protection—covers legal costs arising from any breach of your licence conditions ● Equipment covered anywhere in the UK, Channel Islands and Isle of Man, but not Northern Ireland and Eire ● Fixed Antennas (Aerials) covered ● Frequency, Power and SWR Meters and similar radio-related test equipment covered ● 30 days cover on Western Europe included Free of Charge ● Absolute Security as this scheme is underwritten by a leading member of the British Insurance Association on the London Insurance Market ● Practical Wireless radio receiver and transmitter projects covered (where stated in feature) ● Available to Clubs and Organisations ● Available to Companies

Write directly to B. A. LAYMOND & PARTNERS LTD, for a special application form and full details enclosing the coupon below.

Cover for property contained in vehicles is subject to a Limit of Liability of £250, increased to £750 where the vehicle is protected by a reputable audible alarm, correctly set and operational.

When the vehicle is unattended, mobile equipment secured so that tools or a key are required to remove it must be disguised or concealed from view. Portable and mobile equipment not so secured must be removed and placed in a locked boot (or removed and adequately concealed from view if the vehicle has no boot), or removed from the vehicle entirely. Equipment not in a secure building or vehicle must not be left unattended.

B. A. Laymond & Partners Ltd., Practical Wireless and the Underwriters wish to make it clear that it is an offence to install or use a radio transmitter in the UK except under the authority of a licence granted by the Secretary of State and it is not their intention to provide cover for or to encourage or condone the illegal use of CB and/or other communications equipment.

How Much Will It Cost?

Claims will be settled after deduction of an excess in the following manner:

Sum to Insure	£1000	£3000	£5000
Annual Premium	£20	£35	£45

The premium is charged on sums insured in the selected bands. Thus equipment totalling £3750 would be in the band up to £5000, and the premium would be £45. Quotations for larger sums available on application.

Type of Loss	Excess
From saloon cars and hatchbacks with fully concealed luggage compartments	15% of claim (minimum £25)
From estate cars, vans and hatchbacks without concealed luggage compartments	25% of claim (minimum £25)
All others:	
Sums insured up to £3000	£25
Sums insured up to £5000	£50

How To Insure

Complete the application form below to obtain immediate insurance cover. Photocopies will not be accepted

APPLICATION FOR PRACTICAL WIRELESS RADIO USERS INSURANCE SCHEME					PW3/85
Name in full (State Mr, Mrs, Miss or Title)					
Address					
Post Code					
Occupation		Age		Phone No. (Home) (Work)	
I/We hereby apply to insure the equipment detailed below					
BLOCK LETTERS	Manufacturer's Name	Model	Serial No.	Description of equipment to be insured e.g. Base station; Mobile; CB; etc.	VALUE £
	1				
	2				
	3	Antennas (Aerials), s.w.r. meters, etc.			
Please continue list of equipment on a separate sheet if necessary					TOTAL SUM TO INSURE £

DECLARATION: I/We hereby declare that: 1 The sums insured represent the full replacement value of the equipment. 2 I/We have not* had insurance cancelled, declined, restricted, or other terms imposed in any way other than the normal Policy terms. 3 This proposal shall be the basis of the contract and that the contract will be on the Underwriters normal terms and conditions for All Risks and Legal Costs/Expenses cover unless otherwise agreed. 4 I/We have not* sustained any loss or damage to any radio communications equipment or been involved in litigation relating to use of radio equipment during the past three years whether insured or not. 5 All the above statements made in connection with this proposal are true and no material information has been withheld. 6 I/We understand no liability shall attach until this proposal shall have been accepted by Laymond's and the premium paid in full and a Certificate issued.

* If you have, please give details on a separate sheet.

Date

Signed

Rush us details of PW Club Insurance

PW Company Insurance

DELAY IN ARRANGING COVER COULD COST YOU A GREAT DEAL OF MONEY COMPLETE THIS APPLICATION AND POST WITH YOUR PREMIUM MADE PAYABLE TO LAYMOND'S NOW ADDRESS TO: PRACTICAL WIRELESS (INSURANCE), B. A. LAYMOND & PARTNERS LTD 562 NORTH CIRCULAR ROAD LONDON NW2 7OZ. TELEPHONE: 01-452 6611.

Super DX Station

Most successful radio amateurs will be fully aware of the critical importance of a suitable antenna for efficient operation. So, read on to learn of a unique opportunity available to Dutch amateurs, kindly provided by Radio Nederland Wereldomroep (Radio Netherlands in English), based in Hilversum, The Netherlands.

As background information, Radio Netherlands will be moving to a new transmitting centre located on the Flevo-polder (see photograph). However, before it enters service on 31 March 1985, local radio amateurs, with the special callsign PA6FLD, have been granted permission to use the Flevo site in a unique experiment.

During the third weekend in February, for a period of 36 hours, two ordinary amateur short wave band transmitters will be set up and then connected to some of the largest high-gain antennas in the world!

Operating in both s.s.b. and c.w. modes, PA6FLD will be on the air continuously between 0600 UTC (GMT) on Saturday 16 February until 1800 UTC on Sunday 17 February. One transmitter will operate on an omnidirectional antenna, intended for European reception. The second, will make full use of the giant curtain arrays beaming to Australia and New Zealand.

A special QSL card, depicting the



new Flevo transmitter site, and of course the amateur radio operation, will be sent to all amateur radio stations and s.w.l.s. submitting reports.

For further information, please contact: *Jonathan Marks, English Section, Radio Nederland Wereldomroep, P.O. Box 222, 1200 JG Hilversum, The Netherlands.*

Repeater News

29MHz: The RMG have almost completed work on the specifications for UK 29MHz f.m. repeaters. Subject to detail negotiations with the DTI it is currently hoped to establish five repeaters on a 12 month experimental basis, which would provide valuable technical and operational information. The objective is to provide a paper to the 1987 IARU Region 1 conference with a view to establishing a common policy. If all goes to plan licences *could* be issued by the end of 1985. The last Region 1 conference voted not to introduce channelisation on 29MHz but made no recommendation prohibiting such development — the RSGB has recognised the *de facto* channelisation and hopes to harmonise band use. It is understood that conventional 1750Hz tone access will be specified with continuous sub-audible tone during overs. Part of the experiment will involve two repeaters operating in close proximity to establish co-channel interference limits. All five devices may well share the same channels although this remains to be confirmed. At all times

Practical Wireless, March 1985

during the experimental phase these units will be regarded primarily as aids for enhancing local mobile activity and not as DX gateways.

144MHz: The Tyne Valley v.h.f. repeater GB3TY, R6, became operational on 6/10/84. Reports please to G8VDM. At a recent RMG meeting it was "agreed in principle" to consider a v.h.f. repeater located near Hemel Hempstead, provisionally given the callsign GB3VB. At this time no spare channels are available — a sign of the times? Further info from G3MEH.

430MHz: The Newcastle u.h.f. repeater GB3NT (RBO), which has been QRT for some four years, recently became operational. However, a site change is pending... Reports to G4PFE. A letter of intent has been lodged with the RMG to establish an RTTY repeater on Edge Hill (Warks.), info G8MFP. Also on the books GB3RR, the Sussex Coast RTTY device, provisionally assigned RB12, info G6MFJ.

DTI negotiations will soon be underway for the Cardiff u.h.f. repeater GB3SG (South Glam) RB15, info

GW6CUR. The IBA have given permission for use of their TV mast at Chiller-ton Down IOW to allow re-site of GB3IW (RB4), hopefully by late 1985, if approved.

By the time you read this GB3PY should have moved into Cambridge, improving hand portable coverage in the city. GB3BE, RB6. Bury St. Edmunds became operational on 18/11/84, info G3XXX. GB3YS, RB2 Yeovil was due on 21/11/84, info G6AGL. The Leicester RTTY/data repeater came up on 17/10/84 using a variant of the V21 protocol. Its callsign, GB3GD, should by now have been changed to GB3RY (leaving GD for the licenced 144MHz Isle of Man repeater(R1)). GB3SS on Spaeside is back on with improved coverage, following installation of new low-loss feeder.

1.3GHz: A proposal has been considered by the RMG for a 1.3GHz narrow band f.m. repeater in the Cardiff area. This has been allocated the callsign GB3VG, info GW6CUR. Graham Shirville G3VZV of RMG/BATC is to liaise with the Microwave Committee/DTI over the current ATV repeater 25W e.r.p. level. This current level is severely limiting the potential service area of ATV repeaters and it is hoped that the DTI will recognise the "spread spectrum" power distribution aspects of these wideband devices, hopefully allowing up to licence maximum levels. If you have strong views on this subject contact G3VZV direct.

General: The repeater open meeting in Hull was well attended and resulted in the appointment of Chris Reed G8MFP to the RMG with responsibilities for the South Midlands area. Prospective repeater constructors are reminded that RSGB HQ now hold the "Guide to Repeater Licencing" on computer at Potters Bar. As a final this month it is believed that the permanent carriers within the 430MHz band will drop during 1985. To comply with your licence you **must** avoid such transmissions whenever present.

CAST '85

The International Cable and Satellite Television Exhibition and Conference, returns to a UK venue this year.

CAST '85 will run from Tuesday 16 April to Thursday 18 April (inclusive), at the National Exhibition Centre, Birmingham, and *Practical Wireless* will have a stand where we look forward to meeting our readers and friends.

Fuller details will be published nearer the date.

B BULGIN

The name of Bulgin has been familiar to people in radio and electronics for over fifty years. From its origins, selling components from a corner of the butcher's shop which was the family business, A. F. Bulgin & Company moved into manufacturing, producing a range of control knobs, switches, connectors, fuse- and lamp-holders which became virtually industry standards. It is a measure of their popularity that several designs of thirty years ago and more are still produced and sold in large numbers, though most of these are now being made in modern plastics materials, rather than the traditional Bakelite, in order to keep down costs.

Alongside the commitment to maintain availability of popular earlier lines for as long as practicable, Bulgin have developed a whole range of new components. Notable among these are the Buccaneer waterproof connectors, available in multiway versions from 2 to 9 poles and coaxial (BNC) versions in 50Ω and 75Ω impedance. These rugged connectors are moulded in glass-filled Nylon, and find application in industrial, agricultural and domestic

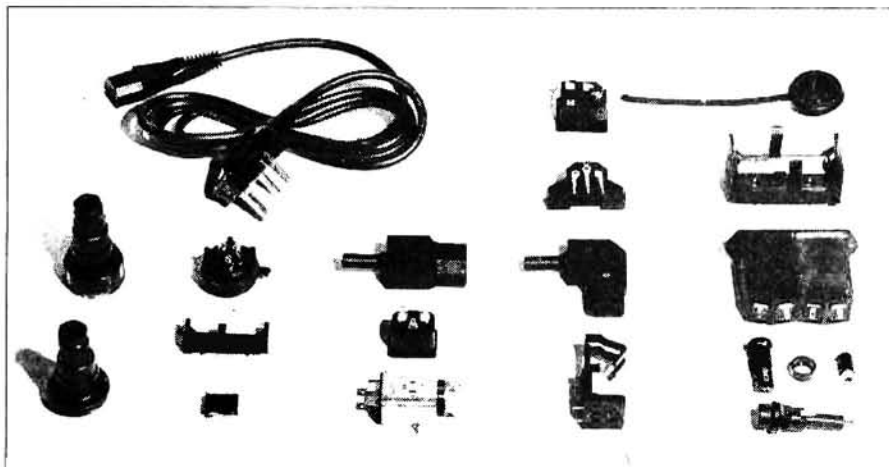

situations where moisture or dust are present. They are accepted by Lloyd's Register of Shipping for nautical applications.

The Power Conversion Division is producing an expanding range of switched-mode and linear power supplies, constant-voltage transformers and no-break power supplies.

The Barking, Essex, factory site of A. F. Bulgin gives them room to grow, and access to a local workforce which the company describes as second to none. Not only is the management a family concern; there are several

families on the factory floor, too.

The recent acquisition by Bulgin of Ambit International and Solent, now amalgamated under the name of Cirkit, puts the company back into the distribution and retail end of the electronic components business, which is where it all began, and gives them an outlet for their products to the enthusiast.

Footnote—The ever-decreasing size of components means the word "Bulgin" will no longer fit on many of them. Instead, they will carry the new trademark consisting of a capital 'B' in a rectangle, as shown above.

Microwave Links

With the prospect of microwave point to point links being introduced into the amateur repeater network at some time in the future we thought that you may be interested in a couple of items contained within the latest shortform catalogue of Terrestrial and Satellite Communications equipment from Thorn EMI Electronics. The post mounted outdoor ML13 Radio Transceiver, shown being adjusted, is available in the frequency range 12.75-13.25GHz with the possibility of up to 480 voice

channels—the general layout seems about right for a similar 10 or 24GHz amateur installation!



For those who reckon on portable microwave operation how about the NSL8B 15GHz Portable Tactical Radio Link? This fully synthesized, rugged and *lightweight*, tripod mounted transceiver has 30 voice channels, low power consumption and comes complete with integral parabolic antenna and dual polarity feed.

Whilst both these items will probably take a long time to pass through their entire service life and into

the hands of the amateur "junk" market it is certainly encouraging to see the comprehensive ranges of UK produced microwave communications equipment now available. Our thanks to: *Thorn EMI Electronics, Communications Division, Wells, Somerset.*

Junk Sale Extravaganza

Following the great success of last year's Junk Sale Extravaganza, the Cambridge Repeater Group intend to extend the event in 1985 and turn it into a "Mini Rally".

With over 500 lots being sold last year, and in anticipation of many more being offered this year, the organisers have employed the services of a professional auctioneer to ensure smooth running of the sale. Additional attractions will include trade stands, demonstration stations, refreshments and licensed bar on site.

The provisional venue is the Pye Telecommunications Centre in Cambridge and the confirmed date for the event is Sunday 24th February, starting at 10.30am.

Further details are available from: *Chris Lorek G4HCL, 11 Bevills Close, Doddington, March, Cambs. PE15 0TT. Tel: (0354) 740672.*



Special Event Station

The Saint David's Day Special Event Station, organised by the BSC Port Talbot Amateur Radio Society, using the special event call sign GB2SDD will again be operational on Friday 1 March 1985, to celebrate the National Day of Wales.

The established popularity of the event is evident from the volume of contacts made during the 1984 celebrations, when 1300 contacts were made in 24 hours.

Amateurs world-wide are again cordially invited to contact the station which will be operational throughout the 24 hours of Friday 1 March 1985. Conditions permitting, GB2SDD will be active on all h.f. and v.h.f. bands.

All QSOs will be acknowledged with a special event QSL card, and the organisers will be very pleased to respond to reports sent in by s.w.l.s.

An attractive award is available to radio amateurs who make contact with the Special Event Station on Saint David's Day, and additionally, five other Welsh amateur stations (from outside the UK) or 10 other Welsh stations (from within the UK) during the months of February and March 1985.

Claims for the award should include copies of logged contacts and a cheque or Postal Order to the value of six IRCs to cover p&p, made out to GB2SDD and addressed to: *The Event Co-ordinator, R. R. Jones GW4HOQ, "Bryn-Ynys", Strawberry Place, Morriston, Swansea, West Glamorgan SA6 7AG.*

RAE Course

A 30-week RAE course is being run at Greenhead College, Huddersfield, Yorkshire.

Although the course will have started by the time you read this, the Course Tutor, Peter Mercer G6CPM, is happy to see late starters joining the course.

Additionally, a Morse Code Course will also be available, and interested parties are similarly invited to join.

For further details, contact: *Peter Mercer G6CPM. Tel: (0484) 33036.*

VHF Sound Broadcasting Conference

Now that the above six-week conference, held in Geneva, has ended (see *News*, page 19, January 1985), the Department of Trade and Industry confirm that all the UK's aims have been fully met.

Briefly, the UK's objectives for the conference were:

- to secure a further two national v.h.f. networks, one to enable BBC Radio 1 and Radio 2 to have separate networks, and the other for the introduction of a new independent national radio service.
- the provision of additional frequencies for the development of BBC and independent local radio.
- the maintenance of the existing v.h.f. networks and improvements to their coverage.

In addition, the UK had to safeguard the position of land mobile services at present still operating in various parts of the band, and a Protocol of Agreement with our neighbours was negotiated.

The plan thus establishes the regulatory framework within which present and future v.h.f. sound broadcasting in the UK can be developed.

New Catalogues

The first Cirkit Catalogue has been published and is available at the cover price of 85p, from leading newsagents throughout the country, or direct from the company.

Brimming with electronic components, kits and associated products plus essential information for the hobbyist, this new catalogue replaces that previously published under the name of *Ambit*.

Many of the products listed in the new catalogue, such as Toko coils and Alps switches, are only available through Cirkit. An additional feature is three £1.00 discount vouchers for orders over £15.00.

For further information, contact: *Cirkit Holdings PLC, Park Lane, Broxbourne, Herts. EN10 7NQ. Tel: Hoddesdon (0992) 444111.*

Electrovalue Ltd., the Egham based suppliers of quality components have their latest catalogue available.

This is Electrovalue's largest mail-order catalogue yet in terms of items stocked and each is shown priced. The company's policy of free postage, discounts and credit card availability continues as ever.

To obtain a free copy of the catalogue write or telephone to: *Electrovalue Ltd., 28 St. Jude's Road, Englefield Green, Egham, Surrey TW20 OHB. Tel: (0784) 33603.*

Cricklewood Electronics Ltd. have their latest catalogue available, which lists hundreds of various semiconductors, plus numerous other components to interest the electronics enthusiast.

A copy of this free catalogue is available, in return for an s.a.e. sent to: *Cricklewood Electronics Ltd., 40 Cricklewood Broadway, London NW2 3ET. Tel: 01-450 0995 & 01-452 0161*

Space News

A recent UOSAT Bulletin carried the sad news that Finn Steenstrup, OX3FS, Senior Research Engineer with SRI International in Greenland, was killed during work on the 30m dish antenna. Finn, a long time radio amateur was instrumental in the recovery operation mounted to rescue OSCAR 11 (UOSAT-2) during 1984. Working in conjunction with SRI Radio Physics Laboratory head Dr. Bob Leonard, KD6DG, Finn was able to set up the observatory dish at Sondre Stromfjord to monitor the +7dBm 1.2GHz receiver local oscillator of the spacecraft, thus providing the vital information that the system was intact. Not only the UOSAT Team but many others around the world who now enjoy using UOSAT-2 owe a debt to the enthusiasm and professional talents of a fine man they never knew. See *On the Air* for more Space News.

More on page 70



ARE
AMATEUR RADIO EXCHANGE LTD

FOR THE FASTEST AND CHEAPEST MAIL ORDER

LONDON: 373 UXBRIDGE ROAD, ACTON, LONDON W3 9RH. Tel: 01-992 57656

&

NORTHERN: 38 BRIDGE STREET, EARLSTOWN, NEWTON LE WILLOWS, MERSEYSIDE WA12 9BA. Tel: 092 52 29881

AR 2001

The AOR AR2001 is an excellent scanning communications receiver which can perform a three mode function on any frequency within the range 25-550MHz. However it has a few weak points such as, no S meter, relatively poor display lighting, and last a sluggish keyboard which, due to the touch membrane construction format, is rather stiff and slow. This article provides details of modifications and amendments to overcome these weak points—the first of which will be the keyboard.

External Keyboard

An examination of the circuit diagram of the AR2001 shows that the keyboard contains nine data lines, 5 × 4, which suit the 20 keys. An external keyboard containing 24 separate keys is proposed and in fact you can build one with 32 keys, rearranging the keys into any position you want, depending upon the method of wiring up. Two separate methods of connecting these keys are possible, hardwired or using a p.c.b., Fig. 3.

Looking at the photograph of the external keyboard five by five rows of keys can be seen. The ENTER key shares two places, but you can give it one place to gain an extra key position. The other four keys are the CLK-SET, DELAY, SPEED, and lastly a new key called SQ STOP. The first three of these keys in fact share the same key places on the original membrane keyboard as (3) (·) and (0) and as you can see the other double keys can also be separated if you wish, which will give you a total of 32 keys.

The SQ STOP is the only key which will lock down—this will allow you to unlock the squelch setting without upsetting the squelch position, and this will be useful for those times when the receiver is scanning or searching and when no signals are present; if you wish to change either the frequency, mode or spacing, then by pressing the SQ STOP key, this will allow you to perform any of the above

changes. Then, by unlocking this key, you can continue as before. It's also useful when you wish to search with the squelch switched off, using the UP and DOWN keys for those weaker signals, or you can unlock the squelch to see if a weak signal is below your squelch threshold.

At this point here is a useful tip for scanning manually—press the MANUAL key, then put the frequency in you want to start from. Then press *continuously* either the UP or DOWN keys, and you will find that it will continue to scan up or down, even if the squelch is switched on or off. Also, whilst pressing one of these two keys, you can press the SPEED key and it will change speed.

You could change the UP and DOWN keys on the new keyboard to the lock-down type, but when it comes across a wanted signal, you will have to unlock these keys quickly to stop the scan, otherwise it will pass over it. It's OK for looking for weak signals, but the author much prefers the press-down to the lock-down type.

So with the added advantage of faster softer keys, you can search all over the bands a lot more quickly than before, which makes the 2001 very much more pleasing.

Keyboard Construction

The nine lines for the new keyboard can either share the same lines that go to the internal keyboard or you can unplug the old flexi-p.c.b. strip, and plug in a new ribbon cable or flexi-strip. The manufacturers have in fact provided a hole for fitting a 15 pin D-sub type socket on the back of the chassis. This has been covered by the black outer plate, which you can cut out with a knife. If you don't want to cut and drill the back plate, then you can wire in an eleven line flat cable and screw the bottom cover down with the cable passing out underneath; this has proved to be satisfactory.

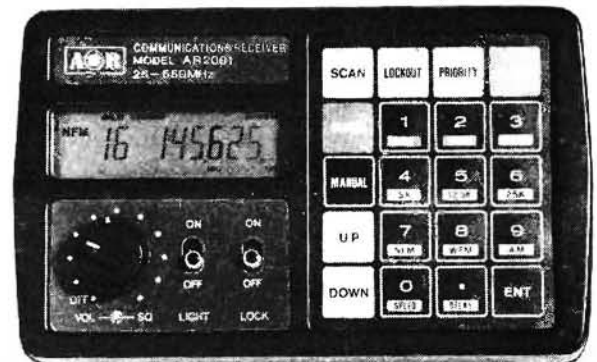
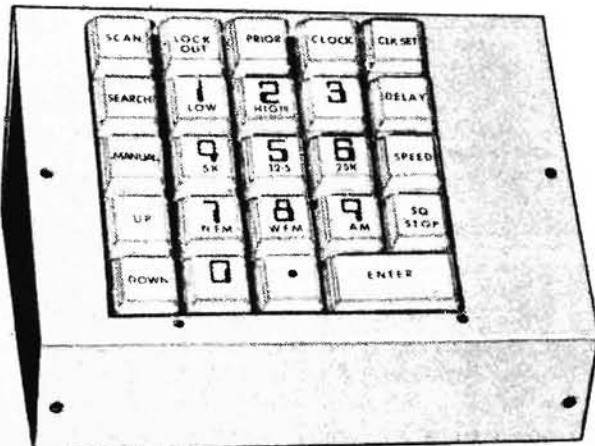

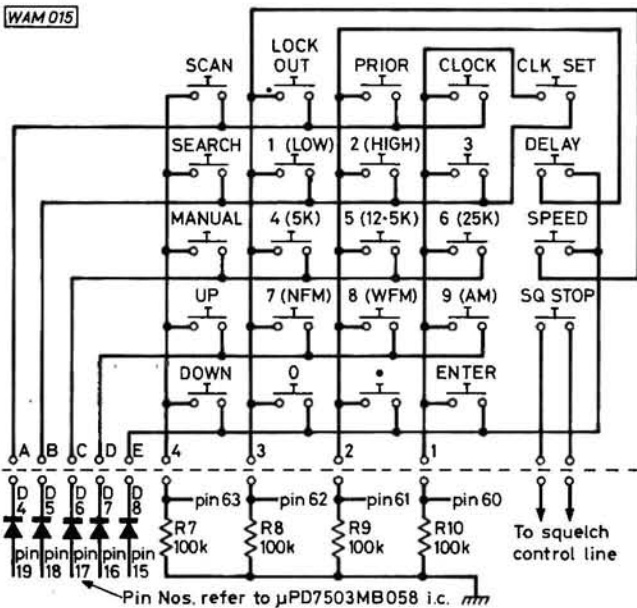

Fig. 1: Wiring and connection details of the external keyboard

To construct the new keyboard you will require a case to suit the 25 keys (and the S meter). The prototype used a black abs plastics case which is 222 × 145 × 65mm in height. A 95mm square hole must be cut out of the front panel, to let the keys through and also a hole to suit the selected S meter. Key switches (KCC 10002), tops and lens can be bought from Cirkit. The markings on the keys are put on with dry transfer lettering and when the lens is fitted, the marking should last forever.

The specified key switches will fit into a mounting plate of the type sold by RS Components (339-667). This plate will accommodate 50 keys so you will have to cut it to suit your requirements. Drill this panel in four places, 3mm dia then offer the mounting plate up to the front panel on the case, the right way round, and mark through the drilled holes; then drill the front panel. Fit the key switches into the plate with the key tops and screw the whole assembly together. Test to make sure the outside keys do not touch the outside edges of the case, otherwise they will jam.

You can wire up the switches as shown in Fig. 1 or make a p.c. board as shown in Fig. 3. This latter technique will help to support the keys more rigidly and it also gives a support for the ribbon cable.

Squelch Stop Switch

The SQUELCH control leads are connected to the small p.c.b. mounted on the VOLUME control, as shown in Fig. 2. On the left hand side there are three wires, yellow, black and violet—if you unsolder the central black wire and solder one of the wires from the SQL STOP switch to this point, the other SQL STOP switch wire is soldered to the black wire taken off.

An extra switch is required to switch the squelch back on when the external keyboard is unplugged. This is done by fitting a matching switch at the back of the AR2001 below the attenuator switch—a hole for the new switch has already been provided on the back panel so you just cut out the black cover over this switch hole and screw in the new switch, wiring the two leads across to the pins going to the squelch switch on the keyboard.

Keep track of the order of wires from the keyboard, so that the five wires will go to the five diodes D4 to D8, and likewise the order of the four wires to the four 100kΩ

IMPORTANT

While the additions and amendments provided in this article will enhance the AR2001, it must be noted that the guarantee will be invalidated. The major importers of this equipment are aware of this article but cannot undertake to do the modifications or supply components.

resistors—all these components are sitting beside the socket used for the internal AR2001 keyboard. The order this is done in is first to remove the top and bottom covers; unplug the speaker; remove the knobs and unscrew the four screws holding the front panel. Next unplug the J1 strip plug with care, and that's as far as you want to go at the moment. On the front panel p.c.b. you will see the flexi-p.c.b. strip going to the keyboard from the black plug. Beside this plug you will see five diodes and four 100kΩ resistors; clean the top of the resistors, so that the new keyboard wires can be soldered to the tops of the resistors and the diodes (Fig. 1). Two wires will go to the squelch board, and the last two wires are used for the S meter.

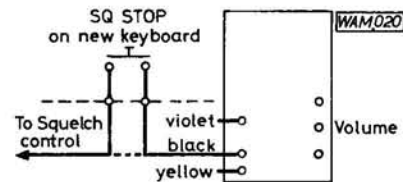

Fig. 2

This should complete the keyboard construction, but before you refit the front panel you have the opportunity to improve the display lighting. First unscrew the p.c.b. from the front panel, and face the front of the p.c.b. display side up. Looking at the l.c.d. display you will see the one small lamp on the right hand side. The lamp sits into a plastics pocket and you will also see a further two pockets at the bottom of the display; it's these two pockets that you will use to fit two sub-miniature 3.2mm dia, 12 volt 60mA bulbs (RS 587-670). Push the two lamps into the pockets and feed the four wires through the holes near the lamp switch, soldering two of the wires to the top position on the lamp switch and the other two wires to an earth point; the best point is the earthy side of the lamp already fitted, see Fig. 4. Test the lamps and the keyboard before screwing

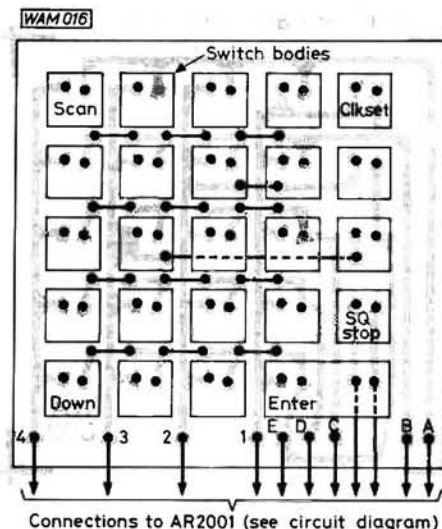

Fig. 3: Reduced scale layout of keyboard p.c.b. A full size paper track pattern is available for 30p from the editorial offices

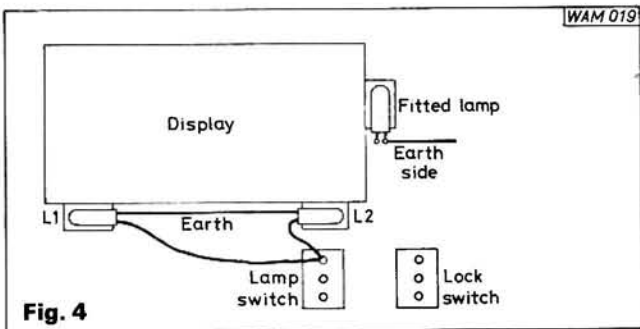

Fig. 4

the front panel back on.

If you add an ex-CB type S meter, you can use the lamp in the meter which will come on when you switch the display lights on. To do this you must run an earth and live lamp wire through to the 15 pin D plug at the back, using pins 13 and 14.

Adding an S Meter

The last modification is to add an S meter which will give relative signal level indication, operating from the receiver's a.g.c. circuit. The a.g.c. output is found on pin 11 of IC3 (NIS-112), see Fig. 5. Connections for this pin plus an earth line are required for the S meter. IC3 is the black chip that sits vertically at the back of the top p.c.b. and the S meter pick up point can be seen on a solder point

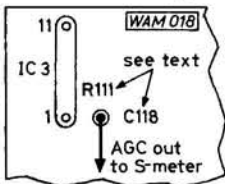

Fig. 5: S meter connection details

beside pin 1. This is the point where C118 and R111 have not been fitted (see Fig. 5), this saves having to lift the p.c.b.

The a.g.c. signal is fed to R1 (Fig. 6) which will vary the signal gain to the base of Tr1. Potentiometer R4 will adjust the meter for a zero reading. To set up the circuit, zero the meter first with no signal coming in and then set R1 on a known signal strength to the correct S reading. Repeat this procedure until the correct S meter reading and "no signal" zero are obtained.

The two 2N1305 transistors (Tandy Stock No. 276-2007) used in the meter circuit are germanium switching types with a low power consumption, in fact the circuit only draws 90µA. The circuit polarity is different to the AR2001 so the two negative lines must not meet. The

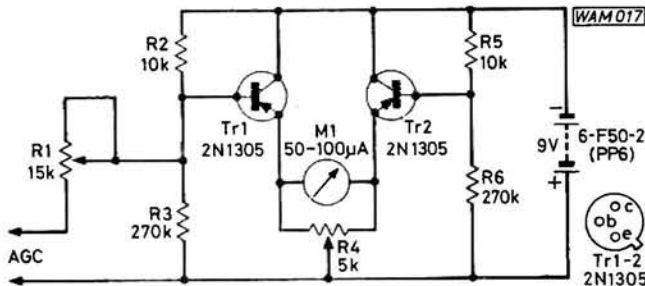

Fig. 6: The add-on S meter circuit

most convenient solution is to use a 6-F50-2 (PP6) 9V battery, which will last for a very long time.

If you intend at a later time to build a larger keyboard with more fittings, then it would be wise to fit a 25 pin D sub-socket on the AR2001, which is the same type as used for RS232 computer ports.

multiple choice... multiple choice... QUESTIONS multiple choice... multiple choice...

If you are an aspiring RAE candidate or just feel like testing your knowledge of amateur radio these multiple choice style questions will fill your needs. The questions are typical of those appearing in both the RAE papers, but they are not taken from these papers. For the answers, together with explanatory notes to help you, please turn to page 54

Paper 1 Section 1. Licensing Conditions—use of callsigns

Question 2

If you are sending your callsign in Morse for identification purposes the speed must not exceed

- a. 10 words per minute
- b. 12 words per minute
- c. 15 words per minute
- d. 20 words per minute

Paper 2 Section 5. Transmitters—modulation

Question 15

This graph shows the audio frequency response of an amateur transmitter. The lower cut-off frequency should be approximately

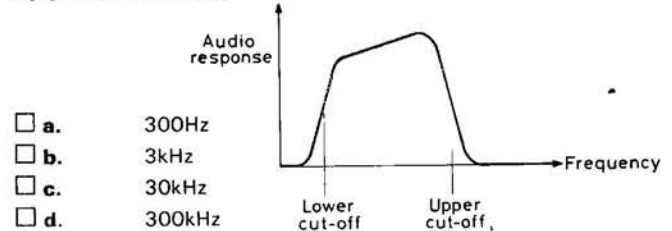

Paper 1 Section 2. Transmitter Interference—low-pass filter

Question 5

A low-pass filter between transmitter and antenna will

- a. increase the strength of the radiated signal
- b. decrease the bandwidth of the radiated signal
- c. reduce the harmonics in the radiated signal
- d. increase the modulation of the modulated signal

Paper 1 Section 1. Licensing conditions—/P

Question 17

The suffix /P should be added to your callsign when operating

- a. at the temporary location or as a pedestrian
- b. at the temporary location or on a push-bike
- c. at the temporary location only
- d. as a pedestrian only

MICROWAVE MODULES LTD

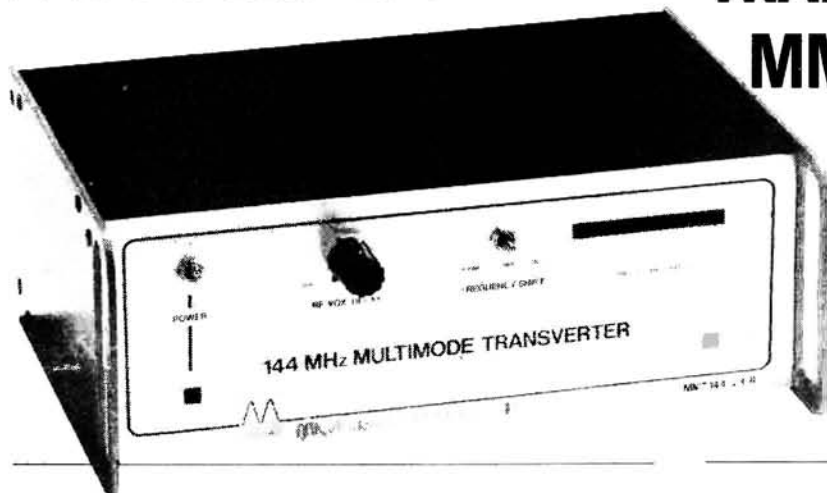

2 METRE MULTIMODE TRANSVERTER

MMT144/28-R

**NEW
RELEASE**

FEATURES

- 25 Watts TX Output
- GaAsFET RF Stage
- Transmit ALC Circuit
- 13.8V DC Operated
- Repeater Shift (normal, simplex, reverse)
- High Level DBM Mixer
- LED Bargraph Power Meter
- RF VOX – Adjustable Delay & PTT Override

SPECIFICATION

GENERAL

INPUT FREQ RANGE : 28-30 MHz
 OUTPUT FREQ RANGE : 144-146 MHz
 REPEATER SHIFT : Simplex, normal, reverse
 DC REQUIREMENTS : 13.8V DC @ 6 Amps

TRANSMIT SECTION

OUTPUT POWER : 25 watts +/- 1dB
 INPUT LEVEL RANGE : 1/4 mW to 300mW
 ALC RANGE : 20dB
 MODES OF OPERATION : SSB, FM, CW, AM, FSK
 SPURIOUS OUTPUTS : -65dB or better

RECEIVE SECTION

GAIN : 22dB +/- 1dB
 N.F. : 2dB or better
 3rd ORDER INTERCEPT : +19dBm (output)

DESCRIPTION

This new transverter has been designed to allow users of existing HF band transceivers to establish a first-class transceive facility on the 144MHz band. The MMT144/28-R incorporates many new and exciting features which combine to make this product simply superb

RECEIVE SECTION

An NEC GaAsFET is employed in a noise-matched configuration feeding a high level double balanced mixer via a bandpass filter. IF gain is achieved by a JFET post amplifier. This combination produces a good signal to noise ratio, excellent immunity to overload and cross modulation, resulting in a rugged receive system having a third order output intercept point of +19dBm.

Two separate low-noise oscillators, operating at 116.00 and 115.40 MHz are included, running from a regulated 8.2 volt supply. Selection of the wanted oscillator is achieved by a quad op-amp circuit, controlled by the front panel mounted 'MODE' switch. This provides simplex, repeater and reverse repeater operation. The output of each oscillator feeds a JFET buffer amplifier via the quartz crystal which acts as a filtering element to reduce amplitude noise and reciprocal mixing products. The resultant high level injection is extremely pure and free-from harmonics.

TRANSMIT SECTION

The incoming 28MHz signal, in the range 1/4mW to 300mW, is initially fed to the RF VOX circuit, ALC control circuit and the input level control.

This signal is then fed into a pair of MOSFETs in a balanced mixer configuration, together with the local oscillator injection, to produce the wanted signal in the range 144-146MHz.

This signal is then amplified by several linear stages upto the specified output power of 25 watts. A visual indication of relative output power is provided by a front panel mounted LED bargraph display.

A rear panel mounted level control allows the user to adjust the sensitivity of the transverter to suit the transceiver in use, and a front panel mounted RF VOX delay control allows adjustment to suit SSB/FM modes.

The ALC circuit has a 20dB dynamic range and has been incorporated to ensure that a totally clean signal is produced by the transverter. This is an important feature which will virtually eliminate compressed signals and the resultant problems caused to local stations.

PRICE: £215 inc. VAT (p+p £3.50)

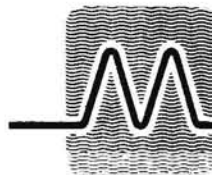

MICROWAVE MODULES LTD.
 Brookfield Drive, Aintree, Liverpool L9 7AN,
 England.
 Telephone: 051-523 4011.
 Telex: 628608 MICRO G.



Goods normally despatched
 within 10 days

HOURS:
MONDAY-FRIDAY
9-12.30, 1-5.00
 E. & O.E.

R WITHERS COMMUNICATIONS

584 HAGLEY ROAD WEST, OLDBURY, WARLEY
B68 OBS (QUINTON, BIRMINGHAM)
Tel: 021-421 8201/2 (24 HR ANSWERPHONE)



"THE FASTEST GROWING AMATEUR RADIO DEALERS IN THE UK"

NEWSFLASH

FULL RANGE OF YAESU, ICOM, TRIO ETC. SOME AT PRE-INCREASE PRICES - PHONE FOR LATEST STOCK LEVELS.

Raycom Limited

Made to measure R.F. amplifiers - off the peg! For the first time a choice of linear or class 'c' designed to match your hand-held or portable radio.

* INPUTS FACTORY ADJUSTABLE FROM 500mV TO 5 WATT - ALL AMPS SET FOR 1-3 WATTS.

* ALL UNITS HAVE RF RELAY CHANGEOVER + SWITCHABLE SSB/FM HANG TIME.

* FULL 12 MONTH PARTS AND LABOUR WARRANTY. * STATUS L.E.D.s.



All units are Toshiba or Mitsubishi RF power modules as used in all new VHF/UHF radios.



Quality British construction. Real Value for money.

FROM ONLY **£39.50** +P&P

UHF UNITS (430-440MHz)

	ORDER CODE	PRICE
25W FM/CW	V25F	£79.50
15W FM/CW/SSB/AM	V16L	£69.50
15W FM/CW	V15F	£59.50

IF YOU REQUIRE A DRIVE LEVEL OTHER THAN 1-3 WATTS PLEASE STATE AT TIME OF ORDERING. PLEASE ADD £2.50 POST + PACKING. TELEPHONE ORDERS ON VISA + ACCESS CARDS. PLEASE MAKE CHEQUES PAYABLE TO R. WITHERS COMMS.

VHF UNITS (144-149MHz)

	ORDER CODE	PRICE
45 FM/CW	V45F	£62.30
35 FM/CW/SSB/AM	V35L	£59.50
25 FM/CW	V25F	£48.50
15 FM/CW/SSB/AM	V15F	£49.50
15 FM/CW	V15F	£39.50

HAVE APPOINTED R.W.C. AS THEIR SOLE DISTRIBUTORS FOR THESE FANTASTIC NEW PRODUCTS FOR 1985

WE'VE DONE IT! 10FM FROM OVER 90% OF LEGAL FM C.B.'s.

* MODS ANY CB WITH THE SANYO LC7136 OR 7137 SYNTH. CHIP TO TEN MTRS FM INCLUDING REPEATER SHIFT.

* MEASURES ONLY 5 1/2" X 3/4"
* SIMPLE TO INSTALL - REQUIRES JUST A SOLDERING IRON, SIGNAL SOURCE PLUS SIMPLE TEST GEAR. ONLY EIGHT WIRES TO SOLDER.

* EVERY BOARD FACTORY TESTED

* COVERS 29.3-29.690MHz (WILL COVER BEYOND 30MHz ON MOST CBS)

* SUITABLE FOR AMSTRAD, BINATONE, LOWE TX40, COLT, PLANET, COLT, LCL, FIDELITY, COBRA, HARRIER, MIDLAND, MUSTANG, UNIDEN + DOZENS MORE.

* NOTE: WE CAN FIT THE BOARD FOR £19.50 BUT ENCOURAGE YOU TO FIT IT YOURSELF. MAIL ORDER - PLEASE INCLUDE £1 FOR POST/PACKING + ALLOW 7-10 DAYS FOR DELIVERY. TWO OR MORE - POST FREE. BOTH PRODUCTS COPYRIGHT FBX-RWC 1984. PATENT APPLIED FOR. SHOP CALLERS WELCOME. LATE NIGHTS THURS + FRI TILL 7.



VALUE FOR MONEY

ONLY **£22.50** + P/P

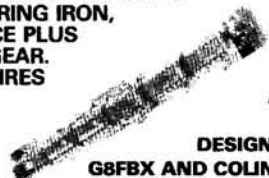

IDEAL FOR SWLs AND BEGINNERS! FROM A PROVEN DESIGN BY BILL SPARKS G8FBX AND COLIN HORRIBIN G3SBI

NEW AMATEUR RADIO SHOP!!

North London Communications Ltd

(Sale, Service, Installation & Rental of Communications Equipment)

211 The Broadway, West Hendon, London NW9 7DE

Tel. No. 01-202 2778 Telex No. 298765 Unique G

Approved dealer for

★ Yaesu ★ Icom ★ Standard ★ Datong ★
★ J-Beam ★ Microwave Modules ★
★ Katsumi ★ Toyo ★ Hi Mound CDE ★

(PMR + Marine Communications Equipment Also Stocked)

Come And See Us Or Phone Us For Our:-
Special Opening Offers + Excellent Discounts

Products

HF Transverter

Until recently the majority of amateur band products from muTek were applicable to v.h.f. regions and above, but with the introduction of the TVHF 230c h.f. transverter they have demonstrated their expertise effectively extends towards the d.c. regions.

Those already in possession of a v.h.f. replacement front-end board or receive pre-amplifier will be aware that muTek design philosophy leans heavily towards the provision of good strong signal-handling/dynamic range performance. Well defined, passbandwidths together with a high stability, low noise synthesised local oscillator stage are all combined within this latest product, which is the result of several years research.

Automatic gain optimisation is provided resulting in the correct receiver sensitivity for the frequency in

use. Sub microvolt sensitivity specifications are impressive (even useful at v.h.f.) but apart from laboratory curiosity inevitably lead to considerable reduction in realisable dynamic range within the h.f. spectrum, where external noise and Megawatt signals predominate.

When used in conjunction with a multimode 144MHz transceiver the TVHF 230c will provide access to all nine UK amateur bands.

Power output is 10W p.e.p. from a conservatively rated push-pull pair p.a. which incorporates an a.l.c. loop and excessive v.s.w.r. protection circuitry. Power supply requirements are 12-5V to 14-5V d.c. at 4A.

Priced at £334.90 including VAT (plus £5.00 carriage), the TVHF 230c is available from: *muTek Limited, Bradworthy, Holsworthy, Devon EX22 7TU. Tel: (040 924) 543.*



27-28MHz Conversion Module

R. Withers Communications have available a modification module, which will convert any current MPT1320 f.m. CB transceiver, fitted with the Sanyo LC137 phase locked loop i.c., to cover the 28MHz (10 metre) amateur band.

Coverage of the frequency range 28-30MHz band is provided in 400kHz, 40 channel steps. Additionally, the unit has built-in repeater offset.

Full installation instructions and circuit description details are provided

with the unit, which is simple to fit, but does require readjustment to the receiver and transmitter sections. Although most radio amateurs will not experience difficulty installing the module, for those who would like the unit installed for them, RWC are prepared to fit the module, providing the CB rig is performing to specification, at an extra charge of £19.50.

The built and tested conversion module costs £22.50 plus £1.00 p&p, and is available from: *R. Withers Communications, 584 Hagley Road West, Oldbury, Warley, West Midlands B68 OBS. Tel: 021-421 8201/2/3.*

10GHz Pre-amps

The latest products available from JVL Electronics include two 10GHz waveguide-mounted GaAs-f.e.t. pre-amplifiers. The WG LN1 features an MGF1402 to provide gain of 9dB with a noise figure of 2.5dB. A version is also available for 5-7GHz.

The WG LN2 uses an MGF1403 device and has a specified noise figure of 1.5dB and associated gain of 11dB at 10GHz! If you are interested in these or any other of the now comprehensive range of u.h.f. and microwave products send an s.a.e. to: *JVL Electronics, 26 Fernhurst Close, Hayling Island, Hants PO11 0DT, or Tel: (0705) 464482.*

144MHz ATU

So often a very simple idea can provide good results for the minimum of outlay.

The unit described here is intended to take up the gain that usually falls off either side of the nominal peaked frequency of a beam antenna. Via two concentric trimmer capacitors, a series/parallel network can be tuned to the specific portion of the band required, enhancing the signal presented to the transceiver.

B & J Telecommunications can supply such a unit, ready-built on a p.c.b. for £3.50 plus 50p p&p. The module then needs mounting into a metal case with appropriate socket terminations and two access holes to tune the capacitors.

B & J Telecommunications, 9 Queen's Walk, Thornbury, Near Bristol BS12 1SR. Tel: (0454) 416381.

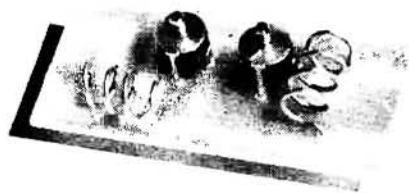

If you please

Please mention this column when applying to manufacturers or suppliers featured on this page.



FOR YAESU, ICOM AND TRIO-KENWOOD

AMATEUR RADIO EXCHANGE LTD

LONDON: 373 UXBRIDGE ROAD, ACTON, LONDON W3 9RH. Tel: 01-992 5765/6

&

NORTHERN: 38 BRIDGE STREET, EARLSTOWN, NEWTON LE WILLOWS, MERSEYSIDE WA12 9BA. Tel: 092 52 29881

VERTICAL ANTENNA FOR 7MHz

by
Stan Crabtree G3OXC

For many of us the idea of a horizontal wire antenna for the lower frequencies at say 10m high is little more than a pipedream. It may be that the garden is just not long enough to accommodate the length or that there are no convenient supports that can be utilised. For those with restrictive space there is really only one alternative—the vertical antenna.

With a little time spent on planning the site and deciding on the best method of construction, good results can be obtained with a vertical. And it need not be sufficiently obvious to invite a letter of enquiry from the local Municipality Building and Planning Office!

If you go to the text books you will see that much is made of an effective earth system for a vertical, especially on the lower frequencies. This is not disputed but there are few who are devoted enough to devastate whatever lawn they have simply to bury a configuration of radials! The antenna to be described makes the most of items in general use to provide a reasonable earth and antenna installation.

The vertical is notorious for picking up man-made noise—certainly when compared with the horizontal dipole. Its uni-directional, low angle of radiation pattern also makes it a source of interference to other receiving apparatus nearby therefore it should be mounted as far away as possible from the house as space will permit. Feeder loss at r.f. using good quality coaxial cable should be negligible. The following describes a suitable arrangement for a 7MHz vertical in an environment of the typical, semi-detached house.

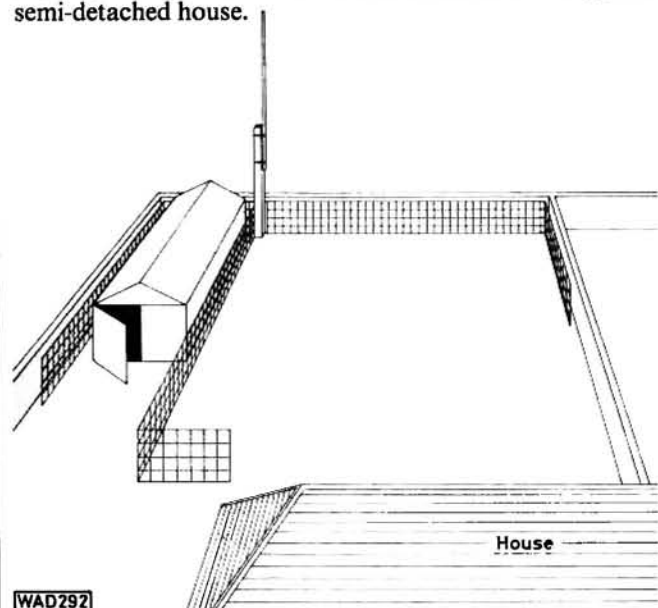

WAD292

Fig. 1: Typical installation of antenna and earthing system

Figure 1 shows an average semi with a garage or shed in the more usual position. The site chosen for the vertical is as far away as possible from your own premises and also your neighbours. Thus BCI and TVI should not be a problem. It is of course assumed you also have a low pass filter connected in series with the r.f. output from your transmitter.

Construction

Due to the angle of radiation, height is not so important but it is useful to erect the antenna clear of obstructions. A piece of hardwood 50 × 50mm and some 10m long serves as the support and should first be creosoted or otherwise protected against the weather. It should be bolted to the side of the garage or otherwise held secure.

Assuming 7MHz is the band required, a length of aluminium tubing preferably not less than 16mm diameter and around 4.5m long will act as the main radiating element. The inductance of a loading coil at the base together with the lead-in to be described will provide a resonant point for 7MHz. (If by chance a 14MHz antenna is needed the above measurements still hold good as using a lead-in of around 0.5m will result in a quarter of a wavelength at this frequency.)

Although wood is an insulator some form of more effective insulation is necessary when fixing the vertical antenna to the support. Ideal are Multi Cable Transit (m.c.t.) blocks as used on industrial electrical projects. However, any solid or non-absorbent insulating material will suffice—TV antenna accessories for instance. The drawing (Fig. 3) shows how the antenna tubing is supported away from the hardwood using "U" bolts of a suitable size. Two fixing positions should be sufficient—enough to ensure the vertical section is rigidly clamped.

The loading coil consists of wire wound on a 203mm long piece of 50mm plastics waste pipe. A strong, quality material such as Terrain is recommended. In the writer's case, 11 turns were needed to produce an s.w.r. of around 1.2:1 over the first 50kHz of the band but various factors including the earth arrangement may mean more or less turns. For a permanent installation a 2BA bolt or similar should pass through a point near the bottom of the tubing and continue through a hole in the plastics tube. One end of the wire coil with a solder tag should also be anchored at this point. The winding should be of thick, copper insulated wire or flex and have sufficient length to provide 12 or 13 turns but be only loosely held in position at this stage. About 100mm along the coil former another hole should be drilled and another bolt inserted. From this position a length of heavy flex or better still 7 strand earthing wire about 0.5m long should be fed through a hole into the garage or shed. A downward loop should be formed just before entry so that any rain will not enter the hole but drop off the wire outside.

Inside, fixed near the cable entry a diecast or other metal box should be used, approximately 75 × 50 × 50mm. This is required to hold an SO239 coaxial socket and also act as an anchor point for all the earth connections. The advantage of having this arrangement inside is that it is virtually maintenance free; the connections will not have to withstand the effects of the rain and ice. The cable from the loading coil is fed into the box via a rubber grommet and soldered to the SO239.

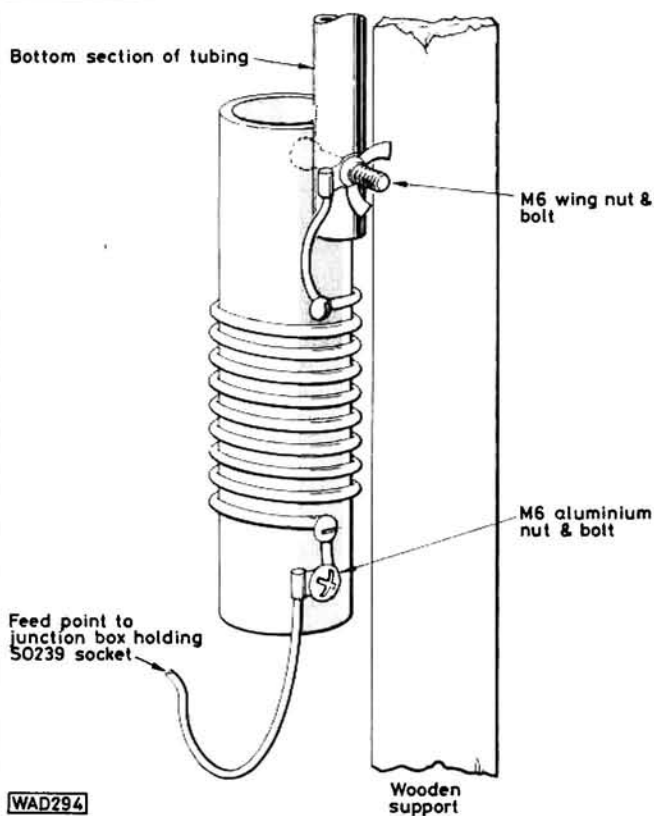

WAD294

Fig. 2: Constructional details of the loading coil for the vertical antenna

Earthing System

You are now ready to install the earthing system. The radials for a vertical quarter-wave, unlike its ground plane counterpart, are not critical. You are really trying to simulate an artificial earth over as wide an area as possible. Ideally this should extend from the base of the antenna to a little more than $\lambda/4$ at the operating frequency. Thus at 7MHz, some 10.3m of wire run is required. You may not have sufficient space but you can afford to "bend" the path a little. One method is to use 36 inch wide "chicken wire" with 2 inch squares. This can be laid out as shown in Fig. 1—along a fence in the direction of the house, turning if necessary; along the boundary perimeter fence again turning if insufficient length; and once again along the back of the garage and turning in a direction towards the driveway. This fencing is mounted vertically and support-

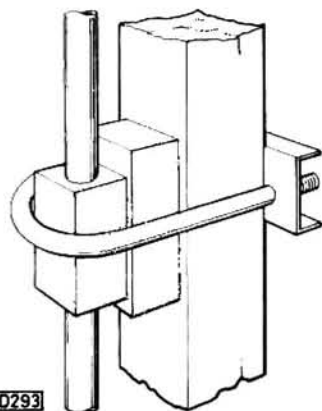

Fig. 3: Details of the method of fixing the antenna tubing to the wooden mast

WAD293

ted as necessary by stakes. It will of course also be useful to hold sweet peas and other climbing plants. The fencing should meet immediately below the base of the antenna and connections made from this framework to the metal box holding the coaxial socket. Few will in fact recognise it as forming part of an antenna installation at all.

Tuning

You are now ready to tune the antenna or, to be more precise, adjust it for the best match to the transmitter by observing the s.w.r. You must decide if your activity is going to be predominantly c.w. or phone. Your choice will decide the resonant point to aim for—either 7020kHz or 7070kHz respectively. Lets assume you are a dedicated c.w. man and select 7020kHz.

Pull the coil windings taut if necessary keeping them temporarily in place by an elastic band or Sellotape. Use 11 turns and then with a crocodile clip on the free end attach this to the lower bolt.

Tune the transmitter on low power to 7005kHz and with no a.t.u. in circuit, note the s.w.r. Retune to 7040kHz and adjusting the drive as necessary to give the same output, again note the s.w.r. If the reading has increased the antenna is effectively too long and the inductance of the coil should be reduced by either spacing the turns or removing one. If the second reading is lower, the antenna is resonating at some higher frequency and the inductance will need to be increased. From these guidelines, continue adjusting the coil windings until the lowest possible s.w.r. reading is obtained at 7020kHz. Remember that apart from altering the number of turns the inductance can be increased by reducing the spacing between them—or bunching the turns together. This is useful for relatively small changes especially in the final stages. Using this method you should be able to produce a very workable s.w.r. of less than 1.5:1 at the centre of the section of the band required. Some schools of thought now advocate the relevant unimportance of a low s.w.r. but in modern solid state transceivers it is essential to have a good antenna match if full output power is to be obtained.

Once the correct setting is achieved the windings should be made as rigid as possible and the free end connected permanently to the lower bolt. The coil could be cemented in position or wound with insulating tape.

Variations

A variation of the above could provide multi-band operation. Two extra large crocodile clips, as used for battery charging in garages, can be fixed by nuts and bolts at both ends of the 50mm plastics tubing. A second anchoring point will be required at the feed through connection and in line with the base of the antenna tubing. This must of course be mounted on but insulated from the wooden support. Coils could then be wound on separate formers and resonated at 7MHz and 3.5MHz. Band changing would simply be a matter of clipping on the relevant coil. As mentioned earlier it should be possible to use the antenna on 14MHz by adjusting the length of the lead-in wire. This could have a strong crocodile clip attached and connect direct to the base of the antenna—there would be no loading coil in circuit.

With a little patience in adjustment the above arrangement will be found to give very satisfactory results. It should certainly come into its own for DX working—and if your space is limited it could be the only answer to your problem. ●

A 12-Element Yagi For 430 MHz

by Dave Powis G4HUP

This article presents the first of two practical antenna designs for the 430MHz band. Both designs are derived from the NBS Antenna Design Information detailed in *Practical Yagi Design* (PW Feb. 1984 and reproduced in *Wires and Waves*). The following sections show the design derivation and "practical" construction details.

An example of Yagi design was given in *Practical Yagi Design*. Continuing from that we will now derive the information necessary to build a 12-element Yagi for the 430MHz band. This antenna is designed to be quite rugged, and for rear mounting; i.e. the mast clamp is behind the reflector, to minimise the effect of the supporting mast structure on the antenna performance.

Design

From Table 1 of the design information (PW Feb. 1984, page 51) we can directly extract the starting values for this design, exactly as with the previous examples. The information for the 12-element Yagi is given in column 4 of Table 1 and is repeated in Table 4. As well as obtaining starting values for the element lengths we also have certain other parameters of the antenna: Overall length 2.2λ ; Gain 12.25dBd; Design Curve B; Element Spacing 0.2λ .

The indication of design curve B refers us to Fig. 1, the nomograph which enables us to compensate for the diameter of the materials to be used.

Selecting the Materials

Before the element lengths can be determined the materials to be used must be selected. In order that adequate support is given, remembering that this antenna is to be rear mounted, a 25mm diameter boom was chosen. This is quite strong enough over the length used for this antenna (2.2λ , or about 1.8m), but for longer booms or when using heavier elements, consideration should be given to using a thicker boom section.

So that a reasonable bandwidth is obtained elements of 9.5mm ($\frac{3}{8}$ in) diameter have been used. The frequency used for the design is 433.2MHz, as this represents a compromise between the f.m. and c.w./s.s.b. allocations of the band. In practice the bandwidth and frequency performance of the antenna are suitable even for ATV use.

Element Lengths

Having selected our materials, there is one more thing to do before we refer to Fig. 1. The diameters of the boom and elements must be converted into fractional wavelength terms. This means expressing the diameter as a fraction of the wavelength (λ) we are designing the antenna for. The wavelength is given by:

$$\lambda = \frac{299\,800\text{mm}}{f \text{ in MHz}}$$

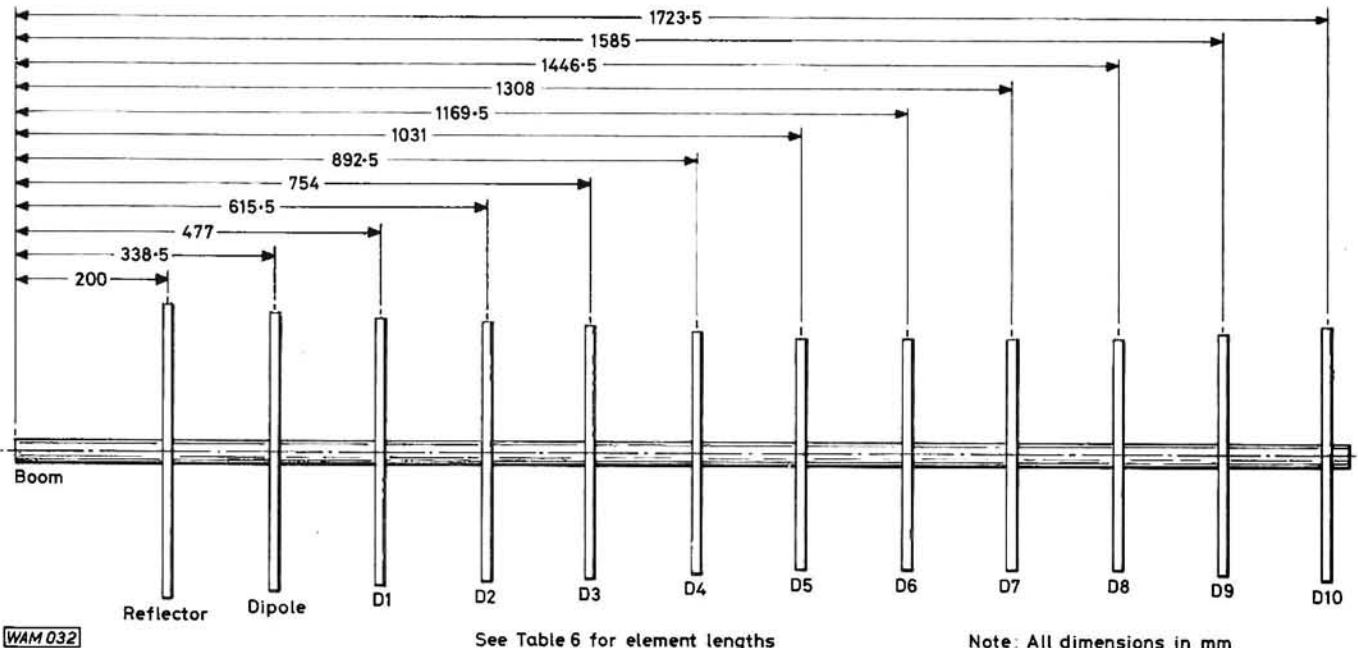

Fig. 4: Rear-mounting 12-element 430MHz band NBS Yagi. Preceding drawings and design tables are contained in *Practical Yagi Design*, PW February 1984, and reproduced in the PW Antenna special publication *Wires and Waves*

Table 4: Basic element lengths

Element	Length
Reflector	0.482λ
D1	0.432λ
D2	0.415λ
D3	0.407λ
D4	0.398λ
D5	0.390λ
D6	0.390λ
D7	0.390λ
D8	0.390λ
D9	0.398λ
D10	0.407λ

So for 433.2MHz

$$\lambda = \frac{299\,800\text{mm}}{433.2} = 692\text{mm}$$

The elements are 9.5mm diameter so the element d/λ ratio is:

$$\frac{9.5}{692} = 0.0137$$

The 25mm (1in) boom gives a d/λ ratio of:

$$\frac{25.4}{692} = 0.036$$

Now we can proceed to design our antenna. Locate, on the horizontal axis of the design nomograph, Fig. 1, the 0.014 point—this is our starting position. Follow this line up until you get to the point where it intersects the "Reflector" design curves, and you will find that it crosses the top line (ABC) at a value of 0.479λ. Thus our compensated reflector length is 0.479λ.

Next we must make the necessary adjustment to the director lengths. Using the same vertical line, find the point where it crosses "Director" curve B. The basic length for D1, from Table 1, is 0.432λ. Our new value, from the 0.014 vertical, is 0.420λ. To find the lengths of the other directors we must transfer the original lengths to the nomograph. Working from the 0.085 vertical (the reference position), and on the B "Director" curve, measure with a pair of dividers from this intersection to the point where the 0.415λ horizontal (D2 basic length) crosses the B curve. Now transfer this measurement to our new reference at 0.420λ on the 0.014 vertical. Measuring down the B curve from this point gives a D2 value of 0.402λ.

For D3 go back to the starting values and measure the difference, along the B curve, between the D1 and D3 lengths—i.e. from 0.432λ to 0.407λ. Transfer this difference to the new D1 point (0.420λ) and this should give you a new D3 length of 0.394λ. This process must be repeated for each director—however, a quick look through the basic director lengths will reveal that there are only five different director lengths in this design. The full list of director lengths, corrected for element diameter, is given in Table 5.

Effect of the Boom

We now have to make the compensation for the diameter of the boom material. This information is contained in Fig. 3, and shows that for a boom of 0.036 D/λ the length of each element must be increased by 0.027λ. Thus the total length of each element is the corrected

Table 5: Basic and corrected element lengths

Element	Basic Length	Corrected Length
Reflector	0.482λ	0.479λ
D1	0.432λ	0.420λ
D2	0.415λ	0.402λ
D3	0.407λ	0.394λ
D4	0.398λ	0.384λ
D5	0.390λ	0.376λ
D6	0.390λ	0.376λ
D7	0.390λ	0.376λ
D8	0.390λ	0.376λ
D9	0.398λ	0.384λ
D10	0.407λ	0.394λ

length, as given in Table 5, plus 0.027λ. The total length and the actual length of each element in mm is given in Table 6.

Driven Element

The driven element used in the prototype was a folded dipole. A family of three dipoles, of overall lengths 320, 330 and 340mm, were constructed and each tried in turn. The 340mm dipole gave the best match at the design frequency. A 4:1 λ/2 coaxial balun constructed from UR43 coaxial cable was used to feed the dipole, to give an approximate 50Ω impedance.

Element Spacing

From Table 1 the spacing between the elements is 0.2λ, which in practical terms is 138.5mm. We are now in a position to show the complete antenna graphically, with all dimensions, in Fig. 4.

Construction

Commence construction by carefully marking out the boom, ready for drilling. First measure from the end of the boom to the reflector position and mark. Then measure from the end of the boom to the dipole position and mark. Repeat this procedure for each element, always measuring from the same point, i.e. the end of the boom, to reduce the degree of error introduced at this stage.

When drilling the boom it is essential that the holes are in line along the boom! An example of a simple jig to aid this is shown in Fig. 5. Drill the first hole, and use this to mount the jig onto the boom. Position the sliding block un-

Table 6: Total and actual element lengths

Element	Corrected Length	Total Length	Actual Length
Reflector	0.479λ	0.506λ	350mm
D1	0.420λ	0.447λ	309mm
D2	0.402λ	0.429λ	296.8mm
D3	0.394λ	0.421λ	291mm
D4	0.384λ	0.411λ	284.4mm
D5	0.376λ	0.403λ	278.9mm
D6	0.376λ	0.403λ	278.9mm
D7	0.376λ	0.403λ	278.9mm
D8	0.376λ	0.403λ	278.9mm
D9	0.384λ	0.411λ	284.4mm
D10	0.394λ	0.421λ	291mm

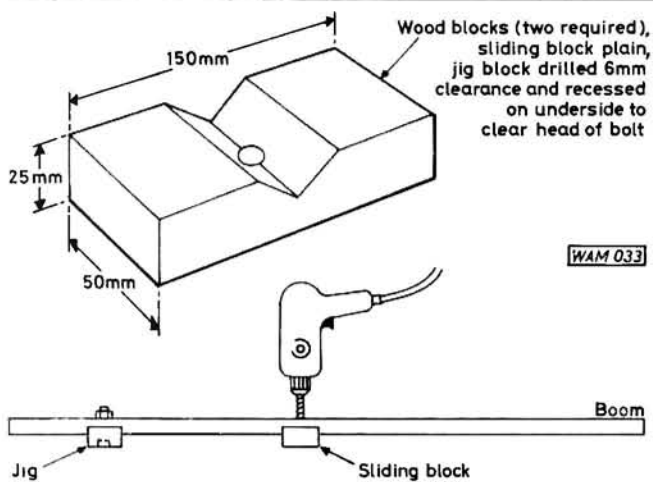

Fig. 5: A simple drilling jig to ensure consistent element alignment

der each place to be drilled—this will help to eliminate any tendency for the boom to twist as you work your way along it. Mark the centre of each element and drill—the author's preference is to drill the centre first, then cut the element to the correct length, thus ensuring that the hole is central. When the boom and parasitic elements have been drilled, and all deburring etc. completed assembly can commence. Using the recommended mounting hardware this is a straightforward operation. Each of the elements is mounted using a 5mm bolt through the element, plastics moulding and boom, as shown in Fig. 6.

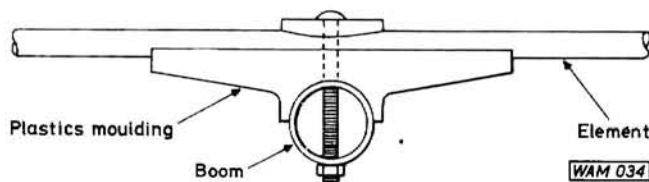

Fig. 6: Element-to-boom assembly detail

Folded Dipole

The folded dipole should be bent from 9.5mm diameter tube, to have an overall length of 340mm. Again, the use of a simple jig can help to make a neat, professional job of it. A suitable jig is shown in Fig. 7 and is a wooden copy of one spotted in an antenna manufacturers production area!

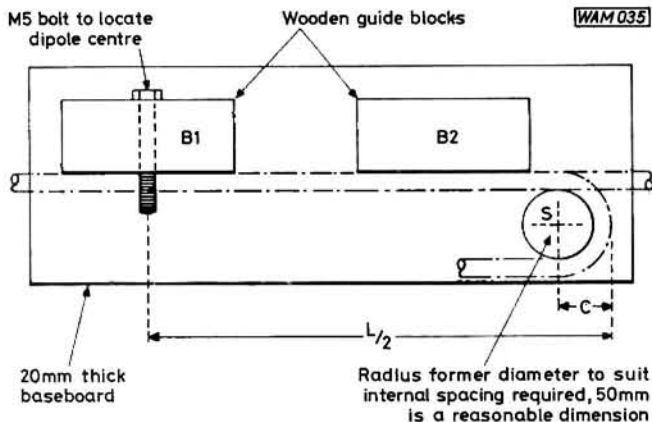

Fig 7: Folded dipole bending jig. The dimension $L/2$ is half the required overall dipole length which for this design is $330/2$ or 165mm. Dimension C is equivalent to the dipole diameter plus the radius of former S

To use the jig first prepare the element by drilling a hole at the centre of what will be the continuous (bottom) part of the dipole. Now fit the tube to the jig, with the hole located over the bolt, as shown dotted in Fig. 7. Gently pull the free end round the spindle to form one bend in the same way. Again, the author's preference is to drill a long piece of tube, bend it, then cut the feed side to the correct dimensions, to ensure that the feed point is centrally located.

Once the dipole has been made, it can be marked and drilled for the mounting hardware. Using the dipole centre as a template, mark the positions for the self tapping screws and drill a suitably sized hole, in the top side of the tube only, for the screws.

Making up the Feed

Cut three pieces of brass sheet or strip and drill and bend them as shown in Fig. 8. These will be the terminations for the coaxial cables used to feed the antenna and to make the balun. Part 2 locates under the head of the bolt which holds the folded dipole to the boom, and the braid of all the cables will be connected to it. Part 1 is used, one on each side, to feed from the balun outputs to the folded dipole via the self tapping screws.

Prepare the balun cable (UR43) and the end of the feeder (don't forget to slip the waterproof cover on to the feeder before fixing it to the dipole assembly!) ready for termination. The length of the balun cable is 246mm but please do note that this length is only valid if UR43 is used. If any other coaxial cable is used the balun length must be recalculated, by multiplying a half wavelength ($692/2$) by the velocity factor of the cable used. The balun length thus obtained, and the quoted length of 246mm, is the length from braid to braid of the balun: note that extra length is required to actually terminate the balun! See Fig. 9 for details. Provided that UR43, or similar size cable is used for the balun it will fold up neatly inside the waterproof housing.

Mount the dipole in a vice and place the centre moulding in position. Fix each part 1 to the dipole using a self-tapping screw through the moulding, and hold part 2 in position with the bolt that will be used to mount the dipole to the boom. Carefully solder the braid of the feeder and the two ends of the balun to the top of part 2, and fold the tabs round. Make sure that the feeder is in the centre position. Solder, or screw terminate, the balun outputs to

BUYING GUIDE

Suitable boom and element materials can be obtained from aluminium stockholders listed in Yellow Pages. Moulded plastics element mounts and dipole hardware are available from: G. Bellis & Co., Sturgess Street, Stoke-on-Trent, Staffs. An s.a.e. will provide details.

★ Costs will depend on general factors including sources and wastage.

Approximate Cost



Construction Rating

INTERMEDIATE

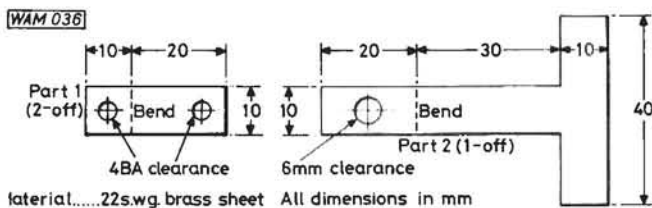
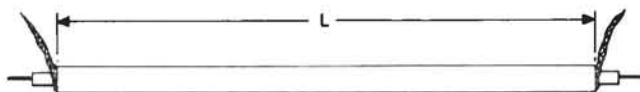

Fig. 8: Folded dipole feed terminal details

the two feeds to the dipole ends. At this stage check that the insulation between inner and outer of the cable has not been damaged during the soldering processes.



L = 246mm for UR43

WAM 037

Fig. 9: Coaxial balun. Note length of "intact" outer braiding

The whole assembly can now be fitted to the boom. Temporarily remove the reflector and slide the folded dipole into position. Tighten up the dipole mounting bolt, slide the cover into place and replace the reflector. Assuming that the other end of the feeder is terminated you are now ready to test your antenna.

Testing

Some comments on testing were made in *Practical Yagi Design*—there is little point in repeating them here. There are no adjustments as such to be made, but if the match obtained is not satisfactory (v.s.w.r. 1.5:1 or better) it may be worth slackening off the dipole and moving it between the reflector and first director to find the position which gives the best match.

Once an acceptable matching condition has been obtained, the antenna can be prepared for installation. Fix the dipole to the boom, and coat the inside of the dipole

mount and all cable ends and terminations with polyurethane varnish. If you are in an area where antennas tend to corrode rapidly it is also worth considering totally varnishing the antenna.

Testing of the prototype antenna was done by comparison against a "known" device as it is very difficult to make accurate absolute measurements at these frequencies, and it is virtually impossible for any such claims to be verified in amateur service. The standard used was the Jaybeam 18-element Parabeam. This was chosen because it represents an average, commercially available antenna, generally known and respected in the amateur community. The tests were performed by picking a site from which a beacon could be heard at reasonable signal strength. Each antenna was mounted on the mast in turn and its directional performance and apparent gain checked using a receiver with the a.g.c. disabled. The gain of the 12-element antenna, rear mounted, was marginally worse than the 18-element Parabeam, and its beamwidth was slightly wider. In both cases this is what was expected and is commensurate with the quoted gain figure for the Parabeam of 14dBd and the NBS design figure of 12.25dBd for the 12-element antenna. Beamwidth for the Parabeam is quoted as 28°, and for the 12-element appeared to be about 35°.

Some of the directors were removed to see if the performance deteriorated. It was found that if two or four middle directors were removed (between D5 and D8) and the remaining ones moved back to close the gap, the gain decreased and the beamwidth increased, as would be expected. Matching however, remained better than 1.5:1 over the frequency range of interest, and was typically 1.2:1 at the design frequency. In this way the antenna can readily be adapted to provide 8, 10 or 12-element versions, the only constraint being that the last two directors must be the original D9 and D10.

Acknowledgments are due to Chris Bellis, G8SWU, for assistance and the loan of an 18-element Parabeam and to Sam Jewell, G4DDK, for assistance with the setting up and testing.

The next article in this series will describe the design, construction and results obtained with a 15-element lightweight antenna for 430MHz. ●

Benny

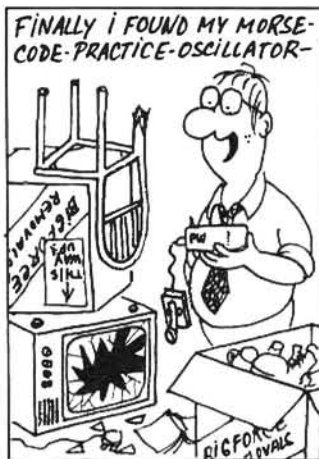

Radio Wave

Part 3 by F. C. Judd G2BCX

The final paragraphs in Part 2 of this series dealt with the reflection of radio waves from the ionosphere and how the angle of arrival of a wave at an ionised layer determines the distance between the place of transmission and where the wave will reach earth again.

A radio wave suffers less attenuation with long single hops than it would covering the same distance by a number of short hops. When a wave is reflected from an ionospheric layer it suffers some attenuation each time it meets earth again. There are, however, two other factors to be taken into account, these being the absorption of the wave within the layer and the frequency of operation.

Critical Frequency

We have seen how vertical incidence pulsed radio waves are used to determine the height of an ionospheric layer, although the height actually recorded by this method is known as the **virtual height** because the wave speed is reduced in the ionosphere and this introduces some time delay. As the frequency of transmission is increased during height measurements of this nature, we eventually come to a frequency at which the electron concentration is not dense enough to cause the refractive bending that will turn the wave back to earth. The highest frequency that is returned to earth and which applies only to waves travelling vertically to an ionised layer, is known as the **critical frequency**. Vertical incidence waves penetrate a layer at all frequencies higher than the critical frequency and travel on into outer space.

However, the controlling factor is the density of electrons within the layers and this is greatest during periods of maximum sunspot activity. The critical frequency is therefore highest for both the E and F layers when sunspot activity is at maximum and lowest when this is at minimum. The graphs in Fig. 3.1 show the variations that occur with time of day and the season, i.e. winter or summer. Note: Although the F1 layer is shown in the graphs, it is much less important than F2 for long distance ionospheric propagation.

Maximum Useable Frequency

Reflection from an ionospheric layer can still be obtained even when the frequency is increased beyond the critical, **providing the wave enters the layer at an oblique angle**. This allows sufficient bending by refraction to take place and the wave to leave the layer for return to earth at an angle equal to the angle of entry. It is because of this that long distance transmissions can be made at frequencies some three to four times higher than the critical frequency.

The maximum frequency that can be returned to earth for an oblique angle of entry into the layer is called the **maximum useable frequency** or m.u.f. which apart from being dependent on the critical frequency, is also subject to seasonal and daily variations. It is generally accepted that to employ effectively any suitable m.u.f. for very long dis-

WAD288

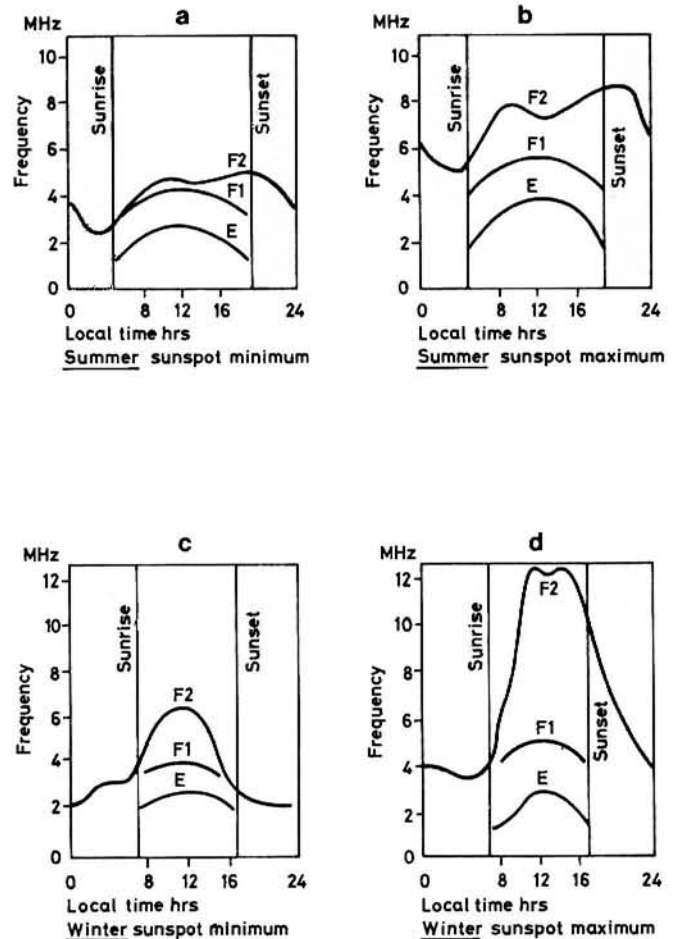

Fig. 3.1: Critical frequencies during 24 hours. A-B=summer and C-D=winter. Shaded areas are approximate hours of darkness

tance working, the antenna should ideally radiate at a very low angle with respect to earth. Note, that m.u.f. is also dependent on the height of reflection from the layer.

Transmission Distance and Layer Height

The behaviour of waves meeting an ionised layer is shown in Fig. 3.2. Vertical and near vertical incidence waves travelling straight up from the transmitting antenna penetrate the layer when the frequency is just slightly above the critical. When the **critical angle of arrival** is reached and refraction can take place, waves will be returned to earth, the distance being determined by the height at which reflection takes place and the angle of arrival. For medium angles the single hop distance will be short, for example to the points A or A1. Therefore a number of hops

Propagation

would be required to cover distances greater than these. On the other hand, as the angle of entry becomes lower the wave will be returned to earth at a much greater distance, for example to point B. When the angle is very low, e.g. at near zero degrees, the wave returned from the layer will meet the earth tangentially, at or near point C, thus providing the longest single hop and which also represents the greatest skip distance. Generally the least amount of attenuation is incurred by ionospheric layer absorption so the greatest signal will always be obtained at the point of arrival on earth from **any single hop**. If a large number of hops are required to propagate a radio wave over a given distance there will be some attenuation at each point of reflection of the wave from earth back to the ionospheric layer.

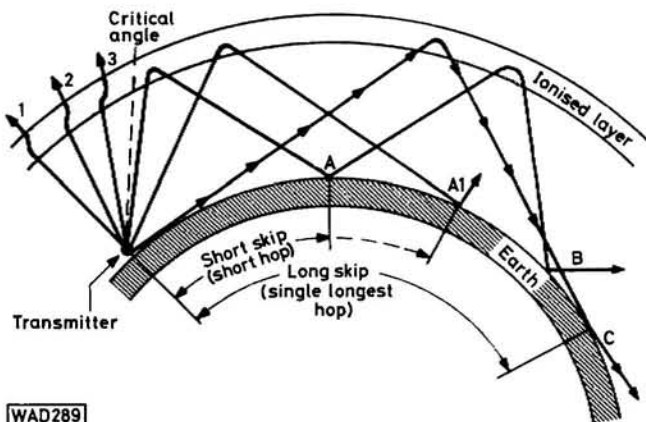

WAD289

Fig. 3.2: Radio waves entering an ionospheric layer at angles higher than the critical angle are not returned to earth. Single hop distances are greater as the angle of entry becomes lower. See text

Experimental Antenna System

The special antenna to be described was set up for the purpose of measuring signal levels from 7MHz transmissions reflected from the F layer at angles from 90 degrees (vertical incidence) to 60 degrees and lower and at times when the critical frequency was higher than 7MHz. Horizontal antennas used for the 3-5MHz and 7MHz amateur bands do not normally have a great height above ground and even for 7MHz this may not be much above 10 to 12m. This means that maximum radiation is at high angles, often at 90 degrees (vertical to the ground) but the radiation diminishes rapidly at angles nearer to ground although this still provides more than satisfactory short hop working providing the critical frequency is above the frequency of operation.

Details of the experimental antenna are given in Fig. 3.3. Effectively, the antenna is a 3-element beam utilising

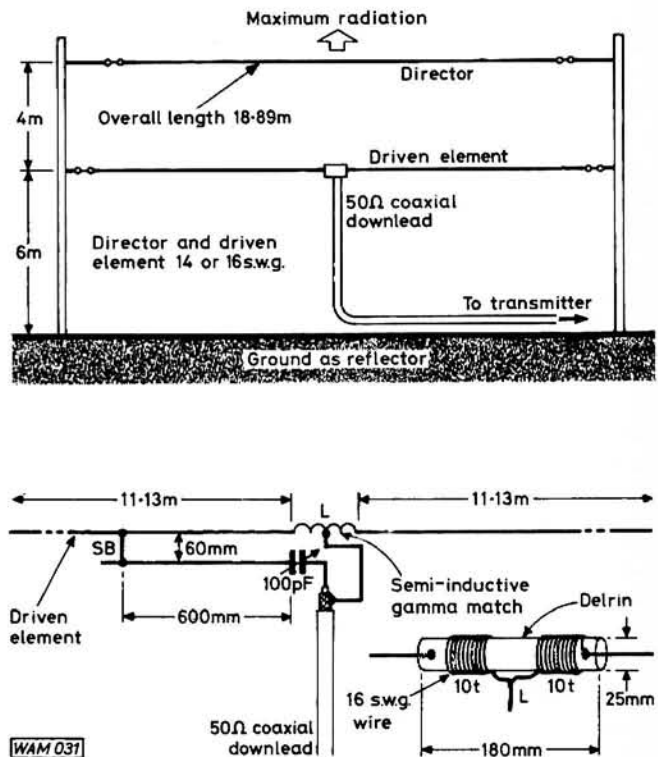

Fig. 3.3: Experimental antenna used for ionospheric propagation tests on 7MHz. See text for details

the ground as an infinite plane reflector. Above the ground at a height of 0.15λ is a half-wave driven element, fully resonant at 7MHz and gamma matched to a 50Ω coaxial feed cable. At 0.1λ above the driven element is a resonant director. The antenna has maximum radiation at 90 degrees (vertical from ground) and with gain over a half-wave in the region of 6dB. The beam width at -3dB is approximately 60 degrees and the cross section area at this point is more or less circular. The upward going radiation is therefore spread over a large circular area on reaching the F layer. Taking the height of the F layer at its greatest of about 400km the area of the layer "illuminated" by the radiation is in the region of 167 500 square kilometres which means that **wave propagation from the layer is omni-directional**. This aspect will be dealt with in detail in a later article.

The diagram in Fig. 3.4 shows the antenna radiation pattern with maximum at 90 degrees. If we take the angle of 60 degrees from ground to the F layer and which cuts through either of the -3dB points on the radiation pattern, then follow the reflection path to earth made by this angle, it will be seen that radiation following this path will meet the earth at a point about 450km from the transmitter site. This is a single hop and the signal strength on arrival at this point is at its greatest. With a double hop from this

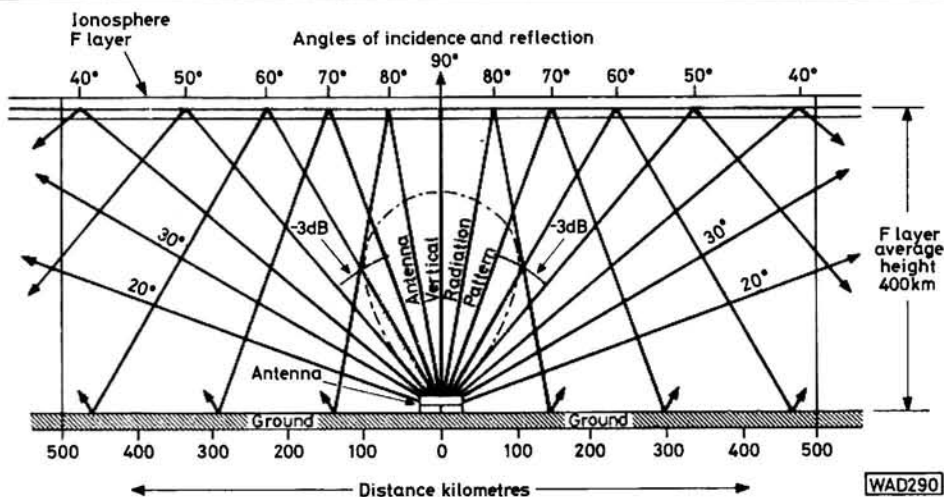

Fig. 3.4: Single hop distances related to angles of incidence and reflection from the F layer with a maximum virtual height of 400km and with reference to the radiation of the experimental antenna

angle the distance covered would be about 900km but there would be little additional attenuation to the signal as only one reflection back from earth is involved. Note, that for previous examples an F layer height of 400km is used, as also in Fig. 3.4. The average virtual height of the F layer is in the region 300 to 350km in which case the hop distances would be a little less than given previously.

For the purpose of the experiment the transmitter was run at about 120 watts p.e.p. The antenna system proved very effective in obtaining consistently high signal reports on 7MHz at distances of 800 to 1000km in all directions from the antenna. On average the signal levels reported

were double those obtained using the same transmitter power and a conventional horizontal end-fed half-wave antenna at a height of about 10m. Note: The special antenna described in Fig. 3.3 is not suitable for very long distance working.

Long Distance Propagation

The maximum single hop distance that can be covered when ionospheric reflection is from the E layer is about

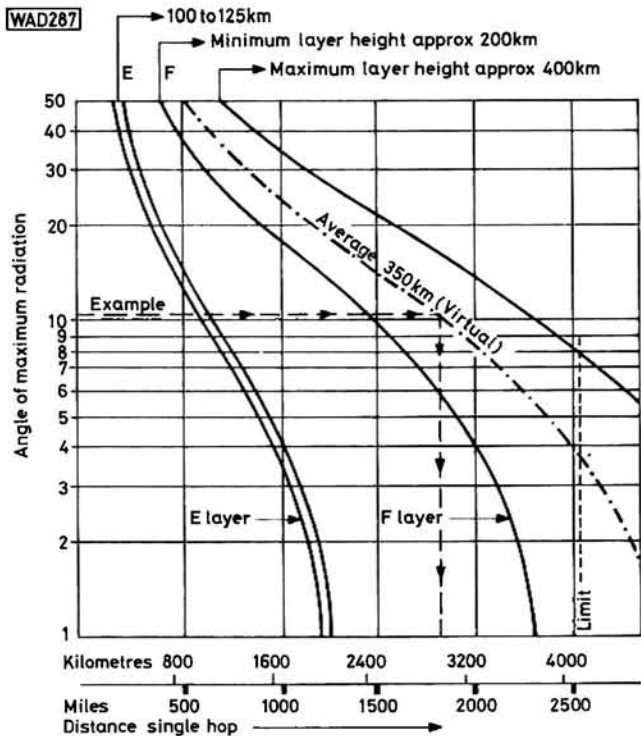

Fig. 3.5: Distance versus wave angle for single hops via the E or F layers with virtual heights as shown. Example (broken line): Antenna radiation angle 10 degrees, F layer height average 350km. Single hop distance 2000km. Note: F1 layer not shown. It is much less important as far as DX working is concerned

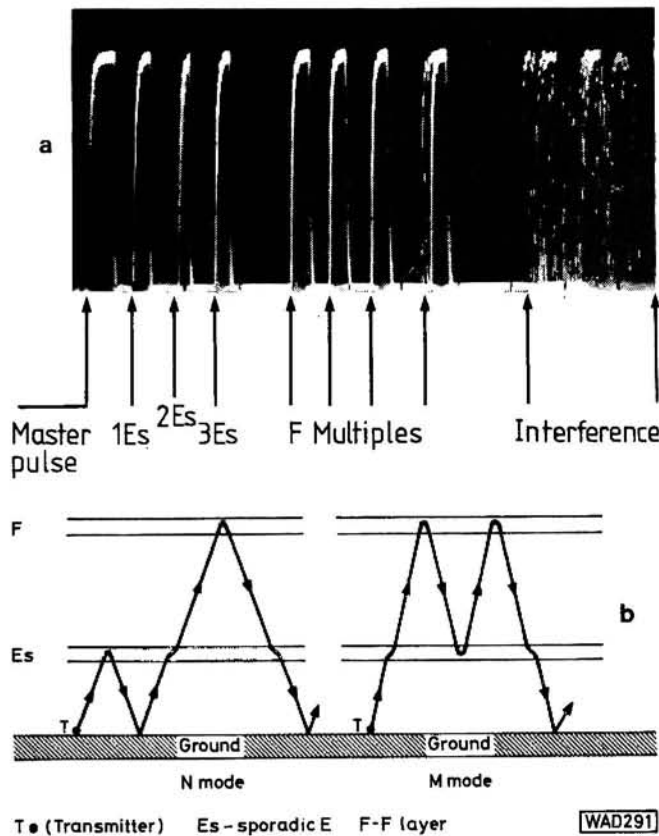

Fig. 3.6: (a) Actual photographic records showing a multiplicity of echoes produced by inter-sporadic-E and F layer reflection modes as illustrated. (b) Modes of ionospheric layer reflection which can occur randomly and are not predictable. Sporadic-E is not normally thick enough to produce the slight bending as a wave passes through as the diagrams indicate

2000km and from the F layer around 4000km, these distances being based on average heights of maximum electron concentration of the respective layers and accepting that radiation is at a very low angle with respect to ground. A reasonable assessment of single hop distances for various antenna vertical angles of radiation can be found from Fig. 3.5. However, the propagation of radio waves over long distances is complicated by other factors, for instance at the frequency in use reflection may be from sporadic-E along some parts of the path of travel and from the F layer for other parts. It will also depend on the time of day or night, the direction of the path and the part of the world over which the wave has to travel. In other words, much depends on the state of the ionospheric layers all along the path itself. It is even possible that during the course of its travel a wave may be reflected downwards from the F layer and then reflected upwards again from a sporadic-E cloud. The result of reflections between sporadic-E and the F layer taken during ionospheric sounding is shown in Fig. 3.6(a), the multiplicity of echoes being produced by what is known as an "N" or "M" mode of reflection as shown in Fig. 3.6(b).

Direction of Travel

Generally a radio wave follows a direct great circle path between any two points on the surface of the earth but because of variations in ionospheric conditions, the direction can be changed slightly from a true great circle path although this may never be by more than a few degrees. Direction of travel does however become important in another way because there are two great circle paths between any two points on the earth's surface. Although most radio communication is made over the shortest path, the use of a longer path in the opposite direction is not uncommon. It may happen that if propagation conditions over the shorter path are poor, they may be better over the long path so it is always worthwhile turning a beam antenna in that direction.

In the following part, other features of ionospheric propagation, i.u.f., electron density, 11 year sunspot cycle etc., will be dealt with.

Swap Spot

Have Heathkit SW717 short wave receiver. Would exchange for good a.t.u. Tel: Leicester 773407. **W729**

Have Ferrograph, 8½ in. reels, Grundig TK18, Advance constant voltage transformer 230V 30W, another 220V 250W. All suitable for amateur shack. Would exchange for test gear, computer, TV service manuals, good radio/communication books. John. Tel: 06065 51303 (Cheshire). **W735**

Have Quad valve outfit, very clean, no speakers. Would exchange for best oscilloscope or computer. John. Tel: 06065 51303 (Cheshire). **W735a**

Have switched mode p.s.u.s. brand new, 5V 20A, 5V 40A. Would exchange for working disc drives, test gear or unfinished NascomII. John. Tel: 06065 51303 (Cheshire). **W735b**

Have Pentax ME 28mm f:2.8 w/angle lens, flash and filter, with e.r. case. Would exchange for a.t.u. and memory for FRG-7700. Seon Smith. Tel: 0436 71181. **W739**

Have Heathkit code practice oscillator, Autovox car radio with 6MHz (49m) band and Sharp car tape. Would exchange for Tandy PRO 47 scanners, Belcom scanner also needed, cash adjustment possible. John GJ8RRP, No. 2 Thornley Bagatelle Road, Jersey, CI. **W743**

Have 25-550MHz a.m./f.m. RX station complete: AOR AR2001 still under guarantee, little used, p.s.u., discone antenna, Triax v.h.f./u.h.f. broadband masthead pre amp. plus 12V interface unit. Would exchange for 934MHz CB mobile/base station or h.f. RX with f.m. Cash adjustments. Tel: Ely 61323 anytime. **W758**

Have Codar CR 70A MkII a.m., s.s.b., c.w. receiver. Would exchange for w.h.y. Scott. Tel: 0631 63164 after 6pm (Argyll). **W765**

Have complete RTTY system, comprising Creed Mk7 printer with silencer box, tape maker, tape reader and terminal. Would exchange for w.h.y Alvin GW40DN. Tel: 06462 3991 (Milford Haven). **W769**

Have Sentinel 144MHz v.h.f. converter, 24/26MHz in 144/146MHz out. Would exchange for 8mm projector or anything connected with s.w.l. Tel: Holbeach (Lincs) 22649 evenings. **W774**

Have Vega 206 eight band radio (6 s.w., 1 l.w., 1 m.w.) brand new. Also have 20in b/w TV, good picture and Praktica p.l.c. 3 camera, with broken back latch, and 135 and 50mm lens. Would exchange for DX160 or DX200 or similar. Tel: Halifax 240201 evenings. **W777**

Have SX200 scanner, also Akai 7in reel tape plus 14 tapes. Would exchange for Trio R-2000 or FRG-7700. W. J. Bannister, 3 Eastbourne Walk, Liverpool 6. Tel: 051-263 6724. **W783**

Have Vic 20 c.p.u., C2N Datasette Unit, p.s.u. and all cables, *Intro to Basic* and six games cassettes value £300 approx when new. Would exchange for 144MHz multimode. Barry. Tel: 0946 812092 (Cumbria). **W802**

Have 3-valve radio built c.1929, complete with handbook. Also many valves, coils and other components same era. Would exchange for 430MHz or 1296MHz voice or TV gear, or any Olympus OM lenses or accessories. Tel: 0327 51716 (Towcester). **W793**

Have FRG-7 receiver and GAF 35mm slide projector. Both in mint condition. Would exchange both for HW8. Tel: 0484 653549. **W892**

Have Yaesu amateur band receiver F50B. Would exchange for Super 8mm projector and camera, or a good 9.5mm projector pos' VOX or 200B plus or 16mm films to the value of £75. P. G. Robins G8BSK, 290 Priory Road, St Denys, Southampton SO2 1LS. **W873**

Have working vintage naval B28/Marconi CR100 receiver. Would exchange for working 1-2HP lightweight outboard motor. Tel: 0380 870034 (Wilts). **W871**



FOR THE BEST PART-EXCHANGE & SECOND HAND BARGAINS

LONDON: 373 UXBRIDGE ROAD, ACTON, LONDON W3 9RH. Tel: 01-992 5765/6



NORTHERN: 38 BRIDGE STREET, EARLSTOWN, NEWTON LE WILLOWS, MERSEYSIDE WA12 9BA. Tel: 092 52 29681

PW REVIEW

YAESU FT-203R

144MHz Transceiver



The Yaesu FT-203R is a hand-held 144MHz f.m. transceiver, small enough to fit into a jacket pocket or handbag and yet, despite its lack of size, is very easy to operate. Looking at the inside layout of the rig it is easy to see how the compact size was achieved. The manufacturers have used leadless components and double sided p.c.b. as well as computer aided design, all to good effect as the photographs here show.

Frequency selection is by three thumbwheel switches and a 0/5kHz latching switch. Other facilities such as ± 600 kHz repeater shift, high and low power and even VOX are available.

Top Panel Controls

Most of the features of this rig are "controlled" from the top panel, with only the minimum of controls on the back panel. Most of the top panel controls are self evident and are fairly standard for this type of rig. Some of the more interesting or unusual are the relative signal strength/relative power output meter and a red and green l.e.d. to show busy channel and indicate when the rig is in transmit mode.

The usual features of frequency selection, earphone and microphone sockets and the high/low power switch are also on the top panel. The squelch and volume rotary controls are placed alongside the bnc socket for the antenna. All of these controls can be seen quite clearly in the photograph.

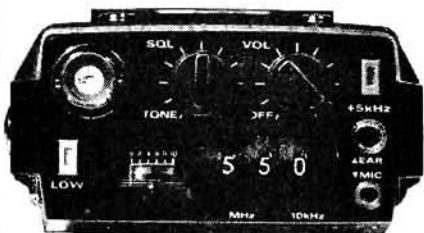

Tone burst facilities are on the side panel of the rig, just above the p.t.t. switch, with the lamp on/off switch, which provides a back light for the meter, on the opposite side panel.

Receiver

The signal is passed first through a low pass filter and then amplified before going through a band pass filter. To avoid cross-modulation or inter-modulation the band pass filter is a three-section varactor-tuned device, its centre frequency automatically tracks the receive frequency by means of the varactor control voltage from the phase locked loop.

From the band pass filter the signal is applied to the first mixer. The first i.f. of 10.695MHz is passed through a crystal filter pair and then onto the second mixer. The signal is then filtered once more and then goes to the second i.f. amplifier, and onto the limiter section. From the limiter the signal is applied to the discriminator and on to the audio output stage.

Obviously the description of the receiver is very brief, but it just shows that there is no shortage of stages and facilities in a rig of this size.

Transmitter

An audio signal from the microphone is amplified and fed to a

★ specification

GENERAL

Frequency coverage:	144-146MHz
Channel steps:	10kHz and +5kHz switch
Mode:	G3E (F3)
Supply voltage:	5.5-13V d.c.
Current:	RX 100mA; standby 20mA TX 700mA (@10.8V, 2.5W r.f.)
Dimensions:	65 x 34 x 153mm
Weight:	450g (approx.)

TRANSMITTER

Input power:	5W d.c. for 2.5W r.f. output into 50 Ω
Deviation:	± 5 kHz
Max. bandwidth:	16kHz
Microphone:	Internal or optional external condenser, 2k Ω

RECEIVER

First i.f.:	10.695MHz
Second i.f.:	455kHz
Sensitivity:	0.25 μ V for 12dB SINAD 1 μ V for 30dB S/N
Selectivity:	± 6 kHz/-6dB ± 12 kHz/-60dB
Audio output:	450mW into 8 Ω for 10% t.h.d. or better

quad operational amplifier. The first three quarters of the quad op-amp serve as an "instantaneous deviation control low pass filter". This ensures that the speech signal applied to the modulator will produce the right amount of f.m. deviation. The final quarter serves as the VOX amplifier, which activates the transmitter automatically when the VOX switch is enabled (only when the rig is used in conjunction with the head set).

The filtered speech is then applied to a varactor diode in the v.c.o. circuit. This oscillates at a set frequency between 70-75MHz. Therefore the audio signal frequency modulates the v.c.o. and this signal is then applied to a doubler.

The filtered transmit signal is then buffered and amplified to the final output power. This is then passed through a final low pass filter to the antenna.

Once again the description is very brief but gives a general idea of how the transmitter section of the FT-203R operates.

The FT-203R is a very useful rig it is not too complicated and yet has plenty of facilities available to the user.

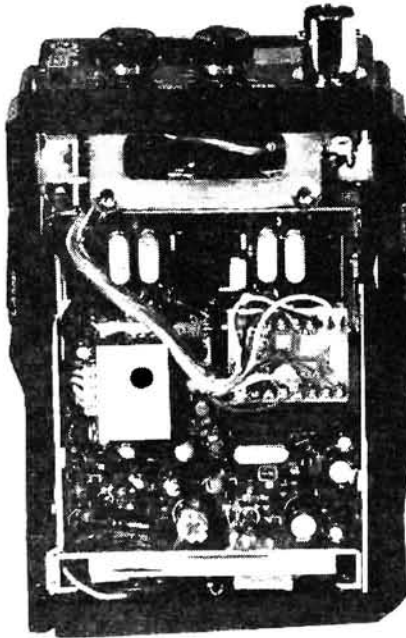

The biggest problem with the rig is the thumbwheel switches for those who find these hard to operate. For anyone with small fingers or long finger nails they shouldn't be too much of a problem.

One really unusual facility is the VOX operation which, during the review period, proved very useful. That was until it was tried mobile, you must remember not to mutter or pass comment on other peoples' driving! The VOX circuit can be set up so that only sounds close to the boom microphone activate the p.t.t. Being able to clip the rig to a belt or back pocket, wear the head set and not having to search for the p.t.t. every time it is your turn to speak was one of the most convenient facilities on the rig. The VOX switch is disabled when the head set is not in use

The FT 203R and accessories is available from **South Midlands Communications, SM House, Rumbidge Street, Totton, Southampton. Tel: 0703 867333**, to whom we offer our thanks for the review sample. The FT-203R c/w 3.5W NiCads costs £190.00. *G4LFM*

Next month in On Sale 1st MARCH



PW Colne
DIRECT CONVERSION RECEIVER
(with audio a.g.c.)

Plus
3.5/7 MHz Amateur Bands
Occupancy
And
Digital Speech Processing



FREE Pocket Magnifier

PRACTICAL ATV TECHNIQUES

Part 1 by Allan Latham G8CMQ

In this series of articles I am going to explain in detail all you need to know and do to get going on 1.3GHz (23/24cm) ATV, either as a licensed amateur with transmit and receive capability or as an s.w.l. (or should it be microwave viewer!). Some theory will be introduced, as and when necessary, but the idea is to get you on the band, not to blind you with science—the emphasis will be *firmly* practical. I am starting the series with a general overview of the band and of amateur TV activity on the band. Many readers will have experience of 430MHz ATV or 1.3GHz narrowband and the comparisons that follow will be a useful guide.

Amateur Television

Readers with amateur licences will have noticed that the licence permits high definition fast scan TV in certain bands. The lowest frequency band available for amateur TV use is at 430MHz (70cm) and until recently this was the band most often used. Technology has advanced to the stage where 430MHz band equipment for ATV and narrowband modes is fairly easy to make and high power can be generated cheaply. However a combination of factors has made life rather difficult for ATV on 430MHz. The large influx of amateurs in recent years, combined

with the advances in technology, has caused a steady migration of 144MHz narrowband users to 430MHz. In many areas other non-amateur primary users cause problems e.g. Syledis—a position fixing system for offshore oil rigs, etc., and the Mould defence communication network. When you recall that the 430MHz band is only 10MHz wide (and in many places effectively only 8MHz) it can easily be understood that a TV receiver looking at say 5.5MHz of the band sees a lot of QRM. On the transmit side it is difficult to squeeze the large bandwidth of a colour TV transmission into the allocated band. It is not unusual for narrow band users (particularly repeater inputs) to suffer interference from ATV as well as ATV suffering from narrow band interference.

When we look at the next highest band available for ATV, we find a very different state of affairs. The 1.3GHz band is very large by comparison to 430MHz, 1240MHz to 1325MHz with a gap at 1260 to 1270MHz where ATV is not permitted, in order to leave a clear gap for space communications (OSCAR 10 mode L). There is room for everyone without causing mutual interference. The band is shared with other non-amateur users, mainly ground based radars. These make certain parts of the band locally unusable in some locations but the band is wide enough to find plenty of space free from QRM.

Technology is advancing all the time and 1.3GHz ATV is becoming easier by the day. Receiver technology has already advanced to the stage where bipolar transistors with noise figures in the 1.5 to 2dB range cost in the £2 to £3 region. Home construction kits for receivers are available at little more than 430MHz kits cost just a few years ago. On the transmit side transistors are becoming available with up to about 10W r.f. output—prices are a little high and gains tend to be low (e.g. 4W in 10W out). The 2C39 range of valves can be used to raise input power levels in the 3 to 4W region up to real QRO at 50W for modest cost.

In short there is now nothing technically in the way of expanding ATV activity on 1.3GHz and the rewards in terms of interference free pictures are well worth the effort.

Results

The first thing everyone asks is the simple question—“What results will I get?”

Such a simple question defies a simple answer! There are several ways of going about answering it and which is most useful depends greatly on the experience of the person asking the question. Is he an experienced 1.3GHz s.s.b. operator? Is he well equipped on 430MHz ATV? Does he use a simple 430MHz converter and the domestic TV antenna to watch his friends 8km away?

We will start by describing the situation in terms of an “average” station on 1.3GHz ATV and we will assume he is in an “average” position, i.e. not on a mountain top or at the bottom of a well! The average station will consist of the following.

TX: 10W of 430MHz frequency modulated (f.m.) TV into a tripler stage giving 4 or 5W out at 1.3GHz. A 3dB cable loss, i.e. about 10m of H-100 coaxial cable plus connectors, short patch leads, etc., resulting in 2W of r.f. at the antenna terminals.

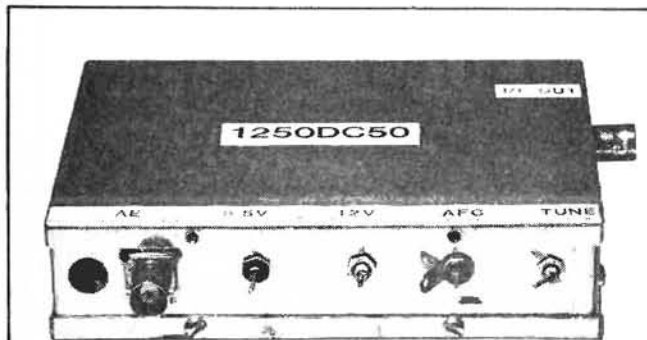

Wood and Douglas produce a comprehensive range of equipment suitable for 1.3GHz ATV. The 1250DC50 is a self-contained down-converter covering the frequency range 1.240–1.325GHz and features a GaAs-f.e.t. front-end

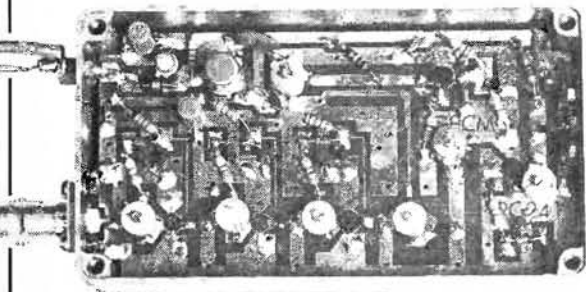

The Solent Scientific down-converter (reviewed in the February 1982 issue of *PW*) provides full coverage of the 1.3GHz band and has an i.f. output in the u.h.f. TV bands

RX: Low noise converter in the 2dB noise figure region, located in the shack and therefore suffering that 3dB feeder loss, feeding an f.m. TV receiver strip.

Antenna: Single long Yagi eg. 21-element Tonna.

Between two such "average" stations under flat conditions ranges of approximately 25-30km can be expected for good quality pictures. Significant deviations from this can be expected due to local obstacles—it is **not** true that 1.3GHz ATV is "line of sight" but local screening and to some extent the intervening terrain do have an effect, as they do on both 144 and 430MHz. For true line of sight paths milliwatts only are needed for even long paths between well equipped stations. For example G4CRJ/G8LES recently worked from High Wycombe to Thames Ditton a distance of 40km with power too low to measure accurately, but certainly less than 10mW. Both these stations have larger antennas than our "average"; G4CRJ lives on a hill top and G8LES uses a masthead GaAs f.e.t. pre-amplifier with a noise figure in the sub-1dB region. Still it shows what can be done.

As for DX, well it depends on the conditions of course but lifts certainly occur on 1.3GHz and these do not always coincide with big lifts on lower bands. There is some evidence that lifts on 1.3GHz are more frequent but often go unnoticed because the band occupancy is lower than 144MHz. At the time of writing G6MPE on a hill overlooking Brighton has got pictures to G4JQU in central Southampton, about 88km, under conditions which were up a lot on 1.3GHz but only slightly up on 144MHz.

Cross channel contacts between the group in Brighton and Worthing and F1EDM and F3LP in Le Havre are a regular occurrence, given even the slightest lift. In better conditions still F1EDM and F3LP have worked right up into Derbyshire on 1.3GHz ATV.

In answer to the question about results to be expected I must add that as far as I am concerned "results" means much more than DX records. It also means quality of pictures received. Because of the interference problems on 430MHz it is almost impossible to get broadcast quality pictures across anything but the shortest of paths, even with QRO equipment. On 1.3GHz the quality of pictures obtained is generally vastly superior. Good linearity comes much easier in an f.m. system and "capture effect" and "f.m. improvement factor" combine to eliminate any slight QRM and to reduce the noise on the picture. In contrast setting up an a.m. TV modulator is extremely difficult and I can think of only very few amateurs who succeed in getting anywhere near broadcast standards for linearity of modulation of a colour ATV signal.

Future articles in this series will cover "results" in more detail from both range and quality viewpoints.

Who's On 1.3GHz ATV

What level of activity can the newcomer to 1.3GHz ATV expect on the band? Well it obviously depends where you live as under flat conditions the range is essentially local. Most areas use 144.750MHz f.m. (often horizontally polarised) as the ATV talkback channel; when activity is very high, for example during lifts, adjacent frequencies are also likely to carry ATV related QSO's. You may miss some of the 1.3GHz ATV activity however since it is not unusual to add sound to the ATV transmission and operate full duplex. Even so most amateurs running ATV will be monitoring 144.750MHz. From time to time, especially during lifts there is an increasing tendency to use 144.170MHz (s.s.b.) \pm QRM, as talkback.

Monitoring 144.750MHz may give you some idea what is going on in your area. Even if the QSO seems like a

"private" one don't be afraid to join it!—144.750MHz is used as a calling and working channel for ATV activities. If the stations on this frequency did not want others to call in they would QSY somewhere else. Once you've joined the QSO ask what's going on in regard to ATV in your area. ATV stations generally are a very friendly lot and newcomers are made very welcome. Everyone who runs 1.3GHz ATV is enthusiastic about it and you are likely to be given useful hints and tips about getting going: many people are only too happy to invite newcomers to the shack to see the result for themselves.

The current level of 1.3GHz activity is less than that on 430MHz for historic reasons. However most large towns now have at least one station on the band. The level of activity is rising all the time. For example in my own area here on the south coast a year ago there was no activity west of Worthing (did G4WHO in Wimborne have an experimental set up but no-one to work?). Now there are stations active from Wimborne (near Bournemouth), through Southampton, Fareham, (near Portsmouth), Havant (again near Portsmouth) and Chichester. You can now travel from Brighton to Bournemouth and never be further than 15 to 25km from someone with 1.3GHz capability. Significantly newcomers in this area are tending to start on 1.3GHz and not 430MHz.

Finally we cannot fail to mention ATV repeaters on the 1.3GHz band. The reasons for having these at all are quite different from those on 144MHz f.m. and I shall be cover-



Probably the simplest of the commercial devices the CQ Centre receiving converter will allow initial ATV experiments to be made at 1.3GHz

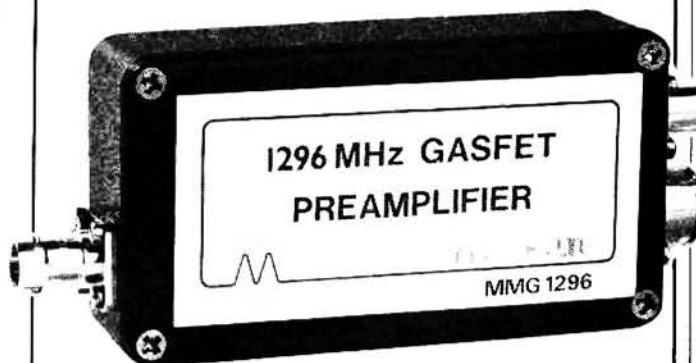

Recently introduced by Microwave Modules the MMG1296 pre-amplifier, with its attendant low noise figure, will elevate the performance of most receiving systems, particularly if installed at the masthead

PRACTICAL ATV TECHNIQUES

ing them in more detail in a later article. The repeaters now in use are the first of many and they have been built because the local activity is sufficient to justify it.

Why Bother Going to 1.3GHz

There are as many reasons for going to 1.3GHz as there are individual amateurs. I can honestly say that whatever is your particular interest in amateur radio there is something for you on 1.3GHz ATV.

First of all it is pioneering work, which in itself is a cornerstone of amateur radio. You will be one of the first on the band; your contribution will be significant whether it is by raising activity in your area (activity breeds activity) or by making important technical improvements, or by increasing our combined knowledge of propagation at these frequencies. Whatever your particular skill there is some need of it to develop this band.

The band itself is an area of potential commercial interest. Broadcasting organisations use nearby frequencies for temporary point to point and mobile f.m. TV links as part of outside broadcasts. There are many non-broadcasting users of video who see the need for these type of links—a small amount of spectrum is available for them but pressure for more will mount as technology makes the equipment cheaper. PMR already uses up to 1GHz—how long before frequencies above 1GHz are needed for extensions to cellular radio? It is essential we preserve the existing 1.3GHz band—a lot has gone already in the last few years. The best way to do this is to use it. **USE IT OR LOSE IT** is the message as far as radio frequencies are concerned. Extensive use of the 1.3GHz band for ATV will be one of the most effective ways of ensuring the band is retained for all amateur activities.

On the subject of amateur activity one of the objects of the licence is self training. On 1.3GHz ATV there is plenty of scope for that. There is for many the first experience of a microwave band, yet the techniques are not dissimilar to those used at 430MHz. The r.f. experimenter can get used to the microwave bands without becoming a plumber as is often necessary say on 10GHz. The inherently broadband nature of TV makes life easier in many ways and it is possibly easier to start on these frequencies with ATV than with phone. I have mentioned earlier in passing that

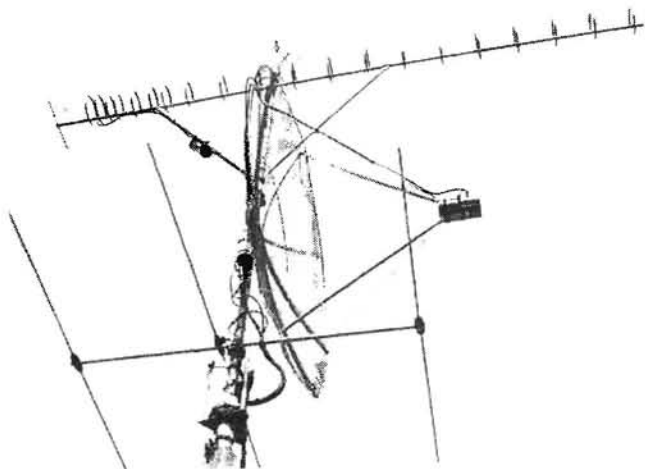

No need to start off with a parabolic dish, but for high gain they just begin to be useful at 1.3GHz

f.m. is used for ATV at these frequencies. Here is another area for self training. FM is the mode of the future for TV. It is used in satellite TV broadcast (DBS), something which no doubt will be as common in ten years time as the VCR is today. Here is your opportunity to learn and experiment with it first hand.

I've already touched on some of the advantages compared with 430MHz but one area of application must be mentioned briefly here (more in a future article)—1.3GHz f.m. TV is superb for portable and mobile applications. The reason is to do with the nature of mobile/portable flutter. This signal disturbance takes the form of amplitude variations. The frequency of the flutter depends on many factors but it often contains components of frequencies over 10Hz. At these frequencies it is impossible for the a.g.c. of an a.m. TV set to compensate for the amplitude variations; the result is severe sync disturbance especially to field sync (50Hz). It is not unusual to receive a noise free picture which "jumps around" all over the place as the transmitting antenna moves. With f.m. there is no problem. As long as the signal strength exceeds a certain minimum level *all* amplitude variation disappears; the result is a perfect picture with no sync problems.

How Easy Is It?

It is now very easy to get on the band. However I must emphasise that attention to detail is all important at these frequencies. If you've graduated to 430MHz from 144MHz you will know that you have to be that bit more careful in everything to do with the r.f.—from the quality of the antenna cable and the way you attach plugs and sockets to it, to the choice of antenna changeover relay. Short cuts and temporary bodes are very unlikely to work well (if at all) at 1.3GHz.

Commercially built equipment is available so to some extent the problems can be hit on the head with a cheque book. True home brew either from own designs or from copying reference material is common on this band. Now that there are kits appearing on the market a halfway house which appeals to many amateurs is available. Great satisfaction can be had from successfully completing a kit project (not to mention the cost saving) and the result is essentially one's own work even if someone else designed it. This approach is almost always a success because the better kit suppliers offer a back up service to complete or align the item if you get stuck (usually at extra cost).

Antenna construction is possible for those who are good at things mechanical. Again all that is needed is care

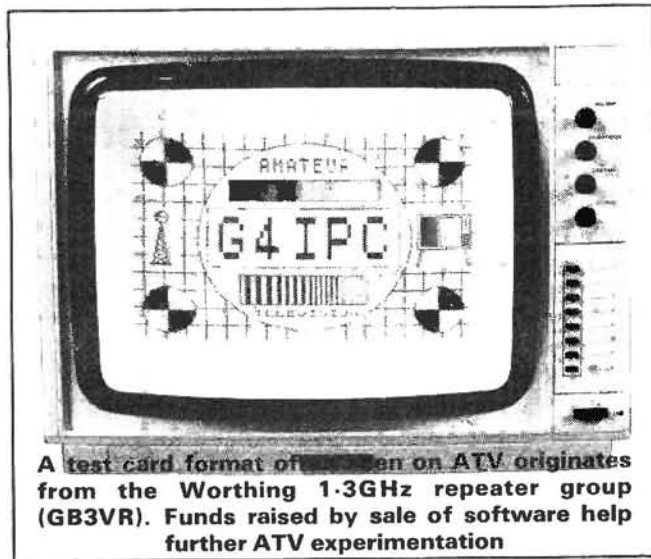

A test card format of ~~origin~~ on ATV originates from the Worthing 1.3GHz repeater group (GB3VR). Funds raised by sale of software help further ATV experimentation

and attention—a few mm doesn't matter at 144MHz, it is very significant when a quarter wave is only about 55mm!

With a little planning you can build up your 1.3GHz ATV station in stages.

- 1) Antenna, feeder and converter: the converter can go straight into your domestic u.h.f. TV. You will have to "slope detect" the f.m. (more in a later article) which will not give you the best possible picture, but at least you can see what's around before spending the earth on it.
- 2) An f.m. receiver.
- 3) Medium power transmitter (about 4W).
- 4) GaAs-f.e.t. pre-amp and separate receive downlead using a top quality changeover relay.
- 5) QRO TX using a 2C39 (about 50W).

At any time of course you can expand your antenna array or put it higher into the sky. This step wise approach means you don't need to find hundreds of pounds to do it all in one go with ready built units.

By the way don't be afraid of being a receive only station. Those with transmitters will welcome reports from you. Of course if you have a 430MHz ATV station you can retransmit the 1.3GHz picture back to its originator either direct or possibly by recording it for later replaying. More on all this in subsequent parts of this series.

The BATC

If you have any interest at all in amateur TV, be it fastscan or slowscan, on any band at all then *please* join the BATC, the British Amateur Television Club. This organisation can be joined for a modest fee and a small annual subscription. It provides a forum for ATV enthusiasts and helps ensure that TV users of the amateur bands have a voice in the right places. Membership is currently about 2000 which makes it one of the largest specialist groups within the amateur radio movement. Four times a year the BATC publishes a magazine called *CQ-TV* which is free to members and is well worth reading. The person to contact (s.a.e. please) regarding membership is: **D. Lawton, Grenehurst, Pinewood Road, High Wycombe, HP12 4DD. Tel: 0494 28899.**

Other useful reading is the *UHF Compendium* which is a translation of a German publication, available from the RSGB. Besides this book and the BATC's publications I have seen little published which is of any use to someone getting onto 1.3GHz ATV. That is the object of this series of articles so I hope you follow the series through and get going on the band.

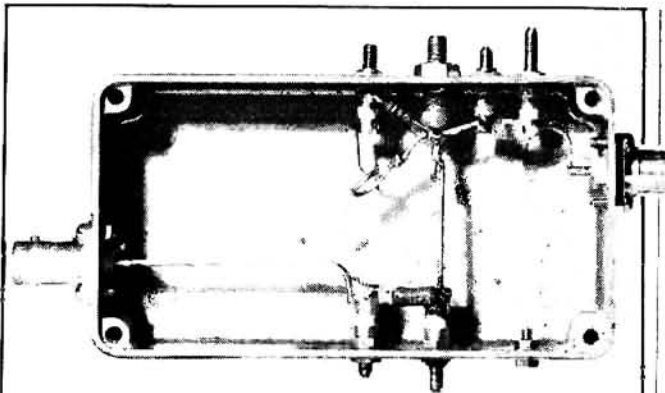

Varactor diode multipliers allow one route towards obtaining modest power levels at 1.3GHz but can be somewhat of a "black-art" to set up

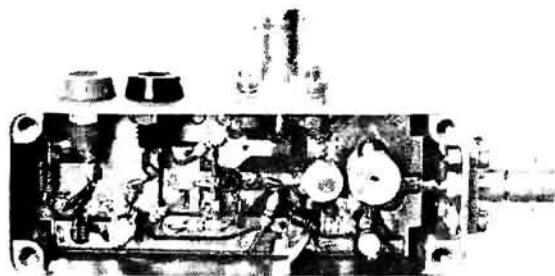

The ready-built 10mW 1.3GHz ATV f.m. micro-transmitter from Solent Scientific

I hope that in this introductory article I have interested you in 1.3GHz ATV. Subsequent parts will explain it all in enough practical detail for you to *succeed* and with enough theory for you to *understand* what you are doing and how it all works. If you do decide to start let me know how you get on. If you are already on the band I would like to hear from you so that I can hopefully publish an activity map of the country. I need to know basic station details as well as your location and the location of any stations you can work on a regular basis.

If you would like me to pass details on to you of anyone who wants to get onto the band in your area so that you can make direct contact I will be happy to do so.

73 for now G8CMQ

HAVING DIFFICULTY GETTING YOUR COPY OF PRACTICAL WIRELESS ?

Then place a regular order with your newsagent **NOW!**



Dear Newsagent,
please reserve/deliver
my monthly copy of
PRACTICAL WIRELESS

Name _____

Address _____

Signed _____

Introducing Short-wave Listening

Part 2 by Charles Molloy

Until quite recently it would have been a simple task to write about receivers for the s.w.l. The communications receiver with numerous controls used with an outdoor antenna, antenna tuning unit and a crystal calibrator would be a typical set up. It is hardly surprising that short wave broadcasting failed to take off in such an environment. A few domestic receivers offered a short wave band but stations were so crammed together, so difficult to find and so easy to lose as they drifted off tune, that only a tiny minority, determined to find an additional source of information and entertainment, were attracted to them.

Suddenly there was a change. A recent survey shows some two million regular s.w. listeners in the United

States. A new type of receiver has appeared—the self-contained table model which uses a whip antenna for short wave reception. It will have digital readout which means that the frequency it is tuned to will be shown on a pocket calculator type display—the uncertainty has gone! The set will be a double superhet which eliminates whistles and one sort of interference. It will have phase locked loop (p.l.l.) circuitry to reduce drift—you tune in a station and you stay tuned to it. Our modern receiver is quite capable of pulling in Australia as it stands! It works best with its whip. Reception is more likely to be impaired than improved if you try to connect an additional antenna to this type of set.

Sony ICF 2001

At the beginning of this decade a medium sized aptly named receiver appeared. It was the Sony ICF 2001, well named as it seemed to be a visitor from the future; the near future as it turned out, not the 21st century. The 2001 looked more like a microcomputer than a radio. It was flat, it didn't have a tuning scale or even a tuning knob. To "tune in" you tapped out the frequency on a keypad, much like a push-button phone. Press the EXECUTE button and the station appeared. A digital display showed the frequency. The set had memories in which you could store the frequency of a favourite station. Press the appropriate button and there it is! The 2001, which covers 150kHz to 30MHz a.m. and 76MHz to 108MHz f.m., had a whip antenna which could be folded away when not in use.

As one might expect there were snags. Performance on some bands was criticised, especially the medium and long waves. Power consumption was excessive, the receiver went through a set of batteries in 5 hours. None-the-less the 2001 was a milestone.

Serious Listening

The successor to the 2001 is known as the 2002 in North America and the ICF 7600D in Europe. It is compact, measuring only 180 x 120 x 30mm, and could easily be taken on holiday as the power consumption has been reduced. Other receivers with direct entry tuning (keypad), digital readout and p.l.l. circuitry have appeared. Examples are the Uniden CR2021, Panasonic RF799, Grundig Satellit 300A, Tandy DX400. If keypad tuning does not appeal, then there are the Panasonic RF3100, Sony ICF6800, Grundig Satellit 1400 and

at the lower end of this price bracket, the Grundig Yacht Boy 700.

There is a tendency to call some of these sets "Portable Communications Receivers". From the users point of view the important feature is whether the set requires an antenna. If it does, then you will have to provide a reasonable one. A communications receiver designed for use with an external antenna will not perform well with a metre or so of wire hanging from the back. The table model, or whatever it may be called, with its own whip antenna is the set for the programme listener who requires a self-contained receiver that will fit into domestic surroundings.

General Coverage or Multi-Band

It cannot be long before every short wave set has digital readout but in the meantime there are still a number of moderately priced receivers on offer that have a conventional tuning scale. Many are reasonably compact and can be described as portables. There are two basic types—"General coverage" and "Multiband".

A general coverage set is one that can be tuned continuously over the short wave spectrum. If it has digital readout then the user may not notice that international broadcasting mainly takes place in nine small segments called bands, lying between 3.9MHz and 26.1MHz. These bands are named 4MHz (75 metres), 6MHz (49 metres), 7MHz (41m), 9MHz (31m), 11MHz (25m), 15MHz (19m), 17MHz (16m), 21MHz (13m), 26MHz (11m). Only a few domestic receivers, the Tandy DX50 and the Ocean Boy 820 for example, give continuous coverage from 3.9 to

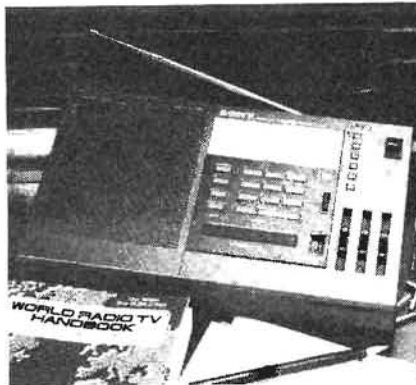

The Sony ICF2001 started the trend towards the modern receiver

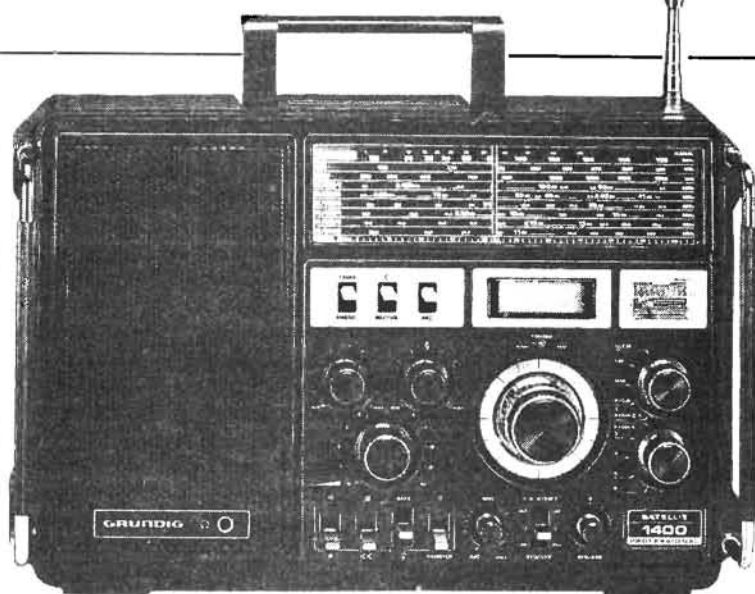

Grundig Satellit 1400 Professional

26.1MHz. When added together these s.w. bands take up about 10 per cent of the available space and this is very apparent when the receiver has a tuning scale. Broadcasting is squeezed into 10 per cent of the scale leaving 90 per cent of little interest to the general listener. As a result, stations are difficult to find. Many receivers have a single s.w. band going from 6MHz to 18MHz. General coverage is not really attractive to the serious listener though it may be to the short wave hobbyist.

Multi-Band Receivers

The multi-band receiver is the answer to the problem. Each band, plus a little extra, is given a separate full length scale to itself. These are usually designated SW1, SW2 etc. If there are fewer than nine of them, check to see if any bands have been left out. The Tandy DX360 is a compromise, covering 6MHz to 22MHz with 5 scales, with gaps in some places where there is no broadcasting. There isn't a great deal to be heard on the 4MHz and 26MHz bands so it may be felt that one can do without them but I personally would not accept any further reduction. There is plenty to be heard on the 21MHz, 17MHz and 15MHz bands!

There are a number of multi-band sets that offer good short wave reception. Examples are the Grundig Yacht Boy 300, Sony ICF7600A (not to be confused with the 7600D), Toshiba RP-F11, Sanyo RP8900, Panasonic 1350L. These receivers are compact enough to fit into a suitcase but there are a few that really do fit into the pocket. The ICF4800 and its successor the 4900, the Panasonic RF-9L for example.

The cheapest conventional set comes from the USSR and is known as the Vega. It is state subsidised and consequently is a good buy as a first receiver until funds stretch to digital readout. This set gives continuous coverage with two scales from 2MHz to 7.5MHz, then 9.3 to 12.1MHz (25m and 31m bands) and a single scale each for 15MHz, 17MHz and 21MHz bands. The Vega, which is imported by Technical & Optical Equipment (London) Ltd, Zenith House, The Hyde, Edgware Road, London, NW9 6EE, is usually advertised in the small ads columns of *PW*.

Receiver Tuning Scales

The correct, internationally agreed method of locating a s.w. station on the frequency spectrum is by its frequency measured in megahertz, abbreviated to MHz. An alternative, obsolete system is by the wavelength in metres.



Grundig Yacht Boy 300

Digital readout displays frequency in either kilohertz or megahertz. The conversion between kHz and MHz is easy. 1000kHz = 1MHz. Just shift the decimal point 3 places. The BBC World Service can be found on 5.975MHz which is the same as 5975kHz.

There are still a number of receivers in use that have their scales marked in metres. There is also the practice, widely followed, of designating a particular station by its frequency but the band it occupies in metres. This probably came from amateur radio. So you may find a short dash marked 49 metres above 6MHz on the scale of a general coverage receiver, while a multi-band set may display 5.9MHz to 6.3MHz on a scale marked 49 metres. As you go up the band in frequency the wavelength decreases!

It is simple to convert from metres to MHz.

$$\text{Metres} = 300 \div \text{MHz} \quad \text{MHz} = 300 \div \text{metres}$$

If the frequency is 6MHz then the wavelength is 50 metres.

A few receivers imported from Continental Europe will have the bands marked in French or German abbreviations, which may be confusing.

GO = Grandes Ondes = Long Waves = LW

PO = Petites Ondes = Medium Waves = MW

OC = Ondes Courtes = KW = Kurtzwelle =

= Short Waves = SW

Thankfully, digital readout will, or should sweep away these complications.

Sources of Supply

Outside of London it may be difficult to find a good selection of short wave receivers. The answer is to write to the UK office of each main distributor and ask for a brochure and the address of a local supplier. The main importers of s.w. receivers are Grundig International, Newlands Park, London SE26; Sony Ltd, 134 Regent Street, London WC1 6DJ; Philips, City House, London Road, Croydon, Surrey, CR9 3QR; National Panasonic, 300 Bath Road, Slough, Berks SL1 6JB.

If you do not like the appearance of a receiver, the layout of its controls etc, then you will never be happy with it. It is also an article of furniture which must fit into the domestic scene. We choose a TV set because it appeals and we assume that it will be adequate for its task. It may not be long before we choose a domestic short wave receiver by the same criteria.

Letters

On a Shoestring

Sir: After reading your greatly appreciated magazine, I am writing to you hoping that this information will increase your QRP column. After thinking and hearing so much about equipment prices, I hope to reassure other readers, wishing to become active operators, at minimum cost. I was Licensed in March 1984 and unemployed. Being frustrated at having my G4 ticket and not being able to use it, I set about learning more about my hobby and building projects. By spending £15 in building the *PW* Severn QRP Transceiver, I have now worked over 27 different prefixes and more than 300 very enjoyable QSO's. I have gained a QRP c.w. award, all on the massive output of one watt, using a half-sized dipole at 7m, cut for the 7MHz band. What more can a man ask for? My shack does not exactly sing and dance but I am very proud that I have, and others can have, a completely home-brewed QSO, with the smallest amount of money and power, and yet still have an enjoyable two-way contact, which is what it is all about is it not?

Brian Fields G4XDJ,
Cleveland.

Propagation

Sir: Long distance contacts and reception on v.h.f other than tropospheric are regularly and invariably reported as sporadic-E propagation although the fact is that they cannot be satisfactorily explained in terms of sporadic i.e. intense E region ionisation.

Emission of X and gamma radiation from solar flares may sporadically increase E region ionisation sufficient to increase its critical frequency to a value for example equal to or greater than the normal F2 region critical frequency. While at the same time the greater penetration of that radiation into our atmosphere may on occasion cause the lower area of E region to encroach upon D region, both effects together possibly leading to long range radio blackout. Now at E and F region altitudes the intensity of ionisation is sufficient to cause refraction back to earth, of appropriate wavelengths, while the frequency of collision between free electrons and atoms in those regions is not of particular significance. At D region altitude the intensity of ionisation is insufficient to cause refraction but because of the greater air density at this altitude the collision frequency is correspondingly greater. Electrons will lose energy at each collision with air molecules and if part of their motion is due to excitation by an incident electric (wireless) wave, the energy of motion imparted to the electron by that wave is lost at each collision. The net result if the collision frequency is sufficiently high as in D region, is overall loss of power from the wave as it traverses the region. Thus D region is an absorbing region.

When sporadic E region ionisation encroaches upon D region as mentioned above, we now have refraction and absorption. A wireless wave incident on the region will excite the electron motion in sympathy and the collision frequency will be modulated accordingly. A second wave incident on the region will now experience an electron collisional frequency and therefore absorption which is varying in sympathy with the first wave, and absorption cross modulation may occur.

Turning to v.h.f. experience and to obtain for example a 900km contact or reception on say 50 to 144MHz and

regarding these as m.u.f.s, we should require the "Intense E" region critical frequency now to be many times greater than a normal F2 critical frequency, correspondingly in fact to the enormous increase in m.u.f. We should also expect the associated great increase in D region ionisation to lead to a possible radio blackout, if indeed that intensity of E region were possible. Further, the alleged "sporadic-E" of v.h.f. experience is also found to be localised in area, say 120km across, in geographical position, and to drift in latitude⁽¹⁾. There is no known mechanism within the earth's orbit whereby the solar radiation, ultra-violet, X or gamma, can be focused on so small an area, a pinpoint in relation to astronomical distance, without drifting. It is also largely of seasonal occurrence but it is normal E region ionisation. But whereas the latter varies directly as the seasonal variation of integrated solar intensity and hours of daylight at any latitude, the occurrence of solar flares is independent of seasonal variations on earth.

The localised nature and seasonal variation of the alleged "sporadic-E" might suggest that it is to be associated with some localised state or event in the earth's atmosphere, and the occurrence of absorption cross modulation which is sometimes observed would indicate that transmission is via an ionised medium, not to be confused with refractive index ducting in the troposphere which occurs during anticyclone conditions^(1,2). A suggestion of American origin⁽³⁾ is that horizontal wind shears in the jetstreams which circle our northern hemisphere may produce strongly ionised clouds, that vertical wind shears in intense thunderstorms may do likewise, and a degree of correlation between these conditions and "sporadic-E" is offered. In this connection we should note that any effect due to scattering would predominate at shorter wavelengths contrary to what is observed, quasi-metallic reflection should not show a pronounced variation with wavelength, while the observed variation with wavelength and time might be consistent with variation in penetration frequency of the cloud. The problem with the wind shear suggestion therefore is to explain an intensity of ionisation which cannot be penetrated by 6m and 2m wavelengths. The net intensity of ionisation will be a balance between rate of production of free electrons and their rate of recombination with atoms, the latter rate increasing with air density. The high rate of recombination at the stratospheric and tropospheric altitudes of jetstreams and thunderstorms respectively would require a phenomenal rate of ion production to maintain a balance. The present trend⁽¹⁾ is to regard the alleged "sporadic-E" as due to drifting clouds of ionisation, but this begs the question of how these clouds are produced.

You may conclude that v.h.f. sporadic is still very much a mystery. The IARU have currently in hand a programme of investigation into "sporadic-E" to which all amateurs everywhere are invited to contribute and further information and report sheets can be obtained by members from the RSGB. R.G. Flavell is the UK co-ordinator and all information via *PW* will also be channelled to him. In addition to the statistical observations of the IARU programme, however, it would be advisable to devise and carry out major experiments of direct observation and measurement of the presumed clouds simultaneously over a range of frequencies; possibly only in this way may the true nature and cause of "sporadic-E" be determined.

Refs: 1. RSGB *VHF/UHF Manual*. 2. RSGB *RadCom* Feb 1984. 3. *PW* October 1983.

L. W. Brown,
Blackpool.

Practical Wireless, March 1985

Tandy®

Realistic® Scanners - The Professional Choice

Direct Entry 8-Channel Programmable Scanner

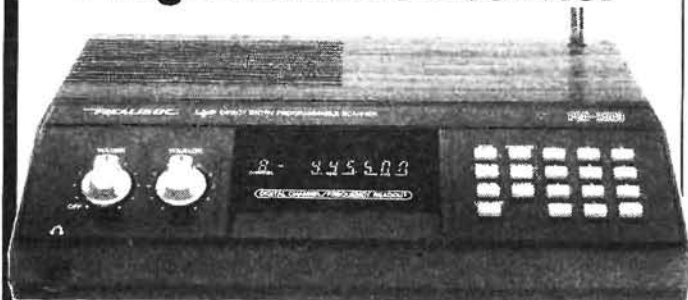

*Monitoring Your Favourite
Frequency Couldn't Be Easier*

£179⁹⁵

- Memory Back-Up
- Features Auto-Scan

Realistic PRO-2009. Direct keyboard entry, with auto-scan and "Search" to find new channels. Two-second scan-delay, channel lockout, monitoring of your favourite frequency, squelch control. Bands: VHF-Lo 68-88 MHz; Ham 144-148 MHz; VHF-Hi 148-174 MHz; Ham 410-450 MHz; UHF-Lo 450-470 MHz; UHF-Hi 470-512 MHz. Built-in speaker, whip antenna, external antenna jack. 2³/₄ x 10¹/₂ x 8". Mains operation. Memory backup requires 9V battery. **20-9109** **£179.95**

16-Channel Portable Programmable Scanner

Covers 68-88 MHz VHF-Lo,
144-148 MHz Ham,
108-136 MHz AM Aircraft,
138-144 MHz, 148-174
MHz VHF Hi, 380-450 MHz
Ham, 450-470 MHz UHF-
Lo, 470-512 MHz UHF-Hi

£229⁹⁵

- Now You Can Listen To
Aircraft, Hams and More -
Wherever You Go No Crystals
To Buy!

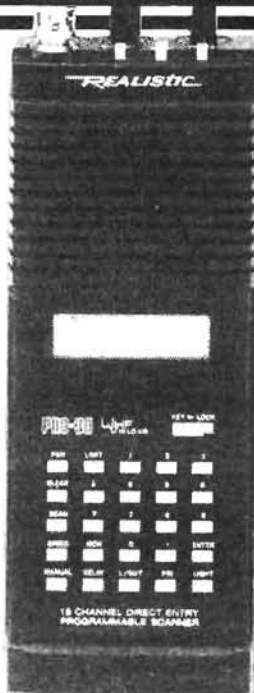

Realistic PRO-30. Scan up to 16 of your favourite channels continuously, or search a selected frequency range for new or unpublicised channels. Scan and Search in two speeds. Two-second Scan Delay, selectable for each channel prevents missed replies. Has jacks for external antenna and earphones. Requires six "AA" batteries or mains or DC adapter. Memory backup requires four silver-oxide batteries. **20-9131**

... And A 60-Channel Programmable Scanner

£279⁹⁵

- Listen to Aircraft, Hams, VHF
Marine and More - Even Your
Favourite Standard FM Stations

Realistic PRO-2003. No crystals to buy - direct keyboard entry of 20,584 frequencies! Use the search circuit to find new channels. Has 2-speed scan and search, Scan Delay, individual channel lockout, priority function and variable squelch control. Bands: VHF-Lo 68-87 MHz; FM Broadcast 88-107 MHz; VHF-Air AM 108-136 MHz; Ham 138-148 MHz; VHF-Hi 148-174 MHz; 410-450 MHz; UHF-Lo 450-470 MHz; UHF-Hi 470-512 MHz. Mains operation or 12V DC negative ground. Memory requires 9V battery. **20-9117**

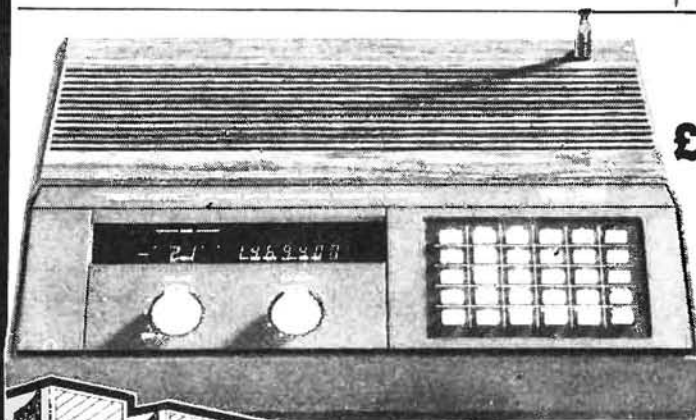

Take A Look At Tandy, Today!

Visit your local store or dealer and see these and many
more bargains. We service what we sell -
over 2,800 exclusive lines!

See Yellow Pages For Address Of Store Nearest You

OVER 9,000 STORES & DEALERSHIPS WORLDWIDE



Known As Radio Shack In The U.S.A.

Prices may vary at Dealers
Offers subject to availability

Nice to see a steady trickle of new clubs into this column each month but would secretaries and other club officials please note my correct QTH as mail is still being sent to my old Ashtead QTH although I left there some 16 months ago. Another small but important note. Would you please always note the meeting place, time, and days of the month on which your club meets in club correspondence so that I can highlight the occasion when a change takes place.

308 ARC Dave Davis G6YQD, 13 Maple Road, Surbiton, Surrey. Tuesdays at 8pm, The Coach House, St Marks Church, Surbiton. Position of secretary still vacant, so any volunteers? Nothing planned for February but get your junk together for a sale on Tuesday March 26.

Acton, Brentford & Chiswick ARC G3IU W. G. Dyer G3GEH, 188 Gunnersbury Avenue, Acton, London W3. Tuesday, February 19 at 7.30pm at the Chiswick Town Hall, High Road, Chiswick, London W4, a meeting to discuss the new Maidenhead locator system. New members and visitors most welcome.

Antrim & District ARC David Hutchinson G14FUM on (08494) 64672 All I can say is that the AGM will be held on Monday March 11, I know not where!

Axe Vale ARC G8CA Bob Newland G3VW on Lyme Regis 5282 First Friday of the month at the Cavalier Inn, West Street, Axminster with a talk on Moonbounce (e.m.e.) on February 1 and G4CFY of Spectrum Comms talking on March 1. Speak up if you want the job of PRO.

Aycliffe & Shildon ARC E. W. Bate on (0388) 774466 or (0325) 314638. At 8pm Tuesdays at the Sunnysdale Leisure Centre, Middridge Lane, Shildon, Co Durham, with Morse code and RAE classes plus lectures.

Basingstoke ARC G3TCR G8JYN Eddie Thompson G4SQZ, 21 Wigmore Road, Tadley, Basingstoke, Hants. Second Tuesdays at 7.30pm, the Swan Inn, Sherbourne St John, near to B'stokes.

Bath & District ARC Colin Ashley G4UMN telephone Frome 63939. Meets at the Englishcombe Inn, E'combe Lane, Bath, on "alternate Wednesdays" so contact sec for details. Newcomers warmly welcomed.

Biggin Hill ARC G4RQT G6TBH Ian Mitchell G4NSD on (09598) 376. Third Tuesday of the month at 8.30pm, the St Marks Church Hall, Biggin Hill, Kent. A demonstration of RTTY techniques is promised for February 19. Present membership is over the 50 mark.

Blackmore Vale ARS M. R. Bailey G1GRG on (0963) 70969. Second Tuesdays are main gatherings with lecture or demo, etc., with general chat and projects evening on the fourth Tuesday, all at the clubhouse in the old coachhouse behind the Bell & Crown at Zeals, Somerset. New members most welcome.

Braintree & District ARS G4JXG G6BRH Jeff Roberts G6OIX on (0376) 47525 daytime and (0376) 44857 evenings. First and third Wednesdays at 8pm, St Peters Church Hall, St Peters Close, B'tree, Essex. Own car park and talk-in on S15.

Brighton & District ARS Peter Turner G4IIL on Brighton 607737. You'll have to contact the sec to find out what "every other Wednesday" means! But it all happens at the Seven Furlong Bar on the Brighton Racecourse at 8pm whenever it is.



CLUB NEWS

Compiled by Eric Dowdeswell G4AR

Reports to: Eric Dowdeswell,
57 The Kingsway, Ewell Village,
Epsom, Surrey KT17 1NA
PLEASE MARK "CLUB NEWS"

Bristol ARC T. E. A. Rowe G8NNU on Bristol 559398. Tuesdays at the YMCA, 6 Park Road, Kingswood, Bristol with RAE and Morse code classes and usual lectures.

North Bristol ARC G4GCT Ted Bidmead G4EUV, 4 Pine Grove, Northville, Bristol. Last Friday of the month at the Self-Help Enterprise, 7 Braemar Crescent, N'ville, Bristol. The RSGB's *Space Shuttle* video show will be on view on February 22 and note a home brew competition takes place on March 29, so don't say you haven't been warned.

South Bristol ARC G4WAW Len Baker G4RZY on telephone (0272) 834282. Wednesdays at 7.30pm, the Whitchurch Folk House, East Dundry Road, Whitchurch, Bristol. On February 6 G4KUQ talks on cables and connectors, on the 13th it's 430MHz activity evening and on the 20th it's 1985 contest planning time.

Bromsgrove ARS G4TUI John Rowlands G4OJS telephone 021-445-3207. Increasing the membership is the current aim of this club which meets at 8pm, British Legion Club, Birmingham Road, Bromsgrove, Worcs on second and fourth Tuesdays of the month. Unusually, only three principal officers with all club matters dealt with in open session. Interests include RTTY, ATV and microwaves.

Bury RS G3BRS G6BRS Brian Tyldsley G4TBT on Burnley 24254. Every Tuesday at 8pm, the Mosses Centre, Cecil Street, Bury with main meeting on second Tuesdays, remaining ones being more or less informal, with operation on the h.f. and v.h.f. bands plus code and RAE classes. Special note of the annual Hamfeast on Sunday February 10 with

detail of this event from G1BWN QTHR. Feature of the February 12 gathering will be G8UVE on the building and launching of the Oscar 10 satellite. First prize for the 1984 constructional contest went to G1IAF for his 144MHz pre-amplifier.

Carmarthen ARS Milly Meredith, 50 Caecoed, Llandybie, Ammanford, Dyfed. Second and fourth Fridays at the Hospital Club, The Quay, C'marthen.

Cheltenham ARA G5BK Gillian Harmsworth G6COH on telephone C'ham 525162. Foregatherers at the Stanton Room, Charlton King's Library, C'ham, as on Monday February 4 when G4CNY will talk on Bermuda and the Bermuda contest.

South Cheshire ARS Nick Gutten G6IGW on Crewe 60062. Centred around Crewe and Nantwich, the club meets on second and fourth Mondays at 8pm at the Victoria Club, Gatefield Street, Crewe with a net every Sunday at 8pm on channel S14.

Cheshunt & District ARC Roger Frisby G4OAA on Hoddesdon 464795. Every Wednesday evening at 8, the Church Room, Church Lane, Wormley near Cheshunt, Herts. On February 6 G4ZCX will lead a discussion on a club project, on the 20th Ron Broadbent G3AAJ will describe the activities of the AMSAT organisation of which he is the secretary. The 13th/27th are natter nights.

Chichester & District ARC C. Bryan G4EHG on Chichester 789587. The Fernleigh Centre, 40 North Street, C'chester, on first and third Thursdays at 7.30. The club has been helping the local Scout group to attain the Scout communicator badges requiring the logging of 50 amateur QSOs.

Cornish RAC N. Pascoe G4USB on Falmouth 40367. Seemingly on the first Thursday of the month for general club meetings with the computer section active on the second Monday, both at the Church Hall, Treleigh, on the old Redruth bypass, at 7.30pm. AMTOR is the subject for G3VWK on February 7. The club's dinner will be held at the Lowenec Hotel, Camborne on Friday March 8 1985. Thinking ahead, the club's mobile rally will be held on Sunday July 21 at the Cornwall Tech, Redruth.

North Cornwall RC John West G6ICW on Bude 4976. First Wednesday of the month at 7.30pm, the RAOB Club, Camelford. On February 6 G4LXS will give a refresher talk on d.f. antennas.

Coulsdon ATS G4FUR Alan Bartle G6HC on 01-684 0610 Second Monday and last Thursday of the month at 8pm, St Swithins Church Hall, Grovelands Road, Purley, Surrey.

Coventry ARS Robin Tew G4JDO on telephone Coventry 73999. Every Friday at 8pm, Baden Powell House, 121 St Nicholas Street, Radford, Coventry, with visitors most welcome.

Derwentside ARC (Consett) June Wallis G1AAJ, 10 Middlewood Road, Lanchester, Durham. Now meets at the Consett AFC, Belle Vue Park, Consett, Mondays at 7pm, with new members most welcome.

North Devon RC George Hughes G4CG, "Crinnis", Highwall, Barnstaple, N. Devon. First Wednesday of the month at new venue of Micro Chips, Castle Street, Barnstaple at 7.30.

Droitwich ARC Gordon Taylor G4HFP on Stourport-on-Severn 3818. Second and fourth Mondays at 8pm, Scout HQ, Union Lane, D'wich, with demos, field days,

Practical Wireless, March 1985

microwave section and all usual club activities.

Dudley ARC G4DAR John Tisdale G4NRA on Kingswinford 278300. Mondays at 7.45pm, Allied Centre, Greenman Alley off Tower Street, Dudley.

Dunfermline RS GM3IDS Ray Mackie telephone D'fermline 73640. Thursday evenings at 7.30 the Outh Wireless Station, Knockhill, by D'fermline, with lifts from the town centre available. More members are sought to fill out the new premises.

Dunstable Downs RC Phil Morris G6EES on Dunstable 607623. Fridays at Chews House, High Street South, D'stable, Beds. February 1 has G3NRW holding forth on AMTOR, RTTY and Packet Radio, while the 15th is devoted to the AGM.

Ealing & District ARS G3UUP G8UUP Anton Berg G4SCR on 01-997 1416. Gatherings on Tuesday evenings from 7.30pm at the Hanwell Community Centre, 71a Northcroft Road, London W13, potential members welcome.

Edgware & District RS G3ASR John Cobby G4RMD on Hatfield 64342. Second and fourth Thursdays at 8pm, 145 Orange Hill Road, Burnt Oak, Edgware, Middx. with slow Morse as required, supplemented by G3AST on Top Band and 144MHz during the week. February 14 is a practical techniques evening with participation in the ARRL c.w. contest on the 16/17th.

Fylde ARS Harry Fenton G8GG on St Annes 725717. First and third Tuesdays with a talk or function on the first, and general get-together on the third. The venue is the Kite Club on Blackpool Airport with the club subscription covering access to the facilities of the Kite Club. Meetings at 7.45 with occasional outings and visits. On February 5 it's *Secret Listeners* from RSGB library.

Glenrothes & District ARC GM4GRC GM3ULG R. I. Lamont GM4LYQ, 132 Ballater Green, Glenrothes, Fife. Club meets on Wednesdays at 7.30pm and on Sundays but time not given, all at Provosts Land, Leslie. RAE and Morse code classes are held at the Balwearie High School, Kirkcaldy.

Grimsby ARS G3CNX G. J. Smith G4EBK, 6 Fenby Close, Grimsby, S. Humberside. "Every other Thursday" and first Mondays which are devoted to the use of computers in amateur radio. So I'm afraid it's the sec for more details. Venue is the Cromwell Social Club, Cromwell Road, Grimsby. On February 7 it's QuizNight with a Q & A session on d.f. matters on the 21st.

Hambleton ARS Tony Wilson G3MAE on telephone Great Smeaton 530. Meets in Room C11 of the Allertonshire School, Northallerton but just when is not too clear, but could be February 4 and 18.

RS of Harrow G3EFX Dave Atkins G8XBZ on Rickmansworth 779942. Every Friday night at 8.15pm at the Harrow Arts Centre, High Road, Harrow Weald, Middx. This is opposite the Alma pub. February 1 has G3OSS discussing the uses and abuses of v.h.f., with slow-scan TV by G8ASI the subject for the 15th. Otherwise it's activity nights on 3.5MHz and 7MHz bands. G3YXZ, it should be noted, concentrates on multi-channel networks on March 1.

Hastings Electronics & RC G6HH GIHHH Dave Shirley G4NVQ on Hastings 420608. Third Wednesday of the month is main meeting time at the West Hill Com-

munity Centre with the firm of Wood & Douglas expected to give some demonstrations on February 20. There is a chat session on Friday nights at Ashdown Farm Community Centre. On Saturday February 23 there is a combined social with two other local groups. The club's AGM is scheduled for March 20. On Friday February 22 the new president of the RSGB, Joan Heathershaw G4CHH, will be visiting the club.

Hilderstone RS Ken Smith G3JIX, Staple Farmhouse, Staple, Canterbury, Kent. Fridays at 7.30, Hilderstone Adult Education Centre, St Peters, Broadstairs, Kent, with all the usual activities including outside visits, and a bent towards constructional projects.

Inverness ARC GM4TPF GMIDZU David Jones GM4SXD on (08083) 240. Every Thursday at 7.30pm at the Cameron Youth Club, Planefield Road, Inverness.

Isle of Man ARS GD4IOM Anthea Mathewman GD4GWQ on (0624) 22295. Mondays at 8pm at the Keppel Hotel, Cregny-Baa, IOM. Local RAE and code classes are held with DXpeditions to local high spots a speciality.

West Kent ARS Brian Guinnessy G4MXL on (0892) 32877. It's every Friday evening at 8, the Adult Centre Annex, Quarry Road, Tunbridge Wells, Kent. The club now transmits official slow Morse on S10 Monday evenings which corresponds to 145-250MHz.

Leighton Linlade RC G4LLR G6LRC Ian Jardine GIACQ on telephone (0525) 376741. To be found in Room A64, Vandyke Community College, Vandyke Road, Leighton Buzzard, Beds starting at 7.30 on the first and third Mondays.

Loughborough ARC G3RAL Jim Smith G4DZL, to be found at the club's home on the top floor of the Brush Sports & Social Club, 18 Fennel Street, L'borough, Leics, near to the central bus station. The meetings are held on Tuesday and Friday each week although the club room is open every evening. Tuesdays are for lectures, demos, etc., with Fridays devoted to the constructors' group, as well as putting the club station on the air. On February 8 there is a demo of SSTV gear and on the 22nd G8BUB will deal with test equipment.

South Manchester RC D. Holland G3WFT on 061-973 1837. Fridays and Mondays at 8pm, the Sale Moor Community Centre, Norris Road, Sale, Cheshire. Main item in February is a midnight d.f. contest on the 23rd.

Mansfield ARS Keith Lawson G4AAH, 233 Southwell Road West, Mansfield, Notts. First Friday and third Tuesday of the month at the Victoria Social Club, Princess Street, M'field. Packet radio will be dealt with by G6CUK on February 1, with "bee-keeping" making a change from AR on the 19th! The deadline for the constructional competition is Friday April 5.

Maxwelltown ARC GM0AEE Trig Rodgers GM4NNC, 5 Elder Avenue, Lincuden, Dumfries. Only formed in October last, the club aims at operational and practical activities, at the Tam O'Shanter Inn, Dumfries, on Wednesdays at 8pm, but check for details with sec first, as a proper clubroom could be in use by the time this appears in print.

Medway ARTS G5MW G8MWA Andy Wallis G4TQS on (0634) 363960. Gathers at the St Lukes Church Hall, King William Road, Gillingham, Kent, on Fridays with a

construction contest on February 1 and the AGM on the 8th.

Midland ARS Peter Edmonds G4OFN 143 Witton Lodge Road, Birmingham B2: 5AR. Peter is the new PRO taking over from Tom Brady G8GAZ who has long supported this column with club info. Club HQ is 294½ Broad Street, B'ham every night of the week. There is a computer section and much contest operation.

Newark & District ARC Michael Gayler G4SDZ on (0636) 702076. The Palace Theatre, Appletongate, Newark, Notts, at 7.30 on the first Thursday of the month. Morse code classes and RAYNET activity plus lectures.

ARC of Nottingham G3EKW G6CW G8IUT Jim Towle G4PJZ on telephone N'ham 624764. Talk "Now and Then" is scheduled for February 14 and there is a junk sale on the 28th. Out of order, I'm afraid, is the Forum to be conducted on the 7th. So it's every Thursday at 7.30pm, the Sherwood Community Centre, Mansfield Road, N'ham.

Oldham ARC Fiona Butterworth G4SPX on 061-652 8862. QRP expert the Rev Dobbs G3RJV will have the attention of the club on February 11 at the Wheatsheaf, Derker Street, Oldham, Lancs. Otherwise it's Mondays at 8pm.

Oswestry & District ARC Brian Goldsmith GW6YIY on (0691) 831023. There will always be a warm welcome in this lovely border area, I'm told, where the club meets first Tuesdays at 8pm in the Bell Hotel, opposite the parish church, Oswestry.

Greater Peterborough ARC G4EHV Frank Brisley G4NRJ, 27 Lady Lodge Drive, Orton, Longueville, Peterborough. Fourth Thursdays at the Southfields Junior School, Stanground, P'boro, with February 28 scheduled to present G3WDG on microwaves.

Port Talbot ARC GW3EOP Joe Griffiths GW4IGR on (0639) 720416. Each Thursday at 7.30pm, in the British Steel Corp Sports & Social Club, Port Talbot.

Reading & District ARC Chris Young G4CCC, 18 Wincroft Road, Caversham, Reading, Berks. "Alternate Tuesdays" which seems to be February 5 and 19, in the clubroom of the White Horse in Peppard Road, Emmer Green, Reading, starting at 8pm.

Rhyl & District ARC GW4ARC GWIARC Melfyn Allington GWIAKT on Nantglyn 469. Note the new venue of the Mona Hotel, Market Street, Rhyl, opposite the Town Hall, first and third Mondays at 7.30pm. There is a talk by a club member on February 4 and an activity night on-the-air on the 18th. On March 4 G3LEQ will be giving the third part of his lecture on antennas and propagation.

St Helens & District ARC Alan Riley G6MXT on 051-430 9227. An RSGB film is planned for February 7 while G8TYY deals with home-brew matters on the 14th. There's a quiz on the 21st and note the junk sale on March 14. So be at the Conservative Rooms, Boundary Road, St Helens at 7.30pm when code classes start off the evenings.

Skelmersdale Radio, Electronics & Computer Club Joe Singleton G4WJR, 3 Willow Drive, Skelmersdale, Lancs. I guess "Electronics" would have covered the name of this brand new club which intends to meet every

Wednesday at 8pm in the Royal British Legion, Liverpool Road, S'dale. Volunteers are required to lecture or demonstrate at the club. It is good to know that the club has a number of CBers who have taken up amateur radio.

Southdown ARS G3WQK G1KAR. T. Rawlance G4MVN, 18 Royal Sussex Crescent, Eastbourne. First Monday of the month at the Chaseley Home, Southcliff, Eastbourne, 7.30pm. A special activity station is to be set up on Saturday February 23 and is regarded as a major social event.

South Tyneside ARS Tony Adamson on (0632) 567305. Anyone with AR interest welcomed any Monday evening at the Martec Club in the grounds of the South Tyneside College if you go in at the Grosvenor Road entrance. Still quite new, the club welcomes new members.

Spenn Valley RS G3SVC Tim Clough G4PHR on Mirfield 499397. The HQ is the Old Bank WMC in Mirfield where the club gathers Thursdays at 8pm. In February a rep from the Leeds Weather Centre will deal with the weather and radio.

Stafford & District ARS A. C. Bairstow G4RSW on Stafford 46306. Talks and demonstrations every week, Tuesdays at 8pm, the Coach & Horses Motel, Weston, which is on the A51, with visitors made most welcome.

Stowmarket & District ARS M. Goodrum G3ZQU on S'market 676288. First Mondays at the Maltings Entertainment Complex, opposite the railway station apparently, with a junk sale on February 4. The club AGM is down for March 4.

Stratford-upon-Avon & District ARC David Boocock G8OVC on S-on-A 750584. Second and fourth Mondays at 7.30pm at the Control Tower, Bearley Radio Station, near Stratford. A surplus gear sale takes place on February 11 with Technical Topics plus discussion of a club constructional project on the 25th. The AGM is slated for March 25, just for your diary.

Sutton & Cheam RS Alan Keech G4BOX, 26 St Albans Road, Cheam, Surrey. It's the third Friday every month at 7.30pm, the Downs Lawn Tennis Club, Holland Avenue, Cheam. Exceptionally it's a drinks evening and natter on Monday February 4 in the Downs Bar. Regular meeting on the 15th will include a junk sale. For the diary, 36th annual dinner, at the Woodstock, Stonecot Hill, Morden, on March 30.

Swale ARC G4SRC Brian Hancock G4NPM on (0795) 873147. Monday evenings at 8pm, the Ivy Leaf Club, Sittingbourne, Kent.

Taunton & District ARC G3XZW L. S. J. Forde G4ZLF, 23 Laburnum Road, Wellington, Somerset. New members and visitors welcome in the basement of the County Hall, The Crescent, Taunton, every Friday at 7.30pm.

Thornton Cleveleys ARS Jack Duddington G4BFH on (0253) 853554. First and third Mondays have guest speakers, second and fifth Mondays Morse code classes by G3ZRZ, and fourth Mondays are informal and constructional times, all at 7.45pm. The venue for all this activity is the 1st Norbreck Scout HQ, Carr Road, Bispham, Blackpool. February 4 has a talk on pte with "Computer Frauds" the subject for the 18th, by G6KOE. A demo of AMTOR on the 25th by G4BVW and G4YVQ ought to be a big draw.

Tiverton (SW) RC G4TSW G. W. Draper G4ZNV on (03634) 235. Important change of venue, now at the Half Moon Inn, Fore Street, Tiverton, Devon, at 7.30pm every Tuesday. Better radio facilities and more comfortable social surroundings are the reason for the move. Radio enthusiasts are most welcome.

Todmorden & District ARS E. Tipping, 3 Cliffe Villas, Longfield Road, Todmorden, Lancs. The club gathers at the Queens Hotel, Todmorden at 8pm on the first Monday of the month.

Trowbridge & District. Gerry Callaghan G4SPE on (0373) 823584. Just over a year old, the club foregathers in the Southwick Village Hall, near Trowbridge, Wilts, on the third Thursday of the month starting at 8pm. A film show is planned for the February meeting, on the 21st.

Vale of White Horse ARS Ian White G3SEK on Abingdon 831600 Ext 359 daytime or 31559 evenings. New meeting place for the club is the upstairs meeting room of the Waterwitch, Cockroft Road, Didcot, Oxon at 7.30pm. First and third Tuesdays with a talk on RTTY and AMTOR on February 5, by G3NRW. Big attraction on March 5 will be G4DGU of MuTek Ltd.

Verulam ARC Hilary Claytonsmith G4JKS on St Albans 59318. A debate entitled "c.w. is a dying art" (rubbish!) is scheduled for February 26. I am informed that there is no truth in the rumour that the proposer is I8CW! Otherwise it's the RAFA HQ, New Kent Road, off Marlborough Road, St Albans, Herts second and fourth Tuesdays at 7.30pm.

North Wakefield RC Steve Thompson G4RCH on (0532) 536633. The Carr Gate WMC every Thursday at 8pm, with an on-the-air night on February 7, a lecture on the 14th, live music night on the 21st.

West Bromwich Central RC John Bates G6ZLW on 021-553 0531. Don't forget the new venue is the Hop & Barleycorn, Dartmouth Street, West Bromwich. RAE and Morse code classes are conducted in addition to lectures, etc., every Sunday evening at 8pm.

Willenhall & District ARS John Perkins G4LWI on Wolverhampton 782036. Venue is the Saracen's Head, Bloxwich Road South, Willenhall, W. Mids, each Wednesday at 8pm.

Wimbledon & District ARS George Cripps G3DWW on 01-540 2180. Second and last Fridays of the month, at 8pm with refreshments laid on. All at the St Johns Ambulance HQ, 124 Kingston Road, Wimbledon, London SW19. Activities include on-the-air operation and Morse code classes.

Wirral ARS Cedric Cawthorne G4KPY on 051-625 7311. Meeting spot is the Heswall Parish Church Hall, Heswall, Wirral, first and third Wednesdays at 8 o'clock. There will be a film show on February 6 and a technical talk is promised for the 20th.

Wirral & District ARC G4MGR G8WDC Gerry Scott G8TRY on 051-630 1393. Get along to the Irby Cricket Club, Irby, Wirral, on the second and fourth Wednesdays.

Wolverhampton ARS Keith Jenkinson BRS84269 on (0902) 24870. The W'hampton Electricity Sports & Social Club, St Marks Road, Chapel Ash, W'hampton, every Tuesday evening at 8. Scheduled for February 5 is a talk by G4JCP on data communications and packet radio. Test gear will be available on the 12th for the testing of member's transmitters. On March 5 it's G6UDX on the subject of frequency synthesis.

Worcester & District ARC Derek Batchelor G4RBD on Worcester 641733. It's formal meetings at the Oddfellows Club, New Street, Worcester, like on February 4 when there will be a slide show. Informally at the Old Pheasant also in New Street, on February 18, all at 8pm. That makes it the first and third Mondays of the month.

Thank you all for your copy for this feature and remember that good, clear photographs of interesting club activities are most welcome. Don't forget that *PW* is published around the first Friday of each month with a cover date for the following month and that six weeks notice is necessary if a particular event is to be published in the appropriate issue.

Cover Date	Deadline	For events from early
May	February 15	April
June	March 15	May
July	April 15	June

Did You Know...

That the first life was saved by radio in 1899?
During a gale in March of that year, a steamship

became stranded on the notorious Goodwin Sands, 11km off the southeast coast of England. Fortunately, the nearby East Goodwin lightship had shortly before been fitted with Marconi apparatus that had been taken out to it in an open boat; it was thus able to report the accident to the lighthouse on the cliffs at South Foreland 19km away which also had a Marconi installation. As a result a lifeboat was sent out, and not only were lives saved but also a valuable cargo worth £50 000—a great fortune in those days. Two months later the Marconi apparatus saved both the lightship and another vessel that had run into her.

Eric Westman

Valved Communications Receivers

by Chas. E. Miller

2 – THE R1155

R1155 receivers were used by the Royal Air Force for many years during and after WWII. They were released onto the civilian market shortly after the end of hostilities and rapidly established for themselves an excellent reputation and a keen following. Over 35 years on they are still highly prized, and more than one dealer has described them to the author as being “like gold!” It is felt that they deserve detailed attention and to that end will be dealt with in two instalments, the first describing the specifications and working principles, the second being concerned with likely modifications, the provision of power supplies and general fault finding/servicing.

During its production run a number of modifications were made to the original R1155, these being denoted by the addition of a suffix letter, e.g., R1155A. In fact the changes were mostly slight and, with one important exception, of no consequence to the civilian user. The R1155A was fitted with filters to ward off interference from m.f. transmitters. It had an aluminium case, as did the original R1155. The R1155D was electrically identical to the R1155 but had a steel case whilst the R1155E had a similar relationship to the R1155A. The R1155M was identical in every way to R1155A but due to an error had been assembled with the use of corrosive flux solder. Receivers of this type would need extra vigilance in respect of bad joints. Variants R1155B (aluminium) and R1155F (steel) were the same as the A or E types with the addition of r.f. chokes to prevent interference from radar transmitters and the R1155C had h.f./d.f. (Huff-Duff) facilities. The two types having interesting modifications were the R1155L (aluminium) and R1155N (steel). They were similar to types B and F but had alterations to the wave-band coverage which are beneficial to most domestic users, (see specification).

The earlier marks of R1155 had the various wave ranges distinguished on the dial by different colours; these were identified on the wave-change switch by coloured dots on a small scale above the knob. They also corresponded with the frequency ranges similarly coded on the associated T1154 transmitter. After the frequency ranges had been changed the relationship was lost, and later dials were painted uniformly black.

Although primarily intended for use in aircraft the T1154/R1155 combination was also found in ground installations, in certain military vehicles, and even in air-sea rescue launches. In all cases power supplies came from rotary converters driven by the main batteries. Thus there

is no internal p.s.u. in the R1155, neither is there any provision for loudspeaker reception. This undoubtedly makes for a more compact receiver, but calls for some care in the design of both items, due to the rather unusual h.t./bias arrangements within the set. This will be discussed fully later.

The R1155 was a dual-purpose receiver providing radio-navigational facilities in addition to its communications role. After the passage of time it is unlikely that an example possessing the d.f. circuits intact will be encountered, but it is felt that they are of sufficient technical interest to warrant a brief description, following that devoted to the communications circuitry. The diagram reproduced here is of the latter only, and in simplified form which omits some details of the wave-band switching and of the Master Switch. This results in a much clearer lay-out which the reader should have no difficulty in following.

General Specification

Frequency coverage, models R1155, A, B, C, D, E, F, M.

Band 1. 18.5MHz–7.5MHz. Band 2. 7.5MHz–3.0MHz. Band 3. 1500kHz–600kHz. Band 4. 500kHz–200kHz. Band 5. 200kHz–75kHz.

R1155L, N as above, but Band 5 deleted and replaced by:
Band 2A. 3.0MHz–1.5MHz.

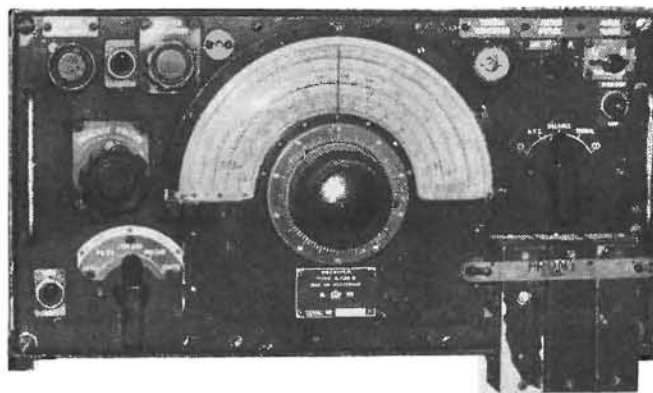

The RAF aircraft receiver, R1155

It will be seen that the last two models have virtually complete coverage from 200kHz–18.5MHz, with only a small gap at 500kHz–600kHz. The intermediate frequency in all models is 510kHz.

Sensitivity: input of 10µV at 210kHz gives better than 50mW output. An input of 9µV at 16MHz gives an equivalent output.

Selectivity: Approximately 4kHz–6kHz for 6db attenuation.

Power output: 200mW max. into 500Ω (for headphone use).

Power consumption: Communications, approx. 45W; d.f., approx. 50W.

Dimensions: Length 418 × 238 × 289mm. Weight: Steel case approx. 14.5kg; aluminium case approx. 12 kg. Valve line up: V1, V2, visual d.f. switching, VR99A. V3, r.f. amplifier, VR100. V4, frequency changer, VR99. V5, V6, i.f. amplifiers, VR100. V7, a.g.c. and b.f.o., VR101. V8, demodulator, d.f. meter limiter, a.f. output, VR101. V9 d.f. meter switching, VR102. V10, tuning indicator, VI102.

Type VR99A is directly equivalent to the Mullard ECH35 and VI103 to the Marconi/Osram Y63, both widely used domestically. Commercial equivalents for the other valves were not found in domestic equipment and are probably more likely to be obtained in service guise. As a guide: VR99/X66, triode-hexode frequency changer similar to the 6K8G; VR100/KTW62, a vari-mu r.f. pentode nearest in equivalent to the 6U7G, although a 6K7G may be used in its stead. The VR101/MHLD6 is a double-diode-triode with the last section taking a much larger anode current than most valves of this type. For this reason the 6Q7G should be avoided if possible and the 6R7G used. For the record (since it will not be required for use) the VR102/BL63 was a double triode of low impedance and unique characteristics.

General description of controls: Across the top front of the receiver are, from left to right, R51 (d.f. METER BALANCE), S5 (a.f. FILTER IN/OUT), R23 (d.f. METER AMPLITUDE), the TUNING INDICATOR, S2 (d.f. meter sensitivity) and S3 (AURAL SENSE—see later). Just below S3 is S1 (d.f. SWITCHING SPEED). To the left of the dial is R8, the VOLUME CONTROL, and to the right the master switch which selects the receiver's operational mode. Centrally below the dial is the main tuning control which has two concentric knobs giving fast or slow motion facilities.

These may be either direct/100:1 or 4.5:1/80:1, according to the type of drive mechanism fitted. On the extreme bottom left is the HET (b.f.o.) ON/OFF switch S4, and next to it the band selector switch. On the bottom right are three Jones type connectors for power supplies, antenna connections, earphones, etc.

The Master Switch in detail: Designated MS on the circuit diagrams, this has five wafers subscribed a, b, c, d, and e; further broken down to "f" (front) or "r" (rear) as applicable. From this it will be seen that the master switch is highly complex! In fact only two of its positions will be used for communications work, but wafers a, b and d are still involved. We will examine their functions more closely after looking at the various knob positions marked on the front of the cabinet. These are (going clockwise) a circle with a dot in its centre signifying OMNI; the letters AVC; BALANCE; VISUAL, and lastly a figure 8 lying on its side which signifies (understandably) figure of eight. The two positions which concern the ordinary listener are OMNI and AVC. In both these positions the d.f. circuits are inoperative, and normal radio reception provided. However, in OMNI the a.g.c. of the set is disabled and its gain is controlled solely by the volume control, which is in fact a two-gang device of 50kΩ and 500kΩ respectively. The 50kΩ section is connected across a negative bias line and the variable voltage fed to the grids of V3, V4, V5 and V6 in graduated amounts to give each valve its appropriate bias. At the same time the grid of V8 (a.f. output) is switched to the top end of the 500kΩ section to render it "flat out".

When AVC is selected the grid of V8 is taken to the wiper of the 500kΩ section which then operates as a normal a.f. volume control. The 50kΩ section is switched out of circuit, and the a.g.c. brought into action.

Remaining positions were used thus: BALANCE enabled the operator to set up the visual display used for d.f. work; VISUAL brought the latter into operation and switched in valves 1, 2 and 9, the a.g.c. was operative. Figure of Eight enabled aural bearings to be taken, in conjunction with S3, to obtain the sense of the signal received. The importance of this will be seen later; a.g.c. was disabled in this position.

The communications circuit in detail: Two antennas were provided on aircraft for communications work, a fixed type strung on insulators and a trailing type that was let down on a hand-winch. The waveband switch automatically selected the appropriate antenna; fixed for

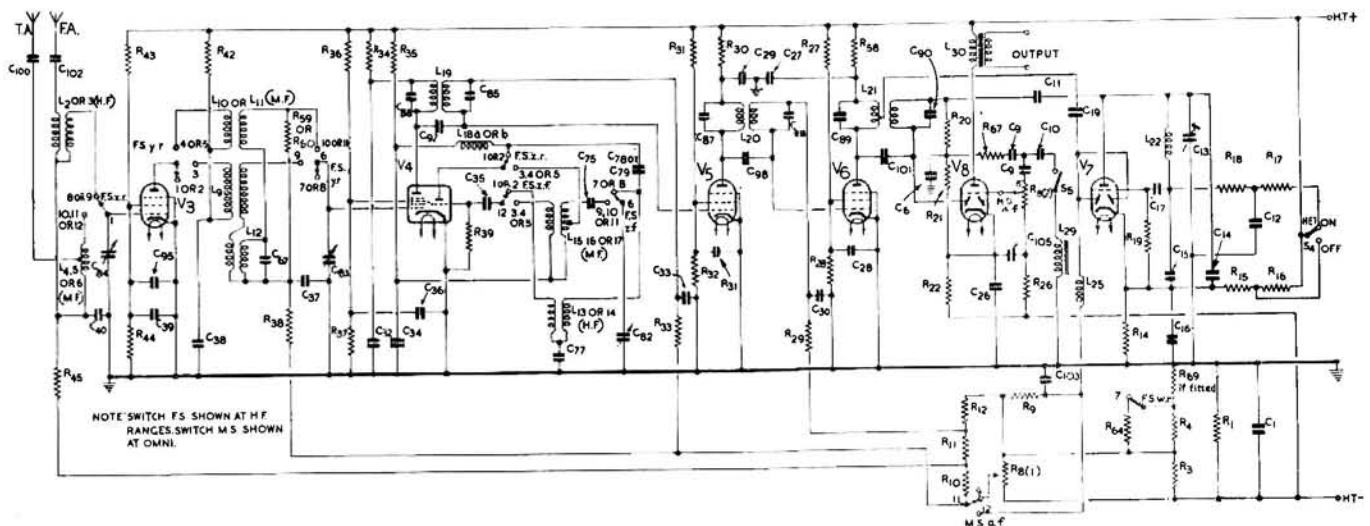

Fig. 1: Simplified Circuit diagram of the R1155. See Fig. 2 for biasing and feed arrangements

ranges 1 and 2, trailing for the others. The tuned input from the antenna coils is amplified by V3 (VR100/KTW62), then transferred by t.r.f. transformer to the grid of the hexode section of V4 (VR99/X66). The triode section of this valve operates as a local oscillator at 560kHz above the signal frequency. The i.f. thus produced is amplified by V5 and V6 (VR100/KTW62). The i.f. transformers are of the band-pass type and give excellent selectivity. The output of the second i.f. amplifier is fed to one diode section of V8 (VR101/MHLD6) which acts as demodulator. The resulting a.f. is passed through r.f. filtering network and the optional a.f. filter to the 500kΩ section of the volume control and thence to the grid of the triode section of V8. The anode of this valve is connected to L30, which is the primary of the earphone matching transformer. Both diode sections of V7 are employed (strapped) for a.g.c. purposes. They are fed from a tapping on the last i.f. transformer so that the voltage developed on them will always be less than the a.f. voltage appearing on the demodulator diode. As noted earlier, the a.g.c. is not employed to control the r.f./i.f. valves in the OMNI position, but the diodes are connected to a 3-6V negative supply (to establish a delay point) and are used to operate the tuning indicator. The same 3-6V supply provides a small standing bias for the r.f./i.f. valves, none of which has cathode biasing. Note that on bands 1 and 2 one section of the band switch reduces the standing bias and the tuning indicator delay voltage, to maintain the gain sensibly constant on all bands. A voltage of approximately -30V is required to fully control the r.f./i.f. valves, and this is obtained by a network of dropping resistors in the h.t. negative line. All other negative voltages are derived from the -30V rail via suitable resistors. It should be noted here that the chassis of the receiver is at +30V with respect to h.t. negative. The latter must not, therefore, be taken directly to chassis in conventional manner, or all biasing voltages will be lost. It is suggested that Fig. 2 be studied closely in conjunction with the foregoing so that the ramifications of the biasing circuit are fully understood.

The triode section of V7 operates as b.f.o., working at 280kHz, (± 1.5 kHz) the second harmonic being used to beat with the i.f. signal. The purpose of this arrangement is to prevent the b.f.o. from being locked to a strong i.f. signal and thus producing zero beat; the sole function of the b.f.o. in all communications receivers of this era was to render c.w. (Morse) signals audible to the operator, and thus the beat frequency had to differ from the i.f. by a few hundred Hz to give a suitable tone. Preset adjustment of the oscillator over 3kHz was available via a small trimmer capacitor accessible through a hole in the front panel.

Outline description of d.f. circuits: In addition to the fixed and trailing antennas referred to the aircraft was also equipped with a rotatable loop antenna. For d.f. purposes wafers of the master switch connect the loop to V3 in positions VISUAL and "figure of eight". In the former position the fixed antenna is switched via a special r.f. transformer to the hexode grids of V1 and V2 (VR99A/ECH35), in anti-phase to each other. The triode sections of these valves work as a push-pull blocking oscillator running at either 30Hz or 80Hz, for reception of a.m. and c.w. signals respectively. The hexode sections are switched on alternately and thus the signal from the fixed antenna is either added or subtracted from that obtained from the loop. The composite signals are passed through the set and demodulated as normal, but the resulting a.f. is not applied to the a.f. output stage but to the grids of the double-triode V9 (VR102/BL63). Switching voltages from the blocking oscillator turn the triodes on/off in step with the two hexodes, producing at the anodes of the triodes a current change equivalent to fixed + loop antenna or fixed-loop antenna. The change in current is displayed visually by a

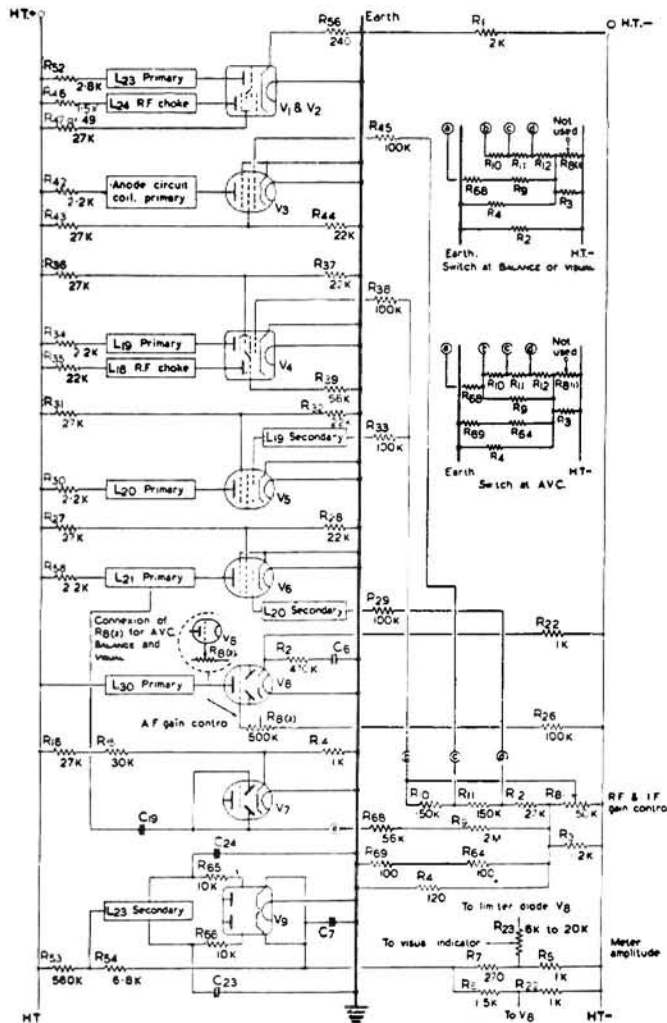

Fig. 2: Biasing and feed arrangements of the R1155 receiver

special double millimeter whose needles operate in vertical arcs. A vertical white line is painted on the face of the instrument centrally between these arcs. The needles will rise in accordance with the anode current drawn by the triodes; if the loop is rotated for zero signal it will not add or detract from the fixed antenna signals and the two needles will rise to the same level, to intersect on the vertical white line. In practice, for homing onto a radio signal, the loop was set athwartships to the aircraft and the pilot steered a course which would keep the needles at the point of intersection. Two levels of meter sensitivity are provided by S2; too sharp a reaction to change of course put a strain on the pilot. The switch operates in conjunction with R23, which controls a special limiting circuit employing the other diode section of V8. This forms, in effect, an a.g.c. circuit with variable delay and when set correctly the meter needles will stay within scale limits during changes of up to 80db in the received signals. Note that it would have been possible for the pilot to steer a course 180° away from that desired, but this could be checked very simply by slight changes of course from time to time and the observation of how this affected the two meter needles. So long as a momentary swing to the left caused the needles to drop to the right all was well; otherwise a very embarrassing situation might develop! Initial matching of the needle movement is obtained by switching to BALANCE, in which the loop is replaced by a dummy which picks up zero signal. Control R51 is then used to make the needles intersect on the centre white line.

For aural d.f. "figure of eight" is selected, the master

switch bringing in the loop antenna as for visual, disabling the blocking oscillator and changing the gain control to manual. A radio station of known position will already have been tuned in on the OMNI mode. When the aircraft is on course the signal pick-up by the loop will be at minimum, and the pilot simply had to steer for zero sound in his earphones. Once again a 180 degrees error was possible, to avoid which the sense switch S3 was provided. When held to the left or right position the appropriate screen grid of either V1 or V2 receives its operating voltage, thus adding or subtracting fixed antenna signals to or from those of the loop. From the resulting changes in the a.f. level the correct course may be deduced.

The R1155 in the Home

An R1155 in good order is capable of giving very satisfactory results for s.w.l.s who do not regard the upper limit of 18.5MHz as a serious drawback. It is reasonably sensitive, has a good tuning system, and is stable in operation. The performance may not appear to match modern receivers from purely the specification point of view, but in practice it will be found to be much more agreeable in use than many of the little imported wonder boxes. It is sometimes said (and by people who ought to know better!) that valves are a thing of the past, they run too hot in service, they are not so reliable as transistors, etc. etc.—I would gently reply that there are many R1155s still working with original valves over 40 years old. Show me a transistor of that age and we'll start talking about reliability!

In the next part of this article we will look at the modifications that are needed to make the R1155 usable in the home (surprisingly modest), some preventative "medicine" and general servicing, including alignment.

Kindly Note

PW Teme-4—February 1985

In the Components List for Module 5, the Power Supply, the 4700 μ F capacitor should be identified as C1.

PW Triambic Keyer—February 1985

In the circuit diagram, Fig. 1, R19 should be 47k Ω . Also Tr1 should be a BC108.

In the Components List the 47k Ω resistor marked R17 should read R19.

multiple choice... multiple choice... ANSWERS multiple choice... multiple choice...

Are you cheating? If you are reading this page before page 24 then you are. Please turn to page 24 for the questions.

Question 2. Answer-d.

Clause 9 (2) of the Amateur Licence states:

"The callsign, which may be sent either by Morse telegraphy at a speed not greater than 20 words per minute or by telephony, shall be sent for identification purposes at the beginning and at the end of each period of sending and whenever the frequency is changed."

Question 15. Answer-a.

For maximum clarity the audio response should be restricted to between 300Hz and 3kHz. Modulating any frequencies below about 300Hz

- takes up a lot of energy.
- does not improve intelligibility.
- introduces the risk of mains hum.

Question 5. Answer-c.

A low-pass filter with a cut-off at about 30MHz will attenuate any harmonics produced in the transmitter which come above that frequency, for example the second harmonic of 28MHz.

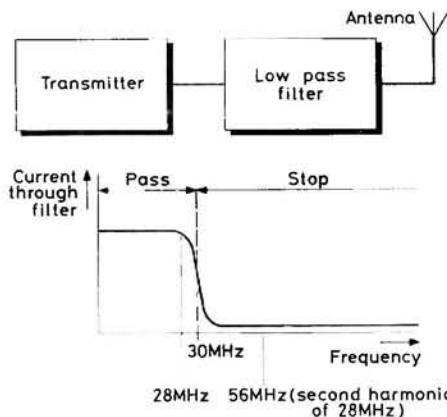

Question 17. Answer-a.

Part of Clause 9 of the Amateur Licence states:

"when the station is used . . . at the temporary location or as a pedestrian the suffix 'P' should be added to the callsign."



FOR RELIABLE AFTER SALES SERVICE

AMATEUR RADIO EXCHANGE LTD

LONDON: 373 UXBRIDGE ROAD, ACTON,
LONDON W3 9RH.
Tel: 01-992 5765/6

&

NORTHERN: 38 BRIDGE STREET, EARLSTOWN,
NEWTON LE WILLOWS, MERSEYSIDE WA12 9BA.
Tel: 092 52 29881

ON THE AIR

AMATEUR BANDS

Reports to: Eric Dowdeswell G4AR, 57 The Kingsway, Ewell Village, Epsom, Surrey KT17 1NA.
Logs by bands in alphabetical order.

It is very noticeable from the letters I get from readers that a lot of s.w.l.s do not take advantage of the very many antenna designs that are available to get the best possible signal into their receivers. Most receivers today can be classed as expensive and it does seem silly to spoil their potential by just sticking the end of a wire antenna into the antenna socket and hoping for the best. The sets' manuals usually stress the importance of using the correct antenna for best performance.

Most receivers are designed to have an input impedance of 50 ohms and only an antenna which is an odd number of quarter wavelengths long will meet this requirement. If, for example, the antenna is 20m long it will be a quarter wave long on the 3-5MHz (80m) band a good match to the receiver. For best results this antenna should be vertical, but in practice it would probably be partly vertical and partly horizontal, Fig. 1.

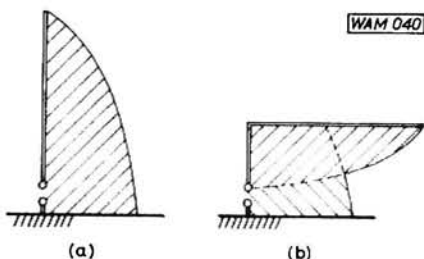

Fig. 1: (a) Current distribution on an antenna a quarter wavelength long, the "dipole" being made up by the reflection of the antenna in the ground. The feed point is low impedance. (b) The likely antenna configuration in practice for the I.f. bands

If the receiver is now switched to, say, the 7MHz (40m) band the input impedance is very high from the antenna and a very bad match indeed to the receiver's low input resistance. On the little used 10MHz band the antenna will be three-quarter wavelengths long and a rough match but on all the other h.f. bands it will be a bad mismatch. The easiest way of overcoming this problem is to feed the antenna into an antenna tuning unit (a.t.u.) which will match the long wire into the low impedance of the receiver at any frequency within its range. Such a.t.u.s are widely available now or one can be constructed quite easily, Fig. 2. Just juggle the tuning capacitor, with

the band switch on the appropriate band, for maximum signal strength. This unit will work with almost any length of wire but 10m or a multiple are to be recommended.

Matching is very important in many applications. In the case of antennas it means the impedance (a.c. resistance if you like) of the antenna at the particular frequency in use must match the feeder impedance and the feeder must match the input impedance of the receiver if the maximum transfer of signal is to be ob-

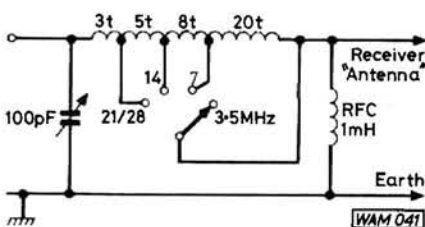

Fig. 2: Circuit for a typical a.t.u. for a long wire antenna. The wire size is not critical. The winding is 50mm long on a 38mm dia former

tained. The simple dipole has an impedance at the centre of about 72 ohms which matches the common 75 ohm coaxial feeder and is not a bad match into the receiver. However, if the dipole is now used at a multiple of the frequency the centre impedance is very high, several thousands of ohms, and a bad mismatch results between the antenna and the feeder. It should be noted that an a.t.u. at the bottom of the coaxial feeder can NOT do anything to rectify the mismatch at the top.

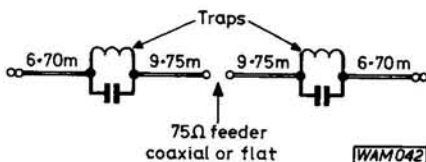

Fig. 3: Trapped dipole for 3-5 to 30MHz. The traps are encapsulated units tuned to approximately 7-2MHz. The wire lengths are a rough guide, depending upon the make of trap. Feeder used with this design should be 75 ohms impedance



by Eric Dowdeswell G4AR

One of the best multi-band antennas that does not require an a.t.u. is the trapped dipole design, Fig. 3, where a parallel tuned circuit tuned to approximately 7-2MHz, with the correct length of end wires, will work well on all bands from 3-5 to 30MHz, presenting the necessary low impedance to the receiver on all bands. Such 7MHz traps are widely advertised and supplied with details of the correct wire lengths required. If space is really restricted then half of Fig. 3 can be used as in Fig. 4. On the 3-5MHz (80m) band the impedance of the antenna will be nearer 35 ohms, so 50 ohm feeder may be better. Like most multiband antennas this antenna is a good compromise but is certainly better than a random length of wire.

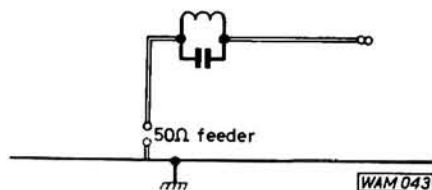

Fig. 4: In restricted spaces half a trapped dipole will still work on all bands but the feeder ought to be 50 ohms

General

A reminder from the RSGB's Council Letter that the next RAE dates are Monday March 18 and Monday May 13, the respective national closing dates being January 15, already past, and February 15 but these dates should be checked with the local exam centre. There are 400 recognised centres with the RSGB organising one in central London and another in Derby. Application forms for these two centres, available from the RSGB's Membership Services Department, with completed forms in by Friday February 15.

ON THE AIR

A bit more info on the research ship *Discovery's* trip to the Antarctic. The ops will be GW4SBB, GW4JAD and GW3RNP with s.s.b., c.w. and possibly RTTY in the 14 and 21MHz bands. UK contacts can be expected on 14-023 and 14-123MHz for c.w. and s.s.b. respectively between 1800 and 2000Z. The rig is an FT-102 with FT-77 back-up rig and dipoles for each band. All this courtesy the *RSGB Council Letter*.

DX Bands

I have received the results of the Cray Valley RS SWL Contest 1984. In the c.w. single-operator section **Donald Piccirillo BRS52868** was placed first with 83 740 points. **John Goodrick BRS44395** was second and **Dick Stanbridge BRS31879** was third. In the telephony single-operator contest **Frans Van Costenbrugge NL4483** in Holland was first with 49 067 points. Some well-known names from this column were placed in the telephony multi-operator section, namely **David Whittaker** and **Arthur Miller** were the certificate winners with **Marcus** and **Dominic Walden** as runners-up. Congrats to all concerned.

David Richardson of Oadby, Leics, has an FRG-7 and two wire antennas 75m and 20m long, and no a.t.u. yet although promised. Only catch on the otherwise dead 28MHz band was J28EG but on 21MHz he logged A4XYH, J37AH, KP4BZ, VP2EC (QSL N5AU), 5N24SHE and, on 14MHz, only DX of note were DU9RG, VU2GI and 9M2ADO. Finally on 3.5MHz OY5J and the highly suspect ZA1RT with QSLs to Radio Tirana, Tirana, Albania, but personally I'd not waste the time and postage in sending a card!

After a break of some 18 months a long letter from **Jon Kempster BRS45205**, late of Tring but now residing in Islington, London N4. His studies resulted in no less than 12 "O" levels so it was all worthwhile. Now in the technical side of the theatre business he is on a course only to find that one of his instructors is a G8 and an ex-government radio op, so he looks set fair as far as the Morse code is concerned. The rig now is a Trio R-1000 with Mizuho KX3 a.t.u. and indoor dipole for 21MHz, only to find that activity on that band is very much on the wane now. Regular logs once again are promised.

Brian Adams G4RFV writes to say that he is the QSL manager for VP8VK

and will also be taking over from GM3ITN as manager for VP8NX and VP8HZ. Brian has found the bands fairly quiet but did manage to catch VP8JC, A71BK, PY0FF and 9K2JF on the 14MHz band with just A61AA worthy of note on 21MHz.

Tim Wilson of Douglas IOM writes in for the first time and says he uses the receive side of an FT-757GX transceiver and a 20m-long wire antenna. He queries VK9ZA heard on 3.795MHz, a strong, clear signal calling CQ several times but seemingly without any takers. This should be Willis Island and according to Tim the op said "it will be dawn here in 10 minutes" which tied up quite well with calculations. Info on this station would be appreciated.

A rather short log this month from **Melvyn Dunn BRS86500**, residing in Grimsby, due to studies. He is hoping to replace his current Realistic DX160 receiver by the Uniden CR2021, plus a Datong active antenna. At the moment the antenna in use is a 40m-long wire. However, I would prefer the long wire myself especially if an a.t.u. were added. Sole station of note on 21MHz was N4JTU/SV and on 14MHz it was JY4MB. Goodies around the top end of the 3.5MHz band were FH4AA, J37AH with cards to W2HK, and VU2GO.

A 40m-long end-fed wire is also preferred by **Bob Parsey** in New Malden, Surrey and it's 5m high, feeding into an FRG-7700. What, no a.t.u.? On Top Band he caught HV2VO (QSL to I2BBJ), and down to 3.5MHz and CE8ABF for a fine one, HH2MC, HZ1AB (QSL K8PYD), J37AH, PY6WO, T77V, VP2MR (QSL W5STI), ZB2HM, 6Y5IC. He found HV2VO again, on 7MHz, plus 5N8BAV. Sole representative worth mentioning on 14MHz was KL7H (QSL W3HKN), on to 21MHz and TG9NX (QSL N4FKZ) and XT2BR (QSL POB 116 Ougadougou, Volta).

First log from **Pete Flower** in Bassut Gottechain, Belgium, is most welcome. He manages to get on the receiver for a couple of hours each morning and evening. He has a 23m-long wire feeding into a French TR6AS receiver of 1971 vintage, he says. He started s.w.l.ing some 30 years ago but let it lapse seven years ago owing to illness, so he's beginning again. On 21MHz it was just 9L1YL/EL2, a YL Sandra, with cards to POB992, Freetown, Sierra Leone. On to the 3.5MHz band for CO2HQ, F9KP, Americans KJ3R and KQ5E, YV5DDF and 3A2EE in Andorra.

Owing to a dearth of reports for the QRP Corner section I am including a report from **Phil Dykes G4XYX** under DX. Actually Phil, of Poole, Dorset, has had little luck on QRP on the 28MHz

band, with a few EAs, Is, and a "handful" of Ws, all weak with deep QSB. He has been concentrating on c.w. operation lately and managed SP8PFI, with 3W input, all with a low dipole only about 3m high. A better antenna is promised soon.

Reports for this feature are welcomed from licensed amateurs as well as s.w.l.s, as are photographs of shacks, etc., preferably clear, sharp photographs.

VHF Forum

Following on from last month's discourse on v.h.f. and u.h.f. gear we come to signal amplifiers. Assuming that everything has been done to get the best possible antenna in the circumstances, the signal amplifier should be placed in a weatherproof box at the top of the mast between the antenna connections and the coaxial cable feeder. Such amplifiers incorporate a receive/transmit switch or relay, often in an evacuated glass tube filled with an inert gas to prevent sparking at the contacts and reduce contact wear.

A pair of wires is run down to the shack and a nominal 12V d.c. supply to activate the relay on transmit, often via the p.t.t. (press-to-talk) switch on the microphone. As the output power on transmit may be up to around 400W the relay must be able to handle this power. As an alternative to this so-called "hard switching" the relay can be operated by sensing the r.f. from the transmitter. In practice the relay will operate at r.f. levels of only a few milliwatts.

The gain of a typical signal amplifier will be of the order of 14dB, or five times in terms of voltage amplification. However, the most important characteristic is the noise figure which, in a good amplifier, may be 1dB or even 0.8dB. To explain, the signal-to-noise ratio is the relation of the signal power to the noise power at the input of an amplifier. The noise figure expresses the ratio between the signal-to-noise ratio at the input and that at the output, usually given in decibels. For example, an n.f. of 6dB shows a s/n power ratio of four times.

Probably the most popular masthead pre-amplifiers are the Microwave Modules MMA144V at around £35, the muTek SBLA144e at about £90 and the muTek GFBA144e costing almost £140. Since all pre-amplifiers can be overloaded by strong local signals, provision to switch them in or out of circuit is usually made. Pre-amplifiers incorporated in linear amplifiers in the shack generally have this facility also.

It is possible to buy kits for simple v.h.f. or u.h.f. amplifiers that are brought into circuit only on receive, with suitable



FOR ALL MAKES OF AMATEUR RADIO EQUIPMENT

LONDON: 373 UXBRIDGE ROAD, ACTON,
LONDON W3 9RH
Tel: 01-992 5765/6



NORTHERN: 38 BRIDGE STREET, EARLSTOWN,
NEWTON LE WILLOWS, MERSEYSIDE WA12 9BA.
Tel: 092 52 29881

ON THE AIR

switching and these can be incorporated in the receiver or transceiver. One such kit is the muTek SLNA145b, although hardly a kit because it is sold as a complete p.c.b. ready wired and pre-tuned, but it does involve removing a couple of components from the Yaesu FT-209R 144MHz transceiver for which it is designed, the board sitting in the space provided by these components. It might also be worth while looking at the Wood & Douglas catalogue at their range of pre-amp kits.

Increased signal levels and an improved noise figure are the result of fitting this particular pre-amplifier which retails at around £27. Generally speaking, amateurs who have modified their FT-209Rs with this pre amp are well satisfied with the results.

It is reported that the Norwegian authorities have issued experimental permits to 25 LA stations for operation on the 50MHz band outside TV hours. With the closedown of Band I TV in LA, a permanent allocation in this band is an-

anticipated as it is in the UK, where 100 50MHz operating permits have now been issued for work outside TV hours. By now all Band I TV in the UK should have ceased operating.

Yours truly has become very interested in Oscar 10 work and recently I worked a WA6 station in southern California on c.w. via Oscar 10 using only 1W output from an FT-790R into an 18-element Parabeam for the uplink and an FT-480R and 9-element Tonna on the downlink, both antennas being horizontal. Next step is the acquisition of a 50W linear for 430MHz and then means of elevating the antennas up to about 55 degrees in order to get maximum use from the satellite.

Don't forget that doubling the sensitivity of a receiver roughly doubles the area from which signals can be picked up in the optimum direction so every effort must be made to avoid losses between the antenna itself and the input terminal of the receiver. Use good-quality coaxial cable like the Pope H100 and "N"-type connectors in preference to the old favourite PL259/SO259 combination, especially at 430MHz.

The 144MHz band came to life on December 10/11 with a classical weather pattern of a high pressure area over the

Continent moving east and a low pressure area moving in from the west. Several stations from central France, BF, BG and BH squares, provided plenty of QSOs with G, GI, EI and GM. Nearer German stations were active while G4FDX/LX in CJ square gave many stations their first LX QSO, using 100W to a 17-element Yagi. Ian provided a good example of how to work DX at such a time, keeping QSOs short and only giving full info on his working conditions every few minutes instead of every contact. It was, as usual, occasionally spoiled by stations seemingly wanting to convey their life history to Ian!

On December 11 conditions remained quite good with LX1GR coming in for a short time, plus a number of DLs. It was very interesting to watch the weather maps on TV and to note conditions changing as the high pressure area moved away. Met man Jim Bacon (G3YLA) on BBC TV, even mentioned that conditions would be good for radio amateurs on v.h.f. and that QRM could be expected on TV pictures from Continental TV stations. Unfortunately I was unable to monitor the 430MHz band but many 144MHz stations were QSYing to that band for QSOs with a European stations.

MW BROADCAST BAND DX

Reports to: Charles Molloy G8BUS, 132 Segars Lane, Southport PR8 3JG.

"In your column you have stated that a loop antenna is not necessary for local radio DXing and that daytime is the best period. I find both these statements arguable", writes **Stewart R. Hinsley** of Coventry. Our reader does most of his m.w. DXing with a Sony ICF-7600D, using this receiver's internal ferrite rod antenna, "due to its controlled directivity and push button tuning". Well, I stick to what I said, though it is rather dangerous to generalise about any aspect of DXing. Perhaps if I expand a little, it might make thing clearer.

Local Radio DXing by Day

By "local" we are thinking of local radio stations, usually low power, scattered across the UK. During the day any DX heard will be by the ground wave, which travels outwards from the transmitter, close to the surface of the earth. Signals become weaker the farther they go, just because they are being spread over a larger area. They are also absorbed by the terrain over which they travel. You will get better reception over the sea than over land since the signal is attenuated less as it passes over water.

There is no sky wave during the day because of absorption in the D layer of the ionosphere. This means that there will be no fading! We are trying to pick up weak but steady DX signals and providing co-channel interference is not too bad, we will do better with a random

wire than with a loop and better with a loop than with an internal ferrite rod antenna. The random wire will pull in weaker signals than the loop and in turn, the loop will pick up weaker DX than the ferrite rod.

The DXer's medium wave loop, although a useful tool, is not the answer to every problem. During the daytime we are less likely to overload the receiver with strong signals than after dark. The band is much quieter during the day. In the United States, DXers on the west coast have organised DX-peditions into sparsely populated areas where, with Beverage antennas, laid temporarily on the ground, they have picked up low power locals on the east coast, during the day. Since a Beverage will be a mile or so long it is unlikely that many of us will be able to use this type of antenna, but even a short random wire connected to a domestic portable will pull in additional DX during the day. Next time we will have a look at local radio DXing after dark.

RADIO ZDK		
Licensee Radio Call	1000 Watts	74 2110
P.R. No. 2100	1100 K.F. A.M.	2110
No. Antennas	900 Mhz 3 M.	Callio Geneva
		Antenna
Service: The Eastern Ltd		
Thank you for your previous report of		

ZDK Radio QSL card



by Charles Molloy G8BUS

Turntables

"I was interested to read in the May issue of *Practical Wireless* about the 'rotatable plastic cake stand' for your Vega portable, this is a simple easy way to turn the whole set", observes **Jack Thomas** from Axminster who goes on to say.

"In my case for 18 years I have been using a 'turntable' as fitted to Roberts radios and purchased from them. It is only 90mm in diameter, on it I screwed a piece of plywood 150 x 100 x 3mm. This has supported a Schaub Lorenz International weighing 6kg, then a Panasonic DR28 (3½kg) and for the past 3½ years a Grundig Satellit 1400 weighing 5½kg. It still rotates as when new although my portables have been rather heavy." It is worth the effort making or adapting a turntable for use with a portable receiver. It is a lot easier to null out offending QRM when the receiver is on a turntable. I used a cakestand but it should be possible to make one out of an old record player instead.

ON THE AIR

Above 1.4MHz

Reader **J. Ratcliffe** of Southport in Australia refers to reception at the h.f. end of the medium waves where, it is claimed, propagation by means of the F layer becomes apparent. "There is one other factor—the increased sensitivity of the receiver at this end of the band due to the improved LC ratio of the tuned circuit at the input of the receiver, compared with the ratio at 600kHz." A higher voltage is developed across the tuned circuit as the ratio of inductance to capacitance (L to C) is increased.

"Given a standard inductor to cover the m.w. band we normally require a tuning capacitor of 350-400pF. At approx 600kHz the capacitor is set around 400pF, at 1.5MHz it is reduced to less than 50pF and therefore the gain of the LC circuit is improved six times." John then goes on to describe an experiment using a constant output signal generator coupled to a field loop and a receiver located some 100m away. "We found the signal at 1.5MHz to be nearly 400 per cent greater than it was at 600kHz."

Yes, this effect is well known and in order to counter it set designers used to wind extra turns on the antenna coupling winding of the input coil so that it resonated around 500kHz with a "standard antenna" connected to it, thus giving a boost to sensitivity at the l.f. end of the medium waves. The sensitivity of a well designed and adjusted receiver should be constant, more or less, right across the band but I have noticed, when adjusting a multi-band set that a station in an overlap section is sometime stronger on the band where it appears at the h.f. end.

If you have a set, like the DX160 for example, which has band C covering 1.55 to 4.5MHz try comparing the strength of a m.w. station around 1.550MHz on the two bands. It may be louder on band B. The effect is sometimes

noticed on the short waves so it is usually better, if there is a choice, to pick up a station at the h.f. end of a band.

WQXR

Dear WQXR Listener:

Thank you for writing to us. It's always a pleasure to welcome a newcomer to the WQXR listening audience.

We appreciate the interest you are taking in our station, and hope the enclosed fact sheet will answer your questions about the WQXR AM-FM operation.

Walter Neiman

Walter Neiman
Vice President,

1560 AM 98.3 FM

WQXR QSL card, New York City, heard on 1560kHz

Readers' Letters

"I have the impression that the amount of DX receivable is decreasing" says Stewart Hinsley who mentions that in the 1960s and even ten years ago, there were many reports of North American DX, with loggings of West Coast USA and Asiatic DX. We have not yet reached the trough of the current rather strange sunspot cycle so it is too early yet to say if this suggestion is correct. Personally I do not believe there is less DX but QRM is certainly worse than it was due to the number of local radio stations in the UK and elsewhere, so DXing will be more difficult, but there are of course the DX slots I referred to last time and these are unchanged. Has anyone any ideas on the subject?

DX Heard

From Belfast comes a note from DXer **Bill Kelly** who has picked up, after midnight, CJYQ St John's in Newfoundland on 930kHz, WBAL in Baltimore on 1090kHz, WCAU in Philadelphia on 1210, WHN New York City on 1050 and the Caribbean Beacon in Anguilla, with religious programming in English on 1610, plus an unidentified US station on

840kHz. This would be WHAS in Louisville, Kentucky which is occasionally heard in the UK. The receiver is an NRD515 with a 20 metre random wire.

Recent items from my own log, heard before midnight, are Tenerife in the Canary Islands on 621kHz in Spanish, Ougadougou in Upper Volta on 747 with French and local languages, Radio Dakar in Senegal on 765kHz in French, Radio Algiers in Arabic on 891, Radio Vision in Caracas, Venezuela on 950, ZDK Antigua on 1100, Radio Caribbean in Dominica on 1210, Radio Globo in Rio de Janeiro, Brasil on 1220, WMRE Boston on 1510, WQXR New York City on 1560. The receiver is a DX160 used with a m.w. loop. Radio Vision on 950 is a consistent signal after 2300 and could easily be mistaken for Spain instead of Venezuela.



Hereward Radio leaflet

On the domestic front, an incredible log of 74 UK stations comes from Stewart Hinsley (Coventry) who used an ICF-7600D with internal antenna. First time loggings were Guernsey on 1161, Jersey on 1026, Norwich (IBA) 1152, Enniskillen (Radio 4) 774, Hull (IBA) 1161, Blackburn 885, Ipswich 1170, Chelmsford (IBA) 1359, Bournemouth 1359, Cardiff (IBA) 1359, Redruth (Radio 4) 756, Ayr (IBA) 1035, Aberdeen (IBA) 1035, Bill Kelly picked up Invicta Sound Canterbury on 603kHz and 1242kHz and Radio Cornwall on 1152, this time using a Grundig Satellit 600 receiver.

SW BROADCAST BANDS

Reports: as for Medium Wave DX, but please keep separate.

"Do all Voice of America programmes come from the same transmitting site?" asks reader **Steve Wilkins** of Staines. No they don't. The VOA uses 18 different sites located in the USA, Thailand, Botswana, Ascension Island, Antigua, Greece, Liberia, West Germany, Philippines, Sri Lanka, Morocco, UK, Brasil, according to the International Listening Guide. Only the programme comes from the United States! Other major broadcasters such as the BBC, Deutsche Welle, Japan, Moscow, Netherlands, Canada make use of relay stations. Even Spanish Foreign Radio has a relay in the Canary

Islands, Fortunately few of the broadcasts listed above can be called DX and in any event several of these stations either do not QSL at all or do so with limitations. Radio Canada International for example will only QSL once a year.

Relay Stations

Why do stations use relays? By getting close to the target area they can be sure of putting in a good signal at the peak listening hour which is usually in the evening local time. To the DXer, relays are a menace as he has little idea which



by Charles Molloy G8BUS

country he is listening to. For the short wave programme listener, relays are a boon as they provide reception of programmes from parts of the world that would otherwise be difficult to pick up regularly at programme value.

Practical Wireless, March 1985

RADIO SHACK FOR EVERYTHING IN AMATEUR RADIO

SPECIFICATIONS

Frequency range:
 66-88 MHz Low Band
 138-144 MHz Extended VHF Range
 144-148 MHz 2-Meter Amateur
 148-174 MHz High Band
 406-420 MHz Extended UHF Range
 420-450 MHz 70-cm Amateur
 450-470 MHz UHF Band
 470-512 MHz UHF 'T' Band

Size: 9" W x 3" H x 9 1/2" D

Weight: 3 lbs.

Power Requirements: 12V DC

Audio Output: 800 Milliwatts RMS

Antenna: Telescoping (supplied)

Sensitivity: 1.0µV for 12 dB SINAD

Scan Rate: Selectable, 5 or 15 channels per second

Connectors: External speaker card edge connector (optional accessory Model No. WH-1)

Performance and Value. Bearcat® 200FB

16 channels. Program 16 frequencies for automatic scanning in any combination of bands and frequencies.

Patented Track Tuning. Electro-patented feature allows scanner to peak on each transmission automatically for optimum reception.

2 banks. Activate or lockout groups of channels quickly. Scan channels 1-10, 11-16, or both.

Priority. Lets you sample a designated frequency, on Channel 1, every two seconds to prevent missing important calls.

On/Off Volume. Power switch and continuously variable volume.

Automatic squelch control. Factory set for easier operation or manually adjust to block out unwanted noise.

Dual scan speed. Scan at either 5 or 15 channels each second.

▼/Limit key. Sets lower and upper frequency limits for Automatic Search. Also used to "step down" through frequencies in Manual Search.

Automatic lockout. By pass any channel not of current interest for faster scanning cycle.

Patented Selective Scan Delay. Adds a two-second delay on desired channels to prevent missing transmissions when "calls" and "answers" are on the same frequency.

▲/Hold key. Stops searching action to hold on frequency of interest. Also used to "step up" through frequencies in Manual Search.

Single Antenna. Single telescopic antenna provides optimized reception without the need for long low band antenna.

Crystal-free. Program thousands of frequencies with pushbutton ease and without a single crystal needed.

Decimal display. Bright vacuum fluorescent display shows frequency being received.

One piece keyboard. Sealed keyboard with "key locator" ridges for positive, easy operation.

8 band coverage. Includes Low, High, UHF and UHF-'T' bands, 2 metre and 70-centimetre Amateur ("ham") bands, extended Land-Mobile bands.

Direct channel access. Go directly to any channel, without stepping through other channels.

Automatic search. Seek and find new active frequencies automatically between frequency limits you select.

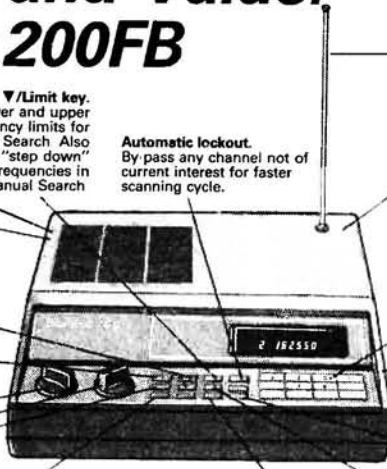

£199.95 Securicor Delivery £6.90



RADIO SHACK LTD

188 BROADHURST GARDENS,
LONDON NW6 3AY

(Just around the corner from West Hampstead Station on the Jubilee Line)
 Giro Account No. 588 7151 Telephone 01-624 7174 Telex: 23718



TV-DX

EQUIPMENT - PROFESSIONAL ADVICE . . .

Our 1985 catalogue includes everything you need to start an exciting new hobby from a suitable television to aerials, rotators, converters, amplifiers and accessories.

ONLY 60p

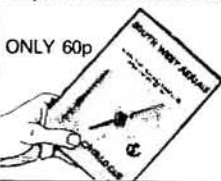

Examples from our range.

WOLSEY HG36 'Quicksilver' Grouped UHF Aerial, 18dB High Gain; (1/2 ratio 28dB average (state group required A, B or C/D)) **£24.70**

WOLSEY 'Quantum' 300 30dB High Gain Grouped UHF Masthead Amplifier, (state group required A, B or C/D) **£17.58**

WOLSEY 002 24 volt Matching Power Supply Unit for above Amplifier **£13.25**

TRAX MTH13 Wideband Band 3 Aerial with twin reflector, 11.9dB gain very rugged construction **£26.80**

TRAX 4000/3LN Wideband Band 3 Masthead Amplifier, 22dB gain with a low Noise figure of only 2.3dB **£25.80**

TRAX 601/68 Power Supply Unit for above Amplifier **£11.75**

UNISON AR250 Rotator complete with Control Console (uses 3 core cable) **£62.25**

(Alignment Bearing available for above to increase head loading)
 Also available Black & White and Colour Multi-Standard VHF/UHF Televisions and Video Recorders (SAE or ring stamping requirement)
 We are **THE DXing Specialists**, advice given on ALL reception problems (ISAE please)

*All prices inclusive of VAT and Carriage
 Delivery 7-10 days
 Access & Visa welcome*

SOUTH WEST AERIALS (PW)

11 Kent Road, Parkstone, Poole, Dorset BH12 2EH
 Tel: 0202 738232



ANTENNA TUNER

ONLY £25.20. for outside or INDOOR antennas, end-fed LONG WIRES or dipoles, 0.1-30MHz, BOOST DX and reduce interference, ideal for FRG7700 etc, or 10W tx, BANDPASS design (not just usual low-pass) with expensive air dielectric capacitor, also adapts to WAVEMETER, field strength meter etc, see Dec 1984 P.W. page 65.

RARE DX UNDER QRM? DIG it OUT with a Tunable Audio Notch Filter, between your receiver and speaker, tunes 350-5000Hz, BOOST your DX/QRM ratio, 40dB notch, £17.40, hear WEAK DX, see Dec 1984 P.W. page 69.

EXPLORE V.L.F., 10-150KHz Receiver £23.20.

Each fun-to-build kit includes ALL parts, case, pre-wound coils, instructions, by-return postage etc and list of other kits.

CAMBRIDGE KITS

45 (PQ) Old School Lane, Milton, Cambridge.

FREQUENCY COUNTERS

HIGH PERFORMANCE
 HIGH RELIABILITY
 LOW COST

EX-STOCK
 DELIVERY

The brand new Meteor series of 8-digit Frequency Counters offer the lowest cost professional performance available anywhere.

- * Measuring typically 2Hz - 1.2GHz
- * Sensitivity < 50mV at 1GHz
- * Setability 0.5ppm
- * High Accuracy
- * 3 Gate Times
- * Low Pass Filter
- * Battery or Mains
- * Factory Calibrated
- * 1-Year Guarantee
- * 0.5" easy to read L.E.D. Display

PRICES (Inc. adaptor/charger, P & P and VAT)

METEOR 100	(100MHz)	£116.72
METEOR 600	(600MHz)	£147.77
METEOR 1000	(1GHz)	£204.12

NOW AVAILABLE WITH
T.C.X.O. OPTION

Illustrated colour brochure with technical specification and prices available on request.

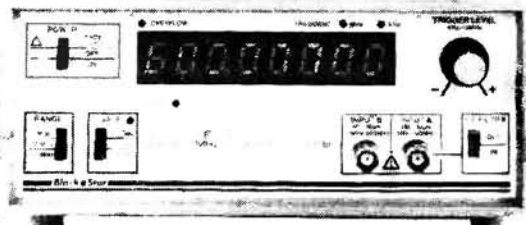

Designed and manufactured in Britain.

Black★Star

BLACK STAR LTD (DEPT. P.W.), 4 Stephenson Road, St. Ives, Huntingdon, Cambs. PE17 4EB, England.
 Tel: (0480) 62440 Telex: 32339

ON THE AIR

Stereo in the Short Waves

NDXE, World Service Broadcasting Corporations' stereo high frequency a.m. station will begin broadcasting from Opelika in Alabama, USA in 1985. NDXE is the callsign, as the prefix N is allocated to the USA as well as W and K which are usually used by broadcasters. According to their press release, NDXE plans for stereo transmissions on worldwide short wave broadcasts on the international bands 6-20MHz. "NDXE Stereo will hopefully be able to make available to listeners through arrangements with commercial sponsors, stereo high frequency radios at a very low cost to the consumer."

Personally I am sceptical, at least in the short term, as it would be quite an achievement at the moment to provide good quality mono transmissions. Single sideband (s.s.b.) is coming in gradually though and presumably this will be the vehicle for stereo. The address of NDXE, when it comes on the air, mono or stereo, will be Box 569, Opelika, Alabama, USA, 36801.

On the Bands

Radibras in Brasil is mentioned by Nigel Coote (G1KEW) who picked it up with a good signal on 15.270MHz at 1800. Nigel, who lives at Stockport in Cheshire, uses a DX302 receiver along with a random wire antenna. "The 15MHz band (19m) seems to be the place to be at the present if you want an evening of round the world entertainment in English—Voice of America, WYFR, Radio Canada, Spanish Foreign Radio, AFRTS to mention a few."

Reader Ingvar Berggren of Ljungbyhed in Sweden uses a 36-year-old home-made receiver along with a Windom antenna constructed out of plastic-covered wire intended for use with electric fences. DX pulled in with this rig included Radio Surinam on 17.755MHz at 1730 in Dutch, Radio Sri Lanka on 11.800 in English, WINB on 17.730 in English before 1745, Libya on 15.450 at 1715 in English. "The October PW asks if the 21

months wait for a QSL from Radio Nigeria is a record. I sent a report to Radio Luxembourg on 15 November 1980 and didn't receive a QSL card until 15 October 1982." Can anyone beat this?

Tom Hambley of Hove has a Selena B210 "which, although not in the top rank of s.w. receivers is very good." When used with an indoor antenna and home-brew a.t.u. his set pulled in the Voice of Greece on 9.815 and 11.640 at 1540, Vienna on 11.660 at 1830, "Red Lion" USA (WINB) on 15.185 at 2130, United Nations 17.730 at 2110, Radio Australia 11.910 at 0600, Radio Algiers 17.740 at 2110. In reply to Jan Nieuwanhuis (Netherlands). Thanks for writing OM, but I would prefer items from your own log. Information from other sources goes out of date sooner.

A Sony ICF-2001 was used with its telescopic antenna by Paul Price (Merthyr Tydfil) to pull in Radio Australia on 6.035MHz at 1730, Radio RSA during the afternoon on 25.790 (11m band), Kuwait 11.675 at 1800, Delhi on 11.620 and 9.912 at 2000 and on 7.155 at 1530, WRNO New Orleans on 15.420 at 1800, Pakistan 15.595 at 1530, Portugal on 11.775/9.740/7.155 at 2030 and on 15.250/11.910 at 2030, Cuba 11.850 at 2010, Israel 9.835/9.920 at 1800, AFRTS 15.430 during the afternoon, Voice of Turkey 9.515/9.660 at 2200 in English, WYFR Family Radio (USA) 11.805 and 11.925 at 1900.

The Vega 206 receiver is popular with newcomers to the short waves and this set is capable of pulling in some interesting broadcasts. Reader A.H.C. Trickey of Bristol heard Cairo on the 17MHz band (16m) and Nigeria, Cuba, Greece, Madrid and RSA on the 15MHz band (19m), Delhi, Beijing, Finland, Japan on the 12MHz band (25m) and Iran, Yugoslavia, Turkey on the 9.5MHz band (31m). The scales on this receiver were until recently marked in metres. D. Haigh of Halifax uses a random wire antenna 6m above the ground and about 18m long. His log includes Family Radio, Vatican Radio and Caracas, all on the 15MHz band (19m). Our reader would like to make contact with other radio hobbyists in his area. Write to 27 Dodge Holme Gardens, Mixenden, Halifax, West Yorkshire.

EDXC Conference 1985

The 19th annual conference of the European DX Council will be held in Madrid, Spain from Friday, 24 May to Monday, 27 May, 1985.

Radio Exterior de España, who are sponsoring and hosting the conference have sent me a tentative conference agenda, hotel facility information and a registration form, with the request that the latter be returned to them by 28 February. Highlights of the four days include a visit to Radio House at Prado del Rey, a reception given by the Director of the R.E.E., a visit to a satellite station and an optional sightseeing tour, plus of course the EDXC Banquet on the Sunday evening

DXers who would like to link their hobby with a visit to the Spanish capital should write for further information to Radio Exterior de España, PO Box 156 202, 28080 Madrid, Spain. The conference will be attended by individual DXers, club leaders and station representatives from many countries outside as well as inside Europe.

Readers' Letters

Sixteen-year-old Alan McMillen of Belfast has a Sony ICF-2001 which has pulled in a good number of stations, Radio Australia for example "which I listen to every evening on 6.035MHz. I am very interested in exchanging information with other s.w.l.s in the UK," continues Alan, who invites readers to write to him at 8 Northwood Parade, Off Shore Road, Belfast N. Ireland. Why not join a DX club Alan? Send 50p in stamps to the EDXC, PO Box 4, Huntingdon, Cambs., PE17 4FE and ask for a copy of the EDXC Club list. You can then take your pick and the list does give background information to help you.

"Can you tell me where to get a b.f.o. and a.t.u. in kit form" asks reader D. Haigh. Cambridge Kits, who advertise regularly in PW can supply an a.t.u. but I don't know a source of supply for a b.f.o. Can anyone help?

SHORTWAVE SERVICE
RADIO NEW ZEALAND



Radio New Zealand QSL card for their service on 6.105 and 15.280MHz



Radio New Zealand pennant

Has New Zealand got a s.w. service to Europe and if so what frequency is it on," asks Steve Wilkins. The s.w. service from NZ has been on the point of closing down for some years now mainly because of the age of the transmitters. These are ex-WD from the last war and operate with only 7.5kW. Try 9.620 and 15.485MHz around breakfast time. The programmes are intended for reception in the Pacific but they are picked up in the UK at times usually at good strength. Has anyone heard New Zealand recently?

Practical Wireless, March 1985



Radio Prague QSL card sent in by Paul Price

VHF BANDS

Reports to: Ron Ham BRS15744, Faraday, Greyfriars, Storrington, West Sussex RH20 4HE.



"Between 1900 and 2100 on November 9 an opening occurred resembling sporadic E type propagation, which seems highly unlikely at this time of year", writes **Tony Gould G4UAM**, Norwich. He adds, "I personally heard a Spanish station on 145.5MHz and received good reports from Belgium on my 20W ATV signal and another local station also worked Austria on 144MHz s.s.b. The following morning I noticed that my car was covered in a very fine red dust which had fallen with the rain some time between 1900 and 2100 the previous evening. This sandy coloured dust was reported to have originated from the Sahara desert and I would like to extend the theory that this silicon dust was responsible for the unusual propagation conditions". A very interesting thought from Tony, who wound up his letter with the following important statement. "A rare and unusual phenomenon for those lucky enough to be in the shack at the time", which I think sums up the meaning of learning about propagation for all of us. It is observations like this one of Tony's that will always give us the chance to find out more about the unexpected side of the propagation of radio waves. (See Satellite column.)

This also applies to our Assistant Editor, **Dick Ganderton G8VFH** and his **XYL**, who were heading due west early in the evening of November 15 when, at an elevation of about 10 degrees, they saw a bright flash, unlike lightning, starting from the centre and travelling outwards in all directions, lasting about 2 seconds and followed by a slowly fading mauve/pink glow. Around the same time our Technical Editor, **John Fell G8MCP**, heard several auroral reflected signals on 144MHz, including **G8XVJ**, Warrington, calling CQ aurora, while he moved his beam heading between north and due east, without finding a peak.

"G8XVJ's signal was also subject to one brief meteor ping taking his signal to S9 + 40", said John, who told me that the event faded in Dorset some 10 minutes later when he was able to hear the Warrington signal, without distortion, via tropo and beaming north. I wonder if Dick saw a fireball break up in front of an auroral glow. There is more to come, at 1930 on this day, a near neighbour of mine, **Fred Pallant G3RNM**, reported hearing a very pronounced auroral type

flutter on the 14MHz band signal of an OH2 and seeing a short duration glow in a northerly direction. **Ron Livesey**, Glasgow, the auroral co-ordinator of the British Astronomical Association tells me that Paul O'Neil, north of Belfast, reported seeing an aurora for some hours on the night of the 15th/16th. H. A. Snip PA3BWY/MM, on a weather-ship west of Scotland, also saw the aurora and heard auroral interference on the signals of about 20 stations. "The southern hemisphere coronal hole on the sun continued its series of auroral magnetic storms which began on August 1 and repeated on the 27th and on September 23, October 18/20 and November 15/16", writes Ron, which I feel sure explains the cause of the fun during the evening of the 15th.

At 2334 on the 15th, **Roland Jeffrey G6DSA**, Winsford, received auroral signals from the 50MHz beacon GB3SIX and from GM3WOJ on 50.115MHz, 16km north of Inverness on a beam heading of 010 degrees. Up in Knutsford, **Dave Coggins** also heard tone-A signals from GM3WOJ and added GM3DOD to his log. Dave listened again around 2230 on the 16th and heard weak auroral signals on the 28MHz band and the 49.75MHz television band.

Solar

"The sun has been quiet all month", writes **Henry Hatfield** on November 17 although, using his spectrohelioscope, he observed one small spot, 5 filaments and a few quiescent prominences on the 15th which may well have contributed to the auroral manifestation mentioned earlier. "At least I have seen the sun again", writes **Patrick Moore**, Selsey, after a spell of overcast skies which are no good to any astronomer. At 1015 on the 22nd, he located two small sunspot groups, Fig. 1, which as the sun rotated, were most likely responsible for the tiny bursts of radio noise and the mild noise storm which I recorded at 143MHz between the 19th and 22nd. "On November 26, there were two spots near the CM, or maybe they were spot groups of moderate size", writes **Ted Waring**, who had difficulty in using his equipment because of the sun's angle at the time of his observation. Henry also saw them and reckons there were about 4 spots in two groups and

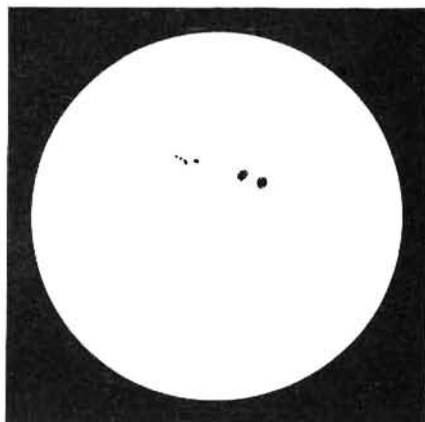
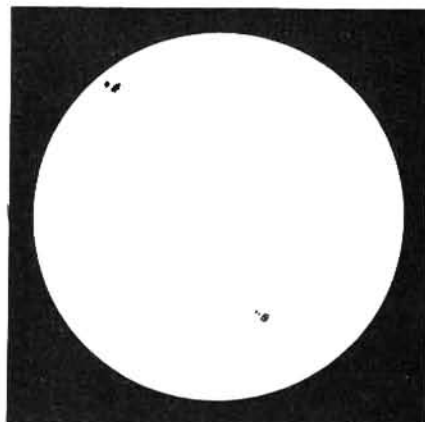

Fig. 1 (top): Sunspot drawing on the 22 November. Fig. 2: Sunspot drawing on the 26 November

Patrick, as usual, sent along a drawing, Fig. 2.

Although these groups were generally quiet and there were no prominences when Henry studied them, he did see 5 filaments which may have caused the



AMATEUR RADIO EXCHANGE LTD

THE LARGEST RETAIL OUTLET IN THE UK

LONDON: 373 UXBRIDGE ROAD, ACTON, LONDON W3 9RH. Tel: 01-992 5765/6



NORTHERN: 38 BRIDGE STREET, EARLSTOWN, NEWTON LE WILLOWS, MERSEYSIDE WA12 9BA. Tel: 092 52 29881

ON THE AIR

noise storm and small bursts of radio noise which deflected my recording pen between the 24th and 28th. They could also have been the reason why Ron Livesey's magnetometer was active on the 30th. Ted also noted a couple of spots on December 6 and both Henry and I received radio noise from the sun on the 10th and 11th. Fortunately the fog lifted in Sevenoaks during the morning of the 11th and Henry identified the cause as a double spot right bang on the central meridian.

The sun has always fascinated me and I well remember the thrill of the first burst of radio noise that I recorded on 7 May 1968 and realising that these radio waves had travelled 93 million miles and taken 8.3 minutes to reach us. Although this time and distance is a mere nothing in real astronomical terms, to us it is very important, because it has such a great influence on the propagation of radio signals around the earth. By mid-June 1984, I had completed 16 years observation of the sun with a simple radio telescope. The graph in Fig. 3 shows the number of days in each of the first 15 full years, 1969-1983, that radio noise from active areas on the sun was recorded. I can supply more precise details if any readers require it.

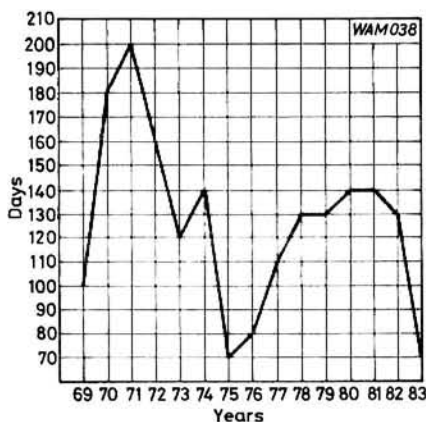

Fig. 3

Propagation Beacons

"You often say that the bands are full of surprises and you are right", said Bill Kelly, Belfast, after tuning around 27MHz at 0500 on the 23rd and finding European stations roaring in, he checked the 28MHz band and at 0600 he logged very strong signals from the German beacons DF0DTH, DK0TEN and DL0IG1. Good job you did log something Bill, because our monthly beacon chart, Fig. 4, is a bit thin and shows the general state of the 28MHz band between November 15 and December 14. This was further confirmed by Henry Hatfield on December 8, who wrote, "There is no need to send a 28MHz beacon report, I have listened every day and not heard one" and on the 7th Ted Waring said, "This is the first

WAM039

MONTH	NOVEMBER															DECEMBER														
	15	16	17	18	19	20	21	22	23	24	25	26	27	28	29	30	1	2	3	4	5	6	7	8	9	10	11	12	13	14
DF0AAB																														
DF0OTH																														
DK0TEN																														
DL0IG1																														
LA5TEN																														
ZS1CTB																														
ZS6PW																														
Z21ANB																														
3B8MS																														
5B4CY																														

Fig. 4

month since my records began in 1979 that I have not heard a beacon on the 28MHz band". "Herewith another lean month for beacons", writes John Coulter, Winchester, who logged more beacons than any of us. Dave Coggins writes, "Very few beacons audible on 28MHz". The chart in Fig. 4 was compiled using logs from Dave Coggins, John Coulter, Bill Kelly and my own log.

I hope that this period of little activity will not discourage Mike Scrivener, Sutton, who is now taking an interest in the International Beacon Project stations on the 28MHz band (see this month's free PW Databank), but I am sure he will understand that it is just as important to know that someone listened and heard nothing, as it is to log a signal. Mike uses FRG-7 and Realistic DX200 receivers and like Henry, is interested in v.h.f. propagation. Henry has built a receiver to monitor the signals of Rugby MSF on 60kHz and is waiting to see what happens to this signal when an aurora is in progress. Perhaps Mike, a member of the Longwave Club of America, has something similar in mind and I for one will be pleased to see the results.

From November 16 to December 7, the signals from the RSGB 144MHz band beacon, at Wrotham on 144.925MHz, was a steady 539 each day with me until the pressure went high on the 8th and for a few days its strength varied between 559 and 599. "GB3VHF and the Angus beacon GB3ANG were heard every day from November 15 to December 8", writes Dave Coggins, who logged GB3VHF at strengths ranging from almost inaudible to S9 and GB3ANG varied from the noise line to about S2.

"The UK 6m Group talkback frequencies for information exchanged and cross-band workings are 3.718, 28.885 and 144.185MHz", writes Roland Jeffrey G6DSA, Winsford. He told me about the new beacon in Greenland OX3VHF on 50.045MHz. This beacon, installed at the home of OX3BX, radiates 20W from a ground plane antenna. During November, Roland kept a regular listening watch on the 50MHz band and logged signals from both UK beacons GB3NHQ 50.050MHz and GB3SIX 50.020MHz at about 519 on days 1, 2, 5, 6, 7, 8, 10, 14 and 21, NHQ only on days 13, 15, 19 and 20 and SIX on 26 and 28. Meteor pings influenced the signals of NHQ on days 6 and 14 and SIX on 1 and 5.

"Both NHQ and SIX were audible every day between November 15 and December 6", writes Dave Coggins and tells me that he heard meteor pings on SIX almost daily between the 15th and 28th and on NHQ on the 15th, 16th and 28th and a good 4 seconds duration burst on the 25th.

28MHz (10m) and 50MHz (6m) Bands

Although Bill Kelly took several looks around the 28MHz band during the month prior to December 4, he found conditions abysmal and nearly always completely shut down. I logged a UA3 on c.w. working a G early on November 18 and Fred Pallant G3RNM, logged an LU at 1550 on the 22nd, a couple of EAs at 1015 on December 1 and was delighted to hear DLs calling CQ, via the 28MHz downlink of RS7, at 1054 on the 9th. Dave Coggins did a bit better, when he received signals via sporadic-E from SM4MBC on November 16, OE5ODL/M, I4UJE and YU2AAU on the 18th and EA1DIS on December 1. As usual Dave keeps a watch on the 50MHz band and between November 15 and December 6, he received c.w. signals from G3IMW, G3LTF, G3OHH, G3USF, G4HK, G4GLT, G5KW, GM3DOD, GM3WOJ and GW3LDH and s.s.b. signals from G3FDW, G3OHH, G3PWK, G3USF, G3UUT, G4HK, G4FXW, G4RXD and GW3LDH.

Tropospheric

One glance at our monthly atmospheric pressure chart, Fig. 5, compiled from the master chart on my Short and Mason Barograph, shows that the general low pressure conditions between November 16 and December 6 were not good for finding DX on any of the v.h.f. or u.h.f. bands. However, with the sharp rise to 30.5in (1032mb) on the 9th followed by a gradual fall, true to form the bands opened up. The 144MHz repeater network was full of stations from most parts of the UK and between 2000 and 2200 on the 10th, I logged, often at amazing strength, signals from Nick Peckett G4KUX, Durham, working into

ON THE AIR

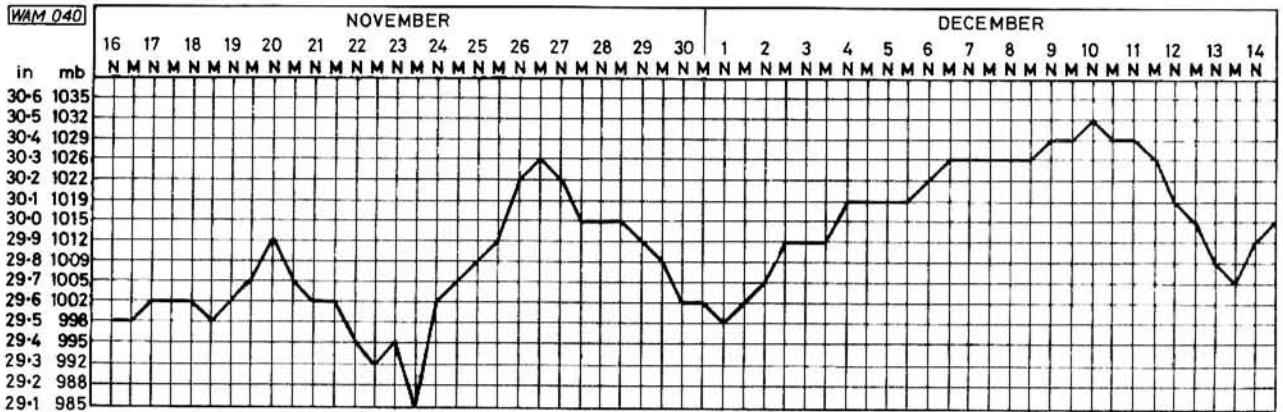

Fig. 5: Monthly atmospheric pressure chart

France, from Ken Saunders G8SFM, Leighterton, and from G4CYA, G4KUJ, GW3MFY, GW6JNE, GW6ZHH, GW8JLY and ON7TH, on 144MHz s.s.b.

This opening continued on the 11th when again the 144MHz band repeaters were packed with stations ranging from the continent to most of the UK and during my periodic checks around 144.3MHz, I logged s.s.b. signals from G8OAG in Manchester calling the Channel Islands, both sides of a QSO between GW6ZUQ and PEIWS and ON1BFG, GW3CBY on the back of my beam and PEIJA and there could have been many more if I stayed in that part of the band, but no doubt next time I will have some fine reports from readers about this spectacular event.

Band II

The generally low atmospheric pressure during the second half of November and early December was no help to DXing between 88 and 104MHz. However, there are always a few local lifts due to the complex weather patterns that cross the UK and although Bill Kelly did not log any foreign stations during the period, he did receive signals from Radios Clyde, City in Liverpool and Redrose in Lancashire, Michael O'Sullivan, Bansha, uses a JVC-T-3VL stereo tuner fed by two 9-element Yagis, some 23m a.g.l., coupled to a masthead pre amplifier and, prior to July 1984, when an Irish station came on and interfered with the signal, he received BBC Radio 3 from Divis at good strength. Michael then turned his antenna toward Wales and received an excellent Radio 3 signal from Blaenplwyf on 90.9MHz and all went well until recently

when another Irish transmitter started about 104km behind him on 91.1MHz and again he has problems with his Radio 3 listening. Unfortunately his antenna directions are limited because he has a 300m-high mountain peak just south of his QTH which, suggests Michael, would be an ideal site for a repeater. There is no easy answer to this Michael, especially in hilly areas and despite careful planning, I feel that such interference may well get worse as more and more stations use Band II. You could write to the BBC Engineering Information Department and see if they can help. If not they will then be aware that a problem exists in your area.

During a trip to Spain in late October, Edward Baker, Cramlington, Editor of the ISWL magazine, *Monitor*, using a Panasonic RF3100 and interior dipole, listed almost 30 stations that he logged between 87.7 and 107.6MHz while at Lloret De Mar. He was even more delighted when, by November 26, he had received QSL cards from Radios Blanes, Olot, Malgrat, Mediterranean, San Felive and Sintonia, plus stickers, etc. A good way of making the most of your tour Edward, perhaps other readers do the same. What about it lads and lasses, I usually find room for special reports and I know that they are of interest to the Band II enthusiasts. On the subject of stickers, John Williams, Charlton Kings, received one, Fig.6, from Signal Radio in addition to their QSL card acknowledging his report on their Band II signals.

As the atmospheric pressure reached a climax during the evening of December 9, John heard an Irish station, most likely from Mt. Leinster, on 94.9MHz giving local news and cinema details for the Brandon, Cork and W. Cork areas. As a result of his warning, I checked Band II



Fig. 6

and found several French stations at good strength. The real opening began during the following afternoon when, at 1500, I counted 17 continental stations between 87 and 104MHz and many more "strangers" that were transmitting music and/or warbling that I could not sort out from the UK stations. I checked again at 0930 on the 11th and the band was just packed full of stations and there was no point in trying to identify them individually.

This situation continued throughout the day and at 1700, Joan, my XYL a Radio 4 addict, using a Sharp radio recorder with its own telescopic antenna, thought she had spent the afternoon listening to London and had a shock when the announcer said it was Radio Cymru. Afterwards Joan explained that when she changes from Radio 3 to 4, she tunes for the strongest signal, which in our case is either Rowridge or Wrotham.



AMATEUR RADIO EXCHANGE LTD

HP & PERSONAL LOANS AVAILABLE

&

LONDON: 373 UXBRIDGE ROAD, ACTON, LONDON W3 9RH. Tel: 01-992 5785/6
 NORTHERN: 38 BRIDGE STREET, EARLSTOWN, NEWTON LE WILLOWS, MERSEYSIDE WA12 9BA. Tel: 092 52 29881

TELEVISION

Reports: as for VHF Bands, but please keep separate.

At the first signs of co-channel interference on the domestic television receiver, a gleam appears in the eyes of many DXers as they scurry to their shacks, the radio amateur to search the 144MHz and 430MHz bands and the TV enthusiast to check Band III and take a more detailed look at the cause of the upset in Bands IV and V. After all, some tropospheric disturbances can increase the range of signals between 100 and 1000MHz for several days and while we enthusiasts play, a large majority of the viewing public are losing their favourite entertainment. That is why the saying "one man's meat is another man's poison", very much applies in these circumstances.

When television re-started after WWII in 1946, the BBC provided the only service and transmitted their signals, for a few hours each day, from Alexandra Palace on Ch. 1 45MHz and later from Sutton Coldfield on Ch. 4 61.757MHz, using a 405-line system in Band I.

The photograph in Fig. 1 shows some of the many old TVs and receivers that can be seen at Chalk Pits Museum, Amberley. Bert Mills GW3LJP is seen with sets (l-r) made by Philips, Bush and Cossor with a Pye B18T hidden behind him. Many readers first saw the effects of sporadic-E on television signals using these types of sets, and readers like Cecil Duncan BRS84943, Shetland, will probably be interested to see such "old time" sets as these. David Rudram, Worthing, and a large number of other engineers, myself included, had the job of explaining to often irate viewers, that the "knitting" on their screens and the foreign voices interrupting their sound, was not a fault in their sets, but due to a disturbance in the upper atmosphere and definitely beyond our control. Unfortunately sporadic-E, being mainly a mid-summer problem, usually coincided with an outside broadcast of the tennis from Wimbledon which made some people even more angry and our careful explanations were often dismissed as absolute rot.

However, as the years passed by the BBC expanded their service across the UK using five channels in Band I (now listed in the *World Radio TV Handbook* as Chs. B1, 2, 3, 4 and 5), considerably increasing the number of programmes and with government approval, their transmission time. In the mid-1950s the Independent Television Authority, now known as the IBA, opened a 405-line service in Band III and was allocated Chs. 6 to 13 (179 to 215MHz referred to as Chs. B6 to B13 in *WRTVH*). Readers should not confuse this with the present day 625-line systems used by European countries and listed as Chs. E5 to E12, 175 to 225MHz. (The frequencies quoted are approximate and refer to the vision channels

only, precise details for each channel can be found in the television section of the *WRTVH*.) By now you may have guessed that we were faced with another problem, signals in Band III are not affected by sporadic-E disturbances, only tropospheric, so you can imagine the trouble we had trying to explain why the BBC pictures in Band I were OK and the pictures from the ITA in Band III were in ruins, or vice versa depending on which part of the earth's atmosphere was behaving abnormally. I am sure that many people were convinced that we in the TV business were barmy, especially when the trouble went on for several days.

The majority of the UK is now covered by both networks through an extensive 625-line u.h.f. service in Bands IV and V between Chs. 21 and 69. Although unaffected by sporadic-E, these frequencies are subject to co-channel interference during more intense tropospheric openings, which is where I began a few paragraphs ago. My prime reason for looking back to the early days is to show the prospective DXer the relationship between the television broadcast bands and the two main natural disturbances which, in their different ways, create the right circumstances for us to receive long-distance television pictures.

New readers often ask how DX stations are identified, well this is relatively easy during a long opening when the signals are steady and captions like those received from Germany (Figs. 2, 3 and 4) by Tony Palfreyman, from Holland (Fig. 5) by Keith Hamer and Garry Smith and from Spain (Fig. 6) by Len Eastman are often seen. However, when conditions are short-lived, or at times when several DX stations are fighting for predominance on the same or similar frequencies, then the glimpse of clock captions, like the ones from Holland (Fig. 7) received by Peter Baylis, Hungary (Fig. 8) and the USSR (Fig. 9) by Keith and Garry and Thai TV (Fig. 10) by Asim Aziz and Rehan Mullick in Lahore, can provide the answer. Do not worry about it, after a full season's activity, one develops an experienced eye for such detail and a knowledge of what to expect when and where.

Seasoned DXers like Simon Hamer, New Radnor, seen at the Chalk Pits Museum in the centre of Fig. 11, sharing a joke with your scribe and David Rudram, keep up a daily check on Band I during the winter months looking for "out of season" sporadic-E. At 1245 on November 15, he logged a short burst of test card from Switzerland PTT-SRG-1 on Ch. E2 48.25MHz. Then at 1950 on the 25th he found sudden, short duration, sporadic-E and although he saw programmes on Chs. E3 55.25MHz, R2 59.29MHz and E4 62.25MHz, none of



by Ron Ham BRS15744

them were visible for long enough to get a positive identification.

Although conditions on this band were generally quiet during the month covered by this report, there were several bursts of pictures on Ch. R1, possibly due to meteor trail reflection, but the only one I could identify was a test card, scribed RS-KH from Czechoslovakia at 0844 on December 3.

Tropospheric

All had been quiet in Band III and the u.h.f. bands until the afternoon of December 10, when I received strong colour pictures from RTE 1 and 2 on their Chs. H and J, in Band III. I also received the RTE-1 clock caption in colour at 1448, a monochrome test card from Belgium BRT TV1 on Ch. E10, colour cartoons of Laurel and Hardy and Popeye on Ch. E4 and a programme caption, *Songs Alive*, which I think was from Belgium RTBF on Ch. E3. In fact, this tropospheric opening was affecting signals from as low as 48MHz, up through Band III and giving some co-channel interference in Band IV and V. I also received strong pictures from the French Canal Plus around Ch. E5, the Good Afternoon caption from Radio Televis Eireann at 1500 and a news programme, *BRT Journal*, in colour on Ch. E10 at 2145. RTE remained strong with me for most of the evening and among the adverts, at the end of part 1 of their 2100 news, was one for the Sinclair Spectrum computer.

Early on the 11th, I logged strong colour test cards from Holland PTT-NED 1 on Ch. E4 and a caption with large figures 970 followed by a programme about animals and birds on Ch. E9. Between 1000 and 1130, I watched a series of farming information charts, on Chs. E3 and 8, headed with the words "Perceval-RTBF" and in the weather section I noted that their atmospheric pressure was the same as ours, 1029mb. At 1430 the letters RVU appeared above a YL announcer on Ch. E3, followed by an Australian film, *Holiday Island*, with I think Dutch sub-titles and the caption KROO, all in strong colour. The same applied to the German test card on Ch. E9, WDR-1, which preceded a caption Video Für Alle, headed by ARD/ZDF Redaction Berlin. Throughout the evening, most u.h.f.

Practical Wireless, March 1985

FRG7 OWNERS ARE GOING — DIGITAL AND SIDEWAYS

And you can join them by using our custom designed DFC70 digital frequency counter. The DFC70 is specifically designed for the FRG7 and gives rock steady read out on all bands with 100Hz resolution. Signal frequency is computed and displayed unambiguously on a state of art LCD display specially made for us in Japan. It is not necessary to drill any holes and only one wire has to be connected to a well marked test point in the receiver.

DFC70 Kit £21.95 Built and tested module £26.95
Will also work with the Lowe SRX30 and Drake SSR1.

With our new FM7 adaptor module, you will be able to receive sideways modulation (FM as it is otherwise known). Our superb state of art FM detector uses the very latest 3359 chip from Motorola, and has a built in IF filter and a variable squelch control for noise free monitoring. Although specially designed with the FRG7 in mind, it will happily work with other receivers or transceivers with a 455KHz IF amplifier. The FM7 will add a whole new dimension to your listening activities. You will of course be able to follow legal CB contacts but you will also hear the exciting DX being worked by amateurs on 10 metre FM. Used in conjunction with our DFC7 counter, you can accurately tune to a specific CB or amateur channel and so be sure that you will not miss whatever goes on. **Kit Price £12.95. Tested Module £15.95** For FM reception on receivers with any IF up to 50MHz, the FM 42 is the answer to all your problems. *Please state frequency required when ordering.* **Kit Price £16.95. Tested Module £21.95. 10.7MHz version FM107 £13.95. Built and tested module £16.95.**

TIMOTHY EDWARDS MK2 144 MHz PRE-AMP HEAR IT LIKE YOU NEVER HEARD IT BEFORE

We are proud to announce that the well known RF consultant Timothy Edwards has given us the exclusive marketing rights to his new 2 metre pre-amp. Timothy Edwards RF designs are used by British Telecom amongst others and so you can be sure that this pre-amp will perform to perfection. It employs the incomparable BF981 which has a better noise figure at 2M than the often used 3SK88. Spec. Size (tiny) 34mm x 9mm x 15mm (same as Mk1) Noise figure 1.0db Gain 26db. 2M PRE kit **£4.95. Built and tested module £9.95.** For Commercial use on 60 to 200MHz Built only **£14.95** (state frequency required). Versions for 156 or 137MHz kit **£4.95** Built and tested module **£10.95.**

AR2001 MODS. SAE for all data.

NEW LCD COUNTERS

At last a new range of 5 digit LCD counters that will cover up to 200MHz and give 1KHz resolution to 39MHz. Ideal for most short wave receivers using common IFs. Similar to the FC177 but cheaper! Supply voltage 5-15V dc. Will operate on 26 different IF offsets. If this counter range won't do what you want probably nothing will. Works with all of Tony Bailey G3WPO designs, ask for conversion data.

DFC40 0-4MHz £19.95 built DFC41 0-32MHz £23.50 kit DFC42 0-200MHz £26.95 kit DFC43 30-200MHz £25.50

LNA144. OUR ace RF designer Timothy Edwards has done it again! In line 144MHz RF switched pre amp which needs no modification to any rig. Just put it in the co-ax feed, supply 12V and your deaf rx will have ear ache. Uses the BF981 with a total of 4 tuned circuits for the best out of band rejection. The relays are 50ohm gas filled with earthed metal cans and are good to over 800MHz. This was originally designed for 'British Telecom Satellite Division' hence the provision for gold 14GHz SMC connectors. 1dB noise figure and 18dB gain is guaranteed to improve all standard rigs on 144-146MHz. Will fit in standard diecast box (not supplied). Try one in the car under a wing mounted aerial and be surprised. **LNA144 kit £16.95. Built and tested module £26.95.**

TCB BURST. Probably the smallest crystal controlled unit available. 1750Hz ± 0.1 Hz. Supply 5-15V. Will fit in the tiniest of rigs or even microphones.

TBI Kit £8.50.

Built and tested module £12.95.

2M CONVERTER. At last a cheap design to allow you to listen to the fascinating world of two metres. Use with any HF receiver that covers 2-4MHz (the FRG7 is ideal) to cover the complete band including SSB-DX, FM simplex and, of course, the love them or hate them Repeaters. The sensitivity is 0.5uV and can be upgraded later to the ultimate of 0.1uV by the use of either of our Pre-Amps.

DCC144 kit £9.95 Built and tested module £16.95

TOP BAND CONVERTER. Listen to the other local nets and DX on 160m with any 2m SSB receiver. Does not need a large aerial and will comfortably out perform most commercial receivers.

UC160 Kit £9.95

UC160 built and tested £16.50

2M MONITOR RECEIVER. A superb design featuring crystal and ceramic filters coupled with the MC3359 and BF981 results in an almost bomb proof monitor. Single channel with squelch and 500mW audio amplifier. No coils to wind and little alignment required. Uses standard crystals from 'PM Electronics'. **MON2M Kit £28.50.** Built and tested module **£37.50.** Versions for 4 Metres (70MHz) or Marine (156MHz), or on any single frequency in the 40-200MHz range, **kit £29.95.** Built and tested module **£39.95.** (State frequency required). Crystals for all versions **£4.60.** Quote frequency or channel number.

WEATHER SATELLITE RECEIVER. The hard work taken out of a Weather Satellite Station. Based on the enormously successful 2M monitor but specially designed to allow satellite reception with only a small aerial. Supplied with a crystal for 137.5MHz for immediate use. Be ahead of everybody with weather reports, already in use by progressive farmers.

WSAT Kit £29.95.

Built and tested module £39.95

BBC software and interface together with aeriels available.

FRONT END MODULE 47-300MHz. A ready built and aligned module covering all of 47 to 300MHz in 2 ranges. Use with the FM107 IF module for a tunable FM RX covering 4m 2M TV and PMR bands. Standard 10.7MHz IF output. The uses for this amazingly versatile module are nearly endless. A version is available with a standard TV IF output for DX TV. **EF4200 £27.95. EF4200TV £23.95.**

GAS FILLED RF RELAY. New Japanese 50 ohm low loss gas filled RF relay. Only 0.3dB loss at 433MHz with up to 35 watts input. Ideal for switching pre-amps and aeriels. VSWR 1.5:1 at 1GHz. 12 volt coil. **DR12V £4.95.**

All prices include postage and VAT. Send 35p for individual data on any of the above.

Mail order only. Please allow up to 28 days for delivery.

TIMESTEP ELECTRONICS LTD, WICKHAMBROOK, NEWMARKET, SUFFOLK.

TELEPHONE NO. 0440 820040 (TECHNICAL ENQUIRIES 3.00 TO 4.00 PM ONLY) TELEX 817015 TIMEST G





Fig. 1



Fig. 2



Fig. 3



Fig. 4



Fig. 5



Fig. 6

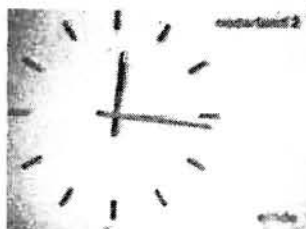

Fig. 7

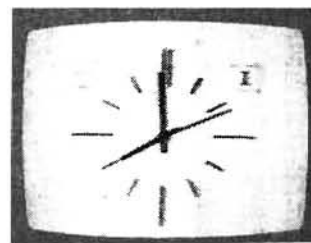

Fig. 8



Fig. 9



Fig. 10



Fig. 11



Fig. 12

channels suffered severe co-channel interference and early on the 12th, the only DXTV left was a caption from Holland, Pauze School TV and a clock showing 0920, on Ch. E4.

Amateur (fast scan) Television

Within the framework of amateur radio, the ingenuity and perseverance of its devotees has played a major role in the pioneering and eventual use of that part of the radio frequency spectrum with wavelengths of less than one metre. Typical of this attitude is the recent work of our technical editor, **John Fell G8MCP**, who has modified a BATC 430MHz crystal-controlled a.m. transmitter to give it a free-running oscillator. By using a Varicap diode across the tuned circuit f.m. ATV is produced. This revised arrangement provides 150mW, to feed a BGY22/23 hybrid module p.a. to give 9W at 430MHz, which in turn drives a home-brew BAY96 varactor diode tripler, giving 4W at 1290MHz after cavity filtering.

At the time of writing P5 colour pictures at this frequency had already been received over a 2.5km obstructed path by **Judith Richardson G6JGR** and **Mervin Staton G4BGT** at Corfe Mullen. The receiver used by Judith and Mervin at the same time was a Wood and Douglas GaAs-f.e.t. front-end into a BATC 50MHz f.m. demodulator/video output

board and the antenna was "half" of a Tonna 1.3GHz Yagi, "hand held" out of the shack window by Judith.

John has received P1 pictures from Sid G4JQU in Southampton and P3 from Nick Foot G4WHO, Wimborne, and asks, "are there any ATV people active on 1.3GHz further west than Corfe Mullen?" What about it readers? Do give him a call if this request affects you. At his home station John also uses 16K Spectrum computer with the Worthing ATV Group's software, a monochrome camera and a G3JVL 24-element quad loop Yagi. After installing the full length Tonna Yagi at 10m a.g.l. G4BGT provided a P4 picture for G8MCP using 4mW of r.f.! Shack background illuminations added up to 1kW! The 55km path from Corfe Mullen to Southampton has now been worked (P3/4 colour signal reports) with an c.r.p. of well under 100mW—anyone else for QRP ATV?

The Moray Firth ATV Group GM8AVT, gave a demonstration of 1.3GHz amateur television, on November 18, in the Community Centre, Lossiemouth, where there was a static display of video equipment and Ewan Crawford GM4GUQ gave a talk about the design of the transmitter, loaned to them by Wood and Douglas. The good attendance, which included enthusiasts from the Fort William Group, saw pictures transmitted from another building away from the Community Centre. "It was a very successful meeting and was the first time that 1.3GHz ATV had been seen in the Moray area", writes Norrie

Macdonald GM4BVU who, along with GM8ETF, sent this report.

SSTV

"I could not find any DX on SSTV", writes **Peter Lincoln**, Aldershot, for the month prior to December 4, although he did receive pictures from SV4CG in Greece and chalk up a new country. Peter usually monitors the SSTV frequencies around 3.740, 7.040 and 14.230MHz on Sunday mornings.

On November 18, in about half an hour Peter received pictures from stations in France, Germany, Italy, Liechtenstein and Poland and comments: "The problem was trying to monitor all the QSOs, I think it is the most activity I have seen in this mode, since the last contest." While checking his tapes Peter came up with a picture of a car, Fig. 12, transmitted by one of the Italian stations he copied. This is a good point to remember about SSTV, the signals, recognisable by their musical tones with a blip at approximately 8 second intervals, can be recorded on a standard cassette recorder and played back into the receiving system at a later date.

Although the SSTV signals never seem to be there when you want them or an s.s.b. station thunders on top of it, I have copied signals using a Scarab Systems program in my Spectrum computer from a weak American station working into the UK, HA5KSJ, I3XQW and noted several bits of picture such as the letters

Practical Wireless, March 1985

ON THE AIR

Station Reports

CQ, K, a man's face, part of a map and the call I3F?? on the 14MHz band at a time when the band was poor, so I am pleased with my first steps in the world of SSTV and delighted to have the equipment ready for use when the signals appear.

"If you receive German teletext (VT) with a UK decoder you get the special German character wrong", writes **Jan van der Horst**, Arnhem, having seen the ARD/ZDF picture we published in our December issue. He points out that the U in the title SPORT ÜBERSICHT (Fig. 10 in the December issue) has two bars

through the top of the letter when it should be an Umlaut. In his letter Jan gave a few other examples of character distortion and says, "that for correct display you need a Dutch/German decoder and not a GB/SK/IT unit". Thanks for the tip Jan, we are always pleased to get information like this because, during the opening on December 10 and 11, I kept an eye open for this and again saw the word ÜBERSICHT with a bar through the U instead of the Umlaut.

SATELLITES

Reports to: Pat Gowen G3IOR, 17 Heath Crescent, Hellesdon, Norwich, Norfolk NR8 6XD.

The current series of active amateur satellites are all performing to expectation with only a few minor problems for those who control and use them.

Over the period of the second week of December, the USSR satellite group carried out a series of experiments to determine the charge-holding capability and storage capacity of the batteries in RS-5, 7 and 8. Whilst RS-8's power source still appears to be in good condition after the three years (exactly) that it has been in operation, the same cannot be said for all of the satellite series. RS-7 is in relatively poor condition, but should be with us for some time to come. RS-5 is now in very poor condition, and it will undoubtedly switch itself off by automatic under-voltage detection protection when it comes back to full-time service following the eclipse season. This is unfortunate, following the demise of RS-6, as the RS 5 has shown itself to be a superb satellite on all of its facilities of transponder, ROBOT, and codestore message acceptance and re-transmission.

UA3CR suggests that the positive identification as to whether the old RS satellite that continues to send "... 55 ..." on 29.400 MHz is RS-1 or RS-2 could be accomplished by visual astronomical observation due to the difference in magnitude of the pair. RS-2 has a surface area twice as great as COSMOS 1024, and RS-1's surface area is ten times that of RS-2, so a keen-eyed observer with a good pair of binoculars should be able to produce some good evidence. Yes—it CAN be done! HAM-SAT members in the Netherlands successfully located OSCAR 11 when "Lost", and when OSCAR-6 first went up, it was seen by two sharp-eyed young ladies of middle school age, by the unaided eye.

UOSAT-OSCAR-9 continues to perform well on a regular schedule, alternating weekly between 21MHz and 2.4GHz beacon operation. The propagation of the 21.002MHz beacon has changed markedly since the high sunspot periods, when the daylight paths would give a long extension of audibility of signal well before and well after the official a.o.s. (acquisition of signal), and l.o.s. (loss of signal) times. It is now only

audible marginally sub-horizon and very little attenuation is evidenced on the direct line path.

A slight hiccup occurred with UOSAT-OSCAR-11 during December, when the gravity gradient was temporarily lost during a re-spin-up manoeuvre from 1 r.p.m. following comparability tests with the research project satellite. By the time you read these notes, all should be on course again.

AMSAT-OSCAR-10 has had to have its schedule changed to meet variations of eclipse and sun-angle. It pays to study the 145-810 and 436-020MHz beacon in order to follow the times, according to the mean anomaly, when the satellite is in mode "B", "L" or off, as more changes are undoubtedly necessary. At times, due to the prior requirement of optimisation of sun-angle in order to keep a well charged battery, the attitude of the satellite has been very poor for Northern Europe. This is because the antennas have been in excess of 30° off-angle to us, producing severe attenuation of both uplink and downlink, and considerable "spin-modulation" even when close to Apogee. This is due to observers seeing the side-lobes of the antennas instead of the main lobe, and even those using good circularly polarised up and downlinks are affected. As we go on further into 1985, the sun-angle will improve, optimising in early March, and then worsening again to the 43° difference (as at mid December 1984) at the end of May '85. In mid-April, we lose the effects of the Perigee eclipse that started in late December 1984, which all means that in the astronomical sense at least, things will be better this year.

A further complicating factor is the very heavy weekend usage which, apart from using up a lot of battery storage power, is attenuating the satellite sensitivity by up to 20dB! Many stations have been recorded as being more than 12dB above the beacon level, and by comparison with a calibrated signal, can be shown to be running powers in excess of 20kW e.i.r.p. to the satellite, e.g. more than 20 times the maximum required power. On a little-used Friday morning, I could hear my own signals, albeit very weakly, from an IC402 running 1.5 watts



by Pat Gowen G3IOR

to a quarter-wave whip. On the following Sunday evening, I could not detect my 800W e.i.r.p. uplink signal! Even the H1, H2 and ACNF frequencies in the guard-band were filled with QRO signals and, to quote one sad would-be-user, it is "... getting like twenty metres ..." Even so, new DX, like A92P, VP8NO and ZD7KH are appearing, and can be worked when the satellite is not abused.

Non-Amateur Satellites

A powerful satellite in a Molniya-type elliptical orbit is being heard with regularity on 2.304GHz, and has been identified as a Cosmos early warning orbiter, intended to detect the boost phase of ballistic missiles by sensing the infrared plume. The ITU allocates 2.304GHz as a primary band for radio-location, with amateur secondary use, so little can be done by way of protest on frequency selection. A few years ago we had a Stamford University satellite at the high end of 435MHz emitting a continuous carrier from a similar orbit. We are not alone!

AMSAT News

AMSAT is to cease publication of *Orbit* magazine, and replace it with a simpler member magazine in order to permit more of AMSAT's financial resources to go toward building the actual spacecraft. It is hoped that the new periodical will be more regular and topical than its predecessor. The current weekly AMSAT Nets, each Sunday, at 1800UTC on 21.280MHz and 1900 on 14.282MHz are suffering from the very poor propagation evident at h.f., and may resort to a monthly basis. When OSCAR 10 is in common view with the USA, look for N4HY and W8GQW on the AMSAT Calling and Net Frequency (ACNF) of

ON THE AIR

145-957MHz at these times for the news. Tom Clarke, W3IWI, has stepped down as President of AMSAT, and hopes to become more involved in the engineering side, whilst "Rip" Riportella, WA2LQQ, Vice-President for these past many years, has taken over the reins of President for the next three years. G3IOR, a Director for the past six years, has decided not to stand for election again this year.

W = Rare DX on Mode "L"

Due to what appears to be an unfortunate accident, USA stations are not at this point in time permitted to use 1.269-1.270GHz, the uplink for Mode "L" on OSCAR 10. Although the frequency range is allocated by WARC (1979) to amateur use, part 97 of the Federal Communications Commission (the W DTI and HO) rules has yet to be amended to assign them to the Amateur Satellite Service. Until this is performed, hopefully soon, we are unlikely to hear any activity from the USA on Mode "L". This is particularly unfortunate for Bill McCaa, K0RZ, who has a superb station for this progressive mode.

Satellites to come

Towards the end of this year, satellite enthusiasts have two new spacecraft to look forward to, namely, the Japanese Amateur Satellite JAS-1, known as FUJI, and the new USSR Radio RS-9.

FUJI will be launched into a 116 minute (ca. 1500km) 50° inclination orbit, and will employ a 1.3GHz uplink in addition to the usual standard v.h.f., with a number of new features. It will have a packet-radio save and forward system for the RTTY enthusiast, permitting the implanting of a message by G4... when the satellite is in his range, to be read off by 3D2.. in Fiji some forty minutes later when the satellite is in range of the South Pacific, as well as any general messages carried in the large memory. With computer controlled transceivers and antenna tracking systems, remote interrogation and loading will be feasible, so that an operator may merely switch on his monitor on his return from work or sleep, and read off his incoming information from the computer memory store. The "flying mailbox" will cover all parts of the World within twelve hours, most within ninety minutes, and could become a valuable source of amateur radio information listing DX information, Aurorae, events and propagational data.

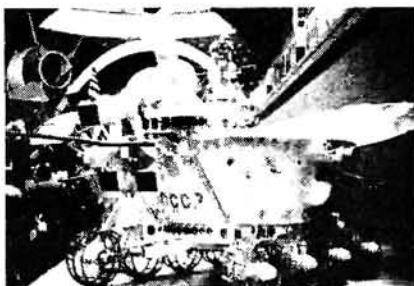

Fig. 1: The Soviet "Lunakod" moon exploration vehicle.

Fig. 2: Orbital communications Soviet satellite with a massive helical wideband array

GM4IHJ has peered into the possibilities of the proposed orbit using one of his elliptical orbit programs, and has discovered that seven consecutive passes out of the twelve orbits per day will be accessible from the UK, giving it a very different perspective from the high inclination orbits of OSCAR and RS that we have become familiar with over the past decade. The first three orbits per day available to the UK will all give coverage deep into China, then, as each orbit moves further west than its predecessor, by the third orbit, QSOs will be possible with USA at the start, and China at the end. The last four orbits in range of UK are all within mutual range of the USA, some of them quite lengthy, and we have coverage to South America in addition.

JARL are quoting "twelve orbits per day" which, if precise, would place the satellite at 1680km, giving even better coverage from the two hour orbit that may evolve, as John's calculations were based on 12.5 orbits per day, e.g. 116 minutes, e.g. 1500km.

Your scribe visited the USSR in September, and spent an enjoyable afternoon with UA3CR and fellow satellite creators at the central radio club in Moscow discussing AMSAT and DOSAAF projects, and the possibility of joint ventures. RADIO RS-9, the latest in the series of highly successful satellites from the USSR stable, is now under test, sitting on top of a high-rise apartment block in Moscow, acting as a local repeater. Unfortunately, due to poor propagation, it cannot be heard in Britain as were its predecessors, but should the sun improve, the beacon will be heard on 29.400MHz, carrying telemetry housekeeping information on c.w.

In addition to the normal Mode "A" 144-28MHz transponder, RS-9 will carry a 21-28MHz transponder, which will bring satellite communications to



those not on v.h.f., as well as helping to keep our high frequency bands open for amateur communications over the period of the Solar minimum, and free from intrusion. In addition, it should prove to be an interesting source of research into angular ducting and scatter, as the ISKRA satellites, also 21-28MHz transponders, could re-translate signals well below the actuator's horizon, and propagate them well beyond its own.

RS-9 should be placed into a 1500km circular high inclination orbit probably in December this year, very similar to the existing RS series.

Considerable mutual interest was expressed in the possibilities of a Lunar transponder or even a beacon, of its heat regulation problems, and maintenance of power during the long Lunar night. Such a source would be very welcome to e.m.e. followers, as well as a source external to the Magnetosphere and all terrestrial discontinuities through which to study variables of attenuation and Faraday rotation, and these associations to libration fading. Unfortunately, a launch opportunity, such as accompanying a Lunakod Moon exploration vehicle, cannot be seen at this time. The Russian group are now working on Mode "B" satellites, e.g. 435 to 145MHz transponders which, if they could accompany one of the MOLNIYA spacecraft, could provide an ideal elliptical orbit, such as that which both Phase IIIa and Phase IIb (now OSCAR 10) should have become.

The Moscow Aviation Institute, UK3ABT, have so far successfully placed into orbit three satellites, the latter two, ISKRA-2 and ISKRA-3, both being 21-28MHz transponders. These are small packages, and are hand-launched from the SALYUT space stations

ARE 
AMATEUR RADIO EXCHANGE LTD

FOR THE BEST DEALS

LONDON: 373 UXBRIDGE ROAD, ACTON, LONDON W3 9RH. Tel: 01-992 5765/6

NORTHERN: 38 BRIDGE STREET, EARLSTOWN, NEWTON LE WILLOWS, MERSEYSIDE WA12 9BA. Tel: 092 52 29681

ON THE AIR

through the air-lock, and only lasted in orbit for one month due to frictional drag. We should have had more ISKRA's during 1984, but the intake of the multinational students that make them was insufficient to build more. This year, student numbers are well up again, and work on the series will go ahead, so we should look for potential launches following any of the automatic transport dockings with SALYUT-7.

"Space Dust"

During the early evening of Friday, 8 November, a remarkable v.h.f. and u.h.f. opening occurred in South-East England, with superb openings to Spain and Southern Europe. Your scribe was at G3IOR/A, a holiday bungalow at the edge of the North Sea that evening, and

found that the evening TV news programmes from the local TV transmitter, only 50km away on u.h.f. were overridden by strong Spanish TV. Spanish amateurs were evident on both 144MHz and 430MHz s.s.b. and f.m., with a characteristic "Es" sound.

The following morning, G3IOR/M, a yellow Lada Estate, was found to be brick red, as were many vehicles, windows and ledges in the area. The cause was first thought to be Sahara sand, brought in by a strong south wind, and deposited widely over East Anglia, producing a red mud when the rain came later.

As one of the causes of Sporadic-E is thought to be due to fall out of the dust resulting from the main meteor showers producing the means of propagation, it could be assumed that sharp silical particles elevated to the upper atmosphere could well have formed the medium responsible for the sudden and unexpected opening.

Follow-up examination later showed

that the dust brought in from Africa was not in fact sand from the Sahara, but fine kaolin of up to 10 micron particle size that had been swept up as clay soil from Northern Morocco, CN8 and EA9, borne aloft out to the Atlantic, and then swept in from the South West to deposit. The quartz content was very low, and it is unlikely that the dust itself was responsible for the propagation, but the shear of the winds that carried it probably were.

Early records show that this phenomena was not unknown, as they date back to Virgil's Aeneid. The Romans called it "blood rain", and attached to it an even greater mystical significance than the present day radio-amateurs, who had such a field day from such an event. So, incidentally, did the local car-wash concerns! Incoming reports from EA amateurs show that they made the most of the occasion, as they were getting excellent pictures from Anglia TV on u.h.f., and making good 430MHz QSOs with South-East England. Investigations are proceeding.

RTTY

Reports: as for VHF Bands, but please keep separate.

"The RTTY bands do not seem to have been good during the end of November, there has been plenty of activity but not much DX", writes **Peter Lincoln**, Aldershot. He adds that OD5NJ appeared on several afternoons around 1400 and a few north Americans from about 1600 on the 14MHz band. Peter also reports that the ZS6CC mailbox has been active and apart from not increasing his new country score during November, he did receive QSL cards confirming his RTTY reports from Germany DL3DK/HB0 and El Salvador YS1TG. Both Peter and **Norman Jennings**, Rye, have been busy making a program for their short wave loggings, in machine code, for their Sharp M700 computers.

"RTTY signals are coming out of the mainland of China and I enclose a sample souvenir QSL card, Fig. 1, which was sent to me recently", writes **Ted Double** G8CDW, Enfield. He continued, "The first RTTY QSOs with European stations took place on September 12 and they have now confirmed a reception report which I sent to them at a later date". Ted also told me that the Chinese were worked on 14.085MHz and that they will QSL direct from Amateur Radio Station of CRSA, P.O. Box 730, Fuzhou, China, and a couple of IRCs would be appreciated.

"I am most fascinated by the printed word on the screen, more so than general short wave listening which I began in 1931", writes **Jack Wingrove**, Battersea. His reception report for November and a part of December is included with my own on the chart in Fig. 2, which confirms Peter's opinion of plenty of activity but not much DX. I feel sure that the

fascination you mention Jack is one of the reasons why the membership of the British Amateur Radio Teleprinter Group has doubled and many more radio enthusiasts are adding RTTY equipment to their stations. I was left in little doubt about the growing interest in RTTY after the tropospheric opening on December 10 and 11 when I had a most enjoyable few hours tuning around 144-600MHz. At 2000 on the 10th, I turned by beam north-west and copied RTTY signals from Danny McDermott G4HXU and G6ZUL in Oxfordshire using 50 baud, Dave Naylor G6CBN, Durham, G4IHO, Buxton, GW8ROW, Gwent, G1AJL, Lincoln, G6XJZ, G6UJB and ON5EX on 45.5 baud. Between 1810 and 2100 on the 11th, with my beam this time facing toward the north-east, I added signals from Chris Barker G6JJE, Norfolk, making his first ever QSO with a station in Luxembourg, Ivan Cline G3EMU working into France, Ron Daly G8VYJ, Newbury and Anthony Turnbull G4CUS, Battle. Other call signs heard were G1ADW, G4YOW, G6IBR, G6OUN, G8DDY, GW3CBY off the side of my beam, F1DFF and ON1UI. I heard ON5EX first on 45.5 baud and then when he made a call to G4HXU he changed to 110 baud, which I was able to follow as it is one of the options on my Tono Theta 550, I also heard PE1IM using 50 baud. Not bad for a first real encounter with RTTY in the 144MHz band. My congratulations to you all for your perseverance and for taking advantage of the DX while it was going, if what I heard was anything to go by, then I am sure that all the RTTY operators had a wonderful time and I would certainly like to



by Ron Ham BRS15744

hear more from them.

"Glad to see the 7MHz band alive with RTTY traffic again, because in 1983 it was quite dead", writes Jack Wingrove, who comments about the enjoyment one can get from Sergio I6DZB-Rome who transmits nearly all day on 14.0948MHz with information and sometimes sends ASCII. Like most of us, Jack logs a large number of Italian stations, they seem to go for RTTY in a big way.

At 1610 on December 10, I copied a very strong signal on 14.094 and 21.093MHz from W1AW, the headquar-



Fig. 1: Souvenir QSL card from mainland China, sent in by Ted Double

ON THE AIR

ters station of the American Radio Relay League, Newington. It was sending propagation predictions and orbital data for the amateur satellites OSCAR 10, RS6 and 7, UO9 and the weather satellite NOAA7 for the 11th and 12th, first in 45-5 baud and then in ASCII.

I have been asked about finding DX among the RTTY signals on the band. Well, try and ignore the hefty signals and tune in to the weak ones and also wait on the frequency for a reply after a station has called CQDX. Don't forget, Sunday mornings and contest times are good for copying a lot of stations.

Fig. 2 ▶

Country	Prefix	Frequency (MHz)			
		3.5	7	14	21
Alaska	AL7			X	
Argentina	LU				X
Australia	VK			X	
Austria	OE	X	X	X	
Azores	CT2				X
Balearic Is.	EA6			X	
Belgium	ON	X			
Bulgaria	LZ			X	
Canada	VE			X	
Canary Is.	EA8			X	
Czechoslovakia	OK			X	
England	G	X			
Finland	OH			X	
France	F	X	X	X	
Germany	DJ	X	X	X	X
Greece	SV			X	
Holland	PA	X			

Country	Prefix	Frequency (MHz)			
		3.5	7	14	21
Hungary	HA			X	
Israel	4X4			X	
Italy	I		X	X	
Japan	JA			X	
Luxembourg	LX		X		
Norway	LA			X	
Poland	SP			X	
Portugal	CT			X	
Sicily	IT9			X	
Spain	EA		X	X	
Sweden	SM	X	X	X	
Switzerland	HB9	X	X		X
USA	W1-9			X	X
USSR	UA,UB			X	
Venezuela	YV			X	
Wales	GW	X			
Yugoslavia	YU		X	X	

News

Ton-Up on 50MHz

The November 1984 RSGB "Council Letter" confirms that the DTI has selected the 60 successful applicants for 50MHz operating permits, additional to the 40 which have already operated in that part of the spectrum since early 1983. So, with the number of operators with 50MHz permits up to 100, the complete list is now as follows:

G13RXV, G13ZSC, G13ZTL, G14LXL, G14MJD, GJ3RAX, GJ3YHU, GM3DOD, GM3JIJ, GM3WCS, GM3WOJ, GM3WTA, GM3YMK, GM3ZBE, GM4BYF, GM4CXP, GM4DIJ, GM4FDT, GM4FZH, GU3UOQ, GW3LDH, GW3MHW, GW4BCD, GW4HBK, GW4HXO, G2ADR, G2AHU, G2AOK, G2SP, G3APY, G3AZI, G3COJ, G3ENY, G3FDW, G3FIJ, G3HZG, G3IMW, G3JVL, G3KEV, G3LEQ, G3LTF, G3MCS, G3NCL, G3NNO, G3NOX, G3NSM, G3OBD, G3OHH, G3OSS, G3PBV, G3PWK, G3RMB, G3SNN,

G3TAA, G3TCU, G3UFS, G3UGF, G3UHH, G3USF, G3UUT, G3VZJ, G3WBN, G3WZT, G3ZIG, G3ZJY, G4AFJ, G4ASR, G4BAO, G4CUT, G4DGU, G4ENA, G4FXW, G4GEE, G4GLT, G4HFO, G4HK, G4HUP, G4IDE, G4IFX, G4IIL, G4IJE, G4JLH, G4LOJ, G4NBS, G4NVS, G4OBK, G4OTV, G4OXY, G4RXD, G4SHP, G4TRQ, G4UPS, G4VET, G5GX, G5KG, G5KW, G5UM, G6NB, G6XM, G8VN.

An interesting development is that the Norwegian authorities have apparently issued 25 experimental permits for operation on the 50MHz band outside TV hours. Norway is expected to close down its Band I television service during 1985/6 and, according to one source, there is "... a very good chance indeed" of a permanent allocation to Norwegian amateurs at 50MHz.

Just N. Qvigstad LA9DL, has now become VHF/UHF Manager of the Norwegian national society, NRRL.

A further item in the "Council Letter" tells of an out-of-the-way case of interference that was recently reported to the Society. A British Telecom "Ambassador" telephone system in Edgware, Middlesex was found to be radiating signals in the 144MHz band at sufficient strength to block channel S20 at an amateur radio station in a different street. The problem was tracked down to a single handset, which was apparently radiating data-type signals between 145.50 to 145.55MHz, 145.62 to 145.63MHz and 145.80 to 145.82MHz: there was also some radiation outside 144MHz. British Telecom have indicated that the offending handset (which is Type 8520, gen. 84/1, embodying Modifications 1 and 2) will be replaced.

The Society would be most interested to hear of other cases of this nature. The interfering signal sounds like a high-pitched tone with superimposed fast pulses.

Diary Dates

The Doncaster Amateur Radio Society will be running the 1985 Doncaster Amateur Radio Show on Thursday, 3 March, starting at 11.00am.

The venue will be at the Doncaster Institute of Higher Education Annexe, Ellers Road, Bessacarr, Doncaster, Yorks, and admission will be by 30p programme.

Talk-in will be available on S22 and for further details, contact: M. J. L. Fowler G8XTU. Tel: Doncaster (0302) 531365.

Pontefract and District Amateur Radio Society have organised their "Components Fair 1985" on Sunday, 10 March, between 11.00am and 4.30pm, and is to be held at the Carleton Community Centre, Pontefract, which is located between Darrington (on the A1) and the town of Pontefract.

Although the event is based on the traditional mobile radio rally, it is intended to bias the Fair towards the home constructor.

Further details are available from the

organisers: N. Whittingham G4ISU, 7 Ridgedale Mount, Pontefract, WF8 1SB. Tel: (0977) 792784, and R. Greenhough G4KMW, 36 Churchbalk Lane, Pontefract. Tel: (0977) 792654.

Racal User Group

Peter Barker G8BBZ who organises the above group, see *News*, page 51 December 1984, has moved.

His new address is: 15 Epping Green, Woodhall Farm, Hemel Hempstead, Herts. HP2 7JP.

Practical Wireless, March 1985

WATERS & STANTON ELECTRONICS

18/20 MAIN ROAD, HOCKLEY, ESSEX. Tel: (0702) 206835
12 NORTH STREET, HORNCHURCH, ESSEX. Tel: (040 24) 44765

PANASONIC!
**A FAMILIAR NAME FOR
2 EXCITING RECEIVERS**

THIS EXCITING NEW RECEIVER
"BRINGS THE WORLD TO YOUR FINGER TIPS"

This receiver has been designed for the serious short wave listener who demands performance and yet portability and versatility. Made by the famous Panasonic company of Japan (yes the same one that makes your TV's, Videos and HI-FI) we reckon this receiver to be the long awaited answer to a reasonably priced receiver for the man on a budget

FEATURES:- ★ Proper S-meter ★ Power/battery indicator ★ 230v AC or dry cell ★ Digital display to 1KHz ★ Built in speaker ★ Headphone jack ★ RF gain control ★ AM wide/narrow switch ★ Rec. socket ★ USB/LSB/CW reception ★ 31 bands ★ Built in whip ★ Dual IF for good image response ★ Phased locked loop synthesizer ★ FM broadcast reception ★ External aerial connector ★ Ferrite antenna for MW/LW

FREQUENCY RANGE:-

150kHz-1.6mHz; 1.6mHz-30mHz; 87.5-108mHz (FM)

£229
INC VAT

THE PANASONIC RF3100 RECEIVER



**A HIGHLY ADVANCED RECEIVER FEATURING
MICRO COMPUTER TUNING & MEMORY BANK**

This highly advanced receiver combines the latest in RF and computer technology to bring to you an extremely advanced receiver at a highly competitive price. We've nothing but praise for this winning design from Panasonic. There's only one snag. These receivers are in very short supply. So please telephone for delivery information — you could be lucky and find we have a couple in stock!

FEATURES:- ★ Direct access tuning to 100Hz ★ Manual tuning via main dial ★ 9 frequency memory bank ★ Memory scanning ★ Digital display to 100Hz plus memory channel information ★ Noise limiter ★ Wide/Narrow filter ★ RF gain control ★ Tuning lock switch ★ Dual Speed tuning ★ Up/down electronic tuning ★ 230v AC or dry cell ★ Built in whip ★ SO239 external ant. socket ★ Headphone jack ★ Rec. socket ★ FM broadcast bands.

FREQUENCY RANGE:-

150kHz-1.6mHz; 1.6mHz-30mHz; 87.5-108mHz (FM)

£399
INC VAT

THE PANASONIC DR-B600

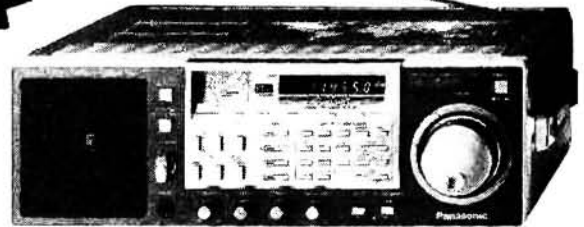

THE ABOVE RECEIVERS CAN BE DELIVERED TO YOUR DOOR WITHIN 24 HOURS VIA SECURICOR — PHONE FOR DETAILS

**AN IDEAL COMPANION FOR THE ABOVE RECEIVERS
OR ANY OTHER SIMILAR MODEL**

£49
AT1000 +£2 p+p

No receiver can give its best unless the aerial is properly matched to the receiver. That's why we commissioned our suppliers in Japan to make for us the AT1000 aerial tuner. This receiving matching unit is purpose designed to improve the performance of your receiving system by giving you the best possible results from your aerial system. A small price to pay for the ultimate!



MAIL ORDER SLIP (all orders despatched same day)

To:- Waters & Stanton, 18-20 Main Road, Hockley, Essex.

Name

Address

Items required

Carriage:- Items under £10-£1.00; Over £10-£1.50;
Larger aerials £6; Securicor £6.

AFFORDABLE ACCURACY

QUALITY MULTIMETERS FROM ARMON

ANALOGUE

HM-102BZ
10ADC Range, 20KΩ/VDC, Buzzer, Battery Test Scale **£13.00**
19 measuring ranges

HM-102R
Low end voltage & current ranges, Jack for Audio a/p Voltages **£11.00**
20 measuring ranges

HM-101B
Rugged Pocket sized meter for general purpose use **£7.50**
16 measuring ranges

Battery, Test Leads and Manual included with each model.

DIGITAL

HC-6010 0.5% Accuracy Standard Model **£33.50**

HC-5010T 0.25% Accuracy, TR Test Facility **£39.50**

All models have full functions and ranges and feature:

- 3½ digit 0.5 LED display
- Low battery indication
- Auto zero & Auto polarity
- ABS Plastic Casing & Trifit Stand
- DC AC 10amp Range
- Overload Protection on all ranges.
- Battery, Spare Fuse, Test Leads and Manual

FULL DETAILS ON APPLICATION FROM:-

ARMON ELECTRONICS LTD

DEPT B, HERON HOUSE, 109 WEMBLEY HILL ROAD, WEMBLEY, MIDDLESEX HA9 8AG
TELEPHONE 01-822 4321 TELEX 923985

PLEASE ADD 15% to your order for VAT. P&P Free of charge. Payment by cheque with order
Offer applicable to mainland UK only

Trade enquiries invited

Please allow 28 days for delivery

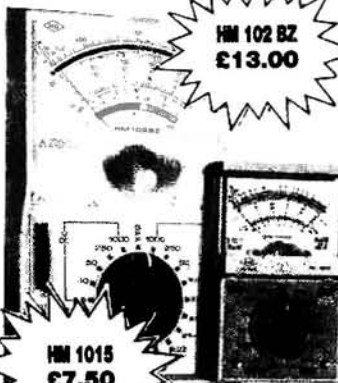

HM 102 BZ
£13.00

HM 101B
£7.50

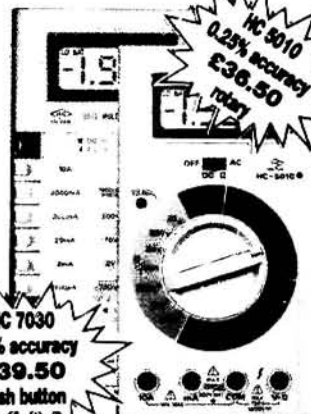

HC 5010
0.25% accuracy
£36.50

HC 7030
0.1% accuracy
£39.50
push button

S.E.M.

UNION MILLS, ISLE OF MAN
Tel: MAROWN (0624) 851277



SEMFACT - Our new range of linears cannot be beaten on receive or transmit.

S.E.M. TRANZMATCH. The most VERSATILE Aerial Matching (Tuning) Unit available. Matches 15-5,000 ohms BALANCED or UNBALANCED feeders up to 1 KW. Air coupled BALUN (no toroids) means no connection to equipment, which can cure TV1 both ways. An SO239 and screw terminals for CO-AX, END FED or TWIN FEEDERS. Size 8 3/4" x 4" x 7 1/4". 3.5-30MHz £80. 1.8-30MHz £90. The highly acclaimed EZITUNE built in (see below) £29.50 extra. 90% we sell have the EZITUNE option All Ex-stock.

NEW S.E.M. WAVEMETER. Have you read your licence? Have you got a wavemeter? Produced following so many requests. 1.5-30MHz in 3 switched bands with a very nice meter. Only £29.50.

S.E.M. IMABIC KEYS. No better fully auto keys anywhere. Uses Curtis chip. R.F. proof. Sidetone etc. £38. A first class twin paddle key £17.50 Ex stock.

BRAID BREAKER/MI PASS FILTER. Stop TVI at TV. £6.50 Ex stock.

RF NOISE BRIDGE. Adjustable 0-infinity ohms, 3" x 1 1/2" x 2" only. SO239s, 1-170MHz. Neat, accurate & economical. £34.50 Ex Stock.

3 WAY ANTENNA SWITCH 1Kw SO239s. Good to 2 metres. £17.50 Ex stock. Or 4th position to earth output £19.80 Ex stock.

S.E.M. 2 METRE TRANZMATCH. 5 1/2" x 2", 3" deep. SO239s. £24.90 Ex stock.

S.E.M. EZITUNE. New circuit. Gives MORE noise & bomb proof operation.

Because no similar unit is made, it's usefulness is not appreciated until you have used one. Eliminates need for S.W.R. bridge.

Clean up the bands, increase your P.A. life by many times, by tuning up without transmitting.

Connects in aerial lead, produces S9 + (1 - 170MHz) noise in receiver. Adjust A.T.U. or aerial for minimum noise. You have now put an exact 50 Ohms into your transceiver. Fully protected, you can transmit through it, save your P.A. and stop QRM SO239s. 3" x 1 1/2" x 2". £34.50 Ex stock. P.c.b. + fixing + instructions to fit in TRANZMATCH or any ATU £29.50 Ex Stock.



NEW RANGE

SENTINEL 2M LINEAR POWER/PRE-AMPLIFIERS

Feature either POWER AMP alone or PRE-AMP alone or both POWER AND PRE-AMP or STRAIGHT THROU when OFF. Plus a gain control on the PRE-AMP from 0 to 20dB. N.F. around 1dB with a neutralised strip line BF981.

Ultra LINEAR for all modes and R.F. or P.T.T. switched. 13.8V. SO239s.

Five Models: Ex. Stock

3/36. 12 times power gain, e.g. 3W in, 36W out. £70

1/36. 36 times gain, 1W in, 36W out. £80.

10/50. 10W in, 50W out. £86.

10/100. 10 to 100W. £135.

1/100. 1 to 100W. £148.

POWER SUPPLIES for our linears 6 amp £34. 12 amp £49.

SENTINEL AUTO 2 METRE or 4 METRE PRE-AMPLIFIER (R.F. Switched) 1dB N.F. and 20dB gain. (gain control adjusts down to unity) 400W P.E.P. power rating. Use on any mode. 12V 25mA. Sizes: 1 1/2" x 2 1/4" x 4". £29.50* Ex stock.

PA5 Same specification as the Auto including 240V P.S.U £33.00* Ex stock.

SENTINEL 2 METRE PRE-AMPLIFIER. No R.F. switch. £15.00* Ex stock.

S.E.M. AUDIO MULTIFILTER (A very good filter at a very good price). The most versatile filter available. Gives "passband" tuning. "variable selectivity" and one or two notches. Switched Hi-pass, Lo-pass, peak or notch. Selectivity from 2.5KHz to 20Hz. Tunable from 2.5KHz to 250Hz. PLUS another notch available in any of the four switch positions which covers 10KHz to 100Hz. 12V supply. Sizes: 6" x 2 1/2" front panel, 3 1/2" deep, all for only £65.00 Ex stock.

SENTINEL AUTO H.F. WIDEBAND PRE-AMPLIFIER 2-40MHz. 15dB gain. Straight through when OFF. 9-12V. 2 1/4" x 1 1/2" x 3". 200W £19.55* Ex stock.

SENTINEL STANDARD H.F. PRE-AMP. No R.F. switching. £12.62* Ex stock.

12 MONTHS COMPLETE GUARANTEE INCLUDING ALL TRANSISTORS.

Prices include VAT and delivery. C.W.D. or phone your credit card number for same day service. *Means Belling Lee sockets, add £1.90 for SO239s or BNC sockets. Ring or write for more information. Place orders or request information on our Ansaphone at cheap rate times.

Goods normally by return.

NEW THIS MONTH

12V SOLENOID. 10mm travel. Overall length 46 x 13 x 15mm. Coil 75R. Only £1.

Z924 Super Modem panel 260x175mm with a host of top quality parts. 2x4way DIL switches, 2 BCD switches, 31 LS chips, TR1602B UART, 2211/2206 FSK Rx and Tx chips. £6.00. **LEADS AT SILLY PRICES!!**

PL616 DC adaptor lead for Walkman, 1.8m long 30p.

PL528 2 pin DIN line skt to phono plug 0.2m long 20p.

PL508 5 pin DIN to 3 pin DIN audio lead 1.2m long 40p.

PL541 Intercom extn lead. 3.5mm line skt to 3.5mm plug. 6m long 40p.

PL708 Video lead PL259 plug to F type plug. 3m low coax 85p.

FM TUNING MODULE. This neat unit 75x40x19mm as used in car radios etc. Standard 10.7MHz IF output. 9-12V DC supply. Full connection data supplied. £2.40. Stereo Cassette Head. Only £1.00.

RADIO/AUDIO PANELS

Z908 - Panel 147x38mm with 2 x TDA1004 6W audio amp IC's not soldered in! so they can easily be removed. Also 1000/16, 1000/10 x 2, 470/16 elec. ceramic discs, R's, also choke (All easily removed). Stereo Amp? Only £3.00 (IC's cost £1 ea).

Z909 - Another board which escaped the clutches of the flow solder machine - 103x39mm, this is an RF panel with a TDA1200 FM/IF chip & uPC1176C noise canceller + R's & C's inc. tanks. Chips cost around £8 together. Price for panel £2.50.

Z910 - 139x39mm, this panel has soldered in components - TCA4500A and TBA651R, AM radio with IF amp. Probably complete RF section of radio as IF's and trimmers are on board, + R's, C's etc. £2.50.

FIBRE OPTICS

Scoop purchase of single and twin cable. For use with visible light or infra-red. Core 1mm dia, overall 2.25mm dia. Single 50p/m; 20m coil £6.30. Twin 90p/m; 20m coil £11.00.

PCB MOUNTING NI-CADS

Much sought after 4.8V 150mA batts with PCB mntg tags on 25mm pitch. Batt size 25x16 Ø. Ideal for paralleling. 99p ea; 10+ 85p; 25+ 70p; 100+ 60p.

1984/85 CATALOGUE

84 page A4 size - Bigger, Brighter, Better - more components than ever before! With each copy there's discount vouchers, Bargain List, Wholesale Discount List, Bulk Buyers List, Order Form and Reply Paid Envelope. All for just £1.00!! Winter Supplement out Now. - Send large SAE for your free copy.

SHOP SALE

23rd Feb to 9th Mar.
Many Bargains - worth a visit!!

1W AMPLIFIER

Z914 - Audio amp panel 95x65mm with TBA820 chip. Gives 1W output with 9V supply. Switch and vol control. Just connect batt. and speaker. Full details supplied. Only £1.50, 10 for £12; 25 for £25; 100 £75.

Z915 - Stereo version of above 115x65mm featuring 2 x TBA820M and dual vol. control. £3.50; 10 for £30; 25 for £65; 100 £200.

AM TUNER PANEL

Z916 - For use with mono amp above. Neat panel 60x45mm. Only £1.50; 10 for £12.00.

POWER/VU METER

Neat unit 40x40mm scaled 0-25 200uA movement. Only £1.00; 10 for £8; 25 £17; 100 £58.

NI-CAD CHARGER PANEL

177x114mm PCB with one massive Varta Deac 57x50mm Ø rated 7.2v 1000mAh and another smaller Deac 32x35mm Ø rated 3.6v 600mA. The price of these Ni-cad stacks new is over £20. Also on the panel is a mains input charger transformer with two separate secondaries wired via bridge rectifiers, smoothing capacitors and a relay to the output tags. The panel weighs 1kgm. All this for just £6.00.

Official orders welcome - minimum invoice charge £10. No. min. on CWO. Goods normally despatched by return of post.

Our store has enormous stock of components and is open from 9.5.30 Mon-Sat. Come & see us. Minimum Access order £5.00.

GREENWELD
4438 Milbrook Road Southamton
SO1 0HX Tel (0703) 772501/783740
ALL PRICES INCLUDE VAT JUST ADD 80p P&P

PRACTICAL WIRELESS P.C.Bs

We have in stock PCBs for every Practical Wireless project from 1978, so delve into those back issues of Practical Wireless and find that project you promised yourself you would build, then give us a call and we will be pleased to quote you for the PCBs.

E.G. January 1980 AF Speech Processor WR068 £2.98
Full Kit for above £23.50

This is just one of the many exciting projects you can build from Practical Wireless.

June 1983	PW RTTY	WR167	£4.50
July 1983	Marchwood Power Unit	WR161	£3.00
July 1983	PW Seven	WR169	£2.75
July 1983	PW Seven	WR168	£2.00
July 1983	PW Prescaler	WR172A	£3.00
July 1983	PW Prescaler	WR171	£1.75
July 1983	PW Capacitance meter	WR174	£2.75
Oct 1983	PW Digital calibrator	WR173	£3.50
Oct 1983	PW Dart	WR176/177/178	£3.75
	Bridport	WR182	(each) £2.75
	Transceiver Box Unit	WR179	£4.00
	PW IF Signal Generator	WR175	£5.00
May 1984	Top Direction Receiver	WR183	£4.00
May 1984	Top Band Receiver	WR184	£4.30
June 1984	Auto Notch Filter	WR185	£3.25
		WR187	£2.50
		WR188	£2.50
	Bug Key with memory	WR189	£4.45
	Modifying FRG7	WR190	£3.25
	Remote MF Loop	WR191	£2.50
	Remote MF Loop	WR192	£3.00
	Bug Key with memory	WR192/A/B	£6.50
	Battery State Indicator	WR193	£3.50
	Modifying FRG7	WR194	£3.50
	Stable Tone Burst	WR195/A/B	£3.50
	PW Teme	WR196	£5.00

Suppliers of R.S. Components.

Please send Cash with Order

Barclaycard Visa

C. BOWES & COMPANY LTD.
Unit 7, Kenwood Road, Reddish, Stockport, Cheshire SK5 6PH.
Tel: 061 432 9434
Goods by Return

MAIL ORDER/RETAIL SALES

VHF/UHF TRANSCEIVERS

Trio TS 780 2M/70cm multimode	934.00
Yaesu FT726R (2M fitted) multimode	839.00
Trio TW4000A 2M/70cm 25W FM mobile	510.97
Trio TM401A 70cm 12W mobile	324.45
Trio TM201A 2M 25W mobile	295.19
Trio TR3500 70cm handheld	277.96
Trio TR2500 2M handheld	257.58
Yaesu FT290R 2M multimode portable	309.00
Yaesu FT209R 2M handheld	239.00
Yaesu FT203R 2M handheld	185.00
Icom IC202 2M handheld	259.00
Icom IC2E 2M handheld	199.00
Icom IC4E 70cm handheld	269.00
Trio TH21E 2M Micro handheld	179.00
Trio TH41E 70cm Micro handheld	199.00



H.F. TRANSCEIVERS

Trio TS 930S Gen. Cov. Rx.	1250.00
Trio TS 430S Gen. Cov. Rx.	733.00
Trio TS 830S	793.10
Trio TS 530SP	698.00
Yaesu FT 757GX Gen. Cov. Rx.	759.00
Yaesu FT77	479.00

H.F. RECEIVERS

Icom IC R71	699.00
Icom IC R70	599.00
Trio R2000	456.63
Trio VC-10 VHF conv. for R2000	122.00
Yaesu FRG 8800	525.00
Yaesu FRT 7700 antenna tuner	48.25
Yaesu FRA 7700 active antenna unit	43.95
Trio R600	285.28

UHF/VHF RECEIVERS

A.O.R. AR2001 25-500MHz	365.00
J.I.L. SX200N	299.00
F.D.K. ATC 720 Airband handheld	175.00
F.D.K. RX 40 141-179 MHz handheld	149.00
R 532 Airband 12V mobile	186.00

ANTENNA BITS

Hi-Q Balun 1:1 5kW PEP	11.95 (0.75)
7.1 MHz Rat-traps - white epoxy - pair	8.95 (1.50)
Self amalgamating Tape 10m x 25mm	3.95 (0.75)
50 Mtrs 16 swg hand drawn copper wire	6.90 (1.00)
T-piece Polyprop. Dipole centre	1.50 (0.40)
Polyprop Strain insulators	0.50 (0.10)
Small ceramic egg insulators	0.50 (0.10)
Large ceramic egg insulators	0.75 (0.10)
75 ohm Twin Feeder - Light duty per metre	0.16 (0.04)
300 ohm Twin Feeder - per metre	0.14 (0.04)
UR67 Low loss coax 50 ohm per metre	0.65 (0.20)
UR76 50 ohm coax per metre	0.25 (0.05)
UR70 70 ohm coax per metre	0.30 (0.05)
4mm Polyester Guy Rope (400kg) per metre	0.16 (0.04)

TEST EQUIPMENT

Black Star Frequency Counter (600MHz)	142.00 (1.50)
Trio DM81 Trio Dip Meter	78.90 (0.75)
A.K.D. VHF Wavemeter (130-450 MHz)	24.95 (-)

WELZ - DRAE - BNOS - JAYBEAM - HY GAIN - TET
MICROWAVE MODULES - DATONG - TONNA -
HIMOUND - AKD

Goods normally despatched within 24 hours

BREDHURST ELECTRONICS — HIGH ST — HANDCROSS — W. SUSSEX — 0444 400786 E&OE



TONO FOR RTTY. 5000E

From the famous TONO stable comes the new THETA - 5000E now ready to send and receive AMTOR as well as CW, RTTY, and ASCII

Features include:- 5" high resolution monitor displaying 400chr. x 16 lines x 2 pages, ARQ/FEC, time clock, Selcal (Selective calling), high speed RTTY demodulator - up to 300 bauds (600 baud using TTL level); 3 shifts (170,425 and 850 Hz) and two tones (2125 and 1275 Hz); manual or automatic Tx/Rx; Battery back-up memory (72 chars x 7 channels and 24 chars x 5 channels); type ahead correctable buffer memory; Morse code 5 - 100 wpm (variable weights) + autotrack on receive; CW practice feature with random generator, Automatic CR/LF with wrap around display, Automatic letters code insertion; Printer interface; Bargraph LED meter for tuning; TOR A, B and L - the list goes on and on..... Power requirements by the way are AC mains or 13.8v DC.



Thanet Electronics Ltd

143 Reculver Road, Herne Bay, Kent, Tel(02273) 63859/63850.

see us at
NEC!

From Scarab Systems

From U.K.'s leading radio software and hardware house.

SSTV 48K SPECTRUM

This slow scan TV program cassette enables you to receive photographs or diagrams without additional hardware. It provides the facility of syncing and the ability to change the grey scale. Images may be transferred to a printer if required. **£17.25 inc. VAT and postage.**

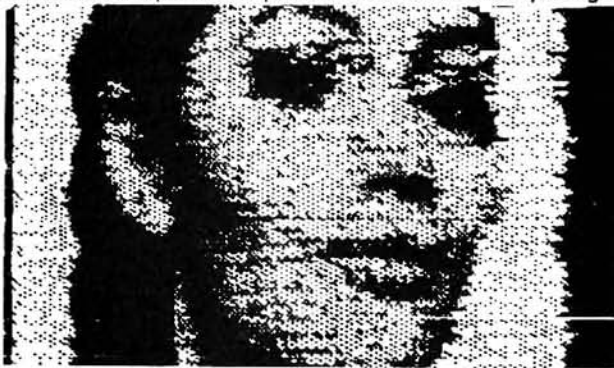

COMMODORE 64 RTTY PROGRAM. This program has several new features which make it the most up to date available. It has five screens and a feature is the instantaneous transmit mode (ITM) which can be used to interrupt the type ahead buffer and insert 'live' information. Other features include CW ident and PTT, automatic repeat on all keys, delete key for type ahead buffer and transmittable real time clock. All you need to join your Commodore

64 to the radio is a terminal unit (MPTU-1) and connecting user port plug

Cassette £10.50. Cassette plus MPTU-1 £78.00. User Port plug £2.50, all inc. VAT and postage.

MPTU-1 TONE ENCODER/DECODER. This phase lock loop circuit is 100% reliable and extremely sensitive **£69.70 inc. VAT and postage (all plugs supplied).**

Trade enquiries welcome. Prices correct at time of going to press



SCARAB SYSTEMS

Scarab Systems produce many other top-quality programs and equipment for the radio amateur. Use the coupon now for details

39 Stafford St, Gillingham, Kent ME7 5EN. Tel: 0634 570441

Please send me

- SSTV for 48K Spectrum £17.25 User port plug £2.50
- Commodore 64 RTTY Program Cassette £10.50 MPTU-1 only £69.70
- Cassette and MPTU-1 £78.00 Free details of other equipment and programs

I enclose a cheque/postal order for

I wish to use my Access/Visa Card No

Name

Address

Tel No

Signature

I understand that, if I am not fully satisfied within 21 days, I can return the equipment with full reimbursement, 14 days delivery.



MJI 102 — A NEW NUMBER IN BRITISH 'SCOPES . . .

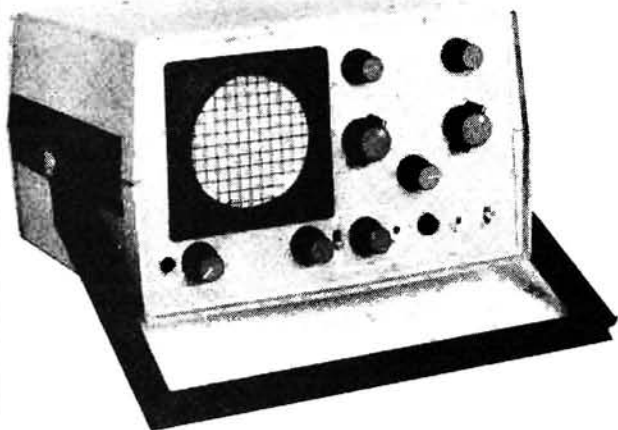

Simple Operation — Fully Automatic Trigger —
Single Beam — 100mV to 50V/Div. — Sensitivity —
10mS to 1μS/Div. — Sweep — X — Y Facility —
Lightweight and Compact

and at a very lightweight price

SEND FOR DETAILS NOW!

£129⁹⁵

MJ Instruments

HILLTOP HOUSE, THINGOE HILL,
BURY ST. EDMUNDS, SUFFOLK, IP32 6BE. Tel: (0284) 67104

HOW DO YOU GET TOP PRICES FOR YOUR SECONDHAND GEAR? ANSWER CONTACT G3RCQ'S USED EQUIPMENT CENTRE

"AUCTION" Auction your surplus gear from the comfort of your own fireside! **HOW?** Let's say you have a Yaesu FT290 for sale and you value it at £200. You send me 10% (£20) for inclusion into the auction. Your reserve price of £200 will not be quoted so you may even get bids over and above what you expect. Whatever the selling price there is no further payment. The first agreed price is all you pay the 10% on, for this fee I will advertise your equipment in LIST A RIG (those of you who have sold gear through the list will know how successful it is).

NATIONAL ADVERTISING FREE! I will advertise nationally in all monthly magazines on a rotation basis lists of all items to be auctioned. Potential purchasers will be invited to submit their bids by post to me before a specified date (auctions will be monthly). All bids will be forwarded to you, the seller. It is then up to you to contact the bidder of your choice and conduct the sale.

NO SALE — NO FEE If after advertising your gear for two months it does not sell I will return your 10%.

LIST-A-RIG To include your advert onto the list but not into the auction, send £2 for a maximum of 40 words. Adverts will remain on the list for 2 months.

INSTANT CASH! If you cannot wait and you must have cash today then I will buy your gear. Please phone or write **I PAY THE BEST PRICES.**

BUY & TRY If you buy a rig from me you have one month to change your mind! If during the first month of purchase you decide you have made a mistake or you simply cannot get on with the rig I will allow you 90% in part exchange for another rig of equal or greater value. If you want cash back without another rig I will give you 80% of your purchase price.

A FAIR DEAL IS MY POLICY When you deal with G3RCQ you get a straight deal — a full no quibble guarantee, coupled with free advice covering 25 years of amateur radio.

SEND S.A.E. TODAY FOR CURRENT LIST TO:

**G3RCQ ELECTRONICS,
USED EQUIPMENT CENTRE,
65 CECIL AVENUE, HORNCHURCH, ESSEX
TELEPHONE: HORNCHURCH (040 24) 55733**

Please leave a message on the answer phone 73's de DAVE & CORAL G3RCQ & G4RCQ.

AMATEUR ELECTRONICS UK

G6XBH



R.A.S. (Nottingham)
Radio Amateur Supplies
Tel: 0602 280267



Visit your Local Emporium

Large selection of New/Used Equipment on Show

AGENTS FOR:

F.D.K.
AZDEN
ICOM
YAESU
FORTOP ATV

ACCESSORIES:

Welz Range
Microwave Modules
Adonics Mics
Mutek Pre-Amps
Barenco Mast Supports
DRAE PSU and
Wave Meters

AERIAL, Tonna, Halbar, New Diamond Range of Mobile Whips

PLUS OWN

'Special' Q.R.P. GW5 HF5 Band Beams

JUST GIVE US A RING

Monday: CLOSED Tuesday-Saturday: 10.00am to 5.00pm

**3 Farndon Green, Wollaton Park, Nottingham,
Off Ring Rd, between A52 (Derby Road) & A609 (Ilkeston Road)**

J. BIRKETT

25 THE STRAIT,
LINCOLN LN2 1JF. TEL 20767

FETS J304 6 for £1, J230 5 for 60p.
TRANSFORMER 240 VOLT INPUT OUTPUT 13.0-13 VOLT. 1 AMP, 12 VOLT 1 AMP
at £1.95 P.P. 95p

VERY SMALL DISC CERAMIC 0.1UF 50VW @ 5p each

SOLDER-IN FEED THRU'S 5PF, 27PF, 300PF, 1000PF, all 20p doz.

MOTOROLA UHF POWER TRANSISTOR MRF511 FT2, 1GHZ 5 WATT @ £3.95.

LOW POWER RF TRANSISTORS 1 WATT 175MHZ BLY34 @ 75p, 2N3866 @ 75p.

2GHZ STRIPLINE NPN TRANSISTORS at 3 for £1.15.

ITT PNT CAPACITORS 0.1UF 250VW at 6 for 25p.

CERAMIC TRIMMERS 2.5 to 6PF, 3 to 10PF, 4 to 20PF, 7 to 35PF, 10 to 50PF, 10 to 60PF, all at 15p each.

VMOS POWER TRANSISTORS VN10KM @ 50p, WM211 @ 40p.

RF SIGNAL TRANSISTORS BFY90 @ 60p, 2N918 @ 25p, 2N5179 @ 50p, 2N5180 @ 50p, BF180 @ 20p.

AIR SPACED VARIABLES 10+10+20PF at £1.30.

MULLARD UHF MODULE BGY21 420 to 470MHZ, 12 VOLT, 1.2 WATT @ £12.

AUDIO I.C. TBA800 @ 70p, 6 1 AMP TRIACS 400PIV £1.

TAPE RECORDER MECHANICAL COUNTERS AT 3 for £1.

100PIV 20 AMP BRIDGES AT £1.30.

20 ASSORTED HCU CRYSTALS FOR £1.

VHF POWER TRANSISTORS BLY90 50 WATT 175MHZ @ £7.50.

TRANSISTORS BSX19, BSX20, BC548, BC549, BC558, ZTX108, ZTX213, ZTX342, 2N706, 2N4123, 2N5220 all 6 for 50p.

WOOD AND DOUGLAS KITS AVAILABLE BY POST AND FOR CALLERS
ACCESS AND BARCLAY CARDS ACCEPTED. P&P 50p, Under £5, over free. Goods normally by return.

SPECIAL PRICES ON SURPLUS EQUIPMENT

Racal RA17 receivers, high grade communications receivers, 500kHz/30MHz in 30 effective bands from **£195.00**. Eddystone receiver 730/4, 500kHz/30MHz in 5 bands **£145.00**. All in excellent condition. Carriage **£15.00**. Sanyo RP8880 9 bands portable communications receivers **£125.00**. Pye Westminster W15 low band AM **£30.00**, p&p £2.50. 27ft telescopic mast with guys, insulator etc £25.00 collected. High Impedance headphones with book mic, new **£7.50**. Avo valve testers **£35.00**, p&p £4.00. New 28 range digital multimeters **£40.25**. PCR receivers, LW/MW/SW, untested less PSU **£20.00**, p&p £5.00. 10ft whip aerials **£4.00**, p&p £1.50. Creed teleprinters **£25.00**. Various single and double beam oscilloscopes, signal generators, valve testers, output meters etc always in stock. Surplus circuit book containing circuits and notes on many surplus receivers, transceivers etc **£7.50**. Send 50p for illustrated catalogue, includes £1 voucher. Over 500 sets in stock. Avo's amateur rigs wanted for cash. New shop open at 218 St Albans Rd. Come and see the bargains!

WEIRMEAD LTD, 218 St Albans Road, Watford, Herts. 0923 49456
Access/Visa Welcome Goods in stock, delivery 7 days

R.F. LINEAR AMPLIFIERS

	D.C. Supply	Power In	Power Out	Preamp Incl.	Kit	Ready Built & Tested
2 METRES	13.8v	2.5w	25w	No	£29.95	£39.95
	13.8v	10w	50w	yes	£29.95	£43.95
	13.8v	2.5w	50w	Yes	£44.95	£57.95
	13.8v	2.5w	100w	Yes	£89.95	£109.50
	13.8v	10w	100w	Yes	£77.50	£96.50
	13.8v	25w	100w	Yes	£65.85	£84.95
	28v	10w	50w	Yes	£28.95	£42.95
70 cms	28v	10w	80w	Yes	£68.50	£82.95
	28v	10w	150w	Yes	£138.50	£158.50
	13.8v	1w	10w	No	£29.95	£42.50
	13.8v	1w	40w	No	£74.50	£86.50
	13.8v	10w	40w	No	£59.50	£69.50
13.8v	10w	80w	No	£89.95	£94.50	

Kits include pre-drilled case/heatsink and all parts except RF Input/Output connectors. Pre-amp gain -22dB, Noise Factor - <1.5dB, Auto Switching changeover.
POWER TARREN 13.8v 5-7 amp Regulated P.S.U.£19.95
SUPPLIES RFD 13.8v 20 amp Regulated P.S.U.£66.50, Built £79.80
NEW - Interested in A.T.V.? Why not run 80 watts, 40 watts or 10 watts Peak Sync.
Power with our combined P.A./modulator?

Terms: Post & Packing £1.20 (p.s.u. £4.50). Please allow 28 days for delivery.

S.A.E. for further information to: **R.F. DEVICES**

49 Roxholme Terrace, Leeds LS7 4JH. Telephone (0632) 623125

FOR QUALITY COMPONENTS
BY MAIL ORDER

ELECTROVALUE

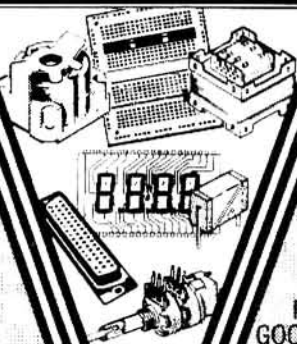

FREE
44 PAGE
PRICED AND
ILLUSTRATED
CATALOGUE
ON REQUEST

FREE POSTAGE
GOOD DISCOUNTS
GOOD SERVICE
THOUSANDS OF
STOCK ITEMS
PHONE YOUR ORDER
ACCESS OR
BARCLAYCARD

ELECTROVALUE LTD 28 St. Jude's Road, Englefield Green, Egham,
Surrey TW20 0HB Phone Egham (0784) 33603. Telex 264475
North Branch, 680 Burnage Lane, Manchester M19 1NA
Phone 061 432 4945
Please mention this publication when replying

Why own a 1st Class Radio with a 2nd Class Sound?

**May
we
suggest
an
answer?**

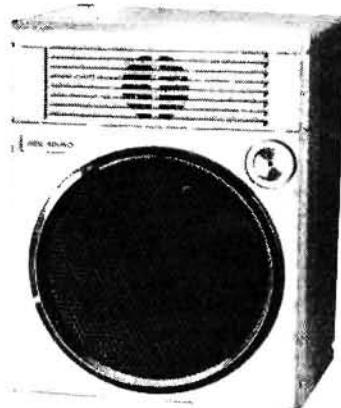

Now for the first time, a new ingenious compact sound system allows you to hear weak signals like never before, sort out the rare ones and listen to quality like you have never heard from your receiver, handle talkie or scanner. Usually, accessory speakers are no more than 50 pence speakers in fifty pound boxes. Their efficiency, frequency response and distortion levels are minimal and since most of all of the new transceivers have less than one watt of audio, our ability to understand becomes very difficult.

The new SS-2 Heil Sound System contains two five watt amplifiers, a 3.5" woofer with a half pound magnet a 1.5" tweeter with a 12 dB per octave passive crossover network. The tweeter is crossed over at 1500 Hz, right where the response of the human ear starts to fall off and the huge woofer fills out the mid-range and low frequency response. No single cheap speaker can begin to give you this type of response.

The second five watt amplifier can be used to drive a second speaker enclosure and will be used in a dual diversity system using the Heil parametric equalization system which will be introduced very soon.

When most receivers are running at a comfortable listening level, their little one half watt amplifiers are being pushed into extreme distortion levels. The extended response, the added efficiency and additional output power of the SS2 will lower your noise floor, reduce noise and allow you to copy signals that formerly were impossible to hear.

Mobile optional with the new Heil Sound System is unbelievable. The 5 watts of output and the tweeter system really adds to the articulation factor making signals so much easier to copy. The system makes Hand Held receivers come alive!

The SS-2 measures 3 3/4" x 5" x 3 3/4". It weighs 2 lbs. and is housed in a high impact silver beige case. Power requirements are 12-13.8 volts D.C. at 400 M.A. A red L.E.D. is mounted on the front panel for power up indication. All input/output connections to the amplifier is made through a 5 pin DIN plug.

You can own this great new addition to your station for only **£65.00** inclusive of VAT and carriage. We suggest that you hurry as there is probably someone calling you right now that your present speaker isn't truly reproducing. Discover the world of high quality audio today!

SS-2 Sound System

£65.00



Amcomm SERVICES LTD.,
194 NORTHOLT ROAD, SOUTH HARROW,
MIDDX. HA2 0EN. ENGLAND.

(Opp. South Harrow Underground Station)

TEL: 01-422 9585. TELEX: 24263

See main ad.
on page 16

VIDEO RECORDERS: Philips 1500 series colour, 6 chan int Rx3 band, RF or Video O/P with circs & two cassettes. 1500 model £45, 1501 £55.
AERIALS: Army telescopic 27ft 6 section, 5ft closed, £28, guy kit for these £8. **MAST KIT:** 30ft 10 section 1" with accs & carrying bag, new cond, £30.
WHIP AE: 16ft 4 section with vehicle type base insul & transit case, £8.50.
LONG WIRE AE KIT with 120ft insul braided copper wire,, 4x chain link insul, & 2x 25ft cords, £6.50. **TAPE RECORDERS MOD/EMI RE301** series 2 chan 2 speed 7 1/2" 15" take 8" spools, these have 3 & 600 ohm O/P with int monitor speaker, level meter, separate Rec & Playback amps, in metal case size 21x18x15" with copy of handbook, £65. **VALVE VOLTMETER:** Marconi TF1041B mains, meas DC volts 300MilliV to 1kv in 8 ranges, AC volts 300MilliV to 300V in 7 ranges Ohms 50 to 500Megs in 8 ranges, as DC/Ohms & AC/RF probe to 1500 Mc/s in case size 11x8x7" tested with book, £48. **SIG GENS:** Type TF144G 85Kc to 25Mc/s in 8 bands O/P Var 1Uv to 1V, int mod, with RF/Mod meter, large bench unit tested with inst book, £65 (spares available for these). **TAPE RECORDERS** for 240v two chan 1/4 track transis units in wood case with lid, supplied with head set with boom mike, reel of tape, circuit, £29. **V.F.O. UNITS** removed from Army HF Tx O/P freq nom 2.5 to 4.5Mc/s scaled 2/16Mc/s transis reqs 18v stab, approx size exc dial 8x8x5" contained in die cast box with s.m. dial with circ, £25. **POWER UNITS:** 240v I/P supplies stab O/P var 0 to 500v DC at 150Ma & 6.3v AC at 5 amps fitted Volt/Ma meter, 19" rack unit, will also give 550/700v DC un stab by int connection, tested, £35. **C.R.T.** Type DG7-32, small 2 3/4" dia general purpose tube with green trace with base & shield, £14. **TERMINALS:** HD type insulated 1/4" stud in black, 2 for £2, 4 for £3.50. **TIMER:** mech type panel mt var 0 to 8 mins as lpr c/o contacts, £6.50. **AUDIO OSC:** old type BFO 20c/s to 20K var O/P into 10/600 ohm with meter, in table case, fair cond, £18. **DEVIATION METERS:** type CT219 2.5 to 100 Mc/s meas dev 0 to 75Kc in 3 ranges with meter indication with book, £55. **AUTO TRANS:** 240/115v at 560 watts, enclosed size 6x4x3", £14.50. **R.T.T.Y. TEST SETS:** TDMs, 5 or 6 £35 ea or £60 pair **VALVE KITS** with 2x6V6, 2xECH35, 2xL63, & 6X5, £4.50. **F.M. TUNER HEAD:** tunes 88/108Mc/s with 10.7 Mc/s O/P reqs 12v DC supply 3 transis unit with var cond tuning new with connec, £4.75.

Above prices include carr/postage & VAT. Allow 14 days for delivery.

Goods ex equipment unless stated new.

S.A.E. with enquiry or 2 x 17p stamps for List 36.

A. H. SUPPLIES

122 Handworth Road, Sheffield S9 4AE.

Telephone: (0742) 444278



SMALL ADS

The prepaid rate for classified advertisements is 38 pence per work (minimum 12 words), box number 60p extra. Semi-display setting £12.60 per single column centimetre (minimum 2.5 cms). All cheques, postal orders etc., to be made payable to Practical Wireless and crossed "Lloyds Bank Ltd". Treasury notes should always be sent registered post. Advertisements, together with remittance should be sent to the Classified Advertisement Dept., Practical Wireless, Room 2612, IPC Magazines Limited, King's Reach Tower, Stamford St, London. SE1 9LS. (Telephone 01-261 5785).

NOTICE TO READERS

Whilst prices of goods shown in advertisements are correct at the time of closing for press, readers are advised to check with the advertiser both prices and availability of goods before ordering from non-current issues of the magazine.

When replying to Classified Advertisements please ensure:

- (A) That you have clearly stated your requirements.
- (B) That you have enclosed the right remittance.
- (C) That your name and address is written in block capitals, and
- (D) That your letter is correctly addressed to the adviser.

This will assist advertisers in processing and despatching orders with the minimum of delay.

Receivers and Components

VINTAGE WIRELESS SPARES. Valves, radios, amplifiers, service data. Antique wireless newsheet sample upon request. Mail order. VINTAGE WIRELESS COMPANY, Cosham Street, Mangotsfield, Bristol BS17 3EN. Tel. 0272-565472

RESISTORS 1,000 mixed 1/8W, 1/4W, 1/2W, 2%, 5%, 10% C. Film £3.45 inc. P&P. D. J. HOOKER, Romney Marsh Electronics, Pennywood, Clark Road, Greatstone, Romney Marsh, Kent TN28 8PB.

RADIO CANADA, Peking, Australia, Voice of America. A Vega 206 (6x SW/MW/LW) pulls these and dozens more. £23.95. Year's guarantee. Return despatch. CORRIGAN-RADIOWATCH, Building 109, Prestwick Airport, KA9 2RT.

CRYSTALS Made to order for any purpose and large stocks of standard frequencies for computers, modems, etc. Amateur CW (ORP) freqs £4.00 and CB conversion crystals at £4.50. **PROGRAMMABLE OSCILLATORS (PXO)** for baud rates, MPU, and freq markers £12.50.

FILTERS Crystal, monolithic, mechanical and ceramic for all standard IF's. Special 10.695MHz for big improvement to most CB rigs at £4.50 each.

S.A.E. FOR LISTS. PRICES INCLUDE VAT AND POST

P. R. GOLLEDGE ELECTRONICS
G3EDW, Merriott, Somerset, TA16 5NS
Tel. 0460 73718

Miscellaneous

NEW LOCATOR SYSTEM (Maidenhead). QRA to QTH conversion. Dec deg conversion. Distance calculation. DX beam headings. QTH to d.m.s. conversion. Etc. CBM64. Cl6. Electron. BBC. Apple. Cassette £6.50 inc p&p. DIDI-DIDA morse tutor and sender for CBM64 £6.50 (disc £9.00) inc p&p. MORAY MICRO COMPUTING, Enzie Slackhead, Buckie, Moray AB5 2BR.

SUPERB INSTRUMENT CASES by BAZELLI, manufactured from PVC. Faced steel. Vast range. Competitive prices start at a low £1.50. Punching facilities at very competitive prices. Suppliers only to Industry and the Trade. BAZELLI, (Dept No. 25), St. Wilfrid's, Foundry Lane, Halton, Lancaster LA2 6LT.

SPECIAL OFFERS - Multi Voltage Mains Adaptor 300ma £3.10, Multitester HM102BZ 20Kohm per volt £13.50, Universal Ni-Cad Battery Charger £6.95. P&P 40p. Thousands of components in stock. Phone or write for price list. SPECTRUM RADIO & ELECTRONICS LTD, 36 Slater Street, Liverpool L1 4BX. 051-709 4628.

HEATHKIT. U.K. Spares and Service Centre. CEDAR ELECTRONICS, Unit 12, Station Drive, Bredon, Tewkesbury, Glos. Tel. (0684) 73127.

BURGLAR ALARM EQUIPMENT. Ring Bradford (0274) 308920 for our catalogue or call at our large showrooms opposite Odsal Stadium.

FREE! Parcel of Components worth £10. Send only 80p postage!. D. HORSLEY, 113 Clare Road, Braintree, Essex.

WAVEGUIDE, FLANGES & DISHES. All standard sizes & Alloys (new material only) from stock. Special sizes to order. Call EARTH STATIONS 01-228 7876. 22 Howie Street, London SW11 4AR.

QSL CARDS. Gloss or tinted cards. SAE for samples to TWROG PRESS, Dept PW, Penybont, Gellilydan, Blaenau Festiniog, Gwynedd.

QSL CARDS, printed to your own design on white or coloured gloss card. S.A.E. for samples to: THE NUTLEY PRESS, 21 Holmethorpe Avenue, Redhill, Surrey RH1 2NB.

Service Sheets

BELL'S TELEVISION SERVICES for service sheets on Radio, TV, etc. £1.50 plus SAE. Service Manuals on Colour TV and Video Recorders, prices on request. SAE with enquiries to B.T.S., 190 Kings Road, Harrogate, N. Yorkshire. Tel. (0423) 55885.

TECHNICAL INFO SERVICES

76 Church St - Larkhall - Lanarks

FULL SIZE SERVICE SHEETS
Any radio, audio £2.50 + i.s.a.e.
CTVs/MusC £3.50 + i.s.a.e. complete set

Worlds largest collection
service manuals 30's - date
from £4.50-£35 each.

Comprehensive T.V. Repair Course
Complete Radio Service & Repair Course
ONLY £9.50 EACH

Repair data/circuits almost
any named TV/video for £10.50

S.a.e. brings any quotation
FREE 50p mag. inc. service sheet!
Pricelists unique elect. publications

FOR FAST QUOTES
RING 0698 883334

FOR FURTHER INFORMATION PLEASE RING 01-261 5785

ORDER FORM PLEASE WRITE IN BLOCK CAPITALS

Please insert the advertisement below in the next available issue of Practical Wireless for
insertions. I enclose Cheque/P.O. for £ CAT. heading
(Cheques and Postal Orders should be crossed Lloyds Bank Ltd. and made payable to Practical Wireless)

NAME

ADDRESS

PRACTICAL WIRELESS
Classified Advertisement Dept., Room 2612,
King's Reach Tower, Stamford Street,
London SE1 9LS Telephone 01-261 5785
Rate 38p per word, minimum 12 words.
Box No. 60p extra

Company registered in England. Registered No. 53626. Registered Office: King's Reach Tower, Stamford Street, London SE1 9LS.

3/85

Veteran & Vintage

VINTAGE RADIOS, over 200 stocked. 1920-1950s. Valve radios-amps etc. Repaired/restored. RADIO VINTAGE, 250 Seabrook Road, Seabrook, Hythe, Kent. Phone anytime (0303) 30693.

TRENCH SET WW1 wanted for Royal Engineers Museum, Chatham ME4 4UG. Reply to curator.

Books and Publications

RADIO & RTTY BOOKS

CONFIDENTIAL FREQUENCY LIST New 8th edition listing thousands of Aero, CV, Coastal, etc. stations worldwide £11.50 + 80p p&p
CLANDESTINE CONFIDENTIAL New guide to Rebel & Secret SW stations £8.20 + 80p p&p
GUIDE TO RTTY FREQUENCIES Lists 4,500 commercial, Aero, UN, Coastal etc. frequencies £8.95 + 80p p&p
WORLD PRESS SERVICES FREQUENCIES - News RTTY Services listings by frequencies, GMT & country, plus more £8.20 + 80p p&p
RTTY TODAY - Beginners Guide to RTTY decoding £8.20 + 80p p&p

2+ BOOKS P&P FREE

INTERPRODUCT LTD

PW13, Stanley, Perth PH1 4QL Tel: 073882-575

Educational

COURSE FOR CITY & GUILDS, Radio Amateurs Examination. Pass this important examination and obtain your licence, with an RRC Home Study Course. For details of this and other courses (GCE, Career and professional examinations, etc.) write or phone: THE RAPID RESULTS COLLEGE, Dept JX15, Tuition House, London, SW19 4DS. Tel. 01-947 7272 (9am-5pm) or use our 24hr Recordcall Service: 01-946 1102 quoting Dept JX15.

Software

SPECTRUM MORSE TUTOR & practice programme will take you from 0 to 30 w.p.m. No additional equipment required. £4.95. C.W.O. 'TAPES', 24 Bamford St. Nelson, Lancashire.

MORSE CODE GENERATION PROGRAMME Spectrum 48K £6. Maths for the radio amateur examination Spectrum 48K £12.50 J. I. BATLEY, 3 Foldon Avenue, Sunderland SR6 9HP

SSTV FOR BBC MICRO. RX/TX Rom and Sideways Ram versions. Software and demonstrations £20. S.A.E. for full details: G6GCM, 1 Goldsmith Drive, Newport Pagnell, Bucks.

MORSE READER PROGRAMMES. Off air onto screen. Programmes for BBC B, Spectrum, ZX81 16K. Dragon, Amstrad 464, Commodore 64 and any Vic 20 Sinclair computers need no interface, others use simple one transistor (BC107) interface. Programmes self tracking 8/30 w.p.m. All connections to existing sockets. Cassette with full instructions and circuit £6.00. J. E. PRICE, 4 Housman Walk, Offmore, Kidderminster.

MORSE READING PROGS. Work on clean signals without hardware interface. ZX81 1K Unexpanded Memory. Translated code with word and line spaces for easy reading. Automatic scroll action. £7 incl. Spectrum 16/48K. Scroll action with 10-page scrolling memory, instantly accessible page by page. £8 incl. All types variable speeds. Feed signal direct into Ear socket. PINEHURST DATA STUDIOS, 69 Pinehurst Park, West Moors, Wimborne, Dorset BH22 0BP.

Morse Software

RTTY/MORSE RADIO SOFTWARE. RTTY/Morse reader for 48K Spectrum. The ultimate RX program. Features include: 45.5 baud RTTY reception-full character set support-ed. Morse reception auto-speed control (5-35 w.p.m.), punctuation and wordspace. Also includes 40 page text memory and copy facility for printer. No extra hardware required. Simple connection to radio via computer ear socket. Price £6.00. Morse TX/RX Program for 48K Spectrum. Allows full transceive operation, includes comprehensive Morse tutor. No extra hardware required. Price £7.50. Morse RX Program for 16K Spectrum and 1K ZX81. Spectrum version includes comprehensive Morse tutor. Price £5.20. All above programs 100% machine code. P. ANDERSON, Wellands, Pilton, Shepton Mallet, Somerset.

Aerials

8 TRAP DI-POLES

Data Sheets, Large 24p
SAE Aerial Guide 75p

G2DYM, UPLOWMAN, TIVERTON, DEVON

Callers Welcome by Appointment ONLY Tel: 03986 215

G2VF D.I.V. H.F. long and medium wave frame antennas. S.A.E. for details: F. RYLANDS, 39 Parkside Avenue, Millbrook, Southampton

For Sale

NEW AND USED Amateur Radio Equipment, supplied, bought and exchanged. See for list. CALBRESO LTD., 258 Fratton Road, Portsmouth, Hants. Telephone: 0705 735003.

AMATEUR RADIO EQUIPMENT, Bought, Sold, Exchanged. For the Best Deal, Guaranteed! Phone Dave on 025 587 663 or 04024 57722. SAE for list to: G4TNY ELECTRONICS, 132 Albany Road, Hornchurch, Essex RM12 4AQ. Mail Order A SPECIALITY.

VALVES

	Minimum Order £1	*Special Quality	VALVES VAT IS INCLUDED								
ECC83	0.65	EY51	0.95	QV03-12	4.20	5R4GY	1.80	6F8G	0.85	12AU7	0.60
ECC84	0.60	EY81	0.65	SP61	1.80	5U4G	0.75	6F12	1.50	12AV6	0.95
ECC85	0.60	EY86/87	0.60	TT21	32.20	5V4G	0.75	6F14	1.15	12AX7	0.65
ECC88	0.80	EY88	0.65	TT22	29.50	5Y3GT	0.95	6F15	1.30	12BA6	0.90
ECC189	0.95	EZ30	0.70	UABCS0	0.75	SZ3	1.50	6F17	3.20	12BE6	1.25
ECC804	0.90	EZ81	0.70	UAF42	1.20	SZ4G	0.75	6F23	0.75	12BH7	3.00
ECC80	0.65	GM4	5.90	UBF80	0.70	SZ4GT	1.05	6F24	1.75	12E1	18.95
ECCF82	0.85	GY501	1.30	UBF89	0.70	6/30L2	0.90	6F33	10.50	12J5T	0.55
ECCF801	1.05	GZ32	1.05	UCC84	0.85	6AB7	0.70	6FH8	12.50	12K7GT	0.70
ECH34	2.25	GZ33	4.20	UCC85	0.70	6AC7	1.15	6GA8	1.95	12K8GT	0.80
ECH42	1.20	GZ34	2.75	UCF80	1.30	6AG5	0.60	6GH8A	1.95	12L7GT	0.60
ECH81	0.70	GZ37	3.95	UCH42	1.65	6AH6	1.15	6H6	1.60	12SC7	0.65
ECH84	0.80	KT66	10.95	UCH81	0.75	6AK5	0.65	6JU6	5.85	12SH7	0.65
ECL80	0.70	KT88	18.40	UCL82	0.95	6AK8	0.60	6J4	1.35	12SJ7	0.70
ECL82	0.75	ML4	2.80	UF41	1.35	6AL5	0.60	6J4W4	2.00	12SD7	1.45
ECL85	0.80	ML6	2.80	UF80	0.95	6AL5W	0.85	6J5	2.30	12SQ7GT	0.85
ECL86	0.90	N78	9.90	UF85	0.95	6AM5	4.20	6J5GT	0.90	12Y4	0.70
EF37A	2.15	O42	0.70	UACB0	0.95	6AM6	4.50	6J6	0.65	13D3	2.80
EF39	1.50	OZ81	1.80	UM180	0.90	6AN8A	2.50	6J6W	0.90	13D5	0.90
EF80	0.65	PCL82	0.95	UM84	0.70	6AQ4	3.40	6FH6	17.80	19AQ5	0.85
EF83	1.75	PCL84	0.90	UY82	0.70	6AQ5	1.00	6K7	0.80	18G3	11.50
EF85	0.60	PCL86	0.75	UY85	0.65	6AO5W	1.80	6JF6C	4.85	19H6	0.50
EF86	0.75	PCL805/85	0.95	VR105/30	1.25	6AS6	1.15	6JS6C	4.05	19G5	39.55
EF89	1.60	PD500/510	4.30	VR150/30	1.35	6AT6	0.90	6KD6	4.50	20D1	0.80
EF91	1.60	PFL200	1.10	X66	0.95	6AU6	0.60	6L6M	2.80	20E1	1.30
EF92	1.50		2.80*	X61M	1.70	6AV6	0.85	6L6CC	3.70	20P1	0.65
EF95	0.65	PL36	1.10	Z759	19.00	6AX4GT	1.30	6L8GT	1.80	25L6GT	0.95
EF96	0.60	PL81	0.85	Z749	0.75	6AX5GT	1.30	6L8	0.70	25Z4G	0.75
EF183	0.80	PL82	0.70	Z800U	3.45	6BA6		6LD20	0.70	35W4	0.80
EF184	0.80	PL83	0.60	Z801U	3.75		0.70/1.20*	807G	1.30	85A2	1.40
EF312	0.75	PL84	0.95	Z803U	6.00	6BE6	0.60/1.20*	6SA7	1.80		2.25*
EFL200	1.85	PL504	1.80	Z900T	2.45	6BG6G	1.60	6SG7	1.50	807	1.60/2.40*
EL32	1.10	PL508	2.40	I43	1.40	6BL6	1.30	6SJT	1.50	813	19.32
EL34	1.80/3.50*	PL509	5.80	I14	0.50	6BQ7A	0.85	6SK7	1.40		69.50*
EL37	5.20	PL519	5.80	I85	0.80	6BR7	4.80	6SR7	4.80	8298	24.00
EL82	0.70	PL802(SE)	2.95	I54	0.45	6BV6	6.20	6SL7GT	0.85	832A	8.90
EL84	0.80	PY80	0.70	I55	0.45	6BW7	1.80	6SN7GT	0.80	886A	3.80
EL86	0.95	PY81/800	0.85	I14	0.45	6CA	0.50	6SQ7	0.95	886E	6.25
EL90	1.00	PY82	0.65	I14	0.80	6C6	0.55	6V6G	1.50	931A	19.80
EL91	6.50	PY88	0.60	1X2B	1.40	6CH6	8.20	6V6GT	0.95	954	1.20
EL95	0.80	PY500A	2.10	2X2A	2.50	6CL6	2.75	6X4	0.95	955	1.20
EL504	1.70	QV03/10	3.20	3A4	0.70	6CW4	8.50	6X5GT	0.65	956	1.20
EL509	3.95		7.90*	3AT2	2.40	6CX8	3.80	6Y6G	0.90	973	4.80
EL519	6.30	QV03-20A	39.28	12.00	6CY5	1.15	6Z4	0.70	6860	1.95	
EL821	6.90		21.50	19.50*	6D6	0.70	9D6	2.30	6880	5.30	
EL822	9.95	QV03-25A	3D6	0.50	6F6	1.60	11E2	19.50	6146	6.80	
EL180(SE)	2.80		36.50	3E29	19.00	6F6GB	1.10	12A6	1.00	6146B	6.80
EM80	0.85	QV06/40A	354	0.60	6F7		12A2T6	0.70	6360	2.85	
EM87	1.30	19.50/36.50*	4B32	18.25	6FH8	17.80	12AT7	0.85	6550	8.05	

VALVES AND TRANSISTORS Telephone enquiries for valves, transistors, etc. Retail 7493934, trade and export 743 0899. PRICES MAY VARY. POSTAGE: £1-£3 50p; £3-£5 60p; £5-£10 80p; £10-£15 £1.00; £15-£20 £1.50; over £20 £2.00. Same day despatch.

COLOMOR (ELECTRONICS LTD.) 170 Goldhawk Rd, London W12
Tel: 01-743 0899 or 01-749 3934. Open Monday to Friday 9 a.m.-5.30 p.m.

PW

TUTORS REQUIRED



CGLI Radio Amateurs Exam

If you would be interested in tutoring students by correspondence, and in writing and revising study material, please write for further details and application form to:

The Senior Tutor (C588)
The Rapid Results College
Tuition House
27/37 St George's Road
London SW19 4DS

You will need to have good Maths and Physics, a practical understanding of radio, and current experience, as well as a detailed knowledge of the syllabus. The College will provide guidance on the techniques of correspondence tuition.

★ Specialists in correspondence education for over 50 years. ★

D.I.Y. ELECTRONICS...

MARCH ISSUE

WITH

NEW FEATURE BBC FORUM

Each month 'PE' will take a look at interfacing, control and peripherals for the BBC Micro.

PROJECTS

- HEART BEAT MONITOR
- LOW COST SPEECH SYNTHESISER FOR THE BBC MICRO

PRACTICAL
ELECTRONICS
 ROBOTICS • MICROS • ELECTRONICS • INTERFACING

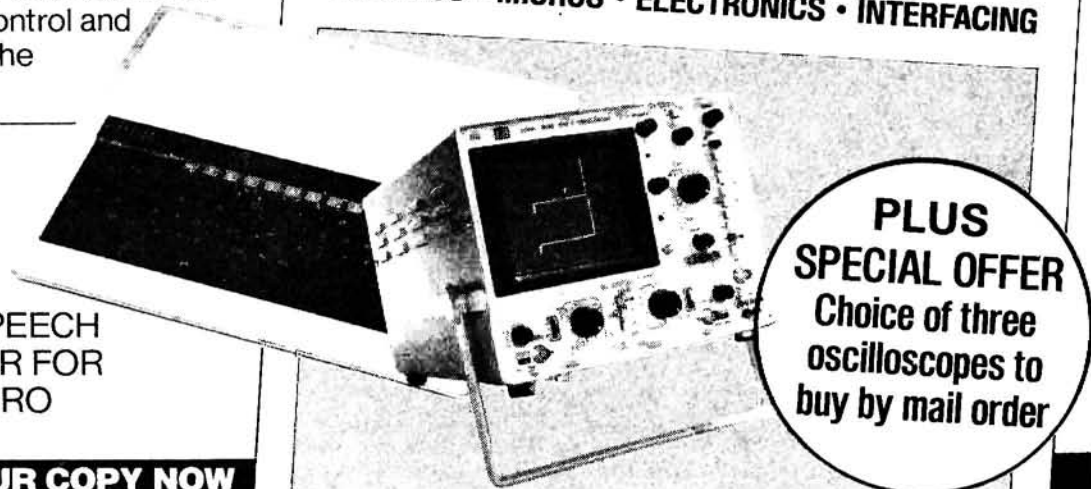

**PLUS
SPECIAL OFFER**
 Choice of three
 oscilloscopes to
 buy by mail order

GET YOUR COPY NOW

A SOUND IDEA...

Take out an annual subscription for **PRACTICAL WIRELESS** and have your copy of Britain's leading magazine for radio enthusiasts delivered direct to

your door. Every month you'll receive the latest product news plus projects, techniques and reports from the amateur and broadcast bands.

SUBSCRIPTION RATES

U.K. £13.00
 Overseas £14.00

**COMPLETE
AND POST
THIS
ORDER FORM
TODAY!**

Practical Wireless

SUBSCRIPTION ORDER FORM

Annual Subscription Rates
 U.K. £13.00
 Overseas £14.00
 (Students deduct £1 and quote Student number)

Complete this form and post it, with payment or credit card authorisation to:
Practical Wireless
 Subscription Dept.
 Oakfield House,
 35 Perrymount Road,
 Haywards Heath,
 West Sussex RH16 3DH

POST COPIES TO:

NAME: _____

ADDRESS: _____

POST CODE: _____

I enclose my cheque/P.O. payable to IPC Magazines Ltd for £. _____

Charge my credit card A/C at quoted rate



Card valid from: _____ to _____

Signature _____ **27**

INDEX TO ADVERTISERS

A.H. Supplies	75	Maplin Supplies	Cover 4
Allweld Engineering	8	Microwave Modules	25
Am. Radio Exchange	9, 21, 27, 37, 54, 56, 61, 63, 68	M&J Instruments	74
Amcomm Services	10, 16, 75	Northern Amateur Radio	79
Antex	Cover 2	Radio Shack Ltd.	59
Armon Products	71	Raedek Electronics	8
Bi-Pak	15	Random Electronics	80
Birkett, J.	74	Rapid Results College	77
B.N.O.S.	11	R.A.S. Nottingham	74
Blackstar	59	R.F. Devices	74
Bredhurst	73	R.S.T. Valve	80
British National Radio and Electronics School	8	R. Withers Comms.	26
Cambridge Kits	59	Scarab Systems	73
C. Bowes	72	S.E.M.	72
C.Q. Centre	11	Skybridge Ltd.	12
Colomor Electronics	77	Skywave Software	14
Commutech	80	South Midlands Comms.	4, 5
Datong Electronics	12	South-West Aerials	59
Davtrend	10	Stephens-James Ltd.	10
Dressler (U.K.) Ltd.	13	Tandy	47
Electrovalue	75	Technical Info Services	76
G2DYM Aerials	77	Technical Software	80
Garex Electronics	14	Thacker, A.H.	80
G3RCQ Electronics	74	Tha-net Electronics	6, 7, 73
Golledge Electronics	76	Timestep	65
Greenweld	72	Ward & Co., Reg	Cover 3
Lecmar Electronics	14	Waters & Stanton	71
Lee Electronics	26	Weirmead Ltd.	74
Low Electronics	2, 3	Wood & Douglas	12

**PLEASE
MENTION
PRACTICAL
WIRELESS
WHEN
REPLYING TO
ADVERTS**

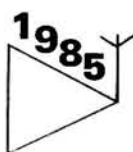

Northern Amateur Radio Societies Association

The Northern Amateur Radio Societies Association
will be holding their
**23rd Annual Radio & Electronics Exhibition
and Mobile Rally**
in the
**Central Hall, BELLE VUE, Redgate Lane,
Longsight, Manchester**
on
Sunday, 10th March, 1985, commencing at 11.00 a.m.
Admission will be £1.00 to the exhibition.
O.A.P.s and Children 50p.
Car park facilities (80p) are available as will be restaurant
and bar.
Contests and a raffle will take place.
There will be a play area for children.
Talk in will be on S22, SU8, or any other clear frequency.

RST

MAIL ORDER CO.
Langrex Supplies Ltd.
Climax House,
159 Fallsbrook Road, Streatham, SW16 6ED.
SPECIAL EXPRESS MAIL ORDER SERVICE

AZ31	Ep	EM81	2.50	PL509	6.00	6AK5	5.99	6L6G	3.00
CL33	4.00	EM87	2.50	PL519	6.00	6AL5	1.50	6L6GC	3.50
DY867	1.50	EN91	6.50	PL802	6.00	6AM6	6.02	6L7	2.75
DY802	1.50	EY61	2.75	PY33	2.50	6AN5	4.75	6L06	7.50
E88CC	8.42	EY86	1.75	PY81	1.50	6AN8A	3.50	6L7	7.75
E180F	10.20	EY88	1.75	PY82	1.50	6AQ5	2.25	6SA7	3.00
E810F	35.48	EY500A	3.00	PY83	1.25	6AR5	25.00	6SC7	2.75
EABC8	1.25	EZ80	1.50	PY88	2.00	6ASE	8.66	6S7J	3.25
EB91	1.50	EZ81	1.50	PY900A	4.00	6AS7G	8.75	6S7K	3.50
EBF80	1.50	GY501	3.00	PY900	1.50	6AT7	1.50	6SL7GT	3.00
EBF89	1.50	GZ32	4.00	QV01	1.50	6AUSGT	5.00	6SN7GT	3.00
EC91	8.00	GZ33	4.75	QV02-6	31.80	6AU6	2.50	6SS7	2.75
ECC33	4.50	GZ34	3.00	QV03-10	23.50	6AW8A	3.75	6SG7M	2.50
ECC35	4.50	GZ37	4.75	QV03-20A	48.38	6B7	3.25	6U8A	2.25
ECC31	1.75	KT66	5.00	QV06-40A	48.38	6B8	3.25	6V8GT	2.25
ECC32	1.75	KT66	5.00	QV06-40A	48.38	6B8A	1.50	6X4	2.00
ECC33	1.75	KT77	12.00	QV03-12	6.80	6BE6	1.50	6X5GT	1.75
ECC35	1.75	KT88	20.00	R18	3.00	6BH6	2.50	12AX7	1.75
ECC38	2.10	N78	15.00	R19	9.24	6BJ6	2.25	12BE6	2.50
ECC39	8.93	OA2	3.25	SP41	6.00	6BN6	2.00	12BY7A	3.00
ECF80	1.50	OB2	4.35	SP61	4.00	6BQ7A	3.50	12HG7	4.50
ECJ35	3.00	OC3	2.50	U19	13.75	6BR7	6.00	30FL12	1.38
ECM42	3.50	OC3	2.50	U25	2.50	6BR8A	3.50	30P4	2.50
ECM81	3.00	OD3	2.50	U26	2.50	6BS7	6.00	30P19	2.50
ECL80	1.50	PC86	2.50	U37	12.00	6BW6	6.00	30PL13	1.80
ECL82	1.50	PC88	2.50	UABC80	1.25	6BW7	1.50	30PL14	1.80
ECL83	3.00	PC92	1.75	UBF89	1.50	6BZ6	2.75	572B	40.00
ECL86	1.75	PC97	1.75	UCH42	2.50	6C4	1.25	805	45.00
EF37A	5.00	PC900	1.75	UCH81	2.50	6C6	1.75	807	3.75
EF39	2.75	PCF80	2.00	UCL82	1.75	6C8BA	2.50	811A	18.33
EF41	3.50	PCF82	1.50	UCL83	2.75	6CD6GA	5.00	812A	29.50
EF42	4.50	PCF86	2.50	UFB99	2.00	6CL6	3.75	813	65.00
EF50	2.50	PCF801	2.50	UL41	5.00	6C4B	13.00	866A	20.00
EF54	5.00	PCF802	2.50	UL94	1.75	6C4W	8.00	872A	20.00
EF55	3.50	PCF805	1.70	UY1	4.25	6D6	1.75	813A	18.50
EF80	1.75	PCF808	1.70	UY85	2.25	6D05	6.00	20E50	7.00
EF86	3.50	PCH200	3.00	VR105/30	2.50	6EA8	3.00	5763	4.50
EF91	2.95	PCL82	2.00	VR150/30	2.50	6EH5	1.85	5814A	4.00
EF92	6.37	PCL83	3.00	Z789	25.00	6F6	3.00	5842	12.00
EF183	2.00	PCL84	2.00	Z803U	19.00	6G6	2.75	6080	14.00
EF184	2.00	PCL85	2.50	ZD21	3.25	6H6	3.00	6146B	12.25
EH90	1.75	PCL86	2.50	3B28	40.00	6HS6	3.77	6828B	8.25
EL32	2.50	PCL805	2.50	4CX250B	46.00	6J5	4.50	6973	4.00
EL33	4.00	PD500	6.00	5R4GY	3.50	6J8	8.93	7360	10.00
EL34	4.00	PFL200	2.50	5UJAG	3.00	6J7	4.75	7586	15.00
EL36	2.50	PL36	2.50	5VAG	2.50	6J8A	6.00	7587	23.00
EL81	5.25	PL81	1.75	5Y3GT	2.50	6J8C	6.00		
EL84	2.25	PL82	1.50	5Z3	4.00	6K4N	2.50		
EL86	2.75	PL83	2.50	5Z4GT	2.50	6K6GT	2.75		
EL91	9.89	PL84	2.00	83CL2	1.75	6K7	3.00		
EL95	2.00	PL504	2.50	6AB7	3.00	6K8	3.00		
EL360	8.50	PL508	2.50	6AH6	5.00	6KD6	7.00		

Open daily to callers: Mon-Fri 9 a.m.-5 p.m.
Valves, Tubes and Transistors - Closed Saturday
Terms C.W.O. only, allow 7 days for delivery. Tel. 01-677 24247.
Prices excluding VAT add 15%
Quotations for any types not listed S.A.E.
Post and packing 50p per order
Telex 946708
Prices correct when going to press

RTTY and CW TRANSCEIVE with NO TERMINAL UNIT

This fantastic program interfaces direct with your rig, slashing the cost of previous systems. Split screen, type ahead, all the usual features and more. Tape and kit for the very simple interface, including PCB and User Port Connector, for only £20. Ready-made interfaces available. For CBM64, BBC-B and VIC20 (+ at least 8k). CW-only version for SPECTRUM £10.

And four superb programs for CBM64, VIC20, BBC-B, SPECTRUM
LOCATOR QTH or Maidenhead locator or lat/long. Distances, headings, contest points, converts between locator and lat/long. Tape £6.

LOGBOOK Date, band, mode, call and remarks. Superfast callsign search. Easy, fast updating of files. Screen/printer output. VIC20 needs at least 8k expansion. Tape £6.

MORSE TUTOR Britain's best. Learn fast in easy stages from absolute beginner to over 40 wpm. Join the hundreds who have succeeded with this program. Tape and full learning guide £6. For ZX81-16k also.

RAE MATHS All the practice and testing you need. Tape and comprehensive reference sheet detailing all you need to know E8 VIC20 needs expansion (any). For ZX81-16k also. Don't let maths make you fail. PASS with this program.

All programs are very easy to use and come with full instructions.
Prices include p&p 1st Class by return. Add £1 per tape if outside UK or Ireland.

technical software (PW)

From, Upper Llandwrog, Caernarfon, Gwynedd LL54 7RF. Tel. 0286 881886

GENERAL COVERAGE RECEIVER KIT FCR 130

Model FCR 130 Receiver kit - Only £75.30 inc VAT. p & p £2.40 Delivery by return



- ★ 30:1 Geared analogue tuning
- ★ 3 Band switch with spare position
- ★ Tape record socket
- ★ Headphone socket
- ★ Signal Meter
- ★ Internal speaker + On/Off sw.
- ★ A.F. Gain and Tone Control
- ★ C.W. A.M. SSB.

This is a complete kit which allows you to build and learn as you go. Suitable for anyone who has an interest in radio and can manage a soldering iron. It really is within the scope of most beginners. You don't have to be a 'semi-professional amateur' to understand how it works as we supply very comprehensive and complete instructions, written in plain language. Well spaced components so its OK for fat fingers! The receiver tunes, in 3 bands from 1 to 30 MHz. Solid aluminium tuning and control knobs and base panel. Black anodised front panel. Nice to build... nice to look at... nice to own.



COMMUTECH (Devon) LTD

Chapel Street, Holsworthy, Devon EX22 6AR.
Tel: (0409) 253504

ANTENNES TONNA (F9FT)

50MHz	1296MHz OR 1269MHz OSCAR UPLINK	23 element	£25.90(b)
5 element	4x23 element - power splitter	- stacking frame	£140.00(a)
144MHz	ALSO AVAILABLE FOR 1250MHz		
4 element	*denotes available for 50Ω or 75Ω		
5 element crossed	all others 50Ω ONLY.		
9* element fixed	PORTABLE ALUMINIUM TELESCOPIC MASTS		
9* element portable	4x1m £20.70(a)	3x2m £24.15(a)	
9* element crossed	4x2m £38.66(a)		
13 element portable	GALVANISED STEEL TELESCOPIC MASTS		
17* element fixed	2x3m £30.48(a)	3x3m £54.77(a)	
435MHz	4x3m £88.41(a)	5x3m £119.60(a)	
9 element	STACKING FRAME KITS FOR 4 ANTENNAS		
19* element	POWER SPLITTERS FOR 2 AND 4 ANTENNAS		
19* element crossed	ANDREW LDF-50 HELIAX COAXIAL CABLE		
21* element 432MHz	ROTATORS - COAXIAL CABLE-CONNECTORS		
21* element ATV			
144/435MHz			
9 & 19 element Oscar			

PLEASE ADD CARRIAGE AS SHOWN (a) £4.00. (b) £1.95. ALL PRICES INCLUDE VAT AT 15%
Cash with order, ACCESS - VISA - Just telephone your card number for immediate despatch.
FOR FULL SPECIFICATIONS SEND 40p FOR CATALOGUE
Callers welcome, but by telephone appointment only please. Goods by return.
RANDOM ELECTRONICS (P)
12 Conduit Road, Abingdon, Oxon OX14 1DB. Tel: (0235) 23060 (24 hours)

Marconi A.F. wattmeter CT44, 200 microwatts to 6 watts in 10 ranges switched - 2150 ohms. £30. P&P paid. Marconi H.F. wattmeter CT211, high power 70 ohms 25 watts, low power 52 ohms, 1 watt. £25. P&P paid. Ex-Gov. 27ft telescopic aerial close to 5ft. Good condition, complete with all base & fittings £45 P&P paid. Callers welcome £25. Pye Pocketfone Nightcall for PF1/TX/RX. New boxed £17.00. Whip aerial Ex-Gov. 4ft collapsible £1.00. Steel 2 in. Interlocking Mast sections 4ft. Price £4.00 each P&P paid, min. 5. Crystals HCBU Ex. Equip. 5,000 mc/s, 7,000 mc/s, 8,000 I.M.C. mc/s, 9,000 mc/s. Also Glass Crystal 100 Kcs, to fit B7G bags. All at £2 P&P paid. Ni-Cad batteries for Pye PF1 RX 5 for £2 P&P paid. Min. order 5. All these batteries are ex-eq. but good condition. 50ft Aluminium masts, kit contains 10 x 5ft interlocking 2" diameter poles complete with guys, base and stakes, as new £65.00 P&P paid, callers £50.00. 12ft Aluminium masts, 3 x 4ft 2" diameter, screw-in sections, 1 x 50ft length of coax cable and four guy ropes in a canvas bag. £16.00 P&P paid, callers £12.00.
Bargain Parcels 14 lbs at £10, 28 lbs at £20 and 56 lbs at £40, P&P paid. Contains pots, res., diodes, tagboards, caps., chassis, valve holders etc. Good value save £ £ £. Lucky dip service. AVO 7X. Tested. Ex. eq. £40 P&P paid. Brand New Carbon resistors 1/4 & 1/2W approx. 550 in each mixed pack £5.00 P&P paid.
Marconi AM Signal Generator. CT 452A 10 Kcs to 72 mc/s. £100 P&P paid.
Fibreglass aerial sections. 3ft x 1/2in dia. Push in type. £2.50 per section, min 5. P&P paid.
Airlite 62 headset boom mike 300ohms as new £20 P&P paid.

Opening times: Monday-Friday 8.30am-5.00pm, Saturday 8.30am-12am
Please allow 14 days for delivery. Mainland only.

A. H. THACKER & SONS LTD

HIGH STREET, CHESLYN HAY NEAR WALSALL, STAFFS.

It's easy to complain about an advertisement. Once you know how.

One of the numbers we keep a check on the advertising that appears in the press, on posters and in the cinema is by responding to consumers' complaints.

Any complaint sent to us is considered carefully and, if there's a case to answer, a full investigation is made.

If you think you've got good reason to complain about an advertisement, send off for a copy of our free leaflet.

It will tell you all you need to know to help us process your complaint as quickly as possible.

The Advertising Standards Authority. ✓
If an advertisement is wrong, we're here to put it right.

ASA Ltd, Dept 1 Brook House,
Torrington Place, London WC1E 7HN

This space is donated in the interests of high standards of advertising

REG. WARD & CO. LTD.

1 WESTERN PARADE, WEST STREET,
AXMINSTER, DEVON, EX13 5NY.

THE SOUTH-WEST'S LARGEST AMATEUR RADIO STOCKIST

Trio

TS930S	9 Band TX General Cov RX	1250.00 (-)
TS303S	160-70cm Transceiver 9 Bands	793.20 (-)
AT230	All Band ATU/Power Meter	150.47 (2.00)
SP230	External Speaker Unit	45.45 (1.50)
TS530S	160m-10m Transceiver	698.00 (-)
TS430S	160m-10m Transceiver	733.55 (-)
PS430	Matching Power Supply	135.00 (3.00)
SP430	Matching Speaker	32.40 (1.50)
MB430	Mobile Mounting Bracket	12.50 (1.50)
FM430	FM Board for TS430	42.00 (1.00)
TS130S	8 Band 200W Pep Transceiver	598.00 (-)
SP120	Base Station External Speaker	29.27 (1.50)
AT130	100W Antenna Tuner	103.45 (1.50)
MC50	Dual Impedance Desk Microphone	34.48 (1.50)
MC35S	Fist Microphone 50K ohm IMP	16.20 (0.75)
FL30A	HF Low Pass Filter 1KW	23.49 (1.00)
TR7930	2M FM Mobile	338.03 (-)
TR9130	2M Multimode	479.62 (-)
TW4000A	2M/70cm mobile	510.97 (-)
TM201A	2M 25W mobile	295.19 (-)
TM401A	7cms FM 12W	324.45 (-)
TR2500	2M FM Synthesised Handheld	257.58 (-)
TR3500	70cm Handheld	277.96 (-)
TR2600	New 2M FM Synthesised Handheld	281.60 (-)
ST2	Base Stand	57.48 (1.50)
SC4	Soft Case	15.16 (1.00)
SMC25	Speaker Mike	17.77 (1.00)
BR25	Spare Battery Pack	27.70 (1.00)
MS1	Mobile Stand	35.52 (1.00)
R600	Gen. Cov. Receiver	285.26 (-)
R2000	Synthesiser 200KHz 30MHz Receiver	456.63 (-)
HC10	Digital Station World Time Clock	75.23 (1.50)
HSS	Deluxe Headphones	25.60 (1.00)
SP40	Mobile External Speaker	15.67 (1.00)

NEW MODELS

TH21E/41E	2M/70cm Mini-Handhelds	179.48/199.00
TM21E/41E	2M/70cm FM Mobiles	377.22/431.03
TS71E/81E	2M/70cm base stations	792.15/898.00
TR3600	70CM Handheld	298.89

Linear Amps

TONO (G series)		
2M40G	2m, 1-3W in, 20-35W out, preamp	89.00 (2.00)
2M90G	2m, 10-15W in, 70-90W out, preamp	89.00 (2.00)
2M130G	2m, 10-15W in, 110-130W out, preamp	159.00 (2.50)
4M70G	70cms, 3-15W in, 40-60W out, preamp	179.00 (2.00)

MICROWAVE MODULES

MML144/30-LS	inc preamp (1/3 w ip)	75.00 (2.00)
MML144/50-S	inc preamp, switchable	16.20 (0.75)
MML144/100-S	inc preamp (10w ip)	143.95 (2.50)
MML144/100-HS	inc preamp (25w ip)	149.95 (2.50)
MML144/100-LS	inc preamp (1/3w ip)	169.95 (2.50)
MML432/30L	inc preamp (1/3w ip)	139.95 (2.00)
MML432/50	inc preamp (10w ip)	129.95 (2.00)
MML432/100	linear (10w ip)	245.00 (2.50)

B.N.O.S.

LPM 144-1-100	2m, 1W in, 100W out, preamp	172.50 (2.50)
LPM 144-3-100	2m, 3W in, 100W out, preamp	172.50 (2.50)
LPM 144-10-100	2m, 10W in, 100W out, preamp	149.50 (2.50)
LPM 144-25-160	2m, 25W in, 160W out, preamp	207.00 (2.50)
LPM 144-3-180	2m, 3W in, 180W out, preamp	235.75 (2.50)
LPM 144-10-180	2m, 10W in, 180W out, preamp	235.75 (2.50)
LPM 432-1-50	70cm, 1W in, 50W out, preamp	184.00 (2.50)
LPM 432-3-50	70cm, 3W in, 50W out, preamp	184.00 (2.50)
LPM 432-10-50	70cm, 10W in, 50W out, preamp	155.25 (2.50)

SWR/PWR Meters

HANSEN		
FS200	1.8-150MHz 20/200 Pep	57.95 (1.50)
FS210	1.8-150MHz 20/200 Auto SWR	63.50 (1.50)
FS5E	3.5-150MHz 20/200/1000W HF	42.75 (1.50)
FS500H	1.8-80MHz 20/200/2000W Pep	79.95 (1.50)
FS710H	1.8-60MHz 15/150/1500W Pep	102.95 (1.50)
WELZ		
SP15	1.8-160MHz PWR/SWR	45.00 (1.50)
SP45	130-470MHz PWR/SWR	65.00 (1.50)
SP10X	1.8-150MHz PWR/SWR	31.00 (1.50)
SP200	1.8-160MHz PWR/SWR	87.00 (1.50)
SP250	1.8-60MHz PWR/SWR	59.95 (1.50)
SP300	1.8-500MHz PWR/SWR	121.00 (1.50)
SP350	1.8-500MHz PWR/SWR	75.50 (1.50)
SP400	130-500MHz PWR/SWR	87.00 (1.50)
SP600	1.8-500MHz PWR/SWR	106.00 (1.50)
TOYO		
T430	144/432 120 W	44.85 (1.00)
T435	144/432 200 W	49.35 (1.00)

SCANNING RECEIVERS

SHF8400	VHF/UHF Scanner	249.00 (2.50)
SX200	VHF/UHF Scanner	298.00 (2.50)
SX400	VHF/UHF Continuous Coverage	588.00 (2.50)
AOR2001	VHF/UHF Continuous Coverage	365.00 (2.50)
FDK RX40	141.00-180.000 MHz	142.00 (2.00)

Icom Products

IC751	HF Transceiver	1239.00 (-)
IC745	HF Transceiver	898.00 (-)
IC730	Mobile HF Transceiver	P.O.A. (-)
PS15	P.S. Unit	185.00 (4.00)
PS30	Systems p.s.u. 25A	259.00 (-)
SM6	Base microphone for 751/745	36.50 (1.00)
IC290D	?n 25w M/Mode	469.00 (-)
IC290E	Low Multi Mode Mobile	399.00 (-)
IC271E	2m 25w M/Mode Base Str.	699.00 (-)
IC271H	100w version of above	889.00 (-)
IC25H	2m 45w FM	359.00 (-)
IC27E	25w FM mobile	359.00 (-)
IC45E	70c 10w FM	345.00 (-)
IC47E	70c 70cm FM mobile	449.00 (-)
ICBU1	BU Supply for 25/45/290	24.50 (1.00)
ICR70	General Coverage Receiver	599.00 (-)
ICR71	General Coverage Receiver	699.00 (-)
IC2E	2m H/Hand	259.00 (-)
ML1	2m 10w Linear	69.00 (2.00)
IC4E	70cm H/Hand	259.00 (-)
IC04E	70cm handheld	269.00 (-)
BC30	Base Charger	56.35 (-)
HM9	Speaker mic	18.55 (1.00)
IC3	Carry Case	5.50 (1.00)
ICBP3	Sid Battery Pack	27.50 (1.00)
BP5	High Power Battery Pack	52.80 (1.00)
CP1	Car Charging Lead	5.50 (1.00)
DC1	12v Adaptor	13.75 (1.00)

Mutek Products

SLNA 50	50MHz Switched preamp	44.90 (1.50)
SLNA 144s	144MHz Low noise switched preamp	39.90 (1.50)
SLNA 145sb	Preamp intended for 290	27.40 (1.50)
GLNA 432b	70cm Mast head preamp	149.90 (2.50)
RPCB 144ub	Front end FT212/225	74.90 (1.50)
RPCB 251ub	Front end IC251/211	79.90 (1.50)
BBA 500u	20 5000MHz Preamp	32.90 (1.50)
GFBA 144e	2m Mast head preamp	139.90 (2.50)
SBLA 144e	2m Mast head preamp	89.90 (2.50)
RPCB 271ub	Front end for IC271	89.90 (1.50)
TVHF 230c	2M-FM Transverter	334.90 (5.00)

Datong Products

PC1	Gen. Cov. Con.	137.40 (1.50)
VLF	Very low frequency conv.	29.90 (1.50)
FL2	Multi-mode audio filter	89.70 (1.50)
FL3	Audio filter for receivers	129.00 (1.50)
ASP/B	r.f. speech clipper for Trio	82.80 (1.50)
ASPA	r.f. speech clipper for Yaesu	82.80 (1.50)
ASP	As above with 8 pin conn	89.70 (1.50)
D75	Manual RF speech clipper	56.35 (1.50)
D70	Morse Tutor	56.35 (1.50)
MK	Keyboard morse sender	137.40 (1.50)
RFA	RF switched pre-amp	33.90 (1.50)
AD270-MPU	Active dipole with mains p.s.u.	51.75 (1.50)
AD370-MPU	Active dipole with mains p.s.u.	69.00 (1.50)
MPU	Mains power unit	6.90 (1.50)
DC144/28	2m converter	39.67 (1.50)
PTS1	Tone squelch unit	46.00 (1.50)
ANF	Automatic notch filter	67.85 (1.50)
SRB2	Auto Woodpecker blanker	86.25 (1.50)

CW/RTTY Equipment

Tono 9000E	Reader/Sender	P.O.A. (-)
Tono 550	Reader	299.00 (2.50)
MICROWAVE MODULES		
MM2001	RTTY to TV converter	189.00 (2.00)
MM4001	RTTY terminal	269.00 (2.00)
MM4001KB	RTTY term with keyboard	299.00 (2.00)
BENCHER		
BY1	Squeeze Key, Black base	53.95 (1.50)
BY2	Squeeze Key, Chrome base	69.95 (1.50)
HI-MOUND MORSE KEYS		
HK702	Up down keyer marble base	30.95 (1.50)
HK703	Up down keyer	29.35 (1.50)
HK704	Up down keyer	19.25 (1.50)
HK705	Up down keyer	15.49 (1.50)
HK706	Up down keyer	16.25 (1.00)
HK708	Up down keyer	14.35 (1.00)
HK802	Up down solid brass	82.85 (1.00)
HK808	Up down keyer	39.95 (1.00)
MK704	Twin paddle keyer	13.50 (1.00)
MK705	Twin paddle keyer marble base	25.50 (1.00)
KENPRO		
KP100	Squeeze CMOS 230/13.8v	79.50 (2.50)
KP200	Memory 4096 Multi Channel	169.50 (2.50)

Yaesu

FT1	HF Transceiver	P.O.A. (-)
FT980	HF Transceiver	1475.00 (-)
SP980	Speaker	64.40 (2.00)
FT77	Mobile HF Transceiver	479.00 (-)
FP700	PSU	145.00 (5.00)
FC700	Tuner	105.00 (2.00)
FT77s	10w. version	449.00 (-)
FMU77	FM Board for FT77	28.35 (1.00)
FT757	HF Transceiver	759.00 (-)
FC757	Auto A.T.U.	245.00 (2.00)
FP757HD	Heavy Duty PSU	179.00 (2.00)
FP757GX	Switched Mode PSU	140.00 (2.00)
FL2050	Linear Amplifier	115.00 (2.00)
FT290	2m M/Mode Port/Transceiver	309.00 (-)
FT290	With Mutek front end fitted	339.00 (-)
FT210	Linear Amplifier	69.00 (1.00)
FT790	70cm M/Mode Port/Transceiver	299.00 (-)
MMB11	Mobile Bracket	28.75 (1.00)
NC11	Charger	10.75 (1.00)
CSC1	Charging Case	4.60 (1.00)
YHA15	2m Helyical	5.75 (1.00)
YHA44D	70cm 1/2wave	9.95 (1.00)
YM49	Speaker Mike	70.30 (1.00)
FT230	2m 25w FM	269.00 (-)
FT730	70cm 20w. FM	239.00 (-)
MMB15	Mobile Bracket	14.55 (1.00)
FT203R	NEW 2m H/Hand/CW FNB3	185.00 (-)
FT209R	NEW 2m H/Hand/CW FNB3	239.00 (-)
FT208	2m H/Hand	209.00 (-)
FT708	70cm H/Hand	189.00 (-)
MMB10	Mobile Bracket	8.80 (0.75)
NC9C	Charger	9.60 (0.75)
NC8	Base/Station Charger	56.75 (2.00)
PA3	Car Adaptor/Charger	16.85 (1.00)
FNB2	Spare Battery Pack	23.00 (1.00)
YM24A	Speaker Mike	23.75 (1.00)
FT26R	2m Base Station	839.00 (-)
430/726	70cm Module for above	270.00 (2.50)
FRG7700	HF Receiver 15-30MHz	385.00 (-)
FRG7700M	As above with memory	455.00 (-)
FR77700	A.T.U. for above	48.30 (1.00)
MH18B	Hand 600 8pin mic	16.85 (1.00)
MD18B	Desk 600 8pin mic	64.40 (1.00)
MF1A3B	Boom mobile mic	19.95 (1.00)
YH77	Lightweight phones	14.95 (1.00)
YH55	Padded phones	14.95 (1.00)
YH1	L/wght Mobile H/set-Boom mic	14.95 (1.00)
SB1	PTT Switch Box 208/708	17.25 (1.00)
SB2	PTT Switch Box 290/790	14.55 (1.00)
QTR24D	World Time Clock	34.50 (1.00)
FF501DX	Low Pass Filter	29.90 (1.00)
YP150	Wattmeter/Dummy Load 150w	97.75 (1.00)

NEW MODELS

FRG8800	HF Receiver	525.00 (-)
FRV8800	Converter 118-175 for above	95.00 (-)
FT703	70cm H/Hand	P.O.A. (-)
FT709	70cm H/Hand	P.O.A. (-)
FT270R	2m 25W F.M.	325.00 (-)
FT270RH	2m 45W F.M.	380.00 (-)
FT2700R	2m/70cm/25W/25W	520.00 (-)

Power Supplies

DRAE			
4 amp	34.00 (2.00)	BNOS	6 amp 52.90 (2.50)
6 amp	53.50 (2.50)	12 amp	95.45 (3.00)
12 amp	75.50 (3.00)	25 amp	138.00 (4.00)
24 amp	110.00 (4.00)	40 amp	276.00 (4.00)

Aerial Rotators

9502B	3 core Lighter Duty	69.50 (2.00)
AR40	5 core Medium Duty	115.00 (2.00)
Med/H Duty		109.95 (2.50)
KR400	6 core Elevation	131.85 (2.50)
KR400RC	6 core Medium Duty	132.50 (2.50)
CD45	8 core Heavy Duty	189.95 (2.50)
KR600RC	8 core Heavy Duty	189.50 (3.00)
HAM1V	8 core Heavier Duty	299.00 (4.00)
T2X	8 core Very Heavy Duty	365.00 (4.00)

Switches

Sigma	2 way SO239	13.00 (1.00)
Sigma	2 way 'n' Skts	19.95 (1.00)
Welz	2 way SO239	21.95 (1.00)
Welz	2 way 'n' Skts	38.75 (1.00)
Drae	3 way SO239	15.40 (1.00)

Miscellaneous

DRAE	Wavemeter	27.50 (1.00)
T30	30W Dummy load	8.05 (1.00)
T100	100W Dummy load	30.48 (1.00)
T200	200W Dummy load	42.55 (1.50)
CT300	300W Dummy load	58.00 (2.00)
DRAE	2m Pre-set A.T.U.	11.80 (1.50)
	Altai Dip Meter	57.00 (1.00)

AERIALS BY:- JAYBEAM - HYGAIN - G. WHIP - TET - TONNA - MINIBEAM USUALLY IN STOCK

WOOD AND DOUGLAS KITS AND BENCHER PRODUCTS NOW IN STOCK

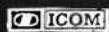

(Tel: 0297-34918)



CLOSED MONDAY/OPEN TUES-SAT 9:00-5:30

(closed for lunch 1:00-2:00)

STOCK ITEMS NORMALLY DESPATCHED WITHIN 48 HOURS

RODNEY G6LUJ

REG G2BSW

Instant credit also available



Mail/Telephone order by Cheque or Credit Card. Cheques cleared before goods despatched.



All new in the 1985 Catalogue

From a gentle purr to a mighty roar, the tightly controlled power of the beast is yours to command!

PROFESSIONAL QUALITY HIGH POWER LOUDSPEAKERS

A new range of superb quality loudspeakers.

- ★ Virtually indestructible high temperature voice-coil reinforced with glass-fibre
- ★ 100% heat overload tolerance
- ★ Advanced technology magnet system
- ★ Rigid cast alloy chassis
- ★ Linen or Plastiflex elastomer surrounds
- ★ 5-year guarantee (in addition to statutory rights)



Available in 5, 8, 10, 12, 15 and 18 inch models with 8Ω and some 16Ω impedances and with input powers ranging from 50W to 300W e.g.

- 5in. 50W 95dB 8Ω: XG39N / 16Ω: XG40T £17.95\$
- 8in. 100W 98dB 8Ω: XG43W £29.95\$
- 10in. 100W 100dB 8Ω: XG46A £29.95\$
- 12in. 100W 101dB 8Ω: XG49D £29.95\$
- 12in. Twin Cone 100W 100dB 8Ω: XG50E / 16Ω: XG51F £31.95\$

Note - the output power doubles for each 3dB increase (ref 1W @ 1m).

PRECISION GOLD MULTIMETERS



A new range of very high quality multimeters offering truly amazing quality at the price.

- Pocket Multimeter, 16 ranges, 2000Ω/V DC/AC £6.95\$ (YJ06G)
- M-102BZ with Continuity buzzer, battery tester and 10A DC range, 23 ranges, 20,000Ω/V DC £14.95\$ (YJ07H)
- M-2020S with Transistor, Diode & LED tester and 10A DC range, 27 ranges, 20,000Ω/V DC £19.95\$ (YJ08J)
- M-5050E Electronic Multimeter with very high impedance, FET input, 53 ranges including peak-to-peak AC, centre-zero and 12A AC/DC ranges £34.95\$ (YJ09K)
- M-5010 Digital Multimeter with 31 ranges including 20Ω and 20μA DC/AC FSD ranges, continuity buzzer, diode test, and gold-plated PCB for long-term reliability and consistent high accuracy (0.25% + 1 digit DCV) £42.50\$ (YJ10L)

N.B. All our prices include VAT and Carriage. A 50p handling charge must be added if your total order is less than £5 on mail order (except catalogue).

MAPLIN ELECTRONIC SUPPLIES LTD.

Mail Order: P.O. Box 3, Rayleigh, Essex SS6 8LR. Tel: Southend (0702) 552911 SHOPS

- BIRMINGHAM Lynton Square, Perry Barr, Tel: 021-356 7292.
 - LONDON 159-161 King Street, Hammersmith, W6. Tel: 01-748 0926.
 - MANCHESTER 8 Oxford Road, Tel: 061-236 0281.
 - SOUTHAMPTON 46-48 Bevois Valley Road, Tel: 0703 25831.
 - SOUTHCOTE 282-284 London Rd, Westcliff-on-Sea, Essex. Tel: 0702-554000
- Shops closed all day Monday.

§ Indicates that a lower price is available in our shops.



Our huge range of top quality electronic components at very competitive prices are all detailed in our catalogue, and with well over 600 new lines in our 1985 edition and many design improvements, it's well worth getting a copy. Here are just a few examples from the catalogue. (The items below are NOT kits).

- ★ Most phono and jack plugs now with integral strain relief sleeve - gold-plated types also available from 14p (gold from 70p)
- ★ Stereo Disco Mixer with cross-fade, talk-over, cue monitoring, aux input, slide controls. Only £58.95 (AF99H)



- ★ 10-Channel Stereo Graphic Equalisers - 3 models - basic; with peak level meter; and with spectrum analyser - from £77.95



- ★ Digital Delay Line permits Slap-back, Doubling, Flanging, Chorus and Echo. 11 controls. Only £195.00 (AF98G)
- ★ Video Enhancer improves picture quality when recording from one VTR to another, and with TV's with monitor input. Only 28.95 (XG59P)
- ★ Detailed descriptions of the exciting new 74HC range of IC's which combine the advantages of CMOS and TTL. From 46p
- ★ Keyboards: sloping keys, two-tone grey, mounted in steel frame, very smart cases (extra) available. 61 keys, only £33.95 (YJ12N) 79 keys, only £37.95 (YJ13P)
- ★ 1% Resistors now 50ppm/°C, 0.4W, only 2p each!
- ★ Auto transformers 120/240V 50VA, £10.75\$ (YJ56L). 100VA £14.95\$ (YJ57M). 150VA £16.95\$ (YJ58N). 250VA £21.95\$ (YJ59P).
- ★ Digital Clinical Thermometer. Only £13.95 (FK51F)



Check our 1985 Catalogue for all our other fascinating new lines.



1985 CATALOGUE

Pick up a copy now at any branch of W.H. Smith or in one of our shops. The price is still just £1.35, or £1.75 by post from our Rayleigh address (quote CA02C).



☎ Phone before 2pm for same day despatch.

Post this coupon now for your copy of the 1985 catalogue. Price £1.35 + 40p post and packing. If you live outside the U.K. send £2.40 or 11 International Reply Coupons. I enclose £1.75.

Name

Address

.....

.....

PW 3/85

All offers subject to availability.

Prices firm until Feb 9th 1985.