

*Making an* A.C. VALVE VOLTMETER

# PRACTICAL WIRELESS

FEBRUARY  
1955  
EDITOR: F.J. CAMM

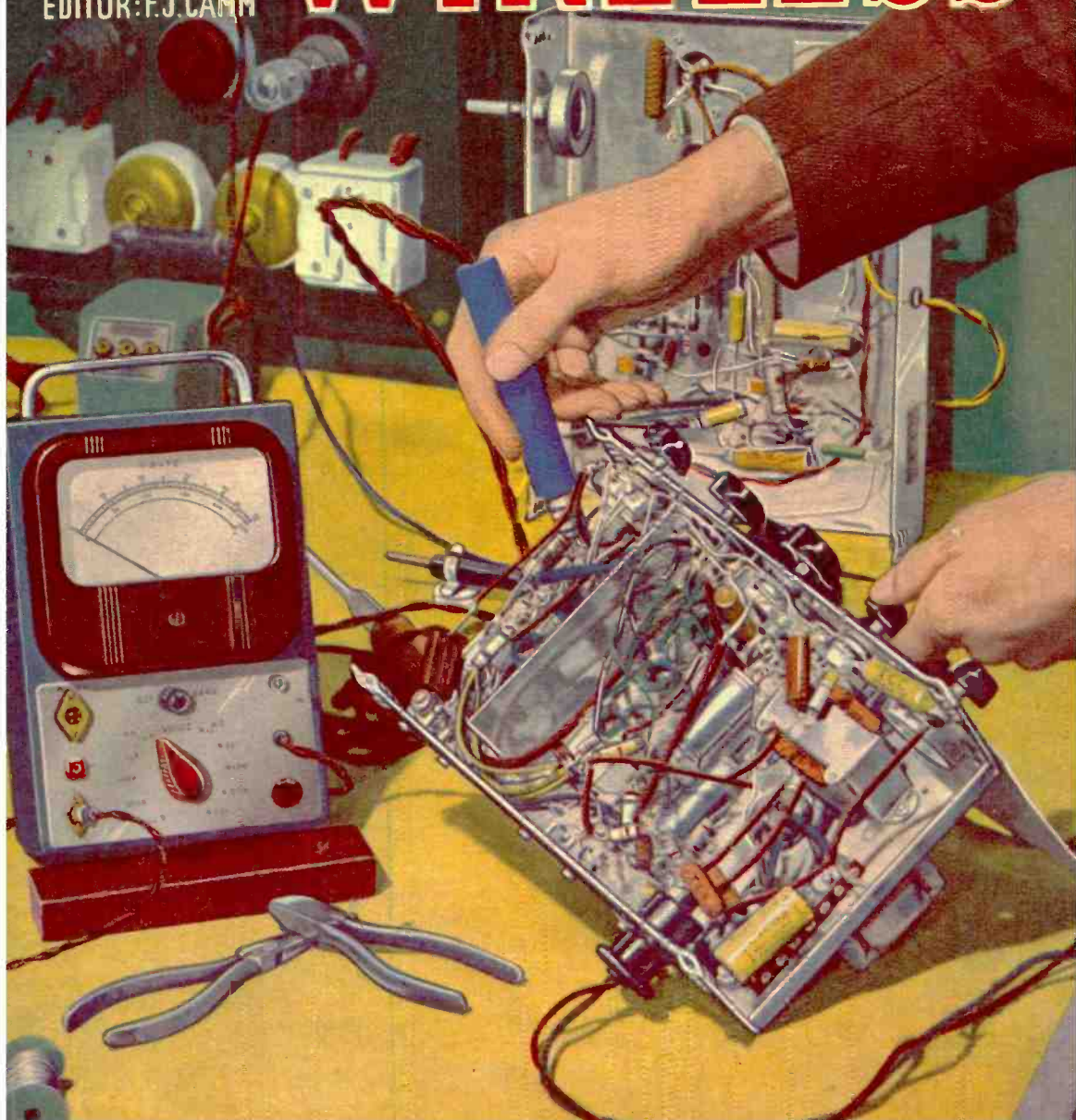

*Supreme in Service*

**'MICROMITE'**

**DRY ELECTROLYTIC CONDENSERS**

These small but high quality electrolytics have proved so popular that the range has been greatly extended. The use of high-gain etched foil electrodes keeps size and weight down, making the condensers suitable for suspension wiring. Conservatively rated; long shelf life ensured; green plastic insulating sleeving prevents short-circuits.



| Capacity in $\mu$ F. | Peak Wkg. Volts | Surge Volts | Dimns. in Ins. |       | Type No. | List Price Each |
|----------------------|-----------------|-------------|----------------|-------|----------|-----------------|
|                      |                 |             | Length         | Diam. |          |                 |
| 50                   | 12              | 15          | 1 1/2"         | 3/32" | CE87B    | 2/9             |
| 25                   | 50              | 60          | 1 1/2"         | 3/32" | CE88DE   | 3/-             |
| 1                    | 350             | 400         | 1 1/2"         | 3/32" | CE86L    | 2/6             |
| 8                    | 350             | 400         | 1 1/2"         | 3/32" | CE99LE   | 3/3             |
| 16                   | 350             | 400         | 2 1/4"         | 3/32" | CE91LE   | 4/-             |
| 32                   | 350             | 400         | 2 1/4"         | 3/32" | CE93LE   | 6/-             |
| 4                    | 450             | 550         | 1 1/2"         | 3/32" | CE99PE   | 3/3             |
| 8                    | 450             | 550         | 1 1/2"         | 3/32" | CE90PE   | 3/6             |
| 16                   | 450             | 550         | 1 1/2"         | 3/32" | CE92PE   | 5/-             |
| 32                   | 450             | 550         | 2 1/4"         | 3/32" | CE94PE   | 7/6             |



**THE TELEGRAPH CONDENSER CO. LTD**

RADIO DIVISION: NORTH ACTON · LONDON · W.3 · Telephone: ACOrn 0061

THE WORLD-FAMOUS

*Stentorian* CAMBRIC CONE

**HIGH FIDELITY UNITS**

*now available with universal impedance speech coil*



Prov. Patent 10037/53

● A most notable advance in loudspeaker design acclaimed by experts (including F. J. Camm, John Gilbert, P. Wilson, H. J. Barton-Chapple and L. Ormond Sparkes). It provides instant matching of the speech coil impedance at 3 ohms, 7.5 ohms and 15 ohms, and is available on the models marked with an asterisk. This development has added immeasurably to the great popularity already achieved among Hi-Fi enthusiasts. Your dealer can show you these new units, or they may be heard at our London Office, 109 Kingsway, any Saturday between 9 a.m. and noon.

**AT REMARKABLY LOW COST**

|             |                      |             |
|-------------|----------------------|-------------|
| Model HF510 | ... 5" Steel Unit    | ... £1.17.6 |
| .. HF510    | ... 5" Die cast Unit | ... £1.19.6 |
| .. HF610    | ... 6" Steel Unit    | ... £2.10.6 |
| .. HF610    | ... 6" Die cast Unit | ... £2.12.6 |
| .. HF810    | ... 8" Steel Unit    | ... £3. 0.6 |
| .. HF812*   | ... 8" Die cast Unit | ... £3. 5.6 |
| .. HF912*   | ... 9" Die cast Unit | ... £3. 9.6 |
| .. HF1012*  | ...10" Die cast Unit | ... £3.17.6 |
| .. HF1214   | ...12" Die cast Unit | ... £9.15.6 |

(Tax paid)



**BASS REFLEX CONSOLE CABINET**

Easily assembled polished walnut veneer cabinet, designed to give maximum reproduction from either the 10" or 12" Cambric Cone unit. Packed flat, with screws, ready for assembly. Size 32" x 22" x 16".

Price **£10-10-0**

Corner Console Cabinet (8" unit). . . . £5.10.0

WHITELEY ELECTRICAL RADIO CO. LTD · MANSFIELD · NOTTS

**MONEY BACK GUARANTEE**  
**DUKE ECHO** Tel: GRA 6677 CWO on COD

**12in. TUBES** £5  
**621 ROMFORD RD. LONDON, E.12.** **3 MONTHS' GUARANTEE**

**Mazda CRM121—A or B.**—A few other types available. As we have been selling for the last three years. Picture shown to callers. INSU-Carr. and Packing 15/6 extra. C.W.O.

**TEST TUBES £1.**—Most makes and types all work Perfectly, but have Cathode to Heater shorts or slight burn, ideal for testing or spares. Insured Carriage 15/6.

**H.T. BATTERY BARGAINS.—1/9.** All dry LT 1.5 and HT minimum 40 volt tested. 3/9, 60 volt + 1.5 LT All dry. 3/9, 674 volt HT Personal Portable type. 3/9, 60 volt HT. 3/9, 87 volt + 64.5 volt + 41 volt, size 9in. x 4in. square. 3/9. Inert cells, G.E.C. 3-volt twins. 1/-, 41 volt New Ever Ready LT or Bell, list price 3/6. P. & P. 1/9 on HT. 9d. on LT and cells. Plugs for Batts., 6d. each.

**SPOTLIGHTS.—8/9.** Butler's ex-W.D., new, 7in. dia., 6in. deep. Pre-focus fitting, post 1/3. Bulbs for above, 6 volt 38 or 42 watt, 12 volt 30, 36 or 48 watt, 4/6, post free.

**REAR LIGHTS.—1/9.** Infra-red glass. Ideal tail or side lamps when glass is changed. Post 9d.

**LADIES ONLY!** Treat the lady and yourself to a heated blanket for the home, 37/6 brings a complete heater kit that a lady can fit by herself *unaided*—with free drawings.

**FIRE-SIDE "RIPPING-LIDS" HEATER.—7/6.** For the home, works or office. Although these are used ex-W.D. they have been all overhauled and work perfectly (paraffin). Carriage 2/6.

**LIFE JACKET RESCUE LIGHTS.—1/3** (Batts. 6d., bulbs 1.5 v., 3d.). Ideal cycles rear or car parking light. Post 4d.

**MORSE KEYS.—New ex-W.D., 2/6.** Bargain. P. & P. 6d.

**MARCONI HEADPHONES.—New.** Not ex-W.D. light weight, very sensitive, very good quality only 12/6. P. & P. 9d. (less lead).

**200 MICRO-AMP METERS.—As new,** boxed moving coil movements 2in. scale in 2 1/2in. square mounting, 12/6, post 1/6, free drawings.

**VALVES—**from 1/9 each.

**CAR RADIO TRANSFORMER.—5/9.** 6 v. pri.; centre tapped sec.; made to very high specification. Post 1/-. 21d. stamp for Catalogue.

**Announcing an Entirely New**

**TAPE UNIT**

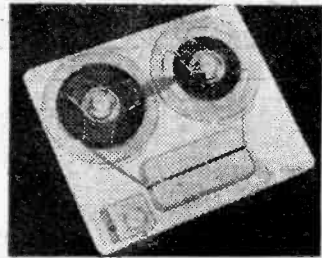

THE **LANE**  
 2 Speed Mark VI.

- ★ Three high grade motors.
- ★ Single knob control electrically and mechanically interlocked.
- ★ Drop-in tape loading.
- ★ Automatic brakes.
- ★ 2 speed. 7 1/2 in./sec., 3 1/2 in./sec.
- ★ Automatic speed change.

Beautifully finished and engineered, this new model offers unequalled value. Write for full details to: **£18.10.0**

**VERDIK SALES LIMITED**

8, Rupert Court, Wardour Street, London, W.1.  
 GERrard 8266.

**FREE To AMBITIOUS ENGINEERS!**

This 144-page Book



Have you sent for your copy?

**'ENGINEERING OPPORTUNITIES'**

is a highly informative guide to the best-paid Engineering posts. It tells you how you can quickly prepare at home on "NO PASS-NO FEE" terms for a recognised engineering qualification, outlines the widest range of modern Home-Study Courses in all branches of Engineering and explains the benefits of our Employment Dept. If you're earning less than £15 a week you cannot afford to miss reading this unique book. Send for your copy to-day—FREE.

--- FREE COUPON ---  
 Please send me your FREE 144-page "ENGINEERING OPPORTUNITIES"

**WHICH IS YOUR PET SUBJECT?**

- Mechanical Eng.
- Electrical Eng.
- Civil Engineering
- Radio Engineering
- Automobile Eng.
- Aeronautical Eng.
- Production Eng.
- Building, Plastics, Draughtsmanship
- Television, etc.

**GET SOME LETTERS AFTER YOUR NAME!**

- A.M.I.Mech.E.
- A.M.I.C.E.
- A.M.I.P.E.
- A.M.I.M.I.
- L.I.O.B.
- A.F.R.Ae.S.
- B.Sc.
- A.M.Bric.I.R.E.
- CITY & GUILDS GEN. CERT OF EDUCATION etc., etc.

NAME .....  
 ADDRESS .....  
 Subject or Exam. ....  
 chat interests me .....  
**Bright Institute of Engineering Technology,**  
 409B, College House, 29-31, Wright's Lane,  
 Kensington, W.8.

**BIET**

**You can rely on us**

**JUST A FEW ITEMS WE STOCK:—**

**MULLARD AMPLIFIER.**—Mains transformer, 35/6. Output transformer, 34/6. Punched chassis, 14/6, with screen.

**TRANSFORMERS.**—Set for amplifiers and receivers, 3/6. Test equipment, 3/6. Black crackle paint, 3/- tin. Special volume and tone controls for Philips and Mullard receivers, 7/6 each. Have you built the **OSRAM 912 QUALITY AMPLIFIER**? Book containing full instructions, 2/6. All parts stocked, including 8in. metal speaker G.E.C. £8.15.0. We have Truvox, Lane, Motek and Wearite tape decks available. H.P., ask for details. (Also all Avo Instruments.)

**A FEW SURPLUS BARGAIN COMPONENTS:—**  
 25 mfd. 25 v. very small, 1/6 each (6 for 7/6); 8 mfd. 450 v., 2/8; 25 mfd. 350 v., 1/- each; 32-32 450 v., 8/-; 32-32 350 v., 6/6; 8-16 450 v., 4/3; 16 mfd. 450 v., 4/-; 4,000 ohm ex-Govt. headphones, 12/8 pair; 6V6G valves, 7/-; 6AM6, 7/-; 3674, 8/6; 1C5GT, 12/-; EY51, 19/6; 12AU7, 9/6; 12AT7, 8/6. All the above are brand new and clean.

**WE STOCK** all enamel, silk, cotton, Eureka, tinned copper instrument wires. Resistors: 1 w., 1 w., 4d.; 1 w., 8d.; 2 w., 14; 5 w., 1/9; 10 w., 2/-; Midret 1 w., 6d.; 1 w., 8d. All values from 10 ohms to 10 meg. High stab. 2% precision 1/2 w., 1/8 each; 100 to 2 meg. Over a million in stock. Linear pots. up to 100 K., 5/-; 1, 1, 1 mc., 6/8; 1, 1, 1 mc., 2 mg. with centre tap, 7/6.

Midret 3-pin plug and socket, 1/-; 4-pin, 1/3; 6-pin, 1/6. Bulletin three colour panel fitting—contains three bulbs that can be switched to give any one of three colours, 12/6. Charger transformers 2 v., 6 v., 12 v., at 2 a., 19/6; at 4 amps, plus 24 v. at 2 a., 22/6; 2 a. metal rectifiers, 10/6; 4 amp type, 14/6.

**MIDGET HUNT'S MILDSEAL CONDENSERS.**—W90, .001, .002, .003, 1/3; .005, .01, 1 mid., 1/6. Silver mica, 8d.

**BOOKS.**—"Radio Gadgets," 3/6; "Amplifier Circuits," 2/6; "Oscilloscope Book," 5/-; "TV Faults," 1/5; "Radio Control of Motors," 5/-; "Radio Servicing Instruments," 4/8; "TV Test Equipment," 5/-; "Magnet Tape Recording," 4/6.

Write for our 6d. Catalogue and we are pleased to quote any components you may require.

Please add sufficient post & packing fee. Goods sent C.O.D. over £1.

**RADIO SERVICING CO.,**

82, SOUTH EATING ROAD, LONDON, W.5. EAL 5737.



# radio products Ltd.

(Dept. P.56) 418 BRIGHTON ROAD, SOUTH CROYDON, SURREY. Telephone: Croydon 5148/9

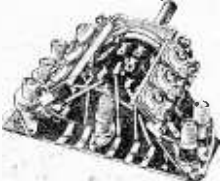

These really powerful units in compact form give quality and performance right out of proportion to their midget size and modest cost. Osmor "Q" Coilpacks have everything that only the highest degree of technical skill can ensure—extra selectivity, super sensitivity, adaptability. Size only 1 1/2 x 3 1/2 x 2 1/2 with variable iron-dust cores and Polystyrene formers. Built-in trimmers. Tropicalised. Prealigned Receiver—tested and guaranteed. Only 5 connections to make. All types for Mains and Battery Superhets and T.R.F. receivers. Ideal for the reliable construction of new sets, also for conversion of the 21 Receiver, TR1196, Type 13, Wartime Utility and others. Send to-day for particulars!

## SEPARATE COILS 4/-

A full range is available for all popular wavebands and purposes. Fully descriptive leaflets and connection data available. (Optional) new simple fixing 2d. extra. Just note these "5 Star" Features. \* Only 1in. high. \* Packed in damp-proof containers. \* Variable iron-dust cores. \* Fitted tabs for easy connection. \* Low loss Polystyrene formers. L. O. M.W. T.R.F. REACTION COIL TYPE QR 11-13 4/9.

A range of coils for F.M. Receivers shortly available.

A special design of coils now available for reflex circuits.



## OSMOR STATION SEPARATOR

The Separator may easily be tuned to eliminate any one station within the ranges stated and fitting takes only a few seconds. Sharp tuning is effected by adjusting the brass screw provided.

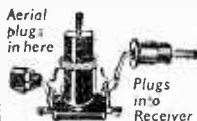

7/6

COMPLETE

## NO. METRES

- 1—141-253
- 2—218-283
- 3—267-311
- 4—319-405
- 5—395-492
- 6—455-537
- 7—1450-1530
- 8—410-550 k.c.

## CHASSIS CUTTER



| Type | Hole Sizes      | Prices |
|------|-----------------|--------|
| 1    | 1in. x 1 1/2in. | 19/6   |
| 2    | 1in. x 1in.     | 18/9   |
| 3    | 1in. x 1 1/4in. | 22/6   |
| 4    | 1 1/2in. x 2in. | 27/3   |

Illustr. list on request.

I.F.s. 465 k/c. Permeability-tuned with flying leads. Standard size 1 1/2in. x 1 1/2in. x 3 1/2in. For use with OSMOR coilpacks and others. 14/6 pair. Midget I.F.s 465 k/c. 1in. x 1in. x 2 1/2in. 21/- pair. PRE-ALIGNED. 1/6 extra, both types.

**FREE!**

Send 5d. (stamps) for fully descriptive literature including "The really efficient 5-valve Superhet Circuit and practical Drawings," 6-valve ditto, 3-valve (plus receiver) T.R.F. circuit, Battery portable Superhet circuit, Coil and Coilpack leaflets, Chassis Cutter leaflet, and full radio and component lists, and interesting miniature circuits, etc.

## DIALS—VARIOUS DIALS CALIBRATED TO COILS

Metal dials, overall size 5 1/2in. square. Cream background, 3-colour Type M1, L.M.S. waves, M2, L. & M. waves, M3, M. and 2 S. waves. Price 3/6 each. Pointer 1/3; Drum, Drive, Spring and Cord. 3/2. Type A glass dial assembly, measuring 7in. x 7in. (9 1/2 x 9 1/2) overall. Mounts in any position. Choice of two 3-colour scales. 24/6. P. & P. 1/6.

OUR TECHNICAL DEPT. WILL BE PLEASED TO ANSWER (BY LETTER ONLY) ANY ENQUIRY RELATING TO CIRCUITS WHICH OSMOR COILS OR COIL PACKS ARE USED OR ARE INTENDED TO BE USED.

WE ENDEAVOUR TO KEEP ABREAST OF THE TIMES BY BUILDING THE VARIOUS CIRCUITS PUBLISHED IN "WIRELESS WORLD," "PRACTICAL WIRELESS," "RADIO CONSTRUCTOR," ETC. WE KEEP STOCKS OF THE COMPONENTS SPECIFIED

### "PRACTICAL WIRELESS"

Coronet Four; Beginners' Superhet; Modern High Power Amplifier 2; Attache Case Portable; RI155 Converter; A.C. Band-Pass 3; Modern 1-Valver; 3-speed AutoGram, modern reflex, etc.

### "WIRELESS WORLD"

"No Compromise" T.R.F. Tuner. "Midget Mains Receiver." Sensitive 2-valve Receiver. Television Converter (special coils in cans available), Midget sensitive T.R.F., etc.

### "RADIO CONSTRUCTOR"

Converting the TR1196 receiver to a general purpose 5-het receiver simple crystal diode set. Radio feeder units. Economy 8 W.P.P. Amplifier. Circuit and details available for adding push-out to the 5/6 valve Osmor superhet.

A LIST OF FIXED CAPACITIES AS REQUIRED FOR SWITCH TUNING AVAILABLE ON APPLICATION

# "Q" COIL UNITS MAKE EASY SWITCHING

Wavebands may be added or changed in a few minutes. Switching arrangements can be increased as required. Multi-waveband coilpacks may be easily made up. The Coil Unit consists of Aerial and Oscillator Coils and Trimmers wired and ready to connect to switch.

THE SIMPLEST AND MOST CONVENIENT METHOD OF SET BUILDING SO FAR DEvised FOR THE AMATEUR.

15/- PER UNIT including 4 foolproof drawings

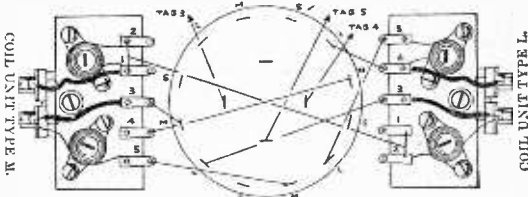

DESIGNERS ARE ASSURED OF FULL CO-OPERATION

PLEASE LET US KNOW YOUR REQUIREMENTS

NEWCOMERS TO RADIO. WE HAVE A NEW DEPARTMENT READY AND WILLING TO HELP SEND US YOUR PROBLEMS



# MAXI-Q IMPROVED TWO WAVEBAND T.R.F. COILS

**REGD.** These Long and Medium waveband T.R.F. Coils are an improvement on our already well-known "C" Coils. If you wish to improve the performance of the "Midget Three Valve A.C. Mains Receiver" by S. W. Amos (*Wireless World*, February, 1950), we strongly recommend the use of these coils. The following points are worth noting:

1. Wound on Polystyrene Colour Coded Formers—C2 R.F. Aerial Transformer, Colour Coded Blue—C3 Detector with Reaction, Colour Coded Green.
2. Litz windings on Long waveband.
3. Single 4 B.A. hole fixing.
4. Coverage: Long wave 800/2,000 metres. Medium wave 190/550 metres.
5. Windings are terminated to tinned copper spalls which ensure ease of soldering.

Retail Price—9/- per pair.  
Send 1/- in stamps for General Catalogue. Obtainable from all reputable stockists or in case of difficulty direct from works.

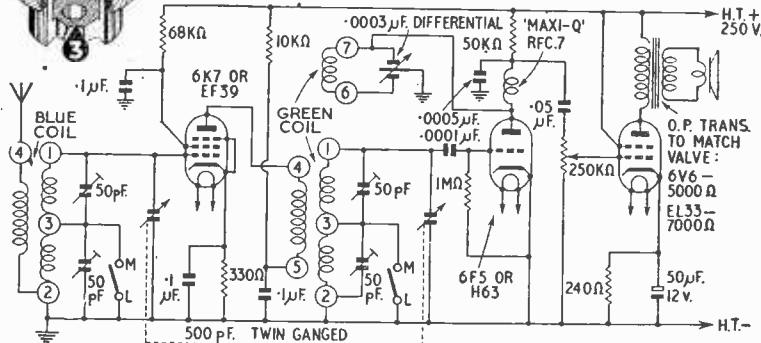

CIRCUIT APPLICATION

**DENCO (CLACTON) LTD., 357/9 Old Road, Clacton-on-Sea, Essex**

STOP PRESS: "Osram" "912" high quality amplifier chassis, 14/6. Front panel finished in bronze complete with control markings, 6/6. "Mullard" "Five-Ten" amplifier chassis, 14/6. Front Panel, 8/6.

# HENRY'S

(RADIO LTD.)

We have over 20,000 American and B.V.A. valves in stock. ALL VALVES NEW AND GUARANTEED.

|       |            |             |                |                   |      |
|-------|------------|-------------|----------------|-------------------|------|
| 1D8GT | 10/- 6AM6  | 9/- 12SA7GT | 8/6 EF36       | 6/6 SP1           | 4/-  |
| 1A7GT | 12/6 42    | 8/6 12SQ7GT | 8/6 EF39       | 6/6 D41           | 5/-  |
| 1H5GT | 10/- 43    | 8/6 12SJ7GT | 8/6 EK32       | 6/6 VP23          | 6/6  |
| 1N5GT | 10/- 75    | 8/6 12SK7GT | 8/6 EL32       | 7/6 HL 23 D D     | 5/-  |
| 1C6GT | 10/- 80    | 8/6 12SR7   | 7/6 EF50 (Red) | 6/6               | 6/6  |
| 1Q5GT | 10/- 6L6G  | 10/- 6D8    | 6/6 5Y1)       | 10/- TP25         | 8/6  |
| 1A5GT | 10/- 9Q7GT | 8/6 6C6     | 6/6 HL2        | 3/6 PEN25         | 6/6  |
| 1S5   | 7/6 6SQ7GT | 8/6 6A7G    | 8/6 LP2        | 4/6 TP22          | 8/6  |
| 1S4   | 7/6 6SS7GT | 6/6 6A8G    | 8/6 KT2        | 5/- QP21          | 8/6  |
| 1P4   | 7/6 6SJ7GT | 8/6 T240    | 37/6 VP2       | 8/6 TP22          | 8/-  |
| 1R5   | 7/6 6SK7GT | 8/6 0Z4     | 7/- SP2        | 8/6 ATP4          | 4/-  |
| 3S4   | 7/6 6SN7GT | 9/- 25Z5G   | 8/6 VDD2A      | 8/6 MS/PENB       | 7/6  |
| 3V4   | 7/6 6SL7GT | 9/- 25Z6G   | 8/6 VP2B       | 8/6               | 7/6  |
| 1LN5  | 8/- 6SC7   | 10/- 35Z4GT | 8/6 215SG      | 4/- MS/PEN        | 7/6  |
| 1LD5  | 8/- 6V6G   | 7/6 35Z5GT  | 8/6 866A       | 15/- VP4 (5 or 7) | 7/6  |
| 5U4G  | 8/6 6V8G   | 7/6 35L8GT  | 8/6 354V       | 5/-               | 8/6  |
| 5Z4G  | 8/6 6F6G   | 7/6 50L6GT  | 8/6 4D1        | 4/- AC/PEN 10/-   | 10/- |
| 523G  | 8/6 6AC7   | 8/6 25A6G   | 8/6 9D2        | 4/- FC13C         | 10/- |
| MU14  | 8/6 6AG7   | 12/6 KT33C  | 10/- 8D2       | 4/- FC13Cs        | 10/- |
| 6B8   | 7/6 6CSGT  | 5/- KT66    | 12/6 PEN46     | 7/6 42SP1         | 6/-  |
| 6K8G  | 9/- 6J5GT  | 5/- EBC33   | 8/6 AC6PEN     | 6/6 VENTD4020     | 10/- |
| 6K7G  | 6/6 12A6   | 7/6 EF51    | 6/- VP41       | 7/6               | 12/6 |
| 6J7G  | 6/6 12K7GT | 8/6 EA54    | 3/6 T1223      | 10/- VT501        | 7/6  |
| 6N7GT | 7/6 12K8GT | 8/6 EA53    | 2/- 41MF       | 7/6 U19           | 10/- |
| 6L7   | 7/6 12Q7GT | 8/6 D1      | 2/- SP61       | 4/- MLJ           | 6/-  |

**INDICATOR UNIT TYPE 182A**

This unit contains VCR517 Cathode Ray 6in. tube, complete with Mu-metal screen, 3 EF50, 4 SP61 and 1 5U4G valves, W/V volume controls, resistors and condensers. Suitable either for basis of T/V or Oscilloscope. Radio Constructor "Scope" constructional circuit included. 67/6 (plus 7/6 carr.).

**CRYSTALS**

200 kc/s. 2-pin (U.S.A.) ... 10/-  
465 kc/s. 2-pin (U.S.A.) ... 10/-  
500 kc. s. 2-pin (British) ... 15/-

T.C.C. 1.5/7,000 v. wkg. Type CP58QO. Bakelite Case, 7/6 each. B.J. 1 2,500 v. wkg. Bakelite Cased, 4/-.

**CATHODE RAY TUBES**

(Brand New)  
VCR97 (slight cut-off) 15/-  
VCR97, guaranteed full T/V Picture ... 40/-  
VCR517C, guaranteed full T/V Picture ... 35/-  
VCR139A, guaranteed full T/V Picture ... 35/-  
3EP1, guaranteed full T/V Picture ... 30/-  
Carr. & packing on all tubes, 2/-.

**NEON INDICATOR STRIKING 80V. 2/6**

**SETS OF VALVES**  
Ten EF50 (Ex-Brand New Units), 5/- each ... 45/- Set  
6K8G, 6K7G, 6Q7G, 5Z4G, 6V6G ... 37/6 ..  
1R5, 1S5, 1T4, 1S4, or (3S4 or 3V4), 26/6 ..  
TP25, HL23,DD,  
VP23, PEN25 (or QP25)  
6K8C, 6K7G, 6Q7G, 25/- ..  
25A6G, 25Z5 or 25Z6G  
12K8GT, 12K7GT, 12Q7GT, 35Z4GT, 35L6GT or 50L6GT 37/6 ..  
12SA7GT, 12SK7GT, 12SQ7GT, 35Z4GT, 36L6GT or 50L6GT 37/6 ..

**CRYSTAL MICROPHONE INSERTS**



8/6 POST FREE 8/6 POST FREE  
Ideal for tape recording and amplifiers. No matching transformer required.

**Brand New R.F. UNITS**  
RF24 20-30 mc/s 15/- post free  
RF25 40-50 mc/s 19/6 post free  
RF26 50-65 mc/s 35/- post free  
RF27 60-80 mc/s 35/- post free

**MORSE PRACTICE BUZZER**

Complete with tapper and 4 volt buzzer on baseboard, 6/-, brand new. Post paid.

**931A PHOTO-CELLS** as described in "P/T" Nov. issue, 50/- each. Data supplied. Equivalent to Mazda 27M/2.

28-page Catalogue, 3d. Open Mon.-Sat. 9-6. Thurs. 1 p.m.

5, HARROW ROAD, PADDINGTON, LONDON, W.2

TEL.: PADDINGTON 1008/9, 0401.

# BARTON'S (Radio)

## BUILD YOUR OWN RADIO!

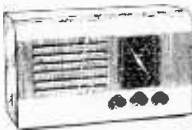

We can supply all the parts (including valves, 5in. moving coil speaker, cabinet, chassis, and everything down to the last nut and bolt) to enable YOU to build a professional-looking radio. The chassis is punched and drilled ready to mount the components. There is a choice of any of three attractive cabinets 12in. long, 5in. wide by 6in. high, as follows: either ivory or brown bakelite, or wooden, finished in walnut. Complete and easy-to-follow point-to-point and circuit wiring diagrams supplied.

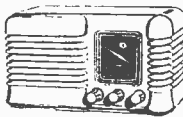

follows: either ivory or brown bakelite, or wooden, finished in walnut. Complete and easy-to-follow point-to-point and circuit wiring diagrams supplied.

### MODEL 1. T.R.F. RECEIVER

This is a 3 valve plus metal rectifier T.R.F. receiver with a valve line-up as follows: 6K7 (HT), 6Z5 (Det) and 6V6 (Output). The dial is illuminated and when assembled the receiver presents a very attractive appearance. Coverage is for the Medium and Long Wave bands. Operates on 200/250 volts A.C. Mains.

Plus 2/6 Packing, Carriage, Insur. **£5.10.0**

T.R.F. RECEIVER. We can supply this Receiver ready built at **£6 15. 6.** plus 3/6 p.c.

### ALL COMPONENTS SUPPLIED ARE GUARANTEED FOR ONE YEAR

Instruction Booklet and priced Parts List for either of the above available separately at 1/-. This money will be refunded if circuit diagram is returned as NEW within 7 days. When ordering please state Model No.

### MAINS NOISE SUPPRESSOR KIT

Consisting of 2 specially designed chokes and 3 condensers. Extremely effective, cuts out all mains noise. Can be assembled in existing receiver or separately as desired. Complete 4/11 plus 1/- with circuit diagram

### BATTERY CHARGER KIT

Incorporates metal rectifier. Transformer is suitable for A.C. mains 200/250 volts. Charges either 12.6 or 2 volt accumulator at 1 amp. Complete with circuit diagram 19/11 plus 1/6 post gram. Price

plus 2/6 Packing, Carriage, Insur. **£7.19.6**

TERMS OF BUSINESS: Cash with order (or C.O.D. Post items only); all orders for small items totalling over £2 post free unless otherwise stated. Money back Guarantee on all goods.

Office: (Dept. P.W.), 34, Montpelier Rise, London, N.W.11. Telephone: Meadway 1738.

Works and Despatch Dept.: 44, Tottenham Street, London, W.1. Tel: Langham 1151. Open 9 to 6 p.m. Daily, Saturdays 1 pm. PERSONAL CALLERS WELCOMED

### 4-watt AMPLIFIER KIT

This is a 3 valve 3 stage Amplifier for use with Gramophone, Microphone or Radio. Valve line-up is as follows: 6SL7, 6V6, 5Y4. Negative feed-back. Tone Control. Voltage adjustment panel incorporated. 4 watts output. For operation on A.C. Mains 200/250 volts.

The complete Kit includes every item down to the last nut and bolt, drilled and punched chassis, and comprehensive point-to-point wiring circuit diagram. Chassis dims.: 8in. x 6in. x 2 1/2in.

### ALL COMPONENTS SUPPLIED ARE GUARANTEED FOR ONE YEAR

PRICE **£4.5.0**  
Plus 2/6 Pkg., Carr. & Ins.

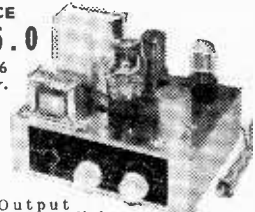

The Output Transformer supplied is for use with a loudspeaker of 3 ohms impedance and we would suggest that the output of the completed amplifier justifies the use of one of the latest W.B. H.F. Speakers which can be supplied as follows: 6in., 80/6; 9in., 87/-; 10in., 73/6. All plus 2/6 pkg., carr., ins.

Circuit Diagram only, available separately at 1/-. To those who require this Amplifier ready-built we can supply it at **£5.1.0** plus 3/6 pkg., carr., ins.

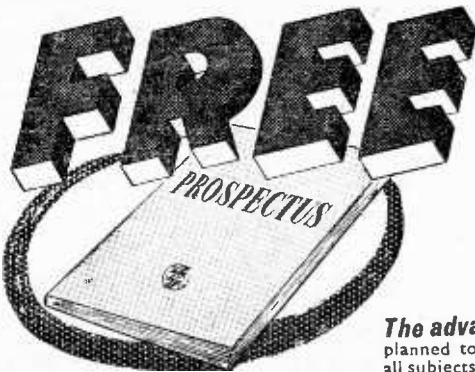

**POST THE COUPON TODAY FOR OUR BROCHURE ON THE LATEST METHODS OF HOME TRAINING FOR OVER 150 CAREERS & HOBBIES**

### PRIVATE AND INDIVIDUAL TUITION IN YOUR OWN HOME

City and Guilds Grouped Certificates in Telecommunications: A.M. Brit. I.R.E. Examination, Radio Amateur's Licence, Radio and Television Servicing Certificates, General Radio and Television Courses, Radar, Sound Recording, etc. Also Courses in all other branches of Engineering and Commerce.

**The advantages of E.M.I. training.** ★ The teaching methods are planned to meet modern industrial requirements. ★ We offer training in all subjects which provide lucrative jobs or interesting hobbies. ★ A tutor is personally allotted by name to ensure private and individual tuition. ★ Free advice covering all aspects of training is given to students before and after enrolling with us.

### NEW LEARN THE PRACTICAL WAY.

With many of our courses we supply actual equipment. Courses include: Radio, Television, Electronics, Draughtsmanship, Carpentry, Photography, and Commercial Art, etc.

Courses from **15/- per month**

# EMI INSTITUTES

The only Postal College which is part of a world-wide Industrial Organisation.

### POST THIS COUPON TODAY

Send without obligation your FREE book. E.M.I. INSTITUTES, Dept. 32K 43 Grove Park Road, London, W.4. Phone: Chiswick 4417/8.

NAME \_\_\_\_\_  
ADDRESS \_\_\_\_\_  
TEL. \_\_\_\_\_  
SUBJECT(S) OF INTEREST \_\_\_\_\_

# Prices slashed at Clydesdale

## SUPPLY UNIT RECTIFIER FOR NO. 43 TRANSMITTER

Ex Canadian Army. In original wood case. Input 110 v. A.C. 50/60 c/s. 1.7 kV. Output (HT1), 2,100 v. 375 mA. (HT2), 500 v. 400 mA., plus H.T. lines 450 v., 265 v., also 383 v. regulated and neg. bias. 250 v., 150 v., 80 v. Making three complete power supplies all fed via double choke condenser, input circuits. Valves are 4/666A/866, 523, 6S5T, 2/6A3, VR150/30 (stab.) and 1V (time delay). The complete unit mounted in metal case with lid lock mounted. Dim.: 2ft. 6in. x 1ft. 6in. x 1ft. 7in. Finish olive drab. Wgt. 420lb. Ask for P/H26.

£15 Carriage 15/- extra.

## BC-456 SPEECH MODULATOR UNITS Part of SCR-274-N. "Command Equipment" (U.S.A. made.)

Complete with valves 1625, 1215 and VR150/30 transformers, relays, etc., less dynamotor. Overall Dim.: 10 1/2 in. x 7 1/2 in. x 4 1/2 in. Loose stored, etc. Ask for P/E42.

17/6 each. Carriage Paid.

Also available, BC-456, as above in original carton. Ask for P/E42A.

27/6 each. Carriage Paid. Circuit, 1/3.

## ELECTRONIC IGNITION TESTER

Type V, E.D. Patt. 563562, by English Electric in original wood case. A Cathode Ray tester for checking ignition of internal combustion engine while engine is operating, will operate from 6, 12 or 24 volts D.C. or 230 v. A.C. Built into black crackle case with hinged front and carrying handle. Dim.: 15 1/2 in. x 8 1/2 in. x 1 1/2 in. No leads or instruction book available. Ask for P/H535.

£15 each. Carriage 10/- extra.

## RECEIVER UNIT TYPE 25

Ref.: 10P/LL. Part of TR1196, range 4.3-6.7 mc/s, with valves, 2/VR53 (EP30), 2/VR56 (EP36), VR55 (EBC33), VR57 (EK32), 2/1 F.T. 460 kc/s, etc., in metal case, 8 1/2 in. x 6 1/2 in. Ask for P/H299.

25/- Post & Packing each. 3/6.

## EX U.S.N. TEST OSCILLATORS, TS-24/ARR2

Low/High frequency, battery powered for TBX alignment. H.F. signal 245 mc/s. I.F. signal tunable 540 to 630 kc/s with valves, 2/955 acorn triodes and clockwork time switch with calibrated dial 0/30 minutes. Unit Dim.: 9 1/2 in. x 7 1/2 in. x 7 1/2 in. Finish black. Ask for P/H364.

27/6 each. Carriage 3/- extra.

## T1154R TRANSMITTER UNIT

Medium/High powered for C.W.-M.C.W. R/T 3 ranges. 10-5.5 mc/s, 5.5-3 mc/s, 500-200 kc/s. Complete with 4 valves, etc., in metal case, 14 1/2 in. x 16 1/2 in. x 8 1/2 in. External Power Supply required.

Ask for P/E5A. 39/6 each. Carriage 7/6 extra.

## SUPPRESSOR UNIT 5C/870

Contains 4 H.F. chokes and 4 tubular condensers 0.1 mfd. 250 v. D.C. carrying 5 amps. (2 sets on each lead), each choke and condenser separately screened in compartments of aluminium alloy box, 4 1/2 in. x 4 1/2 in. x 4 hole fixing. Ask for P/H907.

2/6 each. Post 1/- extra.

## VISUAL INDICATOR TYPE I

Ref.: 100/2.

Dual reading left/right D.F. meter for R1155, 2 1/2 in. Scale overall Dim.: 3 1/2 in. x 2 1/2 in. In used condition. Ask for P/H862A.

12/6 each. Post Paid.

## JEFFERSON TRAVIS U.F-2 TRANS-CEIVER CHASSIS (U.S.A. made).

Less valves and partly stripped by the M.O.S. Ask for P/H518.

17/6 each. Carriage Paid.

Circuit at 2/3.

## INDICATOR UNIT TYPE 6

With VCR-97 tube and valves, 4/VR91 (EF50), VR54 (EB34), 3/VR92 (EA50), VR78 (D1), etc. Dim.: 18 1/2 in. x 8 1/2 in. x 7 1/2 in. Wgt. 2 1/2 lb. In original wood case. Ask for D/H524.

45/- each. Carriage 5/- extra.

## INDICATOR UNIT TYPE 611

With VCR-97 Tube and Valves 4/VR91 (EF50), 3/VR54 (EB34). Dim.: 18 1/2 in. x 8 1/2 in. x 7 1/2 in. Wgt. 2 1/2 lb. In original wood case. Ask for P/E777.

59/6 each. Carriage 5/- extra.

## R.F. UNIT TYPE 24

In original carton. Range 20-30 mc/s switched tuning. Dim.: 9 1/2 in. x 7 1/2 in. x 4 1/2 in. Wgt. 2 1/2 lb. Ask for P/H847.

10/- each. Post 1/6 extra.

## R.F. UNIT TYPE 25

In original carton. Range 40-50 mc/s, otherwise as R.F. 24. Ask for P/H847.

12/6 each. Post 1/6 extra.

Please note Carriage and Postal Charges refer to the U.K. only. Overseas Freight etc., extra.

Order direct from:—

# CLYDESDALE SUPPLY CO. LTD.

2, BRIDGE STREET, GLASGOW, C.S.

Phone: South 4451/7

# ALPHA FOR VALVES

## GUARANTEED NEW AND BOXED.

|         |      |         |      |         |       |          |       |        |      |       |      |       |        |       |      |                                |      |
|---------|------|---------|------|---------|-------|----------|-------|--------|------|-------|------|-------|--------|-------|------|--------------------------------|------|
| AC/P    | 6/0  | H30     | 5/-  | PEX220A | UBC41 | 11/-     | VU111 | 3/6    | 3A5  | 10/-  | 6C4  | 8/-   | 6SJ7GT | 8/-   | 954  | 2/-                            |      |
| AC/P4   | 7/-  | H63     | 7/0  |         | 4/-   | UF41     | 11/-  | VU120A | 3/-  | 306   | 6/0  | 6C5GT | 8/-    | 12A6  | 4/9  | Type CLR. Low resistance 120Ω. |      |
| AC6/1   | 8/-  | HL2     | 6/-  | PL81    | 14/-  | VR53     | 6/8   | W77    | 8/0  | 384   | 8/6  | 6D3   | 7/6    | 6BK7  | 6/3  | 959                            | 3/6  |
| AT4     | 5/6  | H23D    | 7/6  | PL82    | 11/8  | VR54     | 2/-   | W81    | 10/- | 3V4   | 8/-  | 6F6M  | 7/6    | 6BL7  | 8/0  | 10F1                           | 10/- |
| GV173   | 6/0  | HR210   | 6/8  | PL83    | 13/-  | VR55     | 7/6   | X63    | 10/- | 4D1   | 8/-  | 6F8M  | 7/6    | 68NGT | 9/0  | 10F1                           | 10/- |
| CV286   | 7/6  | KBC32   | 8/6  | PM22D   | 5/-   | VR57     | 8/-   | X79    | 11/- | 5U4   | 8/6  | 6F13  | 12/6   | 6R7G  | 8/0  | 10F13                          | 11/6 |
| DH73M   | 10/- | KP35    | 8/6  | PM12M   | 10/-  | VR65     | 3/9   | Y63    | 9/-  | 5Y3GT | 8/6  | 6F15  | 11/6   | 6V6G  | 7/6  | 10P13                          | 11/6 |
| EB41    | 11/- | KL35    | 8/6  | PM22S   | 5/-   | VR83A    | 3/9   | Z21    | 10/- | 5Z3   | 8/6  | 6G60  | 6/6    | 6V8GT | 7/6  | 10P14                          | 11/6 |
| EBP89   | 11/6 | KL32    | 8/6  | PY89    | 11/-  | VR99     | 3/9   | Z22    | 6/9  | 5Z4G  | 8/6  | 6H6   | 3/6    | 6X4   | 8/0  | 12A6                           | 6/9  |
| EC91    | 9/-  | KT2     | 5/-  | PY81    | 11/8  | VR91     | 6/-   | I43    | 9/-  | 6A7   | 10/6 | 6H5GT | 5/6    | 6X4   | 8/0  | 12A7H                          | 5/6  |
| ECC31   | 9/-  | KT33C   | 11/6 | PY82    | 10/8  | VR92     | 6/-   | I45GT  | 6/6  | 6A8G  | 10/6 | 6H5GT | 5/6    | 6X4   | 8/0  | 12A7H                          | 5/6  |
| ECH42   | 10/6 | KT61    | 13/- | PX25    | 15/-  | VR92     | 2/-   | I47    | 11/8 | 6AC7  | 8/6  | 6J5M  | 6/6    | 7B7   | 8/6  | 12A8H                          | 11/6 |
| ECL80   | 14/6 | KT66    | 13/- | QP21    | 7/8   | VR105/30 | 11/6  | IC5GT  | 8/-  | 6A55  | 7/8  | 6J6   | 8/-    | 7C5   | 8/6  | 12A8T                          | 7/6  |
| EBK41   | 11/- | KTW81   | 7/9  | 8Q30    | 8/6   |          | 5/8   | I114   | 7/8  | 6AJ5  | 9/-  | 6J7G  | 6/6    | 7C6   | 8/6  | 12A8T                          | 7/6  |
| EP41    | 10/- | KTW92   | 7/-  | 8Q22    | 6/-   | VR116    | 4/-   | IX55   | 10/- | 6AL5  | 9/-  | 6K6GT | 6/6    | 7D5   | 9/0  | 20D1                           | 10/6 |
| EP80    | 13/6 | KT74    | 8/-  | 8Q20    | 6/9   | VR119    | 4/-   | IX55   | 10/- | 6AL5  | 9/-  | 6K7G  | 6/6    | 7D8   | 9/0  | 20P2                           | 12/6 |
| EL12    | 12/6 | KTZ41   | 6/9  | 8S219   | 5/-   | VR123    | 6/8   | IR3    | 7/6  | 6AM5  | 7/6  | 6K7GT | 6/6    | 7H7   | 8/0  | 20P1                           | 15/- |
| EL33    | 13/- | LP210   | 6/9  | 8Q22    | 6/9   | VR136    | 7/-   | IR4    | 7/6  | 6AM6  | 7/6  | 6K7M  | 6/6    | 7Q7   | 8/0  | 210VPT                         | 5/-  |
| EL41    | 11/8 | LP220   | 6/9  | 8Q22    | 6/9   | VR137    | 6/3   | IR5    | 7/6  | 6AQ5  | 8/6  | 6K8G  | 6/6    | IR7   | 8/0  | 220VPT                         | 5/-  |
| EM31    | 8/-  | M4      | 8/6  | U19     | 9/-   | VC150/30 | 9/-   | IT5    | 7/6  | 6AT6  | 8/6  | 6K8GT | 6/6    | IR7   | 8/0  | 25A6G                          | 9/-  |
| EY51    | 14/6 | MHL4    | 6/0  | U22     | 8/-   |          | 11/8  |        | 9/-  | 6B4   | 8/6  | 6L6G  | 8/-    | 7Y4   | 8/6  | 25L6GT                         | 8/6  |
| EZ40    | 10/- | MV/PEX6 | 6/-  | U25     | 14/6  | VP23     | 8/-   | TTV    | 6/6  | 6BSG  | 8/6  | 6L6GT | 7/6    | 75    | 10/6 | 25L6GT/12/-                    | 8/6  |
| EZ41    | 11/- | P41     | 9/-  | U281    | 10/0  | VT52     | 8/-   | 2A3    | 6/9  | 6BA6  | 8/-  | 6L8   | 11/-   | 77    | 8/0  | 25Y5                           | 9/-  |
| EJ48    | 2/-  | P215    | 5/-  | U463    | 10/0  | VT75     | 7/6   | 2X2    | 5/-  | 6BE6  | 8/-  | 6N7   | 7/6    | 80    | 8/6  | 25Y6G                          | 9/-  |
| EW4/300 | 10/- | PEX25   | 8/6  | UAP42   | 12/-  | VT91     | 6/8   | 3A4    | 8/-  | 6BR7  | 9/6  | 6Q7G  | 8/-    | 807   | 8/6  | 25Z44                          | 9/-  |
|         |      | PEX40   | 8/6  | UB41    | 9/-   | VU39     | 9/-   | 384    | 8/-  | 6BW6  | 8/6  | 6Z4   | 8/-    | 812   | 2/9  | 25Z5                           | 9/-  |

TERMS: Cash with order or C.O.D. Postage to be added to orders as follows: 9d. up to 10/-; 1/- up to 20/-; 1/6 up to 40/-; 2/- up to £5. MAIL ORDER ONLY: Send 6d. in stamps for illus. catalogue.

WHEN ORDERING PLEASE QUOTE "DEPT. P.W."

# ALPHA RADIO SUPPLY CO.

5/6 VINCES CHAMBERS, VICTORIA SQUARE, LEEDS 1.

# PREMIER RADIO COMPANY

B. H. MORRIS & CO., (RADIO) LTD.

Telephone : AMPLIFIER SHOP 4033 PADDINGTON 3271-2

OPEN TILL 6 P.M. SATURDAYS

(Dept.P.W.) 207, EDGWARE ROAD, LONDON, W.2

## BUILD THESE NEW PREMIER DESIGNS

**3-BAND SUPERHET RECEIVER**  
MAY BE BUILT FOR **£7.19.6** Plus 2/6 Pk. & Carr.

Latest type Superhet Circuit using 4 valves and metal rectifiers for operation on 200/250 volts A.C. mains. Waveband coverage—short 16-50 metres, medium 180-550 metres, and long 900-2,000 metres. Valve line-up 6K8 (freq. changer, 6K7 I.P. 6C7 Detector AVC and first A.F. 6V6 output. The attractive cabinet to house the Receiver size 12in. long, 6 1/2in. high, 5 1/2in. deep can be supplied in either WALNUT or IVORY BAKELITE or WOOD.

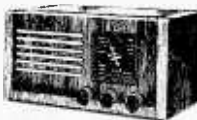

**TRF RECEIVER**  
MAY BE BUILT FOR **£5.15.0** Plus 2/6 Pk. & Carr.

The circuit is the latest type TRF using 3 valves and Metal Rectifiers for operation on 200/250 A.C. mains. Waveband coverage is 180/550 metres on medium wave and 800/2,000 metres on long wave. The dial is illuminated and the Valve line-up is 6K7 H.F. Pentode 6J7 Detector and 6V6—Output.

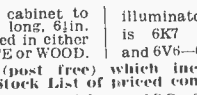

**4-WATT AMPLIFIER**  
MAY BE BUILT FOR **£4.10.0** Plus 2/6 Pk. & Carr.

Valve line-up 6SL7, 6V6 and 6X5. FOR A.C. MAINS 200/250 VOLTS. The output Valve is of the beam type and feeds 4 watts into a specially designed output Transformer which is suitable for either 3-ohm or 15-ohm Speakers. Negative feedback is applied from the secondary of the output Transformer over the whole Amplifier to the input stage giving an excellent frequency response. Due to the high gain and wide range tone controls any type of pick-up may be used. Overall size 9 x 7 x 5in. Price of Amplifier complete, tested and ready for use, £5/5/-, plus 3/6 pkg. and carr.



**CABINETS—PORTABLE**

- Model PC/1 Brown Rexine covered, 22/6. Overall dimensions 15in. x 13 1/2in. x 5in. Clearance under lid when closed 2 1/2in.
  - Model PC/2 Grey Lizard Rexine covered, 45/-. Overall dimensions 13in. x 13in. x 6in. Clearance under lid when closed 2 1/2in.
  - Model PC/3 Rexine type covering in various colours, 69/6. Overall dimensions 16 1/2in. x 11 1/2in. x 10 1/2in. Clearance under lid when closed 6in.
- All the above Cabinets are supplied with Panel, Carrying Handle and Clips. Packing and Postage 2/6.
- Send for details of the Premier Wide angle Television design which may be built for £30.

**DECCA MODEL 37A DUAL SPEED RECORD PLAYER** Includes turnover crystal pick-up with sapphire stylus and a light-weight plastic spring-balanced arm. Heavy gauge pressed steel case with brown enamel finish in good quality for operation on A.C. mains 200/250 v., 50 c.p.s. Supplied complete, £8.19.6. Plus pkg. and carr. 5/-.

**GARRARD S5 GARRARD Rim Drive 78 r.p.m., complete with magnetic pick-up and turntable, £4.19.6. Plus 2/6 pkg. and carr.**

**TERMS OF BUSINESS : CASH WITH ORDER OR C.O.D. OVER £1.**

**C. R. TUBES**  
VCR 517C 6in. picture. This tube is a replacement for the VCR97 and VCR517. Guaranteed full size picture. PRICE, 35/-, Plus 2/6 pkg., carr. ins. VCR 516 9in. Blue picture, Heater Volts 4, Anode 4 Kv., In Manufacturer's original Carton. Plus 5/- pkg., carr. ins. PRICE, £1.19.6.

**COMPONENTS AVAILABLE FOR THE MULLARD AND OSRAM AMPLIFIER DESIGN**

# RADIO SUPPLY CO. (LEEDS) LTD. 32, THE CALLS, LEEDS, 2

Terms C.W.O. or C.O.D. No C.O.D. under £1. 2 extra under £2. 2 1/2 extra under £3. Postage 1/- extra under 10/-. 1/6 extra under £1. Open 9 to 5.30. Sats. until 1 p.m. Catalogue 6d. Trade List 5d. S.A.E. please with enquiries.

**R.S.C. 4 - 5 WATT HIGH GAIN QUALITY AMPLIFIER A5—**For Mains input 200-250, 50c/s. Kit includes 4 valves, punched chassis crackle finished, point to point wiring diagrams and instructions, and every item required. Only 50 m.v. input required for full output, making it suitable for use with any type of pick-up. H.T. and L.T. supply available for Radio Feeder or Tape Deck Preamp Output for 2-3 ohm speaker. Separate Bass and Treble Controls. Suitable for standard or Long-Playing Records in the home or small club, etc. Only £4/15/-, carr. 3/9, or ready for use, 25/- extra.

**CHASSIS (Unpunched)**

|   |       |                   |      |
|---|-------|-------------------|------|
| 18 s.w.g. aluminium amplifier (4-sided).      |       |                   |      |
| 12" x 9" x 2 1/2"                             | 6/11  | 14" x 10" x 3"    | 7/11 |
| 14" x 9" x 2 1/2"                             | 6/11  | 16" x 10" x 3"    | 8/3  |
| 18 s.w.g. aluminium receiver type.            |       |                   |      |
| 6" x 2 1/2" x 1 1/2"                          | 10/7  | 5" x 2"           | 3/3  |
| 7 1/4" x 4 1/2" x 2"                          | 2/9   | 11" x 6" x 2 1/2" | 3/11 |
| 18 s.w.g. aluminium, receiver type.           |       |                   |      |
| 12" x 8" x 2 1/2"                             | 5/3   | 20" x 8" x 2 1/2" | 8/11 |
| 16" x 8" x 2 1/2"                             | 7/6   |                   |      |
| 18 s.w.g. aluminium, amplifier type, 4-sided. |       |                   |      |
| 12" x 8" x 2 1/2"                             | 7/11  | 20" x 8" x 2 1/2" | 13/6 |
| 16" x 8" x 2 1/2"                             | 10/11 | 14" x 19" x 3"    | 13/6 |

**EX-GOVT. TRANSFORMERS, 230 v. 50 c/s.**  
0-11-22 v. 15 a. 35/9; 0-16-19-20 v. 35 a. 79/6; 7.7 v. 7 a. C.T. 4 times, 25/9; 27 v. 1 a. 9/9; 460 v. 200 ma. 6.3 v. 5 a. 27/9; 400 v. C.T. 150 ma. 4 v. 6a., 6.3 v. 6 a., 6.3 v. 6 a., 4 v. 6 a., 4 v. 3 a., 4 v. 3 a., 4 v. 3 a., 5 v. 2 a., 22/9; 1,220 v. 350 ma. 610-0-610 v. 150 ma. 300-0-300 v. 150 ma. 29/9; 865-775-690-0-690-775-865 v. 500 ma. 29/6; 4 v. 2.5 a. 4/9; 1 v. 6 a., High Ins. 7/9; 250-0-250 v. 200 ma. 6.3 v. 6 a., 5 v. 6 a., 22/9; 300-0-300 v. 150 ma. 6.3 v. 4 a., 5 v. 3 a., 22/9.

**AMMETERS Moving Coil G.M.E.C. 0-5 amps, 2in. scale, 11/9.**

**EX-GOVT. AUTO TRANSFORMERS Double Wound, 50 c/s.**  
10-0-200-220-240 v. to 10-0-275-295-315 v. 1,000 watts, 69/6; 0-230 v. to 0-230 v. tapped every 11 v. 4/9; from 57.5 v. 5,000 watts (21 amps.), £6/15/-; 0-110-240 v. to 0-130-140-150-180-170 v. 1,500 watts, 55/-; Single winding, 15-10-5-0-195-215-235 v. 500 w., 27/9.

**EX-GOVT. SMOOTHING CHOKES**  
250 mA, 10 H 50 ohms ... .. 14/9  
250 mA, 10 H 100 ohms ... .. 14/9  
150 mA, 10 H 100 ohms ... .. 11/9  
100 mA, 10 H 150 ohms Trop. ... .. 6/9  
50 mA, 5-10 H 200 ohms... .. 2/9  
L.T. type 1 amp. ... .. 2/9

**EX-GOVT. METAL BLOCK (PAPER) CONDENSERS: 2 mfd., 3,000 v., 2/9; 4 mfd. 500 v., 2/9; 4 mfd. 750 v., 3/9; 4 mfd. 1,500 v., 4/9; 4 mfd. 2,000 v., 7/9; 6-6 mfd. 400 v., 5/11; 8-8 mfd. 500 v., 6/11; 4 mfd. 400 v., plus 2 mfd. 250 v., 1/11; 8 mfd. 500 v., 5/9; 15 mfd. 500 v., 6/9.**

**EX-GOVT. E.H.T. SMOOTHERS**  
.02 mfd. 8,000 v. cans, 1/11; .25 mfd. 4,000 v. Blocks, 4/9; .5 mfd. 2,500 v. Blocks, 3/9; .5 mfd. 3,500 v. cans, 3/9; 1.5 mfd. 4,000 v. Blocks, 5/9; .1 mfd. plus .1 mfd. large Blocks 8,000 v., 9/6.

**EX-GOVT. L.T. SMOOTHING CONDENSERS.—2,000 mfd. 12 v. Small Blocks, 1/11**

**RF26 UNITS, BRAND NEW, CAPTIONED, Only 39/6. Carr. 2/6.**

**EX-GOVT. TRANSMITTER RECEIVERS, Type TR9D, complete with all valves, 47/6, carr. 5/-.**

**EX-GOVT. ACCUMULATORS**  
With Non-Spill Vents. Unused and guaranteed 2 v. 16 A.H., 5/9 each or 3 in wood carrying case 9x7x5ins., 14/9, plus 5/- carr.

**MIDGET MAINS TRANSFORMERS.** Manufacturer's Surplus. Primary 220/240 v. Secs. 275-0-275 v. mA. 6.3 v. 2 a. Only 11/9.

**TV. PREAMPLIFIER (Plessey)**  
For Fringe Areas. Brand New. Complete with 6F13 valve. Only 22/6.

**R.S.C. MASTER INTERCOM. UNIT,** with provision for up to 4 Listen-Talk Back units individually switched. A high gain amplifier allows speech emanating from the rooms containing remote control units to be heard at the master control. The unit is in kit form and point-to-point wiring diagrams are supplied. A walnut veneered wood or brown bakelite cabinet is included. Mains input is 200-250 v. 50 c/s. H.T. line 300 v. CHASSIS IS NOT "ALIVE." Ideal also for use as "Baby Alarm." Sound amplification 4 watts. Price only £5/19/6. "Listen-Talk Back units in walnut veneer cabinets can be supplied at 35/- each. Full descriptive leaflet. The Master Unit can be supplied assembled and tested for 30/- extra.

**EX-GOVT. VALVES (NEW)**

| Each      | Each        | Each       | Each |
|-----------|-------------|------------|------|
| 1T4 7/9   | 6Q7G 9/11   | AC5PenDD   |      |
| 1R5 7/9   | 6SN7GT 9/9  | ECB33 9/9  | 7/9  |
| 155 7/9   | 6V8G 8/9    | EF36 5/9   | 5/9  |
| 3V4 7/9   | 6V8GT 7/9   | EB91 8/9   | 8/9  |
| 353 9/9   | 6X5GT 8/9   | EF91 7/9   | 7/9  |
| 5U4G 10/6 | 8D2 2/11    | EL33 9/6   | 9/6  |
| 5Z4G 9/6  | 807 7/11    | MU1 8/9    | 8/9  |
| 6F6G 7/9  | 912 2/11    | MS/Pen 9/9 | 9/9  |
| 6J5G 5/9  | 12A6 7/9    | SP4 5/9    | 5/9  |
| 6T6G 8/6  | 12K7G 10/6  | SP4 1/11   | 1/11 |
| 6K7G 5/11 | 15D2 4/9    | SP61 2/9   | 2/9  |
| 6K8G 8/11 | 25Z4G 9/6   | U120 2/11  | 2/11 |
| 6SK7 7/9  | 35Z4GT 10/6 |            |      |

**H.T. ELIMINATOR AND TRICKLE CHARGER KIT.** Input 200-250 v. A.C. Output 120 v. 40 mA. fully smoothed and rectified supply to charge 2 v. acc. Price with steel case and circuit, 29/6. Or ready for use, 8/9 extra.

**SILVER MICA CONDENSERS.** 5, 10, 15, 20, 25, 30, 35, 40, 50, 100, 120, 150, 200, 250, 300, 400, 500, 1,000 (.001 mfd.), 2,000 pfd. (.002 mfd.), 6d. each; 3/9 doz. One type.



# Longer Life

## for LONG PLAYING RECORDS

Recording techniques have made such strides over the last two years that if you are to get the really superb reproduction made possible by the latest L.P. records you need one of the Acos "Hi-g" Pick-ups. These have been specially designed to meet the very exacting demands of the new records with their shallow groove and microscopic sound "track". This special design is necessary on two scores—firstly to do justice to the brilliant recording, and secondly to ensure the longest possible life from L.P. records. Such records are expensive; even a single playing with an unsuitable pick-up can cause irreparable harm.

If you want the best reproduction and value from *your* radiogram or record player and L.P. records ask your dealer (or post the coupon below) for details of the "plug-in" ACOS "Hi-g" Pick-ups—specially designed to replace existing pick-ups on most famous makes of record playing equipment. The cost? 32/6d. (plus 10/5d. P.T.)

*... always well ahead*

ACOS devices are protected by patents, patent applications and registered designs in Great Britain and abroad.

**To: COSMOCORD LIMITED, ENFIELD, MIDDLESEX**

*Please send me details of ACOS "Hi-g" replacement pick-up heads*

NAME .....

ADDRESS .....

RW .....

**NUMBER PLEASE!**

*The new restricted form of London Telephone Directory no longer includes subscribers, like Cosmoford, in "fringe" areas. Please note therefore that our number is ENFIELD 4022.*

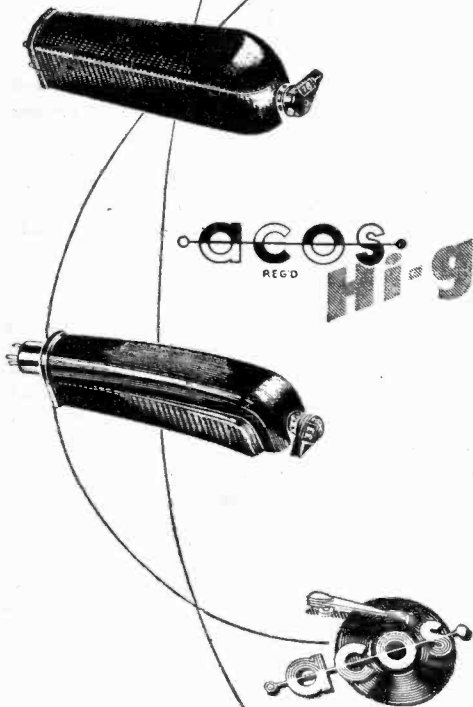

# PRACTICAL WIRELESS

EVERY MONTH  
VOL. XXXI, No 580, FEBRUARY, 1955

EDITOR: F. J. CANN

23rd YEAR  
OF ISSUE  
BY THE EDITOR

COMMENTS OF THE MONTH

## Illegal Radio Fees

ACCORDING to the chairman of the Mobile Radio Users' Association, the Postmaster-General has illegally collected about £400 million in radio and television licences since 1904. He was referring to a recent judgment against the Postmaster-General for £143 6s. 8d. which had been paid in licence fees by a Colchester firm of engineers, who claimed repayment of these fees charged for mobile transmitters and receivers on their vehicles, on the grounds that they were illegal.

It was a test case and the Association was responsible for the case being brought to court. Although the case was concerned with licences for mobile radio users, it applied also to domestic licences, because they are only collectable by the Postmaster-General if the regulation empowering him to do so were laid down. In fact, no regulation has been laid down under the relevant Act of 1904. A spokesman for the G.P.O. commenting on the case, in which the P.M.G. submitted to judgment by consent, said that nothing other than land mobile radio licences was in question. The question of the fees which have been extracted for domestic licences was not before the court, and it seems a great pity, as this was a test case, that this matter was not raised also. It is too late now, for the Government proposes by the usual trick of retrospective legislation to legalise what has been illegally done. If an ordinary citizen does something legal to-day, it can be made illegal by retrospective legislation, and the late Cripps was one who made use of this politically dishonest method in the case of Sir Leonard Lord and Sir John Black. When the Government itself does something illegal it makes it legal by the same method. Thousands of people have been fined and their convictions recorded for the non-payment of wireless licence fees which, as it now turns out, were illegally demanded. The proposed retrospective legislation should contain a clause ordering these convictions to be expunged from the records and the fines refunded. Of course, current wireless licences of all kinds are operating under the Wireless Telegraphy Act, 1949, and no question arises as to the charges under that Act. The retrospective legislation proposed will validate licence fees collected between 1904 and 1949, and presumably, therefore, will also validate the convictions.

The case in question was based on the Bill of

Rights under which no British citizen can be charged a fee by a Government department without the authority of Parliament. Under the 1904 Act licence fees for mobile radios could be charged only if regulations were made by the Post Office and the consent of the Treasury obtained. This has never been done. The same omissions apply to domestic wireless licences, and it is clear that there has been no power since 1904 to make a charge for a wireless licence.

### BONA-FIDE RETAILERS

THE annual report of the Radio and Television Retailers' Association makes it clear that they intend to compile and publish a list of firms who are bona-fide retailers, complying with the definition of a retailer already agreed between R.T.T.A. and other sections of the industry. The other sections, however, are not willing to co-operate in the compilation of this very necessary and much overdue list. We have many times drawn attention to incompetent radio dealers, but unfortunately the publication of such a list, in view of the present state of the law, cannot protect the public against the charlatans, since it is a white list and not a black list, and the omission of a dealer's name from it cannot be taken as indicating that he is not a bona-fide dealer. However, such a list will go a long way towards removing some anomalies in radio trading, especially if wholesalers refuse to supply those not on the list.

### INDEXES FOR VOLUME 30

THE December issue concluded Volume 30 and the index for it will shortly be available price 1s. 1d., post paid. Arrangements have been made for Messrs. Hazell, Watson and Viney, of 52, Long Acre, London, W.C.2, to undertake the binding of your parts in complete volumes with the appropriate index. If you are desirous of having your parts bound, Messrs. Hazell, Watson and Viney will be pleased to let you have a quotation for the work on receipt of an inquiry. Those readers who prefer to have their copies bound by a local bookbinder can obtain not only the above-mentioned index but also an index for any previous volume from us direct. The order should be addressed to the Publishing Department, George Newnes, Tower House, Southampton Street, Strand, London, W.C.2.—F. J. C.

# Round the World of Wireless



## V.H.F. Station

THE opening date of the V.H.F. station to serve East Anglia is not yet known, but it will have a temporary mast at first until a permanent one is erected.

## Printed Circuits Agreement

IT is announced that Pye Limited have acquired an interest in Technograph (Printed Circuits), Ltd., who hold patents for printed circuits all over the world.

Both companies intend to work closely together in furthering the development and application of printed circuits, not only in Britain but throughout the world.

## September Sales Down

RADIO sales figures for September were slightly down on the previous month. 12.1 sets per shop were sold in September, compared with 12.3 in August.

## Radio from Rowridge

THE new Rowridge television station on the Isle of Wight is not intended to be used exclusively for TV. It has been officially announced that the BBC plan to transmit three V.H.F. sound pro-

By "QUESTOR"

grammes from the station when the 500ft. mast replaces the temporary aerial in about a year's time.

## Broadcast Receiving Licences

THE following statement shows the approximate number of broadcast receiving licences issued during the year ended October, 1954. The grand total of sound and television licences was 13,701,205.

| Region                    | Number    |
|---------------------------|-----------|
| London Postal             | 1,524,625 |
| Home Counties             | 1,443,030 |
| Midland                   | 1,207,949 |
| North Eastern             | 1,587,978 |
| North Western             | 1,224,725 |
| South Western             | 992,626   |
| Wales and Border Counties | 618,900   |
| Total England and Wales   | 8,599,833 |
| Scotland                  | 1,040,028 |
| Northern Ireland          | 219,676   |
| Grand Total               | 9,859,537 |

## Overseas Appointments

MR. HUGH CARLETON GREENE, O.B.E., has been appointed Controller, Overseas Services and Mr. Oliver J. Whitley, Assistant Controller, Overseas Services.

## Commercial Radio Possibility

IT has been reported that should the new commercial television service to be introduced this year prove successful, a proposal for commercial radio may be put forward.

The chief advantage of such a service would be the abolishment of licences.

## Radio Telescope

PROF. V. A. AMBART-SUMYAN, a Russian astrophysicist, visited Jodrell Bank experimental station recently as the guest of Prof. A. C. B. Lovell, professor of radio astronomy at Manchester University, who is head of the Jodrell Bank telescope scheme.

He was shown the new £500,000 radio telescope near Chelford which is being constructed to be the largest in the world.

## Decline in Canada

FIGURES issued by the Canadian Radio Television Manufacturers' Association reveal that sales of radio receivers in October last totalled 41,411, a decline of 14,031 on the total for October, 1953.

## Firm's Communication Station

TARSLAG, LTD., a Teeside building and contracting company, have been negotiating with the Northallerton Water Board for the lease of a site on one of the highest points of the Osmotherley Moors, near Northallerton.

The firm intend building a radio station to keep in constant touch with their employees engaged on jobs in North Yorkshire and South Durham.

## Radio Show Dates

THE National Radio Show this year will be held at Earls Court, London, from August 24th to September 3rd, with a preview



Scriptwriters Alan Simpson (left) and Ray Galton (right) show a disgusted Tony Hancock their offering for the latest edition of "Hancock's Half-Hour," heard weekly in the BBC Light Programme.

for overseas and special visitors on August 23rd.

Meanwhile plans are well in hand for a smaller exhibition, the Northern Radio Show, to be held at the City Hall, Manchester, from May 4th to 14th.

#### Mobile Radio Used

MOBILE radio was used by the Sunderland Transport Department to control bus operations when the Queen and the Duke of Edinburgh visited Wearside. Two vans and a walkie-talkie set were used. The transport committee is now to consider using mobile radio permanently in view of its outstanding success on this occasion.

#### Civil Defence Exercise

NOTTINGHAM, Derby, Nottinghamshire and Derbyshire civil defence forces made extensive use of mobile radio for their largest exercise since the war. It was assumed that all telephones were out of action and all communication had to be by radio or field telephone.

#### Obituary

IT is with deep regret that we record the death of Mr. "Jimmy" James, production manager of Whiteley Electrical Radio Co., Ltd., who collapsed and died in his office on Friday, November 12th.

Mr. James was only 49 years of age and had completed nearly 28 years of service with the company. He was an outstanding personality and will be greatly missed by all who knew him.

#### British Institution of Radio Engineers

THE following meetings of the above institution will be held during January:

*London Section.*—Wednesday, January 26th, 6.30 p.m., at the London School of Hygiene and Tropical Medicine, Keppel Street, Gower Street, W.C.1. "A Survey of Tuner Designs for Multi-channel Television Reception." D. J. Fewings, B.Sc., and S. L. Fife, A.M.Brit.I.R.E.

*North-eastern Section.*—Wednesday, January 12th, 6 p.m., at Neville Hall, Westgate Road, Newcastle. Address by the president, Rear-Admiral (L) Sir Philip Clarke, K.B.E., C.B., D.S.O.

*South Wales Section.*—Wednesday, January 12th, 6.30 p.m., at the Glamorgan Technical College, Treforest. "Electronic Counting Devices." F. H. Gage, D.Sc.

*Scottish Section.*—Thursday,

January 20th, 7 p.m., at the Department of Natural Philosophy, the University, Edinburgh. "Modern Ship-to-Shore Communication." G. Macdonald.

#### Marconi Staff Appointments

MR. E. GREEN, M.Sc., having reached the normal retiring age, has relinquished his position as head of the Transmitter Advanced Development Group of Marconi's Wireless Telegraph Co., Ltd. He is, however, continuing his

The transmitter is designed for the transmission of radio-telephonic or telegraphic communications over long distances and under heavy traffic conditions.

#### Communications for Pakistan

PYE LIMITED are to supply and install £150,000 worth of equipment for the Sui Gas Transmission Company's pipeline communications system in Western Pakistan. The system will include an extensive V.H.F. multi-channel

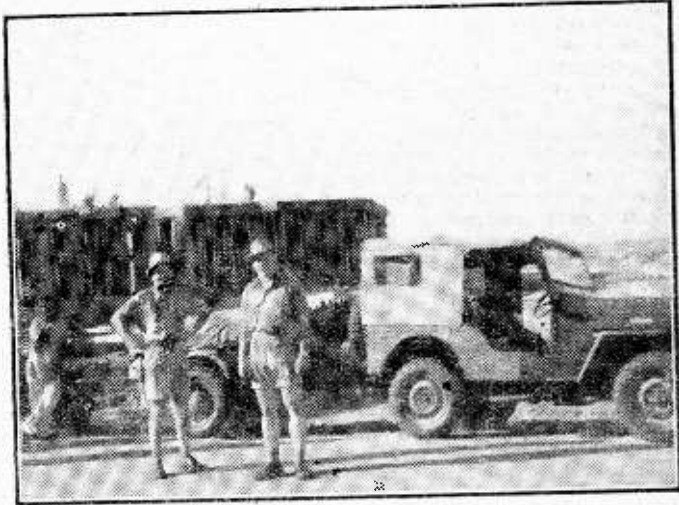

Two members of the Pye radio unit prior to the start of their survey for a communications system in Western Pakistan.

work for the company on a full-time basis as a consultant engineer.

Mr. V. J. Cooper, B.Sc., has been appointed chief engineer, Advanced Development.

#### Radiogram Gift

A COSSOR radiogram was recently presented to the Islington Branch of the Infantile Paralysis Fellowship. This presentation was made on behalf of A. C. Cossor, Ltd. by its medical officer, Dr. L. B. Bourne, in the presence of the Mayor, Councillor Mrs. J. M. Barnes.

#### Transmitter for Belgium

A HIGH-POWER (30 kW) H.F. communication transmitter type HS.51 has been shipped to Belgium from the Chelmsford works of Marconi's Wireless Telegraph Co., Ltd. This transmitter has been manufactured for the Belgian R.T. and T., the equivalent of the British G.P.O., and is to be installed by Marconi engineers at Ruisselode, Belgium.

route, providing speech and teleprinter channels between all the major points; a V.H.F./A.M. Fixed-to-Mobile scheme, giving complete coverage of the pipeline route for maintenance purposes; and a duplex H.F. radio-telephone or teleprinter system between Karachi, Sui and the main intermediate point.

#### Cable and Wireless Limited. 15,000-Mile Cable Chain

A 15,000-mile cable chain, the longest unbroken cable and landline circuit ever formed, is being set up to link Sydney with London direct, via Canada. The chain is intended as a permanent improvement in communications between the United Kingdom and Australia.

#### Savings Scheme

WOLF dealers throughout the country are now operating an "easy-stage" savings scheme for the benefit of prospective purchasers of Wolf Cub equipment.

# A New Technique for Sound Recording

A COMBINATION OF TAPE-RECORDING TECHNIQUE WITH ORDINARY SOUND-ON-FILM

By A. G. Thomson

**C**OST has been the principal factor limiting the use of films with sound effects and recorded commentaries for scientific, educational and commercial purposes. This limitation has been overcome by the development of a powder which, when skilfully bonded to film, provides an easier and far more economical means of adding sound to motion pictures.

Sound may be recorded on film by means of light or by varying the magnetic field, on the principle of the magnetic tape recorder. Magnetic sound tracks are applied in the form of a narrow "stripe" down one edge of film in approximately a similar position to the photographic track. A stripe which occupies the whole area normally used for the optical track is 0.10in. wide and is termed full width stripe or full striping. Since the stripe is opaque any optical track which it covers can no longer be played. It is also possible to apply a half stripe, 0.05in. wide, which may be located on either side of the centre line of the optical track, so that the latter can still be played at a slightly reduced volume level. Half striping produces a slightly lower volume of sound than full striping, but is otherwise equally effective. It is also possible to add a narrow stripe 0.03in. wide to the outside edge of silent (double perforated) film. This is known as edge-striping and has an even lower output than that of half striping, though in other respects it is equally effective.

The use of magnetic striping has led to the development of equipment specially designed to take maximum advantage of the opportunities presented by this very flexible system of sound recording. The scope for this new technique has been greatly extended by the introduction of a magnetic-optical projector, which makes it possible not only to project 16 mm. films of all types, but also to record material from practically any source. Manufactured by Kelvin Hughes for Simplex-Ampro, Ltd., it is claimed to be the only equipment in the world which records from an optical track and has a three-channel mixing unit operating from a remote control panel.

The set has been designed to give the fullest possible facilities, so that recording can be carried out in a truly professional manner. It includes a separate remote control unit, which is provided with twin channel input for recording and monitoring by meter as well as headphones. The complete equipment is supplied in three cases. One case houses the projector proper, its lower half being in the form of a tray in which the projector is mounted. The loudspeaker carrying case forms the loudspeaker baffle and holds a spare 1,600ft. film reel, together with loudspeaker cable. The third carrying case, besides housing the remote control unit, contains a Reslo ribbon microphone with a very wide frequency range, monitor head set, control cable, head cable, and power cable.

## The Sound-head

The projector is provided with a footage counter-meter and has an improved sound-head with no guideways. The film passes from the bottom to the

top of the sound drum which rotates in an anti-clockwise direction. Since the stripe is on the outside of the drum, the magnetic head is able to follow the film and conform to its minute fluctuations. The magnetic head is adjustable in all three planes to give perfect contact with the film. The greater frequency ranges available from magnetic recording made it desirable to design an improved speaker unit, which has been backloaded and baffled to lower the low-frequency response by a full octave. The amplifier is also of a new and improved design and uses valves of standard makes.

The projector operates on 105-125 volts alternating current, but can be operated on A.C. supplies outside this range by using an Ampro transformer. It will accommodate reels from 400ft. to 2,000ft. capacity and may be used to project sound films at a constant speed of 24 frames/sec., or silent films at a constant speed of 16 frames/sec. This projector has been specially designed to play edge stripe on double perforated film, half track, or full track. It will play optical and magnetic tracks on colour or black and white film either separately or simultaneously, and can change from one half track to the other with no mechanical switchover whatsoever. It will record from two sources separately or mixed (e.g., microphone and gramophone), and it will record from existing optical track with the addition or insertion of extra material from other sources in a single operation.

One of the main advantages of the equipment is that the remote control unit can be placed well away from the projector, so that even the minute amount of noise made by the recording instrument

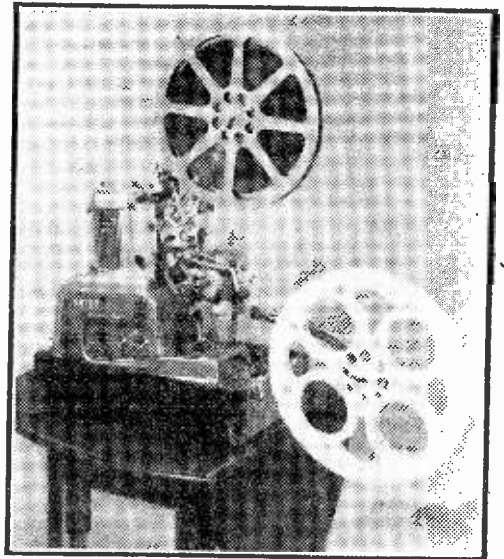

*A view of the new projector.*

can be completely eliminated. In fact, for fully professional results it is preferable to have the commentary read from another room. This can be easily achieved with the remote control unit which allows the projector to be operated and the recording to be fully monitored.

### Operation

When recording from a magnetic track, the striped film is threaded through an erase head and into the

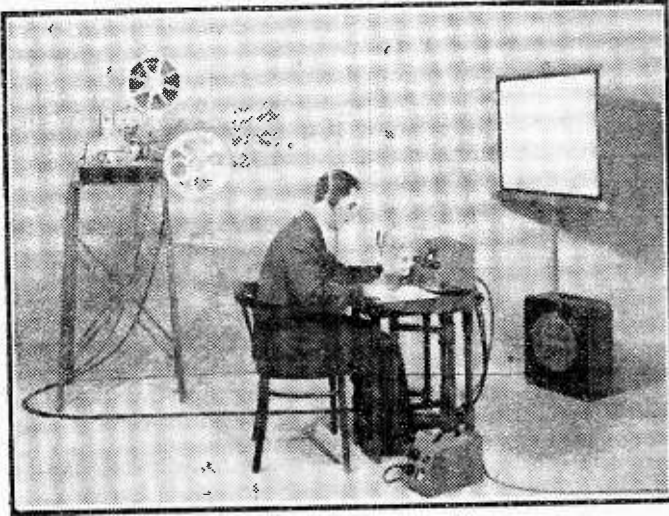

*The complete equipment, with an operator making a magnetic recording.*

projector in the usual manner. When the recording amplifier is switched to the record position, a red signal lamp comes on. The operator then switches on a turntable and checks the level of the opening music, which should peak at the full zero level on the programme meter. He next checks his voice on the second channel of the three-channel mixing unit. His voice should peak at full zero, but if the music is a background to speech it should be peaking at minus 3, and this will be clearly indicated on the programme meter. In the monitor 'phones the operator can hear both the level of the music and his voice. Switching on the projector he records his message. Should he make a mistake, he has merely to reverse the projector to a point prior to the error and re-record the passage. The offending section is automatically removed by a special erase head, which operates continuously during recording to ensure that no previously recorded sound track still exists.

To record from the optical track of a film the operator plugs the output from the speaker line into the 15 ohms position on channel 2 of the remote-control unit. The optical volume on the projector is turned to three-quarters and the tone-control to the desired position. The operator can then switch the channel selector switch into the 15 ohms position and record the message from the optical track, adding music from a gramophone disc or any other source, or making additional comments at the appropriate times.

The recordings are played back in the conventional

manner, using the volume-control marked microphone for the magnetic volume and the normal volume-control for the optical volume where required on half-track recordings.

There are virtually no limits to the facilities offered by this remarkably versatile equipment. From the remote-control position the operator can switch the projector on and off and monitor on his head-set by following the visual indications of the programme meter. He can mix both music and speech and record from the optical track of the film at will, or he can use the 15 ohms input from another projector or tape-recorder or sound effects. If the output of a gramophone is too small for recording purposes, he can take out the speaker plug and plug it into the sound amplifier position, controlling the tone from the recorder itself.

An inexperienced amateur doubtful of his ability to mix sound and speech together can first record the music throughout the length of the required section of a film. He can then rewind the film, by-passing the erase head, and run it through again to record whatever commentary is desired. By this means the original music recording is automatically dropped to background level behind the speech.

In order to prevent assistants on field work from altering the original commentator's carefully chosen words, the projector has been so designed that the erase head can be unplugged, thereby ensuring that

the recording will not be changed.

It is evident that there are four ways in which recordings made by means of magnetic striping can be played back. It is possible to play either the original optical track or the track containing the original optical recording and the new magnetic recording. Again, by careful thought and the use of the two volume-controls selected sequence can be played back from either track or both tracks can be played together. The practical significance of these novel facilities is at once apparent.

If a film is out of date it can be half striped and the material or policy, or any important passages that should be retained, can be recorded on to the magnetic striping at the same time as new speech or new background music is being added to the magnetic track.

When a documentary film is made for use in schools several different commentaries for the various age groups are required. Formerly it was necessary to make each of these commentaries on a separate optical track. Now it is a simple matter to make a copy for the oldest group, half stripe it, and record the commentary for the youngest group. The two recordings can each be played back separately, or the sequences from both play-backs can be mixed to provide the recording for the middle group.

### Training

Most hospital groups consider that films of operations play a valuable part in the training of medical students and nurses, because the camera can show

close-ups that could not be seen by the majority of those present in the theatre. Before the development of magnetic optical projectors, the surgeon had to be in attendance whenever the film was shown in order to provide the necessary commentary. Now the film can be half striped and a suitable commentary can be recorded, enabling the film to be shown at any time without the surgeon being present. Moreover, by varying the recorded commentary the same film can be adapted to the requirements of any type of audience.

Nowadays, there are many industrial users who have a 16 mm. silent camera and have never attempted to reproduce sound or speech. At a very modest cost they can now have their silent films copied and striped and record suitable commentaries with effects. There are many potential applications in factories for staff training and the training of service engineers. A

particularly important advantage of half stripes is that they enable the language difficulty to be overcome. For example, a film illustrating the production, operation or uses of any particular equipment can be made in Britain, copied, striped, and sent all over the world, commentaries in the appropriate language being added in each country. The method also offers an ideal solution to the language problems when films are shown in such vessels as oil tankers, whose crews may be drawn from a number of different countries.

Magnetic optical recordings of the type described are also likely to be extensively used in the motion-picture industry itself, since they offer full studio facilities at a very much lower cost. In fact, the opinion has been expressed that because of its greater efficiency and economy, magnetic recording will eventually be universally employed in place of optical tracks.

## Surplus Lip and Throat Microphones

By E. G. Bulley

**T**HE lip and throat microphones were originally developed for use by the armed forces, and are both similar in construction. The former type is worn on the upper lip and does to a certain extent prevent or limit unwanted background noise. Likewise, the throat type is placed against the throat and, by so doing, background noise is reduced.

Basically, these microphones consist of one or two carbon buttons, the former being known as the single button, whereas the latter is the double button type.

The single button type consists of a metal diaphragm which rests against an insulated dish containing carbon granules, the granules being commonly known as the button. One electrical connection is taken from a metal backplate, and the other is taken from the diaphragm. The double button type, however, can be said to consist of two single button types connected in a push-pull arrangement. This type must not be confused with the lip-type differential microphone, the latter type of microphone having two carbon buttons, one arranged on either side of the diaphragm but having only one electrically connected. It is assumed that the purpose of the other button is to assist in physical balance between the two sides of the diaphragm. Furthermore, should the reader purchase one of these microphones,

he will notice that there are holes on both sides of the outer casing, these holes being located at the base of the instrument. The purpose of the holes is to allow the sound waves to enter both sides of the microphone and create equal and opposite pressures on the diaphragm.

### Operation

The operation of the carbon microphone is simple, and only a brief explanation will therefore be necessary for the reader to appreciate the types that are available on the surplus market. As previously mentioned, the electrical connections are taken from the diaphragm and the case, current being fed from a suitable supply which flows through the loosely-packed carbon granules, and as the diaphragm vibrates, the pressure on the granules increases and decreases. These phenomena causes a fluctuation of current in the circuit in which it is connected.

Typical circuits utilising the single and double types are shown in Figs. 2 and 3.

Many of the lip and throat microphones are of American manufacture, the units being moulded in rubber with an elastic neck- or head-band. Nevertheless, the moulded rubber casing can be removed and the microphone used for various experiments.

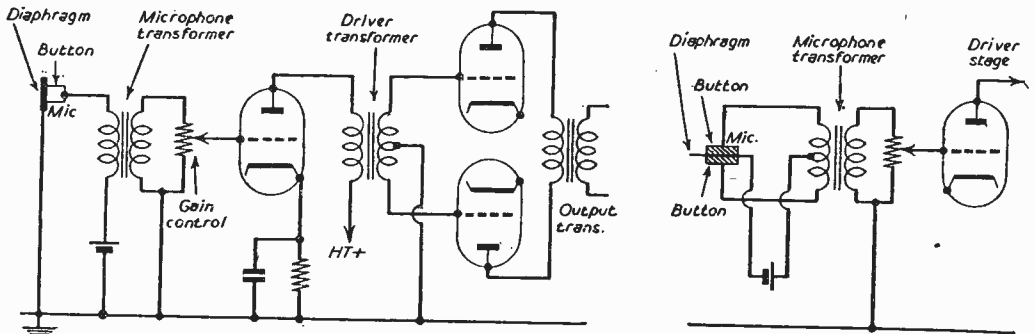

Fig. 1. (left)—Circuit using the single carbon button type of microphone. Fig. 2. (right)—Circuit employing the double-button type.

# Using TEST INSTRUMENTS



Part 2 of a New Series of Articles  
Dealing with the Practical Application  
of Standard Test Equipment

By Gordon J. King, A.M.I.P.R.E.

(Continued from page 14 January issue)

LET us look again at the simple circuit in Fig. 4: we know, by calculation, that 200 volts are developed between points B and A—or between points B and C for that matter. Yet when we endeavour to prove this by making a voltage measurement the meter indication is nothing like it should be.

If we refer back to the voltmeter circuit of Fig. 2, we shall immediately realise that by putting a voltmeter across either of the two points we are in effect shunting either R1 or R2 by the internal resistance of the instrument.

### Instrument Sensitivity (3)

The magnitude of this resistance is, of course, dependent on how much current is required to provide f.s.d. on the meter. Clearly, then, this is governed by the sensitivity of the meter itself, which in turn determines the overall sensitivity of the instrument proper. This characteristic is revealed in the term "ohms per volt."

Let us consider a meter that requires 1 milliampere for f.s.d. If we adapt this to read 1 volt f.s.d., then we find; by using Ohms law, that the meter circuit must possess a total resistance of 1,000 ohms ( $1 \times 1,000/1$  mA). We know, of course, that the meter itself has resistance, but this figure is included in the total resistance value, so that a 1,000 ohms of resistance exists between the actual terminals of such a 1-volt meter.

Thus, we now know that an instrument using a 0.1 milliampere movement has a sensitivity of a 1,000 ohms per volt—bearing in mind that the current to be considered is that necessary for f.s.d. A meter which has a f.s.d. of, say, 0.5 milliampere would, of course, go to make a voltmeter of 2,000 ohms per volt sensitivity—20,000 ohms per volt sensitivity would be realised by using a meter of 50 microamperes (0.05 milliampere) f.s.d., and so on.

We shall now have a much better idea what happens when we connect our, say, 1,000 ohms per volt meter—set on the 200 volts range—across points B and A of Fig. 4. The circuit will most certainly be disturbed by the total voltmeter resistance—now 200,000 ohms ( $1,000 \times 200$  ohms)—shunting R1. This is illustrated by Fig. 5, where a little simple calculation will soon reveal the error of our measurement.

We know that the total resistance of two resistors connected in parallel is equal to  $R1 \times R2 / R1 + R2$ . Working this out for R1

and the total resistance of our 1,000 ohms per volt voltmeter set on the 200 volts range, we quickly discover that in place of the 1 megohm resistor R1 we now have an effective resistance of 166,666 ohms.

This, being still in series with R2 across the voltage source, incites a rise in circuit current from 0.2 milliampere to a little over 0.34 milliampere, whilst the voltage across R1 and the instrument resistance falls to something like 56 volts. And this is precisely what our voltmeter will register—quite a difference between this and the actual 200 volts!

From this reasoning it will be evident that if we increase the voltage setting on the range switch, say, turning it to the 500 volts position, we shall obtain a more accurate reading as then the terminal resistance of the instrument is that much larger. For this reason, when testing voltages in high-resistance circuits it is desirable to employ the highest range possible, consistent, of course, with useful scale indication.

If, on the other hand, we reduce the voltage setting, the terminal resistance of the instrument reduces accordingly, the circuit under test becomes even more heavily shunted, and as the result it is very unlikely that an increase in needle deflection will be achieved.

Engineers and experimenters who are in possession of commercial receiver service data will have noticed that circuit voltage figures are given with respect to a specific type instrument. This applies particularly to the valve electrode voltage figures. In cases where a specific instrument is not quoted, or if a meter sensitivity figure is not given, the voltage readings should be taken only indicatively. An experimenter using a 1,000 ohms per volt instrument, for example, will get an entirely different set of readings from an experimenter using a 20,000 ohms per volt instrument. For the same reason it is desirable also to know the actual voltage range to which the instrument was adjusted when the test readings were taken.

Where possible, then, one should always aim at acquiring a multi-range meter of high sensitivity. This applies more particularly to the television and radio

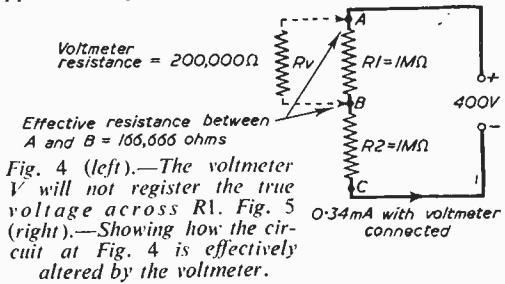
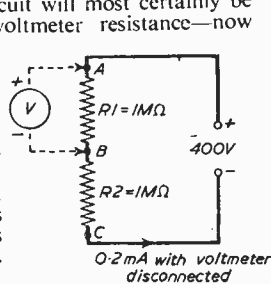

Fig. 4 (left).—The voltmeter V will not register the true voltage across R1. Fig. 5 (right).—Showing how the circuit at Fig. 4 is effectively altered by the voltmeter.



experimenter. For the electrical engineer an accurate instrument of mediocre sensitivity is all that will normally be required, for such an operator's work will generally be on low-resistance circuits where the shunting effect of the instrument will be negligible.

At this point it will be interesting to note that by using a 20,000 ohms per volt instrument, set on the 200 volts range, approximately 175 volts will be measured across  $R_1$  (Fig. 4). The accuracy would be even greater by using the instrument set on the 500 volts range.

#### Measuring Valve Electrode Voltages (4)

When we measure valve electrode voltages the above reasoning holds good in a large number of cases. Let us look at the circuit at Fig. 6. This shows a pentode valve connected as a typical voltage

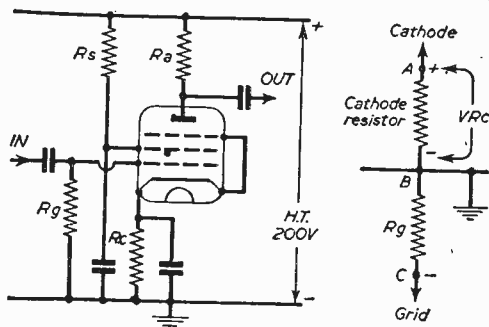

Fig. 6. (left).—A typical voltage amplifier circuit. Fig. 7 (right).—Since there is no current in  $R_g$  under normal conditions, both sides of  $R_g$  are negative with respect to cathode.

amplifier. We shall observe that the stage embodies a cathode biasing arrangement, which means that the resistor  $R_c$  in the cathode circuit causes the cathode to rise to a positive potential relative to the control grid (grid 1) or earth, by reason of the voltage drop across it.

Clearly, then, if we connect a voltmeter across  $R_c$  we are effectively measuring the bias voltage of the valve. Moreover, an accurate voltage reading will be obtained at this point owing to the relatively high ratio between the resistance of the meter and the resistance of  $R_c$ .

It would be quite a different matter, however, if we were silly enough to make a voltage measurement between grid 1 and cathode. If we used a very sensitive instrument we should probably get a reasonable indication. But when we realise that we are obtaining such a reading by putting  $R_g$  in the meter circuit we should well expect a considerable error. Most of us know that the value of  $R_g$  might well range between 0.25 megohms and 10 megohms, and, even though the valve itself may not be taking grid current to provoke a voltage drop across  $R_g$ , the meter must pass current to take energy from the circuit to move the pointer.

This fact is brought out better in Fig. 7, which clearly shows both sides of  $R_g$  negative with respect to cathode—this is because there is no current in  $R_g$  under normal conditions. The voltage drop is VRC across the cathode resistor, so why measure this through  $R_g$ ? It seems from our "Query Service" that a number of experimenters feel that unless an

actual voltmeter connection is made to the control grid a measurement of G.B. voltage is not possible.

If we wish to measure the voltage on the screen of the valve, things become a little more involved. Let us assume that we are using an instrument having a sensitivity of 1,000 ohms per volt set on the 200 volts range, and that the value of the screen feed resistor  $R_s$  is 100,000 ohms. If, without the instrument connected, the screen current is 0.5 milliampere, application of Ohms law will reveal that  $R_s$  will drop 50 volts and that 150 volts will exist between the screen and earth.

The circuit is perfectly happy until we connect our voltmeter between the screen electrode and earth. In effect, this is the same as connecting a 200,000 ohms resistor between screen and earth.

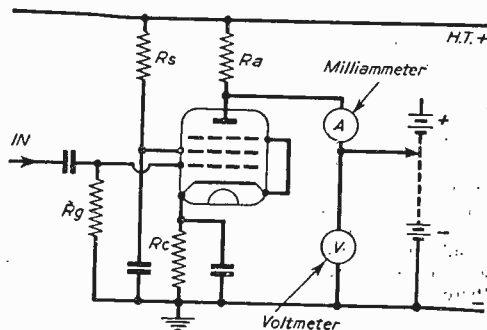

Fig. 8.—A method of accurately assessing the electrode voltage of a valve. The current in  $R_a$  is measured under normal conditions and then the electrode is energised from a low-resistance H.T. source, being measured by V. The voltage is adjusted so that A indicates the normal current in  $R_a$ .

This resistor in conjunction with  $R_s$  thus forms a potential divider circuit from which the screen is fed.

The result is that the current in  $R_s$  increases, the screen voltage falls, and as a direct consequence the valve takes less screen current. This is indeed a complex state of affairs, and one that cannot be readily analysed, for the reduced screen current does not incite a rise in screen voltage equal to the voltage drop caused by the resistance of the instrument. If the two voltage deviations were equal and out-balancing, measurement of the screen voltage would be a relatively simple matter. Of if we could look at the screen cathode path of the valve as a pure resistance, a resistance connected in series with  $R_s$  could be substituted for the valve and analysis made as for the simple potential divider circuit shown in Fig. 4. Unfortunately this is not possible if great accuracy is required, since the voltage-current relationship of the valve does not follow Ohms law.

This reasoning applies equally, of course, to measurement of the anode potential, or any high-resistance valve electrode taking current. If it is essential to take a very accurate measurement the following procedure should be adopted.

First, take careful note of the electrode current, and then disconnect the electrode from the H.T. line. Next connect a H.T. battery or a low resistance H.T. source to the H.T. negative line of the set, and feed the valve electrode from this through a milliammeter.

(To be continued)



# On Your Wavelength

BY THERMION

## The International Short Wave League

SEVERAL of my readers, in view of my comments on clubs which claim national or international status, have written to me regarding the International Short Wave League which operates from 86, Barrenger Road, London, N.10. One of my readers says that there is an honorary secretary and honorary editors, but no mention of a treasurer. He also tells me that there is no indication of annual area elections nor do members receive a balance-sheet accounting for receipts and expenditure. In the journal issued by this League it has been stated that the league membership stands at several thousands. One reader says that his membership number is approaching 6,000. The annual subscription is 10s. a year, so there is a considerable sum received by the League in subscriptions alone. I should have thought that under such circumstances, with a comparatively large sum of money involved, there would have been an annual general meeting and balance-sheet distributed together with a list of members. After all, a man who joins an *international* organisation wants to know who his fellow members are. Personally, I have no knowledge of the League, nor have I had any complaints concerning it. I gather, however, that no one has received a balance-sheet, although when I wrote to the hon. secretary I was informed that they would be "pleased to show me all our books and records, which are in any case always open to inspection and scrutiny by members." I can only comment here that it is quite unreasonable to expect thousands of members to call at the headquarters of the League in London in order to inspect the books. The secretary does not state in his letter to me whether these books and records have been independently audited.

It is said by some readers that all they receive is a membership card and copies of a roneoed journal.

I understand, however, that no officer receives any emoluments, although it is not clear whether they receive expenses. My letter to them invited answers to the following questions: Is an annual general meeting held and are the officers elected annually? Is the secretary a permanent secretary who cannot be removed from office? As you claim to have some thousands of members at 10s. a year, this represents a considerable sum of money. Is a balance-sheet published to members showing how the money is expended? Is this balance-sheet independently audited? What benefits do the members receive? Is a list of members published as would, of course, be necessary in the event of a balance-sheet, so that members could assess revenue?

The reply was: "In view of your request for 'suitable' answers to a series of searching questions, and that the form of our answers is apparently intended to represent the other side of some 'story', we should be pleased to show you all our books and records, which are in any case always open to inspection and scrutiny by members. Furthermore, we

should be very pleased and proud to explain the whole set-up of the I.S.W.L. to you or your representative at your earliest convenience."

Accordingly, the secretary was invited to call at the office of this journal, but countered with a request for us to visit them. Surely a visit should be quite unnecessary, and it should have been easy for the secretary to have answered in writing the questions set forth above?

There is no suggestion, of course, that the club is not properly run, but in order to remove doubts in the minds of readers who have written to me I invite the League to reply to those questions so that I may publish them for the benefit of all concerned.

I belong to many clubs myself, and am always provided with a list of members, notice of annual general meetings and a balance-sheet, accounting for the club's revenue and expenditure. After all, members are entitled to know what the financial position of a particular club is, since they are jointly and severally responsible in law for the club's affairs; being unincorporated they are not a legal entity and members themselves become liable. The hon. secretary and treasurer are now invited to give answers to the questions enumerated above. I also invite correspondence on the subject from members of the League.

## The Radio Amateur Invalid and Bedfast Club

I HAVE been in correspondence with the secretary and others concerned with the Radio Amateur Invalid and Bedfast Club. I do not like that term "bedfast," which is a slang term anyway. My concern is that this club appeals for donations for radio amateurs who are incapacitated and confined to bed. The club also appeals for wireless components and books, and I asked whether I could have further details such as the number of members, whether annual general meetings are held and the officers elected annually, whether a balance-sheet is produced, showing how the donations are being disbursed, together with a statement from the bank and details of all expenditure. If so, could I have a copy? I also wanted to know whether such a balance-sheet, if it exists, has been independently audited. I required to know when the club was founded, how many people have responded to the appeal for donations, and how much has been donated from the commencement. Failing this information, it was pointed out, notices of this club could not appear in this journal. Readers will remember the World Friendship Society of Radio Amateurs which I criticised very severely some time ago and which now seems to have gone out of existence.

Apparently the membership of R.A.I.B.C. at the end of November was 20 with seven local representatives, five of whom are licensed amateurs. Until I receive satisfactory replies to my questions notices, I understand, will not appear in this journal.

# An Economical Quality Receiver

EIGHT STAGES IN FOUR VALVES : VARIABLE SELECTIVITY : NEGATIVE FEEDBACK

By W. N. Stevens

**T**HE problem facing the writer was the construction of a broadcast band receiver which would give good quality and yet have simple circuitry. Primary consideration was good reproduction of the local stations, with a good selection of Continental stations. The trouble is of course, that, generally speaking, the higher the quality desired the more complex the circuitry becomes. Yet, for various reasons, components and cost had, in this case, to be kept to a minimum. Obviously, as in much radio work, the answer was a compromise. The arrangement finally chosen is shown in Fig. 1.

## The Circuit

In the interests of gain, selectivity and general convenience, a superhet circuit was chosen. Ahead of the frequency changer an R.F. amplifier seemed to be desirable, for the usual reasons. On medium waves the stage gain of a tuned R.F. amplifier is considerable, but in the receiver being discussed gain was not the main aim of such a stage. Some extra gain at R.F. was desirable, but the object of the amplifier was primarily to obtain a better signal-to-noise ratio and to prevent cross-modulation distortion. In view of all this, it was decided to use an untuned amplifier, thus obviating the need for extra coils and an extra gang on the variable tuning capacitor.

Here it might be mentioned that one of the con-

siderations involved in building the receiver was to use as many components as possible that were already on hand; hence the unusual valve complement. The R.F. stage uses a 6AC7 high slope pentode, but this is not critical. Alternative types which come readily to mind include 6SG7, 6AG7, 6SK7 or, in the double-ended types, valves such as the 6K7. The R.F. stage is an orthodox untuned amplifier, except perhaps for the cathode bias arrangement, which will be described later. The grid resistor R1 is returned to the AGC line, with the object of preventing overloading on strong signals.

The output of the R.F. stage is capacitance coupled to the mixer stage through a variable capacitor C4, which is pre-set to the best value on completion. Since best results are obtained when the output is coupled to a high impedance, the capacitor is returned to the junction of the mixer grid, tuning capacitor and coil. In the original model the coil is the secondary winding (grid) of a standard medium-wave inductor with the primary winding left unconnected. If greater selectivity is required, normal transformer coupling can be used between the R.F. stage and the mixer. It will be seen from the circuit that AGC control is applied to the mixer stage.

## Frequency Changer

This is a normal shunt-fed circuit, using standard coils. There are, however, a few points of interest.

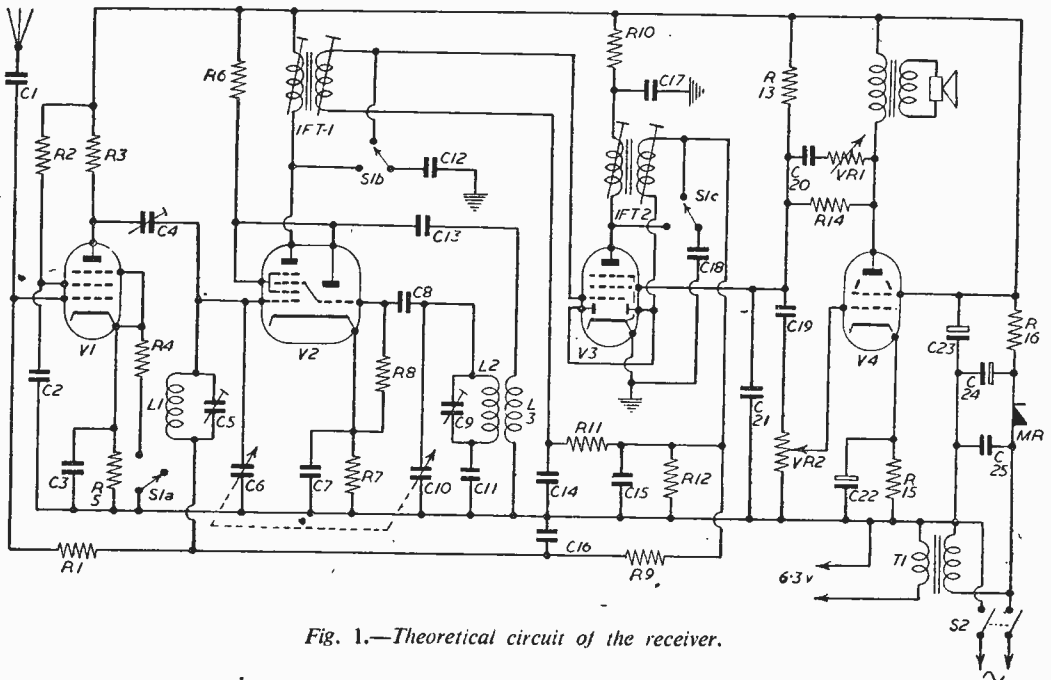

Fig. 1.—Theoretical circuit of the receiver.

Since the maximum conversion is obtained when the oscillator anode and mixer screen are at the same potential (in this case 100 volts for the 6K8), they are fed from a common point, R6 being the common dropping resistor. This arrangement simplifies wiring and does not have any deleterious effects through interaction.

The switching system in the mixer anode circuit is to enable a choice of two degrees of selectivity—Normal and Wideband. In position "1," the 5 pF capacitor C12 is, in effect, shunted across the primary of IFT-1. The receiver is lined up in this position. By switching to position "2," the capacitor is taken off the primary circuit and shunted across the secondary circuit and shunted across the secondary circuit, this change-over providing wide-band characteristics. Another pole on the rotary switch performs a similar operation in the anode circuit of the I.F. amplifier. At the same time, a third pole on the switch affects the gain of the R.F. amplifier. In position "1" (Normal) the resistor R4 (220 ohms) is switched in circuit so that the amplifier is functioning at normal efficiency. But in position "2" (wide-band) the normal bias resistor R4 is switched out of circuit, leaving in its place a high-value resistor (R5), thereby reducing the gain considerably.

The switching system enables the receiver to be operated in the normal manner when tuning to distant stations, especially where the weaker signals require maximum gain and selectivity. When listening to

local stations (and, possibly, the more powerful Continental stations) one may enjoy the benefits of a wide bandwidth in the I.F. circuits since there will be no side-band cutting and, at the same time, the reduction in R.F. gain reduces the possibility of interference from any nearby stations.

**Reflex Amplifier**

The third valve V3 (a 6B8 double-diode-pentode) performs four separate functions and thus enables considerable economies to be made. In the first place it accepts I.F. signals from the frequency changer and operates as a normal pentode I.F. amplifier. At the

same time, the signals are rectified (demodulated) by the two diodes—which are strapped for convenience. The resultant audio voltages are picked off the diode load, fed back to the grid of the pentode and amplified at audio frequency. The A.F. output is taken off the screen-grid which is used as a triode "anode." Additionally, the audio voltages

| LIST OF COMPONENTS                |   |
|-----------------------------------|---|
| <b>Resistors :</b>                | <b>Capacitors :</b>                     |
| R1, 12. 470,000 $\Omega$ .        | C1. 40 pF.                              |
| R2, 11, 13. 100,000 $\Omega$ .    | C2, 3, 7, 16, 17, 19, 21. 0.01 $\mu$ F. |
| R3, 8. 47,000 $\Omega$ .          | C4, 5, 9. 70 pF, trimmer.               |
| R4. 220 $\Omega$ .                | C6, 10. 470 pF swing, twin-gang.        |
| R5. 10,000 $\Omega$ (see text).   | C8, 13. 100 pF.                         |
| R6. 27,000 $\Omega$ , 1 watt.     | C11, 14, 15. 470 pF.                    |
| R7. 330 $\Omega$ .                | C12, 18. 5 pF.                          |
| R9. 2.2 M $\Omega$ .              | C20. 0.001 $\mu$ F.                     |
| R10. 27,000 $\Omega$ .            | C22. 25 $\mu$ F, 25 v. wkg.             |
| R14. 470,000 $\Omega$ (see text). | C23, 24. 8 + 16 $\mu$ F, 350 v. wkg.    |
| R15. 150 $\Omega$ (see text).     | C25. 0.1 $\mu$ F, 1,000 v. wkg.         |
| R16. 1,000 $\Omega$ , 5 watt.     |   |

appearing across the load resistor are fed back to the grid circuits of V1 and V2, through the filter R9/C16, to provide AGC control. It should be noted that no AGC is applied to V3, because, in addition to being an I.F. amplifier, it also functions as an A.F. amplifier and must therefore operate at a fixed gain.

R11, C14 and C15 comprise the usual R.F. filter to prevent any residual R.F. from being fed into the

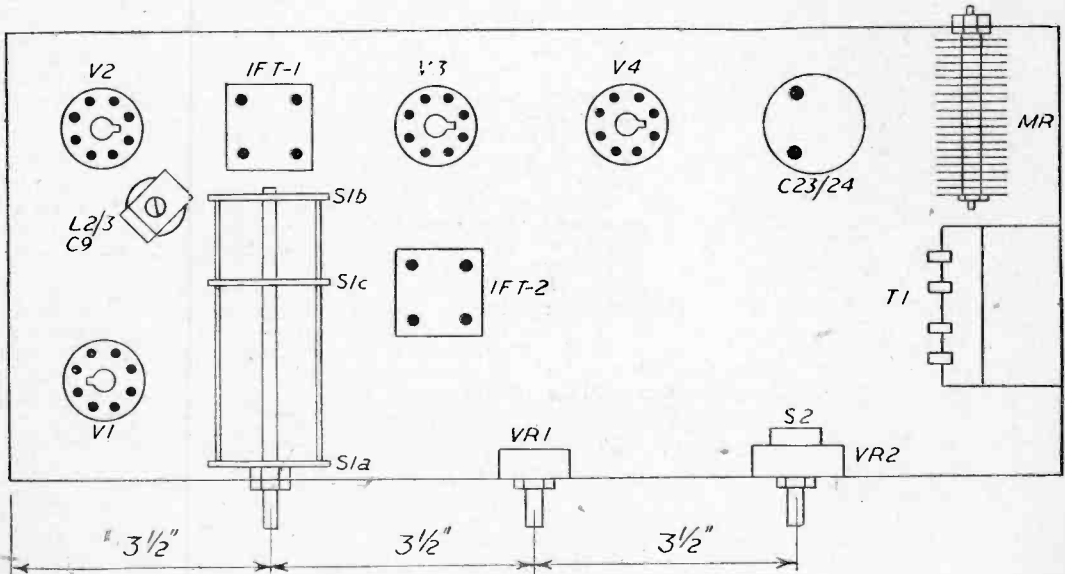

Fig. 2.—Layout and principal measurements.

audio stages and thus causing instability. The by-pass capacitors are smaller than usual so that they do not by-pass the audio voltages as well as the R.F. voltages. The reflex stage is provided with individual anode decoupling (R10, C17) as an aid to stability, although this may not be necessary in many cases (see later).

### Output Stage

The final stage in the receiver is a conventional output amplifier. In the original model the valve is an EL33, simply because one happened to be available. The choice is wide and any of the usual types

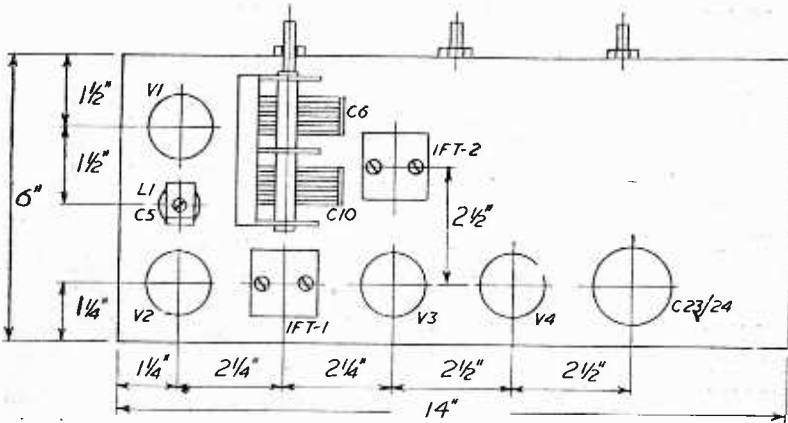

Fig. 3.—Detailed chassis layout.

may, of course, be used as convenient, although the value of the bias resistor (R15) should be noted. Of the more popular types we might mention the 6V6 (cathode resistor 240 ohms), 6F6 (410 ohms), KT63 (420 ohms), KT33C (190 ohms), etc., using a main H.T. rail of 250 volts.

In the interests of quality simple voltage feedback is provided, R14 being the negative feedback resistor. Shunted across this resistor is a tone-control system comprising C20 and VR1, the latter being the manual tone control. This simple top-cut control provides a considerable range of variation to suit most tastes and conditions. VR2 in the grid circuit is the usual manual gain control.

### Power Supply

The total H.T. current consumption of the receiver is under 75 mA at 250 volts. The simplest and cheapest H.T. supply to provide this power, using components already to hand, consisted of a metal rectifier and simple smoothing filter of an 8+16  $\mu$ F electrolytic and a 5-watt 2,000 ohms resistor in place of the conventional smoothing choke.

The L.T. requirements are 6.3 volts at 2 amps (or 1.5 amps if a 6V6 is used as the output valve). This is supplied by a suitable heater transformer across the mains supply.

### Construction

The receiver was built into a spare cabinet which had been earmarked for such a purpose for some time previously. The chassis measured 13in.  $\times$  6in.  $\times$  2in., but it is possible to construct the receiver on a much smaller chassis, as a little "juggling" with the main components will show. Fig. 3 shows the main drilling dimensions and placing of above-chassis components.

There is little point in discussing at length the actual wiring-up of the receiver as even the beginner should have no difficulty providing that the main parts are mounted as shown and care is taken in the usual directions. It is a good point to fit solder tags to each of the valveholder mounting bolts to provide quick earth returns. Most of the components can be mounted around their respective valveholders or from the tags of major components. In the original model it was not found necessary to fit any tag strips at all.

Earth returns for each stage should be taken to a

common point to prevent earthing at different R.F. points and thus inviting instability. Particular care should be taken in wiring up the V3 circuit, but provided leads are kept reasonably short and direct there should be no troubles arising from the rather complicated action of this stage.

The matter of screened leads is best tackled in the following manner: Wire up the receiver without any screened leads at all, except the two from (a) the aerial terminal

to the V1 signal grid and (b) gain control VR2. Then, should any of the usual troubles be experienced, vital leads can be replaced by leads in screened cable until the trouble is cured. The most vulnerable leads are those from the secondary of IFT-1 to the grid of V3, from the secondary of IFT-2 and any leads which pass through the chassis from L1, C6 or C10.

In the original receiver only the two leads mentioned above required screening. The use of screened cable should, of course, be avoided where possible to avoid undue losses.

### Final Adjustments

The first job on completion is, of course, to line up the I.F. transformers in the usual way. This should be done with S1 in position "1" (normal). Then the R.F. circuits may be aligned. In addition, there may be a few other adjustments required to ensure good results.

For instance, the coupling capacitor C4 should be adjusted so that adequate coupling takes place with the lowest possible capacitance. If the coupling is too tight the tuned circuit in the mixer grid will be damped and selectivity will suffer to some extent. C4 should be slackened off so that sufficient gain is obtained consistent with selectivity. When making this adjustment, remember that one side of the capacitor is at high potential.

Also, the resistor R5 may need attention. In the London area, in which the original receiver is used, anything up to 10,000 ohms will be suitable. In some areas, however, it may be necessary to reduce this value to obtain adequate gain; shunting temporary resistors across R5 in situ will soon determine how

(Concluded on page 110)



# 'AVO' Precision ELECTRICAL TESTING INSTRUMENTS

A dependably accurate instrument for testing and fault location is indispensable to the amateur who builds or services his own set.

## The UNIVERSAL AVOMINOR

(as illustrated) is a highly accurate moving-coil instrument, conveniently compact, for measuring A.C. and D.C. voltage, D.C. current, and also resistance: 22 ranges of readings on a 3-inch scale. Total resistance 200,000 ohms.

Size: 4½ ins. x 3½ ins. x 1½ ins.  
Nett weight: 18 ozs.

Complete with leads, interchangeable prods and crocodile clips, and instruction book.

Price: £10 : 10 : 0

D.C. Voltage  
0—75 millivolts  
0—5 volts  
0—25 "  
0—100 "  
0—250 "  
0—500 "

A.C. Voltage  
0—5 volts  
0—25 "  
0—100 "  
0—250 "  
0—500 "

D.C. Current  
0—2.5 milliamps  
0—5 "  
0—25 "  
0—100 "  
0—500 "

Resistance  
0—20,000 ohms  
0—100,000 "  
0—500,000 "  
0—2 megohms  
0—5 "  
0—10 "

**GUARANTEE:** The registered Trade Mark "Avo" is in itself a guarantee of high accuracy and superiority of design and craftsmanship. Every new AvoMinor is guaranteed by the Manufacturers against the remote possibility of defective materials or workmanship.

## The D.C. AVOMINOR

is a 2½-inch moving coil meter providing 14 ranges of readings of D.C. voltage, current and resistance up to 600 volts, 120 milliamps, and 3 megohms respectively. Total resistance 100,000 ohms.

Size: 4½ ins. x 3½ ins. x 1½ ins.  
Nett weight: 12 ozs.

Complete as above  
Price: £5 : 5 : 0

Sole Proprietors and Manufacturers:—

**AUTOMATIC COIL WINDER & ELECTRICAL EQUIPMENT CO., LTD.**  
Winder House, Douglas Street, London, S.W.1. Phone: VIctoria 3404-9

# Osram 912

a modern high quality amplifier & reproducer for the home constructor

## BUILD THIS HIGH QUALITY AMPLIFIER

- Every part specified and readily obtainable from your Radio dealer.
- Every stage in construction clearly explained with step-by-step wiring, in instruction book.
- Rock-like stability in performance—no hum, no microphony, wide frequency response (9 octaves), low harmonic distortion at full power (12 watts) and ensured reliability, with Osram valves specified.
- Full control on frequency characteristic to introduce "art" into listening.
- Unparalleled clarity of both speech and music when used in conjunction with G.E.C. Metal Cone Loudspeaker in octagonal loaded-port cabinet.

Overall frequency response of the complete equipment, comprising L.P. record, specified pick-up, Osram 912 amplifier and G.E.C. Metal Cone Loudspeaker in octagonal loaded-port cabinet.

## How to build the Osram 912

A book giving full constructional details is obtainable from your dealer, or by post (3d. extra) from The Osram Valve and Electronics Dept.

PRICE  
**3/6**

THE GENERAL ELECTRIC CO. LTD. MAGNET HOUSE, KINGSWAY, LONDON, W.C.2.

Great Britain's Valve Mail-Order House

|      |      |      |      |        |      |        |      |
|------|------|------|------|--------|------|--------|------|
| 1B4  | 9/6  | 6BJ6 | 11/- | 6X5    | 8/6  | 3524   | 11/- |
| 1C6  | 9/6  | 6BW6 | 10/6 | 7A7    | 10/6 | 3525   | 12/6 |
| 1G4  | 8/6  | 6C4  | 8/6  | 7B7    | 11/6 | 37     | 9/-  |
| 1LN5 | 6/6  | 6C6  | 9/-  | 7C5    | 10/- | 41     | 10/6 |
| 1LA4 | 9/6  | 6C8  | 11/- | 7C6    | 10/6 | 42     | 10/6 |
| 1P5  | 9/6  | 6D6  | 9/-  | 7H7    | 10/- | 45     | 10/6 |
| 1R4  | 9/6  | 6F6  | 10/- | 7N7    | 10/6 | 46     | 10/6 |
| 1R5  | 10/- | 6F7  | 9/-  | 7Q7    | 11/- | 50L6   | 11/- |
| 1S4  | 10/- | 6F8  | 11/- | 7R7    | 11/- | 53KU   | 12/6 |
| 1S5  | 10/- | 6G6  | 9/-  | 7S7    | 12/6 | 57     | 9/6  |
| 1T4  | 10/- | 6G8  | 9/6  | 7V7    | 10/- | 58     | 10/6 |
| 1T5  | 10/6 | 6H6  | 5/-  | 7Y4    | 10/- | 62BT   | 14/6 |
| 1U5  | 10/- | 6J5  | 7/6  | 8A1    | 11/6 | 71A    | 9/6  |
| 1V   | 5/-  | 6J6  | 12/- | 8D2    | 11/6 | 72     | 10/6 |
| 2A6  | 9/6  | 6J7  | 8/6  | 9D2    | 6/6  | 73     | 10/6 |
| 2A7  | 11/- | 6K6  | 10/6 | 12AL5  | 8/-  | 75     | 9/6  |
| 2X2  | 6/6  | 6K7  | 8/6  | 12A7   | 10/6 | 76     | 8/6  |
| 3D6  | 9/-  | 6K7M | 9/6  | 12H6   | 6/6  | 77     | 10/6 |
| 3S4  | 10/- | 6K8  | 11/6 | 12J5   | 8/-  | 78     | 10/6 |
| 5U4  | 10/6 | 6L5  | 7/6  | 12SA7  | 10/6 | 84     | 8/6  |
| 5X4  | 12/- | 6L6  | 11/6 | 12SH7  | 8/6  | 84/6Z4 | 9/6  |
| 5Z3  | 11/- | 6N7  | 11/- | 12SJ7  | 9/6  | 117Z6  | 8/6  |
| 5Z4  | 10/6 | 6Q7  | 12/6 | 12J7   | 11/6 | 117N7  | 17/- |
| 6A6  | 9/-  | 6R7  | 7/9  | 12K7   | 11/6 | 210L1  | 6/6  |
| 6A8  | 12/6 | 6R7M | 7/9  | 12SK7  | 10/- | 805    | 30/- |
| 6AC5 | 9/-  | 6S47 | 9/6  | 12SL7  | 12/- | 807    | 9/6  |
| 6AC7 | 8/6  | 6S67 | 9/6  | 12SQ7  | 10/- | 866A   | 9/6  |
| 6AG5 | 9/6  | 6SH7 | 8/6  | 12SR7  | 9/-  | 85A    | 5/6  |
| 6AL5 | 9/6  | 6SJ7 | 9/6  | 12Y4   | 9/6  | 955    | 6/6  |
| 6AK6 | 9/6  | 6SK7 | 9/6  | 12AX7  | 9/6  | 956    | 6/6  |
| 6AM6 | 11/- | 6SL7 | 11/6 | 14F6   | 10/- | 1289A  | 8/6  |
| 6AQ5 | 9/6  | 6SN7 | 11/6 | 25A C5 | 6/6  | 1625   | 9/6  |
| 6AT6 | 10/- | 6SS7 | 8/-  | 25Z4   | 9/-  | 1626   | 9/6  |
| 6B4  | 9/-  | 6TH8 | 9/6  | 25Z5   | 10/- | 7193   | 6/6  |
| 6B7  | 11/- | 6U7  | 9/6  | 19     | 10/- | 9004   | 7/6  |
| 6B8  | 10/6 | 6V6  | 10/- | 32     | 8/6  | 9006   | 7/6  |
| 6BA6 | 11/6 | 6ZY5 | 10/- | 33     | 9/6  |        |      |
| 6BE6 | 8/9  | 6W5  | 11/- | 35     | 9/6  |        |      |
| 6BH6 | 11/- | 6X4  | 10/- | 35L6   | 10/6 |        |      |

**SALE**  
2000  
**VALVES**  
BRITISH AMERICAN BATTERY A.C. and UNIVERSAL TYPES.  
All fully guaranteed  
FROM 2/-

DEMOBBER VALVES MANUAL 2/6

**RADIO BULLS VALVES**  
246 HIGH ST HARLESDEN AWD

Giving equivalents of British and American Service and Cross Reference of Commercial Types with an Appendix of B.Y.A. Equivalents and Comprehensive Price List. We have still some Valves left at very old Budget Rates (33%) which are actually sold at the old price. (1951 rate.)

**PIFCO**  
All in - one Radio - meter A.C./D.C. Tests everything in Radio. Complete with Test prods.  
29/6. Post 1/6.



9" TUBE CRT 516 Magnetic 4 v. heater, 4 to 5 kv. E.H.T. Int. Octal Base.  
**BARGAIN.** Carr. and Crate, 4/6. 57/6

**TAYLOR METERS on EASY TERMS**  
Ask for Catalogue

**R.T.H. GERMANIUM CRYSTAL DIODE.** Complete with Blueprint and operating instructions, 2/-.  
**ROD ANTENNAS.** 1ft. sections interlocking and extending. copper plated steel. **BARGAIN.** Dozen 2/6.

**UNIQUE SERVICE**



**SERVICE SHEETS**  
The one you require enclosed if available in a dozen assorted of our best choice. 10/6.

**Q-MAX**  
Chassis Cutters with Keys  
The easiest and quickest way of cutting holes in sheet metal. The cutter consists of three parts: A die, a punch and an Allen screw. The operation is quite simple. Prices incl. key: 1in., 12/4; 1 1/4in., 13/4; 1 1/2in. and 1 3/4in., 16/- each; 1 7/8in. and 1 3/2in., 18/- each; 1 3/4in., 19/8; 2 1/4in., 31/8; 2 1/2in., 36/9; 1in. square, 24/3. Post 1/-.



**TYANA TRIPLE THREE**  
Small Soldering Iron. Latest development. Complete with detachable bench stand, 17/6. Post 1/-.

**7/6 MICROPHONE** 7/6  
This U.S.A. Throat Mike Made by Universal Microphone Company, in California, is highly sensitive. Complete with neck piece clip and illustrated 4-page specification and in original carton. Bargain Price Only fraction of original cost. Limited quantity. Post 9d.

Continued here w. British Types next month

Post 9d.

**NEW!**

**EXPERIMENTAL KITS in Radio, T.V. etc.**

**LEARN THE PRACTICAL WAY**

Specially prepared sets of radio parts (which you receive upon enrolment) with which we teach you, in your own home, the working of fundamental electronic circuits and bring you easily to the point when you can construct and service radio sets. Whether you are a student for an examination; starting a new hobby; intent upon a career in industry; or running your own business — these Practical Courses are intended for YOU — and may be yours at very moderate cost.

**EASY TERMS FROM 15/- A MONTH**

All lessons and equipment supplied immediately and become your own property.

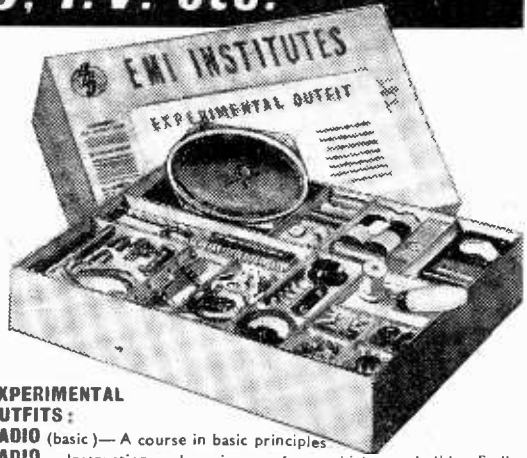

**POST THIS COUPON TODAY**

Please send me your FREE book on Practical Courses  
To: E.M.I. INSTITUTES, Dept. 32X, Grove Park Road, London, W.4.

NAME .....

ADDRESS .....

SUBJECT(S) .....

**EXPERIMENTAL OUTFITS:**

**RADIO (basic)** — A course in basic principles  
**RADIO** — Instruction and equipment from which you build a Radio Receiver.  
**TELEVISION** — Instruction and equipment for building a Television Receiver.

Also for Mechanics, Electricity, Chemistry, Photography, Carpentry, Draughtsmanship, Commercial Art, Amateur S.W. Radio, Languages.

**E.M.I. INSTITUTES** The only Postal College which is part of a world-wide Industrial Organisation

# SHORT-WAVE SECTION

## BUILDING COMMUNICATIONS RECEIVERS

### 3.—DOUBLE SUPERHETS AND TUNING INDICATORS

(Continued from page 23 January issue)

#### Double Superhets

SOME ex-service and other communications-type receivers employ two frequency changers and two sets of I.F. amplifier stages. Such a circuit might employ conventional R.F. and F.C. stages, followed by I.F. stages such as shown last month. The output from this section of the receiver would not, however, be taken to the detector stage, but to the second F.C. stage, a typical circuit for which is shown in Fig. 2. This stage changes the frequency to a different one from that already employed and further I.F. amplifier stages, all operating on this new frequency, then follow.

A number of advantages arise from such a method of operation, which increases selectivity and sensitivity greatly. With a large number of I.F. stages operating on one frequency, instability may easily arise, and this is avoided by a number of the stages operating upon one frequency, and the remainder upon a different frequency, as with the double superhet. The rejection of adjacent-channel interference is also increased.

The circuit in Fig. 2 is typical, and A.V.C. could be applied. The tuning of the oscillator coil is not variable, as with the first F.C. stage, but pre-set by means of C2. C1 is the usual coupling condenser. The selection of suitable I.F. transformers and oscillator coil is not difficult, and many standard and ex-service transformers can be used, while an ordinary "unit" coil, possibly dust cored, can be used for the oscillator circuit. If 465 kc/s transformers are used in the initial I.F. stages, 110 kc/s

transformers may be used in the stages following the second F.C. stage. If, however, ex-service transformers of rather higher frequency are employed in the initial stages, then 465 kc/s transformers can be used in the later stages. Alternatively, numbers of small long-wave ex-service coils exist which may readily be used in the later stages, 465 kc/s transformers being used in the first section of the I.F. amplifier so that standard signal-frequency and oscillator coils can be used in the R.F. and first F.C. stages.

The frequency of the oscillator coil may readily be determined by adding together the first I.F. and second I.F. transformer frequencies. With 465 and 110 kc/s components, this would be 575 kc/s, which is approximately 520 metres. A coil tunable to this wavelength would be obtainable without difficulty. Fairly high initial intermediate frequencies are more usual, though not essential, and may be of about 1 to 7 Mc/s.

#### Typical Valve Sequences

The use of the maximum number of stages is by no means the most desirable feature, but the provision of adequate selectivity and sensitivity, with low

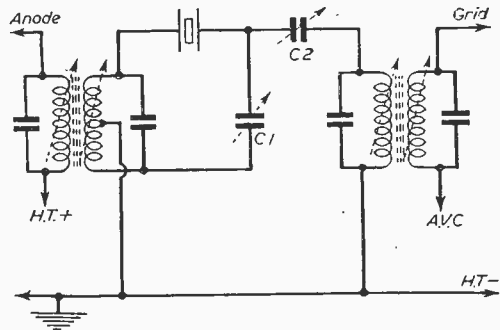
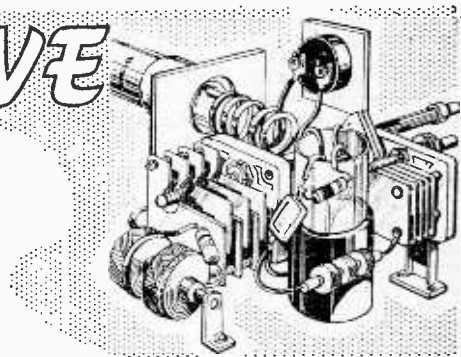

Fig. 1.—A crystal I.F. circuit.

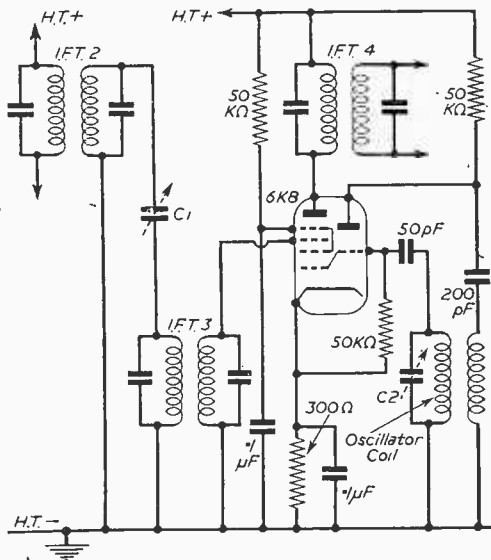

Fig. 2.—A Double Superhet circuit.



noise ratio. A study of commercial communications receivers will show that three I.F. stages are seldom exceeded, even in very expensive equipment. More than one tuned R.F. stage may be found, but is not very usual, and is best avoided in home-built equipment. Some double-superhet receivers employ no I.F. stage at the initial frequency, the first F.C. stage, with transformer or transformers, being followed immediately by the second F.C. stage, which may feed a single I.F. stage to be followed by the detector. Where two or more I.F. stages are used, the double-superhet is not very often employed, except when extremely high standards of selectivity and sensitivity are required.

It will therefore be seen that the construction of such equipment is not necessarily one of great cost, and about six to ten valves, in all, will be found a convenient number to employ. (Usually, of course, no great difficulty should arise in adding further stages later, if wanted.)

Where simplicity is important, the FC/2-I.F./DDT/Output type of circuit can give exceedingly good results, further improved by the addition of an R.F. stage. If both R.F. stages and a further I.F. stage be used, a standard of performance adequate for most purposes can be obtained. Usually, a very high audio output is not required, and a single stage, delivering 3 to 5 watts, is ample. Quality of reproduction need be by no means poor, and negative feedback, combined with "flat" tuning may be used for local-station listening, resulting in a circuit with the widest possible usefulness.

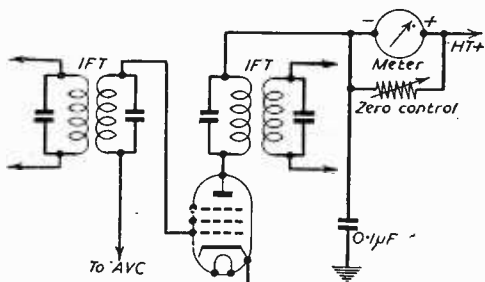

Fig. 3.—Tuning meter in I.F. anode circuit.

### Tuning and Signal Strength Meters

Many of the simpler communications type receiver have no signal strength or tuning meter. With other receivers, such a meter is built in, or can be purchased as a plug-in, separate unit, usually in a small desk-type housing, with flexible lead. A tuning meter may be added to any superhet, and will then indicate the correct tuning point for any R.T. signal, or show the relative strength of the carrier wave of such a transmitter. It is not suitable for I.C.W. Morse transmissions, since in the intervals between letters, or the symbols of a letter, there is no carrier wave to deflect the meter. The meter thus endeavours to follow the keying. When employed for its usual purpose, no such difficulty arises, and a steady indication is obtained, irrespective of speech, music, or other carrier-wave content. A signal strength device is much more sensitive to small changes than the human ear, and also provides a definite reading which may be noted from day to day, or compared with readings made from other transmissions. Any

modification which increases signal strength at the receiver (such as improvements at the transmitter, or an improved aerial, etc., at the receiver) will be shown at once by an increased reading.

A tuning meter is primarily concerned with showing the point of exact tuning for any station, and may consist of a Magic Eye or moving-coil meter. For this type of indicator, the Magic Eye has the advantage of low cost, small panel size, and robustness. The meter is, however, better when comparisons of signal strength are required, and is almost essential for the signal strength type of circuit.

### Meter Tuning Circuit

A simple and effective method of using a meter for tuning indication is shown in Fig. 3. The meter may be connected in the anode circuit of the frequency-changer, mixer, or I.F. valve, provided the valve chosen is under the control of the A.V.C. system. It is also feasible to group together the anode circuits of two or more valves, so that the meter reads the combined anode current.

In operation, the anode current depends upon the A.V.C. voltage, which, in turn, depends upon signal strength. Anode current is at maximum with zero signal, and at minimum with maximum signal. Resonance is thus the lowest obtainable meter reading, while the greater the signal strength of the transmitter, the lower will the reading be. Such a meter thus provides comparison of signal strengths, and accurate tuning.

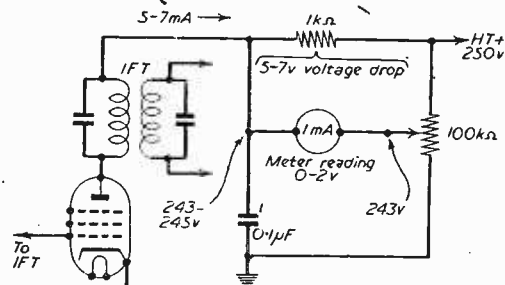

Fig. 4.—A typical signal strength meter.

The anode current change of an average I.F. valve type will be about 2 to 3 mA. In order that a zero signal strength indication may be obtained on the meter scale, the meter should be of a type having a full-scale deflection under the normal anode current rating of the valve or valves to which it is connected. The "Zero" control shown consists of a wire-wound variable shunt. In use, the receiver is tuned to a point where no signal is obtained, and the control adjusted until the meter indicates full-scale. The control is then left untouched. When a station is tuned in, the pointer will fall back to an extent depending upon the signal strength of the station. A 1 mA. or 2 mA. meter, suitably shunted, is satisfactory. The .1 μF condenser is for decoupling. Such a meter may be added to any commercial or amateur-built superhet.

### The "S" Meter

The "S" or "R" (Signal strength or Readability) meter employed in communications equipment

usually has a circuit such as that shown in Fig. 4. Though frequently fitted in the F.C. or mixer anode circuit, any A.V.C. operated valve may be employed. Operation is rather different from that of the circuit in Fig. 6.

Assuming, as example, that the anode current of the valve is 5 mA. at maximum signal, and 7 mA. at minimum signal, the voltage drop in the 1 K. resistor will be 5 v. for maximum signal, and 7 v. for minimum signal. The voltage at one meter terminal would thus be approximately 243 for minimum signal, and 245 v. for maximum signal. If the meter is able to read from 0 to 2 v., and has its second-terminal maintained at 243 v. by the potential divider, it will read zero for minimum signal, the reading rising to full-scale for maximum signal. With this circuit, the receiver is thus tuned for maximum deflection. The circuit may initially be set up in such a way that zero and maximum meter readings are obtained with certain minimum and maximum signal strength levels. In practice, zero reading will be obtained with zero signal.

Initially, the 100 K. potentiometer requires to be set with the slider towards the H.T. positive end

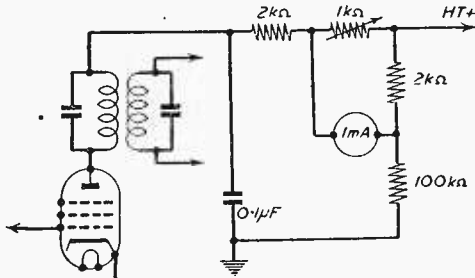

Fig. 5.—An alternative method of connecting the meter of Fig. 4.

of the circuit, or a heavy current may flow as the rectifier warms up. This should be watched. When the receiver has reached a stable operating temperature, the control may be adjusted. If the meter moves the wrong way on tuning in a signal, connections to it require to be reversed. To avoid possible damage due to turning the potentiometer slider too far towards the negative side of the circuit, the potential-divider may be made up from one fixed and one variable resistor or potentiometer.

A second circuit giving similar results is shown in Fig. 5, the potential-divider circuit being fixed, and the 1 K. resistor variable. The operation of this circuit is basically the same as that in Fig. 4. The 2 K.Ω resistor and .1 μF condenser are included for decoupling.

**Magic Eye Circuits**

The magic eye is usually operated directly from the A.V.C. circuit, the A.V.C. voltage controlling the anode current of the triode section of the eye. Many ex-Service magic eye or tuning indicator valves are cheaply obtainable, and will generally be satisfactory. It should be noted that a small number of such eyes have no triode section, and a separate valve would be required, here, if such an eye were used. In addition, the triode section control grid voltage required for zero shadow angle (or sensitivity of the eye)

varies from type to type. This value may be modified within limits by changing the load resistor value. Reduced target and anode voltages reduce the A.V.C. voltage required for zero shadow angle. The control voltage ranges from about 8 to 22 volts for an eye such as the 6U5, down to 3.3 to 8 volts for types such as the 1629.

Fig. 6A shows the usual circuit. The 100 K. resistor and .05μF condenser may be omitted where no instability arises. Used in this way, the eye will show accurate tuning positions for any transmitter powerful enough to operate the A.V.C. system, and also give some indication of signal strength.

An improved circuit is shown in Fig. 6B, and enables the voltage applied to the control grid of the eye to be adjusted. Generally, the .5 megohm control may replace the A.V.C. circuit fixed resistor found in this position. With this circuit, a sensitive eye may be adjusted until its range corresponds to zero and maximum signal strengths. A further method is to employ a certain shadow angle as reference, and have the .5 megohm control panel operated, with a scale. When the signal strength of a station is to be read, the control is then adjusted until the exact shadow angle

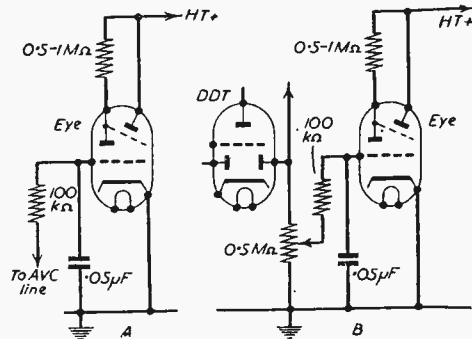

Fig 6 —Magic eye tuning indicator circuit

is obtained. The control pointer will then indicate the relative signal strength, against its scale. With the control left in a middle position, the eye can be used for tuning only in the usual way.

Where manual R.F. or I.F. gain controls are fitted, the influence of these must not be overlooked. For example, the meter reading would fall back if gain were reduced in any preceding stage, or in a following stage which comes within the A.V.C. network. This difficulty may be overcome by employing a switch to cut out any R.F. or I.F. cathode or screen-grid gain control, gain being at maximum when the switch is closed. Volume can, if required, be kept down by the A.F. volume control, this having no effect on the meter reading.

Such a precaution is only necessary when making definite readings of signal strength. The meter or eye will, of course, continue to function as a tuning meter, irrespective of the setting of a manual control in another stage. Such a manual control should not, however, be used in the stage where the meter is employed.

In addition, it should be assured that the beat-frequency oscillator (if present) is not operating, as in some circuits this will change the signal reaching the second detector in such a way that the A.V.C. voltage is modified.

# Diode-transistor Loudspeaker Receiver

A VALVELESS MIDGET OF INTERESTING DESIGN

By Capt. Graham

TESTS showed that one transistor is practically useless for broadcast reception. More than one calls for bias resistors, transformers, etc., imposing pre-set loads, and limiting the output of the final transistor to an output which is much less than it could give if it were unhampered. Diodes work on very high frequencies, and so it occurred to me to use a diode to feed a transistor. The result was that the transistor gave out a remarkably higher output. Further tests showed that a pre-set bias is not necessary for broadcast reception. A very simple circuit was therefore evolved with only one diode and one transistor, which works to its full capacity in a most efficient manner, gives an output sufficient to work a loudspeaker, and has very good fidelity. In fact, it is so good that for the past nine months it was used in preference to four other expensive receivers. Also, recordings on a new Ferrograph 2B are superior to recordings from a commercial Hi-Fi valve tuner

except that the transistor must be correctly and carefully soldered; any false connection will destroy it. If not overloaded it should last a lifetime, at negligible cost.

## The Circuit (Fig. 1)

The Brimar GD3 germanium diode is connected with the red end to the coil centre tap, to rectify and supply a modulating negative potential to the transistor. The other end of GD3 is connected to the base of a Mullard OC71 germanium junction transistor of the p-n-p type.

When the aerial is disconnected, the transistor base is at the same D.C. potential as the grounded emitter; the meter reads zero, and then the transistor does not allow any current from the battery to flow through it. But when the aerial is connected and the coils are tuned to a station, the meter shows a reading, and now the transistor does allow the battery current to flow through it to work the loudspeaker.

Consider what happens during half of a cycle of a radio-carrier frequency. When the grounded end of the coil is positive and the centre tap is at a negative potential, the coil is supplying current derived from the aerial. Electrons tend to flow from negative to positive just as in the valve theory we all know. The rectifier diode GD3, being connected as it is, accepts the electrons from the negative centre tap. Electrons pass through it to the base of the transistor and because it is p-n-p type the base likewise accepts. Electrons flow through the transistor to the grounded emitter, which is at the same positive potential as the grounded end of the coil attracting these electrons. This completes one circuit and current has passed through the transistor.

If instead of the 3-volt battery a micro-amp meter is connected, it shows a reading. This proves that some of the electrons from the coil flow from base to collector, through the transformer, the 5 mA meter, the  $\mu$ A meter to the earthed end of the coil, completing another circuit, and some of the aerial current may flow through the transistor in this circuit, since both the emitter and the collector are at the same potential as the grounded end of the coil in so far as these electrons are concerned.

From the foregoing it becomes evident that a very pronounced change takes place in a transistor when a current flows through it: Without a current and with base at same potential as the emitter, it does not pass battery current, but with a negative potential at base and current flowing through, a secondary effect takes place, it does pass a very considerable current. Furthermore, this greater current is controlled by the transistor to pass through in very definite proportions, depending upon the amount of aerial current flowing at any instant or depending upon D.C. potential at the base and a steady current flowing, and so curves can be plotted. Negative pulses produced by the diode are enormously amplified and are passed through the transformer. Since these half-cycle-pulses are modulated by music, etc., sounds are reproduced in the speaker.

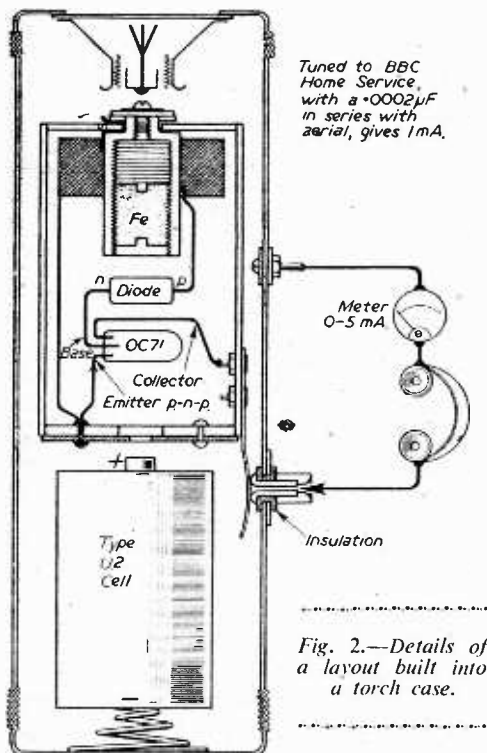

Fig. 2.—Details of a layout built into a torch case.

diode. There is no background noise and negligible crackling during a storm and high-voltage low-current discharges. A first-class horizontal aerial and earth is necessary. High-"Q" coils and wiring with short leads avoid capacity losses. Care should be taken not to overload the transistor by powerful local stations. In all other respects there are no signs

**Battery Effect**

There are two good reasons why a very much greater current passes from the battery. Firstly, the three-volt battery has a higher voltage than the small fractions of a volt at the base, and it can give a current far in excess of requirements, whereas the diode can only supply the few microamps available from the aerial. And secondly, because the junction transistor can pass an excessive current which will destroy it, even with a small voltage. It is constructed with fair contact surfaces and thin junctions having little resistance and high efficiency when working as stated.

If the battery connections were to be reversed with the negative terminal connected to earth, the transistor would allow such a high current to pass through it from the battery that it would be destroyed and the milliamp meter would also be damaged. Hence the warning: be very careful to connect the transistor and the battery correctly. Test with a high-resistance voltmeter having one milliamp full-scale deflection in place of the mA meter. If the transistor or battery is wrongly connected, the voltmeter will show almost the full battery voltage, but if correctly connected it will show a very small reading near zero. Do not use an ohmmeter to test a transistor; some such meters will pass a damaging current. Use a voltmeter in series with a battery, then you know that the maximum current will be less than full-scale deflection current, and the meter reading will show what proportion of the current is passing through. Half of full-scale deflection represents  $\frac{1}{2}$  milliamp, etc.

During the positive half-cycle the diode naturally rejects and current does not pass through with wrong polarity to interfere with the proper working of the transistor which now has a period time of half a cycle to completely dispose of the negative pulse it received. The .002  $\mu\text{F}$  condenser is to by-pass any stray R.F. from interfering, and it retains some of the negative potential and acts as a bias device. The meter reads a shade higher when this condenser is connected from base to ground. If the diode is shorted or removed, and the base connected to a tapped coil, the reception is not much better than with the diode alone; apparently some sort of a mixture of various conditions takes place in the transistor which as yet cannot adequately deal with R.F. all on its own: still thinner ones or composite ones may be evolved in time even for R.F. amplification, and short aeriels.

This receiver works like a D.C. valve amplifier. If the coil is disconnected and a small D.C. negative potential is applied to the diode (p) or the transistor base, the meter shows a mA reading in definite proportion and curves can be plotted as for a valve. These curves show a remarkably

high slope which works out to over 60 mA/v. There is no receiver valve which can give such high efficiency, mostly not a tenth of it.

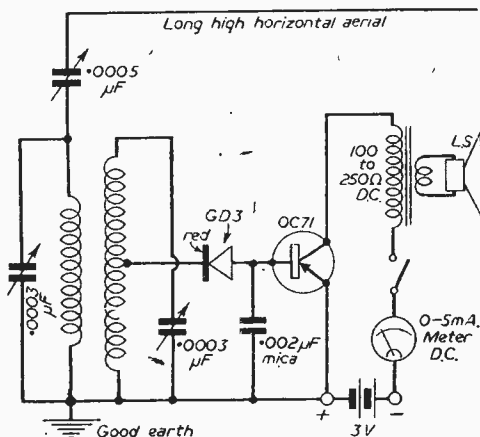

Fig. 1.—The final circuit.

**Coils**

Home-made coils can be made quite easily with good efficiency by making radial slots in a round disc of insulating material; 28 or 30 s.w.g. insulated wire is wound starting with 2in. inner diameter and zig-zagging from one side of one slot to the other side of another; single layers are wound one on top of the other forming an interlaced spider's web spiral on each side, with an air space between each section for which an odd number of 7 or 9 slots are needed. Aerial coil number of turns will depend upon the size of aerial, 60 to 70, may be more, and 100 for the diode coil. Such pancake coils are very convenient for soldering a tap to any desired turn. Plug-in coils can be made by removing the glass bulb of old 4 or 5 pin valves and slotting the base with a saw cut into which the disc is attached and glued. Separate coils about 3in. apart and tune to the Third programme. If the condensers are nearly fully meshed, all is well for the medium band, if only half or three-quarter meshed, remove a few turns and try again. Now tune in any station accurately for highest meter reading not exceeding 3 mA and 3 volt battery. Reduce series aerial capacitance if meter reads too high and retune accurately. Now bring the coils slowly closer together; the meter will rise and then begin to drop. Note the distance between coils; best magnetic coupling is when meter begins to drop as coils are being separated. Use "open" wiring to start with, then fit receiver into any small battery receiver cabinet.

**Output Transformer**

The output transformer for the speaker should be a good one with low resistance primary not exceeding 250 ohms D.C. That means a large one to accommodate the many turns of thicker gauge wire needed for efficiency. Too high a resistance or a mis-match will cause the meter to dip badly to lower readings on loud passages of music broadcast. The meter should give a reasonably steady reading for good fidelity. If meter dips appreciably, reduce volume by reducing aerial condenser capacitance and retune. Best results are at 1 to 2 milliamps and 3 volts, with present-day transistors. If meter tends to show a

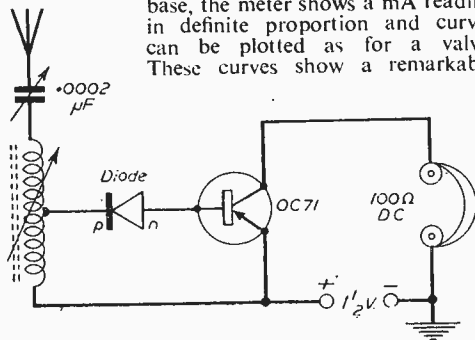

Fig. 3.—A basic arrangement.

higher reading, reduce battery voltage. Do not overload the transistor, it can be burned out in Bedford by tuning in either the Third or Home stations. The aerial series condenser is, therefore, necessary for attenuating, but since it increases selectivity it is all to the good and it acts as a volume control. At 3 mA the meter begins to dip, loud passages become slightly distorted and the transistor is beginning to be overloaded so reduce the signal. The .0005 series condenser is never full in at Bedford for BBC stations, only for foreign stations which can be heard on the speaker or using low-resistance phone in place of transformer. The war surplus balanced armature or moving-coil phones of about 100 ohms are best for this. Clear signals can be heard with meter reading only .02 mA when the speaker begins to sound.

Diodes vary, transistors more so. The meter is very useful for testing. It should give no reading with aerial disconnected if the transistor is a good one. Some show a leakage, of .02 mA or more. The meter is a very accurate tuning indicator. It can be used to find the best tap for the diode, the best tap for any aerial to improved reception selectivity. For best coil coupling and-for plotting curves.

A relay could be used instead of the transformer

to switch on an alarm bell when BBC begin to broadcast in the morning. The receiver can be used for plotting field strength of a transmitter aerial and directional properties. It automatically switches off battery current when the BBC stops broadcasting; the meter drops to zero. A small receiver was built into a tube of insulating material the same size as a U2 battery with a metal pip at the top to make contact with an aerial instead of a bulb, and a metal disc at the bottom to contact with an ordinary U2 battery pip supplying positive potential, and its negative to the pocket battery case to which a small bolt was fixed for earth and one end of phone leads. The other lead from phones connects to another bolt on the metal battery case but insulated very carefully from the case. This bolt makes contact with a small bronze spring at the side of the U2 receiver and thus to the collector. The emitter is connected to the metal plate at the bottom of U2 receiver. One end of a single coil is likewise connected, to the plate, the other end to the pip at the top and centre tap to diode (p) other end of diode to base of transistor. The small coil was pre-tuned by a dust core to suit the small aerial and the Home station. The aerial was naturally long enough to give loudspeaker results but not long enough to overload. (Figs. 2 and 3).

## News from the Clubs

### NEWARK AND DISTRICT AMATEUR RADIO SOCIETY

Hon. Sec.: R. Clayton, 160, Wolsey Road, Newark.

MEETINGS are held on the first Sunday evening of each month in the Northern Hotel, at 7 p.m., together with a mid-monthly meeting in Northgate House, the date of the latter being announced at the preceding Sunday meeting.

New members and visitors are always welcomed.

### READING RADIO SOCIETY

Hon. Sec.: L. A. Hensford (G2BHS), 30, Boston Avenue, Reading, Berks.

MEETINGS of the above Society will take place at the Abbey Gateway at 7 p.m. on January 8th and 29th, 1955. On February 12th Mr. E. W. Berth-Jones, B.Sc., of the Record Engineering Dept. of E.M.I., will give a lecture and demonstration.

### CLIFTON AMATEUR RADIO SOCIETY

Hon. Sec.: C. H. Bullivant (G3DIC), 25, St. Fillans Road, Catford, S.E.6.

THE main event during November was the visit to the clubrooms on November 19th of Mr. W. H. Andrews (G2YG). Mr. Andrews gave an account of the Metropolitan Police radio system and demonstrated the mobile equipment used.

The programme for January is as follows: 21st, Discussion; 14th and 28th, Constructional Evenings.

Meetings are held every Friday evening at 7.30 p.m. at the clubrooms, 225, New Cross Road, S.E.14.

### WIRRAL AMATEUR RADIO SOCIETY

Hon. Sec.: A. C. Wattleworth, 17, Iris Avenue, Claughton, Birkenhead.

MEETINGS are held on the first and third Wednesday in the month at the Y.M.C.A., Whetstone Lane, Birkenhead. The meetings commence at 7.45 p.m.

Visitors, particularly short-wave listeners and novices, will be most welcome.

### TORBAY AMATEUR RADIO SOCIETY

Hon. Sec.: L. H. Webber (G3GDW), 43, Lime Tree Walk, Newton Abbot.

IT has been decided to hold a Social Evening and Dinner at 7.30 p.m., on Saturday, February 5th, 1955, at the Oswalds Hotel, Babbacombe, Torquay, for members and their ladies.

Reservations may be made through Donald Cawley (G2GM), 1, Littlegate Road, Paignton, Devon, at 8s. 6d. each.

### WARRINGTON AND DISTRICT RADIO SOCIETY (G3CKR)

Hon. Sec.: G. H. Flood, 32, Capesthorpe Road, Orford, Warrington, Lancs.

RECENT events have included a demonstration of radio control for models by W. Sanson and his home constructed power launch.

The results of the society's inter-club top band contest are:

1st, G3CSG N. Kendrick, of Wirral; 2nd, G3ELL I. Griffiths, of Liverpool; 3rd, G3ITY E. Yates, of Chester.

Rx. 1st., N. Richardson, of Chester; 2nd., A. H. D. Looney, of Liverpool; 3rd., G. H. Flood, of Warrington.

Meetings are now held on the first and third Thursdays in each month, at the King's Head Hotel, Winwick Street.

### BRADFORD AMATEUR RADIO SOCIETY

Hon. Sec.: F. J. Davies, 39, Pullan Avenue, Bradford, 2.

ON January 11th Mr. G. F. Craven will give a lecture entitled "Oscilloscopes—Design and Construction." The meetings will commence at 7.30 p.m. at Cambridge House.

### ROMFORD AND DISTRICT AMATEUR RADIO SOCIETY (G4KF-P)

Hon. Sec.: N. Miller, 18, Mascells Gardens, Brentwood, Essex. The weekly meetings are held on Tuesdays at 8.15 p.m. at R.A.F.A. House, 18, Carlton Road, Romford, Essex.

### BRIGHTON AND DISTRICT RADIO CLUB (G3EVE)

Hon. Sec.: T. J. Huggett, 15, Waverley Crescent, Brighton, Sussex.

THE club meets every Tuesday at the Eagle Inn, Gloucester Road, Brighton. Meetings commence at 7.30 p.m. The club transmitter is on the air on 80 metres and top band, using both 'phone and c.w.

### WELLINGBOROUGH AND DISTRICT RADIO AND TELEVISION SOCIETY

Hon. Sec.: J. Graves, 1, Millers Close, Finedon, Wellingborough, Northants.

THE above club meets each Thursday at 7.30 p.m. at their headquarters in Silver Street, Wellingborough (above Co-op. fruit shop).

Lectures are being arranged by the newly formed committee; a club transmitter is being built and Morse classes have commenced. It is hoped to arrange visits to places of interest and exchange visits to other clubs in the area.

New members will be welcomed at the club-room any Thursday and details of membership can be obtained from the secretary.

### NORTHAMPTON SHORT WAVE RADIO CLUB (G3GWB)

Hon. Sec.: A. J. Kightley, 23, Garrick Road, Northampton.

THE club will be organising some "Listening Competitions" on the amateur bands during the winter months.

### SOUTHEND AND DISTRICT RADIO SOCIETY (G5QK)

Hon. Sec.: J. H. Barrance, M.B.E. (G3BUJ), 49, Swanage Road, Southend-on-Sea, Essex.

MR. H. R. SPINKS, a radio engineer who has been working his amateur station in the Far East for several years, answered questions fired at him by members at their recent meeting in the Ekco Canteen.

THREE COMPLETELY ASSEMBLED "ALL-WAVE" SUPERHET CHASSIS

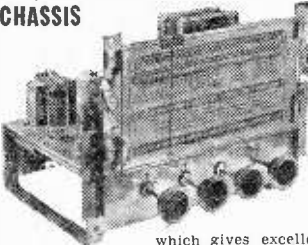

Modernise your old Radiogram

The three receivers are for operation on A.C. mains, and employ the very latest miniature valves. They are designed to the most modern specification, great attention having been given to the quality of reproduction

which gives excellent clarity of speech and music on both gram, and radio, making them the ideal replacement chassis for that "old Radiogram," etc.

- Model H3, A 5-valve 3 waveband receiver £12.10.0. (Plus 7/6 carr. and ins.) H.P. Terms £3.4.0 Dep. and 12 Months at 17/8.
Model H.3.P.P. A 6-valve 3 waveband Receiver with PUSH-PULL OUTPUT. £15.15.0. (Plus 7/6 carr. and ins.) H.P. Terms £3.19.0 Dep. 12 Months at £12.2.
Model H.3.P.P./H.F. A 7-valve 3 waveband Receiver incorporating an R.F. stage with PUSH-PULL OUTPUT. £18.18.0 (Plus 7/6 carr. and ins.) H.P. Terms £4.13.0 Dep. 12 Months at £16.9.

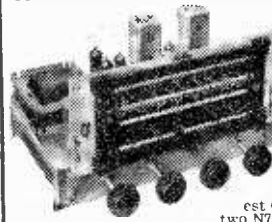

A BULK PURCHASE ENABLER. WE ALSO OFFER THIS "PUSH-PULL" 7-VALVE SUPERHET RECEIVER

for only £12.19.6. (Plus 7/6 carr. and ins.) H.P. Terms £3.4.0 Dep. 12 Months at 18/4. Model AW7 Receivers are made by a well-known manufacturer and incorporate the latest Osram Valve line-up, having two N78s in Push-Pull for approx. 7

watts output. They cover 3 wavebands and are for operation on A.C. mains. They make an excellent replacement radiogram chassis. THEY ARE BRAND NEW AND FULLY GUARANTEED.

A GENUINE SPECIAL OFFER!

This THREE SPEED AUTOCHANGER is by a famous manufacturer and is offered for £11.10.0. (Plus 7/6 carr. and ins.) Normal price £16.10.0. H.P. Terms £2.17.6. Dep. and 12 months at 16/4.



- Complete with High Fidelity Crystal Turnover Head which incorporates separate stylus for L.P. and 78 r.p.m. records.
Will autochange on 7in., 10in., and 12in. records, not intermixed.
Brand New in Maker's Cartons, complete with mounting instructions.
WE ALSO HAVE "MIXER" UNITS

The "SUPER-SIX" A DESIGN FOR HOME CONSTRUCTORS

A compact and highly efficient superhet Radiogram chassis of outstanding quality for operation on A.C. mains. YOU CAN BUILD IT FOR £10.7.6. This receiver can be made to incorporate the new B.V.A. miniature valve line-up or the Octal valve line-up, and is designed to the very latest specification. Great attention has been paid to the quality of the reproduction of both Radio reception and Record playing, and excellent clarity of speech and music is obtained. Covers 3 wavebands. Employs 6 valves having PUSH-PULL output for 5-6 watts output. A 4 position Tone Control operates on both Radio and Gram. THE INSTRUCTION & ASSEMBLY MANUAL is available for 2/-.

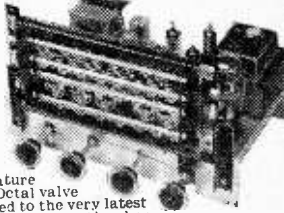

Send S.A.E. for our illustrated and descriptive leaflet; it includes details of various KITS and ASSEMBLED MODELS as follows: AMPLIFIERS AND TONE CONTROL UNITS

- (a) WILLIAMSON, models G.W.18 and G.W.12, together with Tone Control Units, etc.
(b) LEAK model T.L./10, together with Pre-Amplifier Tone Control Unit.
(c) OSRAM "912" AMPLIFIER available as an assembled amplifier.
(d) MULLARD AMPLIFIER, also available completely assembled.
(e) STERN'S PRE-AMP./TONE CONTROL UNIT. Can be used with any amplifier.
STERN'S TAPE RECORDER. A Twin Track 2 speed recorder... will play the new pre-recorded tapes and will take all standard reels up to 1,200 ft. Constructors can build it for £40 including the NEW TRUVOX TAPE DECK, an assembled AMPLIFIER, MICROPHONE, 1,200 ft. REEL OF TAPE, and an attractive PORTABLE CARRY CASE.
RADIO SETS
(a) THE NEW ARMSTRONG F.C.48 CHASSIS... an 8 valve 4 waveband chassis having provision for the attachment of an F.M. UNIT.
(b) 4 VALVE SUPERHET PORTABLE in small Attache Case... for Battery or Mains operation.
(c) 2 or 3 VALVE BATTERY PORTABLE all dry T.R.F. design.
(d) CAR RADIO. A Superhet design for 6 or 12 volt supplies.
(e) 4 VALVE T.R.F. CHASSIS. Completely assembled for £6.9.6. Bakelite Case 16/6 extra if required.
DENCO F.M. Unit. Consisting of 5 Valve Superhet design incorporating R.F. and F/C Stages followed by two I.F.s and Ratio Discriminator.
STERN'S MAINS UNIT KITS. Two types available: (a) For 60 volts and 1.4 volts; (b) For 90 volts and 1.4 volts.

TWO COMPLETE Hi-Fi AMPLIFIER KITS

A HIGH QUALITY 8-10 watt AMPLIFIER The Ideal Amplifier for General Home Use; and for Small Halls, etc.

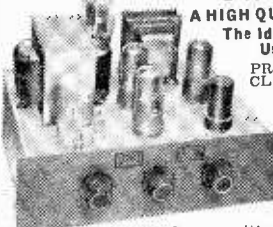

PRICE OF COMPLETE KIT INCLUDING VALVES AND DRILLED CHASSIS £7.10.0. (Plus 2/6 carr. and ins.) WE WILL SUPPLY IT COMPLETELY BUILT FOR £9.10.0. (Plus 5/- carr. and ins.) Designed for high quality reproduction up to an output level of 10 watts, having 6V6s in Push-Pull and incorporating negative feed-back. Suitable

for use with all types of Pick-ups and most types of microphones and the output transformer provides for use of 4 and 15 ohm speakers. BRIEF FEATURES: Valve line-up 6J5, 6SN7, 5Z4, with 6V6s in push-pull. First class reproduction of radio (where a tuning unit is used) and record playing. Separate Bass Boost and Treble controls provide an excellent range of frequency control. THE ASSEMBLY MANUAL is available for 1/- and includes detailed layouts and component Price List.

A 12-Watt "HIGH FIDELITY" Push-Pull AMPLIFIER

Comprising a Main Amplifier Chassis and a Remote Control Pre-Amplifier/Tone Control Unit. The remote control unit measures only 7in. x 4in. x 2in. and contains four controls, being: Bass-Treble, Volume and a Radio, Gram, Microphone Switch control. It incorporates its own feed-back circuit on and ins. 3/- extra.) the Bass Channel. Loop negative feed-back is employed on the Main Amplifier which has a valve line up of 6J5-6N7-5U4 with two 6X25s in push-pull and 6J5 and 6SN7 are used in the remote control unit. THE COMPLETE UNIT ASSEMBLED AND READY FOR USE £17.0.0. (Carr. and ins. 3/- extra.) H.P. Terms £4.5.0 Dep. 12 Months at £13.11.



THE COMPLETE KIT IS AVAILABLE FOR £14.0.0. (Carr. and ins. 3/- extra.)

This Amplifier compares well with the Williamson and similar designs at a fraction of their cost. The complete set of assembly instructions are available for 2/-.

STERN RADIO LTD. 109 & 115 FLEET ST., E.C.4.

Telephone CENTral 5812/3/4

# PRECISION BUILT MATCHED COMPONENTS

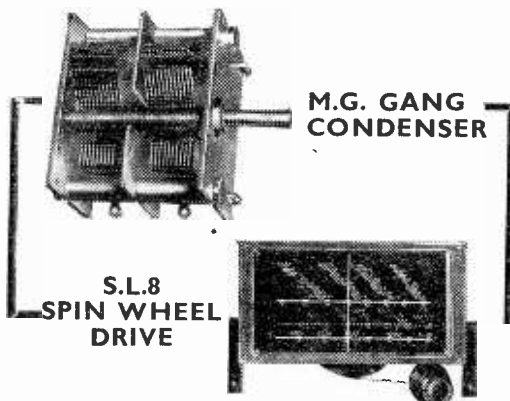

**M.G. GANG  
CONDENSER**

**S.L.8  
SPIN WHEEL  
DRIVE**

## M.G. GANG CONDENSER

Available as 1, 2 or 3 gang, 490 p.F. nominal capacity, matched and standardised to close limits. Supplied with trimmers if required.

Other capacities available—details on request.

Cadmium plated steel frame:

Aluminium Vanes.

Low loss non-hygroscopic insulation.

Spindle  $\frac{1}{4}$  in. dia. projects  $1\frac{1}{16}$  in. from front plate.

Front area  $2\frac{3}{8}$  in. x  $2\frac{9}{16}$  in. including sweep of vanes.

Length excluding spindle : Price

1 gang —  $1\frac{7}{16}$  in. 9/3d.

2 gang —  $2\frac{9}{16}$  in. 14/-d.

3 gang —  $3\frac{9}{16}$  in. 18/3d.

## S.L.8 SPIN WHEEL DRIVE

A precision slide rule drive. Complete with 3-band glass scale, 9 in. x  $4\frac{3}{4}$  in.

Printed—short, medium and long wave bands with station names.

Scale length 7 in.

The spin wheel drive gives easy control through a ratio of 24-1. Fitted with constant velocity coupling, eliminating strain on the Condenser, and providing mechanical and electrical isolation from vibration and noise.

Supplied with florentine bronze escutcheon.

Price — 27/6d. complete.

Write for fully illustrated catalogue.

# JACKSON

BROS. (LONDON) LTD.

KINGSWAY · WADDON  
SURREY

Telegrams :

WALFILCO, SOUPHONE, LONDON

Telephone : CROYDON 2754-5



L. 4679 A

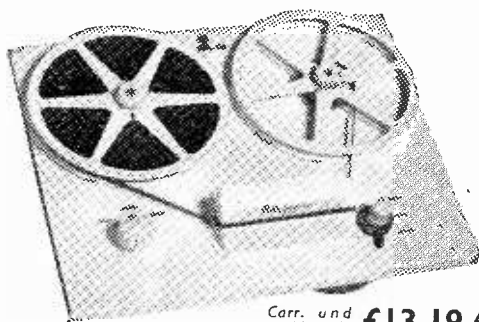

Carr. and packing 7/6 **£13.19.6**

# Burgoyne

## TWO-SPEED TAPE DECK $3\frac{1}{2}$ " & $7\frac{1}{2}$ " / sec.

Here is the heart of your Tape Recorder. If you are building or modernising your own equipment you **MUST** have the latest **BURGOYNE** Tape Deck giving 2 speeds, designed for building into complete recorders.

### EASY H.P. FACILITIES

Send only 10% deposit, balance over any period up to 18 months.

### TECHNICAL DATA

★ 2 HOURS' PLAYING TIME. ★ Fully automatic speed change. ★ Instantaneous and positive braking. ★ Powered by 3 high-grade motors. ★ Twin track heads. ★ Minimum wow and flutter. ★ Frequency range 50/10,000 c/s at  $7\frac{1}{2}$ " / sec. ★ 200/250 v. A.C. mains.

Made exclusively for :

**E. & G. MAIL ORDER SUPPLY CO.** The Radio Centre  
33, Tottenham Court Road, London, W.1. MUSEum 6667

# WE SPECIALISE ONLY IN RADIO COMPONENTS—

LET US QUOTE YOU BY  
RETURN FOR ANY RADIO  
VALVES OR PARTS YOU  
REQUIRE

HIRE PURCHASE TERMS ON KITS,  
INSTRUMENTS, ETC.

Osram "912" and Mullard "510"  
Amplifier Parts in Stock.

NEW CATALOGUE WITH H.P. TERMS 6d.  
QUOTES S.A.E.

## RADIO SERVICING COMPANY

82 SOUTH EALING ROAD  
LONDON W.5 EAL. 5737  
NEXT DOOR SOUTH EALING TUBE STATION (TURN LEFT)

# The Beginner's Guide to Radio



The Twenty-second Article of a Series Explaining the Fundamentals of Radio Transmission and Reception.

This Month Rectifiers are Dealt With

By F. J. CANN

IT must be remembered that Ohm's law for alternating current, or rather the formula relating to it, differs from that relating to direct current. We have seen that in an alternating current circuit, Ohm's law expresses a relation between the E.M.F., of the circuit, the current flowing and the circuit impedance (E, I, and Z respectively) from which  $E$  equals  $IZ$ . This brings us to the question of what is known as the R.M.S. value, or the root mean square value of alternating current or voltage. It is the square root of the mean value of the squares of the instantaneous values taken over a complete cycle, and when an alternating current or voltage is specified, it is almost invariably the root mean square value that is used. It is sometimes referred as the *effective value*. In brief, this means that 230 volts A.C. is not the same thing as 230 volts D.C.

## Rectifiers

It is important to remember in mains transformers that after transforming the voltage it is still alternating current and must therefore be converted into D.C. This is achieved by either *half-wave or full-wave rectification*, and this achieved by a particular type of rectifier.

Even after rectification, the current is still too "rough" as it is a pulsating D.C. supply, and smoothing must be introduced.

Rectifiers are of two types, the valve rectifier and the metal rectifier, although there are other types, such as chemical rectifiers, the Tungar rectifier, the vibrating reed rectifier, as used in car radio, the rotary converter, the mercury vapour rectifier and the copper-oxide rectifier. For radio purposes, a selenium metal rectifier is mostly used today.

Valve and metal rectifiers are available in half-wave or full-wave types; the symbols for these are illustrated in Fig. 96.

Now a rectifier suppresses the flow of current in one direction and it therefore follows that a half-

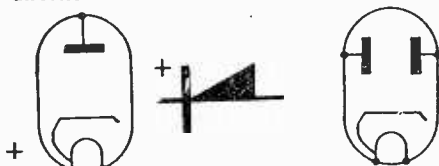

Fig. 96.—A half-wave valve rectifier, a metal rectifier and a full-wave valve rectifier.

wave rectifier gives pulses at half frequency, and a full-wave rectifier at double frequency. Neither, however, actually delivers direct current but a pulsating current of fixed polarity. Rectifiers are used for rectification of the H.F. signal, or to put it another way, for high-frequency rectification as well as for providing power supplies for high-tension purposes.

Signal rectifiers, whether of the valve or metal type are much smaller than those required for power supplies since the requirements are smaller. Typical signal rectifiers are the Westector and germanium diodes. It is important to note that half-wave rectifiers for power supplies are only used where the current supplies are very small. If a current greater than that of an individual valve, whether employed for full-wave or half-wave rectification is called for, then two or more valves may be connected in parallel.

Metal rectifiers are also used in voltage doubler or bridge circuits, as shown in Figs. 97 and 98. The *voltage doubler* as shown in Fig. 97 uses a metal rectifier, and it is connected together with fixed condensers to provide a bridge circuit, resulting in a step-up in voltage. The condensers used in the voltage doubler circuit are of critical value, and the makers' recommendations must be adhered to.

In the circuit shown, the bare rectifier circuits are illustrated; the A.C. input may consist of a mains supply or, as is more usual, a mains transformer. The D.C. output will, of course, be fed into a suitable smoothing circuit to be dealt with later.

## Smoothing Chokes

Reference has been made to the necessity for smoothing and for this purpose a choke is employed. A choke is a simple component consisting essentially of a length of wire wound on a former built up from

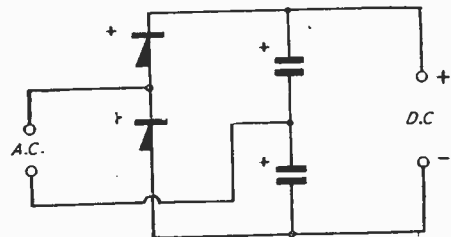

Fig. 97.—A metal rectifier voltage doubler circuit.



a number of iron laminations by the method already described for low-frequency choke transformers. The simplest type of iron-core choke is one intended for coupling together two valves on the choke capacity principle, or for connecting a loudspeaker to an output valve. The essential design data is an induc-

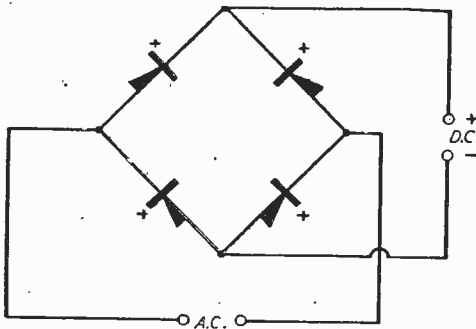

Fig. 98.—A bridge rectifier circuit.

tance of not less than 50 henries at the normal working current, a D.C. resistance of 2,000 ohms or less, and a safe current carrying capacity of not less than 20 mA. When dealing with currents above, say, 50 mA, it is advisable to employ a smoothing choke of greater dimensions and having a lower D.C. resistance. It is also an advantage for the choke to be of the constant inductance type, so that its inductance does not vary measurably when the current passing through the winding is varied. In order that a choke should show such characteristics, there must be an air gap in the core. That is to say, the T- and the U-pieces should not touch each other, but should be arranged with a small gap between them. The iron-cored choke can be used for any purpose where a choke is required, but it is specially suitable for use in powerful mains receivers for smoothing or feeding the loudspeaker. It can also be used successfully as a loudspeaker field replacement choke. Smoothing chokes generally should have an inductance of not less than 30 henries, when carrying the maximum D.C. current. In some instances it is found convenient to employ the field coil of an energised moving-coil loudspeaker as a smoothing choke, but in that case it is essential

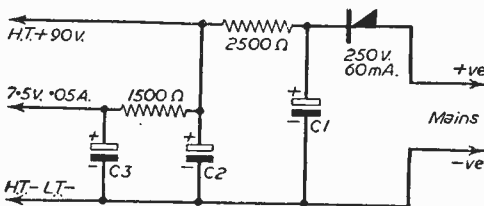

Fig. 99.—A half-wave rectifier with resistance smoothing.

that there should be a fairly considerable surplus H.T. voltage, since the resistance of the field winding is generally about 2,500 ohms.

**Resistance for Smoothing**

A resistance may be used for smoothing where the current requirements of the set are low, but it must be remembered that whereas a choke has a low

resistance, a resistance will cause a much greater voltage drop and necessitate adjustment of other values in the circuit. The circuits in Figs. 99 and 100 show choke and resistance smoothing respectively.

It is important to remember that any coil may be considered as a choke, even a tuning coil, for the correct definition of a choke is that it is an inductance, and all coils have inductance. Inductance is a term often misunderstood, but an idea of its meaning can be grasped by considering it as providing resistance to alternating or H.F. current. No matter how a length of wire is coiled, its resistance to D.C., which is governed by Ohm's law, does not change, the resistance of a wire being proportional to its length. That is to say, the resistance of 2 yds. of wire of a given gauge will be twice that of 1 yd. of wire of the same gauge. The impedance or reactance of the coil, however, to alternating current varies greatly. For example, the length of wire used for the average H.F. choke has a resistance to D.C. of about 300 ohms, whilst its inductance may be approximately 250,000 micro henries. This means that its impedance to low-frequency current has a frequency of 1,000 cycles per second (equivalent to the highest note of the human voice), is 1,500 ohms, whilst the impedance to a current 100,000 times per second (the frequency equivalent to a wavelength of 300 metres) is 1,500,000 ohms.

**Low-frequency Chokes**

A similar state of affairs exists with regard to low-frequency chokes, for one which is rated at, say, 20 henries would have an approximate D.C. resistance of 250 ohms. But the impedance of the choke to an alternating current of 50 cycles would be about 6,000 ohms, or 12,000 ohms if the frequency were doubled. These examples show one important use of inductance. An inductance coil or choke can be designed to provide an easy path for direct current whilst offering a considerable resistance to alternating current, or by using a smaller inductance value to

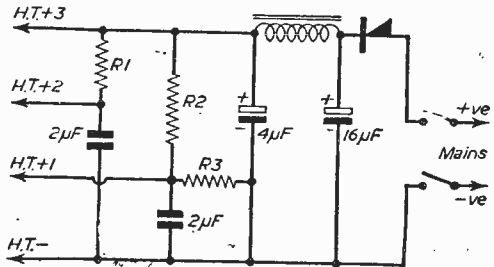

Fig. 100.—A similar circuit, but with choke smoothing.

offer a comparatively low-impedance to low-frequency alternating current, and a high-impedance to high-frequency current. This, in brief, means that the impedance of a choke increased with inductance and frequency, and vice versa. (To be continued.)

**EVERYMAN'S WIRELESS BOOK**

11th Edition.

By F. J. CAMM 12/6, by post 13/-

From

**GEORGE NEWNES, LTD.,**

Tower House, Southampton Street, Strand, W.C.2.

# A Valve-Voltmeter

A TEST-SET OPERATING DIRECT FROM A.C. MAINS

By "Radio Engineer"

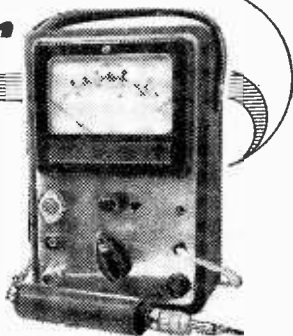

On the right is a view of the finished instrument.

**A**FTER building several valve voltmeters, some bad, and some better, I ultimately built one operated directly from the mains; that is to say, I omitted the H.T. winding, using a filament transformer at slightly reduced voltage. The object was to keep the cost down as much as possible, at the same time seeing that the efficiency was not impaired. Simple to use and not too big was the thing I was after. The accompanying illustrations will give an idea of the resultant build-up.

The first question was . . . to what extent the mains variation would affect the accuracy of the meter.

I made a check on two commercial valve voltmeters and one which I had already built and which had P.P. with primary 325-0-325 volts, F.W. rectification, and the results in all cases were the same. When in use with the mains voltage reduced by 10 per cent. on 250 volt mains, the accuracy of reading on the 100-volt scale was 5 volts lower; exactly the same result as with one directly fed from the mains, so, unless one buys or makes one's own with stabilised P.P. and multivalve balancing arrangement, there is not much hope in expecting accuracy of two per cent. or less from the average valve voltmeter.

## Design

The main emphasis around which I have built the latest valve voltmeter is as follows:

Input resistance 10 meg. on D.C. and A.C. up to 1,000 volts. The A.C. is rectified by two separate diodes built in the probes. One reads up to 250 volts, 50 c/s. to 150 Mc/s—the second can be used on 10 volts to 1,000 volts or more, depending on the condenser rating selected. The first valve is a 6AL5 double-diode. The 1,000-volt probe has an EY51 valve

rated at 5 k/w. R.M.S. so it is quite capable of handling 1,000 volts A.C. The valve being wire-ended and with small dimensions makes it very suitable for fitting into a probe, but the frequency is limited to about 10 Mc/s—this one is primarily built for ranges between 500 to 1,000 volts A.C. As will be seen from the circuit, a double-triode is bridge connected, and a 0.5 mA. meter is used as balance indicator. P.P. as mentioned; L.T. transformer; 2 RM1; two 8 $\mu$ F electrolytics; 10 K. smoothing resistor, and neon parallel with D.C. output is fed to 10 K. potentiometer (zero set) via 2.2 K. to the anodes of 12 AU7 and the meter.

The positive input terminal is connected to the earth side, that is to say, to H.T. negative, and the H.T. negative is positive from the P.P., so that if the negative lead is connected first, some deflection may be obtained—ignore this—the final reading with both leads connected will be correct. The input voltage is fed through a 10 meg. chain of resistors assembled around a ceramic switch, having three wafers: two of them are one-pole five-way, and the third one is for switching in and out the calibration controls. The original switch used was three-wafer, one-pole five-way—the third was altered accordingly.

## Case

The case is made of .024in. thick tin-plate, which is very easy to bend and the brackets holding all the components can be easily soldered to it. It is composed of four parts, the top and bottom bent round 1/16in. to 3/32in. to form the lids. The centre piece is a strip 3in. wide and 28in. long bent on to 3/4in. round steel to make rounded corners, joint soldered, and bottom lid soldered to it. Ventilation holes drilled on both sides with two holes opened up 3/16in. or 3/8in. to be able to reach with screwdriver the calibration controls (see Fig. 3), without opening the instrument.

The top lid of the case is made in a similar manner to the bottom, except that dural or aluminium panel is added to strengthen the lid. The lid serves as a chassis to hold all the components, which are fixed on the brackets. The brackets are made of 5/16in. round brass drilled and tapped both ends and the ends

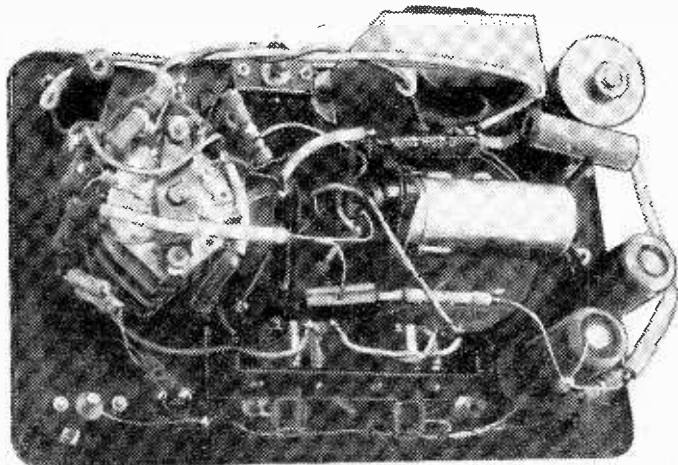

View of rear of panel.

of the strip are soldered to the back of the lid to act as the pillars. Five will be needed—two for the transformer, two for the bracket which holds the calibration controls, and one short pillar to hold the

rectifiers. All the necessary holes should be drilled for switch, zero set, fuse, neon, mains in, and two terminals, and one to take A.C. socket for probes.

As can be seen from the photograph, the A.C. socket is four points, but three are quite satisfactory and this is shown in the diagram. The sockets and plugs must be of very high insulating quality (not from H.T. battery). In the prototype, they were made from polystyrene of  $\frac{5}{8}$  in. diameter. The valve-

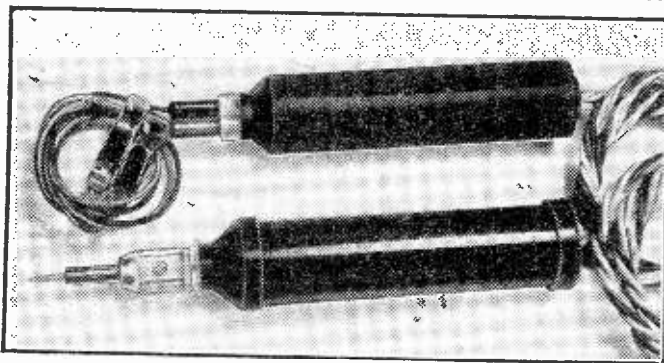

View of the two probes. Top, the 250-volt and below the 1,000-volt probe.

**LIST OF**

- Valves 12AU7
- 6AL5
- EY51
- 1 ceramic switch, 1 p. 3-pin socket, 2 plugs.
- 2 terminal sockets and 1 10K W.W. potentiometer
- 2 5K W.W. preset (ca.  $\frac{1}{2}$  w. (see diagram).
- Chain of resistors 10 10K
- Remaining resistors 2
- 1 neon G.E.C. and holder
- 1 fuseholder 250-500 v.
- 2 RM1 150 v. each.
- 1 filament transformer 2 0.75 ohm 10 w., W.1
- 1 M.C. meter 0.5 mA
- 2 8  $\mu$ F 450 v. D.C. electrolytic
- 3 0.01  $\mu$ F mica-moulded
- 2 0.002  $\mu$ F mica-moulded
- 1 0.01  $\mu$ F bakelite-mica
- 1 0.02  $\mu$ F 1,200 v. D.C.

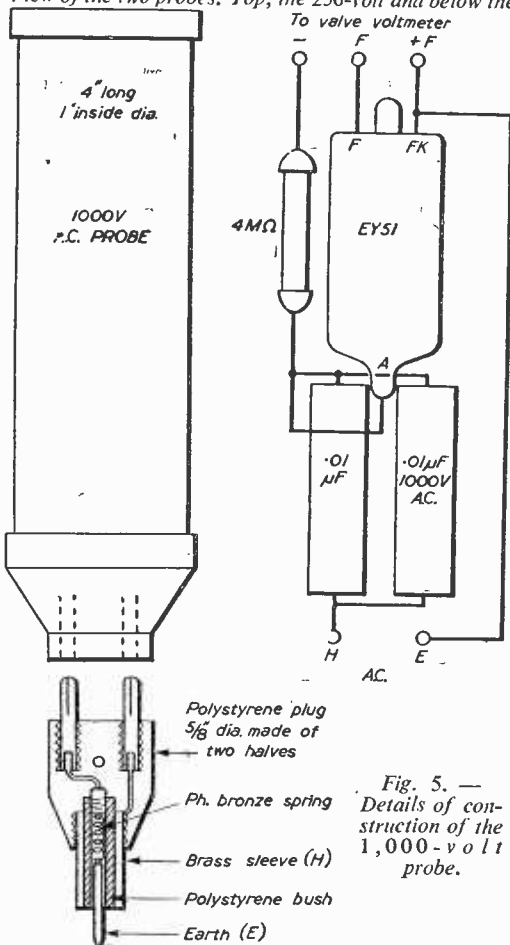

Fig. 5. — Details of construction of the 1,000-volt probe.

holder is also fixed on a strip of tin-plate and soldered to the lid. This also should be well made and preferably shock-proof with rubber mounting,

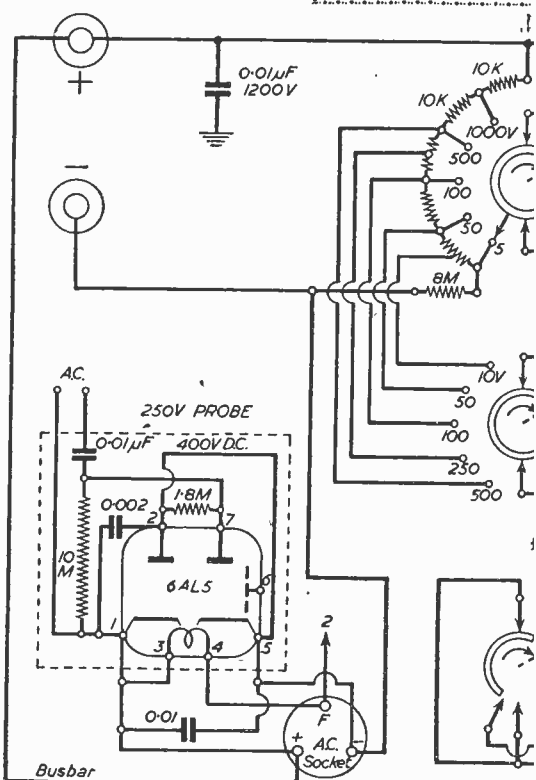

Fig. 1.—Full circuit

not forgetting the hole for meter. The side of the lid is drilled to take 8 B.A. screws, and nuts are soldered inside the case to hold the lid, and finally holes are made for a leather strap or handle.

The two H.T. electrolytics are fixed with a strap made of tin-plate and soldered. Before commencing assembly, a coat of black paint and "Panel" should be applied to the outside to give a professional finish. The panel on the top should be numbered and letter stamped and polished.

**COMPONENTS**

- 0.3 a.
- 0.3 a.
- 0.09 a.
- wafers.

controls).  
 cal. H.S. 1-2 per cent.  
 cent. H.S. 1/2 w.  
 (ins).

- 1 a.
- (general notes).
- (selection).
- (ics).
- (D.C.
- (D.C.
- (0 v. D.C.
- (0.01 μF 1,000 v. A.C.)

**Assembly**

Make wire busbar, connect all negatives to one side of the

mains and L.T., but do not connect anything to the case except one 0.01 μF condenser. Do not fix switch and calibrating control bracket—it will leave you more room for soldering if unconnected.

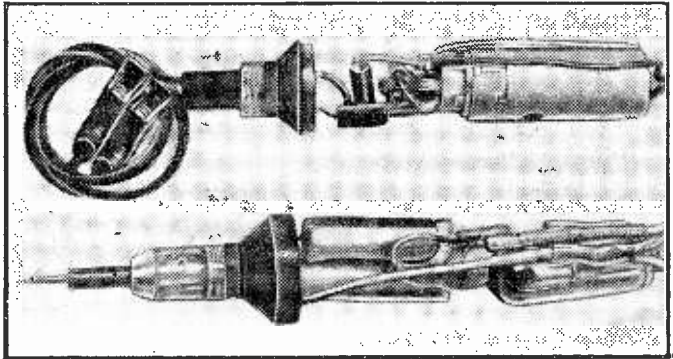

*Interior details of the two probes.*

The photograph will give a good idea of the lay-out. The ceramic switch will have to be dismantled and cut to 2 1/2 in. high, the bottom wafer stripped of all contacts except two continuity shorting, and two more shorting contacts are riveted on.

The shorting ring is cut in half and the other half removed, so that as you rotate the switch, one half of the shorting ring will be in continuous contact on five positions. This wafer is on the bottom of the switch, the first one when you start to assemble the switch. The shorting ring of the second wafer will be exactly opposite the shorting ring of the third wafer, just engaging number one point, so that when the switch is assembled you will get five contacts to your left and five to your right, and on the bottom wafer continuous contact to switch A.C. and D.C., calibration on and off. The top wafer holds all the 10 meg. resistors, and the middle one is for the A.C. range, and holds wire tapping from 10 megs. resistor chain. The order of reading on A.C. is different from D.C. Solder all selected resistors as in Fig. 4. The resistors should be two per cent. H.S. The accuracy of the instrument depends on them. When all resistors are fixed, connect D.C. calibrating control, check all the wiring against the diagram, plug valve in and connect meter; positive side of the meter should be from No. 6 pin on valve. Negative from No. 1 pin via calibration control, through wafer No. 1, from there to negative on the meter. Do not forget 250 mA fuse; it is very important to have one because you deal directly with the mains voltage. The D.C. side of the instrument is now ready. Set the switch to 100 volts D.C. and plug in. The neon should now be alight and the pointer will travel across the scale (H.T. is on before valve warms up); as soon as heaters are warm, the pointer will settle down on zero. If it does not, adjust "zero set." Leave the meter on for 10 to 20 minutes and in the meantime try all ranges on the switch and note if pointer alters its zero. It should stay on all ranges except 5 volts. It will move 0.2 volts here, but no more. Take a reading against known voltage from H.T. or L.T. battery and adjust with calibration control. For

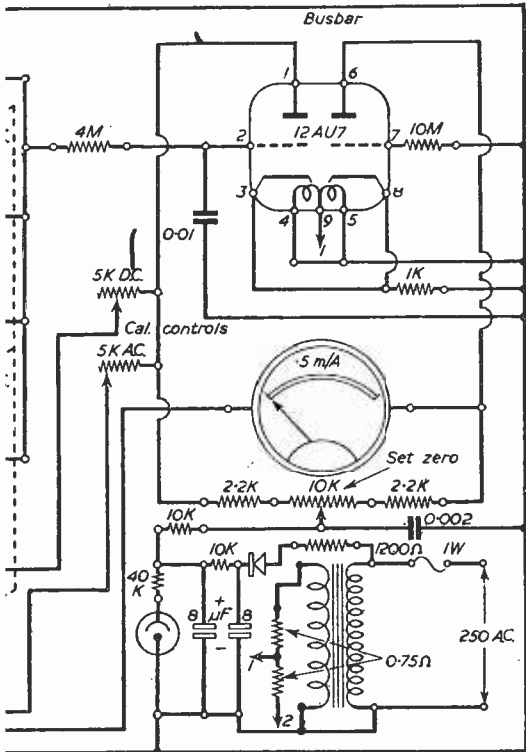

*Wiring of the voltmeter.*

example—connect 90 volt battery with the help of calibration control, bring pointer to 90 volts on 100-volt scale and, if the resistors are carefully selected, you should be able to read on all D.C. ranges. The same process is to calibrate the A.C. side. If one has a meter, 10 K. or 20 K. per volt, connect it across input terminals of valve voltmeter, and then compare the reading.

For the sake of argument the writer has tried the A.C. range with mains voltage of 250 volts; meter set to 250-volt scale and adjusted for full deflection, and after re-checking on all A.C. ranges the result

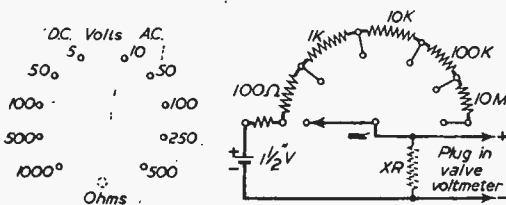

Fig. 6.—The ohms' adaptor. The unmarked resistor has a value between 8.2 and 9.2 Ω.

was not far out. It is as well to point out that the success of the valve voltmeter depends on the 10 meg. chain of resistors and they should be 2 per cent. or better. The rest of the resistors can be between 2.5 per cent. tolerance.

**A.C. Probes**

A.C. voltages in D.C. valve voltmeters do not easily mix. They are very simple to look at until

one tries to make them read on a D.C. scale. The most important factor is the flow of current through the diode when the input is zero, making the pointer move from zero. It depends on the cathode temperature and the load resistance. The best way to control the flow is to connect a similar diode to it.

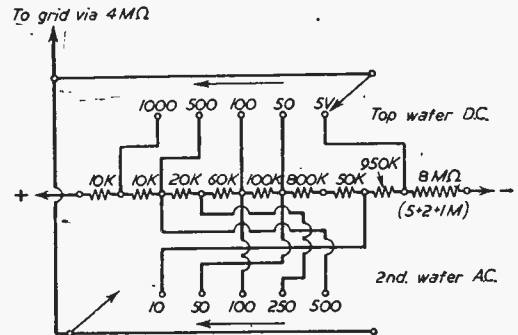

Fig. 4.—Wiring arrangement for the resistors.

The 250-volt probe is a simplified rectifier—amplifier type; input capacitor is 0.01 μF, load resistor 10 megs. Diode No. 1 is known as the shunt diode rectifier. This is followed by a second incidental diode 1.8 MΩ resistor and 0.002 μF capacitor, making a low-pass filter for smoothing out fluctuation present in the D.C. output of the first diode.

A valve voltmeter hardly uses any current so the loading resistance can be 10 megs. This minimises

the load of the circuit under test and gives higher D.C. output from the first diode. The double-diode circuit is negative peak responsive and adjusted to read on D.C. scale. The positive and negative error is very small and with the help of calibration control, it will read very well on 10-volt scale. I have used a probe as high as 400 volts without doing any harm—the maker's rating of 6AL5 is 250-volt R.M.S. The terminals on the end of the probe are fitted in a plug and when the plug is withdrawn the test leads can be plugged in. It is made of polystyrene. Both A.C. contacts for testing are assembled in the tube so that the inside one which protrudes is at earth potential and the outside contact is high potential or condenser side. The earth potential is spring loaded.

When testing experiment it has been found to be not very easy to reach various points with a solid single end probe (by this it is meant that both contacts

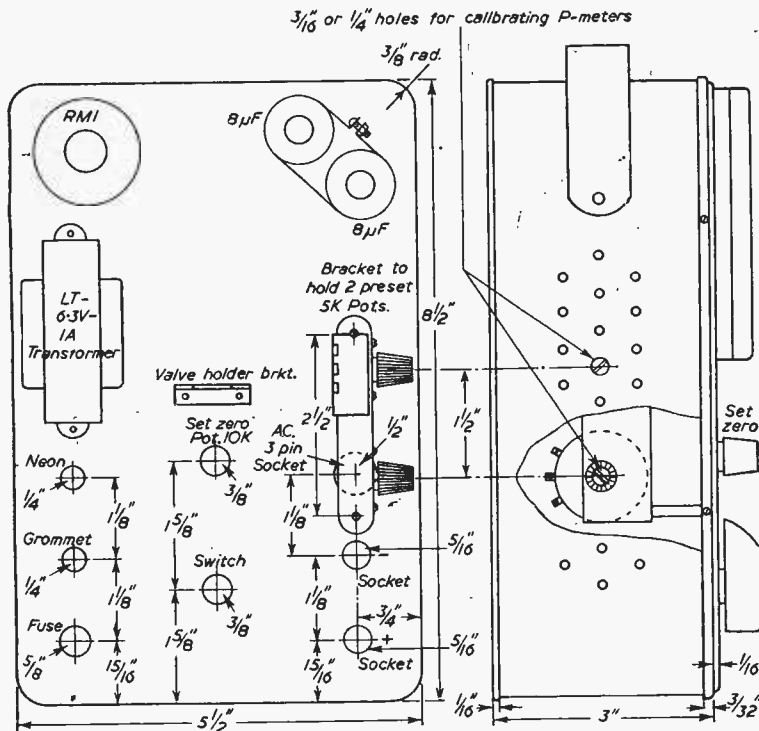

Figs. 2 and 3.—Details of a suitable case, with drilling data.

(Concluded on page 114)

**PLASTIC CABINET** as illustrated, 11½ x 6½ x 5½ in., in walnut or cream, ALSO IN POLISHED WALNUT, complete with T.R.F. chassis, 2 waveband scale, station names, new waveband, backplate, drum, pointer, spring, drive spindle, 3 knobs and back, 22/6. P. & P., 3/6.

As above with Superhet Chassis, 23/6. P. & P., 3/6.

As above complete with new 5in. speaker to fit and O.P. trans. 37/6. P. & P. 3/6 with Superhet Chassis, 39/6. P. & P. 3/6.



Used metal rectifier, 230 v. 50mA. 3/6; gang with trimmers, 6/6; M. & L. T.R.F. coils, 5/-; 3 Govt. valves, 3v/h and circuit, 4/8; heater trans. 6/-; volume control with switch, 3/6; wave-change switch, 2/-; 32 x 32 mfd., 4/-; bias condenser, 1/-; resistor kit, 2/-; condenser kit, 4/-.

M. & L. Superhet Coils with circuit, 6/6; iron core 465 IFS, 7/6; min. gang, 5/6; volume control with switch, 4/-; wave-change switch, 2/6; heater trans. 7/6; 4 v/h. 1/6; 4 Ex Govt. valves, metal rectifier and Xtal. diode with circuit, 14/6; 25 x 25 mfd. 1/-; 16 x 16 mfd., 3/3; condenser kit (17), 7/6; resistor kit (14), 3/6.

Medium and Long Wave Crystal set, in attractive plastic cabinet incorporating Germanium diode, 16/-.

Headphones to match above, per pair 7/6.

**COMPLETELY BUILT SIGNAL GENERATOR**

Coverage 120 Kc/s-300 Kc/s., 900 Kc/s-900 Kc/s., 900 Kc/s-2.75 Mc/s., 2.75 Mc/s-8.5 Mc/s., 8.5 Mc/s-25 Mc/s., 17 Mc/s-50 Mc/s., 25.5 Mc/s-75 Mc/s. Metal case 10 x 6 1/4 x 4 1/4 in., size of case 6 1/2 x 3 1/4 in., 2 valves and rectifier. A.C. mains 200-250 v. Internal modulation 400 c.p.s. to a depth of 30%. Modulated or unmodulated R.F. output continuously variable 100 millivolts. C.W. and mod. switch, variable A.F. output and moving coil output meter. Black crackle finished case and white panel, £4/19/6, or 34/- deposit and 3 monthly payments of 25/-. Post and Packing 4/- extra.

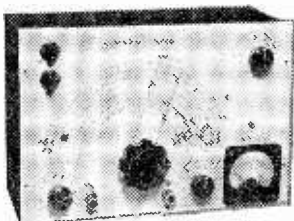

High impedance plastic recording tape by famous manufacturer, 1,200 feet complete on spool, 17/6. P. & P. 1/6. 600 feet B/-, P. & P. 1/-.

Pr. 200/250 v., secondary 3, 4, 5, 6, 8, 9, 10, 12, 15, 18, 20, 24 and 30 volt at 2 amps. Drop thro' 230-260, 200 mA., 6 v. 5 amps., 5 v. 3 amps., 27/6.

Terms of business: Cash with order. Despatch of goods within three days from receipt of order. Where post and packing charge is not stated, please add 1/6 up to 10/-, 2/- up to £1 and 2/6 up to £2. All enquiries S.A.E. Lists 5d. each.

**D. COHEN**, RADIO AND TELEVISION COMPONENTS, 23, HIGH STREET, ACTON, W.3. (Opposite Granada Cinema)

Hours of Business: Saturdays 9-5 p.m. Wednesdays 9-1 p.m. Other days 9-4.30 p.m.

**Heater Transformer.** Pri. 230-250 v. 6 v. 1½ amp., 6/-; 2 v. 2½ amp., 5/-.

**R.I. MAINS TRANSFORMERS**, chassis mounting, feet and voltage panel. Primaries 200/250.

|   |  |
|---|--|
| 350-0-350 75 mA. 6.3 v. 3 a. tap 4 v. 6.3 v. 1 a., 13/6.                                |  |
| 150-0-350 70 mA. 4 v. 5 a., 4 v. 2.5 a., C.T., 18/6. P. & P. on above transformers 2/-. |  |
| 500-0-500 120 mA. 4 v. C.T. 4 a. 4 v. C.T. 4 a. 4 v. C.T. 2.5 a. 27/6.                  |  |
| 500-0-500 250 mA. 4 v. C.T. 5 a. 4 v. C.T. 5 a. 4 v. C.T. 4 a., 39/6.                   |  |
| P. & P. on the above transformers 3/-.  |  |
| 32 mfd., 350 wkg. .... 2/-  |  |
| 16 x 24 350 wkg. .... 1/2   |  |
| 4 mfd., 200 wkg. .... 3/6   |  |
| 40 mfd., 450 wkg. .... 4/6  |  |
| 16 x 8 mfd., 500 wkg. .... 5/9  |  |
| 16 x 16 mfd., 500 wkg. .... 3/9   |  |
| 32 x 32 mfd., 350 wkg. .... 4/-   |  |
| 8 x 16 mfd., 450 wkg. .... 6/6  |  |
| 25 wkg. .... 11d.   |  |
| 25 mfd., 25 wkg. .... 1/-   |  |
| 125 mfd., 100 v. wkg. .... 3/3  |  |
| 16 mfd., 500 v. wkg., wire ends .... 2/6  |  |
| 8 mfd., 350 v. wkg., tag ends .... 1/6  |  |
| 50 mfd., 25 v. wkg., wire ends .... 4/-   |  |
| 100 mfd., 350 wkg. .... 9/6   |  |
| 100 + 200 mfd., 350 wkg. .... 3/3   |  |
| 16 x 16 mfd., 350 wkg. .... 2/6   |  |
| Ex Govt. 8 mfd., 500 v. wkg., size 3 1/4 x 1 1/2 for .... 7/-                           |  |
| 60 + 100 mfd., 280 v. wkg. .... 6/-   |  |
| 32 + 32 mfd., 350 wkg. .... 1/9   |  |
| 50 mfd., 180 wkg. .... 1/8  |  |
| 60 mfd., 200 wkg. .... 8/6  |  |
| 60 + 100 mfd., 280 wkg. .... 11d.   |  |
| 50 mfd., 12 wkg. .... 4/-   |  |
| 32 + 32 mfd., min. 275 wkg. .... 1/9  |  |
| 50 mfd., 50 wkg. 8 mfd., wkg., wire ends .... 7d.                                       |  |

Miniature wire ends moulded 100 pf. .... 7d.

500 pf., and .001 ea. .... 14/6

280-0-280 80 mA. 4 v. 4 a., 4 v. 2 a. .... 19/6

250 v. 350 mA. 6.3 v. 4 a. twice 2 v. 2 a. 4 v. trans., input 200/250 HT 500 v. .... 19/6

250 mA. 6 v. 4 a. twice 2 v. 2 a. .... 10/6

250-0-250 60 mA. 6.3 v. 1.5 a., 0.5-6.3 v. 1.5 a. ....

**PATTERN GENERATOR** 40-70 Mc/s. direct calibration, checks frame and line time base, frequency and linearity, vision channel alignment, sound channel and sound rejection circuits, and vision channel band width. Silver plated coils, black crackle finished case, 10 x 6 1/4 x 4 1/4 in. and white front panel. A.C. mains 200-250 v.

This instrument will align any TV receiver. Cash price, £3-19/6 or £19.0 deposit and 3 monthly payments of £1. Post and packing 4/- extra.

**TV. CONVERTER** for the new commercial stations, complete with 2 valves. Frequency — can be set to any channel within the 19-196 Mc/s. band. I.F. — will work into any existing TV. receiver, designed to work between 42-68 Mc/s. Sensitivity 10 MuV. with any normal TV. set. Input — arranged for 300 ohm feeder. 90 ohm feeder can be used with slight reduction in R.F. gain. Circuit EF83 as local oscillator, ECC81 as R.F. amplifier and mixer. The gain of the first stage, grounded grid R.F. amplifier, 10 db. Requires power supply of 200 v. D.C. at 25 mA., 6.3 v. A.C. at 0.6 amp. Input filter ensuring complete freedom from unwanted signals. 2 simple adjustments only. £2.10.0. Post and packing 2/6.

**Volume Controls.** Long spindle less switch, 50 K., 500 K., 1 meg. 2/6 each. P. & P. 3d. each.

**CONSTRUCTOR'S PARCEL**

**MEDIUM & LONG-WAVE A.C. MAINS 230/250 2-VALVE PLUS METAL RECTIFIER, 22/6.**

Comprising chassis 10 1/4 x 4 1/4 in., 2 waveband scale, tuning condenser, wave-change switch, volume-control, 4 heater trans., metal rectifier, 2 valves and v/holders, smoothing and bias condensers, resistors and small condensers, and medium- and long-wave coil, litz wound. Circuit and point-to-point, 1/3. Post and packing, 2/6 extra.

**Volume Controls.** Long spindle and switch, 1, 1, 1 and 2 meg., 4/- each; 10 K. and 50 K., 3/6 each. 1 and 1 meg., long spindle, double pole switch, miniature, 5/-.

**Standard Wave-change Switches.** 4-pole 3-way, 1/9; 5-pole 3-way, 1/6. Miniature 3-pole 4-way, 4-pole 3-way, 2/6. 2-pole 11-way twin wafer, 5/-, 1-pole 12-way single wafer, 5/-.

**Valveholders.** Paxolin octal, 4d. Moulded octal, 7d. EF50, 7d. Moulded B7G, 7d. Local amphenol, 7d. Local pax., 4d. B8A, B7A amphenol, 7d. E7C with screening can, 1/6. Duocadal paxolin, 9d.

**Twin-gang .0005 Tuning Condensers, 5/-.** With trimmers, 6/6.

**Midget .00037 dust cover and trimmers, 8/6.**

**RADIOGRAM CHASSIS.**—5 valve A.C./D. 3-way band superhet, 195/255 volts, 10-49, 200/550 and 1,000-2,000 metres, fly-wheel tuning frequency, 470 Kc/s iron-cored coils and IFS. Size of chassis, 13 x 6 1/2 x 2 1/4. Complete with valves and 8in. P.W. speaker, p. & p. 5/-, £8.17.6.

**Constructor's parcel,** comprising chassis 12 1/4 x 8 x 2 1/4 in., cad. plated, 18 gauge, v/h. IF and trans. cut-outs, back-plate, 2 supporting brackets, 3-waveband scale, new wavelength stations names. Size of scale 11 1/2 x 4 1/4 in., drive sp. drum, 2 pulleys, pointer, 2 bulb holders, 5 pax 1.0 v/h, 4 knobs and pair of 465 IFS, twin gang, 16 x 16 mfd. 350 wkg., mains trans. 250-0-250 60 mA. 6.3 v. 2 amp., 5 v. 2 amp. and 6 1/2 in. M.E. speaker with O.P. trans. P. & P. 3/6, 39/6.

R. & A. M.E. 6 1/2 in. speaker with O.P. trans., field coil 175 ohms. 9/6. P. & P. 2/6. R. & A. 6 1/2 in. M.E. speaker with O.P. trans., field 440 ohms. 10/6. P. & P. 2/6.

**Battery Charger,** input 230/250 v., output 6 & 12 v. 1 amp. Black crackle finished case size 10 x 6 x 4 1/4 in. P. & P. 3/-, 22/-.

**Potato & Vegetable Peeler,** by famous manufacturer, capacity 4 1/2 lbs., complete with water pump. All aluminium construction, white stove-enamel finish. Originally intended for adaption on an electric food-mixer, can be easily converted for hand operation. 39/6. P. & P. 3/-.

**Primary.** 200-250 v. P. & P. 2/-, 300-0-300 100 mA., 6 v. 3 amp., 5 v. 2 amp., 22/6.

**Drop thro'** 350-0-350 v. 70 mA., 6 v. 2.5 amp., 5 v. 2 amp., 14/6.

**Drop thro'** 250-0-250 v. 80 mA., 6 v. 3 amp., 5 v. 2 amp., 14/6.

**280-0-280,** drop through, 80 mA., 6 v. 3 amp., 5 v. 2 amp., 14/6.

**250-0-250 80 mA.,** 6 v. 4 amp., 14/-.

**Drop thro'** 270-0-270, 80 mA., 6 v. 3 amp., 4 v. 1.5 amp., 13/6.

**Drop thro'** 270-0-270, 80 mA., 6 v. 3 amp., 11/6.

**Auto Trans.** Input 200/250. H.T. 350 v. 350 mA., Separate L.T. 6.3 v. 7 a., 6.3 v. 1 amp., 5 v. 3 amp., 25/-, P. & P. 3/-.

**Pri. 200/250,** Secondary 9 v. 3 v. 5 amp., 6.3 v. 3 amp., 12/6.

**Pri. 230 v.** Sec. 500-0-500 and 500-0-500 250 mA., both windings, 4 v. 3 amp., 4 v. 3 amp., 39/6. P. & P. 5/-.

**Mains Transformer,** fully impregnated, input 200, 220, 230 and 240. Sec. 600-0-600 275 mA., and 200 v. at 30 mA., complete with separate heater transformer. Input 210, 220, 230, 240. Sec. 6.3 v. 2 amp. three times, 0, 4, 6 1/2 v. at 3 amp. and 5 v. 3 amp., 45/-, P. & P. 5/-.

**Mains Transformer,** fully impregnated, Input 210, 220, 230, 240. Sec. 350-0-350, 100 mA., with separate heater transformer. Pri. 210, 220, 230, 240. Sec. 6.3 v. 2 amp., 6.3 v. 3 amp., 4 v. 6 amp., and 5 v. 2 amp. 50/-, P. & P. 5/-.

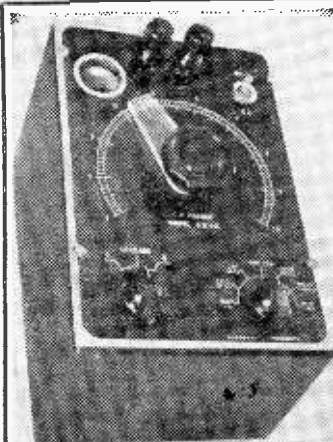

**CR50 BRIDGE**

Measures capacitance from 10 pF to 100 nF and resistance from 1 ohm to 10 megohms in four-teen ranges. Neon leakage test for condensers. Operates from 200/250 volt A.C. mains. Indication of balance is given by magic eye. Specially designed for bench use, with case and panel of steel finished black wrinkle. Complete with all valves and instructions. PRICE £6/19/6, plus 4/6 carr./packing. Hire Purchase: £3 deposit and four monthly payments of 22/.

**SIGNAL GENERATOR, SG50**, covers 100 kc/s to 80 Mc/s in six bands on fundamentals, either unmodulated or internally modulated with 400 cps. Uses two type Z77 valves and SenTerCel rectifier and double wound mains transformer. In olive green metal case with carrying handle, size 12in. x 8in. x 4in. deep. Front panel of green perspex engraved in white. We claim this to be the best value on the market at only £7/19/6, plus 6/- carr./packing.

Please send stamped, addressed envelope for illustrated leaflets by return post.

Obtainable from sole London stockist: **Charles Britain (Radio), Ltd.**, 11, Upper Saint Martins Lane, W.C.2, or direct from the manufacturers—

**GRAYSHAW INSTRUMENTS**  
54, Overstone Road, Harpenden, Herts.

**HANNEY of BATH offers:—**

**OSRAM 912** Erie resistor-pot. kit with ceramic tube resistors, very highly recommended, 29/6; Lab resistor kit, 32/6; T.C.C. condensers, 55/-; **PARTIUM** Components, with loose lead terminations, Mains trans., 44/-; Smoothing Choke, 29/6; Output trans., 76 B. Price includes Partridge carriage/packing charge. Printed panel, 14/8. W.B. chassis, 28/6. Send for complete list.

**MULLARD 5 VALVE, 10 WATT AMPLIFIER**, T.C.C. Condensers, 45/-; Erie resistor-pot. kit, 27/6; Elstone Mains trans., 36/-; Elstone Output trans., 45/- (both types); Denco chassis, 14/6. Small parts as per our list. Matched pairs of valves are available for both the above designs.

All Components for the . . .  
**NEW FURY FOUR** and the **P.W. TAPE RECORDER**.  
Send for priced parts list.

**COILPACKS**, Denco, CP 4/L and CP 4/M, 33/4; CP 3/370 pf. and CP 3/500 pf., 42/8; OSMOR "Q" HO, 43/-; LM, 40/-; Batt., 50/-; TRF, 49/-; HF stage for HO pack, 20/-; ETA 4-Station pack, 43/8. We stock COILS by Weymouth, Osmor, Wearite, Denco, Teletron and R.E.P.

**ELSTONE** Mains Trans. for the **SIMPLEX TV**, 49/-.

**VIEWMASTER, WIDE ANGLE VIEWMASTER CONVERSION**. Complete set of parts for converting existing Viewmaster to W.A., less valves, tube and mask, £14/18/6. W.A. Conversion instructions, 3/6; WB113, 49/6; WB14, 29/6; WB15, 42/-; WB16 and WB17, 7/8 each; WB118, 22/8; WB19, 26/9; WB121 3/6; WB124, 10/8; Westinghouse 36/EHT/50, 17/-; Plus condensers and resistors as per our general list.

**WIDE ANGLE COMPONENTS**, ALLEN, Teleking Chassis, 50/-; Collsets (TK & Super-visor), 44/6; LO.303, 40/-; FO.305, 21/-; DC.300c, 39/6; FC302, 31/-; CL.15 & 18, 7/6 each; SC.312, 21/-; AT.110, 30/-; OP.117, 9/-; BT.314, 15/-; Denco Chassis Magnaview, 37/8; Chassis, Super-visor, 51/6; Collsets, M-3ma, view, 41/2; WADCA1, 43/-; WAF/CA1, 31/-; WAI/CI and WCI, 7/8 each; WAF/MA1, 21/-; WAI/LOT1, 42/-; WAF/BT1, 16/-; Send 6d. stamps for our General List of components for Viewmaster, Soundmaster, Williamson Amplifier, Teleking, Magnaview (Brimar & English Electric large screen Tw), Super-visor, Mullard Universal, Close tolerance Silver Micacs, etc. etc. Please add 1/- postage to orders under 1l.

**L. F. HANNEY**

**77, LOWER BRISTOL ROAD, BATH**  
Tel.: 3811

**GET ON THE BEAM!**

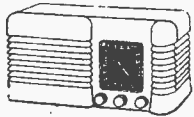

.. with the  
**METEOR III**  
**GUARANTEED**  
**A.C. Mains Set.**

**SIMPLICITY ITSELF!**

Complete **KIT** only

**95/-**

plus 2/6 for  
postage & packing.

Instructions, Point to  
point Diagrams and  
Parts List sent for 1/-,  
Post FREE.

You could almost do this job with a knife and fork—it's so simple! Screwdriver, pliers and soldering iron will make this spot-on 3 valve, 2 wave band set. Complete Kit includes valves. Ready-to-use Chassis Brown or Ivory Moulded Cabinet. A.C./D.C. Universal Model available at 97/6, plus p. & pkg., at 2/6. Visit our new branch at 97, Stratford Rd., Sparkbrook, to inspect our range of T.V.s, Radios, Cabinets and Components for Home Instructors.

**NORMAN H. FIELD**  
68, Hurst St., Birmingham 5.

**SATISFACTION—or we REFUND your CASH!**

**—THIS CAN BE YOURS FOR—**  
**7/4!** and 8 monthly payments of the same amount (Cash Price £2.19.6).



**OTHER TYPES AVAILABLE**  
RANGING FROM 25/6 to 59/6.  
All available on easy terms. Send for leaflets and full details.

Did you know we also supply Wolf Cub Drills and accessories, Black and Decker Equipment (special terms available to readers of P.W.), Burgess Sprayer, Vibro-Tools, Bridges Equipment, etc., etc. All on Easy Terms. Send S.A.E. for quotation  
**LAFCO COMPOUNDS, LTD.** (Desk 113)  
3, Corbatts Passage, Rotherhithe New Road, London, S.E.16.  
Telephone: BERmondsey 4341.

**REP HIGH GAIN COILS**

Dual Range Miniature Crystal Set Coil with Circuit, Type **DRX1** ... 2/6  
Dual Range Coil with Reaction with 2 mains and 2 battery Circuits, Type **DRR2** 4/-. Matched Pair Dual Range T.R.F. Coils with Reaction; with battery and mains circuits, Type **DRM3** Pair 8/-

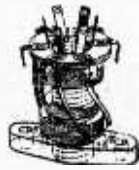

(Regd. Design)

★ All Coils wound on Low-loss Formers  
★ Individually Tested and Guaranteed  
★ Post 3d. on all Orders ★ Trade Supplied

**RADIO EXPERIMENTAL PRODUCTS LTD**  
33 MUCH PARK STREET COVENTRY

# TRANSMITTING TOPICS

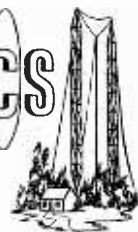

## STARTING ON TOPBAND

By O. J. Russell, B.Sc.(Hons.), (G3BHJ)

**T**HE topband has a considerable fascination for a number of amateurs. It is, of course, the ideal band for short distance work, and is consequently a great favourite for Sunday morning get-togethers and discussion of work on other bands. Moreover, contacts on the experimental V.H.F. bands are very often arranged via topband contacts, so that communication can be established between experimenters, while tests and adjustments are made to the V.H.F. equipment without a possible loss of contact, or even without obtaining a contact. Further, the DX man anxious for difficult feats is already arming himself for the coming Transatlantic and Worldwide DX tests scheduled for the winter. In addition, the thrill of European DX and the "Worked All British Countries" Contests, plus Club contests, low-power field days, field days,

set-up, a straight crystal oscillator unit will be found eminently satisfactory, particularly if the crystal frequency is chosen so as to avoid the powerful coastal stations. A typical example of the circuit of a straightforward crystal oscillator capable of running at inputs of up to 10 watts is shown in Fig. 1.

The simple tuned-anode type of grid-plate oscillator will be found particularly easy and straightforward to get running. Suitable oscillator tubes are the 6V6, 6BW6, 6AM6, 6K6 and 6L6. Even the EF50 will operate at some 5 watts or so, and give a healthy signal. There is certainly no trouble in running the 6V6, 6BW6 or 6L6 at at least 7 watts input, even with restricted power supplies. In fact, a 6L6 oscillator may be run at over 10 watts input. It should be noted that the significance of this is that by using suitable coils, the transmitter may be operated on 80 metres or 40 metres by using the right crystals and tuning coils. Thus, in the event of a breakdown of the main transmitter, the small set would serve to keep a schedule in emergency. The component parts are so few that the expense need not prove a drawback to anyone.

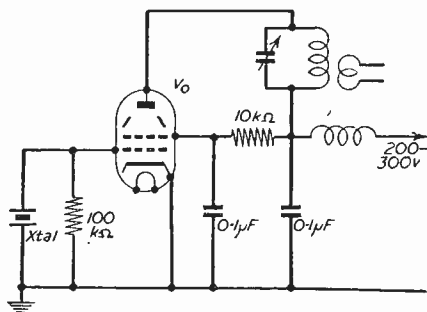

Fig. 1.—The simplest type of rig for Topband operation. (V<sub>0</sub> 6V6, 6L6, 6F6, 6K6, EF50, EF91, 6AM5, 6AM6, TT11, QV04/7, 6BW6, KT66, 807, etc.)

transistor experiments and others, make the topband a rewarding band for the amateur. Moreover, the Radio Amateurs Emergency Network makes great use of topband for exercises and field and mobile experiments. Finally, of course, the topband makes a convenient jumping-off ground for the beginner in amateur work, as the freedom from some of the vagaries of the lower bands enables worthwhile operating experience to be accumulated without much difficulty from QRM, despite the fact that the band is "shared" with essential coastal and shipping services. In fact, the great help given by amateur stations during the great gale is yet another illustration of the worthwhile aspect of operation upon this band.

### Equipment

Topband "rigs" may vary from the ultra-simple to the over-complicated, but the power limit of ten watts does enable some attractively simple arrangements to be constructed. For the "simplest possible"

### Operation

However, there are a few points of operation which may be explained, so that optimum operation can be obtained. The anode tuned circuit must, of course, tune to the required band or frequency of operation. However, the crystal will not oscillate unless the tuned circuit is tuned somewhat higher in frequency than the crystal frequency. In fact, starting with the anode circuit tuned considerably higher than the crystal frequency, R.F. output will increase as the tuning condenser is increased in capacity (circuit tuned in the direction of lower frequencies). This increase suddenly stops sharply at a critical point, and output decreases to zero abruptly. If a plate milliammeter is included in the anode circuit, the reading will decrease as oscillation becomes stronger, only to jump suddenly to a high value at the point where oscillation ceases. A flashlamp bulb loosely coupled to the tuning coil by a turn or two of wire will glow more and more brightly until the critical point is reached, when the glow ceases as an indication of stopping of oscillation.

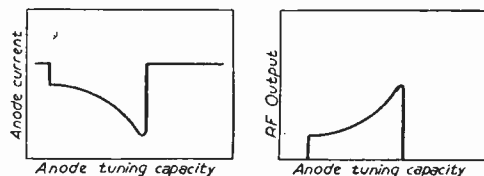

Fig. 2.—Behaviour of the simple circuit of Fig. 1 when tuning the Anode Tuning Condenser.



As maximum R.F. output is generated just on the edge of the critical point, it would seem desirable to work as closely as possible to this point. This is, however, not the best method of operating, as a chirpy note, failure of the oscillator to follow keying and similar troubles may result. It is necessary to tune a little to the high frequency side of the critical point and accept a slight loss of R.F. output for the trouble-free operation thus given. It also follows that when a coupled load such as an aerial circuit is coupled into the crystal oscillator it will also react somewhat upon the anode tuning adjustment, so

valves should not be overlooked, as very compact units may be constructed with them. Such valves as the EF91, 6AM6 or the 5763 make ideal VFO valves. The PA may be a 6V6, 6K6 or 6L6 or even an EF50 in standard sized valves, but the use of miniature valves such as the 6AM5, the 6BW6 and the 5763 should be considered if no standard types are on hand. Despite their size the miniature valves handle healthy inputs. The 6BW6, for example, has identical electrical characteristics to the 6V6 and will handle some 20 watts of input. It will certainly get

hot, for the maker's ratings permit a maximum bulb temperature of 250 deg. Centigrade. This is to avoid any alarm at the heat generated when the 6BW6 runs at full input! However, on 10 watts in a topband set the 6BW6 is well within its ratings with average PA efficiency. The only point to watch is that the compact miniature tubes may need a little more care in layout and wiring up if R.F. feedback is to be avoided.

Fig. 3 gives, therefore, a simple VFO/PA circuit. There are some points of interest, however, as while the VFO may run happily on 1.8 Mc/s. if operated on half frequency, that is in the broadcast band, enough doubling will take place in the anode circuit to drive the PA. Also note that the drive to the PA is taken through a variable condenser rather than through a fixed one. The variable condenser is adjusted so that only enough drive is provided for the PA. Tighter coupling, that is a high value of capacity, will give little more drive but may cause pulling of the VFO. The rig may be keyed in the VFO cathode, or preferably in the PA cathode lead. It is also desirable to feed the VFO with neon stabilised H.T. However, if the PA is arranged to draw a safe load from the

(Continued on page 105)

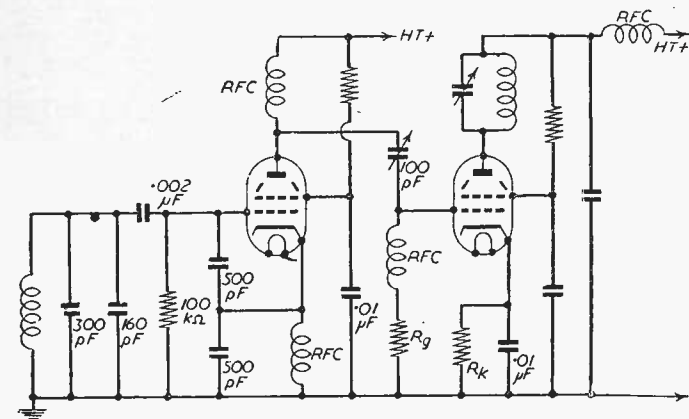

Fig. 3.—A simple VFO/PA rig for topband working.  $R_g$  and  $R_k$  vary with the PA valve. Generally  $R_g$  will be around 20,000 ohms.  $R_k$  should give sufficient protective bias to prevent the PA valve drawing excessive current under key-up conditions. The usual L.F. amplifier cathode resistor value will serve.

that one should not strive to extract the last ounce of R.F. from the circuit but rather operate somewhat away from the critical adjustment point. In this way good R.F. output and trouble-free keying will result. Fig. 2 illustrates the "critical point" effects.

Keying for such a simple set-up may be effected either by a key directly in the anode lead or by a key in the cathode lead. The cathode jackplug should be by-passed by an .01  $\mu$ F condenser which serves also to prevent key clicks. Screen keying may also be tried if desired. The monitored note should be sharp on keying and free from chirps. It should be noted that even on topband a crystal oscillator if overloaded may give a chirpy note.

Crystal oscillator arrangements, however, are unlikely to appeal to some, as the VFO with its ability to put the signal into any conveniently clear spot on the band makes rockbound operating unpopular with many. Despite this, a number of operators have done, and still are doing, very good work on 160 with straight crystal oscillator rigs. The writer has used such an outfit for some time and beyond having to grind the original crystal to dodge coastal interference found operation enjoyable.

However, the VFO ability of dodging QRM is too valuable to pass over, so that some simple form of VFO must be mentioned. It is quite feasible, of course, to go on the air with only a VFO. The writer, in fact, has done a little QRP work in that direction, but it is not a procedure to be recommended to the beginner. Some form of VFO/PA is needed. In this respect the newer miniature

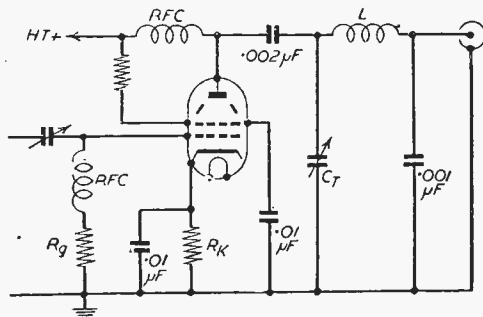

Fig. 4.—A Pi tank modification of the circuit of Fig. 3. Generally CT should have a value of around 200 pF, and the tank inductance should be tuned to enable resonance to be reached with approximately 200 pF total tuning capacity in circuit. CT may be arranged by paralleling a high-grade mica condenser with an air variable to give the required 200 pF.



**Invite you to build this 4 valve, 2 wave-band, superhet portable for only**

**6½ GNS.**

Full details, circuit diagram, point to point wiring instructions, and complete list of components. Available 2/6 ea. Case can be supplied separately. Available in the following attractive colours:

- Lizard Grey;
- Blue;
- Maroon;
- Brown.

All components can be supplied separately.



**CARRYING CASE**  
Suitable for use as a projector or recording case, size 15in. x 9in. x 13in. Internal dimensions: 14in. long, 11 1/2in. deep, 5 1/2in. front H.T., 8 1/2in. rear H.T. With a black rexine finish. Weight 8 1/2lb. 18/6 ea. Post and packing 2/6.

**CHOKES**  
20H, 250Ω, 60 mA. Clamp construction 6/- ea.  
10H, 200Ω, 90 mA. Clamp construction 9/3 ea.  
6H, 250 mA, 200Ω. Fully shrouded. 18/3 ea.

**TRANSFORMERS FOR BATTERY CHARGERS**  
230 v. Input Tapped 6-12 v. 1 amp. 13/6 ea.  
230 v. Input Tapped 6-12 v. 3 amp. 18/- ea.  
Both with tap on Primary for 2.5 v. Pilot light.

**HEATER TRANSFORMERS**  
230 v. Input 2 volt .5 amp. 4/6  
230 v. Input 2 volt 3.0 amp. 7/9  
230 v. Input 4 volt 1.5 amp. 5/-  
230 v. Input 4 volt 3.0 amp. 10/-  
230 v. Input 5 volt 2.0 amp. 10/-  
230 v. Input 6.3 volt .5 amp. 5/-  
230 v. Input 6.3 volt 1.5 amp. 6/-  
230 v. Input 6.3 volt 3.0 amp. 9/-  
230 v. Input 12 volt .75 amp. 5/-

**SENTREX RECTIFIERS**  
RM1, 3/9 ea.; RM2, 4/2 ea.; RM3, 6/- ea.; RM4, 16/- ea.

**METAL RECTIFIERS**  
12 v. 1/2 amp., 1/6 ea.; 12 v. 1 amp., 4/6 ea.; 2 v. 1 amp., 3/- ea.; 250 v. 45 mA., 6/3 ea.; 250 v. 75 mA., 7/6 ea.; 300 v. 60 mA., 7/6 ea.

**GOLDING PICK-UP HEADS.** Pick-up head type No. 112 (2,000 ohms), complete with lead. Price 17/6 each.

**TINNED COPPER WIRE**—All 4 oz. Tins:  
16 S.W.G. .... 2/-  
18 S.W.G. .... 2/2  
20 S.W.G. .... 2/4  
22 S.W.G. .... 2/6  
24 S.W.G. .... 2/8  
26 S.W.G. .... 2/10

**ENAMELED COPPER WIRE**—All 4 oz. Reels

| S.W.G. | Price | S.W.G. | Price |
|--------|-------|--------|-------|
| 16     | 1/11  | 30     | 3/1   |
| 18     | 2/1   | 32     | 3/3   |
| 20     | 2/3   | 34     | 3/5   |
| 22     | 2/5   | 36     | 3/7   |
| 24     | 2/7   | 38     | 3/11  |
| 26     | 2/9   | 40     | 4/2   |
| 28     | 2/11  | 40     | 4/2   |

**CHASSIS**  
Aluminium finished with Reinforced Corners. Available in the following sizes:  
6in. x 4in. x 2 1/2in. .... 4/6 ea.  
8in. x 6in. x 2 1/2in. .... 6/3 ea.  
10in. x 7in. x 2 1/2in. .... 7/3 ea.  
12in. x 8in. x 2 1/2in. .... 8/6 ea.  
14in. x 8in. x 2 1/2in. .... 9/6 ea.  
16in. x 9in. x 2 1/2in. .... 12/- ea.  
All are four sided—ideal for radio receivers—amplifiers—powerpacks, etc.

**PERSEK IMPLORATION GUARDS**  
Incorporating switch-on and filter. 12in. type, 11/6 ea.; 16in. type, 14/6 ea.

**POCKET TEST METER**  
Ex-Govt. volt meter two ranges 0-15 v.; 0-250 v. D.C. Complete in case, 17/6 ea.

**IRON ELEMENTS**  
Standard adaptable type, 230 v., 450 v., 1 1/8 ea. Morphy Richards, replacement type, 3/9 ea. H.M.V. replacement type, 3/- ea.  
**PLIERS**, with side cutters, 4/3 pair.

**CONTROL KNOBS IN MODERN STYLING**  
Tastefully and clearly engraved in gold.  
Size A. Diameter 1 1/4in. Depth 3/4in.  
Size B. Diameter 1 1/2in. Depth 3/4in.  
These Mouldings are available in two colours: Walnut and Ivory.  
They are suitable for use with 1/4in. spindles and are simply and firmly held by means of a grub screw and locking nut.  
**Prices:**  
Type "A" — 1/6 each.  
Type "B" — 1/2 each.  
Plain Knobs can be supplied in either size or colour: Price 1/- each and 8d. each respectively. Inscriptions available:—  
"RADIO"; "Volume"; "VI On-Off"; "Wave-change"; "Tuning"; "S.M.L. Gram"; "Radio-Gram"; "Tune"; "On-Off"; "TELEVISION"; "Contrast"; "Brilliance"; "Brilliance On-Off"; "Focus"; "Brightness."  
AMPLIFIER: "Trebble"; "Bass" (plus any of those shown above). TAPE RECORDER: "Record-Play."

**NYLON DRIVE CORD**  
25 yard reel nylon drive cord on wooden reel, 2/9 ea.

**CRYSTAL DIODES**  
Plastic case, wire ends, 2 for 2/1.

**BI CONDENSERS**  
Waxed cartons, with flying leads. 4 mfd., 500 v., 1/6 ea.; 4 x 4 mfd., 500 v., 3/4 ea.

**LOUDSPEAKER UNITS**  
Rola 5in. Speaker with transformer..... 16/- ea.  
Elac 5in. .... 18/9 ea.  
Plessey 6 1/2in. light weight unit 16/6 ea.  
Rola 6 1/2in. standard type..... 17/6 ea.  
Lectrona 6 1/2in. with transformer..... 18/- ea.  
Truvox 6 1/2in. wafer type..... 20/- ea.  
Plessey 8in. light weight unit 17/6 ea.  
R. & A. 8in. Standard type..... 17/6 ea.  
Plessey 10in. unit..... 19/6 ea.  
Elac 10in. .... 22/6 ea.  
R. & A. 10in. .... 22/6 ea.  
Goodmans 10in. unit with transformer..... 26/6 ea.  
Elliptical 4in. x 7in. unit..... 18/6 ea.  
Mains energised 8in. unit, 1,000 Ω..... 21/- ea.  
Mains energised 6 1/2in. unit, 600 Ω..... 17/6 ea.

**BAKELITE CASED BI CONDENSERS**  
0 mfd., 1,000 v.; .01 mfd., 4 Kv.; .01 mfd., 4 Kv.; .03 mfd., 4 Kv.; .03 mfd., 500 v.; All 1, 6 ea.

**DUBLIER NITROGOL CONDENSER**  
12 mfd., 350 v., 5/6 ea.

**OSMOR COIL PACKS**  
Type H.O., 48/- ea. Type L.M., 40/- ea.  
Type T.D., 50/- ea. Type TRF, 40/- ea.

**SPRAGUE CONDENSERS**  
.65 mfd., 500 v.; .01 mfd., 1,000 v.; .1 mfd., 250 v.; .02 mfd., 750 v.  
All 9/- doz.

**TCC VISCONOL CATHODRAY CONDENSERS**  
Type CP57XO, .002 mfd., 18 Kv., 7/6 ea. Type CP55XO, .001 mfd., 6 Kv., 5/- ea. Type CP55TO, 500 pF., 10 Kv., 5/- ea.

**VIBRATORS, ETC.**  
Vibrator unit for 6 v. operation, 14/6 ea. Post 1/6. 6 v. and 12 v. Vibrators, 4-pin UXT types, 6/6 ea.

**DOUBLE TRIMMERS**  
250/250 pF.; 100/100; 100/50. All 6d. each.

**YAKLEY SWITCHES**  
3 pole, 3 way, 1 bank, 1/6 ea.  
3 pole, 3 way, 3 bank, 1/6 ea.  
Octal Plug and Socket (screened), 1/- ea.

**PRE-SET CONTROLS (CARBON)**  
50 K Ω, 1 Meg Ω, 1 Meg Ω, 2 Meg Ω, 1/9 ea.

**GOLDTONE BAKELITE CASED BUZZERS** ..... 2/6 ea.

**PENCIL RECTIFIERS**

|                                  |                                |
|----------------------------------|--------------------------------|
| 8 x 8 mfd. 450 v. .... 4/-       | 32 x 32 mfd. 350 v. .... 5/9   |
| 8 x 16 mfd. 450 v. .... 4/-      | 25 mfd. 25 v. .... 5/9         |
| 8 x 24 mfd. 350 v. .... 3/-      | 60 mfd. 450 v. .... 2/9        |
| 8 x 32 mfd. 475 v. .... 3/-      | 64 mfd. 350 v. .... 2/-        |
| 12 x 4 mfd. 450 v. .... 2/9      | Dialler (B. Range):            |
| 16 mfd. 450 v. .... 3/-          | RR. 850. 8 mfd. .... 2/9       |
| 16 x 8 mfd. 350 v. .... 3/6      | RR. 500 v. .... 2/9            |
| 16 x 16 mfd. 350 v. .... 3/6     | RR. 1650. 16 mfd. .... 3/3     |
| 16 x 16 x 8 mfd. 350 v. .... 3/6 | RR. 500 v. .... 3/3            |
| 20 x 20 mfd. 300 v. .... 2/9     | RR. 2050. 20 mfd. .... 3/6     |
| 24 mfd. 450 v. .... 2/9          | RR. 500 v. .... 3/6            |
| 24 x 16 mfd. 350 v. .... 3/6     | RR. 8 x 8 mfd. 300 v. .... 4/- |
| 32 mfd. 450 v. .... 3/6          | RR. 501. 50 mfd. .... 1/9      |
| 32 x 8 mfd. 350 v. .... 3/6      | RR. 12 v. 500 v. .... 1/9      |
| 32 x 32 mfd. 450 v. 8/11         | RR. 16 x 16 mfd. 500 v. 5/-    |
| 32 x 32 x 8 mfd. 350 v. 8/11     | RR. 16 x 8 mfd. 500 v. 4/9     |

**HUNTS CONDENSERS**  
Type W99, 200 pF., 350 v., 7d. ea.  
Type W99, .005 mfd., 150 v., 7d. ea.  
Type W48, .1 mfd., 400 v., 1/- ea.  
Type L44, .1 mfd., 500 v., 8d. ea.

**RESISTORS 2 WATT**  
120 K Ω, 470 Ω, 7.5 K Ω, 22 Ω  
2.2 K Ω, 5.6 K Ω, 300 Ω, 150 K Ω  
100 K Ω, 1 meg. Ω, 1.5 meg. Ω, 56 K Ω  
All 4d. ea.

★ ★ ★ ★ ★  
**EX GOVERNMENT AND SURPLUS CONTROLS**

This popular range is suitable for all Television constructions, etc. Keep your costs down when building the "Argus" or "Simplex" receivers.  
Available: 500 Ω, 600 Ω, 1,000 Ω double type, 2 1/2 K Ω, 5 K Ω, 10 K Ω, 20 K Ω, 25 K Ω, 30 K Ω, 200 K Ω, 100 K Ω, 1 meg. Ω, 1 meg. Ω, 2 meg. Ω, 50 K Ω double type. All 1/2 each.

**COLVERN PRE SET CONTROLS**  
Type CLR 1106/88, 1,000 Ω ... 1/9 ea.  
Type CLR 1126/78, 250 Ω ... 1/9 ea.

★ ★ ★ ★ ★  
**RESISTORS**

The following range of Resistors is available in 1/3 watt and 1 watt.  
Prices 1 1/2 watt 38. ea., 1 watt 6d. ea.  
10 Ω, 25 Ω, 1.5 K Ω, 18 Ω  
12 Ω, 15 Ω, 1.8 K Ω, 22 K Ω  
15 Ω, 180 Ω, 2.2 K Ω, 27 K Ω  
18 Ω, 220 Ω, 2.7 K Ω, 33 K Ω  
22 Ω, 270 Ω, 3.3 K Ω, 39 K Ω  
27 Ω, 330 Ω, 3.9 K Ω, 47 K Ω  
33 Ω, 390 Ω, 4.7 K Ω, 56 K Ω  
39 Ω, 470 Ω, 5.6 K Ω, 68 K Ω  
47 Ω, 560 Ω, 6.8 K Ω, 82 K Ω  
56 Ω, 680 Ω, 8.2 K Ω, 100 K Ω  
68 Ω, 820 Ω, 10 K Ω, 120 K Ω  
82 Ω, 1 K Ω, 1.2 K Ω, 150 K Ω  
100 Ω, 1.2 K Ω, 15 K Ω, 180 K Ω

**SOLDERING IRONS**  
Sohna type 964 fitted with oval bit ..... 10/11 ea.  
Sohna type 968 fitted with pencil bit ..... 10/11 ea.

Both types are complete with approx. 6ft. of Henley 3 core cable and are suitable for 250/250 v.

**SOLDERING PASTE**  
Large tin soldering paste by Tyne Chemical Co., approx. 1 lb. ..... 1/9 per tin

**CONDENSERS**  
The following is a selection of our stocks of manufacturers' surplus condensers all by well-known makers—DUBLIER, B.I.C. BICO (E.L.I.-SWAN), SPRAGUE, etc.  
Aluminium Can Types, Clip Fixing: each

**TERMS:** Cash with order or C.O.D. Postage and Packing charges extra, as follows: Orders value 10/- add 9d.; 20/- add 1/4; 40/- add 1/6; 65 add 2/- unless otherwise stated. Minimum C.O.D. fee and postage 2/3.

**MAIL ORDER ONLY**

WHEN ORDERING PLEASE QUOTE "DEPT. P.W."



## ALFRED PADGETT

40 MEADOW LANE, LEEDS, 11

Established 20 years.

**150 ONLY.**—Navy Receiver Type M361, coverage 4,500-2,000 kc. 2,250-1,000 kc. 1,080-450 kc. 510-215 kc. 235-100 kc. Clean condition. Less valves £1-15-0. Carr. and packing, 8s. Best buy we have offered so far.

**SELECTIONAL METAL RECTIFIERS.**—Small in size, 250 volts at 100 mA. Brand new. 6/6, 50/- per doz. Post free.

**STEP-DOWN TRANSFORMERS.**—200-250 volts, 50 cycles, 4:1 per dozen panels. Amps 30, 24, 20, 18, 15, 14, 12, 10, 9, 8, 5, 4, 3 volts. Worth Double. 12 months' guarantee. Price 17/- Post free.

**SINGLE HEADPHONES.**—Low resistance, 1/8. Post paid.

**MIXED RADIO PANELS.**—Full of Resistors and Condensers, 4:1 per dozen panels. Post free. Wonderful Value.

**TYPE 1125 SETS.**—Complete with two 8D2 valves. New. 6/6. Post 2/4.

**LINE CORD.**—Point two or point three. Two-, Three- or Four-Way. Cut lengths of 1,000 ohms, 3/6, or 1/- per yard. Post free.

**CRYSTAL DIODES.**—Two for 2/2, 12/- per doz. These are not rejects.

**DIAL LAMP BULBS.**—3.2 volts at 3 amps. 5/- per doz. Post free. Fully guaranteed.

**A SCOPE ALL BUT MADE.**—B.C.929 Tube Unit, complete with 3BP1 tube 2X2. 6K5, 6SH7s, 6H6, 6G6. Brand New. £3-12-6. Carriage free.

**BANKRUPT STOCK** of Heavy Chromium Plated U2 Size Focusing torch cass. Price 1/- Post 6d.

## RADIO KIT 19/6



Build this high quality portable radio in 45 mins. Exceptionally sensitive, twin-triode circuit, using unique assembly system, can be built by anyone. Size only 6 1/2 in. x 5 in. x 3 in. in handsome black-crackle steel case with beautiful black and gold dial (stations printed!). Covers all medium and long-waves. Uses one only self-contained dry battery, cost less than id. for 5 hrs.!

Many unsolicited testimonials.—*Mr. Norton of Oxford, writes: "Yesterday evening on the medium waveband, I counted 32 separate stations. I am very pleased with the set, which is well worth the money."* *Mr. Fraser, of Ipswich, writes: "Its performance is almost unbelievable. It gives me stations I've never been able to get on my large radio."*

Send To-day Cheque/C.V.O. COD. 22/- (includes 2/6 post/packing) for Case, Dial, Handle, Plans, Parts Lists, etc. (Cost of Parts to Complete the Radio only 27/6.) Sent by return. (Overseas orders welcomed.)

**BRIGHTON RADIO CO. (Dept. PW9),**  
69, Preston Street, Brighton, 1

### HIGH FIDELITY COMPONENTS IN STOCK FOR THE MULLARD 5-10 OSRAM 912 AMPLIFIERS

Price lists and 43-page catalogue free on request to

**J. T. FILMER,**  
MAYPOLE ESTATE, BEXLEY, KENT

Tel: Bexleyheath 7267

## L. J. T.

MAIL ORDER SUPPLIES  
119, WESTBOURNE GROVE,  
LONDON, W.2.

### VALVES

|      |     |     |     |       |     |
|------|-----|-----|-----|-------|-----|
| 6X5  | 7/- | 3V4 | 7/6 | 7C6   | 9/- |
| EA50 | 1/9 | 354 | 7/6 | 12K8  | 9/- |
| 80   | 8/6 | 1L4 | 7/6 | 12K7  | 9/- |
| 6K7  | 5/3 | 1U5 | 7/6 | EB91  | 7/- |
| 5Z4  | 8/6 | 6V6 | 7/6 | EF91  | 6/- |
| 6Q7  | 8/9 | 6K8 | 8/6 | 12BE6 | 5/6 |
| 35Z4 | 8/9 | 757 | 9/- | 6AQ5  | 8/- |
| 35L6 | 8/9 | 7B7 | 9/- | 6BW6  | 8/- |
| 1T4  | 7/6 | 7Q7 | 9/- | 6X4   | 7/6 |
| 1R5  | 7/6 | 7H7 | 9/- | 6X4   | 7/6 |
| 155  | 7/6 | 7C5 | 9/- | 35W4  | 7/6 |

| ELECTROLYTICS | Mould Seals         |
|---------------|---------------------|
| 8+16          | 450 v. 3/- .05 7/d. |
| 32+32         | 450 v. 4/4 .04 7/d. |
| 8.450 200MA   | 450 v. 2/3          |

Resistors.—1 watt, 1½d.; ½ watt, 2d.; 1 watt, 3d.; minimum, 12 each.

3 Valve Amplifiers.—A.C. only. 4 watts Output, Tone Control, etc. Few only (suitable all types Pickups), £3 7s. 6d. each.

Radio Cabinet Kit.—Complete, size 11½ in. x 7 in., x 5 in., 26/6 each.

All goods offered subject to being unsold. Equivalents will be supplied unless otherwise stated. All valves guaranteed. Terms:

Cash with Order or C.O.D. Packing Free. Postage at cost on orders under £5.

### TESTSCOPE Mains Tester

For high and low voltage testing—1-30 and 100-850 volts A.C. or D.C. Write for interesting leaflet 29F 16 page manual (how to make 50 electrical tests) 1/- post free.



### RUNBAKEN-MANCHESTER

## TAPE RECORDERS P.W. and SOUND MASTER

We can supply complete kits or separate components for both the P.W. and Sound Master Tape Recorders.

Sound Master Instructions, 6/6.

### FULL HIRE PURCHASE FACILITIES

Only 2/- in the £ deposit.

## WATTS RADIO,

8, Apple Market, Kingston-on-Thames, Surrey.

Phone: KINGston 4099.

### RENEWBAT



Don't scrap that failing car battery or radio cell! Try Renewbat conditioner. Works like a charm. Simple and safe to use. Full instructions. Car size 3/-, p.p. 6d.; Radio size 1/9.

**CHAMPION PRODUCTS,**  
43, Uplands Way, London, N.21.  
Phone: LAB 4457

Introducing the:—

## TYANA TRIPLE THREE

MAKE SOLDERING  
A PLEASURE  
SMALL

SOLDERING IRON

Complete with detachable

BENCH STAND 19/6

The smallest high-power

soldering iron. Length

only 8½"; adjustable long

bit dia. 3/16"; mains volt-

ages 100/110, 200/220,

230/250.

The "STANDARD" Iron

now reduced to 14/11.

Replacement Elements and

Bits for both types always

available.

**KENROY LIMITED**

152/297 UPPER ST.,

ISLINGTON, LONDON,

N.1.

Telephone: Canonbury 4905-4663



Reg. Design  
No. 867804

## Fidelia

HAND  
BUILT  
RADIO  
UNITS

THE  
FIDELIA  
MAJOR 10

Hand built high quality radiogram chassis at economic price. 10 valve, model illustrated, £35-8-4, De-luxe 9 valve model £25-5-0, 7 valve £21-12-0, 5 valve £15-15-4

Technical data sheets free.

Electro Acoustic Developments, 2, Amburst Road, Telcombe Cliffs, Sussex.

### 1-Finger Pianists

Build your own electronic keyboard and play everything! Send for true leaflet. Guitar, cello, flute and trumpet are all easy. Write now...

**C & S, 10 Duke St., Darlington,  
Co. Durham**

power pack when not excited, the output of the pack will not soar so much as when the PA is cut off completely in idle periods. This in itself is often enough to prevent chirp on a topband VFO rig.

### Tuned PA

A conventional tuned tank PA is shown in Fig. 3, but a PI network tank circuit may appeal to many.

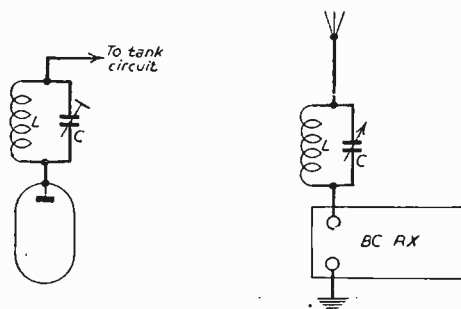

Fig. 5.—Traces of TVI may be alleviated by a tuned trap in the anode circuit of the PA and oscillator stages. A few turns of wire of  $\frac{1}{4}$  in. diameter are resonated by an air trimmer to the TV channel.

Fig. 6.—Image type of BCI may be cured by a wavetrap in the broadcast receiver aerial lead. Additional traps may be added if necessary. The traps are tuned to the transmitter frequency causing BCI.

For a topband set-up there is little point in making the output capacitor variable, especially if feeding a coaxial line feeding an aerial tuning unit. Therefore, for a rig intended to run at 10 watts input at 300 volts H.T., i.e., say, 33 mA at 300 volts, the constants shown in Fig. 4 will be found quite suitable. A 1,000 pF output capacitor such as a high-grade mica type will be suitable, while the tank coil inductance should be such as to give resonance with a total anode capacitance of around 200 pF. These values should give an optimum operating Q value for the loaded tank circuit.

### TV Interference

It should be noted that in *all* cases it is assumed that operation will be into an aerial tuning network, and that the rigs described will be link-coupled into such aerial tuning units. In this way harmonic rejection will be obtained and the possibility of TVI lessened. It must be mentioned that while TVI is not such a problem on topband as on the higher bands, it is still a possibility, particularly in weak signal areas on the fringe of TVI service areas. One method of value for suppressing TVI is the use of a tuned TVI trap (Fig. 5) inserted in the PA anode circuit. A few turns of wire are resonated with a small air condenser to the TV channel. This precaution and the use of a similar trap in the VFO anode may reduce mild TVI to nothing. Where *real* TVI is experienced, only the full gamut of anti-TVI devices will be effective, but really stringent TVI measures are not always needed on topband.

One type of interference occasionally noticed when operating on topband are BCI complaints. These are generally due nowadays to second channel interference on superhet receivers, rather than to swamp

effects on straight receivers. It will be found in cases of "second channel" BCI that the frequency of topband operation is given by adding twice the BC receiver 1F to the frequency to which the BC receiver is tuned. These second-channel images tune sharply just like a normal signal, but may, of course, be superimposed on a BBC channel when operating at certain topband frequencies. Thus a BC receiver of 465 1F if tuned to 900 kc/s may receive the image frequency of  $900 + 2 \times 465 = 1,830$  kc/s, if it has poor aerial circuit selectivity. As 1,830 kc/s is a popular topband frequency, trouble may easily arise in this way. The remedy is to supply a wavetrap tuned to the offending topband frequency and fit the trap in the aerial lead of the broadcast receiver. This does not, of course, solve the problem in the case of receivers with built-in frame aeriels, and the simplest solution is to avoid the topband frequencies which give an image frequency that falls on the Home or Light programme frequencies. Generally, however, BCI problems are generally curable on topband, although the closeness to the broadcast band does tend to accentuate some forms of BCI.

### Image BCI

It will be appreciated that with the usual 465 kc/s 1F for broadcast superhets, image BCI may occur when working on any frequency between 1.8 and 2 Mc/s in the topband. This will show up as image interference on signals between 870 kc/s to 1,070 kc/s in the broadcast band. In the London area the region around 1,830 kc/s is one that might cause trouble to BBC listeners. However, in some areas where the BBC programme is received on some other channel, image BCI might be caused when working on some other topband frequency. Differing intermediate frequencies may also cause image signals to appear on frequencies a little outside the range of 870 to 1,070. Thus a 456 1F broadcast receiver might respond to images tuning (apparently) at from 852 kc/s to 1,052 kc/s on the receiver corresponding to actual topband operation in the range 1.8 to 2 Mc/s. Depending on the area of operation and the local BBC frequencies, therefore, it may be necessary to protect two or even three spots on the broadcast receiver corresponding to programme channels. Fortunately, in such cases two or three wavetraps may be inserted in series in the aerial lead of the receiver thus interfered with, and each trap may be tuned to a different spot. By this means even bad or multiple image interference may be cured. With this one point of BCI interference, therefore, topband operation is generally plain sailing, so that a rig for operation on 160 metres adds a further source of enjoyment to amateur activities.

## PRACTICAL WIRELESS CIRCUITS

16th Edition

By F. J. CAMM

10/6, by post 10/11

From

GEORGE NEWNES, LTD., Tower House,  
Southampton Street, Strand, W.C.2.

# AMPLIFIER DESIGN

## 11.—TUNED AMPLIFIERS

By R. Hindle

(Continued from page 12 January issue)

### Mismatch

THE tetrode is somewhat different with regard to output loading. It will be seen from Fig. 42 that an increase in loading (making the slope of the load line less) will run the valve more into the curved regions at the extremes of the load line and so would give rise to increased distortion but a decrease in load making the line slightly steeper would have less effect on the distortion produced. Generally speaking, however, one has to be more careful to match the tetrode or pentode than the triode. Of course, the same factor of variation in the impedance of a speaker with frequency, as was mentioned previously, applies also to the case of a tetrode and this also tends to be more serious in its results with the tetrode.

### Converting to Tetrode Working

The comparison between triode and tetrode working is easily tried out with the units the construction of which has been described, and it is very likely that the constructor will prefer to leave the tetrode connection in operation for general use in view of the fact that the output is six times as great for substantially the same input. All that has to be done with both versions of the output amplifier is to break the link between pins 5 and 6 of V1 (Fig. 38 and Fig. 41), leaving the output transformer connected to pin 5. Pin 6 is then connected directly to H.T., conveniently on the electrolytic smoothing capacitor to the tag to which the H.T. end of the output transformer is already connected. The bias resistor, R2, has then to be reduced to 240 ohms either by substitution of one of the correct size or by connecting across the 300-ohm resistor one of 1,000 ohms. The matching of speaker may need to be altered if the triode was given its correct load of 4,000 ohms but as was explained earlier a tapping giving a load of 5,000 ohms was used for the triode connections as this was the nearest available ratio and in this case no change had to be made for tetrode.

When discussing untuned amplifiers it was stated that the frequency of operation of the signal did not alter the basic theory of amplification, and it is true that the resistance-capacitance type of coupling there discussed would work equally well at any frequency if the resistive load at that frequency was of the order mentioned in the design data. The first R.F. amplifiers were, in fact, resistance-coupled triodes, but, unfortunately, the amplification obtained was very much less than was to be expected from the size of load used. The basic reason for this, as a matter of fact, was also dealt with when dealing with a audio amplification. The reader will perhaps

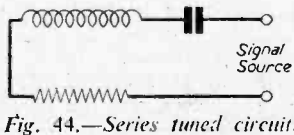

Fig. 44.—Series tuned circuit.

*A Series of Articles Dealing with the Theoretical Considerations of Amplifier Design, and Containing at a Later Stage Constructional Details of Various Types of Amplifier.*

remember that the amplification of the upper audio frequencies was limited by the inevitable stray capacitances, and as these were found to be more effective the higher the frequency it is not surprising that

they are even more effective at the much higher radio frequencies. These stray capacitances, even with reasonably careful construction, are likely to be about 40 pF, and are effectively in parallel with the load resistor. The load specified for the amplifier (Fig. 14, on page 342 of the June issue) was 100K $\Omega$  for the triode case, but the reactance of the strays even on medium wave ranges is only about 4,000 $\Omega$ , and on the short waves will be only a few hundred ohms. The gain on the medium wave range works out then (using the formula (3) on page 233 of the April issue) at only three times. For the pentode case the specified load was 220K $\Omega$ , and the gain is gm. Req (page 343 of June issue) or about four times on the medium wave range instead of 176 times as was found to apply at the audio frequencies where the effect of the strays was negligible.

This is not the whole story, unfortunately, and even the very limited gains quoted above are impracticable for other reasons. The anode load has its effect on the input impedance of the valve. When explaining the Miller Effect it was pointed out that with a resistive load a capacitance is fed back to the input circuit. When the anode load is predominantly capacitive, as in the case now being discussed, the effect is equivalent to a resistance across the grid circuit. Now if, as would be usual, there were a tuned circuit at the grid the resistance would have the effect of damping it and so reducing its selectivity and lowering the amplitude of signal existing in the tuned circuit so that the gain is still further reduced. In fact, in the average case under these circumstances it is very likely that there will be a reduction instead of an increase in signal.

### Reasons for R.F. Amplification

If R.F. amplification is so hard to achieve why bother about it at all? Audio amplification, we have seen, is reasonably easy and gains of well over 100 times per stage are practicable, so at first glance the solution would appear to be first to convert the signals into audio by means of a detector and then to amplify. There are many reasons why this is not

(Continued on page 109)

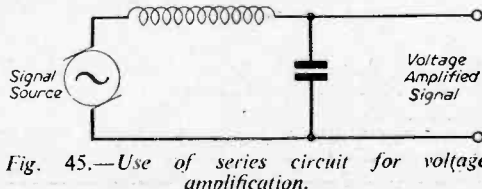

Fig. 45.—Use of series circuit for voltage amplification.

**MULLARD AMPLIFIER**



A high quality Amplifier designed by Mullard engineers. Robust, high fidelity, with a power output exceeding 10 watts and a harmonic distortion less than 4% at 10 watts. Its frequency response is extremely wide and level being almost flat from 10 to 20,000 c.p.s.—three controls are provided and the whole unit is very suitable for use with the Collaro Studio and most other good pick-ups. The price of the unit completely made up and ready to work is £12.10.0 plus 10/- carriage and insurance. Alternatively if you wish to make up the unit yourself we shall be glad to supply the components separately. Send for the Mullard Amplifier shopping list.

**ADJUSTABLE THERMOSTAT**

250v. Heavy silver contacts can be adjusted to operate between 70 deg.-300 deg. F. These are suitable for Aquarium heaters, Electric Blankets, etc., etc. 1 amp. model. 3/6; 2 amp. model. 5/6; 5 amp. model. 8/6. Post. etc., 6d. extra.



4ft. long made from heavy gauge sheet steel (galvanised), 1 kW, suitable A.C. or D.C. Price £2, or with thermostat £3.15.0. Note: The thermostat mounts separately and will control up to three heaters.



**CONNECTING WIRE SNIP**

P.V.C. insulated 23 s.w.g. copper wire in 100ft. coils, 2/9 each. Colours available: Black, Brown, Red, Orange, Pink, Yellow, White, Transparent. 4 coils for 10/-.

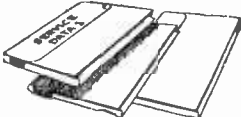

**SERVICE DATA**

100 service sheets, covering British receivers which have been sold in big quantities, and which every service engineer is ultimately bound to meet. The following makers are included: Aerodyne, Alba, Bush, Cosser, Ekco, Ever-Ready, Ferguson, Ferranti, G.E.C., H.M.V., Kolster Brandes, Lissen, McMichael, Marconi, Mullard, Murphy, Philco, Philips, Pye, Ultra. Undoubtedly a mine of information invaluable to all who earn their living from radio servicing. Price £1 for the complete folder.

Our folder No. 2 consists of 100 data sheets covering most of the popular American T.R.F. and superhet receivers "all dry", etc., which have been imported into this country. Names include Spanton, Emmerson, Admiral, Crossley, R.C.A., Victor, etc. Each sheet gives circuit diagrams and component values, alignment, procedure, etc., etc. Price for the folder of 100 sheets is £1. Post free.

**THE ELPREO TAPE RECORDER**



This instrument combines the M.ITU Truvox Tape Deck and the Cleveland Wide Band Amplifier with a special high flux speaker and forms one of the finest tape recorder combinations available today. It will, of course, play pre-recorded tapes as well as make its own recordings of radio, music, meetings, tele-

phone conversations, letters, etc., etc. The price, complete with reel of tape and ready to operate, is 35 Gns. Carriage and insurance 12/6. Hire Purchase terms if required.

**TERRIFIC NEW CIRCUIT**

We have evolved a new T.R.F. circuit which gives really amazing results—equal in fact to many superhets—yet really should make one up. Mains driven of course. For all the parts including valves (6K7, 6J7, 6F6, 6X5) and bakelite case with back, we charge only £5.10.0, plus 2/6 post and ins. Data is free with parts or available separately at 2/-.



**THIS MONTH'S SNIP**

**ATTACHE CASE**



Complete with leather handle and Y clasps—suitable for almost any portable instrument. Limited quantity—price 23/6. Carriage and packing, 2/6. A similar model but slightly smaller and in one colour, 19/6, plus 2/6 carriage.

**MAKE A CONVECTOR**



Almost any metal case can be converted into a useful convector type if you use our elements. Wound on porcelain at 250 watts, price 2/6 plus 6d. postage. Four or more post free.

**SNIP FOR CONNOISSEUR**

Decca crystal pick-up—turnover head—suitable for long-playing or standard records—limited quantity—29/6, post and packing 2/-.

**BARGAINS FOR CONSTRUCTORS**

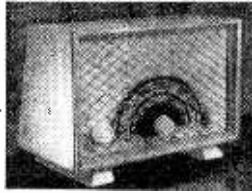

Price £5. Data, 1/6 (free with components).

Modern style cabinet in contrasting veneers, with metal chassis, three knobs, coloured scale and pointer. Price 29/6 post, etc., 2/-. All other components to build 2-wave band superhet.

**MULTI-METER KIT**



The Multi-Meter illustrated measures D.C. volts, D.C. m/amps and ohms. It has a sensitivity of 200 ohms per volt and is equally suitable for the keen experimenter, service engineer or student. All the essential parts including 2in. moving coil meter, selected resistors, wire for shunts, 8-point range selector, calibrated scale, stick-on range indicator and full instructions for making it available as a kit, price 15/-, plus 9d. post and packing.

**1in. MICROMETER**

Exceptional purchase enables us to offer a 1in. precision micrometer at the very low price of 10/-. A micrometer is an essential part of an engineer's equipment. You will have found the need for one on many occasions in the past for measuring wire gauge, etc. If you act quickly you can now acquire this precision instrument at the remarkably low price of 10/-, post free.



**THE F.M. FEEDER UNIT**

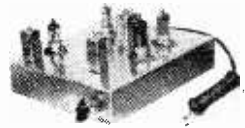

All the parts necessary to make the Denco F.M. Unit are now available. The unit gives an A.F. output suitable for feeding in at the pick-up sockets of any standard broadcasting receiver and superior results can be expected. The full constructional details as prepared by the Denco technicians are available at price 1/6 post free. Alternatively, they will be given free to those ordering all the parts which come to £8. 7. 6, plus 2/6 post and packing. Note: four valves and everything including a prepared metal chassis is supplied. Approximate chassis measurements are 6 x 6 x 1 1/2.

**BETHOVEN 5-VALVE SUPERHET**

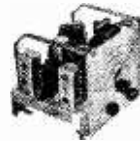

Complete with valves and Rola loudspeaker, ready to work off A.C. mains—three waves (L., M. and S.)—large dial, slow motion drive, dust cored coils, etc. £8. 17. 6, or £2 deposit (balance over 12 months), carr. 7/6.



Fine walnut veneered and polished cabinet to take the Beethoven 5-valve Superhet with 6in. loudspeaker, thus making a really excellent table model—worth £18-£20. Price 49/6, carr. and packing 5/- extra. If bought with the Beethoven chassis, the hire purchase deposit is £3, carr. 10/-.

**ELECTRONIC PRECISION EQUIPMENT, LTD.**

Post orders should be addressed to Dept. 7, RUISLIP.

Personal shoppers, however, can call at:

- 42-46, Windmill Hill, Ruislip, Middx. Phone: RUISLIP 5780 Half day, Wednesday.
- 152-3, Fleet Street, E.C.4. Phone: CENTRAL 2633 Half day, Saturday.
- 29, Strand Green Rd., Finsbury Park, N.4. Phone: ARCHWAY 1049 Half day, Thursday.
- 249, Kilburn High Road, Kilburn. (Now Open)

**UNIVERSAL SHUNTS** 1% accuracy for any 1 mA. or 500 µA meter. Only one simple adjustment to make, no calibrating meter being required. With instructions. Guaranteed one year. 8505 (1 mA.) covers 1, 5, 25, 100 and 500 mA. 851 (1 mA.) covers 2, 10, 30, 200, mA and 1 amp. Price 15/-.

Shunts for all meters with ranges to your specification. Reasonable prices. Please give meter details, ranges required and accuracy.

**D.C. MULTIMETER KIT** for 500µA meter. Complete kit of six 1% High Stability Resistors, three other resistors. Shunt S505. Potentiometer and Instructions. 26/-.

**A.C./D.C. MULTIMETER KIT**—As above, but with 4 extra 1% High Stability Resistors and Westinghouse Meter Rectifier to give 4 A.C. volts ranges. 45/6.

18-way. Single Pole. Switch. 7/-.

Westinghouse Meter Rectifiers, with 1% multipliers for four A.C. volts ranges and circuit. For 500 µA or 1 mA meter. 19/6.

**RESISTANCE BOX STANDARDS**—Twelve 0.5% Wirewound Resistors. 1, 2, 2, 5, 10, 20, 20, 50, 100, 200, 200, and 500 ohms, giving 1 to 1,110 ohms in 1 ohm steps. 30/-.

**BRIDGE RATIO ARMS**—Nominal 100 ohms. Ratio 1 to 1. Ratio accuracy 0.01% 5/8; 0.1%, 4/6; 1%, 3/6.

**PRECISION RESISTORS**—Any value 1 to 1,000 ohms, accuracy 0.5%. Eureka wound on strip, 2/9.

**CALIBRATION SERVICE FOR RESISTANCE CAPACITY BRIDGES and SIGNAL GENERATORS**—Reasonable Charges.

## MASSEY

58, Wakefield Ave., Hull.

## MORSE CODE Training

Send for the Candler  
**BOOK OF FACTS**

It gives details of all Courses which include a Special one for securing amateur licence.

**CANDLER SYSTEM CO.** Dept. 510  
52b, Abingdon Road, London, W.8.  
Candler System Co., Denver, Colorado, U.S.A.

## The OSRAM

NINE - ONE - TWO

Amplifier Instruction  
Book and Highest  
Quality Components

Available from

## COVENTRY RADIO

189, Dunstable Road,  
LUTON. Phone 2677

Price 3/6, plus 3d. postage.  
also

Our 1954-5  
Component Catalogue at 1/-

## CABINETS

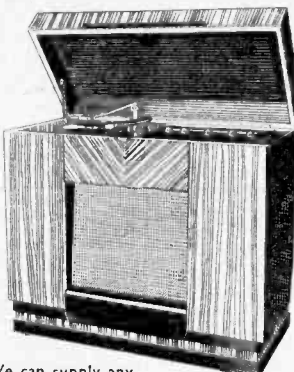

We can supply any Cabinet to **YOUR OWN SPECIFICATION**. The one illustrated can be obtained in Walnut, Oak or Mahogany for £19/15/-, or as a complete **RADIOGRAM** including a 5-valve 3-waveband superhet chassis, 3-speed autochanger and 10in. speaker for £45. (H.P. Terms can be arranged.) Send I/P. for Complete Catalogue of Cabinets, Chassis, Autochangers and Speakers. (Refunded on receipt of Order.)

## LEWIS RADIO CO.

120, GREEN LANES,  
PALMERS GREEN, LONDON, N.13.  
BOWes Park 6064

## ANNAKIN'S Great Bargain

**A HISS FILTER CHOKE** which reduces surface noise from badly worn records. Fully screened. Easily installed. A very real improvement. Limited number only. At the very special price of only 10/- each, post paid U.K. and Eire. C.W.O. only. Money Back Guarantee. Write now for free list of other bargains.

25, ASHFIELD PLACE, OTLEY, YORKS.

## SPOT FREQUENCY SIG. GEN. KIT

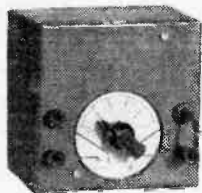

Fully screened in steel case, 4in. x 4in. x 3in. Six switched Freqs., 3 Med., 3 Long Wave. No external batteries. Easily built, 35/-. OTHER KITS. 465 Kc/s L.F. Aligner (Similar to Sig. Gen.) 445 to 485 Kc/s, 17/6. Six Range Res/Cap Bridge, 10 ohms to 5 meg. & 500pf to 50 pfd., 31/6. Audio Bridge, 50 to 16,000 cycles, 38/6; Inductance Bridge, 42/6. Multi Ohmer. 25/-. Full Instructions, P. & P. 1/6. Stamp for lists.

**RADIO MAIL,**  
4 & 6, Raleigh Street, Nottingham.

## VALVES SAME DAY SERVICE

All Guaranteed New and Boxed  
1.4v. miniatures. 1R5, 1S4 1S5, 1T4, 3S4,  
3V4, DAF9L, DF9L, DK9L, DL92, DL94, 7/3 ;  
any 4 for 27/6.

|       |       |         |       |        |      |            |
|-------|-------|---------|-------|--------|------|------------|
| 1A7GT | 6K8G  | 8/6     | 25Z4G | 9/-    | EL91 | 7/9        |
|       | 11/6  | 8K8CT   | 9/-   | 25Z6G  | 8/6  | EY61 12/-  |
| 1C3GT | 9/6   | 8K25    | 11/6  | 35L6GT | E240 | 8/6        |
|       |       | 1H5GT   | 8/6   | 6L2D   | 9/6  | EZ41 9/6   |
|       |       |         | 11/6  | 6P25   | 7/6  | FW4/500    |
| 1N5GT | 6P28  | 17/-    | 8/6   |        |      | 12/6       |
|       | 11/6  | 6Q7GT   | 9/-   | 35Z5GT | KT63 | 7/6        |
| 1R3   | 7/3   | 8SNTGT  | 8/6   | MU14   | 8/6  | 8/6        |
| 1S4   | 7/3   | 8S6L6GT | 8/6   | N78    | 11/6 | 11/6       |
| 1S5   | 7/3   | 8U4GT   | 8/6   | Pen45  | 15/- | 15/-       |
| 1T4   | 7/3   |         |       | 8/6    | PL81 | 11/6       |
| 3Q4   | 7/6   | 8V6G    | 7/6   | AZ31   | 11/6 | 9/6        |
| 3Q5GT | 8V6GT | 7/6     | D77   | 6/9    | PL83 | 12/6       |
|       | 11/6  | 8K4     | 7/6   | DAC32  | EY80 | 9/6        |
| 3S4   | 7/3   | 8X5GT   | 8/6   | 9/9    | 11/6 | 10/-       |
| 3V4   | 7/3   | 7B7     | 7/6   | DF33   | 11/6 | PY82 9/6   |
| 5U4G  | 8/6   | 7C5     | 7/6   | DH77   | 8/6  | PZ30 17/-  |
| 5Y3GT | 7/9   | 7C6     | 7/6   | DK32   | 11/6 | T41 15/-   |
| 5Z4G  | 9/-   | 7H7     | 7/6   | DK92   | 7/6  | U14 8/6    |
| 6A3T  | 10/6  | 8T7     | 7/6   | DL33   | 11/6 | U22 7/6    |
| 6A5L  | 6/9   | 7Y4     | 8/6   | DL35   | 8/6  | U24 17/6   |
| 6AM5  | 7/9   | 10C1    | 12/6  | EB91   | 6/9  | U25 12/-   |
| 6AM6  | 7/9   | 10F1    | 10/-  | EB33   | 7/6  | U50 7/9    |
| 6AT6  | 8/6   | 10LD11  | 10/-  | EB34   | 10/- | U78 8/6    |
| 6B2E  | 8/6   | 10P13   | 10/-  | EBF90  | U04  | 9/-        |
| 6B2H  | 6/6   | 10P13   | 10/-  | ECC81  | 9/6  | UBC14 10/6 |
| 6B2J  | 6/6   | 10P14   | 13/6  | ECC85  | 9/6  | UBC41 9/6  |
| 6B6W  | 7/6   | 12A8H   | 10/-  | EBF80  |      | UBF80      |
| 6B7W  | 9/6   | 12AT7   | 9/6   |        | 11/9 | 10/6       |
| 6CB6  | 8/6   | 12AU6   | 7/6   | ECH42  |      | UCH42 11/8 |
| 6C4   |       | 12AU7   |       |        |      | UF41 9/6   |
| 6C9   | 8/6   |         | 10/6  | ECL80  | 10/- | UF42 13/6  |
| 6P6G  | 7/6   | 12J7GT  |       | EF37A  | 10/- | UF43 13/6  |
| 6F12  | 7/9   |         | 10/6  | EF3A   |      | UF41 11/6  |
| 6F13  | 13/6  | 12K7GT  | 9/-   | EP39   | 17/6 | U58 18/6   |
| 6F14  | 13/6  | 12K7GT  | 9/-   | EP39   | 6/6  | U41 9/6    |
| 6F15  | 10/6  | 12K3GT  | 8/6   | EP41   | 9/6  | VP4B 12/6  |
| 6J6   | 8/6   |         | 10/6  | EP50   | 7/6  | W77 5/6    |
| 6J7GT | 7/6   | 12Q7GT  |       | EP80   | 10/- | N78 13/6   |
| 6K7G  | 8/6   |         | 9/6   | EP91   | 7/9  | Y63 7/6    |
| 6K7GT | 8/-   | 20D1    | 9/-   | EP92   | 5/6  | Z77 7/9    |

**READERS RADIO** 24, Colberg Place, Stamford Hill, London, N.16.

## TELETRON SUPER INDUCTOR COILS

Originators of Type HAX selective Xtal diode coil, as Radio unit. In Tape and quality Amplfns., 3/- ea. Dual valve TRF coils (Illustrated) matched pair, 7/-. **FERRITE ROD** Aerials, MW. 8/8; Dual valve, 12.8. E.C.O. Coils, IFT's, etc. Stamp for list and circuits. The Teletron Co. Ltd., 286, Nightingale Rd., London, N.9. H.O.W. 2527



## THE POCKET LOUDSPEAKER SET

Using our clear drawings and instructions you can build a midget loudspeaker receiver small enough to fit in the jacket pocket. This receiver is fully self-contained—no aerial, earth, or external power supply being required. The midget batteries used are of the new layer type specially produced by a famous British maker for this class of receiver. Only one single-gang midget variable condenser is used for tuning, and the receiver requires no alignment. The midget components chosen are current British production, not surplus or foreign. Instructions and Drawings, including Theoretical Circuit and Point-to-Point Wiring Diagram.

**PRICE 3/6 POST FREE**  
This offer applies only to Gt. Britain, Irish Republic and Northern Ireland.

## SWIFT RADIO

102, BATH RD., WILLSBRIDGE,  
Nr. BRISTOL  
Orders by post only.

a practicable solution. First, a perfect detector cannot be set up. A detector is basically a non-linear conductor and the voltage at which the resistance changes from a high value to a low one is not sharply defined. The characteristic shows a gradual curve, and over this range distortion is produced. Now a small input signal will never move off this curve and so the audio will be distorted before it reaches the audio amplifier, and nothing done there will restore it. For satisfactory results it is essential that the signal fed to the detector should be large, so that the detector is swung well over the curve and into the straight part of the characteristic. Not many people are so favourably placed that all the signals that they wish to listen to are so strong that they will provide a detector directly with a sufficiently large input; and so some form of R.F. amplification is inevitable. Secondly, a high degree of selectivity is required, particularly for modern conditions. This is best achieved for ordinary purposes by means of a number of tuned circuits. Other methods that may provide adequate selectivity with perhaps only one tuned circuit invariably limit the bandwidth to which the equipment will respond (as will be seen later). All the tuned circuits could be put before the detector, but gain will suffer even further and also the detector circuit itself has the effect of damping the tuned circuits at its grid and so preventing the selectivity that is being sought. There are detector circuits that aim at avoiding this damping, but they have their own problems.

We have then to face the problem of R.F. amplification, and there is, in fact, a very convenient way of preventing the ill effects of stray capacitance; that is to cancel it out with a reactance of the opposite kind. Now inductive reactance is opposite in kind to capacitive reactance, and if an inductance of reactance equal to that of the strays is added to those stray capacitive reactances there will be no residual reactance and we are left only with the resistance of the circuit. This is, of course, what tuning means. The apparent snag is that a capacitance and an inductance can have equal reactances only at one frequency; above that frequency capacitive reactance decreases and inductive reactance increases. This snag can be changed into a virtue by using an inductance smaller than would be required to cancel out the capacitive reactance, and then adding more capacitance in the form of a variable capacitor. The capacitor can then be adjusted to cancel the inductance at the frequency required at the time; in other words, the circuit can be tuned so that it will select the wanted transmission and reject those not wanted. The strays now become part of the tuning capacitance, and can have no ill effects apart from reducing the amount of capacitance required of the variable component for a given frequency.

### Tuned Circuits

It is necessary now to give some consideration to the nature of circuits combining inductance and capacitance. A circuit consisting of both inductance and capacitance is a tuned circuit; it inevitably has resistance as well for neither the metal plates of the capacitor nor the metal wire used to wind the inductance can have zero resistance. The currents flowing in the tuned circuit have to pass via the resistive paths, and so there is a power loss. The reactance of an inductance is  $2\pi fL$  and the reactance

of a capacitor is  $-\frac{1}{2\pi fC}$ , the minus sign in this case being used quite arbitrarily to indicate that capacitive reactance is exactly opposite in character to inductive reactance. The circuit has a resonant frequency, being the frequency at which the two reactances are equal numerically. The resonant frequency can thus be easily found. It is the frequency at which

$$2\pi fL = \frac{1}{2\pi fC}$$

$$\text{i.e., } 4\pi^2 f^2 LC = 1$$

$$f^2 = \frac{1}{4\pi^2 LC}$$

$$\text{and the resonant frequency } f = \frac{1}{2\pi\sqrt{LC}}$$

### Series Resonance

Now if the inductance and capacitance are considered as being in series as in Fig. 44 the reactances, being equal and opposite, will cancel out and a zero reactance is presented by the two together. There is still the resistance of the components, however, and this is shown in Fig. 44 as a separate component so that it will not be forgotten. This resistance, then, is the only opposition to the flow of current and the magnitude of the current is determined entirely by the resistance and not at all by the inductance or the capacitance. This current has to flow through the capacitance, however, and a voltage is produced across the component according to Ohm's Law; similarly, a voltage is produced across the inductance and as the current is the same in each case and as the reactances are equal the voltages generated across each component will be the same (so far as the resonant frequency is concerned and for the moment conveniently forgetting the resistance that is, in practice, integral with the components). As the reactances are of opposite sign, however, the voltages across the individual components are of opposite polarity and will cancel each other out, just as two batteries of equal voltage, if connected in series incorrectly by connecting like poles (e.g., positive to positive instead of positive to negative), will cancel each other out and give zero voltage. So the total voltage applied by the source in Fig. 44 appears across the resistance (for the time being considered as a separate component) and satisfies in the light of Ohm's Law the original stipulation that the resistance was the only effective opposition to the flow of current.

By restricting the resistance in the series tuned circuit there is no reason why quite a large current should not pass through the circuit even with a quite modest applied signal voltage; if the perfect components without resistance could be made the current would be infinity with the smallest voltage! In practice the resistance can be made so low that the resulting current flowing produces across the inductance (and also across the capacitance, each component considered separately) a voltage very much higher than that originally applied from the source and thus a voltage amplification can be obtained in the tuned circuit alone, even without any valve or other device connected to it. The degree of magnification obtained in this way depends on the ratio of reactance of either component to the resistance of the circuit. This ratio measures the "goodness" of the circuit and is called the circuit "Q." Be careful to note, however, that to make use of the



amplification of a series tuned circuit the output must be taken across only one component of the tuned circuit (either inductance or capacitance) as shown in Fig. 45.

### Parallel Tuned Circuit

A series tuned circuit obviously has a low impedance

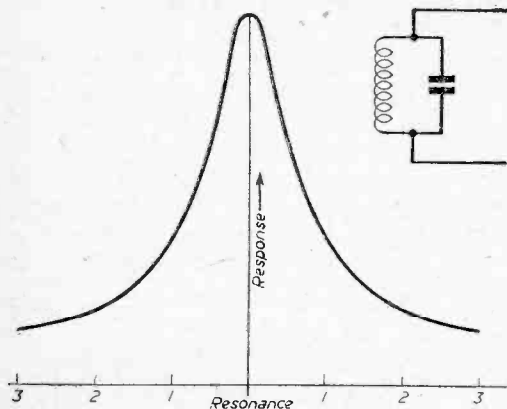

Fig. 46 (Top).—A parallel-tuned circuit. Fig. 47 (Bottom).—Resonant curve. Parallel impedance plotted against  $Q \times K$ 's off Resonance Resonant frequency.

as the resistance has been reduced to a minimum to give the best  $Q$ , and the two main reactive components cancel out, whereas we were searching

for a large impedance with which to load an amplifier, so the search has to be continued elsewhere. In the series tuned case a voltage from the signal source was seen to drive a common current through each component and it was found to produce large voltages across each component. In the parallel tuned case (Fig. 46) the signal voltage is common to (i.e., across) both inductance and capacitance and the current divides between the parallel arms. The magnitude of current flowing in each arm is determined, again using Ohm's Law, by dividing the voltage by the reactance of each arm, but as at resonance the two reactances are numerically equal the current flowing in the two arms of the parallel circuit will be equal. The reactances are of opposite sign, however, and therefore the currents will be flowing in opposite directions and so will cancel out. If the circuit could be quite without resistance, then no matter how large the signal voltage applied no current would flow into the parallel circuit (except for the initial flow to charge the capacitor) because the current at a given instant in the inductance is supplied by the current flowing in the capacitor at the same instant but in the opposite direction, and none is required from outside. Inevitably, resistance is again present and some current is taken, in fact, but only to replace that taken by the resistance and transformed into heat. Clearly again, the lower the resistance the less power will be taken from the signal source for a given voltage, and so the higher the  $Q$  of the circuit the higher is the apparent impedance of the whole circuit; it can be very much higher than the reactance of one arm of the circuit. This is the circuit of use for the present purpose, a circuit with a high impedance that can be used as a load for a valve.

(To be continued)

## ECONOMY QUALITY RECEIVER

(Continued from page 82)

far this value must be reduced. It is suggested that resistors of 6,800, 4,700 and 3,900 be tried experimentally if a reduction is considered necessary.

Another component which may need alteration is R14, which provides the negative feedback path. Naturally, the lower the value of this component the greater will be the feedback—and the lower the overall gain. Raising the value of R14 will increase the gain but reduce the amount of feedback. Again it is a matter of compromise; suggested values for R14 are 250,000 ohms, 500,000 ohms, 750,000 ohms and one megohm. If possible, use the lowest value mentioned to obtain maximum feedback.

During alignment it may be found that the receiver tends to develop self-oscillation as the I.F. transformers are brought into alignment. This is not an uncommon occurrence in superhet receivers and is generally due to long, straggling leads, poor solder connections, incorrect operating conditions or a poor physical layout and screening. Or, of course, any combination or permutation of these faults. Quite often this trouble can be cured by wiring in stopper resistors (of around 220 ohms) direct to the signal or screen grids of the I.F. amplifier. Similarly, inadequate screening of vital leads can produce the trouble through inductive coupling.

However, in the case of a reflexed amplifier, all the usual precautions may still be inadequate. Fig. 1 shows that the amplifier has individual anode circuit decoupling (R10, C17). These components may not

be necessary and, indeed, the receiver may first be tried without them. But if there is any tendency towards oscillation, the filter may help considerably to eliminate the condition.

If I.F. instability of a stubborn nature persists, check that all earth contacts are sound, that valve screening is satisfactory (earth pin 1 of the 6B8 if a metal type is used and take all earth returns to this point) and that all other factors previously mentioned are in order. Should the oscillation still persist it may be necessary to shunt the secondary of IFT-1 with a damping resistor the value of which must be chosen by experiment and may be anything from about 220,000 ohms down to 39,000 ohms. The largest possible value which will stop the oscillation should be used if selectivity and gain are not to be seriously impaired. The fitting of such a damping resistor should be looked upon as a last resort when it becomes obvious that nothing short of a complete rebuild is likely to cure the trouble! Another system is to neutralise the amplifier by connecting a very small capacitance (of only a few pF) between the anode and grid.

Lest prospective constructors feel that the building of the receiver appears to be beset with troubles, perhaps it is advisable to state that I.F. instability is likely to occur in any home-constructed superhet, and the above notes should be taken in a general way, applicable to this and most other superhets. For there *should* be no troubles of this nature with the receiver, but a combination of bad layout and wiring *could* result in instability as it can in other receivers.

Volume Controls

Midget Edison type. Long spindles. Guaranteed 1 year. All values 10,000 ohms to 2 Meg. ohms.

3- 4/-
COAX PLUGS ... 1/2
SOCKETS ... 1/-
LINE CONNECTOR 1/2
OUTLET BOXES ... 4/6

BALANCED TWIN FEEDER per yd. 8d. } 80
TWIN SCREENED FEEDER per yd. 1/- } ohms
50 OHM COAX CABLE .8d. per yd. 1/4 in. dia.

WIRE-WOOD RESISTORS.—Best Makes Minitors Ceramic Type—5 w., 15 ohm to 4 K. 1/9 ; 10 w., 20 ohm to 6 K. 2/3 ; 15 w., 30 ohm to 10 K. 2/9 ; 5 w. Vitreous, 12 K. to 25 K. 3/-.

WIRE-WOOD POTS. 3 WATT. FUMOUS MAKE Pre-Set Min. T.V. Type. Standard Size Pots. 24in. Knurled Slotted. High Grade. All Values. 10m ohms to 30 K. 3/- ca. 50 K. 4/-

WOODEN WALNUT CABINET.—12in. x 7in. x 5in. TRF or superhet. rump patched chassis, dial, back-plate, drive, pointer, etc., 28/6, plus post 2/-.

WOODEN WALNUT CABINET.—12in. x 7in. x 5in. TRF or superhet. rump patched chassis, dial, back-plate, drive, pointer, etc., 28/6, plus post 2/-.

WOODEN WALNUT CABINET.—12in. x 7in. x 5in. TRF or superhet. rump patched chassis, dial, back-plate, drive, pointer, etc., 28/6, plus post 2/-.

WOODEN WALNUT CABINET.—12in. x 7in. x 5in. TRF or superhet. rump patched chassis, dial, back-plate, drive, pointer, etc., 28/6, plus post 2/-.

80 ohm COAX

STANDARD 1/4 in. diam. Polythene insulated. GRADE "A" ONLY

8d. yd. SPECIAL.—Semi-air spaced polythene. 80 ohm Coax 1/4 in. diam. Stranded core. Josses cut 50% (just released) 9d. yd.

WIRE-WOOD RESISTORS.—Best Makes Minitors Ceramic Type—5 w., 15 ohm to 4 K. 1/9 ; 10 w., 20 ohm to 6 K. 2/3 ; 15 w., 30 ohm to 10 K. 2/9 ; 5 w. Vitreous, 12 K. to 25 K. 3/-.

WIRE-WOOD POTS. 3 WATT. FUMOUS MAKE Pre-Set Min. T.V. Type. Standard Size Pots. 24in. Knurled Slotted. High Grade. All Values. 10m ohms to 30 K. 3/- ca. 50 K. 4/-

WOODEN WALNUT CABINET.—12in. x 7in. x 5in. TRF or superhet. rump patched chassis, dial, back-plate, drive, pointer, etc., 28/6, plus post 2/-.

WOODEN WALNUT CABINET.—12in. x 7in. x 5in. TRF or superhet. rump patched chassis, dial, back-plate, drive, pointer, etc., 28/6, plus post 2/-.

WOODEN WALNUT CABINET.—12in. x 7in. x 5in. TRF or superhet. rump patched chassis, dial, back-plate, drive, pointer, etc., 28/6, plus post 2/-.

WOODEN WALNUT CABINET.—12in. x 7in. x 5in. TRF or superhet. rump patched chassis, dial, back-plate, drive, pointer, etc., 28/6, plus post 2/-.

WOODEN WALNUT CABINET.—12in. x 7in. x 5in. TRF or superhet. rump patched chassis, dial, back-plate, drive, pointer, etc., 28/6, plus post 2/-.

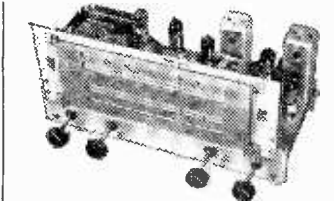

ALL WAVE RADIOGRAM CHASSIS THREE WAVEBANDS FIVE VALVES S.W. 16 m.—50 m. LATEST OSRAM Brand. 200 m.—550 m. X79, W77, DH77, L.W. 800 m.—1,600 m. B78, V78, M78

BARGAIN OFFERS RECOMMENDED FOR ABOVE CHASSIS GREAT REDUCTIONS

Brand New Plessey 3-speed Autochanger Mixer Unit for 7, 10 and 12in. Records. Twin Hi-Fi Xial Box with Dupont sapphire stylus. Plays 4,000 records. Spring mounting. Superb Quality. Bargain Price 8/ gas. post free.

Table with columns: NEW BOXED, VALVES, ALL GUARANTEED. Lists various valve types and their prices.

SUB MINIATURE VALVES WIRE ENDS

Table listing sub-miniature valves with wire ends, including types like XFW 10, XFW 20, 507 AX, 1F66, 1F70 and their prices.

VCR97 £2 TESTED FULL PICTURE

CRYSTAL DIODE.—Very sensitive. (G.E.C.) 3/6. H.R. PHONES.—(Hi-grade Amer.) 15/6 per S. G. BROWN'S, 4,000 ohms, 15/6 pr.

T.R.S. RADIO COMPONENT SPECIALISTS

370 1665, Whites 68 and 133 pass door. 370, WHITEHOUSE RD., WEST open all day CROYDON, SURREY. SATURDAY 10 to 5.45. £1 orders post free. Lists 3d. ALL MAINS TRANS.—1/- extra postage.

PYE Aerial Plug and Socket, 1/6 pr. 5in. RADIO SCREWDRIVERS.—Sheffield made blade, 2 1/2 in. x 1 in. Ins. handle, 5,000 v., 4jd. each

CONDENSERS.—New Stock .001 mfd. 6 kV. T.A.C. 5/6. Ditto, 12.5 kV. 9/6 ; 2 pf. to 500 pf. Mica, 6d. x .001, Mica or Tub. T.A.C. 500 v., .01 Mica, 500 v., .02 N.S.P. 300 v., 1 mfd. 500 v., Micromol Tub., 9d. ; Hunts Molbsol 500 v., .005, .01 mfd., 9d. ; .05 mfd. and 1 mfd., 1/- .25 mfd., 1/8 ; 1 mfd., 600 v., 1/3 ; Tubular .5 mfd. 350 v., 1/9.

SILVER MICA CONDENSERS.—10%. 5 pf. to 500 pf., 1/- ; 500 pf. to 3,000 pf., 1/3. DITTO 1% (ex stock). 1.5 pf. to 500 pf., 1/8. 515 pf. to 1,000 pf., 2/-.

ELECTROLYTICS ALL TYPES NEW STOCK. Tubular Wire ends 50/25 v. Plessey 1/9 16+16/500 v. Dublier 5/6 50/50 v. Plessey 2/-

COLLS.—Wearite "P" type, 2/6 each. Osmer 4/6. Type with dust cover, 3/6 each. All ranges. REACTION CON.—.0001, .0003, .0005 mfd., 3/6 each.

ALUMINIUM CHASSIS.—18 s.w.g. Plain, anodized, folded 4 sides and riveted corners lattice fixing holes. Strong and soundly constructed with 2 1/2 in. sides x 4 in., 5/6 ; 1 1/2 in. x 7 in., 6/9 ; 1 3/4 in. x 6 in., 8/0 ; 1 1/2 in. x 11 in., 10/6 ; and 1 1/2 in. x 3 in., 11/6.

CHARGER TRANS. PRIM.—0-200/250 v. at .25, .5, 1.5 v. (for charging 6 v. and 12 v.) 1.5A, 13/6 ; 2A, 16/6 ; 3A, 18/6 ; 4A, 21/6 ; 6A, 28/6.

SWITCH CLEANER FLUID, squirt sprout, 3/9 tin. TWIN GANG TUNING CONDENSERS.—.0005 mfd. midget with trimmers, 8/6 ; 375 pf. midget less trimmers, 6/6 ; .0005 Stankard size with trimmers and 1000 v. 9/- ; less trimmers, 8/- ; ditto, solid, 2/6.

LOUDSPEAKERS P.M., 3 OHM. 3in. Plessey, 12/6. Goodmans 4in. square, 15/6 3in. 14/6. 6in. 16/-. 7in. Elliptical 18/6. 8in. R. & A. 17/6. 10in. Plessey, 25/-. 6in. with trans, 7,000 ohms to 3, 19/6.

I.F. TRANSFORMERS

465 Kc/s Sing tuning Miniature Circular Can, 2 1/2 in. by 1 1/2 in. diameter. Fly-leader holder cut out. High impedance bandwidth. By Eye Radio. Two mounting sets. BRAND NEW, 6/9 PAIR

# FIRST-CLASS RADIO COURSES . .

**GET A CERTIFICATE!**

**QUALIFY AT HOME—IN SPARE TIME**

After brief, intensely interesting study—undertaken at home in your spare time—**YOU** can secure your professional qualification. Prepare for **YOUR** share in the post-war boom in Radio. Let us show you how!

**— FREE GUIDE —**

The New Free Guide contains 132 pages of information of the greatest importance to those seeking such success-compelling qualifications as **A.M.Brit.I.R.E., City and Guilds Final Radio, P.M.G. Radio Amateurs, Exams., Gen. Cert. of Educ., London B.Sc. (Eng.), A.M.I.P.E., A.M.I.Mech.E., Draughtsmanship (all branches),** etc., together with particulars of our remarkable Guarantee of

**SUCCESS OR NO FEE**

Write now for your copy of this invaluable publication. It may well prove to be the turning point in your career.

**FOUNDED 1885—OVER 150,000 SUCCESSES**

**NATIONAL INSTITUTE OF ENGINEERING**  
(Dept. 461), 148, HOLBORN, LONDON, E.C.1

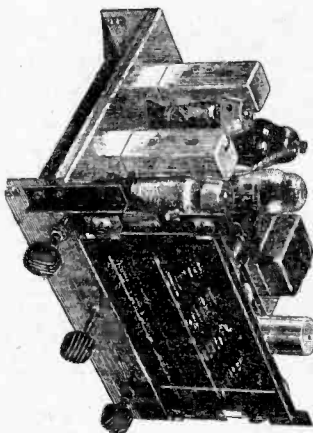

**RODING LABORATORIES** (Dept. C3) BOURNEMOUTH, AIRPORT, CHRISTCHURCH, HANTS.

**THE COPPERNET FOUR**  
This outstanding receiver designed by "Practical Wireless" around our "R130 Tuning Unit is only one of the many Receivers, Feeders, Amplifiers and Test Gear fully described together with blueprint circuits and complete parts lists in the famous  
**RODING HOME CONSTRUCTOR'S HANDBOOK**  
+ Also obtainable from leading booksellers and component stockists

**YOU** can build these outfits so send 2/6d. NOW and receive the finest value the radio enthusiast can get to-day. Beautifully printed on finest glossy art paper it also contains Set Building and Servicing Hints, Facts and Formulae, Resistance Colour Code, Symbols, etc., AND our current Catalogue. **SO DON'T DELAY—SEND TO-DAY!** \*REMEMBER! These Tuning Units are pre-aligned and sealed for maximum efficiency—no test gear being required by the Constructor. All components, chassis and cabinet are available from us at reasonable prices and are fully identified. **FREE "A.B.C."** Construction Sheets available (see Handbook for details).

Just Published

## RADIO AND TELEVISION ENGINEERS' REFERENCE BOOK

Edited by E. Molloy and W. E. Pannett.  
Broadcasting · Communications · Navigation · Servicing, etc. 36 specialist contributors. Over 1,600 pages. Over 1,860 diagrams. Post Free.

Practical TV Aerial Manual for Bands I and III, by R. Laidlaw. 4s. 6d., postage 4d.

Practical Wireless Encyclopaedia, NEW 13th EDN., by F. J. Camm. 21s., postage 9d.

Electronic Measuring Instruments, by E. H. W. Banner. 45s., postage 1s.

Handbook of Line Communication, Vol. 1, by The Royal Signals. 30s., postage 1s.

Radio Control of Models, by G. Sommerhoff. 5s., postage 3d.

Radio Valve Data, 4th edn., compiled by "Wireless World." 3s. 6d., postage 3d.

Please write or call for our Catalogue.

**THE MODERN BOOK CO.,**

BRITAIN'S LARGEST STOCKISTS OF BRITISH & AMERICAN TECHNICAL BOOKS

19-23 PRAED STREET, (Dept. W.1.), LONDON, W.2.

\*Phone: PADdington 4185. Open all day Saturday.

## BETTER BARGAINS

BRAND NEW. ORIGINAL CARTONS. R.F. UNITS. TYPES 26 or 27, 27/6, 24, 15/- (Postage 2/6).

**CONDENSERS.** Variable min. spindle 15, 25, 50, 75 p.f.s. 1/3. **DYNA-VICTORS, D.C.** approx. 250 v. 80 mA. (6 v.). 8/6. Filters for these, 2/6. **I.F.T.'s**, new, canned, 10/13 Mc's. 1/6. **POWER UNIT 285.** 230 v. 50 c. input. Outputs D.C. 2 kv 5 mA, 350 v. 150 mA. A.C. 8.3 v. 15 a. 3 valves. No test gear, paid inland. **TRANSFORMERS**, new, std. mains input: 250-0-250 v. 70 mA, tapped 203 v., 6.3 v. 3 a., 4 v. 2 a., 10/6. 600 v. H.W., 6.3 v. 3 a., 4 v. 2 a., 10/6. 230 v. to 6.3 v. 5 a. and 10 a., 17/6. 2 kv 5 mA, 2 v. 2 a., 22/6. 350-0-350 v. 150 mA, 5 v. 3 a., 25/-, 55 v. 30 mA (twice), 6.3 v. 3.2 a., 9/-, 250 v. H.W., 30 mA, 6.3 v. 1.5 a., 8/6. 190 v. 8 mA., 6.3 v. 1.5 a., 8/6. 740-0-740 v. 165 VA. 470-0-470 v. 220 VA., 4 v. 8 a., C.T. (twice), 30/- (carr. 5/-). 350-0-350 v. 120 mA, 6.3 v. 4 a., 4 v. 2 a., 16/- (postage 2/- each).

**POTENTIOMETERS**, carbon, 10/6 doz. asstd. **R1115** Coilpacks, new, 12/6; used, 9/6; twin-knob S.M. drives, 7/6; **I.F. Filters**, 2/6. **METAL RES.**, H.W., 270 v. 80 mA, 6/-; 240 v. 30 mA, 4/-; 480 v. 80 mA, 6/6; 600 v. 30 mA, 6/-; 200 v. 150 mA, 8/-; 12 v. 1 a., C.T., 1/6. **RECORD PLAYERS**, brand new, xtal. P.U. (famous maker), 331/78 r.p.m., 79/6. **CRYSTALS**, 100 kc/s 2-pin. English, 15/-; **RELAYS**, Siemens H.S., 1/1. **1 K coils**, 10/6. **HEADPHONES**, new 3 k, 11/6; **I.F. CHOKES**, 15 H 200 mA, 4/6; 9 H 100 mA, 7/6; 8 H 80 mA, 4/6. **VALVE BARGAINS**, at 2/-: **VR55A**, VR56, 7193, VR54, 4D1, 991, VR7B, VR92, 8D2, RK34, 954, CV54, at 4/-: EF50, EF54, EC52, 6AG5, 6C4, 9001, VR116, KT241, 2C26, MS/Pen, MH41, 12SHT, at 5/-: 12SK7, ARP12, 6SH7, NGT1, CV68, T711, 6J5G, EF36, 6AC7, 6AB7, 6C6, 12SC7.

Callers: and Post: **W. A. BENSON (FW),** 308, Rathbone Road, Liverpool 13. **Callers only: SUFFIELD LTD. (W.Chapel),** 116 Whitechapel, Liverpool 1. **ROY 1130**

## COPPER WIRE

| S.W.G. | COTTON COVERED |        | SILK COVERED |        |
|--------|----------------|--------|--------------|--------|
|        | 2 ozs.         | 4 ozs. | 2 ozs.       | 4 ozs. |
| 16     | 1/4            | 2/-    | 1/4          | 2/-    |
| 17     | 1/4            | 2/1    | 1/4          | 2/1    |
| 18     | 1/4            | 2/2    | 1/4          | 2/2    |
| 19     | 1/5            | 2/3    | 1/6          | 2/5    |
| 20     | 1/5            | 2/4    | 1/7          | 2/8    |
| 21     | 1/5            | 2/5    | 1/8          | 2/10   |
| 22     | 1/6            | 2/6    | 1/9          | 3/-    |
| 23     | 1/7            | 2/7    | 1/10         | 3/2    |
| 24     | 1/7            | 2/8    | 1/10         | 3/2    |
| 25     | 1/8            | 2/9    | 1/11         | 3/4    |
| 26     | 1/9            | 2/11   | 2/-          | 3/6    |
| 27     | 1/9            | 3/1    | 2/1          | 3/8    |
| 28     | 1/10           | 3/2    | 2/2          | 3/10   |
| 29     | 1/11           | 3/4    | 2/3          | 4/-    |
| 30     | 2/-            | 3/6    | 2/4          | 4/2    |
| 31     | 2/1            | 3/7    | 2/5          | 4/4    |
| 32     | 2/1            | 3/8    | 2/7          | 4/8    |
| 33     | 2/3            | 3/11   | 2/10         | 5/2    |
| 34     | 2/4            | 4/2    | 2/11         | 5/4    |
| 35     | 2/4            | 4/2    | 3/1          | 5/8    |
| 36     | 2/6            | 4/8    | 3/1          | 6/4    |
| 37     | 3/-            | 5/6    | 3/5          | 6/4    |
| 38     | 3/4            | 6/2    | 3/7          | 6/8    |
| 39     | —              | —      | 3/10         | 7/2    |
| 40     | 4/6            | 8/-    | 4/1          | 7/8    |

POSTAGE EXTRA. POST ORDERS ONLY PLEASE. Send stamp for comprehensive lists.

**CRYSTAL SET** INCORPORATING THE SILICON **CRYSTAL VALVE** Adjustable Iron Cored Coil. **RECEPTION GUARANTEED** Polished wood cabinet, 15/-, post 1/- **A REAL CRYSTAL SET, NOT A TOY** **POST RADIO SUPPLIES** 33 Bourne Gardens, London, E.4

# Oscillatory Circuits

AN EXPLANATION OF THE WORKING OF THE VALVE AS AN OSCILLATOR

By E. E. Apps

(Continued from page 50 January issue)

**R**EFERRING back to the simple feedback oscillator as described in Part I, it is of interest to note that this type of oscillatory circuit is the basis of the reaction receiver as originally used. The feedback of negative-resistance or energy tended to neutralise the damping of the positive resistance of the circuit, and thus the circuit amplified up to a point where oscillations were set up.

### The Reinartz Circuit (Fig. 1)

This was a circuit that had one coil only for aerial and grid reaction circuits. The aerial and grid tapplings should be noted. The reaction is applied by means of a variable condenser connected between anode and the bottom end of the coil. This circuit was, a few years ago, a favourite with short-wave enthusiasts, and gave very good reception if care was taken with the setting of the reaction condenser.

### Power from the Oscillatory Circuit

In transmitters and radio-frequency heating apparatus it is desirous to draw large amounts of power from the oscillatory circuit (Fig 2). Here the total current flowing through the valve is made up of  $I_0$  plus an oscillating component whose instantaneous value is represented by  $i_0$ . The current in the coil  $L$  is also composed of  $I_0 + i_L$ . The current in the capacity  $C$  consists only of an oscillating component whose instantaneous value is  $i_c$ . When the circuit is self-oscillating, the peak value of the oscillatory anode current is limited by the magnitude of  $I_0$ . The oscillatory anode-filament PD is similarly limited by the H.T. voltage. Thus, it will be seen, that the larger the value of the mean anode-current and the D.C. voltage applied to the anode, the larger will be the power in the oscillatory circuit.

### The Meissner Oscillator (Fig. 3)

This circuit, as will be seen from diagram, has no conductive coupling. The oscillatory circuit is coupled inductively to both grid and anode coils. Where it is inadvisable to tap the coils, this circuit is advantageous.

### Resistance-coupled Oscillator (Fig. 4)

This uncommon type of oscillator makes use of a resistance, as a coupling between anode and grid circuits. When the two circuits are tuned so that  $L_1 C_1 = L_2 C_2$ , the E.M.F. generated by the valve, the potential across the anode circuit, and the potential across the coupling resistance, are all nearly in phase, and the phase of the potential applied to the grid differs by 180 deg. from that of the E.M.F. generated

in the valve. Thus conditions for oscillation are set up and, in this case, frequency stability is high.

### Relaxation Oscillators (Fig. 5)

In a circuit in which the frequency is governed by the capacitance and resistance, and there is a swing from one state of quasi-equilibrium to another, the name of relaxation oscillator is given. As there is no inductance in the circuit, the type of oscillation produced differs considerably from a tuned circuit oscillator. The wave-form is generally non-sinusoidal, and there are harmonics of considerable amplitude. The frequency generated can be varied by the capacitance or resistance, between very wide limits. Fundamental frequencies can be as high as 1 Mc/s or as low as 1 cycle per minute. Fig. 5 shows a simple type of glow discharge oscillator. When a D.C. voltage of a magnitude greater than the striking voltage of the tube is applied, current will flow through  $R$  and the voltage across  $C$  will rise until the striking voltage is reached. The current through  $R$  then increases rapidly and the condenser discharges until the potential across it equals the extinction voltage of the tube. The condenser is now charged again until the striking voltage is again reached. The period of the tube flashes can be varied by adjustment of  $R$  and  $C$ . When  $C$  is large, flashes at a very low rate can be produced. The amplitude is comparatively small, but can be increased by a circuit tuned to the operating frequency inserted in the resistance arm.

### Multivibrator Oscillator

This is a relaxation oscillator of a much better type. It is essentially a two-stage resistance-coupled amplifier, in which the voltage developed by the output of  $V_2$  is applied to the input of  $V_1$ . As each valve produces a phase shift of 180 deg., thus causing the output of  $V_2$  to supply to  $V_1$  an

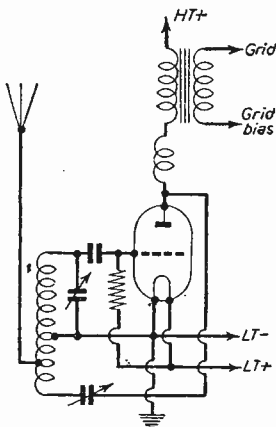

Fig. 1—The Reinartz circuit.

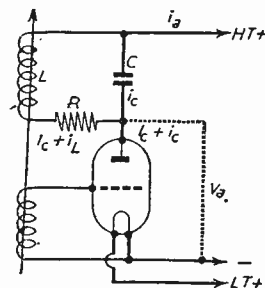

Fig. 2.—Tuned-anode oscillator showing current flowing in different parts of the circuit.

input voltage of the correct phase relationship, oscillations can be maintained.

**Action of Multivibrator**

If a minute voltage of a positive potential appears at the grid of V1, this voltage is amplified by both

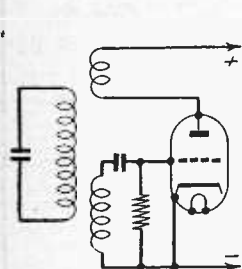

Fig. 3.—Meissner oscillator.

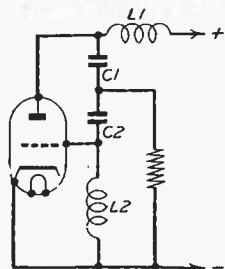

Fig. 4.—Resistance-coupled oscillator.

valves and reappears at the same point. This action continues very rapidly, so that the grid potential of V1 rises whilst the grid potential of V2 falls. A point is reached when the anode current of V2 is reduced to zero by the falling grid potential, and the anode current of V1 is large. However, the leakage through the grid circuit resistances gradually restores the grid potentials to normal. When this leakage reaches a point when anode current commences in V2 the process is repeated in the reverse direction. The frequency is determined by the grid resistance R and the grid capacitance C1, and is given

approximately by  $f = \frac{1}{(C_1 + C_2)R}$  if all four resistances are equal to R. Fig.

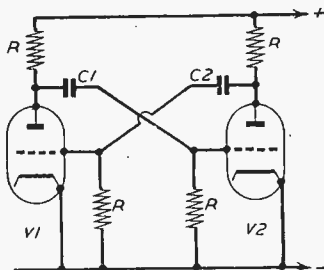
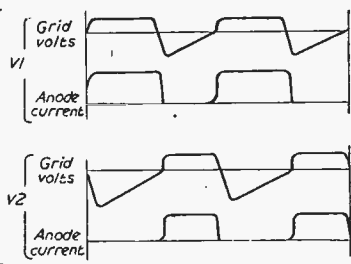

Fig. 6.—Simple multivibrator and current and voltage curves.



6(A) shows that the wave-form of the current in the anode circuits is rich in harmonics, so that, if a standard frequency of known value is used to control the frequency of the multivibrator, it is possible to obtain a large number of frequencies all related to the known frequency. It can be thus seen that the multivibrator is a useful means of

generating known frequencies for measuring purposes. If, for instance, a standard tuning-fork of a frequency of 1 kc/s were employed to generate a standard frequency, it would be possible to use the harmonics generated either directly or with a

higher frequency vibrator synchronised by a harmonic of the 1 kc/s.

The frequency at which this circuit oscillates is governed, of course, by the values of C and R, and it may be changed by changing the values of these. This forms a very convenient way of making a variable-frequency oscillator, and will be familiar to many, of course, in the television field, being used for timebase operation.

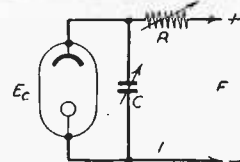

Fig. 5.—Glow discharge oscillator.

**A VALVE VOLTMETER** (Cont. from page 98) are terminated in one end). Having earth end pushed by spring  $\frac{3}{16}$  in. out, it gives extra length when it is not easy to reach with the top terminal.

**1,000 Volts A.C. Probe (Fig. 5)**

This probe was built for 500 volts and 1,000 volts A.C. It is important to note that it is not suitable for high frequencies.

The probe is made of bakelite tube of 1 in. dia. inside, 1/16 in. thick, 4 in. long; the covers are of ebonite, the terminal socket of polystyrene. It is much safer than a metal probe. All connections are insulated with plastic sleeving and the joints are brushed over with polystyrene cement. The three outgoing wires are all plastic covered and two of them must be capable of carrying 1,000 volts D.C. Also, condenser must be at least 1,200 volts D.C. if it is to be used for A.C. 1,000 volts. When dealing with mains voltage always make sure that the earth potential is connected first.

As you can see from the photograph, the segment below the volts scale is left uncalibrated. In my own case, I shall calibrate it to read decibels. The ohms range can be added in the form of external adaptor which would consist of switch. H.S. resistors. 1½-volt

battery, four terminals as in Fig. 6. It will read 0-100 ohms to 100 megs. Resistors on the switch can be connected in series or parallel. The meter will read from left to right so that the highest unknown value will be near the full deflection end. Only slight modification will be necessary on the valve voltmeter. One more contact must be added to the D.C. wafer. This contact is connected to the negative terminal. It will then give full deflection of the voltmeter with 1 volt only. If you use the 5-volt position on D.C. you will need 5 volts for full deflection, and the adaptor unit will have to be much bigger to take 5½ volt cells.

To save the cost of two filament resistors, the L.T. transformer can be dismantled and about six turns taken off to drop the voltage to about 6 volts on no load. Reduced F voltage gives greater stability, but if reduced too much, it will take too long to warm up.

When calibrating the instrument, start with D.C. side, check on all ranges, adjust calibrating control in such a way that error on all ranges will be no more than 2 per cent. When calibrating, always check zero set. With the A.C. range, proceed as with D.C. and the result should be as good as with D.C. Always allow about two to five minutes to warm up.

**R.S.C. A4 HI-FIDELITY 25 WATT AMPLIFIER**

A new design for 1955. "Push-Pull" output. "Built-in" Tone Control Pre-amp. stages. Increased sensitivity. Even further improved performance figures. Includes 7 valves, specially designed sectionally wound output transformer, block paper reservoir condenser and reliable small condensers of current manufacture. TWO SEPARATE INPUTS CONTROLLED BY SEPARATE VOLUME CONTROLS allow simultaneous use of "Mike" and Gram., or Tape and Radio, etc. etc. INDIVIDUAL CONTROLS FOR BASS AND TREBLE "Lift" and "Cut." Frequency response 3 db. 30-30,000 c/c. Six negative feedback loops. Hum level 68 db. down. ONLY 20 millivolts INPUT required for FULL OUTPUT. Certified harmonic distortion only 0.35% measured at 10 watts. Comparable with the very best designs.

ENTIRELY SUITABLE FOR SMALL HOMES OR LARGE HALLS, CLUBS, GARDEN PARTIES, DANCE HALLS, etc.



etc. For ELECTRONIC ORGAN or GUITAR. For STANDARD or LONG-PLAYING RECORDS. FOR ANY "MIKE" or PICK-UP. **9 GNS.**

**H.M.V. LONG PLAYING RECORD TURNTABLE WITH CRYSTAL PICK-UP** (Sapphire Stylus). Speed 33 1/3 r.p.m. For A.C. mains 200-250 v. Limited supply. Brand New Cartoned. Perfect. Only £3/19/6. Plus carr. 5/- (Normal price £3 approx.)

**BATTERY SET CONVERTER KIT.** All parts for converting any type of Battery receiver to All Mains. A.C. 200-250 v. 50 c/c. Kit will supply fully smoothed H.T. of 120 v., 90 v. or 60 v. at up to 40 mA, and fully smoothed L.T. of 2 v. at 0.4 to 1 a. Price, complete with circuit, wiring diagrams and instructions, only 4/9. Or ready to use, 8/9 extra.

**PERSONAL SET BATTERY SUPERSEDER KIT.** A complete set of parts for construction of a Unit (housed in metal case) to replace Batteries where A.C. Mains supply is available. Input 200-250 v. 50 c/c. Outputs 90 v. 10 mA, and 1.4 v. 250 mA. Fully smoothed. For 4-valve receivers. Price complete with circuit. Only 3/9. Or ready to use, 4/6. Size of unit, 5 1/4 x 4 1/4 in.

**BATTERY CHARGER KITS**  
For mains 200-250 v. 50 c/c.  
To charge 6 v. acc. at 2 a., 25/6.  
To charge 6 or 12 v. acc. at 2 a., 31/6.  
To charge 6 or 12 v. acc. at 4 a., 49/9.  
Above consist of transformer, full wave rectifier, fuses, resistors and steel can. Any type assembled and tested, 6/9 extra.

**THE SKY CHIEF T.R.F. RECEIVER.** A design of a 4-stage, 3-valve 200-250 v. A.C. Mains receiver with selenium rectifier. It consists of a variable Mu high gain H.F. stage followed by a low distortion grid detector triode. The next stage is a further triode amplifier with tone correction by negative feedback. Finally comes the output stage consisting of a parallel connected double triode giving ample output at an extraordinarily low level of distortion. Point to point wiring diagrams, instructions, and parts list, 2/6. This receiver can be built for a maximum of £4/19/6 including attractive Brown or Cream Bakelite or Walnut veneered wood cabinet 12 x 6 1/2 x 5 1/2 in.

**ELECTROLYTICS** (Current production. Not ex-Gov.L).

| Tubular Types | 8uF 500 v. | 2/6              |      |
|---------------|------------|------------------|------|
| 8uF 350 v.    | 1/9        | 16uF 450 v.      | 2/9  |
| 8uF 450 v.    | 1/11       | 24uF 350 v.      | 2/11 |
| 8uF 500 v.    | 2/11       | 32uF 350 v.      | 2/11 |
| 16uF 350 v.   | 2/3        | 32 mfd. 450 v.   | 4/9  |
| 16uF 450 v.   | 2/9        | 40uF 450 v.      | 4/11 |
| 24uF 350 v.   | 3/6        | 64uF 450 v.      | 3/9  |
| 32uF 350 v.   | 3/6        | 8uF 350 v.       | 3/9  |
| 8uF 25 v.     | 1/3        | 8uF 450 v.       | 3/9  |
| 50uF 12 v.    | 1/3        | 8-16 mfd. 450 v. | 2/11 |
| 50uF 50 v.    | 2/3        | 8-16uF 450 v.    | 3/11 |
| Can Types     |            |                  |      |
| 8 mfd. 350 v. | 1/3        | 16-32uF 50 v.    | 5/3  |
| 8uF 450 v.    | 2/3        | 32-32uF 450 v.   | 5/11 |

Terms: C.W.O. or C.O.D. NO C.O.D. under £1. Post 1/- extra under 10/- 1/6 extra under £1. 2/- extra under £3. Open 9 to 5.30; Sats. until 1 p.m. List 6d. Trade List 5d. S.A.E. with all enquiries.

**RADIO SUPPLY CO. 32, THE CALLS, LEEDS, 2**

Size approx. 12-9 7/16 in. For A.C. mains 200-230-250v. 50 c/c. Outputs for 3- and 16-ohm speakers. Kit is complete to last run. Chassis is fully punched. Full instructions and point-to-point wiring diagrams supplied. Unapproachable value at 9 Gns., or ready to use, 50/- extra. If required, however as illustrated can be supplied for 17/6. H.P. TERMS AVAILABLE.

**R.S.C. 10 WATT "PUSH-PULL" HIGH-FIDELITY AMPLIFIER A3**

Complete with integral Pre-amp. Tone control stage (as A4 amplifier), using negative feedback, giving humproof individual bass and treble lift and cut tone control. SIX Negative Feedback Loops. Completely negligible hum and distortion. Frequency response +3 db. 30-20,000 c.p.s. Two independently controlled inputs. Six B.V.A. valves. A.C. mains 200-230-250 v. input only. Outputs for 3 or 15 ohm speakers. Kit of parts complete in every detail. £7/19/6. plus 5/- carriage or ready for use, 45/- extra. Illustrated leaflet, 5s.

**FOUR STAGE RADIO FEEDER UNIT.** Design of a High Fidelity Tuner Unit. L. & M. Wave. Full decoupling. Metal-contained heater supply. Detailed wiring diagrams, parts list, and illustration, 2/6. Total building cost, £3/15/-.

**COAXIAL CABLE, 75 ohms, 1 in., 7d. Yard.** Twin Screen Feeder, 8d. Yard. M.E. SPEAKERS, All 2 ohms, 8in. R.A. Field 600 ohms, 12/9. 10in. R.A. Field 1,000 or 1,500 ohms, 23/9.

**VOLUME CONTROLS** with long (In.) spindles, all valves, less switch, 2/9, with S.P. switch, 3/9. D.P. sw. 4/6.

| SELENIUM RECTIFIERS   |                   |      |
|-----------------------|-------------------|------|
| L.T. Types            |                   |      |
| 2/6 v. 1 a. H.W. 1/9  | 6/12 v. 6 a.      | 19/9 |
| 6/12 v. 1 a. H.W. 2/9 | 6/12 v. 10 a.     | 35/- |
| F.W. Bridge Type      | 24 v. 10 a.       | 59/6 |
| 6/12 v. 1 a.          | 12 T. Types H.V.  |      |
| 6/12 v. 1.5 a.        | 150 v. 40 mA      | 3/9  |
| 6/12 v. 2 a.          | 250 v. 50 mA      | 5/9  |
| 6/12 v. 3 a.          | 250 v. 80 mA      | 7/9  |
| 6/12 v. 4 a.          | RM4 250 v. 250 mA | 11/9 |

**A PUSH-PULL 3-4 watt HIGH-GAIN AMPLIFIER FOR £2/19/6.** For mains input 200-250 v. 50 c/c. Complete kit of parts including circuit, point to point wiring diagram, and instructions. Amplifier can be used with any type of Feeder Unit, or Pick-up. This is not A.C./D.C. only 400-400 v. trans. (Output is for 2-3 ohm speaker.) Supplied ready for use for 25/- extra. Carr. 2/6. Descriptive leaflet, 7d.

**P.M. SPEAKERS.** All 2-3 ohms, 6in. Plessey 16/9. 8in. Plessey 15/9. 10in. Plessey 18/6. 10in. R.A. 26/9. 10in. Rola with trans. 29/6. 10in. W.B. "Stentorian" 3 or 15 ohm type HF1012 10 watts. Highly recommended for use with any of our amplifiers, £3/13/6.

**PLESSEY 3-SPEED MIXER AUTO-CHANGERS.** With crystal pick-up. Duo point alloy stylus (switched) for standard or long playing records for Mains 200-250 v. 50 c/c. Brand New £10/10/- Carr. 5/-.

**MICROPHONES.** Crystal type, good quality. Recommended for use with our amplifiers. Hand type, 59/6; Stand type, with adjustable stand, £6/19/6.

**FULLY SHROUDED UPRIGHT**  
250-0-250 v. 60 mA, 6.3 v. 2 a, 5 v. 2 a, ... 12/11  
280-0-280 v. 70 mA, 6.3 v. 2 a, 5 v. 2 a, ... 14/11  
350-0-350 v. 80 mA, 6.3 v. 2 a, 5 v. 2 a, ... 17/9  
275-0-275 v. 80 mA, 6.3 v. 2 a, 4 v. 2.5 a ... 14/11  
250-0-250 v. 100 mA, 6.3 v. 4 a, 5 v. 3 a ... 21/9  
300-0-300 v. 100 mA, 6.3 v. 4 a, 5 v. 3 a ... 21/9  
350-0-350 v. 100 mA, 6.3 v. 4 a, 5 v. 3 a ... 21/9  
350-0-350 v. 100 mA, 6.3 v. 4 a C.T., 0-4-5 v. 3 a ... 22/9  
350-0-350 v. 150 mA, 6.3 v. 4 a, 5 v. 3 a ... 27/9  
350-0-350 v. 150 mA, 6.3 v. 2 a, 6.3 v. 2 a 5 v. 3 a ... 29/11

| FULLY SHROUDED DROPTHROUGH                            |     |       |
|---|-----|-------|
| 250-0-250 v. 70 mA, 6.3 v. 2.5 a.                     | ... | 12/11 |
| 280-0-280 v. 70 mA, 6.3 v. 2 a, 5 v. 2 a.             | ... | 14/11 |
| 350-0-350 v. 80 mA, 6.3 v. 2 a, 5 v. 2 a.             | ... | 17/9  |
| 275-0-275 v. 80 mA, 6.3 v. 2 a, 4 v. 2.5 a.           | ... | 14/11 |
| 250-0-250 v. 100 mA, 6.3 v. 4 a, 5 v. 3 a.            | ... | 21/9  |
| 300-0-300 v. 100 mA, 6.3 v. 4 a, 5 v. 3 a.            | ... | 21/9  |
| 350-0-350 v. 100 mA, 6.3 v. 4 a, 5 v. 3 a.            | ... | 21/9  |
| 350-0-350 v. 100 mA, 6.3 v. 4 a C.T., 0-4-5 v. 3 a.   | ... | 22/9  |
| 350-0-350 v. 150 mA, 6.3 v. 4 a, 5 v. 3 a.            | ... | 27/9  |
| 350-0-350 v. 150 mA, 6.3 v. 2 a, 6.3 v. 2 a 5 v. 3 a. | ... | 29/11 |

**ELIMINATOR TRANSFORMERS**  
Primaries 200-250 v. 50 c/c. 120 v. 40 mA 7/9  
130 v. 50 mA, 6 v. 3 a ... 14/9

**R.S.C. MAINS TRANSFORMERS (FULLY GUARANTEED)**  
Interleaved and impregnated. Primaries 200-230-250 v. 50 c/c Screened  
**TOP SHROUDED, DROP THROUGH**  
250-0-250 v. 70 mA, 6.3 v. 2.5 a. ... 12/11  
280-0-280 v. 70 mA, 6.3 v. 2 a, 5 v. 2 a. ... 14/11  
350-0-350 v. 80 mA, 6.3 v. 2 a, 5 v. 2 a. ... 17/9  
275-0-275 v. 80 mA, 6.3 v. 2 a, 4 v. 2.5 a ... 14/11  
250-0-250 v. 100 mA, 6.3 v. 4 a, 5 v. 3 a ... 21/9  
300-0-300 v. 100 mA, 6.3 v. 4 a, 5 v. 3 a ... 21/9  
350-0-350 v. 100 mA, 6.3 v. 4 a, 5 v. 3 a ... 21/9  
350-0-350 v. 100 mA, 6.3 v. 4 a C.T., 0-4-5 v. 3 a ... 22/9  
350-0-350 v. 150 mA, 6.3 v. 4 a, 5 v. 3 a ... 27/9  
350-0-350 v. 150 mA, 6.3 v. 2 a, 6.3 v. 2 a 5 v. 3 a ... 29/11

**FILAMENT TRANSFORMERS**  
All with 200-250 v. 50 c/c primaries 6.3 v. 1.5 a, 5/9; 6.3 v. 2 a, 7/9; 6.4-6.3 v. 2 a, 7/9; 12 v. 1 a, 7/11; 6.3 v. 8/11; 6.3 v. 6 a, 17/6; 12 v. 3 a or 2.4 v. 1.5 a, 17/6.

**CHARGER TRANSFORMERS**  
All with 200-230-250 v. 50 c/c Primaries:  
0-9-15 v. 1 a, 11/9; 0-9-15 v. 3 a, 16/9;  
0-9-15 v. 4 a, 18/9; 0-9-15 v. 6 a, 22/9.

**SMOOTHING CHOKES**  
250 mA 3-5 H 50 ohms ... 11/9  
150 mA 7-10 H 250 ohms ... 11/9  
100 mA 10 H 175 ohms Potted ... 8/9  
80 mA 10 H 350 ohms ... 5/6  
60 mA 10 H 400 ohms ... 4/11

**E.H.T. TRANSFORMERS**  
2500 v. 5 mA, 2-0-2 v. 1.1 a, 2-0-2 v. 1.1 a. for VCR57, VCR57, etc. ... 36/6

**OUTPUT TRANSFORMERS**  
Midget Battery Pentode 66 : 1 for 35d, etc. ... 3/9  
Standard Pentode 5,000 Ω to 3 Ω ... 3/9  
Standard Pentode 5,000 Ω to 3 Ω ... 4/9  
Standard Pentode 7,800 Ω to 3 Ω ... 4/9  
Standard Pentode 10,000 Ω to 3 Ω ... 4/9  
Multi-ratio 40 mA, 30 : 1, 45 : 1, 60 : 1, 90 : 1, Class B Push-Pull ... 5/6  
Push-Pull 10-12 watts 6V6 to 3V6 or 15 Ω ... 15/9  
Push-Pull 10-12 watts to match 6V6 to 3-5-8 or 15 Ω ... 16/9  
Push-Pull 20 watts, sectionally wound, 6L6, KT66, etc., to 3 or 15 Ω ... 47/9  
Williamson type exact to spec. ... 85/-

(LEEDS) LTD.

Best Buy at Britain's

COMMUNICATIONS RECEIVER R1155.—World-wide reception is ensured by the R.F. and two I.F. stages. Five wavebands (2 L.W., M.W. and 2 S.W.). Magic-eye, large dial and vernier make tuning simple. Contained in attractive black cracked cabinet, its handsome appearance does justice to its superb performance. Supplied with FREE BOOKLET giving circuit data and details of the power pack required for A.C. mains operation. Fully aerial-tested before despatch. Gladly demonstrated callers. BRAND NEW. "MINT" CONDITION. IN ORIGINAL MAKER'S TRANSPORT CASES. £11.19.6. Shop-soiled models, as new, £9.19.6. A few only used models, £7.19.6, plus 10/6 carriage.

A.C. MAINS POWER PACK & OUTPUT STAGE.—These enable the R1155 to be used on the mains WITHOUT ANY MODIFICATION. Three types available. £4.10.0, £5.5.0, and de-luxe model with 8in. speaker, £6.10.0. Carriage 3/6. All Power Packs guaranteed six months. 5/6 each. DUCT 10.—WHEATSTONE RECEIVER AND POWER PACK TOGETHER. Send S.A.E. for full details of Power Packs and Receivers or 1/3 for booklet.

RECEIVER TYPE CR100.—A super communications receiver covering 60 kc/s to 30 mc/s in six bands. Built-in A.C. mains power pack. 2 I.F. stages, 3 I.F. stages, variable selectivity Xtal Filter, B.F.O., etc. Good condition, complete with new valves and air tested. A bargain at £27.10.0, plus £1 carriage.

TR.1196 RECEIVERS (25/73).—This is a six-valve superhet receiver with 465 kc/s. 1 E.C. Complete with all valves, 2 E78, 1 EK32, 2 EF36, 1 EB33. In Good Condition with full conversion data. ONLY 27/6 each, plus 2/6 post.

SPECIAL BARGAIN OFFER.—Admiralty Receiver A2714 certain standard A.C. mains power pack output 31.5-315 v. 70 mA. 6.3 v. 2 a. and 5 v. 2 a. (Admiralty rating). Metal-cased paper smoothing condensers. 10 H. choke, two .0003 mF variables, 31 resistors, 34 condensers and stacks of useful components, including output transformer, 6:1 transformer, etc. In grey metal case, size 11in. x 6in. x 16in. Good condition. ONLY 18/6, plus 5/6 carriage.

MINIATURE MODEL MOTORS.—2in. long x 1 1/2in. diam., 3/16in. diam. spindle, weight 5 ozs. Will work from 6-volt dry battery and are reversible. Ball bearings. 10/6 each.

L. M. & S. COIL PACKS.—With circuit diagram and connections. Gram. position on switch. 14/6 each.

THREE-GANG CONDENSERS.—390 pF., with slow-motion drive and anti-backlash device. With trimmers. Brand new, boxed, 3/6, plus 1/- postage.

E.M.I. OUTPUT METER.—Desk Type, consists of a 2 1/2in. 1 mA. meter with full wave bridge rectifier. Ranges 0-500 milliwatts and 0-5 watts. Brand New and boxed. ONLY 35/- each, plus 1/6 post.

METAL RECTIFIERS.—Heavy duty Selenium 10 1/2in. long with 3 1/2in. square plates. Two are required for a 5/6 volt bridge giving 48 volts 10 amps. Brand new and ridiculously cheap at only 5/76 per pair, plus 2/6 post. R.M.4, 250 volts 250 mA. Only 12/6. R.M.2, 4/3 each for 2 or 8 -. Selenium, 300 volts 100 mA. Brand new. ex-W.D. 6/9 each.

WAVEY BARGAINS.—Brand New boxed E150 heavy duty pentode, 6.3 v. 8.8 watts, at 7/6. 7193, same as 6J5 with top grid and anode at 6/6 for 10/6, post paid.

HEAVY DUTY twin circular polythene cable for extension mains leads, etc. Price 7/6 per dozen yards or 100 yards for only 3/6, plus 3/6 carriage.

ROTARY POWER UNIT TYPE 104.—Input 12 v., Output 230 volt 60 mA. and 6.3 v. at 2.5 amp. Fully filtered and smoothed and noise suppressed. Ideal for car radio, etc. Only 15/- each.

THE VALVE SPECIALISTS

Bentley Acoustic Corp. Ltd.

38, Chalcot Road, N.W.1.

PRImrose 9090

Table listing various vacuum tube types and their prices. Columns include tube type, price, and other specifications.

Special offer of miniatures: CK503AX, CK565AX, CK523AX, CK525AX, XFW10, XFW20, XFY10, XFY12, XFY23, XH11.5, XSG1.5, all at 6/8 each. All boxed with refund guarantee. Post 6d. each. Immediate despatch. C.W.O. or C.O.D.

COMMUNICATIONS RECEIVER R.1155.

Another purchase from the Air Ministry enables us to once again offer this superlative Communications Receiver at prices to suit every pocket. A World Station Tester, this covers 5 wave bands: 16.5-7.5 mc/s, 7.5-3.0 mc/s, 1.50-630 kc/s, 533-200 kc/s, 200-75 kc/s, and is easily and simply adapted for mains use, full details, with circuits of receiver being supplied. New in Maker's Cases and aerial tested. £11.19.6. Ditto but slightly used for demonstration purposes, £9.19.6. Used, good condition, aerial tested, £7.19.6.

A.C. MAINS POWER PACK OUTPUT STAGE.—In black metal case enabling the receiver to be operated immediately without any modification, can be supplied as follows:—Less Speaker, £24.10/-; with 6in. P.M. DEDUCT 10/- IF PURCHASING RECEIVER & POWER PACK TOGETHER. Please add carriage costs of 10/6 for Receiver and 6/- for Power Pack.

TRANSFORMERS.—Manufactured to our specifications and fully guaranteed. Normal primaries, 425v.-0-425 v. 250 ma., 4.3 v. 4 a., 6.3 v. 4 a., 5 v. 3 a. ONLY 50/-; 0.0-0-350 v. 160 ma., 6.3 v. 6 a., 6.3 v. 3 a., 3 v. 3 a., 5 v. 3 a. ONLY 32/6. 350 v. 0-350 v. 150 ma., 6.3 v. 5 a., 0-4.5 v. 3 a. ONLY 32/6. The above are fully shrouded upright mounting, 5.5 kv. E.H.T. with 2 windings of 2 v. 1 a., ONLY 72/6. 7 kv. E.H.T. with 4 v. 1 a., ONLY 82/6. PLEASE ADD 2/- POSTAGE FOR EACH TRANSFORMER. (CRYSTALS.—British Standard 2 pin 500 kc/s, 15/-; Miniature 200 kc/s and 465 kc/s, 10/- each.)

H.R.O. of America. Output 165 v. 80 ma., 6.3 v. 3 a. Contains 6X5 rectifier and full smoothing. Self contained in black cracked cabinet size 7in. x 7 1/2in. x 6in. ONLY 29/6 (postage, etc., 2/-).

AMERICAN ROTARY TRANSFORMERS.—12 v. D.C. input, output 255 v. 65 ma., useful for car radio, or running electric shaver from car battery, etc. ONLY 22/6. VACUUM PUMPS.—These are ex-R.A.F. rotary and type, and are suitable for handymen and model makers, etc. New and Unused, ONLY 22/6 (postage, etc., 2/-).

INDICATOR UNITS, TYPE 6.—Contain VCR97 Tube with mu-metal screen, 4 valves: EF50 and 2 of EB34. BRAND NEW CONDITION. ONLY 59/6 (carriage, etc., 7/6).

TYPE 45 Mcs. I.F. Strips. The strip that is ready made for the London Voice Channel. Complete with 6 valves, EF50 and 1 of EA50. BRAND NEW. ONLY 70/-.

INDICATOR UNITS TYPE 23.—For use with the R1355 or any other receiver with a 6.3 v. supply. These are the variable tuning units which use 2 valves EF54, and 1 of EC52. Type 26 covers 65-65 Mcs. (5.6-6 metres) and Type 27 covers 85-85 Mcs. (3.5-3.0 metres). Complete with valves and BRAND NEW IN MAKER'S CARTONS. ONLY 35/- each.

LONG LIFE MOTOR.—Only 2in. long and 1 1/2in. diameter with 4in. long spindle. Reversible poles. Will operate on 12 v. or 24 volts D.C. ONLY 12/6.

CHASSIS OF INDICATOR 233.—Contains VCR97 C.R.T. holder, 11 valve-holders, resistors, condensers, etc., etc. BRAND NEW ONLY 10/0 (carriage, etc., 5/-).

METERS

Table listing meter types and prices. Columns include meter type and price.

F.S.D. SIZE AND TYPE PRICE

1 m.a. D.C. 2 1/2in. Flush square ..... 15/-

1 " D.C. 2 1/2in. Flush circular ..... 22/6

1 " D.C. 2 1/2in. Flush circular ..... 25

50 " D.C. 2 1/2in. Flush square ..... 7/6

100 " D.C. 2 1/2in. Flush circular ..... 12/6

150 " D.C. 2 1/2in. Flush square ..... 7/6

50 " thermo 2in. Flush square ..... 5/-

500 " thermo 2in. Proj. circular ..... 5/-

25 amps D.C. 2in. Proj. circular ..... 7/6

40 amps D.C. 2in. Proj. circular ..... 7/6

30-0-50 amp D.C. Car type moving iron 5-15 volts A.C. 2 1/2in. Flush, circ., mov. iron 8/6

All meters Brand New in Maker's Cartons

Amounts given for carriage refer to inland only.

U.E.I. CORPORATION,

133, Gray's Inn Road, London, W.C.1 (Phone: TERMINUS 7837)

(Open until 1 p.m. Saturdays. We are 2 mins. from High Holborn (Chancery Lane Station) and 5 mins. by bus from King's Cross.)

CHARLES BRITAIN (RADIO) LTD. 11, Upper Saint Martin's Lane, London, W.C.2. TEM 0545 Shop hours, 9-6 p.m. (9-1 p.m. Thursday) OPEN ALL DAY SATURDAY

# Programme Pointers



## Somerset Maugham Festival

THE most notable event since my last contribution has been the *Somerset Maugham Festival*, in honour of the famous author's eightieth birthday. I heard the following plays:—"Lady Frederick," "The Circle," "For Services Rendered" and "Sheppey." There were also adaptations of some of his novels and short stories and, as I write, there is more to come.

It can be said, without qualification, that everything gave unalloyed pleasure. Mr. Maugham boasts of being an entertainer first, last and all the time and a right royal one he is. He never philosophises or tries to "teach" his listeners in the Shavian manner. Nor does he boggle over sex, which rides triumphantly through much of his best work. But he can point a moral and underline it, too, as in the terrific anti-patriotic finale to "For Services Rendered," which created such a furore when originally produced in the West End, or the anti-gambling and other high-toned moralities of "Sheppey." Everything in short makes for perfect radio fare; not better than Shaw and some others, of course, but different and all that could be asked of an author.

There was much fine acting during the Festival and the productions seemed uniformly good. I particularly liked almost everyone in "The Circle"—Ronald Squire is always Ronald Squire. Monica Gray and Belle Chrystall in "For Services Rendered" and Sonia Dresdel in "Sheppey" stood out. Charles Leno in the latter title rôle was rather too much on one note, whilst Rachel Gurney in "Lady Frederick" was not quite the "femme fatale" conveyed by the dialogue. By the way, surely the dressing-room scene in this is one of the best things of its kind in English comedy since the screen scene in "The School for Scandal" which it slightly resembles.

## Other Plays

Among other good plays were two American ones, "The Wooden Dish" and "Winter Journey." The American drama always has great vitality, gusto and charm whatever else it may either possess or lack. These two pieces made no exception. "The Wooden Dish," by Edmund Morris, was one of those plays I mentioned in connection with "Return to Tyassi" which fail in the West End in spite of glowing tributes from the Press. It was a dramatic tale of the sad conflict between age and youth and the demands of the latter on the former. Joan Miller, Bessie Love, Finlay Currie and many others wrung our withers and our hearts according, doubtless, to the age group of each one of us listening.

"Winter Journey," by Clifford Odets, was a "back-stage" play posing no problems concerning society and its welfare and containing those two powerful and popular puppets Sam Wanamaker and Constance Cummings, as well as Guy Kingsley Pointer, Reginald Tate, etc. I enjoyed both.

I cannot stay on radio drama any longer except

Our Critic, Maurice  
Reeve Reviews Some  
Recent Programmes

to mention that "The English Captain" also had excellent qualities, but that "Mr. Mysterious" afforded an exception to an otherwise exceptionally good month.

## Ted Ray for Humour

"Ted Ray Time" seems to have a fair share of humour whenever I have heard it. Ted himself, with Harold Berens, should assure this. Audrey Jeans effectively takes Kitty Bluett's place. Saturday night's "Variety Playhouse" always seems a hundred per cent. better when Vic Oliver is the host and master of ceremonies.

There have been some irritating changes in the hitherto fixed times for the presentation of "Music Magazine," "The Critics" and Alistair Cooke's "Letter from America," either of the original transmission or the repeat. Furthermore, the repeat times are distinctly variable and cannot be relied upon. Although doubtless plenty of listeners are glad of the changes, I do hope there are many who, like myself, have been annoyed and inconvenienced.

"The Adventures of Sherlock Holmes" have long been a classic in their special genre. Like Gilbert and Sullivan, Oscar Wilde and Dickens, they carry the Victorian flavour in its most attractive guise into our more sophisticated age irrespective of the current fashion in greenback "whodunit." Their charm is perennial proof of their quality. The present series has afforded great pleasure to the older listener who remembers their original appearances in the lamented *Strand*, as well as to those unacquainted with them. The casting of Sir John Gielgud and Sir Ralph Richardson as Holmes and Watson was sufficient proof of the importance that was, I submit, correctly attached to the series. Val Gielgud, John Cazabon and William Fox complete the almost perfect cast.

## Music

Music, too, has been in full spate, as it ever is. I liked an original programme of French and Russian numbers conducted by Jean Martinon, whilst the following week he included that most famous of modern—40 years old now—masterpieces, Stravinsky's "Petrouchka," just as lovely in the concert hall as the theatre. Artur Schnabel was his ever brilliant self in a Beethoven concerto and a Liszt programme. There can be few finer Liszt players to-day. Moiseiwitsch gave a Schumann recital and included the fascinating but seldom heard "Kreisleriana." Here, too, is a master in a certain type of music.



## News from the Trade

### The Brenell Tape Deck

THE new Brenell Tape Deck is introduced as a high-quality unit at a moderate price.

Of particular interest is the new toggle-action grip between capstan and pinch wheel which ensures a tape drive free from slip and which eliminates one of the major causes of "wow" and flutter. The capstan is directly coupled to a heavy flywheel which is driven by a rubber belt from a motor of adequate power.

Three independent motors are employed to ensure reliable operation with simple switching. Braking is arranged mechanically and gives an effective, quick stop action with complete freedom from tape

tearing yet leaving the tape correctly set for immediate recording or playback.

They are both virtually entirely new designs but we have used the present models as standards of comparison to summarise the main improvements.

Amplifier: Total harmonic distortion at 8 watts now only .12 per cent. Frequency response:  $\pm 25$ db 20-30,000 c.p.s. Output Transformer: Sectionalised and fitted C-core lamination material. Three alternative output impedance selected by simply plugging in appropriate impedance plug. Correct feedback resistor automatically fitted, no soldering required. Presence Control: Optional presence control fitted to enable optimum performance when using new G.E.C. "FR" loudspeaker.

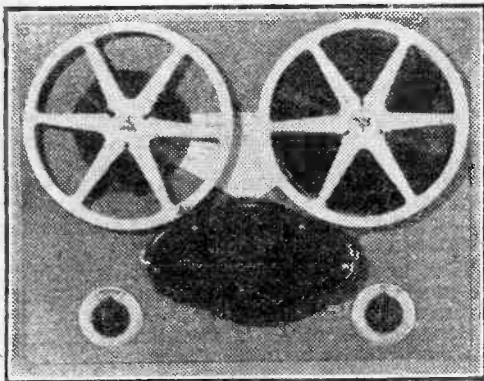

The new Brenell Tape Deck showing underside with switch interlock.

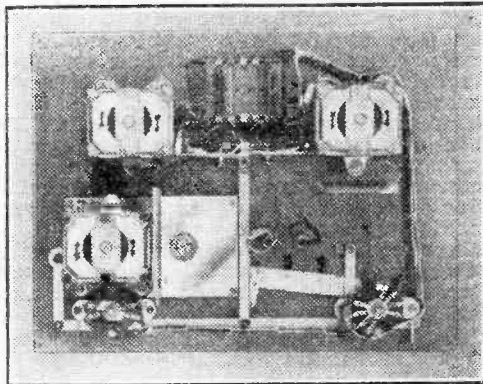

Three speeds are available with a playing time of:—

- 2 hours at  $3\frac{3}{4}$  in. a second.
- 1 hour at  $7\frac{1}{2}$  in. a second.
- $\frac{1}{2}$  hour at 15 in. a second.

The record/playback head is a high-impedance type and does not require a matching transformer. It is fitted with a heavy gauge Mumetal screen to ensure elimination of 50-cycle hum due to magnetic fields from motors, transformers, etc.

The erase head is a low-impedance type which requires to be fed from a low-impedance winding on the oscillator coil.

The tape drive is from left to right, using the upper track to conform to British Standards.

With overall dimensions of 15 in. by 11 $\frac{1}{2}$  in., with  $3\frac{3}{4}$  in. below deck, this instrument costs £15.10s. complete.—Brenell Engineering Co., Ltd., 2, Northington Street, London, W.C.1.

### The RD Junior Amplifier and Control Unit

THE RD Junior Amplifier and Control Unit are being introduced to replace the present RD Baby de-luxe Mk. II amplifier and

Control Unit: Treble control now continuously variable. In the circuit used this results in a more satisfactory characteristic, lacking the "blare" associated with some forms of control when boost is applied. A switched bass control has been retained as here the more satisfactory characteristic is obtained with a circuit employing switching. Tape Jacks: Previously only included on the Senior model, are now fitted to the front panel.

The Main Amplifier costs £16 and the Control Unit, £9.—Rogers Developments Co., Rodevo House, 116, Blackheath Road, Greenwich, London, S.E.10.

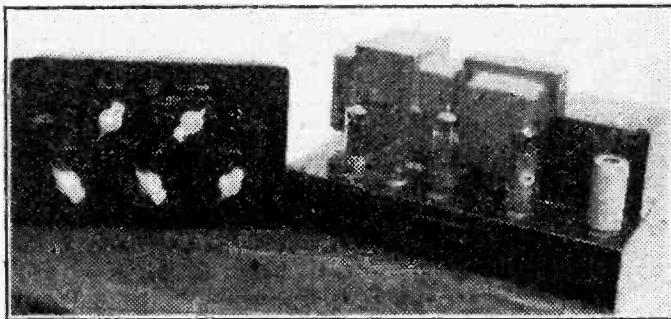

The RD Junior Amplifier and Control Unit.

# LASKY'S PAGE OF MONEY-SAVING OFFERS

## METAL RECTIFIERS

|                    |      |         |      |
|--------------------|------|---------|------|
| 6 and 12 volt F.W. |      |         |      |
| 2A                 | 9/-  | 11B.2   | 4/3  |
| 4A                 | 12/- | 11B.3   | 5/-  |
| 6A                 | 19/6 | 11B.4   | 16/- |
| 6 Volt             |      |         |      |
| 1 amp.             | 2/6  | 12 Volt |      |
| 1 amp.             | 4/6  | 1 amp.  | 3/11 |
| R.M.I.             | 3/10 | 1 amp.  | 8/6  |

## I.F. TRANSFORMERS

|                  |                             |
|------------------|-----------------------------|
| MINIATURE        | 1 x 1 x 1 1/2 ins.          |
| WEARITE TYPE 550 | PRICE 10/6 pair.            |
| WEARITE TYPE 500 | 445-520 kc/s. 8/6 per pair. |
|                  | 450-470 kc/s. 8/6 per pair. |

## CRYSTAL DIODES

|                      |     |
|----------------------|-----|
| Wire ends. Glass     | 1/6 |
| Type WX.6. Wire ends | 1/6 |

## TELESCOPIC PORTABLE AERIAL MASTS

Made of lightweight but extremely strong alloy. Extends to 15ft. Guyed at top and centre. Supplied complete with all guy lines.

**LASKY'S PRICE, 25/-**  
Carriage free.

**R.F. 25 UNITS.** Complete with 3 valves. New 19/6. Secondhand, 15/-.  
Carriage, 2/6 each extra.

## SUPERHET COIL PACKS

With Circuit:  
No. 1. L.M.S.G. Size: 4 1/2 x 5 x 2 1/2 ins. With 1 in. spindle.....19/6  
No. 2. M.S.S. Size: 4 x 4 3/8 ins. With 1/2 in. spindle 16/-  
Both for use with 465 kc/s I.F.

## LOUDSPEAKERS

First Quality. All 3 ohms speech coil. Less output trans. 19/6  
5in.....14/6 8in.....19/11  
6in.....15/- 10in.....19/6

## ENERGISED SPEAKERS

8in. With O/Trans. 600Ω.....15/6  
8in. Less O/Trans. 600Ω.....12/6  
8in. Less O/Trans. 1,200Ω.....12/6  
6in. With O/Trans. 600Ω.....14/-

## PLASTIC ESCUTCHEON MASKS

With dark screen filter.  
12in.....12/6 16in.....25/-

## BRIMSTONS

Type CZ.1, 1/6 each.  
CZ.3, 10id. each or 9/- doz.

## HIRE PURCHASE TERMS ON CERTAIN ITEMS

Down payments can be arranged to suit you. Send us details of your requirements.

## POSTAGE & PACKING CHARGES

(unless otherwise stated)  
Orders value £1.....1/- extra  
" " £5.....2/-  
" " £10.....3/6  
" " Over £10 carriage free.  
All goods fully insured in transit.

**NOTE—Open all day Saturday. Early closing Thursday.**

# LASKY'S RADIO

LASKY'S,  
(HARROW ROAD) LTD.,

## COMPLETE 5 VALVE RADIO CHASSIS



Brand New and Unused  
A.C. D.C. Mains. 200/250 volts.  
\* I.F. 465 kc/s. \* A.V.C.  
\* 4 Watts output.  
\* 3 Station Pre Set.  
\* Frame aerial  
\* Fully aligned  
\* Chassis size only 10ins. x 5 1/2ins. Max. height 5 1/2ins.

Completely wired and ready for use, with the addition of a speaker and output transformer. Two controls—Volume and Station switch. Valves used: 10C1, 10F9 or UF41, 16LD11, 10P14, U404 or UY41.

**LASKY'S PRICE, 89.6. less Valves.** Postage 3/6 extra.  
**PRICE COMPLETE, £5.19.6.**

## LASKY'S RADIO CONSTRUCTOR PARCELS

**NO. 1. A.C. SUPERHET.**—4 valves plus metal rectifier. Long, medium and short wavebands. In very attractive cabinet, either walnut veneer or ivory or walnut plastic. For 200/250 v. 50 c.p.s. All components, valves, mains transformer, cabinet, dial and metalwork. **LASKY'S PRICE, £7.19.6.** Post & pkg. 2/6 extra.  
**NO. 2. A.C.T. R.F.**—3 valves plus metal rectifier. L. & M. wavebands. For construction in attractive wood or plastic cabinet, walnut or ivory finish. For 200/250 v. 50 c.p.s. All components, mains transformer, cabinet, dial and metalwork.  
**LASKY'S PRICE, £5.10.0.** Post & pkg. 2/6 extra.

**NO. 3. 4-WATT A.C. AMPLIFIER.**—Uses 1 each 6SL7, 6V6 and 5Z4. All components, chassis, valves, output trans., mains trans.  
**LASKY'S PRICE, £4.5.0.** Post & pkg. 2/6 extra.  
Instruction Books for the above Kits, price 1/- each.

## 3-WATT MIDGET AC/DC AMPLIFIERS

**PUSH PULL, VERY HIGH GAIN**  
4 valves: 2 U41 in push pull, 1 UC42 and 1 UAF42. Input voltage 100/110 A.C./D.C. Very easily converted to 230 volts. Supplied with circuit diagram and full details.  
Size: 9 x 4 x 4 ins. Uses 2 metal rectifiers, 1 each RM1 and RM2. Ideal for ships' record players, tape recorders, home record players, baby alarms, etc. etc. Supplied complete, fully assembled and wired, with 4 valves, **65/-**. **POST FREE.**

## GANGED TUNING CONDENSERS .0005 MFD.

|  |      |
|--|------|
| Standard 2-gang. Size: 2 1/2 x 1 1/2 x 2 1/2 in. Spindle                               | 5/-  |
| Standard 3-gang. Size: 2 1/2 x 1 1/2 x 3 1/2 in. Spindle                               | 7/6  |
| Midget 2-gang with trimmers. Size: 1 1/2 x 1 1/2 x 2 1/2 in. Spindle                   | 7/6  |
| Midget 3-gang with trimmers and perspex cover. Size: 1 1/2 x 1 1/2 x 2 1/2 in. Spindle | 12/6 |

**RESIN CORED SOLDER.**..... 7/6 per 1-lb. reel

## HAVE YOU SEEN LASKY'S NEW WEST END BRANCH?

Everything for the serviceman, "ham" and home constructor. Radio, Television, Hi-Fi, Electronics, P.A. Equipment, Recorders, etc.

Wharfedale, Stentorian, Goodmans, Baker's, Leak, Cosmocoord, Vitavox, Hunts, T.C.C., Dubilier, Acos, Garrard, G.E.C., W.B., Grundig, etc.

## SPECIAL OFFER MOVING COIL MICROPHONES

switch incorporated.  
Listed at £5.5.0.  
**LASKY'S PRICE, 59/6.**  
Postage 2/6 extra.

## EX-A.M. RECEIVER TYPE R.1155

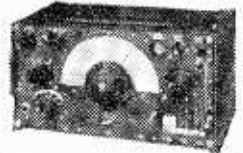

5 Frequency ranges: 18.5-7.3 Mc/s.; 7.5-3.0 Mc/s.; 1,500-600 kc/s.; 500-200 kc/s.; 200-75 kc/s.  
Supplied in maker's original wood transit case.

**LASKY'S PRICE**  
BRAND NEW, **£11.19.6.**

Secondhand, Grade 1, **£9.19.6**  
Secondhand, Grade 2, **£7.19.6**  
Carriage 17/6 extra, including 10/- returnable on packing case.

## ASSEMBLED POWER PACK/OUTPUT STAGE FOR R.1155 RECEIVER

For use on 200-250 v. A.C. mains. Complete with 2 valves. In metal case size: 12 x 7 x 5 1/2 ins.  
**LASKY'S PRICE 79/6**  
Carr. 5/- extra.

Power Pack as above. Fitted with 6in. p.m. speaker.  
**LASKY'S PRICE £5.5.0**  
Carriage 5/- extra.

**L. & M. WAVE T.R.F. COILS.** With Circuit 4/6 pair

**L. & M. DUAL WAVE Superhet Coils.** Aerial and oscillator 5/11 pair

**AERIAL ROD SECTIONS** Steel, heavily copper plated, 12ins. long, 1/4 in. diameter. Any number may be fitted together. **PRICE 2/6 per doz.** Post free.

**100K. CARBON POTENTIOMETERS.** Special offer. 1/6 each

## TELEVISION SELENIUM RECTIFIERS

The very latest "Sentercel" S.T.C. range.  
K3/40, 3.2 kV..... 6/-  
K3/45, 3.6 kV..... 8/2  
K3/50, 4.0 kV..... 8/8  
K3/100, 8.0 kV..... 14/8  
K3/160, 12.8 kV..... 21/6  
K3/200, 16 kV..... 26/-



TWO ADDRESSES FOR PERSONAL CALLERS

**42 TOTTENHAM COURT ROAD, W.I.**

Between Tottenham Court Rd. and Goadge St. Stns. Tel.: MUS 2605

**370 HARROW ROAD, PADDINGTON, W.9.**

Opposite Paddington Hospital. Tel.: CUNningham 1979-7214

**ALL MAIL ORDERS TO HARROW ROAD PLEASE**

# LYONS RADIO LTD.

Dépt. M.P. 3, GOLDHAWK ROAD, SHEPHERDS BUSH, LONDON, W.12  
Telephone : SHEPHERDS Bush 1729

**BRIDGE MEGGERS.** An invaluable testing set comprising a Meg. insulation tester and a complete Wheatstone bridge for the accurate measurement of resistance. Incorporating a constant pressure hand generator, a direct reading ohmmeter which also serves as a galvanometer of the Wheatstone bridge, a direct reading adjustable resistance and the necessary ratio and change-over switches. Testing volts 250 v. insulation range 0/100 Megohms. Resistance measuring range 0.01 ohm to 999.9 K.ohms. In good condition and supplied in leather carrying case. PRICE, £21.

**VIBRATORS.** Standard 4-pin non-synchronous type for 24 v. operation. In good working order. PRICE ONLY 5/- post 9d.

**SPEAKER GRILLE.** Woven metal. approx. size 15 x 12in., with smart gold sprayed finish. PRICE, 3/6, post paid.

**AMMETERS.** Switch board mounting projection pattern. 4 1/2in. dia. Moving iron type calibrated 0/14 amps. A.C. or D.C. First grade meters in maker's original carton, as new. SPECIAL PRICE ONLY 12/6, post 1/3.

**SPECIAL BARGAIN IN VR91's.** These are dirty and marked on the outside but are all tested and guaranteed electrically sound. PRICE for 3, 10/6 ; 6 for 19/6 ; 12 for 35/-.

**TIERMOMETERS.** Consists of a circular glass-fronted dial 2 1/2in. dia. with metal temperature detection stem protruding 5in. at right angles from back of dial. The temperature is clearly calibrated on face of dial from -70 deg. C. to +50 deg. C. and is indicated by a rotating pointer. PRICE, 10/6, post 9d.

Kit of parts for the simple construction of a first class Tape Deck, comprising complete set of accurately machined components with every nut and bolt and full instructions for building a high quality 2-speed Tape Deck. Very compact, 11in. x 7 1/2in., taking 600 ft. reels. Twin Track recording with the very latest type High Fidelity Ferroxcube heads (30-12,000 C/S at 7 1/2in.) High speed capstan, precision balanced flywheel, ball bearing pressure roller giving remarkable freedom from "wow". Fitted with the latest Collaro constant speed motor.

Price £7.10.0

E.W.A.,

266, Warbreck Drive, Blackpool

**1/4" Black & Decker**  
PORTABLE ELECTRIC DRILL  
200V. OR 250V. AC  
COMPLETELY SUITABLE FOR RADIO AND TV INTERFERENCE  
FULLY GUARANTEED



MANY ACCESSORIES ALSO AVAILABLE

SENT POST FREE FOR DEPOSIT AND NINE FURTHER MONTHLY PAYMENTS OF 12/6. CASH PRICE £5.9.6

**£1**

Frith RADIOWORKS Ltd  
PHONE 58927  
69-71 CHURCH GATE LEICESTER

## 20

### CIRCUITS

for 2/6 only

Our Super-Handbook, "The Home Constructor" with its supplements (68 pages altogether) now incorporates

- \*20 CIRCUITS—Superhets, T.R.F., Test Equipment, Feeder Units.
- \*SUPERHETS—Full constructional details. Full layout and point-to-point wiring diagrams for building superhets.
- \*COIL PACK—Full constructional details for building a superhet coil pack.
- \*CAR RADIO—Full constructional details.
- \*BATTERY CHARGER—Complete details for building a CHEAP CHARGER.
- \*RADIO GEN.—Pages of information, Resistance Colour Code, Formulae, and "know-how" with theoreticals.
- \*RADIO CONTROL—Supplement with theoreticals.
- \*CATALOGUE—Profusely illustrated catalogue and price list.

**YOU CAN'T GET BETTER VALUE! IT'S TOPS!**  
"The most helpful book in the Trade."

And, of course, our famous iron-valve at 3/- each. 10-30, 15-50, 30-75, 75-200, 190-650, 800-2,000 metres. Aerial H.F. or Osc.

**SUPACOILS** (Dépt. P.2)  
21, Markhouse Road, London, E.17

## SPARKS' DATA SHEETS

### SHORT WAVES

All-dry Battery operation. Simplified Band-Spread Tuning. Latest Eddystone Plug-In Coils down to 10 Metres. High-Efficiency Pentode Detector Circuit with Dual Control Reaction Circuit. Thoroughly Tested. No S.W.DX.1. Single Valver. No S.W.DX.2. Two-Valver. (Det. plus pentode output). Full-Size Simplified Data Sheet, showing every detail, plus Descriptive and Operational Instructions, 2/6 each, plus 2d. stamp.

**NEW MULLARD AMPLIFIER**

The 27in. x 23in. Data Sheet shows in detail my version of a Tested Practical Layout, together with descriptive matter and all values, Etc., Etc., of this outstanding Mullard circuit. The ideal design for the quality enthusiast. Chassis and all parts available. Data Sheet, Etc. 3/9 Post Free.

**MANY OTHER DESIGNS AVAILABLE**  
Send 2d. stamp for Latest List.  
**COMPONENTS AND DRILLED CHASSIS SUPPLIED**

**L. ORMOND SPARKS (P),**  
8, Court Road, Swanage, Dorset.

**ASTRAL RADIO PRODUCTS**

"HOME RADIO," 32-page booklet fully illustrated. Simple wiring instructions for Crystal Set. 1-, 2-, 3-Valvers, etc. 2/- postage 3d.

T.R.F. COILS for All Dry 3, Band 3, Push-button 4, etc. 6/6 pair, postage 6d.

"K" COILS A.C. Bandpass 3 2/3 each, postage 6d.

FRAME AERIALS, m.w., 5/-, Postage 1d.

138, THE RIDGWAY, WOODINGDEAN, BRIGHTON, 7

## W. B. SUPPLIES

100, Oldham St., MANCHESTER 4.

**TERMS.**—Cash with order. Orders under 20/-, add 6d.; over 20/-, add 1/- postage.

**CARBON RESISTORS.**—25 assorted, 2-packet.

**RADIO-INTERFERENCE SUPPRESSORS** for all electrical interference, 5/-, complete with instructions.

**SCREWDRIVER SETS.**—4 detachable blades (2 standard drivers and 2 Phillips star type), per-sep insulated handle, complete set in wallet, 7/6.

**"RIB" WIRE STRIPPERS.** 3/6: Tyana lightweight Soldering Irons for radio use, 230-250 volts, 14 1/2.

**DUAL-READING METERS.**—Moving coil, 0-200 volts, 0-200 volts, complete with leads, 10/6.

**VARIABLE TYPE SWITCHES.**—2-pole, 6-way (2 bank), 2/3; 4-pole, 3-way midgets, 1/6; 5,000 $\Omega$  wirewound pots, 1/- each.

**VARIABLE CONDENSERS.**—Air spaced, 50 pF., 1-; 115 pF., 2/6.

**RECTIFIERS.**—250 volt 60 mls., 5/-; 75 mls., 7/6.

**"VALVE EQUIVALENTS MANUAL."**—Latest publication, giving equivalents for both ex-Government and commercial valves, 5/-.

**JONES TYPE 4-pin plugs and sockets,** 1/- complete.

**MANSBRIDGE CONDENSERS,** 1 mfd. 1,500 volts working, 1/6.

**SPEAKER PRETS.**—Metal, 12in. x 12in., 4/6; 18in. x 12in., 6/9 (coloured gold); Fabric, 12in. x 12in., 2/6; 18in. x 12in., 3/9.

**8in. MANSBRIDGE SPEAKERS** in metal case with stand and on/off switch, P.M. type, ex-Govt., very good for extension speakers, 25/-.

**VALVES.**—VR51, 2/-; VR92, 1/6; 6V6GT (American), 6/11.

**WIREWOUND POTS.** (5 watts).—15K, 20K, 25K, 1/3 each.

"Midget Radio Construction Manual," 3/9 post paid.

Huge selection of Components and Valves. All enquiries stamped addressed envelope, please.

## J. B. SERVICE (BEXLEYHEATH) LTD.

RADIO COMPONENT SPECIALISTS

5, MAYPLACE ROAD WEST, BEXLEYHEATH, KENT.

Phone : BEXLEYHEATH 1000  
Wednesday Half Day

44, CHURCH ROAD, UPPER NORWOOD, S.E.19

Phone : LIVINGSTONE 6222  
Wednesday Half Day

All types of Valves Old or Modern Wanted for Cash. Send Full Particulars for prompt offer. N.B.—Not Secondhand used valves.

## Television, Radio, Record CABINETS MADE TO ORDER

ANY SIZE OR FINISH  
CALL OR SEND DRAWINGS FOR QUOTATION

## B. KOSKIE

(DEPT. C.)  
72-76 Leather Lane, Holborn, E.C.1.  
Phone : CHAncery 6791/2

# Open to Discussion

## For the Deaf

**SIR,**—Your correspondent E. W. Lark (January issue) writing of his difficulty in fitting a relative's National Health deaf-aid earpiece for radio reception direct from the receiver may not know of the several excellent matching devices which are fed from the "extra speaker" sockets on the set. It is a simple matter to match either high or low impedance magnetic or crystal earpieces to the standard output arrangement of the set. The person using the deaf-aid earpiece adjusts the volume control incorporated in the matching device to suit himself.

A most satisfactory type of radio receiver for a deafened person is the self-contained battery-operated portable. Output is ample for his deaf-aid earpiece and the built-in speaker is an obvious advantage to other people with normal hearing. The same matching device is used, this being plugged into two sockets connected across the primary of the output transformer in the set.

With a view to a more permanent arrangement, I should be pleased to hear of a transformer manufacturer who can offer output transformers for mains and for battery output valves with two separate secondary windings, one to match a 50 ohms deaf-aid earpiece and the other a 3 ohms loudspeaker.—P. J. CARTWRIGHT (Stockton-on-Tees).

## Changing Listening Conditions

**SIR,**—I heartily agree with the letter on p. 761 December issue.

Certainly under to-day's chaotic listening conditions, especially on the medium-waveband, there is not one set in the normal commercial range which could satisfy the discriminating listener. I have tried several very large sets but without success, and unless the receivers have a variable selectivity switch and vernier dials there is not much hope to get any of the stations, especially as the Americans are occupying just the same wavelength as the Russians, so that interference and oscillation are provoked. A good frame aerial could also help to better the reception, but I am afraid the normal radio trade makes good business, so why worry?

Why are so-called international agreements made like the Copenhagen wave plan, if nobody keeps to it? Germany, for example, got only VHF-senders allocated.—A. K. RICHTER (Bristol).

## Amplifier Design

**SIR,**—Further to my letter asking if Mr. Hindle would deal with cathode follower output, and perhaps evolve a circuit. I would like him, if dealing with the matter, to refer also to what I call "horse and pony" output.

It seems likely that if, say, two 6V6 valves are used in pull-push (cathode follower output) then the

characteristics (which includes distortion) of 6V6 are multiplied, probably by four. Similarly in regard to the two 6J5s used to feed the 6V6s.

Example: Two 6J5s feeding two 6V6s (290 volts cathode-f. output):

Remove one 6V6 and substitute a KT66.

Remove the 6J5 now feeding KT66 and substitute 6C5.

(Of course, K and g volts ought to receive attention, but never mind that for the moment.)

It seems likely that instead of multiplying 6V6 and 6J5 characteristics by possibly four, you now have four different characters in your output, each of one only. It may be that, by

proper designing, a circuit far in advance of anything yet produced can be evolved on these lines—the four different valves cancelling out each other's peak tendencies. In any case, using this method on my Williamson (cathode output) I can accept

much more volume, and the bass is reed-like instead of muffled drum-like, if you know what I mean by that—and instead of one "brilliance" there are two "brilliances," one being on the violins and the other nearer the bass. By that I mean a "realism" in the music.—O. G. KERSLAKE (Orpington).

## A Six-valve A.C. Superhet

**SIR,**—Reference the above set, details for the construction of which appeared in your July issue.

I thought you may be interested to know I recently built this set, and after checking, plugged into the mains, connected a short indoor aerial and switched on. Without any adjustment whatever, I found I was receiving Moscow Radio "loud and clear." I had not even touched the tuning condenser!

(I have since fitted a "magic eye" type of visual tuning indicator—an idea I would commend to your readers as being a simple yet accurate means of bringing the circuits into perfect alignment.)

I consider this a tribute to the soundness of PRACTICAL WIRELESS circuits and Messrs. Osamor Radio's coilpacks and components.—H. SEXTON (Sanderstead).

## High Fidelity

**SIR,**—After reading the most excellent and humorous article on High Fidelity by "Grid Current" published in your December issue, I feel I must put pen to paper and express my views, although they concur in many respects to those of your critic.

No doubt other "hams" like myself keep life and soul together by servicing domestic equipment, and have encountered the fact that when the equipment is returned to its expectant owner, he immediately adjusts his "tone" control, because he does not like the setting you have left. In many cases the

*Whilst we are always pleased to assist readers with their technical difficulties, we regret that we are unable to supply diagrams or provide instructions for modifying surplus equipment. We cannot supply alternative details for receivers described in these pages. WE CANNOT UNDERTAKE TO ANSWER QUERIES OVER THE TELEPHONE. If a postal reply is required a stamped and addressed envelope must be enclosed with the coupon from page iii of cover.*

frequency output response is cut at certain frequencies by as much as 50 per cent. One setting of this "tone" control may appear "muffled" by one individual, while another considers it to be quite adequate and correct.

Now the only solution, in my opinion, for any equipment to be labelled "high fidelity" is that such equipment should possess bass boost, treble boost and both bottom and top cut-off controls or any combination which would control the extremities of the frequency response.

Possibly in the near future one manufacturer will strike a note of genius and provide us with a middle-cut control, just to please the "boys" who like their supersonic bangs and screeches alone!

One further note to this epistle is that I am afraid that I fall into the category who delight in volume when it is there to use.

I have found that at certain levels the balance of reproduction is perfect but at higher volume both bass and high frequencies tend to mingle, particularly with the reproduction of L.P. records. Many people think this is due to the loudspeaker, but here again I do not agree. The American trend to this problem was partly solved by a Phono-preamp circuit which appeared in a recent American publication. The controls consisted of two rotary switches with 10 different selections, each of the selections being coded by letters. The article provided a list of both British and American labels together with the code letters at which the switch selectors must be set when playing each particular label. This of course compensates for the different recording characteristics of each particular label.

However, the question of high fidelity is not solved at any one end of the equipment alone, as the question remains entirely with the person who operates the controls.

In finishing, I feel I must congratulate both you and your staff for providing a most enjoyable year of really first class publications. I can only add that I hope that PRACTICAL WIRELESS has a most successful year in 1955.—B. G. HAVENHAND (nr. Royston).

SIR,—I agree with the comments of your correspondent, Mr. S. T. Pinder, in his letter in your January issue and in connection with my contribution "What is Hi-Fi?" For any degree of pleasurable listening, balance is perhaps one of the most important matters, but the Hi-Fi enthusiast usually claims a large measure of a reality of reproduction.

We have heard in a number of recent demonstrations some astonishing reproductions of percussion, broken glass, and other "noises," but somehow although one admires the accuracy of such reproductions there appears to be still something lacking in the reproduction of certain musical instruments and orchestral effects. This in spite of assumptions that extended range covers harmonics, and deals

with transients, and that cross-modulation and phase distortion is not present.

One is left with a feeling that in many cases the extension of the top range has satisfied the Hi-Fi enthusiast that he has put realism into his reproduction.

A non-technical but keen violinist recently suggested to me that Hi-Fi reproduction now gave a fairly true rendering of violin tone in a general sort of way, but it was still incapable of giving reproduction which would discriminate between the tonal qualities of a good violin played by a master and an inferior instrument. It would be interesting if some of your readers with a keen musical ear and some knowledge and experience of instrumental work, would give us their considered and critical opinion of Hi-Fi reproduction such as is so called to-day.

Are there still some fields to conquer in this direction?—"GRID CURRENT" (Middlesex).

### Series Modulation

SIR,—Your correspondent C. McLean in the December issue of PRACTICAL WIRELESS uses the subject of series modulation as a plea for the granting of higher power.

I should like to draw his attention to your article in the November issue, which gives some good examples of modulation at a very reasonable cost to anyone wishing to build them. The most reasonable one being of course, clamp modulation, and, if Mr. McLean will also consider it, there is NBFM. Any of these will modulate a full 150 watts efficiency, enough for the needs of the most exacting amateur.

On the subject of higher power, I would rather suggest a decrease to something like 75 or even 50 watts maximum, and if your correspondent should ever visit this country and listen to the 14 Mc/s 'phone band when the DL4 stations are in full swing with their BC610 and ET4336 transmitters, he will see my point of view.—K. SMETHURST (DL2UY) (B.A.O.R. 39).

### Modern Reflex Receiver

SIR,—I built the "Modern Reflex Receiver," two months ago, for use on A.C. mains with a transformer for supplying the heater current. On moving to my present address, I found that the supply was D.C. As the normal current dropper was rather large and would not fit into my cabinet, I tried a 60 watt bulb in series with the filament and found that it worked excellently, the supply being 230 v. D.C.

I have now fitted the lamp to the set and so have a compact reading lamp and wireless.

Perhaps other readers will find the above suggestion useful. The set gives good volume on all stations, using the fender as an aerial. The set measures 7in. x 7in. x 4in.—H. PARKER (Clacton-on-Sea).

Editorial and Advertisement Offices: "Practical Wireless," George Newnes, Ltd., Tower House, Southampton Street, Strand, W.C.2. Phone: Temple Bar 4368.

Registered at the G.P.O. for transmission by Canadian Magazine Post.

The Editor will be pleased to consider articles of a practical nature suitable for publication in "Practical Wireless." Such articles should be written on one side of the paper only, and should contain the name and address of the sender. Whilst the Editor does not hold himself responsible for manuscripts, every effort will be made to return them if a stamped and addressed envelope is enclosed. All correspondence intended for the Editor should be addressed: The Editor, "Practical Wireless," George Newnes, Ltd., Tower House, Southampton Street, Strand, W.C.2. Owing to the rapid progress in the design of wireless apparatus and to our efforts to keep our readers in touch with the latest developments, we give no warranty that apparatus described in our columns is not the subject of letters patent. Copyright in all drawings, photographs and articles published in "Practical Wireless" is specifically reserved throughout the countries signatory to the Berne Convention and the U.S.A. Reproductions or imitations of any of these are therefore expressly forbidden. "Practical Wireless" incorporates "Amateur Wireless."



# MONTROSE MULTIMETER

## MODEL 44A

**7 Ranges**—Voltage : 0-6-30-150-300 Volts } A.C. &  
 Current : 0-30 mA-300 mA-3 Amperes } D.C.

**Circuit Tests**—Self-contained, easily accessible 1½ v. cell provides quick continuity testing.

**Reliability**—Robustly built moving iron movement, designed to stand up to everyday use.

**Convenient pocket size**—Weight 8 oz.

**Price £2. 10. 0.** Prompt delivery.

Please note that other Taylor instruments are available on "no interest" Hire Purchase on a 3 months' credit scheme. Alternative Hire Purchase terms for 10 and 15 monthly instalments. Some typical examples are :

**120A Multirange Meter** 1,000 o.p.v. A.C./D.C. pocket size, 2½in. scale  
 Cash Price £9.10.0.

**3 MONTHS**  
 Deposit £18.6. And 3 monthly payments of £3.0.7.

**10 MONTHS**  
 Deposit 19/5. And 10 monthly payments of 19/1.

**15 MONTHS**  
 Deposit 19/5. And 15 monthly payments of 13/6.

**71A Multirange Meter** Portable. 1,000 o.p.v. A.C./D.C. 5½in. scale  
 Cash Price £12.10.0.

Deposit £117.6. And 3 monthly payments of £3.18.8.

Deposit £15.8. And 10 monthly payments of £1.5.1.

Deposit £15.8. And 15 monthly payments of 17/9.

**66A Signal Generator** 100 Kc/s—180 Mc/s.  
 Cash Price £19.0.0.  
 Write for literature.

Deposit £217.0. And 3 monthly payments of £6.1.2.

Deposit £118.0. And 10 monthly payments of £1.18.3.

Deposit £118.0. And 15 monthly payments of £1.7.1.

**TAYLOR ELECTRICAL INSTRUMENTS LTD.**  
 Montrose Avenue, Slough, England. Telephone : SLOUGH 21381/3.

## WEYRAD SIGNAL GENERATORS

Improved versions are now in large-scale production. A number of modifications have been introduced in the circuit which provide superior performance and higher efficiency.

Fundamental coverage 100 Kc/s-70 Mc/s. Calibration accuracy ±2% on all bands. R.F. output C.W. or M.C.W. to co-ax. cable. Separate fixed A.F. output. Controls on front panel—range switch, attenuator, tuning, modulation on/off and mains on/off.

Fitted in stout metal case finished cream with leather handle. Front panel black with natural lettering.

**S.G.M.I.**—Mains operated with double-wound impregnated transformer.

**S.G.B. I.**—All-dry battery operated.

Illustrated Leaflet, 2d.

**WEYMOUTH RADIO MFG. CO. LTD.**  
 CRESCENT ST., WEYMOUTH, DORSET

- T/V TECHNOLOGY
- RADIO ENGINEERING
- ELECTRONICS
- RADIO SERVICING

There's a big future in T/V and Radio. Act now ! Increase your knowledge. Back up experience with a sound theoretical background. I.C.S. offer courses of instruction in—

- T/V TECHNOLOGY
- ADVANCED SHORT-WAVE RADIO
- RADIO ENGINEERING
- RADIO SERVICE ENGINEERING
- RADAR
- ELEMENTARY ELECTRONICS
- FREQUENCY MODULATION

I.C.S. will also coach you for the following examinations :—

- B.I.R.E. ; P.M.G. Certificate for Wireless Operators ; Radio Servicing Certificate (R.T.E.B.) ; C. & G. Telecommunications, etc., etc.

**DON'T DELAY—WRITE TO-DAY** for free descriptive booklet, stating which subject or examination interests you. Fees include all books needed. Examination students coached until successful. Reduced terms for H.M. Forces.

Dept. 170D, I.C.S., 71, Kingsway, W.C.2.

**INTERNATIONAL CORRESPONDENCE SCHOOLS,**  
 (Dept. 170D), International Buildings, Kingsway,  
 London, W.C.2.

Please send booklet on.....

Name..... Age.....  
 (Block letters, please)

Address.....



# YOURS for only

**5/-** deposit and  
6 monthly  
payments of  
12/-

Postage, packing &  
insurance 1/6d.

**Cash  
Price  
70/-**



**LOW  
VOLTAGE**

**QUICK, SURE  
SOLDERING**

**LOW CONSUMPTION**

**NOW!** The Primax Instant heating solder gun with exclusive alloy tip. Never needs re-tinning. Beautifully balanced, with auto trigger control, it heats instantly—uses current **only** while actually soldering.

**A ROBUST ENGINEERING JOB for PROFESSIONAL and AMATEUR**

**The PRIMAX Balanced Grip**

220/250 V.  
A.C. only,  
50/60 C.P.S.

## Solder Gun

Obtainable on the above terms **ONLY FROM**

Dept.  
B7J

# AUSTIN, KAYE & CO. LTD.

408 STRAND, LONDON, W.C.2

## SUPERIOR RADIO SUPPLIES

# !!! CONSTRUCTORS !!!

OBTAIN "SUPERIOR RESULTS" WITH THESE RECEIVERS

**THE SUPERIOR T.R.F. RECEIVER (BUILDING COST £7/5/-).** Suitable A.C. Mains 220/240 volts. Medium and Long Wavebands. Attractive walnut veneered cabinet finished two contrasting colours. All brand new components available individually for construction. Valve line-up: 6SG7, 6SG7, 6V6gt, 6X6gt. Complete construction booklet with theoretical and practical diagrams, also price list of recommended parts. 1/6 post free.

**THE SUPREX "ATTACHE" ALL DRY PORTABLE (BUILDING COST £7/15/-).** A really superb 4 VALVE SUPERHET receiver, giving first-class results on Long and Medium Wavebands. Cabinet is compact (Size 11 1/2" x 8 1/2" x 4 1/2") of attractive case type, covered twin colours, high quality leatherette. Weight complete receiver less batteries 8lbs. All components used of highest grade: OSNOR HIGH Q COILS and FRAME-AERIAL, Plessey-Amplion Midget I.F.T.s. Provision also made for 7in. x 4in. Elliptical Speaker. Valve line-up: 1J16, 1T4, 185, 3V4. Soud for BOOK-LET giving full building details and practical wiring diagrams. 1/6 post free.

**THE SUPREX UPRIGHT PORTABLE (BUILDING COST £7/15/-)** Chassis arrangement and components almost identical to attache model with exception of cabinet. This is of the upright model with large speaker aperture in front, dial and controls under lift-up lid in top of cabinet. Covered twin colours, leatherette. Cabinet size: 10 1/2" x 8 1/2" x 4 1/2". Soud for BOOKLET. 1/6 post free.

**S.R. 2-4 WATT AMPLIFIER KIT (BUILDING COST £4/15/-).** Designed on attractive lines and incorporating Bass, Treble, Middle, and Volume controls. Suitable for most types pick-ups. Chassis hammer-finished mottled grey or bronze and given professional finish with engraved control knobs. Complete P.U. and L.S. panels, O/P Transformer, Mains Transformer, etc. Valve line-up: 6BE7, 6A3gt, 6V6gt. For A.C. Mains 240/230 volts. Soud for LEAFLET giving home construction details. 6d. post free. The above amplifier is available ready built and tested, price £8/5/- post free.

Large range of Radio and Television components and special purpose valves at competitive prices.

**TERMS:** Cash with order or C.O.D. Extra charge for C.O.D. Please add postage. (U.K. and N. Ireland only.) **OPEN:** 9 a.m. to 6 p.m. Monday to Saturday, 1 p.m. Thursday. **PERSONAL CALLERS WELCOMED.**

## SUPERIOR RADIO SUPPLIES

37, Hillside, Stonebridge, London, N.W.10.

Phone: FLGor 3644.

## The Walk-around Shop

has a fine display for New Year customers

Here's a selection :-

**RECEIVER UNIT Ex-TR1143A.** Suitable for conversion to 2 metres and F.M. Wrotham. Circuit diagram free. Price, less valves, 9/- post paid.

**TRANSMITTER UNIT Ex-TR1143A.** Suitable for conversion to 2 metres. Circuit diagram and coil conversion details supplied free. Price, less valves, 5/- post paid.

**AMPLIFIER UNIT Ex-TR1143A.** A 3-stage transformer coupled amplifier. Push pull VT52s output to modulate push pull VT501s. Circuit diagram free. 4/6 post paid.

**R.F. UNIT (Ex-BC800).**

Can be converted for use on 2 metres or 70 cm. Contains (3) 956 valves, etc. Brand new in tropical packed cartons.

PRICE 17/6 post paid.

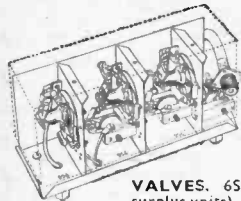

**VALVES.** 6SN7gt, 6/9; 25SN7gt, 6/9 (Ex new surplus units). 807 (American), 8/6; 807 (VT60A),

4/3. Disc-Sealed Triode (Lighthouse tube GL446A (19E4)) Boxed, New, 25/- All post paid. Ericsson Counter Valves (Decatrons) type G.C.10A, 10/- All post paid. **ALL HOME CONSTRUCTORS** should send for full details of the "Medresco" Deal-Aids which can be converted into many interesting devices.

**"MEDRESCO"** Units all in perfect working order (checked by experts) complete with Crystal Microphone and incorporating three Miniature valves are a wonderful bargain at only 27/6 each. Postage 1/-.

See our advertisement on Page 60 of "Practical Wireless" issue dated January, 1955.

**NOTE:** ORDERS AND ENQUIRIES TO DEPT. 'P.' We have a well organised Post Order Dept. giving prompt service.

**PROOPS BROS. LTD.** LAngham 0141.  
52 Tottenham Court Road, W.1.

Shop hours 9-6 p.m. Thurs. 9-1 p.m. Open all day Saturday.

## SOUTHERN RADIO'S WIRELESS BARGAINS

**TRANSCEIVERS.** Type "38" Mark II (Walkie-Talkie). With 5 valves and ready for use. Metal carrying case. Less external attachments. 30/- per set.

**TELESONIC 4-Valve Battery Portable.** Complete with Hivac Valves. In Metal Carrying Case. Simply converted to Personal Portable. £2 including Conversion Sheet.

**TRANSMITTER-RECEIVERS.** Type "18" Mark III. COMPRISING SUPERHET RECEIVER and TRANSMITTER. TWO UNITS CONTAINED IN METAL CARRYING CASE. Complete 8-Valves. £4/10/0.

**RECEIVERS TYPE "109".** 8-VALVES WITH VIBRATOR PACK FOR 6-valts BUILT-IN SPEAKER. 1.8 to 8.5mc/s. Contained in Metal Case. Perfect. 100 ONLY. £5.

**BOMBSIGHT COMPUTERS.** Ex-R.A.F. New. Contains Gyro Motors, Rev. Counters, Gear Wheels, etc. etc. Ideal for Model Makers, etc. £3/5/0, plus 10/- carriage.

**CRYSTAL MONITORS.** Type 2. New in Transit Case. Less Crystals, 8/- each.

**LUFBRA HOLE CUTTERS.** ADJUSTABLE 1/4 in. to 3/4 in. For Metal, Wood, Plastic, etc., 6/6.

**RESISTANCES.** 100 Assorted. Useful Values, Wire End, 12/5 per 100.

**CONDENSERS.** 100 Assorted. Mica, Metal Tub. etc., 15/- 100.

**PLASTIC CASES.** 14in. by 10 1/2 in. Transparent, Ideal for Maps, Photos, Display, etc., 5/6.

**STAR IDENTIFIERS.** Type I A-N. Covers both Hemispheres. In Case, 5/6.

**CONTACTOR TIME SWITCHES.** Complete in Sound Proof Case. 2 Impulses per sec. Thermostatic Control, 11/6.

**REMOTE CONTACTORS** for use with above, 7/6.

**MORSE TAPPERS.** Standard Type ex-Govt., 3/6. Heavy Duty Type "D", 8/6. COMPLETE MORSE PRACTICE SET with BUZZER, 6/9.

**MAGNETIC RELAYS SWITCH.** Bakelite, 5 c/273, 2/6 each.

**METERS AND AIRCRAFT INSTRUMENTS.** Only need adjustment or with broken cases. TWELVE INSTRUMENTS (including 3 brand New Aircraft Instruments), 35/- for TWELVE ITEMS.

Postage or carriage extra. Full List of RADIO BOOKS, 2 1/2 d.

## SOUTHERN RADIO SUPPLY LTD.,

11, LITTLE NEWPORT STREET, LONDON, W.C.2  
GERrad 6653.

# G2AK This Month's Bargains G2AK

**RACK SIZE CHASSIS.**—17in. long x 2 1/2in. deep x 12in., 16/6; x 10in., 15/-; x 8in., 14/-. P. & P. 1/-. All 16 s.w.g. ALL **POCKET VOLTMETERS.** Dual range, 0-15 v. and 0-250 v., 345 O.P.V., M.C. Worth 50/-. Our price 17/6 post free. **CRYSTAL HAND MICROPHONES.** High quality, very sensitive. Chrome finish, complete with screened lead and standard jack plug. Our price only 25/- ea. Few only. **VALVES.** B7G base, IT4, IS5, IR5, IS4, 354, 3V4, 7/6 ea., or 4 for 27/6. 807's, 10/- ea. or 2 for 17/6. Most of the 1.4 v. B7G range available at 8/6 ea. **HEADPHONES.** Low resistance type CLR No. 3, 9/6. DLR No. 2, 13/6. High resistance CHR Mar 2, 17/6, and the most sensitive of all DHR, No. 5B, 18/6 per pair. P. & P. 1/- pair. **METERS.**—0.5 ma. 2in. square, i0/-; 0.50 ma., 7/6. 0-10 A., D.C., 7/6. 0-1 ma., 20/-; 0-350 ma. thermo, 7/6. 0-4 A., 5/-; 2 1/2in. flush 0-100 ma., 0-10 ma., 12/6 ea. **Germanium Diodes,** 2/- ea., or 6 for 9/-. **Deaf-Aid Crystal mike units,** 12/6 ea. **V.H.F. FANS.** Air Space Co-axial Cable. 150 ohm, good to 600 Mc/s; normal price, 3/11 per foot. Our Price, 20 yard coil, 1/1. Very limited quantity available. **FISK SOLARISCOPE.**—Complete with charts. Give World time, light and darkness paths. Invaluable to the DX man. List 21/-, our price 7/6, post free. **PANL Home Crackle.** Black, Brown or Green, 3/- tip. P. & P. 8d. **TEST METER.** 7 ranges as follows: 1.5 v. 3 v. 150 v. 6 ma., 60 ma., 5,000 ohms, 25,000 ohms, 2 1/2in. Dia. scale M.C. meter. Rotary selector switch. Black bakelite case, 6 x 4 1/2 x 4 1/2, fitted with removable lid, also provision for internal batts., ranges can be easily extended. Bargain Price, 30/-. plus 1/6 post **NEW MULLARD QUALITY AMPLIFIER.** Chassis and all specified parts, available from stock. Postage free on all orders over £1 except where specifically stated. **PLEASE PRINT YOUR NAME AND ADDRESS.**

## C. H. YOUNG, G2AK

All callers. 110, Dale End, Birmingham 4 (CEN 1635) Mail Orders to Dept. "P" 102, Holloway Head, Birmingham 1 (MID 3254)

MONEY BACK GUARANTEE **DUKE** Tel: GRA 6677 CWO OR COD  
621 ROMFORD RD. LONDON, E.12.

## T.V. TUBES £5 - 12"

**THREE MONTHS' GUARANTEE ON EMISSION** Mazda CRM121—A or B.—A few extra types available. As we have been selling for the last three years. Picture shown to callers. INSU-Carr. and Packing 15/6 extra. **TEST TUBES 30/-**—Most makes and types, all work P. rfectly, but have Cathode to Heater shorts or slight burn, ideal for testing or spares. Insured Carriage 15/6. **AMPLIFIERS, 77/6.**—Push-pull. 4 valve and rec. Full tone range, variable. Output 3-7.5 ohms matching. A.C. or Universal. Ready to plug in. Post 2/6. **AMPLIFIERS, 57/6.**—4 waltz, 3 valves. Switched tone range 2-5 ohms output. Good quality. A.C. or A.C./D.C. Ready to plug in. Post 2/6. **AMPLIFIERS, 7/6.**—EX-W.D. Less valve. Complete with FREE Drawings. Post 1/6. **T.V., 12in. CHASSIS, 97/6.**—Complete chassis by famous manufacturer, easily adapted to Channel 3, R.F. E.H.T. Unit included. Drawing FREE. Easily fitted to Table or Consul (Power, Sound and Vision, Time base), inter-connected. THIS CHASSIS IS LESS VALVES AND TUBE, but see our catalogue for cheap valves. Our £5 Tube fits this Chassis. List of valves by request. Carr. 5/-.

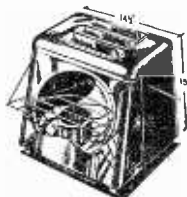

**RIPPINGILL "FYRESIDE" HEATER, 77/6.**—For the home, works or office. Although these are used ex-W.D. they have all been overhauled and work perfectly (Paraffin). Carriage 2/6.

**H.T. BATTERY BARGAINS, 1/9.**—All dry J.T. 1.5 and H.T. minimum 40 volt tested, 3/9; 60 volt + 1.5 L.T. All-Dry, 3/9; 67 1/2 volt H.T. Personal Portable type, 3/9; 60 volt H.T., 5/9; 87 volt + 64.5 volt + 41 volt, size 9in. x 4 1/2in. square, 3/9. Inert cells, G.E.C. 3 volt twins, 1/-; P. & P. 1/9 on H.T., 9d. on L.T. and cells. Plugs for Batt., 6d. each. Send 21d. stamp for Catalogue.

## Finest Soldering? Always specify ERSIN MULTICORE to be precise

Wherever precision soldering is essential, manufacturers, engineers and handymen rely on MULTICORE. There's a MULTICORE solder just made for the job you have in hand. Here are some of them.

### SIZE 1 CARTON

4 specifications for radio enthusiasts.

5/-



**HANDYMAN'S CARTON**  
Sufficient for 200 average joints. **6d.**

### TAPE SOLDER

**MELTS WITH A MATCH!**  
Real tin/lead solder containing cores of Ersin Flux. Needs no soldering iron or extraflux.

1/- PER CARD



### BIB WIRE STRIPPER AND CUTTER

The 3 in 1 tool. For stripping insulation without nicking wire, cutting without leaving rough edges and splitting extruded flex. **3/6 EACH**

MANUFACTURERS ARE INVITED TO WRITE FOR DETAILS OF BULK PACKS AT BULK PRICES

## MULTICORE SOLDERS LTD.

MULTICORE WORKS, HEMEL HEMPSTEAD, HERTS (BOXMOOR 3636)

## NZ ZCI. Mk. II

### TRANS-RECEIVER COMPLETE

Comprising of Brand New Set complete with 12 Volt Vibrator Valves and built-in 12 Volt Vibrator Power Unit. Frequency 2-8 Mc/s. 2 Headset, 4 Mic's, 2 control units, 2 coils (70 yds.), wire connectors (each Control Unit incorporates a key). **CARR. PAID £15.15.0 IN CASE.**

**22 SET.**—Trans-Rec. complete with 12 Volt Vibrator. Power unit (separate), covers 2-4.5 Mc. 4.5-8 Mc., £4.17.6, carr. paid. Circuit diagrams 2/6 each. **48 SET.**—Canadian Walkie-Talkie, separate TX and RX in common case which has space for batteries. Covers 6-9 Mc. range 15 miles. complete with valves and aerial. Carr. paid £4.7.6. New condition. Circuit diagram, 2/-. **18 SET.**—Similar set to above "48" but W.D. British. Covers 6-9 Mc. all as above. Complete valves and aerial. £3.7.6 carr. paid. Circuit diagram, 2/-. **38 SET.**—Walkie-Talkie, 6-9 Mc. range 15 miles. Overall size, 9in. x 4in. 120 volt H.T. battery, 3 volt L.T. not included). Complete with valves. 39/-. Circuit diagram, 1/-. **T.1403.**—New TX in grey steel cabinet, approx. 20in. x 14in. x 12in. Covers 2-9 Mc. Crystal (not included). Valve line up 26V6, 1EBC3, 1807. Less valves. Price £3.7.6 carr. paid. Circuit, 2/6.

### VALVES

| ALL GUARANTEED. |     |               |     | EX-GOV'T. |      |
|-----------------|-----|---------------|-----|-----------|------|
| EF50            | 4/- | EF50w(Sy)16/3 | 2/6 | SP41      | 2/6  |
| EB34            | 2/- | EA50          | 2/- | 6J5       | 9/-  |
| 6J5 (M)         | 6/- | 6H6(M)        | 4/6 | 6SH7(M)   | 5/-  |
| EF36            | 4/6 | EP8           | 7/6 | EF54      | 5/-  |
| EC52            | 5/- | EP8           | 7/6 | EL32      | 7/-  |
| EBC33           | 7/6 | EC54          | 4/6 | EL32      | 7/-  |
| 6BW6            | 8/6 | EK32          | 7/- | 6AM6      | 7/6  |
| IT4             | 7/- | IR5           | 7/- | 9BW6      | 8/6  |
| 3S4             | 8/6 | 3V4           | 8/6 | 154       | 7/-  |
| VU139           | 8/6 | 5Z3           | 8/6 | 3A4       | 7/6  |
| 6X5             | 7/6 | FW4/500       | 8/6 | 5Z4       | 8/6  |
| Pen220          | 3/6 | CV188         | 6/6 | 807       | 8/6  |
| VU133           | 3/- | U22           | 7/6 | 6K8       | 11/- |
| 6Q7             | 8/6 | 6V6           | 8/6 | VR116     | 4/-  |
| 50L6            | 8/6 | 3524          | 8/6 | 12A6      | 7/-  |
|                 |     |               |     | 6K7       | 6/-  |
|                 |     |               |     | 35L6      | 8/6  |
|                 |     |               |     | 1289A     | 6/-  |

### VINER'S (Middlesbrough).

Radio Government Supplies Electrical  
26, EAST STREET, MIDDLESBROUGH  
Telephone: MID 3418



**LOUDSPEAKERS** repaired promptly. **MODEL LOUDSPEAKER SERVICE**, Bullingdon Rd., Oxford.

**AMATEURS.**—Valves, Meters, Spares, for sale, cheap; s.a.e. for list. Box No. 252.

**GERMANIUM DIODES.** 1/- each. Quantities cheaper. BDC. 591, Green Lanes, London, N.8.

**EVERYTHING** for radio constructors. Condensers, Coils, Valves, Resistors, etc. Send stamp for list. SMITH, 98, West End Road, Morecambe. Quick service.

**WINWOOD FOR VALVE.** EF91, EB91, 6 for 32/6; EF37A, 9/-; 6K3, 807, 6SN7, 6SL7, 6V6M, 7/6 each, 6 for 41/6. New stock, 25mf/25v and 50mf/50v, 16, doz.; 450v Electrolytics, 8mf 1/6, 16mf 2/4, 8x16mf 3/6, 16x16mf 3/9, 32x32mf 4/9, 0.1-350v 6d, 500v 7d., 05-500v 7d. Full detailed lists available. WINWOOD, 12, Carnarvon Road, London, E.10. (Mail only.)

**ELECTROLYTICS,** capacity, voltage, size, type of mounting, price, post paid, 8, 450v, 1 x 2, clip, 2/-; 50, 12v, 2 x 1 1/2, tag, 1/6; 150, 25v, 1 x 1 1/2, clip, 2/-; 250, 12v, 1 x 1 1/2, wire, 2/3; 40 x 40, 275v, 1 x 2, clip, 3/3; 24 x 24 + 16, 350/425v, 1 1/2 x 2, clip, 4/9; 60 x 200, 275/350v, 1 1/2 x 1 1/2, clip, 6/6; 4, 150v, 1 x 1 1/2, 1/1; 500, 12v, 2 x 1 1/2, tag, 2/3; 150, 25v, 1 x 2, clip, 1/9; 32, tag, 32, 350/425v, 1 1/2 x 2, clip, 5/-; 8 + 16, 450/525v, 1 x 2, clip, 4/-; 2, 450/525v, 1 x 1 1/2, tag, 1/6; 8, 450v, 1 x 2, clip, 1/9; 32 + 32, 450/525v, 1 1/2 x 3, W/E, 5/6; 16 + 16, 450/525v, 1 1/2 x 2, W/E, 4/6; 1,000 + 1,000, 6v, 1 x 3, Lug, 3/3; all alicans. Some with sleeves all voltages wkg., surge where marked, new stock, guaranteed. Set of 3 Components comprising line output trans, with E.M.T. winding to give 7Kv, using EY51 (theater winding for EY51 also included) and fitted with width control. Scanning coils, low impedance line and frame, focus coil high (10,000 ohms). Set of 3, 42/- plus 2/- postage. Diagram of line trans. supplied. Mains Trans PRI 0-240-240, SEC. 250-0-250v, 80ma; 6.3v, 2.5a; 6.3v, 0.6a. 12- Loudspeakers 6in. P.M., New, boxed, 14/6 post paid. **RADIO CLEARANCE LIMITED**, 27, Tottenham Court Road, London, W.1. (Telephone: Museum 9188.)

### SITUATIONS VACANT

The engagement of persons answering these advertisements must be made through a Local Office of the Ministry of Labour or a Scheduled Employment Agency if the applicant is a man over 18-64, inclusive, or a woman aged 18-59, inclusive, unless he or she, or the employment, is exempt from the provisions of the Notification of Vacancies Order, 1952.

**T/V AND RADIO.**—A.M. Brit. I.R.E., City and Guilds, R.T.E.B. Cert., etc. on "no pass—no fee" terms. Over 95% successes. Details of exams, and home training courses in all branches of radio and T/V; write for 144-page handbook—free. B.I.E.T. (Dept. 242G), 29, Wright's Lane, London, W.8.

**A.M.I. Mech.E., A.M. Brit. I.R.E., City and Guilds, etc.** on "no pass—no fee" terms; over 95% successes. For details of exams, and courses in all branches of engineering, building, etc., write for 144-page handbook, free. B.I.E.T. (Dept. 242B), 29, Wright's Lane, London, W.8.

**CITY AND GUILDS** (Electrical, etc.) on "no pass—no fee" terms. Over 95% successes. For full details of modern courses in all branches of Electrical Technology send for our 144-page handbook—free and post free. B.I.E.T. (Dept. 242A), 29, Wright's Lane, London, W.8.

**RATES:** 5/- per line or part thereof, average five words to line, minimum 2 lines. Box No. 1/- extra. Advertisements must be prepaid and addressed to Advertisement Manager, "Practical Wireless," Tower House, Southampton St., Strand, London, W.C.2.

**50 ASSORTED CONDENSERS** and Resistors, all good values, for 5/6; 6AM6 Valves 5/6. S.A.E. lists. E.S.S., 133, Leaveden Rd., Watford.

**ARE YOU STUCK** on Electrical or Radio Control? Large stock of Transformers, Rectifiers, Lamps, Rotary Converters, Motors, Technical Books. S.A.E. for bargain lists. LAWRENCE, 134, Cranley Gardens, N.10. (CL1. 6641.)

**VALVE BARGAINS.** 1R5, 1S5, 3V4, 6V/- each. 1T4 5/-. MISC. BARGAINS. Germanium Diode, 1/3; cabinet, walnut veneered, ideal for that spare set or bedroom radio with s/het. chassis and dial and 3 knobs, 18/-, cabinet separate 16/-. Dim. 12 x 6 x 6. All items new, money back guarantee. Post paid. A. BLACKBURN, Central House, Bury Wharf, Bury St., Ruislip, Mdx.

**VALVES, New, Tested and Guaranteed.** Matched Pairs, KT66, 25/-; 6V6G and GT, 17/- per pair; 6K8G, 6Q7G, 6SN7GT, 6SL7GT, 6AT6, 6BE6, 6BR7, 6BS7, 6SA7, 6S7GT, 6SK7, 6X4, 6X5GT, 8/-; 1R5, 1T4, 1S5, 3V4, 6AM6, 5763, Y63, 6U5, 7/6; EBC33, EZ40, KT33C, 25A6G, 12AT7, 8/6; PL81, PL82, ECL80, 1H5, 1N3, 10/6; 12AX7, 6/9. Coax cable, stranded, 75 ohms/in., 6d. yd. R. J. COOPER, 32, South End, Croydon, Surrey. (CRO. 9185.)

**ALL TYPES** of Valves required for cash. State quantity and condition. **RADIO FACILITIES LTD.**, 38, Chalcut Road, N.W.1. (PRIMrose 9090.)

**VALVES WANTED.** EB91, EF80, ECL80, PL81, EY51, and all TV types, 5Z4G, 6Q7, etc., etc. Brand new only, prompt cash. Send us your offers. **RADIO HAM SHACK LTD.**, 155, Swan Arcade, Bradford, 1.

**WANTED, Valves** 5Z4, ECL80, EY51, EF80, KT66, 6U4GT, KT61, and all TV types; also P.M. Speaker Units, 3in., 5in., 6in., 8in., 10in.; prompt cash. **WM. CARVIS LTD.**, 103, North St., Leeds, 7.

**AUCTION SALE,** Exeter, late Jan., Electrical Components. Postal bids accepted. Catalogue 6d. from **SAMPSONS**, Auctioneers, Dawlish, Devon.

**ALUMINIUM CHASSIS** made to your requirements, 16 & 18 gauge, any quantity, large or small. We will be pleased to quote. **MACHINE CONTACTS**, Building 336, Hurn Airport, Christchurch, Hants.

**AMERICAN MAGAZINES.**—One-year "Audio Engineering," 35/-, specimen copy, 3/6; "Popular Science," 28/6; "High Fidelity," 50/-, specimen copy, 4/6. Free booklet quoting others. **WILLEN LTD.**, Dept. 40, 101, Fleet Street, London, E.C.4.

**BOOKLETS.** "How to Use Ex-Gov. Lenses and Prisms," Nos. 1 and 2, price 2/6 ea. Ex-Govt. Optical lists free for s.a.e. **H. ENGLISH**, Rayleigh Rd., Hutton, Brentwood, Essex.

**I.P.R.E. TECHNICAL PUBLICATIONS.** 6,500 Alignment Peaks for Super-heterodynes, 5/9, post free. Data for constructing T.V. Aerial Strength Meter, 7/6. Sample copy T.V. Practical Radio Engineer, quarterly publication of the Institute, 2/-; membership and examination data, 1/-; Secretary, I.P.R.E., 20, Fairfield Rd., London, N.9.

**THE "BRENNEL" TAPE DECK** incorporates many important design features originally developed for the famous Sound Master. A new toggle-action grip between capstan and pinch wheel ensures a slip-free tape drive and eliminates the chief cause of "wow" and flutter. Three motors are used and the highly ingenious interlocking switching gives instant control of the tape drive in either direction without the slightest risk of damage. Three speeds are available, 3 1/2 in., 7 1/2 in., and 15 in. per second with a playing time respectively of 2 hrs., 1 hr. and 30 min. The Brennell Record/Playback head is a twin-track high-impedance type requiring no matching transformer. Due to its exceptionally small gap it will extend the frequency response to at least 11 Kc/s at a tape speed of 7 1/2 in. with a suitably corrected amplifier. The Brennell Erase head is a low-impedance type which requires to be fed from a low-impedance winding on the oscillator coil. Beautifully made to the highest precision standards the Brennell Tape Deck used with an appropriate amplifier is ideal for the new H.M.V. pre-recorded Tapes. Price £15/10/- complete. Send for illustrated leaflet to **HOTAX PRODUCTS LTD.**, 59, Grays Inn Road, London, W.C.1. Trade enquiries only to **BRENNEL ENGINEERING CO. LTD.**, 2, Northington Street, London, W.C.1.

**MIDGET AMPLIFIERS, £3/19/6,** D & P, 2/6, having built-in power pack for 200-250 A.C. Dimensions 10 x 3 x 2 1/2, fits all normal record players leaving room for speaker, 4 watts quality output, suitable for all speakers and with standard or L.P. pickups. Valves 6J7 and 6V6 available at 20/- per pair extra if required. Other models from £4/12/6, also cabinets and accessories. **SPECIAL:** Our new RDJ midget 4 watt amplifier to fit into the Phillip's "Disc Jockey" is now available. Send 6d. for new 8 page illustrated catalogue. **ELECTRO-ACOUSTIC LABORATORIES**, Tain, Ross-shire, Scotland.

**THE INSTITUTE** of Practical Radio Engineers Home Study Courses are suitable coaching text for I.P.R.E. and other qualifying examinations. Fees are moderate. Syllabus of seven modern courses post free from **SECRETARY, I.P.R.E.**, 20, Fairfield Road, London, N.8.

**FREE!** Brochure giving details of Home Study Training in Radio, Television, and all branches of Electronics. Courses for the Hobby Enthusiast or for those aiming at the A.M. Brit. I.R.E., City and Guilds, R.T.E.B. and other Professional examinations. Train with the college operated by Britain's largest Electronics organisation; moderate fees. Write to **E.M.I. INSTITUTES**, Dept. PW.28, London, W.4.

**SEE THE WORLD** as a Radio Officer. Short training; low fees; scholarships; boarding/day students. Stamp for prospectus. **WIRELESS COLLEGE**, Colwyn Bay.

**MERCHANT NAVY** Wireless School, Overseas House, Brooks' Bar, M/cr 16.

**THE WIRELESS SCHOOL.**—Training in Wireless, Telegraphy, **RADIO HOUSE**, Manor Gdns., N.7.

**WIRELESS.**—Day and Evening Class instruction for P.M.G. Certificate of Proficiency and Amateur Wireless Licence. Morse instruction only if required, also postal courses. Apply **B.S.T. LTD.**, 179, Clapham Rd., London, S.W.9.

**SERVICE SHEETS.**—Send 1/- now 4,000 Sheets, listed from 2/3; Radio and T.V. Sheets; post only. **RATEL**, 171, Norris St., Preston.

WANTED, Midget Power Pack for M.C.R.1. CORNISH, 4, Bay Villas, Long Rock, Penzance.

THE CHEAPEST Multi-range Meter on the Market. Measures: 0-6V D.C., 0-240V A.C., 0-30mA D.C., 0-6V A.C., 0-240V A.C., 0-30mA A.C. plus a circuit testing scale powered by internal battery and a valve socket for testing English 4 & 5 pin valves. Brand new in makers' boxes with instruction leaflet at 29/6 each, post 1/6. Neon Testers, screwdriver type, operates from 100-500V A.C. or D.C. and is a very useful pocket screwdriver, complete with protecting cap and pocket clip, 6/- each. VCR5175, O.K. for TV, etc., no cut-off, 19/6, post 2/6. 2in. 0-1mA Meters, 14/6 each. SERVO RADIO, 156/8, Merton Rd., Wimbledon, S.W.19. (L1BER 6525.)

TELEKIT SUPPLY

MAIL ORDER DEPT.

Chantry Lane Works, Chantry Lane, Bromley, Kent. Phone: Rav. 5845.

Please mention P.W. and enclose 6d. postage

Table with columns: VALVES, NEW & SURPLUS, GUARANTEED. Lists various valve types and their prices.

BECKENHAM, KENT

THE SHOP FOR THE CONSTRUCTOR NOW OPEN AT 104, HIGH STREET, BECKENHAM 3720

STAN WILLETTS

43, SPON LANE, WEST BROMWICH, STAFFS. Tel: WBS. 2382. VALVES.—Brand New. Every one guaranteed. 6SN7, 6SL7, 7/6. 6K7, 4/6. VT52 (EL32), 5/-. 6P6G, 5/6. 6V6GT, 6X5GT, 6/9. 67/- doz. 6K8G, 8/6, 90/- doz. RK34, 2C34, 1/9. 18/- doz. ATP4, 3/6. VR65, (SP61), 2/- EA50, 1/9. 6E77, (EF80), 7/9. EC52, 4/9. 1T4, 1R5, 1R5, 3R4, or 1S4, 24/9 Set of 4, 6/9 each. P. & P. 6d. TRIPLET 1MA METER RECTIFIER. Brand New with Circuit, 5/6, P. & P. 4d. GERMANIUM XTAL DIODES.—G.E.C. Brand New, 1/-, 10/9 doz. P. & P. 3d. SET OF PARTS.—For 2-Waveband Crystal Set with Circuit, 7/11, P. & P. 6d. VOLUME CONTROLS, with S.P. Switch. 11in. spindle, 1 and 1 mer., 2/-. Post 4d. HEATER TRANSFORMERS.—220 volts input. 6.3 at 11 amps. output. 5/6, P. & P. 9d.

WANTED—VALVES Best Prices Offered

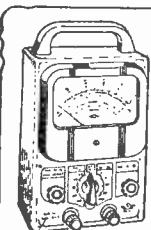

PULLIN SERIES 100 TEST METER AC/DC 10,000 A/V 21 RANGES 100uA to 1000V COMPLETE IN DIE-CAST CASE WITH TEST LEADS CLIPS AND PRODS FULLY GUARANTEED

SENT POST FREE FOR £2.10s. DEPOSIT AND TEN FURTHER MONTHLY PAYMENTS OF £1. CASH PRICE 11GNS

Frith RADIOCRAFT Ltd PHONE 58927 69-71 CHURCH GATE LEICESTER

RADIO UNLIMITED, offer: Valve Sets, 6V6, 6K7, 6K8, 6Q7, 6Z4, 31/-; 1T4, 1S5, 1R5, 3S4, 28/-; 6V6M, 6K6G, 6SN7, 6SL7, EBC3, 5U4, 6X5C, 6BE6, EF91, EB91, EF39, 807, EF50, 6J7M, 6AK5, EF92, 7/6 each; ECL80, 9/-; EF80, 10/-; KT33c, 9/-; EF37a, 9/-; EBC41, 8/6; UY41, 8/6; ML6, 6/6. Heater Trans., 200/240V, 6.3v at 1.5A, 5/9. Mains Trans., 350/350V, 6v, 5V, 4v, 80 MA, 19/6. V/controls, i-j meg, lin. Sp., 1/- each. Crystal Diode, 1/6. Full range Instrument Wires, Nuts, Bolts, etc. List. Two-valve + Rec. Amplifier kit, incl. valves, 59/6. Full range Teletron Coils in stock. Full lists available. RADIO UNLIMITED, Elm Road, London, E.17. Callers to Eastern Road and Hoe Street, London, E.17. (Telephones: KEY 4813 & LAR 6377.)

TELEVISION

The advance of Radio Technique will offer unlimited opportunities of high pay and secure posts for those Radio Engineers who have had the foresight to become technically qualified. How you can do this quickly and easily in your spare time is fully explained in our unique handbook. Full details are given of A.M. BRITAIN'S CITY & GUIDES Exams, and particulars of up-to-date courses in Wireless Engineering, Radio Servicing, Short Waves, Television, Mathematics, etc., etc. We guarantee NO PASS—NO FEE. Prepare for to-morrow's opportunities and future competition by sending for this very informative 144-page guide NOW—FREE and without obligation.

BRITISH INSTITUTE OF ENGINEERING TECHNOLOGY (Dept. 242), COLLEGE HOUSE, 29-31, Wright's Lane, Kensington, W.8

MULTIMETER KITS, 2 1/2in. M/C meter. Reads D.C. volts 3-30-150-300-600 mA, 0-40 ohms 0-5,000. With Bakelite Case, 27/6. 6 v. VIBRATOR PACKS. Self contained in Steel Box. Output 150 v. 30 mA, 22/6. Ideal for Battery Radios.

FISHING ROD AERIALS. 12in. Set 3, 7/6. Mounting Base, 3/6.

0.5 AMPMETERS, 2 1/2in. square M/C. 11/- GERMANIUM DIODES, 3/9.

FREQUENCY CRYSTALS, 9,100 and 4,500 Kc., 10/6; 4,880, 4,800, 2,400, 594, 4,250, 505 Kc., 6/6. 1in. Space Pins.

SELENIUM RECTIFIERS, F.W. 6 or 12 v. 4 A., 22/6; 6 A., 30/-; 3 A., 14/6; 100 mA., 3/6; 1 A., 9/6; 2 1/2 v. 2 A., 30/-; 250 v. 100 mA. H.W. 9/-; 250 v. 275 mA., 17/6; 250 v. 80 mA., 6/6.

TRANSFORMERS, 200-240 volts, tapped 3-4-5-6-8-9-10-12-15-18-20-24 and 30 volts at 2 A., 21/6. Tapped 17-11-5 volts 5 A., 22/6; Tapped 17-11-5 volts 1 1/2 A., 16/6; 6.3 v., 21 A., 8/6. One year guarantee.

M/C MICROPHONES AND TRANSFORMERS, 15/6.

EX-W.D. PHONES. Low Resistance, 9/6. NEW OAK, 6 v. 4-pin Vibrators, 10/6.

MORSE KEYS, 3/-; BUZZERS, 3/-; 12/24 v. BLOWER MOTORS, 14/6 A.C./D.C.

CARBON TWIST DRILLS. Set of 7, 1/16th to 1 or 9 1/16th to 3/16th, 3/6.

U.D.F. AERIALS, 180-200 Mc/s covering band, complete with case, 6/6.

OVERLOAD SWITCHES. Breaks at 1 Amp., 3/6.

TR1196, Transmitter Section. New and complete, 4,6/8 Mc/s. Easily converted. Less valves, 15/- with valves 22/-.

Throat Microphones with cord, 4/-; Pocket Voltmeters, 2in. M/c 0-20-200, 11/6.

New VR65/SP61 Valves, 5/8, 4 for 20/-.

ALL POST PAID IN U.K.

THE RADIO & ELECTRICAL MART 253b, Portobello Road, London, W.11. 'Phone: Park 6026.

WALNUT Radiogram Cabinets of distinction; stamp details. R. SHAW, 69, Fairlop Rd., E.11.

UNIVERSAL METER, Taylor Model 90A, BS.89, first-grade accuracy, 1,000 o.p.v., AC/DC, £8/10/- only; also Valve Tester, 45A/S, with adaptors measuring mutual conductance of almost all modern valves, £14, both in perfect condition, practically new. Write: STRAUSS, 5, Gloucester Ave., Slough, Bucks.

AMERICAN RADIO Plans and Devices. Now available. Hundreds of new and startling devices you can make. Only designs of this type available in UK. Receivers, walkie talkies, amplifiers, recorders, magic eye alarms, etc., etc. Full lists, data, illustrations Free for stamp. Send to-day. — A.P.S. (PW), Sedgford, King's Lynn.

CONDENSER CLEARANCE !!

All new goods. Types at same price may be mixed to make up dozens. MCA.—10, 15, 20, 30, 50, 75, 100, 150, 200, 240, 1,300 p.F., 3/6 doz. Larger type 400, 450, 700, 3,000, 4,500 p.F., 2/6 doz. Our assortment, 50 for 8/9. REALLY MIDGET TUBULARS.—Wire ended, 0.04, 0.01, 3/8 doz. STANDARD SIZE, 0.01 mid., 1,000 v., 3/6 doz. METAL BLOCK.—225 mfd., 350 v., 6 for 1/3. 6 MFD, 2,000 v. TEST.—Metal block 3/9, post 1/- COAX.—stranded core, 80 p., app. lin., 6d., yd. Coax fittings: universal plug 11d., socket, 1/3. outlet box, 4/6, line connector (double socket) 1/3. SPECIAL: 32 mfd., 450 v. (U.S.A.) 4 1/2 in. x 2 in., 1/6. ELECTROLYTIC.—40 mfd., 450 v., 4/-; 8 + 16 450 v. (small), 4/3; 16 + 32, 350 v., 4/9; 32 + 32, 250 v., 5/3; 32 + 32, 400 v., 6/-. PVC covered types: 16, 450 v., 2/8; 50, 50 v., 2/-; 25, 25 v., 1/9. WIRE WOUND RES.—(cement coated, wire ended, 25, 50, 100, 150, 200, 250, 300, 1,000, 1,500, 2,000, 2,500, 3,000, 10,000 p.F., 1/3; 10 w., 1/6 15 w., 1/8; 15, 20, 25, 30 K, 3 w., 1/9; 10 w., 2/3; 30 K, 5 w., 2/3; 10 w., 2/9. Over 21, post paid. List 3d.

REED & FORD, 2A, BURNLEY ROAD, AINSDALE, SOUTHPORT.

RECEIVER R1155

BRAND NEW. AERIAL TESTED In maker's original transit case. Now is the chance to get one from the best delivery we have had from the Ministry. £119.6 Carr. 10/6

Send S.A.E. for further details or 1/3 for publication giving circuit diagrams, etc. Others available from £9.10.0 according to condition.

HIGH PHONES.—High Resistance Type CHR. New, 12/6 pair, post 1/6.

MICROAMMETERS.—250 F.S.D. 3 1/2in. Flush Model S37. Specially scaled for test meters. Knife edge pointers, magnetic shield. Brand New, 55/-.

VOLTMETERS.—0/300 Flush D.C. Moving Coil, 10/6; 0/20, 2in. Flush Moving Coil, 7/6; 0/40 2in. Flush M.C., 10/8, post 1/-.

CONDENSERS. PAPER BLOCK TYPE 5mfd., 1,000 v., 2/6 | 8mfd., 500 v., 7/6 4mfd., 350 v., 4/6 | 8mfd., 750 v., 10/6 4mfd., 2,000 v., 7/6 | 10mfd., 350 v., 10/8

WILCO ELECTRONICS Dept. P.W. 204, Lower Addiscombe Rd., Croydon.

H.A.C. SHORT WAVE EQUIPMENT

Noted for over 18 years for . . . S.W. Receivers and Kits of Quality.

Improved designs with Denco coils: One-Valve Kit, Model "C" Price, 25/- Two " " " "E" " " 50/-

All kits complete with all components, accessories, and full instructions. Before ordering call and inspect a demonstration receiver, or send stamped, addressed envelope for descriptive catalogue.

"H.A.C." SHORT-WAVE PRODUCTS (Dept. TH), 11, Old Bond Street, London, W.1.

## An OPPORTUNITY

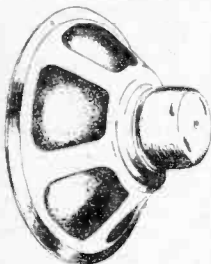

to secure a super quality TRUVOX BX.11 12in. moving coil permanent magnet loudspeaker at a bargain price. Brand new in maker's carton. Available in 3 ohm speech coil only. Limited quantity at the special price while stocks last of

**ONLY 50/-** carriage paid.

Our full list of loudspeakers will be sent on receipt of your name and address and 2d. stamp.

## A TESTER IN YOUR POCKET

Combined Neon Tester and screwdriver. Complete with clip for pocket and shield for screwdriver blade.

Tests A.C. and D.C. voltages 110 v. to 500 v. An essential pocket instrument for every engineer and constructor. Send for one to-day.

**PRICE ONLY 6/- POST PAID**

We carry the full range of components for the "Fury Four," Mullard S-10 amplifier, G.E.C. "912" amplifier, etc. Send S.A.E. for price list.

Dealers and bona fide radio engineers send for our trade list of condensers and resistors, etc.

## HOME RADIO OF MITCHAM

187 London Road, Mitcham, Surrey MIT 3282

Open every day including Saturday until 6.30 (Weds. 1 p.m.)

FREE!

*to you!*  
—if you seek  
**SUCCESS!**

If you lack the qualifications which would get you a better job; more pay and quicker progress; if you wish to know how The Bennett College can guarantee to teach you up to qualification stage by one of the easiest, quickest and soundest methods of mind training; if you wish to learn how Personal Postal Tuition can prove that you are cleverer than perhaps you think you are — if you like the idea of studying in your own time, at your own pace, with your own tutor guiding you, helping you, teaching you by post — send at once for this recently published important book — "Train your mind to SUCCESS". It is quite free, just fill in the coupon below and name the subject you are interested in (some of the many Courses available are listed here). Then send in the coupon to us TODAY. You will never, never regret it. But do it today. Act NOW!

**WHAT'S YOUR LINE ?**

|  |   |
|--|---|
| <ul style="list-style-type: none"> <li>Building</li> <li>Carpentry</li> <li>Commercial Art</li> <li>Diesel Engines</li> <li>Draughtsmanship</li> <li>Electrical Eng.</li> <li>Fire Engineering</li> <li>Mechanical Eng.</li> <li>Motor Engineering</li> <li>Quantity Surveying</li> <li>Radio Eng.</li> <li>Surveying</li> <li>Surveyor's Exams.</li> <li>Telecommunications</li> <li>Textiles</li> <li>Wireless Telegraphy</li> </ul> | <ul style="list-style-type: none"> <li>Accountancy Exams.</li> <li>Auctioneer's Exams.</li> <li>Book-keeping</li> <li>Civil Service</li> <li>Costing</li> <li>English</li> <li>General Education</li> <li>Journalism</li> <li>Languages</li> <li>Mathematics</li> <li>Police Subjects</li> <li>Salesmanship</li> <li>Secretarial Exams.</li> <li>Shorthand</li> <li>Short Story Writing</li> <li>and many others</li> </ul> |
|--|---|

GENERAL CERT. OF EDUCATION

BENNETT COLLEGE

(DEPT. B102F), SHEFFIELD

Please send me, without obligation, a free copy of "Train your mind to SUCCESS" and the College Prospectus on:

SUBJECT \_\_\_\_\_

NAME \_\_\_\_\_

ADDRESS \_\_\_\_\_

AGE (if under 21) \_\_\_\_\_

Please write in Block Letters

**THIS DAY**  
COULD BE THE TURNING-POINT IN YOUR LIFE.

**THIS COUPON**  
COULD BE YOUR PERSONAL PASSPORT TO SUCCESS.

*Send it NOW!*

## DIRECT FROM THE MANUFACTURER

**DULCI RADIO/RADIOGRAM CHASSIS**  
Built to Highest Technical Standard's

**FULLY GUARANTEED**

All chassis 11 in. x 7 in. x 8 in. high. Latest type valves 6BE6, 6BA6, 6AT6, 6BW6, 6X4. Flywheel tuning. Negative feedback over entire audio section. Engraved knobs. 3 tone positions for radio and gram.

For A.C. Mains 100/120 and 200/250 volts

|  |                 |
|--|-----------------|
| Model B3.—Long. Medium, Short                                  | <b>£12/12/0</b> |
| 5 Valves. Output 3½ watt                                       |                 |
| Model B3.—Plus Push Pull Stage                                 | <b>£15/15/0</b> |
| 6 Valves. Output 6 watt  |                 |
| Model B3.—Double Feature with P/Pull & R.F. Stage.             | <b>£18/18/0</b> |
| 7 Valves. Output 6 watt  |                 |
| Model B6.—Six Wavebands, Med., Long, 4 Short. (3 Bands spread) | <b>£15/15/0</b> |
| 5 valves. Output 3½ w.   |                 |
| Model B6.—Plus Push Pull Stage                                 | <b>£18/18/0</b> |
| 6 Valves. Output 6 watt  |                 |
| Model B6.—Double Feature with P/Pull & R.F. Stage.             | <b>£23/2/0</b>  |
| 7 Valves. Output 6 watt  |                 |

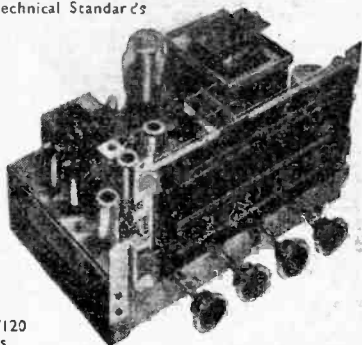

**ALL PRICES TAX PAID**

Escutcheon for 9in. x 5in. dial, 4/9 extra. Matching speakers P.M. Type 3 ohms. 8in. or 10in. available. Chassis sent under money back guarantee conditions against remittance. Free particulars from the manufacturers.

**THE DULCI CO. LTD.,**  
99 VILLIERS RD., LONDON, N.W.2. Telephone: Willesden 7773

## BUILD THIS AMAZING RADIO

**POWERFUL! PERSONAL! PORTABLE!**

FOR **30/-**  
POST FREE

- Selective tuning.
- Acorn low drain valve.
- Loud clear tone.
- Long range.
- No earth.
- Short aerial, 2ft.
- Welded steel case.
- Easy to assemble.
- All parts for this set are sold separately.

Ideal for :

- Fishing, Camping.
- Cycling, Touring.
- On the beach, etc.

### MAIL ORDER ONLY

This little set was designed to give you a real personal portable radio that you can enjoy anywhere without disturbing others. Use it on camping trips, in bed, in your office, or just anywhere. Send 2/- for layout, Wiring diagram and Component Price List.

Details of our 30/- Short Wave Receiver are now ready. Send 2/- for Layout, Circuits and Component Price List.

**R. C. S. PRODUCTS (RADIO) LTD.,**  
11, OLIVER ROAD, LONDON, E.17

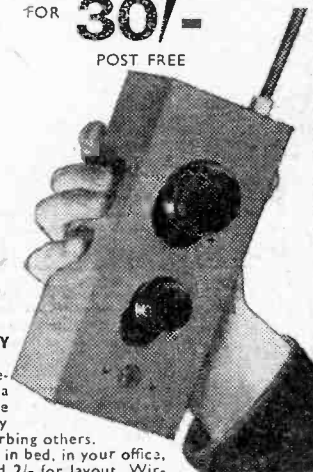

Practical Wireless

# BLUEPRINT SERVICE

## PRACTICAL WIRELESS

|  | <i>No. of<br/>Blueprint</i> |
|--|-----------------------------|
| <b>CRYSTAL SETS</b>                                |                             |
| <b>1/6d. each</b>                                  |                             |
| 1937 Crystal Receiver ...                          | PW71*                       |
| The "Junior" Crystal Set ...                       | PW94*                       |
| <b>2s. each</b>                                    |                             |
| Dual - Wave "Crystal Diode" ...                    | PW95*                       |
| <b>STRAIGHT SETS</b>                               |                             |
| <b>Battery Operated</b>                            |                             |
| <b>One - valve : 2s. each</b>                      |                             |
| The "Pyramid" One-valver (HF Pen) ...              | PW93*                       |
| The Modern One-valver ...                          | PW96*                       |
| <b>Two-valve : 2s. each.</b>                       |                             |
| The Signet Two (D & LF) ...                        | PW76*                       |
| <b>3s. each.</b>                                   |                             |
| Modern Two-valver (two band receiver) ...          | PW98*                       |
| <b>Three-valve : 2s. each.</b>                     |                             |
| Summit Three (HF Pen, D, Pen) ...                  | PW37*                       |
| The "Rapide" Straight 3 (D, 2 LF (RC & Trans)) ... | PW82*                       |
| F. J. Camm's "Sprite" Three (HF, Pen, D, Tet) ...  | PW87*                       |
| <b>3s. each.</b>                                   |                             |
| The All-dry Three ...                              | PW97*                       |
| <b>Four-valve : 2s. each.</b>                      |                             |
| Fury Four Super (SG, SG, D, Pen) ...               | PW34C*                      |
| <b>Mains Operated</b>                              |                             |
| <b>Two-valve : 2s. each.</b>                       |                             |
| Selectone A.C. Radiogram Two (D, Pow) ...          | PW19*                       |
| <b>Three-valve : 3s. 6d. each.</b>                 |                             |
| A.C. Band-Pass 3 ...                               | PW99*                       |
| <b>Four-valve : 2s. each.</b>                      |                             |
| A.C. Fury Four (SG, SG, D, Pen) ...                | PW20*                       |
| A.C. Hall-Mark (HF Pen, D, Push Pull) ...          | PW45*                       |
| <b>SUPERHETS</b>                                   |                             |
| <b>Battery Sets : 2s. each.</b>                    |                             |
| F. J. Camm's 2-valve Superhet ...                  | PW52*                       |
| <b>Mains Operated : 3s. 6d. each.</b>              |                             |
| "Coronet" A.C.4 ...                                | PW100*                      |
| AC/DC "Coronet" Four                               | PW101*                      |

|   | <i>No. of<br/>Blueprint</i> |
|---|-----------------------------|
| <b>SHORT-WAVE SETS</b>  |                             |
| <b>Battery Operated</b>   |                             |
| <b>One-valve : 2s. each.</b>  |                             |
| Simple S.W. One-valver  | PW88*                       |
| <b>Two-valve : 2s. each.</b>  |                             |
| Midget Short-wave Two (D, Pen) ...  | PW38A*                      |
| <b>Three-valve : 2s. each.</b>  |                             |
| Experimenter's Short-wave Three (SG, D, Pow) ...  | PW30A*                      |
| The Perfect 3 (D, 2 LF (RC and Trans)) ...  | PW63*                       |
| The Band-spread S.W. Three (HF, Pen, D, (Pen), Pen) ...   | PW68*                       |
| <b>PORTABLES</b>  |                             |
| <b>1s. 6d.</b>  |                             |
| The "Mini-Four" All-dry (4-valve superhet) ...  | *                           |
| <b>MISCELLANEOUS</b>  |                             |
| <b>2s. each.</b>  |                             |
| S.W. Converter-Adapter (1 valve) ...  | PW48A*                      |
| <b>(2 sheets), 7s. 6d.</b>  |                             |
| The P.W. 3-speed Autogram ...   | *                           |
| The P.W. Electronic Organ (2 sheets), 7s. 6d.   | *                           |
| <b>TELEVISION</b>   |                             |
| <b>The Practical Television Receiver.</b>   |                             |
| (3 sheets), 10/6  |                             |
| The "Argus" (6in. C.R. Tube), 2/6*  | *                           |
| The "Super-visor" (3 Sheets) 7/6*   | *                           |
| The "Simplex" ...   | 3/-*                        |
| <p><i>All the following blueprints, as well as the PRACTICAL WIRELESS numbers below 94 are pre-war designs, kept in circulation for those amateurs who wish to utilise old components which they may have in their spares box. The majority of the components for these receivers are no longer stocked by retailers.</i></p> |                             |
| <b>AMATEUR WIRELESS AND WIRELESS MAGAZINE</b>   |                             |
| <b>STRAIGHT SETS</b>  |                             |
| <b>Battery Operated</b>   |                             |
| <b>One-valve : 2s.</b>  |                             |
| B.B.C. Special One-valver ...   | AW387*                      |
| <b>Mains Operated</b>   |                             |
| <b>Two-valve : 2s. each.</b>  |                             |
| Conso'etric Two (D, Pen), A.C. ...  | AW403                       |

**SPECIAL NOTE**

THESE blueprints are drawn full size. The issues containing descriptions of these sets are now out of print, but an asterisk denotes that constructional details are available, free with the blueprint.

The index letters which precede the Blueprint Number indicate the periodical in which the description appears. Thus P.W. refers to PRACTICAL WIRELESS, A.W. to *Amateur Wireless*, W.M. to *Wireless Magazine*.

Send (preferably) a postal order to cover the cost of the Blueprint (stamps over 6d. unacceptable) to PRACTICAL WIRELESS, Blueprint Dept., George Newnes, Ltd., Tower House, Southampton Street, Strand, W.C.2.

|  | <i>No. of<br/>Blueprint</i> |
|--|-----------------------------|
| <b>SHORT-WAVE SETS</b>   |                             |
| <b>Battery Operated</b>  |                             |
| <b>One-valve : 2s. each.</b>   |                             |
| S.W. One-valver for American ...   | AW429*                      |
| <b>Two-valve : 2s. each.</b>   |                             |
| Ultra-short Battery Two (SG, det Pen) ...  | WM402*                      |
| <b>Four-valve : 3s. each.</b>  |                             |
| A.W. Short Wave World-beater (HF Pen, D, RC Trans) ...   | AW436*                      |
| Standard Four - valver Short-waver (SG, D, LF, P) ...  | WM383*                      |
| <b>Mains Operated</b>  |                             |
| <b>Four-valve : 3s.</b>  |                             |
| Standard Four-valve A.C. Short-waver (SG, D, RC, Trans) ...  | WM391*                      |
| <b>MISCELLANEOUS</b>   |                             |
| <b>Enthusiast's Power Amplifier (10 Watts) (3/-)</b>   |                             |
| WM387*   |                             |
| <b>Listener's 5-watt A.C. Amplifier (3/-)</b>  |                             |
| WM392*   |                             |
| <b>De Luxe Concert A.C. Electrogram (2/-)</b>  |                             |
| WM403*   |                             |
| <p><b>QUERY COUPON</b></p> <p>This coupon is available until Feb. 7th, 1955, and must accompany all queries, sent in accord with the notice on page 121.</p> <p>PRACTICAL WIRELESS, Feb., 1955</p> |                             |

Published on the 7th of each month by GEORGE NEWNES, LIMITED, Tower House, Southampton Street, Strand, London, W.C.2. and printed in England by W. SPEAIGHT & SONS, Exmoor Street, London, W.10. Sole Agents for Australia and New Zealand: GORDON & GOTCH (A sia), LTD. South Africa: CENTRAL NEWS AGENCY, LTD. Subscription rate including postage, for one year: Inland and Abroad 13s. 6d. (Canada 13s.) Registered at the General Post Office for the Canadian Magazine Post

# Build this HIGH QUALITY LOW COST AMPLIFIER

★ Circuit designed by  
Mullard research engineers.

★ Specified components  
available from most  
radio dealers.

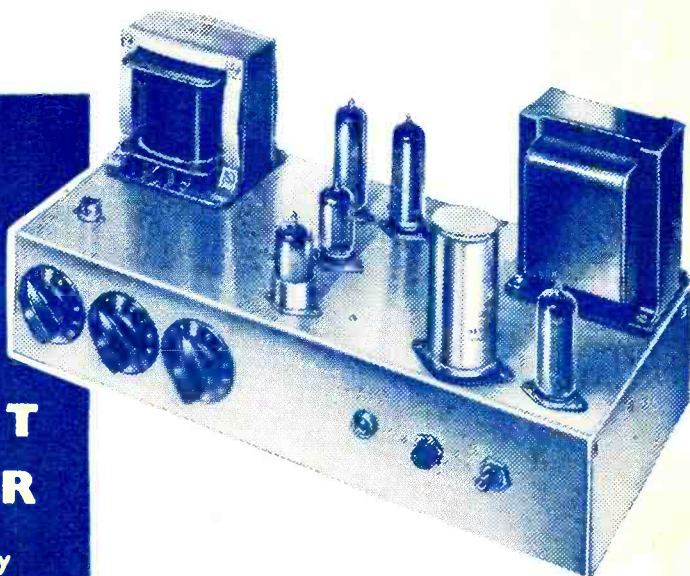

Here's an entirely new amplifier circuit which brings high quality sound reproduction within the reach of thousands more enthusiasts. It has been

designed by Mullard research engineers with special regard for easy construction and low cost.

Full details of the circuit are included in the 2s. 6d. book which is obtainable from radio dealers or direct from Mullard Ltd. Valve Sales Department—2s. 10d. post free. Get your copy now.



|   |   |                          |  |
|---|---|--------------------------|--|
| EASY TO BUILD<br>AT LOW COST                        | GOOD TRANSIENT<br>RESPONSE  | LOW OUTPUT<br>RESISTANCE | LOW HUM<br>AND NOISE                                 |
| NEGLIGIBLE<br>DISTORTION AT<br>ALL OUTPUT<br>LEVELS | DESIGNED ROUND<br>FIVE MULLARD MASTER VALVES<br>EF86 ECC83 2 x EL84<br>GZ30 or EZ80 |                          | UNIFORM<br>FREQUENCY<br>RESPONSE IN<br>AUDIBLE RANGE |

## Mullard



MULLARD LTD., CENTURY HOUSE, SHAFTESBURY AVENUE, LONDON, W.C.2

MVM3 8C