

www.hi-fiworld.co.uk

hi-fi WORLD



DECEMBER 2002 UK £2.75
Malaysia Rm18

DIY SUPPLEMENT No. 70
INSIDE THIS ISSUE!

& computer audio

TWIN PEAKS

Is Meridian's 800/861 DVD-A player & processor combination the pinnacle of digital audio?

plus : affordable tubes - we test four entry level integrated valve amps

plus

- Quad 22L 'speakers
- Marantz DV-12 DVD-A player
- Beauhom B2 'speakers
- Philips DVD763SA DVD/SACD player

● Computer Audio World

- MuVo Creative Labs MP3 player
- ST Audio's Media 7.1

COMPETITION
Win a pair of superb Wilson Benesch Arc loudspeakers

DECEMBER 2002



+ 100s of classified ads full of secondhand bargains!!!
World Radio History

“Sets a new standard at the price”

- Hi-Fi World (August 2002)

“The scale and authority of their performance is breathtaking”

- What Hi-Fi? (August 2002)



...since 1956, our chief product has not
changed an iota, and our philosophy is the
same: to produce a speaker that is as good as
the original. This philosophy has
earned Quad the respect of serious audiophiles
and music lovers alike, and has made us
one of the most successful and profitable
audio companies in the world.

Our all-new T-Series loudspeakers are
an exciting reflection of this philosophy.
They combine the best of Quad's
technology with a new, more powerful
driver and resolution of detail that
does not exist in the original. The sound is
clear, bright, and dynamic, and the
bass is deep, warm, and powerful.

The T-Series loudspeakers are all we
need to get you started with your
Quad system. They are available in
black, silver, or gold, and are priced
from just £299.

If you would like to know more about
Quad's products and the benefits of the
full range of Quad products, including
our famous 11-forty valve system, call us on
0845 458 0011 or visit our website at
www.quad-hifi.co.uk

0845 458 0011
www.quad-hifi.co.uk

Phone for free Product and
Review book



Q U A D

the quietest reproduction of the
original sound

the crew

Contact Numbers Mon-Fri 9am-5pm

Editor

Simon Pope
tel/fax +44 (0) 1908 614 996
e-mail: editorial@hi-fiworld.co.uk

Computer Audio World Editor

David Price
email: editorial@computeraudio.co.uk

Design & Layout Editor

Faiza Chunara
tel: +44 (020) 7625 3129
fax: +44 (020) 7328 1844
e-mail: adproduction@hi-fiworld.co.uk

Production/Photography Editor

David Noble
tel: +44 (020) 7625 3134
fax: +44 (020) 7328 1844
e-mail: classifieds@hi-fiworld.co.uk

Contributors

Dominic Todd
Alan Sircom
Paul Miller

Advertising

Amanda Sweeney
tel/fax +44 (020) 8864 4760
e-mail: advertising@hi-fiworld.co.uk

Accounts

tel: +44 (020) 7625 8032
fax: +44 (020) 7328 1844

Credit Control

Louise Palfrey
tel: +44 (0) 1923 270 833
fax: +44 (0) 1923 260 588
e-mail: subscriptions@hi-fiworld.co.uk

WORLD AUDIO DESIGN

Technical Manager – Nick Lucas

www.worldaudiodesign.co.uk

tel/fax: +44 (0) 1908 218 836
e-mail: nick@worldaudiodesign.co.uk

Publisher

Noel Keywood
e-mail: publisher@hi-fiworld.co.uk

Private & Trade Classified Ads

tel: +44 (020) 7625 3134
fax: +44 (020) 7328 1844
e-mail: classifieds@hi-fiworld.co.uk

Subscriptions & Back Issues

9:30am - 12:00 noon
tel: +44 (0) 1923 270 833
fax: +44 (0) 1923 260 588
e-mail: subscriptions@hi-fiworld.co.uk

Distributed by

Comag Magazine Marketing,
Tavisstock Road, West Drayton,
Middlesex UB7 7QE
Tel: +44 (0) 1895 444 055

Printed by

Southern Print, Dorset
Tel: +44 (0) 1202 622 226

Our Agents in Malaysia

Millennium Hi-Fi & AV
Simon Chang
Showroom & office, 500-1-3 First Floor
Wisma Indah (Shen Court), Jalan Tun Razak
50400 Kuala Lumpur, Malaysia
Tel: 603 9283 8171 Fax: 603 9281 3762
e-mail: info@millennium-audio.com

All unsolicited submissions and goods are at the owner's risk. We accept no responsibility for such submissions, nor do we undertake to return them.

No material may be reproduced from this magazine without the publisher's written permission.
© Audio Publishing Ltd



simon pope

It can be a confusing and paradoxical life in hi-fi. For example, coloration is a dubious word when used in the context of audio. If used in a review of either an amplifier or, more likely, a loudspeaker it tends to signify that the product is not up to scratch because the 'be all and end all' of the purist audiophile is neutrality. However, neutrality is bad

when attributed to a live concert review but coloration is good, as musical communication - the art of turning black dots on telegraph poles into an emotion - is based on mood and colour.

You see my predicament? The problem is that I was into music a long time before I was into hi-fi and for me when something has colour, it has life and vibrancy but when it is neutral it's lifeless, grey and dull. This can be a problem when it comes to describing products, knowing what sensitive souls manufacturers and product designers are! It's my natural instinct when I'm impressed by the way a certain product communicates music to describe the colours that a certain orchestra or instrumentalist creates. Read a glowing review of any of the recent Promenade concerts, for example, and I'll bet my system that the critic will talk of the range of colours that were brought to the performance to make it stand out as an enjoyable experience. After all, how does a violin or acoustic guitar create that rich tone? Shock, horror - it's cabinet coloration!

The idea of both professional audio and high fidelity is to represent with the truest faithfulness, the source material. If an instrument or voice is coloured enough, then surely it would need little or no 'touching up'? Fair enough, but there's nothing wrong with a bit of spicing up if used sensibly. Use a high quality valve amp through a 'neutral' pair of Quad electrostatics and what's the result? Sonic heaven, because the rounded sound of the valve amp is accompanied, but not cancelled out by the supreme neutrality of the 'speaker. And 'boxy' speakers have a habit of adding a touch of fullness or fruitiness to the sound from high-end transistor amplifiers, which can make material sound analytical and cold, even grey. It's like choosing between a holiday on Musique or Canvey Island. Take your pick - but I know which one sounds the more appealing to me!

how we test the products

- Hi-Fi World has its own advanced test laboratory and acoustically treated listening room.
- Hi-Fi World has a dedicated in-house team of experienced listeners. We review thoroughly by extensive auditioning, rather than by quick-fire group listening tests.
- Hi-Fi World's engineering team designs a wide range of products in-house. No other hi-fi magazine is so expert and dedicated.

£ **NICE PRICE** - Represents excellent value for money.

● ● ● ● **EXCELLENT** - Superb sound, among the best available.

● ● ● **VERY GOOD** - Well worth a listen.

● ● **ADEQUATE** - Room for improvement.

● **POOR** - Seriously flawed. Forget it!

● **Half globes are added for those products that we feel are between categories**

www.hi-fiworld.co.uk

HI-FI WORLD
SUITE G4, ARGO HOUSE
KILBURN PARK ROAD
LONDON, NW6 5LF

contents

features

TOMORROW'S HI-FI WORLD 16

Noel Keywood guides us through the DVD-A format and talk's to Meridian's Bob Stuart about its audiophile potential.

THREE TO TANGO 40

HFW's round up of the latest high resolution format releases.

reviews

digital

MERIDIAN 800/861 DVD-A PLAYER AND PROCESSOR 19

Described as the most advanced optical disc player on the planet, Simon Pope listens to the 800 DVD-Audio player and its matching 861 surround-sound processor.

ARCAM CD82 CD PLAYER 34

Arcam attempt to lead the midprice CD player market with this new CD spinner. How will Dominic Todd find it?

PHILIPS DVD763SA DVD-V/SACD PLAYER 37

This new 'budget' player from Philips brings DVD and SACD players down to a new low price. David Price listens in.

MARANTZ DV-12SI DVD-AUDIO PLAYER 53

Marantz follow up their SACD player with a DVD-Audio player. Hi-Fi World finds out how it compares to its stablemate.

amplifiers

INTEGRATED VALVE AMPLIFIER GROUP TEST 9

We gather in four stylish and affordable integrated valve amplifiers for those who wish to take the tube without breaking the bank or their backs!

CYRUS AV8 SURROUND PREAMP 42

This is the latest attempt from the Huntingdon company to bring audiophile quality to multichannel equipment. Will it complete the task successfully?

loudspeakers

BEAUHORN B2 50

The B2 is a highly distinctive horn loaded design from the makers of the Virtuoso. Simon Pope looks at style and content.

QUAD 22L 62

Quad's reputation is back with a vengeance. Noel Keywood listens to the top range floorstander in the successful L Series.

system

RED ROSE SPIRIT SYSTEM 58

A ribbon loudspeaker and amplifier package conceived by US hi-fi guru Mark Levinson for under £2,000? You'd better believe it, says Alan Sircom.

accessories

TOASTED AND CONNECTED 61

Simon Pope listens to a new affordable interconnect and tries a unique way of burning-in your wires.

TURNTABLE TUNE UPS 76

David Price suggests three ways of making your vinyl sing even more sweetly.

CLASSIC CUTS 70

Andy Giles chooses Sir Thomas Beecham's selection of Delius' orchestral pieces as this month's classic disc.

OLDE WORLDE 74

Goldmund's awesome Reference Turntable is this month's classic statement product of choice.

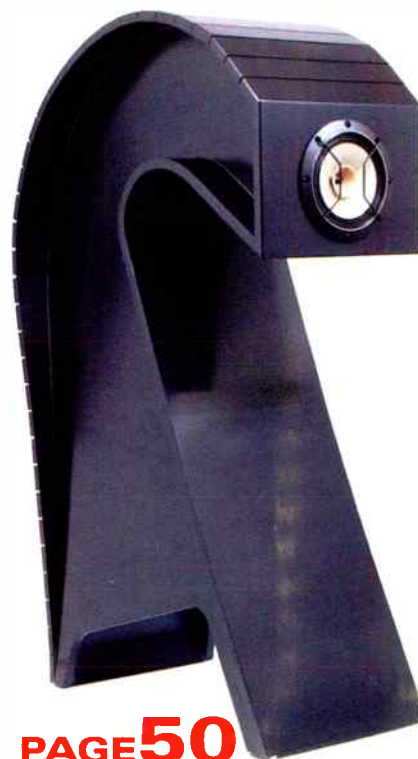

PAGE 50



PAGE 19

computer audio

COMPUTER NEWS 81

SIMPLE MINDS 83

We listen to the new MuVo mp3 player from Creative Labs.

NEW MEDIA 85

ST Audio's Media 7.1 soundcard offers advanced audio at a budget price.

PAGE 85



BUYING GUIDE

www.hi-fiworld.co.uk

visit our website for a comprehensive list of all the products we have reviewed over the past 11 years

SUBSCRIPTIONS HOTLINE

01923 270833

MON - FRI 9.30AM - 12.00 NOON

FAX: +44 01923 260 588

regulars

WORLD NEWS 6

NEXT ISSUE 7

READERS LETTERS 44

Got a burning issue that you would like to tell everyone about? Suffering from below-par performance in the stereo area? Fret not, Hi-Fi World's wise men will reply to your letters and e-mails and put you back on the right course. And don't forget, every letter or e-mail we print wins a superb prize.

SUBSCRIPTIONS 54

Spare yourself the frenzied riot as you struggle with the hordes to claim the last copy of Hi-Fi World in the newsagent - Subscribe today!

HI-FI WORLD KITS 64

Solder in one hand, glue in the other, satisfy your creative urges with a World kit.

HI-FI WORLD LIBRARY 68

A comprehensive selection of titles covering audio, valve amplifiers, loudspeakers, solid state electronics and more.

SPECIALIST HI-FI DEALERS 72

The perfect mix - excellent coffee, a comfortable sofa, and someone who really knows how to guide you through the world of hi-fi.

COLUMNS 71,73,75

The World team get to grips with issues facing both the industry and hi-fi alike.

DIAL-A-DEALER 78

Look before you leap, or alternatively listen before you buy. These are the people to talk to.

MEET YOUR MAKER 80

Not a call to the spiritual, but a list of manufacturers detailing who makes what, and how to get in touch.

WORLD FAVOURITES 87

Thinking of an upgrade or even a new system? Here's where to find our recommendations from the mass of hi-fi we've reviewed.

WORLD CLASSICS 92

Our list of products that have stood the test of time.

MARKETPLACE 107

READERS CLASSIFIED 123

The definitive place to find classic audio components.

ADVERTISERS INDEX 130

supplement No. 70

DIY CONTENTS 95

DIY NEWS 97

All the latest from the weird and wonderful world of Do-It-Yourself hi-fi

BUDGET BULBS 98

Nick Lucas and Andy Grove guide you through our new bargain priced integrated valve amp, the Kecl82.

DIY LETTERS 105

Correspondence and queries from our DIY readership.

competition

This month it's your chance to win a pair of superb Wilson Benesch loudspeakers worth £2,400.



PAGE 26

PAGE 9



CHORD'S CHORAL SYMPHONY

Three incredibly stylish new products were unveiled by Chord Electronics at the AV EXPO Show at Heathrow. The products join the DAC64 in the so-called Choral range which amalgamate Chord's traditional high-end look and sound in a smaller package with a more affordable price tag.

The first product is the £2,750 Prima preamplifier which comes supplied with the superb looking system touch screen remote. The preamp operates Chord's new dual bus system which allows tapping from any source whilst listening to another and also features the new UHF designed power supply. The audio circuit uses fully balanced line internal architecture with six input gain



adjustments for the five line inputs (one of which is balanced XLR) and low impedance outputs.

The matching £2,300 Mezzo power amplifier also features the same slimline casework and weight (8kgs) as the Prima. Based

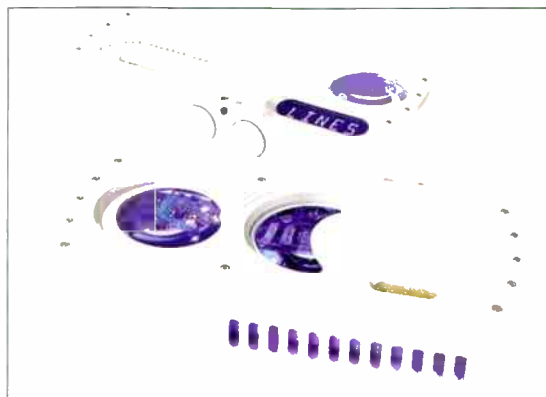

on Chord's existing power supply technologies, along with additional unique drive circuitry operating at over 1.2MHz, the Mezzo delivers 30W per channel into 8ohms and can be used in bridged mono mode for 60W of power.

The pre and power amps are complimented by Chord's latest phono stage, the Symphonic. This is an update of the long-standing existing model and is designed for moving coil cartridges only. It offers a vast range of impedance and gain options as well as balanced and unbalanced input options. It also features a new rumble filter, and is priced at £1,900.

Chord Electronics
Tel +44 (0)1622 721444
www.chordelectronics.co.uk

FURTHER EXPOSURE

Re-vitalised Exposure Electronics have now launched their next range of products, known as the Classic Series. The new Exposure 22 CD player, priced at £1,175, is available in either black or titanium silver and it comes with a full system remote control.

The new CD is accompanied by the Exposure 23 line level pre-amplifier and the 80W Exposure 28 power amplifier, priced at £1,275. The range also includes the 26 dedicated phono stage and an optional phono card for use with the 23 preamp, price to be confirmed.



range feature distinctive red LEDs and displays, high quality internal components and a thick, machined, satin aluminium faceplate.

Exposure Electronics Ltd
Tel: +44 (0)1273 430619
www.exposurehifi.com

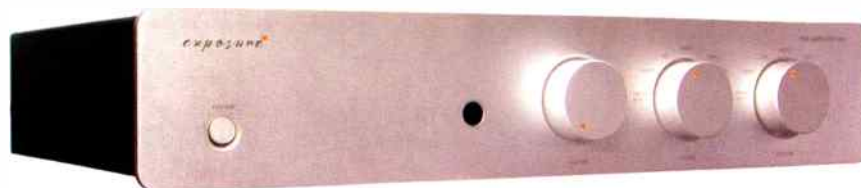

AE'S LATEST MARK

The latest version of the classic AEI high-end mini monitor has been unveiled by Acoustic Energy after three years research and development work. The new MkIII is available in a gloss and metallic finish with a 10mm thick alloy plate baffle and duo-wall MDF/steel plate construction for the cabinet. This is further strengthened by tensioned steel cross bolts and a screwed-in rear panel. The drive units consist of a 120mm custom built bass/mid unit with a 105mm anodised alloy cone and a magnesium die cast chassis.

The tweeter is also custom built for AE and is a "Ring Dome" radiator with a doped fabric diaphragm and metal chassis. The tweeter is directly interfaced with the metal baffle for low vibration. At the rear are heavy duty WBT terminals and a low resonance port.

The black gloss version is priced at £1990, with wood veneers at £1790 and black ash £1690.

Acoustic Energy Ltd
Tel +44 (0)1285 654432
www.acoustic-energy.co.uk

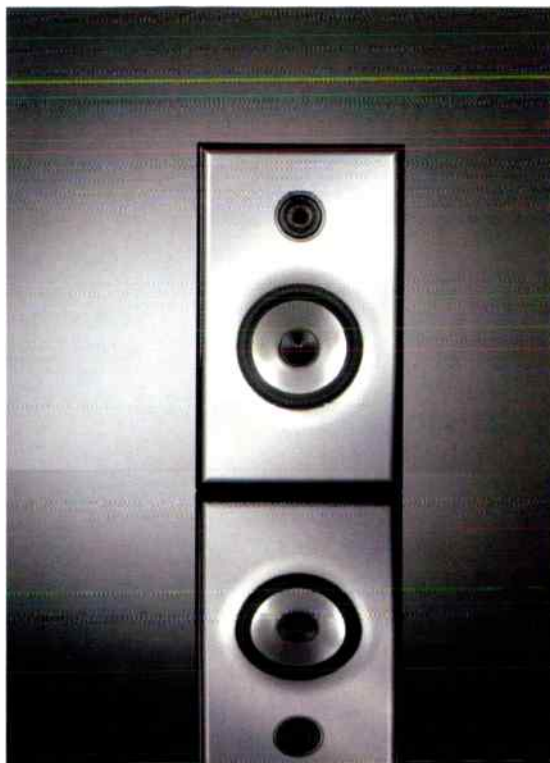

EVOLUTIONARY WHARFEDALES

Wharfedale have introduced their latest range of 'speakers, the Pacific Evo. This range is the successor to the Pacific Series and bears little resemblance to the previous set of designs. The most discernable difference to the new range is the introduction of a curved cabinet in an effort to combat standing waves. There is also a curved baffle which aims to improve the speaker's dispersion characteristics. The in-house drive units consist of Kevlar polymer mid/bass units, plus neodymium tweeters housed in integral aluminium pods.



The range consists of a total of five 'conventional' loudspeakers, plus a centre channel, a dedicated surround 'speaker and two subwoofer models. For the main models there are two standmounts, the EVO and EVO-10. The former uses a 5" bass/midrange drive unit and the latter a 6.5" version.

There are three floorstanding models, the two-way EVO-20 and two three-way models, the EVO-30 and larger EVO-40. Prices range from £249.95 for the EVO-8 to £749.95 for the top of the range EVO-40.

Wharfedale International Ltd
Tel +44 (0)1480 447700
www.wharfedale.co.uk

Here's a little taster of what we hope to bring you in January's issue

WHARFEDALE EVO-8

This is the entry level standmount 'speaker in the stylish new midrange Pacific EVO series.

SONY RCD-W1

Shock, horror - a CD recorder from the champions of MiniDisc? Find out what all the fuss is about next month.

PIONEER DV-656A

With capability for SACD and DVD-A, as well as DVD-V and CD, this is perhaps the first affordable truly universal player to hit the UK shelves.

Ortofon



Pro-Ject



The new
**Pro-Ject
RPM9**

Exclusively at
**Centres of
EXCELLENCE**

Town

Aberdeen
Aldridge (West Mids)
Ashby De La Zouch
Bedford
Birmingham (Sollhul)
Birmingham (Edgbaston)
Brentwood
Bristol
Bristol
Cambridge
Cardiff
Castleford
Chester
Colchester
Darlington
Doncaster
Dunstable
East Grinstead
Edinburgh
Edinburgh
Exeter
Glasgow
Harrow
Helston, Cornwall
Hitchin, Herts
Huddersfield
Hull
Ipswich
Ireland (Dungannon)
Kidderminster

Dealer

Sevenoaks Hi-Fi
Sound Cinergy
Zouch Audio
Richards A/V
Music Matters
Music Matters
Audio T
Radford HiFi
Audio Excellence
The Audiofile
Sevenoaks S&V
Eric Wiley
Audio Excellence
Grayston S&V
Hi-Fi Experience
The Hi-Fi Studios
Technosound
Audio Designs**
Hi-Fi Corner
Russ Andrews*
Sevenoaks S&V**
Glasgow Audio
Harrow Audio**
Sounds Perfection
David Orton A/V
Huddersfield Hi-Fi
Sevenoaks S&V
Sevenoaks S&V
Kronos Hi-Fi
Midland Audio*

Town

Leamington
Leeds
Leeds
Leicester
Lincoln
London (East Sheen)
London (Euston)
London (Holburn)
Maidenhead
Manchester
Manchester
New Malden, Surrey
Newbury
Newcastle
Norwich
Nottingham
Oxford
Peterborough
Rainham (Kent)
Reading
Reading
Salisbury
Sheffield
Southampton
Swansea
Swiss Cottage
Warrington
Worthing
Yeovil
York

Dealer

Stratford Hi-Fi
Sevenoaks S&V
Yorkshire Audio**
Leicester Hi-Fi
Sevenoaks S&V
Choice Hi-Fi
Kamia
Sevenoaks S&V
Audio Venue
Practical HiFi
Sevenoaks S&V**
Unilet
B&B Hi-Fi**
Lintone Audio
Sevenoaks S&V
Notts Hi-Fi Centre
Oxford Audio
Sevenoaks S&V
Progressive Audio
B&B Hi-Fi**
Audio T*
Salisbury Hi-Fi**
Moorgate Acoustics
Phase Three**
Sevenoaks S&V
Sevenoaks S&V
Doug Brady*
Phase Three
Mike Manning*
Vickers Hi-Fi

* Ortofon only
** Pro-ject only

For a full dealer list and more information contact:

Henley Designs Ltd, Unit 11 Moorbrook, Southmead Industrial Park, Didcot, Oxon, OX11 7HP
Tel: 01235 511166, Fax: 01235 511266, E-mail info@henleydesigns.co.uk, WWW.henleydesigns.co.uk

HEART OF GLASS

David Price rounds up a quartet of entry level integrated valve amplifiers - perfect partners for those yearning for something more than what mere solid-state can deliver.

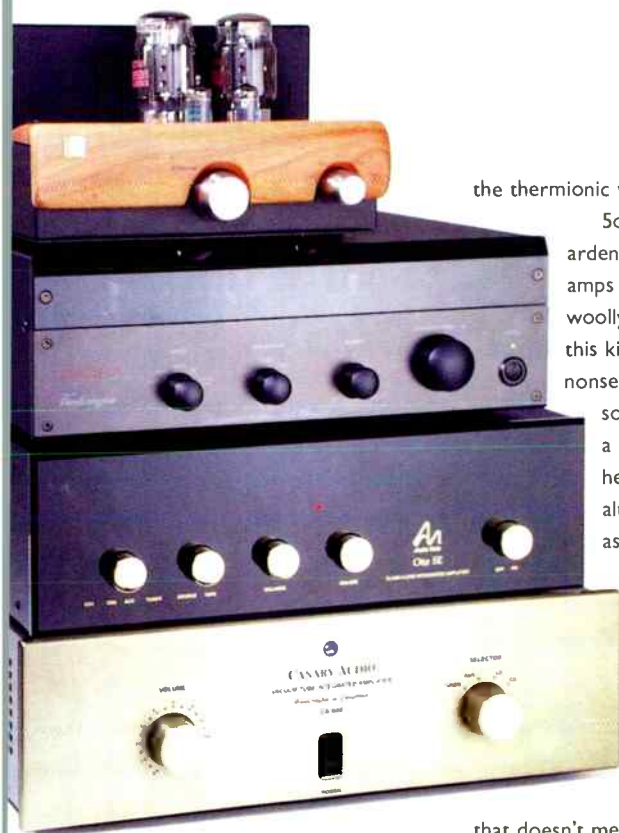

the thermionic valve.

Solid-state's most ardent fans dismiss valve amps as being soft and woolly. This test shows why this kind of talk is patent nonsense. For every warm, soggy tube amp there's a big, punchy headbanger as an alternative. With tubes as with solid-state, it's very much a case of it ain't what you do, it's the way that you do it. Of course, valve amps tend to be warmer and smoother than transistors, but

that doesn't mean to say there aren't tremendous differences between the various brands on offer.

The group here all represent a logical step up from a mid to high end integrated transistor amp - such as, say, the Audiolab 8000A you may have bought five or so years ago. Although fairly pricey, they're not prohibitively expensive for those wishing to have something they're going to use everyday for the next decade or so. Indeed, a couple here represent an excellent investment, with resale values higher than an equivalent transistor design simply because of their relative scarcity and novelty.

The beauty of modern valve

amps is that they're all well made and likely to give many years of sterling service, with just a change of valves (costing some £20 or so) about five years away. Gone are the days of them catching fire or leaking onto your carpet!

The challenge for each member of this group is to offer something tangibly superior to the equivalent budget transistor pre-power or super-integrated, without falling down in other areas too conspicuously. These contestants should be able to outperform solid-state in terms of musicality and sense of occasion, without giving too much away in traditional 'hi-fi' areas like imaging and grip. It's perfectly possible - as this test shows - to give a more musically enjoyable sound price-for-price.

Before we launch into the test however, it's important to underline that none of these contenders will drive your 1987 Acoustic Energy AE1 standmounters to nightclub levels - you'll have to partner them with a good pair of modern, high efficiency loudspeakers having a non-reactive load. They don't have to be esoteric horns - for the purposes of the test, I used my Mission 752s - a brilliant mid-nineties design with a sensitivity of 91dB and very benign load characteristics. The message is partner carefully, and be prepared to tune your system around your amp, rather than vice versa.

It's a familiar tale. Schooled on transistor amps, after a while many up-and-coming audiophiles find themselves wanting something more from their amplification. At the £1,000 to £2,000 price point, they have a choice of buying into the bottom rung of high-end transistor options from the likes of Linn or Naim et al - or going out on a limb and getting into valves. The problem is that, while many may like the idea of greatly enhanced musicality, tonal colour and warmth - not to mention the real style cachet that tubes offer - most aspiring audiophiles are all at sea when it comes to going the way of

CANARY AUDIO CSA608 £2000

It's made in the USA, don't you know. Lugging this thing up the stairs, the thought wouldn't even cross your mind that this hails from the land of mile-long Sports Utility Vehicles that require their own personal oil field in Texas to run. Yes, this is made in California alright - and just in case you didn't realise, there's a tasteful italicised legend on the front panel to remind you! Aside from the volume control, there's just a power switch and a four position input selector to look at up front, complete with one input marked LD (LaserDisc) - how quaint! Round the back are a brace of the largest loudspeaker binding posts I've ever seen - this is American, of course.

Under the gargantuan hood - measuring 19x19.5x6 inches (in old USA money) and weighing 58lbs - you'll find four EL 34 tubes working in push-pull mode. Input signals are routed through pure silver/Teflon coaxial cable to an ALPS volume control. In conjunction with the two 6SN7GTB and one 12AX7 input tubes, the result is a quoted 40W RMS per channel. As well as causing your neighbour's lights to flicker when switching on, its 265W power consumption should contribute to global warming in the best US tradition.

The Canary Audio does indeed run hot - and performs in a typically Yank high-end way, which means loads of power and an extremely gutsy, authoritative sound. Any



prejudice that solid-state fans might have about a 'tube' amp's lack of welly will be well and truly quashed by five minutes with this and some high energy rock or rap music. Rather like a Dodge Viper, it has power everywhere and never ceases to remind you of this fact. Most obvious is its bass performance which is a bit overblown. It's as if someone's pressed an imaginary loudness button, the result being that the CS608 does 'quantity' rather than 'quality' in the nether regions. While this makes for a fun, classically valve-like sound, it's an acquired taste. Fun Lovin' Criminals' 'King of New York' was big and expansive, with plenty of impact and presence, but after the initial pleasing effect had worn off, it began to sound rhythmically plodding. This wasn't helped by a distinctly curtailed treble which was smooth to the point of sucking all the extension out of the music. Midband wasn't bad - it imaged with confidence - but nor was it anywhere near as detailed as, say, a Cyrus 7/PSX-R solid-state integrated. At times the lumpy bass

kind of took the swing out of the rhythmically lucid midband, so neither did it sound any more musical. Like a V8 engined car it has power alright, but is inclined to be lazy with it, and isn't as fleet of foot as its smaller European rivals here.

This amplifier will appeal to those with relatively simple needs - it easily drives speakers that would have some of its rivals here huffing and puffing. It makes a big, fat, smooth, warm sound and it obviates the need for any other kind of heating in your listening room. It's simply too 'old school' for my tastes, majoring on a warm, sumptuous sound for which tubes are famous, yet at the same time falling into the classic traps (lack of detail, air, space) that the middling valve amps of yesteryear used to.

Canary Audio CSA608 £2000

Definitive Audio

Tel: +44 (0)115 9733222

www.definitiveaudio.co.uk

MEASURED PERFORMANCE

The Canary uses EL34 output pentodes, which can give an easy 21W of power. Unlike the Graaf though, the CA608 amplifier looked decidedly unhappy at higher power levels. Its output waveform started to triangulate quite severely - a sign of strong third harmonic distortion. This suggests output transformer overload due to saturation, magnetic saturation typically producing excessive third harmonic and being level dependent. The spectrum analyzer revealed around 2% distortion at high output comprising mainly third harmonic. This will impart a hard, bright sound to the amplifier if it is pushed hard.

At lower levels the Canary was linear enough, luckily, so if used at modest volumes it may well sound as clean and clear as any. However, this sort of problem is purely down to poor design and is unnecessary. It will give the CA608 a particular sound, likely one that some might like, finding it fast and well defined (i.e. sharpened). It isn't accurate though.

Otherwise the CA608 measured well enough in all areas. **NK**

Power	21 watts
CD/tuner/aux.	
Frequency response	16Hz-25kHz
Separation	74dB

Noise	-80dB
Distortion	0.14%
Sensitivity	80mV

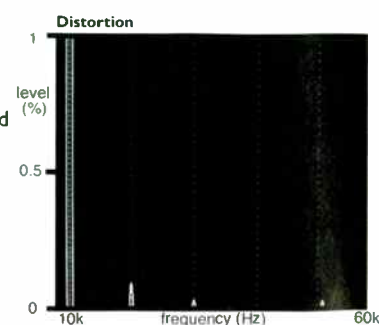

World Verdict

Big and bold and well built - but not competitive with the best at the price

GRAAF VENTICINQUE £1700

This amplifier is pure European sports car - made in Modena, home of Ferrari, it is sleek and purposeful in its smooth satin black finish. The smoked Perspex front panel strip is the only concession to frippery - like the aforementioned supercar, it lets you see inside to remind you why you bought it!

The fascia boasts knobs for volume, balance, tape monitor plus a five-step input selector, one position of which can be set to switch the optional phono stage. In marked contrast to the Canary, the rear panel has two pairs of very low rent speaker binding posts - shame!

Switch the Venticinque on and you'll see four 5881 valves, plus the two 6922 (ECC88) and single 6922 input drivers glowing through the aforementioned front panel window - more worth watching than most things on telly, in my humble opinion.

The compact 410x145x385mm case lifts to reveal a conventional Class A push-pull design kicking out 25W RMS per side. Unlike the company's larger designs, it's not output transformerless (OTL), but features a bespoke GRAAF design. Interestingly, there's a toroidal mains transformer, plus two PC-style cooling fans to prevent it popping its head gasket. These turn slowly at low volumes but cleverly speed up when you hit the loud pedal - curious as because it's Class A then it should run at a constant (high) temperature, regardless of volume?

Anyway, these didn't present any



distraction during the listening session, and were often quieter than the Canary's mains hum!

Although still satisfyingly warm, bass was less obviously overblown and far tighter than from the Canary. This made for an instantly more rhythmically engaging sound which proved a joy to set ears on. Although a bit down on power, the Venticinque wasn't at an obvious disadvantage with my very tube-friendly Mission loudspeakers. It was satisfyingly firm and strong, and didn't wheeze until called upon to deliver quite high levels.

Dynamics were also impressive - not in the large scale solid-state amp sense, but in the amp's ability to follow the tiny 'microdynamic' inflections in the music. It made for a very bouncy, musical sound which made me come back for more. Indeed, its midband proved very impressive - considerably more transparent than the Canary, it also did tonal colour and textural far better too. Rather than making everything sound 'warm', it gave a real sense of the different flavours of all instruments used. Of course, it

still erred on the sweet side - no shattering wine glasses here! Treble was also very good - sweet and clean, it faithfully recreated the air and space of the recorded acoustic in Joan Armatrading's 'Me Myself I'. Although lacking the hypnotic rhythmic swing of the AudioNote OTO SE, the GRAAF proved an extremely capable performer due to its high all round competency. Its strong, wide, clearly defined stereo imaging and excellent sense of depth perspective put it at the top of the class in this respect, making for a very even overall performance with few obvious weak points to detract from its genuinely endearing nature. It's the sort of valve amp you can use straight after a Cyrus 7/PSX-R solid-stater and not feel short-changed in any particular respect, while still enjoying its obvious 'valve sound'.

Graaf Venticinque £1700

UKD

Tel: +44 (0) 1753 652669

www.ukd.co.uk

MEASURED PERFORMANCE

The Graaf produces a useful 21W per channel from 5881 output tetrodes, about as expected. It has unusually extended treble due to some peaking out at 100kHz, but in spite of this high frequency distortion was quite low, measuring around 0.1% at 1W output. Run within its limits the Graaf was fairly linear and behaved itself, producing relatively low amounts of distortion until it approached full output, and even then it was cleaner than many. Our distortion analysis shows low amounts of second and third harmonic and these rose together as

output neared maximum. With good sensitivity and low noise the Graaf measures well, turning in the sort of results expected for the type. It should sound clean enough and produce reasonable volume from sensitive loudspeakers. **NK**

Power	21 watts
CD/tuner/aux.	
Frequency response	6Hz-80kHz
Separation	67dB
Noise	-80dB
Distortion	0.2%
Sensitivity	120mV

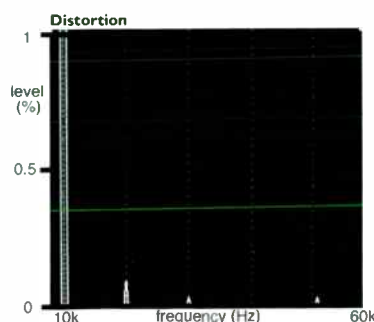

World Verdict
Smooth, sophisticated and musical - well worth considering for tranny fans and valve-heads alike.

AUDIONOTE OTO SE £1200

This AudioNote is in the style of a late eighties Mercedes Benz. A big slab of piano black gloss on the fascia and some dubiously tasteful gold knobs (handling variously, power, source, balance, volume and tape monitor) is what you get, while the back panel sports four pairs of basic RCA phonos (CD1, CD2, aux and tuner) and low rent loudspeaker binding posts. Still, it's barely smaller than the Canary at 440x140x410mm and not an awful lot lighter at 17kg - plenty of metal for the money, then.

Inside you'll see neatly laid out circuitry, with separate PCBs for the preamp, driver and output stages. A pair of double triode valves plus a pair of 7025/12AX7WAs drive two pairs of parallel-linked EL84 triode-connected pentodes in single-ended configuration. Pure class A operation, valve rectification and zero negative feedback are claimed features of the design. AudioNote claims 10W RMS per channel into 8 ohms. Switch this beast on and it's near silent - no cooling fans and only a slight mains hum. It runs cooler than the Canary or GRAAF - with a modest 100W power consumption it doesn't super-heat the listening room, so you won't have to strip down to your Calvin Kleins after one LP side.

Having heard the original OTO many years ago, I was deeply suspicious of this amplifier. I'm happy to report that it sounds quite unlike its predecessor, which had a bass line like a blancmange perched on a jelly.



By contrast, the OTO SE is extremely impressive throughout - obviously more open, clean and detailed than even the GRAAF, it takes you a step back from the microphone and gives a more panoramic, widescreen view of things. It's obviously lighter and weaker in the bass - but is still generous by solid-state standards - yet extremely tuneful. Treble is sweeter and more open, with yet more atmosphere and a wonderful (albeit not strictly accurate) silkiness that's hard to live without after a while.

Prefab Sprout's 'Electric Guitars' showed the OTO SE to be a consummately musical performer - it set up a decently large acoustic, served up some beautifully bouncy bass, plenty of midband detailing and a decently defined stereo image. It's obvious that this amp is far from neutral - tonally it does the old valve trick of investing everything with a deliciously sugary texture. Unlike the GRAAF, it can't really do 'rough' or 'raw', meaning you get 'that old valve magic' in everything you play. Whereas the Canary introduces a fuzzy, muzzy valve haze, the AudioNote's

coloration is actually nice to have. No need for transparent fascias here - your ears tell you you're tubed as soon as the music starts. As for female vocals, they're positively sublime.

The great thing about the OTO SE though is its combination of brilliant rhythmic ability and the aforementioned sepia tinged tonal colouring. This thing doesn't rock so much as 'slink' - it lacks any real large scale dynamics but makes up for it with incredibly liquid, visceral 'microdynamics', letting the music's accents and phrasing shine through. In this respect it's a textbook example of single-ended tubes, and it's so hypnotic that you begin to wonder why you ever liked your Naim six pack. It gets into the groove like no other equivalently priced amp of any type can - even at low volumes it's an utterly addictive listen - well worth the title of 'budget esoterica'.

Audionote OTO SE £1200

Audionote (UK) Ltd
Tel: +44 (0) 1273 220511
www.audionote.co.uk

MEASURED PERFORMANCE

Audionote use parallel EL84 output pentodes for the Oto SE. They are known to have a very sweet sound, are in plentiful supply and are therefore inexpensive. However, EL84s do not handle large amounts of power and even in parallel the Oto SE only manages 8W output. As a result it will need very sensitive loudspeakers if it is to go loud and generally this means floorstanders. Obviously, the Oto is no headbanger; it has been designed to deliver a sound that is very valve like, with a smoothness impossible from solid-state. The distortion characteristics reflect this to quite some extent,

second harmonic dominating from low output right up to full output. The distortion characteristic changes less with level than many of the designs here, which is a good sign, since the ear readily detects changes in distortion patterns. Absolute distortion levels weren't low but being primarily second harmonic they were satisfactory.

In all other respects the Oto measured well. It has low noise, good sensitivity and plenty of bandwidth. This is a design for those who want valve sweetness over all else.

NK

Power	8watts
CD/tuner/aux.	
Frequency response	16Hz-57kHz
Separation	62dB
Noise	-95dB
Distortion	0.45%
Sensitivity	220mV

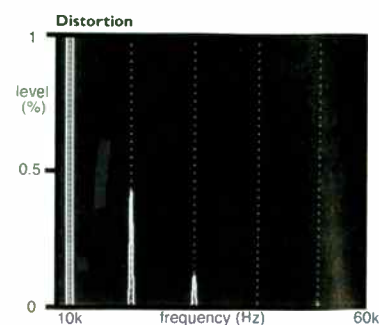

World Verdict £
The smooth and detailed OTO SE gives you a taste of super-fi for Arcam money.

UNISON RESEARCH S2K £1100

And finally we have this exotic creation, its styling the work of Claudio Chiarello. The smallest model of the ARIA range, it eschews the GRAAF's busy fascia for the bare minimum of (stainless steel machined) knobs and buttons set into the relatively small (275x375x165mm) casing which weighs in at a back-friendly 14kg. Still, round the back there's enough room for five pairs of RCA phono inputs plus tape out, and brilliantly chunky speaker binding posts. Factor in the cute little wooden radio frequency remote (you can use it in another room!) and it's a small but perfectly formed package.

Beyond the sumptuous cherry wood adorned fascia panel lurk the S2K's crown jewels - one pair of ECC82 (12AU7A) and one pair of KT88 tubes running in parallel single-ended pure Class-A mode. Using 10dB of negative feedback, this has allowed the designers to squeeze a quoted 12W RMS from each channel, with an environmentally friendly power consumption of just 85W. Under the ironwork behind the valves are the massive Unison transformers (single-ended amps need chunkier output trannies) and the silver soldered (and wired) PCB complete with gold plated input and output connections.

The Dandy Warhols' 'Bohemian Like You' showed the Unison to have a truly big-hearted, punchy sound with a good deal less coloration than the OTO SE. Whereas the AudioNote gives you three sugars

and double cream with your coffee, this amp proved tonally altogether more neutral. It brought the stereo image forward and closer to the plane of the speakers, making for a more immediate feel, and pushed it out wider, with more energy. This effect, combined with an obviously less coloured midband, made for a more upfront, 'out there' sound. Treble seemed more airy than the AudioNote, although I still think the GRAAF was better in terms of clarity and focus.

Bass was lighter and tighter than the OTO SE, but less well articulated nevertheless. The fact that the AudioNote's low frequencies could be both looser yet more tuneful would seem to be a contradiction in terms, yet it was true all the same. It simply had a musical 'swing' to it right across its entire frequency range that the S2K didn't. This is not to say that the latter wasn't musical, but that it forsook some bounce for a good deal more punch. The trade-off is actually an extremely successful one, because the Unison can still really boogie. Despite its meagre power output it's able to summon up boundless energy and enthusiasm for

any kind of music you care to feed it. The result is a joyfully rousing, emotive sound that those reared on big, powerful transistor integrations will love.

Downsides? The S2K isn't big on subtlety and doesn't have the visceral, organic quality that many would call 'the magic of valves'. Instead of charming and beguiling its way to your affections, its character is upfront and immediate yet still open in the true single-ended way. Whatever music you play through it - from the quiet strains of Herbie Hancock's 'The Prisoner' to the rock histrionics of Rainbow's 'Since You've Been Gone', the Unison belts it out with gusto and drama. It does one hell of a lot for just £1100, making it superb value for money. It's an incredibly honest product that would make a superb first valve amp for converts.

Unison Research S2K £1100

UKD

Tel: +44 (0) 1753 652669

www.ukd.co.uk

MEASURED PERFORMANCE

The S2K is a modest single-ended design. As such it is limited in power output and exhibits quite high distortion, but single-ended is as pure and simple as it gets and many people love the sound. With just 4W to play with from the S2K however, sensitive loudspeakers are needed if it's to deliver any volume - and this usually means using big floorstanders. The distortion it produced was primarily second harmonic, so although the figures don't look so good in truth they are perfectly acceptable, since correlated second harmonic is totally

inoffensive to the ear at these levels. Also, single-ends overload gently, becoming progressively muddled and muddier, rather than harsh. This allows them to be pushed harder than the power figures would suggest.

With adequate bandwidth, acceptable dynamic distortion characteristics and low noise the S2K measures well enough as S.E.s go. **NK**

Power 4watts
CD/tuner/aux.
Frequency response 8Hz-52kHz

Separation 70dB
Noise -94dB
Distortion 1.4%
Sensitivity 110mV

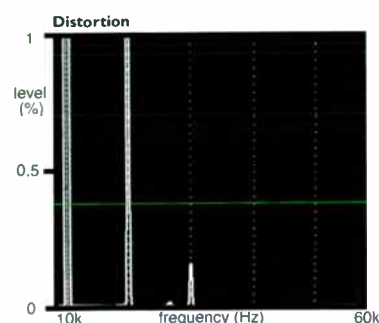

World Verdict £
A steal at the price. Fast and open but not the last word in finesse. Great styling, too.

evolution

Cyrus' legendary amplifiers have evolved!

Back in 2001, Cyrus began a project to evolve our integrated amplifier designs to incorporate technologies researched over the last five years. After many months of acoustic tuning and detailed electrical re-evaluation lasting more than a year, we are proud to announce the arrival of our evolutionary new Cyrus 8.

This extraordinary amplifier sets new standards and strengthens Cyrus' position at the leading edge of what's possible in audio design today.

For the full story on how our amplifiers have evolved, please visit our website at www.cyrusaudio.com.



CYRUS

Advanced Audio and Video Systems

Cyrus Electronics
Huntingdon, Cambridgeshire, PE29 6XY

Tel: +44 (0)1480 435577
Fax: +44 (0)1480 437715
email: info@cyrusaudio.com

www.cyrusaudio.com

conclusion

It always amuses me how solid-state's most ardent advocates manage to dismiss valve amps so summarily. The point is of course that - as this group test makes crystal clear - not all valve amplifiers are created equal. As the breed has been around so long - and was already well developed by the nineteen fifties - there's nothing particularly radical here in terms of engineering. The differences come from the particular circuits, components and output transformers the designers have opted to go for, and how well they've implemented them. Therein lies the crux!

Firstly, the Canary was both the most powerful by far. It gives what the breed's detractors would consider a quintessentially 'valve sound' - big, fat and powerful, with deep bass but rhythmically ponderous. However, it will work with a wide range of loudspeakers that the others here could only dream of.

Next the GRAAF. A product I could happily live with, it has a less generous bass than the Canary but is still well endowed downstairs. Across the midband and treble however, there's a whole load more

detail and grip. Although it has that characteristic 'tube' warmth, this amp is incisive enough to communicate the tonal differences between, say, different recording studios being used across the tracks of a single album. It has subtlety and incision, but still does the traditional valve thing of warming up and smoothing out everything it touches - in this sense, it's a fine working compromise. The downside is its lack of power - although not anemic, you'll need to match it carefully to speakers of 91dB or more - and the price, which is a little on the high side.

Having reviewed the original OTO way back in 1995 and been utterly unimpressed, the SE was a joyous surprise - the sound of the former's output transformers saturating at 'transistor radio' volumes was depressing to say the least. Now it's an extremely musical amp that's undoubtedly the most rhythmically beguiling here. It is brilliant at communicating those all-important gaps between the notes. The sugary treble is a joy (if not strictly accurate), and there's a good degree of detail right across the frequency band. The only downsides

are the lack of power (you'll need speakers of over 91dB sensitivity, or a very small room) and the tonal homogeneity - everything sounds laced with saccharin, even if it was originally sour. Still, at just £1,200 it's stonking value for money.

Last is the Unison Research S2K. An interesting one, this. In a sense it's the ultimate entry level valve amplifier - offering exotic styling, an obviously sweet and open valve sound and a decently strong loudspeaker driving ability. It'll give something that solid-state never will - a tremendously enthusiastic and unselfish sound that's unconcerned with the quality of the recording and doesn't mind modest ancillaries. Whatever you feed it, you get a big, breezy, musical and involving sound coming out the other end! However, it isn't as subtle as either the GRAAF or the AudioNote. Superb value all the same. Overall then - for poise go for the AudioNote, for punch get the Unison Research, and for a nicely judged halfway house between the two then get the GRAAF. The Canary is for those with big and bold tastes, as opposed to detail-and-dynamics freaks.



CANARY AUDIO CSA608 £2000

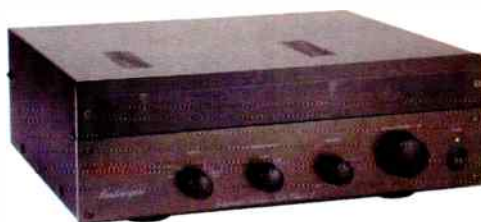

GRAAF VENTICINQUE £1700



AUDIONOTE OTO SE £1200



UNISON RESEARCH S2K £1100

TOMORROW'

DVD-Audio is one of the ways forward for high quality audio in the home. Noel Keywood explains why, with a little help from Meridian's Bob Stuart. . .

Massive sales of DVD players have catapulted the format forward. At present DVD

means 'video' to most people, but a new generation of players capable of producing super quality audio are now available. You might be surprised to know that one classic British hi-fi manufacturer has made a significant contribution to this technology: Meridian. If you want to know about what to expect from hi-fi tomorrow there's no need to go to Japan; just drive to Huntingdon, the spiritual home of British hi-fi. That's what I did to find out about DVD-Audio and the sort of hi-fi system we can expect to be using tomorrow, or perhaps a day after.

That the Japan based DVD Forum (www.dvdforum.org) should adopt an obscure piece of British audio coding in the shape of MLP (Meridian Lossless Packing) for mandatory inclusion in the DVD format is a surprise perhaps. But whilst the video side of DVD is complex and of course very demanding in terms of storage space, data rate and what have you, audio exerted an undue influence on DVD in the days of its formulation. It was as if the DVD forum were scared that if they didn't get audio right the whole thing would founder, irrespective of the fact that DVD is primarily a video carrier.

As a result DVD Video can be accompanied by a variety of differing audio tracks and DVD Audio, where the disc effectively becomes a very high quality CD carrying little video, gets even more complex and advanced. It promises to be the hi-fi medium that supersedes Compact Disc.

Talking to Bob Stuart, founder of Meridian, about DVD technology and



the future brought up at least one major surprise - that an idea first worked on in the late 1970s, that of sound field encoding to perfectly reproduce an entire acoustic environment complete with height information, could well be revived. You might either be horrified or excited by this, because it means loudspeakers in the ceiling. But it also means perfectly reproducing any venue, from cathedral to rock stadium, in the home.

More dramatically, it also means being able to approximately recreate the acoustic environment of a scene in a film in your own living room, which could be startling. People's voices would take up a specific position around you and of course aircraft, helicopters - or anything else that takes to the skies - would whiz overhead. If height information was incorporated into an updated surround-sound standard movies would take on new impact.

Because DVD-Audio is almost infinitely complex let me recap on the simple basics of what to expect from it in terms of sound quality. Bear in mind that unlike CD, which

just offers two channels of audio at 16bit resolution and 44.1kHz sampling rate, DVD can carry music in different configurations and sampling rates, plus still pictures. This is why it is seemingly so complicated.

Players must provide a certain minimum of functions, mandated by the DVD Forum specification (i.e. they must be fitted). They may carry additional functions too. But what discs carry is up to their producers. Not surprisingly DVD discs usually carry at least one of the mandated formats, so they will play on any player.

A DVD-Audio player must reproduce linear PCM (i.e. normal digital, not data reduced Dolby or DTS digital) from 16bit to 24bit, at sampling rates from 44.1kHz (CD standard) up to 192kHz. Up to 96kHz sample rate, six channels are possible, but above this DVD-A currently reverts to two channels. A critical point here is that 6 channels at 96kHz give a data rate of 13.8Mbps, which exceeds DVD's maximum rate of 9.4Mbps. Because DVD-Audio is a high quality audio carrier, a way of reducing data rate

HI-FI WORLD

without discarding data (data reduction or compression) was needed and in the end the DVD Forum chose Meridian Lossless Packing. It provides a critical 2:1 reduction, enough to squeeze in six channels of 24/96 audio, which offers a level of sound quality well above CD.

If the thought of 24bit resolution at 96kHz sampling rate sounds good (well OK, it actually sounds like tech. twaddle, but in practice it really does sound good, I can assure you), then 24/192 should be nirvana. Technically, it's meant to be. 24bit resolution and 192kHz sampling rate is not only meant to provide a level of quality way beyond criticism or dispute, but also allow a degree of leeway in design to accommodate hardware limitations, such as phase shift in filters.

However, at present few studios can record at such resolution, since 24/192 analogue-to-digital convertors are only just becoming available, so whilst DVD-A discs currently carry re-mastered analogue material, old digital (16/48) or 24/96 surround-sound, in future we can expect them to offer even better quality. Listeners not interested in surround-sound may be delighted to know that the best DVD-A can do will likely be in stereo only.

It is likely that most DVD Audio players will be able to decode Dolby Digital surround-sound, which accompanies most video, although they do not have to; it's not mandatory. Up to ninety nine still pictures per track are possible.

From the outset US film studios demanded surround-sound for their movies if they were to support DVD, introducing a need for six channels. As it is, the video on a DVD video disc is heavily compressed using MPEG 2 coding, to get a reasonable (2hrs) playing time. Six channels of accompanying audio are compressed most

commonly by Dolby Digital. Both are lossy techniques. They remove data from the signal that, supposedly, we cannot perceive and do not need. But lossy systems have problems, conceptually and in practice. Artists, copyright owners, libraries and national museum sound archives and such like are not happy about the idea of storing mutilated versions of original recordings. And irrespective of how adamant proponents are about the inaudibility of their compression techniques, in practice they can be detected.

Even a robust low compression system like Sony's ATRAC will fall apart if an appropriately difficult multi-tone, full level test signal is applied. This translates in practice to an orchestra or rock band playing at full volume with every type of instrument being used. In my experience it is violin sections that seem to fall apart most perceptibly in compressed data channels, as DAB (Digital Audio Broadcasting) so readily demonstrates.

Meridian Lossless Packing answers all these problems. It can double playing time, reduce data rate and provide a digital signal of perfect fidelity, because nothing has been taken away. Being lossless it is acceptable for archival purposes.

Meridian were aware of the desire expressed by everyone, from musicians to studios to libraries, that they wanted the original digits to remain intact all the way to the consumer, so MLP also possesses other crucial abilities. It can validate the final data stream to ensure it is a

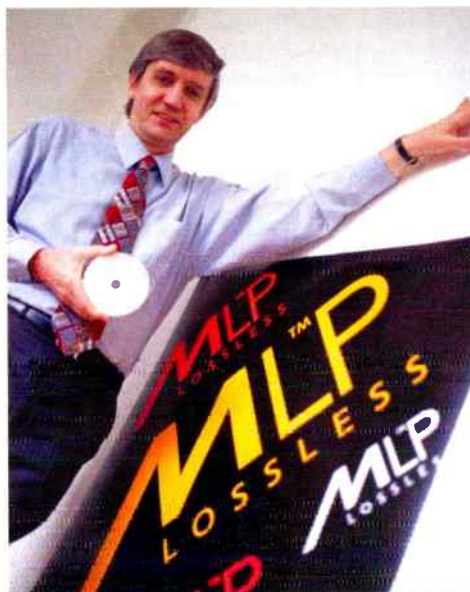

perfect copy of the original, and it makes it resistant to dropouts from disc damage. MLP also provides cueing points so that in the event of data loss, recovery is perfect.

Unlike lossy compression systems, MLP is 'cascadable', so a signal can be compressed and re-compressed without problem. At present, lossy systems do not cascade well; recording DAB radio or mp3 onto MiniDisc can result in audible degradation. In fact, MLP is sort of what you might expect a proper hi-fi company to do with digital - make it high fidelity!

When you buy a DVD-Audio player it will contain an MLP decoder, since it is mandatory. So DVD Audio is hi-fi not just because it is high data rate digital, but also because it has Meridian Lossless Packing to guarantee the integrity of the data stream. That makes it high fidelity.

High quality 24/96 sound accompanying video on a DVD video disc gives significantly better quality than CD, as our graph indicates.

The increase in amplitude resolution from 16bit to 24bit significantly lowers digital distortion, giving a smoother, cleaner sound than CD. The increase in analogue bandwidth to 48kHz gives an extra octave to accommodate extended harmonics and musical energy. This gives a more airy quality and it also makes for a faster sound that is less hard edged and indelicate than CD.

DVD Audio extends analogue bandwidth even further, not to accommodate music energy so much as to ensure filter aliasing, phase and fold down effects do not blight the music. This also gives design margin for filters with improved phase characteristics. Digital audio of this quality demands huge amounts of disc storage though and has a data rate 8x greater than CD

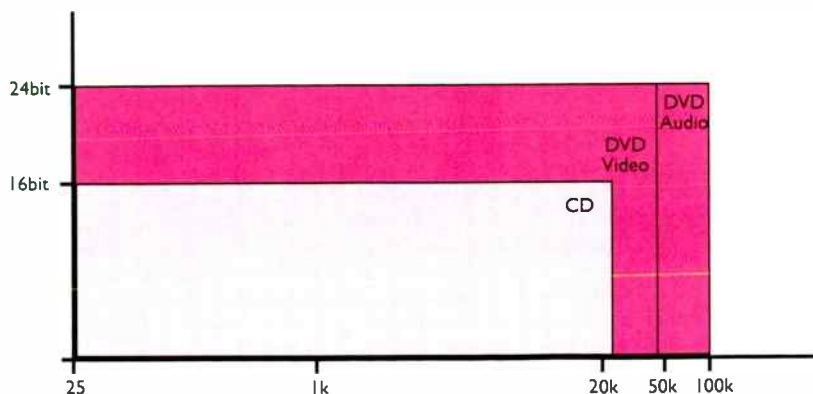

Acknowledgements from so many customers and specialists confirm why M J Acoustics make the definitive small subwoofers.

The Pro 50 & Pro 100 have uniquely achieved outstanding tributes from many respected Reviewers for, Audiophile Musicality, Compactness, and as Discreet and Powerful Performers. They are the choice of Audiophiles and Home Cinema Enthusiasts! - Worldwide.

hi>fi
WORLD

June 2002

"At £299 the Pro 50 is a serious bit of kit for the money"
"Sound wise its a fine performer with both movies and especially music."



March 2002



"this could be one of the audio bargains of the year"



November 2001 & December 2001

"indeed, the joy of this sub is its ability to blend in - sonically and visually."



Pro 50
From £299

Pro 100
From £599

hi>fi
WORLD



November 2002

"a beautifully taut and tuneful bass that was low and fast"



April 2002

"A treat for eyes and ears."



April 2002



March 2002

"I recommend it without reservation."



Excellence

Tel: 08707 44 50 80
Fax: 08707 46 93 80

www.mjacoustics.co.uk



ACOUSTICS
MJ

**NOW, FOR THE FIRST TIME,
HEAR SOUND REPRODUCED AS IT WAS MEANT TO BE**

VINYL IMPERATIVE

Correct alignment and support of the LP on the platter is the most important aspect of vinyl reproduction. The new Anniversary Ringmat, at £70, is THE pre-eminent record mat for virtually all turntables. Further improvements can then be achieved by using:

- LP Blue Statmat and Statcap, at £45, to remove static;
- Ringcap MkII, at £15, to remove vibrations emanating from the centre of the record;
- Ringmat Spacers to provide an improved interface between platter and record, to remove resonance from your turntable and platter and to fine tune stylus rake angle/VTA.

All these can also be purchased in one fell swoop as the Ringmat Support System for £210.

DRAMATICALLY IMPROVE YOUR CD, SACD and DVD SOUND

For digital sources, the CDi Blue Statmat, at £37.50, will totally transform playback.

**FROM ILLUSION TO REALITY WITH RINGMAT AUDIOPHILE CABLES
SIMPLY, THE FINEST CABLES FOR LINKING-UP YOUR HI-FI SYSTEM**

Our Pure Signal Interconnects from £105 per stereo pair and Pure Power Speaker Cable from £25 per mono metre are the finest, most affordable cables available to you.

"So dropping them straight in... immediately after the Valhallas probably wasn't the kindest thing I could have done! Surprisingly, the Ringmat leads stood up remarkably well, which speaks volumes for their musical balance, evenness and coherence. ... and that's quite a feat when you consider the extent to which the Valhallas embarrass the vast majority of even the most expensive competition."
Roy Gregory Hi-Fi+ Issue 19 Sept-Oct 2002

PLUS, THE BEST ISOLATION PRODUCTS AVAILABLE

Protect all your equipment, including your TV and speakers, from static, by using a Statfoot, from £10, underneath each one. Ringmat Feet and/or Ringmat Domes, our isolation "soft feet" approach from £17.45, must also be used if you want the best sound (and picture).

NEW PRODUCT LINE-UP, PRICE LIST and MONEY-BACK GUARANTEE

Call us for details or visit our Website: www.ringmat.com.

RINGMAT DEVELOPMENTS

PO Box 200 Brentwood Essex CM15 9FB GB

cal 01277 200 210 visit www.ringmat.com or e-mail enghw@ringmat.com

SEE YOU AT THE MANCHESTER HI-FI SHOW 16 - 17 NOVEMBER

**PUTTING SOUND
INTO FOCUS**

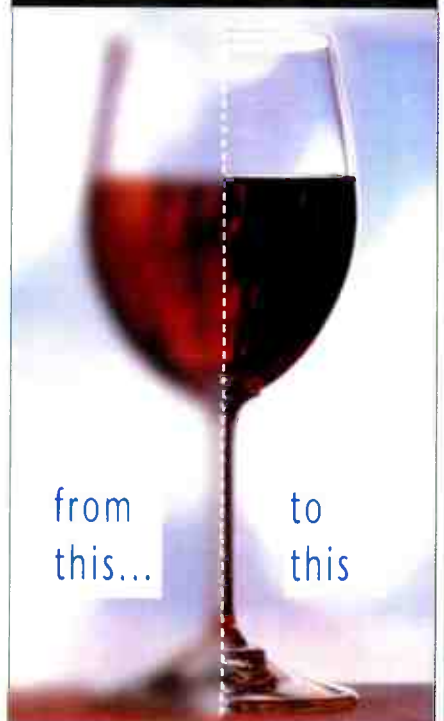

from
this...

to
this

©RINGMAT

TWIN PEAKS



Meridian Audio have been at the forefront of DVD-A development since its inception, so who better to produce the format's ultimate system? Simon Pope sits agog at the 800/861 V3 DVD-A player and surround sound controller. . .

Under Bob Stuart perhaps no other company has done more to perfect the sound of digital audio than Meridian. Their ability with digital audio has led them to the forefront of DVD-Audio development and the only UK hi-fi manufacturer on the DVD Forum Working Group 4. It's only to be expected then, that Meridian have in their considerable arsenal the 800 Series of DVD products, featured here in Version 3 form, that are undoubtedly the pinnacle of DVD-Audio replay.

Very little equipment that enters the HFW portals is greeted with a stunned silence as it emerges from the box but the 800/861 combination almost demands it. The look, never mind the theory, behind the 800/861 combination is awesome. It's only when you start to even comprehend a mere fraction of what's going on inside that you realise just how awesome it is. Here

is one very, very serious example of both high fidelity and digital engineering - the 800 DVD-Audio/Video player is quite possibly the most technically advanced optical disc player in existence.

Let's start with appearance. Both units are finished in beautiful black lacquer and in operation feel like a million dollars. The bold 'Meridian' stamp is accompanied on the front fascia by a high quality green LED display and neat and luxuriously oversized control buttons. Smaller, advanced controls lay beneath flip-down panels.

There's a lot going on here (the literature and manual are of near-biblical proportions), too much to cover fully in a few pages, but basically there are a number of key points that should be explained. The phrase 'high fidelity' is almost inadequate for this combination; it is not so much hi-fi as a highly advanced and programmable digital music server that is also built to last

for another reason - it has awesome upgradability for future applications.

BUILDING BLOCKS

The point to note here is that the whole system, or "architecture", is modular. The 800 and 861 are, as Bob Stuart puts it, "built like a computer", with a combination of cards that provide the customers own configuration. All of these cards and drives are removable and replaceable. This can range from additional digital outputs or progressive video output on the 800 player to component video cards and even an MC phono card (!) for the 816 controller. Future software upgrades will be available to download for customers from the company's website.

The V3 (Version 3) 800 player uses a ROM drive (there are actually two drive bays in the machine), so chosen by Meridian for its reliability in recovering data accurately. Meridian then use their proven audio

The World's Finest Sound and Vision Systems



Expert Multi-Channel and Multi-Room Installations - Nationwide



Visit our West End store to see an incomparable selection of hi-fi components plasma screens and projection systems

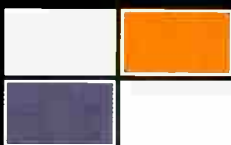

*West **kj** One*

KJ WEST ONE

26 New Cavendish Street London W1G 8TY Phone: 020 7486 8262/3

BRANCHES IN NORTHAMPTON (01604) 637871 & PETERBOROUGH (01733) 341755

www.kjwestone.com

**NEW 2003
BROCHURE
Call For Your
FREE COPY**

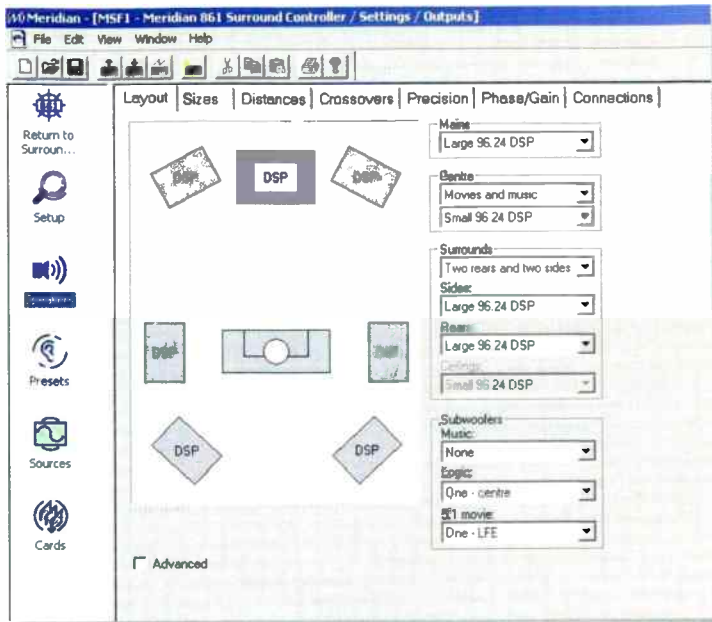

The 800/861 is configured via a computer program

technology to get the best possible audio quality from this data.

Another important feature in the 800 is its upsampling capability where a complex digital filter doubles the rate of samples from the source so that the system that follows can produce the sound more accurately. So CD information, for example, starts at 44.1kHz/16-bit and the Meridian proprietary DSP upsamples this to 88.2kHz and 24-bit. DVDs with 48kHz sampling are upsampled to 96kHz and 24-bit. It can handle sampling frequencies of up to 192kHz and the output analogue cards use a very high quality, studio grade digital-to-analogue conversion system.

Any 24/192 DVD-A information will be downsampled by the 800 to 24/96. However, as Bob Stuart is at pains to point out, there is as yet no industry standard digital interface for 192kHz, hence the need to downsample for an external digitally connected unit like the 816. When a standardised interface is agreed then Meridian will configure a suitable card.

The 800 is, of course, a very high quality DVD video player which has an optional progressive output card for improved picture quality with less shimmer, and it also has a translation feature for PAL or NTSC for those displays that don't support one of the formats. It will decode Dolby Digital and DTS DVD video discs and provide both multichannel and two channel outputs.

If you intend to use an all-

Meridian system, then the 800 can be used alone, with the player simply feeding straight into the company's DSP loudspeakers. We used alternative transducers in the form of Quad electrostatics (actually, a fine match!) and the cheaper L Series loudspeakers. Therefore we put the 861 processor into use.

This beast, when used in combination with the 800, uses Meridian's Smart Link connection which, very importantly, transfers high-band data digitally for optimum sound quality - necessary for use with Meridian's bass and time delay management. The 861 is multiroom capable and can be configured with up to ten 24/96 outputs, with bass management available for all formats. There's a mind boggling variety of DSP modes (fourteen in all) for personal preference. If you require 7.1 Dolby EX decoding, then a Dolby bitstream connection must be made from the 800 to the 861 for full decoding.

SETTING THE SCENE

This equipment isn't something you merely chuck in the boot of your car from the retailer's loading bay; it needs expert installation. You even need to consult the retailer about your particular system requirements before anything arrives at the house. Installation needs to be carried out by a Meridian trained installer and a laptop PC is required for this process. The system is built with bi-directional computer control via the RS232 interface. Simply taking the

things out of the box and plugging them won't work if you actually want to hear and see something! Even the most hardened gadget freak would balk at this combination, so leave it to a professional, as I wisely did. Once completed this apparent minefield of technology is -amazingly - a doddle to use.

I started by using the 800/861 in good old stereo CD mode, with a pair of Quad ESL 988 electrostatics and an MJ Acoustics Pro100 sub used very subtly. Power was supplied by Meridian's own stereo 557 power amp and speaker cables were Chord Company Odyssey and Anthem interconnects. With a variety of discs ranging from Taverner's unaccompanied choral music, via Bruckner symphonies, right up to the aural onslaught of Rage Against The Machine, the combination simply couldn't fail. I use a Meridian 506.24 as my reference CD player and the 800 had all the traits of the sound of it's humbler brother, but magnified them a hundredfold.

I was first struck by the amount of musical detail present. It was combined, essentially, with a beautifully inherent smoothness that few players of any kind provide with Compact Disc. There was a great balance between intricacy and warmth, one that makes for extremely easy listening over a long period of time - and let's face it, when you pay this kind of money

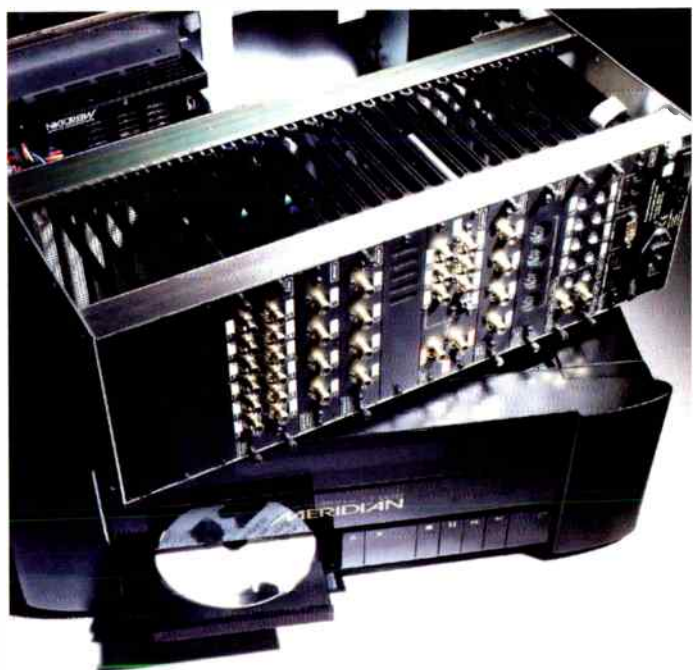

The 861 processor can be fully equipped with a variety of input/output sockets.

EXPERIENCE THE CHORD EFFECT!

The first time you hear your sound system with Chord interconnecting cables will be the first time you've **really heard it.**

Be warned - the effect can be shattering.

Your eyes and ears will be opened. Your music will never sound the same again.

Specify Chord cables - Hear the light!



FOR SALES AND INFORMATION
CALL: 01722 331674 FAX: 01722 411388
E-MAIL: CHORD@CHORD.CO.UK
OR VISIT US AT WWW.CHORD.CO.UK

definitive audio

Living Voice · Vitavox · Electrofluidics · Art Audio · Border Patrol
Canary · DNM · Sugden · Wavac · Lyra · Monarchy · Western Electric*
Wadia · Michell · Stax · Tom Evans · Nottingham Analogue · EMT
Kuzma · Resouuton · Benz Micro · Tri-planar · SME* · Van den Hul

*W.E. valves - in stock • *SME turntables and tonearms - In stock

Sale of Part Exchange and Ex-dem Items

	Sale	New
Living Voice Airscout, Mahogany - Rare 3 way horn.	£9500	£19500
Living Voice Auditorium Walnut 1999	£900	£1500
Living Voice Avatar Cherry 1999	£1900	£2700
Living Voice Avatar OBX-R Rosewood 2000	£2500	£4000
ProAc Response 1SC Mahogany Boxed Current spec.	£550	£1200
Dynaudio Confidence 3, Rosewood, boxed, June '02	£3000	£4800
Horning Agathon - 98dB 2 way horn mahogany	£1500	£3400
Snell Type C Rare floor standing 3 way	£500	
Celestion A2 Rosewood, boxed	£600	£1400
Art Audio Diavolo (black/gold) 300B SE integrated 13w	£2500	£4500
Mirage 890i - fine condition - give away	£250	
Linn Kelidh - fine condition - give away	£250	
Art Audio Symphony (full chrome) 300B SE 10 w int.	£2250	£4000
Art Audio Concerto 6550 push pull line integrated	£1400	£2650
Art Audio Concerto 6550 push pull power amplifier	£1000	£2250
Art Audio Vinyl 1 mm phono stage Chrome	£1000	£1550
Art Audio VP1 line pre, Chrome	£1000	£2000
Tube Technology MAC mm and mc phono - as new	£900	£1400
Canary Audio 300B SE 10 watt mohos new	£2000	£3500
Border Patrol 300B SE 10 watt	£3000	£4500
Audio Innovations L2 line pre	£400	£750
SJS Electroacoustics Arcadia line pre - rare	£600	
Conrad Johnson PV10 phono and line pre (new valves)	£400	£1500
AudioNote Soro Phono integrated. Serviced, new valves	£700	£1900
Cary 2A3 B watt stereo with Cary pre amp New valves	£700	
Musical Fidelity M3 NuVista integrated amp, 6 months	£2250	£3000
Mark Levinson 334 Power amp April '02 boxed perfect	£4500	£6000
XTC pre power 4 channel 400 watt beefcake amp	£1800	£4000
Trichord Dino phono stage and power supply June '02	£400	£500
Audio Research LS2 B line pre	£1250	
Resolution Audio 2 box upsampling CD player Aug '02	£2000	£2850
Musical Fidelity NuVista CD player April '02 boxed	£2250	£3000
SME Series IV	£850	£1250
SME Series V	£1250	£1650
Ortophon Rohman - June 02 <10hrs use	£600	£1000
Origin Live Silver 250 "	£500	£600
Nottingham Analogue Interspace - current spec + new Space arm	£900	£1100

Tel: 0115 973 3222 Fax: 0115 973 3666
internet: www.definitiveaudio.co.uk email: shout@definitiveaudio.co.uk

campaign audio design

Hi-Fi Cables Manufacturer and Supplier

"Love Hertz"



Getting a better, more involving sound often means spending a lot of hard earned money. It's such a waste, because every system can benefit from our cables and accessories, at a fraction of the cost of some new "black box". Here are some of the ways we can help.

We have Linear Crystal Oxygen Free Copper interconnects (£12.48) up to High Purity Silver balanced cables (£99.00) and high definition

loudspeaker cables in Silver Plated Copper or Pure Silver. Our mains cables add weight, power and scale, and with non-inductive RF filtering (£10.00) and over-voltage protection (£3.00) enhance performance still further. Gold plated AV cables, both RF (£19.95) and O/C Sear with PTFE insulation (£30.19), help bring picture quality in line with NICAM sound resolution.

We also have a cure for your noisy fridge or central heating motor (£3.50), enabling you to throw away your big mains noise suppressor, which has been giving you that "sat upon sound" for years. There's lots we can do to bring you closer to the emotion and energy of the performance. So confident are we, that we offer a 21 day money back guarantee.

Ring or write for details:-

CAMPAIGN AUDIO DESIGN
Ty-Mawr Road (HW)
Cardiff CF3 3BS
Tel:- 02920 779401

Website: <http://business.virgin.net/cad.cables/>



Trade and International Enquiries Welcome.



you should aim to get your money's worth out of it!

The Meridian combo doesn't have the organic 'whole' of Linn's similarly priced Sondek CD12 but concentrates more on the layers of the music to create its beguiling appeal. Despite this warmth, there's plenty of bass and attack, as heavy rock and dance music discs revealed.

YOU'RE SURROUNDED

Already enamoured with the 800 as a CD player alone, turning the configuration to multichannel really showed the stellar heights to which this Meridian pair can soar. At its best the system literally took my breath away with its performance. The 861 has a list of configurable settings far too long to go into, but once the 800 player is set up in two channel mode (via the on-screen menu) then the 861 was configured to switch into Trifield mode with two-channel (stereo) discs.

Trifield mode uses the two main left and right loudspeakers, along with the centre and subwoofer, to create an impressive enhanced form of 'stereo' replay which brings a new take to the format. The sound is naturally stretched way back into the room and there's a superb sense of three-dimensionality to it all, creating literally (with the Quads anyway) a curved wall of sound studded with images.

Let's not forget that whilst this is ultimately, and primarily, a system for the music lover it also plays movies, and very well too. The superbly choreographed fight scenes in *Crouching Tiger, Hidden Dragon* had awesome impact, with near perfect picture quality. It also made me

realise that, as daft as it may sound, the Quad electrostatic is a damn fine A/V 'speaker'. There's no boom and tizz, of course, but what you do get, especially through the Meridian kit, is a fast, natural and dynamic sound with great dispersion.

Where the Meridian gear really came into its own though was with multichannel DVD-Audio discs where it showed what exactly can be achieved, sound wise, with the format. A range of different types of music showed that it can handle dexterity, delicacy and sheer clout in equal measures. And all with indisputably superior sound quality. I've never heard the Teldec series of Beethoven symphonies sound so real. When the opening bars of the fifth symphony sprung into action there was a sense of realistic drive and sheer energy that is a light year away from Compact Disc, no matter how good the recording. String tones were exceptionally natural and the violin section sounded like I've rarely heard it in the home, muscular and sinuous.

Where the format shows what it can do in a pure audiophile way is in the space and lightness that accompanies any woodwind passage, which can be simply jaw-dropping. The rear channel 'speakers, in the shape of Quad's fast and detailed ILLs acted as natural surrounds, creating ambience and space in, again, a highly realistic manner.

Moving on to the Debussy preludes for piano, the Meridian delivered a well balanced and fluid sound that also had oodles of presence and good detail. Again, the way the recording acoustic was captured was especially impressive.



Both the 800 and 861 are configured like a computer with removable cards.

With multichannel studio mix rock from in-yer-face bands like Stone Temple Pilots the sound was big and all-encompassing, with full-on attack and plenty of taut, deep bass. Indeed, so good is the sound in multichannel DVD-A that I would challenge any seasoned listener or critic of either DVD-A or multichannel to find fault. It certainly changed my outlook on everything both sonically and domestically - analogue watermarking, intrusive rear channel 'speakers, extra bulky amps etc. all became irrelevant, as the sound was simply breathtaking at times and took audio to another level.

END BITS

It's both very easy to sum this system up, yet very difficult! Obviously, it's frighteningly expensive, but then again, lest we forget, so are many cars that you get shot of in three years and will have depreciated by an equivalent amount.

This isn't a transitory gadget - it's more an investment for the soul! Soundwise, it's perhaps not ultimately as ultra-detailed and intricate as the very top, similarly priced super high-end hi-fi I've heard, but to me it's more musical. What's important is that you never lose sight of the fact that this is for edification and enjoyment, as opposed to hi-fi for hi-fi's sake - techno-religion where the 'listener' kneels at the shrine of the blessed rack and pays more attention to the manual than the music.

Overall, the 800 is perhaps the finest overall CD player I've ever laid ears on. When you consider that there are some CD-only players round that demand this outlay, the price tag doesn't seem all that eye-watering. In the past I've been lucky

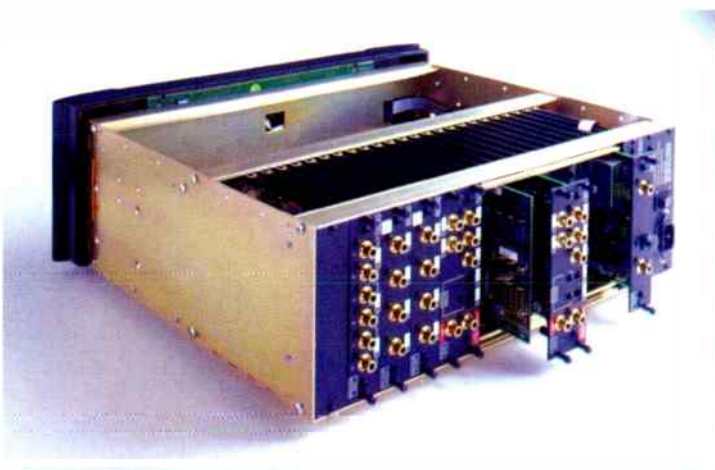

The cards are added to the chassis according to particular requirements



Faithful to your music



Music as it was meant to be heard • Systems start from £3000

For your nearest stockist call +44 (0)1722 332266. Or visit www.naim-audio.com
World Radio History



enough to be in close proximity to top class orchestras banging out the best music, and at times this combination with DVD-Audio discs honestly brought me the closest to the experience than any other hi-fi system I've encountered. And that is no mean feat.

With the enjoyment I've experienced from using this system, I'd buy it tomorrow if I was in the position to. However, like many others, I can't. Unless I become President of the World Bank overnight, sell my family into slavery or poison any wealthy relatives!

Meridian 800V3 DVD
computer/player £10,295
Meridian 861 Surround Sound
Controller £7,635

Meridian Audio Ltd.
Tel: +44 (0)14880 445678
www.meridian-audio.com

MEASURED PERFORMANCE

In common with most DVD-A players, the 800-series accommodates all 5.1 channel decode modes (except dts 96/24), while the enhanced offboard processing of the 861 delivers the full 7.1 channels possible with Dolby EX.

Digital data is transferred from 800 to 861 in two ways. Compressed Dolby and dts bitstreams are passed in the usual fashion while, uniquely, up to 6 channels of uncompressed digital audio may be transferred via three S/PDIF links using the encrypted MHR (Meridian High Resolution) protocol. Depending on your choice of software, the 800 decodes up to 5.1 channels and then either upsamples (in the case of 44.1kHz CD or 48kHz DVD) or downsamples this data (in the case of 192kHz DVD-A) to a common 96kHz/24bit format recognised by the 861 external processor. This limits 192kHz sampled DVD-A audio to 45kHz analogue bandwidth maximum, instead of 95kHz.

The performance of the 861 is clearly optimized for 96kHz/24bit data, for while 44kHz/16bit CD replay is very good, there are clear reductions in distortion and gains in low-level linearity with 96kHz/24bit DVD-A. For example, although Meridian's digital inputs are all crystal-locked and buffered for incoming sample rates from 44.1-96kHz, jitter falls from a mere 130psec with 44.1kHz CD to an astonishingly low 30psec with 96kHz DVD-A.

With 44.1kHz and (multi-channel) 48kHz data, distortion ranges from 0.002-0.0008% from 20Hz-20kHz at full signal level, increasing slightly to 0.004-0.007% at -20dB below full level. However, with true 24bit data, Figure (1) shows distortion falling to a minimum of 0.0005% at 1kHz, with best-case figures of 0.001% and 0.0015% at -

20dB and -30dB below full level, respectively. This results in an exceptionally 'clean' looking spectrum at levels where there's plenty of musical action taking place.

Regardless of data, care must be taken with the volume setting. If peak digital levels are present on the source material then the 800/861's volume should not exceed "93". This is equivalent to a 3V maximum analogue output, beyond which it is immediately plunged into clipping.

The next graph (figure 2) demonstrates the 861's superb low-level linearity that, despite its A-wtd S/N amounting to just 106dB, remains true to -110dB down, with averaged errors of <1dB from -115dB to an astonishing -120dB.

Of course, true 24bit data holds the promise of a 146dB dynamic range, but this is never realised in practice because of limitations in associated analogue circuitry.

With 96kHz sampled digital sources, the 800/861's analogue response is -0.3dB down at 20Hz but flat to 45kHz unless "HS Output" is selected on the 861, which provides a roll off beyond ~32kHz amounting to -1.8dB at 45kHz.

DVD-A players typically offer far lower levels of ultrasonic noise than their SACD cousins, but the 800/861 is particularly impressive in this regard. Figure (3) illustrates the low noise and distortion (~0.004%) associated with a 40kHz signal, derived from 24bit/96kHz data (indigo trace). The equivalent output from Philips' DVD-7635A (bright blue trace), also tested in this issue, in SACD mode is included for reference.

Figure (3) also reveals a digital image that escapes the 861's digital filter with 96kHz DVD-A data. As this appears well above the audio range, it's unlikely to have any impact, though images associated with 44.1kHz and 48kHz digital audio are better suppressed at ~105dB.

Overall, the 800/861 represents a technical reference in many areas of performance, continuing the tradition of the marque. **PM**

	CD	DVD-A
frequency response	8Hz-21kHz	8Hz-45kHz
distortion	0dB	0.001
	-30dB	0.008
noise (A-wtd)	-106	-106



Figure 1

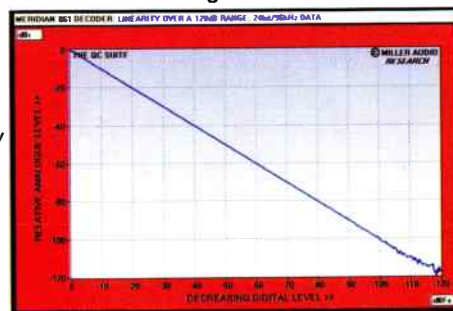

Figure 2

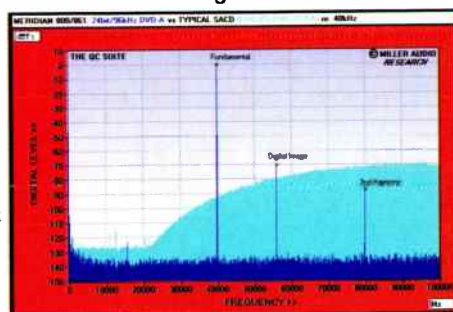



Figure 3

World Verdict  Takes audio to another level, if you can afford it. Without doubt the finest optical disc playing system we've encountered. Smooth and cohesive, it plays anything you chuck at it with ultimate finesse.

HI-FI WORLD'S GREAT COMPETITION GIVEAWAY

WIN A PAIR OF WILSON BENESCH ARC LOUDSPEAKERS WORTH £2400 IN THIS MONTH'S SUPERB COMPETITION

There are actually very few hi-fi companies based in the UK that can be truly described as being 'high-end' but Wilson Benesch are one such outfit. Acclaimed for their design status, superior sonic attributes and superlative build quality, the company produce some of the best looking and sounding gear on the market.

Wilson Benesch, founded in 1989, are based in one of the country's most traditional locations for British manufacturing - once famous for its Stainless Steel production - Sheffield in Yorkshire. The UK sales and public relations side of the business is currently run by husband and wife director team Craig and Christina Milnes. These two have presided over a steady growth in the company's homeland over the past few years as the audiophile's demand for quality ever increases.

Although a manufacturer of select high-end loudspeaker designs over the past seven years, the company also have a little audiophile ace up their sleeve in the shape of the highly respected Full Circle

turntable/tonarm/cartridge package. This vinyl replay system was actually their second turntable product and makes full use of carbon fibre materials which is the basis for all of the company's products and an essential part of their research and development theory, which help make Wilson Benesch unique amongst the competition.

The company has a proven track record when it comes to innovation - such as the quarter of a million pound DTI SMART research project in which they developed the world's first multi-role driver. Known as the Tactic ©, it can fulfill the role of both a conventional drive unit and clamshell Isobaric system where two drivers face each other. This technology is featured throughout their Odyssey range, which ranges from the standmounting Arc to the flagship loudspeaker, the £15,000 Chimera.

There are many new things in the pipeline for Wilson Benesch, such as a new version of the company's classic ACT One 'speaker which was shown at the recent London Hi-Fi Show and is due for release in December. This lays claim to being the stiffest and most inert loudspeaker enclosure ever assembled by a manufacturer.

The superb Arc loudspeakers that we have to give away here are simply one of the finest sounding and built

standmount 'speakers money can buy. In our review of the Arc, we noticed that the 'speaker was "a very dynamic, low coloration and high-resolution design" and that they "are also superb at rendering depth, atmosphere and ambience, bringing recordings to life".

There's little to touch these little 'speakers when it comes to finesse, detail and sophistication, they're simply stunning.

If you want to benefit from the enjoyment the Arcs could bring to your system, then here's your opportunity. Winning a pair of these fantastic 'speakers couldn't be easier. Simply answer the following questions on a postcard and send it to the address below by November 30th. The first correct entry out of the bag will receive these superb speakers.

Competition Questions

[1] In which year was the company founded?

- [a] 1989
- [b] 1990
- [c] 1991
- [d] 1999

[2] Where is the company based?

- [a] Leeds
- [b] Bradford
- [c] Sheffield
- [d] Batley

[3] What is the name of the turntable/tonarm/cartridge package?

- [a] Full Stop
- [b] Full Circle
- [c] Circle Line
- [d] Full Up

[4] What is the name of the company's flagship loudspeaker?

- [a] The Camera
- [b] The Chamade
- [c] The Chimera
- [d] The Capri

December Competition

Hi-Fi World Magazine
Unit G4 Argo House
The Park Business Centre
Kilburn Park Rd.
London NW6 5LF

Hi-Fi & Computer Audio World Competition rules and conditions of entry

1. Only one entry per house hold.
2. Multiple entries will be automatically disqualified.
3. Purchase of the magazine is not a pre-condition of entry.
4. No correspondence will be entered into.
5. The Editor's decision is final.
6. No employees of Audio Publishing Limited, or of any companies associated with the production or distribution of the prizes may enter.



CONGRATULATIONS

...to Mr. M Tracey of Gloucester, B Flatman of Cambs, Dr. B McAdam of Baddesley, Mr A. Green of London, and David Smith of Eastbourne, the winners of our October competition. A pair of Quad 11L loudspeakers are on their way to you!

Sevenoaks Sound & Vision

Stocks a comprehensive range of DVD players, amplifiers, speakers, plasma monitors, televisions and projection systems from all the leading manufacturers.



From starter systems to custom designed multi-room and home cinema installations, our friendly staff are available in all outlets to advise, demonstrate and guide you through the home entertainment jungle.

If you're interested in home entertainment and want to avoid the confusion, contact your local Sevenoaks Sound & Vision outlet on freephone 0800 587 9909 and experience more.

0% interest free option* is available on most products. *Written details on request. Licensed credit brokers.

Minimum balance £400. Subject to status.

**Hi-Fi Separates & Systems • Home Cinema
Plasma & Projection • Multi-Room Systems**

MUSICAL FIDELITY *Tri-Vista 300*

In celebration of the company's twentieth anniversary, Musical Fidelity are introducing the limited edition (500 only) Tri-Vista 300 'super' integrated amplifier. Delivering an enormous 340W per channel, the 300 uses Tri-Vista mini-tubes similar to the Nu-Vista tubes previously used in Musical Fidelity's highly acclaimed, limited edition, Nu-Vista series of products. The Tri-Vista Series will shortly be enhanced with the addition of 800 Tri-Vista SACD/CD Players, 300 Tri-Vista Pre-Amplifiers and Power Amplifiers.

Tri-Vista 300 Integrated Amplifier £3994.95



New Outlets in Poole, Shirley (Solihull), Swindon and Wolverhampton

We are delighted to announce that towards the end of October our new store at Latimer House, 44-46 High Street, Poole will be opening - please call 01202 671677 to confirm before travelling. Additional new outlets in Shirley (Solihull), Swindon and Wolverhampton are due to open* over the next few months. For further details please see our outlets listing on Page 7.

*Subject to legal completion.

Outlets Nationwide

Aberdeen • Bedford • Birmingham • Brighton • Bristol • Bromley • Cambridge • Cardiff
Chelsea • Cheltenham • Crawley • Croydon • Edinburgh • Epsom • Exeter • Glasgow
Guildford • Holborn • Hull • Ipswich • Kingston • Leicester • Leeds • Lincoln
Liverpool • Maidstone • Manchester • Newcastle • Norwich • Nottingham • Oxford
Peterborough • Plymouth • Poole • Preston • Reading • Sevenoaks • Sheffield • Southampton
Southgate • Swansea • Swiss Cottage • Tunbridge Wells • Watford • Witham (Essex)



By combining technologies from their Reference and Q Series, KEF have introduced the new XQ speaker range. Featuring KEF Uni-Q® 'point source' arrays for unrivalled off-axis performance and 'super audio' Hypertweeters™, the XQ range fully exploits the wide bandwidth of digital formats like SACD and DVD-A. The range comprises the XQ one and three stand mounters, the XQ five floorstanders and XQ two c centre speaker. All XQ models are available in a variety of finishes



www.sevenoakssoundandvision.co.uk

experience

more

World Radio History



WHAT Hi-Fi? 2002
Best Buy
WINNER & HOME CINEMA AWARDS
TURNTABLES
 Up to £150

PRO-JECT

Debut II Turntable (Black) £114.95

"The original Debut turntable romped away with a Product of the Year Award in 1999, and the MKII version continues the extremely good work. It's a simple affair, that's easy to set up, but don't let the price fool you - it sounds a whole lot more expensive than that. This

is a fine turntable - and it clearly reveals the benefits of listening to vinyl - with a rich and detailed soundstage - and a good dynamic response.

It's available in six funky colours - so you should find one to suit your decor - and at just a smidge over £100 - you can have no excuse not to keep that old vinyl collection in employment for a good few years yet."

WHAT Hi-Fi? ★★★★★ Awards 2000

Selected outlets are Project Turntable Centres. Colour Options are available at additional cost.



Turntables & Tuners

Arcam DIVA T61 Tuner.....	£249.95
Denon TU260L MKII Tuner.....	£109.95
Marantz ST4000 Tuner.....	£119.95
Michell Gyro SE/RB300 Turntable.....	£1017.95
Project Debut Phono SB Turntable.....	£159.95
Project Debut II Turntable (colours).....	£129.95
Project RPM4 Turntable.....	£324.95
Sony ST-D777ES FM/DAB Tuner.....	£549.95
Videologic DRX-601E DAB Tuner.....	£249.95

ROTEL RCD-02 CD Player £379.95 RA-02 Amplifier £349.95

RCD-02 CD Player "Whether it's the raw, and sometimes just plain barking vocals of Tom Waits, or the stinging guitar stabs of Pete Townshend on some old Who tracks - the Rotel is one of those players that can't help but bring a smile to the face - it's a breath of fresh air."

WHAT Hi-Fi? ★★★★★ September 2002

RA-02 Amplifier "The amp has a fast, detailed and yet satisfyingly full presentation. That allows it to make a fine job of the beats of Groove Armada's *Goodbye Century* set without losing sight of the fine details of the mix - and also husking out Marianne Faithfull's deliciously smutty vocals on *Kissing Time* with real relish. Add in decent levels of equipment - and the convenience of remote control, and we reckon Rotel has a winner on its hands."

Also Available
Marantz PM4200 • £149.95



WHAT Hi-Fi? ★★★★★ August 2002

(((AE))) AEGIS EVO Series Acoustic Energy Evo One Speakers £179.95

"The original Aegis Ones were great speakers, to the extent that they were category winners in our 1998 awards. Since then a host of new models have raised the standards in the sub-£200 category, and the Aegis Ones soon went from stunner to also ran. AE's response to that is an EVO version.



The Aegis Ones genes are clearly evident. The original's refinement and bass weight are preserved and backed up with better openness and more free-flowing dynamic ability. The old speakers would have delivered a cool and calm version of Pink's *Missundaztood* set - they'd be enjoyable - but would lack a little drive and excitement. The new speakers - however - address those limitations. Add authority and good stereo imaging to the list of plus points and it comes as no surprise to find these speakers at home with classical, too. Indeed, running



through our test room's extensive CD library we couldn't find a genre that these AE's weren't happy playing." **WHAT Hi-Fi? ★★★★★ July 2002**

CD Players

Arcam DIVA CD62T.....	£369.95
Arcam DIVA CD72T.....	£449.95
Arcam DIVA CD92T.....	£899.95
Arcam FMJ CD23T.....	£1199.95
Cyrus CD7.....	£799.95
Denon DCD485.....	£139.95
Linn Genki.....	£994.95
Linn Ikemi.....	£1949.95
Marantz CD4000.....	£99.95
Marantz CD6000Ki Signature.....	£399.95
Meridian 507.....	£1194.95
Meridian 588.....	£2099.95
Musical Fidelity A308.....	£1999.95
Musical Fidelity NuVista 3D.....	£2999.95
Rotel RCD1070.....	£494.95
Sony CDPXE570.....	£109.95

Please Note: Some products may not be available at all outlets. Advertisement valid until at least 13th November 2002. E&OE



more entertaining



Amplifier Selection

Arcam DiVA A65 Plus Amplifier	£369.95
Arcam DiVA A75 Plus Amplifier	£469.95
Arcam FMJ A32 Amplifier	£1149.95
Cyrus ACA7 5 Pre Amplifier	£699.95
Cyrus Smart Power Amplifier	£599.95
Cyrus 5 Amplifier	£499.95
Denon PMA355 Amplifier	£229.95
Linn Kolektor Pre Amplifier	£494.95
Linn LK85 Power Amplifier	£494.95
Marantz PM4200 Amplifier	£149.95
Musical Fidelity A3 2 Pre Amplifier	£999.95
Musical Fidelity A3 2 Power Amplifier	£999.95
Musical Fidelity A308 Amplifier	£1999.95
Sony TA-FE570 Amplifier	£149.95



ARCAM SOUND & VISION

DiVA CD82T CD Player

£599.95

DiVA A85 Integrated Amplifier

£799.95

DiVA CD82T Arcam's latest sounds like a more mature version of its little brother. On an initial listen the increased solidity and refinement are obvious, but over time the subtler dynamic shading and more assured handling of transients come to the fore... The Arcam CD82T is one of the best CD players available at this price point. **WHAT Hi-Fi? ***** September 2002**

DiVA A85 'You'll have realised by now that we rather like this amp. It took us completely by surprise, and further strengthens Arcam's already impressive product range... The A85 is superb, and we can't wait to put it up against its peer in a group test.' **WHAT Hi-Fi? ***** March 2001**



Also Available NEW Arcam
FMJ AV8 & P7
£5,499.95



Best Buy
2002
SPEAKERS
£201-£350

B&W Bowers & Wilkins DM602S3 Speakers £299.95

But the B&W 602 S3 are our winners. They're big and not particularly beautiful, yet if it were our money they're what we would buy. No rival can match the wide ranging dynamics or low frequency performance of these not so compact standmounters. Add all-round sonic excellence and the choice is easy. Give them sufficient space to breathe, then sit back and enjoy the music.

WHAT Hi-Fi? *** Supertest Winner August 2002**

Also Available (Pictured Right)
B&W CDM NT Series • Prices start from £749.95



PURE DIGITAL DRX-701ES Digital Tuner £249.95

This new tuner from the recently renamed Pure is based on the 2001 Award-winning Videologic DRX-601ES, but under the lid is an all-new third-generation digital radio engine, in the form of Frontier Silicon's Chorus FS1010. Its biggest advantages are lower energy consumption and above all cost - it's the major reason why the DRX-701ES is £100 less than last year's model.

The tuner uses 24-bit 192kHz conversion with 4x upsampling and data interpolation, and is powered by a low noise inductal transformer - such attention to sonic detail pays off. Digital outputs are provided

on electrical and optical feed, but most people will use the

analogue out, and these sound very good indeed. As usual the tuner is subject to the signal quality off-air

but when it's fed from a high-quality outdoor aerial and a good signal it's capable of a crisp, powerful and detailed presentation. Even more populist music stations like Radio 6 benefit from the mix of a neutral balance and fine weight, while speech is also neutral and easy to follow... If you want a quality home tuner for digital radio, you need look no further. **WHAT Hi-Fi? ***** October 2002**



Also Available
Denon TU260L/II • £109.95



CD7Q CD Player £1149.95
7 Integrated Amplifier £699.95

Cyrus 7Q CD How it compares directly (with the competition) is a matter for a group test, but I can tell you now that it'll be a close one because the CD7Q is a fantastic CD Player offering all you'd expect from a disc spinner at this price, and more... The CD7Q is a major upgrade from the class-leading CD7. Its weighty, detailed sound puts it at the pinnacle of CD players at this price.

WHAT HI-FI? ★★★★★ July 2002



Cyrus 7 Amplifier This is a fabulous amplifier. It's fast, punchy and has bags of power on tap but crucially delivers huge sackfuls of subtlety when the music requires. Some of the other amplifiers in this group may be better with particular genres of music but as an all-rounder it takes some beating.

WHAT HI-FI? ★★★★★ November 1999

ROKSAN Kandy KA1 MKIII Amplifier £549.95

When we last reviewed Roksan's Kandy integrated amp in February it fought off serious competition to come top in a *Supertest*. This is its replacement, the MkIII.

Internal changes include an updated power supply for the preamp section and identical mono modules for the left and right power amp sections. Roksan also claims 50 percent lower distortion on line-level inputs and a whopping 150 percent less on the phono input. The rated power output is an impressive 120 watts per channel into 8 ohms, and this amp has a confident, muscular way with music that bears this out. But don't be fooled into thinking this amp is raw but unrefined. With Van Morrison's *Down the Road* the Kandy has the guts to render the performance exciting and dynamic, but also the guile to deliver subtle details.



The upgraded Kandy MkIII is an excellent amp. The MkII version was impressive, but MkIII is a stunner. It betters all the amps here in the timing department, and has a wonderfully robust character that works well with all types of music. It manages to retain the good points of the MkII while adding extra resolution and subtlety. All the amps here have a place in the market. It's just that at £550 the Kandy really does set the pace.

WHAT HI-FI? ★★★★★ October 2002



11L Speakers £379.95

"Quad is best known for its superlative electrostatic designs, which start at £3500. So any £379 pair of speakers that carries the company's name has to be going some to avoid tarnishing the family reputation. The first surprise is that the 11Ls come in real-wood veneers covered with piano-gloss lacquer. This type of finish is almost unheard of at the £1000 mark, let alone at this price. Has anything been sacrificed for such a luxury finish? Here's the second surprise: apparently not.

The final surprise? Well, saving the best for the last, the sound quality of the 11Ls is phenomenally good. These are small speakers at just 33cm



tall, but the scale and authority of their performance is terrific. The laws of physics dictate bass extension limitations, but thanks to a clever dual rear firing port arrangement the 11Ls plumb the depths with the determination of a rottweiler, even when placed in free space.

If you're in the market for a pair of top quality standmounters, these Quads are a must listen. Quite simply, they're good enough to scare the competition big time.

WHAT HI-FI? ★★★★★ August 2002

Speaker Selection

Acoustic Energy Aegis Evo Three	£349.95
B&W CDM 1NT	£749.95
B&W CDM 7NT	£1249.95
B&W DM303	£1799.95
B&W DM601 S3	£2499.95
Cyrus CLS70 (Black)	£799.95
KEF Q1	£249.95
KEF Q3	£399.95
Linn Katan (Maple)	£634.95
Linn Ninka (Maple)	£894.95
Mission 780	£269.95
Mission 782	£629.95
Mission m/11	£129.95
Monitor Audio Gold Reference 10	£799.95
Monitor Audio Gold Reference 20	£1499.95
Ruark Epilogic II	£344.95
Wharfedale 8.1	£99.95

Please Note: Some products may not be available at all outlets. Advertisement valid until at least 13th November 2002. E&OE



more entertaining

World Radio History



MUSICAL FIDELITY A3.2 Series

A3.2 CD Player £999.95
A3.2 Amplifier £979.95

Replacing the **WHAT HI-FI? SOUND AND VISION** Award Winning A3 CD and Amplifier, the new A3.2 models have been further refined and re-styled. The A3.2 CD Player now incorporates the same DAC, filter assembly and control mechanism as the highly-acclaimed Nu-Vista CD Player. The A3.2 Amplifier draws on experience gained through the development of the Nu-Vista M3 amplifier and as such has inherited many of its qualities, producing a sense of ease and flexibility that is normally only associated with far more expensive designs.



MONITOR AUDIO Silver S6 Speakers £599.95

British loudspeaker manufacturer Monitor Audio has introduced a replacement series for its acclaimed and award winning Silver Series speakers. "The aim has been to offer real advances in performance and value", says technical director Dean Hartley. Every single aspect of the existing range was analysed, every user comment studied. We could have improved what we had, but instead we decided to design a whole new range of speakers from the ground up. New models include the S1 and S2 standmounters, the S6, S8 and S10 floorstanders.

"With a close-miked track such as James Taylor's *Line 'Em Up* from SACD they really deliver the character of the singer's voice and they're just as expressive with the cultured rhythms of Groove Armada's latest outing, having just the right mix of rhythmic control and fluidity... But amazingly the best is yet to come - these are simply beautiful speakers for classical music, once a few days' thrashing has tamed their initial rawness. With the latest release of Holst's *The Planets* on DVD-Audio they thunder out *Mars* with true conviction.

These are rather magical speakers, with a poise and grace that belies their ability to turn on the power when required. Pair them with a good CD player and suitably accomplished amp, and you won't go far wrong."

WHAT HI-FI? ★★★★★ October 2002



Also Available
Gold Reference
GR10 & GR20



"While it looks simple the Pioneer has an impressive array of features, including the handy double-speed disc finalization and CD-Text compatibility. Internally, the PDR609 is a big step up from the Award-winning PDR-509 it replaced: the DAC is now a 24-bit/96kHz number, aided and abetted by Pioneer's Legato Link conversion technology, and it has 24-bit A-to-D conversion which is ideal for copying your vinyl onto CD. If this is your plan you'll appreciate that the Pioneer makes it easy to create first-rate copies from any source, helped by the manual recording-level controls. It was hard to tell our copy of Jim White's *No Such Place* from the original.

While the Pioneer's replay quality can't match the Marantz, it costs £120 less, which would buy you a lot of blank discs. If you've already got a dedicated CD player, we'd go with this recorder."

WHAT HI-FI? ★★★★★ August 2001

Recorder Selection

- Marantz DR6000 CD-RW **£299.95**
- Sony MDS-JE770 MiniDisc **£229.95**
- Yamaha KX393 Cassette Deck **£119.95**
- Yamaha KX580SE Cassette Deck **£199.95**



TAG McLaren



Aphrodite Music System **£2994.95**

TAG McLaren by the company's nature have always had it in their blood to produce a stylish product. After all, they are tightly linked to Formula 1 racing which very much has its own charisma. The alluring shape of the Aphrodite reviewed here, is their attempt

Aphrodite

to bring some of that style into high-end audio. For too long the stylish one-box system has looked the business but more often than not failed to deliver the goods when it comes to sound and TAG wanted to put an end to that.

Firstly, there's the look and build of this beauty. The minute you lay your hands on the cold metal you know this is one very, very serious attempt to bring a one-box system up into the echelons of the real high-end. It weighs a fairly substantial 10 kilos and is housed in a classy ergonomically rounded brushed metallic chassis that's available in a variety of carefully judged colours. The case houses a CD Player, FM tuner and amplifier that delivers 50W per channel into 8ohms - enough muscle to run most modern speakers comfortably.

This system is a serious proposition for those in the market for a high-end sound from user friendly equipment. Few separates systems can deliver such quality plus style, for the same cost. Although expensive, the Aphrodite offers good value for those in the market for a sophisticated product - and it's miles ahead of certain lifestyle systems that offer poorer build quality and sound for little less cost. **Hi-Fi World November 2002**



TAG McLaren • Calliope Speakers **£1994.95**

J A Michell Gyro SE Turntable **£1017.95**



Founded in Borehamwood by mechanical engineer John Michell. For over thirty years, Michell Engineering have been at the forefront of quality audio with world-wide appreciated products like the GyroDec and Orbe Turntables. In the early eighties, the revolutionary GyroDec Turntable with its elegant and effective suspension system, was introduced.

The Gyro SE is a smaller and cheaper package that retains the classy sound of the GyroDec and can be upgraded to the full GyroDec specification by adding a plinth and dustcover.

"The beautifully engineered Gyro SE not only looks the part but has a wonderfully clean and fluid sound." **WHISKY HQ-FTZ Awards 2001** ★★★★★

Price includes Rega RB300 Tone Arm



LINN

Linn Classik Music System **£999.95**

The Classik Music System is an alternative to the sound and looks of mass market compact systems. Designed to be useful throughout the home, the Classik is simple and stylish with all the advanced features needed to satisfy the most demanding hi-fi enthusiast or discriminating music lover.



Classik • Movie System **£1999.95**

"Since the Scottish company added a tuner to the amp/CD player, mouths have gaped even wider in appreciation. The addition of colour options panders to the public's taste for kit to match their interior design, but it doesn't just look lovely in the lounge, the Classik sounds simply marvellous. Boasting fine impact and drive, it retains its grip even as it thumps out rock and dance tracks. Ask it to play quiet acoustic music and its smooth, liquid presentation impresses still further. The Classik offers the performance you'd expect from high quality separates in one lovely package - this is a very superior product." **WHISKY HQ-FTZ Awards 2001** ★★★★★

Please Note: Some products may not be available at all outlets. Advertisement valid until at least 13th November 2002, E&OE



more entertaining

World Radio History



scotland and north

- Aberdeen** 491 Union Street **01224 587070**
- Edinburgh** 5 The Grassmarket **0131 229 7267**
- Glasgow** 88 Great Western Road **0141 332 9655**
- Hull** 1 Savile Row, Savile Street **01482 587171**
- Leeds** 112 Vicar Lane **0113 245 2775** Open Sunday
- Liverpool** 16 Lord Street **0151 707 8417**
- Manchester** 69 High Street, City Centre **0161 831 7969**
- Newcastle** 19 Newgate Street **0191 221 2320**
- Preston** 40-41 Lune Street **01772 825777** Open Sunday
- Sheffield** 635 Queens Road, Heeley **0114 255 5861** Open Sunday

midlands and east

- Bedford** 29-31 St Peters Street **01234 272779**
- Cambridge** 17 Burleigh Street **01223 304770**
- Ipswich** 12-14 Dogs Head Street **01473 286977**
- Leicester** 10 Loseby Lane **0116 253 6567**
- Lincoln** 20-22 Corporation Street **01522 527397**
- Norwich** 29/29a St Giles Street **01603 767605**
- Nottingham** 597-599 Mansfield Road **0115 911 2121**
- Oxford** 41 St Clements Street **01865 241773**
- Peterborough** 36-38 Park Road **01733 897697** Open Sunday

midlands and west

- Birmingham** 12 Queensway Arches, Livery Street **0121 233 2977**
- Bristol** 92b White Ladies Road, Clifton **0117 974 3727**
- Cardiff** 104-106 Albany Road **029 2047 2899**
- Cheltenham** 14 Pitville Street **01242 241171**
- Exeter** 28 Cowick Street **01392 218895**
- Plymouth** 107 Cornwall Street **01752 226011**
- Poole** Latimer House, 44-46 High Street **01202 671677** Opening late-October*
- Shirley (Solihull)** Opening Soon Subject to Legal Completion **0121 733 3727**
- Swansea** 24 Mansel Street **01792 465777** Open Sunday
- Swindon** Opening Soon Subject to Legal Completion **01793 610992**
- Wolverhampton** Opening Soon Subject to Legal Completion **01902 312225**

london and south east

- Brighton** 57 Western Road, Hove **01273 733338**
- Bromley** 39a East Street **020 8290 1988**
- Chelsea** 403 Kings Road **020 7352 9466**
- Crawley** 32 The Boulevard **01293 510777**
- Croydon** 369-373 London Road **020 8665 1203** Open Sunday
- Epsom** 12 Upper High Street **01372 720720** Open Sunday
- Guildford** 73b North Street **01483 536666**
- Holborn** 144-148 Grays Inn Road **020 7837 7540**
- Kingston** 43 Fife Road **020 8547 0717** Open Sunday
- Maidstone** 96 Week Street **01622 686366** Open Sunday
- Reading** 3-4 Kings Walk Shopping Centre **0118 959 7768**
- Sevenoaks** 109-113 London Road **01732 459555**
- Southampton** 33 London Road **023 8033 7770**
- Southgate** 79-81 Chase Side **020 8886 2777**
- Swiss Cottage** 21 Northways Parade, Finchley Rd **020 7722 9777** Open Sunday
- Tunbridge Wells** 28-30 St Johns Road **01892 531543**
- Watford** 478 St Albans Road **01923 213533** Open Sunday
- Witham (Essex)** 1 The Grove Centre **01376 501733**

Please call to verify hours of business.

Contact our outlets via **E-Mail** outlet@sevenoakssoundandvision.co.uk

who are sevenoaks?

Founded in 1972 Sevenoaks Sound & Vision are one of the largest and most successful hi-fi and home cinema retailers in the country.

Each Sevenoaks Sound & Vision outlet stocks a wide range of quality products, covering all categories of specialist home entertainment from DVD Players to Widescreen Plasma Televisions and Projection Systems, all at highly competitive prices.

Friendly staff are available in all stores to advise, demonstrate and guide you through the home entertainment jungle.

new outlets

Towards the end of October, our new store at Latimer House, 44-46 High Street, Poole should be opening - please call to verify before travelling. Other new outlets in Shirley (Solihull), Swindon and Wolverhampton will be opening* over the next few months. Full details to follow soon. *Subject to legal completion.

staff wanted

We are currently recruiting staff at several locations. If you are enthusiastic, knowledgeable, have good customer service skills and would like a career within the audio/visual industry, call Janys Ness on 01732 466214 for more information.

croydon store re-fit

We are pleased to announce that the Croydon store has now been completely refurbished and we would like to take this opportunity to invite customers new and old to come and see the new look shop.

sevenoaks online

The Sevenoaks Sound & Vision website has news and information on the Sevenoaks group and its outlets nationwide. The website is designed to provide you with answers to the questions you may have when buying new equipment.

The site has comprehensive guides to a range of products and technologies from vinyl and compact disc to all the latest formats, including DVD Audio, SACD and widescreen plasma monitors and front projection systems.

There are regularly updated stock clearance lists with hundreds of products on offer and detailed pages to help you locate your nearest outlet.

For impartial advice and information, just click on sevenoakssoundandvision.co.uk

stock clearance

With over forty outlets nationwide, the Sevenoaks Sound & Vision group stock and display a wide range of products. As technology delivers improvements in performance, so individual models and product ranges are changed or superseded. The preceding models are made available at a reduced price, for clearance. Visit our Website for an up-to-date list of the clearance stock, listed by outlet, within the Sevenoaks Sound and Vision group.

0% finance option*

Spread the cost of buying. 0% finance option is available on the vast majority of products we stock. *Written details on request. Licensed credit brokers. Minimum balance £400. Subject to status.

pricing policy

Whilst we do not claim always to be the cheapest, we try to ensure our prices are highly competitive. Take into account the expert advice, unrivalled product selection, demonstration facilities and excellent pre, during and after sales service and the lower price might not look such good value.

In the event you can find the same products and excellent service at a lower price, please bring it to our store managers' attention. We will always endeavour to offer you the best deal.

NEXT IN LINE



Arcam have traditionally had the mid-price CD market wrapped up. Dominic Todd listens to the latest contender in this sector from the Cambridge company, the CD82T.

In terms of mid-range CD players, Arcam have been caught on the hop of late. The previous Alpha 7, 8 and SE versions of both, proved immensely popular and were always near the top of their respective classes. When the DiVA range was launched a couple of years ago, the £400 CD72 carried on this tradition and received rave reviews. Yet seven or eight months ago the competition began to hot up and, in my opinion, both the Rotel RCD1070 and Exposure 2010 have eclipsed the CD72. To be fair to Arcam, though, the Rotel and Exposure cost £525 and £600 respectively, and therefore Arcam weren't really competing on a level playing field. Well now, with the introduction of the CD82T, they most certainly are.

In true Arcam tradition the CD82T looks just like the other models in the DiVA range. It even shares the same Sony based transport featuring CD Text. What it boasts over its little brother though is a significantly upgraded DAC. Out goes the single Delta-Sigma unit, to be replaced by two 24/192 Wolfson

components in a dual mono configuration. Furthermore, it features a high stability Class 1 crystal oscillator and, finally, they've also made use of some decent quality Burr Brown op-amps in the output stage.

Featurewise, Arcam have added an extra set of outputs for connection to multi-room systems but otherwise the unit is pure DiVA, which equates to excellent build quality and all the features you could realistically ask for.

The CD82T was hooked up to my usual system with a Rotel RCD-1070 and my notes on the Exposure 2010 alongside for comparison's sake. The first disc to hit the tray was Jools Holland's 'I'm in a dancing mood'. I chose this bouncy track to see whether Arcam have managed to produce a little more dynamic vigour than the extremely refined yet somewhat over polite sounding CD72.

In part Arcam have succeeded. Compared to its baby brother, the CD82 appeared to have a greater scope for dynamic contrast, and a slightly deeper, marginally firmer bass response. However, the Rotel still

proved to have the broader sound stage and "bigger boned" presentation. The Arcam did sound a little pinched by comparison. Of the two it was the Rotel that was more likely to get my foot tapping. Yet it didn't all go the 1070's way. The CD82 manages to eke out subtleties in the music that were once the preserve of far more expensive machines, and beyond the Rotel here. Holland's vocals were beautifully articulated, and each instrument had fine separation from each other, despite the slightly narrower staging.

Eva Cassidy's 'The Letter' was better suited to the Arcam. Such was the detail retrieval that the listener was given insight in to the manner in which the bass guitar string was plucked and just how the rooms' acoustics played its part in shaping the reverberation. Likewise, the old reviewer cliché of cymbal decay, was there to behold. Probably because of the slightly slower pace, the timing appeared to improve here although, from memory, the Exposure still has the upper hand.

There were times when I just wanted the Arcam to let its hair



down and boogie, instead of cruising through the piece with immaculate refinement and none of the rough edges that can mar the 2010's performance. It was certainly impressive, but a little frustrating too.

This frustration really came to light with something like Eminem's, 'Drug Ballard'. Here the CD82 was simply too smooth. The introduction should have the 'speakers' woofers moving with pistonic precision and alacrity. Instead the dynamic contrast had been traded for smoothed out peaks and troughs - pleasant enough to listen to, but not really appropriate here. On the plus side the female backing vocalists were imbued with a wonderful breathy nature that had eluded the 1070. Whilst it may not have been the most dynamic, it would also be wrong to think of the CD82 as in any way anaemic. There was still a

decently powerful bass response and fat soundstage, just not quite as bold as the best in the class.

Finzi's Music for Love's Labour Lost was, unsurprisingly, more the Arcam's bag. The sweet, fluid string tone had a beguiling manner that would make for pleasant lengthy listening sessions. The brass perhaps lacked a little rasp yet, as with the other instruments, the timbral balance was excellent. As with Eva Cassidy, one also got a real insight into the recording room's acoustics from simply hearing the decay and reverb from the surrounding surfaces. In this instance the CD82 turned the tables and proved a more involving listen than the 1070.

Cutting straight to the chase, as good as the CD82T is, I would say that the class best is still the identically priced Exposure 2010. It has an ebullient rhythm that the

Arcam simply can't match. Neither can it beat the fulsome presentation of the Rotel RCD-1070. However, it does have its redeeming features. For subtlety and insight I would say that the Arcam is the new class favourite. It's also the most refined CD player I've ever heard at this price point. If you favour light classical and acoustic music over symphonic or high-energy dance themes then the Arcam could well be your machine. Likewise, if your amp and speakers are already on the boisterous side, the CD82T could be perfect. All other things being equal, though, for me the Arcam just fails to beat the best, but is a mighty fine effort none the less.

Arcam CD82T CD player £699

Arcam Ltd.
Tel: 01223 203200
www.arcam.co.uk

MEASURED PERFORMANCE

Arcam usually engineer a broad, flat frequency response with slow top-end roll off, to add some characteristic warmth and smooth out the sound a little. The CD82 follows this pattern, our response analysis shows, treble falling away slowly above 10kHz. The player just made it up to 21kHz within 1dB limits.

Linearity was excellent. The distortion trace clearly shows little in the way of quantisation noise or harmonic distortion, the residual at -30dB reading just 0.006%. This performance was maintained at -60dB, good linearity contributing to a 110dB dynamic range figure. A -90dB dithered signal produced just 2.4% distortion. The CD82 measures

very well in all respects. **NK**

Frequency response 4Hz -21kHz

Distortion	left	right
-6dB	0.005	0.005
-30dB	0.005	0.006
-60dB	0.346	0.35
-90	2.4	2.4

Separation	left	right
1kHz	124	126
20kHz	104	106

Noise -105dB

Dynamic range 110dB

Output 2.2V

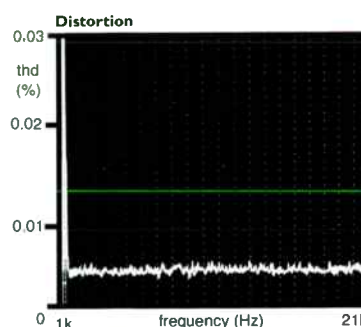
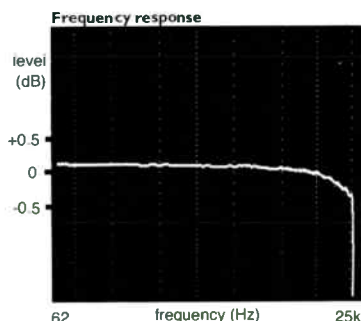

World Verdict

Extremely refined and subtle for the price but if you want ultimate excitement look to the plentiful competition.

MICHELL GYRODEC SE

A SYMBOL OF PRECISION



WHAT HI-FI?
June 2002

Michell Engineering Ltd, 2 Theobald St, Borehamwood, Herts, WD6 4SE
Tel: 0208 953 0771 Web: www.michell-engineering

THE AFFORDABLE PHONO AMPLIFIER

FROM TRICHORD RESEARCH

only £299.00 inc VAT (complete with
toroidal PSU)

DINO

Moving Coil
Moving Magnet
Switchable Gain
Switchable Loading
Super Regulators
Discrete Output Stage
Add a 'Dino+' PSU for true
high end performance



WHAT HI-FI?
June 2001



FOR Sweet and revealing sound;
fine soundstaging, upgradability

Against Nothing we can think of.

Verdict A great moving magnet/
moving coil phono stage that offers
a slice of high-end performance at
a very competitive price.

World Verdict



A real 'hi-fi' sound and
all that many will need.
Highly recommended.

October 2001

tel: +44(0)1684 573524
fax: +44(0)1684 577380

www.trichordresearch.com

SUPER DISCOUNT!



Just a couple of years after the first SACD players arrived, the latest machines cost a mere fraction of their predecessors. David Price reviews Philips' latest budget blockbuster, the DVD763SA.

It only seems yesterday when I was testing Marantz's seminal SA-1, a £5,000 behemoth that made one of the sweetest sounds from silver disc I've ever heard. Although the research I'd done into the respective merits of DVD-Audio and SACD had lead me to plump for the former, when I slid a Super Audio CD into the Marantz, I was forced to rethink. Smooth and seductive, it made 24/192 PCM from DVD-A sound hard and showy. I was hooked.

Since then, the bulk of SACD players have come from Sony, which - to its credit - has had a jolly good go at making the format affordable. I still remember, some eighteen months back, people gasping in amazement as the SCD-940QS was launched. It offered SACD and CD playback (although not CD-R, famously) for a

trifling £600! Now though, the company does far cheaper designs (Richer Sounds is currently selling the SCD-XE670 for £130), meaning the fight for the low budget, high volume end of the market is on in earnest.

It is into this context that this Philips fits. For £249 (again, less if you shop around), you get not only SACD playback (in stereo or multichannel), but DVD video, Compact Disc (CD-R and CD-RW), MP3-CD (at 96, 112, 128, 256kbps and VBR) and VCD. In short, it spins practically anything small and shiny, except DVD-A. In addition, it comes with onboard Dolby Digital/AC3, DTS, MPFG and 24/96 PCM decoding. CD Text is also included, along with an audio and video bitrate indicator and - notably - full SACD Bass Management.

Frankly, the DVD763SA isn't the most drop-dead-gorgeous looking thing you'll see in the showrooms this year. It's small (at 435 x 7.5 x 303.5mm), light (3.3kg) and plasticky. In fact, the exquisitely made Supra FS SCART lead that I plugged into it rather put it to shame! Still, the fascia is cleanly designed, with the usual transport controls plus a 'Sound' button which selects the required mode - CD, SACD stereo or SACD multichannel (the Philips will downmix multichannel discs to stereo if you wish - handy feature for us stereophiles).

At the back there are six phono sockets which together provide multichannel audio output, a pair of phonos for the stereo audio out, one optical and one coaxial digital output, plus the video outputs (CBVS, component, S-Video and two

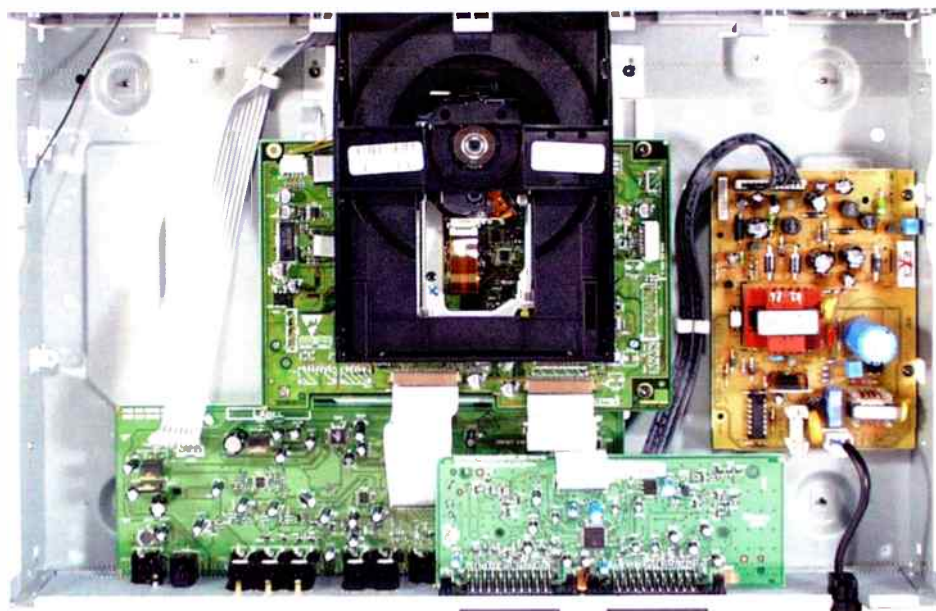

SCARTs). A captive power lead completes the picture. A passable illuminated remote is included, complete with three different switchable brightnesses. The package itself includes the player, remote, batteries, user manual, SCART cable, video cable and a pair of very cheap and nasty phono audio leads.

SOUND QUALITY

The Philips DVD7635A has a quoted frequency response of DC to 100kHz (in SACD mode, of course). This promises a beautifully open treble performance, with none of the distortion problems (that manifests as upper midband hardness) of 16/44 PCM. Cue up an SACD like Marvin Gaye's 'Midnight Love' in this player and you can hear the format doing its thing. There's little of the clanky, fizzy, muzzy sound that Red Book CD invariably serves up. Instead, the midband and treble is smooth,

smooth, smooth. But before you go thinking this is an SA-1 in a cheap box, remember that it has cheapo digital converters and all the noise that a budget digital video section can muster.

The upshot is that the tonal colouring that SACD can produce (as evinced by the aforementioned SA-1) is nowhere to be seen. The Human League's 'Dare' is a brilliantly warm disc - packed, as it is, with all those classic analogue synthesisers - but you wouldn't know it from listening to this. The Philips is actually rather cold and steely, albeit not harsh. Essentially then, it sounds like a budget machine with a difference. You don't get the aggro of 16/44's nasties, but you do suffer from the fact that the DVD7635A is a dual purpose audio-video machine, built down to a price.

In other respects, it's not bad. Staying with SACD, bass is a little soft

but still quite fluid. Midband is open and there's a surprising amount of depth. Imaging lacks the holographic quality of more expensive machines like Pioneer's DV-747A, but does the job. Treble isn't sweet, but it's commendably free from harshness - doubtless thanks to that 2.822MHz sampling frequency! Overall, it's a decently tuneful and involving performer, but still very much of the budget 'oeuvre' even when spinning SACDs.

Critically, put it against a top budget CD player, such as NAD's C521 (£200) and it's a very close fight - with the NAD's 16/44 sound coming very close and in some respects bettering the Philips SACD. Certainly the NAD has a fuller, fatter sound with nicer tonal detailing - it's only the upper midband or treble that's inferior to the Philips playing SACDs. Feed the Philips with a standard CD and it falls miles behind.





It's vague, woolly, lightweight and really struggles to be called hi-fi at

all. The Teardrop Explodes' 'Passionate Friend' (CD remaster) showed the DVD763SA to be out of its depth with fast, punchy, power pop. Its timing is well off the pace compared to the NAD, and it wasn't

altogether successful at communicating dynamic crescendos or phrasing. Bass was loose, midband thin and one dimensional and the treble sounded quite curtailed. All in

all, you shouldn't buy this unless you intend to use it for mainly SACD or DVD video use - as an aside, its video performance isn't half bad.

All in all, it's hard to recommend Philips DVD763SA to serious audiophiles, unless you intend to use it almost exclusively with SACDs (when it performs decently). Its mediocre CD performance is such that it isn't a great dual-format machine. Still, factor in its video capability and you can't dispute it offers great value for money - it's just that hi-fi buyers may find it a false economy.

Philips DVD763SA £249.95
www.philips.co.uk

MEASURED PERFORMANCE

This player's performance with both SACD and 48kHz or 96kHz digital audio on DVD-V discs is very good indeed. For example, jitter was exceptionally low with 44.1kHz CD and 48kHz DVD audio, amounting to just 155psec of primarily data-induced peaks. These are highlighted in the jitter graph by red coloured markers, expressed as pairs either side of the main signal.

Distortion was also impressively low at less than 0.0009% at the player's full output of 1.9V, falling to a stupendous 0.00035% at -6dB (950mV), then rising to just 0.0045% at -30dB, where much of the musical action takes place.

Distortion increases to 0.02% at 20kHz with CD, but holds to 0.015% right up to 40kHz with both SACD and 96kHz DVD signals. However, as the graph demonstrates, there's significantly more ultrasonic noise associated with SACD source

material (bright blue trace) than the 'equivalent' 96kHz DVD (dark blue trace). This noise will cause some unpredictability in the sound of the DVD763SA with different amplifiers.

Naturally, the responses differ, with CD possessing a gentle HF roll-off that amounts to -0.4dB/20kHz while 96kHz DVD continues to -1.2dB at 40kHz just before the 45kHz cut-off. Incidentally, the digital filter provides 44.1kHz CD and 48kHz DVD a good 90dB suppression of digital images, while 96kHz DVD has just 30dB.

SACD does not require digital filtering and its response extends to 100kHz (albeit at -14.8dB). Otherwise, the S/N ratio is fixed at 106-7dB, but resolution does improve with this format. So, low level errors amount to +0.5/-0.0dB at -90dB with CD but improve with SACD to +/-0.0dB at -90dB, +0.3/-

0.1dB at -100dB and +0.9/-0.5dB down to -110dB. This is a fine result for a budget machine, showing Philips are on top form these days with their products. **PM**

Frequency Response <5Hz - 20.1kHz (CD)

	Left	Right
Distortion		
-6dBfs	0.00035%	0.00035%
-30dBfs	0.0045%	0.0045%
-60dBfs	0.15%	0.16%
-90dBfs	2.7%	2.9%
Separation		
1kHz	106dB	105dB
20kHz	101dB	102dB
Noise (IEC A)	-106.7dB	-106.0dB
Output	1.91V	1.90V

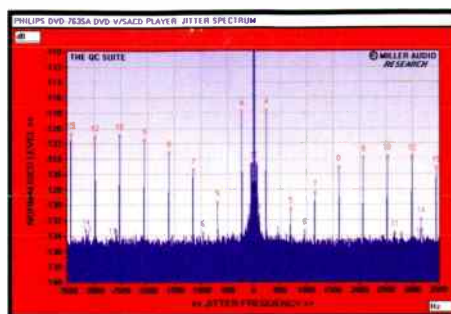
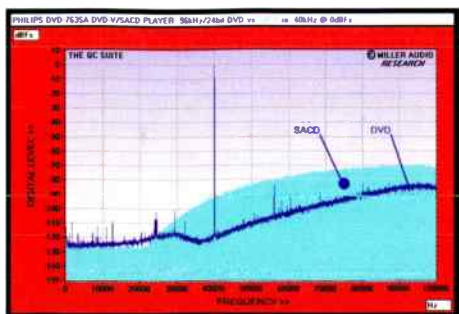

World Verdict £ 
Brilliant value if you want a do-it-all machine for next to nothing, but audiophiles will find its decent SACD performance offset by poor CD sound.

MORE THAN J

Hi-Fi World listens to the latest classic remastered high resolution discs to hit the shops.

FLEETWOOD MAC RUMOURS DVD-A

Reputedly the sixth best selling album of all time, it doesn't come as a complete surprise that Rumours has got an early DVD-A release. This Grammy award winning slice of 1977 vintage Fleetwood Mac sees the band at its most commercial, although by all accounts the songs were recorded in some very acrimonious circumstances. Having held the US album chart number one slot for some thirty weeks, it's likely that most people have heard something from this album before - it spawned 'Dreams', 'Don't Stop', 'Go Your Own Way' and 'The Chain' (famously used by the BBC for their Formula One motoring racing theme for many years).

Another good reason for this album's DVD-A release is its famed sound quality. Back in the late seventies it was the staple dem disc of every self-respecting hi-fi store, thanks to its superb analogue recording quality and FM radio-friendly production values. This is here in 24/96 glory on the new release, along with a new MLP 24/96 multi-channel remix courtesy of a number of the original production team, including Ken Caillat, Rich Fowler, James Stone and the legendary Bob Ludwig. Even a 448kbps Dolby Digital mix is bundled for those running standard DVD players without DVD-A decoding. The running order has been changed slightly compared to the original LP release - 'Silver Springs' wasn't featured on the original due to LP playback time constraints, but appears now after 'Go Your Own Way', with 'Songbird' at the end.

The stereo mix sounds disappointing. Make no mistake, it's head and shoulders above the 16/44

CD version, but it lacks the fluidity and warmth of the original LP. On some tracks especially, vocals are steely, guitars sound brittle and the general impression is one of a forward, aggressive sound. True, there's stacks of detail, tremendous speed and the trademark DVD-A dynamics, but it's far less 'organic' sounding than, say, Human League's 'Dare' SACD. Doubtless it will be a great demo disc again, but I'd find it hard to live with.

At least the multi-channel mix is tastefully done - no silly surround sound placement here! A partial centre fill is all you get from the middle speaker, the surround speakers serving to widen out the soundstage of the 'core' two channel mix. Instruments are placed midway between the front and rear channels, with few specific uses of the rears other than this. Close, but no cigar.

AMERICA HOMECOMING DVD-A

'Horse with no Name' is the one everyone remembers from this early seventies soft-rock band, but that's only the start of the story. Released in November 1972, 'Homecoming' was the band's 'difficult second album', attempting to repeat the runaway success of that certain song. It sees the original band members down to Gerry Beckley, Dewey



Bunnell and Dan Peek from the original four-piece. All were children of US servicemen stationed in the UK, in a unique position to be influenced by fast, tuneful sixties British pop and the rock tendencies of the US scene.

The album was produced by the band themselves, with two veteran musicians of Los Angeles' Record Plant Studios, Hal Blaine and Joe Osborne, who lend percussion skills and a wealth of experience to a very young band. The band was an embarrassment of riches, each member boasting great song writing skills, although they took it upon themselves to cover John Martin's 'Head and Heart' as their only non-original composition. The overall result is beautifully crafted 'folk rock' that's both melodious and thought provoking.

The superb vocal harmonies owe much to The Byrds, while in turn there's quite a lot here that could have inspired 'Fables of the Reconstruction'-era REM. That the album was largely recorded live (with just the occasional overdub) is all the more remarkable. The album takes the band's return to California in 1971 as its theme, being a kind of 'travelogue' of their journey. The lyrical style is both wide-eyed and celebratory, but also tinged with a little (British-style) cynicism. 'Ventura Highway' still sounds as arresting today as it ever did, and rightly deserves to be the song the band are remembered for.

JUST A RUMOUR

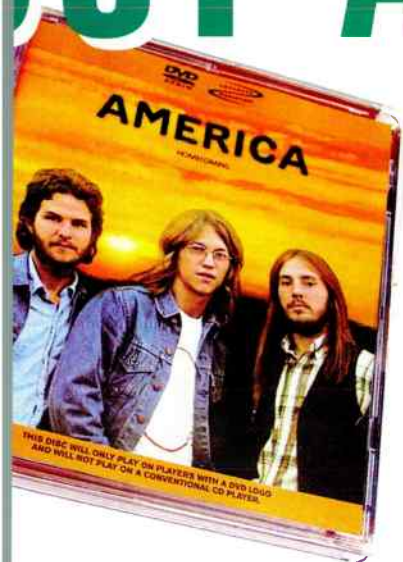

Rhino's DVD-

Audio release is brilliantly presented - the artwork is magnificent, giving a taste of the gatefold spread of the original LP. The sound is superb too. Unlike 'Rumours', for example, it's dramatically better even than a first pressing on LP. Incredibly clean and open, yet beautifully smooth, it really hits the spot. It's all the more surprising because 'Homecoming' is not what you'd call a typical 'audiophile' album! Bass is incredibly full and deep, soundstaging impressive (although it was never recorded in the Albert Hall), and treble smooth and sweet. The vocal sound is quite stunning. This is a brilliant effort by Warners/Rhino.

The surround mix is good, albeit a touch unsubtle. With lots of rear channel content and a good deal of panning front to rear, it's not quite as polished as 'Rumours' in this respect, although it does give a big, beefy, bold result. For those with only DVD video machines, there's a Dolby Digital 3/2.1 mix which isn't half bad. A gallery of archive photographs, song lyrics and an audio interview with Gerry Beckley and Dewey Bunnell completes the goodies. Superb sound, lavish packing and a decent multi-channel mix makes this an unexpected delight.

HUMAN LEAGUE DARE SACD

Philip Oakey once said that he couldn't have got through his teenage years without David Bowie and Roxy

Music, but it was hearing Walter Carlos's soundtrack to 'A Clockwork Orange' that got him into making music with synthesisers. Thus began The Human League, a group which enjoyed considerable success in the late seventies with its experimental 'electronic rock'. By 1980 however, the strains were showing between Phil Oakey and Adrian Wright's pop sensibilities and the more austere electronica beloved of Ian Craig Marsh and Martyn Ware. The group duly split in half in October 1980, with the smart money going on the future success of Ware and Marsh's British Electric Foundation project, whose Heaven 17 spin-off achieved great critical success with '(We Don't Need This) Fascist Groove Thang'.

Few people expected to hear from Oakey and Wright again, but while the latter was teaching himself to play synthesisers, the former was teaming up with producer Martin Rushent and bumping into two schoolgirls at Sheffield's Crazy Daisy disco. Susan Ann Sulley and Joanne Catherall subsequently joined as vocalists and thus was born The Human League (Mk II). In July 1981 the silence was broken with the release of 'Love Action (I Believe in Love)', which reached number five in the UK singles charts. Ian Burden duly became a permanent member and synthesiser player Jo Callis was recruited from The Rezillos. The rest was history.

In December of that year, Dare was released to ecstatic reviews from the likes of The Face and New

Musical Express. 'Don't You Want Me?' reached the top spot both sides of the Atlantic the next month, and the band secured its place in pop history. It's hard to understate the importance of Dare at the time of its release.

The first all-synthesiser album to venture out of the avant-garde and into ordinary teenage bedrooms, it virtually defined what came to be called the 'synth-pop' genre. The fashion-magazine inspired cover, along with photos of heavily made up band members, crystallised 'new romantic' style.

Recording quality is excellent - the original LP was a thunderously good listen, showcasing the big, fat, sumptuous sounds of those early Roland and Korg analogue synthesisers brilliantly. With such deep, powerful, resonant basslines and great squelchy powerchords, it's easy to see why those original synths are so sought after now.

Oakey's voice was wobbly, and the girls didn't always hit the right notes, but the effect is sublime nevertheless. Just as its name suggests, Dare has attitude - a sense of its own importance and purpose - which shines out from the first bar to the last. The SACD is a brilliant transcription - there's little to say about it except that it faithfully recreates the warmth and power of the original LP brilliantly. The result is a very sweet, detailed and smooth sound that is a convincing argument for the relative sonic merits of this new format. That it also contains a superbly remastered 16/44 PCM CD layer is icing on the cake. Superb.

Thanks to: Vivante Music Ltd (website: www.vivante.co.uk, tel: 01293 822186) for assistance in preparation of this review.

SECOND ORD

Cyrus's AV8 preamp is the company's second attempt at bringing together the hi-fi and multichannel markets. If this doesn't succeed, says David Price, then nothing will!



Cyrus's AV5 was one of those avant-garde hi-fi separates that singularly failed to capture the buying public's imagination. Sure, it sold steadily enough - especially to devotees of the brand - but considering what it did and what it meant - it was tragically overlooked. In the best tradition of innovative British designs, it was a 'crossover product' that brought together two different buying 'constituencies' - namely those of audiophile hi-fi and audio-visual.

These two groups have been living apart for many years now, AV growing up in the early nineties and establishing its own conventions, practices and outlook. To us dyed-in-the-grain audiophiles, these have been somewhat baffling - disconcerting even. Whereas two-channel has been a keen advocate of minimalism (short signal paths, no tone controls, filters or frills), multichannel has necessarily had to evolve differently. With six speakers in the listening room (making it an acoustic minefield), and the need to handle vastly differing programme material (from Hollywood action movies to BBC Radio 3), signal processing is essential.

The result is that when hi-fi nuts start looking at AV products, they're reduced to paroxysms of anguish. Horrendously complex, with little conspicuous attention to audiophile

detail, your average Japanese AV receiver is enough to send running out of the showroom at a not inconsiderably fast pace. Now though, this is all changing. Linn, Naim, Meridian, TAG, Arcam et al are doing multi-channel sound with audiophile values. My point is that Cyrus's AV5 preamp processor, launched a few years back, was one of the very first.

Suddenly you had something that was ostensibly a hi-fi preamp, but with a small amount of digital decoding and processing onboard (Dolby AC3, DTS, PCM), a slick user interface with a brilliant auto set-up facility and delicious 'audiophile' aesthetics. Most important was its sound. Pretty much akin to the old two channel Cyrus Pre (i.e. sweet, smooth and lucid), when paired up with Cyrus's XPA stereo or Cyrus Power monoblocks it was in another league to your average Jap AV receiver. Nice.

The AV8 is essentially the AV5 with the bugs ironed out. Visually almost identical, it's housed in the same inverted half-width (73x215x360mm) alloy case with large backlit green LC display. Inside, its predecessor's 40VA toroidal PSU

is retained but the circuitry is tweaked for an improved signal to noise ratio, with better clocking for lower jitter. The former's Spartan feature set is bolstered by Dolby Pro Logic II (which brings separate full bandwidth surround channel decoding, configurable for either movies or music). This is worth having, but it's hardly earth-shattering stuff. Audiophiles know that DTS is where it's happening right now, the omission of DTS-ES Extended Surround is a shame. Still, better sub bass bandwidth, improved MC-BUS software, an enhanced bass management system and new DTS mixdown options are added. Best of all for us two-channel migrants is the new provision of a 'stereo and sub' mode, which lets you run multichannel sources into ye olde two-channel hi-fi speaker pairs.

Round the back, the AV8 is proof positive that it is possible to cover every last square centimetre with phono socketry. With its six digital inputs, three pairs of analogue stereo ins, Cyrus MC-BUS connectors and six pairs of analogue outputs (front, surround, centre and two subs) and single digital output connected, it looks busier than Trafalgar Square on

R CROSSOVER

Millennium Eve. Just as well then that there's no video switching. Audio and video circuitry are unhappy bedfellows, and don't do great things for one another, so I'm not sad to see it omitted.

Rear panel cable connecting contortions excepted, this amp is extremely easy to set up. The AV8 can automatically configure your speakers to any given room, using the supplied microphone. You simply tell it their sizes and whether or not a subwoofer is present, then press a couple of buttons on the remote. The system then plays a series of test tones, and computes the respective time delay settings automatically. A nice feature is the variable digital crossover, which lets you closely match your main speakers to your subs.

What then of the sound? Using the AV8 in stereo mode as a line level preamp is a great way to assess the product's intrinsic quality. In this mode, you get a characteristically 'Cyrus' sound - which means smooth and detailed, with just a modicum of dynamic compression and softening of attack transients. Feed it with Simply Red's 'Holding Back the Years' on CD and you'll be impressed by the depth perspective, the relaxed but beguiling rhythms and the fine handling of micro-dynamics (making the phrasing on the keyboard playing particularly lucid). The result is a very satisfying performance.

It's only when you give it some Nirvana that you realise it's not the grippiest bit of kit on the block. Compared to a Naim NAC202 (which, admittedly, is a dedicated

two-channel design), you notice a slight lack of bass grip and energy, and a subtle softening of the hi-hat sound. Dynamics become just a little less well articulated

and there's a gentle loss of midband detailing. This isn't to say it's a dull sounding product - because it's generally very open and neutral - it's just that if it errs either way, then it's on the smooth side.

In 5.1 channel line-level mode, the extra resolution from a DVD-A pressing of America's 'Homecoming' really got the Cyrus singing. Whereas your average £2,000 Japanese AV amp sounds edgy and forward with high resolution digital, the AV8 positively shone, giving a beautifully full and open performance. Treble was sweet and atmospheric, with plenty of air and space. Midband was vast, with a walkaround soundstage, and bass full and powerful. A great performance, and head and shoulders above its non-specialist competition.

The onboard digital conversion/processing was also first rate. Simple 16/44 PCM again had that characteristically smooth but subtle Cyrus sound - I'd say it would actually improve upon most sub £800 standalone CD players in this mode. Dolby Digital was - as always - a bit of a let down, but that's the

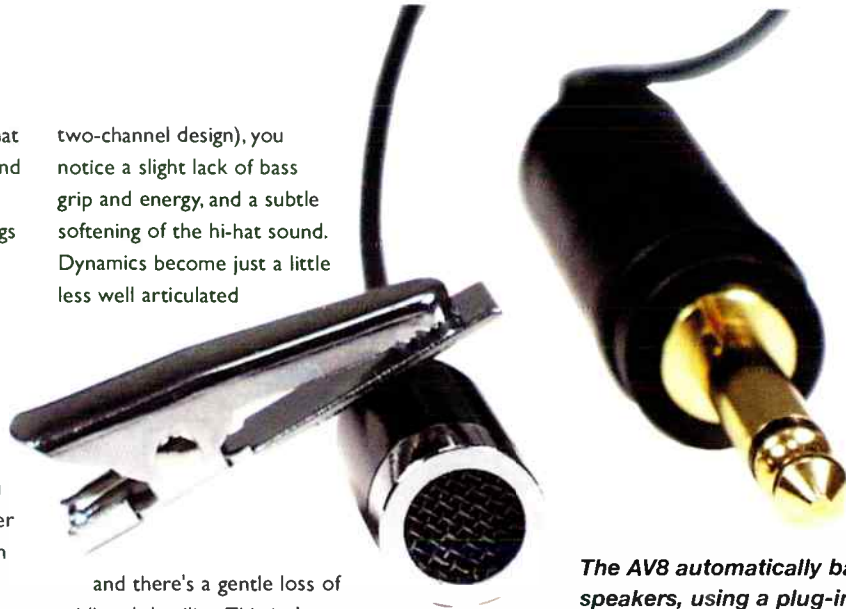

The AV8 automatically balances the loudspeakers, using a plug-in microphone, to compensate for their position.

codec for you. All I can report is that Bobby Womack's 'Across 110th Street' (the opening track to Jackie Brown) was carried better through the AV8 than almost any other AV preamp I've heard. DTS sound was great - rich and sweet and rhythmically very involving. I'd always recommend searching out movies encoded in DTS over Dolby.

This product is a great bridge for two-channel users wishing to go multi-channel. Unless you're running a high-end specialist preamp (of Michell Orca quality, or thereabouts), you'll lose little if any quality by switching to the AV8, and it will improve on the preamp stages of most integrateds. The bonus is, of course, that you'll also have full 5.1 channel capability (for movies or music) and DTS decoding (which is a boon for music-only multichannel devotees) which betters practically any foreign competition in sonic, ergonomic and aesthetic terms. Short of spending £2,500 on Naim's superb AV2 (which is £1,400 more than the Cyrus), I can think of few multichannel preamps that even come close. A true audiophile bargain.

World Verdict £ 
A combination of excellent sound, easy set-up and brilliant packaging makes this the one to have at the price.

Cyrus AV8 £1,100

Tel: +44 (0) 1480 43 55 77
www.cyrus.co.uk



Visit our website at www.hi-fiworld.co.uk or send your e-mails to letters@hi-fiworld.co.uk Every letter we print wins a superb prize including Precious Metals interconnects and a **FREE** subscription to **Hi-Fi World** for the letter of the month!!

letters & emails

letter of the month

PLUS C'EST LA CHANGE.

Unfortunately I recently picked up a copy of Hi-Fi World, as Trout & Salmon wasn't in yet! I had no idea that so much yet so little has changed since I last dabbled back in the early eighties. I was up to my neck in twin amps, quad decoders, massive boom boxes and 'Dark Side of the Moon' in SQ. Come to think of it - that was rather like the current saga with SACD and DVD-A! After reading and re-reading the mag from cover to cover I have decided on a winter project to upgrade my ailing low-fi.

I have in the loft a Garrard 401 SME3012 in perfect condition but it needs a new cartridge and a new plinth. I have a Marantz CD4000 which will do for the moment until the SACD/DVD-A thing sorts itself out. I'm not interested in the surround-sound TV bit at all - it just compromises the music. I also have a Tresham DR11 DR102/ PS102 in excellent condition. Is it worth making them the nerve centre of my project? I also have a very sweet Marantz 2225 receiver which I like very much when teamed with the 401 and my old Heathkit three-way speakers with 12" Goodmans drivers. At the time I remember it all sounded sublime, but time moves on and upgrade we must! Your advice please on amplification, speakers and cartridges? I'm really looking forward to buying my first new LP for more than twenty years!

**JR Saunders,
Llandysul**

You face the classic dilemma - do you stay with your 'retro' system or start performing some wholesale modernisation? Okay, let's start with the turntable. Obviously the Garrard 401 is one of the best turntables ever made (in some respects, at least) and so it would be perfectly fine to keep it with just a little tweaking. The first question is, 'how much do you love your SME twelve incher?' To be brutally frank, it's miles off the pace these days and even the updated 312 isn't the

match of the giant killing Origin Live modded Rega RB250. To wit, if you're going to get your deck replinched, I'd get a Loricraft plinth predrilled for the Rega arm. If you must keep your SME, you could always get a second cut-out drilled for it and use it as an ancillary arm, but frankly I'd sell it to the vintage brigade who'd give you a fine price for it. You could then spend the money on the likes of Dynavector DX10X4 to go with the OL RB250.

This done, you'll have a front-end right up in the Linn LP12/Michell GyroDec class (if not right at the front of it), which will give you a great start along the way to a seriously good sound.

Next the amplification. The Marantz 2225 is a lovely old lump, with a big, strong and sweet sound, but whether it's up to today's best is another question altogether. I'd say it isn't - so the Tresham would be the one to use. Clean all its contacts,

Your Heathkit three-way speakers are likely to be the least serviceable of all your components, but ironically the hardest to replace. It will be practically impossible to find a set of modern speakers that have such as big, fat, warm sound with the physicality afforded by those twelve inch drivers. Rather, modern speakers will give you a far tighter and more detailed performance, with better dynamics but an altogether less euphonic tonality. As a result, you'll find it harder to find something you like without a seriously big financial outlay. By all means go around the dealers and look for a sound you like, but I'm tempted to suggest you seek out some classic loudspeakers on the second-hand market offering more of your Heathkit speakers' character - well preserved/ re-coned examples of KEF's 104AB, IMF's TLS80 or even Sendor's BCI would be worth investigating. **DP**



mains plugs etc. with Kontak (this stuff works wonders!) and use good interconnects and speakers cables - the old ones will be well past it by now. You might also give the volume pot a squirt of switch cleaner too, as it could well have got noisy after such a long slumber.

With a little tweaking, the Garrard 401 is still one of the best turntables you can get your hands on. . .

DIGI FIX

Should I upgrade, buffer, interpolate or upsample? I want to improve the detail and realism in my system. My Eikos CD player is an original model which can be upgraded through to the reference version. I could attach a Chord DAC64 with its buffering technology, or even Perpetual Technologies PA3-PA1/Monolith power supply with its interpolating and upsampling. My system comprises a Gamma Space Reference Power amp and Era Reference pre-amp, with Border Patrol MB power supply with Gamma Reference speakers, Russ Andrews mains, Townshend supports and cables.

Simply sending my Eikos back to Tom Evans for upgrading would give me the added improvements that I want and would keep the same overall sound that I enjoy at the moment. But I am intrigued by the newer technologies being offered by other companies and could do with a little advice, as I am unable to audition all the possible variables. Would these other approaches work in my system (300B single-ended negative feedback)? Does my Eikos have the right connections and can it do the job as a transport, does the Chord upsample or just have a memory buffer? What would give me the best improvements? My system has a realistic, natural 'being there' feel to it and I would like to improve upon this if possible.

**Kevin H
Eastbourne**

Firstly, the Chord DAC64 is essentially a DAC with some clever digital signal processing build in. It uses a 64bit digital reconstruction filter, with a Pulse Array DAC chip using seventh-order noise-shaping realised with 64bit precision. The idea is that any mathematical errors due to the filtering and noise-shaping calculations will be way below the analogue noise floor, and thus inaudible. In addition to this, there's a special "Watts Transient Aligned" digital filter said to minimise timing errors and an interesting RAM buffer system using a much larger memory stack. It's an interesting and possibly worthwhile upgrade - giving a fuller, deeper, smoother 16bit sound - with only the lack of HDCD compatibility as a demerit.

I haven't heard the Eikos Reference, but have it on good authority that the upgrade is well worthwhile. Indeed, this would be the path I'd take if I were you - for

this reason. I believe that the forthcoming generation of DVD-A and SACD players are going to make CD less and less appealing as a commercial proposition and I can't see the logic in making substantial financial outlays on additional 'bolt on' boxes designed to upgrade 16/44 digital systems. Why try and squeeze a quart from a pint pot, when you can now buy the real thing anyway? You could use your upgraded Eikos to get the best from your existing software and slowly move to high resolution digital, or go the whole hog now and get a Marantz DV-12 (for DVD-Audio playback) or an SA-12 (for SACD playback) - both of which also play 16/44 very well. Worthy as some may be, I believe that interest in 'CD wonder cures' will soon be waning.

DP

DEAR ME!

I have recently purchased a system costing £187,000 and would be interested in your recommendations of insurance companies who deal specifically with high-end hi-fi. Do you KNOW music? Do you FEEL music? Are you MOVED by music? Is it possible to pay more than this for a system? I must be insane.

**Thank you
Dr. R. Meah Boitr**

Er...not a psychiatrist by any chance are you Dr. Boitr? Yes, it is possible to pay more for a system but at the end of the day, why bother? If you know, feel and are moved by music that much, did you know you could sponsor a fair chunk of the London Symphony Orchestra for the price of your hi-fi?

Jibes apart, it's a good point about specialist insurance and one that we've touched on before. Basically there aren't any that we know of that deal specifically with high-end hi-fi. The 'big' insurers include consumer electronics as a part of your household contents and any further extension to the total value of contents demands a premium based on how much extra you wish to insure for. Insurers basically don't imagine people to spend the kind of money you're talking about on hi-fi (or anything in the home) and often sit in stunned silence when you mention such figures. Believe it or not, it's hard to come up with a special cover for hi-fi. A search on website such as www.sisa.co.uk will reveal as much - exotic birds and

fish, multiple birth insurance, even Masonic Lodge insurance (whatever that involves) are all there - but no separate hi-fi insurance.

However, there are a few specialist insurers that deal with policies for musical instruments and (usually professional) audio equipment that may be worth contacting. These items are usually insured because they are transported around and don't stay in the home and this is the crucial point that makes them separate from household insurance. A few enquiries to such insurers revealed that they would try to help with any enquiries with their underwriters and come up with a policy. Two of the companies we tried who were helpful in this matter were Victor Knight in London (www.victorknight.co.uk) and Lombard in Slough (www.lombardinsurance.co.uk). Otherwise contact your current house insurer - presuming you've still got a house after shelling out that amount! **SP**

SUPPLY AND DEMAND

My front-end system consists of an LPI2, Rega tonearm and a Dynavector DV20X cartridge. The Linn was bought in the very early 80s and has the Cirkus mod, but does not have either a Valhalla or Lingo power supply. I'm wondering whether it would be best to buy, as far as sound quality is concerned, the new Lingo, or get the Origin Live motor replacement. The second option appeals due to cost, plus it replaces a twenty year old motor, but the former is easier to connect, a boon when you have three small children who always want to "help".

**Yours
David Morse**

As a recent convert from the Valhalla to the new Lingo I have no reservations whatsoever in recommending this simple but stunningly effective bit of kit. If you've not been used to an upgraded power supply for your LPI2 the results should astound, even when compared to the old Lingo. The Origin Live is a good buy and would be an effective upgrade for you and your ageing motor but the latest Lingo should knock spots off it. You'd get a bigger and more open soundstage and increased detail, along with more muscular grip on the music as a whole. And as you rightly state it's a doddle to add and a trained chimp could set it up. So my advice is to save up the pennies and plug and play. You won't regret it, even in years to come! **SP**

90% of our customers prefer our "warm and old-valve" sound to their expensive transistor preamplifiers & power amplifiers. We have a signed testimonial to prove that one customer prefers £900 "EL34 Lim Signature" to £2,600 preamp / power amp/power supply made by a famous name.

Do you need further proof that price is not a substitute for the "valve sound"? Money refunded to 10% of customers who prefer transistor amplifiers.

Money back guarantee (less £30 return carriage, within 1 month) that our valve amplifiers deliver clear sweet treble, without harshness, from CD players + 100% fatigue free + Sibilance on female voices is well controlled and greatly reduced.

'His' sound like 'His' and not 'Hisssssssk'

- + Singers accentuation and accents become blatantly obvious + Random background noise/crossover distortion disappears, creating an inky black silence, so you can hear quiet notes, breathing noise, artificial reverberation, etc
- + more powerful bass slam than most transistor amplifiers and most Single Ended amplifiers + 40 watts (EL34)



£900 • £600

Money back guarantee (less £30) that you prefer our £900 or £1,350 "KT88 Triode Connection" valve amplifiers to most transistor amplifiers, most transistor / valve hybrid amplifiers, most Single Ended valve amplifiers, most Ultra Linear valve amplifiers selling for £2,000 to £20,000.

"Proper" Triode Push Pull valve amplifiers should sound better, so they are excluded from our Money Back Guarantee. However, they cost £6,000 and upward.

Price is not a guarantee for sound quality. Some products are overpriced and pretentious.

Telephone 01634 268662 anytime or 01634 373410 for Mr Andrew Everard's review in Gramophone Magazine and Summary of 18 testimonials from satisfied customers + www.affordablevalvecompany.com + Amplifier shown without CE safety cage, to prove that this is a genuine valve amplifier. Customers must not remove the CE safety cage.

Free delivery to U.K. Subsidised £50 UPS delivery to other countries. Return carriage for Money Back Guarantee is £30 for U.K. £100 for other countries.

Proven reliability. 2 years guarantee.

more bass

Black Rhodium

"Your Small Speakers Sound Much Larger and the Leading Edges and Decays in Music More Natural"

AST100x3 BiWire Speaker Cable

MADE IN ENGLAND

"Makes for Exciting Listening" HI-FI World

"Great Cables for Fat Bass" HI-FI Choice

32 Derwent Business Centre, Clarke Street, Derby DE1 2BU
tel: 01332 361390, fax: 01332 200698
email: enquiries@blackrhodium.co.uk

RESERVE YOUR COPY TODAY!

Complete this form and hand to your local newsagent

Please reserve/deliver*(delete as appropriate) Hi-Fi & Computer Audio World on a regular basis, commencing with the next issue, until further notice.

Name _____

Address _____

Signed _____ Date _____



Distributed to the newstrade by

COMAG
MAGAZINE MARKETING



The latest version of the Lingo will breathe new life into your old LP12

COST NO OBJECT

I intend to spend \$35,000 Australian Dollars on my ultimate system. I deeply respect your opinions, listen to all types of music, and want to experience the reality of such for the amount of money that I am intending to spend. I currently have a shortlist of hi-fi gear that I am attempting to purchase and would appreciate any comments on the quality and sound that the following system may generate. Any recommendation would be greatly appreciated - it comprises the power amp, Classe Audio CP47.5 preamp, Arcam FMJ CD23T CD player, Wilson Benesch Discovery speakers, plus Nordost Blue Heaven interconnects and speaker cables.

I was also considering using the new Chord DAC 64 to improve the sound quality of the Arcam FMJ CD player. I've heard that it would, but others have advised that the FMJ's own internal DAC is quite good. I want 'exceptional' however, so do I purchase a higher-end CD player? I was also considering Musical Fidelity's new 3.2 Series amp combos and Meridian's 5021557 combo. Also, on my shortlist of speakers are the Quad ESL 988/989, B&W Nautilus 804/ 803s, and Living Voice Avatar/Avatar OBX-Rs and Spondor S9s. As for speaker cables and interconnects, I was also considering Nordost SPM or Red Dawn, but have been told that the Blue Heaven would be sufficient and that the sound difference of these two would be little?

Dave Meyer

Dave, this is a tricky one. It's one of those 'how long is a piece of string'-type questions that are really hard to answer in a couple of paragraphs in a magazine. The problem is that there's

a lot of money at stake, and that you're going into territory where respective bits of kit aren't 'better' so much as 'different'. Not even hi-fi reviewers have heard all the permutations of CD players, amps and speakers that you mention - all we can do is offer our two cents on the merits of various products in splendid isolation (i.e. in our own reference systems!) My point is that at this price more than at any other, you need to find yourself a couple of really good dealers, audition a wide range of kit, and find those that cohere (i.e. work synergistically) best of all. All I can do is offer very general pointers, based on my own subjective findings.

The system you outline would undoubtedly produce a good sound - Arcam's FMJ CD23 is a fine mid price player, and the Classe gear is quality stuff (albeit slightly too 'North American sounding' for my ears). Likewise the WB speakers are very good, as is Nordost cabling.

Is it the best sound A\$35,000 will get you? No, absolutely not. I feel that you should be refocusing towards the front end, going for something like Marantz's SA-1 SACD player (now discontinued but I'm sure there are some still around ex-dem). Alternatively, Meridian's 598 DVD-Audio player practically recommends itself - a brand new design that (like the SA-1) sounds great with CD but brilliant with DVD-Audio. My point is that if you're sailing into superfi waters, you need the best source - and anything that spins ye olde 16/44 CDs exclusively won't be it!

Having found a digital disc player you like, my next move would be to audition some speakers. The problem is that while Quad ESL 989s and B&W Nautilus 803s are both superb designs, they sound radically different

thanks to their transducer technology and cabinet design. Which do you prefer? You can only decide with a serious, day-long dem!

Having arrived at your speakers and source, it's then a case of picking amplification. Again, you have a mouth-watering range of options at your disposal. If it were me, I'd go for either a Naim NAC282/ NAP300/ SUPERCAP, or a Michell Orca/Alecto monoblock combo, depending on whether you chose the B&W or Quad speakers respectively. Cables should be used for fine tuning - rather like matching tyres to motor-bikes, there's no best buy - it's a case of finding the solution that gives you the balance you want.

Sorry if you haven't got the shopping list you'd hoped for. The message is: find a good dealer and use your ears, not mine! It's your money and you're going to have to live with your decision, not me! Invest a few days travelling around the right dealers and you'll save thousands of bucks, not to mention future heartache. Good luck. **DP**

Just to really confuse things, let me chuck in a few suggestions! The system you've penciled in is good, and the Discoveries are a very fine purchase if you can spare the cash. The Blue Heaven will give a clean and fast sound (don't consider the exorbitantly expensive SPM at this stage!) but maybe you could grab a listen to the likes of the Audionet ART V2 CD player which retails in the UK for £2,300 in place of the Arcam. The Arcam is an accomplished all rounder but the V2 offers more detail and smoothness as well as a whole lot more high-end appeal, with its granite base and top loading mech, for relatively not that much more money.

As for the Classé amplification, this too is good, but models from the likes of Sugden, Bryston and the Lavardin integrations (not to mention the Michell amps that David mentions) are also available at this price and have a tad more sonic appeal in my view, offering greater openness and insight.

Finally, the Living Voice Avatars are very well balanced and easy going but the WB Discoveries and the Quads, for me at least, offer that little bit of something different, which gives them the edge. If you audition the Quads, try them with a decent sub to get nearer the bandwidth of your other choices. **SP**

SERIOUS WELLY WANTED

Please help! My wife and I are trying to work out how to put our system 'right'. We currently use a Linn Mimik, NAD C370 integrated amplifier, C270 power amp and Linn Kaber speakers bi-amped with Linn K20 cables. This sounds great at low to moderate volumes but turn up the wick and it goes seriously wrong! High frequencies get very edgy, the bass lets go of any control it has and the whole sound starts to break up and distort. We suspect that, as we have to drive the NADs with the volume knob at around the 2 o'clock position to get some real loudness coming through, it's the NADs running out of puff rather than the speakers distorting.

We have spent the last couple of months at dealers hearing many different opinions and options. We tried changing the Kabers for JM Labs Cobalt 826, which are really easy to drive and very detailed but far too bright, and the PMC FB1 which are okay but nowhere near as musical as the Kabers.

We also got the opportunity to use a Kairn pre-amp and three LK100s hooked up to the Kabers but it still couldn't drive the Kabers to very high levels. We are now thinking that some serious amps could be the answer instead of changing speakers, so what do you advise? We have a budget of around £2,000 and are happy to search the classifieds if that could open up more options for us.

D & J Mayer

I'm in no doubt that what you describe is the sound of your NAD combo running out of steam. Linn Kabers aren't the most efficient loudspeakers around, and frankly your NAD amplification is more at home driving speakers of lower ability at lower levels. It's budget kit, and unfair to ask more of it. I'm surprised however that a brace of Linn LK100s still couldn't do the job. Although not 'muscle amps' in the traditional sense, they've a lot more grunt than your NADs! Still, I'm happy that you've kind-of admitted that you want to stick with your speakers, which makes recommending stuff far easier. In truth, like all Linn speakers the Kabers aren't the very best all rounders at the price, but what they do, they do passionately. And as you've identified, they do 'music'.

At £2,000 you have plenty of choices. If you want to buy new, then the obvious candidate is Musical Fidelity's A308. This has a clean, open

and neutral nature, which will give loads more detail and grip than your NADs. You may also find it a little brighter - not because the MF is hard but the NADs that you're used to are a touch smooth. You'll find its 150W (plus) per channel is more than enough to stir the Kabers from their sleep - power isn't an issue with this integrated. If you don't mind buying used, then a pair of XA-200 power amplifiers (temporarily using your NAD as a preamp) would be just the job. These have even more muscle than the MF integrated, and can be had for under £900 second-hand. They're faster and cleaner, too.

The other alternative - one of interest to all power hungry folk out there - is to invest in Naim amplification. While not as 'well endowed' as either of the aforementioned MFs, Naim's new NAP250 actually sounds just as - if not more - punchy thanks to its massive 400VA power supply and superb stability into any load. I've never heard another power amp rated at 'just' 80W RMS per channel (into 8 ohm loads) sound so strong and unflappable. I also believe it to be an excellent sonic match to your Linn Kabers. At £1,914 it fits into your budget, although you'll soon be wanting to use something better than your NAD preamp section - suitably connected to Naim's new entry level NAC202 (£1,170) it will sing. You can then upgrade to Naim's top preamp/power supply combo at a later date. All three options will give you a vastly more powerful and confident sound - the one you choose depends on which subsequent upgrade path you want to embark upon. **DP**

the more recent addition of a CD source. For the past 5 years my turntable and vinyl collection has been locked away due to building work at home and has only recently been resurrected. This re-discovery of the "joy of vinyl" has made me realise a couple of things. Firstly, the sound of the system has generally degraded over the last few years from how I remember it and secondly, the quality of the system with CD is dramatically inferior to vinyl. I think it's about time the system had a bit of a makeover.

The system is as follows. Turntable: Rega Planar 3 with RB300 arm (from first batch shipped out with this combination), cartridge is a Stilton bodied Nagoka MPI I. Amplifier: Myst tma 3. Speakers: Monitor Audio 352s, cables Naim. Stands are self made but similar design to period Targets. CD player: Marantz CD63.

The first part of the upgrade must be the cartridge since the MPI I stylus is no longer available. As for the rest, I am looking for the biggest bang for my bucks - my budget is £500-700. I also have no problem with going the used equipment route since I have had some success with this in the past and am technically competent enough to do some work myself.

So there you have it. The challenge is to jump two decades and bring my system up to spec.

Regards.

Mike Dolan
Silverstone, Northamptonshire.

Hi Mike. Although components do gradually burn out it's very rare for a system to generally degrade, sound-wise (unless you have a bunch of valves that are on their last legs). It's more likely that it merely sounds different (i.e. dated) to the equivalent of



The Musical Fidelity A308 is the obvious choice for power and neutrality

BACK TO THE PRESENT

My system is essentially as it was in 1983 when I set it up originally, save for

what's around at the moment, or other stuff you've heard.

There are a variety of ways in which your system can be morphed into something sonically viable and it doesn't necessarily have to be done all at once, meaning that saving a bit

more money over a period of time means you can go that one notch extra, which would be worth it here.

For the front-end you can muster up a very good sounding package based around your Planar 3. With the risk of sounding like a stuck record (pun intended!) giving your RB300 the Origin Live modification will reap instantaneous sonic rewards. Bass will be tighter, instruments more focussed and everything much more detailed. Add to this a Goldring 1042 and for a little under £300 you'll have yourself a totally revitalised vinyl replay system that will bring new life to your records. To really make it sing, £350 spent on an Ortofon Kontrapunkt A will bring refinement, plus speed and detail, taking the sound onto another level altogether.

Next, amplification. If you don't mind trawling through the second-hand adverts a good bet would be something from Musical Fidelity for clarity and power. A used XA-1/XA-2 or A3 integrated can be picked up for a sensible £400 or so and will last a good few years and the A3 has a fine internal MM/MC phono input.

The same also goes for a secondhand Puccini or Puccini SE. The older (pre 'Remote') versions will be around £250-£300 at most and have smooth and musical cohesion with, again, a very good MM/MC input for the money. They don't have the clout or depth of a Musical Fidelity but are more organic and fluid. It may be worth holding on to find one of these, as there should be examples on the market and either are miles better than anything equivalently priced new, save a NAD C350/C370, which is your best bet for anything new.

Speakers: Monitor Audio are traditionally good if you like punch and attack, but aren't the last word in refinement or low level detail, yet I gather from your question that you're after a big sound. For a mixture of both you could try the Mission m53, which has detail and good imaging, plus good, deep bass and commendable speed for such a price point. Otherwise, from the Mission camp in the secondhand stakes, older examples such as the 773e have plenty of welly and loudness, due to good basic engineering coupled with very high sensitivity. Or a used pair of 782s will bring clout, depth and amazing detail for around £300 or less.

Moving away from both Mission

and floorstanders, a pair of the new Epos M12s will bring weight and authority to your system in the shape of a largish standmount model. Otherwise, there's always the classic tried and tested formula of B&W's 602, which is a big and lively sound with relatively low coloration.

Finally, changing your cables for a package from the Chord Company will benefit the sound. The overall 'house sound' of the company is well balanced and uncoloured but smooth and lyrical. Prices are also very sensible, with the superb Cobra 2 interconnect at £50 (and the equally impressive Calypso at £30) and the Rumour 2 'speaker cable at £10 per metre.

The toughest part of the question lies with the CD player. You can now consider something that plays more than just Compact Discs to an acceptable standard. The world of optical disc players is changing rapidly and you can pick up a player from Pioneer that reads literally everything (DVD-A/DVD-V/SACD/CD!) bar the kitchen sink for £400. Philips and Sony also have some good DVD-Video and SACD combination players for a sensible price. Otherwise, for impressive CD quality at rock bottom prices look to NAD's C521 (£200) and the more sophisticated C541 (£330), both of which offer great value for money. **SP**

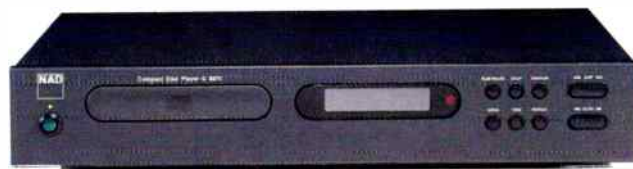

The NAD C521i is a good and affordable replacement as a digital source.

CLEAN COPIES?

Do you have any recommendations for computer software to allow me to copy my precious vinyl to CD? I have an old copy of Computer Audio World from 1999 which I seem to remember came with your mag. They used Steinberg Clean! Would this still be available or is there new software out there somewhere? Do you also have anything to do with sound cards for the same purpose? Alternatively could you put me in touch with someone?

Paul

At least vinyl to CD transcription is one kind of music copying we can still do on computers without interference - providing it's for our own use, of course! The latest incarnation of Steinberg Clean! is called Clean 3, and is an excellent (and much improved) version of the original version I tested back in 1999. It costs around £30 and comes with Steinberg's latest WaveLab Lite for recording purposes. If you want a simple, get-you-going package, then I can't think of anything better.

However, I'd recommend you splashed out on Syntrillium's Cool Edit 2000 v1.1, which costs \$69 to download from www.syntrillium.com. This is the consumer version of the software that is used at Abbey Road Studios (and David Price Studios, for that matter!) and is blindingly good.

What you can't do with CE2000 isn't worth doing. It's far smoother, more seamless and more intuitive than the Steinberg package, which is already no slouch in these respects. You can record, edit, process and even burn CDs (on the latest version) with ease. And if you don't believe me then you can always download the cut-down 30 day demo version for free!

As for soundcards, there's a wealth of good designs around. Turtle Beach's Montego II Plus (£129.95) is a fine entry level product, complete

with high quality digital in and outputs. Its onboard converters are good, although you might like to spend a little more on a card with a better analogue-to-digital section, which is all-important for vinyl archiving. To wit, TerraTec's AudioSystem EVX 24/96 is worth the extra outlay. At £149 it's still reasonably priced, but boasts the latest 24bit, 96kHz oversampling chipset for which a signal-to-noise ratio of over 100dB (A-D) and 110dB (D-A) is quoted. Importantly, it doesn't use any unnecessary sample rate conversion, unlike Creative Labs Audigy, which you'll probably have already considered. At under £100 now, this is a great starter soundcard but not quite up to the job if sound is all-important. **DP**

B2 OR NOT 2B?

Old fashioned technology inside a 21st Century shell. That'll be the striking B2 horn loudspeaker from Beauhorn. Simon Pope listens.

Despite being the holy grail for many, horns are an acquired taste. There's a list of audiophiles as long as your arm who have been bitterly disappointed when they've actually got round to hearing a full range horn for the first time. This is partly due to the fact that very few horns indeed deliver a true full range sound that a top spec two or three-way floorstander can deliver. The few that can are impressive but cost a packet and take over your house in a somewhat obtrusive manner.

What horns lack in true bandwidth, though, they make up for in speed and immediacy. Here they present lifelike transients and accuracy that few other designs can match. So what choice is there for those who want all the strengths of a full range horn but don't want to remortgage and build a separate room to get the

damn things in? This is where the new Beauhorn B2 comes in.

If your idea of the traditional single drive unit horn is an expensive, wardrobe-proportioned monstrosity with the pipe smoking customer in mind, then think again. Although Beauhorn do, indeed, produce horns of near-wardrobe sized dimensions in the form of the Virtuoso with a choice of one of three Lowther drive units, they happen to have this exceptionally different looking beauty in the wings. And what's more, it's some £4,000 cheaper than any of their Virtuoso options.

One of the reasons for this is that it uses a more affordable Fostex full-range drive unit, as opposed to the more expensive Lowthers. The downside of this is that the Fostex drive unit is less sensitive than the Lowthers, but still at an approximate 96dB you won't be needing a Krell power amp! The company realised that to save money by making the B2 much smaller than the Virtuoso simply wouldn't work; the B2 therefore stands 47" tall.

The design is very much simpler than that of its bigger brother and it uncannily resembles the figure 2 as used in the corresponding BBC television station! What we have then, is a horn 'speaker that bizarrely doubles as a bit of a style product. The Fostex unit is of 8ohms nominal impedance and is used at an axial height of 37" (940mm). The unit is wired with solid core annealed silver cable and has a quoted frequency response of 50Hz-20kHz.

I have to admit that my previous experience of all but the largest horns is that they're superb for well recorded string quartets and badly recorded, distorted dub, but if your tastes venture any further than this you'll be left wanting a bit more from your hi-fi! I let the B2s settle in

for a good few days before giving them the full onslaught of an eclectic music collection. One important thing must be pointed out: like all horns, the Beauhorn is best suited to low wattage single-ended valve amplifiers. Put anything of the transistor type through these and the sound is decidedly dodgy, even unpleasant at times. However, use the transparent and lucid nature of a Unison Research single-ended S2K KT88 integrated using KT88 valves, or our own 7.5W 2A3 single ended design and you'll find the B2 far more at home.

First I put my mind at rest by treating them to some string chamber music in the form of Bach's sublime Cello Suites played by Yo-Yo Ma, and a couple of Shostakovich's string quartets courtesy of the Emerson Quartet. True to form the sound was immediate and impressively quick. Rhythms were exact and realistic and string tone was generally good with very little of that sucked-out 'cuppiness' that horn designs bring to the sound. Also impressive was jazz



in the form of 'Miles Davis's Kind Of Blue' on CD and John Coltrane's 'A Love Supreme' on vinyl (which helped the smoothness immensely!).

Quite impressive - and somewhat surprising - was the sweetness of cymbals that the Fostex unit delivered which was somewhat smoother than I had expected. Imaging also impressed, delivering a near-pinpoint accurate performance of the mix.

Where the B2 was less impressive was in its sense of scale and bandwidth. Large orchestral works such as Mahler's Sixth symphony lacked space and breadth and also were slightly dynamically compressed. Another type of music that suffered in this respect was

unaccompanied
choral
music,
which

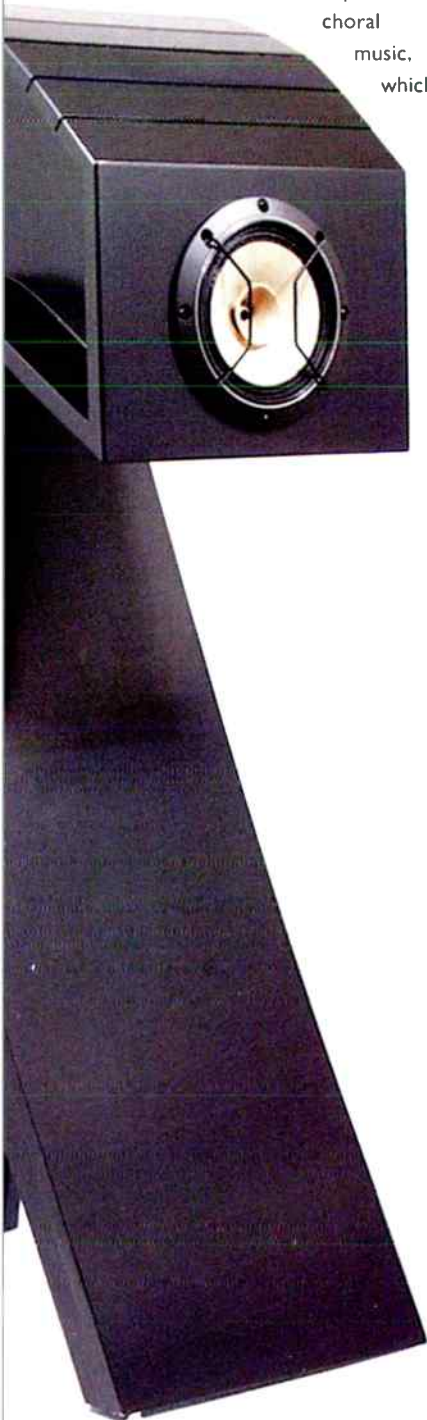

sounded a tad sucked out and without sufficient acoustic ambience.

At the end of the day the B2 is a serious yet fun bit of kit. It looks mightily different from anything else on the market but sonically it's quirky. Quirky in the respect that you must be acquainted with the particular traits of a horn design to appreciate what's going on and quirky in the respect that it will only play certain sections of your music collection well. If you're into large dynamic orchestral showpieces, choral music or balls-out rock, look elsewhere. If however, your taste is for simplicity such as classical chamber music and solo instruments (and hardcore dub!) then definitely give them a listen. The optional VibraPlinths at £556, it should be said, should also be considered, as they tune up the sound to good effect. If you're into detail and accuracy of low level information it may be worth saving up a few more bob and checking out something from Quad (an electrostatic) or

Wilson Benesch.

Whilst the Beauhorn B2 may not be the ultimate sonic experience that could convert the uninitiated to the horn sound it nevertheless gives a taste of the esoteric at a relatively affordable price point. What let's them down - something that horns in general suffer - is their fussiness. They can't play a wide variety of musical genres and recording styles with equal ability, which is OK if you buy your collection in order to suit the sound of your hi-fi - but that sort of defeats the whole object of high-fidelity! One thing that the B2 proves, though, is that 'true' horns needn't be big, expensive and ugly - merely fairly big, fairly expensive and...well, quite stylish actually!

Beauhorn B2 £2445

Beauhorn
Tel: +44 (0)1424 813888
www.beauhorn.com

MEASURED PERFORMANCE

The Beauhorn uses a short horn behind a single, full range drive unit. Truncated horns, as they are known, don't measure too well unfortunately, in spite of their size. To deliver bass a horn must be massive, bigger than the Beauhorn, which reached down to 80Hz at best. Even at this frequency it was a good -6dB down and the horn exit provided little extra low frequency energy. The drive unit in untreated form reaches up to 20kHz but its output is ragged by today's standards. With high frequencies above 5kHz shelved down by -4dB or so and a prominent midrange the Beauhorn will sound light and bright, probably detailed, but not spitty. Comparison with the smaller Loth-X shows the huge cabinet offers little advantage in terms of frequency response and it does little to damp the cone at bass resonance, our impedance analysis shows.

The Beauhorn was massively sensitive (and efficient). It produces a deafening 96dB from just one nominal watt of input and, with an overall impedance of 12ohms, draws little current of power from any amplifier. Possessing little reactance it will

be very easy on feedback loops too.

The Beauhorn might be best close to room corners where it will take up less space and drive room modes well, to augment its bass. It will likely provide a pretty detailed and coherent sound from low power valve amps in particular, with which it should be partnered. Even a 3wattter will give plenty of volume. **NK**

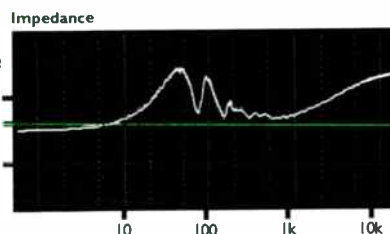
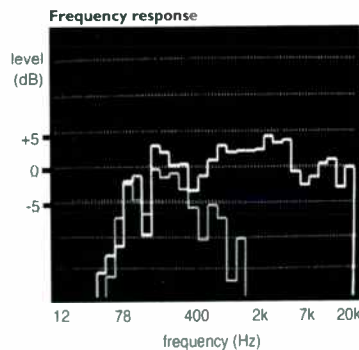

World Verdict 
Highly unusual look and a fast and immediate sound but very recording fussy - audition very carefully before purchase.

SOUNDS PERFECTION



**SPECIALIST IN ANALOGUE AND DIGITAL
WE STOCK**

J.M.LABS * LEXICON * PARASOUND * PRIMARE * PROJECT * TRIANGLE
REL SUBWOOFERS * VIENNA ACOUSTICS * AVID * PROJECT * SME *
ROKSAN * STRAIGHT WIRE * MICHELL * ACOUSTIC DESIGN *
AUDIONOTE * MONITOR AUDIO * BOSTON * SUGDEN
AUDIO ANALOGUE * GRAFF * NAD * PHILOSOPHY CABLES
MUSICAL FIDELITY

**PLUS MANY OTHER TOP BRANDS
NORDOST VALHALLA CABLES
PROJECT CENTRE OF EXCELLENCE**

**AVID TURNTABLES
PHILOSOPHY CABLES
L S M TV'S**

PRODUCT SALE LIST

ATC ACTIVE SCM 50 ROSEWD BXD MINT 6MTHS OLD	£4995
LEXICON MC 1 PROCESSOR USED MINT BOXED	£3225
ATC SIA 2 ISO INTEGRATED AMPLIFIER BOXED MINT ONLY	£1495
AUDIONOTE OTO SE LINE / BORDER PATROL PSU	£1195
VIENNA ACOUSTIC MOZART SPKS ROSENUIT BOXED	£1095
PARASOUND DAC 2000 (JOHN CURL SPECIAL) ONLY	£875
ELECTROCOMPANET 4.6 PRE AMP BOXED ONLY	£795
BOSTON ACOUSTIC 10X SATS SET OF 4 MINT BOXED	£795
AUDIONOTE ZERO PRE & MONOBLOCKS MINT BOX	£795
AUDIONOTE AN-J SPX SPEAKERS BLACK	£775
ELEMENTAL AUDIO REF SPEAKER STANDS BARGAIN	£795
PRIMARE V20 DVD PLAYER DEMO UNIT BOXED MINT	£695
TRIANGLE ANTAL'S XS SPEAKERS BOXED NEW	£729
AUDIONOTE PI SE POWER AMP BOXED	£695
ELEMENTAL 2 TIER REFERENCE STAND MINT	£575
VIENNA ACOUSTICS HADYNS NEW BOXED	£549
MERIDIAN S55 POWER AMP BOXED	£495
AUDIONOTE AZ3 SPEAKERS MARKED BOXED ONLY	£475
TRIANGLE ZEPHYRS XS MARKED HENCE BOXED	£449
REL STRATA II BOXED ONLY	£395
CASTLE DURHAM 2 SPEAKERS BLACK	£395
PRIMARE A10 AMP DISPLAY ONLY	£375
TRIANGLE COMETE XS SPEAKERS MINT BOXED	£335
KINSHAW PERCEPTION DAC MINT	£285
ROGERS STUDIO 3 SPEAKERS BOXED	£275
PARASOUND CD-P 1000 CD PLAYER	£249
ARCAYDIS BABY 2 NEW BOXED £400 NOW ONLY	£295
NAD 804 SPEAKERS EX COND BOXED ONLY	£225
ARISTON RD 80 TURNTABLE, EX COND. BOXED	£195
ATACAMA STANDS, FILLED SE 20'S	£50

FOR FRIENDLY SERVICE CALL NIGEL

01209 719049
MOBILE:- 07766 404869
Email :- nigel@soundsperection.co.uk
kathryn@soundsperection.co.uk
Web :- www.soundsperection.co.uk

**Amazing, but true. All
acoustic recordings –
voices, strings and, yes,
even triangles – sound
better if the system can
produce really deep bass.
Why does it matter?**

Deep bass

- for triangles??

You will take a major step towards greater **REALISM** if your system can produce really deep, clean bass – for all types of music. Even madrigals.

Many people shy away from this aim
a) because capable speakers and amplifiers cost a fortune and
b) because bass done badly booms, slows rhythm and colours everything.

So why spoil everything for bass you don't need? – because a lot of the **HALL AMBIENCE** resides in the lowest frequencies. Reproduce them well and music comes to life. Mid-range fills out, underpinned by the **SUB-HARMONICS**, as colours brighten when the sun shines.

Another problem is that all rooms amplify deep bass, called **ROOM GAIN**. The deeper your speakers go the more likely you will suffer **BOOM**.

We find **70%** of customers' systems are spoiled by weak or bloated bass.

THE ANSWER is a "smart" subwoofer which can be controlled at *both* ends of its range: especially at the bottom to **DRIVE THE ROOM** cleanly.

The **AUDIO PHYSIC LUNA** does this, and its servo control means it never slows the music. You get power in the bass, but also glorious imaging.

Enthusiastically reviewing the bigger AP sub, US magazine Stereophile said, "In my small room the Rhea made the illusion of a large venue believable..."

Customers say we make some of the **BEST SOUNDS** they have ever heard, so you know we can do the same in your home. Our advice will take account of your best components and guide you where change is needed, in stages you can afford.

You **AVOID EXPENSIVE MISTAKES**, enjoy music along the way and save money in the long run.

JUST LISTEN AND YOU'LL KNOW

The
Right
Note
As seen in the Press

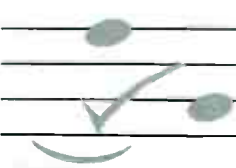

BATH

01225 874728

CD: ACCUPHASE, ADVANTAGE, AUDIO SYNTHESIS, BAT, dCS (ELGAR, DELIUS PURCELL, VERDI) MERACUS, PASS, SAT, SUGDEN, WADIA. **VINYL:** BASIS, CLEARAUDIO, CROWN JEWEL, DNM, GRAHAM, THE GROOVE, LEHMANN, MICHELL, SUMIKO BLUE POINT SPECIAL, TRANSFIGURATION. **AMPLIFIERS:** ACCUPHASE, ADVANTAGE, BALANCED AUDIO TECHNOLOGY, CAT, DNM, GAMUT, HOVLAND, NAGRA, PASS, SAT, SONNETEER, SUGDEN. **LOUDSPEAKERS:** AUDIO PHYSIC, BKS, ETHOS, LUMLEY, NEAT, TOTEM, VERITY AUDIO. **TUNERS:** ACCUPHASE, MAGNUM DYNALAB. **CABLES:** ARGENTO, CHORD CO., DNM, HOVLAND, NORDOST, SILTECH, YAMAMURA CHURCHILL ETC. **SUPPORTS:** ARCICI, KINABALU, STANDS UNIQUE

ALTERNATIVE, LIFESTYLE

Forget format wars - Marantz now offers the choice of high end SACD, DVD-Audio players. David Price examines the glorious DV-12S1 DVD player.



Marantz is now offering its high-end customers the choice of two DVD players, one of which also plays SACDs (the SA-12), and the other DVD-Audio discs (the DV-12S1, you see before you). There's also the cheaper DV8300 which plays both!

The DV-12 is one of the new breed of high-end hi-fi machines - ones that come complete with video decoding and modulation and plug into your telly too. It is designed to be used as part of a 5.1 channel system (or more, if you like). It does, however, obligingly sport two-channel (i.e. stereo) RCA phono outputs and the facility, via its on-screen menu (ironically) to output stereo (downmixed, if need be) through them.

Aside from the on-off, open/close and play buttons, the most vital control on the DV-12 is the 'video off' switch. Used in

conjunction with the 'display off', it turns an 'impressive' sounding DVD-A player into something altogether more serious. But more of that later.

Outside, the DV-12 is a classy looking item. It's solid (as its 13.2kg kerbweight attests), and beautifully suited and booted with tactile metal buttons, a nice clear blue display and a simply delicious remote control - no tripping the 'plastic fantastic' here!

Inside, two professional grade 24/192 resolution digital converters take care of the front channels, whereas 24/96 DACs are used for centre, surround and sub channels. Marantz's Super-Ring toroidal transformer supplies the juice, while selected passive componentry, high grade internal wiring, copper HDAM op amps, copper grounded circuit boards and an ultra low jitter master clock complete the picture.

This new Marantz is a little slow to access discs admittedly, but feed the DV-12 a standard 16/44 Compact Disc and you may be surprised how good it sounds - providing you hit

the Video Off and (less importantly) the Display Off buttons. Inside, the player is divided tidily up into various areas (audio, video, power supply, etc), all religiously separated by copper dividers.

As soon as the video circuitry is 'rested', this player gains a vastly more commanding manner. Suddenly it's rather vague and pleasant CD manner becomes tight, punchy and powerful. Its bottom-end is full and weighty, and tuneful too, if not the tightest around. Naim CDX users need not worry! Midband is also commendably smooth and detailed, while its treble performance is the epitome of good breeding - cymbals and female vocals have none of CD's customary fizz or brittleness. This is in marked contrast to the vague, rolled off, sat-upon sound of Denon's DVD-A1 spinning CDs.

The real test comes with DVD-Audio, of course. Here, the Marantz was initially a disappointment. Running through a Musical Fidelity A308 into my reference Yamaha

UK SUBSCRIPTION £27

VISIT OUR WEBSITE: www.hi-fiworld.co.uk



YES! I want to subscribe to Hi-Fi World for:-

£27.00 for 12 months

Your Details

Title _____ Initial _____ Surname _____

Address _____

Post Code _____

Daytime Tel: _____

Start Issue _____

Delivery Address (if different) _____

I would like to pay by cheque made payable to Audio Publishing Ltd.

Please debit my VISA MASTER SWITCH AMEX

Switch card issue No Expiry Date: ____/____/____

Cardholder Signature: _____



Please choose service:-

Airmail Middle East & South-East Asia £60

Airmail Europe £50

Airmail USA, Canada, Australia, Japan, Korea & China £70

Surface Mail £40

Send this form to:

Hi-Fi World, Freepost LON3478,
London, NW6 6YR

hi-fi
WORLD
NOVEMBER 2002
UK £2.75
Malaysia RM 10
DIY SUPPLEMENT No. 69
INSIDE THIS ISSUE!

& computer audio

DENON'S DVD DELIGHT

We review the DVD-3800 DVD-Audio & Video player

plus: We test out four bookshelf speakers with a difference from Elac, Harbeth, Loth-X and PMC

plus:

- Unison Research Unico DM power amp
- Pure DRX-701ES & Acoustic Solutions SP110 budget DAB Tuners
- Audionote Soro SE integrated amp
- Celestion AVF302/S10 speaker system
- AAD E-44 speakers
- Project RPM 6 turntable
- Audio Analogue Cherubini Tuner

Computer Audio World

- CDs & PCs - Part II of our CD copycoding feature
- Terratec Car 4000 hard disc recorder

COMPETITION
Win a superb Celestion subwoofer/satellite speaker system

+ 100s of classified ads full of secondhand bargains!!!

Get your issue of hi-fi world straight to your door!

Get to our amazing classified ads first and grab a bargain!!

➤ **Run by dedicated hi-fi engineers and enthusiasts.**

➤ **Hi-Fi World has become famous for its informative reviews and radical kit designs.**

Credit Card Hotline
+44 01923 270 833
Monday - Friday 9.30am - 12.00 noon: Fax +44 01923 260 588

MISSED AN ISSUE?

Back issues also available at a cost of £3.50 only (includes P&P), payment by cheque only -

Overseas please contact subscriptions department for details.

Send cheque to: Hi-Fi World, Freepost LON3478, London, NW6 6YR.

NS1000M loudspeakers, it turned in a rather plodding performance. The Eagles' 'New Kid in Town' was less impressive than via Denon's DVD-A1 - don't get me wrong, it didn't sound bad, it's just the Marantz failed to really get into its rhythmic stride.

Switching to Fleetwood Mac's 'The Chain', and it sounded a touch bright, although to be fair this whole disc has quite a hard midband (as a DVD-A pressing, at least). It was only when I cued up America's 'Ventura Highway' that it really sang.

The point is of course that it's a very neutral performer. The Fleetwood Mac disc is fierce through the Denon, less so through the Marantz. Only America's 'Homecoming' - a sublime remaster than trounces even the original US vinyl pressing - can really flourish with the neutral, matter of fact Marantz.

With a top notch disc, you can expect an extremely powerful bass (albeit just a tad on the warm side, as

is Marantz tradition), a warm, clean and smooth and even midband with strong imaging and depth perspective (although not as tight as the likes of a Naim CDX), and sweet vinyl-like treble. It's got a nicely varied tonal palette too, with real subtlety in its dealings with the texture and grain of voices and instruments. True, the DV-12 does still sound digital, but less so than rival DVD-A spinners.

Marantz's DV-12S1 is an impressive performer, even for £2.5k. It even spins CDs with a fidelity not that far behind, say, an Arcam FMJ CD23T, so it's a versatile machine to say the least. However, DVD-A still isn't quite there in my mind. It's a very nice upgrade on CD for sure, but there are more enchanting ways of extracting music from discs (of the black or silver variety) - such as

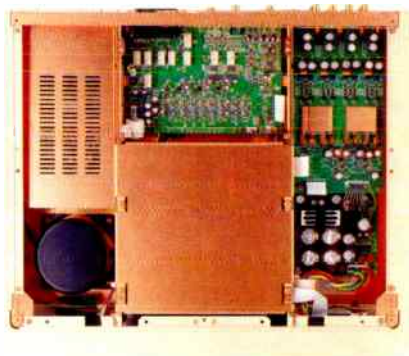

FORMATS

DVD-Audio, stereo CD, CD-R/RW, DVD-Video, VCD 2.0 playback, Dolby Digital 5.1, Dolby ProLogic, MP3, DTS and 3D True Surround decoding; THX Ultra certification

Marantz's very own SA-12. Heavens above - I do believe I prefer SACD!

Marantz DV-12 £2,500

Tel: +44 (0) 1753 680868

www.marantz.com

MEASURED PERFORMANCE

Although Marantz's DV-12S1 looks very similar to its companion SA-12S1 DVD/SACD player, the internal technology, including choice of DACs, is very different. Distortion is very low, amounting to 0.0008% at its 2.0V peak output, falling to 0.0005% at -10dB before increasing to a mere 0.004% at -30dB. This holds true from 20Hz to ~3kHz, beyond which the distortion increases, as is typical, before topping out at 0.008% re. 20kHz/0dB.

However, while the DV-12S1 puts in an exemplary performance through the audioband, it's progressively less impressive at higher frequencies with 96kHz and 192kHz DVD-A material. Jitter increases from an already disappointing 1230psec (see Fig 1) while, at 40kHz, jitter, stopband intermodulation and

other spurious distortions dominate the spectrum (see Fig 2). The contrast with its 'cleanliness' at lower frequencies and its sister product, the SA-12S1, could not be more marked.

With CD, the DV-12S1's response shows a mild -0.2dB treble roll-off (exaggerated with pre-emphasised material) but with 192kHz DVD-A extends to 80kHz (-3dB).

Channel separation is quite superb at >110dB across the audiorange.

Good crystal selection yields a mere -5ppm clock error while the DAC's integral digital filter helps suppress digital images by >104dB.

Overall, CD performance is very good, albeit compromised by power supply-related jitter, while

96kHz/192kHz DVD-A material is arguably less well served, suffering a little from jitter, noise and intermodulation products - a pity. **PM**

Frequency Response 10Hz - 20.1kHz (CD)

Distortion	Left	Right
-6dBFs	0.0005%	0.0004%
-30dBFs	0.004%	0.004%
-60dBFs	0.18%	0.17%
-90dBFs	3.2%	3.2%

Separation	Left	Right
1kHz	115dB	116dB
20kHz	110dB	111dB

Noise (IEC A) -105.2dB -104.7dB

Output 1.95V 2.01V

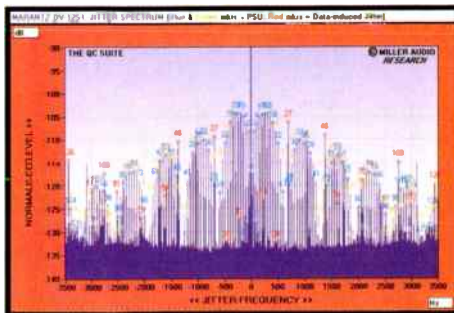
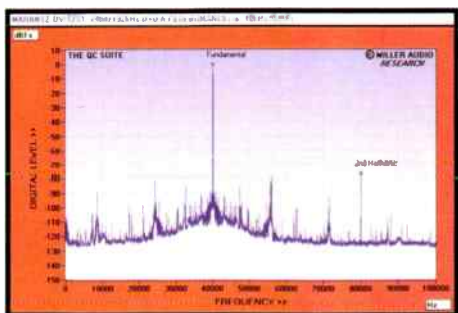

World Verdict
This does so much so well - probably the best DVD-A player at the price right now.



Lincoln 01522 527397

Apollo Aria 5 Modular Stand Class A £149
B&W CMC Centre Speaker £249
Cyrus CLS50 Loudspeakers £399
Cyrus Icon Loudspeakers £1999
Cyrus Quattro Q-Power CLS50 Package £999
Denon ADV700 DVD Receiver £599
Denon AVR1602 AV Receiver £99
Def Tech Coda 2 Loudspeakers £849
Lexicon LS7001 System Remote £249
Mission 780 Loudspeakers £1249
Mission 782 Loudspeakers £595
Monitor Audio GR60 Loudspeakers £1495
Monitor Audio Silver 8 Loudspeakers £499
Monitor Audio Silver C10i Centre Speaker £229
Monitor Audio Silver FXi Di Pole Speakers £299
Musical Fidelity NuVista 3D CD Player £2499
Musical Fidelity NuVista M3 Amplifier £2899
Naim CDX CD Player £1999
Naim Hi Cap Power Supply £649
Naim NAC 82 Pre Amplifier £1949
Naim NAP 102 Pre Amplifier £999
Naim NAP 180 Power Amplifier £1549
Naim NAP 250 Power Amplifier £1949
Naim Super Cap Power Supply £1699
Onkyo TXDS797 AV Receiver £499
Roksan Kandy Tuner £395
Sim2 HT200DM DLP Projector £4999

Manchester 0161 831 7969

B&W VM1 Loudspeakers £99
Cyrus AV5 AV Amplifier £749
Cyrus DVD7 DVD Player £749
Cyrus Q Power Amplifier £349
Def Tech Pro 80 Centre Speaker £99
Def Tech Pro 80 Sub Woofer £225
Def Tech Pro 80 Surround Speakers £175
Denon AVCA115R AV Receiver £1299
Denon AVR1602 AV Receiver £349
Denon AVR1802 AV Receiver £499
Denon DV02800 I DVD Player £1149
Kef Q1 Loudspeakers £249
Kef Q3 Loudspeakers £249
Kef Q5 Loudspeakers £449
Lexicon DC2 AV Processor £2999
Linn S103 AV Processor £3349
Marantz DV4100 DVD Player £239
Marantz SR4200 AV Receiver £129
Marantz SR5300 AV Receiver £339
Marantz ST6000 Tuner £129
Mission 780S Di-Pole Speakers £374
Mission 781 Loudspeakers £499
Mission M7C Centre Speaker £84
Mission M71 Loudspeakers £99
Mission M73 Loudspeakers £649
Mission M74 Loudspeakers £1129
Monitor Audio GR10 Loudspeakers £679
Monitor Audio Silver 4i Loudspeakers £279
Monitor Audio Silver 5i Loudspeakers £329
Monitor Audio Silver C10i Centre Speaker £199
Musical Fidelity A310 Pre Amplifier £749
Musical Fidelity A300CR Power Amplifier £1599
Musical Fidelity NuVista 3D CD Player £2199
Onkyo DV555 DVD Player £299
Parasound HCA2205 Power Amplifier £1779
Pioneer DVS474 DVD Audio Player £725
Sony SS-LA500 Loudspeakers £99
Teac AGH300 Amplifier £99
Toshiba SD110E DVD Player £179
Videologic DR5601EM Digital Tuner £199
Videologic DRX601E Digital Tuner £199
Videologic DRX601E Digital Tuner £279
Wharfedale B3 Loudspeakers £129
Wharfedale B3.3 Loudspeakers £179
Yamaha DPX1 DLP Projector £4499
Yamaha MDX596 Mini Disc Player £129
Yamaha TX480 Tuner £49

Nottingham 0115 911 2121

Acoustic Energy Aegis 2 Loudspeakers £149
Arcam DVA P75 Power Amplifier £229
Arcam DVA A65 Amplifier £279
Arcam DVA A75 Amplifier £369
B&W CM4 Loudspeakers £695
Denon AVR2802 AV Receiver £399
Denon DVD1600 DVD Player £349
Denon SCAVF100 NXT Speaker Package £349
M J Acoustics Pro 100 Sub Woofer £549
Marantz CD6000KI CD Player £349
Marantz CD6000SE LE CD Player £229
Monitor Audio Silver 5i Loudspeakers £229
Monitor Audio Silver C10i Centre Speaker £219
Onkyo DVS555 DVD Player £319
Onkyo DV5939 DVD Player £1499
Onkyo TXDS595 AV Receiver £349
Onkyo TXDS988 AV Receiver £1999
Primare A30 5 Power Amplifier £849
Primare P30 AV Processor £999
Primare V20 DVD Player £499
Rel D200E Sub Woofer £499
Roksan Kandy Amplifier £399
Roksan Kandy Tuner £319
Teac MDH100 Mini Disc Player £199
Teac RWH500 CD Recorder £249
Toshiba SD210E DVD Player £149
Yamaha DSPAX620 AV Amplifier £249
Yamaha RXV620RDS AV Receiver £269

Oxford 01865 241773

Arcam Alpha One Amplifier £129
Denon ADV700 AV Receiver £649
Denon AVR1602 AV Receiver £279

Denon DVD1600 DVD Audio Player £419
Loewe Aconda A9381ZW Widescreen TV £1599
Marantz DV4200 DVD Player £249
Marantz DV6200 DVD Player £519
Marantz Eclipse 19 System £499
Mission 772 Loudspeakers £129
Mission 783 Loudspeakers £749
MJ Acoustics Cinema 1 Sub Sat Package £799
MJ Acoustics Pro 100 Sub Woofer £499
Onkyo DR52 0 DVD Receiver £699
Onkyo TXDS797 AV Receiver £899
Panasonic DVNR200 DVD Player £259
Philips DV757 DVD Player £259
Rotel RSX922 AV Receiver £439
Rotel RSX922 AV Receiver £749
Sony DWS335 DVD Player £209
Sony DVS335 DVD Player £379
Sony DVS335 DVD Player £379
Yamaha RXV1000 AV Receiver £549

Peterborough 01733 897697

Castle Classic Sub Woofer £649
Castle Keep 2 Centre Speaker £189
Kef Cresta Centre Speaker £79
Linn Klout Power Amplifier £1349
Marantz SR9200 AV Receiver £1499
Monitor Audio Silver 3i Loudspeakers £239
Monitor Audio Silver 4i Loudspeakers £299
Monitor Audio Silver 5i Loudspeakers £379
Monitor Audio Silver 8i Loudspeakers £595
Onkyo DV5757 DVD Player £799
Onkyo TXDS696 AV Receiver £649
Onkyo TXDS988 AV Receiver £1999
Pioneer DV343 DVD Player £129
Pioneer DV444 DVD Player £149
Roksan Kandy Amplifier £469
Soundstyle XS-250 DVD Rack £249
Talk Thunder 1 CD Player £399

Reading 0118 959 7768

Arcam DVA DV88 DVD Player £899
Arcam DVA DV89 DVD Player £1149
Arcam DVA T51 Tuner £199
B&W S100 Surround Speakers £79
Cyrus AV5 AV Processor £899
Def Tech BP1X Di Pole Surround Speakers £299
Def Tech Pro 80 AV Speaker Package £749
Lexicon DC2 AV Processor £2249
Meridian DSP5000 Loudspeakers £2999
Meridian DSP5000C Centre Speaker £1799
Monitor Audio Silver 3i Loudspeakers £299
Panasonic DVDA360 DVD Player £249
Pioneer DV525 DVD Player £149
Pioneer DV626 DVD Player £749
Sony DWS335 DVD Player £239
Teac MDH 100 Mini Disc Player £179
Teac VRD59 CD Player £399
Videologic DRX601E Digital Tuner £299

Sheffield 0114 255 5861

Arcam DVA DV88 DVD Player £799
B&W LM1 Loudspeakers £139
Castle Severn 25E Loudspeakers £399
Denon AVR2802 AV Receiver £499
Denon DV3300 DVD Audio Player £499
Kef Cresta Centre Speaker £59
Lexicon DC2 AV Processor £2199
Linn Espak Loudspeakers £1799
Linn Tinkan Centre Speaker £399
Loewe Planus 4781ZP Widescreen TV £1099
Marantz RC5000i Remote Control £239
Marantz SR4200 AV Receiver £249
Marantz SR7200 AV Receiver £499
Mission FS2 AV AV Speaker Package £399
Onkyo DR52 0 DVD System £749
Pioneer DV444 DVD Player £149
Pioneer DV545 DVD Player £249
Roksan Caspian CD Player £699
Roksan Caspian Tuner £499
Roksan Kandy CD Player £499
Roksan Kandy Tuner £199
Ruark Vita 100 AV Speaker Package £1049
Sonus Systems 3 Shelf AV Rack £249
Sonus Systems 5 Shelf Equipment Rack £199
Teac AVH5000 AV Amplifier £279
Videologic DRX601E Digital Tuner £239
Yamaha RXV595A Receiver £169

Southampton 023 8033 7770

Arcam DVA DV88 DVD Player £799
B&W DM602 5 Loudspeakers £299
Cyrus CL550 Centre Speaker £249
Cyrus Q Power Amplifier £299
Denon AVR1802 AV Receiver £299
Denon AVR2802 AV Receiver £499
Denon DRA455 Receiver £159
Denon DVD2800 DVD Player £549
Energy Take 5 Speaker Package £449
Kef Coda 70 Loudspeakers £139
Kef Coda 80 Centre Speaker £399
Kef Coda 90 Loudspeakers £299
Marantz DV41000SE DVD Player £249
Marantz DV4200 DVD Player £319
Marantz Eclipse 19 System £399
Marantz PM4200 Amplifier £119
Marantz SR4200 AV Receiver £199
Marantz SR5200 AV Receiver £299
Marantz SR7200 AV Receiver £449
Marantz ST4000 Tuner £99
Monitor Audio Silver 3i Loudspeakers £249
Mission 780 Loudspeakers £549
Mission 782 Loudspeakers £549
Mission FS2 AV Speaker Package £399
Mission M7C1 Centre Speaker £69

Mission M72 Loudspeakers £129
Mission M73 Loudspeakers £149
Mission M74 Loudspeakers £229
Monitor Audio GR20 Loudspeakers £999
Musical Fidelity A32 CD Pre £1499
Onkyo DR30 DVD AV Receiver £349
Onkyo DVS555 DVD Player £219
Pioneer DV7474 DVD Audio SACD Player £699
Roksan Caspian CD Player £799
Roksan Kandy CD Player £399
Rotel RCD1070 CD Player £399
Ruark Vita 50 5.1 Speaker Package £699
Sim2 HT200DM DLP Projector £4449
Sony DWPNS300 DVD Player £299
Teac MDH300 Mini Disc Player £239
Teac MDH500 Mini Disc Player £279
Toshiba SD510E DVD Audio Player £299
Wharfedale Diamond Centre Speaker £79

Southgate 020 8886 2777

Arcam Alpha One Amplifier £179
Arcam DVA A65 Amplifier £329
Arcam DVA A75 Amplifier £349
Arcam DVA T51 Tuner £199
Celestion AVP100 5.1 Speaker System £229
Denon AVR1602 AV Receiver £249
Denon DV3300 DVD Player £699
Fujitsu PDS429E 42" Plasma Screen £3199
Linn Keosa Loudspeakers £349
Marantz Eclipse 19 System £149
Mission 771E Speakers £349
Mission 781 Loudspeakers £409
Mission 782 Loudspeakers £749
Mission FS2 AV Speaker Package £499
Mission M71 Loudspeakers £94
Mission M72 Loudspeakers £139
Mission M73 Loudspeakers £119
Mission M74 Loudspeakers £199
Monitor Audio Silver 9i Loudspeakers £749
Monitor Audio Silver 10i Centre Speaker £239
Musical Fidelity A300 Amplifier £599
Musical Fidelity A32 CD Pre £399
Musical Fidelity A3 Pre Amplifier £799
Musical Fidelity X-A100R Amplifier £799
Myrryad T10 CD Player £299
Onkyo DR52 0 DVD System £799
Pioneer A300R Precision Amplifier £249
Pioneer DV340 DVD Player £159
Pioneer DV343 DVD Player £199
Roksan Kandy Amplifier £449
Rotel RA972 Amplifier £299
Rotel RCD1070 Pre Amplifier £249
Rotel RCD581 CD Player £349
Rotel RCD581 CD Player £349
Rotel RDV985 DVD Player £449
Tag McLaren Aphrodite System £3999
Tag McLaren AV32R AV Processor £1999
Yamaha DSPAX620 AV Amplifier £289
Yamaha DVDS700 DVD Player £799

Watford 01923 213533

Arcam DVA T51 Tuner £199
Boston Micro 90 Loudspeakers £279
Boston VRS Loudspeakers £199
Boston VRS Micro Loudspeakers £129
Castle Classic Sub Woofer £549
Monitor Audio ST17AI CD Player £499
Marantz PM17 II KI Amplifier £999
Marantz SM17 Power Amplifier £449
Marantz ST17 Tuner £399
Meridian 590 DVD Player £2299
Mission 780C Centre Speaker £289
Mission 780S Di Pole Speakers £289
Mission FS2A AV Speaker Package £329
Mission FS2A AV Speaker Package £149
Monitor Audio Silver 10i Loudspeakers £549
Monitor Audio Studio 20SE Loudspeakers £899
Onkyo DR52 0 DVD System £649
Onkyo DVS555 DVD Player £299
Onkyo TXDS595 AV Receiver £349
Pioneer DV340 DVD Player £199
Pioneer DV343 DVD Player £159
Sound Organisation Z52 Stand £79
Sound Organisation Z540 Stand £139
Toshiba SD110E DVD Player £119
Toshiba SD110E DVD Player £99
Yamaha YSTS205 Sub Woofer £149

Brighton 01273 733338
Bromley 020 8290 1988
Croydon 020 8665 1203
Guildford 01483 536666
Sevenoaks 01732 459556
Tunbridge Wells 01892 531543
Witham 01376 501733

Arcam Alpha One Amplifier £149
Arcam DVA A65 Amplifier £249
Arcam DVA P75 Power Amplifier £299
Arcam DVA T51 Tuner £199
Arcam DV88-Prog DVD Player £1899
Arcam FMJ T21 Tuner £259
Arcam FMJ P25 Power Amplifier £639
Celestion CAC Centre Speaker £139
Cyrus ACAT Pre Amplifier £519

Cyrus AV5 AV Processor £649
Cyrus DAD30-24 CD Player £679
Cyrus DVD7 DVD Player £549
Cyrus MR3 Multi-Room Amplifier £389
Denon AVCA15E AV Amplifier £1599
Denon AVR1602 AV Receiver £219
Denon AVR1802 AV Receiver £279
Denon DAV1600 DVD Player £329
Denon DVD2800BAS DVD Player £349
Denon DVD2800 DVD Player £499
Denon DVD3300 DVD Player £1299
Denon SCAVF100 5.1 Speaker System £319
Denon SH4200 AV Receiver £219
Denon SR4200 AV Receiver £229
Denon SR5200 AV Receiver £289
Denon SR6200 AV Receiver £339
Denon SR7200 AV Receiver £399
Jamo A410PDD Speaker Package £329
John Shearme Phase 6 Amplifier £599
John Shearme Phase 7 CD Player £899
Linn S140 Loudspeakers £1319
Marantz DR110 CD Recorder £249
Marantz DR700 CD Recorder £299
Marantz DV3100 OSE DVD Player £249
Marantz DV4100 OSE DVD Player £249
Marantz DV4200 DVD Player £209
Marantz DVD890 DVD Player £339
Marantz Eclipse 19 System £399
Marantz Eclipse 25 System £599
Marantz Eclipse 35 System £799
Marantz Eclipse 70 AV System £929
Marantz Eclipse 80 AV System £1349
Marantz PM6010 OSE Amplifier £149
Marantz PM6010 Signature Amplifier £249
Marantz PM6010K Signature Amplifier £259
Marantz SD4050 Cassette Deck £119
Marantz SR6200 AV Receiver £329
Meridian 501.2 Pre Amplifier £529
Meridian 504 Tuner £499
Meridian 541 Processor £749
Meridian 551 Amplifier £599
Meridian DSP5000C Centre Speaker £1399
Meridian M60 Loudspeakers £149
Mission 780C Centre Speaker £189
Mission 7735 Loudspeakers £189
Mission 781 Speakers £279
Mission 782 Speakers £389
Mission 783 Speakers £549
Mission Cinema M71 Speaker Package £199
Mission FS2A Speaker Package £299
Mission M71 Speakers £89
Mission M72 Speakers £99
Mission M73 Speakers £109
Monitor Audio GR212 Sub Woofer £779
Monitor Audio Silver FXi Speakers £199
NAD CS40 CD Player £249
Nakamichi DVD10S DVD Player £399
Onkyo DR52 0 DVD System £619
Onkyo DVS555 DVD Player £259
Onkyo TXDS787 AV Receiver £639
Panasonic DVDA7 DVD Player £399
Panasonic DVDPV40 DVD Player £239
Panasonic DVDR20 DVD Player £229
Panasonic DVFX40S DVD Player £199
Panasonic NVF710 Video Recorder £189
Panasonic NVHS825 Video Recorder £199
Parasound HCA1500 Power Amplifier £669
Philips 32PW9613P 32" Widescreen TV £999
Philips 36PW9525 36" Widescreen TV £1349
Philips DV0870 DVD Player £299
Philips DVD970 DVD Player £239
Philips DVD958 DVD Player £239
Philips VR76 Video Recorder £199
Pioneer DV340 DVD Player £99
Pioneer DV343 DVD Player £99
Pioneer DVD943 DVD Player £499
Pioneer NSDV88 DVD System £499
Project Deb Phono Turntable £119
Roksan Caspian DSP AV Processor £799
Roksan Caspian Tuner £399
Roksan Kandy Tuner £299
Rotel RCD951 CD Player £199
Rotel RDV985 DVD Player £599
Ruark CL5 Centre Speaker £449
Ruark CL20 Loudspeakers £919
Ruark Cloude L Loudspeakers £389
Ruark Solus Loudspeakers £699
Ruark Vita 50 5.1 AV Speaker Package £549
Ruark Vita 100 5.1 AV Speaker Package £849
Selec SV5000 CRT Projector £4999
Sony DWPNS300 DVD Player £149
Sony DWS335 DVD Player £229
Sony DVS536 DVD Player £229
Sony SCDX8940 SACD Player £249
Sony STRDB90 AV Receiver £269
Tag McLaren T20 Tuner £599
Teac AVH5000 AV Amplifier £259
Toshiba 42WP18P 42" Widescreen TV £1499
Toshiba 42WP18P 42" Plasma Screen £3699
Toshiba DV200E DVD Player £149
Toshiba SD210E DVD Player £149
Toshiba SD210E DVD Player £159
Toshiba SD210E DVD Player £259
Toshiba SD500E DVD Audio Player £199
Yamaha DSPAX620 AV Amplifier £249
Yamaha DVS5510 DVD Player £159
Yamaha DVS795 DVD Player £229
Yamaha RXV620RDS AV Receiver £249
Yamaha RXV1000RDS AV Receiver £399
Yamaha RXV1200RDS AV Receiver £599

MY LOVE IS I



With Mark Levinson at the helm Red Rose Music are trying to convince the audio world that high-end audio needn't be big and expensive. Alan Sircom and Simon Pope listen to their new Spirit music system.

Some people class high-end audio simply by price, others by brand-names. A few smart ones judge by performance - and performance alone. The Red Rose Spirit system is for those who judge on performance.

Red Rose is the brain-child of Mark Levinson, the man formerly behind ultra-high end brands like Mark Levinson and Cello. Realising that paying £100,000 for an interconnect cable disenfranchises

more people than it entuses, Levinson recently turned his back on the lunatic fringe of high-end and developed the Red Rose brand. Based initially in a chic store on New York's Madison Avenue, Red Rose has produced a range of solid-state and valve amplifiers and ribbon-based speakers. While it's possible to buy a select range of Red Rose separates components, Red Rose has also developed a systemic approach, starting with the Spirit system, which includes integrated amplifier, speakers and speaker cables, all for £2,000.

Although it has no source of interconnect cable supplied, this Spirit could be considered the high-end midi system (in the States, the Spirit kit is even sold on-line at Amazon.com). It comes supplied in a big white box that weighs close to 75lbs, so when it gets delivered, have some friends nearby! First out of the box is the Spirit amplifier and the 336J speaker cables. Then, deeper and hidden behind layer upon layer of cardboard are the small ribbon bookshelf Spirit speakers.

Sold separately at £1,250, the

KEA . . .



Spirit IAI amplifier is a tall, narrow 35W per channel amplifier with funky S-shaped heatsinks which takes minimalism to new levels: no headphone socket or balance control, only four line inputs and a tape loop. Luxuries include a power switch and a little blue LED denoting which source is in use.

Also independently priced at £1,250, the Spirit LSI speakers are a two-way bookshelf design, featuring single wiring with solid speaker terminals, a large rear port and a driver configuration of a 50mm ribbon tweeter and the 125mm polypropylene bass driver, all in a heavy, deep cabinet. They are supposed to be used in complete free-space like a good near-field monitor and have an efficiency rating of around 87dB/W/m and a nominal impedance of eight ohms.

The only other component in the box is a 15foot pair of Red Rose 336J speaker cables, worth £150 a pair outside of the system box. This is a well-made cable with 336 strands of oxygen-free cable per side (hence the name). At the end of the grey sheath are two sets of extremely solid spade-lugs, which fit snugly into the big speaker terminals of both amp and speaker: 4mm plugs would be even better, but this is quibbling. It's not a complete system yet,

there is no source or interconnect cable. Red Rose makes its own Silver One interconnect (not supplied with the system). This costs around £300/m and is a silver Litz design. It's extremely free and open sounding, but is probably too expensive in the context of a £2,000 amp and speaker. Still, it's a worthwhile present to your system at a later date.

The choice of source is a bit tougher. Red Rose Stateside recommends SACD extremely vociferously and the Spirit amp has an SACD label instead of CD on one of the sources. Unless you have a heavily-tweaked Sony SCD1 or similar sitting round, however, forget that and go for a good CD player instead. Get a good CD player of £1,000 or more at the front of the system and you can really get to hear what the Red Rose kit is doing. Our CD recommendations for the Spirit system? Try an Audio Analogue Maestro for warmth, an AVI S21MC 4 for precision or a Rega Jupiter for musicality.

Whatever you choose, the Red Rose Spirit system has practically all the sonic benefits of more exotic kit at the sort of price tag normally populated by me-too humble stuff. In fact, it gets to within a hair's whisker of The Rosette/Rosebud kit reviewed in these pages at the start of the year, but shaving almost four grand off the asking price! Oh, the joys of mass-production.

It's a fabulously open, holographic sound with a touch of warmth and a lot of beauty. If you want to experience three-dimensional sound without resort to electrostatics and OTL amps, this gets you closer than it has hitherto been possible at the price. You get a decently wide, extremely deep soundstage with even some semblance of image height. Stick on something well-recorded with a fine soundstage – Ruben Gonzalez for example – and the Spirit has Tardis-like expansion qualities to the living room. This fine soundstaging is partnered with a

highly listenable, lovely sound. It is warm for solid state gear, but not so warm that it masks information dramatically. It is clear and slightly rich sounding too. All of which adds up to a sound that is extremely natural and pleasing. So you can play disc after disc without the merest hint of fatigue.

Better still, in the average British living room, this is all the speaker you will need unless you live for organ music or dub reggae. It goes surprisingly deep for a small, free space box.

So, why buy anything more expensive? The Spirit system is not the most detailed kit on the planet; rich and warm yes, clean, definitely, but absolutely detailed, no. You never get that feeling on knowing what gauge of strings the guitarist is using or what colour socks the conductor likes to wear that real high-end detail freaks crave. This is where it ultimately differs from the far more expensive Rosette/Rosebud pairing. Nor is this the system for those so tied to the rhythmic qualities of a piece of music they try to tap their foot to a dial tone. And, as you move higher up the Red Rose price list, so you get more of what proves so attractive in the Spirit system in the first place; warmth, beauty and holographic imaging.

For £2,000, the Spirit system is a steal. Put simply, you need to spend double to get a similar level of high-endity, at least in purely sonic virtues.



World Verdict

High-end sound without the high-end price tag or the struggle of selecting all those components. Just add a good CD for beautiful music-making.

The Musical Design Company
PO Box 4146, Epping,
Essex CM16 6HJ
Tel: +44 (0) 1992 573030

"Probably the best tonearm in the world"

Hi-Fi World 2002



Origin Live Tonearms

"The Silver 250 is the very best tonearm I've ever heard....the £599 price tag is laughably low....could probably charge five times this amount....words can't express how good this is - one of the designs of the decade"

Hi-Fi World 2002

"There may be better value propositions around to upgrade your system but if there is I haven't heard them....A fantastic product then from Origin Live and this particular audiophiles dream review tool."

TNT Audio 2002

Very occasionally new products appear that are so advanced as to render all previous benchmarks obsolete. People believe our new range of tonearms are just such products and we invite you to experience an unprecedented leap in your system performance - regardless of your current tonearm. Arrange for an audition now.

Silver - £599

Encounter - £970

Illustrious - £1570

All products carry a full no risk money back guarantee and are available via your nearest Origin Live dealer or by direct mail order.

For more information visit our website or contact us at:

Origin Live, Unit 5, 362b Spring Road, Sholing, Southampton, SO19 2PB, UK

Tel/Fax: 02380 578877 e-mail: originlive@originlive.com

www.originlive.com



Walrus Systems

11 New Quebec St, London W1

amazon
amphion
apollo furniture
argento
audible illusions
audio note
audio physic
avantgarde
breuer dynamic
brinkmann
carfrae
cartridge man
cawsey
chord electronics
clearaudio
croft
decca london
dnm
duevel
dynavector
ear yoshino
es lab
final lab
gamut
graham slee
hadcock
incognito
klimo
laverdin



loricraft
lyra
michell engineering
morch
musical fidelity
nordost
nottingham analogue
origin live
ortofon
papworth
phy cables
pink triangle
pluto
rega turntables
ringmat
shun mook
sme
spendor
stax
sugden
sumiko
tannoy
tci cables
tivoli audio
tom evans
townshend audio
transfiguration
trichord
van den hul
verdier



For info on these, and much more, including our numerous second-hand items, please visit our popular website: www.walrus.co.uk

* interest free credit available on most items, subject to status *

tel: 020 7724 7224
fax: 020 7724 4347
email: mail@walrus.co.uk
web: www.walrus.co.uk

TOASTED & CONNECT

Simon Pope discovers a different way to make your cable sing, and encounters an entertaining new budget interconnect . .

It's an acknowledged fact among the audiophile contingent that, like the majority of hi-fi componentry, a cable sounds better the longer it's run in for. Now there's a way for the impatient to experience the full capability of their cabling straight from the box. A service has been set up that utilises Nordost's CBID-1 cable burn-in device to run in, or 'toast' 'speaker and interconnect cable for twenty quid per 48 hours. If the whole thing sounds like a load of cobblers to you, worry not, it did to me, which is why I had to swallow my pride when I tried out the service and compared one toasted and one un-toasted pair of the same interconnects.

The CBID-1, nicknamed the "toaster" uses two dedicated circuits, one for interconnects, the other for 'speaker cables. Each of these circuits creates a series of oscillating signals that operate throughout a wide bandwidth. When connected, this feeds the cables a fast and intense amount of data that covers both extremes of frequency and harmonic configurations.

The process apparently releases the gasses trapped in dielectric materials during the manufacturing process. The unit works in 24 hour cycles, after which it shuts down automatically.

For our test we used two pairs of John Dory's Analogue Spiral interconnect, an update of a cable that impressed us earlier in the year with excellent detail and good instrumental separation. The difference between the two cables was subtle but definite. With the toasted cable the sound was overall warmer and fuller, with increased imaging

properties. Female vocals had a tad more body and there was good separation between instruments, which resulted in good detail. The un-toasted cable was still well detailed but sounded somewhat colder and a bit more sterile in comparison. The sound staging of the toasted cable was also slightly deeper than that of its non-treated counterpart. In comparison the bass of the toasted cable was more solid.

There's no doubt that it most definitely works and adds more depth and warmth to the cable, with a subtle difference to the original. And for the price of a curry and a pint you get an effective 'upgrade'.

www.cabletoasting.com

www.jdhifi.co.uk (John Dory Hi-Fi)

ACOUSTIC RESEARCH MS230 MASTER SERIES

Once a name to be conjured with in the loudspeaker and electronics market, Acoustic Research now concentrate their efforts on affordable accessories for the Audio/Visual market. This interconnect is part of the company's top-end Master Series, yet still demands a reasonable price tag of £50 for a 0.9m pair. This cable looks like it should cost a lot more than it actually does. It's packaged in a futuristic, pod-like case which is opened by unscrewing either end with the aid of a crosshead screwdriver.

Then there's the cable itself. It has unique, robust 24k gold-plated locking connectors and at the non-source end of the cable there is a plastic clamp that is AR's exclusive FNT (Ferrite Noise Technology). It is based on a standard recognised by the

computer industry and aims to deliver a "comprehensive and advanced protection" against noise and interference from electronic and wireless equipment.

Construction-wise, it's a twisted pair, balanced and directional configuration. The cable uses frequency-corrected, silver-coated and multi-stranded 99.99% pure Oxygen Free Copper. There are two layers of shielding, one being 100% overlapped Mylar foil for RFI isolation and one 95% copper braid for EMI protection (Electro Magnetic Interference - not the record company!).

Sound wise the Master Series interconnect is very well balanced and musical. It gives an overall fluid and detailed response that doesn't concentrate too much on any particular aspect of reproduction but copes with any equipment and music with equal effort, which is a good trait to have. The top-end is fast and immediate without being grating, and the midrange is very open with vocals, a good thing at this price point.

Acoustic Research MS230 Master Series interconnect £50

Acoustic Research Accessories
Tel: 0161 702 5010
www.araccessories.com



World Verdict

A very system friendly cable that's well balanced and inoffensive sounding. Very good value.

FOUR SQUARE

Quad's latest floorstander in the successful 'L' Series hits the stores. Noel Keywood admires their attempt to appeal to all in the sophisticated form of the 22L.

Seven coats of piano lacquer over a richly patterned Birds Eye Maple veneer is enough to make Quad's 22L floorstanders an attractive feature in the room. This light hued and richly patterned wood catches the eye and looks superb in a modern setting. There's little you can get from Ikea to Habitat (and John Lewis) with a finish like this that is so distinctive, which is why the Quads stand out. But of course appearance, although important, is only half the battle to win the approval of a potential buyer. After the eye has seen the ear will listen and anyone who knows a little about Quad will wonder whether the 22Ls are likely to follow tradition, which means - or meant - catering to conservative tastes and delivering supreme refinement.

As much as anybody, I am a Quad man, you could say, having used ESL63 electrostatics for many years. I am well aware that Quad's famous electrostatics possess a level of subtle ability far beyond conventional loudspeakers. They are one of the world's greats. Do the 22Ls carry forward this tradition? Are they better off with Mozart than Motorhead?

The short answer is "no"! Quad are now out to compete in a wide market and are trying to appeal to broader tastes. The 22Ls tackle rock music with gusto and, in that they have an extra bass driver for added oomph, could be seen to be the company's premiere rock proponent. At the same time though, Quad are a company who have always valued accuracy and the 22L is, under measurement, very accurate too. In other words, these speakers should

reproduce violin as well vocal.

The 22Ls are not idiosyncratic; they follow normal design principles in an attempt to fit in with modern tastes and expectations. A woven Kevlar bass/mid unit (170mm/6.5in) works in conjunction with a textile tweeter to cover most of the audio band. An additional Kevlar unit of the same dimensions works below 150Hz to supplement bass output and increase power handling. This is an important feature for listeners who will be turning volume up to get real bass power, because if you want to go loud there's no substitute for multiple drivers. Quad claim to use top quality drive units, designed and built in-house. The crossover uses quality components and allows bi-wiring. A rear port provides reflex loading and the plinth carries threaded holes for floor spikes for stability.

In their handbook Quad rate the 22L as being able to handle 300W, considerably more than the other speakers in their range. This is largely because of the twin drivers. The 22Ls are really aimed at use with powerful amplifiers of 60W or more in order to be able to get high volume, so sensitivity isn't much of an issue.

I drove the Quads with a Mission Cyrus 7 amplifier bi-wired with Van den Hul cables and fed by a Denon DVD-3800. In basic character the 22Ls struck me from the first CD onward as a fairly brightly lit but concise loudspeaker, with plentiful bass. Having measured them I guessed they would have a sheen, since there's no absence of upper treble and this was a feature that occasionally made itself known with poorer recordings. Spinning a DVD-A track like Toy Matinee's 'Last Plane



Out' showed the sort of dramatic dynamics the 22Ls are able to convey. A cohesive production like this showed the Quads to be full bodied and powerful, able to keep a tight control on rhythm and viscerally fast but muscular too. Their hard edged embodiment of vocalists almost took my breath away.

Staying on solid rock from DVD-A, Foreigner's 'Juke Box Hero' again showed just how clean and powerful things can get from the Quads; they've got the sort of bottom-end grunt needed to underpin a track like this. Vocal harmonies came over as a little strained and short of real depth at times though.

The Corrs DVD-A album, *In Blue*, had the hit single *Breathless* sounding a little jangly and incohesive, but I suspect this is partly down to the recording. However,

moving back to Cro-Magnon digital (you know, where the digits bonk you on the head) showed the 22Ls revealing surprising amounts of bass detail within the ample bass lines of Angelique Kidjo's Tatchedogbe. There was real power and good control too. For gut wrenching bass lines, the 22Ls acquit themselves well. They are ahead of the opposition here.

It was with older material that the Quads sometimes proved a little too revealing, to the point of being a little ruthless. Disgusted that a modern survey of one hundred most popular female vocalists failed to even mention Janis Joplin, I put on 'Cry Baby' from Pearl, to expunge the very thought of Emma Bunton. The Quads were a tad hard here, and a bit short on depth resolution too. True, some of those old recordings could be a little suspect in the fidelity department but they invariably have atmosphere and Pearl is no exception. However, as loudspeakers become progressively flatter in their response and tweeters match up better, without the once-common crossover dip, they have also become brighter and this sort of presentation isn't uncommon nowadays.

But of course Quad have always been known for their highbrow approach so, putting on my carpet slippers, I popped in a reasonably modern (1999) digital recording of



Wagner's Rienzi Overture. The Quads were nice and clean, but certainly forward. They pushed orchestral sections into a plane in front of the 'speakers, bringing a vividness and sense of detail to some sections unlike anything I've heard before. This effect was accompanied by a flattening of perspectives, giving drama precedence over naturalness. There's no problem with orchestral scale. With ample, well controlled bass Orff's Carmina Burana kicked off with suitably powerful timpani thwacks, choir well to the fore with each section again vividly lit.

As long as the recording is a good one, the 22Ls come across as clean and highly detailed, a DVD-

Audio disc of Beethoven's Eroica passing muster in this respect. With classical vocal music, Renee Fleming's voice was a little too light and edgy for my belief system to fully engage. As recordings got older and dodgier then so the Quads became more critical. In a nutshell then, the 22Ls handled classical well, but they favour good, modern recordings and I did find, by the way, that the DVD3800 was not good enough with CD to be used with them; even an NAD 521i sounded a lot better!

Quad's 22Ls are good, modern floorstanders. By this I mean they are ruthlessly revealing, which rather favours good recordings over historical ones, shall I say! Their accuracy cannot be denied, nor can their ability. The way they project is dramatic and as a result partnering equipment needs to be chosen with care. In particular they need a very smooth sounding CD/DVD player as a source, plus a matching amplifier from Quad, Mission or Creek, I'd suggest. So equipped, the 22Ls are a superb package that provides the elegance Quad products are known for, together with a super-modern, high tech, presentation of what lies on your discs.

Quad 22L £699

Quad Electroacoustics
Tel: + 44 (0) 1480 447700
www.quad-hifi.co.uk

MEASURED PERFORMANCE

Output from the 22L reaches down to 40Hz and there's plenty of it, so I would expect this floorstander to produce good amounts of deep bass. More unusual is the speaker's impedance curve which suggests more damping than usual to cone movement, meaning the 22L is likely to give a tighter sound at low frequencies.

The 22L's frequency response extends smoothly right up to 16kHz and in this respect it performs well against the best modern designs. I would expect good levels of detail and quite well defined treble, but an up-front sound that will tip very obviously into brightness with bright CDs.

Sensitivity was normal at 86dB for one nominal watt of input (2.84V). Amplifiers of 40W or more should be adequate. With a measured impedance of 6ohms the 'speaker' measures much the same as rivals here. Reactance stays low; there are no sudden changes of impedance, so on balance measurement shows the 22L is a fairly reasonable load.

The Quad 22L measures very well in all areas. It should sound smooth, detailed and concise, and is likely to have plenty of solid, well controlled bass. It will be on the bright side though.

NK

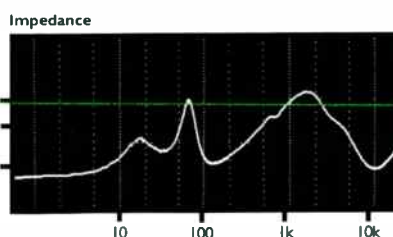
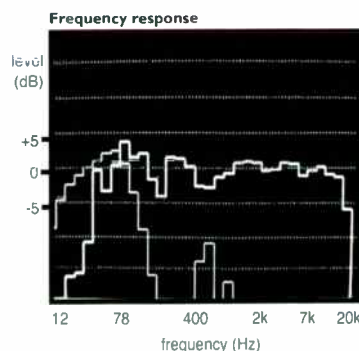

World Verdict

Very revealing, with a definite monitor-like accuracy. The 22Ls have impressively low and tight bass but could be a tad too forward for some. Superb finish and build.

NEW DEMONSTRATION ROOM NOW OPEN AT 12A SPRING GARDENS, NEWPORT PAGNELL, MILTON KEYNES, BUCKS MK16 0EE - CALL FOR DETAILS ON 01908 218836

KECL82 VALVE AMPLIFIER KIT

The Kecl82 is our latest introduction for the true beginner and designed by Andy Grove. A simple and elegant design based on the classic ECL82 valve, a triode and power pentode sharing the same glass envelope. The amplifier consists of two ECL82s per channel, the triode sections work as the input/phase splitter and the pentode sections work in push-pull for the output stage. The amplifier offers 8 watts into an 8 ohm load, the hum level is extremely low, comparison to solid state standards. The chassis is constructed of 1.6mm mild steel with a black powder coat finish. There is only one signal input pair controlled at the front by a volume control for that simple touch. The speaker connects are the standard 4mm banana type, positioned at the rear, as are the mains input which is received through an IEC lead, mains switch and earth post. We have made the construction as simple as is humanly possible with comprehensive instructions. The circuitry is based on a single printed circuit board. Ultimately this kit is for the guy who has always fancied a go at building a kit, but never dared. Simon Pope says, "It's a great introduction to the valve sound. For its humble price it delivers a full and rich sound with great detail and good depth." Kecl82 weighs 9kg. External dimensions are 30cm(w)x23.5cm(d)x11cm(h)

NEW KIT

£195



KIT6550 VALVE INTEGRATED AMPLIFIER KIT & KAT6550 VALVE POWER AMPLIFIER KIT

£595



**KIT6550
upgrade kit now
available £130**

£580



**KAT6550
upgrade kit now
available £120**

These are our new 6550 series amplifiers. A pure class A design providing 40 watts into a 8 ohm load. (available in a 4 ohm version if required) A truly high end design by Andy Grove, using Svetlana 6550Cs in push-pull (any 6550 or KT88 tube can be used with this amp). It features valve rectification (5U4) a choke pi filter power supply and is hard wired. Weighs 19kg with dimensions 390mm(w) x

330mm(d) x 190mm(h) with valves or 220mm(h) with cage. Simon Pope says - "If you favour attack and rhythmic grip, together with a smoothness of sound that's incredibly easy to live with, the Kit6550 could well be the kit amp for you. The 6550 is one for those who like a valve sound married to the attack and clout of a good quality solid state design".

Kel84 VALVE INTEGRATED AMPLIFIER KIT

The Kel84 features a pair of EL84 valves per channel in push-pull configuration. They give 15 watts into an 8 ohm load. The output transformers are Ultra Linear. Up front the ECF80 input/phase splitter valve has an extremely smooth sound. The Kel84 has very low hum, for simplicity the kit is built on a printed circuit board. A strong steel chassis is fronted by a 3mm anodised front panel and attractive chromed custom made knobs. There are five line level inputs, plus one monitor input, with a tape output included, all controlled from the front panel. At the rear is a mains switch/IEC power input, earth post, phonos, and 4mm banana sockets. Simon Pope says, "The quality that can be gleaned from this amp is a fine introduction to the joys of the valve sound. The Kel84 will highlight all the intricacies and depth of detail in your favourite recordings whilst retaining a warmth and fullness that is almost exclusive to pure valve amps and is rare at this price point." Kel84 weighs 10kg. External dimensions with valves are 300mm(w) x 270mm(d) x 150mm(h).

£278



2A3 PSE INTEGRATED AMPLIFIER KIT

The 2A3 PSE integrated amplifier offers a seriously hi-end sound, but without the cost usually associated with single-ended amplifiers. The stereo chassis houses, on the output, 2 x 2A3 in parallel single ended configuration and a single 6SN7 as the driver tube per channel. The valve rectified power supply consists of a 5U4 and a 10h choke. This feedbackless design provides 8.5watts into an 8 ohm load, so a good sensitivity speaker is required above 90dB. It can accept 6 line-level inputs fully controllable from the front panel. We provide the excellent Alps Blue potentiometer as standard. The amplifier is hard wired so plenty of scope for tweaking in the future. Simon Pope says, "The 2A3 PSE is extremely impressive piece of kit, good imaging, wide sound stage, nicely extended on the high frequency and tremendous bass thump. Weight - 20kg, external dimensions with valves fitted - 390mm(w) x 360mm(d) x 220mm(h)

£550



DIY KITS IN THE WORLD

ALL NEW SERIES II MODULAR PRE-AMP KIT

The PRE-II is a valve pre-amplifier with six inputs, tape monitor and two sets of output sockets. It utilises a high quality line driver transformer and x5 gain. The PHONO-II is a dedicated valve phono stage that incorporates a step-up transformer for MC users. Finally, PSU-II is a power supply unit that feeds both the PRE-II and PHONO-II.

Power Supply Unit (PSU-II)	£195.00
Pre-amplifier (PRE-II)	£195.00
Phono Stage (PHONO-II)	£110.00
Moving coil step-up transformer	£77.00
Passive pre-amplifier (PAS-II)	£215.00 NEW!

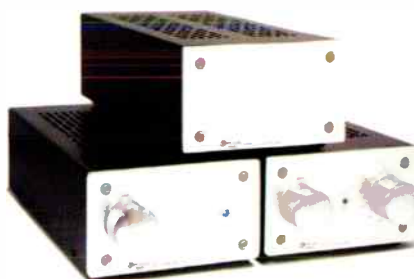

KAT34 VALVE POWER AMPLIFIER KIT & KIT34 VALVE INTEGRATED AMPLIFIER KIT

£480

NEW KITS

£495

**KaT34
upgrade kit now
available £120**

**KIT34
upgrade kit now
available £130**

KaT34 is a 32 watt stereo valve integrated amplifier, featuring a pair of EL34s, in push-pull mode, per channel, plus an ECF80 pentode/triode as input/phase splitter. The power supply is valve rectified (2 x 5U4), using a heavy duty choke to achieve exceptional smoothing. The output transformers are 14% Ultra Linear tapped to keep distortion down to its lowest level and the kit is totally hard wired utilising three tag boards. It has five line level inputs, plus a tape-in and tape

out, all controllable from the front. Simon Pope says, "This integrated bring together the best sonic virtues of our Kit88, kel34 and top of the range 300B PSE in an affordable package. The highlights of the sound are a deep and taut bass response, together with an open and highly detailed mid and high frequency response that only the best valve designs can achieve... a true valve classic." Weight 22kg, External dimensions with valves fitted - 390mm(w) x 360mm(d) x 210mm(h)

300B PSE MONOBLOC KIT

Our Parallel Single Ended amplifiers offer ultimate sound quality Each monobloc has two of the beautifully linear 300B directly heated triode in its output stage, producing 20 watts into an 8 ohm load. At the front we have a 6AU6 pentode and an ECC82 as the driver valve. This design utilises a 5U4 rectifier valve in the power supply, in combination with a 10H choke, giving an extremely quiet supply. Both mains and output transformers we E/I pattern.

For purists, feedback is switchable and the kit is totally hard-wired. For those that require valves we provide the superb Tesla 300Bs, Russian 5U4s and European 6AU6s & ECC82. Simon Pope says, "Not to put too fine a point on it, the sound these monoblocs create is among the finest that can be encountered in hi-fi." Our 300B PSE kit bears an affordable price of £875.00 (UK price) excluding valves. Each monobloc weighs 23kgs., external dimensions with valves: 25cm(w) x 38cm(h) x 22cm(d) per monobloc.

**300B PSU
upgrade kit now
available £150**

**£875
A pair**

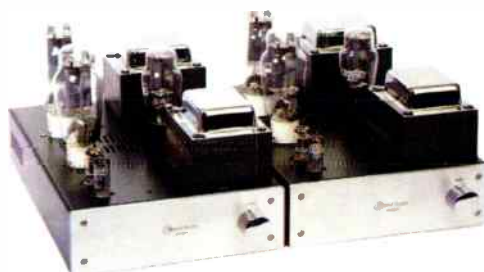

KEL80 MONOBLOC AMPLIFIER KIT

Following the success of our budget KEL34 40watt kit amplifier, we have come up with a 'big brother' design. The output stage uses two pairs of TESLA EL34 pentodes in parallel-push-pull mode, allowing KEL80 to turn out 80 watts into an 8ohm load. Heading up the input stage we have the wonderfully linear Russian 6AU6 working into an American 5687 phase-splitter. KEL80's output transformers are 4ohm and 8ohm tapped. With an input sensitivity at around 380mV for full output, it will happily partner both passive and active pre-amplifiers. It is easy to assemble. Simon Pope says, "The proof of the pudding is in the eating and the KEL80 is a feast for the ears, with solid bass attack, lightning fast reactions, that emphasises musicality as well as power. At £649.00 a pair, a definite valve winner. Each monobloc weighs 12kgs., external dimensions with valves: 14cm(w) x 8cm(h) x 43.5cm(d).

**£649
A pair**



HD83 VALVE HEADPHONE AMPLIFIER KIT

The HD83 headphone amplifier is a beautifully simple design using Mullard ECL83 valves, a triode and power pentode housed in the same envelope. It works directly from any source, be it CD, tape, tuner etc., or from an amplifier's tape out or pre-amp out sockets. The circuit uses high specification E/I output transformers that will drive any headphone load from 16 ohms to over 300 ohms depending on how the secondaries are wired up. The HD83 is a single-ended design with the power pentode wired up in triode configuration for added sonic purity, and it is as quiet as a mouse. For sound quality Jon Marks says, "The bass is punchy and controlled without becoming artificial, while treble has the crispness of the best solid-state, with the tonal purity, delicacy and speed associated with valves." External

dimensions 18cm(w) x 30cm(l) x 8cm (h) weight 4kg.

£195



NEW DEMONSTRATION ROOM NOW OPEN AT 12A SPRING GARDENS, NEWPORT PAGNELL,
MILTON KEYNES, BUCKS MK16 0EE - CALL FOR DETAILS ON 01908 218836

Kel84 Upgrade kit
1 x 100K Alps blue Potentiometer
2 x 1000uF, 16V Black Gate
4 x 100uF, 50V Black Gate
4 x 0.22uF, 400V Jensen paper in oil

£100

KiT34 Upgrade kit
1 x 100K Alps blue Potentiometer
2 x 1000uF, 16V Black Gate
4 x 100uF, 50V Black Gate
4 x 0.22uF, 630V Jensen paper in oil

£130

KiT6550 Upgrade kit
1 x 100K Alps blue Potentiometer
2 x 2200uF, 16V Black Gate
4 x 100uF, 100V Black Gate
4 x 0.22uF, 630V Jensen paper in oil

£130

KaT34 Upgrade kit
2 x 1000uF, 16V Black Gate
4 x 100uF, 50V Black Gate
4 x 0.22uF, 630V Jensen paper in oil

£120

KaT6550 Upgrade kit
2 x 2200uF, 16V Black Gate
4 x 100uF, 100V Black Gate
4 x 0.22uF, 630V Jensen paper in oil

£120

300B PSE Upgrade kit
2 x 470uF, 16V Black Gate
4 x 100uF, 100V Black Gate
2 x 0.22uF, 630V Jensen paper in oil
2 x 0.47uF, 630V Jensen paper in oil
4 x 35A Bridge Rectifier KBPC3502
4 x 4700uF, 16V

£150



"KIT34 Upgrade Kit"



E/I mains transformer 120 lam, Primary: 110/120/230/240Vac
Secondary: 4 x 0V- 4Vac, 2A
(suitable for 2A3 heaters for DC), 0V-5Vac, 3A (heater for 5U4 etc)
0V-6.3V, 2A and 370V-0V-370Vac, 250mA **Price - £65.00**

2A3 PSE chassis and base plate (without face plate), slight flaw on pain work, can hold 1 x 120 lam, 2 x 78 lam E/I transformer, 3 x octals an 4 x UX4s, hardwired. **Price - £50.00**

Kel84 chassis and base plate (Without face plate), slight flaw on pain work, can hold 1 x 78 lam, 2 x 29 lam E/I transformers and 6 x B9A **Price - £40.00**

Audax drive unit, HMI30Z0, aerogel, 5 inch mid/base unit
UK price £35.00 each

5687 valves, double triode
UK price £7.00 each

KaT88 chassis - **UK price £30.00 each**

Kel34 chassis - **UK price £30.00 each**

Pls fax/tel
00 44 (0) 1908 218836
to order

Mains transformers & Chokes

KIT6550/KAT6550 mains transformers
2 inch stack, 130mm(h)x120mm(w)x135mm(l) drop through fitting with zinc cap. Secondaries: 0V-240V, 350mA, 0V-5V, 6A, 3.15V, 0V-3.15V, 9A. Suitable for 120V & 240Vac operation

KEL84 mains transformer
1.5 inch stack, 90mm(h)x 80mm(w)x 95mm(d) drop through fitting with zinc cap. Secondaries: 0V-240V 300mA, 3.15V-0V-3.15V, 5.5A, suitable for 120/240V operation

KIT88/KAT88 mains toroidal transformer
120mm dia. x 60mm(h). Secondaries: 195V-0V-95V, 450mA/0V-27V, 100mA/3.15V-0V-3.15V, 9A, suitable for 120/240V operation

KIT34/KAT34/KIT6550/KAT6550 choke
1.25 inch stack, 65mm(h)x105mm(w) with fitting holes x 60mm(d), clamp fitting, 2.5 H, 350mA

300B PSE mains E/I transformer
130mm(h) x 95mm(w) x 115mm(d), drop through fitting with zinc cap. Secondaries: 380V-0V-380V, 180mA/150-0V-150V, 25mA/0V-5V, 1.2A/0V-5V, 1.2A/0V-5V/3A/3.15V-0V-3.15V/0.4A suitable for 120/240V operation

KEL80 mains toroidal transformer (encapsulated)
130mm dia. x 65mm(h). Secondaries: 195V-0V-195V, 390mA/0V-27V, 100mA/3.15V-0V-3.15V, 7.5A, suitable for 120/240V operation

HD83 mains toroidal transformer
80mm dia. x 35mm(h). Secondaries: 0V-165V, 75mA/3.15V-0V-3.15V, 1A, suitable for 120/240V operation

PSU-II mains toroidal transformer
80mm dia. x 35mm(h). Secondaries: 0V-270V, 60mA/0V-10V, 2A, suitable for 120/240V operation

TRANS1 mains toroidal transformer
95mm dia. x 50mm(h). Secondaries: 0V-370V, 150mA/0V-6.3V, 3.5A 300B E/I choke 65mm(h) x 70mm(d) x 80mm(w) open frame fitting, 10H, 180mA.

KEL84 E/I choke
0.5 inch stack, 40mm(h)x 35mm(d)x 70mm(w) clamp fitting, 1H, 250mA

PSU-II E/I
40mm(h) x 35mm(d) x 70mm (w) clamp fitting, 15H, 20mA

KIT34/KAT34 mains transformer
2.5 inch stack, 120mm(h)x115mm(w)x95mm(d), drop through fitting with zinc cap. Secondaries: 365V - 0V - 365V, 300mA/0V - 5V, 6A/3.15V - 0V - 3.15V, 7.5A. Suitable for 120/240V operation.

Output transformers

KIT6550/KAT6550 E/I 16% TAPPED UL push-pull output transformer
2 inch stack, 80mm(w) x 95mm(l) x 100mm(h), drop through fitting with zinc cap. Primary-secondary 4.5K, 16% UL tapped. Secondary 4 Ohm, 8 ohm, pls specify on order. max output 45 watts, max current 180mA, valves, KT88, 6550 etc

KEL84 E/I Ultra Linear push-pull output transformer
1.25 inch stack, 76mm(h)x 65mm(w)x 76mm(d) Primary - secondary, 8K with 12.5% UL tap - 8ohms, max o/p-15watts, max current 150mA valves EL84 etc

KIT88/KAT88 E/I push-pull output transformer
80mm(w)x95mm(l)x100mm(h). Primary-secondary 10K - 8ohms, max o/p-40watts, max current-160mA valves-KT88, 6550, EL34

KIT34/KAT34 E/I 14% tapped Ultra Linear push-pull output transformer
2 inch stack, 80mm(w)x95mm(l)x100mm(h), drop through fitting with zinc cap. Primary-secondary 6.4K, 14% UL taps, Secondary 8ohm, max output 34watts, max current 150mA, valves EL34, 6L6, 6CA7

KEL80 E/I parallel-push-pull output transformer
95mm(w)x115mm(l)x133mm(h). Primary-secondary 4.6K - 8 & 4ohms, max o/p-80watts, max current-250mA valves-EL34, 5881, 6L6

HD83 E/I single ended output transformer
40mm(w)x50mm(l) x 55mm(h). Primary-secondary 4K - 4 x 64ohms windings, max o/p-1watts, max current-25mA valves-ECL83 etc

Pre-II E/I driver transformer
80mm(w)x60mm(l) x 65mm(h). 6:1 step down transformer, max current-10mA valves-6922 etc pre-amp stage

300B PSE E/I parallel single ended output transformer
130mm(h) x 95mm(w) x 115mm(d). drop through fitting with zinc cap. Primary 1K5 Secondary 8R, cap.

Printed circuit boards

- Kel84 Printed Circuit Board 280mm(w) x 135mm(l) x 1.6mm(d).
- KIT88/KAT88 Printed Circuit Board 140mm(w) x 310mm(l) x 2.4mm(d).**
- Kel34 Printed Circuit Board 140mm(w) x 310mm(l) x 2.4mm(d).
- Kel80 Printed Circuit Board (a pair) 120mm(w) x 215mm(l) x 1.6mm(d).**
- HD83 Printed Circuit Board 140mm(w) x 160mm(l) x 1.6mm(d).
- Pre-II Printed Circuit Board 105mm(w) x 130mm(l) x 1.6mm(d).**
- PHONO-II Printed Circuit Board 105mm(w) x 130mm(l) x 1.6mm(d).**



Hi-Fi World in Malaysia at Millennium Hi-Fi & Av. Kuala Lumpur, Malaysia

Hi-Fi World is now distributed through good bookshops and newstands in Malaysia. For back issues, general enquiries and advertising, contact Simon Chang at Millennium Hi-Fi & Av.

Also available are products by World Audio Design, Michell, Trichord, Lowther and ReThm loudspeakers.

Millennium Hi-Fi & Av
500-1-3 First Floor, Wisma Indah (Shen Court),
Jalan Tun Razak 50400 K.L.

tel: 603 9283 8171 fax: 603 9281 3762

137 Jalan Pendekar 2, Taman Skudai Baru, 81300 Skudai, Johor DT
tel: 607 554 5171 fax: 607 554 7645

e-mail: info@millennium-audio.com

WE HAVE OVER 30 TITLES ON OFFER!!!

AUDIO ELECTRONIC THEORY BOOKS



Electronics made Simple
by Ian Sinclair
This books covers the basic theory and principles of electronics. A good read for the beginner.
Code No. 1420
£12.99 + £2.50 P&P (UK)



Build your own High-End Audio Equipment
by Elektor
Build your own High-End Audio equipment contains construction projects for solid state preamplifiers and power amplifiers, active cross-over filters, an active subwoofer, a mono/stereo compressor and a headphone amplifier.
Code No. 1390
£14.95 + £2.50 P&P (UK)

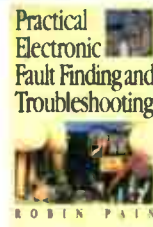

Practical Electronic Fault-Finding and Troubleshooting
by Robin Pain
This book explains the basic techniques needed to be a troubleshooter, using a basic equipment: a digital multimeter and an oscilloscope. Simple circuit examples are used to illustrate principles and concepts fundamental to the process of fault finding.
240pp, Paperback Code No. 1430
£20.99 + £2.50 P&P (UK)



Build your own Electronic Test Instruments
by Elektor
This book contains designs for 17 measuring instruments, seven generators and analysers, ten miscellaneous instruments and a number of test ancillaries and auxiliaries. The designs range from a simple multimeter cable designs contain a special printed circuit, drawing of which are given in an appendix.
Code No. 1400
£15.95 + £3.25 P&P (UK)



The LP is back
by Audio Amateurs
Your complete guide to LP care and maintenance designed to offer you everything useful for those who love and enjoy this older music medium. This covers the theory and care of LPs and the electronics and mechanics of its players.
154pp Paperback, Code No. 1620
£8.00 + £2.00 P&P (UK)

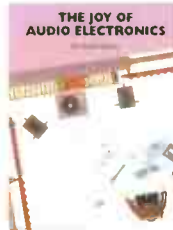

The Joy of Audio Electronics
by Charles Hansen
This is a fail-safe guide to the pleasures of hands-on electronic construction. This book covers test and measurement projects, how to build simple kits, safety issues, the workplace, theory and resources. A must for the beginner who plans to build more advanced electronic projects in the future.
124pp Paperback, Code No. 1650
£10.50 + £2.50 P&P (UK)

VALVE BOOKS



GEC Audio Tube Data
Full of data and circuits concerning the three most well known MO Valve power tetrodes, the KT66, KT77 and KT88, (the KT77 was GEC's answer to Mullard's EL34) and some data on the PX4 and PX25 triodes. The first section concerns preamplifiers of various types, with information regarding equalisation, tone controls, filters and suchlike. An excellent book for all valve heads.
Paperback Code No. 1780
£14.95 + £2.00 (UK)



The Best of Audionetorial projects
by Luciano Marci
This book contains six excellent audio projects - a high sensitivity speaker, a superb tube pre-amp, a 2A3 amplifier design, a project using the Russian 6C33CB and two projects using 300Bs as output valves. Overall the book is a fabulous read.
62pp, paperback book code 1750
£12.00 + £2.00 UK p+p



Vacuum Tube Amplifiers
by Valley & Wallman
This book is a well known reference valve text book and is assembled from pieces by ten knowledgeable authors absolute bible when it comes to val electronics.
734pp, Paperback, Code 1770
£29.95 + £ 4.30 P&P (UK)

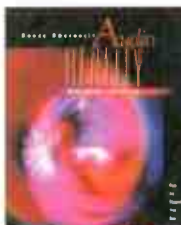

Audio Reality
by Bruce Rozenblitz
Investigates conductors, skin effect, impedance, interconnects, speaker cables, balanced lines, transmission lines, isolation transformers, tubes, acoustics and much more. Also, includes 6 excellent detailed valve design projects, 80watt OTL, 25watt OTL grounded grid pre-amp, 150watt amp., 6550 SE amp. and a grounded grid cascode phono preamp.
Paperback 128pp, Code No. 1640
Price 21.50 + 2.50 P&P (UK)



An Approach to Audio Electronic Valves in Audio Frequency Amplifiers
by E. Rodenhuis
Discussing the use of valve data, the function of different amplifier stages and includes detailed descriptions of eight designs. A wealth of practical data, measurements and interesting features will be found. A very good read.
Paperback 147pp, Code No. 1520
Price £12.95 + £2.00 P&P (UK)



Build your own Audio Valve Amplifiers
by Rainier Zur Linde
This book covers construction projects for preamplifiers, power amplifiers and amplifiers for musical instruments aimed at the practical audio/hifi enthusiast, it offers much information on the operation of electron tubes, while the first chapter gives a short history of the thermionic valve.
paperback, 251pp, Code No. 1320
£14.95 + 2.50 P&P (UK)



Audio/Radio Handbook
By National Semiconductor
National Semiconductor's manual is an essential aid to engineers and experienced hobbyists in the application of National's line of consumer audio and radio ICs. Not only does it hold comprehensive data of their ICs but discusses theory aspects of amplifiers and preamps and covers electronic principals.
paperback 200pp, Code No. 1810
£13.95 + £2.00 P&P (UK)



The Cunningham Radiotron Manual
Technical Series RC-12
This book presents RCA's commercial valve line-up as it was in 1934. The manual covers valve terminology, technology and application, valve testing and then a larger section giving some circuit ideas and plenty of data on numerous valves, e.g. 2A3, 6N7, 6L6 to name a few.
paperback 154pp, Code No. 1800
£13.95 + £2.00 P&P (UK)



The Beginner's Guide to Tube Design
by Bruce Rozenblitz
This book takes a comprehensive look at tube audio design. It explains how vacuum tubes work and how to design with them. Rozenblitz covers stabilisation, testing, a description of 13 famous and classic amps and preamps and how to work effectively as a designer. A handy on guide to construction techniques, tools and choosing components and tubes is provided. 1997.
132pp Paperback Code No. 1341
£15.50 + £2.50 P&P (UK)



Fundamentals of Radio-Valve Technique
J. Deketh
This is part of the Philips technical series written in 1947 it was one of the most authoritative and comprehensive treatments of the nature and function of the vacuum tube.
534pp, Paper back
Code No. 1630
£21.50 + £2.50 P&P (UK)



Glass Audio Projects - 17 Vacuum Tube Designs
This book features 17 valve project, designed, tried and tested by some of the best authors state side. Designs such as a 300B push-pull amp, a 33 power amp a 6528 single ended a 300B parallel single-ended amp, a 6C33CB single ended amp, a 70W KT88 push-pull amp, a 2A3 single ended amp to name a few. All information is provided so most projects can be built from scratch.
Paperback 73pp, Code 1790,
£8.00 + £1.50 P&P (UK)



Mullard Tube Circuits for Audio Amplifiers
Includes full designs for eleven power and control amps, including 520, using valves. Begins with a four chapter tutorial on getting the best sound from valve amplifiers.
142pp 8" x 10" Paperback
Code 1030
£13.95 + £2.00 P&P (UK)



The Williamson Amplifier
by D.T.N. Williamson.
Offers practical advice on how to build and set up the amplifier for best results.
40pp Paper back
Code No. 1040
£9.95 + £1.50 P&P (UK)



Valve & Transistor Audio Amplifiers
by J.L. Hood
Describes the earliest valve amps to the latest solid state design. It is the complete world guide to audio amp design. Other contents: active & passive components, amplifiers, pre-amplifiers and power supplies.
250pp, Paperback,
Code No. 1530
£20.99 + £3.50 P&P (UK)

SEE OUR NEW TITLES

Glass Audio Projects - 17 Vacuum Tube Designs

GEC Audio Tube Data

AUDIO LIBRARY

world audio design

ORDER 4 BOOKS & OVER & PAY ONLY £7.00 FOR P&P (UK ONLY)

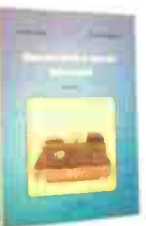

Manuale Hi-Fi a valvole Schemario 2*
An Italian publication with all circuit diagrams in standard conformation, therefore, all circuits are easy to follow. This book is dedicated to self makers and to Hi-Fi tube engineers. With a wealth of circuit diagrams from some of the best valve amplifiers, pre-amplifiers and phono equipment producers in the world. Including, Audio Research, Altec, Conrad Johnson, Art Audio, Luxman, Carver, Dynaco, Electrovoice, Leak, MacIntosh, Marantz, Quad, Radford, Quick Silver, numerous OTL designs, Verdier, VTL and Western Electric. Well worth the money.
208pp 210mm x 300mm Paperback
Code No. 1720
£44.00 + £4.00 P&P (UK)



Getting the most out of Vacuum Tubes
by **Robert B. Tomer**
From the cover, "Types and causes of tube failures, what to expect from tubes, testing methods and all about tube maintenance programs." This book is intended to offer explanations of why tubes fail and what to do about it. Discussions of catastrophic and degenerative failures; selecting tubes and tube types and testing and predicting tube performance.
160pp 140mm x 216mm
Paperback,
Code No. 1710
£13.95 + £2.00 P&P (UK)

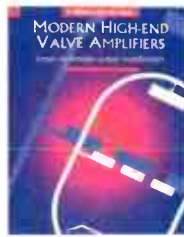

Modern High-End Valve Amplifiers Based on Toroidal Output Transformers
by **Menno van der Veen**
Explains the why and wherefores of toroidal output transformers at various technical levels. Discussed extensively within this book are designs for amplifiers from 10 to 100 watts. Finally, the author gives some attention to a number of special valve amplifiers, and to the theory and practice of negative feedback.
250pp 170mm x 240mm
Hard back
Code No. 1670
£24.95 + £3.30 P+P (UK)



First in High Fidelity
The Products and History of H.J. Leak & Co. Ltd.
by **Stevyn Spicer**
This book is the unique and comprehensive story about one of the world's best high-fidelity audio companies. Contained are 300 pictures, 30 circuit diagrams for classic designs of the day. There are also numerous anecdotes and contributions from ex-employees. A wonderful historical read.
270pp 195mm x 264mm Paperback
Code no. 1740
£19.95 + £3.55 p+p UK



Basic Theory and Application of Electron Tubes
A US Army & Navy Publication
This book is an excellent introduction into valves. It does just about everything its title suggests. Written in 1957 it was used by the US military as a text book in their electronics department. Superbly written it contains all you need to know.
215pp
200mm x 260mm Paperback
book code 1760
£17.95 + £3.50 P&P (UK)



Sylvania Technical Manual
by **Sylvania Electric Products Inc.**
This 13th edition contains data on more than 3300 electron tubes and semiconductor devices. Reprinted here without the TV picture tube section, this manual contains detailed information on Sylvania's devices including charts and diagrams. A master index is found in the front of the book for reference.
516pp 140mm x 216mm Paper back
Code No. 1700
£16.95 + £3.80 UK p+p

LOUDSPEAKER BOOKS



Testing Loudspeakers*
by **Joe D'Appolito**
Joe D'Appolito, loudspeaker designer and consultant, has written the definitive text on testing loudspeakers. Dr. D'Appolito brings his expertise to the subject and provides you with a hands-on discussion of testing drivers and systems. He brings you the theory and physics behind loudspeaker testing in this volume.
Paperback
Code No. 1580
£24.95 + £3.00 P&P (UK)



Electrostatic Loudspeaker Design and Construction
by **Ronald Wagner**
Step by step guide to the design and construction of a full range electrostatic loudspeaker, including basic operating principles. Strongly recommended for those wanting to either build, repair and/or restore, or who are just interested in electrostatics.
243pp 7" x 9 5/8" Paperback
Code No. 1080
£16.95 + £3.25 P&P (UK)



The Loudspeaker Design Cookbook, 6th edition (new)
by **Vance Dickason**
This best seller offers up-to-date design information for the home constructor. It uses modern Thiele-Small theory and parameters.
288pp 8 1/2" x 11 1/2" Paperback
Code No. 1090
£29.50 + £4.00 P&P (UK)



Bullock On Boxes
by **Robert M. Bullock III.**
Using Thiele-Small parameters clearly, it offers lots of helpful tables and graphs to get to grips with the sizing of the box and port of a reflex loudspeaker.
72pp 8 1/2" x 11" Paperback
Code No. 1100
£12.95 + £2.50 P&P (UK)

ORDER ON-LINE
www.worldaudiodesign.co.uk



Horn Loudspeaker Design
by **Mr J. Dinsdale**
A collection of papers by Mr J. Dinsdale, that discuss the design and theory of this wonderful breed of loudspeaker. The book contains detailed drawings of numerous designs, including some Lowther classics. Also, included with the book is a 3.5inch floppy disc with straight forward software to assist in the design process. A serious reference for those with an interest in horn speakers.
112pp paper back & 3.5 floppy disc
210mm x 300mm
Code: 1730
£29.50 + £2.50 P&P (UK)



Audio Amateur Loudspeaker Projects
A collection of the 25 best speaker articles published in the Audio Amateur throughout the 1970s, this popular book is proof that great designs are never out of date. This volume is a rich source of theory, practice and design.
135pp 8 1/2" x 11" Paperback
Code No. 1550
£16.95 + £2.50 P&P (UK)



Loudspeakers: The Why and How of Good Reproduction
by **G.A. Briggs**
An easy to understand book on building loudspeakers, using empirical techniques that pre-date computer analysis. Strongly recommended for beginners.
88pp 5 1/2" x 8 1/2" Paperback
Code No. 1070
£10.95 + £2.00 P&P (UK)

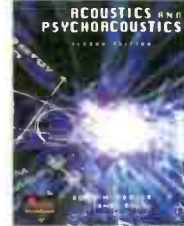

Acoustics & Psychoacoustics 2nd Edition
by **David M. Howard & James Angus**
An introduction to acoustics, covering human perception of sound, notes and harmony, musical dynamics, timbre of musical instruments, acoustic model for musical instruments, hearing music in different environments, deceiving the ear and processing sound electronically.
224pp 244 x 189mm
paperback
Code: 1370
£29.99 + £3.50 P&P (UK)

ORDER FORM

Please send (Code No.) _____ (enter codes clearly)
Pay: World Audio Publishing Ltd. £ _____ or debit my Mastercard/Visa/Switch/Solo (Card No) _____
Expiry date: _____ (Switch/Solo only) Valid Date: _____ Issue No. _____ Name: _____ Signed: _____
Delivery Address: _____
Tel: (Day) _____ Please return to: W.A.P. Ltd. 12A Spring Gardens, Newport Pagnell, Milton Keynes, MK16

0955 ENGLAND TEL/FAX: 01908 218836 **ORDER ON LINE** Website: www.worldaudiodesign.co.uk E-Mail: nick@worldaudiodesign.co.uk

Please contact us for overseas P&P charges. Allow 28 days for delivery. All orders subject to availability. If further space is required please attach separate sheet. TICK BOX IF YOU HAVE ORDERED BEFORE

CLASSIC CUTS

Andy Giles recommends a captivating musical anthology from England's least English composer, Frederick Delius; conducted by England's most English conductor, Sir Thomas Beecham.

This is a tale of two Englishmen whose incongruity is hard to imagine. Frederick Delius – one of the most disregarded of English composers – was born in England 1862, lived and worked in Florida, Germany, Norway and France, where he died in 1934, and was buried in an English country churchyard in 1935. The fact that his countrymen disregard Delius is understandable, as it seems he never actually wanted to be English. He generally spoke in German, composed operas and songs in German, Danish and Norwegian and lived mainly abroad throughout his life. His music does not fall into the English tradition of Elgar and it is also gratifyingly distant from the more bucolic style of English music as pursued by the 'cow-pat' school, unintentionally championed by Vaughan Williams. It is more impressionistic, certainly at one with nature and even more certainly – immediately recognisable. It rustles with the sighing of autumn trees and the winnowing of light summer grass. Choral works are interspersed with travails. You know Delius's music when you hear it. It can be nobody else. And, without question, under the baton of Sir Thomas Beecham, it is peerless.

Beecham (1879 - 1961) – arguably England's finest conductor – was born in St Helen's, Lancashire, into great affluence; his father, Sir Joseph Beecham, was the producer of "Beecham's Pills". He made his professional debut as a conductor with the Queen's Hall Orchestra in London in 1905 and continued to rise to both prominence and eminence until his death, by which

time he was known as much for his unashamed arrogance, eloquence and, some would say, bloody rudeness than for his prowess as a conductor! Despite his impeccable Englishness he cared little for English music. After conducting a concert in a festival of English music Sir Thomas remarked 'Well, I think we have successfully paved the way this afternoon for another quarter of a century of German music!' The most important aspect of his career as far as this piece is concerned is his discovery of the music of Delius. Beecham's understanding and mastery of Delius showed an incandescent creativity rarely caught in the recording studio. This highly satisfying EMI classic cut contains the complete stereo collection of Beecham's remarkable readings of the Delius canon. Beecham conducts his own Royal Philharmonic Orchestra with the Beecham Choral Society.

It has been said that perhaps it was a pity that EMI chose not to open this compilation with *Brigg Fair*, Delius's magnum opus among his shorter orchestral works, which is so matchlessly played here. There is a feeling of complete rapture at the opening, the plaintive call of the oboe solo contrasting with the soft pliability of the flute. Everything is so perfectly balanced and when, later, the long-breathed string melody arrives, it is given a sensuous lazy sleepwalking effect that perfectly encapsulates a warm English summer afternoon. The actual string sound here (as in the gentle syncopated dance of the third movement of the *Florida Suite*) has a misty, almost

unfocused sparkle that is unique to Beecham and is delightfully wedged by the recording engineers. The glowing implied strings and radiant woodwind at the opening of *On Hearing the First Cuckoo in Spring*, the textural grace of *Summer Night on the River*, glowing like a French painting, or the free flexibility of tempo in *Summer Evening* are breathtaking moments on this recording. Beecham said, with characteristic nonchalance, that he found Delius's music as alluring as a wayward woman, and determined to tame it. The results are so sensuously and radiantly delectable to justify the sexual metaphor—there is a communication of musical ecstasy here which shows how close Delius's pantheistic response to nature was to the human sexual experience, yet there is an innocence too and a refinement that transcend physical associations.

The tracks vary in appeal and Delius isn't to everyone's taste. His music is neither anthemic nor nationalistic. It eschews the sacred and steers clear of the sweet. Delius was a wanderer in sequestered byways, one who had all the time to 'stand and stare'.

This truly ecstatic set of Delius compositions is the only Delius recording you need own. Beecham's excellence is never more manifest and it's a must-have album.





I'm slowly warming to DVD-Audio and, in particular, the idea of surround-sound. It's turning out to be a hi-fi enthusiasts dream, but what the average man in the street will ever make of it I don't know - and I shudder to think. You see, I had a conversation with another very technical reviewer recently where we both admitted we did not understand DVD! It's not the technology, nor the broad and confusing multiple standards, so much as the uniquely different way each manufacturer chooses to build their machine. It affects reviewers more than buyers, because they have to struggle to understand each machine from its handbook - and from what I've read incomprehension extends into the handbooks too. Will the sheer complexity of DVD-Audio prevent it ever becoming a mass market medium? I suspect it will, which will be a pity, because it is beginning to deliver stunning sound quality.

A good 24/96 recording will blow your socks off, and DVD can do a lot better than this. But before I dive into the sound quality issue, let me make clear a distinction. DVD-Audio offers two distinct benefits: higher intrinsic sound quality than CD, and surround-sound. You can have either or both.

When I say 24/96 will blow your socks off I'm talking about pure sound quality, and an improvement in CD is long overdue. I won't go into details: 24/96 digital code on DVD produces much less distortion than CD, it has greater dynamic range and it doesn't rudely chop out the music above 20kHz. And for those of you who believe there is no music above 20kHz - it's not the case. I use a Hewlett Packard spectrum analyzer that works up to 100kHz and believe me, there's

plenty of harmonic info above 20kHz in modern recordings. DVD-Audio can offer even better than 24/96 - it will give 24/192 - or mega fidelity! So if you just want better sound quality, DVD can provide it. But what about surround-sound?

The issue of surround-sound is an interesting one. Being an old cynic - and having suffered surround-

“ Even though I'm a dyed-in-the-wool audio enthusiast I admit I have no love of the physical intrusion of cables.

sound 1970s style (SQ, QS and CD-4) - the thought of 1990s digital surround-sound hasn't much appealed to me. However, as we step into the next century, perhaps things will be different and better this time around. Surround-sound is meant to add real depth perspective and, after all, this is exactly what we are trying to achieve, to a limited extent, with valve amps and high-end hi-fi in general.

What's interesting now is that as we start to get decent modern surround-sound recordings coming through, sound quality - at least with decent equipment - is stunning. The spatial delineation of artists and instruments that's possible with surround-sound is way beyond the best stereo, as Simon Pope, our Editor, found out listening to Meridian's top-end system. So modern surround-sound does genuinely add to the overall drama of good hi-fi. But of course there's a little more to all this than just sound quality.

In the real world most people don't view their lounge as a hi-fi storage centre. Whilst the world's consumer electronics industry has gone into a possibly-premature

feeding frenzy over DVD, believing sales of loudspeakers and surround-sound amps will shortly take off on the back of spiralling DVD player sales, somehow I doubt it. At least, I cannot imagine a majority of Britons heaving yet more full size boxes into their lounge.

Recently I even admit to critically eyeing up my large loudspeakers and the space they consume, and wondering whether I ought to reconfigure my lounge completely to take small, wall mounted front and rear speakers, a good subwoofer and underfloor cables. I well know that sats and subs don't offer the cohesiveness of full range, single-cabinet loudspeakers;

there's nothing like a good, big floorstander. But whilst sound quality will suffer in this respect, it will gain in terms of improved depth perspectives, better spatial separation and the heightened sense of immersion and believability surround-sound can bring. Perhaps the trade-off is worth it, in one room at least? Using a small sat/sub system of good quality frees up floor space; I've just got to rip up the floorboards! OK for an audio enthusiast perhaps, but will others less keen on hi-fi do likewise? I'm not convinced.

Then there's the expense. DVD music discs cost £16 or so and are hardly commonplace yet. Their sleeve notes are illegible and often indecipherable when it comes to the audio format used, as if it didn't matter. But with a DVD disc it does matter, because of the variety of different formats available.

Technically, DVD is great. As an easy to understand and use consumer product I think it is a confusing shambles. If I were Philips or Sony I would start considering whether a better worked out system could be devised, based on the Blue-Ray disc. ●

specialist hi-fi dealers

LONDON

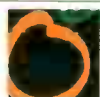

THE INNOVATIVE HI-FI, HOME CINEMA AND MULTI ROOM RETAILER/INSTALLER

SERVING LONDON FROM BATTERSEA

ORANGES & LEMONS

Friendly and efficient service
0% finance

JUICY FRUIT FROM LONDON'S FRESHEST RETAILER

ARCAM B&W CABLE TALK CASTLE CHORD CREEK DENON EPOS LINN MARANTZ NAD NEAT PMC QED REGA ROKSAN ROTEL RUARK STANDS UNIQUE SOUNDSTYLE YAMAHA XANTECH and many others

020-7924 2040

61/63 WEBBS ROAD, SW11

website: oandhifi.co.uk



We aim to provide a well chosen selection of quality hi-fi and accessories including

FMJ, ARCAM, B&W, NAUTILUS, DYNVECTOR, LINN, LOEWE, MERIDIAN, M&K, NAIM, PIONEER, PROCEED, NEAT, REGA, ROTEL, SHAHINIAN, YAMAHA + more

www.infidelity.co.uk

Open:
Tues-Fri
10.30am-7pm,
Saturday
10am-6pm

Infidelity

INDECENTLY GOOD HI-FI

9 High Street, Hampton Wick,
Kingston upon Thames, Surrey KT1 4DA
Tel: 020 8943 3530

~~AUDIO CONCEPT~~

27 BOND STREET, EALING
LONDON W5 5AS
TEL. 081 - 567 8703

Audio Analogue, Art Glass, Ash Designs, Avik, B&O, B&W, Cabeltalk, Chord Company, Creek, Denon, Epos, Harman Kardon, Infinity, KEF, Lat, Marantz, Musical Fidelity, NAD, Nakamichi, Nordost, Orelle, Onkyo, Primare, Quad, Roksan, Rotel, Ruark, Sennheiser, SonicLink, Sound Style, Stands Unique, Straightwire, Supra, Tag McLaren, Target, Teac, Thorens, van den Hul

10 - 6 pm Mon., Tues., Friday, & Sat.
Late night Thur., closed Wed.

Two demonstration rooms.
Free local delivery and installation.
Repairs and Services

SOUTH

WORTHING AUDIO

20 Treville Gate, W.Sussex BN11 1UA
(01903) 212133

The music shop with the best sound system in the South.
Talk Electronics - Friendly Advice - 3 Year Guarantee
Easy Parking - Open Mon-Sat. 10am-6pm
Late Night Wed 7.30pm.

Agencies include: Dynaudio, Ruark, Gradient, Roksan, Harman, Orelle, Sonneteer, Kora, Cymbal, Talk Electronics, and many more...

SOUTH WEST

SOUTH WEST ANALOGUE

SME - MICHELL - NOTTINGHAM ANALOGUE - LORICRAFT GARRARD - PROJECT - ORTOFON - TUBE TECHNOLOGY 64bit Valve CD Player, Remote Control Hybrid Integrated Valve Amplifier CROFT VOODOO Isolation platforms/Loudspeakers, Equipment Stands and T/Turntable lift off Perspex Covers. Record cleaning service - Secondhand equipment
01643 851 351
graham@southwestanalogue.fsnet.co.uk

NORTH

Basically Sound

NORWICH • NORFOLK

Audio Analogue, Bryston, Cabeltalk, Chario, Chord Co, Denon, Epos, Final, Ivoblu, Naim Audio PMC, ProAc, Rega, Stax, Talk Electronics, Teac, UKD Opera, Audio Note and many others

The Old School
School Road, Bracon Ash
Nr Norwich, Norfolk, NR1 1 8HG
Tel (01508) 570829



EAST

STOWSOUNDS audio consultants

These And More Available From:

Creek
Epos
Exposure

JM Labs
Living Voice
Neat Acoustics

For A Demonstration & Expert Advice Call
Stowmarket (01449) 675060

Stone Farm, Borough Lane, Gt. Finborough, Stowmarket

VALVES & TUBES



Chelmer Valve Company
For audio valves

Buy CVC. PREMIUM HI - FI valves direct from us. All valves processed for improved performance. We also have stock of MAJOR BRAND types inc. MULLARD, GEC, BRIMAR, RCA, GE, PHILIPS, etc.

Theables, Baddow Park, Great Baddow, Chelmsford, Essex, CM2 7SY
Tel: 01245 241301 Fax: 01245 241309
Email: sales@chelmervalue.com



£600

Mr. Andrew Everard in Gramophone Magazine "delivers a sound that's both smooth and refined ... allied to a good degree of clarity and finesse" Hi-Fi Choice "It's a 'classic valve sound'... warm and cuddly...vocals are generally lifelike and involving" FREE colour literature. £600 with free delivery Phone 01634 373410 anytime. 1 month home trial www.affordablevalvecompany.com 40 watts

SERVICES & CONSULTANTS

Front End Problem?

contact

The Cartridge Man

It doesn't have to cost an arm and a leg to get the best - listen to my Koetsu - and Decca -eater.

Also agents for Croft, Haddock, E.A.R. Michell & Moth.

plus cartridge re-tipping service
020 8688 6565

Website: www.thecartridgeman.com

atv

- Service & Repairs
- Valve & transistor amplifiers
- Vintage valve Radios
- Hi-Fi VCR's
- Valves Tested

ATV SERVICES
LEATHERHEAD
01372 456921

VINYL

THE DIRECT DISC VINYL VINYL VINYL

Thousands of records always in stock.
+ a full range of sought after compact discs.
Extensive search service for wanted albums.
Comprehensive 96 page full catalogue available at £1.50

Telephone / Fax 01992 447764

Or visit our web site on

www.directdisc.demon.co.uk

MAIL ORDER



Russ Andrews

Mail Order Cables & Accessories



Free catalogue!

Don't buy new equipment!
What you have is much better than you think!
Our NEW catalogue will show you how to release the full potential of your system.

For your free copy just call UK FREEPHONE
0800 373467
and quote AH122

Information and products that really work.

Russ Andrews Accessories Ltd., FREEPOST NWW001A, KENDAL LA8 9ZA Tel: +44 (0)1539 825500 Fax: +44 (0)1539 825540
E-mail: AH122@russandrews.com www.russandrews.com

TO

ADVERTISE

PLEASE CALL

AMANDA

SWEENEY ON

020 8864 4760



DVD is the fastest growing new technology format ever. This much we know as those clever chaps at the Guinness Book of Records have told us. All the indications are that this Christmas will be yet another bumper year for the format, but a saturated market (as happened with mobile phones last Christmas) is still some time off. With the price for many machines now well below £100, I would have thought that Compact Disc was in grave danger from the conquering new format.

When DVD launched just five years ago, many predicted the total demise of CD within a decade. Yet this is far from being the case. As a whole, the CD hardware market continues to thrive. More in-car units than ever now use a Compact Disc player. Whilst DVD systems incorporating navigational aids are available the standard fitment is still a small fraction of that of CD. As cassette continues to decline and the price of DVD based car systems remains high, CD's in-car dominance should be set to remain for some time to come, at least the next five years at any rate.

DVD has made a greater impact on 'lifestyle' hi-fi, those shiny, all in one hi-fis seen filling department stores across the country. The 1980's gave us the midi system and the 90's the mini. Lifestyle systems are the mass-market hi-fi choice for the turn of the century. More of these are now incorporating DVD, perhaps best typified by Sony's DAVS systems and Linn's Classik at the other end of the scale. All the same, CD is still the source of choice for most listeners; higher resolution discs are hardly available in record stores. Let us also not forget the seemingly endless array of personal, and portable CD

players that can be swiped through a Tesco counter for less than the cost of a roast dinner for four (especially if you like lamb!).

Yet it's the sales performance of separate CD players I'm more concerned with here. Although some retailers have noticed a decline in player sales, many have noted that the fall hasn't been as great as

When DVD launched just five years ago, many predicted the total demise of CD within a decade.

expected. Typically, retailers report static sales or falls, typically, of between 6-8%. Certainly, the falls haven't been as great as those of separate cassette decks over the past few years, and those manufacturers who are predicting the demise of two-channel audio are perhaps being somewhat premature.

A recent demonstration showed me why DVD isn't obliterating the CD market. The machine in question was a Toshiba SD220 DVD player. Those in the know would rate it as one of the best budget designs around. Yet, despite what was undeniably impressive picture quality, CD replay quality was most unimpressive. This is meant to be one of the more competent DVDs in terms of sound quality, yet it was easily seen off by a humble £100 Cambridge CD5. Sadly, the Toshiba's sound quality was no better than a portable player of around £60.

The potential buyer was not impressed, since he wanted the SD220 to replace both his video and CD player. In the end, he paid more than half as much again for the NAD T535 at £350. The NAD is a fine machine for CD play back, just like their dedicated players, yet had he

spent the same amount on a CD player the poor old T535 wouldn't have stood a chance. You probably get the gist of it by now. It doesn't seem to matter how much or how little one spends on a DVD player, the performance with stereo CD is never as good as that of a separate player.

It shouldn't really come as a surprise I suppose, as you're paying for far more versatility in a DVD player, so something's got to give in terms of quality. Of course, for those who want the ultimate audio performance there's always DVD-A. It is an impressive format and one that has the potential to oust CD.

There are also a good deal more machines offering this format available now than a year or so ago. Yet there are plenty of people still sceptical at having to position five - or more - 'speakers around the room. No doubt the same could have been said about the switch from mono to stereo; why have two 'speakers when a single one does a perfectly good job! The deciding factor however, will be if the public are willing to switch from CD surround-sound and DVD-A. Even allowing for the fact that CDs are far cheaper at the moment, the sheer back catalogue available would take DVD-A years to replicate.

Then there's the further thorn in DVD-A's side in the form of SACD. Yet despite the marketing power of its backers, Sony and Philips, in the longer term I'd be surprised to see SACD win out over DVD-A.

Nevertheless, despite DVD's current success, total domination by DVD is some time off. I believe the demise of the Compact Disc will be far slower than many have predicted. The point where I would unreservedly recommend a DVD player over and above a CD in terms of sound quality is still some way off. Be assured, though, that when I do you'll be the first to know! 🎧

SOLID GOLD

David Price looks at hi-fi's ultimate 'statement' product, the Goldmund Reference Turntable.

Turntables are a particularly hotly contested area of hi-fi. Few would dispute, however, that the mantle of the world's 'most impressive' vinyl spinner is the Goldmund Reference. Absurdly expensive, lavishly finished and ridiculously over-engineered, back in the 1980s this was the kind of hi-fi product you'd buy just because you could.

The Reference was not Goldmund's first product, but the one that put the young company on the map. Back in 1978, a group of physics students designed the tonearm that was to become the Goldmund T3. By the end of the following year, it was garnering rave reviews in the US and a matching turntable was being planned. By 1981 the company had the original Goldmund Studio turntable on the market. At 1983's Chicago CES however, Goldmund surpassed itself

- and everyone else - with the launch of the Reference.

Claimed to offer a unique blend of "very advanced design, traditional Swiss craftsmanship and beautiful finish", the new Georges Bernard design was like nothing the world had ever seen before. It incorporated a variety of interesting - if not innovative - solutions to the problems of vinyl disc replay. First was its massive 600x540x750mm plinth, which together with its integral 'support table' was finished in gold plated brass, black anodised aluminium, steel and black methacrylate. Massively heavy, its shape and surfaces were optimised to give optimum "mechanical grounding" (i.e. vibration transfer) in the top-to-bottom direction. At the time, turntable isolation was still a very inexact science, and this was radical thinking indeed. In conjunction with the very strong damped spring suspension, it made a sterling job of keeping bad vibes at bay.

Next was its speed control system. Belt drive was - of course - de rigeur for any self respecting European superdeck by the early eighties, so the Reference featured a very high quality AC synchronous motor mounted in a suspended heavy base to reduce vibration, powered by a computer controlled speed regulator giving a claimed accuracy of 0.01%. Speed adjustment of +/- 4% was provided, along with a Technics-style four digit tachymeter speed display. The '14 function' computer even featured a resettable time counter that could keep track of your stylus's total playing life. All this was accessed by an illuminated gold-plated touch control panel - nice!

The 30kg aluminium subchassis (complete with lead inserts for

damping) supported a massive 15kg platter made from a methacrylate and brass sandwich, claimed to have just 0.005cm of eccentricity. This rested on a bearing shaft machined from hardened, non-magnetic stainless steel, sitting on a micron-toleranced hard bronze receptacle. The stunning servo-controlled, fully automatic parallel tracking Goldmund T3F tonearm was mounted on a 40mm methacrylate support to minimise resonances, its seven programmed movements controlled via the turntable's control panel.

Sound was superb - if not to the taste of your average British audiophile. Very transparent, the Goldmund neither added nor subtracted anything from the original recording. Rather, you got an extremely open window on the world. If any objections could be levelled, it was this 'matter of factness' that some audiophiles objected to. Rather than majoring on rhythms and dynamics, you got an accurate and even summation of the recording and all its flaws. Tonally and texturally superb, it was a revelation by the standards of the day.

Considering that total production of the Goldmund Reference ran to just 300 (whereas some 1,000 T3F tonearms exist), and its original mid-eighties retail price approached £10,000 - it's unlikely that you'll pickup a bargain in the classifieds. Nowadays these decks are highly sought after for their sound, 'period' eighties styling and general rarity value, so price will be a matter of negotiation between you and the seller. A beguiling and emotive reminder of another age - sadly, Goldmund's website (www.goldmund.com) bears no mention of it now. ●





Pour through the classifieds in this magazine from ten years ago, and you get a fascinating snapshot of the then contemporary hi-fi scene. The prices of various bits of kit, from newish CD players to vintage turntables, says much about the fashions of the day.

Furthermore, if you compare the amounts being asked for gear then with now, you get a great insight into what's hot and what's not right now.

Interestingly, CD players from a decade ago have all but been forgotten. The budget designs of the day are all practically worthless in 2002, while no one's really interested in mid-market Marantz (like the very respectable CD80, for example) or Denons (such as the DCD-1520, etc.). To my mind, this is curious. One thing I've cottoned onto after nearly a decade of reviewing is that - the recent developments in DVD-A and SACD notwithstanding - digital hasn't got better, it's just got cheaper. Look at the build quality of either of the aforementioned Japanese players - both of which you can pick up for a song - and you'll struggle to get better from something new costing £1,000 plus.

When you move up the scale to the high-end Japanese stuff of ten years back (like the Marantz CD94, for example), you'll find much of it is now going for less than £300. By any standards, this is incredible value, as players like this are built like old Mercedes cars, and will last no less long. Obviously, as DVD is now encroaching well into the territory once held by high-end hi-fi CD players, it's difficult to compare like with like. But to find a DVD spinner with the engineering equivalent of the Marantz's diecast aluminium

CDM-1 Pro transport and Double Crown TDM1541 DACs now, you're talking £3,000 plus. Classic CD spinners are currently amazing value for money.

Compare this to vinyl and the difference a decade makes is staggering - turntables have gone up in value dramatically, some by amazing amounts. What's most

“I've tried hard to redress what I consider to be the anti-Japanese bias of the UK hi-fi press.”

surprising is the cost of Japanese gear - a decade ago, even a decent middle-market Technics or Denon deck from the late seventies or early eighties was worth next-to-nothing. So unfashionable were they that you'd find them in junk shops for a matter of pounds. Now though, even deeply mediocre Nipponese stuff is fetching a decent sum - £150 for a Trio KD2055, anybody?

Why the change? Well, Hi-Fi World for one has run a lot of stuff on Japanese 'analogue players' (as they're called at home), and it's not beyond the realms of possibility that there's some bandwagon jumping going on. Personally speaking, I've tried hard to redress what I consider to be the anti-Japanese bias of the UK hi-fi press, especially during the seventies and eighties. But if I'd known people would start paying through the nose for rubbish then maybe I'd have shut up.

Of course, on a wider level the cult of Technics has given serious street cred to that once-ridiculed breed, the Japanese Direct Drive, so I guess DJ culture is really to blame! Still, the rise in residuals seems to

have run the gamut of the turntable market. Take, for example, the humble Thorens TD160S. This was a perfectly good late seventies suspended subchassis design, but in truth a properly set up Rega Planar 3 would have had the legs on it. A decade ago there were still Thorens decks turning up in the classifieds for £30-£50. Now though, they're closer to £150.

If you think this is a healthy gain, then look at Michell turntables, whose second-hand values have gone stratospheric. In 1992, I picked up a dusty Hydraulic Reference from a hi-fi shop for £40, and I recently saw an identical one sell on eBay for over £600. Even the price of a humble Focus - with none of the traditional suspended weights and gold-plated ephemera so beloved by fans of the marque - has gone through the roof.

Right now is plainly not a good time to pick up a classic turntable then, but audiophile bargain hunters can be comforted by the risible residuals of classic digital. Sooner or later, people will realise that there's no better way to play plain old 16/44 Compact Discs (of which there are still a lot around, obviously!) than a purpose-built, top quality CD player. With DVD muscling its way into people's hi-fi systems in the guise of a modern, multi-function CD player expect to see a flood of abandoned CD players soon. But as people realise that current DVD players do a bad job with CD they may well regret such a hasty move into tomorrow's technology, as so many have in the past regretted junking their LP collections. With DVD and SACD being the new kids on the block, CD has gone rapidly out of fashion - with player manufacturers at least, if not with the disc buying public. For the moment, this means there's a fine selection of classic CD players around at sensible prices. ●

TURNTABLE

David Price suggests three ways of making your vinyl sing even more sweetly.



Avondale Taps



AVONDALE TAPS

Suitable for all turntables with the Philips MB10/MB12 synchronous motor, this external power supply unit works with a large number of specialist belt drive decks, from Linns to Regas to Aristons to Thorens. It's an austere looking product - very 'eighties black box' - but then again it should be heard and not seen. Essentially, it's very similar in design to Michell Engineering's original 'GyroPower' (the transparent one that looked like Orac from Blakes' Seven!), and works by generating a pure 50Hz feed, free from the vagaries of the mains. It's easily connected (no surgery required) and comes with a connecting lead and simple installation instructions.

Interestingly, Avondale supply it on a 'sale or return' basis - if you don't like it then you can get your money back. This is a bold and novel concept in hi-fi retailing to be sure, but as soon as I connected it up to my Rega Planar 3 I can see why it is commercially viable. The TAPS sieves out a substantial layer of mains mush, making things sound so much cleaner, tighter and rhythmically coherent. It's amazing how good a humble Rega can sound given a clean feed of power such as this - it's punchier and more dynamic, yet less ragged in the treble and a good deal more sprightly in the bass. After you've made the mod, you really won't want to go back - hence the money back guarantee I guess! The

only downside is that it works at 33 RPM only - so there's no electronic speed switching. Still, you can't have everything for £242 (including delivery). A bargain!

Avondale Audio
Tel: 01246 200096

DONNER CLAMP

This record clamp is manufactured in Germany by Dr Andreas Donner, an avowed Revox turntable fanatic (remember the B790 parallel tracker of the late 1970s!). As well as bespoke Revox clamps, he makes this 'universal' model too. It's weighty at 365g, but should be just about light enough not to upset suspended subchassis decks. It's beautifully hewn

TUNE UPS



Donner Clump



Michell Unicovert



Michell Unicovert

from a single piece of stainless steel (and looks a million dollars), but it does ring a little when you tap it, so I'd suggest adding a ring of suede or felt underneath to damp it.

Placed on my Technics SL150/II, it worked a treat. Despite what the likes of Linn say, I reckon gently clamping the disc to the platter can only be a good thing. You get a tighter, punchier and more detailed sound with obviously firmer bass and smoother treble. Of course, I can't predict the results on every deck, but I'd say it should benefit most. The Michell Clamp is better finished, lighter and works equally well (if not better), but there's something really cool about just placing this over the spindle without having to twist any-

thing! Highly recommended at around £35 plus carriage.

Andreas Donner, Ennepestr. 21,
44807 Bochum, Germany
email: DRA.DONNER@t-online.de

MICHELL UNICOVERT

Another bright idea from the great mind of John Michell, this product is ideal for the new generation of plinthless, dustcoverless turntables (which he himself inspired!). It's also great for those, like me, who've removed their dustcovers because they wreck the sound quality (try it, LP12 owners!). The Unicovert is a beautifully finished but oddly shaped bit of clear Perspex (i.e. Acrylic)

which simply sits on your deck when it's not in use.

It's designed to keep dust off your platter and the tonearm, without you having to go to the trouble of putting your original dustcover back on. It works! It's designed for Michell Orbe SE and GyroDec SE users, but - due to the universal relationship between the tonearm and platter centre (unless a 12 inch arm is used) - actually fits most decks. Everything from big SMEs to my old Pioneer fully automatic turntable, complete with S-shaped tonearm, took it happily, so I'd say it's near-universal. Top value at £44, then.

J.A. Michell Engineering Ltd.
Tel: +44 (0) 20 8953 0771

DIAL A DEALER

This is a comprehensive directory of Hi-Fi Dealers throughout the UK and Ireland.

BEDFORDSHIRE

RICHARD'S AUDIO VISUAL 4 Greyfriars Bedford. Tel: 01234 365165. Stockists of: Arcam, Audioquest, Beyer, B&W, Bose, Cable Talk, Cyrus Denon, Marantz, Mission, Moth, Ortofon, Pioneer, Pro-Ject, Quad, REL, Rotel, Ruark, Sennheiser, Sound Style, Stands Unique, Teac, van den Hul & more! Expert friendly service: Listening room, Pioneer Reference Point, Visa / Access.

BRISTOL & BATH

THE RIGHT NOTE Tel: (01225) 874728. Just think: most audiophiles listen for most of the time to systems that are 'not quite right'. Are you happy with yours? Forget the reviews and trying to put together a system like a patchwork quilt with the 'best' bits around. It's our job to do the assessing, you judge our results. We'll help you to plan a system for the future, even if you spread the purchases. Leave the 'up-grade-itis' behind, save money and enjoy music all the time. Just listen, and you'll know. CD: Acuras, Audio Synthesis, Classe, DCS, Enlightened Audio Design, Mercurus, Orelle, Wadia, XTC. Vinyl: Basis, Crown, Jewel, Graham, Michell, Sumiko, Transfiguration. Amps: Acurus, Audio Sculpture & more. Speakers: Audio Artistry, Audio Physics & more. Tuners: Fanfare, Magnum Dynalab & many more. Cables: Chord, DNM, Silver Sounds & more. (Credit Cards Accepted).

VAUDIO HiFi Consultants: 36 Druid Hill, Stoke Bishop, Bristol, BS9 1EJ. Tel: 0117 968 6005. ATC, AVI, Alon, Audio Analogue, Audiomeca, Cadence Valve, Chord Amps, Electrocompaniet, Harman Kardon, Heybrook, Jamo, LFD, Lyra, Opera, Ortofon, Pink Triangle, Ruark, Mark Levinson, Michell, REL, SME, Shearpe, Sonic Link, Sugden, Townshend, Triangle, Unison Research Valve Amps. Home Cinema demonstrated including, A/V Amps, DVD Players, Video Projectors and Screens. Demos by appointment only. Home trial facilities. Free installations We are not a shop.

BUCKINGHAMSHIRE

NORTHWOOD AUDIO 98 Cambridge St. Aylesbury, Tel: 01296 428790. Established since 1992. Independent specialist retailer. Extensive Hi-Fi, A/V and Multiroom experience catering to your needs. From Vinyl to SACD, Valve to Solid State, from LCD to Plasma, Audiomeca, Audio Note, Cable Talk, Castle, Chord, The Chord Company, Cura, Denon, Elac, Epos, Exposure, Heart, JM Labs, KEF, Linn, Marantz, Michell, Micromega, Monitor Audio, NAD, Nakamichi, PMC, ProAc, Quadraspire, Rega, REL, Revox, Roksan, Rose, Rotel, Ruark, Sony, Sennheiser, Sonus, Talk Electronics, Tannoy, Teac, Tube Technology, Videologic, Vienna Acoustic. Export orders welcome. 2 demo rooms. Credit facilities available. Website: www.northwoodaudio.co.uk Email: info@northwoodaudio.co.uk

TECHNSOUND 8 Granville Square, Willen, Milton Keynes, MK15 9JL. Tel: (01908) 604949. Fax: (01908) 202166. Audiophile Hi-Fi and Home Cinema specialists. All major brands stocked from Arcam to Yamaha, Meridian Digital Home Theatre dealer. Video projection, Plasma screens. Custom installation. 2 dem rooms and expert advice. Email: hifi@technosound.co.uk www.technosound.co.uk

CAMBRIDGESHIRE

THE AUDIO FILE 41 Victoria Road, Cambridge. Tel: 01223 368305. For the best in British Hi-Fi and Home Cinema entertainment. Visit or call to arrange a dem with products from: Arcam, Linn, Naim, Rega, Cyrus, Absolute Sounds, Kef, Sony, Yamaha, Rel, Ruark, Denon.

CHESHIRE

ACOUSTICA 17 Hoole Rd, Chester CH2 3NH. www.acoustica.co.uk. Tel 01244 344227. All that's best in HiFi & Home Cinema from quality manufacturers including Naim, Rega, Arcam, Musical Fidelity, Rotel, Selec Projectors, Kef, Ruark, Densen, Primare, Teac, JM Lab, Nakamichi, Quadraspire, Celestion & Crimson. We offer friendly, helpful advice, interest free credit & trade-in facilities, and deliver & install systems throughout Cheshire, Merseyside & North Wales. Opening hours are Tuesday to Saturday 10.00 until 5.30, evenings by arrangement

ACTION GATE AUDIO 4 Ruabon Road, Wrexham, North Wales, Tel. 01978 364500. Audio Visual Specialists. Arcam, Audio Analogue, Bose, B&W, Celestion, Castle, Denon, Harmon Kardon, Jamo, Marantz, Michell, Mission, Onkyo, Pro-Ject, Musical Fidelity, NAD, Micromega, Myrad, QUAD, Radford, Rotel, Ruark, Tannoy, TDL, Teac, Thorens, UKD, Unison Research, Yamaha, DSP Club Member,

Demo Room, installation service. Easy Parking and Motorway access. All major credit cards accepted. 9.30 - 5.30 daily. Closed Sunday & Monday.

DOUG BRADY HI-FI Kingsway Studios, Kingsway North, Warrington, WA1 3NU Tel 01925 828009 Fax 01925 825773. Visa, Mastercard, Lombard Tricity. 2 dem rooms, home trial; Agencies include: Arcam, Tag McLaren, AVI, B&W, Castle, Caspian, Chord Electronics, Exposure, Harbeth, Heybrook, Krell, LFD, Michell, Meridian, Musical Fidelity, Monitor Audio, Naim, Nautilus 800 series, Pink Triangle, ProAc, Roksan, SME, Wilson Benesch, XTC and many more.

CORNWALL

SOUNDS PERFECTION 'Cornwall's most exclusive Audio retailer'. Agencies include: Audio Analogue, Audio Design, Audio Note, AudioQuest, Audio Spectrum, AR, Avid, Border Patrol, Boston, Dynavector, Electrocompaniet, Graaf, Henley, JM Labs, Lexicon, Michell, Monitor Audio, Musical Fidelity, Ortofon, Parasound, Primare, Project, NAD, Nakamichi, Nordost, Philoshopy, REL, Roksan, Ruark, Rotel, Totem, Tom Evans, Tsunami, S.M.E., Sugden, Stands Unique, Unison Research, Teac, Vienna Acoustics, Triangle, Trichords, WBT, Sonic Link. Home Demonstrations by Appointment. Tel/Fax: 01326 221372 Mobile 07798 554357 email nigel@soundsperfection.co.uk website www.soundsperfection.co.uk

DORSET

MOVEMENT AUDIO 588 Ashley Road, Poole, Parkstone, Dorset BH14 0AQ. Tel: (01202) 730865/380018. Arcam, B&W, Castle, Chord Electronics, Cyrus, Denon, Marantz, Michell, Mission, Pioneer, Tannoy Dimension, Yamaha. 2 Dem rooms. Listen to the available choice and decide at your leisure - no pressure, no obligation. Our staff enjoy music, with our choice of products, you can too! Service Department. Free installation. Home trial facilities. Access, Visa, Amex, Diners Card. Credit facilities available. Open Tuesday-Saturday 10-5.30. www.movement-audio.co.uk

MOVEMENT AUDIO 926 Wimborne Road, Winton, Bournemouth, Dorset. BH9 4DH. Tel: (01202) 529988/520066 Arcam, B&W, Denon, KEF, Marantz, Mission, Musical Fidelity, Opera, Pioneer, Quad, Roksan, Ruark, Yamaha. Full dem facilities available, also home dem. Friendly expert advice. Service Department. Free installation. Home trial facilities. Access, Visa, Amex. Open Tuesday-Saturday 9.30-5.30

DAWSONS OF WESTBOURNE Home Cinema Specialists. Main agents for Bang & Olufsen, Harman Kardon, JBL, REL, Mordaunt Short, Sony, Technics and TDL. Demonstration facilities include our unique Dolby pro-logic system comparator for the ultimate way to choose the perfect system. Also on demonstration large screen televisions from Thomson, Sony and Ferguson with video projectors from Sharp and Selec. Dawson's, 23 Seamount Road, Westbourne, Bournemouth 01202 764965

WEYMOUTH HI-FI 33-35 Maiden Street, Weymouth, Dorset DT4 8BA. Tel: (01305) 785729/766345. Arcam, B&W, Denon, KEF, Marantz, Mission, Musical Fidelity, Panasonic, Pioneer, Quad, Sony, Tannoy, Yamaha. Dem room. Friendly professional advice. Only quality hi-fi dealer in Weymouth area. Service Department. Free installation. Home trial facilities. Access, Visa, Amex, Switch, KEF, Marantz, Mission, Musical Fidelity, Panasonic, Pioneer, Quad, Sony, Tannoy, Yamaha. Dem room. Friendly professional advice. Only quality hi-fi dealer in Weymouth area. Service Department. Free installation. Home trial facilities. Access, Visa, Amex, Switch, KEF, Marantz, Mission, Musical Fidelity, Panasonic, Pioneer, Quad, Sony, Tannoy, Yamaha. Dem room.

ESSEX

GRAYSTON SOUND & VISION 33 Sir Isaac's Walk, Colchester. (01206) 577682. Alchemist, Arcam, B&W, Boston Acoustics, Castle, Denon, Harman Kardon, KEF, Linn, Loewe Opta, Meridian, Michell, Musical Fidelity, Philips, Pioneer, Project, Rotel, Sennheiser. Superb demo rooms, free regional delivery and installation. Regular musical and surround evenings, home demonstrations. Excellent credit facilities.

GLOUCESTERSHIRE

THE RIGHT NOTE - Bath. For specialist advice and home demonstrations. See BRISTOL & BATH.

HEREFORDSHIRE

ENGLISH AUDIO 37 Whitecross Road, Hereford, HR4 0DE. (01432) 355081. Arcam, A.T.C., B&W, Castle, Cura, Cyrus Centre, Elac, Denon, JM Lab, KEF, Loewe, Marantz, Mission, Musical Fidelity, NAD, Naim, Pink Triangle, Pioneer, Project, QED Systemline, REL, Rotel, Ruark, John Shearpe, Stax,

System Audio, Teac, Vienna Acoustics, Wadia, and Yamaha. Single speaker dem room, home trial facilities, free installation, service dept. Access/Visa. Credit arranged. Open Mon-Sat. 9.30-5.30pm. BADA members.

HERTFORDSHIRE

AUDIO FILE (THE) 27 Hockerill Street, Bishops Stortford, Herts. Tel. (01279) S06576.

DARBY'S OF ST. ALBANS. 6 Market Place, St Albans, Herts. Tel: (01727) 851596. Fax: (01727 812217) Email: sales@darbystvhifi.co.uk Hertfordshire's premier Hi-Fi/Audio Visual specialists established 1946. Full Home Cinema demonstration suite. Whether your needs are large or small, we stock it all; Arcam, Cyrus, JVC, Yamaha, Quad, Denon, Sony, Bang & Olufsen, Pioneer, REL, KEF, Mission, Ruark, Celestion and many more. Free planning service. Free Delivery and basic installation. Full workshop facilities. Open 9-6 Mon-Sat.

LANCASHIRE

ADVENTURES IN HI-FI 5, Bishopgate, off Hallgate, Wigan, WN1 1NL. Tel 01942 234202. For the best hi-fi and home cinema products from quality manufacturers including Naim, Rega, Cyrus, NAD, KEF, Denon, Dynavector, Rotel, Shahinian, JM Lab, PMC, Project, Quadraspire, Selec and Sanyo projectors. We offer friendly advice, excellent demonstration facilities, 0% finance, free delivery and installation throughout the North West. Opening hours 10.00 - 5.30pm Tuesday to Saturday evenings by appointment.

LEICESTERSHIRE

LEICESTER HI-FI 6 Silver Walk, St Martins Square, Leicester LE1 5EW. Tel: (0116) 2539753. Email: info@leicesterhifi.co.uk www.leicesterhifi.co.uk Arcam, B&W, Chord Electronics, Copland, Cyrus, Denon, Greig Loudspeakers, KEF, Marantz, Michell, Miller & Kreisel, Musical Fidelity, NAD, Nakamichi, Nautilus, Mission, Project, Rotel, Sanyo Projection, Talk Electronics, Teac, Technics, Yamaha, and many more. 4 Listening areas over 3 floors. We can demonstrate, deliver and install. Including A.V. and Multiroom. Credit Facilities. All cards taken, open 6 days 9.30-5.30.

LONDON

BABBER ELECTRONICS SERVICE CENTRE 158 Uxbridge Road, West Ealing, London, W13 8SB Tel. 020 8579 6315 Akai, Aiwa, A&R, Celestion, Dual, Goodmans, Harman Kardon, JBL, JVC, Kenwood, Marantz, Panasonic, Sennheiser, Sony, ES range, Tannoy, Technics, Wharfedale, Yamaha and many more. Auth. Service Dept. Credit Facilities. Open 10.30 - 5.30 Mon-Sat.

INFIDELITY 9 High Street, Hampton Wick, Kingston-upon-Thames. Tel: (020) 8943 3530, for full details see entry under SURREY

HIFI EXPERIENCE 227 Tottenham Court Road, London W1. 020 7580 3535. Arcam, Cyrus, Denon Gold, Quad, Kef, Meridian, Yamaha, Marantz, McCormack, Mirage, Nakamichi, Musical Fidelity. PAFF and many more. Open 10.00-7.00 Mon-Fri. 9-6 on Sat. Service dept. Credit facilities, delivery and free installation.

THE LISTENING ROOMS 161 Old Brompton Road, London SW5 0LJ. (020) 7244 7750/59. Fax (020) 7370 0192. Linn, Quad, Meridian, Nakamichi, Arcam, Audiolab, Acoustic Energy, SME, Audio Research, Krell, Wadia, Theta, Apogee, Martin Logan, Pioneer, Tannoy, Systemdek, Stax, Pink Triangle, Michell, Monitor Audio, Yamaha, Marantz, KEF, Bose, Celestion, Epos, Mission, Denon, Neat Petite. Mon-Sat 10-6pm.

THOMAS HEINITZ LTD 35 Moscow Road, Bayswater, London, W2 4AH. Tel: 020 7229 2077.

Fax: 020 7227 9348. Email: info@thomasheinitz.com. Web site: www.thomasheinitz.com. Established in 1952, Thomas Heinitz has a long history of providing the best music and AV systems available. We continue to offer the highest standard of service in the most relaxed atmosphere. Whatever your needs, from multiroom and home cinema to a high quality stereo system, we offer consultation, design specification, architect liaison and installation in order to ensure your system is tailored to your exact requirements. For quotes contact our manager Johnny Drum.

GREATER MANCHESTER

ADVENTURES IN HI-FI 5, Bishopgate, off Hallgate, Wigan, WN1 1NL. Tel 01942 234202. See our main entry under LANCASHIRE

MANCHESTER

REPLAY AUDIO 64 Flixton Road, Urmston, Manchester, M41 5AB Tel 0161 202 9922. Audio Analogue, Bryston, Creek, D'Almeida, Exposure, LFD, Michell, Myrrad, NAD, Onkyo, Ortofon, Pink Triangle, Project, Sonneteer, Sugden, Trichord, Unison Research, Teac, Loudspeakers from Acoustic Energy, A.R.T., Audio Physic, AVI, Blueroom, Epos, Harbeth, Living Voice, Monitor Audio, Neat, PMC, Royd. Lots of cables and accessories available. We are just off Junction 10 of the Manchester Ring Road (M60), five minutes from The Trafford Centre. Our demonstrations are relaxed and informal and help and advice is free! Phone or visit our web site www.replay.dial.pipex.com or email replay@dial.pipex.com

MERSEYSIDE

ACOUSTICA 17 Hoole Rd, Chester CH2 3NH. Tel 01244 344227. See our main entry under "Cheshire".

MIDDLESEX

RIVERSIDE HI-FI 422 Richmond Road, East Twickenham, Middlesex, TW1 2EB. Tel: 020 8892 7613 Fax: 020 8892 7749. www.riversidehifi.co.uk Arcam, Bose, B&O, Castle, Copland, Denon, Krell, Marantz, Martin Logan, Michell, Monitor Audio, Musical Fidelity, NAD, Pioneer, Project, Rel, Sonus Faber, Sony, Tag McLaren Audio, Tannoy, Teac, Theta, Wilson. Finance available. Subject to status. Written details available on request. Export orders welcome. UK mail order available. 3 demonstration rooms. All major credit cards. Open 10am-5.30pm Mon-Sat.

NORFOLK

BASICALLY SOUND The Old School, School Road, Bracon Ash (Nr Norwich), Norfolk, NR14 8HG. Tel: (01508) 570 829. Stockists of the following leading Hi-Fi: Audio Analogue, Beyer, Bryston, Denon, Dynavector, Epos, Grado, Naim, PMC, ProAc, Rega, Royd, Sennheiser, Talk Electronics, Teac and more. Bada members. 2 comprehensive demo rooms.

NORTHAMPTON

CLASSIC HI-FI At Classic Hi-Fi we cover the best in quality sounds. Be it a question of taste, a question of balance or a question of price, we're the ones to help. We stock: Marantz, NAD, Pioneer, Roksan, Yamaha, Heybrook, LFD, Sugden, Rotel, Kenwood, B & W, Kef, Rogers, Monitor Audio, Musical Fidelity, Tannoy, Shearman Audio, Royd, Audio Alchemy, Teac and many more. For more details call: 01536 310855

LISTEN INN 32 Gold Street, Northampton, NN1 1RS Tel: 01604 637 871. The World's Finest Hi-Fi from Arcam, Audio Analogue, Chord Company, Copland, Denon, FMJ, Fujitsu, Kef, Krell, Linn, Loewe, Martin Logan, Meridian, Miller & Kreisel, Mission, NAD, Naim, Proac, Rega, Rotel, Sennheiser, Sonus Faber, Wilson, Benesch, Yamaha. Dedicated Viewing & Listening Rooms. Friendly Staff, Fresh Coffee, 2 Full Years Warranty, Part Exchange Welcome, Free Car Parking, Interest Free Credit, Members of BADA. Open 10am-5.30pm (Closed Thursday).

NOTTINGHAMSHIRE

NOTTINGHAM HI-FI CENTRE 120-122 Alfreton Road, Nottingham. Tel: 0115 9786919. Multi-room specialists. Hi-Fi. Home cinema. All leading brands stocked. Three superb demonstration areas. Two year parts and labour guarantee. Home trials. On site service facility. Full delivery and installation service. Easy free parking. BADA Dealer. Established 1968. Mon-Sat 9.00-5.30

OXFORDSHIRE

OVERTURE HI-FI 3 Church Lane, Banbury, Oxon OX16 8LR. Tel (01295) 272158. Email sales@overture.co.uk Website: www.overture.co.uk Arcam, Bose, Cura, Denon, Kef, Linn Products, Miller & Kreisel, Mission, NAD, Naim Audio, Yamaha. For sensible unbiased advice, call Oxfordshire's audio experts. Superb demo facilities. No appts. necessary. Home Cinema, Plasma TV, Projectors, Lutron Lighting, MultiRoom and Commercial installations. Access/Visa, instant credit. Mon-Fri 10-6, Sat 9.30-5.30.

SHROPSHIRE

ADAMS & JARRETT Hi-Fi and Home Cinema Specialist. Phone or visit us at 6-18, Norman Road, St. Leonards-on-Sea, E.Sussex. (01424) 437165/432398. Stockist of quality equipment including: Audio Innovations, Meridian, Kef, Ruark, Marantz, NAD, JBL, Royd, Dali, Jamo, Onkyo, Rel, Traget, Cable Talk, Technics, TDC, Yamaha, Kenwood. Air conditioned listening rooms, on site service and repair facilities

STAFFORDSHIRE

ACOUSTICA 114 Wolverhampton Rd, Stafford ST17 4AH. www.acoustica.co.uk. Tel 01785 258216. All that's best in Hi-Fi & Home Cinema from quality manufacturers including Naim, B&W, Musical Fidelity, Rotel, Selec Projectors, Kef, Ruark, Teac, JM Lab, Rega, NAD, Yamaha, REL, Sanyo projectors, Fujitsu.

We offer friendly, helpful advice, interest free credit & trade-in facilities, and deliver & install systems throughout Staffordshire & the Midlands. Opening hours are Tuesday to Friday 10.30 until 6.00, Saturday 10.30 until 5.00

SUFFOLK

ANGLIA AUDIO The Street, Hestett, Bury St Edmunds, Suffolk, IP30 9AZ. Tel: 01359 270212. "Hi-Fi and speaker centre dedicated to quality hi-fi since 1971. Open 10-6. Closed Weds and Sundays. Evening and Sunday Demos by appointment.

AUDIO IMAGES 128 London Road North, Lowestoft, Suffolk, NR32 1HB. Tel: 01502 582853. Arcam, Acurus, Castle, Rotel, Moth, Triangle, QTA, Sugden, Denon, Yamaha, Mirage, M & K, Definitive, Musical Fidelity, plus the incredible Rothwell range. Refreshingly different selection. Dem Room, Professional AV installer's from budget to high end. Full credit facilities. 9.30 to 5.30 Mon & Sat ~ 9.30 to 6.00 Tues to Fri.

EASTERN AUDIO 41 Bramford Road, Ipswich, Tel. 01473 217 217. Fax 01473 215705. Quad, Arcam, Audiolab, Meridian, Mission, Denon, Rotel, Marantz, NAD, Sony, Rogers, Nakamichi, Systemdek, Technics, Celestion, B&W, Tannoy, Morel Thorens and Top Tape. Also stock a wide range of accessories. usual credit facilities. A BADA dealer.

SURREY

INFIDELITY 9 High Street, Hampton Wick, Kingston upon Thames, Surrey, KT1 4DA. Tel. 020 943 3530. Email: infidelity@compuserve.com - Web Address: infidelity.co.uk Stockists of: Linn, Naim, Arcam, Meridian, Rega, B&W Nautilus, Neat, Proceed, Royd, M&K, Rotel, Stax, Shahinian, Dynavector. Open 10.30 - 7.00 Tues - Fri, 10.00 - 6 Sat.

SUSSEX (EAST)

ADAMS & JARRETT For the best Audio Visual Specialist with friendly helpful staff phone or visit us at 6-18 Norman Road St. Leonards-On-Sea, East Sussex. Tel. 01424 437165/432398. Copland, Castle, Denon, Densen, Dynaudio, Jamo, Kef, Kenwood, Marantz, Meridian, Musical Fidelity, NAD, Onkyo, Primare, Rel, Rotel, Ruark, Tannoy, Technics, Yamaha. Interest free credit available subject to status. Visa, Mastercard.

WEST MIDLANDS

ACOUSTICA 114 Wolverhampton Rd, Stafford ST17 4AH. See our main entry under "STAFFORDSHIRE".

MUSIC MATTERS

Birmingham - 363, Hagley Road, Edgbaston, B17 8DL. Tel: 0121 429 2811.

Solihull - 93-95, Hobs Moat Road, B92 8JL. Tel: 0121 342 0254.

Stourbridge - 9, Market Street D48 1AB. Tel: 01384 444184.

Sutton Coldfield - 10, Boldmere Road, B73 5TD. Tel: 0121 354 2311. Arcam, Alchemist, Apollo, Audioquest, Audio Research, B&W, Cable Talk, Castle, Celestion, Chord, Copland, Cyrus, Denon, DPA, JBL, Kef, Krell, Marantz, Martin Logan, Meridian, Musical Fidelity, Panasonic, Pioneer, REL, Rotel, Ruark, SME, Sennheiser, Sonus Faber, Tag McLaren, Teac, Theta, Yamaha etc. Classical CD's available at Birmingham only. Demonstration rooms, service and installation. BADA member. VISA / MASTERCARD / AMEX / SWITCH. Open-10-5.30 Tuesday to Saturday. Late night Thursday till 7.00 (not Stourbridge).

SOUND ACADEMY For the Midlands. The Parade, Sutton Coldfield, Tel. 0121 321 2445 & High Street, Bloxwich, Nr Walsall, (sharing the ASDA shopping centre) Tel 01922 493499. Hosts 4 private studios plus a Home Theatre Cinema with Tube & LCD Projectors. The best in hi-fi from Naim, Arcam, Audiolab, Chord, Meridian, Monitor Audio and many more. So... if you've taken time to read this, please let us make you welcome. Phone 0121 321 2445 for Sutton or 01922 493499 for Walsall. Call in and to browse our exciting display of hi-fi and home cinema equipment. Mail order available. interest free credit S.T. Status. Open 6 days, 9am to 5.30pm. Please call for late night. Expert Advice. Cable Dressing and Installation.

WILTSHIRE

SALISBURY HI-FI LTD 15 Catherine Street, Salisbury, Wiltshire SP1 2DF. Tel (01722) 322169/330841. Arcam B&W Celestion, Denon, Kef, Marantz, Meridian, Mission, Musical Fidelity, NAD, Opera, Pioneer, Ruark, Tannoy, Yamaha. 2 Dem rooms. Friendly, relaxed atmosphere. Professional advice. Home dem available. Service department. Free installation. Home trial facilities. Access, Visa, Amex. Interest free credit. Instant credit. Open Mon-Sat 9-5.30.

THE RIGHT NOTE - See under BATH & BRISTOL heading.

YORKSHIRE (NORTH)

SOUND ORGANISATION YORK, 2 Gillygate, York YO3 17EQ. Tel (01904) 627108. Carefully chosen Hi-Fi and AV equipment includes Arcam, B&W, Nautilus, Denon, Linn, Naim, Rega, Rotel, Stax etc 3

dem rooms incl. Home Cinema and Linn connect. Service Department, Home installations. Instant Credit and major credit cards. Closed Mondays. Phone for chat and more details. www.soundorg.co.uk

YORKSHIRE (EAST)

ZEN AUDIO 35 George Street, Hull Tel. 01482 587397. "Comfortable listening rooms; Home dems; Personal, friendly service; Free installations. Agencies include: Arcam, Audiolab, Atacama, Audio Innovations, Audio Note, Audion, Alchemist, B&W, Cable Talk, Chord CO, DPA, Densen, Denon, DNM, EAR, Exposure, Fi-Rax, Harbeth, Heybrook, Impulse, KAR, Kef, Michell, Micromega, Monitor Audio, Musical Technology, Myrrad, NAD, NAIM, Pioneer, REL, Rehdeko, Rotel, Royd, Ruark, Shearman Audio, Stands Unique, Sugden, Spondor, Sonic Link, TEAC, TDL, Tube Technology, Vivanco and many others.

YORKSHIRE (SOUTH)

THE HI-FI STUDIOS

Hi-Fi - Home Cinema - Custom Installation Tel: Doncaster 01302 727274 or 01302 725550. E-Mail: info@thehifistudios.freeserve.co.uk Web Site: www.thehifistudios.co.uk Musical Fidelity, Electrocompaniet, ProAc, PMC, JM Lab, Ruark, Castle, TEAC, Unison Research, Monitor Audio, Impulse, Primare, Harbeth, NAD, Michell Turntables, Nottingham Analogue Studios, Audio Analogue, Living Voice, Densen, Celestion, Kef, Opera, Trichord Research, Nordost, Stands Unique, Ortofon, Project, Goldring, REL, Denon, TAG McLaren, Rotel, Yamaha, Proceed - plus many more. Viewing & Demonstration by appointment in a unique setting. Home trials and installation. Card facilities and 0% available. Please phone for more information. BADA. CEDIA.

YORKSHIRE (WEST)

HUDDERSFIELD HI-FI CENTRE

Hi-Fi • A/V • Widescreen Plasma • Installation Service 4 Cross Church St, Huddersfield, 01484 544669. Brands inc. Arcam, B&W, Castle, Cyrus, Denon, Kef, Marantz, Mission, Musical Fidelity, NAD, Project, Sony etc. 3 Dem Rooms. Mon-Sat 9-5.30. Thurs 9-8. Closed Wed.

HUDDERSFIELD HI-FI CENTRE HALIFAX

3-5 King Cross St, Halifax. 01422 366832. Brands inc. Arcam, B&W, Castle, Kef, Marantz, Mission, Musical Fidelity, NAD, PRO-AC, Project, Sugden etc. 2 Dem Rooms, Mon-Sat 9-5.30. Closed Thursday.

PREMIER AUDIO - now demonstrating - Room 1: DCS Elgar, Purcell & Verdi Transport, Plinius CD Lad & 250 Power, Verity Fidelo & Sonus Faber Speakers, Siltech Cables, Isotek Sub Station, BDA Equipment Stands Room 2: Audio Aero, Audio Synthesis, Kora Pre & Power, Pink Triangle CD/Amp, Martin Logan / Audio Physics Speakers, Arcici Equipment Stand, Isotek Sub Station P/S Audio Synthesis, Audio Physics, Audio Aero, Absolute Sounds, DCS, Kora, Plinius, Siltech, Arcici, BDA, Pink Triangle, Avid Turntables, Project, Ortofon, Van den Hul, Mirage. P/X welcome Home demonstration good selection of S/hand. We are 10mins J39 - M1 10mins J30 M62 Tel: Wakefield 01924 255045 - Colin Grundy.

WALES

NORTH WALES

ACOUSTICA 17 Hoole Rd, Chester CH2 3NH. Tel 01244 344227. See our main entry under "Cheshire".

ACTON GATE AUDIO 4 Ruabon Road, Wrexham, North Wales, Tel. 01978 364500. See our main ad under Cheshire.

VINYL/RECORD MAIL ORDER

DIVERSE VINYL 10 Charles Street, Newport, NP20 1JU. Tel/Fax: 01633 259661/256261. Email: sales@diverse-music.co.uk Probably the most varied and impressive selection of brand new LPs you'll find anywhere: international new releases, reissues and audiophile products. Also UK distributor of the Disco Anti Stat LP Cleaning Device. Call for a free catalogue, or visit www.diverse-music.co.uk

PRE-OWNED MAIL ORDER

AFFORDABLE AUDIO. (NORTHAMPTON) Pre-Owned Hi-Fi Specialists. 168 Wellingborough Road, Northampton, NN1 4DU. Tel/Fax: 01604 231261 or Tel: 01933 273281 Mobile: (0370) 877893. Email: sales@affordable-audio.co.uk Website: www.affordable-audio.co.uk Urgently required: compact disc collections, hi-fi separates, especially Linn products, Naim Audio, Cyrus Electronics, Musical Fidelity, Quad Electronics, almost anything British/American. Cash waiting, part exchange welcome. We also stock lots of audio accessories, compact discs, vinyl, DAT players. All equipment is sold with warranties. All Credit Cards accepted. Please phone anytime for stock update.

TO ADVERTISE IN DIAL A DEALER SECTION PLEASE CALL AMANDA SWEENEY ON 0208 864 4760

meet your maker

A reference guide to Britain's manufacturers and distributors

AFFORDABLE VALVE COMPANY £600 Valve amplifier. Powerful 40 watts. Powerful bass. See colour photograph in 'Specialist Hi-Fi Dealers' section. Mr Andrew Everard in Gramophone Magazine "delivers a sound that's both smooth and refined....allied to a good degree of clarity and finesse" Free colour literature. Telephone 01634 373 410 anytime. Website: www.affordablevalvecompany.com

AUDIOPHILE FURNITURE LTD The Square, Forest Row, East Sussex RH18 5ES Tel: 01342 826262. Fax: 01342 824845. Manufacturers of the patented BASE Vibration Control Platforms and the Modular Audio Support System. These Products are endorsed by Hi-Fi World. Also newly introduced are the Resonance Controlled Hi-Fi Cabinets which are multi level modular design and available in various sizes and wood finishes. Please telephone for more details and a product portfolio.

AUDIO SYNTHESIS Manufacturers of the the outstanding DAX digital to analogue converter, comes DAX-2, a new Hi-End reference converter able to dig deeper into the digital source than ever before! A new addition to the superb PASSION series of all Vishay controllers has just been introduced in the form of PASSION 8, a fully remote controlled uniquely transparent passive preamplifier, the perfect match for DESIRE. By word of mouth our DESIRE power amplifier is rapidly convincing listeners, whether passive or active! New for 1997 is TRANSCEND a state of art CD transport with AES, coaxial, AT&T 50 and Toslink outputs. Audio Synthesis, PO BOX 50, Nottingham, NG9 1DZ. Tel: (+44) (0)115 922 4138. Fax: (+44) (0)115 922 9701.

BLACK RHODIUM 32, Derwent Business Centre, Clarke Street, Derby DE1 2BU. Tel: 01322-361390, Fax: 01322-200698. email: enquiries@blackrhodium.co.uk BLACK RHODIUM offers a complete cabling solution from British made wires for hi-fi and home cinema, including Super mains cables that deliver at less cost as much improvement in listening experience as upgrading expensive equipment. BLACK RHODIUM Component Video cables let you enjoy the highest possible picture quality by using silver plated wires insulated in PTFE. AERO SPACE TECHNOLOGY loudspeaker cables insulated in silicone rubber gives you a more natural sound. We also offer very competitively priced home cinema cables from the best sources around the world in our FIRST BASE brand.

BORDER PATROL 63 Berrisdale Avenue Hove BN3 4JD Tel/Fax 01273 276716. Manufacturers of Power Supply Units for valve amplifiers, Single-Ended Power Amplifiers and high quality Transformers. The Border Patrol PSU: valve-rectified choke input filter power supply units which dramatically improves the sound of valve amplifiers: models available to suit Audionote, Audio Innovations, Audion, Art Audio, Cary, Unison Research, World Audio Designs. The Border Patrol 300B SE single-ended valve amplifier featuring interstage driver transformers and valve rectified choke input filter power supplies. Border Patrol transformers: high quality output (PP and SE), interstage and pre-amp output transformers and high value inductors.

CREEK AUDIO LTD 2 Bellevue Road, Friern Barnet, London N11 3ER Tel: 020 8361 4133, Fax: 020 8361 4136. E-mail: info@creekaudio.co.uk Internet: www.creekaudio.co.uk - Creek Audio build stylish Hi-Fi products in the UK, combining state of the art electronic design, with full bodied, accurate and musically rewarding sound. Our standard size products come in two award-winning ranges, the entry level 43 series and higher priced 53 series. These include: CD43 Mk2 - CD player with 24 bit resolution DAC, T43 AM/FM Tuner, Integrated Amps - 5350, 5350SE and 4330 Mk2 (described by Stereophile Magazine as the best amp under \$1000). Our A43 Mk2 and A53 Power Amps range from 50 to 250 Watts and both P43 and P53 Pre-Amps offer passive and active operation with remote control. In addition we have an award winning OBH range of small products: OBH-8/8SE MM and OBH-9 MC Phono Pre-Amplifiers, OBH-11 and 11 SE Headphone Amplifiers, OBH-10 and 12 Remote Control Passive Pre-Amps and OBH-14 - 24 bit DAC. See our home page for further details or call us for leaflets.

DBS AUDIO. PO BOX 91, Bury St Edmunds, Suffolk, IP32 7JL. Phone: 01284 723933 Fax: 01284 723933. Suppliers of Electro-Acoustic measuring equipment and CAD software to the audio industry. NEW: Clio win and Clio win Lite, the latest Windows versions of the Globally-established Clio Electro-Acoustic measur-

ing system, used for loudspeaker design, Quality Control and electronics testing by many major audio companies. Clio win is the full (lab) system and Clio win Lite a lower-cost version for smaller companies and serious hobbyists. Both use the same purpose-built Clio HR200 ISA card, with its in-built mic, preamp and phantom powering. The matching Mic 01 (or Mic Lite) plugs straight in to make a complete system. Both versions offer the same high accuracy and ease of use: Clio win Lite simply has fewer functions. Common features include MLS testing (to eliminate sound reflections), sine and third-octave analysis, impedance, Thiele Small Parameters, LC meter, software and manual on CD ROM -- plus much more. Measurements may be exported to our Netcalc software for accurate and easy crossover design. Also available: Boxcalc and Boxdraw bass optimisation packages and Outline speaker measuring turntable. Write or E mail and we will send fuller information and prices. Also, visit Audiomatica's new Website at: www.audiomatica.com

EMINENT AUDIO Distributor of Croft Valve Amplification. Tel 01902 656517. Fax. 0121 681 8772 Mobile 0956 921740 U.K. Stockists are: Classique Sounds (Leicester) GT Audio (London NW) Nottingham Analogue, Purist Audio, The Cartridge Man (Len Gregory - Croydon), call for overseas distributors.

EPOS ACOUSTICS 2 Bellevue Road, Friern Barnet, London N11 3ER. Tel: 020 8631 8864, Fax: 020 83614136. Email: info@epos-acoustics.com Website: www.epos-acoustics.com Innovative design and superior sound distinguish EPOS speakers from other brands in a similar price category. Adhering to the EPOS tradition of musicality and communication, the new M12 follows closely the style of the successful ES12, and was awarded five gold stars in the March 2001 edition of *What Hi-Fi?* For more information about the M12 or the new M15 please see our home page or call us for leaflets.

FALCON ACOUSTICS LTD Tabor House, Norwich Road, Mulbarton, Norwich, Norfolk, NR14 8JT. Tel. (01508) 578272. U.K. distributors of FOCAL drive units and SOLEN (Chateauroux) polypropylene capacitors and the largest inductor manufacturer in the U.K. Comprehensive range of DIY Speaker Parts and Kits, Sub-Bass and Electronic Filters. "Everything but the wood" Enquiries should be accompanied by a 44p stamped addressed envelope.

IAN EDWARDS The Old Chapel, 282 Skipton Road, Harrogate, Yorks. Tel. 01423 500442. Somebody Somewhere must make better storage units for CDs, Music, LPs, HiFi, Books, etc. than Ian Edwards. BUT until he appears, why not send for the brochure showing a selection of HAND MADE units. To do this please send 3 x 2nd class stamps.

JEM DISTRIBUTION (FI RAX) Springfield Mills, Spa Street, Ossett, Wakefield, WFs 0HW. Tel: 01924 277626. Fax: 01924 270759. Fi-Rax offers a new dimension in audio visual racking. High quality aluminium construction. Finishes available to your choice. Fully adjustable 6mm glass shelving, sound insulation on shell/feet. Custom created to suit your system. Free delivery throughout the UK. For further information or a free brochure contact JEM Distribution.

LANGREX SUPPLIES LTD 1 Mayo Road, Croydon, Surrey, CR0 2QP. Tel: 020 8684 1166. Fax: 020 8684 3056. One of the largest distributors of electronic valves, tubes and semi-conductors in the UK, and USA manufacturers. stock. We specialise in obsolete types including original UK and USA made audio valves. Telephone or fax for an immediate quotation.

NORTON TECHNOLOGIES LTD Manufacturers of the acclaimed AirPower LP12 Power Supply. 14 Rotherhay Avenue, Chelmsford CM2 9BU. (01245) 283125

NOTTINGHAM ANALOGUE STUDIO Tel: 01773 762947. Design and manufacture of quality analogue audio. We're in the business because we realise how important music is. Our turntable arms and cartridges sell the world over. Our Main UK Dealers: Radlett Audio: Tel: 01727 85577, The Audio Consultants: Tel: 020 7380 0866, Walrus Systems: Tel: 020 7724 7224.

PLATFORM 7 High density marble ISOLATION PLATFORMS for all makes of equipment RACKS/STANDS. An elegant way to UPGRADE. Improves clarity; better BASS control. 3 Abbots Drive, North Wembley, Middlesex HA0 3SB. Tel: 020 8904 2646. Also NEALGAR DISTRIBUTION Tel/Fax 01296 24756.

PMC/BRYSTON Emmy award winning manufacturers of the highest quality loudspeakers and amplification. Industry standard in Mastering, Film Scoring, Broadcast and Post Productions. (5.1 & Stereo) PMC Products: Compacts, Floorstanders, and Large passive & active monitors. Prices range from £500 to £32,000. Finished in a large selection of exquisite real wood veneers, all PMC Loudspeakers are available in horizontal mirrored pairs, centre channels and complementary subs for 5.1 surround systems. Bryston's balanced range of products include R/C Preamps, Integrated Amp modules for all the PMC range, Mono, Stereo 150W to 800W per ch, 3 Ch, 4 ch and 5 channel THX amplifiers, Surround processors, all with distortion figures and build quality to die for. Every product is available in silver or black backed by a 20 year warranty. PMC Ltd 43-45 Crawley Green Road, Luton, LU2 0AA. Tel: 08704 441044 Fax: 08704 441045 Email: sales@promonitor.co.uk Web: www.pmc-speakers.com

REL ACOUSTICS North Road, Bridgend Ind Est. Bridgend, Mid Glamorgan, CF31 3TP. UK. Tel. 01656 768 777. international +44 656 768 777. Fax. 01656 766 093. international. +44 656 766 093. Email: contact@rel.net Web: <http://rel.net> The UK's only specialist sub-bass speaker manufacturer. "The only one that works". Get your dealer to give you a home demo and find out what the fuss is all about.

RDE TANDBERG HI-FI SERVICES Holly Tree House, The Green, Full Sutton, YORK YO4 1HW. Tel: 01759 372795. The service, overhaul and reconditioning of all Tandberg hi-fi products regardless of age.

SOUND BYTES 72 Novar Drive, Hyndland, Glasgow, G12 9TZ. Tel. 0141 339 7595 Fax. 0141 339 7592. e-mail bytes@colloquium.co.uk. We specialise only in mass loading material. After hours exhaustively testing SOUND BYTES with various types of speakers, we know it works and so do you - we have never had a single complaint. Call us for advice on how much to add to your equipment for the best performance and the location of your nearest dealer.

SOUND IMAGE UK LTD. 52 Milton Road, London SW14 8JR. Tel: 020 -8255-6868. Importers and distributors of the finest audio equipment, featuring the stunning Boulder 2,000 series and the complete range from Norwegian manufacturer Electrocompaniet.

J E SUGDEN & CO LTD Valley Works, Station Lane, Heckmondwike, West Yorkshire, WF16 0NF. Tel. 01924 404088. Email jesugden@compuserve.com. Superb amplifiers and compact disc players from the original class A Company. Our unique wide-bandwidth Masterclass series sets new standards in sound reproduction and can be upgraded to 180 Watt balanced monoblocks. Prices start from £549.00 for the incredible Audition-T and £649 for the legendary A21a. Contact us now for Brochures, reviews and purchase details. British owned - British built.

TALK ELECTRONICS Unit 12, Farnborough Business Centre, Eelmoor Road, Farnborough, Hampshire, GU14 7XA. Tel: 01252 378383. Please ring for details

TAG McLAREN AUDIO - The Summit, 11 Latham Road, Huntingdon, Cambs, PE18 6ZU. Tel +44 (0) 1480 415600 Fax +44 (0) 1480 52159. Combining science and technology with distinct style, TAG McLaren Audio's complete range of audio and audio-visual products are designed to bring maximum pleasure to the discerning listener. To find out more visit our website at www.tagmclarenaudio.com, email us at HelpDesk@tagmclarenaudio.com or contact our helpdesk on freephone 0800 783 8007.

tech+link distributes some of the best performing hi-fi and a/v accessories currently available in the UK. These include: Puresonic, best known for its range of high performance interconnects and connectors, and cable adapters for a wide variety of hi-fi and a/v applications in its range; tech+link's own brand of high quality interconnects and connectors - digital compatible, 24k gold plated metal connectors; and hi-fi furniture - a selection of high quality speaker floor stands, surround sound stands and hi-fi racks. For more information, contact: tech+link International, Unit 8, Bat and Ball Enterprise Centre, Bat and Ball Road, Sevenoaks, Kent, TN14 5LJ. Tel: +44 (0) 1732 779400 Fax: +44 (0) 1732 449344

To advertise in Meet Your Maker please call
Amanda Sweeney on
020 8864 4760

computer audio world

advertising@computeraudio.co.uk

editorial@computeraudio.co.uk

news@computeraudio.co.uk

www.computeraudio.co.uk

CREATIVE THINKING

Creative Labs is one of the most prolific purveyors of computer audio products, as the latest market research from Chart Track in July 2002 bears out. The company is said to be number one in the soundcard market with an 83.4% share, and also dominates the speaker market with a 35.7% share. The latter figure puts it at the top of the table, commanding over a third of the PC/console speaker market, as measured by Chart Track.

INSTANT-ANEOUS

Steinberg's latest disc authoring package is claimed to be ideal for the professional burning of movies, music or other data to DVD and CD.

INSTANT CD/DVD 6.5 can reliably burn standard audio and data CDs as well as DVD-R, DVD-RW and DVD-RAM, supporting DAO, TAO, SAO and RAW, as well as CD formats such as ISO 9660, Joliet and HFS. It also produces boot, hybrid, photo and video CDs. It also includes



Clean 2.0 SE, Wavelab Lite 2.0 and MovieXone 4.0 for comprehensive audio and video editing. Cost is £49.99 from Koch Media (tel: 0800 169 1341). More information is on the Steinberg website at www.steinberg.net/creative-tools

VERBATIM TRUTH

Erstwhile software media specialist Verbatim is the latest company to launch a computer DVD burner. The new Omnia DVD+ ReWritable drive is a second generation rewriter with the ability to record vast amounts of music, data, video and music files to DVD+R, DVD+RW, CD-R, CD-RW and high speed CD-RW. The new machine allows users to store up to 4.7GB per recordable DVD, making it ideal for serious music or video applications, although it will also write to cheap, universally compatible recordable CDs. Both DVD+RW and DVD+R disks recorded in this drive can be played back on almost all DVD players and DVD-ROM drives, while it can also read DVD Video, DVD-ROM, CD Audio and CD-ROM discs.

Omnia comes complete with Ahead's Nero Burning ROM (for CD authoring), InCD (for simple drag 'n' drop copying of DVD+RW and CD-RW media), Mediatech's neoDVD (for digital video capture and recording) and WinDVD (for watching DVDs on PCs). The drive is also supplied with DVD+R, DVD+RW, CD-R and Hi-speed CD-RW media. JustLink technology prevents buffer under runs for reliable burning. For more information, point your browser at www.verbatim-europe.com/

NEW SUPERSTORES!

LaCie has introduced its new D2 range of portable hard drives for storing music, photography, video and other computer data. They range from 60GB to record-breaking 250GB capacities, and use a 400Mbps FireWire interface. The 250GB drive can store the equivalent of 385 CDs or 50,000 MP3 songs, or over 20 hours of uncompressed digital video. They're interestingly styled and built, too. Designed by creator Neil Poulton in aluminium and ZAMAC, they're claimed to be elegant and sturdy. The metal alloy dissipates heat from the drive and prolongs drive performance, while an external AC adapter is used to keep the power supply away from the drive to obviate the need for a noisy cooling fan. The result is a drive that's claimed to give up to 50 percent less noise pollution than traditional external drives. Expect to pay from around £139+VAT for the 60GB version to £299+VAT for the 250GB drive. All LaCie drives are Mac and PC compatible. For more information, see www.lacie.co.uk

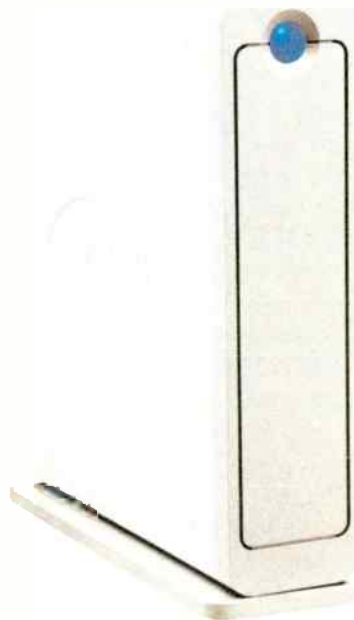

computer

audio world

advertising@computeraudio.co.uk

editorial@computeraudio.co.uk

news@computeraudio.co.uk

www.computeraudio.co.uk

DVD-AUDIO REACHES THE PC

Creative Labs' new SoundBlaster Audigy 2 soundcard not only offers THX Certification but full 24-bit/192kHz DVD-Audio too! Claimed to be the only stand-alone soundcard with THX certification (for 6.1 channel surround sound from Dolby Digital EX movies), DVD-Audio playback and 24bit, 96kHz recording, it packs an impressive punch for its £99 retail price. The company's next generation Creative MediaSource software offers a variety of digital music enhancements, including up-mix of stereo MP3 music into full 6.1 surround sound. Right now, the Sound Blaster Audigy 2 is the only PC audio

solution to offer DVD-Audio with 24bit/192kHz resolution in stereo or 24bit/96kHz in 5.1 surround. The result is a claimed 106dB signal-to-noise ratio.

The card even supports Microsoft's brand new Windows Media Audio 9 Professional format, the web's first digital 5.1 surround-sound audio codec from the new Windows Media 9 Series. As per the original Audigy, the card is offered in a Platinum version for an additional £30 which includes a front drive bay for extra connection to external devices and an infra-red remote control, including full optical and coaxial inputs and outputs, plus a FireWire link. Check out www.creative.com for more details.

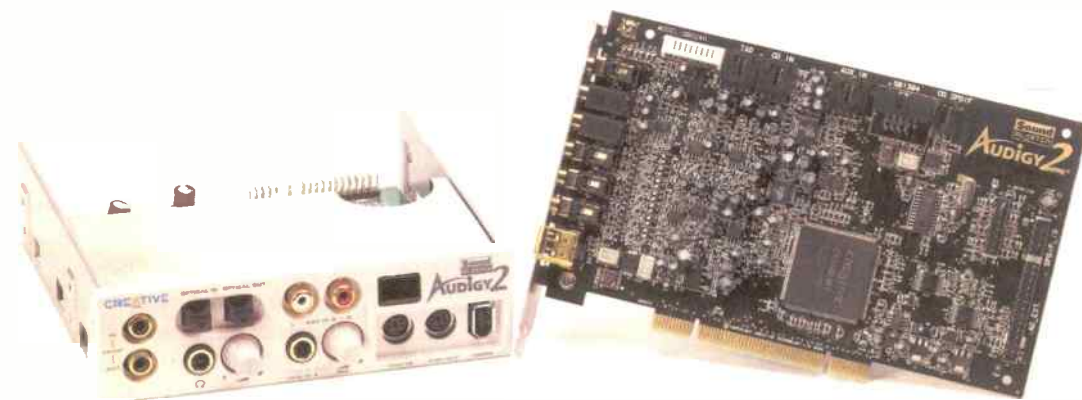

COPY PROTECTION WOBBLER

Several major record labels in the US have put their rolling programmes of copy protecting CDs on hold, due to adverse consumer reaction. Christa Haussler, vice president of new technology at BMG Entertainment is reported to have said, "from our perspective, CD copy protection is unfortunately not as good as we'd all like it to be." This is in the context of the Recording Industry Association of America (RIAA) reporting that CD shipments dropped seven percent during the first half of 2002, compared with the previous year - largely blamed on music downloading and CD copying.

The US market seems to be having trouble with copycoding, unlike Japan where some ten million discs have been released with Midbar Technology's Cactus Data Shield. In America, Universal Music has not gone ahead with it, despite its executives leading the industry last year by saying they would copy-protect a significant proportion of their discs by this summer. It is reported as saying, "The integration of copy-protection technology into some of our CDs is a first step in measuring its effectiveness in a quickly evolving marketplace. We have not finalised our plans for 2002, nor have we made a commitment to put copy protection on all of our CD releases."

Two lawsuits have been filed over protected CDs, the first being country singer Charley Pride's most recent album, which alleged that customers were being misled about the contents of their purchases. There has also been a class-action suit against all five major labels, charging that the big music companies were selling defective CDs without notifying consumers. This has yet to make significant progress. For more information, check out www.riaa.com



SIMPLE MINDS

With its new MuVo, Creative Labs' has gone to town on 'user friendliness'. David Price listens to the company's easiest MP3 player yet.

Interesting, isn't it? Eighteen months ago, the third generation of MP3 portables was becoming ever more 'hi-fi like'. Models from TEAC, Aiwa and Samsung were styled like 'wannabe' MD players of the day - small, svelte, shiny, hewn from silver metallised plastic or even brushed aluminium alloy. Their status as a computer peripheral was downplayed - it was as if they were trying to out-grow their origins and move into the grown up world of the serious audio accessory.

Now though, the latest thinking is to celebrate their connectedness to the world of PCs. They've got so small that it would be silly to design them like conventional audio portables, and as they're all now USB (which registers as a removable disk in Windows Explorer), they've been given removable disk functionality. The £99 MuVo personifies this new approach.

At 73x35x16mm, it is tiny enough to fit on a keyring. It makes a Vivanco Vmax - once something of a statement about what was possible in the design of digital audio players - look pretty run of the mill. Small size brings commensurate weight savings too - the MuVo weighs just 28g without batteries. However, its diminutive dimensions don't limit its functionality - it packs a decent 64MB of memory (enough for one hour of good quality MP3 music), and is also able to act as a USB storage

device.

The player slides apart, and you can then plug its 'MuVo Memory Module' directly into a PC's USB, where it is immediately recognised by Windows as removable storage. You can then easily drag and drop your music, photographs or data files using Windows' Explorer or your mouse pointer. It's an extremely elegant idea, obviating the need even for a cable because it plugs directly in. To turn the MuVo back into an MP3 player, you just slide it back together, plug in your earbuds and go.

Continuing the move away from hi-fi styling, you won't even find an LC display - quite a contrast from the paperback-sized first generation Thomson Lyra with its 6 line alphanumeric extravaganza! In fact, it's an almost Mac-like model of easy ergonomics. There are only six buttons, controlling playback and volume. A single LED glows green when the device is playing, and red when it's stopped or connected to a PC via USB. No 'equaliser' presets are offered - the MuVo is supplied with the company's 'Rock' EQ profile (which delivers a gentle bass boost) on all the time.

The box contains the MuVo itself, a pair of poor quality earbuds (replace them with a pair of



Sennheiser's superb MX500s at your earliest convenience!), a neck cord, a single AAA battery (giving around twelve hours of continuous play), an installation CD, Quickstart guide and -err - that's it. No carrying cases, USB cables, flash memory cards or docking stations here - which is a testament to this player's supreme inherent simplicity. All post-Win 98 SE Microsoft operating systems work automatically - as do Mac OS9 or OS

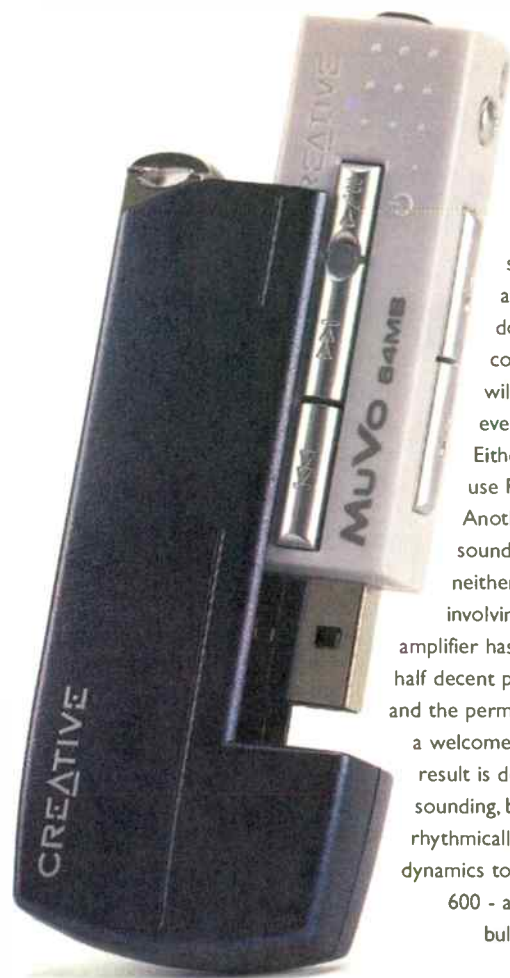

dollars, or ninety nine quid for that matter. In one sense it's so small and light that it's hard to break - 28g hitting the deck is hardly a jolt of seismic proportions after all - but it still doesn't inspire confidence. How long will it stand the rigours of everyday use, I wonder?

Either bring back alloy or use Perspex is wot I say. Another downside is the sound quality. It isn't bad, but neither is it particularly involving. The headphone amplifier has a hard time driving a half decent pair of in-ear phones, and the permanent bass boost isn't a welcome feature either. The result is decently full and warm sounding, but a tad imprecise and rhythmically vague. It also lacks dynamics too. Compared to a Rio 600 - admittedly far more bulbous - it's rather

SPECIFICATIONS

- Memory: 64MB
- Power: 1 AAA Alkaline Battery
- Music Formats: MP3, WMA
- Signal-to-Noise Ratio: >90dB
- Frequency Response: 20Hz-20kHz
- Harmonic Distortion Output: <0.05%
- Headphone output: 5-7mW

anaemic sounding, and lacking in true grit.

Still, in fairness, Creative Labs would doubtless argue it was designed with size and ergonomics as first priorities.

I liked the MuVo - it's a wholesale advance on rival 'tiddlers' - but I couldn't help wanting to pay just a little more for an altogether better built product. If you do buy one, you'll adore its practicality and ease of use, just make sure you don't sit on it - or lose it, for that matter!

Creative Labs MuVo £99.95

<http://uk.europe.creative.com/>

X - although Win 98 users will need to install a driver. Should you require an MP3 or WMA jukebox, Creative Labs' Creative PlayCenter software is included for good measure - although is not necessary to get the MuVo working.

Once you've got this up and running - which involves taking it out of its packaging, putting the battery in, slotting the memory module into your computer, dragging and dropping your music, snapping the two bits together and plugging your earphones in - it's brilliant to use. No fiddling, no faffing around - you simply take your music out and about, listen to it, and then swap it in a matter of seconds when you want to hear something else. It's so simple and so elegant it makes even an iPod seem a bit clumsy - which is really saying something! The ability to move bits of data around using a universal connector (i.e. USB) makes it great for taking work into the office, too.

An ergonomic triumph, it's a shame that the side is let down a little by the general air of 'plasticity'. The MuVo doesn't feel like a million



World Verdict £

Elegant simplicity and brilliant portability makes this one of the best designed digital audio portables around right now.

NEW MEDIA

Remember Hoontech? This is the distant relation of a soundcard Computer Audio World reviewed back in 1999. David Price listens to ST Audio's Media 7.1, and wonders how times have changed.



Hoontech is a South Korean company that made something of a name for itself amongst tweaky computer music types, thanks to its products' impressive feature sets and low, low prices. The Soundtrack Digital card I reviewed some four years ago cost a princely £29, making it the cheapest digital output-equipped audiocard of its day. Now though, as ST Audio, the company is making bigger and better things, but still at silly prices.

The new DSP24 Media 7.1 card - to give it its full name - has come a long way since the ST Digital. Packing true 24bit/96kHz full-duplex multi-channel audio capability, plus a high quality breakout box complete with microphone and phono (RIAA) preamplification, plus an assortment of powerful software, it's a lot of hardware for £150 retail price. There's more too. As its name suggests, this card will output 7.1

channel surround sound when playing DVDs via from the supplied WinDVD software.

The card itself is based on ST Audio's professional range of DSP24 recording interfaces. It offers two simultaneous analogue input channels (i.e. stereo) running at a maximum of 24bit/96kHz resolution, and eight simultaneous analogue output channels also capable of 24/96, thanks to its AKM4529 combined analogue-to-digital and digital-to-analogue converter (claimed to have an A-weighted signal-to-noise ratio of better than 100dB). It is the standard PCI size, and comes with a mic input (for a PC microphone), a 3.5mm line input to connect up the onboard soundcard or TV card, and two internal analogue inputs (i.e. CD and aux).

The breakout box hooks up to the main card by a 25pin D-SUB connector. It's one of the most evolved I've seen at or anywhere near the price. It offers the choice of

optical or coaxial digital inputs and outputs, full 16 channel MIDI (in and out), and an onboard hardware synthesiser using the DREAM/Roland GS soundset. There's a microphone pre-amp with balanced phantom powered 6.3mm input socket and gain control knob, plus a phono pre-amp (with RIAA EQ) which is switchable with the stereo RCA phono line level analogue inputs, plus a headphone amplifier, volume control and 6.3mm jack socket. Round the back, eight gold plated phonos give the 7.1 channel analogue audio output. Made from thick alloy, it's extremely robust considering that it's only slightly more expensive than Creative Labs' highly plasticised Audigy 2!

The package contains the aforementioned DSP24 Media 7.1 PCI card and breakout box, plus a welter of high quality software. This includes Emagic Logic SoundTrack24 (a 24bit/96kHz audio/MIDI-sequencer), Intervideo WinDVD v3.0

(multichannel DVD playback software), Diamond Cut 32 Art v4.0 (audio restoration software), DART Karaoke Studio, DART CD Recorder 4 Basic, Sonic Foundry ACID XPress 3.0 and Sonic Foundry Siren XPress 2.0.

Installation went smoothly enough. The standard PCI card goes in a slot in the back of your PC and connects up to the breakout box via the supplied connector.

The set-up CD got things going without any fuss, and it was then simply a case of installing your required applications.

The bundled software includes a little control panel that offers a choice between the multichannel audio mixer (essentially an elaborate version of Windows' Volume Control), the settings menu (offering the choice of clock and sample rates at up to 96kHz) and the interesting 'Patch-bay'. This offers a graphical representation of the way

intimidating or overtly 'techie' to use.

Sound quality is another big plus. The digital ins and outs work superbly, giving virtually nothing away against my reference Zefiro ZA2 digital interface card. Feeding my Cambridge Audio DACMagic 3, it made a big, clean and confident sound. Comparing its own converters against the Cambridge (at 16/44 resolution) also proved encouraging. You get a very

and it's really cool being able to plug your deck straight into your PC! The only obvious oversight is the lack of an earth terminal on the breakout box - if your arm has a separate earth lead then you'll have to make your own arrangements!

All in all, this is one of the most impressive, best built, well implemented and thought out soundcards I've tried at or anywhere near the price. TerraTec's aforementioned EWX24 is its only obvious price rival, but it's swings and roundabouts. While it may have a marginally more



clean and refined sound, with a fast, tidy, rhythmic bass, and open and smooth midband (if a tad analytical) and very couth treble with lots of detail and atmosphere.

Compared to TerraTec's

AudioSystem EWX24, there's a touch less bass weight and dynamic articulation. Rather than really grooving down to the music, the ST Audio takes a more considered, dispassionate angle. Although just a touch less involving, it's probably more detailed - surprisingly so for

musical sound (and there's really nothing in it), its user interface isn't as good and it lacks a phono stage and surround-sound output. Ultimately, ST Audio's Media 7.1 is an extremely user friendly product, but still aimed at the serious hobbyist/home musician. It's less gimmicky and better built than Creative Labs Audigy 2, too. Highly recommended.

ST Audio DSP24 Media 7.1 £199

Et Cetera Distribution

Tel: +44 (0) 870 873 8731

<http://www.etcetera.co.uk>



the breakout box is connected up, and after you've re-educated yourself to work in a graphical environment is very easy to use. I used Cool Edit Pro for most of my testing, which had absolutely no problems working with this card, its drivers all appearing in CEP's SETTINGS/ DEVICES menu.

Suitably installed and configured, it proved consummately easy to use. Because all the most used controls and socketry is on the breakout box's front panel, there's no need to fiddle around the back with cables, and the Patchbay and Mixer apps are a cinch. You soon feel that you can play, record or switch digital audio as easily as you would with a hi-fi recorder - despite its power, it's not

something of this price.

Things get better still when you crank up the sample rate. It's a whole heap better than 16/44. There is great subtlety, air and space. Instruments can breathe more naturally, and there's a fuller, better articulated bass.

The built-in phono stage proved very quiet. You'll find it betters a QED Discsaver - which is saying something, although if you're doing serious audio transcription/restoration, you'll do better to use the likes of a Creek OBH-8SE. Still, it proved big and bouncy, with plenty of life -

World Verdict
A stack of sensible real world facilities, superb connectivity and fine sound make this a winner.

DRIVER SUPPORT

Windows 9x/ME/2000/XP is supported, with ASIO 2.0 and GSIF. The included ASIO 2.0 drivers of ST Audio's DSP24 series support 2ms latency at 96kHz and 5ms at 44.1/48kHz (even lower values are supported under Windows 2000/XP on faster systems). This means that users of modern software synthesisers like GigaStudio or VST/DXi-plugin instruments can now play their sounds in real time and even using real-time effects (like DirectX- or VST-plugins). It is fully compatible with Logic Audio, Cubase VST, Cakewalk, Samplitude, Cool Edit, Acid, Vegas, etc.

welcome to world favourites

Here's a list of products that are a good buy. We've tried to cater for a range of tastes, identifying strong products in every area. We're agnostic so you'll find a wide range of products, from valve pre-amps through to MiniDisc players. Products marked * are recently out of production but make a good second-hand buy.

Prices shown are those at the time of the review



Sonic Frontiers Transport Cutting edge design and technology.

COMPACT DISC

- ARCAM FMJ CD23** £1100
This British-built player is extremely versatile. Controlled and detailed with a musical insight that few match. (Jul 2000)
- CAMBRIDGE CD4SE*** £200
A touch soft in the treble but outstanding in every other respect. (Feb 98)
- KENWOOD DP-3080/II*** £180
Has great clarity and presence for the price. Not as naturally expressive as the CD4SE though. (Feb 98)
- LINN KARIK III*** £1775
Under rated and overlooked, the final Karik was a gem. Superb transport gives a brilliantly tight, grippy dynamic sound, albeit tonally rather dry.
- MARANTZ CD-17 KI-S** £1100
The Marantz excels in all areas. Without doubt this is one of the most involving CD players on the planet. Build quality is also exemplary. (Sep 97)
- MARANTZ CD-63 MKII KI-S*** £400
Similar to the CD-63SE but more powerful bass and an all-round smoother sound. The famous KI tweaks pay off again. Whether or not it is still pre-eminent against the vastly improved competition is a matter of opinion.
- MERIDIAN 506 20-BIT*** £1100
Very detailed and revealing player. More cerebral than visceral sounding, however. (May 95)
- MUSICAL FIDELITY X-RAY** £800
Commonsense sturdy CD player of exceptional ability. Clear and detailed with high quality internal processing system. The X-Ray is inclined to show up poor recordings, but it's only doing its job! (Feb 99)
- NAD S500** £1000
This dynamic top of the range Silverline spinner delights with any type of music. Exciting, sophisticated sounding and highly recommended. (Jun 2000)

ROKSAN CASPIAN £895
The Caspian has a smooth, slightly bright sound with some of the clearest treble in the business. Very engaging, dynamic character. (Aug 97)

ROTEL RCD 95I £300
HDCD capability at a midrange price. Plain Jane looks but solid construction. There is some higher than average measured distortion which may take the edge off this otherwise tempting product. (Aug 99)

COMPACT DISC TRANSPORTS

SONIC FRONTIERS TRANSPORT £6999
Cutting-edge design and technology combine to make this one very desirable product. The only problem is the fantasy hi-fi price. (Sep 98)

TEAC P-30 £2500
Cheap it isn't, but then it sounds like a million digital dollars. Nothing short of superb. (Jun 97)

TEAC VRDS-TI £600
Excellent mid-price silver disc spinner with a powerful, expansive and warm sound. Easily beats most sub-£1000 designs. A good choice for the budget conscious who want the best. (Feb 95)

DACs

CAMBRIDGE AUDIO DACMAGIC 3* £99
Superb value for money with extensive facilities and solid, detailed sonics. Upgrades any sub-£300 player.

DCS ELGAR £8500
Future-proof convertor which will handle 24/96 and 24/192. Extremely open and natural performer. (Nov 97)

DPA LITTLE BIT 3* £299
A taste of the high end on a budget. Rich, clean, punchy sound transforms budget CD players.

MIDIMAN FLYING COW £299
Excellent as a DAC and doubles as an ADC for archiving to CDR. (Jun 98) Great value, as is junior version Flying Calf at £109. (Feb 99)

MUSICAL FIDELITY X-DAC* £300
A bargain for normal CDs and even better with HDCDs. (Nov 97)

SONIC FRONTIERS PROCESSOR 3 £6999
Quality never comes cheap! This DAC oozes class and when matched with the Transport 3 is certainly up with the best. (Sep 98)

TURNTABLES

LINN SONDEK LP12 BASIK £1100
Off the pace these days in many respects but still an extremely sweet and engaging listen with a quintessentially analogue sound.

MICHELL GYRODEC SE £775
Exquisitely built, infinitely upgradeable deck that gives true high end sound at mid-fi prices.

MICHELL ORBE £2000
Fantastically capable all rounder with commanding, powerful, detailed sound that gets the best from almost any arm and cartridge. Supreme build, brilliant value. (Apr 95)

ORIGIN LIVE STANDARD (KIT) £145
Good in standard form with AC motor; frighteningly good with a DC motor and battery PSU.

PINK TRIANGLE TARANTELLA £680
Not only does the Tarantella have more style than a catwalk full of models, it also combines PT's usual clarity with real authority. (Oct 97)

PRO-JECT DEBUT £110
Straight out of the box and onto the shelf! Nothing short of a bargain. Vinyl's never had it so good, so cheaply!

REGA PLANAR 2 £214
Brilliant starter deck with extremely polished manner. Better built £274 Planar 3 is a great all-in-one package that eats mid-price CD players for breakfast.

ROKSAN XERXES X £1295
DSU or XPS 3.5 power supply £150/170 extra. Excellent pitch stability from a new Swiss motor and onboard power supply. Very tight bass, fine dynamics and revealing clarity. (Jan 97)

SYSTEMDEK IIX900*/RB250 £330
A fine all-rounder and easy to upgrade too. More depth and breadth than Rega Planar 3. (Sep 94)

VESTAX BDT-2000 £225
A stylish looking deck with infinitely variable speed 16-90 rpm, DC belt drive and built-in MM phono stage. Good value, with plenty of chassis room for alternative arms, if required. (Sep 99)

TONEARMS

HADCOCK 242 SE £649
Latest of a long line of unipivot arms. Added mass makes the 242 suitable for both low compliance MCs and straw in-the-wind high compliance types. Revised geometry and chromium plating completes a first-class job. (Jun 2000)

NAIM ARO* £975
Truly endearing and charismatic performer - wonderfully engaging mid-band inakes up for softened frequency extremes

REGA RB300 £180
Some may prefer the simpler RB250 at £130. Detailed, tight, rhythmic sound but tonally rather grey and cold-sounding. Still excellent value, though.



just compare **OUR** prices for the **BEST** deals.



A selection of our ever changing offers for sale (all fully guaranteed)		Equivalent New Price	Sale Price	A selection of our ever changing offers for sale (all fully guaranteed)		Equivalent New Price	Sale Price		
AMPLIFIERS				TUNERS					
Meridian Alpha Mono-Blocs (2 x 100 Watt) VGC	2000.00	995.00	A.V.I. S-2000 HI (F.H. Tuner) MINT / Boxed / Manuals	600.00	389.95				
Musical Fidelity The "Prologos" (PH / MC Phono-Stage) / Dr. Thomas Power-Amp	1000.00	399.95	Rotel RT-950 BX (3-Band Tuner) VGC	200.00 +	99.95				
Naam MK-97 / NAP-90-3 Pre / Power (PH Phono-Stage) MINT / Boxed / Manuals / Leads	950.00	599.95	Sony ST SE 300 (MDS Tuner) MINT	120.00	69.95				
Quad RS 1/2 x 100 Watt Power-Amps VGC	N/A	139.95	Technics ST-610C (Pre-Sets / Digital Display) MINT/Manuals	120.00	59.95				
Q.E.D. Vector Reference Remote Pre-Amplifier (Matching D.A.C. Also Available) MINT	400.00	199.95							
N.V.A. A-60 Power Amplifier MINT	550.00	229.95							
Pioneer A-60SR (2 x 50 Watt / Remote Int. Amps) MINT / Manuals	400.00	199.95							
Rever RA-900 DC (PH / MC Phono-Stage) VGC	2750.00	139.95							
Q.E.D. A-230 Int. / Phono-Stage (Matching Tuner Available) VGC / Manuals	180.00	69.95							
PRODUCT OF THE MONTH				LOUDSPEAKERS					
Teak T-1 (Transports / DT) D.A.C. (2-Box Remote Control) C.D. Player) in MINT Condition Equivalent New Price £1,100.00 Affordable Audio price £599.95				Sov. Lab Dynastat (Hi-Fi Electrostatic) (Coil Bass) VGC / (Space Utilised)				350.00	1395.00
RECORDING EQUIPMENT				Acoustic Spectra 1100 (Hi-Fi Electrostatic) (Coil Bass) VGC / (Space Utilised)				1200.00 +	649.95
Sony TC-4415 (3-Head / 2-Motor / Dolby Hi-Pro Etc.) MINT/Manuals				A.V.I. S-1000 (Hi-Fi Electrostatic) (Coil Bass) VGC / (Space Utilised)				1200.00 +	399.95
Rotel RD-845 (2-Motor / Hi-Pro) MINT / Boxed				A.V.I. S-1000 (Hi-Fi Electrostatic) (Coil Bass) VGC / (Space Utilised)				1200.00 +	169.95
Sony TCR-470 (Var-Bias / Hi-Pro Etc.) MINT/Manuals				A.V.I. S-1000 (Hi-Fi Electrostatic) (Coil Bass) VGC / (Space Utilised)				1200.00 +	169.95
Technics RS-9405 (1-Disk Etc.) VGC / Manuals				A.V.I. S-1000 (Hi-Fi Electrostatic) (Coil Bass) VGC / (Space Utilised)				1200.00 +	169.95
Aria AD-WX 909 (Twin / Auto Reverse / 3-Head / Var. Bias Etc.) VGC				A.V.I. S-1000 (Hi-Fi Electrostatic) (Coil Bass) VGC / (Space Utilised)				1200.00 +	169.95
Aria R-450 (Auto-Reverse / Dolby C / Var-Bias Etc.) VGC				A.V.I. S-1000 (Hi-Fi Electrostatic) (Coil Bass) VGC / (Space Utilised)				1200.00 +	169.95
DIGITAL				MISCELLANEOUS					
Teak T-1 Transports / DT-1 D.A.C. (2-Box Remote Control) MINT / Boxed / Manuals				Mitsubishi SPS-35 (Gold Pl. / Gold or Anodized Brass Finish) Loudspeaker NEW				895	(Per 4)
Rega Planet Top-Loader With Remote-Control MINT / Boxed / Manuals				Mitsubishi SPS-42 (Silver Pl. / Small) Loudspeaker Spikes NEW				799	(Per 4)
Audio Alchemy Digital-Drive-Engine 1.0 / Power-Station II D.A.C. MINT / As New / Boxed				Mitsubishi SPS-45 Spike Kit (Large) NEW				895	(Per 4)
Q.E.D. Digit Reference (Digital to Analogue Converter) MINT				Mini ISS 2 (3-Way Speaker System) NEW				18.95	(Per 4)
Kenwood DP-7090 32fs Remote / Digital-Out Etc.) MINT				Mini 4 (4-Way Banana Plug) (Gold Plated) (No. Above, Only Biggest Short-Hole. Ideal For Bi-Wiring With Heavy-Gauge Cable)				6.95	(Per 4)
Cambridge CD-4 (Balanced-Out Etc.) VGC				Mini ISS 2 (3-Way Speaker System) NEW				18.95	(Per 4)
Cambridge CD-4 (Digital-Out Etc.) VGC / No Remote				Mini ISS 2 (3-Way Speaker System) NEW				18.95	(Per 4)
Creek CSE-60 (20-00 D.A.C.) MINT / Boxed 400.00 129.95				Mini ISS 2 (3-Way Speaker System) NEW				18.95	(Per 4)
Arcam Alpha 6 Remote (Digital-Out Etc.) MINT / Boxed / Manuals				Mini ISS 2 (3-Way Speaker System) NEW				18.95	(Per 4)
Arcam Alpha One Remote (Digital-Out Etc.) MINT / Boxed / Manuals				Mini ISS 2 (3-Way Speaker System) NEW				18.95	(Per 4)
Denon DCD-835 Remote (Digital-Out Etc.) MINT / Boxed / Manuals				Mini ISS 2 (3-Way Speaker System) NEW				18.95	(Per 4)
Denon DCD-835 Remote (Digital-Out Etc.) MINT / Boxed / Manuals				Mini ISS 2 (3-Way Speaker System) NEW				18.95	(Per 4)
Marantz CD-43 SE (Remote / Digital-Out Etc.) VGC / Manuals				Mini ISS 2 (3-Way Speaker System) NEW				18.95	(Per 4)
Sony CDP-552 ES (Digital-Out Etc.) (No Remote) VGC				Mini ISS 2 (3-Way Speaker System) NEW				18.95	(Per 4)
Technics SLP-3670A (Remote Player / Optical-Out) MINT / As New / Boxed / Manuals				Mini ISS 2 (3-Way Speaker System) NEW				18.95	(Per 4)
Philips CD-730 Remote MINT / Manuals				Mini ISS 2 (3-Way Speaker System) NEW				18.95	(Per 4)
TURNTABLES				SYSTEMS					
Dual CS-505 (Multiple Edition) Orator (Grinder) MINT				Dual CS-505 (Multiple Edition) Orator (Grinder) MINT				200.00	79.95
SYSTEMS				Dual CS-505 (Multiple Edition) Orator (Grinder) MINT				200.00	79.95
affordable-audio will happily "build" systems to your individual requirements, and if you purchase three or more components, i.e. (C.D. Player, Amplifier, & Loudspeakers), we will give you a *15% Discount on the total price! Please enquire for further details. *(Does Not Apply to Commission-Based Sales)									

PLEASE VISIT OUR WEB-SITE (UPDATED DAILY) E-MAIL: Sales@affordable-audio.CO.UK WWW.affordable-audio.CO.UK

***** GOOD HI-FI SEPARATES WANTED *****

Phone anytime with your wants, stock changing daily. All equipment is sold with warranties.

Don't forget we can offer mail order. All major credit cards accepted.

WE WELCOME part-exchanging on any of the above. Affordable Audio is always keen to buy (or part-exchange) Good quality Hi-Fi separates in good condition. Especially top British manufacturers' product.

We can also sell your equipment for you on a commission basis. (Lowest rates/best return) (Please phone Paul for details!)

Tube Shop

Tube-Shop.com

Why choose Tube-Shop.Com

- Over 2,500 different tube types in stock at all times
- We offer you the best prices around, Guaranteed
- UK's first fully online tube ordering system
- Expert matching service by PM Valve Labs
- We sell only the world's BEST brands
- Next day delivery (if ordered before 3pm)
- Free delivery (on all orders over £80)
- MONEY BACK GUARANTEE
- Trade enquires welcome

Visit The Tube Shop
www.tube-shop.com

You can even telephone your order
01732 464622

Tube-Shop.Com 26 High Street, Sevenoaks, Kent TN13 1HX

Prices shown are those at the time of the review



Project Phono Box. Provides an inexpensive introduction to all that vinyl has to offer.

SME 3009SII £309
Once state of the art, but no longer. Weak at frequency extremes and detail, but its legendary serviceability makes it a cult in Japan. Can be picked up for peanuts second-hand. (Jan 93)

SME 309 £689
A down-market version of the IV and V with aluminium armtube and detachable headshell. Tight, neutral sound with good tonality, but lacks the IV's pace and precision. Like the older SME 3009 series, this arm is also available in 10" and 12" versions. (Jan 93)

CARTRIDGES

AUDIO TECHNICA AT-110E £30
Great starter cartridge that's refined, detailed and musical beyond its price. Best value MM under £50

GOLDRING 1012GX £74
An accomplished MM with a solid bass, slightly forward midband and clean transients. Very reasonable price for such an able performer. (Jul 93)

DNM MICA £185
Better than Goldring's 1042 and costs only £135 on trade-in. An assured and transparent MM. (Feb 98)

DYNAVECTOR DV20X-H £299
The best modern budget MC combines deliciously sweet sound with fantastic get-up-and-go. High output version works a treat with valve phono stages too.

MUSIC MAKER £575
When mated with a good quality arm, this hand finished high-output pick-up gives an ear-boggling account of itself. Very high compliance ensures maximum information retrieval. An absolute (grain orientated) gem. (Feb 99)

ORTOFON MC 7500 £2000
Conclusive proof that there's hope for the world. It's a long time ago now but this high-priced favourite still earns its niche - CD lovers would die if they heard it. (May 94)

ORTOFON MC 15 SUPER II £140
Not quite as good as the dearer Supremes but the Super II is a splendid introduction to the joys of moving-coil cartridges.

GOLDRING 1042 £130
One of the best Moving Magnet cartridges going, with beautiful treble and muscular bass. New low price makes it a bargain.

ORTOFON ROHMANN £1000
In a way it's MC 2000 meets MC 7500 with great tonal strengths and a dynamo sound. (Apr 96)

INTEGRATED AMPLIFIERS

AUDIO ANALOGUE PUCCINI SE £595
This superbly-built Italian integrated has a lucidity and control which leaves others nowhere. Sound stage a wow. (Dec 97)

AUDIOLAB 8000a * £495
Well rounded integrated with smooth and detailed sound plus a huge feature count. Great build makes later versions a top used buy.

DENON PMA-250SE £160
It might not have bags of grunt but the Denon can sound exceedingly natural and open. (Feb 97)

McINTOSH MA6800* £3735
The MA6800 not so much plays music as takes control of it, with effortless bass drive. (Sep 95)

MISSION CYRUS 2 * £299
Classic eighties minimalism combines arresting styling with clean, open, lively sound. Further upgradable with PSX power supply.

MUSICAL FIDELITY X-CANS2 £160
Warm, sumptuous, sweet sound h/phone amp. gives startling results with a decent set of headphones.

NAIM NAIT 3 * £575
Superb rhythms and dynamics make for great music making, but tonally monochromatic. Super optional phono stage makes it ideal for vinyl junkies.

ROKSAN CASPIAN £695
Smooth, warm integrated with remote control that works happily into most 'speakers. (Dec 97)

SONNETEER ALABASTER £995
Builds on the strengths of the Campion with ample control, colour and drive. (Oct 97)

PHONO STAGES

CREEK OBH-8 SE £180
Punchy, rhythmic character with oodles of detail makes this a great budget audiophile product.

LFD MISTRAL PHONO STAGE * £300
The Mistral has a warmth and involvement that make many pricier stages sound overpriced.

MICHELL DELPHINI MONOBLOCS £1995
Analogue tour-de-force gives supremely clean, detailed and finely resolved sound with breathtaking dynamics. Great value, even at this price.

MUSICAL FIDELITY X-LP £125
One of the famous MF X series. Full marks throughout for clarity and detail. Switchable between MM and MC. Indestructible build! (May 99)

PROJECT PHONO BOX £39
Not the last word in many respects but a thoroughly honest piece of work. Inexpensive introduction to all that vinyl has to offer. MM and MC provision plus choice of two impedances.

ROKSAN ARTAXERXES X £950
With the Atessa PSU the Artaxerxes X MM/MC stage still shines. Great stage depth, neutrality and tonal colour. (Oct 97)

Billy Vee
SOUND SYSTEMS

248 Lee High Rd, London SE13 5PL (Mon - Sat 10am to 6.30pm Closed Thurs & Sun)

A summer bargain not to be missed!

Call (020) 8318 5755 or 8852 1321 now

Factory returns Boxed as new with full 2 year warranty

This is the chance to pick up a late summer bargain with these two popular Arcam products. Both the A85 Amplifier and DV88 DVD player are available in black or silver in very limited quantities, so don't delay - call now!

- 2 year full in house warranty
- Free Delivery & Local Installation
- *0% Interest Free Credit available



Arcam A85 Amplifier £625



Arcam DV88 DVD Player £745

Arcam A85 Amplifier normal Price £799.00
Arcam DV88 DVD Player normal price £999.00

SONNETEER SEDLEY £399
Combines transparency and fine dynamics with excellent rhythmic ability. (May 98)

PRE-AMPLIFIERS

AMC 1100 £150
Suffers from un-defeatable tone controls but an extremely good value piece of kit Partners the similarly budget level AMC 2200 power amplifier, also at £150. Comfortable beginners' choice. (Mar 99)

AUDIO ANALOGUE BELLINI £475
Showcases AA's characteristic mix of clarity and musicality and blasts the competition. (Apr 98)

CHORD CPA1800 £1800
Clarity, insight and control are second to none - an addictive mixture. (Mar 98)

CROFT VITALE £350
A modestly priced valve pre-amp with exceptionally transparent performance. MM phono stage plus three line stages are standard. Volume controls are separate for each channel, thus giving balance adjustment. A remarkable item in all respects. (Feb 2000)

XTC PRE-1 * £1000
Almost valve-like in its smoothness, the line-level Pre-1 is warm and seductively clear. (Nov 96)

POWER AMPLIFIERS

ARCAM 9 * £400
With 70W on tap, the 9P will drive most loudspeakers with a spacious and detailed sound. Good bass welly too. (Dec 96)

CHORD SPM400 £1400
There's a sense of effortless power to the Chord that gives music real scale and presence. (Mar 98)

MARANTZ MODEL 9 * £8000
Authentic reproduction monoblocs still more than cut the sonic mustard. Highly expensive and highly sought after. (Mar 97)

MICHELL ALECTO £1989
Crisp, clean and beautifully controlled with gorgeous styling. Partnered with the £1650 Orca this is a superb winning combo. (Oct 98)

MUSICAL FIDELITY X-A200£1000/pair
200W of high-end monobloc power in a grooved tube. (Aug 98)

NAIM NAPI80 £1060
Partnered with a NAC82, this has classic Naim control, and a superbly rhythmic presentation.

TUNERS

CAMBRIDGE T500 £180
An extremely engaging tuner with a performance at odds with its low price. Not exactly a Troughline, but you may not notice... (Feb 99)

CREEK T43 £399
Excellent detail, separation and dynamics. A great little tuner and unbeatable at this price. (May 98)

MARANTZ ST17 £600
A positive dreadnought of a tuner. Sweet and refined but with a heavy punch when needed. A tuner of this quality demands a decent aerial. (Jul 99)

MISSION CYRUS FM7* £300
Clear and lucid sound puts it up with the best. Superb build too. (Apr 94)

NAIM NAT03 £595
The NAT03's warm, atmospheric sound is further proof of Naim's proficiency with tuners. (Sep 93)

SONY ST-SA3ES* £250
Beguiling RDS tuner for the sonically discerning. Good ergonomics and sensitive too. (Apr 97)

CASSETTE DECKS

AIWA AD-S750* £200
Sonically a very decent machine at the price. Comes fitted with Dolby B, C and the dead handy Dolby S. (Apr 96)

AIWA AD-S950* £300
A stable transport, superb head and Dolby S make the AD-S950 an excellent all-rounder. (Feb 95)

KENWOOD KX-3080* £160
A simple deck, but excellent-quality head and transport give top quality sound. (Oct 96)

PIONEER CT-S740S £430
A great piece of engineering from Pioneer, with first-rate sound. (Jun 96)

YAMAHA KX-580SE* £250
The 'SE' tag is more than a marketing gimmick. Sound is solid and clear with Dolby S. (Sep 97)

LOUDSPEAKERS



Kef Cresta I loudspeakers
A very musical sound

CASTLE EDEN £469
Impressively vice-free 'speakers that offer great transparency and involvement. One of a select band that simply makes music regardless. (Mar 97)

EPOS ES12 * £495
Strong, punchy bass is allied to finely detailed, articulate midrange and sparkling treble. (Oct 96)

KEF CRESTA I £100
Delightfully sophisticated presentation for the price Won't blow the roof off, but will deliver a very musical sound. (April 2000)

KLIPSCH HERESY II £1100
An outstanding high sensitivity loudspeaker with midrange and treble horns coupled with infinite baffle 12" bass driver. Effortless, fast and accurate. (May 99)

MISSION 752 * £495
Cracking mid-price mini towers combined HDA drive units and metal dome tweeters with surprisingly warm results. Benign load characteristics makes them great for valves.

MISSION 771 £170
Characteristically fast, punchy Mission sound from the Aerogel mid/bass and silk-dome tweeter. (Jul 98)

Billy Vee
SOUND SYSTEMS

248 Lee High Rd, London SE13 5PL (Mon - Sat 10am to 6.30pm Closed Thurs & Sun)

Would you like to upgrade your Naim
Call 020 8318 5755 or 8852 1321 now!

Each year we replace our Naim demonstration stock giving you an opportunity to make a substantial saving on our normal price! All products are boxed with full two year warranty. Only one of each available

- NAC 52 Preamp (£3850) £2690
 - SuperCap Power Supply (£2450) £1795
 - NAC 102 Preamp (£1210) £859
 - NAP 180 Power Amplifier (£1220) £859
 - NA CDX Player (£2470) £1729
 - NAP 250 Power Amplifier (£1910) £1339
 - NA CDS/2 Player (£4165) £3099
 - NAP 500 Power Amplifier (£10995) £8995
- Interest Free period of nine months available - please call for details.



Featured
NAC 82 Preamp
one only available
Was (2500) Offer price £1795

Job Opportunity

We have a vacancy for a young enthusiastic 18 - 20 year old sales and customer service person. Experience not necessary but must have good communication skills. Good income potential. Please write to Ian Anderson sending your C.V to the address above.

QUAD ESL 63 * £3450
A reference against which all other loudspeakers are judged, the '63s have superb imaging and genuine transparency.

TANNOY AMS8 * £2700
Bold sounding pro active monitor with solid bass, clear midrange and delicious treble. (Aug 96)

TANNOY MERCURY m2 * £140
A true audiophile bargain which embarrasses many more expensive boxes. Never mind the price, let your ears decide. (May 97)

MINIDISC PLAYERS

KENWOOD DM-9090 £500
One of the best MD players yet. ATRAC 4.5 gives clean and very musical recordings from this Kenwood. (Jan 98)

SONY MDS-JB930Q £250
Great mid-price machine that adds better build and facilities to the '530's already excellent sonics.

SONY MDS-JA50ES * £1300
This Sony can put the wind up Nakamichi cassette decks when used with better blank MDs. (Apr 98)

SONY MDS-JE55ES MiniDisc recorder £520
The best sounding MD deck made so far, thanks to awesome build and heroic ATRAC-DSP Type R coding.

SONY MDS-JE510 £300
An impressive sound and unmatched convenience make this MiniDisc player an excellent buy.



Pioneer DVD-717. A well built and solid performer.

DIGITAL RECORDERS

ALESIS MASTERDISK £1400
A groundbreaking hard disc recorder with a built-in CD drive. An amazing bit of kit, and a glimpse of the future. (July 2000)

KENWOOD DMF-9020 £500
An excellent tool for home recording, combines convenience, superb sound and a fair price. (Aug 99)

MARANTZ DR-17 £1100
Probably the best sounding CD recoder on the market. Built like a brick out house with a true audiophile sound. HDCD compatible. (July 2000)

PHILIPS CDR-765 £360
One of the first twin deck recorders/players that boasts high speed dub facility. Playback could be warmer, but still a bargain. (Oct 99)

PIONEER PDR-555RW £480
Excellent mid-priced CD recorder that both plays and records with equal panache. (Oct 99)

SONY TCD-8 DATMAN * £599
Super clean and detailed sound makes this an amazing portable. Not as robust as it should be though.

DVD PLAYERS

DENON DVD-5000 £1600
Monster build, as you'd expect at this price. Facilities and gadgets galore and drop-dead high end looks. A very smooth and sophisticated sound, although not as good as similarly-priced CD players. (Mar 99)

PIONEER DV-717 £700
Well built and a solid performer, with a 'true' 24/96 digital output. Facilities in abundance and a controlled, exciting way with CD replay. Shame it lacks a Dolby Digital decoder! (Sep 99)

SONY DVP-S725 £490
One of the best buys in the DVD market. Available in a dodgy white case, but the facilities and performance more than make up for this. Excellent with both music and visuals, and a whole host of up to the minute facilities to keep you occupied. (Mar 2000)

HEADPHONES

JECKLIN FLOAT MODEL TWO £99
Wonderful panel-like and open sound from these esoteric-looking headclamps. Do not wear in public unless you like being made a fool of!

SENNHEISSER HD-490 £50
Good value cans with an exciting and bassy sound. Everything one should look for in headphones at a sensible price.

INTERCONNECTS



Nordost Blue Heaven
A simple and effective upgrade

CHORD COMPANY CHAMELEON 2 £90/m
One of our favourite favourites, the Chameleons are musical performers with a smooth yet open sound.

DNM RESON £40/m
Neutral and transparent, and a steal at forty quid!

NORDOST BLUE HEAVEN £150/m
Some of the fastest and most transparent cable around. A simple and effective upgrade.

VAN DEN HUL ULTIMATE THE FIRST £260/0.6m
Carbon interconnects that help you forget the electronics and concentrate on the music. Miraculous transparency.

LOUDSPEAKER CABLE

CHORD COMPANY RUMOUR £9.95/m
The Rumour is our reference at the price. Tight and tuneful bass mixed with air and space results in a cracking cable for the money.

DNM RESON £6.95/m
This cable has a transparency of sound that's rarely heard at the price. Excellent value for money.

NORDOST BLUE HEAVEN £375/3m pair
This isn't cheap, but it sounds absolutely fab. An open and spacious sound that simply carries music.

Billy Vee
SOUND SYSTEMS

SAVE UP TO 50% ON EX-DISPLAY BARGAINS

SOME AS NEW WITH 1 YR WARRANTY. 24HR DEL ONLY £5 CHECK AVAILABILITY BEFORE ORDERING

CALL SALES: (020) 8318 5755 or 8852 1321 - 248 Lee High Road, London, SE13 5PL

0% APR is available on purchases of more than £660. Please call for details. Confirm stock before visit. E&OE

Arcam DV88 DVD Player (1Yr G/tee)	£699.00	Marantz DV7000 DVD Player (1Yr/Gtee)	50% (599.00)	£266.00
Blueroom Minipod Speakers Var colours	£199.00	Naim CDX CD Player (2Yr G/tee)		£1729.00
Linn Karik/2 CD PlayerS/H (1Yr G/tee) (new 1850.00)	£895.00	Naim 102 Preamp (2Yr/Gtee)		£859.00
Linn 5105 Power Amps (2 Yr G/tee) 50%	£549.00	Naim Hi-Cap Power Supply (2Yr G/tee)		£559.00
Linn Kan Speakers (2Yr G/tee)	£229.00	Naim NAP 180 Power Amp (2Yr G/tee)		£879.00
Linn Keosa Speakers (2Yr G/tee)	£299.00	Naim NAP 250 Power Amp S/H (1Yr G/tee)		£995.00
Linn LK140 Power Amp (2Yr G/tee)	£549.00	Naim NAP 250 Power Amp (2Yr G/tee)		£1339.00
Linn Klout Power Amp S/H (1Yr/Gtee)	£999.00	Naim Intro Spkrs - Beech (1Yr G/tee)		£579.00
Linn Kairn Line Preamp (1Yr G/tee) 50%	£799.00	Naim NAP500 Power Amp (2Yr G/tee)		£7995.00
Linn LP12/Lingo/Akito S/H (1Yr G/tee)	£1250.00	ProAc Tablette 2000 Spkrs (2Yr G/tee)		£456.00
Linn Keilidh Blk S/H (1Yr G/tee) 50%	£387.00	Rotel RV 985 DVD Player (2Yr G/tee) 50%		£299.00
Linn Keltik Speakers Wal (2Yr G/tee)	£3950.00	TAG DV32R DVD Player (2Yr/Gtee)		£2995.00
Lexicon MC1 Processor (2Yr G/tee)	£3995.00	Yamaha AX620 AV Amplifier (2Yr/Gtee)		£289.00

welcome to world classics

CASSETTE

NAKAMICHI DR-2

A great machine with Nakamichi's legendary heads. The lowest cost 'true' Nakamichi at the time, retailing for £600.

NAKAMICHI CR-7

The last of the great ones, and definitely the best Nakamichi ever (yes, better than a Dragon)

YAMAHA TC-800G

Early classic in serious cassette. Its ski-slope looks got it a cult following once it had ceased to be simply ugly.

CD PLAYERS

MERIDIAN 207

Beautifully-built two-box with pre-amp stage. Very musical although not as refined as modern Bitstream gear. No digital output.

PIONEER PD-91

Built-to-last player with easy upgrade routes for modifiers. Not knockout as it stands but get one cheap and have a go!

CAMBRIDGE CD1

The first two box player with weighted mechanics and even an optional Dropout/error counter. Radical and effective at the time - a classic.

AMPLIFIERS

LEAK POINT ONE, TL12 & TL10

Ancestors of hi-fi, consequently expensive nowadays. As with all vintage valve stuff, overhauling is de rigueur before use, using original parts if possible.

LEAK PRE-AMPS

Line of 'good for their time' pre-amps. Use of EF86 pentode valve for high gain rules out ultra performance. Not the highest-fi.

LEAK STEREO 20

Excellent workaday classic valve amp. In good order the 20 will not disgrace itself. Various upgrades are available from specialist repairers.

LEAK TL12+

Plentiful monobloc equivalent of Stereo 20. Reasonably inexpensive and a tweakers' dream. Genuine valve hi-fi on a budget.

NAD 3020

You can't argue with success! NAD's budget transistor integrated gave thousands their first taste of hi-fi and remains great value.

QUAD 33/303 PRE/POWER

Great style and construction, also bullet proof. Warm and wooly sound, but easy going. A good introduction to early transistor audio classics.



Garrard 401
A legendary turntable.

QUAD 22/II PRE/POWER

One of the all-time classic valve amplifiers. Unusual circuit but it works beautifully. 22 pre-amp not up to today's standards.

SUGDEN A21

Seventies transistor integrated has an eminently likeable smoothness and musicality. Limited inputs via DIN sockets.

TECHNICS SE-A5 Mk2

Nice transformer and electronics, shame about the casework. With tweaking, this 150watter can sound sweet.

LOUDSPEAKERS

KLIPSCHORN

Not exactly plentiful or cheap but a splendid beast. For efficiency they have seldom been equalled. Space hungry!

AUDIO ILLUSION

23 Langley Broom
Langley, Berkshire SL3 8NB
(2 mins. Junc.5 off the M4)
TEL: (01753) 542761 FAX: (01753) 772532
Open 10am-8pm (Mon-Sat) By appointment only

www.audioillusion.co.uk
mailto:audioillusion@btinternet.com



**EVERYTHING MUST GO
MASSIVE CLEARANCE SALE
AT PRICES NEVER TO BE REPEATED
ALL ITEMS SOLD WITH A WARRANTY
ALL MAJOR CREDIT CARDS ACCEPTED
MANY HALF PRICE OR LESS!!!
STRAIGHT AUDIO/HOME THEATRE!!!**



ACCESSORIES, ETC.

EUPHONIA ISOLATION CONES:

Petite 30: Box of 6. Use 3 Under Amps, etc. NEW/Cased £ 60 £ 30

Grande 46: Box of 3, for Large Power Amps, etc. NEW/Cased £ 90 £ 45

FI-RAX/TARGET STANDS: Many-give us a call Ex.Demo/Mint

MONDIAL: MAGIC BOX - Improves your Picture! NEW/Sealed £ 99 £ 49

ACURUS

A250: 250W Stereo Amplifier (Black) Ex.Demo/Mint £1400 £ 850

A200X3: 3-Channel (3x200w) Power Amp. (Black) Ex.Demo/Mint £1600 £ 975

AERIAL ACOUSTICS (see pictures below for some of the models)

Model 5: Bookshelf Monitors-Pair (Maple) Ex.Demo/Mint £2900 £1495

Model 7B: ** Floorstanding Speakers-Pair (Cherry) Ex.Demo/Mint £5000 £2500

Plus Special Plinths

Model 10T: Reference Loudspeakers-Pair Ex.Demo/Mint £8700 £4350

(Santos Rosewood) including Special Plinths (Stereophile Reference listed)

CC3B: ** Centre Speaker (Natural Cherry) Ex.Demo/Mint £1800 £ 900

SW12: ** 400W Active Remote Control Subwoofer Ex.Demo/Mint £4800 £2400

with Parametric Equalizer (Rose Walnut)



	RETAIL	SALE	AVM	RETAIL	SALE
V2: Remote PreAmplifier (Black)				Ex.Demo/Mint	£1175 £ 595
M2: Mono Power Amplifiers - Pair (Black)				Ex.Demo/Mint	£1975 £995pr
CAIRN / EZO					
K5.5: ** (5 x 100w) Multi Channel Amplifier.				Ex.Demo/Mint	£1500 £ 849
6 Transformers, Bal. Inputs/Outputs (Silver)					
FOG: CD Player fitted with Upsampler (Silver)				Ex.Demo/Mint	£1100 £ 549
(Excellent Review recently - Stereophile)					
NANDA Face Nord: Preamp/Amplifier, 2 Analog Chan.				Ex.Demo/Mint	£1000 £ 499
Dual Mono, 3 Transformers, Bal In/Outputs (Silver)					
ARIA: Integrated Amplifier - Remote (Silver)				Ex.Demo/Mint	£ 450 £ 225
CHORD					
CPM 2600: Integrated Amplifier (Black)				Ex.Demo/Mint	£3500 £2495
MIRAGE					
AVS-500: ** Full Home Theatre Pack (Black L'ette)				Ex.Demo/Mint	£ 399 £ 210
FRX-S8: ** Active Subwoofer (Black)				Ex.Demo/Mint	£ 249 £ 140
HT-1: Spec.Stands for AVS-200 Satellites (Black)				Ex.Demo/Mint	£ 100 £ 40
HT-3: Spec.Stands for AVS-200 Satellite (Black)				Ex.Demo/Mint	£ 50 £ 25
OM-C2: ** Centre Speaker (Piano Black)				Ex.Demo/Mint	£ 599 £ 349
OM-R2: Rear Speakers - Pair (Piano Black)				Ex.Demo/Mint	£ 440 £ 220
PIEGA (P Series - see picture above)					
S3: Satellites with Wall Brackets, Pair (Aluminium)				Ex.Demo/Mint	£ 499 £ 250
S4: Floorstanding Speakers - Pair (Aluminium)				Ex.Demo/Mint	£1095 £ 550
S4C: ** Centre Speaker (Aluminium)				Ex.Demo/Mint	£ 440 £ 220
P4L: ** Floorstanding Speakers - Pair (Aluminium)				Ex.Demo/Mint	£1695 £ 850
P SUB 1: ** Subwoofer (Aluminium)				Ex.Demo/Mint	£1850 £ 925
P4XL: ** Floorstanding Speakers-Pair (Aluminium)				Ex.Demo/Mint	£2210 £ 1105
P5: Floorstanding Speakers (Aluminium)				Ex.Demo/Mint	£2450 £ 1295

** AWARD WINNERS / 5 STAR BEST BUYS !!!!!

LEAK SANDWICH

Rather warm sounding big infinite baffle but cheap with it. With a reasonably powerful amp can sound quite satisfying.

LOWTHER PM6A

High quality full-range driver; still manufactured. High sensitivity, as fitted to many classic horn designs.

MAGNEPLANAR SMGA

Touch dry in the bass but a technological loudspeaker with genuinely musical abilities.

MISSION 770

Father of the 77 range which continues to this day. Well mannered with a warm sound and a kind load to amplifiers.

QUAD ESL57

Unrivalled. Properly serviced there is nothing like them. Their natural presentation may make them caviar to the general.

YAMAHA NS1000M

Hi-tech favourites of the Japanese and Americans. Viewed more warily in the UK but can give excellent results.

TANNOY GRF & AUTOGRAPH

Folded horn monsters which certainly sound good if you have the space. For Tannoy vintage see HFW November 1998.

WHARFEDALE SUPER 8 RS DD

Ideal experimenters' driver. High sensitivity ~14,000 Gauss magnet and extended frequency range. Inexpensive too!

TANNOY YORK, LANCASTER

Many similar models of infinite baffle or reflex design. Not the last word in tautness but the drivers work well in modern cabinets.

VINYL

ACOS LUSTRE

Very honest piece of kit, well made and easily adjusted. Vinyl beginners could do very much worse.

ALPHASON HR100S

First class arm, up to present-day standards. Buy carefully, though, as there's no service available now.

ARISTON RD11

A one-time king of turntables very similar to the Linn LP12. Now deposed but worth a look at the right price.

LINN AXIS

Uncomplicated, lower-price version of the famous Sondek. Less expensive than some of its stablemates.

GARRARD 301 & 401

Legendary turntables, once fairly plentiful. Excellent back-up available; many different custom plinths available. High quality.

GOLDRING Lenco 88 & 99

Great deck for the kitchen table enthusiast. Garrard fans won't look at 'em but cheap and capable. Servicing available.

HADCOCK 228

Recently out-classed by Hadcock's updated 228 Special Edition but a proper hi-fi arm for all that. Makers still service.

MICHELL FOCUS ONE

20 years and still going strong. Early runner in the 'modern' turntable cycle with a first class arm. Factory servicing available.

SHURE M75

Recent line-contact improvements have left the M75 behind but the wide range of needles make it a handy tool.

SME 3009 IIS

Everlasting classic tone-arm. Spares permanently available from SME. No longer the last word but peanuts second-hand.

THORENS TD124

Best classic deck ever? Judging by the prices they fetch it's possible - 78rpm too!

THORENS TD150

Mid-price deck with a keen following. No real difficulty with servicing - novices may find the suspension system unnerving.

TRIO L-07D

Knockout heavyweight from 1980 with stainless bearing and 11lb platter! Not a giveaway and beware! - spares scarce.

TUNERS

LEAK TROUGHLINE (ORIGINAL)

Interesting ornament but no longer hi-fi. Limited coverage of 88MHz to 100MHz only.

LEAK TROUGHLINE II & III MONO

Arguably the best-sounding tuners ever. Adaptation for stereo easy via phono multiplex socket.

LEAK TROUGHLINE III STEREO

Excellent tuner with indifferent stereo decoding circuit. Best when adapted to use modern outboard decoder.

MARANTZ ST-8

Possibly the ultimate Tardis console, including an oscilloscope for checking the strength of signal. Expensive even now.



Leak Troughline II Mono
Arguably the best sounding tuner ever

beyer dynamic



AURAL STIMULATION

Distributed by: Henley Designs
01235 511166 www.henleydesigns.co.uk
e-mail: info@henleydesigns.co.uk

MANTRA AUDIO
Specialist Suppliers of Audio Accessories
www.mantra-audio.co.uk

CARTRIDGE SELECTION		STYLUS	REPLACEMENT STYLUS	
Goldring			Swiss Quality Diamond Stylus	
1006	£76	£62 GEX	£52	ADC XLM Mk III £10.00
1012 GX	£95	£76 GEX	£67	Alkalai AN 5, AN 60 £12.00
1022 GX	£124	£100 GEX	£86	AN2, AN 70 £14.00
1042	£143	£114 GEX	£100	Dual DN 145 E, DN 165 E £16.00
Eroica LX/H	£133	£109 GEX		Goldring G800 £14.00
Elite	£232	£190 GEX		JVC DT 55, DT 60 £12.00
GEX - Exchange price for a Goldring Any make/model of cartridge accepted				
Audio Technica				National EPS 24 CS, P 30 D, P 30 D £12.00
AT 95 E	£23		£15	Ortofon FF 15 E II, VM6 20 E II, OM 20 £16.00
AT 10 E	£28		£16	Pioneer FN 210, FN 220, FN 240 £12.00
AT OC 9 ML	£330		£280 EX	Shure N 75 C, SC 35 C, N 75 ED T2, N 75 EJ T2 £16.00
Denon				N 95 ED, N 95 EJ, N 75 3 (78) £16.00
DL 110	£79			VN 35 E £18.00
DL 160	£95			N 95 HE, N 97 HE, VN 35 HE £25.00
Grado				Sony ND 142 G, ND 155 G, CN234 £12.00
Prestige Black	£40			ND 143 G, ND 150 G, ND 200 G £14.00
Prestige Gold	£110			
Ortofon				*** Over 500 Stylus Types Stocked ***
510 Mk II	£34		£22	HEADPHONE SELECTION
MC 15 Super II	£130		£110 EX	GRADO
MC 25 FL	£227		£193 EX	Prestige Series
MC 10 Supreme	£304		£258 EX	SR-60 £85
MC 20 Supreme	£382		£323 EX	SR-80 £104
MC 30 Supreme	£452		£385 EX	SR-125 £152
Kontrapunkt B	£643		£548 EX	SR-225 £199
Rohmann	£837		£742 EX	SR-325 £294
Shure				Reference Series
M 97 XE	£98		£58	RS-1 £641
V 15 V XMR	£304		£204	RS-2 (net) £495
Sumiko				
Blue Point Special	£265		£237 EX	
EX - Exchange price for MC from above companies				
All items guaranteed authentic new originals see our website for full selection of accessories order direct from our secure online catalogue				
MAIL ORDER (1-10 DAYS) PRICES (INC P&P) + INSURANCE FOR UK DELIVERY - £5 FOR EUROPE DELIVERY & £12 FOR US WORLDWIDE DELIVERY TO COVER INSURANCE ON ORDERS OVER £50 VALUE				
Tel/Fax (01757) 288652 e-mail: enquiry@mantra-audio.co.uk				
MANTRA AUDIO (HFW), 22 GARTH AVENUE, NORTH DUFFIELD, SELBY, NORTH YORKS YO8 5RP				

"The Best in New, Second Hand and X-Dem Equipment"

H I - F I

HOME CINEMA

MULTIROOM INSTALL

BUY / SELL



Choice hi-fi
you choose

Choice hi-fi make it easy for you to fulfill your sonic dreams. Quality hi-fi is not just about expensive brandnames. It's about aspiring to the very best sound, about choosing your ideal system from the widest selection in the country, in a unique no-pressure environment.

your choice

- * Acoustic Energy
- * Advantage
- * ATC
- * Audible Illusions
- * Audio Physic
- * B.A.T
- * Boulder
- * Bryston
- * Cary
- * C.A.T.
- * Chord
- * Clear Audio
- * Denon
- * DNm
- * Egglaston Works
- * Electrograph Delphi
- * Genelec
- * Gryphon
- * Graham
- * Imerge
- * J.M. Lab
- * Krell
- * Lexicon
- * Linn
- * Loewe
- * Lutron
- * Lyra
- * Mark Levinson
- * Michell Eng.
- * Musical Fidelity
- * Naim
- * NEC
- * Nordost
- * Oracle
- * Ortofon
- * Plinius
- * P.M.C.
- * Primare
- * Project
- * Quadraspire
- * REL
- * Rokport
- * Roksan
- * Rotel
- * Ruark
- * Selec
- * SME
- * Straight Wire
- * Sugden
- * Tara Labs
- * Teac
- * Totem
- * Transfiguration
- * Trichord
- * Trilogy
- * Van den Hul
- * VPI
- * Wilson Audio
- * Wilson Research
- * YBA

Quarterly Sale items

	Our Price	Original Retail Price
Kenwood L1000C pre/ L1000M Power Amp	£795.00	£2,500.00
Exposure VII pre + XII psu	£595.00	£1,200.00
Harmon Kardon AVPI	£175.00	£ -
Cary 572 se Monoblocks	£1,295.00	£2,350.00
Dynalab SDA 2.8	£195.00	£600.00
Magnum Dynalab P 200 Pre	£695.00	£1,900.00
Trilogy 901 Pre	£395.00	£995.00
Quad FM4 Tuner	£225.00	£450.00
DPA enlightenment DAC	£395.00	£ -

New this month

POWER AMPLIFIERS

Plinius SA 102 "new"	£On Dem	£3,750.00
Audio Research D200	£1,795.00	£3,400.00
Krell KSA 250	£2,995.00	£6,000.00
Musical Fidelity P180 + CRPS	£895.00	£1,600.00
Musical Fidelity P180	£450.00	£900.00
Musical Fidelity CRPS	£495.00	£900.00
Vincent TAC SV236 integrated	£On Dem	£1,195.00
Bryston BSST	£On Dem	£2,350.00

PRE AMPLIFIERS

Audio Research LS7	£995.00	£1,800.00
Audio Research SP16L	£1,695.00	£1,999.00

LOUDSPEAKERS

Audio Physic Luna Sub (wood)	£On Dem	£1,799.00
Audio Physic Tara	£On Dem	£999.00
Avant Garde Acoustics Trio	£11,995.00	£17,000.00
Vienna Acoustics Mahler	£On Dem	£6,000.00
Vienna Acoustics Mozart	£On Dem	£3,500.00
Vienna Acoustics S.1	£On Dem	£2,170.00
Cabasie io S.1	£On Dem	£2,170.00

CD PLAYERS & DACS

YBA CD 3 Delta	£On Dem	£2,200.00
Audio Alchemy Drive 3/ DDE 3/ PSU 3	£895.00	£ -
Alchemist Kraken 24 bit CD	£795.00	£1,600.00
Audiomeca Damnation CD Transport	£750.00	£1,600.00
Wadia 830 (inc digital i/p board	£1,995.00	£3,600.00
Vincent TAC CD S3	£On Dem	£1,300.00

Power amplifiers

Michaelson Audio Odysseus	£695.00	£1,500.00
Jadis Defy 7 mk III	£2,750.00	£6,000.00
Mark Levinson No 27	£2,495.00	£6,000.00
Linn Treble Active Card	£69.00	£120.00
Linn Bass Active Card	£69.00	£120.00
Audio Research VT150se Monoblocks	£7,995.00	£16,800.00
Cello Duette 350	£4,995.00	£10,000.00
Trilogy 948	£995.00	£2,000.00
Audio Research D125	£1,795.00	£5,000.00
Gamut D200 "new"	£On Dem	£3,250.00
Primare A20 Integrated	£395.00	£750.00
Musical Fidelity P15	£1,395.00	£2,500.00
Audio Innovations S1000 mk III monos	£1,395.00	£3,000.00
Krell Kav 500i	£3,495.00	£5,498.00
Krell FPB250M	£6,450.00	£10,000.00
Krell MDA 300	£4,995.00	£12,000.00
Oracle S3000 Integrated "new"	£5,995.00	£9,950.00
Cary SLA 70 mk II Silver	£1,295.00	£2,250.00
Linn LK 100	£345.00	£650.00
Boulder 500 AE	£795.00	£3,500.00
Acuphase E203 Integrated Amp	£5,995.00	£9,990.00
Krell FPB 300	£895.00	£1,030.00
Linn Klassik CD/Amp silver	£On Dem	£16,500.00
Boulder 1060 Power "new"	£3,495.00	£5,304.00
Cary Audio 300 SE Sig. VVE300B	£1,350.00	£1,500.00
Primare 30.1 mk II Integrated	£2,995.00	£4,698.00
Krell 250 A/3 3 Chapel amp	£On Dem	£5,995.00
YBA Passion Stereo "new"	£995.00	£2,400.00
Sunfire 300 Power Amp	£995.00	£2,400.00
Plinius 250 mk IV "new"	£On Dem	£6,000.00
Cary 805 C Monoblocks "new"	£On Dem	£8,250.00

AV components

AV COMPONENTS

Linn Klassik DVD	£On Dem	£2,000.00
Krell HTS (AV Processor)	£4,495.00	£6,498.00
Audio Refinement Pre 5 "new"	£On Dem	£895.00
Audio Refinement Multi S (Power) "new"	£On Dem	£2,250.00
Lexicon MC1 "new"	£3,500.00	£5,500.00
Lexicon MC12 / MC12B	£On Dem	£8100.00/ £8900.00

TELEVISIONS & DVD PLAYERS BY LOEWE

Loewe Xemix DVD "new"	£On Dem	£495.00
Loewe Aconda	£POA	£ -
Loewe Planus + Std	£POA	£ -
Loewe Xelos + Std	£POA	£ -
Loewe L2A Active Speakers	£POA	£ -

PLASMAS/LCD/PROJECTORS

From NEC/ Panasonic/Pioneer/Sharp from	£4000.00	POA
Electrograph/Delphi/Selec/Sony/Sanyo	-	POA
Panasonic TH-42 PWD4 "new"	£4,995.00	£ -

Pre amplifiers

Audio Research LS1	£945.00	£2,000.00
McCormack Line Drive	£395.00	£995.00
Audio Research LS15	£2,250.00	£3,400.00
CAT SLI (Black)	£2,595.00	£4,995.00
Audio Synthesis Passion 8m ball/ remote	£995.00	£1,895.00
Audio Research LS3	£1,095.00	£1,997.00
Musical Fidelity F22	£695.00	£1,500.00
Audible Illusions P3Amc	£2,450.00	£3,400.00
Audiolab 8000 Q Pre	£695.00	£1,295.00
AVI S2000 MP remote pre	£495.00	£1,000.00
Mark Levinson 380 S	£4,250.00	£6,900.00

Krell KSL 2 Pre	£1,750.00	£3,000.00
Cary SLP98L Remote Pre x-dem	£1,795.00	£2,794.00
Boulder 1012 (pre amp/ 24.96 dac/ Phono)	£On Dem	£13,000.00
Krell KSL + Phono	£1,295.00	£ -
YBA I Alpha Pre mm/mc + psu "new"	£On Dem	£4,900.00
YBA Passion Pre + mc "new"	£On Dem	£5,595.00
Boulder 2010 Pre	E.P.O.A.	£30,000.00
Plinius 16L "new"	£On Dem	£3,200.00
C.A.T. ultimate reference Pre Amp Inc/Phono "new"	£On Dem	£3,750.00
Audible Illusions P3A Pre MM/MC mk II "new"	£On Dem	£3,140.00
Naim 42.5	£150.00	£450.00

PURE POWER AMPLIFIERS

Musical Fidelity F15/ F22	£1,995.00	£4,000.00
Audio Innovations S1000 monos/ L2 Pre	£1,595.00	£3,700.00

Quality speakers

JM Lab 926 (x-demo)	£1,750.00	£2,149.00
JM Lab Sib & Cub (5.1 spk sys)	£On Dem	£859.00
Blue Room Minipod (VWhite)	£225.00	£298.99
Blue Room Minipod + Sub (Blue)	£625.00	£749.00
Blue Room Minipod Sub	£415.00	£468.99
REL Stentor II	£1,295.00	£2,000.00
JM Lab Mini Utopia + Std (Rosewood) "new"	£2,995.00	£5,780.00
REL Stentor (Walnut)	£695.00	£1,500.00
SD Acoustics SD1	£695.00	£1,650.00
Martin Logan SL3	£1,995.00	£3,399.00
JM Lab Cobalt 826	£On Dem	£1,279.00
B+W DM 602 S2	£195.00	£330.00
ATC SCM 20A	£1,995.00	£3,300.00
Audio Physic Avanti III X-dem	£6,499.00	£7,499.00
Genelec 205 Active Monitors	£On Dem	£750.00
Audio Physic Virgo III "new"	£On Dem	£4,000.00
Thiel 7.2	£12,495.00	£18,799.00
JM Lab Utopia (Ex Dem)	£1,395.00	£3,200.00
Audio Plan Contrast 3	£6,995.00	£12,000.00
Avalon Ascents	new	£3,899.00
JM Lab Micro Utopia + Std Blk	£5,499.00	£7,799.00
JM Lab Mezzo Utopia	£On Dem	£2,000.00
Audio Physic Tempo III "new"	£1,295.00	£2,225.00
Naim SBL's	£5995.00 *	£14,500.00
ClaraVox Magnifica	£On Dem	£1,749.00
Audio Physic Spark "new"	£330.00	£430.00
Rogers LS55 "new"	£795.00	£1,200.00
ATC SCM 10 +stds		

CDplayers & DACS

Audio Research CD2	£1,895.00	£3,499.00
Marantz CD7	£2,795.00	£3,500.00
Primare V20 DVD/CD	£750.00	£1,000.00
Perpetual Technologies Dac + Correction Engine PSU	£1,495.00	£2,000.00
Meridian 508/20	£995.00	£1,800.00
Mark Levinson No 39	£3,495.00	£5,000.00
Mark Levinson 3905 (upgrade)	£4,995.00	£6,495.00
Audio Aero 32/192 Capotele CD	£On Dem	£4,500.00
Micromega CD3 + Duo dac	£995.00	£3,000.00
Primare V25 CD/DVD	£On Dem	£1,000.00
Thule Spirit CD	£695.00	£900.00
Wadia X 64.4 AT&T/ Bal	£1,595.00	£5,000.00
Theta Pro Geny	£595.00	£1,295.00
YBA CD I Delta "new"	£On Dem	£4,400.00
Tag Maclaren CD220R	£995.00	£1,500.00
Audio Lab 8000 DAX	£995.00	£1,600.00
Mark Levinson 30.5/ 31	£9,995.00	£24,000.00
Oracle CD2000 Transport	£4,495.00	£7,500.00
Sony CDPRI/ DAS R1	£2,495.00	£6,000.00
Krell KPS 25s 24/96	£14,995.00	£22,500.00
Acuphase DP70V	£1,895.00	£ -
Acuphase 90/91	£6,999.00	£16,000.00
YBA CD Speciale	£395.00 *	£675.00
Boulder 2020 dac	E.P.O.A.	£24,000.00
Krell KPS 25c	£16,995.00	£23,498.00
Theta Data II Transport AT + link	£1,995.00	£4,000.00
YBA CD Integre "new"	£On Dem	£1,195.00

Turntables & analogue

Nordost Quattrofil Tonearm Cable	£399.00	£800.00
SME 30/2 A "new"	£10,495.00	£12,289.00
Moth Record Cleaning m/c	£ -	£395.00
Project RPM4/ Ortofon S10 "new"	£On Dem	£325.00
Project RPM9/ Ortofon Rohmann "new"	£On Dem	£2,050.00
Ortofon Rohmann	£On Dem	£1,050.00
Adjuster Racks (Aluminium/ Perspex)	£On Dem	£1,050.00
Pierre Lurne J1/ SL5	£1,695.00	£4,000.00
Michel Iso Phono + Hera	£325.00	£495.00
Ortofon Kontrapunkt a/b "new"	£On Dem	£500.00

Michell Gyro SE/ RB300 "new"	£On Dem	£1,100.00
Elemental 4 Tier (Fixed)	£1,295.00	£2,000.00
Roksan Shiraz	£450.00	£1,000.00
Michell Orbe/QC	£1,495.00	£2,200.00
Audio Synthesis Phono Eq mm/mc	£795.00	£ -
Voyd Valdi/ Orion	£695.00	£ -
Gryphon Phono Pre-Amp (dual mono) Head Amp	£795.00	£1,600.00
Parasound TQ1600 (remote tuner)	£295.00	£400.00
SME Series V Arm "new"	£1,350.00	£1,650.00
Wlme Benesch Act 2 arm	£895.00	£1,400.00
Musical Surroundings Phenomena Phono Stage	£495.00	£ -
Pink Triangle PT SA/RB300S/Na	£795.00	£ -
Plinius 14 Phono "new"	£On Dem	£2,750.00
Transparent Audio Music Wave Ultra XL Bi-Wire	£1,895.00	£4,000.00
Cary PH301 MM/MC	£895.00	£1,695.00
Nackamichi DR 3	£225.00	£400.00
Tom Evans - The Groove "new"	£On Dem	£1,795.00
Clear Audio Reference Mc phono stage X-demo	£1,695.00	£2,065.00
Rega Planer 3 + Hi Fi News Out Board Power Supply	£320.00	£423.00
Clear Audio Synphono phono stage X-demo MM/MC	£640.00	£740.00
Lavardin Reference Phono "new"	£On Dem	£2,500.00
Linn Akito	£150.00	£250.00

* Reduced this month

tel: 020 8392 1959 & 020 8392 1963
fax: 020 8392 1994 info@choice-hifi.com

Open from 10am to 6pm Mon-Sat and other times by appointment.

Buy, sell, exchange quality hi-fi equipment.

We accept a World Radio History cards. Finance available subject to status

diy supplement/contents

Contact Numbers
Mon-Fri 9am-5pm

WEBSITES
www.worldaudiodesign.co.uk
www.hi-fiworld.co.uk

Editor
Nick Lucas
tel/fax: +44 (0) 1908 218 836
e-mail: nick@worldaudiodesign.co.uk

Design & Layout Editor
Faiza Chunara
tel: +44 (0)20 7625 3129
fax: +44 (0)20 7328 1844
e-mail: adproductions@hi-fiworld.co.uk

Production/Photography Editor
David Noble
tel: +44 (0)20 7625 3134
fax: +44 (0)20 7328 1844
e-mail: classifieds@hi-fiworld.co.uk

Contributors
Andy Grove

Advertising
Amanda Sweeney
tel/fax: +44 (0)20 8864 4760
e-mail: advertising@hi-fiworld.co.uk

Accounts
tel: +44 (0)20 7625 8032
fax: +44 (0)20 7328 1044

Credit Control
Louise Palfrey
tel: +44 (0) 1923 270 033
fax: +44 (0) 1923 260 588
e-mail: subscriptions@hi-fiworld.co.uk

Technical Editor
Noel Keywood
e-mail: publisher@hi-fiworld.co.uk

Private & Trade Classified Ads
tel: +44 (0)20 7625 3134
fax: +44 (0)20 7328 1844
e-mail: classifieds@hi-fiworld.co.uk

Subscriptions & Back Issues
9:30am - 12:00 noon
tel: +44 (0) 1923 270 833
fax: +44 (0) 1923 260 588
e-mail: subscriptions@hi-fiworld.co.uk

News & Letters Email
e-mail: diynews@hi-fiworld.co.uk
e-mail: diyletters@hi-fi-world.co.uk

WORLD AUDIO DESIGN
Technical Manager - Nick Lucas

www.worldaudiodesign.co.uk
tel/fax: +44 (0) 1908 218 836
e-mail: nick@worldaudiodesign.co.uk

Distributed by
Comag Magazine Marketing,
Tavisstock Road, West Drayton,
Middlesex UB7 7QE
Tel: +44 (0) 1895 444 055

Printed by
Southern Print, Dorset
Tel: +44 (0) 1202 622 226

Our Agents in Malaysia
Millennium Hi-Fi & AV
Simon Chang
Showroom & office, 500-1-3 First Floor
Wisma Indah (Shen Court), Jalan Tun Razak
50400 Kuala Lumpur, Malaysia
Tel: 603 9283 8171 Fax: 603 9281 3762
e-mail: info@millennium-audio.com

All unsolicited submissions and goods are at the owner's risk. We accept no responsibility for such submissions, nor do we undertake to return them.

No material may be reproduced from this magazine without the publisher's written permission.
© Audio Publishing Ltd

No. 70

december 2002



NEWS 97

All the latest from the weird and wonderful world of diy hi-fi.

BARGAIN BULBS 98

Nick Lucas describes our new KLC bargain priced valve amp kit.

BOOK REVIEW 103

Understanding Hi-Fi Circuits by Norman Crowhurst - Reviewed by Andy Grove.

LETTERS 105

Correspondence from our DIY readers.

www.hi-fiworld.co.uk

HI-FI WORLD
SUITE G4, ARGO HOUSE
KILBURN PARK ROAD
LONDON, NW6 5LF

WHITE NOISE

AUDIO KITS, MODULES, COMPONENTS

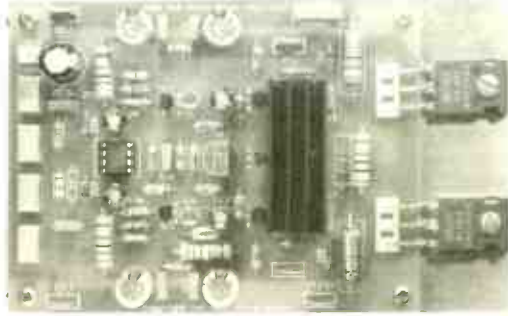

PRODUCTS INCLUDE:- Power Amplifiers 30-250W, Preamplifiers, Phono stages, Active Crossovers, Power Supplies, Buffer Amplifiers, Balanced line drivers / receivers, Stepped attenuators, Gold plated connectors, Cables, Capacitors, Resistors, Semiconductors, Transformers, Subwoofers, Loudspeaker drive units

WHITE NOISE
11 STATION ROAD
BEARSDEN
GLASGOW
G61-4AW

Web:- <http://www.wnaudio.com>
Email:- david.white38@ntlworld.com
Tel:- 0141-942-2460 (until 9pm)
Fax:- 0141-587-7377

*Rediscover
the beauty of
pure sound....*

NEW!
Visit our web site at
www.chelmervalue.com
to view our entire valve
catalogue and buy on
line!

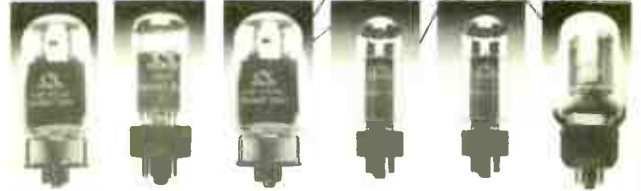

We have been supplying tubes to the audio market for over 40 years. Only valves that pass our stringent in house QC tests are used for the CVC Premium brand, and our no fuss guarantee ensures your complete peace of mind. When available, we also stock the justifiably famous brands such as Brimar, GEC, Mullard, RCA Telefunken etc. So why compromise? Our sales and technical staff are just a telephone call away. To put it simply.....

YOUR NEEDS...OUR BUSINESS.

CVC Chelmer Valve Co Ltd

The Stables, Baddow Park, Great Baddow,
Chelmsford, Essex CM2 7SY
Tel: +44 1245 241300 Email: sales@chelmervalue.com
Fax: +44 1245 241309 www.chelmervalue.com

audioXpress... It Just Sounds Better

Your Favorite Audio – One New Magazine!

PROJECTS

REVIEWS

THE NEWEST
TECHNOLOGIES

AUDIO
CLASSROOM

and Much More!



**Only \$59.95 us
for 12 Issues!**

Subscribe To This
Great Monthly
Publication Today!

audioXpress • PO Box 876 • Peterborough, NH
03458-0876 USA • Phone: 603-924-9464

Fax: 603-924-9467 • E-mail: custserv@audioXpress.com

ORDER
ONLINE AT: www.audioXpress.com

TECHNICAL & GENERAL

SOME NECESSITIES - FROM THE ORIGINAL CLASSIC TURNTABLE SPECIALISTS

CONNOISSEUR				P&P
	BD1/2 Drive Belt		£12.60	£1.90
	BD1/2 Motor Suspension kit		£15.50	£2.50
	SAU 2 Headshell		£18.50	£2.90
	SAU.2 Connecting Lead		£16.50	£3.20
GARRARD STANDARD MODELS				
	Wired arm tubes	from	£14.50	£2.90
	Cartridge carriers (sliders)		£12.50	£1.90
301/401 Transcription models				
Original	Thrust pad assembly		£13.50	£2.50
Original	Idler tension spring		£3.65	£1.90
Original	Brake pad		£3.40	£1.90
Xeroxcopy	Owners Manual 301 incl full size mounting template		£9.30	£1.90
	401		£7.20	£1.90
Replacement	301 control knobs On-Off/Speed select	pair	£21.50	£2.90
Replacement	301 suppressor unit		£7.20	£2.50
Replacement	301 motor pulley (-2%), (-1%), (Std), (+1%)	each	£16.50	£2.50
Replacement	301 Chrome mounting bolts nuts, washers.	set	£7.85	£2.50
Recommended	Lubrication set - early 301 or 301/401	(specify)	£7.20	£1.90
GOLDRING/LENCO				
	Idler wheel (lock-nut or clip fixing)		£22.50	£2.90
	Tension spring		£3.85	£1.90
	Arm pivot bearings - with fitting instructions		£9.85	£1.90
	Spindle/Main bearing assembly	GL.69/72	£21.00	£3.90
		GL.75/78	£26.50	£3.90
	Chassis suspension springs (set of 4)	set	£21.25	£3.90
	Headshells	from	£23.25	£2.80
	Instruction books	from	£5.20	£1.90
THORENS				
	TD.124 series			
	Idler wheel original		£29.50	£2.90
	Idler wheel our redesigned replacement		£16.50	£2.90
	Drive belt		£24.65	£1.90
	Suspension rubbers ('mushrooms')		£17.50	£2.90
	TD.150/160			
	Drive Belt		£19.35	£1.90
	Suspension springs (-1%), (Std), (+1%) (set of 3) set		£14.50	£2.90
	Suspension - main bushes (set of 3)	set	£14.50	£2.90
	Armboards TD.150 blank		£12.50	£2.50
	TD.160		£10.20	£2.90
	CECIL WATTS Dustbugs & spares - incl. Preener wicks			

Cartridges and styli for 78s and Mono LPs in addition to current Stereo LPs

TECHNICAL & GENERAL
PO BOX 53, CROWBOROUGH, EAST SUSSEX, TN6 2BY
TELEPHONE: 01892 654 534

VISATON'S NEW RELEASE

Visaton Loudspeakers from Germany have released a high-end series of shelf-mounted loudspeaker kits. The ARIA 1 is a two-way system using their G20SC tweeter and the titanium coned TI-100; both units are magnetically sealed. The ARIA 2 uses one G20SC tweeter and 2 TI-100s per 'speaker. The ARIA DIPOL 1 is equipped with three G20SCs and one TI-100. This one is switchable, to use in a dipole or in a direct radiating set-up. These speakers are ideal for surround-sound systems and in home cinema. The kits are available from:-

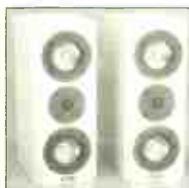

A pair of ARIA 2

Wilmslow Audio Ltd on
01455 286603.

Visatons site is www.visaton.com

FRANCOPHILE AUDIOPHILE

This site has to be seen to be believed. It's not the best site layout, but the picture content is the selling point. It will take a little while to download the homepage as all the pics are provided in 60kB jpegs and there are about 20 of them. The site details the visit of a man to the hi-fi room of Gilles Molinier. As the supplied picture suggests he is into his hi-fi. All the amplifiers and speakers shown are home made.



What a system!

website - <http://www3.sympatico.ca/rsf/France.htm>

"A" IS FOR AUDIO-GRADE

New from "A" Audiosolutions is Lundahl transformers. Their range includes matching, input, interstage, mains and output C-core transformers manufactured in Sweden. Their output transformers are manufactured to suit most valve types in push-pull and single-ended applications and are air gapped to suit individual applications. The primaries are multi-section and can be configured to give different impedance's. Lundahl have a world wide following in studio and professional fields. Typical price for 300b or 2A3 single-ended output would be £100 plus carriage.

Also available is Dynamicap. Manufactured in the USA, this premium range of polypropylene signal and crossover capacitors are available with a plastic wrap finish and also a coated finish, each giving slightly different results - one is much sweeter, the other more dynamic. They are wound to give minimal 'time smearing' using a very special technique. Typical price for 0.1uf £10 each.

"A" Audiosolutions
01977 798844

WHO IS TONY WELSH?

A wonderful home-made site that sells unusual audio grade bits and bobs, obviously a passion for Tony Welsh the owner. He sells power tubes and hi-end audio tubes. For example a 6C33C-B sells

for £13.95. There are valve sockets, Russian ceramic and military capacitors and Russian paper-in-oil capacitors for high voltage power supplies. Also sold are CT hand keys (telegraphy equipment) and vintage computers.

website - <http://www.tonywelsh.com>



A 6C33C-B valve



a 6C33C-B valve socket

VALVES EXPLAINED

This is a great site, simply laid out, detailing all the different types of valves out there. If you ever wondered what a plotron or electron-ray tube is, then this little gem will give you a brief, but concise outline. There also lots of circuits and drawings to back up the text.

www.du.edu/~etuttle/electron/elect27.htm

OUTBACK KITS

Based in Victoria, Australia, Aksa are makers and suppliers of audio grade kit sets. As the site explains, "The Aksa family of amplifiers use solid-state sophistication and efficiency to produce a valve sound." Their range consists of the Aksa 55, a 55Watt amplifier module, the Aksa 100, a 100Watter, a TLP, a unity gain, valve pre-amplifier module and the Alcsomics, a two-way bass reflex speaker. Please

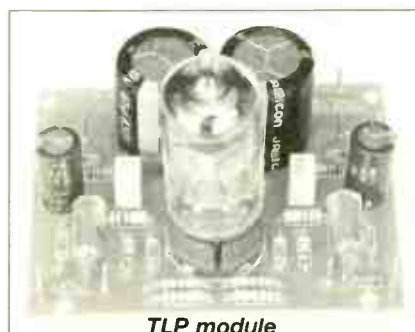

TLP module

note the modules do not come with power supply modules, which are left to you. This is a well thought out site and you can buy on-line.

www.aksaonline.com

BARGAIN BULBS

If you've always thought of valve amps as temperamental and expensive beasts, think again. World Audio Design's latest kit is designed with the budget conscious beginner in mind, explains Nick Lucas.

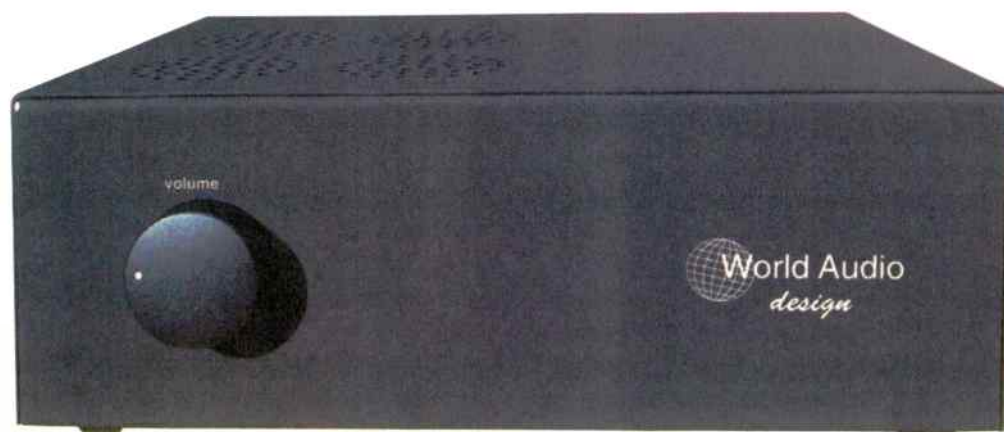

The Kecl82 was created from a brief that demanded simplicity, ease of build and a super low cost. In order to achieve a reasonable power output we went for a push-pull amplifier.

To satisfy the simplicity aspect we went the four-valve route, with two tubes per channel. The valve would have to be a triode/ output pentode type, rather like the one we use in our classic HD83, the ECL86, but due to the higher cost of this particular valve, it was not to be. Consequently, we chose the ECL82, used heavily in the valve's heyday in radios, record players and TVs. This tube is readily available and has a good sound, together with a good price. In push-pull mode it delivers about 9Watts. Remember this is a budget amplifier and has been devised to give the true beginner the opportunity to build a valve amplifier without breaking the bank, or his back for that matter - valve amps are renowned for their heavy weight.

The Kecl82 has a voltage supply of 235Vdc, half that of our 6550 kits, and each tube consumes around 30mA, not as scary as your everyday valve amplifier kit that may provide, say, 30Watts. You would in fact be surprised as to how loud the amp goes, all the same. In an early test of

the prototype I used Quad ESL988s, which have low sensitivity. I still achieved a good listening level without any break-up. But realistically you need a speaker of around 89dB or above. This is possible at a budget price - try the smaller Triangle models, or a Tannoy mX3 or even one of the older Missions like the 773e.

Alternatively, if you want to try a kit loudspeaker check out the Adire Audio HE10.1, as reviewed in our October 2002 issue.

Experience has shown me it is unwise to shortcut on output transformer quality. It is a high cost item that needs to be kept that way

to preserve tonal purity. We maintained full quality here; the output transformers are multi-layer, segmented types with plenty of metal in the core.

Savings made were in the chassis. There's no anodised front plate, chromed knobs or transformer caps, just a simple but elegant black box. You will see that the front has only a volume control, and it is fed by one pair of phono sockets. A selector and tape/source switch were not used in this amplifier as they are tricky to wire up, and the aim was to make it easy to build. In fact, in many ways the Kecl82 would be great powering

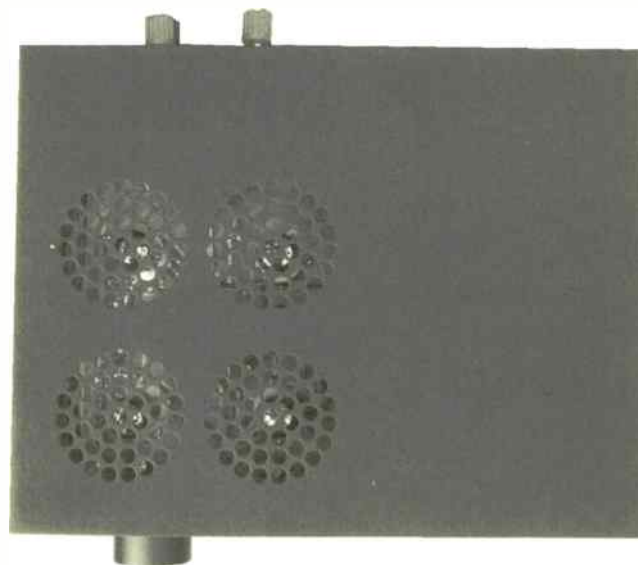

Bird's eye view of the Kecl82

Kecl82 Valve Amplifier

Signal circuit (one channel)

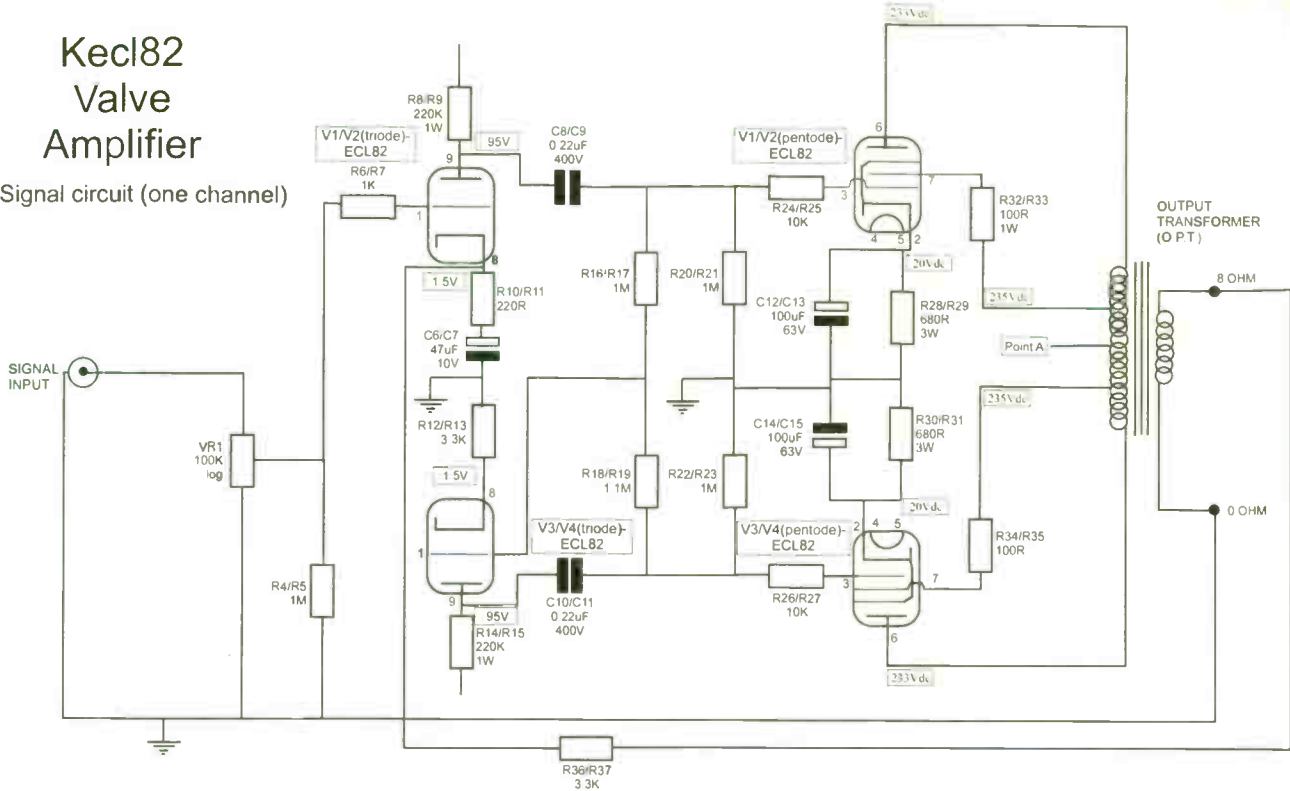

Power supply unit (both channels)

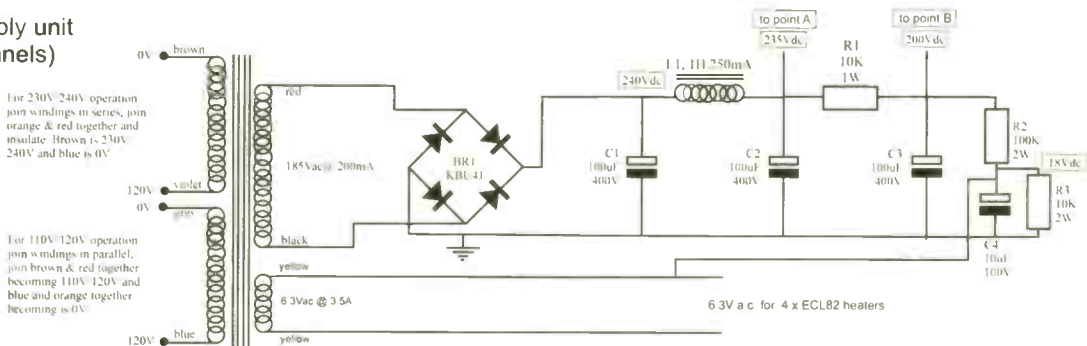

VALVE PIN LAYOUT

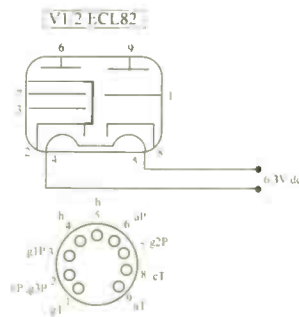

Views are from underneath valve or valve holder
 h = heater hct = heater centre tap c = cathode a = anode g1 = grid 1 g2 = grid 2 g3 = grid 3 (1 = triode P = pentode for V1)

a second system, using a CD player as a source, and will definitely give you a taster of what valves can offer.

CIRCUIT DESCRIPTION BY ANDY GROVE

The Kecl82 kit amplifier follows conventional practice, using the Russian version of the trusty ECL82 triode-output pentode valve. This is a

sweet little valve which has made an appearance in vast numbers of TVs, record players and radios over the years. The pentode section was used as a scan valve in small black and white TV sets, as well as an audio output valve. There is a slightly more powerful version, the ECL86, but these aren't so easily available, and I think that the only ones around are

either N.O.S. (New Old Stock) or from obscure and possibly suspect sources.

The two triode sections are set up as a Floating Paraphase phase splitter, with an unbalanced bridge instead of the usual T network of resistors. The imbalance of resistor values between R16/R17 and R18/R19 makes up for the finite gain

of the actual inverter valve, thereby giving a balanced push-pull voltage to the output valves. Incidentally, there isn't enough HT (due to maximums imposed by the output valves) or gain available from the triode sections to use much else but the floating paraphase arrangement. The output valves are set up with a bit of Ultra Linear to the screen grids. This linearises the valves and reduces screen dissipation at high output levels. Feedback is taken from the output transformer secondary in the usual way and fed to the cathode of the input valve.

The power supply is again conventional, with a solid-state bridge and CLC filter for the main HT voltage and a bit extra for the input stage to keep hum down.

THE KIT

The Keci82 is extremely compact measuring 30cm wide, 23.5cm deep and 11cm height with feet and is entirely self enclosed. Do not fear, the valves are visible through the four upper circular vent holes (one directly above each valve) and two on both sides, so you don't have to take the lid off to impress your friends with the valve glow.

Designed with budget in mind we have kept the look simple with the minimalist front panel holding the volume potentiometer, crowned with a good looking plastic knob from Cliff. The two-part chassis is constructed from 1.6mm mild steel with a durable black powder coat finish. The whole unit is very sturdy but manageable, weighing in at 9kgs.

The signal input is in the form of a pair of gold plated RCA phono sockets that sit at the rear of the chassis. The speaker sockets accept 4mm banana plugs as well as bare wire. The mains switch is positioned at the rear of the amplifier, on the

right hand corner for easy access. This avoids problems with hum pick-up from the mains wiring close to the input valve, a potential problem when the mains switch is situated on the front panel. Mains power is received via an IEC lead. The rear panel also sports an earth post.

THE BUILD

The design and the assembly of the Keci82 is based on a printed circuit (PCB) board, a method that favours easy build as component-to-component connections are done for you in the form of PCB tracks. There is a school of thought that says valves and PCBs do not mix well which is true to a certain degree. Valve amplifiers that use the larger octal base valves (KT88, EL34) and UX4 base valves (300B, 2A3) tend to generate a lot of heat and have quite a high current passing through the tracks. The heat generated in the thin copper tracks can physically distress some boards. However, small amplifiers such as our Keci82 and our Kel84 and pre-amplifiers like our PRE II and PHONO II use B9A (9 pin) valves. These tend to operate at much lower currents and emit a fraction of the heat.

The PCB is easy to follow with all component names, locations and orientations shown clearly. "Orientation" I hear you say! Fear

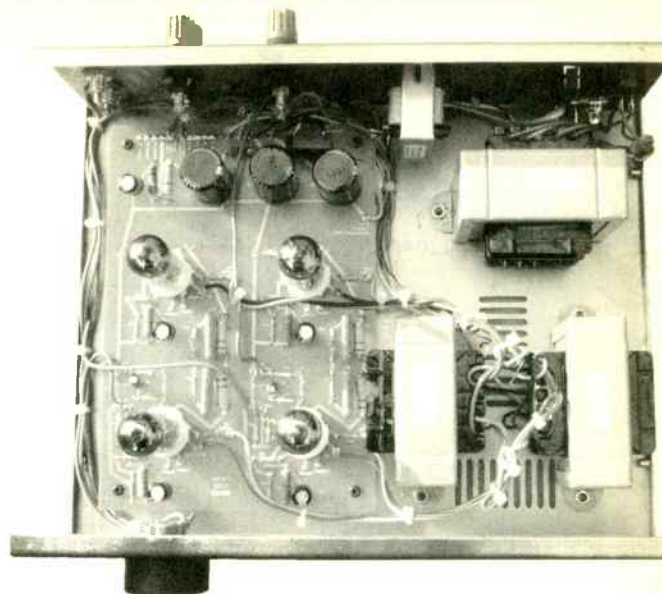

Internal view of the Keci82

not, this applies only to the electrolytics and the bridge rectifier, marked on the board with a "+". Diagrams are provided that illustrate what lead of the component the "+" applies to. On the solder side of the PCB, you will have to wire up the heaters. These are clearly marked as well. Once the board is in place there are twenty five external joins to make, not a tall order as terminal pins are used, so the leads can be wrapped around them before soldering.

The Keci82 has a low hardware component count, adding to its simplicity, with only the phono sockets, speaker sockets, IEC/switch socket, earth post, and the transformer complement, comprising choke, mains and two output transformers. Of all these parts only the two output transformers have to be orientated a specific way, 180 degrees of each other. All that remains is the IEC/switch to be wired in and the volume potentiometer.

The amplifier requires no set up, you just turn it on. It is self biased too, so valves can be changed

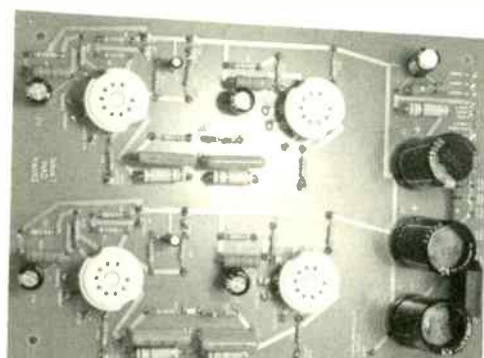

Component side view of populated printed circuit board the Keci82.

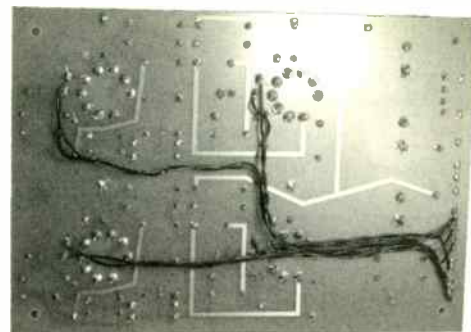

Solder side view of populated printed circuit board the Keci82.

without any need for adjustment.

The kit will come with comprehensive instructions taking you through the build step by step. Numerous diagrams and pictures are provided to help you along the way. We have a help-line manned 9.00am - 5.30pm Mon-Fri, e-mail assistance and a back-to-base repair facility that won't cost the earth.

SOUND QUALITY BY SIMON POPE

The Keci82 is a bit of a steal at the price. Its sound quality at least equals any £600 amplifier you can name on the market, plus it has all the sonic virtues that come with a pure valve amp design.

Indeed, purity is the key to this amplifier's design and sound. Because there's very little to get in the way of the signal what you get is an

exceptionally sweet and simple sound that also has a superbly wholesome roundness to it. A high quality recording of Mahler's Das Lied Von Der Erde on Reference Recordings showed that the Keci82 faithfully reproduced all the depth and space of a full symphonic orchestra without any problems. Violins were smooth and sweet, as was percussion (which virtually sparkled) and the woodwind section was especially impressive, with a spacious and airy sound.

A run through Miles Davis's Kind Of Blue saw the little integrated delivering a detailed and precise sound that highlighted the warmth of Coltrane's tenor sax and the rich, deep sound of the upright bass. Rock and Pop records such as Radiohead's 'Lucky' demonstrated that the valves inside the amp, whilst small, are quite

robust sounding, with commendable clout and bass depth for a humble budget 9W valve amp. This is a great introduction to the sonic art of the valve amp and a big upgrade for anybody with a mid-price solid-state amp that wishes to swap over to something more musically engaging, for a price that's virtually as cheap as chips!

MEASURED PERFORMANCE

Frequency response	+/-3dB 15Hz - 75kHz
power output	8 watts into an 8 ohm load
sensitivity	850mV (suitable for CD)
noise	0.5mV

Keci82 valve amplifier parts list:

RESISTORS:

part No.	Description	quantity
R1	10K, 1W	1
R2	100K, 2W	1
R3	10K, 2W	1
R4	1M, 0.5W	1
R5	1M, 0.5W	1
R6	1K, 0.5W	1
R7	1K, 0.5W	1
R8	220K, 2W	1
R9	220K, 2W	1
R10	220R, 0.5W	1
R11	220R, 0.5W	1
R12	3.3K, 0.5W	1
R13	3.3K, 0.5W	1
R14	220K, 2W	1
R15	220K, 2W	1
R16	1M, 0.5W	1
R17	1M, 0.5W	1
R18	1.1M, 0.5W	1
R19	1.1M, 0.5W	1
R20	1M, 0.5W	1
R21	1M, 0.5W	1
R22	1M, 0.5W	1
R23	1M, 0.5W	1
R24	10K, 0.5W	1
R25	10K, 0.5W	1
R26	10K, 0.5W	1
R27	10K, 0.5W	1
R28	680R, 3W	1
R29	680R, 3W	1
R30	680R, 3W	1
R31	680R, 3W	1
R33	100R, 0.5W	1
R34	100R, 0.5W	1
R35	100R, 0.5W	1
R36	3.3K, 0.5W	1
R37	3.3K, 0.5W	1

VR1	100k, dual log pot	1
CAPACITORS:		
C1	100uF 400V	1
C2	100uF 400V	1
C3	100uF 400V	1
C4	10uF 100V	1
C5	not used	
C6	47uF, 10V	1
C7	47uF, 10V	1
C8	0.22uF, 400V	1
C9	0.22uF, 400V	1
C10	0.22uF, 400V	1
C11	0.22uF, 400V	1
C12	100uF, 63V	1
C13	100uF, 63V	1
C14	100uF, 63V	1
C15	100uF, 63V	1

BRIDGE RECTIFIER

BR1	KBU4J	1
-----	-------	---

TRANSFORMERS

Choke, LI 250mA, 1H	1
Output transformer	2
Mains transformer	1

VALVES

ECL82	4
-------	---

HARDWARE

IEC mains & switch	1
500mA fuse, slow blow	1
Black phono sockets	1
Red phono sockets	1
Speaker terminals	2 pairs
Self adhesive feet	4
B9A valve base	4
M6 fibre washers	4
M3 x 6mm screw	8

M3 x 12mm screw	2
M3 nut	2
M4 x 12mm screw	6
M4 nut	6
earth post	1
solder tag	1
black knob	1
Chassis	2 parts
Printed circuit board	1
Black 1/0.6	2m
Single screened	1m
Yellow/green 24/0.2	0.5m
IEC to UK plug	1

The Keci82 amplifier kit is available from World Audio Design as from 1st December 2002. Tel/fax: 00 44 (0) 1908 218836 or order on-line at www.worldaudiodesign.co.uk

Keci83 amplifier kit (UK price)
£195.00 (inc. vat & carriage)

Keci83 amplifier kit (EU price)
£195.00 (inc. vat, exc. carriage)

Keci83 amplifier kit (Overseas price)
£170.00 (exc. carriage)

Safety gloves (UK price) £14.00 (inc. vat & carriage)

Safety gloves (EU price) £14.00 (inc. vat, exc. carriage)

Safety gloves (Overseas price)
£12.00 (exc. carriage)

kit & component suppliers

CLASSIC TURNTABLES

Technical & General
 P.O. Box 53, Crowborough,
 East Sussex TN6 2BY.
 Tel: 01892 65 45 34.

The original specialist source of spares, replacements and expertise for the classic turntables. Years of actual experience and comprehensive range of parts (originals and re-manufactures), manuals, ancillaries. No dubious 'improvements' - no harmful 'modifications'. Our specialities: Connoisseur; Garrard; Goldring; Lenco; S.M.E.; Thorens; Watts; Ortofon; Shure; Cartridges and styli for 78s, Mono LPs, Stereo LPs.

COMPONENT SUPPLIERS

"A" Audiosolutions
 63 Love Lane
 Pontefract
 West Yorkshire
 WF8 4EG
 01977 798844

email: Audiosolutions@aol.com
 KIWAME resistors - 2w £1.10ea,
 5w £2.20ea

GOLDPOINT stepped attenuators - true ladder type stereo/mono
 JJ - electrolytic capacitors 100uf + 100uf / 500v 32uf + 32uf / 500v £9.00ea
 others available
 BARTOLUCCI - c-core mains and output transformers.

White Noise
 11, Station Road, Bearsden
 Glasgow G61 4AW
 Tel: 0141 942 2460
 Fax: 0141 587 7377
 Email: david.white38@ntlworld.com
<http://www.wnaudio.com>

Supplier of the widest range of standard and audiophile kits for solid state preamplifiers, power amplifiers, headphone amplifiers, power supplies, MM/MC phono stages, active crossovers, balanced i/o modules, and stepped attenuators; more kits in the pipeline. All kits use the highest quality, glass fibre, solder masked, silkscreened, PCBs. We also supply a wide range of active (esp. Japanese transistors and Exicon mosfets) and passive components, gold plated connectors, and silver plated wires. Write, phone or email for a free catalogue. Mail order only.

Audio-Links
 7 Fairmont Crescent,
 Scunthorpe,
 North Lincolnshire DN16 1EL
 Tel: 01724 870432
 Fax: 01724 875340

Email: audiolinks@ukonline.co.uk
 Extensive stock of specialist audiophile components for valve and solid state enthusiasts. Supplier of the largest range of high-end audio volume controls in Europe. 30 page catalogue - Free via e-mail or £3.00 posted.

LOUDSPEAKER KIT SUPPLIERS

Audio Note (UK Ltd)
 Unit C, Peacock Ind. Est.
 125-127 Davigdor Road
 Hove, East Sussex BN13 1SG
 Tel: 01273 220511
 Fax: 01273 731298

Suppliers of a large amount of components for the Audiophile Kit builder. Valve amplification data and vintage circuits also available. See the double page spread in the back section of the main issue for extra & more detailed information.

Falcon DIY Speakers
Falcon Acoustics Ltd.,
 Tabor House,
 Norwich Road, Mulbarton,
 Norfolk
 NR14 8JT.
 Tel: 01508 578272

UK distributors of FOCAL drive units & kits, and ETON loudspeakers, plus SOLEN (SCR-Chateauroux) polypropylene capacitors. We are the largest specialist Audio inductor manufacturer in the UK. We also stock Audio Amateur Publications and Audio Computer Software and a comprehensive range of D.I.Y. speaker kits, parts, accessories and books. Please send large SAE (44p) for free price list. "Everything but the wood".

IPL Acoustics, Chelsea Villa, Torrs Park,
Ilfracombe, North Devon,
EX34 8AY
 Tel/Fax: 01271 867 439

Website: www.iplacoustics.co.uk
 IPL Acoustics supply a range of 7 transmission line, 3 conventional, speaker kits, and kits for centre speakers and active subwoofers. We also supply a full range of drive units from Audax, SEAS, Morel and Legend Acoustics (Ribbon Tweeters) as well as custom built metal coned drivers. Also included is a range of capacitors, inductors and quality cabinet accessories as well as Silver Plated PTFE insulated cables.

SPECIALIST UPGRADE SERVICES

AudioCom (UK),
 Unit 14 Pier Road
 Pembroke Dock
 Pembrokeshire, SA72 6TR
 Tel: 01646 685601
 Fax: 01646 685602

Website: www.audiocom-uk.com
 E-Mail: enquiries@audiocom-uk.com
 Release the full potential of your digital source with CD/DVD upgrades from audiocom. Available is the highly acclaimed SUPERCLOCK master clock oscillator. (Dave Berriman fits the S-Clock to the Teac VRDS-10SE and comments..."there was not one area of music reproduction which didn't improve".) SUPERCLOCK super low noise power supply, & Q-power ultra-low noise dis-

crete regulators. Why not contact us to see how this service can be adapted to suit your requirements?

VALVE AND OUTPUT TRANSFORMER SUPPLIERS

Wilson Valves, 28 Banks Avenue,
Golcar, Huddersfield,
West Yorks HD7 4LZ.
 Tel: 01484 654650/844554
 Fax: 01484 655699

E-mail: wilsonv@zoo.co.uk
 We stock over 2,500 different types of valves, N.O.S. and New. Please send a S.A.E. for full list. No charge for matching. Most major credit cards accepted.

Watford Valves
 3 Ryall Close, Bricket Wood,
 St. Albans, Herts AL2 3TS
 Tel: 01923 893270
 Fax: 01923 679207

Specialist in new old stock and current production valves. Sole UK distributor of the Harma Diamond range selected for their superior performance. Huge range held, stockists of Mullard, GE, Philips, National, Brimar, Sylvania, Telefunken, RCA, MOV and many more. All valves are new boxed and guaranteed. For free price list and specialist advice call or fax Derek Rocco, Watford Valves.

Chelmer Valve Company Ltd
The Stables, Baddow Park
Great Baddow, Chelmsford, Essex
CM2 7SY
 Tel: 01245 241301
 Fax: 01245 241309.

Email: sales@chelmervalue.com
 Web Site: www.chelmervalue.com
 Supplier of premium range of audio valves, other valves and components also available. (Please see our main advertisement in this supplement).

Langrex Supplies Ltd
 1 Mayo Road, Croydon,
 Surrey CR0 2QP
 Tel: 020 86841166
 Fax: 020 86843056

One of the largest distributors of electronic valves, tubes and semi-conductors in the UK by original UK and USA manufacturers. Obsolete types are a speciality. Telephone or fax for an immediate quotation.

Billington Export Ltd.
 1E Gillmans Trading Estate,
 Billingshurst,
 West Sussex
 RH14 9EZ
 Visitors by appointment only please
 Fax: 01403 783519

E-Mail: sales@bel-tubes.co.uk
 Website: www.bel-tubes.co.uk
 Specialists in guaranteed new/old stock, current production valves & tubes. Also CRT for audio, hi fi (as well as industrial uses). A vast archive of vintage and obso-

lete types including limited quantities of Mullard, GEC, Sylvania, Philips, Brimar, Telefunken, RCA and others. Large stocks of Chinese, Russian, El and Tesla etc. A 50-page valve catalogue is available on request. Major stockists of the excellent Billington Gold brand. Contact us for quotations - attractive price on larger orders.

Audio Specialists
 73 Stoneyford Road
 Sutton-In-Ashfield
 Notts
 NG17 2DL

Tel/Fax: 01623 461122
 Email: audiospecialists@talk21.com
 UK distributors for Cardas Audio, Tobias Jensen, Orca & Raven products. Product line includes Silver, copper & tin foil paper in oil signal capacitors, 12AWG & 14AWG 99.99% (O.F.C.) copper foil inductors. Any intermediate value available from 0.00mH to 8mH, copper & aluminium loudspeaker capacitors, Cardas Audio patented 6N 99.99998% golden section litz cable. 99.9997% 5N silver. Full superb range of Cardas Audio connectors. Full range of Orca drive units. Raven (R1-R3) ribbon transducers (95-100dB sensitivity). electro Harmonix valves. Vast range of audio components and accessories. Extensive range of transformers available for modern and vintage audio equipment. One off a speciality, replacement and upgrade transformers for W.A.D., Leak, Marantz, Radford, Quad, (potted) Williamson and many more. Superb range of interconnect loudspeaker and power cord cables. Choke input power supplies available for solid state and valve equipment. (Made to order bespoke range of transformers shunt (parallel) feed a speciality. All products use the very best materials currently available in the world. All types of repairs, modifications & restoration undertaken to valve and solid state equipment. Classic and vintage equipment always sought, working or not. Catalogue £3.50 redeemed on first order over £30.00

**TO ADVERTISE IN
 THE KIT &
 COMPONENT
 SUPPLIERS PAGE
 PLEASE CALL
 020 8864 4760**

Email:

diyadvertising@hi-fiworld.co.uk

book review

Understanding Hi-Fi Circuits by Norman Crowhurst. Reviewed by Andy Grove

This book was originally published in 1957, during the 'Golden Age of Audio', a time before the evil silver discs invaded our homes.

Norman Crowhurst was a well respected technical author of the period who trusted his ears as much as his oscilloscope.

The first chapter, 'The Approach to Hi-Fi' starts the reader off at the dawn of audio. Here Crowhurst tries to get the message through that there is no panacea for all of audio's ills; good sound comes from good engineering practice. My favourite part is the picture of "Triode Man" and "Pentode Man". That alone is worth buying the book for! "Triode Man" is a refined sort of chap with top hat and tails while "Pentode Man" looks like one of Al Capone's henchmen!

In Chapter Two Crowhurst covers most of the output stage types in use at the time, using the 5881 valve connected in various ways to illustrate the relevant points. The efficiencies, distortions and intrinsic damping factors of the different types are discussed. Various types of operation are covered including straight triode and pentode operation, Ultra Linear and Unity Coupling. Crowhurst shows that some of these configurations, although seeming to offer great benefits at first glance, fall apart when given a more stringent analysis.

The following chapter, 'Feedback and Damping', follows the theme of the preceding chapter, by further developing the theory of the output stage/speaker interface and the influence feedback has upon it. Some useful data charts are given which show the maximum feedback ratios versus maximally flat response for a given set of time constants. Crowhurst uses these two chapters to illustrate that even though an amplifier may give an impeccable

measured performance into a resistive load gremlins may, and usually do, rear their heads under real world conditions.

Chapter Three - 'Inverter and Driver stages' - covers just that. Most of the common phase-splitters are covered, although some gained more popularity or were invented after this book was published so are either absent or not so well covered. However the more commonly used ones, like the paraphase and concertina, are analysed with some simple, intuitive mathematics and the use of charts. There is an interesting table which compares the common phase splitters on a one-to-one basis. Once again Crowhurst exposes some hidden problems which probably result in a less than perfect sound from many amplifiers.

Chapter Four 'Input Stages' takes a look at the amplifier's input stage, at both the preamp and power amp. Here, of course, noise and hum are important. Crowhurst gives useful information on how to manage these by sensible design and selection of the right valve.

'Matching' is a very brief chapter which covers some of the theory involved in impedance matching and load matching of the output stage.

'Equalisation' is a bit more of a meaty chapter and discusses the requirements of cutter head, RIAA and microphone matching, there are no complex mathematical formulae so the coverage is limited. However the reader can gain some knowledge as to why equalization is necessary and why sometimes it can cause more problems than it is intended to solve. Crowhurst cites an example of a microphone which was electronically equalized to give the flattest response attained up to that date. However there was a severe time domain problem inherent in the mic. which made the thing unusable.

'Speaker Distribution and Crossovers' is a brief chapter, as

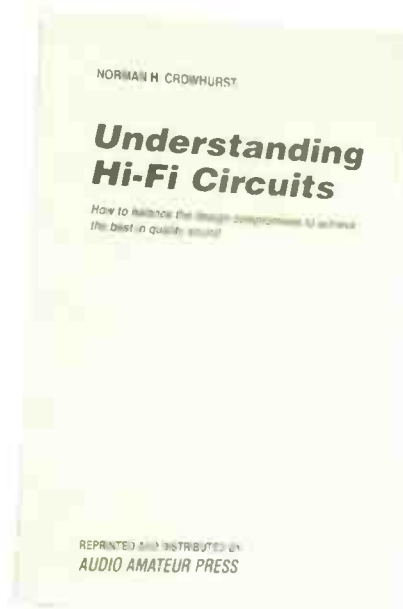

Crowhurst was concentrating on the amplifier side of the hi-fi system. He gives some information on the different types of crossovers in their basic forms and even goes into active crossovers some way. He does an interesting analysis of a multi-amplifier active system and comes up with some interesting results. The penultimate chapters 'Loudness and Volume Controls' and 'Tone Controls' go into some detail on their subjects. Crowhurst reveals some very ingenious and flexible control circuits, including regular bass-treble controls as well as sophisticated variable slope controls and filters similar to those found on vintage preamps from manufacturers such as Leak and QUAD.

The final chapter 'Overall View of Hi-Fi' is a short conclusion where Crowhurst gives a little thought to a complete hi-fi system.

This book is excellent in every way. It was written by one of the leading lights of hi-fi. In it you will find clear, concise information upon a variety of subjects.

This book is available from World Library p68-P69 also through our website

www.worldaudiodesign.co.uk

Code 1820

paperback, 224pp, 140mm x 220mm

Price £13.95 + £2.00 UK P&P

LANGREX SUPPLIES LTD

DISTRIBUTORS OF ELECTRONIC VALVES, TUBES AND SEMI-CONDUCTORS AND I.C.S.

1 MAYO ROAD • CROYDON • SURREY CRO 2QP

24 HOURS EXPRESS MAIL ORDER SERVICE ON STOCK ITEMS

E-MAIL LANGREX@AOL.COM

PHONE
020 8684 1166

FAX
020 8684 3056

A selection of our stocks of **New Original Valves/Tubes.**
Many other brands available

STANDARD TYPES			SPECIAL QUALITY TYPES			OTHER TYPES		
ECC83	E.I	4.00	A2900/CV6091	GEC	17.50	12BY7A	GE	7.00
ECC85	RFT	5.00	E82CC	SIEMENS	7.50	5687WB	ECG	6.00
ECC88	BRIMAR	6.00	E83CC	TESLA	7.50	5814A	GE	5.00
ECC88	MULLARD	10.00	E88CC/CV2492	BRIMAR	15.00	6072A	GE	10.00
ECH81	MULLARD	3.00	E88CC GOLD PIN	TESLA	8.50	6146B	GE	15.00
ECL82	MULLARD	5.00	ECC81/CV4024	MULLARD	6.00	6201	GE	6.00
ECL86	PHILIPS	10.00	ECC81/M8162	MULLARD	7.50	6336A	RCA	35.00
EL36	MULLARD	5.00	ECC81/6201	MULLARD	10.00	6550C	SVET	20.00
EL37	MULLARD	30.00	ECC82/CV4003	MULLARD	15.00	6922	ECG	6.00
EZ81	MULLARD	10.00	ECC82/M8136	MULLARD	17.50	7027A	GE	25.00
EZ80	MULLARD	5.00	ECC83/CV4004	MULLARD	40.00	7308	SYL	5.00
GZ33/37	MULLARD	20.00						
GZ32	MULLARD	25.00						
5Z4G	BRIMAR	6.00						
6V6GT	BRIMAR	7.50						
12BH7	BRIMAR	12.00						
12E1	STC	10.00						
13E1	STC	85.00						
807	HYTRON	7.50						
811A	RCA	25.00						
6080	MULLARD	10.00						
			AMERICAN TYPES					
			5R4GY	RCA	7.50	E88CC	TESLA	4.00
			5U4GB	SYLVANIA	15.00	ECC81	RFT	3.00
			5Y3WGT	SYLVANIA	5.00	ECC82	RFT	6.00
			6BX7GT	GE	7.50	ECC83	RFT	8.00
			6B4G	SYLVANIA	22.00	EF86	USSR	5.00
			6F07	SYLVANIA	7.50	EL84	USSR	3.00
			6L6GC	GE/SYL	20.00	EL34G	SOVTEK	5.00
			6L6WGB	SYL	15.00	EL34	E.I	6.00
			12AX7WA	SYLVANIA	6.00	6SL7GT	USA	7.50
						6SN7GT	USA	7.50

THESE ARE A SELECTION FROM OUR STOCK OF OVER 6000 TYPES. PLEASE CALL OR FAX FOR AN IMMEDIATE QUOTATION ON ANY TYPES NOT LISTED. WE ARE ONE OF THE LARGEST DISTRIBUTORS OF VALVES IN THE UK. SAME DAY DESPATCH VISA/ACCESS ACCEPTABLE. OBSOLETE TYPES A SPECIALITY.

CREDIT CARD MIN ORDER £10.00.

OPEN TO CALLERS MON.- FRI. 9AM - 4PM. CLOSED SATURDAY

U.K. P&P 1-3 VALVES £2.00, 4-6 VALVES £3.00 ADD 17.5% VAT TO TOTAL INC P+P O'SEAS P & P PLEASE ENQUIRE

VISA



Watford Valves

7 DAYS A WEEK 9AM - 9PM The Audiophiles Choice
All output valves multi-tested and digitally matched
Full no quibble guarantee. Expert advice on all valve amps

AC701	Telefunken	150.00	EF86/806S	Tesla	20.00
ECC81	Philips	7.00	EF86/6267	Siemens	20.00
ECC81	Siemens	15.00	EF86/6267	Telefunken	35.00
ECC82	RT	12.00	EL34EH	Sovtek	8.50
E82CC	Siemens	25.00	EL34	Svetlana	10.64
ECC802S	Tesla	25.00	E34L	JJ/Tesla	8.50
FCC83	Sovtek	3.83	EL84	Harma	7.00
ECC83	Philips	12.00	EL84	JJ/Tesla	7.00
ECC83/5751	G.E.	12.00	EL84	Philips	25.00
ECC83/7025	Harma	12.00	EL519	EI	12.00
ECC83	Sylvania	15.00	EZ81	Tesla	12.00
E83CC/803S	Tesla	20.00	GZ32	Harma	9.00
ECC84	R.F.T.	7.00	GZ34	Sovtek	8.00
ECC85	R.F.T.	8.00	KT88	Sovtek	20.00
ECC88	Tesla	6.00	KT88	JJ/Tesla	25.00
E88CC/6922	Philips	8.00	KT88	Svetlana	34.00
E88CC/6922	Harma	15.00	PL519	Siemens	15.00
ECC99	J.J./Tesla	10.00	300B	JJ/Tesla	68.00
ECF80	G.E.	8.00	5R4WGB	Cetron	12.00
ECF80	R.C.A.	10.00	5881WXT	Sovtek	7.00
ECF82	Tungsrain	6.00	6L6	Vissaux	40.00
ECL82	Citfe	12.00	6550C	Svetlana	22.00
ECL83	Mullard	10.00	6550EH	EH/Sovtek	22.00
ECL85	Polam	5.00	6550WE	Sovtek	18.00
ECL86	A.E.G	10.00	7581A	Philips	25.00
EF80	Telefunken	10.00	7591A	EH/Sovtek	16.00

QUAD II REVALVE SPECIAL OFFER



The Harma KT66 has become the industry choice as the closest in performance to the G.E.C. KT66 in these classic amps. This month you can revalve and revitalise your quad at a fraction of the normal cost.

4x Harma KT66, 2x Harma GZ32 & 4 Svet EF86 only £130 The set plus carriage and v.a.t.

ATTENTION ALL 6C33 USERS & GRAAF OWNERS

We are renowned for supplying the high grade military version of the 6C33C. We have selected items which have been matched on plate current & transconductance at the special offer price of £23 each.

Also PC900 Philips on special at £8.50 each.

WATFORD VALVES 3 Ryall Close,
Bricket Wood, St Albans, Herts AL2 3TS

Fast mail order/next day delivery/World Wide shipping
1000's more valves stocked. Prices exclude VAT and carriage.

VISA



01923 893270

Fax: 01923 679207

www.watfordvalves.com



letters & emails

SILVER DREAM AMPS

Dear HFW supplement,

As a long term music lover I have always been interested in getting around the hype surrounding hi-fi components. Several years ago when my interest was at its peak I experimented with various speaker designs and eventually built my own from the panels culled from 4 quad ESL57s running off a pair of vintage BTH valve amps, which came from Mike Pointer of Station Sounds. When one eventually gave up the ghost with a burnt out 40 year old mains transformer after being left on all night (wives please note!) I sold them and bought a pair of Magnaplanar MG3 American high-end panel speakers. I still use them, having been unable to find better; they are like electrostatics, but with more low-end punch and I would recommend anybody to try them. Even the smallest SMGa (slh roughly £350) knock a box into a cocked hat for clarity.

I built a transistor amplifier from Wireless World which was highly regarded by all, until that died after being wrongly wired to the mains during its service by yours truly at 3 o'clock in the morning. It literally blew up in my face, which was peering into circuits at the time, despite having checked and double checked five times. This prompted me to go against my grain and buy something ready made. After trying various designs I decided I wanted a pair of Audion Silver Knights but couldn't get any for the right price so I bought a Krell as a stopgap while I checked out what was available.

I went to see Nick Lucas at Hi-Fi World's offices for a demo of their basic design for their top of the range 300B PSE amps, which share a design heritage with certain silly-money valve amps, but at a fraction of the price. I auditioned a basic demo model on a pair of box speakers and despite that I heard enough to let me take a gamble on the sound with my power hungry Maggies. However, even at 20 watts the 300B PSEs are plenty loud enough.

What I didn't much care for was the Russian tractor factory Industrial finish, so I set about sourcing replacement components. I altered the

chassis design to take a 3-way Lorlin DPDT switch on the back and added two more cold/Teflon phonos from Maplins for extra inputs. I also wired a Neutric professional speaker socket next to the banana jacks.

I upgraded all the signal capacitors to Jensen paper-in-oils, who make them for everybody else (including Angela Instruments in the USA). The transformer caps now had six bolts made of non-inductive brass studding with stainless steel caps on top, while the cloth wrap came from the same material as blackout blinds.

I then re-designed the internal layout on the tagboards to accommodate the volume control - a Danish Audio Connect Stepped Attenuator run between the signal input and first stage to allow finite control of the input signal for each amp independently. This was to ensure no HF signal losses caused by cable capacitance if they were mounted externally in a separate box like, for example, Ben Duncan's Passion. The DACTS were held in place with home-made brackets and all the internal signal wire was the thinnest PTFE covered wire I could find (PTFE has the next lowest insulator capacitance to air, so it's the first choice).

All the screws were changed for stainless steel from a local industrial fastener shop and a remote control shaft was run between the DACT attenuators and the knob on the front. All the metalwork was done in-house with readily available tools. The cutters came from local engineering tools suppliers.

The Yin /Yang symbols were from a New Age suppliers, and the blue LEDs from Farnell - as was electronics, the wire and the elegant on/off toggle switch. The original black sprayed chassis did nothing for me so I had it chromed by a specialist car chromers for the best job. Then it was all put together on my front room floor over a couple of weeks.

I wanted a unique piece of art that nobody else had in the world, that had a practical use. I think I got it.

The sound was exactly what I was looking for full, rich, punchy with plenty of detail and no nasties. It's a very fatigue free listen when played back on my masterlink 24-bit studio CD copier via my own design of speaker cables, which has impedance equalisers called Le Scarabe in-line just before the crossovers, and a Francinsein Actif on the CD output. Both are available from one-time HFW scribe Richard Brice of Perfect Pitch products. They are very affordable and highly recommended.

Robert Hardcastle
Yorks

We try and make the amps as pleasing to the eye as to the ear, Robert, but to keep costs low we concentrate primarily on the sound as I'm sure you understand. However, as you've discovered, a little creativity coupled with some searching can reap rewards and transform your kit amp into something that almost doubles as an ornament. Also it's good that you note the amps will run a pair of power hungry 'Maggies' - they have a beautifully transparent and airy sound which suits the sound of this type of single-ended amp. Providing you don't want to scare the horses or drive out your neighbours, then a 20W valve amp such as ours, with its hefty output transformers, will drive virtually anything. After all, they're a great match for Quad electrostatics, which aren't exactly sensitive!

Nick Lucas



External View of Customised 300B PSE



Falcon Acoustics Ltd

Falcon Electronics, Basically Sound
<http://www.falcon-acoustics.co.uk>

Full Price List and Focal details on Web Site

DRIVE UNITS: by FOCAL & seas, and a pick of the best from other manufacturers.

100+ CROSSOVER NETWORKS: - Active & Passive, Components, Accessories.

COMPONENTS

SOLENE Polypropylene capacitors. 0.1mFd. to 100mFd.

Polyester and Polycarbonate Film Capacitors. 0.1mFd. to 10mFd.

ALCAP Reversible Electrolytic Capacitors (Non-Polar): 50v, 100v & Low Loss. 2mfd. to 600mFd.

FALCON Custom-wound Inductors.

FERRITE:- Standard. High Power. Super Power. Super-Super Power

AIRCORED 0.56 - 1.25mm wire; IRON DUST. 1mm wire

TAPPED INDUCTORS:- 0-10mH in 1mH steps & 0-1mH in 0.1mH steps

AUDIO AMATEUR PUBLICATIONS

Back year sets of Speaker Builder, Audio Amateur & Glass Audio, plus the Audio Anthology Set.

Altogether 50+ books and 50+ Audio Amateur's magazine year sets, 2001 year sets on CD-R only

FOCAL 'State of the Art' Units & Kit Designs'

NEW Focal Unit Range

as pioneered in the Utopia range of systems.

Price List & Unit Specs FREE on Web site - available in .pdf format

5W4211 6W4311 7W4411 8W5411 10W6411

Plus: Audiom 6 WM
&
7K6411 (replacement for Audiom 7K-/7K2)
TC120TD5 - TC90TD5 & TC90TD5B
All normal stock items

SUPPLIERS TO THE TRADE SINCE 1972

Send for our FREE price list PL30: Just send a large S.A.E. (44p stamp) or US\$2 bill overseas. Europe US\$1 bill or 3 International Reply Coupons (IRC) to: (Dept HFW) Tabor House, Norwich Road, MULBARTON, Norwich, Norfolk. NR14 8JT Tel (0)1508 578272

Rediscover
the beauty of
pure sound....

NEW!

Visit our web site at
www.chelmervalue.com
to view our entire valve
catalogue and buy on
line!

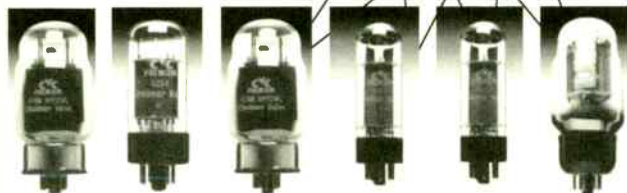

We have been supplying tubes to the audio market for over 40 years. Only valves that pass our stringent in house QC tests are used for the CVC Premium brand, and our no fuss guarantee ensures your complete peace of mind. When available, we also stock the justifiably famous brands such as Brimar, GEC, Mullard, RCA Telefunken etc. So why compromise? Our sales and technical staff are just a telephone call away. To put it simply.....

YOUR NEEDS...OUR BUSINESS.

CVC Chelmer Valve Co Ltd

The Stables, Baddow Park, Great Baddow,
Chelmsford, Essex CM2 7SY

Tel: +44 1245 241300 Email: sales@chelmervalue.com

Fax: +44 1245 241309 www.chelmervalue.com

TECHNICAL & GENERAL

SOME NECESSITIES - FROM THE ORIGINAL CLASSIC TURNTABLE SPECIALISTS

CONNOISSEUR			P&P
	BD1/2 Drive Belt	£12.60	£1.90
	BD1/2 Motor Suspension kit	£15.50	£2.50
	SAU.2 Headshell	£18.50	£2.90
	SAU.2 Connecting Lead	£16.50	£3.20

GARRARD STANDARD MODELS

	Wired arm tubes	from	£14.50	£2.90
	Cartridge carriers (sliders)		£12.50	£1.00

301/401 Transcription models				
Original	Thrust pad assembly		£13.50	£2.50
Original	Idler tension spring		£3.65	£1.90
Original	Brake pad		£3.40	£1.90
Xeroxcopy	Owners Manual 301 incl. full size mounting template		£9.30	£1.90
	401 " " " "		£7.20	£1.90

Replacement	301 control knobs On-Off/Speed select	pair	£21.50	£2.90
Replacement	301 suppressor unit		£7.20	£2.50
Replacement	301 motor pulley (-2%), (-1%), (Std), (+1%)	each	£16.50	£2.50
Replacement	301 Chrome mounting bolts nuts, washers.	set	£7.85	£2.50
Recommended	Lubrication set - early 301 or 301/401	(specify)	£7.20	£1.90

GOLDRING/LENCO

	Idler wheel (lock-nut or clip fixing)		£22.50	£2.90
	Tension spring		£3.85	£1.90
	Arm pivot bearings - with fitting instructions		£9.85	£1.90
	Spindle/Main bearing assembly	GL.69/72	£21.00	£3.90
	" " " "	GL.75/78	£26.50	£3.90
	Chassis suspension springs (set of 4)	set	£21.25	£3.90
	Headshells	from	£23.25	£2.80
	Instruction books	from	£5.20	£1.90

THORENS

TD.124 series				
	Idler wheel	original	£29.50	£2.90
	Idler wheel	our redesigned replacement	£16.50	£2.90
	Drive belt		£24.65	£1.90
	Suspension rubbers ('mushrooms')		£17.50	£2.90
TD.150/160				
	Drive Belt		£19.35	£1.90
	Suspension springs (-1%), (Std), (+1%) (set of 3) set		£14.50	£2.90
	Suspension - main bushes (set of 3)	set	£14.50	£2.90
	Armboards TD.150 blank		£12.50	£2.50
	" TD.160 "		£10.20	£2.90

CECIL WATTS

Dustbugs & spares - incl. Preerener wicks

Cartridges and styli for 78s and Mono LPs in addition to current Stereo LPs

TECHNICAL & GENERAL
PO BOX 53, CROWBOROUGH, EAST SUSSEX, TN6 2BY
TELEPHONE: 01892 654 534

WHITE NOISE

AUDIO KITS, MODULES, COMPONENTS

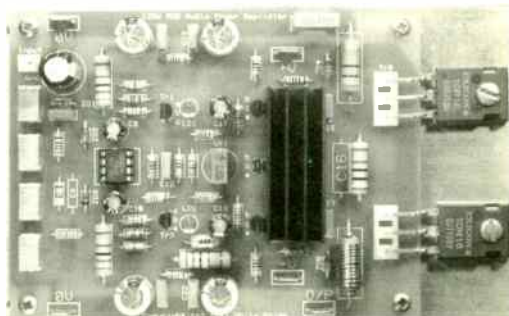

PRODUCTS INCLUDE:- Power Amplifiers 30-250W, Preamplifiers, Phono stages, Active Crossovers, Power Supplies, Buffer Amplifiers, Balanced line drivers / receivers, Stepped attenuators, Gold plated connectors, Cables, Capacitors, Resistors, Semiconductors, Transformers, Subwoofers, Loudspeaker drive units

WHITE NOISE
11 STATION ROAD
BEARSDEN
GLASGOW
G61-4AW

Web:- <http://www.wnaudio.com>
Email:- david.white38@ntlworld.com
Tel:- 0141-942-2460 (until 9pm)
Fax:- 0141-587-7377

WELCOME TO OUR
MARKET PLACE

hi-fi
WORLD
& computer audio

market place

Here are a wide variety of specialist hi-fi products and services. Keep an eye open for regular advertisers, who know the market and serve their customers in a friendly and reliable manner.

CableToasting.com

'Release the potential'

Why wait 100's of hours before your cables begin to perform as they should! Get them 'toasted' by one of our Nordost cable toasters to avoid missing what you're waiting for

Contact

www.cabletoasting.com mobile: 07904 015789

GRAND

M25

AUDIOJUMBLE

SUNDAY 10TH NOVEMBER 2002

10.30AM - 2.30PM

ALL VINTAGE & MODERN HI-FI
PARAPHERNALIA

INCLUDING: VINYL, DISC ETC

FOR STALL BOOKINGS/DETAILS

CALL

07730 134973

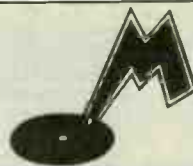

**MUSONIC
STYLI**

**SPECIALIST MANUFACTURER &
SUPPLIER FOR MORE THAN 40 YEARS**

REPLACEMENTS & ORIGINALS

MANY OBSOLETE/78 VERSIONS

PICK-UP CARTRIDGES

RECORD/TAPE/CD ACCESSORIES

**WHY NOT TRY US AND HEAR THE
DIFFERENCE !!**

NAGAOKA CARTRIDGES NOW IN STOCK

For further information tel/fax/e-mail to:-

MUSONIC (UK) LIMITED
Unit 13 Wenta Business Centre Colne Way
Watford Hertfordshire WD24 7ND

Tel: 01923 213344 Fax: 01923 213355
E-mail: sales@musonic.co.uk

VISIT OUR UPDATED WEBSITE
www.musonic.co.uk



Trade and Export enquiries welcome



SELECTED USED & EX-DEM ITEMS

All Fully Tested With Warranty

- ◆ TURNTABLES & ARMS WANTED
- ◆ HI-FI BOUGHT FOR CASH
- ◆ COMMISSION SALES
- ◆ HIGH-END REPAIRS & SERVICE

DUNLOP Systemdeck 3 / Basik LVX / K5	£750	£379
MICHELL ISO HR Phono Stage Ex-dem	£895	£696
MICHELL Gyro (Like new)	£829	£695
MICHELL ISO/HERA Phono Stage	£895	£448
MICHELL ISO HR/HERA Phono Stage	£895	£480
REVOLVER Turntable + Linn LVX arm	£380	£148
ROKSAN Xerxes + RB300 + PSU	£1500	£600
SME 10A with 309 Tone Arm Ex-dem	£3410	£2896
STAX System SR303/SRM313 (Mint)	£850	£648
VOYD Reference inc arm	£14,995	£6000
WILSON BENESCH Full Circle (Mint)	£1995	£1495
WILSON BENESCH ACT 1 Tonearm	£1200	£594

ARCAM Alpha 6 CD	£750	£458
ARCAM Alpha 6 CD + Clock 3	£850	£458
ARCAM Alpha 8 CD	£450	£248
ARCAM Alpha 9 (HDCD)	£800	£420
ASSEMBLAGE DAC2	POA	
AUDIO ALCHEMY V1 + PSU	£489	£169
AUDIO ALCHEMY V3 DAC + PSU	£900	£549
AUDIO MECHA Kreatura Trans	£1500	£648
AUDIO MECHA Damnation + Upgrade	£1250	£599
CYRUS dAD3Q		£498
DPA PDM 1 DAC	£1000	£438
KRELL KPS 25 CD/Pre	£24,998	£16,996
LINN Karik CD	£1850	£1098
LINN Ikemi CD Ex-demo	£1950	£1694
MERIDIAN 203 DAC	£499	£228
MERIDIAN 263 DAC		£398
MERIDIAN 500 Trons	£1400	£798
MICROMEGA DAC 1		£320
NAIM NAC CD3.5	£1300	£798
NAIM CDS Mk2 Ex-dem	£4165	£2924
NAIM CDX Ex-dem	£2470	£1724
NVA Emotive Statement (Must be seen!)	£2200	£998
ORELLE DA10T Trans	£900	£450
PINK TRIANGLE Cardinal (Trans)	£1250	£550
RADFORD WS1 CD Player	£999	£358
REGA Planet	£500	£350
REGA Jupiter Ex-dem	£1000	£658
REVOX B225		£348
TAG CDT20R (Trans)	£2200	£1100
TEAC VRDS 10 (CD Player)		£450
TEAC PS00 (Trans)	£850	£400
THETA Gen Pro IV	£4500	£2400
THETA DATA Basic	£2400	£1100
THETA Pro Basic IIIA (DAC)		£1990
THETA Pro Time II	£2000	£995
THORENS TDC2000(Trans) + TDA2000(DAC)	£2000	£1198
TRICHORD Pulsar 1 DAC + PSU	£1800	£1298
WADIA 8 Tran+DDE12 DAC *****	£7500	£3600

ARCAM Diva P75 Ex-demo	£320	£254
ARCAM Diva P85 Ex-demo	£530	£424
AUDIO ANALOGUE Puccini SE	£700	£498
AUDIOLAB 8000C (Pre)	£600	£290
BAT VK40	£4950	£2600
CYRUS Pre	£700	£358
CYRUS Power	£700	£358
CYRUS III		£358
CYRUS PSXR		£228
DENON AVP-A1D Digital Pre-amp	£2500	£1299
DENON ADV 700 Ex-demo	£750	£644
DEVA 250 Integrated + Matching Power	£1000	£450
EXPOSURE 7/8 pre & Power		£400
HARMON KARDON AVR85 AV Rec	£1000	£498
JEFF ROWLAND C.3 (pre-amp)	£4990	£2490
JEFF ROWLAND Consumate (pre-amp)	£4000	£2196
KRELL KSL (Pre) Inc Phono Stage	£2990	£1350
KRELL KSA 100	£1990	£1000
KRELL KAV250A	£3698	£2490

KRELL FPB650 Mono's. 5 available, price each	£14,000	£8000
LFD LS1 Pre-amp	£1900	£500
LFD LS2 Pre-amp	£950	£250
LFD Zero Integrated		£400
LINN Wakanda (Inc Phono) Ex-demo	£945	£844
LINN LK140 Ex-demo	£750	£644
LINN LK1		£350
LINN LK2		£299
LINN Kairn Pre	£1700	£1098
LINN LK1 Pre	£650	£224
MARK LEVINSON 27.5 Power *****	£6000	£3998
MARK LEVINSON 380 *****	£4495	£2990
McINTOSH MX 132 Pre/Processor Ex-dem	£7990	£4996
McINTOSH MC7108 8 Channel Ex-dem	£2549	£1996
MERIDIAN 201 Pre	£760	£329
MERIDIAN 557 ex demo	£1625	£1294
MERIDIAN 563 Ex-dem	£700	£446
MERIDIAN 518 Digital Processor Ex-dem	£985	£646
MICHELL Argo + Hera		£598
MUSICAL FIDELITY The Pre-Amp 3a		£240
NAD C160 Pre	£420	£278
NAIM NAC 32 (Modified)	£600	£294
NAIM NAC 72 (Inc M/C board)	£1000	£454
NAIM NAP90 (Power)	£600	£378
NAIM NAP90 (Power)	£600	£400
NAIM Hi-Cap (New style)	£780	£498
NAIM Hi-Cap (Ex-dem)	£794	£554
NAIM Super-Cap (Ex-dem)	£2450	£1714
NAIM NAC 102 Pre (Ex-dem)	£1210	£844
NAIM NAC 82 Pre (Ex-dem)	£2500	£1754
NAIM NAP 180 Pre (Power)	£1220	£854
NAIM NAP 250 Pre (Power)	£1910	£1334
NVA P90		£POA
QUAD 66 Pre/remote		£450
REGA Elicit	£750	£498
REGA Curso (Pre) Ex-demo	£1000	£638
REGA Exons (Monoblocks) Ex-demo	£750	£498
ROTEL RC971 (Pre)	£450	£248
ROTEL RB98 (Monoblocks)	£800	£498
SONY SDPEP9ES (Digital)		£298
TALK ELECTRONICS Storm (Intgld)	£650	£370
TESSERAC Pre	£1500	£798
THETA Casanova Pre Ex-dem	£4478	£3596
VERITAS P400 Power *****	£3000	£2496

ARION Electra Integrated	£1200	£598
AUDIO INNOVATIONS		£748
AUDION Silver Knight 300B Amp		£650
AUDION Silver Knight 300B Mono's	£2250	£1390
AUDIONOTE M2 Pre	£1000	£600
AUDIO PRISM Debut (Red Rose)	£2800	£1700
AUDIO PRISM Mantissa (Red Rose)	£3000	£1800
AUDIO RESEARCH LS2 Pre	£2800	£1798
AUDIO RESEARCH LS12 Pre	£3200	£1500
AUDIO RESEARCH LS15 Pre	£2995	£1996
AUDIO RESEARCH BL1	£699	£496
AUDIO RESEARCH LS8 Pre-amp	£1800	£1196
AUDIO RESEARCH V150 Power Amp	£3499	£2496
B&W DM801 (Rosewood)	£1500	£749
CARY CAD300SE monoblocks (As new)	£5000	£3998
CONRAD JOHNSON PV11 Pre	£1600	£999
CONRAD JOHNSON PV14L Pre (3hrs use!)	£2200	£1590
CONRAD JOHNSON 15 Phono Stage	£4500	£2650
CONRAD JOHNSON Premier 17 Pre	£4750	£2750
CONRAD JOHNSON Premier 8 Monoblocks	£16,000	£9750
COPLAND CTA 301Pre	£1299	£899
CR DEVELOPMENTS Carmeta (Pre)	£900	£428
EAR 859 (Integrated)		£1648
GOLDMUND Mimesis 6 Amp Ex-dem	£2900	£1726
GOLDMUND Mimesis 4 Tuner Ex-dem	£6100	£2996
GRAAF 13.5 Blt Pre Ex-dem	£3950	£2996
MICHAELSON Odysseus 40w Int	£1150	£699

NAGRA P1.1 (Linn Level Pre) (Mint)	£5395	£4395
PAPWORTH TVA50	£2000	£1198
PATHOS Twin Towers	£3250	£2495
PM COMPONENTS Monoblocks	£3000	£1498
WELBORN LABS Monoblocks	£1500	£998

AUDIOLAB 800T	£750	£400
LINN Pekin Ex-demo	£545	£444
LUXMAN ST50 (Rare)	£900	£550
MERIDIAN 204	£580	£350
PIONEER VSX859RDS		£398
SONY ST770ES	£440	£250

NAKAMICHI CR2E Cassette	£600	£300
NAKAMICHI DR10 Cassette	£400	£298
REVOX D36 Reel to Reel		£348
REVOX E36 (Reel to reel)		£298
REVOX B710 Mk2		£548

ACOUSTIC ENERGY AE 3 (Inc stands)	£1700	£748
ACOUSTIC ENERGY Argo 2 Ex-demo	£300	£204
ARIEL ACOUSTICS Model 8's (stands) Ex-dem	£5679	£3996
AUDIONOTE AM/E (Inc stands)	£2900	£1748
CASTLE Chester (Blk)	£900	£475
CHORD CEL 301	£3500	£1498
DALI 400	£800	£400
DYNAUDIO SDA 2.4	£650	£348
GAMMA ACOUSTICS Epoch 5	£3000	£998
HALES Signature System 2	£4000	£1848
HEYBROOK Heystack (Rosewood)	£500	£297
HHB Circle 5's (Active)	£900	£430
IMPULSE H7 (Black)	£1000	£480
INFINITY Modulus (Inc stands)	£600	£390
LINN Kober (Black)	£2000	£780
LINN Kober (Rosewood) ACTIVE	£2500	£1350
MAGNA PLANAR 1a Imp	£1400	£850
MAGNA PLANAR MG111A	£3500	£1195
MARTIN LOGAN Aeris i	£2295	£1595
MARTIN LOGAN SL3	£3399	£1995
MARTIN LOGAN CLS (2) Ex-dem	£6998	£4496
McINTOSH LS320 (Speakers) Ex-dem	£1790	£1296
MEADOWLARK Shearwater	£2990	£1990
MERLIN TSM-SE (Mint)	£1600	£1148
MISSION 754P (Rosewood)		£698
MORREL Bass Master (Oak)	£1600	£728
NAIM Credo Ex-dem	£1425	£994
PINK TRIANGLE Ventrical		£950
PROAC Studio 1 Mk2		£350
PROAC Response 1.5 (Rosewood) Ex-dem	£1970	£1596
QUAD ESL63 (Black)	£3500	£1400
REGA Naos Ex-dem		£998
REGA ARA Ex-dem		£255
REGA ELA Ex-dem		£750
REGA XEL (Black)		£990
REL Q100 Sub		£750
ROKSAN Ojan (Ex-dem - Mint)	£1000	£590
RUARK Equinox (Black)	£2200	£1400
RUARK Equinox (Rosewood)	£2000	£1195
RUARK Sceptre		£348
RUARK Lagrhythm (Sub)		£498
SNELL J3 High Sensitivity Monitors	£770	£449
SNELL Type E2		£698
SONUS FABER Grand Piano (Ex-dem)	£1699	£1399
SONUS FABER Concertino (Ex-dem)	£599	£529
SONUS FABER Electra Ex-dem	£1789	£1349
SOUNDLAB Dynastats	£3200	£1400
TANNOY Precision 40	£1000	£490
TRIANGLE Icare	£1500	£748
WILSON Cub (Black Laminate) Ex-dem	£5495	£3496
WILSON Cub (Glass) Ex-dem	£6890	£3996
WILSON 6 (Black) Ex-dem	£19998	£13998
WILSON BENESCH Orator Ex-dem	£2900	£2524
WILSON BENESCH Act-1 Ex-dem	£6999	£4499
WILSON BENESCH Act-2 Ex-dem	£8999	£5999

The Hi-Fi Company's

Trading Station

35 Cowgate
Peterborough PE1 1LZ

World Radio History

Much More Always Available
Please Check Our Web Site
hifitradingstation.com

ALL ABOVE ITEMS IN STOCK
AT TIME OF GOING TO PRESS

PHONE: 0870 608 8211
audiotrader@talk21.com
OPEN: Tues - Sat: 10am - 5.30pm
ALL CREDIT CARDS ACCEPTED
FOR NEXT DAY DELIVERY



Audio & Cinema Experience

Unique specialists in Hi-Fi, A/V & custom installation

For Sale – Used/New

JM Lab Micro Utopias (ebony)	£ 2295
Boston 10X (4 units) satellites (black)	£795
Audio Note TT1 turntable & arm (no cartridge)	£395
NHT Audio Centre 2 reference (piano black)	£395
TDL Studio 1 with plinth (black ash)	£295
Parasound CDP1000 CD player	£295
Kinshaw Overture Power Amplifier	£275
TEAC AG-D9300 A/V receiver/processor	£225
Audioquest Cobalt 2 x 2.5m, 1 x 1.5m	£200
JRT Audio Ref speakers & stands (oak)	£195
Musical Fidelity X 24K DAC	£155
Kinshaw Overture DAC	£145
Denon TU-380RD reference tuner	£85
Frameworks isolation platform	£45

T: 01209 613700
E: info@goingonltd.co.uk
W: www.goingonltd.co.uk

Studios 5, 11& 12, Bosleake R/W
Bosleake, Redruth, Cornwall TR15 3YG

V'AUDIO

Hi-Fi Consultants

TURNTABLES

In the October issue I referred to eagerly awaited items such as the new AVI Integrated and Pro-Nine Plus speakers, but as happens with new products the amp is still not quite ready and I will probably await evaluating the Pro-Nine Plus until I get the new amp. Having just acquired an SME 10A turntable, and having found that the new Infinity Prelude MTS speakers (see Oct) sound particularly good with vinyl, I have spent time playing this turntable, an old VPI TNT, an Audiomeca J1 with SL5 arm, an old Oracle, and plan to dig out one of the original Pink Triangle's. The trouble always with turntables, now we have become accustomed to CD etc. is the time it all takes, especially as the eyes and hands aren't as good as they were!. Invariably they have different arms and cartridges and comparisons are difficult. They all should sound good however. I am playing them through the Trichord Dino Phono Stage, AVI pre-amp & ESLAB Digital poweramp which suits the Preludes very well.

The Preludes are very open and detailed but never get hard when driven. Looking forward to the new 350 watt Eslab amp, which although more powerful than the Preludes need, being efficient, will no doubt change the balance. Will keep you up to date.

www.vaudio.co.uk

V'audio HI-FI Consultants
36 Druid Hill, Stoke Bishop, Bristol BS9 1EJ
Tel/Fax 0117 968 6005

diverse vinyl

10 charles st newport south wales np20 1ju
01633 259661/256261 sales@diversevinyl.com

Forthcoming Releases for October & beyond

Graham Coxon	The Kiss Of Morning	£12.90
Dolly Varden	Forgiven Now (Diverse Records)	£TBC
Foo Fighters	One By One	£TBC
Jackson C Frank	Blues Ran The Game	£14.90
Norah Jones	Come Away With Me (Classic)	£TBC
Rolling Stones	Forty Licks - The Best Of 4LP	£TBC
Lemon Jelly	Lost Horizons	£20.90
Led Zeppelin	The Song Remains The Same	£TBC
Johnny Cash	American IV – Man Come Around	£16.90
U2	Best Of 1990 – 2000	£19.90

ALBUM OF THE MONTH

PETER GABRIEL "UP" – Virgin/Classic Records £18.90

Also available, deluxe Classic Records version (with 7" single) £41.90

New Stock And Recent Releases

ALBUM OF THE MONTH

PETER GABRIEL "UP" – Virgin/Classic Records £18.90

Alison Krauss	Forget About It (Diverse Records)	£16.90
Badly Drawn Boy	Have You Fed The Fish?	£TBC
Billie Holliday	Lady Sings The Blues (Sp Corner)	£19.90
Bob Dylan	Blonde On Blonde (mono)	£25.90
Byrds	Columbia Singles	£25.90
Datsuns	The Datsuns	£10.90
David Axelrod	Anthology Volume 2 (2LP)	£18.90
Death In Vegas	Scorpio Rising	£16.90
Elvis Presley	30 Number 1s	£15.90
Jefferson Airplane	Surrealistic Pillow (Mono)	£16.90
John Squire	Time Changes Everything 2LP	£16.90
Low	Trust	£12.90
Lucky Pierre (Arab Strap)	Hypnogogia	£12.90
Manic Street Preachers	Forever Delayed (Best Of)	£TBC
Mark Knopfler	The Rag Pickers Dream 2LPs	£19.90
Mr Scruif	Trouser Jazz	£14.90
Ms Dynamite	A Little Deeper	£12.90
Paul Desmond	Summertime (CTI Reissue)	£19.90
New Order presents	Back To Mine (Compilation)	£15.90
Richard Ashcroft	Human Condition	£18.90
Roddy Frame	Surf	£9.90
Ryan Adams	Demolition	£12.90
St Etienne	Finisterre	£10.90
Underworld	A Hundred Days Off	£14.90

WARNER JAZZ MASTERS – £7.90 each (call for details)

Roy Ayers, Shelly Manne, Freddie Hubbard, Charlie Palmieri, Jack McDuff

Ring For Accurate Price Details Or Check The Web Site

DISCO ANTI STAT LP CLEANER

Probably the most economical LP

cleaning device on the market

Only £41.95



Call for details

Call for a catalogue of over 3500 brand new LPs, or visit

www.diversevinyl.com

WILLIAMS HART ELECTRONICS

HART ELECTRONIC KITS TRADED FOR OVER 30 YEARS



Moflet Monoblock Power Amp Kits
ONE OF THE BEST AMPLIFIERS YOU WILL HEAR! Regardless of price
ON DEMO @ Bala, Southend, Peterborough and Burnley



Single Ended Class A Valve Sound
15Watt Power Amp modules
FOR THOSE WHO WANT THAT VALVE
MIDBAND BUT BASS AND TREBLE TO MATCH



ACTIVE R/Control SUBWOOFER MODULE £177.30



Speakers Designed & Built to Order

Advertise your Hi-Fi on my website (FREE)

Also Award Winning Phono Stage Kit, Active Crossover Modules, Speaker Drive Units,
M Cap Capacitors, Caddock Resistors, Remote Control Volume and much more

WEB SITE www.williamshart.com e-mail: williamshart@classicfm.net

Tyn-Y-Coed, Llidardau, Bala, Gwynedd, LL23 7SG Tel/Fax for catalogue 01678 520757

PERSONAL VISITORS SHOULD PHONE FIRST TO AVOID DISAPPOINTMENT

Run by former Technical Director of Wilmslow Audio



Mana Audio LTD

www.mana.co.uk



"Now I can only say that until I had the Mana equipment table fitted, my hi-fi system was at best half Coked."

Alan Sircom
Hi-Fi Choice
March '95

"Mana Tables are not cheap. But they are essential if you want to unlock your system's true potential." **BEST BUY**
Malcolm Steward, Hi-Fi Choice February '96

For information on MANA products please contact: Unit E, Amlwch Ind. Est.
Amlwch, Anglesey Wales. LL68 9BX. Email: post@mana.co.uk

Sales: 01248 751 043 Factory 01407 830 530

Fax 01407 830 535



VISIT THE MANA FORUM AT: <http://manaforum.atinfopop.com>

MUSICAL IMAGES

PRODUCT	EX/DEMO	LIST	NOW
ARCAM A65 Silver Amp	EX/DEMO	£380	£300
ARCAM A75 Silver Amp	EX/DEMO	£450	£375
ARCAM AVR100 AV Receiver	EX/DEMO	£800	£500
BOSTON 351 Speakers	EX/DEMO	£200	£150
HARMON KARDON AVR2500 AV Receiver	EX/DEMO	£400	£300
KEF REFERENCE 4-2 Cherry Speakers	EX/DEMO	£3,650	£2,800
KEF TDM23C Black Centre Speaker	EX/DEMO	£400	£275
KEF TDM23F Black Speakers	EX/DEMO	£800	£525
KEF TDM34DS Black Speakers	EX/DEMO	£700	£475
KEF TDM45B THX Subwoofer	S/H	£800	£500
LINN AKTIVMOD Aktiv Modules	EX/DEMO	£125	£50
LINN AV5105 Power Amp	EX/DEMO	£1,200	£650
LINN KEILIDH Rosewood Speakers	EX/DEMO	£850	£475
LINN LP12 Turntable	EX/DEMO	£1,075	£700
LINN SEKRIK Black Wall Speakers	EX/DEMO	£395	£200
MARANTZ CD6000 OSE CD Player	EX/DEMO	£300	£175
MARANTZ ECLIPSE 70 DVD Combi System	EX/DEMO	£1,500	£900
MERIDIAN DSP5000 Cherry Speakers	EX/DEMO	£3,885	£3,100
MERIDIAN DSP5000C Black Centre Speaker	EX/DEMO	£1,995	£1,600
MISSION fs2 AV 5 NXT Speakers with Active Sub	EX/DEMO	£600	£300
MUSICAL FIDELITY A3 Amp	EX/DEMO	£850	£600
MUSICAL FIDELITY A3CR Pre Amp	EX/DEMO	£1,000	£800
MUSICAL FIDELITY HT600 Power Amp	EX/DEMO	£2,000	£1,500
MUSICAL FIDELITY HTP AV Pre Amp	EX/DEMO	£2,000	£1,400
MUSICAL FIDELITY XA100R Amp	EX/DEMO	£1,000	£650
MUSICAL FIDELITY XA200R Amp	EX/DEMO	£700	£500
NAIM BRUNDY Super Logical Interconnect	EX/DEMO	£245	£100
NAIM INTRO Black Speakers	EX/DEMO	£790	£550
NAIM NASBL Speakers	EX/DEMO	£2,360	£1,600
NAIM PREFIXMC Phono Stage	EX/DEMO	£405	£250
PANASONIC DMRE20EBS DVD Recorder	NEW	£1,000	£500
PIONEER DVR7030 DVD Recorder/Player	EX/DEMO	£1,200	£900
PROAC RESPONSE 1SC Speakers	EX/DEMO	£1,200	£850
PROAC RESPONSE 3.8 Cherry Speakers	EX/DEMO	£3,990	£2,800
SONY CDPXB930E QS CD Player	EX/DEMO	£300	£200
SONY DVPNS7000V DVD Player	EX/DEMO	£250	£200
SONY SCD 777ES Gold SACD Player	EX/DEMO	£2,300	£1,800
SONY STRDB1070 Black A/V Receiver	EX/DEMO	£600	£375
SONY STS3000ES Gold ES Tuner	EX/DEMO	£250	£125
SONY STSA3ES ES Tuner	EX/DEMO	£300	£225
SONY VPLHS1 Projector	EX/DEMO	£1,800	£1,600
THORENS TD166 MK2 Turntable + RB250 & AT450E	S/H	£500	£350
YAMAHA RXV620RDS AV Receiver	EX/DEMO	£450	£300

**PLEASE VISIT OUR SHOWROOMS
OR CALL OUR HOTLINE
NUMBER FOR DETAILS.
MANY ARE ONE-OFF ITEMS!!**

HOTLINE 020 7497 1346

Convent Garden
18 Monmouth Street
Convent Garden
London WC2H 9HJ
Tel: 020 7497 1346

E-Mail: sales@musical-images.co.uk

NOT VALID WITH ANY OTHER OFFERS OR PROMOTIONS E&OE

HICAM

**CHERISHED PRE-OWNED HI-FI EQUIPMENT SOLD, PURCHASED, P/X.
CASH WAITING FOR THE FOLLOWING BRANDS
NAIM, MERIDIAN, AUDIOLAB, KRELL, WADIA, SONUS FABER,
MARTIN LOGAN MARK LEVINSON, COPLAND, QUAD**

	WAS	NOW			
AUDIONOTE MEISHU LINE INT AMP NEW		2750	MICHELL GYRO SE/RB300 ARM SEALED BOX	1017	925
ALPHASON AKROS 2 SPEAKER STANDS BOXED	60	30	MICHELL ORCA PRE AMP	1251	1095
AUDIONOTE QUEST MONO AMPS NEW		2750	MYRYAD MT 100 FM TUNER NEW		599.95
AUDIONOTE 0TO INT AMP LINE LEVEL AS NEW	999	850	MICHELL GYRODECK /RB 300 ARM AS NEW		1190PHONE
LYRA HELIKON SL MC CARTRIDGE NEW		1249	STAX OMEGA REF SR 007/SPM 717 TUBE ENERGISER		2795
EAR HEADPHONE AMP HP4 AS NEW	1749	1500	AUDIONOTE AN CDT THREE TRANSPORT NEW		3500
AV1 S2000 MM MONOBLOCKS SEALED BOX	1399	1195	AUDIONOTE DAC 4.1X NEW		4950
BLACK RHODIUM REQUIEM 1 1 METRE PAIR NEW	1247	950	MERIDIAN 5022 BALANCED PREAMP MINT/BOXED	1250	650
BLACK RHODIUM REQUIEM 21 METRE PAIR NEW	1747	1350	AUDIONOTE AN CD 2.1X INT CD PLAYER AS NEW	999	895
BLACK RHODIUM ORATORIO 1 METRE PAI NEW	547	450	DELPHINI MONO PHONO AMP INC LARGE PSU NEW	1850	PHONE
AUDIOLAB 8000 C PRE AMP		195	PSB ALPHA 6 ACTIVE SUBWOOFER AS NEW	500	250
AVI S2000MC REFERENCE 24/96 CD PLAYER	999	895	ELAC CL 3301 JET INC STANDS NEW		2499
BLACK RHODIUM ORATORIO 1 METRE DIGITAL NEW	497	400	RUARK CL10 CHERRY FINISH BOXED	900	525
MYRYAD MA 240 POWER AMP AS NEW	999	850	SONICLINK POWER CORDS X2		5735 each
AUDUSA EUPEN POWER CABLES FULL RANGE		POA	RUARK PROLOGUE CHERRY BOXED	995	550
EAR V 20 INTERGRATED CLASS A MINT	2798	2195	ELAC 201 CENTRE SPEAKER VARIOUS FINISHES		279
NAIM INTRO LOUDSPEAKERS BLACK/BOXED		395	STAX SRS 4040 SYSTEM SIGNATURE 2 MINT	1195	995
AUDIONOTE 0TO PHONO INT AMP 1 MDNTH OLD	1300	1100	ELAC 556 CENTRE 3 WAY CENTR SPK CHERRY FINISH		599
AUDIONOTE DAC 2.1X 24/96	1149	1025	EAR 899 INT/PRE AMP 70 WPC CLASS A NEW		2698
AVI S2000MM 150 WPC MONOBLOCKS NEW	1399	1200	NAIM 32.5 PRE M/C PHONO		295
ELAC CINEMA 2 ESP SPEAKES-SUB		499	TRICHORD DINO PSU NEW		299
EAR 8L6 INTRERGRATED/PRE/MAIN AMP NEW		2298	SONICLINK AST200 BRWIRE SPK CABLE NEW	10	8
EAR 834P CHROME DELUXE MM/MC PHONO AS NEW	788	695	SONICLINK THE BASE I MTR PAIR INTERCONNECT NEW	25	13
EAR 834P MM/MC PHONO STAGE	558	450	TRICHORD ORCA PRE/ LARGE PSU MINT	1650	1450
EAR MC3 MC TRANSFORMER AS NEW	678	595	SONICLINK 8 WAY DISTRIBUTION BLOCK		
EAR 834 INT AMP BOXED MINT	2198	1875	2 MTR CABLE NEW	299	250
HEYBROOK QUARTET ROSEWOOD FINISH	595	225	SONICLINK SIMPLICITY 1 METRE PAIR INT. NEW	35	18
AUDIONOTE AZ TWO LOUDSPEAKERS 93 DB MINT	599	500	CONRAD JOHNSON 17 PRE AMP MINT	4500	2500
LAT SS800 SPEAKER CABLE 5MTR NEW	206	175	SONICLINK VIOLET INTERCONNECT (OFF THE REEL) 15 PER MTR		
LAT 8 WAY DISTRIBUTION BLOCK 3 FT NEW	232	199	STAX SRS 2020 MK2 EARSPEAKERS MINT	449	375
LAT AC2 6 WAY DISTRIBUTION BLOCK 3 FT NEW	201	175	AUDIONOTE M5 LINE LEVEL PRE AMP MINT	4650	4100
LAT AC2 POWER CABLE 9 METRE	81	72	SUMIKO PEARL MM CARTRIDGE NEW		79
LAT IC100 MK2 1 METRE BOXED NEW	105	90	SUMIKO BLUE POINT SPECIAL MC NEW	279	249
BLACK RHODIUM SUPER MAINS 8 DISTRIBUTION BLOCK NEW	299	250	AUDIONOTE ANVX 1 METRE PAIR NEVER USED	574	495
AUDIONOTE ZERO TRANSPORT/DAC	1048	925	TALK ELECTRONIC THUNDER 1 CD PLAYER		
EAR HP4 HEADPHONES AMP	1749	1450	TARGET MX100 SPEAKER STANDS PIANO BLACK		
MYRYAD MI 240 INT AMP 2X120 WPC	1499	1300	EAR PARAVICINI M100 MONO BLOCKS (AMAZING)	199	95
MYRYAD MA 500 5 CHANNEL AMP 5X100WPC		1699PHONE	VDH THE SECOND 8 MTR NEW	230	150
EXPOSURE XV11 AMP BOXED MM PHONO STAGE	1000	395	TRICHORD RESEARCH 500 POWERBLOCK	299	275
LYRA LYDIAN BETA MC CARTRIDGE NOT USED	599	525	EAR 324 TRANSISTOR PREAMP NEW		1880
EAR 890 POWER AMP 70 WPC CLASS A NEW		2548	QED FULL RANGE		POA
AUDIONOTE ANS3 MC STEP UP TRANSFORMER NEW	1299		SOUND ORGANISATION FULL RANGE		POA
MICHELL LARGE PSU NEW	399	399	MYRYAD MD 600 CD PLAYER AS NEW	1299	1050
POWERBLOCK 1000 MAINS CONDITIONER NEW	450	395	AUDIONOTE ANCD 3.1X CD PLAYER NEW		1499
			VDH THE SOURCE HB 0.8 METRE NEW	65	57.5

**AGENTS FOR, EAR, TRICHORD, AUDIONOTE, MICHELL
MYRYAD, AVI, STAX, LAT, VDH, ELAC, RUARK, SME
BLACK RHODIUM, LYRA, SUMIKO, QED**

**OPEN MON-SUN 10AM-6PM
FOR FURTHER DETAILS: TEL 01726 74474/01844 260517
FAX 01726 70387 MOBILE: 07973 233 380
E-MAIL HICAM1@FRENETNAME.CO.UK
OR VISIT OUR WEBPAGE HICAM.CO.UK**



apex acoustics

USED AND EX DEM EQUIPMENT

Audio Analogue Bellini Pre Amp Silver	£ 250.00
Alphason 7 Shelf Smoked Glass Rack	£ 150.00.
Base Isolation Platforms Silver	£ 90.00
B & W Silver Signatures, Inc. HNE Granite Stands	£2795.00
B & W CC6 S'2 Centre Black	£ 125.00
Bryston BP25 Pre. Remote, Silver	£1250.00
Bryston 4B ST Power, Silver	£1600.00
Chord Chameleon I/Connects From	£ 60.00
Chord Chorus I/Connects From	£ 125.00
Chord Chorus XLR (ISET ONLY)	£ 170.00
Chord Siren I/Connects From	£ 55.00
Chord Solid 1m I/Connect	£ 105.00
Chord Pro Dac Digital From	£ 35.00
Copland CDA 266 CD Mint	£ 895.00
Cyrus Quattro & Cyrus Stereo Power Amp	£ 695.00
Cyrus CLS 50's Cherry	£ 300.00
Cyrus 2 Int. & PSX. Serviced. Inc QED Silver Spiral I/Connect	£ 300.00
Denon AVR 3802 Surround Receiver Amp. Black	£ 545.00
Denon TU425RD Tuner	£ 100.00
Ecosse Ref MS2.3 S/Cable Bi-Wire 3m Pair	£ 200.00
Ecosse Ref I/Connects MS2	£ 135.00
Ecosse Ref I/Connects The Legend	£ 350.00
Electrocompaniet EC 4.6 Pre	£ 875.00
Electrocompaniet AW250R Power	£2795.00
Buy Pre. & Power get Silver XLR Leads Inc.	
Epos ES30's Rosewood, Inc. 4m Exposure Tri-Wire S/Cable	£1195.00
KEF Q5 Dark Apple	£ 495.00
Kontak Link 502 I/Connect 1m XLR	£ 40.00
LFD Zero Int. Amp	£ 275.00
Manley Purist Pre. Valve	£ 795.00
Marantz DR700 CD Recorder	£ 150.00
Marantz SR5200 AV Surround Receiver Amp	£ 325.00
Meridian 506 20 bit CD	£ 645.00
Mission 752f Speakers, Rosewood	£ 300.00
PMC FB1 Floorstanders, Oak	£1100.00
PMC DB1 Standmounts, Oak	£ 475.00
PMC TB2 Centre, Oak	£ 315.00
Pink Triangle Cardinal & DaCapo with 1307& 24 Bit Filters, Serviced	£1650.00
Rega Planet CD Black Inc. Remote	£ 365.00
Sony MDS JB920 Mini Disc Remote	£ 125.00
Sugden CD21 Latest Spec	£ 670.00
Teac 6030S Cassette Deck	£ 275.00
Teac VRDS10SE CD Mint	£ 350.00
Totem Model 1's Cherry Inc. Dedicated Stands	£1295.00
Townshend Isolda I/Connects .75 meter	£185.00
Veritas 7's Oak	£ 500.00

ALL ITEMS PRICED TO CLEAR !

**PHONE STEVE ON 01527 450500
/ MOBILE : 07773198336**

E-MAIL Apexnm@aol.com www.apexacoustics.co.uk

We are best known for our single-ended 300B power amplifiers and power supply upgrades for valve amplifiers, but did you know that we supply complete systems, new and used equipment, and components? We also provide support and servicing for Audio Innovations valve products. For full information visit www.borderpatrol.net or ring 01273 276716

passion, grace & fire

www.borderpatrol.net

Selected products from:

BorderPatrol • Living Voice • SME • Audio Note • Cartridge Man • Goldring
Western Electric • Electrofluidics

BorderPatrol Brighton UK
Tel/Fax +44 (0)1273 276716
e-mail: bp@borderpatrol.net
www.borderpatrol.net



BorderPatrol

RETRO Reproduction



Used equipment for sale

Amplifiers		
ARAGON 4004 with matching Preamp and PSU ...may split	£1,195	Rotel RT930 AX Tuner
Arcam 8 Power Amp	£230	Revox Professional PR99 Open Reel
Audio Innovations Series 400 Integrated Amp with Excellent Valve Phone Stage	£450	Revox G36 Open Reel Mint
Audiolab 8000C pre amp	£150	Tascam 22/2 Open Reel
Audionote M1 Valve Pre Amp with Phonostage and Outboard PSU	£475	Leak Troughline Tuner 3 various ...from
Audio Research VT100 MkII	£2,300	
Cary SLP94 Valve Preamp with Outboard PSU	£835	Speakers
Concurrent Excelsior preamp with Outboard PSU	£495	AVI Pro 9
Copland CSAB Integrated Amp as new	£595	B&W 603 S2 Speakers
Crimson 610 pre amp	£95	Celestion SL700
Cyrus II Integrated Amp mint	£195	JBL T12K boxed unopened new £1600
Cyrus PSX Power Supply	£195	Linn Isobank Loudspeakers (Mint Condition)
Cyrus III Remote Integrated Amp	£295	Mission 780 Speakers
EAR 834P Valve Phono Amp	£235	Mission 751 Bookshelf Speakers
EAR 834L Valve Line Stage	£275	Mission 753 Rosewood Speakers boxed
Krell 3001 Integrated Amp (Final Version of this Model)	£1,595	Musical Fidelity MC2 Bookshelf Speakers
Linn Klout Power Amp	£995	Neat Critique rosewood finish speakers
Linn Karn pre amp with latest PSU	£495	QLN Splitfield Signatures
Lumley 120 Mono Blocks 120 Watts per channel	£1,600	Rogers LS33 with AB 33 new £600
Musical Fidelity P180 Power Amp with choke regulated power supply	£495	Solstice Advanced Acoustic Design open baffle design speakers with Outboard Crossovers and stands...new £1000 s7
Musical Fidelity MXL Pre Amp	£195	Tannoy D100 Bookshelf Speakers
Musical Fidelity E10 Integrated Amp	£175	
Micromega Minum Integrated Amp	£195	Turntables, Arms, CD Players
Naim Nat 3 Integrated Amp superb condition	£1,495	Audiolab 8000 CD Player
PASS Alpha 3 Classic Single Ended Amp	£1,495	Audio Research CD2 CD Player
Project 7 Amp very good phono stage	£150	Fons CQ30 with Mission 774 tonearm 78rpm facility
Quad 77 Pre and Power Amp	£595	Linn Kark CD Player
Quad 77 Int Amp grey/blue finish	£275	Linn ITOK Tone Arm
Quad 44 pre - old style	£195	Marantz CD63 top loading CD Player
Richard Allan Class A Integrated Amp	£95	Meridian 207 CD with Preamp
Sony TA/FBQ00N Integrated Amp with remote	£150	Micromega Junior CD Player
Sugden A28 Integrated Amp	£95	Naim CD3 boxed mint condition
Sugden A28 Integrated Amp	£150	Pioneer PDS 703 CD Player
Sugden Model SP30 Class A Dual Mono Power Amp	£550	Pioneer Precision CD Player
Tube Technology Genesis Monoblocks 100Watts ...revalued	£1,350	Quad 77 CD Player
Tube Technology Prophet 2 boxed pre with rare MC stage (new £2700)	£895	Reqa Planar 3 original
		Rotel JCD 965BK CD Player
		SME V Tonearm boxed
		Sony CDP X55 ES heavy weight CD Player
		Sony SACD Model XB940 new £500
		Sony 337 ESD 10kg monster a very fine player new £800
		System Deck IIX turntable ..UPGRADE YOUR REGA from
		Due In
		Audio Research Remote Integrated Amp CA50
		Focal Audio M13VX Drive Units as used in Wilson
		Theta Miles CD Player

Selected products from: ATC, Audio Physic, EAR Yoshino, Nottingham Analogue,
Revox G36 Open Reel Mint Creek, Triangle, Sugden, Dynavector.
Tascam 22/2 Open Reel Leak Troughline Tuner 3 various ...

New Showroom & Dem rooms now open

28a Haddington Place Edinburgh EH7 4AF Phone/Fax 0131 558 9989
Open 11.00am - 5.30pm - closed Monday & Sunday

WE ARE PROUD TO ANNOUNCE THE NEW BEAUHORN B2 HORN
LOUDSPEAKERS IDEAL FOR LOW POWERED SINGLE ENDED VALVE AMPS
ALSO DEMONSTRATING THE NEW GRAHAM SLEE PROJECTS RANGE OF
AFFORDABLE PHONOSTAGES

Now stocking Sonneteer's new Bronte product range including
digital amp from £800 and matching CD player



Ear 869 single ended triode integrated amplifier
An improved version of the classic 834P with revised output
transformers modified input stage with the addition of
an extra signal valve which has allowed an increase to
15watt of single ended power, also the 869 can be used as a
power amp. Don't be fooled by its modest power output this amp
drives real world speakers. price £2298.00

Ear 8L6 Integrated/Pre-main amplifier

Using 8 EL 34 power valves to produce 50watt per channel in
push pull class A with in-house designed output transformers. The
8L6 has been designed to meet a wide variety of needs from the most demanding of audio files to the
professional seeking high quality monitoring equipment in the studio field. Valve life is long and
replacement cost are modest. There is also a balanced power amp version with monoblocking capabil-
ities to produce 100watt per channel. Price £2,298.00

"NOW DEMONSTRATING"

**"HARMONIC TECHNOLOGY SINGLE CRYSTAL
CABLE"**
NOW IN STOCK "AT LAST I HAVE A CARE TO DO ALL THE THINGS THE MANUFACTURE
CLAIMS AND AT A RIDICULOUS LOW PRICE" PHONE FOR MORE DETAILS



There are now four models in the EAR lineup:
The classic 834P uses the same circuit architecture as its
more expensive brothers, and shares the same high quality
sound through MM1 type cartridges, it is enclosed in a tough, rigid
metal case and is fully "CE" type approved price £395.00

The signature builds on the Classic 834P specification by adding a superb
moving coil (MC) input stage, as well as the no-extra-price option of a high
quality volume control. price £550.00

Top to the range, the Deluxe 834P comes in stunning chrome and gold cabinet, and has extra attention
and quality control. With different moving coil input options, this unit will fit the most demanding of
audiophile systems. For the true vinyl enthusiast. price £800.00

MC3 - The ultimate stage for MC matching with 3 fixed transformer taps to cover all types of moving
coil cartridges, and separate left/right grounding. MC3 in use in the new £10,000 312 pre price
£630.00

Oxford Audio Consultants Ltd.

OUR SUPERB SERVICE IS THE SAME REGARDLESS OF PRICE



Now Demonstrating



Ex-Demonstration & Previously Owned Equipment

SALE LIST - October 2002

Graaf 13.5B II	JUST IN	£1999	SH
Graaf GM20 Monoblocks	JUST IN	P.O.A.	SH
Linn Sara speakers walnut	JUST IN	£295	SH
Proac CC1 Centre speaker black	JUST IN	£395	SH
Proac Tablette 2000 Black	JUST IN	£450	SH
Nordost Quattrofil cables - various		P.O.A.	SH
Transparent Cables - various		P.O.A.	SH
Musical Fidelity A1001		£1250	SH
Naim NAIT 3		£ 350	SH
Musical Fidelity MVT preamp		£ 395	SH
Theta Carmen DVD/CD Player silver ex dem		£2695	XD
Martin Logan Prodigy ex dem		£8500	XD
Mission 753 speakers		£ 295	SH
Castle Chester cherry		£295	SH
Tag McLaren AV32 A/V Processor ex dem		£1750	XD
Theta Casanova fully loaded incl Circa Surround Silver	REDUCED	£2995	SH
Proac Response ISC Ex Dem marked rosewood	REDUCED	£ 695	XD
Sonus Faber Signums Ex Dem	REDUCED	£895	XD
Sonus Faber Amator Power Amplifier	REDUCED	£495	SH
Krell FPB300ex Power Amp Latest Model		£8500	XD
Marantz SA12 CD/DVD/SACD		£2750	SH
Unison Research Mystery One/Smart 845s		£2695	SH
Audio Research LS3		£ 650	SH
Audio Research VT60 Power Amp		£ 950	SH
Audio Research D100.2		£2795	SH
Naim 82 Preamp as new ex dem		£1895	XD
Naim 180 Power Amp		£95	XD
Naim Supercap Ex Dem Min		£1950	XD
Naim 102		£ 950	XD
Audio Analogue Bellini Preamp Silver	REDUCED	£250	SH
Wilson System 5.1	REDUCED	£5295	SH
Wilson System 6.1 Ferrari Grey	REDUCED	£13995	SH
Musical Fidelity A3 Preamp/Power Amp Ex Dem		£1295	XD
Krell CD DSP Mk 2 CD Player Glass Lid Top-Loader	REDUCED	£1295	SH
Krell KPS25sc CD Player	REDUCED	£13995	SH

SH - Second Hand XD - EX Demonstration

0% interest free credit

Licensed Credit Broker

REFER TO OUR WEBSITE FOR THE LATEST UPDATED SALE LIST.

Agencies include: Acoustic Energy, Alphasound, Atacama, Audio Analogue, Audio Research, Beyer, BOSE, Castle, Chord Company, Copland, Creston, Denon, Diapason, Dvni Electronics, Einstein, Fujitsu, GM Audio, Goldring, Graaf, Integra Systems, IXOS, Jaded, Jamo, Kef, Koetsu, Krell, Lexicon, Loewe TV/Video, Linn Classic, Lyrx, Marantz, Martin Logan, MRS, Multiroom Systems, Musical Fidelity, NAD, Naim, NEC Gas Plasma Screens, Nakamichi, Nordost, Ortofon, Ogura, Ortofon, Parasound, Pioneer, ProAc, Project Turntables, QED Multiroom, Quad, Quadraspire, REL Subwoofers, Semtech, Serrin, LCD TVs, SME, Sonus Faber, Sonus Systems, Soundstyle, Stands Unique, Stax, Stewart Screens, Tag McLaren, Tannoy, Teac, TITAN, Transparent, Unison Research, Van den Hul, Vibe Acoustics subwoofers, Videologic, Vienna Acoustics, Wilson, Yamaha.

TAX-FREE EXPORT SERVICE
MAIL-ORDER AVAILABLE ON MANY ITEMS

Canta House, Park End Street
Oxford OX1 1JD

Telephone: Oxford (01865) 790879

Facsimile: Oxford (01865) 791665

E-MAIL: oxford.audio@btinternet.com

WEBSITE: www.oxfordaudio.co.uk



V.A.T. No.
729580013

TEL/FAX
0121 747 4246



QUALITY USED
EQUIPMENT,
BOUGHT, SOLD,
PART EXCHANGE

URGENTLY REQUIRED
LINN, NAIM,
MERIDIAN, QUAD,
CASH WAITING

	RRP	NOW £
ACOUSTIC ENERGY AEGIS CENTRE BLACK	150	50
ACCUPHASE DP65V CD	4000	2795
ADVANTAGE A300 POWER AMP	2800	1395
ADVANTAGE M300 MONO'S NEW SEALED BOX	4600	2795
ART AUDIO QUINTET VALVE POWER	1800	495
ATC SPA2-150	3000	1695
AUDIO RESEARCH SP 14	3500	1195
AUDIO RESEARCH LS15	3500	1995
AUDIO RESEARCH VT150 MONO'S	14000	4995
AUDIO RESEARCH VT200	10000	4495
AUDIO RESEARCH D115 MK11	N/A	1095
AUDIO RESEARCH VT50 BALANCED	4400	1995
AUDIO RESEARCH CLASSIC 60	3500	1495
AUDIO RESEARCH SP9 MK 11	N/A	795
AVI S2000MC CD	1300	450
AVI S2000MP+P PRE	1050	395
AVI S2000MM MONOBLOCKS	1600	795
BALANCED AUDIO TECHNOLOGIES VK20 PHONO REMOTE	5000	1995
BALANCED AUDIO TECHNOLOGIES VKD5SE CD	5500	3195
BKS 107 SUPREME RIBBON HYBRID	2000	1295
BOW TECHNOLOGIES WAZOO INTEGRATED AMP	2000	895
CHARIO SYNTAR 100 TOWERS BLACK	550	150
EAR 534 POWER AMP BALANCED 6 MTH OLD	2200	1395
GRYPHON TABU INTEGRATED	3800	2295
HOVLAND HP-100 + M/C PHONO	5750	4495
HOVLAND SAPHIRE POWER AMP	7000	4995
J M I ABS MINI UTOPIA + STANDS	5250	2995
KEF REFERENCE 1 BLACK	N/A	495
LUXMAN K-351 CASSETTE DECK	N/A	195
MAGNUM DYNALAB MD10 VIRTUAL DECODER EX DEM	700	195
MARANTZ SACD 12IS NEW UNUSED	3500	2595
MARK LEVINSON 331	5500	2995
MARK LEVINSON NO29 POWERAMP	N/A	1295
MARK LEVINSON NO36 DAC	4000	1595
MARK LEVINSON NO39	5000	3495
McINTOSH MC 2000 LTD EDITION POWER AMP	15000	8995
McINTOSH CIOO TWO BOX PRE	6500	3495
McINTOSH MR85 TUNER	2300	1695
MICHELL ISO	N/A	150
MICROMEGA STAGE ONE DAC	600	195
MONITOR AUDIO STUDIO 50 ROSEWOOD	3000	1295
MONSTER ZR REFERENCE SPEAKER CABLE 2X10 FT	350	95
MUSE MODEL 8/296 DVD/CD TRANS & 24/96 KHZ DAC	7000	2495
NAIM 82	2500	1495
NAIM CDS 1	4000	1995
NAIM SBL WALNUT	2450	695
NAIM 180	1220	695
NAIM 72	800	350
NAIM 250	1910	895
NAIM SBL LATEST DRIVERS BLACK	2540	695
NAIM PREFIX S	450	250
NAIM Credo CHERRY	1425	695
NAIM Credo EBONY	1425	695
NHT 1.3A SPEAKERS PIANO BLACK EX DEM	500	195
NHT 1.1 SPEAKERS PIANO BLACK EX DEM	400	150
NVA THE INTEGRATED STATEMENT	1300	495
ORACLE 2000 TRANSPORT SPECIAL EDITION EX DEM	8900	4995
PINK TRIANGLE DA CAPO 1307 FILTER	1860	595
PINK TRIANGLE INTEGRAL INTEGRATED	4000	2495
PROAC RESPONSE 3.8 BLACK	4000	2495
PROAC CC2 CENTRE BLACK	1000	595
PROCEED CDD TRANSPORT	2700	995
QUAD ESL 63 BLACK/ROSEWOOD	3800	995
QUAD 34 BRONZE/DIN	N/A	95
REGA CURSA/MAIA PRE POWER	1000	495
SONY SACD 1	4000	2395
SONUS FABER CONCERTO GRAND PIANO MARBLE BASES	2100	995
TANNOY MERCURY M3	250	95
TARA LABS RSC MASTER GENERATION 2 BALANCED 3 MTH	1200	395
TEAC P30 TRANSPORT	2800	1695
TEAC T1 TRANSPORT	550	350
THETA CARMEN CD/DVD TRANSPORT BLACK	4000	2295
VAN DEN HUL REVELATION HB 2X 1.5	800	150
VTL MB125 MONO'S	3000	1595
WADIA 61	N/A	1695
YAMAHA SW 160 SUB	275	150

OPEN MON-SUN 10.00 TO 8.00

Website: www.centralaudio.co.uk.

E-mail: tony@centralaudio.co.uk

ALSO AGENTS FOR

Advantage, Balanced audio technologies, Boulder, Burmester, Egleston, Hovland, Kharma, Lumley, Pass labs, Sound lab, VTL.

HEATHERDALE PRE-OWNED GUARANTEED EQUIPMENT EXPORT FACILITIES AVAILABLE

SPEAKERS

Audio physisc Tempo Speakers	£1995
ATC SCM 50A Active speakers	£3495
Tannoy Kingdom 12 x Demo	£3495
Pre-ac studio 1 speakers mk 2	£395
Casile 7 speakers	£295
ATC SCM 50A Active speakers	£3495
Jean-Marie Reynaud Offrande Speakers	£1495
Audio Note An J Sp. Speakers	£650
Orchid Lwo Speakers (Ex Demo)	£2295
Thiel Scs 2 Speakers (Walnut, Factory Sealed Boxes)	
Normal Price £2395 Our Price	£1595

PRE AMPS

Musical Fidelity MV7 Pre amp	£375
Naim audio MAT 3 pre amp	£425
Exposure 21 Pre Amp (New, with Remote)	£750
NAD 114 Stereo Pre Amp	£99
Adcom GTP 450 Tuner/Pre Amp	£350
Oakley High-end Valve Pre Amp (similar to Conrad Johnson)	£850
Naim NAC 42.5 Pre-Amp	£150

AMPLIFIERS

Ion Obelisk 3x integrated amp with power supply	£1495
Naim audio NAP 90 power amp	£395
Arcam xeta one integrated amp (pro logic)	£395
Mark Levinson No. 334 (Brand New, Sealed Box) Normal Retail £5000	£90A

Krell KST 100 Power Amp	£1695
Nakamichi Pa 5 Stasis Power Amp	£895
Bow Wazoo XI Integrated Amp (New)	£1995
Ion Nexus Mk40 Mono Blocks With SP1 Pre Amp & X Pac 2 Psu	£1199
Heybrook Signature System (Cd Player, Pre & Power Amp)	£995
Adcom GPA 5300 Power Amp	£350
AVI 2000Mi integrated Amp (ex demo)	£750

CD PLAYERS & TRANSPORT

Surgden CD21 CD player	£650
Krell KAV 300 CD Player	£1995
Marantz CD 63 SE CD Player	£1195
Cec T11 Cd Transport Belt Drive (Gold Finish) (Stereophile Recommended)	
Normal Retail £5000	£2650
Marantz Cd 72 Mk2 Se Cd Player (Mint)	£295

DAC'S

Sonic Frontiers SFD1 Digital Processor	£895
Theta Chroma HODD DAC (ex demo)	£775

MISCELLANEOUS

Naim Headphone Amp and power supply	£175
Naim audio PLATINUM power supply	£250
Naim audio NAT 03 tuner	£395
Pioneer 830s 3 head cassette deck	£195
Target Heavy duty speaker stands	£195
Nakamichi tuner 2	£195
Nakamichi cassette deck 1	£395
Nakamichi ZX1 1000 Cassette Deck	£1495

Nakamichi BX-300E 3 Head Cassette Deck	£295
Magnam Dynalab Elyde Tuner	£795
Quadrashire 04 Oak Wall Shelf	£120
Synergetic Reseracti Coax Resouction Reference Balanced Digital Cable	£250
Stax SR007 Omega Ref (SR117 Head Phone & SRM007I dual triod)	
Normal Retail £2995	£1750
Eminent Technology air bearing arm with magnesium wand c/w pump	£1695
Rotel Rq 970 Bx Phono Stage	£99
Shun Mook Record Clamp Normal Retail £1660	£995
Stax Srs404 (SR404 & Sam 006I) Headphones Normal Retail £1195	£750
Nakamichi Cafe Cassette Deck	£1195
Nakamichi C-40 Tape Deck	£225
Harmonix Record Clamp	£195
Luxman K331 W Cassette Deck	£150
Audio Note AN57 MC Transformer with Phono-Phono Stage	£8495

TURNTABLES, CARTRIDGES & TONEARMS

Audio research PH3 Phono stage	£1495
Mark Levinson No.25s Phono Stage with Power Supply	£3495
Ariston PD11 Turntable	£75
Linn Axis Turntable with Linn Akito Arm (Below Average Condition)	£75
Verdier Ebony Wood Arm Board Normal retail £800	£425
Audio Power Supply & Sme Arm	£995
Helius Silver wired tonearm	£995

BRAND NEW LISTENING LOUNGE NOW OPEN
We now offer 0% finance (subject to status)

PLEASE PHONE TO ARRANGE AN AUDITION
MAIN DEALERS FOR MARK LEVINSON, THIEL, AND ABSOLUTE SOUNDS

ALL USED CARTRIDGES ARE CHECKED UNDER A MICROSCOPE BEFORE BEING OFFERED FOR SALE.

VISA - SWITCH - MASTER CARD - AMEX - DINERS CLUB WELCOME.
WE TAKE PART EXCHANGE ON NEW & USED STOCK and buy in for cash

Soundcraft HiFi.com At 40 High Street, Ashford, Kent. TN24 8TE

SPECIAL CLEARANCE SALE October 2002

Hi-Fi Separates (! = Ex - demonstration)

Arcam Xeta II Amp	£200!	Musical Tech Harriers	£499!
Audiolab 8000 Pre/Pwr	£600	M/F A3 Amplifier	£650
B&W DM-603 S3 spks	£495!	M/F HT-6005 Amp+HTP Pro	£3000!
B&W ASW500 Sub/W	£299	Naim CDS II Ex dem	£3665
Castle Richmond ant/oak	£199!	Naim XPS ex dem	£1848
Castle Harlechs ant/oak	£850!	Naim NAC-62/ NAP 90/3	£499
H/K AVR-4000 AV/Rcr	£450!	Naim NAc 72 pre amp	£399!
Linn Intek/Phono	£250	Naim NAP 90/3	£299!
Linn Isobarik Spks Teak Active crossovers		Pioneer PDS-707 CD Player	£199!
3x LK 280 power amps	£2000	Rega Jura's (cherry)	£399!
Linn CD-12 I	£7995!	Rega Radio	£250!
Linn Kairn/Phono	£599		

Our exciting range includes: Arcam, DiVA & FMJ, Chord Electronics, Linn, Lexicon, MC-12, Naim, Rega, Musical Fidelity, Denon, Yamaha, Rotel, B&W Nautilus, PMC, Ruark, Kef, Loewe TV, Hitachi & Pioneer Plasma, Sim 2 DPL!
Hotline: 01233 624441 Fax: 01233 640333.

AV Separates (! = demonstration)

Arcam AVR 100 Receiver	£499	Rotel DSP-966AX Processor	£699!
Naim AV-1 Processor	£650	Sony DVP S-7700 DVD player	£399!
Nakamichi 10-S DVD player	£399!	Yamaha DSP-AX3200 120w X 6	£999!
Plasma Hitachi 32" +stand	£2995	Yamaha RXV-620 RDS Amp	£199!
Plasma 50" Pioneer PDP-503	£6995	Yamaha DSP E 800 processor	£249!
Plasma 50" Pioneer PDP-502	£5995	B&W 802's Red Cherry Ex Dem	£4995
Pioneer DV-444 DVD player	£249!	Linn CD12 Ex dem	£7495
Pioneer NS-DV1 DVD System	£699!	B&W ASW-500 Sub/w	£299
Pioneer XV-DV55 + S-59 spkrs	£599!	Sim 2 HT-200 Projector, ex dem	£3995
Pioneer VSX-859 THX Rcr	£599!	Denon AV-F100s System +NXT panels	£899

Check our web site: soundcraft.hifi.com

Sound Investment

If you have invested expertise and money in building up a sound system to your own unique specifications, then why compromise with indifferent housing units?

Fi-Rax offers a new dimension in audio visual racking - from a range of standard designs to the flexibility to custom create a unit to suit your particular sound system and lifestyle.

- *High quality aluminium construction.
- *Finishes available to your choice.
- *Fully adjustable 6mm glass shelving.
- *Sound isolation on shelving/feet.
- *Custom created to suit your system.
- *Free delivery throughout the UK.

Fi-Rax - a sound investment for those who want the best from their equipment.

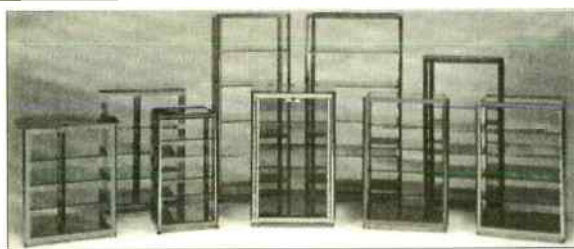

Audio Visual Furniture

For further information or a free brochure contact: JEM Distribution, Springfield Mills, Spa Street, Ossett Wakefield WF5 0HW.
Tel: 01924 277626 Fax: 01924 270759

Are you making the right connections?

Send for Britain's biggest catalogue of specialist cable and connections.

All available by mail order.
Phone 020-8942 9124 or clip the coupon for your Free copy
www.custom-cable.co.uk

CUSTOM CABLE SERVICE

PO Box 4007, London SW17 8XG

Please send me your FREE Custom Cable Catalogue

Name _____

Address _____

Postcode _____

NO FURTHER INFORMATION REQUIRED

Send to: Custom Cable Service
PO Box 4007
London SW17 8XG

HFW 12/02



cartridges

denon
dnm
goldring
lyra
ortofan
sumiko

cables

chord company
dnm
lfd
nordost
qed

trichord
van den hul

headphones

beyer
ergo
grado
sennheiser
stax

stands

frameworks
sound org'n
something solid
soundstyle
stands unique

accessories

creek
densen demagic
discwasher
goldring
kontak
michell

milty

moth
musical fidelity
nordost
pixall
qed

rms

shure

trichord

zerostat

hardware

atc
audio physic
densen
epos

harbeth

in-focus

lexicon

linn products

michell

musical fidelity

nordost

primare

red rose

sme

sugden

trichord

Second hand & ex dem deals



Densen B100 Mk 1 amplifier. S/H in good condition. Gold knobs. An excellent classic amplifier. Current version costs £900. This edition was £600 when new. £285

BOW Wazoo XL line level amplifier, latest spec. Remote volume control with RC5 handset (not included) (£2495) Perfect condition. UK spec, boxed. £1350



Dynaudio Audience 42 loudspeakers. Rosewood print. Excellent condition. S/H boxed. (£400) £225

EAR 85p integrated valve amplifier. Supplied new by Signals 11 months ago. Perfect condition, boxed. (£2400) £1350



Marantz 6000 SE KI Signature CD player. S/H, boxed. Perfect condition. (£500) £285

Marantz 17 mkII KI signature player. S/H, boxed. Perfect condition. (£1150) £750



Primare V10 DVD player. Ex demonstration. (£799) £475



Sugden Stemfoort SF60 integrated amplifier. 60 wpc. Cost £550 ish new. s/h boxed. Choice of silver / black or black / gold. Both one owner. . . £250

Sugden 'Bijou' system.

HeadMaster r/c preamp / headphone amp (£600) £450

AmpMaster power amplifier (£629) £470

CDMaster cd player (£1269) £950

All ex demo., warranted and in good condition.



Nordost specials

All ex demo or trade - ins. All in good condition.

1m pair Quattrofil XLR interconnect (in box) (£1409.90) £845

1m single length Quattrofil phono (£688) £415

0.6m pair Quattrofil 5 pin DIN to RCA (£1269) £760

1m pair SPM interconnect (phono) (£866) £510

1 x 5m pair Red Dawn (rev1) single wire spkr cables (£1274) £760

1 x 5 m single run Red Dawn as above (£637) £380

1 x 5m pair SPM bi-amp loudspeaker cables (£4335) £2600



hi-fi for grown-ups



THE AUDIO ROOM EX DEMONSTRATION AND USED SALE

	WAS £	NOW £	
LINN KLOUT	2400	1000	sh
LINN KARIK 3 CD PLAYER	1850	850	sh
LINN NUMERIK DAC	1500	750	sh
LINN IKEMI	1960	1400	sh
LINN GENKI silver	1030	595	ed
LINN KOLEKTOR silver	530	350	ed
LINN LK85 silver	530	395	ed
LINN 5103 silver	3285	1995	ed
LINN 5125 silver	1785	1195	ed
CYRUS 7	700	500	

NEW VERY LIMITED STOCK

CYRUS 5	500	350	ed
CYRUS 7	700	400	ed
NAIM NAP180	1220	900	ed
NAIM CREDO maple	1425	995	ed
REGA PLANET	498	300	ed
REGA ELICIT	748	450	sh
REGA PLANET 2000	498	400	ed
REGA MIRA	498	400	ed
TOTEM STTAF mahogany	1190	800	ed
TOTEM ARO cherry	970	700	ed

NEW PRODUCTS THIS MONTH.

LINN KLIMAX KONTROL PRE AMP, TRULY AWESOME!
SUGDEN MASTERCLASS INTEGRATED AMP (it's not new but an amp of this quality deserves to be mentioned).
SPENDOR S6 LOUDSPEAKERS, revised from original model, wow what a difference

THE AUDIO ROOM

2 GEORGE STREET, HEDON, HULL, HU12 8JH

T. 01482 891375

E. hifi@theaudiroom.co.uk

W. www.theaudiroom.co.uk

MIDLAND HI-FI STUDIO

HI-FI CONSULTANTS.
FAX/TEL: (01902) 380083 V.A.T.
Registration No. 333 9324 60

9 FINCHFIELD ROAD WEST,
FINCHFIELD, WOLVERHAMPTON,
WEST MIDLANDS, WV3 8AY

AMPLIFICATION

OCM 55 Preamp	Ex Dem £1700	now £750
Musical Fidelity Studio T Power	s/h £395	S/H
Metaxas Marquis Preamp	New £1800	Now £750
Rogers Cadet III excellent condition		£250 ono

DIGITAL

Teac TI Transport D1 DAC	£550 new	s/h £250
DPA TI Transports/h	£595 new	s/h £250
Counterpoint DAI1 Transport (new laser fitted)	£1500 new	s/h £850
Theta Chroma HDCD	Ex Dem £950 new	now £800

* Why not buy a package of s/h Teac or DPA Transport with Theta Chroma for £950!!! *

Many more bargains in stock. Ask

SPEAKERS

Spendor SP2 offers

TURNTABLES

Garrard 401 on SME Plinth c/w SME III	£450
FR F4 Tonearm	£195
Arms from Ultracraft/Hadcock/SME	

OTHERS

Pioneer F91 Reference Tuner	s/h £195
Yamaha TC800 GL Designer Cassette	s/h £100
Two yes 2 Sony WM-D6C Professional Portable Cassette	£225 the pair

COLLECTORS ITEMS

Ortofon ST15T Cartridge	£150
ADC 25 + Alternate Styli	Offers
Worden Articulated Arm	Offers

ipswich (01473) 655171
signals bucklesham
ipswich suffolk IP10 0DY
fax (01473) 655172
email: enq@signals.uk.com
www: signals.uk.com

Ex-Demo Clearance

Sale Of Hi-End And Top Of The Line Components At Up To 50% Off

Red Rose & Wadia (Demonstration models, as new)

M2/M3 'Silver Signature' tube pre-power £17,000 now **£8,500**

Passion integrated solid state 100wpc £3,000 now **£1,999**

Rosebud 1 integrated solid state 50wpc £2,000 now **£1,349**

Rosebud 1 speaker french sycamore £3,000 now from **£1,499**

Rosebud 1 as above piano laquer black £3,300 now **£1,699**

R3 original model with dipole ribbon tweeter £3,500 now **£1,750**

Wadia 270/27ix top of the line transport and Dac latest model was £17,000 noboxes hence only **£8,500**

Home cinema components (Demonstration models)

Seleco SVP310 CRT projector £4,000 now **£1,999**

Faroudja DVD1000 hi-end region 1 player £4,500 now **£1,499**

Proceed AMP5 5 channel theatre amplifier £5,500 now **£2,750**

Lexicon 700T programmable touch screen £1,500 now **£995**

Two channel components (Demonstration models)

Revox Exception top loading cd player £2,500 now **£1,250**

Revox Exception integrated amplifier £2,200 now **£1,100**

Revox Exception FM RDS tuner/timer £1,800 now **£900**

Revox Elegance Prestige floor standing speakers £1,500 now **£750**

Revox Unisub passive subwoofer £300 now only **£75**

Myriad Cameo cd/tuner/amp complete system £1,500 now **£795**

Exposure 2010 integrated amplifier latest model £700 now **£395**

Genesis Digital Lens data relocking computer £1,800 now **£550**

Chario top of the line compact models (Demonstrators)

Academy Millenium I in solid walnut £1,400 now **£799**

Constellation Delphinus solid walnut sides £750 now **£399**

Constellation Lynx solid walnut side cheeks £550 now **£299**

Constellation Lynx as above but solid cherry £550 now **£299**

Dedicated stands for most models available

Chario Syntar and Reference models (Demonstrators)

Syntar 100 compact speakers in various real wood finishes inc walnut, black and cherry £250 now **£129**

Ref 100 compact similar to above in maple £280 now **£139**

Syntar 100 Tower floor stander in real walnut £490 now **£249**

Hyper 2000 floor stander in real walnut £600 now **£299**

Dedicated stands for most models available

Tel; 01992 573030

Fax; 01992 574030

Email; mdc.hifi@virgin.net

Web; mdc-hifi.co.uk

SONIC DESIGN® DAMPING FEET

For CD, SACD, DVD Players:

The CD Damping Feet are made from the same material as the Standard Damping Feet. If the sound of your CD/DVD player is sensitive to vibrations, the CD Feet will be the way to go. The sensitivity to shock and the accompanying mistracking will be reduced with the use of the CD feet. They can also be used with any other audio product that you would like to isolate from vibrations. The set contains four small and one large foot. The large foot is used if the centre of gravity is off-centre or for those CD/DVD players that have five feet. CD Feet cost just **£9.99 per set**.

There are two types available for Loudspeakers:

Audiophile Damping Feet provide the best possible isolation and damping but it is important that the feet are optimised to the weight of your loudspeakers. Both the stiffness and size of the feet are selected to achieve this. Speakers within the range 5 to 200 kg can be optimised. Let us know the mass of your loudspeakers and we can advise you the correct set to purchase.

Audiophile Damping Feet are available for most high-end loudspeakers from **5kg upto 200kg**. Price per set of eight feet: **£60.00**.

The Standard Loudspeaker Damping Feet have a large overload margin, and are lower priced than the Audiophile version. The resonance frequency is a few Hertz higher. The colour is nut brown, except for the stiffest feet which are grey. The standard feet are produced in four different weight classes and do not need to be fine tuned to specific loudspeaker models.

Standard Damping Feet are available in four sizes: upto **12kg, 12-28kg, 28-50kg, 50-100kg**. Price per set of eight feet: **£19.99**.

These feet will give a *substantial decrease in loudspeaker cabinet movement*. This is apparent when you put place one finger softly against the top of the front baffle, as it will vibrate much less after damping. The transmission of vibrations from the cabinet will also be reduced. The music will be cleaner, with a "less coloured" sound quality.

BEFORE >>:
(top) 125 Hz sine signal to the speaker, (lower) floor movement, using spikes



<< AFTER:
(top) 125Hz Sine signal to the speaker, (lower) floor movement, using soft feet (note floor signal magnified x2)

Visit our website at www.sonicdesign.co.uk to see more details or to read *satisfied customer feedback*.

Sonic Design Damping Feet are available from all good specialist hi-fi & accessory retailers.

(trade enquiries are welcome - email: tradesales@sonicdesign.co.uk Or, in case of difficulty, via our web shop at: www.sonicdesign.co.uk

Distributed by: Wavelength Distribution

Tel: 01622 201983 Fax: 01622 201983

www.supradirect.co.uk

The **ONE-STOP SECURE WEBSITE** to buy **SUPRA** cables to improve your **Hi-Fi and/or Home Cinema** system. **** ONLINE CREDIT CARD PURCHASES via 128bit SSL ****

Need a reason to buy Supra cables??

Other good reviews include:

FOUR WHAT HI-FI BEST BUY'S:

Best Buy Component Video cable

(under £100):

AV3 RGB/component video

Best Buy Scart cable (£51+):

AV6 RGB scart to scart

Best Buy Digital cable (£51+):

X-ZAC Fibre optic cable

Best Buy Speaker cable upto £5/m:

Rondo 4x 2.5 Bi-Wire cable

Hi-Fi Choice "Recommended"

LoRad shielded mains cable

Hi-Fi World "Highly recommended":

Quattro 4x4T Bi-Wire

What Video "Best Buy" cable:

Classic 4T

Hi-Fi Choice "Recommended" cable:

Ply 3.4 & Ply 3.4/S shielded

Also available now **EFF-ISL "25th Anniversary"** the updated version of the Hi-Fi Choice "Best Buy" EFF-ISL cable

STOP PRESS:

Visit us in the Audio Atmosphere demo room at the forthcoming Manchester Hi-Fi & Home Cinema Show Hilton Hotel, Manchester Airport from 16th-17th November.

We'll have plenty of award winning Supra cables available at **SPECIAL SHOW PRICES** - so come along and see us !!

These are the 4 easy steps for improving your system

1 - VISIT: www.supradirect.co.uk

2 - VIEW the range on/offline (download the PDF catalogue)

3 - SELECT from the wide range, SAVING money when you buy

4 - ENJOY!!



trust uX

We belong to the Which? Webtrader Code of Practice

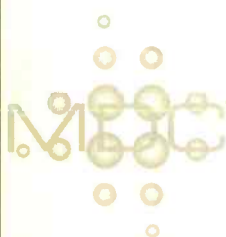

VALVE CD PLAYERS FROM £330.00 ON DEMO -
PLEASE PHONE FOR DETAILS.

AUDIO NOTE P4 MONO BLOCKS	1,999.00
AUDIO NOTE ANJ/SPE INCLUDING STANDS BLACK	699.00
AUDIO NOTE AN-B SPEAKERS - LIGHT OAK	350.00
AUDIO INNOVATIONS 1st AUDIO SERIES 800 - MONO BLOCS	600.00
CASTLE HOWARD S2 PAIR DARK CHERRY - Nr MINT Boxed	699.00
CELESTION A1 SPEAKERS BLACK - EX DEM	399.00
CONRAD JONSON PV6 PRE-AMP	599.00
DPA DS-50 TWO BOX DAC	600.00
DPA ENLIGHTENMENT CD & DAC	750.00
GATE 300B PUSH-PULL MONO-BLOCKS - EX DEM.	1,500.00
GOLDEN TUBE AUDIO - SE40 STEREO CHASSIS S/ ENDED	699.00
HARMAN KARDON HK-1400 LINE AMP	200.00
HELIOS - No 2 CD PLAYER - MINT	699.00
HEART/MARANTZ VALVE O/PUT CD PLAYER - STANDARD	590.00
HEART/MARANTZ VALVE O/PUT CD PLAYER - IMPROVED	650.00
HEART/MARANTZ VALVE O/PUT CD PLAYER -SE	699.00
KRELL KSA 50 mk1	799.00
LEAK STEREO 20 VGC - VGC	350.00
LEAK 12.1 PAIR NICE EXAMPLES - GEC KT'S	1,650.00
LINN SONDEK LP12- BASIC PLUS - VGC	449.00
LINN CLASSIC VARIOUS COLOURS	895.00
LINN KEOSA FLOOR STANDERS - BLACK/MAPLE/CHERRY	350.00
MARK LEVINSON No. 35 DAC HDCD - SERIOUS DAC	2,250.00
MELOS - MA-111 PRE-AMP	450.00

MUSE MODEL 18 ACTIVE SUB WOOFER - SERIOUS SUB	1,550.00
NAKAMICHI LX3 CASSETTE DECK	200.00
PHILIPS 420P10/00 42" PLASMA SCREEN - SPECIAL	4,299.00
PIONEER ER-420 VALVE RECEIVER	155.00
PINK TRIANGLE DA-CAPO DAC	699.00
PRECIOUS METALS COPPERTECH DELTA	59.00
PRECIOUS METALS SILVER SS200 SIGNAL	187.00
PRECIOUS METALS SILVERCOPPERTECH 102 SIGNAL	110.00
PRECIOUS METALS SILVERTECH 52 SIGNAL	81.00
PROJECT 2.9 RECORD DECK WITH ORTOFON CART. CHERRY	399.00
QED PASSIVE CD PRE AMP ALPS POT.	65.00
QUAD FM 1 TUNER	50.00
QUAD FM 3 TUNER	95.00
ROGERS MASTER POWER AMPLIFIER - RARE EXCELLENT	650.00
ROGERS LS88 FLOOR STANDERS -EX DEM.	159.00
ROGERS HG88 MK2 CHASSIS - WORKS FINE	150.00
ROGERS RAVENSBROOK	75.00
ROGERS JUNIOR STEREO CHASSIS + PRE AMP - RARE	350.00
ROGERS CADET CHASSIS WITH SEPARATE PRE-AMP	250.00
SNELL ACOUSTICS TYPE J/II SPEAKERS - OAK	575.00
SOUND ORGANISATION RACK - SILVER 4 SHELVES 40% OFF	120.00
SOUND STYLE XS RACK - ICE BLUE GLASS - 5 SHELVES	299.00
TRIPLETONE STEREO INTERGRATED	95.00
WHARFDALE RUBIANCE FLOOR STANDERS CHERRY/BLK	120.00
WORLD AUDIO 4 WATT SINGLE ENDED - INTEGRATED	399.00
YAMAHA CT710 TUNER	100.00



● HI-FI/THEATRE DEM ROOM NOW AVAILABLE ● VINTAGE HI-FI FOR SALE & WANTED

MICHELL - CELESTION, QED, AUDIOQUEST, MARANTZ - ETC...

NEW AND VINTAGE VALVES - INTERCONNECTS & SPEAKER - OFC & SILVER

WEALTH OF KNOWLEDGE SPANNING OVER 30 YEARS, FOR ENQUIRIES OR

A CONTROVERSIAL CHAT, ASK FOR DAVE OR LEE.

PHONE : (01322) 292391

FAX : (01322) 229908

E-MAIL: INFO@MATRIXHI-FI.CO.UK

WEB: WWW.MATRIXHI-FI.CO.UK

SHOWROOM

65 DARENTH ROAD

DARTFORD

KENT DA1 1LU

FREE EASY PARKING



2nd User Hi-Fi & audio

PRE-OWNED EQUIPMENT

AUDIO INNOVATIONS SERIES 1000 MKII MONO'S	£995
AUDIOLAB 8000A-GREY-PHONO	£199
AUDIOLAB 8000DAC	£399
DEFINITIVE TECHNOLOGY PRO TOWER 400 (INCL TWIN ACTIVE SUBS-£2350 NEW)	£1195
DENON AVP-A1 GOLD BOXED AND IMMACULATE (£3000 NEW)	£995
KRELL KSA100 POWER AMP LOVELY CONDITION	£1495
LINN NUMERIK DAC 20 BIT NON SMPs VGC	£399
LINN ISOBARIKS DMS WALNUT LOVELY CONDITION BUYER COLLECTS	£595
MARANTZ DV4200 DVD PLAYER BLACK SEALED BOX NEW	£299
MERIDIAN 500/566-20 BIT TRANSPORT/DAC BOXED AND IMMACULATE	£1195
MICROMEGA DVD PREMIUM-MULTI REGION	£595
MICROMEGA STAGE 6 IMMACULATE AND BOXED	£495
MICROMEGA DRIVE 3/DAC BOXED AND IMMACULATE	£995
MONITOR AUDIO SILVER 9i CHERRY BOXED AND SUPERB	£595
MONITOR AUDIO MA1800 REFERENCE GOLD LOUDSPEAKERS-BOXED	£595
MUSE MODEL 3 PRE-AMP REMOTE BLACK BOXED AND IMMACULATE	£995
MUSICAL FIDELITY HTP/HT600 AV SILVER 5 MONTHS OLD AS NEW (WERE £4K)	£2995
MUSICAL FIDELITY TI FM ONLY TUNER BOXED AND IMMACULATE	£199
MUSICAL FIDELITY A220 INT AMP PIANO BLACK BOXED AND SUPERB	£499
NAIM NAC 82 GREEN CASE 1 YEAR OLD SUPERB CONDITION	£1895
NAIM NAP140 OLD STYLE BOXED SUPERB CONDITION	£399
NAIM NAP180 SUPERB CONDITION ETC	£695
NAIM HI-CAP-OLD STYLE-BLACK CASE	£429
NAIM NAC 92 PRE AMP BOXED AND IMMACULATE	£279
NAIM NAIT3/PRE OUT MODIFICATION BOXED AND IMMACULATE (1999 MODEL)	£399
NAIM IVO 2-WAY ACTIVE X-OVER WITH VARIABLE FREQUENCY	£349
NAIM NAP140 OLD STYLE SUPERB CONDITION	£399
NAIM NAP90/3 BOXED AND IMMACULATE	£329
NAKAMICHI OMS5E/II CD PLAYER-WAS £1500 NEW-LOVELY CONDITION	£399
NAKAMICHI CASSETTE DECK 2	£179
PIONEER DV-717 MULTI REGION DVD PLAYER-GOLD	£299
PRO-AC TABLET 50 CHERRY-IMMACULATE	£395
PROCEED PCD SERIES 3 CD PLAYER (£3500 NEW)	£1695
REGA PLANAR 3/RH200/REGA SUPER BIAS	£179
RUARK EPILOGUE YEW	£229
RUARK CL20 CHERRY VERY GOOD CONDITION	£895
TAG MACLAREN DAC 20-24 BIT BOXED SUPERB CONDITION	£595
TUBE TECHNOLOGY GENESIS VALVE MONO BLOC'S BOXED SUPERB	£1695
RUARK CL30 CHERRY WOOD (NEW £2500) WITH SILTECH AND XLO INTERNAL	£1695
HARD WIRE UPGRADES AND WBT BINDING POSTS-SAVE OVER £500	£1795

PROFESSIONAL RECORD CLEANING SERVICE - KEITH MONKS MACHINE -
PLEASE RING FOR FURTHER DETAILS AND PRICES.

THREE MONTH WARRANTY ON ALL ITEMS

www.sound-stage.co.uk

STOWSOUNDS

Stone Farm Borough Lane, Great Finborough, Stowmarket, Suffolk, IP14 3AS

Special prices on the following new and used products:

Engine	
Creek CD53	1099
Exposure 2010cd - new player also in	550
Michell ISO	100
Sonneteer Byron cd	450
Trichord Revelation CD	450
Ortofon VMS 20E Mk 2	25
Myriad MC 100 cd	425

GEARBOX	
Exposure 21/18 pre/power - new range also in	1400
Musical Fidelity X 1	375
Exposure 25 integrated	700
Michell Alecto Monoblocs	1250
Exposure 2010 integrated	550
Sonneteer Alabaster integrated	625
Michell Orca pre	1100

EXHAUST	
Neat Petite	675
Chevin Audio-new 5 sided speakers-amazing	950
Linn Kan 4	275
Linn Keosa Maple	349
Epos M12	449
Acoustic Energy Aesprit 300	225
Living Voice Auditorium	1250
Rogers LS4a	100

FURRY DICE	
100s of CDs, interconnects, cables ex dem	phone
Naim Naca 2x7m	60
Fuss Sub and satellite for computer, tv etc	175
Soundstyle Firewoods maple	200
Silver 18" stands	50
Linn Classic movie system - great	1900
Rotel RT 950BX tuner	40
Beyerdynamic DT911	140
Beyerdynamic DT531	80
Target TT 4 shelf black	80
Atacama SE24 or BDS 25	40
Audioquest Video pro50	50
Stands Unique AV rack	275
Soundstyle X midi width rack 320mm blue	90

Various interconnects, supports, cables at reduced prices.
Phone for details

Sale of CDs. Phone for latest list.

TEL: 01449 675060

Sound & Music

93-95 Nantwich Rd., Crewe, Cheshire.
Telephone : 01270 214143

- Linn Sizmik (Maple/XD) - £650
- Creek CAS 3140 Tuner (XD) - £80
- Sanyo PLV30 Projector(XD) -1400
- Monitor Audio FB110 Sub-Woofer (XD) - £300
- NAD 370 Integrated Amplifier (XD) - £350
- Linn 5103 Surround Sound Controller (XD) - £2500
- Linn 5125 Five Channel Power Amplifier (XD) -£1300
- Kef Reference 104/2 Speakers (SH) - £ 500
- Harman Kardon DVD 20 DVD Player (XD) - £200
- Loewe System Tuner/Amplifier/CD (XD) - £800
- Linn Classik Movie System (XD) - £1650
- Arcam A75 Integrated Amplifier (XD) - £300
- Arcam A75 Power Amplifier (XD) - £300
- Arcam Alpha 8R Integrated Amplifier (SH) - £200
- Arcam Alpha 6 Integrated Amplifier (SH) - £150
- Roksan Caspian Integrated Amplifier (XD) - £800
- Musical Fidelity A3 Integrated Amplifier (SH) - £500
- Musical Fidelity CD/Pre.Amp. (XD) - £1400
- Roksan 4 Channel AV Power Amplifier (XD) - £350
- Roksan Kandy Integrated Amplifier (XD) - £350
- Castle Harlech Speakers (Cherry/XD) - £700
- Tannoy Eyris 3 Speakers (Sycamore/XD) - £800
- Infinity Kappa 400 Speakers (XD) - £700
- Castle Warwick (Cherry/XD) - £350
- Arcam Delta 250 / BB50 (SH) - £500
- Meridian D33 Digital Speakers (XD) - £1900
- Meridian Digital Sub-Woofer 2500 (XD) - £1700
- Castle Conway Speakers (Cherry/XD) - £750
- Monitor Audio Silver 8 (Cherry/XD) - £500

Agencies include : Linn, Musical Fidelity, S.M.E., Origin Live, Monitor Audio, Castle, Quad, Wharfedale, Harman Kardon, Creek, Meridian, Tannoy, Infinity, Loewe, Sanyo, Ortofon, VDH, JBL, Pro-ject, Roksan, QED, Cable Talk, Michell, Arcam, Trichord, PMC,

X electrical

We buy, sell & part exchange quality Hi-fi

AMPLIFIERS / RECEIVERS	CD PLAYERS	SPEAKERS	
Linn LX100 Power Amp £295	Marantz CD80 £195	Boose 301 series 4 £275	
Audio Research D70 Valve Monster . £1195	Copland ST822 As new £1075	Acoustical Alliance Spazic £425	
Arcam Alpha 8R £195	Marantz CD 17 K1 signature £695	Monitor Audio Studio 2 £145	
Alchemist Kraken APDBAmk2Power . £425	Sony CDPX8930E as new £145	Acoustic Energy AE100 £120	
Naam NAP140/NAC62 Pre/power . . £525	Linn Mimik/Numerik CD/DAC £1175	Linn Kannis £245	
Kenwood KA5090R £150	Techincs SLPG520 silver £775	Acoustic Energy AE109 £275	
Kenwood XP900 THX Power Amp . . £250	Arcam Alpha 7 £195	Linn Mimika £545	
Musical Fidelity 8200K £145	Sony CDPCK350 300 Disk £195	Tannoy 609 speakers £150	
Musical Fidelity XA1 £325	Philips CDRC80 £135	Tannoy R3 £275	
Myyrad T10 Integrated £245	Marantz CD1020 Silver beauty! . . . £145	Kef Q65 £325	
Myyrad P60 Power amp £215	Micromega Stage 1 £145	Kef RDH3 Cherry £895	
Nakamichi receiver 3 £160	Audio Innovations Alto £150	Audio Physic The Step £415	
Quad 306 Power amp £195	Audiolab 8000 DAC £495	Final Acoustics 03 hybrids £875	
Quad 405-2power amp £245	TUNERS		
Vincent SP996 Mono blocks £295	Marantz S172L £95	Tamaha KA480 £75	
Arcam Delta 790 Integrated £175	Arcam Alpha 7 £135	Nakamichi ZX9 £795	
Linn Kuren Preamp £895	Quad FH4 £245	Yamaha KX5050E £90	
Augusts cadet 3 valve £145	Luxman TD375 champagne £140	Nakamichi DR3 £160	
Naam NAIT 3 £395	Aura AU180 chrome finish £120	FQS	
Alchemist Kraken Integrated £325	NAD C410 as new £130	Techincs SH045 slim £75	
Audiolab 8000s with remote £445	Rotel RI1024 Silver classic £125	Techincs SHG90 £175	
Arcam Alpha 9 integrated as new . . . 275	Linn Pelin Tuner £375	Pioneer GRX520 £60	
Arcam Alpha 9 power amp as new . . £125	TURNTABLES		
Haller Ins pre amp £115	Techincs SL1210 £295	Techincs SH046 touch sens £75	
Rotel RA314 silver £60	NAD S33 Rega copy £165	SYSTEMS	
Techincs S105 £95	Trio RD2055 White finish £125	Denon UDM30 £225	
	Thorens TD160/5/ME3009 £195	Bauig 8 Oluwain Century £745	
	Michell Gyrodec bronze/smoked . . . £275	Sony MHCX99 £145	

Please call us if you have any equipment to sell or are looking for anything in particular. New stock daily
All equipment is fully tested and guaranteed

Also: Music CDs, Games, Musical Equipment, Computers, TV, VCR & Photographic

Web page: www.xelectrical.com email: x@xelectrical.com

125 King Street Hammersmith 020 - 8563 7383
4 Station Bldgs Fife Road Kingston 020 - 8546 1233
Games & CDs upstairs at Kingston 020 - 8546 4442
43 Church Street Croydon 020 - 8680 0007

CLASSIQUE SOUNDS.(LEICESTER) INC ONE THING.

VINTAGE HIIFI & VALVE SPECIALIST TEL 0845 123 5137 (local rate)(UK only)

FOR SALE PRE/POWER AMPLIFIERS

NEW Translucent ULTRA heavy duty 99.99% pure silver conductors. Heavy duty silver plated MK tough plug, silver plated IEC plug. No need to spend £600+. Intrinsically priced at only £249

Ear 834L pre amplifier. Ex condition Valve £ 299	Croft Valve valve pre-amplifier. Mint. Boxed. £ 250
Musical Fidelity B1 integrated amplifier. Good cond £ 125	Richard Allen pure class A integrated amplifier. £ 175
Mendian Modular pre-amplifier. Ex condition £ 249	Quad 306 power amplifier. Ex condition £ 195
Rotel RC972 remote control pre-amp. Mint. Boxed £ 149	Audiolab 8000C pre-amplifier. Boxed/instructions. £ 299
Sugden A21 pure class A int. Wood case 5 pin din . . . £ 175	Naam Nait 3R integrated amp & remote. Mint. Boxed £ 495
Nad C250 int amp. 2 months old. Cost £330. Boxed . . . £ 200	Musical Fidelity E20 pre-amplifier. Boxed/remote. £ 199
Musical Fidelity E30 power amplifier. 100W. Boxed . . . £ 275	Kenwood KA660D integrated amplifier. Black. £ 40
Quad 34 pre amplifier. Ex. cond All phono Boxed . . . £ 295	Audio Innovations S/300 int class A valve amplifier £ 299
Musical Fidelity E11 integrated amplifier. Ex cond . . . £ 160	Marantz PM66SE K1 signature integrated amplifier £ 199
Linn LK1 pre-amp and remote. Good condition. £ 249	Linn LK2 power amplifier. Good condition £ 299
Copland CTA501 power amplifier. Valve. £1800 £799	Naam Nap 180 power amplifier. Mint. Boxed. £ 799
Quad 11s in various condition and prices £125	Sugden A48 integrated amplifier. Ex condition £ 125
Leak Stereo 20 valve power amplifiers from £ PQA	Harman Kardon integrated valve amp 110W. V rare £ 299
Single Leak TL10 and pre-amplifier. Super cond. £ PQA	Leak TL12+ valve amps. Rebuilt by us. As new £ 599
Quad 403 power amplifiers from £ 125	Creek 4040 integrated amplifier. 5 pin din version £ 79
Nakamichi CA5 pre-amplifier. Ex cond. Cost £750 . . . £ 375	Nakamichi PA5 110W/CH power amp. Cost £1300 £ 650
NVA A80 mono power amplifiers X 2. Good cond. £ 799	NVA A60 stereo power amplifier. Good condition. £ 295
AVI S2000 MI int amp & remote. Cost £999. Mint . . . £ 549	Linn LK100 power amplifier. Excellent condition £ 395
Musical Fidelity Pre-8 pre-amplifier. Mint. Boxed . . . £ 175	Arcam Alpha 3 amplifier. Mint. Boxed/ Instructions £ 100
Musical Fidelity The Pre-amplifier, with MM/ MC . . . £ 199	Techincs SHG70 Graphic Equaliser. 12 presets £ 80
Arcam Zeta 1. Pro logic Cinema amp. Cost £999.00 . . £ 450	Quad 33 pre amplifiers. From £ 75
Arcam Alpha 2 amplifier. Mint. Boxed/instr £ 95	Comosius/Sugden stereo valve pre/power amp. mint £ 249

TURNTABLES

Linn Sondek with Valhalla and Basik + tone-arm £ 499	Linn Sondek LP12/mirvana/ceriku/valhalla/trok £ 795
Michell Hydraulic reference turntables. In various condition. As seen on Clockwork Orange. Ring for prices. £ PQA	Dual CS05-2 turntable. Mint condition. Boxed £ 89
Garrard 301/401 chassis in various condition from £ 125	Thorens TD166 MK2 with thorens arm £ 89
Dual S054 record deck. Good condition/instr £ 100	Tro KD550 Direct drive turntable. £ 95

SPEAKERS

Klipsh KG 5.2 Oak oil finish. Ex condition. £ 499	Quad ESL57s. Black pair. Ex working order. £ 500
Rega EL8 floorstanding speakers. black ash. Boxed . . £ 149	Prax 3 loudspeakers. Ex cond. Rosewood. Boxed £ 450
Tannoy Chatsworth with 12 inch monitor golds. £ PQA	B&W DM220 slight cabinet marks. Boxed £ 99
Castle Kendall speakers. Good condition. £ 69	B&W DM4 speakers. Black finish £ 85
Quad ESL 57 speakers. All fully serviced with full 3 months warranty. Hear what ESL57s should sound like. From £750 per pair. Quad ESL57 spkrs. Fully rebuilt. Le 4 Recon bass & 2 recon treble units. All new electronics. 12m warranty. £1199	Mission T73 floor standers. Mint/boxed. Half price £ 199
JPW Millennium speakers. Mint. Boxed £ 399	Magnephaner MG14 Boxed with £400 oak stands £ 999
Raymond Short MS2010 pearl. Brand new. Black £ 169	Roksan Ojan 3. Black. Excellent condition £ 399
Par Lin Kellidh in black with Kustone stands. Absolutely mint. 6 months old 4 yrs warranty. left £1900. B&D £ 495	Naam Intro speakers in black ash. Mint. Boxed £ 395

OTHER ITEMS

Tjybe valve Cd player. Mint/hvd. £ 275	Hearst/Marantz CD5000 valve cd player. Unused. £ 325
EAR 834P/MMMC phono pre amp with volume £ 350	Hart/Lindsay Hood MMMC Phono pre amp £ 150
Rega Planet CD player. mint. boxed £ 275	Cogan Hall loudspeaker cable 1.5 metre. pair. £ 150
Quad 66 tuner. Excellent condition. £ 325	Sugden R21 tuner. Wooden case. Beautiful. £ 95
Musical Fidelity E60 Cd player/remote. Boxed £ 150	Mendian MC Pro cd player. 1983 model. Mint. £ 199
Michell Iso Phono pre amp and PSU. Ex condition. . . £ 249	Phillips 101 top loading cd player. Collectable. £ 125
Audio Alchemy Dac in the box with separate psu £ 99	Marantz CD50 Cd player. Ex condition. £ 79
NVA phono 2 MC pre-amp + 2 X PSU. Awesome £ 499	Nakamichi CDP 2E CD player. Ex condition. £ 250
Meridian 203 DAC. Good condition. £ 125	Rotel 950 CD player. Ex cond. Boxed. £ 100
Audio note. CDT Zero DAC 1 Valve combo CD £ 750	Naam 42.5 pre-amp. MM boards fitted £ 125
Marantz SD275 twin cassette deck. Dolby B/C £ 49	Techincs SL-PG440A Mash CD player/remote. £ 75
Aura AD-S750 Dolby B-C-S/1X pr cassette deck £ 75	Techincs SL-PS620A CD player/remote. £ 75
Rotel 965 BX CD player. Excellent condition £ 150	SME 3009 tonearms from £ 125
Leak Tringhline 3 stereo valve tuner. Fully serviced . . £ 195	Teax TR450 tuner. AM/FM synthesized/RDS. Boxed £ 69
Linn Tuner. Mint. Boxed. Very unusual. Cost £549 . . . £ 249	Quad FM3 tuner in excellent condition. £ 99
Arcam Alpha 5 cd player. Mint. Boxed/remote £ 195	Marantz CD93 top loader cd player. Collectable £ 125
Avantec Beam Echo valve tuner. BM611. AM/FM £ 149	Tro KTR800 synthesiser tuner. AM/FM. Black. £ 75

QUAD ESL57 & EL56 PANEL/SERVING ETC

Restored/conditioned Quad ESL57 speakers from only £750.00. pr. Why spend £4000+? **Have your ESL57 SPEAKERS SERVICED FROM £249.PR. Ring for full details.**
Exchange/ recon ESL57 bass panel £129. Treble £109. ESL63 panels £ 80 refurbished.
ELS63/ESL57 speaker stands. available in black or woodgrain @ £165.00 a pair.
New socks for ELS63s £38 pr. Many other spare parts available. Please ring.
"Classique Sounds servicing restores the Quads to a position where they can hold their head high". Jon Marks. HIFI WORLD. April 1999. Full servicing facilities available.

Trougline tuner service & realignment £95.00. (excludes valves. Rarely needed).
One thing stereo decoder (back in stock) £175.00 Ex review Hifi world.

TRANSLUCENT. (somewhat of a bargain) Hifi World. Jan 1999

PURE SILVER INTERCONNECT CABLE
99.99% pure silver conductors. Quality gold plated RCA phono plugs.
Half Metre terminated £60.00 One metre terminated £80.00
NEW. Translucent ULTRA + Heavy duty 99.99% pure silver (4N) Gold phono. £199.00 Metre
7 day money back guarantee if not better than existing cable. Regardless of price or quality
NEW. 1.0MM 99.99% Pure silver wire @£15m. 0.5mm pure silver wire @ £6.00m
Translucent pure silver mains cable. 3 amp. £129.00
One Thing Mains cables. Class 1 RFI suppressed. Silver plated conductors.
Voltage spike protection. only...£55.00. 6 way mains block & lead only £99.00

NEW EAR/YOSHINO EQUIPMENT

Ear 834P MM/MC phono stage with/without volume. Brand new. Boxed at only £529
Ear 834P MM phono stage. No volume control. Brand new. Boxed at only £379
Ear 834L Line only valve pre-amplifier. Amazing. Brand new. Boxed at only £499

WANTED Vintage and modern hifi eqpt. Part exchange welcome.

TEL 0845 123 5137 (Calls charged at local rate anywhere in the UK)
Tel 0116 2835821 or 07802 213740 (Mobile) Callers by appt only.
Opening times 10.00am-6.00pm Mon-Friday. 10.00am-2.00pm Saturday
61 Aylestone drive, Aylestone. Leicester. LE2 8QE. Email
classique_sounds@yahoo.co.uk

THE EMPORIUM

Willow House, Rectory Road, Brome, Eye, Suffolk, IP23 8AH 3 miles from our old location
Tel/Fac 01379 870873 email: emporium@dircon.co.uk www: www.emporium.dircon.co.uk

CD & DAC & DACS

	COST	PRICE			
ALCHEMIST DAC IN THE BOX, board		80	CELLO SEAPHIMMS active speakers, piano black just fitted with 700 pounds worth of brand new Dynaudio esocar tweeters, with some cables	1500	4000
ARCAM ALPHA cd player, cheap and cheerful		100	DALI GRAND COUPE, rosewood/great speaker with dynaudio drive units	2500	1000
ARCAM DELTA TDS/BLACK BOARD(PI)	1200	300	DYNAUDIO AUDIENCE S black, boxed, similar to audience 40, cheap boxes good drivers	400	2000
ARCAM DELTA T0 cd player		100	HARLEIGH L3/5/8, led edition board finished in ebony, light dials on rear to corners, with matching ebony AB1 subwoofer stands, latest version all board	6000	2500
ARCAM ALPHA 9 CD	900	450	HARBETH LES/5A, led edition board finished in ebony, light dials on rear to corners, with matching ebony AB1 subwoofer stands, latest version all board		850
ARCAM CD72 TEXT board		250	HEIBROOK SEETTES mkl upgraded with mkl2 spec, bass unit, ribbon tweeters board	1250	500
AUDIOLAB BOODIDAM AND LUR excellent	2300	800	IMPULSE M7 line horn in/velvet line renderer REFINED		300
AUDIO NOTE DAC 2	600	750	INFINITY QUANTUM 2 these are big, 9 drivers each a glimpse of the high end for only	(the pair)	450
AUDIO NOTE DAC3 SIGNATURE excellent dynamic dac, board	2500	1150	KEF c200w SUBWOOFERS pair		90
AUDIO MEGAC MIPHISTO mkl transport	2250	850	KEF Q75.2 BOXED MMIT	1500	750
AUDIO RESEARCH DAC 1 upgraded to 20 bit - stereoophile class A recommended component	3500	1000	KEF 105 the dabbles, nice and efficient great with valve amps		500
AUDISON VALVE CD PLAYER - new laser fitted - wild valve! class A	4000	1600	LEAK S06/S07S walnut base pair with twin tweeters, passive, board		700
AV 20 bit dac, board	1000	375	LEAK KEOSA cherry board		325
CEC TLI BELT DRIVE CD TRANSPORT, black	500	2000	LYNNG YOKE AUDIOTONIUM speakers, efficient and dynamic 1500 PLUS STANDS		1500
COUNTERPOINT CD 10 transport board	2000	800	LYNNG YOKE AVATARS excellent		1500
DENSON CD PLAYER beat 400 with gcsmo system remote	1550	900	LUMLEY J.5 floorstanders, nice and efficient, used to be recommended by croft, board		650
HIFI SOUND of transport - chinese made, no frills good sound		400	MAGNEPLANAR 1.4, board		3000
KRELL K201 transport	8000	3000	MERIDIAN M3 active speakers tek		4000
KRELL REFERENCE 64 DAC, two box the best ever	14000	4000	MISSION 707 good student boom boxes		1500
MARANTZ CD67 SE		1500	MISSION 754 freedom, based premium prima vera (oak) finish last version board	1500	2000
MARANTZ CD69 mkl very good		350	MORDAUNT SHORT 840 piano black floorstanders, weigh 50kg each	1995	800
MARANTZ CD6000SE black, board	300	150	MPI MIMOS based, used on sound term ramp, would probably sound quite good with a pair of Quad B	780	425
MERIDIAN 200 transport with inboard clock, board		425	PRAC RESPONSE 2, black, I've had some good sounds out of these	1650	750
MERIDIAN 200 transport		380	QUAD ESL 57 bronze pair, BEING SERVICED at present will be		500 pair
MERIDIAN 207 CD PLAYER/LINE PRE		400	QUAD ESL 57 black pair BEING SERVICED at present will be		600 pair
MERIDIAN 203 DAC, board		150	REL Q BASS sub woofer		150
MERIDIAN 508 20 BIT WITH REMOTE	2000	1000	ROGERS DB110 board, yes the plastic wonders	150	275
MERIDIAN 208, 209 board, of play/price	1500	500	ROYD SORCEON small lead lined mm monitor, musical, (stands available 40)	550	700
MICROMEGA DRIVE ONE transport	2500	250	RUARK CRUSADERS walnut base pair, work nicely in room corners	1500	700
MISSION PCM 7000 ancient cd player	700	100	SHELL II with stands, very sensitive suitable for less st 20 and other low power valve amps, light ash finish, plant pot marks on top of cabinet	250	100
MUSICAL FIDELITY X-RAY 24 BIT, BOARD		500	SOMAS in rosewood, unknown model	250	100
MARACOMI DRAGON CD AND DAC, board, another awesome let	8500	3333	TANNY CHEYOT with knackered 12" hpd, poor cabinets	75 pair	400
PINK TRIANGLE ORIGINAL DAC		400	TANNY GAF cabinets repro pair in walnut with matched pair 15"	red 5000 or gold 4000	350
PINK TRIANGLE 1307 line		150	TOWNSEND GLASTONBURY mkl1 serious speaker, metal cone bass	475	700
MERIDIAN 200 transport with inboard clock, board		425	YERENA AUSTONIUM BACH very small small floorstanders finished in beech, based as new	1200	700
MERIDIAN 200 transport		380			
MERIDIAN 207 CD PLAYER/LINE PRE		400			
MERIDIAN 203 DAC, board		150			
MERIDIAN 508 20 BIT WITH REMOTE	2000	1000			
MERIDIAN 208, 209 board, of play/price	1500	500			
MICROMEGA DRIVE ONE transport	2500	250			
MISSION PCM 7000 ancient cd player	700	100			
MUSICAL FIDELITY X-RAY 24 BIT, BOARD		500			
MARACOMI DRAGON CD AND DAC, board, another awesome let	8500	3333			
PINK TRIANGLE ORIGINAL DAC		400			
PINK TRIANGLE 1307 line		150			
MERIDIAN 200 transport with inboard clock, board		425			
MERIDIAN 200 transport		380			
MERIDIAN 207 CD PLAYER/LINE PRE		400			
MERIDIAN 203 DAC, board		150			
MERIDIAN 508 20 BIT WITH REMOTE	2000	1000			
MERIDIAN 208, 209 board, of play/price	1500	500			
MICROMEGA DRIVE ONE transport	2500	250			
MISSION PCM 7000 ancient cd player	700	100			
MUSICAL FIDELITY X-RAY 24 BIT, BOARD		500			
MARACOMI DRAGON CD AND DAC, board, another awesome let	8500	3333			
PINK TRIANGLE ORIGINAL DAC		400			
PINK TRIANGLE 1307 line		150			
MERIDIAN 200 transport with inboard clock, board		425			
MERIDIAN 200 transport		380			
MERIDIAN 207 CD PLAYER/LINE PRE		400			
MERIDIAN 203 DAC, board		150			
MERIDIAN 508 20 BIT WITH REMOTE	2000	1000			
MERIDIAN 208, 209 board, of play/price	1500	500			
MICROMEGA DRIVE ONE transport	2500	250			
MISSION PCM 7000 ancient cd player	700	100			
MUSICAL FIDELITY X-RAY 24 BIT, BOARD		500			
MARACOMI DRAGON CD AND DAC, board, another awesome let	8500	3333			
PINK TRIANGLE ORIGINAL DAC		400			
PINK TRIANGLE 1307 line		150			
MERIDIAN 200 transport with inboard clock, board		425			
MERIDIAN 200 transport		380			
MERIDIAN 207 CD PLAYER/LINE PRE		400			
MERIDIAN 203 DAC, board		150			
MERIDIAN 508 20 BIT WITH REMOTE	2000	1000			
MERIDIAN 208, 209 board, of play/price	1500	500			
MICROMEGA DRIVE ONE transport	2500	250			
MISSION PCM 7000 ancient cd player	700	100			
MUSICAL FIDELITY X-RAY 24 BIT, BOARD		500			
MARACOMI DRAGON CD AND DAC, board, another awesome let	8500	3333			
PINK TRIANGLE ORIGINAL DAC		400			
PINK TRIANGLE 1307 line		150			
MERIDIAN 200 transport with inboard clock, board		425			
MERIDIAN 200 transport		380			
MERIDIAN 207 CD PLAYER/LINE PRE		400			
MERIDIAN 203 DAC, board		150			
MERIDIAN 508 20 BIT WITH REMOTE	2000	1000			
MERIDIAN 208, 209 board, of play/price	1500	500			
MICROMEGA DRIVE ONE transport	2500	250			
MISSION PCM 7000 ancient cd player	700	100			
MUSICAL FIDELITY X-RAY 24 BIT, BOARD		500			
MARACOMI DRAGON CD AND DAC, board, another awesome let	8500	3333			
PINK TRIANGLE ORIGINAL DAC		400			
PINK TRIANGLE 1307 line		150			
MERIDIAN 200 transport with inboard clock, board		425			
MERIDIAN 200 transport		380			
MERIDIAN 207 CD PLAYER/LINE PRE		400			
MERIDIAN 203 DAC, board		150			
MERIDIAN 508 20 BIT WITH REMOTE	2000	1000			
MERIDIAN 208, 209 board, of play/price	1500	500			
MICROMEGA DRIVE ONE transport	2500	250			
MISSION PCM 7000 ancient cd player	700	100			
MUSICAL FIDELITY X-RAY 24 BIT, BOARD		500			
MARACOMI DRAGON CD AND DAC, board, another awesome let	8500	3333			
PINK TRIANGLE ORIGINAL DAC		400			
PINK TRIANGLE 1307 line		150			
MERIDIAN 200 transport with inboard clock, board		425			
MERIDIAN 200 transport		380			
MERIDIAN 207 CD PLAYER/LINE PRE		400			
MERIDIAN 203 DAC, board		150			
MERIDIAN 508 20 BIT WITH REMOTE	2000	1000			
MERIDIAN 208, 209 board, of play/price	1500	500			
MICROMEGA DRIVE ONE transport	2500	250			
MISSION PCM 7000 ancient cd player	700	100			
MUSICAL FIDELITY X-RAY 24 BIT, BOARD		500			
MARACOMI DRAGON CD AND DAC, board, another awesome let	8500	3333			
PINK TRIANGLE ORIGINAL DAC		400			
PINK TRIANGLE 1307 line		150			
MERIDIAN 200 transport with inboard clock, board		425			
MERIDIAN 200 transport		380			
MERIDIAN 207 CD PLAYER/LINE PRE		400			
MERIDIAN 203 DAC, board		150			
MERIDIAN 508 20 BIT WITH REMOTE	2000	1000			
MERIDIAN 208, 209 board, of play/price	1500	500			
MICROMEGA DRIVE ONE transport	2500	250			
MISSION PCM 7000 ancient cd player	700	100			
MUSICAL FIDELITY X-RAY 24 BIT, BOARD		500			
MARACOMI DRAGON CD AND DAC, board, another awesome let	8500	3333			
PINK TRIANGLE ORIGINAL DAC		400			
PINK TRIANGLE 1307 line		150			
MERIDIAN 200 transport with inboard clock, board		425			
MERIDIAN 200 transport		380			
MERIDIAN 207 CD PLAYER/LINE PRE		400			
MERIDIAN 203 DAC, board		150			
MERIDIAN 508 20 BIT WITH REMOTE	2000	1000			
MERIDIAN 208, 209 board, of play/price	1500	500			
MICROMEGA DRIVE ONE transport	2500	250			
MISSION PCM 7000 ancient cd player	700	100			
MUSICAL FIDELITY X-RAY 24 BIT, BOARD		500			
MARACOMI DRAGON CD AND DAC, board, another awesome let	8500	3333			
PINK TRIANGLE ORIGINAL DAC		400			
PINK TRIANGLE 1307 line		150			
MERIDIAN 200 transport with inboard clock, board		425			
MERIDIAN 200 transport		380			
MERIDIAN 207 CD PLAYER/LINE PRE		400			
MERIDIAN 203 DAC, board		150			
MERIDIAN 508 20 BIT WITH REMOTE	2000	1000			
MERIDIAN 208, 209 board, of play/price	1500	500			
MICROMEGA DRIVE ONE transport	2500	250			
MISSION PCM 7000 ancient cd player	700	100			
MUSICAL FIDELITY X-RAY 24 BIT, BOARD		500			
MARACOMI DRAGON CD AND DAC, board, another awesome let	8500	3333			
PINK TRIANGLE ORIGINAL DAC		400			
PINK TRIANGLE 1307 line		150			
MERIDIAN 200 transport with inboard clock, board		425			
MERIDIAN 200 transport		380			
MERIDIAN 207 CD PLAYER/LINE PRE		400			
MERIDIAN 203 DAC, board		150			
MERIDIAN 508 20 BIT WITH REMOTE	2000	1000			
MERIDIAN 208, 209 board, of play/price	1500	500			
MICROMEGA DRIVE ONE transport	2500	250			
MISSION PCM 7000 ancient cd player	700	100			
MUSICAL FIDELITY X-RAY 24 BIT, BOARD		500			
MARACOMI DRAGON CD AND DAC, board, another awesome let	8500	3333			
PINK TRIANGLE ORIGINAL DAC		400			
PINK TRIANGLE 1307 line		150			
MERIDIAN 200 transport with inboard clock, board		425			
MERIDIAN 200 transport		380			
MERIDIAN 207 CD PLAYER/LINE PRE		400			
MERIDIAN 203 DAC, board		150			
MERIDIAN 508 20 BIT WITH REMOTE	2000	1000			
MERIDIAN 208, 209 board, of play/price	1500	500			
MICROMEGA DRIVE ONE transport	2500	250			
MISSION PCM 7000 ancient cd player	700	100			
MUSICAL FIDELITY X-RAY 24 BIT, BOARD		500			
MARACOMI DRAGON CD AND DAC, board, another awesome let	8500	3333			
PINK TRIANGLE ORIGINAL DAC		400			
PINK TRIANGLE 1307 line		150			
MERIDIAN 200 transport with inboard clock, board		425			
MERIDIAN 200 transport		380			
MERIDIAN 207 CD PLAYER/LINE PRE		400			
MERIDIAN 203 DAC, board		150			
MERIDIAN 508 20 BIT WITH REMOTE	2000	1000			
MERIDIAN 208, 209 board, of play/price	1500	500			
MICROMEGA DRIVE ONE transport	2500	250			
MISSION PCM 7000 ancient cd player	700	100			
MUSICAL FIDELITY X-RAY 24 BIT, BOARD		500			
MARACOMI DRAGON CD AND DAC, board, another awesome let	8500	3333			
PINK TRIANGLE ORIGINAL DAC		400			
PINK TRIANGLE 1307 line		150			
MERIDIAN 200 transport with inboard clock, board		425			
MERIDIAN 200 transport		380			
MERIDIAN 207 CD PLAYER/LINE PRE		400			
MERIDIAN 203 DAC, board		150			
MERIDIAN 508 20 BIT WITH REMOTE	2000	1000			
MERIDIAN 208, 209 board, of play/price	1500	500			
MICROMEGA DRIVE ONE transport	2500	250			
MISSION PCM 7000 ancient cd player	700	100			
MUSICAL FIDELITY X-RAY 24 BIT, BOARD		500			
MARACOMI DRAGON CD AND DAC, board, another awesome let	8500	3333			
PINK TRIANGLE ORIGINAL DAC		400			

UK SUBSCRIPTION £27

VISIT OUR WEBSITE: www.hi-fiworld.co.uk

YES! I want to subscribe to Hi-Fi World for:-

£27.00 for 12 months

Your Details

Title _____ Initial _____ Surname _____

Address _____

Post Code _____

Daytime Tel: _____

Start Issue _____

Delivery Address (if different) _____

I would like to pay by cheque made payable to Audio Publishing Ltd.

Please debit my VISA MASTER SWITCH AMEX

Card No:

Switch card issue No Expiry Date: ____ / ____

Cardholder Signature: _____



Please choose service:-

Airmail Middle East & South-East Asia £60

Airmail Europe £50

Airmail USA, Canada, Australia, Japan, Korea & China £70

Surface Mail £40

Send this form to:

Hi-Fi World, Freepost LON3478,
London, NW6 6YR



Get your issue of hi-fi world straight to your door!

Get to our amazing classified ads first and grab a bargain!!

- > **Run by dedicated hi-fi engineers and enthusiasts.**
- > **Hi-Fi World has become famous for its informative reviews and radical kit designs.**

Credit Card Hotline
+44 01923 270 833
Monday - Friday 9.30am - 12.00 noon: Fax +44 01923 260 588

MISSED AN ISSUE?

Back issues also available at a cost of £3.50 only (includes P&P), payment by cheque only - **overseas** please contact subscriptions department for details.
Send cheque to: Hi-Fi World, Freepost LON3478, London, NW6 6YR.



PHONE FOR LATEST LIST

NEW, EX-DEM AND CLEARANCE ITEMS

	RRP	SALE	
Acoustic Energy AE1 MKII	£995.00	£599.00	D
Arcam Alpha 10	£799.00	£519.00	D
Arcam FMJ P25 power amp	£750.00	£489.00	N
Arcam FMJ CD23 Cd player	£1099.00	£719.00	N
Arcam FMJ A22/Dave AC3 - DTS amp	£1849.00	£1199.00	N
Arcam FMJ P35 power amp	£830.00	£539.00	N
Cyrus SL Amp	£400.00	£199.00	D
Cyrus AV Master Processor	—	£195.00	D
Krell KAV 500i Int. Amp.	£5,498.00	£2,795.00	D
Linn Kaber	£1,995.00	£695.00	D
Meridian M33 Active speakers	£1495.00	£995.00	N+D
Neate Mystique	£735.00	£499.00	D
Neate Elite	£1,200.00	£779.00	D
ProAc 3.8	£3,990.00	£2,299.00	D
Rotel RX965RDS A/V receiver	£950.00	£595.00	D
Mission 781	£399.00	£219.00	D
Mission 773 SE	£399.00	£239.00	N+D
Mission 78AS subwoofer	£699.00	£495.00	N
Mission 783	£995.00	£649.00	D

MUSICAL FIDELITY SPECIAL OFFERS

A3 CD	£799.00	£499.00	D+N
A3 power amp	£999.00	£559.00	D+N
A3 pre amp	£999.00	£559.00	D+N
Musical Fidelity XP100 BARGAIN!!!!	£799.00	£549.00	N

D = EX DEMONSTRATION, N = NEW, S/H = SECOND HAND

Hi-Fi Multiroom and home cinema

ACOUSTIC ENERGY ARCAM ASH DESIGN AUDIO
 RESEARCH CELESTION COPELAND CYRUS
 DENON KEF KRELL LINN TAG MCLAREN MARTIN
 LOGAN MERIDIAN MICHELL MISSION MONITOR
 AUDIO MUSICAL FIDELITY NEAT ACOUSTICS
 PIONEER PROAC QED QUADRASPIRE REL SONUS
 FABER SME STANDS UNIQUE STAX THETA
 WILSON AUDIO ETC...

THE LISTENING ROOMS LTD

161 OLD BROMPTON ROAD LONDON SW5 0LJ
 TEL: 020- 7244 7750/59 FAX: 020 - 7370 0192
 www.listeningrooms.com E-mail: tlr@dial.pipex.com
 Mon-Sat 10-6pm

IAN HARRISON HI-FI TEL: 01283 702875

HIFI AT DISCOUNT PRICES. FREE NATIONWIDE DELIVERY 9am - 9pm
SALE NOW ON! INCLUDING SUNDAYS

TRADE IN YOUR OLD MOVING COIL CARTRIDGE & SAVE UP TO 60% OFF THE RRP.

CARTRIDGES & STYL	HIFI FURNITURE	HEADPHONES	DVD
DENON SHURE AUDIO TECHNICA GOLDRING SUMIKO TRANS- FIGURATION LONDON (DECCA) GRADO ROKSAN VAN DEN HUL ORTOFON RESON CLEAR AUDIO KOETSU	OPTIMUM ASH DESIGN APOLLO SOUND STYLE SOUND ORGANISATION ALPHASON CABLES BLACK RHODIUM TRANSPARENT VAN DEN HUL QED ORTOFON NORDOST ARGENTO AUDIO	SENNHEISER SONY AKG GRADO AUDIO- TECHNICA DAT TASCAM SONY PANASONIC CASSETTE DECKS PIONEER TEAC SONY DENON MINI DISCS SONY DENON TUNERS SONY DENON	SONY DENON PHONO STAGES TRICHORD MOTH CREEK NAD EAR ROKSAN TOM EVANS LOUDSPEAKERS SONY HARBETH CABASSE SHUN MOOK EPOS AMPLIFIERS DENON HALCRO MOTH C.A.T. GAMUT ALOLA EAR

Hifi News Cartridge Alignment Gauge	£5	Audio Technica Stylus	
Hifi News Test Record & Alignment Gauge	£15	Cleaning Fluid	£5
Shure SFG2 Tracking Force Gauge	£25	Clearaudio Carbon Fibre Record	
		Cleaning Brush	£14

PLEASE PHONE TO CONFIRM PRICE & AVAILABILITY PRIOR TO ORDERING.
 ALL GOODS ARE BRAND NEW & BOXED WITH FULL U.K. GUARANTEES.
 NO EX. DEM OR EX DISPLAY GOODS. NO GREY IMPORTS. GOODS ARE NOT
 SUPPLIED ON APPROVAL. SORRY, NO GENERAL CATALOGUES. PLEASE PHONE
 OR WRITE FOR SPECIFIC REVIEWS, BROCHURES OR PRICES.

MAIL ORDER ONLY FROM: IAN HARRISON, 7 MILL HILL, REPTON,
 DERBY, DE65 6GQ. TEL: 01283 702875. 9am - 9pm INCLUDING SUNDAYS.

TEL: 01428-651554 **P.G. Hi-Fi** FAX: 01428-654592

Buying & Selling Vintage HiFi, Valves, Classical LP Records & Spare Parts.

Quad	Valve Alert
All spares available for Quad II and Quad 22	Mullard ECC81 Genuine N.O.S. Blue Box, Made In England £8
Quad 33 + 303 mint & boxed £200	
Quad QC II Pre-amp £40	Mullard ECC83. Genuine N.O.S. blue box, Made in England (the best) £25
Quad FM1 Tuner £40	Valves N.O.S.
Quad II Mains Transformer £120	ECC84 Mullard £5
Quad II Output Transformer £120	ECC84 Brimar £5
Quad II Output Transformer (100v Line) £50	EF80 Mullard £4
Quad II Choke £30	ECC81/CV455 Mullard £7
Quad II Fuse Holder £10	ECC81/CV4024 Haltron £3
Quad II Chassis + Wiring Loom £35	ECC81/CV4024 White Box? £3
Quad FM1 + Decoder £75	
Quad multiplex decoder £50	
Please Phone For Details Of Other Quad/Leak/Garrard Spares	
Leak	Servicing (valve equipment only)
Leak TL12.1 (Pair) £1500	Quad + Leak service + rebuild, to original spec please phone for details
Leak Stereo 20 £300	Most Models Of Leak Mono + Stereo Pre-Amps In Stock.
Leak Troughline FM early type - rare £60	
Valves (G.E.C. Mullard etc.)	
KT66 ECC81/84, EF80	Nakamichi 610 Pre-Amp/ 620 Power-Amp/ 630 FM Tuner £500
Many Others. Please Phone For Details.	Tannoy HPD15" gold crossover (Single) £40
Photocopies Of Circuit Diagrams + Vintage Hi-Fi Literature	HMV 555 Stereoscope Amp with cathode ray tube £450
Spare Parts For Quad + Leak - Transformers Etc.	Sound Sales D.X. plus one tuner SW/MWLW (approx. 1946) very rare £100
Garrard 301 Control Levers	Cambridge T55 FM tuner boxed £50

Quad ESL-57 speakers bronze mint & boxed	£650
Quad ESL-57 speakers black excellent	£550
Tannoy Chatsworths with 12" monitor golds (mint)	£750
Garrard 301 + Decca MKI Arm + FFSS stereo cartridge + plinth + lid (will split)	£420
Garrard 401 + SME 3009 II improved + plinth + lid (will split)	£350
Garrard 401 chassis in original box	£300
Garrard RC88 autochanger turntable (1950's)	£10
Wharfedale super 10 RSSD drive units (pair)	£40
Wharfedale super 3 tweeter drive units (pair)	£40
Wharfedale super 3 drive unit (single) needs new surround	£10
Leak sandwich 15 ohm tweeter	£20
Leak sandwich 15 ohm bass unit	£20
Leak sandwich speakers 15ohm (early type) (pair)	£80
Goodmans 12" drive units (x3) 15ohm - all need recone (early type)	£30
Decca Decola speaker spares	

WANTED Large collections of Classical LP's

Private Ads

hi-fi
WORLD
& computer audio

classifieds

Dealers must not advertise in the Private Classified section. Monthly consecutive insertions will be considered Trade advertising. The Publisher reserves the right to judge submissions.

Special Internet offer see page 130 for details

UNISON RESEARCH Simply Four integrated valve amplifier, excellent condition, original packaging and manuals £650. Creek OBH-8SE MM phono pre-amp, mint condition £95. Tel: 020 7794 6676 (Dec(l))

QUAD 77 pre-amp. Quad 77 tuner. Quad 77 CD player. Quad 707 power amp. All boxed & instructions. B&W 7SE speakers £1200. Tel: Mobile: 07766 572060 (West Yorkshire) (Dec(l))

WILMSLOW VOGUE speaker Scanspeak D2905/9500 treble, bass 18W 8545, Hovland Musicaps £350. Meridian 508 20bit CD player £400, KEF PSW200/HTS 2001 sub/sat speakers, new £300. Tel: 020 8531 5979 (Dec(l))

B&W NAUTILUS 801 Reference Monitors, red cherry finish, 16 months old, excellent condition. New RRP £8500, offered at £6250. Red Dawn balanced interconnects @ £150. Tel: Ken 01903 690 055 (Worthing) (Dec(l))

WANTED: PAIR of LS3/5a loudspeakers in good condition. Rogers, Harbeth or similar. Tel: 01394 388399 (Jan(l))

WANTED. A.D.C. Graphic Equaliser models. Soundshaper 2 IC hi-fi size or Soundshaper 3 19" rack mount. Any condition working or not working. Black or silver. Please contact Sat on 07947 469747, anytime or 020 8539 8513 after 7pm. (Dec(l))

ACCUPHASE C200S preamp £575, P300S power amp 150 wpc, £685, both in matching wood cases, £1150 the pair. Audio Innovations valve power amp series 200 Mk2 £285. Arcam Alpha 7SE CD player, brand new & unused £265. Tel: 01202 767873 (Poole). (Dec(l))

MERIDIAN 501.2 pre amp. £780 new, £400 mint/boxed. Pioneer SPD07 Dolby digital, Pro Logic processor £800 new, £300, superb quality. Arcam Delta 290 amp + phono stage £190. Tel: 01206 542578 or 07787 533170 (Dec(l))

LEAK STEREO 20 professionally rebuilt including new valve bases. Point One pre amp perfect for CD tape etc. Troughline stereo tuner matching gold £380 complete. Tandberg 3300X tape deck £150. Tel: 020 8467 7759 (Dec(l))

MONITOR AUDIO, PMC 703, floorstanding speakers, excellent condition, cost £800 new will accept £425 ono. Also Marantz CD player 63 MkII KJ Signature excellent condition £195 ono Tel: 01254 777554 or Email: karl@nedstram.freereserve.co.uk (Dec (l))

NAIM NAP 140 current model £325. NAC 32/5 £80. Snaic and interconnects, both mint carefully used, boxed, handbooks, 2x 5m Naim NACA5 speaker cable £25. Compare s/h prices. Tel: 01328 711795 (Norfolk) (Dec(l))

LINN KARIK CD player immaculate boxed £650. Linn Majik integrated amplifier immaculate boxed £325. Linn Keilidh loudspeakers black immaculate boxed £325 or £1250 the lot. Tel: Stuart 01536 524495 or Email: stu@rtwatson.fsnet.co.uk (Dec(l))

AUDIO NOTE M1 phono preamplifier mint boxed £375. Castle Howard SII loudspeakers £550. Thorens TD125 turntable SME 3012 12" arm in large SME plinth £250. Tel: 020 8986 1762 (Dec(l))

RUARK PROLOGUES Mark Two floor standing speakers very little use, two months old, dark cherry cabinets £450 ono. Tel: 01279 304671 (Essex) (Dec(l))

FOR SALE. Clearaudio Basik MM/MC phono amp see Hi-Fi Plus review, mint £175. Tel: 01903 247779 (Sussex) (Dec(l))

JAMO CONCERT II, 12 months old, mint, boxed £1250 ono, American cherry. Jamo Concert centre £200 ono, vgc, boxed. Musical Fidelity FMT1 tuner £100 ono Tel: (Mobile) 07833 161646. (Jan(l))

DNM PA35 Power amp £2000 ono. Audio Synthesis Passion 8M full size remote controlled passive pre £850. Proac Response One SC speakers with stands cherry £800. Tel: 01922 477682 (Dec(l))

MUSICAL FIDELITY M3 Nu Vista integrated amplifier £2250 ono. Thiel CS3.6 loudspeakers, world class leading speakers (£5495) absolute bargain at £2495. Tel: 01508 499586 evenings or leave message by day (Feb(l))

DENON DP 2000 with plinth and cover with Linn Ittok LVII black with Audio Technica Art I cartridge £495. Tel: Alan 02392 453382 (Dec(l))

MICHELL GYRODEC RB300 QC power supply free standing motor Orbe modifications very good condition £700 ono. Ring for more details. Tel: 01525 854652 (Beds.) (Dec(l))

THORENS TD124 MkII turntable in heavy oak plinth superb £300. Marantz Tjoeb 99 valve CD player £210. Leak ST20 £250. Alchemist Axiom integrated amp £130. Tel: 01827 261082 (Tamworth, Staffs) (Dec(l))

MERIDIAN SYSTEM 602/606 transport DAC combination £950. 601 preamp £650. Pair 605 monoblocks £1050. ATC SCM20SL with ATC stands £900. Revox B260RDS tuner £530. All excellent boxed. Tel: 01159 242075 or Email: hifi@theview.demon.co.uk (Nottingham) (Dec(l))

MARANTZ CD94 extensive audiophile upgrade £450. Pioneer M-90 amplifier 250 WPC awesome and underrated in UK £450. RMS Revelation II speakers £350. (new £1800) Audio Technica ATH-70 Stereophones £65. Tel: 01159 242075 Email: hifi@theview.demon.co.uk (Nottingham) (Dec(l))

IMPULSE H2 Horn loudspeakers, light ash in good condition £750. Ask for John, can deliver. Tel: 01484 308298 (Dec(l))

CAMBRIDGE R50 Transmission Line Monitors. Classic design updated to modern standards with Scanspeak D2905 tweeters, New Coles Supertweeters, New crossover with high quality Poly prop capacitors and rewired throughout. Superb controlled base and wonderful clear sound. £325 ono. Tel: Peter 01344 751446 (Dec(l))

QUAD II monoblocks in chrome excellent condition £550 ono. Tube Technology Unisis include phono stage £900 ono. Linn Axis mint boxed £185 ono. Tel: 01634 323683 Mobile: 07901 893982 (Dec(l))

B & W 801s MkI, new tweeters fitted otherwise in original condition, literature, boxes can demonstrate £650. Denon CD DCD 890 ASLC 20 bit (£270) £80 remote boxed. Rotel RA970BX amplifier £110. Tel: 01453 546191 (Dec(l))

HEATHCOTE AUDIO

TEL: 01992 653999 MOBILE: 07860 511111 E-MAIL ADDRESS: HeathcoteAudio@aol.com

VALVE AMPS

GRANT G200 AMS LTD EDITION 200 WATT MONOBLOCS & G100P PRE AMP MINT/BOXED £2250
 NESTAROVICH LABS 150 WATT MONOBLOCS (VERY RARE/ FANTASTIC) MINT/BOXED £2495
 LUMLEY REFERENCE 120 MONOBLOCS (TRIODE SWITCHABLE) NEW VALVES 30 HOURS MINT/BOXED £1650
 GAMMA AEON 211 MONOBLOCS REVALVED/SERVICED MINT £1050
 AUDION GOLDEN KNIGHTS MINT £1750
 AUDIONOTE KIT ONE SIGNATURE (£2000 PARTS BUILD FEW HOURS USE-FANTASTIC!) AS NEW/BOXED £1450
 AUDIO RESEARCH D-70 6550 POWER AMP EXCLT £1075
 AUDIO RESEARCH LS-2 PRE AMP MINT/BOXED £1495
 UNISON RESEARCH MYSTERY ONE PRE AMP MINT/BOXED £1095
 UNISON RESEARCH SIMPLY PHONO MINT/BOXED £178A
 MONRIO ASTY VALVE PRE (VERY PRETTY) NEW NEW/BOXED £395
 MICHIRHC-10 PASSIVE PRE AMP MINT/BOXED £375

SOLID STATE

PINK TRIANGLE INTEGRAL (3 MONTHS OLD, NEW PRICE £3995) MINT/BOXED £2995
 BOW TECHNOLOGIES WAZOO-XL (RETAIL £2500) NEW/BOXED £1750
 GAMUT PRE AMP BALANCED/SINGLE ENDED (MATCHES D-200) MINT/BOXED £750
 DNM 3 BOX PRE AMP TBA
 DNM 2 BOX PRE AMP TBA
 MICHIRHA-10 REMOTE PRE AMP (RARE) BOXED £650
 MICHIRHC-10 PASSIVE PRE (RARE/GOOD) MINT/BOXED £375
 REGA CURSA REMOTE PRE AMP MINT/BOXED £275
 MUSICAL FIDELITY MVT 2-BOX PRE AMP MINT £450
 MUSICAL FIDELITY MA-50 CLASS A MONOBLOCS MINT £450
 ELECTROCOMPANET EC-1 REMOTE INTEGRATED (WITH PRE-OUT) EX. DIS/DEM EX DIS /BOXED £750
 ELECTROCOMPANET AW-60 CLASS A POWER AMP (STEREOPHILE MAG REC) EX DIS /BOXED £750
 SUGDEN AU-51 HIGH BIAS POWER AMP (SUPERB) MINT/BOXED £895
 CAIRN EZO ARIA REMOTE INTEGRATED (VERY PRETTY) AS NEW- FEW HOURS USE MINT/BOXED £350
 CAIRN FACE NORD 4808 MINT/BOXED £695
 CAIRN 4808 REMOTE INTEGRATED (FEW HOURS USE) MINT/BOXED £550
 CAIRN K-2 100 WATT MONOBLOCS (FEW HOURS USE) MINT/BOXED £795
 SUGDEN A-41 PRE-AMP MINT/BOXED £325
 ECA VISTA PRE AMP(SUPERB!) AS NEW/BOXED £495
 SONY TA-P 9000ES MULTI CHANNEL PRE AMP CHAMPAYNE GOLD (2 WEEKS OLD REVIEWED) MINT/BOXED £450
 HI FI NEWS AUGUST SPECIAL ORDER FROM SONY COST £800) AS NEW/BOXED £450

CD

MARK LEVINSON NO.39 CD AS NEW/BOXED £3500
 MARK LEVINSON NO.39 CD AS NEW/BOXED £3250
 THETA PEARL TRANSPORT/DS PRO BASIC-11 DAC MINT/BOXED £2250
 MARANTZ CD-94 MK11 TRANSPORT (AT&T/COAX) & CDA-94 DAC MINT/BOXED £995
 AUDIONOTE ZERO TRANSPORT & 24/96 ZERO DAC MINT £650
 AUDIO SYNTHESIS DAX-2 HDCD COMPATABLE COAX/AES-EBU/AT&T/TOSLINK AS NEW/BOXED £1150
 PROCEED PDT-3 PDP-3 TRANSPORT & DAC (AT&T/AES-EBU COAX/OPTICAL IN) MINT/BOXED £1750
 BALANCED & PHONO OUTPUTS MINT/BOXED £450
 MICROMEGA STAGE-6 MINT/BOXED £450
 AMC CDBA(BALANCED&PHONO OUTPUTS) NEW/BOXED £145
 THETA DSPre GEN111 EXCLT/BOXED TBA
 TRICHORD PULSEMASTER DE-JITTER DEVICE MINT £195

VINYL

ROKSAN XERXES/REGA RB300/LINN K-9 MINT £650
 PINK TRIANGLE PT-T00 BOXED £375
 UNISON RESEARCH SIMPLY PHONO (VALVE) MINT/BOXED TBA
 PRIMARE R-20 PHONO STAGE MINT/BOXED £300
 LFD MISTRAL MC PHONO STAGE AS NEW/BOXED £225

LOUDSPEAKERS

WILSON SYSTEM 5 1 PIANO BLACK MINT/CRATED £7500
 KLIPSCHORNS FAMOUS CORNER HORN (104 DB SENSITIVE) MAPLE VENEER MINT TBA
 CELESTION KINGSTONS EX DIS /NEW (VERY RARE -SUPERB NEW£2500) NEW/BOXED £1750
 QUAD 11L PIANO BLACK (FANTASTIC REVIEWS) AS NEW/BOXED £325
 WHARFDALE DIAMOND 8.1 MINT £100
 ACOUSTIC PRECISION LOUDSPEAKERS TBA
 B.K.S. 107 MK.2 RIBBON HYBRID FLOORSTANDERS (HIGHLY REVIEWED) MINT/BOXED £1250
 AUDIONOTE ANK-SPX (SILVER WIRED) MINT/BOXED £675
 MONITOR AUDIO STUDIO 10 (ROSEWOOD) EXCLT £475
 TANNØY ARUNDEL 15 3839 HIGH POWER DRIVERS 95 DB SENSITIVE VERY RARE MINT £1500
 SD OBS FLOORSTANDERS(OPEN BAFFLE) SMALLER BROTHER TO SD1 BOXED £675

MISSION 753 BLACK ASH MINT £475
 PROAC-3 STUDIO MONITORS (ATC DRIVERS) WALNUT MINT £795
 PROAC RESPONSE -2 MINT £695
 PROAC-2 (VOLT DRIVERS) MINT £350
 CASTLE FDENS EXCLT £375
 INFINITY REFERENCE STANDARD KAPPA 5 EMIT RIBBON TWEETER SANTOS ROSEWUUD MINT/BOXED £479
 ROYD EDEN S VGC £250
 IMF TLS 80 S CLASSIC TRANSMISSION LINE MINT £395

TUNERS /TAPE

ONIX BWD-1 AUDIOPHILE TUNER & SEPPSU MINT £325
 SONY TCD-D3 PORTABLE DAT RECORDER/WALKMAN MINT/BOXED £275
 SONY DTC 1000 DAT RECORDER MINT £550

RACKS/STANDS

SOUNDSTYLE XS 105 NEW STYLE (CURVED GLASS) 5 SHELF BLACK OR SILVER EX DIS (£320 RETAIL) £195
 SOUNDSTYLE XS 310 A/V TABLE (£320 RETAIL) EX DIS £195
 SOUND ORG 2540 NEW BLACK FINISH MID! SIZE EX DIS £90
 KUDOS S50? 18 INCH SPEAKER STANDS SAND FILLED GC £50
 ATTACAMA R724 ATTABITE (FEW WEEKS OLD WAS £250) MINT £175
 AUDIONOTE VERY HEAVY STANDS FOR AN-J ETC VGC £175
 TARGET R4 MINT £175

SPECIAL OFFER

SOUNDSTYLE SPEAKER STANDS SOLID PILLAR ATECAMA STYLE 18/24" 1/2 PRICE LAST FEW £50.00

CABLES

LOUDSPEAKER CABLE

NORDOST RED DAWN 3 METRE PAIR(FACTORY TERMINATED) £425
 CARDAS HEXLINK 2 METRE PAIR (FACTORY TERMINATED) £295
 EINSTEIN/VIVACO GREENLINE 3 METRE PAIR (TERMINATED) £250
 VAN DEN HUL THE TEATRACK HYBRID BI-WIRE 5 METRE PAIR £150
 VANDEN HUL MC CS 122 6 METRE PAIR £150
 AUDIONOTE AN-L 2.5 METRE PAIR £80
 ROKSAN HDC 815 2 X 2.9 METRE PAIRS NEW (EACH) £35
 ROKSAN HDC 815 2 METRE PAIR NEW £25
 SILVER SONIC T-14 (AMERICAN) 2 4 METRE LENGTH £50
 VAN DEN HUL M.C.D. 352 1 6 METRE PAIR (TERMINATED) £40
 AUDIOQUEST TYPE 4 CABLE 4 METRE PAIR £25

INTERCONNECT

DPA BLACK SLINK 5 METRE PAIR (MINT) £475
 LINDSAY AUDIOPHILE SATIN GRAY 2 METRE (AMERICAN NEW/PACKED WAS £480) £200
 LINDSAY AUDIOPHILE GRAY 2 METRE (NEW) £175
 AUDIOQUEST LAPIS 5 METRE PAIR TBA
 AUDIOQUEST TURQUOISE 2 X 2 METRE PAIRS (MINT) £35 EACH
 AUDIOQUEST JADE 2 X 2 METRE PAIRS (MINT) £25 EACH
 AUDIOQUEST RUBY 2 X 1 METRE PAIRS (MINT) £65 EACH
 AUDIOQUEST RUBY 2 X 0.5 METRE PAIRS (MINT) £50 EACH
 AUDIOQUEST/AUDIOTRUTH EMERALD 0.8 METRE PAIR (MINT) £150
 AUDIOQUEST LAPIS 1 METRE PAIR (MINT) £225
 AUDIOQUEST/AUDIOTRUTH DIAMOND 2 X 2 METRE PAIRS (MINT) £450 EACH
 QED QUNEX SILVER SPIRAL 0.5 METRE PAIR NEW/PACKAGED £65
 QED QUNEX SILVER SPIRAL 0.5 METRE PAIR EX DEM £60
 VAN DEN HUL SOURCE HB (NEW PACKAGED) £50
 VAN DEN HUL M.C.D.102 MK.111 HYBRID 0.8 METRE £50
 YFERA 1.5 METRE PAIR (MIBNT) £60
 PRECIOUS METALS COPPERTECH BETA 2.5 METRE (AS NEW PACKAGED) £35

DIGITAL

CHORD CO.PRODAC SILVER PLUS (BNC) £60
 REGA DIGITAL INTERCONNECT 1 METRE (NEUTRIK PHONO S) £30
 VAN DEN HUL AES/EBU £40
 AUDIOQUEST VSD-4 SOLID PSS SILVER (PHONO S) £150
 IXOS 75 OHM SILVER CONDUCTOR DIGITAL INTERCONNECT (AS NEW) TBA
 AUDIOQUEST OPTILINK X TOSLINK TBA
 BELDEN-M DATATWISTER AES/EBU 1 METRE £65
 MADRIGAL AES/EBU 0.5 METRE £150

MOST EQUIPMENT STOCKED IS ONE OWNER MINT/BOXED, SIMILAR QUALITY VINTAGE AND MODERN EQUIPMENT REQUIRED FOR IMMEDIATE CASH PURCHASE. THIS IS A SELECTION OF STOCK FOR A FULL CURRENT LIST PLEASE PHONE/E-MAIL GEORGE. MAIL ORDER A SPECIALITY

www.soundsexpensive.com

Hi-Fi & Audio Consultants, Sales and Service

Buy What Hi Fi's Award winners at the cheapest prices!

AUDIOLAB 8000S only £120.
Tel: 01744 736218 (Dec(I))

MUSICAL FIDELITY E100
integrated (pre/power)
amplifier; Manticoor Mantra,
RB300, Chorus black,
Valhalla; Epos ESII with
Target stands plus Soniclink
and Linn cables £900.
Crimson 510 pre, 520
power £150. Tel: Neil
01547 520475 (Dec(I))

NAIM NAT 02 FM tuner
(£1200 new) mint £500. Sony
SACD DVD player black DVP
NS 900 VQS 7 months old
(£500 new) mint £325 Tel:
020 8643 4260 (Sutton)
(Dec(I))

AUDIO RESEARCH SP8
valve preamp with MM
phono stage £1000. Krell
KSA50 power amp £950.
Both one owner 19 years.
Linn Lingo (small case)
£350. All vgc and boxed.
Tel: 020 7834 5434 (Dec(I))

THORENS 125 MkII plinth
cover £250. AR Legend
Mission arm £175. Nakamichi
582 £200. Audionote OTO SE
phono £800. Lentek M/C £75.
Thorens 318 £150. All excel-
lent, other items. Tel: 01522
820179 (I.ins.) (Dec I)

BASE AUDIOPHILE support
system. 5 tiers with shelves.
Excellent isolation. Great
sound. Good condition. Was
£1100, now £529 ono. Extra
shelves also available separate-
ly. Tel: 01256 819198 or
07767 235323 (Basingstoke)
(Dec(I))

VDH FIRST ultimate intercon-
nects. 80cms £95. 60cms £70.
Mint. Tel: 01752 773369
(Dec(I))

ELECTROCOMPANET ECII
dual mono CClass A integrated
amplifier boxed with manuals
£500. Target R1 speaker
stands £100. Tel: 01628
626085 (Dec(I))

PROAC RESPONSE 2.5, cher-
ry, 4 years old £1300.
Quadraspire 5 tier rack, cher-
ry £160. Nordost Solar Wind
speaker cable (bi-wire) 4m
£250. 2x interconnects £60
each. Tel: 07956 526082
(Dec(I))

NAIM NAC62/NAP 140
plus Hi-Cap old style,
owned from new, boxed,
plus cables. Mint condition
£750 ono. May split. Tel:
(evenings) Rob 01372
273980 (Epsom) 020 7335
1626 (daytime) (Dec(I))

CHORD CPA3200 and
matching SPM 1200B piano
black pre and power amps
equiped with Kimber
Powerkords and Silver Streak
XLR interconnects £2800. Tel:
Andy 01606 75254 (Cheshire)
(Dec)

NAIM NAC52 & PSU £2500
ono. Beats an 82 hands down.
Monitor Audio Studio 50
rosewood finish £1200 ono.
Tel: Mark 07968 998 948
(Jan(I))

LINN LP12 Valhalla Basik LVX,
Afro plinth, boxed £440. Keith
Monks Record Cleaner, offers.
Tel: 020 8690 5958 or Email:
crhtk@yahoo.co.uk (Dec(I))

LINSLEY-HOOD HART
clearout. Pair monoblocks,
need attention. Spare trans-
formers. FM tuner. Colloms
bookshelf speakers. Ancient
Technics tape deck. AR T21
tuner. Any offer considered.
Preferably for the lot. Tel:
01235 850635 (Dec(I))

PASS LABS X-350 amplifier
for sale boxed as new condi-
tion £6000 (£10,000). See
www.passlabs.com. Tel: 07769
641748 or Email: ian.john-
son@europe.lego.com (Dec(I))

AUDIO NOTE M.Zero pre-
amp, pair P.Zero monoblocks,
CDT-Zero CD, Dac-Zero,
AN2 speakers, 2x 3mtrs. ter-
minated AN2 speaker cable,
A.N. interconnects. Brand
new unused boxed system
£2000 (£3000 plus) Tel: 01992
300713 (Dec(I))

WILLIAMS HART
Audiophile monoblock
power amplifiers factory
assembled. Boxed new
£700 ono (pair). Roksan
Ojan3 speakers rosewood
finish as new superb sound
£300 ono. Tel: daytime
01268 887730, evening
01268 459442 or Email:
steven_ss156qb@hotmail.com
(Dec(I))

TANNOY'S 3LZ £350. Leak
Stereo 20, Varislope Two
Stereo, Troughline Three
Stereo. Sandwich speakers.
3001 turntable. Denon
103MC boxed. £600 complete
set. All serviced. Re-adver-
tised. Uher 4000AV £500. Tel:
01834 813199
(Pembrokeshire) (Dec(I))

RED DAWN speakers £375.
Mission 775SM £175. A/Note
M.Zero pre £395. Teac PT1
£275. Meridian 563 £395.
Counterpoint SA12 £595.
Alchemist Freya/Genesis £895.
Technics SUC2000 £795.
Levinson No 27 £1895.
Unison Simply 4 £795. Arcam
8 amp £225, DPA
Enlightenment DAC £295. Tel:
07966 267404 or Email:
coom@btinternet.com
(Dec(I))

ARAGON 4004 £795. A/Lab
8000DAC £250. Levinson
No39 £2995. Krell DSP £1695
(ring!). Apogee Calipers
£1095. Exposure IV power
£595. Rok I (upgraded) £395.
Roksan OjanS3X £675 (rose-
wood). Tel: 01277 211685,
Mobile: 07966 267404 or
Email: coom@btinternet.com
(Dec(I))

M/FIDELITY 3A preamp £150.
Technics SLP5400 £250.
A/Note Zero pre £295.
Arcam 70.2 £175. SL600
Signatures stands £295. Aura
VA50 £175. DPA pre/pwr
£695. Linxs Stratos (wow!)
pre/monos £695. Ruark
Talismans II £345. Arcam 8
£275. Rega Jupiter 210 £695.
KEF Q55 £225. Levinson No
39 £2995. Tel: 07966 267404
or Email:
coom@btinternet.com
(Dec(I))

PINK TRIANGLE LPT
Roksan Tabriz top end
Pickering cartridge with
free Nagaoka MP11 Boron.
All mint condition original
packing. Pioneer F737 clas-
sic tuner £375 & £120. Tel:
01904 636174 (Dec(I))

KELLY RIBBONS with lenses.
Pair of unused units with
Decca Diffusion lenses, trans-
formers and crossovers £300
pair. ATC 15" bass units Ref.
PA100-375, unused about 6
years old, £190 pair. Tel:
01206 852209 (Colchester)
(Dec(I))

COLLECTOR ANTIQUE
"Kone" loudspeakers. Free
standing moving iron coolie
hat by Western Electric/S.T.C.
18" diameter monopole from
early 1900's. As new, in origi-
nal box £950 each. Tel: 01206
852209 (Colchester) (Dec(I))

AUDIOLAB 8000Q preamp
£500. 2x Audiolab 8000m
monoblocks £950. Mission
753 speakers £400. All mint
condition, boxed, manuals. Tel:
01663 765980 evenings or
leave message on 07881
587130 (Dec(I))

NAIM NAIT 2 amplifier £200.
Krell KPS20i CD player
£4500. Sansui T-80 tuner £75.
Wanted: Epos ESII speakers
in wood. Tel: 01636 830944 or
07979 536753 (Dec(I))

CABLES GOERTZ MIZ speak-
er cable 2x 5m Stereophile
recommended cost (£450)
accept £195. Audionote silver
ANVX interconnect 5mtr
£195. Audioquest Quartz
5mtr £35. M.F. X Links 8mtr
interconnect £20. Tel: 01634
268660 (Dec(I))

REVOX ORIGINAL rack
system including B77
recorder B750 amplifier
B760 tuner B790 turntable
plus Beovox Denta speak-
ers all very good condition
Offers considered. Tel:
02380 236336
(Southampton) (Dec(I))

MUSICAL FIDELITY A3CD
£499 (£800). A3 amp £549
(£850). Acoustic Energy AEI
Mk2 £549 (£850). All six
months old mint condition
very reluctant sale. Tel: David
02380 315818, Mobile: 07747
603850 (Dec(I))

RUSS ANDREWS 8-way puri-
fier block w/6ft mains £390
ono. 6ft mains hi-current
w/wattgate 350 £190 ono.
Transparent Musiclink super
interconnect £280 ono. All
boxed mint also VDH D102 III
(2 pairs) £40 each Tel: Chris
020 8543 5531 evenings
(Dec(I))

MERIDIAN 500 CD player
reclocked with Vimax 1800
DAC cost £2600 sell £950
ono. Fantastic sound. Tel: 029
2023 5881 day, 029 2077 7156
evening (Jan(I))

Upgrade Your Turntable



"It's value is nothing short of tremendous"
Listener Magazine

"The single most important upgrade you can ever make to any record deck concerns the motor drive...Nothing can compare you for the shock of going DC, in a word, Gobsmaacking"
Common Ground Magazine

"...if you are thinking of upgrading your system.....the Origin Live DC-motor kit should be high on your list for consideration" TNT Audio

Whatever your current turntable, the results in upgrading to the Origin Live DC motor and power supply are simply astounding. Designed as a drop in replacement for almost all turntables, the Origin Live upgrade kit offers vast improvements to all versions of Linn turntables, as well as Ariston, Rega, Systemdeck, Roksan, Rock, Oracle, Thorens, Well Tempered etc. With only a 12 Volt power supply and a full set of illustrated instructions our upgrade is both easy and safe to install. The upgrade is also offered with a full money back guarantee if you are not satisfied. The kit consisting of a high grade dc motor, soldered regulator board and power supply is only £262. This provides an extremely cost effective route to truly high end audio and is significantly superior in performance to other power supply upgrades costing 4 times the price. A larger purpose built transformer is also available as an optional extra at £175.

Turbocharging your Rega arm

"Nothing less than total dynamite" Hi-Fi World



If you are the proud owner of any Rega tonearm, you are now in the enviable position to transform it's performance into the league of super arms with modifications offered by Origin Live - the Origin live structural modification at £75 will enable your Rega to perform at a level exceeding that of arms costing over £1200. High performance rewiring with high grade litz cable is also offered at an additional £70 and external rewiring is £70 this further increases the performance.

"I have to say the Rega modifications turn this humble arm into a real Giant killer. Gone is the rather grey, sterile sound of the cooking Rega. Instead, tonal colour is fresh, dynamics have great speed and impact, and the sound stage is huge."
Hi-Fi World, Nov 97 (structural modification on RB250)

What Hi-Fi? gave this modification 5/5

Structural Modification - £75

Internal Rewiring - £70

External Rewiring - £70

For arm modifications we normally return your arm in 2 - 3 days.

Origin Live Ultra Turntables Build & setup in an hour



Modern



Classic

"...this Vinyl front end had my jaw heading towards the floor with the solidity and transparency of the music it was making....with all these goodies in place the Standard would give turntables at the £1200 -1400 mark a hard time..."

"...Overall a deeply impressive deck....brilliant value for money ...component quality is superb and the build process is a doddle."
Hi-Fi World

"the best sounding deck here (group comparison test of 8 leading turntables)...sounds fantastic."
What Hi-Fi?

What Hi-Fi?

"One of the most enjoyable and musically involving turntables I have ever heard ...Regardless of make or reputation"
Audiophile

Now you can own a professionally built, high performance turntable at a fraction of the normal cost. Origin Live turntable kits are supplied in 3 different specifications:

1. A standard kit of parts to enable you to build your own plinth at **£282**
2. The complete standard kit offered with a non-suspended pre-drilled & finished plinth at **£349**
3. The complete ultra kit comes in two options. The Ultra Kit Classic offering a truly high end suspended sub-chassis turntable with beautifully finished solid wood plinth. The Ultra Kit Modern offers the performance of the Ultra Kit Classic combined with the modern day skeletal styling of our sensational resolution turntable. Both options available at £538.00

All kits are supplied with well illustrated instructions and are easier to assemble than many of today's pre-built turntables.

FOR MORE INFORMATION SEE WEBSITE OR CONTACT

Origin Live, Unit 5, 362b Spring Road, Sholing, Southampton, SO19 2PB, U.K.
Tel: 023 80578877 / 80363249 Fax: 02380 578877 e-mail: originlive@originlive.com

<http://www.originlive.com>

NAIM NAC 102 preamp incl NAPSC and MC c/boards £795. NAP 180 power amp £695. Both only 9 months old and balance of 3 year guarantee Tel: 02380 671366 (Southampton) (Dec/I)

NAKAMICHI CR7E cassette unmarked as new mint condition boxed with remote and instructions plus Nakamichi head de-magnetizer also boxed sell together £1275. Tel: 01275 835334 (Bristol) (Dec/I)

ROKSAN ROK DP-1 CD transport (original top loading design) boxed and in good condition. Works very well with carefully chosen leads and support £375. Tel: 01273 698793 (Dec/I)

AUDIO INNOVATIONS S300 valve amplifier. One channel out so may need new valve(s) £90. Tel: 01784 449669 or Email: martyn1@btinternet.com (Staines) (Dec/I)

MUSICAL FIDELITY A370 Mk1/2 poweramp. Musical Fidelity MX preamp both near mint £900. Kimber KCAG interconnects various Nordost Blueheaven interconnects Chord speaker & interconnects. KEF 104/2 Raymond Cooke mint Mana Soundframes Tel: 07967 646089 or 020 8255 4039 (Dec/I)

LINN LP12 original spec. Unspoilt by progress! With Basik LVX, K9 £200. Alphason equipment rack 4 shelves smoked glass beechwood uprights excellent condition £100. Tel: 01543 493282 (Dec/I)

A.T.C. speakers SCM 7 brand new boxed £250. Buyer collects. Tel: 01744 736218 (Lancs) (Dec/I)

MARK LEVINSON No36 DAC £1450 (£4000). Radford Renaissance MA50 monobloc valve amps, wonderful natural sound £1450 (£4000). Audio Research LSI preamp £650 (£1800). Counterpoint HC808E preamp, equivalent to Krell KRC2 £250 (£1800). Boxes, manuals, all perfect. Tel: Bill 01993 851508 (Dec/I)

CONRAD-JONSON PV10-SE pre and MV55 power amp combination, new Svetlana valves, mint. (£3500) £1500. Proac Studio 150 speakers in gorgeous yew, mint, (boxed), (£1500) £850. Musical Fidelity E600 CD, mint, (boxed), (£600) £200. M.I.T. speaker cables, 3 metre bi-wire pair (£500) £200. Tel: 07810 871731 or Email: peter.mccue@ntlworld.com (Dec I)

BBC LS3/5A Goodmans 15ohm. Boxed £300. Lowther mini Acoustas with blown PM6s. Garrard 301, original arm; Quad gear in sore need of restoration. Offers? Tel: 01249 815033 (Wilts) (Dec/I)

SILTECH LS-80G3 1.5m WBT terminated speaker cable £270, Siltech LS-38G3 1.5m unterminated speaker cable £130, Siltech ST-38G3 0.6m interconnect £135. All very good condition, 1/2 price off list. E-mail: k_nikolakakis@hotmail.com (Dec/I)

NAIM NAC 112/NAP 150 pre/power amplifier, moving coil stageline, speaker cable, guaranteed. £1400 "Hi-Fi Answers". Rogers transmissions line monitor speakers 150 watts, teak veneered P.W.O. £300. Tel: 02392 259300 (Portsmouth) (Dec/I)

VDH FIRST Ultimate 1m RCA. Brand new. Boxed. £145. Yamaha KX580SE award winning cassette deck (£250) £95. Vampire Wire CCS/I 99.9997% continuous cast silver interconnects (\$700) £150. Tel: 020 8566 5293 or 07946 620514 (Dec/I)

UNUSED - EXPORT Audio Innovations Series 300 with Border Patrol Supply, Living Voice Auditorium, not yet run in. Hitachi cable and XLO interconnect plus amp stand, £1500 ovno. Tel: 07736 781 544 (West Sussex) (Dec/I)

TOCA-SECA power amp. Class A, dual mono, single-ended fet. 20/38 WPC. Large heavy construction, marble fascia, sweet sounding. Colin Wonfor design, reviews available (Hi-Fi News/02/95) £995 (£2940) Tel: 01273 325 901 (Dec/I)

DYNAUDIO I.3 MkII black ash, mint condition £650. Tel: 01253 692356 evenings (Dec/I)

REVOX A77 quarter inch tape recorder. Standard speed, suitcase model in excellent condition. Spare NAB adapter and loads of tape (some unused). £150. Tel: 01883 716 213 (Dec/I)

EXPOSURE SUPER 18 Stereo Power Amp £420 or p/ex good subwoofer. Marantz CD17 MkII £420. Various interconnects, speaker cables around half price (QED, Sonic Link etc). Tel: 01934 863621 (Bristol area) or Email: cheri@offcampus.net (Dec/I)

NAIM SBL speakers, four years old, black ash, superb performance, perfect condition, boxed, £1100 ono. Tel: 01362 683 777 or Email: old@ash1.fsworld.co.uk (Norfolk) (Dec/I)

ACOUSTIC ENERGY AE-3 with genuine twin pillar A.E. stands superb condition £750. Musical Fidelity P270.2 power amplifier boxed and immaculate £495. Tel: 01904 763157 or 07960 615375 (York) (Dec/I)

CROFT EPOCH pre amp, brand new with MC phono stage (£1500) £800. Croft V power amp (£800) £400. Copland CDA 288, with remote (£2000+) £1150. All items in mint condition. Tel: 020 8908 4633 (office), 01923 224 404 (home) Dec/I)

ACOUSTIC ENERGY AE1 speakers (black) with matching AE stands, A1 condition, boxed, cost £1350, asking £350. Denon DRM14HX cassette deck (remote control) as new, boxed, cost £250, accept £90. Tel: Steve 07951 746 928 or 020 8550 5192 (Dec/I)

PAIR QUAD II valve amps. Nos. 95/96 in original cabernet. £400 or best offer. Tel: 01865 779804 or 07879 415562 (mobile) (Dec/I)

AUDIOLAB 8000 CD player, good condition, boxed, remote control, upgrade forces sale, £375. Tel: 01268 419013 or mobile 07773 028059 (Dec/I)

LINN LK1/Dirak £350, 280/Spark £350. Linto £350. All together £950 including K600 loudspeaker cable. Great sound, excellent condition, boxes and manuals available. Tel: 01865 881 582 (Oxford) (Dec/I)

NAIM CDX CD player £1650 ono. Kef Reference One Point Two £800 ono. A.V.I. S2000M monoblock amplifiers £650 ono. All in new condition and boxed. Tel: 01492 516875 after 5pm or Email: len.edwards@thalesgroup.com (Jan/I)

CYRUS III AMP plus Chord Solid Gold leads £200. Mission 752 floorstanding speakers (black) with QED Qudos cables £200. Tel: 07810 374202 or Email: andrew.trist@njw.co.uk (Dec/I)

AUDIO ALCHEMY DT1 Pro-32 with Power Station Three £250. Design forerunner of Perpetual Technologies P-1A. Mana Acoustics Reference top £75. Tel: 01642 559 078 (Stockton) (Dec/I)

QUAD 405-2 power amp £225 ono. Quad 44 pre amp £175 ono. Both mint condition, boxed with manuals. Mordaunt Short Signifer speakers, walnut, mint condition, boxed £250 ono. Tel: 01642 405634 (Dec/I)

NAIM 52 pre-amp: two Supercaps: two 250's: CD5: SNAXO 2-4: Flatcap2: 160 (updated): 32.5 (updated). Most items less than three years old. Tel: 01508 470211 or Email: johnoobbs@btinternet.com (Dec/I)

ARCAM ALPHA 8 CD £125. Alpha 8 amplifier £100. Straightwire Chorus interconnect £15 or £225 all together. Mint, boxed, manuals. Tel: 01403 230070 (evenings) (Dec/I)

UNISON RESEARCH Simply Four integrated valve amplifier, excellent condition, original packaging and manuals £650. Creek OBH-8SE MM phono pre-amp, mint condition £95. Tel: 020 7794 6676 (Dec/I)

SILVER - SILVER - SILVER

Both LAT and AUDUSA Eupen mains cable available with silver plated (heavy duty plating 5- 8 microns, anti tarnish finish to BSI standard and treated with ProGold) MK Tough plug and IEC connectors. Upgrade to the silver plated versions add £6. Connectors with silver plated pins/contacts available seperately - Why Silver? Because there is no better conductor of electricity than Silver and Silver reduces contact resistance.

AUDUSA EUPEN CSA 2.5 MAINS CABLE - HI FI CHOICE SEPT 2001 BEST BUY AWARD



AUDUSA-Eupen GNLM 05/2.5 (CSA 2.5)



AUDUSA EUPEN GNLM 5.0/04

CSA and GNLM Cable with FERRITE TECHNOLOGY - A polymer material mixed with a considerable quantity of homogeneously fine high quality ferrite powder. This compound is called EMC/COM and it can be extruded around copper conductors. The ferrite itself is a non-conducting material, but it has a very interesting magnetic behaviour. As a ferromagnetic material, it will go through hysteresis loops whenever it is under influence of an alternating magnetic field. Consecutively magnetizing and demagnetizing the material will cause considerable losses of high frequency energy. This energy is absorbed in the ferrite grains and converted into heat. This effect is more or less proportional to the field frequency. By coating conductors with a thin layer of ferrite compound, high frequencies will be strongly attenuated, because their energy will be absorbed by the ferrite powder. This applies to high frequency disturbances that are propagating on the conductor and which we don't want to disturb the environment, as well as to surrounding interferences, which we want to prevent from disturbing the signals on our cable. The CSA and GNLM cable which in addition to the above described ferrite technology is further protected with a foil shield and a drain wire and specifically manufactured for High End audio use. Ask for the silver plated contacts on IEC and MK Tough plug for an extra £6.

£48 for 1.0m
£58 for 1.5m
£68 for 2.0m
off the reel £30
for 1st meter, £20
per m thereafter.

Fitted with IEC (Martin Kayser) and MK Tough Plug available with Marincos 320 IEC, Figure of eight, 16 amp IEC, Bulgin etc also available as well as USA Hubble, European Schuko, Neutrik, Australian and other mains plugs. Cable can be supplied fitted to our all steel 4, 6 and 8 way distribution blocks. We can rewire the distribution blocks with Eupen cable as an extra cost option. Refer to our web site for details.

LAT AC-2 HI-FI CHOICE - SEPT 2001 - RECOMMENDED MAINS CABLE



AC-2
Power cable
compare with
products costing
ten times as
much, then
decide

LAT AC-2 Power cable. We have developed a cabling (weaving) pattern along with an unusual shielding/filtering system that gets rid of the garbage that contaminates your components. The difference you hear with our cord is astounding. Our power cord takes advantage of silver in its design through use of our proprietary Silverfuse conductors. The conductors are 10 gauge and insulated with PTFE; the best insulation available. Fitted as standard with an IEC and MK Toughplug. . 60cm £62, 90cm £75, 1.2m £88, 1.5m £101, 1.8m £112 etc Other lengths available off the reel at £45 per meter.

4,6 and 8 way all steel mains distribution blocks fitted with UK, Schuko or USA sockets. CE tested and approved mains distribution units manufactured out of heavy gauge steel, finished in black and fitted with high quality Wadsworth 13amp sockets. It has no filters, circuit breakers, surge protection, transformers, resistors, capacitors, LED's, on/off switches, chokes, regulators, just fitted with 1m of LAT AC-2 mains cable. From £166 for 4 way, £198 for 6 way, £229 for 8 way.

LAT AC-2 mains cable available with Shurter 16 amp, Marincos 320 IEC, Figure of eight, Bulgin, USA Hubble, European Schuko, Australian, Swiss, Danish, and Neutrik plugs. Check our web site for other available variants.

SILVERFUSE is a near alloy of silver and copper. IT IS NOT SILVER PLATED OF SILVER CLAD. Plating (or clad, which is the same thing as plating) causes a dioding effect when signal is passed through resulting in brightness and distortion. The Silverfuse process starts with seven nines OFHC copper wire with a diameter that is slightly larger than the required size. It is then pulled through a trough of molten silver. The wire with a silver deposit, is then forced through a compacting die where it is subject to tremendous pressure. The silver and the high purity copper are fused together into a near alloy. The compacting fusion also reduces the wire diameter to the desired size. No dioding subsequently occurs with this process. The result provides for the benefits of silver; which are excellent definition and clarity, with the high purity copper benefit of warmth and mellowness.



LAT INTERNATIONAL - Analogue, Digital and Video interconnects and Speaker cable - better than most other at double the price Refer to www.audusa.com for further details or ask for reviews etc.

AUDUSA -OOM Silverlink Mono Crystal balanced speaker cable - conductor of 3mm diameter, stranded Silver on OFHC, plus three strands of Mono Crystal Copper for improved bass performance. Mylar infill and with protection against RF and EMI Cable OD 14.72 mm Ask for details and amazing price

SUNFIRE CORPORATION - Snohomish USA



New for 2002 Sunfire True Sub Woofer MKIV - 11 inch cube. Signature True Sub Woofer 13 inch cube and Junior Sub Woofer 9 inch cube -all with two drivers, to as low as 16hz, 116 SPL and 360 cu ins of air movement, 1200 or 2700 watt patented amp technology. Classic Tube Pre-amp, Solid state power amps 2 channel (300 x 2 or 600 x 2) and 5 channel (220 x 5 or 430 x 5 - yes total of 2150 watts into 8 ohms or 4300 watts into 4 ohms) patented amp technology (no heat sinks) and Theatre Grand II processor pre-amp.



Trade Ads

hi-fi
WORLD
& computer audio

classifieds

Dealers must not advertise in the Private Classified section. Monthly consecutive insertions will be considered Trade advertising. The Publisher reserves the right to judge submissions.

Special Internet offer see page 130 for details

VINTAGE WIRELESS COMPANY LONDON
Website: www.vintagewirelesslondon.co.uk
Buy-Sell-Exchange. Vintage wireless and classical audio. Repairs, spares, restoration, modification to all valve equipment. Quad II, Leaks etc, shipped worldwide, best prices, call us at 17 Bell Street, London, NW1 5BY. Tel: 020 7258 3448 Fax 020 7258 3449
Email: vwirelesslondon@aol.com (Oct03(I))

WOODSIDE ELECTRONICS service and repair. Woodside, Radford and Quad valve products. Replacement transformers are available to original specifications (Quad transformers are approved by Quad). Tel: 01758 741026, Email: m.davis@virgin.net
Website: <http://freespace.virgin.net/m.davis> (Dec I)

HIFI HUT in Harrogate offer: Bryston, Quad, Creek, Roksan, Harman Kardon, P.M.C., Wharfedale, Epos, J.B.L., Cable Talk, Chord Company, QED, Stands Unique, Soundstyle, Custom Design. Phone for details: 01423 810 990 (Dec I)

AMAZING CABLES! Unlock your system's full potential. Handbuilt silver interconnects from £85, solid speaker cables from £220, £5 p & p. Fantastic performance, money back guarantee. Details: 0115 982 5772 after 7pm or Email: bob@skydivers.co.uk (Feb I)

NAIM SPECIALIST Buys and sells top condition Naim products. Cash waiting for your Naim gear. Plus all products sold are tested with money back guarantee. Telephone. 07971 202742 with requirements. (Dec I)

GRAND M25 Audiojumble at Leatherhead Leisure Centre, M25 Jct 9, Sunday 10th November 10.30am. Tel: 07730 134 973 for details (Dec I)

DYNARHYTHM Speaker kit, 98dB efficiency, 30Hz extension, drivers treated with Dieter Ennemose's C37 Lack, compact floor-stander, real dynamics, real bass! Captures the excitement of the original performance, £595. Email: dyna-rhythm@abra-cadabra.co.uk or Tel: 01642 649 702 (Jan I)

AUDIO COMPUTER valve output or Midiman Audiophile soundcard, rack sized, black, silver, looks like Hi-Fi also PC. Replay/Record, CD, LP, MP3, Wav., Radio. P4, AMDxp from £999. Tel: 01460 65988 or Email: info@silentaudio.co.uk (Jan I)

FARADAY CONCRETE Cabinet loudspeakers, 'a sonic revelation', What Hi-Fi? Our unique low density formulation and design really does produce the ultimate in audio transparency. DIY options available. Tel: 01603 762967 www.faradaysound.co.uk (Feb I)

ELECTRICAL & ELECTRONICS: Stocklists: High-end Audio & Valve, RCA Plugs, Cables, Switches, Adaptors, Sockets, Test Equipment. PA/Disco equipment. Halogen Lights 12v 10pack £12.95. MP3, CD. Sale: Tannoy 15" Lancaster £495. RCA mini 3watts speakers £50. Musical Technology corner speakers, 115cm high, £600. Tel/Fax 020 7349 9675 or 0795 860 7613 (Dec I)

TECHNICS SLP1200 CD £400, SP10 MkII £280, Sony DCD 3000 £1200, Revox PR99 MkIII £1200, PR 99 £750, CII5 £400, C278 £1400, Studer A810L £550, A807L £950, A80 VU £1200, A62 £550. B62 £650, Tel: 01246 275479 or Email: j.i.tipping@amsolve.net (Dec I)

WORTHING AUDIO Summer Specials. Rogue Audio 88 power amp (Magnum) £1250. Audio Note Anvx silver interconnect 1 mtr £550, .75mtr £500. ESLab DX4 200 watt digital power amp £1599. Amphion Argon loudspeakers £599. Silver Arrow mains cables various lengths 'excellent'. P.O.A. Kora products on permanent dem. Tel: 01903 212133 Mobile: 07900 918882 (Dec I)

KORA VALVE Amplifiers on permanent dem. Also 6N-Pure flat silver foil air interconnects with Bucchino phono plugs. Also silver mains cables, Furutech IEC's fitted. Tel: Worthing Audio 01903 212 133 or 07900 918 882 (Dec I)

USED & EX DEMONSTRATION Equipment for sale. Naim CD2 CD player £875. Naim Nac 102 pre-amp £825. Naim 180 power-amp £825. Naim SBL speakers, black (upgraded bass units) £600. PMC FBI speakers, cherry £950. Arcam AVR 100 home cinema receiver £395. Linn Kairn Pro pre-amp SMPS £750. Base 10 shelf cabinet in oak £600 (new £1800). Call Griffin Audio 0121 622 2230 or Email: griffinaudio@fsbdial.co.uk (Dec I)

NAIM NAC 32.5 pre, with phono stage, mint condition £275. Mission 780's, 2 years old, black ash, boxed as new, inc stands, £200. Telephone Jules on 01792 280061, Email: info@sounddrjuleshifi.co.uk Web: www.sounddrjuleshifi.co.uk (Dec I)

VAN DEN Hull the Second, 1.0 mtr RCA Phono, mint. (£200) £120. Van Den Hull the 2nd, 0.6 mtr RCA (Phonos) good condition. (£160) £95. Quad ESL 63's, Mint condition, black, one elderly owner; 5yrs old £1600 Telephone Jules on 01792 280061, Email: info@sounddrjuleshifi.co.uk Web: www.sounddrjuleshifi.co.uk (Dec I)

KRELL KAV300I CD, 18 months old, immaculate, boxed as new, instructions, purchase doc's, £1850. Conrad Johnson PV10A Pre-Amp, Conrad Johnson MV55 Power Amp, 5 weeks old, as new, combo, £2600 (£3600). Telephone Jules on 01792 28006, Email: info@sounddrjuleshifi.co.uk Web: www.sounddrjuleshifi.co.uk (Dec I)

KRELL KRC- 2 pre-amp, as new £1750. Michell Orbe SE, SME IV, immaculate, absolutely stunning. (£3250) £2400 ono. Infinity Renaissance 80 floor-stander's, Oak, £550. Telephone Jules on 01792 28006, Email: sales@sounddrjuleshifi.co.uk Web: www.sounddrjuleshifi.co.uk (Dec I)

KIMBER SELECT Digital KS 2020, 0.75 MTR Interconnect (£546.00) £400. Manticore Turntable, Manticore Manti:less arm, mahogany plinth, Manticore Magician arm, AT-OC9, Mana Reference table, PSU MB6i External upgated P/S, etc (£3,585) £1600. Audio Technica OC9 cartridge brand new £270. Telephone Jules on 01792 28006, Email: info@sounddrjuleshifi.co.uk Web: www.sounddrjuleshifi.co.uk (Dec I)

classifieds ads order form

RATES - ALL ADVERTS MUST BE PRE-PAID

Maximum length per advert is 30 words, each additional word is 50p extra. Telephone numbers and E-mail addresses are treated as one word. Model numbers are treated as one word i.e. Quad 303 = two words. Please tick the box for the advert required

In a rush to get your advert published? Why not use our Instant Internet Advert to get on our website immediately. Only £15 per week (7 days)

Dealers must not advertise in the Private Classified section. Monthly consecutive insertions will be considered Trade advertising. The Publisher reserves the right to judge submissions

SPECIAL OFFER

Book a private or trade classified advert, and get one months *FREE internet advert

*FREE internet adverts are published three weeks AFTER the magazine has been published

Instant Internet Only Advert Private or Trade published immediately	£15 per week	<input type="checkbox"/>
Private magazine advert plus *FREE internet advert	£10 per month	<input type="checkbox"/>
Private magazine advert display black box plus *FREE internet advert	£15 per month	<input type="checkbox"/>
Trade magazine advert plus *FREE internet advert	£10 per month	<input type="checkbox"/>
Trade magazine advert display black box plus *FREE internet advert	£15 per month	<input type="checkbox"/>
Please tick here if you DO NOT WANT your FREE internet advert		<input type="checkbox"/>

Please write or type your advertisement copy in block capitals with one word per box.

Please continue on a separate sheet if necessary.

WE WILL ACCEPT PHOTOCOPIES OF THIS FORM

1	2
3	4
5	6
7	8
9	10
11	12
13	14
15	16
17	18
19	20
21	22
23	24
25	26
27	28
29	30

Name _____
 Address _____
 Post Code _____
 Daytime Tel: _____

Please debit my VISA/MASTER/SWITCH Card No. (Switch card issue No. _____)

Expiry Date: _____ Cardholder Signature: _____

I enclose a cheque/postal order for £ _____ Made payable to: Audio Publishing Ltd.

Send in your private classified ads with our NEW Freepost service. No need for a stamp!

Send this form together with your payment in an envelope marked:

Hi-Fi World, FREEPOST LON3478, LONDON NW6 6YR



ADVERTISERS INDEX

Affordable Audio	88
Affordable Valve	46
Apex Acoustics	112
Audio Illusions	92
Audio Room	116
Audio Vector	117
Audusa	128
Billy Vee	89,90,91
Black Rhodium	46
Cable Toasting	107
Campaign Audio Design	22
Central Audio	114
Choice Hi-Fi	94
Chord Company	22
Classique Sounds	119
Custom Cable	115
Cyrus	14
Definitive Audio (Brighton)	113
Definitive Audio (Notts)	22
Diverse Vinyl	109
Emporium (The)	120
Going On Ltd	109
Heathcote Audio	124
Heatherdale Audio	115
Henley Designs	8,9,3
Hi-Fi Trading Company	108
Hicam	112
Ian Harrison	122
Jem Distribution	115
KJ West One	20
M25 Jumble	107
Mana	111
Mantra Audio	93
Matrix	118
MDC	117
Michell Engineering	36
Midland Audio Exchange	110
Midland Hi-Fi Studio	116
Mission	8C
MJ Acoustics	18
Musical Images	111
Musonic	107
Naim	24
Origin Live	60, 126
Oxford Audio Consultants	114
P.G. Hi-Fi	122
Quad	1FC
Retro Reproduction	113
Ringmat	18
Sevenoaks	27,28,29,30,31,32,33
Sevenoaks	56,57
Signals	116
Sound of Music (Crewe)	119
Soundcraft	115
Sounds Expensive	124
Sounds Perfection	52
Soundstage	118
Stowsounds	118
The Listening Rooms	122
The Right Note	52
Trichord	36
Tube Shop	88
V'Audio	109
Walrus	60
Williams Hart	111
X-Electrical	119

SUPPLEMENT NO.70

Audioexpress	96
Chelmer Valve	96
Falcon Acoustics	106
Kit & Components	102
Langrex	104
Technical & General	96
Watford Valves	104
White Noise	96

PRIVATE & TRADE CLASSIFIED ADVERTS COPY DEADLINES

JANUARY 2003 ISSUE - WEDNESDAY 6TH NOVEMBER 2002

FEBRUARY 2003 ISSUE - WEDNESDAY 4TH DECEMBER 2002

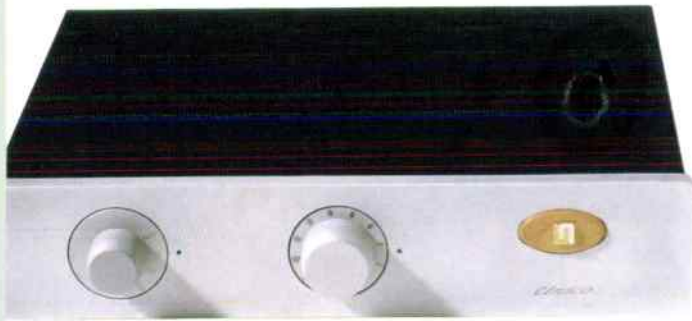

UNISON RESEARCH UNICO

The new Unico integrated amplifier from Unison Research has an impeccable pedigree. Triode valves give the purity of sound that makes listening a pleasure. With styling of understated elegance and 80 watts of power, Unico offers an unbeatable package. As top reviewer Ken Kessler put it (Hi Fi News, July 2002): "No integrated I've used in recent memory delivers so much at this price". Unico is pure luxury – at a sensible price. Complete with radiowave remote control.

Unico Remote (line) £750, (line + phono) £800

OPERA SP2

Beautiful to behold and a delight to listen to, Opera loudspeakers are the genuine article. The solid hardwood 'boat-tailed' cabinet allows the SP2's top quality drive units to produce a lovely, natural sound. Italian craftsmanship, advanced acoustic technology and the very finest materials make SP2 the perfect choice for the discerning music lover.



* Opera SP2 (mahogany), £1350/pair. Other finishes available.

TRIANGLE *Loudspeakers that love music*

Five stars for sound and five stars for value. Triangle are regular winners of top accolades from the world's most prestigious reviewers. As What Hi Fi recently put it "Rarely have we come across loudspeakers that are so lively and communicative...they turn in a sparkling performance that makes others seem bland in comparison". Listen for yourself. You'll be amazed.



Zerius 202

*Zerius 202, £695/pair

PATHOS ACOUSTICS *The Unorthodox Approach*

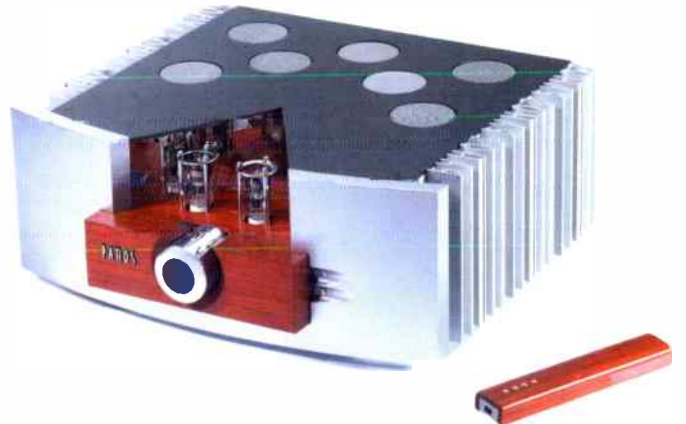

After almost two years of design, prototypes, testing and listening, the stunning new Logos integrated amplifier is finally here. For the lucky few who will own one, it has been worth the wait. Logos is an object of rare *bellezza* - a swan in a world of ugly ducklings. A future classic. And as a machine for playing your favourite music, Logos is simply *delizioso*. Look, listen, and you will know exactly what we mean.

*Pathos Acoustics Logos, 110 Watts/channel, £2495

Contact us for more information or visit our website



23 Richings Way, Iver, Bucks, SL0 9DA, England
Tel: 01753 652 669 Tel: 07000 853 443 Fax: 01753 654 531

www.ukd.co.uk

World Radio History

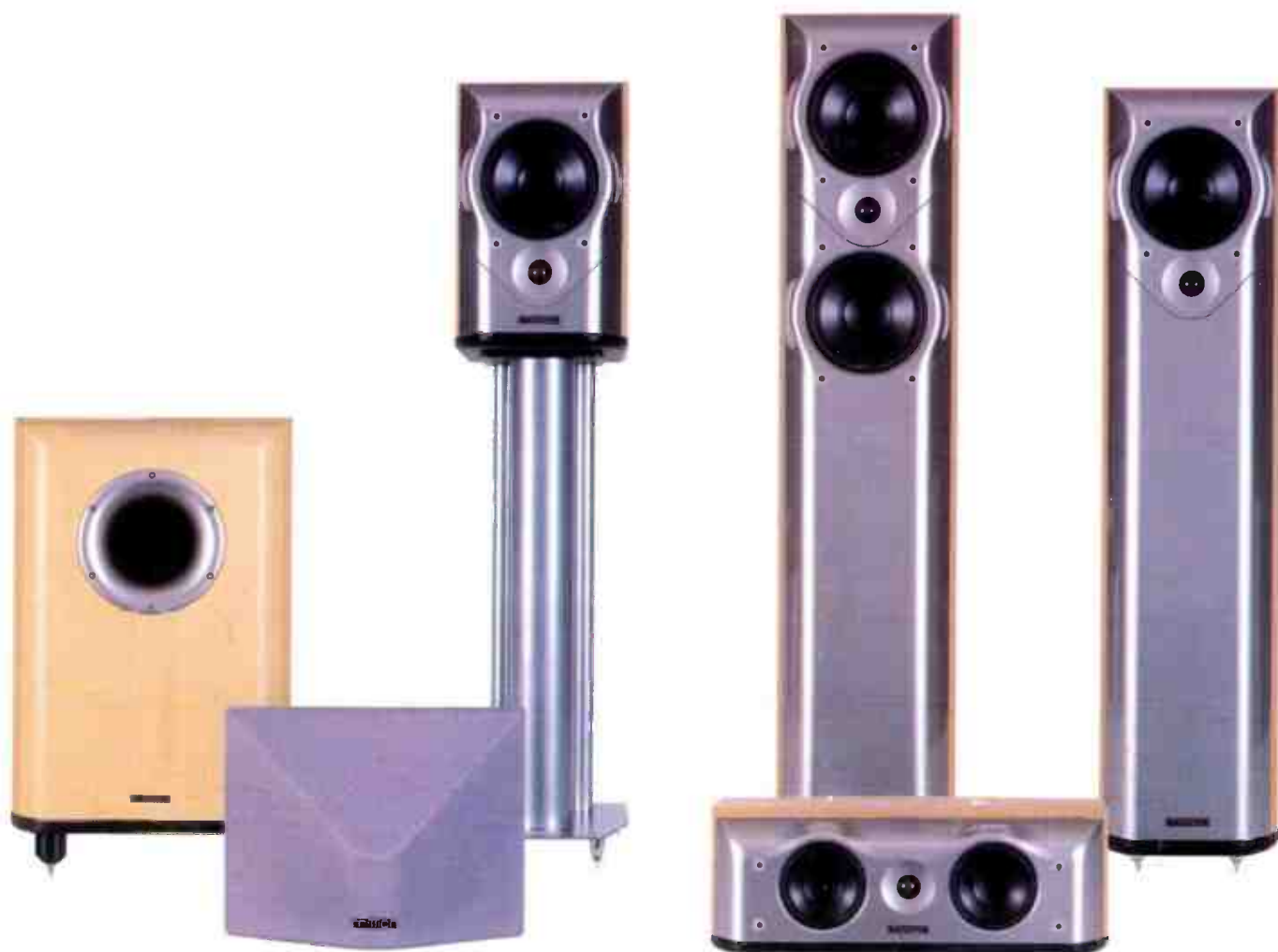

Simple Perfect Sound

M5 series

MISSION

tel: +44 (0) 1480 423700
www.mission.co.uk