

R WITHERS COMMUNICATIONS



**584 HAGLEY ROAD WEST, OLDBURY, WARLEY
B68 0BS (QUINTON, BIRMINGHAM) WEST MIDS.
Tel: 021-421 8201/2 (24 HR ANSWERPHONE)**



RWC SPECIAL OFFERS



**PLEASE ASK ABOUT THE RWC CREDITCARD
AVAILABLE NOW VIA LOMBARD TRICITY**

**M5
JUNCT
3**

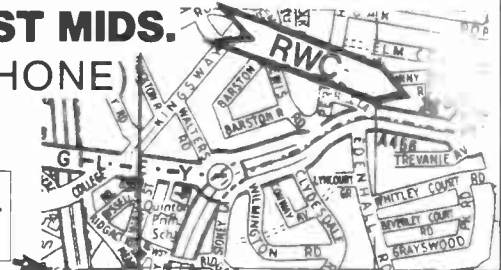

R.W.C.'S BARGAIN WINDOWS – ONCE ONLY OFFERS

<p>2 Mtr</p>	<p>YAESU FT290R £349 With free variable power supply, worth over £40.00. While stocks last. Charger & Ni-Cads £19.98 WHILE STOCKS LAST</p>	<p>TURN THAT BEAM KOPEK ROTATORS 50KG LOAD-ING FULL 1 YEAR WARRANTY OUTSTANDING VALUE £38.50</p>	<p>GOOD QUALITY FIELD-STRENGTH VSWR METERS IN-LINE DESIGN WORK VERY WELL ON 2 METRES £9.50 inc post ONLY 50 AT THIS PRICE</p>	<p>VARIABLE BENCH POWER SUPPLIES 0 to 15 Volts, 3 Ampere, IC Protected Normally over £40.00. RWC SPECIAL AT £19.50 (- £2.50 P&P). 60 Only, UNREPEATABLE OFFER, GET YOURS QUICK...</p>	<p>THE AMAZING NEW ARM MULTI-P6+ VHF-UHF MOBILE ANTENNA, THE MOST VERSATILE ANTENNA EVER MADE. ONLY £34.50 + £2.50 P&P. Colinear element £4.75.</p>
<p>NEW RANGE OF LINEAR AMPLIFIERS FROM RAYCOM LTD SEND SAE FOR FULL DETAILS</p>	<p>10 METRE KIT LCL 2740 & DNT 40FM COMP 2 CRYSTALS 1 CRYSTAL FILTER 2 CAPACITORS & FULL INSTRUCTIONS RWC BEST SELLER, STILL ONLY £12.95 plus £1.00 p&p</p>	<p>DRAE MORSE TUTOR 'SUPER SPECIAL' LEARNING MORSE? HERE'S THE ANSWER FEATURES INCLUDING £49.50 + £2.50 P&P</p>	<p>5% OVER 5% 2 METRE COLINEAR BASE ANTENNA, TERRIFIC VALUE, ONLY £35.98, INCLUDING 5 STAR CARRIAGE TO YOUR DOOR.</p>	<p>WANTED FT225R/D, IC202E/S, FRG-7, IC2E, TR2300 BEST PRICES PAID - WORKING OR NOT</p>	<p>HF ANTENNAS MULTI-BAND VERTICALS FROM £35.95 + CARRIAGE</p>
<p>10 METRES FM QUALITY LOWE TX40G *SUPER SENSITIVE RECEIVER *4 WATTS OUTPUT *4KHz DEVIATION FM *REPEATER OFFSET INCLUDED ONLY 50 JOIN IN THE GROWING ACTION ON AVAILABLE TEN-FM. ONLY £52.50 + £2.50 P&P</p>	<p>RAYCOM SUPER MODIFICATION FOR YAESU FT787QX HF MOBILE FIT THIS MOD YOURSELF, AND HEAR THE DIFFERENCE. ELIMINATES VCO GLITCH, IMPROVING VFO TUNING, AND AS AN ADDED BONUS, INCREASES TUNING SPEED TO 50KHz per DIAL REVOLUTION, SELECTABLE ON 500KHz STEP SWITCH. £29.50, post free, FOR TESTED COMPLETE PCB AND FULL INSTRUCTIONS. SEE AD IN JUNE AMATEUR RADIO.</p>	<p>SEND SAE OR PHONE NOW FOR CATALOGUE AND THE FAMOUS RWC COMPUTER UPDATED SECONDHAND LIST!</p>	<p>RWC'S HB9CV 2 Mtrs £6.99. 70Cms £5.99 post & pck £1.00.</p>	<p>POWER MODULES FOR FDK YAESU ICOM TRIO ETC. EG 25W 2 MTR E WRITE FOR FULL LIST, FROM £35.00</p>	<p>Q5RV HF MULTI-BAND DIPOLE ANTENNA FULL SIZE £14.95 1/2 SIZE £12.95 POST & PACKING FREE!</p>
<p>YAESU FRV 7700A RX CONVERTERS WERE £75.00 NOW £59.00</p>	<p>AKD WAVE METER. A MUST FOR ALL VHF STATIONS £24.95 inc P THE BEST</p>	<p>SMC CBA 10/11 METRE BASE ANTENNA £19.50 SMC IIVII BASE ANTENNA £27.50</p>	<p>HIGH QUALITY RUGGED GUTTER MOUNTS USEABLE ON ALL SORTS OF ANTENNAS ONLY £4.98 £1.00 P&P</p>	<p>HI-Q BALUNS £10.00 HI-Q INSULATOR TRANS-FORMER £9.99</p>	<p>CCTV LENS 39MM JAP 'C' TYPE FIXING 16mm FOCAL LENGTH £7.50 £1.00 P&P</p>
<p>STEEL QUAD SPIDERS FOR 2 ELE QUAD AERIALS ONLY £19.50</p>	<p>TRAVELLING JIM 2M + 70CMS INC LEAD 2M £8.95 + PL259 70CM £6.95 (inc post)</p>	<p>USA MADE PUSH ON PL259 LAST 300 TO CLEAR FOR UR67 UR43 99p FOR THREE!</p>	<p>ALWAYS A LARGE RANGE OF SECONDHAND EQUIPMENT IN STOCK SEND LARGE SAE FOR LATEST LIST</p>	<p>HF AERIAL TRAPS GBKW-W3DZZ TYPE HIGH QUALITY 7.1MHZ £8.95 PAIR POST FREE</p>	<p>YAESU FT102 AM FILTERS XF 8.2 GA £19.50</p>
<p>RWC MOT TEST STILL AVAILABLE!! FULL TEST REPORT INCL SPECTRUM ANALYSIS ONLY £12.50 + CARRIAGE BOTH WAYS</p>	<p>SUN MOBILE ANTENNAS FOR MOST BANDS 2M-70cm 10M-20M, 15M FROM £13.50</p>	<p>HUGE RANGE OF AZTEC ANTENNAS PHONE NOW FOR FULL LIST!!</p>	<p>YAESU FT101ZD AM UNITS ONLY £5.00</p>	<p>HEAVY DUTY MAGNETIC MOUNT S0239 MOUNT 3M COAX + PL259 SPECIAL PRICE £8.95</p>	<p>RF TRANSISTORS OVER 20,000W IN STOCK FOR ALL HF/VHF/UHF RADIOS EG. 2SC 1947 £7.50 2SC 2290 @ £24.00</p>
<p>5 ONLY</p>	<p>YAESU FT102 AM FILTERS XF 8.2 GA £19.50</p>	<p>BIG RANGE OF AERIAL KITS FOR 2 METRES - PHONE -</p>	<p>HUGE RANGE OF AZTEC ANTENNAS PHONE NOW FOR FULL LIST!!</p>	<p>YAESU FT101ZD AM UNITS ONLY £5.00</p>	<p>HEAVY DUTY MAGNETIC MOUNT S0239 MOUNT 3M COAX + PL259 SPECIAL PRICE £8.95</p>

All offers subject to availability on a first come first served basis. Prices subject to change without notice, all correct at time of going to press, E&OE. **TERMS:** No COD. Barclaycard and Access accepted. Post free over £50, under £50 add £2.50 post and handling, unless stated. Please send SAE with all enquiries and for latest secondhand list.

Amateur RADIO

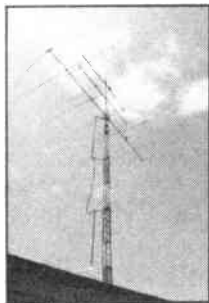

Editor:
Anita Ley
Editorial Assistant:
Jane Berry
Advertisement Manager:
Margaret Hall
Advertisement Executive:
Marian Vidler
Subscriptions:
01-684 3157
Accounts:
Clare Brinkman
Publisher:
Peter Williams
General Manager:
Alan Golbourn
On sale: Fourth
Thursday of the month
preceding cover date
Next issue: Cover date
July 1985 on sale
27 June 1985
Published by: Amateur
Radio Magazines,
Sovereign House,
Brentwood, Essex CM14
4SE, England
(0277) 219876
Printed: in England
ISSN: 0264-2557
News Trade Sales by:
Argus Press Sales &
Distribution Ltd, 12-18
Paul Street, London
EC2A 4JS.
01-247 8233
Front cover: Trio TS940S
reviewed this month (p18) Photo
by Jay Moss-Powell G6XIB
Whilst every care is taken
when accepting
advertisements we cannot
accept responsibility for
unsatisfactory transactions.
We will, however, thoroughly
investigate any complaints.
The views expressed by
contributors are not
necessarily those of the
publishers.
Every care is also taken to
ensure that the contents of
Amateur Radio are accurate,
we assume no responsibility
for any effect from errors or
omissions.

© Copyright 1985
Amateur Radio Magazines

6 Letters

Your opinions on topics of interest

10 Straight and Level

All the latest news, comment and developments on the amateur radio scene

16 DX Diary

Don Field G3XTT with this month's DX news

18 Angus McKenzie tests

This month G3OSS raves about the new Trio TS940S multimode transceiver

27 Beginners' workshop

Circuit board techniques explained by Rev George Dobbs G3RJV

32 DXers go West

Nigel Cawthorne G3TXF reports on this year's Fresno DX Convention

34 SWL

Trevor Morgan GW4OXB details the construction of a homebrew ATU

36 Problems in receivers

Beware of the problems you can acquire with the purchase of a 'black box' by reading Angus McKenzie's informative article

38 Coming next month

What's in store for you

40 On the Beam

Glen Ross G8MWR with all the latest news from VHF, UHF and Microwaves

42 Back to Basics

Bill Mantovani G4ZVB measures up on interference

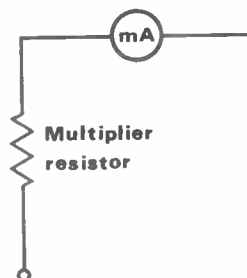
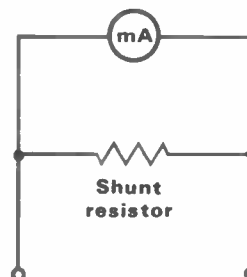

46 Questions and Answers

Multiple choice questions to test you on your knowledge of the RAE syllabus – with all the answers!

50 Secondhand

Hugh Allison G3XSE deals with the problems that can occur with integrated audio amplifiers

53 Free Classified Ads

The market for buying and selling

SERVICES

26 Newsagents order form

51 Subscription order form

55 Free Classified Ad form

57 Radio and Electronics World
subscription order form

58 Advertisers index

58 Advertising rates and information

L·E·T·T·E·R·S

ODD BALL

In the May 1985 issue of *Amateur Radio*, under the heading of *Odd ball*, you published a letter from Mr Waddington of West Yorks. He is justly proud of the fact that he has a 10 valve superhet, a 6 valve TRF (all EF50) receiver and so on. I would say all power to his elbow!

I would guess that he gets more fun out of these than the owners of the present Oriental black box receivers (cost £xxx), and if his receivers go wrong I bet he can repair them in minutes, whereas the Oriental black box is either unrepairable or will have to be sent away for an expensive repair.

However, only having started as a constructor in 1932 Mr Waddington is a new boy to the game. The writer constructed his first wireless set (now called a receiver) as a boy of 10 years old in 1929! This wireless set was a crystal

set. It covered what is now known as the long wave band. On 1500 metres was Daventry (BBC) and somewhere between 1500 metres and 2000 metres were Radio Paris and Hilversum. There was also a German station of unknown origin (after all, not everybody spoke English in those days) which popped up from time to time.

The crystal set consisted of the coil, a .0005 μ F variable condenser, a crystal detector (cat's whisker), a .001 μ F condenser and a pair of headphones. That was how the parts were described in the technical press at that time.

The coil was a honeycomb wound job made by putting 4 rows of nails into a broken piece of garden spade handle shaft around the circumference, and winding on a honeycomb coil of cotton-covered copper wire (about 22swg). The coil was soaked (or impregnated) in

boiling candle wax in an old iron saucepan on the kitchen stove and the resultant blaze nearly set the house on fire!

This of course destroyed the cotton covered insulation on the wire, so apart from being unpopular, I had also lost the coil. So another coil was wound and this time all the candle wax ends were put in the saucepan on a fire lit in the garden, and the bit of spade handle (complete with wound coil) was dipped into this for about 10 minutes and then taken out and allowed to harden.

At this stage the nails were removed and the coil gently slid off the spade shaft. The result was a very professional looking honeycomb coil. Looking back, I wonder how it is that I am still alive to tell the tale. The whole exercise must have been absolutely lethal.

The aerial consisted of about 100 feet of solid copper wire slung from the bedroom

window, with ceramic insulators, to the walnut tree somewhere down the garden. (The wire was scrounged from a GPO man who was putting up some new telephone lines down the road – 100 feet of that wire now would be worth a small fortune!). The earth connection was made to the bedspring!

The crystal set was then assembled onto an ebonite panel, using terminals in lieu of soldered joints, and at last the hour arrived when I went on the air.

Since then I have progressed to valve receivers, an amateur transmitting licence and a lifetime in electronics, including working as a Research Engineer in communications and radar management and marketing in the UK and the United States of America.

Richard Q Marris G2BZQ, Berks

PROGRESSIVE LICENCE

There has been some discussion in the past, both in these columns and elsewhere, of operating standards, content of the RAE syllabus, and that old chestnut the so-called novice licence. I have recently been prompted by local discussion on these subjects to put forward the following proposals which collectively constitute a form of progressive licensing from class B to advanced class A: (1) class B licence; (2) an enhanced class B licence; (3) class A licence; (4) an advanced class A licence.

The RAE needs to include more information of a practical nature, such as operating techniques, similar to that required to pass the

Royal Yachting Association's VHF Radio Operator Examination.

An enhanced class B licence would consist of the RAE plus CW at 6 words per minute (conversational Morse), and would entitle the holder to use any band above 30MHz, including 50MHz. In order to distinguish easily between a class B and the enhanced class B a callsign like G8STK would simply be altered to G88STK.

The class A licence conditions would remain the same except that the holder of a class B (or enhanced class B) would have to have held that licence for a year before venturing up on the HF bands, in order to give that person operating experience. Additionally, it is

suggested that the Morse pass should be valid for 2 years before it has to be cashed in.

There are quite a few class A operators who not only use CW at least to a speed of 25 words per minute but who also hold technical qualifications way and above that of the RAE. In order to give them some form of recognition, it is proposed that an advanced class A category be created for which the qualifications would be CW at not less than 25wpm plus a minimum of a Higher National Certificate in, say, electronics or its equivalent. The callsign would be altered quite simply from, say, G4KCC to G44KCC (in line with the proposal for the enhanced class B).

These proposals are in line with the general concept of progressive incentive licensing with the prime aim of encouraging better standards all round. As regards the so-called novice licence, this would do nothing to enhance ham radio since it would be pandering to the CB lobby who would be delighted to get their hands on our HF frequencies without having to earn the privilege. The novice licence issue must be finally put to rest by means of a formal referendum. Let's have one now.

Any comments anyone may have will be much appreciated. If there are no comments, then I will know I'm perfect!

Howard M Holmden G4KCC, Hants

NO NOVICE LICENCE

As a long time SWL and now a licensed radio ham I should like to call for support in keeping a novice or no-test licence from our bands.

In no way can the RAE be said to be hard as it is only as difficult as the amount of work one is not prepared to put into it. The same may be said of the Morse test. It's no

use just spending a few minutes practising on a Sunday night after the pubs have closed. However, there will always be those who moan that they can't pass and demand the easy option. I have little sympathy for that sort of attitude.

Already in this country we have a novice licence; for £10 people may operate on

27MHz, and have you heard them? Just imagine the chaos if that undisciplined rabble came legitimately within our frequency spectrum? These operators can't or won't abide by their own simple licence conditions.

One only has to look at the local skyline to see the abundance of large CB aerials breaching any licence

they may hold (if indeed they hold a licence at all).

If a no-test licence is granted on our bands I can see its conditions abused as on 27MHz and no one will gain, least of all the radio ham!

As for those who fail the RAE, try harder – it can be done.

A Skalfe G4XIV, Lincs.

L·E·T·T·E·R·S

NOT GUILTY

Referring to G3LIA's letter in the June edition, I am very pleased that someone has attempted to reply for the Police.

Mr Rogers has made an interesting point about the 'police officers being obstructed in the course of their duty' and I see what he means. However, he misses two important points. Firstly, *I was not guilty of the crime I was being accused of. Why should I have to prove my innocence?* Secondly, did the police break the law by operating my station without my permission?

He asks was I helpful to the police? I was driving along breaking no laws whatsoever when I was stopped and

accused, without being given a reason for being under suspicion, of a very serious offence. What does G3LIA expect my reactions to be? I was obviously rather defensive, and the comments made by the officer lead me to believe (subsequently confirmed by the Police Complaints Board) that he did not have any idea about what he was doing. That is why I requested the competent authority.

I find Mr Rogers' comment about there being more police officers than 'duly authorised persons' ridiculous. There are more football supporters than 'duly authorised persons'. Why not give them an A4 sized sheet of erroneous information and

turn them into people to uphold the law? Obviously this is not possible; proper, time consuming training is required.

I am afraid I find Mr Rogers one of the type who think that the Police can do no wrong, and he has conveniently overlooked my imprisonment and other harassments which were due, totally, to the police being incompetent. Would Mr Rogers please comment on this?

I cannot understand Mr Roger's opening statement about the article being a waste of two pages, when it obviously provoked enough interest for people to seek out his comments on the matter.

I would also be interested

to know how a police officer can first of all accuse someone of something serious, then, after examining the gear under suspicion *without the necessary equipment*, decide that it might not be illegal after all. Can the police see RF emissions?

Two final points. One, I don't know why the Police forced my vehicle door – they did have the keys, after all. All I know is that they did it and later offered to pay for the damage they caused. Secondly, ten out of ten to this magazine for having the guts to print my article (*Justice/Injustice*, February 1985). Thank god for the freedom of the press.

Hugh Allison G3XSE, Herts

DRIVEL

Rarely do I surface on 2m. I was asked on the band, by a G6, what my 'handle' was on CB. When he was informed that I didn't have 27MHz capability his attitude was one of disbelief – had I 'chucked the set away' when my amateur licence was issued?

Some people just don't realise that a G4 callsign doesn't automatically mean that you are an ex-CBer.

Sometimes I feel like relinquishing my licence when I hear some of the drivels

spoken on the bands by this brigade, who give themselves away immediately as ex-offenders of the Wireless Telegraphy Act.

When the RAE was made multiple choice it encouraged thousands of people to drift into amateur radio and ruin it for the more dedicated folk.

Black box operating should be stamped out. I learnt the proper way – sitting with my headphones on listening to home-brew equipment into the night. In 1976, at the age of 15, I passed the RAE and took

out the class A callsign a year later. I had no formal tuition, I just sat down, read books and practised examples of equations and circuit design.

I'd like to see a total withdrawal of licences and the reintroduction of the artificial aerial licence and compulsory CW.

The level of your technical knowledge would be decided by different exams and bands allocated for your use accordingly.

This would certainly allow the dog to see the rabbit!
M Shannon G4GJN, Lancs

SOUR GRAPES

Having read Mr L G Slater's letter, *Had enough*, in the May issue with some disbelief, I could not help wondering if it was a cry of 'sour grapes'.

Mr Slater was fortunate enough to be able to attend the RAE course at a college – as my occupation involves a shift system study in this form proved impractical. The only solution therefore was to study at home, reading as many books as possible.

Like Mr Slater I failed one part of the examination, so I tried again until my efforts were rewarded.

Come now Mr Slater, nothing comes easy, as they say, so stop moaning and start studying.

It is worth it and there's a great feeling of satisfaction when your 'ticket' drops on to the mat.

B J Marsh G1JOA, Herts

HAVE A HEART

We at Bonex Ltd, who had a stall at the NEC this year, felt we had to reply to Mr Rickwood's letter, *Non Event*, in the June issue. We wondered if he missed the component section altogether. As a general rule we carry more than 1,000 lines at an exhibition; we do sell out of many items, though we try not to.

At the Birmingham Show we had our entire range of CMOS chips – before the show started that is – but if someone had arrived on Sunday at 4pm we might have had to disappoint them, although we would have had at least 50% in stock.

There seem to have been a lot of moans from people at the show that there were very few component traders, most

stands catering for the black box customers. In reply, the mark up on small components is sometimes less than 30% and when a stand (I use Birmingham as an example) costs £400 + overnight accommodation what chance does a smaller component trader stand to break even, let alone make a profit, on the day? So lads, have a heart for the poor old traders!

John Higgins G6VLT, General Manager, Bonex Ltd, London

PROBLEM

I am the proud possessor of an Icom R70 receiver which has given me much pleasure but for a very annoying feature concerning the A, B VFO facility. This allows two frequencies to be stored

together with the mode but only according to the idea that frequencies above 10MHz are USB and frequencies below 10MHz are automatically changed to LSB. This is fine for amateur traffic only, but since the R70 is a general coverage receiver it is a real nuisance.

Other R70 users appear to feel the same way about the problem and a short conversation with the importers confirmed that some users have also complained to them about it. I believe there would be a considerable response if the importers or some electronics wizard could come up with some modification or an accessory memory facility to overcome this.

Peter Huber, Bucks.

PENFRIEND

I am fourteen years old and would like to write to a boy or girl penfriend from England. I am interested in collecting pictures of hit singers, reading and amateur radio.

If you would like a penfriend in East Germany please write soon to: Catheine Hunger, 9044 Karlmarxstadt, Irkutsker, Stasse 42, (GDR) DDR, E Germany.

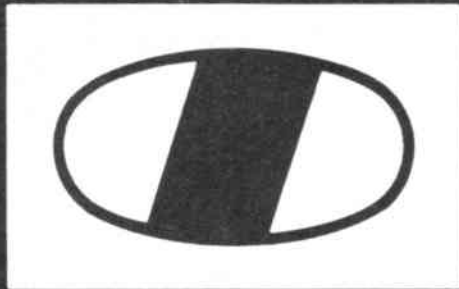

ICOM

GREAT SETS...

IC-735, The Complete HF Radio

This new HF transceiver from ICOM is compact enough to make mobile or portable use a possibility. The IC-735 covers all Amateur frequencies from 1.8MHz to 30MHz including the three new bands 10, 18 and 24MHz. Modes include SSB, CW, AM and FM, all circuits are solid-state and output is approximately 100 watts.

Tuning ranges from 100kHz to 30MHz, made continuous by using a high-side IF and a CPU control system. RTTY operation is also possible. Dynamic range is 105dB with a 70.451 MHz first IF circuit. The direct feed mixer rejects spurious response and gives higher sensitivity and wider dynamic range. Pass-band tuning and a sharp IF notch filter provide clear reception even under duress. Preamp is 10dB and attenuator 20dB.

The new IC-735 from ICOM is easy to operate and versatile, it has various scanning functions, comprehensive LCD and 12 memories. Computer remote control is possible via the RS-232C jack.

Options include: the AT-150 automatic antenna tuner and shown here the PS-55 AC power supply and SM-8 desk mic.

Please contact Thanet Electronics or your local ICOM dealer for even more information on this latest HF transceiver - the IC-735.



A new exciting set is the ICOM IC-3200E FM Dual-band transceiver (144-430/440 MHz). This is the smallest transceiver available.

The IC-3200E employs a function key for low-priority operations to simplify the front panel. LCD display is easy to read in bright places, showing frequency, VFO A.B. memory channel duplex mode and S/R/F meter information.

Other features include a 10 channel memory able to store operating frequencies, Simplex or Duplex. A memory lock-out function allows the memory scan to skip programmed channels when not required. The IC-3200E has a built-in duplexer and can operate on one antenna for both VHF and UHF. Options include: IC-PS45 DC. power supply, HS-15 mobile mic, SM6 and SM8 desk mics. SP-10 external speaker and UT-23 speech synthesizer. A great future is predicted for the IC-3200E.

IC-3200E





ICOM

GREAT VALUE

IC-02E, IC-04E

The direct entry microprocessor controlled IC-02E is a 2 meter handheld, features include: scanning, 10 memories, duplex offset storage in memory and odd offsets also stored in memory. Internal Lithium battery backup and repeater tone are included. Keyboard entry is made through the 16 button pad allowing easy access to frequencies, duplex, memories, memory scan and priority.

The IC-02E has an LCD readout indicating frequency, memory channel, signal strength, transmitter output and scanning functions.

HS-10 Headset also available, with earphone and boom microphone, which operates with either of the following:- HS 10-SB Switch box with pre-amplifier giving biased toggle on, off and continuous transmit. HS 10-SA Voice operated switch box, with pre-amplifier, mic gain, vox gain and delay. The IC-2E and 4E continue to be available.

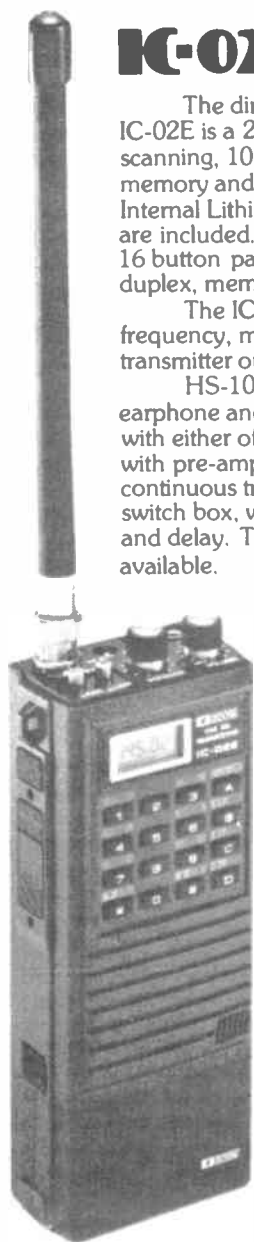

You can get what you want just by picking up the telephone. Our mail-order dept. offers you: free, same-day despatch whenever possible, instant credit, interest-free H.P., telephone Barclaycard and Access facility and a 24 hour answering service.

Please note that we have a retail branch at 95, Mortimer Street, Heme Bay, Kent. Tel: 369464. Give it a visit, BCNU.

Authorised ICOM dealers in the UK

Alexian Electronics Ltd. Edinburgh, 031-554 2591.
 Alyntronics, Newcastle, 0632-761002
 Amateur Radio Exchange, London (Ealing), 01-992 5765.
 Amcomm, London (S. Harrow), 01-422 9585
 Arrow Electronics Ltd., Chelmsford Essex, 0245-381673 26
 Beamrite, Cardiff, 0222-486884
 Booth Holding (Bath) Ltd., Bristol, 02217-2402
 Bredhurst Electronics Ltd., W. Sussex, 0444-400786
 Dressler (UK) Ltd., London (S. Harrow), 01-558 0854
 D.W. Electronics, Widnes Cheshire, 051-420 2559
 Hobbytronics, Knutsford Cheshire, 0565-4040. Until 10pm daily.
 Photo Acoustics Ltd., Buckinghamshire, 0908-610625
 Radcomm Electronics, Co. Cork, Ireland, 01035321-632725
 Radio Shack Ltd., London NW6, 01-624 7174
 Scotcomms, Edinburgh, 031-657 2430.
 Tyrone Amateur Electronics, Co. Tyrone, N. Ireland, 0662-2043
 Reg Ward & Co. Ltd., S.W. England, 0297-34918
 Waters & Stanton Electronics, Hockley Essex, 0702-206835

Listed here are authorised dealers who can demonstrate ICOM equipment all year round. This list covers most areas of the U.K., but if you have difficulty finding a dealer near you, contact Thanet Electronics and we will be able to help you.

Cue Dee Antennas Special Offer!

CUE DEE antennas are designed to last for decades – the best possible aluminium alloy for this purpose is used (SIS 4212-06).

The booms are made of 28mm tubing with 1.5mm wall, with colour marks clearly indicating where to fit the elements. By using tubular boom, and a synthetic guy wire on the long yagis, the windload is reduced by a factor 0.66 compared to using square shaped material for boom and guying.

The driver element is made of 12mm tubing and features a PTFE (Teflon) insulated gamma match which is pre-tuned at the factory and made for 50 ohm feeder with a PL 259 type connector. No further adjustments or power consuming balun needed. This matching system ensures a clean radiation pattern and transfers the power without losses.

The parasitic elements are made of 6mm solid rod and mounted to the boom with the aid of a CUE DEE element washer, boom to element part and a screw. This, together with our intelligible assembly manual, makes an extremely easy and solid assembly which assures the long life of a CUE DEE antenna

2 metre Yagis.

4144A – 4 element, 8dBd gain £19.00.

10144 – 10 element, 11.4dBd gain £37.00.

15144 – 15 element, 14dBd gain £49.00.

Order now while stocks last.

Thanet ICOM
 Thanet ICOM
 Thanet ICOM
 Thanet ICOM
 Thanet ICOM
 Thanet ICOM
 Thanet ICOM
 Thanet ICOM
 Thanet ICOM
 Thanet Electronics
 Dept RW143 Reculver Road, Heme Bay, Kent
 Tel: (0227) 363859

STRAIGHT & LEVEL

All the latest news, comment and developments on the amateur radio scene

A NEW CONCEPT

A compact handheld tester, the Digi-Check 3, is now available from Electronic and Computer Workshop Ltd. It offers many of the facilities previously available only from sophisticated mains-powered instruments.

Small enough to fit into a pocket, the Digi-Check 3 has the benefit of an internal microprocessor that gives it a wide range of automatic features. These include automatic measurement mode selection so that the user does not have to switch the instrument between ac or dc voltage measurement, phase testing or resistance measurements. The Digi-Check 3 is able to sense which test mode is required and automatically prepare itself.

Information is displayed on a clear LCD readout to an accuracy of within \pm one digit or 1.5% of the reading. In addition, four audio signals are provided, giving the operator unambiguous status indication, reading confirmation and overrange signals.

Considerable efforts have been made to ensure the maximum safety under all test conditions. Normal voltage range is from 1 to 999V ac or \pm 999V dc, through a fre-

quency range from 20 to 2000Hz. Resistance range in continuity test is from 0 to 500Kohms.

The internal electronics sample the input signal very quickly – five complete measurement cycles every second – giving the advantage of a quasi-analogue display that changes to reflect fluctuating input levels.

Only two controls are required – one activating the internal battery test function, input circuit checking and semiconductor test facilities, while the other operates a very useful 'hold' function.

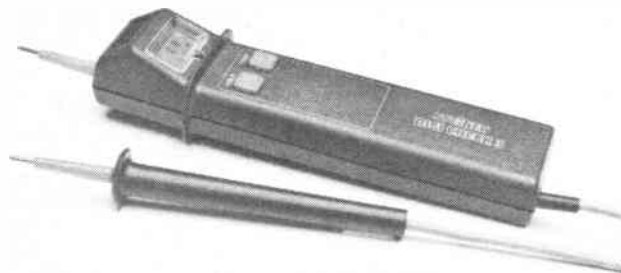

This freezes the display for easier reading and to allow measurement recording.

A wide range of other features is provided by the Digi-Check 3 including automatic switch on and off, automatic low battery voltage indication and the ability to remain stable even under the effects of large voltage pulses – up to 10KV peak, 1.2/50 μ S.

The company has also brought out a miniature, lightweight multimeter, ergonomically designed for simple operating, called the Pantec ZIP.

Fully autoranging, the ZIP has a 3½-digit LCD to display ac/dc voltages of up to 500 volts and resistances of up to two megohms. In addition, the display gives automatic indication of units and other symbols including function, polarity, decimal point and overrange. A simple continuity test is included using a buzzer to show when a circuit is closed.

The ZIP has its electronics, display and selection switches built into one probe. The other probe can be fitted with a crocodile clip, allowing one-handed operation. A display hold function is provided.

Measurement accuracy is 0.5 to 0.7% of full scale deflection for dc voltages, 1.0% for ac voltages and 0.7% for the ohm range. Power consumption is three milliwatts.

Priced at £49.00 (excluding VAT), ECW supplies the ZIP complete with a shock-proof protective case, crocodile clip connector and two batteries.

For further information on either product please contact: *Electronic & Computer Workshop Ltd, 171 Broomfield Road, Chelmsford, Essex CM1 1RY. Tel: (0245) 262149.*

COMPETITIVE PRODUCTS

Six low-price mixers are now available as drop-in alternatives to those offered by Minicircuits (a trademark of Scientific Components Corp). The mixers are manufactured by Synergy Microwave Corp and marketed in the UK by Anglia Microwaves Ltd.

Using new manufacturing techniques, Synergy is able to offer the market, for the first time, a price-competitive alternative for the traditionally low-cost parts available in the 0.5 to 1000MHz frequency

range.

The S-1, S-2 and S-3 models are intended as alternatives to the Minicircuits SBL-1 and SRA-1 mixers. The S-1 is packaged in a rugged, all-metal housing, and covers the 1 to 500MHz frequency range with typically 5.5dB of conversion loss.

The S-2 is the most attractively priced mixer in the range and, except for a conversion loss of 7dB, has an identical specification to the S-1.

The S-3 covers the 0.5 to 500MHz range and is housed

in a hermetically sealed, plug-in package, and meets the MIL-STD-202 environmental requirements in MIL-M-2837.

The S-4 is intended as an alternative to the SBL-1X, has a typical 6dB conversion loss over the range 10 to 1000MHz, and is housed in an all metal case.

The S-5 is intended as an alternative to the ASK-1 and covers the range 1 to 600MHz. It is housed in a very small plastic flat-pack only 0.3 x 0.27 x 0.23 inches high.

The S-6 is housed in a four-pin miniature plug-in pack-

age and requires only 0.115 square inches of board space. Covering 1-1000MHz, it is an alternative to the TFM-2 and meets all the MIL-STD-202 requirements in MIL-M-28837.

Also available from Anglia Microwaves Ltd is the new portable RW501 wattmeter and reflectometer which measures up to 300 watts of direct power, and up to 100 watts of reflected power, in a 50 ohm coaxial cable with an accuracy of 5%.

Mismatching and SWRs are quickly established. It is designed for simple and effi-

STRAIGHT & LEVEL

cient checking of transmitters and line-antenna assemblies working between 65 and 1300MHz. The wide frequency range and power capability are achieved without the need for plug-in units, which introduce errors due to insertion wear.

Ruggedly built and lightweight, the RW501 fits into a convenient carrying case and has its own internal batteries. It features a large display for very precise reading, particularly at low settings, and is very competitively priced.

For further information on any of these products please contact: *Anglia Microwaves Ltd, Radford Business Centre, Radford Way, Billericay, Essex CM12 0BZ. Tel: (02774) 58955.*

CONNECTOR CATALOGUE

Now available from the recently launched specialist distributor – Five Star Connectors – is a full-colour 104 page catalogue outlining one of the most comprehensive ranges of connectors currently available from a single source.

With both part-number and manufacturers indexes, the catalogue provides details of products extending from audio and crimp-PCB devices to insulation displacement and telephone connectors. In addition, information is provided on Five Star's comprehensive custom-assembly service and technical back-up facilities, together with details of delivery and credit arrangements.

Featuring products from such leading manufacturers as Augat, Berg Electronics, BICC-Vero Electronics, Deltron, Harting, ITT Cannon, Molex, Rendar, Souriau, Spectra Strip, 3M Scotchflex and 3M Textool, the catalogue contains concise specifications and is fully illustrated.

Copies of the publication are available, free of charge, from: *Five Star Connectors, Edinburgh Way, Harlow, Essex CM20 2DF. Tel: (0279) 442851.*

NEW SOLDER RANGE

Multicore Solders Limited of Hemel Hempstead have now introduced a completely new range of Handyman do-it-yourself solder products, all packaged on attractive

descriptive cards, with full instructions. These will be displayed on a general purpose rack for easy customer selection.

Multicore have devised this attractively priced range to meet all the needs of do-it-yourself soldering work.

The range comprises five handy solder dispensers, all retailing at 99p each, six small reels of solder with a retail price of £2.99 each and other ancillary products, such as plumber's flux paste 99p, solder cream £2.99, desoldering wick £1.98 and Multicore tape solder 99p. All prices quoted include VAT.

For further information please contact: *BIB Solder Division, Kelsey House, Wood Lane End, Hemel Hempstead, Herts HP2 4RQ. Tel: (0442) 61291.*

BNOS amps

BNOS Electronics Ltd have announced the introduction of two 50W models to their wide range of 2 metre amateur band linear amplifiers.

The LP models are 50W rms output units and are available in 3W or 10W input versions.

They incorporate BNOS's well-known switchable low-noise pre-amplifier and of course have the usual PTT or VOX switching.

The BNC sockets give the unit compatibility with the latest generation of 3W transceivers and the standard mobile mount gives it the versatility for shack or car use.

The LP144-3-50 and LP144-10-50 retail for £108 including VAT.

For further information contact: *BNOS Electronics Ltd, Bigods Hall, Great Dunmow, Essex CM6 3BE.*

ARE SALE

An announcement made recently by Amateur Radio Exchange (ARE) and Amateur Electronics Limited confirms that Amateur Electronics Limited of Birmingham has purchased the lease and goodwill of the shop occupied by Amateur Radio Exchange of London.

The company will continue to operate under the ownership of Amateur Electronics Limited, but both Bernie and Brenda Godfrey, the previous owners, will be available to

Amateur Electronics Limited on a consultancy basis for continuity of the London business for a limited period of time.

Customers who frequent the London shop can be assured that Amateur Electronics Limited will continue to offer the same policies adopted by the previous owners, offering good service and a friendly welcome to all callers.

SELECTRON EXPANSION

TO Supplies (Export) Ltd, of 2A Westbourne Grove Mews, London W11 2RY, have joined the Selectron Group of Companies at their new headquarters at Selectron House, Springhead Enterprise Park, Springhead Road, Gravesend, Kent DA11 8HD.

TO Supplies, who have

been an exporter of electronic components for over 25 years, will be working with PM Components, the Selectron Group main distributor, to provide a comprehensive range of electronic tubes, valves, integrated circuits, semiconductors, video and TV products etc to their customers.

Peter Watson and Mike Leeper of the Selectron Group have also announced that the Meopham Green warehouse, home of PM Components for the last few years, will shortly be re-opening as a surplus superstore in conjunction with Bernard Wellington, formerly of B and T Electronics.

Further information and lists of surplus electronic goods that will be available will be published later this year.

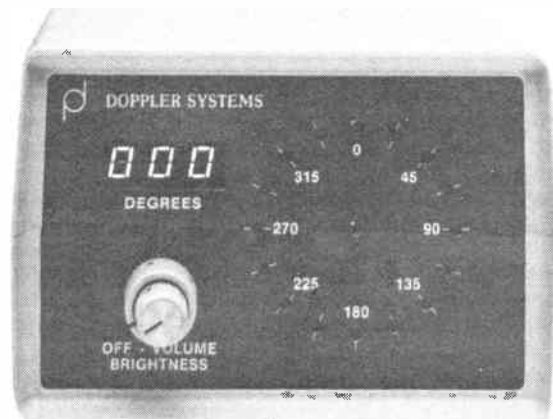

DIRECTION FINDER

Blick International Systems Ltd have just introduced a low cost automatic radio direction finder to their range of communications equipment.

Search, rescue and other public safety networks, as well as private mobile communications, are areas which Blick expect to serve with their newly released automatic radio direction finder.

Already in use in the USA, the Doppler Systems units give continuous coverage of all standard VHF and UHF bands and can be used with any normal existing narrow-band FM receiver without

modifications.

Four models are available, giving a variety of bearing displays – circular, digital, serial RS232, and even synthesised speech for a driver to use in the 'homing' mode without taking his eyes from the road. Prices depend on the model chosen, but Blick say they start at less than £1,000, so they are the most cost effective yet available for their purpose.

Further information can be obtained from: *Blick International Systems Ltd, Blick House, Bramble Road, Swindon SN2 6ER. Tel: (0793) 692401.*



CAPACITANCE METER

Levell Electronics now supply a capacitance meter type CM200.

This instrument has a $4\frac{1}{2}$ -digit liquid crystal display with a capacitance from 1pF to 2,500μF, to an accuracy of

0.2 percent.

The ranges are selected manually with a reading rate of 3 per second and virtually instantaneous settling. A zero calibration control enables the user to null out up to 25pF of test lead capacitance.

NEW BBC ADD-ON

Readers may be interested in a new add-on for the BBC Computer. For the last two years Johnny Melvin G3LIV has been marketing an RTTY unit dedicated to the Beeb for the transmission and reception of radioteletype signals. These units allow both ham radio and commercial signals to be decoded.

The next step in RTTY is a mode called Amtor (amateur microprocessor telex over radio). This is an error checking system between the two transmitting stations where groups of three letter packages are transmitted then checked by the receiving computer.

If correct they are printed on the monitor and an acknowledgement signal is sent to the transmitting end to send the next package.

If an error is received this is caught in the error checking of the receiving station, the letters are not printed on the monitor and a request for Repeat is sent to the transmitting station who re-sends the package. This means that the whole time the stations are in contact the two micros have control of the link. Both transceivers are kept in sync.

The software is available on ROM and hardware is directly connected to the user port of the BBC. All power and terminal to computer connections are on the one 20-way ribbon. The unit is a colour match for the BBC.

Further information can be obtained from: *Johnny Melvin G3LIV, 2 Salters Court, Gosforth, Newcastle, Tyne and Wear NE3 5BH.*

RTTY/CW/ASCII SYSTEM

ICS Electronics Limited have announced a new low cost 'package deal' to permit the newcomer to enter data communications with professionally designed hardware and software at minimal cost.

For £109 including VAT, plus £2.50 p&p, the user receives an RM-1 multimode terminal unit; a cable to connect it to his computer and a full split screen software package on tape.

All interface connectors to allow connection to the transceiver are provided.

This package is available for the Commodore 64, VIC-20 and BBC model B computers only.

Should the user wish to upgrade in future, the RM-1 may be used with ICS's MBATOR multimode Amtor software.

Alternatively, the existing software may be retained and the RM-1 replaced by any one of ICS's range of high quality terminal units with additional filtering. They range in price from £189 to £1,576 and all are plug compatible with each other.

For further details contact: *ICS Electronics Ltd, PO Box 2, Arundel, West Sussex BN18 0NX. Tel: (024 365) 590.*

Levell claim that this system is capable of determining the value of a capacitor faster than most autoranging meters.

A special input socket arrangement allows for the direct connection of a wide variety of capacitors or standard test leads.

The CM200 is lightweight and portable, with operation via an ac line adaptor or batteries with a life in excess of 500 hours.

The instrument is housed in a rugged case with built in tilt stand.

Areas of application include development laboratories, production, quality control and component inspection.

Further information is available from: *Levell Electronics Ltd, Moxon Street, Barnet, Herts EN5 5SD.*

DIGITAL STORAGE 'SCOPE

Electronic Brokers has introduced the new Philips PM3302, which offers digital storage facilities and the direct display capabilities of a conventional 20MHz oscilloscope. The high 20MHz sampling frequency allows the signal to be stored with good resolution, and a 50 nanoseconds interval can be selected between successive samples.

The 2K x 8 bit memory handles signal storage and a signal can be stored on one channel while the other is used for live observation of the test situation. The PM3302 also has a 'second page memory' facility, which enables captured signals to be saved for later reference whilst freeing the original memory for separate storage of channels A and/or B.

Another feature of the instrument is an X-Y display capability, available at all times in both analogue or digital modes. This facility enables display of semiconductor and filter curves, Lisajous figures, and any other representations of parameters related to reference voltages other than time.

The PM3302 is equipped with a facility for producing hard copy in conjunction with an X-Y recorder such as the PM8043.

High sensitivity allows very low signal levels to be handled and the 1mV/div input enables these low-level sig-

nals to be displayed on the screen.

The PM3302 also has a pre-trigger facility, which allows signals to be captured before the trigger signal. A choice of 25, 50, 75, or 100% of the memory capacity can be allocated for pre-trigger operation using a single control button.

Where low frequencies have to be analysed, the oscilloscope uses a 50S/div roll mode to display a picture for up to 8 minutes on the screen.

For further information contact: *Electronic Brokers Limited, 140-146 Camden Street, London NW1 9PB.*

RTTY FOR THE AMSTRAD

A 100% machine code program to enable the Amstrad CPC464 microcomputer to receive and transmit RTTY (radio-teletype) messages when used in conjunction with a suitable terminal unit and radio receiver or transceiver has been introduced by PNP Communications.

The program incorporates split screen operation. The top 14 lines by 72 characters are used to display the received text. The next four lines by 72 characters display the current state of the transmitted text and the bottom three lines by 72 characters display the last 288 characters of the 1024 character type-ahead buffer. The remaining screen area is used to display the current status of the program (ie Tx/Rx switching, baud rate, etc).

User selectable baud rates of 45.45, 50, 60 and 75 are selected from the keyboard and may be changed at any time. No external UART or baud rate clock is required.

Ten user-programmable memories are provided, each of 512 characters. These may be programmed using the simple editor and saved on cassette or disc for future use.

Standard pre-programmed messages such as "CQ CQ CQ de...", "RYRYRYRYRYRYRY", "THE QUICK BROWN FOX...", etc are incorporated. The CQ facility uses the programmed-in call sign and this option is available from switch-on.

An AFSK Morse call sign ident is provided to comply with the requirements of some licensing authorities.

STRAIGHT & LEVEL

If the length of the transmitted line is likely to exceed 72 characters, automatic carriage return/line feed is available. The program 'looks ahead' and will avoid (as far as possible) splitting words at the end of a line.

There is a software switchable USOS (un-shift on space) facility on receive. A "figures shift" character is always sent after any space in a group of figures.



BASIC RADIO ELECTRONICS

By Sam Kelly

Basic Radio Electronics is one of two recent imports from American publisher TAB Books Inc, distributed in this country by John Wiley & Sons, and with more than 300 pages of about 5¼ x 8¼ inches is a fairly hefty paperback.

The title is possibly slightly misleading, for although the book covers the subject of electronics as it applies to radio propagation in reasonable detail, there is also slightly wider coverage of radio generally. This includes the first chapter, which gives an interesting outline of the history of radio experimentation (Hertz, Marconi, *et al*) and a chapter on short wave listening, which does not confine itself strictly to the short wave bands: a wealth of general information is also included.

The treatment of radio electronics strikes a good balance between being too simplistic and overly complex. The text is not as clear at times as it might be, and the odd mistake has crept in (the diagram representing bipolar transistors, for instance: both types appear to be pnp). The section concerning troubleshooting and repair is useful, as is that concerning tools and soldering.

Some good constructional projects are included. They are not intended as step-by-step idiot-proof Meccano

The remaining unused memory, after the program and memory space, is used to store all QSO transactions. This area may be reviewed at a later date and any part selected for printing to provide 'hard-copy'.

Further information is available from:

PNP Communications, 62 Lawes Avenue, Newhaven, East Sussex BN9 9SB. Tel: (0273) 514465.

kits, but should nevertheless prove fairly straightforward for most readers.

Anyone who is put off by the fact that this book is American, and therefore contains much that is irrelevant in this country, need not be. There is, of course, some information that is only of relevance in the States, but this really is a minimal amount.

Prospective purchasers might be more discouraged by the price. It's a good book, but whether you regard it as that good will depend upon the state of your bank balance.

Available from: John Wiley & Sons Ltd, at £16.00. ISBN 0 8306 1542 3

SOFTWARE FOR AMATEUR RADIO

By Joe Kasser G3ZCZ

This is another import from TAB Books in the States, who claim on the back cover that this is the 'definitive volume on BASIC language software for amateur radio'. This example of publisher's hype is slightly removed from the truth, but the book is nevertheless a very good guide to using a computer in this hobby.

The book begins with one of the worst introductions I have read in a long time, and any reader would be well advised to skip this and start straight into the text. Fortunately the rest of the book is unembellished with such unnecessary garbage. Indeed, the text is generally well written, apart from a few curious spelling errors (which I'm sure are not just a result of the funny attitude to English of our transatlantic neighbours).

The first chapter covers some elementary CAD/analysis applications, and forms an easily understood introduction to the style and approach of the author. All the prog-

rams featured are in either Microsoft or Northstar BASIC, and the accompanying text gives a step by step breakdown of the operation of the program. The programs will, of course, need slight modifications to suit particular computers, but with the clarity of the text this should be fairly easy (as long as you've read your computer's manual!)

The book moves on to cover logging, awards and contests (which the contents page lists as 'Contents' rather than contests, typical of some of the poor proof reading by the publisher), antenna positioning, satellites, RTTY, SSTV, etc.

In all these areas the programs are preceded by a fairly clear and comprehensive outline of the mode of communication itself, and an explanation of the problems to be solved.

The format of the book is a little confusing at times, with the text broken up by programs, listings and diagrams in

a manner liable to induce minor irritation. There are also some programs which are not directly applicable in this country, such as the ARRL Sweepstakes contest, but in these cases the outline of how to tailor the program to a specific requirement is useful.

The various examples given of the results are possibly a bit extensive, but it is probably better to print too much rather than too little.

The book is a useful addition to any computer buff's library, but as with the other recent import from TAB it's price tag is a little heavy due to the poor exchange rate. I'd hesitate to recommend that anyone shells out so much for one book (since I'd not want to take the blame if they were then unhappy with it!), but after spending a few hundred pounds on hardware no-one should balk at this comparatively low sum.

Available from: John Wiley & Sons Ltd, at £17.15 ISBN 0 8306 0260 7

ANDY TIPPS by DeeJay

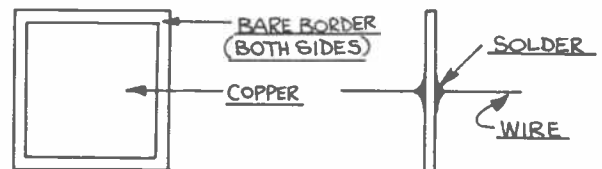

MATERIAL:- 1/16" THICK DOUBLE SIDED FIBRE GLASS P.C. BOARD.

ANDY SAYS:-



"THOSE HARD-TO-COME-BY

HIGH VOLTAGE CAPACITORS YOU NEED FOR MAKING ANTENNA TRAPS CAN BE EASILY MADE FROM ORDINARY DOUBLE SIDED FIBRE GLASS P.C. BOARD. USING 1/16" THICK MATERIAL, THE CAPACITY IS ABOUT 24 pF PER SQUARE INCH. TO AVOID FLASHOVER, A BARE BORDER SHOULD BE MADE BY REMOVING A 3/16" WIDE STRIP OF COPPER EACH SIDE. CAPACITORS CAN BE ANY SHAPE AS LONG AS THE AREA OF THE 'PLATES' IS CORRECT FOR THE REQUIRED CAPACITY."



CLUB NEWS

McMichael ARS rally

The McMichael Amateur Radio Society, in conjunction with the Burnham Beeches RC, the Chiltern ARC and the Maidenhead and District ARC, is staging the third annual Home Counties Mobile Rally at the McMichael Sports and Social Club, Bells Hill, Stoke Poges, Bucks. The date is Sunday 21 July and the doors open at 11am.

A large number of national and local traders have been invited, displaying everything from 'black boxes' through to kits and surplus components. A flea market will be in operation for those with a boot full of items to sell, and there are many other attractions, such as amateur TV and Packet Radio demonstrations, HF stations, radio-controlled models, vintage wireless and a variety of displays and exhibitions. Refreshments, including a CAMRA beer tent, will be available.

An unusual feature of this rally is the emphasis placed on creating a family atmosphere. To this end, there are a number of general interest stalls, fairground attractions and childrens' rides.

BARTG rally

The annual rally of the British Amateur Radio Teleprinter Group (BARTG) will take place at Sandown Park this year, on Sunday 25 August.

Exhibitors are advised to contact the rally manager as soon as possible to reserve a place at this very popular rally.

Further details are available from: *Peter Nicol G8VXY (rally manager), 38 Mitten Avenue, Rubery, Rendal, Birmingham B45 0JB. Tel: (021) 453 2676.*

Red Rose Summer Rally

The West Manchester Radio Club (G4MWC, G6FSA) is holding its annual Red Rose Summer Rally on Sunday 18 August.

The venue is the Haydock Park Racecourse, near Wigan, which is close to the M6, M62, M61 and M56, making it easily accessible from all parts of the country.

Further information is available from: *J E Cooke, 106 Wirral Drive, Winstanley, Wigan WN3 6LD.*

Equipment sale

The Bury Radio Society is holding a surplus equipment sale on Tuesday 2 July at 8pm. The venue will be the Mosses Community Centre, Cecil Street, Bury.

Newcomers are always welcome at meetings, which take place on the second Tuesday of each month, and those interested should contact: *Brian Tyldesley G4TBT, 4 Colne Road, Burnley.*

GB0RAR special event

The Reading and District Amateur Radio Club will be organising the special event station GB0RAR over the weekend of 27/28 July. GB0RAR (Reading Amateur Radio) will be active on all HF bands, and also 2m and 70cm.

The venue is the foyer of Shire Hall, Berkshire County Council HQ, Shinfield, Reading, Berkshire.



Shire Hall is easy to find, being adjacent to Junction 11 of the M4 to the South of Reading. A large free car park is available.

Over the past year there have been many excellent fund raising events to raise money for charity, mainly to alleviate the suffering in Northern Africa (Ethiopia and the Sudan). The committee of the Reading Amateur Radio Club thought that amateur radio could, and should, be able to make a contribution. Accordingly, this event has been organised. The idea is as follows.

GB0RAR will be run in the normal manner for a special event station, contacting as many other amateur radio stations as possible in the period from 12.00hrs on Saturday until 12.00hrs on Sunday. People will be asked to 'sponsor' each contact (or tens of contacts) for an amount of money, in much the same way as a sponsored walk. The catchment area will obviously be around Reading, but donations from elsewhere will be gratefully received.

It is hoped that this special event station will increase the awareness of the general public to amateur radio and also raise much needed sums for charity. Should this be referred to as 'Ham-Aid'?

All queries regarding GB0RAR should be addressed to: *Andrew Barrett G8DOR, Chairman, Reading Amateur Radio Club, 38 Haw Lane, Bledlow Ridge, Bucks.*



The Society takes pleasure in certifying that A.N.Other operating G9ZZZ..... has this day submitted evidence of having worked or heard the requisite number of RNARS special and member stations during its 25th Anniversary Year. This certificate is issued in recognition of this achievement.

Date: Award Manager:

Royal Naval ARS award

To celebrate its silver jubilee, the Royal Naval Amateur Radio Society (RNARS) is sponsoring a Silver Jubilee Award.

The award is available to all radio amateurs and short wave listeners who satisfy the following conditions: 1) amateurs in the UK and Eire should work/hear 5 RNARS special stations and 25 members; 2) those in Europe should work/hear 5 RNARS special stations and 15 members; 3) DX

countries should work/hear 2 RNARS special stations and 5 members; 4) amateurs on VHF only should work/hear 2 RNARS special stations and 10 members.

Contacts must have been made between 1 January and 31 December 1985.

Log data plus an award fee of £1.00 (UK and Eire) or £1.50 (abroad) should be sent to:

D F J Walmsley G3HZL, 3 Meon Court, 609 London Road, Isleworth, Middlesex TW7 4EW.

WIA special prefix

All Australian radio amateurs will be able to use the alternative prefix of Victor India (VI) from 1 June to 31 December to celebrate the Wireless Institute of Australia's seventy-fifth anniversary (see *Amateur Radio*, March 1985).

The WIA is the world's first and oldest national radio society, having been founded in 1910. This will be the first time VI has been available for use throughout VK - although the prefix was used for a short

period for a local event in VK3.

The WIA is encouraging radio amateurs to only use VI if they intend to QSL with a card bearing the prefix.

A commemorative callsign VK75A will also be on air until December, and will be looking for DX contacts. The prefix VK75 with the suffix A is authorised for use throughout the Commonwealth of Australia.

QSL information is via the VK3 bureau, or direct cards can be sent to VK3WI QTHr.

STRAIGHT & LEVEL

Auroral conditions

We recently received a very interesting letter from Michael George-Powell G3NNO, of Patley Bridge, North Yorkshire, about the auroral conditions on 6 metres which he experienced on 20/21 April, on 50MHz.

'My QTH is 505ft asl but has hills nearby in most directions and is by no means the ideal VHF QTH. On 6 metres I use a valve converter with a 6AK5 RF stage into an ECF82 mixer/oscillator. The transmit converter is also home-brew, using four valves, and both are used with my FT101E. The aerial used is a 5 element Tonna at 35ft.

'On Saturday 20 April I

started listening on 6 metres as usual at 2230GMT and heard G3OHH, who was in QSO, and GW3LDH, who was calling CQ and later LA6QBA. Conditions seemed normal.

'I was doing some work on the PA and power supply and had to switch off the equipment at about 0015GMT. When I switched on again at 0033GMT conditions had changed and auroral signals were heard from firstly G13RXV and then the two beacons GB3SIX and GB3NHQ. I made a tape recording of much of what I heard from 0046GMT until I went QRT at 0250GMT.'

Notes were made from that recording and can be seen in the table.

Holyhead and District ARS

We recently heard from the Holyhead and District Amateur Radio Society, which came into being in July 1984 and now has approximately two dozen members.

The society plans to run a special event station for one day during July and 28 July has been put forward as a possibility.

The station will be located on Skerries Island, which is 7 miles off Holyhead on the Welsh coast. Special QSL cards will be produced for this occasion.

The society meets on alternate Sundays at 7.30pm at the Forrester's Arms, Kingsland Road, Holyhead. Radio hams and short wave listeners are catered for by the society and Morse classes are run for beginners.

For further information on the special event station and the society generally contact: *Mr R Richards, 5 Queens Park Court, Holyhead, Gwynedd LL65 1RB.*

TDARS expedition

The Telford and District Amateur Radio Society plan to operate from the Isle of Islay (pronounced 'eye-la') as their portable expedition this year.

The visit will last one week from 27 July and operation will be on various bands, according to individual interests.

Further information is available from the secretary at the club HQ: *Dawley Bank Community Centre, Bank Road, Dawley, Telford, Shropshire TF4 2AZ.*

RAE courses

Courses for the RAE and the Morse test will run from 26 September at the Princes Risborough Adult Education Centre, Merton Road, Princes Risborough.

The courses will cost £22 each, with reductions for OAPs.

For further information contact: *Ron Ray G3NCL, 21 Parish Piece, Holmer Green, Nr High Wycombe, Bucks.*

RAE courses are also being run at the East Herts College (tel: Hoddesdon 466451) and by the Basingstoke Amateur Radio Club (Dave G4WIZ, tel: (07356) 5185).

It is hoped that a 'CW for beginners' course will be available in the Cheshunt area from September. Further details are available from Jim G3OJI (QTHr) on Ware 4316.

Radio lecture

A lecture entitled 'Radio Test Equipment' will take place at the Verulem Amateur Radio Club at 7.30pm on 23 July. The talk will be given by Marconi Instruments Ltd and all visitors are welcome.

The club meets on the second and fourth Tuesdays of each month at: *RAF Association HQ, New Kent Road, St Albans, Herts.*

Dunstable Downs RC

The Dunstable Downs Radio Club has sent us details of planned events for July and August. A junk sale will be held on 5 July, followed on 27 and 28 by the 144 and 432MHz Low Power Contest. On 2 August there will be a talk on radio controlled models and

Time (GMT)	Comments
0033	G13RXV, 43A, CW on 50.100 calling CQ
0036	I called G13RXV several times after quickly wiring up the Tx, but no reply
0046	GB3SIX, 50.2, first time I have heard it from home QTH
0047	GB3NHQ, 50.05MHz
0049	I called CQ 50.10MHz
0050	Swung beam northwards, peaking up on auroral signal from GB3SIX, beam heading about 300, further south than I expected
0051	GB3SIX, S7
0052	GB3NHQ, S4
0053	I called CQ on 50.10MHz
0055	GB3SIX, S7-8
0101	GB3SIX, S7-8 (just started to rain)
0104	GB3NHQ, S1-2
0105	I called CQ on 50.1MHz
0110	GB3SIX, S5-7
0111	GB3NHQ, S1
0111	I called CQ on 50.1MHz
0120	GB3NHQ, less than S1
0120	GB3SIX, S3-4
0125	GB3SIX, S3-4
0126	GB3NHQ, less than S1
0127	GB3SIX, S7 but moving up and down 1S-point
0128	I called CQ on 50.10MHz
0132	GB3NHQ, S5-6
0132	GB3SIX, S9
0137	GB3SIX, S9 + 10dB
0138	GB3NHQ, S5-8, QSB present
0139	I called CQ on 50.10MHz
0142	GB3NHQ, S6-7
0143	GB3SIX, S9
0144	I called CQ on 50.10MHz
0148	GB3SIX, S6-S9 + 10dB sigs changing every few seconds
0149	GB3NHQ, S4-7
0152	I called CQ on 50.10MHz
0157	Listened for beacons on 144MHz, only one heard was GB3CTC but very, very weak. Also tuned up to 50.50MHz but nothing heard
0203	GB3SIX, S6-7
0203	GB3NHQ, S2
0204	GB3SIX, S7
0205	I called CQ on 50.10MHz
0208	Signals going down
0210	GB3NHQ, less than S1
0210	GB3SIX, S1
0211	GB3SIX, less than S1
0214	GB3SIX, S4
0214	GB3NHQ, less than S1
0215	I called CQ on 50.10MHz
0220	GB3SIX, S2
0220	GB3NHQ, less than S1
0221	GB3SIX, 2 meteor pings
0226	GB3SIX, 3 meteor pings in last 2 mins
0227	GB3NHQ, just audible, could hear a weak carrier just off NHQ's frequency but not keyed, not auroral.
0231	GB3NHQ, not heard
0236	GB3NHQ, just audible
0236	GB3SIX, S1
0237	GB3NHQ, not heard
0237	GB3SIX, less than S1
0237	GB3SIX, 2 meteor pings
0240	GB3NHQ, not heard
0242	GB3NHQ, not heard
0242	GB3SIX, just audible
0245	I called CQ on 50.10MHz
0250	QRT

G8VR will be discussing improving DX on 2m on 16 August.

For further details of these events, and the club generally, contact: *Phill Morris G6EES, 10 Seamons Close, Dunstable LU6 3EQ.*

RUGnews

Peter Barker G8BBZ has sent us the second issue of the Racial User Group newsletter (*Rugnews*). It appears that the response to the first edition was very good and as a result Peter has received some useful and interesting

information from readers.

Many correspondents have suggested that a list of users would be a good idea and Peter intends to publish this in the third edition of *Rugnews*.

In this issue Racial identification plates are explained and the Equipment Feature (a regular item) covers the MA197 preselection and protection unit.

Potential contributions should be sent to: *Peter Barker G8BBZ, 15 Epping Green, Woodhall Farm, Hemel Hempstead HP2 7JP.*



DX DIARY

News for HF operators compiled by Don Field G3XTT

There has recently been some correspondence in the amateur radio press relating to facilities which are enjoyed by amateurs elsewhere but are unavailable in the UK. Some of these have particular appeal to HF operators and may be of interest to readers of this column. Most of the facilities described below are best known in the USA, though a number are enjoyed by amateurs in other countries around the world.

Phone-Patch

One of the most well-known privileges is Phone-Patch. Phone-Patch allows a radio amateur to interconnect his station with the telephone network. He is then able to allow friends, neighbours etc, to use his station as part of a long-distance telephone connection. This facility was heavily used some years ago when the Vietnam War was in full swing, so that servicemen could talk to their loved ones back home at minimal expense.

The privilege of being able to interconnect with the telephone network opens up another possibility. Again in the USA, some HF operators, in poor locations or with small gardens, site their station remotely and control it over a phone line (or alternatively, via a UHF link). How about that as a way of putting up the 100ft tower you always dreamed about!

Interconnection of HF and VHF stations offers the possibility of linking an HF station to a VHF repeater. Crossband repeaters (eg 10 metres to 2 metres) may also

be allowed. Both these situations can lead to an HF operator in, say, the UK, being able to talk to someone using a 2m handheld in downtown San Francisco.

Traffic handling

A major feature of HF amateur radio in the US has always been the facility to pass messages on behalf of third parties. It is this which makes Phone-Patch legal. It also gives rise to the traffic nets which have long been a feature of amateur radio in the USA and several other countries. Traffic handling is, in effect, a sort of telegram service. Messages are passed across the country, and even to overseas countries with which there is a third-party messaging agreement, to be delivered to their ultimate destination.

Traffic nets may be on CW, SSB, or other modes as appropriate. As well as performing a community service they are an excellent means of training radio amateurs in slick operating, which could be of particular benefit in an emergency situation. Indeed, US amateurs have often been involved in Raynet-type activities on a much grander scale, during the Guatemalan earthquake and the Grenada invasion, for instance.

Small ads?

I recall being driven down a Californian freeway one Sunday lunchtime while listening on forty metres to the local flea-market net. Stations called in offering equipment for sale or swap and others called in with their offers. Obviously

a privilege that is open to abuse, though there was no indication while I was listening that any of the participants were anything but genuine.

As well as the above, other possibilities spring to mind of ways in which our HF privileges might be extended. Some would be beneficial, others could end up being detrimental to the hobby. I would be interested to receive any views from readers.

Prefixes

Turning now to news items, one which will be of interest to those chasing the prefix awards is that Canadian amateurs will be allowed to use special prefixes from 29 June to 29 August. This is to celebrate the 100th anniversary of Parks Canada. The special prefixes will be as follows: Newfoundland XO1, Labrador XO2, Maritimes XJ1, Quebec XJ2, Ontario XJ3, Manitoba XJ4, Saskatchewan XJ5, Alberta XJ6, British Columbia XJ7, North West Territories XJ8 and Yukon XK1.

In addition, VE6 stations may replace their prefix with VX6 from 14-27 July to celebrate the 100th birthday of the City of Lethbridge in Alberta. I often wonder how on earth our Canadian cousins keep track of which prefix they used for which contact because they seem to acquire special ones on the slightest pretext.

Other news

KH6S is the callsign to be used for an operation from Kalawao County, Hawaii, from

25-28 July. In case readers were not aware, the US Counties Awards are much sought after and special County Hunters nets run on a number of bands. One point to note though is that there are rather more US counties than British ones, about 3000 more in fact!

9X5MH has been reported operational from Rwanda at weekends from 1700GMT on 14333KHz. 9X5NH is operational daily on 14285KHz, also from 1700GMT.

Operation from China seems to be on the increase and several of the club stations have been audible in Europe daily, both morning and evening. It is difficult to realise that just a few years ago China was probably the most sought after country in the world. Who knows, perhaps we may see the same happen to Albania in a few years time. The true blue DXer always lives in hope...

For those needing an LF contact with Greenland, *DX News Sheet* reports that the OX net meets on 3650KHz at 2300GMT on Wednesdays and Sundays.

Award

To celebrate the 40th anniversary year of the United Nations charter, the UN Staff Recreation Council Amateur Radio Club is sponsoring an award. It is available to any amateur (or SWL) who has contacted (or heard) two of the three amateur stations operating with the UN prefix during the calendar year 1985. The stations concerned are 4U1UN, 4U1ITU and 4U1VIC.

The cost of the award is 5

dollars or 15 IRCs, and 4 dollars of this will be donated to UNICEF. Applications, consisting of a countersigned log extract including date, time, mode, band and report, should be sent to: *UNSRC ARC, United Nations Room DC1-0724, Box 20, NY 10017, USA.*

OZ5MAY

A station with the above callsign has been established at the Liberty Museum in Copenhagen and uses ex-WWII radio gear. The station will be open daily from 1100 to 1500 Copenhagen time and visiting amateurs will be able to operate the station. Readers may be aware of other permanent amateur stations located in museums and similar public institutions.

GB2SM operates from the London Science Museum, NN3SI (if I remember the call correctly) from the Smithsonian Institution in Washington DC, and PE2EVO from the Evoluon exhibition site in Eindhoven.

In the case of the latter, presenting a PE2EVO QSL card at the door entitles you to free admission. Apart from the four mentioned, I am sure there are many other such stations.

A British DX group?

Specialist groups in the UK already cater for the interests of RTTY, QRP, SSTV and computer enthusiasts. Surprisingly, there is no national group for HF DXers. G4DYO is currently sounding out views about the possible formation of a British DX Association and would welcome comments to his callbook address.

Contests

Apart from the IARU Radiosport Contest, which I mentioned last month, the most interesting contest in July is probably the SEAnet (South East Asia) DX CW Contest on 20/21 July. The Colombian (HK) Contest also runs the same weekend. Two RSGB contests which will be of interest are the Low Power Field Day on 21 July and the new Hopscotch Contest on 4 August.

Entry for these is, of course, only open to RSGB members and affiliated groups who will already have access to the rules.

Dipole of Delight

I promised last month to include some comments about this antenna which may well be of interest to those whose real estate prevents the erection of a rotary beam. The principle behind the GM3HAT Dipole of Delight is to replace the conventional ferrite balun with a capacitive arrangement which, it is claimed, improves the matching and reduces TVI effects.

Having tried the four-band (40-10 metres) version in an inverted vee configuration

with the feedpoint at 40 feet, I can testify to the antenna's low SWR which is more than adequate to the demands of modern solid-state PAs. Furthermore, to my surprise, in view of the form of construction, the dipole was able to handle full legal power on all bands without breaking down.

Letters I have received from G4VKK and G4PEO also testify to the antenna's effectiveness.

G4VKK uses the antenna as an inverted vee, mainly on phone, and has had success working into North and South America as well as Europe; all this with an FT77. G4PEO uses a TS830S plus linear and has worked all continents with the three band version. He has also been able to load the antenna on 40 and 80 by strapping the feeders and using an ATU.

He comments however that the instructions which come with the antenna recommend that the feeder should drop vertically to the ground before being run to the shack. If the feed is above a lawn frequented by a wife and children this is impossible to achieve. John also notes that, in his case, the SWR on 15 metres rises considerably when the antenna is wet.

My own criticisms would be firstly that, despite the price, no end insulators are provided with the antenna (at least none came with the sample I tested). Secondly, the plastic cover over the centre connector is brittle and broke after vibrating against my mast in a gale. Other users however seem happy with the physical construction.

So there you have it. A British product which, unfortunately, is not marketed with the same professionalism as many overseas products (the instructions are of limited help and badly duplicated). To counter this, users comment on how helpful GM3HAT has been, in one case replacing a faulty antenna at no charge without having been asked to do so. Performance will be on a par with single-band dipoles, but with the benefit of multi-band capability.

Special event stations

Finally this month, a comment about special event stations. I visited one recently at a fairly prestigious event. There were five operators present at the time, working two bands (80 and 2), yet not one of them bothered to speak to myself, my wife or my children when we stopped to watch what was happening. They were not to know I was an amateur and could easily have lost the opportunity to encourage a newcomer into the hobby.

From past experience with special event stations I would say that such a situation is the rule rather than the exception. So, a plea to those of you involved with special event stations over the summer. Remember, the station is not there to give you the chance to do some operating (you have a rig at home for that), but as an opportunity to show off our hobby to others. Let's make the most of such opportunities if our hobby is to prosper.

73 de Don Field, 105 Ship-lake Bottom, Peppard, Henley on Thames RG9 5HJ.

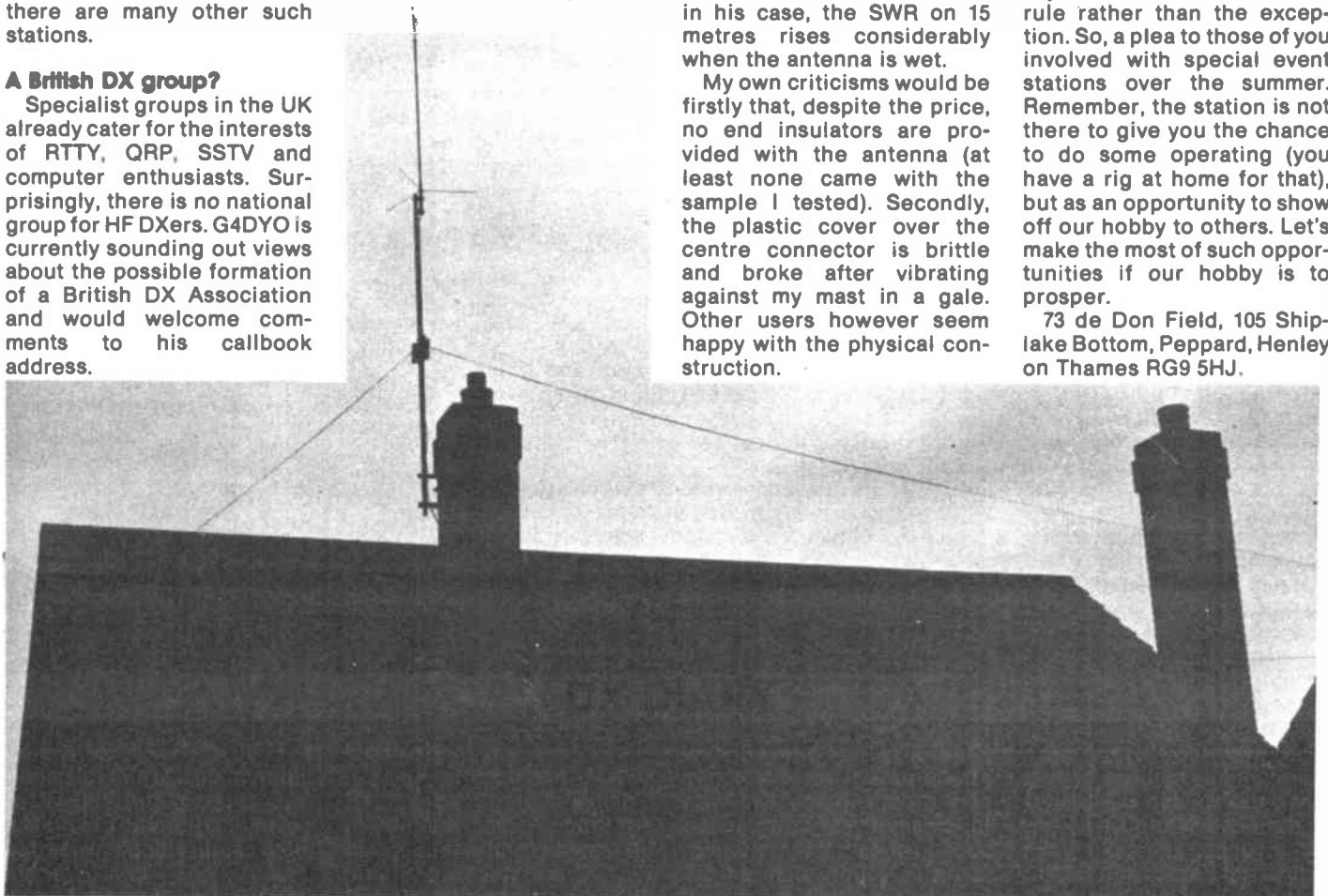

ANGUS MCKENZIE TESTS

Rumours about this fascinating new product from Trio started coming through last year, but it was not until January 1985 that I received more definite news, followed by a loan of the first sample coming into Europe in February. This sample was a pre-production one, and whilst my colleagues and I took many measurements on it, I chose not to review it until a proper production sample arrived in April.

Much of the design is based on the very successful TS930S, which has already earned a very high reputation as one of the best top-class transceivers available on the market. The TS940S shows many advances on the 930S, the main additions being the inclusion of the FM mode and a key pad frequency entry. The rig is entirely solid state, the PA stage running off 28V dc for improved linearity. Let's first look at some of the remarkable facilities.

Front panel functions

The TS940S receives frequencies from 30KHz to 30MHz basically in 10Hz increments. The large tuning knob has a heavy flywheel action, allowing it to be spun quickly, and this action introduces a fast tuning rate mode which allows several hundred KHz to be shifted in only a second or two, the AM/FM tuning rate being ten times faster (100Hz steps). Two large push-buttons step frequency up and down in 1MHz steps but two rows of buttons give direct access to all the amateur bands from 1.8-28MHz, an extra button placing the signal in the 29MHz segment.

Direct keyboard entry of frequency to any desired resolution down to 10Hz is possible by pressing 'Enter' followed by two MHz digits and then KHz etc if required, and then finally pressing 'Enter' again which puts the frequency into the required VFO (if 10Hz resolution is entered, you do not have to press 'Enter' again). Two VFOs are provided with A=B, A/B switching, or split operation. The two VFOs can have different modes selected in them, allowing Tx on SSB, but Rx with all the extensive CW facilities.

Forty memories are included which hold frequency and mode and these are arranged in four switched banks of 10. The 10 number buttons can thus be used to access any of 10 memories in a preselected memory bank. Entering and recalling memory is simplicity itself and the memory to VFO button allows one to VFO away from a memory frequency in the normal way. Very comprehensive scanning including programmable scan facilities are provided, together with scan hold. Searching between memories 9 and 0 is approximately 2S per KHz, which I found much too slow. Suitable microphones, including the Trio MC60,



TRIO TS940S MULTIMODE TRANSCEIVER

80 and 85 models, can provide up and down stepping or slow searching (10Hz steps on SSB, 100Hz on FM/AM).

Modes are selected by a vertical row of six push-buttons for LSB, USB, CW, AM, FM and RTTY, the first letter of the mode being sounded in CW pips to remind you of the mode selected! Dual concentric pots are provided for Rx, AF and RF gain, squelch (all modes) and notch filter tuning, CW audio tone peaking and frequency (operating on CW only), microphone gain (SSB and AM) and power output (all modes), and finally processor input and output gain controls operable when the processor is switched on, the normal mic gain then becoming inoperative.

A dual concentric 32 stepped position split rotary switch provides adjustment of the lower and upper skirt positions in the SSB mode. A separate single 32 stepped control is used for narrowing the selectivity of the CW and RTTY Rx modes, thus allowing separate selectivities to be preset for CW and SSB. The CW selectivity switch also has some action on AM, especially marked when the extra AM filter is fitted. An RIT/XIT control not only allows offset adjustments up to ± 9.99 KHz but small push-buttons can select offset on/off, and offset clear.

The main digital frequency display is quite a large fluorescent type which is very easy to read. Not only are very comprehensive status indications pro-

vided but there is a subsidiary horizontal cursor display showing where you are in the band, switchable to cover 100KHz or 1MHz segments. A subsidiary section of the main display gives you the incremental tuning offset to 100Hz resolution. The main display always reads the actual tuned Rx or Tx frequency. The subsidiary LCD gives many indications including memory channel and its frequency and mode (a scroll button allows all the memories to be checked independently).

Gimmick

One delightful little gimmick is the provision of a mini series of vertical lines side by side which can indicate the selected IF bandwidth at a glance. The same display also tells you that automatic tuning is in progress when that mode is selected.

Three rotary switches are provided for setting Rx front end attenuation in 10dB steps down to -30dB, AGC off/fast/slow, and meter selection. On Rx the meter is always providing signal strength indications, whilst on Tx it can be switched to indicate compression level, ALC, power out, SWR, PA current and PA voltage. Push-buttons select either of two noise blanker modes with a pot for adjusting the threshold, processor in/out, Tx on/off, auto ATU in/bypass, narrow or wide IF filters for AM, CW and RTTY, VOX/MOX, full or semi break in, audio

monitor on Tx on/off, display dim, notch filter on/off, and AF tune on/off (CW only).

A timer switch allows the internal clock to switch the rig on and off at predetermined times, and thereby hangs a tale! When John Wilson of Lowe Electronics first brought the original prototype down to us on a Monday morning he little knew that somebody had been fiddling with it late the previous Saturday afternoon in the shop.

All went well when they were showing us all the functions, and then one of my colleagues, Jonathan G1LMS, commenced testing it in the normal way. He rushed out of the lab at 5.30pm in complete alarm, exclaiming that he had possibly blown the rig up. After much consternation, another colleague checked mains continuity etc, and initially suggested that the power supply must have failed, but shortly after this he started wondering what the 'timer' button was for, pressed it, and on came the rig again. It had managed to remember an instruction to turn off at 5.30pm, one that had totally eluded even my friends at Lowe! What a lovely clock-watcher!

The loudspeaker is mounted under the top panel and by its side is a slide cover which exposes some fascinating controls. Sliders are provided for FM mic gain, carrier level on AM and CW, VOX gain, delay and antiVOX. A slide switch selects the required memory bank, whilst additional switches turn a 100KHz calibrator on and off, display 100KHz/1MHz band position and the main frequency display to 10 or 100Hz resolution. There is even a small preset for setting the optimum viewing angle of the LCD.

Underneath the rig there are four large feet, the front two being extendable. Holes provide access to additional presets: CW sidetone level, beeper level, monitor level, carrier balance adjustment, notch adjustment and S-meter calibration (zero and gain).

Subjective tests

The original prototype production sample was with me for approximately two weeks and included the optional antenna tuning unit, 6KHz bandwidth AM filter and narrow CW filter options. It was also fitted with the VS1 speech frequency read-out board, which speaks frequency to 10Hz resolution when the speech button is depressed. It did not take me long to realise that the performance was very similar to that of the TS930S, but the FM performance was far better than that on any competitive HF transceiver that I have so far tested.

The selectivity of FM was surprisingly narrow and proved adequate for 10KHz channelling on the 10m band, and very good for 12.5KHz channelling on 2m when a transverter was used. The front end sensitivity seemed excellent throughout, and there was always more hiss from the antenna on 10m than was present on the receiver, which is always

a good sign. The 10dB stepped attenuator was extremely useful as it enabled the wide dynamic range window to be placed wherever you needed it on the various bands.

The reciprocal mixing performance was perhaps just a slightly weak point, although it was better than that of most other rigs checked which employed synthesisers. However, transceivers such as the Ten-Tec Corsair, the Icom IC751 and even the older TS930S were better in varying degrees. The 940S did introduce slight crunchy noises underneath very weak stations on the LF bands if very strong signals were close, but see the note at the end of the review concerning extremely important modifications which improve on this.

Audio quality

The audio quality on all modes, except AM, was excellent, and in particular CW and SSB seemed as clean as I have ever heard them. AM seemed just a little distorted but it was better than on most competitive Japanese receivers. The 6KHz AM filter knifed out very weak AM stations extremely well but the sound quality on stronger stations, without this filter, was even better, the HF end extending further than usual but still with quite a steep skirt. I noticed some LF cut on AM but the cut in no way disturbed me on the other modes.

I very much preferred the selectivity controls on this rig to those on any other rig that I have reviewed, for their operation was very efficient and in no way confusing, the miniature slope display reminding one of precisely what has been chosen. The excellent skirt selectivity is maintained when the overall bandwidth is modified and in operation it is rather like having incredibly steep audio high and low pass filters. LF and HF interference can often be completely removed by changing the skirt towards the centre of the passband by a few click steps.

The notch filter could be tuned over a considerable range and gave an excellent notch, although the top of the notch was rather wider than ideal. It could be tuned over a very wide range of frequencies.

On CW, you have the choice of using the SSB filter or an optional narrow CW one, although the latter is only necessary in extremely difficult conditions as there is a CW selectivity control, again with 32 steps, which can narrow it right down, closing both sides in at once. As if this isn't enough, there is also an audio peaking circuit, which can be set to peak over a very wide frequency range whilst rejecting other frequencies. This is really superb for CW reception, an additional control mounted concentrically with it adjusting the CW pitch after the normal IF filter. The RIT and XIT functions worked extremely well, and were very easy to use.

I interconnected the second sample to my main transverter switching box and to the Drake L7 linear which drove my LF and HF aerials. The 940S worked very well into the L7, and audio quality on Tx was praised, often without prompting, by very many stations on all the SSB bands, including VHF, UHF and microwave bands, first when I was using a Trio MC60 and then the MC85, an Electret desk microphone with switching facilities included for operating any of three rigs.

FM quality was particularly fine, and the distortion was always very low. When I switched in the processor there was a marked increase in 'punch power', and yet the processor was less obviously 'in' than usual. I not only checked the break in CW keying function, which was excellent, but we tried out the rig with an AMT2 on Amtor, transmitting and receiving the mode on USB, which therefore gave the facility of the very comprehensive IF selectivity variations. It excelled here and it was still decoding when we could barely hear the station at the other end. All the VOX control functions

Trio TS940S FM received audio response (750µs de-emphasis)

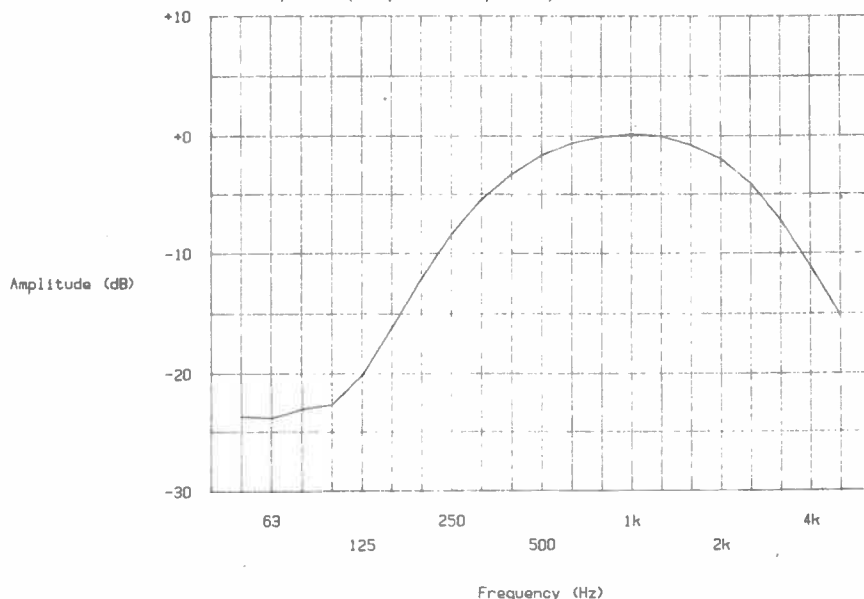

G3OSS TESTS

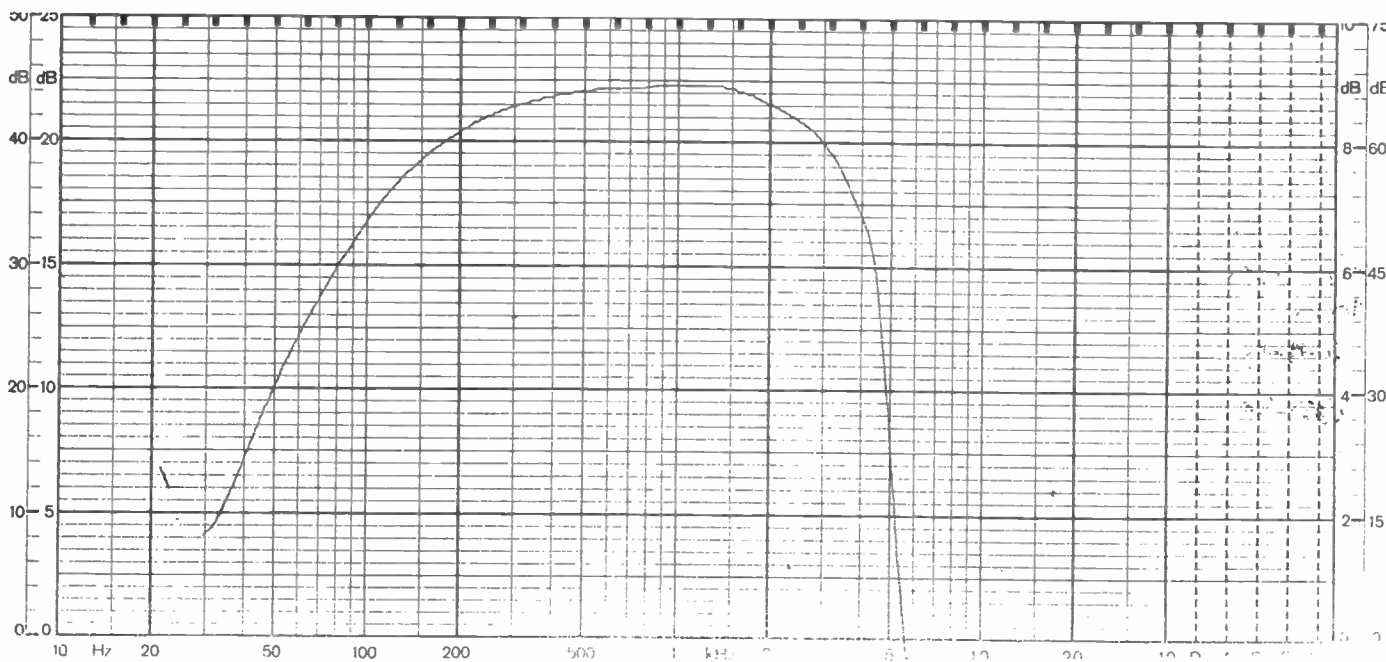

Trio TS940S AM received response with normal filter

worked very well, although I don't normally use VOX.

The noise blankers worked quite well, but could not completely cope with the woodpecker, although ignition interference was virtually removed. The AGC speeds were well compromised, but I noted that on AM AGC was at a fixed speed and could not be turned off.

I checked out all the memory and VFO split functions and these were easier to use than usual. I tended to use one bank for the HF bands and the others for 2m, 70cm and 23cm, using them for both calling frequencies and various beacons. These were all retained when the equipment was switched off and disconnected from the mains. I also operated through repeaters by splitting VFO A and B for input/output. It is a pity however that one could not preset a

fixed offset between them for repeater use, and the absence of a toneburst was unfortunate, although you could easily add one into your mic lead.

Preference

I much preferred entering frequency on the key pad on this rig to many others as you only have to enter the digits that you require, rather than a string of noughts down to 100Hz. The VFO knob controlling the synthesiser is one of the smoothest I have ever encountered, and the steps are less obvious than usual.

The rig is fitted with phono sockets on the back panel for interconnection with the Trio SM220 station monitor, both the broad band and filtered IFs being fed through to the monitor, allowing one to get a panoramic view of up to 200KHz of the band being received, with a very wide

dynamic range of around 80dB on the scope tube. It is also possible to look at one isolated signal on the scope and comment on the modulation. In addition we connected both the RF output of the 940 and of the L7 linear and my colleagues could see some superb two tone and trapezoid patterns, with virtually no visible distortion.

The transverter output produces a very clean 55mW but unfortunately when the PA is turned off the transverter feed is not subject to ALC in the normal way, but if you set the processor out level carefully you can use the latter to control the maximum drive very accurately. The interfacing facilities provided are very comprehensive, including short on Tx, audio input and output at sensible levels, external PTT in and HF antenna in and out on the various multipin DIN sockets.

Trio TS940S AM received response with optional YK-88A-1 filter

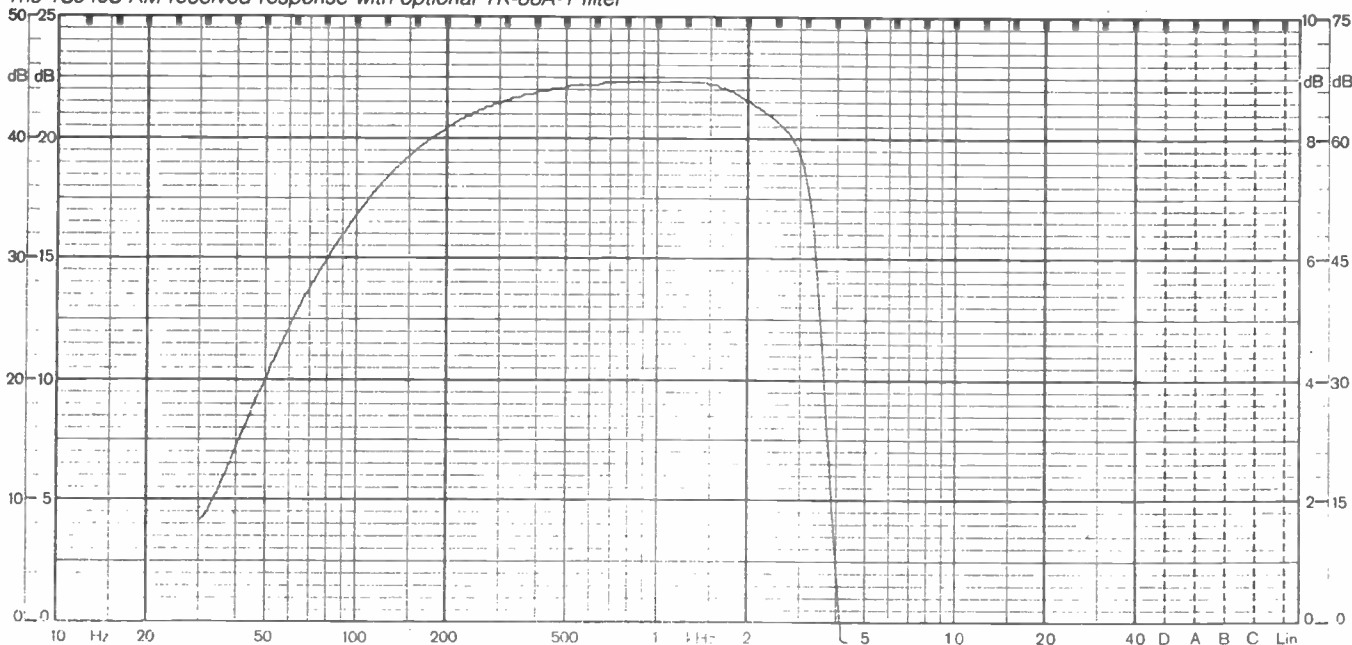

G3OSS TESTS

There is also a connection pin which, when shorted, disables the internal microphone amplifier and enables the external audio line-in connection, which is excellent when you want to play back tapes or for use with Amtor. ALC can be fed back into the rig, both on the transverter socket and linear remote socket, and yet another multipin accessory socket provides comprehensive data control for use with a computer interface.

Additional sockets on the rear panel include a 3.5mm jack for an external speaker (the internal one is quite good though), and a normal 1/4in jack for a CW key. You can also operate with frequency shift keying (phono socket), although I did not try this. There are also phono sockets for in/out phone patch connections, a PC-1A phone patch unit being available to special order. The rig includes an IEC mains socket and an SO239 for the HF antenna. There are two massive heatsinks across the back which include fans which speed up when necessary. At full speed they are just slightly noisy, but not too bothersome.

Irritating fault

After my trials with the normal production sample I noted one irritating fault: there seemed to be some intermittent jitter on the second mixer local oscillator, which is derived from the main synthesiser. On Tx this is used to apply FM, but I found the jitter quite annoying when listening to CW. The rig was returned to Lowe Electronics, who soon corrected the problem, but they also investigated my criticisms of the reciprocal mixing performance and the AM distortion characteristics. John Thorpe devised some excellent modifications for the phase locked loop area in the synthesiser and managed to improve the reciprocal mixing noise by 12dB, which greatly improved the performance on the LF bands, virtually no noise other than

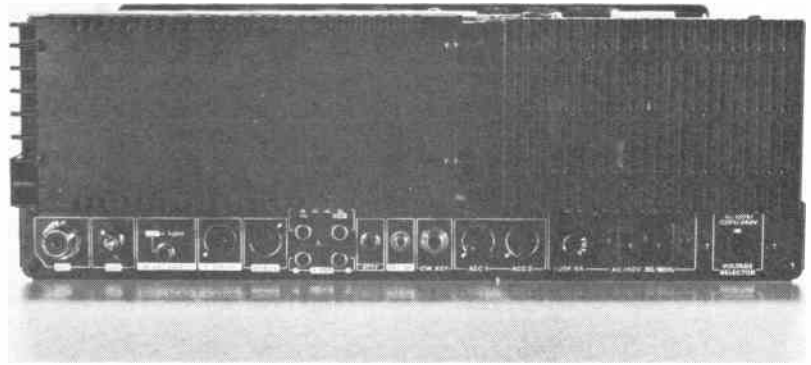

band noise being audible between stations, even very strong ones. Furthermore, he designed a superb little active AM detector, which dramatically reduced AM distortion, thus giving AM quality as good as one would ever want.

The performance on long and medium wave was superb and, despite very many exceptionally strong local signals, there were no serious intermodulation problems created if careful use was made of the input attenuator and of an external low pass filter for long wave. I was fascinated to find just how strongly the 60KHz Rugby transmission could be received, although this frequency was well below the specified 150KHz lower limit mentioned in the instruction book.

The optional automatic antenna tuning unit, which is built into the rig, can be switched in and out and it can be set to the tune mode by depressing the ATT button and then MOX on Tx. In a time from almost instantaneous to around 10 seconds it can cope with an SWR of up to around 3:1, (dependent upon frequency and reactance) bringing the average reading down to around 1.1:1. The display tells you when it is tuned up. The ATU lost around 0.5dB power, but I think this can be ignored. No RF feedback problems

were noted on any band from 1.8 up to 2320MHz, even at the highest powers tested, usually at 400W PEP output. Unfortunately, this is more than can be said about many other rigs tested. The ergonomics were extremely good throughout and, despite the rig having so many facilities, I never felt that any of them were superfluous.

Laboratory tests

The RF sensitivity on all modes, except FM, throughout the complete frequency range was as good as one would ever normally need, the measurements on different bands being very consistent, although FM was slightly disappointing at 29.6MHz. I did not notice any problems on Top Band from extremely strong medium wave stations, this confirming an excellent front end performance. The reciprocal mixing performance measured well down to 20KHz spacing, but very close in it did come up rather too much, although it was decidedly better than the Yaesu synthesiser rigs that I have measured.

John Thorpe's modification improved the 5KHz figure by 12dB, which resulted in the 940S being 7dB better than the 930S. The RF intercept point measured

Trio TS940S FM transmitted response below limiting with 750µS de-emphasis

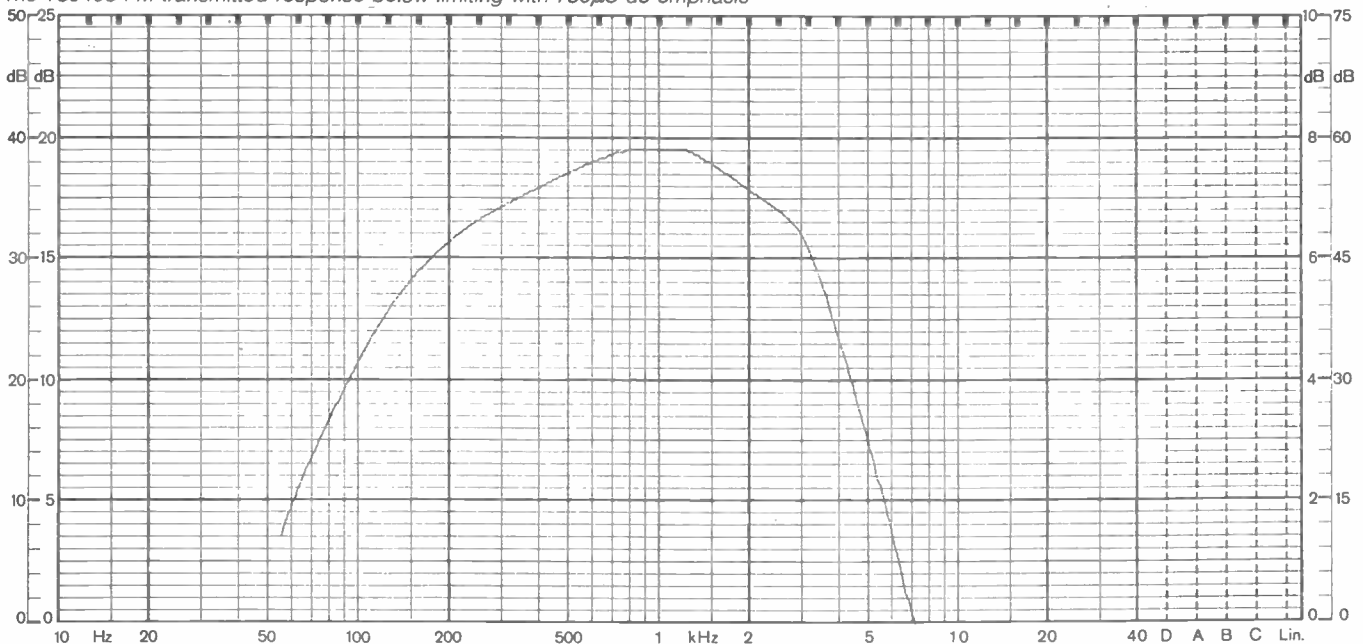

G3OSS TESTS

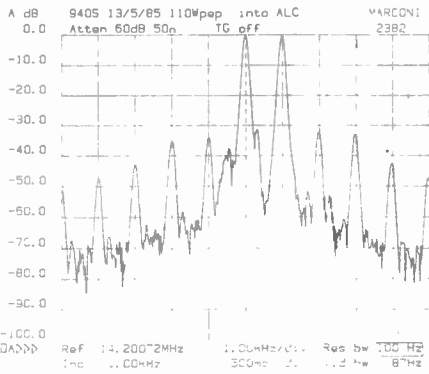

Fig 1 110W into ALC at 14.2MHz

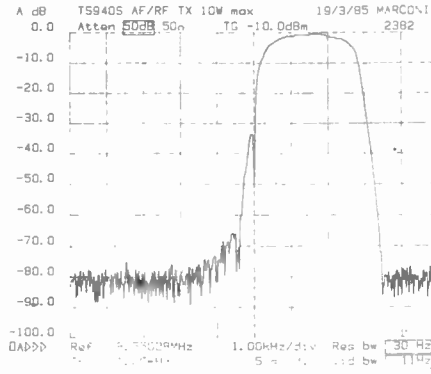

Fig 2 AF/RF USB

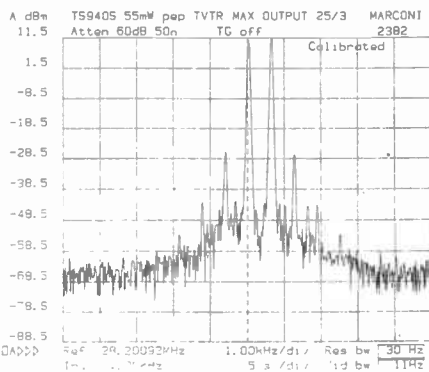

Fig 3 Transverter at 55mW

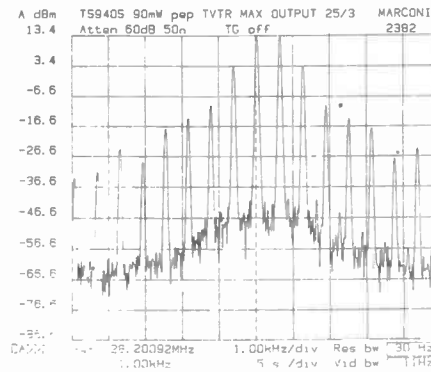

Fig 4 Transverter at 90mW

amazingly well from even fairly close interference, and it was only 5/10KHz and 10/20KHz spacings that showed quite a considerable deterioration. However, even at its worst it was better than any other FM capable transceiver checked, and as good as many dedicated SSB/CW ones. It is certainly good enough for all normal uses, even at LF.

The selectivity on SSB had an excellent shape down to -50dB but below this it opened out moderately, one or two Icom rigs being better. The skirt slope was maintained when the selectivity was varied. Lengthy research showed that the real selectivity was much better but the measurements were affected by RM. After John Thorpe's modifications, the true selectivity measured far better and AM, FM and CW selectivities were all virtually ideal.

The S-meter was far better than usual and indicated a fairly wide range of signals, and presets are provided for you to set S9 where you want it. We noted 28dB between S1 and 9 on all modes, and the +20, 40 and 60dB divisions were stunningly accurate. The reading was remarkably constant at all frequencies.

I very much liked the AGC action for there were no nasty transient spits on the attack, whilst recovery showed a good logarithmic shape. Audio distortion on SSB was far lower than usual, FM was quite good and AM was good at lower modulation levels, but reached 12% on very high modulation. However, the modified active detector board reduced the high level distortion down to a stunning 0.75%; as good as most AM

speaker and into external ones, a 4 ohm speaker sounding very loud before clipping was noted.

The frequency accuracy is phenomenally good, even immediately after switch-on the error being only 30Hz, and after several minutes it was well within 10Hz accuracy. The review sample was fitted with a normal master oscillator but a super stability one is also available, type SO1, which is a thermal compensation crystal oscillator running at 20MHz, but which I feel is redundant for most of us normal folk!

We applied two tone tests in the normal way into the microphone input socket, adjusting mic gain etc to give various output PEPs. At 14.2MHz we noted 110W PEP output just into ALC and the low order products were seen to be very good (see Figure 1). However high orders were just a little higher than I would have liked. At an output level of 30W PEP higher orders were better attenuated, and so driving the 940 into a very good linear with ALC returning should give a very clean output overall.

The performance of 3.7MHz was very similar at 28.55MHz, but at 100W PEP it was slightly better. I have to admit that I would have expected a slightly better performance from a 28V PA, and the TS930S is actually very slightly better. The rig was fully capable of giving at least 100W output on SSB, RTTY, CW and FM, whilst on AM you are advised to turn the carrier level down.

We had a look at the ripple sidebands of 1KHz audio modulation at 100W output on SSB and the ripple components were found to be at very low levels, showing excellent power supply regulation. These plots showed the presence of very slight second harmonic distortion in the

signal generators at their best!

Audio responses on all modes were just about ideal and in no way was FM muffled, although high frequencies were cut very steeply to reduce noise by just about the right amount in the audio amplifier. Very adequate audio power was available, both from the internal

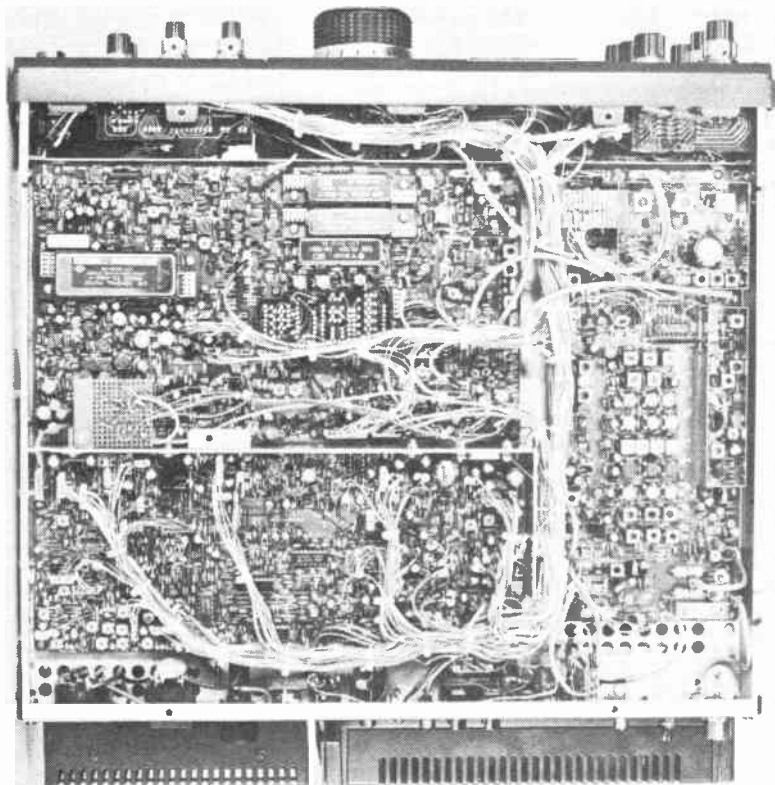

audio amplifier, which is virtually harmless. The AF/RF plot also shows slight audio tailoring at LF and HF before the filter skirts cut the response extremely rapidly. There was virtually no ripple noted in the passband, which is excellent, and no significant difference was noted in the LSB and USB plots. The carrier breakthrough was well down and alternate sideband rejection was excellent.

We took two very fascinating two tone plots of the two tone performance from the transverter socket, with the PA disabled in the normal way. The plot at 55mW output (Figure 3) is as clean as I have ever seen on a transverter drive, but note what happens in Figure 4 when you attempt 90mW output – a total disaster area. Unfortunately, this is so typical when one operator lines up gains and another, with a voice like a loud hailer, takes over after a while and makes himself very unpopular in a contest! It is only a transverter drive subject to ALC which can prevent this problem, unless you use the processor to set maximum output level.

The FM transmitted response from the microphone input socket to the carrier out, with 750µS de-emphasis applied, showed a very steep LF cut below 350Hz and a gentle roll off above 2KHz, which became very steep above 3KHz. This is just about ideal for 10 and 12.5KHz channelling. Transmitted signal to noise ratios were excellent and the maximum deviation on FM was at around 4KHz, a very good compromise.

We checked the harmonic and spurious output performance on all bands. 21 and 28MHz were excellent and all the LF bands were –55dB at worst (second harmonic of 7MHz). 10 and 18MHz measured well but we noted an unwelcome second harmonic from the 24MHz band at –38dB, which is too high. This was however at 100W, which is far above the maximum allowed power. No spurious outputs were noted at any of the frequencies tested. Transmitted frequency accuracies were again excellent throughout. The RF power control can take the power down to around 4W on all bands. The ATU loss was checked and averaged at around 0.5dB when switched in.

Modifications

After we had measured the first production sample very extensively, we discussed the results in detail with John Wilson and John Thorpe of Lowe Electronics, Matlock. John Thorpe carried out much research into the reciprocal mixing problem and by computer circuit analysis designed modifications to the phase locked loop filtering and circuitry, building an additional circuit onto a small circuit board. He obtained a dramatic improvement of 12dB in the close-in measurements, and even at 100KHz spacing there was an improvement to the performance, which was already excellent.

Thorpe and Wilson also designed an

TRIO TS940S LABORATORY RESULTS (Post modification results are in brackets)

Receiver results

Sensitivity		
SSB, for 12dB sinad		
28.55MHz		–123dBm
21.3MHz		–123dBm
1.91MHz		–125dBm
Sensitivity		
FM, for 12dB sinad		
29.55MHz		–120dBm
Attenuator		
'10dB'		9dB
'20dB'		19dB
'30dB'		28dB
Selectivity		
SSB, bandwidth reduced by 4 click positions at LF and HF ends		
3dB		1.97KHz (1.8KHz)
6dB		2.12KHz (2.05KHz)
40dB		3.16KHz (3.12KHz)
60dB		6.39KHz (3.7KHz)
70dB		11.76KHz (5.28KHz)
Selectivity		
FM, off channel blank carriers		
±12.5KHz spacing		63/65.5dB
±25KHz		78/79dB
Off channel signal		
3KHz modulation and 3KHz deviation		
±12.5KHz spacing		10.5/20dB
RM,SSB (ratios)		
+100KHz offset	118dB	(118dB)
+50KHz	109dB	(111dB)
+20KHz	96dB	(105dB)
+10KHz	86dB	(96dB)
+5KHz	75dB	(87dB)
S-meter		
S1		–103dBm
S9		–75dBm
S9+20		–55dBm
S9+40		–35dBm
S9+60		–14dBm
SSB product detector distortion		
		0.6%
FM audio distortion (2.5/0.5KHz deviation)		
		1.2%
AM distortion fixed fast AGC (modification figures on slow AGC)		
30% depth	1KHz modulation	1.5%
	300Hz	2.6%
90% depth	1KHz modulation	12.2% (0.68%)
	300Hz	19.5% (0.7%)
	80Hz	(2.7%)
Maximum audio output power (10% THD)		
4ohms		4.6W
8ohms		3.2W
Calculated intercept point		
SSB, S5 method		
+100/+200KHz spacing		+18.5dBm
+20/+40KHz		+18.5dBm
+10/+20KHz		+2dBm
+5/+10KHz		–10dBm
Calculated intercept point		
SSB, Thorpe method		
+100/+200KHz spacing		+12.5dBm
+50/+100KHz		+7.5dBm
+20/+40KHz		0dBm
+10/+20KHz		–13dBm
+5/+10KHz		–27dBm
CW selectivity		
3dB	16 clicks	28 clicks
6dB	0.77KHz	0.23KHz
40dB	0.96KHz	0.36KHz
	2.0KHz	1.47KHz
Optional narrow CW filter		
6dB	Fully open	–16 clicks
60dB	310Hz	110Hz
	approx 700Hz	approx 600Hz
Size		
		409(W) x 141(H) x 420(D)mm
Weight		
		18.5Kg/20Kg with ATU

G3OSS TESTS

active AM detector circuit board which improves the AM distortion and sound quality very dramatically. Other modifications included the provision of AGC on/off and fast/slow switching on AM, and a very small modification to allow the transceiver to be general coverage at HF, which I required just for testing purposes. The synthesiser noise modification involves adding two resistors and two capacitors in each of two lines between the PLL unit and the RF unit on lines VC1 and 2. This slightly compromises the tuning glitch performance at 10KHz intervals and so a further modification to the PLL unit involving changing four capacitors becomes necessary.

The modifications are as shown in Figure 5 for VC1 and 2. The PLL board mods are as follows: change C184, 5, 6 and 7 to 4.7µF tantalum. The active AM demodulator circuit is shown in Figure 6. It should be fed from the emitter of Q17 (IF unit) with output to W36 (IF unit). Break W36 to disconnect the existing detector AF output. Take HT from the +15V rail. In the normal model, if you have installed the AM 6KHz filter, type YK88 A-1, and pressed in the filter switch you receive AM with the SSB filter which, of course, is dreadful.

It is far more useful to select filter bypass and obtain the response that you would get without the optional filter, thus giving an improved HF sound quality, but obviously a higher susceptibility to interference. For this mod, break track 2 IC401, pin-9 on the small board above the IF board and link pin-9 to pin-7. With the switch in the narrow position this gives 8KHz bandwidth. To enable AGC variation on AM, remove the brown wire from J15 and connect to W43 on the IF board.

The above modifications could be described as fairly esoteric ones for those who are very fussy indeed and who are prepared to spend some time and money to carry them out. I do recommend them, but only if you are particularly enthusiastic about LF band DX and exceptional AM received quality. I do not advise you to attempt the mods yourself, unless you are very experienced, for it is

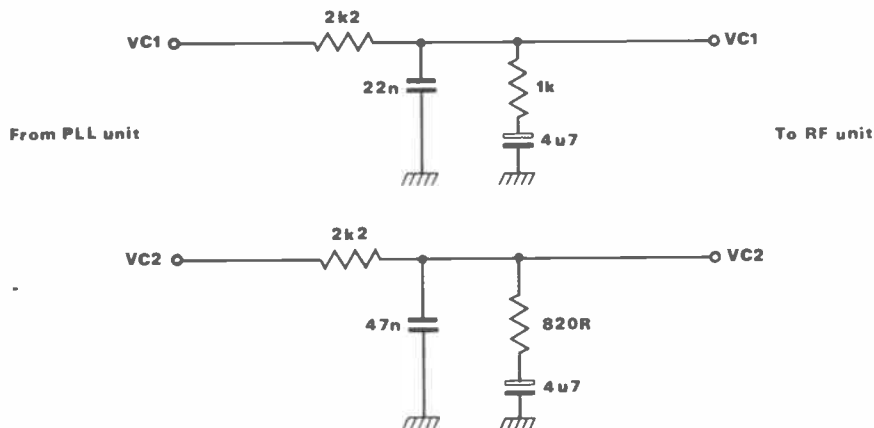

Fig 5 Modifications

all too easy to create havoc with a very expensive transceiver.

All the above modifications can be put into the TS940S, together with a super line-up by Lowe Electronics to special order, but of course at an increased cost. They point out quite rightly that any modifications by a user are highly likely to totally invalidate the guarantee. I most strongly recommend that you therefore get Lowe to carry out any required modifications.

Conclusions

Even without the modifications I consider this transceiver to be one of the most enjoyable to use that I have ever had in the shack. The overall performance is superb, except for the synthesiser noise and AM distortion, but even these parameters measured quite well in comparison with most of the competition. With some rigs it is hardly worthwhile even trying to improve them but because the 940S is so good the modifications are justifiable.

The receiver is clearly a DX man's rig because of the superb CW and SSB performance, and I regard the Amtor capability and the provision of FM as excellent bonuses. The speech synthesiser and pip tones are wonderful for a blind operator and the extensive interfacing possibilities are almost bound-

less.

The one single problem remaining is the enormous cost, although I think it is justified, the rig far outperforming in most areas other rigs at the same or even higher cost.

The modifications clearly gild the lily and what more can I say than I have reached deep into my pocket to purchase the review sample, which has given me so much pleasure. I am now using it on all bands from 1.8 to 2320MHz and on all modes where applicable. However, if you are a DX man, not at all interested in FM and all the magnificent additional facilities, I can still recommend the TS930S which measured up so well fairly recently, the TS830S also being excellent and very good value for money.

I would like to thank my colleague Jonathan G1LMS, for all his help in assisting me with the measurements, and Lowe Electronics for the immense trouble that they have taken, both to loan me the first prototype sample, including a personal delivery, and for supplying the main review sample, which was imported specially by air to get it to me in time for this review. We must have spent hours on the telephone with them discussing the entire project, and what a pleasure it has been talking to them and measuring this rig.

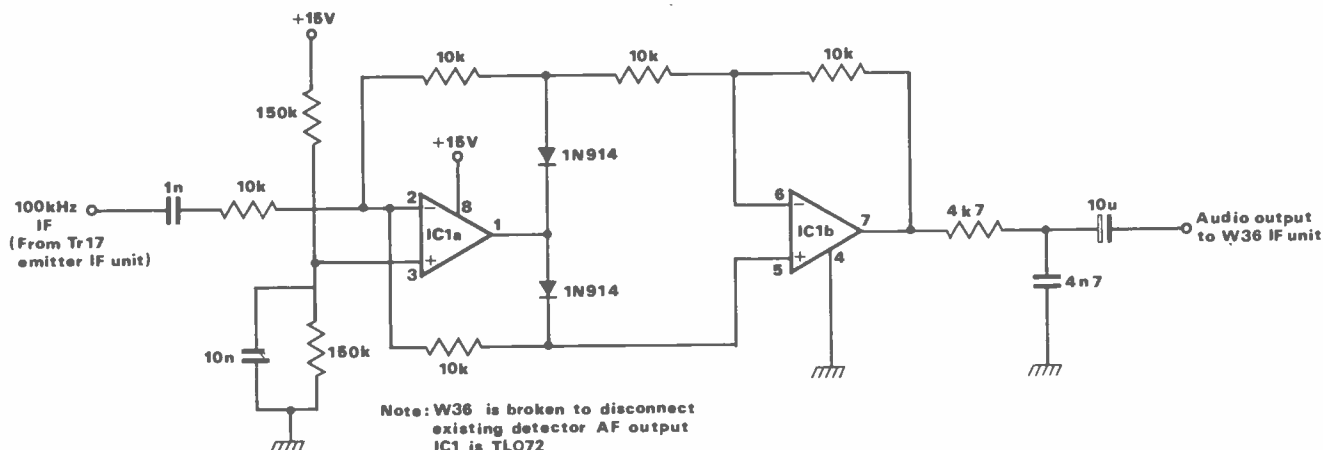

Fig 6 An improved AM detector circuit offering <3% THD at 90% modulation depth

CHANCE PILKINGTON
Reactolite
RAPIDE

Britain's fastest selling sunglasses

NOW £5 OFF!

Choice of 4 types – all at the amazingly low price of £7.95

Last year a staggering 4 out of 10 sunglass wearers chose Reactolite Rapides.

This year, as an extra bonus, we are offering the readers of this magazine the opportunity to buy direct – a massive saving of £5 on the normal retail price of £12.95.

All 4 models have beautifully designed frames and genuine, optically ground, Reactolite Rapide lenses – the fastest reacting photochromic glass in the world!

E93 Pilot Shape The 'cut-away' sporting look. Superbly designed and built incorporating *soft, flexible nose pads* for total comfort and *optical quality hinges* (illustrated). Frames available in 3 colours.

E96 Square Shape High quality specification as above but with a more classical shape.

E80 Unisex Top of the fashion range with a beautifully sculptured 'tortoise shell' type plastic frame in brown and crystal.

E116 Clip-On Designed to fit almost any type of glasses and incorporating an ingenious 'flip-up' action.

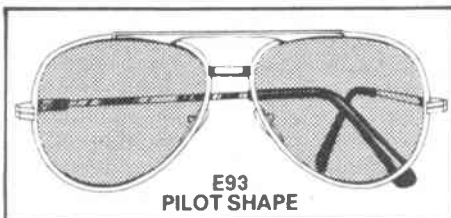

E93 PILOT SHAPE

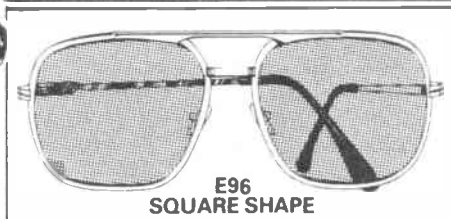

E96 SQUARE SHAPE



E80 UNISEX

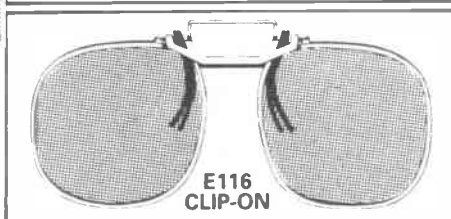

E116 CLIP-ON

FREE!

Crushproof case with every pair ordered!



TO: Amateur Radio

Sunglasses Offer PO Box 211, Brentwood Essex NP4 5DY

Please send me the following pair(s) at £7.95 plus 65p P&P per pair.

- NO REQUIRED
- E93 in Gilt/Nickel/Black* frame
- E96 in Gilt/Nickel/Black* frame
- E80 in 'Tortoise Shell' frame
- E116 in Gilt frame

*Please delete.

I enclose cheque/P.O. for £ made payable to **Amateur Radio**

Name _____
 Address _____

Post Code _____

NO QUIBBLE MONEY BACK GUARANTEE!!

Allow up to 14 days for delivery.

0785

NEW FOR 1985

RADIO

Prefix Award

RADIO

Prefix Award

RADIO

AMATEUR RADIO

HF PREFIX AWARD (TWO-WAY AND SWL)

To qualify for an award you have to have worked/heard and logged:

250 prefixes for the Bronze award
500 prefixes for the Silver award
1000 prefixes for the Gold award

The opening date is 1 January 1985 and further details are available in SWL (page 37)

AMATEUR RADIO

MICROWAVE AWARD

To qualify for an award on one of these bands you have to fulfil each category

Frequency	Countries	Counties	Squares	Distance
144MHz				
Bronze	7	20	20	500 Km
Silver	14	35	40	800 Km
Gold	21	50	60	1200 Km
432 MHz				
Bronze	5	15	40	400 Km
Silver	10	15	30	800 Km
Gold	15	25	45	900 Km
1296MHz				
Bronze	3	10	10	300 Km
Silver	6	15	20	500 Km
Gold	9	20	30	700 Km

The opening date is 1 January 1985 and further details are available in *On the Beam* (page 44)

KEEP IN TUNE WITH AMATEUR RADIO AND THE AMATEUR RADIO AWARDS

Start working towards your chosen award now!
All winners will receive free certificates - and find their names in *Amateur Radio Magazine* (worth it for that alone).
All entries or queries should be sent to:
Trevor Morgan GW4OXB, Glen Ross GBMWR or Amateur Radio.

REG WARD & CO LTD

**1 Western Parade
Axminster Devon EX13 5NY**

**South Wests
Largest Amateur
Radio Dealer**



Official Agents Yaeau, Trio, Icom, FDK

APPROVED
TRIO
DEALER

Complete range stocked:
Full demonstration facilities:
Mail/Phone orders on all items:
Barclaycard, Access, Instant Credit:

Ancillary equipment: Adonis, AKD, AOR, Benchor, BNOS, Datong, Diawa, Drae, Hansen, Hinound, JIL, Kempro, Microwave Modules, Mutek, SEM, Snare, TAU, Tolcyo Hypower, Tono, Toyo, Weiz, Wood & Douglas
Aerials by: G Whip, Hygain, Jaybean, Mini Products, Rexco, TET, Tonna

New complete range Wood & Douglas Kits
TAU Tuner SPC 3000



Cables, plugs, sockets, insulators, etc.
Opening hours: Tues-Sat 9-5.30 (lunch 1-2) Closed Mondays
Tel: Axminster (0297) 34918

NEWSAGENT ORDER FORM

Amateur

RADIO

For all two-way radio enthusiasts

To (name of newsagent)

Please order a copy of *Amateur Radio* for me every month

NAME

ADDRESS

.....

Newtrade distributors: Argus Press, Sales & Distribution Ltd, 12-18 Paul Street, London EC2A 4JS. (Tel: 01-247-8233)

WOOD & DOUGLAS

* NEW CATALOGUE * NEW PRODUCTS * NEW PRICES

Package Price		KiB
1. 500mW TV Transmit	(70FM05T4 + TVM1 + BPF433)	40.00
2. 500mW TV Transceiver	(As 1 above plus TVUP2 + PSI 433)	65.00
3. 10W TV Transmit	(As 1 above plus 70FM10 + BD335)	75.00
4. 10W TV Transceiver	(As 2 above plus 70FM10 + BD335)	100.00
5. 70cms 500mW FM Transceiver	(70T4 + 70RS + SSR1 + BPF)	60.00
6. 70cms 10W FM Transceiver	(As 5 above plus 70FM10)	115.00
7. 2M Linear/Pre-amp 10W	(144PA4/S + 144LIN10B)	45.00
8. 2M Linear/Pre-amp 25W	(144PA4/S + 144LIN25B)	48.00
9. 70cms Synthesised 10W Transceiver	(144PA4/S + 144LIN25C)	51.00
10. 2M Synthesised 10W Transceiver	(RS+SY+AK+MOD+SSR+70FM10)	165.00
11. 2M Crystal Controlled 10W Transceiver	(RS+SY+SYZT+SSR+144FM10A)	125.00
12. 70cms Linear/Pre-amp	(RS+T3+BPF+144FM10+SSR)	95.00
13. 24cms FMTV Receive, video out (Kit)	(70LIN10-70PA2/S)	47.00
14. 24cms FMTV Receive, video out (Ass)	(VIDIF, 125ODC50 Boxed)	105.00
15. 24cms FMTV Receive, Ch 38 out (Kit)	(VIDIF, 125ODC50 Boxed)	120.00
16. 24cms FMTV Receive, Ch 38 out (Ass)	(VIDIF, TVMOD1, 125ODC50 Boxed)	110.00
17. 24cms FMTV Transmit (Kit) (UFMD1)	(VIDIF, TVMOD1, 125ODC50 Boxed)	125.00
18. 24cms FMTV Transmit (Ass) (UFMD1)	70LIN3/LT, 70FM10, WDV400/1200 Boxed)	140.00
	70LIN3/LT, 70FM10, WDV400/1200 Boxed)	170.00
70cms Pre-Amplifiers		
Bipolar Miniature (13dB)	70PA2	8.95 8.85
RF Switched (30W)	70PA2/S	28.50 16.25
GaAs FET (16dB)	70PA5	20.95 13.40
AM TV Products		
Receiver Converter (Ch 36 Output)	TVUP 2	28.75 23.95
Pattern Generator (Mains PSU)	TVPG1	48.50 39.40
TV Modulator (For Transmission)	TVM1	10.15 6.05
Ch 36 Modulator (For TV Injection)	TVMOD1	10.15 5.75
2M Linear		
1.5W to 10W (SSB/FM) (Auto Changeover)	144LIN10B	42.70 32.75
2.5W to 25W (SSB/FM) (Auto Changeover)	144LIN25B	44.90 34.50
10W to 25W (SSB/FM) (Auto Changeover)	144LIN25C	48.20 37.90
1.3W to 30W (SSB/FM) (Auto Changeover)	144LIN30	TBC
2M Pre-Amplifiers		
Low Noise, Miniature	144PA3	9.10 7.75
Low Noise, Improved Performance	144PA4	13.45 8.95
Low Noise, RF Switched, Full Changeover	144PA4/S	25.95 16.25
GENERAL ACCESSORIES		
Toneburst	TB2	7.10 4.70
Pigtone	PT3	8.05 4.90
Keytone	PTK3	9.45 6.65
Relayed Keytone	PTK4R	13.40 9.00
Regulator (12V, low differential)	REG1	7.25 4.85
Solid State Supply Switch	SSR1	10.10 6.10
Microphone Pre-Amplifier	MPA2	6.00 3.85
Reflectorometer	SWR1	6.95 5.60
CW Filter	CHF1	8.95 6.10
TVI Filter (Boxed)	HPF1	5.95
Audio Amplifier	AF1	10.40 7.25
FM TV MODULES		
50mW 420MHz Source (Video Input)	UFMD1	30.10 22.75
50kHz i.f. Processor	VIDIF	58.20 40.90
Varactor Multiplier (Boxed)	WDV400/1200	83.95
1250MHz Downconverter (50MHz i.f) (Boxed)	125ODC50	69.95
1250MHz Matched Pre-amplifier	125ODC50	TBC
Transmit Sound Modulator	SCR-1	TBC
Receive Sound De-Modulator	SCR-2	TBC

Details of these and other new products are included in our 1985 catalogue. This will be posted to you on receipt of an A5 stamped self addressed envelope. Kits are usually available by return of post but please allow 28 days for any unforeseen shortages. Place your order by post or by telephone using your credit card. Please include £1.00 to cover order handling and postage.

Our products are kits or assembled kits consisting of circuit board and all components to mount on the board. We do not include external hardware such as boxes, connectors etc.

If your purchase does not work when assembled then apart from being surprised we will offer to service the module for a small charge depending on the complexity of the project. So please remember...

ANYONE CAN SELL A KIT... REPUTATION SELLS OURS

UNIT 13 YOUNGS INDUSTRIAL ESTATE, ALDERMASTON, READING RG7 4PQ

TEL: (073 88) 71444 TX: 848702

SELECTRONIC

RADIO, TV AND RADIO COMMUNICATION SPECIALISTS

THE UK'S LEADING SUPPLIER OF 934 MHz PERSONAL RADIO EQUIPMENT AND ACCESSORIES

- ★ Everything you need for 934MHz, plugs, cables, masts, towers, SWR/signal meters, aerials, switches etc.
- ★ **Cybernet delta 1** now in stock
- ★ The largest specialist stock of 934MHz in the UK
- ★ Stockist of MET antennae

Full service facilities on all equipment
We have practical and technical experience. Please call us for friendly help and advice. Credit terms and mail order facilities available

For further information please ring Mike Machin on (0268) 691481



**203, HIGH STREET,
CANVEY ISLAND, ESSEX**



G5YHB
G5YHC
G4UJ/J
G4NBA

Amateur Radio smart blue binders, each holding up to 12 issues keeping them in prime condition.

Only
£4.25
inc p&p

Overseas readers please add 30p
Please allow 14 days for delivery:

Send your orders to:
**Edwardschild Ltd, 28 Shenfield Cres.
Brentwood, Essex CM15 8BN**

BEGINNERS'

WORKSHOP

A series for the would-be constructor

PART FOUR: CIRCUIT BOARD CONSTRUCTION

Rev George Dobbs G3RJV



Some constructors are put off circuit board techniques by the assumption that in order to make a smart layout they will have to etch copper clad board with lethal chemicals. The attendant risks of permanently marking their fingers, burning holes in the kitchen table, staining towels and poisoning the cat seem to be too great for the mere pursuit of a hobby.

None of this is true. Etched boards are simple to make and the process is (almost) harmless. Next month I will deal with the etching of boards but for the way here are a couple of useful techniques for making presentable and functional circuit boards without resorting to chemicals.

Perfboard

Part three of this series discussed the use of Veroboard, that cunning stuff with lots of holes and copper strips that enables circuits to be wired up by following and amending the strips. Veroboard is useful and widely used by many amateur constructors but it does have the disadvantage that the circuit has to be designed around the series of lines. There are also doubts about its use for some high frequency applications. The real problem that many newcomers encounter when using Veroboard is careless soldering causing bridges between the tracks of copper.

A similar, but I think somewhat better, alternative commercial prototyping board is Perfboard. This looks very much like Veroboard in that it is made from insulated board with a matrix of holes. Like Veroboard, the holes are usually in a 0.1 inch matrix grid. It is also possible to buy the board with 0.15 inch spacing between the holes.

Unlike Veroboard, Perfboard has no copper strips to form the basis for the connecting links. The board is plain on both sides and wires have to be used to form the intercomponent connections. The component leads go through the holes in the same way as Veroboard and conventional printed circuit boards and the connections are made on the underside. The advantage over Veroboard is that the layout does not depend upon existing tracks and may follow the constructor's own wishes. In fact the completed board is much like a conventional printed circuit board, except for all the little unused holes left around

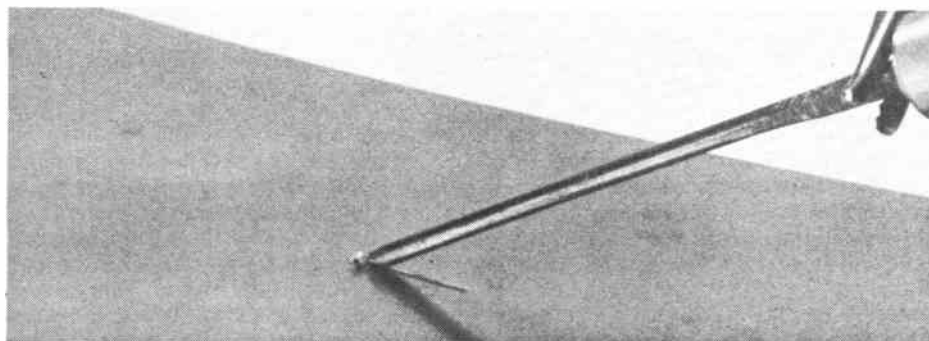

Using a gouging tool to cut a groove in copper clad board

the components.

The use of Perfboard is simple. Study the circuit, work out the layout, insert the components and wire up the interconnections on the underside. The only complex bit is translating from the circuit to the layout and we will look at that later. The underside connections may not require any extra wire. Most wire ended components have plenty of lead length and the spare lead can be used to route the connections underneath the board. From time to time extra wire will be required, especially for power lines and ground connection lines, and these can be made in thin tinned copper wire. Strip the insulation from some PVC covered single strand bell wire or use 5 amp fuse wire for such connections.

I first began to use Perfboard in prototyping work and experimental circuits to try them out prior to making a proper etched printed circuit board. In too many cases the final printed circuit board was never etched because the Perfboard layout worked well enough to be used as the final board. This type of construction seems very popular in the USA and several examples can be seen in some of the American practical construction books and publications. In some cases very complex circuits have been built completely on this board.

One problem with Perfboard is that some circuits really require a 'minimum etch' technique; that is, when the connection tracks are surrounded by spare copper on the board. The connecting strips are etched to be little 'islands in a sea of copper'. The surrounding copper forms an earth (or ground) mat which is useful for screening in some types of circuit.

The other problem with Perfboard is

that it is not cheap. It is possible to pick up offcuts of Veroboard at bargain prices but this is rarely so for Perfboard. Usually the constructor has to pay the full price which is quite expensive. Also it is not as readily available as Veroboard, but one reliable source of supply is the Tandy chain of stores. These stores exist throughout the UK and usually stock Perfboard in both the 0.1 inch and 0.15 inch matrix spacing, in various sizes.

Cut board techniques

A printed circuit board is made by etching the interconnection tracks chemically onto a piece of copper clad insulated board. It is possible to remove copper from the board by physical means and produce neat circuit boards. One common technique is to run the blade of a hacksaw across the copper side of the board and remove grooves of copper. If this is done in rows at right angles to each other a matrix of copper square 'islands' can be made and the circuit based upon these.

This technique, illustrated in *Solid State Basics* published by the ARRL, is a useful way to prototype or even finally build some simpler circuits. However, it is a clumsy way to build circuits with more than two or three simple stages and so is limited. Many other ways of physically removing copper from copper clad board to fashion circuits have been described in the amateur radio literature but few produce results akin to a conventional printed circuit board layout.

However, a method that I have used over the last few years does produce boards that are very much like minimum etched printed circuit boards and was first described to me by G3PDL, who has

BEGINNERS' WORKSHOP

built very complex boards without resorting to chemical etching. This method involves using a wood turning chisel or similar tool and cutting grooves in the copper surface to make tracks which appear as a system of islands in a background of remaining copper.

Some tools easily cut neat grooves in the copper surface of copper clad boards. Several types of tool can be used but the most successful for me, and the first I tried, is a wood turner's gouge. I use a 1/32 inch (1mm) gouge made by Henry Taylor Tools Ltd, of Sheffield. Not a cheap tool but very useful.

Similar results, with some practice, can be obtained using lino cutting tools. These are cheap and replaceable blades fit into a wooden handle. The idea is to draw the tool along the surface of the copper clad board at such an angle as to pare away a neat groove of copper, exposing the insulated material. With practice a thin neat break in the copper can be made in straight line or even curved around to fit a chosen layout.

Figure 1a shows a typical small section of conventionally etched printed circuit board. The tracks appear as lines of copper on the insulated surface and join the pads which contain the holes through which the component leads are passed and soldered.

Figure 1b shows the minimum etch technique. The tracks appear in exactly the same way but this time as much copper as possible is left on the board. The track only has a small section of insulated board around its edges and the rest of the board is filled with copper which forms a ground mat or screen around the tracks.

Figure 1c shows a similar effect produced by cutting away grooves of copper to give tracks, which are surrounded by the remaining copper on the board. This time the tracks are thicker and cruder but from the top side of the board the effect is the same as a conventional printed circuit board. This technique not only eliminates the use of chemical etchants but is very quick to carry out. In fact some people work on the board a stage at a time along a circuit until it is completed, testing each stage as they build it.

The system is good for prototyping boards or one-off completed boards. The only limitation is the skill of the tool

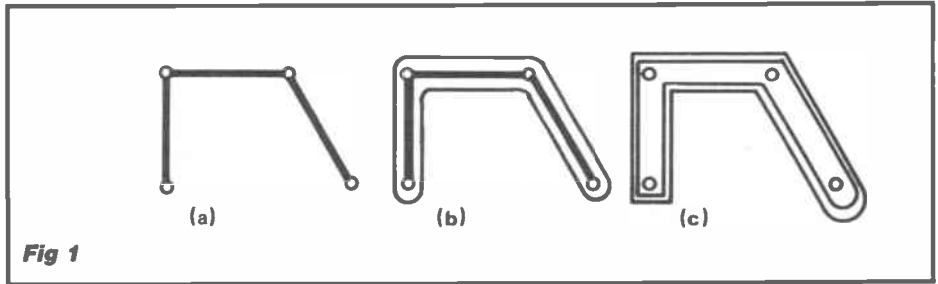

worker in his ability to make thin grooves in the board. Some claim to be able to make lines so thin that they can run a track between two pins on an integrated circuit base (0.1 inch spacing). Good luck to them - I cannot! But for a good many circuits this method will produce quick and neat circuit boards.

The mini amp

The easiest way to learn how to make neat circuit boards is to build up a simple project. For this exercise I have chosen a small audio amplifier. This is based upon the cheap and simple ULN2283 audio amplifier integrated circuit. This device is available for around £1.00 and provides a low cost, easy to build audio amplifier. When built it could be a useful test item around the shack and I will also suggest how it might be mounted into a case. However, the ultimate purpose of building this board is to use it as the final stages of a simple receiver that will be built later in this series.

The circuit is shown in Figure 2, and could not be simpler. The ULN2283 is an 8-pin device but in fact only 4 pins are really used, the central pins on each side being grounded to aid heat dissipation. The four connections are: input on pin 8; output on pin 4; supply line on pin 5 and decoupling on pin 1.

The input in this circuit is coupled via C1 to a volume control, R1. C2 couples the signal to the input at pin 8, with R2 providing the constant input load, which this device likes, and C3 aiding input stability. The supply, decoupled by C6, is applied to pin 5 via the on/off switch SW1. The output is coupled via C5 to an 8 ohm small loudspeaker. The whole amplifier, in this form, is powered by a 9 volt battery, a PP3 in my prototype. An LED and series current limiting resistor, R3, shows when the amplifier is switched on. A nice simple circuit. How do we translate it into

a smart layout on a board?

The first stage is to plan the layout on paper. For this you will need a copy of the circuit diagram (Figure 2), the components to be used and some 0.1 inch spaced graph paper. The actual components are required to enable the spacings between the leads to be accurately marked on the plan. The 0.1 inch grid graph paper is required because integrated circuits (ICs) have a pin spacing of 0.1 inch. It can be difficult to get 0.1 inch grid graph paper in these metric days, so invest in a small stock when it can be found. I have a supply of translucent paper which is ideal for this application as I will explain later.

Planning the board

The object is to translate the circuit into a neat layout avoiding long connecting tracks or tracks which cross and would therefore require extra link wires. In the case of this circuit I began by marking out the position of the IC pins with the input on the left and the output on the right.

I do all my layouts from the top of the board. Although this means having to transfer the connecting track lines to the underside of the paper for the final copper side layout, it is easier to see the layout from the top.

Figure 3 shows the final layout drawing evolved for this little circuit. The IC is centrally placed and the various components are neatly spaced around the IC pins. Note the single dots without connecting lines. These are the grounding points on the circuit. Holes are drilled at these points which simply go into the remaining copper on the board, all of which becomes a ground connection.

Connection points are made for the input, output and power line and next to the input and output points are dots

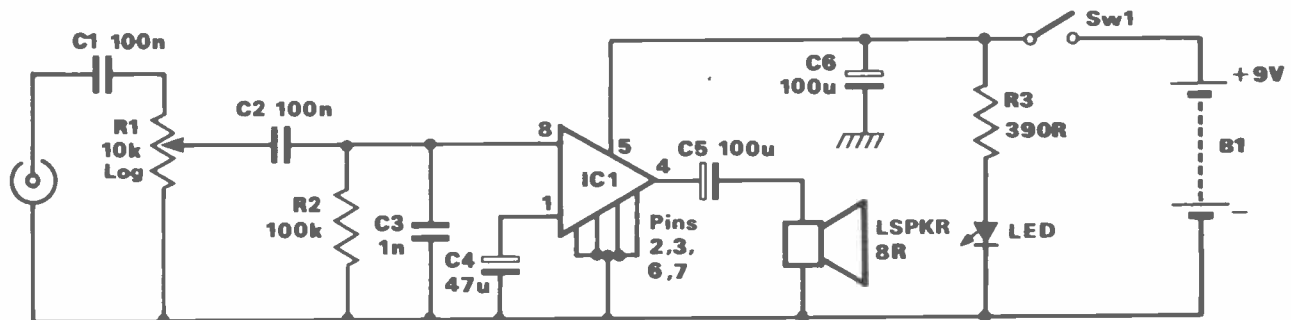

Fig 2 Circuit diagram

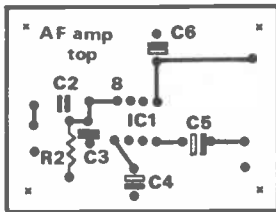

Fig 3 Board layout

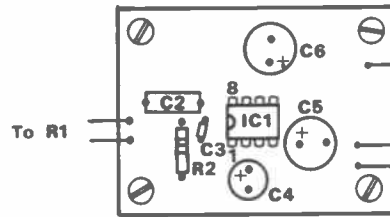
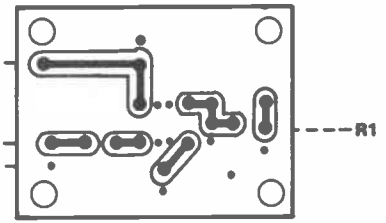

Fig 4 (a) Top



(b) Underside

which show that ground connections are also made because these connections come to and from the board via screened leads. The ground points are all below the components (R2, C3, C4, input and output) except for C6 which is grounded at the top and pins 2, 3, 6 and 7 of IC1 which solder directly into the remaining copper.

Because these lines are drawn on the top of the paper they are on the wrong side so have to be transferred to the underside of the paper to show the real routes taken by the copper tracks. In the case of translucent graph paper these lines can be seen from the reverse side, but on normal graph paper they have to be traced through. This can be done by holding the paper to a light or against a window and drawing the lines onto the back of the paper (the well-equipped may have a lightbox!). This now forms the pattern for cutting the tracks.

I like to drill the holes before I do any cutting. Cut a piece of copper clad board to fit the layout size. Copper clad board can be expensive but many radio rallies and shops do supply off-cuts large enough for small boards at low prices. Aim to get hold of the fibre glass board as this is much better quality than most of the other insulated boards. Apply the graph paper to the copper side of the board, track layout plan (the one traced through) uppermost, with Blu-tack stationary putty. Then, either with a sharp centre punch or a small twist drill, I mark out the places for the holes which I then drill. The less cautious can drill the holes in one go directly through the paper into the board.

Drills

Small twist drills are required for circuit board work and these can be quite expensive. 0.6mm or 0.7mm are suitable for general work but a range of sizes is useful. These drills break with great ease and never more so than when used in a hand-drill. The ideal tool is a small 12 volt drill sold specially for circuit board drilling – a very useful item for the amateur constructor. I have used the same small 12 volt hand-drill for many years with a range of collets for all my circuit board drilling.

It is worth paying a little money to set up the workshop with the correct equipment for circuit board work. Some people use a pin chuck in a conventional stand drill but I have found this can lead to broken drills and prefer the small purpose made low voltage printed circuit board drills.

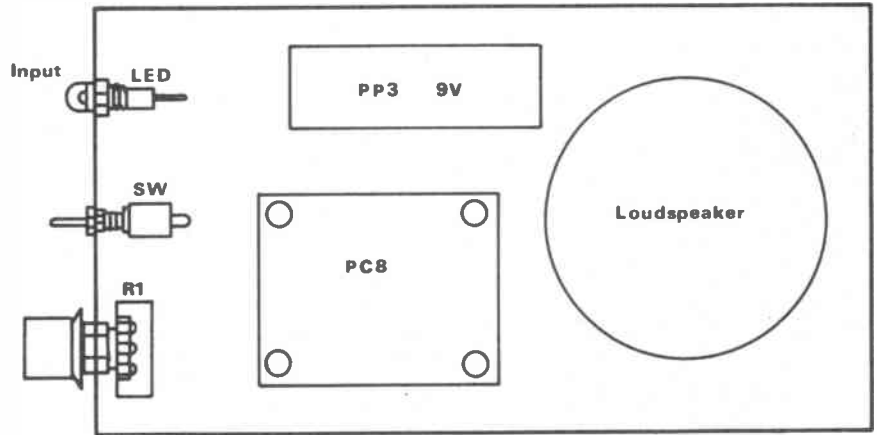

Fig 5 Case layout (top)

Once the holes have been drilled, the tracks to be cut are marked on the copper between the appropriate holes. This can be done with a soft pencil or a fine felt-tipped pen. The object is to now cut the grooves around these lines including the holes in the tracks that remain.

Groove cutter

The groove cutter, gouge or lino-cutter can be a dangerous tool and will cut grooves in hands as easily as in copper. I have a piece of wood into which are screwed several wood screws and I use these to push the board against as I cut the grooves. The board is laid upon the wood base and either one edge can be pushed against two screws (which protrude a little from the wood) or a corner can be pushed between two screws to allow other angles of attack. A little practice will determine the angle at which the cutting tool has to be held in

order to get a clean thin cut into the copper. Turning the corners is difficult, but fun!

Figure 4 shows how the board should look on completion. Figure 4b shows the underside after the cuts have been made. Figure 4a shows where the various circuit components fit into the board. Insert and solder the IC first, making sure it is correctly placed – check twice before soldering. C4, C5 and C6 are all polarised capacitors and should be placed into the board the correct way around. They should have markings which indicate the positive (+) and negative (-) leads. The negative lead goes to ground in every case.

The leads to the board can be soldered directly into the holes in the board or solder pins can be mounted into the holes as connection points. The board has four mounting holes, drilled to accept 6BA nuts and bolts. These are used to mount the board to the bottom of

Circuit built on Perfboard

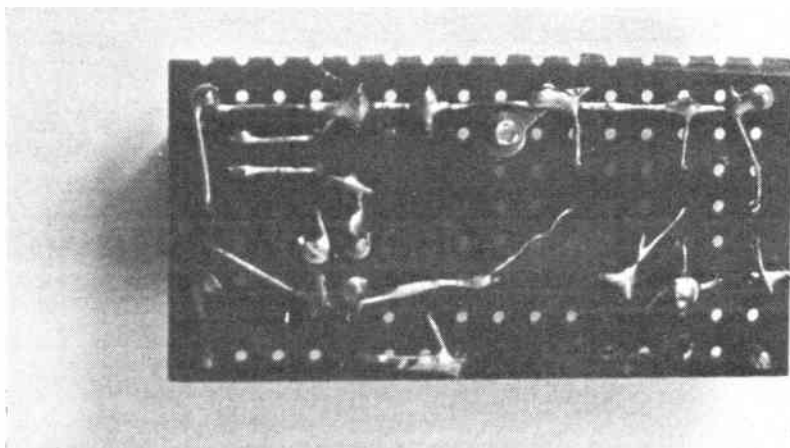

BEGINNERS' WORKSHOP

the case, with a stand-off pillar between the board and the case.

Once built the board can be tested before it is mounted. A simple test is to apply the power (the IC can be used from 3 to 12 volts), in this case a 9 volt battery supply to +9V and the ground, with a small loudspeaker connected to the output. Some hiss should be heard in the speaker and when the input is touched with a finger, left end of C2, a gentle hum should be heard.

The board is now ready for mounting into a case. The prototype was built into a Minffordd's A25 aluminium case with the input socket, the LED, the on/off switch and the volume control on the front

panel. The layout inside the case is shown in *Figure 5*. The PP3 battery fits into the case and is held in place by Bluetack. The speaker also fits into the back of the case pointing upwards, with holes drilled into the top of the case to allow the clear passage of sound and again held to the bottom of the case with Bluetack. The techniques for working on the case and marking the front panel will be dealt with in a later section of this series.

The completed amplifier is limited in use with only a maximum of one watt of audio output, but a general purpose small audio amplifier can be a useful piece of test equipment in the amateur shack. The board will be used later in this

series as part of a complete receiver. The next part of the series will show that etching circuit boards is simple, safe and well within the capacity of any amateur.

Sources

A25 aluminium case: *Minffordd Engineering, Sun Street, Ffestiniog, Gwynedd L141 4NE. Tel: (076676) 2572.*

ULN2282 audio amplifier integrated circuit: *Cirkit, 200 North Service Road, Brentwood, Essex. Tel: (0277) 211490.*

COMPONENTS LIST

R1	10K log potentiometer
R2	100K
R3	390 ohms
C1	0.1µF
C2	0.1µF
C3	1nF (min ceramic)
C4	47µF, 25V min electrolytic
C5	100µF, 25V min electrolytic
C6	as C5
IC1	ULN 2283
LED	miniature red LED in housing
LS	miniature 8 ohm loudspeaker
SW1	miniature toggle on/off switch
B1	PP3 9 volt battery
Input socket phono	
Case A25 Minffordd Engineering	
Battery connector, knob, 4x6BA nuts/bolts	
4x6BA stand-off pillars	

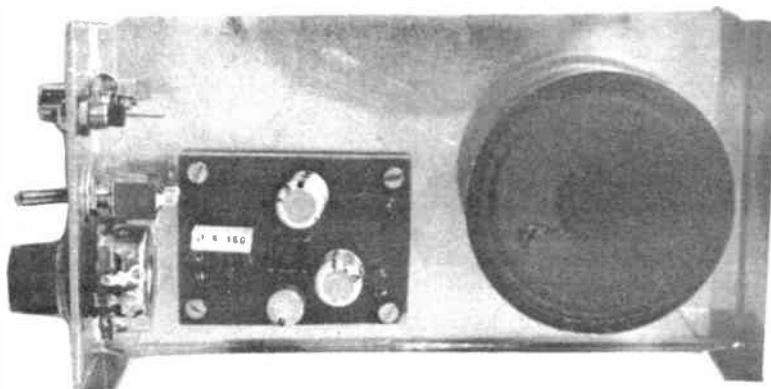

UNIACE TELECOMMUNICATIONS LTD

Proudly present their 934MHz leisure band
tranceiver the

EXCEEDS D.T.I. SPECS. TO BRING YOU PROFESSIONAL SPECIFICATIONS:-

Microprocessor control.
Double balanced Shottky mixers.
T.C.X.O. frequency control.
Cavity filters.
Surface mounted chip components.
Sensitivity .5µV for 20db quieting.
Full 8watt. TX. output power.
Auto and maunal squelch control.
Easy conversion to 40 channels.
State of the art design.
V.O.G.A,D audio processing.

UNIACE 400



RRP £355
INC VAT

Made in Britain, the performance exceeds that of any other rig available now for the 934MHz band.

Available from leading distributors or direct from Uniace.



Unit 8,
Conway Road Industrial Estate

Gwynedd,
North Wales

Tel No. 0492 61 3232
Telex 6155 AIRTEL (Ref UN1)

You can depend on

ELECTROVALUE

to supply the fine
range of test &
measurement
gear by

thandar

Made
in
U.K.

**FREE 44 PAGE
PRICED AND
ILLUSTRATED
CATALOGUE ON
REQUEST**

● Over 6000 items stocked

- counters
- multimeters
- scopes
- signal generators etc.

ELECTROVALUE LTD 28 St. Jude's Road, Englefield Green, Egham,
Surrey TW20 0HB Phone Egham (0784) 33603. Telex 264475
North Branch, 680 Burnage Lane, Manchester M19 1NA
Telephone 061 432 4945
Please mention this publication when replying

BRITAINS FOREMOST QUALITY COMPONENT SUPPLIERS

BECOME A RADIO AMATEUR

**Train now for the
Radio Amateur
Licence
examination. No
previous
knowledge
needed, only a few
hours per week of home study for 3
to 6 months. Post coupon now for
details.**

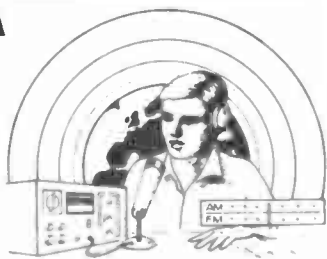

British National Radio & Electronics School, PO Box 7,
Teignmouth, Devon, TQ14 0HS.

FREE brochure without obligation from:-



British National Radio & Electronics School
PO Box 7, TEIGNMOUTH, DEVON, TQ14 0HS

Name

Address

AM7M

BLOCK CAPS PLEASE

For the latest thoughts about the
communications of the future and
to find out what's happening now,
buy **DIRECT LINE** and make it
your guide to the new
communications age

First Issue

DIRECT LINE

Your guide to the new communications age



Going places:
the phone in the car

Television:
by cable and satellite

Prestel:
services at your fingertips

- Designed for easy reading
- Introduces new communications systems
- Read all about it in the first issue
- Electronic mail and shopping from home
- Cellular mobile telephones
- Television by cable and satellite
- Latest technology explained
- Interactive computing
- News of all the latest products
- Exceptional value for money

**MAKE A DIRECT LINE TO
YOUR NEWSAGENT ON JULY 18**

Californian DXers are no ordinary DXers – the sunny state of California is the home of many of the world's top DXers. Californians are renowned for their enormous antenna arrays and powerful HF stations and the 'Californian kilowatt' has become legendary worldwide among HF band DXers.

The agricultural town of Fresno, located halfway between San Francisco and Los Angeles in the heart of California, is the venue for the world's greatest annual DX convention.

Fresno DX Convention

This year's Fresno DX Convention brought together over 500 international DXers under one roof. DXing is just one of the many facets of amateur radio; DXing on the HF bands means trying to contact stations in far away or rare locations. Among the delegates were some of the most famous call signs in the fascinating world of DXing.

American conventions are very different to what we are used to in the UK. At Fresno, delegates arrived at the hotel/convention centre at around 5pm on the Friday afternoon and stayed through until Sunday afternoon. With so many DXers staying in one location there was plenty of opportunity for the swapping of fisherman's tales.

The convention programme itself consists of a series of lectures given by well-known speakers on a range of subjects of special interest to delegate DXers. This year's lecture programme included talks on a DXpedition to Kermadec, on contest DXpeditions to TI1C and EA9KF by Jim Neiger N6TJ, as well as a descriptive lecture from OH8OS and W6KPC on the world's two largest HF amateur band arrays.

Clipperton

Clipperton is legendary among HF band DXers. It is nothing more than a minute atoll in the Pacific Ocean but, because of its status as a 'country' and the difficulty in gaining access and operating, it has become one of the most dreamed of and sought after locations on the DXer's map.

Post-war operations from Clipperton can be counted on the fingers of one hand. This year's Fresno DX Convention coincided with the return to the US of a sixteen man team that had just mounted a very successful operation from Clipperton with the callsign: FO0XX. Ten of the Clipperton operators were able to attend the Fresno convention and their presence was itself one of the highlights of the show. The Clipperton crew gave a slide show of their DXpedition, which included many excellent pictures illustrating the terrific difficulties that had to be overcome in both landing and leaving that remote atoll far away in the Pacific Ocean.

The FO0XX operation amassed a total of just under 31,000 QSOs in six days of operation on that crab and booby bird infested atoll.

To achieve high QSO rates on major DXpeditions operating procedure is all important. WA7NIN said that 'Nothing works better than a perfectly timed tail-

DXers MEET ON THE WEST COAST

by Nigel Cawthorne G3TXF

end call'. He added however that most 'tail-end' calls are far from perfectly timed! Japanese operators have a worldwide reputation for being the most disciplined in pile-ups. Typically if a DX pile-up operator calls for JA9s, all he will get calling will be JA9s. This differs from European pile-ups, where if the operator at the sharp end calls for 'LAs only' he will get Gs, HAs, LZs, SPs and many others coming back!

In order to increase the volume of JA QSOs, the Clipperton crew included JG3LZG, whose task was specifically to work JAs on all bands in Japanese. However, things did not quite work out as planned. To everyone's surprise it was found that the JA pile-ups, normally renowned for their excellent behaviour, decayed into a mess just as soon as the JAs realised that they were calling a Japanese operator at the sharp end of the pile-up.

For Europeans who were unable to work Clipperton during the recent

expedition it was a consolation to hear Rusty W6OAT say that there was 'no good propagation to Europe at any time – it was tough working them on any band'. In direct contrast to the excellent reputation that the Japanese have for discipline in pile-ups, European stations have a reputation for unruliness and bad behaviour in pile-ups.

In reply to a question asking the Clipperton operators for their feelings on the best way to call in a pile-up, Rusty W6OAT said that without doubt the smartest way to call in a pile was with 'the full call phonetically, one time'. The Clipperton operators told delegates that in their experience the use of 'abbreviated' callsigns in pile-ups had the effect of slowing QSO rates down rather than increasing them.

Clipperton DXpeditions are rare – the last one was just six years ago. It was therefore a fortunate coincidence that the FO0XX expedition's return tied in so well with the Fresno DX Convention.

Clipperton DXpedition operators F9LX, JG3LZG and F6GXB display their Fresno DX Convention beer glasses during a pause in the proceedings



DXers GO WEST

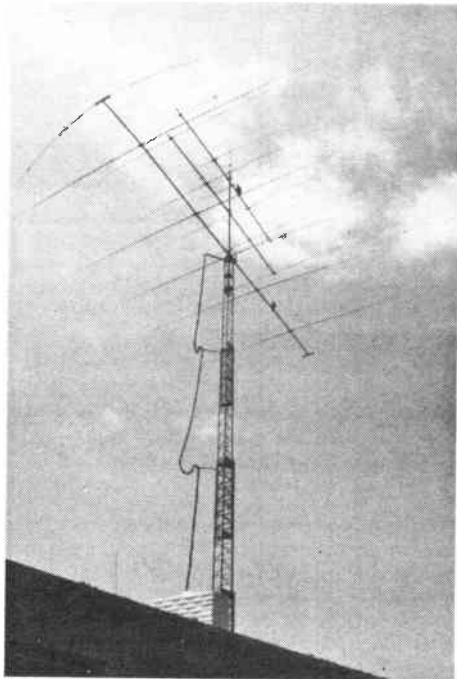

Huge antenna installations are a feature of amateur radio in California, as illustrated in the above photo. On a single tower, Jim W6YA has stacked five-element single band beams for each of the three HF bands as well as a rotatable delta loop for 40m

DXCC: The arguments

During the DX Forum at Fresno two of the hottest topics of interest to DXers were discussed: the Pribiloff's and Baker & Howland Islands. There are strong arguments both for and against these minute entities becoming 'countries' under the rules of DXCC. The Pribiloffs are a small group of islands off Alaska which, it is argued, should be considered as separate from Alaska because of their distance from the Alaskan mainland. The counter argument is based on the fact that they are not far enough from the Aleutian Islands to count as separate. Meanwhile down in the Pacific Ocean there are a series of islands that have had a tangled administrative history. For many years one of the 'freaks' of DXCC was Canton Island, which was administered both by the US and the UK. This meant that amateur operators on the island could get a callsign from either or both administrations. For instance VR1W was given to one operator by the UK administration and KB6DA was given to the same operator by the US administration. One ham, but two calls from the same shack. Each call counted as a different DXCC country!

The recent absorption of some of the islands into the Republic of Kiribati has necessitated a rethink on the status of Baker and Howland Islands, which were previously under US administration. Discussions and debate on these DXCC anomalies are likely to continue for some time. The Fresno DX Convention was an opportunity to air the different arguments and opinions that surround these controversial 'countries' on the amateur radio DXers map!

Monster antennas

To an HF operator using just a 20 metre dipole, a full-size six element beam for 20 metres on a 55ft boom sounds just enormous. Imagine then an array consisting of eight six-element 20m beams stacked into four layers, with two beams at each level. The 240ft high monster array at OH8OS is just that! The Californian end of the monster array experiment is at W6KPC who has a 36 element array consisting of just six six-element 20 metre beams stacked into three layers with two beams at each level.

The owners of both these monster arrays gave a lecture to the Fresno audience on the experiments that have been carried out on the path between California (W6KPC) and Finland (OH8OS). By controlling the feed to the individual beams that make up the array it is possible to alter the angle of fire as well as the effective height above ground of the antenna. For different types of propagation the angle of fire can be optimised.

The gain over a dipole of the OH8OS array is 18dB and the W6KPC array is 17dB. Experiments are being planned to take radio propagation measurements on 20 metres on a continuous basis, with computers doing the monitoring and determining the optimum angle of fire under different conditions. Both arrays are fully rotatable, so that as well as being able to select different vertical angles of radiation, by turning the antenna it will be possible to select the optimum path between the West Coast of the US and Northern Europe.

Since the Great Circle path passes close to the magnetic North Pole, the optimum propagation path for radio signals between the two sites is often other than the direct short-path or long-path along the Great Circle. Under some conditions a 'skew path' may be the optimum.

In conclusion, W6KPC told Fresno DXers that he and OH8OS are keen to find amateurs in other parts of the world with the possibility of building similar

antennas, so that they too could take part in the propagation experiments. With the antenna and computer installations costing around \$1 million, there is unlikely to be a rush of potential participants for these frontier breaking amateur experiments in radio propagation!

CQ hall of fame: ZL1AMO

For many UK HF operators, Ron ZL1AMO has been a regular supplier of new Pacific countries on CW over the past decade. Ron's excellent CW operating technique and extra sharp ears have made it easier for lower powered European stations to contact many exotic Pacific locations, including Tonga A35, Pitcairn VR6, Samoa 5W1 and Kermedec ZL8.

Ron has been a regular Pacific DXpeditioner for a number of years and it was very appropriate that he should receive one of amateur radio's international awards of recognition: the *CQ Magazine's* Hall of Fame Award. John Attaway K4IIF, DX Editor of *CQ Magazine* presented the award to Ron during the Fresno DX Convention banquet.

Big guns and small pistols

California has many big guns in DXing. To name all the well-known calls seen at Fresno would take up too much space, but active UK HF DXers are likely to have run across most of the following over recent years: Lloyd and Iris Colvin, W6KG and W6QL, who have made numerous world-wide DXpeditions; W6AM, Don Wallace, whose rhombic antenna farms are legendary in amateur radio; KH6IJ, Nose, whose CW signal from Hawaii has been coming over the North Pole into Europe for many decades; Dick Norton N6AA, champion contester (often to be heard using the call 9Y4VT) and Jim Neiger N6TJ, another ultra active DX contester, to name but a few.

The Fresno DX Convention is without doubt the single greatest concentration of DXers and contesters to be found anywhere in the world and I was privileged to be there.

Callsign plates are allowed in most states.

'Vanity plates' make it easy to identify the callsign of the occupant as cars pass by



SHORT WAVE LISTENER

TREVOR MORGAN GW40XB

The month of March gave us the CQ WW SSB contest which many of our listeners used to good effect in their DX and prefix hunting. Although I was only able to spend a little time on the air there were plenty of nice prefixes to be had, and the Russians obliged by allocating special callsigns to commemorate the D-Day anniversary. No doubt other countries will be issuing callsigns for the same event so don't be surprised at a few out of the ordinary prefixes. The Russian ones were available from 1 January 1985 and the designations are listed in the table below.

The bands have been showing sporadic periods of excellent lift and some good DX has been available for those able to be on at the right time. Judging by the lists sent in for the awards, full advantage has been taken of these periods by listeners using even the simplest equipment.

Now, when I mooted the idea of the *Prefix Awards* late last year, I had no idea the response was going to be so high. Naturally, the Editor was also curious as to the response as the awards had to be designed and printed.

Of course, some delays in issuing the first awards were inevitable, so please be patient with us. I have to check the lists and send the details to the Editor before

the awards can be issued. To shorten any delays would you please send your entries *direct* to me.

The mailbox

So to this month's mailbox and a very full one it is too!

I am receiving a lot of enquiries regarding the G1FTU RTTY program and the Spectrum interface I published some time ago. I explained at the time that this was really a simple switch box rather than an interface as generally accepted, but the box works as many readers can verify. However, there still seem to be some of you having difficulties with it and I have tried to help those who have written to me.

If you have the components and cannot wire it up successfully, I am prepared to do this for you providing you supply all the parts (see table) and the details of your microphone input socket, as these vary according to the rig you use. The box will be wired for transmit and receive as standard.

If you want to do it yourself, a leaflet has been photocopied and is available if you send an SAE. My mail bill is getting a bit hefty!

Now to the rest of the mail and we go first to Gosport where Reg Keeley-Osgood is using his FRG7700 to good effect when duties upholding the law permit! Like many of

COMPONENTS FOR THE SPECTRUM G1FTU 'INTERFACE'

- 1 four pole two-way rotary switch for Tx/Rx changeover
- 1 two pole two-way toggle switch for PTT line switching
- 1 microphone socket to suit microphone in use
- 1 microphone plug, preferably prewired to about 18 inch lead to fit rig in use
- 4 3.5mm jack sockets for panel mounting for input and output of signal
- 1 jackplug to fit your extension loudspeaker socket

You will also need an extra recorder to computer lead but this need not be sent to me. The box necessary should be about 3in x 4in x 3in and *must be plastic* otherwise an earth loop is formed between the transceiver and the computer.

our readers, Reg is studying for the dreaded RAE and using his listening experience to good advantage.

Alan Mather up in Cadishead has removed his G5RV and replaced it with a multi-bander made with 300 ohm ribbon. He's also an owner of a new CWR610E decoder which is testing his CW somewhat. Hope you made the 'part 2' this time Alan!

Roy Clayton G4SSH uses his Century 21 through an HF5V. As he says, the DX is harder to come by using low power, especially when conditions are as they have been over the past few months (seems like years mate!).

Just as Roy finds the DX, so can the listener and a good pair of phones can make all the difference. There are plenty of distant stations using QRP of only a couple of watts who would love to get a card from a listener with an interesting report. The thing about using low power is that you get so much more satisfaction from the occasional DX contact than when pushing out a kilowatt or so. To suddenly realise your couple of watts has made the trip to, say, Connecticut or the Antarctic despite the pile-ups gives you a hell of a kick. So, if you hear a weak signal, check if he or she is a QRPer.

Talking about exotics brings me to Graham Rigg who included some nice ones in his prefix claim. Now the weather is brightening up he is on the wire knitting kick to complement his 7700. He also mentions the bad operating

by some of the less well mannered of our European neighbours, who make listening or working into a chore, instead of the relaxing hobby it should be. If bad operating was an indictable offence universally the bands would clean up no end.

Malcolm G6JKP is suffering from RF breakthrough with his Sharp MZ700 computer, so if anyone can assist he'd welcome advice.

The problem of RF breakthrough seems to be much worse on two metres where some channels are unworkable (probably harmonically related to the signals put out by the computer components) but HF is still affected to some extent, although I haven't personally found it too much of a problem.

So, that's a few extracts from this month's mail. If there are any delays in replies to letters from this end over the next month or so it's because I had an operation in April and may be out of circulation for a while yet. There is a backlog to catch up with so please bear with me.

Thanks to all of you who have taken the trouble to write about all sorts of topics and I hope I have been able to help out where necessary. Please keep the mail coming.

Now to the *Amateur Radio Prefix Awards*, and what a terrific response we've had. Despite lousy conditions, with fifteen metres coming to life at most unholy hours and ten almost as extinct as the Dodo, our listeners have come up trumps again.

RUSSIAN CALLSIGN DESIGNATIONS

EM - stations located in areas of former guerilla activities

EO - stations in cities that were awarded medals for their contributions to victory

ER - stations located in the city of Moscow

EU - stations situated in the capitals of the 15 Soviet republics

EV - stations situated in capitals of the Soviet autonomous republics

EW - stations located in areas regarded as 'hero' cities

Individual stations are signing /R but for the prefix award scheme these *do not* count as extra scores whereas the 'E' stations do count.

Gold awards

The first claim for the premier award came from Graham Rigg, who bombarded me with Silver and Gold claims in swift succession. The Bermuda and WPX contests were of great help, and with the rise in twenty metres Graham gave the rig a real pasting. He has now logged 124 DXCC countries and is finding 40 a happy hunting ground for the VK/ZL areas.

Basil Woodcock chased Graham into the paddock with a list of 1,020 (just to make sure) and some really choice catches amongst the crowd.

Silver awards

Elmer Liddicoat sent in his claim of 500 plus rounded up using his Eddystone 1830 and a long wire tuned to match with a Global AT1000 that runs up to 120 feet at the high end!

Alan Mather BRS86537 sent in his claim for Silver mainly obtained on 80, 40 and 20 with some very nice catches.

Bronze awards

Roy Clayton G4SSH sent in his first claim for two-way CW contacts, all found with his 25 watts and HF5V. Shows what can be done with limited power.

Philip Begley took time off from managing his farm to use his DX200 and an assortment of aerials (Oh no, not aerial farming Phil?) to catch some tidy DX amongst the lists.

Antony Aspinwall used his 7700 and long wire to good effect to get his first claim with 8P6, J73, PT7, VU2 and VP9 for a taste.

John Leak G6NIJ found his QTH in Halifax ideal for catching 9H4, 6W6, 5B4, VK9 and a host of other niceties.

Don Pye might be in the depths of the Edgware Road (good hunting grounds for gear in the old days Don) but he found JH6, A92, 5N3 and VQ9 to help his total.

Roy Goddard over in

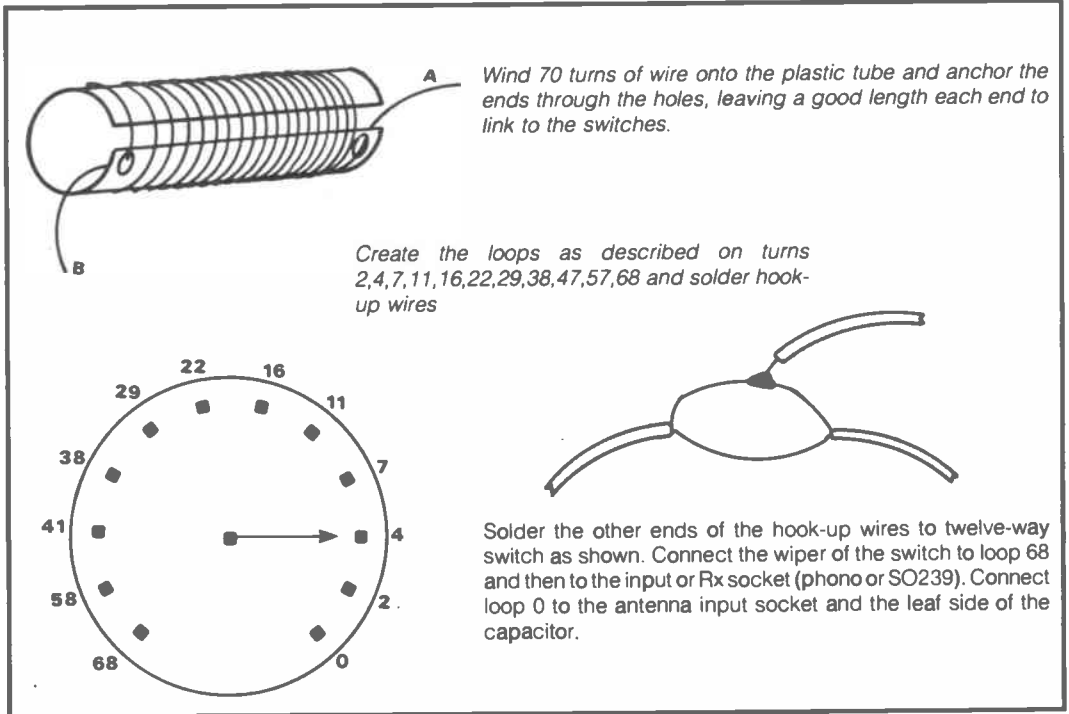

Gloucester coupled his Hallicrafters SX28 to an assortment of aerials to catch PT2, 5N0, 6Y5, 8P6 and HI8 to name a few.

John Simpson puts Macclesfield on the lists with his FRG7 and 60ft endfed to catch 9N1, ZB7, 9K2, PY5, 5N9 and a nice mixed batch.

Graeme Castleton down there in Orpington found A92, JR1, P29, YB0 and OA4OP/P/TI2 and the list was made up nicely in computerised prefix order too.

Gordon Blackley listened hard from Lowestoft to hear 5N6, A71, YT4, ZB2 and a nice BY1 for his first effort.

Philip Davies hails from Market Drayton and sent his claim in which included A71, J37, an infrequent OY5, ZF2 and 5B4.

Last but not least this month, Neil Rogers heard JA7, PT2, PY9 and a host of Russians to get his list off the ground.

Lists are still arriving by each post and they take a bit of time to run through but

there are few errors to be found. Lots of the lists check each other out and I noted many stations heard or worked by more than one of the lads.

Your support for the award scheme has been super and made it all worthwhile, so thanks to all who have taken part and indeed those who have yet to send their lists in.

So now to the item of the month for those of you without hot soldering irons at the ready.

A lot of letters arrive asking about coupling a long wire to their receiver and asking me to recommend a particular antenna tuner. One of the first I ever used was the Joystick ATU which was given to me by a real old timer. This was soon replaced by a homebrew ATU which I describe here for those wanting to use endfed wires with their receivers. It can also be used for QRP operating up to about 40 watts or so.

I don't claim any originality for the circuit as it's been around a long time.

Start by cutting a slot about 3/16in wide along the length of the plastic tubing and drilling one hole at each end for start and finish anchors. Leaving a free space at each end of about 3 or 4in, wind on 70 turns of the enamelled wire, finally anchoring the free ends through the holes.

Now for the tedious bit. Using a knitting needle or similar implement, thread it

through the turns depressing those to be left clear and raising the loops to be connected to the rotary switch (see diagram). Just like weaving a scarf really!

Cut ten pieces of hook-up wire to about 6in. Leaving the 'weaving' tool in place (providing it's metal), scrape the surface of each of the raised loops carefully and solder on the hook-up wires as shown. Using double-sided sticky foam pads, anchor the coil to the base of the casing and solder the other ends of the hook-up wires to the rotary switch in order.

Solder the free ends of the coil to the switch, the capacitor and to the antenna input and output sockets. Finally, fit the capacitor and rotary switch into place and fit the knobs onto the shafts.

Once you have the ATU made up you can try it out on the receiver to check that all is working OK.

That's the easy way to make a simple ATU or 'L match' for long wires. I could go into lots of details on the cabinet and so on but everyone has his own ideas on how the finished item should look.

Well that's it for another issue. Next month I'll be hoping to review a very nice little receiver and we have more award winners to be acclaimed, plus more news from the mailbag.

Until next month, good listening and keep the mail coming. 73 Trevor.

COMPONENTS

- 1 airspaced capacitor of around 250pF
- 1 single pole 12 way rotary switch
- 1 piece of plastic tube about 3 inches long and 1½ inches o/d
- 1 pair of insulated sockets to take 'wander' plugs or 'banana' plugs (black & red)
- 1 chassis mounting phono socket or SO239
- 1 metal cabinet about 5 x 3 x 6 inches
- 2 control knobs
- 22 gauge enamelled copper wire and hook-up wire.

≡ PROBLEMS IN RECEIVERS ≡

PART 1

by Angus McKenzie G3OSS

In the last year or so I have measured 30 HF receivers and transceivers and dozens of VHF, UHF and microwave systems, and as a result I have found some very bad deficiencies in many modern designs. These are mainly due to inadequate engineering, poor quality control and insufficient field testing with market research before the models reach production stage.

Many of these deficiencies are major ones, but could quite easily be put right if they had only been found early enough. Sometimes they are due to such mundane matters as poor board layout, but more usually the main problem is lack of dynamic range of the front end, either with reference to intermodulation performance versus sensitivity or with that of reciprocal mixing.

In some designs performance is poor because the designer's standards are just not high enough, and one wonders how many Japanese engineers actually listen to the products that they are responsible for! The bands in Japan are very different in characteristics to the same bands in western Europe, and the quality of AM reception on the majority of medium and short wave receivers is, in my opinion, abysmal.

Receiver requirements

Over the last few months I have taken many spectrum analyses of signal strengths that would be hitting a receiver front end on various bands. I have measured the approximate average band noise levels at various times of day so as to get an idea about the sensitivity required versus frequency. Before detailing the conclusions reached, let's have a look at some basic facts which may help you appreciate good and bad design. I am numbering them, and they should help you further appreciate many of the comments in my reviews.

1) A pure resistance of 50 ohms, a typical source for testing receivers, generates noise across itself at room temperature. The total amount of noise voltage varies proportionately to the square root of the following: temperature in degrees Kelvin, receiver bandwidth in hertz and its actual resistance.

You can look at this another way by accepting the fact that the noise power developed is proportional to temperature and bandwidth. There is thus a basic noise floor below which it is physically impossible to go when a 50 ohm screened load at room temperature is acting as source to a receiver designed to be noise matched with it.

In an SSB receiver with a bandwidth of around 2.3KHz the noise floor will be at

around $0.022\mu\text{V}$ if the receiver itself is physically perfect, which of course is an impossibility. The finest pre-amps in front of good receivers could, however, be showing a noise floor of only $0.025\mu\text{V}$. This noise can also be represented by noise power, so that perfection would be around -140dBm , with 0dBm equalling 1mW in a 50ohm circuit.

If the SSB bandwidth is increased, such as is usually the case in many cheaper receivers, or when you open up the selectivity of a more expensive set with variable selectivity, then the noise floor will be at a higher level. If you switch in a CW filter of 250Hz bandwidth then the noise floor should drop to around 7.5 nano volts , 1 nano volt being 1000th of a μV .

2) A perfect SSB receiver should give in the region of $0.085\mu\text{V}$ for 12dB sinad, this being equivalent to -128.5dBm . This is assuming the receiver is designed to noise match 50ohms and has a 0dB noise figure, which is impossible.

3) The ideal 12dB sinad performance of an NBFM signal on a perfect set having 10KHz bandwidth IF filters and the most superb discriminator should be similar, around $0.09\mu\text{V}$ or -128dBm . These figures are approximations but should be within 1dB of the ideal.

4) A perfectly matched 50ohm antenna connected to a perfect receiver, with no losses in the cable etc, will act as a 50ohm resistor, as far as noise is concerned, the temperature of the resistor being the temperature of the space or objects at which the aerial is beaming. Allowance has to be made for the temperature of all objects around the side lobes etc, as well as in the direct line of fire. An antenna at microwave looking up into space in the middle of the night can have an extremely low apparent noise if there is no leakage to it from the ground.

Fig 1 3.5MHz band occupancy, morning, fairly weak signals from dipole.

Note max signals at around $100\mu\text{V}$ around 3.64MHz

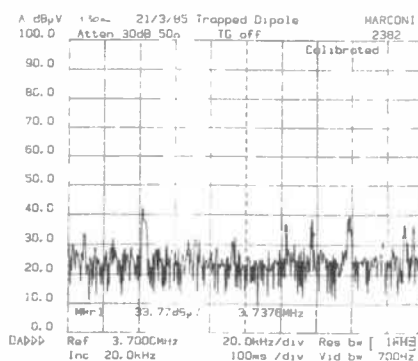

5) Noting 4 above, you can see that cryogenically cooling the pre-amp, and even the dipole, can lower the noise in a very good amplifier and thus improve the signal to noise ratio from incredibly weak signals coming from space.

6) The lower the noise of your receiving system the more dependant it becomes on the noise input to the aerial. In practice there is no point in radio amateurs having a receiver that is more than a few dB quieter than the lowest noise that can be encountered on a frequency at the quietest time of day or night, or at the time of quietest propagation noise.

7) The band noise, at its quietest on the LF bands, 160 and 80m , is so high that the receiver noise contribution can be around 25dB higher than perfection and still be lower than band noise using typical dipole antennas. If the antenna is much less efficient than a dipole then the receiver has to be somewhat nearer to ideal as the band noise picks up, and indeed the strengths of all signals will be many dBs lower.

8) As you go up in frequency to the 10m band the band noise becomes less and less so that by 10m the ideal receiver in practice should have a noise figure approaching 6dB or so.

9) At VHF frequencies the receiver again has to be better and better as you go up, and around 2dB at the antenna is ideal if you are in a superbly quiet location and in the middle of the night.

10) On 70cm your receiver can benefit from being as good as 1.5dB system noise at the antenna for the finest locations and at higher frequencies still, eg on the 23 and 13cm bands you can benefit by using noise figures even better than 1dB .

11) If you have a receiving system with a noise figure of 3dB , and the band noise is equal to this, then the signal to noise ratio will be equivalent to a noise figure

Fig 2 3.5MHz band occupancy, early afternoon, showing slightly greater occupancy and signal strengths than Figure 1. Note $250\mu\text{V}$ signal

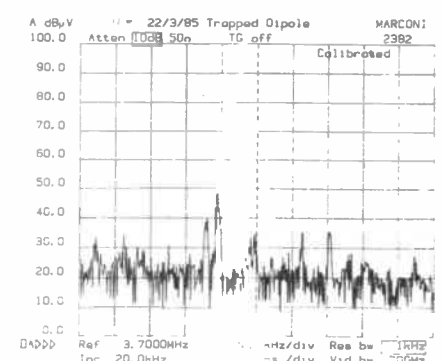

PROBLEMS IN RECEIVERS

of 6dB, ie the system noise power will double. This is why the receiver noise should be as much as 6dB better than the aerial noise if you are to see only a marginal degradation in the signal to noise ratio on a very weak received station.

Band noise, however, even at microwave, is sometimes higher than you think, for even if you are in an incredibly quiet location there is quite a lot of noise power from the sky, the ground and even astronomical objects.

12) The dynamic range of the receiver concerns the performance under typical band usage in which many strong signals are present on the band, often very close to your weak wanted one. The dynamic range concerns the ability of the receiver to be unaffected by the existence of the unwanted strong signals when receiving the wanted one.

Dynamic range is normally controlled by the parameter called RF input intercept point, from which can be calculated the approximate level of RF distortion products produced by two off channel signals. The dynamic range is conventionally calculated as the dB ratio between the receiver's noise floor and the level of each of two tones spaced off-channel by given frequency spacing and double this spacing, whose presence would cause a distortion product on channel, which is the same level as the noise floor.

13) Reciprocal mixing concerns the addition of noise apparently on-channel caused by strong signals off-channel mixing with sideband noise of the local oscillator. This results in extra noise into the first or later intermediate frequency. If this parameter is poor then the dynamic range of a receiver can, in effect, be severely reduced.

Receiver front ends

Virtually all receivers tested have too much available sensitivity on all bands below 10MHz, even for fairly modest antennas. However, many receivers are just not good enough on the 21 and 28MHz bands, and a few can lose you an S-point or so on 28MHz when you are trying to receive a weak station when the band is nearly closed. Many receivers

used on FM at around 29.6MHz are noisier than they should be and need a deaf aid to bring up a weak mobile signal.

It would be true to say that whilst most receivers show reasonably similar sensitivities on their S-meters on all the amateur bands covered, they should be desensitised for LF, which could result in great improvements in their dynamic range performances in practice. What on earth is the point of giving almost every signal you can hear near S9 on the 80m band!

Time and again amateurs complain of high band noise on 80m at times when the actual true noise is not that high, but there are a lot of stations about, both commercial and amateur, giving some receivers such a headache that the receivers themselves can generate much of the noise and crackling by intermodulation and reciprocal mixing problems.

Many very expensive rigs are poor, and even one £5000 rig from the States and a £2000 one from Japan were around 8 to 10dB less sensitive than they should be on 28MHz. Every receiver is around 10 to 20dB more sensitive than necessary on the LF bands, and beware of any receiver that omits at least a 20dB antenna switch or pre-amp in/out switch on its input. The ideal is to have a switched attenuator in 10dB steps down to -30dB.

Most 2m and 70cm rigs from Japan have rather poor sensitivities, and muTek Ltd should have shown the way forward to the Japanese by introducing their well-known front ends, which can dramatically improve receiver performance in practice.

Let's consider a few examples. The Yaesu FT-ONE, Collins KWM380 and Drake TR7 are all notoriously deaf, but so are many 2m rigs. Bearing in mind that you have to counteract cable losses at VHF, some rigs are so obviously deaf that many amateurs use external pre-amps in an attempt to boost up sensitivity, but seriously degrade intermodulation performance to such a degree that they are always moaning about the spreading of strong signals even when these are actually quite clean.

Of course there are many bad ones around and they are usually told, I hope

politely, about their problems. It is selfish to persist with a spreading signal which can cause misery to so many others.

Fortunately, many new rigs do show increased sensitivity where this is required, and a few VHF rigs are now fairly adequate, but even so the addition of a low gain masthead pre-amp can make an appreciable difference if you have a fairly long cable run.

Sensitivity can sometimes be the least of our problems, for a receiver's susceptibility to interference from strong in-band and out-of-band signals can be a menace. In the UK there are literally dozens and dozens of strong AM signals on medium wave which can cause havoc to 1.8MHz band reception on many rigs. It is essential for a rig to have not only a very wide dynamic range capability on LF, which means an available high intercept point, but also a very steep high pass filter acting below 1.8MHz.

Some sets, covering medium wave, simply pop in a 10dB input attenuator within the set when you tune below, say, 1.7MHz. This is a fat lot of good if you are tuning above this if you have an efficient half wave dipole, or even a good quarter wave one on the 1.8MHz bands, especially if you are close to any strong transmitters on medium wave. Some sets have sockets for receive in and out, which are break points in the receive input chain. A really good high-pass filter inserted at this break point can work miracles for your Top Band reception.

Some sets have a tunable front end pre-amp stage which can greatly improve the rejection of out-of-band signals, but it may do little or nothing to reduce problems from strong in-band ones. Many older sets had too much gain in front of the mixer, and thus pounded it with high levels. Too many mixers are both noisy and have a poor intermodulation performance, thus restricting the overall dynamic range.

Pre-selectors, ie tunable RF pre-amps, can have quite a high Q, ie the passband is but a small percentage of the tuned frequency. This therefore gives good rejection at LF, but by the time you are at 28.5MHz the RF selectivity will be almost as wide open as a barn door.

Fig 3 3.5MHz band occupancy, mid evening, showing greater occupancy and signal strengths than previous figures. Nb 10mV signal at 3.655MHz

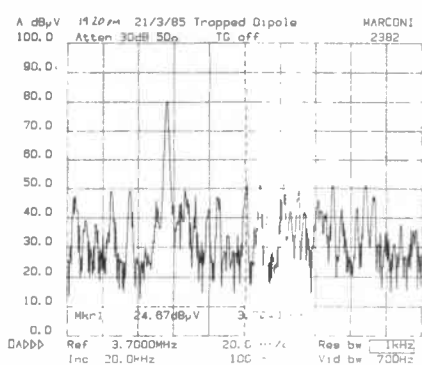

Fig 4 Band occupancy 140-150MHz, mid afternoon, omni-directional antenna 10m above ground, gain made up by 18dB to equal 8/8 at 55ft showing strong out of band signals

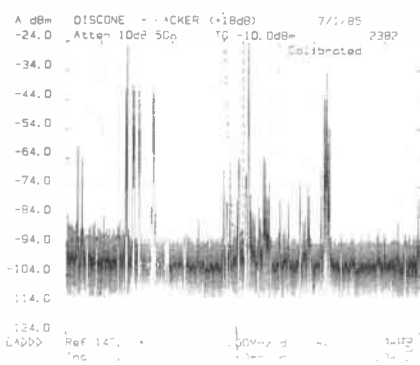
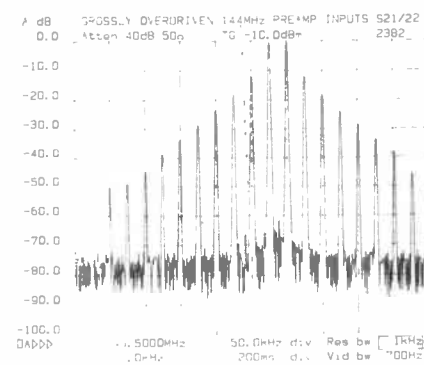

Fig 5 Grossly overdriven 144MHz pre-amp showing intermodulation products which can be generated from 2 extremely strong local signals



PROBLEMS IN RECEIVERS

Modern receivers often employ much better mixers which are less noisy and thus need rather less pre-amplification in front of them to overcome the mixer noise. This all helps dynamic range by keeping signal levels down within the mixer. Many modern receivers thus have very low intermodulation up to the input to the first IF stages. RF pre-amp in/out switches allow you to further improve the apparent dynamic range, especially at LF.

Many receivers now use switchable bandpass circuits for each band which are designed to reject signals way off frequency, but these in no way help in-band ones. A good receiver has filters for every band, but as often as not sets have too few of them and thus each one covers much too wide a range.

Reciprocal mixing

Reciprocal mixing is very difficult to measure for it is a measurement of the noise sidebands of all the local oscillators in the set. I used to measure it at spacings from 100 or 200KHz off-channel down to 20KHz, but in the last year or so I have realised that it is important to see how much noise there is even as close as 5KHz, and this means using an external oscillator which is itself quieter than any set's local oscillators are likely to be.

There are two ways round this problem, the first being to use a very quiet crystal

controlled oscillator with an impeccable performance, whilst the second is to use a good conventional generator feeding through a superbly matched, extremely narrow crystal filter of only a few hundred hertz bandwidth with very sharp skirts which remove noise from the oscillator's output. I prefer to use the first method, which has resulted in showing up how bad some receivers are and how surprisingly good are some old warhorses.

The worst short wave receiver so far that I have measured is the Yaesu FT ONE, but other poor ones are also synthesiser tuned types. This is not to say that synthesisers are all poor, for the Trio TS930 and the Icom IC751 both have remarkably good reciprocal noise measurements.

Analogue type VFOs, usually mixed with crystal oscillators, are frequently so much better, but it might be said that in practice they are needlessly better than a superb synthesiser oscillator. No one spacing should condemn an overall performance, for a set can be poor at 5KHz spacing but good enough in practice with strong signals at least 20KHz off channel. Such a set will add considerable noise if the interfering signals are very close in frequency, but it will be perfectly satisfactory if you just want to work the stronger ones, especially under mobile conditions.

The Yaesu FT ONE gives a 66dB ratio at 5KHz offset, whereas the Trio 930S is around 81dB and the IC751, 88dB. However, the Drake R4C, the Collins KWM2 and the Ten-Tec Corsair are all nearly 100dB. In a recent test a friend substituted a very low noise analogue tuned HP8640B signal generator for a synthesiser local oscillator in a set which had given a measurement of 75dB and saw a stunning improvement to 102dB, so you can see what this is all about.

I suggest that the majority of us should be happy with a set that has a reciprocal mixing performance better than 80dB at 5KHz which continues to drop rapidly to a noise floor better than 105dB.

It seems that Trio and Icom are getting their synthesisers right in general, whilst Yaesu rigs seem to be consistently poorer here. It is no use having a set with adequate sensitivity if weak DX is to be covered up by miscellaneous crackling noises when there are very strong commercial stations etc too close for comfort.

When measuring receivers, any deficiency in one area can actually cause problems in making measurements in many others. I will detail these next month along with a mention on a new method for measuring dynamic range and RF intercept points on awkward receivers, as well as introducing other problem areas further down the line.



**NEXT
MONTH**

Amateur
RADIO

all the regulars. . .

DX Diary
On the Beam
Back to Basics
SWL
Straight and Level
Your letters and
features covering
the whole of
Amateur Radio

■ ANGUS MCKENZIE TESTS

Next month G3OSS reviews the Icom IC3200 and the Yaesu FRG9600 VHF receiver

■ OPERATING IN SCANDINAVIA

An ambitious attempt by three amateurs to operate from Denmark, Sweden and Norway

DON'T MISS THE AUGUST ISSUE

On sale 25 July

AMATEUR ELECTRONICS UK

G6XBH **R.A.S. (Nottingham)** G8UUS
Radio Amateur Supplies
 Tel: 0602 280267

Visit your Local Emporium
 Large Selection of New/Used Equipment on Show

AGENTS FOR:
 F.D.K.
 AZDEN
 ICOM
 YAesu
 FORTOP ATV

ACCESSORIES:
 Web Range
 Microwave Modules
 Adonia Mics
 Mutek Pre-Amps
 Berenco Mast Supports
 DRAE PBU and
 Wave Meters

AERIAL: Tonna, Haibar, New Diamond Range of Mobile Whips

PLUS OWN
 'Special' Q.R.P. GWS HF5 Band Beams
 JUST GIVE US A RING

Monday: CLOSED Tuesday - Saturday: 10.00am to 5.00pm

**3 Farndon Green, Wollaton Park, Nottingham, Off Ring Road
 Between A52 (Derby Road) & A609 (Ilkeston Road)**

<p align="center">EVERYTHING MENU</p> <ol style="list-style-type: none"> 1/2 wave verticals for 10m £11.90 Centre-loaded mobile chips from £7.00 25 watt linear amps from £17.00 P.S.Us from £14.00 Repairs 10m FM Conversions 	<p align="center">FOR 10 FM</p> <p align="center">WANTED URGENTLY! 2nd hand VHF+HF equipment, part X welcome</p> <p align="center">SOUP OF THE DAY Lucas 10M FM RIG Only £45.</p>
---	---

RAINBOW COMMUNICATIONS



68 Gorringe Park Ave
 Mitcham Surrey
 Ask for Howard (G4VWR) or W:IN (xxxxxx)
 01-640 1904

OPEN TILL 8PM MON-FRI
SOUTH LONDON'S BUSIEST EMPORIUM

FORTY OF THE BEST

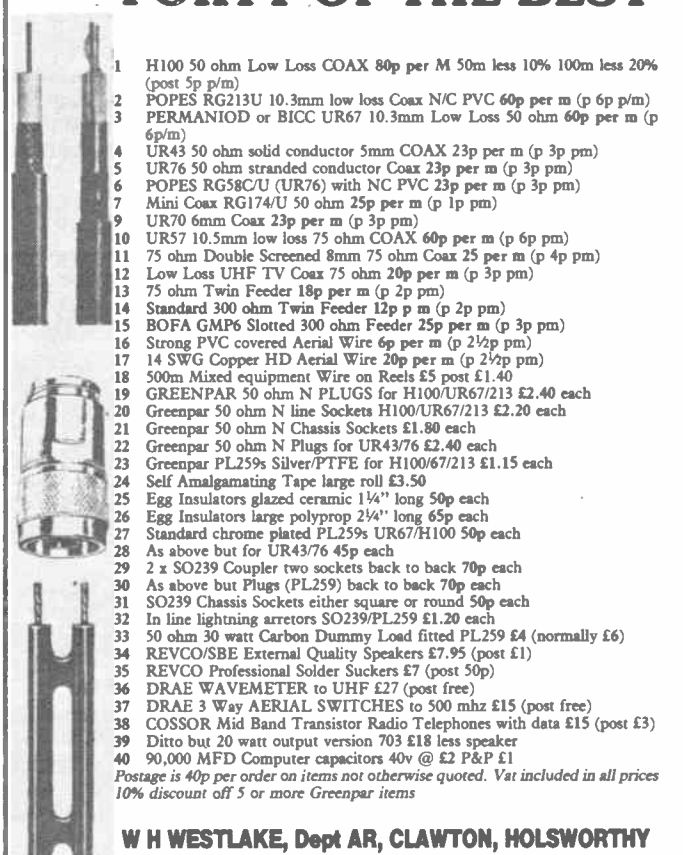

- 1 H100 50 ohm Low Loss COAX 80p per M 50m less 10% 100m less 20% (post 5p/pm)
- 2 POPES RG213U 10.3mm low loss Coax N/C PVC 60p per m (p 6p/pm)
- 3 PERMANIOD or BICC UR67 10.3mm Low Loss 50 ohm 60p per m (p 6p/m)
- 4 UR43 50 ohm solid conductor 5mm COAX 23p per m (p 3p/pm)
- 5 UR76 50 ohm stranded conductor Coax 23p per m (p 3p/pm)
- 6 POPES RG58C/U (UR76) with NC PVC 23p per m (p 3p/pm)
- 7 Mini Coax RG174/U 50 ohm 25p per m (p 1p/pm)
- 9 UR70 6mm Coax 23p per m (p 3p/pm)
- 10 UR57 10.5mm low loss 75 ohm COAX 60p per m (p 6p/pm)
- 11 75 ohm Double Screened 8mm 75 ohm Coax 25p per m (p 4p/pm)
- 12 Low Loss UHF TV Coax 75 ohm 20p per m (p 3p/pm)
- 13 75 ohm Twin Feeder 18p per m (p 2p/pm)
- 14 Standard 300 ohm Twin Feeder 12p per m (p 2p/pm)
- 15 BOFA GMP6 Slotted 300 ohm Feeder 25p per m (p 3p/pm)
- 16 Strong PVC covered Aerial Wire 6p per m (p 2 1/2p/pm)
- 17 14 SWG Copper HD Aerial Wire 20p per m (p 2 1/2p/pm)
- 18 500m Mixed equipment Wire on Reels 55p post £1.40
- 19 GREENPAR 50 ohm N PLUGS for H100/UR67/213 £2.40 each
- 20 Greenpar 50 ohm N line Sockets H100/UR67/213 £2.20 each
- 21 Greenpar 50 ohm N Chassis Sockets £1.80 each
- 22 Greenpar 50 ohm N Plugs for UR43/76 £2.40 each
- 23 Greenpar PL259s Silver/PTEE for H100/67/213 £1.15 each
- 24 Self Amalgamating Tape large roll £3.50
- 25 Egg Insulators glazed ceramic 1 1/4" long 50p each
- 26 Egg Insulators large polyprop 2 1/4" long 65p each
- 27 Standard chrome plated PL259s UR67/H100 50p each
- 28 As above but for UR43/76 45p each
- 29 2 x SO239 Coupler two sockets back to back 70p each
- 30 As above but Plugs (PL259) back to back 70p each
- 31 SO239 Chassis Sockets either square or round 50p each
- 32 In line lightning arrestors SO239/PL259 £1.20 each
- 33 50 ohm 30 watt Carbon Dummy Load fitted PL259 £4 (normally £6)
- 34 REVCO/SBE External Quality Speakers £7.95 (post £1)
- 35 REVCO Professional Solder Suckers £7 (post 50p)
- 36 DRAE WAVEMETER to UHF £27 (post free)
- 37 DRAE 3 Way AERIAL SWITCHES to 500 mhz £15 (post free)
- 38 COSSOR Mid Band Transistor Radio Telephones with data £15 (post £3)
- 39 Ditto but 20 watt output version 703 £18 less speaker
- 40 90,000 MFD Computer capacitors 40v @ £2 P&P £1

Postage is 40p per order on items not otherwise quoted. Vat included in all prices 10% discount off 5 or more Greenpar items

**W H WESTLAKE, Dept AR, CLAWTON, HOLSWORTHY
 DEVON (0409) 253758**

C M HOWES COMMUNICATIONS

FUN TO BUILD KITS BY MAIL ORDER

**139 Highview,
 Vigo Meopham,
 Kent DA13 0UT
 England
 Fairseat (0732) 823129**

Get more fun out of amateur radio with one of our easy to build kits. How about building yourself a station around our CTX transmitter and DcRx receiver kits for portable and holiday use during the summer?

All HOWES kits come complete with a good quality printed circuit board that is drilled and tinned and has the component locations screen printed on it for easy assembly. All board mounted components are included, as are full, clear, instructions. The kits are also available ready assembled. This is an important part of our quality control. Because we assemble the kits for sale ourselves, we are continually checking that there are no design or component problems with the kits. You can be confident that our designs will prove a success in your station.

CTX80 QRP CW TRANSMITTER FOR 80 METERS.
 The CTX80 is proving to be very popular indeed. Read the review by G3VTT in the March 85 issue of Shortwave Magazine. This straightforward CW transmitter will run up to about 5W RF output (the power is adjustable) and features key-click suppression and a five element low-pass output filter. The CTX80 is crystal controlled (one crystal supplied), but can be driven by our CVF80 VFO for full band coverage. Easy to build and great fun to use. There are hundreds of stations equipped for QRP CW on 80 Meters, there is no lack of contacts to be had! We will be producing versions of the CTX for other bands when time permits. The CTX80 works on 12 to 14V DC.
CTX80 kit £12.95. Assembled PCB module £18.95.

CVF80 VFO FOR 80 METERS.
 This is a fully featured VFO for use with our CTX80 transmitter or other homebrew equipment. Stable FET oscillator, dual independent buffered outputs, onboard voltage regulator, IRT (clarifier) control etc. The circuit includes 9 transistors and can drive both a CTX80 and DcRx80 receiver for transceive operation. Requires a 50pF tuning capacitor for full band coverage. We can supply a suitable device giving just under full band coverage (no chance of inadvertent out-of-band operation) at £1.50. Versions of the CVF for other bands will be available later in the year.
CVF80 kit £9.30. Assembled PCB module £14.90.

DcRx DIRECT CONVERSION RECEIVER.
 This design was originally conceived to meet the needs of the newcomer to the hobby. It enables a simple, single band receiver, of surprisingly good performance, to be built by a novice at a sensible price. The kit was reviewed in the May 84 issue of Shortwave Magazine by G3RJV and over the last few months since our CTX80 transmitter has been available, more and more experienced amateurs have been building these receivers as part of a simple low cost QRP setup. It took careful design to produce a simple receiver that would work this well. Compare the DcRx with that expensive black box that sits in your shack. Not quite as good of course, but I bet you can still hear most of the stations you can receive on the other radio.
 The DcRx is available for 20, 30, 80 or 160 Meters. It requires a 12 to 14V DC supply and will produce upto a watt of audio into a speaker or 'phones. Modes: SSB and CW. A case and two tuning capacitors are the only major parts to add to finish your receiver. We have suitable capacitors for all but the 160M version at £1.50 each.
DcRx kit £14.50. Assembled PCB £19.90. PLEASE STATE WHICH BAND YOU REQUIRE.

AP3 AUTOMATIC SPEECH PROCESSOR.
 The AP3 can add a really useful boost to your transmitted signal. The extra "punch" added to your modulation by the AP3 helps to cut through the noise and QRM, so enabling you to make contacts that are not possible without it. The AP3 was described in an article in the September 83 edition of "Ham Radio Today" by Dave G4KQH, and since then we have sold over a thousand units. The AP3 works from a 9 to 14V DC supply and automatically turns itself on and off from your microphones' normal PTT switch output. You simply select the amount of clipping you require (4 steps of approx. 6dB), and speak into the mic. The AP3 automatically compensates for changes in speech levels, so you can still work the DX even if you whisper! Ideal for multi-operator contests! The unit can be used with high or low impedance mics, and is very easy to build. Could an AP3 help your station make a bigger impact on the bands?
AP3 kit £15.90. Assembled PCB module £21.40.

CM2 QUALITY DESK/MOBILE MICROPHONE.
 The CM2 is a good quality microphone kit that consists of an electret condenser microphone capsule and a small electronics module that incorporates a Plessey "VOGAD" chip to give automatic control of modulation levels. The unit produces a nice clear audio signal for your transmitter, no matter whether you talk loudly or quietly, near or further away from the mic, the modulation level is maintained correctly for you. Ideal for a desk microphone or for use in the car as a "hands free" unit. The CM2 can be remotely keyed by a foot or gear-stick switch if required. The unit will work on an 8 to 14V DC supply, drawing only about 30mA from a 9V battery, and the only in transmit mode. The electronics turn off automatically when switching back to receive, no separate on/off switch is required. The CM2 builds into a clean sounding microphone that you will be proud to use on the air. It is always nice to receive complimentary audio reports, especially when you can have the satisfaction of saying "I built it myself".
CM2 kit £10.25. Assembled PCB module + mic. capsule £13.75.

ST2 CW SIDE-TONE or PRACTICE OSCILLATOR.
 The ST2 provides a nice sounding sine-wave note of approx 800Hz for monitoring your sending or Morse practice. It will produce up to 1W of output into an 8 Ohm speaker or 'phones. It can work by direct connection to your key, or by sensing the RF from your transmitter. Will work with HF QRP rigs of as little as half a watt!
ST2 kit £7.30. Assembled PCB module £10.80.



If you would like more information on any product, simply drop us a line, enclosing an SAE. We have an information sheet on each kit.

PLEASE ADD 60p P&P to your total order value

Delivery normally within 7 days.

73 from Dave, G4KQH Technical Manager.

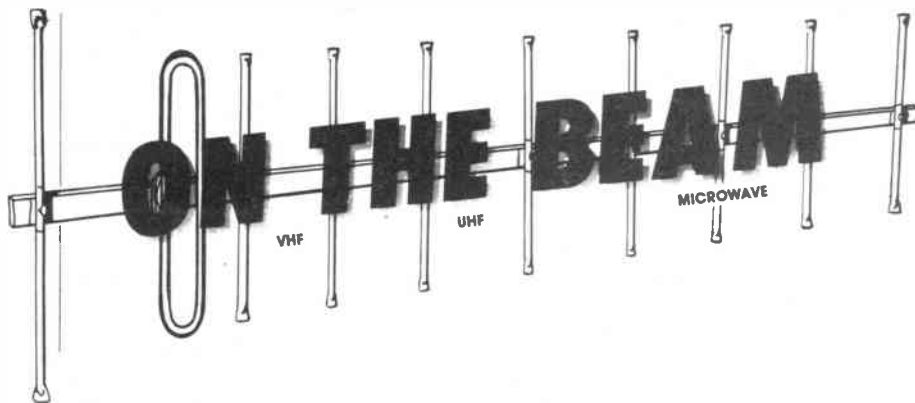

News and comment from Glen Ross G8MWR

Four metres

Last month we looked at the current scene on four metres and expressed the hope that the activity on the band would increase. It certainly seems to have done so as several more reports have been received this month. The first is from G4VOZ who mentions contacts with G4ENA (Gloucester) and G4IOQ (Oswestry). G4EPA (Crick) having just built his transverter and operating on an indoor dipole made contact with G4LRT near Northampton. Fired with enthusiasm he now has 25 watts and a 'decent' aerial system.

Four metres is also used during the day by stations comparing notes on the previous nights activity on 50MHz. Amongst those heard have been G8VN, G5UM, G3ENY, GW3MHW, GW4HBK and G6NB. EI2CA contacted G8VN with good signals both ways and expresses the hope of getting more EI/GI to G activity. G4WND/P was active from Tyne and Wear and was putting a good signal down into the Midlands, as was GM4ODP/P, operating from Scotland in early May. Two other stations reported as active are G3XWZ (Mansfield) and G3TSJ in Rochdale and late news arrives of GM4CAZ (Edinburgh) looking for skeds; he can be contacted on 031-664-3891. It looks as though things are brightening up on the band.

Microwaves

We now move from one end of our spectrum to the other and take a look at what has been happening on 10GHz. The first, and most obvious point, is the tremendous amount of new activity on the band.

Operating from a site in the Midlands, which is not renowned for high activity due to the normally inclement weather, during the first cumulative I heard a total of fifty stations calling for contacts, of which I managed to contact twelve. This is in marked contrast to previous years when I have heard around fifteen stations. The second cumulative was interesting for some very funny propagation conditions. Paths that I could normally work on 'open waveguide' were

not possible with two foot dishes. The path from Markfield to Cleeve Common (about 90Km) is normally easily workable on WBFM but even 30 milliwatts of sideband from G3FYX was not heard.

Surprisingly, G6IRJ on Broadway on virtually the same heading and only a few kilometres less was worked on WBFM. G6CWK operating from Larkstoke comments on not being able to work to Titterstone Clee but making a contact with GW3PFF at Radnor Forest on a similar heading, yet nearly twice the distance. It looks as though a negative K factor condition was causing the problem but this type of problem usually covers an area rather than individual paths.

This was one of the main talking points at the Sheffield Microwave Workshop but real answers seemed to be hard to come by. We would be interested to hear from other operators who have experienced similar conditions. The workshop was again a great success with a large and enthusiastic attendance, and many were the happy faces as problems were sorted out using the impressive array of gear that was available. If all the people with gear start to become active we shall have to start a rota for the use of the highest sites!

Specialist societies

If you fancy having a go at these sort of frequencies the Microwave Society, 81 Ringwood Highway, Coventry, is the specialist society to get in touch with. They, in common with BARTG, the QRP club and the ATV society, have seen a tremendous increase in membership over the last two years. Perhaps this indicates that a lot of people are getting tired of just talking and have decided to get down to actually building something for themselves. It does seem as though those who only use the hobby as a glorified version of CB soon drop out whilst those who stay the course usually have some other, and perhaps more technical interest in what is going on.

There are a number of specialist societies to cater for these various interests and we would be very inter-

ested to hear from them, particularly as to any involvement in the bands above 50MHz.

Space invaders

The latest news on the next space shuttle flight is that it is now scheduled for 15 July but that it may be brought forward to the 12th. Dr Tony England W0ORE plans to operate on two metres using the same type of window mounted aerial as that used on the first space mission. This time there will be no general operating and unless you have a sked set up then you are likely to be unlucky. The word is that this is due to lack of operating time, but one must wonder whether the terrible operating procedures that were experienced on the last occasion may not have something to do with the decision. There are also plans to operate some SSTV on the mission but times and frequencies are not known at the time of writing.

The RSGB will be running special news broadcasts during the flight. These will take place each evening at 5pm and will probably be on 144.250MHz. As an added bonus the commander of the shuttle used to hold an American novice class licence. We get in everywhere!

The news

The mole has been at work again and has come up with the news that the DTI have given the go ahead for the RSGB to broadcast the Sunday morning news on some of the repeater networks for a trial period. It seems possible that this will take place on two 145MHz repeaters, one being GB3CF, and on five or six seventy centimetre units. The precise details and starting times are not yet known but we can tell those who delight in messing things up for other people that the news input will not be 'off air' but will be by direct connection. Sorry to spoil your fun.

This is a facility that has been used with great success in the USA for several years and it should provide much greater, and more reliable, news coverage if my experience over there is anything to go on. This is another good example of the RSGB beaver away to slowly improve the facilities available to the radio amateur. Once again, you saw it first in *Amateur Radio*.

Certificates

We have already had several applications for our own VHF certificates and we hope to get these issued shortly. The delay has been due to some printing problems but this has now been resolved. Don't forget that they are available in three different classes for activity on 2, 70 and 23 at present but higher frequency bands can be incorporated if there is enough interest.

Another point to bear in mind is that QSL cards are *not* required to support your claim, simply a verified copy of your log entries. Full details are available from me on receipt of a stamped, addressed envelope.

There have also been several enquiries about the Dutch PACC awards. These are really good-looking certifi-

ON THE BEAM

cates to adorn your walls and are issued for a tremendous variety of classes. Other awards available are the VHF-6, UHF-6 and SHF-6 certificates for contacts with at least six different countries on 2m, 70 or 23cms. These are all available with stickers to update your country score to any level. QSL cards are not required and there is an issue fee of £2 per certificate.

Claims to, or information from: J Lourens, Keeweer 13, 6862 Oosterbeek, Holland. There is always a lot of interest in certificate chasing, so if you know of anything a little out of the ordinary please let us know.

As my own contribution I am pleased to tell you that I have recently been granted membership of the 'Rag Chewers Club' by the ARRL. This involves producing proof of a contact lasting in excess of two hours on any band and in my case was granted for a four hour contact on 10GHz, apparently the first award issued for this band in the club's fifty year life. There is always a 'first' to be got somewhere, it's just a case of finding it.

GB3GD

A lot of comment has come in about this repeater and very little of it has been good. The repeater was intended to give local area coverage for the Isle of Man and there were some constraints on the power and aerial system to ensure that

there was no co-channel interference. The local repeater people did not quite see it that way and the system came on air outside the specification requirements, according to the RSGB. This resulted in a storm of protest, the group were jumped on and at least the aerial system was modified.

It seems that even this was not enough to solve the problem and I am told that there is now a proposal to change the frequency of three existing repeaters so as to avoid further trouble. Whether this is actually going to happen is anyone's guess but even the idea of moving three existing repeaters is ludicrous. With modern rigs retuning is no problem but what about the thousands of people who are still using crystal control? A repeater on the island is wanted because of the local terrain, but the local amateur population amounts to a total of 130 stations. Even allowing for a seasonal influx it is doubtful if the number ever rises above 200 and a lot of these are not active on two metres.

This means that all the fuss, callsign changes and now frequency changes is to help what is, in effect, a local club to run a local repeater. We have made the point before and we make it again: the time has come to use 12.5KHz spacing. It has been available on most rigs for years and its use on the repeater scene would increase the number of channels avail-

able to at least fourteen with inconvenience to no one.

The obvious idea would be to leave high power 'major' repeaters on the existing channels and to use the 'half' steps for low power, local units. I know that the repeater frequencies tie in with a European agreement, but that came into force years ago and the scene has changed. The RMG must get its act together and start working in the context of today's problems and today's technology, not on the basis of 'it was good enough for Grandad'.

The real problem is that the repeater network never has been planned; instead of deciding on where a national network of repeaters should be sited (as is the case with the new cellular system) and then getting local groups to organise them, it has been done on the basis of groups asking for a repeater and then seeing where they can be fitted in.

Electronic mail

Isn't technology wonderful? Last month I gave my Prestel number for the first time and during the last two weeks I have had more comments arrive on that than through the letterbox. Please keep your comments coming via 81 Ringwood Highway, Coventry or on the magic Prestel using 203616941. May your hobby provide you with much enjoyment and a few problems to keep you on your toes.

SAMSONS

(ELECTRONICS) LTD.
9-10 Chapel Street, Marylebone
London NW1 5DN
21-23 Bell Street, London, NW1
01-262 5125 & 01-723 7851

CREDIT CARDS
ACCEPTED FOR
TELEPHONE
ORDERS

We are stockists of the complete range of "DOUGLAS" transformers.
Please ring or send S.A.E. for details.

<p>Precision made Swiss D.C. motor running on 6-9v dc these motors have a 70:1 gearbox and are extremely powerful! size 26mm x 45mm 3mm output shaft normal coat over £20 our price £4.95 inc VAT & postage.</p> <p>AC 240v BLOWERS ex computer equipment in good condition housed in metal frame size 11"x7"x7" or outlet 4"x3" motor spec 1300 rpm cont rated £5.95 postage £3.00</p> <p>MEMOREX V.D.U. 1377 We do not as yet have full information on these very attractive units which features a 12" monitor mounted in an adjustable cradle, and a full Alpha Numeric Keyboard. But response to them has been such that we feel you should be told about them. Comes with diagrams for monitor offered to you at £85.00 inc VAT. Carriage £17.00. Ring for details.</p> <p>NEW TRANSFORMER BARGAINS By famous makers No. 1. Pri 115-230V Sec 21V 3A + 40V 300mA £5.25 No. 2. Pri 220-240V Sec 17.5V 1A 3 times £5.75 No. 3. Pri 220-240V Sec 29-28-27-0-27-28-29V 0.3A £4.00 No. 4. Pri 220-240V Sec 6.3V 5A CT 6.3V 2ACT £5.00 No. 5. Pri 220-240V Sec 40V 3A £5.25 All prices inc. VAT and carriage</p>	<p>15AMP ISOLATION TRANSFORMERS BY FAMOUS MAKERS These high grade transformers are as new and were manufactured for a top U.K. electronics company to extremely high standards. Each transformer has a large range of tappings for adjusting inputs and outputs. Size approx 220mm x 280mm x 320mm Weight approx 37kgs. Our price £95 inc. VAT Ring For Carriage Details</p> <p>RECHARGEABLE BATTERIES We have on offer these fantastic long life batteries which have a large variety of uses. Completely unspillable using a special jelly electrolyte. Type 1 Dryfit 12v 5.7AH. Size 3 1/2"x6 1/2"; Price £3.50 inc VAT & carr. Type 2 Yuasa 12v2AH. Size 5x6 1/2"x6 1/2"; Price £2.4 inc VAT & carr.</p> <p>FANS MUFFIN 4 1/2" 110v £4.00 WOODS 6" and 8" 240v £3.50 Tangential Blowers 240v approx 3"x15" vent. Very powerful. £11. All prices inc. VAT and carriage</p>	<p>ASCO SOLENOID VALVES Fantastic value!!! These valves are designed for air gas water L.T. Oil normally closed. Approx 1" bore ideal for central heating 240 ac our price £9.50 inc VAT & carr</p> <p>JOYSTCK CONTROL Joystick controls made for the video game industry with sturdy micro switch action 2 way control £1.95 inc VAT & post 2 way heavy service type £2.95 inc VAT & carr</p> <p>DIGITAL CLOCK MOVEMENTS A well made clock movement fitted with timer mechanism and neon illumination. Size approx 110mm x 50mm x 50mm 240V a.c. operation. A Snip At £3.95 inc VAT & Carriage</p> <p>9v 800mA DC SUPPLIES As made for a famous micro computer firm these units have a mains lead and standard jack output £5.50 inc VAT & postage.</p> <p>HIGH GRADE LT TRANSFORMERS ALL PRIMARIES 240V OPEN FRAME TOP PANEL CONNECTIONS No 1 tapped 2-3-4-5-6-7-8-9-10-11-12-13-14-15v 8A £10. No 2 12v 8A £7.50. No 3 tapped 13-12-10-8v 8A £9. No 4 Sec 6.3v 2A 6.3v 2A and 32-0-32v 280 m/a £4.75. No 5 Sec 37v 1.5A, 15v 1/2A, 9v 50 mA £3.95. No 6 Sec 14v 2A £3.95. No 7 Sec 27.5-0-27.5v 1.2A and 7-0-7v 750 mA £3.80. All prices include postage and VAT</p> <p>PARMEKO LT TRANSFORMERS Open frame type top panel connections, prices include postage and VAT No 1 12-18-32V 2A (DC rating) and 12-18-32V 1/2A (DC) £9. No 2 12-18-32V 1A (DC) and 12-18-32V 1/2A £9. No 3 12-18-32V 1/2A (DC) and 12-18-32V 100 mA £3.95. No 4 12-18-32V 1/4A (DC) and 12-18-32V 1/4A (DC) and 12-18-32V 50 mA (DC) £2.50. No 5 32V 100 mA (DC) and 32V 25 mA DC £2.50.</p> <p>L.T. TRANSFORMERS Parmeko Atlantic Series potter type Pri 240v-240v. Sec tapped 2-8-1.6A and 14-4v 1.6A. The following voltages can be obtained 2-4-6-8-12-14-28-36-40-42-44-48v @ 1.6A conservatively rated £7.50 inc VAT & carriage. Pri 240V. Sec 25.3v 3A 10.5v 2A 10.5-0-10.5A open frame type £5.75 inc VAT & postage</p> <p>GARDENERS 'C' CORE TRANSFORMERS PRI+10V, 0V, 200V, 220V, 240V, [screen]. Main outputs separate windings 29V and 3V tapped at 1V while give 26V, 28V, 29V, 30V, 33V at 15amps. Size 150x133x170 Price £18.00 inc. VAT & Carriage.</p>	<p>SPECIAL OFFER. CLAUDE LYONS VOLTAGE STABILISER. Input 210-270V a.c. Output 240V £23.50, carr. £4. VAT £5.02. Pri 240V. Sec 240V, 250 watts, open frame type tag connections, £18, P&P £2, VAT £1.80. Pri 100-110-200-210-220-230-240-250V. Sec 220-230-240V 600W. can be used in reversed open frame type terminal block connections, £15, carr. £2.80, VAT £2.67.</p> <p>GOULD ADVANCE P.S.U.s. 13.8V 30amp d.c. supplies. Great for linear!!! ONLY £86 inc. VAT. Carriage £12. Limited offer</p> <p>6000w CONSTANT VOLTAGE TRANSFORMER BY REGAVOLT This high grade piece of equipment has inputs of either 220 or 240V a.c. - 20% + 12% Output 220 or 240V + - 1% Please Note This C.V.T. Has Isolated Secondary Size 17.5"x11.5"x26" Weight 3cwt Price £550 inc VAT Ring for carriage details Note: this transformer is ideal for computer P.S.U.s</p> <p>GPO JACK FIELDS As new perfect condition 7 contact £6.50 inc VAT & postage</p> <p>E.H.T. TRANSFORMERS High-grade E.H.T. Tranny, Pri 240V, sec 10,000V, 18 MVA. Probably used for boiler ignition but with 101 other uses!!! £5 inc. carr. & VAT</p> <p>PARMEKO OP TRANSFORMERS Pri 6000 or 8000V or CT Sec 3.75 or 15V Ser/Par for EL84 x 2 12.5W £4.50. Pri 5000 for EL84 3W Sec £3.75 or 15V Ser/Par £2.50. Pri 30-45-60-90 to 1 also 90TO for push/pull Sec 3.75V £2. All prices include postage and VAT</p> <p>AC WKG CAPACITORS MFD AC wkg Price £ MFD AC wkg Price 0.25 150v £1.50 5 30v £2.00 0.75 440v £1.50 5 440v £2.00 1 400v £1.50 4 500v £2.00 2.5 350v £1.50 6 300v £2.00 2.7 70v £1.75 8.4 250v £2.00 All prices include postage and VAT</p> <p>ELECTROLYTIC CAPACITORS All prices include VAT & post high ripple type 20,000mfd 40v dc wkg £3.50 7100 mfd 40v dc wkg £2.50 4700 mfd 40v dc wkg £2.50 4500 mfd 64v dc wkg £2.50 6500 mfd 80v dc wkg £2.50</p> <p>PARMEKO HT CHOKES 10H 250mA £5.95 20H 75mA £3.50 5H 250mA £5.50 10H 75mA £2.50 5H 100mA £4.75 7.5H 50mA £2.50 2.5H 500mA £5.50 15H 120mA £3.50 2.5H 250mA £5.50 50H 100mA £2.50 20H 120mA £4.75 25H 80mA £2.75 All prices include postage and VAT</p>	<p>SPECIAL OFFER HIGH-GRADE ISOLATION TRANSFORMERS Open frame terminal block connections £23.50, carr. £4. VAT £5.02. Pri 240V. Sec 240V, 250 watts, open frame type tag connections, £18, P&P £2, VAT £1.80. Pri 100-110-200-210-220-230-240-250V. Sec 220-230-240V 600W. can be used in reversed open frame type terminal block connections, £15, carr. £2.80, VAT £2.67.</p> <p>PARMEKO NEON TRANSFORMERS PRI tapped 200-220-230-240-250V. Size 7000V 55 MVA. Totally enclosed in wall mounting steel case. Size 9 1/2"x8 1/2"x4 1/2". £17.50 inc. VAT and carriage PRI tapped 200-220-230-240-250V. Size 5000V 20 MVA. Totally enclosed in wall mounting steel case. Size 7x6x5 1/2". £12.50 inc. VAT and carriage</p> <p>HIGH GRADE L.T. TRANSFORMERS By famous makers fraction of list price all primaries 240 v price includes postage & VAT. No 1. 43v 3A £8.99 No 2. 40v 3A £8.99. No 3. 21v 3A and 40 v 300mA £8.99. No 4. 27.5-0-27.5v 1.2A and 7-0-7 750mA £4.85. No 5. 17.5v 3 times £6.50. No 6 27v 1A 22v 1A 10v 1A 10v 1A £8.95. No 7. 60v 1A £4.85. No 8. 10-7-0-7-10v 500mA 29-21-0-21-29v 370mA £4.85. No 9. 28-27-0-27-28 350mA £4.85. No 10. 24v 2A £4.80. No 11. 14v 3A £4.80. No 12. 6.3v 2A 6.3v 2A 32-0-32 280mA £4.50. No 13. 13v 2A 15v 1A £4.85. No 14. 27.5v 1A DC £4.50. No 15. 4.5-0-4.5v 200mA 2.2 v 600mA £2.25. No 16. 13-0-13v 1A 10v 500mA £3.85. No 17. 65v 2A 30-0-30v 100mA 10v 300mA £4.85. No 18. 55v 500mA £3.85. No 19. 24.30-32v 2A £4.85</p> <p>STOP PRESS We have in stock a very limited number of Epson portable computers BRAND NEW never been used offered at fantastic low prices. Please ring for details!!!</p> <p>PARMEKO HT TRANSFORMERS ALL PRIMARIES 220-240V POTTED TYPES No 3 No 4 Sec 400-0-400V 150 mA and 150-0-150V 20 mA £8.50 inc postage and VAT. No 5 Sec 350-325-0-325-350V 120 mA £8.50 inc postage and VAT. Grahman Pri 220-240V. Sec 250V 80 mA 6.3V 4.5A 15V 1.2A £5.95 inc postage and VAT. Pri 230-250V. Sec tapped 190-210V or 24 mA 6V 1A £3.95 inc postage and VAT. Pri 220-240V Sec 300V 200 mA 30V 100 mA 6.3V 5A half shrouded, sub chassis mounting £8.50 inc postage and VAT. Pri 220-240V Sec 370-390-410V 6 mA £2.75 inc postage and VAT. WW-16</p>
<p>AUTO STEPDOWN TRANSFORMERS FOR AMERICAN EQUIPMENT 240/110 Volts. 80-2250 watts. Regular stock line. Types 80-1500 watts are fully shrouded. Fitted with American two or three pin socket outlets and 3 core 240V mains lead. Types 1750 and 2250 watts are steel cased with two American socket outlets. Neon indicator, three core mains lead and carrying handle. Send SAE for price list and further details. American sockets, plugs, adaptors also available.</p>				

JULY 1985

please mention AMATEUR RADIO when replying to any advertisement

World Radio History

41

BACK TO BASICS

Bill Mantovani G4ZVB interferes with INTERFERENCE and measures up MEASUREMENTS

Before continuing with transmitter interference, a couple of points from last month's *Back to Basics*. Having said that I hoped that those of you who sat the May RAE exam would be feeling confident of a pass; well, by all accounts it would seem that there are not many confident people about at the moment! If the comments about the May paper that are reaching me are true, a lot of you are probably already looking to the December exam. Please don't be put off though, it will all have been worthwhile when you do get your ticket, believe me, and a few extra months of revision never hurt anyone, did it (don't all throw your RAE manuals at me at once!)?

As for the forthcoming RAE dates published last month, these were supplied to me by the City & Guilds, and even I queried some of them at the time as there are some very odd dates in there. I am however assured that they are correct. Right, having dealt with those points, now down to business.

Harmonics and spurious oscillations

Continuing our investigation of transmitter interference and how to prevent it, we will now look at unwanted outputs that might be generated quite legitimately by the transmitter. These include harmonics of the wanted frequency and products from various mixing processes. Remember that a mixer produces a whole range of unwanted signals as well as the sum and difference frequencies. Then we have spurious oscillations, which are not usually expected but occur because of, say, instability in one of the transmitter stages or the self-resonance of circuit components. Let us look at each one in turn.

Harmonics are frequencies that are related to the wanted frequency, so a signal at twice the wanted frequency would be the *second harmonic*, at three times the wanted frequency you have the *third harmonic* and so on. Fortunately, harmonics become weaker in strength the further away they are from their *fundamental* frequency, but this does not mean to say that some are not strong enough to cause interference to nearby equipment, especially if a) they fall on or close to a frequency used by another service, or b) they are not sufficiently suppressed before they reach the antenna.

It just so happens that most of the amateur bands are harmonically related to each other, and in some instances to certain TV channels, so you can appreciate why radiating harmonics could be a problem. A major concern of many amateurs used to be interference to the old Band I, 405 line VHF TV channels, but this service was finally discontinued in January '85. However, this part of the frequency spectrum will be reallocated to other users, so you still need to have an awareness of the problems. The table

Approximate Tx frequency	Harmonic	Interference to:
144MHz	x 5	UHF TV (Band V, Channel 52)
145MHz	x 5	UHF TV (Band V, Channel 53)
3.56MHz	x 3	VHF FM radio (if tuner IF = 10.7MHz)
14MHz	x 2	amateurs in the 28MHz band
144MHz	x 3	amateurs in the 432MHz band
3.53MHz	x 2	amateurs in the 7MHz band
3.7MHz	x 2	other services

above gives some examples of harmonics which might cause interference.

Harmonics can occur in any of the transmitter stages. A popular circuit for reducing harmonics is the *pi-network* as it acts as a low pass filter. Pi-networks are often used for the PA stage tuned circuit in HF transmitters but can also be employed in an *antenna tuning unit* to play a dual roll: to match the antenna system to the transmitter output and provide additional harmonic filtering.

Care should be taken if designing or building a PA stage, especially a high power one, as any of the various amplifier modes can generate an appreciable level of harmonics. Class C in particular (usually used for CW, FM or AM transmitters) can produce quite a high level of harmonic output as it is very

non-linear. SSB transmitters normally employ the more linear class A and class AB modes, in which harmonic output is far less.

Multiplier stages can also produce harmonics which, if they found their way into the transmitter output, could cause interference both inside and *outside* of the amateur band in question, possibly even in another amateur band. This is especially true at VHF and UHF, where, typically, a series of multiplier stages are used to produce the desired transmitting frequency. The oscillator stage can also be a source of unwanted harmonics so here is yet another good reason for ensuring that the oscillator or VFO is always well screened. For quick reference, ways of minimising harmonics are summarised in the table below.

Problem	Cure/prevention
Excessive bias of frequency multiplier stages and class C amplifiers results in a large drive signal being needed	Bias stages correctly so drive can be kept to reasonable levels
Overdriving <i>any</i> stage – over a certain point the output no longer increases greatly but harmonics will	As above, keep drive down to a reasonable level
Long leads, stray capacitive coupling in tuned circuits, parasitic resonances	Keep all leads to components short, especially around tuned circuits. With coils, wind secondary at the 'earthy' end of the secondary
Inadequate screening of stages, especially oscillator and PA	Screen all stages carefully and use screened leads for all external interconnections as well, including microphone, key and mains. Oscillator screening is particularly important, as is screening of the PA stage, especially a high power one

Another source of transmitter interference mentioned is the output from mixers. To recap: a mixer circuit produces a sum product and a difference product from two input signals—but what about the harmonics of those input signals? These too will be mixed so that, in practice, the output from the mixer stage consists of a whole range of sum and difference products, only one of which is actually required. It may be quite easy to filter out the products (or signals) which are some way removed from the wanted signal, or are low in amplitude, but a signal which is both strong as well as close to the required signal presents more of a problem. By careful choice of signal and oscillator frequencies and the use of balanced or double-balanced mixers, the above problems are greatly reduced.

Next, we have *spurious oscillations*, which cover a very wide field. These are sometimes called *parasitic oscillations* and are usually frequencies totally different from those already discussed and quite unexpected. Instability in certain transmitter stages, such as the power supply or the audio stages, can cause *low-frequency oscillations*. These manifest themselves as multiple sidebands either side of the output frequency and can be detected by monitoring the transmission when no modulation is present and checking for the presence of these sidebands. Spurious low-frequency oscillations can also occur in a circuit where some of the components form a chance 1F tuned circuit. It is possible to prevent these 'hidden' circuits from breaking into impromptu oscillation by the use of *damping* components. This is explained in more detail in the RAE manual but for the exam it should suffice to just remember the basics as outlined above.

Oscillations

Of somewhat greater importance are the oscillations that can occur in a transmitter due to stray capacitances and lead inductances. These oscillations are of a very high order and are termed VHF or UHF parasitics. An example of this would be in a valve PA stage where stray circuit capacitance could combine with the stray inductance of the lead to the valve(s) anode cap to form a very high frequency resonant circuit. Such oscillations may be prevented by keeping all leads as short as possible and threading ferrite beads onto the longer ones, such as to the valve cap. Chokes wound on a low-value resistor as a former are also used.

It is also possible to reduce these oscillations by giving careful thought to the actual physical layout of the circuit, screening etc. Capacitors can add to the problems because at VHF and higher many will exhibit inductive properties, resulting in poor decoupling. It is possible to use multiple decoupling capacitors in parallel, one with a large value that provides good decoupling at the normal operating frequency of a

stage and an additional one to maintain good decoupling at VHF. Avoid the use of physically large capacitors, disc ceramic are ideal, and, as always, keep the leads short.

A stage may break into *self-oscillation* where there is poor screening between its input and output circuits. This can lead to the transmitted signal sounding rough, with clicks on the CW and poor speech quality. Both spurious and self-oscillations can be detected by holding an absorption wavemeter or dip oscillator close to the stage in question and tuning the meter over a wide range.

There are two other types of interference sources to be considered briefly. The choice of antenna and feeder in itself can be a source of possible interference to local TV sets, tuners or hi-fi equipment etc if run in close proximity to mains wiring or the antenna co-ax of other equipment. A long wire antenna, for instance, will give off some radiation right from the point at which it leaves the ATU, so some thought must be given to how it is run out of the shack. Earth connections also have to be made with care.

'Hot' RF

In some instances, the earth return from the ATU may be 'hot' with RF, so connecting it straight to the mains earth is simply asking for trouble. It is surprising how many amateurs unknowingly suffer from this *mains borne interference* but put down their TVI problems to something completely different. Yours truly was one of these when first licensed, but after being told that my transmissions were coming through loud and clear on the neighbours' TV, radio and audio equipment, even after all antennas to the affected equipment had been disconnected, it didn't take too long to realise what the problem was and remedy the situation. I now always check for mains borne interference as a matter of course when trying out a new antenna system. Funny though, there was never any interference in my own household—oh, the wonders of haming!

So, the basic rule is never use the mains earth as an RF earth. Do however make sure that all of the station equipment is well earthed, for your own safety, and as an aside, there is often a question in the RAE about working on 'live' equipment which can be answered by using plain common sense. As for minimising interference from the antenna/feeder system, keep everything well away from house wiring and TV feeders. When using a balanced antenna, such as a dipole, make sure it is fed with either balanced feeder or by co-ax via a balun at the feed point, and try to avoid the use of indoor antennas if possible.

The use of open wire twin-feeder is often recommended when trying to combat interference, but certain rules do have to be observed because it is all too easy to unbalance the line by putting sharp bends in it, running it close to the house, or not bringing it through into the

shack correctly. Balanced line may be preferred to co-ax but the latter may prove more convenient in practice. One final point, certain antennas, such as the G5RV, employ part of the feeder in the actual antenna design, so it goes without saying that radiating feeder should be sited with care.

Defects in affected equipment

Bearing in mind that it is not always (in fact rarely in these days of 'black-boxes') the amateur equipment which may be at fault, we need to look at other reasons why certain equipment may be experiencing interference. These can be briefly listed as follows. In the presence of a strong amateur signal, the RF stages of the affected equipment may be being overloaded even though the amateur transmission is no-where near the frequency to which these stages are tuned. This sometimes results in *cross modulation*: the modulation of the interfering signal becoming superimposed on top of the wanted signal. If the affected receiver has poor overall selectivity it will be able to receive signals over quite a wide bandwidth and again the same thing will happen. Depending on how far removed the amateur frequency is from the frequency that the affected receiver is tuned to, it is sometimes possible to eliminate the interfering signal by fitting a suitable filter in the receiver antenna lead.

Pick-up by the TV antenna feeder can be quite a problem, large RF currents find their way into the set mainly via the co-ax braid as well as the inner conductor. Signals from the TV antenna are in anti-phase but the currents picked up on the feeder are in-phase. A solution is to insert a *braid-breaking* device into the antenna lead, close to the TV, which allows the anti-phase antenna signals to pass through but attenuate in-phase current. Another possible solution is to earth the antenna downlead just before it enters the house, thus taking the interfering current on the braid to earth before it reaches the TV set. Pick-up from the mains supply can sometimes be cured by using a mains filter.

For interference to radio equipment, if the radio has an external antenna, it is possible to reject the amateur signal but not the required signal by fitting various high-pass or *bandstop* filters into the antenna lead. For radios using internal ferrite-rod antennas, clearing the interference can become quite involved and possibly very difficult.

Interference in audio equipment is due to the rectification of the amateur signal in one of the audio stages. The long speaker leads make a very good antenna and sometimes the signal may even be picked up by the tape head of pick-up cartridge. As for TVI, pick-up from the mains or via the speaker leads can sometimes be cured by means of a filter (winding the leads on a ferrite ring or rod to form an RF choke). Alternatively, screened speaker cable or RF decoupling capacitors across the speaker

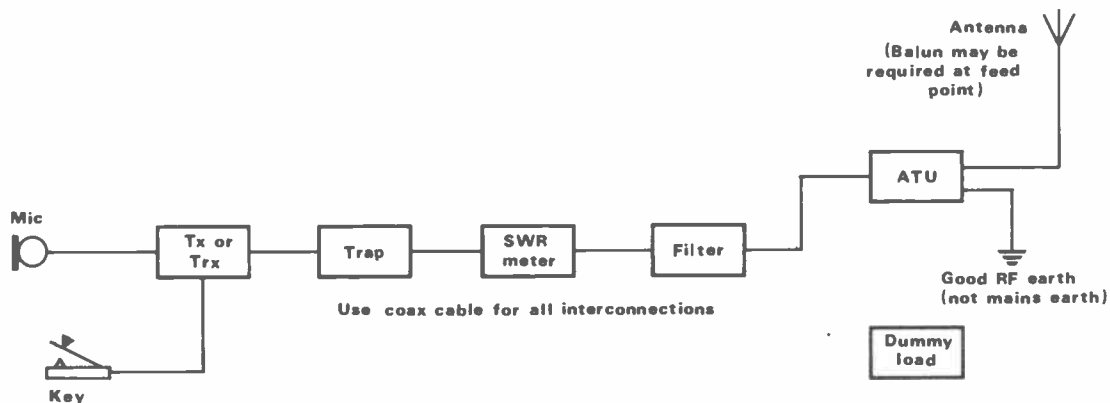

Fig 1 Suggested station layout for keeping interference to a minimum. The trap may not always be necessary

sockets at the amplifier may do the trick, but to cure any other type of pick-up in audio equipment may again be difficult.

Above all, it must be appreciated that any tuned circuit will be capable of picking up an interfering signal from a nearby amateur transmission if the said signal is both strong enough or close enough to the resonant frequency of the tuned circuit, especially if the bandwidth of the latter is wide and selectivity poor.

Equipment layout

The suggested layout for the amateur station equipment is shown in *Figure 1*. Adherence to this should ensure minimum interference, if there is any, from the transmitting station itself, so that if any interference is being received it will probably be the fault of the affected equipment. After all, it is the responsibility of the amateur to ensure that he is not putting out an obvious interfering signal in the first place. The *trap* is only required if there is one particular frequency or harmonic which is causing problems and consists of a tuned circuit acting as a simple stop filter. The *filter*, (*low-pass* for HF, *band-pass* for VHF/UHF), prevents any unwanted transmitter outputs from getting to the antenna.

It is also a condition of the amateur licence that tests be made from time to time to ensure that the station is not radiating interference (harmonic, spurious or otherwise) and that these tests be recorded in the station log. It would appear that this is possibly one of the least remembered conditions by amateurs who have passed the RAE.

All too many amateurs openly declare that they do not possess (nor have need of!) test equipment capable of performing the above tests. In fact, the test equipment required is very simple. A tunable *field strength meter*, or *absorption wavemeter*, will suffice for checking for harmonics etc, and also for any out of band transmissions, which are illegal. As a guard against the latter, an amateur transmission should always be located far enough inside the band edges to allow for the bandwidth of the signal.

Another useful piece of equipment is a crystal calibrator, used for marking the band edges as well as calibrating the transmitter/receiver dial. Most commer-

cial amateur equipment will probably feature an in-built crystal calibrator as part of its specification. Right, this brings us nicely to the part of the RAE syllabus entitled measurements.

Measurements

What is meant by measurements and why is it in the syllabus at all? Well, the simple answer is that the amateur must be able to understand not only how to use the various test instruments mentioned so far but also what information they *really* convey. To use the wrong instrument for a particular test might lead to the wrong conclusion, so regard is also needed for the limitations of certain test instruments. You will not however be asked detailed questions on the circuitry of the various test instruments in the exam.

The radio amateur needs to make measurements for three reasons: to avoid interference to other users of the frequency spectrum; to comply with his licence conditions (both of which have just been discussed), and to ensure his radio equipment is operating at optimum performance. This involves being able to measure voltage, current and frequency. The above is true no matter how simple the transmitter.

dc measurements

The *moving coil meter* consists of a coil wound on a former which is in turn pivoted in the field of a permanent magnet. When current is made to flow through the coil the torque developed causes the coil to move a certain amount, thus moving a pointer attached to it. As the movement of the pointer is proportional to the strength of the field of the permanent magnet and to the current passing through the coil, the scale of the moving coil meter is linear. The meter can therefore be used for measurement of a dc voltage (using a series voltage dropping resistor), dc current (when it is called an *ammeter*, *milliammeter* or *microammeter* according to its *full-scale deflection* or *fsd*) and resistance.

By using a suitable rectifier it can also be adapted for certain ac measurements. The coil is usually wound on an aluminium former to *dampen* the movement and stop the pointer from swinging

around freely after a change of current. The accuracy of such a meter depends on a number of factors but in practice would be about 5%.

Shunts

Moving coil meters are normally manufactured with low fsd values ie 0-50µA or 0-1mA. This means that to enable them to be used for measuring a higher current range, a resistor called a *shunt* must be connected in parallel with the meter as shown in *Figure 2*. The formula for working out the value of this shunt is given by:

$$R_s = \frac{R_m}{n - 1}$$

where R_s is the shunt resistance, R_m is the meter resistance and n is the scale multiplying factor. Look at the sample in the RAE manual and try working out one or two extra examples for yourself.

Multipliers

The resistor connected to a milliammeter to allow it to be used for measuring dc voltages is called a *multiplier* (*Figure*

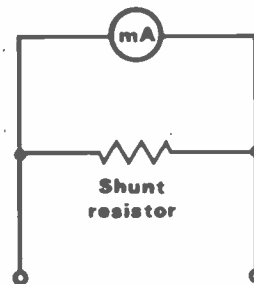

Fig 2 A parallel shunt resistor is used to extend the dc current range of a moving coil meter

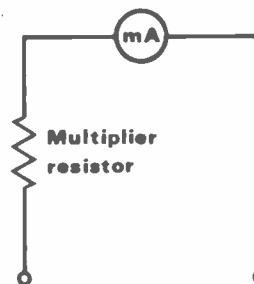

Fig 3 A series multiplier resistor will allow dc voltage to be measured on a moving coil meter

BACK TO BASICS

3) and its value can be found using Ohm's Law ($R = V/I$). Because I is the f.s.d of the meter in mA, the formula can be rewritten as:

$$R_s = \frac{1000V}{I}$$

with V being the required voltage and R_s the resistance of the multiplier. In practice, the resistance of the meter itself can be ignored. It is important to remember that the multiplier resistor will be expected to dissipate power and so should be adequately rated. The dissipation can be calculated from the usual formula $W = I^2 R$. The accuracy of the voltmeter depends greatly on the accuracy of the multiplier, so high stability closely toleranced resistors of adequate power rating need to be used.

It is also important to realise that the actual connection of a voltmeter to a circuit might alter that circuit's operating conditions. For this reason the sensitivity of a voltmeter, which is expressed in *ohms per volt*, should ideally be very high and preferably in the order of 10,000 to 20,000 ohms/volt.

To modify a moving coil meter to measure ac a rectifier is used, but this type of instrument is inaccurate if measuring anything other than a sine-wave. Such a meter would be calibrated in rms values even though it would actually be indicating average value. For a true reading of rms value a *thermocouple* or *thermojunction meter* should be used, but these meters have a number of disadvantages and should be used with great care to avoid burning out the thermojunction.

Measuring RF voltages

To measure voltage at high frequencies the rectifier instrument is unsuitable and an electronic type of voltmeter is needed, which consists of a diode detector producing a dc voltage proportional to the peak value of the ac voltage being measured, and an amplifier to feed this dc signal to a meter, which is calibrated in volts. Such an electronic voltmeter would have a very high sensitivity (about $10M\Omega/V$) and so place negligible load on the circuit under measurement. It is also capable of giving accurate readings right up to very high frequencies.

Measurements for transmitter tuning

For the correct tuning up of a transmitter PA stage, some means of measuring the PA current is essential and a suitable meter should be wired into the PA anode or collector circuit. Unless it is broadband, this circuit may need retuning each time the wavelength or antenna is changed. The meter will also serve to indicate dc input power (= dc input voltage x dc input current), but note that voltage measurements should not be done at the actual collector or anode pin as this would make the PA go off-tune and thus give an incorrect reading.

To avoid interference, tuning up of the transmitter must *not* be performed with

the antenna connected. Instead the transmitter output should be terminated in a *dummy load* of the correct resistance (ie 50ohm) and of adequate wattage rating to match the output power. A dummy load can be made by joining together a number of *non-inductive* resistors in series, or series/parallel configuration, to give the appropriate resistance and wattage rating. If the dissipation of the load needs to be quite high, it can be raised by immersion in oil. Carbon resistors are suitable, but wire wound resistors must never be used as they would act like an inductor and cause the load to radiate! Dummy loads should, in any case, always be screened to prevent possible radiation.

Enough's enough

Well, that's about enough for now, I'm sure we have covered sufficient ground for another month. Before signing off though I would like to add one or two comments to what we have just discussed that you may find of use. You may be wondering why the RAE syllabus deems it necessary to go into what may, at first glance, look like great detail on some topics, such as the two covered this month – transmitter interference and measurements. The answer is quite straightforward; operate an amateur station incorrectly and you could cause problems for other people, amateurs and non-amateurs alike. On top of that, if you don't know how to check that your equipment is functioning correctly you could well end up damaging both it and yourself.

For example: operating a valve PA stage without first ensuring that it is correctly tuned up could result in most of the above problems – interference to local domestic equipment, strong spurious transmissions in other parts of the frequency spectrum, an eventual blown PA stage, or at the worst, personal injury if a component somehow were to break down and put RF or mains onto, say, the transmitter case. All right, so one or two of these are extreme cases, but they could still happen.

In this age of the all solid state transceiver, it seems all too easy to just be able to go out and buy a piece of equipment, connect it to an antenna and away you go – no tune up needed. That's fine if the transmitter in question has its own in-built protection against destroying the PA if operating into a mismatched line, but it won't help you to get many QSOs (contacts). You, the operator, are still required to know how to match that transmitter to the antenna system (or, to be more precise, how to match the antenna system to the transmitter) and how to ensure that all of the available power is both being delivered by the transmitter *and* finding its way to the antenna, not being dissipated in a 'hot spot' somewhere in the shack, or along the transmission line. Let's face it, no one wants to get a shock.

Transmission lines can usually tolerate a highish SWR, as can valve PAs, but this

does not mean that that is how they are supposed to be operated. The RAE is supposed to test the prospective amateur to see that he (or she) understands the basic principles. Some never look into it any further, but after you have your ticket how you enjoy your hobby is up to you.

Dwelling on valve PAs for a moment, just because a lot of equipment today is solid state, do not think that it is unnecessary to know about operating a valve or *hybrid* transmitter. A hybrid is one employing both valves and semiconductors. Whereas solid state transmitters need little tuning up for reasons that will be explained in a moment, a valve PA does. The anode circuit must be brought into resonance by tuning the *plate* control for minimum anode current and the output network (or tank circuit) also needs matching by means of the *load* control.

The anode circuit of a valve presents a high impedance load whereas the transmitter output must be low impedance, hence the need for the tank circuit to perform a matching function just as an ATU does. In fact one particular tank circuit, the *pi-network*, crops up quite often in both transmitter and ATU design because of its good harmonic suppression properties, as stated earlier.

A little easier

With transistor RF power amplifiers life is made a little easier because the collector load needs to be matched into a low impedance anyway. Thus, by making the transistor PA stage broadband and by using filters to allow only the required frequency through to the output, anything else being attenuated, tuning up of the output stage of a solid state transmitter by the operator can be dispensed with altogether and operation made simpler. Some new equipment though still employs valve RF power output stages, as does a lot of amateur equipment in regular use, which is why you are still required to know about tuning up transmitters.

As an aside, spare a thought for the Russian and other 'Iron Curtain' amateurs. They cannot buy amateur equipment like we can, so they must build everything they use. How many of you would ever wish to become amateurs if you had to do that – and people complain of having to pass a Morse test!

That's it, next month frequency and VSWR measurement in a little more detail and measuring the power of an SSB transmitter, on which there is often a question or two. Meanwhile, for some lighthearted studying have a listen on the HF bands. After the silence of winter they are beginning to open up and the DX that is coming through may just give you that little extra bit of inspiration to pass the RAE.

Acknowledgements and references

Radio Amateurs' Examination Manual – G L Benbow G3HB (RSGB).
City and Guilds of London Institute.

QUESTIONS & ANSWERS

RAE PRACTICE DEVISED BY R.E.G. PETRI G8CCJ

PROPAGATION

- The formula relating velocity (c), frequency (f) and wavelength (λ) is:
 - $c = f^2\lambda$
 - $c = f/\lambda$
 - $c = \lambda/f$
 - $c = \lambda f$
- What is the velocity of electromagnetic waves in free space?
 - 3×10^8 m/sec
 - 30×10^8 m/sec
 - 300×10^8 m/sec
 - 300×10^9 m/sec
- The gas molecules of the upper atmosphere are ionised by:
 - the temperature of the earth's surface
 - clouds of ozone in the D layer
 - UV radiation from the sun
 - moisture in the atmosphere
- An electromagnetic radio wave consists of:
 - a circularly polarised 'E' field only
 - both an 'E' and an 'H' field
 - a slant polarised 'H' field only
 - an 'E' field travelling at approximately 30m/sec
- Ground waves are the principal mode of propagation for frequencies:
 - below 2MHz
 - above 3MHz
 - below 20MHz
 - above 27MHz
- What is the principal mode of propagation in the HF band?
 - Ground wave
 - Direct wave
 - Sky wave
 - Ultra violet wave
- What are the approximate lower and upper height limits of the ionosphere?
 - 10m - 100m
 - 40m - 400m
 - 10Km - 200Km
 - 50Km - 400Km
- E, F₁ and F₂ are three of the four principal ionised layers comprising the ionosphere. What is the fourth?
 - D
 - E₂
 - F₃
 - G₁
- What is the approximate height of the F₂ layer?
 - 240 - 400Km
 - 240 - 825Km
 - 100 - 525Km
 - 10 - 100Km
- What is the approximate height of the F₁ layer?
 - 240 - 400Km
 - 240 - 824Km
 - 160 - 240Km
 - 100 - 150Km
- What happens to the F₁ layer at night?
 - It merges with the F₂ layer to form a single F layer
 - It changes phase and spins anticlockwise around the earth
 - It changes position with the E layer, causing high attenuation of skip waves.
 - Nothing
- What is the approximate height of the E layer?
 - 30Km
 - 50Km
 - 100Km
 - 250Km
- When are the layers usually most heavily ionised?
 - Early morning
 - Around midday
 - Late evening
 - Around midnight
- What unusual condition occurs in the E layer causing signals from the top end of the HF band up to the middle of the VHF band to be received and transmitted over greater distances than would normally be expected?
 - Sporadic-E
 - Sparodic-E
 - Intense-E
 - Enhanced-E
- The condition referred to in Q14 above is caused by:
 - temperature changes in the D layer
 - cloud-like regions or areas of high ionisation in the E layer
 - Pollen clouds rising on thermals, mainly in the summer months over agricultural areas
 - Turbulence from high flying jet planes
- Communication during daylight hours via the E layer is possible up to distances of typically:
 - 20Km
 - 160Km
 - 1600Km
 - 32000Km
- What is the approximate height of the D layer (sometimes referred to as the D region)?
 - 0 - 10m
 - 0 - 30Km
 - 50 - 90Km
 - 100 - 500Km
- When would you expect the D layer to be non-existent?
 - Midday
 - During the night
 - During electrical thunderstorms
 - When radiation from illicit 27MHz transmitters is at a peak
- The maximum single hop skip distance via the F₂ layer might be typically about:
 - 50Km
 - 200Km
 - 4000Km
 - 32000Km
- Referring to Q19 above, what mode of propagation makes it possible to achieve communication over even greater distances in the HF band?
 - Multiple hop propagation
 - Ground wave propagation
 - Sea wave propagation
 - A combination of both b) and c) above

This month, as a special treat, we've printed the answers to all of the questions!

21. Having established a communication path using a frequency of 21MHz in the afternoon, it is found impossible to establish communication later that evening. What might you do in an attempt to re-establish communication?
 - a) Reduce carrier power
 - b) Switch to FM
 - c) Increase the antenna feeder losses
 - d) QSY (change frequency) to a lower frequency
22. The maximum usable frequency (MUF) is the highest frequency that will:
 - a) not be reflected back to earth from the ionosphere
 - b) be reflected back to a given point from the ionosphere
 - c) remain in orbit round the F₂ layer
 - d) penetrate the F₂ layer
23. When a wave strikes one of the ionised layers at vertical incidence the highest frequency returned to earth from that layer is referred to as the:
 - a) critical frequency
 - b) maximum usable frequency (MUF)
 - c) lowest usable frequency (LUF)
 - d) optimum traffic frequency (OTF)
24. Maximum usable frequencies are usually highest around noon and:
 - a) during periods of high sunspot activity
 - b) midnight
 - c) during bright moonlight
 - d) very early morning
25. Maximum sunspot activity occurs in cycles of approximately:
 - a) 11 hours
 - b) 4 lunar weeks
 - c) 5 years
 - d) 11 years
26. The principal mode of propagation in the VHF/UHF band is:
 - a) reflection from the D layer
 - b) sporadic-E
 - c) extended line of site
 - d) ground wave
27. Under normal conditions VHF communication path distances might lie between about 30 and 80Km, but sometimes much greater distances are achieved. This could be due to:
 - a) merging of the F₁ and F₂ layers
 - b) changes in temperature and water vapour causing the signal to be refracted or bent around the surface of the earth
 - c) de-ionisation of the D layer
 - d) increased ionisation of the F₂ layer
28. Two other possible causes of short term, long distance communication in the VHF band are sporadic-E and:
 - a) Gaussian distribution
 - b) equatorial thunderstorms
 - c) auroral storms (northern or southern lights)
 - d) irregular clouds of hot air rising from a point centred on NGR TQ 302795
29. When a signal arrives at a receiver via two different paths it is possible that:
 - a) adjacent channel interference will be observed
 - b) the receiver's AF amplifier will be overloaded
 - c) the first RF stage will oscillate
 - d) fading will be experienced
30. A 144MHz signal entering the F₂ layer would:
 - a) remain trapped in that layer
 - b) be returned at a distance of about 1600Km
 - c) be returned at a distance of about 2400Km
 - d) pass through and not be returned.

ANSWERS

1 - d; 2 - a; 3 - c; 4 - b; 5 - a; 6 - c; 7 - d; 8 - a; 9 - a; 10 - c; 11 - a; 12 - c; 13 - b; 14 - a; 15 - b; 16 - c; 17 - c; 18 - b; 19 - c; 20 - a; 21 - d; 22 - b; 23 - a; 24 - a; 25 - d; 26 - c; 27 - b; 28 - c; 29 - d; 30 - d.

Plug the book! Plug the book! Plug the book. . . .

OK then, that's all the questions for this month. Propagation for most students is perhaps one of the most interesting subjects of the syllabus. Also, being fairly easy to grasp it makes a bit of light reading if you've been bogged down by ac theory and the like for a few weeks or more.

It can be fitted into the course at any time since it is not dependent upon what has been taught previously. Propagation, studied at this level, does not even require the use of mathematics, except perhaps for frequency to wavelength conversion.

Try asking yourself the following questions:
 What are the heights of the ionised layers?
 How is the ionisation of the layers affected by the sun?
 How do the ionised layers vary from day to night and summer to winter?
 Why are changes in long distance HF transmission frequencies necessary from day to night?
 What are the principal modes of transmission for the various bands?
 What are the causes of fading, etc?

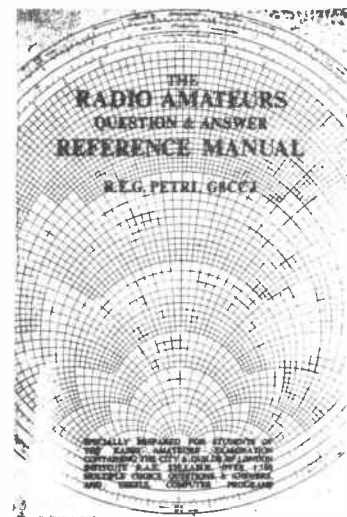

Now, just in case you've not already purchased it (or even heard of it!), I've written a Q&A book specially for the RAE student. It contains about 1,100 questions (with multiple choice answers of course). The questions have been divided into sections and selected to progress with each part of the RAE syllabus. It also contains the C&G syllabus for 1986-88 and some computer programs written in BASIC for the Commodore 64 (which will run on most machines with suitable mods) to assist with the RAE calculations and provide Morse tuition.

The book, *The Radio Amateurs' Q & A Reference Manual (Second Edition)*, is available at £5.95 plus £1 P&P (UK) from:

WP Publications,
11 Wayville Rd,
Dartford, Kent DA1 1RL.

SPEAKERS BC, 0-3W, 2"; 2.25", 2.5", 3" 0-3W, 2.5" 40Q; 64Q or 80Q 80p 80p		OPTO LEDs price includes Clips TL209 Red 3mm 10 TL121 Green 3mm 14 TL122 Yellow 14 TL120 2" Red 12 0-2" Yel, Grn, Amber 14 Rectangular LEDs with two part clip, R, G & Y 48 Rectangl. Stackable LEDs 18 0-2" Flashing LED Red 18 0-2" Bi colour LEDs 18 Red/Green 100 Red/Yellow 80 0-2" Tri colour LEDs 85 Red/Green/Yellow 85 0-2" Red High Bright 89 0-2" Red or Green 100 Yellow 100 DL271 Infra Red (emit) 48 TL32 Infra Red (emit) 82 SFH205 (detector) 118 TL178 (detector) 86 TL38 80 TL81 (82); TL100 90		0.5" LCD DISPLAYS 3/2 digit 498 4 digit 620 6 digit 835		VOLTAGE REGULATORS 1A T0220 Plastic Casing +ve -ve 5V 7805 48p 7905 58p 12V 7812 48p 7908 58p 18V 7815 48p 7912 58p 24V 7824 48p 7918 58p 100mA T092 Plastic Casing 5V 78L05 30p 79L05 80p 6V 78L12 30p 8V 78L32 30p 12V 7812 30p 79L12 80p 15V 78L15 30p 79L15 80p		DIL SOCKETS 8 pin 8p 14 pin 10p 16 pin 10p 18 pin 10p 20 pin 20p 22 pin 22p 24 pin 25p 28 pin 28p 40 pin 30p		SPECTRUM 32K UPGRADE Upgrade your 16K Spectrum to full 48K with our RAM Upgrade Kit. Very simple to fit. Fitting instructions supplied. ONLY £22									
DIODES AA119 8 AA129 10 AA130 10 BA100 10 BY100 18 BY126 12 BY127 10 CRO333 198 OAS 9 OA47 10 OA70 9 OA79 10 OA81 10 OA85 10 OA90 10 OA91 8 OA96 8 OA200 8 OA202 8 IN914 4 IN916 6 IN4001/2 5 IN4003 6 IN4004/5 7 IN4006/7 7 IN4148 8 IN5401 12 IN5404 14 IN5406 18 IN5408 19 1S44 9 1S921 9 6A100V 40 6A400V 40 6A800V 55		BRIDGE RECTIFIERS (plastic case) 1A/50V 18 1A/100V 20 1A/400V 20 1A/600V 30 2A/50V 28 2A/200V 40 2A/400V 42 2A/600V 50 6A/100V 83 6A/400V 96 6A/600V 128 10A/200V 218 10A/600V 298 25A/200V 240 25A/600V 398 BY164 56		7 Segment Displays TL321 5" C.An 140 TL322 5" C.Ch 140 DL704 3" C.Ch 125 DL707 3" C.Anod 125 FND357 or 500 130 5x4x2" 106 5x2.34x1.12" 90 5x2.34x2.2" 130 5x4x1.12" 99 5x4x2.2" 120 6x4x2" 150 6x4x3" 180 8x6x3" 210 10x4.1/4x3" 240 10x7x3" 278 12x5x3" 290 12x8x3" 296		ALUMBOXES 4x2x2x2" 100 4x2.34x2.1/2" 103 4x4x2" 120 4x4x2.1/2" 106 5x4x2" 106 5x2.34x1.12" 90 5x2.34x2.2" 130 5x4x1.12" 99 5x4x2.2" 120 6x4x2" 150 6x4x3" 180 8x6x3" 210 10x4.1/4x3" 240 10x7x3" 278 12x5x3" 290 12x8x3" 296		SLIDE 280V 1A DPDT 14 1A DPDT COFF 15 1/2ADP on/on/off 40		TOGGLE 2A 280V 1A SPST 14 1A DPDT 15 4 pole on off 54		ZIF SOCKET (TEXTBOOK) 24 way 575p 28 way 695p 40 way 845p		PCB Male Header Connector 2 rows 10 way 90p 16 way 130p 20 way 145p 26 way 178p 34 way 208p 40 way 220p		Female Header Connector 85p 110p 150p 165p 200p 250p		Female Card-Edge Connector 120p 195p 240p 320p 340p 420p	
ZENERS Range: 2V7 to 35V 400mW 8p each Range: 3V3 to 33V 1.3W 18p each		FERRIC CHLORIDE Crystals 1lb 195p + 50p p&p		DALO ETCH RESIST Pen plus spare tip 100p		COPPER CLAD BOARDS Fibre Glass 6" x 6" 100p Single-sided 125p Double-sided 225p		VEROBOARD Clad Plain VQ Board 180p 2 1/2 x 3 3/4" 95p 2 1/2 x 5" 110p 3 3/4 x 3 3/4" 110p 3 3/4 x 5" 125p 3 3/4 x 7" 220p 4 1/4 x 18" 890p Pkt. of 100 pins 58p Spot Face Cutter 180p Pin Insertion Tool 185p		AMPHENOL PLUGS 24 way IEEE 485p 36 way Centronic 480p 24 way Female 480p 36 way Centronic Female 470p		ASTEC UHF MODULATORS 6MHz Stand 375p 8MHz Wideband 550p		EDGE CONNECTORS 1" 2x18 way 210p 1" 2x22 way 215p 1" 2x23 way 178p 1" 2x25 way 285p 2" 2x28 way 190p 2" 2x30 way 310p 2" 2x36 way 360p 2" 2x43 way 450p 2" 2x75 way 660p		TURNED PIN Low Profile Professional DIL SOCKET 8 pin 25p 14 pin 40p 16 pin 42p 18 pin 47p 20 pin 60p			
SCR's Thyristors 0-8A-100V 32 5A/300V 38 5A/400V 40 5A/600V 48 8A/300V 50 8A/600V 96 12A/100V 78 12A/400V 98 12A/800V 158 BT106 150 BT118 180 C106D 38 TIC44 24 TIC45 29 TIC47 38 2N5054 38 2N4444 130		TRACAS 3A/100V 48 3A/400V 56 3A/800V 88 8A/100V 60 8A/400V 99 8A/800V 115 12A/100V 78 12A/400V 82 12A/800V 138 16A/100V 103 16A/400V 106 16A/800V 220 25A/400V 185 25A/800V 296 25A/1000V 480 30A/400V 526 T2800D 126		VERO WIRING PEN and Spool Spare Wire (Spool) 75p Wire Wrapping Stakes 100 250p		ASTEC Soldering Irons C15W 825p C157W 545p G18W 580p C517W 570p XS25W 570p		COVERS 75p 70p 85p IDC 25 way Pig. 385p, Skt. 450p		MALE Solder 55p Angle 110p Strait 100p		FEMALE Solder 90p Angle 150p Strait 100p		'D' CONNECTORS: 9 way 15p 15 way 25p 25 way 37p 37 way 50p		TRANSFORMERS (mains Prim. 220-240V) 3-0-3V, 6-0-6V 100mA 130; 9-0-9V 75mA; 12-0-12V 75mA; 15-0-15V 75mA; 6VA: 2x6V-5A; 2x9V-4A; 2x12V-0-3A; 2x15V-2.5A 385 (60p p&p) 12VA: 2x4V5-1.3A; 2x6V-1.2A; 2x12V-5A; 2x15V-4A 345p (35p p&p) 24VA: 6V-15A 6V-1.5A; 9V-1.2A 9V-12A; 12V-1A 12V-1A; 15-8A 15-8A; 20V-6A 20V-6A 385 (60p p&p) 50VA: 2x6V-4A; 2x9V-2.5A; 2x12V-2A; 2x15V-1.5A; 2x20V-1.2A; 2x30V-0.8A 520p (60p p&p) 100VA: 2x12V-4A; 2x15V-3A; 2x20V-2.5A; 2x30V-1.5A; 2x40V-1.2A; 2x50V-1A 965p (60p p&p)			
DIAC 100 45p 500 370p		SOLDERCON PINS 100 45p 500 370p		COMPUTER CORNER ● EPSON RX80 Printer £209 ● EPSON RX80 F/T Printer £219 ● EPSON FX80 Printer £316 ● EPSON FX100 Printer £429 ● KAGA/TAXAN KP810 Printer £252 ● KAGA/TAXAN KP910 Printer £332 ● BROTHER HR15 Daisywheel Printer £329 ● Centronics PRINTER CABLE for all the above printers to interface with the BBC Micro £7 ● ZENITH 12" Hi-RES, Green Monitor 40/80 column select switch, value for money. £66 ● MICROVITEC 14" colour monitor. RGB input. Lead incl. £165 ● MICROVITEC 1451 Hi-res 14" Monitor incl. Lead £237 ● KAGA 12" MED-res £225 ● KAGA 12" Hi-res £310 ● TEX EPROM ERASER. Erases up to 32 ICs in 15-30 min. £30 ● Spare UV lamp bulbs £8 ● 8 1/2" or 9 1/2" Fan fold paper (1000 sheets) £7 (150p)		Plastic Library DISC STORAGE CASES Holds ten 5 1/4" Diskettes. £1.80 DISC ALBUMS Attractively finished in beige leather-vinyl, these conveniently store up to 20 discs. Each disc can easily be seen through the clear view pockets. ONLY £4.25 5 1/4" Disc Drive HEAD CLEANING KIT £9 BBC MICRO WORD PROCESSING PACKAGE A complete word processing package (which can be heavily modified to your requirements, maintaining large discount). We supply everything you need to get a BBC Micro running as a word-processor. Please call in for a demonstration. Example Package: BBC Micro, with DFS Interface, Wordwise, Twin 400K TEC Disc Drives, 12" High-res green monitor, Brother HR15 Daisywheel printer, Beebcalc & Database software on Disc, 10 3M Discs, 500 sheets of paper, 4 way mains trailing socket, manuals and all cables. Only: £1,089		CRYSTALS 32.768KHz 100 100KHz 575 200KHz 370 455KHz 370 1MHz 275 1.008M 275 1.28MHz 460 1.5MHz 420 1.6MHz 696 1.8MHz 275 1.8432M 250 2.0MHz 225 2.4576M 200 2.5MHz 225 2.56250M 220 3.2768M 180 3.57954M 98 3.6864M 300 4.0MHz 150 4.032MHz 290 4.194304M 200 4.33319M 200 4.608MHz 200 4.800MHz 200 5.0MHz 160 5.185MHz 300 5.24288M 390 6.0MHz 140 6.144MHz 150 6.5536MHz 200 7.0MHz 180 7.168MHz 280 7.68MHz 200 8.0MHz 180 8.08333M 396 8.86737M 175 9.00MHz 200 9.375MHz 350 10.0MHz 175 10.5MHz 220 10.7MHz 150 10.24MHz 200 12.0MHz 175 12.528MHz 300 14.31818M 170 14.376M 175 14.765MHz 250 15.0MHz 240 16.0MHz 220 18.0MHz 180 18.432M 180 19.2MHz 180 20.0MHz 280 24.0MHz 170 24.930MHz 325 29.695MHz 180 26.670MHz 325 27.125MHz 290 27.145M 180 27.648MHz 300 38.66667M 240 48.0MHz 240 55.5MHz 400 100MHz 295 116.0MHz 300 145.8MHz 225		BBC MICROCOMPUTER SPECIAL OFFER THIS MONTH ONLY £299 We stock the full range of BBC Micro peripherals, Hardware & Software like, Disc Drives (Top quality Cumana & Mitsubishi), Diskettes, Printers, Printer Paper, Interface Cable, Dust Covers, Cassette Recorder & Cassettes, Monitors, Connectors (Ready made Cables, Plugs & Sockets), Plotter (Graphic Tablet) EPROM Programmer, Lightpen Kit, Joysticks, Sideways ROM Board, EPROM Eraser, Machinecode ROM, The highly sophisticated Watford's 16K BEEB DFS, WORDWISE, BEEBCALC, Software (Educational Application & Games), BOOKS, etc. etc. Please send SAE for our descriptive leaflet. DRIVES CASED WITH PSU & CABLES ● CS100 - TEC Single sided 40 track 100K 5 1/4" Single Disc Drive £119 ● CS200 - Epson Double sided 40 track 200K 5 1/4" Single Disc Drive £139 ● CS400S - MITSUBISHI Double sided 80 track 400K 5 1/4" Single Disc Drive £149 ● CD400 - EPSON Double sided 40 track 400K 5 1/4" TWIN Disc Drives £215 ● CD800S - MITSUBISHI Double sided 80 track 800K 5 1/4" TWIN Disc Drives £295 ● DFS Manual (comprehensive) £7 (NO VAT) ● TWIN Disc Drive CASE with Power Supply to house your own Drives £38 N.B. All single drives with power supply with be supplied in a twin Case for later inclusion of a second Drive. (Carriage on disc drives £7 Securicor)									

WATFORD ELECTRONICS

Tel. (0923) 40588 Telex. 8956095

Tadpoles, again

Referring to the remarks I made last month about these high band FM hand-portables, OK so I was wrong. I'd just posted off last month's copy when a local amateur phoned up. He had bought a tadpole hand-portable and kitted it out with crystals. Transmit, no problem - receive frequency, 25KHz low. I shall not bore you with the details, but if this happens to you snip out the 10pF capacitors soldered in parallel with the receiver crystal sockets and wire a 30pF capacitor in series with the rotor contact of the receive channel switch.

I've had a few more in during the month, some as above and some as last month. It is interesting to speculate on the use the ones as above were originally put to - they are all totally covered in black paint! If the black paint is chipped and looks rough it will come off with determined scraping with the edge of a credit card (preferably one that is out of date!).

Talking of scratched cases, a scratch on a black painted metal case (or sometimes a black crackle finish) can sometimes be easily and completely disguised by filling in the scratch with the ink from a black felt tip pen. A few 'coats' may be required, and if it doesn't work then it will come off with meths. This trick works particularly well with CB transceivers, and can transform a rough looking rig into a pristine machine.

Audio ICs again

A few months ago I mentioned problems that can occur with integrated circuit audio amplifiers, and discussed the Texas 76XXX series that blew replacements for no apparent reason. I have had a few letters from amateurs about similar problems with the TDA2002A and TDA2030 chips. These audio output devices are used in a few HF/VHF transceivers, several hand-portables and lots of CB rigs, including convertible ones like DNTs and LCLs. There are several reasons for failure and one or more of the following may apply.

If you have a scope, look at the output (pin 4). If there are big handfulls of ultrasonic oscillations, often around 50KHz, pouring out try 1000pF on the inputs (pins 1 and 2) to ground or an 0.1µF from supply (pin 5) to ground.

As with most audio chips the output pin should sit at half rail. In most cases a faulty audio stage will have either full rail or no volts showing here. I would suggest unsoldering C1 and C2 (noting polarity first) and checking them out with a multimeter. The *slightest* indication of any leakage current (shown by an ohms check) means capacitor replacement time has come. I had one DNT rig that was a real pain to repair, and eventually discovered C1 had delusions of grandeur and wanted to be a battery. Although giving out 0.75 volts and only being capable of micro-amps of current, this was sufficient to throw the bias haywire.

The good news is that the internal protection of the chip is normally sufficient to save itself and only rarely does the chip require replacement.

Some chips just will not dc stabilise

SECONDHAND EQUIPMENT GUIDE

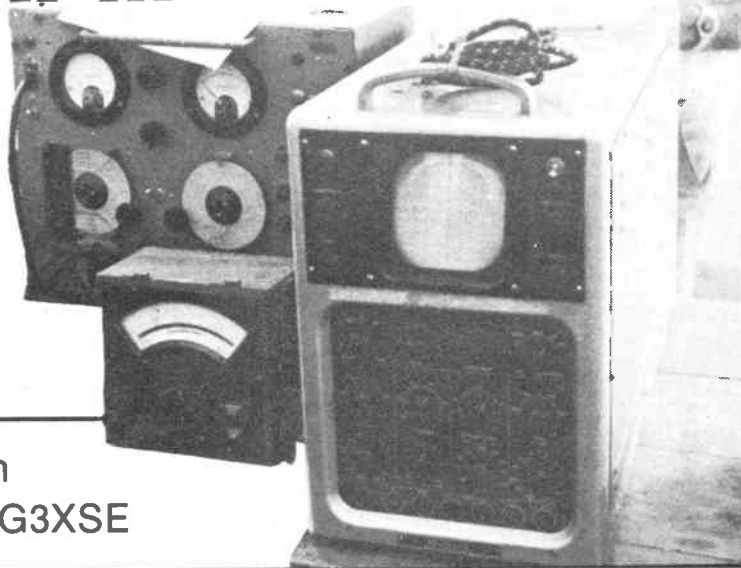

by Hugh
Allison G3XSE

themselves and the output pin voltage wanders up and down, with attendant distortion and low audio output. Changing chips doesn't, as often as not, effect any cure, so I have devised the following solution for these chips. Referring to *Figure 1* you will see that a 1K potentiometer has been added between the output pin and earth. A proportion of the dc volts is fed back via the 22K resistors to the input to achieve a degree of stabilisation.

You will have to determine which input pin to connect with the other end of the resistor since the dc drift may be in either direction, though normally it's pin 2. Set the potentiometer to give half rail at pin 4. If there is a tendency towards oscillation after modification try only one 39K resistor and no 0.1µF capacitor.

FT200/FP200

I have had a letter or two about the suitability of these rigs for newly licensed amateurs as their first HF rig.

Often as not they have been attracted to them by their relative cheapness and wonder if they are any good. As with most things in life, you pay your money and takes your choice, but hopefully the following will help you decide if this early Yaesu rig is for you or not.

First the disadvantages. They are big - beware, they may not look it, but remember the power supply is not built in and will probably occupy the same volume as the rig itself (the rig was at one time available with or without the dedicated PSU, the FP200).

Mobile operation isn't easy, again due to size, and keeping all those heaters glowing is going to give the car battery something to think about. Unless you are a real sadist I wouldn't consider building a mobile PSU for one of these. It would be best to get a more modern transistorised (or part transistorised) rig.

Drift can be a slight problem - expect a few KHz during the first hour or two of each operation, thereafter no problems.

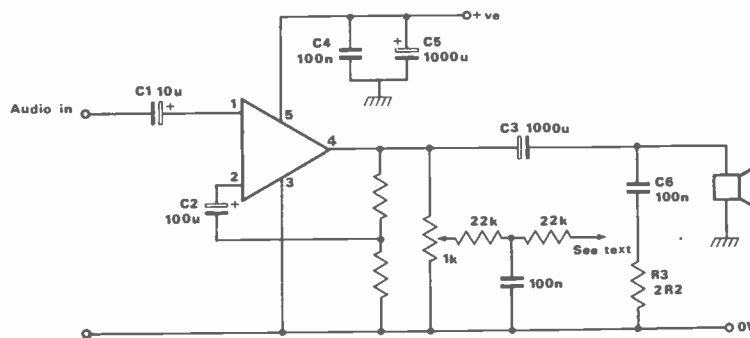

Fig 1 Modification to give dc stabilisation

SECONDHAND

Deafness is a problem to an extent on 15 metres and definitely on 10, although sensitivity is more or less adequate on other bands. Due to the main source of the deafness being noise etc in the RF and mixer stages, an external RF amplifier is of some use. Barefoot, definitely not suitable for on-the-horizon Oscar contacts!

Talking of 10 metres, a lot of rigs came without all of 10 metres fitted, often only 28.5 - 29 being in there. If 10 metre CW appeals check it has the appropriate rock. Due to their age the new bands are not fitted, but it is possible, by sacrificing another near band, to change a rock and

get one of them if you are desperate.

And now the good points. They are easy to work on, most components being standard bits and pieces, and the layout more or less tells you what each part is doing so circuit diagrams aren't needed if you are experienced. They are reliable and also freely available on the second-hand market. However, the best advantage of the FT200 is its price. A good, clean example, with all of 10 metres and the FP200, shouldn't set you back more than £200, *maximum*. One without a PSU or a grotty one would cost £135.

If you consider that they cost £200-£250 when new in the early seventies,

then they have hardly depreciated at all, and it is a fair guess that they will keep their value in years to come.

A final point about the FT200. Have you noticed the number in use in the communist countries? Most stations are home brewed since the importation of transceivers is banned (to save precious foreign currency). However, in about 1973, I think, a special concession was raised permitting the importation of a limited number of FT200s to certain territories. Due to their scarcity they are highly prized by their owners, which is why they proudly tell you all about them on the air.

LOOK WHAT YOU GET EVERY MONTH IN

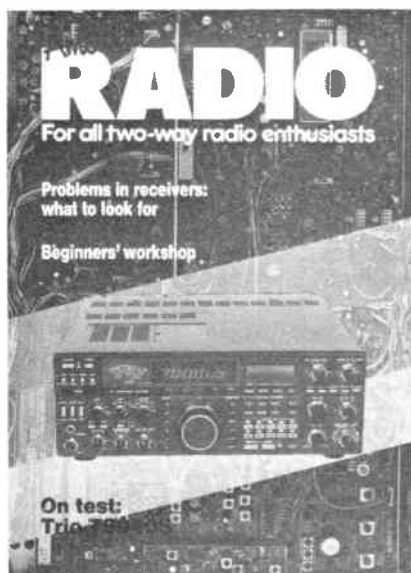

Amateur RADIO

- ★ **DX DIARY** Don Field G3XTT with all the news of rare DX, contests and DXpeditions
- ★ **ON THE BEAM** Glen Ross G8MWR with all the news and comment from bands above 50MHz
- ★ **G3OSS TESTS** Angus McKenzie - the fairest, most comprehensive reviews available anywhere

MORE NEWS, MORE FEATURES, MORE FUN, MORE STYLE THAN ANY MAGAZINE AVAILABLE ON THE MARKET TODAY

Make sure of your copy by placing a regular order at your newsagents or by taking out a post free, inflation proof subscription, with early delivery to your door each month

AMATEUR RADIO SUBSCRIPTION ORDER FORM

To: Subscription Department • Amateur Radio •
513 London Road • Thornton Heath •
Surrey • CR4 6AR Tel: 01-684 3157

PLEASE SUPPLY: (tick box) for 12 issues, all rates include P & P

Inland World-Surface Europe-Air World-Air
 £13.20 £14.30 £19.10 £25.10

NAME

PAYMENT ENCLOSED: £ -

Cheques should be made payable to Amateur Radio. Overseas payment by international Money Order, or credit card

ADDRESS

CREDIT CARD PAYMENT



.....

..... Postcode

Signature



There's more to the motor car than driving to work . . .

Did you know that hundreds of people race each other all over Britain every weekend – legally? Fourteen permanent race tracks and 70 part-time sprint and hillclimb venues play host to 300 events every year.

Motor Racing Magazine will cover this world of high-performance motoring, along with the international glamour and excitement of Grands Prix, Le Mans and Monaco.

MOTOR RACING SUBSCRIPTION ORDER FORM

To: Subscription Department • Motor Racing • 513 London Road • Thornton Heath • Surrey • CR4 6AR
Tel: 01-684 3157

NAME

ADDRESS

.....

Postcode.....

PLEASE SUPPLY: (tick box) for 12 issues, all rates include P&P

Inland £15.20 World-Surface £16.45 Europe-Air £22.55 World-Air £32.15

PAYMENT ENCLOSED: £ - Cheques should be made payable to Motor Racing. Overseas payment by international Money Order, or credit card

CREDIT CARD PAYMENT

.....

Signature

STEP INTO . . .

ARE YOU INTERESTED IN ANY OF THESE SUBJECTS?

- UFO Sightings ● Mysteries of Outer Space ● The Power of Pyramids ● Achievements of Ancient Civilisations ● Alchemy and Prophecy ● Surviving Prehistoric Monsters ● Life after Death ● Ghost Sightings ● Standing Stones ● Ley Lines ● Earth Energy

Although our scientific knowledge has advanced so far that we are able to put a man on the moon, many of the mysteries that bewildered our ancient ancestors still baffle us today

Much written (and even photographic) evidence exists about phenomena that does not have a scientifically provable explanation

The Unknown examines this evidence, investigating myth, legend and hoax and balancing this with the latest scientific research and findings to give readers a well-informed overall picture.

DON'T MISS THE FIRST ISSUE – ON SALE FROM 27 JUNE



THE UNKNOWN SUBSCRIPTION ORDER FORM

TO: Subscription Department *THE UNKNOWN* • 513 London Road • Thornton Heath • Surrey • CR4 6AR. Tel: 01-684 3157.

PLEASE SUPPLY (tick box – all rates include postage)

Inland 1 year £12.30 World - Surface £13.10 Europe - Air £16.70 World - Air £19.90

PAYMENT ENCLOSED: £ - Cheques should be made payable to The Unknown. Overseas payments by International Money Order or credit card

CREDIT CARD PAYMENT: (tick box)

Card Number

SEND TO: Name

Address

Postcode.....

Signature

FREE CLASSIFIED ADS

FREE CLASSIFIED ADS CAN WORK FOR YOU

We are pleased to be able to offer you the opportunity to sell your unwanted equipment and advertise your 'wants'.

Simply complete the order form at the end of these ads, feel free to use an extra sheet of paper if there is not enough space. We will accept ads not on our order form.

Send to: **Amateur Radio Classified Ads**, Sovereign House, Brentwood, Essex CM14 4SE.

DEADLINE AND CONDITIONS

Advertisements will be published in the first available issue on a first come first served basis. We reserve the right to edit or exclude any ad. Trade advertisements are not accepted.

FOR SALE

- Yaesu FRG7 general coverage receiver, vgc, with manual and circuit diagram, £100. Tel: Dean 33115.
- I have a VIC20 CPU, 16K switchable RAM and datacassette, lots of programs (mostly amateur radio and games). Cost new at Christmas '84 over £200, will sell for £110 or vno. Would consider swap for 144MHz linear with pre-amp with 100+ watts output for 10W input. Tel: Darren on (0536 72) 3866.
- Commodore 'Pet' 2001 computer, 32K memory, new ROMs, built in screen, very good condition, includes cassette deck. Could be used for RTTY, logs etc, £130 ono. Andrew Adey. Tel: Wolverhampton 753567 after 5pm.
- Yaesu FT290 2 metre multi-mode, 8 months old, first class condition £225. A Dixon, 129 Sheffield Rd, Penistone, Sheffield S30 6HJ. Tel: Barnsley 764600.
- FT757GX, mint condition, hardly used. SWL only. Reason for sale, lost interest, £525 ono. Tel: (0507) 601514.
- Tektronic oscilloscope type 581A. Complete with plug in units type 'G' and 82 (double beam) 85MHz with manuals for all three. All mint. Tektronic trolley included in price £95. Also extra manual for 581A and unit type 'G', £8 and £5 respectively. Tel: Disley 3602 (East Cheshire), will discuss carriage arrangements.
- 934MHz complete station. Comprising 'Reftec' model two transceiver + professional colinear antenna 7.5dBi + SWR/power meter 900-950MHz + additional external S-meter for transceiver + Realistic noise cancelling mike + magnetic mount colinear antenna 3dBi. £299 or exchange for Icom IC120 23cm transceiver in excellent working condition. All carriage extra unless exchange. Reason for sale: need 23cm urgently for forthcoming contest. Tel: 01-845 4008.
- Stereo system comprising Sony stereo amplifier, Toshiba Dolby cassette deck, Garrard turntable with Shure magnetic cartridge, pair of Tandy speakers, £100.00. Also have Powertran Transcendent 2000 monophonic synthesiser, fully working order with original construction handbook, £100.00. Will consider swapping either item or both for 2 metre SSB transceiver, or working 70cms ATV transmitter. Can deliver within 25 miles radius. Both items must go by end of June. Spook Corner, Bentsbrook Park, Dorking, Surrey RH5 4JL.
- Trio 430S fitted FM, used receive only £630. Trio 2500 2 metre handheld, base charger etc £260. FT790R 70cm multimode portable, nicads etc £220. AOR 2001 scanning receiver £260. FS603M power SWR meter £40. Daiwa 606K audio filter £40. 12AVQ vertical antenna 10-20 metres £40. All but last item in mint condition. Tel: Dronfield 413413 evenings, weekends.
- Sale/swap fishing equipment, Carbon float rod, Sigma wand ledger rod, ABU601 and DAM clipper reels and 2 other rods. Good tackle box with floats, shot, hooks etc. Keep net and landing net. Folding stool, bank sticks and more. Swap for FT290R (cash adjustment either way) or FRG7700 or WHY, money offers considered. Available for inspection. Tel: Michael (779 or 09276) 4172 evenings.
- Pye pocketfone Tx/Rx units £15 pair. Pye multi-charger unit with batteries £20. Pye mobile Rx adaptor unit £12. Tel: (0792) 467384.
- R107 reception set, working order, good condition £30. Peter Ward, 64 London Road, Berkhamsted, Herts HP4 2NF. Tel: (04427) 5277.
- RCA AR88D with matching speaker, eight spare valves, fitted 'S' meter. 6H6s replaced by 5S diodes. Circ. notes booklet, £50 ono. Buyer must remove owing to size and weight. Cannot lift! K Rainford. Tel: (0492) 514718.
- FRG7700 plus FRT7700 £200. Telereader CWR 670E £275. Green screen VDU £80. Datong

- amplifier RFA £15. Would consider exchange for 2m base station (cash adjustment). Gill, 'The Cottage', 83 Barrowell Green, Winchmore Hill, London N21 3AU. Tel: 01-886 9363 evenings.
- Eddystone 770R 19MHz to 165MHz, new valves fitted, complete with instruction manual, £85 ono. Tel: Ashby de la Zouch 411904.
- Quad 9HIGL version for 20,15,10, eight resin coated bamboos, 8ft boom cast alloy & end pieces, four tuned traps. £50 or swap, eg power supply. G4SQA QTHR. Tel: (0733) 232211.
- VHF/UHF Yaesu FT720RV/RU complete 2m/70cm mobile FM rig, including switching unit and all connecting cables. As new, boxed with manual £249.00. Tono MR150W 150W 2m linear £95.00. SMC Oscar 2 10FM rig £30.00, or £350.00 the lot. G4WVX. Tel: (06266) 64415.
- KW202 Rx. Xtal calibrator, Q multi with notch capacity. Top band to 10 metres, £110. Advance audio sig gen £25. Heath RF/1U sig gen £20. All with manuals. Above items callers only. Short Wave mags, Nov 1964 to April 1979 £15 collected. Ham Radio Today, June to Dec 1983 (less Aug), April to Dec 1984 (less June), Jan to May 1985. Practical Wireless, Sept 1982 to Feb 1984. Offers Pryse, 36 Hart Road, Byfleet, Surrey KT14 7NH.
- Heathkit Rx, any offers. Also Colt 210 CB, 120 chan AM and FM, any offers. Tel: Bob on Keynsham 67737.
- AR40 rotator, modified for fixing to flat plate, £20. G4NRG. Tel: Brentwood (0277) 810831.
- FRG8800 receiver and active antenna 2 months old. Genuine reason for selling. £395 no offers. Write to Mr F R Murphy, 75 Gt Peter Street, Westminster, London SW1.
- Attention 35mm slide enthusiasts/lecturers! Imatronix digital 2500S auto-dissolve projector controller for sale. Will flash, slow or fast, crossfade, two projectors automatically. Including 'optional' manual controller for programming effects. This represents over £200 worth of equip. To you - £100 ono or WHY in the fields of amateur radio/SWLing. Handbook - easily connected - good - works. Call in the evening please. Dave Gilligan. Tel: 01-478 5903.
- Datong 2 metre converter complete with 12 volt mains power unit, £30. Global AT1000 aerial tuner. Suitable any short wave receiver £28. Yaesu FRV7700D converter £50. All with makers details, good condition, and post paid. Letters only please to Frank Moore, 76 High Street, Ide, Exeter, Devon EX2 9RW.
- Trio TS430S, PSU PS430, CW, SSB, CW filters, FM board, 8 months old, still under guarantee, £750 ono. G4TZZ, QTHR. Tel: Glos (0452) 720061.
- Yaesu FL2100Z HF linear, 1200W PEP, 9-band, mint cond with orig packing £495 ono. 4mtr Europa xverter 100W PEP output inc matching CPS10 PU, could be modified to 6mtrs £85. MuTek SLNA 144S 2mtr pre-amp £25. Tel: 01-578 4484.
- Ferrograph series 632 stereo tape recorder, 3 speed, £70. Few reels tape. Trio R2000 with VHF and SW MW, 100KHz, 30MHz, 118MHz, 174MHz, all modes with preselector which covers 1MHz to 30MHz, PR40, PA3, 2 metre pre-amp £360 lot. No offers. Bookshelf cabs Armstrong amp for spares £15 ono. Call at 53 Maple Road, London SE20.
- Icom 211E 2m multimode in vgc, £400. Icom ICRM3 remote controller for above tcvr. Eddystone 770R VHF receiver good condition, £80. Tel: 01-340 4978.
- Tandy CB handheld, 40 channel, 4 watt, £65. CB SWR meter, £3. SX200N VHF scanning receiver with discone antenna, 26-514MHz, £220. Power pack 12V 3amp new £10. FT202R Yaesu portable, 2 metres, 6 channels, R1, R2, R7, S20, S21, S22 with nicad rechargeable batteries, £80. CB 4 channel, very good quality channels 2, 14, 21, 39, with rechargeable batteries & 'rubber duck', £44. Mike De-Wynter, 2 Woodside, Wimbledon, London

- SW19. Tel: 01-946 2967, please ask for Jane.
- PS430 power supply, 13.8V at 20A, suits most HF rigs, or 2m rig and 100W linear, £90. 2m transverter module, fits any Yaesu xverter frame, £85. Buyer collects, Manchester area. Tel: (0625) 527250.
- DXTV - Waltham 416 brand new £70. 3 element DXTV beam £20. Icom IC255E 2mtr Tx/Rx mobile, not handset. Brand new in original packing immaculate condition - never used. Many features, digital readout etc, £160. Also 5/7 amp power supply (can be used with IC255E), £15. Excellent condition. Postage on all items extra. Tel: Greig on (0738) 28120 after 6pm.
- FDK multi 725X absolutely mint cond never transmitted for any time. Failed RAE student, 1 year old £190 offers. Chamberlain, 45 Wheatsheaf Gdns, Sheerness, Kent ME12 1YH. Tel: (0795) 662991.
- Kenpro rotator model KR400 incl bottom clamps, one year old incl manual. Jaybeam Q4 2 metre aerial receipt and box available £75. For rotator and bottom clamps for aerial £10. Tel: evenings only (0823) 89481.
- President Dwight D CB 40 channel base station, Mains, or 12V. Professional FM conversion. CW, GAP, 1/2 wave antenna, and many yards of cable. Offers? Buyer to collect. Tel: Stubbington (Hants) 661495.
- VHF converter FRV7700 as brand new with manual £45. A real snip, 2m and airband. Collectors item, Jason tuning unit, working but some attention needed. (With power pack and amp) £14. Mr George Jacob, 23 Waterloo Gardens, Panylan, Cardiff CF2 5AA. Tel: (0222) 487299.
- Sommerkamp TS280 10/1 watt FM mobile. 25KHz steps 144-146MHz, £95. Terry G6DEG. Tel: (061) 761 4184 (Bury).
- Welz CP5 HF antenna, used six months, stored one year. Buyer collects or pays postage. Reason for sale - going horizontal. Price £65.00. Purdy G4RBP. Tel: (0705) 553551.
- Exchange Higan 8 USB, LSB, AM, 120 channels for any good receiver or anything interesting. Tel: (0752) 823163.
- President Grant FM, AM, USB, LSB, 25.625MHz to 28.305MHz, £150. Or swap for 2 metre linear. Tel: Worthing 505296.
- Belcom LS102, 28-30MHz, all modes, vgc, 10W output, with manual and mobile bracket. Offers around £225. Tel: Newark (0636) 702076.
- Eddystone 870A receiver, long, medium, short wave up to 24MHz. Near mint condition, with circuit and original box, £35 ono. Mr Button, 101 The Street, Holt, Trowbridge, Wilts BA14 6QH. Tel: (0225) 782954.
- Gemscan scanning receiver 60-179MHz, 380-519MHz, 70 memories, mains or 12V dc input. Realistic offers please. Allen G3DRN, QTHR. Tel: 01-947 3914.
- Yaesu FT230R 2m trascvr, 25 watts FM, complete with mobile mount and mic, mint condition, £180 ono. Tel: (04468) 261.
- Surplus to requirements, Yaesu FT227 mobile FM 2m rig. 10W output, scans from mic, 5 memories, nice condition, offers around £130. Tel: (0482) 802706.
- SMC HF5 five band vertical antenna, with radial kit, used for only one month, in original box with instructions, £65. Also Jaybeam ten element crossed yagi, £35. Tel: Winchester 760247.
- Trio 9130 144MHz multi-mode tcvr. Usual facilities. 25W output. 18 mths old. Good condition, £350 ono, includes 7/8x gutter mount aerial. STC Starphone single channel 450MHz rig, £15.00. 15 rolls 5-track paper tape, £1 each. Hugh G1BUE. Tel: St Albans 32759 eves and wk/ends.
- Yaesu FRG7700 Rx, excellent condition (almost new), boxed with manual, £250. Philips N4407 stereo reel-to-reel recorder with 20 7 inch tapes, £50. Philips RH702 stereo tuner/amp, £20. David

FREE CLASSIFIED ADS

Kernick. Tel: 01-446 6657.

■ Sony ICF2001 £99. Trio R300 comms receiver £80. Bearcat 220 scanner £130. Standard C800 10 channels 2m autoscanner receiver £55. Tristar 747 multi-mode CB, ideal conversion 10m £60. Tel: 01-643 5063.

■ TS930 Trio, Kenwood transceiver with general coverage and with fitted automatic ATU. The ultimate, cost £1,515, unmarked and in pristine condition. Save £500. Handbook and original carton £995. Tel: 01-486 8286 (work), 01-722 7040 (home).

■ MBA-RC, AEA, Morse, Baudot, ASCII code reader converter and transmitter, as new, £95 ono. I need Yaesu YO901 scope monitor or similar. A F Sephton, 16 Bloemfontein Avenue, Shepherds Bush, London W12 7BL. Tel: 01-749 1454.

■ New Brain computer fully expanded. 96K expansion unit, disc controller, twin 800K Mitsubishi disc drives, 20 Mbytes software (including word processors, databases, spreadsheets, Micro-soft basic, Pascal, Lisp, Cobol, disc utilities, amateur radio programmes, games etc), ICL printer, manuals, new £5,000, sell £1,000! All fully working will take TS780 part exchange. Exchange my TR9130 with excellent output transistors! for KW4000. Tel: Dave (021) 429 9199.

■ Yaesu FRG7700M. Mint condition with manual. £235 incl carriage. Tel: (0783) 367589.

■ Trio 510 HF Tx/Rx and matching PSU, with handbook, £165. FDK 2 metre FM multi 11, most repeater channels, 6 simplex channels, £60. Both gwo. Tel: (0427) 5848 or 5382.

■ Turner 500, mic 30, CB Zenith speech processor P202, £25. Breml 75 watt, £25. Tel: (0283) 221870.

■ Realistic PRO2003 scanner UHF, VHF, FM, 60ch program, VHF 68-87.995, 108-136-174MHz plus FM broadcast band UHF 410-512MHz. Cost new £299 - will exchange for gen coverage receiver, any make, with USB LSB plus AM. Tel: Melksham 705803.

■ Exchange FT225R 2 metre multi-mode with outboard digital frequency meter, in mint condition. This first class rig with cash for a FT757 or Trio 430S with or without PSU. Tel: Scunthorpe 733542.

■ KW204 Tx 160m - 10m CW/SSB, some spare valves, mic, handbook. Used daily until recently. Offers £100 or over. Matches KW202 Rx. WS38 MkIII, offers. G4EUW, QTHr. Tel: (020630) 3071.

■ T1154 transmitter, working but dusty. Selling on behalf of Air Training Corps. Offers. Tel: Kings Langley 65823.

■ R1000 Trio comm receiver 200KHz-30MHz with 2 metre converter 144-146MHz and new unused 2m aerial receiver and converter. Both in very good condition, price £200 or vno. Tel: (061) 962 6186.

■ Sony all band scanner ICF7600D, cost £180, sell £120 or p/ex for Rollie 35 or Balda 35 mini plus outfit. Tel: Littlehampton 723164.

■ SX200N 26 to 520 VHF, UHF, scanner. Also FRG7700 comm receiver. Also lots of mags, £350.00 the lot, or split £175.00 each. Buyer collects, all in good working order. Scanner comes with Discone aerial. All letters answered. D Cross, 51 Larkhay Road, Hucclecote, Gloucester GL3 3NX.

■ Yaesu 7700 in mint condition. Purchased Sept 1984 price £220. IB Eccles, 137 Apple Trees, Barhill, Cambridge CB3 8SP. Tel: Crafts Hill 81004.

■ Exchange Tristar 777, USB, LSB, CW, AM, FM, alpha channels fitted. Plus crystals to convert to 10 metres for receiver or 2 metre, 70cm handheld or WHY. Tel: Durham 701429.

■ Trio R1000 receiver 200KHz-30MHz in perfect condition, boxed with manual, £180. Eddystone EC10 receiver in very good condition with power supply and manual, £40. Both receivers must be sold following bereavement therefore reasonable offers considered. Tel: 01-670 7881 evenings only.

■ Yaesu FT221R, fitted muTek front end, with matching Yaesu. YD148 mic. Mint condition, £295. Tel: Kidsgrove 72100.

■ KW107 super match, this unit now surplus to requirements, therefore price of £85 to clear. Also Microwave Modules 144MHz converter, 10m IF, half new price, £15. Tel: (0386) 832233.

■ FT757GX HF, SSB, CW, AM, FM, transceiver with everything fitted. General coverage receiver, two VFOs, eight memories, RF amp, RF attenuator, noise blanker, audio processor and compressor, CW keyer, full QSK, VOX, IF shift, variable bandwidth, fan etc £550. FP301D 20amp power unit

£75, includes carriage. Tel: (0224) 584774.

■ Yamaha MR10 drum machine, with 16 built-in auto rhythms, with 32 variations. Brand new still in its box, £60 ono, (original £120), or part exchange for any highband receiver, ship to shore marine transceiver or 2m transceiver (cash adjustment can be arranged). Write to A Meachin, 4 Brotherton Close, Bromborough, Wirral L62 7AR.

■ Ham international Concorde 2. 120ch SSB with good PWR mic. £120 or swap for good Superstar, Nato or another ham. Midland 3001 40ch AM £15. Wanted: a pen pal, must be class A amateur. Please write to: Laith, 56 Tehidy Road, Camborne, Cornwall TR14 8LL.

■ FT707 complete with FP707 and FC707, well looked after, £475 ono. TR9500 70cm multimode, £350 ono. Tel: Henry (0376) 29089.

■ Cobra 148GTL DX. Exc cond, converted to cover 27.5MHz to 30+MHz. AM, FM, LSB, USB, CW, 4 watts AM/FM, 12 watts PEP, exc 10m multi-mode, £150. Tel: Maidstone 672116.

■ Elbex B/W surveillance camera, wide angle/zoom lens, pan function, includes wall bracket and PSU good condition, £50 ono. Also 'C' mount lens F1.8 16mm, £6 ono, and F1.3 8mm, £15 ono. Tel: Crawley (0293) 515201.

■ Instruction booklet for Gecophone A11 - electric three valve screen grid receiver cat nos BC3130. Booklet BC5620 September 1930. Offers to G4HFL. Tel: 01-861 4804.

■ Icom IC240 2m FM mobile transceiver £90. Commodore VIC20 colour computer with games £40. R209 general coverage receiver 1-20MHz £20. Tel: Corby (Northants) 69664.

■ Digitrex 600MHz digital frequency counter vgc, £35. VIC20 computer, 16K RAM, C2N cassette unit, books, games and some amateur radio programs. £95 ono. Tel: (0533) 602016.

■ FRG7 general coverage receiver excellent condition, fine tuner bargain, £120 plus transport. Trio R2000, marvellous receiver, ten memories, clock, timer etc. Immaculate, offers over £340 (cost £479). Also new Mizuho ATU, never used, (cost £57.74) bargain £32 plus transport. Tel: Exmouth 278737.

■ Cabin cruiser 14ft GRP. Wood deckhouse. Deck edges need work. No outboard motor. Exchange 2 metre SSB Tx/Rx or FT290R. Robins, 290 Priory Road, St Denys, Southampton SO2 1LS.

■ FRG7000 communications receiver, 0.250MHz to 29.999MHz, original box, manual and receipt, £210, buyer collects. Tel: (0635) 200865 after 6.00pm.

■ 2m equipment: Trio 7010 SSB/CW Tx/Rx no mic £75. Yaesu CPU2500R FM. Tx/Rx 144-148MHz memories, scan, keypad mic. Used as base station only, excellent cond £150. Both rigs with service manual. MML 144/100S 2m amp/pre-amp £95. 9el Tonna with 35° feet of H100 Pope co-ax. Aerial has been treated with weather proofing paint £10. Mr J Haig G4VXU, QTHr. Tel: (0462) 53097.

■ Cobra 148GTL-DX still boxed, mint condition, plus 25 watt linear amp, pre-amp and 13.8 volt power supply - offers. Also 27-30MHz 3 ele beam £25 ono. Tel: Dronfield (0246) 410409 9.00am to 5.00pm daily.

■ 2 metre FM receiver Daiwa search 9. 144-146MHz. VFO plus 11 switched channels (3 xtals fitted - R0, R3 and R6) ideal for fixed/mobile use. 12V operation with stand/mobile mount, instructions, £45. Tel: Bristol 776891 evenings/weekends.

■ Large amount of electronic/electrical items, includes components, mags, books, valves, etc. SAE for lists to: Mr P Coles, 23 Chestnut Walk, Bishopsworth, Bristol 3, Avon BS13 7RJ.

■ Marconi key type no 365EZ £15, plus postage. GW Morse key brass as new £25. Plus postage. Tel: Grimsby (0472) 361842 after 6pm.

■ Icom R71E 4 months old. Absolutely mint cond. Still under guarantee £550. Dressler ARA30 active antenna, cost £86.00. Never yet used. £70.00. 12V adaptor for Icom included. First to see will buy. Save over 21%. Will take 10x50 ZE1SS binoculars (west) in part exchange. Tel: (281) 2493 any evening.

■ SB102 SSB/CW, Tx/Rx, ham bands, inc P/S, sprk + mike + h/books, £200 ono. Good clean condx. 24V dc 10amp, Farnell P/S £10. B/C906 freq meter £8. Collection of military campaign medals value £300. Exchanges Racal freq counter to match RA17L mk2. Eddystone 770R. FR101 Rx with dig readout. A good SWR/PWR meter through type. Exchanges

etc. Tel: Milton Keynes 314095.

■ Swan Astro 102BX six band HF transceiver 1.8 to 29MHz, two VFOs, passband tuning, notch filter, CW wide & narrow, VOX, noise blanker, rit, no-tune transmitter, speech processor, full QSK, operators and comprehensive service manuals. £400 for this unique station, including matching PSU and carriage. Tel: Sid (0224) 584774.

■ FDK 2 metre transceiver 1-25 watts, variable, FM only, ideal mobile rig, complete with accessories, as new, £160. Tel: Alan Phillips, Wrexham (0978) 840473 after 5.30pm. Or write to Gernant, 39 Bryn Glas, Rhos, Wrexham, Clwyd, N Wales LH4 2EA.

■ Shack clearance: Tektronix 581A scope with all leads, probes, adaptors & 6 plug-in units, type G, H, L, K, D & CA dual trace. Exc, will exchange for HF Tx/Rx. Collins TCS station comprising Tx, Rx, mains P/U, leads, control unit, ATU & mike, rare & exc cond, offers around £150 or exch for 2m rig. 4 other Collins units (Tx & Rx) £15-£30 each.

■ Solartron 20MHz counter, exc cond £40. 3 x Solartron power units, 0-500V stab & 6.3V ac as brand new £30 each. BC348R with built-in P/U, exc £55. Collectors item: 1938 RME Communications Rx as original and vgc £75. Sony portable B/W, R-R video recorder, comprises recorder (portable 12V), recorder (mains) camera, mains unit/charger, leads, tapes & high res monitor, all Sony exc quality equipment, offers around £250 or exch for HF rig or good Rx. Will exch any items for good photographic equipment. S A Wright G4LBY, 22 Crown Street, Mansfield, Notts NG18 3JL. Tel: (0623) 29473, evenings only.

■ Turner 500 mic, £35. NATO 2000, suitable for conversion to 2m, £120, ovno. Tel: (0283) 221870.

■ Oscilloscopes for sale: Cossor 339 4inch double beam, working £20. Cossor 1045K 4inch single beam, £35, working. Cossor 1035 4inch double beam, not working, £10. All with circuits. Tel: 01-748 1410.

■ Dragon microcomputer plus software, £65. Nascom II microcomputer, boxed with PSU and software, £65. Both with RFI screening and many extras. Tel: Watford 33235.

■ Lafayette 1200 FM Tx/Rx 26.515-27.855MHz, very good condition, will convert to 28MHz easily, £45. Tel: (021) 355 3173.

■ Reace UH-74 50MHz, 144MHz, 430MHz, VSWR + power meter (10W), £15 ono, mini cond. Also Ham-Master 4500 mike plus compression, £10 ono. Tel: 01-247 6097 (day).

■ Electron and BBC computer users make backup copies of virtually all your tape software. Unlock and lock programs, menu driven machine code program. Send £3.75 cheque or postal order for your copy by return post to Chris Womack, 4 Mill Close, Ackworth, Pontefract, Yorkshire, WF7

Handbook for coil comparator LC100C British Physical Lab. R Davey, 53 Stalham Road, Hoveton, Norwich, Norfolk. Tel: Wroxham 3153.

Wanted by RAIBC member. Does anyone have a copy of 'Practical Test Equipment' by Calverton Publications to borrow, for sale or for copying. Will pay postage and return as soon as possible. Stan Clark G6NUO, 90 Hamstead Road, Gt Barr, B'ham B43 5BN.

Yaesu FT225RD all mode 2 metre transceiver. Mr Elvin Bailey, 23 McCallum Gardens, Strathview, Bellshill, Lanarkshire ML4 1HD. Tel: (0698) 747448.

Datona FL3 filter. Exchange camera gear or cash. Tel: (0436) 71181.

Two metre multimode mobile, Trio or Yaesu. Also gen cov Rx must be cheap. S S Yates, GW1MOL. Tel: (0792) 299566.

Eddystone 888A or EC10 or any amateur bands receiver. Tel: (0228) 26436.

Bird 43 high power VHF/UHF elements. G4NRG. Tel: Brentwood (0277) 810831.

RTTY software/hardware for ZX81. Also cheap crystal 2m or 70cm handheld. Richard Meal, GW6TAM (QTHr). Tel: (0554) 820282 Monday-Thursday 5-9pm.

FT101ZD with FM or Trio TS530S, FC902. 2m and 70cm multi-mode rig, mobile or base, FRG7, R600 or R1000 required. Dave, tel: (04024) 57722.

Recordings of pirate or offshore radio, cassette or open reel, can supply tape if needed. Nick Ashby, 2 Pleasant Way, Wembley, Middx. Tel: 01-997 2367.

Handbook for coil comparator LC100C British Physical Lab. R Davey, 53 Stalham Road, Hoveton, Norwich, Norfolk. Tel: Wroxham 3153.

Wanted by RAIBC member. Does anyone have a copy of 'Practical Test Equipment' by Calverton Publications to borrow, for sale or for copying. Will pay postage and return as soon as possible. Stan Clark G6NUO, 90 Hamstead Road, Gt Barr, B'ham B43 5BN.

Yaesu FT225RD all mode 2 metre transceiver. Mr Elvin Bailey, 23 McCallum Gardens, Strathview, Bellshill, Lanarkshire ML4 1HD. Tel: (0698) 747448.

Datona FL3 filter. Exchange camera gear or cash. Tel: (0436) 71181.

Amateur RADIO SMALL ADS

PNP Communications
Modular terminal units
for
RTTY — MORSE — AMTOR

PL1 RTTY mod/demod	£14.50k	£18.50a
MF1 Morse demod	£12.50k	£18.50a
FP1 Power supply/amp	£11.50k	£14.50a

a = assembled PCB, k = kit of parts. Software available for — Dragon VIC20 CBM 64 BBC Amstrad CPC464 Acorn ATOM. Please ADD VAT at the current rate.

ACCESS & VISA welcome
62 Lawes Avenue, NEWHAVEN
East Sussex BN9 9SB
Telephone (0273) 514465
LARGE SAE for full Catalogue

AKD **Armstrong**
Kirkwood
Developments
10, Willow Green, Grahame Park Estate, London, NW9.
Tel: 01-205 4704

VHF/UHF ABSORPTION WAVEMETER
Covers 120-450 MHz. Extremely sensitive. Low-profile. Requires PP3 battery **£24.95**



HIGH PERFORMANCE RF FILTERS
SLIMLINE, ATTRACTIVE APPEARANCE
Used by British Telecom, Thorn-EMI, IIT, Telefusion, Granada etc.

Standard range terminated in Belling Lee plug/socket (75ohms) — others to order

Model TNF2 Tuned Notch Filters (Braid & Inner) for 2, 10, 15, 20 Metres & CB (state which) **£7.75**
The TNF2 range have a very low insertion loss and very high rejection over the band for which they are supplied. They are the best possible answer for aerial borne interference from a single known frequency or frequency band.

Model RBF1-70cms Notch Filter (inner only) **£8.75**
Model BB1 Braid Breaker **£8.75**
Also available, 3 High Pass models and a "Radar Bp" filter for VCRs. Please send A4 or C4 stamped addressed envelope for filters data sheet and price list.

All items are manufactured by AKD in UK and carry a two year guarantee plus 14 day money back promise (no reason required).

Items usually despatched within two days from receipt of order. Prices include VAT, postage & packing.
(Prop.) J.W. ARMSTRONG
ALSO AVAILABLE FROM MOST LEADING AMATEUR RADIO DEALERS



USED AMATEUR EQUIPMENT? I Buy, Sell & Exchange!

SELLING? I pay the **BEST POSSIBLE PRICES** for your Clean Used Equipment!

BUYING? I have the **BEST SELECTION** of top Quality Used Equipment Available!

For the Deal You've been Looking for, Phone Dave, G4TNY
ANYTIME ON HORNCHURCH (04024) 57722 or Send SAE

G4TNY AMATEUR RADIO
132 Albany Road, Hornchurch, Essex RM12 4AQ

Amateur RADIO SMALL ADS

This method of advertising is available in multiples of a single column centimetres — (minimum 2cms). Copy can be changed every month.

RATES
per single column centimetre:
1 insertion £7.00, 3 — £6.60, 6 — £6.30, 12 — £5.60.

WANTED

Test equipment, receivers, valves, transmitters, components, cable and electronic scrap and quantity. Prompt service and cash.

M & B RADIO
86 Bishopsgate Street,
Leeds LS1 4BB
0532 435649

SERVICE MANUALS

For ANY Age. Make or Model of Electronic Equipment. Amateur Radio, Vintage Wireless, Test Equipment, Old Ministry Equipment, Audio, Televisions, Colour and Mono, Video Recorders, Radiograms etc. etc. Thousands stocked. SAE enquiries and quote BY RETURN

MAURSTRON TECHNICAL SERVICES,
Dept AR, 8 Cherry Tree Road, Chinnor, Oxon, OX9 4QY.

AMATEUR RADIO SMALL AD ORDER FORM

TO: Amateur Radio · Sovereign House
Brentwood · Essex CM14 4SE · England · (0277) 219876

PLEASE RESERVE.....centimetres by.....columns

FOR A PERIOD OF 1 issue..... 3 issues..... 6 issues..... 12 issues.....

COPY enclosed..... to follow.....

PAYMENT ENCLOSED: (Add 15%VAT).... £

CHARGE TO MY ACCOUNT.....

COMPANY

ADDRESS

SIGNATURE **TELEPHONE**.....

R J PRODUCTS

9 Somers Rd, Welham Green,
Hatfield, Herts AL9 7PR
07072 69334

VIDEO RECORDER THEFT!!!

VALUGUARD

Although designed to protect Video Recorders, the VALUGUARD can protect any valuable, ie computer, TV, Ham Radios etc. **£27.50**

CAR THEFT!!!

IMOBILIZER

(Neg chassis Petrol engines only). This unit connects into the ignition system of a vehicle and will only allow it to start after a 'Personal' trigger has been operated. It also resets itself automatically after the ignition has been turned off for 20 seconds. **£15.20**

TRADE ENQUIRIES WELCOME
ALL PRICES INCLUDE P&P
SAE FOR DETAILS
PROPS RT + VEL WAGSTAFFE

McMichael A.R.S. Home
Counties

MOBILE RALLY

Sunday, 21st July, at 11am
Sefton Park, Bells Hill,
Stoke Poges, Slough
Talk-In on S22 & SU8

MORSE TUTOR

£4.00 on cassette. £6.50 on microdrive or floppy disc for Sinclair Spectrum QL/BBC. 4 to 18 words per minute, variable spacing, variable groups of random letters, numbers or mixed; Random sentences, own message, single characters and variable pitch. Feedback on screen, printer, or speech (Currah Microspeech 48K Spectrum only).

WD SOFTWARE (A.R)

Hilltop, St. Mary, Jersey, C.Islands
Telephone (0534) 81392

XXX ADULT VIDEO CLUB

For the genuine adult films. Available only from ourselves. Ring

0924-471811 (24hrs)

For the intimate details or write
ADULT VIDEO CLUB
P.O. Box 12, Batley, W. Yorks.

HEATHERLITE MOBILE MICS

Made to help you drive safely

Reasonably priced to suit your rig, head/neck band, electret mic, control box, variable mic gain, scanning buttons, plug fitted - superb quality. Priced from £20.50inc.

FULLY GUARANTEED

Ring for Details - Heather Q8SAV (0401) 50921

QSL Cards

Printed on white or colour gloss cards, printed to your own design.

Please send SAE for sample to:

Caswell Press
21 Homethorpe Ave, Redhill, Surrey
Tel: (Redhill) 71023

DW ELECTRONICS G3 XCF

Amateur Radio Supplies

71 Victoria Rd, Widsnes

Tel: 061-420 2889

Open Mon-Sat 9.30-6 (closed all day Thurs)
We supply YAESU, ICOM, Tonna, Jaybeam,
Microwave Modules, Datongs etc

G4BMK RADIO SOFTWARE

DRAGON/TRS80C - RTTY+ASCII CW AMTOR
Return old RTTY program with £5 for upgrade to mk3 RTTY+ASCII

Return RTTY/CW cart. with £25 for the addition of AMTOR s/w

CW Tutor Tape £6.50

CBM64 - RTTY - tape £11 disk £14

CBM64 - CW Tx/Rx tape £10 disk £12

VIC20 - RTTY - tape £10

ATOM - RTTY - Utility ROM £16

All are split-screen type-ahead.

State callsign (if any). SAE for details

GROSVENOR SOFTWARE (AR)
2 Grosvenor Road, Seaford, Sussex BN25 2BS
TEL: (0323) 893378

THE PERFECT COMPLEMENT TO AMATEUR RADIO

Packed with construction projects and the latest technology plus pages of readers' classified ads



Take out a **POST-FREE (UK) sub** while offer lasts

- Delivery to your door by publication date each month
- Inflation proof - price guaranteed for 12 months

On sale NOW at your newsagent and at equipment dealers

RADIO & ELECTRONICS WORLD SUBSCRIPTION ORDER FORM

To: Subscription Department • Radio & Electronics
World • 513 London Road • Thornton Heath •
Surrey • CR4 6AR. Tel: 01-684 3157

PLEASE SUPPLY: (tick box) for 12 issues, all rates include P & P

Inland	World-Surface	Europe-Air	World-Air
£11.80..... <input type="checkbox"/>	£13.10..... <input type="checkbox"/>	£19.20..... <input type="checkbox"/>	£25.90..... <input type="checkbox"/>

NAME.....

PAYMENT ENCLOSED:

£ -

Cheques should be made payable to Radio & Electronics World. Overseas payment by International Money Order, or credit card.

ADDRESS.....

CREDIT CARD PAYMENT

.....Postcode.....

Signature

ADVERTISERS INDEX

A R E Communications..60	Rainbow Com 39
B N Res.....31	Samsons Elec 41
P M Components4,5	Selectronic 26
Edwardschild.....26	Thanet Electron 8,9
Electrovalve.....31	Uniace..... 30
C M Howes39	Reg Ward 26
Marco Trading59	Watford Elec 48,49
R A S (Notts).....39	Henry Westlake..... 39
	R W Withers..... 2
	Wood & Douglas 26

Amateur RADIO

ADVERTISING RATES & INFORMATION

DISPLAY AD RATES

depth mm x width mm	ad space	series rates for consecutive insertions			
		1 issue	3 issues	6 issues	12 issues
61 x 90	1/8 page	£66.00	£82.00	£59.00	£53.00
128 x 90 or 61 x 186	1/4 page	£115.00	£110.00	£105.00	£92.00
128 x 186 or 263 x 90	1/2 page	£225.00	£210.00	£200.00	£180.00
263 x 186	1 page	£430.00	£405.00	£385.00	£345.00
263 x 394	double page	£830.00	£780.00	£740.00	£660.00

COLOUR AD RATES

depth mm x width mm	ad space	series rates for consecutive insertions			
		1 issue	3 issues	6 issues	12 issues
128 x 186 or 263 x 90	1/2 page	£305.00	£290.00	£275.00	£245.00
263 x 186	1 page	£590.00	£550.00	£530.00	£470.00
263 x 394	double page	£1,130.00	£1,070.00	£1,010.00	£900.00

SPECIAL POSITIONS

Covers: Outside back cover 20% extra, inside covers 10% extra
 Bleed: 10% extra [Bleed area = 307 x 220]
 Facing Matter: 15% extra

DEADLINES

*Dates affected by public holidays

issue	colour & mono proof ad	mono no proof & small ad	mono artwork	on sale thurs
Aug 85	27 Jun 85	3 Jul 85	5 Jul 85	25 Jul 85
Sep 85	1 Aug 85	7 Aug 85	9 Aug 85	29 Aug 85
Oct 85	29 Aug 85	4 Sept 85	6 Sept 85	26 Sept 85
Nov 85	3 Oct 85	9 Oct 85	11 Oct 85	31 Oct 85

CONDITIONS & INFORMATION

SERIES RATES

Series rates also apply when larger or additional space to that initially booked is taken.

An ad of at least the minimum space must appear in consecutive issues to qualify for series rates. Previous copy will automatically be repeated if no further copy is received.

A 'hold ad' is acceptable for maintaining your series rate contract. This will automatically be inserted if no further copy is received.

Display Ad and Small Ad series rate contracts are not interchangeable.

If series rate contract is cancelled, the advertiser will be liable to pay the unearned series discount already taken.

COPY

Except for County Guides copy may be changed monthly.

No additional charges for typesetting or illustrations (except for colour separations).

For illustrations just send photograph or artwork.

Colour Ad rates do not include the cost of separations.

Printed — web-offset.

PAYMENT

All single insertion ads are accepted on a pre-payment basis only, unless an account is held. Accounts will be opened for series rate advertisers subject to satisfactory credit references.

Accounts are strictly net and must be settled by the publication date.

Overseas payments by International Money Order or credit card.

FOR FURTHER INFORMATION CONTACT
 Amateur Radio, Sovereign House, Brentwood, Essex CM14 4SE.
 (0277) 219876

Commission to approved advertising agencies is 10%.

CONDITIONS

10% discount if advertising in both Amateur Radio and Radio & Electronics World.

A voucher copy will be sent to Display and Colour advertisers only.

Ads accepted subject to our standard conditions, available on request.



MARCO TRADING



TRANSISTORS DIODES

Type	Price (£)	Type	Price (£)	Type	Price (£)	Type	Price (£)	Type	Price (£)	Type	Price (£)	Type	Price (£)	Type	Price (£)
AC127	0.30	BC107	0.10	BC238	0.12	BD233	0.60	BF224	0.20	BR100	0.20	BY179	0.66	OC36	1.75
AC128	0.30	AorB	0.12	BC239C	0.14	BD234	0.62	BF224J	0.16	BR101	0.44	BY182	0.67	OC42	0.72
AC128K	0.34	BC108	0.10	BC251	0.12	BD235	0.63	BF240	0.63	BR102	0.58	BY184	0.40	OC42K	1.40
AC132	0.48	A or C	0.14	BD236	0.14	BD236	0.63	BF241	0.20	BRC443	1.76	BY189	0.72	OC44	0.72
AC141	0.28	BC113	0.14	BC301	0.30	BD237	0.66	BF244	0.26	BRY39	0.38	BY189	4.75	OC45	0.58
AC141K	0.40	BC114	0.12	BC302	0.32	BD238	0.56	BF244A	0.28	BRYS6	0.42	BY198	0.44	OC71	0.50
AC142	0.28	BC115	0.12	BC303	0.32	BD241	0.60	BF244C	0.24	BRYS6	0.86	BY199	0.47	OC72	0.52
AC142K	0.48	BC116	0.15	BC307	0.10	BD243A	0.80	BF244E	0.28	BSS17	0.56	BY206	0.24	OC81	0.68
AC151	0.48	BC117	0.22	BC308A	0.10	BD244A	0.66	BF254	0.18	BSS27	0.92	BY207	0.24	OC200	2.46
AC152	0.48	BC118	0.17	BC323	0.99	BD375	0.52	BF256	0.40	BSS19	0.20	BY210/400	0.28	OC202	2.20
AC176	0.28	BC119	0.30	BC327	0.14	BD410	0.78	BF257	0.32	BSX20	0.34	BY210/600	0.28	ORF12	0.88
AC176K	0.48	BC120	0.12	BC328	0.14	BD434	0.66	BF258	0.30	BSX59	0.62	BY210/800	0.30	R200B	1.50
AC187	0.42	BC140	0.28	BC337	0.12	BD436	0.66	BF259	0.32	BSX76	0.29	BY233	1.20	R201B	1.52
AC187K	0.48	BC141	0.42	BC338	0.12	BD437	0.76	BF262	0.30	BT100A/02	0.94	BY227	0.28	SHG1.5	0.40
AC188	0.44	BC142	0.30	BC350	0.14	BD438	0.76	BF263	0.30	BT101/300	1.15	BY229	0.30	TAG1/100	1.40
AC188K	0.60	BC143	0.30	BC440	0.30	BD439	0.66	BF270	0.30	BT101/500	1.25	BY238	0.68	TAG3/400	1.78
ACY40	0.68	BC147	0.08	BC441	0.32	BD507	0.48	BF271	0.26	BT102/300	1.35	BYX10	0.24	TIC44	0.40
AD142	1.10	A or B	0.10	BC461	0.32	BD508	0.53	BF273	0.18	BT102/500	1.65	BYX36/150	0.22	TIC45	0.48
AD143	1.10	BC148	0.08	BC547	0.12	BD509	0.67	BF274	0.32	BT106	1.50	BYX36/600	0.28	TIC46	0.48
AD149	0.98	A or B	0.10	BC548	0.12	BD510	0.48	BF323	0.92	BT108	1.30	BYX48/300	0.72	TIC47	0.40
AD161	0.42	BC149	0.09	BC549	0.12	BD517	0.56	BF336	0.26	BT109	1.18	BYX49/300	0.47	TIC106A	0.70
AD162	0.42	BC157	0.10	BC550	0.18	BD520	0.66	BF337	0.26	BT116	1.25	BYX55/350	0.29	TIP30A	0.46
AD161/162	0.68	BC158	0.10	BC550C	0.18	BD599	1.25	BF338	0.26	BT119	3.62	BYX55/600	0.33	TIP31C	0.54
AF106	0.48	BC159	0.10	BC555	0.12	BD707	0.88	BF355	0.42	BT120	3.60	BYX71/600	1.18	TIP32	0.40
AF114	2.10	BC160	0.30	BC558	0.12	BDK18	2.35	BF363	0.62	BT121	3.58	BYZ12	0.42	TIP32C	0.60
AF115	2.10	BC161	0.30	BCX34	0.27	BF131	0.16	BF367	0.62	BT138/600	1.30	BYZ12	0.42	TIP33A	0.60
AF116	0.68	BC168B	0.10	BF109	0.15	BF115	0.32	BF371	0.27	BT151/560R	0.90	BYZ12	0.42	TIP33A	0.60
AF117	2.10	BC169C	0.10	BF117	0.17	BF117	0.54	BF422	0.38	BT151/300R	1.15	E9024	0.30	TIP41C	0.48
AF118	0.88	BC170	0.14	BFY72	0.18	BF119	0.82	BF450	0.38	BTY79/400R	2.80	GET872	0.48	TIP42A	0.52
AF121	0.62	BC170B	0.12	BCZ10	1.66	BF120	0.38	BF457	0.33	BU100A	2.30	ITTT44	0.04	TIP47	0.60
AF124	0.48	BC171	0.10	BCZ11	1.48	BF123	0.40	BF458	0.36	BU104	2.00	ITTT2002	0.11	TIP110	0.88
AF125	0.48	BC171	0.10	BD124P	0.90	BF125	0.42	BF459	0.44	BU105	1.20	ME0402	0.20	TIP2955	0.60
AF126	0.48	A or B	0.08	BC130Y	0.68	BF127	0.38	BF490	0.22	BU106	1.70	ME0402/2	0.24	TIP3055	0.60
AF127	0.48	A or B	0.08	BC131	0.24	BF132	0.16	BF490	0.38	BU108	1.80	MEJ21	0.80	TIS43	0.32
AF139	0.68	A or B	0.12	BF134	0.23	BF141	0.23	BF491	0.22	BU124	1.75	MJ400	0.25	TIS88	0.28
AF178	0.68	BC177	0.20	BD131/132	0.95	BF157	0.40	BF491	0.22	BU126	1.25	MJ2955	0.80	TIS90	0.25
AF239	0.68	BC178A	0.22	BD135	0.32	BF158	0.22	BF492	0.32	BU133	1.80	MJ3000	1.98	TIS91	0.28
AF279S	0.75	BC182	0.09	BD136	0.36	BF159	0.24	BF492	0.28	BU204	1.35	MJ3000	1.98	TIS91	0.28
AL100	2.60	A or C	0.09	BD137	0.36	BF160	0.23	BF498	0.34	BU205	1.30	MJE340	0.54	ZTX109	0.12
AL102	5.90	BC182L	0.09	BD138	0.36	BF167	0.30	BF498	1.72	BU206	1.70	MJE370	0.68	ZTX122	0.28
AL113	2.20	A or C	0.09	BD139	0.36	BF173	0.25	BF499	0.38	BU208	1.63	MJE520	0.48	IN4001	0.65
AS180	1.78	BC183	0.09	BD140	0.38	BF177	0.42	BF499	0.38	BU208A	1.63	MJE2955	0.40	IN4003	0.65
AU110	1.40	A or C	0.10	BD144	0.36	BF178	0.30	BFW10	0.79	BU208/02	2.05	MJE3055	0.70	IN4004	0.68
AY102	4.32	BC183L	0.08	BD145	1.82	BF179	0.32	BFW44	0.78	BU326S	1.75	MPS101	0.28	IN4006	0.68
BA102	0.34	A or C	0.12	BD150A	0.51	BF180	0.35	BFX29	0.26	BU407	1.85	MRF475	2.50	IN4007	0.57
BA110	0.67	BC184L	0.10	BD159	0.65	BF181	0.35	BFX30	0.30	BU407D	1.80	MRF479	5.20	IN4148	0.05
BA121	0.40	A or C	0.10	BD160	1.85	BF182	0.32	BFX80	3.56	BUX80	3.70	MVP	10.00	IN5400	0.12
BA128	0.35	BC207	0.18	BD165	0.45	BF183	0.32	BFX84	0.24	BUX20	1.75	OA47	0.10	IN5402	0.15
BA148	0.18	BC298	0.16	BD175	0.60	BF184	0.32	BFX84	0.24	BUX20	1.75	OA90	0.08	IN5405	0.18
BA154	0.08	BC212	0.09	BD182	1.00	BF185	0.32	BFX86	0.28	BUY69B	1.98	OA91	0.09	IN5406	0.18
BA155	0.10	A or C	0.10	BD183	1.10	BF194	0.08	BFX87	0.28	BUY101	0.48	OA95	0.18	IN5408	0.20
BA156	0.08	BC212L	0.08	BD184	1.20	BF195	0.10	BFX89	0.68	BY118	1.10	OA200	0.06	IS920	0.60
BA157	0.28	A or C	0.10	BD201	0.72	BF196	0.10	BFY50	0.21	EY122	0.68	OA202	0.15	2N697	0.55
BA164	0.14	BC213	0.08	BD202	0.87	BF197	0.10	BFY126	0.12	EY126	0.12	OC25	2.10	2N706A	0.33
BB104B	0.52	A or B	0.10	BD204	0.80	BF198	0.14	BFY52	0.21	EY127	0.10	OC26	1.70	2N904	0.28
BB106B	0.30	BC213L	0.10	BD222	0.80	BF199	0.16	BFY57	0.15	EY133	0.18	OC28	1.50	2N906	0.24
BB106C	0.48	A or B	0.10	BD225	0.66	BF200	0.28	BFY90	0.90	EY135	0.25	OC29	2.47	2N926G	0.11
BB110B	0.42	BC237	0.11	BD232	0.45	BF222	0.48	BFY90S	1.34	BY164	0.44	OC35	1.75	2N3953	0.22

FUSES	
QB 20mm 100 mA to 6.3A:	
5p each 100 for £3.50	
Slow Blow 20mm 100mA to 200mA:	
20p, 100 for £15.00	
Slow Blow 20mm 20mA to 800mA:	
12p, 100 for £7.50	
Slow Blow 20mm 1A to 6.3A:	
10p 100 for £5.00	

L.E.D.'s	
RED 3mm - 5mm 10p each, 100 for £6.00	
YELLOW 3mm - 5mm 13p each, 100 for £10.00	
GREEN 3mm - 5mm 13p each, 100 for £10.00	

C-MOS	
4000 0.24 4021 0.58 4036A 2.75	
4001 0.24 4022 0.98 4038 0.70	
4002 0.25 4023 0.35 4039A 2.80	
4007 2.25 4024 0.50 4040A 0.60	
4011 0.24 4025 0.24 4042 0.50	
4012 0.24 4027 0.45 4043 0.42	
4013 0.56 4028 0.45 4044 0.50	
4014 0.80 4029 0.75 4046 0.60	
4015 0.80 4030 0.35 4049 0.38	
4016 0.40 4031 1.30 4050 0.38	
4017 0.80 4033 1.25 4051 0.70	
4018 0.80 4034 1.48 4052 0.60	
4020 0.85 4035 0.70 4053 0.60	

DIODES	
IN916 0.04 AA119 0.12	
IN4001 0.05 AA129 0.18	
IN4004 0.06 AA30 0.16	
IN4005 0.06 BA100 0.24	
IN4007 0.07 BY128 0.12	
IN4148 0.05 BY127 0.10	
IN4149 0.06 BY133 0.16	
IN5400 0.12 BY184 0.40	
IN5401 0.15 OA47 0.40	
IN5402 0.15 OA80 0.08	
IN5404 0.16 OA91 0.09	
IN5406 0.18 OA95 0.18	
IN5408 0.20 OA200 0.68	

TRANSFORMERS	
British made transformers at very attractive prices.	
Primary Secondary Current 1- 10+ 100- 240v 6.0-6v 400mA 58p 52p 43p	
Carriage 45p per transformer £1.60 per 10p	

NEW 1985 CATALOGUE AVAILABLE — Many prices reduced — range increased — 123 pages fully illustrated. Price 65p, per copy (free upon request with orders over £5) — includes 30p Credit Notes special offer sheets, order form and pre-paid envelope. SEND NOW FOR YOUR COPY

RESISTOR KITS	
1/4W pack 10 each value E12 - 10R-1M	
Total: 610 resistors	
ONLY 4.80	
1/4W pack 5 each value E12 10R-1M	
Total: 305 resistors	
ONLY 2.75	
1/2W pack 10 each value E12 2R2-2M2	
Total: 730 resistors	
ONLY 5.25	
1/2W pack 5 each value E12 2R2-2M2	
Total: 365 resistors	
ONLY 3.50	
50V Ceramic Kit 5 ea value 125 per Kit	ONLY £3.50 ea.

BRIDGES	
1 1/2A 50V	0.27
100V	0.28
200V	0.32
400V	0.40
600V	0.58
800V	0.67
2A 100V	0.52
200V	0.55
400V	0.61
600V	0.67
800V	0.70
6A 100V	0.66
200V	0.68
400V	0.74
600V	0.80
800V	0.86

TERMINAL BLOCKS	
2 amp 12 way	0.18
5 amp 12 way	0.20
10 amp 12 way	0.40
15 amp 12 way	0.46
32 amp 12 way	0.90

ZENER DIODES	
400 mW 3v to 75v	
8p each	
100 for £6.00	
1 watt 3v3 to 200v	
15p each	
100 for £12.50	

74LS	
LS00	28p
LS01	28p
LS02	28p
LS03	28p
LS08	3

ARE

38 BRIDGE STREET, EARLESTOWN
NEWTON LE WILLOWS, MERSEYSIDE
TEL: 09252 29881

Communications Ltd.

FOR THE LARGEST SELECTION OF AMATEUR RADIO EQUIPMENT IN THE NORTH OF ENGLAND.

As most of our customers will have heard, Bernie & Brenda have sold their shop in London and are now giving much more time to the Northern branch at Earlestown, Newton Le Willows. As a result Earlestown will carry a much larger selection of new and second hand equipment than ever before.

Peter G4KKN will be pleased to welcome you with the customary cup of Brenda's coffee, and the freedom to wander round the shop to select and try out the masses of equipment at your leisure.

AR 2001

Now with extended frequency cover to 1.2 ghz.



**OUR PRICE
£ PHONE**

Phone us last for the best prices on Trio/Kenwood, Icom and Yaesu.

Mail order now, same day despatch from Earlestown. Phone with Access or Barclaycard for any item related to Amateur Radio.

PHONE 09252 29881

All prices correct at time of going to press

THIS MONTH'S SPECIAL OFFERS

FRG 9600

**OUR PRICE
£449**

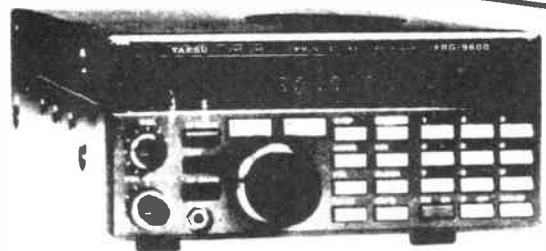

THE LATEST AND GREATEST FROM YAESU

All-mode scanning receiver
60-910MHz — no gaps
FM, AM SSB — 5, 10, 12.5, 25 KC STEPS
Also — 1KHz/100Hz on SSB

Interface for computers
Video output

FT 757 GX

**OUR PRICE
£779**



100w multi mode transceiver
Gen. cover. RX
FM & CW narrow, fitted

New equipment now in stock

- Yaesu FT 709 70 cms H/HELD
- Yaesu FT 703 70 cms H/HELD
- Icom IC 3200 dual bander

Very special offer

- Mutek Transverter
- 2 metres in 6 metres out
- List price £199 **OUR PRICE £169**