



Cisco UCS B200 M4 Blade Server

CONTENTS

OVERVIEW	3
DETAILED VIEWS	4
Blade Server Front View	4
BASE SERVER STANDARD CAPABILITIES and FEATURES	5
CONFIGURING the SERVER	7
STEP 1 VERIFY SERVER SKU	8
STEP 2 CHOOSE CPU(S)	9
STEP 3 CHOOSE MEMORY	12
STEP 4 CHOOSE RAID CONTROLLER AND DISK DRIVE BAYS	18
STEP 5 CHOOSE HARD DISK DRIVES or SOLID STATE DRIVES (OPTIONAL)	21
STEP 6 CHOOSE ADAPTERS	24
STEP 7 ORDER TRUSTED PLATFORM MODULE (OPTIONAL)	29
STEP 8 TORDER SECURE DIGITAL CARDS (OPTIONAL)	31
STEP 9 ORDER INTERNAL USB 3.0 DRIVE (OPTIONAL)	32
STEP 10 CHOOSE OPERATING SYSTEM AND VALUE-ADDED SOFTWARE	34
STEP 11 CHOOSE OPERATING SYSTEM MEDIA KIT	37
STEP 12 CHOOSE SERVICE and SUPPORT LEVEL	38
ORDER OPTIONAL KVM LOCAL I/O CABLE*	43
SUPPLEMENTAL MATERIAL	44
System Board	44
CPUs and DIMMs	45
Physical Layout	45
DIMM Population Rules	46
DIMM Population Order	47
Recommended Memory Configuration	48
Additional DIMM Populations	50
Upgrade and Servicing-Related Parts	51
Drive and Blade Server Blanking Panels	51
Adding an Additional CPU (with CPU heat sink) or Replacing CPUs	52
Motherboard Lithium Battery	52
Thermal Grease (with syringe applicator) for CPU to Heatsink Seal	52
Air Baffle Replacement Kit	52
CPU Heat Sink Cleaning Kit	53
NEBS Compliance	54
Network Connectivity	55
VIC 1340/1240 Adapter	56
Mezzanine Adapters	57
B200 M4 Configured with 1 CPU	58
B200 M4 Configured with 2 CPUs	65
TECHNICAL SPECIFICATIONS	73
Dimensions and Weight	73
Power Specifications	73

OVERVIEW

Delivering performance, versatility and density without compromise, the Cisco UCS B200 M4 Blade Server addresses the broadest set of workloads, from IT and web infrastructure through distributed database.

The enterprise-class Cisco UCS B200 M4 blade server extends the capabilities of Cisco's Unified Computing System portfolio in a half-width blade form factor. The Cisco UCS B200 M4 harnesses the power of the latest Intel® Xeon® E5-2600 v3 and v4 Series processor family CPUs with up to 1536 GB of RAM (using 64 GB DIMMs), two solid-state drives (SSDs) or hard disk drives (HDDs), and up to 80 Gbps throughput connectivity.

Figure 1 Cisco UCS B200 M4 Blade Server



DETAILED VIEWS

Blade Server Front View

Figure 2 is a detailed front view of the Cisco UCS B200 M4 Blade Server.

Figure 2 Blade Server Front View

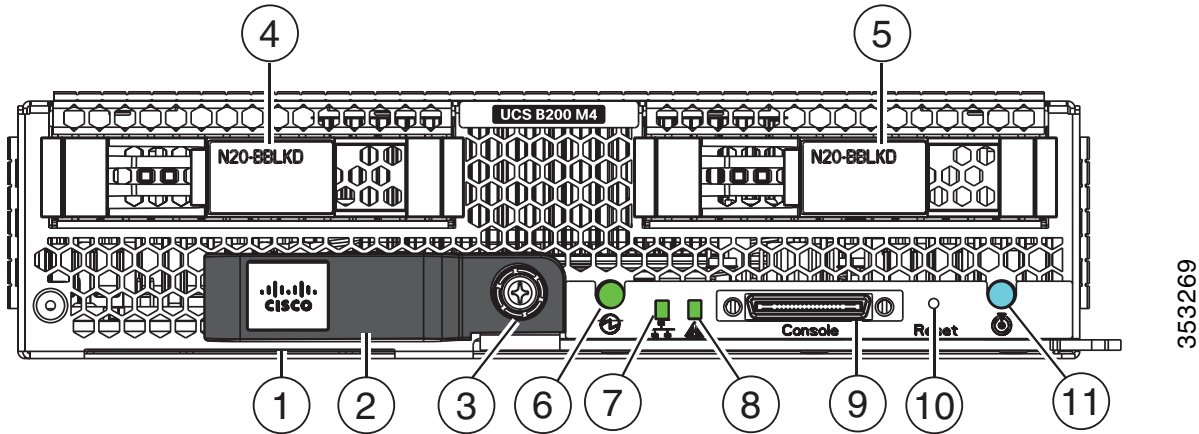

s

1	Asset pull tag Each server has a plastic tag that pulls out of the front panel. The tag contains the server serial number as well as the product ID (PID) and version ID (VID). The tag also allows you to add your own asset tracking label without interfering with the intended air flow.	7	Network link status LED
2	Blade ejector handle	8	Blade health LED
3	Ejector captive screw	9	Console connector ¹
4	Drive bay 1	10	Reset button access
5	Drive bay 2	11	Beaoning LED and button
6	Power button and LED	—	—

Notes...

1. For information about the KVM local I/O cable that plugs into the console connector (a cable is included with every Cisco UCS 5100 Series blade server chassis accessory kit), see [ORDER OPTIONAL KVM LOCAL I/O CABLE*](#) on page 43.

BASE SERVER STANDARD CAPABILITIES and FEATURES

Table 1 lists the capabilities and features of the base server. Details about how to configure the server for a particular feature or capability (for example, number of processors, disk drives, or amount of memory) are provided in *CONFIGURING the SERVER on page 7*.



NOTE: The B200 M4 blade server requires UCS Manager (UCSM) to operate as part of the UCS system.

- The B200 M4 with E5-2600 v4 CPUs requires UCSM 2.2(7) or later
 - Cisco UCS Manager Release 2.2(4) introduced a server pack feature that allows Intel E5-2600 v4 CPUs to run with Cisco UCS Manager Release 2.2(4) or later, provided that the CIMC, BIOS, and Capability Catalog are all running Release 2.2(7) or later.
 - For B200 M4 upgrades to v4 CPUs, please refer to the following link: http://www.cisco.com/c/en/us/td/docs/unified_computing/ucs/hw/blade-servers/install/CPU_Upgrade_Guide_v4_Series.html
- The B200 M4 with E5-2600 v3 CPUs requires UCSM 2.2(3) or later

Table 1 Capabilities and Features



Capability/Feature	Description
Chassis	The UCS B200 M4 Blade Server mounts in a Cisco UCS 5100 Series blade server chassis or UCS Mini blade server chassis.
CPU	One or two Intel® E5-2600 v3 and v4 Series processor family CPUs
Chipset	Intel® C610 chipset
Memory	24 total DIMM slots <ul style="list-style-type: none"> ■ Support for Advanced ECC ■ Support for registered ECC DIMMs (RDIMMs) ■ Support for load-reduced DIMMs (LR DIMMs) ■ Up to 1536 GB total memory capacity (B200 M4 configured with two CPUs using 64 GB DIMMs)
I/O	Mezzanine adapters: <ul style="list-style-type: none"> ■ One connector for Cisco's VIC 1340 or 1240 adapter, which provides Ethernet and Fibre Channel over Ethernet (FCoE)
	<div style="border: 1px solid black; padding: 5px;">  <p>NOTE: The Cisco VIC 1200 Series (1240 and 1280) is compatible in UCS domains that implement either the 6100 or 6200 Series Fabric Interconnects. The Cisco VIC 1300 Series (1340 and 1380) is compatible with 6200 and 6300 Series Fabric Interconnects.</p> </div>
	<ul style="list-style-type: none"> ■ One connector for various types of Cisco adapters and Cisco UCS Storage Accelerator adapters or GPUs.

Table 1 Capabilities and Features *(continued)*

Capability/Feature	Description
Storage controller	<p>Cisco FlexStorage 12G SAS RAID controller (powered by the LSI SAS 3108 chip - see http://www.lsi.com/products/raid-on-chip/pages/lsi-sas-3108.aspx) with drive bays, providing up to 12 Gbps SAS connectivity, offering:</p> <ul style="list-style-type: none"> ■ SAS/SATA support ■ RAID 0 and 1 and JBOD
Storage devices	<ul style="list-style-type: none"> ■ Up to two optional, front-accessible, hot-swappable 2.5-inch small form factor (SFF) SAS or SATA solid-state disks (SSDs), NVMe PCIe SSDs, or hard disk drives (HDDs).
	<hr/> <div style="display: flex; align-items: center;">  <p>NOTE: NVMe PCIe SSDs are controlled through the PCIe bus of CPU2. Therefore, any system that implements NVMe PCIe SSDs must have two CPUs.</p> </div> <hr/>
	<ul style="list-style-type: none"> ■ An internal USB 3.0 port is also supported. A 16 GB USB drive is available from Cisco. ■ Two SD card slots are available on the front left side of the server. 32 GB or 64 GB SD cards are available from Cisco.
Video	<p>The Cisco Integrated Management Controller (CIMC) provides video using the Matrox G200e video/graphics controller:</p> <ul style="list-style-type: none"> ■ Integrated 2D graphics core with hardware acceleration ■ DDR2/3 memory interface supports up to 512 MB of addressable memory (8 MB is allocated by default to video memory) ■ Supports display resolutions up to 1920 x 1200 16bpp @ 60Hz ■ High-speed integrated 24-bit RAMDAC ■ Single lane PCI-Express host interface running at Gen 1 speed
Interfaces	<ul style="list-style-type: none"> ■ Front panel <ul style="list-style-type: none"> • One console connector (see ORDER OPTIONAL KVM LOCAL I/O CABLE* on page 43)
Power subsystem	<p>Integrated in the Cisco UCS 5100 Series blade server chassis or UCS Mini blade server chassis.</p>
Fans	<p>Integrated in the Cisco UCS 5100 Series blade server chassis or UCS Mini blade server chassis.</p>
Integrated management processor	<p>The built-in Cisco Integrated Management Controller (CIMC) GUI or CLI interface enables you to monitor the server inventory, health, and system event logs.</p>

CONFIGURING the SERVER

Follow these steps to configure the Cisco UCS B200 M4 Blade Server:

- *STEP 1 VERIFY SERVER SKU, page 8*
- *STEP 2 CHOOSE CPU(S), page 9*
- *STEP 3 CHOOSE MEMORY, page 12*
- *STEP 4 CHOOSE RAID CONTROLLER AND DISK DRIVE BAYS, page 18*
- *STEP 5 CHOOSE HARD DISK DRIVES or SOLID STATE DRIVES (OPTIONAL), page 21*
- *STEP 6 CHOOSE ADAPTERS, page 24*
- *STEP 7 ORDER TRUSTED PLATFORM MODULE (OPTIONAL), page 29*
- *STEP 8 TORDER SECURE DIGITAL CARDS (OPTIONAL), page 31*
- *STEP 9 ORDER INTERNAL USB 3.0 DRIVE (OPTIONAL), page 32*
- *STEP 10 CHOOSE OPERATING SYSTEM AND VALUE-ADDED SOFTWARE, page 34*
- *STEP 11 CHOOSE OPERATING SYSTEM MEDIA KIT, page 37*
- *STEP 12 CHOOSE SERVICE and SUPPORT LEVEL, page 38*

STEP 1 VERIFY SERVER SKU

Verify the product ID (PID) of the server as shown in [Table 2](#).

Table 2 PID of the Base UCS B200 M4 Blade Server

Product ID (PID)	Description
UCSB-B200-M4	UCS B200 M4 Blade Server without CPU, memory, drive bays, HDD, VIC adapter, or mezzanine adapters

The base Cisco UCS B200 M4 blade server does not include the following components. They must be selected during product ordering:

- CPUs
- Memory
- Cisco FlexStorage RAID controller with drive bays (or blank, for no local drives support)
- Disk drives
- Cisco adapters (such as the VIC 1340, VIC 1380, VIC 1240, VIC 1280, or Port Expander)
- Cisco UCS Storage Accelerators (such as the Fusion-io adapter) or GPUs



NOTE: Use the steps on the following pages to order servers with the configurable components that you want configured in your servers.

STEP 2 CHOOSE CPU(S)

The standard CPU features are:

- Intel Xeon E5-2600 v3 or v4 series processor family CPUs
- Intel C610 series chipset
- Up to 22 cores per processor, for a total of up to 44 cores per server

Select CPUs

The available CPUs are listed in [Table 3](#).

Table 3 Available Intel CPUs

Product ID (PID)	Intel Number	Clock Freq (GHz)	Power (W)	Cache Size (MB)	Cores	QPI	Highest DDR4 DIMM Clock Support (MHz)
E5-2600 v4 Series Processor Family CPUs							
UCS-CPU-E52699E	E5-2699 v4	2.20	145	55	22	9.6 GT/s	2400
UCS-CPU-E52698E	E5-2698 v4	2.20	135	50	20	9.6 GT/s	2400
UCS-CPU-E52697AE	E5-2697A v4	2.60	145	40	16	9.6 GT/s	2400
UCS-CPU-E52697E	E5-2697 v4	2.30	145	45	18	9.6 GT/s	2400
UCS-CPU-E52695E	E5-2695 v4	2.10	120	45	18	9.6 GT/s	2400
UCS-CPU-E52690E	E5-2690 v4	2.60	135	35	14	9.6 GT/s	2400
UCS-CPU-E52683E	E5-2683 v4	2.10	120	40	16	9.6 GT/s	2400
UCS-CPU-E52680E	E5-2680 v4	2.40	120	35	14	9.6 GT/s	2400
UCS-CPU-E52667E	E5-2667 v4	3.20	135	25	8	9.6 GT/s	2400
UCS-CPU-E52660E	E5-2660 v4	2.00	105	35	14	9.6 GT/s	2400
UCS-CPU-E52650E	E5-2650 v4	2.20	105	30	12	9.6 GT/s	2400
UCS-CPU-E52650LE	E5-2650L v4	1.70	65	35	14	9.6 GT/s	2400
UCS-CPU-E52643E	E5-2643 v4	3.40	135	20	6	9.6 GT/s	2400
UCS-CPU-E52640E	E5-2640 v4	2.40	90	25	10	8.0 GT/s	2133
UCS-CPU-E52637E	E5-2637 v4	3.50	135	15	4	9.6 GT/s	2400
UCS-CPU-E52630E	E5-2630 v4	2.20	85	25	10	8/0 GT/s	2133
UCS-CPU-E52630LE	E5-2630L v4	1.80	55	25	8	8.0 GT/s	2133
UCS-CPU-E52623E	E5-2623 v4	2.60	85	10	4	8.0 GT/s	2133
UCS-CPU-E52620E	E5-2620 v4	2.10	85	20	8	8.0 GT/s	2133
UCS-CPU-E52609E	E5-2609 v4	1.70	85	20	8	6.4 GT/s	1866
UCS-CPU-E52658E	E5-2658 v4	2.30	105	35	14	9.6 GT/s	2400

Table 3 Available Intel CPUs (*continued*)

Product ID (PID)	Intel Number	Clock Freq (GHz)	Power (W)	Cache Size (MB)	Cores	QPI	Highest DDR4 DIMM Clock Support (MHz)
E5-2600 v3 Series Processor Family CPUs							
UCS-CPU-E52699D	E5-2699 v3	2.30	145	45	18	9.6 GT/s	2133
UCS-CPU-E52698D	E5-2698 v3	2.30	135	40	16	9.6 GT/s	2133
UCS-CPU-E52697D	E5-2697 v3	2.60	145	35	14	9.6 GT/s	2133
UCS-CPU-E52695D	E5-2695 v3	2.30	120	35	14	9.6 GT/s	2133
UCS-CPU-E52690D	E5-2690 v3	2.60	135	30	12	9.6 GT/s	2133
UCS-CPU-E52683D	E5-2683 v3	2.00	120	35	14	9.6 GT/s	2133
UCS-CPU-E52680D	E5-2680 v3	2.50	120	30	12	9.6 GT/s	2133
UCS-CPU-E52670D	E5-2670 v3	2.30	120	30	12	9.6 GT/s	2133
UCS-CPU-E52667D	E5-2667 v3	3.20	135	20	8	9.6 GT/s	2133
UCS-CPU-E52660D	E5-2660 v3	2.60	105	25	10	9.6 GT/s	2133
UCS-CPU-E52658D	E5-2658 v3	2.20	105	30	12	9.6 GT/s	2133
UCS-CPU-E52650D	E5-2650 v3	2.30	105	25	10	9.6 GT/s	2133
UCS-CPU-E52650LD	E5-2650L v3	1.80	65	30	12	9.6 GT/s	1866
UCS-CPU-E52643D	E5-2643 v3	3.40	135	20	6	9.6 GT/s	2133
UCS-CPU-E52640D	E5-2640 v3	2.60	90	20	8	8.0 GT/s	1866
UCS-CPU-E52637D	E5-2637 v3	3.50	135	15	4	9.6 GT/s	2133
UCS-CPU-E52630D	E5-2630 v3	2.40	85	20	8	8.0 GT/s	1866
UCS-CPU-E52630LD	E5-2630L v3	1.80	55	20	8	8.0 GT/s	1866
UCS-CPU-E52623D	E5-2623 v3	3.00	105	10	4	8.0 GT/s	1866
UCS-CPU-E52620D	E5-2620 v3	2.40	85	15	6	8.0 GT/s	1866
UCS-CPU-E52609D ¹	E5-2609 v3	1.90	85	15	6	6.4 GT/s	1600

Notes...

1. The E5-2609 v3 CPU does not support Intel Hyper-Threading or Intel Turbo Boost technologies.

Supported Configurations

(1) One-CPU Configuration

- Choose one CPU from any one of the rows of [Table 3 on page 9](#).

(2) Two-CPU Configuration

- Choose two identical CPUs from any one of the rows of [Table 3 on page 9](#).

Caveats

- If the mezzanine slot is either empty or contains a Port Expander Card for VIC, only 1 CPU is required, although you may install 2 CPUs.
- If the mezzanine slot contains anything but a Port Expander Card for VIC, 2 CPUs are required to make the mezzanine slot operable.
- See [Table 10 on page 27](#) for more details regarding how many CPUs are required for different I/O or mezzanine adapter card configurations. Also see [B200 M4 Configured with 1 CPU on page 58](#) and [B200 M4 Configured with 2 CPUs on page 65](#).
- See [NEBS Compliance on page 54](#) for complete information on Network Equipment Building Standards (NEBS) support for a B200 M4 configured with 1 CPU or 2 CPUs.

STEP 3 CHOOSE MEMORY

The standard memory features are:

- DIMMs
 - Clock speed: 2400 or 2133 MHz
 - Ranks per DIMM: 1, 2, 4, or 8
 - Operational voltage: 1.2 V
 - Registered ECC DDR4 DIMMs (RDIMMs), TSV-RDIMMs, or load-reduced ECC DDR4 DIMMs (LRDIMMs)
- Memory is organized with four memory channels per CPU, with up to three DIMMs per channel (DPC), as shown in [Figure 3](#).

Figure 3 UCS B200 M4 Memory Organization

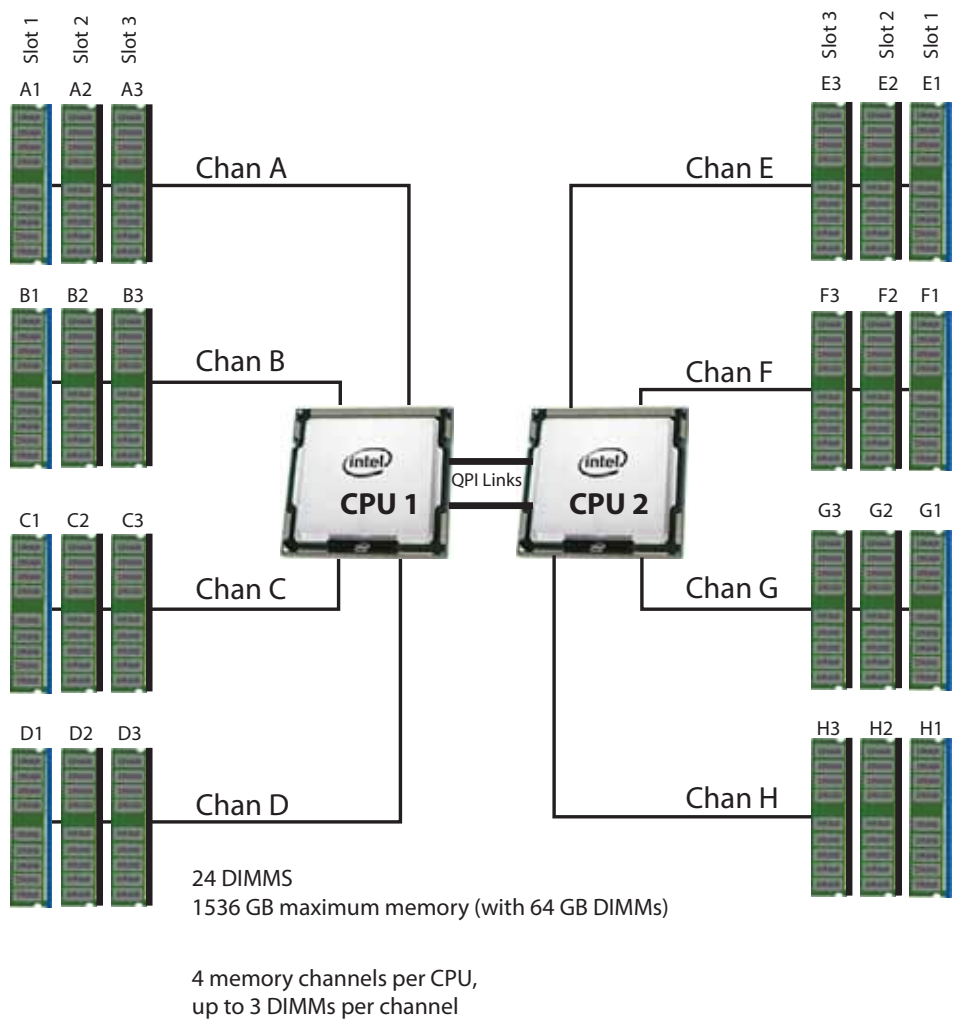

Choose DIMMs and Memory Mirroring

Select the memory configuration and whether or not you want the memory mirroring option. The supported memory DIMMs and the mirroring option are listed in [Table 4](#).



NOTE: When memory mirroring is enabled, the memory subsystem simultaneously writes identical data to two adjacent channels. If a memory read from one of the channels returns incorrect data due to an uncorrectable memory error, the system automatically retrieves the data from the other channel. A transient or soft error in one channel does not affect the mirrored data, and operation continues unless there is a simultaneous error in exactly the same location on a DIMM and its mirrored DIMM. Memory mirroring reduces the amount of memory available to the operating system by 50% because only one of the two populated channels provides data.

The supported memory DIMMs in the UCS B200 M4 are listed in [Table 4](#)

Table 4 Available DDR4 DIMMs

Product ID (PID)	PID Description	Voltage	Ranks /DIMM
2400-MHz DIMM Options			
UCS-ML-1X644RV-A ¹	64GB DDR4-2400-MHz LRDIMM/PC4-19200/quad rank/x4	1.2 V	4
UCS-ML-1X324RV-A	32GB DDR4-2400-MHz LRDIMM/PC4-19200/quad rank/x4	1.2 V	4
UCS-MR-1X322RV-A	32GB DDR4-2400-MHz RDIMM/PC4-19200/dual rank/x4	1.2 V	2
UCS-MR-1X161RV-A	16GB DDR4-2400-MHz RDIMM/PC4-19200/single rank/x4	1.2 V	1
2133-MHz DIMM Options			
UCS-MR-1X648RU-A ^{1,2}	64GB DDR4-2133-MHz TSV-RDIMM/PC4-17000/octal rank/x4	1.2 V	8
UCS-MR-1X322RU-A	32GB DDR4-2133-MHz RDIMM/PC4-17000/dual rank/x4	1.2 V	2
UCS-ML-1X324RU-A	32GB DDR4-2133-MHz LRDIMM/PC3-17000/quad rank/x4	1.2 V	4
UCS-MR-1X162RU-A	16GB DDR4-2133-MHz RDIMM/PC3-17000/dual rank/x4	1.2 V	2
UCS-MR-1X081RU-A	8GB DDR4-2133-MHz RDIMM/PC3-17000/single rank/x4	1.2 V	1
Memory Mirroring Option			
N01-MMIRROR	Memory mirroring option		

Notes...

1. If a GPU is selected, you can choose a maximum of 14 of these DIMMs.
2. Power capping is not supported when using 64 GB TSV-RDIMMS.

Supported Configurations

(1) 1-CPU configuration without memory mirroring:

- Select from 1 to 12 DIMMs. Refer to [DIMM Population Rules on page 46](#) for more detailed information.

(2) 1-CPU configuration with memory mirroring:

- Select 2, 4, 8, or 12 identical DIMMs. The DIMMs will be placed by the factory as shown in the following table.

Total Number of DIMMs	CPU 1 DIMM Placement (for identical DIMMs)		
	Blue Slots	Black Slots	White Slots
2	(A1, B1)	—	—
4	(A1,B1); (C1,D1)	—	—
8	(A1,B1); (C1,D1)	(A2,B2); (C2,D2)	—
12	(A1,B1); (C1,D1)	(A2,B2); (C2,D2)	(A3,B3); (C3,D3)

- Select the memory mirroring option (N01-MMIRROR) as shown in [Table 4 on page 13](#).

(3) 2-CPU configuration without memory mirroring:

- Select from 1 to 12 DIMMs per CPU. Refer to [DIMM Population Rules on page 46](#), for more detailed information.

(4) 2-CPU configuration with memory mirroring:

- Select 2, 4, 8, or 12 identical DIMMs per CPU. The DIMMs will be placed by the factory as shown in the following table.

Number of DIMMs per CPU	CPU 1 DIMM Placement (for identical DIMMs)			CPU 2 DIMM Placement (for identical DIMMs)		
	Blue Slots	Black Slots	White Slots	Blue Slots	Black Slots	White Slots
2	(A1, B1)	—	—	(E1, F1)	—	—
4	(A1,B1); (C1,D1)	—	—	(E1,F1); (G1,H1)	—	—
8 (CPU1) and 4 (CPU2) ¹	(A1,B1); (C1,D1)	(A2,B2); (C2,D2)	—	(E1,F1)	(E2, F2)	—
8	(A1,B1); (C1,D1)	(A2,B2); (C2,D2)	—	(E1,F1); (G1,H1)	(E2,F2); (G2,H2)	—
12	(A1,B1); (C1,D1)	(A2,B2); (C2,D2)	(A3, B3); (C3, D3)	(E1,F1); (G1,H1)	(E2,F2); (G2,H2)	(E3,F3); (G3,H3)

Notes...

1. Not recommended (for performance reasons)

- Select the memory mirroring option (N01-MMIRROR) as shown in [Table 4 on page 13](#).



NOTE: System performance is optimized when the DIMM type and quantity are equal for both CPUs, and when each populated channel is filled completely equally across the CPUs in the server.

Caveats

- System speed is dependent on how many DIMMs are populated per channel and the CPU DIMM speed support. See [Table 5](#) for details.

Table 5 2133-MHz DIMM Memory Speeds with Different v3 CPUs

DIMM Speed	DPC	1600-MHz Capable CPU		1866-MHz Capable CPU		2133-MHz Capable CPU	
		LRDIMM (QR)	RDIMM (8R, DR, SR)	LRDIMM (QR)	RDIMM (8R, DR, SR)	LRDIMM (QR)	RDIMM (8R, DR, SR)
2133 DIMM	1DPC	1600	1600	1866	1866	2133	2133
	2DPC	1600	1600	1866	1866	2133	2133
	3DPC	1600	1600	1600	1600	1866	1866 (32 GB RDIMMs and 16 GB DIMMs) 1600 (64 GB TSV RDIMMs, 8 GB RDIMMs)

Table 6 2400-MHz DIMM Memory Speeds with Different v4 CPUs

DIMM and CPU Frequencies	DPC	LRDIMM (QRx4) - 64 GB	RDIMM (DRx4) - 32 GB	LRDIMM (QRx4) - 32 GB ¹	RDIMM (SRx4) - 16 GB
		1.2 V	1.2 V	1.2 V	1.2 V
DIMM = 2400 MHz CPU = 2400 MHz	1DPC	2400 MHz	2400 MHz	2400 MHz	2400 MHz
	2DPC	2400 MHz	2400 MHz	2400 MHz	2400 MHz
	3DPC	2133 MHz	1866 MHz	2133 MHz	2133 MHz
DIMM = 2400 MHz CPU = 2133 MHz	1DPC	2133 MHz	2133 MHz	2133 MHz	2133 MHz
	2DPC	2133 MHz	2133 MHz	2133 MHz	2133 MHz
	3DPC	1866 MHz	1866 MHz	1866 MHz	1866 MHz
DIMM = 2400 MHz CPU = 1866 MHz	1DPC	1866 MHz	1866 MHz	1866 MHz	1866 MHz
	2DPC	1866 MHz	1866 MHz	1866 MHz	1866 MHz
	3DPC	1866 MHz	1600 MHz	1866 MHz	1600 MHz

- The B200 M4 server supports four different memory reliability, availability, and serviceability (RAS) modes:
 - Independent Channel Mode
 - Mirrored Channel Mode
 - Lockstep Channel Mode
- Below are the system level RAS Mode combination limitations:
 - Mixing of Independent and Lockstep channel mode is not allowed per platform.
 - Mixing of Non-Mirrored and Mirrored mode is not allowed per platform.
 - Mixing of Lockstep and Mirrored mode is not allowed per platform.
- Do not mix RDIMMs, LRDIMMs, TSV-RDIMMs
- Do not mix 64GB DDR4-2133-MHz TSV-RDIMMs with any other DIMMs
- Single-rank DIMMs can be mixed with dual-rank DIMMs in the same channel
- For best performance, observe the following:
 - When single or dual rank DIMMs are populated for 2DPC or 3DPC, always populate the higher number rank DIMM first (starting from the slot farthest from the CPU).
- DIMMs for CPU 1 and CPU 2 (when populated) must always be configured identically.
- When using mirroring, DIMMs must be installed in identical pairs across paired DDR4 buses. That is, mirrored pairs in channels A and B must be identical and pairs in channels C and D

must be identical. However, the DIMMs used in channels A and B can be different from those in channels C and D.

- Pairs of DIMMs (A1/B1, A2/B2, etc) must be the exact same (same PID and DIMM loading order)
- Cisco memory from previous generation servers (DDR3) is not compatible with this server

For more information regarding memory, see [CPUs and DIMMs on page 45](#).

STEP 4 CHOOSE RAID CONTROLLER AND DISK DRIVE BAYS

The UCS B200 M4 can be ordered with or without the Cisco FlexStorage RAID controller with disk drive bays (local storage subsystem).

There is no RAID or local storage controller or drive bays included (embedded) with the B200 M4 server. Therefore, a Cisco FlexStorage RAID controller with drive bays must be purchased in order to support any (1 or 2) local hard disk drives (HDDs) or solid state drives (SSDs). Either Cisco FlexStorage RAID controller supports RAID 0 and 1 as well as JBOD configurations.

For servers that will not need any local HDDs or SSDs (for example, for booting from SAN), you can order the server without a Cisco FlexStorage RAID controller with disk drive bays; however be sure to select the Cisco FlexStorage blanking panels.

The ordering information is listed in [Table 9](#).

Table 7 Cisco UCS B-Series M4 Blade Server RAID Controller¹ and Drive Bay Options

Product ID (PID)	PID Description
UCSB-MRAID12G ²	Cisco FlexStorage 12G SAS RAID controller with drive bays
UCSB-MRAID12G-HE ^{3, 4, 5}	Cisco FlexStorage 12G SAS RAID controller with 2 GB flash-backed write cache with drive bays
UCSB-LSTOR-BK	Cisco FlexStorage blanking panels w/o controller, w/o drive bays
UCSB-LSTOR-PT	Cisco FlexStorage PCIe SSD/Passthrough module with HDD cage ⁶

Notes...

1. Cisco FlexStorage 12G SAS RAID controller (powered by the LSI SAS 3108 chip - see <http://www.lsi.com/products/raid-on-chip/pages/lsi-sas-3108.aspx>) with drive bays, providing up to 12 Gbps SAS connectivity, offering:
 - SAS/SATA support
 - RAID 0 and 1 and JBOD
2. The UCSB-MRAID-12G RAID controller runs iMegaRAID, which has a lower-capability software stack, provides RAID 0/1 levels, and has no support for caching. Note that you cannot upgrade from this RAID controller to the UCSB-MRAID12G-HE RAID controller.
3. The UCSB-MRAID12G-HE RAID controller runs a MegaRAID fully-featured software stack, has access to cache, and is recommended for VSAN. Its queue depth is much higher than that of the UCSB-MRAID-12G. Supports RAID 0/1/5/6 levels. Note that you can implement either the UCSB-MRAID-12G RAID controller or the UCSB-MRAID12G-HE RAID controller. However, if you are using a UCSB-MRAID-12G RAID controller, there is no kit available that allows you to upgrade from the UCSB-MRAID-12G RAID controller to the UCSB-MRAID12G-HE RAID controller. The only way to do that is to swap out controllers.
4. The flash-backed write cache provides RAID controller cache protection using NAND flash memory and a supercapacitor. In the event of a power or server failure, cached data is automatically transferred from the RAID controller DRAM write cache to flash. Once power is restored, the data in the NAND flash is copied back into the DRAM write cache until it can be flushed to the disk drives.
5. The B200 M4 with the UCSB-MRAID12G-HE requires UCSM 2.2(6) or later
6. If selected, can only select with NVMe SSD PCIe option (cannot select any SAS/SATA HDD/SSDs).

See [Figure 4 on page 20](#) for a top view of the B200 M4 server with and without the Cisco FlexStorage SAS RAID controller and drive bays. See [Figure 5 on page 20](#) for a front view of these configurations. When no drive bays are installed, blanking panels must be installed.

Figure 4 UCS B200 M4 With and Without RAID Controller and Drive Bays (Top View)

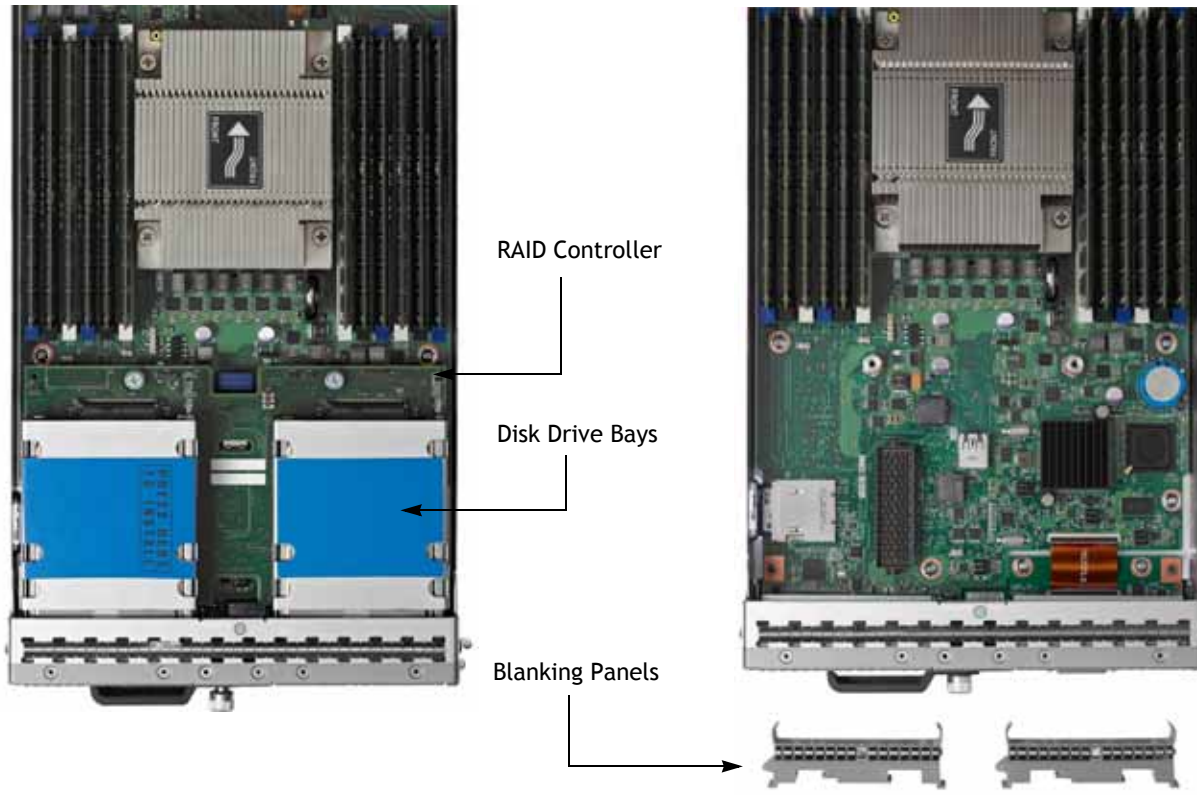

(a) Server with RAID Controller and drive bays

(b) Server with no RAID Controller or drive bays

Figure 5 UCS B200 M4 With and Without RAID Controller (hidden) and Drives (Front View)

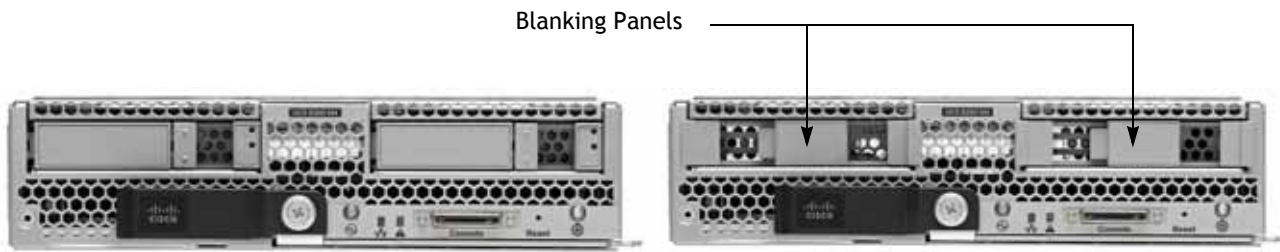

(a) Server with RAID Controller and drives

(b) Server with no RAID Controller or drives

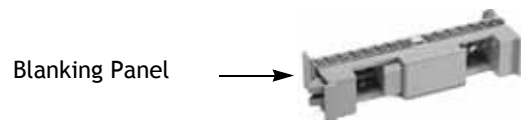

STEP 5 CHOOSE HARD DISK DRIVES or SOLID STATE DRIVES (OPTIONAL)

The UCS B200 M4 can be ordered with or without drives. The standard disk drive features are:

- 2.5-inch small form factor
- Hot-pluggable
- Sled-mounted



NOTE: The UCS B200 M4 blade server meets the external shared storage target (SAN, NAS, and iSCSI) and storage switch certifications as described in the following link:

<http://www.cisco.com/en/US/docs/switches/datacenter/mds9000/interoperability/matrix/Matrix8.html#wp323852>

Choose Drives

The supported drives in the UCS B200 M4 are listed in [Table 8](#).



NOTE: 4K format drives are not qualified or supported at this time with B-Series UCS servers.

Table 8 Supported Hot-Pluggable Sled-Mounted HDDs and SSDs

Product ID (PID)	PID Description	Drive Type	Size
HDDs			
12 Gbps Drives			
UCS-HD600G15K12G	600 GB 12G SAS 15K RPM SFF HDD (Seagate Valkyrie, Toshiba 13SX-MLK)	SAS	600 GB
UCS-HD450G15K12G	450 GB 12G SAS 15K RPM SFF HDD	SAS	450 GB
UCS-HD300G15K12G	300 GB 12G SAS 15K RPM SFF HDD (Seagate Valkyrie, Toshiba 13SX-MLK)	SAS	300 GB
UCS-HD12TB10K12G	1.2 TB 12G SAS 10K RPM SFF HDD (Seagate Thunderbolt, Cobra F, Toshiba AL14S)	SAS	1.2 TB
UCS-HD900G10K12G	900 GB 12G SAS 10K RPM SFF HDD	SAS	900 GB
UCS-HD600G10K12G	600 GB 12G SAS 10K RPM SFF HDD (Seagate Thunderbolt, Toshiba 14SE)	SAS	600 GB
UCS-HD300G10K12G	300 GB 12G SAS 10K RPM SFF HDD (Seagate Thunderbolt, Toshiba 14SE)	SAS	300 GB

Table 8 Supported Hot-Pluggable Sled-Mounted HDDs and SSDs (continued)

Product ID (PID)	PID Description	Drive Type	Size
6 Gbps Drives			
A03-D600GA2	600 GB 6G SAS 10K RPM SFF HDD	SAS	600 GB
A03-D300GA2	300 GB 6Gb SAS 10K RPM SFF HDD	SAS	300 GB
SSDs			
12 Gbps Drives			
UCS-SD16TB12S4-EP	1.6 TB 2.5 inch Enterprise Performance 12G SAS SSD (10X endurance) (SanDisk Lightning)	SAS	1.6 TB
UCS-SD800G12S4-EP	800 GB 2.5 inch Enterprise Performance 12G SAS SSD (10X endurance) (Samsung 1635)	SAS	800 GB
UCS-SD400G12S4-EP	400 GB 2.5 inch Enterprise Performance 12G SAS SSD (10X endurance) (SanDisk Lightning)	SAS	400 GB
6 Gbps Drives			
UCS-SD16TB12S3-EP	1.6 TB 2.5 inch Enterprise Performance 6 GSATA SSD (3X endurance) (Intel 3610)	SATA	SSD
UCS-SD800G0KS2-EP	800 GB 2.5 inch Enterprise Performance SAS SSD (Samsung 1625)	SAS	800 GB
UCS-SD480G12S3-EP	480 GB 2.5 inch Enterprise Performance 6G SATA SSD (3X endurance) (Intel 3610)	SATA	480 GB
UCS-SD400G0KS2-EP	400 GB 2.5 inch Enterprise Performance SAS SSD (Samsung 1625)	SAS	400 GB
UCS-SD200G0KS2-EP	200 GB 2.5 inch Enterprise Performance SAS SSD (Samsung 1625)	SAS	200 GB
UCS-SD38TBKS4-EV	3.8 TB 2.5 inch Enterprise Value 6G SATA SSD	SATA	3.8 TB
UCS-SD16TBKS4-EV	1.6T B 2.5 inch Enterprise Value 6G SATA SSD (Intel 3510)	SATA	1.6 TB
UCS-SD960GBKS4-EV	960 GB 2.5 inch Enterprise Value 6G SATA SSD (Samsung PM863)	SATA	960 GB
UCS-SD960G0KS2-EV	960 GB 2.5 inch Enterprise Value 6G SATA SSD (Samsung 853T)	SATA	960 GB
UCS-SD480GBKS4-EV	480 GB 2.5 inch Enterprise Value 6G SATA SSD (Intel 3510))	SATA	480 GB
UCS-SD240GBKS4-EV	240 GB 2.5 inch Enterprise Value 6G SATA SSD	SATA	240 GB
UCS-SD120GBKS4-EV	120 GB 2.5 inch Enterprise Value 6G SATA SSD (Intel 3510)	SATA	120 GB

Table 8 Supported Hot-Pluggable Sled-Mounted HDDs and SSDs (*continued*)

Product ID (PID)	PID Description	Drive Type	Size
NVMe PCIe SSDs ¹			
UCS-SDHPCIE800GB	800 GB 2.5 inch NVMe based PCIe SSD	NVMe SSD	800 GB
UCS-SDHPCIE16TB	1.6 TB 2.5 inch NVMe based PCIe SSD	NVMe SSD	1.6 TB

Notes...

1. If selected then UCSB-LSTOR-PT must be selected, SSDs and HDDs cannot be selected, and the number of CPUs selected must be two.

Supported Configurations

(1) 1-Drive System

- Select one of the drives listed in [Table 8](#).

(1) 2-Drive System

- Select two drives from [Table 8](#).

Caveats

- For RAID'ed configurations, if you select two drives, they must be identical in type (HDD or SSD) and capacity.
- For JBOD configurations, if you select two drives, you can mix and match any combination of HDD and SSD, regardless of capacity.
- A maximum of two NVMe PCIe SSDs can be ordered.
- NVMe PCIe SSDs are not bootable.
- NVMe PCIe SSDs cannot be controlled with a UCSB-MRAID12G or UCSB-MRAID12G-HE RAID controller.
- Two CPUs must be ordered when one or two NVMe PCIe SSDs are ordered.

STEP 6 CHOOSE ADAPTERS

The adapter offerings are:

■ Cisco Virtual Interface Cards (VICs)

Cisco developed 1200 Series and 1300 Series Virtual Interface Cards (VICs) to provide flexibility to create multiple NIC and HBA devices. The VICs also support adapter Fabric Extender and Virtual Machine Fabric Extender technologies. The VIC features are listed here:

- 1200 Series VICs enable advanced networking features including Netflow for network statistics, and DPDK, USNIC for low-latency computing applications.
- 1300 Series VICs include all of the 1200 Series features plus additional enhancements including network overlay offload support for NVGRE and VXLAN, and RoCE services.
- In addition, 1300 Series VICs support PCIe Gen 3.0 for greater bandwidth than 1200 Series VICs
- Two Converged Network Adapter (CNA) ports, supporting both Ethernet and FCoE
- Delivers 80 Gbps total I/O throughput to the server
 - VIC 1240 supports dual 4 x 10 Gbps Unified I/O ports
 - VIC 1340 supports dual 4x 10 Gbps Unified I/O ports or 2x40 (native) Gbps Unified I/O ports
- Creates up to 256 fully functional unique and independent PCIe adapters and interfaces (NICs or HBAs) without requiring single-root I/O virtualization (SR-IOV) support from operating systems or hypervisors
- Provides virtual machine visibility from the physical network and a consistent network operations model for physical and virtual servers
- Supports customer requirements for a wide range of operating systems and hypervisors

■ Cisco UCS Storage Accelerator Adapters

Cisco UCS Storage Accelerator adapters are designed specifically for the Cisco UCS B Series M4 blade servers and integrate seamlessly to allow improvement in performance and relief of I/O bottlenecks.

■ GPUs

NVIDIA GPUs are designed specifically for the Cisco UCS B Series M4 blade servers and provide outstanding processing power to offload the CPUs.



NOTE: For environments with 6100 Series Fabric Interconnects, you must configure only the VIC 1240/1280 adapters (1200 Series) and not 1340/1380 (1300 Series). From an I/O connectivity standpoint, configure only the VIC 1200 Series with the 6100 Series Fabric Interconnects.



NOTE: There are two slots on the server. One is a dedicated slot for the VIC 1340/1240 adapter only and one accommodates Cisco adapters or Cisco Storage Accelerator adapters as well as other options. [Table 9](#) shows which adapters plug into each of the two slots. Only the VIC 1340 or 1240 adapter plugs into the mLOM slot. All other adapters plug into the mezzanine adapter slot.



NOTE: You must have a B200 M4 configured with 2 CPUs to support cards that plug into the mezzanine connector. The VIC 1340 and 1240 adapters are supported on both 1- and 2-CPU configured systems.

Choose a Mezzanine Adapter

The supported mezzanine adapters in the UCS B200 M4 are listed in [Table 9](#).

Table 9 Supported Mezzanine Adapters

Product ID (PID)	PID Description	Connector
Virtual Interface Cards (VICs)		
UCSB-MLOM-40G-03 ¹	Cisco UCS VIC 1340 modular LOM for blade servers	mLOM
UCSB-VIC-M83-8P ¹	Cisco UCS VIC 1380 mezzanine adapter	Mezzanine
UCSB-MLOM-40G-01 ²	Cisco UCS VIC 1240 modular LOM for blade servers	mLOM
UCS-VIC-M82-8P	Cisco UCS VIC 1280 mezzanine adapter	Mezzanine
Cisco Storage Accelerators³		
UCSB-F-FIO-1600MS	UCS 1600 GB Fusion ioMemory3 SX Scale line for B-Series	Mezzanine
UCSB-F-FIO-1300MP	UCS 1300 GB Fusion ioMemory3 PX Performance line for B-Series	Mezzanine
Port Expander Card for VIC Option		
UCSB-MLOM-PT-01	Cisco UCS Port Expander Card for VIC. This is a hardware option to enable an additional 4 ports of the VIC 1340 or VIC 1240, bringing the total capability of the VIC 1340 or VIC 1240 to a dual native 40G interface or a dual 4 x 10 GbE port-channelled interface, respectively.	Mezzanine
Crypto Card		
UCSB-MEZ-INT8955 ⁴	Intel Crypto Mezz Card for B-Series	Mezzanine
GPUs		
UCSB-GPU-M6 ⁵	UCS Blade Server M6 GPU - GRID 2.0 SW required for VDI	Mezzanine

Notes...

1. The VIC 1340/1380 are only supported with the 6200 and 6300 Series Fabric Interconnects. They are not supported with the 6100 Series Fabric Interconnects.
2. The VIC 1240/1280 are supported with the 6100, 6200, and 6300 Series Fabric Interconnects.
3. Do not mix Fusion io storage accelerator families. That is, do not mix "MP" or "MS" (ioMemory3) with "M" (ioDrive2) family cards.
4. If selected, N20-FW012 v2.2 or N20-FW014 v3.1 is required, Invalid with any other selections.
5. The spare (PID UCSB-GPU-M6=) comes with a riser board and the necessary tool for installation. For further installation details, see <http://www.cisco.com/c/en/us/support/servers-unified-computing/ucs-b-series-blade-servers/products-installation-guides-list.html>

Supported Configurations

The supported configurations are listed in [Table 10](#). Choose one configuration. Refer to [B200 M4 Configured with 1 CPU on page 58](#) and [B200 M4 Configured with 2 CPUs on page 65](#) for more details.



NOTE: When the Cisco UCS 6324 Fabric Interconnect is implemented in the UCS Mini, it combines the functions of both Fabric Extender and Fabric Interconnect. Therefore, when the 6324 FI is used, the 2304, 2208XP, 2204XP, or 2104XP Fabric Extenders are not used. The 2 x 6324 column in the table indicates if the 6324 is supported and the total bandwidth for each case.

Table 10 Supported B200 M4 I/O Configurations

Adapter Configurations		Fabric Extenders Aggregate Bandwidth (Gb/s)				Fabric Interconnects					CPUs Req'd
Adapter Slot 1 (mLOM)	Adapter Slot 2	2 x 2304	2 x 2208XP	2 x 2204XP	2 x 2104XP ¹	2 x 61xx ¹ support?	2 x 62xx support?	2 x 6324 (UCS Mini) support?	2 x 6332 support?	2 x 6332-16UP support?	
VIC 1340	not populated	40 ²	40 ²	20	no support	no	yes	yes 20Gb/s	yes	yes	1 or 2
VIC 1340	Port Expander Card for VIC	80 ³	80 ⁴	40	no support	no	yes	yes 40 Gb/s	yes	yes	1 or 2
VIC 1340	VIC 1380	80 ⁴	80 ⁴	40	no support	no	yes	yes 40 Gb/s	yes	yes	2
VIC 1340	non-IO mezz (for example, Fusion-io or GPU)	40 ²	40 ²	20	no support	no	yes	yes 20 Gb/s	yes	yes	2
VIC 1240	not populated	40 ²	40 ²	20	20	yes ¹	yes	yes 20 Gb/s	yes	yes	1 or 2
VIC 1240	Port Expander Card for VIC	80	80 ⁴	40	IO card in slot 2 ignored	yes ¹	yes	yes 40 Gb/s	yes	yes	1 or 2
VIC 1240	VIC 1280	80 ⁴	80 ⁴	40	IO card in slot 2 ignored	yes ¹	yes	yes 40 Gb/s	yes	yes	2
VIC 1240	non-IO mezz (for example, Fusion-io or GPU)	40 ²	40 ²	20	20 Gb/s	yes ¹	yes	yes 20 Gb/s	yes	yes	2

Notes...

- Support until UCSM 2.2.x (but not UCSM 3.x and later)
- This combination uses two 2x10G port-channels (see [Figure 20 on page 65](#) and [Figure 24 on page 68](#))
- This combination uses a dual native 40G interface
- This combination uses dual 40G via four 2x10G port-channels (see [Figure 21 on page 66](#) and [Figure 25 on page 69](#))

To check that your operating system is compatible with the adapter you have selected, please check the Hardware Compatibility List at this URL:

http://www.cisco.com/en/US/products/ps10477/prod_technical_reference_list.html

Caveats

- You must have VIC 1340 or VIC 1240 adapter installed in order to have I/O connectivity.

STEP 7 ORDER TRUSTED PLATFORM MODULE (OPTIONAL)

Trusted Platform Module (TPM) is a computer chip or microcontroller that can securely store artifacts used to authenticate the platform or server. These artifacts can include passwords, certificates, or encryption keys. A TPM can also be used to store platform measurements that help ensure that the platform remains trustworthy. Authentication (ensuring that the platform can prove that it is what it claims to be) and attestation (a process helping to prove that a platform is trustworthy and has not been breached) are necessary steps to ensure safer computing in all environments. See [Figure 7 on page 44](#) for the mounting location of the TPM.

The TPM ordering information is listed in [Table 11](#).

Table 11 Trusted Platform Module

Product ID (PID)	PID Description
UCSX-TPM2-001	Trusted Platform Module 1.2 for UCS (SPI-based)
UCSX-TPM2-002	Trusted Platform Module 2.0 for UCS servers



NOTE: The module used in this system conforms to TPM v1.2 and 2.0, as defined by the Trusted Computing Group (TCG). It is also SPI-based.



NOTE: TPM installation is supported after-factory. However, a TPM installs with a one-way screw and cannot be replaced, upgraded, or moved to another server. If a server with a TPM is returned, the replacement server must be ordered with a new TPM. If there is no existing TPM in the server, you can install TPM 2.0. You must first upgrade to UCS firmware that supports Intel E5-2600 v4 CPUs, which is Cisco UCS Manager Release 2.2(7) and later or Release 3.1(1) and later (because Cisco aligned support for TPM 2.0 with these CPUs).



CAUTION: If the Cisco UCS server (with Intel E5-2600 v4 or v3 CPUs) is running UCS firmware that added support for Intel E5-2600 v4 CPUs, then it will work with TPM version 2.0. However, if you downgrade the firmware and BIOS to a version earlier than Release 2.2(7) or earlier than Release 3.1(1), then you are vulnerable to a potential security exposure. See the following support matrix for TPM versions.

Table 12 TPM Support Matrix by Intel CPU Version

Intel CPU	TPM Version	Minimum UCS Manager (UCSM) Version
Intel E5-2600 v3	TPM 1.2	Release 2.2(3)
	TPM 2.0	Release 2.2(7) or Release 3.1(1)
Intel E5-2600 v4	TPM 1.2	Release 2.2(7) or Release 3.1(1)
	TPM 2.0	Release 2.2(7) or Release 3.1(1)

STEP 8 TORDER SECURE DIGITAL CARDS (OPTIONAL)

Dual SDHC flash card sockets are provided on the front left side of the server.



NOTE: Dual card support (mirroring) is supported.

The SDHC card ordering information is listed in [Table 13](#).

Table 13 Supported Secure Digital Cards

Product ID (PID)	PID Description
UCS-SD-64G-S	64 GB SD Card module for UCS Servers
UCS-SD-32G-S	32 GB SD Card module for UCS Servers

Supported Configurations

(1) Select either one or two 64 GB SD cards or one or two 32 GB SD cards. Do not mix 64 GB SD cards with 32 GB SD cards.

STEP 9 ORDER INTERNAL USB 3.0 DRIVE (OPTIONAL)

You may order one optional internal USB 3.0 drive. The USB drive ordering information is listed in [Table 14](#).

Table 14 USB 3.0 Drive

Product ID (PID)	PID Description
UCS-USBFLSHB-16GB	UCS Servers 16GB Flash USB Drive



NOTE: A clearance of 0.950 inches (24.1 mm) is required for the USB device to be inserted and removed (see the following figures). A “peephole” is provided so you can see the connector for the USB drive (see also the figures on the following page).

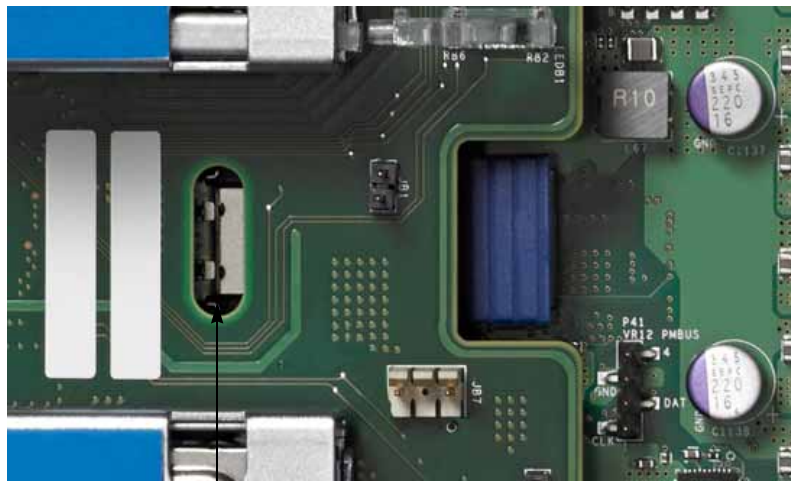
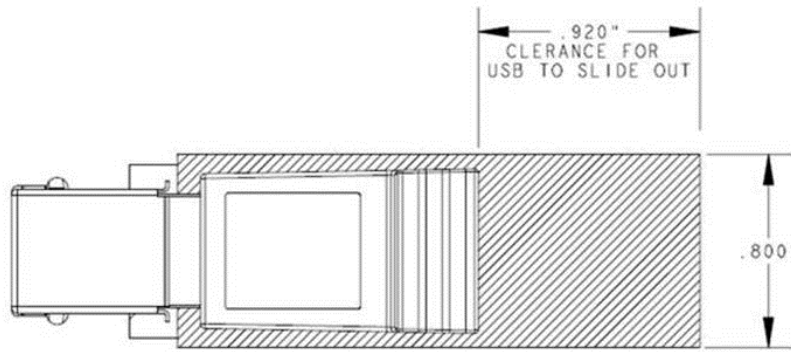

Peephole

See [Figure 7 on page 44](#) for the location of the USB connector on the motherboard.



NOTE: The figures below show a “peephole” provided on the RAID controller board where you can look to make sure the USB drive is fully inserted into the USB connector.

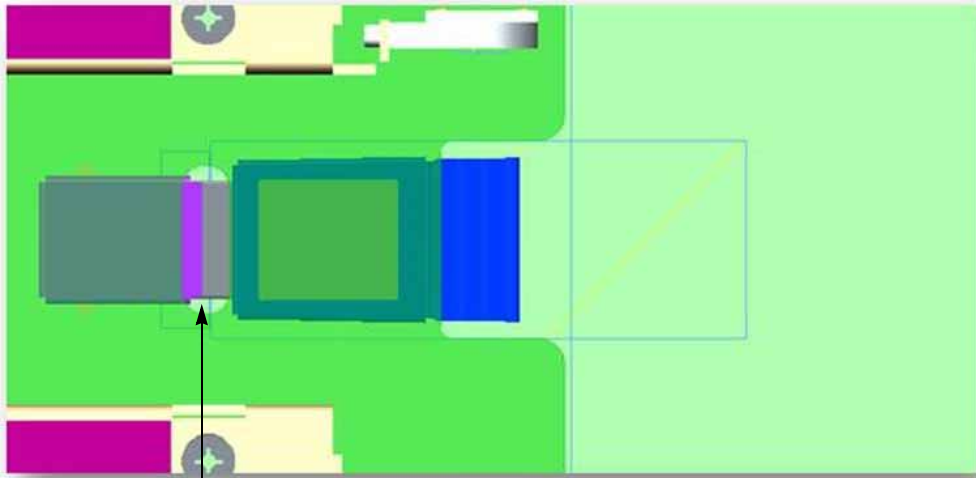

Peephole

(a) USB drive plugged into connector

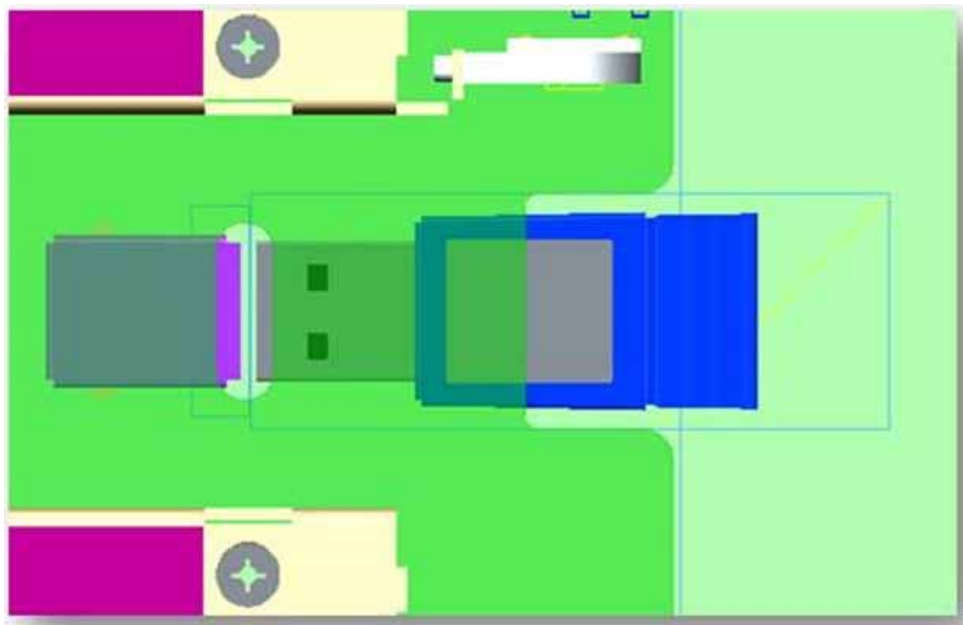

(b) USB drive unplugged from connector

STEP 10 CHOOSE OPERATING SYSTEM AND VALUE-ADDED SOFTWARE

Several operating systems and value-added software programs are available. Select as desired from [Table 15](#).

Table 15 OSs and Value-Added Software (for 2-CPU servers)

PID Description	Product ID (PID)
Cisco One	
C1F2PUCSK9	Cisco ONE Foundation Perpetual UCS
C1F2SICFBK9	Cisco ONE Foundation Subsr Intercloud Fabric For Business
C1A1PUCSK9	Cisco ONE Enterprise Cloud Perpetual UCS
C1UCS-OPT-OUT	Cisco One Data Center Compute Opt Out Option
Microsoft Windows Server	
MSWS-12-ST2S	Windows Server 2012 Standard (2 CPU/2 VMs)
MSWS-12-DC2S	Windows Server 2012 Datacenter (2 CPU/Unlimited VMs)
MSWS-12-ST2S-NS	Windows Server 2012 Standard (2 CPU/2 VMs) No Cisco SVC
MSWS-12-DC2S-NS	Windows Server 2012 Datacenter (2 CPU/Unlim VM) No Cisco SVC
MSWS-12R2-ST2S	Windows Server 2012 R2 Standard (2 CPU/2 VMs)
MSWS-12R2-DC2S	Windows Server 2012 R2 Datacenter (2 CPU/Unlimited VMs)
MSWS-12R2-ST2S-NS	Windows Server 2012 R2 Standard (2 CPU/2 VMs) No Cisco SVC
MSWS-12R2-DC2S-NS	Windows Server 2012 R2 Datacen (2 CPU/Unlim VM) No Cisco Svc
SUSE	
SLES-2S2V-1A	SUSE Linux Enterprise Svr (1-2 CPU,1 Phys);1yr Support Reqd
SLES-2S2V-3A	SUSE Linux Enterprise Svr (1-2 CPU,1 Phys);3yr Support Reqd
SLES-2S2V-5A	SUSE Linux Enterprise Svr (1-2 CPU,1 Phys);5yr Support Reqd
SLES-2SUV-1A	SUSE Linux Enterprise Svr (1-2 CPU,Unl Vrt);1yr Support Reqd
SLES-2SUV-3A	SUSE Linux Enterprise Svr (1-2 CPU,Unl Vrt);3yr Support Reqd
SLES-2SUV-5A	SUSE Linux Enterprise Svr (1-2 CPU,Unl Vrt);5yr Support Reqd
SLES-2S-HA-1S	SUSE Linux High Availability Ext (1-2 CPU); 1yr Support Reqd
SLES-2S-HA-3A	SUSE Linux High Availability Ext (1-2 CPU); 3yr Support Reqd
SLES-2S-HA-5A	SUSE Linux High Availability Ext (1-2 CPU); 5yr Support Reqd
SLES-2S-GC-1S	SUSE Linux GEO Clustering for HA (1-2 CPU); 1yr Support Reqd
SLES-2S-GC-3S	SUSE Linux GEO Clustering for HA (1-2 CPU); 3yr Support Reqd
SLES-2S-GC-5S	SUSE Linux GEO Clustering for HA (1-2 CPU); 5yr Support Reqd
SLES-SAP-2S2V-1A	SLES for SAP Applications (1-2 CPU,1 Phys); 1yr Support Reqd
SLES-SAP-2S2V-3A	SLES for SAP Applications (1-2 CPU,1 Phys); 3yr Support Reqd
SLES-SAP-2S2V-5A	SLES for SAP Applications (1-2 CPU,1 Phys); 5yr Support Reqd
SLES-SAP-2SUV-1A	SLES for SAP Applications (1-2 CPU,Unl Vrt);1yr Support Reqd
SLES-SAP-2SUV-3A	SLES for SAP Applications (1-2 CPU,Unl Vrt);3yr Support Reqd
SLES-SAP-2SUV-5A	SLES for SAP Applications (1-2 CPU,Unl Vrt);5yr Support Reqd
Nexus 1000V for Hyper-V and vSphere	

Table 15 OSs and Value-Added Software (for 2-CPU servers) *(continued)*

PID Description	Product ID (PID)
N1K-VSG-UCS-BUN	Over half off N1K and VSG w/ purchase of UCS B/C Series
N1K-VLEM-UCS-1	Nexus 1000V License Paper Delivery (1 CPU) for bundles
VSG-VLEM-UCS-1	VSG License Paper Delivery (1 CPU) for bundles
UCS Director	
CUIC-PHY-SERV-BM-U	Cisco Cloupia Resource Lic - One Phy Server node bare metal
CUIC-PHY-SERV-U	Cisco Cloupia Resource Lic - One physical Server node
CUIC-TERM	Acceptance of Cisco Cloupia License Terms
UCS Performance Manager	
UCS-PM-IE	UCS Performance Manager
UCS-PM-EE	UCS Performance Manager Express
EVAL-UCS-PM-IE	UCS Performance Manager - 60 days evaluation
EVAL-UCS-PM-EE	UCS Performance Manager Express - 60 days evaluation
NFR-UCS-PM-IE	UCS Performance Manager - Not For Resale
NFR-UCS-PM-EE	CS Performance Manager Express - Not For Resale
IMC Supervisor	
EVAL-CIMC-SUP	EVAL: IMC Supervisor-Branch Mgt SW for C/E-Series - 50 Svrs
EVAL-CIMC-SUP-BAS	EVAL: IMC Supervisor One-time Site Installation License
CIMC-SUP-B01	IMC Supervisor-Branch Mgt SW for C-Series & E-Series up to 100 Svrs
CIMC-SUP-B02	IMC Supervisor- Branch Mgt SW for C-Series & E-Series up to 250 Svrs
CIMC-SUP-B10	IMC Supervisor- Branch Mgt SW for C-Series & E-Series up to 1K Svrs
CIMC-SUP-BASE-K9	IMC Supervisor One-time Site Installation License
CIMC-SUP-TERM	Acceptance of Cisco IMC Supervisor License Terms
VMware 5	
VMW-VS5-STD-1A	VMware vSphere 5 Standard for 1 Processor, 1 Year, Support Rqd
VMW-VS5-STD-2A	VMware vSphere 5 Standard for 1 Processor, 2 Year, Support Rqd
VMW-VS5-STD-3A	VMware vSphere 5 Standard for 1 Processor, 3 Year, Support Rqd
VMW-VS5-STD-4A	VMware vSphere 5 Standard for 1 Processor, 4 Year, Support Rqd
VMW-VS5-STD-5A	VMware vSphere 5 Standard for 1 Processor, 5 Year, Support Rqd
VMW-VS5-ENT-1A	VMware vSphere 5 Enterprise for 1 Processor, 1 Year Support Rqd
VMW-VS5-ENT-2A	VMware vSphere 5 Enterprise for 1 CPU, 2 Yr Support Rqd
VMW-VS5-ENT-3A	VMware vSphere 5 Enterprise for 1 CPU, 3 Yr Support Rqd
VMW-VS5-ENT-4A	VMware vSphere 5 Enterprise for 1 Processor, 4 Year Support Rqd
VMW-VS5-ENT-5A	VMware vSphere 5 Enterprise for 1 CPU, 5 Yr Support Rqd
VMW-VS5-ENTP-1A	VMware vSphere 5 Enterprise Plus for 1 Processor, 1 Year Support Rqd
VMW-VS5-ENTP-2A	VMware vSphere 5 Enterprise Plus for 1 CPU, 2 Yr Support Rqd
VMW-VS5-ENTP-3A	VMware vSphere 5 Enterprise Plus for 1 Processor, 3 Year Support Rqd
VMW-VS5-ENTP-4A	VMware vSphere 5 Enterprise Plus for 1 Processor, 4 Year Support Rqd
VMW-VC5-STD-1A	VMware vCenter 5 Server Standard, 1 yr support required
VMW-VC5-STD-2A	VMware vCenter 5 Server Standard, 2 yr support required

Table 15 OSs and Value-Added Software (for 2-CPU servers) *(continued)*

PID Description	Product ID (PID)
VMW-VC5-STD-3A	VMware vCenter 5 Server Standard, 3 yr support required
VMW-VC5-STD-4A	VMware vCenter 5 Server Standard, 4 yr support required
VMW-VC5-STD-5A	VMware vCenter 5 Server Standard, 5 yr support required



NOTE: For additional information, see OS/hypervisor support matrix at the following link:

http://www.cisco.com/en/US/products/ps10477/prod_technical_reference_list.html

STEP 11 CHOOSE OPERATING SYSTEM MEDIA KIT

Choose the optional operating system media listed in [Table 16](#).

Table 16 OS Media

Product ID (PID)	PID Description
RHEL-6	RHEL 6 Recovery Media Only (Multilingual)
SLES-11	SLES 11 media only (multilingual)

STEP 12 CHOOSE SERVICE and SUPPORT LEVEL

A variety of service options are available, as described in this section.

Unified Computing Warranty, No Contract

If you have noncritical implementations and choose to have no service contract, the following coverage is supplied:

- Three-year parts coverage.
- Next business day (NBD) parts replacement eight hours a day, five days a week.
- 90-day software warranty on media.
- Downloads of BIOS, drivers, and firmware updates.
- UCSM updates for systems with Unified Computing System Manager. These updates include minor enhancements and bug fixes that are designed to maintain the compliance of UCSM with published specifications, release notes, and industry standards.

Unified Computing Support Service

For support of the entire Unified Computing System, Cisco offers the Cisco Unified Computing Support Service. This service provides expert software and hardware support to help sustain performance and high availability of the unified computing environment. Access to Cisco Technical Assistance Center (TAC) is provided around the clock, from anywhere in the world.

For UCS blade servers, there is Smart Call Home, which provides proactive, embedded diagnostics and real-time alerts. For systems that include Unified Computing System Manager, the support service includes downloads of UCSM upgrades. The Unified Computing Support Service includes flexible hardware replacement options, including replacement in as little as two hours. There is also access to Cisco's extensive online technical resources to help maintain optimal efficiency and uptime of the unified computing environment. You can choose a desired service listed in [Table 17](#).

Table 17 Unified Computing Support Service

Product ID (PID)	On Site?	Description
CON-PREM-B200M4	Yes	ONSITE 24X7X2 UCS B200 M4 Blade Server
CON-OSP-B200M4	Yes	ONSITE 24X7X4 UCS B200 M4 Blade Server
CON-OSE-B200M4	Yes	ONSITE 8X5X4 UCS B200 M4 Blade Server
CON-OS-B200M4	Yes	ONSITE 8X5XNBD UCS B200 M4 Blade Server
CON-S2P-B200M4	No	SMARTNET 24X7X2 UCS B200 M4 Blade Server
CON-SNTP-B200M4	No	SMARTNET 24X7X4 UCS B200 M4 Blade Server
CON-SNTE-B200M4	No	SMARTNET 8X5X4 UCS B200 M4 Blade Server
CON-SNT-B200M4	No	SMARTNET 8X5XNBD UCS B200 M4 Blade Server

Unified Computing Warranty Plus Service

For faster parts replacement than is provided with the standard Cisco Unified Computing System warranty, Cisco offers the Cisco Unified Computing Warranty Plus Service. You can choose from several levels of advanced parts replacement coverage, including onsite parts replacement in as little as four hours. Warranty Plus provides remote access any time to Cisco support professionals who can determine if a return materials authorization (RMA) is required. You can choose a service listed in [Table 18](#).

Table 18 UCS Computing Warranty Plus Service

Product ID (PID)	Service Level GSP	On Site?	Description
CON-UCW7-B200M4	UCW7	Yes	UC PLUS 24X7X4OS UCS B200 M4 Blade Server
CON-UCW5-B200M4	UCW5	Yes	UC PLUS 8X5XNBDOS UCS B200 M4 Blade Server

Unified Computing Partner Support Service

Cisco Partner Support Service (PSS) is a Cisco Collaborative Services service offering that is designed for partners to deliver their own branded support and managed services to enterprise customers. Cisco PSS provides partners with access to Cisco's support infrastructure and assets to help them:

- Expand their service portfolios to support the most complex network environments
- Lower delivery costs
- Deliver services that increase customer loyalty

Partner Unified Computing Support Options enable eligible Cisco partners to develop and consistently deliver high-value technical support that capitalizes on Cisco intellectual assets. This helps partners to realize higher margins and expand their practice.

PSS is available to all Cisco PSS partners, but requires additional specializations and requirements. For additional information, see the following URL:

www.cisco.com/go/partnerucssupport

The two Partner Unified Computing Support Options include:

- Partner Support Service for UCS
- Partner Support Service for UCS Hardware Only

Partner Support Service for UCS provides hardware and software support, including triage support for third party software, backed by Cisco technical resources and level three support. See [Table 19](#).

Table 19 Partner Support Service for UCS

Product ID (PID)	Service Level GSP	On Site?	Description
CON-PSJ1-B200M4	PSJ1	No	UCS SUPP PSS 8X5XNBD UCS B200 M4 Blade Server
CON-PSJ2-B200M4	PSJ2	No	UCS SUPP PSS 8X5X4 UCS B200 M4 Blade Server
CON-PSJ3-B200M4	PSJ3	No	UCS SUPP PSS 24X7X4 UCS B200 M4 Blade Server
CON-PSJ4-B200M4	PSJ4	No	UCS SUPP PSS 24X7X2 UCS B200 M4 Blade Server

Partner Support Service for UCS Hardware Only provides customers with replacement parts in as little as two hours. See [Table 20](#).

Table 20 Partner Support Service for UCS (Hardware Only)

Product ID (PID)	Service Level GSP	On Site?	Description
CON-PSW2-B200M4	PSW2	No	UCS W PL PSS 8X5X4 UCS B200 M4 Blade Server
CON-PSW3-B200M4	PSW3	No	UCS W PL PSS 24X7X4 UCS B200 M4 Blade Server
CON-PSW4-B200M4	PSW4	No	UCS W PL PSS 24X7X2 UCS B200 M4 Blade Server

Unified Computing Combined Support Service

Combined Services makes it easier to purchase and manage required services under one contract. SMARTnet services for UCS help increase the availability of your vital data center infrastructure and realize the most value from your unified computing investment. The more benefits you realize from the Cisco Unified Computing System (Cisco UCS), the more important the technology becomes to your business. These services allow you to:

- Optimize the uptime, performance, and efficiency of your UCS
- Protect your vital business applications by rapidly identifying and addressing issues
- Strengthen in-house expertise through knowledge transfer and mentoring
- Improve operational efficiency by allowing UCS experts to augment your internal staff resources
- Enhance business agility by diagnosing potential issues before they affect your operations

You can choose a service listed in [Table 21](#).

Table 21 UCS Computing Combined Support Service

Product ID (PID)	Service Level GSP	On Site?	Description
CON-NCF2-B200M4	NCF2	No	CMB SPT SVC 24X7X2 UCS B200 M4 Blade Server
CON-NCF2P-B200M4	NCF2P	Yes	CMB SPT SVC 24X7X2OS UCS B200 M4 Blade Server
CON-NCF4P-B200M4	NCF4P	Yes	CMB SPT SVC 24X7X4OS UCS B200 M4 Blade Server
CON-NCF4S-B200M4	NCF4S	Yes	CMB SPT SVC 8X5X4OS UCS B200 M4 Blade Server
CON-NCFCS-B200M4	NCFCS	Yes	CMB SPT SVC 8X5XNBDOS UCS B200 M4 Blade Server
CON-NCFE-B200M4	NCFE	No	CMB SPT SVC 8X5X4 UCS B200 M4 Blade Server
CON-NCFP-B200M4	NCFP	No	CMB SPT SVC 24X7X4 UCS B200 M4 Blade Server
CON-NCFT-B200M4	NCFT	No	CMB SPT SVC 8X5XNBD UCS B200 M4 Blade Server

Unified Computing Drive Retention Service

With the Cisco Unified Computing Drive Retention (UCDR) Service, you can obtain a new disk drive in exchange for a faulty drive without returning the faulty drive. In exchange for a Cisco replacement drive, you provide a signed Certificate of Destruction (CoD) confirming that the drive has been removed from the system listed, is no longer in service, and has been destroyed.

Sophisticated data recovery techniques have made classified, proprietary, and confidential information vulnerable, even on malfunctioning disk drives. The UCDR service enables you to retain your drives and ensures that the sensitive data on those drives is not compromised, which reduces the risk of any potential liabilities. This service also enables you to comply with regulatory, local, and federal requirements.

If your company has a need to control confidential, classified, sensitive, or proprietary data, you might want to consider one of the Drive Retention Services listed in [Table 22](#).



NOTE: Cisco does not offer a certified drive destruction service as part of this service.

Table 22 Drive Retention Service Options

Service Description	Service Program Name	Service Level GSP	Service Level	Product ID (PID)
UCS Support Service With Drive Retention	UC SUPP DR	UCSD5	8x5xNBD Onsite	CON-UCSD5-B200M4
		UCSD7	24x7x4 Onsite	CON-UCSD7-B200M4
UCS Warranty Plus With Drive Retention	UC PLUS DR	UCWD5	8x5xNBD Onsite	CON-UCWD5-B200M4
		UCWD7	24x7x4 Onsite	CON-UCWD7-B200M4

For more service and support information, see the following URL:

http://www.cisco.com/en/US/services/ps2961/ps10312/ps10321/Cisco_UC_Warranty_Support_DS.pdf

For a complete listing of available services for Cisco Unified Computing System, see this URL:

http://www.cisco.com/en/US/products/ps10312/serv_group_home.html

ORDER OPTIONAL KVM LOCAL I/O CABLE*

The KVM local I/O cable ships with every UCS 5100 Series blade server chassis accessory kit. The KVM local I/O cable provides a connection into the server, with a DB9 serial connector, a VGA connector for a monitor, and dual USB ports for a keyboard and mouse. With this cable, you can create a direct connection to the operating system and the BIOS running on the server.

The KVM local I/O cable ordering information is listed in [Table 23](#).

Table 23 KVM Local I/O Cable

Product ID (PID)	PID Description
N20-BKVM=	KVM local IO cable for UCS servers console port

Figure 6 KVM Local I/O Cable

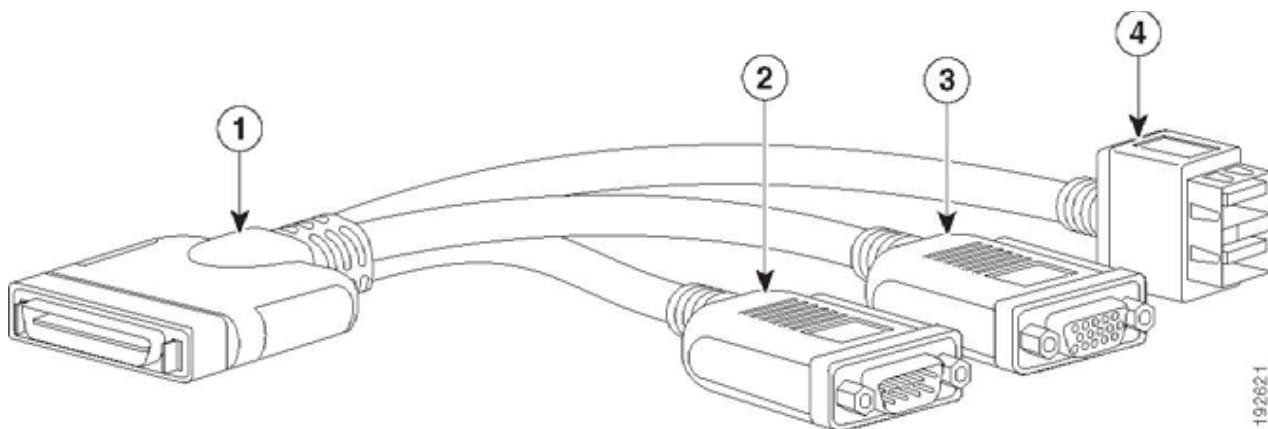

1	Connector (to server front panel)	3	VGA connector (for a monitor)
2	DB-9 serial connector	4	Two-port USB connector (for a mouse and keyboard)



NOTE: *The blade chassis ships with the KVM local I/O cable.

SUPPLEMENTAL MATERIAL

System Board

A top view of the UCS B200 M4 system board is shown in *Figure 7*.

Figure 7 UCS B200 M4 System Board

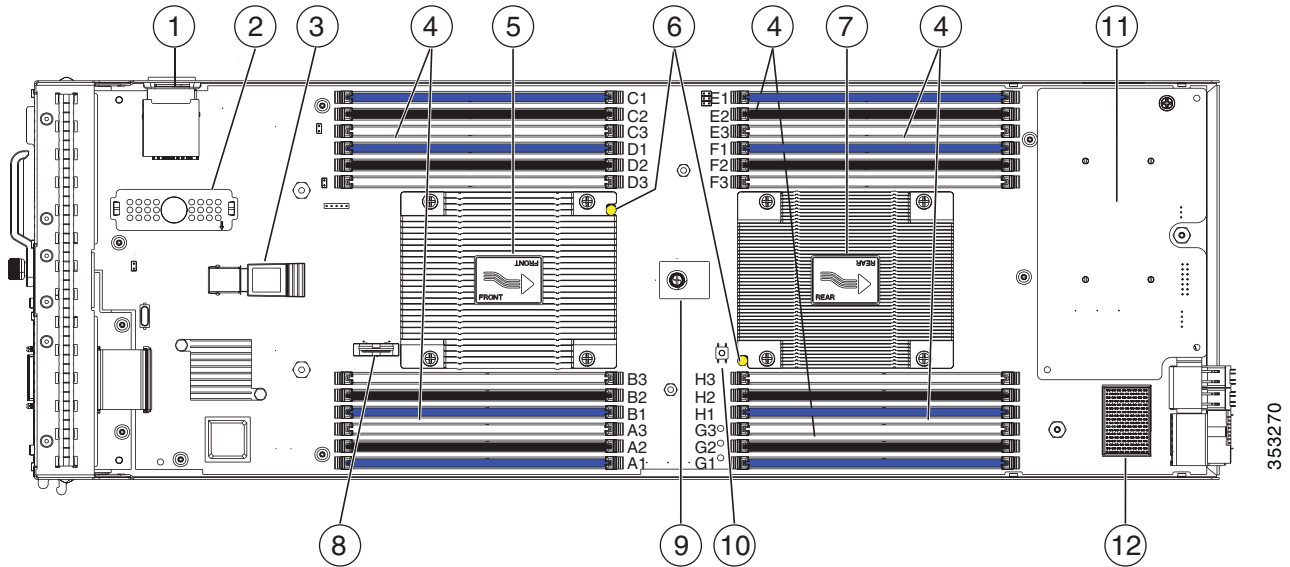

1	SD card slots	7	Rear heat sink and CPU 2
2	Modular storage subsystem connector	8	CMOS battery
3	USB connector Cisco UCS-USBFLSHB-16GB= is recommended, but if another USB drive will be used it must be no wider than 0.8 inches, and no more than 1.345 inches long in order to provide needed clearances to install or remove the USB drive.	9	Trusted Platform Module (TPM)
4	DIMM slots	10	DIMM diagnostic LED button
5	Front heat sink and CPU 1	11	Adapter slot 1
6	CPU heat sink install guide pins	12	Adapter slot 2

CPUs and DIMMs

Physical Layout

Memory is organized as shown in [Figure 8](#).

Figure 8 UCS B200 M4 Memory Organization

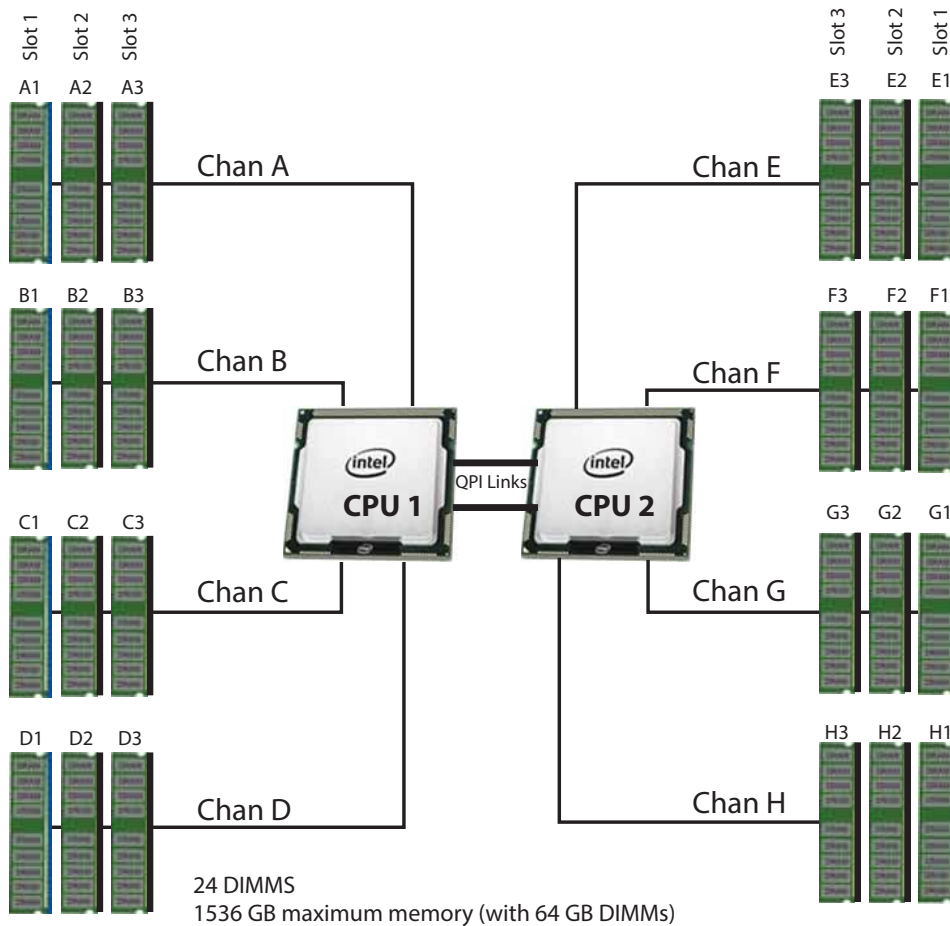

4 memory channels per CPU,
up to 3 DIMMs per channel

Each CPU controls four memory channels (A, B, C, D) with three slots (1, 2, 3) within each channel:

- CPU1: Channels A, B, C, and D
 - Slot 1 - A1, B1, C1, and D1 (blue DIMM slots)
 - Slot 2 - A2, B2, C2, and D2 (black DIMM slots)
 - Slot 3 - A3, B3, C3, and D3 (white DIMM slots)
- CPU2: Channels E, F, G, and H
 - Slot 1 - E1, F1, G1, and H1 (blue DIMM slots)

- Slot 2 - E2, F2, G2, and H2 (black DIMM slots)
- Slot 3 - E3, F3, G3, and H3 (white DIMM slots)

The DIMM and CPU physical layout is shown in [Figure 7 on page 44](#). The 12 DIMM slots at the left are controlled by CPU 1 and the 12 DIMM slots on the right are controlled by CPU 2.

DIMM Population Rules

When considering the memory configuration, take into account the following:

- Each channel has three DIMM slots (for example, channel A = slots A1, A2, and A3).
 - A channel can operate with one, two, or three DIMMs installed.
 - If a channel has only one DIMM, populate slot 1 first (the blue slot).
- When both CPUs are installed, populate the DIMM slots of each CPU as follows.
 - Fill blue slots in the channels first
 - Fill black slots in the channels second
 - Fill white slots in the channels third
- Any DIMM installed in a DIMM socket for which the CPU is absent is not recognized.
- Observe the DIMM mixing rules shown in [Table 24](#)

Table 24 DIMM Rules for B200 M4 Servers

DIMM Parameter	DIMMs in the Same Channel	DIMM in the Same Slot ¹
<u>DIMM Capacity</u>		
RDIMM = 8 ² , 16, or 32 GB LRDIMM = 32 or 64 GB TSV-RDIMM = 64 GB	DIMMs in the same channel (for example, A1, A2, and A3) can have different capacities. Do not mix TSV-RDIMMS with LRDIMMs nor RDIMMS	For best performance, DIMMs in the same slot (for example, A1, B1, C1, D1) should have the same capacity. Do not mix TSV-RDIMMS with LRDIMMs nor RDIMMS
<u>DIMM Speed</u>		
2400-MHz 2133-MHz	DIMMs will run at the lowest speed of the CPU installed	DIMMs will run at the lowest speed of the CPU installed
<u>DIMM Type</u>		
TSV-RDIMMS, RDIMMS, or LRDIMMs	Do not mix DIMM types in a channel	Do not mix DIMM types in a slot
1 DPC, 2 DPC, or 3 DPC		
DIMMs per Channel (DPC)	See Table 5 on page 15 for valid LRDIMM and RDIMM 1 DPC, 2 DPC, and 3 DPC memory configurations	

Notes...

1. Although different DIMM capacities can exist in the same slot, this will result in less than optimal performance. For optimal performance, all DIMMs in the same slot should be identical.
2. On the B200 M4, only 8 GB 2133-MHz (not 2400-MHz) DIMMs are supported and only with v3 CPUs.

DIMM Population Order

Populate the DIMMs for a CPU according to [Table 25](#). See also [Figure 9](#).

Table 25 DIMM Population Order per CPU

DIMMs per CPU	Populate CPU 1 Slots	Populate CPU 2 Slots
1	A1	E1
2	A1, B1	E1, F1
3	A1, B1, C1	E1, F1, G1
4	A1, B1, C1, D1	E1, F1, G1, H1
8	A1, B1, C1, D1, A2, B2, C2, D2	E1, F1, G1, H1, E2, F2, G2, H2
12	A1, B1, C1, D1, A2, B2, C2, D2 A3, B3, C3, D3	E1, F1, G1, H1, E2, F2, G2, H2 E3, F3, G3, H3

Figure 9 DIMM Population Order

DIMM Population Order							
DIMMs for CPU 1	4	8	12	DIMMs for CPU 2	4	8	12
Install in Slots:	A1	A1	A1	Install in Slots:	E1	E1	E1
Blue	B1	B1	B1	Blue	F1	F1	F1
	C1	C1	C1	Blue and Black	G1	G1	G1
	D1	D1	D1		H1	H1	H1
		A2	A2			E2	E2
		B2	B2			F2	F2
		C2	C2			G2	G2
		D2	D2			H2	H2
			A3				E3
			B3				F3
			C3				G3
			D3				H3

Recommended Memory Configuration

This section explains the recommended DIMM population order rules for the B200 M4 blades.

- All DIMMs must be DDR4 DIMMs.
- Do not mix:
 - DIMMs with different clock rates in a channel
 - TSV-RDIMMs with RDIMMs nor LRDIMMs
- There are blue, black, and white DIMM slots. Populate blue slots first.
- When DIMMs ranks are mixed in the same channel, always populate the highest rank DIMM in the blue DIMM slot and lower rank DIMM(s) in the black and white DIMM slots.

Many memory configurations are possible. For best results, follow [Table 26](#) when populating 2133-MHz DIMMs for Intel Xeon E5-2600 v3 CPUs and [Table 27](#) when populating 2400-MHz DIMMs for Intel Xeon E5-2600 v4 CPUs.



NOTE: These tables list only some recommended and suggested configurations. There are numerous other possible configurations supported by Cisco. Cisco supports all mixing and population configurations of the Cisco DIMMs as long as the mixing does not violate the few fundamental rules noted in this document.

Table 26 Recommended Memory Configurations for Intel Xeon E5-2600 v3 CPUs (with 2133-MHz DIMMs)¹

Total System Memory Size	CPU 1 DIMMs			CPU 2 DIMMs			DIMM Max Speed (MHz)	Total DIMMs
	Blue Slots Slot 1 (A1,B1, C1,D1)	Black Slots Slot 2 (A2,B2, C2,D2)	White Slots Slot 3 (A3,B3, C3,D3)	Blue Slots Slot 1 (E1,F1, G1,H1)	Black Slots Slot 2 (E2,F2, G2,H2)	White Slots Slot 3 (E3,F3, G3,H3)		
64 GB	4x8 GB	–	–	4x8 GB	–	–	2133	8
128 GB	4x8 GB	4x8 GB	–	4x8 GB	4x8 GB	–	2133	16
	4x16 GB	–	–	4x16 GB	–	–	2133	8
192 GB	4x8 GB	4x8 GB	4x8 GB	4x8 GB	4x8 GB	4x8 GB	1600	24
	4x16 GB	4x8 GB	–	4x16 GB	4x8 GB	–	2133	16
256 GB	4x16 GB	4x16 GB	–	4x16 GB	4x16 GB	–	2133	16
	4x32 GB	–	–	4x32 GB	–	–	2133	8
384 GB	4x16 GB	4x16 GB	4x16 GB	4x16 GB	4x16 GB	4x16 GB	1866	24
	4x32GB	4x16GB	–	4x32GB	4x16GB	–	2133	16
512 GB	4x32 GB	4x32 GB	–	4x32 GB	4x32 GB	–	2133	16
	4x64 GB	–	–	4x64 GB	–	–	2133	8
768 GB	4x32 GB	4x32 GB	4x32 GB	4x32 GB	4x32 GB	4x32 GB	1866	24
1024 GB	4x64 GB	4x64 GB	–	4x64 GB	4x64 GB	–	2133	16

Table 26 Recommended Memory Configurations for Intel Xeon E5-2600 v3 CPUs (with 2133-MHz DIMMs)¹ (continued)

Total System Memory Size	CPU 1 DIMMs			CPU 2 DIMMs			DIMM Max Speed (MHz)	Total DIMMs
	Blue Slots Slot 1 (A1,B1, C1,D1)	Black Slots Slot 2 (A2,B2, C2,D2)	White Slots Slot 3 (A3,B3, C3,D3)	Blue Slots Slot 1 (E1,F1, G1,H1)	Black Slots Slot 2 (E2,F2, G2,H2)	White Slots Slot 3 (E3,F3, G3,H3)		
1536 GB	4x64 GB	4x64 GB	4x64 GB	4x64 GB	4x64 GB	4x64 GB	1600	24

Notes...

1. Rows marked in yellow indicate best performance.

Table 27 Recommended Memory Configurations for Intel Xeon E5-2600 v4 CPUs (with 2400-MHz DIMMs)¹

Total System Memory Size	CPU 1 DIMMs			CPU 2 DIMMs			DIMM Max Speed (MHz)	Total DIMMs
	Blue Slots Slot 1 (A1,B1, C1,D1)	Black Slots Slot 2 (A2,B2, C2,D2)	White Slots Slot 3 (A3,B3, C3,D3)	Blue Slots Slot 1 (E1,F1, G1,H1)	Black Slots Slot 2 (E2,F2, G2,H2)	White Slots Slot 3 (E3,F3, G3,H3)		
128 GB	4x16 GB	—	—	4x16 GB	—	—	2400	8
256 GB	4x32 GB	—	—	4x32 GB	—	—	2400	8
384 GB	4x16 GB	4x16 GB	4x16 GB	4x16 GB	4x16 GB	4x16 GB	2133	24
	4x32GB	4x16GB	—	4x32GB	4x16GB	—	2400	16
512 GB	4x32 GB	4x32 GB	—	4x32 GB	4x32 GB	—	2400	16
	4x64 GB	—	—	4x64 GB	—	—	2400	8
768 GB	4x32 GB	4x32 GB	4x32 GB	4x32 GB	4x32 GB	4x32 GB	2133	24
1024 GB	4x64 GB	4x64 GB	—	4x64 GB	4x64 GB	—	2400	16
1536 GB	4x64 GB	4x64 GB	4x64 GB	4x64 GB	4x64 GB	4x64 GB	2133	24

Notes...

1. Rows marked in yellow indicate best performance.

Additional DIMM Populations

The list in [Table 28](#) is not a complete list of all supported DIMM populations, but highlights common configuration options.

Table 28 Supported DIMM Configurations

CPU 1 DIMMs	Total DIMMs for CPU 1	CPU 1 Capacity	CPU 2 DIMMs	Total DIMMs for CPU 2	CPU 2 Capacity	Total Capacity for 2 CPUs
1 x 8 GB ¹	1	8 GB	1 x 8 GB	1	8 GB	16 GB
2 x 8 GB ¹	2	16 GB	2 x 8 GB	2	16 GB	32 GB
1 x 16 GB	1	16 GB	1 x 16 GB	1	16 GB	32 GB
4 x 8 GB ¹	4	32 GB	4 x 8 GB	4	32 GB	64 GB
2 x 16 GB	2	32 GB	2 x 16 GB	2	32 GB	64 GB
1 x 32 GB	1	32 GB	1 x 32 GB	1	32 GB	64 GB
8 x 8 GB ¹	8	64 GB	8 x 8 GB	8	64 GB	128 GB
4 x 16 GB	4	64 GB	4 x 16 GB	4	64 GB	128 GB
2 x 32 GB	2	64 GB	2 x 32 GB	2	64 GB	128 GB
12 x 8 GB ¹	12	96 GB	12 x 8 GB	12	96 GB	192 GB
8 x 16 GB	8	128 GB	8 x 16 GB	8	128 GB	256 GB
4 x 32 GB	4	128 GB	4 x 32 GB	4	128 GB	256 GB
12 x 16 GB	12	192 GB	12 x 16 GB	12	192 GB	384 GB
8 x 32 GB	8	256 GB	8 x 32 GB	8	256 GB	512 GB
12 x 32 GB	12	384 GB	12 x 32 GB	12	384 GB	768 GB
12 x 64 GB	12	768 GB	12 x 64 GB	12	768 GB	1536 GB

Notes...

1. 8 GB DIMMs are to be used only with 2133-MHz v3 CPUs

Upgrade and Servicing-Related Parts

This section lists the upgrade and servicing-related parts you may need during the life of your UCS B200 M4 server. Some of these parts are configured with every server or with every UCS 5108 blade server chassis, and some may be ordered when needed or may be ordered and kept on hand as spares for future use. See [Table 29](#).

Table 29 Upgrade and Servicing-related Parts for UCS B200 M4 Server

Spare Product ID (PID)	Description
UCSB-LSTOR-BK=	2.5-inch HDD Blanking Panel ¹
N20-CBLKB1=	Blade slot blanking panel for UCS 5108/single slot ²
UCSB-HS-EP-M4-F=	CPU Heat Sink for UCS B200 M4 socket 1 (front) ¹
UCSB-HS-EP-M4-R=	CPU Heat Sink for UCS B200 M4 socket 1 (rear) ¹
UCS-CPU-LPCVR=	CPU load plate dust cover (for unpopulated CPU sockets)
UCSB-BAFF-B200-M4=	Air Baffle Replacement Kit for B200 M4 Server ¹
N20-MBLIBATT=	Replacement Lithium Battery for Server Motherboard (CR2032) ¹
N20-BKVM=	KVM local IO cable for UCS servers console port ²
UCS-CPU-GREASE3=	CPU thermal grease syringe - needed for heatsink seal ³
UCSX-HSCK=	UCS Processor Heat Sink Cleaning Kit (when replacing a CPU) ³
UCSB-GPU-M6= ⁴	UCS Blade Server M6 GPU - GRID 2.0 SW required for VDI

Notes...

1. This part is included/configured with your UCS server (in some cases, as determined by the configuration of your server).
2. This part is included/configured with the UCS 5108 blade server chassis.
3. This part is included with the purchase of each optional or spare Intel Xeon E5-2600 v3 or CPU processor kit.
4. The spare (PID UCSB-GPU-M6=) comes with a riser board and the necessary tool for installation. For further installation details, see

<http://www.cisco.com/c/en/us/support/servers-unified-computing/ucs-b-series-blade-servers/products-installation-guides-list.html>

Drive and Blade Server Blanking Panels

A drive blanking panel (UCSB-LSTOR-BK=) must be installed if you remove a disk drive from a UCS server. Similarly, a blade server blanking panel (N20-CBLKB1=) must be installed if you remove a half-width blade server (such as a UCS B200 M4 server) from a blade server chassis. If no FlexStorage RAID controller module or FlexStorage Passthrough Module (used in B200 M4 for VVMe-based PCIe SSD support) is used, the FlexStorage blanking panels (UCSB-LSTOR-BK=) must be installed. Two panels are used for servers with two drive bay openings. These panels are required to maintain system temperatures at safe operating levels, and to keep dust away from system components.

Adding an Additional CPU (with CPU heat sink) or Replacing CPUs

All Cisco UCS two CPU socket-capable servers can be upgraded from having one to having two CPUs configured or can also support replacement of the CPUs. You will need to order and install a heat sink when adding any additional CPU to a server. Instructions for installing the new CPU or replacing CPUs and heat sink can be found at the following link:

http://www.cisco.com/c/en/us/td/docs/unified_computing/ucs/hw/blade-servers/B200M4.html



NOTE: Unlike previous generation servers, the B200 M4 has tool-less CPU sockets, so no separate tools (such as “pick n place” tools) are required to add or replace CPUs.

Motherboard Lithium Battery

You can order a replacement motherboard battery. Installation instructions are found at this link:

http://www.cisco.com/c/en/us/td/docs/unified_computing/ucs/hw/blade-servers/B200M4.html

Thermal Grease (with syringe applicator) for CPU to Heatsink Seal

Thermal grease must be applied to the top of the CPU where it comes in contact with the heat sink (a grease syringe also ships with each CPU spare option kit). Instructions for applying thermal grease are found at:

http://www.cisco.com/c/en/us/td/docs/unified_computing/ucs/hw/blade-servers/B200M4.html



CAUTION: Use only the thermal grease specified for this server (UCS-CPU-GREASE3=). This thermal grease comes in a white-tipped syringe.

DO NOT use thermal grease available for purchase at any commercial electronics store. If these instructions are not followed, the CPU may overheat and be destroyed.



NOTE: When you purchase a spare CPU, the thermal grease with syringe applicator is included.

Air Baffle Replacement Kit

Air baffles are designed to direct airflow through the server to maintain server temperature at a safe operating level. The UCS B200 M4 server comes shipped with two identical air baffles covering the DIMM socket areas of the server. These baffles must always remain installed during server operation. The Air Baffle Replacement Kit includes the two (identical) air baffles needed for one UCS B200 M4 server. For instructions on how to remove and replace the air baffles, see the following link:

http://www.cisco.com/c/en/us/td/docs/unified_computing/ucs/hw/blade-servers/B200M4.html

CPU Heat Sink Cleaning Kit

The cleaning kit is used to remove the existing thermal compound from the bottom of the heat sink during a CPU replacement process. Instructions for cleaning are found at the following link:

http://www.cisco.com/c/en/us/td/docs/unified_computing/ucs/hw/blade-servers/B200M4.html



NOTE: When you purchase a spare CPU, the CPU cleaning kit is included.

NEBS Compliance

When configured with choices from the specific set of components shown in [Table 30](#), the UCS B200 M4 blade server meets Network Equipment Building Standards (NEBS) Level 1 and Level 3 compliance.

Table 30 B200 M4 NEBS Compliant Components

Component Category	Description	Product ID (PID)
Chassis	UCS 5108 Blade AC Chassis/0 PSU/8 fans/0 fabric extender	UCSB-5108-AC2
	UCS 5108 Blade DC Chassis/0 PSU/8 fans/0 fabric extender	UCSB-5108-DC2
Power Supply	2500 W Dual Voltage AC PSU	UCSB-PSU-2500ACDV
	2500W -48V DC PSU	UCSB-PSU-2500DC48
Fabric Extender	Cisco UCS 2208XP	UCS-IOM-2208XP
Blade Server	UCS B200 M4 Blade Server w/o CPU, memory, HDD, MLOM, or mezzanine adapters	UCSB-B200-M4
CPUs	Up to two CPUs: Intel Xeon 2.30 GHz E5-2699V3 145W 18C/45MB Cache/DDR3 2133MHz	UCS-CPU-E52699D
	Up to two CPUs: Intel Xeon 2.20 GHz E5-2658V3 105W 12C/30MB Cache/DDR3 2133MHz	UCS-CPU-E52658D
DIMMs	Up to 24: 16GB DDR4-2133-MHz RDIMM/PC3-17000/dual rank/x4	UCS-MR-1X162RU-A
	Up to 24: 8GB DDR4-2133-MHz RDIMM/PC3-17000/single rank/x4	UCS-MR-1X081RU-A
RAID Controller	Cisco FlexStorage 12G SAS RAID Controller & Drive Bays	UCSB-MRAID12G
HDDs	Up to two: 1.2 TB 6G SAS 10K RPM SFF HDD	UCS-HD12T10KS2-E
	Up to two: 300 GB 6 Gb SAS 15K RPM SFF HDD	UCS-HDD300GI2F105
	Up to two: 600 GB 6 Gb SAS 10K RPM SFF HDD	A03-D600GA2
mLOM Cards	Cisco UCS VIC 1240 adapter	UCSB-MLOM-40G-01
	Cisco UCS VIC 1340 modular LOM for blade servers	UCSB-MLOM-40G-03
Mezzanine Cards	Cisco UCS VIC 1380 mezzanine adapter	UCSB-VIC-M83-8P
	Cisco UCS Port Expander Card for VIC	UCSB-MLOM-PT-01

Network Connectivity

This section explains how the UCS B200 M4 server connects to Fabric Interconnects (FIs) using the network adapters in the UCS B200 M4 blade server and the Fabric Extender (FEX) modules in the UCS 5108 blade server chassis. The UCS B200 M4 server plugs into the front of the UCS 5108 blade server chassis. The Fabric Extender modules plug into the back of the UCS 5108 Series blade server chassis. A midplane connects the UCS B200 M4 blade server to the Fabric Extenders. *Figure 10* shows an example configuration where 4 x 10G KR ports are routed from the VIC 1340/1240 adapter to the Fabric Extender modules and the remaining 4 x 10G KR ports are routed from the mezzanine adapter to the Fabric Extender modules.

Note that you cannot mix VIC 13xx Series adapters with VIC 12xx Series adapters. For example, if you install a VIC 1340, you cannot install a VIC 1280. In this case, you must install a VIC 1380. Also, the VIC 13xx Series adapters are compatible with systems implementing 6200 and 6300 Series Fabric Interconnects, but 61xx Series FIs are not supported. All FIs are supported with the VIC 12xx Series adapters. 61xx/21xx Series FIs/FEXs are supported on the B200 M4, but only with the VIC 12xx Series adapters.

Figure 10 UCS B200 M4 Connections to the Fabric Extenders

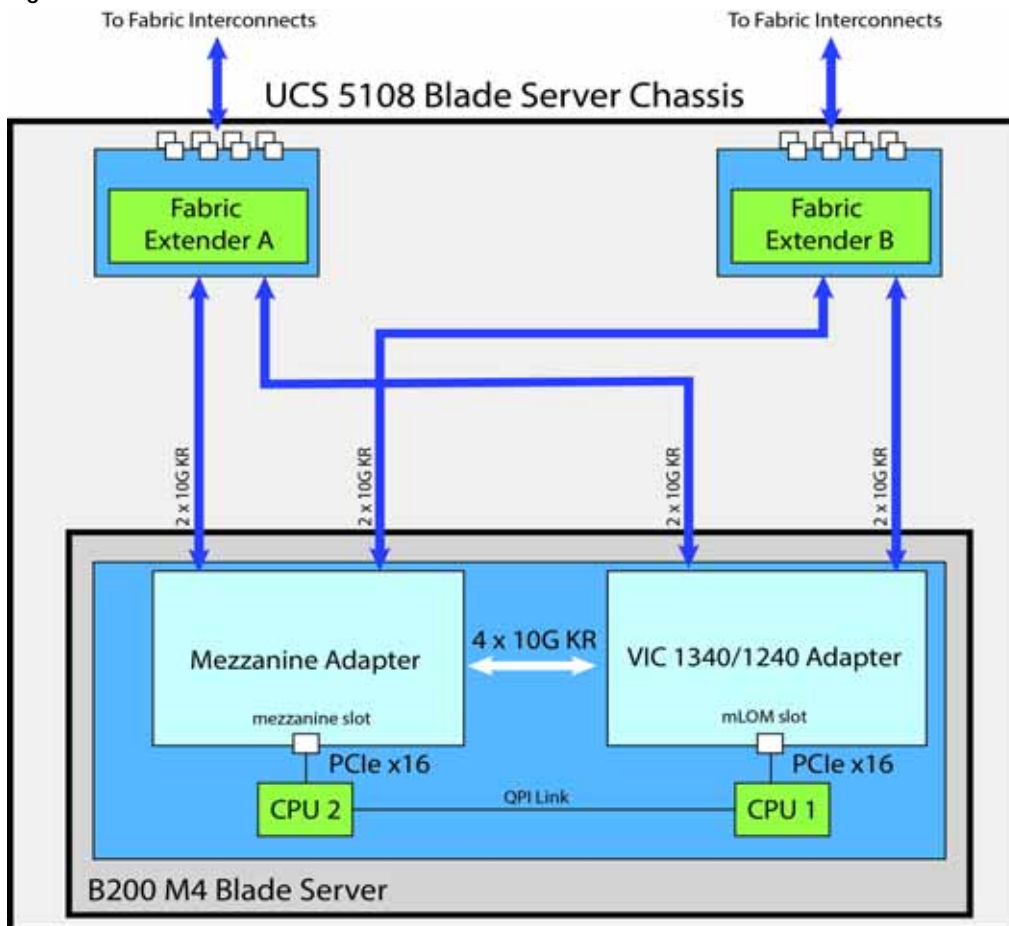

The B200 M4 server accommodates different types of adapter cards. The mLOM slot only accommodates the VIC 1240 and VIC 1340 adapters, while the mezzanine slot accommodates all other adapters (such as port expander, VIC 1280/1380, and Cisco adapters).

The network adapter options are:

- Cisco VIC 1340/1240 adapter. This adapter plugs into the mLOM slot. Both cards can support up to dual 4x10 Gbps ports (requires Port Expander for VIC) and 256 PCIe devices. The VIC 1340 is capable of supporting native 40 Gbps. The capabilities of the adapter can easily be expanded by using the Port Expander Card for VIC in the mezzanine slot.
- Cisco VIC 1380/1280 Mezzanine adapter. This adapter plugs into the mezzanine slot and is capable of up to dual 2x10 Gbps ports in the UCS B200 M4 server, depending on the Fabric Extender chosen (see [Table 10 on page 27](#)) and 256 PCIe devices.
- Cisco Port Expander Card for VIC. This I/O expander plugs into the mezzanine slot and enables additional bandwidth to and from the server with the VIC 1340/1240 (see [Table 10 on page 27](#)).
- Cisco Storage Accelerators or GPUs plug into the mezzanine slot. These devices do not have network connectivity; instead they provide independent high-speed storage or GPU processing power controlled by CPU 2. See [Table 9 on page 26](#) for descriptions.



NOTE: The bandwidth/port count on these adapters depends on the Fabric Extender. For example, the VIC 1380/1280 only supports up to 4x10 Gbps in this blade because each mezzanine slot (or mLOM slot) only supports up to 4x10 Gbps.

VIC 1340/1240 Adapter

The only adapter that can be plugged in to the mLOM slot is the VIC 1340/1240, Cisco-designed PCIe based adapters that provide up to eight (depending on the Fabric Extender option chosen) 10 Gigabit Data Center Ethernet (DCE) network interfaces.

There are two groups of four ports on the VIC 1340/1240. Two ports of the first group and two ports of the second group are wired through the UCS 5108 Blade Server chassis to Fabric Extender A and Fabric Extender B. The other two ports of each group are wired to the mezzanine slot, as represented in [Figure 11](#).

Figure 11 VIC 1340/1240 Port Connectivity

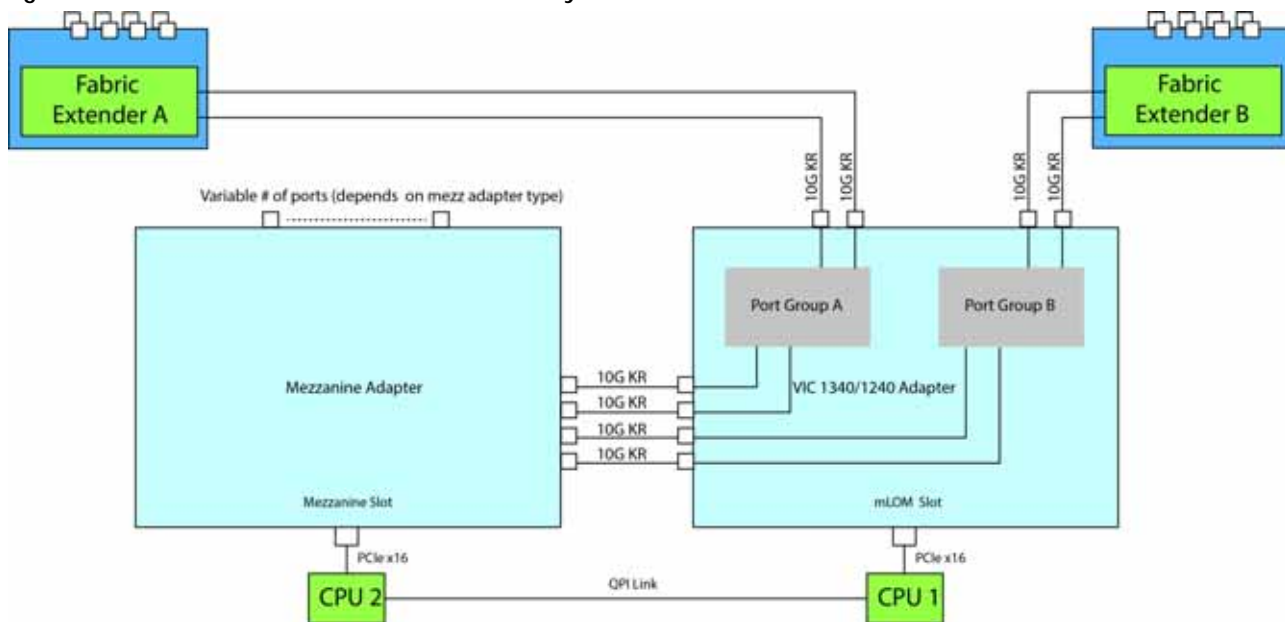

The number of ports available at the mezzanine adapter depends on the type of mezzanine adapter that is plugged into the mezzanine slot on the system board. The maximum number of ports is four. The VIC 1340/1240 senses the type of adapter plugged into the mezzanine slot. In the event a Port Expander Card for VIC occupies the mezzanine slot, the four 10G KR ports between the adapters are used for port expansion; otherwise, they are unused.

Mezzanine Adapters

There are multiple options for the mezzanine slot:

- I/O-based PCIe adapters (such as network adapters), or
- Cisco Storage Accelerator adapters (such as Fusion-io cards)
- GPUs



NOTE: In a B200 M4 configured with 1 or 2 CPUs, a UCS B200 M4 blade server must have a VIC 1340/1240 installed to provide I/O connectivity.

Specific examples of mezzanine adapters are:

- Cisco adapters
 - VIC 1380/1280
 - Port Expander Card for VIC
- Cisco Storage Accelerator adapters
 - Cisco UCS 1300 GB Fusion ioMemory3 PX Performance line
 - Cisco UCS 1600 GB Fusion ioMemory3 SX Scale line
- GPUs
 - UCSB-GPU-M6 (UCS Blade Server M6 GPU - GRID 2.0 SW required for VDI)

The following sections explain the various I/O options that are possible with the different Fabric Extenders (Cisco UCS 2304, 2208XP, 2204XP, and 2104XP) and the VIC 1340/1240 and mezzanine adapters.

B200 M4 Configured with 1 CPU

In a B200 M4 configured with 1 CPU, the mezzanine card slot is not under the control of a CPU (in a B200 M4 configured with 2 CPUs, CPU 2 controls that slot). Therefore, the only adapter that can be placed in the mezzanine slot in a B200 M4 configured with 1 CPU is the Cisco UCS Port Expander Card for VIC, and the VIC 1340/1240 is always required to be installed in the mLOM slot.

Connectivity using the Cisco UCS 2304 Fabric Extender

The Cisco UCS 2304 is the third-generation Fabric Extender, and shares the same form factor as the current UCS 2100 and 2200 Series. The 2304 is backwards compatible with the UCS 5108 Blade server chassis.

The options shown in *Figure 12*, *Figure 13*, and *Figure 14* demonstrate how the server uses these options:

- VIC 1340/1240 to 2304
- VIC 1240 plus Port Expander Card for VIC to 2304
- VIC 1340 plus Port Expander Card for VIC to 2304

In *Figure 12*, two ports from the VIC 1340/1240 are channeled to 2208XP Fabric Extender A and two are channeled to 2208XP Fabric Extender B. The result is 20 Gbps of bandwidth to each Fabric Extender.

Figure 12 Option 1 - VIC 1340/1240 to UCS 2304 Fabric Extender (no mezzanine adapter)

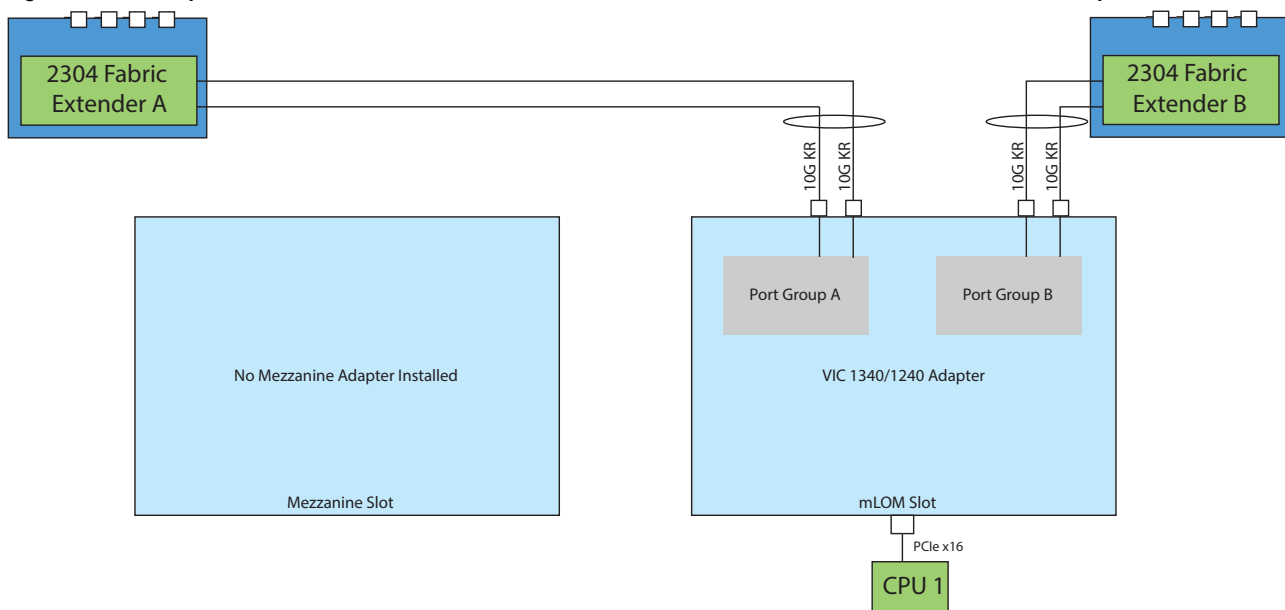

In *Figure 13*, two ports from the VIC 1240 are channeled to 2304 Fabric Extender A and two are channeled to 2304 Fabric Extender B. The Port Expander Card for VIC installed in the mezzanine slot acts as a pass-through device to channel two ports to each of the Fabric Extenders. The result is 40 Gbps of bandwidth to each Fabric Extender.

Figure 13 Option 2 - VIC 1240 and Port Expander Card for VIC to UCS 2304

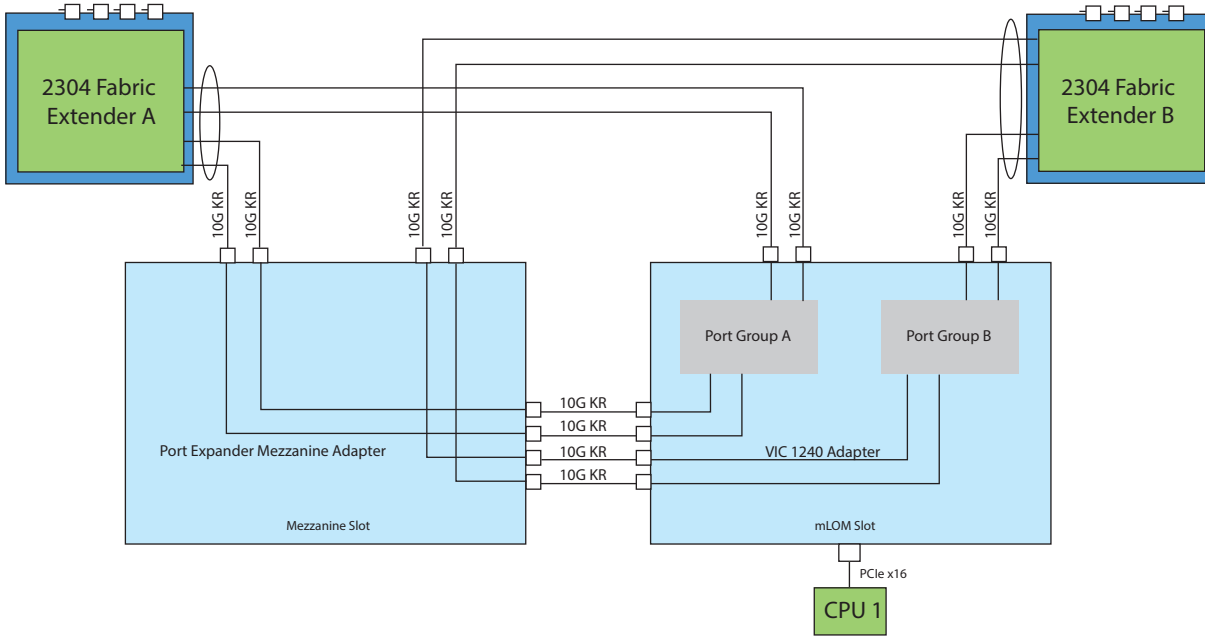

In *Figure 14*, two ports from the VIC 1340 are connected to 2304 Fabric Extender A and two are connected to 2304 Fabric Extender B. The Port Expander Card for VIC installed in the mezzanine slot acts as a pass-through device to provide two additional ports to each of the port groups and thus create a native 40G interface to each of the Fabric Extenders. The result is 40 Gbps of bandwidth to each Fabric Extender.

Figure 14 Option 3- VIC 1340 and Port Expander Card for VIC to UCS 2304

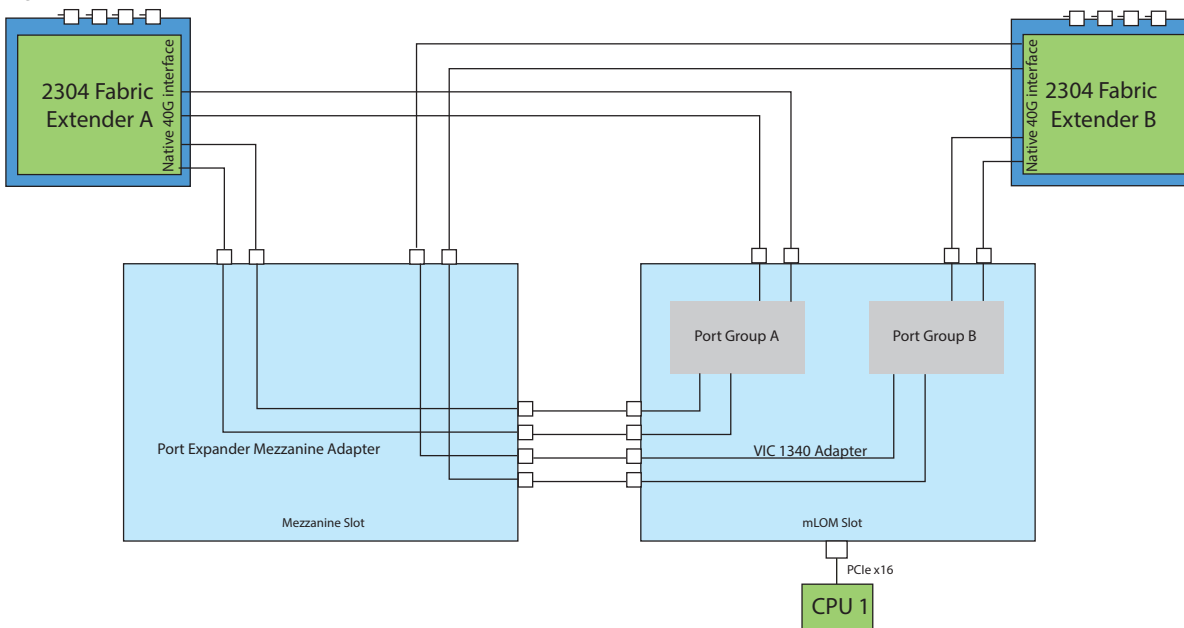

Connectivity using the Cisco UCS 2208XP Fabric Extender

The Cisco UCS 2208XP is the second-generation Fabric Extender, and shares the same form factor as the current UCS 2100 Series. The 2208XP is backwards compatible with the UCS 5108 Blade server chassis.

The options shown in *Figure 15* and *Figure 16* demonstrate how the server uses these options:

- VIC 1340/1240 to 2208XP
- VIC 1340/1240 plus Port Expander Card for VIC to 2208XP

In *Figure 15*, two ports from the VIC 1340/1240 are channeled to 2208XP Fabric Extender A and two are channeled to 2208XP Fabric Extender B. The result is 20 Gbps of bandwidth to each Fabric Extender.

Figure 15 Option 1 - VIC 1340/1240 to UCS 2208XP Fabric Extender (no mezzanine adapter)

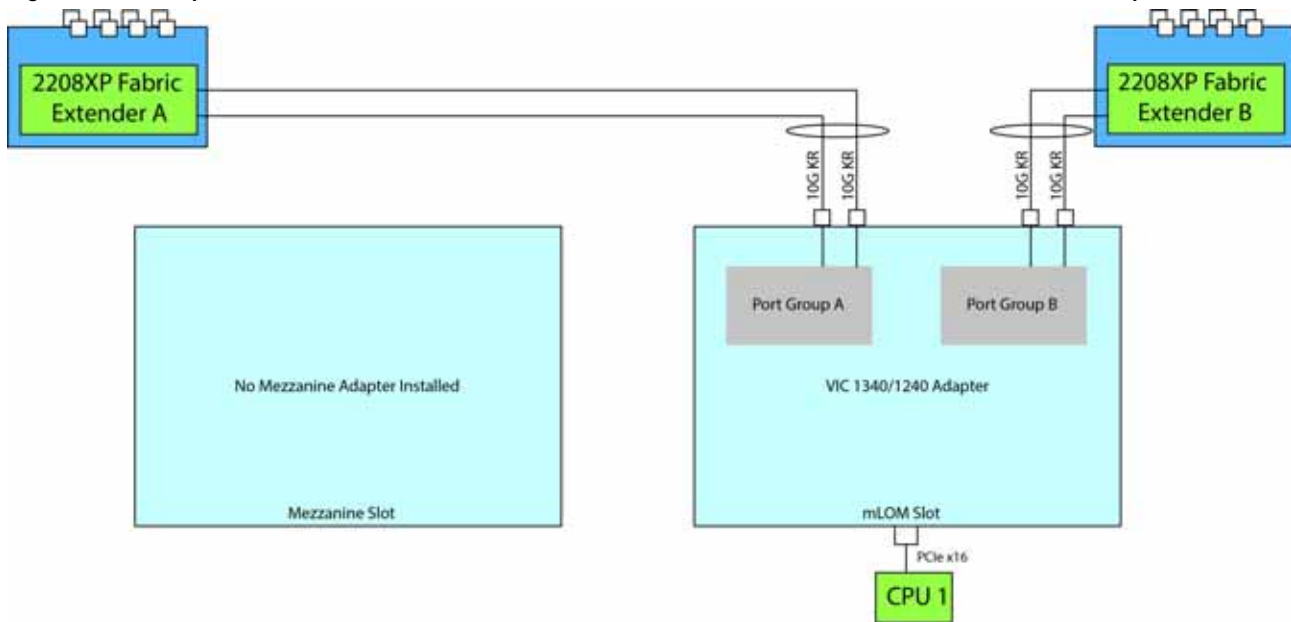

In *Figure 16*, two ports from the VIC 1340/1240 are channeled to 2208XP Fabric Extender A and two are channeled to 2208XP Fabric Extender B. The Port Expander Card for VIC installed in the mezzanine slot acts as a pass-through device to channel two ports to each of the Fabric Extenders. The result is 40 Gbps of bandwidth to each Fabric Extender.

Figure 16 Option 2 - VIC 1340/1240 and Port Expander Card for VIC to UCS 2208XP

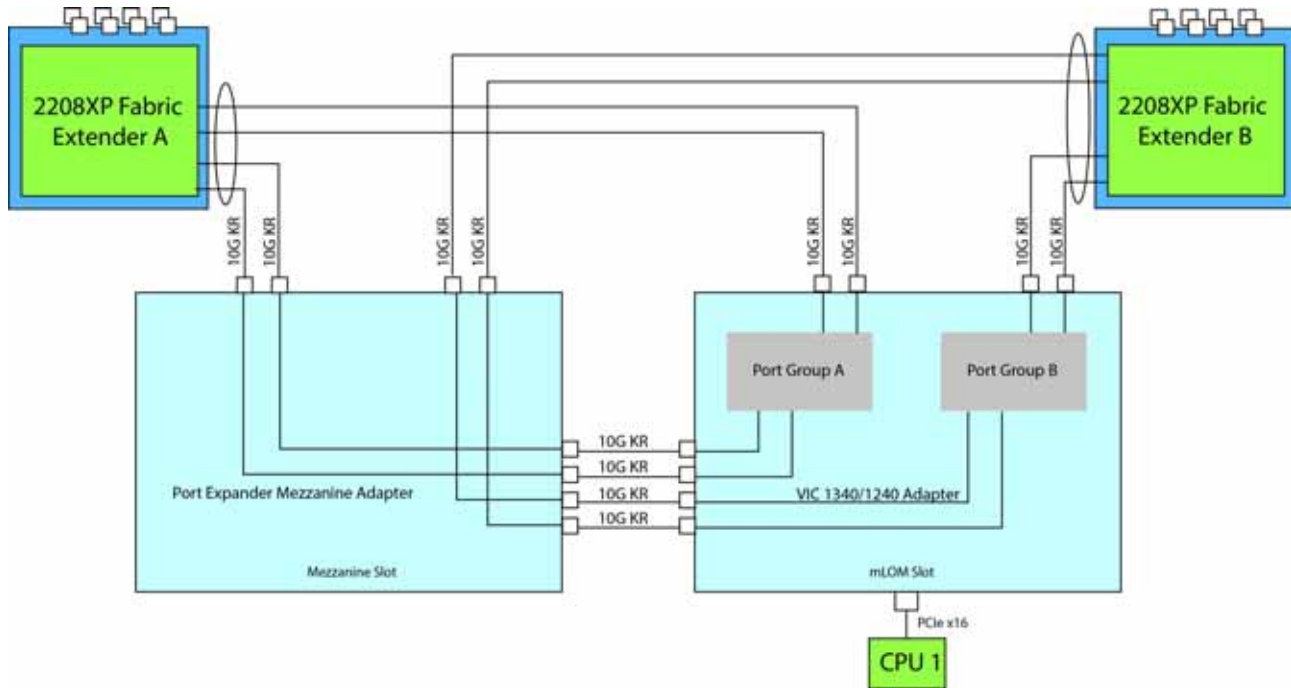

Connectivity using the Cisco UCS 2204XP Fabric Extender

The Cisco UCS 2204XP is a second-generation Fabric Extender, and shares the same form factor as the current UCS 2100 Series. The 2204XP is backwards compatible with the UCS 5108 Blade serve chassis.

The options shown in *Figure 17* and *Figure 18* demonstrate how the server uses these options:

- VIC 1340/1240 to 2204XP
- VIC 1340/1240 plus Port Expander Card for VIC to 2204XP

In *Figure 17*, one port from the VIC 1340/1240 is channeled to 2204XP Fabric Extender A and one is channeled to 2204XP Fabric Extender B. The result is 10 Gbps of bandwidth to each Fabric Extender.

Figure 17 Option 1 - VIC 1340/1240 to UCS 2204XP Fabric Extender (no mezzanine adapter)

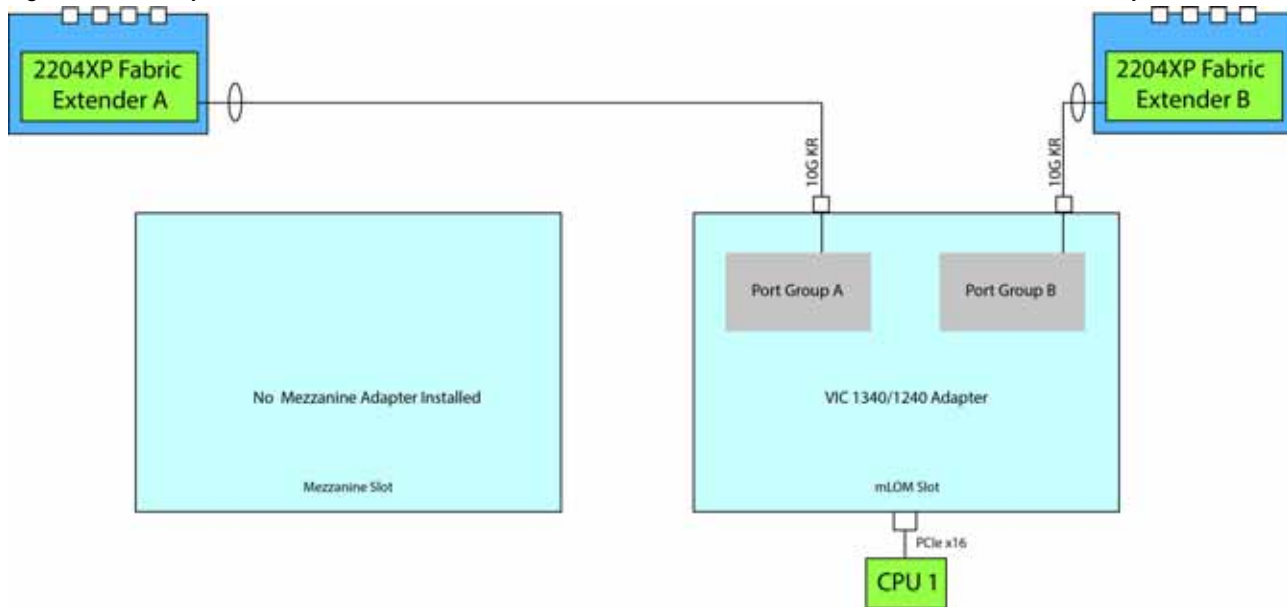

In *Figure 18*, one port from the VIC 1340/1240 is channeled to 2204XP Fabric Extender A and one is channeled to 2204XP Fabric Extender B. The Port Expander Card for VIC installed in the mezzanine slot acts as a pass-through device to channel one port to each of the Fabric Extenders. The result is 20 Gbps of bandwidth to each Fabric Extender.

Figure 18 Option 2 - VIC 1340/1240 and Port Expander Card for VIC to UCS 2204XP Fabric Extender

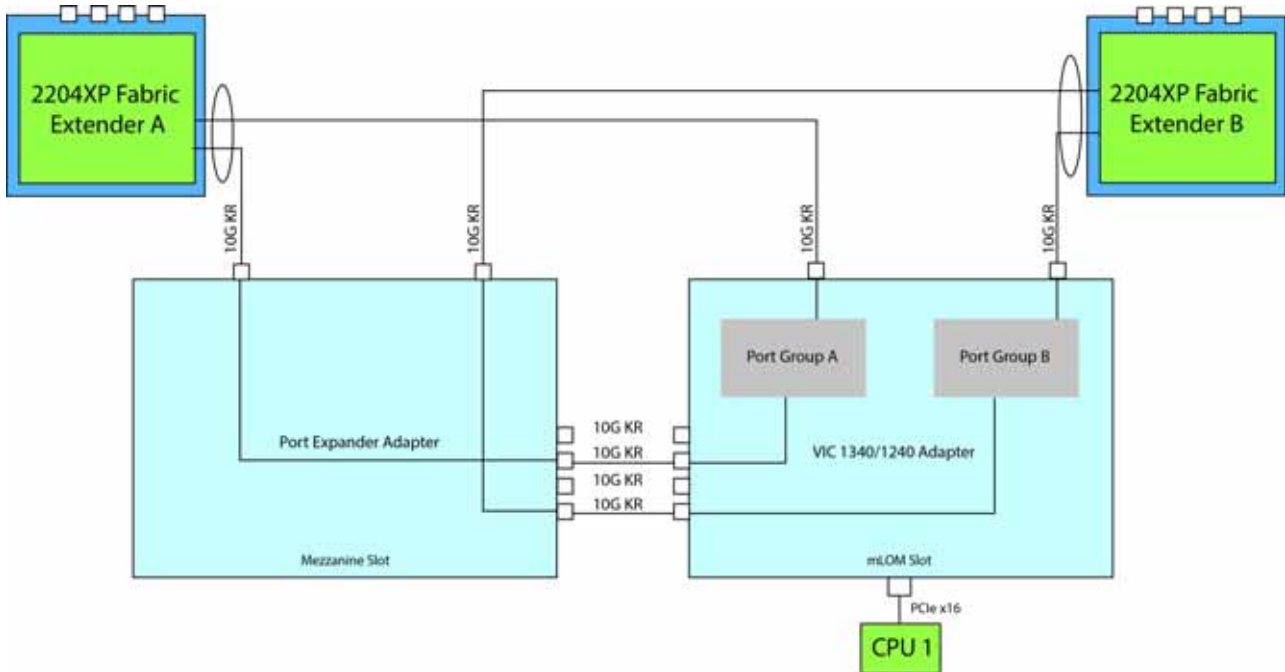

Connectivity using the Cisco UCS 2104XP Fabric Extender

The option shown in *Figure 19* demonstrates how the UCS B200 M4 blade server connects to a UCS 2104XP Fabric Extender.

In *Figure 19*, one port from the VIC 1240 is channeled to 2104XP Fabric Extender A and one is channeled to 2104XP Fabric Extender B. The result is 10 Gbps of bandwidth to each Fabric Extender.

Figure 19 Option 1 - VIC 1240 to UCS 2104XP Fabric Extender (no mezzanine adapter)

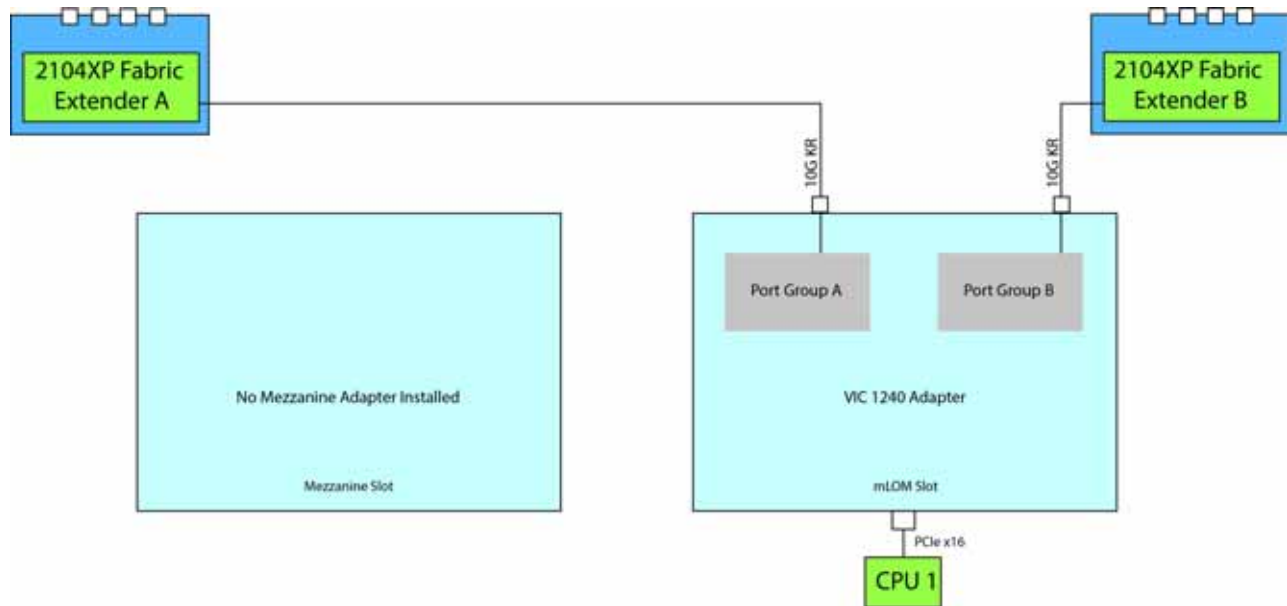

B200 M4 Configured with 2 CPUs

Connectivity using the Cisco UCS 2304 Fabric Extender

The Cisco UCS 2304 is the third-generation Fabric Extender, and shares the same form factor as the current UCS 2100 and 2200 Series. The 2304 is backwards compatible with the UCS 5108 Blade serve chassis.

The options shown in [Figure 20](#) through [Figure 23](#) demonstrate how the server uses these options:

- VIC 1340/1240 to 2304
- VIC 1340/1240 and VIC 1380/1280 to 2304
- VIC 1240 plus Port Expander Card for VIC to 2304
- VIC 1340 plus Port Expander Card for VIC to 2304



NOTE: A Cisco Storage Accelerator adapter or a GPU may also be plugged into the mezzanine adapter. There is no network connectivity for this kind of adapter; instead it provides high-speed storage to the system and is controlled by CPU 2.

In [Figure 20](#), two ports from the VIC 1340/1240 are channeled to 2304 Fabric Extender A and two are channeled to 2304 Fabric Extender B. The result is 20 Gbps of bandwidth to each Fabric Extender.

Figure 20 Option 1 - VIC 1340/1240 to UCS 2304 Fabric Extender (no mezzanine adapter)

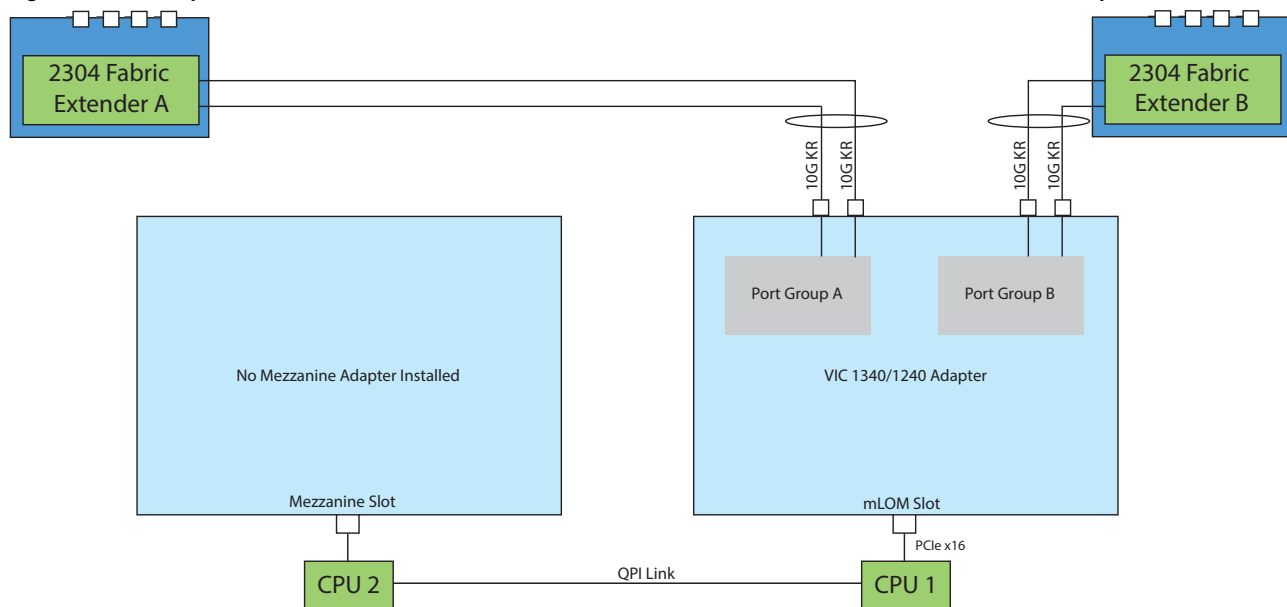

In *Figure 21*, two ports from the VIC 1340/1240 are channeled to 2304 Fabric Extender A and two are channeled to 2304 Fabric Extender B. The VIC 1380/1280 installed in the mezzanine slot also channels two ports to each of the Fabric Extenders. The result is 40 Gbps of bandwidth to each Fabric Extender.

Figure 21 Option 2 - VIC 1340/1240 and VIC 1380/1280 to UCS 2304 Fabric Extender

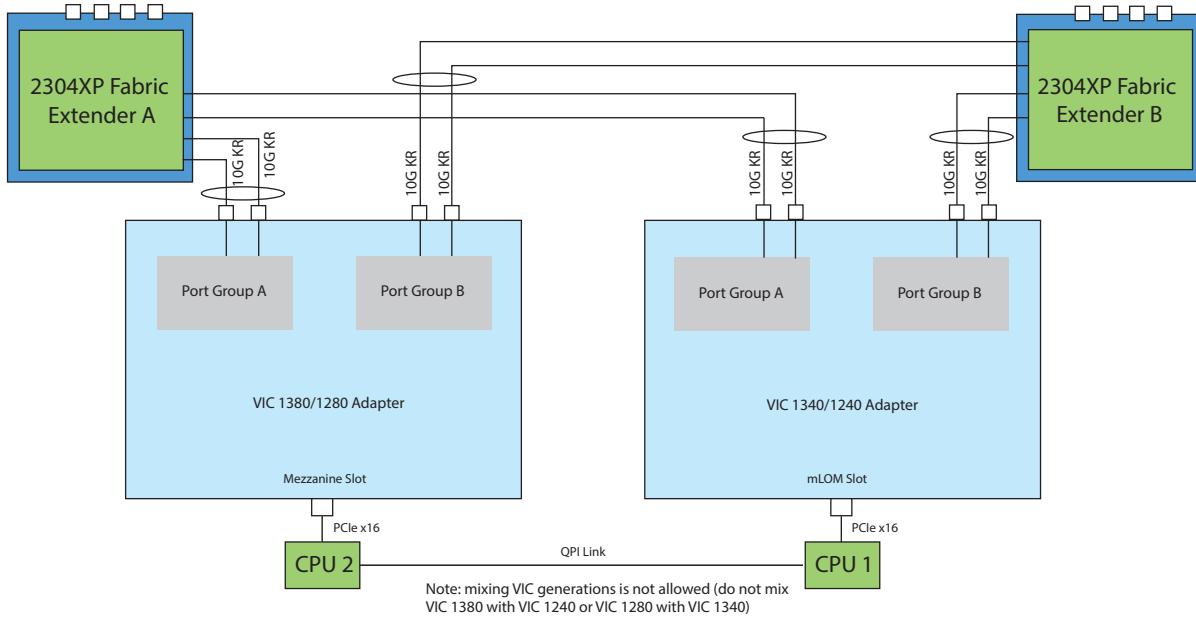

In *Figure 22*, two ports from the VIC 1240 are channeled to 2304 Fabric Extender A and two are channeled to 2304 Fabric Extender B. The Port Expander Card for VIC installed in the mezzanine slot acts as a pass-through device to channel two ports to each of the Fabric Extenders. The result is 40 Gbps of bandwidth to each Fabric Extender.

Figure 22 Option 3 - VIC 1240 and Port Expander Card for VIC to UCS 2304 FEX

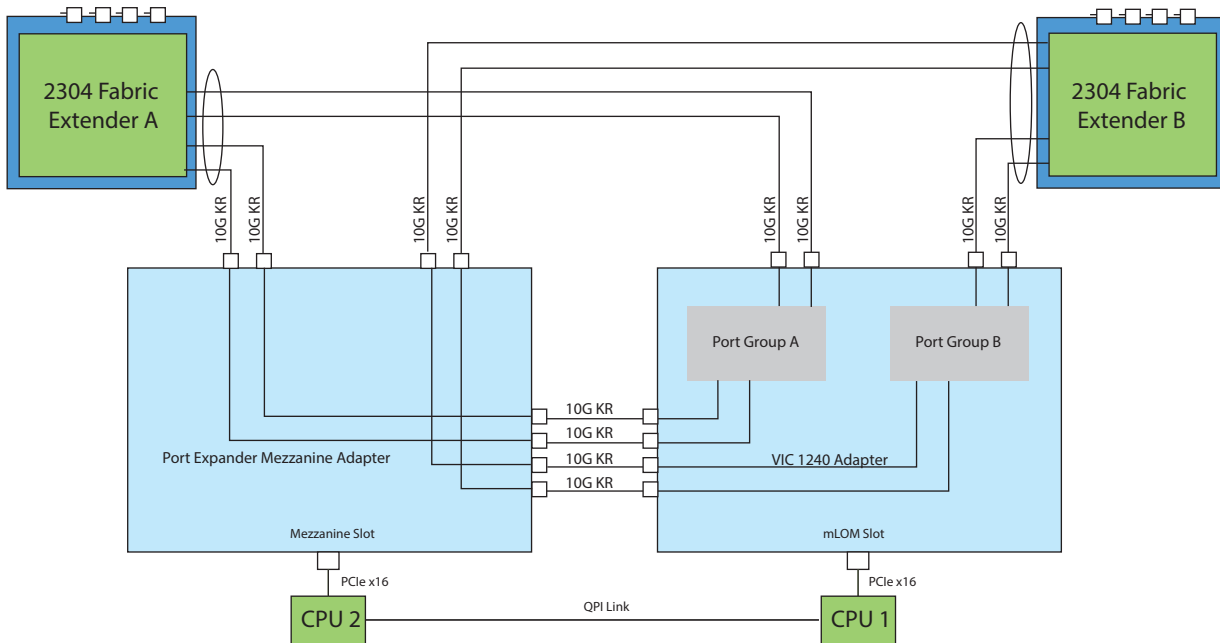

In *Figure 23*, two ports from the VIC 1340 are connected to 2304 Fabric Extender A and two are connected to 2304 Fabric Extender B. The Port Expander Card for VIC installed in the mezzanine slot acts as a pass-through device to provide two additional ports to each of the port groups and thus create a native 40G interface to each of the Fabric Extenders. The result is 40 Gbps of bandwidth to each Fabric Extender.

Figure 23 Option 4 - VIC 1340 and Port Expander Card for VIC to UCS 2304 FEX

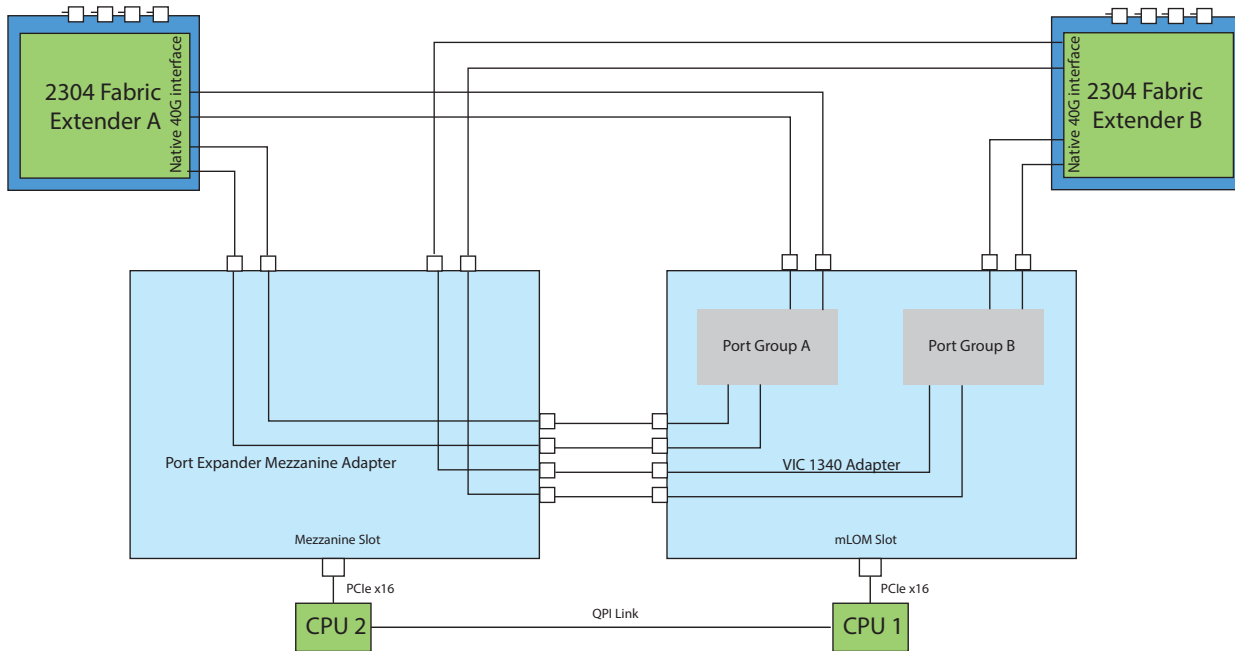

Connectivity using the Cisco UCS 2208XP Fabric Extender

The Cisco UCS 2208XP is the second-generation Fabric Extender, and shares the same form factor as the current UCS 2100 Series. The 2208XP is backwards compatible with the UCS 5108 Blade serve chassis.

The options shown in *Figure 24* through *Figure 26* demonstrate how the server uses these options:

- VIC 1340/1240 to 2208XP
- VIC 1340/1240 and VIC 1380/1280 to 2208XP
- VIC 1340/1240 plus Port Expander Card for VIC to 2208XP



NOTE: A Cisco Storage Accelerator adapter or a GPU may also be plugged into the mezzanine adapter. There is no network connectivity for this kind of adapter; instead it provides high-speed storage to the system and is controlled by CPU 2.

In *Figure 24*, two ports from the VIC 1340/1240 are channeled to 2208XP Fabric Extender A and two are channeled to 2208XP Fabric Extender B. The result is 20 Gbps of bandwidth to each Fabric Extender.

Figure 24 Option 1 - VIC 1340/1240 to UCS 2208XP Fabric Extender (no mezzanine adapter)

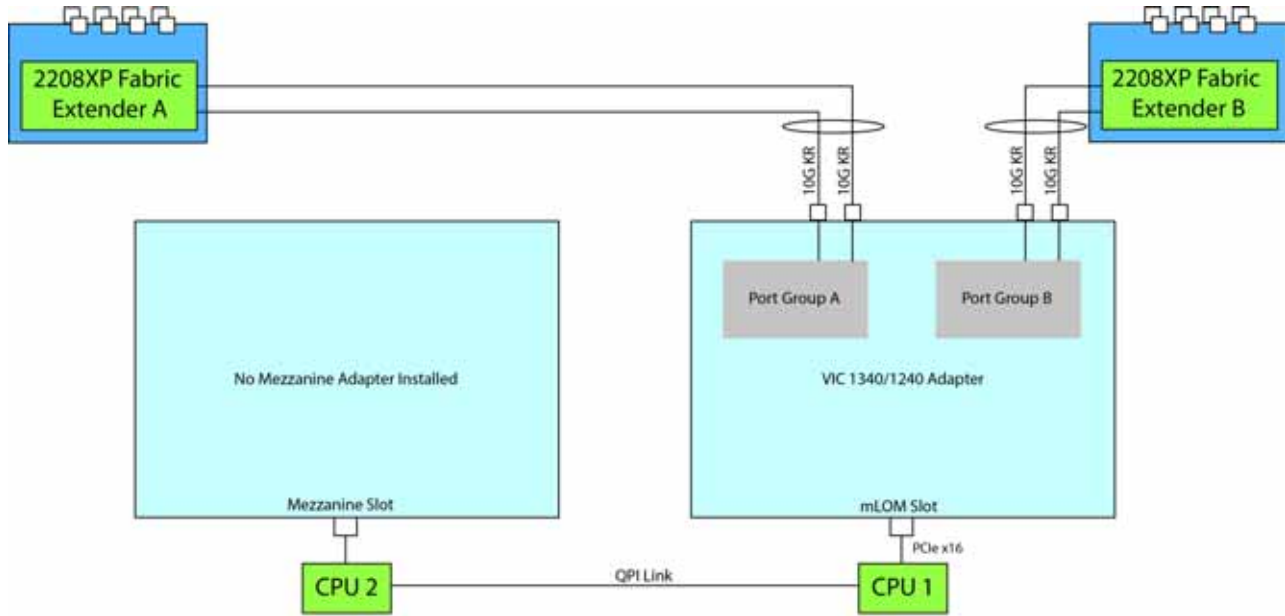

In *Figure 25*, two ports from the VIC 1340/1240 are channeled to 2208XP Fabric Extender A and two are channeled to 2208XP Fabric Extender B. The VIC 1380/1280 installed in the mezzanine slot also channels two ports to each of the Fabric Extenders. The result is 40 Gbps of bandwidth to each Fabric Extender.

Figure 25 Option 2 - VIC 1340/1240 and VIC 1380/1280 to UCS 2208XP Fabric Extender

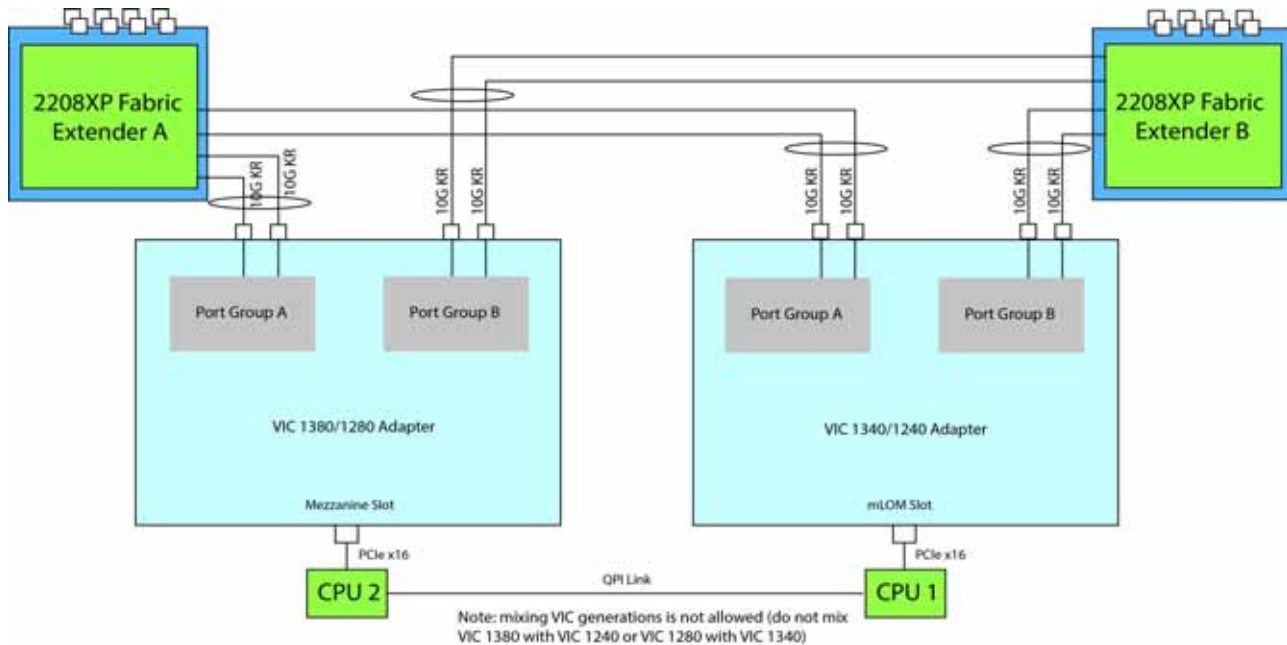

In *Figure 26*, two ports from the VIC 1340/1240 are channeled to 2208XP Fabric Extender A and two are channeled to 2208XP Fabric Extender B. The Port Expander Card for VIC installed in the mezzanine slot acts as a pass-through device to channel two ports to each of the Fabric Extenders. The result is 40 Gbps of bandwidth to each Fabric Extender.

Figure 26 Option 3 - VIC 1340/1240 and Port Expander Card for VIC to UCS 2208XP FEX

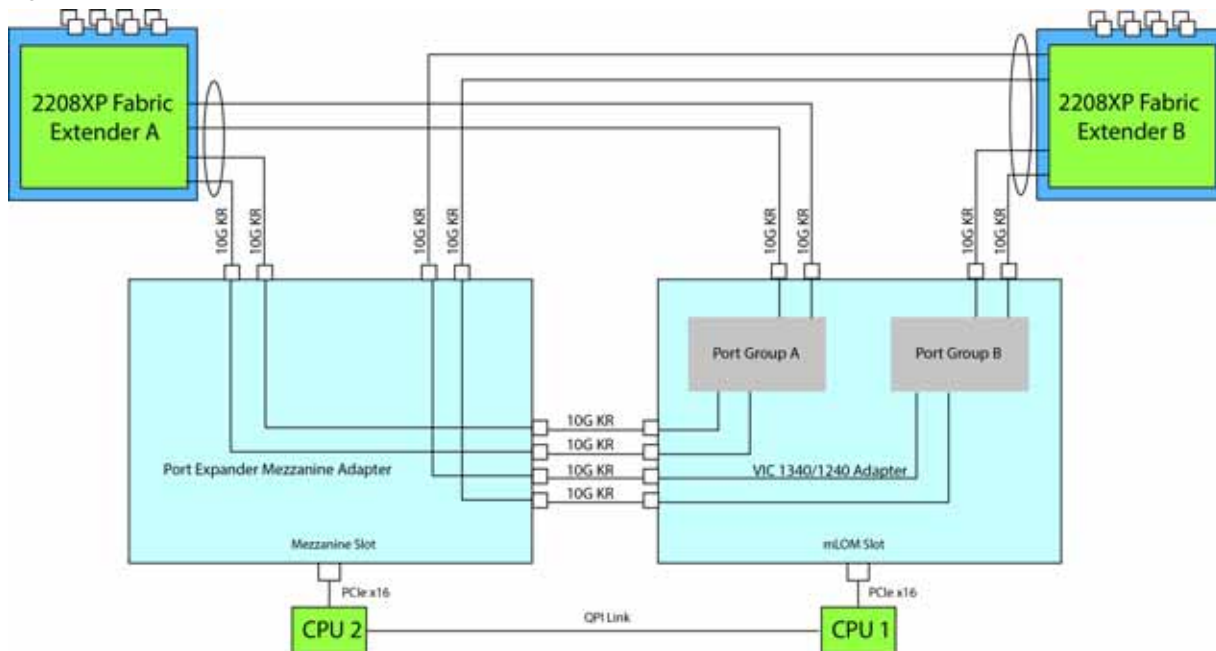

Connectivity using the Cisco UCS 2204XP Fabric Extender

The Cisco UCS 2204XP is a second-generation Fabric Extender, and shares the same form factor as the current UCS 2100 Series. The 2204XP is backwards compatible with the UCS 5108 Blade serve chassis.

The options shown in *Figure 27* through *Figure 29* demonstrate how the server uses these options:

- VIC 1340/1240 to 2204XP
- VIC 1340/1240 and VIC 1380/1280 to 2204XP
- VIC 1340/1240 plus Port Expander Card for VIC to 2204XP



NOTE: A Cisco Storage Accelerator adapter or GPU may also be plugged into the mezzanine adapter. There is no network connectivity for this kind of adapter; instead it provides high-speed storage or GPU processing power to the system and is controlled by CPU 2.

In *Figure 27*, one port from the VIC 1340/1240 is channeled to 2204XP Fabric Extender A and one is channeled to 2204XP Fabric Extender B. The result is 10 Gbps of bandwidth to each Fabric Extender.

Figure 27 Option 1 - VIC 1340/1240 to UCS 2204XP Fabric Extender (no mezzanine adapter)

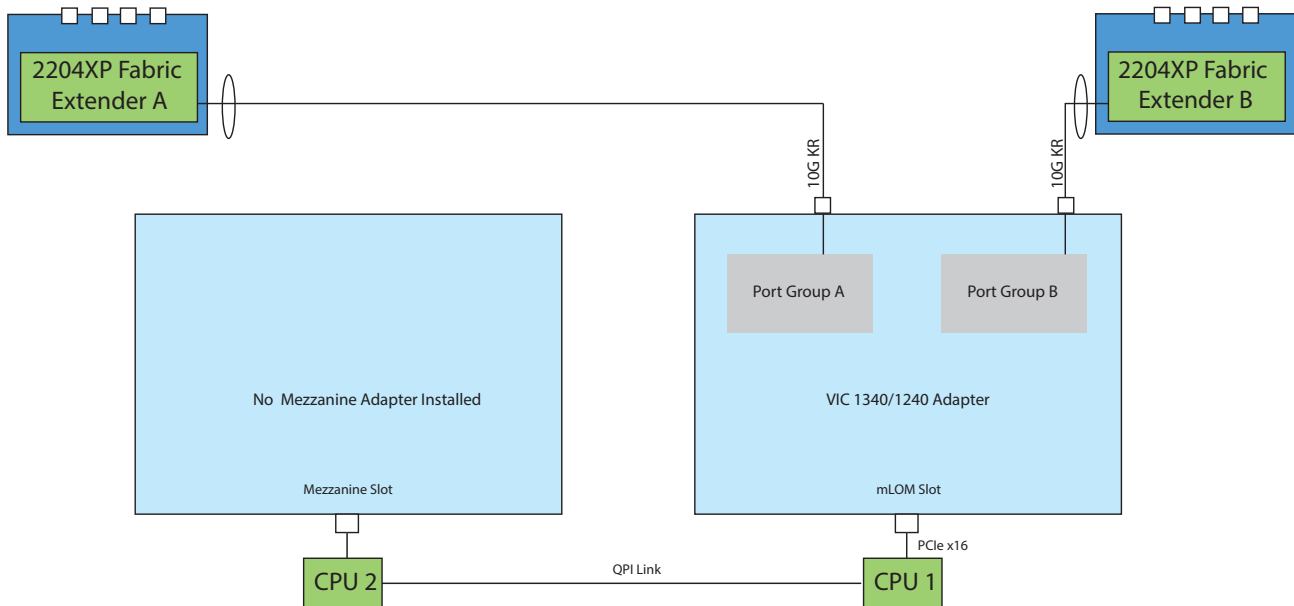

In *Figure 28*, one port from the VIC 1340/1240 is channelled to 2204XP Fabric Extender A and one is channelled to 2204XP Fabric Extender B. The VIC 1380/1280 installed in the mezzanine slot also channels one port to each of the Fabric Extenders. The result is 20 Gbps of bandwidth to each Fabric Extender.

Figure 28 Option 2 - VIC 1340/1240 and VIC 1380/1280 to UCS 2204XP Fabric Extender

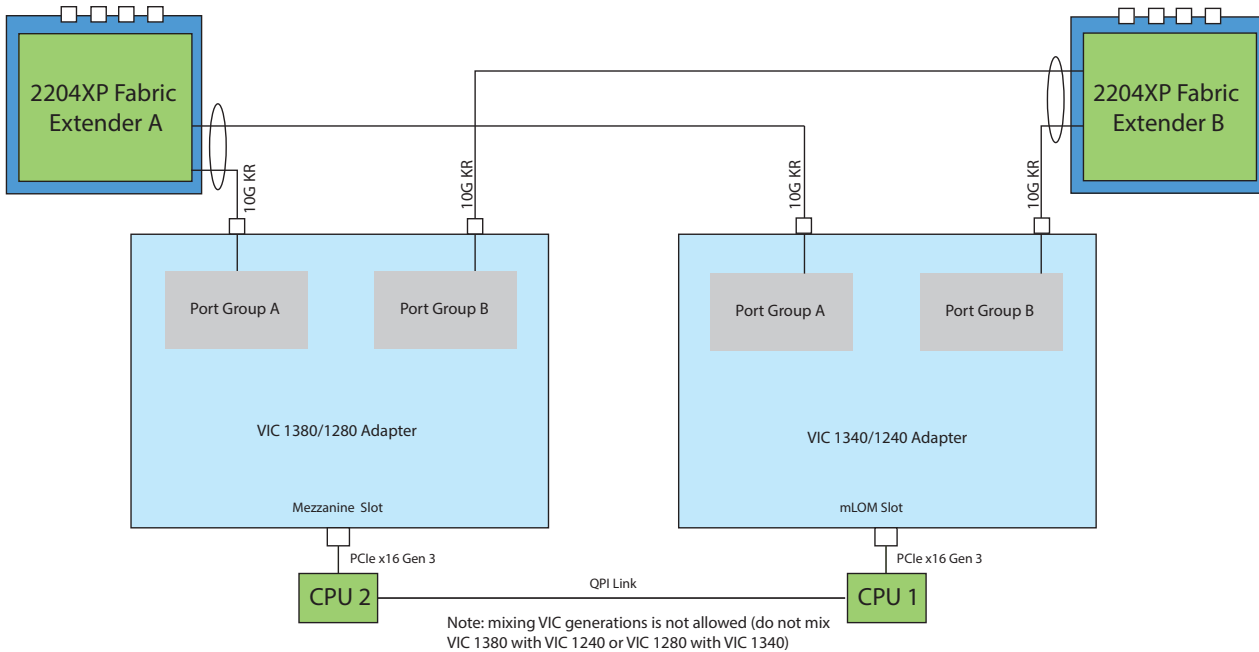

In *Figure 29*, one port from the VIC 1340/1240 is channelled to 2204XP Fabric Extender A and one is channelled to 2204XP Fabric Extender B. The Port Expander Card for VIC installed in the mezzanine slot acts as a pass-through device to channel one port to each of the Fabric Extenders. The result is 20 Gbps of bandwidth to each Fabric Extender.

Figure 29 Option 3 - VIC 1340/1240 and Port Expander Card for VIC to UCS 2204XP FEX

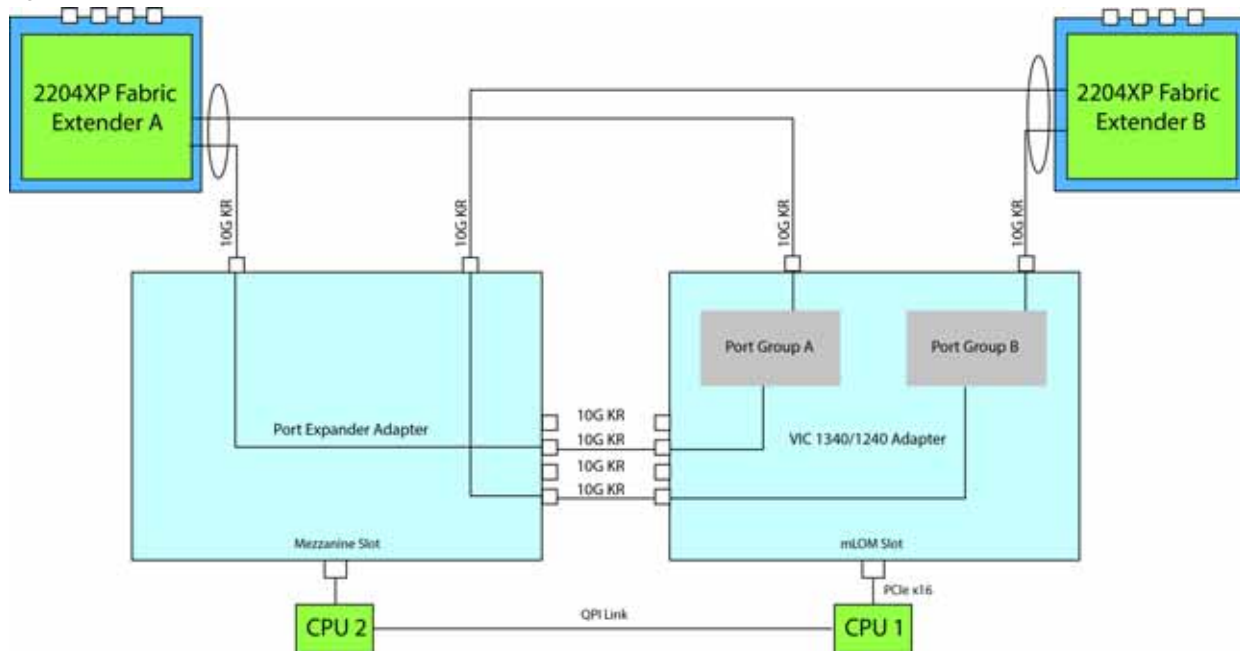

Connectivity using the Cisco UCS 2104XP Fabric Extender

The options shown in *Figure 30* and *Figure 31* demonstrate how the UCS B200 M4 blade server connects to a UCS 2104XP Fabric Extender. With this option, the mezzanine connector can either be empty or contain an independent Cisco Storage Accelerator adapter or GPU that communicates with CPU 2 through the PCIe bus.

In *Figure 30*, one port from the VIC 1240 is channeled to 2104XP Fabric Extender A and one is channeled to 2104XP Fabric Extender B. The result is 10 Gbps of bandwidth to each Fabric Extender. With this option, no adapter is located in the mezzanine connector.

Figure 30 Option 1 - VIC 1240 to UCS 2104XP Fabric Extender (no mezzanine adapter)

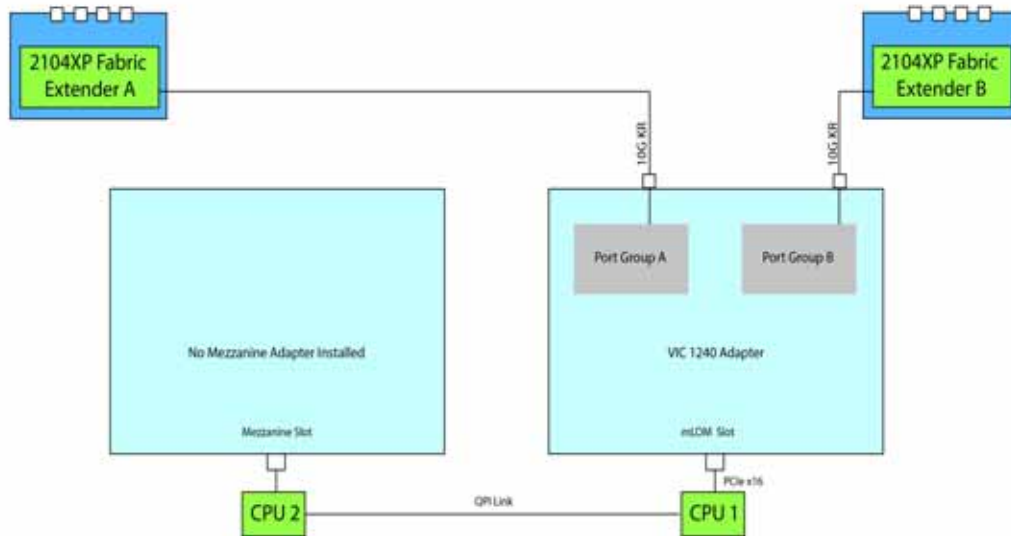

In *Figure 31*, one port from the VIC 1240 is channeled to 2104XP Fabric Extender A and one is channeled to 2104XP Fabric Extender B. The result is 10 Gbps of bandwidth to each Fabric Extender. The Cisco Storage Accelerator adapter or GPU is located in the mezzanine connector as an independent device controlled by CPU 2.

Figure 31 Option 2 - VIC 1240 to UCS 2104XP Fabric Extender (Cisco Storage Accelerator/GPU)

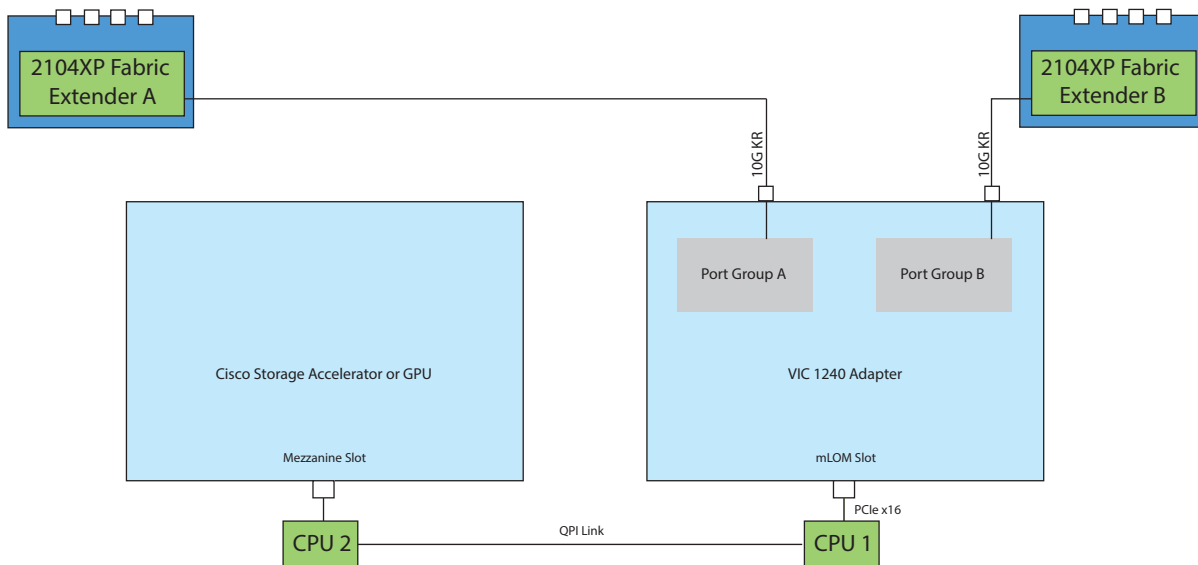

TECHNICAL SPECIFICATIONS

Dimensions and Weight

Table 31 UCS B200 M4 Dimensions and Weight

Parameter	Value
Height	1.95 in. (50 mm)
Width	8.00 in. (203 mm)
Depth	24.4 in. (620 mm)
Weight	<ul style="list-style-type: none">■ Base server weight (no HDDs, no CPUs, no DIMMs, no mezzanine adapters or memory) = 9.51 lbs (4.31 kg)■ Minimally configured server (no HDDs, 1 CPU, 8 DIMMs, VIC 1340/1240 but no mezzanine adapter) = 11.29 lbs (5.12 kg)■ Fully configured server (2 HDDs, 2 CPUs, 24 DIMMs, VIC 1340/1240 and mezzanine adapter both populated) = 15.98 lbs (7.25 kg)

Power Specifications

For configuration-specific power specifications, use the Cisco UCS Power Calculator at:

<http://ucspowercalc.cisco.com>



Americas Headquarters
Cisco Systems, Inc.
San Jose, CA

Asia Pacific Headquarters
Cisco Systems (USA) Pte. Ltd.
Singapore

Europe Headquarters
Cisco Systems International BV Amsterdam,
The Netherlands

Cisco has more than 200 offices worldwide. Addresses, phone numbers, and fax numbers are listed on the Cisco Website at www.cisco.com/go/offices.

Cisco and the Cisco Logo are trademarks of Cisco Systems, Inc. and/or its affiliates in the U.S. and other countries. A listing of Cisco's trademarks can be found at www.cisco.com/go/trademarks. Third party trademarks mentioned are the property of their respective owners. The use of the word partner does not imply a partnership relationship between Cisco and any other company. (1005R)