

TEKTRONIX®

7613/R7613
STORAGE
OSCILLOSCOPE
SERVICE

INSTRUCTION MANUAL

BEFORE READING

*PLEASE CHECK FOR CHANGE INFORMATION
AT THE REAR OF THIS MANUAL.*

THIS MANUAL REPRINTED OCT 1974

TEKTRONIX®

7613/R7613
STORAGE
OSCILLOSCOPE

SERVICE

INSTRUCTION MANUAL



WARRANTY

All TEKTRONIX instruments are warranted against defective materials and workmanship for one year. Any questions with respect to the warranty should be taken up with your TEKTRONIX Field Engineer or representative.

All requests for repairs and replacement parts should be directed to the TEKTRONIX Field Office or representative in your area. This will assure you the fastest possible service. Please include the instrument Type Number or Part Number and Serial Number with all requests for parts or service.

Specifications and price change privileges reserved.

Copyright © 1972 by Tektronix, Inc., Beaverton, Oregon. Printed in the United States of America. All rights reserved. Contents of this publication may not be reproduced in any form without permission of Tektronix, Inc.

U.S.A. and foreign TEKTRONIX products covered by U.S. and foreign patents and/or patents pending.

TEKTRONIX is a registered trademark of Tektronix, Inc.

TABLE OF CONTENTS

	Page
SECTION 1 OPERATING INFORMATION	1-1
Controls And Connectors	1-2
SECTION 2 CALIBRATION	2-1
Test Equipment Required	2-2, 2-3
Index to Calibration Procedure	2-4
SECTION 3 CIRCUIT DESCRIPTION	3-1
Block Diagram of 7613	3-2
Basic Storage Block Diagram	3-50
SECTION 4 MAINTENANCE	4-1
Preventive Maintenance	4-1
Circuit Board Locator	4-4, 4-5
Troubleshooting Chart	4-9
Corrective Maintenance	4-10
SECTION 5 ELECTRICAL PARTS LIST	
SECTION 6 DIAGRAMS	
SECTION 7 MECHANICAL PARTS LIST	



The TEKTRONIX 7613 Storage Oscilloscope is a solid-state, light-weight instrument designed for general purpose applications. This instrument has three plug-in compartments that accept TEKTRONIX 7000-Series plug-in units to form a complete measurement system. The two plug-in compartments on the left are for vertical preamplifiers. The right plug-in compartment is connected to the horizontal deflection system. Electronic switching is used to connect either vertical plug-in to the vertical deflection system. It is possible to alternately display the vertical signals (multi-trace display). The flexibility of this plug-in feature and variety of plug-in units available allow this system to be used for many measurement applications.

This instrument features a large screen, 8 X 10 division display; each division equals 0.9 centimeter. The Cathode ray tube (CRT) provides small spot size and a fast storage writing speed. Storage operation uses a variable Persistence mode and a Save mode. The variable Persistence mode electrically controls the retention of the CRT. The Save mode provides longer retention of the stored display, and a lockout function to prevent accidental erasure of the stored display.



OPERATING INFORMATION

The 7613/R7613 can be operated from either a 110-volt or a 220-volt line source. In addition, three operating ranges can be selected by a jumper located on the Rectifier board. Select a range which is centered about the average line voltage to which the instrument is connected.

See Table 1-1 for ranges and proper fuses.

TABLE 1-1
Regulating Range and Fuse Data

Pins Selected	Regulating Range	
	110-volt nominal	220-volt nominal
LOW	90 to 110 volts	180 to 220 volts
MED	99 to 121 volts	198 to 242 volts
HI	108 to 132 volts	218 to 262 volts
Line fuse	3.2 A slow-blow	1.6 A slow-blow

The 7613 can be operated where the ambient air temperature is between 0° and +50°C. The instrument is cooled by forced air. Adequate clearance must be provided on back and bottom of the instrument. The R7613 is cooled by forced air. Adequate clearance must be provided behind the air filter and on the right side. A thermal cutout in the instrument provides thermal protection by interrupting the power to the instrument if the internal temperature exceeds a safe operating level.

OPERATING SET-UP INFORMATION

INTENSITY	Midrange
READOUT	Midrange
FOCUS	Well defined display
STORED INTENSITY	Midrange
PERSISTENCE	Midrange
SAVE TIME	Clockwise
STORE	Out (release)
SAVE	Out (release)
NON-STORE	In (pressed in)
VERT MODE	LEFT (pressed in)
TRIG SOURCE	VERT MODE
GRATICULE ILLUM	As desired
POWER	On (pulled out)

Display Modes

Install two vertical plug-in units into the vertical compartments. Set the deflection factor for two volts/division. Connect the 4 V calibrator signal to both vertical plug-in units. Use a pin jack to BNC connector and a dual input coupler connector. Install a time-base plug-in unit in the horizontal compartment. Set the time/division switch to 0.5 millisecond/division, and adjust the trigger level for a stable display. The left vertical signal is displayed.

Press the RIGHT button of the VERT MODE switch. The display should be stable for either vertical unit selected.

Press the ALT button of the VERT MODE switch. Adjust the position controls of each vertical unit so that two displays are present on the CRT screen. One vertical signal is displayed per sweep and the other vertical signal is displayed at the next sweep. This is a dual trace mode.

Press the CHOP button of the VERT MODE switch. A dual trace will be displayed on the CRT screen. Each vertical signal is displayed during the sweep, on a time-sharing basis.

Press the ADD button of the VERT MODE switch. The display is the algebraic sum of both vertical signals.

Stored Displays

Obtain a display by following the instructions under OPERATING SET-UP INFORMATION and Display Modes.

Press the STORE button, the instrument is in the variable persistence mode. Change the vertical position, and note that the stored display will fade out and the new position will be stored. The time that a display is stored on the screen of the CRT is controlled by the PERSISTENCE control (clockwise decreases the retention).

Press the SAVE button. All functions are locked out except the SAVE TIME control and the STORED INTENSITY control. The STORED INTENSITY controls the brightness of the stored display. The SAVE TIME controls the length of time that a display is stored. When the SAVE TIME control is at MAX and in the switch detent (minimum intensity) the display is not visible. Turning the SAVE TIME control clockwise will make the stored display visible, but will reduce the storage time. While in the MAX save mode, the stored information will remain stored for long periods of time even with the power turned off. Turn the instrument on, and adjust the SAVE TIME control setting for a visible display.

Care of Storage Screen

1. Use minimum beam intensity to produce a clear well defined display.
2. Avoid repeated use of the same area of the CRT.
3. Do not leave a stored display on the screen when it is no longer needed.
4. Use MAX SAVE when storing a display for extended periods of time (minimum intensity).
5. Operate in the NON-STORE mode unless storage is required.

BEAM FINDER

The BEAM FINDER switch provides a means of locating a display which overscans the viewing area.

Press and hold the BEAM FINDER switch in. Increase the vertical and horizontal deflection factors until the display is reduced to about two divisions, and adjust the horizontal and vertical position control settings to center the display. Release the switch for normal operation.

For more detailed operating instructions see the 7613/R7613 Operators Manual.

FUNCTIONS OF CONTROLS AND CONNECTORS

FRONT PANEL

1. INTENSITY—Controls brightness of the display. Control is inoperative when horizontal compartment is vacant.
2. READOUT—Turns on the readout display and controls the readout intensity.
3. FOCUS—Provides adjustment for optimum display definition.
4. GRATICULE ILLUM—Controls graticule illumination.
5. BEAM FINDER—When pressed, the display is limited within the graticule area.
6. TRIG SOURCE—Selects source of internal trigger signal for the time base plug-in in the horizontal compartment.

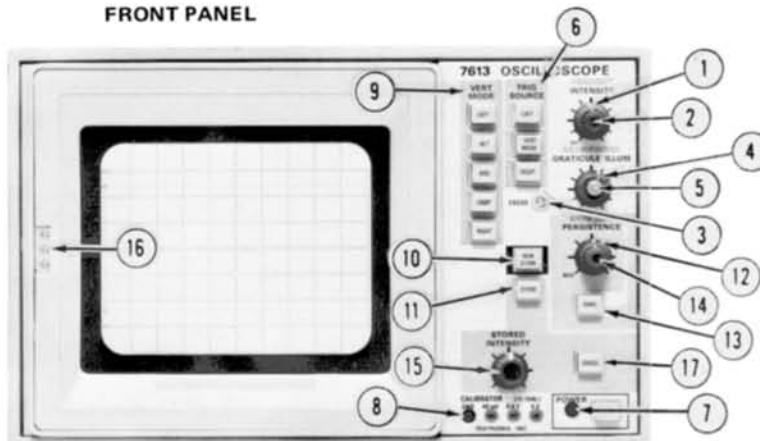

LEFT: The trigger signal is obtained from the plug-in unit in the left vertical compartment only.

VERT MODE: Trigger signal automatically follows the vertical display except in CHOP and ADD; then the trigger signal is the algebraic sum of the signals from the left and right vertical compartments.

RIGHT: The trigger signal is obtained from the plug-in unit in the right vertical compartment only.

7. POWER—Switch controls the power to the instrument. Light indicates that the power switch is on and that the instrument is connected to a line voltage source.
8. CALIBRATOR—Calibrator output pin jacks (4 V, 0.4 V, 40 mV, and ground). Positive-going pulse or DC voltage selected by changing internal jumper.
9. VERT MODE—Selects vertical mode of operation.

LEFT: Signals from plug-in unit in left vertical compartment are displayed.

ALT: Signals from both plug-in units in both the left and right vertical compartments are displayed (dual trace). Display switches between vertical plug-in units after each sweep.

ADD: Signals from plug-in units in both the left and right

vertical compartments are algebraically added and the sum is displayed on the CRT.

CHOP: Signals from plug-in units in both the left and right vertical compartments are displayed (dual trace). The display is switched between vertical plug-in units at approximately a one megahertz rate.

RIGHT: Signals from plug-in unit in right vertical compartment is displayed.

10. NON-STORE—Selects non-store operation.
11. STORE—Selects storage operation.
12. PERSISTENCE—Controls the retention of the stored display.
13. SAVE—Prevents accidental erasure or additional storage of information.
14. SAVE TIME—Used with the SAVE mode for extending retention. When in the MAX detent there is no visible stored display in all storage modes.
15. STORED INTENSITY—Selects stored writing speed and view time combination (controls brightness of stored display).
16. Camera Power (Not Labeled)—Three-pin connector on CRT bezel provides power output (+15 V). Receives remote single sweep reset signal from compatible camera systems, and a ground pin connection.
17. ERASE—Erases stored display.

REAR PANEL

1. FUSE—Line voltage fuse.
2. REMOTE ERASE IN—Provides external connection for remote erase.
3. EXT SS RESET IN—Remote single sweep reset.
4. EXT Z AXIS IN—Input for intensity modulation of the CRT display.
5. VERT SIG OUT—Vertical signal selected by TRIG SOURCE switch (LEFT, RIGHT, ALT and ADD).
6. +GATE OUT—Gate signal selected by gate selector switch (Main, Auxiliary, and Delay).
7. +SAWTOOTH OUT—Positive-going sawtooth from time-base unit.

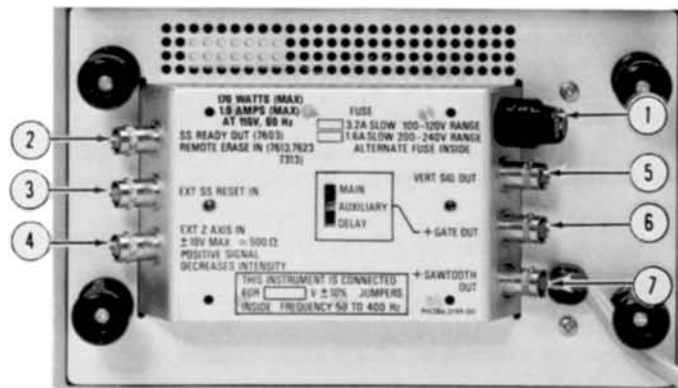

CALIBRATION

Calibration Interval

To assure instrument accuracy, check the calibration of the 7613 every 1000 hours of operation, or every six months if used infrequently. Before complete calibration, thoroughly clean and inspect this instrument as outlined in the Maintenance section.

TEKTRONIX Field Service

Tektronix, Inc. provides complete instrument repair and recalibration at local Field Service Centers and the Factory Service Center. Contact your local TEKTRONIX Field Office or representative for further information.

Using This Procedure

General. This section provides several features to facilitate calibration of the 7613. These are:

Index. An index is given preceding the calibration procedure to aid in locating a step.

Partial Procedure. A partial calibration is often desirable after replacing components, or to touch up the adjustment of a portion of the instrument between major recalibrations. To calibrate only part of the instrument, set the controls as given under Preliminary Control Settings and start with the nearest Equipment Required list preceding the desired portion. To prevent unnecessary recalibration of other parts of the instrument, re-adjust only if the tolerance given in the CHECK- part of the step is not met. If re-adjustment is necessary, also check the calibration of any steps listed in the INTERACTION- part of the step.

Complete Calibration Procedure. Completion of each step in the following calibration procedure insures that this instrument is both correctly adjusted and performing within all given tolerances.

IMPORTANT NOTE

All waveforms shown in this section were taken with a TEKTRONIX Oscilloscope Camera System, unless noted otherwise.

TEST EQUIPMENT REQUIRED

General

The test equipment and accessories, or its equivalent, given in the Test Equipment table is required for complete

calibration of the 7613. Specifications given for the test equipment are the minimum necessary for accurate calibration. Therefore, the specifications of any test equipment used must meet or exceed the listed specifications. All test equipment is assumed to be correctly calibrated and operating within the listed specification. Detailed operating instructions for the test equipment are not given in this procedure. Refer to the instruction manual for the test equipment if more information is needed.

Special Calibration Fixtures

Special TEKTRONIX calibration fixtures are used in this procedure only where they facilitate instrument calibration. These special calibration fixtures are available from Tektronix, Inc. Order by part number through your local TEKTRONIX Field Office or representative.

Calibration Equipment Alternatives

All of the listed test equipment is required to completely check and adjust this instrument. This Calibration procedure is based on the first item of equipment given as an example of applicable equipment. When other equipment is substituted, control settings or calibration setup may need to be altered slightly to meet the requirements of the substitute equipment. If the exact item of test equipment given as an example in the Test Equipment table is not available, first check the Specifications column carefully to see if any other equipment is available which might suffice. Then check the Usage column to see what this item of test equipment is used for. If used for a check or adjustment which is of little or no importance to your measurement requirements, the item and corresponding step(s) can be deleted.

The following procedure is written to completely check and adjust the 7613 to the limits given in Section 2 of the Operators Manual and to allow interchanging 7000-series plug-in units between 7000-series mainframes without the need to recalibrate the instruments each time. If the applications for which you will use the 7613 do not require the full available performance from the 7613/plug-in combination, this procedure and the required equipment list can be shortened accordingly. For example, the basic measurement capabilities of this instrument can be verified by checking vertical deflection accuracy, vertical square-wave response, and basic horizontal timing with 7000-series real-time plug-in units and an accurate square wave signal. Also, if the 7613/plug-in combination is to be used as a fixed system without the need to interchange plug-in units, all tests can be made by substituting vertical plug-in units and applicable test signals for the 067-0587-01 mainframe standardizer calibration fixture.

TEST EQUIPMENT

Description	Minimum Specifications	Usage	Examples of Applicable Test Equipment
1. Precision DC voltmeter	Range, zero to 150 volts; accuracy, within 0.2%.	Calibrator output accuracy check and adjustment. Low-voltage power supply adjustment.	a. TEKTRONIX 7D13 Digital Multimeter (test oscilloscope must have Readout System). b. Fluke Model 825A Differential DC Voltmeter.
2. DC voltmeter (VOM)	Range, zero to 4000 volts; accuracy, checked to within 1% at -1500 volts.	High-voltage power supply check. Z-axis DC levels adjustment.	a. Triplet Model 630-NA. b. Simpson Model 262.
3. Time-mark generator	Marker outputs, 10 nanoseconds to 0.1 second; marker accuracy, within 0.1%. Trigger output, one millisecond.	CRT geometry check and adjustment. Horizontal timing check and adjustment.	a. TEKTRONIX 2901 Time-Mark Generator. b. TEKTRONIX 184 Time-Mark Generator.
4. High-frequency constant amplitude signal generator	Frequency, 65 to above 190 megahertz, reference frequency, 3 megahertz output amplitude variable from 0.5 volt to 5 volts; amplitude accuracy, within 1% of reference as output frequency changes.	Vertical bandwidth check. Vertical amplifier isolation check.	TEKTRONIX calibration fixture 067-0532-01 recommended.
5. Medium-frequency constant-amplitude signal generator	Frequency, 50 to 70 megahertz; reference frequency, 50 kilohertz; output amplitude, variable from five millivolts to five volts peak to peak into 50 ohms; amplitude accuracy, constant within 3% of reference as output frequency changes.	External Z-axis operation check. Vertical bandwidth check. Vertical amplifier isolation check. Horizontal bandwidth check.	a. TEKTRONIX 191 Constant Amplitude Signal Generator. b. General Radio 1215-C with 1263-C Amplitude Regulating Power Supply.
6. Low-frequency signal generator	Frequency, 35 kilohertz; output amplitude, variable from 50 to 100 millivolts.	X-Y phase shift check.	a. General Radio 1310-B Oscillator.
7. Test-oscilloscope system (dual-trace)	Bandwidth, DC to 50 megahertz; minimum deflection factor, 10 millivolts/division; accuracy, within 3%.	Horizontal limit centering adjustment and + GATE OUT.	a. TEKTRONIX 7503 or 7504 Oscilloscope with two 7A15A or 7A16 Amplifier and 7B50 or 7B53A Time-Base plug-in units, and two P6053 Probes. b. TEKTRONIX 453A Oscilloscope with two P6054 Probes.
8. Vertical plug-in unit (two identical units required), and a dual display vertical unit.	TEKTRONIX 7A-series 65 megahertz bandwidth required for complete procedure as written.	Used throughout procedure to provide vertical input to 7613 under calibration. Identical units required only for X-Y phase shift check. The 7A18 is used to check READOUT operation.	a. TEKTRONIX 7A15A and a 7A18 Amplifier (may be shared with 7000-series test oscilloscope) b. Any 7A-series plug-in unit (tolerances in some steps may be limited if low-frequency units used).

TEST EQUIPMENT (cont)

Description	Minimum Specifications	Usage	Examples of Applicable Test Equipment
9. Time base plug-in unit	TEKTRONIX 7B-series.	Used through procedure to provide sweep.	a. TEKTRONIX 7B53A or 7B52 Time Base. b. Any 7B-series plug-in unit.
10. Mainframe standardizer calibration fixture	Produces gain-check and pluse-response waveforms.	Used throughout procedure to standardize instrument so plug-in units can be interchanged without complete recalibration.	a. TEKTRONIX Calibration Fixture 067-0587-01. b. Calibrated 7000-series plug-in units with suitable signal sources may be substituted if lower performance is acceptable.
11. 10X passive probe	Compatible with 7B-series external trigger input.	Chopped mode operation check (adjustment procedure).	a. TEKTRONIX P6053 or P6054 Probe (may be shared with test oscilloscope).
12. T connector	Connectors, BNC.	External Z-axis operation check.	a. TEKTRONIX Part No. 103-0030-00.
13. Termination	Impedance, 50 ohms; accuracy, $\pm 2\%$; connectors, BNC.	Horizontal timing check and adjustment. X-Y phase shift check.	a. TEKTRONIX Part No. 011-0049-01.
14. Dual-input coupler	Connectors, BNC.	Added operation check. X-Y phase shift check.	a. TEKTRONIX Calibration Fixture 067-0525-00.
15. Cable (two required)	Impedance, 50 ohms; type, RF-58/U; length, 18 and 42 inches; connectors, BNC.	Used throughout procedure for signal interconnection.	a. TEKTRONIX Part No. 012-0076-00 (18-inch). TEKTRONIX Part No. 012-0057-01 (42-inch).
16. GR in-line termination	Impedance, 50 ohms; accuracy, $\pm 2\%$; connectors, GR874 input with BNC male output.	External Z-axis operation check. Vertical bandwidth check. Vertical amplifier isolation check. Horizontal bandwidth check.	a. TEKTRONIX Part No. 017-0083-00.
17. Cable	Impedance, 50 ohms; type RG-213/U; electrical length, five nanoseconds; connectors, GR874.	External Z-axis operation check. Vertical bandwidth check. Vertical amplifier isolation check. Horizontal bandwidth check.	a. TEKTRONIX Part No. 017-0502-00.
18. BNC to pin-jack cable	Adapts pin jacks to BNC male connector.	Added operation check. Trigger source operation check. Astigmatism adjustment.	a. TEKTRONIX Part No. 175-1178-00 (one supplied as standard accessory).
19. Screwdriver	Three-inch shaft, 3/32-inch bit.	Used throughout adjustment procedure to adjust variable resistors.	a. Xcelite R-3323.
20. Low-capacitance screwdriver	1 1/2-inch shaft.	Used throughout adjustment procedure to adjust variable capacitors.	a. TEKTRONIX Part No. 003-0000-00.

Setup Procedure

NOTE

This instrument should be adjusted at an ambient temperature of +25°C ±5°C for best overall accuracy.

1. Remove the side covers from the 7613 or the top cover and side panel from the R7613.

2. Connect the instrument to a power source which meets the voltage and frequency requirements. The applied voltage should be near the center of the voltage range marked on the rear panel (see Section 1 for information on converting this instrument from one operating voltage to another).

NOTE

If correct line voltage is not available, use a variable autotransformer to provide the correct input voltage.

3. Set the controls as given under Preliminary Control Settings. Allow at least 20 minutes warmup before proceeding.

NOTE

Titles for external controls of this instrument are capitalized in this procedure (e.g., INTENSITY). Internal adjustments are initial capitalized only (e.g., CRT Grid Bias).

Preliminary Control Settings

Set the 7613 controls as follows:

INTENSITY	Midrange
FOCUS	Adjust for well-defined display
BEAM FINDER	Out
GRATICULE ILLUM	As desired
VERT MODE	LEFT
TRIG SOURCE	VERT MODE
NON STORE	IN
POWER	ON
PERSISTENCE	MAX
STORED INTENSITY	Counterclockwise
SAVE	Out
SAVETIME	Counterclockwise (not in detent)

Introduction

The following procedure returns the 7613 to correct calibration. All limits and tolerances given in this procedure are calibration guides, and should not be interpreted as instrument specifications except as listed in Section 2 of the Operators Manual.

Index to Calibration Procedure

Power Supply

1. Adjust —50 Volt Power Supply	Page 3-5
2. Check Remaining Power-Supply Voltages	Page 3-5
3. Check High-Voltage Power Supply	Page 3-6

Display and Z-Axis

4. Adjust CRT Grid Bias	Page 3-6
5. Adjust Astigmatism	Page 3-7
6. Adjust Trace Rotation	Page 3-7
7. Adjust Y-Axis Alignment	Page 3-8
8. Adjust Geometry	Page 3-8
9. Check External Z-Axis Operation	Page 3-8
10. Check Beam Finder	Page 3-8

Vertical Deflection System

11. Adjust Bias Adjustment	Page 3-9
12. Adjust Vertical Centering	Page 3-9
13. Check Vertical Gain	Page 3-9
14. Check Vertical Linearity	Page 3-10
15. Adjust Vertical High-Frequency Compensation	Page 3-10
16. Check Vertical Amplifier Bandwidth	Page 3-10
17. Check Vertical Amplifier Isolation	Page 3-11
18. Check Added Operation	Page 3-11
19. Check Alternate Operation	Page 3-11
20. Check Vertical Chopped Mode Operation	Page 3-12

Triggering System

21. Check Trigger Source Operation	Page 3-12
------------------------------------	-----------

Horizontal Deflection System

- 22. Adjust Horizontal Amplifier Gain and Low-Frequency Linearity
- 23. Adjust Horizontal Amplifier Centering
- 24. Adjust Horizontal Amplifier Limit Centering
- 25. Adjust High-Frequency Timing
- 26. Check X-Y Phase Shift
- 27. Check Horizontal Bandwidth

Z-Axis and Auto Focus

- 28. Adjust Z-Axis Compensation
- 29. Adjust Auto Focus Compensation and Operating Levels

Calibrator

- 30. Adjust Calibrator Output Voltage
- 31. Check Calibrator Repetition Rate

Signals Out

- 32. Check SINGLE SWEEP READY OUT
- 33. Check EXT S S RESET IN
- 34. Check VERT SIG OUT
- 35. Check +GATE OUT
- 36. Check +SAWTOOTH OUT

Readout Operation

- 37. Check READOUT SYSTEM Operation
- 38. Check READOUT Gate Triggered Operation

Storage System

- 39. Check Storage Operation
- 40. Check Stored Writing Rate
- 41. Check Save Functions
- 42. Check Remote Erase

POWER SUPPLY

Equipment Required

- 1. Precision DC voltmeter
- 2. DC voltmeter (VOM)
- 3. Three-inch screwdriver

Control Settings

Set the controls as given under Preliminary Control Settings.

1. Adjust -50 Volt Power Supply

- a. Set the INTENSITY control fully counterclockwise.
- b. Connect the precision DC voltmeter between TP-50 (see Fig. 2-1A) and chassis ground.
- c. CHECK—Meter reading; -50 volts ± 0.1 volt.
- d. ADJUST— -50 volts adjustment R881 (see Fig. 2-1B) for a meter reading of exactly -50 volts.

e. INTERACTION—Change in setting of R881 may affect operation of all circuits within the 7613.

2. Check Remaining Power-Supply Voltages

a. CHECK—Table 2-1 lists the low-voltage power supplies in this instrument. Check each supply with the precision DC voltmeter for output voltage within the given tolerance (connect meter ground lead to chassis ground). Power supply test points are shown in Fig. 2-1A.

b. Disconnect the precision DC voltmeter.

NOTE

Ripple and regulation of the individual power supplies can be checked using the procedure given under Troubleshooting Techniques in Section 4.

TABLE 2-1

Power Supply Tolerance

Power Supply	Test Point	Output Voltage Tolerance
-50 Volt	Pin 8 P1170	± 0.1 Volt
-15 Volt	Pin 7 P1170	± 0.1 Volt
+5 Volt	Pin 5 P1170	± 0.07 Volt
+15 Volt	Pin 4 P1170	± 0.1 Volt
+50 Volt	Pin 3 P1170	± 0.3 Volt
+130 Volt	Pin 2 P1170	± 5.2 Volt

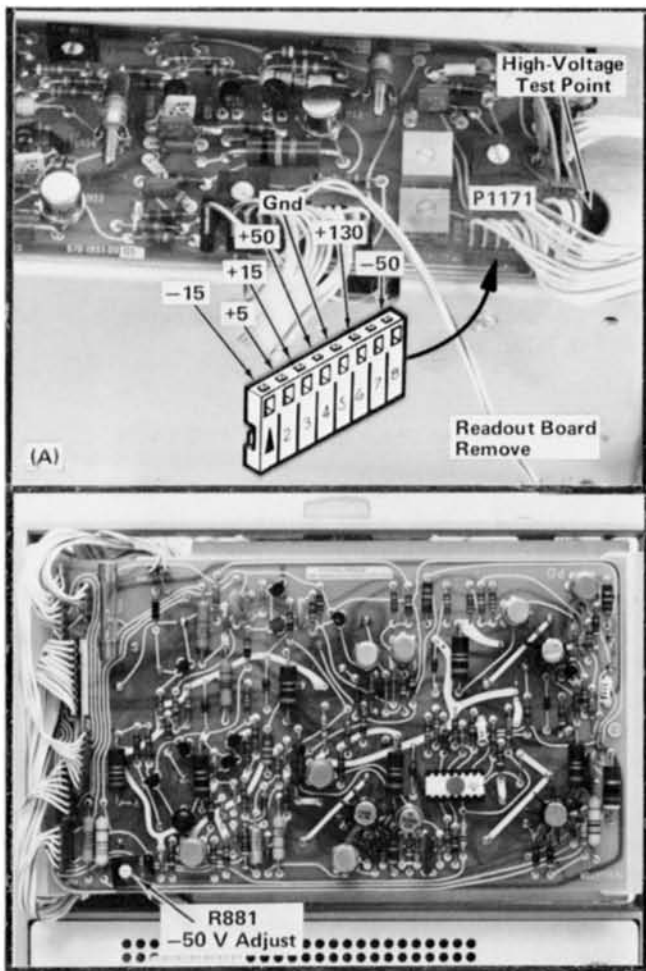

Fig. 2-1. (A) Location of power supply and high-voltage test points (right side of instrument); (B) Location of -50 V adjustment (Low Voltage Regulator board).

3. Check High-Voltage Power Supply

- a. Turn off instrument.
- b. Set the DC voltmeter (VOM) to measure at least 3000 volts. Then, connect it between the high-voltage test point (see Fig. 2-1A) and chassis ground.
- c. Press power switch (turn on instrument). Check meter reading; -1475 volts \pm 45 volts.
- d. Turn off instrument. Disconnect the DC voltmeter.
- e. Turn on instrument.

DISPLAY AND Z-AXIS

Equipment Required

1. Mainframe standardizer calibration fixture
2. 7B53A plug-in unit

3. DC Voltmeter (VOM)
4. 7A15A plug-in unit
5. Time-mark generator
6. Medium-frequency generator
7. BNC to pin-jack cable
8. 18-inch 50-ohm BNC cable
9. 42-inch 50-ohm BNC cable
10. Five-nanosecond GR cable
11. 50-ohm GR in-line termination
12. BNC T connector
13. Three-inch screwdriver
14. Low-capacitance screwdriver

Control Settings

Set the controls as given under Preliminary Control Settings.

4A. Adjust CRT Grid Bias

a. Install the mainframe standardizer calibration fixture (or a vertical plug-in) in the left vertical compartment and depress the LEFT VERT MODE button. Set the fixture for Vert or Horiz +Step Resp, amplitude fully counterclockwise, and Position to midrange.

b. Install the time base plug-in in the horizontal compartment, and set it for 1.0 ms/division. Adjust triggering for a free-running sweep. If a 7B53A time base plug-in is to be used with the 7613 (R7613), set it for Intensified sweep.

c. Adjust the fixture Position control to bring the trace on screen, then rotate both the INTENSITY and READ-OUT INTENSITY controls fully counterclockwise.

d. Connect a 10X probe from the test-oscilloscope to the Z-Axis test point (see Fig. 2-2) and the probe ground lead to chassis ground.

e. Set the test-oscilloscope to DC input and a display of 5 volts/division (including probe attenuation), position the trace to the center graticule line.

f. ADJUST-INTENSITY control for a display amplitude 2 volts above the center graticule line.

g. ADJUST-CRT Bias adjustment R1261 (see Fig. 2-2) until the trace on the 7613 (R7613) is just extinguished. Set INTENSITY for a viewable trace.

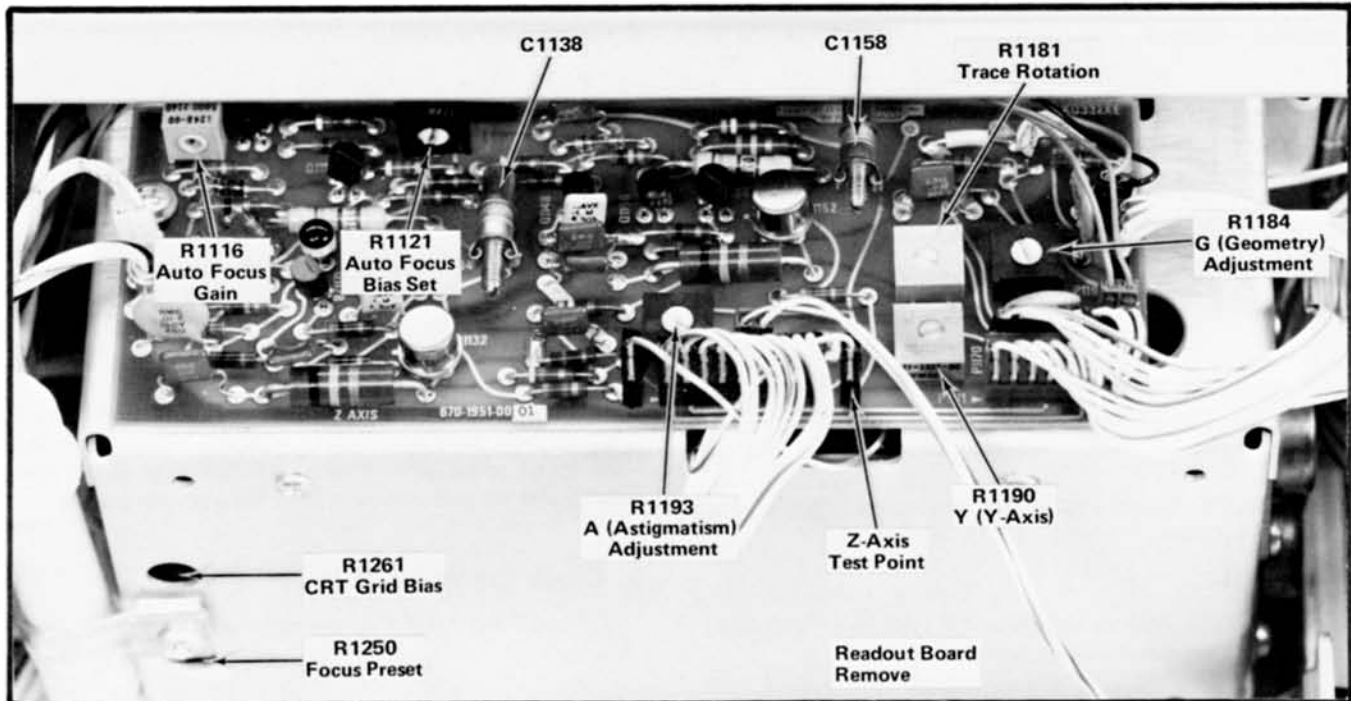

Fig. 2-2. Location of Display and Z Axis adjustments and test points.

4B. Check Z-Axis DC Levels

a. Set the test-oscilloscope for 10 V/division, DC input, and connect its 10X probe to the 7613 (R7613) Z-Axis test point (see Fig. 2-2) and probe ground lead to chassis ground.

b. Set the time base plug-in in the 7613 (R7613) to 50 ms/division, not intensified, and the test-oscilloscope time base to 1 sec/div.

c. Set the calibration fixture Position control to position the trace vertically off screen, and set the INTENSITY control fully clockwise.

d. CHECK—The test-oscilloscope display amplitude should be at least 58 volts, note this reading.

e. Set the 7613 (R7613) time base plug-in to 0.1 second/division.

f. CHECK—Pulse amplitude deflection on the test-oscilloscope should decrease to between 25 volts to 35 volts less than the amplitude in step d.

g. Disconnect the test oscilloscope 10X probe from the 7613 (R7613) and reduce the INTENSITY setting to a normal intensity. Position the trace within the graticule area.

5. Adjust Astigmatism

a. Set the 7B53A for auto, internal triggering at a sweep rate of one millisecond/division.

b. Set the mainframe standardizer calibration fixture Test switch to Vert or Horiz Aux In.

c. Connect the 4 V Calibrator pin-jack to the Aux In connector of the calibration fixture with the BNC to pin-jack cable.

d. Set the calibration fixture Position control for a centered display, and the Amplitude control for about two divisions of vertical deflection.

e. CHECK—CRT display is well defined.

f. ADJUST—FOCUS control and A (astigmatism) adjustment R1193 (see Fig. 2-2) to obtain best display definition.

g. Disconnect the cable.

6. Adjust Trace Rotation

a. Set the INTENSITY control to midrange.

b. Move the trace to the center horizontal line with the mainframe standardizer Position control.

Calibration—7613/R7613 Service

c. CHECK—Trace aligns with the center horizontal line within 0.1 division.

d. ADJUST—Trace Rotation adjustment R1181 (see Fig. 2-2) to align the trace with the center horizontal line.

7. Adjust Y-Axis Alignment

a. Inter-change the 7B53A and mainframe standardizer plug-in units.

b. Move the trace to the center vertical line with the mainframe standardizer Position control.

c. CHECK—Trace aligns with the center vertical line within 0.1 division.

d. ADJUST—Y-Axis adjustment R1190 (see Fig. 2-2) to align the trace with the center vertical line.

8. Adjust Geometry

a. Remove the mainframe standardizer and install the 7B53A in the horizontal compartment. Replace the mainframe standardizer in the left vertical compartment.

b. Set the VERT MODE switch to LEFT.

c. Connect the marker output of the time-mark generator to the Aux In connector of the calibration fixture with an 18-inch 50-ohm BNC cable.

d. Connect the trigger output of the time-mark generator to the external trigger input connector of the 7B53A with a 42-inch 50-ohm BNC cable.

e. Set the time-mark generator for one-millisecond markers and one-millisecond triggers.

f. Set the calibration fixture Test switch to Vert or Horiz Aux In and the Amplitude Step or Aux control fully clockwise.

g. Set the 7B53A for auto triggering from the external source at a sweep rate of 0.5 millisecond/division (magnifier off).

h. Set the 7B53A variable time/division control to obtain exactly one marker for each major graticule division.

i. Set the time-mark generator for both one- and 0.1-millisecond markers.

j. Position the baseline of the markers as far toward the bottom of the graticule as possible with the calibration fixture Position control.

k. CHECK—Vertical bowing and tilt of the marker display is less than 0.1 division (each 0.1-millisecond marker represents 0.1 division).

l. ADJUST—Geometry adjustment R1184 (see Fig. 2-2) for minimum bowing of time markers. Adjustment may have to be compromised to obtain less than 0.1 division bowing and tilt everywhere within the graticule area.

9. Check External Z-Axis Operation

a. Install the 7A15A in the right vertical compartment.

b. Connect the output of the medium-frequency constant-amplitude signal generator to the input of the 7A15A through the five-nanosecond GR cable, 50-ohm GR in-line termination, and the BNC T connector.

c. Set the 7A15A for a deflection factor of one volt/division.

d. Set the 7B53A for auto, internal triggering at a calibrated sweep rate of 10 microseconds/division.

e. Set the medium-frequency generator for a two-division display at its reference frequency (50 kilohertz).

f. Connect the output of the BNC T connector to the EXT Z-AXIS connector with the 42-inch 50-ohm BNC cable.

g. CHECK—Top portion of displayed waveform blanked out.

h. Disconnect cable from external Z-AXIS connector.

10. Check Beam Finder

a. Set the 7A15A deflection factor to 20 millivolts/division. Notice that the display exceeds the viewing area.

b. Press the BEAM FINDER switch.

- c. CHECK—Display compressed within graticule area.
- d. Increase the 7A15A deflection factor until the compressed display is reduced in amplitude.
- e. Release the BEAM FINDER switch.
- f. CHECK—Display remains within graticule area.
- g. Disconnect all test equipment and remove the plug-in units.

VERTICAL DEFLECTION SYSTEM

Equipment Required

1. Mainframe standardizer calibration fixture
2. 7B53A plug-in unit
3. High-frequency generator
4. 7A15A plug-in unit (two)
5. 10X probe
6. Five-nanosecond GR cable
7. 50-ohm GR in-line termination
8. BNC to pin-jack cable
9. Dual-input coupler
10. Three-inch screwdriver
11. Low-capacitance screwdriver

Control Settings

Set the controls given under Preliminary Control Settings.

11. Adjust Bias Adjustment

- a. Install the 7B53A in the horizontal compartment.
- b. Set the 7B53A for auto, external triggering at a sweep rate of one millisecond/division.
- c. Install the mainframe standardizer calibration fixture in the left vertical compartment. Set the calibration fixture Test switch to VERT or HORIZ Gain and the Rep Rate switch to 250 kHz.

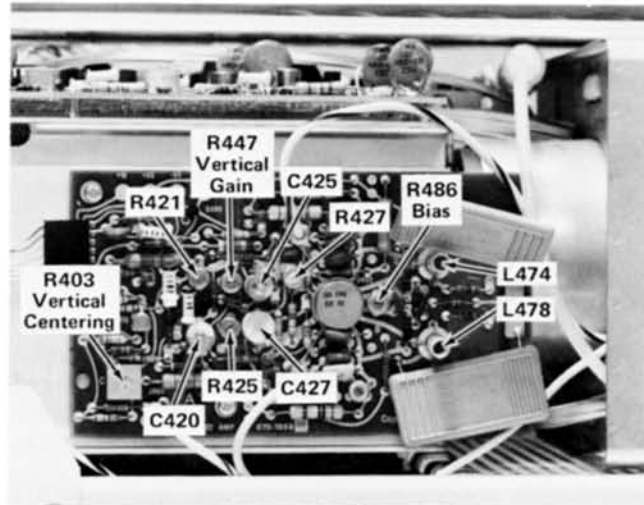

Fig. 2-3. Location of vertical system adjustments (Vertical Output board).

- d. ADJUST—Bias R486 for maximum gain. (See Fig. 2-3.)

12. Adjust Vertical Centering

- a. Set the calibration fixture Test switch to Triggering Gain.
- b. The trace should be within 0.3 division of the graticule center line.
- c. ADJUST—Vertical Centering adjustment R403 (see Fig. 2-3) to position the trace to the center horizontal line.

13. Adjust Vertical Gain

- a. Set the calibration fixture Test switch to Vert or Horiz Gain.
- b. Position the display so the first and seventh traces are near the top and bottom lines of the graticule.
- c. CHECK—Deflection between the second and sixth traces should be six divisions ± 0.06 division.
- d. ADJUST—Vertical Gain adjustment R447 (see Fig. 2-3) for exactly six divisions of deflection between the second and sixth traces.
- e. Remove the calibration fixture from the left vertical compartment and install it in the right vertical compartment.

f. Set the VERT MODE switch to RIGHT.

g. CHECK—Deflection between the second and sixth traces should be the same as part d or e $\pm 1\%$.

h. ADJUST—If necessary, re-adjust R447 for correct tolerance in both parts d and h.

14. Check Vertical Linearity

a. Remove the mainframe standardizer calibration fixture. Install the 7A15A in the left vertical compartment and connect a 0.4 volt square wave signal from the CALIBRATOR out jacks. Set the VERT MODE switch to left.

b. Set the 7A15A Volts/Div switch to 0.2 volt/division. Adjust the position control to keep the display centered on the graticule and adjust the Variable Volts/Div control if needed for a two division display.

c. CHECK—Position the two divisions of display vertically and check for not more than 0.1 division of compression or expansion anywhere within the graticule area. Remove the 7A15A and install the mainframe standardizer calibration fixture.

15. Adjust Vertical High-Frequency Compensation

a. Set the calibration fixture Test switch to Vert or Horiz +Step Resp, Rep Rate switch to 250 kHz, and adjust the Amplitude control for a six-division display.

b. Set the 7B53A for a calibrated sweep rate of five nanoseconds/division (use X10 magnifier). Set the trigger source switch internal adjust trigger level control and position control for a stable display, centered on the graticule.

c. CHECK—Check for optimum square corner and flat top on displayed pulse with aberrations not to exceed +0.1 or -0.1 division with total peak-to-peak aberrations not to exceed 0.1 division.

d. ADJUST—Long term flat response R455 and R465 for a flat-top pulse with positioning from top to bottom of screen.

e. ADJUST—High-frequency compensation as given in Table 2-2 for optimum square leading corner and flat top with minimum aberrations within limits given in part c. Location of adjustments is shown in Fig. 2-3. Use the low-capacitance screwdriver to adjust the variable capacitors. Repeat the complete adjustment procedure several times to obtain optimum adjustment.

TABLE 2-2

High-Frequency Compensation

Adjustment	Primary Area Of Pulse Affected	Best Sweep Rate
C420 and R421	First 50 nanoseconds	50 nanoseconds/division
R425, C425, L474, and L478	First 20 nanoseconds	20 nanoseconds/division
C427 and R427	First 5 nanoseconds	20 nanoseconds/divisions

f. Remove the calibration fixture from the left vertical compartment and install it in the right vertical compartment.

g. Set the VERT MODE switch to RIGHT.

h. CHECK—Optimum square leading corner and flat top on the displayed pulse with aberrations not to exceed +0.1 or -0.1 division, with total peak-to-peak aberrations not to exceed 0.1 division.

i. ADJUST—If necessary, compromise the adjustment of C420, R421, R425, C425, L474, L478, C427, and R427 for best response from both the left and right vertical compartments.

j. To verify correct high-frequency compensation, perform the bandwidth check as given in next step.

16. Check Vertical Amplifier Bandwidth

a. Connect the high-frequency constant-amplitude signal generator to the CW In connector of the mainframe standardizer calibration fixture.

b. Set the Test switch of the calibration fixture to Vert or Horiz Freq Resp.

c. Set the 7B53A for a sweep rate of 0.2 microsecond/division.

d. Set the high-frequency generator for six divisions of deflection, centered on the graticule, at a reference frequency of 3 megahertz.

e. Without changing the output amplitude, increase the output frequency of the high-frequency generator until the display is reduced to 4.2 divisions (-3 dB point).

f. CHECK—Output frequency must be 110 megahertz or higher if using test fixture. If using amplifier, see systems specification.

g. Remove the calibration fixture from the right vertical compartment and install it in the left vertical compartment (leave signal connected).

h. Set the VERT MODE switch to LEFT.

i. Repeat parts d through f. Actual frequency (right vertical), 115 megahertz or higher.

j. Disconnect all test equipment (leave plug-in units installed).

17. Check Vertical Amplifier Isolation

a. Remove the mainframe standardizer calibration fixture from the right vertical compartment and install the 7A15A in this compartment.

b. Set the 7A15A for a deflection factor of 0.1 volt/division.

c. Connect the output of the high-frequency generator to the input of the 7A15A.

d. Set the high-frequency generator for eight divisions of deflection at 100 megahertz.

e. Set the VERT MODE switch to RIGHT.

f. CHECK—CRT display for not more than 0.1 division of 100 megahertz signal (channel isolation at least 100:1).

g. Remove the 7A15A from the left vertical compartment and install it in the right vertical compartment (leave signal connected).

h. Set the high-frequency generator for eight divisions of deflection at 100 megahertz.

i. Set the VERT MODE switch to LEFT.

j. CHECK—CRT display for not more than 0.1 division of 100 megahertz signal.

k. Disconnect all test equipment.

18. Check ADD Operation

a. Install the other 7A15A in the left vertical compartment.

b. Set both 7A15A units for a deflection factor of 0.2 volt/division.

c. Connect the 0.4 V Calibrator signal to the inputs of the 7A15A units with the BNC to pin-jack cable and dual-input coupler.

d. Set the 7B53A for auto, internal triggering at a sweep rate of 0.5 millisecond/division.

e. Center the display with the left 7A15A Position control and note the vertical deflection.

f. Set the VERT MODE switch to RIGHT.

g. Center the display with the right 7A15A Position control and note the vertical deflection.

h. Set the VERT MODE switch to ADD.

i. CHECK—CRT display; vertical deflection should approximately equal the algebraic sum of the deflection noted in parts e and g of this step.

j. Disconnect the BNC to pin-jack cable and dual-input coupler.

19. Check Alternate Operation

a. Set the VERT MODE switch to ALT.

b. Position the traces about two divisions apart.

c. Turn the 7B53A Time/Division switch throughout its range.

d. CHECK—Trace alternation between the left and right 7A15A units at all sweep rates. At faster sweep rates, alternation will not be apparent; instead display appears as two traces on the screen.

20. Check Vertical Chopped Mode Operation

- a. Connect the 10X probe to the external trigger input of the 7B53A.
- b. Connect the probe tip to TP67 (see Fig. 2-4).
- c. Position the trace several divisions above the center line with the Position control.
- d. Set the VERT MODE switch to CHOP.
- e. Set the 7B53A for auto, external triggering at a sweep rate of 0.2 microsecond/division.
- f. CHECK—CRT display for chopped waveform display with duration of the time segment from each channel, including the blanked portion, between two and three divisions. Also, check that the unblanked (visible) portion of the time segment from each channel consists of at least 75% of the duration of the total channel segment.
- g. Disconnect the probe and remove all plug-in units.

TRIGGERING SYSTEM

Equipment Required

1. Mainframe standardizer calibration fixture
2. 7B53A plug-in unit
3. 7A15A plug-in unit
4. BNC to pin-jack cable

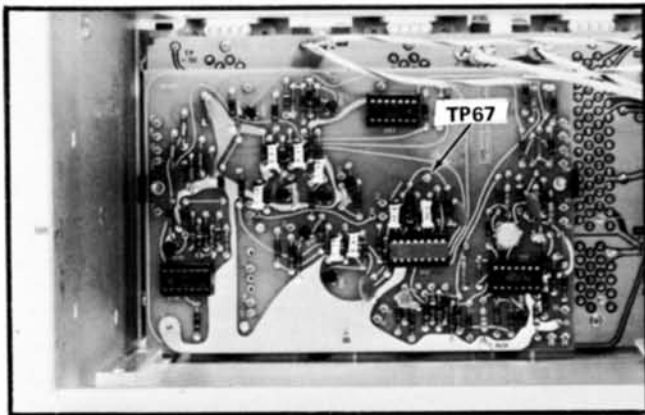

Fig. 2-4. Location of TP67 on Logic board (shown with power unit removed).

Control Settings

Set the controls as given under Preliminary Control Settings.

21. Check Trigger Source Operation

- a. Install the mainframe standardizer calibration fixture in the right vertical compartment and the 7A15A in the left vertical compartment.
- b. Install the 7B53A in the horizontal compartment.
- c. Set the 7B53A for auto, internal triggering at a sweep rate of 0.5 millisecond/division.
- d. Set the 7A15A for a deflection factor of 0.2 volt/division.
- e. Connect the 0.4 V Calibrator pin-jack to the input of the 7A15A with the BNC to pin-jack cable.
- f. Position the Calibrator waveform display in the upper half of the graticule area with the 7A15A Position control.
- g. Set the VERT MODE switch to RIGHT.
- h. Set the calibration fixture Test switch to Vert or Horiz +Step Resp, Rep Rate switch to 250 Hz, and adjust the Amplitude control for a two-division display. Position the display in the lower half of the graticule area.
- i. Set the VERT MODE switch to ALT.
- j. CHECK—CRT display; both square-wave displays are stable.
- k. Set the TRIG SOURCE switch to LEFT.
- l. CHECK—CRT display; Calibrator display only is stable.
- m. Set the TRIG SOURCE switch to RIGHT.
- n. CHECK—CRT display; calibration fixture display only is stable.
- o. Disconnect the BNC to pin-jack cable and remove the plug-in units.

HORIZONTAL DEFLECTION SYSTEM

Equipment Required

1. 7B53A plug-in unit
2. 7A15A plug-in unit (two)
3. Mainframe standardizer calibration fixture
4. Test-oscilloscope system with two 10X probes
5. Time-mark generator
6. Low-frequency generator
7. Medium-frequency generator
8. Dual-input coupler
9. Five-nanosecond GR cable
10. 50-ohm GR in-line termination
11. 42-inch 50-ohm BNC cable
12. 50-ohm BNC termination
13. Three-inch screwdriver
14. Low-capacitance screwdriver

Control Settings

Set the controls as given under Preliminary Control Settings.

22. Adjust Horizontal Amplifier Limit Centering

- a. Install the 7B53A in the horizontal compartment.
- b. Set the 7B53A for auto, internal triggering at a sweep rate of one millisecond/division with the magnifier on.
- c. Connect 10X probes to both inputs of the test oscilloscope. Connect the probe tips to the horizontal deflection plate connectors of the 7613 (be sure probes are compensated).
- d. Set both channels of the test oscilloscope for a vertical deflection factor of 1.0 volt/division (ten volts/division at probe tip) in the chop dual-trace mode with the input coupling set to ground.

e. Position the ground-reference traces displayed on the test oscilloscope to the center horizontal line of the graticule. Do not change the test-oscilloscope position controls after establishing this ground reference.

f. Set the test oscilloscope for DC input coupling and set the triggering controls so the test oscilloscope is triggered from the signal on channel 1 only. Set the triggering controls for a stable display at a sweep rate of two milliseconds/division.

g. CHECK—The base line of both displayed waveforms should be at the same DC level within 0.2 division (see Fig. 2-5).

h. ADJUST—Limit Centering adjustment R535 (see Fig. 2-6) to match the DC levels of both waveforms.

i. Disconnect all test equipment and remove the 7B53A.

23. Adjust Horizontal Amplifier Centering

a. Install the calibration fixture in the horizontal compartment and set the Test Switch to Triggering Gain.

b. CHECK—Spot produced by 7B53A should align with the vertical center line of the graticule within 0.3 division.

c. ADJUST—Horizontal Centering adjustment R525 (see Fig. 2-6) to position the spot to the vertical center line.

d. INTERACTION—If R525 is adjusted, re-check steps 22 and 23.

e. Remove the calibration fixture from the horizontal compartment.

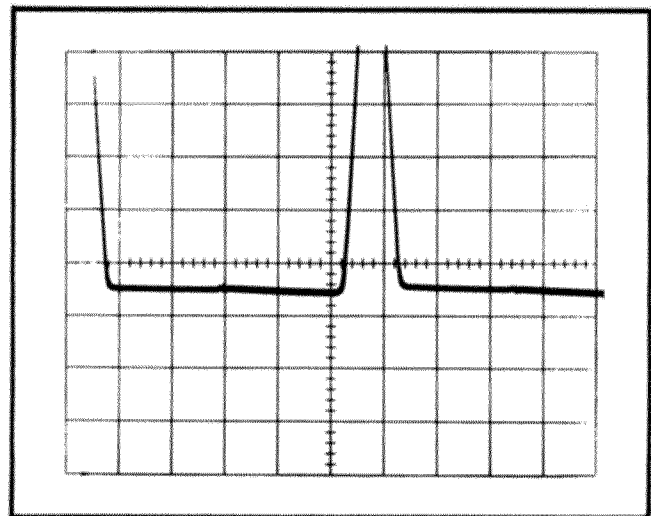

Fig. 2-5. Test oscilloscope waveforms when horizontal limit centering is properly adjusted.

24. Check/Adjust Horizontal Amplifier Gain and Low-Frequency Linearity

a. Install the 7A15A in the horizontal compartment and the 7B53A in the vertical compartment. Set the 7A15A Volts/Div switch to 0.2 volt/division. Connect a 0.4 volt square wave CALIBRATOR signal to the 7A15A; adjust the Position control to keep the display centered on the graticule and adjust the Variable Volts/Div control if needed for two division display.

b. Check—Position the two division display horizontally and check for not more than 0.1 division compression or expansion anywhere within the graticule area. Remove the 7A15A and install the mainframe standardizer calibration fixture. Set the Test switch on the calibration fixture to Vert or Horiz gain, and Rep Rate to 250 kHz.

c. Set the 7B53A for auto, external triggering at a sweep rate of one millisecond/division.

d. Position the display so the first and ninth traces are near the far left and right vertical lines of the graticule.

e. CHECK—Deflection between the second and eighth traces is eight divisions ± 0.08 division.

f. ADJUST—Horizontal Gain adjustment R512 (see Fig. 2-6) for exactly eight divisions of deflection between the second and eighth traces.

g. CHECK—With gain set exactly, all nine vertical traces align with their respective graticule lines within 0.05 division.

h. INTERACTION—If R512 is adjusted, recheck steps 22 and 23.

i. Remove the calibration fixture and install the 7B53A in the horizontal compartment.

25. Adjust High-Frequency Timing

a. Install the 7A15A in the left vertical compartment.

b. Connect the time-mark generator to the input connector of the 7A15A with the 42-inch 50-ohm BNC cable and the 50-ohm BNC termination.

c. Set the time-mark generator for one-millisecond markers. Set the deflection factor of the 7A15A so the markers are at least two divisions in amplitude.

d. Set the 7B53A for auto, internal triggering at a sweep rate of one millisecond/division.

e. Position the first marker to the left vertical line of the graticule.

f. Set the 7B53A Swp Cal adjustment for one marker each major graticule division between the first and ninth lines.

g. Set the time-mark generator for 10-nanosecond markers.

h. Set the 7B53A for a sweep rate of 0.1 microsecond/division with the X10 magnifier on; set the deflection factor of the 7A15A as necessary so the markers are about two divisions in amplitude for the rest of step 25.

i. CHECK—CRT display for one marker each division over the center eight divisions.

j. ADJUST—For SN B070000-up—C588 for one marker each division (For SN below B070000, adjust C568 and C588 for one marker each division while maintaining approximately equal capacitances.) Use low capacitance adjustment tool for all adjustments in this step.

k. Set the 7B53A for a sweep rate of 0.05 microsecond/division with X10 magnifier on.

l. ADJUST—For SN B070000-up—C566 and C586 for one marker each two divisions while maintaining approximately equal capacitances. (For SN below 070000, readjust C568 and C588 for best compromise between 5 nanosecond and 10 nanosecond timing.)

m. Repeat parts j, k, and l to achieve the best compromise for 5 nanosecond and 10 nanosecond timing over the center 8 horizontal divisions.

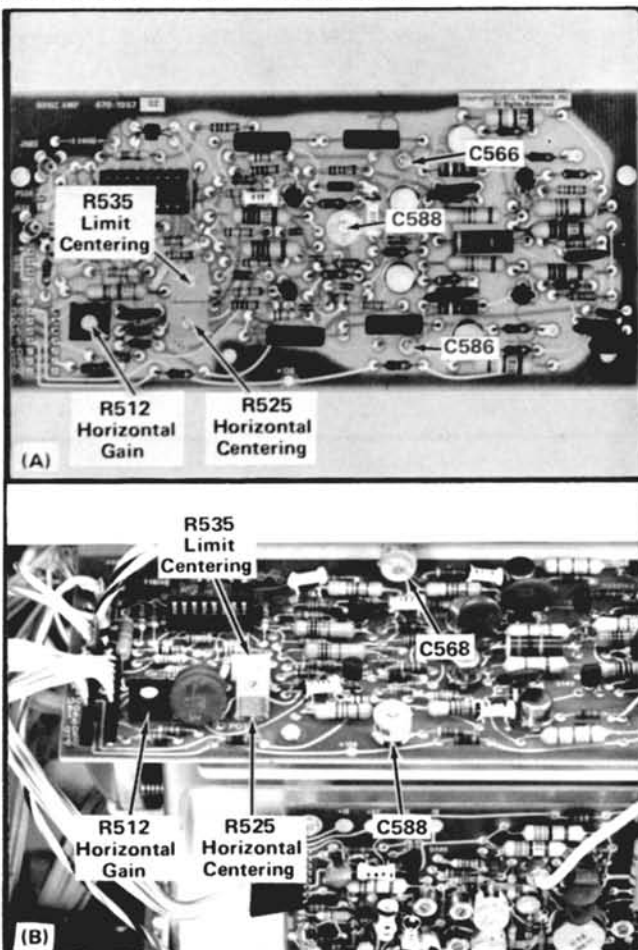

Fig. 2-6. Location of Horizontal adjustments (Horizontal Amplifier board (A) SNB020000-up; (B) Below SNB020000.

26. Check X-Y Phase Shift

a. Install the 7A15A plug-in units in the left vertical and horizontal compartments.

b. Set both 7A15A units for a deflection factor of 10 millivolts/division with DC input coupling.

c. Connect the low-frequency signal generator to the inputs of both 7A15A plug-in units with the 42-inch 50-ohm BNC cable, 50-ohm BNC termination, and dual-input coupler.

d. Set the low-frequency generator for eight divisions of vertical and horizontal deflection at an output frequency of 35 kilohertz.

e. CHECK—CRT lissajous display for an opening at the center vertical line of 0.28 division or less (indicates 2° or less phase shift; see Fig. 2-7).

f. Disconnect all test equipment (leave plug-in units installed).

27. Check Horizontal Bandwidth

a. Install the 7B53A in the right vertical compartment.

b. Set the VERT MODE switch to RIGHT.

c. Set the 7B53A for auto triggering at a sweep rate of one millisecond/division (display will free run).

d. Connect the medium-frequency generator to the input of the 7A15A in the horizontal compartment with

the five-nanosecond GR cable and the 50-ohm GR in-line termination.

e. Set the medium-frequency generator for 8 divisions of horizontal deflection at its reference frequency (50 kilohertz).

f. Without changing the output amplitude, increase the output frequency of the generator to two megahertz.

g. CHECK—For at least 5.6 division of signal amplitude.

h. Disconnect all test equipment and remove the plug-in units.

Z-AXIS and AUTO FOCUS SYSTEM

Equipment Required

1. 7B53A plug-in unit
2. 7A15A plug-in unit
3. 10X passive probe
4. Medium-frequency generator
5. 42-inch 50-ohm BNC cable
6. 50-ohm BNC termination

28. Adjust Z-Axis Compensation

a. Install the 7A15A in the right vertical compartment.

b. Set the VERT MODE switch to RIGHT.

c. Connect the 10X probe to the input of the 7A15A. Check the probe compensation.

d. Set the 7B53A for a sweep rate of one microsecond/division with the X10 magnifier on.

e. Connect the probe tip to R1157, Z-Axis output and connect the ground strap to the 7613 chassis.

f. Set the 7A15A for a deflection factor of one volt/division (10 volts/division at probe tip).

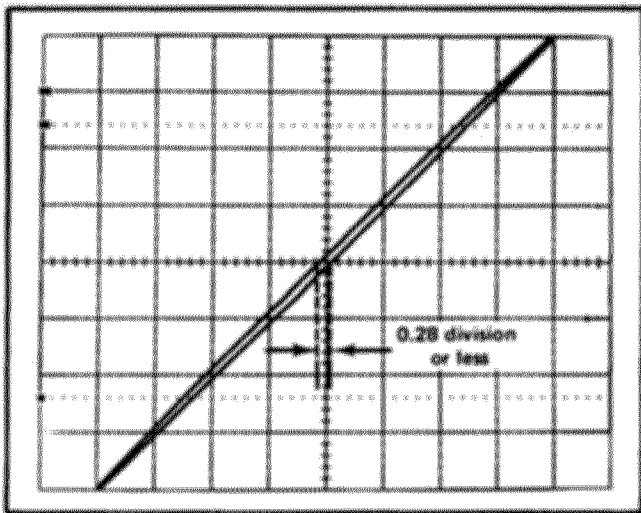

Fig. 2-7. Typical CRT display when checking X-Y phase shift.

Calibration—7613/R7613 Service

g. ADJUST—the INTENSITY control for three divisions of vertical deflection on the CRT. Position the display so the positive leading edge of the waveform is displayed.

h. ADJUST—C1158 for optimum square positive leading corner (use a low capacitance screwdriver to adjust the variable capacitor).

i. Disconnect the probe.

29. Auto Focus Compensation and Operating Levels

a. Connect the probe tip to R1137, Z-Axis output.

b. ADJUST—the INTENSITY control for three divisions of vertical deflection on the CRT. Position the display so the negative leading edge of the waveform is displayed.

c. ADJUST—C1138 for optimum square negative leading corner (use a low capacitance screwdriver to adjust the variable capacitor).

d. Disconnect the probe.

e. Set the 191 constant amplitude signal generator to 50 kHz only.

f. Connect the 191 output to the input of the 7A15A. Adjust the amplitude of the 191 for a two division display.

g. Midrange R1045, the front panel FOCUS control.

h. Reduce the intensity so the display is just visible. Adjust R1250, the Focus Preset control, for optimum focus.

i. Increase the INTENSITY control to midrange and adjust R1121 Auto Focus bias set control for optimum focus.

j. Increase the intensity to almost maximum and adjust R1116 Auto Focus Gain for optimum focus.

k. Repeat steps m through o. Focus the display for a low intensity display and change the intensity to a brighter display. Check that the focus of the display remains optimized.

l. Disconnect all test equipment.

CALIBRATOR

Equipment Required

1. Precision DC voltmeter
2. 7A15A plug-in unit
3. 7B53A plug-in unit
4. BNC to pin-jack cable.
5. Three-inch screwdriver

Control Settings

Set the controls as given under Preliminary Control Settings.

30. Adjust Calibrator Output Voltage

a. Change jumper P1066 (see Fig. 2-8) to the DC position.

b. Connect the precision DC voltmeter between the 4 V and GND pin jacks.

c. CHECK—Meter reading; 4 volts ± 0.04 volt (within ± 0.08 volt if this measurement is made outside the $+15^{\circ}\text{C}$ to $+35^{\circ}\text{C}$ range).

d. ADJUST—4 Volts adjustment R1077 (see Fig. 2-8) for a meter reading of exactly 4 volts.

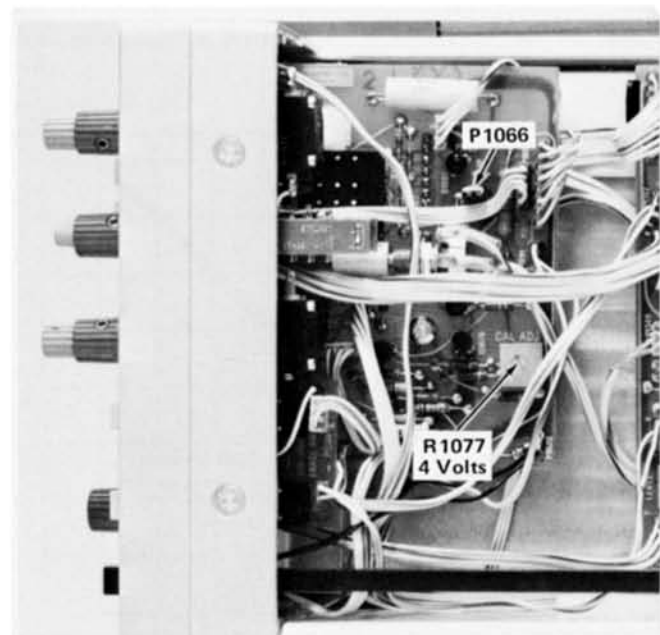

Fig. 2-8. Location of Calibrator adjustments (Calibrator board).

e. Connect the precision DC voltmeter between the 0.4 V Calibrator pin-jack and pin-jack ground.

f. CHECK—Meter reading; 0.4 volt ± 0.004 volt (within 0.008 volt if this measurement is made outside the $+15^{\circ}\text{C}$ to $+35^{\circ}\text{C}$ range).

g. Connect the precision DC voltmeter between the 40 mV Calibrator pin-jack and pin-jack ground.

h. CHECK—Meter reading; 40 millivolts ± 0.4 millivolt (within 0.8 millivolt if this measurement is made outside the $+15^{\circ}\text{C}$ to $+35^{\circ}\text{C}$ range).

i. Disconnect the precision DC voltmeter.

31. Check Calibrator Repetition Rate

a. Change jumper P1066 (see Fig. 2-8) to the 1 kHz position.

b. Install the 7A15A in the left vertical compartment and the 7B53A in the horizontal compartment.

c. Set the 7A15A for a deflection factor of one volt/division.

d. Set the 7B53A for auto, internal triggering at a sweep rate of 0.2 millisecond/division.

e. Connect the 4 V calibrator pin-jack to the input of the 7A15A with the BNC to pin-jack cable.

f. Position the start of the square wave to the left line of the graticule.

g. CHECK—CRT display for length of one complete cycle between 4.2 and 6.3 divisions (one kilohertz $\pm 20\%$).

SIGNALS IN AND OUT

Equipment Required

1. 7A15A (two)
2. 7B53A
3. DC Voltmeter
4. BNC to pin-jack cable

5. Test Oscilloscope

32. Check REMOTE ERASE IN

a. Set the controls as given under Preliminary Control Settings.

b. Press the STORE button - a stored display should be visible.

c. CHECK—That when the REMOTE ERASE IN input connector is grounded, that the stored display is erased.

33. Check EXT S S RESET IN

a. CHECK—that when the EXT SS RESET IN input is grounded that the time base single sweep function is reset.

34. Check VERT SIG OUT

a. Set the 7B53A to Auto and adjust the trigger level for stable display at 1 microsecond/division.

b. Connect a BNC cable to the VERT SIG OUT connector and to the 7A15A in the right vertical compartment. Set TRIG SOURCE switch to LEFT VERT.

c. Connect the 0.4 V CALIBRATOR signal to the input of 7A15A in the left vertical compartment. Set both vertical amplifiers for a deflection factor of 0.2 volts/division.

d. CHECK—that a 2 division signal is displayed by the left vertical amplifier.

e. Set VERT Mode switch to RIGHT and, check that a signal of about 5 divisions is displayed by the right vertical amplifier.

Calibration—7613/R7613 Service

f. Interchange the connections to the vertical amplifiers. Set the TRIG SOURCE switch to right.

g. CHECK—that a 2 division signal is displayed by the right vertical amplifier.

h. Set the VERT MODE switch to LEFT and check that a signal of about 5 divisions is displayed.

i. Install a 50 Ω termination between the cable and the input of the right vertical amplifier.

j. Set the deflection factor of the left vertical to 10 mV/division. Check for a display of about 5 divisions.

k. Disconnect all cables.

35. Check +SAWTOOTH OUT

a. Connect the +SAWTOOTH OUT to the input of the left vertical amplifier. Set the deflection factor of the left vertical amplifier for 2 volts/division.

b. CHECK—for a sawtooth display of about 5 divisions in amplitude and greater than 10 cm in length.

36. Check +GATE OUT

a. Connect the +GATE OUT to the vertical input of the test-oscilloscope and set the deflection factor to 2 volts/division. Set the time/division switch to 1 ms/div. Place the GATE selector switch in the MAIN GATE position.

b. CHECK—that displayed signal is about 5 divisions in amplitude.

c. Disconnect all test equipment and remove the 7B53A and the 7A15A units.

READOUT OPERATION

Equipment Required

1. 7A18 dual display vertical plug-in unit

37. Check READOUT Operation

NOTE

If the CRT has been replaced, the words identify may not be positioned horizontally as described in steps 37a, e, and f. Select a value for R519 which will provide a correct display.

a. Install the 7A18 in the left vertical compartment. Set the 7A18 to a dual trace mode. Push and hold the Identify buttons on the 7A18. (Switch S2110 should be in the free run position.) Check that the word identify is within the top division and the bottom division of the graticule. Check that the words identify are positioned within the left third of the graticule. Check completeness of characters without over scanning (over scanning causes a bright dot where traces overlap).

b. ADJUST—Vertical Separation R2291 so the channel 1 characters are within top division, and the channel 2 characters are within bottom division.

c. ADJUST—Character height size R2273 as needed.

d. ADJUST—character scan R2128 if characters are over scanned.

e. Remove the 7A18 from the left vertical and install it in the right vertical compartment. Push and hold the identify buttons on the 7A18. Check that the words identify are positioned within the center third of the graticule.

f. Remove the 7A18 from the right vertical and install it in the horizontal compartment. Push and hold the identify buttons on the 7A18. Check that the words identify are positioned within the right third of the graticule.

g. If the correct characters are displayed there is no need to adjust the Row Match adjustment R2183 or the Column Match adjustment R2214.

h. ADJUST—Row Match adjustment R2183 and Column Match adjustment R2214 for correct readout display.

READOUT GATE TRIG'D OPERATION

38. Check Readout Gate Trig'd Operation

a. Set switch S2110 to Gate Trig'd position.

b. Set sweep rate to 1 sec/division.

c. CHECK—that during the sweep that there is no readout information displayed, until after the sweep has been displayed. At fast sweep rates this is not noticeable.

This completes the non-store calibration and checkout procedure for the 7613/R7613.

STORAGE SYSTEM

Equipment Required

1. 7A15A
2. 7B53A
3. Low frequency sine-wave generator
4. 42 inch 50-ohm BNC cable

39. Check Storage Operation

a. Set controls as given under Preliminary Controls Settings. Then press the STORE button for the storage mode of operation.

b. Turn the STORED INTENSITY control fully clockwise.

c. CHECK—that screen is bright with uniform intensity.

d. ADJUST—CE1 and CE3 for uniformity of brightness.

e. Turn STORED INTENSITY fully counterclockwise.

f. CHECK—that screen turns dark.

g. Press and release the erase button.

h. CHECK—that the screen turns bright and then dark.

i. ADJUST—Level Preset (R1473) if necessary so screen turns dark after erase cycle (see Fig. 2-9 for location of adjustments on storage board). Turn STORED INTENSITY control clockwise. Screen should turn bright.

j. Set test oscilloscope to normal triggering at 20 ms/div and 5 volts/div vertical deflection. Connect a 10X probe to the test oscilloscope and connect the tip to test point target on the storage board.

k. Press and hold the ERASE button for a repetitive erase cycle. Adjustment of the trigger level may be necessary for a proper display. See Fig. 2-10.

l. CHECK—for the proper display. It may be possible for the CRT to meet steps b to i and still be out of adjustment.

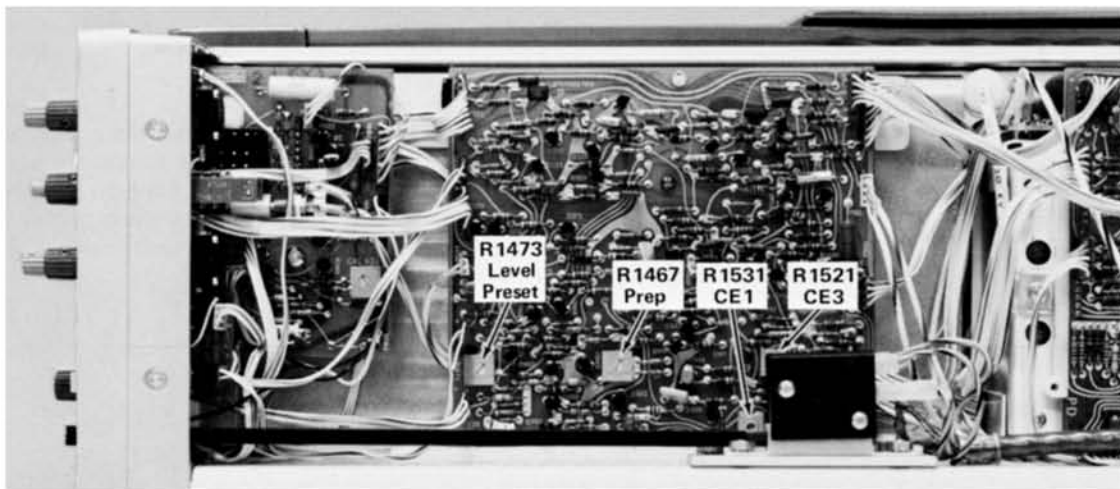

Fig. 2-9. Location of adjustment on storage board.

Calibration—7613/R7613 Service

m. ADJUST—Level Preset (R1473) and Prep (R1467) adjustments if necessary, decrease both levels to -10 volts on the test oscilloscope. Increase both levels equally until the screen turns bright. Increase the Prep adjustment level for approximately 4 volts higher than the Level Preset level.

n. Release ERASE switch. Turn PERSISTENCE control clockwise, note 15-volt pulses on test oscilloscope. Turn PERSISTENCE control counterclockwise and note change in pulse width.

40. CHECK Stored Writing Rate

a. Connect a low frequency sine-wave generator set at 250 kHz through BNC cable and a 50 ohm termination to the input of the 7A15A in the vertical compartment of the 7613. The sine-wave amplitude should be about 6 divisions.

b. Set the 7613 time base unit to single sweep, and PERSISTENCE to Max. Press the ERASE button and reset the time base unit.

c. CHECK—that the display is stored on the screen. If no display is stored, increase the Stored intensity control setting, and reset the time base sweep. Check that the display is stored for more than 15 seconds.

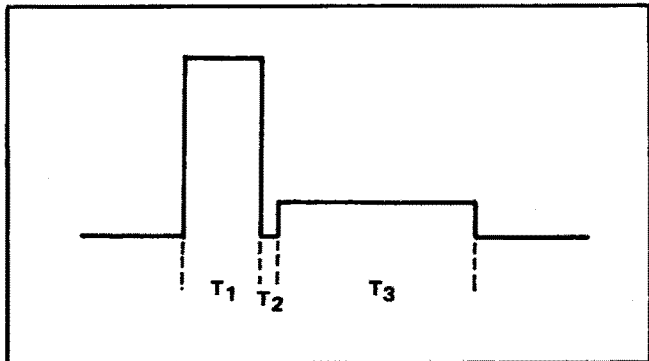

Fig. 2-10. Erase pulses from Storage Target Backplate Amplifier.

d. Change the frequency of the low frequency sine-wave generator to 50 kHz. Reset the sweep of the time base unit.

e. CHECK—that the stored display is stored on the screen for more than 60 seconds. For longer viewtimes, reduce the STORED INTENSITY control setting.

41. Check Save Functions

a. Store a display.

b. Press the SAVE button (in).

c. Turn SAVETIME control clockwise for a visible display.

d. CHECK—that the erase switch will not erase the display when pressed.

e. Turn SAVETIME control counterclockwise and into switch detent. Press the SAVE button (out).

f. CHECK—that display is not stored. Turn SAVETIME control out of switch detent.

42. Check Remote Erase

a. Ground center pin of the remote erase connector on rear panel.

b. CHECK—for an erase cycle.

This completes the calibration/checkout procedure for the 7613. Disconnect all test equipment and replace the side panels. If the instrument has been completely checked and adjusted to the tolerances given in this procedure, it will meet or exceed the specifications given in the Operators Manual.

CIRCUIT DESCRIPTION

Introduction

This section of the manual contains a description of the circuitry used in the 7613 Oscilloscope. The description begins with a discussion of the instrument using the basic block diagram shown in Fig. 3-1. Then, each circuit is described in detail using detailed block diagrams to show the interconnections between the stages within each major circuit and the relationship of the external controls and connectors to the individual stages.

A complete block diagram is located in the Diagrams section at the back of this manual. This block diagram shows the overall relationship between all of the circuits. Complete schematics of each circuit are also given in the Diagrams section. Refer to these diagrams throughout the following circuit description for electrical values and relationship.

BLOCK DIAGRAM

The following discussion is provided to aid in understanding the overall concept of the 7613 before the individual circuits are discussed in detail. A basic block diagram of the 7613 is shown in Fig. 3-1. Only the basic interconnections between the individual blocks are shown on this diagram. Each block represents a major circuit within the instrument. The number on each block refers to the complete circuit diagram located at the rear of the manual.

Vertical signals to be displayed on the CRT are applied to the Vertical Interface circuit from both vertical plug-in compartments. The Vertical Interface circuit determines whether the signal from the left and/or right vertical unit is displayed. The selected vertical signal is then amplified by the Vertical Amplifier circuit to bring it to the level necessary to drive the vertical deflection plates of the CRT.

Horizontal signals for display on the CRT are connected to the Horizontal Amplifier circuit from the horizontal plug-in compartment. The Horizontal Amplifier circuit amplifies this signal to provide the horizontal deflection for the CRT.

The internal trigger signals from the vertical plug-in units are connected to the Trigger Selector circuit. This circuit selects the trigger signal which is connected to the

horizontal plug-in unit. The Calibrator circuit produces a square-wave output signal with accurate amplitude which can be used to check the calibration of this instrument and the compensation of probes.

The Logic circuit develops control signals for use in other circuits within this instrument and the plug-in units. These output signals automatically determine the correct instrument operation in relation to the plug-ins installed and/or selected, plug-in control settings, and 7613 control settings. The CRT circuit produces the voltages and contains the controls necessary for operation of the cathode-ray tube. It also contains the Z-Axis Amplifier which provides the drive signal to control the intensity level of the CRT display.

The power necessary for the operation of this instrument is produced by the Low-Voltage Power Supply circuit. These voltages are connected to all circuits within the instrument.

CIRCUIT OPERATION

This section provides a detailed description of the electrical operation and relationship of the circuits in the 7613. The theory of operation for circuits unique to this instrument is described in detail in this discussion. Circuits which are commonly used in the electronics industry are not described in detail. If more information is desired on these commonly used circuits, refer to the following textbooks (also see books under Logic Fundamentals):

TEKTRONIX Circuit Concepts Books (order from your local TEKTRONIX Field Office or representative).

Cathode-Ray Tubes, TEKTRONIX Part No. 062-0852-01.

Horizontal Amplifier Circuits, TEKTRONIX Part No. 062-1144-00.

Oscilloscope Trigger Circuits, TEKTRONIX Part No. 062-1056-00.

Power Supply Circuits, TEKTRONIX Part No. 062-0888-01.

Sweep Generator Circuits, TEKTRONIX Part No. 062-1098-01.

Vertical Amplifier Circuits, TEKTRONIX Part No. 062-1145-00.

Storage Cathode-Ray Tubes and Circuits, TEKTRONIX Part No. 062-0861-01.

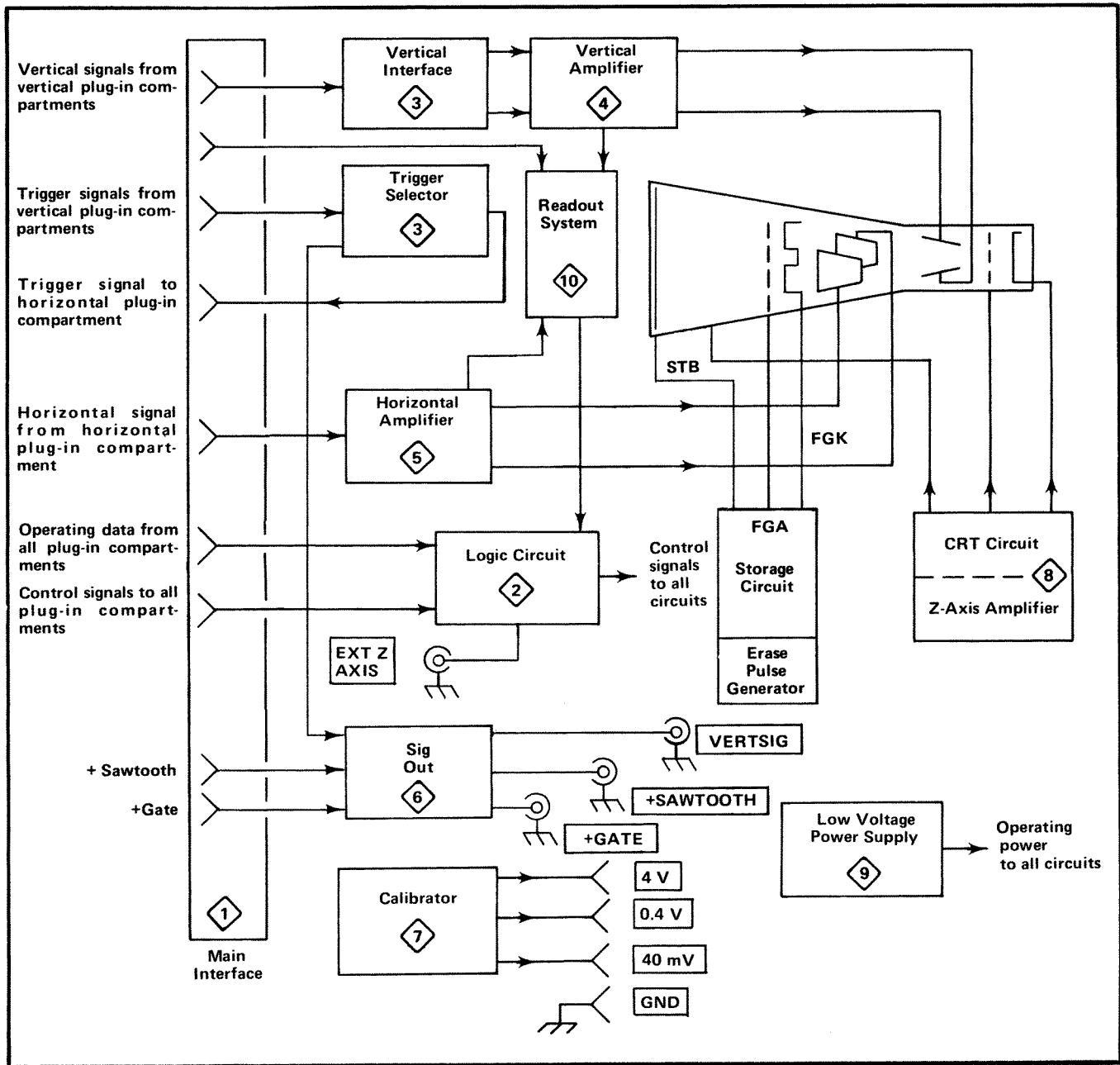

Fig. 3-1. Basic block diagram of 7613 Oscilloscope.

Phillip Cutler, "Semiconductor Circuit Analysis", McGraw-Hill, New York, 1964.

Lloyd P. Hunter (Ed.), "Handbook of Semiconductor Electronics", second edition, McGraw-Hill, New York, 1962.

Jacob Millman and Herbert Taub, "Pulse, Digital, and Switching Waveforms", McGraw-Hill, New York, 1965.

The following circuit analysis is written around the detailed block diagrams which are given for each major circuit. These detailed block diagrams give the names of the individual stages within the major circuits and show how they are connected together to form the major circuit. The block diagrams also show the inputs and outputs for each circuit and the relationship of the external controls and connectors to the individual stages. The circuit diagrams from which the detailed block diagrams are derived are shown in the Diagrams section.

LOGIC FUNDAMENTALS

Digital logic techniques are used to perform many functions within this instrument. The function and operation of the logic circuits are described using logic symbology and terminology. This portion of the manual is provided to aid in the understanding of these symbols and terms. The following information is a basic introduction to logic concepts, not a comprehensive discussion of the subject. For further information on binary number systems and the associated Boolean Algebra concepts, the derivation of logic functions, a more detailed analysis of digital logic, etc., refer to the following textbooks:

TEKTRONIX Circuit Concepts booklet, "Digital Concepts", TEKTRONIX Part No. 062-1030-00.

Robert C. Baron and Albert T. Piccirilli, "Digital Logic and Computer Operation", McGraw-Hill, New York, 1967.

Thomas C. Bartee, "Digital Computer Fundamentals", McGraw-Hill, New York, 1966.

Yaohan Chu, "Digital Computer Design Fundamentals", McGraw-Hill, New York, 1962.

Joseph Millman and Herbert Taub, "Pulse, Digital, and Switching Waveforms", McGraw-Hill, New York, Chapters 9 – 11, 1965.

Symbols

The operation of circuits within the 7613 which use digital techniques is described using the graphic symbols set forth in military standard MIL-STD-806B. Table 3-1 provides a basic logic reference for the logic devices used within this instrument. Any deviations from the standard symbology, or devices not defined by this standard will be described in the circuit description for the applicable device.

TABLE 3-1
Basic Logic Reference





Device	Symbol	Description	Input/Output Table																		
AND gate		A device with two or more inputs and one output. The output of the AND gate is HI if and only if all of the inputs are at the HI state.	<table border="1"> <thead> <tr> <th colspan="2">Input</th> <th>Output</th> </tr> <tr> <th>A</th> <th>B</th> <th>X</th> </tr> </thead> <tbody> <tr> <td>LO</td> <td>LO</td> <td>LO</td> </tr> <tr> <td>LO</td> <td>HI</td> <td>LO</td> </tr> <tr> <td>HI</td> <td>LO</td> <td>LO</td> </tr> <tr> <td>HI</td> <td>HI</td> <td>HI</td> </tr> </tbody> </table>	Input		Output	A	B	X	LO	LO	LO	LO	HI	LO	HI	LO	LO	HI	HI	HI
Input		Output																			
A	B	X																			
LO	LO	LO																			
LO	HI	LO																			
HI	LO	LO																			
HI	HI	HI																			
NAND gate		A device with two or more inputs and one output. The output of the NAND gate is LO if and only if all of the inputs are at the HI state.	<table border="1"> <thead> <tr> <th colspan="2">Input</th> <th>Output</th> </tr> <tr> <th>A</th> <th>B</th> <th>X</th> </tr> </thead> <tbody> <tr> <td>LO</td> <td>LO</td> <td>HI</td> </tr> <tr> <td>LO</td> <td>HI</td> <td>HI</td> </tr> <tr> <td>HI</td> <td>LO</td> <td>HI</td> </tr> <tr> <td>HI</td> <td>HI</td> <td>LO</td> </tr> </tbody> </table>	Input		Output	A	B	X	LO	LO	HI	LO	HI	HI	HI	LO	HI	HI	HI	LO
Input		Output																			
A	B	X																			
LO	LO	HI																			
LO	HI	HI																			
HI	LO	HI																			
HI	HI	LO																			
OR gate		A device with two or more inputs and one output. The output of the OR gate is HI if one or more of the inputs are at the HI state.	<table border="1"> <thead> <tr> <th colspan="2">Input</th> <th>Output</th> </tr> <tr> <th>A</th> <th>B</th> <th>X</th> </tr> </thead> <tbody> <tr> <td>LO</td> <td>LO</td> <td>LO</td> </tr> <tr> <td>LO</td> <td>HI</td> <td>HI</td> </tr> <tr> <td>HI</td> <td>LO</td> <td>HI</td> </tr> <tr> <td>HI</td> <td>HI</td> <td>HI</td> </tr> </tbody> </table>	Input		Output	A	B	X	LO	LO	LO	LO	HI	HI	HI	LO	HI	HI	HI	HI
Input		Output																			
A	B	X																			
LO	LO	LO																			
LO	HI	HI																			
HI	LO	HI																			
HI	HI	HI																			
NOR gate		A device with two or more inputs and one output. The output of the NOR gate is LO if one or more of the inputs are at the HI state.	<table border="1"> <thead> <tr> <th colspan="2">Input</th> <th>Output</th> </tr> <tr> <th>A</th> <th>B</th> <th>X</th> </tr> </thead> <tbody> <tr> <td>LO</td> <td>LO</td> <td>HI</td> </tr> <tr> <td>LO</td> <td>HI</td> <td>LO</td> </tr> <tr> <td>HI</td> <td>LO</td> <td>LO</td> </tr> <tr> <td>HI</td> <td>HI</td> <td>LO</td> </tr> </tbody> </table>	Input		Output	A	B	X	LO	LO	HI	LO	HI	LO	HI	LO	LO	HI	HI	LO
Input		Output																			
A	B	X																			
LO	LO	HI																			
LO	HI	LO																			
HI	LO	LO																			
HI	HI	LO																			

TABLE 3-1 (cont)
Basic Logic Reference



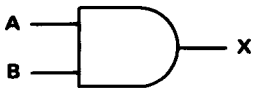

Device	Symbol	Description	Input/Output Table																				
Inverter		A device with one input and one output. The output state is always opposite to the input state.	<table border="1"> <thead> <tr> <th colspan="2">Input</th> <th>Output</th> </tr> <tr> <th>A</th> <th></th> <th>X</th> </tr> </thead> <tbody> <tr> <td>LO</td> <td></td> <td>HI</td> </tr> <tr> <td>HI</td> <td></td> <td>LO</td> </tr> </tbody> </table>	Input		Output	A		X	LO		HI	HI		LO								
Input		Output																					
A		X																					
LO		HI																					
HI		LO																					
LO-state indicator		A small circle at the input or output of a symbol indicates that the LO state is the significant state. Absence of the circle indicates that the HI state is the significant state. Two examples follow:																					
		AND gate with LO-state indicator at the A input. The output of this gate is HI if and only if the A input is LO and the B input is HI.	<table border="1"> <thead> <tr> <th colspan="2">Input</th> <th>Output</th> </tr> <tr> <th>A</th> <th>B</th> <th>X</th> </tr> </thead> <tbody> <tr> <td>LO</td> <td>LO</td> <td>LO</td> </tr> <tr> <td>LO</td> <td>HI</td> <td>HI</td> </tr> <tr> <td>HI</td> <td>LO</td> <td>LO</td> </tr> <tr> <td>HI</td> <td>HI</td> <td>LO</td> </tr> </tbody> </table>	Input		Output	A	B	X	LO	LO	LO	LO	HI	HI	HI	LO	LO	HI	HI	LO		
	Input		Output																				
A	B	X																					
LO	LO	LO																					
LO	HI	HI																					
HI	LO	LO																					
HI	HI	LO																					
	OR gate with LO-state indicator at the A input: The output of this gate is HI if either the A input is LO or the B input is HI.	<table border="1"> <thead> <tr> <th colspan="2">Input</th> <th>Output</th> </tr> <tr> <th>A</th> <th>B</th> <th>X</th> </tr> </thead> <tbody> <tr> <td>LO</td> <td>LO</td> <td>HI</td> </tr> <tr> <td>LO</td> <td>HI</td> <td>HI</td> </tr> <tr> <td>HI</td> <td>LO</td> <td>LO</td> </tr> <tr> <td>HI</td> <td>HI</td> <td>HI</td> </tr> </tbody> </table>	Input		Output	A	B	X	LO	LO	HI	LO	HI	HI	HI	LO	LO	HI	HI	HI			
Input		Output																					
A	B	X																					
LO	LO	HI																					
LO	HI	HI																					
HI	LO	LO																					
HI	HI	HI																					
Edge symbol		Normally superimposed on an input line to a logic symbol. Indicates that this input (usually the trigger input of a flip-flop) responds to the indicated transition of the applied signal.																					
Triggered (toggle) Flip-Flop		A bistable device with one input and two outputs (either or both outputs may be used). When triggered, the outputs change from one stable state to the other stable state with each trigger. The outputs are complementary (i.e., when one output is HI the other is LO). The edge symbol on the trigger (T) input may be of either polarity depending on the device.	<table border="1"> <thead> <tr> <th colspan="2">Input</th> <th colspan="2">Output</th> </tr> <tr> <th>Condition before trigger pulse</th> <th>Condition after trigger pulse</th> <th>X</th> <th>X̄</th> </tr> </thead> <tbody> <tr> <td>X</td> <td>X̄</td> <td>X</td> <td>X̄</td> </tr> <tr> <td>LO</td> <td>HI</td> <td>HI</td> <td>LO</td> </tr> <tr> <td>HI</td> <td>LO</td> <td>LO</td> <td>HI</td> </tr> </tbody> </table>	Input		Output		Condition before trigger pulse	Condition after trigger pulse	X	X̄	X	X̄	X	X̄	LO	HI	HI	LO	HI	LO	LO	HI
Input		Output																					
Condition before trigger pulse	Condition after trigger pulse	X	X̄																				
X	X̄	X	X̄																				
LO	HI	HI	LO																				
HI	LO	LO	HI																				

TABLE 3-1 (cont)
Basic Logic Reference

Device	Symbol	Description	Input/Output Table																																				
Set-Clear (J-K) Flip-Flop		A bistable device with two inputs and two outputs (either or both outputs may be used). The outputs change state in response to the states at the inputs. The outputs are complementary (i.e., when one output is HI the other is LO).	<table border="1"> <thead> <tr> <th colspan="2">Input</th> <th colspan="2">Output</th> </tr> <tr> <th>A</th> <th>B</th> <th>X</th> <th>\bar{X}</th> </tr> </thead> <tbody> <tr> <td>LO</td> <td>LO</td> <td colspan="2">No change</td> </tr> <tr> <td>LO</td> <td>HI</td> <td>LO</td> <td>HI</td> </tr> <tr> <td>HI</td> <td>LO</td> <td>HI</td> <td>LO</td> </tr> <tr> <td>HI</td> <td>HI</td> <td colspan="2">Changes state</td> </tr> </tbody> </table>	Input		Output		A	B	X	\bar{X}	LO	LO	No change		LO	HI	LO	HI	HI	LO	HI	LO	HI	HI	Changes state													
Input		Output																																					
A	B	X	\bar{X}																																				
LO	LO	No change																																					
LO	HI	LO	HI																																				
HI	LO	HI	LO																																				
HI	HI	Changes state																																					
D (data) Type Flip-Flop		A bistable device with two inputs and two outputs (either or both outputs may be used). When triggered the state of the "1" output changes to the state at the data (D) input prior to the trigger. The outputs are complementary (i.e., when one output is HI the other is LO). The edge symbol on the trigger (T) input may be of either polarity, depending on the device.	<table border="1"> <thead> <tr> <th colspan="2">Input</th> <th colspan="2">Output</th> </tr> <tr> <th>A</th> <th>X</th> <th>\bar{X}</th> <th></th> </tr> </thead> <tbody> <tr> <td>LO</td> <td>LO</td> <td>HI</td> <td></td> </tr> <tr> <td>HI</td> <td>HI</td> <td>LO</td> <td></td> </tr> </tbody> </table> <p>Output conditions shown after trigger pulse</p>	Input		Output		A	X	\bar{X}		LO	LO	HI		HI	HI	LO																					
Input		Output																																					
A	X	\bar{X}																																					
LO	LO	HI																																					
HI	HI	LO																																					
Triggered Set-Clear (J-K) Flip-Flop		A bistable device with three or more inputs and two outputs (either or both outputs may be used). When triggered, the outputs change state in response to the states at the inputs prior to the trigger. The outputs are complementary (i.e., when one output is HI the other is LO). The edge symbol on the trigger (T) input may be of either polarity depending on the device.	<table border="1"> <thead> <tr> <th colspan="2">Input</th> <th colspan="2">Output</th> </tr> <tr> <th>A</th> <th>B</th> <th>X</th> <th>\bar{X}</th> </tr> </thead> <tbody> <tr> <td>LO</td> <td>LO</td> <td colspan="2">No change</td> </tr> <tr> <td>LO</td> <td>HI</td> <td>LO</td> <td>HI</td> </tr> <tr> <td>HI</td> <td>LO</td> <td>HI</td> <td>LO</td> </tr> <tr> <td>HI</td> <td>HI</td> <td colspan="2">Changes state</td> </tr> </tbody> </table> <p>Output conditions shown after trigger pulse</p>	Input		Output		A	B	X	\bar{X}	LO	LO	No change		LO	HI	LO	HI	HI	LO	HI	LO	HI	HI	Changes state													
Input		Output																																					
A	B	X	\bar{X}																																				
LO	LO	No change																																					
LO	HI	LO	HI																																				
HI	LO	HI	LO																																				
HI	HI	Changes state																																					
Flip-flop with direct inputs (may be applied to all triggered flip-flops)		For devices with direct-set (S_D) or direct-clear (C_D) inputs, the indicated state at either of these inputs over-rides all other inputs (including trigger) to set the outputs to the states shown in the input/output table.	<table border="1"> <thead> <tr> <th colspan="4">Input</th> <th colspan="2">Output</th> </tr> <tr> <th>A</th> <th>B</th> <th>C</th> <th>D</th> <th>X</th> <th>\bar{X}</th> </tr> </thead> <tbody> <tr> <td>1</td> <td>1</td> <td>LO</td> <td>LO</td> <td colspan="2">No change¹</td> </tr> <tr> <td>Φ</td> <td>Φ</td> <td>LO</td> <td>HI</td> <td>LO</td> <td>HI</td> </tr> <tr> <td>Φ</td> <td>Φ</td> <td>HI</td> <td>LO</td> <td>HI</td> <td>LO</td> </tr> <tr> <td>Φ</td> <td>Φ</td> <td>HI</td> <td>HI</td> <td colspan="2">Undefined</td> </tr> </tbody> </table> <p>Φ = Has no effect in this case</p> <p>¹Output state determined by conditions at triggered inputs</p>	Input				Output		A	B	C	D	X	\bar{X}	1	1	LO	LO	No change ¹		Φ	Φ	LO	HI	LO	HI	Φ	Φ	HI	LO	HI	LO	Φ	Φ	HI	HI	Undefined	
Input				Output																																			
A	B	C	D	X	\bar{X}																																		
1	1	LO	LO	No change ¹																																			
Φ	Φ	LO	HI	LO	HI																																		
Φ	Φ	HI	LO	HI	LO																																		
Φ	Φ	HI	HI	Undefined																																			

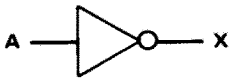
NOTE

Logic symbols used on the diagrams depict the logic function and may differ from the manufacturer's data.

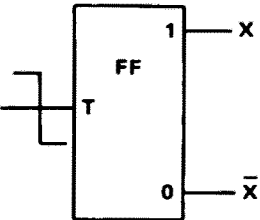
Logic Polarity

All logic functions are described using the positive logic. Positive logic is a system of notation where the more positive of two levels (HI) is called the true or 1-state; the more negative level (LO) is called the false or 0-state. The HI-LO method of notation is used in this logic description. The specific voltages which constitute a HI or LO state vary between individual devices.

NOTE

The HI-LO logic notation can be conveniently converted to 1-0 notation by disregarding the first letter of each step. Thus:

HI = 1

LO = 0

Wherever possible, the input and output lines are named to indicate the functions that they perform when at the HI (true) state. For example, the line labeled, "Display B Command" means that the B Time-Base unit will be displayed when this line is HI or true. Likewise, the line labeled "X-Compensation Inhibit" means that the X-Compensation function is inhibited or disabled when this line is HI.

Input/Output Tables

Input/output (truth) tables are used in conjunction with the logic diagrams to show the input combinations which are of importance to a particular function, along with the resultant output conditions. This table may be given either for an individual device or for a complete logic stage. For examples of input/output tables for individual devices, see Table 3-1.

Non-Digital Devices

It should be noted that not all of the integrated circuit devices in this instrument are digital devices. The function of non-digital devices will be described individually using operating waveforms or other techniques to illustrate their function.

MAIN INTERFACE

Diagram 1 shows the plug-in interface and the interconnections between the plug-in compartments, circuit boards, etc. of this instrument.

LOGIC CIRCUIT

The Logic Circuit develops control signals for use in other circuits within this instrument and in the associated plug-in units. These output signals automatically determine the correct instrument operation in relation to the plug-in installed and/or selected, plug-in control settings, and the 7613 control settings. A schematic of this circuit is shown on diagram 2 at the rear of this manual.

Logic Block Diagram

A block diagram of the Logic Circuit is shown in Fig. 3-2. This diagram shows the source of the input control signals, the output signals produced by this circuit, and the basic interconnections between blocks. The interconnections shown are intended only to indicate inter-relationship between blocks and do not indicate a direct connection or that only a single connection is made between the given blocks. Details of the inter-relationship between stages within this circuit are given in the circuit description which follows.

The operation of each of these stages is discussed relating the input signals and/or levels to the output, with consideration given to the various modes of operation that may affect the stage. A logic diagram is also provided where applicable. These diagrams are not discussed in detail, but are provided to aid in relating the function performed by a given stage to standard logic techniques. It should be noted that these logic diagrams are not an exact representation of the circuit but are only a logic diagram of the function performed by the stage. An input/output table is given, where applicable, for use along with this circuit description and logic diagram. These input/output tables document the combination of input conditions which are of importance to perform the prescribed function of an individual stage.

Z-Axis Logic

The Z-Axis Logic stage produces an output current which sets the intensity of the display on the CRT. The level of this output current is determined by the setting of the front-panel INTENSITY control, an external signal from the rear panel EXT Z AXIS input connector, or signals from the plug-in compartments. The Vertical Chopped Blanking from U55 is applied to this stage to blank the CRT display during vertical trace switching. The Intensity Limit input from the horizontal plug-in compartment provides protection for the CRT phosphor at slow sweep rates.

The Z-Axis Logic stage consists of transistor 108, dual-transistor Q90 and integrated circuit U99, which is a five-transistor array. A simplified schematic of the Z-Axis

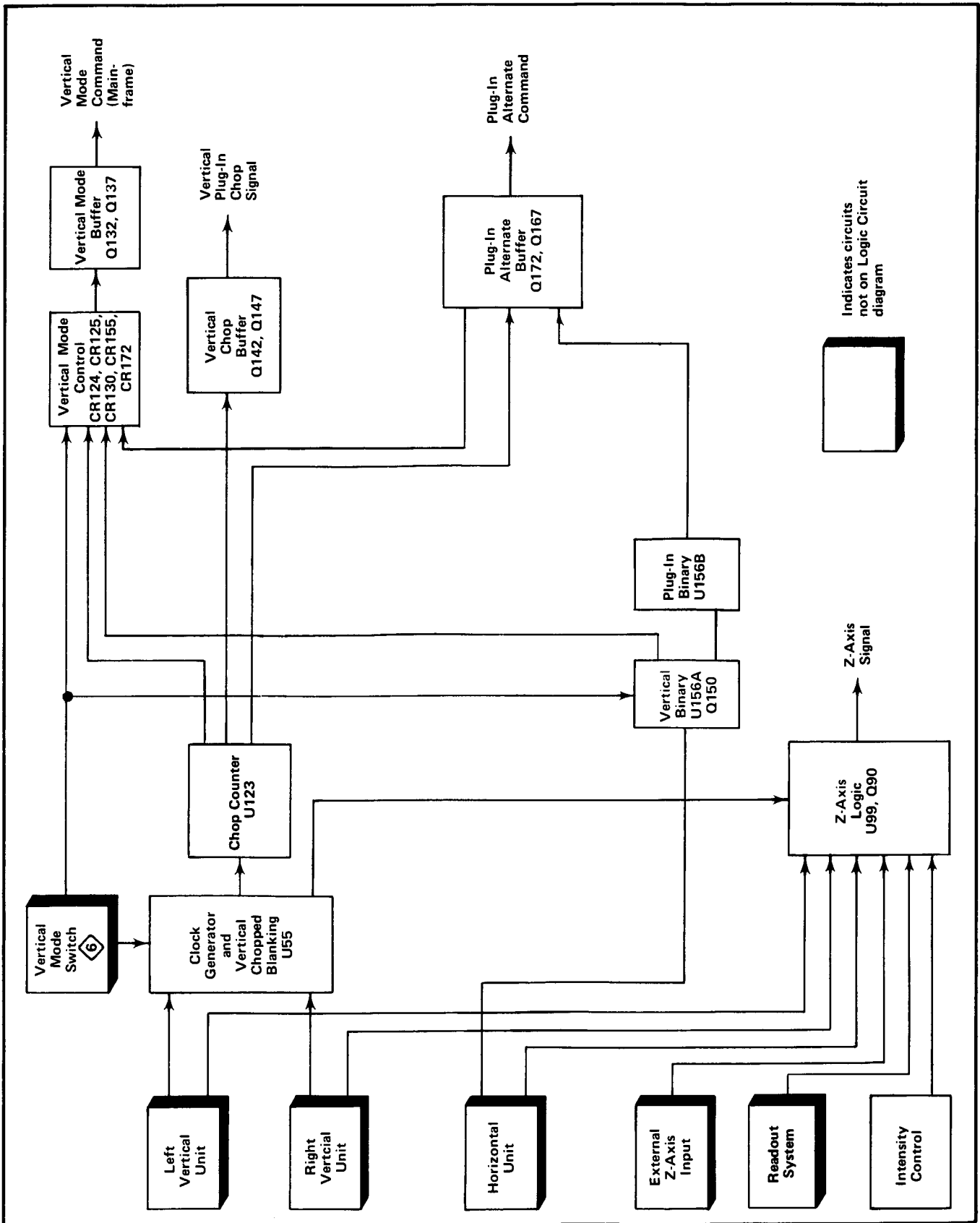

Fig. 3-2. Block diagram of Logic circuit.

Circuit Description—7613/R7613 Service

Logic stage is shown in Fig. 3-3. Only the components essential to operation of this stage are shown in this simplified schematic.

Transistor U99C is connected in the common-base configuration to provide the output for this stage. The collector load for U99C is provided by the Z-Axis Amplifier in the CRT Circuit. Transistors U99D and U99E provide a current-limiting action for this stage. The collector current of U99D, represented by I_t , is the maximum amount of current that can flow in the circuit. The amount of this current is determined by the relationship between the Intensity Limit and Vertical Chopped Blanking. When both of these inputs are HI the collector current of U99D, I_t , is

maximum. This maximum level of I_t is determined by current I_1 in the base circuit of U99D established by networks R76-R77 and R62-R63 into R110 and the collector of U99E. During Vertical Chopped Blanking, the respective input level goes LO. This shunts the current I_1 from the base of U99D so the collector current of U99D, I_t , drops to minimum to blank the CRT display during vertical trace switching.

The Intensity Limit function limits the output current of this stage to protect the CRT phosphor whenever the time-base unit is set to a slow sweep rate. For conditions that do not require limiting, quiescent current is added to I_1 from the +15-volt supply through R76-R77. When the time-base unit is set to a sweep rate which requires intensity

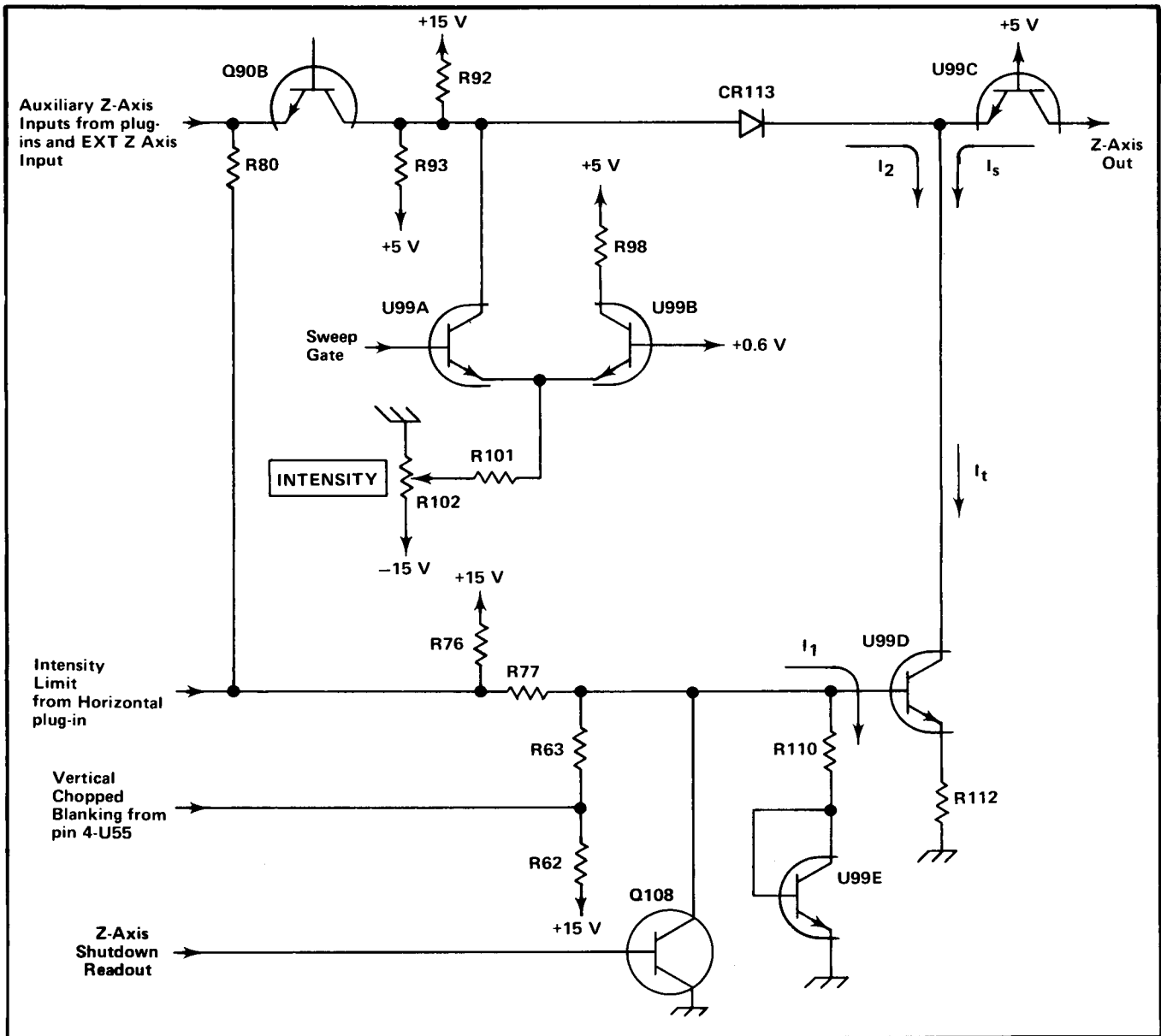

Fig. 3-3. Simplified schematic of Z-Axis Logic stage.

limiting, the Intensity Limit input goes to ground level in the plug-in unit. This reduces the level of I_1 at the base of U99D and therefore reduces I_t and the output current to reduce the intensity of the display. At the same time, the ground level from the Intensity Limit input is connected to the emitter of Q90B through R80. This connection limits the maximum level to which the INTENSITY control can be set to aid in obtaining intensity limiting at slow sweep rates.

The collector current of U99D is made up of two currents; I_s and I_2 is determined by divider R92 and R93. When the Sweep Gate level at the base of U99A is LO (no sweep in progress), I_2 is at its maximum level so that I_s is minimum to provide minimum intensity of the display ($I_s + I_2$ is always equal to I_t). During sweep time, the Sweep Gate level at the base of U99A as established by INTENSITY control R102 determines the output current. As the INTENSITY control is turned toward maximum, the level of I_2 decreases. This allows I_s to increase to produce a brighter display. The Auxiliary Z-Axis Inputs from the plug-in compartments and the intensity modulating signal from the EXT Z-AXIS input connector are connected to the emitter of Q90B. These signals modulate the level of I_2 to, in turn, modulate the intensity of the display.

When readout information is to be displayed on the CRT, the Z-Axis shutdown goes LO. This forward biases Q180, and it saturates, shunting I_1 , through Q108 to ground. This reduces the output current to zero during the readout time.

Clock Generator

One half of integrated circuit U55 along with the external components shown in Fig. 3-4A make up the Clock Generator stage. R1, Q1, Q2, and Q3 represent an equivalent circuit contained within U55A. This circuit along with discrete components C59, R56, R57, and R59 comprise a two-megahertz free-running oscillator to provide a timing signal (clock) for mainframe vertical and plug-in chopping.

The stage operates as follows: Assume that Q2 is conducting and Q1 is off. The collector current of Q2 produces a voltage drop across R1 which holds Q1 off. This negative level at the collector of Q2 is also connected to pin 14 through Q3 (see waveforms in Fig. 3-4B at time T_0). Since there is no current through Q1, C59 begins to charge towards -15 volts through R56-R57. The emitter of Q1 goes negative as C59 charges until it reaches a level about 0.6 volt more negative than the level at its base. Then, Q1 is forward biased and its emitter rapidly rises positive. Since

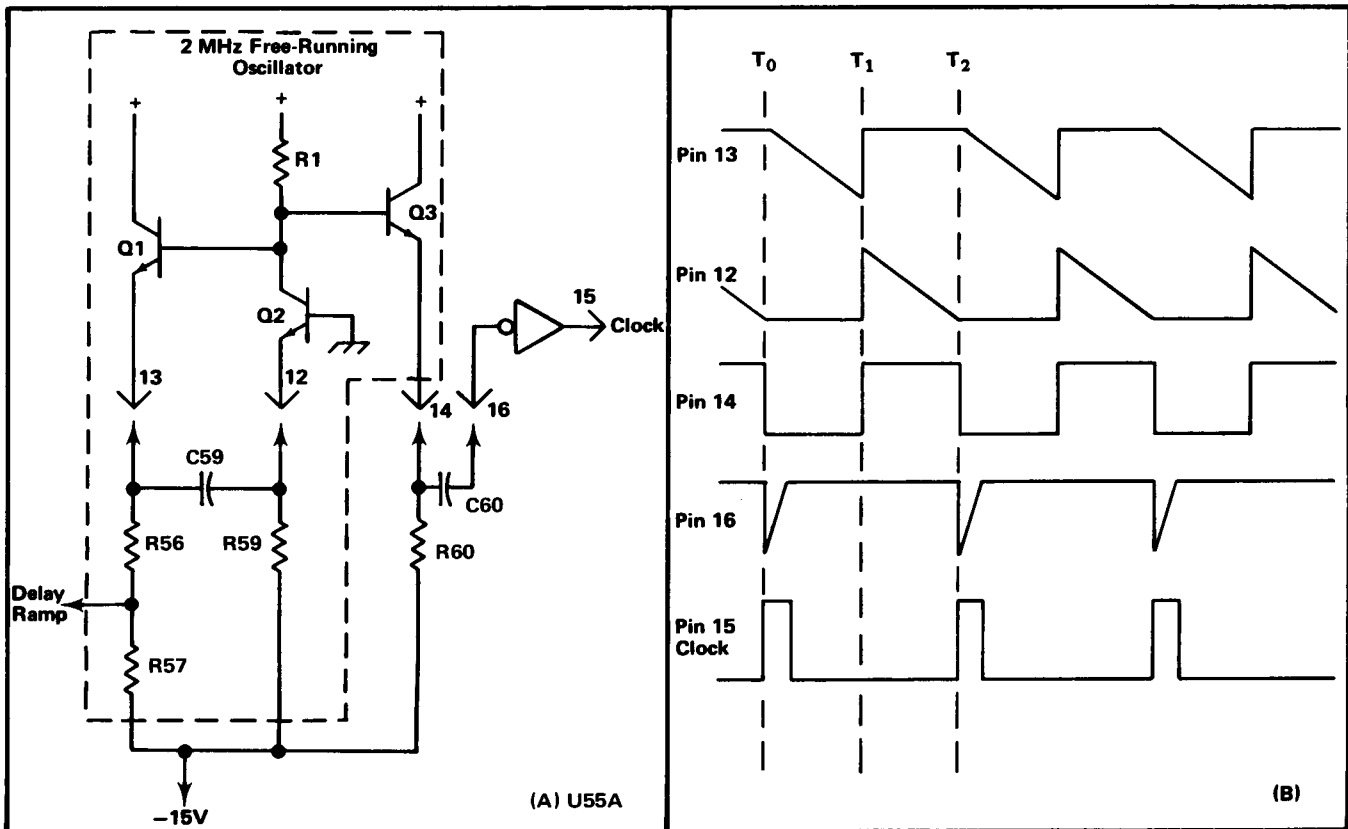

Fig. 3-4. (A) Diagram of Clock Generator stage. (B) Idealized waveforms from Clock Generator stage.

C59 cannot change its charge instantaneously, the sudden change in voltage at the emitter of Q1 pulls the emitter of Q2 positive also, to reverse-bias it. With Q2 reverse biased, its collector rises positive to produce a positive output level at pin 14 (see time T_1 on the waveforms).

Now, conditions are reversed. Since Q2 is reverse biased, there is no current through it. Therefore, C59 can begin to discharge through R59. The emitter level of Q2 follows the discharge of C59 until it reaches a level about 0.6 volt more negative than its base. Then Q2 is forward biased and its collector drops negative to reverse-bias Q1. The level at pin 14 drops negative also, to complete the cycle. Once again, C59 begins to charge through R56-R57 to start the second cycle.

Two outputs are provided from this oscillator. The Delay Ramp signal from the junction of R56-R57 is connected to the Vertical Chopped Blanking stage. This signal has the same waveshape as shown by the waveform at pin 13, with its slope determined by the divider ratio between R56-R57. A square-wave output is provided at pin 14. The frequency of this square wave is determined by the RC relationship between C59 and R1. The duty cycle is determined by the ratio of R56-R57 to R59.

The square wave at pin 14 is connected to pin 16 through C60. C60, along with the internal resistance of U55A, differentiates the square wave at pin 14 to produce a negative-going pulse coincident with the falling edge of the square wave (positive-going pulse coincident with rising edge has no effect on circuit operation). This negative-going pulse is connected to pin 15 through an inverter-shaper which is also part of U55A. The output at pin 15 is a positive-going Clock pulse at a repetition rate of about two megahertz.

Vertical Chopped Blanking

The Vertical Chopped Blanking stage is made up of the remaining half of integrated circuit U55B, Fig. 3-6A. This stage determines if Vertical Chopped Blanking pulses are required, based upon the operating mode of the vertical system or the plug-in units (dual trace units only). Vertical Chopped Blanking pulses are produced if: (1) VERT MODE switch is set to CHOP; (2) dual-trace vertical unit is operating in the chopped mode and that unit is being displayed; (3) dual-trace vertical unit is operating in the chopped mode with the VERT MODE switch set to ADD. The repetition rate of the negative-going Vertical Chopped Blanking pulse output at pin 4 is always two megahertz as determined by the Clock Generator stage.

The Delay Ramp signal from the Clock Generator stage determines the repetition rate and pulse width of the Vertical Chopped Blanking pulses. The Delay Ramp applied to pin 10 starts to go negative from a level of about +1.1 volts coincident with the leading edge of the Clock pulse (see waveforms in Fig. 3-5B). This results in a HI quiescent condition for the Vertical Chopped Blanking pulse. The slope of the negative-going Delay Ramp is determined by the Clock Generator stage. As it reaches a level slightly negative from ground, the Vertical Chopped Blanking pulse output level changes to the LO state. This signal remains LO until the Delay Ramp goes HI again. Notice the delay between the leading edge of the Clock pulse generated by U55A and the leading edge of the Vertical Chopped Blanking pulses (see Fig. 3-5B). The amount of delay between the leading edges of these pulses is determined by the slope of the Delay Ramp applied to pin 10. This delay is necessary due to the delay line in the vertical deflection system. Otherwise, the trace blanking resulting from the Vertical Chopped Blanking pulse would not coincide with the switching between the displayed traces. The duty cycle of the square wave produced in the Clock Generator stage determines the pulse width of the Vertical Chopped Blanking pulses (see Clock Generator discussion for more information).

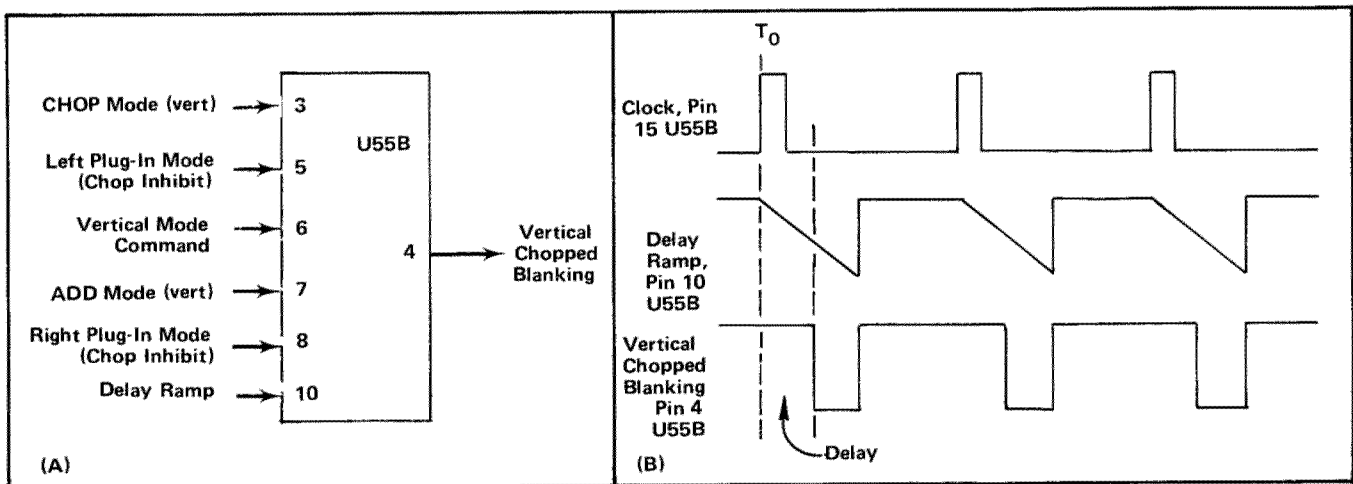

Fig. 3-5. (A) Input and output pins for Vertical Chopped Blanking stage, (B) Idealized waveforms for Vertical Chopped Blanking stage.

Whenever this instrument is turned on, the Vertical Chopped Blanking pulses are being produced at a two-megahertz rate. However, these pulses are available as an output at pin 4 only when the remaining inputs to U55B are at the correct levels. The following discussions give the operating conditions which produce Vertical Chopped Blanking pulses to blank the CRT during vertical trace switching. Fig. 3-5A identifies the functions of the pins of U55B.

1. CHOP VERTICAL MODE

When the VERT MODE switch is set to CHOP, Vertical Chopped Blanking pulses are available at pin 4 at all times. The input conditions necessary are:

Pin 3 HI—VERT MODE switch set to CHOP.

Pin 7 LO—VERT MODE switch set to any position except ADD.

Pin 10 LO—Delay Ramp more negative than about 0 volts.

2. LEFT VERTICAL UNIT SET FOR CHOPPED OPERATION

If the Left Vertical unit is set for chopped operation, the setting of the VERT MODE switch determines whether the Vertical Chopped Blanking pulses are available. If the VERT MODE switch is set to the CHOP position, conditions are as described in No. 1 above. Operation in the ADD position of the VERT MODE switch is given later. For the LEFT position of the VERT MODE switch, or when the left vertical unit is to be displayed in the ALT mode, Vertical Chopped Blanking pulses are available at all times (two-megahertz rate). The input conditions are:

Pin 3 LO—VERT MODE switch set to any position except CHOP.

Pin 5 LO—Left vertical unit set to chopped mode.

Pin 6 LO—Left vertical unit to be displayed (Vertical Mode Command LO).

Pin 7 LO—VERT MODE switch set to any position except ADD.

Pin 10 LO—Delay Ramp more negative than about 0 volts.

Notice that the Vertical Mode Command at pin 6 must be LO for output pulses to be available at pin 4. This means that when the VERT MODE switch is set to ALT, Vertical Chopped Blanking pulses are produced only during the time that the left vertical unit is to be displayed (unless right vertical unit is also set for chopped operation).

3. RIGHT VERTICAL UNIT SET FOR CHOPPED OPERATION

If the right vertical unit is set for chopped mode, operation is the same as described previously for the left vertical unit except that Vertical Chopped Blanking pulses are produced when the VERT MODE switch is set to RIGHT or when the Vertical Mode Command is HI in the ALT mode. The input conditions are:

Pin 3 LO—VERT MODE switch set to any position except CHOP.

Pin 6 HI—Right vertical unit to be displayed (Vertical Mode Command HI).

Pin 7 LO—VERT MODE switch set to any position except ADD.

Pin 8 LO—Right vertical unit set to chopped mode.

Pin 10 LO—Delay Ramp more negative than about 0 volts.

4. ADD VERTICAL MODE

When the VERT MODE switch is in the ADD position and either or both of the vertical units are operating in the chopped mode, Vertical Chopped Blanking pulses must be available to block out the transition between traces of the vertical units. The input conditions are:

Pin 3 LO—VERT MODE switch set to any position except CHOP.

Pin 5 LO—Left vertical unit set to chopped mode (can be HI if pin 8 is LO).

Pin 7 HI—VERT MODE switch set to ADD.

Pin 8 LO—Right vertical unit set to chopped mode (can be HI if pin 5 is LO).

Pin 10 LO—Delay Ramp more negative than about 0 volt.

Fig. 3-6A shows a logic diagram of the Vertical Chopped Blanking stage. Notice the comparator block on this diagram (one input connected to pin 10). The output of this comparator is determined by the relationship between the levels at its inputs. If pin 10 is more positive (HI) than the grounded input, the output is HI also; if it is more negative (LO), the output is LO. An input/output table for this stage is given in Fig. 3-6B.

Chop Counter

The Chop Counter stage produces the Mainframe Chop Signal and the Vertical Plug-In Chop Signal. The Clock

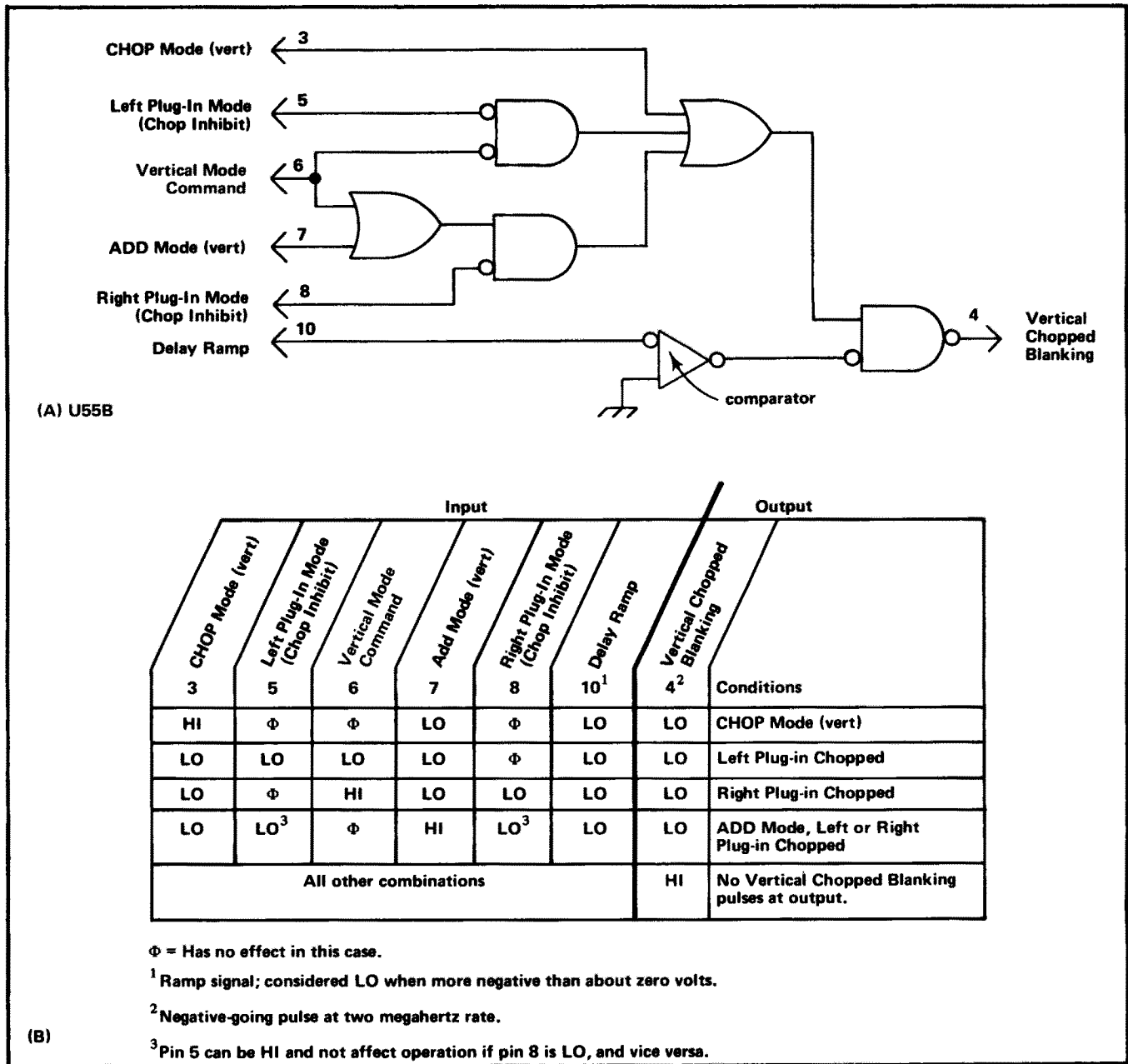

Fig. 3-6. (A) Logic diagram for Vertical Chopped Blanking stage, (B) Table of input/output combinations for Vertical Chopped Blanking stage.

pulse produced by the Clock Generator stage provides the timing signal for this stage. A logic diagram of the Chop Counter, identifying the inputs and outputs, is shown in Fig. 3-7.

The Chop Counter stage consists of integrated circuit U123, a dual D-type flip-flop with direct-set, direct-clear inputs (see Table 3-1 for operation of D-type flip-flop). As connected in this circuit, these D-type flip-flops operate as triggered (toggle) flip-flops.

The two-megahertz clock pulses from the Clock Generator stage are connected to the trigger (T) input of U123B. As connected, U123B changes output states with each positive-going Clock pulse, and the signal at its "1" output is a square wave which switches between the HI and LO levels at a one-megahertz rate. This signal is connected to the Vertical Mode Control stage to provide the Vertical Mainframe Chop Signal. It is also connected to the trigger input of U123A. U123A also changes output states with each positive-going pulse at its trigger input to produce a 500 kilohertz square wave at its "1" output. The output from U123A provides the Vertical Plug-In Chop Signal to

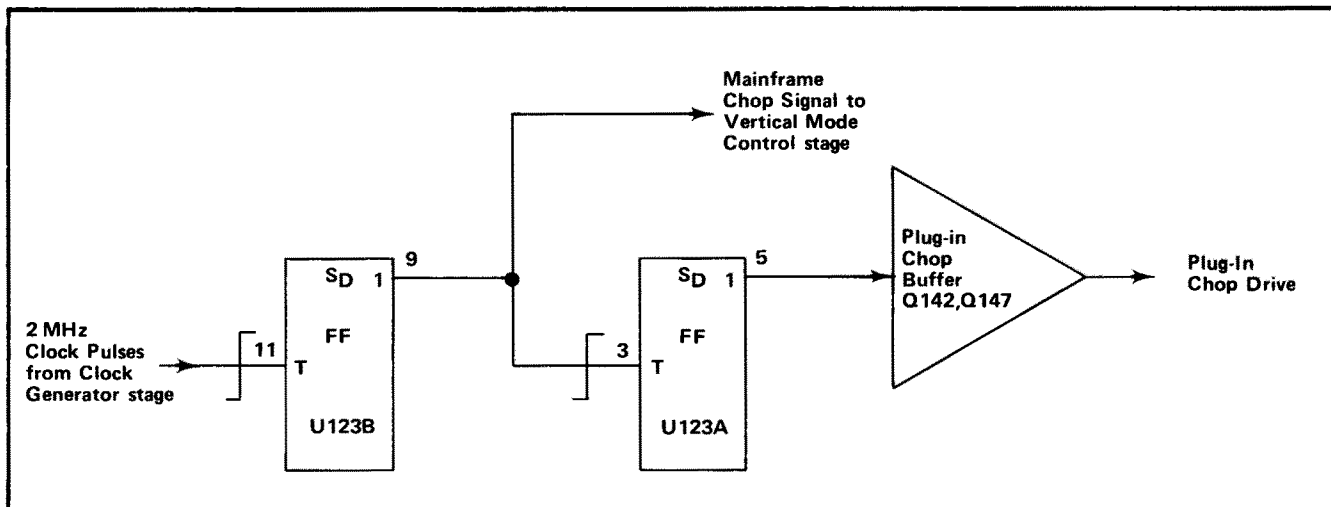

Fig. 3-7. Detailed logic diagram of Chop Counter stage.

the Plug-In Chop Buffer stage. Idealized waveforms showing the timing relationship between the input and output signals for this stage are shown in Fig. 3-8.

Vertical Mode Control

The Vertical Mode Control stage is made up of discrete components CR124-CR125, CR126, CR130-CR155, CR172, and buffer amplifier Q132-Q137. These components develop the Mainframe Vertical Mode Command which is connected to the Main Interface circuit (vertical plug-in compartments and trigger selection circuitry) and the Vertical Interface circuit to indicate which vertical unit is to be displayed. When this output level is HI, the right vertical unit is displayed and when it is LO, the left vertical unit is displayed.

The VERT MODE switch located on diagram 7 provides control levels for this stage. This switch provides a HI level on only one of four output lines to indicate the selected

vertical mode; the remaining lines are LO. The fifth mode, LEFT, is indicated when all four output lines are LO. Operation of this stage in all positions of the VERT MODE switch is as follows:

Right. When the VERT MODE switch is set to RIGHT, a HI level is connected to the Buffer Amplifier through R126 and CR126. The LO level at the anodes of diodes CR125 and CR130 holds them reverse biased. The resultant Vertical Mode Command output from the Vertical Mode Buffer Amplifier is a HI level to indicate that the right vertical unit is to be displayed.

Chop. In the CHOP position of the VERT MODE switch, a HI level is applied to the anodes of diodes CR124-CR125 through R125. Both diodes are forward biased so the Vertical Chop Signal from pin 9 of U123B can pass to the emitter of Q132. This signal switches between the HI and LO levels at a one-megahertz rate and it produces a corresponding Mainframe Vertical Mode Command output at the emitter of Q137. When this output is

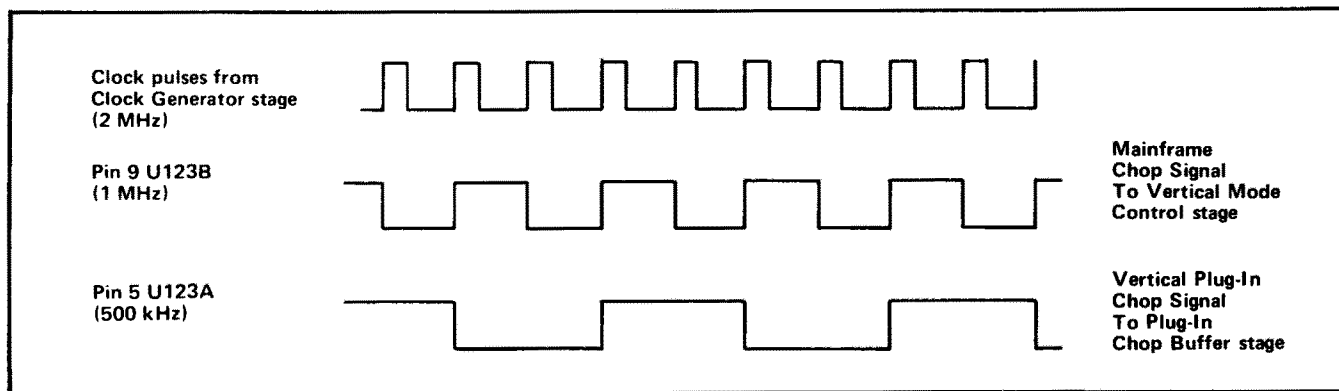

Fig. 3-8. Idealized input and output waveforms for Chop Counter stage.

Circuit Description—7613/R7613 Service

HI, the right vertical unit is displayed and when it switches to LO, the left vertical unit is displayed.

Alt. In the ALT mode, the VERT MODE switch applies a HI level to the anodes of diodes CR130-CR155 through R130. These diodes are forward biased so the Display Right Command from pin 5 of U156A can pass to the emitter of Q132 to determine the Mainframe Vertical Mode Command level. The Display Right Command switches between its HI and LO levels at a rate determined by the Vertical Binary stage.

Add and Left. The control levels in the ADD and LEFT positions of the VERT MODE switch are not connected to this stage. However, since only the line corresponding to the selected vertical mode can be HI, the RIGHT, CHOP, and ALT lines must remain at their LO level when either LEFT or ADD are selected. Therefore, the emitter of Q132 remains LO to produce a LO Mainframe Vertical Mode Control output level. Final control of LEFT or ADD mode is made by the Vertical Interface circuit.

A logic diagram of the Vertical Mode Control stage is shown in Fig. 3-9. The discrete components which make up each logic function are identified. The gate connected to the input of the Vertical Mode Buffer Amplifier is a phantom-OR gate. A phantom-OR gate performs the OR logic function merely by interconnection of the three inputs.

Vertical Binary

The Vertical Binary stage consists of integrated circuit U156A and transistor Q150. U156A is a D-type flip-flop

with direct-set and direct-clear inputs (see Table 3-1 for operating details). The connection between the "0" output and the data (D) input enables this flip-flop to operate in the triggered mode. A logic diagram of the Vertical Binary stage is shown in Fig. 3-10.

The operation of the Vertical Binary stage is controlled by the level of the ALT Mode line from the VERT MODE switch. When this switch is set to ALT, a HI level is connected to the emitter of Q150 through R152. This HI level disables Q150 so its collector remains HI. As a result, Q150 has no effect upon operation of the Vertical Binary stage and the direct-clear input of U156A remains HI so it does not affect the operation of U156A. Therefore, U156A operates as a basic triggered flip-flop which changes output states with each positive-going Sweep Holdoff pulse at the trigger (T) input. The Sweep Holdoff pulse goes positive at the end of each sweep. The signal at the "1" output of U156A switches between the HI and LO level at one-half the rate of the Sweep Holdoff signal from the horizontal plug-in unit. Fig. 3-11 shows the time relationship between the input and output signals for this stage, and gives the resultant display with each signal combination.

For any other position, the emitter of Q150 is pulled LO by the ALT Mode command from the VERT MODE switch. This enables Q150, but it does not change output state unless the level at the "1" output of U156A is HI. Quiescently, the output of Q150 is LO. Therefore, when the positive-going Sweep Hold-off pulse is received at the end of the sweep, the "1" output of U156A goes HI. This activates Q150 and its output goes LO to provide a direct-clear reset to U156A. The "1" output of U156A is reset to its LO level, and Q150 is again disabled so its output returns to the HI level. The stage is now ready for

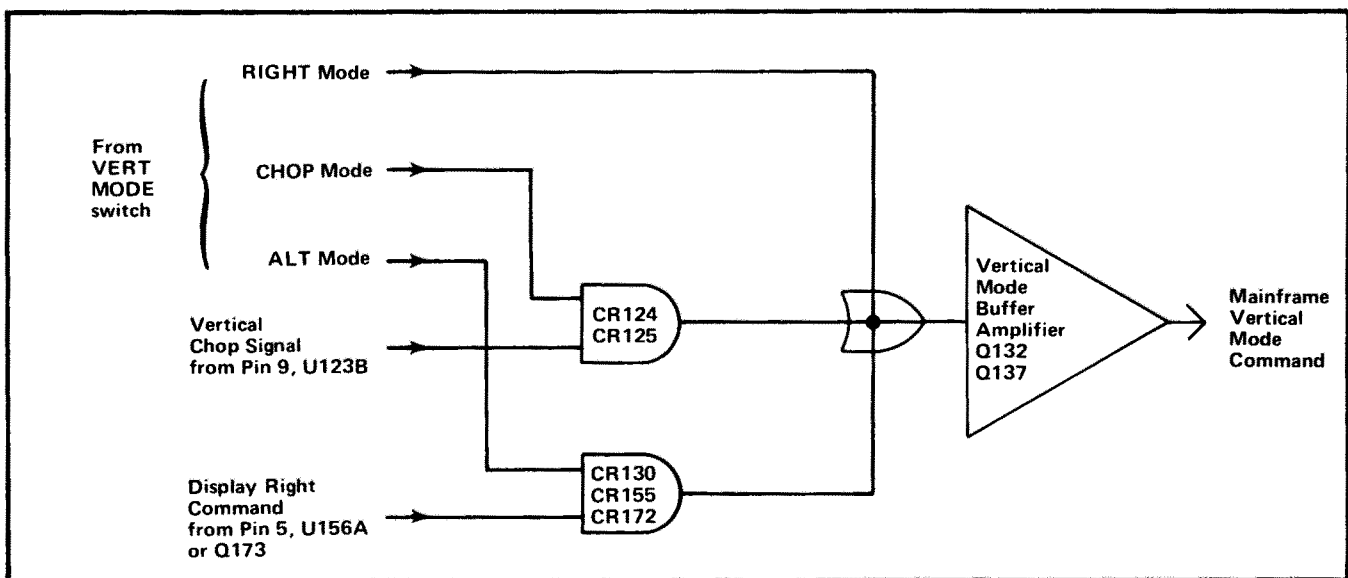

Fig. 3-9. Logic diagram of Vertical Mode Control and Vertical Mode Buffer Amplifier stages.

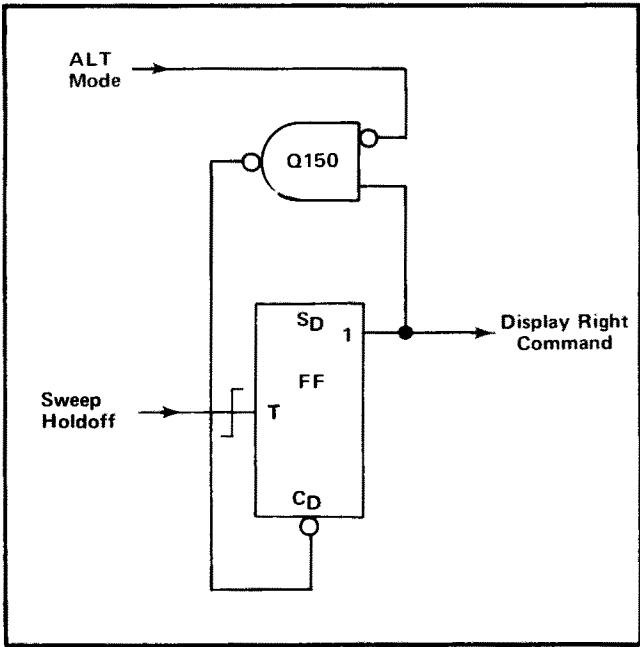

Fig. 3-10. Logic diagram of Vertical Binary stage.

the next positive-going Sweep Hold-off pulse. The action is the same with each pulse, so the signal at the output of this stage is at the same repetition rate as the Sweep Holdoff

input. Therefore, this stage is now operating as a divide-by-one counter rather than a divide-by-two counter as described previously. The output under this condition is used only by the Plug-In Binary stage.

Since the Vertical Binary stage can change output states only at the end of each sweep, there will be no Alternate Drive signal for either the mainframe or vertical plug-in units if a sweep is not being produced by the horizontal plug-in unit.

Plug-In Binary

The Plug-In Binary stage consists of U156B, which is connected as a triggered flip-flop with direct-set input. The trigger input for this stage is the Display Right Command from the Vertical Binary stage. When the VERT MODE switch is set to ALT, the repetition rate of the Display Channel 2 Command output of this stage is one-fourth of the Sweep Holdoff input (see waveforms in Fig. 3-11). For any position of the VERT MODE switch except ALT, the repetition rate of the output signal from this stage is one-half of the Sweep Holdoff input. A logic diagram of the Plug-In Binary stage is shown in Fig. 3-12.

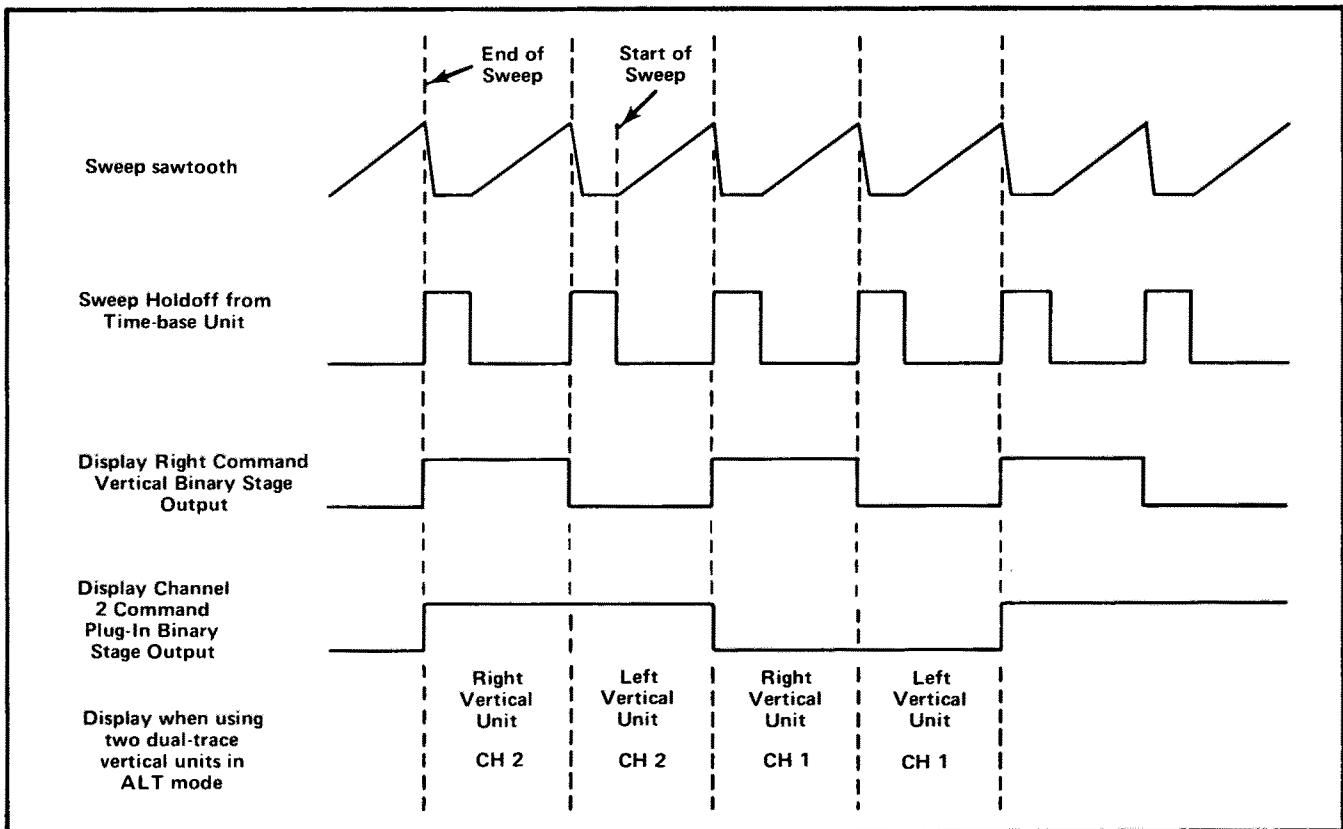

Fig. 3-11. Idealized waveforms showing relationship between input and output waveforms for Vertical Binary and Plug-In Binary stages when operating in ALT mode.

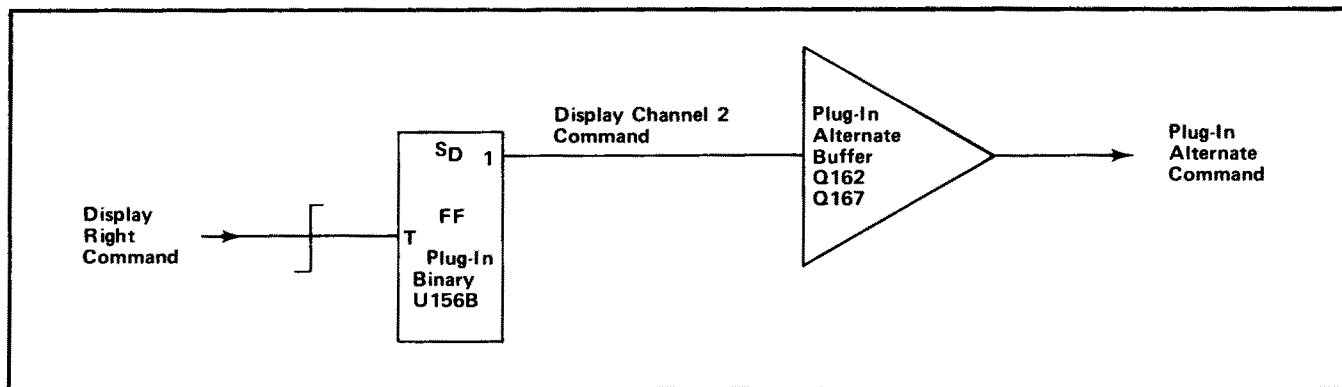

Fig. 3-12. Logic diagram of Plug-In Binary and Plug-In Alternate Buffer stages.

Output Buffers

The output switching commands from the Logic circuit are provided through buffer stages Q142-Q137, Q142-Q147, Q162-Q167, and Q182-Q187. Each of these stages includes a common-base input transistor to provide a low-impedance load for the associated driving stages. The output transistor is connected as an emitter-follower to provide isolation between the Logic circuit and other circuits within this instrument or the plug-in units.

TRIGGER SELECTOR

The Trigger source switch determines which vertical signal is connected to the time-base unit, and which vertical signal, that is provided at VERT SIG/OUT connector on the rear panel. Fig. 3-13 shows a detailed block diagram of the Trigger Selector circuit, along with a simplified diagram of all the circuitry involved in selection of the trigger source. A schematic of the Trigger Selector circuit is shown on diagram 3 at the rear of this manual. Also, see diagrams 6 and 7 for the signal selection circuitry not shown on diagram 3.

Trigger Mode and Add Signals

General. The circuitry shown on the left side of the simplified diagram in Fig. 3-13 determines the operation of the Trigger Channel Switch stage. TRIG SOURCE switch S1011 controls Trigger Channel Switch U324 through Q314. When the TRIG SOURCE switch is set to the VERT MODE position, the setting of the VERT MODE switch determines the trigger selection. In the LEFT or RIGHT positions, the trigger signal is obtained from the indicated vertical unit. The following discussions give detailed operation in each position of the TRIG SOURCE switch.

Vert Mode. In the VERT MODE position of the TRIG SOURCE switch, the setting of the VERT MODE switch determines the operation of the Trigger Channel Switch stage. In the LEFT position of the VERT MODE switch,

the base of Q314 is connected to ground through the ALT and RIGHT sections of S1021, CR1021 and CR1026, and S1011. This holds Q314 reverse biased to provide a LO level to pin 4 of U324 (see Fig. 3-14).

When the VERT MODE switch is set to ALT, +5 volts is applied to the base of Q314 through CR1021 and S1011. Q314 is forward biased and its emitter level is determined by the Mainframe Vertical Mode Command signal from the Logic circuit applied to its collector. This signal switches between the HI level (Right Vertical unit to be displayed) and the LO level (Left Vertical unit to be displayed) at the end of each sweep. When the Mainframe Vertical Mode Command is HI, it provides a positive collector voltage to Q314. Q314 is saturated due to CR1021, and its emitter level is very near the collector level. This provides a HI output level to the Trigger Channel Switch stage. As the Mainframe Vertical Mode Command goes LO, the collector supply for Q314 also goes negative. Q314 remains saturated and the output again follows the collector level to supply a LO output level to U324.

For ADD and CHOP vertical mode operation, +5 volts is connected to pin 14 of U324 through CR1023 or CR1024 and S1011. At the same time, the base of Q314 is held LO by the ground connection through the ALT and RIGHT section of S1021 so the level at pin 4 of U324 is LO also (produces an ADD mode in Trigger Channel Switch; see description of this circuit which follows). In the RIGHT position of the VERT MODE switch, +5 volts is connected to the base of Q314 through CR1026 and S1011 to forward-bias the transistor. The Mainframe Vertical Mode Command signal connected to the collector of Q314 is also HI in this mode, and a HI output level is produced at the emitter of Q314.

Left. When the LEFT trigger source is selected, the VERT MODE switch is disconnected from the trigger selector circuitry. Now the ground connection through the

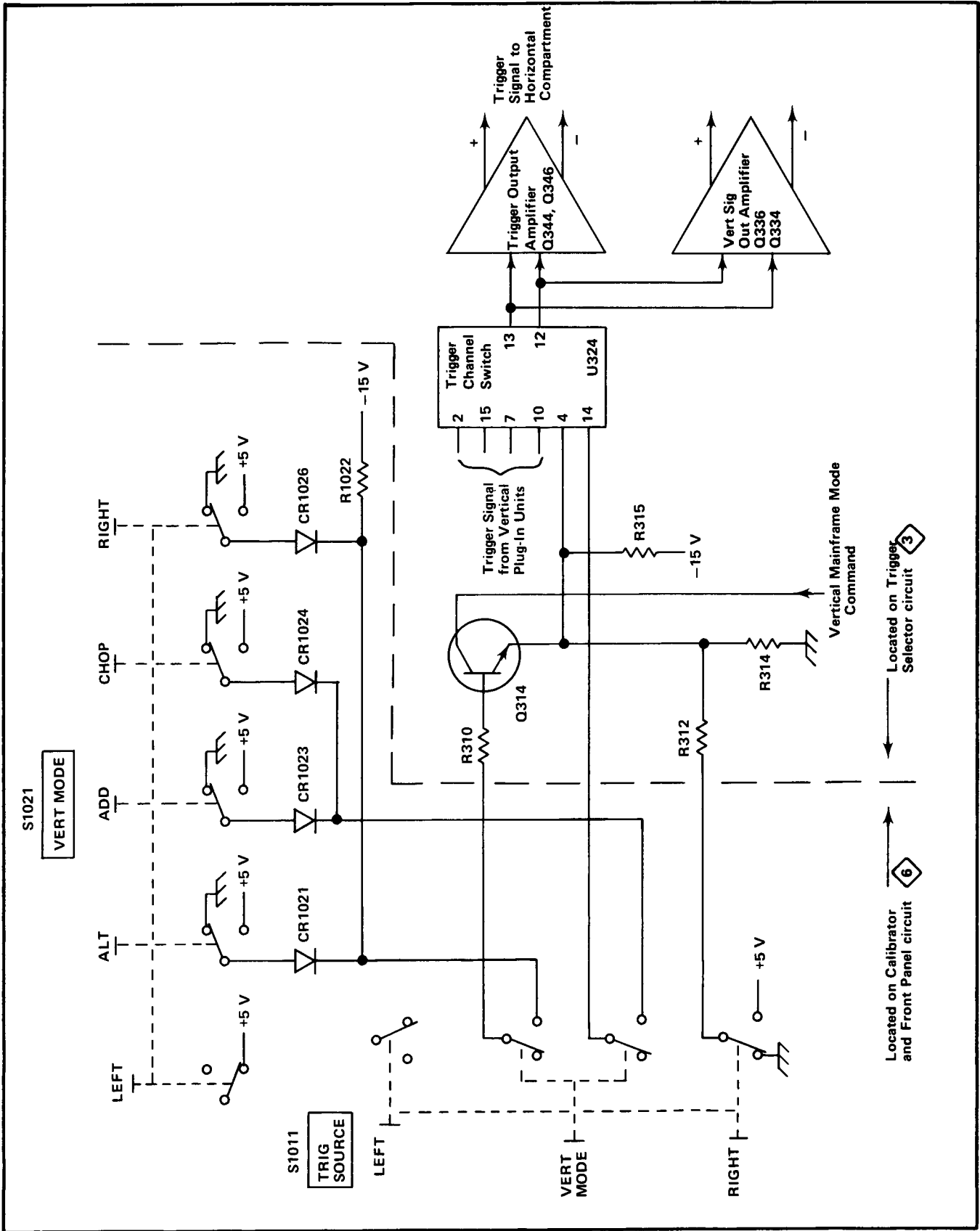
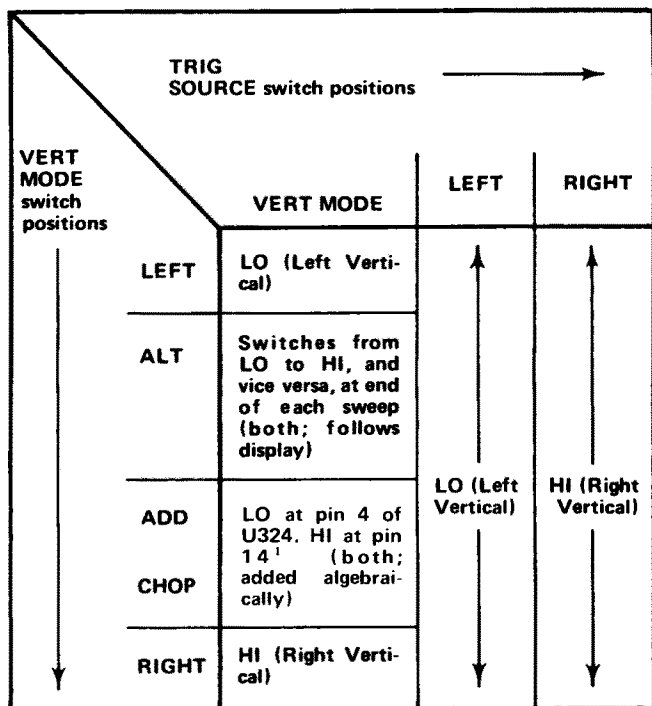

Fig. 3-13. Detailed block diagram of Trigger Selector circuit along with simplified diagram of trigger source selection circuitry.



¹ Pin 14 LO for all other conditions.

Fig. 3-14. Input levels at pin 4 of U324 (source of triggering is shown in parenthesis).

RIGHT section of S1011 establishes a LO output level at the emitter of Q314.

Right. In the RIGHT position of the TRIG SOURCE switch, +5 volts is connected to the emitter of Q314 through S1011 and R312. This produces a HI output level to the Trigger Channel Switch stage.

Trigger Channel Switch

The Trigger Channel Switch stage determines which input signal provides the trigger signal to the horizontal compartment as controlled by the Trigger Mode and ADD signals from the trigger selection circuitry. Refer to diagram 3 during the following discussion.

Resistors R317-R319 establish the input resistance and provide a load for the trigger signal from the right vertical plug-in unit. Resistors R307 and R308 provide the input resistance and load for the left vertical plug-in unit. R321-R323-R324 and R326-R327-R328 establish the operating level of the Trigger Channel Switch; R321-R323 and R326-R328 set the current gain for each channel. This stage is made up primarily of integrated circuit U324. An input/output table for U324 is shown in Fig. 3-15. U324 provides a high impedance differential input for the trigger signal from the left vertical unit at pins 2 and 15, and for

the trigger signal from the right vertical unit at pins 7 and 10. The output signal at pins 12 and 13 is a differential signal. The sum of the DC current at pins 12 and 13 is always equal to the sum of the DC currents at pins 1, 8, 9, and 16 in all modes. This provides a constant DC bias to the stages which follow as the TRIG SOURCE or the VERT MODE switches are changed.

When the level at pin 4 is LO (see Trigger Mode and ADD Signals discussion and Fig. 3-15), the trigger signal from the left vertical unit passes to the output, while the trigger signal from the right vertical unit is blocked. A HI level at pin 4 connects the trigger signal from the right vertical unit to the output and the trigger signal from the left vertical unit is blocked. For VERT MODE operation in the ALT position of the VERT MODE switch, the level at pin 4 switches between the LO and HI level at a rate determined by the Vertical Binary stage (see Logic circuit description). This action obtains the trigger signal from the left vertical unit when the left vertical unit is being displayed and from the right vertical unit when it is being displayed.

When the level at pin 4 is LO and the level at pin 14 is HI, the trigger signal from both the left and right vertical units passes to the output pins. This condition occurs only when the TRIG SOURCE switch is set to VERT MODE and the VERT MODE switch is set to either ADD or CHOP. Under this operating mode, the trigger output signal is the algebraic sum of the trigger input signals from the left and right vertical units to prevent triggering on the vertical chopping transition, or only on one signal of an added display.

Trigger Output Amplifier

The trigger output at pins 12 and 13 of U324 is connected to the bases of Q344-Q346 to provide the internal trigger signal for the horizontal unit (via the Main Interface circuit). The horizontal unit provides a 50-ohm differential load for this stage. If it is removed from its compartment, the collector load for Q344-Q346 changes and the voltage at their collectors increases. This stage prevents this change from affecting the vertical signal for the Output Signals board. CR341-CR349 clamp the collectors of Q344 and Q346 at about +0.6 volt to prevent these transistors from saturating under this no-load condition.

Vertical Signal Buffer

The trigger output signal at pin 12 and 13 of U324 is also connected to the emitter of a common-base amplifier Q336 and Q334. The output signal at the collector of Q336 and Q334 is connected to the signals out board.

Input		Output
Trigger Mode Signal 4	Trigger ADD 14	Trigger Output Signal 12, 13
LO	LO	Left trigger signal
HI	LO	Right trigger signal
LO	HI	Both (added algebraically)

Fig. 3-15. Input/output table for Trigger Channel Switch stage.

VERTICAL INTERFACE

The Vertical Interface circuit selects the vertical deflection signal from the output of the left vertical and/or the right vertical plug-in unit. Fig. 3-16 shows a detailed block

diagram of the Vertical Interface circuit. A schematic of this circuit is shown on diagram 3 at the rear of this manual.

Vertical Channel Switch

The Vertical Channel Switch stage determines which input signal provides the vertical signal to the Delay-Line Driver stage as controlled by the Mainframe Vertical Mode Command from the Logic circuit. Resistors R200-R202 and R204-R206 establish the input resistance of this stage and provide a load for the left and right vertical units. Resistors R209-R211-R212 and R216-R218-R219 establish the operating levels for this stage. R209-R212 and R216-R219 set the current gain for each channel. C208-R208 and C215-R215 provide frequency compensation.

This stage is made up primarily of integrated circuit U214, which is the same type as used for the Trigger Channel Switch. An input/output table for U214 is shown in Fig. 3-17. U214 provides a high impedance differential input for the signal from the left vertical unit at pins 2 and 15, and the signal from the right vertical unit at pins 7 and 10. The output signal at pins 12 and 13 is a differential signal which is connected to the Delay-Line Driver stage through R222-R224. The sum of the DC output currents at

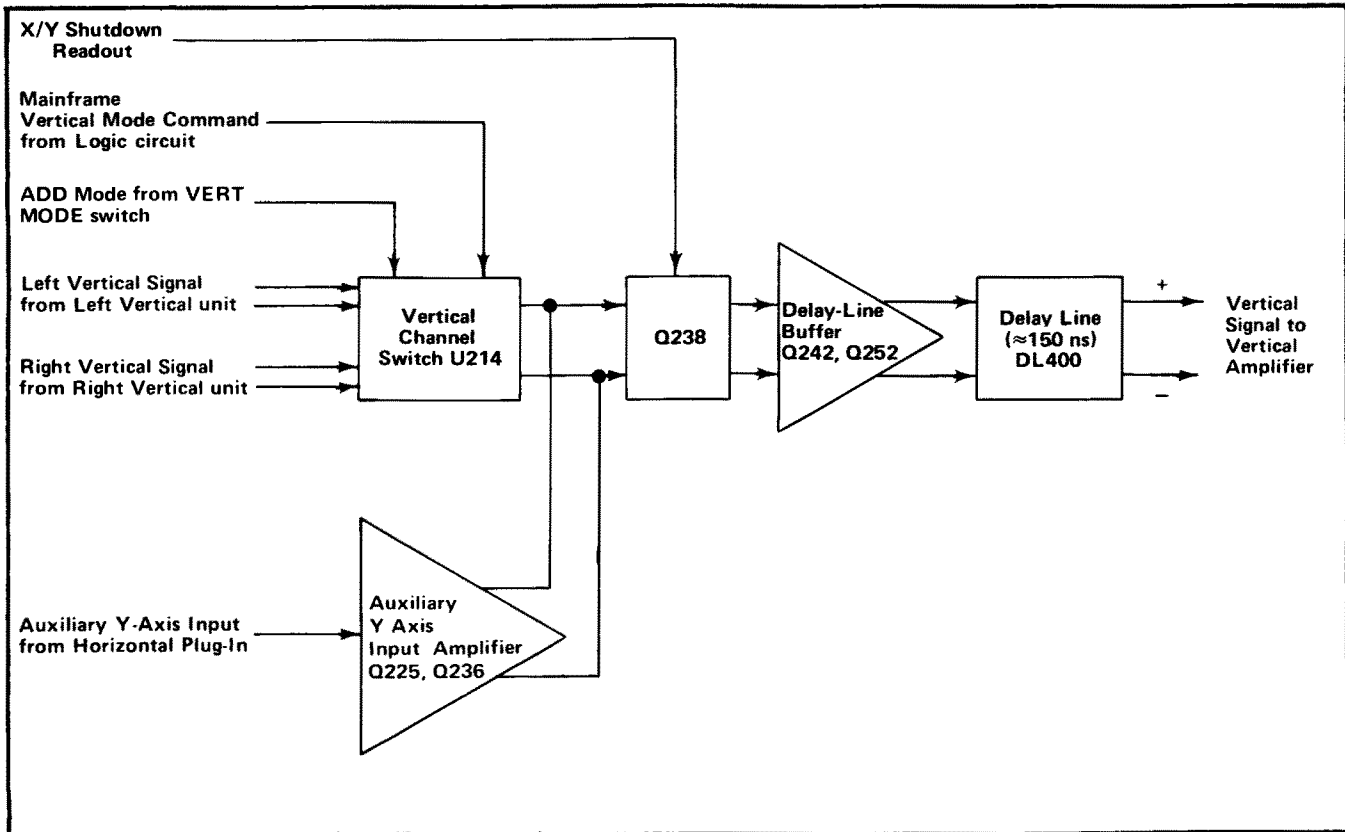

Fig. 3-16. Vertical Interface detailed block diagram.

Mainframe Vertical Mode Command 4	ADD Mode (Vert) 14	Output signal 12, 13
LO	LO	Left vertical signal
HI	LO	Right vertical signal
LO	HI	Both (added algebraically)

Fig. 3-17. Input/output table for Vertical Channel Switch.

pins 12 and 13 is always equal to the sum of the DC input currents at pins 1, 8, 9, and 16 in all modes. This provides a constant DC bias to the following stage as the VERT MODE switch is changed.

When the VERT MODE switch is set to LEFT, the level at pin 4 is LO. This level allows the signal from the left vertical unit to pass to the output while the signal from the right vertical unit is blocked. In the RIGHT position of the VERT MODE switch, the level at pin 4 is HI. Now, the signal from the right vertical unit is connected to the output while the signal from the left vertical unit is blocked.

When the VERT MODE switch is set to either ALT or CHOP, the Mainframe Vertical Mode Command at pin 4 switches between the LO and HI levels at a rate determined by either the Chop Counter or the Vertical Binary stages (see Logic circuit description). This action allows the signal from the left vertical unit to be displayed when the Mainframe Vertical Mode Command is LO and the signal from the right vertical unit is displayed when the Mainframe Vertical Mode Command is HI. When ADD vertical mode operation is selected, a HI level is applied to pin 14 and the level at pin 4 is LO as determined by the Vertical Mode Control stage in the Logic Circuit. This allows both the right and left vertical signals to pass to the output pins. Now, the signal from both vertical units is algebraically added and the resultant signal determines the vertical deflection.

The X/Y Shutdown signal from the Readout system is applied to pin 6 of U214. It has final control over the output signal from U214. Quiescently, the X/Y Shutdown signal is LO and the signal from the selected vertical can pass to the output pins 12 and 13. However, when the

Readout system is ready to display Readout information, the level at pin 6 goes HI. This level blocks the signals from both vertical compartments and there is no output from U214 under this condition. Transistor Q238 will conduct and provide about the same current for the output stage as under normal conditions. This limits any change in positioning that would otherwise occur when the X/Y Shutdown signal from the Readout system is applied.

Auxiliary Y-Axis Input Amplifier

The Auxiliary Y-Axis Input Amplifier accepts an input from horizontal plug-in units having compatible features. Normally, this input is a positioning voltage to offset the display. The single-ended signal connected to the input of this stage is converted to a push-pull signal at the collectors of Q225 and Q236. This signal is connected to the Delay-Line Buffer stage along with the output from the Vertical Channel Switch.

Delay-Line Buffer

The output of the Vertical Channel Switch stage, along with any signal from the Auxiliary Y-Axis Input Amplifier, is connected to the emitters of Q242-Q252. These transistors are connected as common-base amplifiers to provide a low-impedance current-summing point. The signal at the collectors of Q242-Q252 is connected to Delay Line DL400. Resistor R260 provides reverse termination for the Delay Line.

Delay Line

Delay Line DL400 provides approximately 150 nanoseconds delay for the vertical signal, to allow the horizontal circuits time to initiate a sweep before the vertical signal reaches the vertical deflection plates of the CRT. This allows the instrument to display the leading edge of the signal originating the trigger pulse when using internal triggering. The delay line used in this instrument has a characteristic impedance of about 50 ohms per side, or about 100 ohms differentially. It is of the coaxial type, which does not produce preshoot or phase distortion in the CRT display.

VERTICAL AMPLIFIER

The Vertical Amplifier circuit provides final amplification for the vertical signal before it is applied to the vertical deflection plates of the CRT. This circuit includes an input from the BEAM FINDER switch to compress an over-scanned display within the viewing area of the CRT. Fig. 3-18 shows a detailed block diagram of the Vertical Amplifier circuit. A schematic of this circuit is shown on diagram 4 at the rear of this manual.

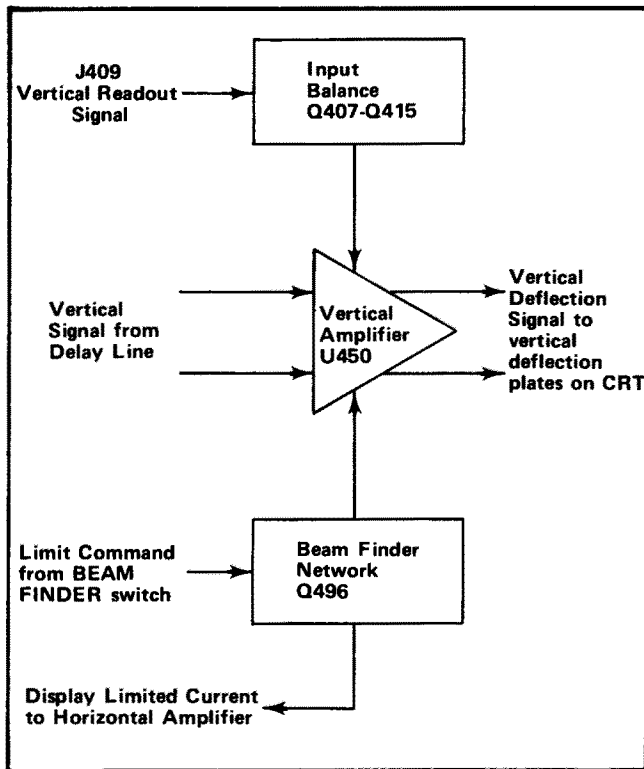

Fig. 3-18. Vertical Amplifier detailed block diagram.

Input Balance

Q407-Q415 comprise a paraphase amplifier to provide input balance for the Vertical Amplifier by changing the DC levels at pins 2 and 4 of U450. Vertical Centering adjustment R403 determines the bias at the base of Q407. As this bias is changed, the levels at the collectors of Q407 and Q415 change due to paraphase action. This DC level is connected to pin 2 of U450 through R408-R423 and to pin 4 through R414-R424. R403 is adjusted so the trace is displayed at the center of the CRT when the inputs to this circuit are at the same potential.

The input to the base of Q407 through J409 is used for Vertical readout signal.

Output Amplifier

Amplification of the vertical signal is accomplished by integrated circuit U450. The circuit shown within the shaded area is a representation of the circuit contained within U450. Notice that the circuit is made up of three similar push-pull stages. Each stage has a pair of common emitter transistors driving a pair of low input impedance common base transistors. Frequency compensation is provided by the networks connected between pins 2 and 4 in the first amplifier stage and pins 7 and 8, 13 and 14 in the

third amplifier stage. The resistive network connected to pins 3, 6, and 16 determines the gain of the Vertical Amplifier. Vertical Gain adjustment R447 sets the gain of the second amplifier stage to determine the overall gain of the vertical deflection system and thereby provide a calibrated deflection factor. Bias adjustment R486 sets the voltage level at pin 10 of U450 (nominally 4.3 volts) to balance the third amplifier stage for maximum gain-bandwidth operation.

Beam Finder Network

The Beam Finder Network, consisting of transistor Q496 and associated components, provides a means of locating a display which overscans the graticule area. Under normal operation, -15 volts is connected to the base of Q496 from the BEAM FINDER switch (see diagram 7) to reverse bias it. Therefore, the normal operating levels for U450 are determined by the resistive network connected to pins 3, 6, and 16. When the BEAM FINDER switch is pressed, the -15 volts is interrupted and the base of Q496 rises positive to turn it on. The resulting change in current of U450 unbalances the second amplifier stage so as to limit its gain. This action compresses the display vertically within the display area.

HORIZONTAL AMPLIFIER

The Horizontal Amplifier circuit amplifies the push-pull horizontal deflection signals from the plug-in unit in the horizontal compartment and connects it to the horizontal deflection plates of the CRT. Fig. 3-19 shows a detailed block diagram of the Horizontal Amplifier circuit. A schematic of this circuit is shown on diagram 5 at the rear of this manual.

Horizontal Channel Switch

The horizontal signals from the plug-in unit in the horizontal compartment are connected to pin 2 and pin 15 of U510. The Readout signal is connected to pin 7 of U510. Integrated circuit U510 determines which input signal will provide the signal for the Horizontal amplifier circuit as controlled by the X/Y Shutdown signal from the Readout system. When the X/Y Shutdown is LO, the signal from horizontal compartment is passed to the output of U510. When the X/Y Shutdown is high, the Readout signal is passed to the output of U510. Resistors R514, R515, R521, and R522 establish the operating levels for this circuit. R512 adjusts the circuit gain. R511 and R513 establish the range for the gain adjustment (see Trigger Channel Switch under TRIGGER SELECTOR in this section).

For normal operation, the gain and current level resistors are connected to the Display Limit Command line. The

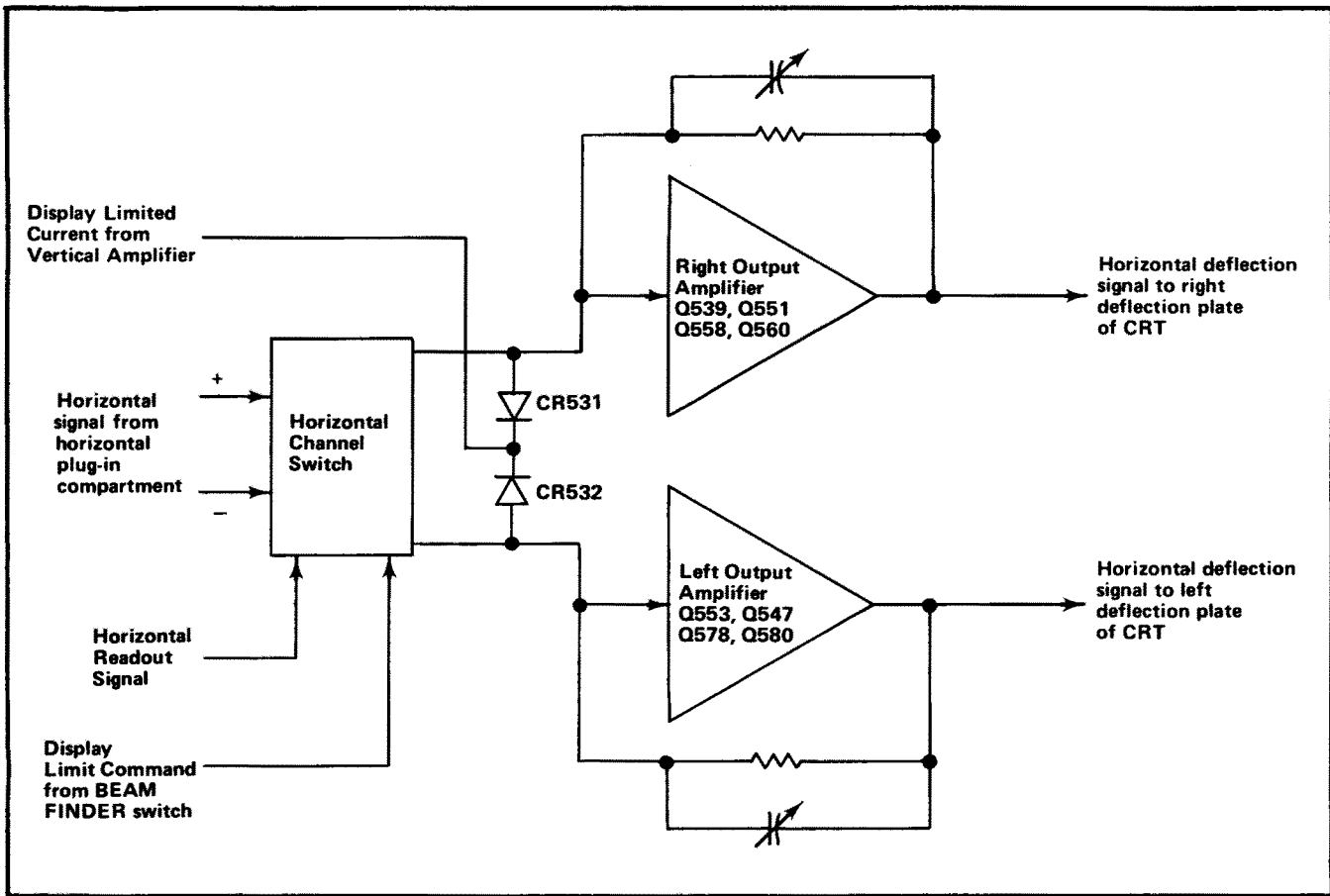

Fig. 3-19. Horizontal Amplifier detailed block diagram.

Display Limit Command is connected to the -15 supply through the BEAM FINDER switch. When the BEAM FINDER switch is actuated, the -15 volt is interrupted to limit the current to U510. At the same time, current is added through CR531 and CR532 from the display limited current line. This added current maintains about the same DC currents through the output circuit in both positions of the BEAM FINDER switch. The signal at the output is connected to the right and left amplifier inputs. Resistor R525 adjusts the amplifier for center screen deflection in the absence of an input signal to U510.

Output Amplifier

Transistors Q539, Q551, Q558, and Q560 function as a current driven feedback amplifier. The input current is converted to a voltage output signal to drive the right horizontal CRT deflection plate. R558 establishes the quiescent current level for series connected transistors Q558 and Q560.

The CRT deflection plates present a capacitive load to the amplifier, which requires additional current during fast transients. Extra current for positive excursions is provided

by Q551 via R555, C555, and Q558; for negative excursions, by Q560 via R563.

Resistor R556 reduces the power dissipation in Q558. Resistors R566, R567, and R569 provide DC feedback and establish low frequency gain. Capacitors C566 and C588 (C588 for lower serial numbers) are adjusted for correct gain at fastest sweep rates (in later serial numbered instruments, C588 replaces C568 and a differently located C588, a thermal compensation network C584-R584 is added).

Basic operation of the Left Output Amplifier stage is the same as described for the Right Output Amplifier. C586 and C588 set the gain for the fastest sweep rates (C588 is relocated for later serial numbers and affects both Right and Left Output Amplifiers). The output signal at the collectors of Q578-Q580 connects to the left deflection plate of the CRT through R585.

The series circuit CR549 and R549 stabilize the output amplifier during fast retrace intervals. R535 is adjusted to balance the negative excursions of the right and left sides of the amplifier when the time base plug-in is used in X10 Magnified mode.

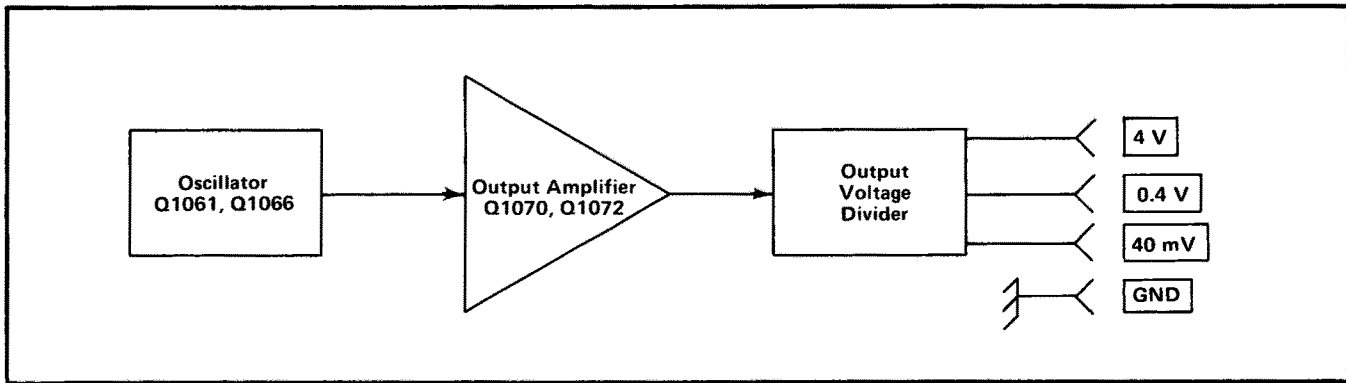

Fig. 3-20. Calibrator detailed block diagram.

CALIBRATOR AND FRONT PANEL SWITCHING

The Calibrator and Front Panel Switching circuit provides output voltage to the front-panel Calibrator pin-jacks and includes the front-panel switches and controls. Fig. 3-20 shows a detailed block diagram of the Calibrator portion of this circuit. A schematic of this circuit is shown on diagram 7 at the rear of this manual.

Mode Switch Logic

The VERT MODE switch determines the operating mode of the Vertical Interface circuit. The levels established by this switch are also used in various other circuits throughout this instrument. This switch is designed so it is self-cancelling (i.e., only one button can be pressed at a time). Specific operation of this switch is described in connection with the circuits that it controls.

The TRIG SOURCE switch controls the operation of the Trigger Selector circuit. This switch is also self-cancelling so only one of the buttons can be pressed at a time. Operation of this switch is discussed in connection with the Trigger Selector circuit.

Calibrator

General. The Calibrator circuit provides accurate voltage output at the front-panel Calibrator pin-jacks. Repetition rate of the output signal is about one kilohertz.

Oscillator. Q1061 and Q1066 are connected as a square-wave oscillator to determine the repetition rate of the Calibrator circuit. Oscillation occurs as follows: Assume that Q1061 is conducting and Q1066 is off. The collector current of Q1061 through R1061 produces a voltage level which holds the base of Q1066 low. This keeps Q1066

turned off, and since there is no current through it, its collector goes positive to produce the positive portion of the square wave. At the same time, C1064 begins to charge toward -15 volts through R1069. The emitter of Q1066 goes negative also as C1064 charges, until it reaches a level about 0.6 volt more negative than the level at its base. Then, Q1066 is forward biased and its emitter rapidly rises positive. Since C1064 cannot change its charge instantaneously, the sudden change in voltage at the emitter of Q1066 pulls the emitter of Q1061 positive also, to reverse bias it. The current through Q1066 produces a voltage drop at its collector to produce the negative portion of the square wave.

Now, conditions are reversed. Since Q1061 is reverse biased, there is no current through it. Therefore, C1064 can begin to discharge through R1063. The emitter level of Q1061 follows the discharge of C1064 until it reaches about -0.6 volt. Then, Q1061 is forward biased and its collector drops negative to reverse bias Q1066. This interrupts the current through Q1066, and its collector goes positive again to complete the square wave. Once again, C1064 begins to charge through R1069 to start the second cycle. The signal produced at the collector of Q1066 has a repetition rate of about one kilohertz.

The Oscillator stage can be changed by jumper P1066. When this jumper is installed in the DC position, the Oscillator is disabled and the collector of Q1066 rises positive. This produces a positive DC voltage output to the front-panel Calibrator pin-jacks.

Output Amplifier. Transistors Q1070 and Q1072 are connected as a comparator with the reference level at the base of Q1072 determined by the network R1073-R1074-R1076-R1077. The 4 Volts adjustment R1077, is set to provide accurate output voltage at the 4 V Calibrator pin-jack.

Circuit Description—7613/R7613 Service

The output of the Oscillator stage is connected to the base of Q1070. This signal controls the conduction of comparator Q1070-Q1072. When the base of Q1070 is high, it is off and Q1072 is conducting. This produces a positive output voltage at the Calibrator pin-jacks. When the level at the base of Q1070 is switched low, Q1070 conducts and Q1072 is reverse biased. Now, the voltage level at the Calibrator pin-jacks drops to zero.

divider made up of resistors R1079 through R1085. This divider is designed to provide a low output resistance in the 40 mV and 0.4 V positions while providing accurate output voltages. The output resistance at the 4 V pin-jack is about 450 ohms and at the 0.4 V and 40 mV pin-jacks is about 50 ohms.

Output Voltage Divider. The collector current of Q1072 in the Output Amplifier stage is applied across the voltage

CRT CIRCUIT

The CRT Circuit produces the high-voltage potentials and provides the control circuits necessary for the operation of the cathode-ray tube (CRT). This circuit also includes the Z-Axis Amplifier stage to set the intensity of the CRT display and the Auto Focus amplifier to assure

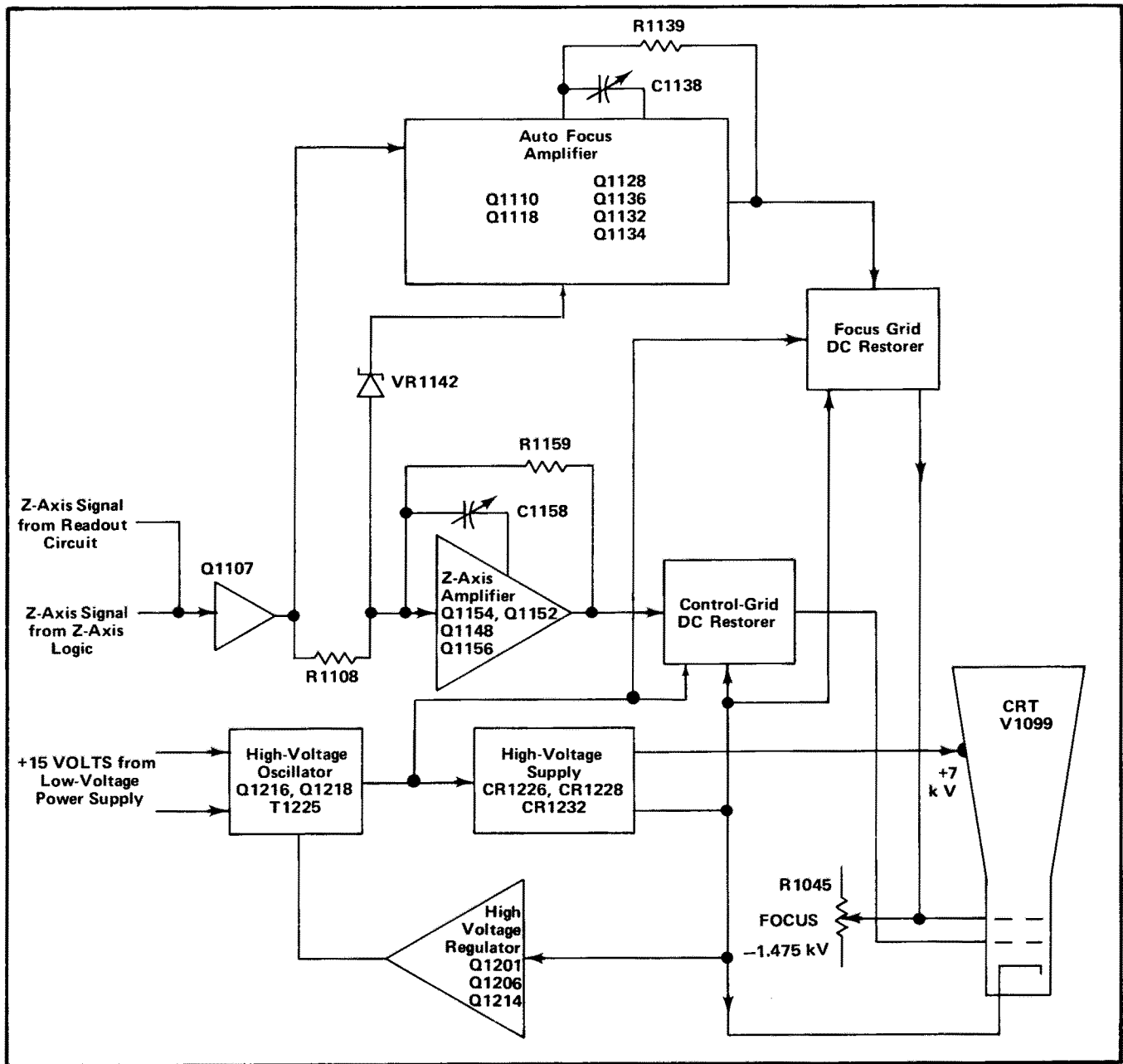

Fig. 3-21. CRT Circuit detailed block diagram.

optimum focus. Fig. 3-21 shows a detailed block diagram of the CRT Circuit. A schematic of this circuit is shown on diagram 8 at the rear of this manual.

Z-Axis Amplifier

The Z-Axis signal from the Logic circuit and the Z-Axis signal from the Readout system are connected to the emitter of Q1107. Transistor Q1107 is a common-base amplifier to establish a low input impedance for the input signals. Transistors Q1148, Q1152, Q1154, and Q1156 form a current driven operational amplifier. The input and output transistors are complementary to provide a fast rise-time and a fast fall-time response. The amplifier input is through resistor R1108. Resistor R1152 establishes a low current in the series connected output transistors. Transistor Q1148 supplies additional current through C1151 for the positive transients, and transistor Q1156 supplies additional current through C1158 for negative transients. Capacitor C1158 is adjusted for optimum square-wave output, resistors R1158 and R1159 along with capacitor C1158 form the feedback network. Zener diode VR1142 provides the necessary change of voltage from the collector of Q1107 to the base of Q1156.

Auto Focus Amplifier

The voltage developed across R1108 by the Z-Axis amplifier driving current is inverted and amplified non-linearly by Q1110 and Q1118, to conform to the requirements of the CRT focus electrode. As the base of Q1110 is driven negative CR1115 is forward biased, producing a knee in the amplifier response. The Level where the knee occurs is determined by the adjustment R1121. The operation of the remaining amplifier is identical to the Z-Axis amplifier.

High-Voltage Oscillator

Power for operation of the high-voltage supply is provided from the +15-Volt Supply. At the time of turn-on, CR1215 is reversed biased holding the collector of Q1214 positive. This allows the starting base bias current for the High-Voltage Oscillator to be supplied from the +5-Volt Supply through R1214, Q1214, and the base feedback windings of T1225 while the emitter potential of Q1216-Q1218 is established by the negative side of the +15-Volt Supply. As the output of the high-voltage supply increases to its required output level, the collector of Q1214 goes negative until CR1215 is forward biased. Then the collector level of Q1214 is clamped about 0.6 volt more negative than the negative side of the +15-Volt Supply. This configuration provides a controlled starting current for the High-Voltage Oscillator at turn-on, and at the same time allows the High-Voltage Regulator stage to control the

current for the High-Voltage Oscillator after the stage reaches operating potentials to provide a regulated high-voltage output.

Q1216-Q1218 and the associated circuitry comprise an oscillator to drive high-voltage transformer T1225. When the instrument is turned on, assume that Q1216 comes into conduction first. The collector current of Q1216 produces a corresponding current increase in the base-feedback winding of T1225 to further increase the conductivity of Q1216. At the same time, the voltage developed across the base-feedback winding connected to Q1216 holds Q1218 reverse biased.

As long as the collector current of Q1216 continues to increase, voltage is induced into the base-feedback windings of T1225 which holds Q1216 forward biased and Q1218 reverse biased. However, when the collector current of Q1216 stabilizes, the magnetic field built up in T1225 begins to collapse. This induces an opposite current into the base windings which reverse biases Q1216, but forward biases Q1218. When the induced voltage at the base of Q1218 exceeds the bias set by the High-Voltage Regulator, Q1218 conducts and the amplified current at its collector adds to the current flowing through T1225 due to the collapsing field. Then, as the current through T1225 stabilizes again, the magnetic field around it once more begins to collapse. This reverses the conditions to start another cycle.

The signal produced across the primary of T1225 is a sine wave at a frequency of 35 to 45 kilohertz. The amplitude of the oscillations in the primary of T1225 is controlled by the High-Voltage Regulator to set the total accelerating potential for the CRT. Filter network C1222-L1222 decouples high peak operating current from the +15-Volt Supply.

High-Voltage Regulator

A sample of the secondary voltage from T1225 is connected to the High-Voltage Regulator stage through divider R1245A-R1245B. Q1201 and Q1206 are connected as an error amplifier to sense any change in the voltage level at the base of Q1201. The ground reference for the emitter of Q1201 through R1202, establishes the reference level for this stage. The output voltage is set by the fixed values of the components in this circuit.

Regulation occurs as follows: If the output voltage at the -1475 V test point starts to go positive (less negative), a sample of this positive-going change is connected to the base of Q1201 through R1245B. Both Q1201 and Q1206

Circuit Description—7613/R7613 Service

are forward biased by this positive change, which in turn increases the conduction of Q1214. This results in a greater bias current delivered to the bases of Q1216-Q1218 through Q1214. Now, the bases of both Q1216 and Q1218 are biased closer to their conduction level so the feedback voltage induced into their base-feedback windings produces a larger collector current. This results in a larger induced voltage in the secondary of T1225 to produce a more negative level at the -1475 V test point to correct the original error. In a similar manner, the circuit compensates for output changes in a negative direction. Since the amplitude of the voltage induced into the secondary of T1225 also determines the output level of the positive High-Voltage Supply and the Control-Grid Supply, the total high-voltage output is regulated by sampling the output of the negative High-Voltage Supply.

High-Voltage Supplies

High-voltage transformer T1225 has two output windings. One winding provides filament voltage for the cathode-ray tube. The other winding provides the negative and positive accelerating potential for the CRT and the bias voltage for the control grid. All of these voltages are regulated by the High-Voltage Regulator stage to maintain a constant output voltage as previously described.

Positive accelerating potential for the CRT anode is supplied by the voltage doubler. The applied voltage from the secondary of T1225 is about 3.5 kilovolts peak-to-peak. This results in an output voltage of about +7 kilovolts at the CRT anode. The negative accelerating potential for the CRT cathode is also obtained from this same secondary winding. Half-wave rectifier CR1232 provides an output voltage of about -1.475 kilovolts which is connected to the CRT cathode through R1234. The cathode and filament are connected together through R1275 to prevent cathode-to-filament breakdown due to a large difference in potential between these CRT elements. A sample of the negative accelerating voltage is connected to the High-Voltage Regulator to maintain a regulated high-voltage output.

The network consisting of diodes CR1269-CR1268-CR1270-CR1264-VR1264 provides the negative voltage for the control grid of the CRT. Output level of this supply is set by CRT Grid Bias adjustment R1261. Approximately 600 volts peak-to-peak from the secondary of T1225 is connected to the Control-Grid Supply through C1266 and R1266. Diodes CR1268 and CR1264 clip this signal to determine the operating level at the control grid. CR1268 limits the negative excursion of the signal; quiescently when the CRT is blanked, the anode of CR1268 is set at about +15 volts by the Z-Axis Amplifier stage. The positive clipping level at the cathode of CR1264 is set by CRT Grid Bias adjustment R1261. R1261 is adjusted to bias the control grid of the CRT just

enough negative so the trace is blanked between sweeps. Under normal conditions, this biases the control grid about 80 volts more negative than the cathode.

The negative level at the CRT cathode is connected to the cathode of CR1270. This level is held constant by the High-Voltage Regulator as described previously. The clipped voltage developed by diodes CR1264 and CR1268 is peak to peak rectified by diodes CR1269 and CR1270 and super-imposed on this negative voltage to result in a level at the grid of the CRT which is more negative than the CRT cathode level. C1269 acts as a filter to provide a constant voltage output level. The unblanking gate level developed by the Z-Axis Amplifier stage is applied to the anode of CR1268 through R1157. The fast rising and falling portions of this signal are coupled directly to the output through C1269. The overall effect of the unblanking gate is to further clip the negative excursions thereby reducing the voltage difference between grid and cathode of the CRT. This allows the cathode current of the CRT to pass to the anode so the display can be viewed.

CRT Control Circuits

The focus of the display is determined by the FOCUS control R1045. This control and the Auto Focus amplifier maintains a well-defined display for fast changes in the intensity of the display. The network consisting of CR1255, CR1254, CR1253, CR1258, and VR1258 provide the negative voltage for the focus grid of the CRT. Approximately 600 volts peak-to-peak from the secondary of T1225 is connected to the focus grid supply through C1257 and R1257. The positive clipping level at the anode of CR1258 is set by the FOCUS control setting. This determines the operating level at the focus grid. Under normal operating conditions the voltage applied to the focus grid is more positive (less negative) than the control grid or the cathode of the CRT. The signal developed by the Auto Focus amplifier is coupled to the focus grid by C1254. When there is a sudden change in intensity levels the focus grid level will change to maintain a well-defined display. Astigmatism adjustment R1193, which is used in conjunction with the FOCUS control to obtain a well-defined display, varies the positive level on the astigmatism grid. Geometry adjustment R1184 varies the positive level on the horizontal deflection-plate shield to control the overall geometry of the display.

Two adjustments control the trace alignment by varying the magnetic fields induced by coils around the CRT. Y-Axis Alignment R1190 controls the current through L1098, which affects the CRT beam after vertical deflection, but before horizontal deflection. Therefore, it affects only the vertical (Y) components of the display. Beam Rotation adjustment R1181 controls the current through L1099 and affects both the vertical and horizontal rotation of the display.

LOW-VOLTAGE POWER SUPPLY

The Low-Voltage Power Supply circuit provides the operating power for this instrument from six regulated supplies. Electronic regulation is used to provide stable, low-ripple output voltages. Each supply (except the +130 V supply, which is fused) contains a short-protection circuit to prevent instrument damage if a supply is inadvertently over-loaded or shorted to ground. Fig. 3-22 shows a detailed block diagram of the Low-Voltage Power Supply circuit. A schematic of this circuit is shown on diagram 9 at the rear of this manual.

Power Input

Power is applied to the primary of transformer T801 through line fuse F1000, thermal cutout S1000, and POWER switch S1001. The Voltage-Selector Jumper, P1001, connects the two halves of the primary of T801 in parallel for 110-volt (nominal) operation. Voltage-Selector Jumper P1002 connects the two halves of the primary in series for 220-volt (nominal) operation. The line fuse, F1000, must be changed to provide the correct protection for 220-volt nominal operation.

Each half of the primary of T801 has taps above and below the 110-volt (220-volt) nominal point. When the Voltage Selector Jumper is moved from LOW to MED to HI, more turns are effectively added to the primary winding and the turns ratio is decreased to compensate for the increased primary voltage. This configuration extends the regulating range of the 7613.

A fan provides forced-air cooling. The fan is connected in parallel with one half of the primary winding of T801. Therefore, it always has the same voltage applied regardless of the position of the Voltage-Selector Jumper.

Thermal cutout S1000 provides thermal protection for this instrument. If the internal temperature of the instrument exceeds a safe operating level, S1000 opens to interrupt the applied power. When the temperature returns to a safe level, S1000 automatically closes to re-apply the power.

–50-Volt Supply

The following discussion includes the description of the 50 V Rectifier, –50 V Series Regulator, –50 V Feedback Amplifier, –50 V Reference, and –50 V Current Limiting stages. Since these stages are closely related in the operation of the –50-volt regulated output, their performance is most easily understood when discussed as a unit.

The 50 V Rectifier assembly CR808 rectifies the output at the secondary of T801 to provide the unregulated voltage source for both the –50- and +50-volt supplies. CR808 is connected as a bridge rectifier and its output is filtered by C808-C809. Transistors Q886, Q896, Q900 operate as a feedback-stabilized regulator circuit to maintain a constant –50-volt output level. Q886 is connected as a differential amplifier to compare the feedback voltage at the base of Q886B against the reference voltage at the base of Q886A. The error output at the collector of Q886B reflects the difference, if any, between these two inputs. The change in error-output level at the collector of Q886B is always opposite in direction to the change in the feedback input at the base of Q886B (out of phase).

Zener diode VR890 sets a reference level of about –9 volts at the base of Q886A. A feedback sample of the output voltage from this supply is connected to the base of Q886B through divider R880-R881-R882. R881 in this divider is adjustable to set the output level of this supply. Notice that the feedback voltage to this divider is obtained from a line labeled –50 V Sense. Fig. 3-23 illustrates the reason for this configuration. The inherent resistance of the interconnecting wire between the output of the –50-Volt Supply and the load produces a voltage drop which is equal to the output current multiplied by the resistance of the interconnecting wire. Even though the resistance of the wire is small, it results in a substantial voltage drop due to the high output current of this supply. Therefore, if the feedback voltage were obtained ahead of this drop, the voltage at the load might not maintain close regulation. However, the –50 V Sense feedback configuration overcomes this problem since it obtains the feedback voltage from a point as close as practical to the load. Since the current in the –50 V Sense line is small and constant, the feedback voltage is an accurate sample of the voltage applied to the load.

Regulation occurs as follows: If the output level of this supply decreases (less negative) due to an increase in load, or a decrease in input voltage (as a result of line voltage changes or ripple), the voltage across divider R880-R881-R882 decreases also. This results in a more positive feedback level at the base of Q886B than that established by the –50 V Reference stage at the base of Q886A. Since the transistor with the more positive base controls the conduction of the differential amplifier, the output current at the collector of Q886B increases. This increase in output from Q886B allows more current to flow through Q896 and Q900 to result in increased conduction of –50 V Series Regulator Q903. The load current increases and the output voltage of this supply also increases (more negative). As a result, the feedback voltage from the –50 V Sense line increases and the base of Q886B returns to the same level as the base of Q886A. Similarly, if the output level of this supply increases (more negative), the output current of Q886B decreases. The feedback through Q896 and Q900 reduces the conduction of the –50 V Series Regulator to decrease the output voltage of this supply.

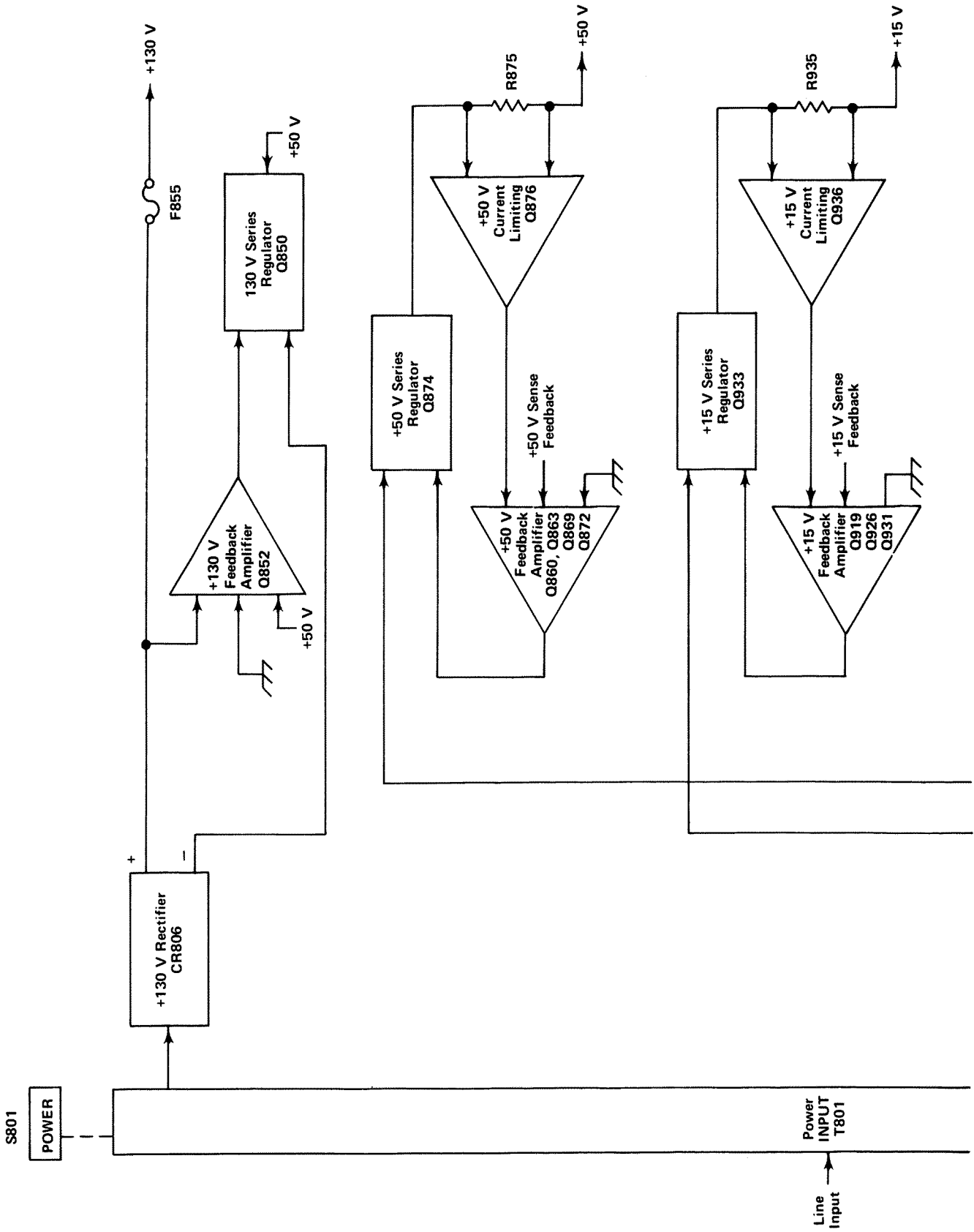

Fig. 3-22. Low-Voltage Power Supply detailed block diagram.

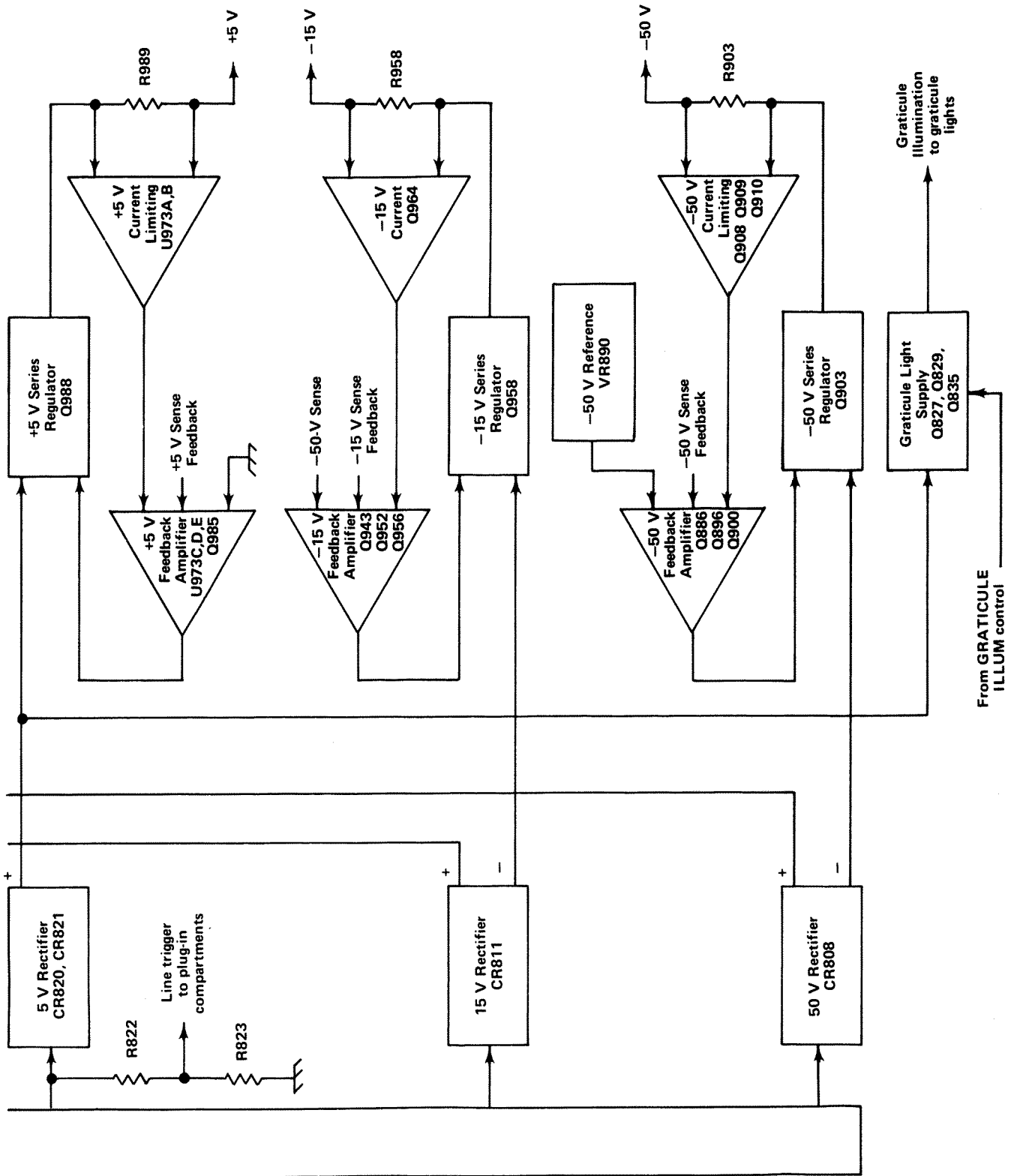

Fig. 3-22. Low-Voltage Power Supply detailed block diagram (cont).

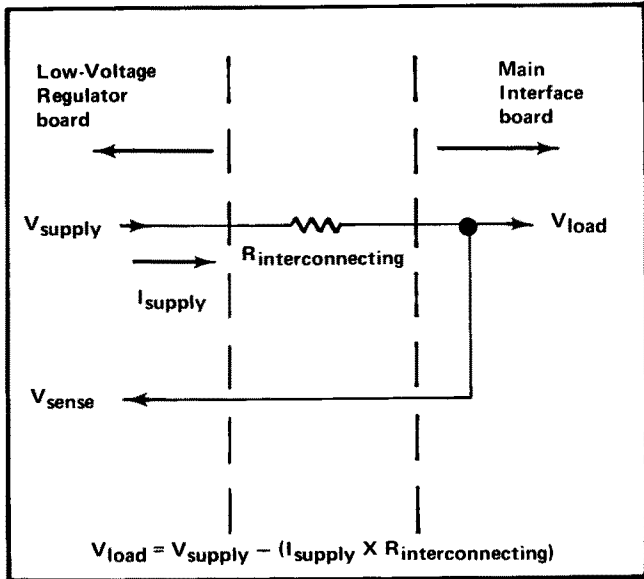

Fig. 3-23. Schematic illustrating voltage drop between power supply output and load due to resistance of interconnecting wire.

−50 Volts adjustment R881 determines the divider ratio to the base of Q886B and thereby determines the feedback voltage. This adjustment sets the output level of the supply in the following manner: If R881 is adjusted so the voltage at its variable arm goes less negative (closer to ground), this appears as an error signal at the base of Q886B. In the same manner as described previously, this positive-going change at the feedback input of the differential amplifier increases the conduction of the −50 V Series Regulator to produce more current to the load, and thereby increase the output voltage of this supply. This places more voltage across divider R880-R881-R882 and the divider action returns the base of Q886B to about −9 volts. Notice that the feedback action of this supply forces a change in the output level which always returns the base of Q886B to the same level as the base of Q886A. In this manner, the output level of the −50-Volt Supply can be set to exactly −50 volts by correct adjustment of R881.

The −50 V Current Limiting stage Q908-Q909-Q910 protects the −50-Volt Supply if excess current is demanded from this supply. All of the output current from the −50-Volt Supply flows through R903. Transistor Q908 senses the voltage at the collector of the −50 V Series Regulator Q903 and compares it against the −50 V output level at the base of Q909 which is obtained from the other side of R903. Under normal operation, Q908 is held in conduction and Q909 is off. However, when excess current is demanded from the −50 V Series Regulator due to a short circuit or similar malfunction at the output of this supply, the voltage drop across R903 increases until the base of Q908 goes more negative than the level at the base of Q909. Then Q909 takes over conduction of the comparator. The collector current of Q909 increases the

voltage drop across R896 to reduce the conduction of Q896 in the −50 V Feedback Amplifier and limit the conduction of Q903. Q910 is connected as a constant-current source for Q908-Q909.

−15-Volt Supply

Basic operation of all stages in the −15-V Supply is the same as for the −50-Volt Supply. Reference level for this supply is established by divider R945-R946 between ground and the −50 V Sense voltage. The divider ratio of R945-R946 sets a level of −15 volts at the base of Q943A. The level on the −50 V Sense line is held stable by the −50-Volt Supply as described previously. The −15 V Sense voltage is connected to the base of Q943B through R940. Any change at the output of the −15-Volt Supply appears at the base of Q943B as an error signal. The output voltage is regulated in the same manner as described for the −50-Volt Supply.

+5-Volt Supply

Basic operation of the +5-Volt Supply is the same as described for the previous supplies. The +5 V Current Limiting and +5 V Feedback Amplifier (except for Q985) is made up of a five-transistor array U973. Notice that both U973C and Q985 in the +5 V Feedback Amplifier are connected as emitter followers, since inversion is not necessary in the feedback path for positive output voltages. Reference voltage for the +5 V Feedback Amplifier stage is established by divider R970-R971 between the +5 V Sense and −50 V Sense feedback voltages. This divider establishes a quiescent level of about 0 volt at the base of U973E.

+15-Volt Supply

The +15-Volt Supply operates in the same manner as described for the previous supplies. The unregulated +15-Volt Supply provides the source voltage for the High-Voltage Oscillator stage in the CRT circuit through fuse F814 and P870.

+50-Volt Supply

Operation of the +50-Volt Supply is the same as described for the previous supplies. The unregulated +50 volts, from 50 V Rectifier CR808, is used to provide a positive starting voltage for the −50-Volt Supply.

+130-Volt Supply

The +130-V Rectifier CR806 provides the rectified voltage for the +130-Volt Supply. However, this secondary winding of T801 does not supply the full potential necessary to obtain the +130-volt output level. To provide the required output level, the +50-Volt Supply is connected in series with this supply through Q850. Basic regulation of

the output voltage is provided by +130 V Feedback Amplifier Q852, and +130 V Series Regulator Q850.

The output voltage of this supply is connected across divider R855-R856. This divider provides a quiescent level of about +50 volts at the base of Q852. The reference level for this supply is provided by the +50-Volt Supply connected to the emitter of Q852. If the output of this supply changes, this change is sensed by Q852 and an amplified error signal is connected to the base of Q850. This error signal changes the conduction of the +130 V Series Regulator Q850 to correct the output error. Fuse F855 protects this supply if the output is shorted. However, since the response time of F855 is slow to a shorted condition, VR851 provides additional current to the base of Q850 to protect it from damage due to over-voltage. Diode CR852 limits the reverse bias on Q852 to about 0.6 volt when F855 is blown.

Graticule Light Supply

Power for the graticule lights is supplied by the Graticule Light Supply. Rectified voltage for this supply is provided by 5 V Rectifier CR820-CR821. Q835 operates as a series regulator transistor. Emitter follower Q829 determines the conduction of this series regulator as controlled by front panel GRATICULE ILLUM Control R1095. Current-limiting to protect this supply is provided by Q827. Under normal operation, divider R830-R831-R833 sets the base of Q827 below its conduction level. However, if excess current is demanded from this supply, the voltage drop across R837-R838 increases until Q827 comes into conduction. The collector of Q827 then limits the conduction of this supply to limit its output current.

Divider R822-R823 provides a sample of the line voltage in the secondary of T801 to the plug-in unit. This provides a line-frequency reference to the plug-in units for internal triggering at line frequency or for other applications.

SIGNAL OUT BOARD

VERT SIG OUT

The vertical signal is selected by the TRIG SOURCE switch. The vertical signal selected is applied to the bases of a differential amplifier Q606 and Q618. A single-ended signal is taken off the collector of Q618 and connected to an output buffer Q620. CR621 and CR622 provide protection against a high voltage inadvertently applied to the output connector.

+ GATE OUT

The gate signal is connected to a comparator circuit Q662 and Q666 through resistor R660. From the comparator the gate signal is connected to the emitter of an output buffer Q672. Gate Selector switch connects one of the gate signals to R660, the input of the Gate Amplifier. Possible gate signals are MAIN gate and, with a dual-sweep time-base unit, a DELAY or an AUXILIARY gate signal can be selected. CR674 and CR676 provide protection against a high voltage inadvertently applied to the output connector.

+ SAWTOOTH OUT

The sawtooth signal is connected to the Sawtooth Amplifier through R36. Q631, Q634, and Q640 comprise a negative feedback amplifier with a gain of two, determined by the ratio of feedback resistor R645 to the combined input resistance of R630 and R63. CR635 and CR676 provide protection against a high voltage inadvertently applied to the output connector.

READOUT SYSTEM

The Readout System in the 7613 provides alphanumeric display of information encoded by the plug in units. This display is presented on the CRT and is written by the CRT beam on a time-shared basis. Schematics for the total Readout System are shown on diagrams at the rear of this manual.

The definitions of several terms must be clearly understood to follow this description of the Readout System. These are:

Character—A character is a single number, letter, or symbol which is displayed on the CRT, either alone or in combination with other characters.

Word—A word is made up of a related group of characters. In the 7613 Readout System, a word can consist of up to ten characters.

Frame—A frame is a display of all words for a given operating mode and plug-in combination. Up to six words can be displayed in one frame. Fig. 3-24 shows one complete frame (simulated readout) and the position at which each of the six words is displayed.

Circuit Description—7613/R7613 Service

Column—One of the vertical lines in the Character Selection Matrix (see Fig. 3-25). Columns C-0 (column zero) to C-10 (column 10) can be addressed in the 7613 system.

Row—One of the horizontal lines in the Character Selection Matrix (Fig. 3-25). Rows R-1 (row 1) to R-10 (row 10) can be addressed in the 7613 system.

Time-slot—A location in a pulse train. In the 7613 Readout System, the pulse train consists of 10 negative-going pulses. Each of these time-slots is assigned a number between one and ten. For example, the first time-slot is TS-1.

Time-multiplexing—Transmission of data from two or more sources over a common path by using different time intervals for different signals.

Each word in the readout display can contain up to 10 characters, although the typical display will contain between two and seven characters per word. The characters are selected from the Character Selection Matrix shown in Fig. 3-25. Any one of the 50 separate characters can be addressed and displayed on the CRT. In addition, 12 operational addresses are provided for special instructions to the Readout System. The unused locations in the Matrix (shaded areas) are available for future expansion of the Readout System. The method of addressing the locations in the Character Selection Matrix is described in the following discussion.

Developing the Display. The following basic description of the Readout System uses the block diagram shown in Fig. 3-27. This description is intended to relate the basic function of each stage to the operation of the overall Readout System. Detailed information on circuit operation is given later.

Display Format. Up to six words of readout information can be displayed on the 7613 CRT. The position of each word is fixed and is directly related to the plug-in unit from which it originated. Fig. 3-24 shows the area of the graticule where the readout from each plug-in unit is displayed. Notice that channel 1 of each plug-in unit is displayed within the top division of the CRT and channel 2 is displayed directly below within the bottom division. Fig. 3-26 shows a typical display.

The key block in the Readout System is the Timer stage. This stage produces the basic signals which establish the timing sequences within the Readout System. Period of the timing signal is about 250 microseconds (drops to about 210 microseconds when Display-Skip is received; see detailed description of Timing stage for further information). This stage also produces control signals for other stages within this circuit and interrupt signals to the Vertical Interface, Horizontal Interface, CRT Circuit, and Z-Axis Logic stage which allow a readout display to be presented. The Time-Slot Counter stage receives a trapezoidal voltage signal from the Timer stage and directs it to one of ten output lines. These output lines are labeled TS-1 through TS-10 (time-slots one through ten) and are connected to the vertical and horizontal plug-in compartments as well as to various stages within the Readout System. The output lines are energized sequentially so there is a pulse on only one of the 10 lines during any 250 microsecond timing period. When the Time-Slot Counter stage has completed time-slot 10, it produces an End-of-Word pulse which advances the system to the next channel.

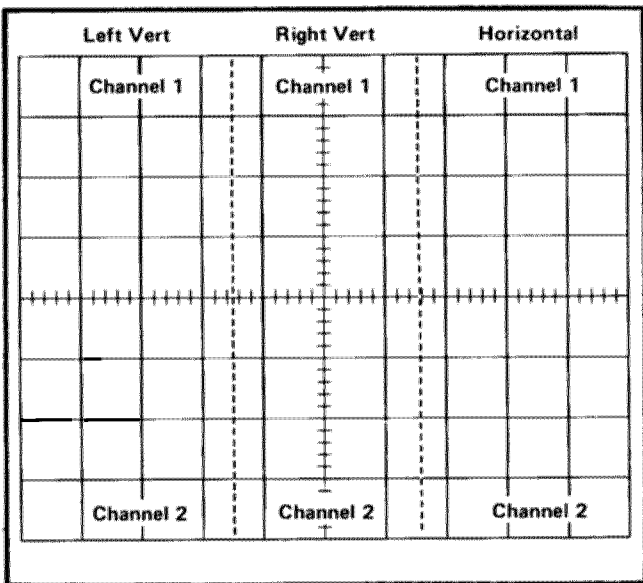

Fig. 3-24. Location of readout words on the CRT identifying the originating plug-in unit and channel (one complete frame shown, simulated readout).

Two output lines, row and column, are connected from each channel of the plug-in units back to the Readout System. Data is encoded on these output lines by connecting resistors between them and the time-slot input lines. The resultant output is a sequence of ten analog current levels which range from zero to one milliamper (100 microamperes/step) on the row and column output lines. This row and column correspond to the row and column of the Character Selection Matrix in Fig. 3-25. The

Column Number →												
Row Number ↓	Current (Milli-amperes)	C-0	C-1	C-2	C-3	C-4	C-5	C-6	C-7	C-8	C-9	C-10
R-1	0	0	0	1	2	3	4	5	6	7	8	9
R-2	0.1	/	<	I	/	/	+	-	+	C	Δ	>
R-3	0.2	Add* one zero	Add* two zeros	Reduce* prefix	Reduce* prefix and add one zero							IDENTIFY*
R-4	0.3	m	μ	n	p	X	X	K	M	G	T	R
R-5	0.4	S	V	A	W	H	H	d	B	c	Ω	E
R-6	0.5	U	N	L	Z	Y	Y	P	F	J	Q	D
R-7	0.6			Decimal* point location No. 3	Decimal* point location No. 4	Decimal* point location No. 5	Decimal* point location No. 6	Decimal* point location No. 7				
R-8	0.7											
R-9	0.8											
R-10	0.9											
		← SKIP* →										
		Add Space In Display*										

Fig. 3-25. Character Selection Matrix for 7613 Readout System.

 Unused locations. Available for future expansion of Readout System
Operational address.

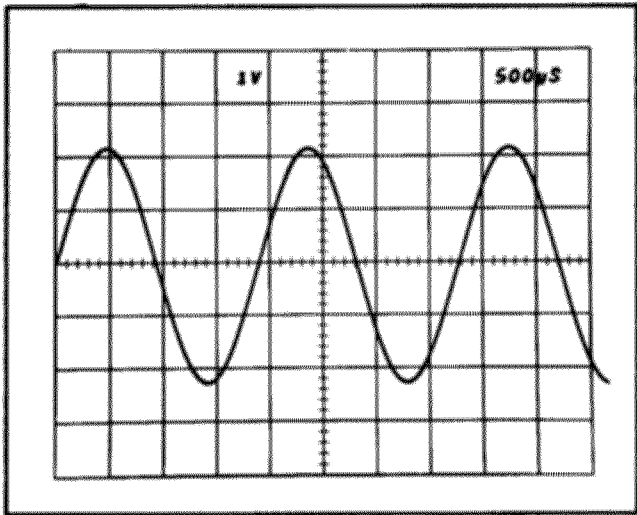

Fig. 3-26. Typical readout display where only channel 1 of the Right Vertical and Horizontal units is displayed.

standard format in which information is encoded onto the output lines is given in Table 3-2 (special purpose plug-in units may have their own format for readout; these special formats will be defined in the manuals for these units).

The encoded column and row data from the plug-in units is selected by the Column Data Switch and Row Data Switch stages respectively. These stages take the analog currents from the six data lines (two channels from each of the three plug-in compartments) and produce a single time-multiplexed analog voltage output which contains all of the column or row information from the plug-ins. The Column Data Switch and Row Data Switch are sequenced by the binary Channel Address No. 1 code from the Channel Counter.

The time multiplexed output of the Column Data Switch is monitored by the Display-Skip Generator to determine if it represents valid information which should be displayed. Whenever information is not encoded in a time-slot, the Display-Skip Generator produces an output level to prevent the Timer stage from producing the control signals which normally interrupt the CRT display and present a character.

The analog outputs of the Column Data Switch and Row Data Switch are connected to the Column Decoder and Row Decoder stages respectively. These stages sense the magnitude of the analog voltage input and produce an

output current on one of ten lines. The outputs of the Column Decoder stage are identified as C-1 to C-10 (column 1 to 10) which correspond to the column information encoded by the plug-in unit. Likewise, the outputs of the Row Decoder stage are identified as R-1 to R-10 (row 1 to 10) which correspond to the row information encoded by the plug-in unit. The primary function of the row and column outputs is to select a character from the Character Selection Matrix to be produced by the Character Generator stage. However, these outputs are also used at other points within the system to indicate when certain information has been encoded. One such stage is the Zeros Logic and Memory. During time-slot 1 (TS-1), this stage checks if zero-adding or prefix-shifting information has been encoded by the plug-in unit and stores it in memory until time-slots 5, 6, or 8. After storing this information, it triggers the Display-Skip Generator stage so there is no display during this time slot (as defined by Standard Readout Format; see Table 3-2). When time-slots 5, 6, and 8 occur, the memory is addressed and any information stored there during time-slot 1 is transferred out and connected to the input of the Column Decoder stage to modify the analog data during the applicable time-slot.

TABLE 3-2

Standard Readout Format

Time-Slot Number	Description
TS-1	Determines decimal magnitude (number of zeros displayed or prefix change information) or the IDENTIFY function (no display during this time-slot).
TS-2	Indicates normal or inverted input (no display for normal).
TS-3	Indicates calibrated or uncalibrated condition of plug-in variable control (no display for calibrated condition).
TS-4	1-2-5 scaling.
TS-5 TS-6 TS-7	Not encoded by plug-in unit. Left blank to allow addition of zeros by Readout System.
TS-8	Defines the prefix which modifies the units of measurement.
TS-9 TS-10	Define the units of measurement of the plug-in unit. May be standard units of measurement (V, A, S, etc.,) or special units selected from the Character Selection Matrix.

Another operation of the Zeros Logic and Memory stage is to produce the IDENTIFY function. When time-slot 1 is encoded for IDENTIFY (column 10, row 3), this stage produces an output level which connects the Column Data Switch and Row Data Switch to a coding network within the Readout System. Then, during time-slots 2 through 9, an analog current output is produced from the Column Data Switch and Row Data Switch which addresses the correct points in the Character Selection Matrix to display the word "IDENTIFY" on the CRT. The Zeros Logic and Memory stage is reset after each word by the Word Trigger pulse.

The Character Generator stage produces the characters which are displayed on the CRT. Any of the 50 characters shown on the Character Selection Matrix of Fig. 3-24 can be addressed by proper selection of the column and row current. Only one character is addressable in any one time-slot; a space can be added into the displayed word by the Decimal Point Logic and Character Position Counter stage when encoded by the plug-in. The latter stage counts how many characters have been generated and produces an output current to step the display one character position to the right for each character. In addition, the character position is advanced once during each of time-slots 1, 2, and 3 whether a character is generated during these time-slots or not. This action fixes the starting point of the standard-format display such that the first digit of the scaling factor always starts at the same point within each word regardless of the information encoded in time-slot 2 (normal/invert) or time-slot 3 (cal/uncal) which precedes this digit. Also, by encoding row 10 and column 0 during any time-slot, a blank space can be added to the display. Decimal points can be added to the display at any time by addressing row 7 and columns 3 through 7 (see Character Selection Matrix for location of these decimal points). The Decimal Point Logic and Character Position Counter stage is reset after each word by the Word Trigger pulse.

The Format Generator stage provides the output signals to the vertical and horizontal deflection systems of the instrument to produce the character display. The binary Channel Address No. 2 code from the Channel Counter stage is connected to this stage so that the display from each channel is positioned to the area of the CRT which is associated with the plug-in and channel originating the word (see Fig. 3-24). The positioning current or decimal point location current generated by the Decimal Point Logic and Character Position Counter stage is added to the horizontal (X) signal at the input to the Format Generator stage to provide horizontal positioning of the characters within each word. The X- and Y-output signals are connected to the Horizontal Amplifier and Vertical Amplifier through the Horizontal Output and Vertical Output stages respectively.

The Word Trigger stage produces a trigger from the End-of-Word pulse generated by the Time-Slot Counter

stage after the tenth time-slot. This Word Trigger pulse advances the Channel Counter to display the information from the next channel or plug-in. It also provides a reset pulse to the Zeros Logic and Memory stage and the Decimal Point Logic and Character Position Counter stage. The Word Trigger stage can also be advanced to jump a complete word or a portion of a word when a Jump command is received from the Row Decoder stage.

The Single-Shot Lockout stage allows the display sequence of the Readout System to be changed. Normally, the Readout System operates in a free-running mode so the waveform display is interrupted randomly to display characters. However, under certain conditions (such as single-shot photography), it is desirable that the Readout System operate in a triggered mode where the readout portion of the display is normally blanked out but can be presented on command. The Readout Mode switch determines the operating mode of the readout system.

Circuit Analysis of Readout System

The following analysis of the Readout System describes the operation of each stage in detail. Complete schematics of the Readout System are shown on diagram 11 at the rear of this manual.

Timer

Timer U2126 establishes the timing sequence for all circuits within the Readout System. This stage produces seven time-related output waveforms (see Fig. 3-28). The triangle waveform produced at pin 6 forms the basis for the remaining signals. The basic period of this triangle waveform is about 250 microseconds as controlled by RC network C1214-R1214. The triangle waveform is clipped and amplified by U1210 to form the trapezoidal output signal at pin 10. The amplitude of this output signal is exactly 15 volts as determined by V2126 (exact amplitude necessary to accurately encode data in plug-in units; see Encoding the Data). The Trigger output at pin 5 provides the switching signal for the Time-Slot Counter and Word Trigger stages.

The signals at pins 12, 13, 14, and 16 are produced only when the triangle waveform is on its negative slope and the trapezoidal waveform has reached the lower level. The timing sequence of these waveforms is very important to the correct operation of the Readout System (see expanded waveforms in Fig. 3-29). The Z-Axis Logic OFF Command at pin 14 is produced first. This negative-going signal provides a blanking pulse to the Z-Axis Logic stage (see diagram 2) to blank the CRT before the display is switched to the Readout System. It also produces the Strobe pulse through R2137, Q2138, and CR2142 to signal other stages within the Readout System to begin the sequence necessary

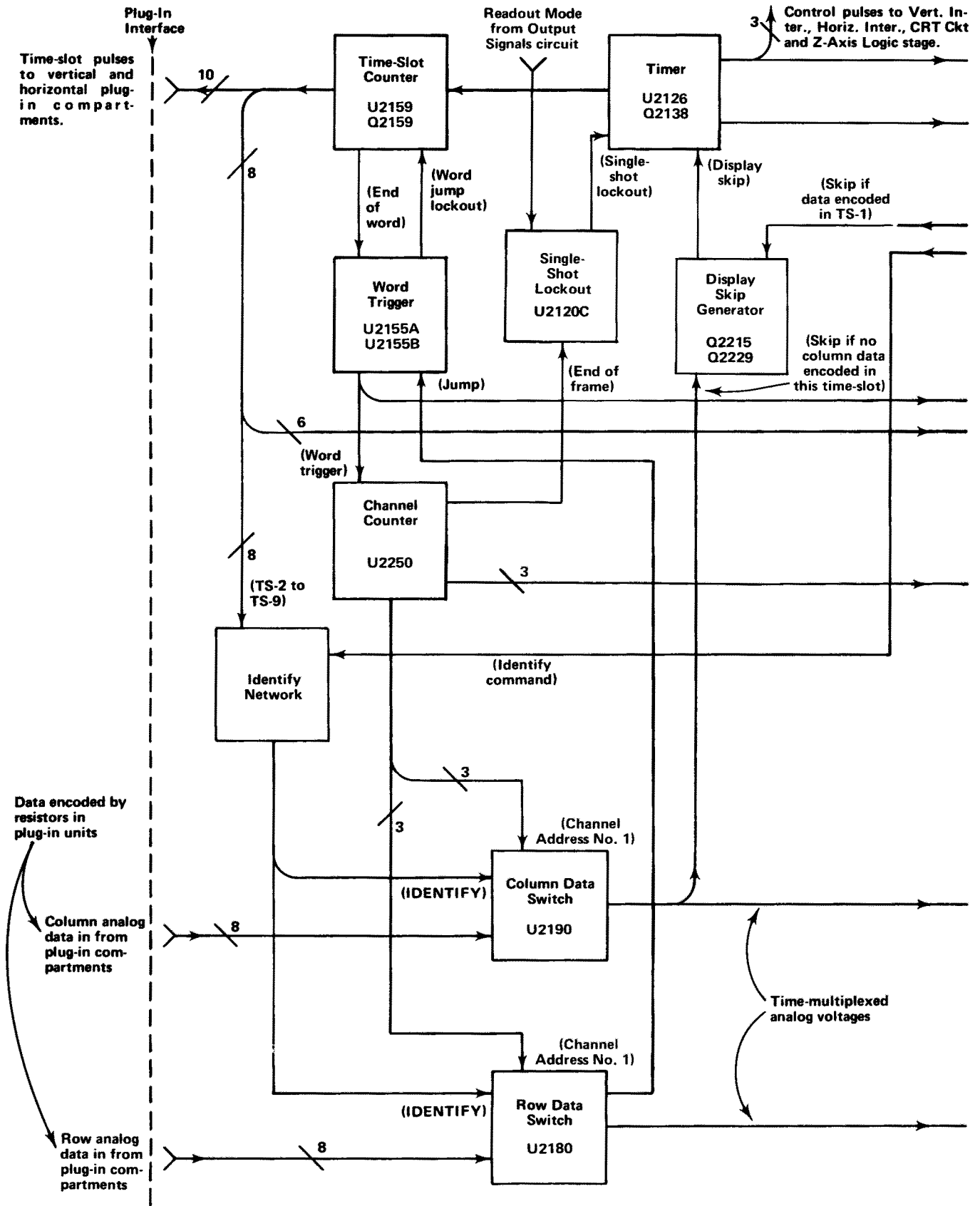

Fig. 3-27. Detailed block diagram of Readout System.

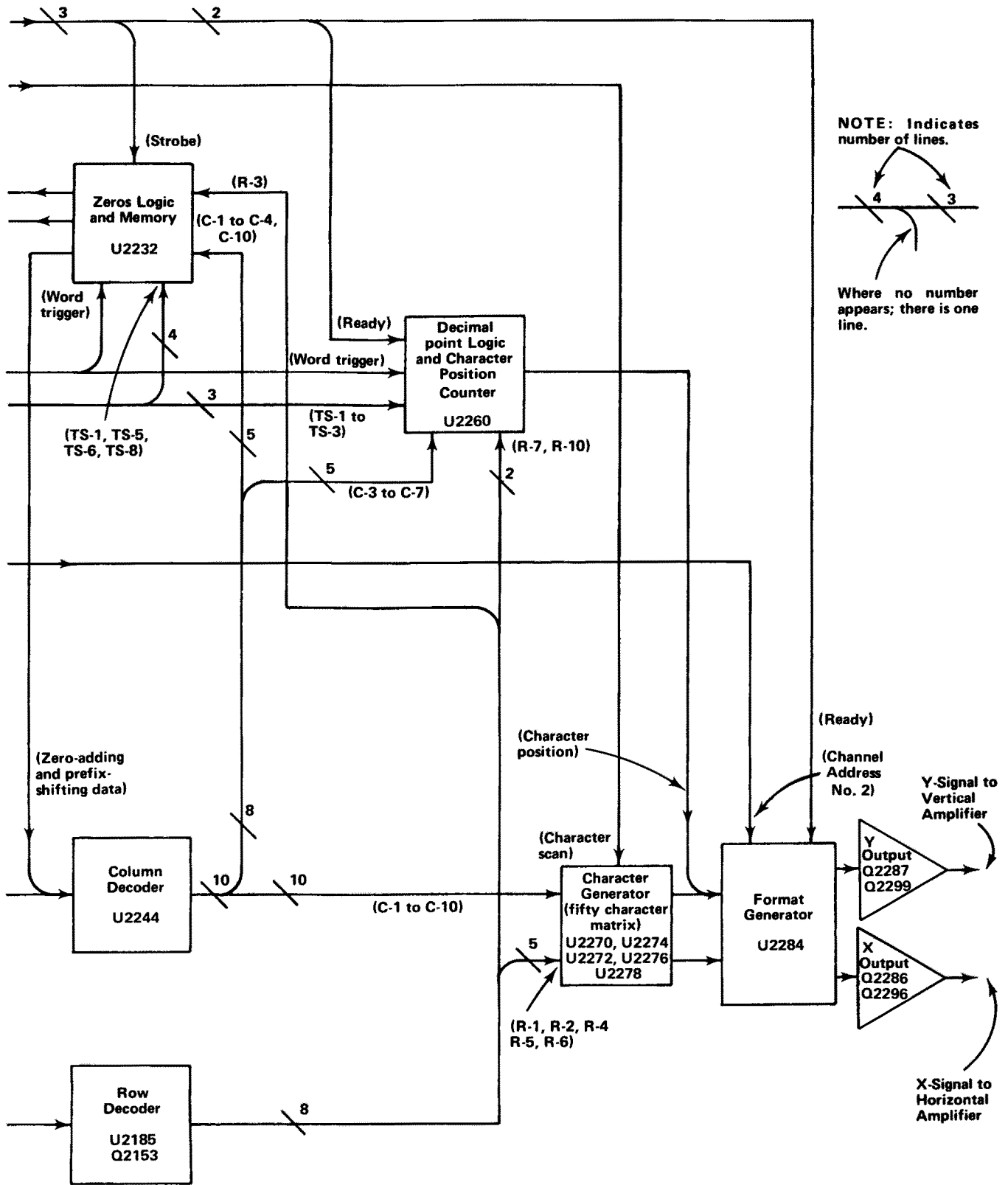

Fig. 3-27. Detailed block diagram of Readout System (cont).

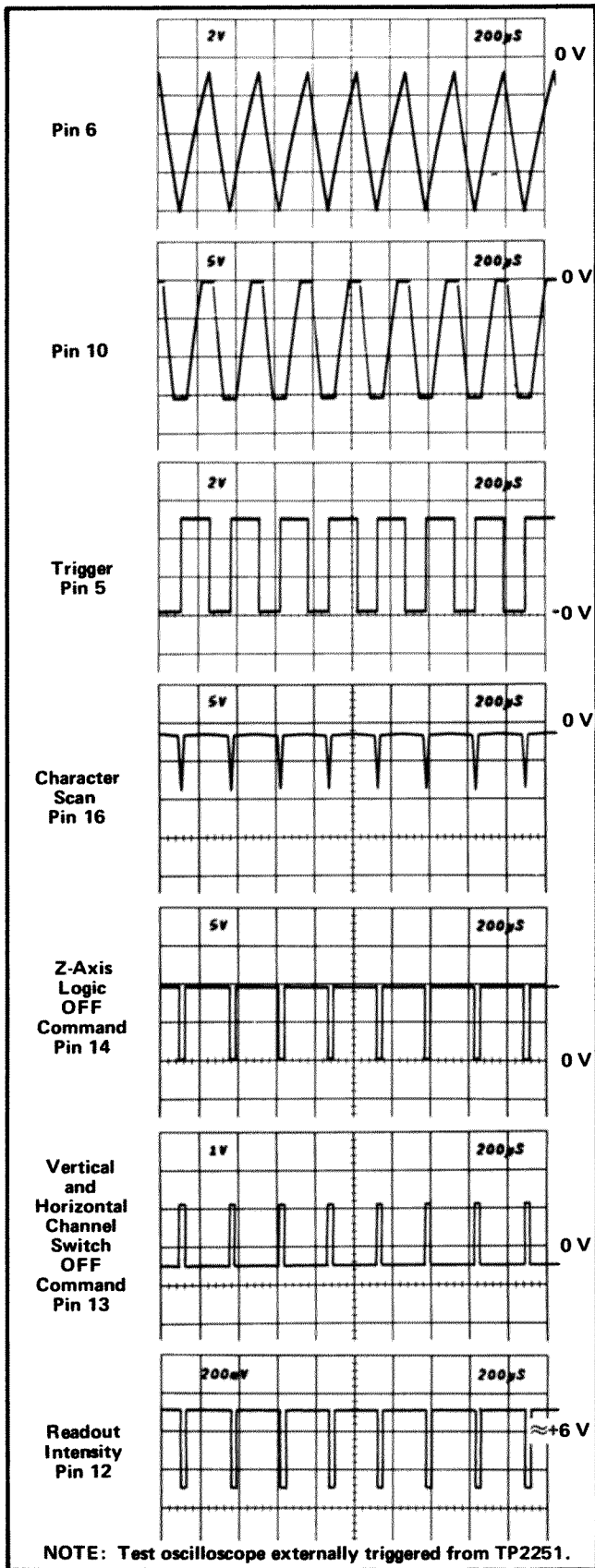

Fig. 3-28. Output waveforms of Timer stage.

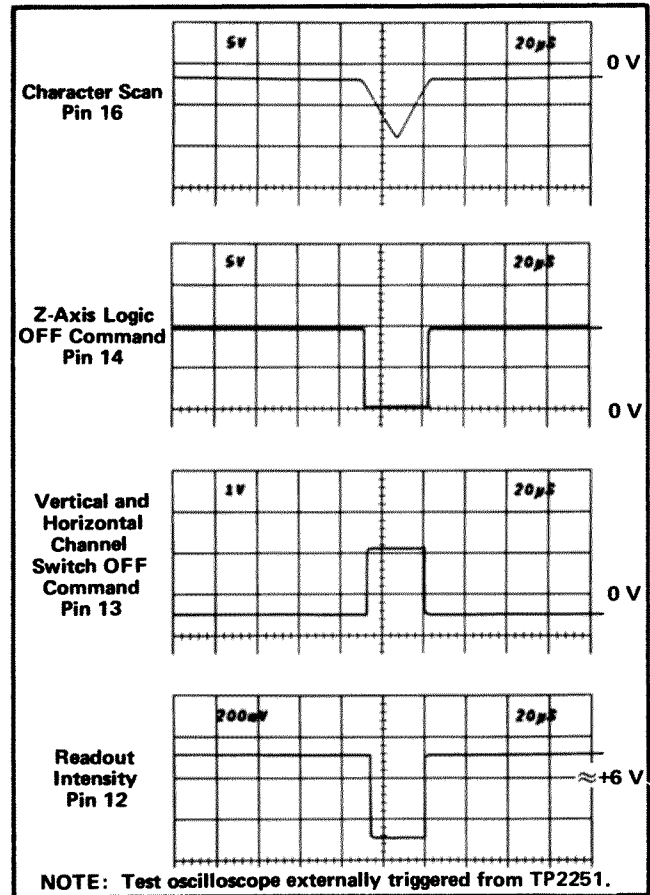

Fig. 3-29. Detail of outputs at pins 12, 13, 14, and 16 of U2126.

to produce a character. The collector of Q2138 is also connected to Character Generator No. 2, U2272 through C2140, CR2140. This activated U2272 during the quiescent period of the Strobe pulse (collector of Q2138 negative) and diverts the output current of Row Decoder U2185 to row 2. The purpose of this configuration is to prevent the Zeros Logic and Memory stage U2232 from storing incorrect data during the quiescent period of the Strobe pulse. When the Strobe pulse goes positive, CR2140 is reverse biased to disconnect Q2138 from U2272 and allow the Row Decoder stage to operate in the normal manner.

The next signal to be produced is the Vertical/Horizontal Channel Switch OFF Command at pin 13. This positive-going signal disconnects the plug-in signals in the vertical and horizontal deflection systems so the plug-in units do not control the position of the CRT beam during the readout display. The Ready signal derived from this output is connected to the Decimal Point Logic and Character Position Counter stage and the Format Generator stage (see diagram 11). The Readout Intensity output at pin 12 is produced next. This current is connected to the CRT Circuit to unblank the CRT to the intensity level determined by READOUT intensity control R2124. The Character Scan ramp at pin 16 started to go negative as this

timing sequence began. However, character-generation does not start until the readout intensity level has been established. The triangular Character Scan ramp runs negatively from about -2 volts to about -8.5 volts and then returns back to the original level. This waveform provides the scanning signal for the Character Generator stages (see diagram 11). The Full Character Scan adjustment R2128 sets the DC level of the Character Scan ramp to provide complete characters on the display.

The Timer stage operates in one of two modes as controlled by the Display-Skip level at pin 4. The basic mode just described is a condition which does not occur unless all ten characters of each word (60 characters total) are displayed on the CRT. Under typical conditions only a few characters are displayed in each word. The Display-Skip level at pin 4 determines the period of the Timer output signal. When a character is to be generated, pin 4 is LO and the circuit operates as just described. However, when a character is not to be displayed, a HI level is applied to pin 4 of U2126 through CR2125 from the Display-Skip Generator stage. This signal causes the Timer to shorten its period of operation to about 210 microseconds. The waveforms shown in Fig. 3-30 show the operation of the Timer stage when the Display-Skip condition occurs for all positions in a word. Notice that there is no output at pin 12, 13, 14, and 16 under this condition. This means that the CRT display is not interrupted to display characters. Also notice that the triangle waveform at pin 6 does not go as far negative and that the negative portion of the trapezoidal waveform at pin 10 is shorter. Complete details on operation of the Display-Skip Generator are given later.

The Single-Shot Lockout level at pin 2 determines the operating mode of U2126. If this level is LO, the Timer operates as just described. However, if the Single-Shot Lockout stage sets a HI level at this pin, the Timer stage is locked out and can not produce any output signals (see Single-Shot Lockout description for further information).

The READOUT intensity control R2124 sets the intensity of the readout display independently of the INTENSITY control. The READOUT intensity control also provides a means of turning the Readout System off when a readout display is not desired. When R2124 is turned fully counterclockwise, switch S102 opens. The current to pin 11 of U2126 is interrupted and at the same time a positive voltage is applied to pin 4 through R2122 and CR2124. This positive voltage switches the stage to the same conditions as were present under the Display-Skip condition. Therefore, the CRT display is not interrupted to present characters. However, time-slot pulse continue to be generated.

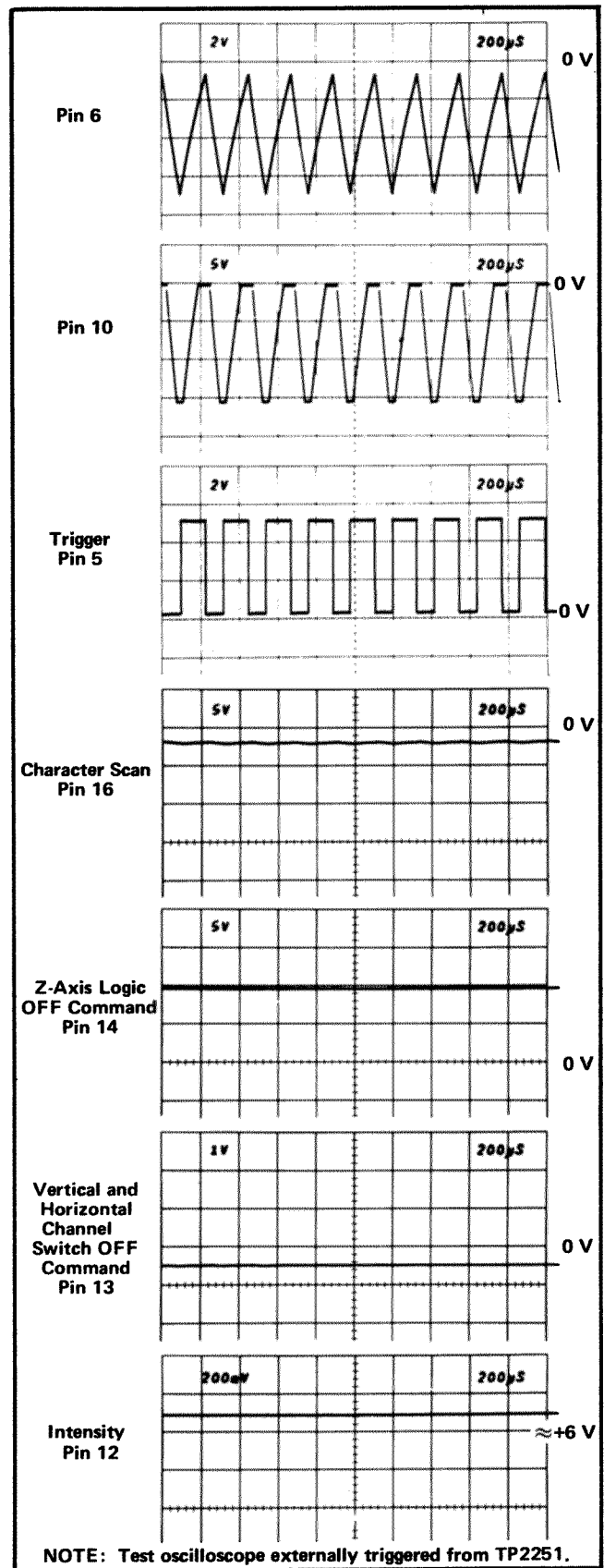

NOTE: Test oscilloscope externally triggered from TP2251.
 Fig. 3-30. Timer stage operation when Display-Skip condition occurs.

Time-Slot Counter

Time-Slot Counter U2126 is a sequential switch which directs the trapezoidal waveform input at pin 8 to one of its 10 output lines. These time-slot pulses are used to interrogate the plug-in units to obtain data for the Readout System. The Trigger pulse at pin 15 switches the Time-Slot Counter to the next output line; the output signal is sequenced consecutively from time-slot 1 through time-slot 10. Fig. 3-31 shows the time-relationship of the time-slot pulses. Notice that only one of the lines carries a time-slot pulse at any given time. When time-slot 10 is completed, a negative-going End-of-Word pulse is produced at pin 2. The End-of-Word pulse provides a drive pulse for the Word Trigger stage and also provides an enabling level to the Display-Skip Generator during time-slot 1 only.

Pin 16 is a reset input for the Time-Slot Counter. When this pin is held LO, the Time-Slot Counter resets to time-slot 1. The Time-Slot Counter can be reset in this manner only when a Jump signal is received by U2155C (see following discussion).

Word Trigger

The Word Trigger stage is made up of the 4 two-input NOR gates contained in U2155. Quiescently, pin 2 of U2155A is LO as established by the operating conditions of U2155D and U2155C. Therefore, the LO End-of-Word pulse produced by the Time-Slot Counter results in a HI level at pin 1 of U2155A. This level is inverted by U2155B to provide a negative-going advance pulse to the Channel Counter.

An advance pulse is also produced by U2155A when a Jump signal is received at pin 8 of U2155C. This condition can occur during any time-slot (see Row Decoder for further information on origin of the Jump signal). U2155D and U2155C are connected as a bistable flip-flop. The positive-going Jump signal at pin 8 of U2155C produces a LO at pin 10. This LO is inverted by U2155D to produce a HI at pin 13, which allows pin 9 of U2155C to be pulled HI through R2155. The flip-flop has now been set and it remains in this condition until reset, even though the Jump signal at pin 8 returns to its LO level. The HI output level at pin 13 turns on Q2159 through R2158 to pull pin 16 of the Time-Slot Counter LO. This resets the Time-Slot Counter to time-slot 1 and holds it there until U2155C is reset. At the same time, a HI level is applied to pin 4 of the Timer through CR2125 and CR2124. This HI level causes the Timer to operate in the display-skip mode so that a character is not generated.

The next Trigger pulse is not recognized by the Time-Slot Counter since U2159 is locked in time-slot 1 by U2155. However, this Trigger pulse resets the Word Trigger

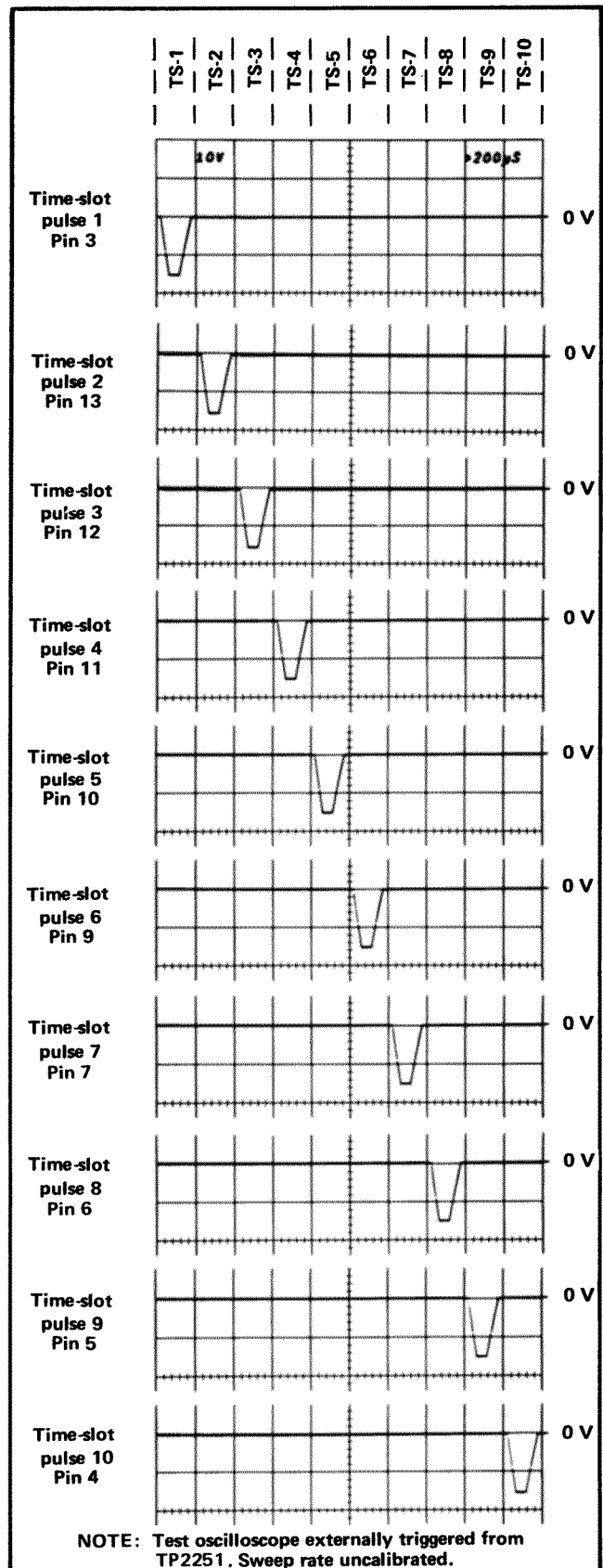

Fig. 3-31. Time relationship of the time-slot (TS) pulses produced by U2126.

stage through C2155. Pin 13 of U2155D goes LO to enable the Time-Slot Counter and Timer stages for the next time-slot pulse. At the same time, the negative-going edge produced at U2155D switches output states which is connected to pin 3 of U2155D. This results in a negative-going Word Trigger output at pin 4 of U2155B to advance the Channel Counter to the next word. When the next Trigger pulse is received at pin 15, the Time-Slot Counter returns to the normal sequence of operation and produces an output on the time-slot 1 line.

Channel Counter

The Channel Counter, made up of integrated circuit U2250 is a binary counter which produces the Channel Address code for the Column and Row Decoder stages and the Format Generator stage. This code instructs these stages to sequentially select and display the six channels of data from the plug-in units. The input channel which is displayed with each combination of the Channel Address code is given in the discussion of the applicable stages.

Single-Shot Lockout

Q2108, Q2117, and U2120 makes up the Single-Shot Lockout stage. This stage allows a single readout frame (Six complete words) to be displayed on the CRT, after which the Readout System is locked out so further readout displays are not presented until the circuit is reset. U2120C and U2120B are connected to form a bistable flip-flop. For normal operation, pin 3 of U2120 is pulled HI through R2108. This activates U2120C to result in a LO output level at pin 10. This level enables the Timer stage so it can operate in the free-running manner as described previously. The LO at pin 10 of U2120C is also applied to pin 5 of U2120B. Since pin 6 of U2120A is LO, U2120B is disabled and its output goes HI.

The output of this stage remains LO to allow U2126 to operate in the free-running mode until a LO is received at pin 8 of U2120C. When this occurs, the output level at pin 10 of U2120C does not change immediately. However, the Readout System is now enabled as far as the single-shot lockout function is concerned. If the Channel Counter has not completed word six (Channel 2 of the Horizontal unit), the Readout System continues to operate in the normal manner. However, when word six is completed, a positive-going End-of-Frame pulse is produced at pin 9 of U2120B as the Channel Counter shifts to the code necessary to display word one. This pulse is coupled to pin 3 of U2120A and pin 12 of U2120D. The momentary HI at pin 3 activates U2120B and its output goes LO to disable U2120C (pin 3 already LO). The output of U2120C goes HI to disable the Timer so it operates in the display-skip mode. The HI at pin 10 of U2120C also holds U2120B enabled so it maintains control of the flip-flop.

The Single-Shot Lockout stage remains in this condition until a positive-going trigger pulse is applied to pin 8 of U2120C. This trigger pulse produces a LO at pin 10 of U2120C which enables U2120B and disables U2120C. Now, the Timer can operate in the normal manner for another complete frame. When word six is completed, the Channel Counter produces another End-of-Frame pulse to again lock out the Timer stage.

Encoding the Data

Data is conveyed from the plug-in units to the Readout System in the form of an analog code having up to 11 current levels (from zero to one milliampere in 100 microampere steps). The characters which can be selected by the encoded data are shown on the Character Selection Matrix (see Fig. 3-25). Each character requires two currents to define it; these currents are identified as the column current and the row current which correspond to the column and row of the matrix. The column and row data is encoded by resistive programming in the plug-in units. Fig. 3-32 shows a typical encoding scheme for a voltage-sensing amplifier plug-in unit. Notice that the 10 time-slot (TS) pulses produced by the Time-Slot Counter stage are connected to the plug-in unit. However, time-slots 5, 6, 7, and 10 are not used by the plug-in unit to encode data when using the Standard Readout Format (see Table 3-2 for Standard Readout Format). The amplitude of the time-slot pulses is exactly -15 volts as determined by the Timer stage. Therefore, the resultant output current from the plug-in units can be accurately controlled by the programming resistors in the plug-in units.

For example, in Fig. 3-32, resistors R10 through R90 control the row analog data which is connected back to the Readout System. These resistors are of fixed value and define the format in which the information will be presented by the Readout System. Fig. 3-33A shows an idealized output current waveform of row analog data which results from the 10 time-slot pulses. Each of the steps of current shown in these waveforms corresponds to 100 microamperes of current. The row numbers on the left-hand side of the waveform correspond to the rows in the Character Selection Matrix shown in Fig. 3-35. The row analog data is connected back to the Readout System via terminal B37 of the plug-in interface.

The Column analog data is defined by resistors R110 through R190. The program resistors are connected to the time-slot lines by switch closures to encode the desired data. The data as encoded by the circuit shown in Fig. 3-32 indicates a 100 microvolt sensitivity with the display inverted and calibrated vertical deflection factors. This results in the idealized output current waveforms shown in Fig. 3-33B at the column analog data output, terminal A37 of the plug-in interface. Resistor R111, connected between time-slot 1 and the column analog data output, encodes two units of current during time-slot 1. Referring to the

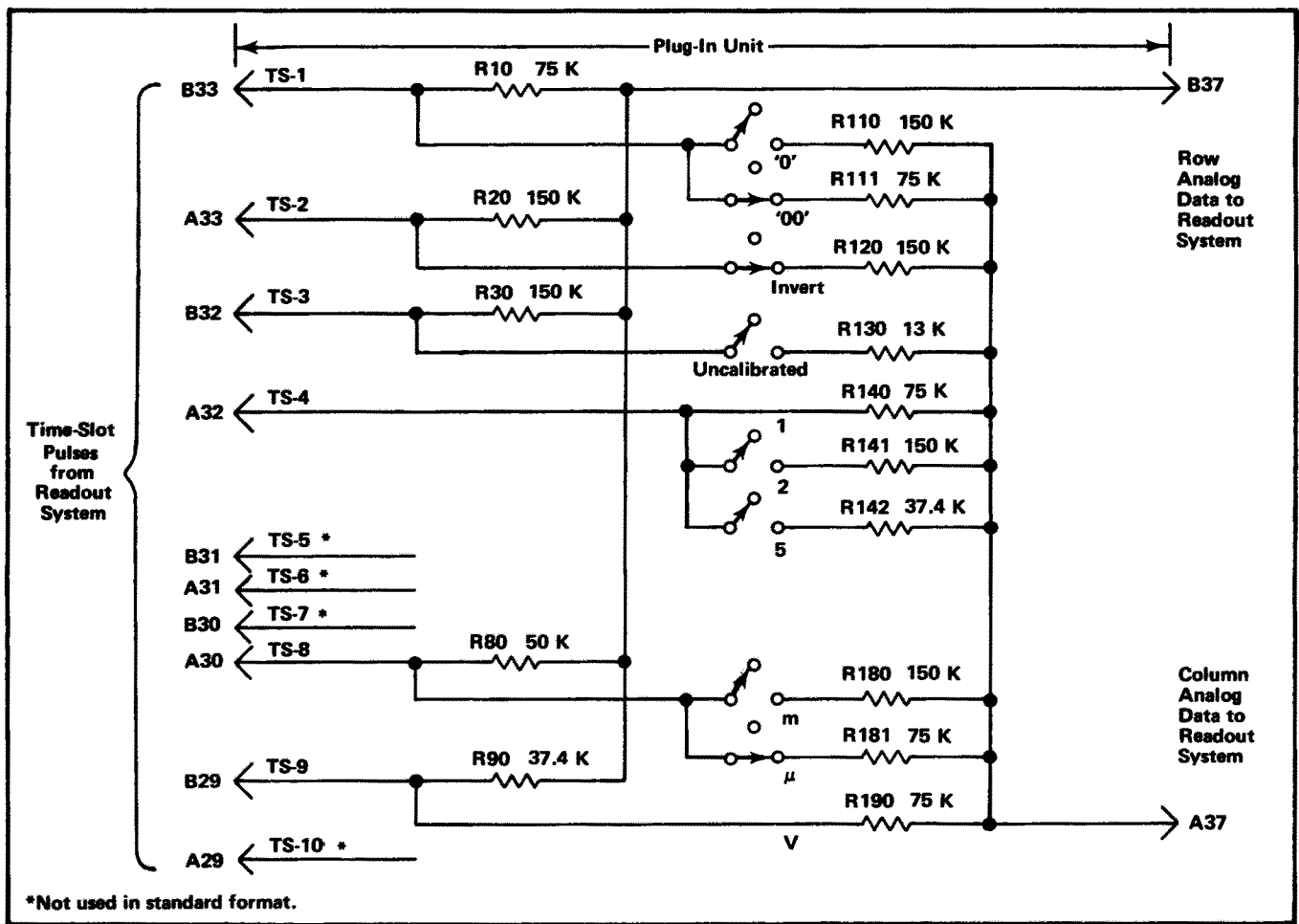

Fig. 3-32. Typical encoding scheme for voltage-sensing amplifier plug-in unit. Coding shown for deflection factor of 100 microvolts.

Character Selection Matrix, two units of column current along with the two units of row current encoded by R10 (row 3) indicates that two zeros should be added to the display. Resistor R120 adds one unit of column current during time-slot 2 and along with the one unit of current from the row output, the Readout System is instructed to add an invert arrow to the display. R130 is not connected to the time-slot 3 line since the vertical deflection factors are calibrated. Therefore, there is no column current output during this time-slot and there is no display on the CRT (see Display-Skip Generator for further information). During time-slot 4, two units of column current are encoded by R140. There is no row current encoded during this time-slot and this results in the numeral 1 being displayed on the CRT. Neither row nor column analog data is encoded during time-slots 5, 6, and 7 as defined by the Standard Readout Format. During time-slot 8, two units of column current and three units of row current are encoded by resistors R181 and R80 respectively. This addresses the μ prefix in the Character Selection Matrix. The final data output is provided from time-slot 9 by R190 connected to the column output and R90 to the row output. These resistors encode three units of column current and four units of row current to cause a V (volts) to be displayed.

Time-slot 10 is not encoded in accordance with the Standard Readout Format. The resultant CRT readout will be $\downarrow 100 \mu V$.

In the above example, the row analog data was programmed to define which row of the Character Selection Matrix was addressed to obtain information in each time-slot. The column data changes to encode the applicable readout data as the operating conditions change. For example, if the variable control of the plug-in unit was activated, R130 would be connected between time-slot 3 and the column analog data output lines. This encodes 10 units of column current (see shaded area in time-slot 3 of the waveform shown in Fig. 3-33B). Since one unit of row current is also encoded during this time-slot by R30, a $>$ symbol is added to the display. The CRT readout will now say $\downarrow >100 \mu V$. In a similar manner, the other switches can change the encoded data for the column output and thereby change the readout display. See the descriptions which follow for decoding this information.

The column analog data encoded by the plug-in can be modified by attenuator probes connected to the input

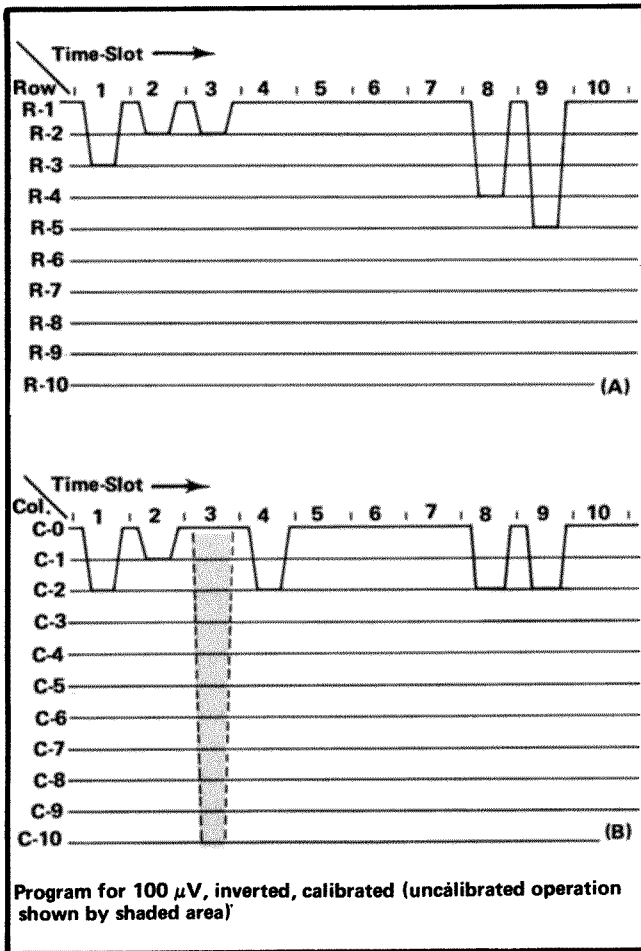

Fig. 3-33. Idealized current waveforms of: (A) Row analog data, (B) Column analog data.

connectors of vertical plug-in units. A special coding ring around the input connector of the plug-in unit senses the attenuation ratio of the probe (with readout-coded probes only). The probe contains a resistor which results in additional column current. For example, if a 10X attenuator probe is connected to a plug-in with the coding for 100 microvolts as shown in Fig. 3-32, an additional unit of current is added to the column analog data during time-slot 1. Since two units of current were encoded by R111 (see Fig. 3-32), this additional current results in a total of three units of column analog current during this time-slot. Referring to the Character Selection Matrix, three units of column current along with the two units of row current encoded by R10 indicates that the prefix should be reduced. Since this instruction occurs in the same time-slot which previously indicated that two zeros should be added to the display and only one instruction can be encoded during a time-slot, the zeros do not appear in the display. The CRT readout will now be changed to 1 mV (readout) program produced by plug-in same as for previous example.

Likewise, if a 100X readout-coded probe is connected to the input of the plug-in unit, the column current during

time-slot 1 will be increased two units for a total of four units of column current. This addresses an instruction in the Character Selection Matrix which reduces the prefix and adds one zero to the display. The resultant CRT readout with the previous program is 10 mV.

Three other lines of information are connected from the plug-in compartments to the Readout System. The column and row analog data from channel 2 of a dual-channel plug-in are connected to the Readout System through terminals A38 and B38 of the plug-in interface, respectively. Force readout information is encoded on terminal A35; function of this input is described under Column and Row Data Switches.

The preceding information gave a typical example of encoding data from an amplifier plug-in unit. Specific encoding data and circuitry is shown in the individual plug-in unit manual.

Column and Row Data Switches

The readout data from the plug-in units is connected to the Column and Row Data Switch stages in the Readout System. A column-data line and a row-data line convey analog data from each of the eight data sources (two channels from each of the four plug-in compartments).

TABLE 3-3

Channel Address

Pin 1 U2232 "Identify" Command	Pin 11 U2250	Pin 8 U2250	Pin 9 U2250	Channel Selected
HI	HI	HI	HI	Channel 1 Left Vertical
HI	HI	HI	LO	Channel 2 Left Vertical
HI	HI	LO	HI	Channel 1 Right Vertical
HI	HI	LO	LO	Channel 2 Right Vertical
HI	LO	HI	HI	Channel 1 Horizontal
HI	LO	HI	LO	Channel 2 Horizontal

The Column Data Switch U2190 and the Row Data Switch U2180 receive the Channel Address No. 1 code from the Channel Counter. This binary code directs the Column Data Switch and the Row Data Switch as to which channel should be the source of the readout data. Table 3-3

Circuit Description—7613/R7613 Service

gives the eight combinations of the Channel Address No. 1 code and the resultant channel which is selected with each combination. These stages have nine inputs and provide a single time-multiplexed output at pin 7 which includes the information from all of the input channels. Eight of the nine inputs to each stage originate in the plug-in units; the ninth input comes from a special data-encoding network composed of resistors R2201 through R2209 and R2191 through R2199 (see Zeros Logic and Memory description for further information on ninth channel).

In addition to the data inputs from the plug-in units, channel-inhibit inputs are provided from each of the plug-in units. The channel inhibit lines are LO only when the associated plug-in unit has been selected for display. When a plug-in unit is not selected, the respective line is HI which forward biases the associated diode CR2162, CR2163, CR2167, CR2166, CR2171, CR2170, CR2175, or CR1174 to by-pass the encoded data from this plug-in. However, since it may be desired to display information from special-purpose plug-ins even though they do not produce a normal waveform display on the CRT, a feature is provided to over-ride the channel inhibit. This is done by applying a LO to the associated forcing over-ride input. The LO level diverts the HI channel inhibit current and allows the data from this plug-in unit to reach the Column Data Switch, even though it has not been selected for display by the mode switches.

Display-Skip Generator

The Display-Skip Generator, Q2215, Q2223, Q2229, and Q2225 monitors the time-multiplexed column data at the output of the Column Data Switch during each time-slot to determine if the information at this point is valid data which should result in a CRT display. The voltage at the base of Q2215B is set by divider R2219, R2220, and R2221. Quiescently, there is about 100 microamperes of current flowing through R2213 and R2214 from Q2240 and the Zeros Logic and Memory stage (purpose of this quiescent current will be discussed in connection with the Zeros Logic and Memory stage). This current biases Q2215A so its base is about 0.2 volt more positive than the base of Q2215B in the absence of column data. Therefore, since Q2215A and Q2215B are connected as a comparator, Q2215A will remain on unless its base is pulled more negative than the base of Q2215B. The analog data output from the Column Data Switch produces a 0.5 volt change at the base of Q2215A for each unit of column current that has been encoded by the plug-in unit. Therefore, whenever any information appears at the output of the Column Data Switch, the base of Q2215A is pulled more negative than the base of Q2215B resulting in a negative (LO) Display-Skip output to the Timer stage through Q2225. Recall that a LO was necessary at the skip input of the Timer so it could perform the complete sequence necessary to display a character.

Q2223-Q2229 also provide display-skip action. The End-of-Word level connected to their emitters through R2229 is LO only during time-slot 1. This means that Q2223-Q2229 are enabled only during time-slot. These transistors allow the Zeros Logic and Memory stage to generate a display-skip signal during time-slot 1 when information has been stored in memory which is not to be displayed on the CRT (further information given under Zeros Logic and Memory discussion).

Column and Row Decoder

The Column Decoder U2244 and Row Decoder U2185 sense the magnitude of the analog voltages at their inputs and produce a binary output on one of ten lines corresponding to the column or row data which was encoded by the plug-in. These outputs provide the Column Digital Data and Row Digital Data which is used by the Character Generator stages to select the desired character for display on the CRT. The column and row data is also used throughout the Readout System to perform other functions. The input current at pin 9 of the Column Decoder stage is steered to only one of the ten Column Digital Data outputs. The size of the character which will be displayed on the CRT is determined by the value of R2227. When a display-skip signal is present (collector of Q2225 is HI), pin 9 is pulled HI through CR2226. This ensures that no current is connected to the Character Generator stage under this condition. Notice the corresponding input on the Row Decoder. This input is connected to ground and causes only one of the ten row outputs to saturate to ground.

The network at the input of the Row Decoder, made up of Q2153 and its associated components, is a Row 13 detector which produces the Jump command. This row current is encoded by special-purpose plug-ins to cause all or part of a word to be jumped. Whenever row 13 (thirteen units of row current; 1.3 milliamperes) is encoded, the base of Q2153 is pulled negative enough so that this transistor is reverse biased to produce a HI Jump output at its collector. This Jump command is connected to the Word Trigger stage (diagram 10) to advance the Channel Counter stage to the next word and to reset the Time-Slot Counter to time-slot 1.

Zeros Logic and Memory

The Zeros Logic and Memory stage U2232 stores data encoded by the plug-in units to provide zeros-adding and prefix-shifting logic for the Readout System. The Strobe pulse at pin 15 goes positive when the data has stabilized and can be inspected. This activates the Zeros Logic and Memory stage so it can store the encoded data. A block representation of the memory sequence is shown in Fig. 3-34. Typical output waveforms for the five possible input conditions that can occur are shown in Fig. 3-35. When time-slot 1 occurs, a store command is given to all of the

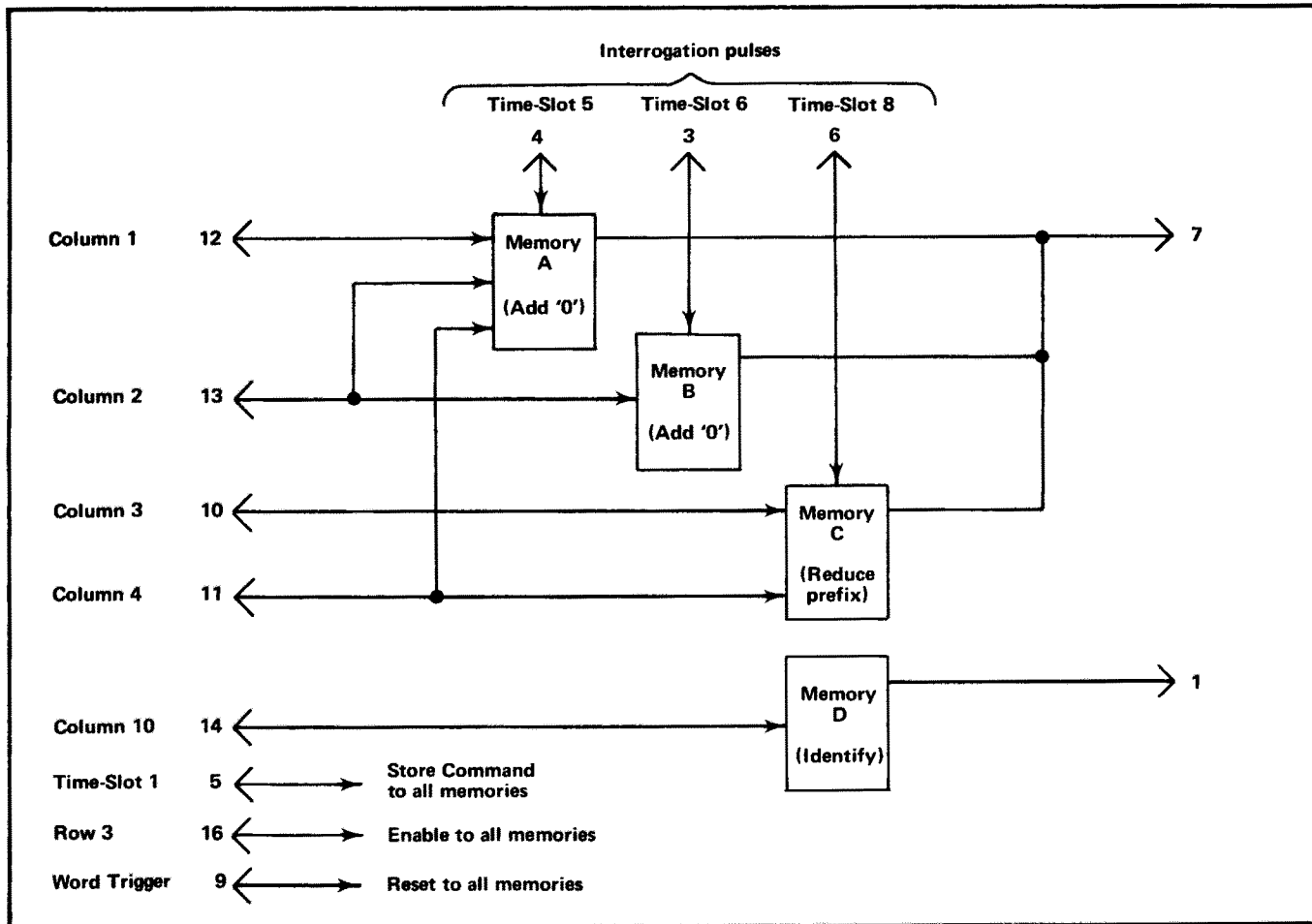

Fig. 3-34. Block representation of memory sequence in U2232.

memories. If the plug-in unit encoded data for column 1, 2, 3, 4, or 10 during time-slot 1, the appropriate memory (or memories) is set. Notice that row 3 information from the Row Decoder must also be present at pin 16 for data to be stored in the memory of U2232. If data was encoded during time-slot 1, a negative-going output is produced at pin 7 as the memories are being set. This negative-going pulse is connected to the base of Q2229 in the Display-Skip Generator to produce a Display-Skip output. Since the information that was encoded during time-slot 1 was only provided to set the memories and was not intended to be displayed on the CRT at this time, the display-skip output prevents a readout display during this time-slot.

During time-slot 5, memory A is interrogated. If information was stored in this memory, a positive-going output is produced at pin 7. This pulse is connected to pin 10 of the Column Decoder through Q2240 to add one unit of current at the input of the Column Decoder. This produces a zero after the character displayed on the CRT during time-slot 4. During time-slot 6, memory B is interrogated to see if another zero should be added. If another zero is necessary, a second positive output is

produced at pin 7 which again results in a column 1 output from the Column Decoder and a second zero in the CRT display.

Finally, memory C is interrogated during time-slot 8 to obtain information on whether the prefix should be reduced or left at the value which was encoded. If data has been encoded which calls for a reduction in prefix, a negative-going output level is produced at pin 7. This negative level subtracts one unit of column current from the data at the input to the Column Decoder. Notice on the Character Selection Matrix of Fig. 3-24 that a reduction of one column when row 4 is programmed results in a one unit reduction of the prefix. For example, with the 100 μ V program shown in Fig. 3-31, if the data received from the plug-in called for a reduction in prefix, the CRT readout would be changed to 1 mV (zeros deleted by program; see Encoding the Data).

The 100 microamperes of quiescent current through R2213 and R2214 that was provided by Q2240 (see Display-Skip Generator) allows the prefix to be reduced

Input Pins of Zeros Logic & Memory	Command	Time Slot
14	IDENTIFY	
12	Add one zero	
13	Add two zeros	
10	Decrease prefix	
11	Decrease prefix and add one zero	

Fig. 3-35. Typical output waveforms for Zeros Logic and Memory stage operation (at pin 7 of U2232).

from m (100 microamperes column current; column 1) to no prefix (zero column current; column zero) so only the unit of measurement encoded during time-slot 9 is displayed. Notice that reducing the prefix program from column 1 to column 0 programs the Readout System to not display a character at this readout location.

A further feature of the Zeros Logic and Memory is the Identify function. If 10 units of column current are encoded by the plug-in unit along with row 3 during time-slot 1, the Zeros Logic and Memory produces a negative-going output pulse at pin 1 which switches the Column Data Switch and Row Data Switch to the ninth channel. Then, time-slot pulses 2 through 9 encode an output current through resistors R2191-R2199 for column data and R2201-R2209 for row data. This provides the currents necessary to display the word IDENTIFY on the CRT in the word position allotted to the channel which originated the Identify command. After completion of this word, the Column Data Switch and Row Data Switch continue with the next word in the sequence.

The Word Trigger signal from the Word Trigger stage is connected to pin 9 of U2232 through C2242. At the end of each word of readout information, this pulse goes LO. This erases the four memories in the Zeros Logic and Memory in preparation for the data to be received from the next channel.

Character Generators

The Character Generator stage consists of five similar integrated circuits U2270, U2272, U2274, U2276, and U2278, which generate the X (horizontal) and Y (vertical) outputs at pins 16 and 1 respectively to produce the character displayed on the CRT. Each integrated circuit can produce 10 individual characters. U2270, which is designated as the "Numerals" Character Generator, can produce the numerals 0 through 9 shown in row 1 of the Character Selection Matrix (Fig. 3-24). U2272 can produce the symbols shown in row 2 of the Character Selection Matrix and U2274 produces the prefixes and some letters of the alphabet which are used as prefixes in row 4. U2276 and U2278 produce the remaining letters of the alphabet shown in rows 5 and 6 of the Character Selection Matrix. All of the stages receive the column digital data from Column Decoder U2244 in parallel. However, only one of the character generators receives row data at a particular time; only the stage which receives both row and column data is activated. For example, if column 2 is encoded by a plug-in unit, the five Character Generators are enabled so that either a 1, μ , V, or an N can be produced. However, if at the same time row 4 has also been encoded by the plug-in unit, only the Prefix Character Generator U2274 will produce an output to result in a μ displayed on the screen. This integrated circuit provides current outputs to the Format Generator which produce the selected character on

the CRT. In a similar manner, any of the 50 characters shown in the Character Selection Matrix can be displayed by correct addressing of the row and column.

Decimal Point Logic and Character Position Counter

The Decimal Point Logic and Character Position Counter stage U2260 performs two functions. The first function is to produce a staircase current which is added to the X (horizontal) signal to space the characters horizontally on the CRT. After each character is generated, the negative-going edge of the Ready signal at pin 5 advances the Character Position Counter. This produces a current step output at pin 3 which, when added to the X signal, causes the next character to be produced one character space to the right. This stage can also be advanced when a Space instruction is encoded by the plug-in unit so that a space is left between the displayed characters on the CRT. Row 10 information from the Row Decoder is connected to pin 4 of U2260 through R2265. When row 10 and column 0 are encoded, the output of this stage advances one step to move the next character another space to the right. However, under this condition, no display is produced on the CRT during this time-slot.

Time-slot pulses 1, 2, and 3 are also connected to pin 4 of U2260 through VR2262, VR2263, and VR2264 respectively and R2262-R2265. This configuration adds a space to the displayed word during time-slots 1, 2, and 3 even if information is not encoded for display during these time-slots. With this feature, the information which is displayed during time-slot 4 (1-2-5 data) always starts in the fourth character position whether data has been displayed in the previous time-slots or not. Therefore, the resultant CRT display does not shift position as normal/invert or cal/uncal information is encoded by the plug-in. The Word Trigger pulse connected to pin 8 of U2260 through C2255 resets the Character Position Counter to the first character position at the end of each word.

The Decimal Point Logic portion of this stage allows decimal points to be added to the CRT display as encoded by the plug-in units. When row 7 is encoded in coincidence with columns 3 through 7 (usually encoded during time-slot 1), a decimal point is placed at one of the five locations on the CRT identified in row 7 of the Character Selection Matrix (Fig. 3-24). This instruction refers to the decimal point location in relation to the total number of characters that can be displayed on the CRT (see Fig. 3-36). For example, if column 3 and row 7 are encoded during time-slot 1, the system is instructed to place a decimal point in location No. 3. As shown in Fig. 3-36, this displays a decimal point before the third character that can be displayed on the CRT (first three time-slots produce a space whether data is encoded or not; see previous paragraph). The simultaneous application of row 7 data to the Y-input

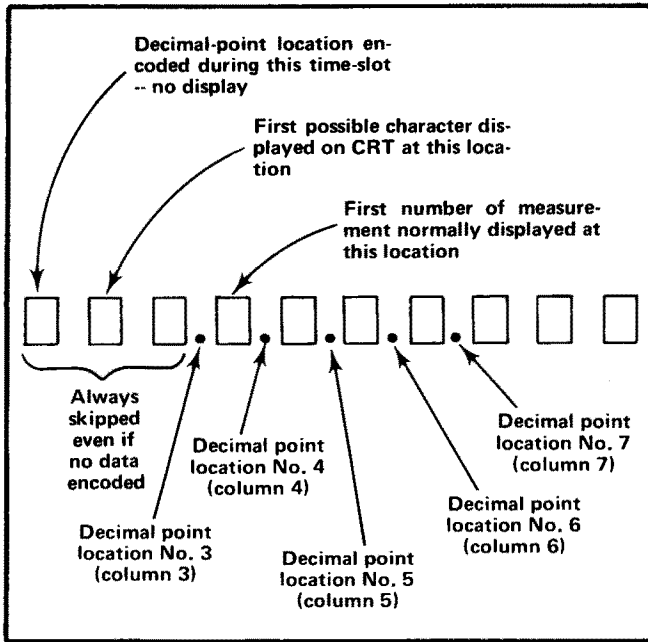

Fig. 3-36. Readout word relating 10 possible character locations to the decimal-point instructions that can be encoded and the resulting display.

of the Format Generator through R2280 raises the decimal point so it appears between the displayed characters.

When decimal-point data is encoded, the CRT is unblanked so a readout display is presented. However, since row 7 does not activate any of the five Character Generators, the CRT beam is not deflected but instead remains in a fixed position to display a decimal point between the characters along the bottom line of the readout word. After the decimal point is produced in the addressed location, the CRT beam returns to the location indicated by the Character Position Counter to produce the remainder of the display.

Format Generator

The X- and Y-deflection signals produced by the Character Generator stage, are connected to pins 2 and 7 respectively of Format Generator U2284. The Channel Address No. 2 code from the Channel Counter is also connected to pins 1, 8, and 15 of this stage. The Channel Address No. 2 code directs the Format Generator to add current to the X and Y signals to deflect the CRT beam to the area of the CRT which is associated with the plug-in channel that originated the information (see Fig. 3-24). The Channel Address No. 2 Code and the resultant word positions are shown in Table 3-4. In addition, the character

position current from the Decimal Point Logic and Character Position stage is added to the X (horizontal) input signal to space the characters horizontally on the CRT (see previous discussion). The Ready signal at pin 13 (coincident with Vertical/Horizontal Channel Switch OFF Command) activates this stage when a character is to be displayed on the CRT.

TABLE 3-4
Channel Address No. 2 Code

Pin 11 U2250	Pin 8 U2250	Pin 9 U2250	Channel Displayed
LO	LO	LO	Channel 1 Left Vertical
LO	LO	HI	Channel 2 Left Vertical
LO	HI	LO	Channel 1 Right Vertical
LO	HI	HI	Channel 2 Right Vertical
HI	LO	LO	Channel 1 Horizontal
HI	LO	HI	Channel 2 Horizontal

Y-Output Amplifiers

The Y-output signal at pin 6 of U2284 is connected to the Y-Output Amplifier Q2287-Q2299. This stage provides a low impedance load for the Format Generator while providing isolation between the Readout System and the Vertical Amplifier. Vertical Separation adjustment R2291 changes the gain of this stage to control the vertical separation between the readout words displayed at the top and bottom of the graticule area.

X-Output Amplifier

The X-Output Amplifier Q2286-Q2296 operates similarly to the Y-Output Amplifier to provide the horizontal deflection from the readout signal available at pin 4 of U2284. The gain of this stage is fixed by the values of the resistors in the circuit.

Display Sequence

Fig. 3-37 shows a flow chart for the Readout System. This chart illustrates the sequence of events which occurs in the Readout System each time a character is generated and displayed on the CRT.

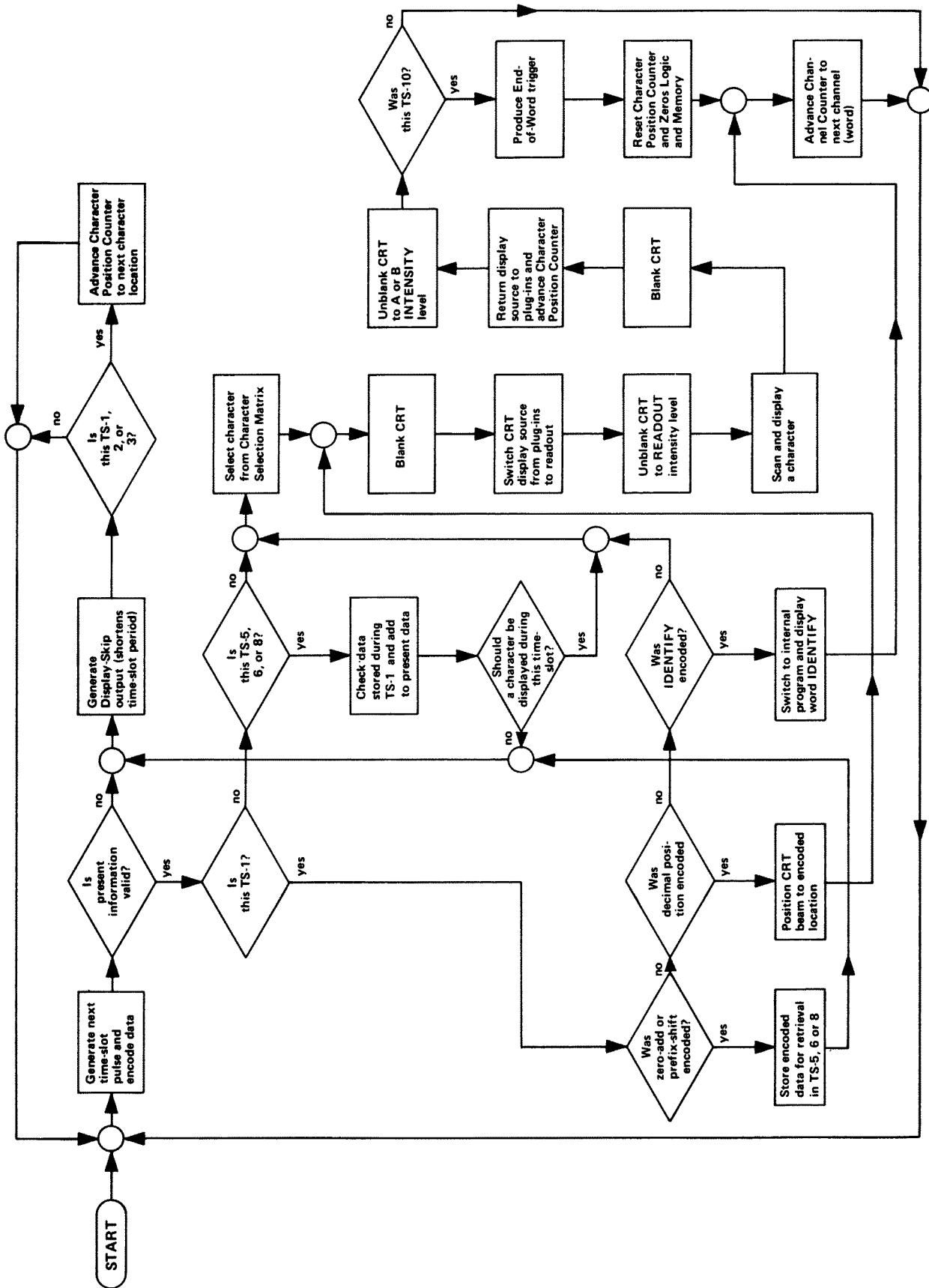

Fig. 3-37. Flow chart of character generation sequence by the Readout System.

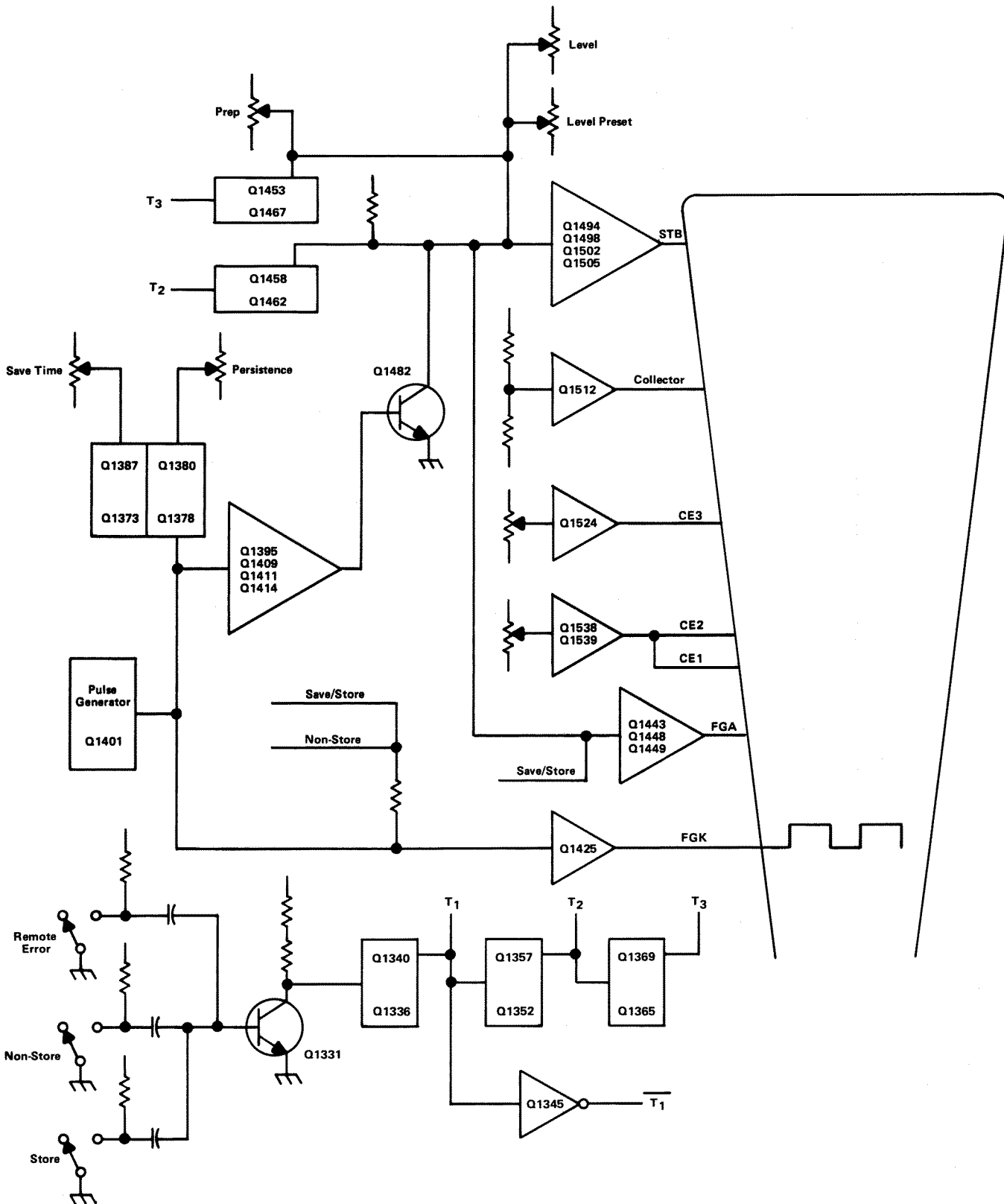

Fig. 3-38. Basic Storage Block Diagram.

STORAGE BOARD CIRCUITRY

The Cathode-Ray tube of the 7613 is a standard transmission halftone storage tube. The collector electrode is a coarse mesh which accelerates electrons toward the target area. The target is a fine mesh with a highly insulative dielectric layer deposited on it. It is in the dielectric layer that storage occurs. The flood guns cover the entire storage target with a continuous stream of low velocity electrons; these electrons are prevented from reaching the phosphor screen unless a display has been written on the storage target.

The collimation bands are used as a lens which uniformly distributes flood-gun electrons over the storage target area. Adjustment R1531 controls the output voltage of the collimation amplifier (Q1538 and Q1539) used for the first two bands. In the non-store mode, the collimation bands have no control over the CRT. Adjustment R1521 controls the emitter-followers output that controls the third collimation band. Transistor Q1512 and voltage divider R1510 and R1511 establishes the collector voltage for the CRT. (See storage basic block diagram Fig. 3-38.)

Switching from the non-store mode to the store mode is done by grounding the store line. This enables the ERASE switch, REMOTE ERASE switch, and the SAVE switch.

Transistor Q1329 is biased on in the non-store mode. The output of Q1329 is coupled to the base of Q1331, the input to the Erase Timing Generator. When transistor Q1331 is turned off, an erase cycle is started. In the store mode, transistor Q1329 is biased off and transistor Q1331 is biased on. When changing modes from non-storage to storage operation, an erase cycle is generated automatically. When the REMOTE ERASE switch is pressed, it grounds one side of capacitor C1318. Capacitor C1318 discharges into the base circuitry of Q1331, turning it off momentarily. When the ERASE switch is pressed, Q1331 is biased off so that repetitive erase cycles can occur.

VARIABLE PERSISTENCE AND SAVE CIRCUITRY

Transistors Q1373 and Q1378 form a switch that allows either the PERSISTENCE control or the SAVETIME control to control the storage operation. Transistor Q1373 is on in the store mode without save. Transistor Q1378 is biased off and Q1380 is biased on. This allows the collector circuit of Q1380 to control the storage operation. Transistor Q1378 is turned on when resistor R1371 in the base circuit of Q1373 is grounded by the SAVE switch. This lowers the emitter voltage, allowing Q1378 to turn on and Q1373 to turn off. When transistor Q1373 turns off, Q1387 turns on, allowing the collector circuit of Q1387 to control the storage operation. See Fig. 3-39.

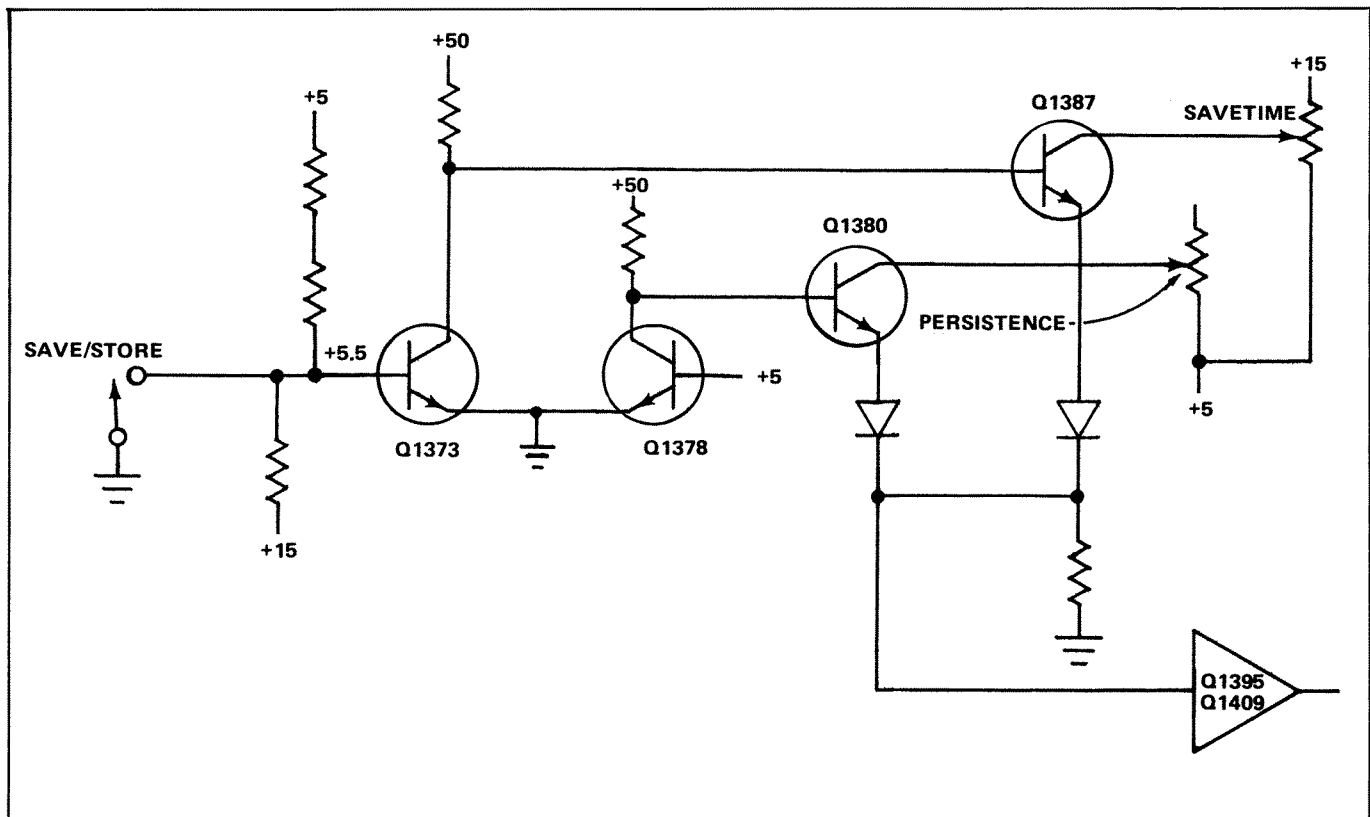

Fig. 3-39. Variable Persistence and Save switching circuit.

Semiconductor Q1401 is a programmable unijunction transistor that is used as a 100-millisecond pulse generator. Capacitor C1391 and resistor R1392 are the timing components along with the gate voltage divider circuit. Coupling capacitor C1406 couples the pulses to a current amplifier (Q1409 and Q1395). The pulses are direct coupled to a voltage amplifier (Q1411 and Q1414). In the variable persistence mode, the pulses are coupled to the Storage Target Backplate Amplifier. In the Save mode of storage, the pulses are coupled to the flood-gun cathodes through Q1425; this reduces the background intensity of the stored display. In the non-store mode, the timing elements are grounded and no pulses are generated.

ERASE TIMING GENERATOR

Transistors Q1336 and Q1340 form a 50-millisecond monostable multivibrator. The output is connected to transistor Q1345 (for inverting) and to coupling capacitor

C1347. The outputs from this stage are called T_1 and \bar{T}_1 . Capacitor C1347 couples the output signal (T_1) to the base of transistor Q1352. Transistors Q1352 and Q1357 form a 10-millisecond monostable multivibrator. The output signal from this stage is called T_2 and is connected to coupling capacitor C1360, which couples T_2 to the base of transistor Q1365. Transistors Q1365 and Q1369 form a 400-millisecond monostable multivibrator. The output signal is called T_3 . These monostable multivibrators are cascaded to provide a sequential train of pulses. See Fig. 3-40 for the basic block diagram of the Erase Timing Generator and idealized waveforms.

The pulses are connected to the Storage Target Backplate Amplifier and to the circuits controlling the flood-gun cathodes and anode. Pulse T_1 turns on transistor Q1423, which saturates Q1425, grounding the flood-gun cathodes. Pulse \bar{T}_1 also provides a sweep lockout pulse that goes to the time-base plug-in unit through transistor Q1432, and a pulse that goes to the Flood-Gun Anode Amplifier. This applies a positive pulse to the flood-gun anode.

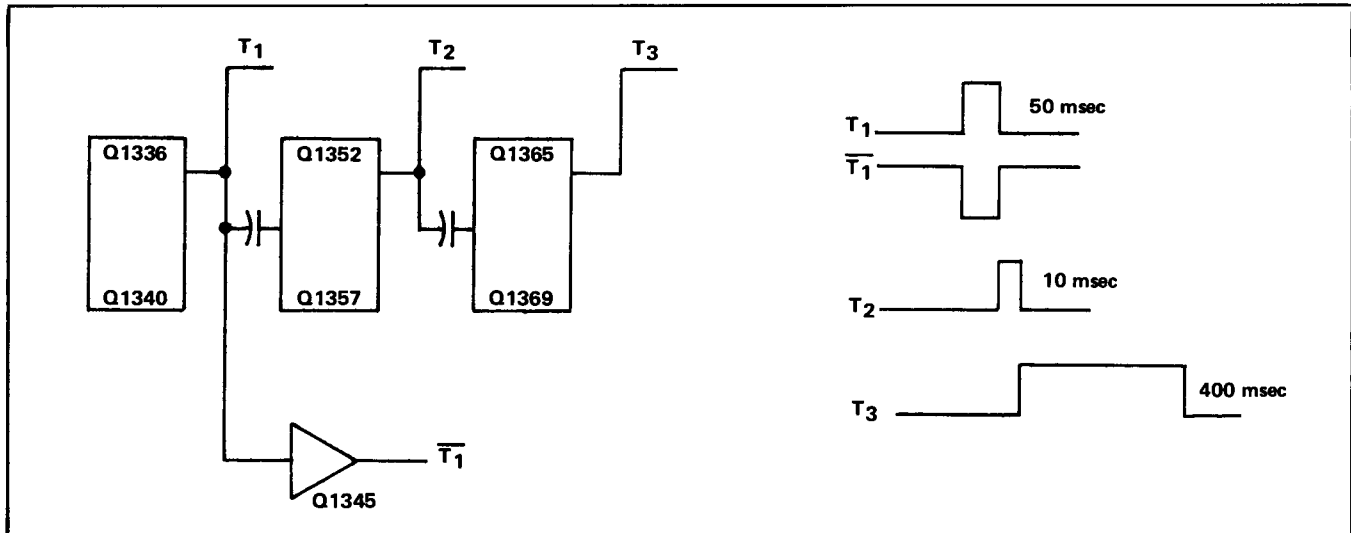

Fig. 3-40. Erase timing pulse generator.

STORAGE TARGET BACKPLATE AMPLIFIER

The Storage Target Backplate (STB) operational amplifier is a current-to-voltage conversion amplifier. It consists of transistors Q1494, Q1498, Q1502, and Q1505. The level control and the level preset adjustment provide quiescent control over the STB amplifier. During an erase cycle, pulses T_1 , \bar{T}_1 , T_2 , and T_3 are generated. Operation of the Erase Pulse Generator is discussed with the Erase Pulse Operator circuit.

At time \bar{T}_1 , the STB amplifier is pulsed with a negative pulse 50 ms in duration. This negative pulse causes a high

positive level at the output of the STB amplifier. At time T_2 , transistor Q1458 is turned on for 10 ms and Q1462 is turned off. When transistor Q1462 is off, CR1480 is forward biased so that current from the collector circuit of Q1482 is not part of the input current to the STB amplifier. This reduces the output voltage of the STB amplifier. During the T_3 pulse, transistor Q1453 turns on and transistor Q1467 turns off, allowing current from the collector circuit of Q1467 to go into the input of the STB amplifier. This raises the output voltage of the STB amplifier. See Fig. 3-41 for idealized waveforms.

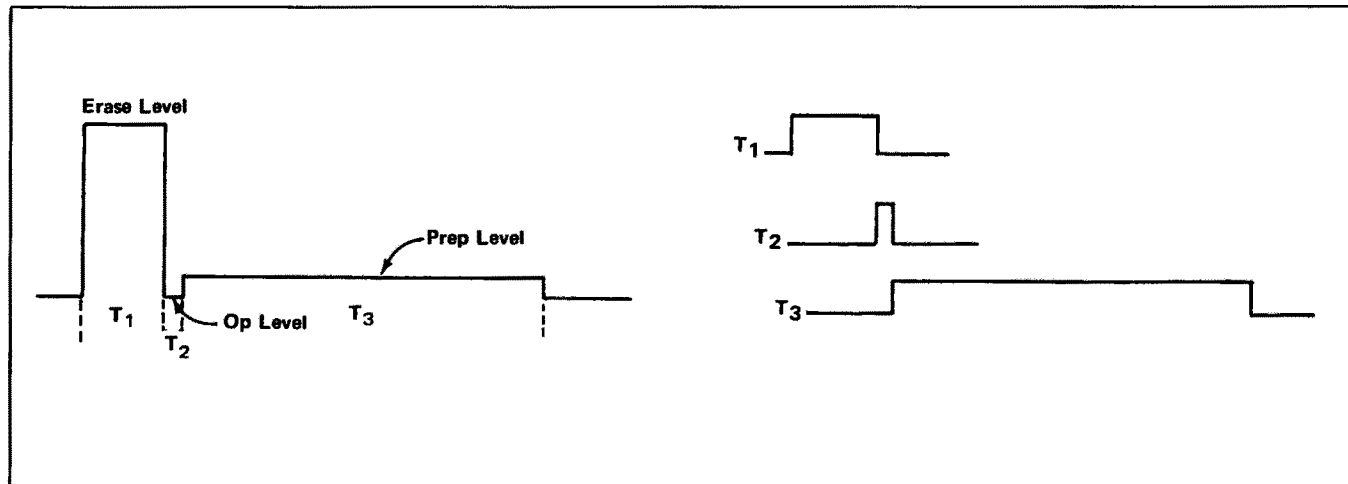

Fig. 3-41. Erase cycle out of Storage Target Backplate.

MAINTENANCE

This section of the manual contains maintenance information for use in preventive maintenance, corrective maintenance, or troubleshooting of the 7613.

Panel Removal

WARNING

Dangerous potentials exist at several points throughout this instrument. When the instrument is operated with the covers removed, do not touch exposed connections or components. Some transistors have voltages present on their cases. Disconnect power before cleaning the instrument or replacing parts.

Cabinet Model. The side panels of the 7613 are held in place by spring-action of the panels themselves. To remove the panels, push the panel toward the top of the instrument until the bottom of the panel is clear of the slot along the bottom rail of the instrument. Then, pull the panel out at the bottom and lift away from the instrument. The bottom panel is held in place with eight screws. The panels protect this instrument from dust in the interior, and also provide protection to personnel from the operating potentials present. They also reduce the EMI radiation from this instrument or EMI interference to the display due to other equipment.

Rack Model. The top cover is held in place with six screws. To remove the cover, the screws need only be loosened slightly to slide the cover out of the slots.

A panel on the left side of the instrument, held in place with six screws, allows access to the vertical amplifier circuit board.

A cover on the rear of the instrument, held in place with four screws, allows access to the power supply regulating transistors. It also allows access to three of the five screws holding the regulating circuit board assembly in the instrument.

Power-Unit Removal

The power unit can be slid out of the back of the 7613 to gain access to the Logic and Rectifier circuit boards and for power-unit maintenance. The power unit can be left connected to the rest of the instrument so that it can be operated in this position for troubleshooting. To remove the power unit, use the following procedure:

1. Remove the side panels (top panel for R7613).
2. Remove the six screws which secure the power unit to the sides of the instrument (see Fig. 4-1 for locations of screws on R7613).
3. Slide the power unit out of the rear of the instrument until it can be set down on the work surface (guide the interconnecting cables so they do not catch on other parts of the instrument).

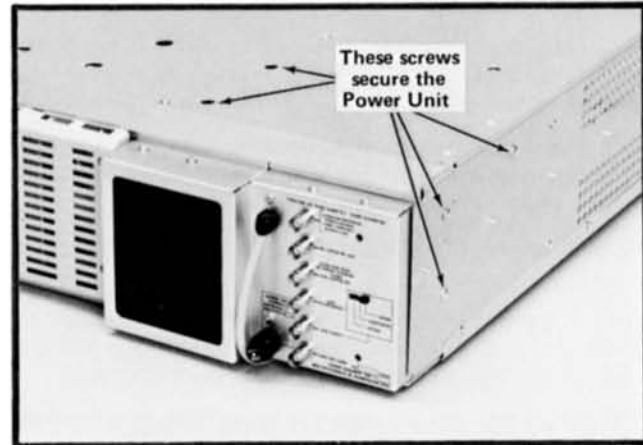

Fig. 4-1. Power unit removal for the R7613.

PREVENTIVE MAINTENANCE

General

Preventive maintenance consists of cleaning, visual inspection, lubrication, etc. Preventive maintenance performed on a regular basis may prevent instrument breakdown and will improve the reliability of this instrument. The severity of the environment to which the 7613 is subjected determines the frequency of maintenance. A convenient time to perform preventive maintenance is preceding recalibration of the instrument.

Cleaning

The 7613 should be cleaned as often as operating conditions require. Accumulation of dirt in the instrument can cause overheating and component breakdown. Dirt on components acts as an insulating blanket and prevents efficient heat dissipation. It also provides an electrical conduction path which may result in instrument failure. The side panels provide protection against dust in the interior of the instrument. Operation without the panels in place necessitates more frequent cleaning.

CAUTION

Avoid the use of chemical cleaning agents which might damage the plastics used in this instrument. Avoid chemicals which contain benzene, toluene, xylene, acetone, or similar solvents.

Exterior. Loose dust accumulated on the outside of the 7613 can be removed with a soft cloth or small brush. The brush is particularly useful for dislodging dirt on and around the front-panel controls. Dirt which remains can be removed with a soft cloth dampened in a mild detergent and water solution. Abrasive cleaners should not be used.

Maintenance—7613/R7613 Service

CRT. Clean the plastic light filter, faceplate protector, and the CRT face with a soft, lint-free cloth dampened with denatured alcohol.

The optional CRT mesh filter can be cleaned in the following manner:

1. Hold the mesh filter in a vertical position and brush lightly with a soft No. 7 water-color brush to remove light coatings of dust or lint.
2. Greasy residues or dried-on dirt can be removed with a solution of warm water and a neutral-pH liquid detergent. Use the brush to lightly scrub the filter.
3. Rinse the filter thoroughly in clean water and allow to air dry.
4. If any lint or dirt remains, use clean low-pressure air to remove it. Do not use tweezers or other hard cleaning tools on the filter, as the special finish may be damaged.
5. When not in use, store the mesh filter in a lint-free, dust-proof container such as a plastic bag.

Interior. Dust in the interior of this instrument should be removed occasionally due to its electrical conductivity under high-humidity conditions. The best way to clean the interior is to blow off the accumulated dust with dry, low-pressure air. Remove any dirt which remains with a soft brush or a cloth dampened with a mild detergent and water solution. A cotton-tipped applicator is useful for cleaning in narrow spaces or for cleaning ceramic terminal strips and circuit boards.

The high-voltage circuits, particularly parts located in the high-voltage compartment and the area surrounding the post-deflection anode lead, should receive special attention. Excessive dirt in these areas may cause high-voltage arcing and result in improper instrument operation.

Air Filter (For Rackmount Versions only). The air filter should be visually checked every few weeks and cleaned or replaced if dirty. More frequent inspections are required under severe operating conditions. If the filter is to be replaced, order new filters from your local Tektronix Field Office or representative; order by Tektronix Part No. 378-0041-01. The following procedure is suggested for cleaning the filter.

1. Remove the filter by pulling it out of the retaining frame on the rear panel. Be careful not to drop any of the accumulated dirt into the instrument.
2. Flush the loose dirt from the filter with a stream of hot water.
3. Place the filter in a solution of mild detergent and hot water and let soak for several minutes.
4. Squeeze the filter to wash out any dirt which remains.
5. Rinse the filter in clean water and let dry.

6. Coat the dry filter with an air-filter coating (available from air conditioner suppliers or order Tektronix Part No. 006-0580-00).

7. Let the filter thoroughly dry.

8. Re-install the filter in the retaining frame.

Lubrication

The reliability of potentiometers, switches, and other moving parts can be maintained if they are kept properly lubricated. However, over-lubrication is as detrimental as too little lubrication. A lubrication kit containing necessary lubricants and instructions is available from Tektronix, Inc. Order Part No. 003-0342-01.

Visual Inspection

The 7613 should be inspected occasionally for such defects as broken connections, improperly seated semiconductors, damaged or improperly installed circuit boards, and heat-damaged parts. The corrective procedure for most visible defects is obvious; however, particular care must be taken if heat-damaged components are found. Overheating usually indicates other trouble in the instrument; therefore, it is important that the cause of overheating be corrected to prevent recurrence of the damage.

Semiconductor Checks

Periodic checks of the semiconductors in the 7613 are not recommended. The best check of semiconductor performance is actual operation in the instrument. More details on checking semiconductor operation are given under troubleshooting.

Recalibration

To assure accurate measurements, check the calibration of this instrument after each 1000 hours of operation or every six months if used infrequently. In addition, replacement of components may necessitate recalibration of the affected circuits. The calibration procedure can also be helpful in localizing certain troubles in the instrument. In some cases, minor troubles may be revealed and/or corrected by recalibration.

TROUBLESHOOTING

Introduction

The following information is provided to facilitate troubleshooting of the 7613. Information contained in other sections of this manual should be used along with the following information to aid in locating the defective component. An understanding of the circuit operation is very helpful in locating troubles, particularly where integrated circuits are used. See the Circuit Description section for complete information.

Troubleshooting Aids

Diagrams. Complete circuit diagrams are given on fold-out pages in the Diagrams section. The component number and electrical value of each component in this instrument are shown on these diagrams. Each main circuit is assigned a series of component numbers. Table 4-1 lists the main circuits in the 7613 and the series of component numbers assigned to each. Important voltages and waveforms are also shown on the diagrams. The portions of the circuit mounted on circuit boards are enclosed with blue lines.

Circuit Boards. Fig. 4-2 shows the location of the circuit boards within the 7613; Fig. 4-3 shows the location of circuit boards in the R7613. Pictures of these circuit boards are shown in Figs. 6-1 through 6-11. These pictures are located in the Diagrams section on the back of the page opposite the circuit diagram, to aid the cross-referencing between the diagrams and the circuit-board components. Each electrical component on the boards is identified by its circuit number. The color and location of the interconnecting connectors are also shown. The circuit boards are also outlined on the diagrams with a blue line to show which portions of the circuit are located on a circuit board.

TABLE 4-1
Component Numbers

Component numbers on diagrams	Diagram numbers	Circuit
1-49	1	Main Interface
50-199	2	Logic Circuit
300-399	3	Trigger Selector
200-299	3	Vertical Interface
400-499	4	Vertical Amplifier
500-599	5	Horizontal Amplifier
600-699	6	Output Signals
1000-1099	7	Calibrator and Front Panel
1100-1299	8	CRT Circuit and High Voltage
800-999	9	Low Voltage Power Supply
1300-1499	10	Storage Circuit
2100-2299	11	Readout System

Multi-Pin Connector Color-Code. The multi-pin connectors used for interconnection between circuit boards are color-coded to aid in circuit tracing. The color of the connector body matches the resistor color-code for the last digit of the circuit number; e.g., P601 is brown, P603 is orange, etc.

Wiring Color-Code. All insulated wire and cable used in the 7613 is color-coded to facilitate circuit tracing.

NOTE

Color code of the AC power cord is as follows (in accordance with National Electrical Code):

<i>Black</i>	<i>Line</i>
<i>White</i>	<i>Neutral</i>
<i>Green with yellow stripe</i>	<i>Safety earth (ground)</i>

Resistor Color-Code. In addition to the brown composition resistors, some metal-film resistors and some wire-wound resistors are used in the 7613. The resistance values of wire-wound resistors are usually printed on the body of the component. The resistance values of composition resistors and metal-film resistors are color-coded on the components with EIA color-code (some metal-film resistors may have the value printed on the body). The color-code is read starting with the stripe nearest the end of the resistor. Composition resistors have four stripes which consist of two significant figures, a multiplier, and a tolerance value (see Fig. 4-2). Metal-film resistors have five stripes consisting of three significant figures, a multiplier, and a tolerance value.

Capacitor Marking. The capacitance values of common disc capacitors and small electrolytics are marked on the side of the component body. The white ceramic capacitors used in the 7613 are color-coded in picofarads using a modified EIA code (see Fig. 4-4).

Diode Color-Code. The cathode end of each glass-encased diode is indicated by a stripe, a series of stripes, or a dot. For most silicon or germanium diodes with a series of stripes, the color-code identifies the three significant digits of the TEKTRONIX Part Number using the resistor color-code system (e.g., a diode color-coded pink- or blue-, brown-gray-green indicates TEKTRONIX Part No. 152-0185-00). The cathode and anode ends of metal-encased diodes can be identified by the diode symbol marked on the body.

Semiconductor Lead Configuration. Fig. 4-5 shows the lead configuration for the semiconductors used in this instrument. This view is as seen from the bottom of the semiconductors.

Troubleshooting Equipment

The following equipment is useful for troubleshooting the 7613.

1. Transistor Tester

Description: TEKTRONIX Type 576 Transistor-Curve Tracer or equivalent.

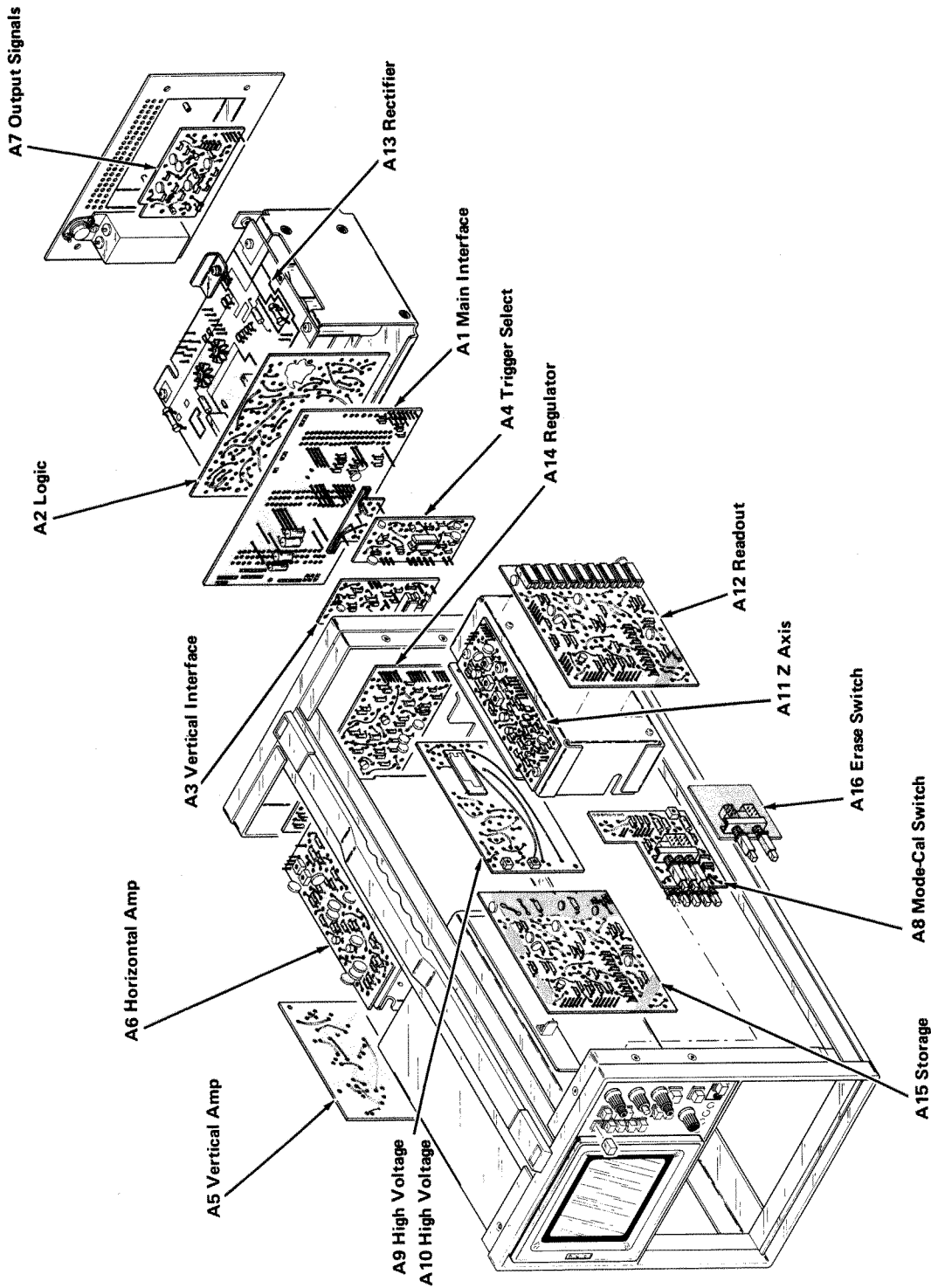

Fig. 4-2. Location of circuit boards in the 7613.

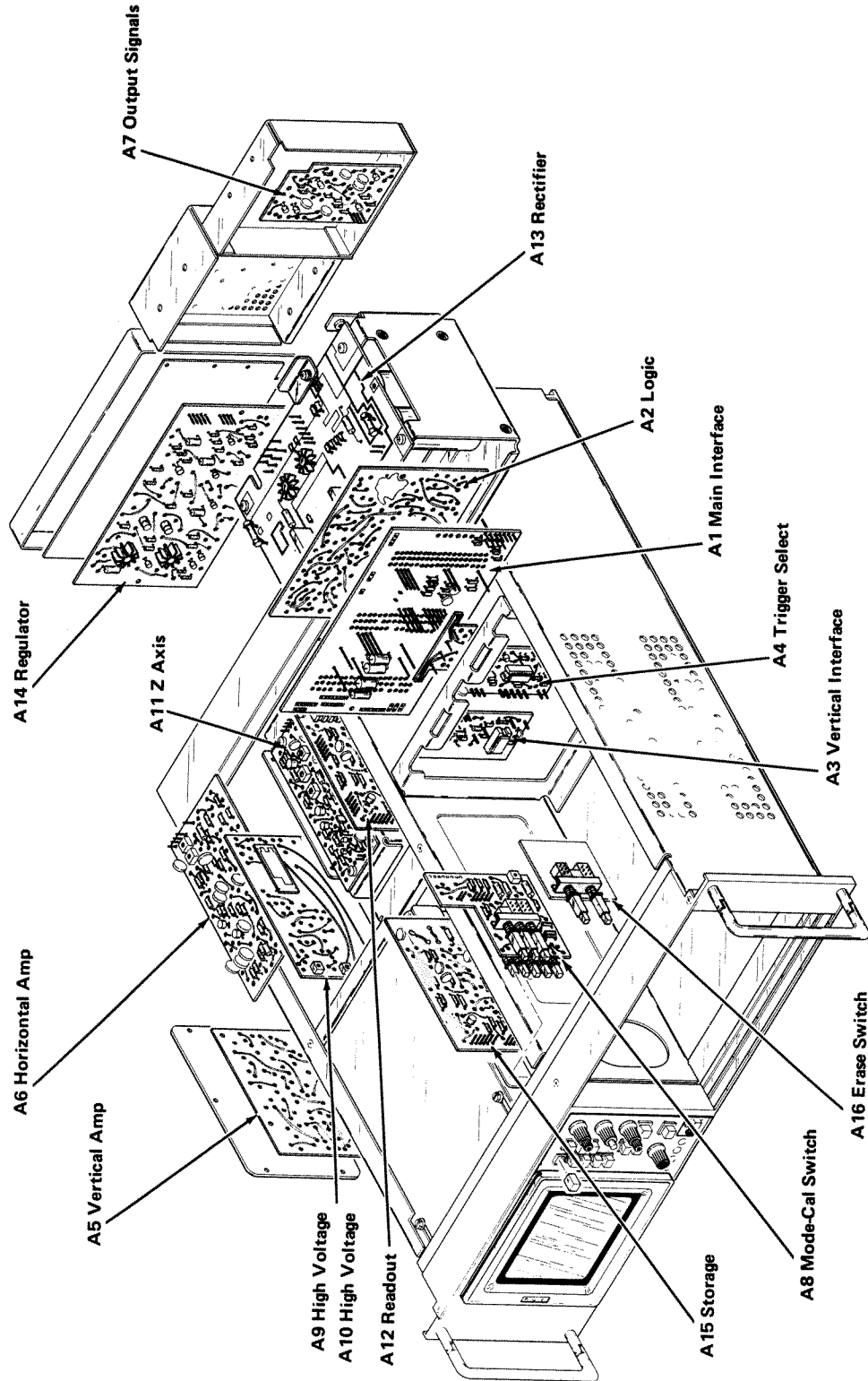

Fig. 4-3. Location of circuit boards in the R7613.

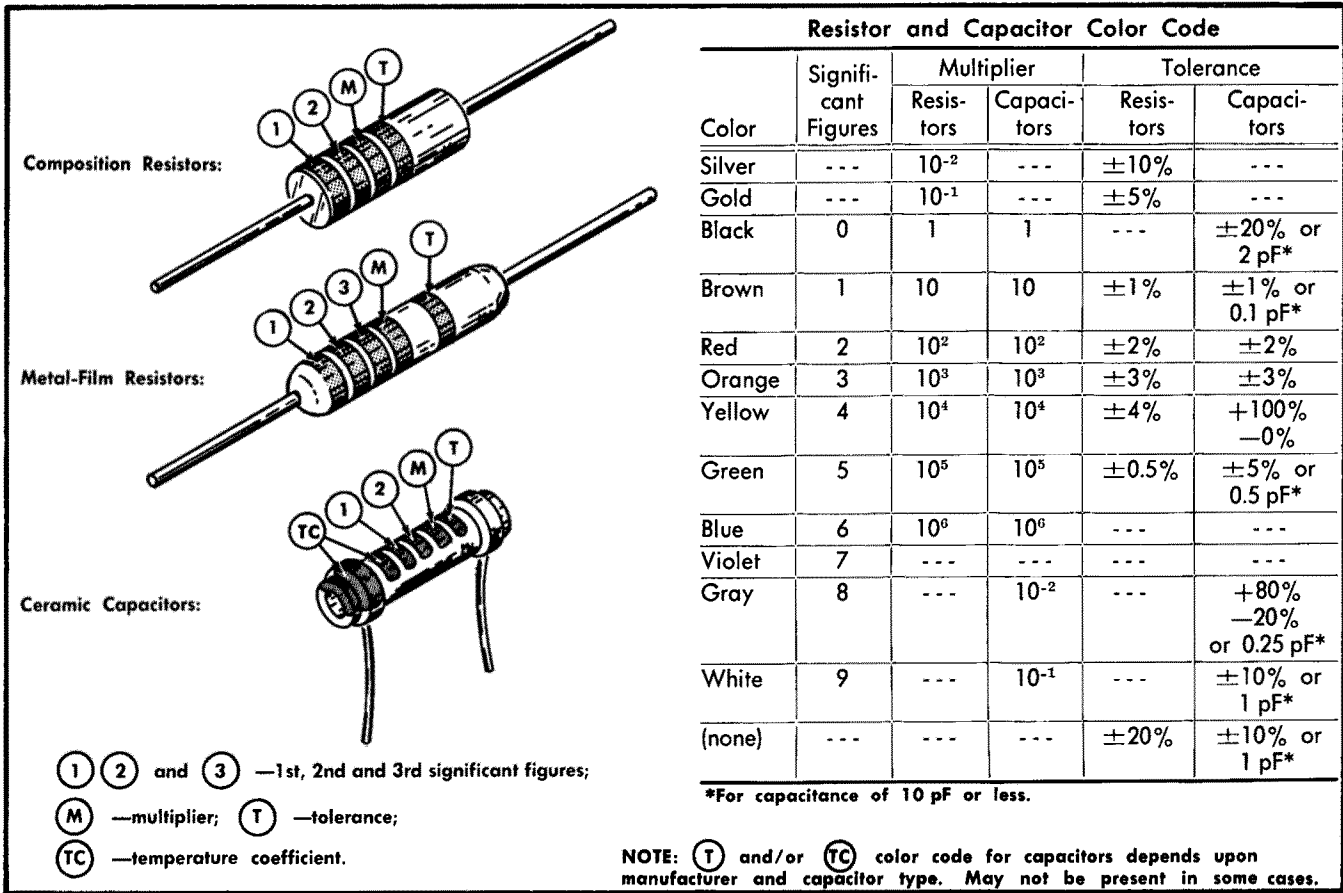

Fig. 4-4. Color code for resistors and ceramic capacitors.

Purpose: To test the semiconductors used in this instrument.

2. Multimeters

Description: Digital voltmeter, 10 megohm input impedance and 0 to 500 volts range; ohmmeter, 0 to 2 megohms. Accuracy, within 1%. Test probes must be insulated to prevent accidental shorting.

Purpose: To check voltages and for general troubleshooting in this instrument.

NOTE

A 20,000 ohms/volt VOM can be used to check the voltages in this instrument if allowances are made for the circuit loading of the VOM at high-impedance points.

3. Test Oscilloscope

Description: Frequency response, DC to 50 megahertz; deflection factor, 50 volts/division. A 10X probe should be used to reduce circuit loading.

Purpose: To check operating waveforms in this instrument.

Troubleshooting Techniques

This troubleshooting procedure is arranged in an order which checks the simple trouble possibilities before proceeding with extensive troubleshooting. The first few checks assure proper connection, operation, and calibration. If the trouble is not located by these checks, the remaining steps aid in locating the defective component. When the defective component is located, it should be replaced following the replacement procedures given under corrective maintenance.

1. **Check Control Settings.** Incorrect control settings can indicate a trouble that does not exist. If there is any question about the correct function or operation of any control, see the Operating Instructions section.

2. **Check Associated Equipment.** Before proceeding with troubleshooting of the 7613, check that the equipment used with this instrument is operating correctly.

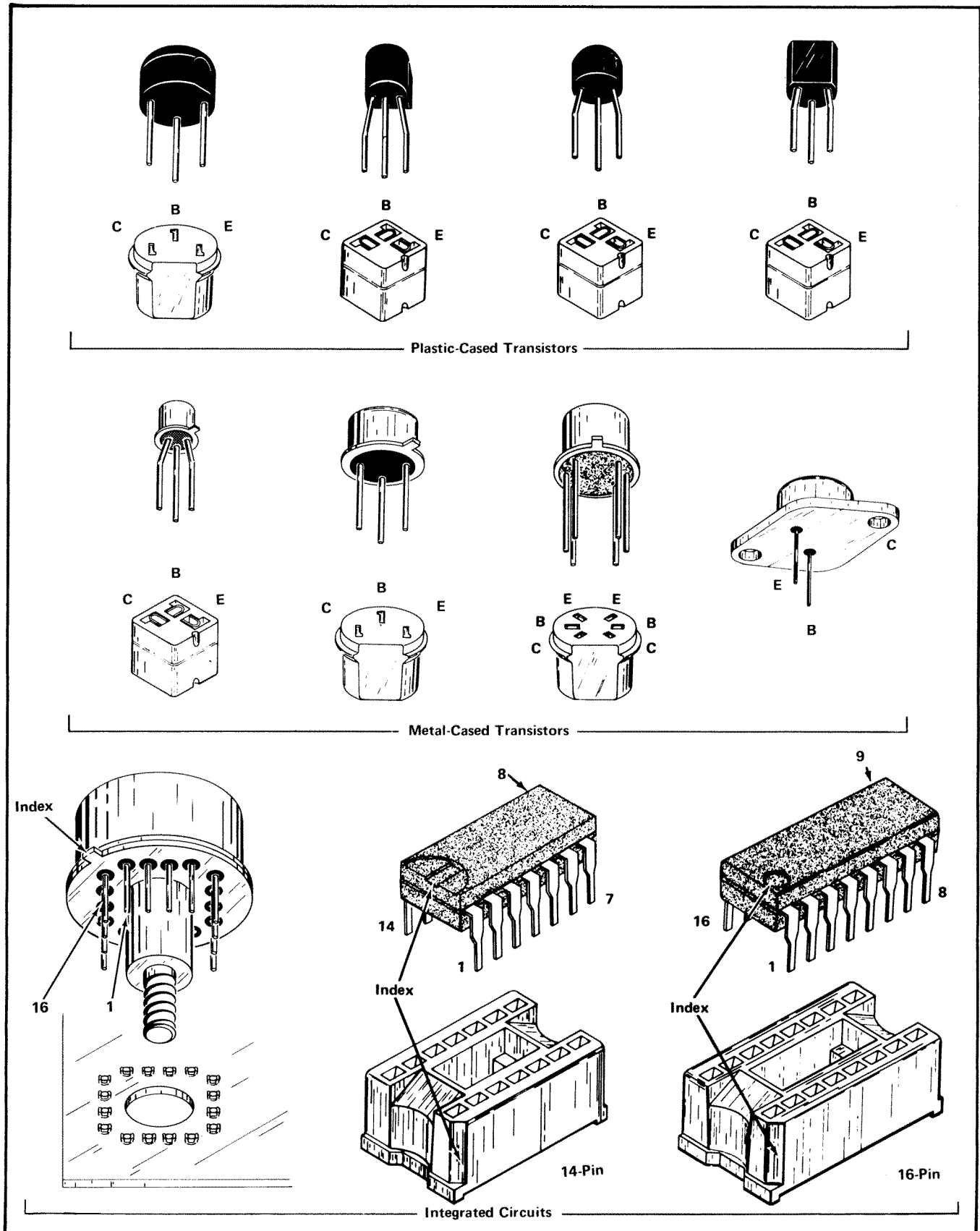

Fig. 4-5. Electrode configuration for semiconductors used in this instrument.

Check that the signal is properly connected and that the interconnecting cables are not defective. Also, check the power source. The associated plug-in units can be checked for proper operation by substituting other units which are known to be operating properly (preferably of the same types). If the trouble persists after substitution, the 7613 is probably at fault.

3. Visual Check. Visually check the portion of the instrument in which the trouble is located. Many troubles can be located by visual indications such as unsoldered connections, broken wires, damaged circuit boards, damaged components, etc.

4. Check Instrument Calibration. Check the calibration of this instrument, or the affected circuit if the trouble appears in one circuit. The apparent trouble may only be a result of misadjustment, or may be corrected by calibration. Complete calibration instructions are given in the Calibration section.

5. Isolate Trouble To a Circuit. To isolate trouble to a particular circuit, note the trouble symptom. The symptom often identifies the circuit in which the trouble is located. For example, poor focus indicates that the CRT circuit (includes high-voltage supplies) is probably at fault. When trouble symptoms appear in more than one circuit, check affected circuits by taking voltage and waveform readings. Typical voltages and waveforms are given on the schematics in the Diagrams section.

Incorrect operation of all circuits often indicates trouble in the power supply. Check first for correct voltage of the individual supplies. A defective component elsewhere in the instrument can appear as a power-supply trouble and may also affect the operation of other circuits. Table 4-2 lists the tolerances of the power supplies in this instrument. These voltages are measured between the power-supply test points (see Section 2 for test-point location) and ground. If a power-supply voltage is within the listed tolerance, the supply can be assumed to be working correctly. If outside the tolerance, the supply may be misadjusted or operating incorrectly. Use the procedure given in the Calibration section to adjust the power supplies.

Fig. 4-6 provides a guide for locating a defective circuit. This chart does not include checks for all possible defects; use steps 6 and 7 in such cases. Start from the top of the chart and perform the given checks on the left side of the page until a step is found which does not produce the indicated results. Further checks and/or the circuit in which the trouble is probably located are listed to the right of this step.

TABLE 4-2

Power Supply Tolerance and Ripple

Power Supply	Test Point	Output Voltage Tolerance	Maximum ripple (peak-to-peak)
-50 Volt	TP-50 (back of Main Interface board) on P1170-Pin 1	±0.1 volt	5 mV
-15 Volt	P1170-Pin 8	±0.3 volt	2 mV
+5 Volt	P1170-Pin 6	±0.15 volt	2 mV
+15 Volt	P1170-Pin 5	±0.3 volt	2 mV
+50 Volt	P1170-Pin 4	±0.6 volt	5 mV
+130 Volt	P1170-Pin 3	±5.2 volts	300 mV

If incorrect operation of the power supplies is suspected, connect the 7613 to a variable autotransformer. Then, check for correct regulation with a DC voltmeter (0.1% accuracy) and correct ripple with a test oscilloscope while varying the autotransformer throughout the regulating range of this instrument.

After the defective circuit has been located, proceed with steps 6 and 7 to locate the defective component(s).

6. Check Voltages and Waveforms. Often the defective component can be located by checking for the correct voltage or waveform in the circuit. Typical voltages and waveforms are given on the diagrams.

NOTE

Voltages and waveforms given on the diagrams are not absolute and may vary slightly between instruments. To obtain operating conditions similar to those used to take these readings, see the first diagram page.

7. Check Individual Components. The following procedures describe methods of checking individual components in the 7613. Components which are soldered in place are best checked by first disconnecting one end. This isolates the measurement from the effects of surrounding circuitry.

A. SEMICONDUCTORS.



Power switch must be turned off before removing or replacing semiconductors.

CIRCUIT ISOLATION TROUBLESHOOTING CHART

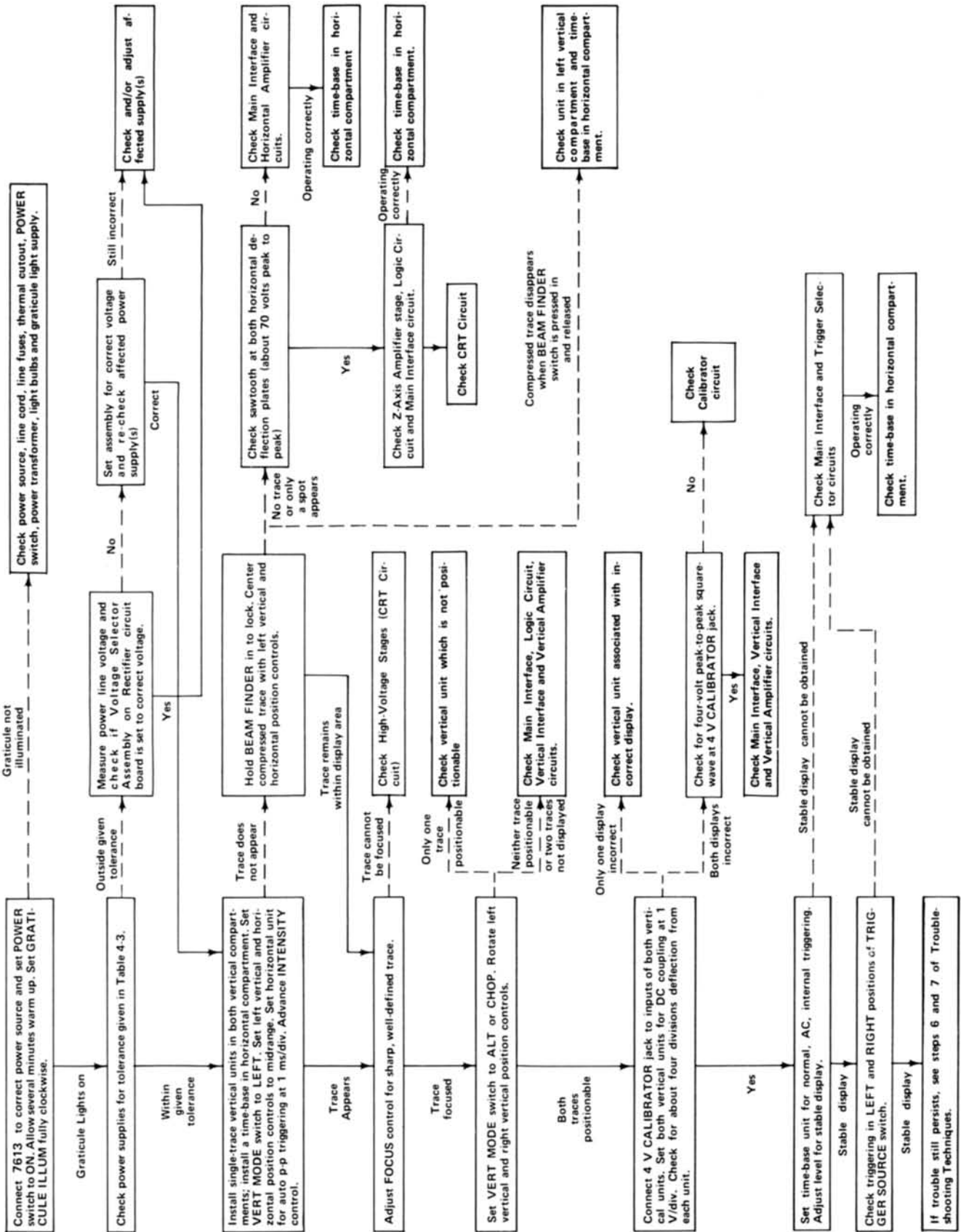

Fig. 4-6.

Maintenance—7613/R7613 Service

A good check of transistor operation is actual performance under operating conditions. A transistor can most effectively be checked by substituting a new component for it (or one which has been checked previously). However, be sure that circuit conditions are not such that a replacement transistor might also be damaged. If substitute transistors are not available, use a dynamic tester. Static-type testers are not recommended, since they do not check operation under simulated operating conditions.

Integrated circuits can be checked with a voltmeter, test oscilloscope, or by direct substitution. A good understanding of the circuit operation is essential to troubleshooting circuits using integrated circuits. In addition, operating waveforms, logic levels, and other operating information for the integrated circuits are given in the Circuit Description section. Use care when checking voltages and waveforms around the integrated circuits so adjacent leads are not shorted together. A convenient means of clipping a test probe to the 14- and 16-pin integrated circuits is with an integrated-circuit test clip. This device also doubles as an integrated-circuit extraction tool.

B. DIODES.

A diode can be checked for an open or shorted condition by measuring the resistance between terminals. With an ohmmeter scale having an internal source of between 800 millivolts and 3 volts, the resistance should be very high in one direction and very low when the meter leads are reversed.

CAUTION

Do not use an ohmmeter scale that has a high internal current. High currents may damage the diodes under test.

C. RESISTORS.

Check the resistors with the ohmmeter. See the Electrical Parts List for the tolerance of the resistors used in this instrument. Resistors normally do not need to be replaced unless the measured value varies widely from the specified value.

D. INDUCTORS.

Check for open inductors by checking continuity with an ohmmeter. Shorted or partially shorted inductors can usually be found by checking the waveform response when high-frequency signals are passed through the circuit. Partial shorting often reduces high-frequency response (roll-off).

E. CAPACITORS.

A leaky or shorted capacitor can best be detected by checking resistance with an ohmmeter on the highest scale. Do not exceed the voltage rating of the capacitor. The resistance reading should be high after initial charge of the capacitor. An open capacitor can best be detected with a capacitance meter or by checking if the capacitor passes AC signals.

8. Repair and Readjust the Circuit. If any defective parts are located, follow the replacement procedures given in this section. Be sure to check the performance of any circuit that has been repaired or that has had any electrical components replaced.

CORRECTIVE MAINTENANCE

General

Corrective maintenance consists of component replacement and instrument repair. Special techniques required to replace components in this instrument are given here.

Obtaining Replacement Parts

Standard Parts. All electrical and mechanical part replacements for the 7613 can be obtained through your local TEKTRONIX Field Office or representative. However, many of the standard electronic components can be obtained locally in less time than is required to order them from Tektronix, Inc. Before purchasing or ordering replacement parts, check the parts list for value, tolerance, rating, and description.

NOTE

When selecting replacement parts, it is important to remember that the physical size and shape of a component may affect its performance in the instrument, particularly at high frequencies. All replacement parts should be direct replacements unless it is known that a different component will not adversely affect instrument performance.

Special Parts. In addition to the standard electronic components, some special components are used in the 7613. These components are manufactured or selected by Tektronix, Inc. to meet specific performance requirements, or are manufactured for Tektronix, Inc. in accordance with our specifications. Most of the mechanical parts used in this instrument have been manufactured by Tektronix, Inc. Order all special parts directly from your local TEKTRONIX Field Office or representative.

Ordering Parts. When ordering replacement parts from Tektronix, Inc., include the following information:

1. Instrument type.
2. Instrument serial number.
3. A description of the part (if electrical, include circuit number).
4. TEKTRONIX part number.

Soldering Techniques

WARNING

Disconnect the instrument from the power source before soldering.

The reliability and accuracy of this instrument can be maintained only if proper soldering techniques are used when repairing or replacing parts. General soldering techniques which apply to maintenance of any precision electronic equipment should be used when working on this instrument. Use only 60/40 rosin-core electronic-grade solder. The choice of soldering iron is determined by the repair to be made. When soldering on circuit boards, use a 35- to 40-watt pencil-type soldering iron with a 1/8-inch wide, wedge-shaped tip. Keep the tip properly tinned for best heat transfer to the solder joint. A higher wattage soldering iron may separate the wiring from the base material. Avoid excessive heat; apply only enough heat to remove the component or to make a good solder joint. Also, apply only enough solder to make a firm solder joint; do not apply too much solder.

For metal terminals (e.g., switch terminals, potentiometers, etc.) a higher wattage-rating soldering iron may be required. Match the soldering iron to the work being done. For example, if the component is connected to the chassis or other large heat-radiating surface, it will require a 75-watt or larger soldering iron. The pencil-type soldering iron used on the circuit board can be used for soldering to switch terminals, potentiometers, or metal terminals mounted in plastic holders.

After soldering is completed, clean the area around the solder connection with a flux-remover solvent. Be careful not to remove any information printed in the area.

Component Replacement

WARNING

Disconnect the instrument from the power source before replacing components.

General. The exploded-view drawings associated with the Mechanical Parts List (located at rear of manual) may be helpful in the removal or disassembly of individual components or sub-assemblies.

Circuit Board Replacement. If a circuit board is damaged beyond repair, the entire assembly including all soldered-on components, can be replaced. Part numbers are given in the Mechanical Parts List.

NOTE

Even though unwired boards are available without components, use of the completely wired replacement board is recommended due to the large number of components mounted on most of the boards.

Most of the circuit boards in this instrument are mounted on the chassis; pin connectors are used for interconnection with other circuits. Use the following procedure to remove the chassis-mounted circuit boards (removal instructions for the exceptions will be given later).

A. CHASSIS-MOUNTED BOARDS.

1. Disconnect any pin connectors on the board or connected to other portions of the instrument. Note the order of these connectors so they can be correctly replaced.

2. Remove the securing screws.

3. Remove the board.

4. To replace the board, reverse the order of removal. Match the arrows on the multi-pin connectors to the arrows on the board. Correct location of the pin connectors is shown in the circuit board illustrations in the Diagrams section.

B. TRIGGER SELECTOR AND VERTICAL INTERFACE CIRCUIT BOARD REPLACEMENT.

The Trigger Selector and Vertical Interface circuit boards plug onto the front of the Main Interface circuit board. Use the following procedure to replace either board.

Maintenance—7613/R7613 Service

1. Remove the securing screws.
2. Pull out on the edges of the board until the board clears the interconnecting terminals. Hold the board parallel to the Main Interface board until the board is free, so as not to bend the interconnecting terminals.
3. To replace the circuit board, position it so the interconnecting pins and sockets mate properly.
4. Gently press the circuit board against the mounting surface. Be sure that all the interconnecting pins and sockets mate properly.
5. Replace the securing screws.

C. LOGIC CIRCUIT BOARD REPLACEMENT.

1. Slide out the power unit as described previously.
2. Disengage the plastic snaps which secure the sides of the board.
3. Pull out on the edges of the board until the board clears the interconnecting terminals. Hold the board parallel to the Main Interface board until the board is free, so as not to bend the interconnecting terminals.
4. To replace the Logic board, position it so the guide holes in the board mate with the guide posts. Check that all the interconnecting pins and sockets mate properly.
5. Gently press the board against the Main Interface board until the plastic snaps secure the board.

D. MAIN INTERFACE CIRCUIT BOARD REPLACEMENT.

1. Slide out the power unit as described previously.
2. Remove all of the plug-on circuit boards from the Main Interface board (remove plug-in units to gain access to plug-on boards on front of Main Interface board).
3. Disconnect the multi-pin connectors from the rear of the Main Interface board. Note the order of these connectors so they can be correctly replaced.

4. Remove the three screws from inside each plug-in compartment which hold the plug-in interface connectors to the chassis (total of nine screws). Also remove the hexagonal posts which secure the ground straps to the Main Interface board.

5. Remove the Main Interface board assembly through the rear of the instrument.

6. To replace the Main Interface board, reverse the order of removal. Match the arrows on the multi-pin connectors to the arrows on the board. Correct location of the pin connectors is shown in the circuit board illustration in the Diagrams section.

E. LOW-VOLTAGE REGULATOR CIRCUIT BOARD REPLACEMENT.

1. Remove the four screws which secure the heat radiator to the rear frame of the instrument.
2. Slide the heat radiator out of the rear of the instrument and disconnect the pin connectors. Remove the heat radiator from the instrument.
3. Remove the four screws which secure the plastic protective cover to the heat radiator.
4. Remove the power transistors from the back of the heat radiator. Note the location of each power transistor.
5. To replace the Low-Voltage Regulator board, reverse the order of removal.

NOTE

After replacing the power transistors, check that the transistor cases are not shorted to the heat radiator before applying power.

F. RECTIFIER BOARD REPLACEMENT.

To replace the Rectifier board, proceed as follows:

1. Slide out the power unit as described previously.
2. Disconnect the pin connectors from the board.
3. Disconnect the wires soldered to the top of the board.

4. Unsolder all of the power transformer wires connected to the top of the board. Use a vacuum-type desoldering tool to remove the solder from the hole in the circuit board.

5. Remove the screws holding each corner of the board to the chassis.

6. To replace the Rectifier board, reverse the order of removal. Be sure that all of the transformer wires are properly placed before resoldering. Match the arrows on the multi-pin connectors to the arrows on the board. Correct location of the pin connectors and the wire color code is shown on the circuit board illustration in the Diagrams section.

G. CALIBRATOR BOARD REPLACEMENT.

1. Unsolder power on/off indicator.

2. Remove FOCUS, INTENSITY, BEAM FINDER and GRATICULE ILLUM knobs.

3. Remove securing nut which holds INTENSITY and GRATICULE ILLUM control to front panel.

4. Disengage the power switch actuating rod from the coupler. Remove the rod and plastic bushing through the front of the instrument.

5. Remove two screws holding the VERT MODE switch to the front sub-panel.

6. Remove the screw holding the calibrator board to the support on the CRT shield.

7. Pull the Calibrator board out far enough to allow the multi-pin connectors and wire leads to be disconnected from the Calibrator board (note the wire color code).

8. Remove the board.

9. To replace the circuit board, reverse the removal procedure. Match the arrows on the multi-pin connectors to the arrows on the circuit board.

Plug-In Interface Connectors. The individual contacts of the plug-in interface connectors can be replaced. However, it is recommended that the entire Main Interface board be replaced if a large number of the contacts are damaged. An alternative solution is to refer the maintenance of the damaged Main Interface board to your local TEKTRONIX Field Office or representative. Use the following procedure to replace an individual contact of the plug-in interface connector.

1. Remove the Main Interface circuit board from the instrument as described previously.

2. Snap the connector cover (white plastic) off the side of the plug-in interface connector which needs repair.

3. Unsolder and remove the damaged contact.

4. Install the replacement contact. Carefully form it to the required shape to fit against the connector body.

5. Snap the connector cover back onto the plug-in interface connector. Check that the contact which was replaced is aligned with the other contacts.

6. Replace the Main Interface board.

Access To The Fan Motor

1. Remove the four screws holding the Low-Voltage Regulator sub-assembly to the main chassis (see Fig. 4-7).

2. Pull the Low-Voltage regulator sub-assembly out through the rear of the instrument as far as cables will permit.

3. Remove the two screws holding the motor to the bracket; be careful not to lose the spacers between the motor and the bracket.

4. To replace the motor, reverse the order of removal.

Access To The Fan Motor For The R7613

1. Remove the eight screws holding the Signals-Out rear panel to the chassis. Pull rear panel out as far as cables will permit (see Fig. 4-8).

2. Remove the four corner bolts securing the motor to the chassis.

3. To replace the motor, reverse the order of removal.

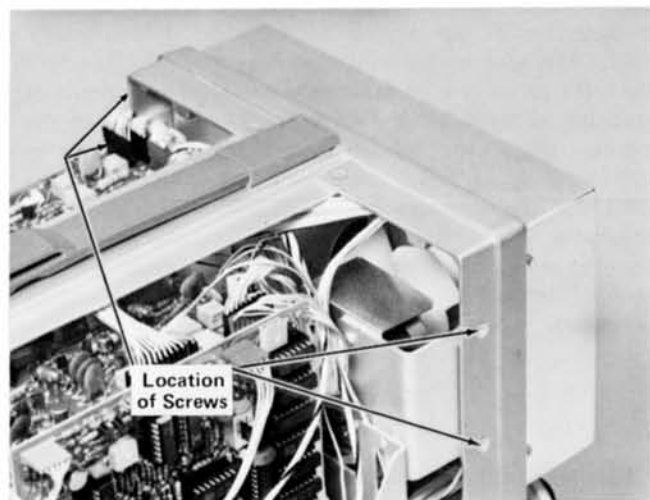

Fig. 4-7. Location of screws holding Low Voltage sub-chassis.

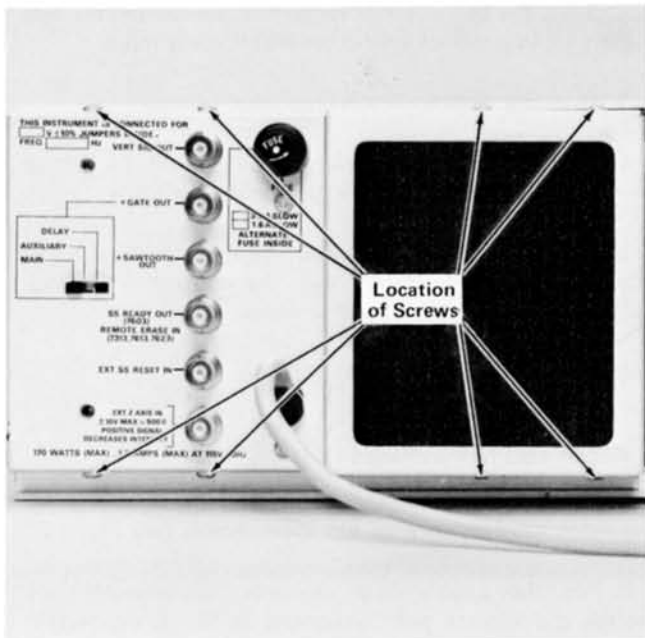

Fig. 4-8. Location of screws holding Signals Out rear panel.

Semiconductor Replacement. Semiconductors should not be replaced unless actually defective. If removed from their sockets during routine maintenance, return them to their original sockets. Unnecessary replacement of semiconductors may affect the calibration of this instrument. When semiconductors are replaced, check the operation of the part of the instrument which may be affected.

CAUTION

POWER switch must be turned off before removing or replacing semiconductors.

Replacement semiconductors should be of the original type or a direct replacement. Fig. 4-5 shows the lead configuration of the semiconductors used in this instrument. Some plastic case transistors have lead configurations which do not agree with those shown here. If a replacement transistor is made by a different manufacturer than the original, check the manufacturer's basing diagram for correct basing. All transistor sockets in this instrument are wired for the standard basing as used for metal-cased transistors. Transistors which have heat radiators or are mounted on the chassis use silicone grease to increase heat transfer. Replace the silicone grease when replacing these transistors.

WARNING

Handle silicone grease with care. Avoid getting silicone grease in the eyes. Wash hands thoroughly after use.

An extracting tool should be used to remove the 14- and 16-pin integrated circuits to prevent damage to the pins. This tool is available from Tektronix, Inc. Order TEKTRONIX Part No. 003-0619-00. If an extracting tool is not available when removing one of these integrated circuits, pull slowly and evenly on both ends of the device. Try to avoid having one end of the integrated circuit disengage from the socket before the other, as this may damage the pins.

Access to Power Transistors. The power transistors associated with the Low-Voltage Power Supply are mounted on the heat radiator at the rear of the instrument. To gain access to these transistors, remove the screws which secure the plastic protective cover to the heat radiator. The transistors are mounted in sockets so they can be removed from the rear by taking out the two screws in the mounting tabs (cases elevated above chassis; be sure power is off). To replace the sockets, refer to the procedure for removal of the Low-Voltage Regulator circuit board.

NOTE

After replacing a power transistor, check that the collector is not shorted to ground before applying power.

Interconnecting Pin Replacement. Interconnecting pins are used to interconnect many of the circuit boards in the 7613. Two types of mating connectors are used for these interconnecting pins. If the mating connector is mounted on a plug-on circuit board, a special socket is soldered into the board. If the mating connector is on the end of a lead, an end-lead pin connector is used which mates with the interconnecting pin. The following information provides the replacement procedure for the various types of interconnecting methods.

A. CIRCUIT-BOARD PINS.

NOTE

A circuit-board pin replacement kit including necessary tools, instructions and replacement pins is available from Tektronix, Inc. Order TEKTRONIX Part No. 040-0542-00.

To replace a pin which is mounted on a circuit board, first disconnect the pin connectors. Then, unsolder the damaged pin and pull it out of the circuit board with a pair of pliers. Be careful not to damage the wiring on the board with too much heat. Ream out the hole in the circuit board with a 0.031-inch drill. Remove the ferrule from the new interconnecting pin and press the new pin into the hole in the circuit board. Position the pin in the same manner as the old pin. Then, solder the pin on both sides of the circuit board. If the old pin was bent at an angle to mate with a connector, bend the new pin to match the associated pins.

B. CIRCUIT-BOARD PIN SOCKETS.

The pin sockets on the circuit boards are soldered to the rear of the board. To replace one of these sockets, first unsolder the pin (use a vacuum-type desoldering tool to remove excess solder). Then straighten the tabs on the socket and remove it from the hole in the circuit board. Place the new socket in the circuit board hole and press the tabs down against the board. Solder the tabs of the socket to the circuit board; be careful not to get solder into the socket.

NOTE

The spring tension of the pin sockets ensures a good connection between the circuit board and the pin. This spring tension can be destroyed by using the pin sockets as a connecting point for spring-loaded probe tips, alligator clips, etc.

C. END-LEAD PIN CONNECTORS.

The pin connectors used to connect the wires to the interconnecting pins are clamped to the ends of the associated leads. To replace damaged end-lead pin connectors, remove the old pin connector from the end of the lead and clamp the replacement connector to the lead.

Some of the pin connectors are grouped together and mounted in a plastic holder; the overall result is that these connectors are removed and installed as a multi-pin connector. To provide correct orientation of this multi-pin connector when it is replaced, an arrow is stamped on the circuit board and a matching arrow is molded into the plastic housing of the multi-pin connector. Be sure these arrows are aligned as the multi-pin connector is replaced. If the individual end-lead pin connectors are removed from the plastic holder, note the color of the individual wires for replacement.

Cathode-Ray Tube Replacement. To replace the cathode-ray tube, proceed as follows:

WARNING

Use care when handling a CRT. Protective clothing and safety glasses should be worn. Avoid striking it on any object which might cause it to crack or implode. When storing a CRT, place it in a protective carton or set it face down in a protected location on a smooth surface with a soft mat under the faceplate to protect it from scratches.

A. REMOVAL.

1. Remove the heat radiator/Low-Voltage Regulator circuit board assembly as described previously.

2. Remove the CRT base socket from the rear of the CRT.

3. Loosen the two screws located on each side of the CRT socket until the tension of the springs on these screws is released. Then, press in on the screws to be sure that the CRT clamp is loose.

4. Disconnect the deflection-plate connectors. Be careful not to bend these pins.

5. Disconnect the CRT anode plug from the jack located on the front of the high-voltage compartment. Ground this lead to the chassis to dissipate any stored charge.

6. Remove the two screws securing the CRT bezel to the front panel. Remove the plastic faceplate protector and light filter.

7. Hold one hand on the CRT faceplate and push forward on the CRT base with the other. As the CRT starts out of the shield, grasp it firmly. Guide the anode lead through the cutout in the CRT shield as the CRT is removed.

B. REPLACEMENT.

1. Loosen clamp blocks located at each corner of CRT shield. Insert the CRT into the shield. Guide the anode lead through the hole in the CRT shield.

2. Clean the CRT faceplate, plastic faceplate protector, and the light filter with denatured alcohol.

3. Re-install the CRT bezel, faceplate protector, and light filter. Firmly tighten the two screws.

4. Push forward on the CRT base to be certain that the CRT is as far forward as possible. Then tighten the two screws beside the CRT base until the springs on the screws are fully compressed.

5. Reposition and tighten down clamp blocks to hold the faceplate of the CRT tightly against the implosion shield. The clamps are located at each corner of the CRT shield.

6. Replace the CRT base socket.

7. Reconnect the CRT anode plug.

Maintenance—7613/R7613 Service

8. Re-install the heat radiator/Low-Voltage Regulator circuit board assembly.

9. Carefully reconnect the deflection-plate connectors. After each connector is installed, lightly pull on its lead to be sure that it will remain in its socket.

10. Check the calibration of the complete instrument. Calibration procedure is given in Section 2.

Switch Replacement. The pushbutton switches used in the 7613 are not repairable and should be replaced as a unit if defective.

Graticule-Bulb Replacement. To remove a graticule bulb, first remove the two screws securing the CRT bezel to the front panel. Remove the plastic light shield and retaining spring. Now, firmly grasp the defective bulb and pull straight out. Push the replacement bulb straight into the socket as far as it will go. Replace the retaining spring, light shield, and CRT bezel.

Power Transformer Replacement. Replace the power transformer only with a direct replacement transformer. When removing the transformer, tag the leads with the corresponding terminal numbers to aid in connecting the new transformer. After the transformer has been replaced, check the performance of the complete instrument using the procedure given in the Calibration section.

High-Voltage Compartment. The components located in the high-voltage compartment can be reached for maintenance or replacement by using the following procedure. Diagram 6 shows the location of the components in the high-voltage compartment and color-coding of the wires.

NOTE

All solder joints in the high-voltage compartment should have smooth surfaces. Any protrusions may cause high-voltage arcing at high altitudes.

1. Remove the heat radiator/Low-Voltage Regulator assembly as described previously.

2. Disconnect the CRT base socket.

3. Disconnect the CRT anode plug and discharge it to the chassis. Using an insulated probe or wire, discharge the jack portion of the CRT anode connector to chassis ground.

4. Disconnect the multi-pin connectors on the Z-Axis Amplifier board.

5. Remove the screw on the bottom of the high-voltage compartment and the two screws located at the top.

6. Guide the high-voltage compartment away from the instrument chassis. Be careful not to damage any of the components or the pin connectors on the High-Voltage or Z-Axis Amplifier circuit boards. Disconnect the multi-pin connectors on the High-Voltage board.

7. Using an insulated shorting strap, discharge the exposed connections to chassis ground.

8. Remove the two power transistors and the four screws which secure the High-Voltage board to the high-voltage compartment. Now, all of the circuitry in the high-voltage box can be reached for maintenance or replacement except those in the encapsulated assembly.

9. To replace the encapsulated assembly, remove the four screws located on the bottom of the High-Voltage circuit board (remove board to reach screws).

10. To replace the high-voltage compartment, reverse the above procedure. Be careful not to pinch any of the interconnecting wires when re-attaching the high-voltage compartment to the chassis.

Fuse Replacement. Table 4-3 gives the rating, location, and function of the fuses used in this instrument.

TABLE 4-3

Fuse Rating

Circuit Number	Rating	Location	Function
F 1000	3.2 A Slow	Rear panel	110-volt line
F 1000	1.6 A Slow	Rectifier board	220-volt line
F 814	2 A Fast	Rectifier board	High voltage
F 855	0.15 A Fast	Low-Voltage Regulator board	+130 volts

Recalibration After Repair

After any electrical component has been replaced, the calibration of that particular circuit should be checked, as well as the calibration of other closely related circuits.

Since the low-voltage supply affects all circuits, calibration of the entire instrument should be checked if work has been done in the low-voltage supply or if the power transformer has been replaced.

Instrument Repackaging

If the 7613 is to be shipped for long distances by commercial means of transportation, it is recommended that it be repackaged in the original manner for maximum protection. The original shipping carton can be saved and used for this purpose. The repackaging illustration in the

Mechanical Parts List shows how to repackage the 7613 and gives the part number for the packaging components. New shipping cartons can be obtained from Tektronix, Inc. Contact your local TEKTRONIX Field Office or representative.

NOTE

The packaging material is not designed to protect the plug-ins if shipped installed in the plug-in compartments. The plug-ins should be shipped in their own shipping cartons.

ELECTRICAL PARTS LIST

Replacement parts should be ordered from the Tektronix Field Office or Representative in your area. Changes to Tektronix products give you the benefit of improved circuits and components. Please include the instrument type number and serial number with each order for parts or service.

ABBREVIATIONS AND REFERENCE DESIGNATORS

A	Assembly, separable or repairable	FL	Filter	PTM	paper or plastic, tubular molded
AT	Attenuator, fixed or variable	H	Heat dissipating device (heat sink, etc.)	R	Resistor, fixed or variable
B	Motor	HR	Heater	RT	Thermistor
BT	Battery	J	Connector, stationary portion	S	Switch
C	Capacitor, fixed or variable	K	Relay	T	Transformer
Cer	Ceramic	L	Inductor, fixed or variable	TP	Test point
CR	Diode, signal or rectifier	LR	Inductor/resistor combination	U	Assembly, inseparable or non-repairable
CRT	cathode-ray tube	M	Meter	V	Electron tube
DL	Delay line	Q	Transistor or silicon-controlled rectifier	Var	Variable
DS	Indicating device (lamp)	P	Connector, movable portion	VR	Voltage regulator (zener diode, etc.)
Elect.	Electrolytic	PMC	Paper, metal cased	WW	wire-wound
EMC	electrolytic, metal cased	PT	paper, tubular	Y	Crystal
EMT	electrolytic, metal tubular				
F	Fuse				

Ckt. No.	Tektronix Part No.	Serial/Model No. Eff	Disc	Description
ASSEMBLIES				
A1	670-1956-00	B010100	B239999	INTERFACE Circuit Board Assembly
A1	670-1956-01	B240000		INTERFACE Circuit Board Assembly
A2	670-1370-02	B010100	B029999	LOGIC Circuit Board Assembly
A2	670-1370-04	B210000		LOGIC Circuit Board Assembly
A3	670-1373-06			VERT INTERFACE Circuit Board Assembly
A4	670-1371-05			TRIGGER SELECTOR Circuit Board Assembly
A5	670-1958-00			VERT AMPL Circuit Board Assembly
A6	670-1957-00	B010100	B019999	HORIZ. AMPL Circuit Board Assembly
A6	670-1957-01	B020000	B069999	HORIZ. AMPL Circuit Board Assembly
A6	670-1957-02	B070000	B239999	HORIZ. AMPL Circuit Board Assembly
A6	670-1957-03	B240000		HORIZ. AMPL Circuit Board Assembly
A7	670-1961-00			SIGNAL OUTPUT Circuit Board Assembly
A8	670-2038-00			CALIBRATION & MODE SWITCH Ckt Board Assembly
A9	670-1953-00			HV BOARD #2 Circuit Board Assembly
A10	670-1952-01	B010100	B199999	HV BOARD #1 Circuit Board Assembly
A10	670-1952-03	B200000		HV BOARD #1 Circuit Board Assembly
A11	670-1951-00	B010100	B199999	Z AXIS Circuit Board Assembly
A11	670-1951-03	B200000		Z AXIS Circuit Board Assembly
A12	670-1900-01	B010100	B219999	READOUT Circuit Board Assembly
A12	670-1900-03	B220000		READOUT Circuit Board Assembly
A13	670-1382-01			RECTIFIER Circuit Board Assembly
A14	670-1376-10			REGULATOR Circuit Board Assembly
A15	670-2129-00			STORAGE Circuit Board Assembly
A16	670-1960-00			ERASE SWITCH Circuit Board Assembly
A17	670-0702-03			GRATICULE LIGHTS Circuit Board Assembly
MOTOR				
B1001	119-0390-00			Fan, axial
CAPACITORS				
C1	290-0271-00			9 μ F, Elect., 125 V, +20%-15%
C3	290-0302-00			100 μ F, Elect., 20 V, 10%
C5	290-0302-00			100 μ F, Elect., 20 V, 10%

ELECTRICAL PARTS LIST (cont)

Ckt. No.	Tektronix Part No.	Serial/Model No. Eff	Disc	Description
CAPACITORS (cont)				
C7	290-0302-00			100 μ F, Elect., 20 V, 10%
C9	290-0271-00			9 μ F, Elect., 500 V, +100%-0%
C16	283-0068-00			0.01 μ F, Cer, 500 V, +100%-0%
C18	283-0068-00			0.01 μ F, Cer, 500 V, +100%-0%
C44	283-0068-00	B010100	B239999	0.01 μ F, Cer, 500 V, +100%-0%
C44	283-0081-00	B240000		0.1 μ F, Cer, 25 V, +80%-20%
C47	281-0638-00	B010100	B239999X	240 pF, Cer, 500 V, 5%
C48	283-0068-00	B010100	B239999	0.01 μ F, Cer, 500 V, +100%-0%
C48	283-0081-00	B240000		0.1 μ F, Cer, 25V, +80%-20%
C55	283-0003-00			0.01 μ F, Cer, 150 V, +80%-20%
C58	283-0003-00			0.01 μ F, Cer, 150 V, +80%-20%
C59	283-0672-00			200 pF, Mica, 500 V, 1%
C60	281-0564-00			24 pF, Cer, 500 V, 5%
C67	281-0605-00			200 pF, Cer, 500 V
C76	283-0000-00			0.001 μ F, Cer, 500 V, +100%-0%
C89	283-0003-00			0.01 μ F, Cer, 150 V, +80%-20%
C136	281-0547-00			2.7 pF, Cer, 500 V, 10%
C137	283-0000-00			0.001 μ F, Cer, 500 V, +100%-0%
C138	281-0503-00			8 pF, Cer, 500 V, \pm 0.5 pF
C146	281-0547-00			2.7 pF, Cer, 500 V, 10%
C148	281-0503-00			8 pF, Cer, 500 V, \pm 0.5 pF
C149	283-0000-00			0.001 μ F, Cer, 500 V, +100%-0%
C152	283-0000-00			0.001 μ F, Cer, 500 V, +100%-0%
C166	281-0547-00			2.7 pF, Cer, 500 V, 10%
C168	281-0503-00			8 pF, Cer, 500 V, \pm 0.5 pF
C193	283-0026-00			0.2 μ F, Cer, 25 V, +80%-20%
C195	283-0003-00			0.01 μ F, Cer, 150 V, +80%-20%
C196	283-0026-00			0.2 μ F, Cer, 25 V, +80%-20%
C198	283-0026-00			0.2 μ F, Cer, 25 V, +80%-20%
C207	281-0538-00			1 pF, Cer, 500 V, 20%
C208	281-0528-00			82 pF, Cer, 500 V, 10%
C215	281-0589-00			170 pF, Cer, 500 V, 5%
C217	281-0537-00			0.68 pF, Cer, 500 V, 20%
C220	283-0177-00			1 μ F, Cer, 25 V, +80%-20%
C227	281-0503-00			8 pF, Cer, 500 V, \pm 0.5pF
C260	283-0000-00			0.001 μ F, Cer, 500 V, +100%-0%
C301	283-0003-00			0.01 μ F, Cer, 150 V, +80%-20%
C305	283-0004-00			0.02 μ F, Cer, 150 V
C322	281-0572-00			6.8 pF, Cer, 500 V, \pm 0.5 pF
C329	281-0572-00			6.8 pF, Cer, 500 V, \pm 0.5 pF
C342	283-0000-00			0.001 μ F, Cer, 500 V, +100%-0%
C348	283-0000-00			0.001 μ F, Cer, 500 V, +100%-0%
C401	290-0522-00			1 μ F, Elect., 50 V, 20%
C418	281-0629-00			33 pF, Cer, 600 V, 5%
C420	281-0153-00			1.7-10 pF, Var, Air, 250 V
C421	281-0504-00			10 pF, Cer, 500 V, \pm 0.5 pF
C425	281-0153-00			1.7-10 pF, Var, Air, 250 V
C427	281-0160-00			7-25 pF, Var, Cer, 350 V
C433	290-0522-00			1 μ F, Elect., 50 V, 20%
C455	283-0187-00	B010100	B029999	0.047 μ F, Cer, 500 V, 10%
C455	283-0341-00	B030000		0.047 μ F, Cer, 100 V, 10%
C456	283-0199-00			2200 pF, Cer, 200 V, 5%
C458	283-0116-00			820 pF, Cer, 500 V, 5%
C459	290-0522-00			1 μ F, Elect., 50 V, 20%
C465	283-0211-00			0.1 μ F, Cer, 200 V, 10%
C466	283-0100-00			0.0047 μ F, Cer, 200 V, 10%
C468	283-0005-00			0.01 μ F, Cer, 250 V, +100%-0%

ELECTRICAL PARTS LIST (cont)

Ckt. No.	Tektronix Part No.	Serial/Model No. Eff	Disc	Description
CAPACITORS (cont)				
C480	290-0522-00			1 μ F, Elect., 50 V, 20%
C486	283-0000-00			0.001 μ F, Cer, 500 V, +100%-0%
C491	283-0110-00	XB030000		0.005 μ F, Cer, 150 V
C494	283-0000-00			0.001 μ F, Cer, 500 V, +100%-0%
C496	281-0523-00			100 pF, Cer, 350 V, 20%
C521 ¹		B010100	B019999X	
C522 ¹		B010100	B019999X	
C527	281-0504-00	B010100	B019999X	10 pF, Cer, 500 V, 10%
C545	281-0550-00			120 pF, Cer, 500 V, 10%
C552	283-0024-00			0.1 μ F, Cer, 500 V
C555	283-0083-00			0.0047 μ F, Cer, 500 V, 20%
C566	281-0095-00	XB020000	B069999	0.2-1.5 pF, Var, Teflon
C566	281-0064-00	B070000		0.25-1.5 pF, Var, Plastic
C567	281-0557-00	B010100	B019999X	1.8 pF, Cer, 500 V
C568	281-0097-00	B010100	B019999	9-35 pF, Var, Cer
C568	281-0089-00	B020000	B069999X	2-8 pF, Var, Cer
C569	281-0579-00	B010100	B019999X	21 pF, Cer, 500 V, 5%
C571	283-0002-00			0.01 μ F, Cer, 500 V
C574	283-0002-00			0.01 μ F, Cer, 500 V
C575	283-0083-00			0.0047 μ F, Cer, 500 V, 20%
C584	281-0546-00	XB070000		330 pF, Cer, 500 V, 10%
C586	281-0095-00	XB020000	B069999	0.2-1.5 pF, Var, Teflon
C586	281-0064-00	B070000		0.25-1 pF, Var, Plastic
C587	281-0557-00	B010100	B019999X	1.8 pF, Cer, 500 V
C588	281-0092-00	B010100	B019999	9-35 pF, Var, Cer
C588	281-0091-00	B020000		2-8 pF, Var, Cer
C589	281-0579-00	B010100	B019999X	21 pF, Cer, 500 V, 5%
C591	283-0002-00			0.01 μ F, Cer, 500 V
C593	283-0002-00			0.01 μ F, Cer, 500 V
C595	283-0081-00	B010100	B060599	0.1 μ F, Cer, 25 V, +80%-20%
C595	283-0024-00	B060600		0.1 μ F, Cer, 30 V, +80%-20%
C597	283-0081-00	B010100	B060599	0.1 μ F, Cer, 25 V, +80%-20%
C597	283-0024-00	B060600		0.1 μ F, Cer, 30 V, +80%-20%
C599	283-0081-00	B010100	B060599	0.1 μ F, Cer, 25 V, +80%-20%
C599	283-0024-00	B060600		0.1 μ F, Cer, 30 V, +80%-20%
C605	281-0612-00			5.6 pF, Cer, 200 V, \pm 0.5 pF
C610	283-0000-00			0.001 μ F, Cer, 500 V, +100%-0%
C615	281-0513-00			27 pF, Cer, 500 V, 20%
C619	283-0000-00			0.001 μ F, Cer, 500 V, +100%-0%
C622	283-0003-00			0.01 μ F, Cer, 150 V, +80%-20%
C637	281-0510-00			22 pF, Cer, 500 V, 20%
C639	283-0111-00			0.1 μ F, Cer, 50 V
C643	283-0111-00			0.1 μ F, Cer, 50 V
C662	283-0080-00			0.022 μ F, Cer, 25 V, +80%-20%

¹ Added if necessary.

ELECTRICAL PARTS LIST (cont)

Ckt. No.	Tektronix Part No.	Serial/Model No. Eff	Disc	Description
CAPACITORS (cont)				
C667	283-0000-00			0.001 μ F, Cer, 500 V, +100%-0%
C669	283-0111-00			0.1 μ F, Cer, 50 V
C679	283-0111-00			0.1 μ F, Cer, 50 V
C806	290-0468-00			250 μ F, Elect., 75 V, +75%-10%
C808	290-0507-00			1800 μ F, Elect., 75 V, +75%-10%
C809	290-0507-00			1800 μ F, Elect., 75 V, +75%-10%
C810	285-0555-00			0.1 μ F, PTM, 100 V, 20%
C811	290-0581-00			14000 μ F, Elect., 25 V, +75%-10%
C813	290-0506-00			9600 μ F, Elect., 25 V, +100%-10%
C814	290-0506-00			9600 μ F, Elect., 25 V, +100%-10%
C820	285-0555-00			0.1 μ F, PTM, 100 V, 20%
C821	290-0508-00			18000 μ F, Elect., 15 V, +100%-10%
C823	283-0004-00			0.02 μ F, Cer, 150 V
C827	283-0077-00	XB080000		330 pF, Cer, 500 V, 5%
C858	283-0078-00			0.001 μ F, Cer, 500 V, 20%
C866	283-0078-00			0.001 μ F, Cer, 500 V, 20%
C876	283-0328-00	XB070000		0.03 μ F, Cer, 200 V, +80%-20%
C880	283-0638-00			130 pF, Mica, 100 V, 1%
C889	290-0415-00			5.6 μ F, Elect., 35 V, 10%
C923	281-0591-00			5600 pF, Cer, 200 V, 20%
C936	283-0178-00	XB070000		0.1 μ F, Cer, 100 V, +80%-20%
C943	283-0078-00	XB090000		0.001 μ F, Cer, 500 V, 20%
C950	283-0083-00			0.0047 μ F, Cer, 500 V, 20%
C975	283-0000-00			0.001 μ F, Cer, 500 V, +100%-0%
C979	281-0591-00			5600 pF, Cer, 200 V, 20%
C985	283-0083-00			0.0047 μ F, Cer, 500 V, 20%
C1064	285-0703-00			0.1 μ F, PTM, 100 V, 5%
C1079	281-0605-00			200 pF, Cer, 500 V
C1105	283-0003-00			0.01 μ F, Cer, 150 V, +80%-20%
C1124	283-0004-00			0.02 μ F, Cer, 150 V
C1126	283-0004-00			0.02 μ F, Cer, 150 V
C1128	283-0111-00			0.1 μ F, Cer, 50 V
C1131	283-0004-00			0.02 μ F, Cer, 150 V
C1138	281-0053-00			0.35-1.37 pF, Var, Cer
C1141	283-0004-00			0.02 μ F, Cer, 150 V
C1144	283-0004-00			0.02 μ F, Cer, 150 V
C1146	283-0004-00			0.02 μ F, Cer, 150 V
C1148	283-0111-00			0.1 μ F, Cer, 50 V
C1151	283-0004-00			0.02 μ F, Cer, 150 V
C1158	283-0053-00			0.35-1.37 pF, Var, Cer
C1184	283-0003-00			0.01 μ F, Cer, 150 V, +80%-20%
C1188	283-0003-00			0.01 μ F, Cer, 150 V, +80%-20%
C1193	283-0003-00			0.01 μ F, Cer, 150 V, +80%-20%
C1196	283-0004-00			0.02 μ F, Cer, 150 V
C1204	281-0605-00	XB200000		200 pF, Cer, 500 V
C1215	285-0629-00			0.047 μ F, PTM, 100 V, 20%
C1222	290-0287-00			47 μ F, Elect., 25 V, 20%
C1226	283-0300-00			0.001 μ F, Cer, 10000 V, +80%-20%
C1228	283-0300-00			0.001 μ F, Cer, 10000 V, +80%-20%
C1229	283-0300-00			0.001 μ F, Cer, 10000 V, +80%-20%
C1232	283-0105-00			0.01 μ F, Cer, 2000 V, +80%-20%
C1234	283-0105-00			0.01 μ F, Cer, 2000 V, +80%-20%
C1240	290-0391-00			15 μ F, Elect., 30 V, 10%
C1241	283-0203-00			0.47 μ F, Cer, 50 V, 20%
C1247	283-0044-00			0.001 μ F, Cer, 3000 V

ELECTRICAL PARTS LIST (cont)

Ckt. No.	Tektronix Part No.	Serial/Model No. Eff	Disc	Description
CAPACITORS (cont)				
C1250	283-0013-00			0.01 μ F, Cer, 1000 V
C1254	283-0044-00			0.001 μ F, Cer, 3000 V
C1255	283-0044-00			0.001 μ F, Cer, 3000 V
C1257	281-0513-00			27 pF, Cer, 500 V, 20%
C1258	290-0164-00			1 μ F, Elect., 150 V
C1264	290-0164-00			1 μ F, Elect., 150 V
C1266	281-0513-00			27 pF, Cer, 500 V, 20%
C1268	283-0044-00			0.001 μ F, Cer, 3000 V
C2169	283-0105-00			0.01 μ F, Cer, 2000 V, +80%-20%
C1275	281-0543-00			270 pF, Cer, 500 V, 10%
C1276	283-0044-00	B010100	B199999	0.001 μ F, Cer, 3000 V
C1276	283-0261-00	B200000		0.01 μ F, Cer, 4000 V, 20%
C1318	283-0023-00			0.1 μ F, Cer, 10 V, +80%-20%
C1325	283-0178-00			0.1 μ F, Cer, 100 V, +80%-20%
C1327	283-0178-00			0.1 μ F, Cer, 100 V, +80%-20%
C1329	283-0177-00			1 μ F, Cer, 25 V, +80%-20%
C1331	283-0067-00			0.001 μ F, Cer, 200 V, 10%
C1337	290-0246-00			3.3 μ F, Elect., 15 V, 10%
C1347	283-0000-00			0.001 μ F, Cer, 500 V, +100%-0%
C1357	290-0267-00			1 μ F, Elect., 35 V
C1360	283-0000-00			0.001 μ F, Cer, 500 V, +100%-0%
C1369	290-0135-00			15 μ F, Elect., 20 V, 20%
C1391	283-0239-00	B010100	B079999	0.022 μ F, Cer, 50 V, 10%
C1391	283-0211-00	B080000		0.1 μ F, Cer, 200 V, 10%
C1405	283-0111-00	XB080000		0.1 μ F, Cer, 50 V, 20%
C1406	283-0000-00			0.001 μ F, Cer, 500 V, +100%-0%
C1435	283-0178-00			0.1 μ F, Cer, 100 V, +80%-20%
C1503	283-0108-00			220 pF, Cer, 200 V, 10%
C1505	283-0211-00			0.1 μ F, Cer, 200 V, 10%
C1507	283-0169-00			1.2 pF, Cer, 200 V, \pm 0.1 pF
C1587	283-0092-00			0.3 μ F, Cer, 200 V, +80%-20%
C1589	283-0178-00			0.1 μ F, Cer, 100 V, +80%-20%
C1591	283-0178-00			0.1 μ F, Cer, 100 V, +80%-20%
C1593	283-0178-00			0.1 μ F, Cer, 100 V, +80%-20%
C1595	283-0178-00			0.1 μ F, Cer, 100 V, +80%-20%
C1597	283-0178-00			0.1 μ F, Cer, 100 V, +80%-20%
C2101	283-0004-00			0.02 μ F, Cer, 150 V
C2109	283-0003-00			0.01 μ F, Cer, 150 V, +80%-20%
C2112	283-0077-00			330 pF, Cer, 500 V, 5%
C2115	290-0534-00			1 μ F, Elect., 35 V, 20%
C2117	290-0534-00			1 μ F, Elect., 35 V, 20%
C2119	290-0534-00			1 μ F, Elect., 35 V, 20%
C2121	283-0594-00			0.001 μ F, Mica, 100 V, 1%
C2135	285-0698-00			0.0082 μ F, PTM, 100 V, 5%
C2140	283-0103-00			180 pF, Cer, 500 V, 5%
C2144	281-0544-00			5.6 pF, Cer, 500 V, 10%
C2145	290-0534-00			1 μ F, Elect., 35 V, 20%
C2155	283-0103-00			180 pF, Cer, 500 V, 5%
C2183	283-0032-00			470 pF, Cer, 500 V, 5%
C2185	283-0004-00			0.02 μ F, Cer, 150 V
C2214	283-0032-00			470 pF, Cer, 500 V, 5%
C2242	283-0000-00			0.001 μ F, Cer, 500 V, +100%-0%
C2244	283-0004-00			0.02 μ F, Cer, 150 V
C2255	283-0000-00			0.001 μ F, Cer, 500 V, +100%-0%
C2281	283-0054-00	XB220000		150 pF, Cer, 200 V, 5%

ELECTRICAL PARTS LIST (cont)

Ckt. No.	Tektronix Part No.	Serial/Model No. Eff	Disc	Description
DIODES				
CR26	152-0141-02			Silicon, 1N4152
CR27	152-0141-02			Silicon, 1N4152
CR33	152-0141-02			Silicon, 1N4152
CR42	152-0141-02	B010100	B239999X	Silicon, 1N4152
CR44	152-0141-02	XB240000		Silicon, 1N4152
CR48	152-0141-02	XB240000		Silicon, 1N4152
CR84	152-0333-00			Silicon, FDH6012
CR85	152-0333-00			Silicon, FDH6012
CR93	152-0141-02			Silicon, 1N4152
CR124	152-0141-02			Silicon, 1N4152
CR125	152-0141-02			Silicon, 1N4152
CR126	152-0141-02			Silicon, 1N4152
CR130	152-0141-02			Silicon, 1N4152
CR140	152-0141-02			Silicon, 1N4152
CR155	152-0141-02			Silicon, 1N4152
CR160	152-0141-02			Silicon, 1N4152
CR238	152-0141-02			Silicon, 1N4152
CR341	152-0141-02			Silicon, 1N4152
CR349	152-0141-02			Silicon, 1N4152
CR460	152-0269-00			Silicon, Var. capacity 33 pF, 1N3182
CR461	152-0269-00			Silicon, Var. capacity 33 pF, 1N3182
CR496	152-0141-02			Silicon, 1N4152
CR530	152-0153-00			Silicon, FD7003 or CD5574
CR531	152-0141-02			Silicon, 1N4152
CR532	152-0141-02			Silicon, 1N4152
CR533	152-0153-00			Silicon, FD7003 or CD5574
CR543	152-0141-02			Silicon, 1N4152
CR544	152-0141-02			Silicon, 1N4152
CR549	152-0153-00			Silicon, FD7003 or CD5574
CR621	152-0141-02			Silicon, 1N4152
CR622	152-0141-02			Silicon, 1N4152
CR635	152-0141-02			Silicon, 1N4152
CR641	152-0141-02			Silicon, 1N4152
CR672	152-0141-02			Silicon, 1N4152
CR674	152-0141-02			Silicon, 1N4152
CR676	152-0141-02			Silicon, 1N4152
CR806	152-0488-00			Silicon, bridge, full wave, 1.5A, 200 V
CR808	152-0488-00			Silicon, bridge, full wave, 1.5A, 200 V
CR811	152-0406-00			Silicon, bridge, full wave, 3A, 250 V
CR820	152-0423-00			Silicon, MR1033B
CR821	152-0423-00			Silicon, MR1033B
CR852	152-0141-02			Silicon, 1N4152
CR861	152-0141-02			Silicon, 1N4152
CR867	152-0061-00			Silicon, CD8393 or FDH2161
CR868	152-0061-00			Silicon, CD8393 or FDH2161

ELECTRICAL PARTS LIST (cont)

Ckt. No.	Tektronix Part No.	Serial/Model No. Eff	Disc	Description
DIODES (cont)				
CR875	152-0066-00			Silicon, diffused, selected from 1N3194
CR883	152-0141-02			Silicon, 1N4152
CR885	152-0141-02			Silicon, 1N4152
CR888	152-0141-02			Silicon, 1N4152
CR891	152-0141-02			Silicon, 1N4152
CR894	152-0141-02			Silicon, 1N4152
CR896	152-0141-02			Silicon, 1N4152
CR903	152-0066-00			Silicon, diffused, selected from 1N3194
CR920	152-0141-02			Silicon, 1N4152
CR924	152-0061-00			Silicon, CD8393 or FDH2161
CR925	152-0061-00			Silicon, CD8393 or FDH2161
CR935	152-0066-00			Silicon, diffused, selected from 1N3194
CR941	152-0141-02			Silicon, 1N4152
CR950	152-0141-02			Silicon, 1N4152
CR951	152-0141-02			Silicon, 1N4152
CR952	152-0141-02			Silicon, 1N4152
CR958	152-0066-00			Silicon, diffused, selected from 1N3194
CR961	152-0141-02			Silicon, 1N4152
CR973	152-0061-00	XB060000		Silicon, CD8393 or FDH2161
CR980	152-0141-02			Silicon, 1N4152
CR981	152-0141-02			Silicon, 1N4152
CR989	152-0066-00			Silicon, diffused, selected from 1N3194
CR1021	152-0141-02			Silicon, 1N4152
CR1023	152-0141-02			Silicon, 1N4152
CR1024	152-0141-02			Silicon, 1N4152
CR1026	152-0141-02			Silicon, 1N4152
CR1028	152-0141-02			Silicon, 1N4152
CR1115	152-0153-00			Silicon, FD7003 or CD5574
CR1215	152-0141-02			Silicon, 1N4152
CR1226	152-0409-00			Silicon, VG-12X
CR1228	152-0409-00			Silicon, VG-12X
CR1232	152-0409-00			Silicon, VG-12X
CR1244	152-0141-02			Silicon, 1N4152
CR1253	152-0242-00			Silicon, selected from 1N486A
CR1254	152-0242-00			Silicon, selected from 1N486A
CR1255	152-0242-00			Silicon, selected from 1N486A
CR1258	152-0242-00			Silicon, selected from 1N486A
CR1264	152-0242-00			Silicon, selected from 1N486A
CR1268	152-0242-00			Silicon, selected from 1N486A
CR1269	152-0242-00			Silicon, selected from 1N486A
CR1270	152-0242-00			Silicon, selected from 1N486A
CR1318	152-0141-02			Silicon, 1N4152
CR1319	152-0141-02			Silicon, 1N4152
CR1325	152-0141-02			Silicon, 1N4152
CR1327	152-0141-02	B010100	B049999	Silicon, 1N4152
CR1327	152-0242-00	B050000		Silicon, selected from 1N486A
CR1329	152-0141-02	B010100	B049999	Silicon, 1N4152
CR1329	152-0242-00	B050000		Silicon, selected from 1N486A
CR1348	152-0141-02			Silicon, 1N4152
CR1349	152-0141-02			Silicon, 1N4152
CR1361	152-0141-02			Silicon, 1N4152
CR1362	152-0141-02			Silicon, 1N4152

ELECTRICAL PARTS LIST (cont)

Ckt. No.	Tektronix Part No.	Serial/Model No. Eff	Disc	Description
DIODES (cont)				
	CR1380	152-0141-02		Silicon, 1N4152
	CR1387	152-0141-02		Silicon, 1N4152
	CR1391	152-0141-02		Silicon, 1N4152
	CR1393	152-0141-02	B010100 B079999X	Silicon, 1N4152
	CR1394	152-0141-02		Silicon, 1N4152
	CR1395	152-0141-02		Silicon, 1N4152
	CR1396	152-0141-02	XB080000	Silicon, 1N4152
	CR1398	152-0141-02		Silicon, 1N4152
	CR1399	152-0141-02		Silicon, 1N4152
	CR1406	152-0141-02		Silicon, 1N4152
	CR1408	152-0141-02		Silicon, 1N4152
	CR1410	152-0141-02	XB080000	Silicon, 1N4152
	CR1412	152-0141-02	XB080000	Silicon, 1N4152
	CR1414	152-0141-02	XB080000	Silicon, 1N4152
	CR1418	152-0141-02		Silicon, 1N4152
	CR1419	152-0141-02		Silicon, 1N4152
	CR1424	152-0129-00		Germanium, 1N87A
	CR1430	152-0141-02		Silicon, 1N4152
	CR1431	152-0141-02		Silicon, 1N4152
	CR1434	152-0141-02		Silicon, 1N4152
	CR1442	152-0141-02		Silicon, 1N4152
	CR1448	152-0141-02		Silicon, 1N4152
	CR1454	152-0141-02		Silicon, 1N4152
	CR1456	152-0141-02		Silicon, 1N4152
	CR1462	152-0141-02	XB050000	Silicon, 1N4152
	CR1469	152-0141-02		Silicon, 1N4152
	CR1470	152-0141-02		Silicon, 1N4152
	CR1475	152-0141-02		Silicon, 1N4152
	CR1480	152-0141-02		Silicon, 1N4152
	CR1482	152-0141-02		Silicon, 1N4152
	CR1490	152-0141-02		Silicon, 1N4152
	CR1492	152-0141-02		Silicon, 1N4152
	CR1493	152-0141-02	XB080000	Silicon, 1N4152
	CR1495	152-0141-02		Silicon, 1N4152
	CR1503	152-0141-02		Silicon, 1N4152
	CR1513	152-0141-02		Silicon, 1N4152
	CR1525	152-0141-02		Silicon, 1N4152
	CR1534	152-0141-02		Silicon, 1N4152
	CR1535	152-0141-02		Silicon, 1N4152
	CR1537	152-0141-02		Silicon, 1N4152
	CR1538	152-0141-02		Silicon, 1N4152
	CR2124	152-0141-02		Silicon, 1N4152
	CR2125	152-0141-02		Silicon, 1N4152
	CR2127	152-0141-02		Silicon, 1N4152
	CR2140	152-0141-02		Silicon, 1N4152
	CR2141	152-0141-02		Silicon, 1N4152
	CR2142	152-0141-02		Silicon, 1N4152
	CR2145	152-0141-02		Silicon, 1N4152
	CR2146	152-0141-02		Silicon, 1N4152
	CR2156	152-0141-02		Silicon, 1N4152

ELECTRICAL PARTS LIST (cont)

Ckt. No.	Tektronix Part No.	Serial/Model No. Eff	Disc	Description
DIODES (cont)				
CR2157	152-0141-02			Silicon, 1N4152
CR2162	152-0141-02			Silicon, 1N4152
CR2163	152-0141-02			Silicon, 1N4152
CR2166	152-0141-02			Silicon, 1N4152
CR2167	152-0141-02			Silicon, 1N4152
CR2170	152-0141-02			Silicon, 1N4152
CR2171	152-0141-02			Silicon, 1N4152
CR2174	152-0141-02			Silicon, 1N4152
CR2175	152-0141-02			Silicon, 1N4152
CR2192	152-0141-02			Silicon, 1N4152
CR2193	152-0141-02			Silicon, 1N4152
CR2196	152-0141-02			Silicon, 1N4152
CR2198	152-0141-02			Silicon, 1N4152
CR2226	152-0141-02			Silicon, 1N4152
VR244	152-0243-00			Zener, 1N965B, 0.4 W, 15 V, 5%
VR254	152-0243-00			Zener, 1N965B, 0.4 W, 15 V, 5%
VR851	152-0283-00			Zener, 1N976B, 0.4 W, 43 V, 5%
VR890	152-0124-00			Zener, 1N938A, 0.5 W, 9 V, 5%
VR1142	152-0055-00			Zener, 1N962B, 0.4 W, 11 V, 5%
VR1258	152-0282-00			Zener, 1N972B, 0.4 W, 30 V, 5%
VR1264	152-0149-00			Zener, 1N961B, 0.4 W, 10 V, 5%
VR1379	152-0326-00			Zener, selected from 1N775A
VR2262	152-0405-00			Zener, 1N5567B, 1 W, 15 V, 5%
VR2263	152-0405-00			Zener, 1N5567B, 1 W, 15 V, 5%
VR2264	152-0405-00			Zener, 1N5567B, 1 W, 15 V, 5%
DELAY LINE				
DL400	119-0368-00			Delay line
BULBS				
DS1001	150-0121-02			Incandescent, 60 mA
DS1090	150-0029-00			Incandescent, GE #349
DS1091	150-0029-00			Incandescent, GE #349
DS1092	150-0029-00			Incandescent, GE #349
FUSES				
F814	159-0021-00			Cartridge, 2A, 3AG, fast-blo
F855	159-0083-00			Cartridge, 0.15A, 3AG, fast-blo
F1000	159-0026-00			Cartridge, 3.2A, 3AG, slo-blo
CONNECTORS				
J1	131-0767-02	B010100	B039999	Receptacle, electrical, 76 contact
J1	131-0767-08	B040000		Receptacle, electrical, 76 contact
J2	131-0767-02	B010100	B039999	Receptacle, electrical, 76 contact
J2	131-0767-08	B040000		Receptacle, electrical, 76 contact
J3	131-0767-00	B010100	B039999	Receptacle, electrical, 76 contact
J3	131-0767-07	B040000		Receptacle, electrical, 76 contact
J26	131-1003-00			Receptacle, coaxial cable
J27	131-1003-00			Receptacle, coaxial cable
J401	131-1003-00			Receptacle, coaxial cable

ELECTRICAL PARTS LIST (cont)

Ckt No.	Tektronix Part No.	Serial/Model No. Eff	Disc	Description
CONNECTORS (cont)				
J409	131-1003-00			Receptacle, coaxial cable
J431	131-1003-00			Receptacle, coaxial cable
J503	131-1003-00			Receptacle, coaxial cable
J508	131-1003-00			Receptacle, coaxial cable
J601	131-1003-00			Receptacle, coaxial cable
J603	131-1003-00			Receptacle, coaxial cable
J629	131-0955-00			Receptacle, electrical, BNC, female
J649	131-0955-00			Receptacle, electrical, BNC, female
J679	131-0955-00			Receptacle, electrical, BNC, female
J1047	131-0955-00			Receptacle, electrical, BNC, female
J1049	131-0955-00			Receptacle, electrical, BNC, female
J1050	131-0955-00			Receptacle, electrical, BNC, female
J1132	131-1003-00			Receptacle, coaxial cable
J2132	131-1003-00			Receptacle, coaxial cable
J2138	131-1003-00			Receptacle, coaxial cable
J2139	131-1003-00			Receptacle, coaxial cable
J2192	131-1003-00			Receptacle, coaxial cable
J2296	131-1003-00			Receptacle, coaxial cable
J2299	131-1003-00			Receptacle, coaxial cable
INDUCTORS				
L425	108-0707-00			150 nH
L474	114-0330-00			0.8-2 μ H, Var, Core 276-0568-00
L478	114-0330-00			0.8-2 μ H, Var, Core 276-0568-00
L1098 ¹	108-0605-00			Y Axis Alignment
L1099 ¹				
L1222	108-0646-00			80 μ H
L2283	108-0331-00			0.75 μ H
LR55	108-0245-00	XB210000		3.9 μ H
LR193	108-0604-00	B010100	B209999	3.2 μ H (wound on a 7.5 Ω , 1/4 W, 5%, res.)
LR193	108-0245-00	B210000		3.9 μ H (wound on a 7.5 Ω , 1/4 W, 5%, res.)
LR195	108-0604-00	B010100	B209999	3.2 μ H (wound on a 7.5 Ω , 1/4 W, 5%, res.)
LR195	108-0245-00	B210000		3.9 μ H (wound on a 7.5 Ω , 1/4 W, 5% res.)
LR198	108-0604-00	B010100	B209999	3.2 μ H (wound on a 7.5 Ω , 1/4 W, 5%, res.)
LR198	108-0245-00	B210000		3.9 μ H (wound on a 7.5 Ω , 1/4 W, 5%, res.)
LR482	108-0331-00			0.75 μ H (wound on a 120 Ω , 1/4 W, 5%, res.)
CONNECTOR				
P60	131-0589-00	XB240000		Connector, term. pin
TRANSISTORS				
Q90A,b	151-0232-00			Silicon, NPN, replaceable by 2N2919, dual
Q108	151-0199-00			Silicon, PNP, MPS3640
Q132	151-0199-00			Silicon, PNP, MPS3640
Q137	151-0223-00			Silicon, 2N4275
Q142	151-0199-00			Silicon, PNP, MPS3640
Q147	151-0223-00			Silicon, NPN, 2N4275
Q150	151-0223-00			Silicon, NPN, 2N4275
Q162	151-0199-00			Silicon, PNP, MPS3640
Q167	151-0223-00			Silicon, NPN, 2N4275
Q236A,B	151-0232-00			Silicon, NPN, replaceable by 2N2919, dual
Q238	151-0190-00			Silicon, NPN, 2N3904 or TE3904
Q242	151-0221-00			Silicon, PNP, 2N4258
Q252	151-0221-00			Silicon, PNP, 2N4258
Q314	151-0190-00			Silicon, NPN, 2N3904 or TE3904

¹ Furnished as a unit with DS400.

ELECTRICAL PARTS LIST (cont)

Ckt. No.	Tektronix Part No.	Serial/Model No. Eff	Disc	Description
TRANSISTORS (cont)				
Q334	151-0190-00			Silicon, NPN, 2N3904 or TE3904
Q336	151-0190-00			Silicon, NPN, 2N3904 or TE3904
Q344	151-0221-00			Silicon, PNP, 2N4258
Q346	151-0221-00			Silicon, PNP, 2N4258
Q407	151-0301-00			Silicon, PNP, 2N2907
Q415	151-0301-00			Silicon, PNP, 2N2907
Q496	151-0190-00			Silicon, NPN, 2N3904 or TE3904
Q539	151-0220-00			Silicon, PNP, 2N4122
Q547	151-0220-00			Silicon, PNP, 2N4122
Q551	151-0103-00			Silicon, NPN, 2N2219
Q553	151-0103-00			Silicon, NPN, 2N2219
Q558	151-0270-00	B010100	B019999	Silicon, PNP, selected from 2N3495
Q558	151-0406-00	B020000		Silicon, PNP, Tek Spec
Q560	151-0347-00			Silicon, NPN, 2N5551
Q578	151-0270-00	B010100	B019999	Silicon, PNP, selected from 2N3495
Q578	151-0406-00	B020000		Silicon, PNP, Tek Spec
Q580	151-0347-00			Silicon, NPN, 2N5551
Q606	151-0221-00			Silicon, PNP, 2N4258
Q618	151-0221-00			Silicon, PNP, 2N4258
Q620	151-0220-00			Silicon, PNP, 2N4122
Q631	151-0190-00			Silicon, NPN, 2N3904 or TE3904
Q634	151-0190-00			Silicon, NPN, 2N3904 or TE3904
Q640	151-0220-00			Silicon, PNP, 2N4122
Q662	151-0190-00			Silicon, NPN, 2N3904 or TE3904
Q666	151-0190-00			Silicon, NPN, 2N3904 or TE3904
Q672	151-0188-00			Silicon, PNP, 2N3906
Q827	151-0223-00			Silicon, NPN, 2N4275
Q829	151-0223-00			Silicon, NPN, 2N4275
Q835	151-0334-00			Silicon, NPN, MJE520
Q850	151-0337-00			Silicon, NPN, replaceable by 2N3055
Q852	151-0276-00			Silicon, PNP, 2N5087
Q860	151-0347-00			Silicon, NPN, 2N5551
Q863	151-0347-00			Silicon, NPN, 2N5551
Q869	151-0347-00			Silicon, NPN, 2N5551
Q872	151-0279-00			Silicon, NPN, SE7056
Q874	151-0336-00			Silicon, NPN, replaceable by 2N3055
Q876A,B	151-0232-00			Silicon, NPN, replaceable by 2N2919, dual
Q886A,B	151-0232-00			Silicon, NPN, replaceable by 2N2919, dual
Q896	151-0228-00			Silicon, PNP, selected from 2N4888
Q900	151-0347-00			Silicon, NPN, 2N5551
Q903	151-0336-00			Silicon, NPN, replaceable by 2N3055
Q908	151-0292-00			Silicon, NPN, A5T5058
Q909	151-0292-00			Silicon, NPN, A5T5058
Q910	151-0292-00			Silicon, NPN, A5T5058
Q919A,B	151-0232-00			Silicon, NPN, replaceable by 2N2919, dual
Q926	151-0347-00			Silicon, NPN, 2N5551
Q931	151-0260-02			Silicon, NPN, 2N5859
Q933	151-0337-00			Silicon, NPN, replaceable by 2N3055
Q936A,B	151-0232-00			Silicon, NPN, replaceable by 2N2919, dual
Q943A,B	151-0232-00			Silicon, NPN, replaceable by 2N2919, dual
Q952	151-0134-00			Silicon, PNP, 2N2905A
Q956	151-0260-02			Silicon, NPN, 2N5859
Q958	151-0337-00			Silicon, NPN, replaceable by 2N3055

ELECTRICAL PARTS LIST (cont)

Ckt No.	Grid Loc	Tektronix Part No.	Serial/Model No. Eff	Disc	Description
TRANSISTORS (cont)					
Q964A,B		151-0232-00			Silicon, NPN, replaceable by 2N2919, dual
Q985		151-0136-00			Silicon, NPN, 2N3053
Q988		151-0337-00			Silicon, NPN, replaceable by 2N3055
Q1061		151-0224-00			Silicon, NPN, 2N3692
Q1066		151-0224-00			Silicon, NPN, 2N3692
Q1070		151-0220-00			Silicon, PNP, 2N4122
Q1072		151-0220-00			Silicon, PNP, 2N4122
Q1107		151-0190-00			Silicon, NPN, 2N3904 or TE3904
Q1110		151-0188-00			Silicon, PNP, 2N3906
Q1118		151-0188-00			Silicon, PNP, 2N3906
Q1128		151-0188-00			Silicon, PNP, 2N3906
Q1132		151-0270-00	B010100	B019999	Silicon, PNP, selected from 2N3495
Q1132		151-0406-00	B020000		Silicon, PNP, Tek Spec
Q1134		151-0250-00	B010100	B019999	Silicon, NPN, replaceable by FPS5551M
Q1134		151-0347-00	B020000		Silicon, NPN, 2N5551
Q1136		151-0223-00			Silicon, NPN, 2N4275
Q1148		151-0188-00			Silicon, PNP, 2N3904
Q1152		151-0270-00	B010100	B019999	Silicon, PNP, selected from 2N3495
Q1152		151-0406-00	B020000		Silicon, PNP, Tek Spec
Q1154		151-0250-00	B010100	B019999	Silicon, NPN, replaceable by FPS5551M
Q1154		151-0347-00	B020000		Silicon, NPN, 2N5551
Q1156		151-0223-00	B010100	B199999	Silicon, NPN, 2N4275
Q1156		151-0195-00	B200000		Silicon, NPN, selected from MPS6515
Q1201		151-0126-00			Silicon, NPN, 2N2484
Q1206		151-0188-00			Silicon, PNP, 2N3906
Q1214		151-0136-00			Silicon, NPN, 2N3053
Q1216		151-0140-00	B010100	B089999	Silicon, NPN, selected from 2N3055
Q1216		151-0140-01	B090000	B159999	Silicon, NPN, selected from 2N3055
Q1216		151-0140-00	B160000		Silicon, NPN, selected from 2N3055
Q1218		151-0140-00	B010100	B089999	Silicon, NPN, selected from 2N3055
Q1218		151-0140-01	B090000	B159999	Silicon, NPN, selected from 2N3055
Q1218		151-0140-00	B160000		Silicon, NPN, selected from 2N3055
Q1329		151-0188-00			Silicon, PNP, 2N3906
Q1331		151-0190-00			Silicon, NPN, 2N3904 or TE3904
Q1336		151-0190-00			Silicon, NPN, 2N3904 or TE3904
Q1340		151-0190-00			Silicon, NPN, 2N3904 or TE3904
Q1345		151-0190-00			Silicon, NPN, 2N3904 or TE3904
Q1352		151-0190-00			Silicon, NPN, 2N3904 or TE3904
Q1357		151-0190-00			Silicon, NPN, 2N3904 or TE3904
Q1365		151-0190-00			Silicon, NPN, 2N3904 or TE3904
Q1369		151-0190-00			Silicon, NPN, 2N3904 or TE3904
Q1373		151-0190-00			Silicon, NPN, 2N3904 or TE3904
Q1378		151-0190-00			Silicon, NPN, 2N3904 or TE3904
Q1380		151-0195-00			Silicon, NPN, selected from MPS6515
Q1387		151-0195-00			Silicon, NPN, selected from MPS6515
Q1395		151-0188-00			Silicon, PNP, 2N3906
Q1401		151-0508-00			Silicon, programmable unijunction, 2N6027
Q1409		151-0126-00			Silicon, NPN, 2N2484
Q1411		151-0188-00			Silicon, PNP, 2N3906
Q1414		151-0190-00			Silicon, NPN, 2N3904 or TE3904
Q1423		151-0190-00			Silicon, NPN, 2N3904 or TE3904
Q1425		151-0347-00			Silicon, NPN, 2N5551
Q1432		151-0190-00			Silicon, NPN, 2N3904 or TE3904
Q1443		151-0190-00			Silicon, NPN, 2N3904 or TE3904

ELECTRICAL PARTS LIST (cont)

Ckt. No.	Tektronix Part No.	Serial/Model No. Eff	Disc	Description
TRANSISTORS (cont)				
Q1448	151-0347-00			Silicon, NPN, 2N5551
Q1449	151-0292-00			Silicon, NPN, A5T5058
Q1453	151-0190-00			Silicon, NPN, 2N3904 or TE3904
Q1458	151-0190-00			Silicon, NPN, 2N3904 or TE3904
Q1462	151-0190-00			Silicon, NPN, 2N3904 or TE3904
Q1467	151-0190-00			Silicon, NPN, 2N3904 or TE3904
Q1482	151-0190-00			Silicon, NPN, 2N3904 or TE3904
Q1494	151-0342-00			Silicon, PNP, 2N4249
Q1498	151-0342-00			Silicon, PNP, 2N4249
Q1502	151-0292-00			Silicon, NPN, A5T5058
Q1505	151-0292-00			Silicon, NPN, A5T5058
Q1512	151-0347-00			Silicon, NPN, 2N5551
Q1524	151-0347-00			Silicon, NPN, 2N5551
Q1538	151-0347-00			Silicon, NPN, 2N5551
Q1539	151-0292-00			Silicon, NPN, A5T5058
Q2108	151-0223-00			Silicon, NPN, 2N4275
Q2112	151-0221-00			Silicon, PNP, 2N4258
Q2138	151-0188-00			Silicon, PNP, 2N3906
Q2153	151-0192-00			Silicon, NPN, selected from MPS6521
Q2159	151-0190-00			Silicon, NPN, 2N3904 or TE3904
Q2215A,B	151-0232-00			Silicon, NPN, replaceable by 2N2919, dual
Q2223	151-0190-00			Silicon, NPN, 2N3904 or TE3904
Q2225	151-0188-00			Silicon, PNP, 2N3906
Q2229	151-0190-00			Silicon, NPN, 2N3904 or TE3904
Q2240	151-0190-00			Silicon, NPN, 2N3904 or TE3904
Q2286	151-0188-00			Silicon, PNP, 2N3906
Q2287	151-0188-00			Silicon, PNP, 2N3906
Q2296	151-0188-00			Silicon, PNP, 2N3906
Q2299	151-0188-00			Silicon, PNP, 2N3906
RESISTORS				
R12	321-0260-00			4.99 k Ω , 1/8 W, 1%
R14	321-0260-00			4.99 k Ω , 1/8 W, 1%
R20	315-0103-00			10 k Ω , 1/4 W, 5%
R21	315-0103-00			10 k Ω , 1/4 W, 5%
R26	315-0122-00	XB240000		1.2 k Ω , 1/4 W, 5%
R28	315-0510-00			51 Ω , 1/4 W, 5%
R29	315-0510-00			51 Ω , 1/4 W, 5%
R31	315-0122-00			1.2 k Ω , 1/4 W, 5%
R33	315-0682-00			6.8 k Ω , 1/4 W, 5%
R34	315-0122-00			1.2 k Ω , 1/4 W, 5%
R35	315-0122-00			1.2 k Ω , 1/4 W, 5%
R36	321-0231-00			2.49 k Ω , 1/8 W, 1%
R37	315-0152-00	XB240000		1.5 k Ω , 1/4 W, 5%
R38	315-0152-00			1.5 k Ω , 1/4 W, 5%
R39	315-0152-00			1.5 k Ω , 1/4 W, 5%
R42	315-0105-00			1 M Ω , 1/4 W, 5%
R44	315-0334-00	B010100	B239999	330 k Ω , 1/4 W, 5%
R44	315-0152-00	B240000		1.5 k Ω , 1/4 W, 5%

ELECTRICAL PARTS LIST (cont)

Ckt. No.	Tektronix Part No.	Serial/Model No. Eff	Disc	Description
RESISTORS (cont)				
R46	315-0151-00	B010100	B239999X	150 Ω, 1/4 W, 5%
R47	315-0683-00	B010100	B239999	68 kΩ, 1/4 W, 5%
R47	315-0243-00	B240000		24 kΩ, 1/4 W, 5%
R48	315-0334-00	B010100	B239999	330 kΩ, 1/4 W, 5%
R48	315-0152-00	B240000		1.5 kΩ, 1/4 W, 5%
R49	315-0105-00	B010100	B239999	1 MΩ, 1/4 W, 5%
R49	315-0104-00	B240000		100 kΩ, 1/4 W, 5%
R50	315-0223-00			22 kΩ, 1/4 W, 5%
R51	321-0193-00			1 kΩ, 1/8 W, 1%
R53	315-0223-00			22 kΩ, 1/4 W, 5%
R54	321-0193-00			1 kΩ, 1/8 W, 1%
R55	315-0470-00	B010100	B209999X	47 Ω, 1/4 W, 5%
R56	315-0471-00	B010100	B209999	470 Ω, 1/4 W, 5%
R56	321-0169-00	B210000		62 Ω, 1/8 W, 1%
R57	315-0682-00	B010100	B209999	562 Ω, 1/8 W, 1%
R57	321-0266-00	B210000		5.76 kΩ, 1/8 W, 1%
R58	315-0101-00			100 Ω, 1/4 W, 5%
R59	315-0103-00	B010100	B209999	10 kΩ, 1/4 W, 5%
R59	321-0282-00	B210000		8.45 kΩ, 1/8 W, 1%
R61	315-0512-00			5.1 kΩ, 1/4 W, 5%
R62	315-0103-00			10 kΩ, 1/4 W, 5%
R63	315-0102-00			1 kΩ, 1/4 W, 5%
R67	315-0512-00			5.1 kΩ, 1/4 W, 5%
R74	315-0510-00			51 Ω, 1/4 W, 5%
R76	315-0222-00			2.2 kΩ, 1/4 W, 5%
R77	315-0392-00	B010100	B209999	3.9 kΩ, 1/4 W, 5%
R77	315-0362-00	B210000		3.6 kΩ, 1/4 W, 5%
R78	315-0392-00			3.9 kΩ, 1/4 W, 5%
R80	321-0258-00			4.75 kΩ, 1/8 W, 1%
R82	315-0510-00			51 Ω, 1/4 W, 5%
R83	315-0510-00			51 Ω, 1/4 W, 5%
R84	315-0510-00			51 Ω, 1/4 W, 5%
R85	315-0471-00			470 Ω, 1/4 W, 5%
R86	315-0100-00			10 Ω, 1/4 W, 5%
R88	321-0230-00			2.43 kΩ, 1/8 W, 1%
R89	315-0910-00			91 Ω, 1/4 W, 5%
R90	315-0362-00			3.6 kΩ, 1/4 W, 5%
R92	321-0202-00			1.24 kΩ, 1/8 W, 1%
R93	315-0102-00			1 kΩ, 1/4 W, 5%
R95	315-0152-00			1.5 kΩ, 1/4 W, 5%
R96	315-0511-00			510 Ω, 1/4 W, 5%
R98	315-0511-00			510 Ω, 1/4 W, 5%
R99	315-0221-00			220 Ω, 1/4 W, 5%
R101	315-0302-00			3 kΩ, 1/4 W, 5%
R102A,B ¹	311-1404-00			2 x 5 kΩ, Var
R104	315-0103-00			10 kΩ, 1/4 W, 5%
R105	315-0472-00			4.7 kΩ, 1/4 W, 5%
R106	315-0273-00			27 kΩ, 1/4 W, 5%
R109	321-0243-00			3.32 kΩ, 1/8 W, 1%
R110	321-0097-00			100 Ω, 1/8 W, 1%
R112	321-0097-00			100 Ω, 1/8 W, 1%

¹Furnished as a unit with S102.

ELECTRICAL PARTS LIST (cont)

Ckt. No.	Tektronix Part No.	Serial/Model No. Eff	Disc	Description
RESISTORS (cont)				
R123	315-0102-00			1 k Ω , 1/4 W, 5%
R124	315-0511-00			510 Ω , 1/4 W, 5%
R125	315-0102-00			1 k Ω , 1/4 W, 5%
R126	315-0102-00			1 k Ω , 1/4 W, 5%
R130	315-0102-00			1 k Ω , 1/4 W, 5%
R132	315-0222-00			2.2 k Ω , 1/4 W, 5%
R133	315-0102-00			1 k Ω , 1/4 W, 5%
R134	315-0821-00			820 Ω , 1/4 W, 5%
R135	315-0123-00			12 k Ω , 1/4 W, 5%
R136	315-0681-00			680 Ω , 1/4 W, 5%
R137	315-0221-00			220 Ω , 1/4 W, 5%
R138	315-0472-00			4.7 k Ω , 1/4 W, 5%
R140	315-0391-00			390 Ω , 1/4 W, 5%
R141	315-0122-00			1.2 k Ω , 1/4 W, 5%
R142	315-0222-00			2.2 k Ω , 1/4 W, 5%
R143	315-0102-00			1 k Ω , 1/4 W, 5%
R144	315-0821-00			820 Ω , 1/4 W, 5%
R145	315-0123-00			12 k Ω , 1/4 W, 5%
R146	315-0681-00			680 Ω , 1/4 W, 5%
R147	315-0181-00			180 Ω , 1/4 W, 5%
R148	315-0472-00			4.7 k Ω , 1/4 W, 5%
R149	315-0100-00			10 Ω , 1/4 W, 5%
R150	315-0103-00			10 k Ω , 1/4 W, 5%
R152	315-0101-00			100 Ω , 1/4 W, 5%
R154	315-0223-00			22 k Ω , 1/4 W, 5%
R155	315-0391-00			390 Ω , 1/4 W, 5%
R157	315-0102-00			1 k Ω , 1/4 W, 5%
R159	315-0510-00			51 Ω , 1/4 W, 5%
R160	315-0391-00			390 Ω , 1/4 W, 5%
R161	315-0122-00			1.2 k Ω , 1/4 W, 5%
R162	315-0222-00			2.2 k Ω , 1/4 W, 5%
R163	315-0102-00			1 k Ω , 1/4 W, 5%
R164	315-0821-00			820 Ω , 1/4 W, 5%
R165	315-0123-00			12 k Ω , 1/4 W, 5%
R166	315-0681-00			680 Ω , 1/4 W, 5%
R168	315-0472-00			4.7 k Ω , 1/4 W, 5%
R200	321-1068-02			50.5 Ω , 1/8 W, 1/2%
R202	321-1068-02			50.5 Ω , 1/8 W, 1/2%
R204	321-1068-02			50.5 Ω , 1/8 W, 1/2%
R206	321-1068-02			50.5 Ω , 1/8 W, 1/2%
R208	315-0393-00			39 k Ω , 1/4 W, 5%
R209	321-0741-02			40.9 Ω , 1/8 W, 1/2%
R211	322-0197-00			1.1 k Ω , 1/4 W, 1%
R212	321-0741-02			40.9 Ω , 1/8 W, 1/2%

ELECTRICAL PARTS LIST (cont)

Ckt. No.	Tektronix Part No.	Serial/Model No. Eff	Disc	Description
RESISTORS (cont)				
R214	322-0212-00			1.58 kΩ, 1/4 W, 1%
R215	315-0393-00			39 kΩ, 1/4 W, 5%
R216	321-0741-02			40.9 Ω, 1/8 W, 1/2%
R218	322-0197-00			1.1 kΩ, 1/4 W, 1%
R219	321-0741-02			40.9 Ω, 1/8 W, 1/2%
R222	315-0330-00			33 Ω, 1/4 W, 5%
R224	315-0330-00			33 Ω, 1/4 W, 5%
R225	315-0911-00			910 Ω, 1/4 W, 5%
R226	321-0069-00			51.1 Ω, 1/8 W, 1%
R228	321-0060-00			41.2 Ω, 1/8 W, 1%
R230	321-0236-00			2.8 kΩ, 1/8 W, 1%
R232	321-0060-00			41.2 Ω, 1/8 W, 1%
R234	321-0069-00			51.1 Ω, 1/8 W, 1%
R236	315-0911-00			910 Ω, 1/4 W, 5%
R238	315-0912-00			9.1 kΩ, 1/4 W, 5%
R240	323-0149-00			348 Ω, 1/2 W, 1%
R241	321-0212-00			1.58 kΩ, 1/8 W, 1%
R246	315-0331-00			330 Ω, 1/4 W, 5%
R250	323-0149-00			348 Ω, 1/2 W, 1%
R251	321-0212-00			1.58 kΩ, 1/8 W, 1%
R259	321-0069-00			51.1 Ω, 1/8 W, 1%
R261	321-0069-00			51.1 Ω, 1/8 W, 1%
R301	307-0106-00			4.7 Ω, 1/4 W, 5%
R303	307-0106-00			4.7 Ω, 1/4 W, 5%
R305	307-0103-00			2.7 Ω, 1/4 W, 5%
R307	321-0069-00			51.1 Ω, 1/8 W, 1%
R308	321-0069-00			51.1 Ω, 1/8 W, 1%
R310	315-0103-00			10 kΩ, 1/4 W, 5%
R312	315-0562-00			5.6 kΩ, 1/4 W, 5%
R314	315-0103-00			10 kΩ, 1/4 W, 5%
R315	315-0513-00			51 kΩ, 1/4 W, 5%
R317	321-0069-00			51.1 Ω, 1/8 W, 1%
R319	321-0069-00			51.1 Ω, 1/8 W, 1%
R320	321-0218-00			1.82 kΩ, 1/8 W, 1%
R321	321-0061-00			42.2 Ω, 1/8 W, 1%
R322	315-0101-00			100 Ω, 1/4 W, 5%
R323	321-0061-00			42.2 Ω, 1/8 W, 1%
R324	322-0184-00			806 Ω, 1/4 W, 1%
R326	321-0061-00			42.2 Ω, 1/8 W, 1%
R327	322-0184-00			806 Ω, 1/4 W, 1%
R328	321-0061-00			42.2 Ω, 1/8 W, 1%
R329	315-0101-00			100 Ω, 1/4 W, 5%
R330	321-0049-00			31.6 Ω, 1/8 W, 1%
R332	321-0220-00			1.91 kΩ, 1/8 W, 1%
R333	321-0143-00			301 Ω, 1/8 W, 1%
R334	321-0082-00			69.8 Ω, 1/8 W, 1%
R335	321-0049-00			31.6 Ω, 1/8 W, 1%
R336	321-0129-00			215 Ω, 1/8 W, 1%
R337	321-0129-00			215 Ω, 1/8 W, 1%

ELECTRICAL PARTS LIST (cont)

Ckt. No.	Tektronix Part No.	Serial/Model No. Eff	Disc	Description
RESISTORS (cont)				
R338	321-0069-00			51.1 Ω , 1/8 W, 1%
R339	321-0069-00			51.1 Ω , 1/8 W, 1%
R340	321-0214-00			1.65 k Ω , 1/8 W, 1%
R341	315-0680-00			68 Ω , 1/4 W, 5%
R342	315-0331-00			330 Ω , 1/4 W, 5%
R344	321-0040-00			25.5 Ω , 1/8 W, 1%
R345	315-0561-00			560 Ω , 1/4 W, 5%
R346	321-0040-00			25.5 Ω , 1/8 W, 1%
R348	315-0331-00			330 Ω , 1/4 W, 5%
R349	315-0680-00			68 Ω , 1/4 W, 5%
R350	321-0214-00			1.65 k Ω , 1/8 W, 1%
R352	315-0430-00			43 Ω , 1/4 W, 5%
R401	321-0068-00			49.9 Ω , 1/8 W, 1%
R403	311-1228-00			10 k Ω , Var
R404	321-0326-00			24.3 k Ω , 1/8 W, 1%
R405	321-0322-00			22.1 k Ω , 1/8 W, 1%
R407	321-0306-00			15 k Ω , 1/8 W, 1%
R408	321-0230-00			2.43 k Ω , 1/8 W, 1%
R409	323-0237-00			2.87 k Ω , 1/2 W, 1%
R411	321-0236-00			2.8 k Ω , 1/8 W, 1%
R413	323-0237-00			2.87 k Ω , 1/2 W, 1%
R414	321-0230-00			2.43 k Ω , 1/8 W, 1%
R415	315-0153-00			15 k Ω , 1/4 W, 5%
R416	315-0911-00			910 Ω , 1/4 W, 5%
R417	315-0301-00			300 Ω , 1/4 W, 5%
RT417	307-0125-00			500 Ω , Thermal
R418	315-0751-00			750 Ω , 1/4 W, 5%
R420	315-0271-00			270 Ω , 1/4 W, 5%
R421	311-1261-00			500 Ω , Var
R423	317-0470-00			47 Ω , 1/8 W, 5%
R424	317-0470-00			47 Ω , 1/8 W, 5%
R425	311-1260-00			250 Ω , Var
R427	311-1007-00			20 Ω , Var
R429	321-0114-00			150 Ω , 1/8 W, 1%
R433	321-0068-00			49.9 Ω , 1/8 W, 1%
R440	321-0181-00			750 Ω , 1/8 W, 1%
R442	321-0092-00			88.7 k Ω , 1/8 W, 1%
R443	321-0201-00			1.21 k Ω , 1/8 W, 1%
R444	321-0092-00			88.7 Ω , 1/8 W, 1%
R446	321-0097-00			100 Ω , (nominal value), selected
R447	311-1260-00			250 Ω , Var
R448	321-0097-00			100 Ω , (nominal value), selected
R450	321-0181-00			750 Ω , 1/8 W, 1%
R452	323-0148-00			340 Ω , 1/2 W, 1%
R453	323-0148-00			340 Ω , 1/2 W, 1%

ELECTRICAL PARTS LIST (cont)

Ckt. No.	Tektronix Part No.	Serial/Model No. Eff	Disc	Description
RESISTORS (cont)				
R455	311-0635-00			1 k Ω , Var
R456	315-0181-00	B010100	B019999	180 Ω , 1/4 W, 5%
R456	315-0181-00	B020000		180 Ω , (nominal value), selected
R457	Selected			
R458	315-0161-00	B010100	B019999	160 Ω , 1/4 W, 5%
R458	315-0161-00	B020000		160 Ω , (nominal value), selected
R459	301-0471-00			470 Ω , 1/4 W, 5%
R460	315-0510-00			51 Ω , 1/4 W, 5%
R461	315-0824-00			820 k Ω , 1/4 W, 5%
RT461	307-0181-00			100 k Ω , Thermal
R462	323-0148-00			340 Ω , 1/2 W, 1%
R463	323-0148-00			340 Ω , 1/2 W, 1%
R465	311-0635-00			1 k Ω , Var
R466	315-0271-00	B010100	B019999	270 Ω , 1/4 W, 5%
R466	315-0271-00	B020000		270 Ω , (nominal value), selected
R467	Selected			
R468	315-0301-00	B010100	B019999	300 Ω , 1/4 W, 5%
R468	315-0301-00	B020000		300 Ω , (nominal value), selected
R473	315-0820-00			82 Ω , 1/4 W, 5%
R474	310-0701-00			430 Ω , 8 W, 1%
R477	315-0820-00			82 Ω , 1/4 W, 5%
R478	310-0701-00			430 Ω , 8 W, 1%
R480	307-0103-00			2.7 Ω , 1/4 W, 5%
R484	321-0197-00			1.1 k Ω , 1/8 W, 1%
R486	311-1260-00			250 Ω , Var
R488	323-0054-00			35.7 Ω , 1/2 W, 1%
R490	307-0103-00			2.7 Ω , 1/4 W, 5%
R491	315-0100-00			10 Ω , 1/4 W, 5%
R495	315-0822-00			8.2 k Ω , 1/4 W, 5%
R501	321-1068-01			50.5 Ω , 1/8 W, 1/2%
R502	315-0100-00			10 Ω , 1/4 W, 5%
R503	321-1068-01			50.5 Ω , 1/8 W, 1/2%
R505	321-0297-00			12.1 k Ω , 1/8 W, 1%
R506	321-0069-00			51.1 Ω , 1/8 W, 1%
R508	321-0184-00			806 Ω , 1/4 W, 1%
R509	321-0069-00			51.1 Ω , 1/8 W, 1%
R511	321-0155-00			402 Ω , 1/8 W, 1%
R512	311-1224-00			500 Ω , Var
R513	321-0136-00			255 Ω , 1/8 W, 1%
R514	323-0219-00			1.87 k Ω , 1/2 W, 1%
R515	323-0219-00			1.87 k Ω , 1/2 W, 1%
R517	321-0212-00			1.58 k Ω , 1/8 W, 1%
R519	321-0108-00	B010100	B029999	130 Ω , 1/8 W, 1%
R519	321-0108-00	B030000		130 Ω , (nominal value), selected
R520 ¹		B010100	B019999X	
R521	321-0261-00			5.11 k Ω , 1/8 W, 1%
R522	321-0261-00			5.11 k Ω , 1/8 W, 1%
R524	321-0202-00			1.24 k Ω , 1/8 W, 1%
R525	311-1222-00			100 Ω , Var
R526	321-0202-00			1.24 k Ω , 1/8 W, 1%
R527	315-0222-00	B010100	B019999X	2.2 k Ω , 1/4 W, 5%
R529	315-0473-00			47 k Ω , 1/4 W, 5%
R531	323-0222-00			2 k Ω , 1/2 W, 1%
R532	323-0222-00			2 k Ω , 1/2 W, 1%

¹Added if necessary.

ELECTRICAL PARTS LIST (cont)

Ckt. No.	Tektronix Part No.	Serial/Model No. Eff	Disc	Description
RESISTORS (cont)				
R534	321-0269-00			6.19 k Ω , 1/8 W, 1%
R535	311-1225-00			1 k Ω , Var
R536	321-0269-00			6.19 k Ω , 1/8 W, 1%
R538	321-0320-00			21 k Ω , 1/8 W, 1%
R540	321-0225-00			2.15 k Ω , 1/8 W, 1%
R542	315-0300-00			30 Ω , 1/4 W, 5%
R543	321-0193-00			1 k Ω , 1/8 W, 1%
R544	315-0300-00			30 Ω , 1/4 W, 5%
R546	321-0320-00			21 k Ω , 1/8 W, 1%
R548	321-0225-00			2.15 k Ω , 1/8 W, 1%
R549	315-0102-00			1 k Ω , 1/4 W, 5%
R551	303-0470-00			47 Ω , 1 W, 5%
R555	315-0470-00			47 Ω , 1/4 W, 5%
R556	301-0393-00			39 k Ω , 1/2 W, 5%
R558	323-0231-00			2.49 k Ω , 1/2 W, 1%
R559	315-0100-00			10 Ω , 1/4 W, 5%
R561	315-0100-00			10 Ω , 1/4 W, 5%
R562	323-0097-00			100 Ω , 1/2 W, 1%
R563	323-0066-00			47.5 Ω , 1/2 W, 1%
R565	315-0101-00			100 Ω , 1/4 W, 5%
R566	323-0287-00			9.53 k Ω , 1/2 W, 1%
R567	323-0287-00			9.53 k Ω , 1/2 W, 1%
R568	315-0471-00	B010100	B019999X	470 Ω , 1/4 W, 5%
R569	321-0189-00			909 Ω , 1/8 W, 1%
R570	321-0251-00			4.02 k Ω , 1/8 W, 1%
R571	321-0830-03			2.41 k Ω , 1/8 W, 1/4%
R573	321-0273-00			6.81 k Ω , 1/8 W, 1%
R574	323-0352-00			45.3 k Ω , 1/2 W, 1%
R575	315-0470-00			47 Ω , 1/4 W, 5%
R576	301-0393-00			39 k Ω , 1/2 W, 5%
R578	323-0231-00			2.49 k Ω , 1/2 W, 1%
R579	315-0100-00			10 Ω , 1/4 W, 5%
R581	315-0100-00			10 Ω , 1/4 W, 5%
R582	323-0097-00			100 Ω , 1/2 W, 1%
R583	323-0066-00			47.5 Ω , 1/2 W, 1%
R584	315-0185-00	XB070000		1.8 M Ω , 1/4 W, 5%
R585	315-0101-00			100 Ω , 1/4 W, 5%
R586	323-0287-00			9.53 k Ω , 1/2 W, 1%
R587	323-0287-00			9.53 k Ω , 1/2 W, 1%
R588	315-0471-00	B010100	B019999X	470 Ω , 1/4 W, 5%
R589	321-0189-00			909 Ω , 1/8 W, 1%
R593	315-0100-00			10 Ω , 1/4 W, 5%
R595	307-0106-00			4.7 Ω , 1/4 W, 5%

ELECTRICAL PARTS LIST (cont)

Ckt. No.	Tektronix Part No.	Serial/Model No. Eff	Disc	Description
RESISTORS (cont)				
R597	315-0100-00			10 Ω , 1/4 W, 5%
R599	307-0103-00			2.7 Ω , 1/4 W, 5%
R602	315-0101-00			100 Ω , 1/4 W, 5%
R605	315-0561-00			560 Ω , 1/4 W, 5%
R607	321-0020-00			15.8 Ω , 1/2 W, 1%
R608	321-0089-00			82.5 Ω , 1/8 W, 1%
R610	307-0106-00			4.7 Ω , 1/4 W, 5%
R612	321-0193-00			1 k Ω , 1/8 W, 1%
R613	321-0222-00			2 k Ω , 1/8 W, 1%
R615	315-0240-00			24 Ω , 1/4 W, 5%
R617	321-0020-00			15.8 Ω , 1/8 W, 1%
R619	315-0101-00			100 Ω , 1/4 W, 5%
R622	321-0208-00			1.43 k Ω , 1/8 W, 1%
R623	307-0106-00			4.7 Ω , 1/4 W, 5%
R625	321-0224-00			2.1 k Ω , 1/8 W, 1%
R627	315-0101-00			100 Ω , 1/4 W, 5%
R630	315-0101-00			100 Ω , 1/4 W, 5%
R633	315-0222-00			2.2 k Ω , 1/4 W, 5%
R636	315-0241-00			240 Ω , 1/4 W, 5%
R637	315-0152-00			1.5 k Ω , 1/4 W, 5%
R639	315-0101-00			100 Ω , 1/4 W, 5%
R641	315-0272-00			2.7 k Ω , 1/4 W, 5%
R643	315-0220-00			22 Ω , 1/4 W, 5%
R645	321-0260-00			4.99 k Ω , 1/8 W, 1%
R647	321-0190-00			931 Ω , 1/8 W, 1%
R651	315-0201-00			200 Ω , 1/4 W, 5%
R652	315-0123-00			12 k Ω , 1/4 W, 5%
R654	315-0201-00			200 Ω , 1/4 W, 5%
R655	315-0123-00			12 k Ω , 1/4 W, 5%
R657	315-0201-00			200 Ω , 1/4 W, 5%
R658	315-0123-00			12 k Ω , 1/4 W, 5%
R660	315-0101-00			100 Ω , 1/4 W, 5%
R662	315-0821-00			820 Ω , 1/4 W, 5%
R663	321-0193-00			1 k Ω , 1/8 W, 1%
R667	315-0561-00			560 Ω , 1/4 W, 5%
R669	307-0106-00			4.7 Ω , 1/4 W, 5%
R670	321-0143-00			301 Ω , 1/8 W, 1%
R672	321-0180-00			732 Ω , 1/8 W, 1%
R673	321-0226-00			2.21 k Ω , 1/8 W, 1%
R675	321-0189-00			909 Ω , 1/8 W, 1%
R677	315-0390-00			39 Ω , 1/4 W, 5%
R679	307-0106-00			4.7 Ω , 1/4 W, 5%
R805	307-0113-00	B010100	B219999X	5.1 Ω , 1/4 W, 5%
R806	302-0473-00			47 k Ω , 1/2 W, 10%
R808	302-0223-00			22 k Ω , 1/2 W, 10%

ELECTRICAL PARTS LIST (cont)

Ckt. No.	Tektronix Part No.	Serial/Model No. Eff	Disc	Description
RESISTORS (cont)				
R809	302-0223-00			22 kΩ, 1/2 W, 10%
R811	302-0472-00			4.7 kΩ, 1/2 W, 10%
R814	302-0472-00			4.7 kΩ, 1/2 W, 10%
R821	302-0472-00			4.7 kΩ, 1/2 W, 10%
R822	315-0102-00			1 kΩ, 1/4 W, 5%
R823	315-0151-00			150 Ω, 1/4 W, 5%
R824	315-0470-00			47 Ω, 1/4 W, 5%
R826	315-0302-00			3 kΩ, 1/4 W, 5%
R827	315-0472-00			4.7 kΩ, 1/4 W, 5%
R830	315-0911-00			910 Ω, 1/4 W, 5%
R831	315-0392-00			3.9 kΩ, 1/4 W, 5%
R833	315-0683-00			68 kΩ, 1/4 W, 5%
R837	307-0054-00			3.6 Ω, 1/2 W, 5%
R838	307-0054-00			3.6 Ω, 1/2 W, 5%
R853	315-0473-00			47 kΩ, 1/4 W, 5%
R855	323-0309-00			16.2 kΩ, 1/2 W, 1%
R856	323-0289-00			10 kΩ, 1/2 W, 1%
R858	321-0924-07			40 kΩ, 1/8 W, 1/10%
R859	321-0924-07			40 kΩ, 1/8 W, 1/10%
R860	315-0684-00			680 kΩ, 1/4 W, 5%
R862	315-0204-00			200 kΩ, 1/4 W, 5%
R864	315-0203-00			20 kΩ, 1/4 W, 5%
R866	315-0332-00			3.3 kΩ, 1/4 W, 5%
R867	315-0824-00			820 kΩ, 1/4 W, 5%
R870	315-0122-00			1.2 kΩ, 1/4 W, 5%
R872	315-0151-00			150 Ω, 1/4 W, 5%
R875	308-0677-00			1 Ω, 2 W, WW, 5%
R876	315-0154-00			150 kΩ, 1/4 W, 5%
R877	315-0511-00			510 Ω, 1/4 W, 5%
R878	315-0104-00			100 kΩ, 1/4 W, 5%
R879	315-0124-00			120 kΩ, 1/4 W, 5%
R880	323-0272-00			6.65 kΩ, 1/2 W, 1%
R881	311-1223-00			250 Ω, Var
R882	323-0206-00			1.37 kΩ, 1/2 W, 1%
R883	321-0223-00			2.05 kΩ, 1/8 W, 1%
R884	323-0306-00			15 kΩ, 1/2 W, 1%
R886	315-0224-00			220 kΩ, 1/4 W, 5%
R889	315-0911-00			910 Ω, 1/4 W, 5%
R890	323-0264-00			5.49 kΩ, 1/2 W, 1%
R891	315-0473-00			47 kΩ, 1/4 W, 5%
R892	315-0682-00			6.8 kΩ, 1/4 W, 5%
R894	315-0245-00			2.4 MΩ, 1/4 W, 5%
R896	301-0363-00			36 kΩ, 1/2 W, 5%
R898	315-0182-00			1.8 kΩ, 1/4 W, 5%
R901	315-0151-00			150 Ω, 1/4 W, 5%
R903	308-0677-00			1 Ω, 2 W, WW, 5%
R904	308-0679-00			0.51 Ω, 2 W, WW, 5%
R906	315-0304-00			300 kΩ, 1/4 W, 5%
R907	315-0104-00	B010100	B209999	100 kΩ, 1/4 W, 5%
R907	315-0753-00	B210000		75 kΩ, 1/4 W, 5%

ELECTRICAL PARTS LIST (cont)

Ckt. No.	Tektronix Part No.	Serial/Model No. Eff	Disc	Description
RESISTORS (cont)				
R908	315-0431-00			430 Ω , 1/4 W, 5%
R910	315-0681-00			680 Ω , 1/4 W, 5%
R911	315-0563-00			56 k Ω , 1/4 W, 5%
R912	315-0182-00			1.8 k Ω , 1/4 W, 5%
R915	321-1296-07			12 k Ω , 1/8 W, 1/10%
R916	321-0924-07			40 k Ω , 1/8 W, 1/10%
R918	301-0683-00			68 k Ω , 1/2 W, 5%
R921	315-0912-00			9.1 k Ω , 1/4 W, 5%
R922	315-0623-00			62 k Ω , 1/4 W, 5%
R923	315-0512-00			5.1 k Ω , 1/4 W, 5%
R924	315-0623-00			62 k Ω , 1/4 W, 5%
R927	315-0472-00			4.7 k Ω , 1/4 W, 5%
R932	315-0182-00			1.8 k Ω , 1/4 W, 5%
R935	308-0678-00			0.1 Ω 2 W, WW, 5%
R936	301-0273-00			27 k Ω , 1/2 W, 5%
R937	315-0361-00	B010100	B189999	360 Ω , 1/4 W, 5%
R937	321-0151-00	B190000		365 Ω , 1/8 W, 1%
R938	315-0303-00	B010100	B189999	30 k Ω , 1/4 W, 5%
R938	321-0330-00	B190000		26.7 k Ω , 1/8 W, 1%
R939	315-0184-00	B010100	B189999	180 k Ω , 1/4 W, 5%
R939	321-0409-00	B190000		178 k Ω , 1/8 W, 1%
R940	315-0822-00			8.2 k Ω , 1/4 W, 5%
R942	315-0154-00			150 k Ω , 1/4 W, 5%
R945	321-0332-07			28 k Ω , 1/8 W, 1/10%
R946	321-1296-07			12 k Ω , 1/8 W, 1/10%
R948	315-0914-00			910 k Ω , 1/4 W, 5%
R950	315-0681-00			680 Ω , 1/4 W, 5%
R952	301-0303-00			30 k Ω , 1/2 W, 5%
R954	315-0472-00			4.7 k Ω , 1/4 W, 5%
R956	307-0103-00			2.7 Ω , 1/4 W, 5%
R957	315-0151-00			150 Ω , 1/4 W, 5%
R958	308-0678-00			0.1 Ω , 2 W, WW, 5%
R959	308-0680-00			0.45 Ω , 3 W, WW, 10%
R961	315-0221-00			220 Ω , 1/4 W, 5%
R963	315-0682-00			6.8 k Ω , 1/4 W, 5%
R966	315-0123-00			12 k Ω , 1/4 W, 5%
R967	315-0364-00			360 k Ω , 1/4 W, 5%
R970	321-0926-07			4 k Ω , 1/8 W, 1/10%
R971	321-0924-07			40 k Ω , 1/8 W, 1/10%
R973	315-0104-00	B010100	B059999	100 k Ω , 1/4 W, 5%
R973	315-0683-00	B060000		68 k Ω , 1/4 W, 5%
R974	315-0303-00	XB060000		30 k Ω , 1/4 W, 5%
R975	315-0362-00			3.6 k Ω , 1/4 W, 5%
R977	315-0184-00			180 k Ω , 1/4 W, 5%
R979	315-0822-00			8.2 k Ω , 1/4 W, 5%
R980	315-0164-00			160 k Ω , 1/4 W, 5%
R983	315-0472-00			4.7 k Ω , 1/4 W, 5%
R985	304-0470-00			47 Ω , 1 W, 10%

ELECTRICAL PARTS LIST (cont)

Ckt. No.	Tektronix Part No.	Serial/Model No. Eff	Disc	Description
RESISTORS (cont)				
R986	315-0122-00			1.2 k Ω , 1/4 W, 5%
R989	308-0678-00			0.1 Ω , 2 W, WW, 5%
R991	315-0753-00			75 k Ω , 1/4 W, 5%
R993	315-0241-00			240 Ω , 1/4 W, 5%
R994	315-0124-00			120 k Ω , 1/4 W, 5%
R995	315-0562-00			5.6 k Ω , 1/4 W, 5%
R1018	315-0102-00			1 k Ω , 1/4 W, 5%
R1019	315-0102-00			1 k Ω , 1/4 W, 5%
R1020	315-0150-00			15 Ω , 1/4 W, 5%
R1022	315-0303-00			30 k Ω , 1/4 W, 5%
R1045	311-0125-00	B010100	B039999	50 k Ω , Var
R1045	311-1529-00	B040000		50 k Ω , Var
R1061	315-0223-00			22 k Ω , 1/4 W, 5%
R1062	315-0362-00			3.6 k Ω , 1/4 W, 5%
R1063	315-0433-00			43 k Ω , 1/4 W, 5%
R1066	315-0183-00			18 k Ω , 1/4 W, 5%
R1067	315-0513-00			51 k Ω , 1/4 W, 5%
R1069	315-0433-00			43 k Ω , 1/4 W, 5%
R1071	323-0260-00			4.99 k Ω , 1/2 W, 1%
R1073	315-0222-00			2.2 k Ω , 1/4 W, 5%
R1074	315-0102-00			1 k Ω , 1/4 W, 5%
R1076	315-0752-00			7.5 k Ω , 1/4 W, 5%
R1077	311-1227-00			5 k Ω , Var
R1079	321-0318-00			20 k Ω , 1/8 W, 1%
R1081	321-0812-07			455 Ω , 1/8 W, 1/10%
R1082	321-0825-03			50.8 Ω , 1/8 W, 1/4%
R1084	321-0816-07			5 k Ω , 1/8 W, 1/10%
R1085	321-1068-07			50.5 Ω , 1/8 W, 1/10%
R1087 ¹	308-0679-00			0.51 Ω , 2 W, WW, 5%
R1095 ¹	311-1055-00			5 k Ω , Var
R1101	315-0470-00			47 Ω , 1/4 W, 5%
R1103	315-0471-00			470 Ω , 1/4 W, 5%
R1105	315-0103-00			10 k Ω , 1/4 W, 5%
R1106	315-0123-00			12 k Ω , 1/4 W, 5%
R1108	315-0471-00			470 Ω , 1/4 W, 5%
R1111	321-0233-00			2.61 k Ω , 1/8 W, 1%
R1113	315-0102-00			1 k Ω , 1/4 W, 5%
R1114	315-0511-00			510 Ω , 1/4 W, 5%
R1115	315-0121-00			120 Ω , 1/4 W, 5%
R1116	311-1248-00			500 Ω , Var
R1119	315-0102-00			1 k Ω , 1/4 W, 5%
R1120	301-0563-00			56 k Ω , 1/2 W, 5%
R1121	311-1237-00			1 k Ω , Var
R1122	315-0912-00			9.1 k Ω , 1/4 W, 5%
R1124	315-0562-00			5.6 k Ω , 1/4 W, 5%
R1126	303-0203-00			20 k Ω , 1 W, 5%
R1128	315-0102-00			1 k Ω , 1/4 W, 5%

¹Furnished as a unit with S1030.

ELECTRICAL PARTS LIST (cont)

Ckt. No.	Tektronix Part No.	Serial/Model No. Eff	Disc	Description
RESISTORS (cont)				
R1129	315-0102-00			1 kΩ, 1/4 W, 5%
R1131	315-0100-00			10 kΩ, 1/4 W, 5%
R1132	315-0392-00			3.9 kΩ, 1/4 W, 5%
R1135	315-0103-00			10 kΩ, 1/4 W, 5%
R1137	315-0121-00			120 Ω, 1/4 W, 5%
R1138	315-0682-00			6.8 kΩ, 1/4 W, 5%
R1139	323-0312-00			17.4 kΩ, 1/2 W, 1%
R1141	315-0912-00			9.1 kΩ, 1/4 W, 5%
R1144	315-0562-00			5.6 kΩ, 1/4 W, 5%
R1146	303-0203-00			20 kΩ, 1 W, 5%
R1148	315-0102-00			1 kΩ, 1/4 W, 5%
R1149	315-0102-00			1 kΩ, 1/4 W, 5%
R1151	315-0100-00			10 Ω, 1/4 W, 5%
R1152	315-0392-00			3.9 kΩ, 1/4 W, 5%
R1155	315-0103-00			10 kΩ, 1/4 W, 5%
R1157	315-0121-00			120 Ω, 1/4 W, 5%
R1158	315-0392-00			3.9 kΩ, 1/4 W, 5%
R1159	323-0312-00			17.4 kΩ, 1/2 W, 1%
R1181	311-1227-00			5 kΩ, Var
R1184	311-1235-00			100 kΩ, Var
R1187	315-0363-00			36 kΩ, 1/4 W, 5%
R1188	315-0822-00			8.2 kΩ, 1/4 W, 5%
R1190	311-1227-00			5 kΩ, Var
R1193	311-1235-00			100 kΩ, Var
R1195	315-0183-00	B010100	B089999	18 kΩ, 1/4 W, 5%
R1195	315-0362-00	B090000		3.6 kΩ, 1/4 W, 5%
R1196	315-0183-00	B010100	B089999	18 kΩ, 1/4 W, 5%
R1196	315-0362-00	B090000		3.6 kΩ, 1/4 W, 5%
R1202	315-0102-00			1 kΩ, 1/4 W, 5%
R1204	315-0474-00			470 kΩ, 1/4 W, 5%
R1207	315-0102-00			1 kΩ, 1/4 W, 5%
R1208	315-0104-00			100 kΩ, 1/4 W, 5%
R1210	315-0562-00	B010100	B089999X	5.6 kΩ, 1/4 W, 5%
R1211	315-0562-00			5.6 kΩ, 1/4 W, 5%
R1214	315-0102-00			1 kΩ, 1/4 W, 5%
R1224	306-0333-00	XB160000		33 kΩ, 2 W, 10%
R1227	301-0305-00			3 MΩ, 1/2 W, 5%
R1228	301-0305-00			3 MΩ, 1/2 W, 5%
R1229	301-0305-00			3 MΩ, 1/2 W, 5%
R1230	301-0305-00			3 MΩ, 1/2 W, 5%
R1231	301-0305-00			3 MΩ, 1/2 W, 5%
R1234	315-0203-00	B010100	B199999	20 kΩ, 1/4 W, 5%
R1234	315-0103-00	B200000		10 kΩ, 1/4 W, 5%
R1241	315-0562-00	B010100	B199999	5.6 kΩ, 1/4 W, 5%
R1241	315-0392-00	B200000	B209999	3.9 kΩ, 1/4 W, 5%
R1241	315-0392-00	B210000		3.9 kΩ, (nom value), selected
R1242	315-0101-00			100 Ω, 1/4 W, 5%
R1243	315-0434-00			430 kΩ, 1/4 W, 5%
R1245A	307-0386-01			250 kΩ
R1245B				24.5 MΩ, Thick film
R1245C				20.4 MΩ
R1245D				7.15 MΩ

ELECTRICAL PARTS LIST (cont)

Ckt No.	Grid Loc	Tektronix Part No.	Serial/Model No. Eff	Disc	Description
RESISTORS (cont)					
R1247		315-0475-00	B010100	B199999	4.7 M Ω , 1/4 W, 5%
R1247		315-0335-00	B200000		3.3 M Ω , 1/4 W, 5%
R1250		311-1257-00			5 M Ω , Var
R1252		315-0915-00			9.1 M Ω , 1/4 W, 5%
R1253		315-0103-00			10 k Ω , 1/4 W, 5%
R1257		315-0105-00	B010100	B199999	1 M Ω , 1/4 W, 5%
R1257		315-0754-00	B200000		750 k Ω , 1/4 W, 5%
R1258		315-0103-00			10 k Ω , 1/4 W, 5%
R1259		315-0103-00			10 k Ω , 1/4 W, 5%
R1261		311-1232-00			50 k Ω , Var
R1263		315-0103-00			10 k Ω , 1/4 W, 5%
R1264		315-0103-00			10 k Ω , 1/4 W, 5%
R1266		315-0105-00	B010100	B199999	1 M Ω , 1/4 W, 5%
R1266		315-0754-00	B200000		750 k Ω , 1/4 W, 5%
R1270		315-0103-00			10 k Ω , 1/4 W, 5%
R1271		315-0915-00			9.1 M Ω , 1/4 W, 5%
R1274		315-0104-00			100 k Ω , 1/4 W, 5%
R1275		315-0474-00			470 k Ω , 1/4 W, 5%
R1305		315-0473-00			47 k Ω , 1/4 W, 5%
R1311		315-0473-00			47 k Ω , 1/4 W, 5%
R1313		315-0473-00	B010100	B049999X	47 k Ω , 1/4 W, 5%
R1318		315-0473-00			47 k Ω , 1/4 W, 5%
R1320		315-0272-00			2.7 k Ω , 1/4 W, 5%
R1321		315-0223-00			22 k Ω , 1/4 W, 5%
R1323		315-0223-00			22 k Ω , 1/4 W, 5%
R1325		315-0473-00			47 k Ω , 1/4 W, 5%
R1327		315-0473-00			47 k Ω , 1/4 W, 5%
R1329		315-0473-00			47 k Ω , 1/4 W, 5%
R1331		315-0472-00			4.7 k Ω , 1/4 W, 5%
R1333		315-0472-00			4.7 k Ω , 1/4 W, 5%
R1334		315-0104-00			100 k Ω , 1/4 W, 5%
R1336		315-0472-00			4.7 k Ω , 1/4 W, 5%
R1338		321-0616-00			52.6 k Ω , 1/8 W, 1%
R3140		315-0102-00			1 k Ω , 1/4 W, 5%
R1344		315-0103-00			10 k Ω , 1/4 W, 5%
R1345		315-0103-00			10 k Ω , 1/4 W, 5%
R1350		321-0616-00			52.6 k Ω , 1/8 W, 1%
R1352		315-0102-00			1 k Ω , 1/4 W, 5%
R1353		315-0103-00			10 k Ω , 1/4 W, 5%
R1355		315-0104-00			100 k Ω , 1/4 W, 5%
R1357		315-0102-00			1 k Ω , 1/4 W, 5%
R1363		321-0385-00			100 k Ω , 1/8 W, 1%
R1365		315-0102-00			1 k Ω , 1/4 W, 5%
R1366		315-0103-00			10 k Ω , 1/4 W, 5%
R1368		315-0104-00			100 k Ω , 1/4 W, 5%
R1369		315-0102-00			1 k Ω , 1/4 W, 5%
R1371		315-0473-00			47 k Ω , 1/4 W, 5%
R1372		315-0302-00			3 k Ω , 1/4 W, 5%
R1374		315-0474-00			470 k Ω , 1/4 W, 5%
R1376		315-0273-00			27 k Ω , 1/4 W, 5%
R1378		315-0474-00			470 k Ω , 1/4 W, 5%
R1379		315-0395-00			3.9 M Ω , 1/4 W, 5%

Electrical Parts List--7613/R7613 Service

Ckt. No.	Tektronix Part No.	Serial/Model No. Eff	Disc	Description
RESISTORS (cont)				
R1384 ¹	311-1404-00			5 kΩ, Var
R1387	315-0753-00	B010100	B079999	75 kΩ, 1/4 W, 5%
R1387	315-0333-00	B080000		33 kΩ, 1/4 W, 5%
R1389 ²	311-1404-00			5 kΩ, Var
R1392	315-0914-00	B010100	B079999	910 kΩ, 1/4 W, 5%
R1392	321-0423-00	B080000		249 kΩ, 1/8 W, 1%
R1394	315-0183-00			180 kΩ, 1/4 W, 5%
R1395	315-0443-00			43 kΩ, 1/4 W, 5%
R1397	315-0683-00			68 kΩ, 1/4 W, 5%
R1399	315-0102-00			1 kΩ, 1/4 W, 5%
R1402	315-0273-00			27 kΩ, 1/4 W, 5%
R1403	315-0122-00			1.2 kΩ, 1/4 W, 5%
R1405	315-0101-00			100 Ω, 1/4 W, 5%
R1406	315-0474-00	XB080000		470 kΩ, 1/4 W, 5%
R1407	315-0754-00	XB080000		750 kΩ, 1/4 W, 5%
R1408	315-0154-00			150 kΩ, 1/4 W, 5%
R1409	315-0223-00			22 kΩ, 1/4 W, 5%
R1410	315-0203-00	XB080000		20 kΩ, 1/4 W, 5%
R1412	315-0103-00			10 kΩ, 1/4 W, 5%
R1414	315-0102-00			1 kΩ, 1/4 W, 5%
R1416	315-0472-00			4.7 kΩ, 1/4 W, 5%
R1418	315-0222-00			2.2 kΩ, 1/4 W, 5%
R1419	315-0222-00			2.2 kΩ, 1/4 W, 5%
R1421	315-0472-00			4.7 kΩ, 1/4 W, 5%
R1422	315-0103-00			10 kΩ, 1/4 W, 5%
R1425	315-0473-00			47 kΩ, 1/4 W, 5%
R1430	315-0104-00			100 kΩ, 1/4 W, 5%
R1434	315-0104-00			100 kΩ, 1/4 W, 5%
R1435	315-0102-00			1 kΩ, 1/2 W, 5%
R1437	315-0561-00			560 Ω, 1/4 W, 5%
R1438	315-0203-00			20 kΩ, 1/4 W, 5%
R1440	315-0223-00			22 kΩ, 1/4 W, 5%
R1445	321-0400-00			143 kΩ, 1/8 W, 1%
R1446	321-0385-00			100 kΩ, 1/8 W, 1%
R1448	315-0154-00			150 kΩ, 1/4 W, 5%
R1451	315-0103-00			10 kΩ, 1/4 W, 5%
R1453	315-0102-00			1 kΩ, 1/4 W, 5%
R1455	315-0222-00			2.2 kΩ, 1/4 W, 5%
R1457	315-0103-00			10 kΩ, 1/4 W, 5%
R1459	315-0103-00			10 kΩ, 1/4 W, 5%
R1460	315-0103-00			10 kΩ, 1/4 W, 5%
R1462	315-0472-00			4.7 kΩ, 1/4 W, 5%
R1464	315-0223-00			22 kΩ, 1/4 W, 5%
R1465	315-0223-00			22 kΩ, 1/4 W, 5%
R1467	311-1228-00			10 kΩ, Var
R1469	321-0356-00			49.9 kΩ, 1/8 W, 1%
R1471	321-0356-00			49.9 kΩ, 1/8 W, 1%
R1473	311-1228-00			10 kΩ, Var
R1475	321-0444-00			412 kΩ, 1/8 W, 1%
R1477	311-0125-00	B010100	B179999	50 kΩ, Var
R1477	311-0164-00	B180000		50 kΩ, Var
R1482	315-0103-00			10 kΩ, 1/4 W, 5%
R1484	315-0103-00			10 kΩ, 1/4 W, 5%
R1486	321-0406-00			165 kΩ, 1/8 W, 1%

¹Furnished as a unit with R1389 & S1389.

²Furnished as a unit with R1384 & S1384.

ELECTRICAL PARTS LIST (cont)

Ckt. No.	Tektronix Part No.	Serial/Model No. Eff	Disc	Description
RESISTORS (cont)				
R1493	315-0392-00			3.9 k Ω , 1/4 W, 5%
R1494	315-0102-00			1 k Ω , 1/4 W, 5%
R1496	321-0414-00			200 k Ω , 1/8 W, 1%
R1498	315-0392-00			3.9 k Ω , 1/4 W, 5%
R1499	315-0472-00			4.7 k Ω , 1/4 W, 5%
R1501	301-0393-00			39 k Ω , 1/2 W, 5%
R1502	301-0203-00			20 k Ω , 1/2 W, 5%
R1505	315-0101-00			100 Ω , 1/4 W, 5%
R1507	321-0405-00			162 k Ω , 1/8 W, 1%
R1510	321-0362-00			57.6 k Ω , 1/8 W, 1%
R1511	321-0414-00			200 k Ω , 1/8 W, 1%
R1513	315-0754-00			750 k Ω , 1/4 W, 5%
R1520	321-1381-03			92 k Ω , 1/8 W, 1/4%
R1521	311-1232-00			50 k Ω , Var
R1522	321-0373-00			75 k Ω , 1/8 W, 1%
R1525	315-0474-00			470 k Ω , 1/4 W, 5%
R1531	311-1232-00			50 k Ω , Var
R1533	321-0385-00			100 k Ω , 1/8 W, 1%
R1534	321-0378-00			84.5 k Ω , 1/8 W, 1%
R1536	321-0385-00			100 k Ω , 1/8 W, 1%
R1538	315-0184-00			180 k Ω , 1/4 W, 5%
R1545	308-0290-00			8 Ω , 5 W, WW, 5%
R1587	315-0470-00			47 Ω , 1/4 W, 5%
R1589	315-0220-00			22 Ω , 1/4 W, 5%
R1591	307-0106-00			4.7 Ω , 1/4 W, 5%
R1593	307-0103-00			2.7 Ω , 1/4 W, 5%
R1595	307-0106-00			4.7 Ω , 1/4 W, 5%
R1597	315-0220-00			22 Ω , 1/4 W, 5%
R2101	315-0682-00			6.8 k Ω , 1/4 W, 5%
R2102	315-0103-00			10 k Ω , 1/4 W, 5%
R2104	315-0333-00			33 k Ω , 1/4 W, 5%
R2105	315-0153-00			15 k Ω , 1/4 W, 5%
R2107	315-0510-00			51 Ω , 1/4 W, 5%
R2108	315-0512-00			5.1 k Ω , 1/4 W, 5%
R2109	315-0221-00			220 Ω , 1/4 W, 5%
R2112	315-0102-00			1 k Ω , 1/4 W, 5%
R2113	315-0301-00			300 Ω , 1/4 W, 5%
R2122	315-0432-00			4.3 k Ω , 1/4 W, 5%
R2123	315-0683-00			68 k Ω , 1/4 W, 5%
R2127	315-0302-00			3 k Ω , 1/4 W, 5%
R2128	311-1225-00	B010100	B219999	1 k Ω , Var
R2128	311-1263-00	B220000		1 k Ω , Var
R2129	315-0183-00			18 k Ω , 1/4 W, 5%
R2135	315-0393-00			39 k Ω , 1/4 W, 5%
R2137	315-0752-00			75 k Ω , 1/4 W, 5%
R2139	315-0242-00			2.4 k Ω , 1/4 W, 5%

ELECTRICAL PARTS LIST (cont)

Ckt. No.	Tektronix Part No.	Serial/Model No. Eff	No. Disc	Description
RESISTORS (cont)				
R2144	315-0104-00			100 kΩ, 1/4 W, 5%
R2146	315-0152-00			1.5 kΩ, 1/4 W, 5%
R2148	315-0103-00			10 kΩ, 1/4 W, 5%
R2150	321-0403-00			154 kΩ, 1/8 W, 5%
R2151	321-0372-00			73.2 kΩ, 1/8 W, 1%
R2153	315-0103-00			10 kΩ, 1/4 W, 5%
R2155	315-0512-00			5.1 kΩ, 1/4 W, 5%
R2158	315-0152-00			1.5 kΩ, 1/4 W, 5%
R2161	315-0102-00			1 kΩ, 1/4 W, 5%
R2162	315-0751-00			750 Ω, 1/4 W, 5%
R2163	315-0751-00			750 Ω, 1/4 W, 5%
R2165	315-0102-00			1 kΩ, 1/4 W, 5%
R2166	315-0751-00			750 Ω, 1/4 W, 5%
R2167	315-0751-00			750 Ω, 1/4 W, 5%
R2169	315-0102-00			1 kΩ, 1/4 W, 5%
R2170	315-0751-00			750 Ω, 1/4 W, 5%
R2171	315-0751-00			750 Ω, 1/4 W, 5%
R2173	315-0102-00			1 kΩ, 1/4 W, 5%
R2174	315-0751-00			750 Ω, 1/4 W, 5%
R2175	315-0751-00			750 Ω, 1/4 W, 5%
R2177	315-0511-00			510 Ω, 1/4 W, 5%
R2178	315-0511-00			510 Ω, 1/4 W, 5%
R2179	315-0511-00			510 Ω, 1/4 W, 5%
R2182	321-0262-00			5.23 kΩ, 1/8 W, 1%
R2183	311-1224-00			500 Ω, Var
R2191	315-0513-00			51 kΩ, 1/4 W, 5%
R2192	315-0133-00			13 kΩ, 1/4 W, 5%
R2193	315-0133-00			13 kΩ, 1/4 W, 5%
R2194	315-0753-00			75 kΩ, 1/4 W, 5%
R2196	321-0308-00			15.8 kΩ, 1/8 W, 1%
R2197	315-0513-00			51 kΩ, 1/4 W, 5%
R2198	321-0319-00			20.5 kΩ, 1/8 W, 1%
R2199	321-0335-00			30.1 kΩ, 1/8 W, 1%
R2201	315-0154-00			150 kΩ, 1/4 W, 5%
R2202	321-0335-00			30.1 kΩ, 1/8 W, 1%
R2203	321-0344-00			37.4 kΩ, 1/8 W, 1%
R2204	321-0335-00			30.1 kΩ, 1/8 W, 1%
R2206	315-0513-00			51 kΩ, 1/4 W, 5%
R2207	315-0154-00			150 kΩ, 1/4 W, 5%
R2208	321-0335-00			30.1 kΩ, 1/8 W, 1%
R2209	321-0335-00			30.1 kΩ, 1/8 W, 1%
R2211	315-0752-00			7.5 kΩ, 1/4 W, 5%
R2213	321-0259-00			4.87 kΩ, 1/8 W, 1%
R2214	311-1224-00			500 Ω, Var
R2215	315-0133-00			13 kΩ, 1/4 W, 5%
R2217	315-0124-00			120 kΩ, 1/4 W, 5%
R2219	315-0751-00			750 Ω, 1/4 W, 5%
R2220	321-0299-00			12.7 kΩ, 1/8 W, 1%
R2221	321-0212-00			1.58 kΩ, 1/8 W, 1%

ELECTRICAL PARTS LIST (cont)

Ckt. No.	Tektronix Part No.	Serial/Model No. Eff	Disc	Description
RESISTORS (cont)				
R2226	315-0222-00			2.2 k Ω , 1/4 W, 5%
R2227	321-0268-00			6.04 k Ω , 1/8 W, 1%
R2229	321-0210-00			1.5 k Ω , 1/8 W, 1%
R2231	315-0303-00			30 k Ω , 1/4 W, 5%
R2235	315-0203-00			20 k Ω , 1/4 W, 5%
R2236	315-0203-00			20 k Ω , 1/4 W, 5%
R2237	315-0203-00			20 k Ω , 1/4 W, 5%
R2238	315-0203-00			20 k Ω , 1/4 W, 5%
R2241	321-0326-00			24.3 k Ω , 1/8 W, 1%
R2251	315-0102-00			1 k Ω , 1/4 W, 5%
R2252	315-0102-00			1 k Ω , 1/4 W, 5%
R2253	315-0102-00			1 k Ω , 1/4 W, 5%
R2254	315-0303-00	XB220000		30 k Ω , 1/4 W, 5%
R2261	315-0272-00			2.7 k Ω , 1/4 W, 5%
R2262	315-0102-00			1 k Ω , 1/4 W, 5%
R2265	315-0512-00			5.1 k Ω , 1/4 W, 5%
R2266	315-0912-00			9.1 k Ω , 1/4 W, 5%
R2268	321-0296-00			11.8 k Ω , 1/8 W, 1%
R2273	311-1226-00			2.5 k Ω , Var
R2274	321-0153-00			383 Ω , 1/8 W, 1%
R2275	321-0170-00			576 Ω , 1/8 W, 1%
R2276	315-0223-00			22 k Ω , 1/4 W, 5%
R2277	321-0250-00			3.92 k Ω , 1/8 W, 1%
R2278	315-0823-00	XB220000		82 k Ω , 1/4 W, 5%
R2279	321-0222-00			2 k Ω , 1/8 W, 1%
R2280	315-0823-00			82 k Ω , 1/4 W, 5%
R2281	315-0101-00	XB220000		100 Ω , 1/4 W, 5%
R2282	315-0332-00			3.3 k Ω , 1/4 W, 5%
R2283	315-0753-00	XB220000		75 k Ω , 1/4 W, 5%
R2284	321-0216-00			1.74 k Ω , 1/8 W, 1%
R2285	321-0245-00			3.48 k Ω , 1/8 W, 1%
R2286	321-0209-00			1.47 k Ω , 1/8 W, 1%
R2287	321-0199-00			1.15 k Ω , 1/8 W, 1%
R2288	321-0273-00			6.81 k Ω , 1/8 W, 1%
R2289	321-0193-00			1 k Ω , 1/8 W, 1%
R2291	311-1225-00			1 k Ω , Var
R2292	315-0132-00			1.3 k Ω , 1/4 W, 5%
R2293	321-0245-00			3.48 k Ω , 1/8 W, 1%
R2294	321-0255-00			4.42 k Ω , 1/8 W, 1%
R2295	321-0241-00			3.16 k Ω , 1/8 W, 1%
R2297	315-0102-00	B010100	B059999	1 k Ω , 1/4 W, 5%
R2297	315-0152-00	B060000		1.5 k Ω , 1/4 W, 5%
R2298	315-0102-00			1 k Ω , 1/4 W, 5%
R2299	315-0511-00	B010100	B219999	510 Ω , 1/4 W, 5%
R2299	315-0431-00	B220000		430 Ω , 1/4 W, 5%
SWITCHES				
S102 ¹				READOUT
S659	260-0984-00			Slide, GATE SELECTOR
S1000	260-0724-00	B010100	B241706	Thermostatic, open 83.3 deg C, close 66.7 deg C
S1000	260-1759-00	B241707		Thermostatic, open 83.3 deg C, close 66.7 deg C
S1001 ²				Push, POWER
S1011	260-1379-00			Push, TRIG SOURCE
S1021	260-1378-00			Push, VERT MODE
S1030 ³				BEAM FINDER
S1300	260-1442-00			Push SAVE/ERASE

¹Furnished as a unit with R102A,B²See Mechanical Parts List for replacement parts.³Furnished as a unit with R1095.

ELECTRICAL PARTS LIST (cont)

Ckt. No.	Tektronix Part No.	Serial/Model No. Eff	Disc	Description
SWITCHES				
S1306 ₁	260-1441-00			Push, NON STORE/STORE
S1389 ₁				SAVETIME
S2110	260-0723-00			Slide, READOUT MODE
TRANSFORMERS				
T523	120-0546-00	XB020000		Toroid, 4 turns, bifilar
T801	120-0708-00			Power
T1125	120-0810-00	B010100	B199999	HV Power
T1125	120-0906-00	B200000		HV Power
INTEGRATED CIRCUITS				
U55	155-0011-00			Monolithic, clock & chop blanking
U99	156-0048-00			Five NPN transistor array, CA3046
U123	156-0041-00			Dual 15 MHz D-type pos-edge-trig flip-flop, SN7474N
U156	156-0041-00			Dual 15 MHz D-type pos-edge-trig flip-flop, SN7474N
U214	155-0022-00			Monolithic, channel switch
U324	155-0022-00			Monolithic, channel switch
U450	155-0080-00			Hybrid, vert out amp.
U510	155-0022-00			Monolithic, channel switch
U973	156-0065-00			Five NPN transistor array, CA3045
U2120	156-0043-00			Quad 2-input positive nor gate, SN7402N
U2126	155-0021-00	B010100	B191253	Monolithic, timing generator
U2126	155-0021-01	B191254		Monolithic, timing generator
U2155	156-0043-00			Quad 2-input positive nor gate, SN7402N
U2159	155-0017-00			Monolithic, 5 MHz decade counter
U2180	155-0015-01			Monolithic, analog data switch
U2185	155-0014-01			Monolithic, analog to decimal converter
U2190	155-0015-01			Monolithic, analog data switch
U2232	155-0018-00			Monolithic, zeros logic
U2244	155-0014-01			Monolithic, analog to decimal converter
U2250	156-0032-00			Single 10 MHz 1-&-3-bit binary ripple counter, SN7493N
U2260	155-0019-00			Monolithic, decimal point and spacing
U2270	155-0023-00			Monolithic, character generator
U2272	155-0024-00			Monolithic, character generator
U2274	155-0025-00			Monolithic, character generator
U2275	155-0026-00			Monolithic, character generator
U2278	155-0027-00			Monolithic, character generator
U2284	155-0020-00			Monolithic, channel switching output assembly
ELECTRON TUBE				
V1099	154-0670-00	B010100	B010199	CRT
V1099	154-0670-10	B010200		CRT

¹Furnished as a unit with R1384 & R1389.

DIAGRAMS AND CIRCUIT BOARD ILLUSTRATIONS

Symbols and Reference Designators

Electrical components shown on the diagrams are in the following units unless noted otherwise:

Capacitors =	Values one or greater are in picofarads (pF). Values less than one are in microfarads (μ F).
Resistors =	Ohms (Ω)

Symbols used on the diagrams are based on USA Standard Y32.2-1967.

Logic symbology is based on MIL-STD-806B in terms of positive logic. Logic symbols depict the logic function performed and may differ from the manufacturer's data.

The following special symbols are used on the diagrams:

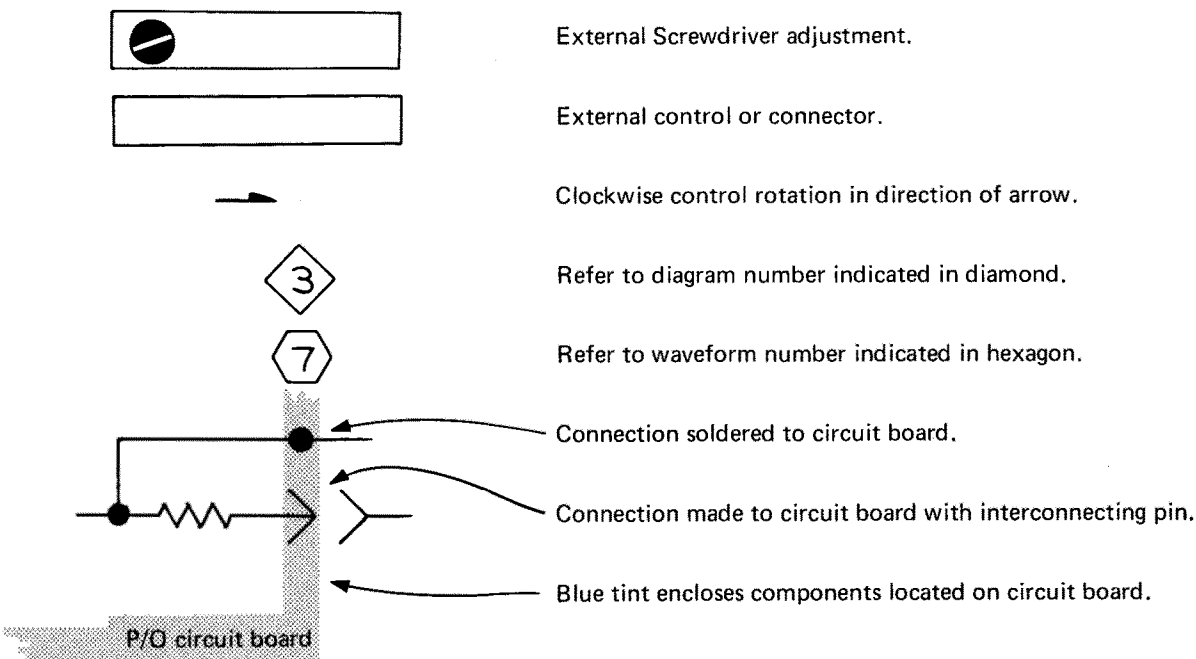

The following prefix letters are used as reference designators to identify components or assemblies on the diagrams.

A	Assembly, separable or repairable (circuit board, etc.)	LR	Inductor/resistor combination
AT	Attenuator, fixed or variable	M	Meter
B	Motor	Q	Transistor or silicon-controlled rectifier
BT	Battery	P	Connector, movable portion
C	Capacitor, fixed or variable	R	Resistor, fixed or variable
CR	Diode, signal or rectifier	RT	Thermistor
DL	Delay line	S	Switch
DS	Indicating device (lamp)	T	Transformer
F	Fuse	TP	Test point
FL	Filter	U	Assembly, inseparable or non-repairable (integrated circuit, etc.)
H	Heat dissipating device (heat sink, heat radiator, etc.)	V	Electron tube
HR	Heater	VR	Voltage regulator (zener diode, etc.)
J	Connector, stationary portion	Y	Crystal
K	Relay		
L	Inductor, fixed or variable		

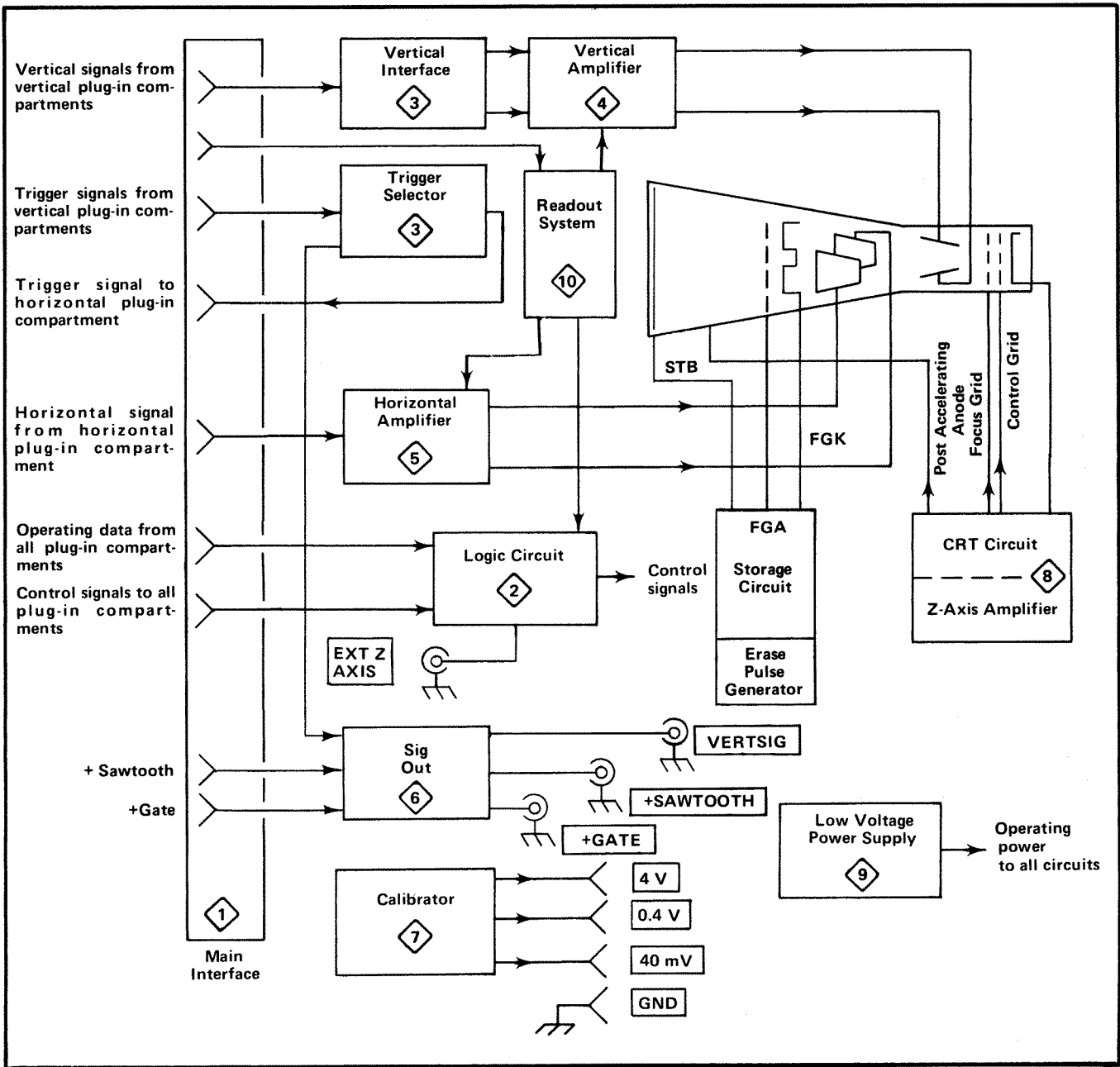
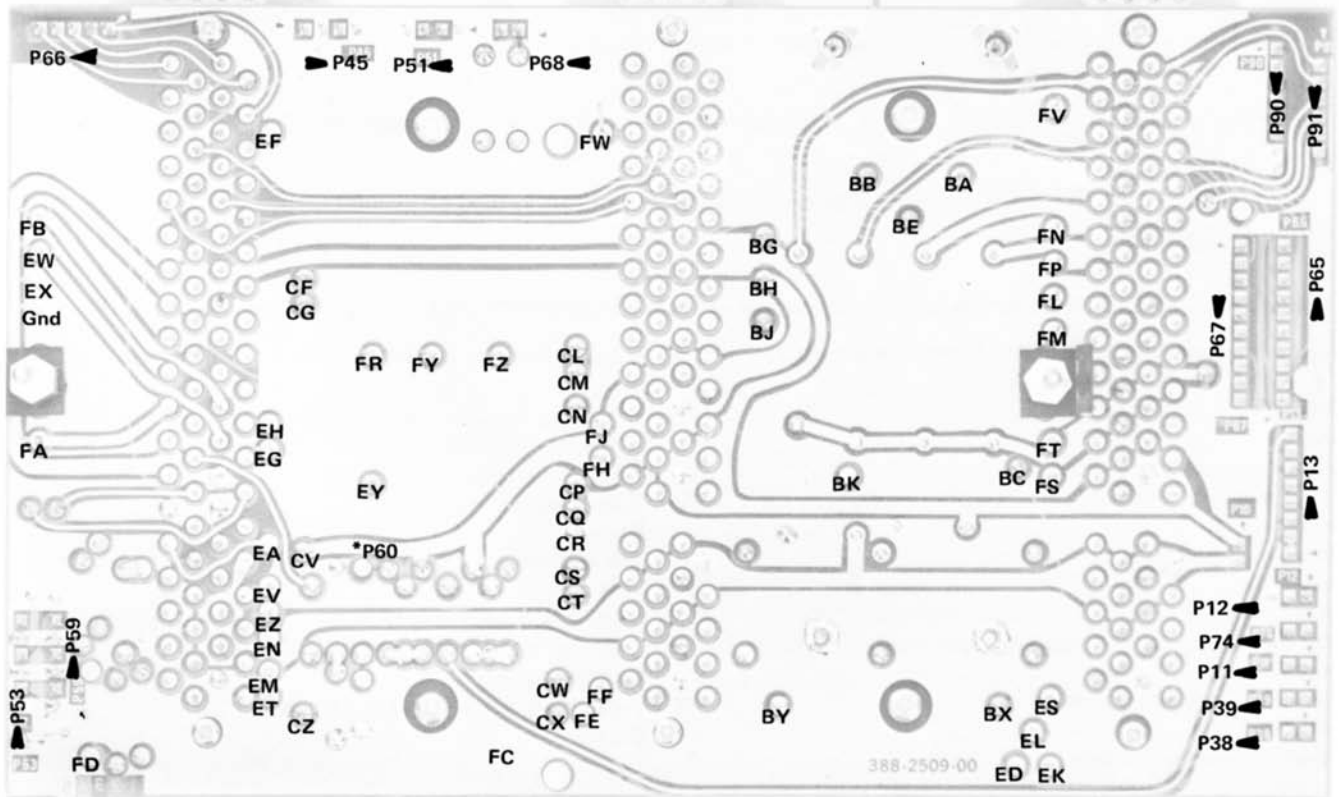
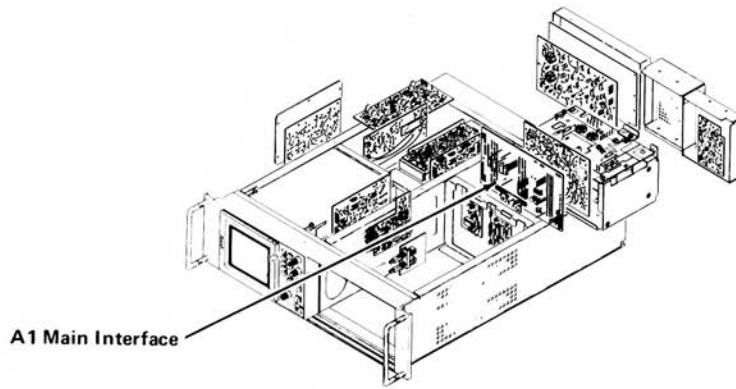

Fig. 6-1. Block Diagram.

REV. MAY 1974



*See Parts List for serial number ranges.

Fig. 6-3. A1. Main Interface (rear) circuit board.

REV. B, SEPT. 1974

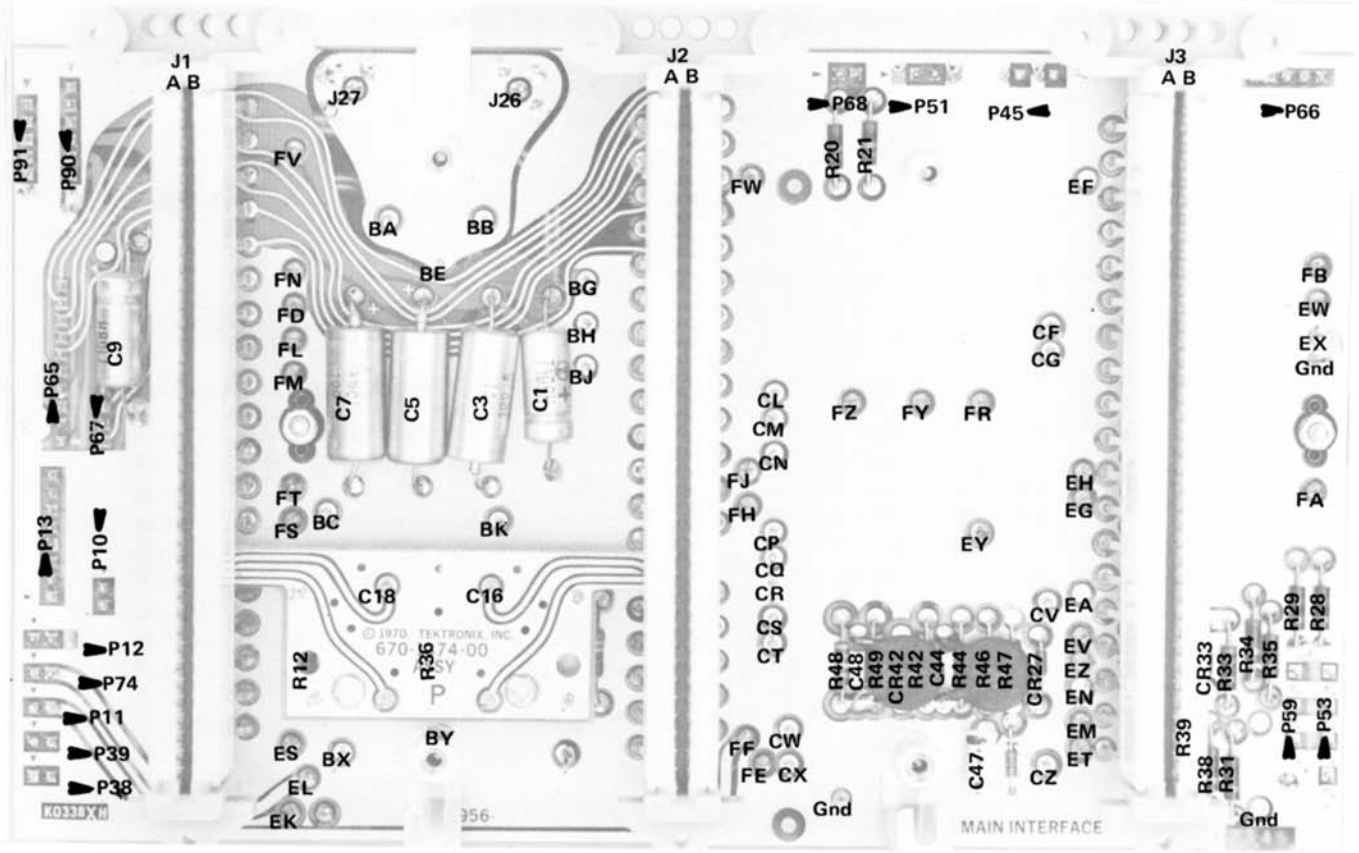

FIG. 6-2B. A1—Main Interface (front) circuit board below SN B240000.

REV. B, SEPT. 1974

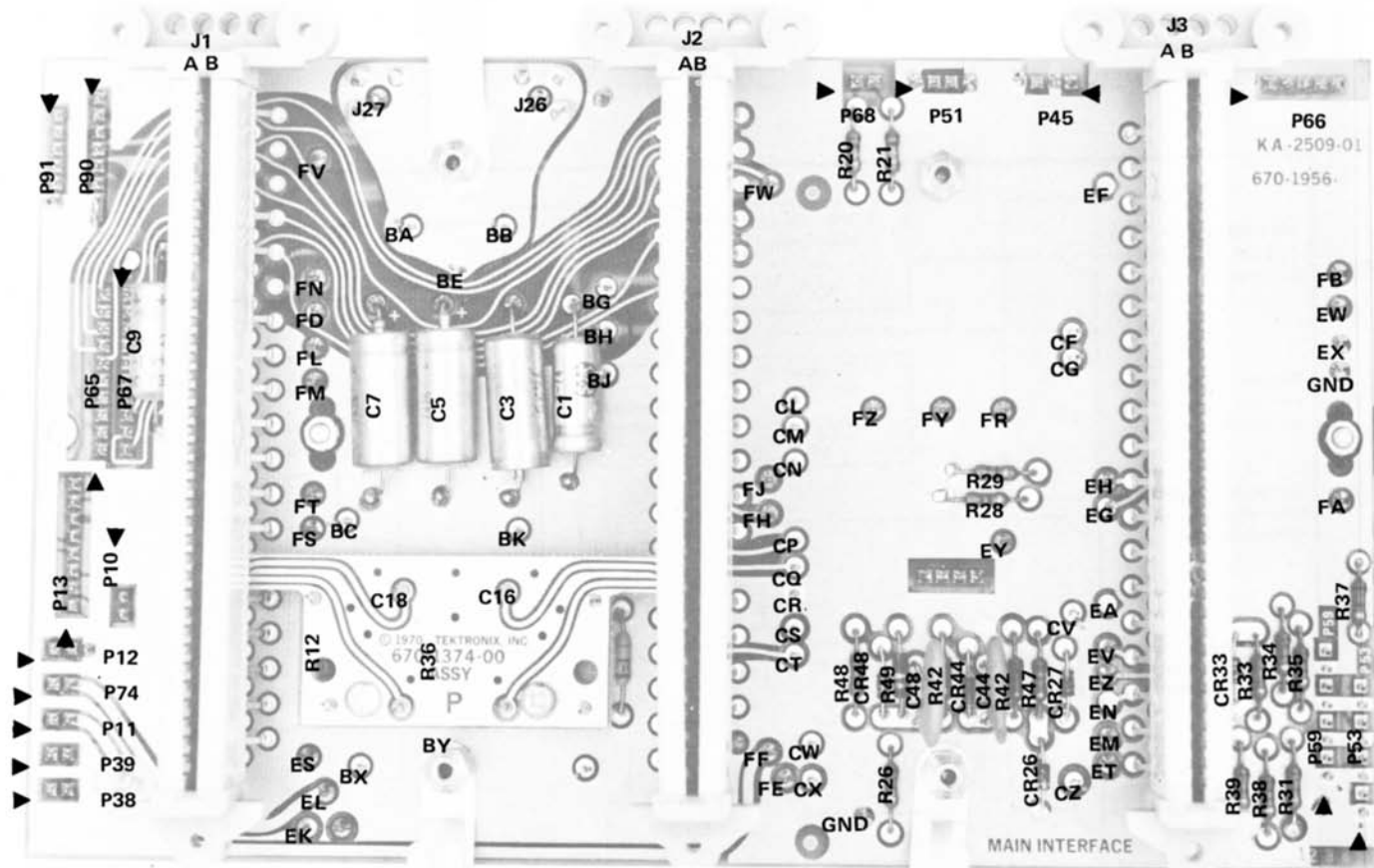
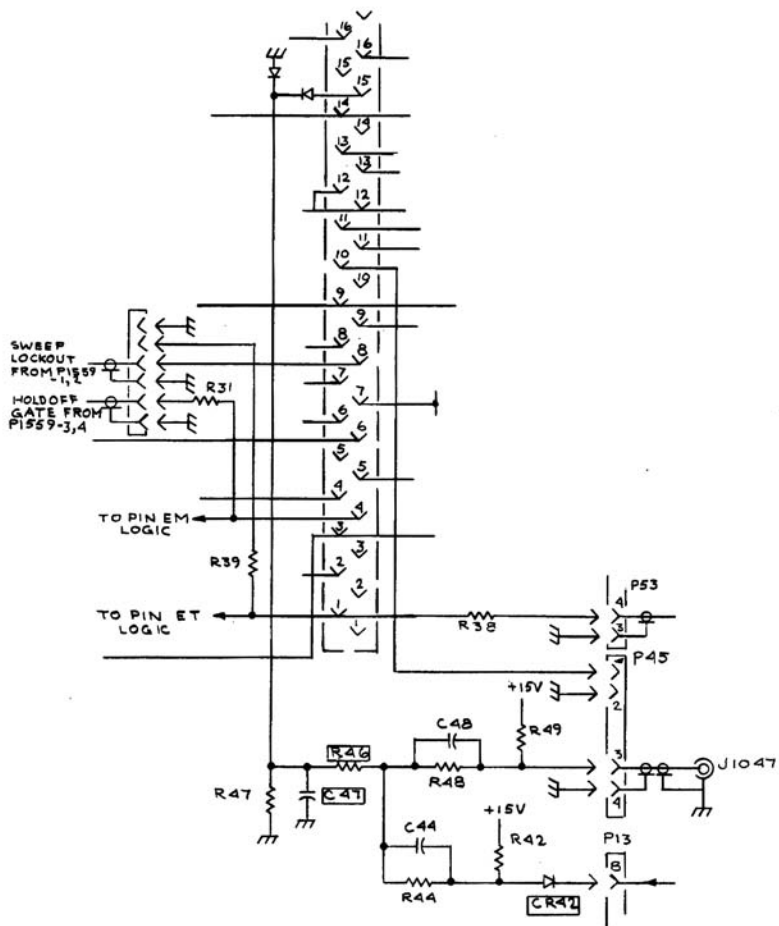

FIG. 6-2A. A1—Main Interface (front) circuit board SN B240000 & up.



VOLTAGES AND WAVEFORMS

The voltages and waveforms shown on this diagram were obtained by using the recommended test equipment and test set-ups listed below.

RECOMMENDED TEST EQUIPMENT

ITEM	SPECIFICATIONS	RECOMMENDED TYPE
Oscilloscope	Frequency response DC to 65 MHz Deflection factor 5 mV to 5 V/Div Input impedance 10 M Ω , 20 pF Sweep rate 500 ns	Tektronix 7603 or 7613 equipped with 7A15A Amplifier and 7B50 Time-Base unit, or equivalent.
Probe	Fast rise 10X attenuation probe compatible with the vertical amplifier of the test oscilloscope.	Tektronix P6053A, or equivalent.
Voltmeter (Non-Loading Digital Multimeter)	Input impedance 10 M Ω Range 0 – 500 V	Tektronix 7D13 Digital Multimeter (test oscilloscope must have readout system) or Fairchild Model 7050, or equivalent.

Voltage Measurements

Voltage measurements on this diagram were made under the following conditions:

Set front panel controls (knob type) to mid-range.

Set VERT MODE for CHOP

Set TRIG SOURCE for VERT MODE

Set for NON STORE condition

No plug-in units are installed.

Voltmeter common is connected to chassis ground.

Waveforms

Waveforms shown on this diagram were obtained under the following conditions:

7613 OSCILLOSCOPE UNDER TEST. Front panel controls are set the same as for voltage measurements. A 7A15AN Vertical plug-in unit and a 7B53AN Time Base unit are installed in the mainframe under test. The test oscilloscope 4 Volts calibration signal is applied to the vertical amplifier. The vertical amplifier is set for 1 V/Division deflection centered on the CRT. The 7B53AN is set for free running sweep, 1 ms/Division sweep rate.

TEST OSCILLOSCOPE. The test oscilloscope is externally triggered from the +GATE OUT (MAIN) of the 7613 mainframe under test. The test oscilloscope is AC coupled.

Tolerances of voltages and waveforms shown are 20%.

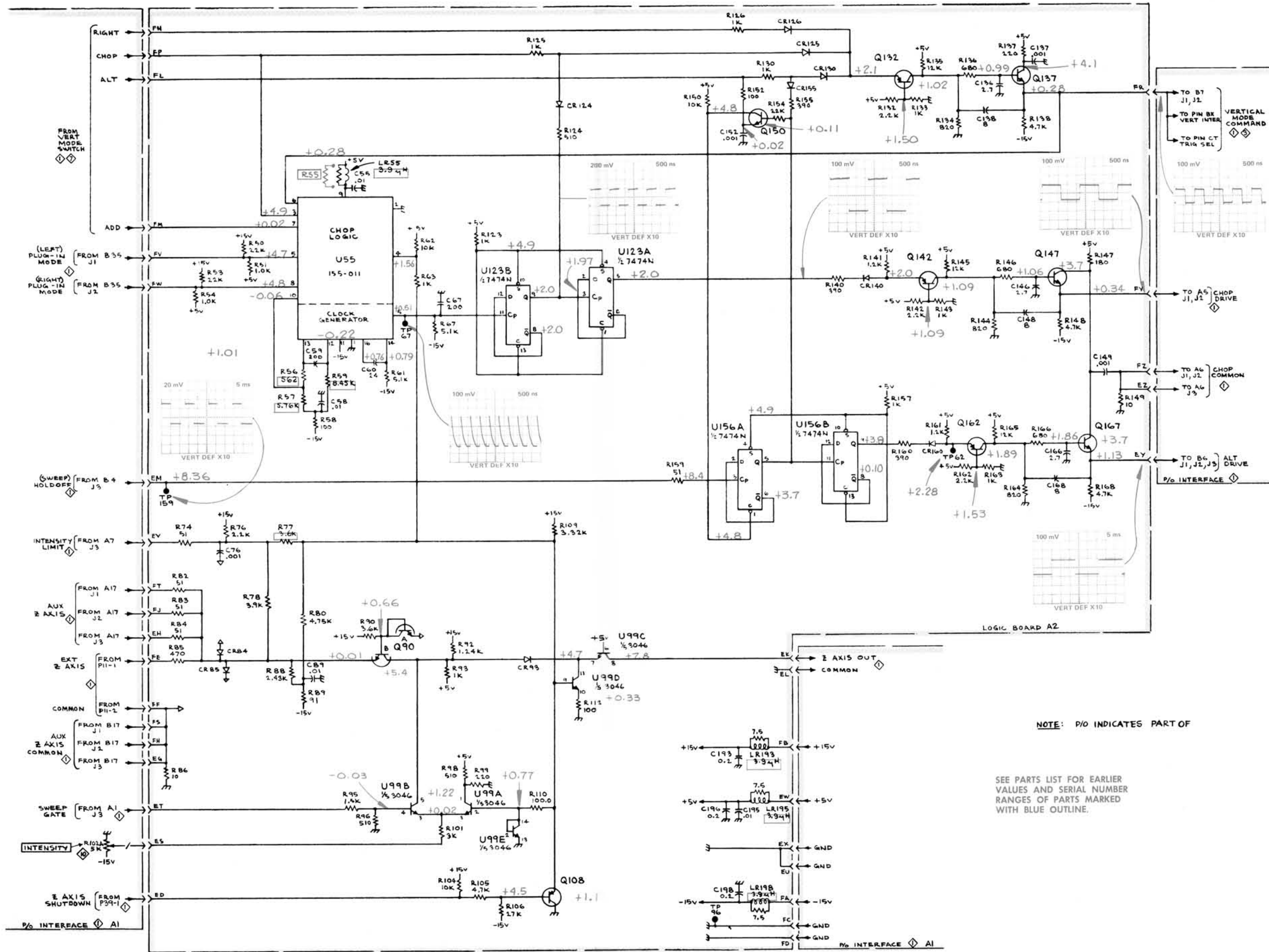

VOLTAGES AND WAVEFORMS

The voltages and waveforms shown on this diagram were obtained by using the recommended test equipment and test set-ups listed below.

RECOMMENDED TEST EQUIPMENT

ITEM	SPECIFICATIONS	RECOMMENDED TYPE
Oscilloscope	Frequency response DC to 65 MHz Deflection factor 5 mV to 5 V/Div Input impedance 10 M Ω , 20 pF Sweep rate 500 ns	Tektronix 7603 or 7613 equipped with 7A15A Amplifier and 7B50 Time-Base unit, or equivalent.
Probe	Fast rise 10X attenuation probe compatible with the vertical amplifier of the test oscilloscope.	Tektronix P6053A, or equivalent.
Voltmeter (Non-Loading Digital Multimeter)	Input impedance 10 M Ω Range 0 – 500 V	Tektronix 7D13 Digital Multimeter (test oscilloscope must have readout system) or Fairchild Model 7050, or equivalent.

Voltage Measurements

Voltage measurements on this diagram were made under the following conditions:

Set front panel controls (knob type) to mid-range.

Set VERT MODE for CHOP

Set TRIG SOURCE for VERT MODE

Set for NON STORE condition

No plug-in units are installed.

Voltmeter common is connected to chassis ground.

Waveforms

Waveforms shown on this diagram were obtained under the following conditions:

7613 OSCILLOSCOPE UNDER TEST. Front panel controls are set the same as for voltage measurements. A 7A15AN Vertical plug-in unit and a 7B53AN Time Base unit are installed in the mainframe under test. The test oscilloscope 4 Volts calibration signal is applied to the vertical amplifier. The vertical amplifier is set for 1 V/Division deflection centered on the CRT. The 7B53AN is set for free running sweep, 1 ms/Division sweep rate.

TEST OSCILLOSCOPE. The test oscilloscope is externally triggered from the +GATE OUT (MAIN) of the 7613 mainframe under test. The test oscilloscope is AC coupled.

Tolerances of voltages and waveforms shown are 20%.

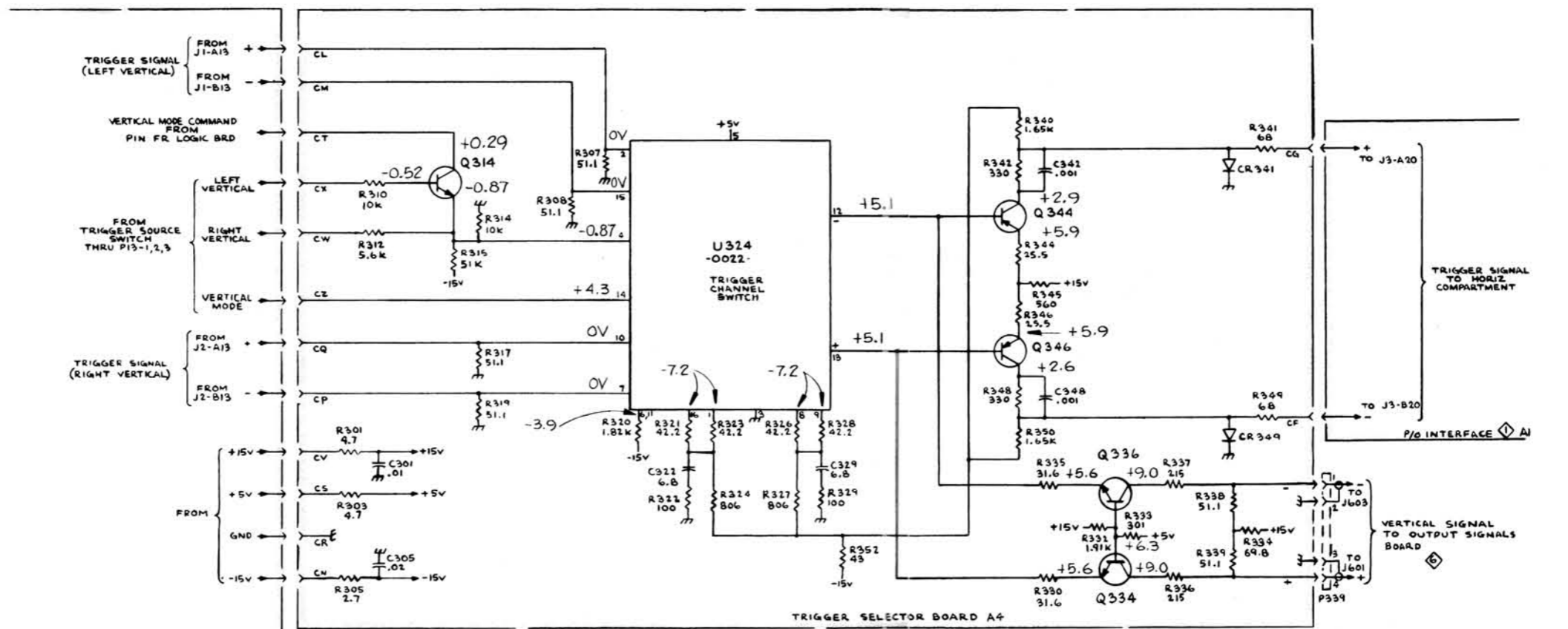

TRIGGER SELECTOR BOARD A4

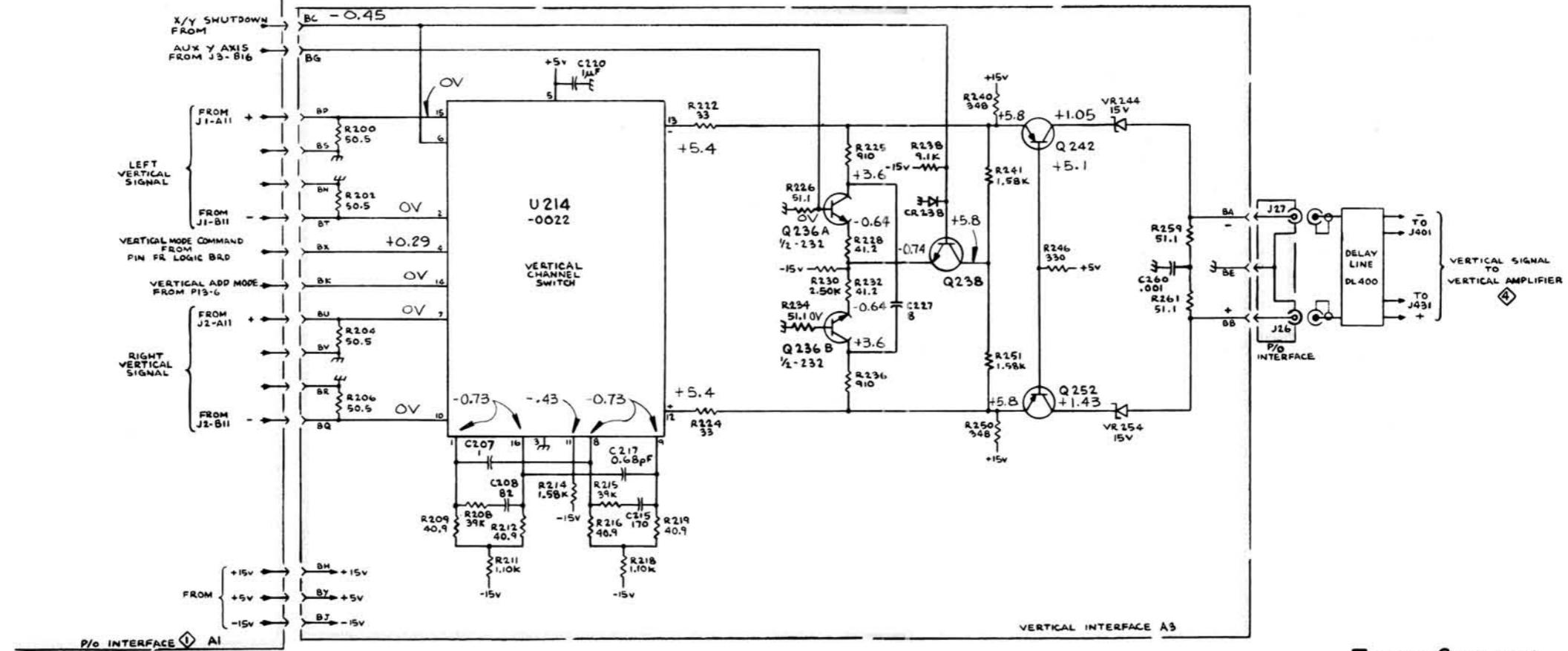

VERTICAL INTERFACE A3

NOTE: P/O INDICATES PART OF

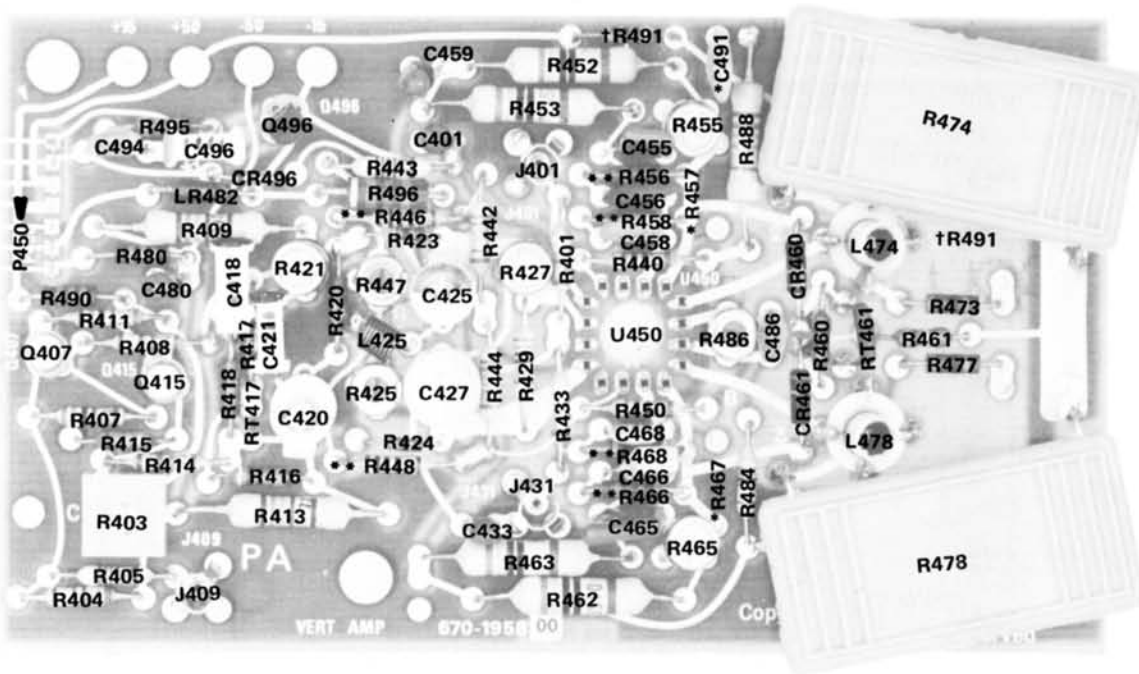
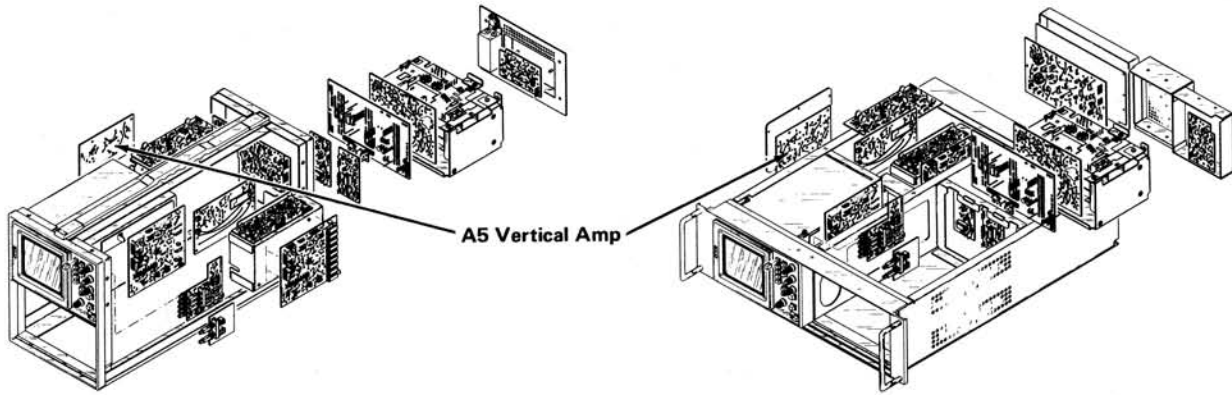

*See Parts List for serial number ranges.

Fig. 6-7. A5. Vertical Amp circuit board.

REV. MAY 1974 (A)2

† Alternate component location for some serial numbers.

**Selectable

VOLTAGES AND WAVEFORMS

The voltages and waveforms shown on this diagram were obtained by using the recommended test equipment and test set-ups listed below.

RECOMMENDED TEST EQUIPMENT

ITEM	SPECIFICATIONS	RECOMMENDED TYPE
Oscilloscope	Frequency response DC to 65 MHz Deflection factor 5 mV to 5 V/Div Input impedance 10 M Ω , 20 pF Sweep rate 500 ns	Tektronix 7603 or 7613 equipped with 7A15A Amplifier and 7B50 Time-Base unit, or equivalent.
Probe	Fast rise 10X attenuation probe compatible with the vertical amplifier of the test oscilloscope.	Tektronix P6053A, or equivalent.
Voltmeter (Non-Loading Digital Multimeter)	Input impedance 10 M Ω Range 0 – 500 V	Tektronix 7D13 Digital Multimeter (test oscilloscope must have readout system) or Fairchild Model 7050, or equivalent.

Voltage Measurements

Voltage measurements on this diagram were made under the following conditions:

Set front panel controls (knob type) to mid-range.

Set VERT MODE for CHOP

Set TRIG SOURCE for VERT MODE

Set for NON STORE condition

No plug-in units are installed.

Voltmeter common is connected to chassis ground.

Waveforms

Waveforms shown on this diagram were obtained under the following conditions:

7613 OSCILLOSCOPE UNDER TEST. Front panel controls are set the same as for voltage measurements. A 7A15AN Vertical plug-in unit and a 7B53AN Time Base unit are installed in the mainframe under test. The test oscilloscope 4 Volts calibration signal is applied to the vertical amplifier. The vertical amplifier is set for 1 V/Division deflection centered on the CRT. The 7B53AN is set for free running sweep, 1 ms/Division sweep rate.

TEST OSCILLOSCOPE. The test oscilloscope is externally triggered from the +GATE OUT (MAIN) of the 7613 mainframe under test. The test oscilloscope is AC coupled.

Tolerances of voltages and waveforms shown are 20%.

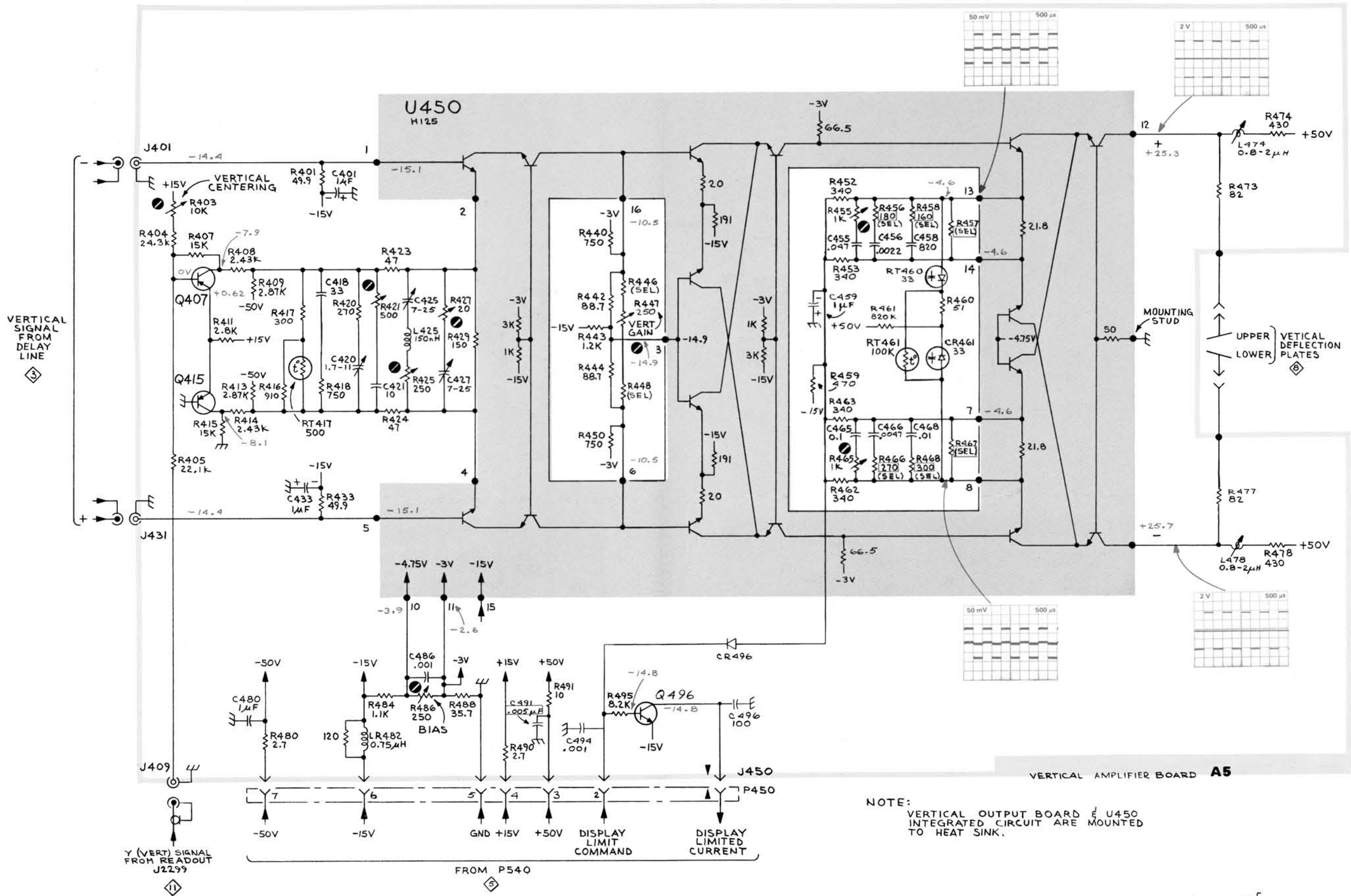

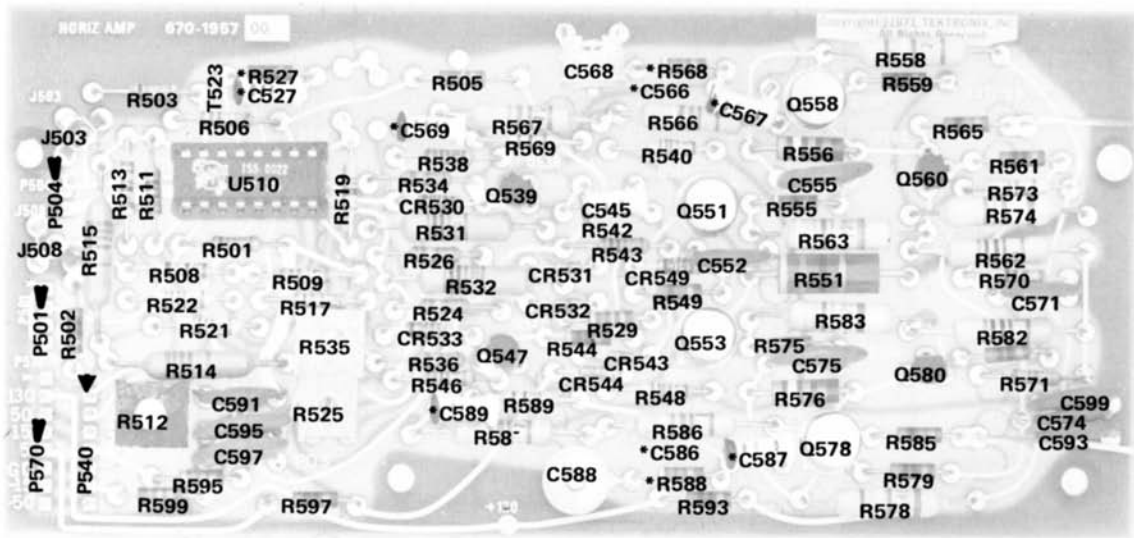

*See Parts List for serial number ranges.

Fig. 6-8B. A6. Horizontal Amplifier circuit board below SN B070000. REV. C, SEPT. 1974

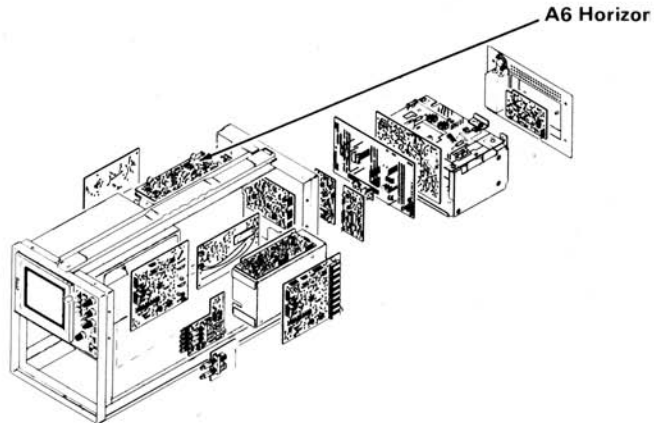

7613/R7613—Service

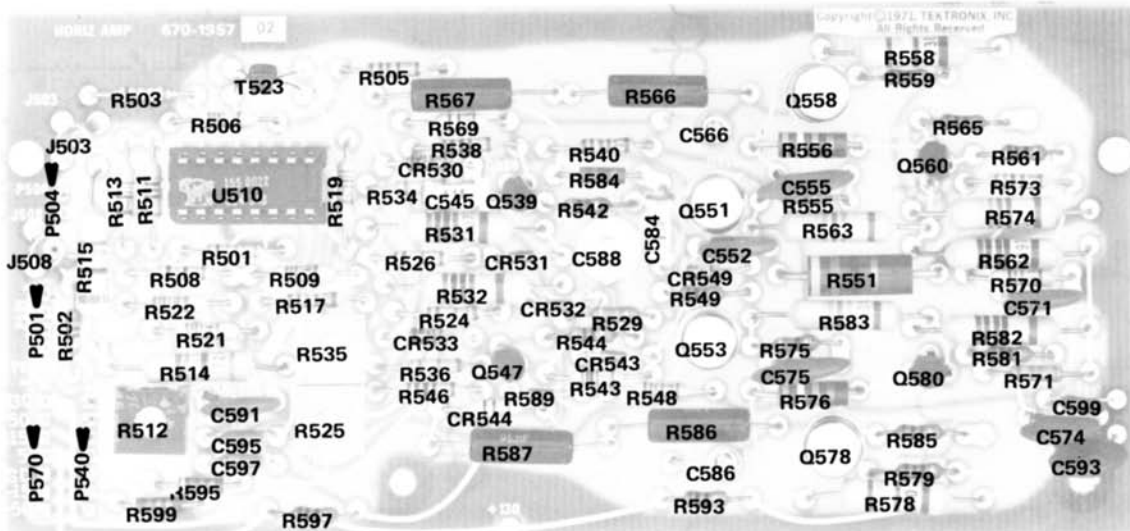

Fig. 6-8A. A6. Horizontal Amplifier circuit board, SN B070000-up. REV. MAY 1974

VOLTAGES AND WAVEFORMS

The voltages and waveforms shown on this diagram were obtained by using the recommended test equipment and test set-ups listed below.

RECOMMENDED TEST EQUIPMENT

ITEM	SPECIFICATIONS	RECOMMENDED TYPE
Oscilloscope	Frequency response DC to 65 MHz Deflection factor 5 mV to 5 V/Div Input impedance 10 M Ω , 20 pF Sweep rate 500 ns	Tektronix 7603 or 7613 equipped with 7A15A Amplifier and 7B50 Time-Base unit, or equivalent.
Probe	Fast rise 10X attenuation probe compatible with the vertical amplifier of the test oscilloscope.	Tektronix P6053A, or equivalent.
Voltmeter (Non-Loading Digital Multimeter)	Input impedance 10 M Ω Range 0 – 500 V	Tektronix 7D13 Digital Multimeter (test oscilloscope must have readout system) or Fairchild Model 7050, or equivalent.

Voltage Measurements

Voltage measurements on this diagram were made under the following conditions:

Set front panel controls (knob type) to mid-range.

Set VERT MODE for CHOP

Set TRIG SOURCE for VERT MODE

Set for NON STORE condition

No plug-in units are installed.

Voltmeter common is connected to chassis ground.

Waveforms

Waveforms shown on this diagram were obtained under the following conditions:

7613 OSCILLOSCOPE UNDER TEST. Front panel controls are set the same as for voltage measurements. A 7A15AN Vertical plug-in unit and a 7B53AN Time Base unit are installed in the mainframe under test. The test oscilloscope 4 Volts calibration signal is applied to the vertical amplifier. The vertical amplifier is set for 1 V/Division deflection centered on the CRT. The 7B53AN is set for free running sweep, 1 ms/Division sweep rate.

TEST OSCILLOSCOPE. The test oscilloscope is externally triggered from the +GATE OUT (MAIN) of the 7613 mainframe under test. The test oscilloscope is AC coupled.

Tolerances of voltages and waveforms shown are 20%.

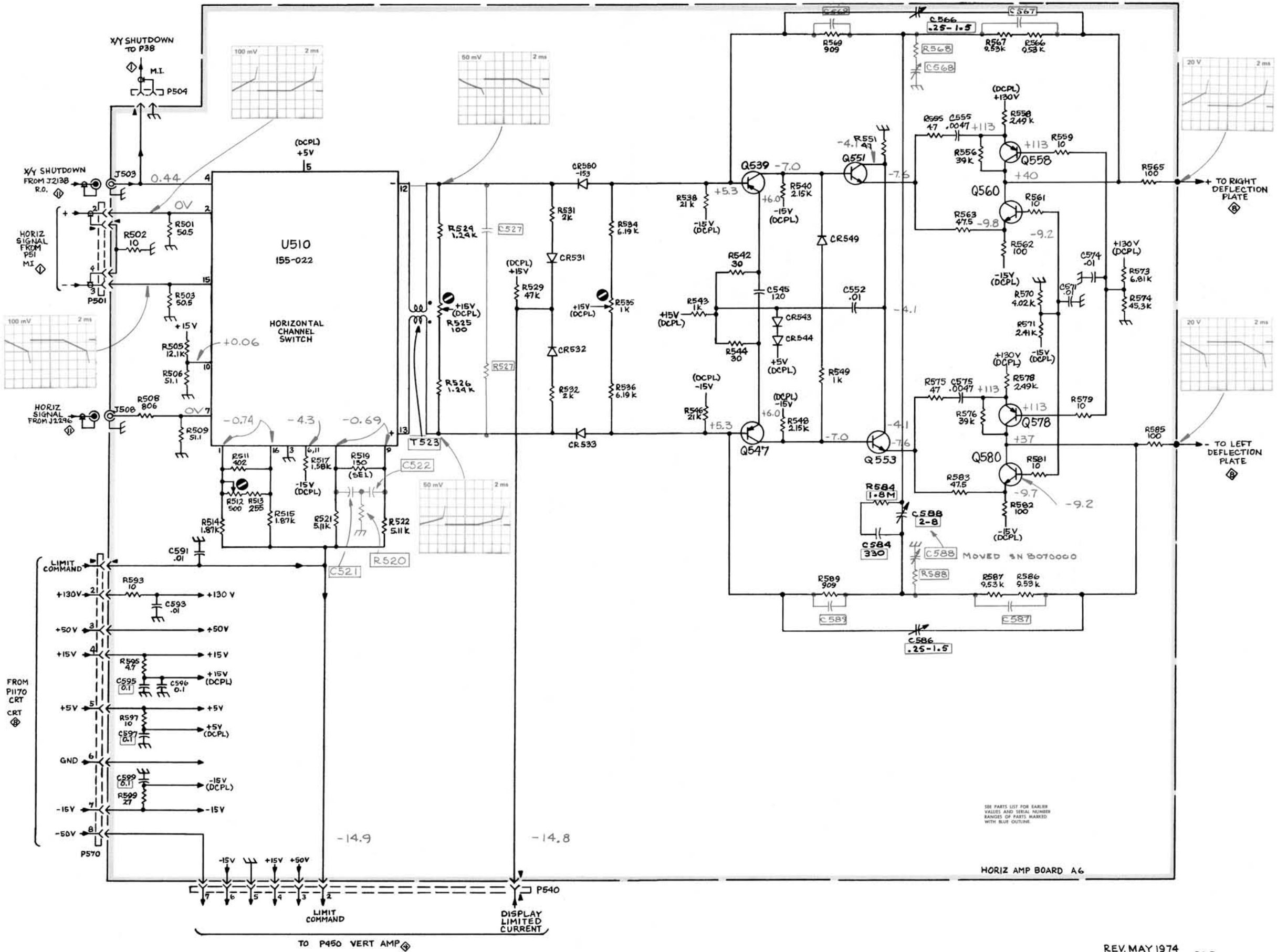

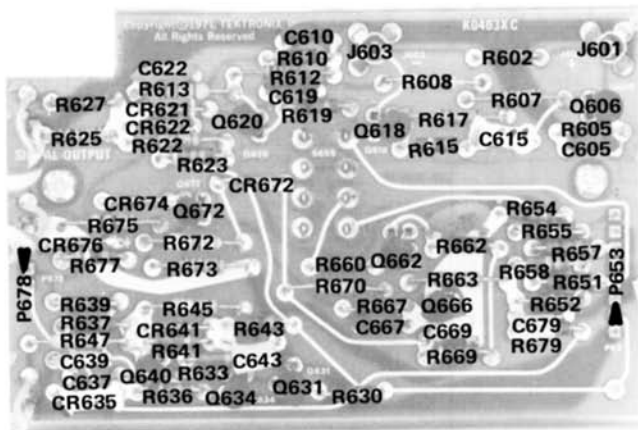
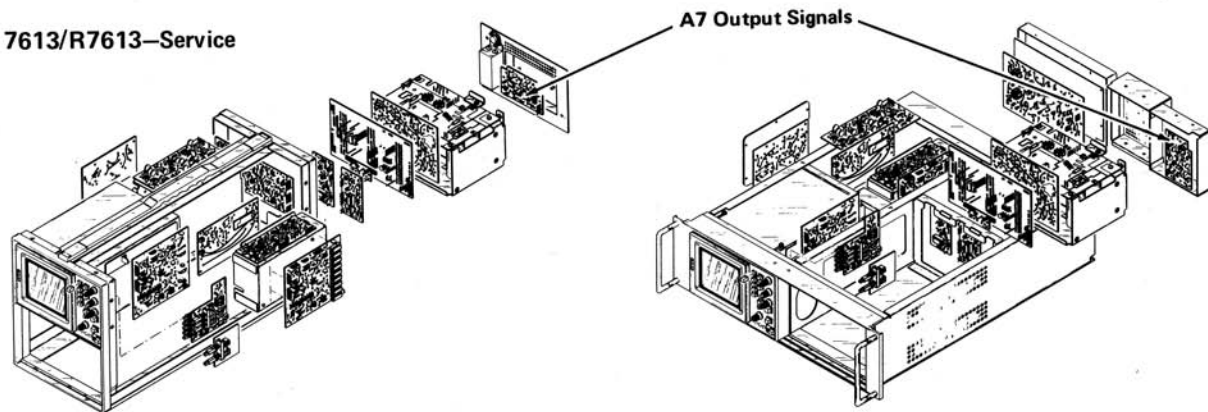

Fig. 6-9. A7. Signal Output circuit board.

A2

REV. MAY 1974

VOLTAGES AND WAVEFORMS

The voltages and waveforms shown on this diagram were obtained by using the recommended test equipment and test set-ups listed below.

RECOMMENDED TEST EQUIPMENT

ITEM	SPECIFICATIONS	RECOMMENDED TYPE
Oscilloscope	Frequency response DC to 65 MHz Deflection factor 5 mV to 5 V/Div Input impedance 10 M Ω , 20 pF Sweep rate 500 ns	Tektronix 7603 or 7613 equipped with 7A15A Amplifier and 7B50 Time-Base unit, or equivalent.
Probe	Fast rise 10X attenuation probe compatible with the vertical amplifier of the test oscilloscope.	Tektronix P6053A, or equivalent.
Voltmeter (Non-Loading Digital Multimeter)	Input impedance 10 M Ω Range 0 – 500 V	Tektronix 7D13 Digital Multimeter (test oscilloscope must have readout system) or Fairchild Model 7050, or equivalent.

Voltage Measurements

Voltage measurements on this diagram were made under the following conditions:

Set front panel controls (knob type) to mid-range.

Set VERT MODE for CHOP

Set TRIG SOURCE for VERT MODE

Set for NON STORE condition

No plug-in units are installed.

Voltmeter common is connected to chassis ground.

Waveforms

Waveforms shown on this diagram were obtained under the following conditions:

7613 OSCILLOSCOPE UNDER TEST. Front panel controls are set the same as for voltage measurements. A 7A15AN Vertical plug-in unit and a 7B53AN Time Base unit are installed in the mainframe under test. The test oscilloscope 4 Volts calibration signal is applied to the vertical amplifier. The vertical amplifier is set for 1 V/Division deflection centered on the CRT. The 7B53AN is set for free running sweep, 1 ms/Division sweep rate.

TEST OSCILLOSCOPE. The test oscilloscope is externally triggered from the +GATE OUT (MAIN) of the 7613 mainframe under test. The test oscilloscope is AC coupled.

Tolerances of voltages and waveforms shown are 20%.

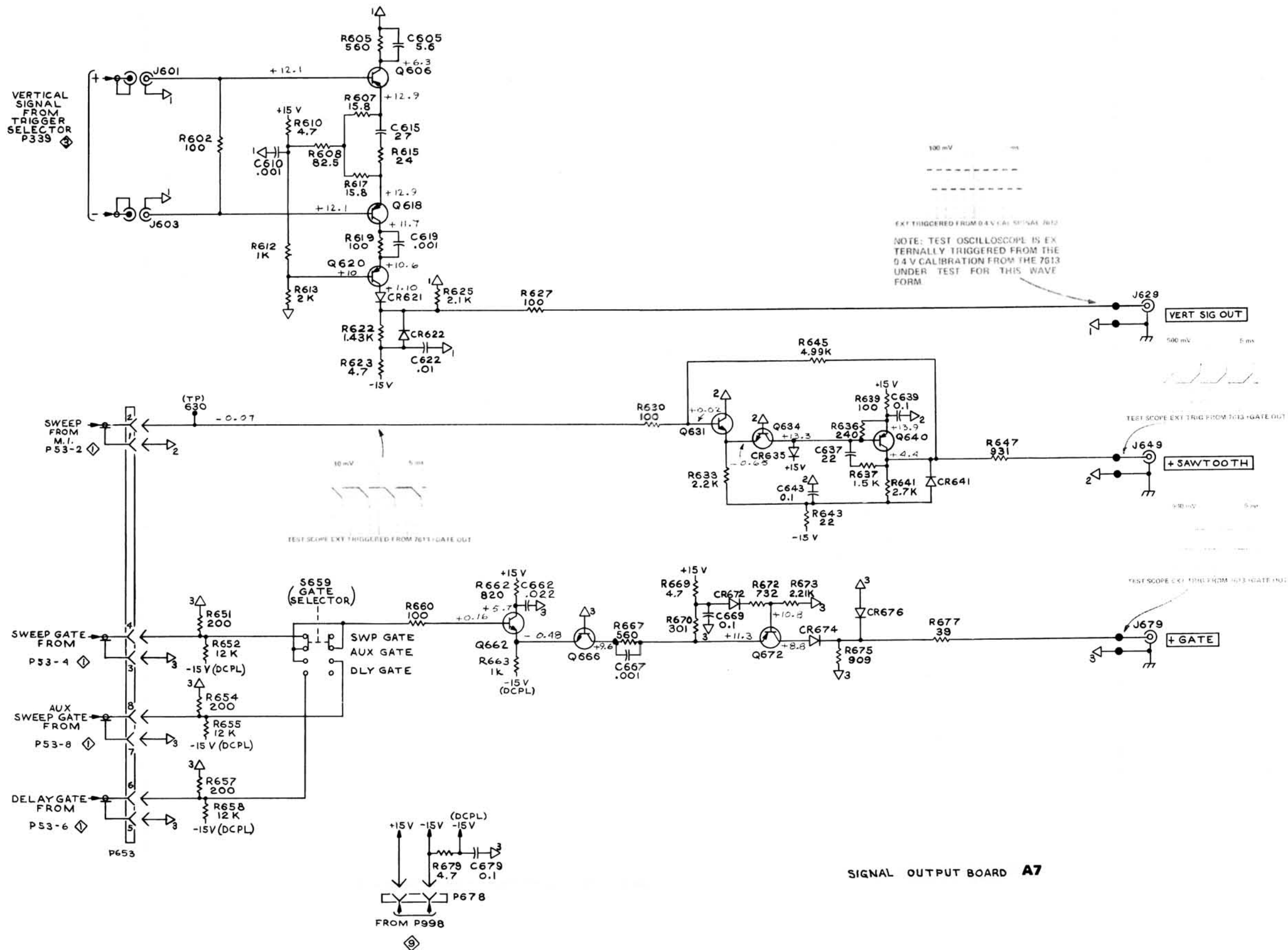

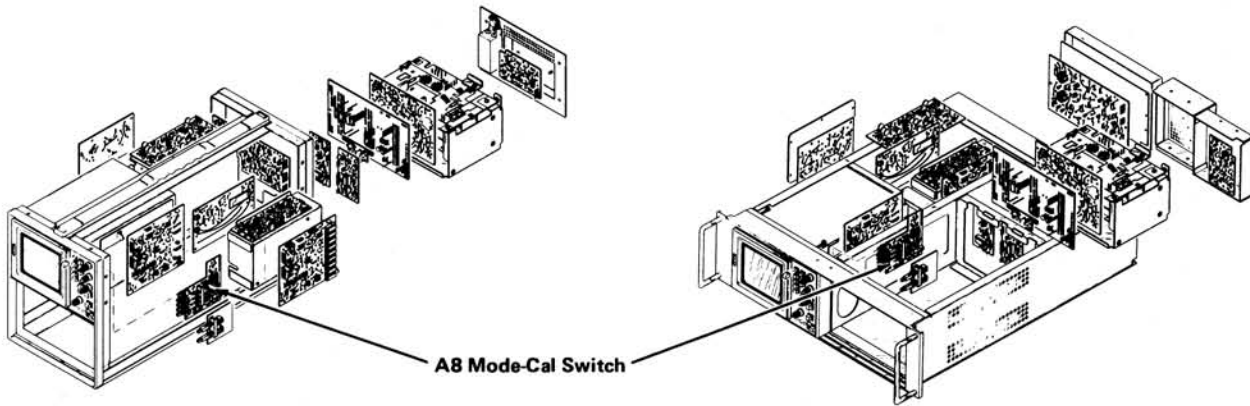

S1021
Located on back of board.

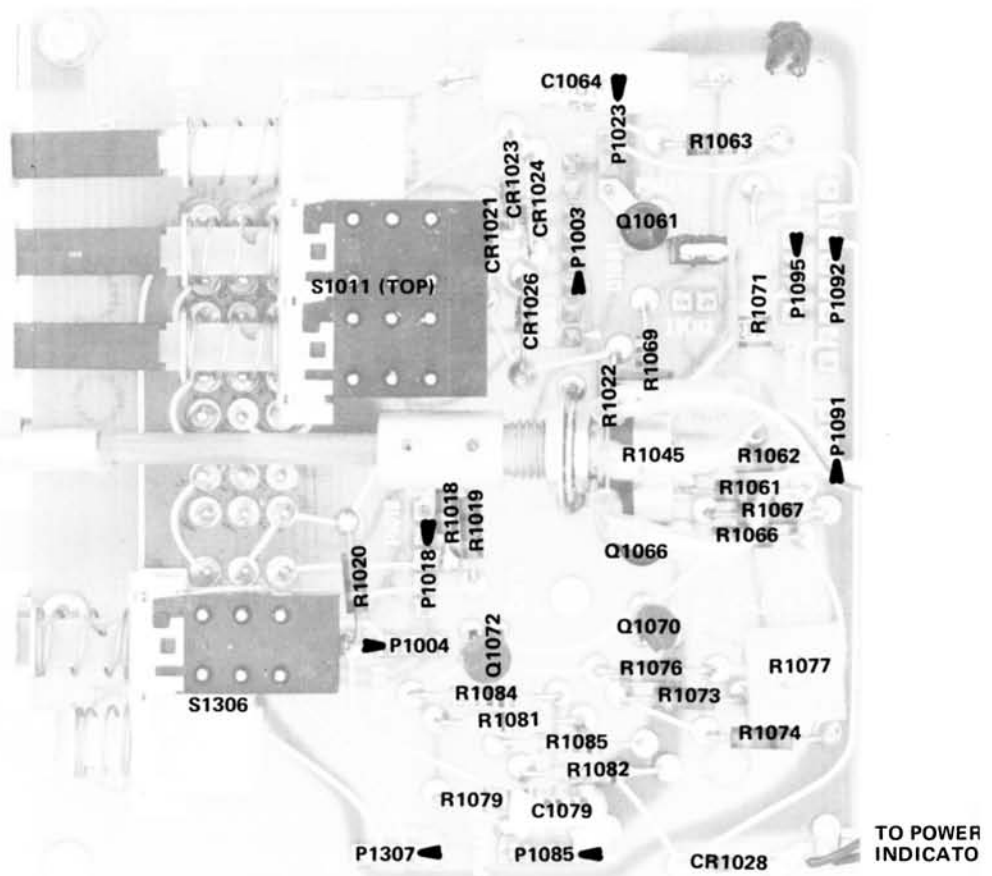

R1087
Located on back of board.

REV. MAY 1974

Fig. 6-10. A8. Calibrator-Mode Switch Circuit Board.

VOLTAGES AND WAVEFORMS

The voltages and waveforms shown on this diagram were obtained by using the recommended test equipment and test set-ups listed below.

RECOMMENDED TEST EQUIPMENT

ITEM	SPECIFICATIONS	RECOMMENDED TYPE
Oscilloscope	Frequency response DC to 65 MHz Deflection factor 5 mV to 5 V/Div Input impedance 10 M Ω , 20 pF Sweep rate 500 ns	Tektronix 7603 or 7613 equipped with 7A15A Amplifier and 7B50 Time-Base unit, or equivalent.
Probe	Fast rise 10X attenuation probe compatible with the vertical amplifier of the test oscilloscope.	Tektronix P6053A, or equivalent.
Voltmeter (Non-Loading Digital Multimeter)	Input impedance 10 M Ω Range 0 – 500 V	Tektronix 7D13 Digital Multimeter (test oscilloscope must have readout system) or Fairchild Model 7050, or equivalent.

Voltage Measurements

Voltage measurements on this diagram were made under the following conditions:

Set front panel controls (knob type) to mid-range.

Set VERT MODE for CHOP

Set TRIG SOURCE for VERT MODE

Set for NON STORE condition

No plug-in units are installed.

Voltmeter common is connected to chassis ground.

Waveforms

Waveforms shown on this diagram were obtained under the following conditions:

7613 OSCILLOSCOPE UNDER TEST. Front panel controls are set the same as for voltage measurements. A 7A15AN Vertical plug-in unit and a 7B53AN Time Base unit are installed in the mainframe under test. The 4 Volt Calibration signal from the mainframe under test is disconnected to the input of the vertical amplifier. The vertical amplifier is set for 1 V/Division deflection centered on the CRT. The 7B53AN is set for free running sweep; 1 ms/Division sweep rate.

TEST OSCILLOSCOPE. The test oscilloscope is AC coupled and internally triggered.

Tolerances of voltages and waveforms shown are 20%.

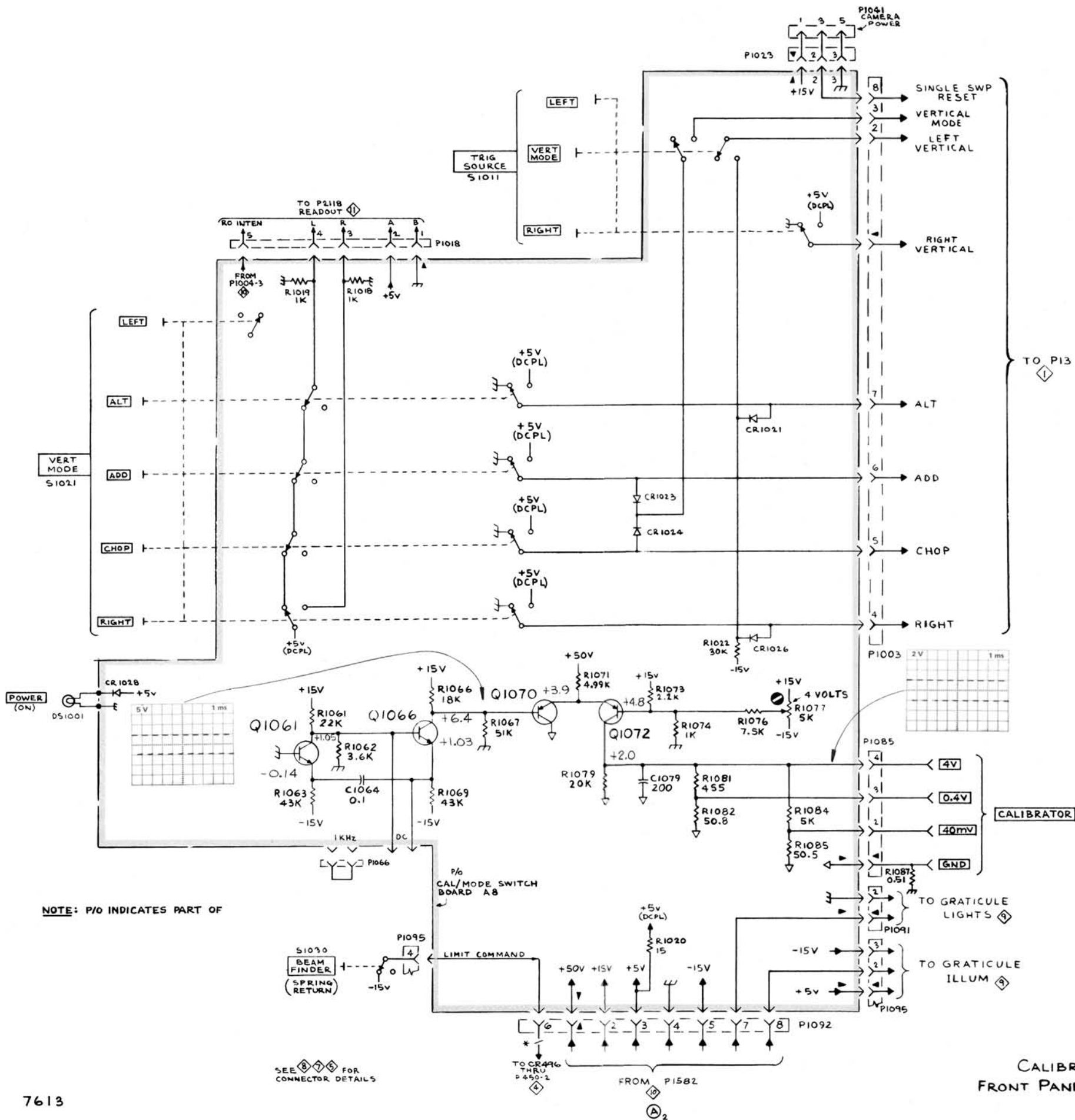

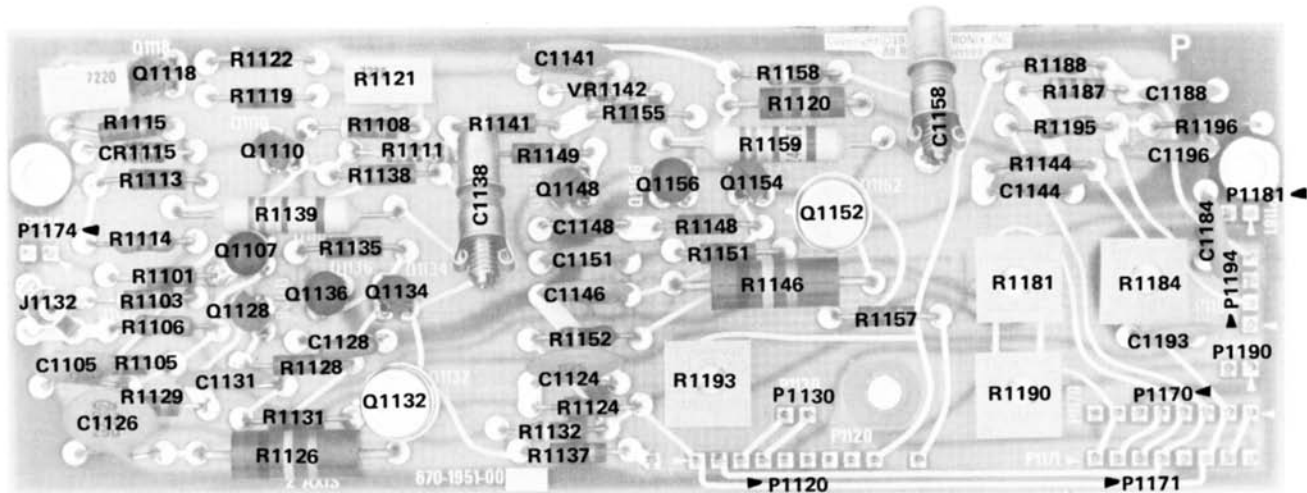
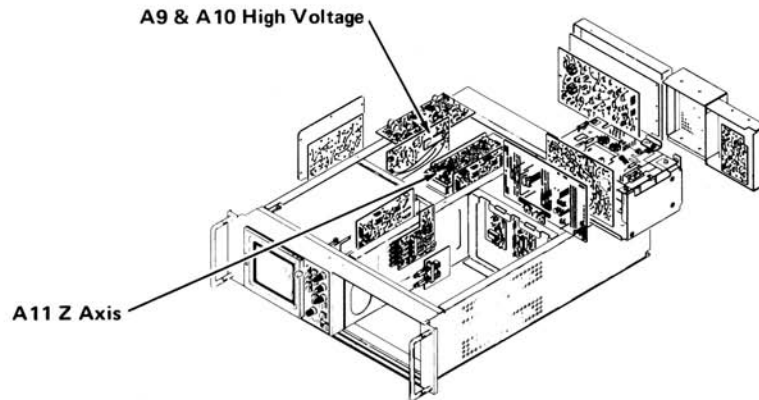

Fig. 6-12. A11. Z Axis circuit board.

REV. MAY 1974 (A)

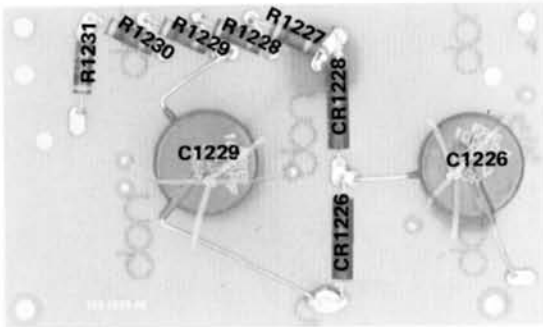

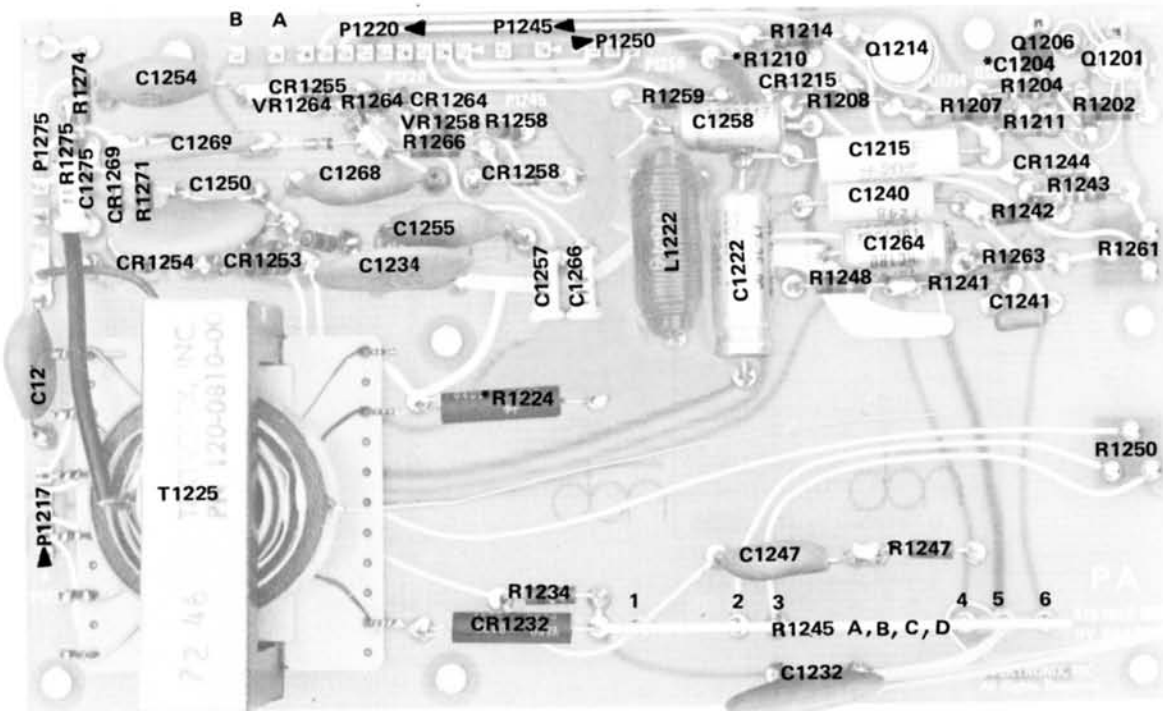

Fig. 6-11A. A9. High Voltage circuit board No. 2. 
REV. MAY 1974



*See Parts List for serial number ranges.

Fig. 6-11B. A10. High Voltage circuit board No. 1.

REV. MAY 1974

VOLTAGES AND WAVEFORMS

The voltages and waveforms shown on this diagram were obtained by using the recommended test equipment and test set-ups listed below.

RECOMMENDED TEST EQUIPMENT

ITEM	SPECIFICATIONS	RECOMMENDED TYPE
Oscilloscope	Frequency response DC to 65 MHz Deflection factor 5 mV to 5 V/Div Input impedance 10 M Ω , 20 pF Sweep rate 500 ns	Tektronix 7603 or 7613 equipped with 7A15A Amplifier and 7B50 Time-Base unit, or equivalent.
Probe	Fast rise 10X attenuation probe compatible with the vertical amplifier of the test oscilloscope.	Tektronix P6053A, or equivalent.
Voltmeter (Non-Loading Digital Multimeter)	Input impedance 10 M Ω Range 0 – 500 V	Tektronix 7D13 Digital Multimeter (test oscilloscope must have readout system) or Fairchild Model 7050, or equivalent.

Voltage Measurements

Voltage measurements on this diagram were made under the following conditions:

Set front panel controls (knob type) to mid-range.

Set VERT MODE for CHOP

Set TRIG SOURCE for VERT MODE

Set for NON STORE condition

No plug-in units are installed.

Voltmeter common is connected to chassis ground.

Waveforms

Waveforms shown on this diagram were obtained under the following conditions:

7613 OSCILLOSCOPE UNDER TEST. Front panel controls are set the same as for voltage measurements. A 7A15AN Vertical plug-in unit and a 7B53AN Time Base unit are installed in the mainframe under test. The test oscilloscope 4 Volts calibration signal is applied to the vertical amplifier. The vertical amplifier is set for 1 V/Division deflection centered on the CRT. The 7B53AN is set for free running sweep, 1 ms/Division sweep rate.

TEST OSCILLOSCOPE. The test oscilloscope is externally triggered from the +GATE OUT (MAIN) of the 7613 mainframe under test. The test oscilloscope is AC coupled.

Tolerances of voltages and waveforms shown are 20%.

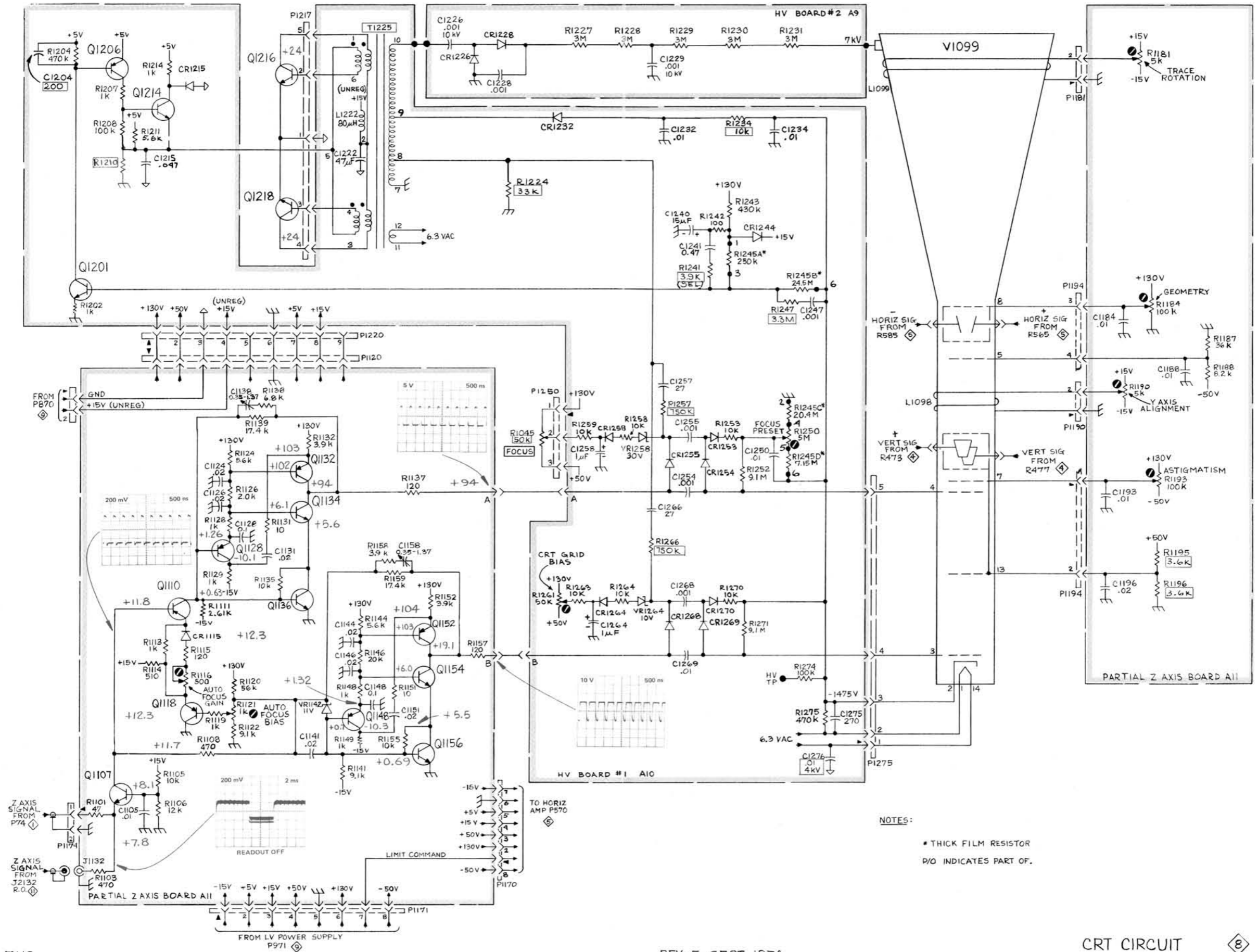

NOTES:
 * THICK FILM RESISTOR
 P/O INDICATES PART OF.

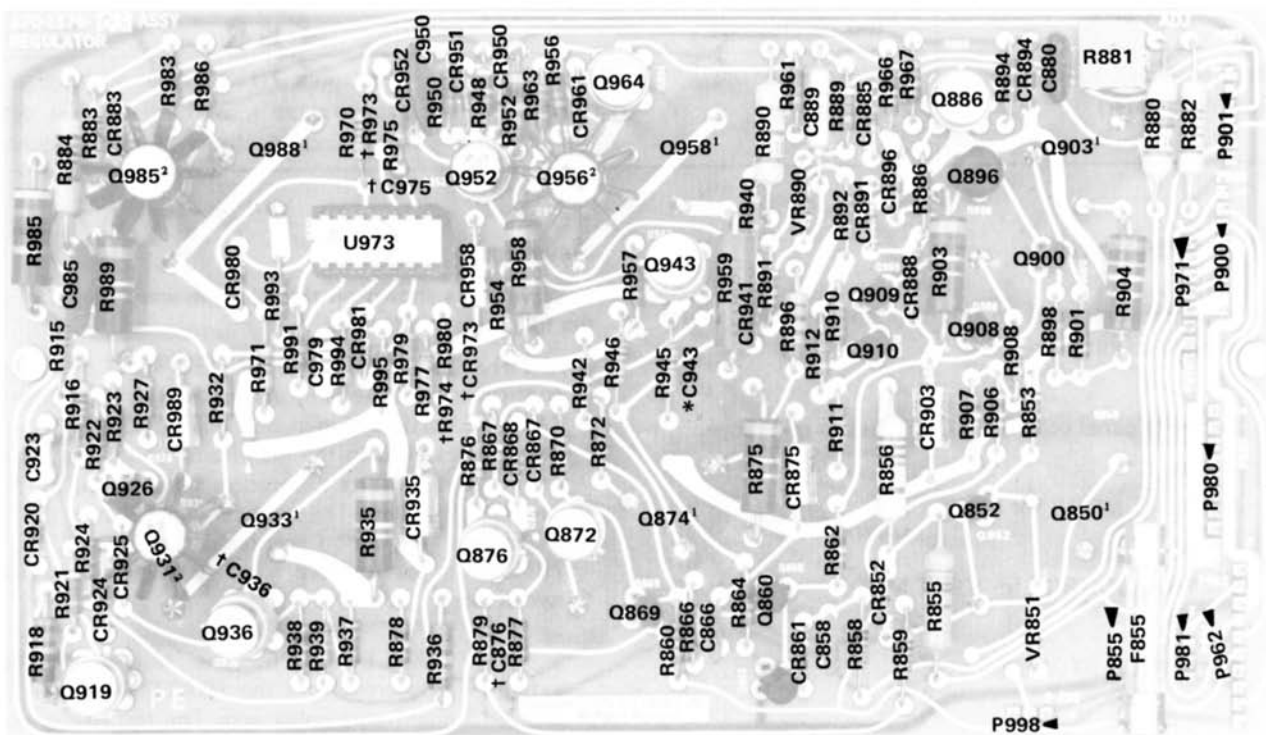

¹ Mounted on heat sink

² Have heat sinks

*See Parts List for
serial number ranges.

†Alternate location

Fig. 6-14. A14. Low-Voltage Regulator circuit board.

Located on back of board for
some serial numbers:

*C827 *CR973 R973
*C876 *CR975 *R974
*C936
*C975

REV. MAY 1974

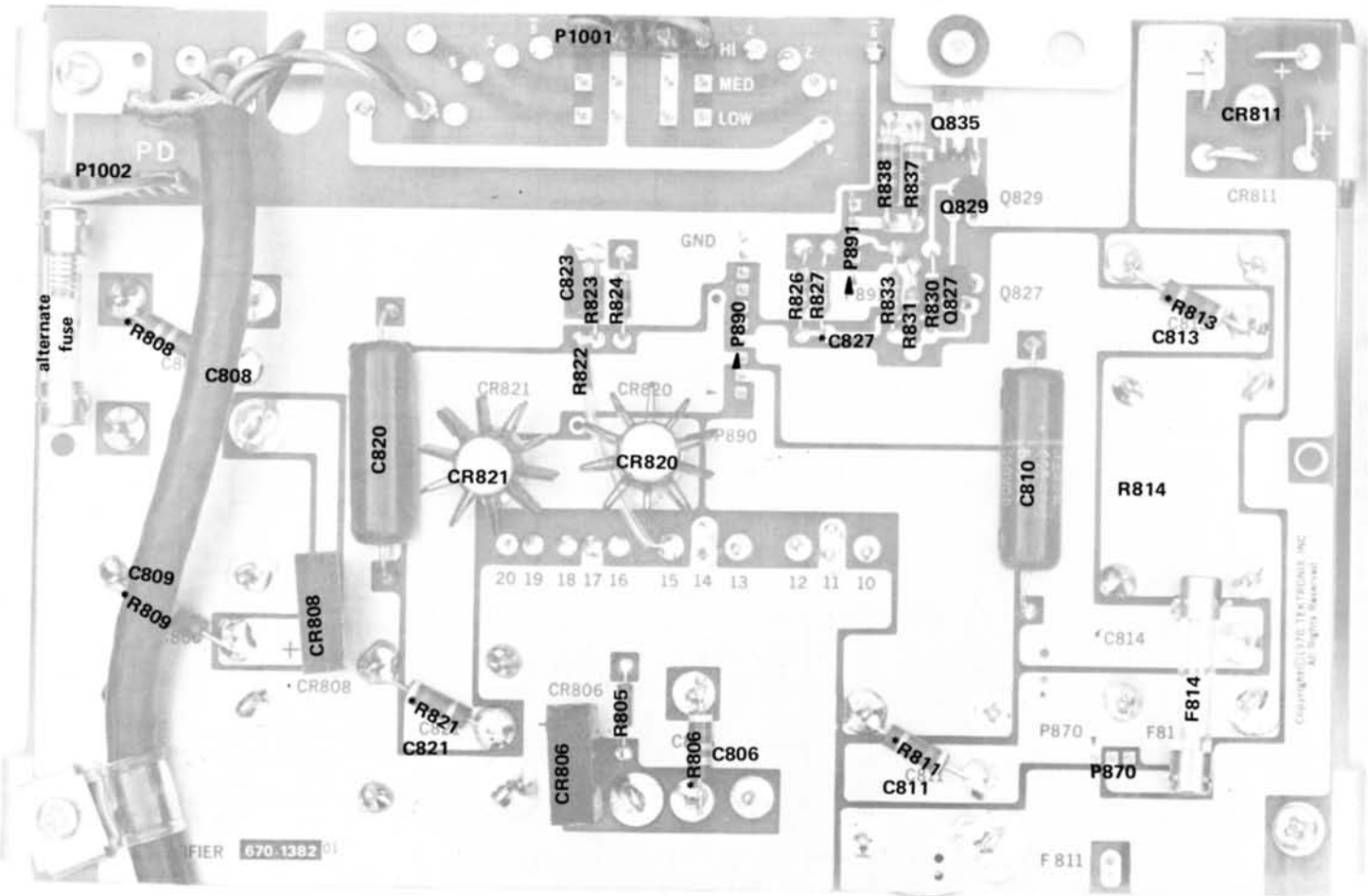
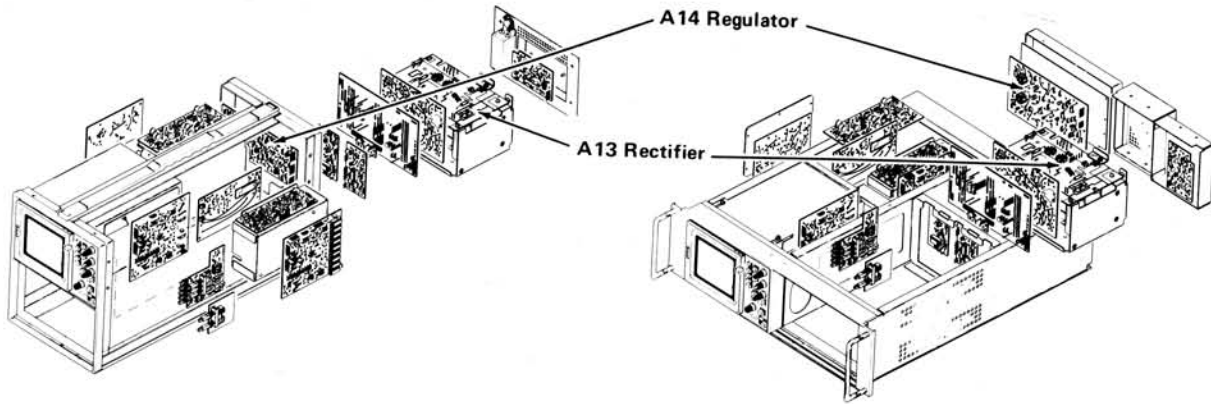

*See Parts List for serial number ranges.

Fig. 6-13B. A13. Rectifier circuit board below B090850.

REV. MAY 1974 ©

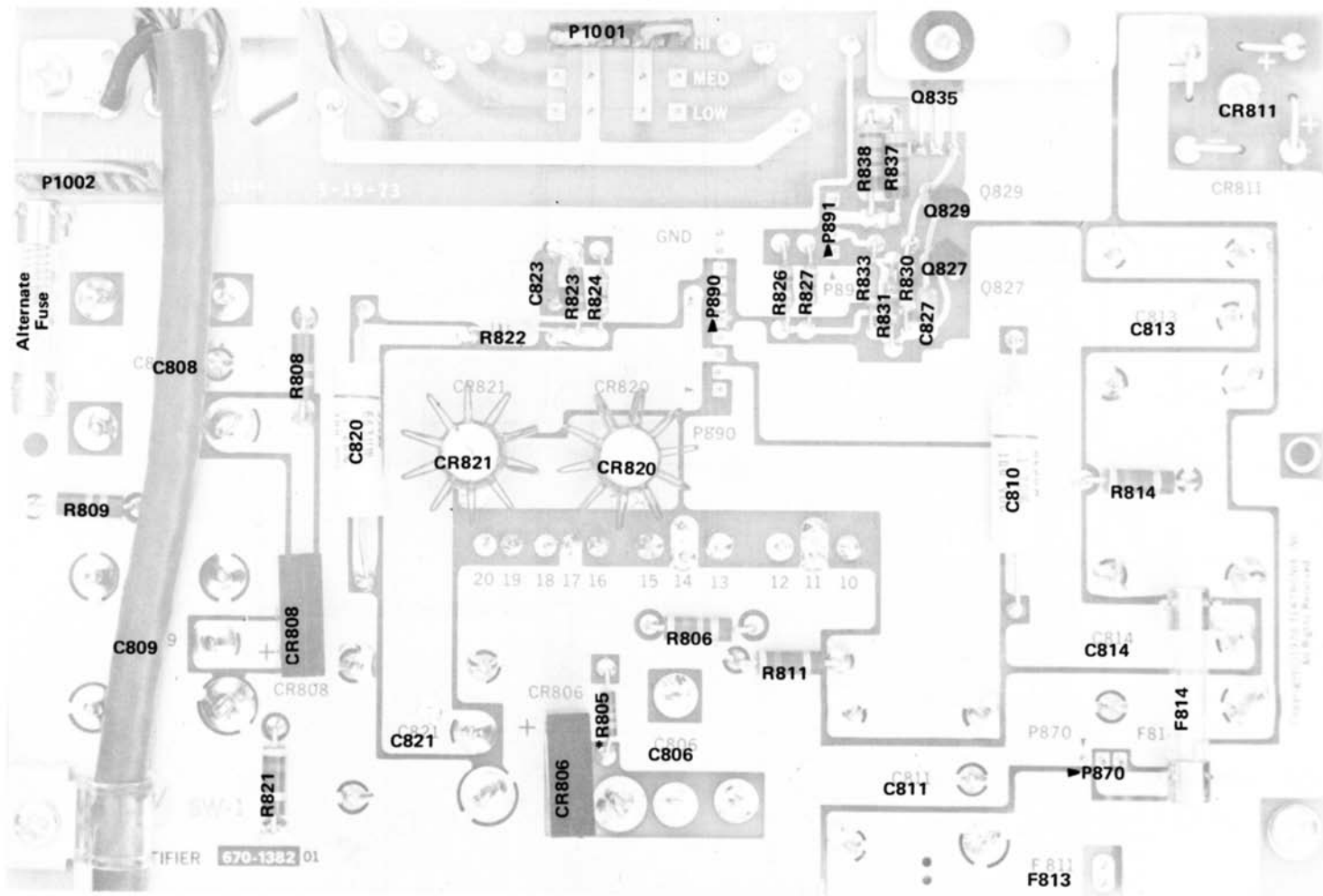

*See Parts List for
serial number ranges.

Fig. 6-13A. A13. Rectifier circuit board B090850-up.

REV. B, SEPT. 1974

VOLTAGES AND WAVEFORMS

The voltages and waveforms shown on this diagram were obtained using the recommended test equipment and test set-ups listed below.

RECOMMENDED TEST EQUIPMENT

ITEM	SPECIFICATIONS	RECOMMENDED TYPE
Oscilloscope	Frequency response DC to 65 MHz Deflection factor 5 mV to 5 V/Div Input impedance 10 MΩ, 20 pF Sweep rate 500 ns	Tektronix 7603 or 7613 equipped with 7A22 Amplifier and 7B50 Time-Base unit, or equivalent.
Probe	Fast rise 10X attenuation probe compatible with the vertical amplifier of the test oscilloscope.	Tektronix P6053A, or equivalent.
Voltmeter (Non-Loading Digital Multimeter)	Input impedance 10 MΩ Range 0 – 500 V	Tektronix 7D13 Digital Multimeter (test oscilloscope must have readout system) or Fairchild Model 7050, or equivalent.
Calibration Fixture	Used for loading power supply for ripple waveforms.	Tektronix Signal Standardizer, Tektronix Part Number 067-0587-01, or equivalent.

Voltage Measurements

Voltage measurements on this diagram were made under the following conditions:

Set knob type front panel controls (except READ-OUT) to mid-range.

Turn READOUT to off.

Set VERT MODE for CHOP.

Set for NON STORE condition.

Set TRIG SOURCE for VERT MODE.

No plug-ins are installed.

Voltmeter common is connected to chassis ground.

Waveforms

Waveforms shown on this diagram were obtained under the following conditions:

7613 OSCILLOSCOPE UNDER TEST. Front panel controls are set the same as for voltage measurements. A signal standardizer plug-in unit is installed in the vertical plug-in position and a 7B53AN Time Base unit in a horizontal position. The signal standardizer plug-in unit is used for power supply loading and is set for AUX IN with a REP RATE of 100 Hz. No signal is applied. The 7B53AN is set for free running sweep of 1 ms/Division.

TEST OSCILLOSCOPE. The test oscilloscope is AC coupled and set for LINE trigger. A 7A22 Vertical plug-in unit is installed and set as follows:

HF -3 dB POINT	30 kHz
LF -3 dB POINT	DC
+INPUT	AC
-INPUT	GND

Tolerances of voltages and waveforms shown are 20%.

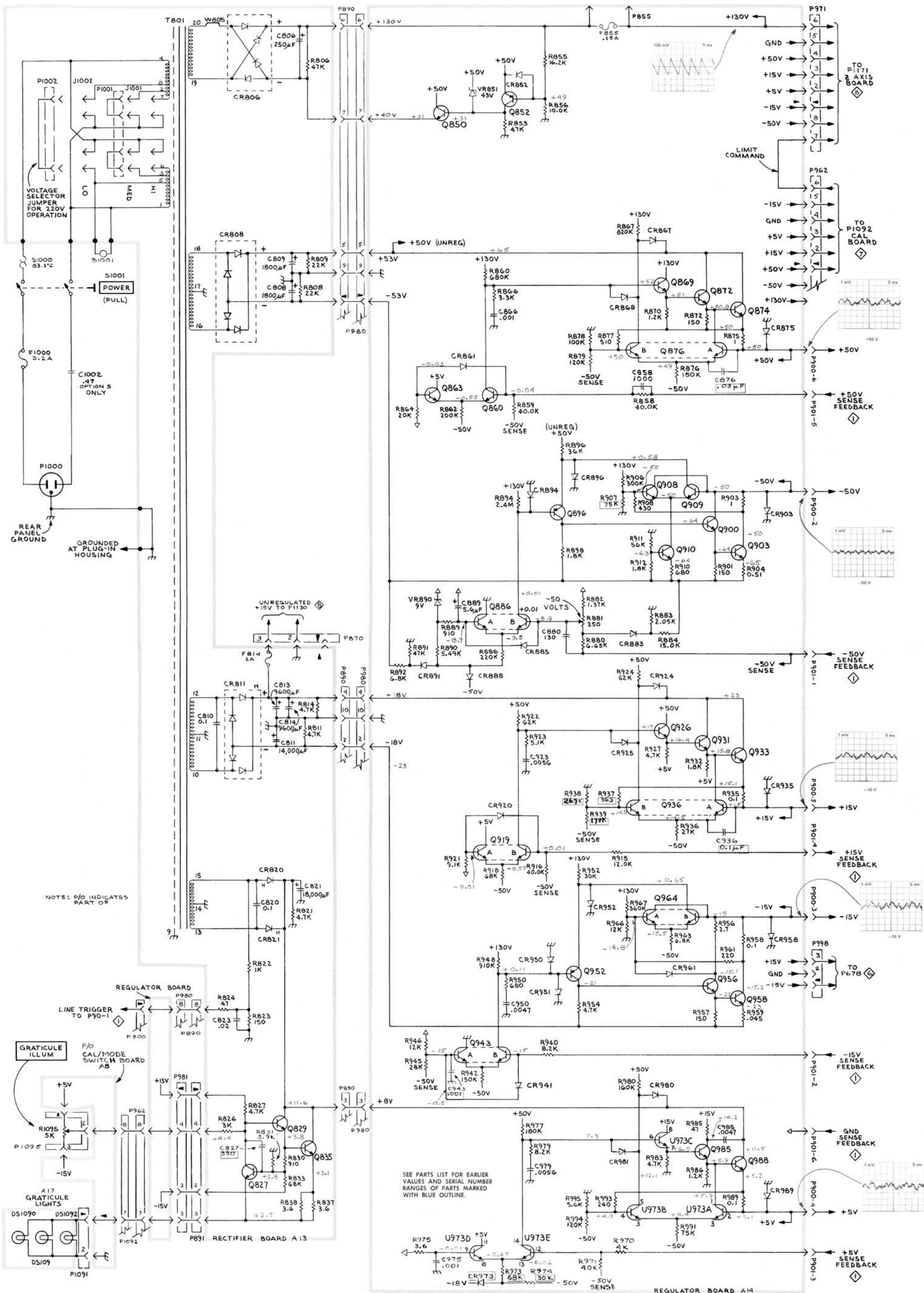

NOTE: P/O INDICATES PART OF

SEE PARTS LIST FOR EARLIER VALUES AND SERIAL NUMBER RANGES OF PARTS MARKED WITH BLUE OUTLINE.

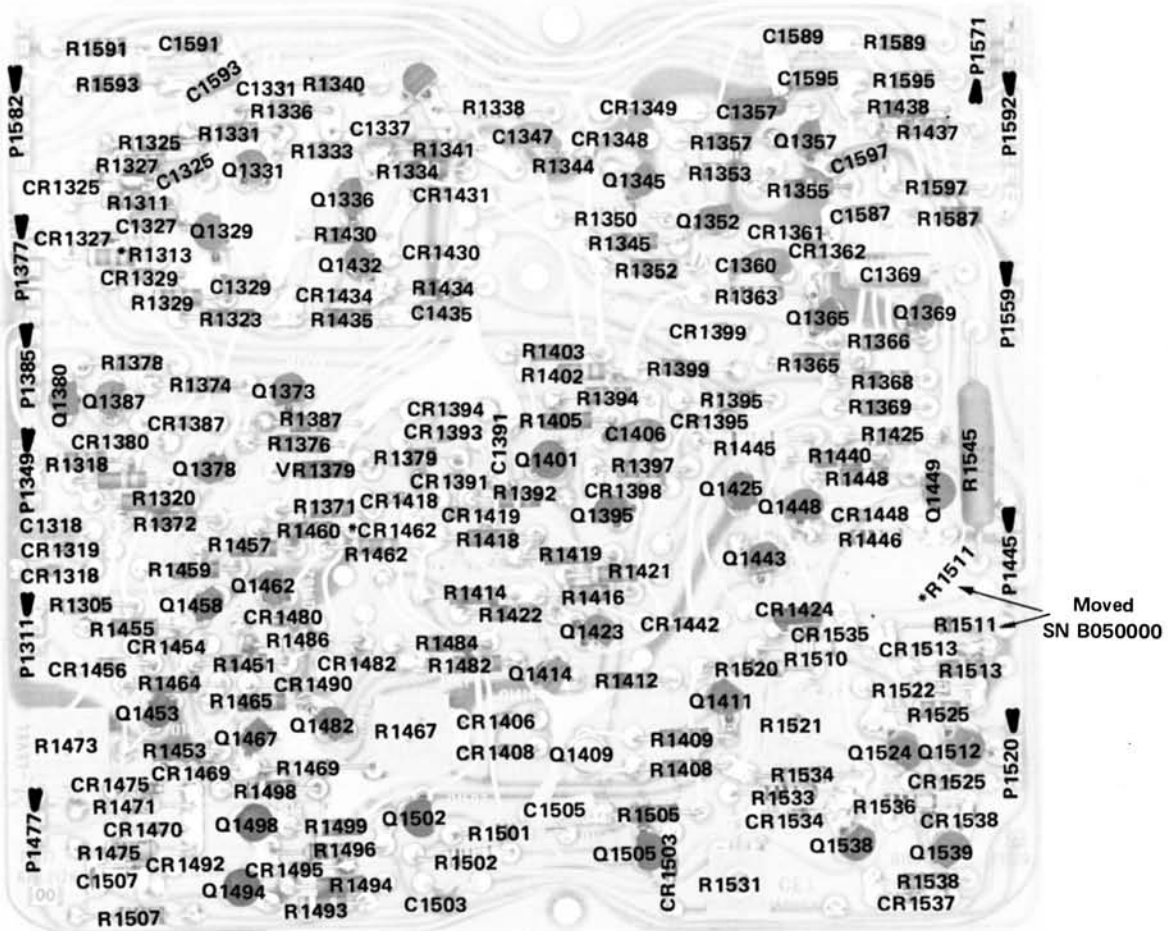
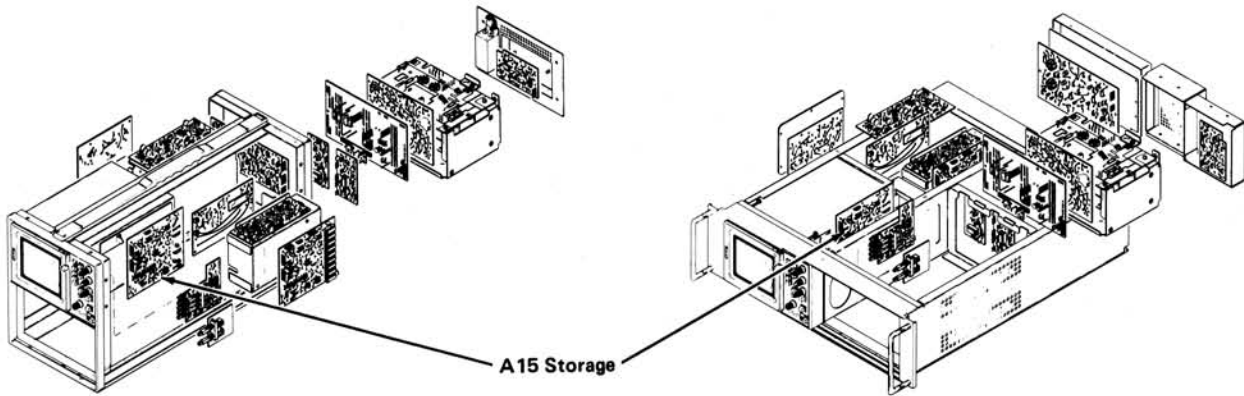

Fig. 6-15. A15. Storage circuit board.

REV. MAY 1974

*See Parts List for serial number ranges.

VOLTAGES AND WAVEFORMS

The voltages and waveforms shown on this diagram were obtained by using the recommended test equipment and test set-ups listed below.

RECOMMENDED TEST EQUIPMENT

ITEM	SPECIFICATIONS	RECOMMENDED TYPE
Oscilloscope	Frequency response DC to 65 MHz Deflection factor 5 mV to 5 V/Div Input impedance 10 M Ω , 20 pF Sweep rate 500 ns	Tektronix 7603 or 7613 equipped with 7A15A Amplifier and 7B50 Time-Base unit, or equivalent.
Probe	Fast rise 10X attenuation probe compatible with the vertical amplifier of the test oscilloscope.	Tektronix P6053A, or equivalent.
Voltmeter (Non-Loading Digital Multimeter)	Input impedance 10 M Ω Range 0 – 500 V	Tektronix 7D13 Digital Multimeter (test oscilloscope must have readout system) or Fairchild Model 7050, or equivalent.

Voltage Measurements

Voltage measurements on this diagram were made under the following conditions:

Set front panel controls (knob type) to mid-range.

Set VERT MODE for CHOP

Set TRIG SOURCE for VERT MODE

Set for STORE condition

No plug-in units are installed.

Voltmeter common is connected to chassis ground.

Waveforms

Waveforms shown on this diagram were obtained under the following conditions:

7613 OSCILLOSCOPE UNDER TEST. Front panel controls are set the same as for voltage measurements. A 7A15AN Vertical plug-in unit and a 7B53AN Time Base unit are installed in the mainframe under test. The 4 Volt Calibration signal from the mainframe under test is disconnected to the input of the vertical amplifier. The vertical amplifier is set for 1 V/Division deflection centered on the CRT. The 7B53AN is set for free running sweep; 1 ms/Division sweep rate.

TEST OSCILLOSCOPE. The test oscilloscope is AC coupled and internally triggered.

Tolerances of voltages and waveforms shown are 20%.

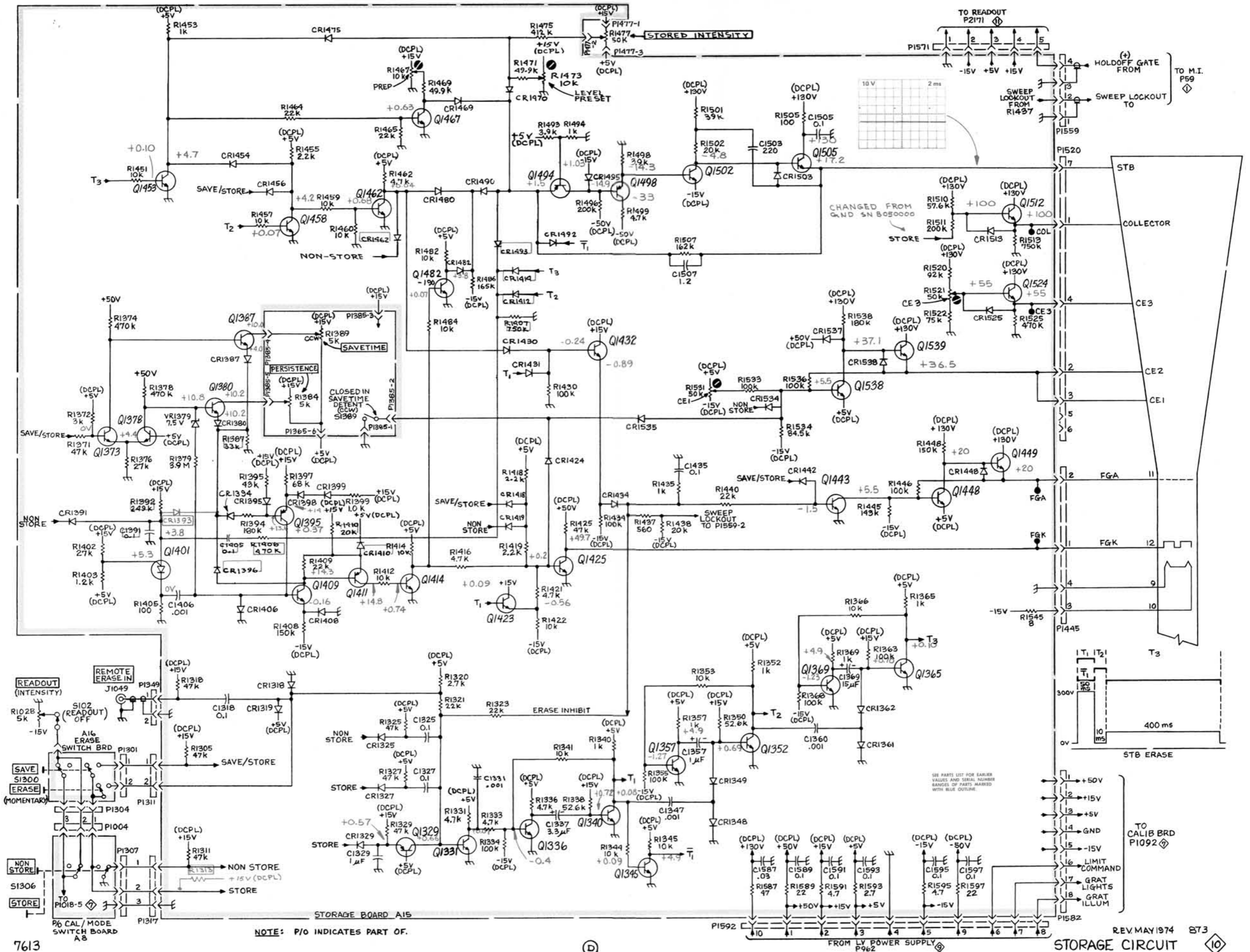

VOLTAGES AND WAVEFORMS

The voltages and waveforms shown on this diagram were obtained by using the recommended test equipment and test set-ups listed below.

RECOMMENDED TEST EQUIPMENT

ITEM	SPECIFICATIONS	RECOMMENDED TYPE
Oscilloscope	Frequency response DC to 65 MHz Deflection factor 5 mV to 5 V/Div Input impedance 10 M Ω , 20 pF Sweep rate 500 ns	Tektronix 7603 or 7613 equipped with 7A15A Amplifier and 7B50 Time-Base unit, or equivalent.
Probe	Fast rise 10X attenuation probe compatible with the vertical amplifier of the test oscilloscope.	Tektronix P6053A, or equivalent.
Voltmeter (Non-Loading Digital Multimeter)	Input impedance 10 M Ω Range 0 – 500 V	Tektronix 7D13 Digital Multimeter (test oscilloscope must have readout system) or Fairchild Model 7050, or equivalent.

Voltage Measurements

Voltage measurements on this diagram were made under the following conditions:

Set front panel controls (knob type) to mid-range.

Set VERT MODE for CHOP

Set TRIG SOURCE for VERT MODE

Set for NON STORE condition

No plug-in units are installed.

Voltmeter common is connected to chassis ground.

Waveforms

Waveforms shown on this diagram were obtained under the following conditions:

7613 OSCILLOSCOPE UNDER TEST. Front panel controls are set the same as for voltage measurements. No plug-ins are installed.

MECHANICAL PARTS LIST

Replacement parts should be ordered from the Tektronix Field Office or Representative in your area. Changes to Tektronix products give you the benefit of improved circuits and components. Please include the instrument type number and serial number with each order for parts or service.

ABBREVIATIONS

BHB	binding head brass	h	height or high	OHB	oval head brass
BHS	binding head steel	hex.	hexagonal	OHS	oval head steel
CRT	cathode-ray tube	HHB	hex head brass	PHB	pan head brass
csk	countersunk	HHS	hex head steel	PHS	pan head steel
DE	double end	HSB	hex socket brass	RHS	round head steel
FHB	flat head brass	HSS	hex socket steel	SE	single end
FHS	flat head steel	ID	inside diameter	THB	truss head brass
Fil HB	fillister head brass	lg	length or long	THS	truss head steel
Fil HS	fillister head steel	OD	outside diameter	w	wide or width

FIG. 1 FRONT & FRAME

Fig. & Index No.	Tektronix Part No.	Serial/Model No.		Q † y	Description
		Eff	Disc		
1-1	426-0514-00			1	FRAME, mask plastic
-2	378-0625-02			1	FILTER, light, CRT, gray
-3	331-0258-03			1	MASK, graticule
-4	200-0939-01			1	BEZEL, CRT
	- - - - -			-	mounting hardware: (not included w/bezel)
-5	212-0023-00			4	SCREW, 8-32 x 0.375 inch, PHS
	131-1022-00	XB0230000		2	CONTRACT, electrical, mask, CRT
-6	337-1159-00			1	SHIELD, implosion
-7	331-0245-00			1	MASK, CRT
-8	333-1691-00			1	PANEL, front
-9	386-1884-03			1	SUPPORT, CRT
	- - - - -			-	support includes:
-10	386-1517-00			4	SUPPORT, CRT, front
	- - - - -			-	mounting hardware: (not included w/support)
-11	212-0040-00	B010100	B070654	2	SCREW, 8-32 x 0.375 inch, 100° csk, FHS
	212-0040-00	B070655		1	SCREW, 8-32 x 0.375 inch, 100° csk, FHS
	212-0023-00	B070655		1	SCREW, 8-32 x 0.375 inch, PHS
-12	211-0510-00			2	SCREW, 6-32 x 0.375 inch, PHS
-13	204-0380-00			1	BODY, terminal
-14	131-0765-00			3	TERMINAL, feedthru
-15	348-0031-00			1	GROMMET, plastic, 0.156 inch, OD
-16	- - - - -			1	CIRCUIT BOARD ASSEMBLY--GRATICULE LIGHT (See A17
	- - - - -			-	electrical list)
	- - - - -			-	circuit board assembly includes:
-17	378-0614-00			1	REFLECTOR, light
-18	344-0179-00			2	CLIP, reflector
	- - - - -			-	mounting hardware for each: (not included w/clip)
-19	211-0062-00			1	SCREW, 2-56 x 0.312 inch, RHS
-20	366-1402-02			2	PUSHBUTTON--LEFT
-21	366-1402-03			1	PUSHBUTTON--ALT
-22	366-1402-04			1	PUSHBUTTON--ADD
-23	366-1257-31			1	PUSHBUTTON--CHOP

FIG. 1 FRONT & FRAME (cont)

Fig. & Index No.	Tektronix Part No.	Serial/Model No. Eff	Disc	Q					Description	
				t	y	1	2	3		4
1-24	366-1402-06			2						PUSHBUTTON--RIGHT
-25	366-1402-07			1						PUSHBUTTON--VERT MODE
-26	366-1402-08			1						PUSHBUTTON--NON STORE
-27	366-1402-18			1						PUSHBUTTON--STORE
-28	366-1402-21			1						PUSHBUTTON--SAVE
-29	366-1257-84			1						PUSHBUTTON--ERASE
-30	366-1480-01			1						PUSHBUTTON--ON
-31	136-0387-01			1						JACK, tip, black
-32	136-0387-00			3						JACK, tip, gray
-33	366-1207-00			1						KNOB, gray--STORED INTENSITY
	- - - - -			-						knob includes:
	213-0153-00			1						SETSCREW, 5-40 x 0.125 inch, HSS
-34	366-1077-00			1						KNOB, gray--INTENSITY
	- - - - -			-						knob includes:
	213-0153-00			1						SETSCREW, 5-40 x 0.125 inch, HSS
-35	366-1391-00			1						KNOB, gray--READOUT
	- - - - -			-						knob includes:
	213-0140-00			1						SETSCREW, 2-56 x 0.094 inch, HSS
-36	366-1215-00			1						KNOB, gray--GRATICULE ILLUM
	- - - - -			-						knob includes:
	213-0153-00			1						SETSCREW, 5-40 x 0.125 inch, HSS
-37	366-1059-00			1						PUSHBUTTON--BEAMFINDER
-38	366-1077-00			1						KNOB, gray--PERSISTANCE
	- - - - -			-						knob includes:
	213-0153-00			1						SETSCREW, 5-40 x 0.125 inch, HSS
-39	366-1391-00			1						KNOB, gray--SAVE TIME
	- - - - -			-						knob includes:
	213-0140-00			1						SETSCREW, 2-56 x 0.094 inch, HSS
-40	426-0681-00			13						FRAME, pushbutton
-41	358-0378-00			1						BUSHING, sleeve
-42	333-1612-00			1						PANEL, front
-43	- - - - -			1						CIRCUIT BOARD ASSEMBLY--CAL & MODE SWITCH (See A8 electrical list)
-44	131-0589-00			8						TERMINAL, pin, 0.46 inch long
	131-0608-00			37						TERMINAL, pin, 0.365 inch long
-45	136-0252-04			12						SOCKET, pin connector
-46	260-1378-00			1						SWITCH, push--VERT MODE
-47	260-1379-00			1						SWITCH, push--TRIG SOURCE
-48	260-1441-00			1						SWITCH, push--STORE, NONSTORE
-49	361-0411-00			14						SPACER, push switch
-50	- - - - -			1						RESISTOR, variable
	- - - - -			-						mounting hardware: (not included w/resistor)
-51	210-0562-00			2						NUT, hex., 0.25-40 x 0.312 inch
-52	210-0046-00			1						WASHER, lock, 0.261 ID x 0.40 inch OD
-53	386-2285-00			1						PLATE, variable resistor mounting
-54	210-0455-00			2						NUT BLOCK
	- - - - -			-						mounting hardware for each: (not included w/nut block)
-55	211-0008-00			1						SCREW, 4-40 x 0.25 inch, PHS
	- - - - -			-						mounting hardware: (not included w/circuit board assy)
-56	211-0105-00			2						SCREW, 4-40 x 0.188 inch, 100° csk, FHS
-57	211-0589-00			1						SCREW, 6-32 x 0.312 inch, PHB

FIG. 1 FRONT & FRAME (cont)

Fig. & Index No.	Tektronix Part No.	Serial/Model No.		Q f y	Description
		Eff	Disc		
1-58	385-0016-00			1	ROD, 0.312 OD x 1.0 inch long
	-----			-	mounting hardware: (not included w/post)
	211-0589-00			1	SCREW, 6-32 x 0.312 inch, PHB (not shown)
-59	384-1136-00			3	SHAFT, extension
-60	376-0150-00	B010100	B039999X	1	COUPLING, shaft
-61	384-1112-02	B010100	B039999X	1	SHAFT, extension
-62	-----			1	RESISTOR, variable
	-----			-	mounting hardware: (not included w/resistor)
	210-0583-00			1	NUT, hex., 0.25-32 x 0.312 inch
	210-0940-00			1	WASHER, flat, 0.25 ID x 0.375 OD
-63	210-0223-01			1	TERMINAL, lug, 0.25 inch ID, SE
-64	-----			3	RESISTOR, variable
	-----			-	mounting hardware for each: (not included w/resistor)
-65	210-0583-00			1	NUT, hex., 0.25-32 x 0.312 inch
-66	210-0940-00			1	WASHER, flat, 0.25 ID x 0.375 inch OD
-67	210-0046-00			1	WASHER, lock, 0.261 ID x 0.40 inch OD
-68	-----			1	CIRCUIT BOARD ASSEMBLY--NONSTORE SWITCH (See A16 electrical list)
	-----			-	circuit board assembly includes:
-69	131-0608-00			6	TERMINAL, pin, 0.365 inch long
-70	260-1442-00			1	SWITCH, push--SAVE & ERASE
-71	361-0411-00			4	SPACER, push switch
-72	220-0637-00			1	NUT BLOCK
	-----			-	mounting hardware: (not included w/nut block)
-73	211-0008-00			2	SCREW, 4-40 x 0.25 inch, PHS
	211-0001-00			2	SCREW, 2-56 x 0.25 inch, PHS
	-----			-	mounting hardware: (not included w/ckt bd assy)
	211-0105-00			2	SCREW, 4-40 x 0.188 inch, 100 deg csk, FHS
-74	386-2119-00			1	SUBPANEL, front
	-----			-	mounting hardware: (not included w/subpanel)
-75	211-0538-00			4	SCREW, 6-32 x 0.375 inch, 100° csk, FHS
	211-0589-00			2	SCREW, 6-32 x 0.312 inch, PHB
	644-0437-01			1	POWER SWITCH ASSEMBLY
	-----			-	power switch assembly includes:
-76	200-1318-00			1	COVER, power switch
-77	260-1368-01			2	SWITCH, push
-78	211-0020-00	B010100	B060759	2	SCREW, 4-40 x 1.125 inches, PHS
	211-0021-00	B060760		2	SCREW, 4-40 x 1.25 inches, PHS
-79	220-0665-00			2	NUT, self-locking, 4-40 x 0.25 inch
-80	214-1689-00			1	ACTUATOR, switch
-81	214-1226-01			1	SPRING, helical compression
	-----			-	mounting hardware: (not included w/power switch assembly)
-82	211-0538-00			2	SCREW, 6-32 x 0.312 inch, 100° csk, FHS
-83	210-0457-00			2	NUT, keps, 6-32 x 0.312 inch

Mechanical Parts List—7613/R7613 Service

FIG. 1 FRONT & FRAME

Fig. & Index No.	Tektronix Part No.	Serial/Model No.		Q t y	Description
		Eff	Disc		
1-84	407-1124-00			1	BRACKET, power switch
	- - - - -			-	mounting hardware: (not included w/bracket)
	211-0559-00			2	SCREW, 6-32 x 0.375 inch, 100° csk, FHS
-85	210-0457-00			2	NUT, keps, 6-32 x 0.312 inch
-86	210-0202-00			1	TERMINAL, lug, SE #6
-87	337-1760-00			1	SHIELD, switch
-88	384-1058-00			1	SHAFT, extension
-89	351-0295-00			3	GUIDE, slide
	- - - - -			-	mounting hardware for each: (not included w/guide)
-90	211-0101-00			1	SCREW, 4-40 x 0.25 inch, 100° csk, FHS
-91	343-0004-00			1	CLAMP, cable, 0.312 inch ID
	- - - - -			-	mounting hardware: (not included w/clamp)
-92	211-0538-00			1	SCREW, 6-32 x 0.312 inch, 100° csk, FHS
-93	210-0457-00			1	NUT, keps, 6-32 x 0.312 inch
-94	210-0863-00			1	WASHER, loop clamp
-95	210-0202-00			1	TERMINAL, lug, SE #6
	- - - - -			-	mounting hardware: (not included w/terminal)
-96	211-0504-00			1	SCREW, 6-32 x 0.25 inch, PHS
-97	210-0407-00			1	NUT, hex., 6-32 x 0.25 inch
-98	200-0728-00			2	COVER, handle end, plastic
-99	367-0108-00			1	HANDLE, carrying
	- - - - -			-	mounting hardware: (not included w/handle)
-100	212-0597-00			4	SCREW, shoulder, 10-32 x 0.355 inch long
-101	386-1624-00			2	PLATE, retaining, handle
-102	386-1283-02			2	PLATE, handle mounting plastic
	343-0006-00	XB240000		1	CLAMP, cable
	- - - - -			-	mounting hardware: (not included w/clamp)
	211-0559-00	XB240000		1	SCREW, 6-32 x 0.375 inch, 100 deg csk, FHS
	210-0457-00	XB240000		1	NUT, keps, 6-32 x 0.312 inch
-103	348-0074-00			2	FOOT, bail limiting, right fr and left r
	- - - - -			-	mounting hardware for each: (not included w/foot)
-104	211-0532-00			2	SCREW, 6-32 x 0.75 inch, Fil HS
-105	377-0119-00			4	INSERT, foot, plastic
-106	348-0073-00			2	FOOT, bail limiting, left fr and right r
	- - - - -			-	mounting hardware for each: (not included w/foot)
-107	211-0532-00			2	SCREW, 6-32 x 0.75 inch, Fil HS
-108	348-0282-00			1	FLIP-STAND, cabinet
-109	390-0204-00			1	CABINET, bottom
	- - - - -			-	mounting hardware: (not included w/cabinet)
-110	211-0503-00			2	SCREW, 6-32 x 0.188 inch. FHS

FIG. 1 FRONT & FRAME

Fig. & Index No.	Tektronix Part No.	Serial/Model No.		Q † y	Description
		Eff	Disc		
1-	352-0084-02	XB030000		1	BUSHING, " TRACE ROT "
-111	390-0345-00	B010100	B029999	2	CABINET SIDE
	390-0345-00	B030000		1	CABINET SIDE
	390-0345-01	B030000		1	CABINET SIDE, right
	- - - - -			-	each cabinet side includes:
	214-0816-00			2	LATCH ASSEMBLY
	- - - - -			-	each latch assembly includes:
-112	214-0603-01			1	PIN, securing
-113	214-0604-00			1	SPRING, latch
-114	386-0227-00			1	PLATE, index, plastic
-115	386-1151-00			1	PLATE, locking
	426-1042-00			1	FRAME ASSEMBLY
	- - - - -			-	frame assembly includes:
-116	426-0857-00			1	FRAME SECTION, cabinet, bottom right
	- - - - -			-	mounting hardware: (not included w/frame section)
	210-0782-00			5	RIVET, solid, 0.125 OD x 0.25 inch long
-117	426-0858-00			1	FRAME SECTION, cabinet, bottom left
	- - - - -			-	mounting hardware: (not included w/frame section)
	210-0782-00			5	RIVET, solid, 0.125 OD x 0.25 inch long
-118	426-0741-06			1	FRAME, cabinet, front
	- - - - -			-	mounting hardware: (not included w/frame)
	210-0782-00			4	RIVET, solid, 0.125 OD x 0.25 inch long
-119	426-0741-03			1	FRAME, cabinet, rear
	- - - - -			-	mounting hardware: (not included w/frame)
	210-0782-00			4	RIVET, solid, 0.125 OD x 0.25 inch long
-120	426-0753-00			1	FRAME SECTION, cabinet, center
-121	380-0238-00			1	HOUSING, plug-in
-122	311-0930-00			2	CONTACT, electrical, plug-in ground
	- - - - -			-	mounting hardware for each: (not included w/contact)
-123	211-0008-00			1	SCREW, 4-40 x 0.25 inch, PHS
-124	210-0586-00			1	NUT, keps, 4-40 x 0.25 inch
-125	131-0799-00			2	CONTACT, electrical, plug-in ground, upper
	- - - - -			-	mounting hardware for each: (not included w/contact)
-126	211-0008-00			1	SCREW, 4-40 x 0.25 inch, PHS
	210-0586-00			1	NUT, keps, 4-40 x 0.25 inch
-127	131-1018-00			4	CONTACT, electrical, plug-in ground
	- - - - -			-	mounting hardware for each: (not included w/contact)
-128	211-0008-00			1	SCREW, 4-40 x 0.25 inch, PHS
-129	210-0586-00			1	NUT, keps, 4-40 x 0.25 inch
-130	- - - - -			1	CIRCUIT BOARD ASSEMBLY--TRIGGER SELECTOR (See A4
	- - - - -			-	electrical list)
	- - - - -			-	circuit board assembly includes:

FIG. 1 FRONT & FRAME (cont)

Fig. & Index No.	Tektronix Part No.	Serial/Model No.		Q t y	Description
		Eff	Disc		
-131	131-0589-00			4	TERMINAL, pin, 0.46 inch long
-132	136-0252-04			15	SOCKET, pin connector, 0.178 inch long
-133	136-0260-01			1	SOCKET, integrated circuit, 16 pin
-134	136-0263-03			16	SOCKET, pin terminal
-135	211-0008-00			2	SCREW, 4-40 x 0.25 inch, PHS
-136	- - - - -			1	CIRCUIT BOARD ASSEMBLY--VERTICAL INTERFACE (See A3 electrical list)
-137	136-0252-04			15	SOCKET, pin connector, 0.178 inch long
-138	136-0263-03			18	SOCKET, pin terminal
-139	136-0260-01			1	SOCKET, integrated circuit, 16 pin
-140	211-0008-00			2	SCREW, 4-40 x 0.25 inch, PHS
-141	- - - - -			1	CIRCUIT BOARD ASSEMBLY--INTERFACE (See A1 electrical list)
-142	- - - - -			1	CIRCUIT BOARD ASSEMBLY--VERTICAL INTERCONNECT (See A1 electrical list)
-143	131-0787-00			8	TERMINAL, pin, 0.64 inch long
-144	211-0008-00			2	SCREW, 4-40 x 0.25 inch, PHS
-145	351-0213-00			2	GUIDE-POST, lock, 4-40 x 0.285 inch
-146	386-1558-00			2	SUPPORT, circuit board
-147	131-0591-00			32	TERMINAL, pin, 0.835 inch long
-148	131-0592-00			26	TERMINAL, pin, 0.855 inch long
-149	131-0608-00			85	TERMINAL, pin, 0.365 inch long
-150	129-0308-00			4	POST, hex., 4-40 x 0.188 x 0.465 inch long
-150	211-0008-00			4	SCREW, 4-40 x 0.25 inch, PHS
-150	210-0803-00	XB070000		1	WASHER, flat, 0.15 ID x 0.375 inch OD
-151	131-1003-00			2	CONNECTOR, receptacle, coaxial cable
-151	131-0767-02	B010100	B039999	2	CONNECTOR, receptacle, electrical, 76 contact
-151	131-0767-08	B040000		2	CONNECTOR, receptacle, electrical
-152	200-0950-00			2	COVER, plastic
-153	204-0365-00			1	BODY, plastic
-153	131-0726-00	B010100	B039999	38	CONTACT, straight
-153	131-0726-00	B040000		35	CONTACT, offset
-153	131-0727-00	B010100	B039999	38	CONTACT, offset
-153	131-0727-00	B040000		35	CONTACT, offset
-153	131-0899-00			4	CONTACT, short tail
-154	213-0232-00			3	SCREW, thread forming, 2-56 x 0.312 inch, PHB
-154	131-0767-00	B010100	B039999	1	CONNECTOR, receptacle, electrical, 76 contact
-154	131-0767-07	B040000		1	CONNECTOR, receptacle, electrical
-155	200-0950-00			2	COVER, plastic
-156	204-0365-02			1	BODY, plastic
-157	131-0726-00	B010100	B039999	38	CONTACT, straight
-157	131-0726-00	B040000		35	CONTACT, straight

FIGURE 1 FRONT & FRAME (cont)

Fig. & Index No.	Tektronix Part No.	Serial/Model No.		Q † y	Description
		Eff	Disc		
1-158	131-0727-00	B010100	B039999	38	CONTACT, offset
	131-0727-00	B040000		35	CONTACT, offset
	- - - - -			-	mounting hardware: (not included w/connector)
-159	123-0232-00			2	SCREW, thread forming, 2-56 x 0.312 inch, PHS
	210-0906-00			1	WASHER, fiber, 0.125 ID x 0.203 inch OD
-160	131-0804-00			1	LINK, terminal connecting, 1.17 inches long
-161	131-0805-00			2	LINK, terminal connecting, 0.90 inch long
-162	214-1568-00			2	PIN, guide
	- - - - -			-	mounting hardware for each: (not included w/pin)
-163	210-0406-00			1	NUT, hex., 4-40 x 0.188 inch
-164	210-0054-00			1	WASHER, lock, split, 0.118 ID x 0.212 OD
-165	344-0147-00			2	CLIP, plastic
	- - - - -			-	mounting hardware: (not included w/circuit board assembly)
-166	213-0034-00			9	SCREW, thread forming, 4-40 x 0.312 inch, PHS
-167	- - - - -			1	CIRCUIT BOARD ASSEMBLY--LOGIC (See A2 electrical list)
	- - - - -			-	circuit board assembly includes:
-168	131-0566-00			1	LINK, terminal connecting
-169	136-0235-00			1	SOCKET, 6 pin terminal
-170	136-0252-04			24	SOCKET, pin connector
-171	136-0260-01			1	SOCKET, integrated circuit, 16 pin
-172	136-0263-03			33	SOCKET, pin terminal
-173	136-0269-00			3	SOCKET, integrated circuit, 14 pin
-174	214-0579-00			4	TERMINAL, test point
-175	348-0278-00			2	SHIELDING GASKET, electronic

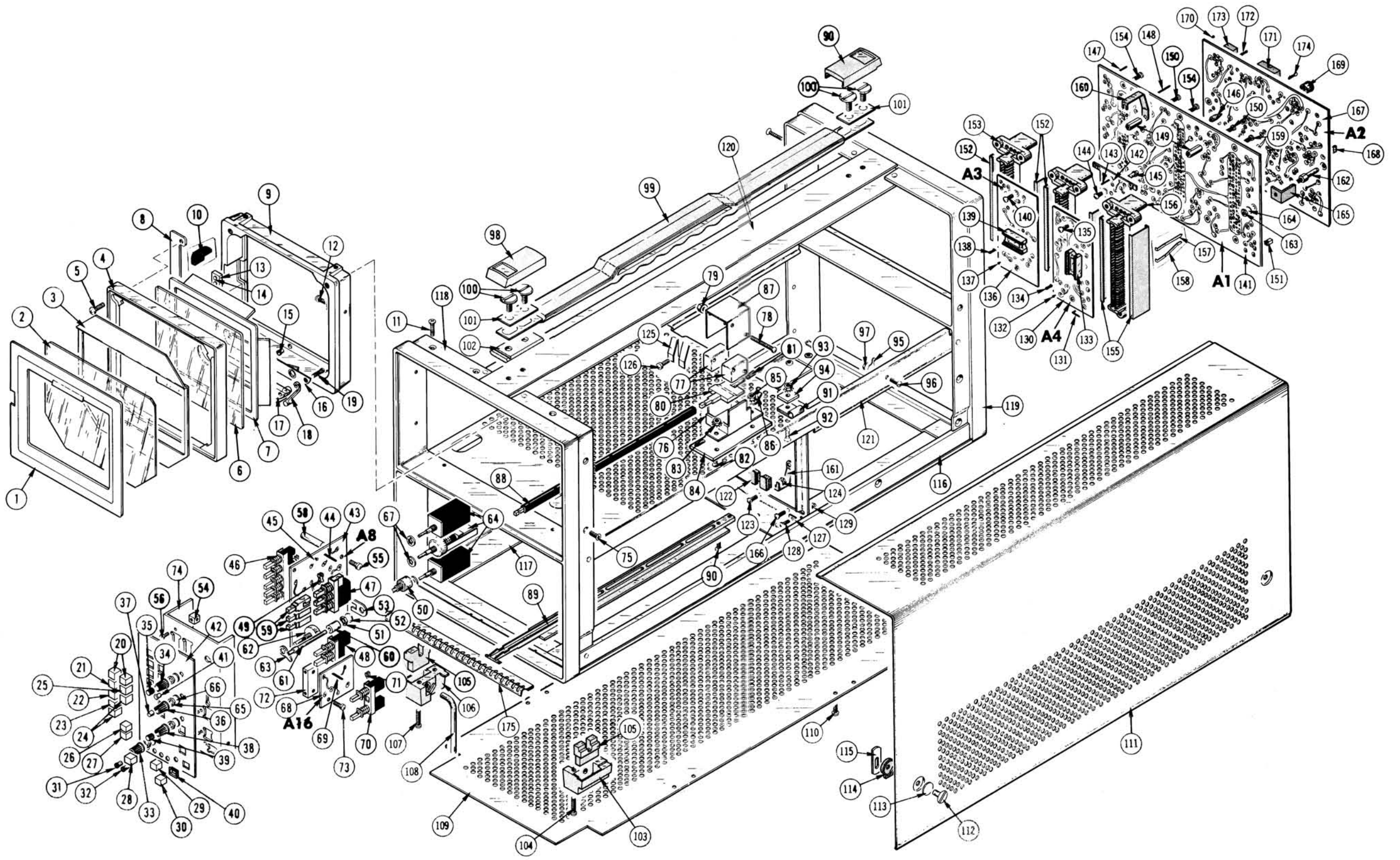

7613/R7613 STORAGE OSCILLOSCOPE

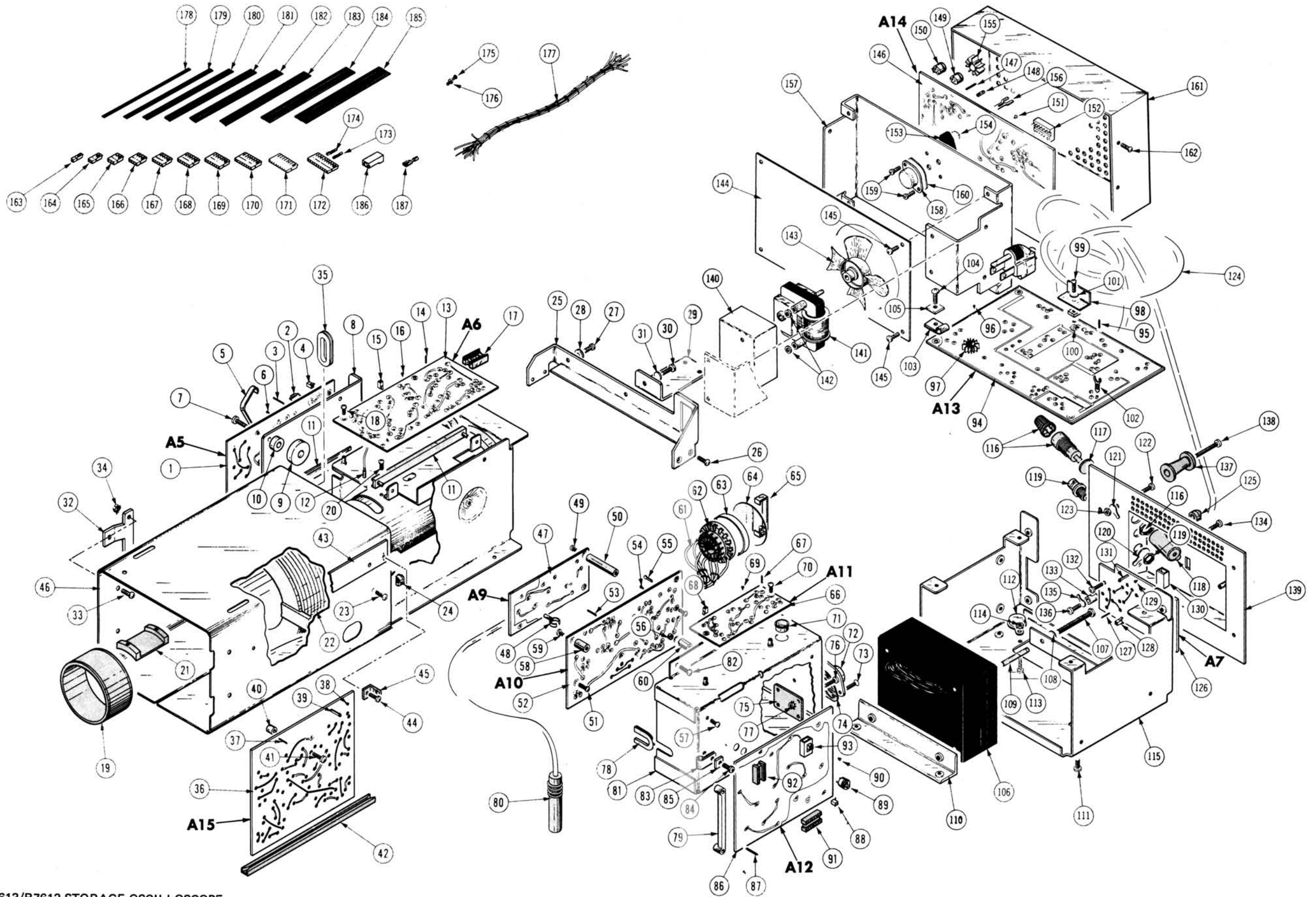

7613/R7613 STORAGE OSCILLOSCOPE

FIGURE 2 CHASSIS

Fig. & Index No.	Tektronix Part No.	Serial/Model No.		Q † y	Description
		Eff	Disc		
2-1	- - - - -			1	CIRCUIT BOARD ASSEMBLY--VERTICAL AMPLIFIER (See A5 electrical list)
-2	131-0566-00			1	LINK, terminal connecting
-3	131-0589-00			7	TERMINAL, pin, 0.50 inch long
-4	131-1003-00			1	CONNECTOR, receptacle, coaxial cable
-5	131-1303-00			1	CONTACT, electrical, integrated circuit ground
-6	136-0252-04			9	SOCKET, pin connector, 0.181 inch long
	136-0252-01			19	SOCKET, pin connector, 0.178 inch long
	- - - - -			-	mounting hardware: (not included w/circuit board assy)
-7	211-0014-00			2	SCREW, 4-40 x 0.50 inch, PHS
	211-0008-00			1	SCREW, 4-40 x 0.25 inch, PHS
-8	214-1652-00			1	HEATSINK, vertical amplifier
-9	214-1757-00			1	HEATSINK, integrated circuit
-10	361-0477-00			2	SPACER, sleeve, 0.228 ID x 0.50 OD x 0.27 inch long
-11	351-0087-00			2	GUIDE, circuit board, 4.75 inches long
-12	131-0472-01			4	CONNECTOR, pin, female
-13	- - - - -			1	CIRCUIT BOARD ASSEMBLY--HORIZONTAL AMPLIFIER (See A6 electrical list)
	- - - - -			-	electrical list)
	- - - - -			-	circuit board assembly includes:
-14	131-0608-00			17	TERMINAL, pin, 0.365 inch long
-15	131-1003-00			2	CONNECTOR, receptacle, coaxial cable
-16	136-0252-04			25	SOCKET, pin connector, 0.181 inch long
	136-0252-01			2	SOCKET, pin connector
	129-0075-00	XB020000	B069999X	1	INSULATOR, standoff
	361-0007-00	XB020000	B069999X	1	SPACER, terminal strip
-17	136-0260-01			1	SOCKET, integrated circuit, 16 pin
	- - - - -			-	mounting hardware: (not included w/circuit board assy)
-18	211-0008-00			2	SCREW, 4-40 x 0.25 inch, PHS
-19	- - - - -			1	COIL, y-axis
	- - - - -			-	mounting hardware: (not included w/coil)
-20	213-0138-00			2	SCREW, thread forming, 4-24 x 0.188 inch, PHS
-21	343-0217-00			1	CLAMP, coil, plastic
-22	119-0368-00			1	DELAY LINE ASSEMBLY
	- - - - -			-	mounting hardware: (not included w/delay line assembly)
-23	213-0034-00			2	SCREW, thread cutting, 4-40 x 0.312 inch, PHS
-24	348-0064-00			1	GROMMET, plastic, 0.625 inch diameter
-25	386-2416-00			1	SUPPORT, chassis
	- - - - -			-	mounting hardware: (not included w/support)
-26	211-0541-00			4	SCREW, 6-32 x 0.25 inch, 100° csk, PHS
	210-0457-00			4	NUT, keps, 6-32 x 0.312 inch
-27	211-0510-00			1	SCREW, 6-32 x 0.375 inch, PHS
-28	210-0993-00			1	WASHER, flat, 0.141 ID x 0.75 inch OD

FIGURE 2 CHASSIS (cont)

Fig. & Index No.	Tektronix Part No.	Serial/Model No.		Q t y	Description
		Eff	Disc		
2-29	407-1002-00			1	BRACKET, support
	- - - - -			-	mounting hardware: (not included w/bracket)
	211-0538-00			2	SCREW, 6-32 x 0.312 inch, PHS
	210-0457-00			2	NUT, keps, 6-32 x 0.312 inch
-30	211-0510-00			1	SCREW, 6-32 x 0.375 inch, PHS
-31	210-0993-00			1	WASHER, flat, 0.141 ID x 0.75 inch OD
-32	407-1001-00			1	BRACKET, CRT shield, front
	- - - - -			-	mounting hardware: (not included w/bracket)
-33	211-0589-00			2	SCREW, 6-32 x 0.375 inch, PHS
-34	210-0457-00			2	NUT, keps, 6-32 x 0.312 inch
	211-0538-00			2	SCREW, 6-32 x 0.312 inch, 100° csk, PHS
-35	255-0334-00			ft	PLASTIC CHANNEL, 3.75 inches
-36	- - - - -			1	CIRCUIT BOARD ASSEMBLY--STORAGE (See A15 electrical list)
	- - - - -			-	circuit board assembly includes:
-37	131-0608-00			52	TERMINAL, pin, 0.365 inch
-38	136-0252-04			111	SOCKET, pin connector
-39	214-0579-00			6	TERMINAL, test point
	- - - - -			-	mounting hardware: (not included w/circuit board assy)
-40	361-0527-00			1	SPACER, circuit board
-41	211-0034-00			1	SCREW, 4-40 x 0.50 inch, PHS
-42	351-0179-01			1	GUIDE, readout chassis
	- - - - -			-	mounting hardware: (not included w/guide)
	211-0101-00			2	SCREW, 4-40 x 0.25 inch, 100° csk, PHS
-43	441-1048-00			1	CHASSIS, oscilloscope
	- - - - -			-	mounting hardware: (not included w/chassis)
	211-0008-00			2	SCREW, 4-40 x 0.25 inch, PHS
-44	344-0133-00			2	CLIP, circuit board
	- - - - -			-	mounting hardware for each: (not included w/clip)
-45	213-0088-00			1	SCREW, thread forming, 4-24 x 0.25 inch, PHS
-46	- - - - -			1	SHIELD & CHASSIS ASSEMBLY
	- - - - -			-	mounting hardware: (not included w/shield & chassis assy)
	211-0589-00			2	SCREW, 6-32 x 0.312 inch, PHB
	210-0457-00 XB220000			2	NUT, keps, 6-32 x 0.312 inch
	211-0590-00 XB220000			2	SCREW, 6-32 x 0.312 inch, PHS
	621-0466-01			1	ASSEMBLY, high voltage box
	- - - - -			-	assembly includes:
-47	- - - - -			1	CIRCUIT BOARD ASSEMBLY--HIGH VOLTAGE #2 (See A9 electrical list)
	- - - - -			-	circuit board assembly includes:
-48	343-0088-00			1	CLAMP, retaining, 0.062 inch ID
	346-0032-00 B010100 B029999			2	STRAP, mousetail
	253-0011-00 B030000			ft	CORD, lacing, 10 inches
	- - - - -			-	mounting hardware: (not included w/circuit board assy)
-49	211-0040-00			1	SCREW, plastic, 4-40 x 0.25 inch, PHS

FIGURE 2 CHASSIS (cont)

Fig. & Index No.	Tektronix Part No.	Serial/Model No. Eff	Disc	Q t y	Description					
					1	2	3	4	5	
2-50	129-0251-00			4						POST, 0.25 OD x 1.125 inches long
-51	211-0008-00			3						SCREW, 4-40 x 0.25 inch, PHS
-52	- - - - -			1						CIRCUIT BOARD ASSEMBLY--HIGH VOLTAGE #1 (See A10 electrical list)
	- - - - -			-						circuit board assembly includes:
-53	131-0589-00			5						TERMINAL, pin, 0.46 inch long
	131-0608-00			19						TERMINAL, pin, 0.365 inch long
-54	136-0252-04			9						SOCKET, pin connector
-55	214-1292-00			1						TERMINAL, test point
-56	166-0292-00			2						SLEEVE, support, 0.155 OD x 0.65 inch long
	- - - - -			-						mounting hardware: (not included w/circuit board assy)
-57	211-0008-00			3						SCREW, 4-40 x 0.25 inch, PHS
-58	129-0143-00			3						POST, 0.312 OD x 0.406 inch long
	- - - - -			-						mounting hardware for each: (not included w/post)
-59	211-0008-00			1						SCREW, 4-40 x 0.25 inch, PHS
-60	129-0236-00			1						POST, hex., 0.187 x 0.375 inch long
	- - - - -			-						mounting hardware: (not included w/post)
	211-0008-00			1						SCREW, 4-40 x 0.25 inch, PHS
-61	136-0506-00			1						WIRING HARNESS, CRT socket
	- - - - -			-						wiring harness includes:
-62	136-0304-02			1						SOCKET, CRT, w/connector
-63	200-0917-01			1						COVER, CRT socket
-64	367-0117-00			1						HANDLE, CRT socket
-65	343-0235-00			1						CLAMP, CRT socket
	- - - - -			1						CIRCUIT BOARD ASSEMBLY--Z AXIS (See All electrical list)
	- - - - -			-						circuit board assembly includes:
-67	131-0608-00			36						TERMINAL, pin, 0.365 inch long
-68	131-1003-00			1						CONNECTOR, receptacle, coaxial cable
-69	136-0252-01			1						SOCKET, pin connector, 0.181 inch long
	136-0252-04			35						SOCKET, pin connector, 0.178 inch long
	- - - - -			-						mounting hardware: (not included w/circuit board assy)
-70	211-0008-00			3						SCREW, 4-40 x 0.25 inch, PHS
-71	348-0031-00			1						GROMMET, plastic, 0.485 ID x 0.50 inch OD
-72	- - - - -			2						TRANSISTOR
	- - - - -			-						mounting hardware for each: (not included w/transistor)
-73	213-0146-00			2						SCREW, thread tapping, 6-20 x 0.312 inch, PHS
-74	386-0978-00			1						PLATE, mica, 1.17 x 1.70 inches
-75	136-0280-00			2						SOCKET, transistor
	- - - - -			-						mounting hardware for each: (not included w/transistor)
-76	211-0101-00			2						SCREW, 4-40 x 0.25 inch, 100° csk, PHS
-77	210-0586-00			2						NUT, keps, 4-40 x 0.25 inch
-78	348-0012-00			1						GROMMET, rubber, 0.625 inch
	348-0085-00			1						GROMMET, plastic, U-shaped
-79	351-0324-00			2						GUIDE, circuit card
-80	131-0773-00			1						CONNECTOR, receptacle, anode lead
-81	337-1538-01			1						SHIELD, electrical, high voltage
	- - - - -			-						mounting hardware: (not included w/shield)
-82	211-0504-00			3						SCREW, 6-32 x 0.25 inch, PHS

FIGURE 2 CHASSIS (cont)

Fig. & Index No.	Tektronix Part No.	Serial/Model No.		Q					Description		
		Eff	Disc	t	y	1	2	3		4	5
2-83	343-0002-00					1					CLAMP, cable, 0.188 inch ID
											mounting hardware: (not included w/clamp)
-84	211-0503-00					1					SCREW, 6-32 x 0.312 inch, PHS
-85	210-0863-00					1					WASHER, loop clamp
-86											CIRCUIT BOARD ASSEMBLY--READOUT (See A12 electrical list)
											circuit board assembly includes:
-87	131-0608-00					42					TERMINAL, pin, 0.365 inch long
-88	131-1003-00					6					CONNECTOR, receptacle, coaxial cable
-89	136-0235-00					1					SOCKET, transistor, 6 pin
-90	136-0252-04					42					SOCKET, pin connector, 0.181 inch long
	136-0252-01					14					SOCKET, pin connector, 0.178 inch long
-91	136-0260-01					14					SOCKET, integrated circuit, 16 pin
-92	136-0269-00					3					SOCKET, integrated circuit, 14 pin
	214-0579-00					19					TERMINAL, test point
-93	260-0723-00					1					SWITCH, slide
											mounting hardware: (not included w/circuit board assy)
	211-0205-00					1					SCREW, 4-40 x 0.42 inch, RHS
	361-0527-00					1					SPACER, circuit board
-94						1					CIRCUIT BOARD ASSEMBLY--RECTIFIER (See A13 electrical list)
											circuit board assembly includes:
-95	131-0608-00					28					TERMINAL, pin, 0.365 inch long
-96	136-0252-04					6					SOCKET, pin connector, 0.181 inch long
-97	214-1292-00					2					HEATSINK, transistor
-98	214-1731-00	B010100	B050499			1					HEATSINK, transistor
	214-1731-01	B050500				1					HEATSINK, transistor, w/pem nut
											mounting hardware: (not included w/heatsink)
-99	211-0014-00					1					SCREW, 4-40 x 0.50 inch, PHS
-100	210-0586-00					1					NUT, keps, 4-40 x 0.25 inch
-101	210-0935-00					1					WASHER, fiber, 0.14 ID x 0.375 inch OD
	131-0566-00					1					CONNECTOR, link
-102	344-0154-00					4					CLIP, electrical, fuse
											mounting hardware: (not included w/circuit board assy)
	211-0507-00					2					SCREW, 6-32 x 0.312 inch, PHS
	211-0511-00					1					SCREW, 6-32 x 0.50 inch, PHS
	211-0008-00	XB050500				1					SCREW, 4-40 x 0.25 inch, PHS
-103	343-0004-00					1					CLAMP, loop, 0.312 inch ID
											mounting hardware: (not included w/clamp)
-104	211-0510-00					1					SCREW, 6-32 x 0.375 inch, PHS
-105	210-0863-00					1					WASHER, loop clamp
-106						1					TRANSFORMER
											mounting hardware: (not included w/transformer)
-107	212-0522-00					2					SCREW, 10-32 x 2.50 inches, HHS
-108	210-0812-00					2					WASHER, fiber, 0.188 ID x 0.375 inch OD
-109	166-0457-00					2					TUBE, insulating, 1.875 inches long

FIGURE 2 CHASSIS (cont)

Fig. & Index No.	Tektronix Part No.	Serial/Model No. Eff	No. Disc	Q					Description
				†	1	2	3	4	
2-110	407-0921-00			1					BRACKET, angle
	- - - - -			-					mounting hardware: (not included w/bracket)
-111	212-0023-00			2					SCREW, 8-32 x 0.375 inch, PHS
	210-0804-00	XB020734		2					WASHER, flat, 0.17 ID x 0.375 inch OD
-112	- - - - -			1					SWITCH, thermostatic
	- - - - -			-					mounting hardware: (not included w/switch)
-113	211-0008-00			2					SCREW, 4-40 x 0.25 inch, PHS
-114	210-0586-00			2					NUT, keps, 4-40 x 0.25 inch
-115	441-0993-01			1					CHASSIS, power supply
	- - - - -			-					mounting hardware: (not included w/chassis)
	212-0040-00			6					SCREW, 8-32 x 0.375 inch, 100° csk, PHS
-116	352-0076-00			1					FUSEHOLDER ASSEMBLY, w/hardware
	- - - - -			-					mounting hardware: (not included w/fuseholder assy)
-117	210-0873-00			1					WASHER, rubber, 0.50 ID x 0.487 inch OD
-118	200-1388-00			1					COVER, fuseholder
-119	131-0955-00			6					CONNECTOR, receptacle, electrical, BNC, female
	- - - - -			-					w/hardware
	- - - - -			-					mounting hardware for each: (not included w/connector)
-120	210-0255-00			1					TERMINAL, lug, SE, 0.39 inch ID
-121	210-0202-00			1					TERMINAL, lug SE #6
	- - - - -			-					mounting hardware: (not included w/terminal)
-122	211-0504-00			1					SCREW, 6-32 x 0.25 inch, PHS
-123	210-0407-00			1					NUT, hex., 6-32 x 0.25 inch
-124	161-0033-09			1					CABLE ASSEMBLY, power, electrical
-125	358-0323-00			1					BUSHING, strain relief
-126	- - - - -			1					CIRCUIT BOARD ASSEMBLY--SIGNAL OUT (See A7 electrical list)
	- - - - -			-					list)
	- - - - -			-					circuit board assembly includes:
-127	131-0608-00			11					TERMINAL, pin, 0.365 inch
-128	131-1003-00			2					CONNECTOR, receptacle, coaxial cable
-129	136-0252-01			2					SOCKET, pin connector, 0.178 inch long
	136-0252-04			27					SOCKET, pin connector, 0.181 inch long
-130	260-0984-00			1					SWITCH, slide
-131	214-0579-00			1					TERMINAL, test point
	- - - - -			-					mounting hardware: (not included w/circuit board assy)
-132	211-0008-00			2					SCREW, 4-40 x 0.25 inch, PHS
-133	385-0149-00			1					POST, 4-40 x 0.25 OD x 0.625 inch long
	- - - - -			-					mounting hardware: (not included w/post)
-134	211-0008-00			1					SCREW, 4-40 x 0.25 inch, PHS
-135	210-0201-00			1					TERMINAL, lug, SE #4
	- - - - -			-					mounting hardware: (not included w/terminal)
-136	211-0008-00			1					SCREW, 4-40 x 0.25 inch, PHS

FIGURE 2 CHASSIS (cont)

Fig. & Index No.	Tektronix Part No.	Serial/Model No.		Q t y	Description
		Eff	Disc		
2-137	348-0191-00			4	FOOT, cabinet
	- - - - -			-	mounting hardware for each: (not included w/foot)
-138	211-0529-00			1	SCREW, 6-32 x 1.125 inches, PHS
-139	386-2199-00			1	PANEL, rear
-140	337-1756-00			1	SHIELD, fan motor
-141	147-0008-00			1	MOTOR, AC
	- - - - -			-	mounting hardware: (not included w/motor)
-142	210-1112-00			2	WASHER, flat, plastic, 0.228 ID x 0.375 inch OD
	212-0557-00			2	SCREW, 10-32 x 0.50 inch, PHS
-143	369-0037-00			1	FAN, plastic, 3.50 inches diameter
-144	378-0811-00			1	BAFFLE, air
	- - - - -			-	mounting hardware: (not included w/baffle)
-145	211-0008-00			4	SCREW, 4-40 x 0.25 inch, PHS
-146	- - - - -			1	CIRCUIT BOARD ASSY--REGULATOR (See A14 elec. list)
	- - - - -			-	circuit board assembly includes;
-147	131-0608-00	B010100	B209999	45	TERMINAL, pin, 0.365 inch long
	131-0608-00	B210000		47	TERMINAL, pin, 0.365 inch long
-148	131-0847-00			12	TERMINAL, post, 0.435 inch long
-149	136-0183-00			3	SOCKET, transistor, 3 pin
-150	136-0235-00			6	SOCKET, transistor, 6 pin
-151	136-0252-04			36	SOCKET, pin connector, 0.181 inch long
-152	136-0269-00			1	SOCKET, integrated circuit, 14 pin
-153	136-0361-00			6	SOCKET, transistor
-154	136-0384-00			12	SOCKET, pin terminal
-155	214-1291-00			3	HEATSINK, transistor
-156	344-0154-00	B010100	B209999X	2	CLIP, electrical, fuse
-157	441-1129-01			1	CHASSIS, oscilloscope, heatsink
	- - - - -			-	mounting hardware: (not included w/chassis)
	211-0538-00			1	SCREW, 6-32 x 0.312 inch, 100 deg csk, FHS
	211-0507-00			2	SCREW, 6-32 x 0.25 inch, PHS
	211-0025-00			2	SCREW, 4-40 x 0.375 inch, 100 deg, csk, FHS
	343-0213-00			1	CLAMP, cable, press mounted plastic
-158	- - - - -			6	TRANSISTORS
	- - - - -			-	mounting hardware for each: (not included w/transistors)
-159	211-0511-00			2	SCREW, 6-32 x 0.50 inch, PHS
-160	386-0978-00			1	PLATE, mica, 1.17 x 1.70 inches long
-161	337-1757-00			1	SHIELD, electrical
	- - - - -			-	mounting hardware: (not included w/shield)
-162	211-0097-00			4	SCREW, 4-40 x 0.312 inch, PHS
-163	352-0171-00			5	HOLDER, terminal connector, 1 wire (black)
-164	352-0169-00			4	HOLDER, terminal connector, 2 wire (black)
	352-0169-01			3	HOLDER, terminal connector, 2 wire (brown)

FIGURE 2 CHASSIS (cont)

Fig. & Index No.	Tektronix Part No.	Serial/Model No.		Q † y	Description
		Eff	Disc		
2-	352-0169-03			2	HOLDER, terminal connector, 2 wire (orange)
	352-0169-04			2	HOLDER, terminal connector, 2 wire (yellow)
	352-0169-08			2	HOLDER, terminal connector, 2 wire (gray)
	352-0169-09			2	HOLDER, terminal connector, 2 wire (white)
-165	352-0161-00			4	HOLDER, terminal connector, 3 wire (black)
	352-0161-02			3	HOLDER, terminal connector, 3 wire (red)
	352-0161-07			2	HOLDER, terminal connector, 3 wire (purple)
	352-0161-09			2	HOLDER, terminal connector, 3 wire (white)
-166	352-0162-01			4	HOLDER, terminal connector, 4 wire (brown)
	352-0162-04			1	HOLDER, terminal connector, 4 wire (yellow)
	352-0162-05			4	HOLDER, terminal connector, 4 wire (green)
	352-0162-09			2	HOLDER, terminal connector, 4 wire (white)
-167	352-0163-00			1	HOLDER, terminal connector, 5 wire (black)
	352-0163-01			4	HOLDER, terminal connector, 5 wire (brown)
	352-0163-02			1	HOLDER, terminal connector, 5 wire (red)
	352-0163-05			5	HOLDER, terminal connector, 5 wire (green)
	352-0163-06			2	HOLDER, terminal connector, 5 wire (blue)
-168	352-0164-01			2	HOLDER, terminal connector, 6 wire (brown)
-169	352-0165-00			2	HOLDER, terminal connector, 7 wire (black)
-170	352-0166-00			4	HOLDER, terminal connector, 8 wire (black)
	352-0166-01			2	HOLDER, terminal connector, 8 wire (brown)
	352-0166-02			2	HOLDER, terminal connector, 8 wire (red)
	352-0166-03			2	HOLDER, terminal connector, 8 wire (orange)
-171	352-0167-00			2	HOLDER, terminal connector, 9 wire (black)
-172	352-0168-00			2	HOLDER, terminal connector, 10 wire (black)
	352-0168-02			2	HOLDER, terminal connector, 10 wire (red)
	352-0168-05			4	HOLDER, terminal connector, 10 wire (green)
	352-0168-07			4	HOLDER, terminal connector, 10 wire (purple)
-173	131-0707-00			337	CONNECTOR, terminal
-174	131-0708-00			14	CONNECTOR, terminal
-175	210-0775-00			9	EYELET, 0.126 OD x 0.23 inch long
-176	210-0774-00			9	EYELET, 0.152 OD x 0.245 inch long
-177	179-1825-00			1	WIRING HARNESS, vertical signal
	- - - - -			-	wiring harness includes:
	131-0707-00			2	CONNECTOR, terminal
	131-0708-00			2	CONNECTOR, terminal
	352-0162-09			1	HOLDER, terminal connector, 4 wire (white)
	210-0775-00			2	EYELET, 0.126 OD x 0.23 inch long
	210-0774-00			2	EYELET, 0.245 OD x 0.245 inch long
	179-1826-00			1	WIRING HARNESS, sweepgate
	- - - - -			-	wiring harness includes:
	131-0707-00			8	CONNECTOR, terminal
	131-0708-00			8	CONNECTOR, terminal
	352-0166-03			2	HOLDER, terminal connector, 8 wire (orange)
	179-1828-00			1	WIRING HARNESS, reset
	- - - - -			-	wiring harness includes:
	131-0707-00			2	CONNECTOR, terminal
	131-0708-00			2	CONNECTOR, terminal
	352-0169-05			1	HOLDER, terminal, holder, 2 wire (green)
	352-0169-09			1	HOLDER, terminal holder, 2 wire (white)
-178	175-0825-00			ft	WIRE, electrical, 2 wire ribbon, 22 inches
-179	175-0826-00			ft	WIRE, electrical, 3 wire ribbon, 80 inches
-180	175-0827-00			ft	WIRE, electrical, 4 wire ribbon, 21 inches

FIGURE 2 CHASSIS (cont)

Fig. & Index No.	Tektronix Part No.	Serial/Model Eff No. Disc	Q					Description	
			t	1	2	3	4		5
2-181	175-0828-00		ft						WIRE, electrical, 5 wire ribbon, 41 inches
-182	175-0829-00		ft						WIRE, electrical, 6 wire ribbon, 15 inches
-183	175-0830-00		ft						WIRE, electrical, 7 wire ribbon, 7 inches
-184	175-0831-00		ft						WIRE, electrical, 8 wire ribbon, 98 inches
-185	175-0833-00		ft						WIRE, electrical, 10 wire ribbon, 67 inches
	175-0855-00		ft						WIRE, electrical, 10 wire ribbon, 12 inches
-186	200-1075-00		4						COVER, terminal plastic
-187	131-0861-00		4						CONNECTOR, quick disconnect

FIGURE 3/R7613 FRONT & FRAME

Fig. & Index No.	Tektronix Part No.	Serial/Model No. Eff	Disc	Q					Description	
				f	y	1	2	3		4
3-1	426-0514-00			1						1 FRAME, mask, plastic
-2	378-0625-08			1						1 FILTER, light, CRT
-3	331-0258-03			1						1 MASK, graticule
-4	200-0939-01			1						1 BEZEL, CRT
	- - - - -			-						mounting hardware: (not included w/bezel)
-5	212-0023-00			4						4 SCREW, 8-32 x 0.375 inch, PHS
	131-1022-00	B230000		2						2 CONTACT, electrical, mask, CRT
-6	337-1159-00			1						1 SHIELD, implosion
-7	331-0245-00			1						1 MASK, CRT
-8	333-1509-00			1						1 PANEL, front, left
-9	386-1884-03			1						1 SUPPORT, CRT, front
	- - - - -			-						suppot includes:
-10	386-1517-00			4						4 SUPPORT, CRT, front
	- - - - -			-						mounting hardware: (not included w/support)
-11	212-0040-00			2						2 SCREW, 8-32 x 0.375 inch, 100° csk, FHS
	211-0589-00			2						2 SCREW, 6-32 x 0.312 inch, PHB
-12	211-0510-00			2						2 SCREW, 6-32 x 0.375 inch, PHS
-13	204-0380-00			1						1 BODY, terminal
-14	131-0765-00			3						3 TERMINAL, feedthru
-15	348-0031-00			1						1 GROMMET, plastic, 0.156 inch, OD
-16	- - - - -			1						1 CIRCUIT BOARD ASSEMBLY--GRATICULE LIGHT (See A17 electrical list)
	- - - - -			-						circuit board assembly includes:
-17	378-0614-00			1						1 REFLECTOR, light
-18	344-0179-00			2						2 CLIP, reflector
	- - - - -			-						mounting hardware for each: (not included w/clip)
-19	211-0062-00			1						1 SCREW, 2-56 x 0.312 inch, RHS
-20	366-1402-02			2						2 PUSHBUTTON--LEFT
-21	366-1402-03			1						1 PUSHBUTTON--ALT
-22	366-1402-04			1						1 PUSHBUTTON--ADD
-23	366-1257-31			1						1 PUSHBUTTON--CHOP
-24	366-1402-06			2						2 PUSHBUTTON--RIGHT
-25	366-1402-07			1						1 PUSHBUTTON--VERT MODE
-26	366-1402-08			1						1 PUSHBUTTON--NON STORE
-27	366-1402-18			1						1 PUSHBUTTON--STORE
-28	366-1402-21			1						1 PUSHBUTTON--SAVE
-29	366-1257-84			1						1 PUSHBUTTON--ERASE
-30	366-1480-01			1						1 PUSHBUTTON--ON
-31	136-0387-01			1						1 JACK, tip, black
-32	136-0387-00			3						3 JACK, tip, gray
-33	366-1207-00			1						1 KNOB, gray--STORED INTENSITY
	- - - - -			-						knob includes:
	213-0153-00			1						1 SETSCREW, 5-40 x 0.125 inch, HSS
-34	366-1077-00			1						1 KNOB, gray--INTENSITY
	- - - - -			-						knob includes:
	213-0153-00			1						1 SETSCREW, 5-40 x 0.125 inch, HSS
-35	366-1391-00			1						1 KNOB, gray--READOUT
	- - - - -			-						knob includes:
	213-0140-00			1						1 SETSCREW, 2-56 x 0.094 inch, HSS

FIGURE 3/R7613 FRONT & FRAME (cont)

Fig. & Index No.	Tektronix Part No.	Serial/Model No.		Q					Description		
		Eff	Disc	t	y	1	2	3		4	5
3-36	366-1215-00					1					1 KNOB, gray--GRATICULE ILLUM
	- - - - -					-					knob includes:
	213-0153-00					1					1 SETSCREW, 5-40 x 0.125 inch, HSS
-37	366-1059-00					1					1 PUSHBUTTON--BEAMFINDER
-38	366-1077-00					1					1 KNOB, gray--PERSISTANCE
	- - - - -					-					knob includes:
	213-0153-00					1					1 SETSCREW, 5-40 x 0.125 inch, HSS
-39	366-1391-00					1					1 KNOB, gray--SAVE TIME
	- - - - -					-					knob includes:
	213-0140-00					1					1 SETSCREW, 2-56 x 0.094 inch, HSS
-40	426-0681-00					13					FRAME, pushbutton
-41	358-0378-00					1					1 BUSHING, sleeve
-42	333-1612-00					1					1 PANEL, front
-43	- - - - -					1					1 CIRCUIT BOARD ASSEMBLY--CAL & MODE SWITCH See A8
	- - - - -					-					electrical list)
	- - - - -					-					circuit board assembly includes:
-44	131-0589-00					8					8 TERMINAL, pin, 0.46 inch long
	131-0608-00					37					37 TERMINAL, pin, 0.365 inch long
-45	136-0252-04					12					12 SOCKET, pin connector
-46	260-1378-00					1					1 SWITCH, push--VERT MODE
-47	260-1379-00					1					1 SWITCH, push--TRIG SOURCE
-48	260-1441-00					1					1 SWITCH, push--STORE, NONSTORE
-49	361-0411-00					14					14 SPACER, push switch
-50	- - - - -					1					1 RESISTOR, variable
	- - - - -					-					mounting hardware: (not included w/resistor
-51	210-0562-00					2					2 NUT, hex., 0.25-40 x 0.312 inch
-52	210-0046-00					1					1 WASHER, lock, 0.261 ID x 0.40 inch OD
-53	386-2285-00					1					1 PLATE, variable resistor mounting
-54	220-0455-00					2					2 NUT BLOCK
	- - - - -					-					mounting hardware for each: (not included w/nut block)
-55	211-0008-00					1					1 SCREW, 4-40 x 0.25 inch, PHS
	- - - - -					-					mounting hardware: (not included w/circuit board assy)
-56	211-0105-00					2					2 SCREW, 4-40 x 0.188 inch, 100° csk, FHS
-57	211-0589-00					1					1 SCREW, 6-32 x 0.312 inch, PHB
-58	385-0016-00					1					1 ROD, 0.312 OD x 1.0 inch long
	- - - - -					-					mounting hardware: (not included w/post)
	211-0589-00					1					1 SCREW, 6-32 x 0.312 inch, PHB (not shown)
-59	384-1136-00					3					3 SHAFT, extension, pushbutton
-60	376-0150-00	B010100	B039999X			1					1 COUPLING, shaft
-61	384-1112-01	B010100	B039999X			1					1 SHAFT, extension
-62	- - - - -					1					1 RESISTOR, variable
	- - - - -					-					mounting hardware: (not included w/resistor)
	210-0583-00					1					1 NUT, hex., 0.25-40 x 0.312 inch
	210-0940-00					1					1 WASHER, flat, 0.25 ID x 0.375 OD
-63	210-0223-01					1					1 TERMINAL, lug, 0.25 inch ID, SE

FIGURE 3/R7613 FRONT & FRAME (cont)

Fig. & Index No.	Tektronix Part No.	Serial/Model No.		Q t y	Description
		Eff	Disc		
3-64	- - - - -			3	RESISTOR, variable
	- - - - -			-	mounting hardware for each: (not included w/resistor)
	210-0583-00			1	NUT, hex., 0.25-40 x 0.312 inch
	210-0940-00			1	WASHER, flat, 0.25 ID x 0.375 OD
-65	210-0046-00			1	WASHER, lock, 0.261 ID x 0.40 inch OD
-66	- - - - -			1	CIRCUIT BOARD ASSEMBLY--NON STORE SWITCH (See A16 electrical list)
	- - - - -			-	circuit board assembly includes:
-67	131-0608-00			6	TERMINAL, pin, 0.365 inch long
-68	260-1442-00			1	SWITCH, push--SAVE & ERASE
-69	361-0411-00			4	SPACER, push switch
-70	220-0637-00			1	NUT, block
	- - - - -			-	mounting hardware: (not included w/nut)
-71	211-0008-00			2	SCREW, 4-40 x 0.25 inch, PHS
	211-0001-00			2	SCREW, 2-56 x 0.25 inch, PHS
	- - - - -			-	mounting hardware: (not included w/ckt bd assy)
	211-0105-00			2	SCREW, 4-40 x 0.188 inch, 100 deg csk, FHS
-72	386-2119-00			1	SUBPANEL, front
	- - - - -			-	mounting hardware: (not included w/subpanel)
-73	211-0538-00			4	SCREW, 6-32 x 0.375 inch, 100° csk, FHS
	211-0589-00			2	SCREW, 6-32 x 0.312 inch, PHS
	644-0437-01			1	POWER SWITCH ASSEMBLY
	- - - - -			-	power switch assembly includes:
-74	200-1318-00			1	COVER, switch
-75	260-1368-01			2	SWITCH, push
-76	211-0020-00	B010100	B060759	2	SCREW, 4-40 x 1.125 inches, PHS
	211-0021-00	B060760		2	SCREW, 4-40 x 1.25 inches, PHS
-77	220-0665-00			2	NUT, self-locking, 4-40 x 0.25 inch
-78	214-1689-00			1	ACTUATOR, switch
-79	214-1226-01			1	SPRING, helical compression
	- - - - -			-	mounting hardware: (not included w/power switch assy)
-80	210-0586-00			1	NUT, keps, 4-40 x 0.25 inch
-81	210-0201-00			1	TERMINAL, lug, SE #4
-82	337-1760-00			1	SHIELD, switch
-83	384-1183-00			1	SHAFT, extension
	352-0084-03	XB030000		1	BUSHING, "TRACE ROT"
-84	390-0229-00	B010100	B029999	1	CABINET TOP, oscilloscope
	390-0229-01	B030000		1	CABINET TOP, oscilloscope
	- - - - -			-	mounting hardware: (not included w/cabinet top)
	211-0008-00			6	SCREW, 4-40 x 0.25 inch, PHS
-85	211-0559-00			2	SCREW, 6-32 x 0.375 inch, 100° csk, FHS
-86	351-0295-02			3	GUIDE, slide
	- - - - -			-	mounting hardware for each: (not included w/guide)
-87	211-0105-00			1	SCREW, 4-40 x 0.188 inch, 100° csk, FHS
	211-0101-00			1	SCREW, 4-40 x 0.25 inch, 100° csk, FHS

Mechanical Parts List--7613/R7613 Service

FIGURE 3/R7613 FRONT & FRAME (cont)

Fig. & Index No.	Tektronix Part No.	Serial/Model No. Eff	Disc	Q					Description	
				†	Y	1	2	3		4
3-88	200-1401-00			1						COVER, access, readout
	- - - - -			-						mounting hardware: (not included w/cover)
-89	211-0101-00			5						SCREW, 4-40 x 0.25 inch, 100° csk, FHS
-90	351-0305-01			3						GUIDE, plug-in
	- - - - -			-						mounting hardware for each: (not included w/guide)
-91	211-0105-00			1						SCREW, 4-40 x 0.188 inch, 100° csk, FHS
-92	367-0138-00			2						HANDLE, bow
	- - - - -			-						mounting hardware for each: (not included w/handle)
-93	212-0518-00			2						SCREW, 10-32 x 0.312 inch, PHS
-94	386-2054-00			1						SUPPORT, power supply
	- - - - -			-						mounting hardware: (not included w/support)
	211-0101-00			2						SCREW, 4-40 x 0.25 inch, 100° csk, FHS
-95	200-1448-00			1						COVER, access, vertical
	- - - - -			-						mounting hardware: (not included w/cover)
-96	211-0101-00			6						SCREW, 4-40 x 0.25 inch, 100° csk, FHS
-97	351-0313-00			lpr						GUIDE, rackmount, 19.218 inches long (pair)
	- - - - -			-						mounting hardware: (not included w/guide)
-98	210-0458-00			9						NUT, keps, 8-32 x 0.344 inch
-99	- - - - -			-						CIRCUIT BOARD ASSEMBLY--REGULATOR (See A14 electrical list)
	- - - - -			-						circuit board assembly includes:
-100	131-0608-00			45						TERMINAL, pin, 0.365 inch long
-101	131-0847-00			12						TERMINAL, post, 0.435 inch long
-102	136-0183-00			3						SOCKET, transistor, 3 pin
-103	136-0235-00			6						SOCKET, transistor, 6 pin
-104	136-0252-04			36						SOCKET, pin connector, 0.181 inch long
-105	136-0269-00			1						SOCKET, integrated circuit, 14 pin
-106	136-0361-00			6						SOCKET, transistor
	136-0384-00			12						SOCKET, pin terminal
-107	214-1291-00			3						HEATSINK, transistor
-108	344-0154-00			2						CLIP, electrical, fuse
-109	441-1060-01			1						CHASSIS, oscilloscope, heatsink
	- - - - -			-						mounting hardware: (not included w/chassis)
-110	211-0538-00			1						SCREW, 6-32 x 0.312 inch, 100° csk, FHS
-111	211-0507-00			2						SCREW, 6-32 x 0.25 inch, PHS
-112	211-0025-00			2						SCREW, 4-40 x 0.375 inch, 100° csk, FHS
-113	- - - - -			6						TRANSISTOR
	- - - - -			-						mounting hardware for each: (not included w/transistor)
-114	211-0511-00			2						SCREW, 6-32 x 0.50 inch, PHS
-115	386-0978-00			1						PLATE, mica, 1.17 x 1.70 inches long

FIGURE 3/R7613 FRONT & FRAME (cont)

Fig. & Index No.	Tektronix Part No.	Serial/Model No.		Q t y	Description
		Eff	Disc		
3-116	337-1731-00			1	SHIELD, electrical
	-----			-	mounting hardware: (not included w/shield)
-117	211-0507-00			4	SCREW, 6-32 x 0.25 inch, PHS
-118	407-1145-02			1	BRACKET, heatsink, right
	-----			-	mounting hardware: (not included w/bracket)
-119	211-0504-00			2	SCREW, 6-32 x 0.25 inch, PHS
-120	220-0614-00			1	NUT BLOCK, 4-40 x 0.72 x 1.20 inches long
	-----			-	mounting hardware: (not included w/nut block)
-121	211-0507-00			2	SCREW, 6-32 x 0.312 inch, PHS
-122	343-0004-00			1	CLAMP, cable, 0.312 inch diameter
	-----			-	mounting hardware: (not included w/clamp)
-123	211-0511-00			1	SCREW, 6-32 x 0.50 inch, PHS
-124	210-0863-00			1	WASHER, loop clamp
-125	210-0457-00			1	NUT, keps, 6-32 x 0.312 inch
-126	210-0202-00			1	TERMINAL, lug, SE #6
-127	343-0004-00			2	CLAMP, cable, 0.312 inch diameter
	-----			-	mounting hardware for each: (not included w/clamp)
-128	211-0507-00			1	SCREW, 6-32 x 0.312 inch, PHS
-129	210-0863-00			1	WASHER, loop clamp
-130	386-2412-00			1	SUPPORT, CRT
	-----			-	mounting hardware: (not included w/support)
	211-0538-00			2	SCREW, 6-32 x 0.312 inch, 100° csk, FHS
	210-0457-00			3	NUT, keps, 6-32 x 0.312 inch, FHS
	211-0507-00			1	SCREW, 6-32 x 0.312 inch, PHS
-131	437-0143-00	B010100	B090989	1	CABINET, oscilloscope
	-----			-	cabinet includes:
-132	348-0274-00	B010100	B090989	2	SHIELDING GASKET, electronic
	-----			-	mounting hardware for each: (not included w/shielding
	-----			-	gasket)
-133	210-0632-00	B010100	B090989X	3	EYELET, 0.089 OD x 0.125 inch long
	437-0143-01	B090990		1	CABINET, oscilloscope
	348-0354-00	B090990		2	SHIELDING GASKET, electronic
	200-0103-00	XB070750		1	NUT, knurled, 0.25-28 x 0.375 inch OD
	355-0131-00	XB070750		1	STUD, binding post
	-----			-	mounting hardware: (not included w/stud)
	212-0023-00	XB070750		1	SCREW, 8-32 x 0.375 inch, PHS
	210-0008-00	XB070750		1	WASHER, lock, internal, #8
	129-0441-00	XB050000		2	POST, 2-56 x 5 inches long
	-----			-	mounting hardware for each: (not included w/post)
	211-0087-01	XB050000		2	SCREW, 2-56 x 0.188 inch, 82° csk, FHS

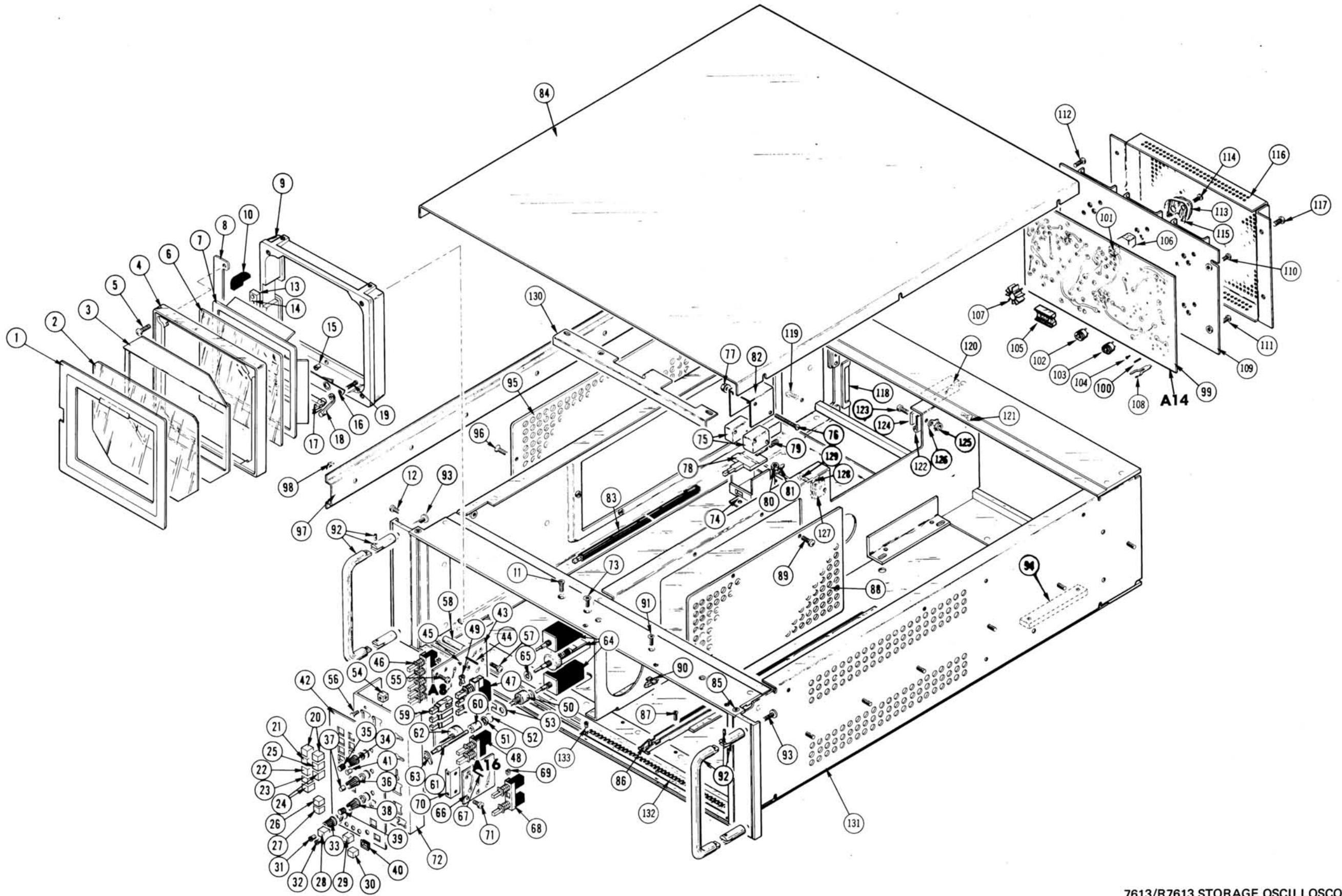

7613/R7613 STORAGE OSCILLOSCOPE

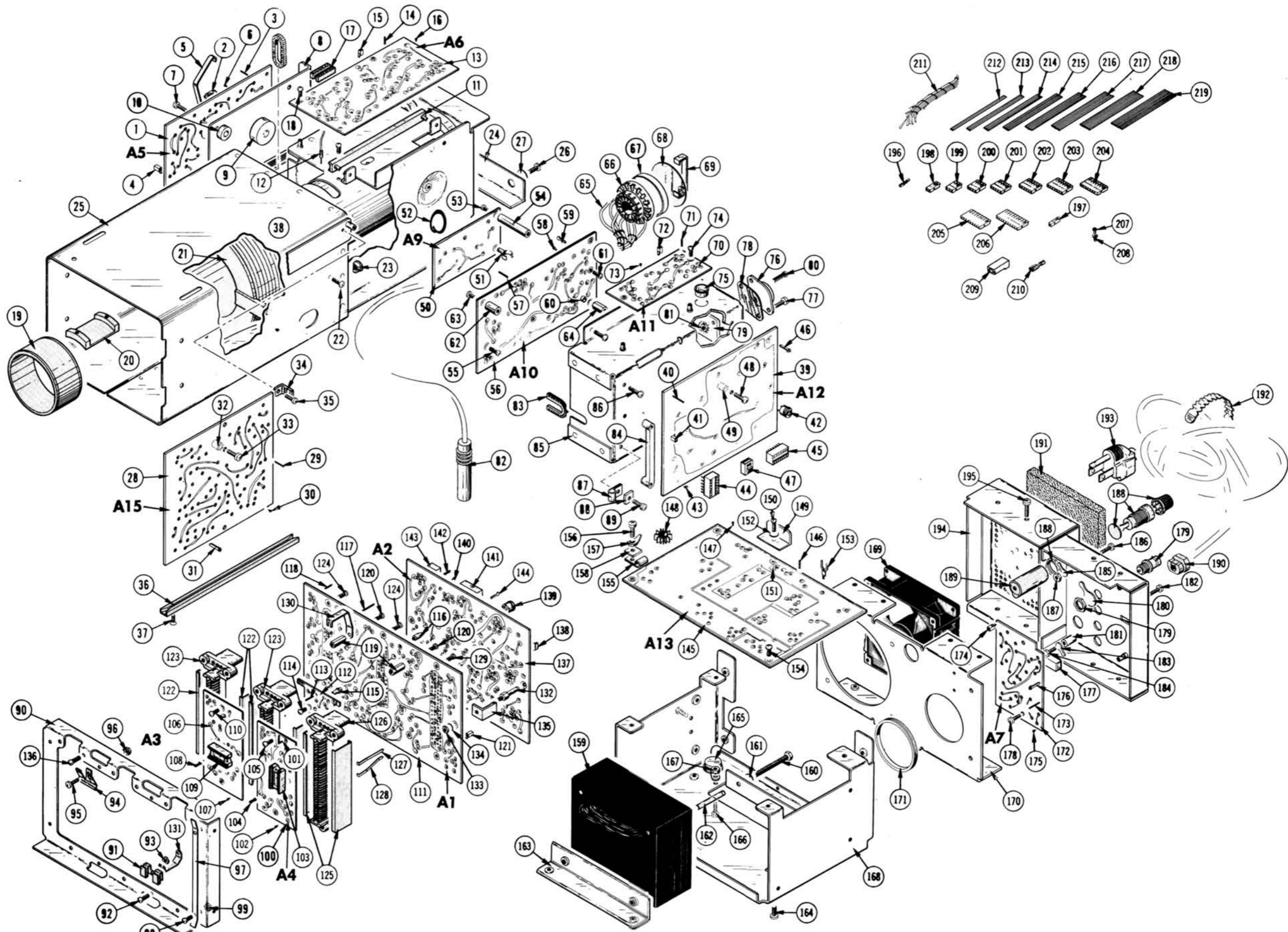

7613/R7613 STORAGE OSCILLOSCOPE

FIGURE 4/R7613 CHASSIS

Fig. & Index No.	Tektronix Part No.	Serial/Model No.		Q † y	Description
		Eff	Disc		
4-1	- - - - -			1	CIRCUIT BOARD ASSEMBLY--VERTICAL AMPLIFIER (See A5 electrical list)
	- - - - -			-	circuit board assembly includes:
-2	131-0566-00			1	LINK, terminal connecting
-3	131-0589-00			7	TERMINAL, pin, 0.50 inch long
-4	131-1003-00			1	CONNECTOR, receptacle, coaxial cable
-5	131-1303-00			1	CONTACT, electrical, integrated circuit ground
-6	136-0252-04			9	SOCKET, pin connector, 0.181 inch long
	136-0252-01			19	SOCKET, pin connector, 0.178 inch long
	- - - - -			-	mounting hardware: (not included w/circuit board assy)
-7	211-0014-00			2	SCREW, 4-40 x 0.50 inch, PHS
	211-0008-00			1	SCREW, 4-40 x 0.25 inch, PHS
-8	214-1652-00			1	HEATSINK, vertical amplifier
-9	214-1757-00			1	HEATSINK, integrated circuit
-10	361-0477-00			2	SPACER, sleeve, 0.228 ID x 0.50 OD x 0.27 inch long
-11	351-0087-00			2	GUIDE, circuit board, 4.75 inches long
-12	131-0472-01			4	CONNECTOR, pin, female
-13	- - - - -			1	CIRCUIT BOARD ASSEMBLY--HORIZONTAL AMPLIFIER (See A6 electrical list)
	- - - - -			-	circuit board assembly includes:
-14	131-0608-00			17	TERMINAL, pin, 0.365 inch long
-15	131-1003-00			2	CONNECTOR, receptacle, coaxial cable
-16	136-0252-04			25	SOCKET, pin connector, 0.181 inch long
	136-0252-01			2	SOCKET, pin connector, 0.178 inch long
	129-0075-00	XB020000	B069999X	1	INSULATOR, standoff
	361-0007-00	XB020000	B069999X	1	SPACER, terminal strip
-17	136-0260-01			1	SOCKET, integrated circuit, 16 pin
	- - - - -			-	mounting hardware: (not included w/circuit board assy)
-18	211-0008-00			2	SCREW, 4-40 x 0.25 inch, PHS
-19	- - - - -			1	COIL, y-axis
	- - - - -			-	mounting hardware: (not included w/coil)
	213-0138-00			2	SCREW, thread forming, 4-24 x 0.188 inch, PHS
-20	343-0217-00			1	CLAMP, coil, plastic
-21	119-0368-00			1	DELAY LINE ASSEMBLY
	- - - - -			-	mounting hardware: (not included w/delay line assy)
-22	213-0034-00			2	SCREW, thread cutting, 4-40 x 0.312 inch, PHS
-23	348-0064-00			1	GROMMET, plastic, 0.625 inch diameter
-24	407-1186-00			1	BRACKET, crt mounting, rear
	- - - - -			-	mounting hardware: (not included w/bracket)
	211-0507-00			3	SCREW, 6-32 x 0.312 inch, PHS
	210-0457-00			3	NUT, keps, 6-32 x 0.312 inch
	211-0510-00			1	SCREW, 6-32 x 0.375 inch, PHS
	210-0995-00			1	WASHER, flat, 0.141 ID x 0.75 inch OD

Mechanical Parts List--7613/R7613 Service

FIGURE 4/R7613 CHASSIS (cont)

Fig. & Index No.	Tektronix Part No.	Serial/Model No. Eff	Disc	Q					Description	
				t	y	1	2	3		4
4-25	- - - - -			1						SHIELD & CHASSIS ASSEMBLY
	- - - - -			-						mounting hardware: (not included w/shield & chassis assy)
	211-0541-00			2						SCREW, 6-32 x 0.25 inch, 100° csk, FHS
-26	211-0510-00			2						SCREW, 6-32 x 0.375 inch, PHS
-27	210-0993-00			2						WASHER, flat, 0.141 ID x 0.50 inch OD
-28	- - - - -			1						CIRCUIT BOARD ASSEMBLY--STORAGE (See A7 electrical list)
	- - - - -			-						circuit board assembly includes:
-29	131-0608-00			52						TERMINAL, pin, 0.365 inch long
-30	136-0252-04			111						SOCKET, pin connector
-31	214-0579-00			6						TERMINAL, test point
	- - - - -			-						mounting hardware: (not included w/circuit board assy)
-32	361-0527-00			1						SPACER, circuit board
-33	211-0034-00			1						SCREW, 4-40 x 0.50 inch, PHS
-34	344-0133-00			2						CLIP, circuit board
	- - - - -			-						mounting hardware for each: (not included w/clip)
-35	213-0088-00			1						SCREW, thread forming, 4-24 x 0.25 inch, PHS
-36	351-0179-01			1						GUIDE, readout chassis
	- - - - -			-						mounting hardware: (not included w/guide)
-37	211-0101-00			2						SCREW, 4-40 x 0.25 inch, 100° csk, FHS
-38	441-1048-00			1						CHASSIS, oscilloscope
	- - - - -			-						mounting hardware: (not included w/chassis)
	211-0008-00			2						SCREW, 4-40 x 0.25 inch, PHS
-39	- - - - -			-						CIRCUIT BOARD ASSEMBLY--READOUT (See A12 electrical list)
	- - - - -			-						circuit board assembly includes:
-40	131-0608-00			42						TERMINAL, pin, 0.365 inch long
-41	131-1003-00			6						CONNECTOR, receptacle, coaxial cable
-42	136-0235-00			1						SOCKET, transistor, 6 pin
-43	136-0252-04			42						SOCKET, pin connector, 0.181 inch long
	136-0252-01			14						SOCKET, pin connector, 0.178 inch long
-44	136-0260-01			14						SOCKET, integrated circuit, 16 pin
-45	136-0269-00			3						SOCKET, integrated circuit, 14 pin
-46	214-0579-00			19						TERMINAL, test point
-47	260-0723-00			1						SWITCH, slide
	- - - - -			-						mounting hardware: (not included w/circuit board assembly)
-48	211-0205-00			1						SCREW, 4-40 x 0.50 inch, RHS
-49	361-0527-00			1						SPACER, circuit board
	621-0466-01			1						ASSEMBLY, high voltage box
	- - - - -			-						assembly includes:
-50	- - - - -			1						CIRCUIT BOARD ASSEMBLY--HIGH VOLTAGE #2 (See A9 electrical list)
	- - - - -			-						circuit board assembly includes:
-51	343-0088-00			1						CLAMP, retaining, 0.062 inch ID

FIGURE 4/R7613 CHASSIS (cont)

Fig. & Index No.	Tektronix Part No.	Serial/Model No.		Q † y	Description
		Eff	Disc		
4-52	346-0032-00 258-0011-00 ----- 211-0040-00	B010100 B030000	B029999	2 ft - 1	STRAP, mouse tail CORD, lacing mounting hardware: (not included w/circuit board assy) SCREW, plastic, 4-40 x 0.25 inch, PHS
-54	129-0251-00			4	POST, 0.25 OD x 1.125 inches long
-55	211-0008-00			3	SCREW, 4-40 x 0.25 inch, PHS
-56	----- ----- -----			1 - -	CIRCUIT BOARD ASSEMBLY--HIGH VOLTAGE #1 (See A10 electrical list) circuit board assembly includes:
-57	131-0589-00 131-0608-00			5 19	TERMINAL, pin, 0.46 inch long TERMINAL, pin, 0.365 inch long
-58	136-0252-04			9	SOCKET, pin connector
-59	214-1292-00			1	TERMINAL, testpoint
-60	166-0292-00 -----			2 -	SLEEVE, support, 0.155 OD x 0.65 inch long mounting hardware: (not included w/circuit board assy)
-61	211-0008-00			3	SCREW, 4-40 x 0.25 inch, PHS
-62	129-0143-00 ----- 211-0008-00			3 - 1	POST, 0.312 OD x 0.406 inch long mounting hardware for each: (not included w/post) SCREW, 4-40 x 0.25 inch, PHS
-63	129-0236-00 -----			1 -	POST, hex., 0.187 x 0.375 inch long mounting hardware: (not included w/post)
-64	211-0008-00			1	SCREW, 4-40 x 0.25 inch, PHS
-65	136-0506-00 -----			1 -	WIRING HARNESS, CRT socket wiring harness includes:
-66	136-0304-02			1	SOCKET, CRT w/connectors
-67	200-0917-01			1	COVER, CRT socket
-68	367-0117-00			1	HANDLE, CRT socket
-69	343-0235-00			1	CLAMP, CRT socket
-70	----- ----- -----			1 - -	CIRCUIT BOARD ASSEMBLY--Z AXIS (See All electrical list) circuit board assembly includes:
-71	131-0608-00			36	TERMINAL, pin, 0.365 inch long
-72	131-1003-00			1	CONNECTOR, receptacle, coaxial cable
-73	136-0252-01 136-0252-04 -----			1 35 -	SOCKET, pin connector, 0.181 inch long SOCKET, pin connector, 0.178 inch long mounting hardware: (not included w/circuit board assy)
-74	211-0008-00			3	SCREW, 4-40 x 0.25 inch, PHS
-75	348-0063-00			1	GROMMET, plastic, 0.485 ID x 0.50 inch OD
-76	----- ----- -----			2 - -	TRANSISTOR mounting hardware for each: (not included w/transistor)
-77	213-0146-00			2	SCREW, thread tapping, 6-20 x 0.312 inch, PHS
-78	386-0978-00			1	PLATE, mica, 1.17 x 1/70 inches
-79	136-0280-00 -----			2 -	SOCKET, transistor mounting hardware for each: (not included w/transistor)
-80	211-0101-00			2	SCREW, 4-40 x 0.25 inch, 100° csk, PHS
-81	210-0586-00			2	NUT, keps, 4-40 x 0.25 inch

FIGURE 4/R7613 CHASSIS (cont)

Fig. & Index No.	Tektronix Part No.	Serial/Model Eff Disc	No. Q t	y					Description
				1	2	3	4	5	
4-82	131-0773-00		1						CONNECTOR, receptacle, anode lead
-83	348-0012-00		ft						GROMMET, rubber, 0.625 inch diameter
	348-0085-00		1						GROMMET, plastic, U-shaped
-84	351-0324-00		2						GUIDE, circuit card
-85	337-1538-01		1						SHIELD, electrical, high voltage
	- - - - -		-						mounting hardware: (not included w/shield)
-86	211-0504-00		3						SCREW, 6-32 x 0.25 inch, PHS
-87	343-0002-00		1						CLAMP, cable, 0.188 inch ID
	- - - - -		-						mounting hardware: (not included w/clamp)
-88	211-0503-00		1						SCREW, 6-32 x 0.312 inch, PHS
-89	210-0813-00		1						WASHER, loop clamp
-90	407-0973-00		1						BRACKET, connector
	- - - - -		-						mounting hardware: (not included w/contact)
	211-0507-00		4						SCREW, 6-32 x 0.312 inch, PHS
-91	131-0930-00		2						CONTACT, electrical, plug-in ground
	- - - - -		-						mounting hardware for each: (not included w/contact)
-92	211-0008-00		1						SCREW, 4-40 x 0.25 inch, PHS
-93	210-0586-00		1						NUT, keps, 4-40 x 0.25 inch
-94	131-0799-00		2						CONTACT, electrical, plug-in ground, upper
	- - - - -		-						mounting hardware for each: (not included w/contact)
-95	211-0008-00		1						SCREW, 4-40 x 0.25 inch, PHS
-96	210-0586-00		1						NUT, keps, 4-40 x 0.25 inch
-97	131-0800-00		2						CONTACT, electrical, plug-in ground
	- - - - -		-						mounting hardware for each: (not included w/contact)
-98	211-0008-00		2						SCREW, 4-40 x 0.25 inch, PHS
-99	210-0586-00		2						NUT, keps, 4-40 x 0.25 inch
-100	- - - - -		1						CIRCUIT BOARD ASSEMBLY--TRIGGER SELECTOR (See A4
	- - - - -		-						electrical list)
	- - - - -		-						circuit board assembly includes:
-101	131-0589-00		4						TERMINAL, pin, 0.46 inch long
-102	136-0252-04		15						SOCKET, pin connector, 0.178 inch long
-103	136-0260-01		1						SOCKET, integrated circuit, 16 pin
-104	136-0263-03		16						SOCKET, pin terminal
	- - - - -		-						mounting hardware: (not included w/circuit board ass)
-105	211-0008-00		2						SCREW, 4-40 x 0.25 inch, PHS
-106	- - - - -		1						CIRCUIT BOARD ASSEMBLY--VERTICAL INTERFACE (See A3
	- - - - -		-						electrical list)
	- - - - -		-						circuit board assembly includes:
-107	136-0252-04		15						SOCKET, pin connectors, 0.178 inch long
-108	136-0263-03		18						SOCKET, pin terminal
-109	136-0260-01		1						SOCKET, integrated circuit, 16 pin
	- - - - -		-						mounting hardware: (not included w/circuit board assy)
-110	211-0008-00		2						SCREW, 4-40 x 0.25 inch, PHS

FIGURE 4/R7613 CHASSIS (cont)

Fig. & Index No.	Tektronix Part No.	Serial/Model No.		Q † y	Description
		Eff	Disc		
4-111	- - - - -			1	CIRCUIT BOARD ASSEMBLY--MAIN INTERFACE (See A1 electrical list)
-112	- - - - - ¹			1	CIRCUIT BOARD ASSEMBLY--VERTICAL INTERCONNECT circuit board assembly includes:
-113	131-0787-00			8	TERMINAL, pin, 0.64 inch long mounting hardware: (not included w/circuit board assy)
-114	211-0008-00			2	SCREW, 4-40 x 0.25 inch, PHS
-115	351-0213-00			2	GUIDE-POST, lock, 4-40 x 0.275 inch
-116	386-1558-00			2	SUPPORT, circuit board
-117	131-0591-00			32	TERMINAL, pin, 0.835 inch long
-118	131-0592-00			26	TERMINAL, pin, 0.855 inch long
-119	131-0608-00			85	TERMINAL, pin, 0.365 inch long
-119	129-0308-00			4	POST, hex., 4-40 x 0.188 x 0.465 inch long mounting hardware: (not included w/post)
-120	211-0008-00			4	SCREW, 4-40 x 0.25 inch, PHS
	210-0803-00			1	WASHER, flat, 0.15 ID x 0.375 inch OD
-121	131-1003-00			2	CONNECTOR, receptacle, coaxial cable
	131-0767-02	B010100	B039999	2	CONNECTOR, receptacle, electrical, 76 contact
	131-0767-08	B040000		1	CONNECTOR, receptacle, electrical each connector includes:
-122	200-0950-00			2	COVER, plastic
-123	204-0365-00			1	BODY, plastic
	131-0726-00	B010100	B039999	38	CONTACT, straight
	131-0726-00	B040000		35	CONTACT, straight
	131-0727-00	B010100	B039999	38	CONTACT, offset
	131-0727-00	B040000		35	CONTACT, offset
	131-0899-00			4	CONTACT, short tail mounting hardware for each: (not included w/connector)
-124	213-0232-00			3	SCREW, thread forming, 2-56 x 0.312 inch, PHS
	131-0767-00	B010100	B039999	1	CONNECTOR, receptacle, electrical, 76 contact
	131-0767-07	B040000		1	CONNECTOR, receptacle, electrical connector includes:
-125	200-0950-00			2	COVER, plastic
-126	204-0365-02			1	BODY, plastic
-127	131-0726-00	B010100	B039999	38	CONTACT, straight
	131-0726-00	B040000		35	CONTACT, straight
-128	131-0727-00	B010100	B039999	38	CONTACT, offset
	131-0727-00	B040000		35	CONTACT, offset mounting hardware: (not included w/connector)
-129	213-0232-00			2	SCREW, thread forming, 2-56 x 0.312 inch, PHS
	210-0906-00			1	WASHER, fiber, 0.125 ID x 0.203 inch OD
-130	131-0804-00			1	LINK, terminal connecting, 1.17 inches long
-131	131-0805-00			2	LINK, terminal connecting, 0.90 inch long
-132	214-1568-00			2	PIN, guide mounting hardware for each: (not included w/pin)
-133	120-0406-00			1	NUT, hex., 4-40 x 0.188 inch
-134	210-0054-00			1	WASHER, lock, split, 0.118 ID x 0.212 inch OD

FIGURE 4/R7613 CHASSIS (cont)

Fig. & Index No.	Tektronix Part No.	Serial/Model No.		Q					Description	
		Eff	Disc	y	1	2	3	4		5
4-135	344-0147-00								2	CLIP, plastic
-136	213-0034-00								-	mounting hardware: (not included w/circuit board assy)
-137	- - - - -								9	SCREW, thread forming, 4-40 x 0.312 inch, PHS
-138	131-0566-00								-	CIRCUIT BOARD ASSEMBLY--LOGIC (See A2 electrical list)
-139	136-0235-00								-	circuit board assembly includes:
-140	136-0252-04								1	LINK, terminal connecting
-141	136-0260-01								1	SOCKET, 6 pin transistor
-142	136-0263-03								24	SOCKET, pin connector
-143	136-0269-00								1	SOCKET, integrated circuit, 16 pin
-144	214-0579-00								33	SOCKET, pin terminal
-145	- - - - -								3	SOCKET, integrated circuit, 14 pin
-146	131-0608-00								4	TERMINAL, test point
-147	136-0252-04								1	CIRCUIT BOARD ASSEMBLY--RECTIFIER (See A13 electrical list)
-148	214-1292-00								-	circuit board assembly includes:
-149	214-1731-00	B010100	B050499						28	TERMINAL, pin, 0.365 inch long
-150	214-1731-01	B050500							6	SOCKET, pin connector, 0.181 inch long
-151	- - - - -								2	HEATSINK, transistor
-152	211-0014-00								1	HEATSINK, transistor
-153	210-0586-00								1	HEATSINK, transistor, w/pem nut
-154	210-0935-00								-	mounting hardware: (not included w/heatsink)
-155	344-0154-00								1	SCREW, 4-40 x 0.50 inch, PHS
-156	211-0507-00								1	NUT, keps, 4-40 x 0.25 inch
-157	211-0511-00								1	WASHER, fiber, 0.14 ID x 0.375 inch OD
-158	211-0008-00	XB050500							4	CLIP, electrical, fuse
-159	343-0004-00								-	mounting hardware: (not included w/circuit board assy)
-160	211-0510-00								2	SCREW, 6-32 x 0.312 inch, PHS
-161	210-0202-00								1	SCREW, 6-32 x 0.50 inch, PHS
-162	210-0863-00								1	SCREW, 4-40 x 0.25 inch, PHS
-163	407-0921-00								1	CLAMP, cable, 0.312 inch ID
-164	212-0522-00								-	mounting hardware: (not included w/clamp)
-165	210-0812-00								1	SCREW, 6-32 x 0.375 inch, PHS
-166	166-0457-00								1	TERMINAL, lug, SE #6
-167	- - - - -								1	WASHER, clamp loop
-168	- - - - -								1	TRANSFORMER
-169	212-0522-00								-	mounting hardware: (not included w/transformer)
-170	210-0812-00								2	SCREW, 10-32 x 0.2.50 inches, HSS
-171	166-0457-00								2	WASHER, fiber, 0.188 ID x 0.375 inch OD
-172	407-0921-00								2	TUBE, insulating, 1.875 inches long
-173	212-0023-00								1	BRACKET, angle
-174	210-0804-00	XB020734							-	mounting hardware: (not included w/bracket)
-175	- - - - -								2	SCREW, 8-32 x 0.375 inch, PHS
-176	- - - - -								2	WASHER, flat, 0.17 ID x 0.375 inch OD

FIGURE 4/R7613 CHASSIS (cont)

Fig. & Index No.	Tektronix Part No.	Serial/Model No.		Q	Description
		Eff	Disc		
4-165	- - - - -			1	SWITCH, thermostatic
	- - - - -			-	mounting hardware: (not included w/switch)
-166	211-0008-00			2	SCREW, 4-40 x 0.25 inch, PHS
-167	210-0586-00			2	NUT, keps, 4-40 x 0.25 inch
-168	441-0993-01			1	CHASSIS, power supply
	- - - - -			-	mounting hardware: (not included w/chassis)
	212-0004-00			5	SCREW, 8-32 x 0.312 inch, PHS
-169	119-0390-00			1	FAN, axial
	- - - - -			-	mounting hardware: (not included w/fan)
	210-0457-00			4	NUT, keps, 6-32 x 0.312 inch
-170	386-2410-00	B010100	B070712	1	SUBPANEL, rear
	386-2410-01	B070713		1	SUBPANEL, rear
	- - - - -			-	mounting hardware: (not included w/subpanel)
	211-0504-00			4	SCREW, 6-32 x 0.25 inch, PHS
-171	255-0334-00			ft	PLASTIC CHANNEL, 6.25 inches
-172	- - - - -			1	CIRCUIT BOARD ASSEMBLY--SIGNALS OUT (See A7 electrical list)
	- - - - -			-	circuit board assembly includes:
-173	131-0608-00			10	TERMINAL, pin, 0.365 inch long
-174	131-1003-00			2	CONNECTOR, receptacle, coaxial cable
-175	136-0252-04			27	SOCKET, pin connector, 0.178 inch long
	136-0252-01			2	SOCKET, pin connector, 0.181 inch long
-176	214-0579-00			1	TERMINAL, test point
-177	260-0984-00			1	SWITCH, slide
	- - - - -			-	mounting hardware: (not included w/circuit board assy)
-178	211-0008-00			2	SCREW, 4-40 x 0.25 inch, PHS
-179	131-0955-00			6	CONNECTOR, receptacle, electrical, BNC female w/hardware
	- - - - -			-	mounting hardware for each: (not included w/connector)
-180	210-0255-00			1	TERMINAL, lug, SE, 0.391 inch ID
-181	385-0149-00			1	ROD, plastic, 0.25 diameter x 0.625 inch long
	- - - - -			-	mounting hardware: (not included w/rod)
-182	211-0008-00			1	SCREW, 4-40 x 0.25 inch, PHS
-183	210-0201-00			1	TERMINAL, lug, SE #4
	- - - - -			-	mounting hardware: (not included w/terminal)
-184	211-0008-00			1	SCREW, 4-40 x 0.25 inch, PHS
-185	210-0202-00			1	TERMINAL, lug, SE #6
	- - - - -			-	mounting hardware: (not included w/terminal)
-186	211-0504-00			1	SCREW, 6-32 x 0.25 inch, PHS
-187	210-0407-00			1	NUT, hex., 6-32 x 0.25 inch

FIGURE 4/R7613 CHASSIS (cont)

Fig. & Index No.	Tektronix Part No.	Serial/Model No.		Q t y	Description
		Eff	Disc		
4-188	352-0076-00			1	FUSEHOLDER ASSEMBLY, w/hardware
-189	200-1388-00			1	COVER, fuseholder
-190	358-0025-00	B010100	B070712	1	BUSHING, strain relief
	358-0161-00	B070713		1	BUSHING, strain relief
-191	378-0041-01			1	FILTER, air
-192	346-0077-00			1	STRAP, power cord
-193	161-0033-09			1	CABLE ASSEMBLY, power, electrical
-194	386-2401-00	B010100	B070712	1	PANEL, rear
	386-2401-02	B070713		1	PANEL, rear
	- - - - -			-	mounting hardware: (not included w/panel)
-195	211-0008-00	B010100	B070712	8	SCREW, 4-40 x 0.25 inch, PHS
	211-0008-00	B070713		4	SCREW, 4-40 x 0.25 inch, PHS
	211-0101-00	B070713		4	SCREW, 4-40 x 0.25 inch, 100° csk, FHS
-196	131-0707-00			324	CONNECTOR, terminal
	131-0708-00			14	CONNECTOR, terminal
-197	352-0171-00			5	HOLDER, terminal connector, 1 wire (black)
-198	352-0169-00			2	HOLDER, terminal connector, 2 wire (black)
	352-0169-01			4	HOLDER, terminal connector, 2 wire (brown)
	352-0169-04			2	HOLDER, terminal connector, 2 wire (yellow)
	352-0169-08			4	HOLDER, terminal connector, 2 wire (gray)
	352-0169-09			1	HOLDER, terminal connector, 2 wire (white)
-199	352-0161-00			2	HOLDER, terminal connector, 3 wire (black)
	352-0161-02			1	HOLDER, terminal connector, 3 wire (red)
	352-0161-03			2	HOLDER, terminal connector, 3 wire (orange)
	352-0161-04			2	HOLDER, terminal connector, 3 wire (yellow)
	352-0161-07			3	HOLDER, terminal connector, 3 wire (purple)
	352-0161-08			2	HOLDER, terminal connector, 3 wire (gray)
-200	352-0162-01			4	HOLDER, terminal connector, 4 wire (brown)
	352-0162-05			1	HOLDER, terminal connector, 4 wire (green)
	352-0162-09			1	HOLDER, terminal connector, 4 wire (white)
-201	352-0163-00			1	HOLDER, terminal connector, 5 wire (black)
	352-0163-01			2	HOLDER, terminal connector, 5 wire (brown)
	352-0163-06			2	HOLDER, terminal connector, 5 wire (blue)
	352-0163-08			2	HOLDER, terminal connector, 5 wire (gray)
-202	352-0164-01			2	HOLDER, terminal connector, 6 wire (brown)
	352-0164-05			1	HOLDER, terminal connector, 6 wire (green)
	352-0164-09			1	HOLDER, terminal connector, 6 wire (white)
-203	352-0165-00			2	HOLDER, terminal connector, 7 wire (black)
-204	352-0166-00			4	HOLDER, terminal connector, 8 wire (black)
	352-0166-01			3	HOLDER, terminal connector, 8 wire (brown)
	352-0166-02			3	HOLDER, terminal connector, 8 wire (red)
	352-0166-03			2	HOLDER, terminal connector, 8 wire (orange)
-205	352-0167-00			2	HOLDER, terminal connector, 9 wire (black)
-206	352-0168-00			2	HOLDER, terminal connector, 10 wire (black)
	352-0168-02			2	HOLDER, terminal connector, 10 wire (red)
	352-0168-05			2	HOLDER, terminal connector, 10 wire (green)
	352-0168-07			2	HOLDER, terminal connector, 10 wire (purple)
-207	210-0775-00			9	EYELET, 0.126 OD x 0.23 inch long
-208	210-0774-00			9	EYELET, 0.152 OD x 0.245 inch long
-290	200-1075-00			4	COVER, terminal, plastic
-210	131-0861-00			4	CONNECTOR, quick disconnect

FIGURE 4/R7613 CHASSIS (cont)

Fig. & Index No.	Tektronix Part No.	Serial/Model No.		† y	Q	Description
		Eff	Disc			
-211	179-1828-00			1		WIRING HARNESS, reset
	- - - - -			-		wiring harness includes:
	131-0707-00			2		CONNECTOR, terminal
	131-0708-00			2		CONNECTOR, terminal
	352-0169-05			1		HOLDER, terminal connector, 2 wire (green)
	352-0169-09			1		HOLDER, terminal connector, 2 wire (white)
	179-1825-00			1		WIRING HARNESS, vertical signal
	- - - - -			-		wiring harness includes:
	131-0707-00			3		CONNECTOR, terminal
	131-0708-00			1		CONNECTOR, terminal
	352-0162-00			1		HOLDER, terminal connector, 4 wire (black)
	210-0775-00			2		EYELET, 0.126 OD x 0.23 inch long
	210-0774-00			2		EYELET, 0.152 OD x 0.245 inch long
	179-1826-00			1		WIRING HARNESS, sweep gate
	- - - - -			-		wiring harness includes:
	131-0707-00			8		CONNECTOR, terminal
	131-0708-00			8		CONNECTOR, terminal
	352-0166-03			2		HOLDER, terminal connector, 8 wire (orange)
-212	175-0825-00			ft		WIRE, electrical, 2 wire ribbon, 22 inches
-213	175-0826-00			ft		WIRE, electrical, 3 wire ribbon, 80 inches
-214	175-0827-00			ft		WIRE, electrical, 4 wire ribbon, 21 inches
-215	175-0828-00			ft		WIRE, electrical, 5 wire ribbon, 41 inches
-216	175-0829-00			ft		WIRE, electrical, 6 wire ribbon, 15 inches
-217	175-0830-00			ft		WIRE, electrical, 7 wire ribbon, 7 inches
-218	175-0831-00			ft		WIRE, electrical, 8 wire ribbon, 98 inches
-219	175-0833-00			ft		WIRE, electrical, 10 wire ribbon, 67 inches
	175-0855-00			ft		WIRE, electrical, 10 wire ribbon, 12 inches

R7613 ACCESSORIES

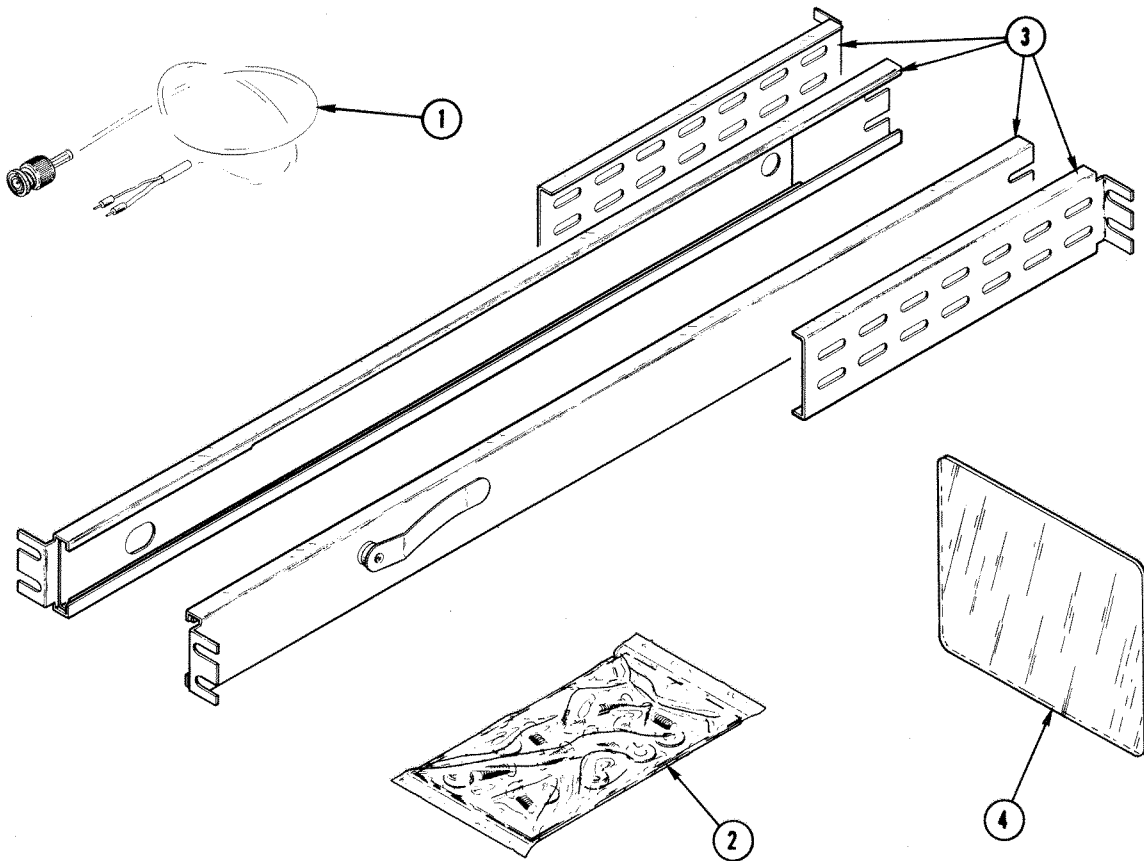

Fig. & Index No.	Tektronix Part No.	Serial/Model No.		Q t y	1	2	3	4	5	Description
		Eff	Disc							
6-1	175-1178-00			1						CABLE, special purpose
-2	016-0131-00			1						HARDWARE KIT
-3	351-0314-00			1						SLIDE-GUIDE, rackmount, 19.25 inches long, pair
-4	378-0625-00			1						FILTER, light, CRT, gray
	070-1365-00			1						MANUAL, instruction, operators (not shown)
	070-1463-00			1						MANUAL, instruction, service (not shown)

7613 ACCESSORIES

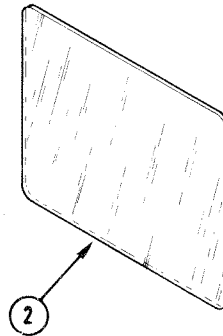
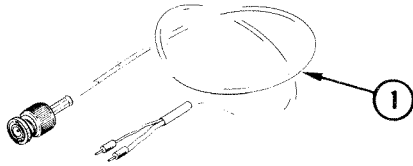

Fig. & Index No.	Tektronix Part No.	Serial/Model No.		Q t y						Description	
		Eff	Disc		1	2	3	4	5		
5-1	175-1178-00			1							CABLE, special purpose, rf
-2	378-0625-00			1							FILTER, light, CRT, gray
	070-1365-00			1							MANUAL, instruction, operators (not shown)
	070-1463-00			1							MANUAL, instruction, service (not shown)

REPLACEABLE PARTS FOR FACTORY INSTALLED OPTIONS

OPTION 3 Without Signals Out

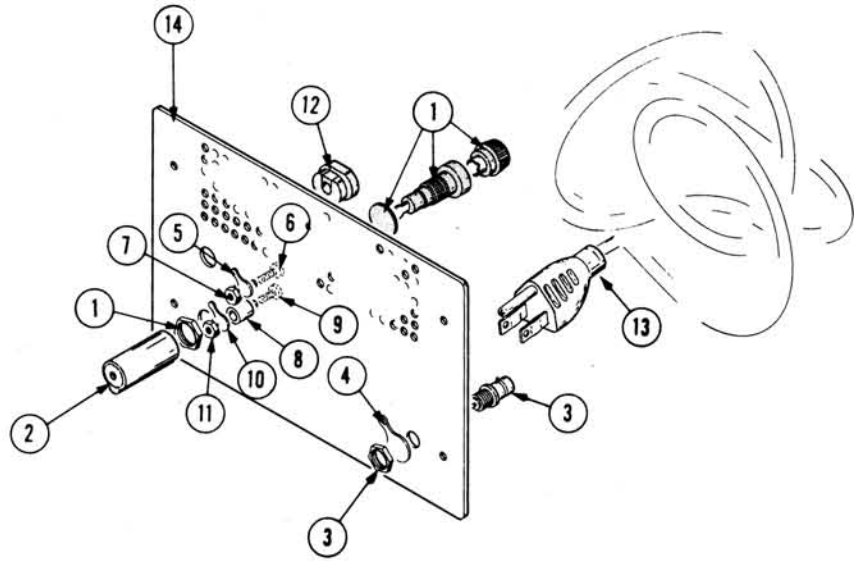

Fig. & Index No.	Tektronix Part No.	Serial/Model No. Eff	Serial/Model No. Disc	Qty	Description				
					1	2	3	4	5
7-1	352-0076-00			1	FUSEHOLDER ASSEMBLY				
-2	200-0237-00			1	COVER, fuseholder				
-3	131-0955-00			1	CONNECTOR, receptacle, BNC, w/hardware				
-4	210-0255-00			1	TERMINAL, lug, 0.391 inch diameter				
-5	210-0202-00			1	TERMINAL, lug, SE #6				
-6	211-0504-00			1	SCREW, 6-32 X 0.25 inch, PHS				
-7	210-0407-00			1	NUT, hex., 6-32 X 0.25 inch				
-8	385-0100-00			1	ROD, plastic, 0.312 diameter X 0.50 inch long				
-9	211-0504-00			1	SCREW, 6-32 X 0.25 inch, PHS				
-10	210-0202-00			1	TERMINAL, lug, SE #6				
-11	210-0407-00			1	NUT, hex., 6-32 X 0.25 inch				
-12	358-0323-00			1	BUSHING, strain relief				
-13	161-0033-09			1	CABLE ASSEMBLY, power				
-14	386-2329-00			1	PANEL, rear				

OPTION 7 Electromagnetic Interference (EMI)

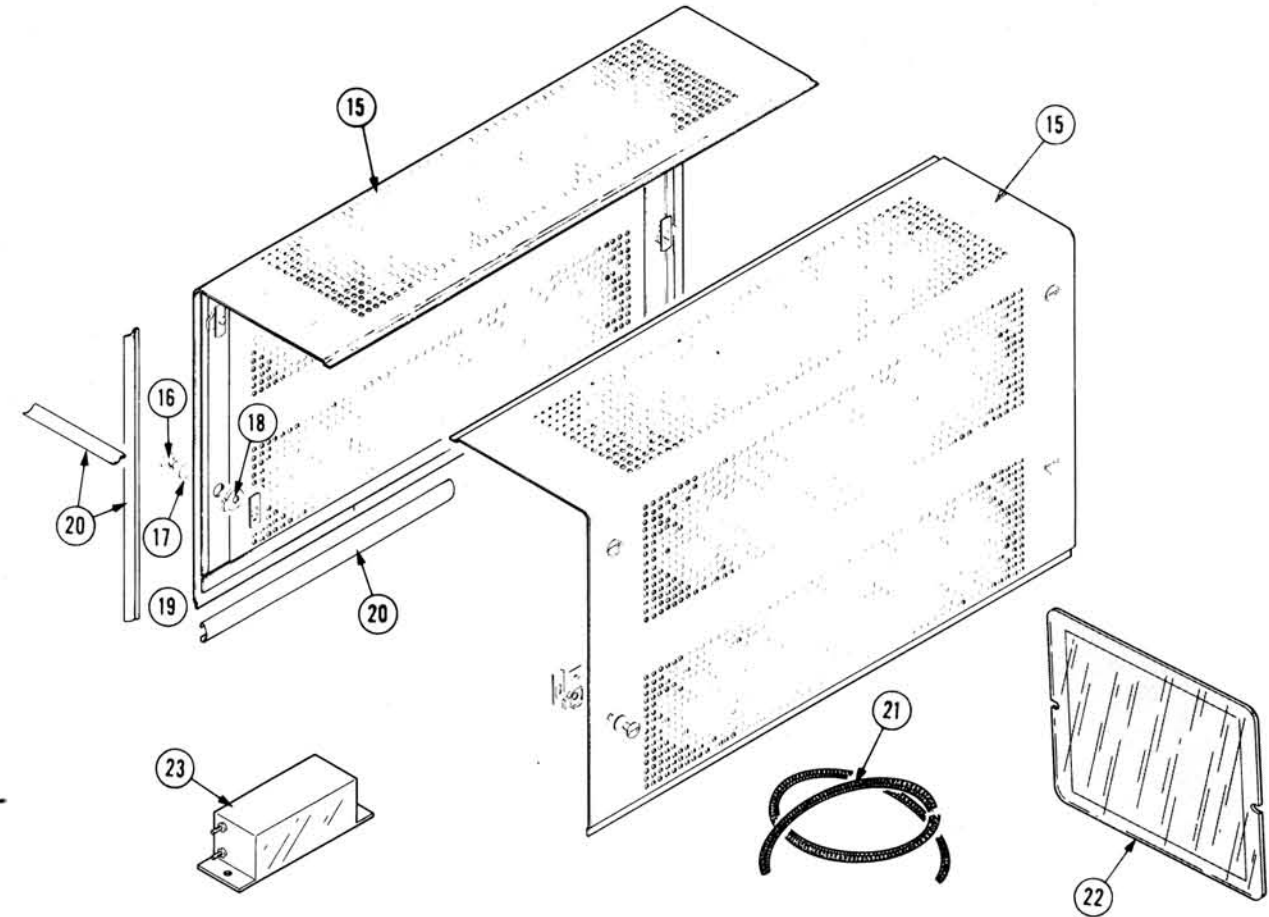

Fig. & Index No.	Tektronix Part No.	Serial/Model No. Eff	Serial/Model No. Disc	Qty	Description				
					1	2	3	4	5
7-15	390-0346-00			2	CABINET SIDE				
-				-	each cabinet side includes:				
-	214-0816-00			6	LATCH ASSEMBLY				
-				-	each latch assembly includes:				
-16	214-0603-01			1	PIN, securing				
-17	214-0604-00			1	SPRING, latch				
-18	386-0227-00			1	PLATE, index				
-19	386-1151-00			1	PLATE, locking				
-20	348-0274-00			4	SHIELDING GASKET, electronic, 48 inches long				
-21	348-0234-00			1	SHIELDING GASKET, electronic, 39.50 inches long				
-22	378-0696-00			1	FILTER, light, CRT				
-23	119-0113-05			1	FILTER, radio interference				
	390-0355-00			1	CABINET BOTTOM (not shown)				

OPTIONAL ACCESSORY

016-0155-00	1	PLUG-IN PANEL, blank (not shown)			
-------------	---	----------------------------------	--	--	--

R7613 PACKAGING

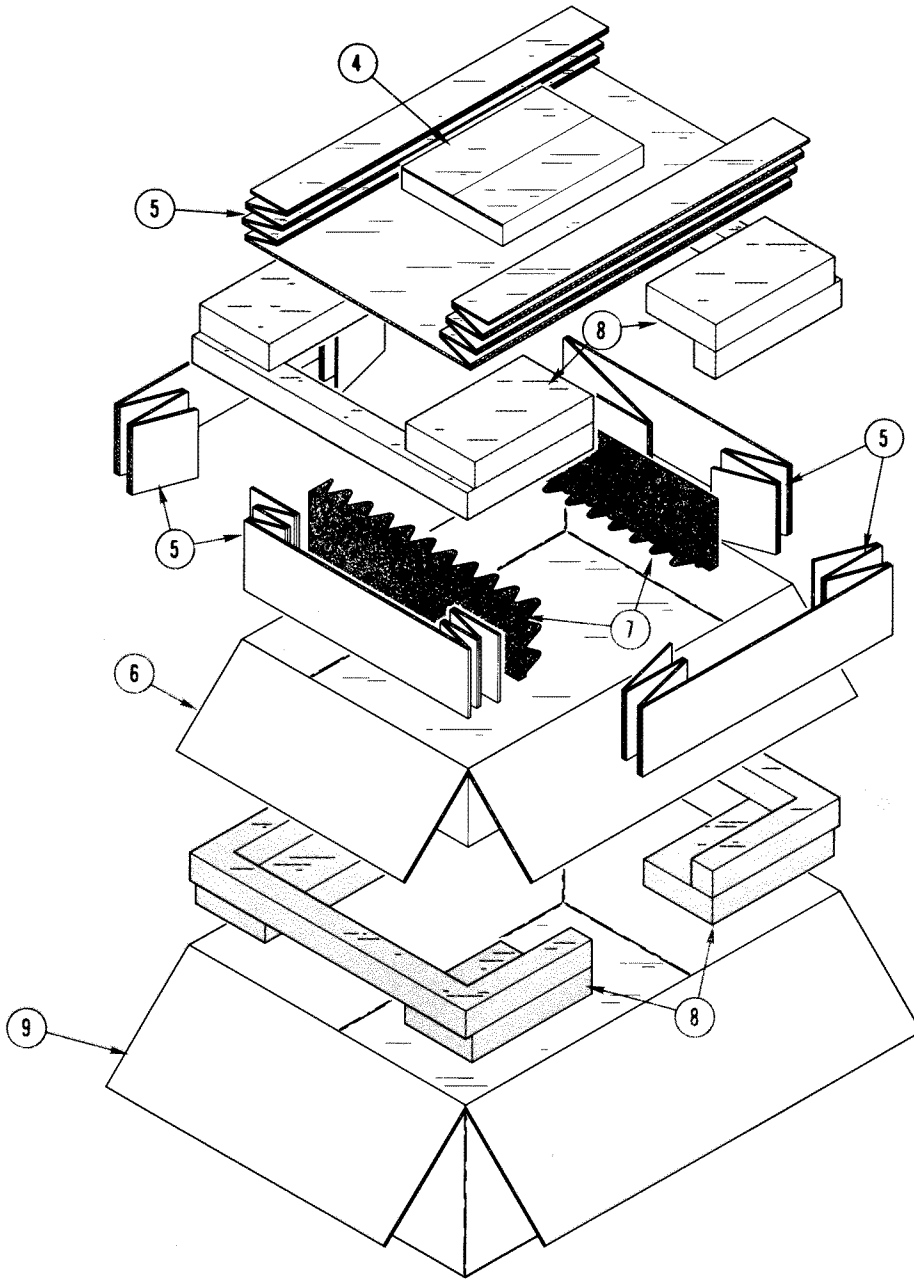

Fig. & Index No.	Tektronix Part No.	Serial/Model No.		Q t y	1 2 3 4 5	Description
		Eff	Disc			
8-	065-0181-00			1		CARTON ASSEMBLY
	-----			-		carton assembly includes:
-4	004-0462-00			1		CARTON, accessory
-5	004-1160-00			1		PAD SET
-6	004-0853-00			1		BOX, inner
-7	004-1210-00			1		PAD SET
-8	004-0276-00			2		ETHAFRAME
-9	004-0852-00			1		BOX, outer

7613/R7613 STORAGE OSCILLOSCOPE

7613 PACKAGING

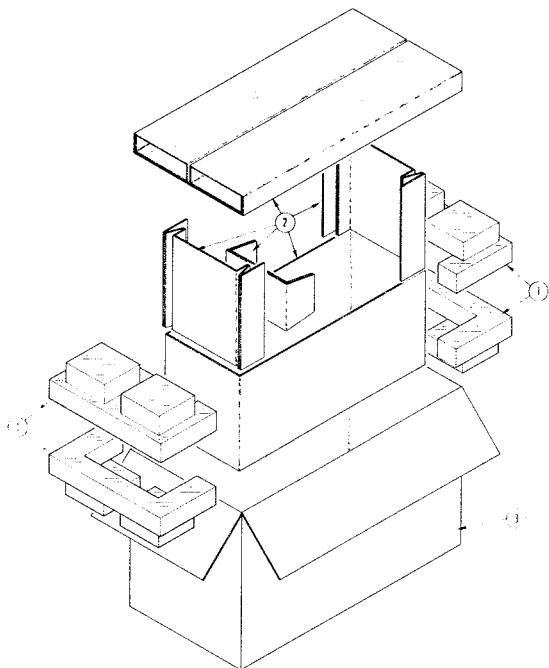

Fig. & Index No.	Tektronix Part No.	Serial/Model No.		Q t y	Description
		Eff	Disc		
8-1	065-0154-00			1	CARTON ASSEMBLY
-1	004-0281-00			-	carton assembly includes:
-2	004-1092-00			1	ETHAFRAME
-3	004-0766-00			1	PAD SET, 5 piece
				1	CARTON

MANUAL CHANGE INFORMATION

At Tektronix, we continually strive to keep up with latest electronic developments by adding circuit and component improvements to our instruments as soon as they are developed and tested.

Sometimes, due to printing and shipping requirements, we can't get these changes immediately into printed manuals. Hence, your manual may contain new change information on following pages.

A single change may affect several sections. Sections of the manual are often printed at different times, so some of the information on the change pages may already be in your manual. Since the change information sheets are carried in the manual until ALL changes are permanently entered, some duplication may occur. If no such change pages appear in this section, your manual is correct as printed.

7613 and 7623 OPTION 5

Instruments containing OPTION 5 are designed to operate on any power Line Frequency from 50 Hz to 400 Hz. If your instrument was ordered with OPTION 5 it will differ from the basic instrument to the extent described in this option supplement. Refer to the main portion of this manual or the change section at the back for all other information concerning your instrument.

ELECTRICAL PARTS LIST

B1001	119-0396-00	FAN, Axial, 50-400 Hz, 115 V
C1002	285-0562-00	0.47 μ F, Cer, 400 V

MECHANICAL PARTS LIST

441-1201-00	1	CHASSIS, oscilloscope
378-0050-00	1	BAFFLE, air
211-0530-00	4	SCREW, 6-32 x 1.750
344-0116-00	1	CLIP, capacitor mounting
131-0761-00	3	TERMINAL POST, screw mounting
211-0504-00	3	SCREW, 6-32 x .250
211-0008-00	1	SCREW, 4-40 x .250
211-0507-00	4	SCREW, 6-32 x .312
119-0396-00	1	FAN, axial, 50-400 Hz, 115 V

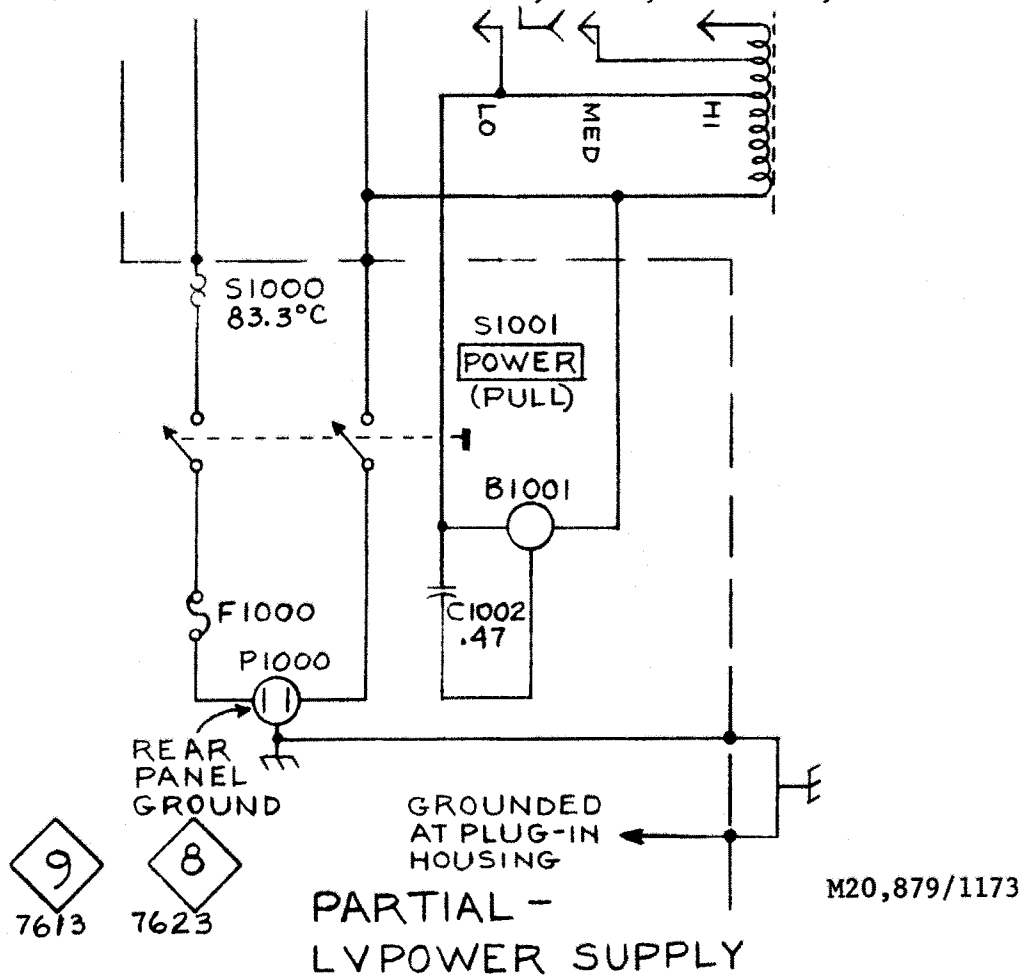

VERTICAL AMPLIFIER CIRCUIT USING 670-3154- and 670-3186- CIRCUIT BOARDS

GENERAL

The 7613 and R7613 with serial numbers above B150000 contain different vertical output amplifier and vertical interface circuitry from the ones shown in the main portion of the 7613/R7613 manual. Instrument specifications are not affected, and portions of the manual other than those listed in the following paragraph are unaltered by this change.

This insert includes the Calibration Procedure, Circuit Description, Electrical Parts List, Mechanical Parts List, Board Layouts with Adjustment Locations, and Schematic Diagrams that replace the existing Diagram 4 and part of Diagram 3 in the 7613/R7613 Service Manual. Future changes affecting this circuitry will be mentioned by inserts that refer to M20610 insert or Serial Numbers B150000 and up. Where possible, any such changes will be incorporated in revisions of this M20610 insert.

CALIBRATION PROCEDURE FOR 7613/R7613 VERTICAL AMPLIFIER SN B150000-up

(Replaces Steps 11 through 15 of existing procedure)

NOTE

Adjustable components in this procedure are marked with an adjustment number. This number is marked on the circuit board, board layout drawing, and schematic diagram to aid in locating the component to be adjusted.

If the instrument being calibrated is not equipped with the readout feature, set the Thermal Balance control R2527 (adjustment 3) for a reading of +8.65 volts at the R2527 end of C2524 (see Fig. 6-7A) and omit step 13 of this procedure.

11. Adjust Vertical Centering

a. Install the 7B53A in the horizontal compartment and set it for auto, internal + Slope triggering at the sweep rate of one millisecond/division.

b. Install the mainframe standardizer calibration fixture (067-0587-01) in the left vertical compartment. Set the calibration fixture Test switch to Triggering Gain, and the Rep Rate switch to 1 kHz.

c. CHECK—That the trace is within 0.3 division of the graticule center line.

d. ADJUST—Vertical Centering adjustment R2433 (adjustment 1), see Fig. 6-7A, to position the trace to the center horizontal line.

e. Set VERT MODE to RIGHT and repeat step c. Readjust R2433 for steps c and e if necessary.

f. Set VERT MODE to LEFT.

12. Adjust Vertical Gain

a. Set the calibration fixture Test switch to Vert or Horiz Gain, and set the Time Base to 50 μ s.

b. Position the bright center line of the display to the center horizontal graticule line.

c. CHECK—Deflection for the center seven traces should be six divisions ± 0.06 division.

d. ADJUST—Vertical Gain adjustment R2446 (adjustment 2) (see Fig. 6-7A) for exactly six divisions of deflection for the center seven traces.

e. Remove the calibration fixture from the left vertical compartment and install it in the right vertical compartment.

f. Set the VERT MODE switch to RIGHT.

g. CHECK—Deflection for the center seven traces should be the same as in part c or d $\pm 1\%$.

h. ADJUST—If necessary, re-adjust R2446 (adjustment 2) for correct tolerances in both parts d and h.

13. Adjust Thermal Balance (See NOTE preceding step 11)

a. Set the calibration fixture to + Step Resp and Amplitude to minimum. Position the trace to the top graticule line.

b. Insert a 7A15A plug-in in the left vertical compartment. Set the 7613 VERT MODE to ALT. Position the 7A15A trace to the bottom graticule line. Set the 7B53A to 10 ms/division. Set the 7613 INTENSITY to center of range. Advance READOUT INTENSITY until readout is viewable.

c. ADJUST—Thermal Balance control R2527 (adjustment 3) for minimum vertical movement of the displayed readout characters. If appreciable adjustment is required, re-check Step 12 Gain Adjustment.

d. Remove the 7A15A from the left vertical compartment.

e. Set the VERT MODE switch to RIGHT, and 7B53A to one millisecond/division.

14. Check Vertical Linearity

a. Adjust the calibration fixture Position control to keep the display centered on the graticule, and adjust the Amplitude control for a two-division display.

b. CHECK—Vertically position the two divisions of display and check for not more than 0.1 division of compression or expansion anywhere within the graticule area.

c. Remove the calibration fixture from the right vertical compartment and install it in the left vertical compartment.

d. Set the VERT MODE switch to LEFT.

e. Repeat steps a and b for the Left vertical amplifier.

15. Adjust Vertical High-Frequency Compensation

a. Adjust the calibration fixture Amplitude and Position controls for a centered six-division display. Set the Rep Rate to 100 kHz, and the 7B53A to 1 μ s/division. Adjust trigger level for a stable display.

b. CHECK—Check for optimum square corner and flat top on displayed pulse with aberrations not to exceed +0.1 or -0.1 division with total peak-to-peak aberrations not to exceed 0.2 division.

c. ADJUST—R2409 (adjustment 4) for a flat pulse top and minimum aberrations in the first one microsecond area.

d. Set the 7B53A to 0.5 microseconds/division and adjust trigger level for a stable display.

e. CHECK—For a flat top on the first 500 nanosecond portion of the pulse, within the limits in step b.

f. ADJUST—R2509 (adjustment 5) for a flat pulse top in the first 500 nanosecond area.

g. Adjust the calibration fixture Rep Rate to one MHz and set the 7B53A to 0.1 μ s/division. Adjust the trigger level for a stable display.

h. CHECK—For a flat first 120 nanosecond area of the pulse top within aberration limits listed in step b.

i. ADJUST—R2511 (adjustment 7) and C2511 (adjustment 8) for flatness and minimum aberrations of the first 120 nanosecond area of the pulse top (adjustment 7 for tilt and adjustment 8 for flatness).

j. Set the 7B53A to 0.05 μ s and trigger level for a stable display.

k. CHECK—For a flat first 30 nanosecond area of the pulse top within aberration limits listed in step b.

l. ADJUST—R2411 (adjustment 6) for flatness in the first 30 nanoseconds of the pulse top.

m. Set the 7B53A to 0.2 μ s/division and Mag to X10 (20 ns/div). Adjust trigger level for a stable display.

n. CHECK—For optimum leading corner and flat pulse top with minimum aberrations in the first 10 nanoseconds, within the limits listed in step b.

o. ADJUST—Refer to attached Table 2-2A for settings and adjustments for the first 2, 5, and 10 nanoseconds of the pulse top. Repeat steps a through o as necessary to obtain optimum response with minimum aberrations.

TABLE 2-2A

High-Frequency Compensation

Adjustment	Primary Area of Pulse Affected	Best Sweep Rate
C2416 (11) R2416 (12) R2519 (13)	First 10 nanoseconds	20 nanoseconds/division
C2418 (9) R2418 (10) C2456 (14)	First 5 nanoseconds First 2 nanoseconds	20 nanoseconds/division 5 nanoseconds/division (X10 Mag and 0.05 μ s)
C2469 (located off the board, see Fig. 6-7A).	Adjust for minimum overall aberrations	20 nanoseconds/division

p. ADJUST—Position the top of the 6 division display to the center horizontal graticule line. Set the 7B53A to 5 nanoseconds/division (X10 Mag and 0.05 μ s). Adjust triggering for a stable + Slope display. Adjust C2456 (adjustment 14) for 0.2 divisions of aberration on the front corner of the pulse top. Adjust calibration fixture position control for a centered six-division display and check for aberrations as in step 15b. Remove the calibration fixture from the left vertical compartment and install it in the right vertical compartment.

q. Set the VERT MODE switch to RIGHT.

r. CHECK—For optimum square leading corner and flat top on the displayed pulse with aberrations not to exceed +0.1 or -0.1 division, with total peak-to-peak aberrations not to exceed 0.2 division (use Time/Div and Rep Rate settings as listed in steps a through o).

s. ADJUST—If necessary, compromise the adjustments in steps a through o to obtain best response for both left and right vertical compartments.

t. To verify correct high-frequency compensation, perform the bandwidth check as given in step 16 of the 7613/R7613 Service Manual Calibration Procedure.

Refer to your 7613/R7613 Service Manual for the remainder of the calibration procedure (Step 16 and up).

CIRCUIT DESCRIPTION CHANGES FOR 7613/R7613 VERTICAL AMPLIFIER SN B150000-up

Replace the text in your 7613/R7613 Service Manual for VERTICAL INTERFACE, VERTICAL AMPLIFIER, and Figures 3-16, 3-17, and 3-18 with the following:

VERTICAL INTERFACE

General

The Vertical Interface circuit selects the vertical deflection signal from the output of the left vertical or the right vertical plug-in unit. Fig. 3-16A shows a detailed block diagram of the Vertical Interface circuit. A schematic of this circuit is shown on the accompanying diagram.

Vertical Channel Switch

The Vertical Channel Switch stage (controlled primarily by the Mainframe Vertical Mode Command from the Logic circuit) determines which vertical signal is to be sent to the Delay-Line Driver stage. Resistors R2333-R2335 and R2337-R2339 establish the input resistance of this stage and provide a load for the left and right vertical units. Resistors R2347-R2349 and R2357-R2359-R2329 establish the operating levels for this stage. R2343 and R2353 set the current gain for each channel. C2345-R2345 and C2355-R2355 provide frequency compensation.

The Vertical Channel Switch stage is made up primarily of integrated circuit U2340, which is the same type as used for the Trigger Channel Switch. An input/output table for U2340 is shown in Fig. 3-17A. U2340 provides a high impedance differential input for the signal from the left vertical unit at pins 2 and 15, and the signal from the right vertical unit at pins 7 and 10. The output signal at pins 12 and 13 is a differential signal that is connected to the Delay-Line Driver stage through R2366-R2376. The sum of the DC output currents at pins 12 and 13 is always equal to the sum of the DC input currents at pins 1, 8, 9, and 16 in all modes. This provides a constant DC bias to the following stage as the VERT MODE switch is changed.

When the VERT MODE switch is set to LEFT, the level at pin 4 is LO. This level allows the signal from the left vertical unit to pass to the output while the signal from the right vertical unit is blocked. In the RIGHT position of the VERT MODE switch, the level at pin 4 is HI. Now, the signal from the right vertical unit is connected to the output while the signal from the left vertical unit is blocked.

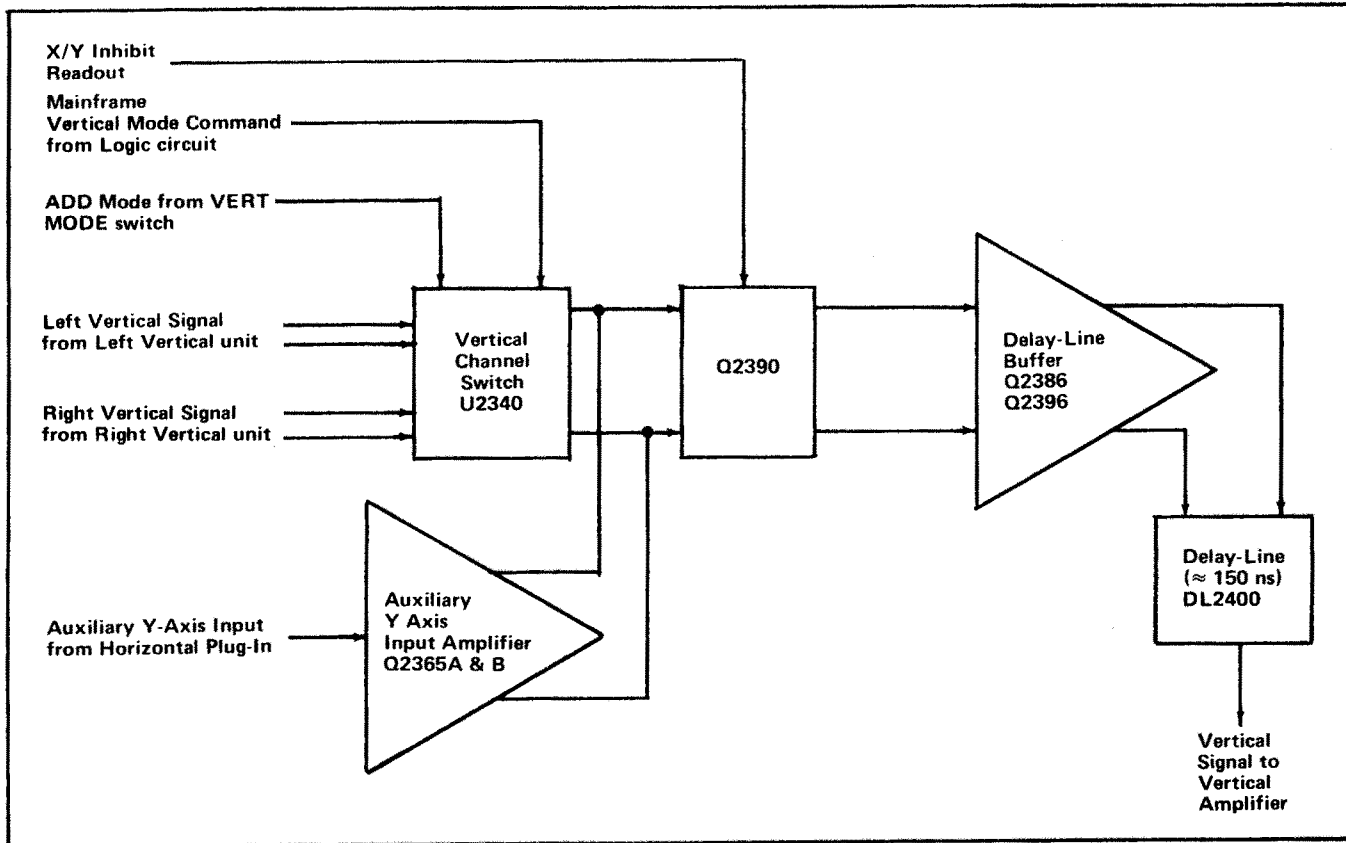

Fig. 3-16A. Vertical Interface detailed block diagram for SN B150000 and up.

Input		Output
Mainframe Vertical Mode Command	ADD Mode (Vert)	Output signal
4	14	12, 13
LO	LO	Left vertical signal
HI	LO	Right vertical signal
LO	HI	Both (added algebraically)

LO ≈ -0.6 V
HI ≈ +1.1 V

Fig. 3-17A. Input/output table for Vertical Channel Switch.

When the VERT MODE switch is set to either ALT or CHOP, the Mainframe Vertical Mode Command at pin 4 switches between the LO and HI levels at a rate determined by either the Chop Counter or the Vertical Binary stages (see Logic circuit description). This action allows the signal from the left vertical unit to be displayed when the

Mainframe Vertical Mode Command is LO and the signal from the right vertical unit is displayed when the Mainframe Vertical Mode Command is HI. When ADD vertical mode operation is selected, a HI level is applied to pin 14 and the level at pin 4 is LO as determined by the Vertical Mode Control stage in the Logic Circuit. This allows both the right and left vertical signals to pass to the output pins. Now, the signal from both vertical units is algebraically added and the resultant signal determines the vertical deflection.

The X/Y inhibit signal from the Readout system is applied to pin 6 of U2340. It has final control over the output signal from U2340. Quiescently, the X/Y Inhibit signal is LO and the signal from the selected vertical can pass to the output pins 12 and 13. However, when the Readout system is ready to display Readout information, the level at pin 6 goes HI. This level blocks the signals from both vertical compartments and there is no signal output from U2340 under this condition. Transistor Q2390 will conduct and provide about the same current for the output stage as under normal conditions. This limits any change in positioning that would otherwise occur when the X/Y Inhibit signal is applied from the Readout system.

Auxiliary Y-Axis Input Amplifier

The Auxiliary Y-Axis Input Amplifier accepts an input from horizontal plug-in units having compatible features. Normally, this input is a positioning voltage to offset the display. The single-ended signal connected to the input of this stage is converted to a push-pull signal at the collectors of Q2365 A and B. This signal is connected to the Delay-Line Buffer stage along with the output from the Vertical Channel Switch.

Delay-Line Buffer

The output of the Vertical Channel Switch stage, along with any signal from the Auxiliary Y Axis Input Amplifier, is connected to the bases of Q2386 and Q2396. These transistors are connected in a common emitter shunt feedback configuration to provide a low impedance summing point, and voltage gain. L2386-L2396, C2387-R2387 and C2397-R2397 provide high-frequency peaking and reverse termination for the Delay Line.

Delay Line

Delay Line DL2400 provides approximately 150 nanoseconds delay for the vertical signal, to allow the horizontal circuits time to initiate a sweep before the vertical signal reaches the vertical deflection plates of the CRT. This allows the instrument to display the leading edge of the signal originating the trigger pulse when using internal triggering. The delay line used in this instrument has a characteristic impedance of about 50 ohms per side, or about 100 ohms differentially. It is of the coaxial type, which does not produce preshoot or phase distortion in the CRT display.

VERTICAL AMPLIFIER

General

The Vertical Amplifier circuit provides final amplification for the vertical signal before it is applied to the vertical deflection plates of the CRT. This circuit includes an input from the BEAM FINDER switch to compress an over-scanned display within the viewing area of the CRT. Fig. 3-18A shows a detailed block diagram of the Vertical Amplifier circuit. A schematic of this circuit is shown on the diagram accompanying this insert.

Centering and Readout Amplifier

Q2530-Q2430 compose a paraphase amplifier to provide balance or centering control for the vertical amplifier by changing the ratio of the current that is summed at the emitters of Q2441-Q2541. In addition this stage provides the input for the vertical readout signal through J2534 and the base of Q2530.

Input Amplifier

Forward termination of the delay line is accomplished by R2402-R2501, in conjunction with the input impedance of Q2405-Q2505. R2402-R2501 also act as load resistors for the Delay Line Buffer stage. Q2405-Q2441-Q2505-Q2541 are connected in a cascode configuration. The RC networks in the emitters of Q2405-Q2505 compensate for the losses in the delay line and provide some temperature compensation for the vertical amplifier.

Thermal balancing of the vertical amplifier is accomplished by adjusting the base voltage of Q2441-Q2541.

The signal from Q2441-Q2541 is connected to the output amplifier through the transmission line, which is terminated by L2448-L2548 and R2448-R2548. The Vertical Gain is adjusted by loading the collectors of Q2441-Q2541 with R2446.

Beam Finder Network

The Beam Finder Network provides a means of locating a display that overscans the graticule area. Under normal operation, the Display Limit Command is at -15 volts, which holds Q2427 cut off and allows Display Limit Current for the Horizontal Amplifier to rise to about $+15$ volts. During this time, Q2423 is held on and emitter current from Q2405-Q2505 flows through Q2423 to ground. When the Beam Finder switch is pressed, the Display Limit Command rises positive, turning Q2427 on and Q2423 off. This pulls the Display Limit Current to -15 volts, and reduces the emitter current of Q2405-Q2505 to a

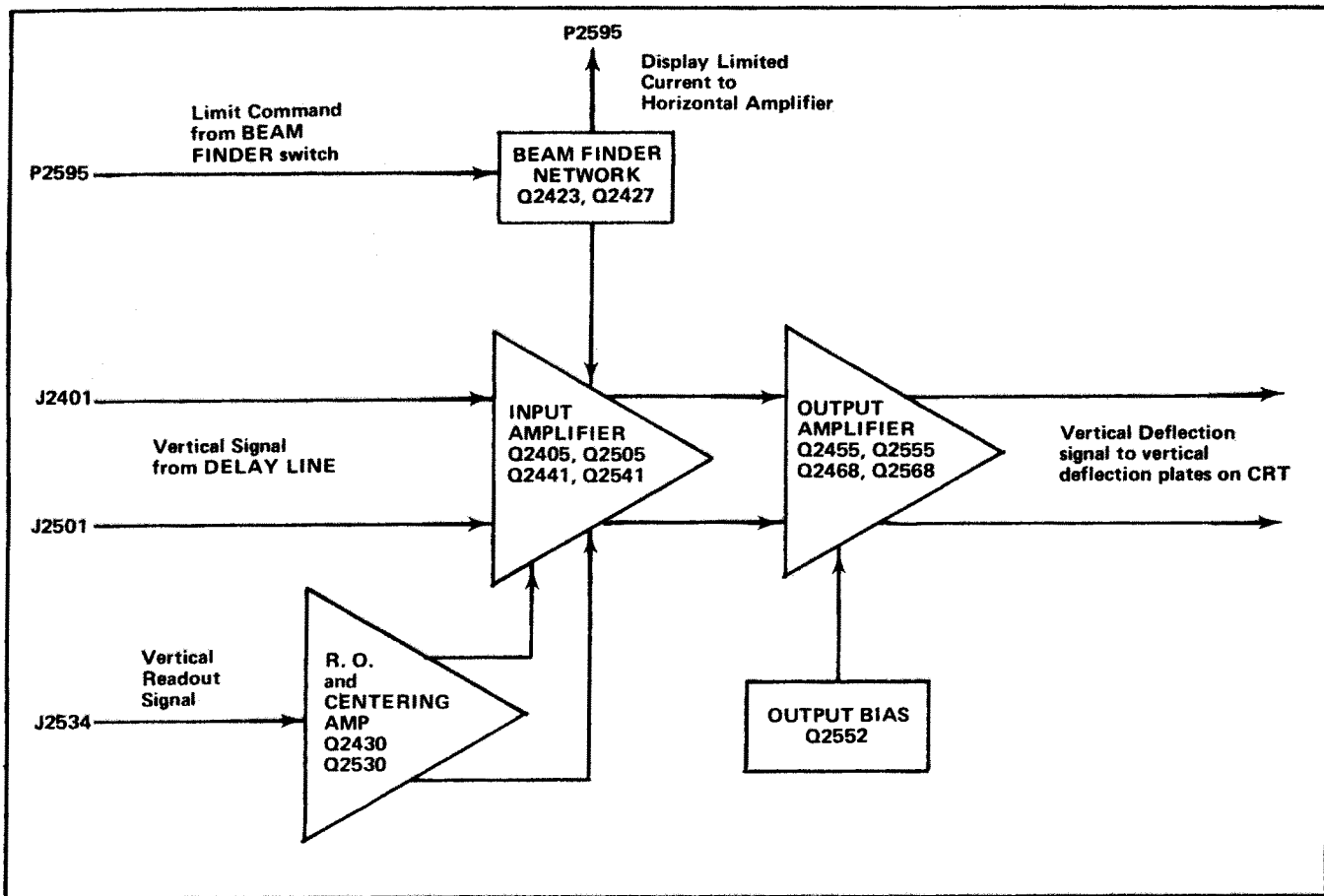

Fig. 3-18A. Vertical Amplifier detailed block diagram for SN B150000 and up.

level that limits the dynamic range of the input stage. R2523-R2524 serve to maintain the proper common mode voltage at the output of the amplifier when BEAM FINDER is used.

Output Amplifier

The output cascode amplifier is driven through "T coils" to increase high-frequency gain. High-frequency compensation is provided by C2456 and the varactor network in the emitters of Q2455-Q2555.

Output common base stage Q2468-Q2568 is driven through the RC matching networks between the collectors of Q2455-Q2555 and emitters of Q2468-Q2568. The output signal at the collectors of Q2468-Q2568 provides the vertical deflection signal for the CRT. LR networks provide peaking to overcome the effects of CRT plate capacity and prevent oscillations in the output transistors.

ELECTRICAL PARTS LIST

Ckt. No.	Tektronix Part No.	Serial/Model No. Eff	Disc	Description
ASSEMBLIES				
	670-3154-00	B010100	B169999	VERTICAL AMPLIFIER Circuit Board Assembly
	670-3154-02	B170000		VERTICAL AMPLIFIER Circuit Board Assembly
	670-3186-00			VERTICAL INTERFACE Circuit Board Assembly
CAPACITORS				
C2341	283-0177-00			1 μ F, Cer, 25 V, +80%-20%
C2345	283-0159-00			18 pF, Cer, 50 V, 5%
C2347	281-0627-00			1 pF, Cer, 600 V
C2348	283-0185-00			2.5 pF, Cer, 50 V, 5%
C2355	283-0159-00			18 pF, Cer 50 V, 5%
C2357	281-0627-00			1 pF, Cer, 600 V
C2358	283-0185-00			2.5 pF, Cer, 50 V, 5%
C2366	281-0562-00			3 pF, Cer, 500 V
C2376	281-0562-00			3 pF, Cer, 500 V
C2387	281-0509-00			15 pF, Cer, 500 V, \pm 1.5 pF
C2397	281-0509-00			15 pF, Cer, 500 V, \pm 1.5 pF
C2403	283-0003-00			0.1 μ F, Cer, 150 V, +80%-20%
C2409	283-0077-00			330 pF, Cer, 500 V, 5%
C2411	281-0564-00			24 pF, Cer, 500 V, 5%
C2416	281-0123-00			5-25 pF, Var, Cer, 100 V
C2418	281-0158-00			7-45 pF, Var, Cer, 50 V
C2429	283-0000-00			0.001 μ F, Cer, 500 V, +100%-0%
C2445	283-0000-00			0.001 μ F, Cer, 500 V, +100%-0%
C2448	281-0661-00			0.8 pF, Cer, 500 V, \pm 0.1 pF
C2456	281-0122-00			2.5-9 pF, Var, Cer, 100 V
C2465	283-0103-00			180 pF, Cer, 500 V, 5%
C2469	281-0167-00			9-45 pF, Var, Cer, 200 V
C2509	283-0649-00			105 pF, Mica, 300 V, 1%
C2511	281-0205-00			5.5-65 pF, Var, Plastic, 100 V
C2524	283-0000-00			0.001 μ F, Cer, 500 V, +100%-0%
C2545	283-0000-00			0.001 μ F, Cer, 500 V, +100%-0%
C2548	281-0661-00			0.8 pF, Cer, 500 V, \pm 0.1 pF
C2565	283-0103-00			180 pF, Cer, 500 V, 5%
C2593	283-0111-00			0.1 μ F, Cer, 50 V, 20%
C2595	290-0527-00			15 μ F, Elect., 20 V, 20%
C2597	290-0527-00			15 μ F, Elect., 20 V, 20%
DIODES				
CR2331	152-0141-02			Silicon, 1N4152
CR2414	152-0612-00			Voltage Var Capacitance, 17.5 pF, \pm 2.5 pF, at 4 V
CR2456	152-0612-00			Voltage Var Capacitance, 17.5 pF, \pm 2.5 pF, at 4 V
CR2514	152-0612-00			Voltage Var Capacitance, 17.5 pF, \pm 2.5 pF, at 4 V
CR2556	152-0612-00			Voltage Var Capacitance, 17.5 pF, \pm 2.5 pF, at 4 V
CONNECTORS				
J2401	131-1003-00			Receptacle, electrical, coaxial cable
J2501	131-1003-00			Receptacle, electrical, coaxial cable
J2534	131-1003-00			Receptacle, electrical, coaxial cable

ELECTRICAL PARTS LIST (cont)

Ckt. No.	Tektronix Part No.	Serial/Model No. Eff	Disc	Description
INDUCTORS				
L2386	108-0606-00			50 nH
L2396	108-0606-00			50 nH
L2441	276-0528-00			Core, ferramic suppressor
L2448	108-0579-00			120 nH
L2519	108-0707-00			150 nH
L2541	276-0528-00			Core, ferramic suppressor
L2548	108-0579-00			120 nH
L2595	108-0538-00			2.7 μ H
LR2472	108-0777-00			115 μ H
LR2572	108-0777-00			115 μ H
TRANSISTORS				
Q2365 A,B	151-0232-00			Silicon, NPN, replaceable by 2N2919, dual
Q2386	151-0447-00			Silicon, NPN, selected from 2N5341
Q2390	151-0190-00			Silicon, NPN, 2N3904
Q2396	151-0447-00			Silicon, NPN, selected from 2N5841
Q2405	151-0447-00			Silicon, NPN, selected from 2N5841
Q2423	151-0302-00			Silicon, NPN, 2N2222A
Q2427	151-0302-00			Silicon, NPN, 2N2222A
Q2430	151-0192-00			Silicon, NPN, selected from MPS6521
Q2441	151-0271-00			Silicon, PNP, SAB4113
Q2455	151-0448-00			Silicon, NPN, selected from 2N5836
Q2468	151-0451-00			Silicon, NPN, selected from 2N5943
Q2505	151-0447-00			Silicon, NPN, selected from 2N5841
Q2530	151-0192-00			Silicon, NPN, selected from MPS6521
Q2541	151-0271-00			Silicon, PNP, SAB4113
Q2552	151-0301-00			Silicon, PNP, 2N2907
Q2555	151-0448-00			Silicon, NPN, selected from 2N5836
Q2568	151-0451-00			Silicon, NPN, selected from 2N5943
RESISTORS				
R2329	323-0131-00			226 Ω , 1/2 W, 1%
R2331	315-0912-00			9.1 k Ω , 1/4 W, 5%
R2333	321-1068-01			50.5 Ω , 1/8 W, 1/2%
R2335	321-1068-01			50.5 Ω , 1/8 W, 1/2%
R2337	321-1068-01			50.5 Ω , 1/8 W, 1/2%
R2339	321-1068-01			50.5 Ω , 1/8 W, 1/2%
R2341	315-0100-00			10 Ω , 1/4 W, 5%
R2343	321-0082-00			69.8 Ω , 1/8 W, 1%
R2345	315-0622-00			6.2 k Ω , 1/4 W, 5%
R2347	321-0193-01			1 k Ω , 1/8 W, 1/2%
R2349	321-0193-01			1 k Ω , 1/8 W, 1/2%
R2351	322-0212-00			1.58 k Ω , 1/4 W, 1%
R2353	321-0082-00			69.8 Ω , 1/8 W, 1%
R2355	315-0622-00			6.2 k Ω , 1/4 W, 5%
R2357	321-0193-01			1 k Ω , 1/8 W, 1/2%

ELECTRICAL PARTS LIST (cont)

Ckt. No.	Tektronix Part No.	Serial/Model No. Eff	Disc	Description
RESISTORS (cont)				
R2359	321-0193-01			1 k Ω , 1/8 W, 1/2%
R2362	321-0044-00			28 Ω , 1/8 W, 1%
R2364	321-0069-00			51.1 Ω , 1/8 W, 1%
R2366	315-0240-00			24 Ω , 1/4 W, 5%
R2368	315-0911-00			910 Ω , 1/4 W, 5%
R2369	322-0182-00			768 Ω , 1/4 W, 1%
R2372	321-0044-00			28 Ω , 1/8 W, 1%
R2374	321-0069-00			51.1 Ω , 1/8 W, 1%
R2376	315-0240-00			24 Ω , 1/4 W, 5%
R2378	315-0911-00			910 Ω , 1/4 W, 5%
R2379	322-0182-00			768 Ω , 1/4 W, 1%
R2384	321-0203-00			1.27 k Ω , 1/8 W, 1%
R2386	321-0141-00			287 Ω , 1/8 W, 1%
R2387	321-0062-00			43.2 Ω , 1/8 W, 1%
R2390	321-0227-00			2.26 k Ω , 1/8 W, 1%
R2393	323-0085-00			75 Ω , 1/2 W, 1%
R2394	321-0203-00			1.27 k Ω , 1/8 W, 1%
R2396	321-0141-00			287 Ω , 1/8 W, 1%
R2397	321-0062-00			43.2 Ω , 1/8 W, 1%
R2402	322-0645-00			52.5 Ω , 1/4 W, 1/2%
R2403	323-0079-00			64.9 Ω , 1/2 W, 1%
R2405	323-0093-00			90.9 Ω , 1/2 W, 1%
R2407	315-0511-00			510 Ω , 1/4 W, 5%
R2409	311-1231-00			25 k Ω , Var
R2411	311-1466-00			2 k Ω , Var
R2412	315-0470-00			47 Ω , 1/4 W, 5%
R2416	311-1260-00			250 Ω , Var
R2418	311-1259-00			100 Ω , Var
R2419	321-0117-00			162 Ω , 1/8 W, 1%
R2421	323-0134-00			243 Ω , 1/2 W, 1%
R2423	321-0163-00			487 Ω , 1/8 W, 1%
R2425	315-0223-00			22 k Ω , 1/4 W, 5%
R2426	315-0562-00			5.6 k Ω , 1/4 W, 5%
R2427	315-0562-00			5.6 k Ω , 1/4 W, 5%
R2429	315-0822-00	B010100	B169999	8.2 k Ω , 1/4 W, 5%
R2429	315-0432-00	B170000		4.3 k Ω , 1/4 W, 5%
R2430	315-0471-00			470 Ω , 1/4 W, 5%
R2432	321-0297-00			12.1 k Ω , 1/8 W, 1%
R2433	311-1224-00			500 Ω , Var
R2434	315-0221-00			220 Ω , 1/4 W, 5%

ELECTRICAL PARTS LIST (cont)

Ckt. No.	Tektronix Part No.	Serial/Model No. Eff	Disc	Description
RESISTORS (cont)				
R2436	321-0068-00			49.9 Ω , 1/8 W, 1%
R2442	315-0101-00			100 Ω , 1/4 W, 5%
R2445	312-0201-00			200 Ω , 1/4 W, 5%
R2446	311-1266-00			2.5 k Ω , Var
R2448	321-0093-00			90.9 Ω , 1/8 W, 1%
R2455	323-0105-00			121 Ω , 1/2 W, 1%
R2456	321-0067-00			48.7 Ω , 1/8 W, 1%
R2458	315-0103-00			10 k Ω , 1/4 W, 5%
R2461	315-0104-00			100 k Ω , 1/4 W, 5%
R2463	315-0622-00			6.2 k Ω , 1/4 W, 5%
R2465	315-0330-00			33 Ω , 1/4 W, 5%
R2466	315-0330-00			33 Ω , 1/4 W, 5%
R2468	315-0820-00			82 Ω , 1/4 W, 5%
R2470	308-0758-00			430 Ω , 7 W, WW, 1%
R2501	322-0645-00			52.5 Ω , 1/4 W, 1/2%
R2505	323-0093-00			90.9 Ω , 1/2 W, 1%
R2507	315-0201-00			200 Ω , 1/4 W, 5%
R2509	311-1228-00			10 k Ω , Var
R2510	315-0112-00			1.1 k Ω , 1/4 W, 5%
R2511	311-1225-00			1 k Ω , Var
R2512	315-0470-00			47 Ω , 1/4 W, 5%
R2514	315-0474-00			470 k Ω , 1/4 W, 5%
R2515	315-0103-00			10 k Ω , 1/4 W, 5%
R2516	315-0124-00			120 k Ω , 1/4 W, 5%
R2517	315-0104-00			100 k Ω , 1/4 W, 5%
R2519	311-1260-00			250 Ω , Var
R2521	323-0134-00			243 Ω , 1/2 W, 1%
R2523	323-0176-00			665 Ω , 1/2 W, 5%
R2524	321-0204-00			1.3 k Ω , 1/8 W, 1%
R2526	321-0143-00			301 Ω , 1/8 W, 1%
R2527	311-1222-00			100 Ω , Var
R2530	315-0391-00			390 Ω , 1/4 W, 5%
R2532	321-0331-00			27.4 k Ω , 1/8 W, 1%
R2533	312-0172-00			604 Ω , 1/8 W, 1%
R2534	321-0233-00			2.61 k Ω , 1/8 W, 1%
R2536	321-0068-00			49.9 Ω , 1/8 W, 1%
R2537	323-0177-00			681 Ω , 1/2 W, 1%
R2542	315-0101-00			100 Ω , 1/4 W, 5%
R2545	315-0201-00			200 Ω , 1/4 W, 5%
R2548	321-0093-00			90.9 Ω , 1/8 W, 1%
R2550	321-0181-00			750 Ω , 1/8 W, 1%
R2551	321-0181-00			750 Ω , 1/8 W, 1%
R2553	301-0750-00			75 Ω , 1/2 W, 5%
R2555	323-0105-00			121 Ω , 1/2 W, 1%
R2565	315-0330-00			33 Ω , 1/4 W, 5%

ELECTRICAL PARTS LIST (cont)

Ckt. No.	Tektronix Part No.	Serial/Model No. Eff	Disc	Description
RESISTORS (cont)				
	R2566	315-0330-00		33 Ω , 1/4 W, 5%
	R2568	315-0820-00		82 Ω , 1/4 W, 5%
	R2570	308-0758-00		430 Ω , 7 W, WW, 1%
	R2593	315-0120-00		12 Ω , 1/4 W, 5%
	R2597	323-0022-00		16.5 Ω , 1/2 W, 1%
	RT2463	307-0181-00		100 k Ω , Thermal
	RT2507	307-0127-00		1 k Ω , Thermal
	RT2510	307-0124-00		5 k Ω , Thermal
	RT2517	307-0181-00		100 k Ω , Thermal
INTEGRATED CIRCUIT				
	U2340	155-0022-00		Monolithic, channel switch
DIODES, ZENER				
	VR2445	152-0279-00		Zener, 1N751A, 0.4 W, 5.1 V, 5%
	VR2545	152-0279-00		Zener, 1N751A, 0.4 W, 5.1 V, 5%

MECHANICAL PARTS LIST

Fig. & Index No.	Tektronix Part No.	Serial/Model No. Eff Disc	Q					Description		
			t	y	1	2	3		4	5
			1						1	CIRCUIT BOARD ASSEMBLY--VERTICAL AMPLIFIER
			-							circuit board assembly includes:
	131-0608-00		8							TERMINAL, pin, 0.365 inch long
	131-0775-00		2							TERMINAL, stud
	136-0252-04		36							SOCKET, pin connector
	131-0566-00		4							LINK, terminal connecting
	211-0503-00		2							SCREW, 6-32 x 0.188 inch, PHS
	211-0008-00		3							SCREW, 4-40 x 0.25 inch, PHS
	214-0579-00		2							TERMINAL, test point
			1							CIRCUIT BOARD ASSEMBLY--VERTICAL INTERFACE
			-							circuit board assembly includes:
	136-0252-04		31							SOCKET, pin connector
	136-0263-04		18							SOCKET, pin terminal
	210-0406-00		8							NUT, hex, 4-40 x 0.188 inch
	210-0599-00		2							NUT, sleeve, 4-40 x 0.391 inch long
	210-0627-00		2							RIVET, solid
	211-0008-00		4							SCREW, 4-40 x 0.25 inch, PHS
	211-0012-00		4							SCREW, 4-40 x 0.375 inch, PHS
	214-0368-00		2							SPRING, heatsink holder
	214-1138-00		2							HEATSINK, transistor
	343-0097-00		1							CLAMP, transistor heat sink, counter clockwise
	343-0120-00		1							CLAMP, transistor heatsink, clockwise
	352-0062-00		2							HOLDER, transistor
	441-1192-00		1							CHASSIS

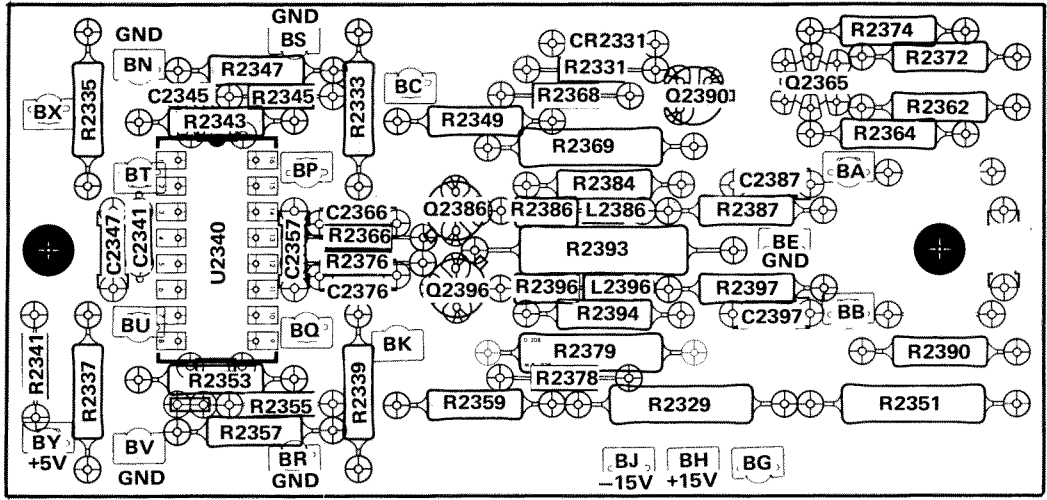

Fig. 6-6A. A3. Vertical Interface circuit board, SN B15000-up

Located on back of board:
 C2348
 C2358

NOTE: R2402, R2405, R2421, R2442, R2455, R2501, R2505, R2521, R2542, R2555 are located on back of board.
 Numbers in circles indicate calibration adjustment.

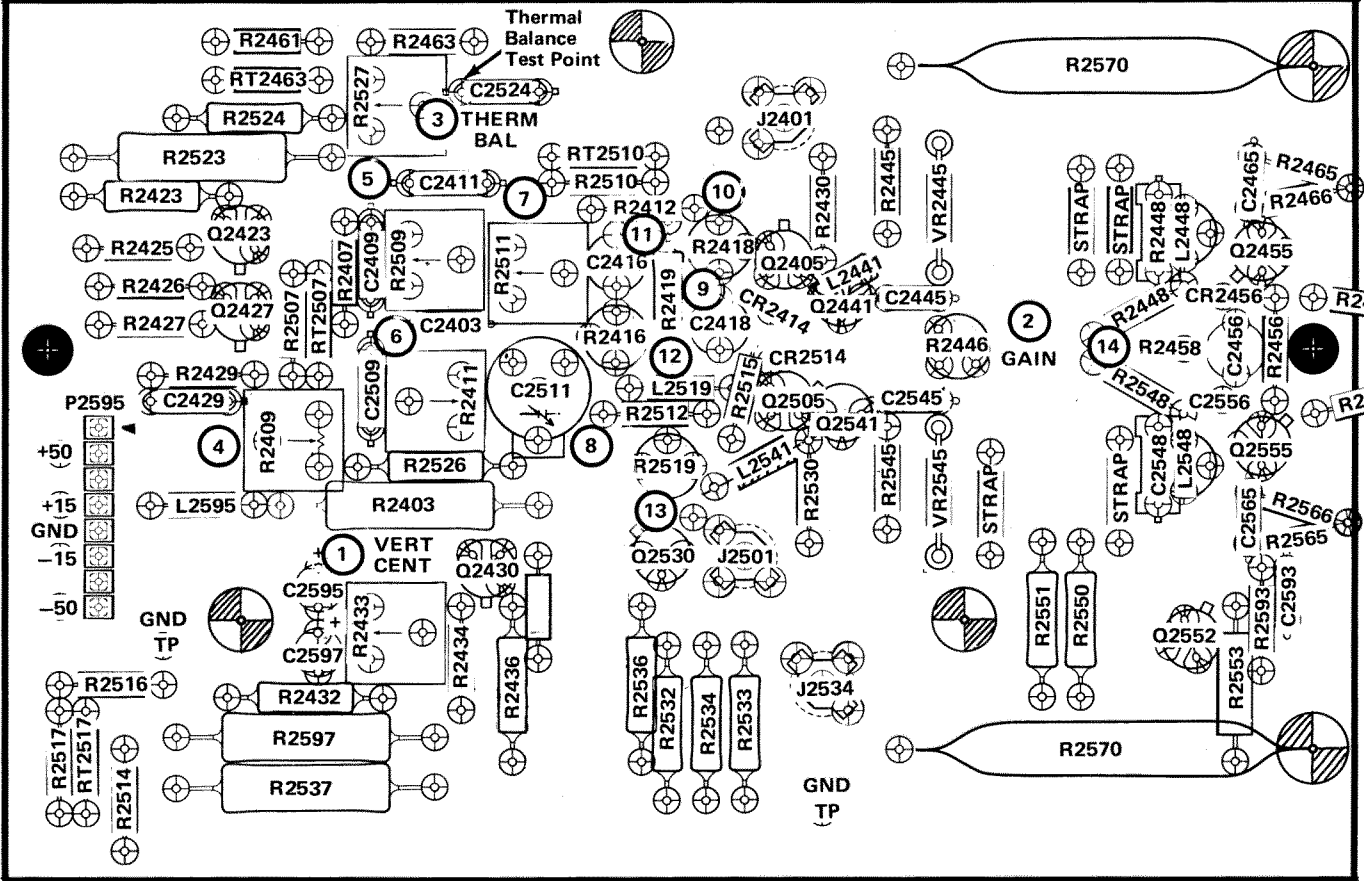
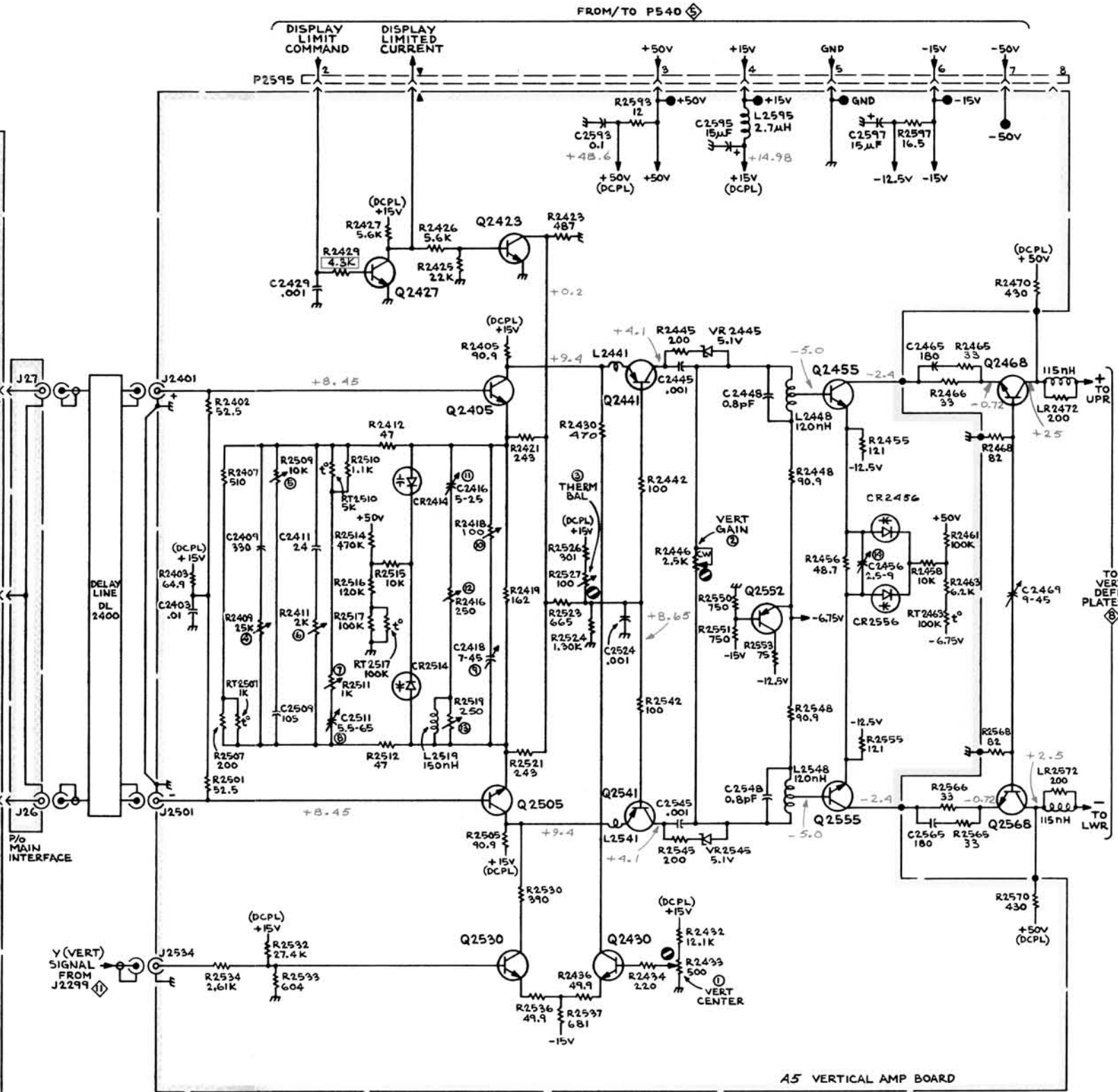
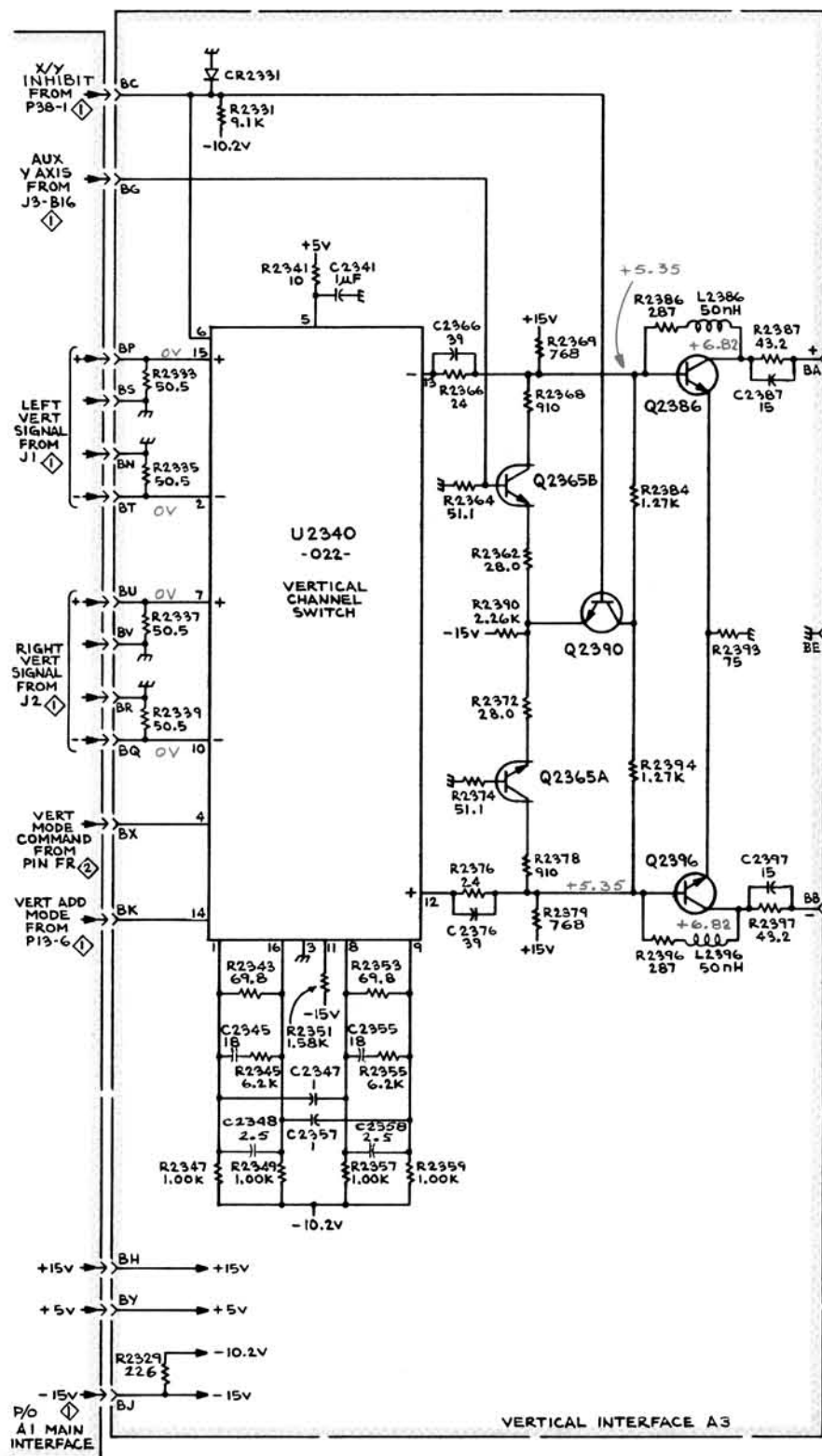

Fig. 6-7A. A5. Vertical Amplifier circuit board, SN B15000-up

VOLTAGE CONDITIONS
 NO INPUT SIGNAL
 NO PLUG-IN IN LEFT VERTICAL COMPARTMENT
 VERT MODE LEFT BUTTON DEPRESSED
 READOUT INTENSITY OFF (FULL CCW)
 1 = ADJUSTMENT NUMBER ETCHED ON BOARD



7503
7504
7514
7603/R7603
7613/R7613
7704
R7704
7704A
R7903
7904

Option 3 EMI Modification or EMI Conversion Kit
Installed
(Operators or Instruction Manuals)

SPECIFICATION SECTION

ADD TO: Existing information concerning Option 3:

Any unused plug-in compartments must also be covered with an EMI shielded blank plug-in panel in order to meet the EMI interference specifications. Order or use Tektronix Part No. 016-0155-00 only. One is required for each unused compartment. This applies whether the mainframe was ordered as an Option 3 or modified with the appropriate EMI Conversion Kit.

OPERATING INSTRUCTIONS SECTION

ADD TO: Existing information concerning Plug-In units, Installation:

All of the plug-in compartments do not have to be filled to operate the instrument; the only plug-ins needed are those required for the measurement to be made. At environmental extremes, excess interference may be radiated into or out of the instrument through the plug-in compartments. To reduce such interference, or to meet EMI specifications on factory equipped Option 3 or field EMI modified instruments, all unused plug-in compartments must be covered with an EMI shielded blank plug-in panel. Order or use only Tektronix Part No. 016-0155-00. One is required for each unused compartment.

Service or Instruction Manual

MECHANICAL PARTS LIST

INSTRUMENT OPTIONS

ADD TO: OPTION 3

OPTIONAL ACCESSORIES

016-0155-00	1	PLUG-IN, PANEL, Blank, EMI Shielded (not shown)
-------------	---	--

S19,269/1172



MANUAL CHANGE INFORMATION

PRODUCT see below

CHANGE REFERENCE M22,320

DATE 10-31-74

CHANGE:

DESCRIPTION

7313/R7313 Service EFF SN B150000-up
 7403N/R7403N Service EFF SN B210000-up
 7603/R7603 Service EFF SN B190000-up
 7623A/R7623A Service EFF SN B070880-up
 7633/R7633 Service EFF SN B090759-up
 7613/R7613 Service EFF SN B260000-up

ELECTRICAL PARTS LIST CHANGE

CHANGE TO:

Q874	151-0487-00	TRANSISTOR:SILICON, NPN	2N3773
Q903	151-0487-00	TRANSISTOR:SILICON, NPN	2N3773
Q933	151-0487-00	TRANSISTOR:SILICON, NPN	2N3773
Q958	151-0487-00	TRANSISTOR:SILICON, NPN	2N3773