

ACTIVAL™

Electro-Mechanical Actuator for Control Ball Valve

General

Model MY53X0A actuator is designed specifically for Models VY5302 two-way and VY5303 three-way proportional control ball valves.

ACTIVAL Model MY53X0AX000 has a reversible synchronous motor, which operates at a low voltage of 24 V AC.

Three kinds of control signals are available to operate the ACTIVAL ball valves:

- Floating (3-position) with nominal 135 Ω feedback potentiometer
- 2-10 V DC input
- Floating (3-position)

These control signals provide proportional control in combination with an electric/electronic proportional controller or a PLC (Programmable Logic Controller).



Features

- Compact and lightweight
The ACTIVAL can be installed in a limited space.
- Easy and simple mounting onto Models VY5302 and VY5303 valves
The actuator can be mounted without tools, and no adjustment is required (one-touch lever-locking mechanism).
- IEC IP54
Dust-proof and splash-proof enclosure enables to be installed in an AHU (air handling unit).
- Easy manual override
The actuator operation can be switched to manual from electric. It besides can be manually operated without tools.
- Highly-visible position indicator
Valve position is easily recognized with the indicator/manual lever.
- Energy-saving:
No power is consumed in fully open/closed position of the valve because of the limit switch mechanism. (Only for Model MY5310A.)
- Built-in auxiliary switch (except Model MY5370A):
The switch is adjustable between 20-80% position.
- 90° stroke in 60 seconds (50 Hz) / 50 seconds (60 Hz) operating time.
- ACTIVAL Model MY53X0A conforms to all the standards related to CE Marking.





Safety Instructions

Please read instructions carefully and use the product as specified in this manual. Be sure to keep this manual nearby for quick reference.



Usage Restrictions



This product is targeted for general air conditioning. Do not use this product in a situation where human life might be affected. Also, do not install this product in an atmosphere containing explosive gas or flammable gas. If this product is used in a clean room or a place where particularly high reliability or control accuracy is required, please contact our sales representative. Azbil Corporation will not bear any responsibility for the results produced by the operators











Warnings and Cautions

 WARNING	Alerts users that improper handling may cause death or serious injury.
 CAUTION	Alerts users that improper handling may cause minor injury or material loss.

Signs

	Alerts users possible hazardous conditions caused by erroneous operation or erroneous use. The symbol inside I indicates the specific type of danger. (For example, the sign on the left warns of the risk of electric shock.)
	Notifies users that specific actions are prohibited to prevent possible danger. The symbol inside Q graphically indicates the prohibited action. (For example, the sign on the left notifies that disassembly is prohibited.)
	Instructs users to carry out a specific obligatory action to prevent possible danger. The symbol inside d graphically indicates the actual action to be carried out. (For example, the sign on the left indicates general instructions.)

 WARNING	
	Before wiring, maintenance or setting the switch, be sure to turn off the power to the product. Failure to do so might cause electric shock or device failure.
	Detach the cover only when wiring, setting the product or maintenance and reattach the cover after wiring, setting the product or maintenance. Failure to do so might cause electric shock.

 CAUTION 1/2	
	Install and use this product under the operating conditions (for temperature, humidity, power, vibration, shock, mounting direction, atmosphere, etc.) listed in the specifications. Failure to do so might cause fire or device failure.
	Use the product within its lifespan and avoid instrumentations that keep the product to operate excessively. Continued use beyond the lifespan might cause fire or device failure.
	Keep the products in package for storage. Failure to do so might damage or stain the products.
	Do not allow any shock on the product. Doing so might damage the product.
	Installation and wiring must be performed by qualified personnel in accordance with all applicable safety standards.
	Do not install the product nearby a steam coil, pressurized hot-water coil, or any high heat source. High temperature radiation might cause malfunction of its actuator.
	Do not use the product in an atmosphere corrosive to the actuator, valve, and their components. Doing so might damage the product.
	Do not put load or weight on the actuator of the product. Doing so might damage the product.
	All wiring must comply with applicable codes and ordinances.
	Provide circuit breaker/fuse protection when powering this product.

 CAUTION

2/2



Provide a circuit protector (e.g., a fuse, circuit breaker) for the control panel to ensure your safety.



For wiring, strip each wire insulation as specified in this manual. If the strip length is longer than the specified, the stripped part of the wires will be exposed, causing electric shock or short circuit between adjacent terminals. If it is shorter, the stripped part will not contact the connector.



Use crimp terminals with insulation for connections to the product terminals. Failure to do so might cause short circuit leading to fire or device failure.



Firmly tighten the terminal screws. Insufficient tightening of the terminal screws might cause fire or overheating.



Do not touch the moving parts of the product. Doing so might cause injury.



Do not disassemble the product. Doing so might cause device failure.



Dispose of the product as industrial waste in accordance with your local regulations. Do not reuse all or part of this product.

IMPORTANT:

In case an Azbil Corporation product fails, you are required to provide your Equipment with safety design such as fool-proof design^{*1}, and fail-safe design^{*2} (anti-flame propagation design, etc.), whereby preventing any occurrence of physical injuries, fires, significant damage, and so forth. Furthermore, fault avoidance^{*3}, fault tolerance^{*4}, or the like should be incorporated so that the said Equipment can satisfy the level of reliability and safety required for your use.

*1. A design that is safe even if the user makes an error.

*2. A design that is safe even if the device fails.

*3. Avoidance of device failure by using highly reliable components, etc.

*4. The use of redundancy.

Specifications

Item	Specification		
Power supply	24 V AC \pm 15 %, 50 Hz/60 Hz		
Applicable valves	Two-way control ball valves : Model VY5302B Three-way control ball valves : Model VY5303B		
Power consumption	Model MY5310A/MY5370A : Max. 4 VA Model MY5340A : Max. 7 VA		
Timing	60 \pm 6 sec. (50 Hz) / 50 \pm 6 sec. (60 Hz)		
Control signal	Floating (3-position) with nominal 135 Ω feedback potentiometer <div style="display: flex; align-items: center; justify-content: center;"> <div style="font-size: 2em; margin-right: 10px;">{</div> <div style="display: flex; flex-direction: column; align-items: center;"> <div style="margin-bottom: 5px;">Feedback potentiometer</div> <div style="margin-bottom: 5px;">Total resistance: Nominal 135 Ω</div> <div>Max. applied voltage: 5 V DC</div> </div> </div> 2 V DC to 10 V DC input (input impedance: 150 k Ω or higher) Floating (3-position)		
Environmental conditions		Rated operating conditions	Transport/storage conditions
	Ambient temperature	* -4 $^{\circ}$ F to 122 $^{\circ}$ F (-20 $^{\circ}$ C to 50 $^{\circ}$ C) (Fluid temperature: 32 $^{\circ}$ F to 212 $^{\circ}$ F (0 $^{\circ}$ C to 100 $^{\circ}$ C)) * Do not allow the fluid to freeze.	-4 $^{\circ}$ F to 158 $^{\circ}$ F (-20 $^{\circ}$ C to 70 $^{\circ}$ C)
	Ambient humidity	5 % RH to 95 % RH	5 % RH to 95 % RH
	Vibration	16.1 fps ² (5 m/s ²) 10 Hz to 150 Hz	64.3 fps ² (20 m/s ²) 10 Hz to 150 Hz
Materials	Case: Plastic (polycarbonate resin) (Color: Gray) Cover: Plastic (polycarbonate resin) (Color: Gray) Yoke: Plastic (polyphenylene sulfide resin) (Color: Black)		
Auxiliary switch (except Model MY5370A)	One SPST Maximum applied voltage/current : 30 V AC, 1 A Actuating position : variable within 20 % to 80 % Setting accuracy : \pm 10 %		
Installation locations	Indoor and outdoor without direct sunlight. (Avoid using in acid fumes, corrosive gas and organic solvent atmosphere)		
Installation orientation	Installable in any position ranging from upright to sideways.		
Valve position indication	Indicator/manual lever shows the valve position by pointing at the value of the scale on the actuator bilateral sides. 0 (%): fully closed for Model VY5302 / for Port B (B-AB) of Model VY5303 100 (%): fully open for Model VY5302 / for Port A (A-AB) of Model VY5303		
Manual override	Disconnect from the power supply. Turn the indicator/manual lever while pressing the lever release button.		
Wiring	Electrical connection: Quick-fit screwless terminal Conduit thread: G1/2 (ISO 7-1)		
Enclosure rating	Equivalent to IEC IP54: Dust-proof and splash-proof		
Insulation	Between terminal and case : 5 M Ω or higher at 500 V DC		
Dielectric strength	Between terminal and case: 500 V/min with 1 mA or less leakage current		
Position for shipment	100 % (fully open) Auxiliary switch: 50 %		
Weight	1.1 lb (0.5 kg)		

Model Numbers with Control Signals and Auxiliary Switch

Model number	Control signal	Built-in auxiliary switch
MY5310A1000	Floating (3-position) with nominal 135 Ω feedback potentiometer	One auxiliary switch
MY5340A1000	2 to 10 V DC input	One auxiliary switch
MY5370A0000	Floating (3-position)	None

CE Marking Conformity

This product complies with the following Electromagnetic Compatibility (EMC).

EMC: EN61000-6-2, EN55011 Class A

Dimensions and Parts Identification

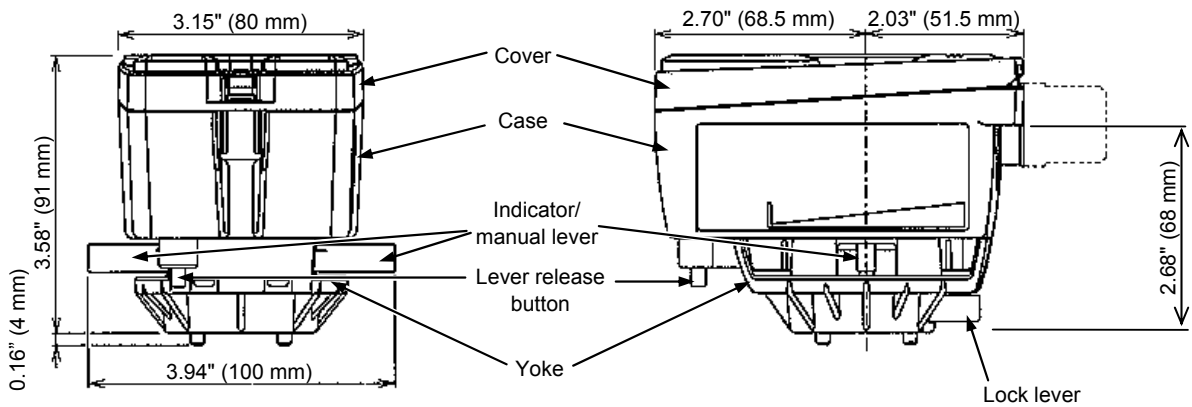

Figure 1. Dimensions and parts identification

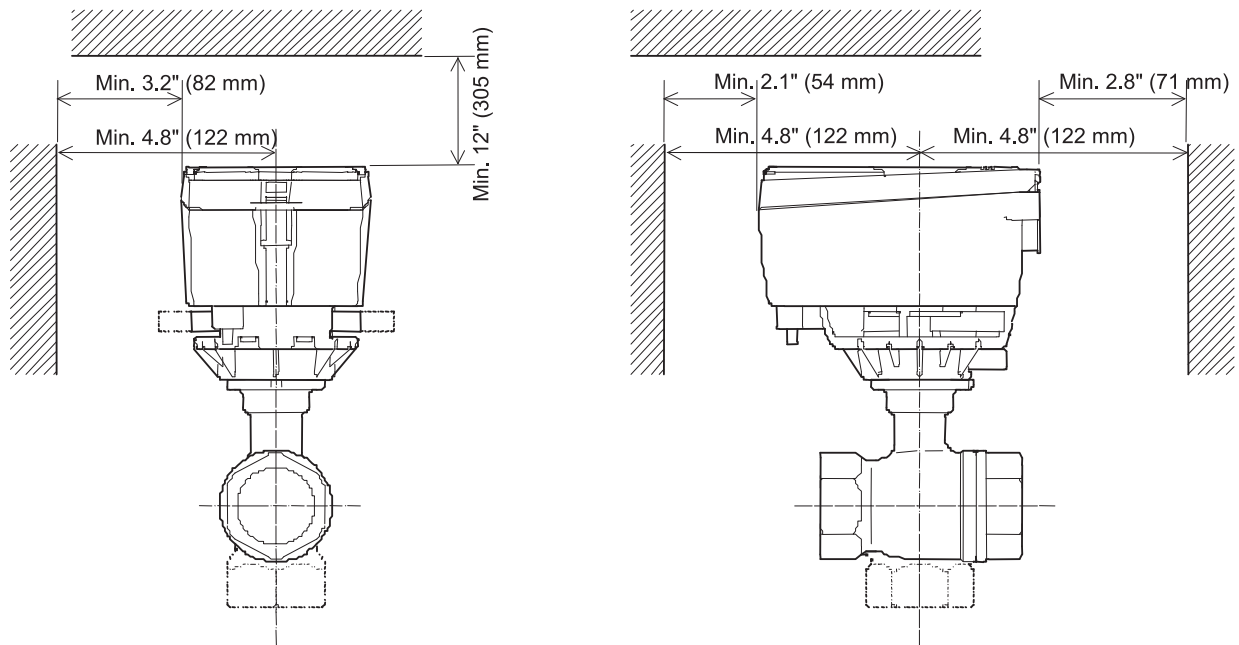







Figure 2. Mounting dimensions with clearance

Installation

⚠ CAUTION	
	Install and use this product under the operating conditions (for temperature, humidity, power, vibration, shock, mounting direction, atmosphere, etc.) listed in the specifications. Failure to do so might cause fire or device failure.
	Installation and wiring must be performed by qualified personnel in accordance with all applicable safety standards.
	Do not put load or weight on the actuator of the product. Doing so might damage the product.

Installation location

⚠ CAUTION	
	Provide a circuit protector (e.g., a fuse, circuit breaker) for the control panel to ensure your safety.
	Do not use the product in an atmosphere corrosive to the actuator, valve, and their components. Doing so might damage the product.

IMPORTANT:	
<ul style="list-style-type: none"> • The case, cover, and terminal cover might be corroded by various chemicals, organic solvents, their vapor, etc. Avoid wiping the product by various chemicals and organic solvents, or using it in their atmosphere. • The product can be used in a high humidity atmosphere (max. 95 % RH). Do not immerse the actuator in water. • The product can be used outdoors. But avoid direct sunlight on the actuator. 	

- Install the product where maintenance or inspection can be done easily.
Note: For the allowable maintenance or inspection space, refer to Fig. 2.
- When installing the product in the ceiling, make a trapdoor within 20" (50 cm) around the valve.

Mounting orientation

The product can be mounted with any position from upright to sideways (max. 90-degree inclination). Mount the product so that the actuator is located above the valve (see Fig. 3). When the product is installed outdoors, place it in upright position.

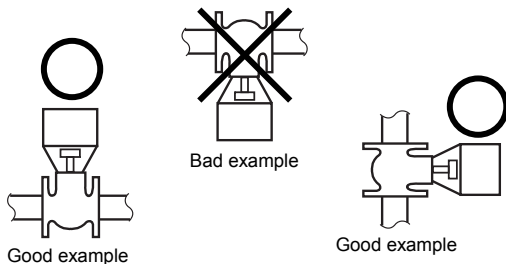



Figure 3. Mounting orientation

Position for shipment

The actuator shaft is at 100% (in fully open position) for shipment. Make sure the indicator/manual lever is positioned at "100" when the actuator is unpacked. (See Fig. 4)

Manual operation

⚠ CAUTION	
	Do not touch the moving parts of this product. Doing so might cause injury.

IMPORTANT:	
<ul style="list-style-type: none"> • Before opening or closing the valve manually, be sure to turn off the power. If the valve is manually opened or closed while the power 24 V DC active, there is a possibility that the actuator will break down. • Never manually open or close the valve more than 100 % or less than 0 % scale. 	

- (1) Turn off the power.
- (2) While pressing the lever release button shown in Fig. 4, turn the indicator/manual lever.
Note: No tool is required.

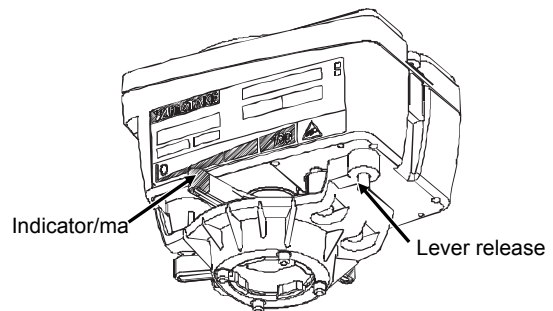
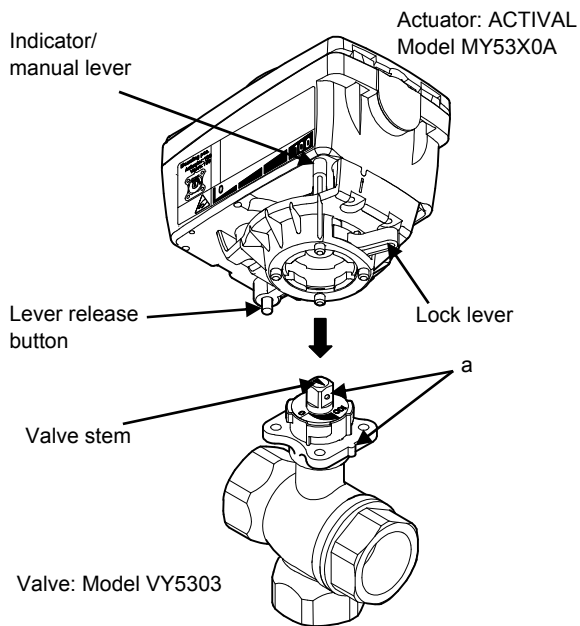

Figure 4. Manual operation

Mounting on the valve (Model VY5302/VY5303)

IMPORTANT:	
<ul style="list-style-type: none"> - The actuator can be horizontally rotated every 90 degrees to fit into the valve mounting position (4 mounting positions). Make sure the positions of the actuator and the valve are as follows. (see Fig. 5.) <ul style="list-style-type: none"> • Actuator: The indicator/manual lever points at 100 (fully open). • Valve: An arrow on the top of the valve stem points at 100. - Align the hole on the side of the valve stem with the tip at the valve flange. (See "a" in Fig. 5.) - If the valve and actuator are assembled in their different positions, counter actions etc. will occur and the valve cannot be controlled correctly. 	



5) Move the lock lever to the left-end (marked with the marker).

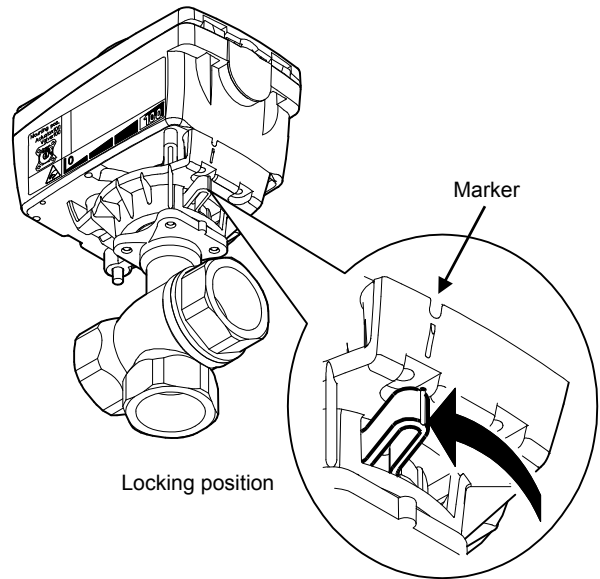
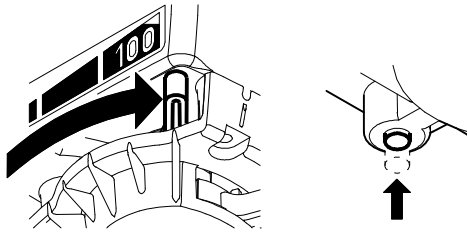
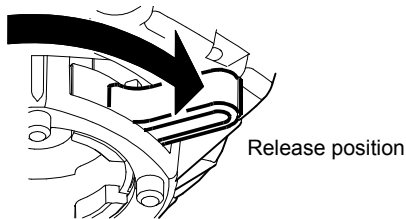

Figure 5. Mounting Model MY53X0A actuator on Model VY5303 valve

1) Adjust the indicator/manual lever to "100" with the lever release button pushed in.



2) Move the lock lever to the right-end.



3) Adjust the valve stem to "100".

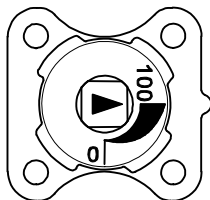

4) Mount Model MY53X0A onto the flange of the valve (Model VY5302/VY5303). Insert the four pins into the four holes on the valve.

Wiring

⚠ WARNING	
⚠	Before wiring, maintenance or setting the switch, be sure to turn off the power to the product. Failure to do so might cause electric shock or device failure.
⚠	Detach the cover only when wiring, setting the product or maintenance and reattach the cover after wiring, setting the product or maintenance. Failure to do so might cause electric shock.

⚠ CAUTION	
!	Installation and wiring must be performed by qualified personnel in accordance with all applicable safety standards.
!	All wiring must comply with applicable codes and ordinances.
!	Provide circuit breaker/fuse protection when powering this product.
!	Provide a circuit protector (e.g., a fuse, circuit breaker) for the control panel to ensure your safety.
	For wiring, strip each wire insulation as specified in this manual.
!	If the strip length is longer than the specified, the stripped part of the wires will be exposed, causing electric shock or short circuit between adjacent terminals. If it is shorter, the stripped part will not contact the connector.

IMPORTANT:
This product is designed for 24V AC power supply. DO NOT apply any other power voltage (e.g., 120 V AC, 240 V AC) to the product.

Cable connection

Connect the cable as follows:

- 1) Open the cover by pressing the area where Fig. 6 shows.

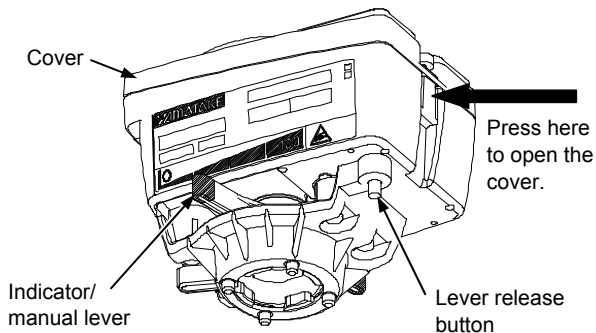

Figure 6. Cover removal

- 2) Let the lead wires go through the wiring conduit. (See Fig. 7) Connect the lead wires to the corresponding terminals while pushing clamp buttons.

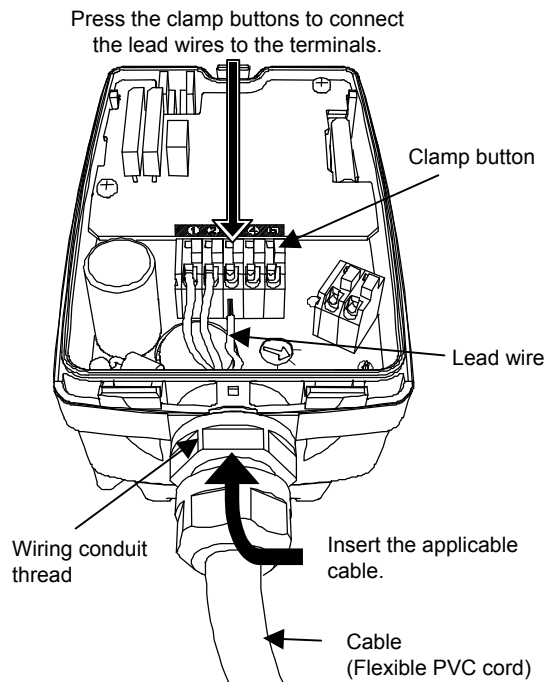

Figure 7. Lead wire connection

The strip length of the lead wires are 0.31" to 0.43" (8 mm to 11 mm).

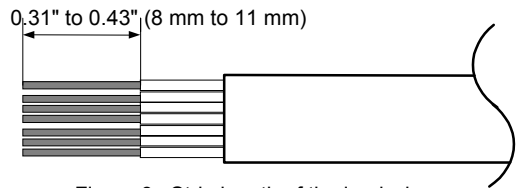

Figure 8. Strip length of the lead wires

- 3) After wiring, pull each lead wire lightly to check that each lead wire will not come off from the terminals.

For splash-proof enclosure...

- 1) Be sure to completely close the cover.
- 2) Waterproof the conduit hole with water-proof cable gland.
Recommended water-proof cable gland:
Part No. 83104346-012 (for 0.24" Dia. to 0.31" Dia. (6 mm Dia. to 8 mm Dia.) cable)
Part No. 83104346-013 (for 0.28" Dia. to 0.35" Dia. (7 mm Dia. to 9 mm Dia.) cable)
Part No. 83104346-014 (for 0.35" Dia. to 0.43" Dia. (9 mm Dia. to 11 mm Dia.) cable)

Adjusting the Auxiliary Switch

Model MY5310A1000 has one built-in auxiliary switch connected to the terminals 7 and 8.

Model MY5340A1000 have one built-in auxiliary switch connected to the terminals 6 and 7.

When the ACTIVAL is in open operation from 0 % position, the auxiliary switch is turned on (the terminals 7 and 8 or 6 and 7 are electrically connected) at the preset position.

Terminals 7 and 8 for Model MY5310A.

Terminals 6 and 7 for Models MY5340A.

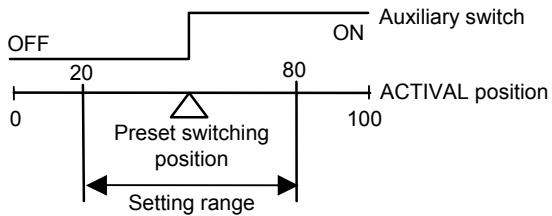

Setting procedure

1) Disconnect the power supply. Manually turn the indicator/manual lever to "0" with the lever release button pushed in.

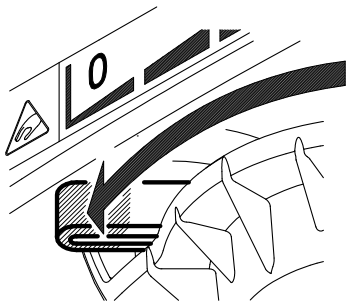

2) Remove the cover.

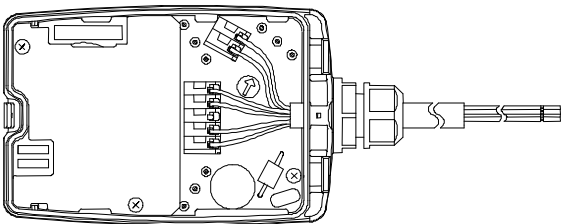

3) Set the switch adjustment dial to the desired position with a slotted screwdriver. (Adjustable between 20 and 80%)

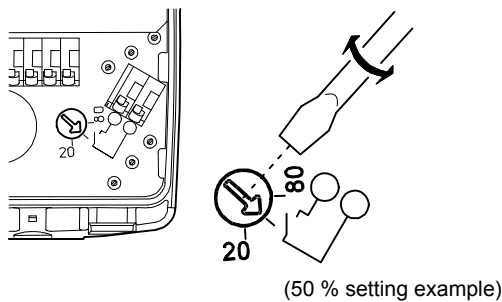

4) Turn the indicator/manual lever to the preset position while pushing the lever release button. Check that the switch is turned on. (Make contact) If switch is not turned on, finely adjust the adjustment dial.

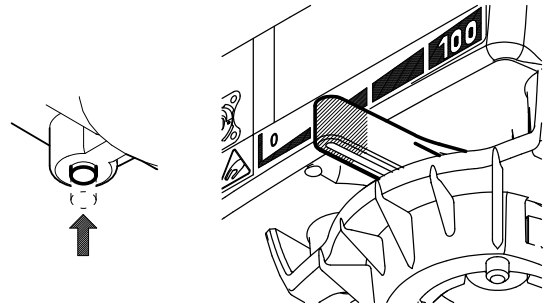

5) Turn the indicator/manual lever to 100 % while pushing the lever release button. Check that the switch is turned on. (Make contact).

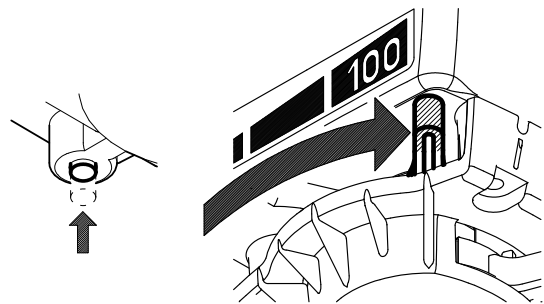

6) Be sure to put back the cover.

Wiring Terminals

Model MY5310A1000 (Nominal 135 Ω feedback potentiometer, with auxiliary switch)

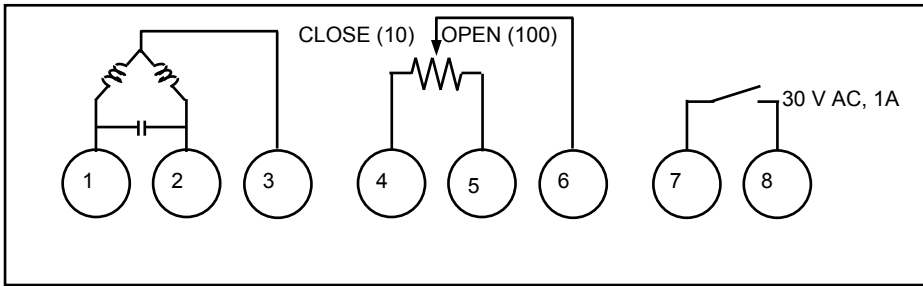

Model MY5340A1000 (2-10 V DC, with auxiliary switch)

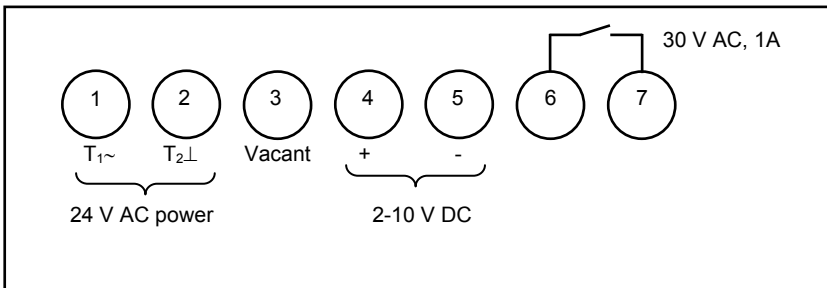

Model MY5370A0000 (Floating (3-position), with auxiliary switch)

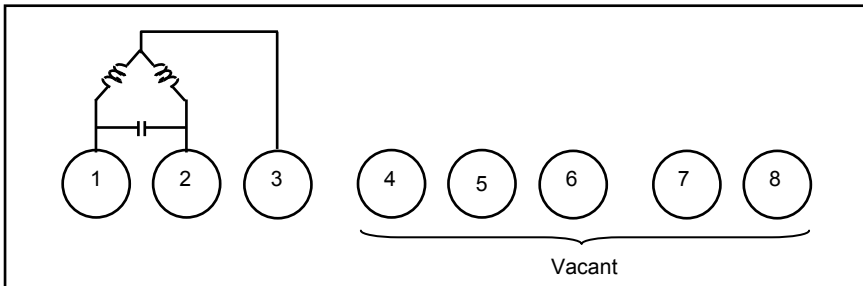
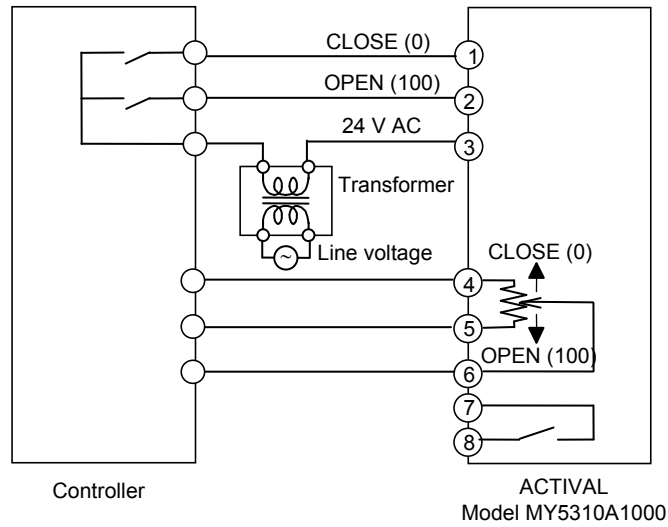

Figure 9. Wiring terminal diagrams

Connection Examples

- Model MY5310A1000: Floating (3-position) with nominal 135 Ω feedback potentiometer



Note: Terminals 2 and 5 are connected inside the actuator.

- Model MY5340A1000: 2-10 V DC input with auxiliary switch

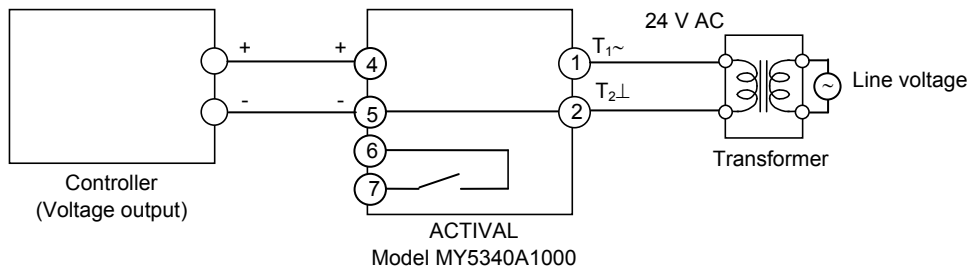

Note: Terminals 2 and 5 are connected inside the actuator.

- Model MY5370A0000: Floating (3-position)

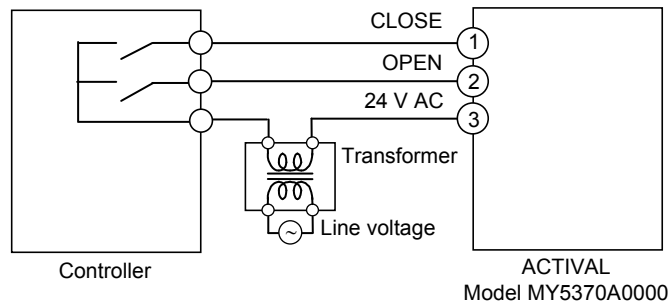

Application

- 2-10 V DC input (an input signal used in common)

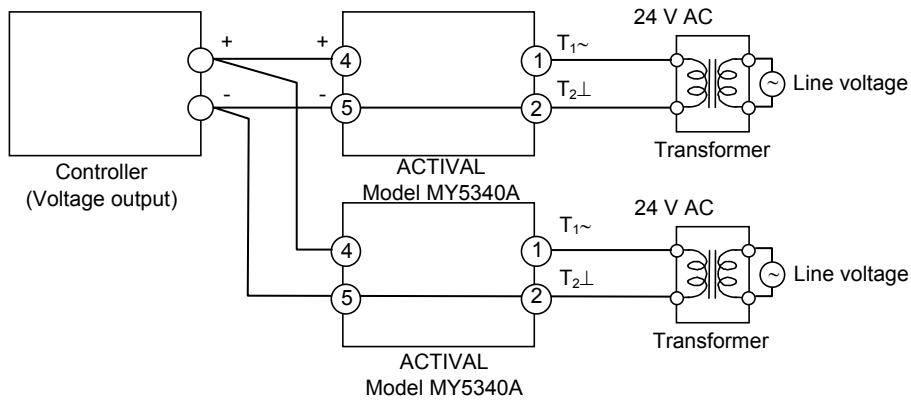

Notes:

1. Terminals 2 and 5 are connected inside the actuator.
2. Two ACTIVAL as shown in the figure above must be the same-type (same model number).

- 2-10 V DC input (power supply used in common)

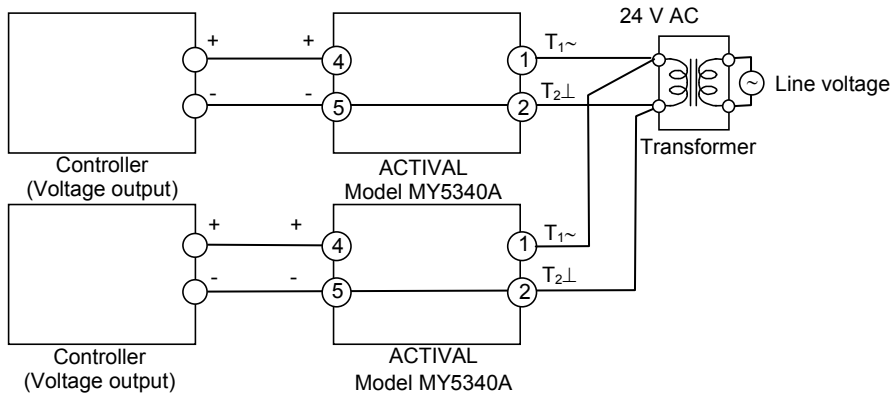

Notes:

1. All actuators must be in phase when using common transformer supply. Connect one transformer terminal to T_1 on each actuator. Connect the other transformer terminal to T_2 on each actuator.
2. Do not connect the actuator power supply terminals in parallel.
3. If you do not connect the lead wire properly, actuator and wiring might get damaged.
4. Terminals 2 and 5 are connected inside the actuator.
5. Two ACTIVAL as shown in the figure above must be the same-type (same model number).

- 2-10 V DC input (both input signal and power supply used in common)

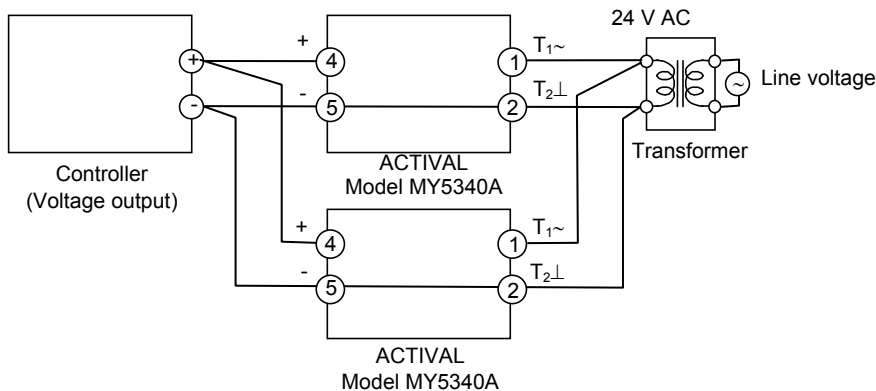

Notes:

1. All actuators must be in phase when using common transformer supply. Connect one transformer terminal to T_1 on each actuator. Connect the other transformer terminal to T_2 on each actuator.
2. Do not connect the actuator power supply terminals in parallel. Do not connect the actuator signal input terminals in parallel.
3. If you do not connect the lead wire properly, actuator and wiring might get damaged.
4. Terminals 2 and 5 are connected inside the actuator.
5. Two ACTIVAL as shown in the figure above must be the same-type (same model number).

- 2-10 V DC input (system common wiring)
Ground line (\perp) is used as a common line (for analog signal (-) transmission). Actuator thus has to have mutual ground as the connected controller.

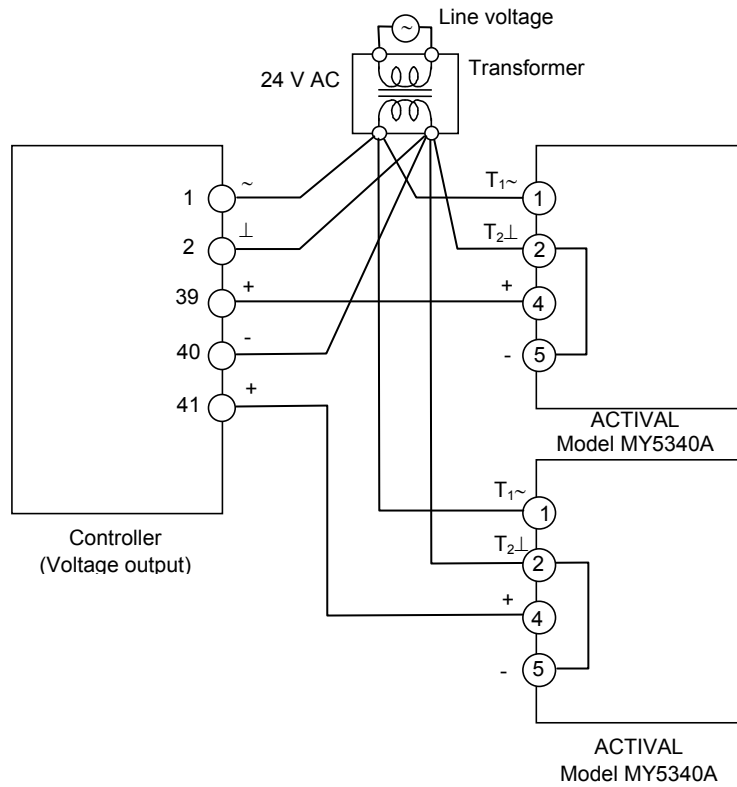



Notes:

1. Controller to be connected needs to be applicable to system common wiring.
2. Wiring length between the actuator terminal " \perp " and 0 V branch connection point of the transformer secondary side must be:
10 m or shorter for conducting wire with 1.25 mm² cross section
5 m or shorter for conducting wire with 0.75 mm² cross section
3. Terminals 2 and 5 are connected inside the actuator.
4. Two ACTIVAL as shown in the figure above must be the same-type (same model number).

Inspection and Troubleshooting

 WARNING
 Before wiring, maintenance or setting the switch, be sure to turn off the power to the product. Failure to do so might cause electric shock or device failure.

 CAUTION
 Do not touch the moving parts of the product. Doing so might cause injury.

- Manually open/close the product at least once a month if it is left in inactive state for a long period after installation.
- Inspect the product according to Table 1.
- Visually inspect the product (e.g., fluid leakage) every six months. If any of the problems described in Table 2 are found, take corresponding actions shown in the table. If your problem is not solved by the corresponding action, please contact us.

Table 1. Inspection items and details

Inspection item	Inspection interval	Inspection detail
Visual inspection	Semiannual	<ul style="list-style-type: none"> • Valve and actuator damages. • Fluid leakage from the valve gland/pipe connecting part. • Loosened lock lever of the ACTIVAL mounted onto the valve.
Operating status	Semiannual	<ul style="list-style-type: none"> • Valve unstable open/close operation. • Abnormal noise and vibration.
Routine inspection	Any time	<ul style="list-style-type: none"> • Valve unstable open/close operation. • Abnormal noise and vibration. • Valve hunting

Table 2. Troubleshooting

Problem	Part to check	Action
<ul style="list-style-type: none"> • Valve does not operate smoothly / valve stops halfway / valve does not operate at all. 	Conditions of the power applied and of the input signal applied. Wiring condition / disconnected wires. Jammed foreign substance (may block the valve open/close operation).	Check the power supply and the controller connected to the valve. Check the wiring. Remove the jammed foreign substances by manual operation.
<ul style="list-style-type: none"> • Auxiliary switch does not operate at all. 	Condition of the auxiliary switch (cam switch) dial. Wiring condition / disconnected wires.	Adjust the dial setting. Check the wiring.
<ul style="list-style-type: none"> • Fluid leaks when the ACTIVAL fully closes the valve. 	ACTIVAL incorrect mounting onto the valve.	Re-mount the actuator onto the valve referring to "Installation" on P.5..
<ul style="list-style-type: none"> • Valve hunting occurs. 	Secondary pressure condition and differential pressure condition. Unstable control.	Adjust the inlet and outlet pressure. Correct the control parameter setting of controller.
<ul style="list-style-type: none"> • ACTIVAL mounting position vibrates or produces abnormal noise. 	Lock lever status. Yoke damages.	Lock (close) the lock lever. Consult with our sales/service personnel.
<ul style="list-style-type: none"> • ACTIVAL produces abnormal noise when being in operation. 	—	Consult with our sales/service personnel.

This blank page is added for page layout purposes.

ACTIVAL is a trademark of Azbil Corporation in Japan or in other countries.

azbil

Specifications are subject to change without notice.

Azbil Corporation

Building Systems Company

1-12-2 Kawana, Fujisawa, Kanagawa

251-8522 JAPAN

<http://www.azbil.com/>

Azbil North America, Inc.

**9033 N. 24th Ave., Suite 6
Phoenix, AZ 85021**

888-262-4639

602-216-8199

<http://us.azbil.com/>