

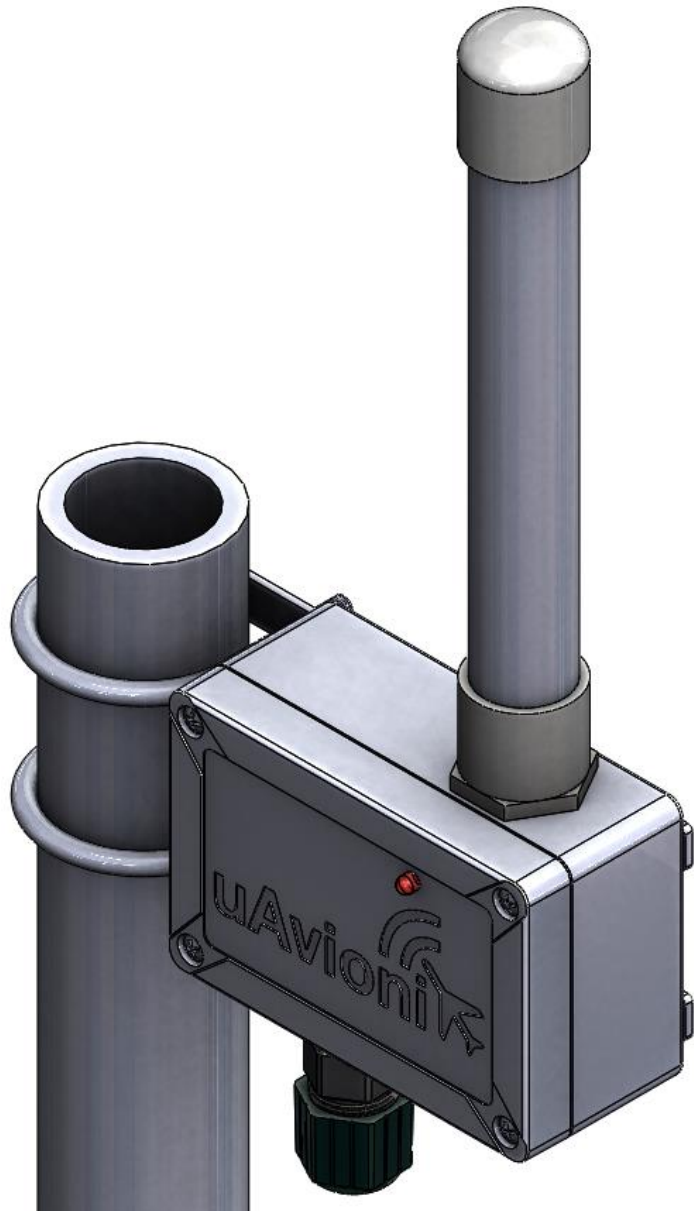

**pingStation
ICD
Rev P**



1 Overview

pingStation is an environmentally protected, networked dual-link ADS-B receiver. It can be configured for use in both internet connected and disconnected environments, and provides an extensible platform for collecting and processing surveillance data.

A single Ethernet port provides data connectivity and power to the device using Power-over-Ethernet (PoE). The device contains a DHCP client, and accepts DHCP leases based on existing network policy. To determine the assigned device address please consult your network administrator.

Surveillance data may be consumed using the methods detailed here.

2 Data Class

Data is received by pingStation and undergoes processing. The received aircraft data is parsed and assembled, it may contain information derived from a number of packets. This information is JSON formatted, stateless and fully self-describing.

2.1 JSON Traffic object

The pingStation delivers fields in the traffic table that are valid where field validity can be determined. This includes coordinates, altitude, heading, velocity, callsign, squawk, vertical velocity, and barometer difference. The JSON array of fields are dynamic.

The JSON document consists of an array of aircraft containing the following fields:

Field Name	Data Type	Description
icaoAddress	%02X%02X%02X	ICAO of the aircraft
trafficSource	%d	0 = 1090ES 1 = UAT
latDD	%f	Latitude expressed as decimal degrees
lonDD	%f	Longitude expressed as decimal degrees
altitudeMM	%ld	Geometric altitude or barometric pressure altitude in millimeters
headingDE2	%d	Course over ground in centi-degrees
horVelocityCMS	%lu	Horizontal velocity in centimeters/sec
verVelocityCMS	%ld	Vertical velocity in centimeters/sec with positive being up
squawk	%d	Squawk code
altitudeType	%d	Altitude Source

		0 = Pressure 1 = Geometric
callsign	%c%c%c%c %c%c%c%c	Callsign
emitterType	%d	Category type of the emitter 0 = No aircraft type information 1 = Light (ICAO) < 15,500 lbs 2 = Small - 15,500 to 75,000 lbs 3 = Large - 75,000 to 300,000 lbs 4 = High Vortex Large (e.g., B757) 5 = Heavy (ICAO) - > 300,000 lbs 6 = Highly Maneuverable > 5G acceleration and high speed 7 = Rotorcraft 8 = (Unassigned) 9 = Glider/sailplane 10 = Lighter than air 11 = Parachutist/sky diver 12 = Ultralight/hang glider/paraglider 13 = (Unassigned) 14 = Unmanned aerial vehicle 15 = Space/trans-atmospheric vehicle 16 = (Unassigned) 17 = Surface vehicle-emergency vehicle 18 = Surface vehicle-service vehicle 19 = Point Obstacle (includes tethered balloons) 20 = Cluster Obstacle 21 = Line Obstacle 22-39 = (Reserved)
sequenceNumber	%d	Auto incrementing packet sequence number
pingStationGuid	%02x%02x%02x%02x %02x%02x%02x%02x	Unique pingStation identifier
utcSync	%d	UTC time flag
timeStamp	%s	Time packet was received at the pingStation ISO 8601 format: YYYY-MM-DDTHH:mm:ss:ffffffZ

A field called “detail” may be present containing the following data:

Field Name	Data Type	Description
Common Fields to 1090ES and UAT		
navIntegrity	%d	Navigation integrity category (NIC) 0 = RC >=37.04 km (20 NM) Unknown Integrity 1 = RC < 37.04 km (20 NM) RNP-10 containment radius 2 = RC < 14.816 km (8 NM) RNP-4 containment radius 3 = RC < 7.408 km (4 NM) RNP-2 containment radius 4 = RC < 3.704 km (2 NM) RNP-1 containment radius 5 = RC < 1852 m (1 NM) RNP-0.5 containment radius 6 = RC < 1111.2 m (0.6 NM) RNP-0.3 containment radius 7 = RC < 370.4 m (0.2 NM) RNP-0.1 containment radius 8 = RC < 185.2 m (0.1 NM) RNP-0.05 containment radius 9 = RC < 75 m and VPL < 112 m e.g., SBAS, HPL, VPL 10 = RC < 25 m and VPL < 37.5 m e.g., SBAS, HPL, VPL 11 = RC < 7.5 m and VPL < 11 m e.g., GBAS, HPL, VPL 12 = (Reserved) (Reserved) 13 = (Reserved) (Reserved) 14 = (Reserved) (Reserved) 15 = (Reserved) (Reserved)
navAccuracy	%d	Navigation accuracy category (NACv) 0 = Unknown or >= 10 m/s Unknown >= 50 feet (15.24 m) per second 1 = < 10 m/s < 50 feet (15.24 m) per second 2 = < 3 m/s < 15 feet (4.57 m) per second 3 = < 1 m/s < 5 feet (1.52 m) per second 4 = < 0.3 m/s < 1.5 feet (0.46 m) per second 5 = (Reserved) (Reserved) 6 = (Reserved) (Reserved) 7 = (Reserved) (Reserved)
verVelocitySrc	%d	Vertical velocity source 0 = Pressure 1 = Geometric
emergencyStatus	%d	Emergency status 0 = No-Emergency 1 = General Emergency 2 = Lifeguard/Medical 3 = Min Fuel 4 = No Comm 5 = Unlawful Interference 6 = Downed Aircraft
sysIntegrityLevel	%d	Source Integrity Level (SIL) - indicates the probability of the reported horizontal position exceeding the containment radius defined by the NIC
sysDesignAssurance	%d	System Design Assurance (SDA) – indicated the probability of an ADS-B system malfunction causing false or misleading position
airGroundState	%d	Airborne or ground 0 = Airborne subsonic condition

		1 = Airborne supersonic condition 3 = On ground condition
svHeadingType	%d	Track angle from heading 0 = Data Not Available 1 = True Track Angle 2 = Magnetic Heading 3 = True Heading
verticalVelType	%d	Vertical rate information 0 = Pressure 1 = Geometric
navPositionAccuracy	%d	The reported State Vector has sufficient position accuracy for the intended use (NACp) 0 = EPU >= 18.52 km (10 NM) 1 = EPU < 18.52 km (10 NM) 2 = EPU < 7.408 km (4 NM) 3 = EPU < 3.704 km (2 NM) 4 = EPU < 1852 m (1NM) 5 = EPU < 926 m (0.5 NM) 6 = EPU < 555.6 m (0.3 NM) 7 = EPU < 185.2 m (0.1 NM) 8 = EPU < 92.6 m (0.05 NM) 9 = EPU < 30 m and VEPU < 45 10 = EPU < 10 m and VEPU < 15 11 = EPU < 3 m and VEPU < 4 m 12 = (Reserved) 13 = (Reserved) 14 = (Reserved) 15 = (Reserved)
navVelocityAccuracy	%d	The least accurate velocity component being transmitted (NACv) 0 = Unknown or >= 10 m/s Unknown or >= 50 feet (15.24 m) per second 1 = < 10 m/s < 50 feet (15.24 m) per second 2 = < 3 m/s < 15 feet (4.57 m) per second 3 = < 1 m/s < 5 feet (1.52 m) per second 4 = < 0.3 m/s < 1.5 feet (0.46 m) per second 5 = (Reserved) (Reserved) 6 = (Reserved) (Reserved) 7 = (Reserved) (Reserved)
navIntegrityBaro	%d	Barometer checked (NICbaro) 0 = Barometric Pressure Altitude has NOT been cross checked 1 = Barometric Pressure Altitude has been cross checked
geoVerticalAccuracy	%d	Geometric Vertical Accuracy (GVA) 0 Unknown or > 150 meters 1 ≤ 150 meters 2 ≤ 45 meter
tcasAcasOperating	%d	Aircraft is fitted with a TCAS (ACAS) computer and that computer is turned on and operating in a mode that can generate Resolution Advisory (RA) alerts
tcasAcasAdvisory	%d	TCAS II or ACAS computer is currently issuing a Resolution Advisory
identSwActive	%d	Ident switch is activated

atcServicesRecvd	%d	ATC pilot message mode setting 0 = Not receiving ATC messages 1 = Receiving ATC messages
magHeading	%d	True north or magnetic north 0 = True north 1 = Magnetic north
utcCoupledCondition	%d	Represents if the Ground Station is UTC-Coupled 0 = Ground Station is not UTC coupled 1 = Ground Station is UTC coupled
1090ES Specific Fields		
surveilStatus	%d	Surveillance status 0 = No Condition 1 = permanent alert 2 = temp alert 3 = SPI
baroaltDiffMM	%ld	Difference between the pressure altitude and the gnss altitude in mm
1090esMopsVersion	%d	1 = DO-260A 2 = DO-260B
UAT Specific Fields		
secondaryAltType	%d	Altitude source 0 = Pressure 1 = Geometric
secondaryAltitudeMM	%ld	Geometric altitude or barometric pressure altitude in millimeters
tisBSiteld	%d	The tisBSiteld is unit-less and is from the a transmitted TISb UAT message signifies which uplink tower transmitted the TISb frame
transmitMSO	&d	the transmitMSO is the 6bit field from the transmitted UAT message which should signify which MSO the message was transmitted in. MSO's can range from 0 to 3951 but only transmit the 6 LSB's of the actual MSO if transmitted. Received range is from 0 - 63.
addressQualifier	%d	Defines the type of target that delivered the data 0 = ADS-B target with ICAO 24-bit 1 = Reserved for National use 2 = TIS-B target with ICAO 24-bit address 3 = TIS-B target with track file identifier 4 = Surface Vehicle 5 = Fixed ADS-B Beacon 6 = (Reserved) 7 = (Reserved)
uatMopsVersion	%d	1 = DO-282A 2 = DO-282B
callSignID	%d	0 = Fightplan 1 = CallSign
RID Specific Fields		
uvin	%02x%02x%02x%02x-%02x%02x-02x%02x-%02x%02x%02x%02x-%02x%02x%02x%02x	UVIN that contains the hex values of the UVIN identifier I.E. 5129d5c8-a300-464e-8614-a678ccb26f80

	%02x%02x	
toLatDD	%f	Takeoff latitude expressed as decimal degrees
toLonDD	%f	Takeoff longitude expressed as decimal degrees
missionType	%d	Numeric representation of the type of mission being flown 0 = recreational 1 = photography/videography 2 = media 3 = point/structure inspection 4 = agriculture 5 = mapping 6 = surveillance 7 = law enforcement / first responder 8 = search and rescue 9 = delivery 10 = urgent delivery 11 = other
phoneNumber	%d	Phone number attached to the mission
fltplanFiled	%d	NOTAM/UAO flight plan filed flag

2.2 JSON Status object

Periodic health and status JSON.

Field Name	Data Type	Description
pingStationGuid	%02x%02x%02x%02x%02x%02x%02x%02x	Unique pingStation identifier
pingStationVersionMajor	%d	PINGSTATION_MAJOR_VERSION
pingStationVersionMinor	%d	PINGSTATION_MINOR_VERSION
pingStationVersionBuild	%d	PINGSTATION_BUILD_VERSION
timeStamp	%s	Time packet was received at the pingStation ISO 8601 format
pingStationLatDD	%f	Fixed station latitude expressed as decimal degrees
pingStationLonDD	%f	Fixed station longitude expressed as decimal degrees
pingStationAltType	%d	0 = Barometric Altitude 1 = GNSS Altitude
pingStationAltMM	%d	Altitude in mm
gpsStatus	%d	The communication and health status of the pingStation GPS 0 = GPS not present or functioning 1 = Not locked 2 = 2D fix 3 = 3D fix 4 = DGPS fix
receiverStatus	%d	The communication and health status of the pingStation receiver 0 = functioning normally 1 = excessive communication errors 2 = device not transmitting

3 Protocols

3.1 UDP

The pingStation JSON data can be delivered as UDP to a specified host IP address and port number. The UDP destination and port number can be entered using the webpage interface at <http://nnn.nnn.nnn.nnn/>. As aircraft data is received into the pingStation, it is timestamped and formatted before being pushed to the UDP listener as JSON. Each UDP datagram contains a single aircraft update. The aircraft JSON data will contain the optional “detail” object. Data will be continually streamed out to the UDP listener as aircraft updates arrive. Every 30 seconds a status object will be delivered. The data is dynamic in that only valid fields will be formatted and sent on to the UDP host.

To disable UDP send functionality, enter an IP address of 0.0.0.0 on the configuration webpage at <http://nnn.nnn.nnn.nnn/>.

3.2 REST

The pingStation data can be accessed in a basic pull model using the REST protocol which will return the JSON formatted data. Data can be accessed by using the GET method to the pingStation URL (nnn.nnn.nnn.nnn).

The pingStation base URL is:

<http://nnn.nnn.nnn.nnn/api/v1/>

Example resource path are:

<http://nnn.nnn.nnn.nnn/api/v1/traffic>

<http://nnn.nnn.nnn.nnn/api/v1/status>

No GET query strings are currently supported to limit returned data sets.

4 JSON Example Sentences

4.1 Traffic Object

```
{
  "aircraft": [
    {
      "icaoAddress": "39C812",
      "trafficSource": 0,
      "latDD": 47.538528,
      "lonDD": -115.133696,
      "altitudeMM": 13106400,
      "headingDE2": 203,
      "horVelocityCMS": 23149,
      "verVelocityCMS": 0,
      "squawk": 1362,
      "altitudeType": 0,
      "callsign": "LEA022H ",
      "emitterType": 2,
      "pingStationGuid": "7541622b4f4c2e59",
      "utcSync": 1,
      "timeStamp": "2017-02-13T14:42:00.111Z",
      "detail": {
        "navIntegrity": 8,
        "navAccuracy": 2,
        "verVelocitySrc": 1,
        "emergencyStatus": 0,
        "surveilStatus": 0,
        "baroaltDiffMM": 0,
        "sysIntegrityLevel": 3,
        "airGroundState": 0,
        "svHeadingType": 0,
        "verticalVelType": 1,
        "navPositionAccuracy": 10,
        "navVelocityAccuracy": 2,
        "navIntegrityBaro": 1,
        "tcasAcasOperating": 1,
        "tcasAcasAdvisory": 0,
        "identSwActive": 0,
        "magHeading": 0,
        "utcCoupledCondition": 0
      }
    },
    {
      "icaoAddress": "780A70",
      "trafficSource": 0,
      "headingDE2": 289,
      "horVelocityCMS": 24127,
      "verVelocityCMS": -32,
      "altitudeType": 0,
      "emitterType": 0,
      "pingStationGuid": "7541622b4f4c2e59",
      "utcSync": 1,
      "timeStamp": "2017-02-13T14:41:57.189Z",
      "detail": {
```

```

        "navIntegrity":0,
        "navAccuracy":2,
        "verVelocitySrc":0,
        "emergencyStatus":0,
        "surveilStatus":0,
        "baroaltDiffMM":0,
        "sysIntegrityLevel":0,
        "airGroundState":0,
        "svHeadingType":0,
        "verticalVelType":0,
        "navPositionAccuracy":0,
        "navVelocityAccuracy":2,
        "navIntegrityBaro":0,
        "tcasAcasOperating":0,
        "tcasAcasAdvisory":0,
        "identSwActive":0,
        "magHeading":0,
        "utcCoupledCondition":0
    }
}
]
}

```

4.2 Status Object

```

{
  "status": {
    "pingStationGuid":"7541622b4f4c2e59",
    "pingStationVersionMajor":0,
    "pingStationVersionMinor":9,
    "pingStationVersionBuild":4,
    "timeStamp":"2017-02-13T14:42:00.18872Z",
    "pingStationLatDD":48.091530,
    "pingStationLonDD":-114.105026,
    "gpsStatus":3,
    "receiverStatus":0
  }
}

```