

NPN

New Product News



CHASE 8 MILL

90° FACING & SHOULDERING

New ML Chip Former for the SQKU 07 Insert



KEY POINT

TaeguTec has released a new ML chip former for the CHASE-8-MILL's SQKU 07 insert.

The new SQKU 07 ML chip former, with 8 cutting edges, is capable of 90° step machining. The new ML chip former enables stable machining with a lower cutting force, in order to provide excellent performance in a variety of workpieces and in harsh machining conditions.

For more details about the new chip former, please contact the product manager.

Features

- Economical 90° machining insert with 8 cutting edges
- Minimized mismatch and improved machining due to the low cutting force
- Stable machining even under unstable fixture conditions
- Improved surface roughness due to the wiper on the bottom of the insert

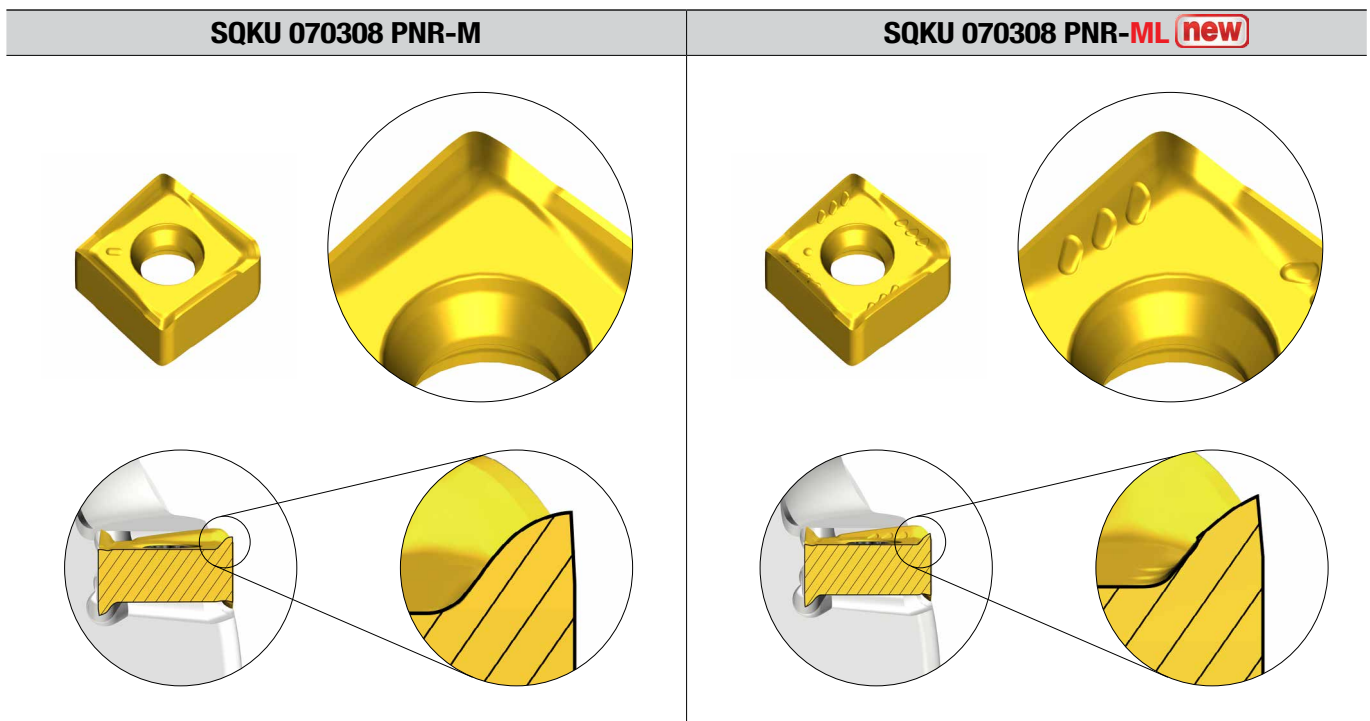

SQK(H)U



Inserts

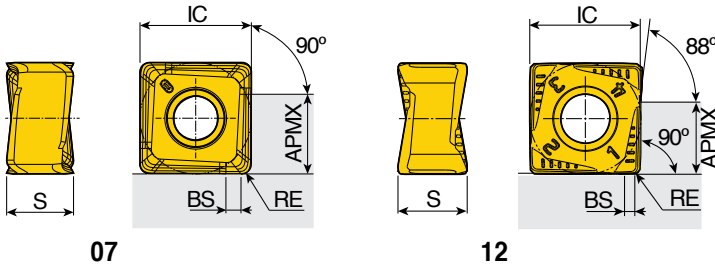

Size	Dimension (mm)				
	IC	S	APMX	BS	RE
07	7.0	4.16	5.0	0.9	0.8
12	12.2	8.06	8.0	1.1	0.8



Insert	Designation	Recommended machining conditions		Coated								Uncoated			
		ap (mm)	Feed (mm/tooth)	TT9080	TT9030	TT8080	TT8020	TT8525B	TT7080	TT7515	TT6080	TT2510	K10		
	SQKU 070308 PNR-M	1.0-4.0	0.20-0.10	●		●						●	●		
	SQKU 070308 PNR-ML new	1.0-4.0	0.20-0.10	●		●									
	SQKU 120608 PNR-M	2.0-6.5	0.25-0.15	●				●				●	●		
	SQHU 120608 PNR-MM	2.0-6.5	0.25-0.15	●								●			

●: Standard items