

Instructor's Manual

to accompany

Chapman

Electric Machinery Fundamentals

Fourth Edition

Stephen J. Chapman
BAE SYSTEMS Australia

Instructor's Manual to accompany *Electric Machinery Fundamentals*, Fourth Edition

Copyright © 2004 McGraw-Hill, Inc.

All rights reserved. Printed in the United States of America. No part of this book may be used or reproduced in any manner whatsoever without written permission, with the following exception: homework solutions may be copied for classroom use.

ISBN: ???

TABLE OF CONTENTS

CHAPTER 1: INTRODUCTION TO MACHINERY PRINCIPLES	1
CHAPTER 2: TRANSFORMERS	23
CHAPTER 3: INTRODUCTION TO POWER ELECTRONICS	63
CHAPTER 4: AC MACHINERY FUNDAMENTALS	103
CHAPTER 5: SYNCHRONOUS GENERATORS	109
CHAPTER 6: SYNCHRONOUS MOTORS	149
CHAPTER 7: INDUCTION MOTORS	171
CHAPTER 8: DC MACHINERY FUNDAMENTALS	204
CHAPTER 9: DC MOTORS AND GENERATORS	214 
CHAPTER 10: SINGLE-PHASE AND SPECIAL-PURPOSE MOTORS	270
APPENDIX A: REVIEW OF THREE-PHASE CIRCUITS	280
APPENDIX B: COIL PITCH AND DISTRIBUTED WINDINGS	288
APPENDIX C: SALIENT POLE THEORY OF SYNCHRONOUS MACHINES	295
APPENDIX D: ERRATA FOR ELECTRIC MACHINERY FUNDAMENTALS 4/E	301

PREFACE

TO THE INSTRUCTOR

This Instructor's Manual is intended to accompany the fourth edition of *Electric Machinery Fundamentals*. To make this manual easier to use, it has been made self-contained. Both the original problem statement and the problem solution are given for each problem in the book. This structure should make it easier to copy pages from the manual for posting after problems have been assigned.

Many of the problems in Chapters 2, 5, 6, and 9 require that a student read one or more values from a magnetization curve. The required curves are given within the textbook, but they are shown with relatively few vertical and horizontal lines so that they will not appear too cluttered. Electronic copies of the corresponding open-circuit characteristics, short-circuit characteristics, and magnetization curves are also supplied with the book. They are supplied in two forms, as MATLAB MAT-files and as ASCII text files. Students can use these files for electronic solutions to homework problems. The ASCII files are supplied so that the information can be used with non-MATLAB software.

Please note that the file extent of the magnetization curves and open-circuit characteristics have changed in this edition. In the Third Edition, I used the file extent *.mag for magnetization curves. Unfortunately, after the book was published, Microsoft appropriated that extent for a new Access table type in Office 2000. That made it hard for users to examine and modify the data in the files. In this edition, all magnetization curves, open-circuit characteristics, short-circuit characteristics, etc. use the file extent *.dat to avoid this problem.

Each curve is given in ASCII format with comments at the beginning. For example, the magnetization curve in Figure P9-1 is contained in file p91_mag.dat. Its contents are shown below:

```
% This is the magnetization curve shown in Figure
% P9-1. The first column is the field current in
% amps, and the second column is the internal
% generated voltage in volts at a speed of 1200 r/min.
% To use this file in MATLAB, type "load p91_mag.dat".
% The data will be loaded into an N x 2 array named
% "p91_mag", with the first column containing If and
% the second column containing the open-circuit voltage.
% MATLAB function "interp1" can be used to recover
% a value from this curve.
    0         0
0.0132     6.67
    0.03     13.33
    0.033     16
    0.067     31.30
    0.1       45.46
    0.133     60.26
    0.167     75.06
    0.2       89.74
```

0.233	104.4
0.267	118.86
0.3	132.86
0.333	146.46
0.367	159.78
0.4	172.18
0.433	183.98
0.467	195.04
0.5	205.18
0.533	214.52
0.567	223.06
0.6	231.2
0.633	238
0.667	244.14
0.7	249.74
0.733	255.08
0.767	259.2
0.8	263.74
0.833	267.6
0.867	270.8
0.9	273.6
0.933	276.14
0.966	278
1	279.74
1.033	281.48
1.067	282.94
1.1	284.28
1.133	285.48
1.167	286.54
1.2	287.3
1.233	287.86
1.267	288.36
1.3	288.82
1.333	289.2
1.367	289.375
1.4	289.567
1.433	289.689
1.466	289.811
1.5	289.950

To use this curve in a MATLAB program, the user would include the following statements in the program:

```
% Get the magnetization curve. Note that this curve is
% defined for a speed of 1200 r/min.
load p91_mag.dat
if_values = p91_mag(:,1);
ea_values = p91_mag(:,2);
n_0 = 1200;
```

Unfortunately, an error occurred during the production of this book, and the values (resistances, voltages, etc.) in some end-of-chapter artwork are not the same as the values quoted in the end-of-chapter problem text. I have attached corrected pages showing each discrepancy in Appendix D of this manual. Please print these pages and distribute them to your students before assigning homework problems. (Note that this error will be corrected at the second printing, so it may not be present in your student's books.)

The solutions in this manual have been checked carefully, but inevitably some errors will have slipped through. If you locate errors which you would like to see corrected, please feel free to contact me at the address shown below, or at my email address schapman@tpgi.com.au. I greatly appreciate your input! My physical and email addresses may change from time to time, but my contact details will always be available at the book's Web site, which is <http://www.mhhe.com/engcs/electrical/chapman/>.

I am also contemplating a homework problem refresh, with additional problems added on the book's Web site mid-way through the life of this edition. If that feature would be useful to you, please provide me with feedback about which problems that you actually use, and the areas where you would like to have additional exercises. This information can be passed to the email address given below, or alternately via you McGraw-Hill representative.

Thank you.



Stephen J. Chapman
Melbourne, Australia
January 4, 2004

Stephen J. Chapman
278 Orrong Road
Caulfield North, VIC 3161
Australia
Phone +61-3-9527-9372

Chapter 1: Introduction to Machinery Principles

- 1-1. A motor's shaft is spinning at a speed of 3000 r/min. What is the shaft speed in radians per second?

SOLUTION The speed in radians per second is

$$\omega = (3000 \text{ r/min}) \left(\frac{1 \text{ min}}{60 \text{ s}} \right) \left(\frac{2\pi \text{ rad}}{1 \text{ r}} \right) = 314.2 \text{ rad/s}$$

- 1-2. A flywheel with a moment of inertia of $2 \text{ kg} \cdot \text{m}^2$ is initially at rest. If a torque of $5 \text{ N} \cdot \text{m}$ (counterclockwise) is suddenly applied to the flywheel, what will be the speed of the flywheel after 5 s? Express that speed in both radians per second and revolutions per minute.

SOLUTION The speed in radians per second is:

$$\omega = \alpha t = \left(\frac{\tau}{J} \right) t = \frac{5 \text{ N} \cdot \text{m}}{2 \text{ kg} \cdot \text{m}^2} (5 \text{ s}) = 12.5 \text{ rad/s}$$

The speed in revolutions per minute is:

$$n = (12.5 \text{ rad/s}) \left(\frac{1 \text{ r}}{2\pi \text{ rad}} \right) \left(\frac{60 \text{ s}}{1 \text{ min}} \right) = 119.4 \text{ r/min}$$

- 1-3. A force of 5 N is applied to a cylinder, as shown in Figure P1-1. What are the magnitude and direction of the torque produced on the cylinder? What is the angular acceleration α of the cylinder?

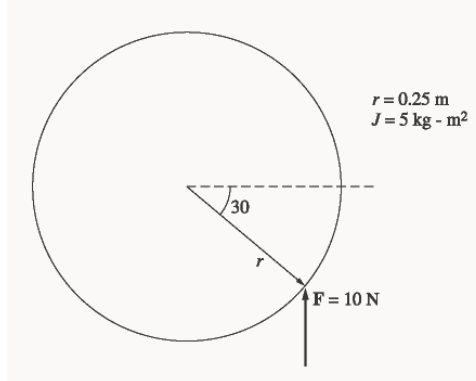

SOLUTION The magnitude and the direction of the torque on this cylinder is:

$$\tau_{\text{ind}} = rF \sin \theta, \text{ CCW}$$

$$\tau_{\text{ind}} = (0.25 \text{ m})(10 \text{ N}) \sin 30^\circ = 1.25 \text{ N} \cdot \text{m}, \text{ CCW}$$

The resulting angular acceleration is:

$$\alpha = \frac{\tau}{J} = \frac{1.25 \text{ N} \cdot \text{m}}{5 \text{ kg} \cdot \text{m}^2} = 0.25 \text{ rad/s}^2$$

- 1-4. A motor is supplying $60 \text{ N} \cdot \text{m}$ of torque to its load. If the motor's shaft is turning at 1800 r/min, what is the mechanical power supplied to the load in watts? In horsepower?

SOLUTION The mechanical power supplied to the load is

$$P = \tau\omega = (60 \text{ N} \cdot \text{m})(1800 \text{ r/min}) \left(\frac{1 \text{ min}}{60 \text{ s}} \right) \left(\frac{2\pi \text{ rad}}{1 \text{ r}} \right) = 11,310 \text{ W}$$

$$P = (11,310 \text{ W}) \frac{1 \text{ hp}}{746 \text{ W}} = 15.2 \text{ hp}$$

- 1-5. A ferromagnetic core is shown in Figure P1-2. The depth of the core is 5 cm. The other dimensions of the core are as shown in the figure. Find the value of the current that will produce a flux of 0.005 Wb. With this current, what is the flux density at the top of the core? What is the flux density at the right side of the core? Assume that the relative permeability of the core is 1000.

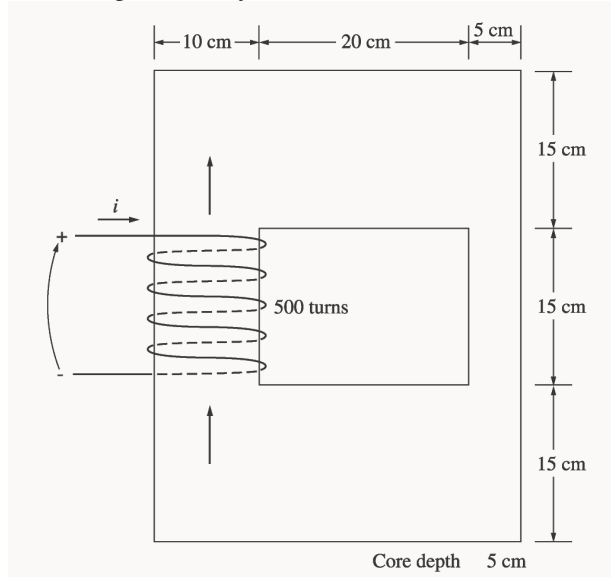

SOLUTION There are three regions in this core. The top and bottom form one region, the left side forms a second region, and the right side forms a third region. If we assume that the mean path length of the flux is in the center of each leg of the core, and if we ignore spreading at the corners of the core, then the path lengths are $l_1 = 2(27.5 \text{ cm}) = 55 \text{ cm}$, $l_2 = 30 \text{ cm}$, and $l_3 = 30 \text{ cm}$. The reluctances of these regions are:

$$\mathcal{R}_1 = \frac{l}{\mu A} = \frac{l}{\mu_r \mu_o A} = \frac{0.55 \text{ m}}{(1000)(4\pi \times 10^{-7} \text{ H/m})(0.05 \text{ m})(0.15 \text{ m})} = 58.36 \text{ kA} \cdot \text{t/Wb}$$

$$\mathcal{R}_2 = \frac{l}{\mu A} = \frac{l}{\mu_r \mu_o A} = \frac{0.30 \text{ m}}{(1000)(4\pi \times 10^{-7} \text{ H/m})(0.05 \text{ m})(0.10 \text{ m})} = 47.75 \text{ kA} \cdot \text{t/Wb}$$

$$\mathcal{R}_3 = \frac{l}{\mu A} = \frac{l}{\mu_r \mu_o A} = \frac{0.30 \text{ m}}{(1000)(4\pi \times 10^{-7} \text{ H/m})(0.05 \text{ m})(0.05 \text{ m})} = 95.49 \text{ kA} \cdot \text{t/Wb}$$

The total reluctance is thus

$$\mathcal{R}_{\text{TOT}} = \mathcal{R}_1 + \mathcal{R}_2 + \mathcal{R}_3 = 58.36 + 47.75 + 95.49 = 201.6 \text{ kA} \cdot \text{t/Wb}$$

and the magnetomotive force required to produce a flux of 0.003 Wb is

$$\mathcal{F} = \phi \mathcal{R} = (0.005 \text{ Wb})(201.6 \text{ kA} \cdot \text{t/Wb}) = 1008 \text{ A} \cdot \text{t}$$

and the required current is

$$i = \frac{\mathcal{F}}{N} = \frac{1008 \text{ A} \cdot \text{t}}{400 \text{ t}} = 2.52 \text{ A}$$

The flux density on the top of the core is

$$B = \frac{\phi}{A} = \frac{0.005 \text{ Wb}}{(0.15 \text{ m})(0.05 \text{ m})} = 0.67 \text{ T}$$

The flux density on the right side of the core is

$$B = \frac{\phi}{A} = \frac{0.005 \text{ Wb}}{(0.05 \text{ m})(0.05 \text{ m})} = 2.0 \text{ T}$$

- 1-6. A ferromagnetic core with a relative permeability of 1500 is shown in Figure P1-3. The dimensions are as shown in the diagram, and the depth of the core is 7 cm. The air gaps on the left and right sides of the core are 0.070 and 0.020 cm, respectively. Because of fringing effects, the effective area of the air gaps is 5 percent larger than their physical size. If there are 400¹ turns in the coil wrapped around the center leg of the core and if the current in the coil is 1.0 A, what is the flux in each of the left, center, and right legs of the core? What is the flux density in each air gap?

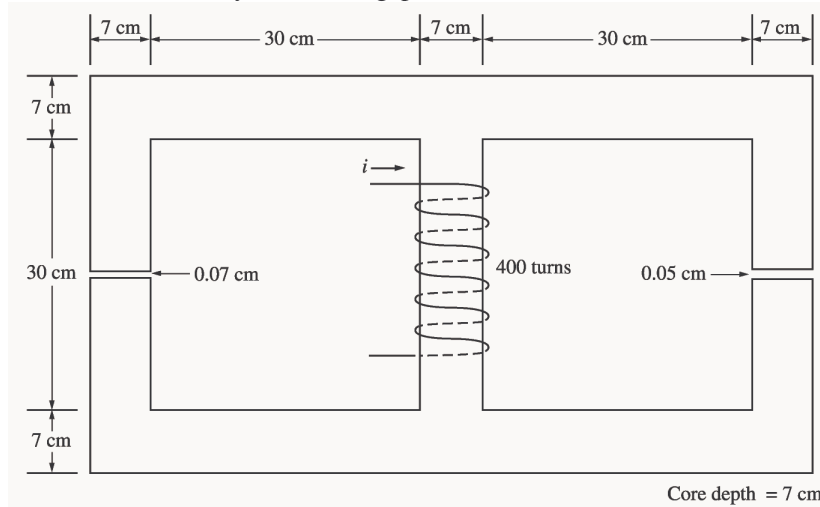

SOLUTION This core can be divided up into five regions. Let \mathcal{R}_1 be the reluctance of the left-hand portion of the core, \mathcal{R}_2 be the reluctance of the left-hand air gap, \mathcal{R}_3 be the reluctance of the right-hand portion of the core, \mathcal{R}_4 be the reluctance of the right-hand air gap, and \mathcal{R}_5 be the reluctance of the center leg of the core. Then the total reluctance of the core is

$$\mathcal{R}_{\text{TOT}} = \mathcal{R}_5 + \frac{(\mathcal{R}_1 + \mathcal{R}_2)(\mathcal{R}_3 + \mathcal{R}_4)}{\mathcal{R}_1 + \mathcal{R}_2 + \mathcal{R}_3 + \mathcal{R}_4}$$

$$\mathcal{R}_1 = \frac{l_1}{\mu_r \mu_0 A_1} = \frac{1.11 \text{ m}}{(2000)(4\pi \times 10^{-7} \text{ H/m})(0.07 \text{ m})(0.07 \text{ m})} = 90.1 \text{ kA} \cdot \text{t/Wb}$$

$$\mathcal{R}_2 = \frac{l_2}{\mu_0 A_2} = \frac{0.0007 \text{ m}}{(4\pi \times 10^{-7} \text{ H/m})(0.07 \text{ m})(0.07 \text{ m})(1.05)} = 108.3 \text{ kA} \cdot \text{t/Wb}$$

$$\mathcal{R}_3 = \frac{l_3}{\mu_r \mu_0 A_3} = \frac{1.11 \text{ m}}{(2000)(4\pi \times 10^{-7} \text{ H/m})(0.07 \text{ m})(0.07 \text{ m})} = 90.1 \text{ kA} \cdot \text{t/Wb}$$

$$\mathcal{R}_4 = \frac{l_4}{\mu_0 A_4} = \frac{0.0005 \text{ m}}{(4\pi \times 10^{-7} \text{ H/m})(0.07 \text{ m})(0.07 \text{ m})(1.05)} = 77.3 \text{ kA} \cdot \text{t/Wb}$$

$$\mathcal{R}_5 = \frac{l_5}{\mu_r \mu_0 A_5} = \frac{0.37 \text{ m}}{(2000)(4\pi \times 10^{-7} \text{ H/m})(0.07 \text{ m})(0.07 \text{ m})} = 30.0 \text{ kA} \cdot \text{t/Wb}$$

The total reluctance is

¹ In the first printing, this value was given incorrectly as 300.

$$\mathcal{R}_{\text{TOT}} = \mathcal{R}_5 + \frac{(\mathcal{R}_1 + \mathcal{R}_2)(\mathcal{R}_3 + \mathcal{R}_4)}{\mathcal{R}_1 + \mathcal{R}_2 + \mathcal{R}_3 + \mathcal{R}_4} = 30.0 + \frac{(90.1 + 108.3)(90.1 + 77.3)}{90.1 + 108.3 + 90.1 + 77.3} = 120.8 \text{ kA} \cdot \text{t/Wb}$$

The total flux in the core is equal to the flux in the center leg:

$$\phi_{\text{center}} = \phi_{\text{TOT}} = \frac{\mathcal{F}}{\mathcal{R}_{\text{TOT}}} = \frac{(400 \text{ t})(1.0 \text{ A})}{120.8 \text{ kA} \cdot \text{t/Wb}} = 0.0033 \text{ Wb}$$

The fluxes in the left and right legs can be found by the “flux divider rule”, which is analogous to the current divider rule.

$$\phi_{\text{left}} = \frac{(\mathcal{R}_3 + \mathcal{R}_4)}{\mathcal{R}_1 + \mathcal{R}_2 + \mathcal{R}_3 + \mathcal{R}_4} \phi_{\text{TOT}} = \frac{(90.1 + 77.3)}{90.1 + 108.3 + 90.1 + 77.3} (0.0033 \text{ Wb}) = 0.00193 \text{ Wb}$$

$$\phi_{\text{right}} = \frac{(\mathcal{R}_1 + \mathcal{R}_2)}{\mathcal{R}_1 + \mathcal{R}_2 + \mathcal{R}_3 + \mathcal{R}_4} \phi_{\text{TOT}} = \frac{(90.1 + 108.3)}{90.1 + 108.3 + 90.1 + 77.3} (0.0033 \text{ Wb}) = 0.00229 \text{ Wb}$$

The flux density in the air gaps can be determined from the equation $\phi = BA$:

$$B_{\text{left}} = \frac{\phi_{\text{left}}}{A_{\text{eff}}} = \frac{0.00193 \text{ Wb}}{(0.07 \text{ cm})(0.07 \text{ cm})(1.05)} = 0.375 \text{ T}$$

$$B_{\text{right}} = \frac{\phi_{\text{right}}}{A_{\text{eff}}} = \frac{0.00229 \text{ Wb}}{(0.07 \text{ cm})(0.07 \text{ cm})(1.05)} = 0.445 \text{ T}$$

- 1-7. A two-legged core is shown in Figure P1-4. The winding on the left leg of the core (N_1) has 400 turns, and the winding on the right (N_2) has 300 turns. The coils are wound in the directions shown in the figure. If the dimensions are as shown, then what flux would be produced by currents $i_1 = 0.5 \text{ A}$ and $i_2 = 0.75 \text{ A}$? Assume $\mu_r = 1000$ and constant.

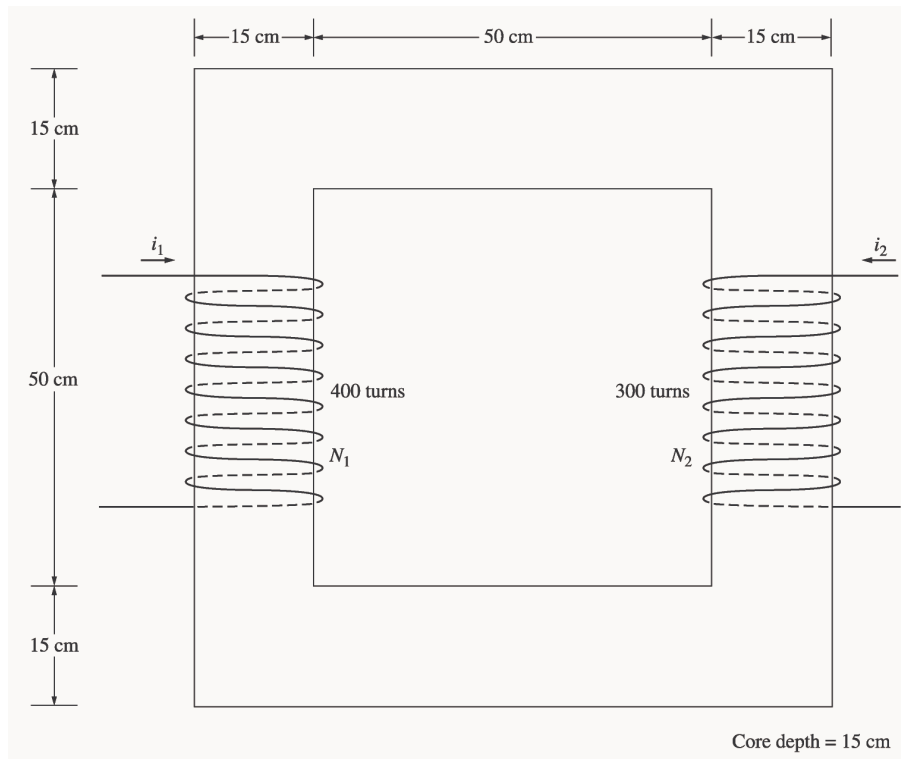

SOLUTION The two coils on this core are wound so that their magnetomotive forces are additive, so the total magnetomotive force on this core is

$$\mathcal{F}_{\text{TOT}} = N_1 i_1 + N_2 i_2 = (400 \text{ t})(0.5 \text{ A}) + (300 \text{ t})(0.75 \text{ A}) = 425 \text{ A} \cdot \text{t}$$

The total reluctance in the core is

$$\mathcal{R}_{\text{TOT}} = \frac{l}{\mu_r \mu_0 A} = \frac{2.60 \text{ m}}{(1000)(4\pi \times 10^{-7} \text{ H/m})(0.15 \text{ m})(0.15 \text{ m})} = 92.0 \text{ kA} \cdot \text{t/Wb}$$

and the flux in the core is:

$$\phi = \frac{\mathcal{F}_{\text{TOT}}}{\mathcal{R}_{\text{TOT}}} = \frac{425 \text{ A} \cdot \text{t}}{92.0 \text{ kA} \cdot \text{t/Wb}} = 0.00462 \text{ Wb}$$

- 1-8.** A core with three legs is shown in Figure P1-5. Its depth is 5 cm, and there are 200 turns on the leftmost leg. The relative permeability of the core can be assumed to be 1500 and constant. What flux exists in each of the three legs of the core? What is the flux density in each of the legs? Assume a 4% increase in the effective area of the air gap due to fringing effects.

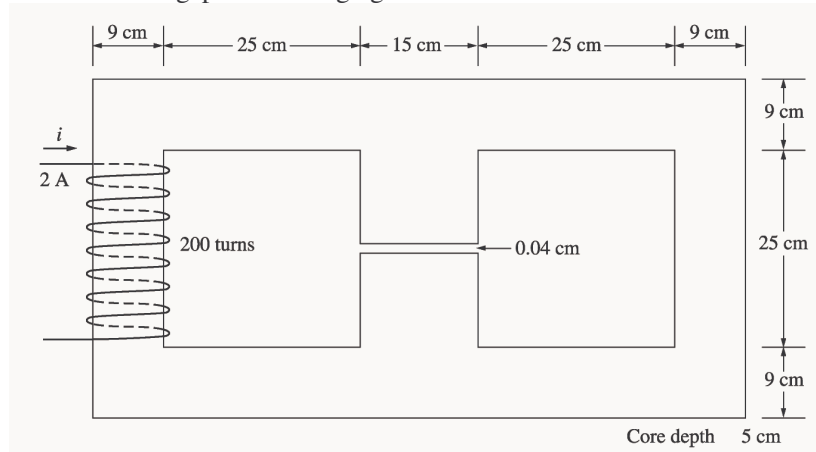

SOLUTION This core can be divided up into four regions. Let \mathcal{R}_1 be the reluctance of the left-hand portion of the core, \mathcal{R}_2 be the reluctance of the center leg of the core, \mathcal{R}_3 be the reluctance of the center air gap, and \mathcal{R}_4 be the reluctance of the right-hand portion of the core. Then the total reluctance of the core is

$$\mathcal{R}_{\text{TOT}} = \mathcal{R}_1 + \frac{(\mathcal{R}_2 + \mathcal{R}_3)\mathcal{R}_4}{\mathcal{R}_2 + \mathcal{R}_3 + \mathcal{R}_4}$$

$$\mathcal{R}_1 = \frac{l_1}{\mu_r \mu_0 A_1} = \frac{1.08 \text{ m}}{(1500)(4\pi \times 10^{-7} \text{ H/m})(0.09 \text{ m})(0.05 \text{ m})} = 127.3 \text{ kA} \cdot \text{t/Wb}$$

$$\mathcal{R}_2 = \frac{l_2}{\mu_r \mu_0 A_2} = \frac{0.34 \text{ m}}{(1500)(4\pi \times 10^{-7} \text{ H/m})(0.15 \text{ m})(0.05 \text{ m})} = 24.0 \text{ kA} \cdot \text{t/Wb}$$

$$\mathcal{R}_3 = \frac{l_3}{\mu_0 A_3} = \frac{0.0004 \text{ m}}{(4\pi \times 10^{-7} \text{ H/m})(0.15 \text{ m})(0.05 \text{ m})(1.04)} = 40.8 \text{ kA} \cdot \text{t/Wb}$$

$$\mathcal{R}_4 = \frac{l_4}{\mu_r \mu_0 A_4} = \frac{1.08 \text{ m}}{(1500)(4\pi \times 10^{-7} \text{ H/m})(0.09 \text{ m})(0.05 \text{ m})} = 127.3 \text{ kA} \cdot \text{t/Wb}$$

The total reluctance is

$$\mathcal{R}_{\text{TOT}} = \mathcal{R}_1 + \frac{(\mathcal{R}_2 + \mathcal{R}_3)\mathcal{R}_4}{\mathcal{R}_2 + \mathcal{R}_3 + \mathcal{R}_4} = 127.3 + \frac{(24.0 + 40.8)127.3}{24.0 + 40.8 + 127.3} = 170.2 \text{ kA} \cdot \text{t/Wb}$$

The total flux in the core is equal to the flux in the left leg:

$$\phi_{\text{left}} = \phi_{\text{TOT}} = \frac{\mathcal{F}}{\mathcal{R}_{\text{TOT}}} = \frac{(200 \text{ t})(2.0 \text{ A})}{170.2 \text{ kA} \cdot \text{t/Wb}} = 0.00235 \text{ Wb}$$

The fluxes in the center and right legs can be found by the “flux divider rule”, which is analogous to the current divider rule.

$$\phi_{\text{center}} = \frac{\mathcal{R}_4}{\mathcal{R}_2 + \mathcal{R}_3 + \mathcal{R}_4} \phi_{\text{TOT}} = \frac{127.3}{24.0 + 40.8 + 127.3} (0.00235 \text{ Wb}) = 0.00156 \text{ Wb}$$

$$\phi_{\text{right}} = \frac{\mathcal{R}_2 + \mathcal{R}_3}{\mathcal{R}_2 + \mathcal{R}_3 + \mathcal{R}_4} \phi_{\text{TOT}} = \frac{24.0 + 40.8}{24.0 + 40.8 + 127.3} (0.00235 \text{ Wb}) = 0.00079 \text{ Wb}$$

The flux density in the legs can be determined from the equation $\phi = BA$:

$$B_{\text{left}} = \frac{\phi_{\text{left}}}{A} = \frac{0.00235 \text{ Wb}}{(0.09 \text{ cm})(0.05 \text{ cm})} = 0.522 \text{ T}$$

$$B_{\text{center}} = \frac{\phi_{\text{center}}}{A} = \frac{0.00156 \text{ Wb}}{(0.15 \text{ cm})(0.05 \text{ cm})} = 0.208 \text{ T}$$

$$B_{\text{right}} = \frac{\phi_{\text{right}}}{A} = \frac{0.00079 \text{ Wb}}{(0.09 \text{ cm})(0.05 \text{ cm})} = 0.176 \text{ T}$$

- 1-9.** A wire is shown in Figure P1-6 which is carrying 5.0 A in the presence of a magnetic field. Calculate the magnitude and direction of the force induced on the wire.

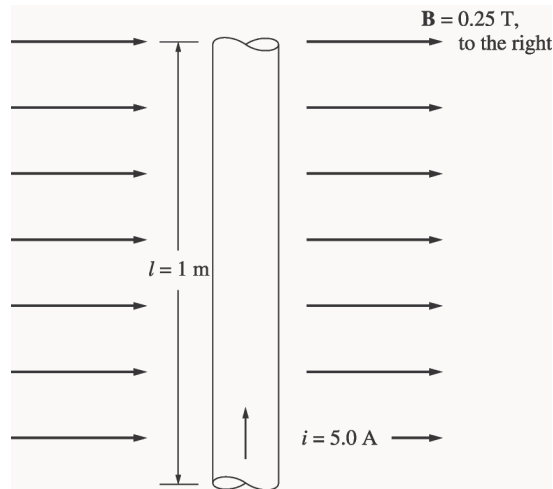

SOLUTION The force on this wire can be calculated from the equation

$$\mathbf{F} = i(\mathbf{l} \times \mathbf{B}) = ilB = (5 \text{ A})(1 \text{ m})(0.25 \text{ T}) = 1.25 \text{ N, into the page}$$

- 1-10.** The wire is shown in Figure P1-7 is moving in the presence of a magnetic field. With the information given in the figure, determine the magnitude and direction of the induced voltage in the wire.

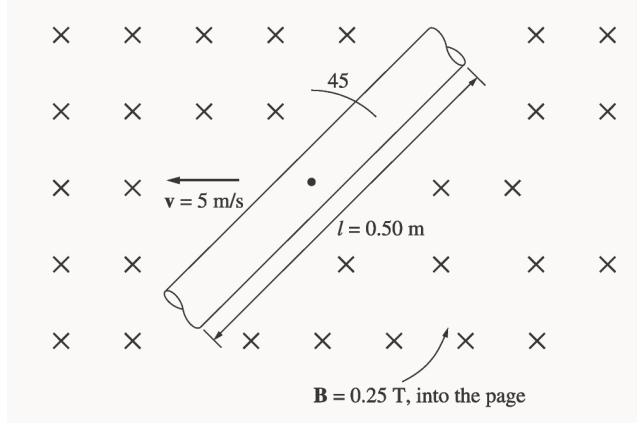

SOLUTION The induced voltage on this wire can be calculated from the equation shown below. The voltage on the wire is positive downward because the vector quantity $\mathbf{v} \times \mathbf{B}$ points downward.

$$e_{\text{ind}} = (\mathbf{v} \times \mathbf{B}) \cdot \mathbf{l} = vBl \cos 45^\circ = (5 \text{ m/s})(0.25 \text{ T})(0.50 \text{ m}) \cos 45^\circ = 0.442 \text{ V, positive down}$$

- 1-11.** Repeat Problem 1-10 for the wire in Figure P1-8.

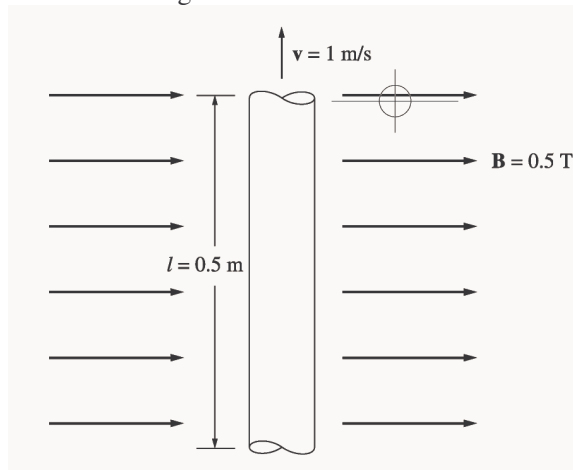

SOLUTION The induced voltage on this wire can be calculated from the equation shown below. The total voltage is zero, because the vector quantity $\mathbf{v} \times \mathbf{B}$ points into the page, while the wire runs in the plane of the page.

$$e_{\text{ind}} = (\mathbf{v} \times \mathbf{B}) \cdot \mathbf{l} = vBl \cos 90^\circ = (1 \text{ m/s})(0.5 \text{ T})(0.5 \text{ m}) \cos 90^\circ = 0 \text{ V}$$

- 1-12.** The core shown in Figure P1-4 is made of a steel whose magnetization curve is shown in Figure P1-9. Repeat Problem 1-7, but this time do *not* assume a constant value of μ_r . How much flux is produced in the core by the currents specified? What is the relative permeability of this core under these conditions? Was the assumption in Problem 1-7 that the relative permeability was equal to 1000 a good assumption for these conditions? Is it a good assumption in general?

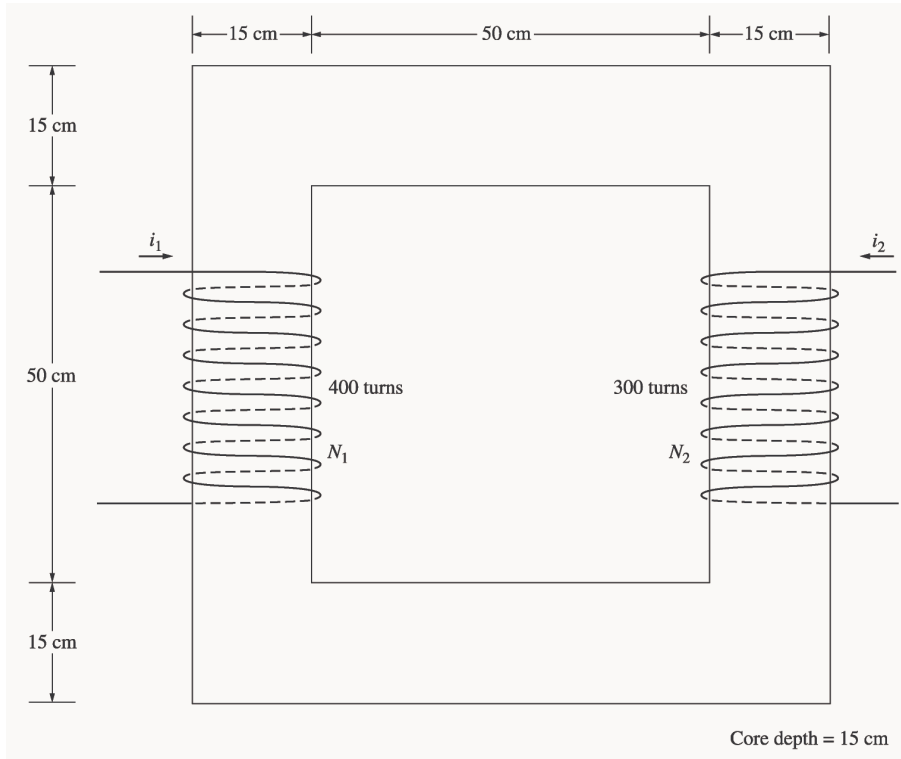

SOLUTION The magnetization curve for this core is shown below:

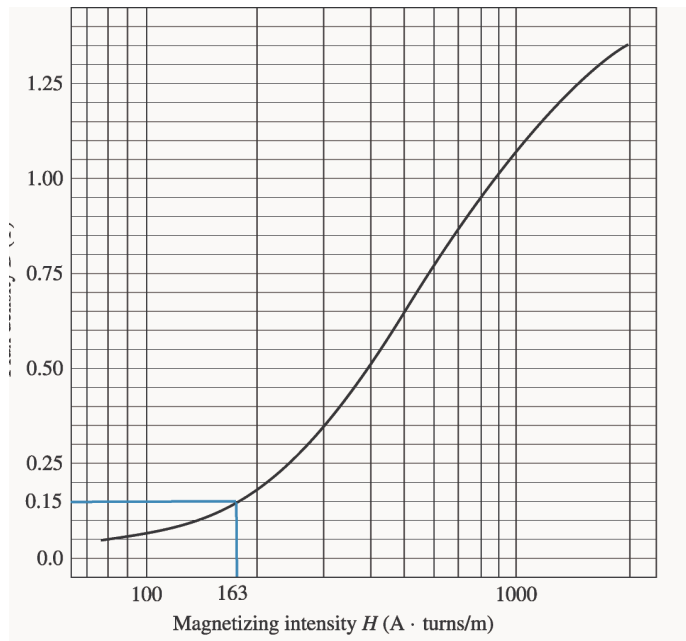

The two coils on this core are wound so that their magnetomotive forces are additive, so the total magnetomotive force on this core is

$$\mathcal{F}_{\text{TOT}} = N_1 i_1 + N_2 i_2 = (400 \text{ t})(0.5 \text{ A}) + (300 \text{ t})(0.75 \text{ A}) = 425 \text{ A} \cdot \text{t}$$

Therefore, the magnetizing intensity H is

$$H = \frac{\mathcal{F}}{l_c} = \frac{425 \text{ A} \cdot \text{t}}{2.60 \text{ m}} = 163 \text{ A} \cdot \text{t/m}$$

From the magnetization curve,

$$B = 0.15 \text{ T}$$

and the total flux in the core is

$$\phi_{\text{TOT}} = BA = (0.15 \text{ T})(0.15 \text{ m})(0.15 \text{ m}) = 0.0033 \text{ Wb}$$

The relative permeability of the core can be found from the reluctance as follows:

$$\mathcal{R} = \frac{\mathcal{F}_{\text{TOT}}}{\phi_{\text{TOT}}} = \frac{l}{\mu_r \mu_0 A}$$

Solving for μ_r yields

$$\mu_r = \frac{\phi_{\text{TOT}} l}{\mathcal{F}_{\text{TOT}} \mu_0 A} = \frac{(0.0033 \text{ Wb})(2.6 \text{ m})}{(425 \text{ A} \cdot \text{t})(4\pi \times 10^{-7} \text{ H/m})(0.15 \text{ m})(0.15 \text{ m})} = 714$$

The assumption that $\mu_r = 1000$ is not very good here. It is not very good in general.

1-13. A core with three legs is shown in Figure P1-10. Its depth is 8 cm, and there are 400 turns on the center leg. The remaining dimensions are shown in the figure. The core is composed of a steel having the magnetization curve shown in Figure 1-10c. Answer the following questions about this core:

- (a) What current is required to produce a flux density of 0.5 T in the central leg of the core?
- (b) What current is required to produce a flux density of 1.0 T in the central leg of the core? Is it twice the current in part (a)?
- (c) What are the reluctances of the central and right legs of the core under the conditions in part (a)?
- (d) What are the reluctances of the central and right legs of the core under the conditions in part (b)?
- (e) What conclusion can you make about reluctances in real magnetic cores?

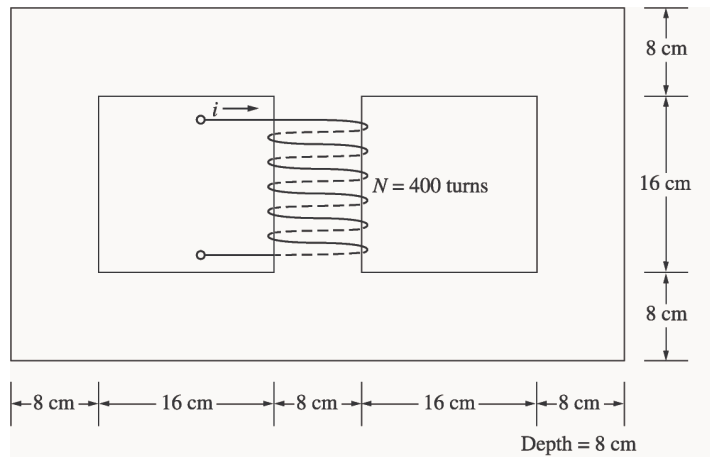

SOLUTION The magnetization curve for this core is shown below:

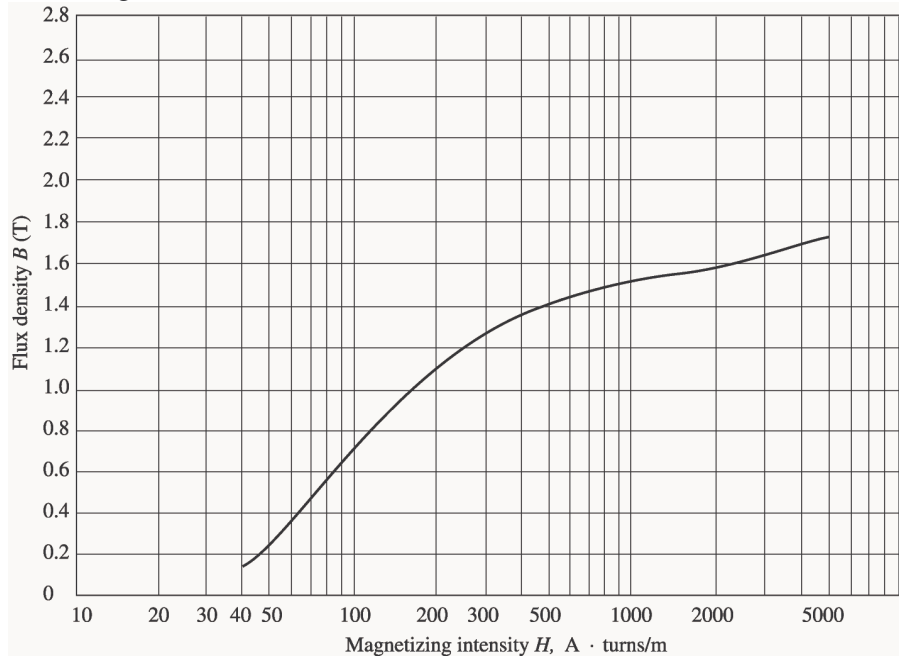

(a) A flux density of 0.5 T in the central core corresponds to a total flux of

$$\phi_{\text{TOT}} = BA = (0.5 \text{ T})(0.08 \text{ m})(0.08 \text{ m}) = 0.0032 \text{ Wb}$$

By symmetry, the flux in each of the two outer legs must be $\phi_1 = \phi_2 = 0.0016 \text{ Wb}$, and the flux density in the other legs must be

$$B_1 = B_2 = \frac{0.0016 \text{ Wb}}{(0.08 \text{ m})(0.08 \text{ m})} = 0.25 \text{ T}$$

The magnetizing intensity H required to produce a flux density of 0.25 T can be found from Figure 1-10c. It is 50 A·t/m. Similarly, the magnetizing intensity H required to produce a flux density of 0.50 T is 70 A·t/m. Therefore, the total MMF needed is

$$\begin{aligned} \mathcal{F}_{\text{TOT}} &= H_{\text{center}} l_{\text{center}} + H_{\text{outer}} l_{\text{outer}} \\ \mathcal{F}_{\text{TOT}} &= (70 \text{ A} \cdot \text{t/m})(0.24 \text{ m}) + (50 \text{ A} \cdot \text{t/m})(0.72 \text{ m}) = 52.8 \text{ A} \cdot \text{t} \end{aligned}$$

and the required current is

$$i = \frac{\mathcal{F}_{\text{TOT}}}{N} = \frac{52.8 \text{ A} \cdot \text{t}}{400 \text{ t}} = 0.13 \text{ A}$$

(b) A flux density of 1.0 T in the central core corresponds to a total flux of

$$\phi_{\text{TOT}} = BA = (1.0 \text{ T})(0.08 \text{ m})(0.08 \text{ m}) = 0.0064 \text{ Wb}$$

By symmetry, the flux in each of the two outer legs must be $\phi_1 = \phi_2 = 0.0032 \text{ Wb}$, and the flux density in the other legs must be

$$B_1 = B_2 = \frac{0.0032 \text{ Wb}}{(0.08 \text{ m})(0.08 \text{ m})} = 0.50 \text{ T}$$

The magnetizing intensity H required to produce a flux density of 0.50 T can be found from Figure 1-10c. It is 70 A·t/m. Similarly, the magnetizing intensity H required to produce a flux density of 1.00 T is about 160 A·t/m. Therefore, the total MMF needed is

$$\begin{aligned}\mathcal{F}_{\text{TOT}} &= H_{\text{center}} I_{\text{center}} + H_{\text{outer}} I_{\text{outer}} \\ \mathcal{F}_{\text{TOT}} &= (160 \text{ A} \cdot \text{t/m})(0.24 \text{ m}) + (70 \text{ A} \cdot \text{t/m})(0.72 \text{ m}) = 88.8 \text{ A} \cdot \text{t}\end{aligned}$$

and the required current is

$$i = \frac{\phi_{\text{TOT}}}{N} = \frac{88.8 \text{ A} \cdot \text{t}}{400 \text{ t}} = 0.22 \text{ A}$$

This current is less *not* twice the current in part (a).

(c) The reluctance of the central leg of the core under the conditions of part (a) is:

$$\mathcal{R}_{\text{cent}} = \frac{\mathcal{F}_{\text{TOT}}}{\phi_{\text{TOT}}} = \frac{(70 \text{ A} \cdot \text{t/m})(0.24 \text{ m})}{0.0032 \text{ Wb}} = 5.25 \text{ kA} \cdot \text{t/Wb}$$

The reluctance of the right leg of the core under the conditions of part (a) is:

$$\mathcal{R}_{\text{right}} = \frac{\mathcal{F}_{\text{TOT}}}{\phi_{\text{TOT}}} = \frac{(50 \text{ A} \cdot \text{t/m})(0.72 \text{ m})}{0.0016 \text{ Wb}} = 22.5 \text{ kA} \cdot \text{t/Wb}$$

(d) The reluctance of the central leg of the core under the conditions of part (b) is:

$$\mathcal{R}_{\text{cent}} = \frac{\mathcal{F}_{\text{TOT}}}{\phi_{\text{TOT}}} = \frac{(160 \text{ A} \cdot \text{t/m})(0.24 \text{ m})}{0.0064 \text{ Wb}} = 6.0 \text{ kA} \cdot \text{t/Wb}$$

The reluctance of the right leg of the core under the conditions of part (b) is:

$$\mathcal{R}_{\text{right}} = \frac{\mathcal{F}_{\text{TOT}}}{\phi_{\text{TOT}}} = \frac{(70 \text{ A} \cdot \text{t/m})(0.72 \text{ m})}{0.0032 \text{ Wb}} = 15.75 \text{ kA} \cdot \text{t/Wb}$$

(e) The reluctances in real magnetic cores are not constant.

- 1-14.** A two-legged magnetic core with an air gap is shown in Figure P1-11. The depth of the core is 5 cm, the length of the air gap in the core is 0.06 cm, and the number of turns on the coil is 1000. The magnetization curve of the core material is shown in Figure P1-9. Assume a 5 percent increase in effective air-gap area to account for fringing. How much current is required to produce an air-gap flux density of 0.5 T? What are the flux densities of the four sides of the core at that current? What is the total flux present in the air gap?

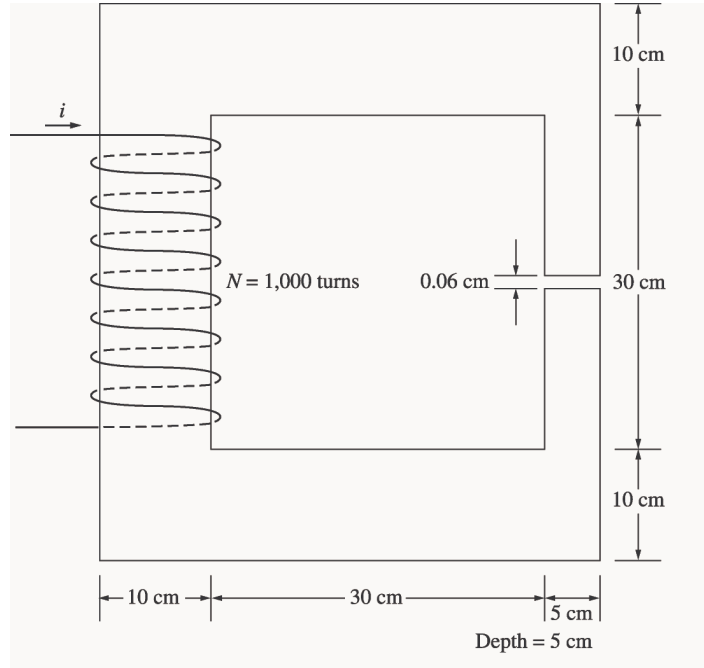

SOLUTION The magnetization curve for this core is shown below:

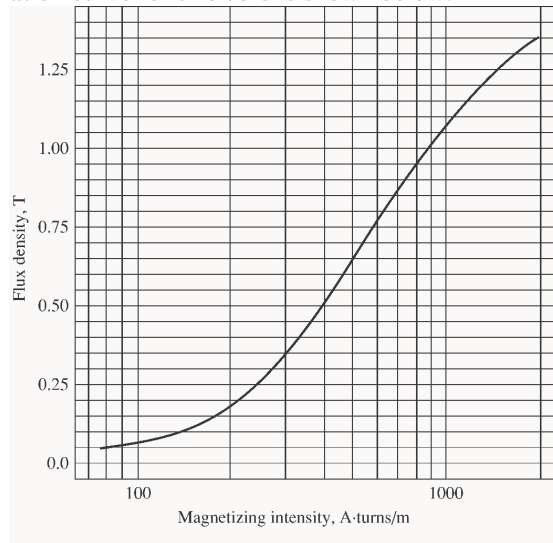

An air-gap flux density of 0.5 T requires a total flux of

$$\phi = BA_{\text{eff}} = (0.5 \text{ T})(0.05 \text{ m})(0.05 \text{ m})(1.05) = 0.00131 \text{ Wb}$$

This flux requires a flux density in the right-hand leg of

$$B_{\text{right}} = \frac{\phi}{A} = \frac{0.00131 \text{ Wb}}{(0.05 \text{ m})(0.05 \text{ m})} = 0.524 \text{ T}$$

The flux density in the other three legs of the core is

$$B_{\text{top}} = B_{\text{left}} = B_{\text{bottom}} = \frac{\phi}{A} = \frac{0.00131 \text{ Wb}}{(0.10 \text{ m})(0.05 \text{ m})} = 0.262 \text{ T}$$

The magnetizing intensity required to produce a flux density of 0.5 T in the air gap can be found from the equation $B_{ag} = \mu_0 H_{ag}$:

$$H_{ag} = \frac{B_{ag}}{\mu_0} = \frac{0.5 \text{ T}}{4\pi \times 10^{-7} \text{ H/m}} = 398 \text{ kA} \cdot \text{t/m}$$

The magnetizing intensity required to produce a flux density of 0.524 T in the right-hand leg of the core can be found from Figure P1-9 to be

$$H_{right} = 410 \text{ A} \cdot \text{t/m}$$

The magnetizing intensity required to produce a flux density of 0.262 T in the top, left, and bottom legs of the core can be found from Figure P1-9 to be

$$H_{top} = H_{left} = H_{bottom} = 240 \text{ A} \cdot \text{t/m}$$

The total MMF required to produce the flux is

$$\begin{aligned} \mathcal{F}_{TOT} &= H_{ag} l_{ag} + H_{right} l_{right} + H_{top} l_{top} + H_{left} l_{left} + H_{bottom} l_{bottom} \\ \mathcal{F}_{TOT} &= (398 \text{ kA} \cdot \text{t/m})(0.0006 \text{ m}) + (410 \text{ A} \cdot \text{t/m})(0.40 \text{ m}) + 3(240 \text{ A} \cdot \text{t/m})(0.40 \text{ m}) \\ \mathcal{F}_{TOT} &= 278.6 + 164 + 288 = 691 \text{ A} \cdot \text{t} \end{aligned}$$

and the required current is

$$i = \frac{\mathcal{F}_{TOT}}{N} = \frac{691 \text{ A} \cdot \text{t}}{1000 \text{ t}} = 0.691 \text{ A}$$

The flux densities in the four sides of the core and the total flux present in the air gap were calculated above.

- 1-15.** A transformer core with an effective mean path length of 10 in has a 300-turn coil wrapped around one leg. Its cross-sectional area is 0.25 in², and its magnetization curve is shown in Figure 1-10c. If current of 0.25 A is flowing in the coil, what is the total flux in the core? What is the flux density?

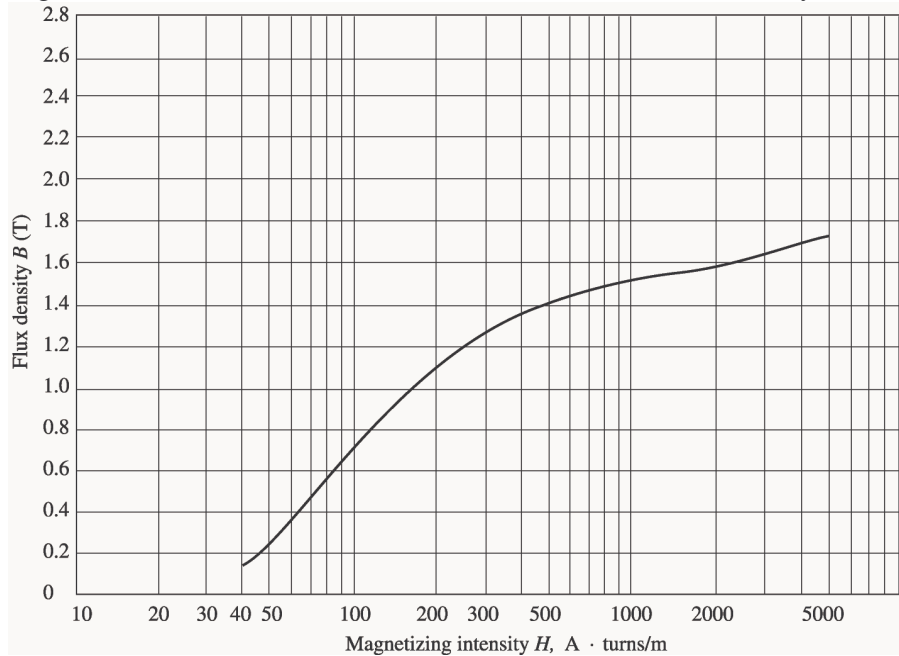

SOLUTION The magnetizing intensity applied to this core is

$$H = \frac{\mathcal{F}}{l_c} = \frac{Ni}{l_c} = \frac{(300 \text{ t})(0.25 \text{ A})}{(10 \text{ in})(0.0254 \text{ m/in})} = 295 \text{ A} \cdot \text{t/m}$$

From the magnetization curve, the flux density in the core is

$$B = 1.27 \text{ T}$$

The total flux in the core is

$$\phi = BA = (1.27 \text{ T})(0.25 \text{ in}^2) \frac{0.0254 \text{ m}}{1 \text{ in}} = 0.000205 \text{ Wb}$$

- 1-16.** The core shown in Figure P1-2 has the flux ϕ shown in Figure P1-12. Sketch the voltage present at the terminals of the coil.

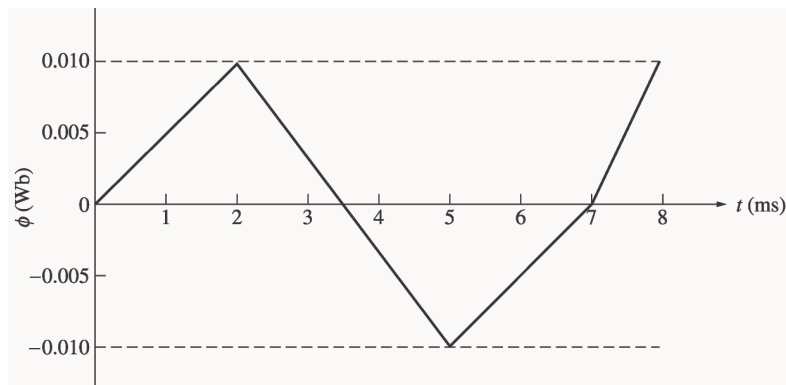
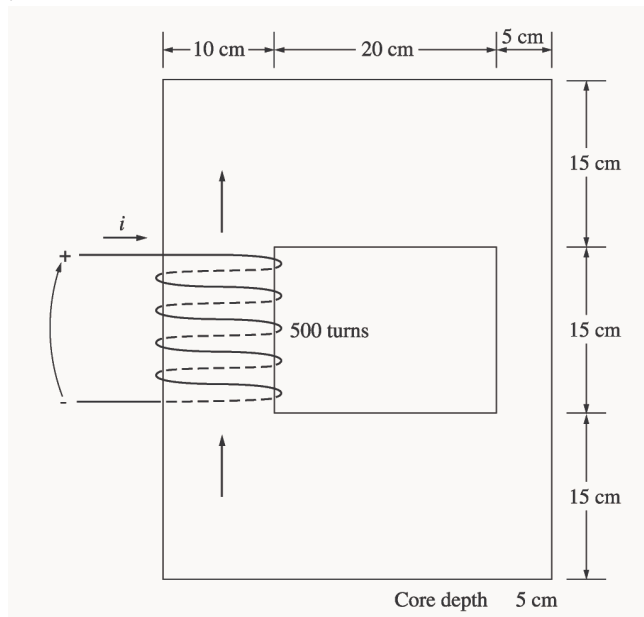

SOLUTION By Lenz' Law, an increasing flux in the direction shown on the core will produce a voltage that tends to oppose the increase. This voltage will be the same polarity as the direction shown on the core, so it will be positive. The induced voltage in the core is given by the equation

$$e_{\text{ind}} = N \frac{d\phi}{dt}$$

so the voltage in the windings will be

Time	$N \frac{d\phi}{dt}$	e_{ind}
$0 < t < 2 \text{ s}$	$(500 \text{ t}) \frac{0.010 \text{ Wb}}{2 \text{ s}}$	2.50 V
$2 < t < 5 \text{ s}$	$(500 \text{ t}) \frac{-0.020 \text{ Wb}}{3 \text{ s}}$	-3.33 V
$5 < t < 7 \text{ s}$	$(500 \text{ t}) \frac{0.010 \text{ Wb}}{2 \text{ s}}$	2.50 V
$7 < t < 8 \text{ s}$	$(500 \text{ t}) \frac{0.010 \text{ Wb}}{1 \text{ s}}$	5.00 V

The resulting voltage is plotted below:

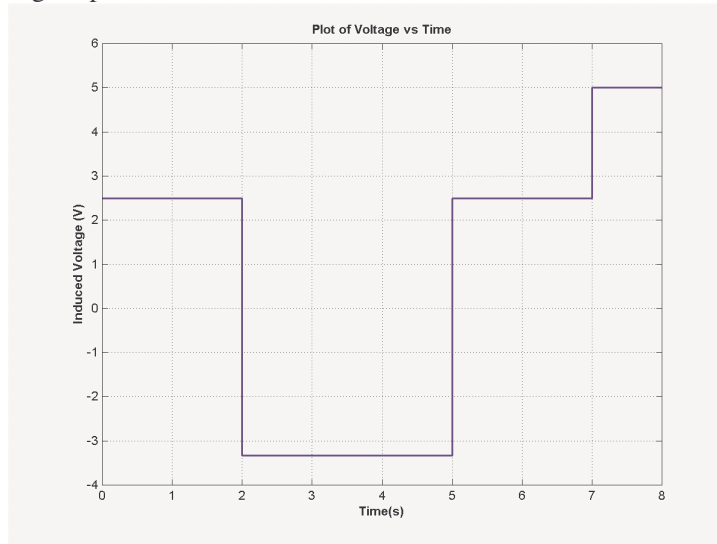

- 1-17. Figure P1-13 shows the core of a simple dc motor. The magnetization curve for the metal in this core is given by Figure 1-10c and d. Assume that the cross-sectional area of each air gap is 18 cm^2 and that the width of each air gap is 0.05 cm. The effective diameter of the rotor core is 4 cm.

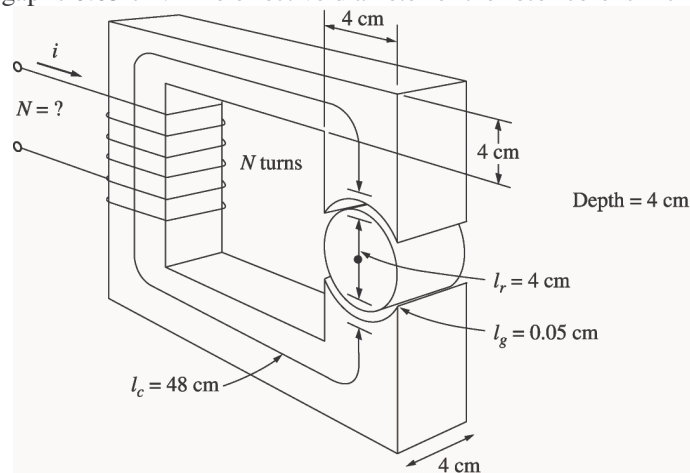

SOLUTION The magnetization curve for this core is shown below:

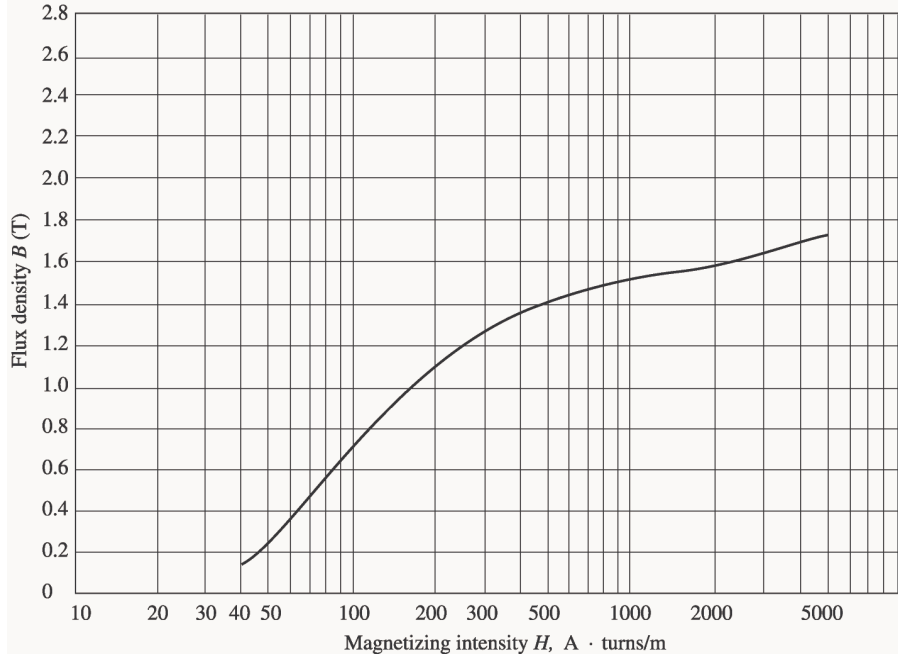

The relative permeability of this core is shown below:

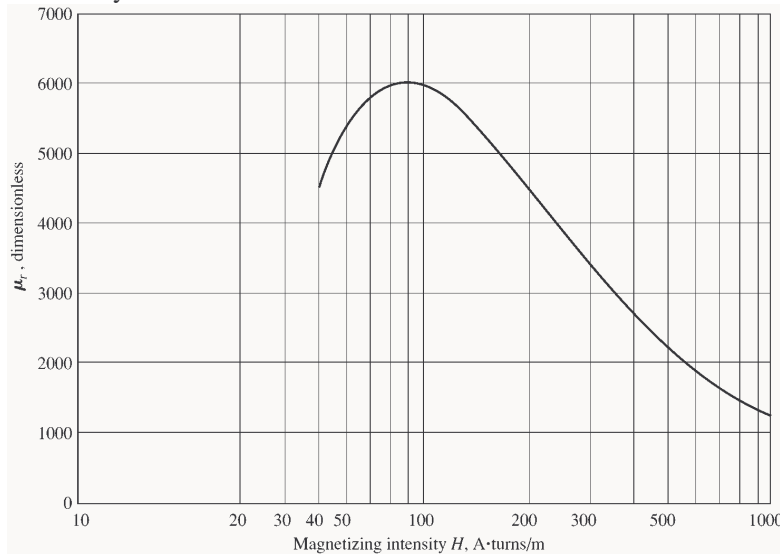

Note: This is a design problem, and the answer presented here is not unique. Other values could be selected for the flux density in part (a), and other numbers of turns could be selected in part (c). These other answers are also correct if the proper steps were followed, and if the choices were reasonable.

- (a) From Figure 1-10c, a reasonable maximum flux density would be about 1.2 T. Notice that the saturation effects become significant for higher flux densities.
- (b) At a flux density of 1.2 T, the total flux in the core would be

$$\phi = BA = (1.2 \text{ T})(0.04 \text{ m})(0.04 \text{ m}) = 0.00192 \text{ Wb}$$
- (c) The total reluctance of the core is:

$$\mathcal{R}_{\text{TOT}} = \mathcal{R}_{\text{stator}} + \mathcal{R}_{\text{air gap 1}} + \mathcal{R}_{\text{rotor}} + \mathcal{R}_{\text{air gap 2}}$$

At a flux density of 1.2 T, the relative permeability μ_r of the stator is about 3800, so the stator reluctance is

$$\mathcal{R}_{\text{stator}} = \frac{l_{\text{stator}}}{\mu_{\text{stator}} A_{\text{stator}}} = \frac{0.48 \text{ m}}{(3800)(4\pi \times 10^{-7} \text{ H/m})(0.04 \text{ m})(0.04 \text{ m})} = 62.8 \text{ kA} \cdot \text{t/Wb}$$

At a flux density of 1.2 T, the relative permeability μ_r of the rotor is 3800, so the rotor reluctance is

$$\mathcal{R}_{\text{rotor}} = \frac{l_{\text{rotor}}}{\mu_{\text{rotor}} A_{\text{rotor}}} = \frac{0.04 \text{ m}}{(3800)(4\pi \times 10^{-7} \text{ H/m})(0.04 \text{ m})(0.04 \text{ m})} = 5.2 \text{ kA} \cdot \text{t/Wb}$$

The reluctance of both air gap 1 and air gap 2 is

$$\mathcal{R}_{\text{air gap 1}} = \mathcal{R}_{\text{air gap 2}} = \frac{l_{\text{air gap}}}{\mu_{\text{air gap}} A_{\text{air gap}}} = \frac{0.0005 \text{ m}}{(4\pi \times 10^{-7} \text{ H/m})(0.0018 \text{ m}^2)} = 221 \text{ kA} \cdot \text{t/Wb}$$

Therefore, the total reluctance of the core is

$$\begin{aligned} \mathcal{R}_{\text{TOT}} &= \mathcal{R}_{\text{stator}} + \mathcal{R}_{\text{air gap 1}} + \mathcal{R}_{\text{rotor}} + \mathcal{R}_{\text{air gap 2}} \\ \mathcal{R}_{\text{TOT}} &= 62.8 + 221 + 5.2 + 221 = 510 \text{ kA} \cdot \text{t/Wb} \end{aligned}$$

The required MMF is

$$\mathcal{F}_{\text{TOT}} = \phi \mathcal{R}_{\text{TOT}} = (0.00192 \text{ Wb})(510 \text{ kA} \cdot \text{t/Wb}) = 979 \text{ A} \cdot \text{t}$$

Since $\mathcal{F} = Ni$, and the current is limited to 1 A, one possible choice for the number of turns is $N = 1000$.

1-18. Assume that the voltage applied to a load is $\mathbf{V} = 208\angle -30^\circ \text{ V}$ and the current flowing through the load is $\mathbf{I} = 5\angle 15^\circ \text{ A}$.

(a) Calculate the complex power \mathbf{S} consumed by this load.

(b) Is this load inductive or capacitive?

(c) Calculate the power factor of this load?

(d) Calculate the reactive power consumed or supplied by this load. Does the load consume reactive power from the source or supply it to the source?

SOLUTION

(a) The complex power \mathbf{S} consumed by this load is

$$\begin{aligned} \mathbf{S} &= \mathbf{VI}^* = (208\angle -30^\circ \text{ V})(5\angle 15^\circ \text{ A})^* = (208\angle -30^\circ \text{ V})(5\angle -15^\circ \text{ A}) \\ \mathbf{S} &= 1040\angle -45^\circ \text{ VA} \end{aligned}$$

(b) This is a capacitive load.

(c) The power factor of this load is
 $\text{PF} = \cos(-45^\circ) = 0.707$ leading

(d) This load supplies reactive power to the source. The reactive power of the load is
 $Q = VI \sin \theta = (208 \text{ V})(5 \text{ A}) \sin(-45^\circ) = -735 \text{ var}$

1-19. Figure P1-14 shows a simple single-phase ac power system with three loads. The voltage source is $\mathbf{V} = 120\angle 0^\circ \text{ V}$, and the three loads are

$$\mathbf{Z}_1 = 5\angle 30^\circ \Omega \quad \mathbf{Z}_2 = 5\angle 45^\circ \Omega \quad \mathbf{Z}_3 = 5\angle -90^\circ \Omega$$

Answer the following questions about this power system.

- (a) Assume that the switch shown in the figure is open, and calculate the current \mathbf{I} , the power factor, and the real, reactive, and apparent power being supplied by the source.
- (b) Assume that the switch shown in the figure is closed, and calculate the current \mathbf{I} , the power factor, and the real, reactive, and apparent power being supplied by the source.
- (c) What happened to the current flowing from the source when the switch closed? Why?

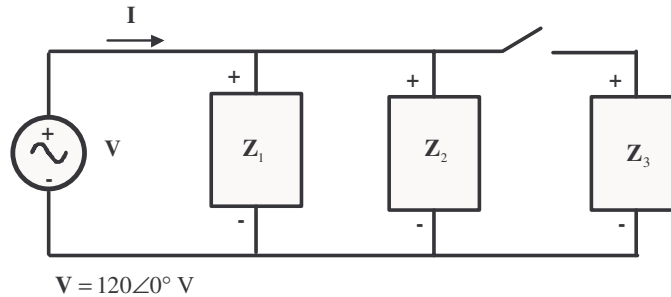

SOLUTION

- (a) With the switch open, only loads 1 and 2 are connected to the source. The current \mathbf{I}_1 in Load 1 is

$$\mathbf{I}_1 = \frac{120\angle 0^\circ \text{ V}}{5\angle 30^\circ \text{ A}} = 24\angle -30^\circ \text{ A}$$

The current \mathbf{I}_2 in Load 2 is

$$\mathbf{I}_2 = \frac{120\angle 0^\circ \text{ V}}{5\angle 45^\circ \text{ A}} = 24\angle -45^\circ \text{ A}$$

Therefore the total current from the source is

$$\mathbf{I} = \mathbf{I}_1 + \mathbf{I}_2 = 24\angle -30^\circ \text{ A} + 24\angle -45^\circ \text{ A} = 47.59\angle -37.5^\circ \text{ A}$$

The power factor supplied by the source is

$$\text{PF} = \cos \theta = \cos(-37.5^\circ) = 0.793 \text{ lagging}$$

The real, reactive, and apparent power supplied by the source are

$$P = VI \cos \theta = (120 \text{ V})(47.59 \text{ A}) \cos(-37.5^\circ) = 4531 \text{ W}$$

$$Q = VI \sin \theta = (120 \text{ V})(47.59 \text{ A}) \sin(-37.5^\circ) = -3477 \text{ var}$$

$$S = VI = (120 \text{ V})(47.59 \text{ A}) = 5711 \text{ VA}$$

- (b) With the switch open, all three loads are connected to the source. The current in Loads 1 and 2 is the same as before. The current \mathbf{I}_3 in Load 3 is

$$\mathbf{I}_3 = \frac{120\angle 0^\circ \text{ V}}{5\angle -90^\circ \text{ A}} = 24\angle 90^\circ \text{ A}$$

Therefore the total current from the source is

$$\mathbf{I} = \mathbf{I}_1 + \mathbf{I}_2 + \mathbf{I}_3 = 24\angle -30^\circ \text{ A} + 24\angle -45^\circ \text{ A} + 24\angle 90^\circ \text{ A} = 38.08\angle -7.5^\circ \text{ A}$$

The power factor supplied by the source is

$$\text{PF} = \cos \theta = \cos(-7.5^\circ) = 0.991 \text{ lagging}$$

The real, reactive, and apparent power supplied by the source are

$$P = VI \cos \theta = (120 \text{ V})(38.08 \text{ A}) \cos(-7.5^\circ) = 4531 \text{ W}$$

$$Q = VI \cos \theta = (120 \text{ V})(38.08 \text{ A}) \sin(-7.5^\circ) = -596 \text{ var}$$

$$S = VI = (120 \text{ V})(38.08 \text{ A}) = 4570 \text{ VA}$$

(c) The current flowing *decreased* when the switch closed, because most of the reactive power being consumed by Loads 1 and 2 is being supplied by Load 3. Since less reactive power has to be supplied by the source, the total current flow decreases.

- 1-20.** Demonstrate that Equation (1-59) can be derived from Equation (1-58) using simple trigonometric identities:

$$p(t) = v(t) i(t) = 2VI \cos \omega t \cos(\omega t - \theta) \quad (1-58)$$

$$p(t) = VI \cos \theta (1 + \cos 2\omega t) + VI \sin \theta \sin 2\omega t \quad (1-59)$$

SOLUTION

The first step is to apply the following identity:

$$\cos \alpha \cos \beta = \frac{1}{2} [\cos(\alpha - \beta) + \cos(\alpha + \beta)]$$

The result is

$$p(t) = v(t) i(t) = 2VI \cos \omega t \cos(\omega t - \theta)$$

$$p(t) = 2VI \frac{1}{2} [\cos(\omega t - \omega t + \theta) + \cos(\omega t - \omega t - \theta)]$$

$$p(t) = VI [\cos \theta + \cos(2\omega t - \theta)]$$

Now we must apply the angle addition identity to the second term:

$$\cos(\alpha - \beta) = \cos \alpha \cos \beta + \sin \alpha \sin \beta$$

The result is

$$p(t) = VI [\cos \theta + \cos 2\omega t \cos \theta + \sin 2\omega t \sin \theta]$$

Collecting terms yields the final result:

$$p(t) = VI \cos \theta (1 + \cos 2\omega t) + VI \sin \theta \sin 2\omega t$$

- 1-21.** A linear machine has a magnetic flux density of 0.5 T directed into the page, a resistance of 0.25 Ω , a bar length $l = 1.0$ m, and a battery voltage of 100 V.

(a) What is the initial force on the bar at starting? What is the initial current flow?

(b) What is the no-load steady-state speed of the bar?

(c) If the bar is loaded with a force of 25 N opposite to the direction of motion, what is the new steady-state speed? What is the efficiency of the machine under these circumstances?

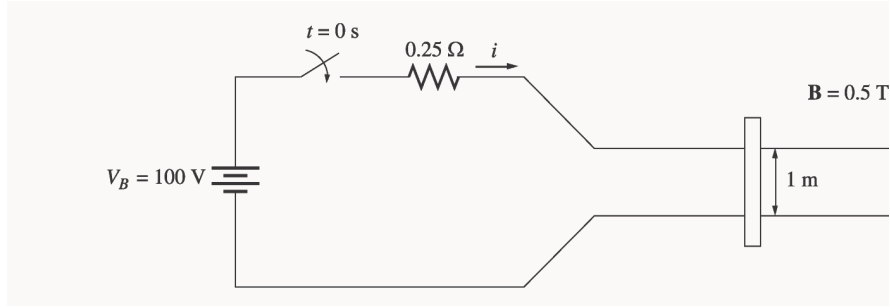

SOLUTION

(a) The current in the bar at starting is

$$i = \frac{V_B}{R} = \frac{100 \text{ V}}{0.25 \Omega} = 400 \text{ A}$$

Therefore, the force on the bar at starting is

$$\mathbf{F} = i(\mathbf{l} \times \mathbf{B}) = (400 \text{ A})(1 \text{ m})(0.5 \text{ T}) = 200 \text{ N, to the right}$$

(b) The no-load steady-state speed of this bar can be found from the equation

$$V_B = e_{\text{ind}} = vBl$$

$$v = \frac{V_B}{Bl} = \frac{100 \text{ V}}{(0.5 \text{ T})(1 \text{ m})} = 200 \text{ m/s}$$

(c) With a load of 25 N opposite to the direction of motion, the steady-state current flow in the bar will be given by

$$F_{\text{app}} = F_{\text{ind}} = ilB$$

$$i = \frac{F_{\text{app}}}{Bl} = \frac{25 \text{ N}}{(0.5 \text{ T})(1 \text{ m})} = 50 \text{ A}$$

The induced voltage in the bar will be

$$e_{\text{ind}} = V_B - iR = 100 \text{ V} - (50 \text{ A})(0.25 \Omega) = 87.5 \text{ V}$$

and the velocity of the bar will be

$$v = \frac{V_B}{Bl} = \frac{87.5 \text{ V}}{(0.5 \text{ T})(1 \text{ m})} = 175 \text{ m/s}$$

The *input* power to the linear machine under these conditions is

$$P_{\text{in}} = V_B i = (100 \text{ V})(50 \text{ A}) = 5000 \text{ W}$$

The *output* power from the linear machine under these conditions is

$$P_{\text{out}} = V_B i = (87.5 \text{ V})(50 \text{ A}) = 4375 \text{ W}$$

Therefore, the efficiency of the machine under these conditions is

$$\eta = \frac{P_{\text{out}}}{P_{\text{in}}} \times 100\% = \frac{4375 \text{ W}}{5000 \text{ W}} \times 100\% = 87.5\%$$

1-22. A linear machine has the following characteristics:

$$B = 0.33 \text{ T into page} \quad R = 0.50 \Omega$$

$$l = 0.5 \text{ m}$$

$$V_B = 120 \text{ V}$$

- (a) If this bar has a load of 10 N attached to it opposite to the direction of motion, what is the steady-state speed of the bar?
- (b) If the bar runs off into a region where the flux density falls to 0.30 T, what happens to the bar? What is its final steady-state speed?
- (c) Suppose V_B is now decreased to 80 V with everything else remaining as in part (b). What is the new steady-state speed of the bar?
- (d) From the results for parts (b) and (c), what are two methods of controlling the speed of a linear machine (or a real dc motor)?

SOLUTION

(a) With a load of 20 N opposite to the direction of motion, the steady-state current flow in the bar will be given by

$$F_{\text{app}} = F_{\text{ind}} = i l B$$

$$i = \frac{F_{\text{app}}}{B l} = \frac{10 \text{ N}}{(0.33 \text{ T})(0.5 \text{ m})} = 60.5 \text{ A}$$

The induced voltage in the bar will be

$$e_{\text{ind}} = V_B - i R = 120 \text{ V} - (60.5 \text{ A})(0.50 \Omega) = 89.75 \text{ V}$$

and the velocity of the bar will be

$$v = \frac{e_{\text{ind}}}{B l} = \frac{89.75 \text{ V}}{(0.33 \text{ T})(0.5 \text{ m})} = 544 \text{ m/s}$$

(b) If the flux density drops to 0.30 T while the load on the bar remains the same, there will be a speed transient until $F_{\text{app}} = F_{\text{ind}} = 10 \text{ N}$ again. The new steady state current will be

$$F_{\text{app}} = F_{\text{ind}} = i l B$$

$$i = \frac{F_{\text{app}}}{B l} = \frac{10 \text{ N}}{(0.30 \text{ T})(0.5 \text{ m})} = 66.7 \text{ A}$$

The induced voltage in the bar will be

$$e_{\text{ind}} = V_B - i R = 120 \text{ V} - (66.7 \text{ A})(0.50 \Omega) = 86.65 \text{ V}$$

and the velocity of the bar will be

$$v = \frac{e_{\text{ind}}}{B l} = \frac{86.65 \text{ V}}{(0.30 \text{ T})(0.5 \text{ m})} = 577 \text{ m/s}$$

(c) If the battery voltage is decreased to 80 V while the load on the bar remains the same, there will be a speed transient until $F_{\text{app}} = F_{\text{ind}} = 10 \text{ N}$ again. The new steady state current will be

$$F_{\text{app}} = F_{\text{ind}} = i l B$$

$$i = \frac{F_{\text{app}}}{B l} = \frac{10 \text{ N}}{(0.30 \text{ T})(0.5 \text{ m})} = 66.7 \text{ A}$$

The induced voltage in the bar will be

$$e_{\text{ind}} = V_B - iR = 80 \text{ V} - (66.7 \text{ A})(0.50 \Omega) = 46.65 \text{ V}$$

and the velocity of the bar will be

$$v = \frac{e_{\text{ind}}}{Bl} = \frac{46.65 \text{ V}}{(0.30 \text{ T})(0.5 \text{ m})} = 311 \text{ m/s}$$

(d) From the results of the two previous parts, we can see that there are two ways to control the speed of a linear dc machine. *Reducing* the flux density B of the machine *increases* the steady-state speed, and *reducing* the battery voltage V_B *decreases* the steady-state speed of the machine. Both of these speed control methods work for real dc machines as well as for linear machines.

Chapter 2: Transformers

- 2-1. The secondary winding of a transformer has a terminal voltage of $v_s(t) = 282.8 \sin 377t$ V. The turns ratio of the transformer is 100:200 ($a = 0.50$). If the secondary current of the transformer is $i_s(t) = 7.07 \sin(377t - 36.87^\circ)$ A, what is the primary current of this transformer? What are its voltage regulation and efficiency? The impedances of this transformer referred to the primary side are

$$\begin{aligned} R_{eq} &= 0.20 \, \Omega & R_C &= 300 \, \Omega \\ X_{eq} &= 0.750 \, \Omega & X_M &= 80 \, \Omega \end{aligned}$$

SOLUTION The equivalent circuit of this transformer is shown below. (Since no particular equivalent circuit was specified, we are using the approximate equivalent circuit referred to the primary side.)

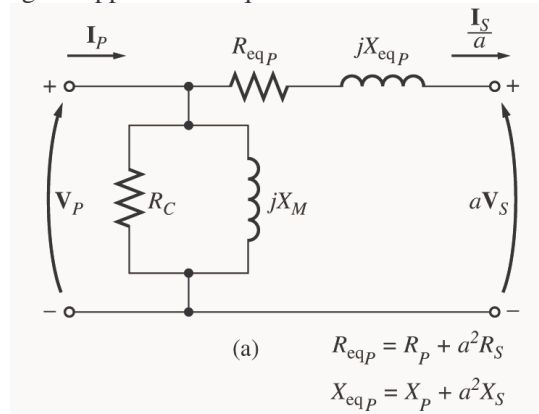

The secondary voltage and current are

$$\begin{aligned} \mathbf{V}_S &= \frac{282.8}{\sqrt{2}} \angle 0^\circ \text{ V} = 200 \angle 0^\circ \text{ V} \\ \mathbf{I}_S &= \frac{7.07}{\sqrt{2}} \angle -36.87^\circ \text{ A} = 5 \angle -36.87^\circ \text{ A} \end{aligned}$$

The secondary voltage referred to the primary side is

$$\mathbf{V}'_S = a \mathbf{V}_S = 100 \angle 0^\circ \text{ V}$$

The secondary current referred to the primary side is

$$\mathbf{I}'_S = \frac{\mathbf{I}_S}{a} = 10 \angle -36.87^\circ \text{ A}$$

The primary circuit voltage is given by

$$\begin{aligned} \mathbf{V}_P &= \mathbf{V}'_S + \mathbf{I}'_S (R_{eq} + jX_{eq}) \\ \mathbf{V}_P &= 100 \angle 0^\circ \text{ V} + (10 \angle -36.87^\circ \text{ A})(0.20 \, \Omega + j0.750 \, \Omega) = 106.2 \angle 2.6^\circ \text{ V} \end{aligned}$$

The excitation current of this transformer is

$$\begin{aligned} \mathbf{I}_{EX} &= \mathbf{I}_C + \mathbf{I}_M = \frac{106.2 \angle 2.6^\circ \text{ V}}{300 \, \Omega} + \frac{106.2 \angle 2.6^\circ \text{ V}}{j80 \, \Omega} = 0.354 \angle 2.6^\circ + 1.328 \angle -87.4^\circ \\ \mathbf{I}_{EX} &= 1.37 \angle -72.5^\circ \text{ A} \end{aligned}$$

Therefore, the total primary current of this transformer is

$$\mathbf{I}_p = \mathbf{I}_s' + \mathbf{I}_{EX} = 10\angle -36.87^\circ + 1.37\angle -72.5^\circ = 11.1\angle -41.0^\circ \text{ A}$$

The voltage regulation of the transformer at this load is

$$\text{VR} = \frac{V_p - aV_s}{aV_s} \times 100\% = \frac{106.2 - 100}{100} \times 100\% = 6.2\%$$

The input power to this transformer is

$$P_{IN} = V_p I_p \cos \theta = (106.2 \text{ V})(11.1 \text{ A}) \cos 2.6^\circ = 1184 \text{ W}$$

$$P_{IN} = (106.2 \text{ V})(11.1 \text{ A}) \cos 43.6^\circ = 854 \text{ W}$$

The output power from this transformer is

$$P_{OUT} = V_s I_s \cos \theta = (200 \text{ V})(5 \text{ A}) \cos(36.87^\circ) = 800 \text{ W}$$

Therefore, the transformer's efficiency is

$$\eta = \frac{P_{OUT}}{P_{IN}} \times 100\% = \frac{800 \text{ W}}{854 \text{ W}} \times 100\% = 93.7\%$$

2-2. A 20-kVA 8000/480-V distribution transformer has the following resistances and reactances:

$$\begin{array}{ll} R_p = 32 \Omega & R_s = 0.05 \Omega \\ X_p = 45 \Omega & X_s = 0.06 \Omega \\ R_c = 250 \text{ k}\Omega & X_M = 30 \text{ k}\Omega \end{array}$$

The excitation branch impedances are given referred to the high-voltage side of the transformer.

(a) Find the equivalent circuit of this transformer referred to the high-voltage side.

(b) Find the per-unit equivalent circuit of this transformer.

(c) Assume that this transformer is supplying rated load at 480 V and 0.8 PF lagging. What is this transformer's input voltage? What is its voltage regulation?

(d) What is the transformer's efficiency under the conditions of part (c)?

SOLUTION

(a) The turns ratio of this transformer is $a = 8000/480 = 16.67$. Therefore, the secondary impedances referred to the primary side are

$$R_s' = a^2 R_s = (16.67)^2 (0.05 \Omega) = 13.9 \Omega$$

$$X_s' = a^2 X_s = (16.67)^2 (0.06 \Omega) = 16.7 \Omega$$

The resulting equivalent circuit is

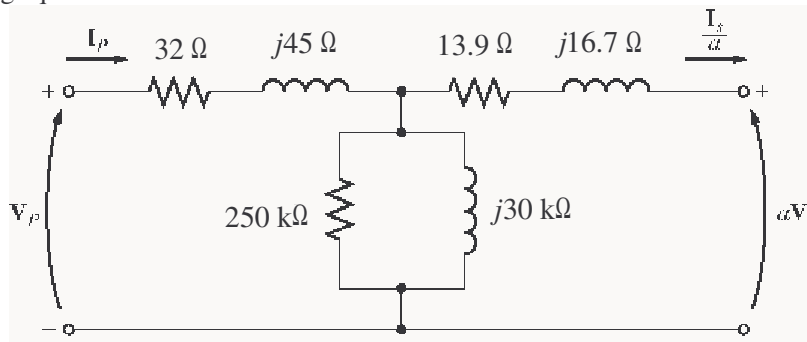

(b) The rated kVA of the transformer is 20 kVA, and the rated voltage on the primary side is 8000 V, so the rated current in the primary side is $20 \text{ kVA}/8000 \text{ V} = 2.5 \text{ A}$. Therefore, the base impedance on the primary side is

$$Z_{\text{base}} = \frac{V_{\text{base}}}{I_{\text{base}}} = \frac{8000 \text{ V}}{2.5 \text{ A}} = 3200 \Omega$$

Since $Z_{\text{pu}} = Z_{\text{actual}} / Z_{\text{base}}$, the resulting per-unit equivalent circuit is as shown below:

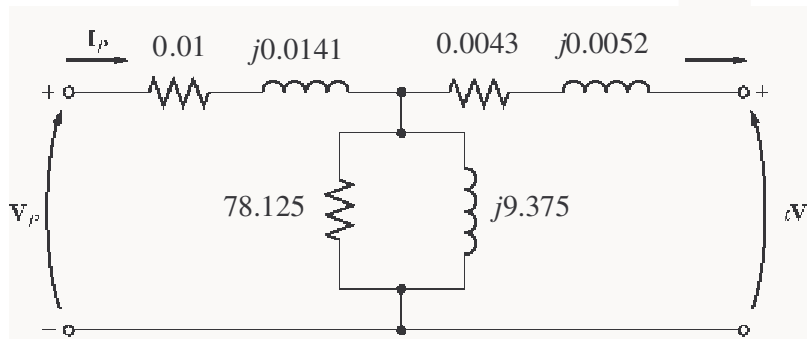

(c) To simplify the calculations, use the simplified equivalent circuit referred to the primary side of the transformer:

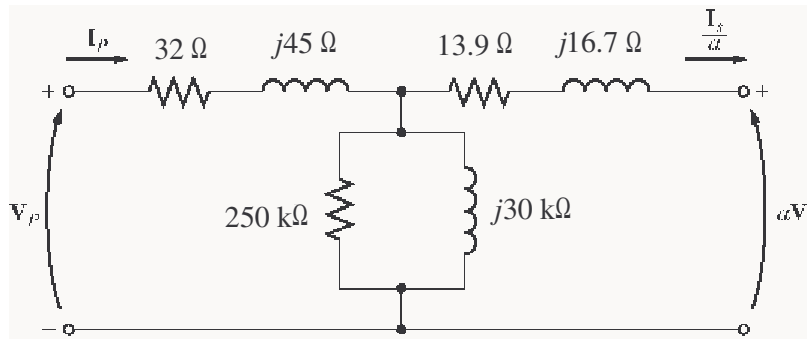

The secondary current in this transformer is

$$I_s = \frac{20 \text{ kVA}}{480 \text{ V}} \angle -36.87^\circ \text{ A} = 41.67 \angle -36.87^\circ \text{ A}$$

The secondary current referred to the primary side is

$$I_s' = \frac{I_s}{a} = \frac{41.67 \angle -36.87^\circ \text{ A}}{16.67} = 2.50 \angle -36.87^\circ \text{ A}$$

Therefore, the primary voltage on the transformer is

$$\begin{aligned} \mathbf{V}_p &= \mathbf{V}_s' + (\mathbf{R}_{\text{EQ}} + j\mathbf{X}_{\text{EQ}}) \mathbf{I}_s' \\ \mathbf{V}_p &= 8000 \angle 0^\circ \text{ V} + (45.9 + j61.7)(2.50 \angle -36.87^\circ \text{ A}) = 8185 \angle 0.38^\circ \text{ V} \end{aligned}$$

The voltage regulation of the transformer under these conditions is

$$\text{VR} = \frac{8185 - 8000}{8000} \times 100\% = 2.31\%$$

(d) Under the conditions of part (c), the transformer's output power copper losses and core losses are:

$$P_{\text{OUT}} = S \cos \theta = (20 \text{ kVA})(0.8) = 16 \text{ kW}$$

$$P_{\text{CU}} = (I_s')^2 R_{\text{EQ}} = (2.5)^2 (45.9) = 287 \text{ W}$$

$$P_{\text{core}} = \frac{V_s'^2}{R_c} = \frac{8185^2}{250,000} = 268 \text{ W}$$

The efficiency of this transformer is

$$\eta = \frac{P_{\text{OUT}}}{P_{\text{OUT}} + P_{\text{CU}} + P_{\text{core}}} \times 100\% = \frac{16,000}{16,000 + 287 + 268} \times 100\% = 96.6\%$$

- 2-3.** A 1000-VA 230/115-V transformer has been tested to determine its equivalent circuit. The results of the tests are shown below.

Open-circuit test	Short-circuit test
$V_{\text{OC}} = 230 \text{ V}$	$V_{\text{SC}} = 19.1 \text{ V}$
$I_{\text{OC}} = 0.45 \text{ A}$	$I_{\text{SC}} = 8.7 \text{ A}$
$P_{\text{OC}} = 30 \text{ W}$	$P_{\text{SC}} = 42.3 \text{ W}$

All data given were taken from the primary side of the transformer.

- (a) Find the equivalent circuit of this transformer referred to the low-voltage side of the transformer.
 (b) Find the transformer's voltage regulation at rated conditions and (1) 0.8 PF lagging, (2) 1.0 PF, (3) 0.8 PF leading.
 (c) Determine the transformer's efficiency at rated conditions and 0.8 PF lagging.

SOLUTION

(a) OPEN CIRCUIT TEST:

$$|Y_{\text{EX}}| = |G_c - jB_M| = \frac{0.45 \text{ A}}{230 \text{ V}} = 0.001957$$

$$\theta = \cos^{-1} \frac{P_{\text{OC}}}{V_{\text{OC}} I_{\text{OC}}} = \cos^{-1} \frac{30 \text{ W}}{(230 \text{ V})(0.45 \text{ A})} = 73.15^\circ$$

$$Y_{\text{EX}} = G_c - jB_M = 0.001957 \angle -73.15^\circ \text{ mho} = 0.000567 - j0.001873 \text{ mho}$$

$$R_c = \frac{1}{G_c} = 1763 \Omega$$

$$X_M = \frac{1}{B_M} = 534 \Omega$$

SHORT CIRCUIT TEST:

$$|Z_{EQ}| = |R_{EQ} + jX_{EQ}| = \frac{19.1 \text{ V}}{8.7 \text{ A}} = 2.2 \Omega$$

$$\theta = \cos^{-1} \frac{P_{SC}}{V_{SC} I_{SC}} = \cos^{-1} \frac{42.3 \text{ W}}{(19.1 \text{ V})(8.7 \text{ A})} = 75.3^\circ$$

$$Z_{EQ} = R_{EQ} + jX_{EQ} = 2.20 \angle 75.3^\circ \Omega = 0.558 + j2.128 \Omega$$

$$R_{EQ} = 0.558 \Omega$$

$$X_{EQ} = j2.128 \Omega$$

To convert the equivalent circuit to the secondary side, divide each impedance by the square of the turns ratio ($a = 230/115 = 2$). The resulting equivalent circuit is shown below:

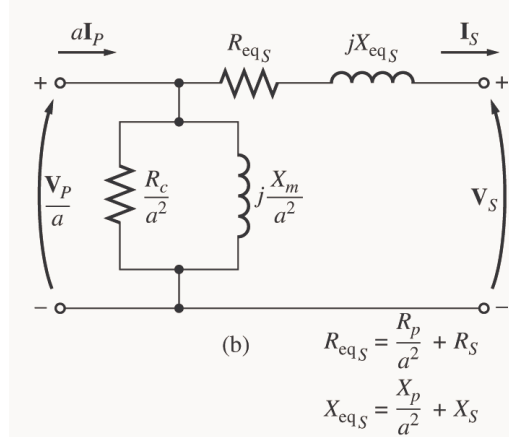

$$R_{EQ,s} = 0.140 \Omega$$

$$X_{EQ,s} = j0.532 \Omega$$

$$R_{C,s} = 441 \Omega$$

$$X_{M,s} = 134 \Omega$$

(b) To find the required voltage regulation, we will use the equivalent circuit of the transformer referred to the secondary side. The rated secondary current is

$$I_s = \frac{1000 \text{ VA}}{115 \text{ V}} = 8.70 \text{ A}$$

We will now calculate the primary voltage referred to the secondary side and use the voltage regulation equation for each power factor.

(1) 0.8 PF Lagging:

$$\mathbf{V}'_p = \mathbf{V}_s + Z_{EQ} \mathbf{I}_s = 115 \angle 0^\circ \text{ V} + (0.140 + j0.532 \Omega)(8.7 \angle -36.87^\circ \text{ A})$$

$$\mathbf{V}'_p = 118.8 \angle 1.4^\circ \text{ V}$$

$$\text{VR} = \frac{118.8 - 115}{115} \times 100\% = 3.3\%$$

(2) 1.0 PF:

$$\mathbf{V}'_p = \mathbf{V}_s + Z_{EQ} \mathbf{I}_s = 115 \angle 0^\circ \text{ V} + (0.140 + j0.532 \Omega)(8.7 \angle 0^\circ \text{ A})$$

$$\mathbf{V}'_p = 116.3 \angle 2.28^\circ \text{ V}$$

$$\text{VR} = \frac{116.3-115}{115} \times 100\% = 1.1\%$$

(3) 0.8 PF Leading:

$$\mathbf{V}_p' = \mathbf{V}_s + \mathbf{Z}_{\text{EQ}} \mathbf{I}_s = 115 \angle 0^\circ \text{ V} + (0.140 + j0.532 \Omega)(8.7 \angle 36.87^\circ \text{ A})$$

$$\mathbf{V}_p' = 113.3 \angle 2.24^\circ \text{ V}$$

$$\text{VR} = \frac{113.3-115}{115} \times 100\% = -1.5\%$$

(c) At rated conditions and 0.8 PF lagging, the output power of this transformer is

$$P_{\text{OUT}} = V_s I_s \cos \theta = (115 \text{ V})(8.7 \text{ A})(0.8) = 800 \text{ W}$$

The copper and core losses of this transformer are

$$P_{\text{CU}} = I_s^2 R_{\text{EQ},s} = (8.7 \text{ A})^2 (0.140 \Omega) = 10.6 \text{ W}$$

$$P_{\text{core}} = \frac{(V_p')^2}{R_c} = \frac{(118.8 \text{ V})^2}{441 \Omega} = 32.0 \text{ W}$$

Therefore the efficiency of this transformer at these conditions is

$$\eta = \frac{P_{\text{OUT}}}{P_{\text{OUT}} + P_{\text{CU}} + P_{\text{core}}} \times 100\% = \frac{800 \text{ W}}{800 \text{ W} + 10.6 \text{ W} + 32.0 \text{ W}} = 94.9\%$$

2-4. A single-phase power system is shown in Figure P2-1. The power source feeds a 100-kVA 14/2.4-kV transformer through a feeder impedance of $40.0 + j150 \Omega$. The transformer's equivalent series impedance referred to its low-voltage side is $0.12 + j0.5 \Omega$. The load on the transformer is 90 kW at 0.80 PF lagging and 2300 V.

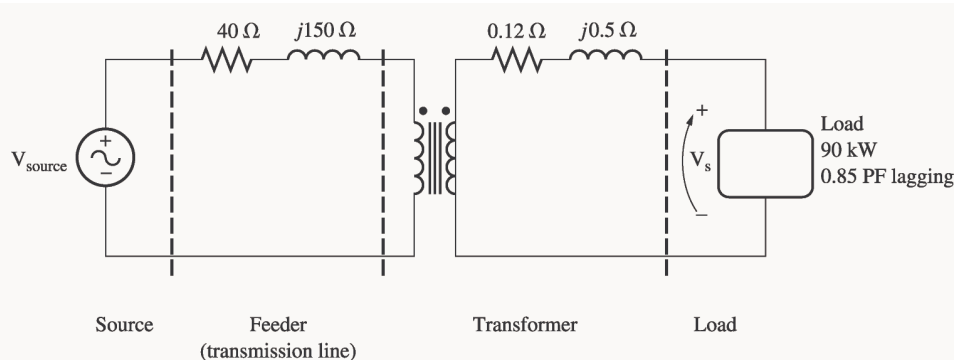

- (a) What is the voltage at the power source of the system?
- (b) What is the voltage regulation of the transformer?
- (c) How efficient is the overall power system?

SOLUTION

To solve this problem, we will refer the circuit to the secondary (low-voltage) side. The feeder's impedance referred to the secondary side is

$$Z_{\text{line}}' = \frac{2.4 \text{ kV}}{14 \text{ kV}}^2 (40 \Omega + j150 \Omega) = 1.18 + j4.41 \Omega$$

The secondary current \mathbf{I}_S is given by

$$I_S = \frac{90 \text{ kW}}{(2300 \text{ V})(0.85)} = 46.03 \text{ A}$$

$$\mathbf{I}_S = 46.03 \angle -31.8^\circ \text{ A}$$

(a) The voltage at the power source of this system (referred to the secondary side) is

$$\mathbf{V}_{\text{source}}' = \mathbf{V}_S + \mathbf{I}_S \mathbf{Z}_{\text{line}}' + \mathbf{I}_S \mathbf{Z}_{\text{EQ}}$$

$$\mathbf{V}_{\text{source}}' = 2300 \angle 0^\circ \text{ V} + (46.03 \angle -31.8^\circ \text{ A})(1.18 + j4.11 \Omega) + (46.03 \angle -31.8^\circ \text{ A})(0.12 + j0.5 \Omega)$$

$$\mathbf{V}_{\text{source}}' = 2467 \angle 3.5^\circ \text{ V}$$

Therefore, the voltage at the power source is

$$\mathbf{V}_{\text{source}} = (2467 \angle 3.5^\circ \text{ V}) \frac{14 \text{ kV}}{2.4 \text{ kV}} = 14.4 \angle 3.5^\circ \text{ kV}$$

(b) To find the voltage regulation of the transformer, we must find the voltage at the primary side of the transformer (referred to the secondary side) under full load conditions:

$$\mathbf{V}_P' = \mathbf{V}_S + \mathbf{I}_S \mathbf{Z}_{\text{EQ}}$$

$$\mathbf{V}_P' = 2300 \angle 0^\circ \text{ V} + (46.03 \angle -31.8^\circ \text{ A})(0.12 + j0.5 \Omega) = 2317 \angle 0.41^\circ \text{ V}$$

There is a voltage drop of 17 V under these load conditions. Therefore the voltage regulation of the transformer is

$$\text{VR} = \frac{2317 - 2300}{2300} \times 100\% = 0.74\%$$

(c) The overall efficiency of the power system will be the ratio of the output power to the input power. The output power supplied to the load is $P_{\text{OUT}} = 90 \text{ kW}$. The input power supplied by the source is

$$P_{\text{IN}} = V_{\text{source}}' I_S \cos \theta = (2467 \text{ V})(46.03 \text{ A}) \cos 35.3^\circ = 92.68 \text{ kW}$$

Therefore, the efficiency of the power system is

$$\eta = \frac{P_{\text{OUT}}}{P_{\text{IN}}} \times 100\% = \frac{90 \text{ kW}}{92.68 \text{ kW}} \times 100\% = 97.1\%$$

- 2-5.** When travelers from the USA and Canada visit Europe, they encounter a different power distribution system. Wall voltages in North America are 120 V rms at 60 Hz, while typical wall voltages in Europe are 220 to 240 V at 50 Hz. Many travelers carry small step-up / step-down transformers so that they can use their appliances in the countries that they are visiting. A typical transformer might be rated at 1-kVA and 120/240 V. It has 500 turns of wire on the 120-V side and 1000 turns of wire on the 240-V side. The magnetization curve for this transformer is shown in Figure P2-2, and can be found in file p22_mag.dat at this book's Web site.

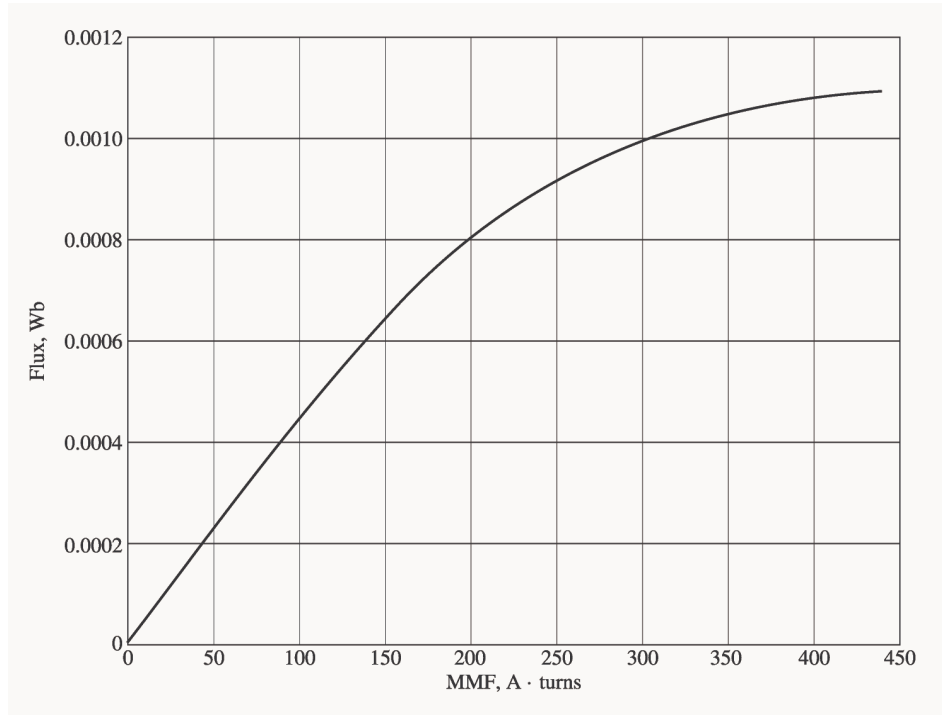

- (a) Suppose that this transformer is connected to a 120-V, 60 Hz power source with no load connected to the 240-V side. Sketch the magnetization current that would flow in the transformer. (Use MATLAB to plot the current accurately, if it is available.) What is the rms amplitude of the magnetization current? What percentage of full-load current is the magnetization current?
- (b) Now suppose that this transformer is connected to a 240-V, 50 Hz power source with no load connected to the 120-V side. Sketch the magnetization current that would flow in the transformer. (Use MATLAB to plot the current accurately, if it is available.) What is the rms amplitude of the magnetization current? What percentage of full-load current is the magnetization current?
- (c) In which case is the magnetization current a higher percentage of full-load current? Why?

Note: An electronic version of this magnetization curve can be found in file p22_mag.dat, which can be used with MATLAB programs. Column 1 contains the MMF in A · turns, and column 2 contains the resulting flux in webers.

SOLUTION

- (a) When this transformer is connected to a 120-V 60 Hz source, the flux in the core will be given by the equation

$$\phi(t) = -\frac{V_M}{\omega N_p} \cos \omega t \quad (2-101)$$

The magnetization current required for any given flux level can be found from Figure P2-2, or alternately from the equivalent table in file p22_mag.dat. The MATLAB program shown below calculates the flux level at each time, the corresponding magnetization current, and the rms value of the magnetization current.

```
% M-file: prob2_5a.m
% M-file to calculate and plot the magnetization
% current of a 120/240 transformer operating at
% 120 volts and 60 Hz. This program also
```

```

% calculates the rms value of the mag. current.

% Load the magnetization curve. It is in two
% columns, with the first column being mmf and
% the second column being flux.
load p22_mag.dat;
mmf_data = p22(:,1);
flux_data = p22(:,2);

% Initialize values
S = 1000; % Apparent power (VA)
Vrms = 120; % Rms voltage (V)
VM = Vrms * sqrt(2); % Max voltage (V)
NP = 500; % Primary turns

% Calculate angular velocity for 60 Hz
freq = 60; % Freq (Hz)
w = 2 * pi * freq;

% Calculate flux versus time
time = 0:1/3000:1/30; % 0 to 1/30 sec
flux = -VM/(w*NP) * cos(w .* time);

% Calculate the mmf corresponding to a given flux
% using the MATLAB interpolation function.
mmf = interp1(flux_data,mmf_data,flux);

% Calculate the magnetization current
im = mmf / NP;

% Calculate the rms value of the current
irms = sqrt(sum(im.^2)/length(im));
disp(['The rms current at 120 V and 60 Hz is ', num2str(irms)]);

% Calculate the full-load current
i_fl = S / Vrms;

% Calculate the percentage of full-load current
percnt = irms / i_fl * 100;
disp(['The magnetization current is ' num2str(percnt) ...
      '% of full-load current.']);

% Plot the magnetization current.
figure(1)
plot(time,im);
title ('\bfMagnetization Current at 120 V and 60 Hz');
xlabel ('\bfTime (s)');
ylabel ('\bf\itI_{m} \rm(A)');
axis([0 0.04 -0.5 0.5]);
grid on;

```

When this program is executed, the results are

» **prob2_5a**

The rms current at 120 V and 60 Hz is 0.31863

The magnetization current is 3.8236% of full-load current.

The rms magnetization current is 0.318 A. Since the full-load current is $1000 \text{ VA} / 120 \text{ V} = 8.33 \text{ A}$, the magnetization current is 3.82% of the full-load current. The resulting plot is

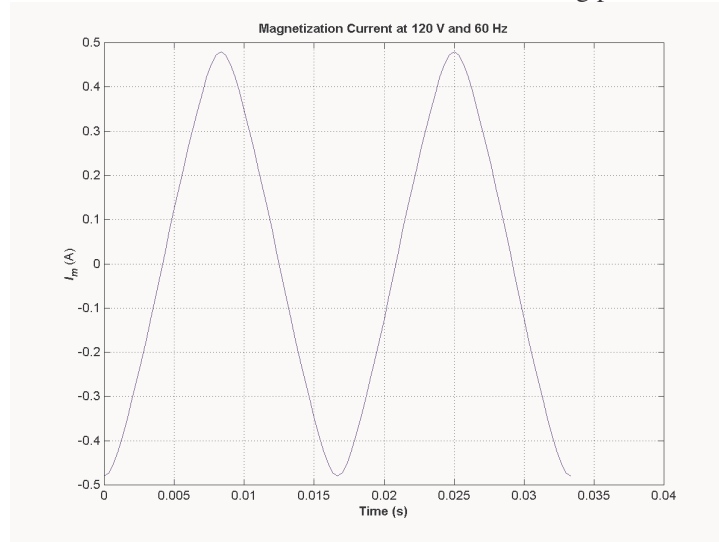

(b) When this transformer is connected to a 240-V 50 Hz source, the flux in the core will be given by the equation

$$\phi(t) = -\frac{V_M}{\omega N_s} \cos \omega t$$

The magnetization current required for any given flux level can be found from Figure P2-2, or alternately from the equivalent table in file p22_mag.dat. The MATLAB program shown below calculates the flux level at each time, the corresponding magnetization current, and the rms value of the magnetization current.

```
% M-file: prob2_5b.m
% M-file to calculate and plot the magnetization
% current of a 120/240 transformer operating at
% 240 volts and 50 Hz. This program also
% calculates the rms value of the mag. current.

% Load the magnetization curve. It is in two
% columns, with the first column being mmf and
% the second column being flux.
load p22_mag.dat;
mmf_data = p22(:,1);
flux_data = p22(:,2);

% Initialize values
S = 1000; % Apparent power (VA)
Vrms = 240; % Rms voltage (V)
VM = Vrms * sqrt(2); % Max voltage (V)
NP = 1000; % Primary turns

% Calculate angular velocity for 50 Hz
freq = 50; % Freq (Hz)
w = 2 * pi * freq;

% Calculate flux versus time
time = 0:1/2500:1/25; % 0 to 1/25 sec
```

```

flux = -VM/(w*NP) * cos(w .* time);

% Calculate the mmf corresponding to a given flux
% using the MATLAB interpolation function.
mmf = interp1(flux_data,mmf_data,flux);

% Calculate the magnetization current
im = mmf / NP;

% Calculate the rms value of the current
irms = sqrt(sum(im.^2)/length(im));
disp(['The rms current at 50 Hz is ', num2str(irms)]);

% Calculate the full-load current
i_fl = S / Vrms;

% Calculate the percentage of full-load current
percnt = irms / i_fl * 100;
disp(['The magnetization current is ' num2str(percnt) ...
      '% of full-load current.']);

% Plot the magnetization current.
figure(1);
plot(time,im);
title ('\bfMagnetization Current at 240 V and 50 Hz');
xlabel ('\bfTime (s)');
ylabel ('\bf\itI_{m} \rm(A)');
axis([0 0.04 -0.5 0.5]);
grid on;

```

When this program is executed, the results are

» **prob2_5b**

The rms current at 50 Hz is 0.22973

The magnetization current is 5.5134% of full-load current.

The rms magnetization current is 0.318 A. Since the full-load current is $1000 \text{ VA} / 240 \text{ V} = 4.17 \text{ A}$, the magnetization current is 5.51% of the full-load current. The resulting plot is

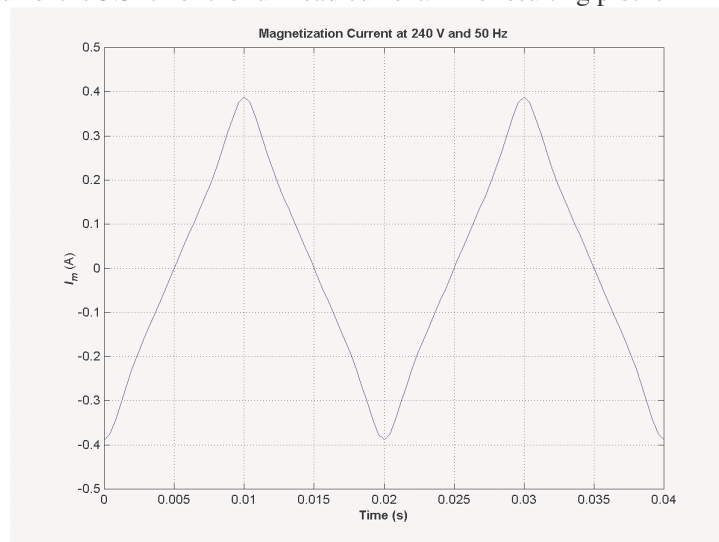

(c) The magnetization current is a higher percentage of the full-load current for the 50 Hz case than for the 60 Hz case. This is true because the peak flux is higher for the 50 Hz waveform, driving the core further into saturation.

2-6. A 15-kVA 8000/230-V distribution transformer has an impedance referred to the primary of $80 + j300 \Omega$. The components of the excitation branch referred to the primary side are $R_C = 350 \text{ k}\Omega$ and $X_M = 70 \text{ k}\Omega$.

(a) If the primary voltage is 7967 V and the load impedance is $Z_L = 3.2 + j1.5 \Omega$, what is the secondary voltage of the transformer? What is the voltage regulation of the transformer?

(b) If the load is disconnected and a capacitor of $-j3.5 \Omega$ is connected in its place, what is the secondary voltage of the transformer? What is its voltage regulation under these conditions?

SOLUTION

(a) The easiest way to solve this problem is to refer all components to the *primary* side of the transformer. The turns ratio is $a = 8000/230 = 34.78$. Thus the load impedance referred to the primary side is

$$Z'_L = (34.78)^2 (3.2 + j1.5 \Omega) = 3871 + j1815 \Omega$$

The referred secondary current is

$$\mathbf{I}'_s = \frac{7967 \angle 0^\circ \text{ V}}{(80 + j300 \Omega) + (3871 + j1815 \Omega)} = \frac{7967 \angle 0^\circ \text{ V}}{4481 \angle 28.2^\circ \Omega} = 1.78 \angle -28.2^\circ \text{ A}$$

and the referred secondary voltage is

$$\mathbf{V}'_s = \mathbf{I}'_s Z'_L = (1.78 \angle -28.2^\circ \text{ A})(3871 + j1815 \Omega) = 7610 \angle -3.1^\circ \text{ V}$$

The actual secondary voltage is thus

$$\mathbf{V}_s = \frac{\mathbf{V}'_s}{a} = \frac{7610 \angle -3.1^\circ \text{ V}}{34.78} = 218.8 \angle -3.1^\circ \text{ V}$$

The voltage regulation is

$$\text{VR} = \frac{7967 - 7610}{7610} \times 100\% = 4.7\%$$

(b) The easiest way to solve this problem is to refer all components to the *primary* side of the transformer. The turns ratio is again $a = 34.78$. Thus the load impedance referred to the primary side is

$$Z'_L = (34.78)^2 (-j3.5 \Omega) = -j4234 \Omega$$

The referred secondary current is

$$\mathbf{I}'_s = \frac{7967 \angle 0^\circ \text{ V}}{(80 + j300 \Omega) + (-j4234 \Omega)} = \frac{7967 \angle 0^\circ \text{ V}}{3935 \angle -88.8^\circ \Omega} = 2.025 \angle 88.8^\circ \text{ A}$$

and the referred secondary voltage is

$$\mathbf{V}'_s = \mathbf{I}'_s Z'_L = (2.025 \angle 88.8^\circ \text{ A})(-j4234 \Omega) = 8573 \angle -1.2^\circ \text{ V}$$

The actual secondary voltage is thus

$$V_s = \frac{V_s'}{a} = \frac{8573 \angle -1.2^\circ \text{ V}}{34.78} = 246.5 \angle -1.2^\circ \text{ V}$$

The voltage regulation is

$$\text{VR} = \frac{7967 - 8573}{8573} \times 100\% = -7.07\%$$

- 2-7.** A 5000-kVA 230/13.8-kV single-phase power transformer has a per-unit resistance of 1 percent and a per-unit reactance of 5 percent (data taken from the transformer's nameplate). The open-circuit test performed on the low-voltage side of the transformer yielded the following data:

$$V_{\text{OC}} = 13.8 \text{ kV} \quad I_{\text{OC}} = 15.1 \text{ A} \quad P_{\text{OC}} = 44.9 \text{ kW}$$

- (a) Find the equivalent circuit referred to the low-voltage side of this transformer.
 (b) If the voltage on the secondary side is 13.8 kV and the power supplied is 4000 kW at 0.8 PF lagging, find the voltage regulation of the transformer. Find its efficiency.

SOLUTION

- (a) The open-circuit test was performed on the low-voltage side of the transformer, so it can be used to directly find the components of the excitation branch relative to the low-voltage side.

$$|Y_{\text{EX}}| = |G_C - jB_M| = \frac{15.1 \text{ A}}{13.8 \text{ kV}} = 0.0010942$$

$$\theta = \cos^{-1} \frac{P_{\text{OC}}}{V_{\text{OC}} I_{\text{OC}}} = \cos^{-1} \frac{44.9 \text{ kW}}{(13.8 \text{ kV})(15.1 \text{ A})} = 77.56^\circ$$

$$Y_{\text{EX}} = G_C - jB_M = 0.0010942 \angle -77.56^\circ \text{ S} = 0.0002358 - j0.0010685 \text{ S}$$

$$R_C = \frac{1}{G_C} = 4240 \ \Omega$$

$$X_M = \frac{1}{B_M} = 936 \ \Omega$$

The base impedance of this transformer referred to the secondary side is

$$Z_{\text{base}} = \frac{V_{\text{base}}^2}{S_{\text{base}}} = \frac{(13.8 \text{ kV})^2}{5000 \text{ kVA}} = 38.09 \ \Omega$$

so $R_{\text{EQ}} = (0.01)(38.09 \ \Omega) = 0.38 \ \Omega$ and $X_{\text{EQ}} = (0.05)(38.09 \ \Omega) = 1.9 \ \Omega$. The resulting equivalent circuit is shown below:

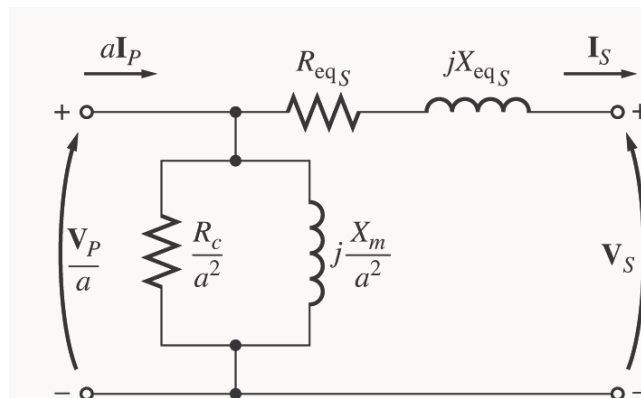

$$\begin{aligned} R_{EQ,s} &= 0.38 \Omega & X_{EQ,s} &= j1.9 \Omega \\ R_{C,s} &= 4240 \Omega & X_{M,s} &= 936 \Omega \end{aligned}$$

(b) If the load on the secondary side of the transformer is 4000 kW at 0.8 PF lagging and the secondary voltage is 13.8 kV, the secondary current is

$$\begin{aligned} I_s &= \frac{P_{LOAD}}{V_s PF} = \frac{4000 \text{ kW}}{(13.8 \text{ kV})(0.8)} = 362.3 \text{ A} \\ \mathbf{I}_s &= 362.3 \angle -36.87^\circ \text{ A} \end{aligned}$$

The voltage on the primary side of the transformer (referred to the secondary side) is

$$\begin{aligned} \mathbf{V}_p' &= \mathbf{V}_s + \mathbf{I}_s Z_{EQ} \\ \mathbf{V}_p' &= 13,800 \angle 0^\circ \text{ V} + (362.3 \angle -36.87^\circ \text{ A})(0.38 + j1.9 \Omega) = 14,330 \angle 1.9^\circ \text{ V} \end{aligned}$$

There is a voltage drop of 14 V under these load conditions. Therefore the voltage regulation of the transformer is

$$VR = \frac{14,330 - 13,800}{13,800} \times 100\% = 3.84\%$$

The transformer copper losses and core losses are

$$\begin{aligned} P_{CU} &= I_s^2 R_{EQ,s} = (362.3 \text{ A})^2 (0.38 \Omega) = 49.9 \text{ kW} \\ P_{core} &= \frac{(V_p')^2}{R_C} = \frac{(14,330 \text{ V})^2}{4240 \Omega} = 48.4 \text{ kW} \end{aligned}$$

Therefore the efficiency of this transformer at these conditions is

$$\eta = \frac{P_{OUT}}{P_{OUT} + P_{CU} + P_{core}} \times 100\% = \frac{4000 \text{ kW}}{4000 \text{ kW} + 49.9 \text{ kW} + 48.4 \text{ kW}} = 97.6\%$$

2-8. A 200-MVA 15/200-kV single-phase power transformer has a per-unit resistance of 1.2 percent and a per-unit reactance of 5 percent (data taken from the transformer's nameplate). The magnetizing impedance is $j80$ per unit.

- Find the equivalent circuit referred to the low-voltage side of this transformer.
- Calculate the voltage regulation of this transformer for a full-load current at power factor of 0.8 lagging.
- Assume that the primary voltage of this transformer is a constant 15 kV, and plot the secondary voltage as a function of load current for currents from no-load to full-load. Repeat this process for power factors of 0.8 lagging, 1.0, and 0.8 leading.

SOLUTION

(a) The base impedance of this transformer referred to the primary (low-voltage) side is

$$Z_{base} = \frac{V_{base}^2}{S_{base}} = \frac{(15 \text{ kV})^2}{200 \text{ MVA}} = 1.125 \Omega$$

$$\begin{aligned} \text{so } R_{EQ} &= (0.012)(1.125 \Omega) = 0.0135 \Omega \\ X_{EQ} &= (0.05)(1.125 \Omega) = 0.0563 \Omega \end{aligned}$$

$$X_M = (100)(1.125 \Omega) = 112.5 \Omega$$

The equivalent circuit is

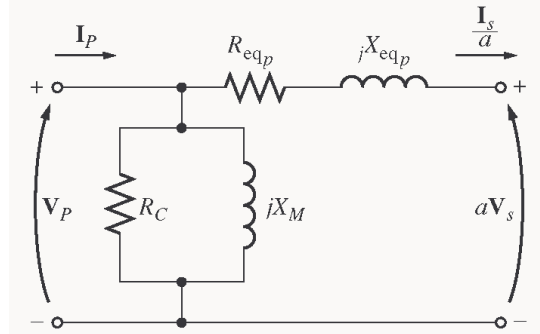

$$R_{EQ,P} = 0.0135 \Omega \qquad X_{EQ,P} = j0.0563 \Omega$$

$$R_C = \text{not specified} \qquad X_M = 112.5 \Omega$$

(b) If the load on the secondary side of the transformer is 200 MVA at 0.8 PF lagging, and the referred secondary voltage is 15 kV, then the referred secondary current is

$$I_s' = \frac{P_{LOAD}}{V_s \text{ PF}} = \frac{200 \text{ MVA}}{(15 \text{ kV})(0.8)} = 16,667 \text{ A}$$

$$I_s' = 16,667 \angle -36.87^\circ \text{ A}$$

The voltage on the primary side of the transformer is

$$V_P = V_s' + I_s' Z_{EQ,P}$$

$$V_P = 15,000 \angle 0^\circ \text{ V} + (16,667 \angle -36.87^\circ \text{ A})(0.0135 + j0.0563 \Omega) = 15,755 \angle 2.24^\circ \text{ V}$$

Therefore the voltage regulation of the transformer is

$$\text{VR} = \frac{15,755 - 15,000}{15,000} \times 100\% = 5.03\%$$

(c) This problem is repetitive in nature, and is ideally suited for MATLAB. A program to calculate the secondary voltage of the transformer as a function of load is shown below:

```
% M-file: prob2_8.m
% M-file to calculate and plot the secondary voltage
% of a transformer as a function of load for power
% factors of 0.8 lagging, 1.0, and 0.8 leading.
% These calculations are done using an equivalent
% circuit referred to the primary side.

% Define values for this transformer
VP = 15000; % Primary voltage (V)
amps = 0:166.67:16667; % Current values (A)
Req = 0.0135; % Equivalent R (ohms)
Xeq = 0.0563; % Equivalent X (ohms)

% Calculate the current values for the three
% power factors. The first row of I contains
% the lagging currents, the second row contains
% the unity currents, and the third row contains
```

```

% the leading currents.
I(1,:) = amps .* ( 0.8 - j*0.6); % Lagging
I(2,:) = amps .* ( 1.0           ); % Unity
I(3,:) = amps .* ( 0.8 + j*0.6); % Leading

% Calculate VS referred to the primary side
% for each current and power factor.
aVS = VP - (Req.*I + j.*Xeq.*I);

% Refer the secondary voltages back to the
% secondary side using the turns ratio.
VS = aVS * (200/15);

% Plot the secondary voltage (in kV!) versus load
plot(amps,abs(VS(1,:)/1000),'b-','LineWidth',2.0);
hold on;
plot(amps,abs(VS(2,:)/1000),'k--','LineWidth',2.0);
plot(amps,abs(VS(3,:)/1000),'r-.','LineWidth',2.0);
title ('\bfSecondary Voltage Versus Load');
xlabel ('\bfLoad (A)');
ylabel ('\bfSecondary Voltage (kV)');
legend('0.8 PF lagging','1.0 PF','0.8 PF leading');
grid on;
hold off;

```

The resulting plot of secondary voltage versus load is shown below:

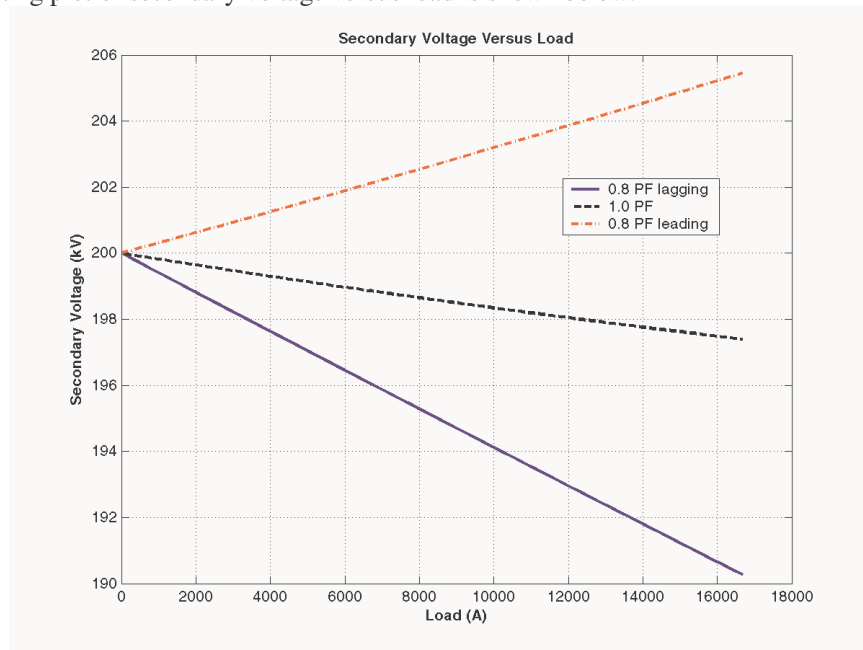

- 2-9.** A three-phase transformer bank is to handle 600 kVA and have a 34.5/13.8-kV voltage ratio. Find the rating of each individual transformer in the bank (high voltage, low voltage, turns ratio, and apparent power) if the transformer bank is connected to (a) Y-Y, (b) Y- Δ , (c) Δ -Y, (d) Δ - Δ , (e) open- Δ , (f) open-Y—open- Δ .

SOLUTION For the first four connections, the apparent power rating of each transformer is 1/3 of the total apparent power rating of the three-phase transformer. For the open- Δ and open-Y—open- Δ connections, the apparent power rating is a bit more complicated. The 600 kVA must be 86.6% of the total apparent

power rating of the two transformers, implying that the apparent power rating of each transformer must be 231 kVA.

The ratings for **each transformer** in the bank for each connection are given below:

Connection	Primary Voltage	Secondary Voltage	Apparent Power	Turns Ratio
Y-Y	19.9 kV	7.97 kV	200 kVA	2.50:1
Y-Δ	19.9 kV	13.8 kV	200 kVA	1.44:1
Δ-Y	34.5 kV	7.97 kV	200 kVA	4.33:1
Δ-Δ	34.5 kV	13.8 kV	200 kVA	2.50:1
open-Δ	34.5 kV	13.8 kV	346 kVA	2.50:1
open-Y—open-Δ	19.9 kV	13.8 kV	346 kVA	1.44:1

Note: The open-Y—open-Δ answer assumes that the Y is on the *high-voltage side*; if the Y is on the low-voltage side, the turns ratio would be 4.33:1, and the apparent power rating would be unchanged.

- 2-10.** A 13,800/480 V three-phase Y-Δ-connected transformer bank consists of three identical 100-kVA 7967/480-V transformers. It is supplied with power directly from a large constant-voltage bus. In the short-circuit test, the recorded values on the high-voltage side for one of these transformers are

$$V_{SC} = 560 \text{ V} \qquad I_{SC} = 12.6 \text{ A} \qquad P_{SC} = 3300 \text{ W}$$

- (a) If this bank delivers a rated load at 0.85 PF lagging and rated voltage, what is the line-to-line voltage on the primary of the transformer bank?
- (b) What is the voltage regulation under these conditions?
- (c) Assume that the primary voltage of this transformer bank is a constant 13.8 kV, and plot the secondary voltage as a function of load current for currents from no-load to full-load. Repeat this process for power factors of 0.85 lagging, 1.0, and 0.85 leading.
- (d) Plot the voltage regulation of this transformer as a function of load current for currents from no-load to full-load. Repeat this process for power factors of 0.85 lagging, 1.0, and 0.85 leading.

SOLUTION From the short-circuit information, it is possible to determine the per-phase impedance of the transformer bank referred to the high-voltage side. The primary side of this transformer is Y-connected, so the short-circuit phase voltage is

$$V_{\phi,SC} = \frac{V_{SC}}{\sqrt{3}} = \frac{560 \text{ V}}{\sqrt{3}} = 323.3 \text{ V}$$

the short-circuit phase current is

$$I_{\phi,SC} = I_{SC} = 12.6 \text{ A}$$

and the power per phase is

$$P_{\phi,SC} = \frac{P_{SC}}{3} = 1100 \text{ W}$$

Thus the per-phase impedance is

$$\begin{aligned} |Z_{EQ}| &= |R_{EQ} + jX_{EQ}| = \frac{323.3 \text{ V}}{12.6 \text{ A}} = 25.66 \Omega \\ \theta &= \cos^{-1} \frac{P_{SC}}{V_{SC} I_{SC}} = \cos^{-1} \frac{1100 \text{ W}}{(323.3 \text{ V})(12.6 \text{ A})} = 74.3^\circ \\ Z_{EQ} &= R_{EQ} + jX_{EQ} = 25.66 \angle 74.3^\circ \Omega = 6.94 + j24.7 \Omega \end{aligned}$$

$$R_{EQ} = 6.94 \Omega$$

$$X_{EQ} = j24.7 \Omega$$

(a) If this Y- Δ transformer bank delivers rated kVA (300 kVA) at 0.85 power factor lagging while the secondary voltage is at rated value, then each transformer delivers 100 kVA at a voltage of 480 V and 0.85 PF lagging. Referred to the *primary side* of one of the transformers, the load on each transformer is equivalent to 100 kVA at 7967 V and 0.85 PF lagging. The equivalent current flowing in the secondary of one transformer referred to the primary side is

$$I'_{\phi,S} = \frac{100 \text{ kVA}}{7967 \text{ V}} = 12.55 \text{ A}$$

$$\mathbf{I}'_{\phi,S} = 12.55 \angle -31.79^\circ \text{ A}$$

The voltage on the primary side of a single transformer is thus

$$\mathbf{V}_{\phi,P} = \mathbf{V}'_{\phi,S} + \mathbf{I}'_{\phi,S} Z_{EQ,P}$$

$$\mathbf{V}_{\phi,P} = 7967 \angle 0^\circ \text{ V} + (12.55 \angle -31.79^\circ \text{ A})(6.94 + j24.7 \Omega) = 8207 \angle 1.52^\circ \text{ V}$$

The line-to-line voltage on the primary of the transformer is

$$V_{LL,P} = \sqrt{3} V_{\phi,P} = \sqrt{3}(8207 \text{ V}) = 14.22 \text{ kV}$$

(b) The voltage regulation of the transformer is

$$\text{VR} = \frac{8207 - 7967}{7967} \times 100\% = 3.01\%$$

Note: It is much easier to solve problems of this sort in the per-unit system, as we shall see in the next problem.

(c) This sort of repetitive operation is best performed with MATLAB. A suitable MATLAB program is shown below:

```
% M-file: prob2_10c.m
% M-file to calculate and plot the secondary voltage
% of a three-phase Y-delta transformer bank as a
% function of load for power factors of 0.85 lagging,
% 1.0, and 0.85 leading. These calculations are done
% using an equivalent circuit referred to the primary side.

% Define values for this transformer
VL = 13800; % Primary line voltage (V)
VPP = VL / sqrt(3); % Primary phase voltage (V)
amps = 0:0.0126:12.6; % Phase current values (A)
Req = 6.94; % Equivalent R (ohms)
Xeq = 24.7; % Equivalent X (ohms)

% Calculate the current values for the three
% power factors. The first row of I contains
% the lagging currents, the second row contains
% the unity currents, and the third row contains
% the leading currents.
```

```

re = 0.85;
im = sin(acos(re));
I(1,:) = amps .* ( re - j*im); % Lagging
I(2,:) = amps .* ( 1.0      ); % Unity
I(3,:) = amps .* ( re + j*im); % Leading

% Calculate secondary phase voltage referred
% to the primary side for each current and
% power factor.
aVSP = VPP - (Req.*I + j.*Xeq.*I);

% Refer the secondary phase voltages back to
% the secondary side using the turns ratio.
% Because this is a delta-connected secondary,
% this is also the line voltage.
VSP = aVSP * (480/7967);

% Plot the secondary voltage versus load
plot(amps,abs(VSP(1,:)),'b-','LineWidth',2.0);
hold on;
plot(amps,abs(VSP(2,:)),'k--','LineWidth',2.0);
plot(amps,abs(VSP(3,:)),'r-.','LineWidth',2.0);
title ('\bfSecondary Voltage Versus Load');
xlabel ('\bfLoad (A)');
ylabel ('\bfSecondary Voltage (V)');
legend('0.85 PF lagging','1.0 PF','0.85 PF leading');
grid on;
hold off;

```

The resulting plot is shown below:

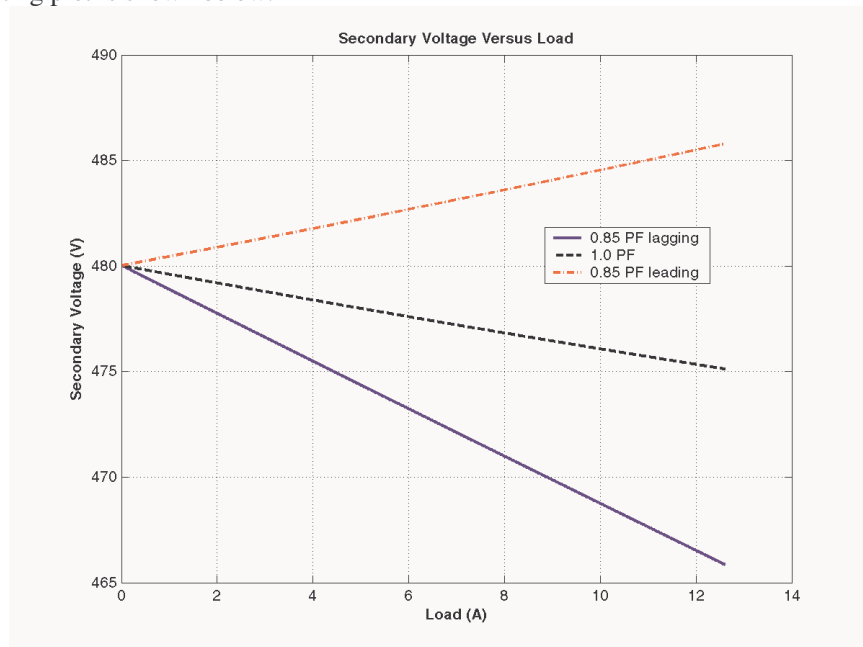

(d) This sort of repetitive operation is best performed with MATLAB. A suitable MATLAB program is shown below:

```
% M-file: prob2_10d.m
```

```

% M-file to calculate and plot the voltage regulation
% of a three-phase Y-delta transformer bank as a
% function of load for power factors of 0.85 lagging,
% 1.0, and 0.85 leading. These calculations are done
% using an equivalent circuit referred to the primary side.

% Define values for this transformer
VL = 13800;           % Primary line voltage (V)
VPP = VL / sqrt(3);  % Primary phase voltage (V)
amps = 0:0.0126:12.6; % Phase current values (A)
Req = 6.94;          % Equivalent R (ohms)
Xeq = 24.7;          % Equivalent X (ohms)

% Calculate the current values for the three
% power factors. The first row of I contains
% the lagging currents, the second row contains
% the unity currents, and the third row contains
% the leading currents.
re = 0.85;
im = sin(acos(re));
I(1,:) = amps .* ( re - j*im); % Lagging
I(2,:) = amps .* ( 1.0      ); % Unity
I(3,:) = amps .* ( re + j*im); % Leading

% Calculate secondary phase voltage referred
% to the primary side for each current and
% power factor.
aVSP = VPP - (Req.*I + j.*Xeq.*I);

% Calculate the voltage regulation.
VR = (VPP - abs(aVSP)) ./ abs(aVSP) .* 100;

% Plot the voltage regulation versus load
plot(amps,VR(1,:),'b-','LineWidth',2.0);
hold on;
plot(amps,VR(2,:),'k--','LineWidth',2.0);
plot(amps,VR(3,:),'r-.','LineWidth',2.0);
title ('\bfVoltage Regulation Versus Load');
xlabel ('\bfLoad (A)');
ylabel ('\bfVoltage Regulation (%)');
legend('0.85 PF lagging','1.0 PF','0.85 PF leading');
grid on;
hold off;

```

The resulting plot is shown below:

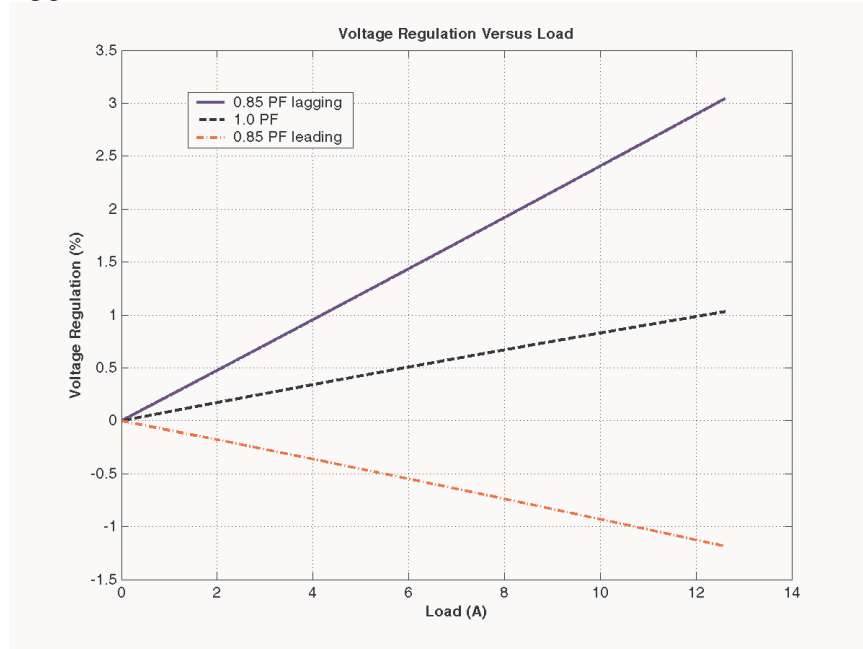

- 2-11.** A 100,000-kVA 230/115-kV Δ - Δ three-phase power transformer has a per-unit resistance of 0.02 pu and a per-unit reactance of 0.055 pu. The excitation branch elements are $R_C = 110$ pu and $X_M = 20$ pu .
- If this transformer supplies a load of 80 MVA at 0.85 PF lagging, draw the phasor diagram of one phase of the transformer.
 - What is the voltage regulation of the transformer bank under these conditions?
 - Sketch the equivalent circuit referred to the low-voltage side of one phase of this transformer. Calculate all of the transformer impedances referred to the low-voltage side.

SOLUTION

(a) The transformer supplies a load of 80 MVA at 0.85 PF lagging. Therefore, the secondary line current of the transformer is

$$I_{LS} = \frac{S}{\sqrt{3}V_{LS}} = \frac{80,000,000 \text{ VA}}{\sqrt{3}(115,000 \text{ V})} = 402 \text{ A}$$

The base value of the secondary line current is

$$I_{LS,\text{base}} = \frac{S_{\text{base}}}{\sqrt{3}V_{LS,\text{base}}} = \frac{100,000,000 \text{ VA}}{\sqrt{3}(115,000 \text{ V})} = 502 \text{ A}$$

so the per-unit secondary current is

$$\mathbf{I}_{LS,\text{pu}} = \frac{I_{LS}}{I_{LS,\text{pu}}} = \frac{402 \text{ A}}{502 \text{ A}} \angle \cos^{-1}(0.85) = 0.8 \angle -31.8^\circ$$

The per-unit phasor diagram is shown below:

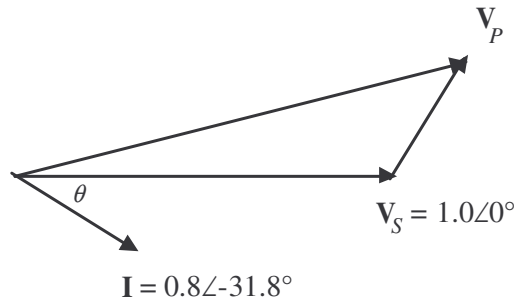

(b) The per-unit primary voltage of this transformer is

$$\mathbf{V}_P = \mathbf{V}_S + \mathbf{I} Z_{EQ} = 1.0\angle 0^\circ + (0.8\angle -31.8^\circ)(0.02 + j0.055) = 1.037\angle 1.6^\circ$$

and the voltage regulation is

$$\text{VR} = \frac{1.037 - 1.0}{1.0} \times 100\% = 3.7\%$$

(c) The base impedance of the transformer referred to the low-voltage side is:

$$Z_{\text{base}} = \frac{3 V_{\phi, \text{base}}^2}{S_{\text{base}}} = \frac{3(115 \text{ kV})^2}{100 \text{ MVA}} = 397 \Omega$$

Each per-unit impedance is converted to actual ohms referred to the low-voltage side by multiplying it by this base impedance. The resulting equivalent circuit is shown below:

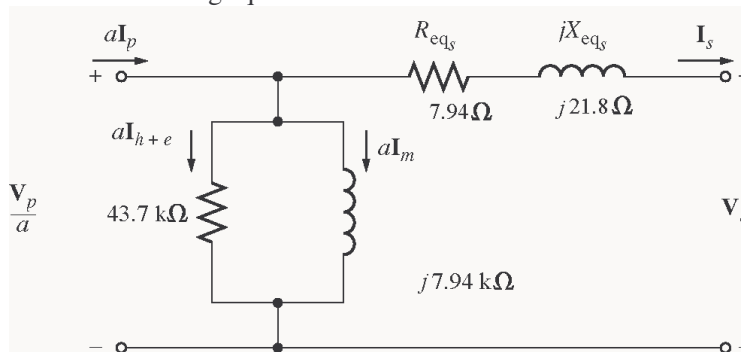

$$R_{EQ,S} = (0.02)(397 \Omega) = 7.94 \Omega$$

$$X_{EQ,S} = (0.055)(397 \Omega) = 21.8 \Omega$$

$$R_C = (110)(397 \Omega) = 43.7 \text{ k}\Omega$$

$$X_M = (20)(397 \Omega) = 7.94 \text{ k}\Omega$$

Note how easy it was to solve this problem in per-unit, compared with Problem 2-10 above.

2-12. An autotransformer is used to connect a 13.2-kV distribution line to a 13.8-kV distribution line. It must be capable of handling 2000 kVA. There are three phases, connected Y-Y with their neutrals solidly grounded.

(a) What must the N_C / N_{SE} turns ratio be to accomplish this connection?

(b) How much apparent power must the windings of each autotransformer handle?

(c) If one of the autotransformers were reconnected as an ordinary transformer, what would its ratings be?

SOLUTION

(a) The transformer is connected Y-Y, so the primary and secondary phase voltages are the line voltages divided by $\sqrt{3}$. The turns ratio of each autotransformer is given by

$$\frac{V_H}{V_L} = \frac{N_C + N_{SE}}{N_C} = \frac{13.8 \text{ kV}/\sqrt{3}}{13.2 \text{ kV}/\sqrt{3}}$$

$$13.2 N_C + 13.2 N_{SE} = 13.8 N_C$$

$$13.2 N_{SE} = 0.6 N_C$$

Therefore, $N_C / N_{SE} = 22$.

(b) The power advantage of this autotransformer is

$$\frac{S_{IO}}{S_W} = \frac{N_C + N_{SE}}{N_C} = \frac{N_C + 22N_C}{N_C} = 23$$

so 1/22 of the power in each transformer goes through the windings. Since 1/3 of the total power is associated with each phase, the windings in each autotransformer must handle

$$S_W = \frac{2000 \text{ kVA}}{(3)(22)} = 30.3 \text{ kVA}$$

(c) The voltages across each phase of the autotransformer are $13.8/\sqrt{3} = 7967 \text{ V}$ and $13.2/\sqrt{3} = 7621 \text{ V}$. The voltage across the common winding (N_C) is 7621 kV, and the voltage across the series winding (N_{SE}) is $7967 \text{ kV} - 7621 \text{ kV} = 346 \text{ V}$. Therefore, a single phase of the autotransformer connected as an ordinary transformer would be rated at 7621/346 V and 30.3 kVA.

2-13. Two phases of a 13.8-kV three-phase distribution line serve a remote rural road (the neutral is also available). A farmer along the road has a 480 V feeder supplying 120 kW at 0.8 PF lagging of three-phase loads, plus 50 kW at 0.9 PF lagging of single-phase loads. The single-phase loads are distributed evenly among the three phases. Assuming that the open-Y—open- Δ connection is used to supply power to his farm, find the voltages and currents in each of the two transformers. Also find the real and reactive powers supplied by each transformer. Assume the transformers are ideal.

SOLUTION The farmer's power system is illustrated below:

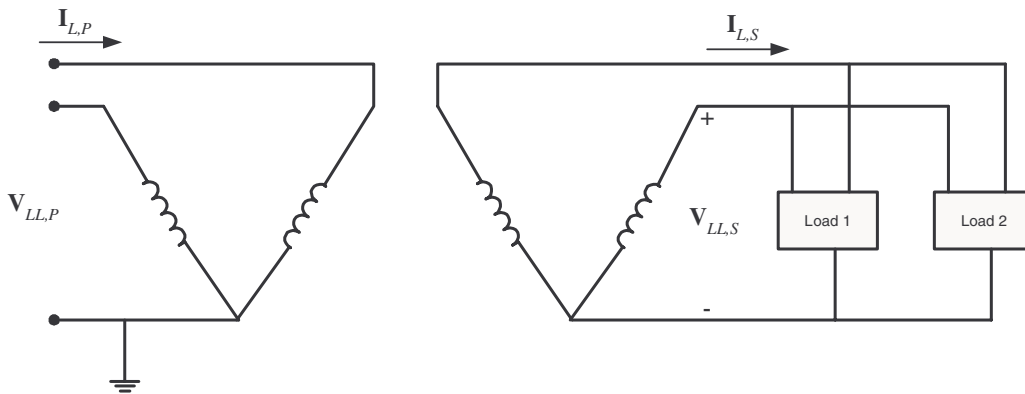

The loads on each phase are balanced, and the total load is found as:

$$P_1 = 120 \text{ kW}$$

$$Q_1 = P_1 \tan \theta = (120 \text{ kW}) \tan \cos^{-1}(0.8) = 90 \text{ kvar}$$

$$P_2 = 50 \text{ kW}$$

$$Q_2 = P_2 \tan \theta = (50 \text{ kW}) \tan \cos^{-1}(0.9) = 24.2 \text{ kvar}$$

$$P_{\text{TOT}} = 170 \text{ kW}$$

$$Q_{\text{TOT}} = 114.2 \text{ kvar}$$

$$\text{PF} = \cos \tan^{-1} \frac{Q_{\text{TOT}}}{P_{\text{TOT}}} = \cos \tan^{-1} \frac{114.2 \text{ kvar}}{170 \text{ kW}} = 0.830 \text{ lagging}$$

The line current on the secondary side of the transformer bank is

$$I_{LS} = \frac{P_{\text{TOT}}}{\sqrt{3} V_{LS} \text{PF}} = \frac{170 \text{ kW}}{\sqrt{3}(480 \text{ V})(0.830)} = 246.4 \text{ A}$$

The open-Y—open Δ connection is shown below. From the figure, it is obvious that the secondary voltage across the transformer is 480 V, and the secondary current in each transformer is 246 A. The primary voltages and currents are given by the transformer turns ratios to be 7967 V and 14.8 A, respectively. If the voltage of phase A of the primary side is arbitrarily taken as an angle of 0° , then the voltage of phase B will be at an angle of -120° , and the voltages of phases A and B on the secondary side will be $V_{AS} = 480\angle 0^\circ \text{ V}$ and $V_{BS} = 480\angle -120^\circ \text{ V}$ respectively.

Note that line currents are shifted by 30° due to the difference between line and phase quantities, and by a further 33.9° due to the power factor of the load.

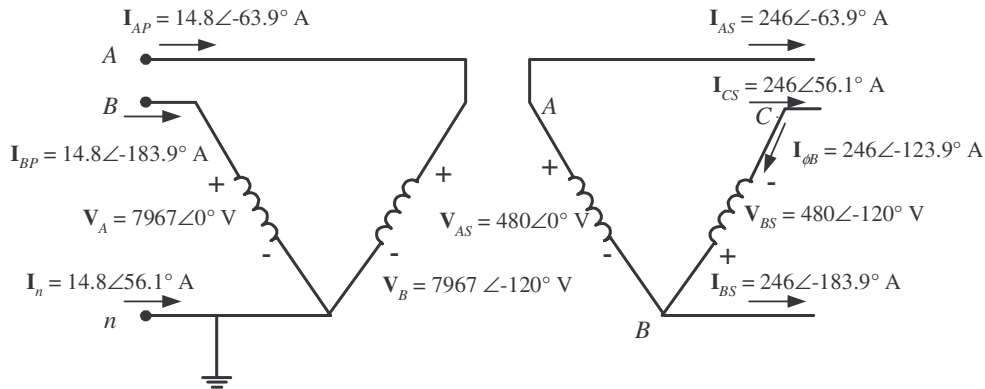

The real and reactive powers supplied by each transformer are calculated below:

$$P_A = V_{AS} I_A \cos \theta = (480 \text{ V})(246.4 \text{ A}) \cos 0 \quad (63.9) \quad 52.0 \text{ kW}$$

$$Q_A = V_{AS} I_A \sin \theta = (480 \text{ V})(246.4 \text{ A}) \sin 0 \quad (63.9) \quad 106.2 \text{ kvar}$$

$$P_B = V_{BS} I_{\phi B} \cos \theta = (480 \text{ V})(246.4 \text{ A}) \cos 120 \quad (123.9) \quad 118 \text{ kW}$$

$$Q_B = V_{BS} I_{\phi B} \sin \theta = (480 \text{ V})(246.4 \text{ A}) \sin 120 \quad (123.9) \quad 8.04 \text{ kvar}$$

Notice that the real and reactive powers supplied by the two transformers are radically different, but the apparent power supplied by each transformer is the same. Also, notice that the total power $P_A + P_B$ supplied by the transformers is equal to the power consumed by the loads (within roundoff error), while the total reactive power $Q_A + Q_B$ supplied by the transformers is equal to the reactive power consumed by the loads.

- 2-14. A 13.2-kV single-phase generator supplies power to a load through a transmission line. The load's impedance is $Z_{\text{load}} = 500 \angle 36.87^\circ \Omega$, and the transmission line's impedance is $Z_{\text{line}} = 60 \angle 53.1^\circ \Omega$.

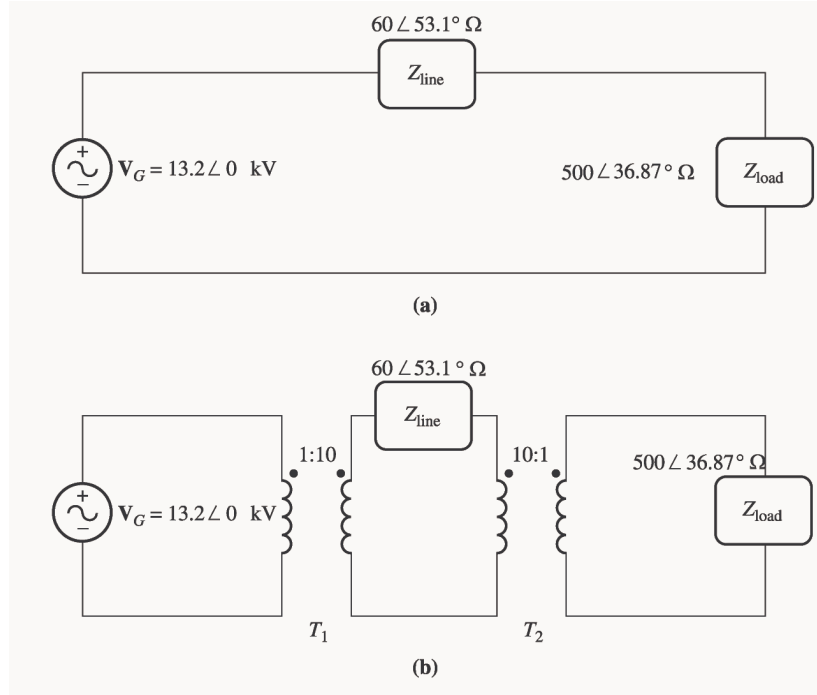

- (a) If the generator is directly connected to the load (Figure P2-3a), what is the ratio of the load voltage to the generated voltage? What are the transmission losses of the system?
- (b) If a 1:10 step-up transformer is placed at the output of the generator and a 10:1 transformer is placed at the load end of the transmission line, what is the new ratio of the load voltage to the generated voltage? What are the transmission losses of the system now? (Note: The transformers may be assumed to be ideal.)

SOLUTION

- (a) In the case of the directly-connected load, the line current is

$$\mathbf{I}_{\text{line}} = \mathbf{I}_{\text{load}} = \frac{13.2 \angle 0^\circ \text{ kV}}{60 \angle 53.1^\circ \Omega + 500 \angle 36.87^\circ \Omega} = 23.66 \angle -38.6^\circ \text{ A}$$

The load voltage is

$$\mathbf{V}_{\text{load}} = \mathbf{I}_{\text{load}} Z_{\text{load}} = (23.66 \angle -38.6^\circ \text{ A})(500 \angle 36.87^\circ \Omega) = 11.83 \angle -1.73^\circ \text{ kV}$$

The ratio of the load voltage to the generated voltage is $11.83/13.2 = 0.896$. The resistance in the transmission line is

$$R_{\text{line}} = |Z_{\text{line}}| \cos \theta = 60 \cos(53.1^\circ) = 36 \Omega$$

so the transmission losses in the system are

$$P_{\text{loss}} = I_{\text{line}}^2 R_{\text{line}} = (23.66 \text{ A})^2 (36 \Omega) = 20.1 \text{ kW}$$

- (b) In this case, a 1:10 step-up transformer precedes the transmission line and a 10:1 step-down transformer follows the transmission line. If the transformers are removed by referring the transmission line to the voltage levels found on either end, then the impedance of the transmission line becomes

$$Z'_{\text{line}} = \frac{1}{10}^2 Z_{\text{line}} = \frac{1}{10}^2 (60 \angle 53.1^\circ \Omega) = 0.60 \angle 53.1^\circ \Omega$$

The current in the referred transmission line and in the load becomes

$$I'_{\text{line}} = I_{\text{load}} = \frac{13.2 \angle 0^\circ \text{ kV}}{0.60 \angle 53.1^\circ \Omega + 500 \angle 36.87^\circ \Omega} = 26.37 \angle -36.89^\circ \text{ A}$$

The load voltage is

$$V_{\text{load}} = I_{\text{load}} Z_{\text{load}} = (26.37 \angle -36.89^\circ \text{ A})(500 \angle 36.87^\circ \Omega) = 13.185 \angle -0.02^\circ \text{ kV}$$

The ratio of the load voltage to the generated voltage is $13.185/13.2 = 0.9989$. Also, the transmission losses in the system are reduced. The current in the transmission line is

$$I_{\text{line}} = \frac{1}{10} I_{\text{load}} = \frac{1}{10} (26.37 \text{ A}) = 2.637 \text{ A}$$

and the losses in the transmission line are

$$P_{\text{loss}} = I_{\text{line}}^2 R_{\text{line}} = (2.637 \text{ A})^2 (36 \Omega) = 250 \text{ W}$$

Transmission losses have decreased by a factor of more than 80.

2-15. A 5000-VA 480/120-V conventional transformer is to be used to supply power from a 600-V source to a 120-V load. Consider the transformer to be ideal, and assume that all insulation can handle 600 V.

- (a) Sketch the transformer connection that will do the required job.
- (b) Find the kilovoltampere rating of the transformer in the configuration.
- (c) Find the maximum primary and secondary currents under these conditions.

SOLUTION (a) For this configuration, the common winding must be the *smaller* of the two windings, and $N_{\text{SE}} = 4N_{\text{C}}$. The transformer connection is shown below:

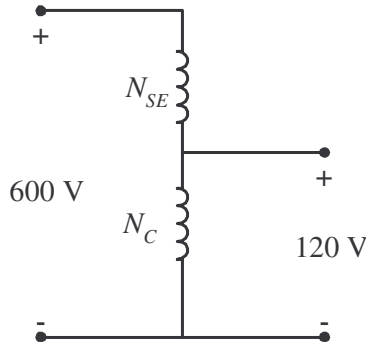

- (b) The kVA rating of the autotransformer can be found from the equation

$$S_{\text{IO}} = \frac{N_{\text{SE}} + N_{\text{C}}}{N_{\text{SE}}} S_{\text{W}} = \frac{4N_{\text{C}} + N_{\text{C}}}{4N_{\text{C}}} (5000 \text{ VA}) = 6250 \text{ VA}$$

- (c) The maximum primary current for this configuration will be

$$I_{\text{P}} = \frac{S}{V_{\text{P}}} = \frac{6250 \text{ VA}}{600 \text{ V}} = 10.4 \text{ A}$$

and the maximum secondary current is

$$I_s = \frac{S}{V_s} = \frac{6250 \text{ VA}}{120 \text{ V}} = 52.1 \text{ A}$$

- 2-16.** A 5000-VA 480/120-V conventional transformer is to be used to supply power from a 600-V source to a 480-V load. Consider the transformer to be ideal, and assume that all insulation can handle 600 V. Answer the questions of Problem 2-15 for this transformer.

SOLUTION (a) For this configuration, the common winding must be the *larger* of the two windings, and $N_C = 4N_{SE}$. The transformer connection is shown below:

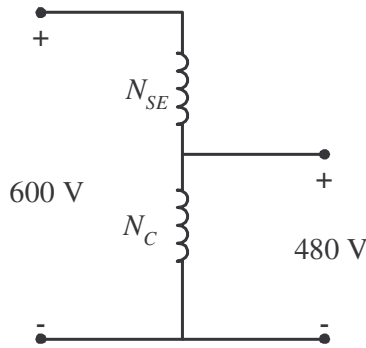

- (b) The kVA rating of the autotransformer can be found from the equation

$$S_{IO} = \frac{N_{SE} + N_C}{N_{SE}} S_w = \frac{N_{SE} + 4N_{SE}}{N_{SE}} (5000 \text{ VA}) = 25,000 \text{ VA}$$

- (c) The maximum primary current for this configuration will be

$$I_p = \frac{S}{V_p} = \frac{25,000 \text{ VA}}{600 \text{ V}} = 41.67 \text{ A}$$

and the maximum secondary current is

$$I_s = \frac{S}{V_s} = \frac{25,000 \text{ VA}}{480 \text{ V}} = 52.1 \text{ A}$$

Note that the apparent power handling capability of the autotransformer is *much* higher when there is only a small difference between primary and secondary voltages. Autotransformers are normally only used when there is a small difference between the two voltage levels.

- 2-17.** Prove the following statement: If a transformer having a series impedance Z_{eq} is connected as an autotransformer, its per-unit series impedance Z'_{eq} as an autotransformer will be

$$Z'_{eq} = \frac{N_{SE}}{N_{SE} + N_C} Z_{eq}$$

Note that this expression is the reciprocal of the autotransformer power advantage.

SOLUTION The impedance of a transformer can be found by shorting the secondary winding and determining the ratio of the voltage to the current of its primary winding. For the transformer connected as an ordinary transformer, the impedance referred to the primary (N_C) is:

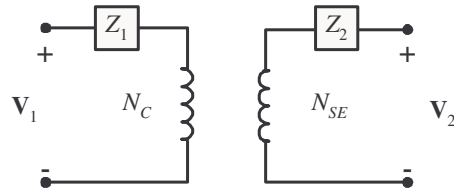

$$Z_{eq} = Z_1 + \frac{N_C}{N_{SE}}^2 Z_2$$

The corresponding equivalent circuit is:

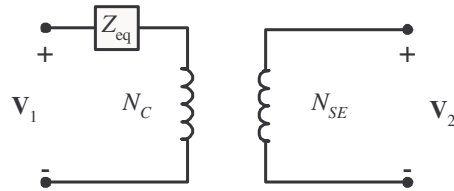

When this transformer is connected as an autotransformer, the circuit is as shown below. If the output windings of the autotransformer are shorted out, the voltages V_H will be zero, and the voltage V_L will be

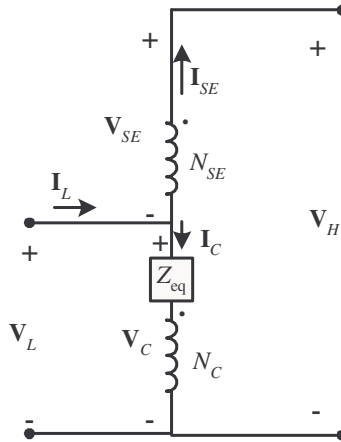

$$V_L = I_C Z_{eq}$$

where Z_{eq} is the impedance of the ordinary transformer. However,

$$I_L = I_C + I_{SE} = I_C + \frac{N_C}{N_{SE}} I_C = \frac{N_{SE} + N_C}{N_{SE}} I_C$$

or
$$I_C = \frac{N_{SE}}{N_{SE} + N_C} I_L$$

so the input voltage can be expressed in terms of the input current as:

$$V_L = I_C Z_{eq} = \frac{N_{SE}}{N_{SE} + N_C} I_L Z_{eq}$$

The input impedance of the autotransformer is *defined* as $Z_{eq} = V_L / I_L$, so

$$Z_{\text{eq}}' = \frac{V_L}{I_L} = \frac{N_{SE}}{N_{SE} + N_C} Z_{\text{eq}}$$

This is the expression that we were trying to prove.

- 2-18.** Three 25-kVA 24,000/277-V distribution transformers are connected in Δ -Y. The open-circuit test was performed on the low-voltage side of this transformer bank, and the following data were recorded:

$$V_{\text{line,OC}} = 480 \text{ V} \quad I_{\text{line,OC}} = 4.10 \text{ A} \quad P_{3\phi,\text{OC}} = 945 \text{ W}$$

The short-circuit test was performed on the high-voltage side of this transformer bank, and the following data were recorded:

$$V_{\text{line,SC}} = 1600 \text{ V} \quad I_{\text{line,SC}} = 2.00 \text{ A} \quad P_{3\phi,\text{SC}} = 1150 \text{ W}$$

- (a) Find the per-unit equivalent circuit of this transformer bank.
 (b) Find the voltage regulation of this transformer bank at the rated load and 0.90 PF lagging.
 (c) What is the transformer bank's efficiency under these conditions?

SOLUTION (a) The equivalent of this three-phase transformer bank can be found just like the equivalent circuit of a single-phase transformer if we work on a per-phase bases. The open-circuit test data on the low-voltage side can be used to find the excitation branch impedances referred to the secondary side of the transformer bank. Since the low-voltage side of the transformer is Y-connected, the per-phase open-circuit quantities are:

$$V_{\phi,\text{OC}} = 277 \text{ V} \quad I_{\phi,\text{OC}} = 4.10 \text{ A} \quad P_{\phi,\text{OC}} = 315 \text{ W}$$

The excitation admittance is given by

$$|Y_{EX}| = \frac{I_{\phi,\text{OC}}}{V_{\phi,\text{OC}}} = \frac{4.10 \text{ A}}{277 \text{ V}} = 0.01480 \text{ S}$$

The admittance angle is

$$\theta = -\cos^{-1} \frac{P_{\phi,\text{OC}}}{V_{\phi,\text{OC}} I_{\phi,\text{OC}}} = -\cos^{-1} \frac{315 \text{ W}}{(277 \text{ V})(4.10 \text{ A})} = -73.9^\circ$$

Therefore,

$$Y_{EX} = G_C - jB_M = 0.01483 \angle -73.9^\circ = 0.00410 - j0.01422$$

$$R_C = 1/G_C = 244 \ \Omega$$

$$X_M = 1/B_M = 70.3 \ \Omega$$

The *base impedance* for a single transformer referred to the low-voltage side is

$$Z_{\text{base,S}} = \frac{(V_{\phi,S})^2}{S_\phi} = \frac{(277 \text{ V})^2}{25 \text{ kVA}} = 3.069 \ \Omega$$

so the excitation branch elements can be expressed in per-unit as

$$R_C = \frac{244 \ \Omega}{3.069 \ \Omega} = 79.5 \text{ pu} \quad X_M = \frac{70.3 \ \Omega}{3.069 \ \Omega} = 22.9 \text{ pu}$$

The short-circuit test data can be used to find the series impedances referred to the high-voltage side, since the short-circuit test data was taken on the high-voltage side. Note that the high-voltage is Δ -connected, so $V_{\phi,SC} = V_{SC} = 1600 \text{ V}$, $I_{\phi,SC} = I_{SC} / \sqrt{3} = 1.1547 \text{ A}$, and $P_{\phi,SC} = P_{SC} / 3 = 383 \text{ W}$.

$$|Z_{EQ}| = \frac{V_{\phi,SC}}{I_{\phi,SC}} = \frac{1600 \text{ V}}{1.155 \text{ A}} = 1385 \ \Omega$$

$$\theta = \cos^{-1} \frac{P_{\phi,SC}}{V_{\phi,SC} I_{\phi,SC}} = \cos^{-1} \frac{383 \text{ W}}{(1600 \text{ V})(1.155 \text{ A})} = 78.0^\circ$$

$$Z_{EQ} = R_{EQ} + jX_{EQ} = 1385 \angle 78.0^\circ = 288 + j1355 \ \Omega$$

The *base impedance* referred to the high-voltage side is

$$Z_{\text{base},P} = \frac{(V_{\phi,P})^2}{S_\phi} = \frac{(24,000 \text{ V})^2}{25 \text{ kVA}} = 23,040 \ \Omega$$

The resulting per-unit impedances are

$$R_{EQ} = \frac{288 \ \Omega}{23,040 \ \Omega} = 0.0125 \text{ pu} \qquad X_{EQ} = \frac{1355 \ \Omega}{23,040 \ \Omega} = 0.0588 \text{ pu}$$

The per-unit, per-phase equivalent circuit of the transformer bank is shown below:

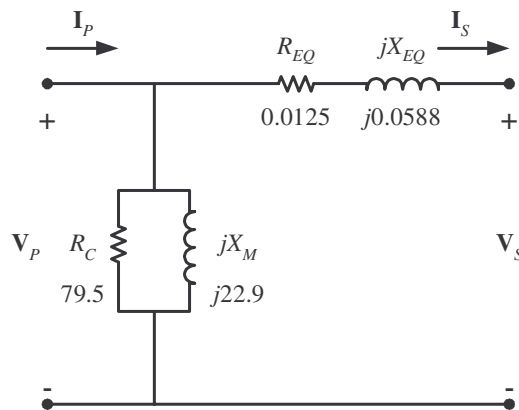

(b) If this transformer is operating at rated load and 0.90 PF lagging, then current flow will be at an angle of $-\cos^{-1}(0.9)$, or -25.8° . The per-unit voltage at the primary side of the transformer will be

$$\mathbf{V}_P = \mathbf{V}_S + \mathbf{I}_S Z_{EQ} = 1.0 \angle 0^\circ + (1.0 \angle -25.8^\circ)(0.0125 + j0.0588) = 1.038 \angle 2.62^\circ$$

The voltage regulation of this transformer bank is

$$\text{VR} = \frac{1.038 - 1.0}{1.0} \times 100\% = 3.8\%$$

(c) The output power of this transformer bank is

$$P_{\text{OUT}} = V_S I_S \cos \theta = (1.0)(1.0)(0.9) = 0.9 \text{ pu}$$

The copper losses are

$$P_{\text{CU}} = I_S^2 R_{EQ} = (1.0)^2 (0.0125) = 0.0125 \text{ pu}$$

The core losses are

$$P_{\text{core}} = \frac{V_p^2}{R_C} = \frac{(1.038)^2}{79.5} = 0.0136 \text{ pu}$$

Therefore, the total input power to the transformer bank is

$$P_{\text{IN}} = P_{\text{OUT}} + P_{\text{CU}} + P_{\text{core}} = 0.9 + 0.0125 + 0.0136 = 0.926$$

and the efficiency of the transformer bank is

$$\eta = \frac{P_{\text{OUT}}}{P_{\text{IN}}} \times 100\% = \frac{0.9}{0.926} \times 100\% = 97.2\%$$

2-19. A 20-kVA 20,000/480-V 60-Hz distribution transformer is tested with the following results:

Open-circuit test (measured from secondary side)	Short-circuit test (measured from primary side)
$V_{OC} = 480 \text{ V}$	$V_{SC} = 1130 \text{ V}$
$I_{OC} = 1.60 \text{ A}$	$I_{SC} = 1.00 \text{ A}$
$P_{OC} = 305 \text{ W}$	$P_{SC} = 260 \text{ W}$

- (a) Find the per-unit equivalent circuit for this transformer at 60 Hz.
 (b) What would the rating of this transformer be if it were operated on a 50-Hz power system?
 (c) Sketch the equivalent circuit of this transformer referred to the primary side *if it is operating at 50 Hz.*

SOLUTION

(a) The base impedance of this transformer referred to the primary side is

$$Z_{\text{base},P} = \frac{(V_p)^2}{S} = \frac{(20,000 \text{ V})^2}{20 \text{ kVA}} = 20 \text{ k}\Omega$$

The base impedance of this transformer referred to the secondary side is

$$Z_{\text{base},S} = \frac{(V_s)^2}{S} = \frac{(480 \text{ V})^2}{20 \text{ kVA}} = 11.52 \Omega$$

The open circuit test yields the values for the excitation branch (referred to the *secondary* side):

$$|Y_{EX}| = \frac{I_{\phi,OC}}{V_{\phi,OC}} = \frac{1.60 \text{ A}}{480 \text{ V}} = 0.00333 \text{ S}$$

$$\theta = -\cos^{-1} \frac{P_{OC}}{V_{OC} I_{OC}} = -\cos^{-1} \frac{305 \text{ W}}{(480 \text{ V})(1.60 \text{ A})} = -66.6^\circ$$

$$Y_{EX} = G_C - jB_M = 0.00333 \angle -66.6^\circ = 0.00132 - j0.00306$$

$$R_C = 1/G_C = 757 \Omega$$

$$X_M = 1/B_M = 327 \Omega$$

The excitation branch elements can be expressed in per-unit as

$$R_C = \frac{757 \Omega}{11.52 \Omega} = 65.7 \text{ pu} \quad X_M = \frac{327 \Omega}{11.52 \Omega} = 28.4 \text{ pu}$$

The short circuit test yields the values for the series impedances (referred to the *primary* side):

$$|Z_{EQ}| = \frac{V_{SC}}{I_{SC}} = \frac{1130 \text{ V}}{1.00 \text{ A}} = 1130 \ \Omega$$

$$\theta = \cos^{-1} \frac{P_{SC}}{V_{SC} I_{SC}} = \cos^{-1} \frac{260 \text{ W}}{(1130 \text{ V})(1.00 \text{ A})} = 76.7^\circ$$

$$Z_{EQ} = R_{EQ} + jX_{EQ} = 1130 \angle 76.7^\circ = 260 + j1100 \ \Omega$$

The resulting per-unit impedances are

$$R_{EQ} = \frac{260 \ \Omega}{20,000 \ \Omega} = 0.013 \text{ pu}$$

$$X_{EQ} = \frac{1100 \ \Omega}{20,000 \ \Omega} = 0.055 \text{ pu}$$

The per-unit equivalent circuit is

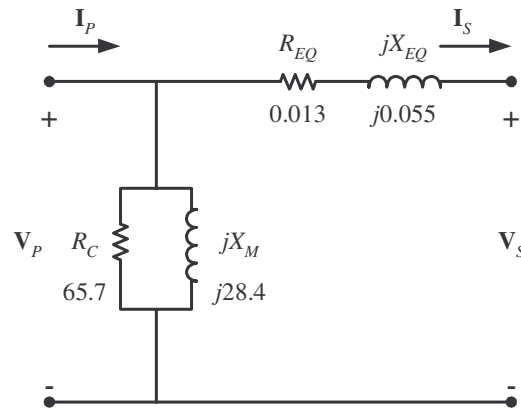

(b) If this transformer were operated at 50 Hz, both the voltage and apparent power would have to be derated by a factor of 50/60, so its ratings would be 16.67 kVA, 16,667/400 V, and 50 Hz.

(c) The transformer parameters referred to the primary side at 60 Hz are:

$$R_C = Z_{\text{base}} R_{C,\text{pu}} = (20 \text{ k}\Omega)(65.7) = 1.31 \text{ M}\Omega$$

$$X_M = Z_{\text{base}} X_{M,\text{pu}} = (20 \text{ k}\Omega)(28.4) = 568 \text{ k}\Omega$$

$$R_{EQ} = Z_{\text{base}} R_{EQ,\text{pu}} = (20 \text{ k}\Omega)(0.013) = 260 \ \Omega$$

$$X_{EQ} = Z_{\text{base}} X_{EQ,\text{pu}} = (20 \text{ k}\Omega)(0.055) = 1100 \ \Omega$$

At 50 Hz, the resistance will be unaffected but the reactances are reduced in direct proportion to the decrease in frequency. At 50 Hz, the reactances are

$$X_M = \frac{50 \text{ Hz}}{60 \text{ Hz}} (568 \text{ k}\Omega) = 473 \text{ k}\Omega$$

$$X_{EQ} = \frac{50 \text{ Hz}}{60 \text{ Hz}} (1100 \ \Omega) = 917 \ \Omega$$

The resulting equivalent circuit referred to the primary at 50 Hz is shown below:

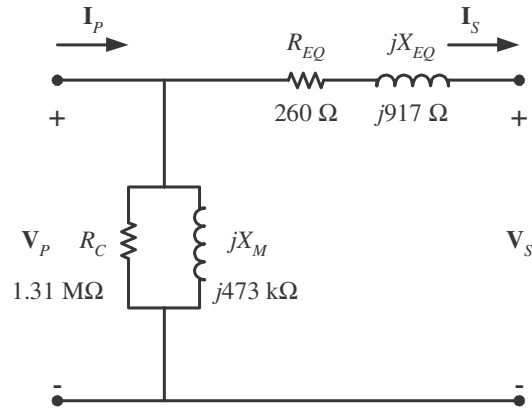

- 2-20.** Prove that the three-phase system of voltages on the secondary of the Y-Δ transformer shown in Figure 2-38b lags the three-phase system of voltages on the primary of the transformer by 30°.

SOLUTION The figure is reproduced below:

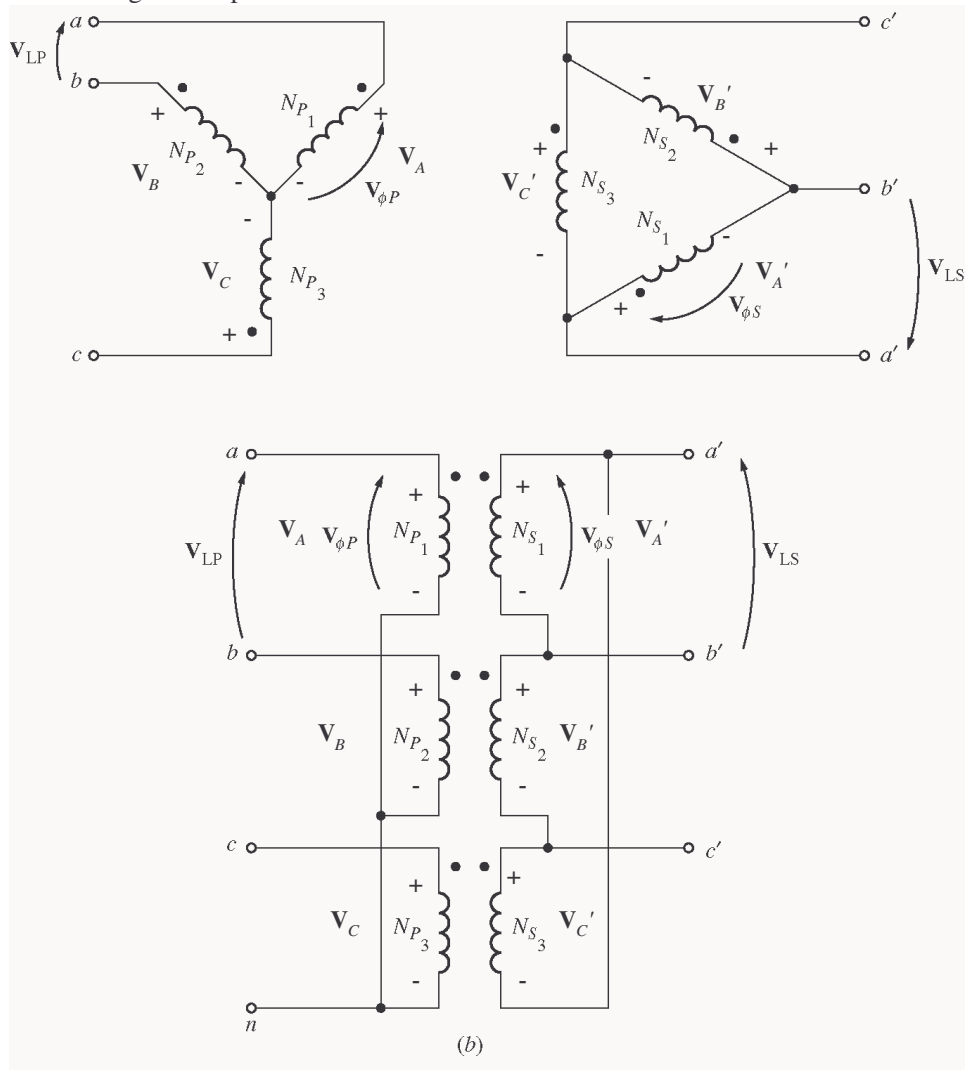

Assume that the phase voltages on the primary side are given by

$$\mathbf{V}_A = V_{\phi P} \angle 0^\circ \quad \mathbf{V}_B = V_{\phi P} \angle -120^\circ \quad \mathbf{V}_C = V_{\phi P} \angle 120^\circ$$

Then the phase voltages on the secondary side are given by

$$\mathbf{V}'_A = V_{\phi S} \angle 0^\circ \quad \mathbf{V}'_B = V_{\phi S} \angle -120^\circ \quad \mathbf{V}'_C = V_{\phi S} \angle 120^\circ$$

where $V_{\phi S} = V_{\phi P} / a$. Since this is a Y-Δ transformer bank, the line voltage \mathbf{V}_{ab} on the primary side is

$$\mathbf{V}_{ab} = \mathbf{V}_A - \mathbf{V}_B = V_{\phi P} \angle 0^\circ - V_{\phi P} \angle -120^\circ = \sqrt{3} V_{\phi P} \angle 30^\circ$$

and the voltage $\mathbf{V}_{a'b'} = \mathbf{V}'_A = V_{\phi S} \angle 0^\circ$. Note that the line voltage on the secondary side lags the line voltage on the primary side by 30° .

- 2-21.** Prove that the three-phase system of voltages on the secondary of the Δ-Y transformer shown in Figure 2-38c lags the three-phase system of voltages on the primary of the transformer by 30° .

SOLUTION The figure is reproduced below:

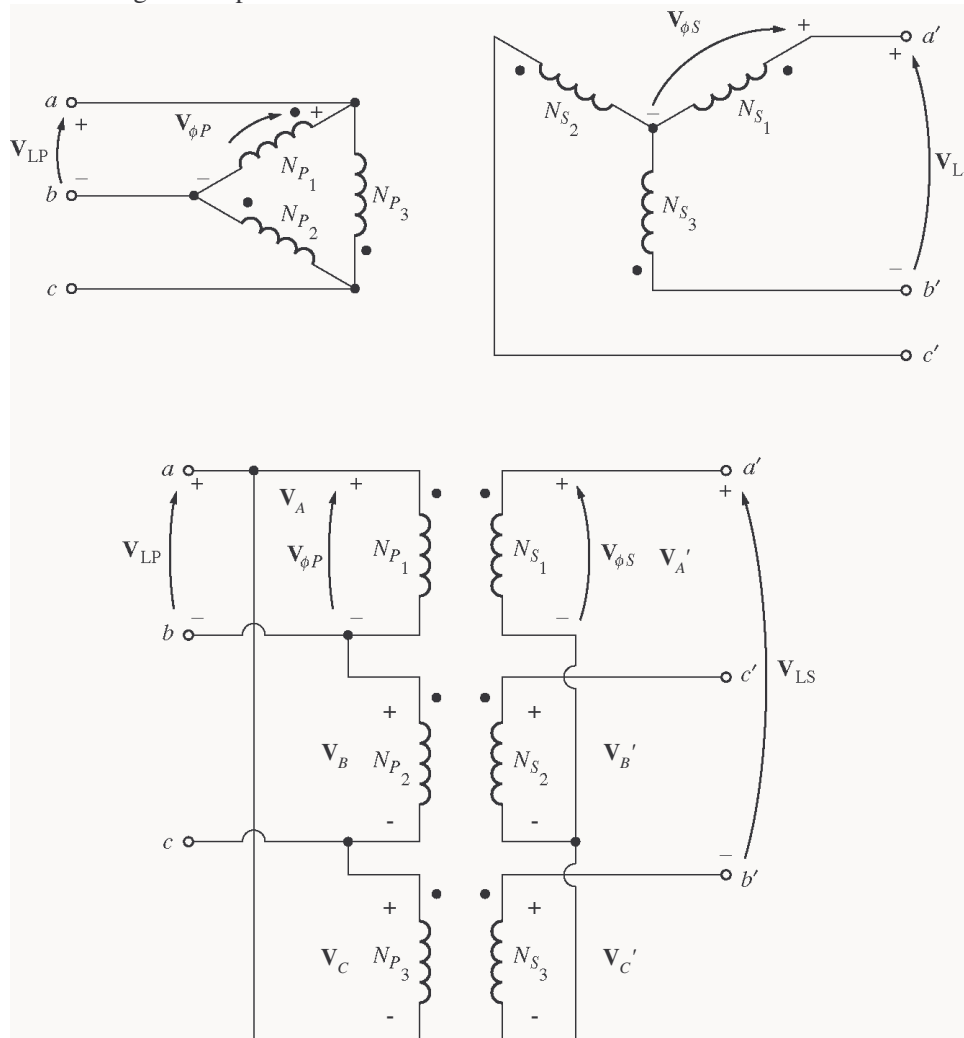

Assume that the phase voltages on the primary^(c) side are given by

$$\mathbf{V}_A = V_{\phi P} \angle 0^\circ \quad \mathbf{V}_B = V_{\phi P} \angle -120^\circ \quad \mathbf{V}_C = V_{\phi P} \angle 120^\circ$$

Then the phase voltages on the secondary side are given by

$$\mathbf{V}'_A = V_{\phi S} \angle 0^\circ \quad \mathbf{V}'_B = V_{\phi S} \angle -120^\circ \quad \mathbf{V}'_C = V_{\phi S} \angle 120^\circ$$

where $V_{\phi S} = V_{\phi P} / a$. Since this is a Δ -Y transformer bank, the line voltage \mathbf{V}_{ab} on the primary side is just equal to $\mathbf{V}_A = V_{\phi P} \angle 0^\circ$. The line voltage on the secondary side is given by

$$\mathbf{V}_{a'b'} = \mathbf{V}_A - \mathbf{V}_C = V_{\phi P} \angle 0^\circ - V_{\phi P} \angle 120^\circ = \sqrt{3} V_{\phi P} \angle -30^\circ$$

Note that the line voltage on the secondary side lags the line voltage on the primary side by 30° .

- 2-22.** A single-phase 10-kVA 480/120-V transformer is to be used as an autotransformer tying a 600-V distribution line to a 480-V load. When it is tested as a conventional transformer, the following values are measured on the primary (480-V) side of the transformer:

Open-circuit test	Short-circuit test
$V_{OC} = 480 \text{ V}$	$V_{SC} = 10.0 \text{ V}$
$I_{OC} = 0.41 \text{ A}$	$I_{SC} = 10.6 \text{ A}$
$P_{OC} = 38 \text{ W}$	$P_{SC} = 26 \text{ W}$

- (a) Find the per-unit equivalent circuit of this transformer when it is connected in the conventional manner. What is the efficiency of the transformer at rated conditions and unity power factor? What is the voltage regulation at those conditions?
- (b) Sketch the transformer connections when it is used as a 600/480-V step-down autotransformer.
- (c) What is the kilovoltampere rating of this transformer when it is used in the autotransformer connection?
- (d) Answer the questions in (a) for the autotransformer connection.

SOLUTION

- (a) The base impedance of this transformer referred to the primary side is

$$Z_{\text{base},P} = \frac{(V_P)^2}{S} = \frac{(480 \text{ V})^2}{10 \text{ kVA}} = 23.04 \Omega$$

The open circuit test yields the values for the excitation branch (referred to the *primary* side):

$$|Y_{EX}| = \frac{I_{\phi,OC}}{V_{\phi,OC}} = \frac{0.41 \text{ A}}{480 \text{ V}} = 0.000854 \text{ S}$$

$$\theta = -\cos^{-1} \frac{P_{OC}}{V_{OC} I_{OC}} = -\cos^{-1} \frac{38 \text{ W}}{(480 \text{ V})(0.41 \text{ A})} = -78.87^\circ$$

$$Y_{EX} = G_C - jB_M = 0.000854 \angle -78.87^\circ = 0.000165 - j0.000838$$

$$R_C = 1/G_C = 6063 \Omega$$

$$X_M = 1/B_M = 1193 \Omega$$

The excitation branch elements can be expressed in per-unit as

$$R_C = \frac{6063 \Omega}{23.04 \Omega} = 263 \text{ pu} \quad X_M = \frac{1193 \Omega}{23.04 \Omega} = 51.8 \text{ pu}$$

The short circuit test yields the values for the series impedances (referred to the *primary* side):

$$|Z_{EQ}| = \frac{V_{SC}}{I_{SC}} = \frac{10.0 \text{ V}}{10.6 \text{ A}} = 0.943 \Omega$$

$$\theta = \cos^{-1} \frac{P_{SC}}{V_{SC} I_{SC}} = \cos^{-1} \frac{26 \text{ W}}{(10.0 \text{ V})(10.6 \text{ A})} = 75.8^\circ$$

$$Z_{EQ} = R_{EQ} + jX_{EQ} = 0.943 \angle 75.8^\circ = 0.231 + j0.915 \ \Omega$$

The resulting per-unit impedances are

$$R_{EQ} = \frac{0.231 \ \Omega}{23.04 \ \Omega} = 0.010 \text{ pu} \quad X_{EQ} = \frac{0.915 \ \Omega}{23.04 \ \Omega} = 0.0397 \text{ pu}$$

The per-unit equivalent circuit is

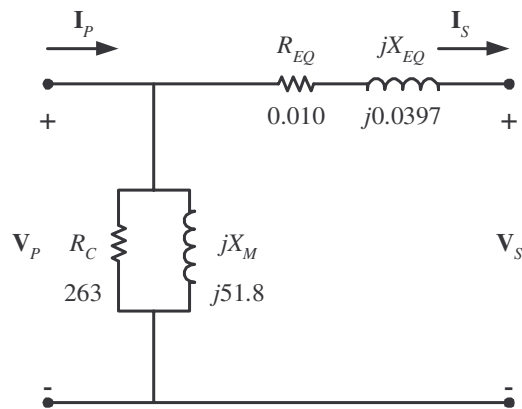

At rated conditions and unity power factor, the input power to this transformer would be $P_{IN} = 1.0$ pu.

The core losses (in resistor R_C) would be

$$P_{\text{core}} = \frac{V^2}{R_C} = \frac{(1.0)^2}{263} = 0.00380 \text{ pu}$$

The copper losses (in resistor R_{EQ}) would be

$$P_{\text{CU}} = I^2 R_{EQ} = (1.0)^2 (0.010) = 0.010 \text{ pu}$$

The output power of the transformer would be

$$P_{\text{OUT}} = P_{\text{IN}} - P_{\text{CU}} - P_{\text{core}} = 1.0 - 0.010 - 0.0038 = 0.986$$

and the transformer efficiency would be

$$\eta = \frac{P_{\text{OUT}}}{P_{\text{IN}}} \times 100\% = \frac{0.986}{1.0} \times 100\% = 98.6\%$$

The output voltage of this transformer is

$$V_{\text{OUT}} = V_{\text{IN}} - \mathbf{I}Z_{EQ} = 1.0 - (1.0 \angle 0^\circ)(0.01 + j0.0397) = 0.991 \angle -2.3^\circ$$

The voltage regulation of the transformer is

$$\text{VR} = \frac{1.0 - 0.991}{0.991} \times 100\% = 0.9\%$$

(b) The autotransformer connection for 600/480 V stepdown operation is

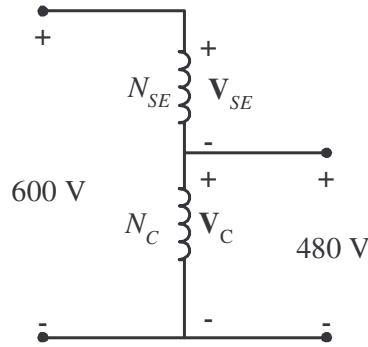

(c) When used as an autotransformer, the kVA rating of this transformer becomes:

$$S_{IO} = \frac{N_C + N_{SE}}{N_{SE}} S_w = \frac{4+1}{1} (10 \text{ kVA}) = 50 \text{ kVA}$$

(d) As an autotransformer, the per-unit series impedance Z_{EQ} is decreased by the reciprocal of the power advantage, so the series impedance becomes

$$R_{EQ} = \frac{0.010}{5} = 0.002 \text{ pu}$$

$$X_{EQ} = \frac{0.0397}{5} = 0.00794 \text{ pu}$$

while the magnetization branch elements are basically unchanged. At rated conditions and unity power factor, the input power to this transformer would be $P_{IN} = 1.0$ pu. The core losses (in resistor R_C) would be

$$P_{core} = \frac{V^2}{R_C} = \frac{(1.0)^2}{263} = 0.00380 \text{ pu}$$

The copper losses (in resistor R_{EQ}) would be

$$P_{CU} = I^2 R_{EQ} = (1.0)^2 (0.002) = 0.002 \text{ pu}$$

The output power of the transformer would be

$$P_{OUT} = P_{OUT} - P_{CU} - P_{core} = 1.0 - 0.002 - 0.0038 = 0.994$$

and the transformer efficiency would be

$$\eta = \frac{P_{OUT}}{P_{IN}} \times 100\% = \frac{0.994}{1.0} \times 100\% = 99.4\%$$

The output voltage of this transformer is

$$V_{OUT} = V_{IN} - IZ_{EQ} = 1.0 - (1.0 \angle 0^\circ)(0.002 + j0.00794) = 0.998 \angle -0.5^\circ$$

The voltage regulation of the transformer is

$$VR = \frac{1.0 - 0.998}{0.998} \times 100\% = 0.2\%$$

2-23. Figure P2-4 shows a power system consisting of a three-phase 480-V 60-Hz generator supplying two loads through a transmission line with a pair of transformers at either end.

(a) Sketch the per-phase equivalent circuit of this power system.

- (b) With the switch opened, find the real power P , reactive power Q , and apparent power S supplied by the generator. What is the power factor of the generator?
- (c) With the switch closed, find the real power P , reactive power Q , and apparent power S supplied by the generator. What is the power factor of the generator?
- (d) What are the transmission losses (transformer plus transmission line losses) in this system with the switch open? With the switch closed? What is the effect of adding Load 2 to the system?

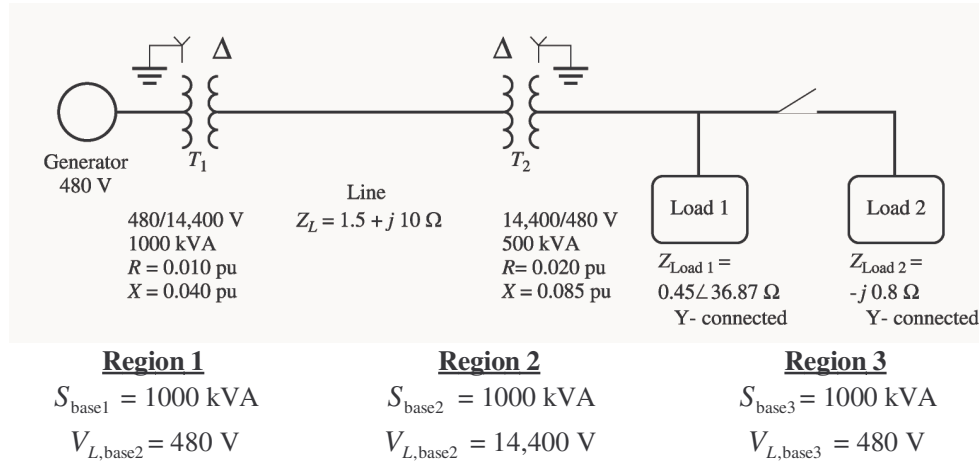

SOLUTION This problem can best be solved using the per-unit system of measurements. The power system can be divided into three regions by the two transformers. If the per-unit base quantities in Region 1 are chosen to be $S_{\text{base1}} = 1000 \text{ kVA}$ and $V_{L,\text{base1}} = 480 \text{ V}$, then the base quantities in Regions 2 and 3 will be as shown above. The base impedances of each region will be:

$$Z_{\text{base1}} = \frac{3V_{\phi1}^2}{S_{\text{base1}}} = \frac{3(277 \text{ V})^2}{1000 \text{ kVA}} = 0.238 \Omega$$

$$Z_{\text{base2}} = \frac{3V_{\phi2}^2}{S_{\text{base2}}} = \frac{3(8314 \text{ V})^2}{1000 \text{ kVA}} = 207.4 \Omega$$

$$Z_{\text{base3}} = \frac{3V_{\phi3}^2}{S_{\text{base3}}} = \frac{3(277 \text{ V})^2}{1000 \text{ kVA}} = 0.238 \Omega$$

(a) To get the per-unit, per-phase equivalent circuit, we must convert each impedance in the system to per-unit on the base of the region in which it is located. The impedance of transformer T_1 is already in per-unit to the proper base, so we don't have to do anything to it:

$$R_{1,\text{pu}} = 0.010$$

$$X_{1,\text{pu}} = 0.040$$

The impedance of transformer T_2 is already in per-unit, but it is per-unit to the base of transformer T_2 , so it must be converted to the base of the power system.

$$(R, X, Z)_{\text{pu on base 2}} = (R, X, Z)_{\text{pu on base 1}} \frac{(V_{\text{base 1}})^2 (S_{\text{base 2}})}{(V_{\text{base 2}})^2 (S_{\text{base 1}})} \tag{2-60}$$

$$R_{2,\text{pu}} = 0.020 \frac{(8314 \text{ V})^2 (1000 \text{ kVA})}{(8314 \text{ V})^2 (500 \text{ kVA})} = 0.040$$

$$X_{2,\text{pu}} = 0.085 \frac{(8314 \text{ V})^2 (1000 \text{ kVA})}{(8314 \text{ V})^2 (500 \text{ kVA})} = 0.170$$

The per-unit impedance of the transmission line is

$$Z_{\text{line,pu}} = \frac{Z_{\text{line}}}{Z_{\text{base2}}} = \frac{1.5 + j10 \Omega}{207.4 \Omega} = 0.00723 + j0.0482$$

The per-unit impedance of Load 1 is

$$Z_{\text{load1,pu}} = \frac{Z_{\text{load1}}}{Z_{\text{base3}}} = \frac{0.45 \angle 36.87^\circ \Omega}{0.238 \Omega} = 1.513 + j1.134$$

The per-unit impedance of Load 2 is

$$Z_{\text{load2,pu}} = \frac{Z_{\text{load2}}}{Z_{\text{base3}}} = \frac{-j0.8 \Omega}{0.238 \Omega} = -j3.36$$

The resulting per-unit, per-phase equivalent circuit is shown below:

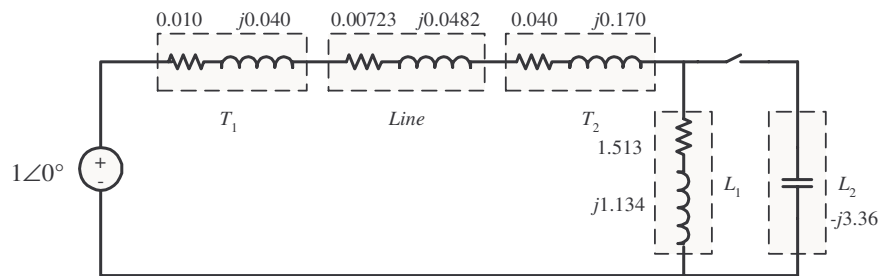

(b) With the switch opened, the equivalent impedance of this circuit is

$$Z_{\text{EQ}} = 0.010 + j0.040 + 0.00723 + j0.0482 + 0.040 + j0.170 + 1.513 + j1.134$$

$$Z_{\text{EQ}} = 1.5702 + j1.3922 = 2.099 \angle 41.6^\circ$$

The resulting current is

$$\mathbf{I} = \frac{1 \angle 0^\circ}{2.099 \angle 41.6^\circ} = 0.4765 \angle -41.6^\circ$$

The load voltage under these conditions would be

$$\mathbf{V}_{\text{Load,pu}} = \mathbf{I} Z_{\text{Load}} = (0.4765 \angle -41.6^\circ)(1.513 + j1.134) = 0.901 \angle -4.7^\circ$$

$$V_{\text{Load}} = V_{\text{Load,pu}} V_{\text{base3}} = (0.901)(480 \text{ V}) = 432 \text{ V}$$

The power supplied to the load is

$$P_{\text{Load,pu}} = I^2 R_{\text{Load}} = (0.4765)^2 (1.513) = 0.344$$

$$P_{\text{Load}} = P_{\text{Load,pu}} S_{\text{base}} = (0.344)(1000 \text{ kVA}) = 344 \text{ kW}$$

The power supplied by the generator is

$$P_{G,\text{pu}} = VI \cos \theta = (1)(0.4765) \cos 41.6^\circ = 0.356$$

$$Q_{G,\text{pu}} = VI \sin \theta = (1)(0.4765) \sin 41.6^\circ = 0.316$$

$$S_{G,\text{pu}} = VI = (1)(0.4765) = 0.4765$$

$$P_G = P_{G,\text{pu}} S_{\text{base}} = (0.356)(1000 \text{ kVA}) = 356 \text{ kW}$$

$$Q_G = Q_{G,\text{pu}} S_{\text{base}} = (0.316)(1000 \text{ kVA}) = 316 \text{ kVAR}$$

$$S_G = S_{G,\text{pu}} S_{\text{base}} = (0.4765)(1000 \text{ kVA}) = 476.5 \text{ kVA}$$

The power factor of the generator is

$$\text{PF} = \cos 41.6^\circ = 0.748 \text{ lagging}$$

(c) With the switch closed, the equivalent impedance of this circuit is

$$Z_{\text{EQ}} = 0.010 + j0.040 + 0.00723 + j0.0482 + 0.040 + j0.170 + \frac{(1.513 + j1.134)(-j3.36)}{(1.513 + j1.134) + (-j3.36)}$$

$$Z_{\text{EQ}} = 0.010 + j0.040 + 0.00788 + j0.0525 + 0.040 + j0.170 + (2.358 + j0.109)$$

$$Z_{\text{EQ}} = 2.415 + j0.367 = 2.443 \angle 8.65^\circ$$

The resulting current is

$$\mathbf{I} = \frac{1 \angle 0^\circ}{2.443 \angle 8.65^\circ} = 0.409 \angle -8.65^\circ$$

The load voltage under these conditions would be

$$\mathbf{V}_{\text{Load,pu}} = \mathbf{I} Z_{\text{Load}} = (0.409 \angle -8.65^\circ)(2.358 + j0.109) = 0.966 \angle -6.0^\circ$$

$$V_{\text{Load}} = V_{\text{Load,pu}} V_{\text{base3}} = (0.966)(480 \text{ V}) = 464 \text{ V}$$

The power supplied to the two loads is the power supplied to the resistive component of the parallel combination of the two loads: 2.358 pu.

$$P_{\text{Load,pu}} = I^2 R_{\text{Load}} = (0.409)^2 (2.358) = 0.394$$

$$P_{\text{Load}} = P_{\text{Load,pu}} S_{\text{base}} = (0.394)(1000 \text{ kVA}) = 394 \text{ kW}$$

The power supplied by the generator is

$$P_{G,\text{pu}} = VI \cos \theta = (1)(0.409) \cos 6.0^\circ = 0.407$$

$$Q_{G,\text{pu}} = VI \sin \theta = (1)(0.409) \sin 6.0^\circ = 0.0428$$

$$S_{G,\text{pu}} = VI = (1)(0.409) = 0.409$$

$$P_G = P_{G,\text{pu}} S_{\text{base}} = (0.407)(1000 \text{ kVA}) = 407 \text{ kW}$$

$$Q_G = Q_{G,\text{pu}} S_{\text{base}} = (0.0428)(1000 \text{ kVA}) = 42.8 \text{ kVAR}$$

$$S_G = S_{G,\text{pu}} S_{\text{base}} = (0.409)(1000 \text{ kVA}) = 409 \text{ kVA}$$

The power factor of the generator is

$$\text{PF} = \cos 6.0^\circ = 0.995 \text{ lagging}$$

(d) The transmission losses with the switch *open* are:

$$P_{\text{line,pu}} = I^2 R_{\text{line}} = (0.4765)^2 (0.00723) = 0.00164$$

$$P_{\text{line}} = P_{\text{line,pu}} S_{\text{base}} = (0.00164)(1000 \text{ kVA}) = 1.64 \text{ kW}$$

The transmission losses with the switch *closed* are:

$$P_{\text{line,pu}} = I^2 R_{\text{line}} = (0.409)^2 (0.00723) = 0.00121$$

$$P_{\text{line}} = P_{\text{line,pu}} S_{\text{base}} = (0.00121)(1000 \text{ kVA}) = 1.21 \text{ kW}$$

Load 2 improved the power factor of the system, increasing the load voltage and the total power supplied to the loads, while simultaneously decreasing the current in the transmission line and the transmission line losses. This problem is a good example of the advantages of power factor correction in power systems.

Chapter 3: Introduction to Power Electronics

3-1. Calculate the ripple factor of a three-phase half-wave rectifier circuit, both analytically and using MATLAB.

SOLUTION A three-phase half-wave rectifier and its output voltage are shown below

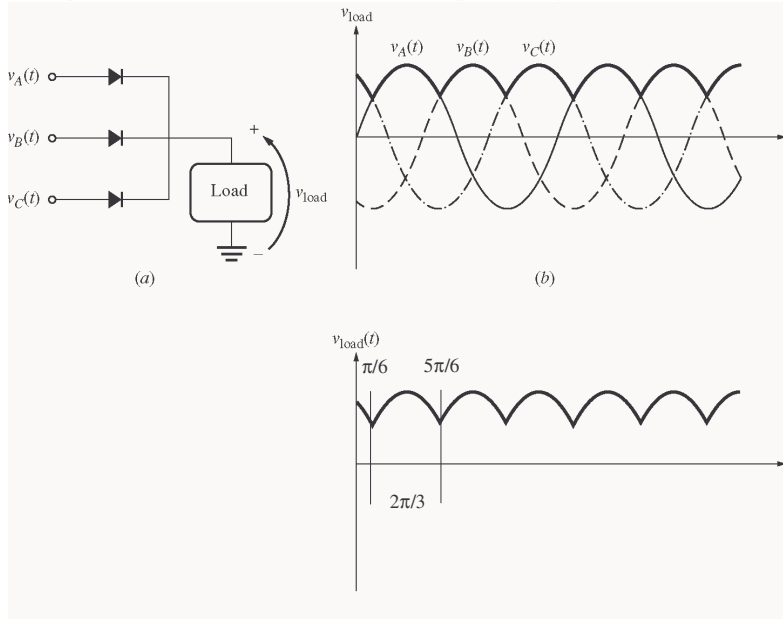

$$\begin{aligned}
 v_A(t) &= V_M \sin \omega t \\
 v_B(t) &= V_M \sin(\omega t - 2\pi/3) \\
 v_C(t) &= V_M \sin(\omega t + 2\pi/3)
 \end{aligned}$$

SOLUTION If we find the average and rms values over the interval from $\pi/6$ to $5\pi/6$ (one period), these values will be the same as the average and rms values of the entire waveform, and they can be used to calculate the ripple factor. The average voltage is

$$\begin{aligned}
 V_{DC} &= \frac{1}{T} \int_{\pi/6}^{5\pi/6} v(t) dt = \frac{3}{2\pi} \int_{\pi/6}^{5\pi/6} V_M \sin \omega t d(\omega t) \\
 V_{DC} &= -\frac{3V_M}{2\pi} \cos \omega t \Big|_{\pi/6}^{5\pi/6} = -\frac{3V_M}{2\pi} \left[-\frac{\sqrt{3}}{2} - \frac{\sqrt{3}}{2} \right] = \frac{3\sqrt{3}}{2\pi} V_M = 0.8270 V_M
 \end{aligned}$$

The rms voltage is

$$\begin{aligned}
 V_{rms} &= \sqrt{\frac{1}{T} \int_{\pi/6}^{5\pi/6} v(t)^2 dt} = \sqrt{\frac{3}{2\pi} \int_{\pi/6}^{5\pi/6} V_M^2 \sin^2 \omega t d(\omega t)} \\
 V_{rms} &= \sqrt{\frac{3V_M^2}{2\pi} \left[\frac{1}{2} \omega t - \frac{1}{4} \sin 2\omega t \right]_{\pi/6}^{5\pi/6}}
 \end{aligned}$$

$$V_{\text{rms}} = \sqrt{\frac{3V_M^2}{2\pi} \left[\frac{1}{2} \frac{5\pi}{6} - \frac{\pi}{6} - \frac{1}{4} \sin \frac{5\pi}{3} - \sin \frac{\pi}{3} \right]}$$

$$V_{\text{rms}} = \sqrt{\frac{3V_M^2}{2\pi} \left[\frac{\pi}{3} - \frac{1}{4} \sin \frac{5\pi}{3} - \sin \frac{\pi}{3} \right]} = \sqrt{\frac{3V_M^2}{2\pi} \left[\frac{\pi}{3} - \frac{1}{4} - \frac{\sqrt{3}}{2} - \frac{\sqrt{3}}{2} \right]}$$

$$V_{\text{rms}} = \sqrt{\frac{3V_M^2}{2\pi} \left[\frac{\pi}{3} - \frac{1}{4} - \frac{\sqrt{3}}{2} - \frac{\sqrt{3}}{2} \right]} = \sqrt{\frac{3V_M^2}{2\pi} \left[\frac{\pi}{3} + \frac{\sqrt{3}}{4} \right]} = 0.8407 V_M$$

The resulting ripple factor is

$$r = \sqrt{\frac{V_{\text{rms}}^2}{V_{\text{DC}}^2} - 1} \times 100\% = \sqrt{\frac{0.8407 V_M^2}{0.8270 V_M^2} - 1} \times 100\% = 18.3\%$$

The ripple can be calculated with MATLAB using the ripple function developed in the text. We must write a new function halfwave3 to simulate the output of a three-phase half-wave rectifier. This output is just the largest voltage of $v_A(t)$, $v_B(t)$, and $v_C(t)$ at any particular time. The function is shown below:

```
function volts = halfwave3(wt)
% Function to simulate the output of a three-phase
% half-wave rectifier.
%   wt = Phase in radians (=omega x time)

% Convert input to the range 0 <= wt < 2*pi
while wt >= 2*pi
    wt = wt - 2*pi;
end
while wt < 0
    wt = wt + 2*pi;
end

% Simulate the output of the rectifier.
a = sin(wt);
b = sin(wt - 2*pi/3);
c = sin(wt + 2*pi/3);

volts = max( [ a b c ] );
```

The function ripple is reproduced below. It is identical to the one in the textbook.

```
function r = ripple(waveform)
% Function to calculate the ripple on an input waveform.

% Calculate the average value of the waveform
nvals = size(waveform,2);
temp = 0;
for ii = 1:nvals
    temp = temp + waveform(ii);
end
average = temp/nvals;

% Calculate rms value of waveform
```

```
temp = 0;
for ii = 1:nvals
    temp = temp + waveform(ii)^2;
end
rms = sqrt(temp/nvals);

% Calculate ripple factor
r = sqrt((rms / average)^2 - 1) * 100;
```

Finally, the test driver program is shown below.

```
% M-file: test_halfwave3.m
% M-file to calculate the ripple on the output of a
% three phase half-wave rectifier.

% First, generate the output of a three-phase half-wave
% rectifier
waveform = zeros(1,128);
for ii = 1:128
    waveform(ii) = halfwave3(ii*pi/64);
end

% Now calculate the ripple factor
r = ripple(waveform);

% Print out the result
string = ['The ripple is ' num2str(r) '%.'];
disp(string);
```

When this program is executed, the results are

```
» test_halfwave3
The ripple is 18.2759%.
```

This answer agrees with the analytical solution above.

- 3-2.** Calculate the ripple factor of a three-phase full-wave rectifier circuit, both analytically and using MATLAB.

SOLUTION A three-phase half-wave rectifier and its output voltage are shown below

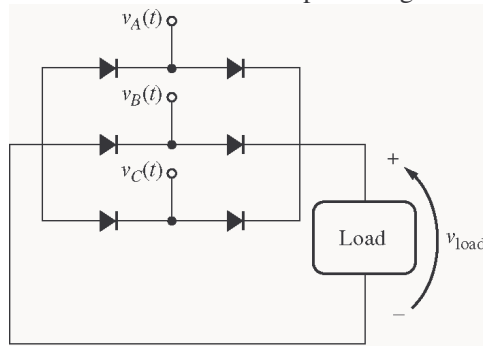

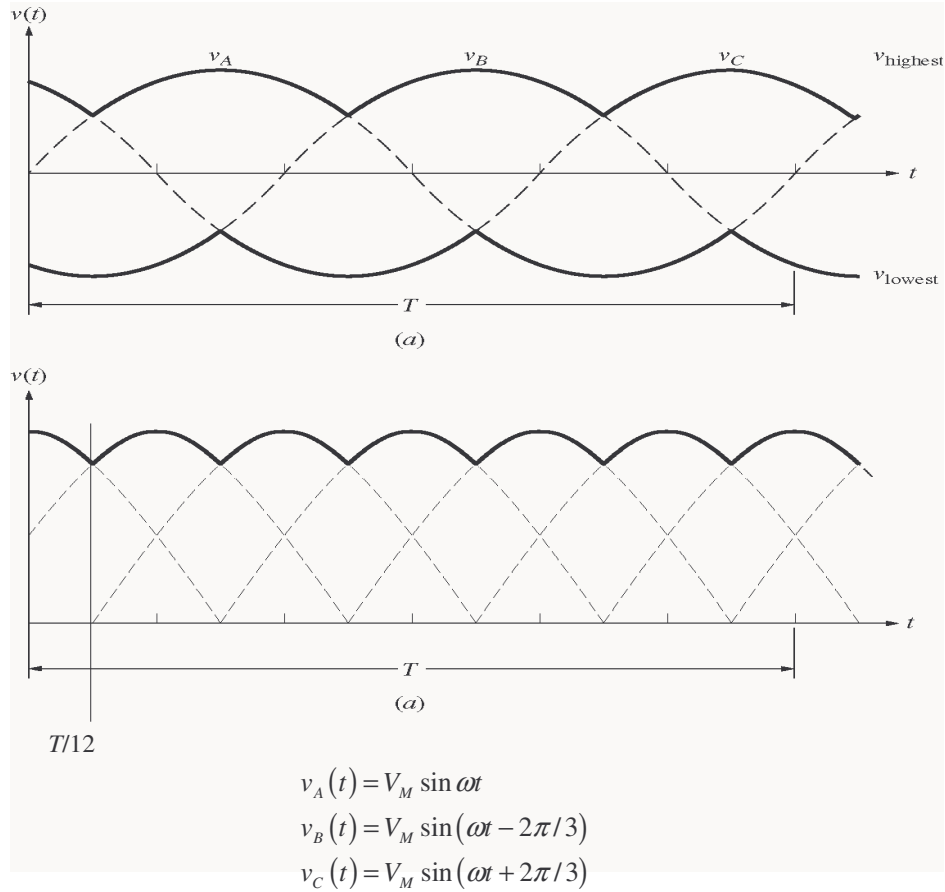

SOLUTION By symmetry, the rms voltage over the interval from 0 to $T/12$ will be the same as the rms voltage over the whole interval. Over that interval, the *output* voltage is:

$$v(t) = v_C(t) - v_B(t) = V_M \sin \left(\omega t + \frac{2\pi}{3} \right) - V_M \sin \left(\omega t - \frac{2\pi}{3} \right)$$

$$v(t) = V_M \left[\sin \omega t \cos \frac{2\pi}{3} + \cos \omega t \sin \frac{2\pi}{3} \right] - V_M \left[\sin \omega t \cos \frac{2\pi}{3} - \cos \omega t \sin \frac{2\pi}{3} \right]$$

$$v(t) = V_M \left[2 \cos \omega t \sin \frac{2\pi}{3} \right] = \sqrt{3} \cos \omega t$$

Note that the period of the waveform is $T = 2\pi/\omega$, so $T/12$ is $\pi/6\omega$. The average voltage over the interval from 0 to $T/12$ is

$$V_{DC} = \frac{1}{T} \int_0^{T/12} v(t) dt = \frac{6\omega}{\pi} \int_0^{\pi/6\omega} \sqrt{3} V_M \cos \omega t dt = \frac{6\sqrt{3}}{\pi} V_M \sin \omega t \Big|_0^{\pi/6\omega}$$

$$V_{DC} = \frac{3\sqrt{3}}{\pi} V_M = 1.6540 V_M$$

The rms voltage is

$$V_{rms} = \sqrt{\frac{1}{T} \int_0^{T/12} v(t)^2 dt} = \sqrt{\frac{6\omega}{\pi} \int_0^{\pi/6\omega} 3V_M^2 \cos^2 \omega t dt}$$

$$V_{\text{rms}} = \sqrt{\frac{18\omega}{\pi} V_M^2 \frac{1}{2} t + \frac{1}{4\omega} \sin 2\omega t \Big|_0^{\pi/6\omega}}$$

$$V_{\text{rms}} = V_M \sqrt{\frac{18\omega}{\pi} \frac{\pi}{12\omega} + \frac{1}{4\omega} \sin \frac{\pi}{3}} = V_M \sqrt{\frac{3}{2} + \frac{9\sqrt{3}}{4\pi}} = 1.6554 V_M$$

The resulting ripple factor is

$$r = \sqrt{\frac{V_{\text{rms}}^2}{V_{\text{DC}}^2} - 1} \times 100\% = \sqrt{\frac{1.6554 V_M^2}{1.6540 V_M^2} - 1} \times 100\% = 4.2\%$$

The ripple can be calculated with MATLAB using the `ripple` function developed in the text. We must right a new function `fullwave3` to simulate the output of a three-phase half-wave rectifier. This output is just the largest voltage of $v_A(t)$, $v_B(t)$, and $v_C(t)$ at any particular time. The function is shown below:

```
function volts = fullwave3(wt)
% Function to simulate the output of a three-phase
% full-wave rectifier.
%   wt = Phase in radians (=omega x time)

% Convert input to the range 0 <= wt < 2*pi
while wt >= 2*pi
    wt = wt - 2*pi;
end
while wt < 0
    wt = wt + 2*pi;
end

% Simulate the output of the rectifier.
a = sin(wt);
b = sin(wt - 2*pi/3);
c = sin(wt + 2*pi/3);

volts = max( [ a b c ] ) - min( [ a b c ] );
```

The test driver program is shown below.

```
% M-file: test_fullwave3.m
% M-file to calculate the ripple on the output of a
% three phase full-wave rectifier.

% First, generate the output of a three-phase full-wave
% rectifier
waveform = zeros(1,128);
for ii = 1:128
    waveform(ii) = fullwave3(ii*pi/64);
end

% Now calculate the ripple factor
r = ripple(waveform);

% Print out the result
string = ['The ripple is ' num2str(r) '%.'];
disp(string);
```

When this program is executed, the results are

```
» test_fullwave3
```

The ripple is 4.2017%.

This answer agrees with the analytical solution above.

- 3-3. Explain the operation of the circuit shown in Figure P3-1. What would happen in this circuit if switch S_1 were closed?

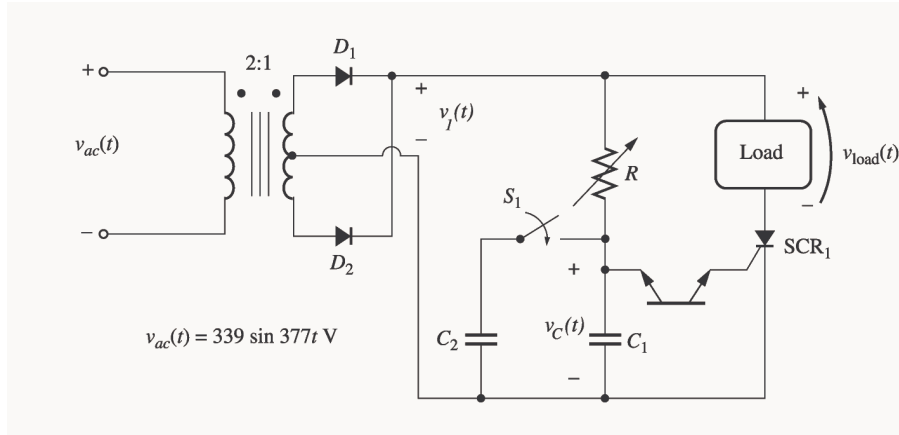

SOLUTION Diode D_1 and D_2 together with the transformer form a full-wave rectifier. Therefore, a voltage oriented positive-to-negative as shown will be applied to the SCR and the control circuit on each half cycle.

- (1) Initially, the SCR is an open circuit, since $v_1 < V_{BO}$ for the SCR. Therefore, no current flows to the load and $v_{LOAD} = 0$.
- (2) Voltage v_1 is applied to the control circuit, charging capacitor C_1 with time constant RC_1 .
- (3) When $v_C > V_{BO}$ for the DIAC, it conducts, supplying a gate current to the SCR.
- (4) The gate current in the SCR lowers its breakover voltage, and the SCR fires. When the SCR fires, current flows through the SCR and the load.
- (5) The current flow continues until i_D falls below I_H for the SCR (at the end of the half cycle). The process starts over in the next half cycle.

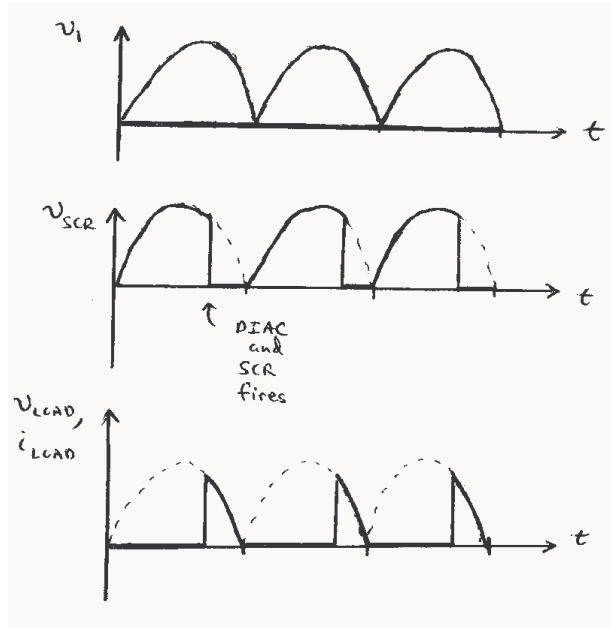

If switch S_1 is shut, the charging time constant is increased, and the DIAC fires *later* in each half cycle. Therefore, less power is supplied to the load.

- 3-4.** What would the rms voltage on the load in the circuit in Figure P3-1 be if the firing angle of the SCR were (a) 0° , (b) 30° , (c) 90° ?

SOLUTION The input voltage to the circuit of Figure P3-1 is

$$v_{ac}(t) = 339 \sin \omega t, \text{ where } \omega = 377 \text{ rad/s}$$

Therefore, the voltage on the secondary of the transformer will be

$$v_{ac}(t) = 169.5 \sin \omega t$$

(a) The average voltage applied to the load will be the integral over the conducting portion of the half cycle divided by π/ω , the period of a half cycle. For a firing angle of 0° , the average voltage will be

$$V_{ave} = \frac{1}{T} \int_0^T v(t) dt = \frac{\omega}{\pi} \int_0^{\pi/\omega} V_M \sin \omega t dt = -\frac{1}{\pi} V_M \cos \omega t \Big|_0^{\pi/\omega}$$

$$V_{ave} = -\frac{1}{\pi} V_M [-1 - 1] = \frac{2}{\pi} V_M = (0.637)(169.5 \text{ V}) = 108 \text{ V}$$

(b) For a firing angle of 30° , the average voltage will be

$$V_{ave} = \frac{1}{T} \int_{\pi/6}^T v(t) dt = \frac{\omega}{\pi} \int_{\pi/6}^{\pi/\omega} V_M \sin \omega t dt = -\frac{1}{\pi} V_M \cos \omega t \Big|_{\pi/6}^{\pi/\omega}$$

$$V_{ave} = -\frac{1}{\pi} V_M [-1 - \frac{\sqrt{3}}{2}] = \frac{2 + \sqrt{3}}{2\pi} V_M = (0.594)(169.5 \text{ V}) = 101 \text{ V}$$

(c) For a firing angle of 90° , the average voltage will be

$$V_{ave} = \frac{1}{T} \int_{\pi/2}^T v(t) dt = \frac{\omega}{\pi} \int_{\pi/2}^{\pi/\omega} V_M \sin \omega t dt = -\frac{1}{\pi} V_M \cos \omega t \Big|_{\pi/2}^{\pi/\omega}$$

$$V_{ave} = -\frac{1}{\pi}V_M[-1] = \frac{1}{\pi}V_M = (0.318)(169.5 \text{ V}) = 54 \text{ V}$$

- 3-5. For the circuit in Figure P3-1, assume that V_{BO} for the DIAC is 30 V, C_1 is 1 μF , R is adjustable in the range 1-20 k Ω , and that switch S_1 is open. What is the firing angle of the circuit when R is 10 k Ω ? What is the rms voltage on the load under these conditions?

Note: Problem 3-5 is significantly harder for many students, since it involves solving a differential equation with a forcing function. This problem should only be assigned if the class has the mathematical sophistication to handle it.

SOLUTION At the beginning of each half cycle, the voltages across the DIAC and the SCR will both be smaller than their respective breakover voltages, so no current will flow to the load (except for the very tiny current charging capacitor C), and $v_{load}(t)$ will be 0 volts. However, capacitor C charges up through resistor R , and when the voltage $v_C(t)$ builds up to the breakover voltage of D_1 , the DIAC will start to conduct. This current flows through the gate of SCR_1 , turning the SCR ON. When it turns ON, the voltage across the SCR will drop to 0, and the full source voltage $v_S(t)$ will be applied to the load, producing a current flow through the load. The SCR continues to conduct until the current through it falls below I_{Hr} , which happens at the very end of the half cycle.

Note that after D_1 turns on, capacitor C discharges through it and the gate of the SCR. At the end of the half cycle, the voltage on the capacitor is again essentially 0 volts, and the whole process is ready to start over again at the beginning of the next half cycle.

To determine when the DIAC and the SCR fire in this circuit, we must determine when $v_C(t)$ exceeds V_{BO} for D_1 . This calculation is much harder than in the examples in the book, because in the previous problems the source was a simple DC voltage source, while here the voltage source is sinusoidal. However, the principles are identical.

- (a) To determine when the SCR will turn ON, we must calculate the voltage $v_C(t)$, and then solve for the time at which $v_C(t)$ exceeds V_{BO} for D_1 . At the beginning of the half cycle, D_1 and SCR_1 are OFF, and the voltage across the load is essentially 0, so the entire source voltage $v_S(t)$ is applied to the series RC circuit. To determine the voltage $v_C(t)$ on the capacitor, we can write a Kirchhoff's Current Law equation at the node above the capacitor and solve the resulting equation for $v_C(t)$.

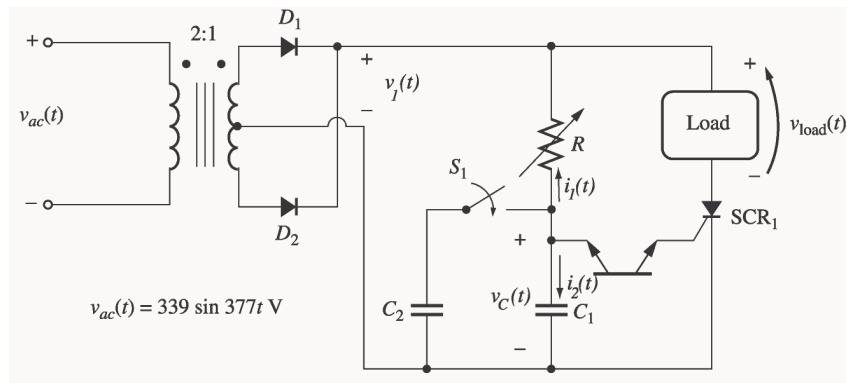

$$i_1 + i_2 = 0 \quad (\text{since the DIAC is an open circuit at this time})$$

$$\frac{v_C - v_1}{R} + C \frac{d}{dt} v_C = 0$$

$$\frac{d}{dt}v_c + \frac{1}{RC}v_c = \frac{1}{RC}v_1$$

$$\frac{d}{dt}v_c + \frac{1}{RC}v_c = \frac{V_M}{RC}\sin \omega t$$

The solution can be divided into two parts, a natural response and a forced response. The natural response is the solution to the differential equation

$$\frac{d}{dt}v_c + \frac{1}{RC}v_c = 0$$

The solution to the natural response differential equation is

$$v_{c,n}(t) = A e^{-\frac{t}{RC}}$$

where the constant A must be determined from the initial conditions in the system. The forced response is the steady-state solution to the equation

$$\frac{d}{dt}v_c + \frac{1}{RC}v_c = \frac{V_M}{RC}\sin \omega t$$

It must have a form similar to the forcing function, so the solution will be of the form

$$v_{c,f}(t) = B_1 \sin \omega t + B_2 \cos \omega t$$

where the constants B_1 and B_2 must be determined by substitution into the original equation. Solving for B_1 and B_2 yields:

$$\frac{d}{dt}(B_1 \sin \omega t + B_2 \cos \omega t) + \frac{1}{RC}(B_1 \sin \omega t + B_2 \cos \omega t) = \frac{V_M}{RC}\sin \omega t$$

$$(\omega B_1 \cos \omega t - \omega B_2 \sin \omega t) + \frac{1}{RC}(B_1 \sin \omega t + B_2 \cos \omega t) = \frac{V_M}{RC}\sin \omega t$$

cosine equation:

$$\omega B_1 + \frac{1}{RC}B_2 = 0 \Rightarrow B_2 = -\omega RC B_1$$

sine equation:

$$-\omega B_2 + \frac{1}{RC}B_1 = \frac{V_M}{RC}$$

$$\omega^2 RC B_1 + \frac{1}{RC}B_1 = \frac{V_M}{RC}$$

$$\omega^2 RC + \frac{1}{RC} B_1 = \frac{V_M}{RC}$$

$$\frac{1 + \omega^2 R^2 C^2}{RC} B_1 = \frac{V_M}{RC}$$

Finally,

$$B_1 = \frac{V_M}{1 + \omega^2 R^2 C^2} \quad \text{and} \quad B_2 = \frac{-\omega RC V_M}{1 + \omega^2 R^2 C^2}$$

Therefore, the forced solution to the equation is

$$v_{c,f}(t) = \frac{V_M}{1 + \omega^2 R^2 C^2} \sin \omega t - \frac{\omega RC V_M}{1 + \omega^2 R^2 C^2} \cos \omega t$$

and the total solution is

$$v_c(t) = v_{c,n}(t) + v_{c,f}(t)$$

$$v_c(t) = A e^{-\frac{t}{RC}} + \frac{V_M}{1 + \omega^2 R^2 C^2} \sin \omega t - \frac{\omega RC V_M}{1 + \omega^2 R^2 C^2} \cos \omega t$$

The initial condition for this problem is that the voltage on the capacitor is zero at the beginning of the half-cycle:

$$v_c(0) = A e^{-\frac{0}{RC}} + \frac{V_M}{1 + \omega^2 R^2 C^2} \sin 0 - \frac{\omega RC V_M}{1 + \omega^2 R^2 C^2} \cos 0 = 0$$

$$A - \frac{\omega RC V_M}{1 + \omega^2 R^2 C^2} = 0$$

$$A = \frac{\omega RC V_M}{1 + \omega^2 R^2 C^2}$$

Therefore, the voltage across the capacitor as a function of time before the DIAC fires is

$$v_c(t) = \frac{\omega RC V_M}{1 + \omega^2 R^2 C^2} e^{-\frac{t}{RC}} + \frac{V_M}{1 + \omega^2 R^2 C^2} \sin \omega t - \frac{\omega RC V_M}{1 + \omega^2 R^2 C^2} \cos \omega t$$

If we substitute the known values for R , C , ω , and V_M , this equation becomes

$$v_c(t) = 42 e^{-100t} + 11.14 \sin \omega t - 42 \cos \omega t$$

This equation is plotted below:

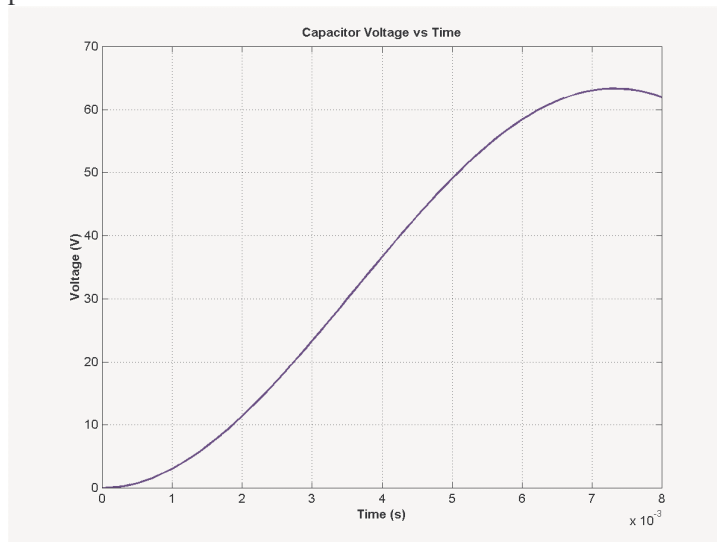

It reaches a voltage of 30 V at a time of 3.50 ms. Since the frequency of the waveform is 60 Hz, the waveform there are 360° in $1/60$ s, and the *firing angle* α is

$$\alpha = (3.50 \text{ ms}) \frac{360^\circ}{1/60 \text{ s}} = 75.6^\circ \text{ or } 1.319 \text{ radians}$$

Note: This problem could also have been solved using Laplace Transforms, if desired.

(b) The rms voltage applied to the load is

$$V_{\text{rms}} = \sqrt{\frac{1}{T} \int_{\alpha}^{\pi} v(t)^2 dt} = \sqrt{\frac{\omega}{\pi} \int_{\alpha}^{\pi} V_M^2 \sin^2 \omega t dt}$$

$$V_{\text{rms}} = \sqrt{\frac{V_M^2}{\pi} \left[\frac{1}{2} \omega t - \frac{1}{4} \sin 2\omega t \right]_{\alpha}^{\pi}}$$

$$V_{\text{rms}} = \sqrt{\frac{V_M^2}{\pi} \left(\frac{1}{2}(\pi - \alpha) - \frac{1}{4}(\sin 2\pi - \sin 2\alpha) \right)}$$

$$V_{\text{rms}} = V_M \sqrt{0.3284} = 0.573 V_M = 97.1 \text{ V}$$

3-6. One problem with the circuit shown in Figure P3-1 is that it is very sensitive to variations in the input voltage $v_{ac}(t)$. For example, suppose the peak value of the input voltage were to decrease. Then the time that it takes capacitor C_1 to charge up to the breakover voltage of the DIAC will increase, and the SCR will be triggered later in each half cycle. Therefore, the rms voltage supplied to the load will be reduced *both* by the lower peak voltage *and* by the later firing. This same effect happens in the opposite direction if $v_{ac}(t)$ increases. How could this circuit be modified to reduce its sensitivity to variations in input voltage?

SOLUTION If the voltage charging the capacitor could be made constant or nearly so, then the feedback effect would be stopped and the circuit would be less sensitive to voltage variations. A common way to do this is to use a zener diode that fires at a voltage greater than V_{BO} for the DIAC across the RC charging circuit. This diode holds the voltage across the RC circuit constant, so that the capacitor charging time is not much affected by changes in the power supply voltage.

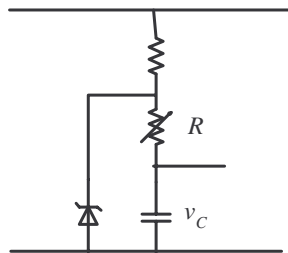

3-7. Explain the operation of the circuit shown in Figure P3-2, and sketch the output voltage from the circuit.

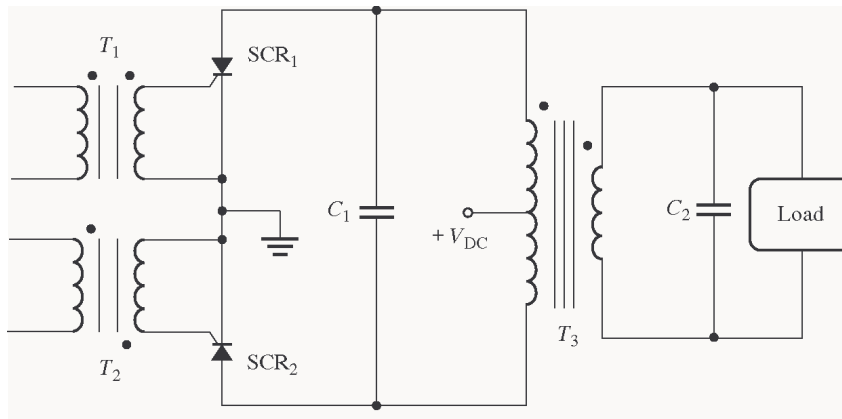

SOLUTION This circuit is a single-phase voltage source inverter.

- (1) Initially, suppose that both SCRs are OFF. Then the voltage on the transformer T_3 will be 0, and voltage V_{DC} will be dropped across SCR_1 and SCR_2 as shown.
- (2) Now, apply a pulse to transformer T_1 that turns on SCR_1 . When that happens, the circuit looks like:

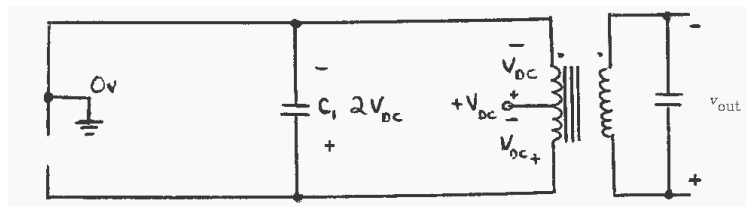

Since the top of the transformer is now grounded, a voltage V_{DC} appears across the upper winding as shown. This voltage induces a corresponding voltage on the lower half of the winding, charging capacitor C_1 up to a voltage of $2V_{DC}$, as shown.

Now, suppose that a pulse is applied to transformer T_2 . When that occurs, SCR_2 becomes a short circuit, and SCR_1 is turned OFF by the reverse voltage applied to it by capacitor C_1 (*forced commutation*). At that time, the circuit looks like:

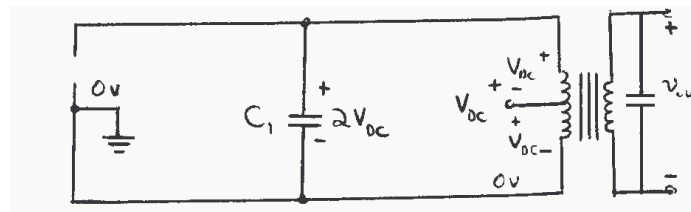

Now the voltages on the transformer are reversed, charging capacitor C_1 up to a voltage of $2V_{DC}$ in the opposite direction. When SCR_1 is triggered again, the voltage on C_1 will turn SCR_2 OFF.

The output voltage from this circuit would be roughly a square wave, except that capacitor C_2 filters it somewhat.

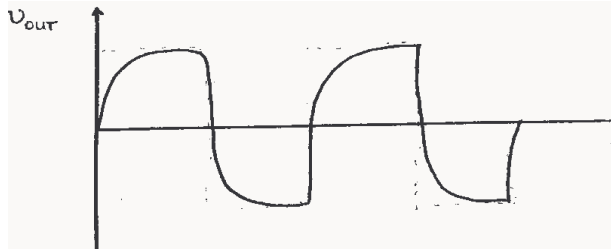

(Note: The above discussion assumes that transformer T_3 is never in either state long enough for it to saturate.)

3-8. Figure P3-3 shows a relaxation oscillator with the following parameters:

$$\begin{array}{ll}
 R_1 = \text{variable} & R_2 = 1500 \Omega \\
 C = 1.0 \mu\text{F} & V_{\text{DC}} = 100 \text{ V} \\
 V_{\text{BO}} = 30 \text{ V} & I_H = 0.5 \text{ mA}
 \end{array}$$

(a) Sketch the voltages $v_C(t)$, $v_D(t)$, and $v_o(t)$ for this circuit.

(b) If R_1 is currently set to $500 \text{ k}\Omega$, calculate the period of this relaxation oscillator.

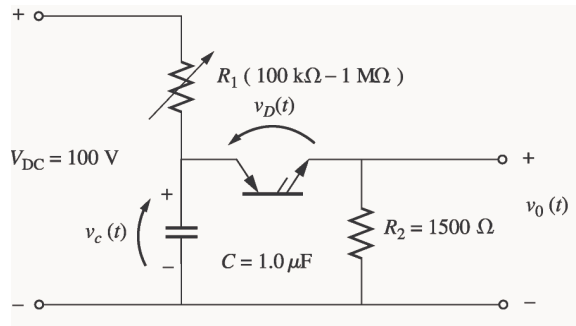

SOLUTION

(a) The voltages $v_C(t)$, $v_D(t)$ and $v_o(t)$ are shown below. Note that $v_C(t)$ and $v_D(t)$ look the same during the rising portion of the cycle. After the PNP Diode triggers, the voltage across the capacitor decays with time constant $\tau_2 = \frac{R_1 R_2}{R_1 + R_2} C$, while the voltage across the diode drops immediately.

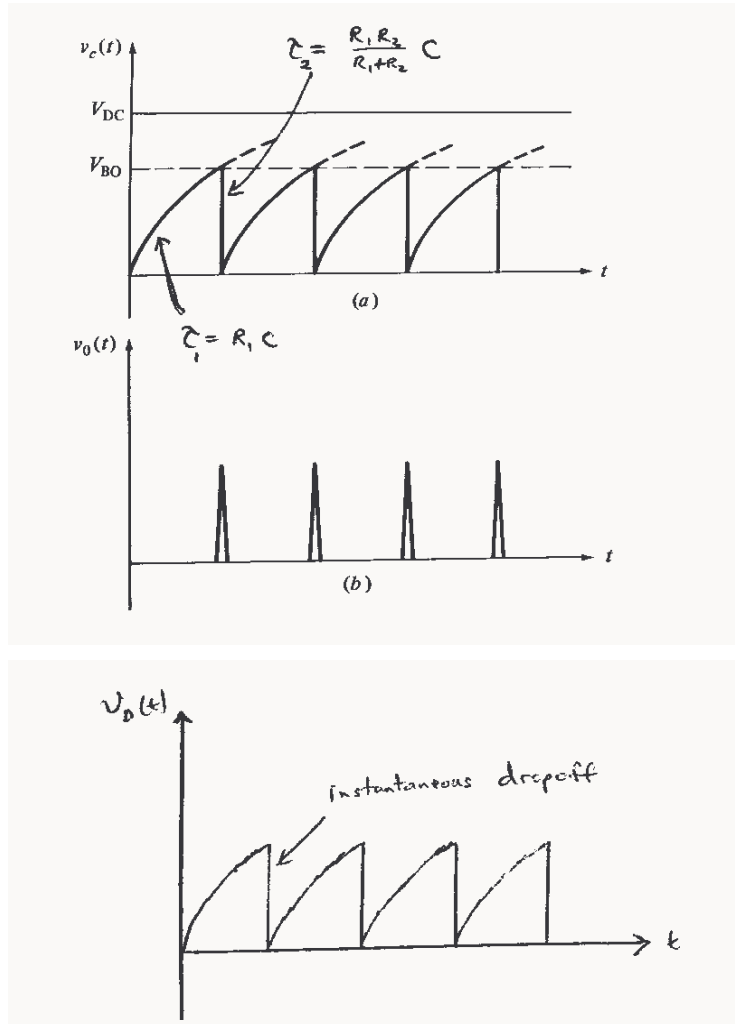

(b) When voltage is first applied to the circuit, the capacitor C charges with a time constant $\tau_1 = R_1 C = (500 \text{ k}\Omega)(1.00 \text{ }\mu\text{F}) = 0.50 \text{ s}$. The equation for the voltage on the capacitor as a function of time during the charging portion of the cycle is

$$v_C(t) = A + B e^{-\frac{t}{R_1 C}}$$

where A and B are constants depending upon the initial conditions in the circuit. Since $v_C(0) = 0 \text{ V}$ and $v_C(\infty) = 100 \text{ V}$, it is possible to solve for A and B .

$$A = v_C(\infty) = 100 \text{ V}$$

$$A + B = v_C(0) = 0 \text{ V} \Rightarrow B = -100 \text{ V}$$

Therefore,

$$v_C(t) = 100 - 100 e^{-\frac{t}{0.50}} \text{ V}$$

The time at which the capacitor will reach breakover voltage is found by setting $v_C(t) = V_{BO}$ and solving for time t_1 :

$$t_1 = -0.50 \ln \frac{100 \text{ V} - 30 \text{ V}}{100 \text{ V}} = 178 \text{ ms}$$

Once the PNP Diode fires, the capacitor discharges through the parallel combination of R_1 and R_2 , so the time constant for the discharge is

$$\tau_2 = \frac{R_1 R_2}{R_1 + R_2} C = \frac{(500 \text{ k}\Omega)(1.5 \text{ k}\Omega)}{500 \text{ k}\Omega + 1.5 \text{ k}\Omega} (1.0 \text{ }\mu\text{F}) = 0.0015 \text{ s}$$

The equation for the voltage on the capacitor during the discharge portion of the cycle is

$$v_C(t) = A + B e^{-\frac{t}{\tau_2}}$$

$$v_C(t) = V_{BO} e^{-\frac{t}{\tau_2}}$$

The current through the PNP diode is given by

$$i_D(t) = \frac{V_{BO}}{R_2} e^{-\frac{t}{\tau_2}}$$

If we ignore the continuing trickle of current from R_1 , the time at which $i_D(t)$ reaches I_H is

$$t_2 = -R_2 C \ln \frac{I_H R_2}{V_{BO}} = -(0.0015) \ln \frac{(0.0005 \text{ A})(1500 \text{ }\Omega)}{30 \text{ V}} = 5.5 \text{ ms}$$

Therefore, the period of the relaxation oscillator is $T = 178 \text{ ms} + 5.5 \text{ ms} = 183.5 \text{ ms}$, and the frequency of the relaxation oscillator is $f = 1/T = 5.45 \text{ Hz}$.

- 3-9.** In the circuit in Figure P3-4, T_1 is an autotransformer with the tap exactly in the center of its winding. Explain the operation of this circuit. Assuming that the load is inductive, sketch the voltage and current applied to the load. What is the purpose of SCR_2 ? What is the purpose of D_2 ? (This chopper circuit arrangement is known as a *Jones circuit*.)

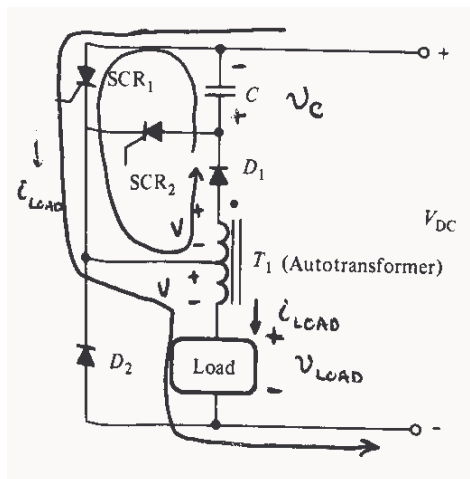

SOLUTION First, assume that SCR_1 is triggered. When that happens, current will flow from the power supply through SCR_1 and the bottom portion of transformer T_1 to the load. At that time, a voltage will be applied to the bottom part of the transformer which is positive at the top of the winding with respect to the bottom of the winding. This voltage will induce an equal voltage in the upper part of the autotransformer

winding, forward biasing diode D_1 and causing the current to flow up through capacitor C . This current causes C to be charged with a voltage that is positive at its bottom with respect to its top. (This condition is shown in the figure above.)

Now, assume that SCR_2 is triggered. When SCR_2 turns ON, capacitor C applies a reverse-biased voltage to SCR_1 , shutting it off. Current then flow through the capacitor, SCR_2 , and the load as shown below. This current charges C with a voltage of the opposite polarity, as shown.

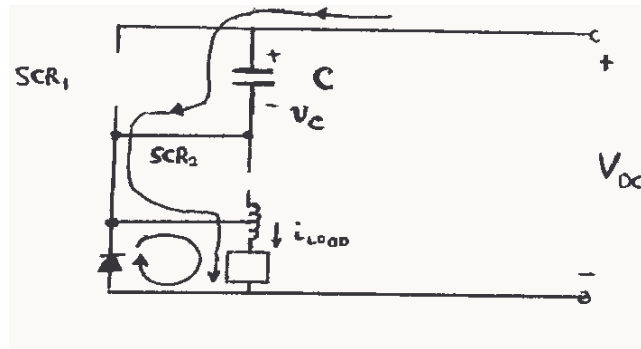

SCR_2 will cut off when the capacitor is fully charged. Alternately, it will be cut off by the voltage across the capacitor if SCR_1 is triggered before it would otherwise cut off.

In this circuit, SCR_1 controls the power supplied to the load, while SCR_2 controls when SCR_1 will be turned off. Diode D_2 in this circuit is a free-wheeling diode, which allows the current in the load to continue flowing for a short time after SCR_1 turns off.

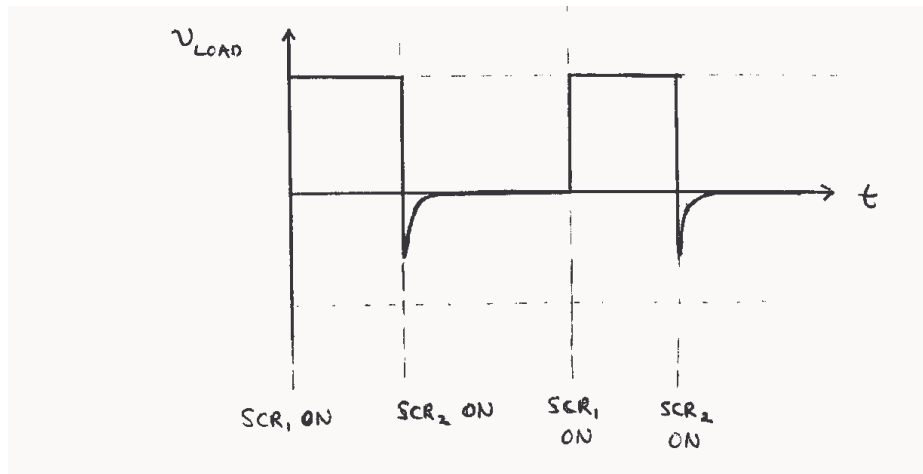
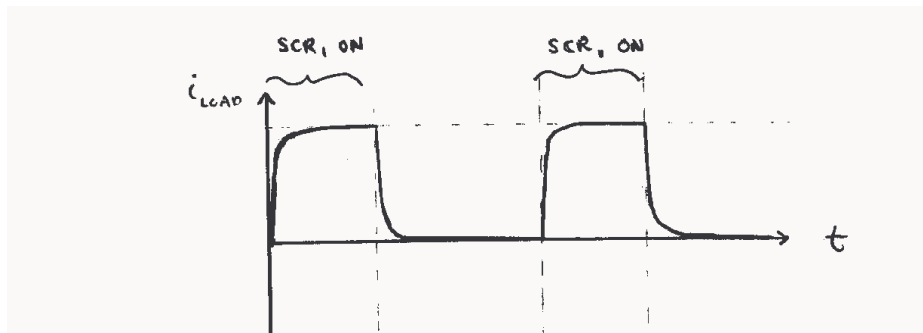

3-10. A series-capacitor forced commutation chopper circuit supplying a purely resistive load is shown in Figure P3-5.

$$\begin{aligned} V_{DC} &= 120 \text{ V} & R &= 20 \text{ k}\Omega \\ I_H &= 8 \text{ mA} & R_{LOAD} &= 250 \Omega \\ V_{BO} &= 200 \text{ V} & C &= 150 \mu\text{F} \end{aligned}$$

- When SCR₁ is turned on, how long will it remain on? What causes it to turn off?
- When SCR₁ turns off, how long will it be until the SCR can be turned on again? (Assume that three time constants must pass before the capacitor is discharged.)
- What problem or problems do these calculations reveal about this simple series-capacitor forced commutation chopper circuit?
- How can the problem(s) described in part (c) be eliminated?

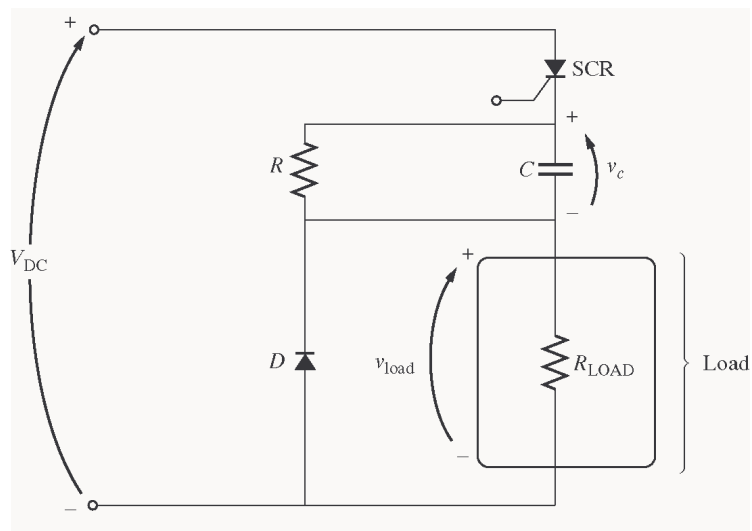

Solution

(a) When the SCR is turned on, it will remain on until the current flowing through it drops below I_H . This happens when the capacitor charges up to a high enough voltage to decrease the current below I_H . If we ignore resistor R (because it is so much larger than R_{LOAD}), the capacitor charges through resistor R_{LOAD} with a time constant $\tau_{LOAD} = R_{LOAD}C = (250 \Omega)(150 \mu\text{F}) = 0.0375 \text{ s}$. The equation for the voltage on the capacitor as a function of time during the charging portion of the cycle is

$$v_c(t) = A + B e^{-\frac{t}{R_{LOAD}C}}$$

where A and B are constants depending upon the initial conditions in the circuit. Since $v_c(0) = 0 \text{ V}$ and $v_c(\infty) = V_{DC}$, it is possible to solve for A and B .

$$A = v_c(\infty) = V_{DC}$$

$$A + B = v_c(0) = 0 \Rightarrow B = -V_{DC}$$

Therefore,

² The first printing of this book incorrectly stated that I_H is 6 mA.

$$v_C(t) = V_{DC} - V_{DC} e^{-\frac{t}{R_{LOAD}C}} \text{ V}$$

The current through the capacitor is

$$i_C(t) = C \frac{d}{dt} v_C(t)$$

$$i_C(t) = C \frac{d}{dt} V_{DC} - V_{DC} e^{-\frac{t}{R_{LOAD}C}}$$

$$i_C(t) = \frac{V_{DC}}{R_{LOAD}} e^{-\frac{t}{R_{LOAD}C}} \text{ A}$$

Solving for time yields

$$t = -R_{LOAD}C \ln \frac{i_C(t)R_2}{V_{DC}} = -0.0375 \ln \frac{i_C(t)R_2}{V_{DC}}$$

The current through the SCR consists of the current through resistor R plus the current through the capacitor. The current through resistor R is $120 \text{ V} / 20 \text{ k}\Omega = 6 \text{ mA}$, and the holding current of the SCR is 8 mA , so the SCR will turn off when the current through the capacitor drops to 2 mA . This occurs at time

$$t = -0.0375 \ln \frac{(2 \text{ mA})(250 \Omega)}{120 \text{ V}} = 0.206 \text{ s}$$

(b) The SCR can be turned on again once the capacitor has discharged. The capacitor discharges through resistor R . It can be considered to be completely discharged after three time constants. Since $\tau = RC = (20 \text{ k}\Omega)(150 \mu\text{F}) = 3 \text{ s}$, the SCR will be ready to fire again after 9 s .

(c) In this circuit, the ON time of the SCR is much shorter than the reset time for the SCR, so power can flow to the load only a very small fraction of the time. (This effect would be less exaggerated if the ratio of R to R_{LOAD} were smaller.)

(d) This problem can be eliminated by using one of the more complex series commutation circuits described in Section 3-5. These more complex circuits provide special paths to quickly discharge the capacitor so that the circuit can be fired again soon.

3-11. A parallel-capacitor forced commutation chopper circuit supplying a purely resistive load is shown in Figure P3-6.

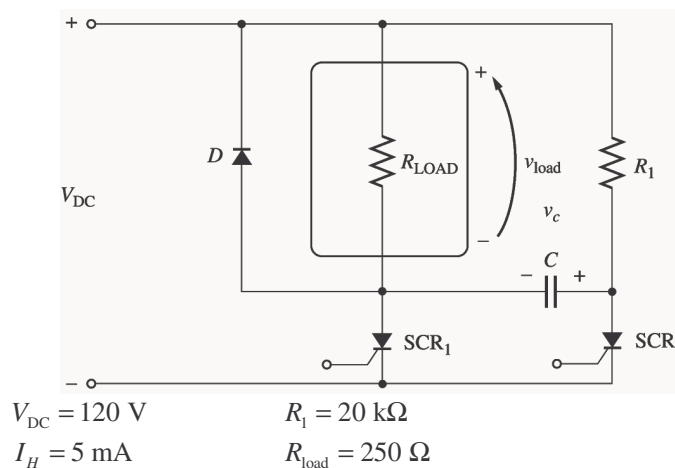

$$V_{BO} = 250 \text{ V} \quad C = 15 \mu\text{F}$$

- (a) When SCR_1 is turned on, how long will it remain on? What causes it to turn off?
- (b) What is the earliest time that SCR_1 can be turned off after it is turned on? (Assume that three time constants must pass before the capacitor is charged.)
- (c) When SCR_1 turns off, how long will it be until the SCR can be turned on again?
- (d) What problem or problems do these calculations reveal about this simple parallel-capacitor forced commutation chopper circuit?
- (e) How can the problem(s) describe in part (d) be eliminated?

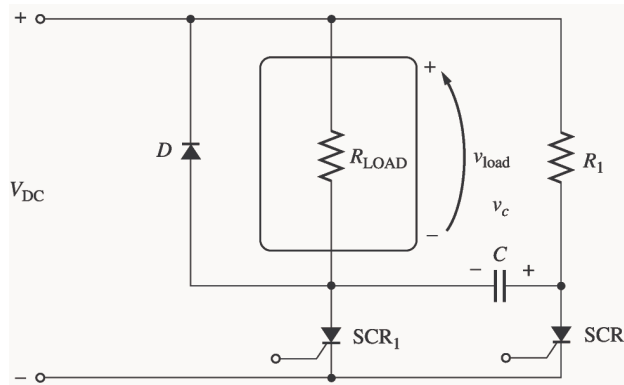

SOLUTION

- (a) When SCR_1 is turned on, it will remain on indefinitely until it is forced to turn off. When SCR_1 is turned on, capacitor C charges up to V_{DC} volts with the polarity shown in the figure above. Once it is charged, SCR_1 can be turned off at any time by triggering SCR_2 . When SCR_2 is triggered, the voltage across it drops instantaneously to about 0 V, which forces the voltage at the anode of SCR_1 to be $-V_{DC}$ volts, turning SCR_1 off. (Note that SCR_2 will spontaneously turn off after the capacitor discharges, since $V_{DC} / R_1 < I_H$ for SCR_2 .)
- (b) If we assume that the capacitor must be fully charged before SCR_1 can be forced to turn off, then the time required would be the time to charge the capacitor. The capacitor charges through resistor R_1 , and the time constant for the charging is $\tau = R_1 C = (20 \text{ k}\Omega)(15 \mu\text{F}) = 0.3 \text{ s}$. If we assume that it takes 3 time constants to fully charge the capacitor, then the time until SCR_1 can be turned off is 0.9 s.

(Note that this is not a very realistic assumption. In real life, it is possible to turn off SCR_1 with less than a full V_{DC} volts across the capacitor.)

- (c) SCR_1 can be turned on again after the capacitor charges up and SCR_2 turns off. The capacitor charges through R_{LOAD} , so the time constant for charging is

$$\tau = R_{LOAD} C = (250 \Omega)(15 \mu\text{F}) = 0.00375 \text{ s}$$

and SCR_2 will turn off in a few milliseconds.

- (d) In this circuit, once SCR_1 fires, a substantial period of time must pass before the power to the load can be turned off. If the power to the load must be turned on and off rapidly, this circuit could not do the job.

(e) This problem can be eliminated by using one of the more complex parallel commutation circuits described in Section 3-5. These more complex circuits provide special paths to quickly charge the capacitor so that the circuit can be turned off quickly after it is turned on.

3-12. Figure P3-7 shows a single-phase rectifier-inverter circuit. Explain how this circuit functions. What are the purposes of C_1 and C_2 ? What controls the output frequency of the inverter?

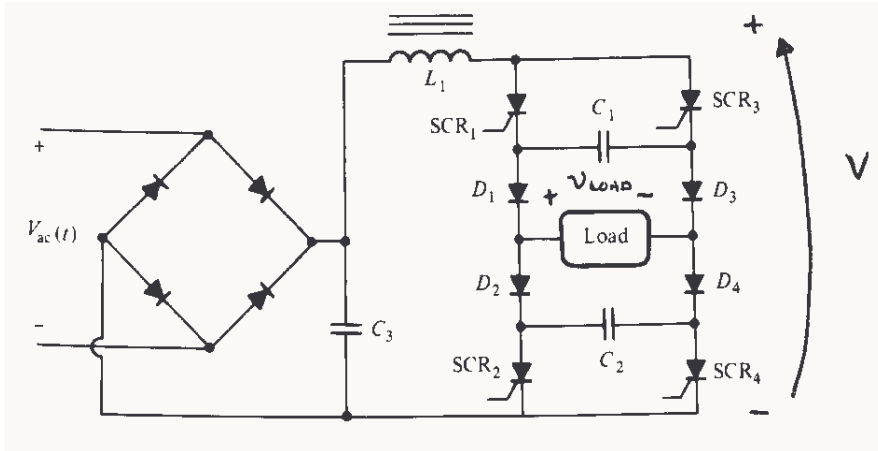

SOLUTION The last element in the filter of this rectifier circuit is an inductor, which keeps the current flow out of the rectifier almost constant. Therefore, this circuit is a *current source inverter*. The rectifier and filter together produce an approximately constant dc voltage and current across the two SCRs and diodes at the right of the figure. To understand the behavior of the inverter portion of this circuit, we will step through its operation.

(1) First, assume that SCR_1 and SCR_4 are triggered. Then the voltage V will appear across the load positive-to-negative as shown in Figure (a). At the same time, capacitor C_1 will charge to V volts through diode D_3 , and capacitor C_2 will charge to V volts through diode D_2 .

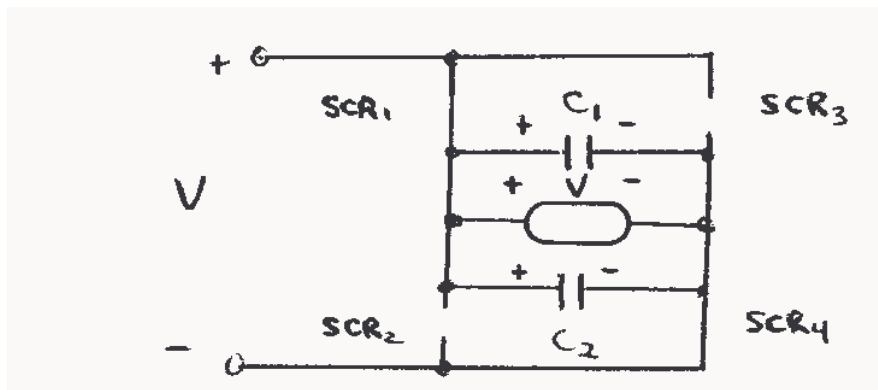

(a)

(2) Now, assume that SCR_2 and SCR_3 are triggered. At the instant they are triggered, the voltage across capacitors C_1 and C_2 will reverse bias SCR_1 and SCR_4 , turning them OFF. Then a voltage of V volts will appear across the load positive-to-negative as shown in Figure (b). At the same time, capacitor C_1 will charge to V volts with the opposite polarity from before, and capacitor C_2 will charge to V volts with the opposite polarity from before.

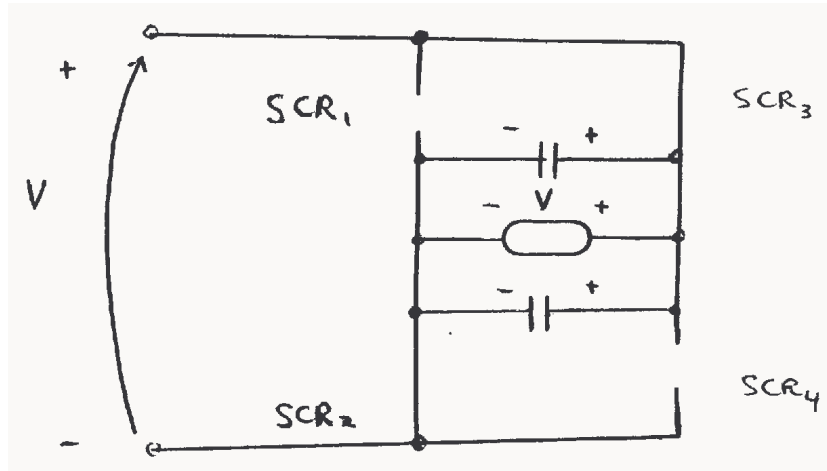
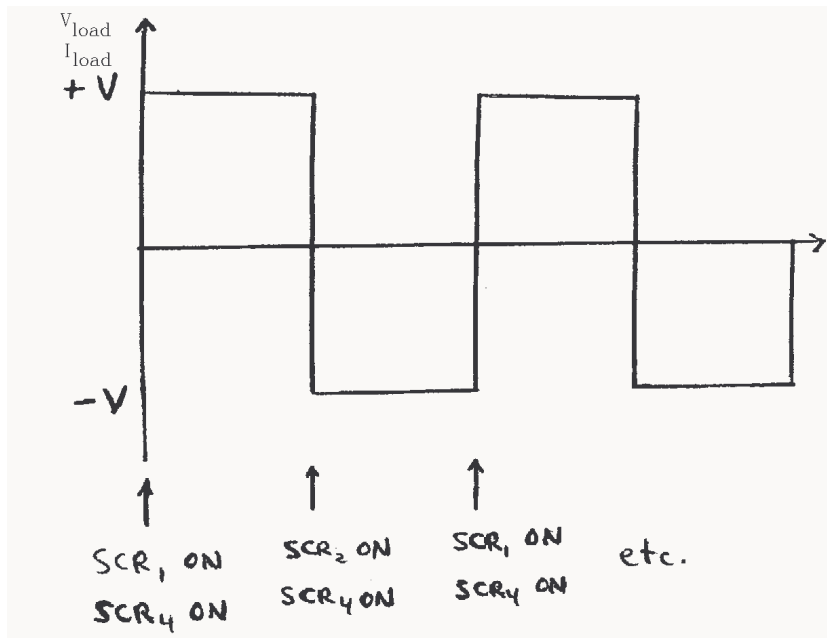

Figure (b)

(3) If SCR_1 and SCR_4 are now triggered again, the voltages across capacitors C_1 and C_2 will force SCR_2 and SCR_3 to turn OFF. The cycle continues in this fashion.

Capacitors C_1 and C_2 are called commutating capacitors. Their purpose is to force one set of SCRs to turn OFF when the other set turns ON.

The output frequency of this rectifier-inverter circuit is controlled by the rates at which the SCRs are triggered. The resulting voltage and current waveforms (assuming a resistive load) are shown below.



3-13. A simple full-wave ac phase angle voltage controller is shown in Figure P3-8. The component values in this circuit are:

$$R = 20 \text{ to } 300 \text{ k}\Omega, \text{ currently set to } 80 \text{ k}\Omega$$

$$C = 0.15 \mu\text{F}$$

$$V_{BO} = 40 \text{ V (for PNP Diode } D_1)$$

$$V_{BO} = 250 \text{ V (for SCR}_1)$$

$$v_s(t) = V_M \sin \omega t \quad \text{volts}$$

where $V_M = 169.7 \text{ V}$ and $\omega = 377 \text{ rad/s}$

- (a) At what phase angle do the PNPN diode and the SCR turn on?
 (b) What is the rms voltage supplied to the load under these circumstances?

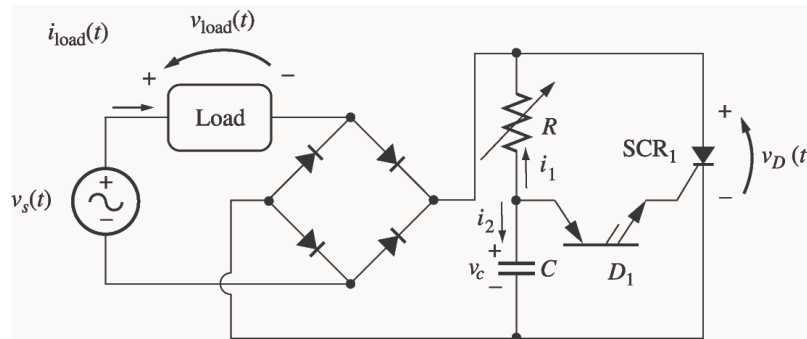

Note: Problem 3-13 is significantly harder for many students, since it involves solving a differential equation with a forcing function. This problem should only be assigned if the class has the mathematical sophistication to handle it.

SOLUTION At the beginning of each half cycle, the voltages across the PNPN diode and the SCR will both be smaller than their respective breakover voltages, so no current will flow to the load (except for the very tiny current charging capacitor C), and $v_{load}(t)$ will be 0 volts. However, capacitor C charges up through resistor R , and when the voltage $v_C(t)$ builds up to the breakover voltage of D_1 , the PNPN diode will start to conduct. This current flows through the gate of SCR_1 , turning the SCR ON. When it turns ON, the voltage across the SCR will drop to 0, and the full source voltage $v_s(t)$ will be applied to the load, producing a current flow through the load. The SCR continues to conduct until the current through it falls below I_H , which happens at the very end of the half cycle.

Note that after D_1 turns on, capacitor C discharges through it and the gate of the SCR. At the end of the half cycle, the voltage on the capacitor is again essentially 0 volts, and the whole process is ready to start over again at the beginning of the next half cycle.

To determine when the PNPN diode and the SCR fire in this circuit, we must determine when $v_C(t)$ exceeds V_{BO} for D_1 . This calculation is much harder than in the examples in the book, because in the previous problems the source was a simple DC voltage source, while here the voltage source is sinusoidal. However, the principles are identical.

- (a) To determine when the SCR will turn ON, we must calculate the voltage $v_C(t)$, and then solve for the time at which $v_C(t)$ exceeds V_{BO} for D_1 . At the beginning of the half cycle, D_1 and SCR_1 are OFF, and the voltage across the load is essentially 0, so the entire source voltage $v_s(t)$ is applied to the series RC circuit. To determine the voltage $v_C(t)$ on the capacitor, we can write a Kirchhoff's Current Law equation at the node above the capacitor and solve the resulting equation for $v_C(t)$.

$$i_1 + i_2 = 0 \quad \text{(since the PNPN diode is an open circuit at this time)}$$

$$\frac{v_c - v_1}{R} + C \frac{d}{dt} v_c = 0$$

$$\frac{d}{dt} v_c + \frac{1}{RC} v_c = \frac{1}{RC} v_1$$

$$\frac{d}{dt} v_c + \frac{1}{RC} v_c = \frac{V_M}{RC} \sin \omega t$$

The solution can be divided into two parts, a natural response and a forced response. The natural response is the solution to the equation

$$\frac{d}{dt} v_c + \frac{1}{RC} v_c = 0$$

The solution to the natural response equation is

$$v_{c,n}(t) = A e^{-\frac{t}{RC}}$$

where the constant A must be determined from the initial conditions in the system. The forced response is the steady-state solution to the equation

$$\frac{d}{dt} v_c + \frac{1}{RC} v_c = \frac{V_M}{RC} \sin \omega t$$

It must have a form similar to the forcing function, so the solution will be of the form

$$v_{c,f}(t) = B_1 \sin \omega t + B_2 \cos \omega t$$

where the constants B_1 and B_2 must be determined by substitution into the original equation. Solving for B_1 and B_2 yields:

$$\frac{d}{dt} (B_1 \sin \omega t + B_2 \cos \omega t) + \frac{1}{RC} (B_1 \sin \omega t + B_2 \cos \omega t) = \frac{V_M}{RC} \sin \omega t$$

$$(\omega B_1 \cos \omega t - \omega B_2 \sin \omega t) + \frac{1}{RC} (B_1 \sin \omega t + B_2 \cos \omega t) = \frac{V_M}{RC} \sin \omega t$$

cosine equation:

$$\omega B_1 + \frac{1}{RC} B_2 = 0 \Rightarrow B_2 = -\omega RC B_1$$

sine equation:

$$-\omega B_2 + \frac{1}{RC} B_1 = \frac{V_M}{RC}$$

$$\omega^2 RC B_1 + \frac{1}{RC} B_1 = \frac{V_M}{RC}$$

$$\omega^2 RC + \frac{1}{RC} B_1 = \frac{V_M}{RC}$$

$$\frac{1 + \omega^2 R^2 C^2}{RC} B_1 = \frac{V_M}{RC}$$

Finally,

$$B_1 = \frac{V_M}{1 + \omega^2 R^2 C^2} \quad \text{and} \quad B_2 = \frac{-\omega RC V_M}{1 + \omega^2 R^2 C^2}$$

Therefore, the forced solution to the equation is

$$v_{c,f}(t) = \frac{V_M}{1 + \omega^2 R^2 C^2} \sin \omega t - \frac{\omega RC V_M}{1 + \omega^2 R^2 C^2} \cos \omega t$$

and the total solution is

$$v_C(t) = v_{c,n}(t) + v_{c,f}(t)$$

$$v_C(t) = A e^{-\frac{t}{RC}} + \frac{V_M}{1 + \omega^2 R^2 C^2} \sin \omega t - \frac{\omega RC V_M}{1 + \omega^2 R^2 C^2} \cos \omega t$$

The initial condition for this problem is that the voltage on the capacitor is zero at the beginning of the half-cycle:

$$v_C(0) = A e^{-\frac{0}{RC}} + \frac{V_M}{1 + \omega^2 R^2 C^2} \sin 0 - \frac{\omega RC V_M}{1 + \omega^2 R^2 C^2} \cos 0 = 0$$

$$A - \frac{\omega RC V_M}{1 + \omega^2 R^2 C^2} = 0$$

$$A = \frac{\omega RC V_M}{1 + \omega^2 R^2 C^2}$$

Therefore, the voltage across the capacitor as a function of time before the PNP diode fires is

$$v_C(t) = \frac{\omega RC V_M}{1 + \omega^2 R^2 C^2} e^{-\frac{t}{RC}} + \frac{V_M}{1 + \omega^2 R^2 C^2} \sin \omega t - \frac{\omega RC V_M}{1 + \omega^2 R^2 C^2} \cos \omega t$$

If we substitute the known values for R , C , ω , and V_M , this equation becomes

$$v_C(t) = 35.76 e^{-83.3t} + 7.91 \sin \omega t - 35.76 \cos \omega t$$

This equation is plotted below:

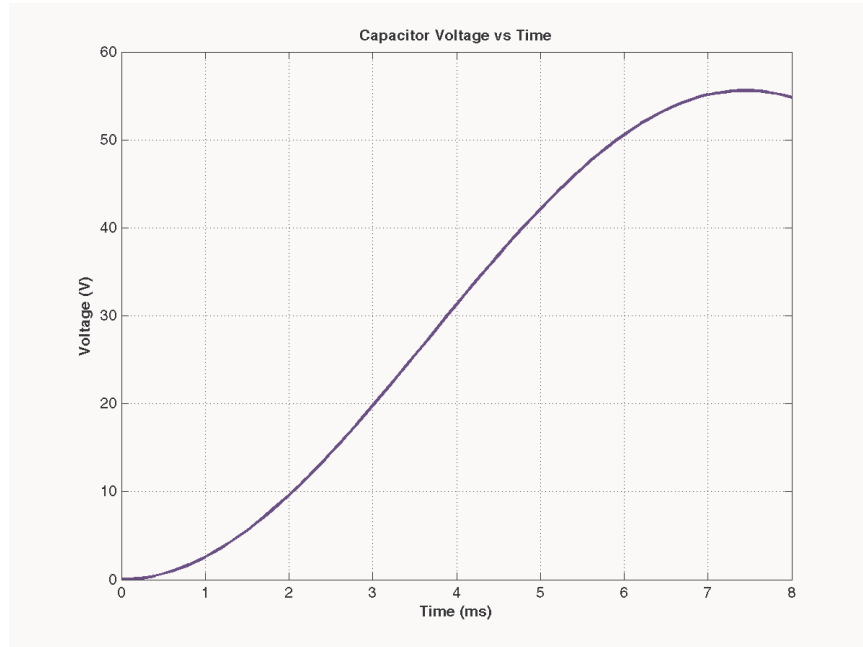

It reaches a voltage of 40 V at a time of 4.8 ms. Since the frequency of the waveform is 60 Hz, the waveform there are 360° in $1/60$ s, and the *firing angle* α is

$$\alpha = (4.8 \text{ ms}) \frac{360^\circ}{1/60 \text{ s}} = 103.7^\circ \text{ or } 1.810 \text{ radians}$$

Note: This problem could also have been solved using Laplace Transforms, if desired.

(b) The rms voltage applied to the load is

$$V_{\text{rms}} = \sqrt{\frac{1}{T} \int_{\alpha}^{\pi/\omega} v(t)^2 dt} = \sqrt{\frac{\omega}{\pi} \int_{\alpha}^{\pi/\omega} V_M^2 \sin^2 \omega t dt}$$

$$V_{\text{rms}} = \sqrt{\frac{V_M^2}{\pi} \left[\frac{1}{2} \omega t - \frac{1}{4} \sin 2\omega t \right]_{\alpha}^{\pi/\omega}}$$

$$V_{\text{rms}} = \sqrt{\frac{V_M^2}{\pi} \left[\frac{1}{2} (\pi - \alpha) - \frac{1}{4} (\sin 2\pi - \sin 2\alpha) \right]}$$

Since $\alpha = 1.180$ radians, the rms voltage is

$$V_{\text{rms}} = V_M \sqrt{0.1753} = 0.419 V_M = 71.0 \text{ V}$$

3-14. Figure P3-9 shows a three-phase full-wave rectifier circuit supplying power to a dc load. The circuit uses SCRs instead of diodes as the rectifying elements.

(a) What will the load voltage and ripple be if each SCR is triggered as soon as it becomes forward biased? At what phase angle should the SCRs be triggered in order to operate this way? Sketch or plot the output voltage for this case.

(b) What will the rms load voltage and ripple be if each SCR is triggered at a phase angle of 90° (that is, half way through the half-cycle in which it is forward biased)? Sketch or plot the output voltage for this case.

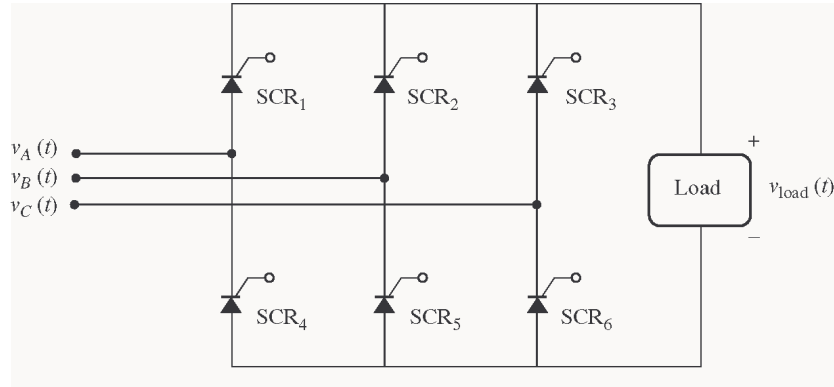

SOLUTION Assume that the three voltages applied to this circuit are:

$$v_A(t) = V_M \sin \omega t$$

$$v_B(t) = V_M \sin(\omega t - 2\pi/3)$$

$$v_C(t) = V_M \sin(\omega t + 2\pi/3)$$

The period of the input waveforms is T , where $T = 2\pi/\omega$. For the purpose of the calculations in this problem, we will assume that ω is 377 rad/s (60 Hz).

(a) The when the SCRs start to conduct as soon as they are forward biased, this circuit is just a three-phase full-wave bridge, and the output voltage is identical to that in Problem 3-2. The sketch of output voltage is reproduced below, and the ripple is 4.2%. The following table shows which SCRs must conduct in what order to create the output voltage shown below. The times are expressed as multiples of the period T of the input waveforms, and the firing angle is in degrees relative to time zero.

Start Time (ωt)	Stop Time (ωt)	Positive Phase	Negative Phase	Conducting SCR (Positive)	Conducting SCR (Negative)	Triggered SCR	Firing Angle
$-T/12$	$T/12$	c	b	SCR ₃	SCR ₅	SCR ₅	-30°
$T/12$	$3T/12$	a	b	SCR ₁	SCR ₅	SCR ₁	30°
$3T/12$	$5T/12$	a	c	SCR ₁	SCR ₆	SCR ₆	90°
$5T/12$	$7T/12$	b	c	SCR ₂	SCR ₆	SCR ₂	150°
$7T/12$	$9T/12$	b	a	SCR ₂	SCR ₄	SCR ₄	210°
$9T/12$	$11T/12$	c	a	SCR ₃	SCR ₄	SCR ₃	270°
$11T/12$	$T/12$	c	b	SCR ₃	SCR ₅	SCR ₅	330°

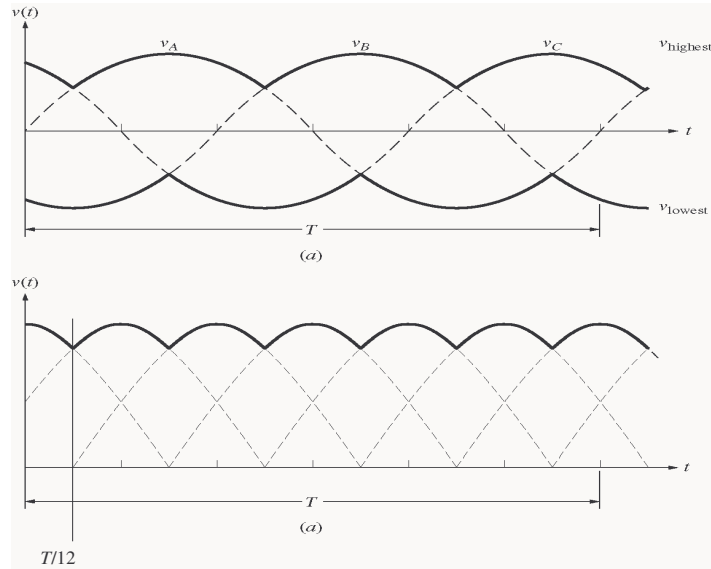

(b) If each SCR is triggered halfway through the half-cycle during which it is forward biased, the resulting phase *a*, *b*, and *c* voltages will be zero before the first half of each half-cycle, and the full sinusoidal value for the second half of each half-cycle. These waveforms are shown below. (These plots were created by the MATLAB program that appears later in this answer.)

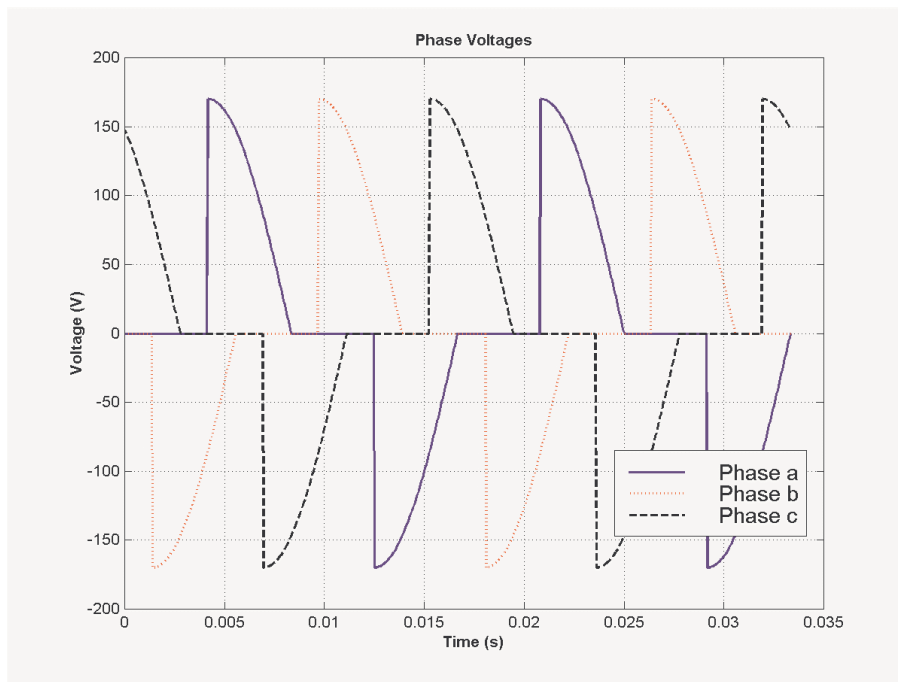

and the resulting output voltage will be:

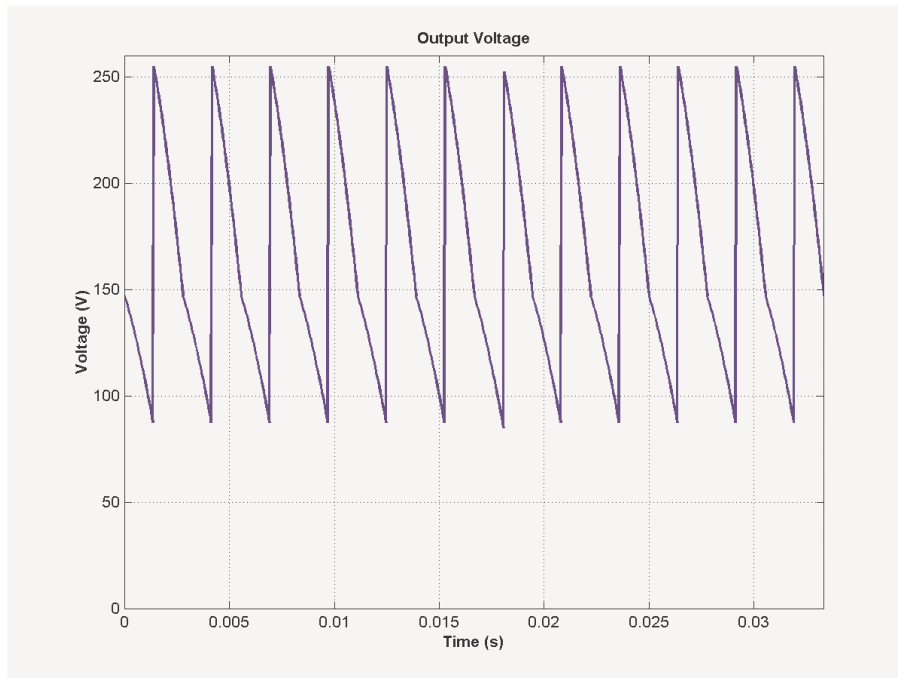

A MATLAB program to generate these waveforms and to calculate the ripple on the output waveform is shown below. The first function `biphase_controller.m` generates a switched ac waveform. The inputs to this function are the current phase angle in degrees, the offset angle of the waveform in degrees, and the firing angle in degrees.

```
function volts = biphase_controller(wt,theta0,fire)
% Function to simulate the output of an ac phase
% angle controller that operates symmetrically on
% positive and negative half cycles. Assume a peak
% voltage VM = 120 * SQRT(2) = 170 V for convenience.
%
%   wt      = Current phase in degrees
%   theta0  = Starting phase angle in degrees
%   fire    = Firing angle in degrees

% Degrees to radians conversion factor
deg2rad = pi / 180;

% Remove phase ambiguities: 0 <= wt < 360 deg
ang = wt + theta0;
while ang >= 360
    ang = ang - 360;
end
while ang < 0
    ang = ang + 360;
end

% Simulate the output of the phase angle controller.
if (ang >= fire & ang <= 180)
    volts = 170 * sin(ang * deg2rad);
elseif (ang >= (fire+180) & ang <= 360)
    volts = 170 * sin(ang * deg2rad);
else
```



```

    volts = 0;
end

```

The main program below creates and plots the three-phase waveforms, calculates and plots the output waveform, and determines the ripple in the output waveform.

```

% M-file: prob3_14b.m
% M-file to calculate and plot the three phase voltages
% when each SCR in a three-phase full-wave rectifier
% triggers at a phase angle of 90 degrees.

% Calculate the waveforms for times from 0 to 1/30 s
t = (0:1/21600:1/30);
deg = zeros(size(t));
rms = zeros(size(t));
va = zeros(size(t));
vb = zeros(size(t));
vc = zeros(size(t));
out = zeros(size(t));
for ii = 1:length(t)

    % Get equivalent angle in degrees. Note that
    % 1/60 s = 360 degrees for a 60 Hz waveform!
    theta = 21600 * t(ii);

    % Calculate the voltage in each phase at each
    % angle.
    va(ii) = biphas_controller(theta,0,90);
    vb(ii) = biphas_controller(theta,-120,90);
    vc(ii) = biphas_controller(theta,120,90);

end

% Calculate the output voltage of the rectifier
for ii = 1:length(t)
    vals = [ va(ii) vb(ii) vc(ii) ];
    out(ii) = max( vals ) - min( vals );
end

% Calculate and display the ripple
disp( ['The ripple is ' num2str(ripple(out))] );

% Plot the voltages versus time
figure(1)
plot(t,va,'b','Linewidth',2.0);
hold on;
plot(t,vb,'r','Linewidth',2.0);
plot(t,vc,'k--','Linewidth',2.0);
title('\bfPhase Voltages');
xlabel('\bfTime (s)');
ylabel('\bfVoltage (V)');
grid on;
legend('Phase a','Phase b','Phase c');
hold off;

```

```

% Plot the output voltages versus time
figure(2)
plot(t,out,'b','Linewidth',2.0);
title('\bfOutput Voltage');
xlabel('\bfTime (s)');
ylabel('\bfVoltage (V)');
axis( [0 1/30 0 260]);
grid on;
hold off;

```

When this program is executed, the results are:

```

» prob_3_14b
The ripple is 30.9547

```

3-15. Write a MATLAB program that imitates the operation of the Pulse-Width Modulation circuit shown in Figure 3-55, and answer the following questions.

- Assume that the comparison voltages $v_x(t)$ and $v_y(t)$ have peak amplitudes of 10 V and a frequency of 500 Hz. Plot the output voltage when the input voltage is $v_{in}(t) = 10 \sin 2\pi ft$ V, and $f = 50$ Hz.
- What does the spectrum of the output voltage look like? What could be done to reduce the harmonic content of the output voltage?
- Now assume that the frequency of the comparison voltages is increased to 1000 Hz. Plot the output voltage when the input voltage is $v_{in}(t) = 10 \sin 2\pi ft$ V, and $f = 50$ Hz.
- What does the spectrum of the output voltage in (c) look like?
- What is the advantage of using a higher comparison frequency and more rapid switching in a PWM modulator?

SOLUTION The PWM circuit is shown below:

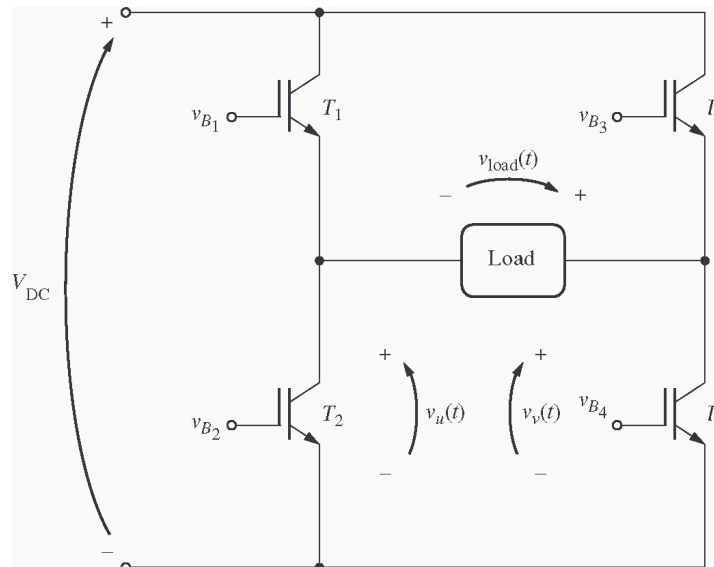

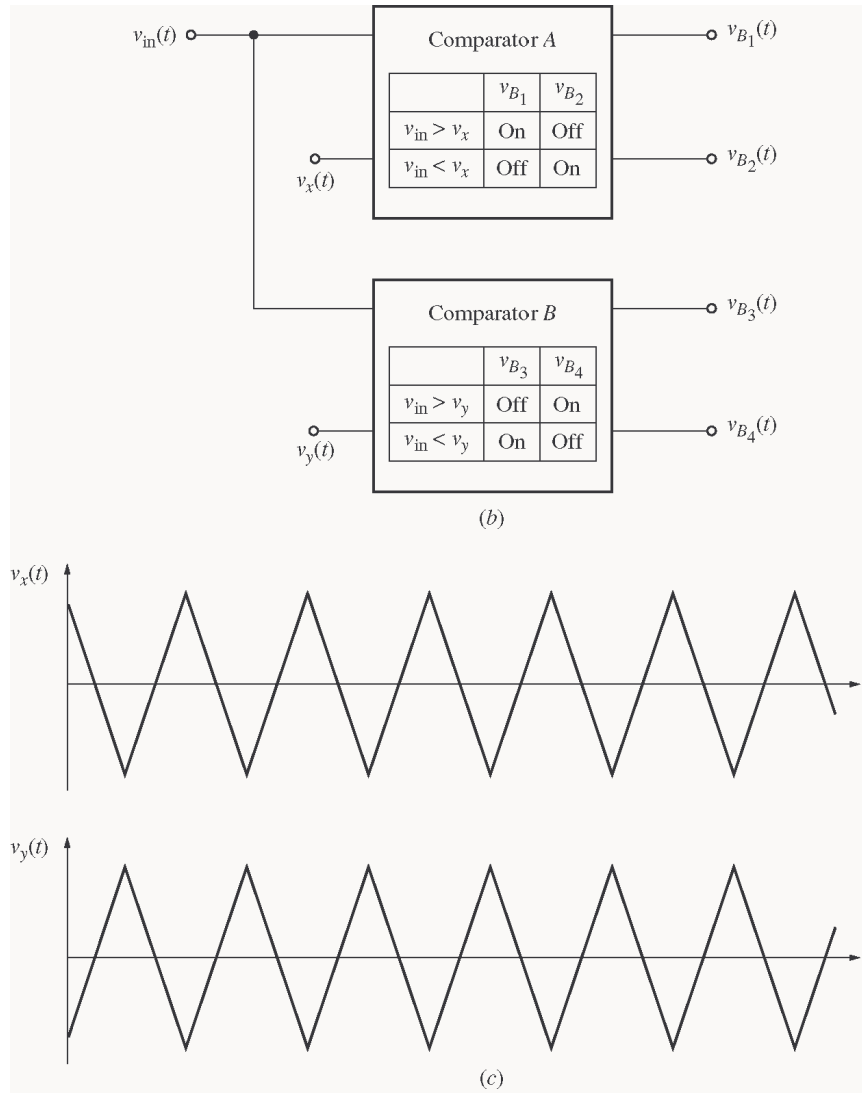

(a) To write a MATLAB simulator of this circuit, note that if $v_{in} > v_x$, then $v_u = V_{DC}$, and if $v_{in} < v_x$, then $v_u = 0$. Similarly, if $v_{in} > v_y$, then $v_v = 0$, and if $v_{in} < v_y$, then $v_v = V_{DC}$. The output voltage is then $v_{out} = v_v - v_u$. A MATLAB function that performs these calculations is shown below. (Note that this function arbitrarily assumes that $V_{DC} = 100$ V. It would be easy to modify the function to use any arbitrary dc voltage, if desired.)

```
function [vout,vu,vv] = vout(vin, vx, vy)
% Function to calculate the output voltage of a
% PWM modulator from the values of vin and the
% reference voltages vx and vy. This function
% arbitrarily assumes that VDC = 100 V.
%
% vin    = Input voltage
% vx     = x reference
% vy     = y reference
% vout   = Output voltage
% vu, vv = Components of output voltage
```

```

% fire = Firing angle in degrees

% vu
if ( vin > vx )
    vu = 100;
else
    vu = 0;
end

% vv
if ( vin >= vy )
    vv = 0;
else
    vv = 100;
end

% Caclulate vout
vout = vv - vu;

```

Now we need a MATLAB program to generate the input voltage $v_{in}(t)$ and the reference voltages $v_x(t)$ and $v_y(t)$. After the voltages are generated, function vout will be used to calculate $v_{out}(t)$ and the frequency spectrum of $v_{out}(t)$. Finally, the program will plot $v_{in}(t)$, $v_x(t)$ and $v_y(t)$, $v_{out}(t)$, and the spectrum of $v_{out}(t)$. (Note that in order to have a valid spectrum, we need to create several cycles of the 60 Hz output waveform, and we need to sample the data at a fairly high frequency. This problem creates 4 cycles of $v_{out}(t)$ and samples all data at a 20,000 Hz rate.)

```

% M-file: prob3_15a.m
% M-file to calculate the output voltage from a PWM
% modulator with a 500 Hz reference frequency. Note
% that the only change between this program and that
% of part b is the frequency of the reference "fr".

% Sample the data at 20000 Hz to get enough information
% for spectral analysis. Declare arrays.
fs = 20000; % Sampling frequency (Hz)
t = (0:1/fs:4/15); % Time in seconds
vx = zeros(size(t)); % vx
vy = zeros(size(t)); % vy
vin = zeros(size(t)); % Driving signal
vu = zeros(size(t)); % vx
vv = zeros(size(t)); % vy
vout = zeros(size(t)); % Output signal
fr = 500; % Frequency of reference signal
T = 1/fr; % Period of refernce signal

% Calculate vx at fr = 500 Hz.
for ii = 1:length(t)
    vx(ii) = vref(t(ii),T);
    vy(ii) = - vx(ii);
end

% Calculate vin as a 50 Hz sine wave with a peak voltage of

```

```

% 10 V.
for ii = 1:length(t)
    vin(ii) = 10 * sin(2*pi*50*t(ii));
end

% Now calculate vout
for ii = 1:length(t)
    [vout(ii) vu(ii) vv(ii)] = vout(vin(ii), vx(ii), vy(ii));
end

% Plot the reference voltages vs time
figure(1)
plot(t,vx,'b','Linewidth',1.0);
hold on;
plot(t,vy,'k--','Linewidth',1.0);
title('\bfReference Voltages for fr = 500 Hz');
xlabel('\bfTime (s)');
ylabel('\bfVoltage (V)');
legend('vx','vy');
axis( [0 1/30 -10 10]);
hold off;

% Plot the input voltage vs time
figure(2)
plot(t,vin,'b','Linewidth',1.0);
title('\bfInput Voltage');
xlabel('\bfTime (s)');
ylabel('\bfVoltage (V)');
axis( [0 1/30 -10 10]);

% Plot the output voltages versus time
figure(3)
plot(t,vout,'b','Linewidth',1.0);
title('\bfOutput Voltage for fr = 500 Hz');
xlabel('\bfTime (s)');
ylabel('\bfVoltage (V)');
axis( [0 1/30 -120 120]);

% Now calculate the spectrum of the output voltage
spec = fft(vout);

% Calculate sampling frequency labels
len = length(t);
df = fs / len;
fstep = zeros(size(t));
for ii = 2:len/2
    fstep(ii) = df * (ii-1);
    fstep(len-ii+2) = -fstep(ii);
end

% Plot the spectrum
figure(4);
plot(fftshift(fstep),fftshift(abs(spec)));
title('\bfSpectrum of Output Voltage for fr = 500 Hz');
xlabel('\bfFrequency (Hz)');
ylabel('\bfAmplitude');

```

```

% Plot a closeup of the near spectrum
% (positive side only)
figure(5);
plot(fftshift(fstep),fftshift(abs(spec)));
title('\bfSpectrum of Output Voltage for fr = 500 Hz');
xlabel('\bfFrequency (Hz)');
ylabel('\bfAmplitude');
set(gca,'Xlim',[0 1000]);

```

When this program is executed, the input, reference, and output voltages are:

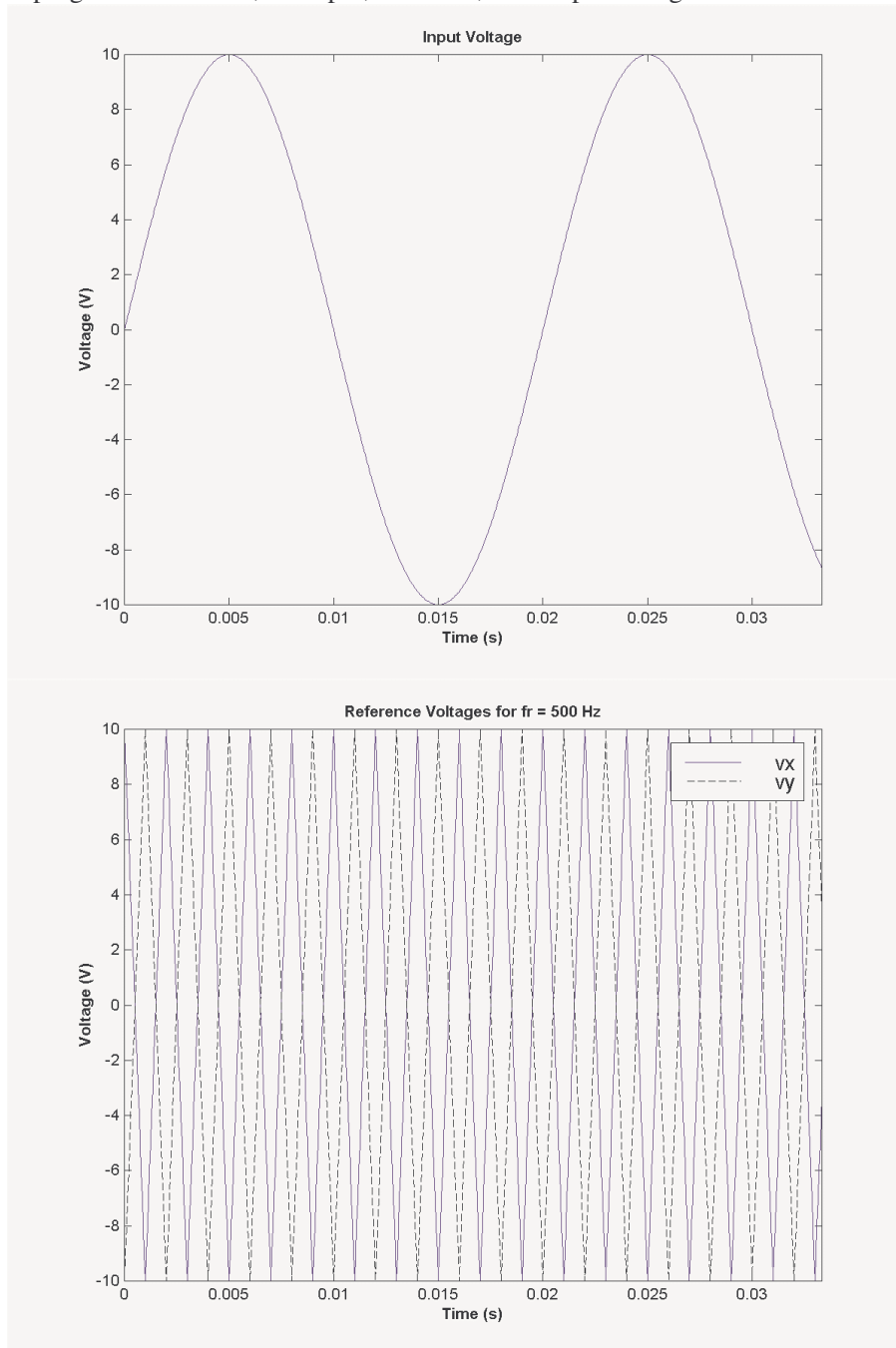

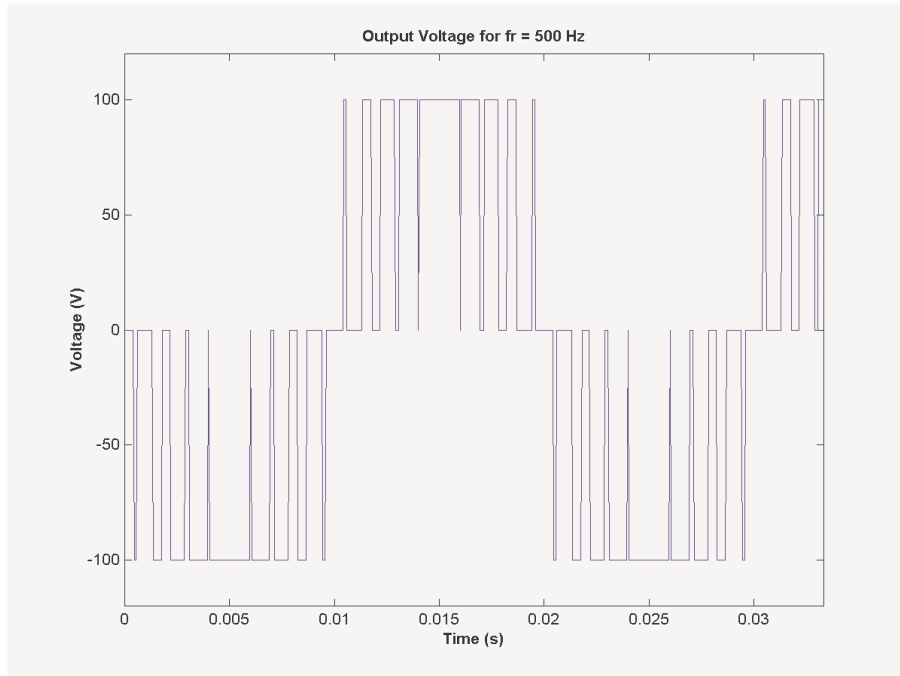

(b) The output spectrum of this PWM modulator is shown below. There are two plots here, one showing the entire spectrum, and the other one showing the close-in frequencies (those under 1000 Hz), which will have the most effect on machinery. Note that there is a sharp peak at 50 Hz, which is there desired frequency, but there are also strong contaminating signals at about 850 Hz and 950 Hz. If necessary, these components could be filtered out using a low-pass filter.

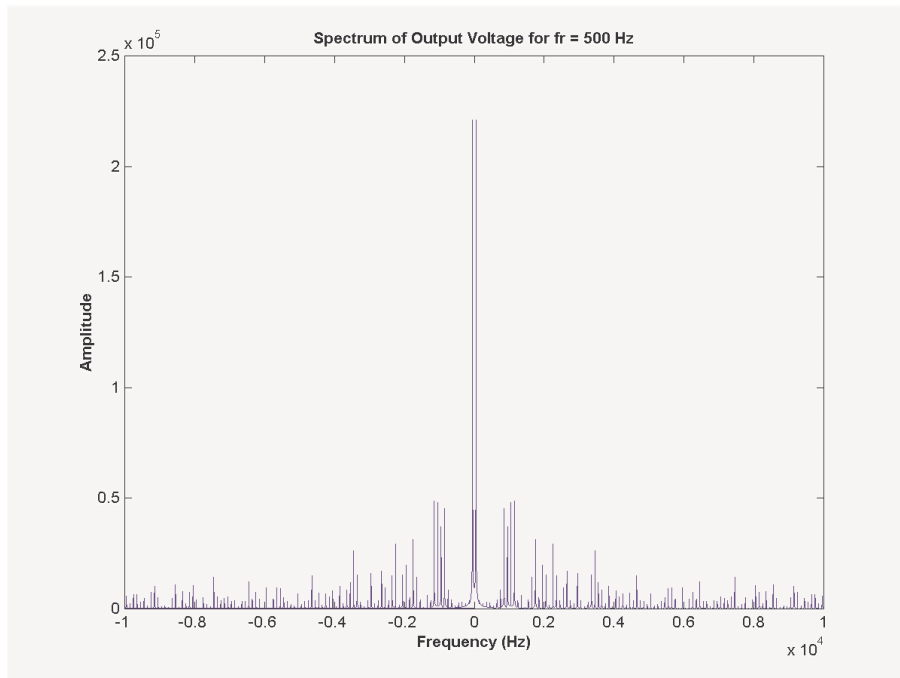

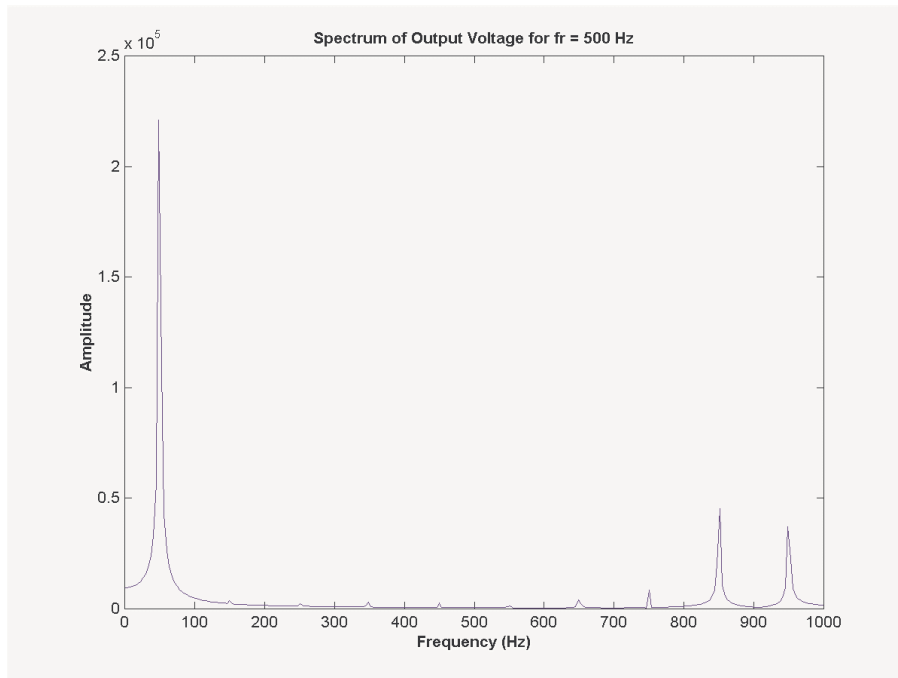

(c) A version of the program with 1000 Hz reference functions is shown below:

```
% M-file: prob3_15b.m
% M-file to calculate the output voltage from a PWM
% modulator with a 1000 Hz reference frequency. Note
% that the only change between this program and that
% of part a is the frequency of the reference "fr".

% Sample the data at 20000 Hz to get enough information
% for spectral analysis. Declare arrays.
fs = 20000;           % Sampling frequency (Hz)
t = (0:1/fs:4/15);   % Time in seconds
vx = zeros(size(t)); % vx
vy = zeros(size(t)); % vy
vin = zeros(size(t)); % Driving signal
vu = zeros(size(t)); % vx
vv = zeros(size(t)); % vy
vout = zeros(size(t)); % Output signal
fr = 1000;           % Frequency of reference signal
T = 1/fr;            % Period of reference signal

% Calculate vx at 1000 Hz.
for ii = 1:length(t)
    vx(ii) = vref(t(ii),T);
    vy(ii) = - vx(ii);
end

% Calculate vin as a 50 Hz sine wave with a peak voltage of
% 10 V.
for ii = 1:length(t)
    vin(ii) = 10 * sin(2*pi*50*t(ii));
end
```



```

% Now calculate vout
for ii = 1:length(t)
    [vout(ii) vu(ii) vv(ii)] = vout(vin(ii), vx(ii), vy(ii));
end

% Plot the reference voltages vs time
figure(1)
plot(t,vx,'b','Linewidth',1.0);
hold on;
plot(t,vy,'k--','Linewidth',1.0);
title('\bfReference Voltages for fr = 1000 Hz');
xlabel('\bfTime (s)');
ylabel('\bfVoltage (V)');
legend('vx','vy');
axis( [0 1/30 -10 10]);
hold off;

% Plot the input voltage vs time
figure(2)
plot(t,vin,'b','Linewidth',1.0);
title('\bfInput Voltage');
xlabel('\bfTime (s)');
ylabel('\bfVoltage (V)');
axis( [0 1/30 -10 10]);

% Plot the output voltages versus time
figure(3)
plot(t,vout,'b','Linewidth',1.0);
title('\bfOutput Voltage for fr = 1000 Hz');
xlabel('\bfTime (s)');
ylabel('\bfVoltage (V)');
axis( [0 1/30 -120 120]);

% Now calculate the spectrum of the output voltage
spec = fft(vout);

% Calculate sampling frequency labels
len = length(t);
df = fs / len;
fstep = zeros(size(t));
for ii = 2:len/2
    fstep(ii) = df * (ii-1);
    fstep(len-ii+2) = -fstep(ii);
end

% Plot the spectrum
figure(4);
plot(fftshift(fstep),fftshift(abs(spec)));
title('\bfSpectrum of Output Voltage for fr = 1000 Hz');
xlabel('\bfFrequency (Hz)');
ylabel('\bfAmplitude');

% Plot a closeup of the near spectrum
% (positive side only)
figure(5);
plot(fftshift(fstep),fftshift(abs(spec)));

```

```
title('\bfSpectrum of Output Voltage for fr = 1000 Hz');  
xlabel('\bfFrequency (Hz)');  
ylabel('\bfAmplitude');  
set(gca,'Xlim',[0 1000]);
```

When this program is executed, the input, reference, and output voltages are:

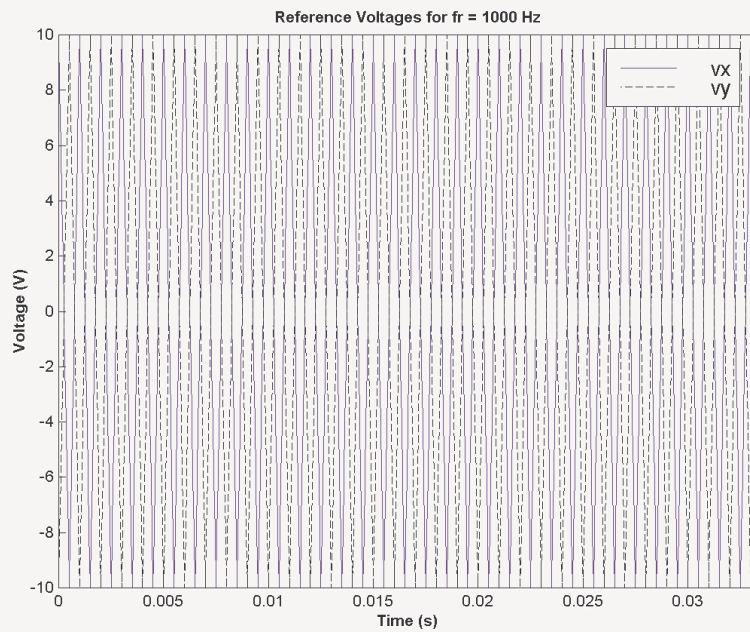
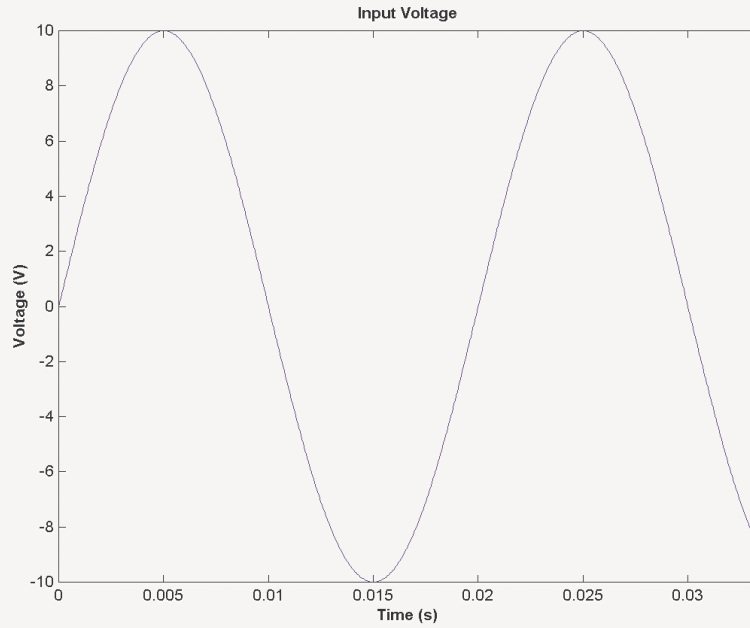

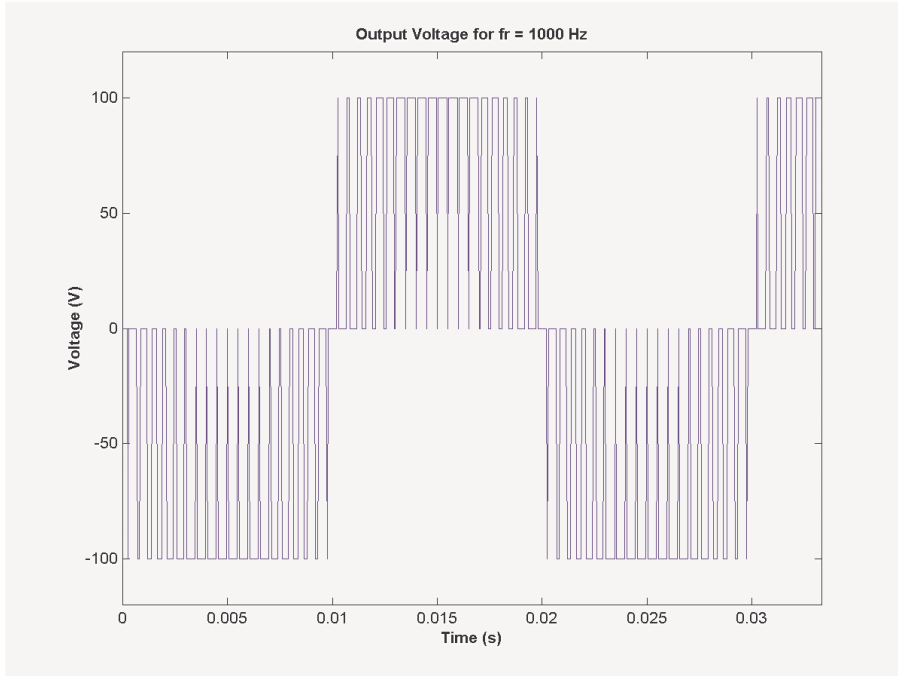

(d) The output spectrum of this PWM modulator is shown below.

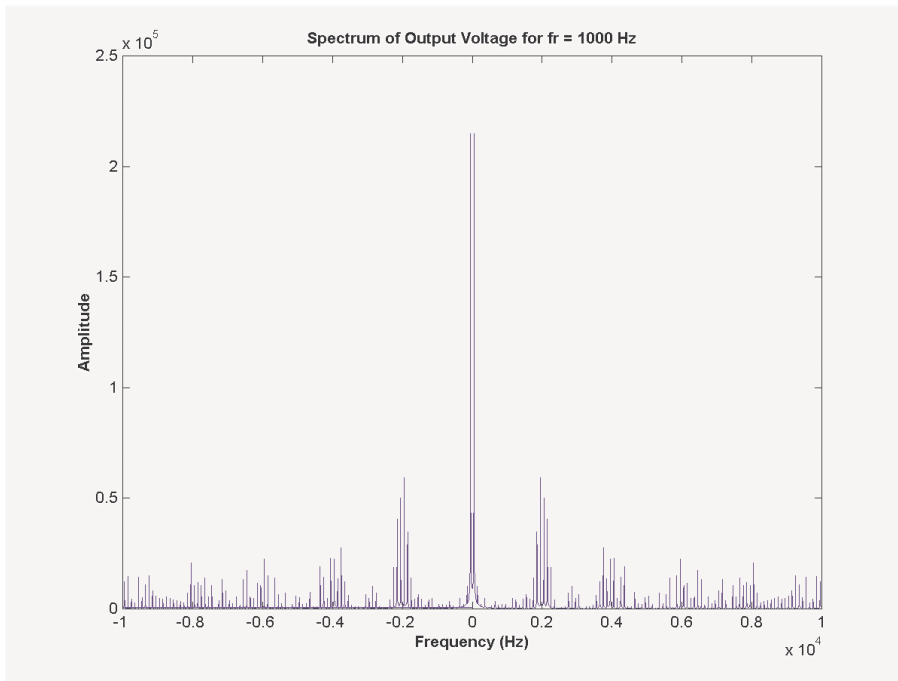

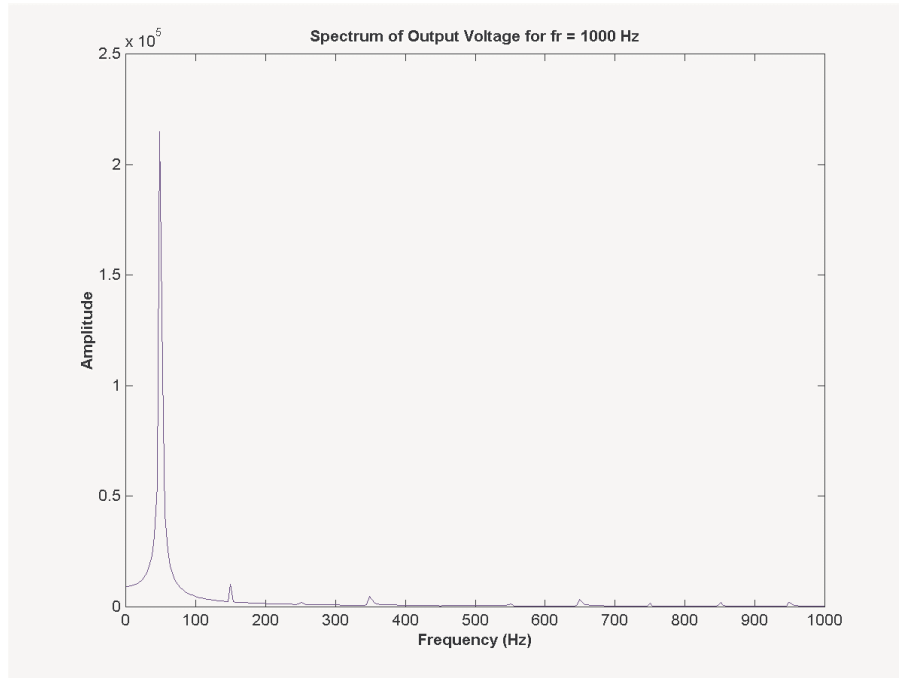

(e) Comparing the spectra in (b) and (d), we can see that the frequencies of the first large sidelobes doubled from about 900 Hz to about 1800 Hz when the reference frequency was doubled. This increase in sidelobe frequency has two major advantages: it makes the harmonics easier to filter, and it also makes it less necessary to filter them at all. Since large machines have their own internal inductances, they form natural low-pass filters. If the contaminating sidelobes are at high enough frequencies, they will never affect the operation of the machine. Thus, it is a good idea to design PWM modulators with a high frequency reference signal and rapid switching.

Chapter 4: AC Machinery Fundamentals

4-1. The simple loop is rotating in a uniform magnetic field shown in Figure 4-1 has the following characteristics:

$$\mathbf{B} = 0.5 \text{ T to the right} \quad r = 0.1 \text{ m}$$

$$l = 0.5 \text{ m} \quad \omega = 103 \text{ rad/s}$$

- Calculate the voltage $e_{\text{tot}}(t)$ induced in this rotating loop.
- Suppose that a 5Ω resistor is connected as a load across the terminals of the loop. Calculate the current that would flow through the resistor.
- Calculate the magnitude and direction of the induced torque on the loop for the conditions in (b).
- Calculate the electric power being generated by the loop for the conditions in (b).
- Calculate the mechanical power being consumed by the loop for the conditions in (b). How does this number compare to the amount of electric power being generated by the loop?

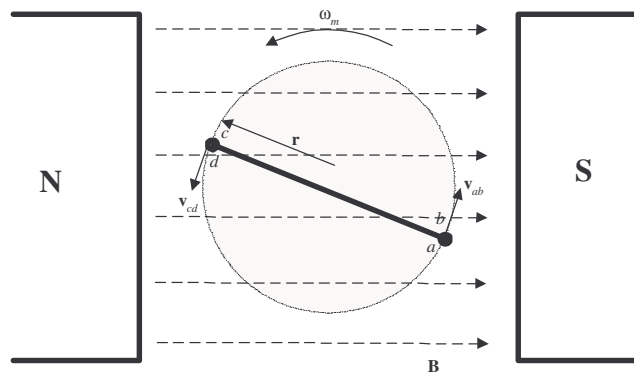

\mathbf{B} is a uniform magnetic field, aligned as shown.

SOLUTION

(a) The induced voltage on a simple rotating loop is given by

$$e_{\text{ind}}(t) = 2r\omega Bl \sin \omega t \quad (4-8)$$

$$e_{\text{ind}}(t) = 2(0.1 \text{ m})(103 \text{ rad/s})(0.5 \text{ T})(0.5 \text{ m}) \sin 103t$$

$$e_{\text{ind}}(t) = 5.15 \sin 103t \text{ V}$$

(b) If a 5Ω resistor is connected as a load across the terminals of the loop, the current flow would be:

$$i(t) = \frac{e_{\text{ind}}}{R} = \frac{5.15 \sin 103t \text{ V}}{5 \Omega} = 1.03 \sin 103t \text{ A}$$

(c) The induced torque would be:

$$\tau_{\text{ind}}(t) = 2rilB \sin \theta \quad (4-17)$$

$$\tau_{\text{ind}}(t) = 2(0.1 \text{ m})(1.03 \sin \omega t \text{ A})(0.5 \text{ m})(0.5 \text{ T}) \sin \omega t$$

$$\tau_{\text{ind}}(t) = 0.0515 \sin^2 \omega t \text{ N} \cdot \text{m, counterclockwise}$$

(d) The instantaneous power generated by the loop is:

$$P(t) = e_{\text{ind}} i = (5.15 \sin \omega t \text{ V})(1.03 \sin \omega t \text{ A}) = 5.30 \sin^2 \omega t \text{ W}$$

The average power generated by the loop is

$$P_{\text{ave}} = \frac{1}{T} \int_0^T 5.30 \sin^2 \omega t \, dt = 2.65 \text{ W}$$

(e) The mechanical power being consumed by the loop is:

$$P = \tau_{\text{ind}} \omega = (0.0515 \sin^2 \omega t \text{ V})(103 \text{ rad/s}) = 5.30 \sin^2 \omega t \text{ W}$$

Note that the amount of mechanical power consumed by the loop is equal to the amount of electrical power created by the loop. This machine is acting as a generator, converting mechanical power into electrical power.

- 4-2.** Develop a table showing the speed of magnetic field rotation in ac machines of 2, 4, 6, 8, 10, 12, and 14 poles operating at frequencies of 50, 60, and 400 Hz.

SOLUTION The equation relating the speed of magnetic field rotation to the number of poles and electrical frequency is

$$n_m = \frac{120 f_e}{P}$$

The resulting table is

Number of Poles	$f_e = 50 \text{ Hz}$	$f_e = 60 \text{ Hz}$	$f_e = 400 \text{ Hz}$
2	3000 r/min	3600 r/min	24000 r/min
4	1500 r/min	1800 r/min	12000 r/min
6	1000 r/min	1200 r/min	8000 r/min
8	750 r/min	900 r/min	6000 r/min
10	600 r/min	720 r/min	4800 r/min
12	500 r/min	600 r/min	4000 r/min
14	428.6 r/min	514.3 r/min	3429 r/min

- 4-3.** A three-phase four-pole winding is installed in 12 slots on a stator. There are 40 turns of wire in each slot of the windings. All coils in each phase are connected in series, and the three phases are connected in Δ . The flux per pole in the machine is 0.060 Wb, and the speed of rotation of the magnetic field is 1800 r/min.
- (a) What is the frequency of the voltage produced in this winding?
- (b) What are the resulting phase and terminal voltages of this stator?

SOLUTION

(a) The frequency of the voltage produced in this winding is

$$f_e = \frac{n_m P}{120} = \frac{(1800 \text{ r/min})(4 \text{ poles})}{120} = 60 \text{ Hz}$$

(b) There are 12 slots on this stator, with 40 turns of wire per slot. Since this is a four-pole machine, there are two sets of coils (4 slots) associated with each phase. The voltage in the coils in one pair of slots is

$$E_A = \sqrt{2} \pi N_c \phi f = \sqrt{2} \pi (40 \text{ t})(0.060 \text{ Wb})(60 \text{ Hz}) = 640 \text{ V}$$

There are two sets of coils per phase, since this is a four-pole machine, and they are connected in series, so the total phase voltage is

$$V_\phi = 2(640 \text{ V}) = 1280 \text{ V}$$

Since the machine is Δ -connected, $V_L = V_\phi = 1280 \text{ V}$.

- 4-4.** A three-phase Y-connected 50-Hz two-pole synchronous machine has a stator with 2000 turns of wire per phase. What rotor flux would be required to produce a terminal (line-to-line) voltage of 6 kV?

SOLUTION The phase voltage of this machine should be $V_\phi = V_L / \sqrt{3} = 3464 \text{ V}$. The induced voltage per phase in this machine (which is equal to V_ϕ at no-load conditions) is given by the equation

$$E_A = \sqrt{2}\pi N_c \phi f$$

so

$$\phi = \frac{E_A}{\sqrt{2}\pi N_c f} = \frac{3464 \text{ V}}{\sqrt{2}\pi(2000 \text{ t})(50 \text{ Hz})} = 0.0078 \text{ Wb}$$

- 4-5.** Modify the MATLAB program in Example 4-1 by swapping the currents flowing in any two phases. What happens to the resulting net magnetic field?

SOLUTION This modification is very simple—just swap the currents supplied to two of the three phases.

```
% M-file: mag_field2.m
% M-file to calculate the net magnetic field produced
% by a three-phase stator.

% Set up the basic conditions
bmax = 1;           % Normalize bmax to 1
freq = 60;         % 60 Hz
w = 2*pi*freq;     % angular velocity (rad/s)

% First, generate the three component magnetic fields
t = 0:1/6000:1/60;
Baa = sin(w*t) .* (cos(0) + j*sin(0));
Bbb = sin(w*t+2*pi/3) .* (cos(2*pi/3) + j*sin(2*pi/3));
Bcc = sin(w*t-2*pi/3) .* (cos(-2*pi/3) + j*sin(-2*pi/3));

% Calculate Bnet
Bnet = Baa + Bbb + Bcc;

% Calculate a circle representing the expected maximum
% value of Bnet
circle = 1.5 * (cos(w*t) + j*sin(w*t));

% Plot the magnitude and direction of the resulting magnetic
% fields. Note that Baa is black, Bbb is blue, Bcc is
% magenta, and Bnet is red.
for ii = 1:length(t)

    % Plot the reference circle
    plot(circle, 'k');
    hold on;

    % Plot the four magnetic fields
    plot([0 real(Baa(ii))], [0 imag(Baa(ii))], 'k', 'LineWidth', 2);
    plot([0 real(Bbb(ii))], [0 imag(Bbb(ii))], 'b', 'LineWidth', 2);
```

```

plot([0 real(Bcc(ii))],[0 imag(Bcc(ii))],'m','LineWidth',2);
plot([0 real(Bnet(ii))],[0 imag(Bnet(ii))],'r','LineWidth',3);
axis square;
axis([-2 2 -2 2]);
drawnow;
hold off;

```

end

When this program executes, the net magnetic field rotates clockwise, instead of counterclockwise.

- 4-6. If an ac machine has the rotor and stator magnetic fields shown in Figure P4-1, what is the direction of the induced torque in the machine? Is the machine acting as a motor or generator?

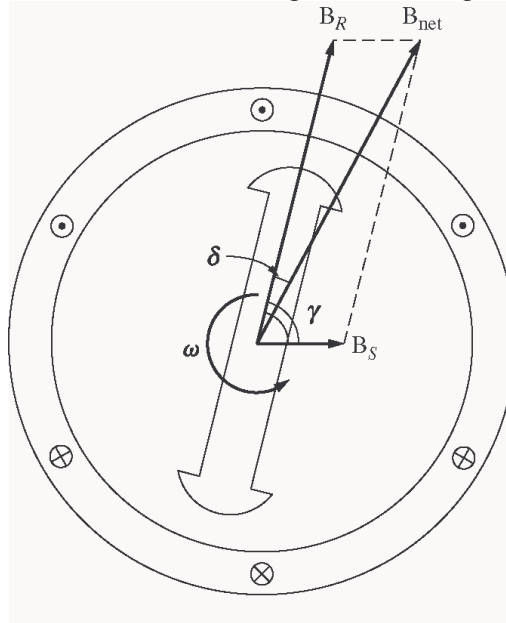

SOLUTION Since $\tau_{\text{ind}} = k\mathbf{B}_R \times \mathbf{B}_{\text{net}}$, the induced torque is *clockwise*, opposite the direction of motion. The machine is acting as a *generator*.

- 4-7. The flux density distribution over the surface of a two-pole stator of radius r and length l is given by

$$B = B_M \cos(\omega_m t - \alpha) \quad (4-37b)$$

Prove that the total flux under each pole face is

$$\phi = 2rlB_M$$

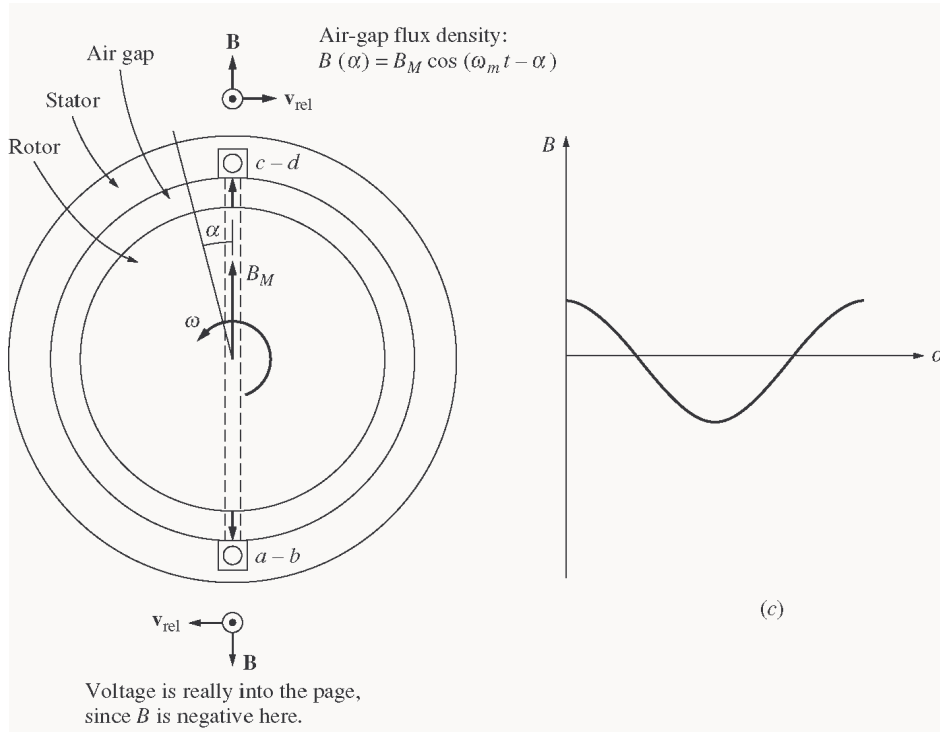

SOLUTION The total flux under a pole face is given by the equation

$$\phi = \mathbf{B} \cdot d\mathbf{A}$$

Under a pole face, the flux density \mathbf{B} is always parallel to the vector $d\mathbf{A}$, since the flux density is always perpendicular to the surface of the rotor and stator in the air gap. Therefore,

$$\phi = B dA$$

A differential area on the surface of a cylinder is given by the differential length along the cylinder (dl) times the differential width around the radius of the cylinder ($r d\theta$).

$$dA = (dl)(r d\theta) \quad \text{where } r \text{ is the radius of the cylinder}$$

Therefore, the flux under the pole face is

$$\phi = B dl r d\theta$$

Since r is constant and B is constant with respect to l , this equation reduces to

$$\phi = rl B d\theta$$

Now, $B = B_M \cos(\omega t - \alpha) = B_M \cos \theta$ (when we substitute $\theta = \omega t - \alpha$), so

$$\phi = rl B d\theta$$

$$\phi = rl \int_{-\pi/2}^{\pi/2} B_M \cos \theta d\theta = rl B_M \left[\sin \theta \right]_{-\pi/2}^{\pi/2} = rl B_M (1 - (-1))$$

$$\phi = 2rl B_M$$

4-8. In the early days of ac motor development, machine designers had great difficulty controlling the core losses (hysteresis and eddy currents) in machines. They had not yet developed steels with low hysteresis, and were not making laminations as thin as the ones used today. To help control these losses, early ac motors in the USA were run from a 25 Hz ac power supply, while lighting systems were run from a separate 60 Hz ac power supply.

- (a) Develop a table showing the speed of magnetic field rotation in ac machines of 2, 4, 6, 8, 10, 12, and 14 poles operating at 25 Hz. What was the fastest rotational speed available to these early motors?
- (b) For a given motor operating at a constant flux density B , how would the core losses of the motor running at 25 Hz compare to the core losses of the motor running at 60 Hz?
- (c) Why did the early engineers provide a separate 60 Hz power system for lighting?

SOLUTION

(a) The equation relating the speed of magnetic field rotation to the number of poles and electrical frequency is

$$n_m = \frac{120 f_e}{P}$$

The resulting table is

Number of Poles	$f_e = 25 \text{ Hz}$
2	1500 r/min
4	750 r/min
6	500 r/min
8	375 r/min
10	300 r/min
12	250 r/min
14	214.3 r/min

The highest possible rotational speed was 1500 r/min.

(b) Core losses scale according to the 1.5th power of the speed of rotation, so the ratio of the core losses at 25 Hz to the core losses at 60 Hz (for a given machine) would be:

$$\text{ratio} = \frac{1500}{3600}^{1.5} = 0.269 \text{ or } 26.9\%$$

(c) At 25 Hz, the light from incandescent lamps would visibly flicker in a very annoying way.

Chapter 5: Synchronous Generators

- 5-1.** At a location in Europe, it is necessary to supply 300 kW of 60-Hz power. The only power sources available operate at 50 Hz. It is decided to generate the power by means of a motor-generator set consisting of a synchronous motor driving a synchronous generator. How many poles should each of the two machines have in order to convert 50-Hz power to 60-Hz power?

SOLUTION The speed of a synchronous machine is related to its frequency by the equation

$$n_m = \frac{120 f_e}{P}$$

To make a 50 Hz and a 60 Hz machine have the same mechanical speed so that they can be coupled together, we see that

$$n_{\text{sync}} = \frac{120(50 \text{ Hz})}{P_1} = \frac{120(60 \text{ Hz})}{P_2}$$

$$\frac{P_2}{P_1} = \frac{6}{5} = \frac{12}{10}$$

Therefore, a 10-pole synchronous motor must be coupled to a 12-pole synchronous generator to accomplish this frequency conversion.

- 5-2.** A 2300-V 1000-kVA 0.8-PF-lagging 60-Hz two-pole Y-connected synchronous generator has a synchronous reactance of 1.1Ω and an armature resistance of 0.15Ω . At 60 Hz, its friction and windage losses are 24 kW, and its core losses are 18 kW. The field circuit has a dc voltage of 200 V, and the maximum I_f is 10 A. The resistance of the field circuit is adjustable over the range from 20 to 200 Ω . The OCC of this generator is shown in Figure P5-1.

- (a) How much field current is required to make V_T equal to 2300 V when the generator is running at no load?
- (b) What is the internal generated voltage of this machine at rated conditions?
- (c) How much field current is required to make V_T equal to 2300 V when the generator is running at rated conditions?
- (d) How much power and torque must the generator's prime mover be capable of supplying?
- (e) Construct a capability curve for this generator.

Note: An electronic version of this open circuit characteristic can be found in file p51_occ.dat, which can be used with MATLAB programs. Column 1 contains field current in amps, and column 2 contains open-circuit terminal voltage in volts.

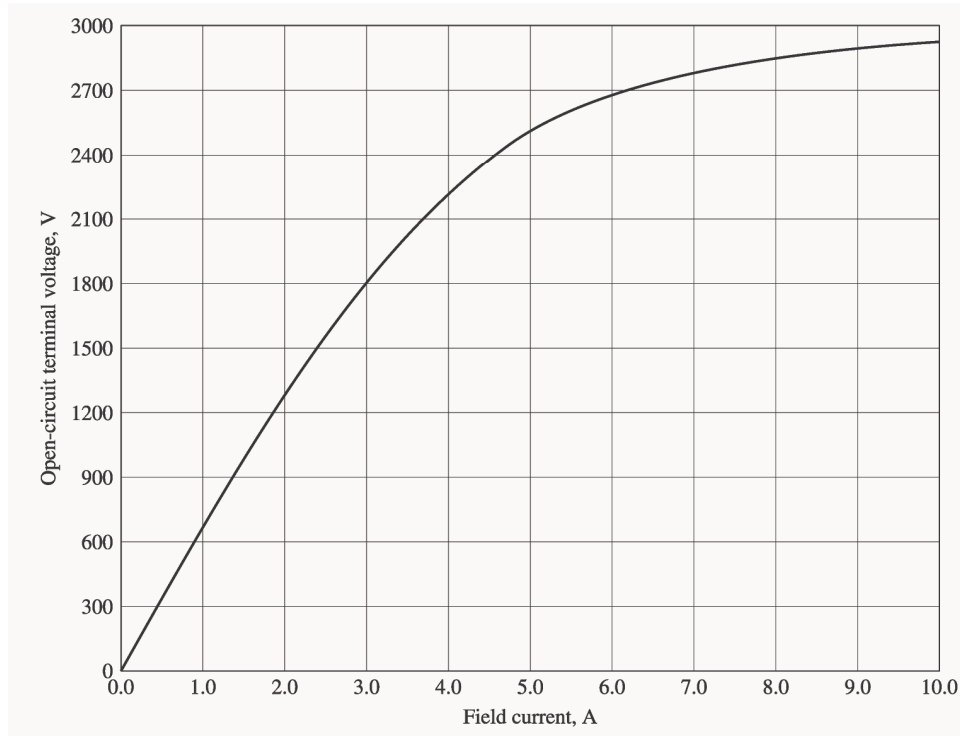

SOLUTION

(a) If the no-load terminal voltage is 2300 V, the required field current can be read directly from the open-circuit characteristic. It is 4.25 A.

(b) This generator is Y-connected, so $I_L = I_A$. At rated conditions, the line and phase current in this generator is

$$I_A = I_L = \frac{P}{\sqrt{3} V_L} = \frac{1000 \text{ kVA}}{\sqrt{3} (2300 \text{ V})} = 251 \text{ A at an angle of } -36.87^\circ$$

The phase voltage of this machine is $V_\phi = V_T / \sqrt{3} = 1328 \text{ V}$. The internal generated voltage of the machine is

$$\mathbf{E}_A = \mathbf{V}_\phi + R_A \mathbf{I}_A + jX_S \mathbf{I}_A$$

$$\mathbf{E}_A = 1328 \angle 0^\circ + (0.15 \Omega)(251 \angle -36.87^\circ \text{ A}) + j(1.1 \Omega)(251 \angle -36.87^\circ \text{ A})$$

$$\mathbf{E}_A = 1537 \angle 7.4^\circ \text{ V}$$

(c) The equivalent open-circuit terminal voltage corresponding to an E_A of 1537 volts is

$$V_{T,oc} = \sqrt{3}(1527 \text{ V}) = 2662 \text{ V}$$

From the OCC, the required field current is 5.9 A.

(d) The input power to this generator is equal to the output power plus losses. The rated output power is

$$P_{OUT} = (1000 \text{ kVA})(0.8) = 800 \text{ kW}$$

$$P_{CU} = 3I_A^2 R_A = 3(251 \text{ A})^2 (0.15 \Omega) = 28.4 \text{ kW}$$

$$P_{F\&W} = 24 \text{ kW}$$

$$P_{\text{core}} = 18 \text{ kW}$$

$$P_{\text{stray}} = (\text{assumed } 0)$$

$$P_{\text{IN}} = P_{\text{OUT}} + P_{\text{CU}} + P_{\text{F\&W}} + P_{\text{core}} + P_{\text{stray}} = 870.4 \text{ kW}$$

Therefore the prime mover must be capable of supplying 175 kW. Since the generator is a two-pole 60 Hz machine, to must be turning at 3600 r/min. The required torque is

$$\tau_{\text{APP}} = \frac{P_{\text{IN}}}{\omega_m} = \frac{175.2 \text{ kW}}{(3600 \text{ r/min}) \left(\frac{1 \text{ min}}{60 \text{ s}} \right) \left(\frac{2\pi \text{ rad}}{1 \text{ r}} \right)} = 465 \text{ N} \cdot \text{m}$$

(e) The rotor current limit of the capability curve would be drawn from an origin of

$$Q = -\frac{3V_{\phi}^2}{X_s} = -\frac{3(1328 \text{ V})^2}{1.1 \Omega} = -4810 \text{ kVAR}$$

The radius of the rotor current limit is

$$D_E = \frac{3V_{\phi}E_A}{X_s} = \frac{3(1328 \text{ V})(1537 \text{ V})}{1.1 \Omega} = 5567 \text{ kVA}$$

The stator current limit is a circle at the origin of radius

$$S = 3V_{\phi}I_A = 3(1328 \text{ V})(251 \text{ A}) = 1000 \text{ kVA}$$

A MATLAB program that plots this capability diagram is shown below:

```
% M-file: prob5_2.m
% M-file to display a capability curve for a
% synchronous generator.

% Calculate the waveforms for times from 0 to 1/30 s
Q = -4810;
DE = 5567;
S = 1000;

% Get points for stator current limit
theta = -95:1:95;          % Angle in degrees
rad = theta * pi / 180;    % Angle in radians
s_curve = S .* ( cos(rad) + j*sin(rad) );

% Get points for rotor current limit
orig = j*Q;
theta = 75:1:105;         % Angle in degrees
rad = theta * pi / 180;   % Angle in radians
r_curve = orig + DE .* ( cos(rad) + j*sin(rad) );

% Plot the capability diagram
figure(1);
plot(real(s_curve), imag(s_curve), 'b', 'LineWidth', 2.0);
hold on;
plot(real(r_curve), imag(r_curve), 'r--', 'LineWidth', 2.0);

% Add x and y axes
```

```

plot( [-1500 1500],[0 0], 'k');
plot( [0,0],[-1500 1500], 'k');

% Set titles and axes
title ('\bfSynchronous Generator Capability Diagram');
xlabel ('\bfPower (kW)');
ylabel ('\bfReactive Power (kVAR)');
axis( [ -1500 1500 -1500 1500] );
axis square;
hold off;

```

The resulting capability diagram is shown below:

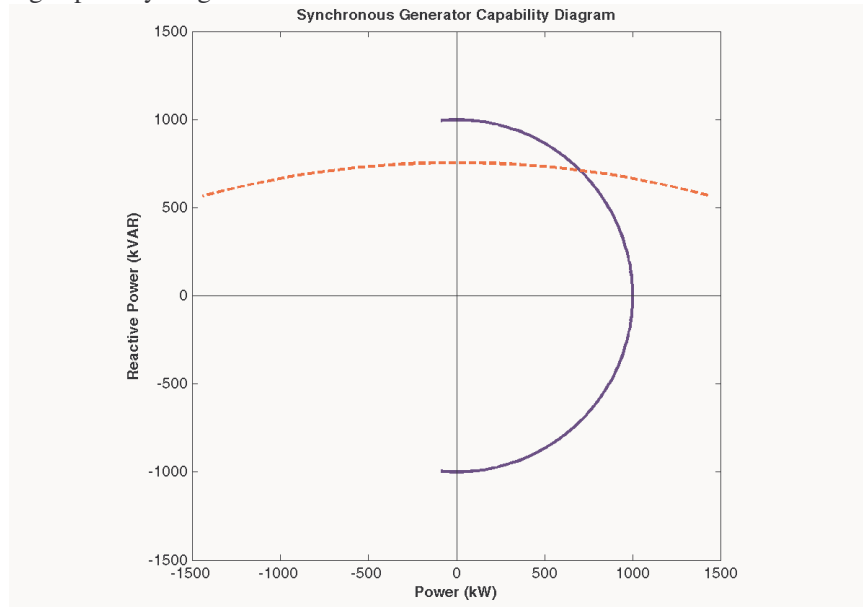

- 5-3.** Assume that the field current of the generator in Problem 5-2 has been adjusted to a value of 4.5 A.
- What will the terminal voltage of this generator be if it is connected to a Δ -connected load with an impedance of $20\angle 30^\circ \Omega$?
 - Sketch the phasor diagram of this generator.
 - What is the efficiency of the generator at these conditions?
 - Now assume that another identical Δ -connected load is to be paralleled with the first one. What happens to the phasor diagram for the generator?
 - What is the new terminal voltage after the load has been added?
 - What must be done to restore the terminal voltage to its original value?

SOLUTION

(a) If the field current is 4.5 A, the open-circuit terminal voltage will be about 2385 V, and the phase voltage in the generator will be $2385/\sqrt{3} = 1377$ V.

The load is Δ -connected with three impedances of $20\angle 30^\circ \Omega$. From the Y- Δ transform, this load is equivalent to a Y-connected load with three impedances of $6.667\angle 30^\circ \Omega$. The resulting per-phase equivalent circuit is shown below:

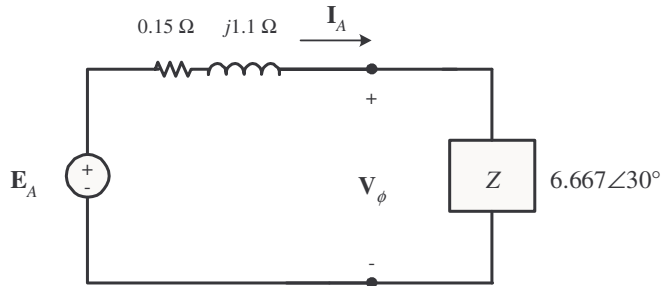

The magnitude of the phase current flowing in this generator is

$$I_A = \frac{E_A}{|R_A + jX_S + Z|} = \frac{1377 \text{ V}}{|0.15 + j1.1 + 6.667 \angle 30^\circ|} = \frac{1377 \text{ V}}{1.829 \Omega} = 186 \text{ A}$$

Therefore, the magnitude of the phase voltage is

$$V_\phi = I_A Z = (186 \text{ A})(6.667 \Omega) = 1240 \text{ V}$$

and the terminal voltage is

$$V_T = \sqrt{3} V_\phi = \sqrt{3} (1240 \text{ V}) = 2148 \text{ V}$$

(b) Armature current is $\mathbf{I}_A = 186 \angle -30^\circ \text{ A}$, and the phase voltage is $\mathbf{V}_\phi = 1240 \angle 0^\circ \text{ V}$. Therefore, the internal generated voltage is

$$\mathbf{E}_A = \mathbf{V}_\phi + R_A \mathbf{I}_A + jX_S \mathbf{I}_A$$

$$\mathbf{E}_A = 1240 \angle 0^\circ + (0.15 \Omega)(186 \angle -30^\circ \text{ A}) + j(1.1 \Omega)(186 \angle -30^\circ \text{ A})$$

$$\mathbf{E}_A = 1377 \angle 6.8^\circ \text{ V}$$

The resulting phasor diagram is shown below (not to scale):

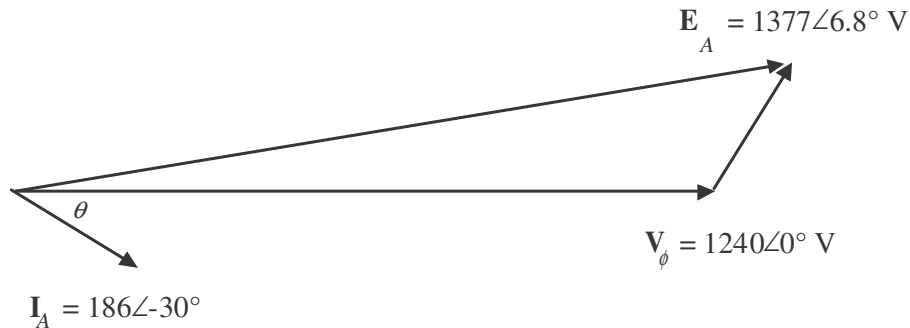

(c) The efficiency of the generator under these conditions can be found as follows:

$$P_{\text{OUT}} = 3 V_\phi I_A \cos \theta = 3(1240 \text{ V})(186 \text{ A})(0.8) = 554 \text{ kW}$$

$$P_{\text{CU}} = 3 I_A^2 R_A = 3(186 \text{ A})^2 (0.15 \Omega) = 15.6 \text{ kW}$$

$$P_{\text{F\&W}} = 24 \text{ kW}$$

$$P_{\text{core}} = 18 \text{ kW}$$

$$P_{\text{stray}} = (\text{assumed } 0)$$

$$P_{\text{IN}} = P_{\text{OUT}} + P_{\text{CU}} + P_{\text{F\&W}} + P_{\text{core}} + P_{\text{stray}} = 612 \text{ kW}$$

$$\eta = \frac{P_{OUT}}{P_{IN}} \times 100\% = \frac{554 \text{ kW}}{612 \text{ kW}} \times 100\% = 90.5\%$$

(d) When the new load is added, the total current flow increases at the same phase angle. Therefore, $jX_S \mathbf{I}_S$ increases in length at the same angle, while the magnitude of E_A must remain constant. Therefore, E_A “swings” out along the arc of constant magnitude until the new $jX_S \mathbf{I}_S$ fits exactly between V_ϕ and E_A .

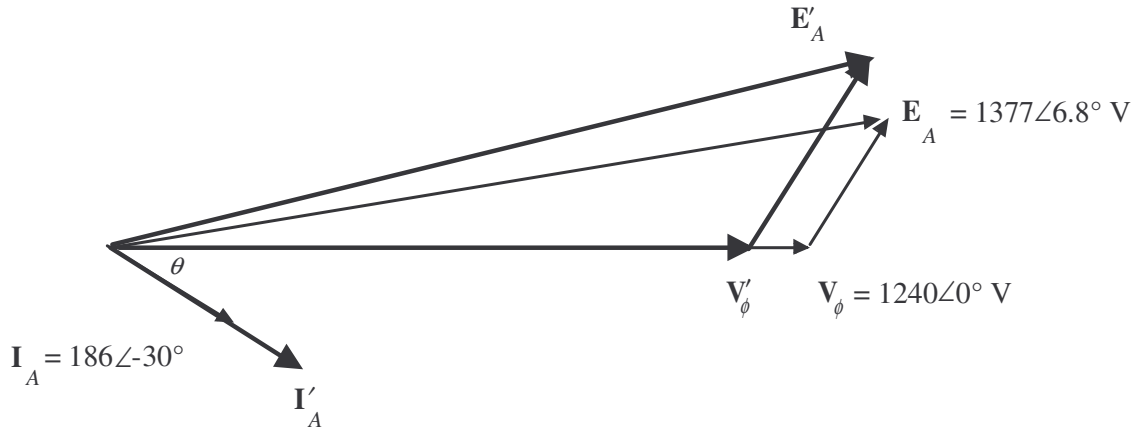

(e) The new impedance per phase will be half of the old value, so $Z = 3.333\angle 30^\circ \Omega$. The magnitude of the phase current flowing in this generator is

$$I_A = \frac{E_A}{|R_A + jX_S + Z|} = \frac{1377 \text{ V}}{|0.15 + j1.1 + 3.333\angle 30^\circ|} = \frac{1377 \text{ V}}{1.829 \Omega} = 335 \text{ A}$$

Therefore, the magnitude of the phase voltage is

$$V_\phi = I_A Z = (335 \text{ A})(3.333 \Omega) = 1117 \text{ V}$$

and the terminal voltage is

$$V_T = \sqrt{3} V_\phi = \sqrt{3} (1117 \text{ V}) = 1934 \text{ V}$$

(f) To restore the terminal voltage to its original value, increase the field current I_F .

5-4. Assume that the field current of the generator in Problem 5-2 is adjusted to achieve rated voltage (2300 V) at full load conditions in each of the questions below.

- What is the efficiency of the generator at rated load?
- What is the voltage regulation of the generator if it is loaded to rated kilovoltamperes with 0.8-PF-lagging loads?
- What is the voltage regulation of the generator if it is loaded to rated kilovoltamperes with 0.8-PF-leading loads?
- What is the voltage regulation of the generator if it is loaded to rated kilovoltamperes with unity-power-factor loads?
- Use MATLAB to plot the terminal voltage of the generator as a function of load for all three power factors.

SOLUTION

(a) This generator is Y-connected, so $I_L = I_A$. At rated conditions, the line and phase current in this generator is

$$I_A = I_L = \frac{P}{\sqrt{3} V_L} = \frac{1000 \text{ kVA}}{\sqrt{3}(2300 \text{ V})} = 251 \text{ A at an angle of } -36.87^\circ$$

The phase voltage of this machine is $V_\phi = V_T / \sqrt{3} = 1328 \text{ V}$. The internal generated voltage of the machine is

$$\begin{aligned} \mathbf{E}_A &= \mathbf{V}_\phi + R_A \mathbf{I}_A + jX_S \mathbf{I}_A \\ \mathbf{E}_A &= 1328 \angle 0^\circ + (0.15 \Omega)(251 \angle -36.87^\circ \text{ A}) + j(1.1 \Omega)(251 \angle -36.87^\circ \text{ A}) \\ \mathbf{E}_A &= 1537 \angle 7.4^\circ \text{ V} \end{aligned}$$

The input power to this generator is equal to the output power plus losses. The rated output power is

$$\begin{aligned} P_{\text{OUT}} &= (1000 \text{ kVA})(0.8) = 800 \text{ kW} \\ P_{\text{CU}} &= 3I_A^2 R_A = 3(251 \text{ A})^2 (0.15 \Omega) = 28.4 \text{ kW} \\ P_{\text{F\&W}} &= 24 \text{ kW} \\ P_{\text{core}} &= 18 \text{ kW} \\ P_{\text{stray}} &= (\text{assumed } 0) \\ P_{\text{IN}} &= P_{\text{OUT}} + P_{\text{CU}} + P_{\text{F\&W}} + P_{\text{core}} + P_{\text{stray}} = 870.4 \text{ kW} \\ \eta &= \frac{P_{\text{OUT}}}{P_{\text{IN}}} \times 100\% = \frac{800 \text{ kW}}{870.4 \text{ kW}} \times 100\% = 91.9\% \end{aligned}$$

(b) If the generator is loaded to rated kVA with lagging loads, the phase voltage is $\mathbf{V}_\phi = 1328 \angle 0^\circ \text{ V}$ and the internal generated voltage is $\mathbf{E}_A = 1537 \angle 7.4^\circ \text{ V}$. Therefore, the phase voltage at no-load would be $\mathbf{V}_\phi = 1537 \angle 0^\circ \text{ V}$. The voltage regulation would be:

$$\text{VR} = \frac{1537 - 1328}{1328} \times 100\% = 15.7\%$$

(c) If the generator is loaded to rated kVA with leading loads, the phase voltage is $\mathbf{V}_\phi = 1328 \angle 0^\circ \text{ V}$ and the internal generated voltage is

$$\begin{aligned} \mathbf{E}_A &= \mathbf{V}_\phi + R_A \mathbf{I}_A + jX_S \mathbf{I}_A \\ \mathbf{E}_A &= 1328 \angle 0^\circ + (0.15 \Omega)(251 \angle 36.87^\circ \text{ A}) + j(1.1 \Omega)(251 \angle 36.87^\circ \text{ A}) \\ \mathbf{E}_A &= 1217 \angle 11.5^\circ \text{ V} \end{aligned}$$

The voltage regulation would be:

$$\text{VR} = \frac{1217 - 1328}{1328} \times 100\% = -8.4\%$$

(d) If the generator is loaded to rated kVA at unity power factor, the phase voltage is $\mathbf{V}_\phi = 1328 \angle 0^\circ \text{ V}$ and the internal generated voltage is

$$\mathbf{E}_A = \mathbf{V}_\phi + R_A \mathbf{I}_A + jX_S \mathbf{I}_A$$

$$\begin{aligned} E_A &= 1328\angle 0^\circ + (0.15 \Omega)(251\angle 0^\circ \text{ A}) + j(1.1 \Omega)(251\angle 0^\circ \text{ A}) \\ E_A &= 1393\angle 11.4^\circ \text{ V} \end{aligned}$$

The voltage regulation would be:

$$\text{VR} = \frac{1393 - 1328}{1328} \times 100\% = 4.9\%$$

(e) For this problem, we will assume that the terminal voltage is adjusted to 2300 V at no load conditions, and see what happens to the voltage as load increases at 0.8 lagging, unity, and 0.8 leading power factors. Note that the maximum current will be 251 A in any case. A phasor diagram representing the situation at lagging power factor is shown below:

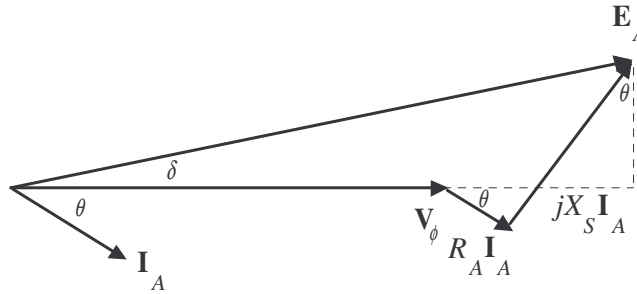

By the Pythagorean Theorem,

$$\begin{aligned} E_A^2 &= (V_\phi + R_A I_A \cos \theta + X_S I_A \sin \theta)^2 + (X_S I_A \cos \theta - R_A I_A \sin \theta)^2 \\ V_\phi &= \sqrt{E_A^2 - (X_S I_A \cos \theta - R_A I_A \sin \theta)^2} - R_A I_A \cos \theta - X_S I_A \sin \theta \end{aligned}$$

A phasor diagram representing the situation at leading power factor is shown below:

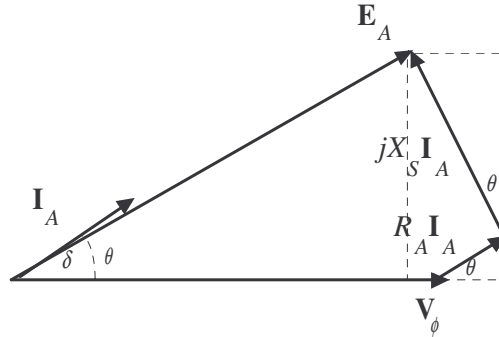

By the Pythagorean Theorem,

$$\begin{aligned} E_A^2 &= (V_\phi + R_A I_A \cos \theta - X_S I_A \sin \theta)^2 + (X_S I_A \cos \theta + R_A I_A \sin \theta)^2 \\ V_\phi &= \sqrt{E_A^2 - (X_S I_A \cos \theta + R_A I_A \sin \theta)^2} - R_A I_A \cos \theta + X_S I_A \sin \theta \end{aligned}$$

A phasor diagram representing the situation at unity power factor is shown below:

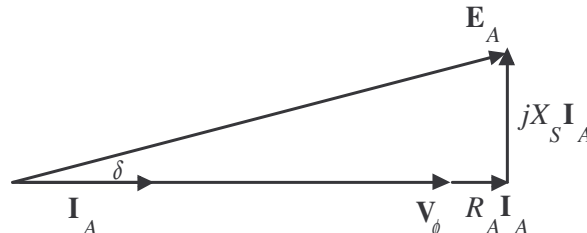

By the Pythagorean Theorem,

$$E_A^2 = V_\phi^2 + (X_S I_A)^2$$

$$V_\phi = \sqrt{E_A^2 - (X_S I_A)^2}$$

The MATLAB program is shown below takes advantage of this fact.

```
% M-file: prob5_4e.m
% M-file to calculate and plot the terminal voltage
% of a synchronous generator as a function of load
% for power factors of 0.8 lagging, 1.0, and 0.8 leading.

% Define values for this generator
EA = 1328; % Internal gen voltage
I = 0:2.51:251; % Current values (A)
R = 0.15; % R (ohms)
X = 1.10; % XS (ohms)

% Calculate the voltage for the lagging PF case
VP_lag = sqrt( EA^2 - (X.*I.*0.8 - R.*I.*0.6).^2 ) ...
        - R.*I.*0.8 - X.*I.*0.6;
VT_lag = VP_lag .* sqrt(3);

% Calculate the voltage for the leading PF case
VP_lead = sqrt( EA^2 - (X.*I.*0.8 + R.*I.*0.6).^2 ) ...
        - R.*I.*0.8 + X.*I.*0.6;
VT_lead = VP_lead .* sqrt(3);

% Calculate the voltage for the unity PF case
VP_unity = sqrt( EA^2 - (X.*I).^2 );
VT_unity = VP_unity .* sqrt(3);

% Plot the terminal voltage versus load
plot(I,abs(VT_lag), 'b-', 'LineWidth',2.0);
hold on;
plot(I,abs(VT_unity), 'k--', 'LineWidth',2.0);
plot(I,abs(VT_lead), 'r-.', 'LineWidth',2.0);
title ('\bfTerminal Voltage Versus Load');
xlabel ('\bfLoad (A)');
ylabel ('\bfTerminal Voltage (V)');
legend('0.8 PF lagging','1.0 PF','0.8 PF leading');
axis([0 260 1500 2500]);
grid on;
hold off;
```

The resulting plot is shown below:

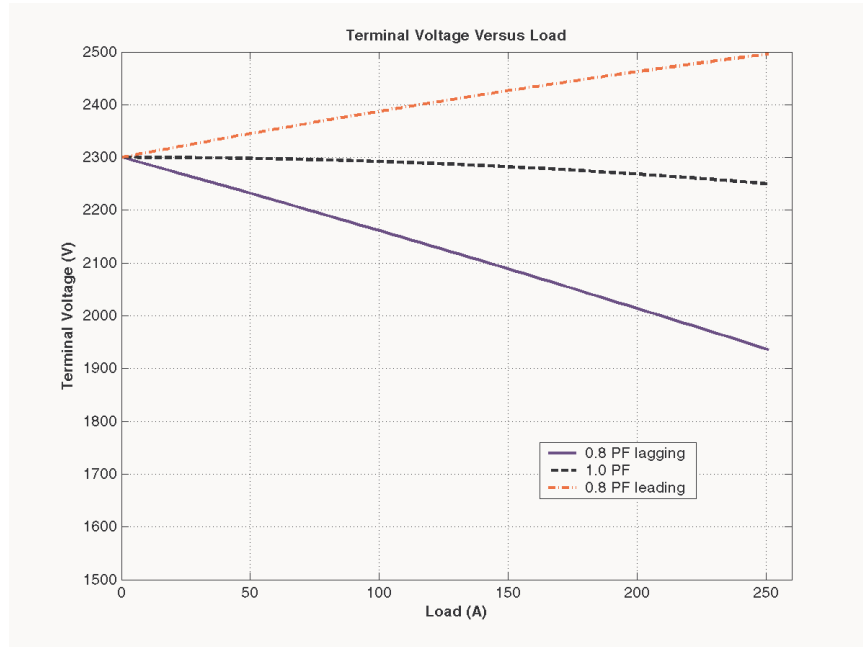

5-5. Assume that the field current of the generator in Problem 5-2 has been adjusted so that it supplies rated voltage when loaded with rated current at unity power factor. (You may ignore the effects of R_A when answering these questions.)

- (a) What is the torque angle δ of the generator when supplying rated current at unity power factor?
 (b) When this generator is running at full load with unity power factor, how close is it to the static stability limit of the machine?

SOLUTION

- (a) The torque δ angle can be found by calculating \mathbf{E}_A :

$$\begin{aligned}\mathbf{E}_A &= \mathbf{V}_\phi + R_A \mathbf{I}_A + jX_S \mathbf{I}_A \\ \mathbf{E}_A &= 1328 \angle 0^\circ + (0.15 \Omega)(251 \angle 0^\circ \text{ A}) + j(1.1 \Omega)(251 \angle 0^\circ \text{ A}) \\ \mathbf{E}_A &= 1393 \angle 11.4^\circ \text{ V}\end{aligned}$$

Thus the torque angle $\delta = 11.4^\circ$.

- (b) The static stability limit occurs at $\delta = 90^\circ$. This generator is a very long way from that limit. If we ignore the internal resistance of the generator, the output power will be given by

$$P = \frac{3V_\phi E_A}{X_S} \sin \delta$$

and the output power is proportional to $\sin \delta$. Since $\sin 11.4^\circ = 0.198$, and $\sin 90^\circ = 1.00$, the static stability limit is about 5 times the current output power of the generator.

5-6. A 480-V 400-kVA 0.85-PF-lagging 50-Hz four-pole Δ -connected generator is driven by a 500-hp diesel engine and is used as a standby or emergency generator. This machine can also be paralleled with the normal power supply (a very large power system) if desired.

- (a) What are the conditions required for paralleling the emergency generator with the existing power system? What is the generator's rate of shaft rotation after paralleling occurs?

- (b) If the generator is connected to the power system and is initially floating on the line, sketch the resulting magnetic fields and phasor diagram.
- (c) The governor setting on the diesel is now increased. Show both by means of house diagrams and by means of phasor diagrams what happens to the generator. How much reactive power does the generator supply now?
- (d) With the diesel generator now supplying real power to the power system, what happens to the generator as its field current is increased and decreased? Show this behavior both with phasor diagrams and with house diagrams.

SOLUTION

(a) To parallel this generator to the large power system, the required conditions are:

1. The generator must have the *same voltage* as the power system.
2. The *phase sequence* of the oncoming generator must be the same as the phase sequence of the power system.
3. The *frequency* of the oncoming generator should be *slightly* higher than the frequency of the running system.
4. The circuit breaker connecting the two systems together should be shut when the above conditions are met and the generator is *in phase* with the power system.

After paralleling, the generator's shaft will be rotating at

$$n_m = \frac{120 f_e}{P} = \frac{120(50 \text{ Hz})}{4} = 1500 \text{ r/min}$$

(b) The magnetic field and phasor diagrams immediately after paralleling are shown below:



(c) When the governor setpoints on the generator are increased, the emergency generator begins to supply more power to the loads, as shown below:

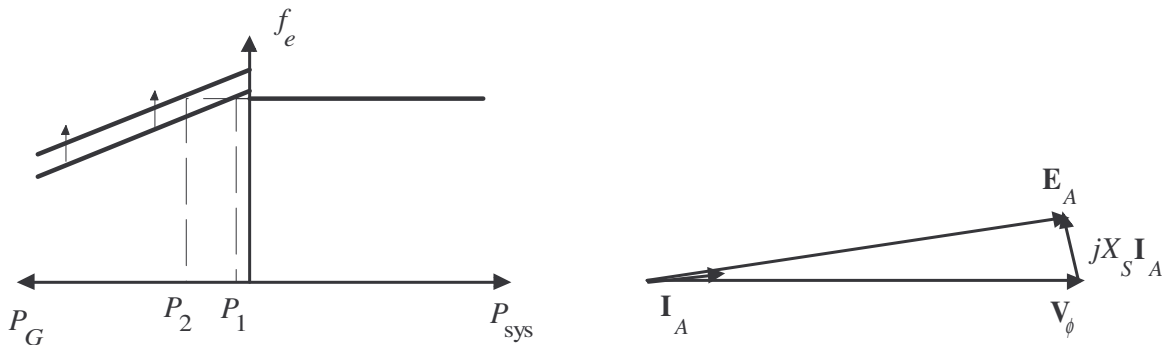

Note that as the load increased with $|E_A|$ constant, the generator began to consume a small amount of reactive power.

(d) With the generator now supplying power to the system, an increase in field current increases the reactive power supplied to the loads, and a decrease in field current decreases the reactive power supplied to the loads.

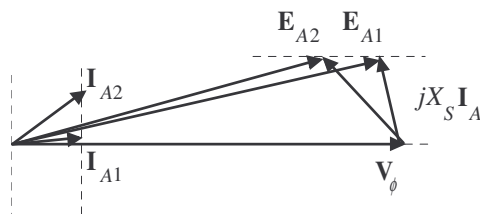
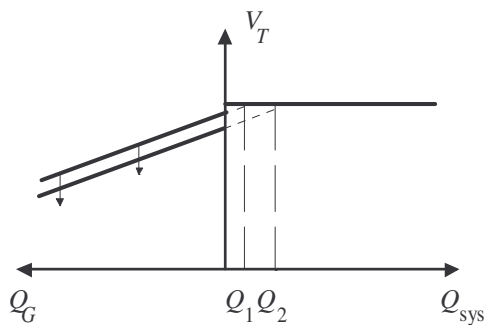
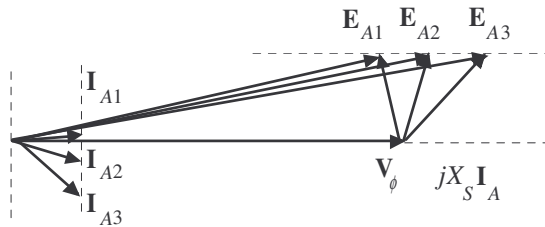
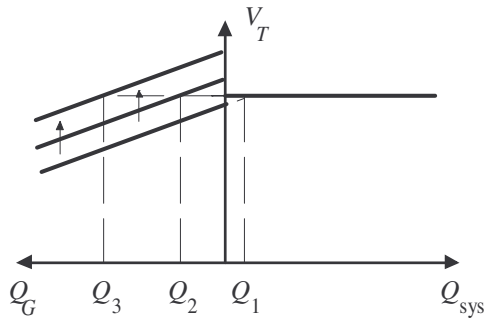

- 5-7.** A 13.8-kV 10-MVA 0.8-PF-lagging 60-Hz two-pole Y-connected steam-turbine generator has a synchronous reactance of 12Ω per phase and an armature resistance of 1.5Ω per phase. This generator is operating in parallel with a large power system (infinite bus).
- What is the magnitude of E_A at rated conditions?
 - What is the torque angle of the generator at rated conditions?
 - If the field current is constant, what is the maximum power possible out of this generator? How much reserve power or torque does this generator have at full load?
 - At the absolute maximum power possible, how much reactive power will this generator be supplying or consuming? Sketch the corresponding phasor diagram. (Assume I_F is still unchanged.)

SOLUTION

(a) The phase voltage of this generator at rated conditions is

$$V_\phi = \frac{13,800 \text{ V}}{\sqrt{3}} = 7967 \text{ V}$$

The armature current per phase at rated conditions is

$$I_A = \frac{S}{\sqrt{3} V_T} = \frac{10,000,000 \text{ VA}}{\sqrt{3} (13,800 \text{ V})} = 418 \text{ A}$$

Therefore, the internal generated voltage at rated conditions is

$$\begin{aligned} \mathbf{E}_A &= \mathbf{V}_\phi + R_A \mathbf{I}_A + jX_S \mathbf{I}_A \\ \mathbf{E}_A &= 7967 \angle 0^\circ + (1.5 \Omega)(418 \angle -36.87^\circ \text{ A}) + j(12.0 \Omega)(418 \angle -36.87^\circ \text{ A}) \\ \mathbf{E}_A &= 12,040 \angle 17.6^\circ \text{ V} \end{aligned}$$

The magnitude of E_A is 12,040 V.

(b) The torque angle of the generator at rated conditions is $\delta = 17.6^\circ$.

(c) Ignoring R_A , the maximum output power of the generator is given by

$$P_{\text{MAX}} = \frac{3 V_\phi E_A}{X_S} = \frac{3(7967 \text{ V})(12,040 \text{ V})}{12 \Omega} = 24.0 \text{ MW}$$

The power at maximum load is 8 MW, so the maximum output power is three times the full load output power.

(d) The phasor diagram at these conditions is shown below:

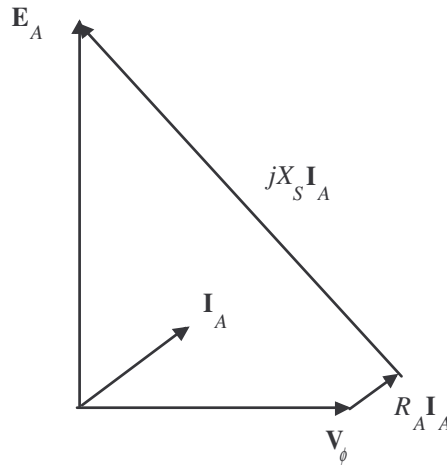

Under these conditions, the armature current is

$$I_A = \frac{E_A - V_\phi}{R_A + jX_S} = \frac{12,040 \angle 90^\circ \text{ V} - 7967 \angle 0^\circ \text{ V}}{1.5 + j12.0 \Omega} = 1194 \angle 40.6^\circ \text{ A}$$

The reactive power produced by the generator at this point is

$$Q = 3 V_\phi I_A \sin \theta = 3(7967 \text{ V})(1194 \text{ A}) \sin(0^\circ - 40.6^\circ) = -18.6 \text{ MVAR}$$

The generator is actually consuming reactive power at this time.

5-8. A 480-V, 100-kW, two-pole, three-phase, 60-Hz synchronous generator's prime mover has a no-load speed of 3630 r/min and a full-load speed of 3570 r/min. It is operating in parallel with a 480-V, 75-kW, four-pole, 60-Hz synchronous generator whose prime mover has a no-load speed of 1800 r/min and a full-load speed of 1785 r/min. The loads supplied by the two generators consist of 100 kW at 0.85 PF lagging.

- Calculate the speed droops of generator 1 and generator 2.
- Find the operating frequency of the power system.
- Find the power being supplied by each of the generators in this system.
- If V_T is 460 V, what must the generator's operators do to correct for the low terminal voltage?

SOLUTION The no-load frequency of generator 1 corresponds to a frequency of

$$f_{nl1} = \frac{n_m P}{120} = \frac{(3630 \text{ r/min})(2)}{120} = 60.5 \text{ Hz}$$

The full-load frequency of generator 1 corresponds to a frequency of

$$f_{fl1} = \frac{n_m P}{120} = \frac{(3570 \text{ r/min})(2)}{120} = 59.5 \text{ Hz}$$

The no-load frequency of generator 2 corresponds to a frequency of

$$f_{nl2} = \frac{n_m P}{120} = \frac{(1800 \text{ r/min})(4)}{120} = 60.00 \text{ Hz}$$

The full-load frequency of generator 2 corresponds to a frequency of

$$f_{fl2} = \frac{n_m P}{120} = \frac{(1785 \text{ r/min})(4)}{120} = 59.50 \text{ Hz}$$

(a) The speed droop of generator 1 is given by

$$SD_1 = \frac{n_{nl} - n_{fl}}{n_{fl}} \times 100\% = \frac{3630 \text{ r/min} - 3570 \text{ r/min}}{3570 \text{ r/min}} \times 100\% = 1.68\%$$

The speed droop of generator 2 is given by

$$SD_2 = \frac{n_{nl} - n_{fl}}{n_{fl}} \times 100\% = \frac{1800 \text{ r/min} - 1785 \text{ r/min}}{1785 \text{ r/min}} \times 100\% = 0.84\%$$

(b) The power supplied by generator 1 is given by

$$P_1 = s_{P1} (f_{nl1} - f_{sys})$$

and the power supplied by generator 2 is given by

$$P_2 = s_{P2} (f_{nl2} - f_{sys})$$

The power curve's slope for generator 1 is

$$s_{P1} = \frac{P}{f_{nl} - f_{fl}} = \frac{0.1 \text{ MW}}{60.5 \text{ Hz} - 59.5 \text{ Hz}} = 0.1 \text{ MW/Hz}$$

The power curve's slope for generator 2 is

$$s_{P2} = \frac{P}{f_{nl} - f_{fl}} = \frac{0.075 \text{ MW}}{60.00 \text{ Hz} - 59.50 \text{ Hz}} = 0.150 \text{ MW/Hz}$$

The no-load frequency of generator 1 is 60.5 Hz and the no-load frequency of generator 2 is 60 Hz. The total power that they must supply is 100 kW, so the system frequency can be found from the equations

$$P_{LOAD} = P_1 + P_2$$

$$P_{LOAD} = s_{P1} (f_{nl1} - f_{sys}) + s_{P2} (f_{nl2} - f_{sys})$$

$$100 \text{ kW} = (0.1 \text{ MW/Hz})(60.5 \text{ Hz} - f_{sys}) + (0.15 \text{ MW/Hz})(60.0 \text{ Hz} - f_{sys})$$

$$100 \text{ kW} = 6050 \text{ kW} - (0.10 \text{ MW/Hz}) f_{sys} + 9000 \text{ kW} - (0.15 \text{ MW/Hz}) f_{sys}$$

$$(0.25 \text{ MW/Hz}) f_{sys} = 6050 \text{ kW} + 9000 \text{ kW} - 100 \text{ kW}$$

$$f_{sys} = \frac{14,950 \text{ kW}}{0.25 \text{ MW/Hz}} = 59.8 \text{ Hz}$$

(c) The power supplied by generator 1 is

$$P_1 = s_{P1}(f_{nl1} - f_{sys}) = (0.1 \text{ MW/Hz})(60.5 \text{ Hz} - 59.8 \text{ Hz}) = 70 \text{ kW}$$

The power supplied by generator 2 is

$$P_2 = s_{P2}(f_{nl2} - f_{sys}) = (0.15 \text{ MW/Hz})(60.0 \text{ Hz} - 59.8 \text{ Hz}) = 30 \text{ kW}$$

(d) If the terminal voltage is 460 V, the operators of the generators must increase the field currents on both generators simultaneously. That action will increase the terminal voltages of the system without changing the power sharing between the generators.

5-9. Three physically identical synchronous generators are operating in parallel. They are all rated for a full load of 3 MW at 0.8 PF lagging. The no-load frequency of generator A is 61 Hz, and its speed droop is 3.4 percent. The no-load frequency of generator B is 61.5 Hz, and its speed droop is 3 percent. The no-load frequency of generator C is 60.5 Hz, and its speed droop is 2.6 percent.

(a) If a total load consisting of 7 MW is being supplied by this power system, what will the system frequency be and how will the power be shared among the three generators?

(b) Create a plot showing the power supplied by each generator as a function of the total power supplied to all loads (you may use MATLAB to create this plot). At what load does one of the generators exceed its ratings? Which generator exceeds its ratings first?

(c) Is this power sharing in (a) acceptable? Why or why not?

(d) What actions could an operator take to improve the real power sharing among these generators?

SOLUTION

(a) Speed droop is defined as

$$SD = \frac{n_{nl} - n_{fl}}{n_{fl}} \times 100\% = \frac{f_{nl} - f_{fl}}{f_{fl}} \times 100\%$$

so
$$f_{fl} = \frac{f_{nl}}{\frac{SD}{100} + 1}$$

Thus, the full-load frequencies of generators A, B, and C are

$$f_{fl,A} = \frac{f_{nl,A}}{\frac{SD_A}{100} + 1} = \frac{61 \text{ Hz}}{\frac{3.4}{100} + 1} = 59.0 \text{ Hz}$$

$$f_{fl,B} = \frac{f_{nl,B}}{\frac{SD_B}{100} + 1} = \frac{61.5 \text{ Hz}}{\frac{3.0}{100} + 1} = 59.71 \text{ Hz}$$

$$f_{fl,C} = \frac{f_{nl,C}}{\frac{SD_C}{100} + 1} = \frac{60.5 \text{ Hz}}{\frac{2.6}{100} + 1} = 58.97 \text{ Hz}$$

and the slopes of the power-frequency curves are:

$$S_{PA} = \frac{3 \text{ MW}}{2 \text{ Hz}} = 1.5 \text{ MW/Hz}$$

$$S_{PB} = \frac{3 \text{ MW}}{1.79 \text{ Hz}} = 1.676 \text{ MW/Hz}$$

$$S_{PC} = \frac{3 \text{ MW}}{1.53 \text{ Hz}} = 1.961 \text{ MW/Hz}$$

(a) The total load is 7 MW, so the system frequency is

$$P_{\text{LOAD}} = s_{PA}(f_{\text{nlA}} - f_{\text{sys}}) + s_{PB}(f_{\text{nlB}} - f_{\text{sys}}) + s_{PC}(f_{\text{nlC}} - f_{\text{sys}})$$

$$7 \text{ MW} = (1.5)(61.0 - f_{\text{sys}}) + (1.676)(61.5 - f_{\text{sys}}) + (1.961)(60.5 - f_{\text{sys}})$$

$$7 \text{ MW} = 91.5 - 1.5f_{\text{sys}} + 103.07 - 1.676f_{\text{sys}} + 118.64 - 1.961f_{\text{sys}}$$

$$5.137f_{\text{sys}} = 306.2$$

$$f_{\text{sys}} = 59.61 \text{ Hz}$$

The power supplied by each generator will be

$$P_A = s_{PA}(f_{\text{nlA}} - f_{\text{sys}}) = (1.5 \text{ MW/Hz})(61.0 \text{ Hz} - 59.61 \text{ Hz}) = 2.09 \text{ MW}$$

$$P_B = s_{PB}(f_{\text{nlB}} - f_{\text{sys}}) = (1.676 \text{ MW/Hz})(61.5 \text{ Hz} - 59.61 \text{ Hz}) = 3.17 \text{ MW}$$

$$P_C = s_{PC}(f_{\text{nlC}} - f_{\text{sys}}) = (1.961 \text{ MW/Hz})(60.5 \text{ Hz} - 59.61 \text{ Hz}) = 1.74 \text{ MW}$$

(b) The equation in part (a) can be re-written slightly to express system frequency as a function of load.

$$P_{\text{LOAD}} = (1.5)(61.0 - f_{\text{sys}}) + (1.676)(61.5 - f_{\text{sys}}) + (1.961)(60.5 - f_{\text{sys}})$$

$$P_{\text{LOAD}} = 91.5 - 1.5f_{\text{sys}} + 103.07 - 1.676f_{\text{sys}} + 118.64 - 1.961f_{\text{sys}}$$

$$5.137f_{\text{sys}} = 313.2 - P_{\text{LOAD}}$$

$$f_{\text{sys}} = \frac{313.2 - P_{\text{LOAD}}}{5.137}$$

A MATLAB program that uses this equation to determine the power sharing among the generators as a function of load is shown below:

```
% M-file: prob5_9b.m
% M-file to calculate and plot the power sharing among
% three generators as a function of load.

% Define values for this generator
fnlA = 61.0;           % No-load freq of Gen A
fnlB = 61.5;           % No-load freq of Gen B
fnlC = 60.5;           % No-load freq of Gen C
spA = 1.5;             % Slope of Gen A (MW/Hz)
spB = 1.676;           % Slope of Gen B (MW/Hz)
spC = 1.961;           % Slope of Gen C (MW/Hz)
Pload = 0:0.05:10;     % Load in MW

% Calculate the system frequency
fsys = (313.2 - Pload) ./ 5.137;

% Calculate the power of each generator
PA = spA .* ( fnlA - fsys);
PB = spB .* ( fnlB - fsys);
PC = spC .* ( fnlC - fsys);

% Plot the power sharing versus load
plot(Pload, PA, 'b-', 'LineWidth', 2.0);
```

```

hold on;
plot(Pload,PB,'k--','LineWidth',2.0);
plot(Pload,PC,'r-.','LineWidth',2.0);
plot([0 10],[3 3],'k','LineWidth',1.0);
plot([0 10],[0 0],'k:');
title ('\bfPower Sharing Versus Total Load');
xlabel ('\bfTotal Load (MW)');
ylabel ('\bfGenerator Power (MW)');
legend('Generator A','Generator B','Generator C','Power Limit');
grid on;
hold off;

```

The resulting plot is shown below:

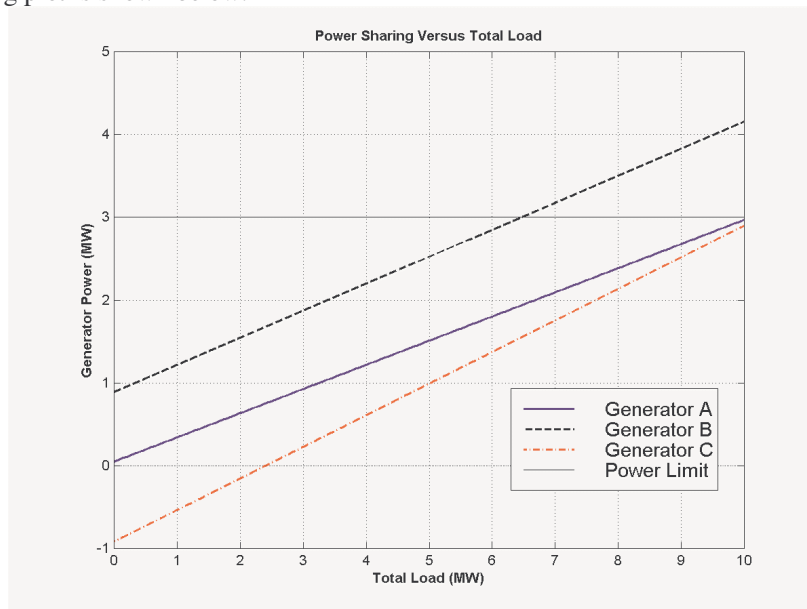

This plot reveals that there are power sharing problems both for high loads and for low loads. Generator B is the first to exceed its ratings as load increases. Its rated power is reached at a total load of 6.45 MW. On the other hand, Generator C gets into trouble as the total load is reduced. When the total load drops to 2.4 MW, the direction of power flow reverses in Generator C.

(c) The power sharing in (a) is not acceptable, because Generator 2 has exceeded its power limits.

(d) To improve the power sharing among the three generators in (a) without affecting the operating frequency of the system, the operator should decrease the governor setpoints on Generator B while simultaneously increasing them in Generators A and C.

- 5-10.** A paper mill has installed three steam generators (boilers) to provide process steam and also to use some its waste products as an energy source. Since there is extra capacity, the mill has installed three 5-MW turbine generators to take advantage of the situation. Each generator is a 4160-V 6250-kVA 0.85-PF-lagging two-pole Y-connected synchronous generator with a synchronous reactance of 0.75Ω and an armature resistance of 0.04Ω . Generators 1 and 2 have a characteristic power-frequency slope s_p of 2.5 MW/Hz, and generators 2 and 3 have a slope of 3 MW/Hz.

(a) If the no-load frequency of each of the three generators is adjusted to 61 Hz, how much power will the three machines be supplying when actual system frequency is 60 Hz?

- (b) What is the maximum power the three generators can supply in this condition without the ratings of one of them being exceeded? At what frequency does this limit occur? How much power does each generator supply at that point?
- (c) What would have to be done to get all three generators to supply their rated real and reactive powers at an overall operating frequency of 60 Hz?
- (d) What would the internal generated voltages of the three generators be under this condition?

SOLUTION

(a) If the system frequency is 60 Hz and the no-load frequencies of the generators are 61 Hz, then the power supplied by the generators will be

$$P_1 = s_{P1}(f_{nl1} - f_{sys}) = (2.5 \text{ MW/Hz})(61 \text{ Hz} - 60 \text{ Hz}) = 2.5 \text{ MW}$$

$$P_2 = s_{P2}(f_{nl2} - f_{sys}) = (2.5 \text{ MW/Hz})(61 \text{ Hz} - 60 \text{ Hz}) = 2.5 \text{ MW}$$

$$P_3 = s_{P3}(f_{nl3} - f_{sys}) = (3.0 \text{ MW/Hz})(61 \text{ Hz} - 60 \text{ Hz}) = 3.0 \text{ MW}$$

Therefore the total power supplied by the generators is 8 MW.

(b) The maximum power supplied by any one generator is $(6250 \text{ kVA})(0.85) = 5.31 \text{ MW}$. Generator 3 will be the first machine to reach that limit. Generator 3 will supply this power at a frequency of

$$5.31 \text{ MW} = (3.0 \text{ MW/Hz})(61 \text{ Hz} - f_{sys})$$

$$f_{sys} = 59.23 \text{ Hz}$$

At this point the power supplied by Generators 1 and 2 is

$$P_1 = P_2 = s_{P1}(f_{nl1} - f_{sys}) = (2.5 \text{ MW/Hz})(61 \text{ Hz} - 59.23 \text{ Hz}) = 4.425 \text{ MW}$$

The total power supplied by the generators at this condition is 14.16 MW.

(c) To get each of the generators to supply 5.31 MW at 60 Hz, the no-load frequencies of Generator 1 and Generator 2 would have to be adjusted to 62.12 Hz, and the no-load frequency of Generator 3 would have to be adjusted to 61.77 Hz. The field currents of the three generators must then be adjusted to get them supplying a power factor of 0.85 lagging. At that point, each generator will be supplying its rated real and reactive power.

(d) Under the conditions of part (c), which are the rated conditions of the generators, the internal generated voltage would be given by

$$\mathbf{E}_A = \mathbf{V}_\phi + R_A \mathbf{I}_A + jX_S \mathbf{I}_A$$

The phase voltage of the generators is $4160 \text{ V} / \sqrt{3} = 2402 \text{ V}$, and since the generators are Y-connected, their rated current is

$$I_A = I_L = \frac{S}{\sqrt{3} V_T} = \frac{6250 \text{ kVA}}{\sqrt{3}(4160 \text{ V})} = 867 \text{ A}$$

The power factor is 0.85 lagging, so $\mathbf{I}_A = 867 \angle -31.8^\circ \text{ A}$. Therefore,

$$\mathbf{E}_A = \mathbf{V}_\phi + R_A \mathbf{I}_A + jX_S \mathbf{I}_A$$

$$\mathbf{E}_A = 2402 \angle 0^\circ + (0.04 \Omega)(867 \angle -31.8^\circ \text{ A}) + j(0.75 \Omega)(867 \angle -31.8^\circ \text{ A})$$

$$E_A = 2825 \angle 10.9^\circ \text{ V}$$

Problems 5-11 to 5-21 refer to a two-pole Y-connected synchronous generator rated at 470 kVA, 480 V, 60 Hz, and 0.85 PF lagging. Its armature resistance R_A is 0.016Ω . The core losses of this generator at rated conditions are 7 kW, and the friction and windage losses are 8 kW. The open-circuit and short-circuit characteristics are shown in Figure P5-2.

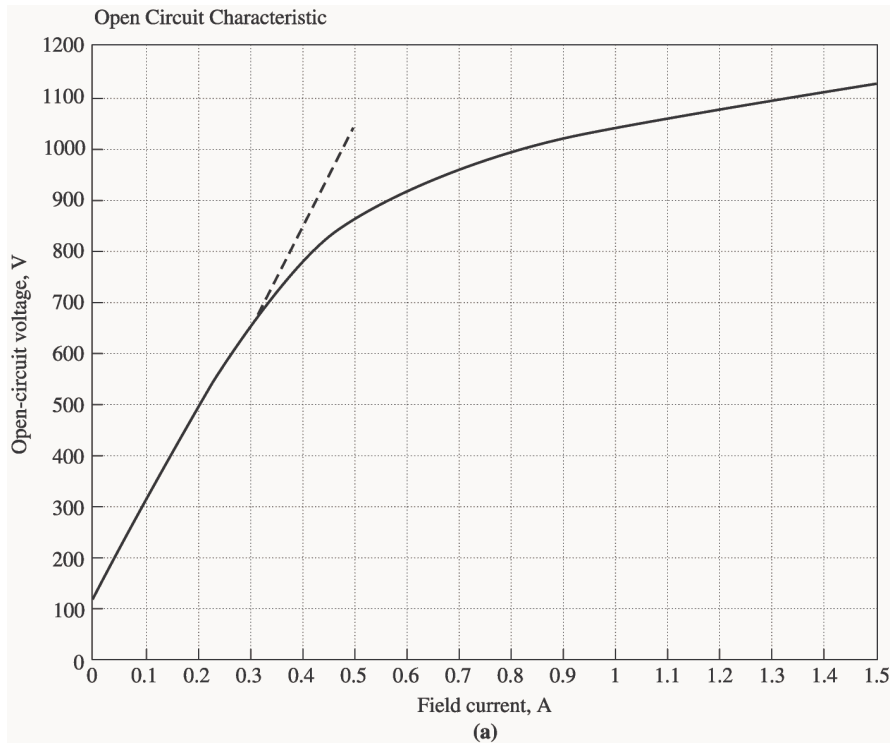

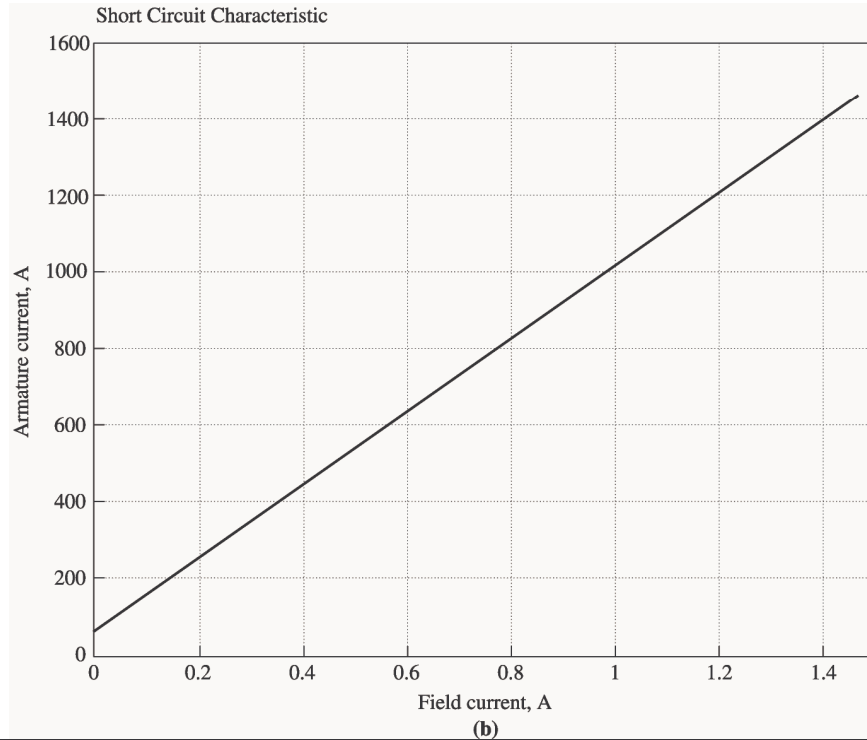

Note: An electronic version of the saturated open circuit characteristic can be found in file p52_occ.dat, and an electronic version of the air-gap characteristic can be found in file p52_ag_occ.dat. These files can be used with MATLAB programs. Column 1 contains field current in amps, and column 2 contains open-circuit terminal voltage in volts. An electronic version of the short circuit characteristic can be found in file p52_scc.dat. Column 1 contains field current in amps, and column 2 contains short-circuit terminal current in amps.

- 5-11. (a) What is the saturated synchronous reactance of this generator at the rated conditions? (b) What is the unsaturated synchronous reactance of this generator? (c) Plot the saturated synchronous reactance of this generator as a function of load.

SOLUTION

(a) The rated armature current for this generator is

$$I_A = I_L = \frac{S}{\sqrt{3} V_T} = \frac{470 \text{ kVA}}{\sqrt{3} (480 \text{ V})} = 565 \text{ A}$$

The field current required to produce this much short-circuit current may be read from the SCC. It is 0.534 A³. The open circuit voltage at 0.532 A is 880 V⁴, so the open-circuit phase voltage (= E_A) is $880/\sqrt{3} = 508 \text{ V}$. The approximate saturated synchronous reactance X_S is

³ If you have MATLAB available, you can use the file p52_scc.dat and the interp1 function to look up this value as shown below. Note that column 1 of p52_scc contains field current, and column 2 contains short-circuit terminal current.

```
load p52_scc.dat
if = interp1(p52_scc(:,2), p52_scc(:,1), 565)
if =
```

$$X_s = \frac{508 \text{ V}}{565 \text{ A}} = 0.899 \Omega$$

(b) The unsaturated synchronous reactance X_{su} is the ratio of the air-gap line to the SCC. This is a straight line, so we can determine its value by comparing the ratio of the air-gap voltage to the short-circuit current at any given field current. For example, at $I_F = 0.50 \text{ A}$, the air-gap line voltage is 1040 V, and the SCC is 532 A.

$$X_{su} = \frac{(1040 \text{ V})/\sqrt{3}}{532 \text{ A}} = 1.13 \Omega$$

(c) This task can best be performed with MATLAB. The open-circuit characteristic is available in a file called `p52_occ.dat`, and the short-circuit characteristic is available in a file called `p52_scc.dat`. Each of these files are organized in two columns, where the first column is field current and the second column is either open-circuit terminal voltage or short-circuit current. A program to read these files and calculate and plot X_s is shown below.

```
% M-file: prob5_11c.m
% M-file to calculate and plot the saturated
% synchronous reactance of a synchronous
% generator.

% Load the open-circuit characteristic. It is in
% two columns, with the first column being field
% current and the second column being terminal
% voltage.
load p52_occ;
if_occ = p52(:,1);
vt_occ = p52(:,2);

% Load the short-circuit characteristic. It is in
% two columns, with the first column being field
% current and the second column being line current
% (= armature current)
load p52_scc;
if_scc = p52(:,1);
ia_scc = p52(:,2);

% Calculate Xs
if = 0.001:0.02:1;           % Current steps
vt = interp1(if_occ,vt_occ,if); % Terminal voltage
ia = interp1(if_scc,ia_scc,if); % Current
Xs = (vt ./ sqrt(3)) ./ ia;
```

0.534

⁴ If you have MATLAB available, you can use the file `p52_occ.dat` and the `interp1` function to look up this value as shown below. Note that column 1 of `p52_occ` contains field current, and column 2 contains open-circuit terminal voltage.

```
load p52_occ.dat
vt = interp1(p52_occ(:,1),p52_occ(:,2),0.534)
vt =
    880.400
```

```
% Plot the synchronous reactance
figure(1)
plot(If,Xs,'LineWidth',2.0);
title ('\bfSaturated Synchronous Reactance \itX_{s} \rm');
xlabel ('\bfField Current (A)');
ylabel ('\bf\itX_{s} \rm\bf(\Omega)');
grid on;
```

The resulting plot is:

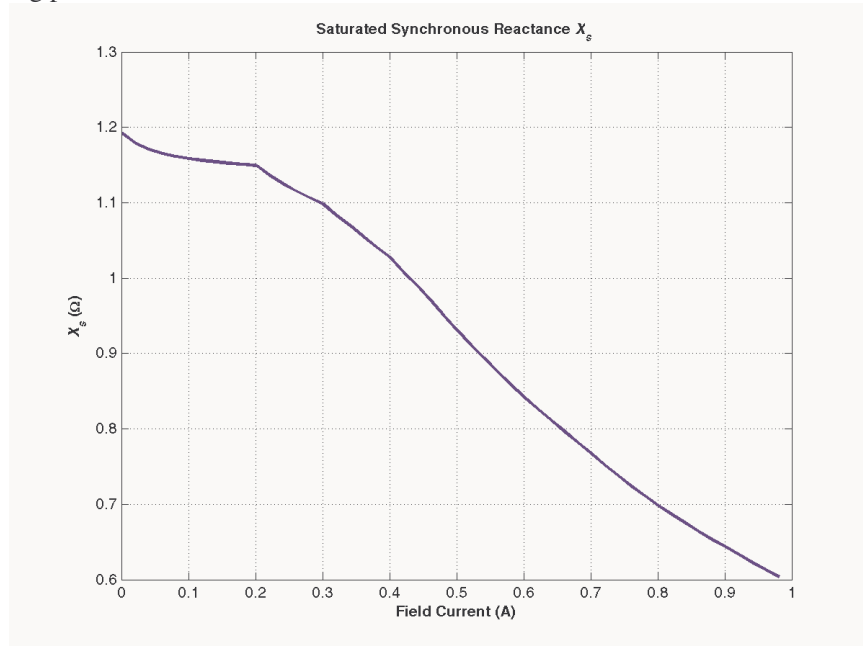

- 5-12.** (a) What are the rated current and internal generated voltage of this generator? (b) What field current does this generator require to operate at the rated voltage, current, and power factor?

SOLUTION

(a) The rated line and armature current for this generator is

$$I_A = I_L = \frac{S}{\sqrt{3} V_T} = \frac{470 \text{ kVA}}{\sqrt{3} (480 \text{ V})} = 565 \text{ A}$$

The power factor is 0.85 lagging, so $\mathbf{I}_A = 565.3 \angle -31.8^\circ \text{ A}$. The rated phase voltage is $V_\phi = 480 \text{ V} / \sqrt{3} = 277 \text{ V}$. The saturated synchronous reactance at rated conditions was found to be 0.450Ω in the previous problem. Therefore, the internal generated voltage is

$$\begin{aligned} \mathbf{E}_A &= \mathbf{V}_\phi + R_A \mathbf{I}_A + jX_S \mathbf{I}_A \\ \mathbf{E}_A &= 277 \angle 0^\circ + (0.016 \Omega)(565.3 \angle -31.8^\circ \text{ A}) + j(0.899 \Omega)(565.3 \angle -31.8^\circ \text{ A}) \\ \mathbf{E}_A &= 509 \angle 30.5^\circ \text{ V} \end{aligned}$$

(b) This internal generated voltage corresponds to a no-load terminal voltage of $\sqrt{3}(509) = 881 \text{ V}$. From the open-circuit characteristic, the required field current would be 0.535 A.

- 5-13.** What is the voltage regulation of this generator at the rated current and power factor?

SOLUTION The voltage regulation is

$$\text{VR} = \frac{V_{T,nl} - V_{T,\Omega}}{V_{T,\Omega}} \times 100\% = \frac{881 - 480}{480} \times 100\% = 83.5\%$$

- 5-14.** If this generator is operating at the rated conditions and the load is suddenly removed, what will the terminal voltage be?

SOLUTION From the above calculations, V_T will be 881 V.

- 5-15.** What are the electrical losses in this generator at rated conditions?

SOLUTION The electrical losses are

$$P_{\text{CU}} = 3I_A^2 R_A = 3(565 \text{ A})^2 (0.016 \Omega) = 15.3 \text{ kW}$$

- 5-16.** If this machine is operating at rated conditions, what input torque must be applied to the shaft of this generator? Express your answer both in newton-meters and in pound-feet.

SOLUTION To get the applied torque, we must know the input power. The input power to this generator is equal to the output power plus losses. The rated output power and the losses are

$$P_{\text{OUT}} = (470 \text{ kVA})(0.85) = 400 \text{ kW}$$

$$P_{\text{CU}} = 3I_A^2 R_A = 3(565 \text{ A})^2 (0.016 \Omega) = 15.3 \text{ kW}$$

$$P_{\text{F\&W}} = 8 \text{ kW}$$

$$P_{\text{core}} = 7 \text{ kW}$$

$$P_{\text{stray}} = (\text{assumed } 0)$$

$$P_{\text{IN}} = P_{\text{OUT}} + P_{\text{CU}} + P_{\text{F\&W}} + P_{\text{core}} + P_{\text{stray}} = 430.3 \text{ kW}$$

Therefore, the applied torque is

$$\tau_{\text{APP}} = \frac{P_{\text{IN}}}{\omega_m} = \frac{430.3 \text{ kW}}{(1800 \text{ r/min}) \frac{2\pi \text{ rad}}{1 \text{ r}} \frac{1 \text{ min}}{60 \text{ s}}} = 2280 \text{ N} \cdot \text{m}$$

or
$$\tau_{\text{APP}} = \frac{7.04 P}{n_m} = \frac{7.04 (430.3 \text{ kW})}{1800 \text{ r/min}} = 1680 \text{ lb} \cdot \text{ft}$$

- 5-17.** What is the torque angle δ of this generator at rated conditions?

SOLUTION From the calculations in Problem 5-12, $\delta = 30.5^\circ$.

- 5-18.** Assume that the generator field current is adjusted to supply 480 V under rated conditions. What is the static stability limit of this generator? (*Note:* You may ignore R_A to make this calculation easier.) How close is the full-load condition of this generator to the static stability limit?

SOLUTION At rated conditions, $\mathbf{E}_A = 509 \angle 30.5^\circ \text{ V}$. Therefore, the static stability limit is

$$P_{\text{MAX}} = \frac{3 V_\phi E_A}{X_s} = \frac{3(277 \text{ V})(509 \text{ V})}{0.899 \Omega} = 471 \text{ kW}$$

The full-load rated power of this generator is reasonably close to the static stability limit. Normal generators would have more margin than this.

- 5-19.** Assume that the generator field current is adjusted to supply 480 V under rated conditions. Plot the power supplied by the generator as a function of the torque angle δ . (Note: You may ignore R_A to make this calculation easier.)

SOLUTION We will again ignore R_A to make this calculation easier. The power supplied by the generator is

$$P_G = \frac{3 V_\phi E_A}{X_s} \sin \delta = \frac{3(277 \text{ V})(509 \text{ V})}{0.899 \Omega} \sin \delta = (471 \text{ kW}) \sin \delta$$

The power supplied as a function of the torque angle δ may be plotted using a simple MATLAB program:

```
% M-file: prob5_19.m
% M-file to plot the power output of a
% synchronous generator as a function of
% the torque angle.

% Calculate Xs
delta = (0:1:90); % Torque angle (deg)
Pout = 561 .* sin(delta * pi/180); % Pout

% Plot the output power
figure(1)
plot(delta,Pout,'LineWidth',2.0);
title ('\bfOutput power vs torque angle \delta');
xlabel ('\bfTorque angle \delta (deg)');
ylabel ('\bf\itP_{OUT} \rm\bf(kW)');
grid on;
```

The resulting plot is:

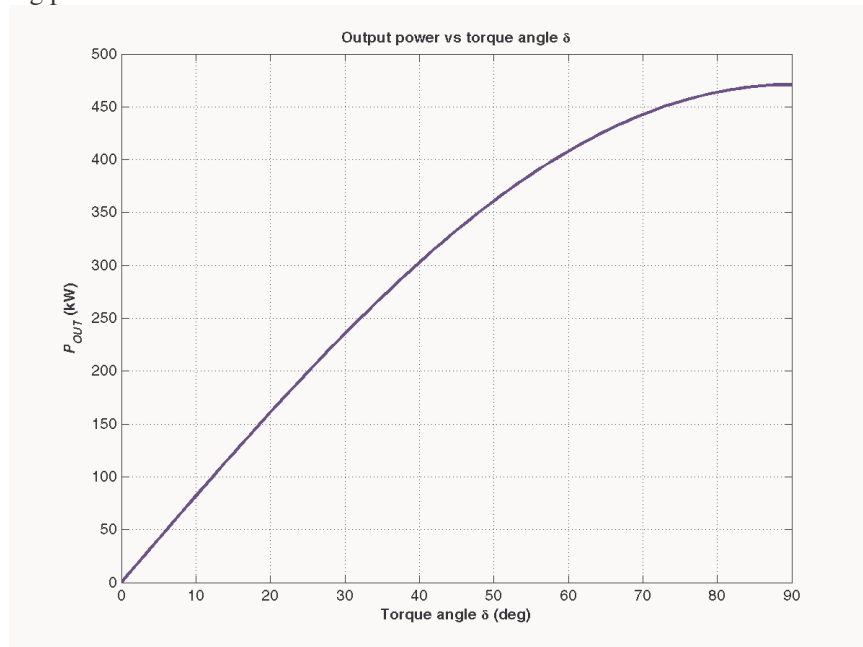

- 5-20.** Assume that the generator's field current is adjusted so that the generator supplies rated voltage at the rated load current and power factor. If the field current and the magnitude of the load current are held constant, how will the terminal voltage change as the load power factor varies from 0.85 PF lagging to 0.85 PF

leading? Make a plot of the terminal voltage versus the impedance angle of the load being supplied by this generator.

SOLUTION If the field current is held constant, then the magnitude of E_A will be constant, although its angle δ will vary. Also, the magnitude of the armature current is constant. Since we also know R_A , X_S , and the current angle θ , we know enough to find the phase voltage V_ϕ , and therefore the terminal voltage V_T . At lagging power factors, V_ϕ can be found from the following relationships:

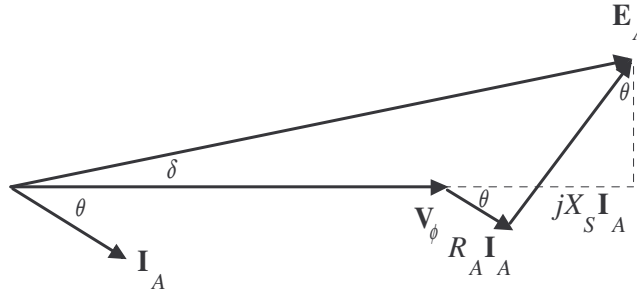

By the Pythagorean Theorem,

$$E_A^2 = (V_\phi + R_A I_A \cos \theta + X_S I_A \sin \theta)^2 + (X_S I_A \cos \theta - R_A I_A \sin \theta)^2$$

$$V_\phi = \sqrt{E_A^2 - (X_S I_A \cos \theta - R_A I_A \sin \theta)^2} - R_A I_A \cos \theta - X_S I_A \sin \theta$$

At unity power factor, V_ϕ can be found from the following relationships:

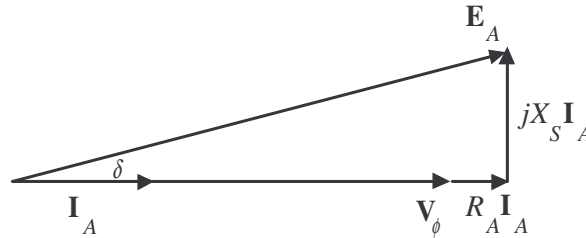

By the Pythagorean Theorem,

$$E_A^2 = V_\phi^2 + (X_S I_A)^2$$

$$V_\phi = \sqrt{E_A^2 - (X_S I_A)^2}$$

At leading power factors, V_ϕ can be found from the following relationships:

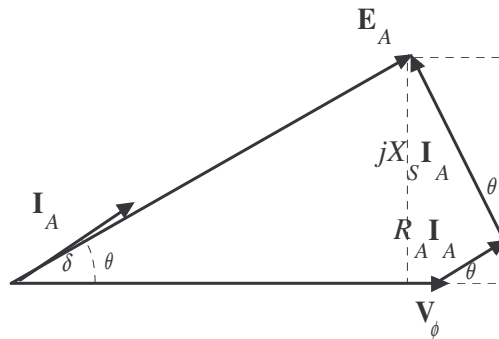

By the Pythagorean Theorem,

$$E_A^2 = (V_\phi + R_A I_A \cos \theta - X_S I_A \sin \theta)^2 + (X_S I_A \cos \theta + R_A I_S \sin \theta)^2$$

$$V_\phi = \sqrt{E_A^2 - (X_S I_A \cos \theta + R_A I_S \sin \theta)^2} - R_A I_A \cos \theta + X_S I_A \sin \theta$$

If we examine these three cases, we can see that the only difference among them is the sign of the term $\sin \theta$. If θ is taken as positive for lagging power factors and negative for leading power factors (in other words, if θ is the *impedance angle*), then all three cases can be represented by the single equation:

$$V_\phi = \sqrt{E_A^2 - (X_S I_A \cos \theta - R_A I_S \sin \theta)^2} - R_A I_A \cos \theta - X_S I_A \sin \theta$$

A MATLAB program that calculates terminal voltage as function of impedance angle is shown below:

```
% M-file: prob5_20.m
% M-file to calculate and plot the terminal voltage
% of a synchronous generator as a function of impedance
% angle as PF changes from 0.85 lagging to 0.85
% leading.

% Define values for this generator
EA = 509; % Internal gen voltage
I = 361; % Current (A)
R = 0.04; % R (ohms)
X = 0.695; % XS (ohms)

% Calculate impedance angle theta in degrees
theta = -31.8:0.318:31.8;
th = theta * pi/180; % In radians

% Calculate the phase voltage and terminal voltage
VP = sqrt( EA^2 - (X.*I.*cos(th) - R.*I.*sin(th)).^2 ) ...
    - R.*I.*cos(th) - X.*I.*sin(th);
VT = VP .* sqrt(3);

% Plot the terminal voltage versus power factor
figure(1);
plot(theta,abs(VT),'b-','LineWidth',2.0);
title ('\bfTerminal Voltage Versus Impedance Angle');
xlabel ('\bfImpedance Angle (deg)');
ylabel ('\bfTerminal Voltage (V)');
%axis([0 260 300 540]);
grid on;
hold off;
```

The resulting plot of terminal voltage versus impedance angle (with field and armature currents held constant) is shown below:

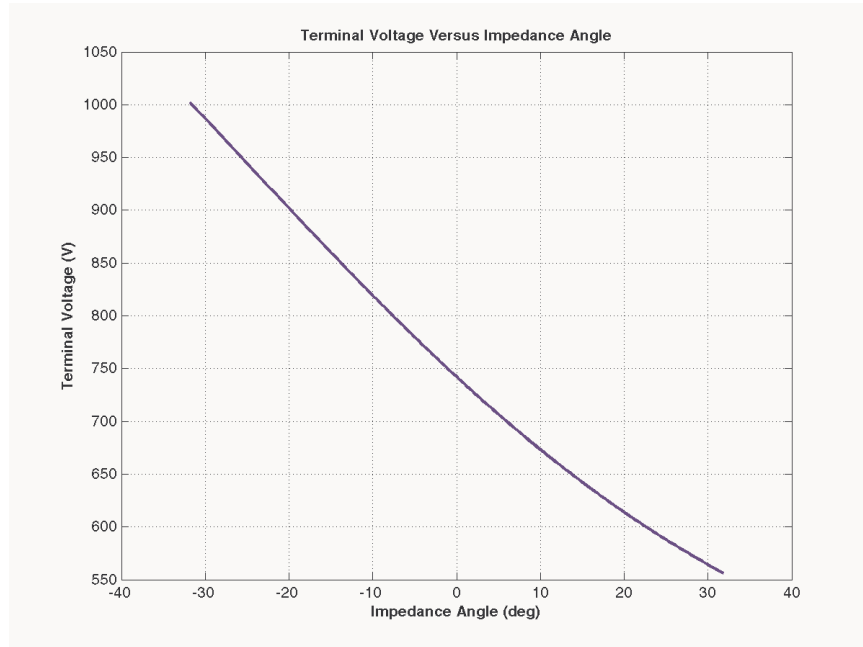

5-21. Assume that the generator is connected to a 480-V infinite bus, and that its field current has been adjusted so that it is supplying rated power and power factor to the bus. You may ignore the armature resistance R_A when answering the following questions.

- (a) What would happen to the real and reactive power supplied by this generator if the field flux (and therefore E_A) is reduced by 5%.
- (b) Plot the real power supplied by this generator as a function of the flux ϕ as the flux is varied from 75% to 100% of the flux at rated conditions.
- (c) Plot the reactive power supplied by this generator as a function of the flux ϕ as the flux is varied from 75% to 100% of the flux at rated conditions.
- (d) Plot the line current supplied by this generator as a function of the flux ϕ as the flux is varied from 75% to 100% of the flux at rated conditions.

SOLUTION

(a) If the field flux in increase by 5%, nothing would happen to the real power. The reactive power supplied would increase as shown below.

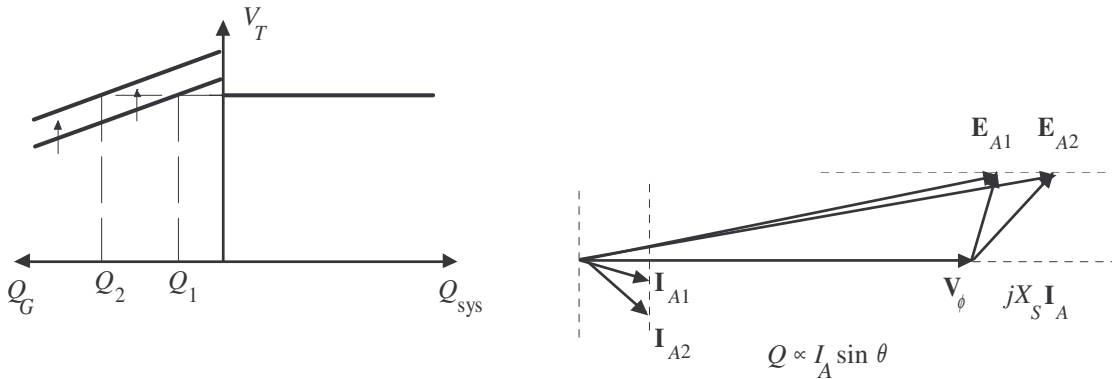

The reactive power

(b) If armature resistance is ignored, the power supplied to the bus will not change as flux is varied. Therefore, the plot of real power versus flux is

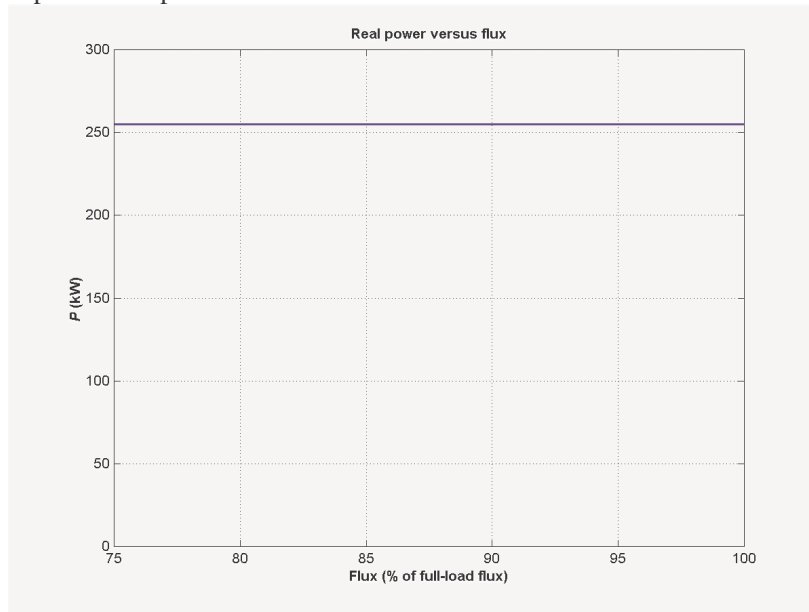

(c) If armature resistance is ignored, the internal generated voltage \mathbf{E}_A will increase as flux increases, but the quantity $E_A \sin \delta$ will remain constant. Therefore, the voltage for any flux can be found from the expression

$$E_A = \left(\frac{\phi}{\phi_r} \right) E_{Ar}$$

and the angle δ for any E_A can be found from the expression

$$\delta = \sin^{-1} \left(\frac{E_{Ar}}{E_A} \sin \delta_r \right)$$

where ϕ is the flux in the machine, ϕ_r is the flux at rated conditions, E_{Ar} is the magnitude of the internal generated voltage at rated conditions, and δ_r is the angle of the internal generated voltage at rated conditions. From this information, we can calculate \mathbf{I}_A for any given load from equation

$$\mathbf{I}_A = \frac{\mathbf{E}_A - \mathbf{V}_\phi}{jX_S}$$

and the resulting reactive power from the equation

$$Q = 3V_\phi I_A \sin \theta$$

where θ is the impedance angle, which is the negative of the current angle. Ignoring R_A , the internal generated voltage at rated conditions is

$$\begin{aligned} \mathbf{E}_A &= \mathbf{V}_\phi + jX_S \mathbf{I}_A \\ \mathbf{E}_A &= 277 \angle 0^\circ + j(0.899 \Omega)(565.3 \angle -31.8^\circ \text{ A}) \end{aligned}$$

$$E_A = 695 \angle 38.4^\circ \text{ V}$$

so $E_{Ar} = 461 \text{ V}$ and $\delta_r = 27.5^\circ$. A MATLAB program that calculates the reactive power supplied voltage as a function of flux is shown below:

```
% M-file: prob5_21c.m
% M-file to calculate and plot the reactive power
% supplied to an infinite bus as flux is varied from
% 75% to 100% of the flux at rated conditions.

% Define values for this generator
flux_ratio = 0.90:0.01:1.00; % Flux ratio
Ear = 695; % Ea at full flux
dr = 38.4 * pi/180; % Torque ang at full flux
Vp = 277; % Phase voltage
Xs = 0.899; % Xs (ohms)

% Calculate Ea for each flux
Ea = flux_ratio * Ear;

% Calculate delta for each flux
d = asin( Ear ./ Ea .* sin(dr));

% Calculate Ia for each flux
Ea = Ea .* ( cos(d) + j.*sin(d) );
Ia = ( Ea - Vp ) ./ (j*Xs);

% Calculate reactive power for each flux
theta = -atan2(imag(Ia),real(Ia));
Q = 3 .* Vp .* abs(Ia) .* sin(theta);

% Plot the power supplied versus flux
figure(1);
plot(flux_ratio,Q/1000,'b-','LineWidth',2.0);
title ('\bfReactive power versus flux');
xlabel ('\bfFlux (% of full-load flux)');
ylabel ('\bf\itQ\rm\bf (kVAR)');
grid on;
hold off;
```

When this program is executed, the plot of reactive power versus flux is

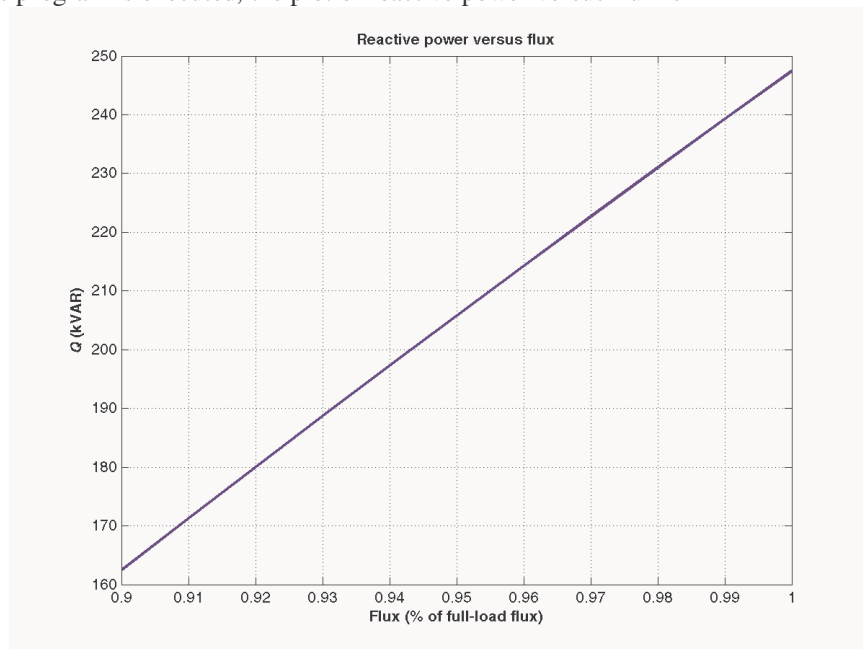

(d) The program in part (c) of this program calculated \mathbf{I}_A as a function of flux. A MATLAB program that plots the magnitude of this current as a function of flux is shown below:

```
% M-file: prob5_21d.m
% M-file to calculate and plot the armature current
% supplied to an infinite bus as flux is varied from
% 75% to 100% of the flux at rated conditions.

% Define values for this generator
flux_ratio = 0.75:0.01:1.00; % Flux ratio
Ear = 695; % Ea at full flux
dr = 38.4 * pi/180; % Torque ang at full flux
Vp = 277; % Phase voltage
Xs = 0.899; % Xs (ohms)

% Calculate Ea for each flux
Ea = flux_ratio * Ear;

% Calculate delta for each flux
d = asin( Ear ./ Ea .* sin(dr));

% Calculate Ia for each flux
Ea = Ea .* ( cos(d) + j.*sin(d) );
Ia = ( Ea - Vp ) ./ (j*Xs);

% Plot the armature current versus flux
figure(1);
plot(flux_ratio,abs(Ia),'b-','LineWidth',2.0);
title ('\bfArmature current versus flux');
xlabel ('\bfFlux (% of full-load flux)');
ylabel ('\bf\itI_{A}\rm\bf (A)');
grid on;
```

hold off;

When this program is executed, the plot of armature current versus flux is

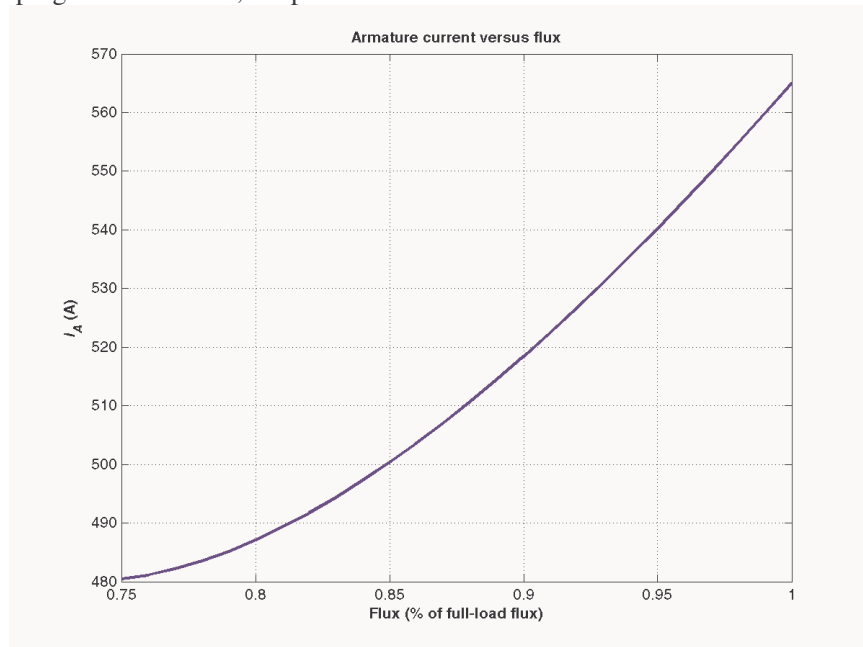

- 5-22.** A 100-MVA 12.5-kV 0.85-PF-lagging 50-Hz two-pole Y-connected synchronous generator has a per-unit synchronous reactance of 1.1 and a per-unit armature resistance of 0.012.
- What are its synchronous reactance and armature resistance in ohms?
 - What is the magnitude of the internal generated voltage E_A at the rated conditions? What is its torque angle δ at these conditions?
 - Ignoring losses in this generator, what torque must be applied to its shaft by the prime mover at full load?

SOLUTION The base phase voltage of this generator is $V_{\phi, \text{base}} = 12,500 / \sqrt{3} = 7217 \text{ V}$. Therefore, the base impedance of the generator is

$$Z_{\text{base}} = \frac{3 V_{\phi, \text{base}}^2}{S_{\text{base}}} = \frac{3(7217 \text{ V})^2}{100,000,000 \text{ VA}} = 1.56 \Omega$$

- (a) The generator impedance in ohms are:

$$R_A = (0.012)(1.56 \Omega) = 0.0187 \Omega$$

$$X_S = (1.1)(1.56 \Omega) = 1.716 \Omega$$

- (b) The rated armature current is

$$I_A = I_L = \frac{S}{\sqrt{3} V_T} = \frac{100 \text{ MVA}}{\sqrt{3}(12.5 \text{ kV})} = 4619 \text{ A}$$

The power factor is 0.8 lagging, so $\mathbf{I}_A = 4619 \angle -36.87^\circ \text{ A}$. Therefore, the internal generated voltage is

$$\mathbf{E}_A = \mathbf{V}_\phi + R_A \mathbf{I}_A + jX_S \mathbf{I}_A$$

$$\begin{aligned} \mathbf{E}_A &= 7217\angle 0^\circ + (0.0187\ \Omega)(4619\angle -36.87^\circ\ \text{A}) + j(1.716\ \Omega)(4619\angle -36.87^\circ\ \text{A}) \\ \mathbf{E}_A &= 13,590\angle 27.6^\circ\ \text{V} \end{aligned}$$

Therefore, the magnitude of the internal generated voltage $E_A = 13,590\ \text{V}$, and the torque angle $\delta = 23^\circ$.

(c) Ignoring losses, the input power would equal the output power. Since

$$P_{\text{OUT}} = (0.85)(100\ \text{MVA}) = 85\ \text{MW}$$

and

$$n_{\text{sync}} = \frac{120f_e}{P} = \frac{120(50\ \text{Hz})}{2} = 3000\ \text{r/min}$$

the applied torque would be

$$\tau_{\text{app}} = \tau_{\text{ind}} = \frac{85,000,000\ \text{W}}{(3000\ \text{r/min})(2\pi\ \text{rad/r})(1\ \text{min}/60\ \text{s})} = 270,000\ \text{N}\cdot\text{m}$$

5-23. A three-phase Y-connected synchronous generator is rated 120 MVA, 13.2 kV, 0.8 PF lagging, and 60 Hz. Its synchronous reactance is $0.9\ \Omega$, and its resistance may be ignored.

- (a) What is its voltage regulation?
 (b) What would the voltage and apparent power rating of this generator be if it were operated at 50 Hz with the same armature and field losses as it had at 60 Hz?
 (c) What would the voltage regulation of the generator be at 50 Hz?

SOLUTION

(a) The rated armature current is

$$I_A = I_L = \frac{S}{\sqrt{3} V_T} = \frac{120\ \text{MVA}}{\sqrt{3}(13.2\ \text{kV})} = 5249\ \text{A}$$

The power factor is 0.8 lagging, so $\mathbf{I}_A = 5249\angle -36.87^\circ\ \text{A}$. The phase voltage is $13.2\ \text{kV} / \sqrt{3} = 7621\ \text{V}$. Therefore, the internal generated voltage is

$$\begin{aligned} \mathbf{E}_A &= \mathbf{V}_\phi + R_A \mathbf{I}_A + jX_S \mathbf{I}_A \\ \mathbf{E}_A &= 7621\angle 0^\circ + j(0.9\ \Omega)(5249\angle -36.87^\circ\ \text{A}) \\ \mathbf{E}_A &= 11,120\angle 19.9^\circ\ \text{V} \end{aligned}$$

The resulting voltage regulation is

$$\text{VR} = \frac{11,120 - 7621}{7621} \times 100\% = 45.9\%$$

(b) If the generator is to be operated at 50 Hz with the same armature and field losses as at 60 Hz (so that the windings do not overheat), then its armature and field currents must not change. Since the voltage of the generator is directly proportional to the speed of the generator, the voltage rating (and hence the apparent power rating) of the generator will be reduced by a factor of $5/6$.

$$V_{T,\text{rated}} = \frac{5}{6}(13.2\ \text{kV}) = 11.0\ \text{kV}$$

$$S_{\text{rated}} = \frac{5}{6}(120\ \text{MVA}) = 100\ \text{MVA}$$

Also, the synchronous reactance will be reduced by a factor of 5/6.

$$X_s = \frac{5}{6}(0.9 \Omega) = 0.75 \Omega$$

(c) At 50 Hz rated conditions, the armature current would be

$$I_A = I_L = \frac{S}{\sqrt{3} V_T} = \frac{100 \text{ MVA}}{\sqrt{3}(11.0 \text{ kV})} = 5247 \text{ A}$$

The power factor is 0.8 lagging, so $\mathbf{I}_A = 5247 \angle -36.87^\circ \text{ A}$. The phase voltage is $11.0 \text{ kV} / \sqrt{3} = 6351 \text{ V}$. Therefore, the internal generated voltage is

$$\mathbf{E}_A = \mathbf{V}_\phi + R_A \mathbf{I}_A + jX_s \mathbf{I}_A$$

$$\mathbf{E}_A = 6351 \angle 0^\circ + j(0.75 \Omega)(5247 \angle -36.87^\circ \text{ A})$$

$$\mathbf{E}_A = 9264 \angle 19.9^\circ \text{ V}$$

The resulting voltage regulation is

$$\text{VR} = \frac{9264 - 6351}{6351} \times 100\% = 45.9\%$$

Because voltage, apparent power, and synchronous reactance all scale linearly with frequency, the voltage regulation at 50 Hz is the same as that at 60 Hz. Note that this is not *quite* true, if the armature resistance R_A is included, since R_A does not scale with frequency in the same fashion as the other terms.

5-24. Two identical 600-kVA 480-V synchronous generators are connected in parallel to supply a load. The prime movers of the two generators happen to have different speed droop characteristics. When the field currents of the two generators are equal, one delivers 400 A at 0.9 PF lagging, while the other delivers 300 A at 0.72 PF lagging.

(a) What are the real power and the reactive power supplied by each generator to the load?

(b) What is the overall power factor of the load?

(c) In what direction must the field current on each generator be adjusted in order for them to operate at the same power factor?

SOLUTION

(a) The real and reactive powers are

$$P_1 = \sqrt{3} V_T I_L \cos \theta = \sqrt{3}(480 \text{ V})(400 \text{ A})(0.9) = 299 \text{ kW}$$

$$Q_1 = \sqrt{3} V_T I_L \sin \theta = \sqrt{3}(480 \text{ V})(400 \text{ A}) \sin \cos^{-1}(0.9) = 145 \text{ kVAR}$$

$$P_2 = \sqrt{3} V_T I_L \cos \theta = \sqrt{3}(480 \text{ V})(200 \text{ A})(0.72) = 120 \text{ kW}$$

$$Q_2 = \sqrt{3} V_T I_L \sin \theta = \sqrt{3}(480 \text{ V})(200 \text{ A}) \sin \cos^{-1}(0.72) = 115 \text{ kVAR}$$

(b) The overall power factor can be found from the total real and reactive power supplied to the load.

$$P_{\text{TOT}} = P_1 + P_2 = 299 \text{ kW} + 120 \text{ kW} = 419 \text{ kW}$$

$$Q_{\text{TOT}} = Q_1 + Q_2 = 145 \text{ kVAR} + 115 \text{ kVAR} = 260 \text{ kVAR}$$

The overall power factor is

$$\text{PF} = \cos \tan^{-1} \frac{Q_{\text{TOT}}}{P_{\text{TOT}}} = 0.850 \text{ lagging}$$

(c) The field current of generator 1 should be increased, and the field current of generator 2 should be simultaneously decreased.

5-25. A generating station for a power system consists of four 120-MVA 15-kV 0.85-PF-lagging synchronous generators with identical speed droop characteristics operating in parallel. The governors on the generators' prime movers are adjusted to produce a 3-Hz drop from no load to full load. Three of these generators are each supplying a steady 75 MW at a frequency of 60 Hz, while the fourth generator (called the *swing generator*) handles all incremental load changes on the system while maintaining the system's frequency at 60 Hz.

- (a) At a given instant, the total system loads are 260 MW at a frequency of 60 Hz. What are the no-load frequencies of each of the system's generators?
- (b) If the system load rises to 290 MW and the generator's governor set points do not change, what will the new system frequency be?
- (c) To what frequency must the no-load frequency of the swing generator be adjusted in order to restore the system frequency to 60 Hz?
- (d) If the system is operating at the conditions described in part (c), what would happen if the swing generator were tripped off the line (disconnected from the power line)?

SOLUTION

(a) The full-load power of these generators is $(120 \text{ MVA})(0.85) = 102 \text{ MW}$ and the droop from no-load to full-load is 3 Hz. Therefore, the slope of the power-frequency curve for these four generators is

$$s_p = \frac{102 \text{ MW}}{3 \text{ Hz}} = 34 \text{ MW/Hz}$$

If generators 1, 2, and 3 are supplying 75 MW each, then generator 4 must be supplying 35 MW. The no-load frequency of the first three generators is

$$P_1 = s_{p1}(f_{n1} - f_{\text{sys}})$$

$$75 \text{ MW} = (34 \text{ MW/Hz})(f_{n1} - 60 \text{ Hz})$$

$$f_{n1} = 62.21 \text{ Hz}$$

The no-load frequency of the fourth generator is

$$P_4 = s_{p4}(f_{n4} - f_{\text{sys}})$$

$$35 \text{ MW} = (34 \text{ MW/Hz})(f_{n4} - 60 \text{ Hz})$$

$$f_{n4} = 61.03 \text{ Hz}$$

(b) The setpoints of generators 1, 2, 3, and 4 do not change, so the new system frequency will be

$$P_{\text{LOAD}} = s_{p1}(f_{n1} - f_{\text{sys}}) + s_{p2}(f_{n2} - f_{\text{sys}}) + s_{p3}(f_{n3} - f_{\text{sys}}) + s_{p4}(f_{n4} - f_{\text{sys}})$$

$$290 \text{ MW} = (34)(62.21 - f_{\text{sys}}) + (34)(62.21 - f_{\text{sys}}) + (34)(62.21 - f_{\text{sys}}) + (34)(61.03 - f_{\text{sys}})$$

$$8.529 = 247.66 - 4f_{\text{sys}}$$

$$f_{\text{sys}} = 59.78 \text{ Hz}$$

(c) The governor setpoints of the swing generator must be increased until the system frequency rises back to 60 Hz. At 60 Hz, the other three generators will be supplying 75 MW each, so the swing generator must supply $290 \text{ MW} - 3(75 \text{ MW}) = 65 \text{ MW}$ at 60 Hz. Therefore, the swing generator's setpoints must be set to

$$P_4 = s_{P4} (f_{n14} - f_{\text{sys}})$$

$$65 \text{ MW} = (34 \text{ MW/Hz})(f_{n11} - 60 \text{ Hz})$$

$$f_{n11} = 61.91 \text{ Hz}$$

(d) If the swing generator trips off the line, the other three generators would have to supply all 290 MW of the load. Therefore, the system frequency will become

$$P_{\text{LOAD}} = s_{P1} (f_{n11} - f_{\text{sys}}) + s_{P2} (f_{n12} - f_{\text{sys}}) + s_{P3} (f_{n13} - f_{\text{sys}})$$

$$290 \text{ MW} = (34)(62.21 - f_{\text{sys}}) + (34)(62.21 - f_{\text{sys}}) + (34)(62.21 - f_{\text{sys}})$$

$$8.529 = 186.63 - 3f_{\text{sys}}$$

$$f_{\text{sys}} = 59.37 \text{ Hz}$$

Each generator will supply 96.7 MW to the loads.

- 5-26.** Suppose that you were an engineer planning a new electric co-generation facility for a plant with excess process steam. You have a choice of either two 10 MW turbine-generators or a single 20 MW turbine generator. What would be the advantages and disadvantages of each choice?

SOLUTION A single 20 MW generator will probably be cheaper and more efficient than two 10 MW generators, but if the 20 MW generator goes down all 20 MW of generation would be lost at once. If two 10 MW generators are chosen, one of them could go down for maintenance and some power could still be generated.

- 5-27.** A 25-MVA three-phase 13.8-kV two-pole 60-Hz synchronous generator was tested by the open-circuit test, and its air-gap voltage was extrapolated with the following results:

Open-circuit test

Field current, A	320	365	380	475	570
Line voltage, kV	13.0	13.8	14.1	15.2	16.0
Extrapolated air-gap voltage, kV	15.4	17.5	18.3	22.8	27.4

The short-circuit test was then performed with the following results:

Short-circuit test

Field current, A	320	365	380	475	570
Armature current, A	1040	1190	1240	1550	1885

The armature resistance is 0.24Ω per phase.

- (a) Find the unsaturated synchronous reactance of this generator in ohms per phase and in per-unit.
 (b) Find the approximate saturated synchronous reactance X_S at a field current of 380 A. Express the answer both in ohms per phase and in per-unit.

(c) Find the approximate saturated synchronous reactance at a field current of 475 A. Express the answer both in ohms per phase and in per-unit.

(d) Find the short-circuit ratio for this generator.

SOLUTION

(a) The unsaturated synchronous reactance of this generator is the same at any field current, so we will look at it at a field current of 380 A. The extrapolated air-gap voltage at this point is 18.3 kV, and the short-circuit current is 1240 A. Since this generator is Y-connected, the phase voltage is $V_\phi = 18.3 \text{ kV}/\sqrt{3} = 10,566 \text{ V}$ and the armature current is $I_A = 1240 \text{ A}$. Therefore, the *unsaturated* synchronous reactance is

$$X_{Su} = \frac{10,566 \text{ V}}{1240 \text{ A}} = 8.52 \Omega$$

The base impedance of this generator is

$$Z_{\text{base}} = \frac{3 V_{\phi, \text{base}}^2}{S_{\text{base}}} = \frac{3(7967 \text{ V})^2}{25,000,000 \text{ VA}} = 7.62 \Omega$$

Therefore, the per-unit unsaturated synchronous reactance is

$$X_{Su, \text{pu}} = \frac{8.52 \Omega}{7.62 \Omega} = 1.12$$

(b) The saturated synchronous reactance at a field current of 380 A can be found from the OCC and the SCC. The OCC voltage at $I_F = 380 \text{ A}$ is 14.1 kV, and the short-circuit current is 1240 A. Since this generator is Y-connected, the corresponding phase voltage is $V_\phi = 14.1 \text{ kV}/\sqrt{3} = 8141 \text{ V}$ and the armature current is $I_A = 1240 \text{ A}$. Therefore, the *saturated* synchronous reactance is

$$X_{Su} = \frac{8141 \text{ V}}{1240 \text{ A}} = 6.57 \Omega$$

and the per-unit unsaturated synchronous reactance is

$$X_{Su, \text{pu}} = \frac{6.57 \Omega}{7.62 \Omega} = 0.862$$

(c) The saturated synchronous reactance at a field current of 475 A can be found from the OCC and the SCC. The OCC voltage at $I_F = 475 \text{ A}$ is 15.2 kV, and the short-circuit current is 1550 A. Since this generator is Y-connected, the corresponding phase voltage is $V_\phi = 15.2 \text{ kV}/\sqrt{3} = 8776 \text{ V}$ and the armature current is $I_A = 1550 \text{ A}$. Therefore, the *saturated* synchronous reactance is

$$X_{Su} = \frac{8776 \text{ V}}{1550 \text{ A}} = 5.66 \Omega$$

and the per-unit unsaturated synchronous reactance is

$$X_{Su, \text{pu}} = \frac{5.66 \Omega}{7.62 \Omega} = 0.743$$

(d) The rated voltage of this generator is 13.8 kV, which requires a field current of 365 A. The rated line and armature current of this generator is

$$I_L = \frac{25 \text{ MVA}}{\sqrt{3}(13.8 \text{ kV})} = 1046 \text{ A}$$

The field current required to produce a short-circuit current of 10465 A is about 320 A. Therefore, the short-circuit ratio of this generator is

$$\text{SCR} = \frac{365 \text{ A}}{320 \text{ A}} = 1.14$$

- 5-28.** A 20-MVA 12.2-kV 0.8-PF-lagging Y-connected synchronous generator has a negligible armature resistance and a synchronous reactance of 1.1 per-unit. The generator is connected in parallel with a 60-Hz 12.2-kV infinite bus that is capable of supplying or consuming any amount of real or reactive power with no change in frequency or terminal voltage.
- What is the synchronous reactance of the generator in ohms?
 - What is the internal generated voltage \mathbf{E}_A of this generator under rated conditions?
 - What is the armature current \mathbf{I}_A in this machine at rated conditions?
 - Suppose that the generator is initially operating at rated conditions. If the internal generated voltage \mathbf{E}_A is decreased by 5 percent, what will the new armature current \mathbf{I}_A be?
 - Repeat part (d) for 10, 15, 20, and 25 percent reductions in \mathbf{E}_A .
 - Plot the magnitude of the armature current I_A as a function of E_A . (You may wish to use MATLAB to create this plot.)

SOLUTION

- The rated phase voltage of this generator is $12.2 \text{ kV} / \sqrt{3} = 7044 \text{ V}$. The base impedance of this generator is

$$Z_{\text{base}} = \frac{3 V_{\phi, \text{base}}^2}{S_{\text{base}}} = \frac{3(7044 \text{ V})^2}{20,000,000 \text{ VA}} = 7.44 \Omega$$

Therefore,

$$R_A \approx 0 \Omega \text{ (negligible)}$$

$$X_S = (1.1)(7.44 \Omega) = 8.18 \Omega$$

- The rated armature current is

$$I_A = I_L = \frac{S}{\sqrt{3} V_T} = \frac{20 \text{ MVA}}{\sqrt{3}(12.2 \text{ kV})} = 946 \text{ A}$$

The power factor is 0.8 lagging, so $\mathbf{I}_A = 946 \angle -36.87^\circ \text{ A}$. Therefore, the internal generated voltage is

$$\mathbf{E}_A = \mathbf{V}_\phi + R_A \mathbf{I}_A + jX_S \mathbf{I}_A$$

$$\mathbf{E}_A = 7044 \angle 0^\circ + j(8.18 \Omega)(946 \angle -36.87^\circ \text{ A})$$

$$\mathbf{E}_A = 13,230 \angle 27.9^\circ \text{ V}$$

- From the above calculations, $\mathbf{I}_A = 946 \angle -36.87^\circ \text{ A}$.

(d) If E_A is decreased by 5%, the armature current will change as shown below. Note that the infinite bus will keep V_ϕ and ω_m constant. Also, since the prime mover hasn't changed, the power supplied by the generator will be constant.

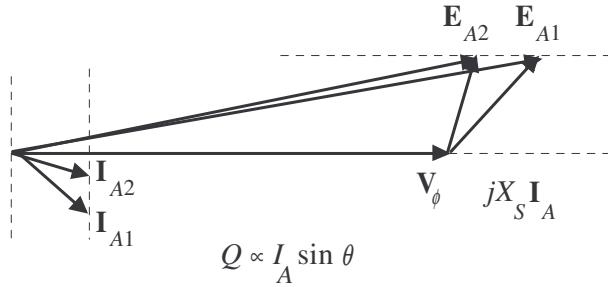

$$P = \frac{3V_\phi E_A}{X_S} \sin \delta = \text{constant}, \text{ so } E_{A1} \sin \delta_1 = E_{A2} \sin \delta_2$$

With a 5% decrease, $E_{A2} = 12,570 \text{ V}$, and

$$\delta_2 = \sin^{-1} \frac{E_{A1} \sin \delta_1}{E_{A2}} = \sin^{-1} \frac{13,230 \text{ V}}{12,570 \text{ V}} \sin 27.9^\circ = 29.5^\circ$$

Therefore, the new armature current is

$$\mathbf{I}_A = \frac{\mathbf{E}_{A2} - \mathbf{V}_\phi}{jX_S} = \frac{12,570 \angle 29.5^\circ - 7044 \angle 0^\circ}{j8.18} = 894 \angle -32.2^\circ \text{ A}$$

(e) Repeating part (d):

With a **10%** decrease, $E_{A2} = 11,907 \text{ V}$, and

$$\delta_2 = \sin^{-1} \frac{E_{A1} \sin \delta_1}{E_{A2}} = \sin^{-1} \frac{13,230 \text{ V}}{11,907 \text{ V}} \sin 27.9^\circ = 31.3^\circ$$

Therefore, the new armature current is

$$\mathbf{I}_A = \frac{\mathbf{E}_{A2} - \mathbf{V}_\phi}{jX_S} = \frac{11,907 \angle 31.3^\circ - 7044 \angle 0^\circ}{j8.18} = 848 \angle -26.8^\circ \text{ A}$$

With a **15%** decrease, $E_{A2} = 11,246 \text{ V}$, and

$$\delta_2 = \sin^{-1} \frac{E_{A1} \sin \delta_1}{E_{A2}} = \sin^{-1} \frac{13,230 \text{ V}}{11,246 \text{ V}} \sin 27.9^\circ = 33.4^\circ$$

Therefore, the new armature current is

$$\mathbf{I}_A = \frac{\mathbf{E}_{A2} - \mathbf{V}_\phi}{jX_S} = \frac{11,246 \angle 33.4^\circ - 7044 \angle 0^\circ}{j8.18} = 809 \angle -20.7^\circ \text{ A}$$

With a **20%** decrease, $E_{A2} = 10,584 \text{ V}$, and

$$\delta_2 = \sin^{-1} \frac{E_{A1} \sin \delta_1}{E_{A2}} = \sin^{-1} \frac{13,230 \text{ V}}{10,584 \text{ V}} \sin 27.9^\circ = 35.8^\circ$$

Therefore, the new armature current is

$$I_A = \frac{E_{A2} - V_\phi}{jX_s} = \frac{10,584\angle 35.8^\circ - 7044\angle 0^\circ}{j8.18} = 780\angle -14.0^\circ \text{ A}$$

With a **25%** decrease, $E_{A2} = 9,923 \text{ V}$, and

$$\delta_2 = \sin^{-1} \frac{E_{A1}}{E_{A2}} \sin \delta_1 = \sin^{-1} \frac{13,230 \text{ V}}{9,923 \text{ V}} \sin 27.9^\circ = 38.6^\circ$$

Therefore, the new armature current is

$$I_A = \frac{E_{A2} - V_\phi}{jX_s} = \frac{9,923\angle 38.6^\circ - 7044\angle 0^\circ}{j8.18} = 762\angle -6.6^\circ \text{ A}$$

(f) A MATLAB program to plot the magnitude of the armature current I_A as a function of E_A is shown below.

```
% M-file: prob5_28f.m
% M-file to calculate and plot the armature current
% supplied to an infinite bus as Ea is varied.

% Define values for this generator
Ea = (0.65:0.01:1.00)*13230; % Ea
Vp = 7044; % Phase voltage
d1 = 27.9*pi/180; % torque angle at full Ea
Xs = 8.18; % Xs (ohms)

% Calculate delta for each Ea
d = asin( 13230 ./ Ea .* sin(d1));

% Calculate Ia for each flux
Ea = Ea .* ( cos(d) + j.*sin(d) );
Ia = ( Ea - Vp ) ./ (j*Xs);

% Plot the armature current versus Ea
figure(1);
plot(abs(Ea)/1000,abs(Ia), 'b-', 'LineWidth',2.0);
title ('\bfArmature current versus \itE_{A}\rm');
xlabel ('\bf\itE_{A}\rm\bf (kV)');
ylabel ('\bf\itI_{A}\rm\bf (A)');
grid on;
hold off;
```

The resulting plot is shown below:

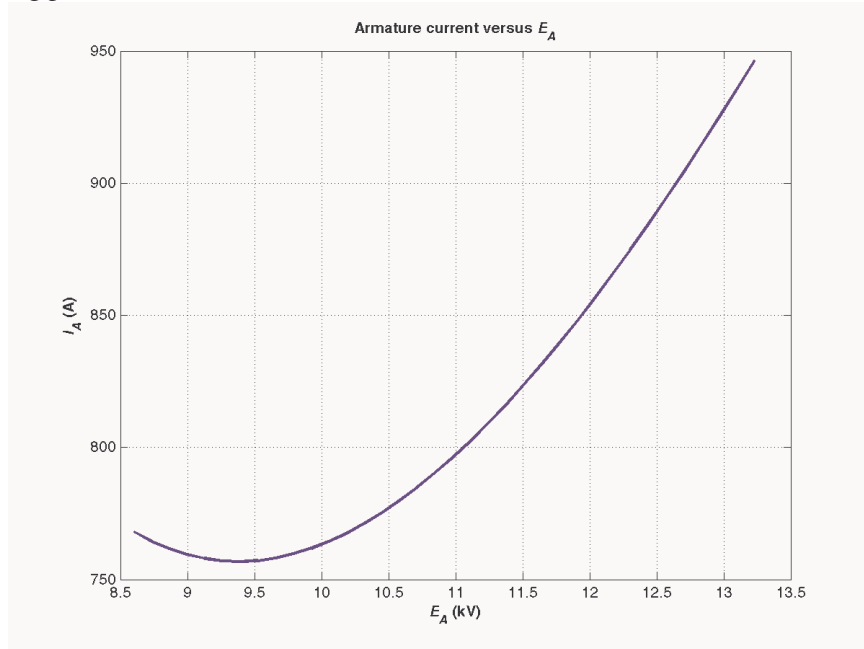

Chapter 6: Synchronous Motors

- 6-1.** A 480-V, 60 Hz, four-pole synchronous motor draws 50 A from the line at unity power factor and full load. Assuming that the motor is lossless, answer the following questions:
- What is the output torque of this motor? Express the answer both in newton-meters and in pound-feet.
 - What must be done to change the power factor to 0.8 leading? Explain your answer, using phasor diagrams.
 - What will the magnitude of the line current be if the power factor is adjusted to 0.8 leading?

SOLUTION

(a) If this motor is assumed lossless, then the input power is equal to the output power. The input power to this motor is

$$P_{\text{IN}} = \sqrt{3} V_T I_L \cos \theta = \sqrt{3} (480 \text{ V})(50 \text{ A})(1.0) = 41.6 \text{ kW}$$

The output torque would be

$$\tau_{\text{LOAD}} = \frac{P_{\text{OUT}}}{\omega_m} = \frac{41.6 \text{ kW}}{(1800 \text{ r/min}) \frac{1 \text{ min}}{60 \text{ s}} \frac{2\pi \text{ rad}}{1 \text{ r}}} = 221 \text{ N} \cdot \text{m}$$

In English units,

$$\tau_{\text{LOAD}} = \frac{7.04 P_{\text{OUT}}}{n_m} = \frac{(7.04)(41.6 \text{ kW})}{(1800 \text{ r/min})} = 163 \text{ lb} \cdot \text{ft}$$

(b) To change the motor's power factor to 0.8 leading, its field current must be increased. Since the power supplied to the load is independent of the field current level, an increase in field current increases $|E_A|$ while keeping the distance $E_A \sin \delta$ constant. This increase in E_A changes the angle of the current I_A , eventually causing it to reach a power factor of 0.8 leading.

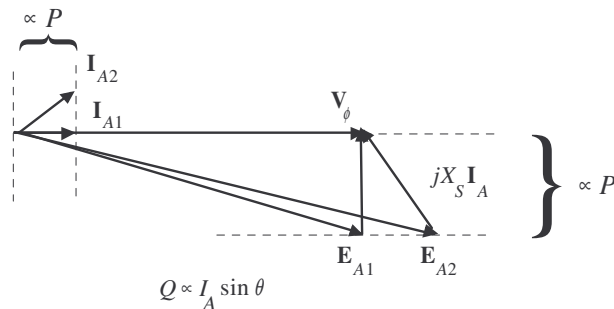

(c) The magnitude of the line current will be

$$I_L = \frac{P}{\sqrt{3} V_T \text{PF}} = \frac{41.6 \text{ kW}}{\sqrt{3} (480 \text{ V})(0.8)} = 62.5 \text{ A}$$

- 6-2.** A 480-V, 60 Hz, 400-hp 0.8-PF-leading six-pole Δ -connected synchronous motor has a synchronous reactance of 1.1 Ω and negligible armature resistance. Ignore its friction, windage, and core losses for the purposes of this problem.

- (a) If this motor is initially supplying 400 hp at 0.8 PF lagging, what are the magnitudes and angles of \mathbf{E}_A and \mathbf{I}_A ?
- (b) How much torque is this motor producing? What is the torque angle δ ? How near is this value to the maximum possible induced torque of the motor for this field current setting?
- (c) If $|\mathbf{E}_A|$ is increased by 15 percent, what is the new magnitude of the armature current? What is the motor's new power factor?
- (d) Calculate and plot the motor's V-curve for this load condition.

SOLUTION

- (a) If losses are being ignored, the output power is equal to the input power, so the input power will be

$$P_{\text{IN}} = (400 \text{ hp})(746 \text{ W/hp}) = 298.4 \text{ kW}$$

This situation is shown in the phasor diagram below:

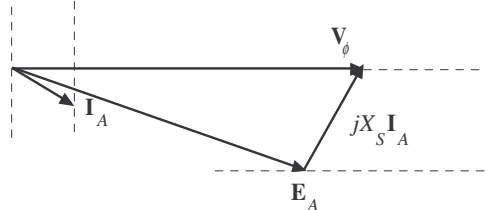

The line current flow under these circumstances is

$$I_L = \frac{P}{\sqrt{3} V_T \text{PF}} = \frac{298.4 \text{ kW}}{\sqrt{3}(480 \text{ V})(0.8)} = 449 \text{ A}$$

Because the motor is Δ -connected, the corresponding phase current is $I_A = 449/\sqrt{3} = 259 \text{ A}$. The angle of the current is $-\cos^{-1}(0.80) = -36.87^\circ$, so $\mathbf{I}_A = 259 \angle -36.87^\circ \text{ A}$. The internal generated voltage \mathbf{E}_A is

$$\mathbf{E}_A = \mathbf{V}_\phi - jX_S \mathbf{I}_A$$

$$\mathbf{E}_A = (480 \angle 0^\circ \text{ V}) - j(1.1 \Omega)(259 \angle -36.87^\circ \text{ A}) = 384 \angle -36.4^\circ \text{ V}$$

- (b) This motor has 6 poles and an electrical frequency of 60 Hz, so its rotation speed is $n_m = 1200 \text{ r/min}$. The induced torque is

$$\tau_{\text{ind}} = \frac{P_{\text{OUT}}}{\omega_m} = \frac{298.4 \text{ kW}}{(1200 \text{ r/min}) \frac{1 \text{ min}}{60 \text{ s}} \frac{2\pi \text{ rad}}{1 \text{ r}}} = 2375 \text{ N} \cdot \text{m}$$

The maximum possible induced torque for the motor at this field setting is

$$\tau_{\text{ind,max}} = \frac{3 V_\phi E_A}{\omega_m X_S} = \frac{3(480 \text{ V})(384 \text{ V})}{(1200 \text{ r/min}) \frac{1 \text{ min}}{60 \text{ s}} \frac{2\pi \text{ rad}}{1 \text{ r}} (1.1 \Omega)} = 4000 \text{ N} \cdot \text{m}$$

- (c) If the magnitude of the internal generated voltage E_A is increased by 15%, the new torque angle can be found from the fact that $E_A \sin \delta \propto P = \text{constant}$.

$$E_{A2} = 1.15 E_{A1} = 1.15(384 \text{ V}) = 441.6 \text{ V}$$

$$\delta_2 = \sin^{-1} \frac{E_{A1}}{E_{A2}} \sin \delta_1 = \sin^{-1} \frac{384 \text{ V}}{441.6 \text{ V}} \sin(-36.4^\circ) = -31.1^\circ$$

The new armature current is

$$\mathbf{I}_{A2} = \frac{\mathbf{V}_\phi - \mathbf{E}_{A2}}{jX_s} = \frac{480\angle 0^\circ \text{ V} - 441.6\angle -31.1^\circ \text{ V}}{j1.1 \Omega} = 227\angle -24.1^\circ \text{ A}$$

The magnitude of the armature current is 227 A, and the power factor is $\cos(-24.1^\circ) = 0.913$ lagging.

(d) A MATLAB program to calculate and plot the motor's V-curve is shown below:

```
% M-file: prob6_2d.m
% M-file create a plot of armature current versus Ea
% for the synchronous motor of Problem 6-2.

% Initialize values
Ea = (1:0.01:1.70)*384;           % Magnitude of Ea volts
Ear = 384;                       % Reference Ea
deltar = -36.4 * pi/180;         % Reference torque angle
Xs = 1.1;                        % Synchronous reactance
Vp = 480;                        % Phase voltage at 0 degrees
Ear = Ear * (cos(deltar) + j * sin(deltar));

% Calculate delta2
delta2 = asin ( abs(Ear) ./ abs(Ea) .* sin(deltar) );

% Calculate the phasor Ea
Ea = Ea .* (cos(delta2) + j .* sin(delta2));

% Calculate Ia
Ia = ( Vp - Ea ) / ( j * Xs);

% Plot the v-curve
figure(1);
plot(abs(Ea),abs(Ia), 'b', 'Linewidth',2.0);
xlabel('\bf\itE_{A}\rm\bf (V)');
ylabel('\bf\itI_{A}\rm\bf (A)');
title ('\bfSynchronous Motor V-Curve');
grid on;
```

The resulting plot is shown below

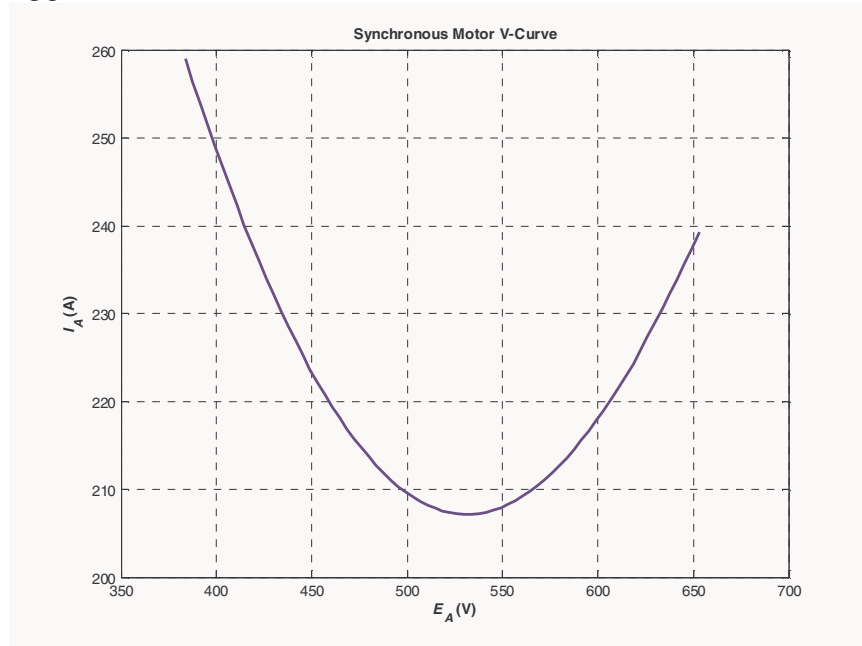

- 6-3.** A 2300-V 1000-hp 0.8-PF leading 60-Hz two-pole Y-connected synchronous motor has a synchronous reactance of 2.8Ω and an armature resistance of 0.4Ω . At 60 Hz, its friction and windage losses are 24 kW, and its core losses are 18 kW. The field circuit has a dc voltage of 200 V, and the maximum I_F is 10 A. The open-circuit characteristic of this motor is shown in Figure P6-1. Answer the following questions about the motor, assuming that it is being supplied by an infinite bus.
- How much field current would be required to make this machine operate at unity power factor when supplying full load?
 - What is the motor's efficiency at full load and unity power factor?
 - If the field current were increased by 5 percent, what would the new value of the armature current be? What would the new power factor be? How much reactive power is being consumed or supplied by the motor?
 - What is the maximum torque this machine is theoretically capable of supplying at unity power factor? At 0.8 PF leading?

Note: An electronic version of this open circuit characteristic can be found in file p61_occ.dat, which can be used with MATLAB programs. Column 1 contains field current in amps, and column 2 contains open-circuit terminal voltage in volts.

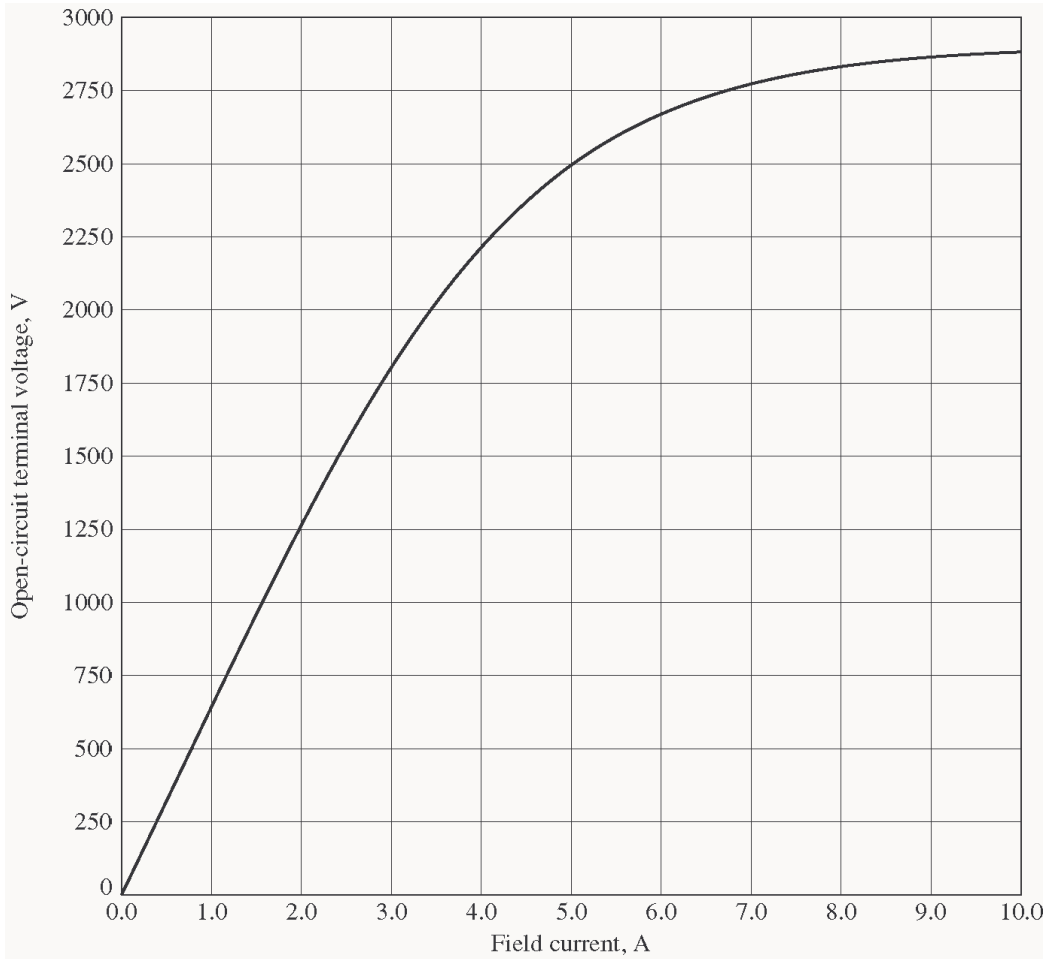

SOLUTION

(a) At full load, the input power to the motor is

$$P_{IN} = P_{OUT} + P_{mech} + P_{core} + P_{CU}$$

We can't know the copper losses until the armature current is known, so we will find the input power and armature current ignoring that term, and then correct the input power after we know it.

$$P_{IN} = (1000 \text{ hp})(746 \text{ W/hp}) + 24 \text{ kW} + 18 \text{ kW} = 788 \text{ kW}$$

Therefore, the line and phase current at unity power factor is

$$I_A = I_L = \frac{P}{\sqrt{3} V_T \text{ PF}} = \frac{788 \text{ kW}}{\sqrt{3}(2300 \text{ V})(1.0)} = 198 \text{ A}$$

The copper losses due to a current of 198 A are

$$P_{CU} = 3I_A^2 R_A = 3(198 \text{ A})^2 (0.4 \Omega) = 47.0 \text{ kW}$$

Therefore, a *better* estimate of the input power at full load is

$$P_{IN} = (1000 \text{ hp})(746 \text{ W/hp}) + 24 \text{ kW} + 18 \text{ kW} + 47 \text{ kW} = 835 \text{ kW}$$

and a *better* estimate of the line and phase current at unity power factor is

$$I_A = I_L = \frac{P}{\sqrt{3} V_T \text{PF}} = \frac{835 \text{ kW}}{\sqrt{3}(2300 \text{ V})(1.0)} = 210 \text{ A}$$

The phasor diagram of this motor operating a unity power factor is shown below:

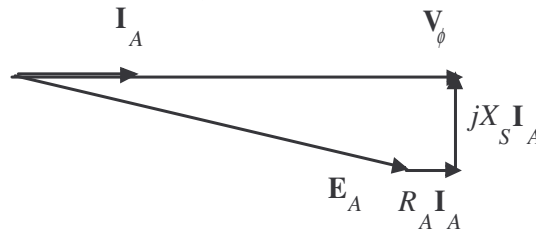

The phase voltage of this motor is $2300 / \sqrt{3} = 1328 \text{ V}$. The required internal generated voltage is

$$\begin{aligned} \mathbf{E}_A &= \mathbf{V}_\phi - R_A \mathbf{I}_A - jX_S \mathbf{I}_A \\ \mathbf{E}_A &= 1328 \angle 0^\circ \text{ V} - (0.4 \Omega)(210 \angle 0^\circ \text{ A}) - j(2.8 \Omega)(210 \angle 0^\circ \text{ A}) \\ \mathbf{E}_A &= 1376 \angle -25.3^\circ \text{ V} \end{aligned}$$

This internal generated voltage corresponds to a terminal voltage of $\sqrt{3}(1376) = 2383 \text{ V}$. This voltage would require a field current of 4.6 A.

(b) The motor's efficiency at full load and unity power factor is

$$\eta = \frac{P_{\text{OUT}}}{P_{\text{IN}}} \times 100\% = \frac{746 \text{ kW}}{835 \text{ kW}} \times 100\% = 89.3\%$$

(c) To solve this problem, we will temporarily ignore the effects of the armature resistance R_A . If R_A is ignored, then $E_A \sin \delta$ is directly proportional to the power supplied by the motor. Since the power supplied by the motor does not change when I_f is changed, this quantity will be a constant.

If the field current is increased by 5%, then the new field current will be 4.83 A, and the new value of the open-circuit terminal voltage will be 2450 V. The new value of E_A will be $2450 \text{ V} / \sqrt{3} = 1415 \text{ V}$. Therefore, the new torque angle δ will be

$$\delta_2 = \sin^{-1} \frac{E_{A1} \sin \delta_1}{E_{A2}} = \sin^{-1} \frac{1376 \text{ V}}{1415 \text{ V}} \sin(-25.3^\circ) = -24.6^\circ$$

Therefore, the new armature current will be

$$\mathbf{I}_A = \frac{\mathbf{V}_\phi - \mathbf{E}_A}{R_A + jX_S} = \frac{1328 \angle 0^\circ \text{ V} - 1415 \angle -25.3^\circ \text{ V}}{0.4 + j2.8 \Omega} = 214.5 \angle 3.5^\circ \text{ A}$$

The new current is about the same as before, but the phase angle has become positive. The new power factor is $\cos 3.5^\circ = 0.998$ leading, and the reactive power supplied by the motor is

$$Q = \sqrt{3} V_T I_L \sin \theta = \sqrt{3}(2300 \text{ V})(214.5 \text{ A}) \sin(3.5^\circ) = 52.2 \text{ kVAR}$$

(d) The maximum torque possible at unity power factor (ignoring the effects of R_A) is:

$$\tau_{\text{ind,max}} = \frac{3 V_\phi E_A}{\omega_m X_S} = \frac{3(1328 \text{ V})(1376 \text{ V})}{(3600 \text{ r/min}) \frac{1 \text{ min}}{60 \text{ s}} \frac{2\pi \text{ rad}}{1 \text{ r}} (2.8 \Omega)} = 5193 \text{ N} \cdot \text{m}$$

If we are ignoring the resistance of the motor, then the input power would be 788 kW (note that copper losses are ignored!). At a power factor of 0.8 leading, the current flow will be

$$I_A = I_L = \frac{P}{\sqrt{3} V_T \text{PF}} = \frac{788 \text{ kW}}{\sqrt{3}(2300 \text{ V})(0.8)} = 247 \text{ A}$$

so $\mathbf{I}_A = 247 \angle 36.87^\circ \text{ A}$. The internal generated voltage at 0.8 PF leading (ignoring copper losses) is

$$\begin{aligned} \mathbf{E}_A &= \mathbf{V}_\phi - R_A \mathbf{I}_A - jX_S \mathbf{I}_A \\ \mathbf{E}_A &= 1328 \angle 0^\circ \text{ V} - j(2.8 \Omega)(247 \angle 36.87^\circ \text{ A}) \\ \mathbf{E}_A &= 1829 \angle -17.6^\circ \text{ V} \end{aligned}$$

Therefore, the maximum torque at a power factor of 0.8 leading is

$$\tau_{\text{ind,max}} = \frac{3 V_\phi E_A}{\omega_m X_S} = \frac{3(1328 \text{ V})(1829 \text{ V})}{(3600 \text{ r/min}) \frac{1 \text{ min}}{60 \text{ s}} \frac{2\pi \text{ rad}}{1 \text{ r}} (2.8 \Omega)} = 6093 \text{ N} \cdot \text{m}$$

- 6-4.** Plot the V-curves (I_A versus I_F) for the synchronous motor of Problem 6-3 at no-load, half-load, and full-load conditions. (Note that an electronic version of the open-circuit characteristics in Figure P6-1 is available at the book's Web site. It may simplify the calculations required by this problem. Also, you may assume that R_A is negligible for this calculation.)

SOLUTION The input power at no-load, half-load and full-load conditions is given below. Note that we are assuming that R_A is negligible in each case.

$$\begin{aligned} P_{\text{IN,nl}} &= 24 \text{ kW} + 18 \text{ kW} = 42 \text{ kW} \\ P_{\text{IN,half}} &= (500 \text{ hp})(746 \text{ W/hp}) + 24 \text{ kW} + 18 \text{ kW} = 373 \text{ kW} \\ P_{\text{IN,full}} &= (1000 \text{ hp})(746 \text{ W/hp}) + 24 \text{ kW} + 18 \text{ kW} = 788 \text{ kW} \end{aligned}$$

If the power factor is adjusted to unity, then armature currents will be

$$\begin{aligned} I_{A,\text{nl}} &= \frac{P}{\sqrt{3} V_T \text{PF}} = \frac{42 \text{ kW}}{\sqrt{3}(2300 \text{ V})(1.0)} = 10.5 \text{ A} \\ I_{A,\text{fl}} &= \frac{P}{\sqrt{3} V_T \text{PF}} = \frac{373 \text{ kW}}{\sqrt{3}(2300 \text{ V})(1.0)} = 93.6 \text{ A} \\ I_{A,\text{fl}} &= \frac{P}{\sqrt{3} V_T \text{PF}} = \frac{788 \text{ kW}}{\sqrt{3}(2300 \text{ V})(1.0)} = 198 \text{ A} \end{aligned}$$

The corresponding internal generated voltages at unity power factor are:

$$\begin{aligned} \mathbf{E}_A &= \mathbf{V}_\phi - jX_S \mathbf{I}_A \\ \mathbf{E}_{A,\text{nl}} &= 1328 \angle 0^\circ \text{ V} - j(2.8 \Omega)(10.5 \angle 0^\circ \text{ A}) = 1328.3 \angle -1.27^\circ \text{ V} \\ \mathbf{E}_{A,\text{half}} &= 1328 \angle 0^\circ \text{ V} - j(2.8 \Omega)(93.6 \angle 0^\circ \text{ A}) = 1354 \angle -11.2^\circ \text{ V} \\ \mathbf{E}_{A,\text{full}} &= 1328 \angle 0^\circ \text{ V} - j(2.8 \Omega)(198 \angle 0^\circ \text{ A}) = 1439 \angle -22.7^\circ \text{ V} \end{aligned}$$

These values of E_A and δ at unity power factor can serve as reference points in calculating the synchronous motor V-curves. The MATLAB program to solve this problem is shown below:

```

% M-file: prob6_4.m
% M-file create a plot of armature current versus field
% current for the synchronous motor of Problem 6-4 at
% no-load, half-load, and full-load.

% First, initialize the field current values (21 values
% in the range 3.8-5.8 A)
If = 2.5:0.1:8;

% Get the OCC
load p61_occ.dat;
if_values = p61_occ(:,1);
vt_values = p61_occ(:,2);

% Now initialize all other values
Xs = 1.5; % Synchronous reactance
Vp = 1328; % Phase voltage

% The following values of Ea and delta are for unity
% power factor. They will serve as reference values
% when calculating the V-curves.
d_nl = -1.27 * pi/180; % delta at no-load
d_half = -11.2 * pi/180; % delta at half-load
d_full = -22.7 * pi/180; % delta at full-load
Ea_nl = 1328.3; % Ea at no-load
Ea_half = 1354; % Ea at half-load
Ea_full = 1439; % Ea at full-load

%%%%%%%%%%%%%%%%%%%%%%%%%%%%%%%%%%%%%%%%%%%%%%%%%%%%%%%%%%%%%%%%%%%%%%%%
% Calculate the actual Ea corresponding to each level
% of field current
%%%%%%%%%%%%%%%%%%%%%%%%%%%%%%%%%%%%%%%%%%%%%%%%%%%%%%%%%%%%%%%%%%%%%%%%
Ea = interp1(if_values,vt_values,If) / sqrt(3);

%%%%%%%%%%%%%%%%%%%%%%%%%%%%%%%%%%%%%%%%%%%%%%%%%%%%%%%%%%%%%%%%%%%%%%%%
% Calculate the armature currents associated with
% each value of Ea for the no-load case.
%%%%%%%%%%%%%%%%%%%%%%%%%%%%%%%%%%%%%%%%%%%%%%%%%%%%%%%%%%%%%%%%%%%%%%%%
% First, calculate delta.
delta = asin ( Ea_nl ./ Ea .* sin(d_nl) );

% Calculate the phasor Ea
Ea2 = Ea .* (cos(delta) + j .* sin(delta));

% Now calculate Ia
Ia_nl = ( Vp - Ea2 ) / (j * Xs);

%%%%%%%%%%%%%%%%%%%%%%%%%%%%%%%%%%%%%%%%%%%%%%%%%%%%%%%%%%%%%%%%%%%%%%%%
% Calculate the armature currents associated with
% each value of Ea for the half-load case.
%%%%%%%%%%%%%%%%%%%%%%%%%%%%%%%%%%%%%%%%%%%%%%%%%%%%%%%%%%%%%%%%%%%%%%%%
% First, calculate delta.
delta = asin ( Ea_half ./ Ea .* sin(d_half) );

% Calculate the phasor Ea
Ea2 = Ea .* (cos(delta) + j .* sin(delta));

```

```

% Now calculate Ia
Ia_half = ( Vp - Ea2 ) / ( j * Xs);

%%%%%%%%%%%%%%%%%%%%%%%%%%%%%%%%%%%%%%%%%%%%%%%%%%%%%%%%%%%%%%%%%%%%%%%%
% Calculate the armature currents associated with
% each value of Ea for the full-load case.
%%%%%%%%%%%%%%%%%%%%%%%%%%%%%%%%%%%%%%%%%%%%%%%%%%%%%%%%%%%%%%%%%%%%%%%%
% First, calculate delta.
delta = asin ( Ea_full ./ Ea .* sin(d_full) );

% Calculate the phasor Ea
Ea2 = Ea .* (cos(delta) + j .* sin(delta));

% Now calculate Ia
Ia_full = ( Vp - Ea2 ) / ( j * Xs);

%%%%%%%%%%%%%%%%%%%%%%%%%%%%%%%%%%%%%%%%%%%%%%%%%%%%%%%%%%%%%%%%%%%%%%%%
% Plot the v-curves
%%%%%%%%%%%%%%%%%%%%%%%%%%%%%%%%%%%%%%%%%%%%%%%%%%%%%%%%%%%%%%%%%%%%%%%%
plot(If,abs(Ia_nl), 'k-', 'Linewidth',2.0);
hold on;
plot(If,abs(Ia_half), 'b--', 'Linewidth',2.0);
plot(If,abs(Ia_full), 'r:', 'Linewidth',2.0);
xlabel('\bfField Current (A)');
ylabel('\bfArmature Current (A)');
title ('\bfSynchronous Motor V-Curve');
grid on;

```

The resulting plot is shown below. The flattening visible to the right of the V-curves is due to magnetic saturation in the machine.

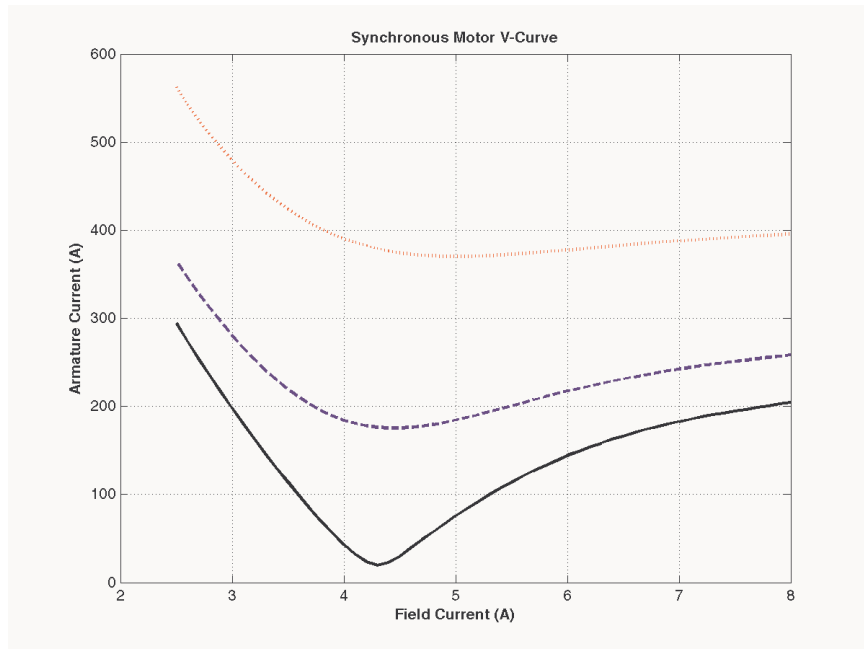

6-5. If a 60-Hz synchronous motor is to be operated at 50 Hz, will its synchronous reactance be the same as at 60 Hz, or will it change? (*Hint:* Think about the derivation of X_s .)

SOLUTION The synchronous reactance represents the effects of the armature reaction voltage \mathbf{E}_{stat} and the armature self-inductance. The armature reaction voltage is caused by the armature magnetic field \mathbf{B}_S , and the amount of voltage is directly proportional to the speed with which the magnetic field sweeps over the stator surface. The higher the frequency, the faster \mathbf{B}_S sweeps over the stator, and the higher the armature reaction voltage \mathbf{E}_{stat} is. Therefore, the armature reaction voltage is directly proportional to frequency. Similarly, the reactance of the armature self-inductance is directly proportional to frequency, so the total synchronous reactance X_S is directly proportional to frequency. If the frequency is changed from 60 Hz to 50 Hz, the synchronous reactance will be decreased by a factor of 5/6.

- 6-6.** A 480-V 100-kW 0.85-PF leading 50-Hz six-pole Y-connected synchronous motor has a synchronous reactance of 1.5Ω and a negligible armature resistance. The rotational losses are also to be ignored. This motor is to be operated over a continuous range of speeds from 300 to 1000 r/min, where the speed changes are to be accomplished by controlling the system frequency with a solid-state drive.
- Over what range must the input frequency be varied to provide this speed control range?
 - How large is E_A at the motor's rated conditions?
 - What is the maximum power the motor can produce at the rated conditions?
 - What is the largest E_A could be at 300 r/min?
 - Assuming that the applied voltage V_ϕ is derated by the same amount as E_A , what is the maximum power the motor could supply at 300 r/min?
 - How does the power capability of a synchronous motor relate to its speed?

SOLUTION

- (a) A speed of 300 r/min corresponds to a frequency of

$$f_e = \frac{n_m P}{120} = \frac{(300 \text{ r/min})(6)}{120} = 15 \text{ Hz}$$

A speed of 1000 r/min corresponds to a frequency of

$$f_e = \frac{n_m P}{120} = \frac{(1000 \text{ r/min})(6)}{120} = 50 \text{ Hz}$$

The frequency must be controlled in the range 15 to 50 Hz.

- (b) The armature current at rated conditions is

$$I_A = I_L = \frac{P}{\sqrt{3} V_T \text{ PF}} = \frac{100 \text{ kW}}{\sqrt{3}(480 \text{ V})(0.85)} = 141.5 \text{ A}$$

so $\mathbf{I}_A = 141.5 \angle 31.8^\circ \text{ A}$. This machine is Y-connected, so the phase voltage is $V_\phi = 480 / \sqrt{3} = 277 \text{ V}$.

The internal generated voltage is

$$\begin{aligned} \mathbf{E}_A &= \mathbf{V}_\phi - R_A \mathbf{I}_A - jX_S \mathbf{I}_A \\ \mathbf{E}_A &= 277 \angle 0^\circ \text{ V} - j(1.5 \Omega)(141.5 \angle 31.8^\circ \text{ A}) \\ \mathbf{E}_A &= 429 \angle -24.9^\circ \text{ V} \end{aligned}$$

So $E_A = 429 \text{ V}$ at rated conditions.

- (c) The maximum power that the motor can produce at rated speed with the value of E_A from part (b) is

$$P_{\max} = \frac{3 V_{\phi} E_A}{X_S} = \frac{3(277 \text{ V})(429 \text{ V})}{1.5 \Omega} = 238 \text{ kW}$$

(d) Since E_A must be decreased linearly with frequency, the maximum value at 300 r/min would be

$$E_{A,300} = \frac{15 \text{ Hz}}{50 \text{ Hz}} (429 \text{ V}) = 129 \text{ V}$$

(e) If the applied voltage V_{ϕ} is derated by the same amount as E_A , then $V_{\phi} = (15/50)(277) = 83.1 \text{ V}$. Also, note that $X_S = (15/50)(1.5 \Omega) = 0.45 \Omega$. The maximum power that the motor could supply would be

$$P_{\max} = \frac{3 V_{\phi} E_A}{X_S} = \frac{3(83.1 \text{ V})(129 \text{ V})}{0.45 \Omega} = 71.5 \text{ kW}$$

(f) As we can see by comparing the results of (c) and (e), the power-handling capability of the synchronous motor varies *linearly* with the speed of the motor.

6-7. A 208-V Y-connected synchronous motor is drawing 40 A at unity power factor from a 208-V power system. The field current flowing under these conditions is 2.7 A. Its synchronous reactance is 0.8 Ω . Assume a linear open-circuit characteristic.

(a) Find the torque angle δ .

(b) How much field current would be required to make the motor operate at 0.8 PF leading?

(c) What is the new torque angle in part (b)?

SOLUTION

(a) The phase voltage of this motor is $V_{\phi} = 120 \text{ V}$, and the armature current is $\mathbf{I}_A = 40\angle 0^\circ \text{ A}$. Therefore, the internal generated voltage is

$$\begin{aligned} \mathbf{E}_A &= \mathbf{V}_{\phi} - R_A \mathbf{I}_A - jX_S \mathbf{I}_A \\ \mathbf{E}_A &= 120\angle 0^\circ \text{ V} - j(0.8 \Omega)(40\angle 0^\circ \text{ A}) \\ \mathbf{E}_A &= 124\angle -14.9^\circ \text{ V} \end{aligned}$$

The torque angle δ of this machine is -14.9° .

(b) A phasor diagram of the motor operating at a power factor of 0.78 leading is shown below.

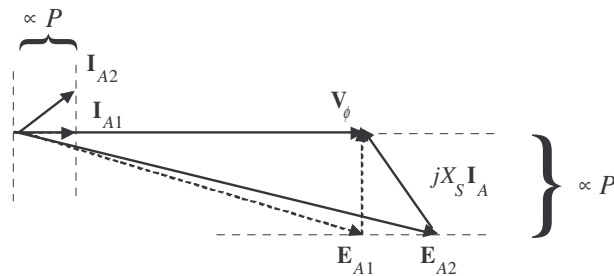

Since the power supplied by the motor is constant, the quantity $I_A \cos \theta$, which is directly proportional to power, must be constant. Therefore,

$$I_{A2}(0.8) = (40 \text{ A})(1.00)$$

$$\mathbf{I}_{A2} = 50\angle 36.87^\circ \text{ A}$$

The internal generated voltage required to produce this current would be

$$\begin{aligned}\mathbf{E}_{A2} &= \mathbf{V}_\phi - R_A \mathbf{I}_{A2} - jX_S \mathbf{I}_{A2} \\ \mathbf{E}_{A2} &= 120\angle 0^\circ \text{ V} - j(0.8 \Omega)(50\angle 36.87^\circ \text{ A}) \\ \mathbf{E}_{A2} &= 147.5\angle -12.5^\circ \text{ V}\end{aligned}$$

The internal generated voltage E_A is directly proportional to the field flux, and we have assumed in this problem that the flux is directly proportional to the field current. Therefore, the required field current is

$$I_{F2} = \frac{E_{A2}}{E_{A1}} I_{F1} = \frac{147 \text{ V}}{124 \text{ V}} (2.7 \text{ A}) = 3.20 \text{ A}$$

(c) The new torque angle δ of this machine is -12.5° .

- 6-8.** A synchronous machine has a synchronous reactance of 2.0Ω per phase and an armature resistance of 0.4Ω per phase. If $\mathbf{E}_A = 460\angle -8^\circ \text{ V}$ and $\mathbf{V}_\phi = 480\angle 0^\circ \text{ V}$, is this machine a motor or a generator? How much power P is this machine consuming from or supplying to the electrical system? How much reactive power Q is this machine consuming from or supplying to the electrical system?

SOLUTION This machine is a motor, *consuming* power from the power system, because \mathbf{E}_A is lagging \mathbf{V}_ϕ . It is also *consuming* reactive power, because $E_A \cos \delta < V_\phi$. The current flowing in this machine is

$$\mathbf{I}_A = \frac{\mathbf{V}_\phi - \mathbf{E}_A}{R_A + jX_S} = \frac{480\angle 0^\circ \text{ V} - 460\angle -8^\circ \text{ V}}{0.4 + j2.0 \Omega} = 33.6\angle -9.6^\circ \text{ A}$$

Therefore the real power consumed by this motor is

$$P = 3V_\phi I_A \cos \theta = 3(480 \text{ V})(33.6 \text{ A}) \cos(9.6^\circ) = 47.7 \text{ kW}$$

and the reactive power consumed by this motor is

$$Q = 3V_\phi I_A \sin \theta = 3(480 \text{ V})(33.6 \text{ A}) \sin(9.6^\circ) = 8.07 \text{ kVAR}$$

- 6-9.** Figure P6-2 shows a synchronous motor phasor diagram for a motor operating at a leading power factor with no R_A . For this motor, the torque angle is given by

$$\begin{aligned}\tan \delta &= \frac{X_S I_A \cos \theta}{V_\phi + X_S I_A \sin \theta} \\ \delta &= \tan^{-1} \frac{X_S I_A \cos \theta}{V_\phi + X_S I_A \sin \theta}\end{aligned}$$

Derive an equation for the torque angle of the synchronous motor *if the armature resistance is included*.

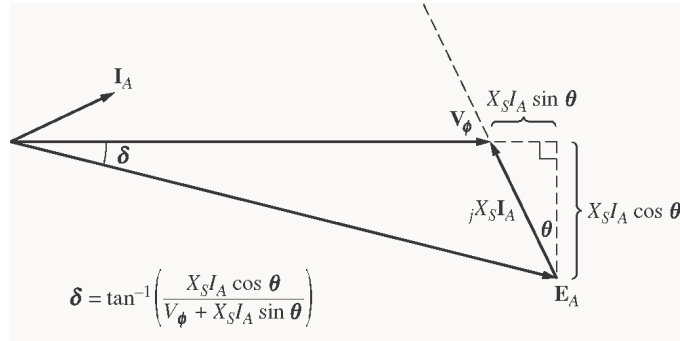

SOLUTION The phasor diagram with the armature resistance considered is shown below.

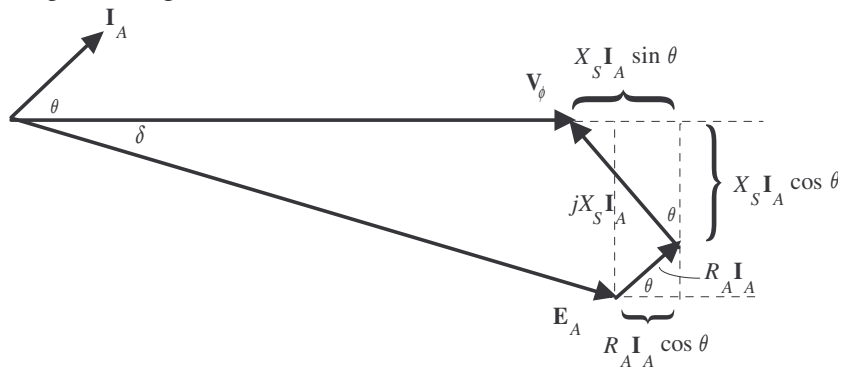

Therefore,

$$\tan \delta = \frac{X_S I_A \cos \theta + R_A I_A \sin \theta}{V_\phi + X_S I_A \sin \theta - R_A I_A \cos \theta}$$

$$\delta = \tan^{-1} \frac{X_S I_A \cos \theta + R_A I_A \sin \theta}{V_\phi + X_S I_A \sin \theta - R_A I_A \cos \theta}$$

6-10. A 480-V 375-kVA 0.8-PF-lagging Y-connected synchronous generator has a synchronous reactance of 0.4 Ω and a negligible armature resistance. This generator is supplying power to a 480-V 80-kW 0.8-PF-leading Y-connected synchronous motor with a synchronous reactance of 1.1 Ω and a negligible armature resistance. The synchronous generator is adjusted to have a terminal voltage of 480 V when the motor is drawing the rated power at unity power factor.

- (a) Calculate the magnitudes and angles of \mathbf{E}_A for both machines.
- (b) If the flux of the motor is increased by 10 percent, what happens to the terminal voltage of the power system? What is its new value?
- (c) What is the power factor of the motor after the increase in motor flux?

SOLUTION

(a) The motor is operating at rated power and unity power factor, so the current flowing in the motor is

$$I_{A,m} = I_{L,m} = \frac{P}{\sqrt{3} V_T \text{ PF}} = \frac{80 \text{ kW}}{\sqrt{3} (480 \text{ V})(1.0)} = 96.2 \text{ A}$$

so $\mathbf{I}_{A,m} = 96.2 \angle 0^\circ \text{ A}$. This machine is Y-connected, so the phase voltage is $V_\phi = 480 / \sqrt{3} = 277 \text{ V}$. The internal generated voltage of the motor is

$$\begin{aligned} \mathbf{E}_{A,m} &= \mathbf{V}_{\phi,m} - jX_S \mathbf{I}_{A,m} \\ \mathbf{E}_{A,m} &= 277 \angle 0^\circ \text{ V} - j(1.1 \Omega)(96.2 \angle 0^\circ \text{ A}) \\ \mathbf{E}_{A,m} &= 297 \angle -20.9^\circ \text{ V} \end{aligned}$$

This same current comes from the generator, so the internal generated voltage of the generator is

$$\begin{aligned} \mathbf{E}_{A,g} &= \mathbf{V}_{\phi,g} + jX_S \mathbf{I}_{A,g} \\ \mathbf{E}_{A,g} &= 277 \angle 0^\circ \text{ V} + j(0.4 \Omega)(96.2 \angle 0^\circ \text{ A}) \\ \mathbf{E}_{A,g} &= 280 \angle 7.9^\circ \text{ V} \end{aligned}$$

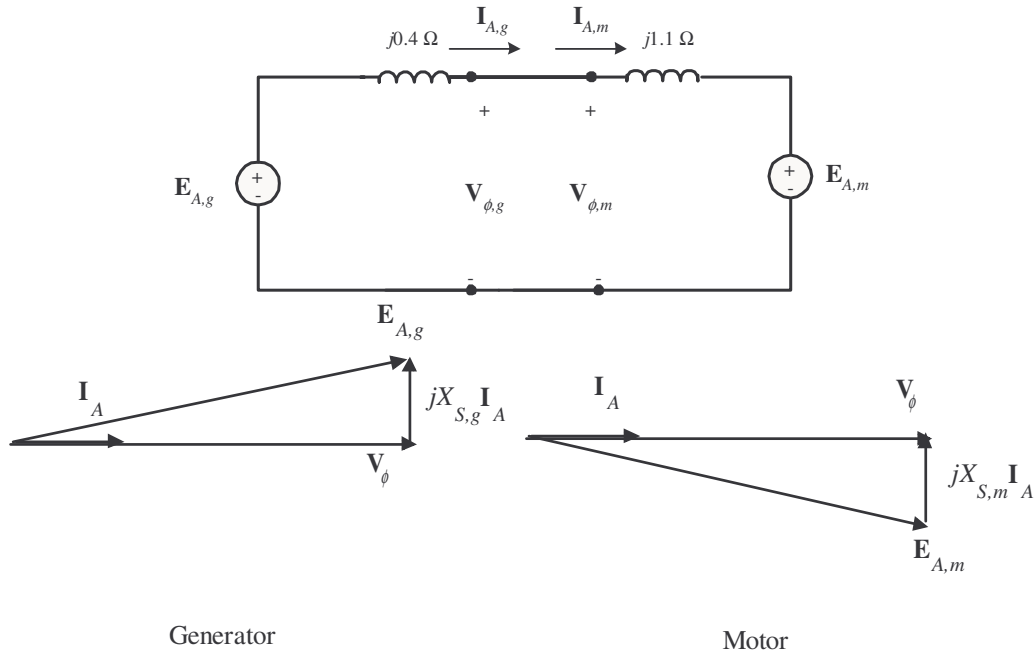

(b) The power supplied by the generator to the motor will be constant as the field current of the motor is varied. The 10% increase in flux will raise the internal generated voltage of the motor to $(1.1)(297 \text{ V}) = 327 \text{ V}$.

To make finding the new conditions easier, we will make the angle of the phasor $\mathbf{E}_{A,g}$ the reference during the following calculations. The resulting phasor diagram is shown below.

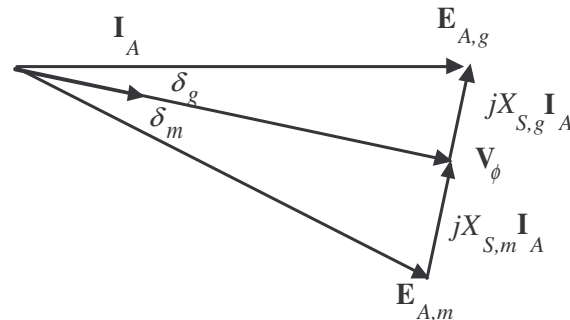

Then by Kirchhoff's Voltage Law,

$$\mathbf{E}_{A,g} = \mathbf{E}_{A,m} + j(X_{S,g} + X_{S,m})\mathbf{I}_A$$

$$\text{or } \mathbf{I}_A = \frac{\mathbf{E}_{A,g} - \mathbf{E}_{A,m}}{j(X_{S,g} + X_{S,m})}$$

Note that this combined phasor diagram looks just like the diagram of a synchronous motor, so we can apply the power equation for synchronous motors to this system.

$$P = \frac{3E_{A,g}E_{A,m}}{X_{S,g} + X_{S,m}} \sin \gamma$$

where $\gamma = \delta_g + \delta_m$. From this equation,

$$\gamma = \sin^{-1} \frac{(X_{S,g} + X_{S,m})P}{3E_{A,g}E_{A,m}} = \sin^{-1} \frac{(1.5 \Omega)(80 \text{ kW})}{3(280 \text{ V})(327 \text{ V})} = 25.9^\circ$$

Therefore,

$$\mathbf{I}_A = \frac{\mathbf{E}_{A,g} - \mathbf{E}_{A,m}}{j(X_{S,g} + X_{S,m})} = \frac{280 \angle 0^\circ \text{ V} - 327 \angle -25.9^\circ \text{ V}}{j1.5 \Omega} = 95.7 \angle 5.7^\circ \text{ A}$$

The phase voltage of the system would be

$$\mathbf{V}_\phi = \mathbf{E}_{A,g} - jX_{S,g}\mathbf{I}_A = 280 \angle 0^\circ \text{ V} - j(0.4 \Omega)(95.7 \angle 5.7^\circ \text{ A}) = 286 \angle -7.6^\circ \text{ V}$$

If we make \mathbf{V}_ϕ the reference (as we usually do), these voltages and currents become:

$\begin{aligned} \mathbf{E}_{A,g} &= 280 \angle 7.6^\circ \text{ V} \\ \mathbf{V}_\phi &= 286 \angle 0^\circ \text{ V} \\ \mathbf{E}_{A,m} &= 327 \angle -18.3^\circ \text{ V} \\ \mathbf{I}_A &= 95.7 \angle 13.3^\circ \text{ A} \end{aligned}$

The new terminal voltage is $V_T = \sqrt{3}(286 \text{ V}) = 495 \text{ V}$, so the system voltage has *increased*.

(c) The power factor of the motor is now $\text{PF} = \cos(-13.3^\circ) = 0.973$ leading, since a current angle of -18.3° implies an impedance angle of 18.3° .

Note: The reactive power in the motor is now

$$Q_{\text{motor}} = 3V_\phi I_A \sin \theta = 3(286 \text{ V})(95.7 \text{ A}) \sin(-13.3^\circ) = -18.9 \text{ kVAR}$$

The motor is now supplying 18.9 kVAR to the system. Note that **an increase in machine flux has increased the reactive power supplied by the motor and also raised the terminal voltage of the system.** This is consistent with what we learned about reactive power sharing in Chapter 5.

6-11. A 480-V, 100-kW, 50-Hz, four-pole, Y-connected synchronous motor has a rated power factor of 0.85 leading. At full load, the efficiency is 91 percent. The armature resistance is 0.08Ω , and the synchronous reactance is 1.0Ω . Find the following quantities for this machine when it is operating at full load:

- (a) Output torque
- (b) Input power
- (c) n_m
- (d) \mathbf{E}_A

(e) $|\mathbf{I}_A|$

(f) P_{conv}

(g) $P_{\text{mech}} + P_{\text{core}} + P_{\text{stray}}$

SOLUTION

(a) Since this machine has 8 poles, it rotates at a speed of

$$n_m = \frac{120f_e}{P} = \frac{120(50 \text{ Hz})}{4} = 1500 \text{ r/min}$$

If the output power is 100 kW, the output torque is

$$\tau_{\text{load}} = \frac{P_{\text{out}}}{\omega_m} = \frac{(100,000 \text{ W})}{(1500 \text{ r/min}) \frac{2\pi \text{ rad}}{1 \text{ r}} \frac{1 \text{ min}}{60 \text{ s}}} = 637 \text{ N} \cdot \text{m}$$

(b) The input power is

$$P_{\text{IN}} = \frac{P_{\text{OUT}}}{\eta} = \frac{100 \text{ kW}}{0.91} = 110 \text{ kW}$$

(c) The mechanical speed is

$$n_m = 1500 \text{ r/min}$$

(d) The armature current is

$$I_A = I_L = \frac{P}{\sqrt{3} V_T \text{ PF}} = \frac{110 \text{ kW}}{\sqrt{3}(480 \text{ V})(0.85)} = 156 \text{ A}$$

$$\mathbf{I}_A = 156 \angle 31.8^\circ \text{ A}$$

Therefore, \mathbf{E}_A is

$$\mathbf{E}_A = \mathbf{V}_\phi - R_A \mathbf{I}_A - jX_S \mathbf{I}_A$$

$$\mathbf{E}_A = (277 \angle 0^\circ \text{ V}) - (0.08 \Omega)(156 \angle 31.8^\circ \text{ A}) - j(1.0 \Omega)(156 \angle 31.8^\circ \text{ A})$$

$$\mathbf{E}_A = 375 \angle -21.8^\circ \text{ V}$$

(e) The magnitude of the armature current is 375 A.

(f) The power converted from electrical to mechanical form is given by the equation $P_{\text{conv}} = P_{\text{IN}} - P_{\text{CU}}$

$$P_{\text{CU}} = 3I_A^2 R_A = 3(156 \text{ A})^2 (0.08 \Omega) = 5.8 \text{ kW}$$

$$P_{\text{conv}} = P_{\text{IN}} - P_{\text{CU}} = 110 \text{ kW} - 5.8 \text{ kW} = 104.2 \text{ kW}$$

(g) The mechanical, core, and stray losses are given by the equation

$$P_{\text{mech}} + P_{\text{core}} + P_{\text{stray}} = P_{\text{conv}} - P_{\text{OUT}} = 104.2 \text{ kW} - 100 \text{ kW} = 4.2 \text{ kW}$$

6-12. The Y-connected synchronous motor whose nameplate is shown in Figure 6-21 has a per-unit synchronous reactance of 0.90 and a per-unit resistance of 0.02.

(a) What is the rated input power of this motor?

(b) What is the magnitude of \mathbf{E}_A at rated conditions?

- (c) If the input power of this motor is 10 MW, what is the maximum reactive power the motor can simultaneously supply? Is it the armature current or the field current that limits the reactive power output?
- (d) How much power does the field circuit consume at the rated conditions?
- (e) What is the efficiency of this motor at full load?
- (f) What is the output torque of the motor at the rated conditions? Express the answer both in newton-meters and in pound-feet.

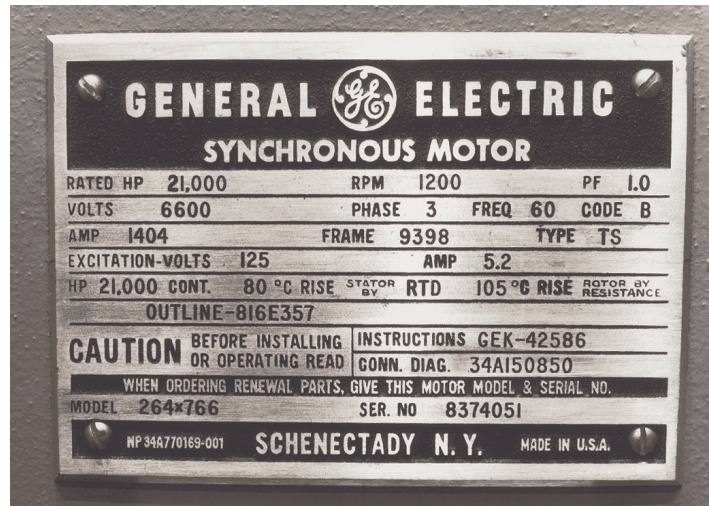

SOLUTION The base quantities for this motor are:

$$V_{T,\text{base}} = 6600 \text{ V}$$

$$V_{\phi,\text{base}} = \frac{6600 \text{ V}}{\sqrt{3}} = 3811 \text{ V}$$

$$I_{A,\text{base}} = I_{L,\text{base}} = 1404 \text{ A}$$

$$S_{\text{base}} = P_{\text{rated}} = \sqrt{3} V_T I_L \text{ PF} = \sqrt{3} (6600 \text{ V})(1404 \text{ A})(1.0) = 16.05 \text{ MW}$$

- (a) The rated input power of this motor is

$$P_{\text{IN}} = \sqrt{3} V_T I_L \text{ PF} = \sqrt{3} (6600 \text{ V})(1404 \text{ A})(1.0) = 16.05 \text{ MW}$$

- (b) At rated conditions, $\mathbf{V}_{\phi} = 1.0 \angle 0^{\circ}$ pu and $\mathbf{I}_{\phi} = 1.0 \angle 0^{\circ}$ pu, so \mathbf{E}_A is given in per-unit quantities as

$$\mathbf{E}_A = \mathbf{V}_{\phi} - R_A \mathbf{I}_A - jX_S \mathbf{I}_A$$

$$\mathbf{E}_A = (1 \angle 0^{\circ}) - (0.02)(1.0 \angle 0^{\circ}) - j(0.90)(1 \angle 0^{\circ})$$

$$\mathbf{E}_A = 1.33 \angle -42.6^{\circ} \text{ pu}$$

The base phase voltage of this motor is $6600 / \sqrt{3} = 3810 \text{ V}$, so \mathbf{E}_A is

$$\mathbf{E}_A = (1.33 \angle -42.6^{\circ})(3810 \text{ V}) = 5067 \angle -42.6^{\circ} \text{ V}$$

- (c) From the capability diagram, we know that there are two possible constraints on the maximum reactive power—the maximum stator current and the maximum rotor current. We will have to check each one separately, and limit the reactive power to the lesser of the two limits.

The stator apparent power limit defines a maximum safe stator current. This limit is the same as the rated input power for this motor, since the motor is rated at unity power factor. Therefore, the stator apparent

power limit is 16.05 MVA. If the input power is 10 MW, then the maximum reactive power that still protects the stator current is

$$Q = \sqrt{S^2 - P^2} = \sqrt{(16.05 \text{ MVA})^2 - (10 \text{ MW})^2} = 12.6 \text{ MVAR}$$

Now we must determine the rotor current limit. The per-unit power supplied to the motor is 10 MW / 16.05 MW = 0.623. The maximum E_A is 5067 V or 1.33 pu, so with E_A set to maximum and the motor consuming 10 MW, the torque angle (ignoring armature resistance) is

$$\delta = \sin^{-1} \frac{X_S P}{3V_\phi E_A} = \sin^{-1} \frac{(0.90)(0.623)}{(1.0)(1.33)} = 24.9^\circ$$

At rated voltage and 10 MW of power supplied, the armature current will be

$$\mathbf{I}_A = \frac{\mathbf{V}_\phi - \mathbf{E}_A}{R_A + jX_S} = \frac{1\angle 0^\circ - 1.33\angle -24.9^\circ}{j0.90} = 0.663\angle 20.2^\circ \text{ pu}$$

In actual amps, this current is

$$\mathbf{I}_A = (1404 \text{ A})(0.663\angle 20.2^\circ) = 931\angle 20.2^\circ \text{ A}$$

The reactive power supplied at the conditions of maximum E_A and 10 MW power is

$$Q = 3V_\phi I_A \sin \theta = 3(3811 \text{ V})(931 \text{ A})\sin(20.2^\circ) = 3.68 \text{ MVAR}$$

Therefore, the *field current limit occurs before the stator current limit* for these conditions, and the maximum reactive power that the motor can supply is 3.68 MVAR under these conditions.

(d) At rated conditions, the field circuit consumes

$$P_{\text{field}} = V_F I_F = (125 \text{ V})(5.2 \text{ A}) = 650 \text{ W}$$

(e) The efficiency of this motor at full load is

$$\eta = \frac{P_{\text{OUT}}}{P_{\text{IN}}} \times 100\% = \frac{(21000 \text{ hp})(746 \text{ W/hp})}{16.05 \text{ MW}} \times 100\% = 97.6\%$$

(f) The output torque in SI and English units is

$$\tau_{\text{load}} = \frac{P_{\text{OUT}}}{\omega_m} = \frac{(21000 \text{ hp})(746 \text{ W/hp})}{(1200 \text{ r/min}) \frac{1 \text{ min}}{60 \text{ s}} \frac{2\pi \text{ rad}}{1 \text{ r}}} = 124,700 \text{ N} \cdot \text{m}$$

$$\tau_{\text{load}} = \frac{5252 P}{n_m} = \frac{5252 (21000 \text{ hp})}{(1200 \text{ r/min})} = 91,910 \text{ lb} \cdot \text{ft}$$

6-13. A 440-V three-phase Y-connected synchronous motor has a synchronous reactance of 1.5 Ω per phase. The field current has been adjusted so that the torque angle δ is 28° when the power supplied by the generator is 90 kW.

(a) What is the magnitude of the internal generated voltage E_A in this machine?

(b) What are the magnitude and angle of the armature current in the machine? What is the motor's power factor?

(c) If the field current remains constant, what is the absolute maximum power this motor could supply?

SOLUTION

(a) The power supplied to the motor is 90 kW. This power is given by the equation

$$P = \frac{3V_{\phi}E_A}{X_s} \sin \delta$$

so the magnitude of E_A is

$$E_A = \frac{X_s P}{3V_{\phi} \sin \delta} = \frac{(1.5 \Omega)(90 \text{ kW})}{3(254 \text{ V}) \sin 28^{\circ}} = 377 \text{ V}$$

(b) The armature current in this machine is given by

$$\mathbf{I}_A = \frac{\mathbf{V}_{\phi} - \mathbf{E}_A}{jX_s} = \frac{254 \angle 0^{\circ} \text{ V} - 377 \angle -28^{\circ}}{j1.5} = 129 \angle 24^{\circ} \text{ A}$$

The power factor of the motor is $\text{PF} = \cos 24^{\circ} = 0.914$ leading.

(c) The maximum power that the motor could supply at this field current

$$P_{\max} = \frac{3V_{\phi}E_A}{X_s} = \frac{3(254 \text{ V})(377 \text{ V})}{1.5 \Omega} = 191.5 \text{ kW}$$

6-14. A 460-V, 200-kVA, 0.80-PF-leading, 400-Hz, six-pole, Y-connected synchronous motor has negligible armature resistance and a synchronous reactance of 0.50 per unit. Ignore all losses.

(a) What is the speed of rotation of this motor?

(b) What is the output torque of this motor at the rated conditions?

(c) What is the internal generated voltage of this motor at the rated conditions?

(d) With the field current remaining at the value present in the motor in part (c), what is the maximum possible output power from the machine?

SOLUTION

(a) The speed of rotation of this motor is

$$n_{\text{sync}} = \frac{120f_e}{P} = \frac{120(400 \text{ Hz})}{6} = 8000 \text{ r/min}$$

(b) Since all losses are ignored, $P_{IN,\text{rated}} = P_{OUT,\text{rated}} = S_{\text{rated}} \times \text{PF} = (200 \text{ kVA})(0.8) = 160 \text{ kW}$. The output torque of this motor is

$$\tau_{\text{load}} = \frac{P_{\text{OUT}}}{\omega_m} = \frac{160 \text{ kW}}{(8000 \text{ r/min}) \frac{1 \text{ min}}{60 \text{ s}} \frac{2\pi \text{ rad}}{1 \text{ r}}} = 191 \text{ N} \cdot \text{m}$$

(c) The phase voltage of this motor is $460 \text{ V} / \sqrt{3} = 266 \text{ V}$. The rated armature current of this motor is

$$I_A = I_L = \frac{P}{\sqrt{3} V_T \text{PF}} = \frac{160 \text{ kW}}{\sqrt{3}(460 \text{ V})(0.80)} = 251 \text{ A}$$

Therefore, $\mathbf{I}_A = 251 \angle 36.87^{\circ} \text{ A}$. The base impedance of this motor is

$$Z_{\text{base}} = \frac{3V_{\phi,\text{base}}^2}{S_{\text{base}}} = \frac{3(266 \text{ V})^2}{200,000 \text{ VA}} = 1.06 \Omega$$

so the actual synchronous reactance is $X_s = (0.50 \text{ pu})(1.06 \Omega) = 0.53 \Omega$. The internal generated voltage of this machine at rated conditions is given by

$$\mathbf{E}_A = \mathbf{V}_\phi - jX_s \mathbf{I}_A$$

$$\mathbf{E}_A = 266 \angle 0^\circ \text{ V} - j(0.53 \Omega)(251 \angle 36.87^\circ \text{ A}) = 362 \angle -17.1^\circ \text{ V}$$

(d) The maximum power that the motor could supply at these conditions is

$$P_{\text{MAX}} = \frac{3V_\phi E_A}{X_s} = \frac{3(266 \text{ V})(362 \text{ V})}{0.53 \Omega} = 545 \text{ kW}$$

6-15. A 100-hp 440-V 0.8-PF-leading Δ -connected synchronous motor has an armature resistance of 0.22Ω and a synchronous reactance of 3.0Ω . Its efficiency at full load is 89 percent.

(a) What is the input power to the motor at rated conditions?

(b) What is the line current of the motor at rated conditions? What is the phase current of the motor at rated conditions?

(c) What is the reactive power consumed by or supplied by the motor at rated conditions?

(d) What is the internal generated voltage \mathbf{E}_A of this motor at rated conditions?

(e) What are the stator copper losses in the motor at rated conditions?

(f) What is P_{conv} at rated conditions?

(g) If E_A is decreased by 10 percent, how much reactive power will be consumed by or supplied by the motor?

SOLUTION

(a) The input power to the motor at rated conditions is

$$P_{\text{IN}} = \frac{P_{\text{OUT}}}{\eta} = \frac{(100 \text{ hp})(746 \text{ W/hp})}{0.89} = 83.8 \text{ kW}$$

(b) The line current to the motor at rated conditions is

$$I_L = \frac{P}{\sqrt{3} V_T \text{ PF}} = \frac{83.8 \text{ kW}}{\sqrt{3}(440 \text{ V})(0.8)} = 137 \text{ A}$$

The phase current to the motor at rated conditions is

$$I_\phi = \frac{I_L}{\sqrt{3}} = \frac{137 \text{ A}}{\sqrt{3}} = 79.4 \text{ A}$$

(c) The reactive power supplied by this motor to the power system at rated conditions is

$$Q_{\text{rated}} = 3V_\phi I_A \sin \theta = 3(440 \text{ V})(79.4 \text{ A}) \sin 36.87^\circ = 62.9 \text{ kVAR}$$

(d) The internal generated voltage at rated conditions is

$$\mathbf{E}_A = \mathbf{V}_\phi - R_A \mathbf{I}_A - jX_s \mathbf{I}_A$$

$$\mathbf{E}_A = 440 \angle 0^\circ \text{ V} - (0.22 \Omega)(79.4 \angle 36.87^\circ \text{ A}) - j(3.0 \Omega)(79.4 \angle 36.87^\circ \text{ A})$$

$$\mathbf{E}_A = 603 \angle -19.5^\circ \text{ V}$$

(e) The stator copper losses at rated conditions are

$$P_{\text{CU}} = 3I_A^2 R_A = 3(79.4 \text{ A})^2 (0.22 \text{ } \Omega) = 4.16 \text{ kW}$$

(f) P_{conv} at rated conditions is

$$P_{\text{conv}} = P_{\text{IN}} - P_{\text{CU}} = 83.8 \text{ kW} - 4.16 \text{ kW} = 79.6 \text{ kW}$$

(g) If E_A is decreased by 10%, the new value is $E_A = (0.9)(603 \text{ V}) = 543 \text{ V}$. To simplify this part of the problem, we will ignore R_A . Then the quantity $E_A \sin \delta$ will be constant as E_A changes. Therefore,

$$\delta_2 = \sin^{-1} \frac{E_{A1}}{E_{A2}} \sin \delta_1 = \sin^{-1} \frac{603 \text{ V}}{543 \text{ V}} \sin(-19.5^\circ) = -21.8^\circ$$

Therefore,

$$\mathbf{I}_A = \frac{\mathbf{V}_\phi - \mathbf{E}_A}{jX_S} = \frac{440 \angle 0^\circ \text{ V} - 543 \angle -21.8^\circ}{j3.0} = 70.5 \angle 17.7^\circ \text{ A}$$

and the reactive power supplied by the motor to the power system will be

$$Q = 3V_\phi I_A \sin \theta = 3(440 \text{ V})(70.5 \text{ A}) \sin(17.7^\circ) = 28.3 \text{ kVAR}$$

6-16. Answer the following questions about the machine of Problem 6-15.

- (a) If $\mathbf{E}_A = 430 \angle 13.5^\circ \text{ V}$ and $\mathbf{V}_\phi = 440 \angle 0^\circ \text{ V}$, is this machine consuming real power from or supplying real power to the power system? Is it consuming reactive power from or supplying reactive power to the power system?
- (b) Calculate the real power P and reactive power Q supplied or consumed by the machine under the conditions in part (a). Is the machine operating within its ratings under these circumstances?
- (c) If $\mathbf{E}_A = 470 \angle -12^\circ \text{ V}$ and $\mathbf{V}_\phi = 440 \angle 0^\circ \text{ V}$, is this machine consuming real power from or supplying real power to the power system? Is it consuming reactive power from or supplying reactive power to the power system?
- (d) Calculate the real power P and reactive power Q supplied or consumed by the machine under the conditions in part (c). Is the machine operating within its ratings under these circumstances?

SOLUTION

(a) This machine is a generator supplying real power to the power system, because \mathbf{E}_A is ahead of \mathbf{V}_ϕ . It is consuming reactive power because $E_A \cos \delta < V_\phi$.

(b) This machine is acting as a generator, and the current flow in these conditions is

$$\mathbf{I}_A = \frac{\mathbf{E}_A - \mathbf{V}_\phi}{R_A + jX_S} = \frac{430 \angle 13.5^\circ - 440 \angle 0^\circ \text{ V}}{0.22 + j3.0} = 34.2 \angle 16.5^\circ \text{ A}$$

The real power supplied by this machine is

$$P = 3V_\phi I_A \cos \theta = 3(440 \text{ V})(34.2 \text{ A}) \cos(-16.5^\circ) = 43.3 \text{ kW}$$

The reactive power supplied by this machine is

$$Q = 3V_\phi I_A \sin \theta = 3(440 \text{ V})(34.2 \text{ A}) \sin(-16.5^\circ) = -12.8 \text{ kVAR}$$

(c) This machine is a motor consuming real power from the power system, because \mathbf{E}_A is behind \mathbf{V}_ϕ . It is supplying reactive power because $E_A \cos \delta > V_\phi$.

(d) This machine is acting as a motor, and the current flow in these conditions is

$$\mathbf{I}_A = \frac{\mathbf{V}_\phi - \mathbf{E}_A}{R_A + jX_S} = \frac{440 \angle 0^\circ \text{ V} - 470 \angle -12^\circ}{0.22 + j3.0} = 33.1 \angle 15.6^\circ \text{ A}$$

The real power consumed by this machine is

$$P = 3V_\phi I_A \cos \theta = 3(440 \text{ V})(33.1 \text{ A}) \cos(15.6^\circ) = 42.1 \text{ kW}$$

The reactive power supplied by this machine is

$$Q = 3V_\phi I_A \sin \theta = 3(440 \text{ V})(33.1 \text{ A}) \sin(15.6^\circ) = +11.7 \text{ kVAR}$$

Chapter 7: Induction Motors

- 7-1. A dc test is performed on a 460-V Δ -connected 100-hp induction motor. If $V_{DC} = 24$ V and $I_{DC} = 80$ A, what is the stator resistance R_1 ? Why is this so?

SOLUTION If this motor's armature is connected in delta, then there will be two phases in parallel with one phase between the lines tested.

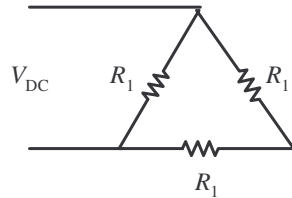

Therefore, the stator resistance R_1 will be

$$\frac{V_{DC}}{I_{DC}} = \frac{R_1(R_1 + R_1)}{R_1 + (R_1 + R_1)} = \frac{2}{3}R_1$$

$$R_1 = \frac{3 V_{DC}}{2 I_{DC}} = \frac{3}{2} \frac{24 \text{ V}}{80 \text{ A}} = 0.45 \Omega$$

- 7-2. A 220-V, three-phase, two-pole, 50-Hz induction motor is running at a slip of 5 percent. Find:
- The speed of the magnetic fields in revolutions per minute
 - The speed of the rotor in revolutions per minute
 - The slip speed of the rotor
 - The rotor frequency in hertz

SOLUTION

- (a) The speed of the magnetic fields is

$$n_{\text{sync}} = \frac{120 f_e}{P} = \frac{120(50 \text{ Hz})}{2} = 3000 \text{ r/min}$$

- (b) The speed of the rotor is

$$n_m = (1 - s) n_{\text{sync}} = (1 - 0.05)(3000 \text{ r/min}) = 2850 \text{ r/min}$$

- (c) The slip speed of the rotor is

$$n_{\text{slip}} = s n_{\text{sync}} = (0.05)(3000 \text{ r/min}) = 150 \text{ r/min}$$

- (d) The rotor frequency is

$$f_r = \frac{n_{\text{slip}} P}{120} = \frac{(150 \text{ r/min})(2)}{120} = 2.5 \text{ Hz}$$

- 7-3. Answer the questions in Problem 7-2 for a 480-V, three-phase, four-pole, 60-Hz induction motor running at a slip of 0.035.

SOLUTION

- (a) The speed of the magnetic fields is

$$n_{\text{sync}} = \frac{120f_e}{P} = \frac{120(60 \text{ Hz})}{4} = 1800 \text{ r/min}$$

(b) The speed of the rotor is

$$n_m = (1-s)n_{\text{sync}} = (1-0.035)(1800 \text{ r/min}) = 1737 \text{ r/min}$$

(c) The slip speed of the rotor is

$$n_{\text{slip}} = sn_{\text{sync}} = (0.035)(1800 \text{ r/min}) = 63 \text{ r/min}$$

(d) The rotor frequency is

$$f_r = \frac{n_{\text{slip}}P}{120} = \frac{(63 \text{ r/min})(4)}{120} = 2.1 \text{ Hz}$$

7-4. A three-phase, 60-Hz induction motor runs at 890 r/min at no load and at 840 r/min at full load.

(a) How many poles does this motor have?

(b) What is the slip at rated load?

(c) What is the speed at one-quarter of the rated load?

(d) What is the rotor's electrical frequency at one-quarter of the rated load?

SOLUTION

(a) This machine has 8 poles, which produces a synchronous speed of

$$n_{\text{sync}} = \frac{120f_e}{P} = \frac{120(60 \text{ Hz})}{8} = 900 \text{ r/min}$$

(b) The slip at rated load is

$$s = \frac{n_{\text{sync}} - n_m}{n_{\text{sync}}} \times 100\% = \frac{900 - 840}{900} \times 100\% = 6.67\%$$

(c) The motor is operating in the linear region of its torque-speed curve, so the slip at 1/4 load will be

$$s = 0.25(0.0667) = 0.0167$$

The resulting speed is

$$n_m = (1-s)n_{\text{sync}} = (1-0.0167)(900 \text{ r/min}) = 885 \text{ r/min}$$

(d) The electrical frequency at 1/4 load is

$$f_r = sf_e = (0.0167)(60 \text{ Hz}) = 1.00 \text{ Hz}$$

7-5. A 50-kW, 440-V, 50-Hz, six-pole induction motor has a slip of 6 percent when operating at full-load conditions. At full-load conditions, the friction and windage losses are 300 W, and the core losses are 600 W. Find the following values for full-load conditions:

(a) The shaft speed n_m

(b) The output power in watts

(c) The load torque τ_{load} in newton-meters

(d) The induced torque τ_{ind} in newton-meters

(e) The rotor frequency in hertz

SOLUTION

(a) The synchronous speed of this machine is

$$n_{\text{sync}} = \frac{120f_e}{P} = \frac{120(50 \text{ Hz})}{6} = 1000 \text{ r/min}$$

Therefore, the shaft speed is

$$n_m = (1 - s) n_{\text{sync}} = (1 - 0.06)(1000 \text{ r/min}) = 940 \text{ r/min}$$

(b) The output power in watts is 50 kW (stated in the problem).

(c) The load torque is

$$\tau_{\text{load}} = \frac{P_{\text{OUT}}}{\omega_m} = \frac{50 \text{ kW}}{(940 \text{ r/min}) \frac{2\pi \text{ rad}}{1 \text{ r}} \frac{1 \text{ min}}{60 \text{ s}}} = 508 \text{ N} \cdot \text{m}$$

(d) The induced torque can be found as follows:

$$P_{\text{conv}} = P_{\text{OUT}} + P_{\text{F\&W}} + P_{\text{core}} + P_{\text{misc}} = 50 \text{ kW} + 300 \text{ W} + 600 \text{ W} + 0 \text{ W} = 50.9 \text{ kW}$$

$$\tau_{\text{ind}} = \frac{P_{\text{conv}}}{\omega_m} = \frac{50.9 \text{ kW}}{(940 \text{ r/min}) \frac{2\pi \text{ rad}}{1 \text{ r}} \frac{1 \text{ min}}{60 \text{ s}}} = 517 \text{ N} \cdot \text{m}$$

(e) The rotor frequency is

$$f_r = sf_e = (0.06)(50 \text{ Hz}) = 3.00 \text{ Hz}$$

- 7-6.** A three-phase, 60-Hz, four-pole induction motor runs at a no-load speed of 1790 r/min and a full-load speed of 1720 r/min. Calculate the slip and the electrical frequency of the rotor at no-load and full-load conditions. What is the speed regulation of this motor [Equation (4-68)]?

SOLUTION The synchronous speed of this machine is 1800 r/min. The slip and electrical frequency at no-load conditions is

$$s_{\text{nl}} = \frac{n_{\text{sync}} - n_{\text{nl}}}{n_{\text{sync}}} \times 100\% = \frac{1800 - 1790}{1800} \times 100\% = 0.56\%$$

$$f_{r,\text{nl}} = sf_e = (0.0056)(60 \text{ Hz}) = 0.33 \text{ Hz}$$

The slip and electrical frequency at full load conditions is

$$s_{\text{fl}} = \frac{n_{\text{sync}} - n_{\text{fl}}}{n_{\text{sync}}} \times 100\% = \frac{1800 - 1720}{1800} \times 100\% = 4.44\%$$

$$f_{r,\text{fl}} = sf_e = (0.0444)(60 \text{ Hz}) = 2.67 \text{ Hz}$$

The speed regulation is

$$\text{SR} = \frac{n_{\text{nl}} - n_{\text{fl}}}{n_{\text{fl}}} \times 100\% = \frac{1790 - 1720}{1720} \times 100\% = 4.1\%$$

- 7-7.** A 208-V, two-pole, 60-Hz Y-connected wound-rotor induction motor is rated at 15 hp. Its equivalent circuit components are

$$\begin{array}{lll}
 R_1 = 0.200 \, \Omega & R_2 = 0.120 \, \Omega & X_M = 15.0 \, \Omega \\
 X_1 = 0.410 \, \Omega & X_2 = 0.410 \, \Omega & \\
 P_{\text{mech}} = 250 \, \text{W} & P_{\text{misc}} \approx 0 & P_{\text{core}} = 180 \, \text{W}
 \end{array}$$

For a slip of 0.05, find

- The line current I_L
- The stator copper losses P_{SCL}
- The air-gap power P_{AG}
- The power converted from electrical to mechanical form P_{conv}
- The induced torque τ_{ind}
- The load torque τ_{load}
- The overall machine efficiency
- The motor speed in revolutions per minute and radians per second

SOLUTION The equivalent circuit of this induction motor is shown below:

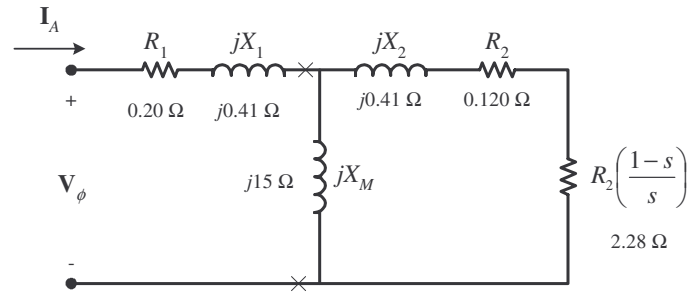

- The easiest way to find the line current (or armature current) is to get the equivalent impedance Z_F of the rotor circuit in parallel with jX_M , and then calculate the current as the phase voltage divided by the sum of the series impedances, as shown below.

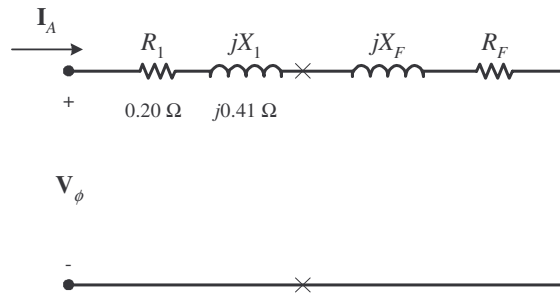

The equivalent impedance of the rotor circuit in parallel with jX_M is:

$$Z_F = \frac{1}{\frac{1}{jX_M} + \frac{1}{Z_2}} = \frac{1}{\frac{1}{j15 \, \Omega} + \frac{1}{2.40 + j0.41}} = 2.220 + j0.745 = 2.34 \angle 18.5^\circ \, \Omega$$

The phase voltage is $208/\sqrt{3} = 120 \, \text{V}$, so line current I_L is

$$I_L = I_A = \frac{V_\phi}{R_1 + jX_1 + R_F + jX_F} = \frac{120\angle 0^\circ \text{ V}}{0.20 \Omega + j0.41 \Omega + 2.22 \Omega + j0.745 \Omega}$$

$$I_L = I_A = 44.8\angle -25.5^\circ \text{ A}$$

(b) The stator copper losses are

$$P_{\text{SCL}} = 3I_A^2 R_1 = 3(44.8 \text{ A})^2 (0.20 \Omega) = 1205 \text{ W}$$

(c) The air gap power is $P_{\text{AG}} = 3I_2^2 \frac{R_2}{s} = 3I_A^2 R_F$

(Note that $3I_A^2 R_F$ is equal to $3I_2^2 \frac{R_2}{s}$, since the only resistance in the original rotor circuit was R_2/s , and the resistance in the Thevenin equivalent circuit is R_F . The power consumed by the Thevenin equivalent circuit must be the same as the power consumed by the original circuit.)

$$P_{\text{AG}} = 3I_2^2 \frac{R_2}{s} = 3I_A^2 R_F = 3(44.8 \text{ A})^2 (2.220 \Omega) = 13.4 \text{ kW}$$

(d) The power converted from electrical to mechanical form is

$$P_{\text{conv}} = (1-s)P_{\text{AG}} = (1-0.05)(13.4 \text{ kW}) = 12.73 \text{ kW}$$

(e) The induced torque in the motor is

$$\tau_{\text{ind}} = \frac{P_{\text{AG}}}{\omega_{\text{sync}}} = \frac{13.4 \text{ kW}}{(3600 \text{ r/min}) \frac{2\pi \text{ rad}}{1 \text{ r}} \frac{1 \text{ min}}{60 \text{ s}}} = 35.5 \text{ N}\cdot\text{m}$$

(f) The output power of this motor is

$$P_{\text{OUT}} = P_{\text{conv}} - P_{\text{mech}} - P_{\text{core}} - P_{\text{misc}} = 12.73 \text{ kW} - 250 \text{ W} - 180 \text{ W} - 0 \text{ W} = 12.3 \text{ kW}$$

The output speed is

$$n_m = (1-s)n_{\text{sync}} = (1-0.05)(3600 \text{ r/min}) = 3420 \text{ r/min}$$

Therefore the load torque is

$$\tau_{\text{load}} = \frac{P_{\text{OUT}}}{\omega_m} = \frac{12.3 \text{ kW}}{(3420 \text{ r/min}) \frac{2\pi \text{ rad}}{1 \text{ r}} \frac{1 \text{ min}}{60 \text{ s}}} = 34.3 \text{ N}\cdot\text{m}$$

(g) The overall efficiency is

$$\eta = \frac{P_{\text{OUT}}}{P_{\text{IN}}} \times 100\% = \frac{P_{\text{OUT}}}{3V_\phi I_A \cos \theta} \times 100\%$$

$$\eta = \frac{12.3 \text{ kW}}{3(120 \text{ V})(44.8 \text{ A})\cos 25.5^\circ} \times 100\% = 84.5\%$$

(h) The motor speed in revolutions per minute is 3420 r/min. The motor speed in radians per second is

$$\omega_m = (3420 \text{ r/min}) \frac{2\pi \text{ rad}}{1 \text{ r}} \frac{1 \text{ min}}{60 \text{ s}} = 358 \text{ rad/s}$$

7-8. For the motor in Problem 7-7, what is the slip at the pullout torque? What is the pullout torque of this motor?

SOLUTION The slip at pullout torque is found by calculating the Thevenin equivalent of the input circuit from the rotor back to the power supply, and then using that with the rotor circuit model.

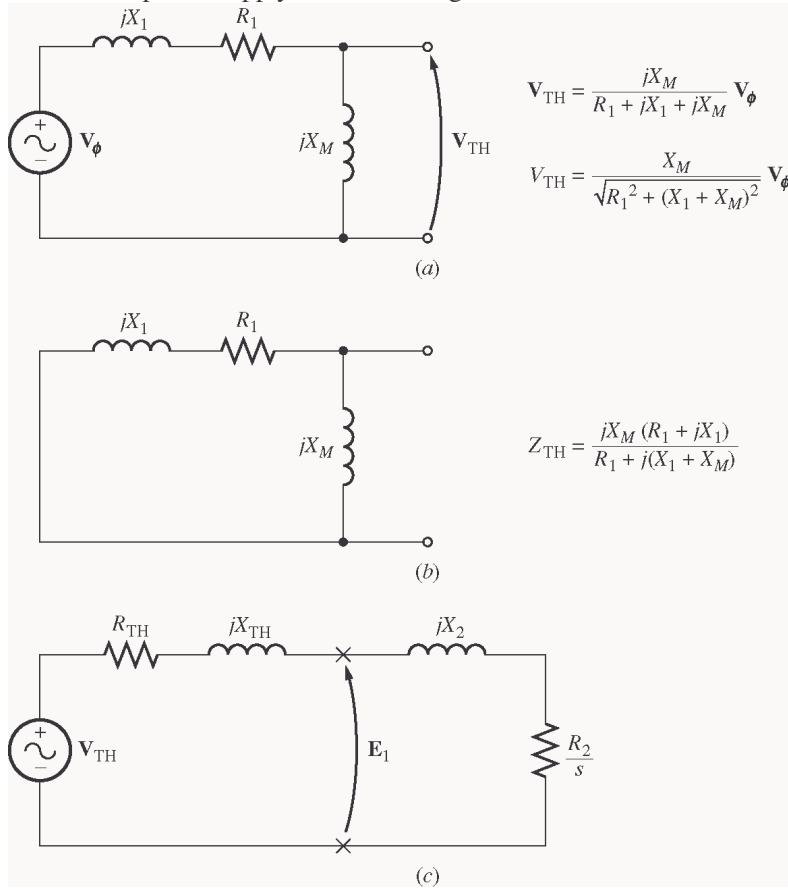

$$Z_{TH} = \frac{jX_M (R_1 + jX_1)}{R_1 + j(X_1 + X_M)} = \frac{(j15 \Omega)(0.20 \Omega + j0.41 \Omega)}{0.20 \Omega + j(0.41 \Omega + 15 \Omega)} = 0.1895 + j0.4016 \Omega = 0.444 \angle 64.7^\circ \Omega$$

$$V_{TH} = \frac{jX_M}{R_1 + j(X_1 + X_M)} V_\phi = \frac{(j15 \Omega)}{0.22 \Omega + j(0.43 \Omega + 15 \Omega)} (120 \angle 0^\circ \text{ V}) = 116.8 \angle 0.7^\circ \text{ V}$$

The slip at pullout torque is

$$s_{\max} = \frac{R_2}{\sqrt{R_{TH}^2 + (X_{TH} + X_2)^2}}$$

$$s_{\max} = \frac{0.120 \Omega}{\sqrt{(0.1895 \Omega)^2 + (0.4016 \Omega + 0.410 \Omega)^2}} = 0.144$$

The pullout torque of the motor is

$$\tau_{\max} = \frac{3V_{TH}^2}{2\omega_{\text{sync}} R_{TH} + \sqrt{R_{TH}^2 + (X_{TH} + X_2)^2}}$$

$$\tau_{\max} = \frac{3(116.8 \text{ V})^2}{2(377 \text{ rad/s}) 0.1895 \Omega + \sqrt{(0.1895 \Omega)^2 + (0.4016 \Omega + 0.410 \Omega)^2}}$$

$$\tau_{\max} = 53.1 \text{ N}\cdot\text{m}$$

- 7-9.** (a) Calculate and plot the torque-speed characteristic of the motor in Problem 7-7. (b) Calculate and plot the output power versus speed curve of the motor in Problem 7-7.

SOLUTION

(a) A MATLAB program to calculate the torque-speed characteristic is shown below.

```
% M-file: prob7_9a.m
% M-file create a plot of the torque-speed curve of the
% induction motor of Problem 7-7.

% First, initialize the values needed in this program.
r1 = 0.200;           % Stator resistance
x1 = 0.410;           % Stator reactance
r2 = 0.120;           % Rotor resistance
x2 = 0.410;           % Rotor reactance
xm = 15.0;           % Magnetization branch reactance
v_phase = 208 / sqrt(3); % Phase voltage
n_sync = 3600;        % Synchronous speed (r/min)
w_sync = 377;         % Synchronous speed (rad/s)

% Calculate the Thevenin voltage and impedance from Equations
% 7-41a and 7-43.
v_th = v_phase * ( xm / sqrt(r1^2 + (x1 + xm)^2) );
z_th = ((j*xm) * (r1 + j*x1)) / (r1 + j*(x1 + xm));
r_th = real(z_th);
x_th = imag(z_th);

% Now calculate the torque-speed characteristic for many
% slips between 0 and 1. Note that the first slip value
% is set to 0.001 instead of exactly 0 to avoid divide-
% by-zero problems.
s = (0:1:50) / 50;    % Slip
s(1) = 0.001;
nm = (1 - s) * n_sync; % Mechanical speed

% Calculate torque versus speed
for ii = 1:51
    t_ind(ii) = (3 * v_th^2 * r2 / s(ii)) / ...
        (w_sync * ((r_th + r2/s(ii))^2 + (x_th + x2)^2) );
end

% Plot the torque-speed curve
figure(1);
plot(nm,t_ind,'k-', 'LineWidth',2.0);
xlabel('\bf\itn_{m}');
ylabel('\bf\itau_{ind}');
title ('\bfInduction Motor Torque-Speed Characteristic');
grid on;
```

The resulting plot is shown below:

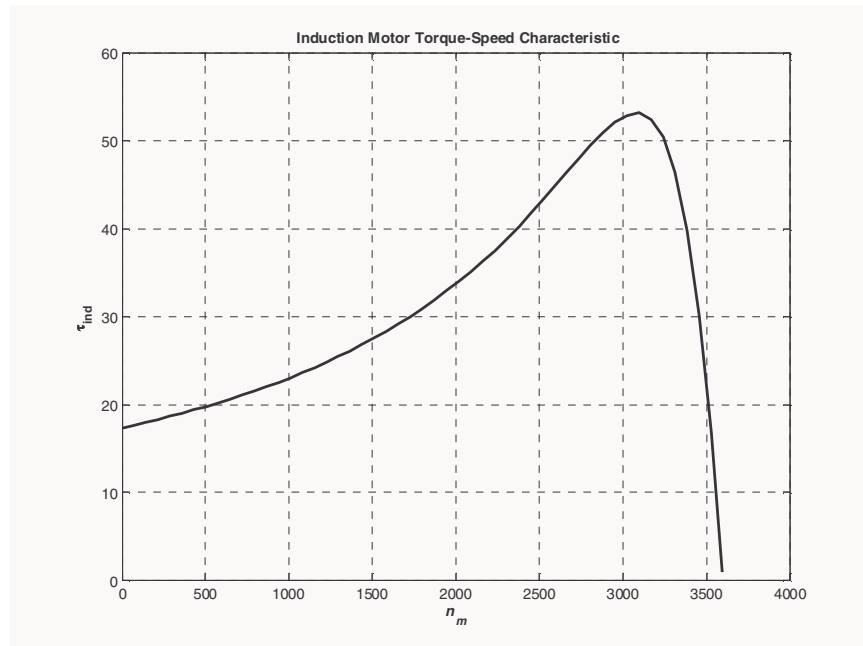

(b) A MATLAB program to calculate the output-power versus speed curve is shown below.

```
% M-file: prob7_9b.m
% M-file create a plot of the output pwer versus speed
% curve of the induction motor of Problem 7-7.

% First, initialize the values needed in this program.
r1 = 0.200; % Stator resistance
x1 = 0.410; % Stator reactance
r2 = 0.120; % Rotor resistance
x2 = 0.410; % Rotor reactance
xm = 15.0; % Magnetization branch reactance
v_phase = 208 / sqrt(3); % Phase voltage
n_sync = 3600; % Synchronous speed (r/min)
w_sync = 377; % Synchronous speed (rad/s)

% Calculate the Thevenin voltage and impedance from Equations
% 7-41a and 7-43.
v_th = v_phase * ( xm / sqrt(r1^2 + (x1 + xm)^2) );
z_th = ((j*xm) * (r1 + j*x1)) / (r1 + j*(x1 + xm));
r_th = real(z_th);
x_th = imag(z_th);

% Now calculate the torque-speed characteristic for many
% slips between 0 and 1. Note that the first slip value
% is set to 0.001 instead of exactly 0 to avoid divide-
% by-zero problems.
s = (0:1:50) / 50; % Slip
s(1) = 0.001;
nm = (1 - s) * n_sync; % Mechanical speed (r/min)
wm = (1 - s) * w_sync; % Mechanical speed (rad/s)

% Calculate torque and output power versus speed
for ii = 1:51
```



```

t_ind(ii) = (3 * v_th^2 * r2 / s(ii)) / ...
            (w_sync * ((r_th + r2/s(ii))^2 + (x_th + x2)^2));
p_out(ii) = t_ind(ii) * wm(ii);
end

% Plot the torque-speed curve
figure(1);
plot(nm,p_out/1000,'k-','LineWidth',2.0);
xlabel('\bf\itn_{m} \rm\bf(r/min)');
ylabel('\bf\itP_{OUT} \rm\bf(kW)');
title ('\bfInduction Motor Ouput Power versus Speed');
grid on;

```

The resulting plot is shown below:

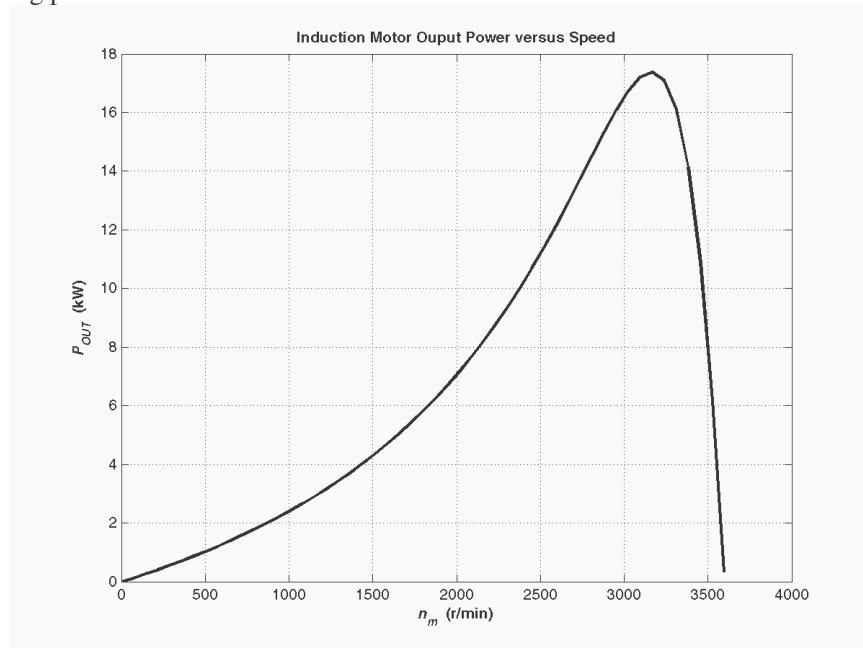

- 7-10.** For the motor of Problem 7-7, how much additional resistance (referred to the stator circuit) would it be necessary to add to the rotor circuit to make the maximum torque occur at starting conditions (when the shaft is not moving)? Plot the torque-speed characteristic of this motor with the additional resistance inserted.

SOLUTION To get the maximum torque at starting, the s_{\max} must be 1.00. Therefore,

$$s_{\max} = \frac{R_2}{\sqrt{R_{TH}^2 + (X_{TH} + X_2)^2}}$$

$$1.00 = \frac{R_2}{\sqrt{(0.1895 \Omega)^2 + (0.4016 \Omega + 0.410 \Omega)^2}}$$

$$R_2 = 0.833 \Omega$$

Since the existing resistance is 0.120Ω , an additional 0.713Ω must be added to the rotor circuit. The resulting torque-speed characteristic is:

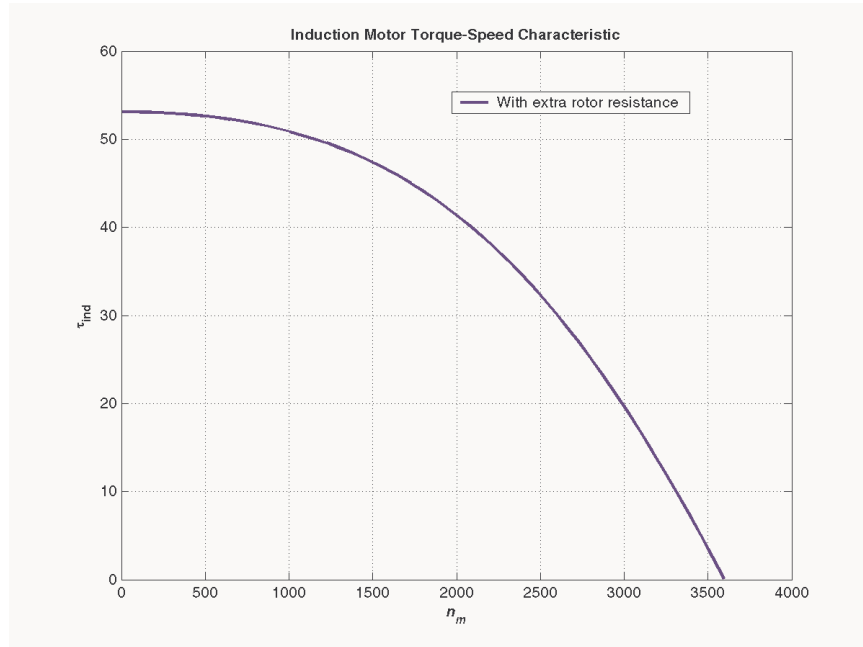

7-11. If the motor in Problem 7-7 is to be operated on a 50-Hz power system, what must be done to its supply voltage? Why? What will the equivalent circuit component values be at 50 Hz? Answer the questions in Problem 7-7 for operation at 50 Hz with a slip of 0.05 and the proper voltage for this machine.

SOLUTION If the input frequency is decreased to 50 Hz, then the applied voltage must be decreased by 5/6 also. If this were not done, the flux in the motor would go into saturation, since

$$\phi = \frac{1}{N} \int_T v dt$$

and the period T would be increased. At 50 Hz, the resistances will be unchanged, but the reactances will be reduced to 5/6 of their previous values. The equivalent circuit of the induction motor at 50 Hz is shown below:

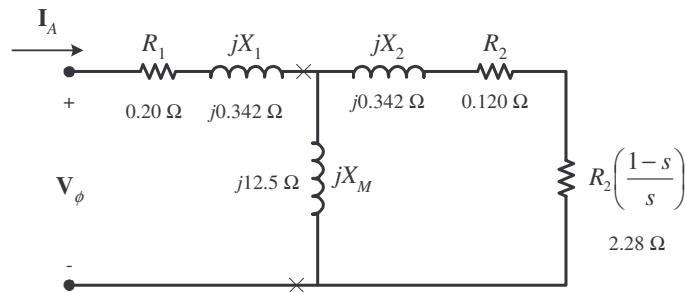

(a) The easiest way to find the line current (or armature current) is to get the equivalent impedance Z_F of the rotor circuit in parallel with jX_M , and then calculate the current as the phase voltage divided by the sum of the series impedances, as shown below.

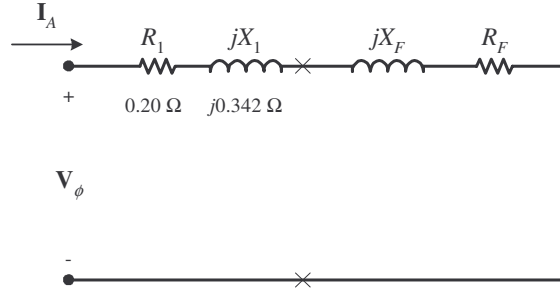

The equivalent impedance of the rotor circuit in parallel with jX_M is:

$$Z_F = \frac{1}{\frac{1}{jX_M} + \frac{1}{Z_2}} = \frac{1}{\frac{1}{j12.5 \Omega} + \frac{1}{2.40 + j0.342}} = 2.197 + j0.744 = 2.32 \angle 18.7^\circ \Omega$$

The line voltage must be derated by 5/6, so the new line voltage is $V_T = 173.3 \text{ V}$. The phase voltage is $173.3 / \sqrt{3} = 100 \text{ V}$, so line current I_L is

$$I_L = I_A = \frac{V_\phi}{R_1 + jX_1 + R_F + jX_F} = \frac{100 \angle 0^\circ \text{ V}}{0.20 \Omega + j0.342 \Omega + 2.197 \Omega + j0.744 \Omega}$$

$$I_L = I_A = 38.0 \angle -24.4^\circ \text{ A}$$

(b) The stator copper losses are

$$P_{\text{SCL}} = 3I_A^2 R_1 = 3(38 \text{ A})^2 (0.20 \Omega) = 866 \text{ W}$$

(c) The air gap power is $P_{\text{AG}} = 3I_2^2 \frac{R_2}{s} = 3I_A^2 R_F$

(Note that $3I_A^2 R_F$ is equal to $3I_2^2 \frac{R_2}{s}$, since the only resistance in the original rotor circuit was R_2/s , and the resistance in the Thevenin equivalent circuit is R_F . The power consumed by the Thevenin equivalent circuit must be the same as the power consumed by the original circuit.)

$$P_{\text{AG}} = 3I_A^2 \frac{R_2}{s} = 3I_A^2 R_F = 3(38 \text{ A})^2 (2.197 \Omega) = 9.52 \text{ kW}$$

(d) The power converted from electrical to mechanical form is

$$P_{\text{conv}} = (1-s)P_{\text{AG}} = (1-0.05)(9.52 \text{ kW}) = 9.04 \text{ kW}$$

(e) The induced torque in the motor is

$$\tau_{\text{ind}} = \frac{P_{\text{AG}}}{\omega_{\text{sync}}} = \frac{9.52 \text{ kW}}{(3000 \text{ r/min}) \frac{2\pi \text{ rad}}{1 \text{ r}} \frac{1 \text{ min}}{60 \text{ s}}} = 30.3 \text{ N} \cdot \text{m}$$

(f) In the absence of better information, we will treat the mechanical and core losses as constant despite the change in speed. This is not true, but we don't have reason for a better guess. Therefore, the output power of this motor is

$$P_{\text{OUT}} = P_{\text{conv}} - P_{\text{mech}} - P_{\text{core}} - P_{\text{misc}} = 9.04 \text{ kW} - 250 \text{ W} - 180 \text{ W} - 0 \text{ W} = 8.61 \text{ kW}$$

The output speed is

$$n_m = (1-s) n_{\text{sync}} = (1-0.05)(3000 \text{ r/min}) = 2850 \text{ r/min}$$

Therefore the load torque is

$$\tau_{\text{load}} = \frac{P_{\text{OUT}}}{\omega_m} = \frac{8.61 \text{ kW}}{(2850 \text{ r/min}) \frac{2\pi \text{ rad}}{1 \text{ r}} \frac{1 \text{ min}}{60 \text{ s}}} = 28.8 \text{ N} \cdot \text{m}$$

(g) The overall efficiency is

$$\eta = \frac{P_{\text{OUT}}}{P_{\text{IN}}} \times 100\% = \frac{P_{\text{OUT}}}{3V_{\phi} I_A \cos \theta} \times 100\%$$

$$\eta = \frac{8.61 \text{ kW}}{3(100 \text{ V})(38.0 \text{ A}) \cos 24.4^{\circ}} \times 100\% = 82.9\%$$

(h) The motor speed in revolutions per minute is 2850 r/min. The motor speed in radians per second is

$$\omega_m = (2850 \text{ r/min}) \frac{2\pi \text{ rad}}{1 \text{ r}} \frac{1 \text{ min}}{60 \text{ s}} = 298.5 \text{ rad/s}$$

7-12. Figure 7-18a shows a simple circuit consisting of a voltage source, a resistor, and two reactances. Find the Thevenin equivalent voltage and impedance of this circuit at the terminals. Then derive the expressions for the magnitude of V_{TH} and for R_{TH} given in Equations (7-41b) and (7-44).

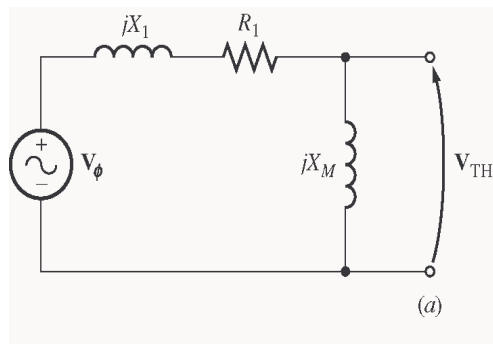

SOLUTION The Thevenin voltage of this circuit is

$$V_{\text{TH}} = \frac{jX_M}{R_1 + j(X_1 + X_M)} V_{\phi}$$

The *magnitude* of this voltage is

$$V_{\text{TH}} = \frac{X_M}{\sqrt{R_1^2 + (X_1 + X_M)^2}} V_{\phi}$$

If $X_M \gg X_1$, then $R_1^2 + (X_1 + X_M)^2 \approx (X_1 + X_M)^2$, so

$$\boxed{V_{\text{TH}} \approx \frac{X_M}{X_1 + X_M} V_{\phi}}$$

The Thevenin impedance of this circuit is

$$Z_{\text{TH}} = \frac{jX_M (R_1 + jX_1)}{R_1 + j(X_1 + X_M)}$$

$$Z_{TH} = \frac{jX_M(R_1 + jX_1)}{R_1 + j(X_1 + X_M)} \cdot \frac{R_1 - j(X_1 + X_M)}{R_1 - j(X_1 + X_M)}$$

$$Z_{TH} = \frac{-R_1X_1X_M + R_1X_1X_M + R_1X_M^2 + j(R_1^2X_M + X_1^2X_M + X_1X_M^2)}{R_1^2 + (X_1 + X_M)^2}$$

$$Z_{TH} = R_{TH} + jX_{TH} = \frac{R_1X_M^2}{R_1^2 + (X_1 + X_M)^2} + j \frac{R_1^2X_M + X_1^2X_M + X_1X_M^2}{R_1^2 + (X_1 + X_M)^2}$$

The Thevenin resistance is $R_{TH} = \frac{R_1X_M^2}{R_1^2 + (X_1 + X_M)^2}$. If $X_M \gg R_1$, then $R_1^2 + (X_1 + X_M)^2 \approx (X_1 + X_M)^2$,

so

$$R_{TH} \approx R_1 \frac{X_M^2}{(X_1 + X_M)^2}$$

$$X_{TH} = \frac{R_1^2X_M + X_1^2X_M + X_1X_M^2}{R_1^2 + (X_1 + X_M)^2}$$

If $X_M \gg R_1$ and $X_M \gg X_1$ then $X_1X_M^2 \gg R_1^2X_M + X_1^2X_M$ and $(X_1 + X_M)^2 \approx X_M^2 \gg R_1^2$, so

$$X_{TH} \approx \frac{X_1X_M^2}{X_M^2} = X_1$$

- 7-13.** Figure P7-1 shows a simple circuit consisting of a voltage source, two resistors, and two reactances in parallel with each other. If the resistor R_L is allowed to vary but all the other components are constant, at what value of R_L will the maximum possible power be supplied to it? *Prove* your answer. (*Hint:* Derive an expression for load power in terms of V , R_S , X_S , R_L and X_L and take the partial derivative of that expression with respect to R_L .) Use this result to derive the expression for the pullout torque [Equation (7-54)].

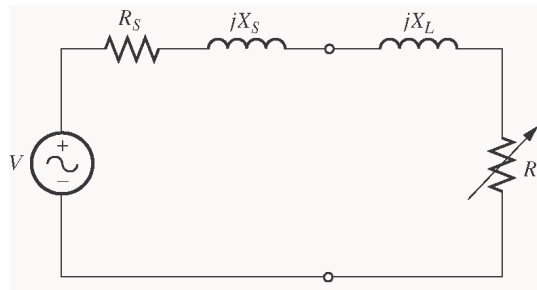

SOLUTION The current flowing in this circuit is given by the equation

$$I_L = \frac{V}{R_S + jX_S + R_L + jX_L}$$

$$I_L = \frac{V}{\sqrt{(R_S + R_L)^2 + (X_S + X_L)^2}}$$

The power supplied to the load is

$$P = I_L^2 R_L = \frac{V^2 R_L}{(R_S + R_L)^2 + (X_S + X_L)^2}$$

$$\frac{\partial P}{\partial R_L} = \frac{(R_S + R_L)^2 + (X_S + X_L)^2 \cdot V^2 - V^2 R_L \cdot 2(R_S + R_L)}{(R_S + R_L)^2 + (X_S + X_L)^2 \cdot 2}$$

To find the point of maximum power supplied to the load, set $\partial P / \partial R_L = 0$ and solve for R_L .

$$(R_S + R_L)^2 + (X_S + X_L)^2 \cdot V^2 - V^2 R_L \cdot 2(R_S + R_L) = 0$$

$$(R_S + R_L)^2 + (X_S + X_L)^2 = 2R_L(R_S + R_L)$$

$$R_S^2 + 2R_S R_L + R_L^2 + (X_S + X_L)^2 = 2R_S R_L + 2R_L^2$$

$$R_S^2 + R_L^2 + (X_S + X_L)^2 = 2R_L^2$$

$$R_S^2 + (X_S + X_L)^2 = R_L^2$$

Therefore, for maximum power transfer, the load resistor should be

$$R_L = \sqrt{R_S^2 + (X_S + X_L)^2}$$

- 7-14.** A 440-V 50-Hz two-pole Y-connected induction motor is rated at 75 kW. The equivalent circuit parameters are

$$R_1 = 0.075 \, \Omega \quad R_2 = 0.065 \, \Omega \quad X_M = 7.2 \, \Omega$$

$$X_1 = 0.17 \, \Omega \quad X_2 = 0.17 \, \Omega$$

$$P_{F\&W} = 1.0 \, \text{kW} \quad P_{\text{misc}} = 150 \, \text{W} \quad P_{\text{core}} = 1.1 \, \text{kW}$$

For a slip of 0.04, find

- The line current I_L
- The stator power factor
- The rotor power factor
- The stator copper losses P_{SCL}
- The air-gap power P_{AG}
- The power converted from electrical to mechanical form P_{conv}
- The induced torque τ_{ind}
- The load torque τ_{load}
- The overall machine efficiency η
- The motor speed in revolutions per minute and radians per second

SOLUTION The equivalent circuit of this induction motor is shown below:

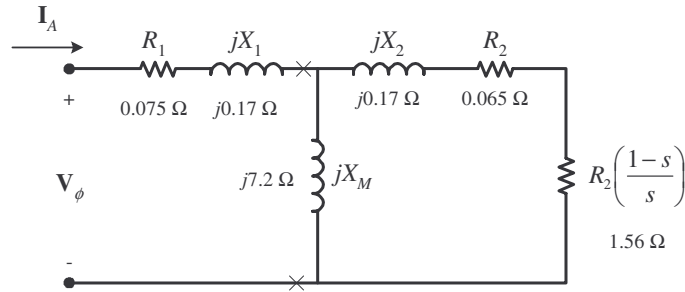

(a) The easiest way to find the line current (or armature current) is to get the equivalent impedance Z_F of the rotor circuit in parallel with jX_M , and then calculate the current as the phase voltage divided by the sum of the series impedances, as shown below.

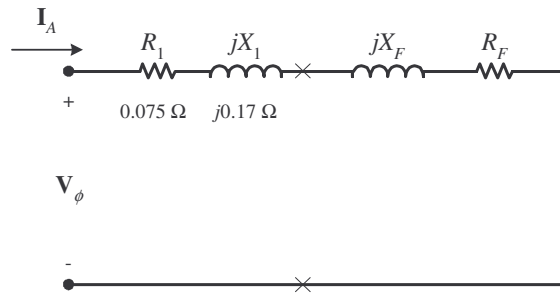

The equivalent impedance of the rotor circuit in parallel with jX_M is:

$$Z_F = \frac{1}{\frac{1}{jX_M} + \frac{1}{Z_2}} = \frac{1}{\frac{1}{j7.2 \Omega} + \frac{1}{1.625 + j0.17}} = 1.539 + j0.364 = 1.58 \angle 13.2^\circ \Omega$$

The phase voltage is $440/\sqrt{3} = 254 \text{ V}$, so line current I_L is

$$I_L = I_A = \frac{V_\phi}{R_1 + jX_1 + R_F + jX_F} = \frac{254 \angle 0^\circ \text{ V}}{0.075 \Omega + j0.17 \Omega + 1.539 \Omega + j0.364 \Omega}$$

$$I_L = I_A = 149.4 \angle -18.3^\circ \text{ A}$$

(b) The stator power factor is

$$\text{PF} = \cos(18.3^\circ) = 0.949 \text{ lagging}$$

(c) To find the rotor power factor, we must find the impedance angle of the rotor

$$\theta_R = \tan^{-1} \frac{X_2}{R_2/s} = \tan^{-1} \frac{0.17}{1.625} = 5.97^\circ$$

Therefore the rotor power factor is

$$\text{PF}_R = \cos 5.97^\circ = 0.995 \text{ lagging}$$

(d) The stator copper losses are

$$P_{\text{SCL}} = 3I_A^2 R_1 = 3(149.4 \text{ A})^2 (0.075 \Omega) = 1675 \text{ W}$$

(e) The air gap power is $P_{\text{AG}} = 3I_2^2 \frac{R_2}{s} = 3I_A^2 R_F$

(Note that $3I_A^2 R_F$ is equal to $3I_2^2 \frac{R_2}{s}$, since the only resistance in the original rotor circuit was R_2/s , and the resistance in the Thevenin equivalent circuit is R_F . The power consumed by the Thevenin equivalent circuit must be the same as the power consumed by the original circuit.)

$$P_{AG} = 3I_2^2 \frac{R_2}{s} = 3I_A^2 R_F = 3(149.4 \text{ A})^2 (1.539 \Omega) = 103 \text{ kW}$$

(f) The power converted from electrical to mechanical form is

$$P_{\text{conv}} = (1-s)P_{AG} = (1-0.04)(103 \text{ kW}) = 98.9 \text{ kW}$$

(g) The synchronous speed of this motor is

$$n_{\text{sync}} = \frac{120f_e}{P} = \frac{120(50 \text{ Hz})}{2} = 3000 \text{ r/min}$$

$$\omega_{\text{sync}} = (3000 \text{ r/min}) \frac{2\pi \text{ rad}}{1 \text{ r}} \frac{1 \text{ min}}{60 \text{ s}} = 314 \text{ rad/s}$$

Therefore the induced torque in the motor is

$$\tau_{\text{ind}} = \frac{P_{AG}}{\omega_{\text{sync}}} = \frac{103 \text{ kW}}{(3000 \text{ r/min}) \frac{2\pi \text{ rad}}{1 \text{ r}} \frac{1 \text{ min}}{60 \text{ s}}} = 327.9 \text{ N} \cdot \text{m}$$

(h) The output power of this motor is

$$P_{\text{OUT}} = P_{\text{conv}} - P_{\text{mech}} - P_{\text{core}} - P_{\text{misc}} = 98.8 \text{ kW} - 1.0 \text{ kW} - 1.1 \text{ kW} - 150 \text{ W} = 96.6 \text{ kW}$$

The output speed is

$$n_m = (1-s)n_{\text{sync}} = (1-0.04)(3000 \text{ r/min}) = 2880 \text{ r/min}$$

Therefore the load torque is

$$\tau_{\text{load}} = \frac{P_{\text{OUT}}}{\omega_m} = \frac{96.6 \text{ kW}}{(2880 \text{ r/min}) \frac{2\pi \text{ rad}}{1 \text{ r}} \frac{1 \text{ min}}{60 \text{ s}}} = 327.6 \text{ N} \cdot \text{m}$$

(i) The overall efficiency is

$$\eta = \frac{P_{\text{OUT}}}{P_{\text{IN}}} \times 100\% = \frac{P_{\text{OUT}}}{3V_\phi I_A \cos \theta} \times 100\%$$

$$\eta = \frac{96.6 \text{ kW}}{3(254 \text{ V})(149.4 \text{ A})\cos(18.3^\circ)} \times 100\% = 89.4\%$$

(j) The motor speed in revolutions per minute is 2880 r/min. The motor speed in radians per second is

$$\omega_m = (2880 \text{ r/min}) \frac{2\pi \text{ rad}}{1 \text{ r}} \frac{1 \text{ min}}{60 \text{ s}} = 301.6 \text{ rad/s}$$

7-15. For the motor in Problem 7-14, what is the pullout torque? What is the slip at the pullout torque? What is the rotor speed at the pullout torque?

SOLUTION The slip at pullout torque is found by calculating the Thevenin equivalent of the input circuit from the rotor back to the power supply, and then using that with the rotor circuit model.

$$Z_{\text{TH}} = \frac{jX_M(R_1 + jX_1)}{R_1 + j(X_1 + X_M)} = \frac{(j7.2 \Omega)(0.075 \Omega + j0.17 \Omega)}{0.075 \Omega + j(0.17 \Omega + 7.2 \Omega)} = 0.0731 + j0.1662 \Omega = 0.182 \angle 66.3^\circ \Omega$$

$$V_{\text{TH}} = \frac{jX_M}{R_1 + j(X_1 + X_M)} V_\phi = \frac{(j7.2 \Omega)}{0.075 \Omega + j(0.17 \Omega + 7.2 \Omega)} (254 \angle 0^\circ \text{ V}) = 248 \angle 0.06^\circ \text{ V}$$

The slip at pullout torque is

$$s_{\text{max}} = \frac{R_2}{\sqrt{R_{\text{TH}}^2 + (X_{\text{TH}} + X_2)^2}}$$

$$s_{\text{max}} = \frac{0.065 \Omega}{\sqrt{(0.0731 \Omega)^2 + (0.1662 \Omega + 0.17 \Omega)^2}} = 0.189$$

The pullout torque of the motor is

$$\tau_{\text{max}} = \frac{3V_{\text{TH}}^2}{2\omega_{\text{sync}} \left[R_{\text{TH}} + \sqrt{R_{\text{TH}}^2 + (X_{\text{TH}} + X_2)^2} \right]}$$

$$\tau_{\text{max}} = \frac{3(248 \text{ V})^2}{2(314.2 \text{ rad/s}) \left[0.0731 \Omega + \sqrt{(0.0731 \Omega)^2 + (0.1662 \Omega + 0.17 \Omega)^2} \right]}$$

$$\tau_{\text{max}} = 704 \text{ N} \cdot \text{m}$$

- 7-16.** If the motor in Problem 7-14 is to be driven from a 440-V 60-Hz power supply, what will the pullout torque be? What will the slip be at pullout?

SOLUTION If this motor is driven from a 60 Hz source, the resistances will be unchanged and the reactances will be increased by a ratio of 6/5. The resulting equivalent circuit is shown below.

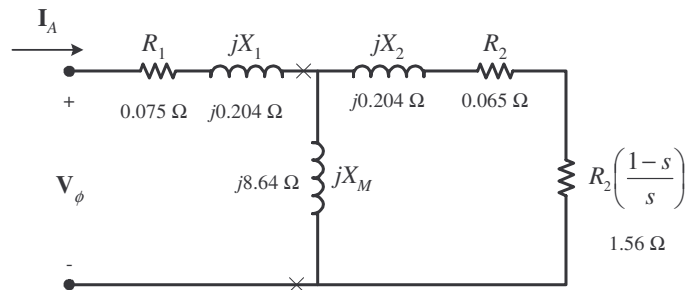

The slip at pullout torque is found by calculating the Thevenin equivalent of the input circuit from the rotor back to the power supply, and then using that with the rotor circuit model.

$$Z_{\text{TH}} = \frac{jX_M(R_1 + jX_1)}{R_1 + j(X_1 + X_M)} = \frac{(j8.64 \Omega)(0.075 \Omega + j0.204 \Omega)}{0.075 \Omega + j(0.204 \Omega + 8.64 \Omega)} = 0.0731 + j0.1994 \Omega = 0.212 \angle 69.9^\circ \Omega$$

$$V_{\text{TH}} = \frac{jX_M}{R_1 + j(X_1 + X_M)} V_\phi = \frac{(j8.64 \Omega)}{0.075 \Omega + j(0.204 \Omega + 8.64 \Omega)} (254 \angle 0^\circ \text{ V}) = 248 \angle 0.05^\circ \text{ V}$$

The slip at pullout torque is

$$s_{\text{max}} = \frac{R_2}{\sqrt{R_{\text{TH}}^2 + (X_{\text{TH}} + X_2)^2}}$$

$$s_{\max} = \frac{0.065 \Omega}{\sqrt{(0.0731 \Omega)^2 + (0.1994 \Omega + 0.204 \Omega)^2}} = 0.159$$

The synchronous speed of this motor is

$$n_{\text{sync}} = \frac{120 f_e}{P} = \frac{120(60 \text{ Hz})}{2} = 3600 \text{ r/min}$$

$$\omega_{\text{sync}} = (3600 \text{ r/min}) \frac{2\pi \text{ rad}}{1 \text{ r}} \frac{1 \text{ min}}{60 \text{ s}} = 377 \text{ rad/s}$$

Therefore the pullout torque of the motor is

$$\tau_{\max} = \frac{3V_{\text{TH}}^2}{2\omega_{\text{sync}} R_{\text{TH}} + \sqrt{R_{\text{TH}}^2 + (X_{\text{TH}} + X_2)^2}}$$

$$\tau_{\max} = \frac{3(248 \text{ V})^2}{2(377 \text{ rad/s}) 0.0731 \Omega + \sqrt{(0.0731 \Omega)^2 + (0.1994 \Omega + 0.204 \Omega)^2}}$$

$$\tau_{\max} = 507 \text{ N} \cdot \text{m}$$

- 7-17.** Plot the following quantities for the motor in Problem 7-14 as slip varies from 0% to 10%: (a) τ_{ind} (b) P_{conv} (c) P_{out} (d) Efficiency η . At what slip does P_{out} equal the rated power of the machine?

SOLUTION This problem is ideally suited to solution with a MATLAB program. An appropriate program is shown below. It follows the calculations performed for Problem 7-14, but repeats them at many values of slip, and then plots the results. Note that it plots all the specified values versus n_m , which varies from 2700 to 3000 r/min, corresponding to a range of 0 to 10% slip.

```
% M-file: prob7_17.m
% M-file create a plot of the induced torque, power
% converted, power out, and efficiency of the induction
% motor of Problem 7-14 as a function of slip.

% First, initialize the values needed in this program.
r1 = 0.075; % Stator resistance
x1 = 0.170; % Stator reactance
r2 = 0.065; % Rotor resistance
x2 = 0.170; % Rotor reactance
xm = 7.2; % Magnetization branch reactance
v_phase = 440 / sqrt(3); % Phase voltage
n_sync = 3000; % Synchronous speed (r/min)
w_sync = 314.2; % Synchronous speed (rad/s)
p_mech = 1000; % Mechanical losses (W)
p_core = 1100; % Core losses (W)
p_misc = 150; % Miscellaneous losses (W)

% Calculate the Thevenin voltage and impedance from Equations
% 7-41a and 7-43.
v_th = v_phase * ( xm / sqrt(r1^2 + (x1 + xm)^2) );
z_th = ((j*xm) * (r1 + j*x1)) / (r1 + j*(x1 + xm));
r_th = real(z_th);
x_th = imag(z_th);
```

```

% Now calculate the torque-speed characteristic for many
% slips between 0 and 0.1. Note that the first slip value
% is set to 0.001 instead of exactly 0 to avoid divide-
% by-zero problems.
s = (0:0.001:0.1);           % Slip
s(1) = 0.001;
nm = (1 - s) * n_sync;       % Mechanical speed
wm = nm * 2*pi/60;           % Mechanical speed

% Calculate torque, P_conv, P_out, and efficiency
% versus speed
for ii = 1:length(s)

    % Induced torque
    t_ind(ii) = (3 * v_th^2 * r2 / s(ii)) / ...
                (w_sync * ((r_th + r2/s(ii))^2 + (x_th + x2)^2) );

    % Power converted
    p_conv(ii) = t_ind(ii) * wm(ii);

    % Power output
    p_out(ii) = p_conv(ii) - p_mech - p_core - p_misc;

    % Power input
    zf = 1 / ( 1/(j*xm) + 1/(r2/s(ii)+j*x2) );
    ia = v_phase / ( r1 + j*x1 + zf );
    p_in(ii) = 3 * v_phase * abs(ia) * cos(atan(imag(ia)/real(ia)));

    % Efficiency
    eff(ii) = p_out(ii) / p_in(ii) * 100;

end

% Plot the torque-speed curve
figure(1);
plot(nm,t_ind,'b-', 'LineWidth',2.0);
xlabel('\bf\itn_{m} \rm\bf(r/min)');
ylabel('\bf\itau_{ind} \rm\bf(N-m)');
title ('\bfInduced Torque versus Speed');
grid on;

% Plot power converted versus speed
figure(2);
plot(nm,p_conv/1000,'b-', 'LineWidth',2.0);
xlabel('\bf\itn_{m} \rm\bf(r/min)');
ylabel('\bf\itP\rm\bf_{conv} (kW)');
title ('\bfPower Converted versus Speed');
grid on;

% Plot output power versus speed
figure(3);
plot(nm,p_out/1000,'b-', 'LineWidth',2.0);
xlabel('\bf\itn_{m} \rm\bf(r/min)');
ylabel('\bf\itP\rm\bf_{out} (kW)');
title ('\bfOutput Power versus Speed');
axis([2700 3000 0 180]);

```

```

grid on;

% Plot the efficiency
figure(4);
plot(nm,eff,'b-','LineWidth',2.0);
xlabel('\bf\itn_{m} \rm\bf(r/min)');
ylabel('\bf\eta (%)');
title('\bfEfficiency versus Speed');
grid on;

```

The four plots are shown below:

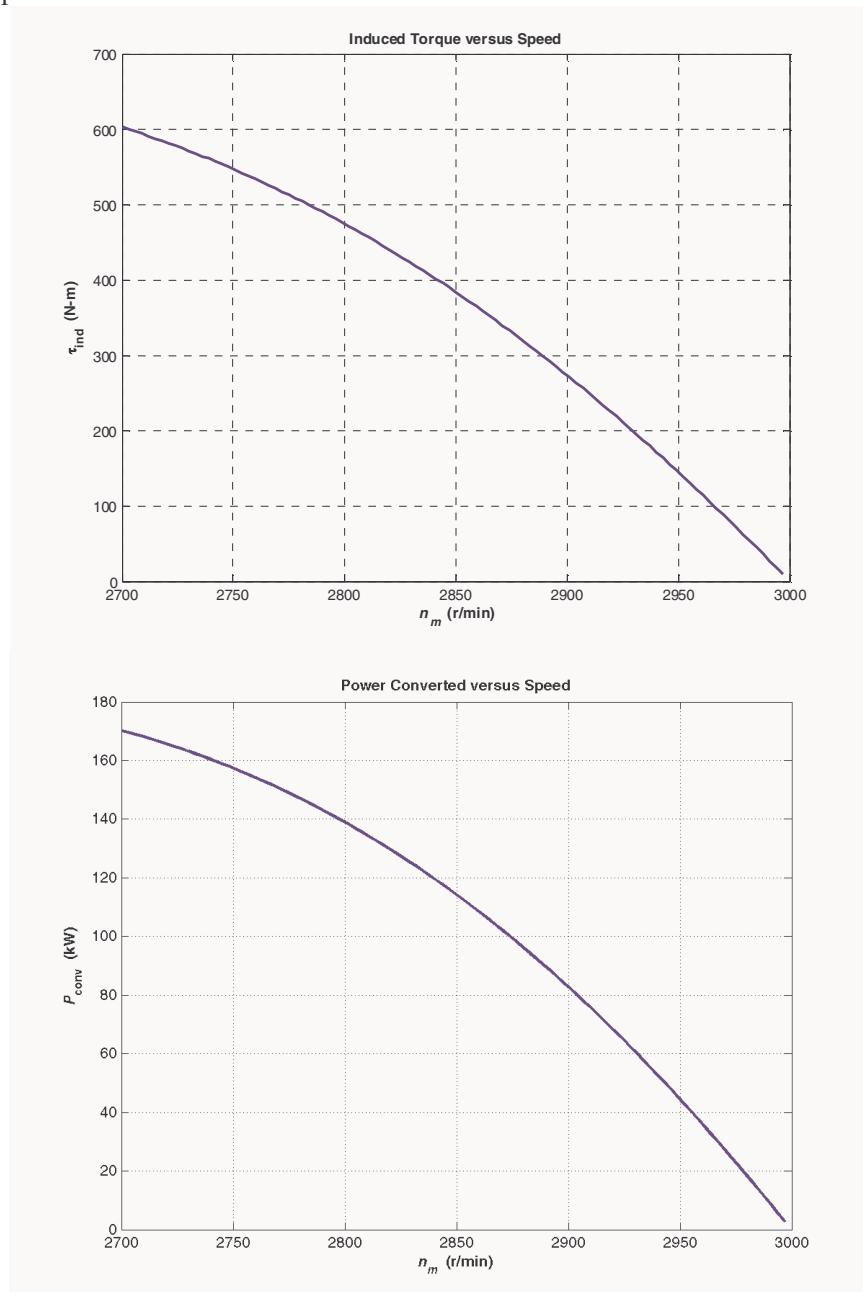

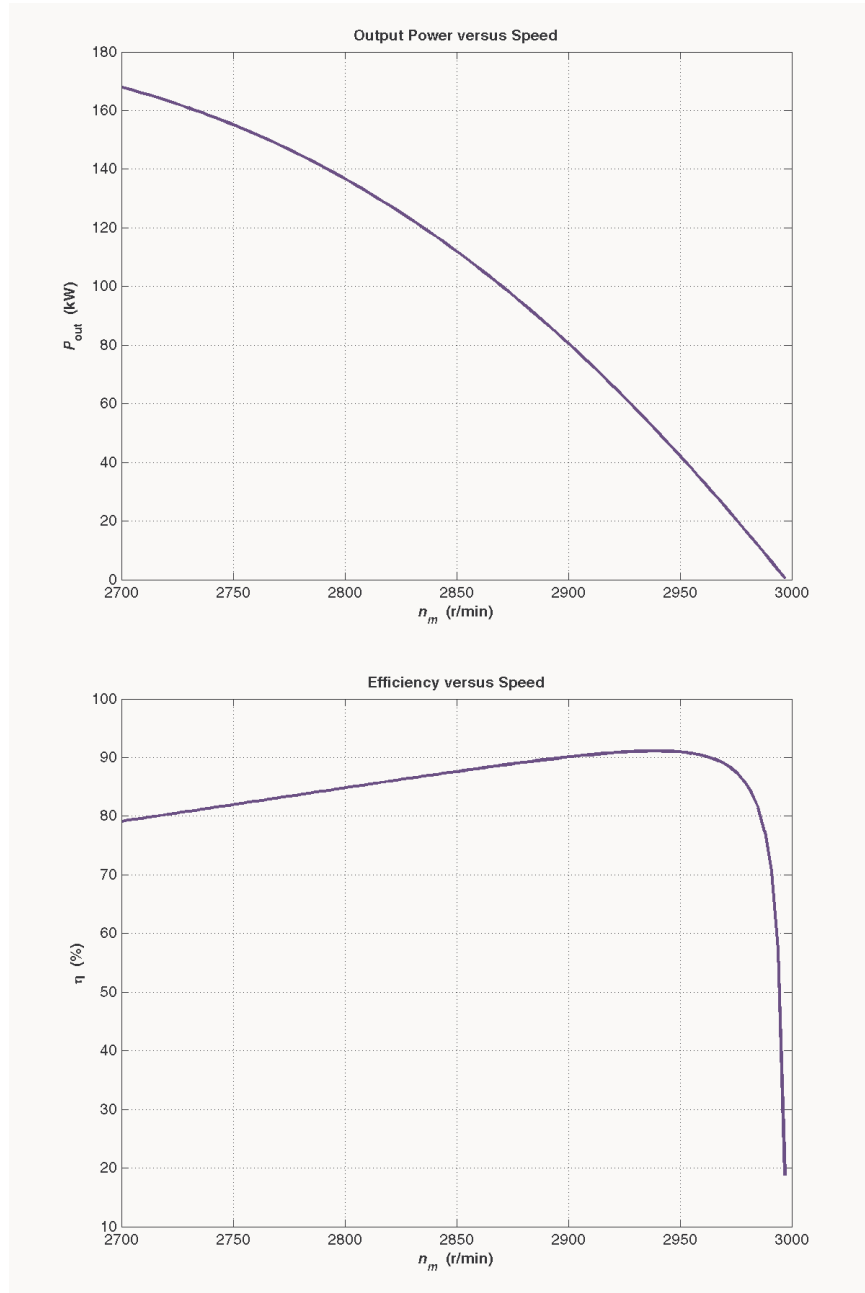

This machine is rated at 75 kW. It produces an output power of 75 kW at 3.1% slip, or a speed of 2907 r/min.

7-18. A 208-V, 60 Hz, six-pole Y-connected 25-hp design class B induction motor is tested in the laboratory, with the following results:

- No load: 208 V, 22.0 A, 1200 W, 60 Hz
- Locked rotor: 24.6 V, 64.5 A, 2200 W, 15 Hz
- DC test: 13.5 V, 64 A

Find the equivalent circuit of this motor, and plot its torque-speed characteristic curve.

SOLUTION From the DC test,

$$2R_1 = \frac{13.5 \text{ V}}{64 \text{ A}} \Rightarrow R_1 = 0.105 \Omega$$

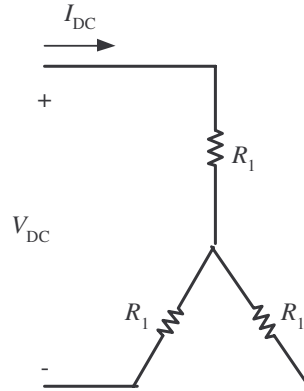

In the no-load test, the line voltage is 208 V, so the phase voltage is 120 V. Therefore,

$$X_1 + X_M = \frac{V_\phi}{I_{A,nl}} = \frac{120 \text{ V}}{22.0 \text{ A}} = 5.455 \Omega @ 60 \text{ Hz}$$

In the locked-rotor test, the line voltage is 24.6 V, so the phase voltage is 14.2 V. From the locked-rotor test at 15 Hz,

$$|Z'_{LR}| = |R_{LR} + jX'_{LR}| = \frac{V_\phi}{I_{A,LR}} = \frac{14.2 \text{ V}}{64.5 \text{ A}} = 0.2202 \Omega$$

$$\theta_{LR} = \cos^{-1} \frac{P_{LR}}{S_{LR}} = \cos^{-1} \frac{2200 \text{ W}}{\sqrt{3}(24.6 \text{ V})(64.5 \text{ A})} = 36.82^\circ$$

Therefore,

$$R_{LR} = |Z'_{LR}| \cos \theta_{LR} = (0.2202 \Omega) \cos(36.82^\circ) = 0.176 \Omega$$

$$\Rightarrow R_1 + R_2 = 0.176 \Omega$$

$$\Rightarrow R_2 = 0.071 \Omega$$

$$X'_{LR} = |Z'_{LR}| \sin \theta_{LR} = (0.2202 \Omega) \sin(36.82^\circ) = 0.132 \Omega$$

At a frequency of 60 Hz,

$$X_{LR} = \frac{60 \text{ Hz}}{15 \text{ Hz}} X'_{LR} = 0.528 \Omega$$

For a Design Class B motor, the split is $X_1 = 0.211 \Omega$ and $X_2 = 0.317 \Omega$. Therefore,

$$X_M = 5.455 \Omega - 0.211 \Omega = 5.244 \Omega$$

The resulting equivalent circuit is shown below:

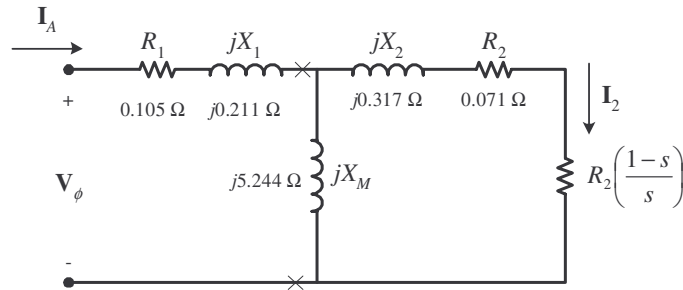

A MATLAB program to calculate the torque-speed characteristic of this motor is shown below:

```
% M-file: prob7_18.m
% M-file create a plot of the torque-speed curve of the
% induction motor of Problem 7-18.

% First, initialize the values needed in this program.
r1 = 0.105; % Stator resistance
x1 = 0.211; % Stator reactance
r2 = 0.071; % Rotor resistance
x2 = 0.317; % Rotor reactance
xm = 5.244; % Magnetization branch reactance
v_phase = 208 / sqrt(3); % Phase voltage
n_sync = 1200; % Synchronous speed (r/min)
w_sync = 125.7; % Synchronous speed (rad/s)

% Calculate the Thevenin voltage and impedance from Equations
% 7-41a and 7-43.
v_th = v_phase * ( xm / sqrt(r1^2 + (x1 + xm)^2) );
z_th = ((j*xm) * (r1 + j*x1)) / (r1 + j*(x1 + xm));
r_th = real(z_th);
x_th = imag(z_th);

% Now calculate the torque-speed characteristic for many
% slips between 0 and 1. Note that the first slip value
% is set to 0.001 instead of exactly 0 to avoid divide-
% by-zero problems.
s = (0:1:50) / 50; % Slip
s(1) = 0.001;
nm = (1 - s) * n_sync; % Mechanical speed

% Calculate torque versus speed
for ii = 1:51
    t_ind(ii) = (3 * v_th^2 * r2 / s(ii)) / ...
        (w_sync * ((r_th + r2/s(ii))^2 + (x_th + x2)^2) );
end

% Plot the torque-speed curve
figure(1);
plot(nm,t_ind,'b-', 'LineWidth',2.0);
xlabel('\bf\itn_{m}');
ylabel('\bf\itau_{ind}');
title ('\bfInduction Motor Torque-Speed Characteristic');
grid on;
```

The resulting plot is shown below:

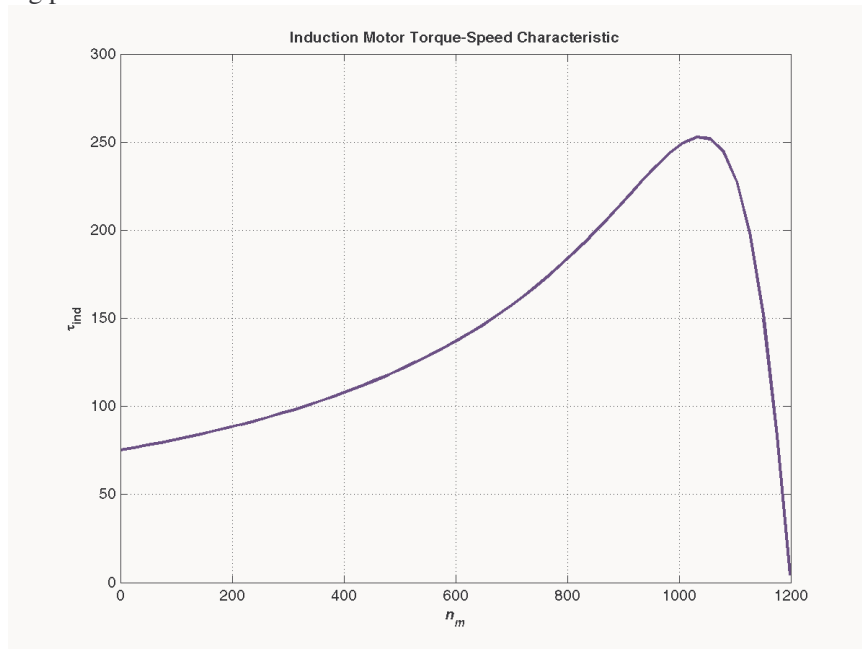

7-19. A 460-V, four-pole, 50-hp, 60-Hz, Y-connected three-phase induction motor develops its full-load induced torque at 3.8 percent slip when operating at 60 Hz and 460 V. The per-phase circuit model impedances of the motor are

$$R_1 = 0.33 \Omega \quad X_M = 30 \Omega$$

$$X_1 = 0.42 \Omega \quad X_2 = 0.42 \Omega$$

Mechanical, core, and stray losses may be neglected in this problem.

- (a) Find the value of the rotor resistance R_2 .
- (b) Find τ_{max} , s_{max} , and the rotor speed at maximum torque for this motor.
- (c) Find the starting torque of this motor.
- (d) What code letter factor should be assigned to this motor?

SOLUTION The equivalent circuit for this motor is

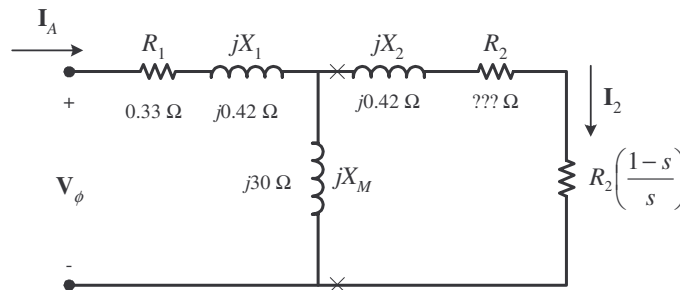

The Thevenin equivalent of the input circuit is:

$$Z_{TH} = \frac{jX_M(R_1 + jX_1)}{R_1 + j(X_1 + X_M)} = \frac{(j30 \Omega)(0.33 \Omega + j0.42 \Omega)}{0.33 \Omega + j(0.42 \Omega + 30 \Omega)} = 0.321 + j0.418 \Omega = 0.527 \angle 52.5^\circ \Omega$$

$$\mathbf{V}_{\text{TH}} = \frac{jX_M}{R_1 + j(X_1 + X_M)} \mathbf{V}_\phi = \frac{(j30 \Omega)}{0.33 \Omega + j(0.42 \Omega + 30 \Omega)} (265.6 \angle 0^\circ \text{ V}) = 262 \angle 0.6^\circ \text{ V}$$

(a) If losses are neglected, the induced torque in a motor is equal to its load torque. At full load, the output power of this motor is 50 hp and its slip is 3.8%, so the induced torque is

$$n_m = (1 - 0.038)(1800 \text{ r/min}) = 1732 \text{ r/min}$$

$$\tau_{\text{ind}} = \tau_{\text{load}} = \frac{(50 \text{ hp})(746 \text{ W/hp})}{(1732 \text{ r/min}) \frac{2\pi \text{ rad}}{1 \text{ r}} \frac{1 \text{ min}}{60 \text{ s}}} = 205.7 \text{ N} \cdot \text{m}$$

The induced torque is given by the equation

$$\tau_{\text{ind}} = \frac{3V_{\text{TH}}^2 R_2 / s}{\omega_{\text{sync}} (R_{\text{TH}} + R_2 / s)^2 + (X_{\text{TH}} + X_2)^2}$$

Substituting known values and solving for R_2 / s yields

$$205.7 \text{ N} \cdot \text{m} = \frac{3(262 \text{ V})^2 R_2 / s}{(188.5 \text{ rad/s}) (0.321 + R_2 / s)^2 + (0.418 + 0.42)^2}$$

$$38,774 = \frac{205,932 R_2 / s}{(0.321 + R_2 / s)^2 + 0.702}$$

$$(0.321 + R_2 / s)^2 + 0.702 = 5.311 R_2 / s$$

$$0.103 + 0.642R_2 / s + (R_2 / s)^2 + 0.702 = 5.311 R_2 / s$$

$$\frac{R_2}{s}^2 - 4.669 \frac{R_2}{s} + 0.702 = 0$$

$$\frac{R_2}{s} = 0.156, \quad 4.513$$

$$R_2 = 0.0059 \Omega, \quad 0.172 \Omega$$

These two solutions represent two situations in which the torque-speed curve would go through this specific torque-speed point. The two curves are plotted below. As you can see, only the 0.172 Ω solution is realistic, since the 0.0059 Ω solution passes through this torque-speed point at an unstable location on the back side of the torque-speed curve.

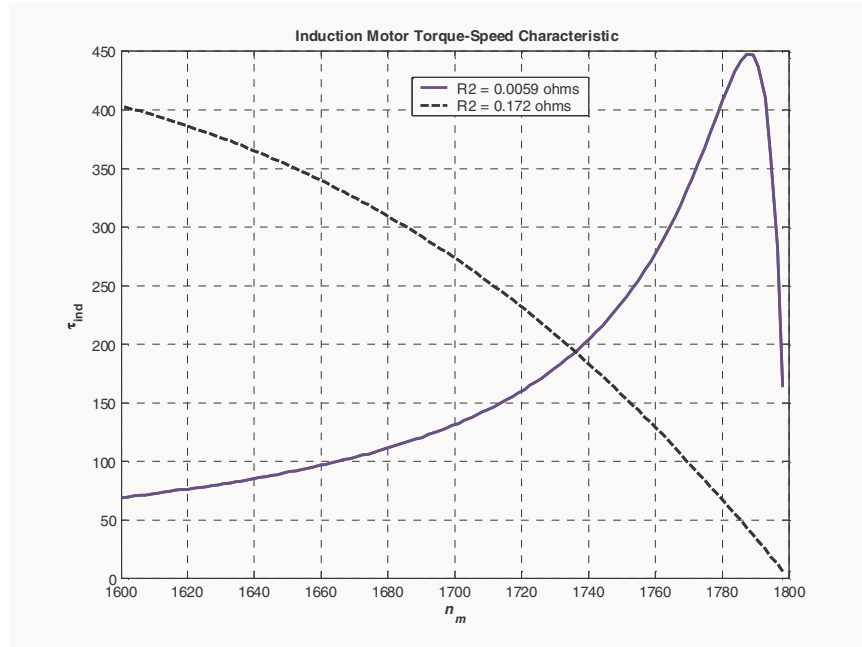

(b) The slip at pullout torque can be found by calculating the Thevenin equivalent of the input circuit from the rotor back to the power supply, and then using that with the rotor circuit model. The Thevenin equivalent of the input circuit was calculate in part (a). The slip at pullout torque is

$$s_{\max} = \frac{R_2}{\sqrt{R_{\text{TH}}^2 + (X_{\text{TH}} + X_2)^2}}$$

$$s_{\max} = \frac{0.172 \, \Omega}{\sqrt{(0.321 \, \Omega)^2 + (0.418 \, \Omega + 0.420 \, \Omega)^2}} = 0.192$$

The rotor speed a maximum torque is

$$n_{\text{pullout}} = (1 - s) n_{\text{sync}} = (1 - 0.192)(1800 \text{ r/min}) = 1454 \text{ r/min}$$

and the pullout torque of the motor is

$$\tau_{\max} = \frac{3V_{\text{TH}}^2}{2\omega_{\text{sync}} R_{\text{TH}} + \sqrt{R_{\text{TH}}^2 + (X_{\text{TH}} + X_2)^2}}$$

$$\tau_{\max} = \frac{3(262 \text{ V})^2}{2(188.5 \text{ rad/s}) 0.321 \, \Omega + \sqrt{(0.321 \, \Omega)^2 + (0.418 \, \Omega + 0.420 \, \Omega)^2}}$$

$$\tau_{\max} = 448 \text{ N} \cdot \text{m}$$

(c) The starting torque of this motor is the torque at slip $s = 1$. It is

$$\tau_{\text{ind}} = \frac{3V_{\text{TH}}^2 R_2 / s}{\omega_{\text{sync}} (R_{\text{TH}} + R_2 / s)^2 + (X_{\text{TH}} + X_2)^2}$$

$$\tau_{\text{ind}} = \frac{3(262 \text{ V})^2 (0.172 \, \Omega)}{(188.5 \text{ rad/s}) (0.321 + 0.172 \, \Omega)^2 + (0.418 + 0.420)^2} = 199 \text{ N} \cdot \text{m}$$

(d) To determine the starting code letter, we must find the locked-rotor kVA per horsepower, which is equivalent to finding the starting kVA per horsepower. The easiest way to find the line current (or armature current) at starting is to get the equivalent impedance Z_F of the rotor circuit in parallel with jX_M at starting conditions, and then calculate the starting current as the phase voltage divided by the sum of the series impedances, as shown below.

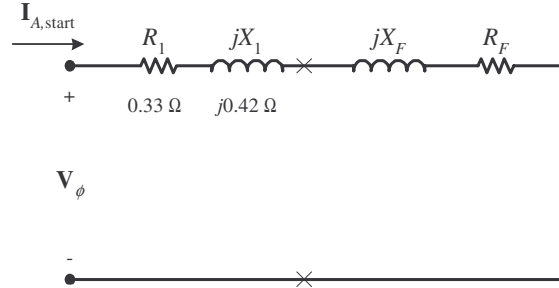

The equivalent impedance of the rotor circuit in parallel with jX_M at starting conditions ($s = 1.0$) is:

$$Z_{F,\text{start}} = \frac{1}{\frac{1}{jX_M} + \frac{1}{Z_2}} = \frac{1}{\frac{1}{j30 \Omega} + \frac{1}{0.172 + j0.42}} = 0.167 + j0.415 = 0.448 \angle 68.1^\circ \Omega$$

The phase voltage is $460/\sqrt{3} = 266$ V, so line current $\mathbf{I}_{L,\text{start}}$ is

$$\mathbf{I}_{L,\text{start}} = \mathbf{I}_A = \frac{\mathbf{V}_\phi}{R_1 + jX_1 + R_F + jX_F} = \frac{266 \angle 0^\circ \text{ V}}{0.33 \Omega + j0.42 \Omega + 0.167 \Omega + j0.415 \Omega}$$

$$\mathbf{I}_{L,\text{start}} = \mathbf{I}_A = 274 \angle -59.2^\circ \text{ A}$$

Therefore, the locked-rotor kVA of this motor is

$$S = \sqrt{3} V_T I_{L,\text{rated}} = \sqrt{3} (460 \text{ V})(274 \text{ A}) = 218 \text{ kVA}$$

and the kVA per horsepower is

$$\text{kVA/hp} = \frac{218 \text{ kVA}}{50 \text{ hp}} = 4.36 \text{ kVA/hp}$$

This motor would have **starting code letter D**, since letter D covers the range 4.00-4.50.

7-20. Answer the following questions about the motor in Problem 7-19.

- If this motor is started from a 460-V infinite bus, how much current will flow in the motor at starting?
- If transmission line with an impedance of $0.35 + j0.25 \Omega$ per phase is used to connect the induction motor to the infinite bus, what will the starting current of the motor be? What will the motor's terminal voltage be on starting?
- If an ideal 1.4:1 step-down autotransformer is connected between the transmission line and the motor, what will the current be in the transmission line during starting? What will the voltage be at the motor end of the transmission line during starting?

SOLUTION

- The equivalent circuit of this induction motor is shown below:

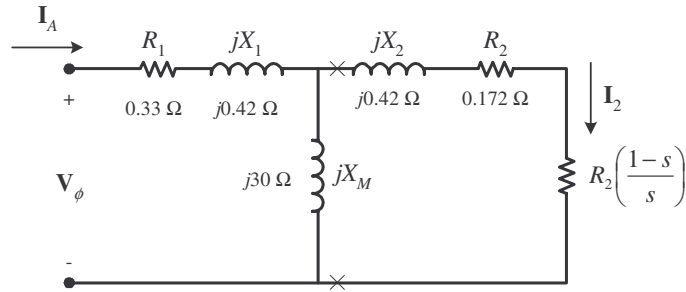

The easiest way to find the line current (or armature current) at starting is to get the equivalent impedance Z_F of the rotor circuit in parallel with jX_M at starting conditions, and then calculate the starting current as the phase voltage divided by the sum of the series impedances, as shown below.

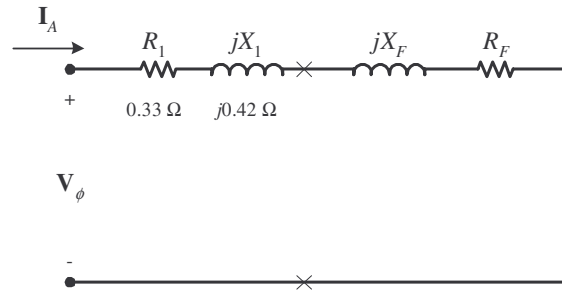

The equivalent impedance of the rotor circuit in parallel with jX_M at starting conditions ($s = 1.0$) is:

$$Z_F = \frac{1}{\frac{1}{jX_M} + \frac{1}{Z_2}} = \frac{1}{\frac{1}{j30 \Omega} + \frac{1}{0.172 + j0.42}} = 0.167 + j0.415 = 0.448 \angle 68.0^\circ \Omega$$

The phase voltage is $460/\sqrt{3} = 266$ V, so line current I_L is

$$I_L = I_A = \frac{V_\phi}{R_1 + jX_1 + R_F + jX_F} = \frac{266 \angle 0^\circ \text{ V}}{0.33 \Omega + j0.42 \Omega + 0.167 \Omega + j0.415 \Omega}$$

$$I_L = I_A = 273 \angle -59.2^\circ \text{ A}$$

(b) If a transmission line with an impedance of $0.35 + j0.25 \Omega$ per phase is used to connect the induction motor to the infinite bus, its impedance will be in series with the motor's impedances, and the starting current will be

$$I_L = I_A = \frac{V_{\phi, \text{bus}}}{R_{\text{line}} + jX_{\text{line}} + R_1 + jX_1 + R_F + jX_F}$$

$$I_L = I_A = \frac{266 \angle 0^\circ \text{ V}}{0.35 \Omega + j0.25 \Omega + 0.33 \Omega + j0.42 \Omega + 0.167 \Omega + j0.415 \Omega}$$

$$I_L = I_A = 193.2 \angle -52.0^\circ \text{ A}$$

The voltage at the terminals of the motor will be

$$V_\phi = I_A (R_1 + jX_1 + R_F + jX_F)$$

$$V_\phi = (194.1 \angle -52.3^\circ \text{ A})(0.33 \Omega + j0.42 \Omega + 0.167 \Omega + j0.415 \Omega)$$

$$V_\phi = 187.7 \angle 7.2^\circ \text{ V}$$

Therefore, the terminal voltage will be $\sqrt{3} (187.7 \text{ V}) = 325$ V. Note that the terminal voltage sagged by about 30% during motor starting, which would be unacceptable.

(c) If an ideal 1.4:1 step-down autotransformer is connected between the transmission line and the motor, the motor's impedances will be referred across the transformer by the square of the turns ratio $a = 1.4$. The referred impedances are

$$\begin{aligned}R'_1 &= a^2 R_1 = 1.96 (0.33 \Omega) = 0.647 \Omega \\X'_1 &= a^2 X_1 = 1.96 (0.42 \Omega) = 0.823 \Omega \\R'_F &= a^2 R_F = 1.96 (0.167 \Omega) = 0.327 \Omega \\X'_F &= a^2 X_F = 1.96 (0.415 \Omega) = 0.813 \Omega\end{aligned}$$

Therefore, the starting current referred to the primary side of the transformer will be

$$\begin{aligned}\mathbf{I}'_L = \mathbf{I}'_A &= \frac{\mathbf{V}_{\phi, \text{bus}}}{R_{\text{line}} + jX_{\text{line}} + R'_1 + jX'_1 + R'_F + jX'_F} \\ \mathbf{I}'_L = \mathbf{I}'_A &= \frac{266 \angle 0^\circ \text{ V}}{0.35 \Omega + j0.25 \Omega + 0.647 \Omega + j0.823 \Omega + 0.327 \Omega + j0.813 \Omega} \\ \mathbf{I}'_L = \mathbf{I}'_A &= 115.4 \angle -54.9^\circ \text{ A}\end{aligned}$$

The voltage at the motor end of the transmission line would be the same as the referred voltage at the terminals of the motor

$$\begin{aligned}\mathbf{V}'_\phi &= \mathbf{I}'_A (R'_1 + jX'_1 + R'_F + jX'_F) \\ \mathbf{V}'_\phi &= (115.4 \angle -54.9^\circ \text{ A})(0.647 \Omega + j0.823 \Omega + 0.327 \Omega + j0.813 \Omega) \\ \mathbf{V}'_\phi &= 219.7 \angle 4.3^\circ \text{ V}\end{aligned}$$

Therefore, the line voltage at the motor end of the transmission line will be $\sqrt{3} (219.7 \text{ V}) = 380.5 \text{ V}$. Note that this voltage sagged by 17.3% during motor starting, which is less than the 30% sag with case of across-the-line starting.

7-21. In this chapter, we learned that a step-down autotransformer could be used to reduce the starting current drawn by an induction motor. While this technique works, an autotransformer is relatively expensive. A much less expensive way to reduce the starting current is to use a device called *Y- Δ starter*. If an induction motor is normally Δ -connected, it is possible to reduce its phase voltage V_ϕ (and hence its starting current) by simply re-connecting the stator windings in Y during starting, and then restoring the connections to Δ when the motor comes up to speed. Answer the following questions about this type of starter.

- (a) How would the phase voltage at starting compare with the phase voltage under normal running conditions?
- (b) How would the starting current of the Y-connected motor compare to the starting current if the motor remained in a Δ -connection during starting?

SOLUTION

(a) The phase voltage at starting would be $1 / \sqrt{3} = 57.7\%$ of the phase voltage under normal running conditions.

(b) Since the phase voltage decreases to $1 / \sqrt{3} = 57.7\%$ of the normal voltage, the starting phase current will also decrease to 57.7% of the normal starting current. However, since the line current for the original delta connection was $\sqrt{3}$ times the phase current, while the line current for the Y starter connection is equal to its phase current, *the line current is reduced by a factor of 3* in a Y- Δ starter.

For the Δ -connection: $I_{L,\Delta} = \sqrt{3} I_{\phi,\Delta}$

For the Y-connection: $I_{L,Y} = I_{\phi,Y}$

But $I_{\phi,\Delta} = \sqrt{3}I_{\phi,Y}$, so $I_{L,\Delta} = 3I_{L,Y}$

7-22. A 460-V 100-hp four-pole Δ -connected 60-Hz three-phase induction motor has a full-load slip of 5 percent, an efficiency of 92 percent, and a power factor of 0.87 lagging. At start-up, the motor develops 1.9 times the full-load torque but draws 7.5 times the rated current at the rated voltage. This motor is to be started with an autotransformer reduced voltage starter.

(a) What should the output voltage of the starter circuit be to reduce the starting torque until it equals the rated torque of the motor?

(b) What will the motor starting current and the current drawn from the supply be at this voltage?

SOLUTION

(a) The starting torque of an induction motor is proportional to the square of V_{TH} ,

$$\frac{\tau_{start2}}{\tau_{start1}} = \frac{V_{TH2}^2}{V_{TH1}^2} = \frac{V_{T2}^2}{V_{T1}^2}$$

If a torque of $1.9 \tau_{rated}$ is produced by a voltage of 460 V, then a torque of $1.00 \tau_{rated}$ would be produced by a voltage of

$$\frac{1.00 \tau_{rated}}{1.90 \tau_{rated}} = \frac{V_{T2}^2}{460^2}$$

$$V_{T2} = \sqrt{\frac{(460 \text{ V})^2}{1.90}} = 334 \text{ V}$$

(b) The motor starting current is directly proportional to the starting voltage, so

$$I_{L2} = \frac{334 \text{ V}}{460 \text{ V}} I_{L1} = (0.726)I_{L1} = (0.726)(7.5I_{rated}) = 5.445 I_{rated}$$

The input power to this motor is

$$P_{IN} = \frac{P_{OUT}}{\eta} = \frac{(100 \text{ hp})(746 \text{ W/hp})}{0.92} = 81.1 \text{ kW}$$

The rated current is equal to

$$I_{rated} = \frac{P_{IN}}{\sqrt{3} V_r \text{ PF}} = \frac{(81.1 \text{ kW})}{\sqrt{3}(460 \text{ V})(0.87)} = 117 \text{ A}$$

Therefore, the motor starting current is

$$I_{L2} = 5.445 I_{rated} = (5.445)(117 \text{ A}) = 637 \text{ A}$$

The turns ratio of the autotransformer that produces this starting voltage is

$$\frac{N_{SE} + N_C}{N_C} = \frac{460 \text{ V}}{334 \text{ V}} = 1.377$$

so the current drawn from the supply will be

$$I_{\text{line}} = \frac{I_{\text{start}}}{1.377} = \frac{637 \text{ A}}{1.377} = 463 \text{ A}$$

7-23. A wound-rotor induction motor is operating at rated voltage and frequency with its slip rings shorted and with a load of about 25 percent of the rated value for the machine. If the rotor resistance of this machine is doubled by inserting external resistors into the rotor circuit, explain what happens to the following:

- (a) Slip s
- (b) Motor speed n_m
- (c) The induced voltage in the rotor
- (d) The rotor current
- (e) τ_{ind}
- (f) P_{out}
- (g) P_{RCL}
- (h) Overall efficiency η

SOLUTION

- (a) The slip s will increase.
- (b) The motor speed n_m will decrease.
- (c) The induced voltage in the rotor will increase.
- (d) The rotor current will increase.
- (e) The induced torque will adjust to supply the load's torque requirements at the new speed. This will depend on the shape of the load's torque-speed characteristic. For most loads, the induced torque will decrease.

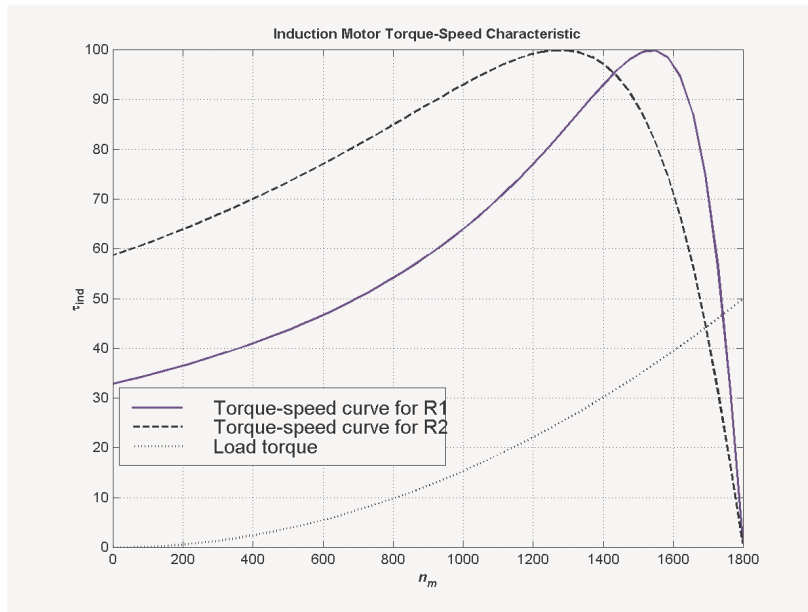

- (f) The output power will generally decrease: $P_{\text{OUT}} = \tau_{\text{ind}} \downarrow \omega_m \downarrow$
- (g) The rotor copper losses (including the external resistor) will increase.

(h) The overall efficiency η will decrease.

7-24. Answer the following questions about a 460-V Δ -connected two-pole 75-hp 60-Hz starting code letter E induction motor:

- (a) What is the maximum starting current that this machine's controller must be designed to handle?
- (b) If the controller is designed to switch the stator windings from a Δ connection to a Y connection during starting, what is the maximum starting current that the controller must be designed to handle?
- (c) If a 1.25:1 step-down autotransformer starter is used during starting, what is the maximum starting current that will be drawn from the line?

SOLUTION

(a) Starting code letter E corresponds to a 4.50 – 5.00 kVA/hp, so the maximum starting kVA of this motor is

$$S_{\text{start}} = (75 \text{ hp})(5.00) = 375 \text{ kVA}$$

Therefore,

$$I_{\text{start}} = \frac{S}{\sqrt{3} V_T} = \frac{375 \text{ kVA}}{\sqrt{3}(460 \text{ V})} = 471 \text{ A}$$

(b) The line voltage will still be 460 V when the motor is switched to the Y-connection, but now the phase voltage will be $460 / \sqrt{3} = 266 \text{ V}$.

Before (in Δ):

$$I_{\phi,\Delta} = \frac{V_{\phi,\Delta}}{(R_{\text{TH}} + R_2) + j(X_{\text{TH}} + X_2)} = \frac{460 \text{ V}}{(R_{\text{TH}} + R_2) + j(X_{\text{TH}} + X_2)}$$

But the line current in a Δ connection is $\sqrt{3}$ times the phase current, so

$$I_{L,\Delta} = \sqrt{3} I_{\phi,\Delta} = \frac{\sqrt{3} V_{\phi,\Delta}}{(R_{\text{TH}} + R_2) + j(X_{\text{TH}} + X_2)} = \frac{797 \text{ V}}{(R_{\text{TH}} + R_2) + j(X_{\text{TH}} + X_2)}$$

After (in Y):

$$I_{L,Y} = I_{\phi,Y} = \frac{V_{\phi,Y}}{(R_{\text{TH}} + R_2) + j(X_{\text{TH}} + X_2)} = \frac{265.6 \text{ V}}{(R_{\text{TH}} + R_2) + j(X_{\text{TH}} + X_2)}$$

Therefore the line current will decrease by a factor of 3 when using this starter. The starting current with a Δ -Y starter is

$$I_{\text{start}} = \frac{471 \text{ A}}{3} = 157 \text{ A}$$

(c) A 1.25:1 step-down autotransformer reduces the phase voltage on the motor by a factor 0.8. This reduces the phase current and line current in the motor (and on the secondary side of the transformer) by a factor of 0.8. However, the current on the primary of the autotransformer will be reduced by another factor of 0.8, so the total starting current drawn from the line will be 64% of its original value. Therefore, the maximum starting current drawn from the line will be

$$I_{\text{start}} = (0.64)(471 \text{ A}) = 301 \text{ A}$$

7-25. When it is necessary to stop an induction motor very rapidly, many induction motor controllers reverse the direction of rotation of the magnetic fields by switching any two stator leads. When the direction of rotation of the magnetic fields is reversed, the motor develops an induced torque opposite to the current direction of rotation, so it quickly stops and tries to start turning in the opposite direction. If power is removed from the stator circuit at the moment when the rotor speed goes through zero, then the motor has been stopped very rapidly. This technique for rapidly stopping an induction motor is called *plugging*. The motor of Problem 7-19 is running at rated conditions and is to be stopped by plugging.

- (a) What is the slip s before plugging?
 (b) What is the frequency of the rotor before plugging?
 (c) What is the induced torque τ_{ind} before plugging?
 (d) What is the slip s immediately after switching the stator leads?
 (e) What is the frequency of the rotor immediately after switching the stator leads?
 (f) What is the induced torque τ_{ind} immediately after switching the stator leads?

SOLUTION

- (a) The slip before plugging is 0.038 (see Problem 7-19).
 (b) The frequency of the rotor before plugging is $f_r = sf_e = (0.038)(60 \text{ Hz}) = 2.28 \text{ Hz}$
 (c) The induced torque before plugging is 205.7 N·m in the direction of motion (see Problem 7-19).
 (d) After switching stator leads, the synchronous speed becomes -1800 r/min , while the mechanical speed initially remains 1732 r/min . Therefore, the slip becomes

$$s = \frac{n_{\text{sync}} - n_m}{n_{\text{sync}}} = \frac{-1800 - 1732}{-1800} = 1.962$$

- (e) The frequency of the rotor after plugging is $f_r = sf_e = (1.962)(60 \text{ Hz}) = 117.72 \text{ Hz}$
 (f) The induced torque immediately after switching the stator leads is

$$\tau_{\text{ind}} = \frac{3V_{\text{TH}}^2 R_2 / s}{\omega_{\text{sync}} (R_{\text{TH}} + R_2 / s)^2 + (X_{\text{TH}} + X_2)^2}$$

$$\tau_{\text{ind}} = \frac{3(262 \text{ V})^2 (0.172 \text{ } \Omega / 1.962)}{(188.5 \text{ rad/s}) (0.321 + 0.172 \text{ } \Omega / 1.962)^2 + (0.418 + 0.420)^2}$$

$$\tau_{\text{ind}} = \frac{3(262 \text{ V})^2 (0.0877)}{(188.5 \text{ rad/s}) (0.321 + 0.0877)^2 + (0.418 + 0.420)^2}$$

$$\tau_{\text{ind}} = 110 \text{ N} \cdot \text{m}, \text{ opposite the direction of motion}$$

Chapter 8: DC Machinery Fundamentals

8-1. The following information is given about the simple rotating loop shown in Figure 8-6:

- | | |
|-----------------------|------------------------------|
| $B = 0.8 \text{ T}$ | $V_B = 24 \text{ V}$ |
| $l = 0.5 \text{ m}$ | $R = 0.4 \ \Omega$ |
| $r = 0.125 \text{ m}$ | $\omega = 250 \text{ rad/s}$ |

- Is this machine operating as a motor or a generator? Explain.
- What is the current i flowing into or out of the machine? What is the power flowing into or out of the machine?
- If the speed of the rotor were changed to 275 rad/s, what would happen to the current flow into or out of the machine?
- If the speed of the rotor were changed to 225 rad/s, what would happen to the current flow into or out of the machine?

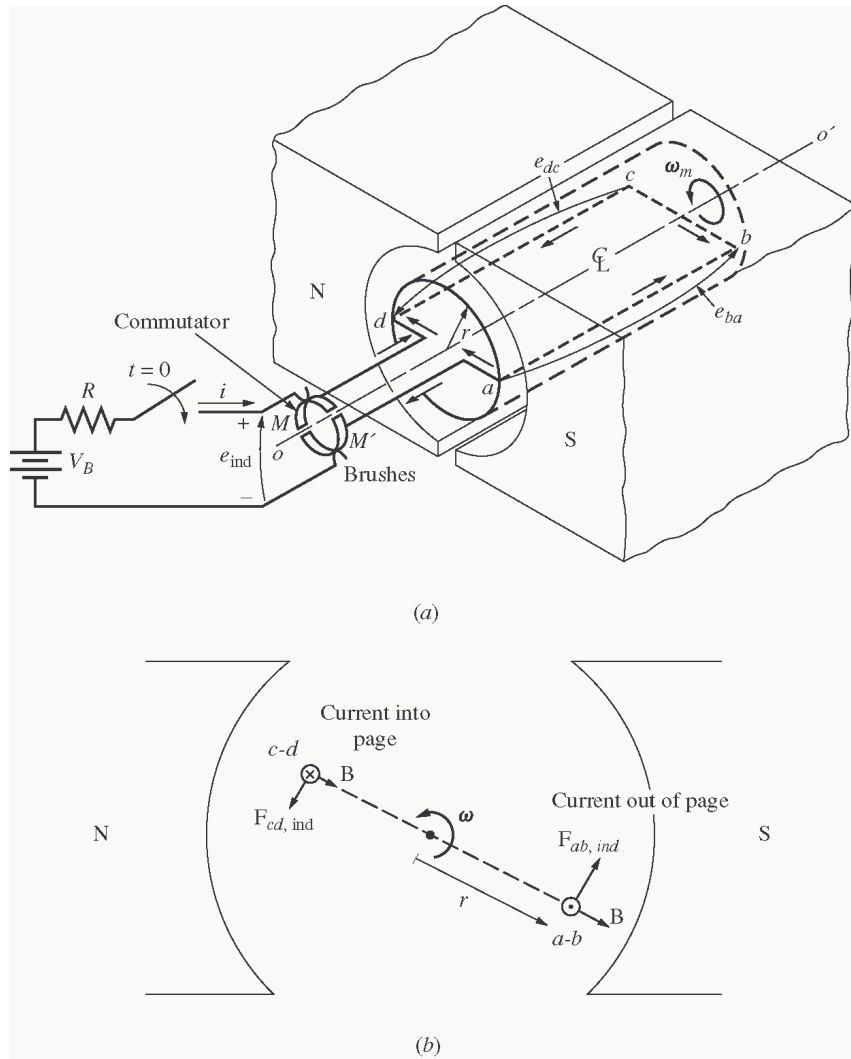

(a) If the speed of rotation ω of the shaft is 500 rad/s, then the voltage induced in the rotating loop will be

$$e_{\text{ind}} = 2rIB\omega$$

$$e_{\text{ind}} = 2(0.125 \text{ m})(0.5 \text{ m})(0.8 \text{ T})(250 \text{ rad/s}) = 25 \text{ V}$$

Since the external battery voltage is only 24 V, this machine is operating as a *generator*, charging the battery.

(b) The current flowing out of the machine is approximately

$$i = \frac{e_{\text{ind}} - V_B}{R} = \frac{25 \text{ V} - 24 \text{ V}}{0.4 \Omega} = 2.5 \text{ A}$$

(Note that this value is the current flowing while the loop is under the pole faces. When the loop goes beyond the pole faces, e_{ind} will momentarily fall to 0 V, and the current flow will momentarily reverse. Therefore, the *average* current flow over a complete cycle will be somewhat less than 2.5 A.)

(c) If the speed of the rotor were increased to 275 rad/s, the induced voltage of the loop would increase to

$$e_{\text{ind}} = 2rIB\omega$$

$$e_{\text{ind}} = 2(0.125 \text{ m})(0.5 \text{ m})(0.8 \text{ T})(275 \text{ rad/s}) = 27.5 \text{ V}$$

and the current flow out of the machine will increase to

$$i = \frac{e_{\text{ind}} - V_B}{R} = \frac{27.5 \text{ V} - 24 \text{ V}}{0.4 \Omega} = 8.75 \text{ A}$$

(d) If the speed of the rotor were decreased to 225 rad/s, the induced voltage of the loop would fall to

$$e_{\text{ind}} = 2rIB\omega$$

$$e_{\text{ind}} = 2(0.125 \text{ m})(0.5 \text{ m})(0.8 \text{ T})(225 \text{ rad/s}) = 22.5 \text{ V}$$

Here, e_{ind} is less than V_B , so current flows into the loop and the machine is acting as a motor. The current flow into the machine would be

$$i = \frac{V_B - e_{\text{ind}}}{R} = \frac{24 \text{ V} - 22.5 \text{ V}}{0.4 \Omega} = 3.75 \text{ A}$$

8-2. Refer to the simple two-pole eight-coil machine shown in Figure P8-1. The following information is given about this machine:

$$B = 1.0 \text{ T} \quad \text{in air gap}$$

$$l = 0.3 \text{ m} \quad (\text{length of coil sides})$$

$$r = 0.08 \text{ m} \quad (\text{radius of coils})$$

$$n = 1700 \text{ r/min} \quad \text{CCW}$$

The resistance of each rotor coil is 0.04Ω .

(a) Is the armature winding shown a progressive or retrogressive winding?

(b) How many current paths are there through the armature of this machine?

(c) What are the magnitude and the polarity of the voltage at the brushes in this machine?

(d) What is the armature resistance R_A of this machine?

- (e) If a $10\ \Omega$ resistor is connected to the terminals of this machine, how much current flows in the machine? Consider the internal resistance of the machine in determining the current flow.
- (f) What are the magnitude and the direction of the resulting induced torque?
- (g) Assuming that the speed of rotation and magnetic flux density are constant, plot the terminal voltage of this machine as a function of the current drawn from it.

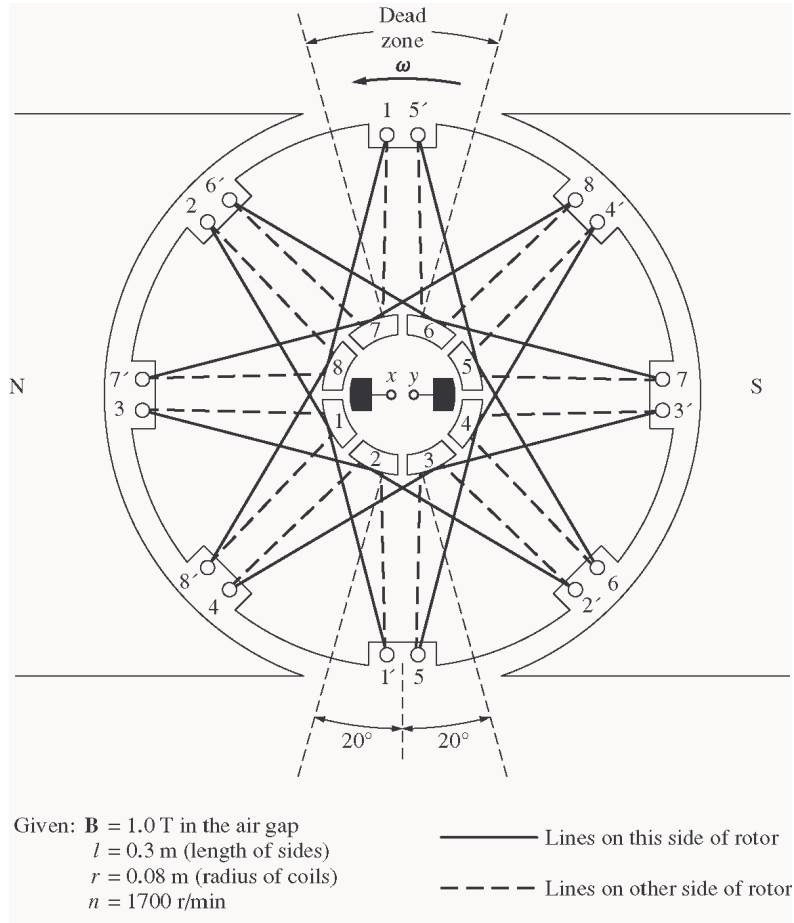

SOLUTION

- (a) This winding is *progressive*, since the ends of each coil are connected to the commutator segments ahead of the segments that the beginnings of the coils are connected to.
- (b) There are *two* current paths in parallel through the armature of this machine (this is a simplex lap winding).
- (c) The voltage is positive at brush *x* with respect to brush *y*, since the voltage in the conductors is positive out of the page under the North pole face and positive into the page under the South pole face.
- (d) There are 8 coils on this machine in two parallel paths, with each coil having a resistance of $0.04\ \Omega$. Therefore, the total resistance R_A is

$$R_A = \frac{(0.04\ \Omega + 0.04\ \Omega + 0.04\ \Omega + 0.04\ \Omega)(0.04\ \Omega + 0.04\ \Omega + 0.04\ \Omega + 0.04\ \Omega)}{0.04\ \Omega + 0.04\ \Omega + 0.04\ \Omega + 0.04\ \Omega + 0.04\ \Omega + 0.04\ \Omega + 0.04\ \Omega + 0.04\ \Omega}$$

$$R_A = 0.08 \Omega$$

(e) The voltage produced by this machine can be found from Equations 8-32 and 8-33:

$$E_A = \frac{ZvBl}{a} = \frac{Zr\omega Bl}{a}$$

where Z is the number of conductors *under the pole faces*, since the ones between the poles have no voltage in them. There are 16 conductors in this machine, and about 12 of them are under the pole faces at any given time.

$$\omega = (1700 \text{ r/min}) \frac{2\pi \text{ rad}}{1 \text{ r}} \frac{1 \text{ min}}{60 \text{ s}} = 178 \text{ rad/s}$$

$$E_A = \frac{Zr\omega Bl}{a} = \frac{(12 \text{ cond})(0.08 \text{ m})(178 \text{ rad/s})(1.0 \text{ T})(0.3 \text{ m})}{2 \text{ current paths}} = 25.6 \text{ V}$$

Therefore, the current flowing in the machine will be

$$I_A = \frac{E_A}{R_A + R_{\text{load}}} = \frac{25.6 \text{ V}}{0.08 \Omega + 10 \Omega} = 2.54 \text{ A}$$

(f) The induced torque is given by Equation 8-46:

$$\tau_{\text{ind}} = \frac{ZrBI_A}{a} = \frac{(12 \text{ cond})(0.08 \text{ m})(0.3 \text{ m})(1.0 \text{ T})(2.54 \text{ A})}{2 \text{ current paths}}$$

$$\tau_{\text{ind}} = 0.366 \text{ N} \cdot \text{m, CW} \quad (\textit{opposite to the direction of rotation})$$

8-3. Prove that the equation for the induced voltage of a single simple rotating loop

$$e_{\text{ind}} = \frac{2}{\pi} \phi \omega \quad (8-6)$$

is just a special case of the general equation for induced voltage in a dc machine

$$E_A = K \phi \omega \quad (8-38)$$

SOLUTION From Equation 8-38,

$$E_A = K \phi \omega$$

where $K = \frac{ZP}{2\pi a}$

For the simple rotation loop,

$$Z = 2 \text{ (There are 2 conductors)}$$

$$P = 2 \text{ (There are 2 poles)}$$

$$a = 1 \text{ (There is one current path through the machine)}$$

Therefore,

$$K = \frac{ZP}{2\pi a} \frac{(2)}{2\pi} \frac{(2)}{(1)} = \frac{2}{\pi}$$

and Equation 8-38 reduces to Equation 8-6.

8-4. A dc machine has 8 poles and a rated current of 100 A. How much current will flow in each path at rated conditions if the armature is (a) simplex lap-wound, (b) duplex lap-wound, (c) simplex wave-wound?

SOLUTION

(a) Simplex lap-wound:

$$a = mP = (1)(8) = 8 \text{ paths}$$

Therefore, the current per path is

$$I = \frac{I_A}{a} = \frac{100 \text{ A}}{8} = 12.5 \text{ A}$$

(b) Duplex lap-wound:

$$a = mP = (2)(8) = 16 \text{ paths}$$

Therefore, the current per path is

$$I = \frac{I_A}{a} = \frac{100 \text{ A}}{16} = 6.25 \text{ A}$$

(c) Simplex wave-wound:

$$a = 2m = (2)(1) = 2 \text{ paths}$$

Therefore, the current per path is

$$I = \frac{I_A}{a} = \frac{100 \text{ A}}{2} = 50 \text{ A}$$

8-5. How many parallel current paths will there be in the armature of a 12-pole machine if the armature is (a) simplex lap-wound, (b) duplex wave-wound, (c) triplex lap-wound, (d) quadruplex wave-wound?

SOLUTION

(a) Simplex lap-wound:

$$a = mP = (1)(12) = 12 \text{ paths}$$

(b) Duplex wave-wound:

$$a = 2m = (2)(2) = 4 \text{ paths}$$

(c) Triplex lap-wound:

$$a = mP = (3)(12) = 36 \text{ paths}$$

(d) Quadruplex wave-wound:

$$a = 2m = (2)(4) = 8 \text{ paths}$$

8-6. The power converted from one form to another within a dc motor was given by

$$P_{\text{conv}} = E_A I_A = \tau_{\text{ind}} \omega_m$$

Use the equations for E_A and τ_{ind} [Equations (8-38) and (8-49)] to prove that $E_A I_A = \tau_{\text{ind}} \omega_m$; that is, prove that the electric power disappearing at the point of power conversion is exactly equal to the mechanical power appearing at that point.

SOLUTION

$$P_{\text{conv}} = E_A I_A$$

Substituting Equation (8-38) for E_A

$$P_{\text{conv}} = (K \phi \omega) I_A$$

$$P_{\text{conv}} = (K \phi I_A) \omega$$

But from Equation (8-49), $\tau_{\text{ind}} = K \phi I_A$, so

$$P_{\text{conv}} = \tau_{\text{ind}} \omega$$

8-7. An eight-pole, 25-kW, 120-V DC generator has a duplex lap-wound armature, which has 64 coils with 16 turns per coil. Its rated speed is 2400 r/min.

(a) How much flux per pole is required to produce the rated voltage in this generator at no-load conditions?

(b) What is the current per path in the armature of this generator at the rated load?

(c) What is the induced torque in this machine at the rated load?

(d) How many brushes must this motor have? How wide must each one be?

(e) If the resistance of this winding is 0.011 Ω per turn, what is the armature resistance R_A of this machine?

SOLUTION

$$(a) \quad E_A = K \phi \omega = \frac{ZP}{2\pi a} \phi \omega$$

In this machine, the number of current paths is

$$a = mP = (2)(8) = 16$$

The number of conductor is

$$Z = (64 \text{ coils})(16 \text{ turns/coil})(2 \text{ conductors/turn}) = 2048$$

The equation for induced voltage is

$$E_A = \frac{ZP}{2\pi a} \phi \omega$$

so the required flux is

$$120 \text{ V} = \frac{(2048 \text{ cond})(8 \text{ poles})}{2\pi(16 \text{ paths})} \phi(2400 \text{ r/min}) \frac{2\pi \text{ rad}}{1 \text{ r}} \frac{1 \text{ min}}{60 \text{ s}}$$

$$120 \text{ V} = 40,960 \phi$$

$$\phi = 0.00293 \text{ Wb}$$

(b) At rated load, the current flow in the generator would be

$$I_A = \frac{25 \text{ kW}}{120 \text{ V}} = 208 \text{ A}$$

There are $a = mP = (2)(8) = 16$ parallel current paths through the machine, so the current per path is

$$I = \frac{I_A}{a} = \frac{208 \text{ A}}{16} = 13 \text{ A}$$

(c) The induced torque in this machine at rated load is

$$\tau_{\text{ind}} = \frac{ZP}{2\pi a} \phi I_A$$

$$\tau_{\text{ind}} = \frac{(2048 \text{ cond})(8 \text{ poles})}{2\pi(16 \text{ paths})} (0.00293 \text{ Wb})(208 \text{ A})$$

$$\tau_{\text{ind}} = 99.3 \text{ N} \cdot \text{m}$$

(d) This motor must have 8 brushes, since it is lap-wound and has 8 poles. Since it is duplex-wound, each brush must be wide enough to stretch across 2 complete commutator segments.

(e) There are a total of 1024 turns on the armature of this machine, so the number of turns per path is

$$N_p = \frac{1024 \text{ turns}}{16 \text{ paths}} = 64 \text{ turns/path}$$

The total resistance per path is $R_p = (64)(0.011 \Omega) = 0.704 \Omega$. Since there are 16 parallel paths through the machine, the armature resistance of the generator is

$$R_A = \frac{0.704 \Omega}{16 \text{ paths}} = 0.044 \Omega$$

8-8. Figure P8-2 shows a small two-pole dc motor with eight rotor coils and four turns per coil. The flux per pole in this machine is 0.0125 Wb.

- (a) If this motor is connected to a 12-V dc car battery, what will the no-load speed of the motor be?
- (b) If the positive terminal of the battery is connected to the rightmost brush on the motor, which way will it rotate?
- (c) If this motor is loaded down so that it consumes 50 W from the battery, what will the induced torque of the motor be? (Ignore any internal resistance in the motor.)

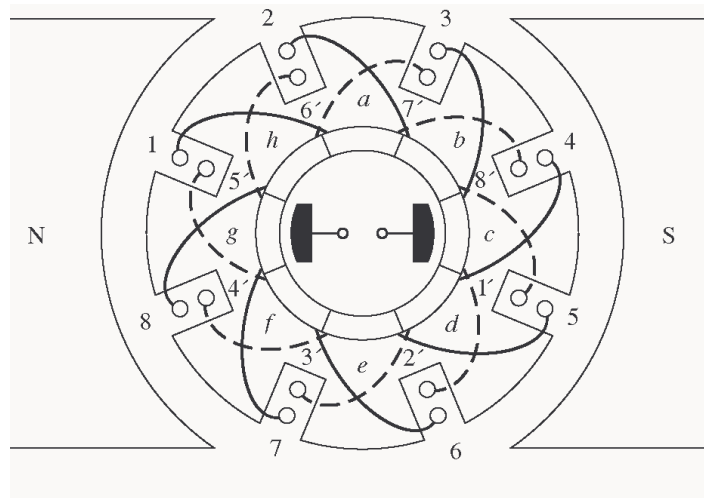

SOLUTION

(a) At no load, $V_T = E_A = K\phi\omega$. If K is known, then the speed of the motor can be found. The constant K is given by

$$K = \frac{ZP}{2\pi a}$$

On the average, about 6 of the 8 coils are under the pole faces at any given time, so the average number of active conductors is

$$Z = (6 \text{ coils})(4 \text{ turns/coil})(2 \text{ conductors/turn}) = 48 \text{ conductors}$$

There are two poles and two current paths, so

$$K = \frac{ZP}{2\pi a} = \frac{(48 \text{ cond})(2 \text{ poles})}{2\pi(2 \text{ paths})} = 7.64$$

The speed is given by

$$\omega = \frac{E_A}{K\phi} = \frac{12 \text{ V}}{(7.64)(0.0125 \text{ Wb})} = 125.6 \text{ rad/s}$$

$$n_m = (125.6 \text{ rad/s}) \frac{1 \text{ r}}{2\pi \text{ rad}} \frac{60 \text{ s}}{1 \text{ min}} = 1200 \text{ r/min}$$

(b) If the positive terminal of the battery is connected to the rightmost brush, current will flow into the page under the South pole face, producing a CW torque \Rightarrow CW rotation.

(c) If the motor consumes 50 W from the battery, the current flow is

$$I = \frac{P}{V_B} = \frac{50 \text{ W}}{12 \text{ V}} = 4.17 \text{ A}$$

Therefore, the induced torque will be

$$\tau_{\text{ind}} = K\phi I_A = (7.64)(0.0125 \text{ Wb})(4.17 \text{ A}) = 0.40 \text{ N} \cdot \text{m, CW}$$

8-9. Refer to the machine winding shown in Figure P8-3.

(a) How many parallel current paths are there through this armature winding?

(b) Where should the brushes be located on this machine for proper commutation? How wide should they be?

(c) What is the plex of this machine?

(d) If the voltage on any single conductor under the pole faces in this machine is e , what is the voltage at the terminals of this machine?

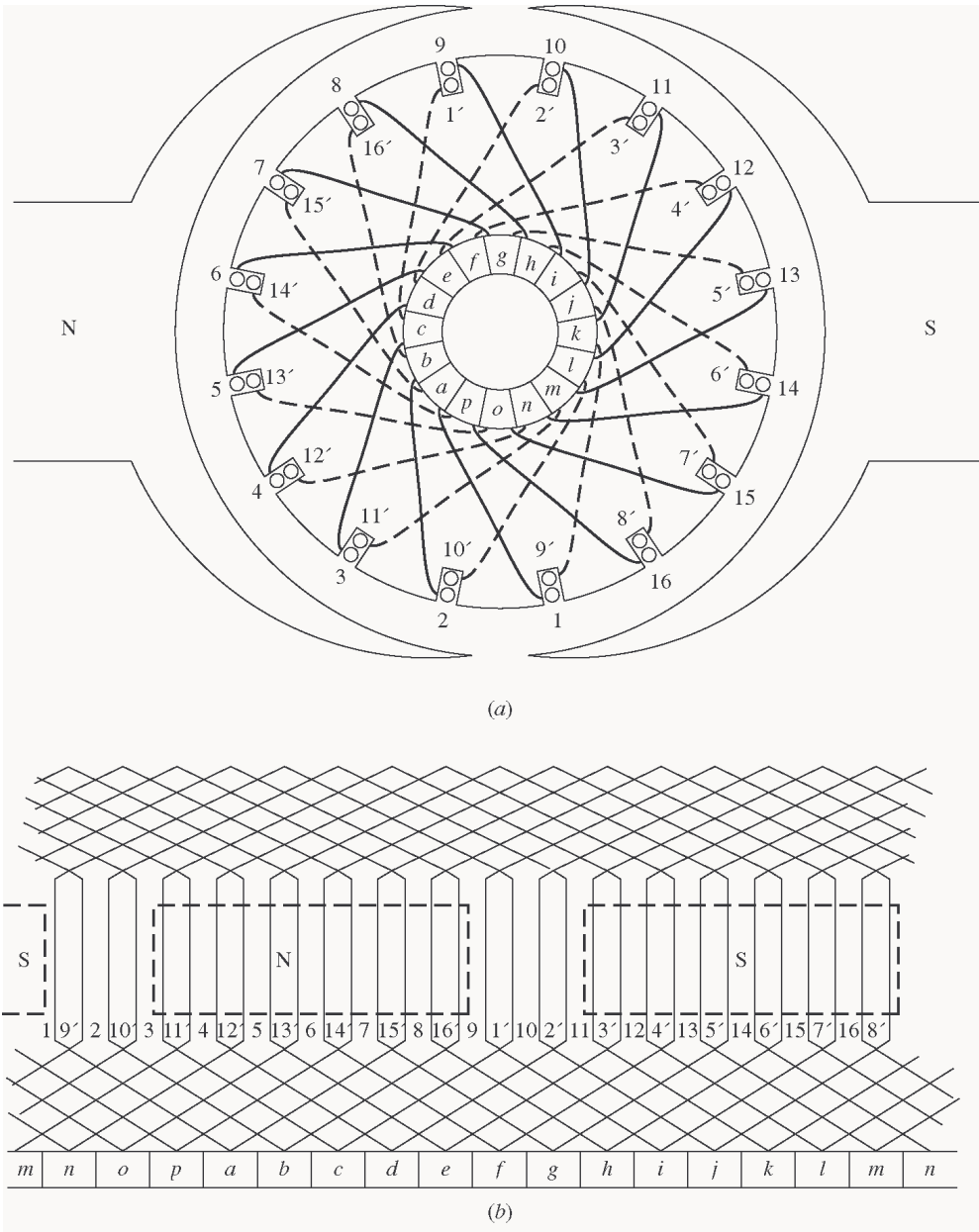

SOLUTION

(a) This is a *duplex, two-pole, lap winding*, so there are 4 parallel current paths through the rotor.

(b) The brushes should be shorting out those windings lying between the two poles. At the time shown, those windings are 1, 2, 9, and 10. Therefore, the brushes should be connected to short out commutator segments *b-c-d* and *j-k-l* at the instant shown in the figure. Each brush should be two commutator segments wide, since this is a duplex winding.

(c) Duplex (see above)

(d) There are 16 coils on the armature of this machine. Of that number, an average of 14 of them would be under the pole faces at any one time. Therefore, there are 28 conductors divided among 4 parallel paths, which produces 7 conductors per path. Therefore, $E_A = 7e = V_T$ for no-load conditions.

8-10. Describe in detail the winding of the machine shown in Figure P8-4. If a positive voltage is applied to the brush under the North pole face, which way will this motor rotate?

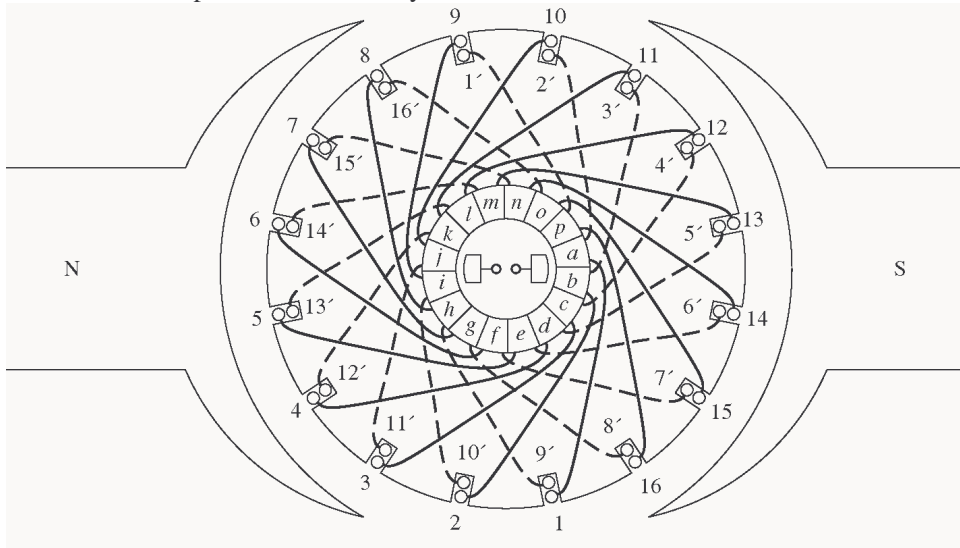

SOLUTION This is a 2-pole, retrogressive, lap winding. If a positive voltage is applied to the brush under the North pole face, the rotor will rotate in a *counterclockwise* direction.

Chapter 9: DC Motors and Generators

Problems 9-1 to 9-12 refer to the following dc motor:

$$P_{\text{rated}} = 15 \text{ hp}$$

$$I_{L,\text{rated}} = 55 \text{ A}$$

$$V_T = 240 \text{ V}$$

$$N_F = 2700 \text{ turns per pole}$$

$$n_{\text{rated}} = 1200 \text{ r/min}$$

$$N_{SE} = 27 \text{ turns per pole}$$

$$R_A = 0.40 \ \Omega$$

$$R_F = 100 \ \Omega$$

$$R_S = 0.04 \ \Omega$$

$$R_{\text{adj}} = 100 \text{ to } 400 \ \Omega$$

Rotational losses = 1800 W at full load. Magnetization curve as shown in Figure P9-1.

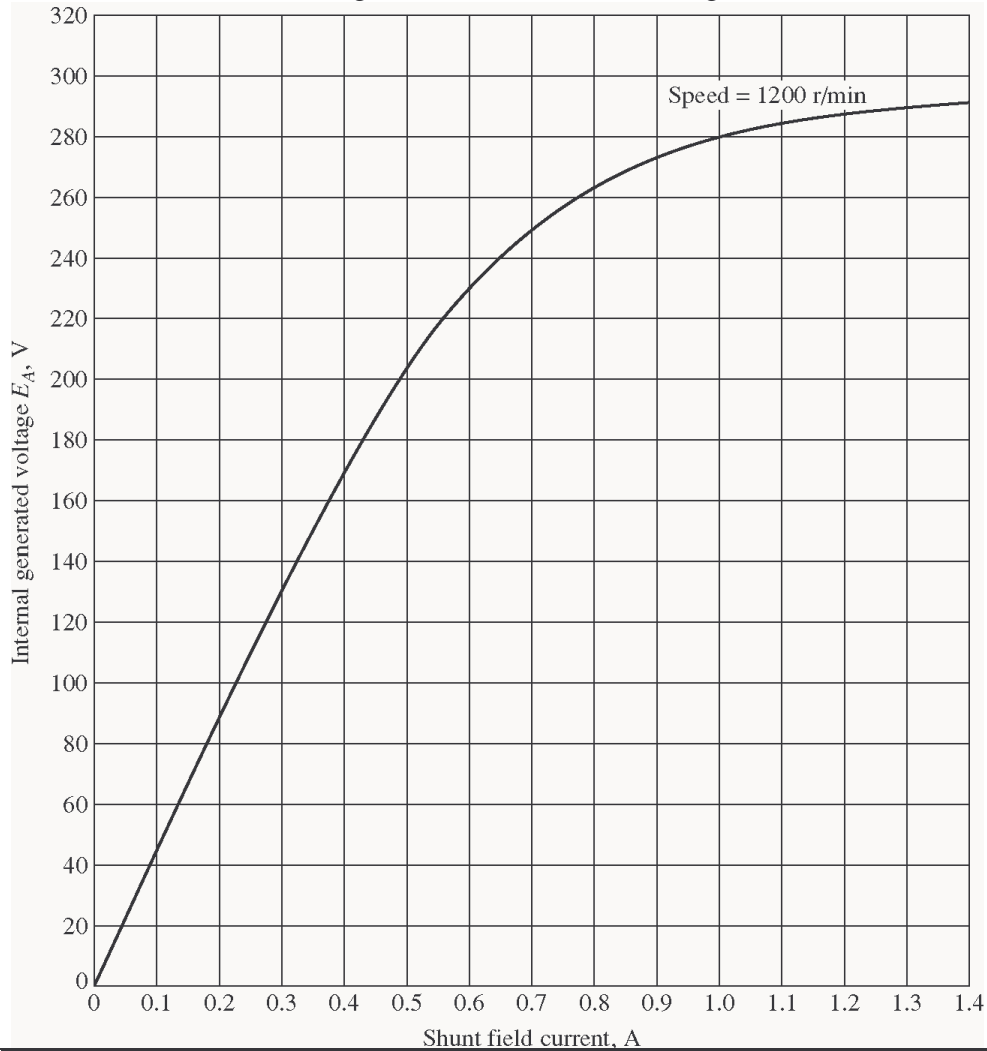

Note: An electronic version of this magnetization curve can be found in file p91_mag.dat, which can be used with MATLAB programs. Column 1 contains field current in amps, and column 2 contains the internal generated voltage E_A in volts.

In Problems 9-1 through 9-7, assume that the motor described above can be connected in shunt. The equivalent circuit of the shunt motor is shown in Figure P9-2.

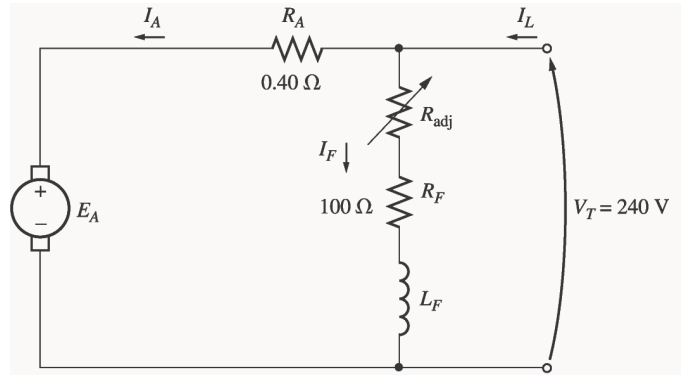

Note: Figure P9-2 shows incorrect values for R_A and R_F in the first printing of this book. The correct values are given in the text, but shown incorrectly on the figure. This will be corrected at the second printing.

9-1. If the resistor R_{adj} is adjusted to 175Ω what is the rotational speed of the motor at no-load conditions?

SOLUTION At no-load conditions, $E_A = V_T = 240 \text{ V}$. The field current is given by

$$I_F = \frac{V_T}{R_{adj} + R_F} = \frac{240 \text{ V}}{175 \Omega + 100 \Omega} = \frac{240 \text{ V}}{275 \Omega} = 0.873 \text{ A}$$

From Figure P9-1, this field current would produce an internal generated voltage E_{Ao} of 271 V at a speed n_o of 1200 r/min . Therefore, the speed n with a voltage E_A of 240 V would be

$$\frac{E_A}{E_{Ao}} = \frac{n}{n_o}$$

$$n = \frac{E_A}{E_{Ao}} n_o = \frac{240 \text{ V}}{271 \text{ V}} (1200 \text{ r/min}) = 1063 \text{ r/min}$$

9-2. Assuming no armature reaction, what is the speed of the motor at full load? What is the speed regulation of the motor?

SOLUTION At full load, the armature current is

$$I_A = I_L - I_F = I_L - \frac{V_T}{R_{adj} + R_F} = 55 \text{ A} - 0.87 \text{ A} = 54.13 \text{ A}$$

The internal generated voltage E_A is

$$E_A = V_T - I_A R_A = 240 \text{ V} - (54.13 \text{ A})(0.40 \Omega) = 218.3 \text{ V}$$

The field current is the same as before, and there is no armature reaction, so E_{Ao} is still 271 V at a speed n_o of 1200 r/min . Therefore,

$$n = \frac{E_A}{E_{Ao}} n_o = \frac{218.3 \text{ V}}{271 \text{ V}} (1200 \text{ r/min}) = 967 \text{ r/min}$$

The speed regulation is

$$\text{SR} = \frac{n_{nl} - n_{fl}}{n_{fl}} \times 100\% = \frac{1063 \text{ r/min} - 967 \text{ r/min}}{967 \text{ r/min}} \times 100\% = 9.9\%$$

- 9-3.** If the motor is operating at full load and if its variable resistance R_{adj} is increased to 250Ω , what is the new speed of the motor? Compare the full-load speed of the motor with $R_{\text{adj}} = 175 \Omega$ to the full-load speed with $R_{\text{adj}} = 250 \Omega$. (Assume no armature reaction, as in the previous problem.)

SOLUTION If R_{adj} is set to 250Ω , the field current is now

$$I_F = \frac{V_T}{R_{\text{adj}} + R_F} = \frac{240 \text{ V}}{250 \Omega + 100 \Omega} = \frac{240 \text{ V}}{325 \Omega} = 0.686 \text{ A}$$

Since the motor is still at full load, E_A is still 218.3 V . From the magnetization curve (Figure P9-1), the new field current I_F would produce a voltage E_{Ao} of 247 V at a speed n_o of 1200 r/min . Therefore,

$$n = \frac{E_A}{E_{Ao}} n_o = \frac{218.3 \text{ V}}{247 \text{ V}} (1200 \text{ r/min}) = 1061 \text{ r/min}$$

Note that R_{adj} has increased, and as a result the speed of the motor n increased.

- 9-4.** Assume that the motor is operating at full load and that the variable resistor R_{adj} is again 175Ω . If the armature reaction is $1200 \text{ A}\cdot\text{turns}$ at full load, what is the speed of the motor? How does it compare to the result for Problem 9-2?

SOLUTION The field current is again 0.87 A , and the motor is again at full load conditions. However, this time there is an armature reaction of $1200 \text{ A}\cdot\text{turns}$, and the *effective* field current is

$$I_F^* = I_F - \frac{AR}{N_F} = 0.87 \text{ A} - \frac{1200 \text{ A}\cdot\text{turns}}{2700 \text{ turns}} = 0.426 \text{ A}$$

From Figure P9-1, this field current would produce an internal generated voltage E_{Ao} of 181 V at a speed n_o of 1200 r/min . The actual internal generated voltage E_A at these conditions is

$$E_A = V_T - I_A R_A = 240 \text{ V} - (54.13 \text{ A})(0.40 \Omega) = 218.3 \text{ V}$$

Therefore, the speed n with a voltage of 240 V would be

$$n = \frac{E_A}{E_{Ao}} n_o = \frac{218.3 \text{ V}}{181 \text{ V}} (1200 \text{ r/min}) = 1447 \text{ r/min}$$

If all other conditions are the same, the motor with armature reaction runs at a higher speed than the motor without armature reaction.

- 9-5.** If R_{adj} can be adjusted from 100 to 400Ω , what are the maximum and minimum no-load speeds possible with this motor?

SOLUTION The minimum speed will occur when $R_{\text{adj}} = 100 \Omega$, and the maximum speed will occur when $R_{\text{adj}} = 400 \Omega$. The field current when $R_{\text{adj}} = 100 \Omega$ is:

$$I_F = \frac{V_T}{R_{\text{adj}} + R_F} = \frac{240 \text{ V}}{100 \Omega + 100 \Omega} = \frac{240 \text{ V}}{200 \Omega} = 1.20 \text{ A}$$

From Figure P9-1, this field current would produce an internal generated voltage E_{Ao} of 287 V at a speed n_o of 1200 r/min . Therefore, the speed n with a voltage of 240 V would be

$$\frac{E_A}{E_{Ao}} = \frac{n}{n_o}$$

$$n = \frac{E_A}{E_{Ao}} n_o = \frac{240 \text{ V}}{287 \text{ V}} (1200 \text{ r/min}) = 1004 \text{ r/min}$$

The field current when $R_{\text{adj}} = 400 \Omega$ is:

$$I_F = \frac{V_T}{R_{\text{adj}} + R_F} = \frac{240 \text{ V}}{400 \Omega + 100 \Omega} = \frac{240 \text{ V}}{500 \Omega} = 0.480 \text{ A}$$

From Figure P9-1, this field current would produce an internal generated voltage E_{Ao} of 199 V at a speed n_o of 1200 r/min. Therefore, the speed n with a voltage of 240 V would be

$$\frac{E_A}{E_{Ao}} = \frac{n}{n_o}$$

$$n = \frac{E_A}{E_{Ao}} n_o = \frac{240 \text{ V}}{199 \text{ V}} (1200 \text{ r/min}) = 1447 \text{ r/min}$$

- 9-6.** What is the starting current of this machine if it is started by connecting it directly to the power supply V_T ? How does this starting current compare to the full-load current of the motor?

SOLUTION The starting current of this machine (ignoring the small field current) is

$$I_{L,\text{start}} = \frac{V_T}{R_A} = \frac{240 \text{ V}}{0.40 \Omega} = 600 \text{ A}$$

The rated current is 55 A, so the starting current is 10.9 times greater than the full-load current. This much current is extremely likely to damage the motor.

- 9-7.** Plot the torque-speed characteristic of this motor assuming no armature reaction, and again assuming a full-load armature reaction of 1200 A·turns.

SOLUTION This problem is best solved with MATLAB, since it involves calculating the torque-speed values at many points. A MATLAB program to calculate and display both torque-speed characteristics is shown below.

```
% M-file: prob9_7.m
% M-file to create a plot of the torque-speed curve of the
% the shunt dc motor with and without armature reaction.

% Get the magnetization curve. Note that this curve is
% defined for a speed of 1200 r/min.
load p91_mag.dat
if_values = p91_mag(:,1);
ea_values = p91_mag(:,2);
n_0 = 1200;

% First, initialize the values needed in this program.
v_t = 240; % Terminal voltage (V)
r_f = 100; % Field resistance (ohms)
r_adj = 175; % Adjustable resistance (ohms)
r_a = 0.40; % Armature resistance (ohms)
i_l = 0:1:55; % Line currents (A)
n_f = 2700; % Number of turns on field
```

```

f_ar0 = 1200;          % Armature reaction @ 55 A (A-t/m)

% Calculate the armature current for each load.
i_a = i_l - v_t / (r_f + r_adj);

% Now calculate the internal generated voltage for
% each armature current.
e_a = v_t - i_a * r_a;

% Calculate the armature reaction MMF for each armature
% current.
f_ar = (i_a / 55) * f_ar0;

% Calculate the effective field current with and without
% armature reaction.  Ther term i_f_ar is the field current
% with armature reaction, and the term i_f_noar is the
% field current without armature reaction.
i_f_ar = v_t / (r_f + r_adj) - f_ar / n_f;
i_f_noar = v_t / (r_f + r_adj);

% Calculate the resulting internal generated voltage at
% 1200 r/min by interpolating the motor's magnetization
% curve.
e_a0_ar = interp1(if_values,ea_values,i_f_ar);
e_a0_noar = interp1(if_values,ea_values,i_f_noar);

% Calculate the resulting speed from Equation (9-13).
n_ar = ( e_a ./ e_a0_ar ) * n_0;
n_noar = ( e_a ./ e_a0_noar ) * n_0;

% Calculate the induced torque corresponding to each
% speed from Equations (8-55) and (8-56).
t_ind_ar = e_a .* i_a ./ (n_ar * 2 * pi / 60);
t_ind_noar = e_a .* i_a ./ (n_noar * 2 * pi / 60);

% Plot the torque-speed curves
figure(1);
plot(t_ind_noar,n_noar,'b-','LineWidth',2.0);
hold on;
plot(t_ind_ar,n_ar,'k--','LineWidth',2.0);
xlabel('\bf\tau_{ind} (N-m)');
ylabel('\bf\itn_{m} \rm\bf(r/min)');
title ('\bfShunt DC Motor Torque-Speed Characteristic');
legend('No armature reaction','With armature reaction');
axis([ 0 125 800 1250]);
grid on;
hold off;

```

The resulting plot is shown below:

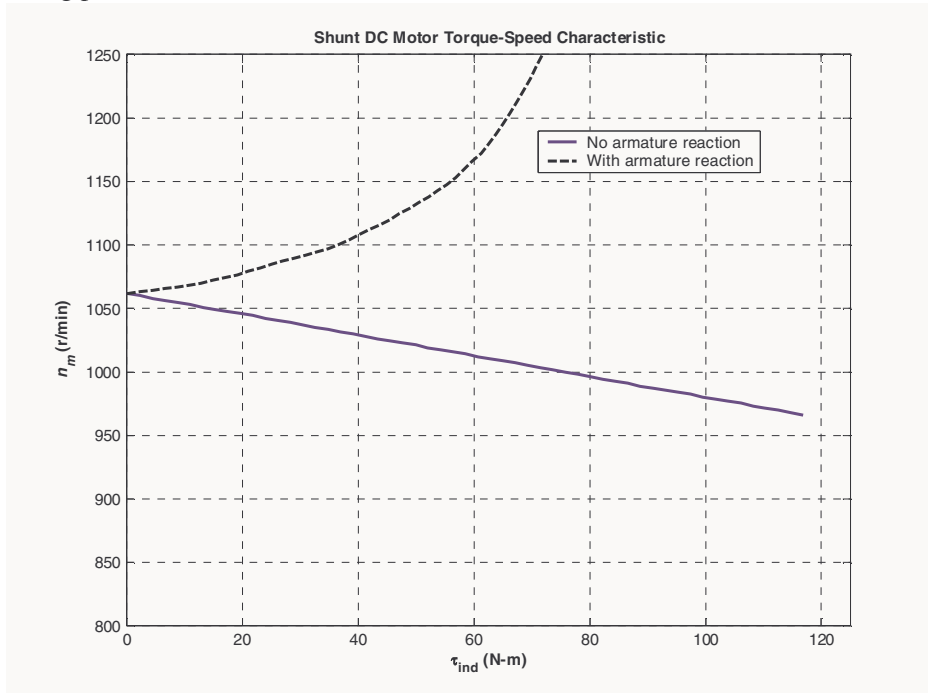

For Problems 9-8 and 9-9, the shunt dc motor is reconnected separately excited, as shown in Figure P9-3. It has a fixed field voltage V_F of 240 V and an armature voltage V_A that can be varied from 120 to 240 V.

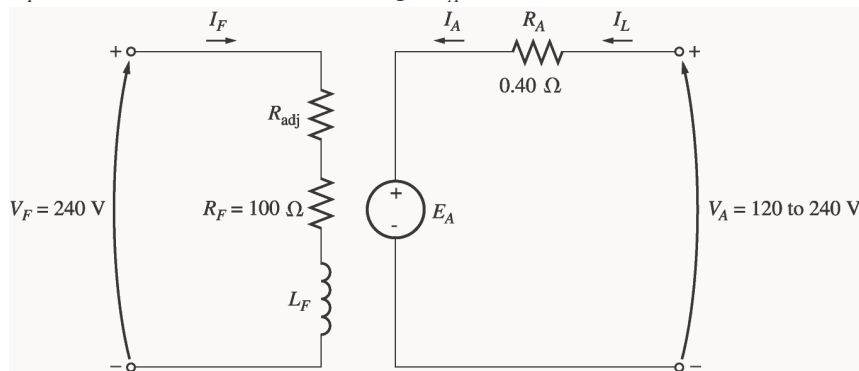

Note: Figure P9-3 shows incorrect values for R_A and R_F in the first printing of this book. The correct values are given in the text, but shown incorrectly on the figure. This will be corrected at the second printing.

- 9-8.** What is the no-load speed of this separately excited motor when $R_{adj} = 175 \Omega$ and (a) $V_A = 120$ V, (b) $V_A = 180$ V, (c) $V_A = 240$ V?

SOLUTION At no-load conditions, $E_A = V_A$. The field current is given by

$$I_F = \frac{V_F}{R_{adj} + R_F} = \frac{240 \text{ V}}{175 \Omega + 100 \Omega} = \frac{240 \text{ V}}{275 \Omega} = 0.873 \text{ A}$$

From Figure P9-1, this field current would produce an internal generated voltage E_{Ao} of 271 V at a speed n_o of 1200 r/min. Therefore, the speed n with a voltage of 240 V would be

$$\frac{E_A}{E_{Ao}} = \frac{n}{n_o}$$

$$n = \frac{E_A}{E_{Ao}} n_o$$

(a) If $V_A = 120$ V, then $E_A = 120$ V, and

$$n = \frac{120 \text{ V}}{271 \text{ V}} (1200 \text{ r/min}) = 531 \text{ r/min}$$

(a) If $V_A = 180$ V, then $E_A = 180$ V, and

$$n = \frac{180 \text{ V}}{271 \text{ V}} (1200 \text{ r/min}) = 797 \text{ r/min}$$

(a) If $V_A = 240$ V, then $E_A = 240$ V, and

$$n = \frac{240 \text{ V}}{271 \text{ V}} (1200 \text{ r/min}) = 1063 \text{ r/min}$$

9-9. For the separately excited motor of Problem 9-8:

(a) What is the maximum no-load speed attainable by varying both V_A and R_{adj} ?

(b) What is the minimum no-load speed attainable by varying both V_A and R_{adj} ?

SOLUTION

(a) The maximum speed will occur with the maximum V_A and the maximum R_{adj} . The field current when $R_{\text{adj}} = 400 \Omega$ is:

$$I_F = \frac{V_T}{R_{\text{adj}} + R_F} = \frac{240 \text{ V}}{400 \Omega + 100 \Omega} = \frac{240 \text{ V}}{500 \Omega} = 0.48 \text{ A}$$

From Figure P9-1, this field current would produce an internal generated voltage E_{Ao} of 199 V at a speed n_o of 1200 r/min. At no-load conditions, the maximum internal generated voltage $E_A = V_A = 240$ V. Therefore, the speed n with a voltage of 240 V would be

$$\frac{E_A}{E_{Ao}} = \frac{n}{n_o}$$

$$n = \frac{E_A}{E_{Ao}} n_o = \frac{240 \text{ V}}{199 \text{ V}} (1200 \text{ r/min}) = 1447 \text{ r/min}$$

(b) The minimum speed will occur with the minimum V_A and the minimum R_{adj} . The field current when $R_{\text{adj}} = 100 \Omega$ is:

$$I_F = \frac{V_T}{R_{\text{adj}} + R_F} = \frac{240 \text{ V}}{100 \Omega + 100 \Omega} = \frac{240 \text{ V}}{200 \Omega} = 1.2 \text{ A}$$

From Figure P9-1, this field current would produce an internal generated voltage E_{Ao} of 287 V at a speed n_o of 1200 r/min. At no-load conditions, the minimum internal generated voltage $E_A = V_A = 120$ V. Therefore, the speed n with a voltage of 120 V would be

$$\frac{E_A}{E_{Ao}} = \frac{n}{n_o}$$

$$n = \frac{E_A}{E_{Ao}} n_o = \frac{120 \text{ V}}{287 \text{ V}} (1200 \text{ r/min}) = 502 \text{ r/min}$$

9-10. If the motor is connected cumulatively compounded as shown in Figure P9-4 and if $R_{adj} = 175 \Omega$, what is its no-load speed? What is its full-load speed? What is its speed regulation? Calculate and plot the torque-speed characteristic for this motor. (Neglect armature effects in this problem.)

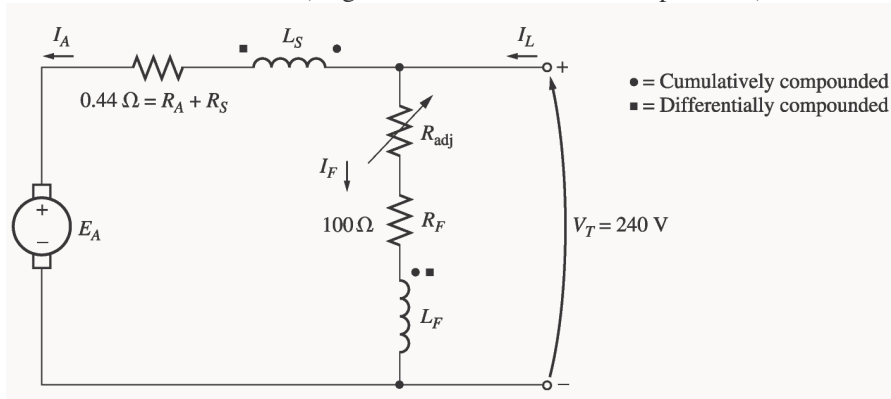

Note: Figure P9-4 shows incorrect values for $R_A + R_S$ and R_F in the first printing of this book. The correct values are given in the text, but shown incorrectly on the figure. This will be corrected at the second printing.

SOLUTION At no-load conditions, $E_A = V_T = 240 \text{ V}$. The field current is given by

$$I_F = \frac{V_F}{R_{adj} + R_F} = \frac{240 \text{ V}}{175 \Omega + 100 \Omega} = \frac{240 \text{ V}}{275 \Omega} = 0.873 \text{ A}$$

From Figure P9-1, this field current would produce an internal generated voltage E_{Ao} of 271 V at a speed n_o of 1200 r/min. Therefore, the speed n with a voltage of 240 V would be

$$\frac{E_A}{E_{Ao}} = \frac{n}{n_o}$$

$$n = \frac{E_A}{E_{Ao}} n_o = \frac{240 \text{ V}}{271 \text{ V}} (1200 \text{ r/min}) = 1063 \text{ r/min}$$

At full load conditions, the armature current is

$$I_A = I_L - I_F = I_L - \frac{V_T}{R_{adj} + R_F} = 55 \text{ A} - 0.87 \text{ A} = 54.13 \text{ A}$$

The internal generated voltage E_A is

$$E_A = V_T - I_A (R_A + R_S) = 240 \text{ V} - (54.13 \text{ A})(0.44 \Omega) = 216.2 \text{ V}$$

The equivalent field current is

$$I_F^* = I_F + \frac{N_{SE}}{N_F} I_A = 0.873 \text{ A} + \frac{27 \text{ turns}}{2700 \text{ turns}} (54.13 \text{ A}) = 1.41 \text{ A}$$

From Figure P9-1, this field current would produce an internal generated voltage E_{Ao} of 290 V at a speed n_o of 1200 r/min. Therefore,

$$n = \frac{E_A}{E_{Ao}} \quad n_o = \frac{216.2 \text{ V}}{290 \text{ V}} (1200 \text{ r/min}) = 895 \text{ r/min}$$

The speed regulation is

$$\text{SR} = \frac{n_{nl} - n_{fl}}{n_{fl}} \times 100\% = \frac{1063 \text{ r/min} - 895 \text{ r/min}}{895 \text{ r/min}} \times 100\% = 18.8\%$$

The torque-speed characteristic can best be plotted with a MATLAB program. An appropriate program is shown below.

```
% M-file: prob9_10.m
% M-file to create a plot of the torque-speed curve of the
% a cumulatively compounded dc motor without
% armature reaction.

% Get the magnetization curve. Note that this curve is
% defined for a speed of 1200 r/min.
load p91_mag.dat
if_values = p91_mag(:,1);
ea_values = p91_mag(:,2);
n_0 = 1200;

% First, initialize the values needed in this program.
v_t = 240;           % Terminal voltage (V)
r_f = 100;          % Field resistance (ohms)
r_adj = 175;        % Adjustable resistance (ohms)
r_a = 0.44;         % Armature + series resistance (ohms)
i_l = 0:55;        % Line currents (A)
n_f = 2700;         % Number of turns on shunt field
n_se = 27;         % Number of turns on series field

% Calculate the armature current for each load.
i_a = i_l - v_t / (r_f + r_adj);

% Now calculate the internal generated voltage for
% each armature current.
e_a = v_t - i_a * r_a;

% Calculate the effective field current for each armature
% current.
i_f = v_t / (r_f + r_adj) + (n_se / n_f) * i_a;

% Calculate the resulting internal generated voltage at
% 1200 r/min by interpolating the motor's magnetization
% curve.
e_a0 = interp1(if_values,ea_values,i_f);

% Calculate the resulting speed from Equation (9-13).
n = ( e_a ./ e_a0 ) * n_0;

% Calculate the induced torque corresponding to each
% speed from Equations (8-55) and (8-56).
```

```
t_ind = e_a .* i_a ./ (n * 2 * pi / 60);

% Plot the torque-speed curves
figure(1);
plot(t_ind,n,'b-','LineWidth',2.0);
xlabel('\bf\tau_{ind} (N-m)');
ylabel('\bf\itn_{m} \rm\bf(r/min)');
title ('\bfCumulatively-Compounded DC Motor Torque-Speed
Characteristic');
axis([0 125 800 1250]);
grid on;
```

The resulting plot is shown below:

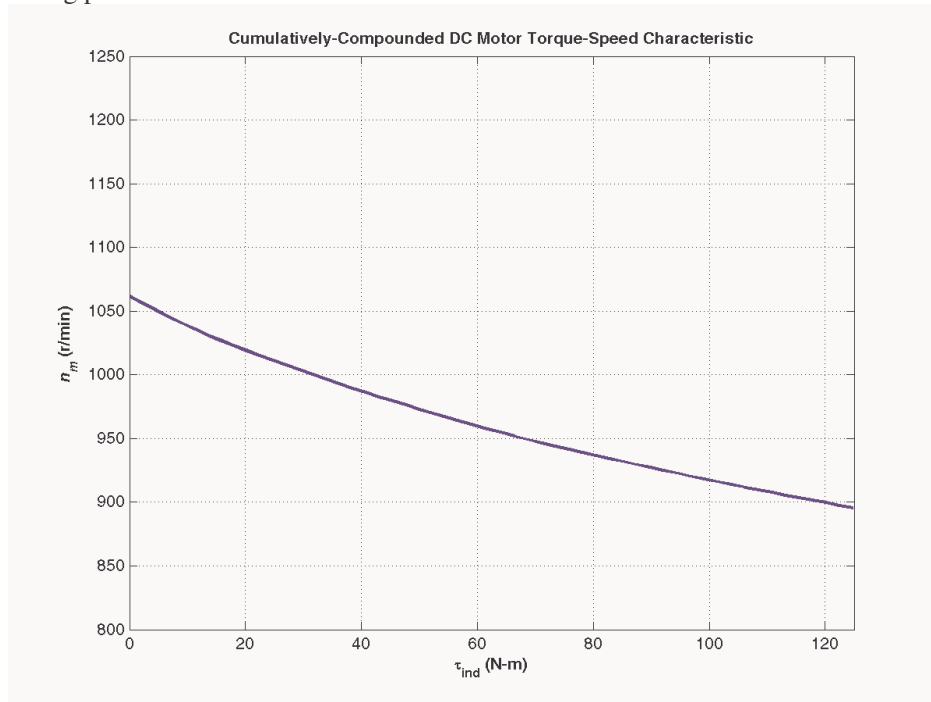

Compare this torque-speed curve to that of the shunt motor in Problem 9-7. (Both curves are plotted on the same scale to facilitate comparison.)

- 9-11.** The motor is connected cumulatively compounded and is operating at full load. What will the new speed of the motor be if R_{adj} is increased to 250Ω ? How does the new speed compare to the full-load speed calculated in Problem 9-10?

SOLUTION If R_{adj} is increased to 250Ω , the field current is given by

$$I_F = \frac{V_T}{R_{adj} + R_F} = \frac{240 \text{ V}}{250 \Omega + 100 \Omega} = \frac{240 \text{ V}}{350 \Omega} = 0.686 \text{ A}$$

At full load conditions, the armature current is

$$I_A = I_L - I_F = 55 \text{ A} - 0.686 \text{ A} = 54.3 \text{ A}$$

The internal generated voltage E_A is

$$E_A = V_T - I_A(R_A + R_S) = 240 \text{ V} - (54.3 \text{ A})(0.44 \Omega) = 216.1 \text{ V}$$

The equivalent field current is

$$I_F^* = I_F + \frac{N_{SE}}{N_F} I_A = 0.686 \text{ A} + \frac{27 \text{ turns}}{2700 \text{ turns}} (54.3 \text{ A}) = 1.23 \text{ A}$$

From Figure P9-1, this field current would produce an internal generated voltage E_{Ao} of 288 V at a speed n_o of 1200 r/min. Therefore,

$$n = \frac{E_A}{E_{Ao}} \quad n_o = \frac{216.1 \text{ V}}{288 \text{ V}} (1200 \text{ r/min}) = 900 \text{ r/min}$$

The new full-load speed is higher than the full-load speed in Problem 9-10.

9-12. The motor is now connected differentially compounded.

- (a) If $R_{adj} = 175 \Omega$, what is the no-load speed of the motor?
 (b) What is the motor's speed when the armature current reaches 20 A? 40 A? 60 A?
 (c) Calculate and plot the torque-speed characteristic curve of this motor.

SOLUTION

(a) At no-load conditions, $E_A = V_T = 240 \text{ V}$. The field current is given by

$$I_F = \frac{V_F}{R_{adj} + R_F} = \frac{240 \text{ V}}{175 \Omega + 100 \Omega} = \frac{240 \text{ V}}{275 \Omega} = 0.873 \text{ A}$$

From Figure P9-1, this field current would produce an internal generated voltage E_{Ao} of 271 V at a speed n_o of 1200 r/min. Therefore, the speed n with a voltage of 240 V would be

$$\frac{E_A}{E_{Ao}} = \frac{n}{n_o}$$

$$n = \frac{E_A}{E_{Ao}} \quad n_o = \frac{240 \text{ V}}{271 \text{ V}} (1200 \text{ r/min}) = 1063 \text{ r/min}$$

(b) At $I_A = 20 \text{ A}$, the internal generated voltage E_A is

$$E_A = V_T - I_A (R_A + R_S) = 240 \text{ V} - (20 \text{ A})(0.44 \Omega) = 231.2 \text{ V}$$

The equivalent field current is

$$I_F^* = I_F - \frac{N_{SE}}{N_F} I_A = 0.873 \text{ A} - \frac{27 \text{ turns}}{2700 \text{ turns}} (20 \text{ A}) = 0.673 \text{ A}$$

From Figure P9-1, this field current would produce an internal generated voltage E_{Ao} of 245 V at a speed n_o of 1200 r/min. Therefore,

$$n = \frac{E_A}{E_{Ao}} \quad n_o = \frac{231.2 \text{ V}}{245 \text{ V}} (1200 \text{ r/min}) = 1132 \text{ r/min}$$

At $I_A = 40 \text{ A}$, the internal generated voltage E_A is

$$E_A = V_T - I_A (R_A + R_S) = 240 \text{ V} - (40 \text{ A})(0.44 \Omega) = 222.4 \text{ V}$$

The equivalent field current is

$$I_F^* = I_F - \frac{N_{SE}}{N_F} I_A = 0.873 \text{ A} - \frac{27 \text{ turns}}{2700 \text{ turns}} (40 \text{ A}) = 0.473 \text{ A}$$

From Figure P9-1, this field current would produce an internal generated voltage E_{Ao} of 197 V at a speed n_o of 1200 r/min. Therefore,

$$n = \frac{E_A}{E_{Ao}} \quad n_o = \frac{227.4 \text{ V}}{197 \text{ V}} (1200 \text{ r/min}) = 1385 \text{ r/min}$$

At $I_A = 60 \text{ A}$, the internal generated voltage E_A is

$$E_A = V_T - I_A (R_A + R_S) = 240 \text{ V} - (60 \text{ A})(0.44 \Omega) = 213.6 \text{ V}$$

The equivalent field current is

$$I_F^* = I_F - \frac{N_{SE}}{N_F} I_A = 0.873 \text{ A} - \frac{27 \text{ turns}}{2700 \text{ turns}} (60 \text{ A}) = 0.273 \text{ A}$$

From Figure P9-1, this field current would produce an internal generated voltage E_{Ao} of 121 V at a speed n_o of 1200 r/min. Therefore,

$$n = \frac{E_A}{E_{Ao}} \quad n_o = \frac{213.6 \text{ V}}{121 \text{ V}} (1200 \text{ r/min}) = 2118 \text{ r/min}$$

(c) The torque-speed characteristic can best be plotted with a MATLAB program. An appropriate program is shown below.

```
% M-file: prob9_12.m
% M-file to create a plot of the torque-speed curve of the
% a differentially compounded dc motor with/without
% armature reaction.

% Get the magnetization curve. Note that this curve is
% defined for a speed of 1200 r/min.
load p91_mag.dat
if_values = p91_mag(:,1);
ea_values = p91_mag(:,2);
n_0 = 1200;

% First, initialize the values needed in this program.
v_t = 240; % Terminal voltage (V)
r_f = 100; % Field resistance (ohms)
r_adj = 175; % Adjustable resistance (ohms)
r_a = 0.44; % Armature + series resistance (ohms)
i_l = 0:50; % Line currents (A)
n_f = 2700; % Number of turns on shunt field
n_se = 27; % Number of turns on series field

% Calculate the armature current for each load.
i_a = i_l - v_t / (r_f + r_adj);

% Now calculate the internal generated voltage for
% each armature current.
e_a = v_t - i_a * r_a;

% Calculate the effective field current for each armature
```

```

% current.
i_f = v_t / (r_f + r_adj) - (n_se / n_f) * i_a;

% Calculate the resulting internal generated voltage at
% 1200 r/min by interpolating the motor's magnetization
% curve.
e_a0 = interp1(if_values,ea_values,i_f);

% Calculate the resulting speed from Equation (9-13).
n = ( e_a ./ e_a0 ) * n_0;

% Calculate the induced torque corresponding to each
% speed from Equations (8-55) and (8-56).
t_ind = e_a .* i_a ./ (n * 2 * pi / 60);

% Plot the torque-speed curves
figure(1);
plot(t_ind,n,'b-','LineWidth',2.0);
xlabel('\bf\tau_{ind} (N-m)');
ylabel('\bf\itn_{m} \rm\bf(r/min)');
title ('\bfDifferentially-Compounded DC Motor Torque-Speed
Characteristic');
axis([0 100 800 1600]);
grid on;

```

The resulting plot is shown below:

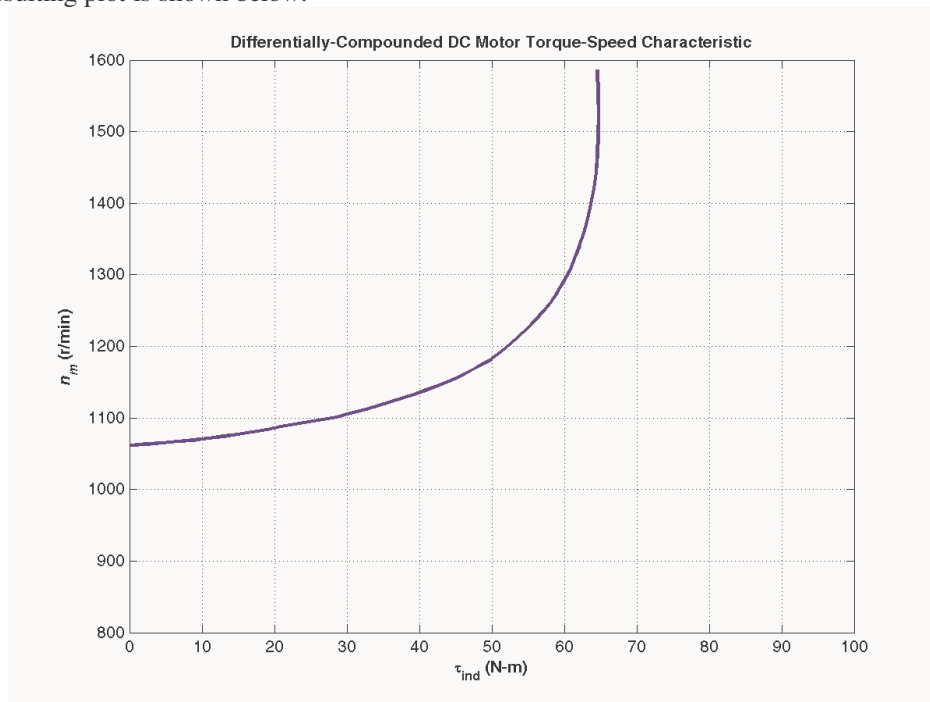

Compare this torque-speed curve to that of the shunt motor in Problem 9-7 and the cumulatively-compounded motor in Problem 9-10. (Note that this plot has a larger vertical scale to accommodate the speed runaway of the differentially-compounded motor.)

- 9-13.** A 7.5-hp 120-V series dc motor has an armature resistance of 0.2Ω and a series field resistance of 0.16Ω . At full load, the current input is 58 A, and the rated speed is 1050 r/min. Its magnetization curve is shown

in Figure P9-5. The core losses are 200 W, and the mechanical losses are 240 W at full load. Assume that the mechanical losses vary as the cube of the speed of the motor and that the core losses are constant.

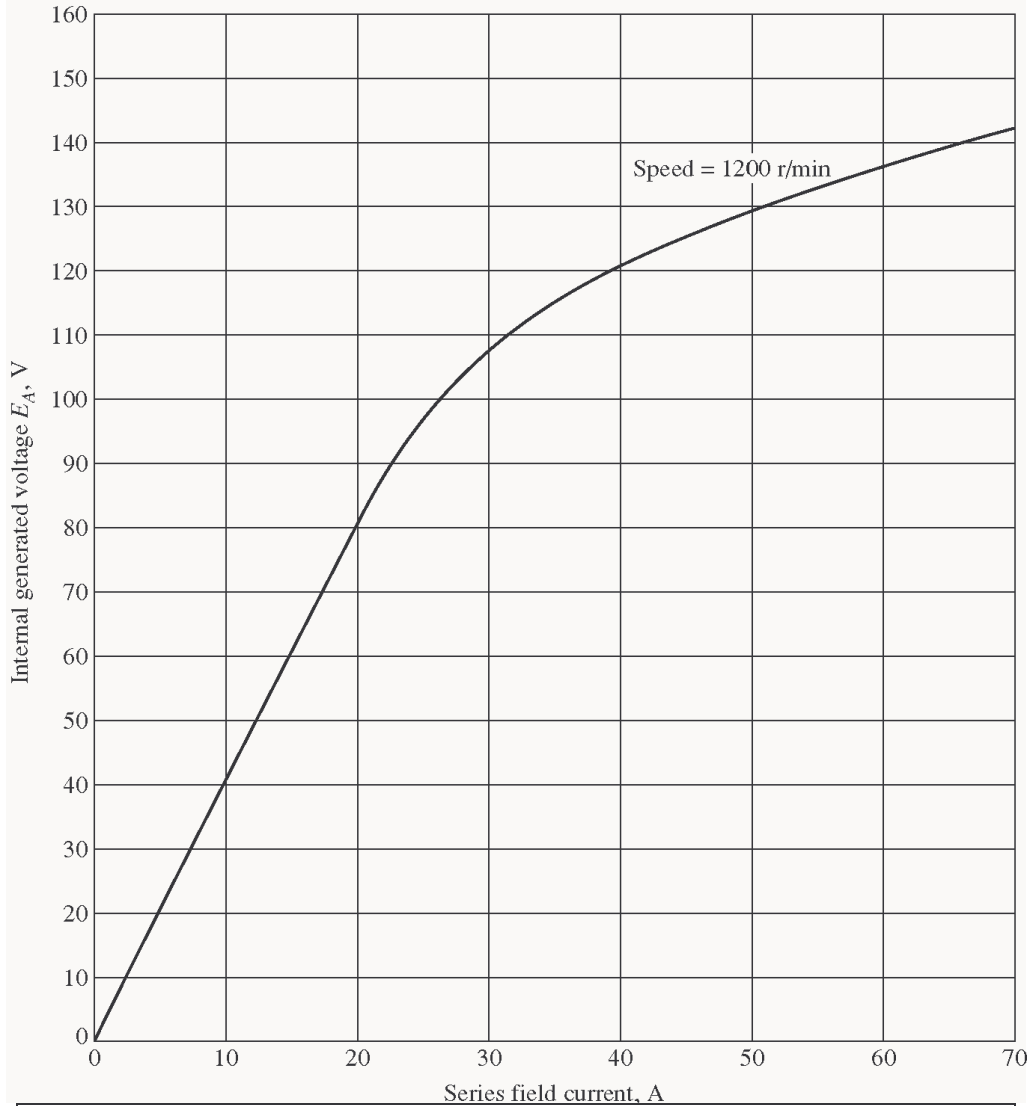

Note: An electronic version of this magnetization curve can be found in file p95_mag.dat, which can be used with MATLAB programs. Column 1 contains field current in amps, and column 2 contains the internal generated voltage E_A in volts.

- (a) What is the efficiency of the motor at full load?
- (b) What are the speed and efficiency of the motor if it is operating at an armature current of 35 A?
- (c) Plot the torque-speed characteristic for this motor.

SOLUTION

(a) The output power of this motor at full load is

$$P_{OUT} = (7.5 \text{ hp})(746 \text{ W/hp}) = 5595 \text{ W}$$

The input power is

$$P_{\text{IN}} = V_T I_L = (120 \text{ V})(58 \text{ A}) = 6960 \text{ W}$$

Therefore the efficiency is

$$\eta = \frac{P_{\text{OUT}}}{P_{\text{IN}}} \times 100\% = \frac{5595 \text{ W}}{6960 \text{ W}} \times 100\% = 80.4\%$$

(b) If the armature current is 35 A, then the input power to the motor will be

$$P_{\text{IN}} = V_T I_L = (120 \text{ V})(35 \text{ A}) = 4200 \text{ W}$$

The internal generated voltage at this condition is

$$E_{A2} = V_T - I_A (R_A + R_S) = 120 \text{ V} - (35 \text{ A})(0.20 \Omega + 0.16 \Omega) = 107.4 \text{ V}$$

and the internal generated voltage at rated conditions is

$$E_{A1} = V_T - I_A (R_A + R_S) = 120 \text{ V} - (58 \text{ A})(0.20 \Omega + 0.16 \Omega) = 99.1 \text{ V}$$

The final speed is given by the equation

$$\frac{E_{A2}}{E_{A1}} = \frac{K \phi_2 \omega_2}{K \phi_1 \omega_1} = \frac{E_{Ao,2} n_2}{E_{Ao,1} n_1}$$

since the ratio $E_{Ao,2}/E_{Ao,1}$ is the same as the ratio ϕ_2/ϕ_1 . Therefore, the final speed is

$$n_2 = \frac{E_{A2}}{E_{A1}} \frac{E_{Ao,1}}{E_{Ao,2}} n_1$$

From Figure P9-5, the internal generated voltage $E_{Ao,2}$ for a current of 35 A and a speed of $n_o = 1200$ r/min is $E_{Ao,2} = 115 \text{ V}$, and the internal generated voltage $E_{Ao,1}$ for a current of 58 A and a speed of $n_o = 1200$ r/min is $E_{Ao,1} = 134 \text{ V}$.

$$n_2 = \frac{E_{A2}}{E_{A1}} \frac{E_{Ao,1}}{E_{Ao,2}} n_1 = \frac{107.4 \text{ V}}{99.1 \text{ V}} \frac{134 \text{ V}}{115 \text{ V}} (1050 \text{ r/min}) = 1326 \text{ r/min}$$

The power converted from electrical to mechanical form is

$$P_{\text{conv}} = E_A I_A = (107.4 \text{ V})(35 \text{ A}) = 3759 \text{ W}$$

The core losses in the motor are 200 W, and the mechanical losses in the motor are 240 W at a speed of 1050 r/min. The mechanical losses in the motor scale proportionally to the cube of the rotational speed so the mechanical losses at 1326 r/min are

$$P_{\text{mech}} = \frac{n_2}{n_1}^3 (240 \text{ W}) = \frac{1326 \text{ r/min}}{1050 \text{ r/min}}^3 (240 \text{ W}) = 483 \text{ W}$$

Therefore, the output power is

$$P_{\text{OUT}} = P_{\text{conv}} - P_{\text{mech}} - P_{\text{core}} = 3759 \text{ W} - 483 \text{ W} - 200 \text{ W} = 3076 \text{ W}$$

and the efficiency is

$$\eta = \frac{P_{\text{OUT}}}{P_{\text{IN}}} \times 100\% = \frac{3076 \text{ W}}{4200 \text{ W}} \times 100\% = 73.2\%$$

(c) A MATLAB program to plot the torque-speed characteristic of this motor is shown below:

```

% M-file: prob9_13.m
% M-file to create a plot of the torque-speed curve of the
%   the series dc motor in Problem 9-13.

% Get the magnetization curve. Note that this curve is
% defined for a speed of 1200 r/min.
load p95_mag.dat
if_values = p95_mag(:,1);
ea_values = p95_mag(:,2);
n_0 = 1200;

% First, initialize the values needed in this program.
v_t = 120;           % Terminal voltage (V)
r_a = 0.36;         % Armature + field resistance (ohms)
i_a = 9:1:58;       % Armature (line) currents (A)

% Calculate the internal generate voltage e_a.
e_a = v_t - i_a * r_a;

% Calculate the resulting internal generated voltage at
% 1200 r/min by interpolating the motor's magnetization
% curve. Note that the field current is the same as the
% armature current for this motor.
e_a0 = interp1(if_values,ea_values,i_a,'spline');

% Calculate the motor's speed, using the known fact that
% the motor runs at 1050 r/min at a current of 58 A. We
% know that
%
%
%

$$\frac{E_{a2}}{E_{a1}} = \frac{K' \phi_2 n_2}{K' \phi_1 n_1} = \frac{E_{a02} n_2}{E_{a01} n_1}$$

%
%

$$\Rightarrow n_2 = \frac{E_{a2} E_{a01}}{E_{a1} E_{a02}} n_1$$

%
% where Ea0 is the internal generated voltage at 1200 r/min
% for a given field current.
%
% Speed will be calculated by reference to full load speed
% and current.
n1 = 1050;           % 1050 r/min at full load
Ea01 = interp1(if_values,ea_values,58,'spline');
Ea1 = v_t - 58 * r_a;

% Get speed
Ea02 = interp1(if_values,ea_values,i_a,'spline');
n = (e_a./Ea1) .* (Ea01 ./ Ea02) * n1;

% Calculate the induced torque corresponding to each
% speed from Equations (8-55) and (8-56).
t_ind = e_a .* i_a ./ (n * 2 * pi / 60);

% Plot the torque-speed curve

```

```

figure(1);
plot(t_ind,n,'b-','LineWidth',2.0);
hold on;
xlabel('\bf\tau_{ind} (N-m)');
ylabel('\bf\itn_{m} \rm\bf(r/min)');
title ('\bfSeries DC Motor Torque-Speed Characteristic');
grid on;
hold off;

```

The resulting torque-speed characteristic is shown below:

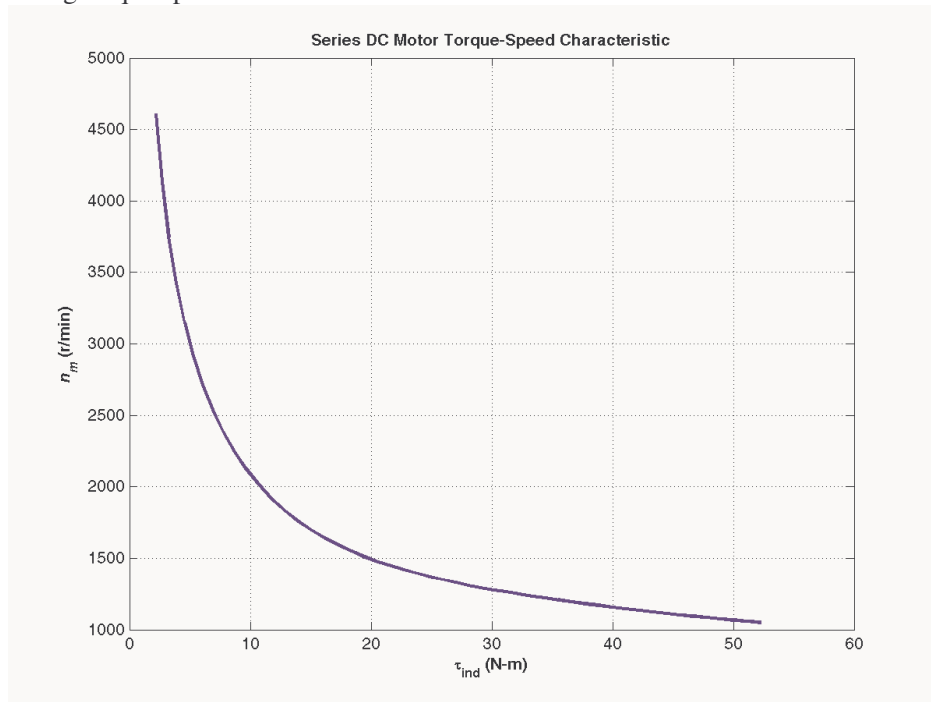

- 9-14.** A 20-hp 240-V 76-A 900 r/min series motor has a field winding of 33 turns per pole. Its armature resistance is 0.09Ω , and its field resistance is 0.06Ω . The magnetization curve expressed in terms of magnetomotive force versus E_A at 900 r/min is given by the following table:

E_A, V	95	150	188	212	229	243
$\mathcal{F}, A \cdot \text{turns}$	500	1000	1500	2000	2500	3000

Note: An electronic version of this magnetization curve can be found in file prob9_14_mag.dat, which can be used with MATLAB programs. Column 1 contains magnetomotive force in ampere-turns, and column 2 contains the internal generated voltage E_A in volts.

Armature reaction is negligible in this machine.

- (a) Compute the motor's torque, speed, and output power at 33, 67, 100, and 133 percent of full-load armature current. (Neglect rotational losses.)
- (b) Plot the terminal characteristic of this machine.

SOLUTION Note that this magnetization curve has been stored in a file called prob9_14_mag.dat. The first column of the file is an array of mmf_values, and the second column is an array of ea_values. These values are valid at a speed $n_o = 900$ r/min. Because the data in the file is relatively sparse, it is

important that interpolation be done using smooth curves, so be sure to specify the 'spline' option in the MATLAB `interp1` function:

```
load prob9_14_mag.dat;
mmf_values = prob9_14_mag(:,1);
ea_values = prob9_14_mag(:,2);
...
Eao = interp1(mmf_values,ea_values,mmf,'spline')
```

(a) Since full load corresponds to 76 A, this calculation must be performed for armature currents of 25.3 A, 50.7 A, 76 A, and 101.3 A.

If $I_A = 25.3$ A, then

$$E_A = V_T - I_A(R_A + R_S) = 240 \text{ V} - (25.3 \text{ A})(0.09 \Omega + 0.06 \Omega) = 236.2 \text{ V}$$

The magnetomotive force is $\mathcal{F} = NI_A = (33 \text{ turns})(25.3 \text{ A}) = 835 \text{ A} \cdot \text{turns}$, which produces a voltage E_{Ao} of 134 V at $n_o = 900 \text{ r/min}$. Therefore the speed of the motor at these conditions is

$$n = \frac{E_A}{E_{Ao}} n_o = \frac{236.2 \text{ V}}{134 \text{ V}} (900 \text{ r/min}) = 1586 \text{ r/min}$$

The power converted from electrical to mechanical form is

$$P_{\text{conv}} = E_A I_A = (236.2 \text{ V})(25.3 \text{ A}) = 5976 \text{ W}$$

Since the rotational losses are ignored, this is also the output power of the motor. The induced torque is

$$\tau_{\text{ind}} = \frac{P_{\text{conv}}}{\omega_m} = \frac{5976 \text{ W}}{(1586 \text{ r/min}) \frac{2\pi \text{ rad}}{1 \text{ r}} \frac{1 \text{ min}}{60 \text{ s}}} = 36 \text{ N} \cdot \text{m}$$

If $I_A = 50.7$ A, then

$$E_A = V_T - I_A(R_A + R_S) = 240 \text{ V} - (50.7 \text{ A})(0.09 \Omega + 0.06 \Omega) = 232.4 \text{ V}$$

The magnetomotive force is $\mathcal{F} = NI_A = (33 \text{ turns})(50.7 \text{ A}) = 1672 \text{ A} \cdot \text{turns}$, which produces a voltage E_{Ao} of 197 V at $n_o = 900 \text{ r/min}$. Therefore the speed of the motor at these conditions is

$$n = \frac{E_A}{E_{Ao}} n_o = \frac{232.4 \text{ V}}{197 \text{ V}} (900 \text{ r/min}) = 1062 \text{ r/min}$$

The power converted from electrical to mechanical form is

$$P_{\text{conv}} = E_A I_A = (232.4 \text{ V})(50.7 \text{ A}) = 11,780 \text{ W}$$

Since the rotational losses are ignored, this is also the output power of the motor. The induced torque is

$$\tau_{\text{ind}} = \frac{P_{\text{conv}}}{\omega_m} = \frac{11,780 \text{ W}}{(1062 \text{ r/min}) \frac{2\pi \text{ rad}}{1 \text{ r}} \frac{1 \text{ min}}{60 \text{ s}}} = 106 \text{ N} \cdot \text{m}$$

If $I_A = 76$ A, then

$$E_A = V_T - I_A(R_A + R_S) = 240 \text{ V} - (76 \text{ A})(0.09 \Omega + 0.06 \Omega) = 228.6 \text{ V}$$

The magnetomotive force is $\mathcal{F} = NI_A = (33 \text{ turns})(76 \text{ A}) = 2508 \text{ A} \cdot \text{turns}$, which produces a voltage E_{Ao} of 229 V at $n_o = 900 \text{ r/min}$. Therefore the speed of the motor at these conditions is

$$n = \frac{E_A}{E_{Ao}} n_o = \frac{228.6 \text{ V}}{229 \text{ V}} (900 \text{ r/min}) = 899 \text{ r/min}$$

The power converted from electrical to mechanical form is

$$P_{\text{conv}} = E_A I_A = (228.6 \text{ V})(76 \text{ A}) = 17,370 \text{ W}$$

Since the rotational losses are ignored, this is also the output power of the motor. The induced torque is

$$\tau_{\text{ind}} = \frac{P_{\text{conv}}}{\omega_m} = \frac{17,370 \text{ W}}{(899 \text{ r/min}) \frac{2\pi \text{ rad}}{1 \text{ r}} \frac{1 \text{ min}}{60 \text{ s}}} = 185 \text{ N} \cdot \text{m}$$

If $I_A = 101.3 \text{ A}$, then

$$E_A = V_T - I_A (R_A + R_S) = 240 \text{ V} - (101.3 \text{ A})(0.09 \Omega + 0.06 \Omega) = 224.8 \text{ V}$$

The magnetomotive force is $\mathcal{F} = NI_A = (33 \text{ turns})(101.3 \text{ A}) = 3343 \text{ A} \cdot \text{turns}$, which produces a voltage E_{Ao} of 252 V at $n_o = 900 \text{ r/min}$. Therefore the speed of the motor at these conditions is

$$n = \frac{E_A}{E_{Ao}} n_o = \frac{224.8 \text{ V}}{252 \text{ V}} (900 \text{ r/min}) = 803 \text{ r/min}$$

The power converted from electrical to mechanical form is

$$P_{\text{conv}} = E_A I_A = (224.8 \text{ V})(101.3 \text{ A}) = 22,770 \text{ W}$$

Since the rotational losses are ignored, this is also the output power of the motor. The induced torque is

$$\tau_{\text{ind}} = \frac{P_{\text{conv}}}{\omega_m} = \frac{22,770 \text{ W}}{(803 \text{ r/min}) \frac{2\pi \text{ rad}}{1 \text{ r}} \frac{1 \text{ min}}{60 \text{ s}}} = 271 \text{ N} \cdot \text{m}$$

(b) A MATLAB program to plot the torque-speed characteristic of this motor is shown below:

```
% M-file: series_ts_curve.m
% M-file to create a plot of the torque-speed curve of the
% the series dc motor in Problem 9-14.

% Get the magnetization curve. Note that this curve is
% defined for a speed of 900 r/min.
load prob9_14_mag.dat
mmf_values = prob9_14_mag(:,1);
ea_values = prob9_14_mag(:,2);
n_0 = 900;

% First, initialize the values needed in this program.
v_t = 240; % Terminal voltage (V)
r_a = 0.15; % Armature + field resistance (ohms)
i_a = 15:1:76; % Armature (line) currents (A)
n_s = 33; % Number of series turns on field

% Calculate the MMF for each load
```

```

f = n_s * i_a;

% Calculate the internal generate voltage e_a.
e_a = v_t - i_a * r_a;

% Calculate the resulting internal generated voltage at
% 900 r/min by interpolating the motor's magnetization
% curve. Specify cubic spline interpolation to provide
% good results with this sparse magnetization curve.
e_a0 = interp1(mmf_values,ea_values,f,'spline');

% Calculate the motor's speed from Equation (9-13).
n = (e_a ./ e_a0) * n_0;

% Calculate the induced torque corresponding to each
% speed from Equations (8-55) and (8-56).
t_ind = e_a .* i_a ./ (n * 2 * pi / 60);

% Plot the torque-speed curve
figure(1);
plot(t_ind,n,'b-','LineWidth',2.0);
hold on;
xlabel('\bf\tau_{ind} (N-m)');
ylabel('\bf\itn_{m} \rm\bf(r/min)');
title ('\bfSeries DC Motor Torque-Speed Characteristic');
%axis([ 0 700 0 5000]);
grid on;
hold off;

```

The resulting torque-speed characteristic is shown below:

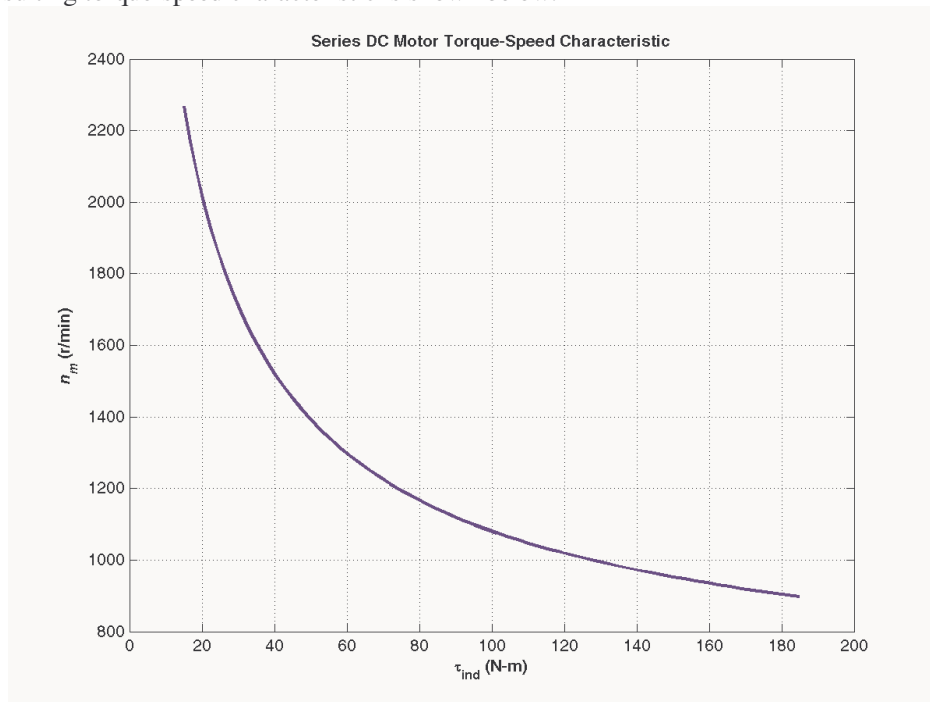

- 9-15.** A 300-hp 440-V 560-A, 863 r/min shunt dc motor has been tested, and the following data were taken:
Blocked-rotor test:

$$V_A = 16.3 \text{ V} \quad \text{exclusive of brushes}$$

$$V_F = 440 \text{ V}$$

$$I_A = 500 \text{ A}$$

$$I_F = 8.86 \text{ A}$$

No-load operation:

$$V_A = 16.3 \text{ V} \quad \text{including brushes}$$

$$I_F = 8.76 \text{ A}$$

$$I_A = 23.1 \text{ A}$$

$$n = 863 \text{ r/min}$$

What is this motor's efficiency at the rated conditions? [Note: Assume that (1) the brush voltage drop is 2 V; (2) the core loss is to be determined at an armature voltage equal to the armature voltage under full load; and (3) stray load losses are 1 percent of full load.]

SOLUTION The armature resistance of this motor is

$$R_A = \frac{V_{A,br}}{I_{A,br}} = \frac{16.3 \text{ V}}{500 \text{ A}} = 0.0326 \Omega$$

Under no-load conditions, the core and mechanical losses taken together (that is, the *rotational losses*) of this motor are equal to the product of the internal generated voltage E_A and the armature current I_A , since this is no output power from the motor at no-load conditions. Therefore, the rotational losses at rated speed can be found as

$$E_A = V_A - V_{\text{brush}} - I_A R_A = 442 \text{ V} - 2 \text{ V} - (23.1 \text{ A})(0.0326 \Omega) = 439.2 \text{ V}$$

$$P_{\text{rot}} = P_{\text{conv}} = E_A I_A = (439.2 \text{ V})(23.1 \text{ A}) = 10.15 \text{ kW}$$

The input power to the motor *at full load* is

$$P_{\text{IN}} = V_T I_L = (440 \text{ V})(560 \text{ A}) = 246.4 \text{ kW}$$

The output power from the motor at full load is

$$P_{\text{OUT}} = P_{\text{IN}} - P_{\text{CU}} - P_{\text{rot}} - P_{\text{brush}} - P_{\text{stray}}$$

The copper losses are

$$P_{\text{CU}} = I_A^2 R_A + V_F I_F = (560 \text{ A})^2 (0.0326 \Omega) + (440 \text{ V})(8.86 \text{ A}) = 14.1 \text{ kW}$$

The brush losses are

$$P_{\text{brush}} = V_{\text{brush}} I_A = (2 \text{ V})(560 \text{ A}) = 1120 \text{ W}$$

Therefore,

$$P_{\text{OUT}} = P_{\text{IN}} - P_{\text{CU}} - P_{\text{rot}} - P_{\text{brush}} - P_{\text{stray}}$$

$$P_{\text{OUT}} = 246.4 \text{ kW} - 14.1 \text{ kW} - 10.15 \text{ kW} - 1.12 \text{ kW} - 2.46 \text{ kW} = 218.6 \text{ kW}$$

The motor's efficiency at full load is

$$\eta = \frac{P_{\text{OUT}}}{P_{\text{IN}}} \times 100\% = \frac{218.6 \text{ kW}}{246.4 \text{ kW}} \times 100\% = 88.7\%$$

Problems 9-16 to 9-19 refer to a 240-V 100-A dc motor which has both shunt and series windings. Its characteristics are

$$R_A = 0.14 \Omega$$

$$N_F = 1500 \text{ turns}$$

$$R_S = 0.04 \Omega$$

$$N_{SE} = 12 \text{ turns}$$

$$R_F = 200 \, \Omega \qquad n_m = 1200 \text{ r/min}$$

$$R_{\text{adj}} = 0 \text{ to } 300 \, \Omega, \text{ currently set to } 120 \, \Omega$$

This motor has compensating windings and interpoles. The magnetization curve for this motor at 1200 r/min is shown in Figure P9-6.

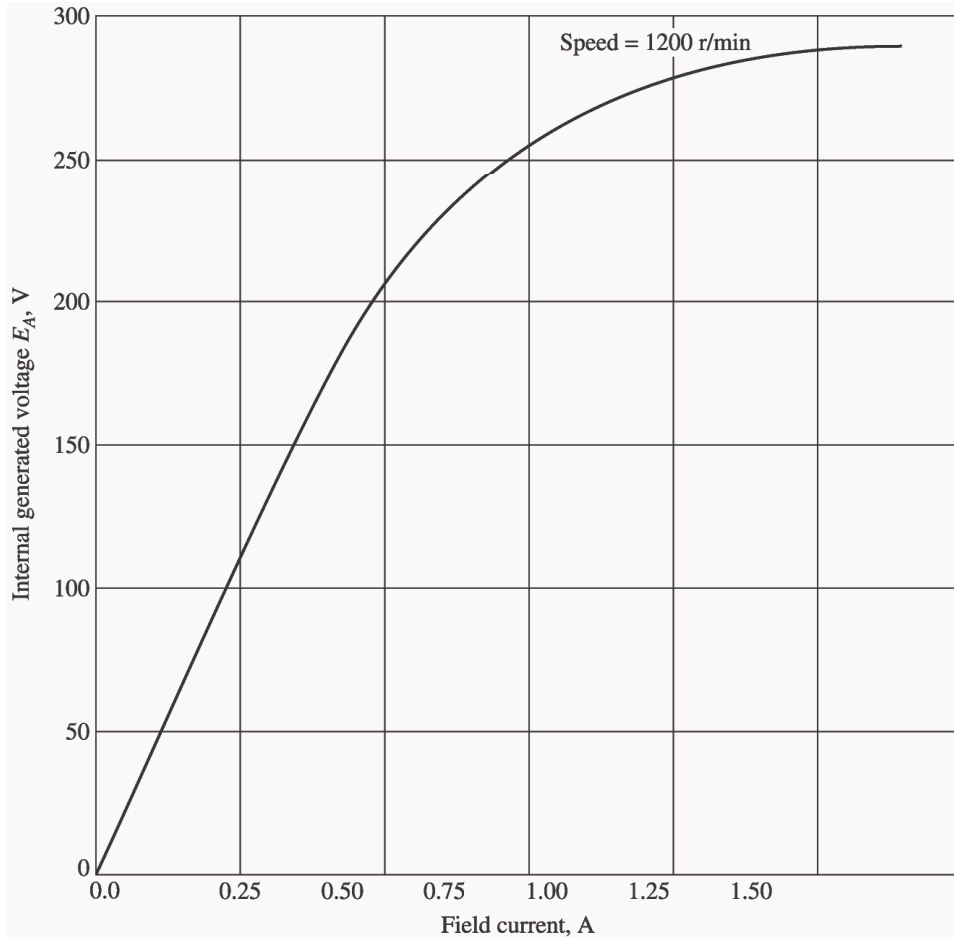

Note: An electronic version of this magnetization curve can be found in file `p96_mag.dat`, which can be used with MATLAB programs. Column 1 contains field current in amps, and column 2 contains the internal generated voltage E_A in volts.

- 9-16.** The motor described above is connected in *shunt*.
- What is the no-load speed of this motor when $R_{\text{adj}} = 120 \, \Omega$?
 - What is its full-load speed?
 - Under no-load conditions, what range of possible speeds can be achieved by adjusting R_{adj} ?

SOLUTION Note that this magnetization curve has been stored in a file called `p96_mag.dat`. The first column of the file is an array of `ia_values`, and the second column is an array of `ea_values`. These values are valid at a speed $n_o = 1200 \text{ r/min}$. These values can be used with the MATLAB `interp1` function to look up an internal generated voltage as follows:

```
load p96_mag.dat;
```

```

if_values = p96_mag(:,1);
ea_values = p96_mag(:,2);
...
Ea = interp1(if_values,ea_values,if,'spline')

```

(a) If $R_{\text{adj}} = 120 \Omega$, the total field resistance is 320Ω , and the resulting field current is

$$I_F = \frac{V_T}{R_F + R_{\text{adj}}} = \frac{240 \text{ V}}{200 \Omega + 120 \Omega} = 0.75 \text{ A}$$

This field current would produce a voltage E_{A_o} of 256 V at a speed of $n_o = 1200 \text{ r/min}$. The actual E_A is 240 V, so the actual speed will be

$$n = \frac{E_A}{E_{A_o}} n_o = \frac{240 \text{ V}}{256 \text{ V}} (1200 \text{ r/min}) = 1125 \text{ r/min}$$

(b) At full load, $I_A = I_L - I_F = 100 \text{ A} - 0.75 \text{ A} = 99.25 \text{ A}$, and

$$E_A = V_T - I_A R_A = 240 \text{ V} - (99.25 \text{ A})(0.14 \Omega) = 226.1 \text{ V}$$

Therefore, the speed at full load will be

$$n = \frac{E_A}{E_{A_o}} n_o = \frac{226.1 \text{ V}}{256 \text{ V}} (1200 \text{ r/min}) = 1060 \text{ r/min}$$

(c) If R_{adj} is maximum at no-load conditions, the total resistance is 500Ω , and

$$I_F = \frac{V_T}{R_F + R_{\text{adj}}} = \frac{240 \text{ V}}{200 \Omega + 300 \Omega} = 0.48 \text{ A}$$

This field current would produce a voltage E_{A_o} of 200 V at a speed of $n_o = 1200 \text{ r/min}$. The actual E_A is 240 V, so the actual speed will be

$$n = \frac{E_A}{E_{A_o}} n_o = \frac{240 \text{ V}}{200 \text{ V}} (1200 \text{ r/min}) = 1440 \text{ r/min}$$

If R_{adj} is minimum at no-load conditions, the total resistance is 200Ω , and

$$I_F = \frac{V_T}{R_F + R_{\text{adj}}} = \frac{240 \text{ V}}{200 \Omega + 0 \Omega} = 1.2 \text{ A}$$

This field current would produce a voltage E_{A_o} of 287 V at a speed of $n_o = 1200 \text{ r/min}$. The actual E_A is 240 V, so the actual speed will be

$$n = \frac{E_A}{E_{A_o}} n_o = \frac{240 \text{ V}}{287 \text{ V}} (1200 \text{ r/min}) = 1004 \text{ r/min}$$

9-17. This machine is now connected as a cumulatively compounded dc motor with $R_{\text{adj}} = 120 \Omega$.

- What is the full-load speed of this motor?
- Plot the torque-speed characteristic for this motor.
- What is its speed regulation?

SOLUTION

(a) At full load, $I_A = I_L - I_F = 100 \text{ A} - 0.75 \text{ A} = 99.25 \text{ A}$, and

$$E_A = V_T - I_A(R_A + R_S) = 240 \text{ V} - (99.25 \text{ A})(0.14 \Omega + 0.05 \Omega) = 221.1 \text{ V}$$

The actual field current will be

$$I_F = \frac{V_T}{R_F + R_{\text{adj}}} = \frac{240 \text{ V}}{200 \Omega + 120 \Omega} = 0.75 \text{ A}$$

and the effective field current will be

$$I_F^* = I_F + \frac{N_{\text{SE}}}{N_F} I_A = 0.75 \text{ A} + \frac{12 \text{ turns}}{1500 \text{ turns}} (99.25 \text{ A}) = 1.54 \text{ A}$$

This field current would produce a voltage E_{A_0} of 290 V at a speed of $n_0 = 1200 \text{ r/min}$. The actual E_A is 240 V, so the actual speed at full load will be

$$n = \frac{E_A}{E_{A_0}} n_0 = \frac{221.1 \text{ V}}{290 \text{ V}} (1200 \text{ r/min}) = 915 \text{ r/min}$$

(b) A MATLAB program to calculate the torque-speed characteristic of this motor is shown below:

```
% M-file: prob9_17.m
% M-file to create a plot of the torque-speed curve of the
% a cumulatively compounded dc motor.

% Get the magnetization curve.
load p96_mag.dat;
if_values = p96_mag(:,1);
ea_values = p96_mag(:,2);
n_0 = 1200;

% First, initialize the values needed in this program.
v_t = 240; % Terminal voltage (V)
r_f = 200; % Field resistance (ohms)
r_adj = 120; % Adjustable resistance (ohms)
r_a = 0.19; % Armature + series resistance (ohms)
i_l = 0:2:100; % Line currents (A)
n_f = 1500; % Number of turns on shunt field
n_se = 12; % Number of turns on series field

% Calculate the armature current for each load.
i_a = i_l - v_t / (r_f + r_adj);

% Now calculate the internal generated voltage for
% each armature current.
e_a = v_t - i_a * r_a;

% Calculate the effective field current for each armature
% current.
i_f = v_t / (r_f + r_adj) + (n_se / n_f) * i_a;

% Calculate the resulting internal generated voltage at
% 1800 r/min by interpolating the motor's magnetization
% curve.
e_a0 = interp1(if_values,ea_values,i_f);
```

```

% Calculate the resulting speed from Equation (9-13).
n = ( e_a ./ e_a0 ) * n_0;

% Calculate the induced torque corresponding to each
% speed from Equations (8-55) and (8-56).
t_ind = e_a .* i_a ./ ( n * 2 * pi / 60 );

% Plot the torque-speed curves
figure(1);
plot(t_ind,n,'b-','LineWidth',2.0);
xlabel('\bf\tau_{ind} (N-m)');
ylabel('\bf\itn_{m} \rm\bf(r/min)');
title ('\bfCumulatively-Compounded DC Motor Torque-Speed
Characteristic');
axis([0 200 900 1600]);
grid on;

```

The resulting torque-speed characteristic is shown below:

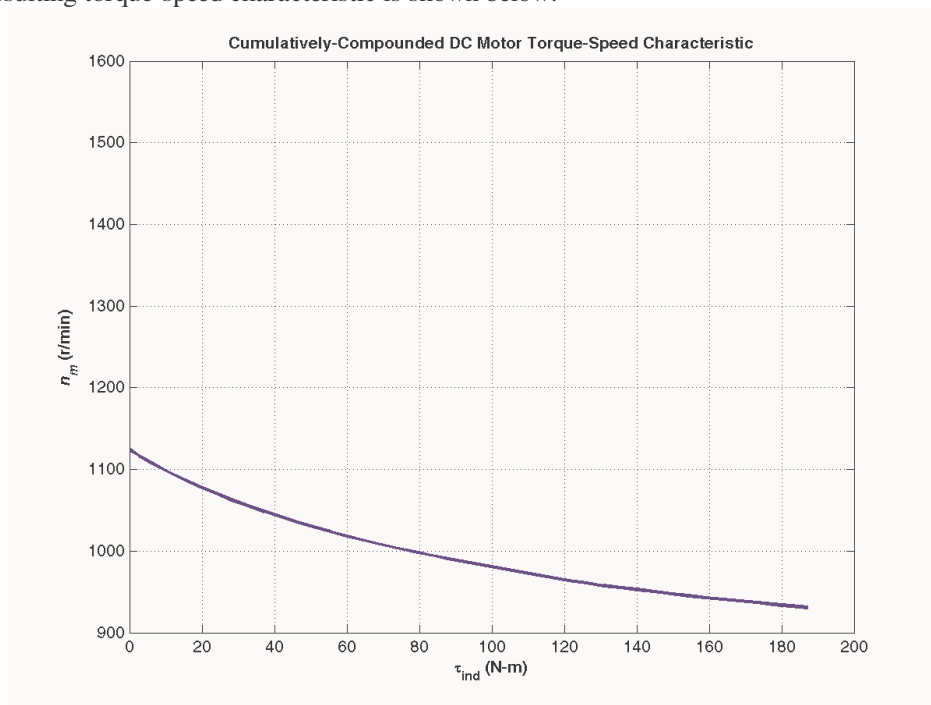

(c) The no-load speed of this machine is the same as the no-load speed of the corresponding shunt dc motor with $R_{adj} = 120 \Omega$, which is 1125 r/min. The speed regulation of this motor is thus

$$SR = \frac{n_{nl} - n_{fl}}{n_{fl}} \times 100\% = \frac{1125 \text{ r/min} - 915 \text{ r/min}}{915 \text{ r/min}} \times 100\% = 23.0\%$$

- 9-18.** The motor is reconnected differentially compounded with $R_{adj} = 120 \Omega$. Derive the shape of its torque-speed characteristic.

SOLUTION A MATLAB program to calculate the torque-speed characteristic of this motor is shown below:

```

% M-file: prob9_18.m
% M-file to create a plot of the torque-speed curve of the

```

```

% a differentially compounded dc motor.

% Get the magnetization curve.
load p96_mag.dat;
if_values = p96_mag(:,1);
ea_values = p96_mag(:,2);
n_0 = 1200;

% First, initialize the values needed in this program.
v_t = 240; % Terminal voltage (V)
r_f = 200; % Field resistance (ohms)
r_adj = 120; % Adjustable resistance (ohms)
r_a = 0.19; % Armature + series resistance (ohms)
i_l = 0:2:40; % Line currents (A)
n_f = 1500; % Number of turns on shunt field
n_se = 12; % Number of turns on series field

% Calculate the armature current for each load.
i_a = i_l - v_t / (r_f + r_adj);

% Now calculate the internal generated voltage for
% each armature current.
e_a = v_t - i_a * r_a;

% Calculate the effective field current for each armature
% current.
i_f = v_t / (r_f + r_adj) - (n_se / n_f) * i_a;

% Calculate the resulting internal generated voltage at
% 1800 r/min by interpolating the motor's magnetization
% curve.
e_a0 = interp1(if_values,ea_values,i_f);

% Calculate the resulting speed from Equation (9-13).
n = ( e_a ./ e_a0 ) * n_0;

% Calculate the induced torque corresponding to each
% speed from Equations (8-55) and (8-56).
t_ind = e_a .* i_a ./ (n * 2 * pi / 60);

% Plot the torque-speed curves
figure(1);
plot(t_ind,n,'b-','LineWidth',2.0);
xlabel('\bf\tau_{ind} (N-m)');
ylabel('\bf\itn_{m} \rm\bf(r/min)');
title ('\bfDifferentially-Compounded DC Motor Torque-Speed
Characteristic');
axis([0 200 900 1600]);
grid on;

```

The resulting torque-speed characteristic is shown below:

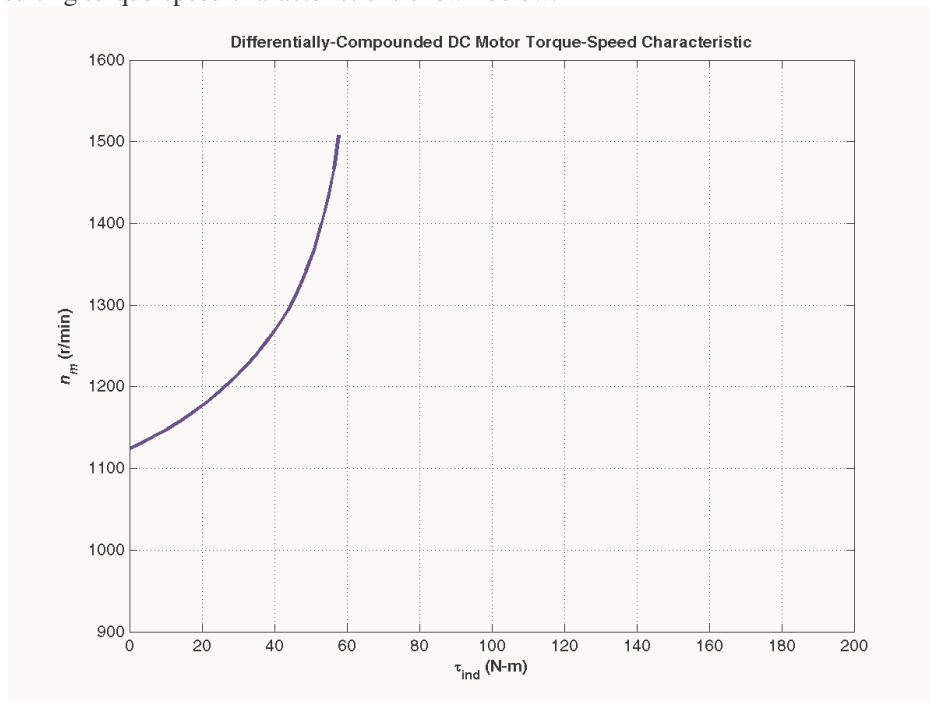

This curve is plotted on the same scale as the torque-speed curve in Problem 6-17. Compare the two curves.

- 9-19.** A series motor is now constructed from this machine by leaving the shunt field out entirely. Derive the torque-speed characteristic of the resulting motor.

SOLUTION This motor will have extremely high speeds, since there are only a few series turns, and the flux in the motor will be very small. A MATLAB program to calculate the torque-speed characteristic of this motor is shown below:

```
% M-file: prob9_19.m
% M-file to create a plot of the torque-speed curve of the
% a series dc motor. This motor was formed by removing
% the shunt field from the cumulatively-compounded machine
% if Problem 9-17.

% Get the magnetization curve.
load p96_mag.dat;
if_values = p96_mag(:,1);
ea_values = p96_mag(:,2);
n_0 = 1200;

% First, initialize the values needed in this program.
v_t = 240;           % Terminal voltage (V)
r_a = 0.19;         % Armature + series resistance (ohms)
i_l = 20:1:45;     % Line currents (A)
n_f = 1500;        % Number of turns on shunt field
n_se = 12;         % Number of turns on series field

% Calculate the armature current for each load.
i_a = i_l;
```

```

% Now calculate the internal generated voltage for
% each armature current.
e_a = v_t - i_a * r_a;

% Calculate the effective field current for each armature
% current. (Note that the magnetization curve is defined
% in terms of shunt field current, so we will have to
% translate the series field current into an equivalent
% shunt field current.
i_f = (n_se / n_f) * i_a;

% Calculate the resulting internal generated voltage at
% 1800 r/min by interpolating the motor's magnetization
% curve.
e_a0 = interp1(if_values,ea_values,i_f);

% Calculate the resulting speed from Equation (9-13).
n = ( e_a ./ e_a0 ) * n_0;

% Calculate the induced torque corresponding to each
% speed from Equations (8-55) and (8-56).
t_ind = e_a .* i_a ./ (n * 2 * pi / 60);

% Plot the torque-speed curves
figure(1);
plot(t_ind,n,'b-','LineWidth',2.0);
xlabel('\bf\tau_{ind} (N-m)');
ylabel('\bf\itn_{m} \rm\bf(r/min)');
title ('\bfSeries DC Motor Torque-Speed Characteristic');
grid on;

```

The resulting torque-speed characteristic is shown below:

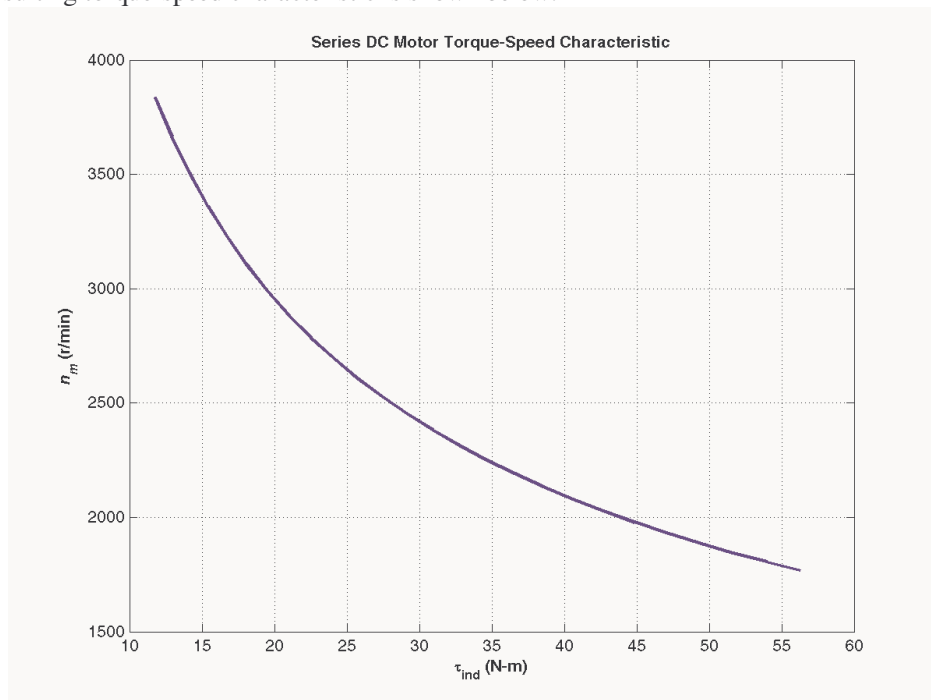

The extreme speeds in this characteristic are due to the very light flux in the machine. To make a practical series motor out of this machine, it would be necessary to include 20 to 30 series turns instead of 12.

- 9-20.** An automatic starter circuit is to be designed for a shunt motor rated at 15 hp, 240 V, and 60 A. The armature resistance of the motor is 0.15Ω , and the shunt field resistance is 40Ω . The motor is to start with no more than 250 percent of its rated armature current, and as soon as the current falls to rated value, a starting resistor stage is to be cut out. How many stages of starting resistance are needed, and how big should each one be?

SOLUTION The rated line current of this motor is 60 A, and the rated armature current is $I_A = I_L - I_F = 60 \text{ A} - 6 \text{ A} = 54 \text{ A}$. The maximum desired starting current is $(2.5)(54 \text{ A}) = 135 \text{ A}$. Therefore, the total initial starting resistance must be

$$R_A + R_{\text{start},1} = \frac{240 \text{ V}}{135 \text{ A}} = 1.778 \Omega$$

$$R_{\text{start},1} = 1.778 \Omega - 0.15 \Omega = 1.628 \Omega$$

The current will fall to rated value when E_A rises to

$$E_A = 240 \text{ V} - (1.778 \Omega)(54 \text{ A}) = 144 \text{ V}$$

At that time, we want to cut out enough resistance to get the current back up to 135 A. Therefore,

$$R_A + R_{\text{start},2} = \frac{240 \text{ V} - 144 \text{ V}}{135 \text{ A}} = 0.711 \Omega$$

$$R_{\text{start},2} = 0.711 \Omega - 0.15 \Omega = 0.561 \Omega$$

With this resistance in the circuit, the current will fall to rated value when E_A rises to

$$E_A = 240 \text{ V} - (0.711 \Omega)(54 \text{ A}) = 201.6 \text{ V}$$

At that time, we want to cut out enough resistance to get the current back up to 135 A. Therefore,

$$R_A + R_{\text{start},3} = \frac{240 \text{ V} - 201.6 \text{ V}}{135 \text{ A}} = 0.284 \Omega$$

$$R_{\text{start},3} = 0.284 \Omega - 0.15 \Omega = 0.134 \Omega$$

With this resistance in the circuit, the current will fall to rated value when E_A rises to

$$E_A = 240 \text{ V} - (0.284 \Omega)(54 \text{ A}) = 224.7 \text{ V}$$

If the resistance is cut out when E_A reaches 224.7 V, the resulting current is

$$I_A = \frac{240 \text{ V} - 224.7 \text{ V}}{0.15 \Omega} = 102 \text{ A} < 135 \text{ A},$$

so there are only three stages of starting resistance. The three stages of starting resistance can be found from the resistance in the circuit at each state during starting.

$$R_{\text{start},1} = R_1 + R_2 + R_3 = 1.628 \Omega$$

$$R_{\text{start},2} = R_2 + R_3 = 0.561 \Omega$$

$$R_{\text{start},3} = R_3 = 0.134 \Omega$$

Therefore, the starting resistances are

$$R_1 = 1.067 \Omega$$

$$R_2 = 0.427 \Omega$$

$$R_3 = 0.134 \Omega$$

- 9-21.** A 15-hp 120-V 1800 r/min shunt dc motor has a full-load armature current of 60 A when operating at rated conditions. The armature resistance of the motor is $R_A = 0.15 \Omega$, and the field resistance R_F is 80Ω . The adjustable resistance in the field circuit R_{adj} may be varied over the range from 0 to 200Ω and is currently set to 90Ω . Armature reaction may be ignored in this machine. The magnetization curve for this motor, taken at a speed of 1800 r/min, is given in tabular form below:

E_A , V	5	78	95	112	118	126
I_F , A	0.00	0.80	1.00	1.28	1.44	2.88

Note: An electronic version of this magnetization curve can be found in file prob9_21_mag.dat, which can be used with MATLAB programs. Column 1 contains field current in amps, and column 2 contains the internal generated voltage E_A in volts.

- (a) What is the speed of this motor when it is running at the rated conditions specified above?
- (b) The output power from the motor is 7.5 hp at rated conditions. What is the output torque of the motor?
- (c) What are the copper losses and rotational losses in the motor at full load (ignore stray losses)?
- (d) What is the efficiency of the motor at full load?
- (e) If the motor is now unloaded with no changes in terminal voltage or R_{adj} , what is the no-load speed of the motor?
- (f) Suppose that the motor is running at the no-load conditions described in part (e). What would happen to the motor if its field circuit were to open? Ignoring armature reaction, what would the final steady-state speed of the motor be under those conditions?
- (g) What range of no-load speeds is possible in this motor, given the range of field resistance adjustments available with R_{adj} ?

SOLUTION

- (a) If $R_{adj} = 90 \Omega$, the total field resistance is 170Ω , and the resulting field current is

$$I_F = \frac{V_T}{R_F + R_{adj}} = \frac{230 \text{ V}}{90 \Omega + 80 \Omega} = 1.35 \text{ A}$$

This field current would produce a voltage E_{Ao} of 221 V at a speed of $n_o = 1800$ r/min. The actual E_A is

$$E_A = V_T - I_A R_A = 230 \text{ V} - (60 \text{ A})(0.15 \Omega) = 221 \text{ V}$$

so the actual speed will be

$$n = \frac{E_A}{E_{Ao}} n_o = \frac{221 \text{ V}}{221 \text{ V}} (1800 \text{ r/min}) = 1800 \text{ r/min}$$

- (b) The output power is 7.5 hp and the output speed is 1800 r/min at rated conditions, therefore, the torque is

$$\tau_{\text{out}} = \frac{P_{\text{out}}}{\omega_m} = \frac{(15 \text{ hp})(746 \text{ W/hp})}{(1800 \text{ r/min}) \frac{2\pi \text{ rad}}{1 \text{ r}} \frac{1 \text{ min}}{60 \text{ s}}} = 59.4 \text{ N} \cdot \text{m}$$

- (c) The copper losses are

$$P_{\text{CU}} = I_A^2 R_A + V_F I_F = (60 \text{ A})^2 (0.15 \Omega) + (230 \text{ V})(1.35 \text{ A}) = 851 \text{ W}$$

The power converted from electrical to mechanical form is

$$P_{\text{conv}} = E_A I_A = (221 \text{ V})(60 \text{ A}) = 13,260 \text{ W}$$

The output power is

$$P_{\text{OUT}} = (15 \text{ hp})(746 \text{ W/hp}) = 11,190 \text{ W}$$

Therefore, the rotational losses are

$$P_{\text{rot}} = P_{\text{conv}} - P_{\text{OUT}} = 13,260 \text{ W} - 11,190 \text{ W} = 2070 \text{ W}$$

(d) The input power to this motor is

$$P_{\text{IN}} = V_T (I_A + I_F) = (230 \text{ V})(60 \text{ A} + 1.35 \text{ A}) = 14,100 \text{ W}$$

Therefore, the efficiency is

$$\eta = \frac{P_{\text{OUT}}}{P_{\text{IN}}} \times 100\% = \frac{11,190 \text{ W}}{14,100 \text{ W}} \times 100\% = 79.4\%$$

(e) The no-load E_A will be 230 V, so the no-load speed will be

$$n = \frac{E_A}{E_{A_o}} n_o = \frac{230 \text{ V}}{221 \text{ V}} (1800 \text{ r/min}) = 1873 \text{ r/min}$$

(f) If the field circuit opens, the field current would go to zero $\Rightarrow \phi$ drops to $\phi_{\text{res}} \Rightarrow E_A \downarrow \Rightarrow I_A \uparrow \Rightarrow \tau_{\text{ind}} \uparrow \Rightarrow n \uparrow$ to a very high speed. If $I_F = 0 \text{ A}$, $E_{A_o} = 8.5 \text{ V}$ at 1800 r/min, so

$$n = \frac{E_A}{E_{A_o}} n_o = \frac{230 \text{ V}}{8.5 \text{ V}} (1800 \text{ r/min}) = 48,700 \text{ r/min}$$

(In reality, the motor speed would be limited by rotational losses, or else the motor will destroy itself first.)

(g) The maximum value of $R_{\text{adj}} = 200 \Omega$, so

$$I_F = \frac{V_T}{R_F + R_{\text{adj}}} = \frac{230 \text{ V}}{200 \Omega + 80 \Omega} = 0.821 \text{ A}$$

This field current would produce a voltage E_{A_o} of 153 V at a speed of $n_o = 1800 \text{ r/min}$. The actual E_A is 230 V, so the actual speed will be

$$n = \frac{E_A}{E_{A_o}} n_o = \frac{230 \text{ V}}{153 \text{ V}} (1800 \text{ r/min}) = 2706 \text{ r/min}$$

The minimum value of $R_{\text{adj}} = 0 \Omega$, so

$$I_F = \frac{V_T}{R_F + R_{\text{adj}}} = \frac{230 \text{ V}}{0 \Omega + 80 \Omega} = 2.875 \text{ A}$$

This field current would produce a voltage E_{A_o} of about 242 V at a speed of $n_o = 1800 \text{ r/min}$. The actual E_A is 230 V, so the actual speed will be

$$n = \frac{E_A}{E_{Ao}} n_o = \frac{230 \text{ V}}{242 \text{ V}} (1800 \text{ r/min}) = 1711 \text{ r/min}$$

9-22. The magnetization curve for a separately excited dc generator is shown in Figure P9-7. The generator is rated at 6 kW, 120 V, 50 A, and 1800 r/min and is shown in Figure P9-8. Its field circuit is rated at 5A. The following data are known about the machine:

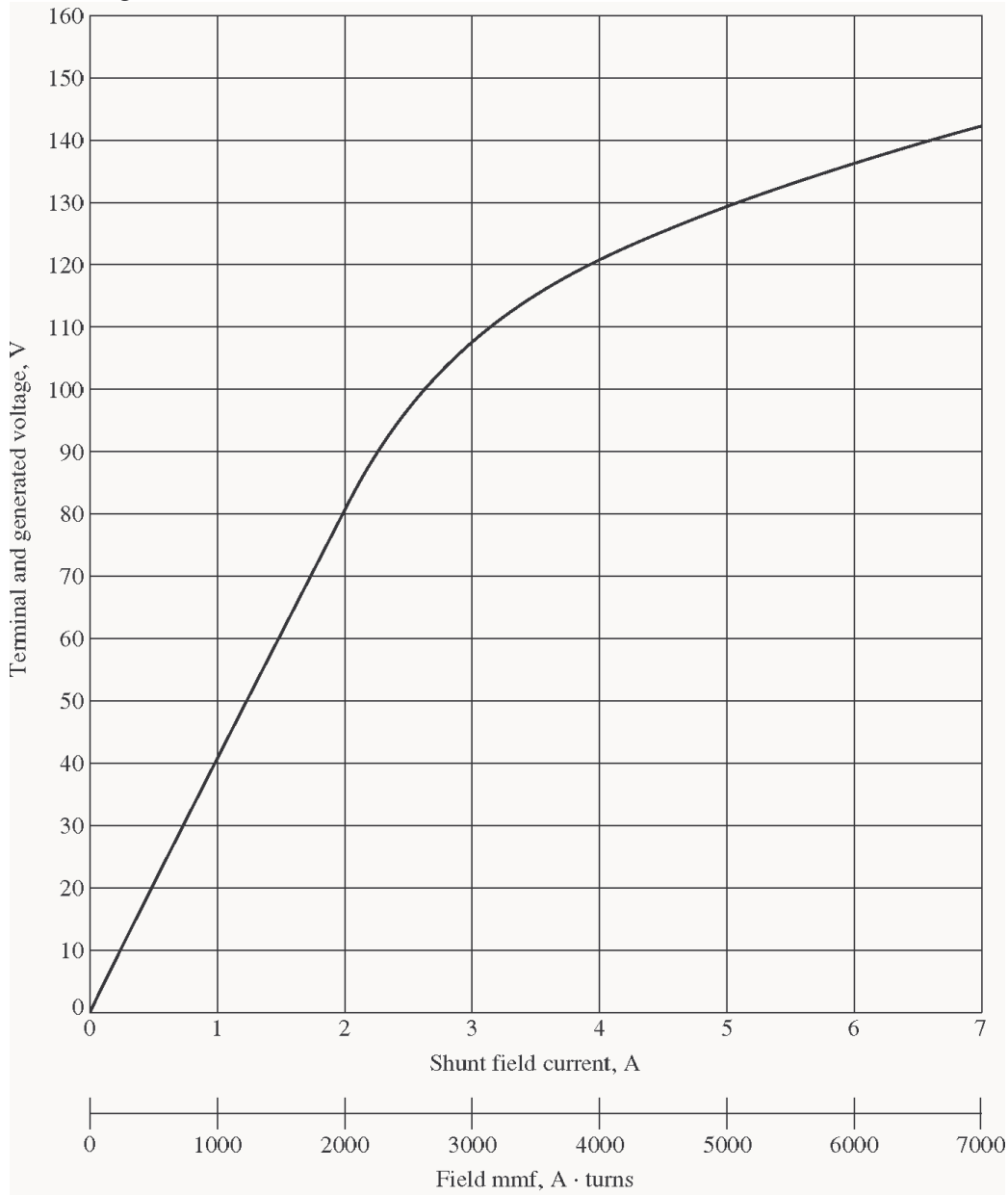

Note: An electronic version of this magnetization curve can be found in file p97_mag.dat, which can be used with MATLAB programs. Column 1 contains field current in amps, and column 2 contains the internal generated voltage E_A in volts.

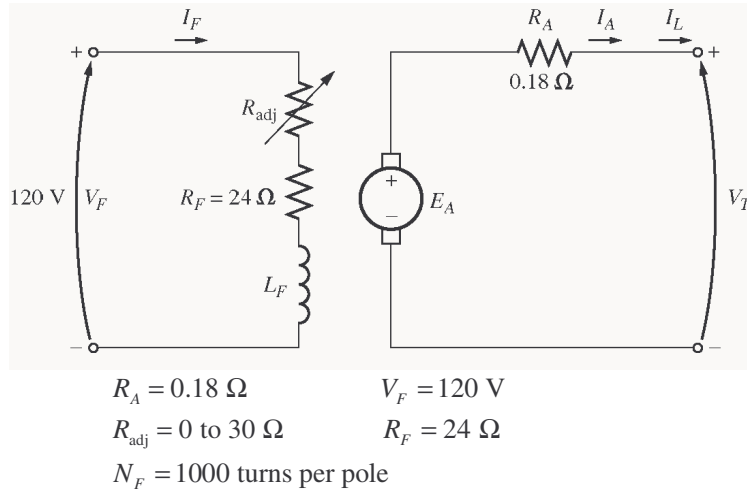

Answer the following questions about this generator, assuming no armature reaction.

- (a) If this generator is operating at no load, what is the range of voltage adjustments that can be achieved by changing R_{adj} ?
- (b) If the field rheostat is allowed to vary from 0 to 30 Ω and the generator's speed is allowed to vary from 1500 to 2000 r/min, what are the maximum and minimum no-load voltages in the generator?

SOLUTION

(a) If the generator is operating with no load at 1800 r/min, then the terminal voltage will equal the internal generated voltage E_A . The maximum possible field current occurs when $R_{adj} = 0 \Omega$. The current is

$$I_{F,\max} = \frac{V_F}{R_F + R_{adj}} = \frac{120 \text{ V}}{24 \Omega + 0 \Omega} = 5 \text{ A}$$

From the magnetization curve, the voltage E_{Ao} at 1800 r/min is 129 V. Since the actual speed is 1800 r/min, the maximum no-load voltage is 129 V.

The minimum possible field current occurs when $R_{adj} = 30 \Omega$. The current is

$$I_{F,\max} = \frac{V_F}{R_F + R_{adj}} = \frac{120 \text{ V}}{24 \Omega + 30 \Omega} = 2.22 \text{ A}$$

From the magnetization curve, the voltage E_{Ao} at 1800 r/min is 87.4 V. Since the actual speed is 1800 r/min, the minimum no-load voltage is 87 V.

(b) The maximum voltage will occur at the highest current and speed, and the minimum voltage will occur at the lowest current and speed. The maximum possible field current occurs when $R_{adj} = 0 \Omega$. The current is

$$I_{F,\max} = \frac{V_F}{R_F + R_{adj}} = \frac{120 \text{ V}}{24 \Omega + 0 \Omega} = 5 \text{ A}$$

From the magnetization curve, the voltage E_{Ao} at 1800 r/min is 129 V. Since the actual speed is 2000 r/min, the maximum no-load voltage is

$$\frac{E_A}{E_{Ao}} = \frac{n}{n_o}$$

$$E_A = \frac{n}{n_o} E_{Ao} = \frac{2000 \text{ r/min}}{1800 \text{ r/min}} (129 \text{ V}) = 143 \text{ V}$$

The minimum possible field current occurs when $R_{\text{adj}} = 30 \Omega$. The current is

$$I_{F,\text{max}} = \frac{V_F}{R_F + R_{\text{adj}}} = \frac{120 \text{ V}}{24 \Omega + 30 \Omega} = 2.22 \text{ A}$$

From the magnetization curve, the voltage E_{Ao} at 1800 r/min is 87.4 V. Since the actual speed is 1500 r/min, the maximum no-load voltage is

$$\frac{E_A}{E_{Ao}} = \frac{n}{n_o}$$

$$E_A = \frac{n}{n_o} E_{Ao} = \frac{1500 \text{ r/min}}{1800 \text{ r/min}} (87.4 \text{ V}) = 72.8 \text{ V}$$

- 9-23.** If the armature current of the generator in Problem 9-22 is 50 A, the speed of the generator is 1700 r/min, and the terminal voltage is 106 V, how much field current must be flowing in the generator?

SOLUTION The internal generated voltage of this generator is

$$E_A = V_T + I_A R_A = 106 \text{ V} + (50 \text{ A})(0.18 \Omega) = 115 \text{ V}$$

at a speed of 1700 r/min. This corresponds to an E_{Ao} at 1800 r/min of

$$\frac{E_A}{E_{Ao}} = \frac{n}{n_o}$$

$$E_{Ao} = \frac{n_o}{n} E_A = \frac{1800 \text{ r/min}}{1700 \text{ r/min}} (115 \text{ V}) = 121.8 \text{ V}$$

From the magnetization curve, this value of E_{Ao} requires a field current of 4.2 A.

- 9-24.** Assuming that the generator in Problem 9-22 has an armature reaction at full load equivalent to 400 A·turns of magnetomotive force, what will the terminal voltage of the generator be when $I_F = 5 \text{ A}$, $n_m = 1700 \text{ r/min}$, and $I_A = 50 \text{ A}$?

SOLUTION When I_F is 5 A and the armature current is 50 A, the magnetomotive force in the generator is

$$\mathcal{F}_{\text{net}} = NI_F - \mathcal{F}_{\text{AR}} = (1000 \text{ turns})(5 \text{ A}) - 400 \text{ A} \cdot \text{turns} = 4600 \text{ A} \cdot \text{turns}$$

or $I_F^* = \mathcal{F}_{\text{net}} / N_F = 4600 \text{ A} \cdot \text{turns} / 1000 \text{ turns} = 4.6 \text{ A}$

The equivalent internal generated voltage E_{Ao} of the generator at 1800 r/min would be 126 V. The actual voltage at 1700 r/min would be

$$E_A = \frac{n}{n_o} E_{Ao} = \frac{1700 \text{ r/min}}{1800 \text{ r/min}} (126 \text{ V}) = 119 \text{ V}$$

Therefore, the terminal voltage would be

$$V_T = E_A - I_A R_A = 119 \text{ V} - (50 \text{ A})(0.18 \Omega) = 110 \text{ V}$$

9-25. The machine in Problem 9-22 is reconnected as a shunt generator and is shown in Figure P9-9. The shunt field resistor R_{adj} is adjusted to $10\ \Omega$, and the generator's speed is 1800 r/min.

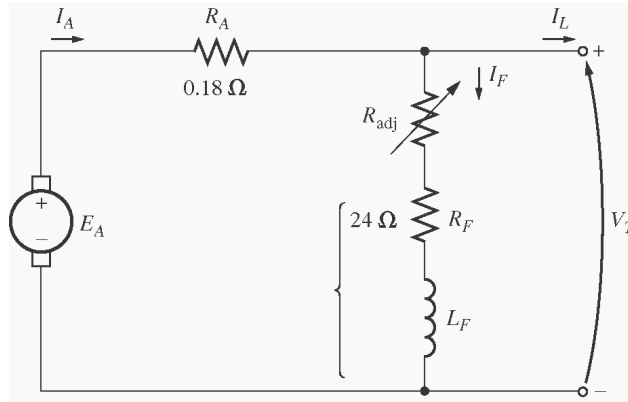

- (a) What is the no-load terminal voltage of the generator?
- (b) Assuming no armature reaction, what is the terminal voltage of the generator with an armature current of 20 A? 40 A?
- (c) Assuming an armature reaction equal to 200 A-turns at full load, what is the terminal voltage of the generator with an armature current of 20 A? 40 A?
- (d) Calculate and plot the terminal characteristics of this generator with and without armature reaction.

SOLUTION

(a) The total field resistance of this generator is $34\ \Omega$, and the no-load terminal voltage can be found from the intersection of the resistance line with the magnetization curve for this generator. The magnetization curve and the field resistance line are plotted below. As you can see, they intersect at a terminal voltage of 112 V.

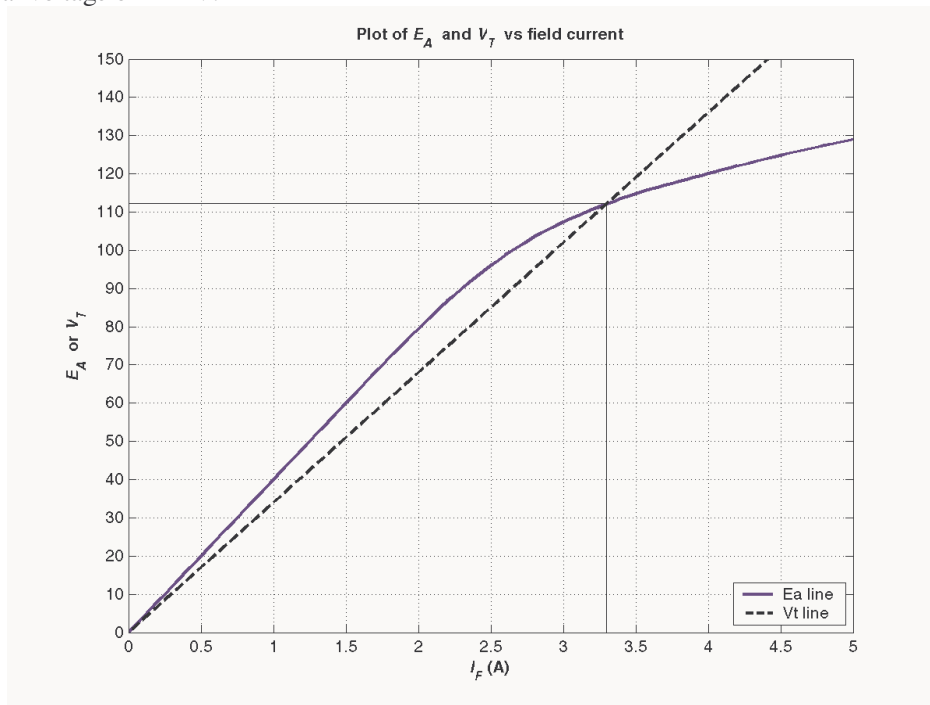

(b) At an armature current of 20 A, the internal voltage drop in the armature resistance is $(20 \text{ A})(0.18 \Omega) = 3.6 \text{ V}$. As shown in the figure below, there is a difference of 3.6 V between E_A and V_T at a terminal voltage of about 106 V.

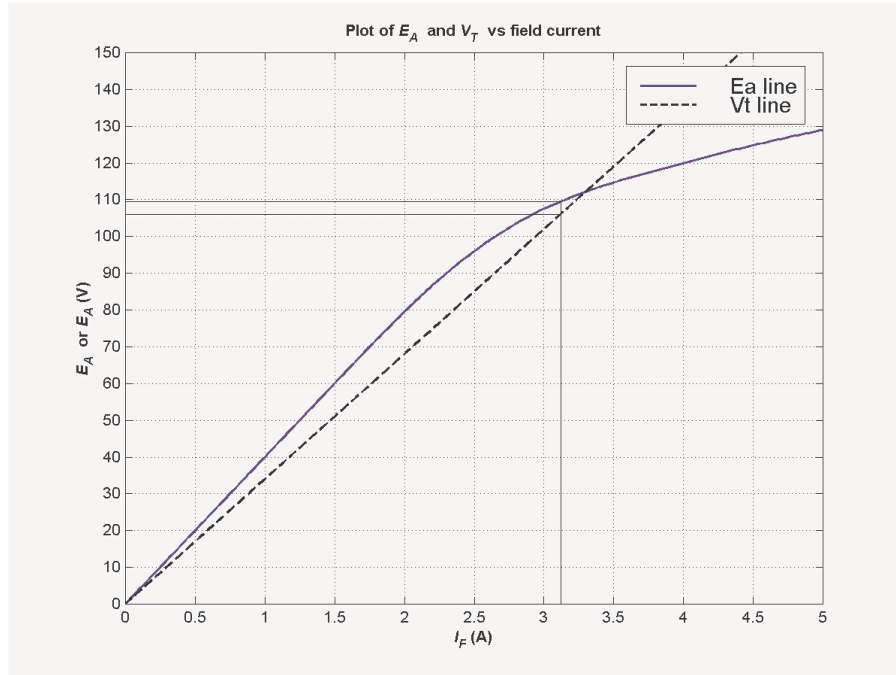

A MATLAB program to locate the position where the triangle exactly fits between the E_A and V_T lines is shown below. This program created the plot shown above. Note that there are actually two places where the difference between the E_A and V_T lines is 3.6 volts, but the low-voltage one of them is unstable. The code shown in bold face below prevents the program from reporting that first (unstable) point.

```
% M-file: prob9_25b.m
% M-file to create a plot of the magnetization curve and the
%   field current curve of a shunt dc generator, determining
%   the point where the difference between them is 3.6 V.

% Get the magnetization curve. This file contains the
% three variables if_values, ea_values, and n_0.
clear all
load p97_mag.dat;
if_values = p97_mag(:,1);
ea_values = p97_mag(:,2);
n_0 = 1800;

% First, initialize the values needed in this program.
r_f = 24;           % Field resistance (ohms)
r_adj = 10;        % Adjustable resistance (ohms)
r_a = 0.19;        % Armature + series resistance (ohms)
i_f = 0:0.02:6;    % Field current (A)
n = 1800;          % Generator speed (r/min)

% Calculate Ea versus If
Ea = interp1(if_values,ea_values,i_f);
```

```

% Calculate Vt versus If
Vt = (r_f + r_adj) * i_f;

% Find the point where the difference between the two
% lines is 3.6 V. This will be the point where the line
% line "Ea - Vt - 3.6" goes negative. That will be a
% close enough estimate of Vt.
diff = Ea - Vt - 3.6;

% This code prevents us from reporting the first (unstable)
% location satisfying the criterion.
was_pos = 0;
for ii = 1:length(i_f);
    if diff(ii) > 0
        was_pos = 1;
    end
    if ( diff(ii) < 0 & was_pos == 1 )
        break;
    end;
end;

% We have the intersection. Tell user.
disp (['Ea = ' num2str(Ea(ii)) ' V']);
disp (['Vt = ' num2str(Vt(ii)) ' V']);
disp (['If = ' num2str(i_f(ii)) ' A']);

% Plot the curves
figure(1);
plot(i_f,Ea,'b-','LineWidth',2.0);
hold on;
plot(i_f,Vt,'k--','LineWidth',2.0);
% Plot intersections
plot([i_f(ii) i_f(ii)], [0 Ea(ii)], 'k-');
plot([0 i_f(ii)], [Vt(ii) Vt(ii)], 'k-');
plot([0 i_f(ii)], [Ea(ii) Ea(ii)], 'k-');
xlabel('\bf\itI_{F} \rm\bf(A)');
ylabel('\bf\itE_{A} \rm\bf or \itV_{T}');
title ('\bfPlot of \itE_{A} \rm\bf and \itV_{T} \rm\bf vs field
current');
axis ([0 5 0 150]);
set(gca,'YTick',[0 10 20 30 40 50 60 70 80 90 100 110 120 130 140
150]')
set(gca,'XTick',[0 0.5 1.0 1.5 2.0 2.5 3.0 3.5 4.0 4.5 5.0]')
legend ('Ea line','Vt line',4);
hold off;
grid on;

```

At an armature current of 40 A, the internal voltage drop in the armature resistance is $(40\text{ A})(0.18\ \Omega) = 7.2\text{ V}$. As shown in the figure below, there is a difference of 7.2 V between E_A and V_T at a terminal voltage of about 98 V.

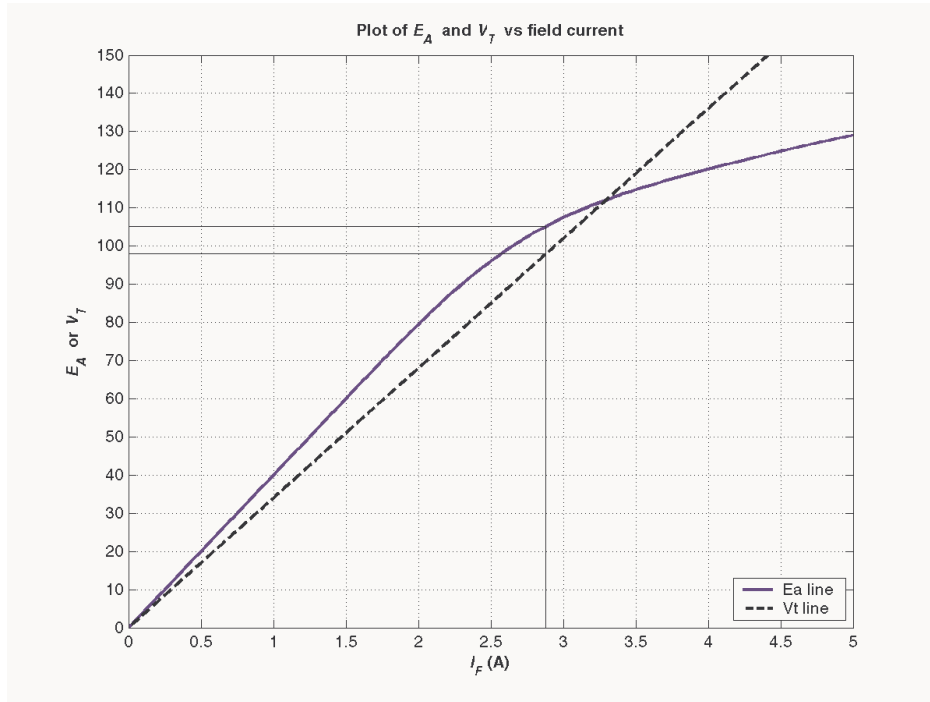

(c) The rated current of this generated is 50 A, so 20 A is 40% of full load. If the full load armature reaction is 200 A-turns, and if the armature reaction is assumed to change linearly with armature current, then the armature reaction will be 80 A-turns. The figure below shows that a triangle consisting of 3.6 V and $(80 \text{ A-turns}) / (1000 \text{ turns}) = 0.08 \text{ A}$ fits exactly between the E_A and V_T lines at a terminal voltage of 103 V.

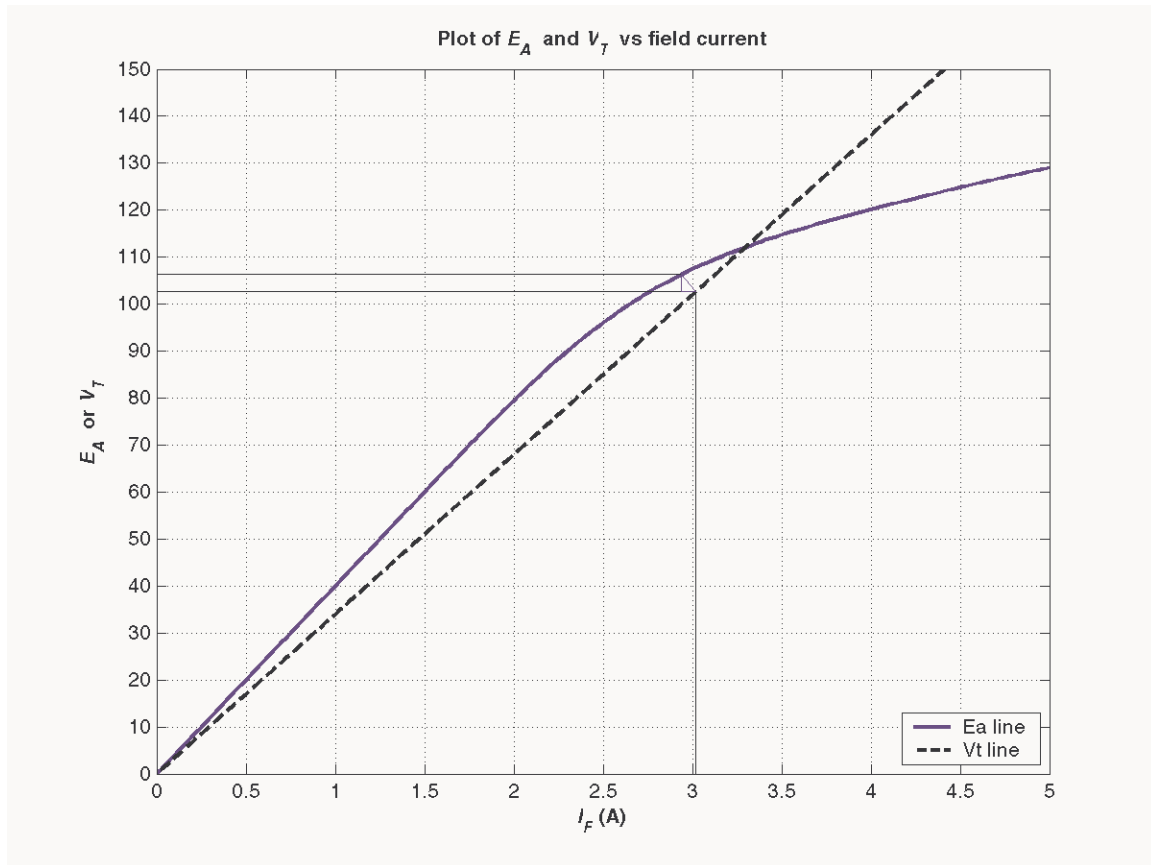

The rated current of this generator is 50 A, so 40 A is 80% of full load. If the full load armature reaction is 200 A·turns, and if the armature reaction is assumed to change linearly with armature current, then the armature reaction will be 160 A·turns. *There is no point* where a triangle consisting of 3.6 V and (80 A·turns)/(1000 turns) = 0.16 A fits exactly between the E_A and V_T lines, so this is not a stable operating condition.

(c) A MATLAB program to calculate the terminal characteristic of this generator without armature reaction is shown below:

```
% M-file: prob9_25d.m
% M-file to calculate the terminal characteristic of a shunt
% dc generator without armature reaction.

% Get the magnetization curve. This file contains the
% three variables if_values, ea_values, and n_0.
load p97_mag.dat;
if_values = p97_mag(:,1);
ea_values = p97_mag(:,2);
n_0 = 1800;

% First, initialize the values needed in this program.
r_f = 24;           % Field resistance (ohms)
r_adj = 10;        % Adjustable resistance (ohms)
r_a = 0.18;        % Armature + series resistance (ohms)
i_f = 0:0.005:6;  % Field current (A)
n = 1800;          % Generator speed (r/min)
```

```

% Calculate Ea versus If
Ea = interp1(if_values,ea_values,i_f);

% Calculate Vt versus If
Vt = (r_f + r_adj) * i_f;

% Find the point where the difference between the two
% lines is exactly equal to i_a*r_a. This will be the
% point where the line line "Ea - Vt - i_a*r_a" goes
% negative.
i_a = 0:1:50;
for jj = 1:length(i_a)

    % Get the voltage difference
    diff = Ea - Vt - i_a(jj)*r_a;

    % This code prevents us from reporting the first (unstable)
    % location satisfying the criterion.
    was_pos = 0;
    for ii = 1:length(i_f);
        if diff(ii) > 0
            was_pos = 1;
        end
        if ( diff(ii) < 0 & was_pos == 1 )
            break;
        end;
    end;

    % Save terminal voltage at this point
    v_t(jj) = Vt(ii);
    i_l(jj) = i_a(jj) - v_t(jj) / ( r_f + r_adj);

end;

% Plot the terminal characteristic
figure(1);
plot(i_l,v_t,'b-','LineWidth',2.0);
xlabel('\bf\itI_{L} \rm\bf(A)');
ylabel('\bf\itV_{T} \rm\bf(V)');
title ('\bfTerminal Characteristic of a Shunt DC Generator');
hold off;
axis( [ 0 50 0 120]);
grid on;

```

The resulting terminal characteristic is shown below:

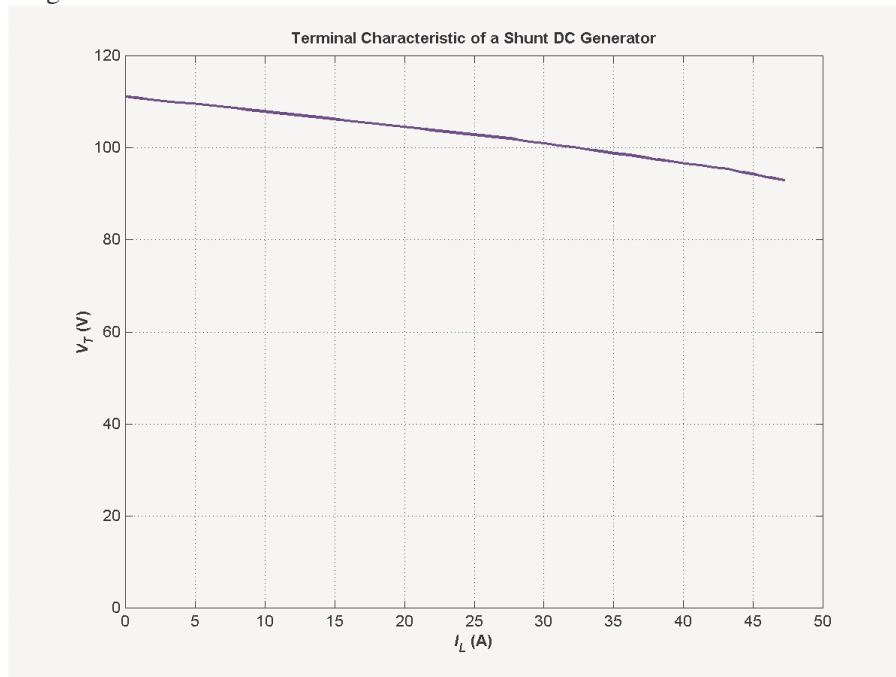

A MATLAB program to calculate the terminal characteristic of this generator with armature reaction is shown below:

```
% M-file: prob9_25d2.m
% M-file to calculate the terminal characteristic of a shunt
% dc generator with armature reaction.

% Get the magnetization curve. This file contains the
% three variables if_values, ea_values, and n_0.
clear all
load p97_mag.dat;
if_values = p97_mag(:,1);
ea_values = p97_mag(:,2);
n_0 = 1800;

% First, initialize the values needed in this program.
r_f = 24; % Field resistance (ohms)
r_adj = 10; % Adjustable resistance (ohms)
r_a = 0.18; % Armature + series resistance (ohms)
i_f = 0:0.005:6; % Field current (A)
n = 1800; % Generator speed (r/min)
n_f = 1000; % Number of field turns

% Calculate Ea versus If
Ea = interp1(if_values,ea_values,i_f);

% Calculate Vt versus If
Vt = (r_f + r_adj) * i_f;

% Find the point where the difference between the Ea
% armature reaction line and the Vt line is exactly
% equal to i_a*r_a. This will be the point where
```

```

% the line "Ea_ar - Vt - i_a*r_a" goes negative.
i_a = 0:1:37;
for jj = 1:length(i_a)

    % Calculate the equivalent field current due to armature
    % reaction.
    i_ar = (i_a(jj) / 50) * 200 / n_f;

    % Calculate the Ea values modified by armature reaction
    Ea_ar = interp1(if_values,ea_values,i_f - i_ar);

    % Get the voltage difference
    diff = Ea_ar - Vt - i_a(jj)*r_a;

    % This code prevents us from reporting the first (unstable)
    % location satisfying the criterion.
    was_pos = 0;
    for ii = 1:length(i_f);
        if diff(ii) > 0
            was_pos = 1;
        end
        if ( diff(ii) < 0 & was_pos == 1 )
            break;
        end;
    end;

    % Save terminal voltage at this point
    v_t(jj) = Vt(ii);
    i_l(jj) = i_a(jj) - v_t(jj) / ( r_f + r_adj);

end;

% Plot the terminal characteristic
figure(1);
plot(i_l,v_t,'b-','LineWidth',2.0);
xlabel('\bf\itI_{L} \rm\bf(A)');
ylabel('\bf\itV_{T} \rm\bf(V)');
title ('\bfTerminal Characteristic of a Shunt DC Generator w/AR');
hold off;
axis([ 0 50 0 120]);
grid on;

```

The resulting terminal characteristic is shown below:

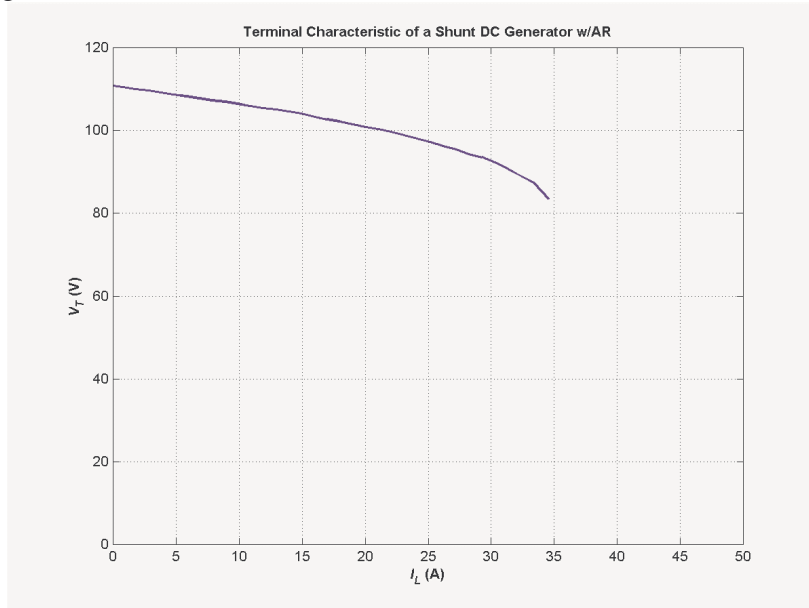

- 9-26.** If the machine in Problem 9-25 is running at 1800 r/min with a field resistance $R_{adj} = 10 \Omega$ and an armature current of 25 A, what will the resulting terminal voltage be? If the field resistor decreases to 5Ω while the armature current remains 25 A, what will the new terminal voltage be? (Assume no armature reaction.)

SOLUTION If $I_A = 25$ A, then $I_A R_A = (25 \text{ A})(0.18 \Omega) = 4.5$ V. The point where the distance between the E_A and V_T curves is exactly 4.5 V corresponds to a terminal voltage of 104 V, as shown below.

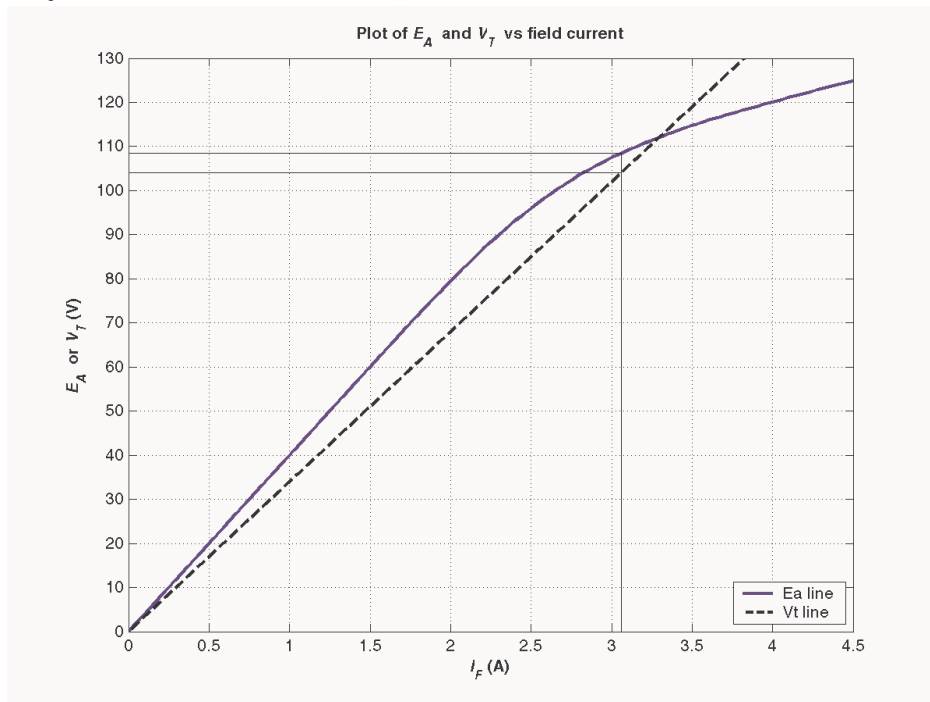

If R_{adj} decreases to $5\ \Omega$, the total field resistance becomes $29\ \Omega$, and the terminal voltage line gets shallower. The new point where the distance between the E_A and V_T curves is exactly $4.5\ \text{V}$ corresponds to a terminal voltage of $115\ \text{V}$, as shown below.

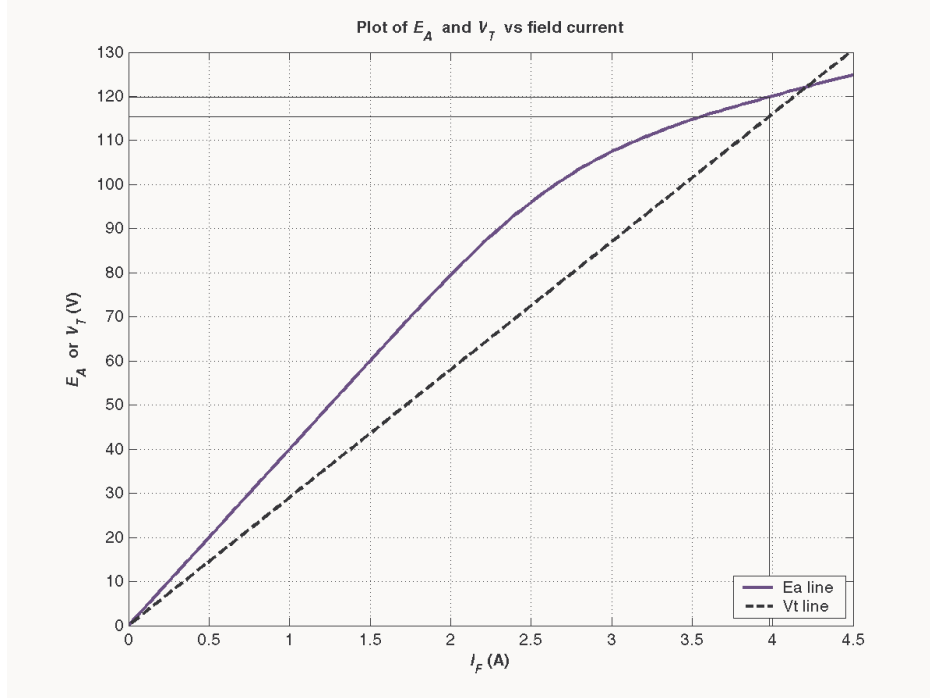

Note that decreasing the field resistance of the shunt generator increases the terminal voltage.

9-27. A 120-V 50-A cumulatively compounded dc generator has the following characteristics:

- | | |
|---|---------------------|
| $R_A + R_S = 0.21\ \Omega$ | $N_F = 1000$ turns |
| $R_F = 20\ \Omega$ | $N_{SE} = 20$ turns |
| $R_{adj} = 0$ to $30\ \Omega$, set to $10\ \Omega$ | $n_m = 1800$ r/min |

The machine has the magnetization curve shown in Figure P9-7. Its equivalent circuit is shown in Figure P9-10. Answer the following questions about this machine, assuming no armature reaction.

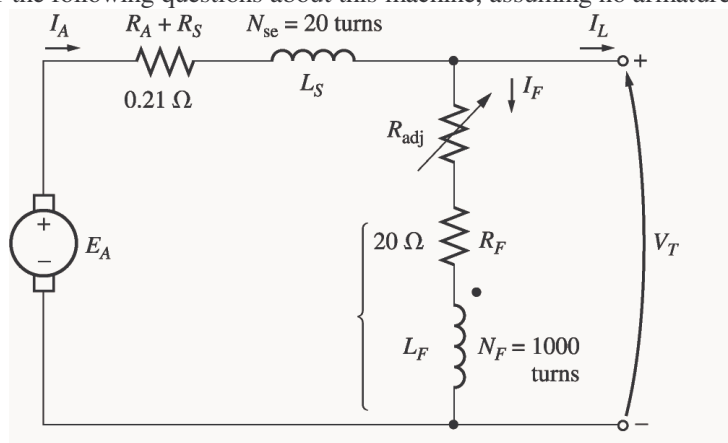

- If the generator is operating at no load, what is its terminal voltage?
- If the generator has an armature current of $20\ \text{A}$, what is its terminal voltage?

- (c) If the generator has an armature current of 40 A, what is its terminal voltage?
 (d) Calculate and plot the terminal characteristic of this machine.

SOLUTION

(a) The total field resistance of this generator is 30 Ω, and the no-load terminal voltage can be found from the intersection of the resistance line with the magnetization curve for this generator. The magnetization curve and the field resistance line are plotted below. As you can see, they intersect at a terminal voltage of 121 V.

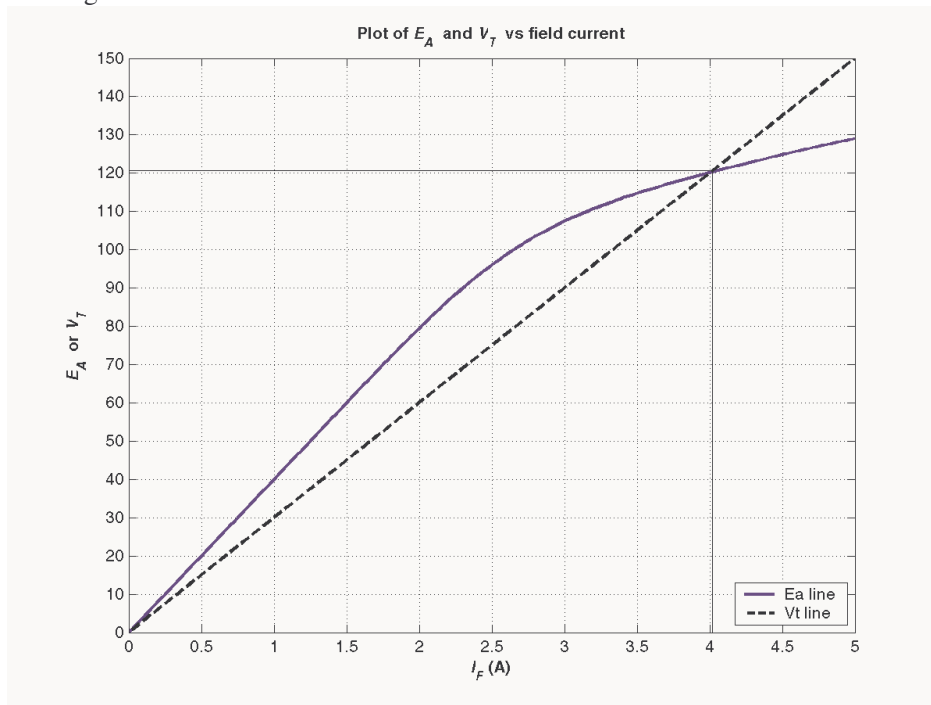

(b) If the armature current is 20 A, then the effective field current contribution from the armature current

$$\frac{N_{SE}}{N_F} I_A = \frac{20}{1000} (20 \text{ A}) = 0.4 \text{ A}$$

and the $I_A(R_A + R_S)$ voltage drop is $I_A(R_A + R_S) = (20 \text{ A}) (0.21 \Omega) = 4.2 \text{ V}$. The location where the triangle formed by $\frac{N_{SE}}{N_F} I_A$ and $I_A R_A$ exactly fits between the E_A and V_T lines corresponds to a terminal voltage of 120 V, as shown below.

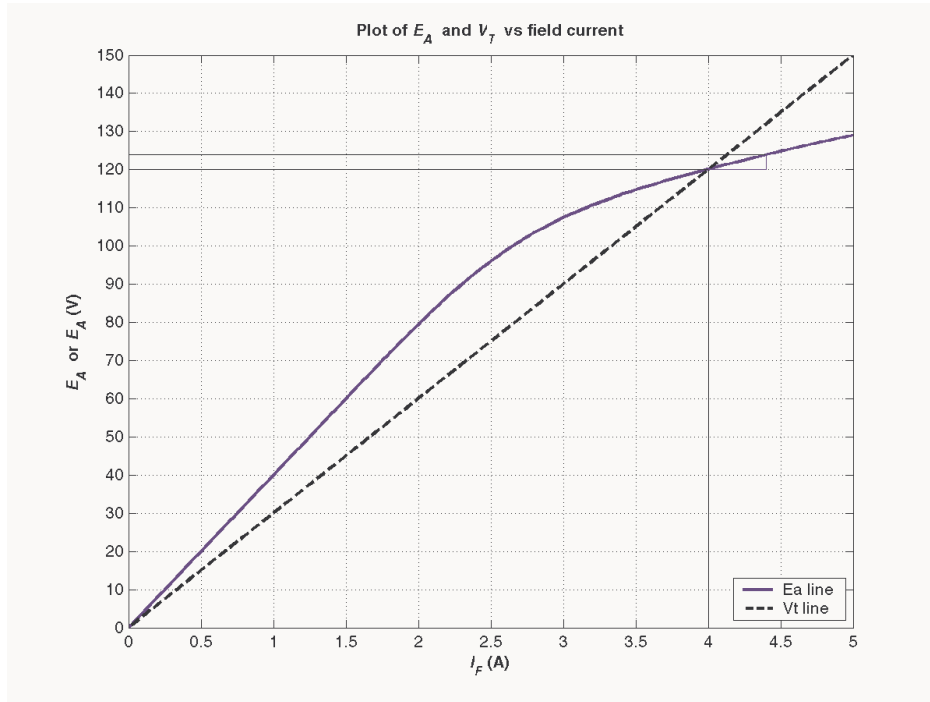

(c) If the armature current is 40 A, then the effective field current contribution from the armature current

$$\frac{N_{SE}}{N_F} I_A = \frac{15}{1000} (40 \text{ A}) = 0.6 \text{ A}$$

and the $I_A(R_A + R_S)$ voltage drop is $I_A(R_A + R_S) = (80 \text{ A})(0.20 \Omega) = 8 \text{ V}$. The location where the triangle formed by $\frac{N_{SE}}{N_F} I_A$ and $I_A R_A$ exactly fits between the E_A and V_T lines corresponds to a terminal voltage of 116 V, as shown below.

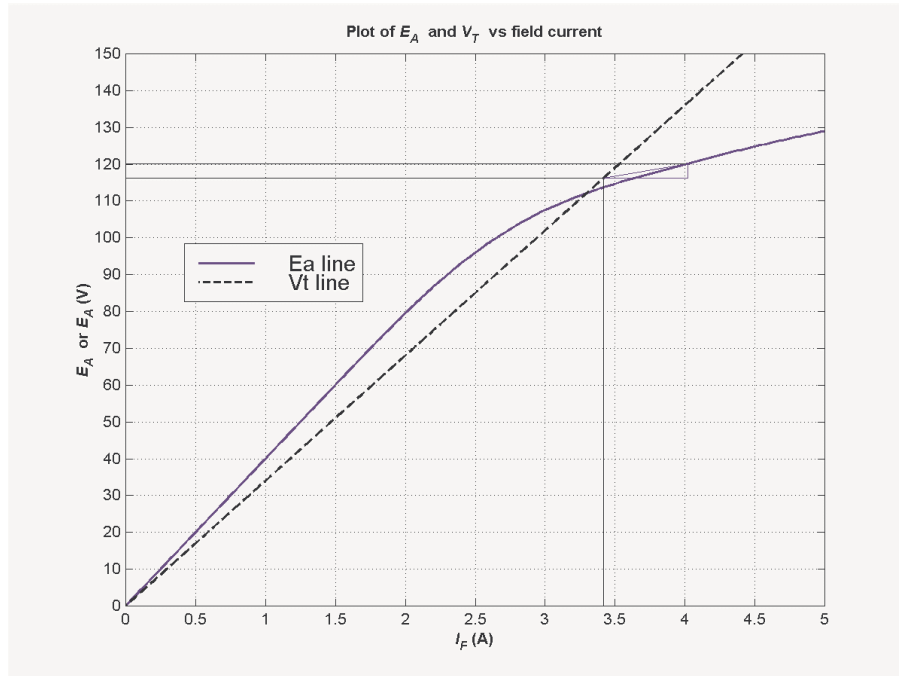

A MATLAB program to locate the position where the triangle exactly fits between the E_A and V_T lines is shown below. This program created the plot shown above.

```
% M-file: prob9_27b.m
% M-file to create a plot of the magnetization curve and the
% field current curve of a cumulatively-compounded dc generator
% when the armature current is 20 A.

% Get the magnetization curve. This file contains the
% three variables if_values, ea_values, and n_0.
clear all
load p97_mag.dat;
if_values = p97_mag(:,1);
ea_values = p97_mag(:,2);
n_0 = 1800;

% First, initialize the values needed in this program.
r_f = 20; % Field resistance (ohms)
r_adj = 10; % Adjustable resistance (ohms)
r_a = 0.21; % Armature + series resistance (ohms)
i_f = 0:0.02:6; % Field current (A)
n = 1800; % Generator speed (r/min)
n_f = 1000; % Shunt field turns
n_se = 20; % Series field turns

% Calculate Ea versus If
Ea = interp1(if_values,ea_values,i_f);

% Calculate Vt versus If
Vt = (r_f + r_adj) * i_f;

% Calculate the Ea values modified by mmf due to the
% armature current
```

```

i_a = 20;
Ea_a = interp1(if_values,ea_values,i_f + i_a * n_se/n_f);

% Find the point where the difference between the
% enhanced Ea line and the Vt line is 4 V. This will
% be the point where the line "Ea_a - Vt - 4" goes
% negative.
diff = Ea_a - Vt - 4;

% This code prevents us from reporting the first (unstable)
% location satisfying the criterion.
was_pos = 0;
for ii = 1:length(i_f);
    if diff(ii) > 0
        was_pos = 1;
    end
    if ( diff(ii) < 0 & was_pos == 1 )
        break;
    end;
end;

% We have the intersection. Tell user.
disp (['Ea_a = ' num2str(Ea_a(ii)) ' V']);
disp (['Ea   = ' num2str(Ea(ii))   ' V']);
disp (['Vt   = ' num2str(Vt(ii))   ' V']);
disp (['If   = ' num2str(i_f(ii)) ' A']);
disp (['If_a = ' num2str(i_f(ii)+ i_a * n_se/n_f) ' A']);

% Plot the curves
figure(1);
plot(i_f,Ea,'b-','LineWidth',2.0);
hold on;
plot(i_f,Vt,'k--','LineWidth',2.0);

% Plot intersections
plot([i_f(ii) i_f(ii)], [0 Vt(ii)], 'k-');
plot([0 i_f(ii)], [Vt(ii) Vt(ii)], 'k-');
plot([0 i_f(ii)+i_a*n_se/n_f], [Ea_a(ii) Ea_a(ii)], 'k-');

% Plot compounding triangle
plot([i_f(ii) i_f(ii)+i_a*n_se/n_f], [Vt(ii) Vt(ii)], 'b-');
plot([i_f(ii) i_f(ii)+i_a*n_se/n_f], [Vt(ii) Ea_a(ii)], 'b-');
plot([i_f(ii)+i_a*n_se/n_f i_f(ii)+i_a*n_se/n_f], [Vt(ii)
Ea_a(ii)], 'b-');

xlabel('\bf\itI_{F} \rm\bf(A)');
ylabel('\bf\itE_{A} \rm\bf or \itE_{A} \rm\bf(V)');
title ('\bfPlot of \itE_{A} \rm\bf and \itV_{T} \rm\bf vs field
current');
axis ([0 5 0 150]);
set(gca,'YTick',[0 10 20 30 40 50 60 70 80 90 100 110 120 130 140
150]');
set(gca,'XTick',[0 0.5 1.0 1.5 2.0 2.5 3.0 3.5 4.0 4.5 5.0]');
legend ('Ea line','Vt line',4);
hold off;
grid on;

```

(d) A MATLAB program to calculate and plot the terminal characteristic of this generator is shown below.

```
% M-file: prob9_27d.m
% M-file to calculate the terminal characteristic of a
% cumulatively compounded dc generator without armature
% reaction.

% Get the magnetization curve. This file contains the
% three variables if_values, ea_values, and n_0.
clear all
load p97_mag.dat;
if_values = p97_mag(:,1);
ea_values = p97_mag(:,2);
n_0 = 1800;

% First, initialize the values needed in this program.
r_f = 20; % Field resistance (ohms)
r_adj = 10; % Adjustable resistance (ohms)
r_a = 0.21; % Armature + series resistance (ohms)
i_f = 0:0.02:6; % Field current (A)
n = 1800; % Generator speed (r/min)
n_f = 1000; % Shunt field turns
n_se = 20; % Series field turns

% Calculate Ea versus If
Ea = interp1(if_values,ea_values,i_f);

% Calculate Vt versus If
Vt = (r_f + r_adj) * i_f;

% Find the point where the difference between the two
% lines is exactly equal to i_a*r_a. This will be the
% point where the line line "Ea - Vt - i_a*r_a" goes
% negative.
i_a = 0:1:50;
for jj = 1:length(i_a)

    % Calculate the Ea values modified by mmf due to the
    % armature current
    Ea_a = interp1(if_values,ea_values,i_f + i_a(jj)*n_se/n_f);

    % Get the voltage difference
    diff = Ea_a - Vt - i_a(jj)*r_a;

    % This code prevents us from reporting the first (unstable)
    % location satisfying the criterion.
    was_pos = 0;
    for ii = 1:length(i_f);
        if diff(ii) > 0
            was_pos = 1;
        end
        if ( diff(ii) < 0 & was_pos == 1 )
            break;
        end;
    end;
end;
```

```

    % Save terminal voltage at this point
    v_t(jj) = Vt(ii);
    i_l(jj) = i_a(jj) - v_t(jj) / ( r_f + r_adj);

end;

% Plot the terminal characteristic
figure(1);
plot(i_l,v_t,'b-','LineWidth',2.0);
xlabel('\bf\itI_{L} \rm\bf(A)');
ylabel('\bf\itV_{T} \rm\bf(V)');
string = ['\bfTerminal Characteristic of a Cumulatively ' ...
         'Compounded DC Generator'];
title(string);
hold off;
axis([ 0 50 0 130]);
grid on;

```

The resulting terminal characteristic is shown below. Compare it to the terminal characteristics of the shunt dc generators in Problem 9-25 (d).

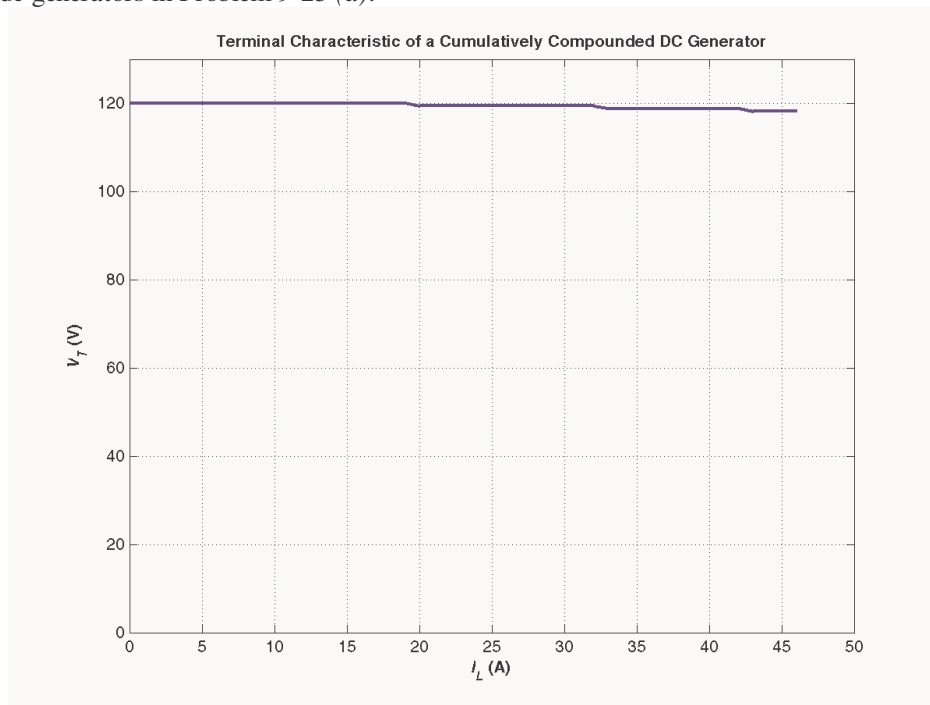

- 9-28.** If the machine described in Problem 9-27 is reconnected as a differentially compounded dc generator, what will its terminal characteristic look like? Derive it in the same fashion as in Problem 9-27.

SOLUTION A MATLAB program to calculate and plot the terminal characteristic of this generator is shown below.

```

% M-file: prob9_28.m
% M-file to calculate the terminal characteristic of a
% differentially compounded dc generator without armature
% reaction.

```

```

% Get the magnetization curve. This file contains the

```

```

% three variables if_values, ea_values, and n_0.
clear all
load p97_mag.dat;
if_values = p97_mag(:,1);
ea_values = p97_mag(:,2);
n_0 = 1800;

% First, initialize the values needed in this program.
r_f = 20;           % Field resistance (ohms)
r_adj = 10;        % Adjustable resistance (ohms)
r_a = 0.21;        % Armature + series resistance (ohms)
i_f = 0:0.02:6;    % Field current (A)
n = 1800;          % Generator speed (r/min)
n_f = 1000;        % Shunt field turns
n_se = 20;         % Series field turns

% Calculate Ea versus If
Ea = interp1(if_values,ea_values,i_f);

% Calculate Vt versus If
Vt = (r_f + r_adj) * i_f;

% Find the point where the difference between the two
% lines is exactly equal to i_a*r_a. This will be the
% point where the line line "Ea - Vt - i_a*r_a" goes
% negative.
i_a = 0:1:26;
for jj = 1:length(i_a)

    % Calculate the Ea values modified by mmf due to the
    % armature current
    Ea_a = interp1(if_values,ea_values,i_f - i_a(jj)*n_se/n_f);

    % Get the voltage difference
    diff = Ea_a - Vt - i_a(jj)*r_a;

    % This code prevents us from reporting the first (unstable)
    % location satisfying the criterion.
    was_pos = 0;
    for ii = 1:length(i_f);
        if diff(ii) > 0
            was_pos = 1;
        end
        if ( diff(ii) < 0 & was_pos == 1 )
            break;
        end;
    end;

    % Save terminal voltage at this point
    v_t(jj) = Vt(ii);
    i_l(jj) = i_a(jj) - v_t(jj) / ( r_f + r_adj);

end;

% Plot the terminal characteristic
figure(1);

```

```

plot(i_l,v_t,'b-','LineWidth',2.0);
xlabel('\bf\itI_{L} \rm\bf(A)');
ylabel('\bf\itV_{T} \rm\bf(V)');
string = ['\bfTerminal Characteristic of a Cumulatively ' ...
         'Compounded DC Generator'];
title(string);
hold off;
axis([ 0 50 0 120]);
grid on;

```

The resulting terminal characteristic is shown below. Compare it to the terminal characteristics of the cumulatively compounded dc generator in Problem 9-28 and the shunt dc generators in Problem 9-25 (*d*).

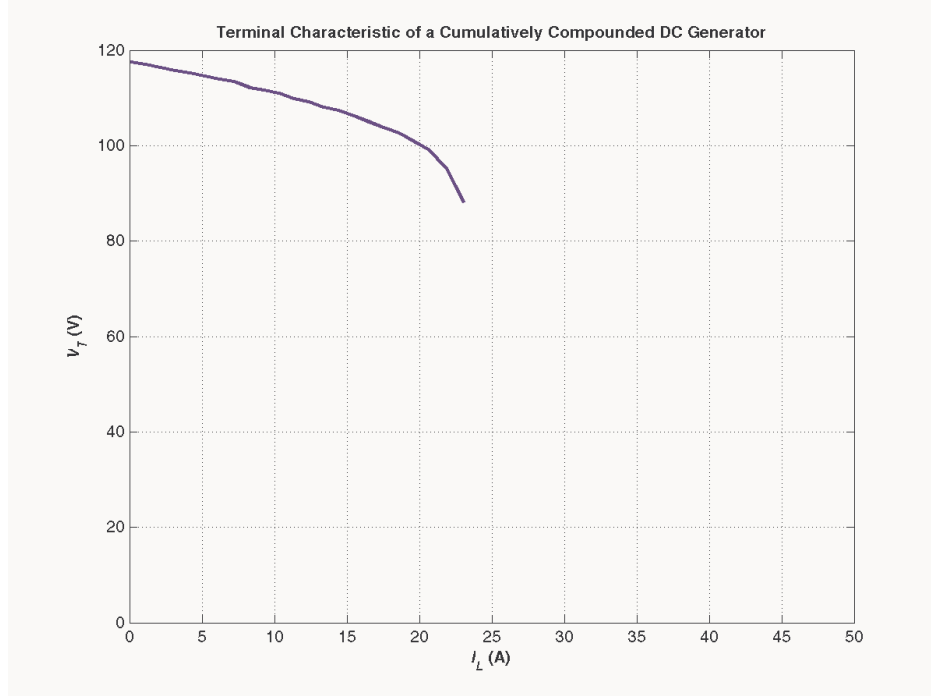

- 9-29.** A cumulatively compounded dc generator is operating properly as a flat-compounded dc generator. The machine is then shut down, and its shunt field connections are reversed.
- If this generator is turned in the same direction as before, will an output voltage be built up at its terminals? Why or why not?
 - Will the voltage build up for rotation in the opposite direction? Why or why not?
 - For the direction of rotation in which a voltage builds up, will the generator be cumulatively or differentially compounded?

SOLUTION

- The output voltage will not build up, because the residual flux now induces a voltage in the opposite direction, which causes a field current to flow that tends to further reduce the residual flux.
- If the motor rotates in the opposite direction, the voltage will build up, because the reversal in voltage due to the change in direction of rotation causes the voltage to produce a field current that increases the residual flux, starting a positive feedback chain.
- The generator will now be differentially compounded.

9-30. A three-phase synchronous machine is mechanically connected to a shunt dc machine, forming a motor-generator set, as shown in Figure P9-11. The dc machine is connected to a dc power system supplying a constant 240 V, and the ac machine is connected to a 480-V 60-Hz infinite bus.

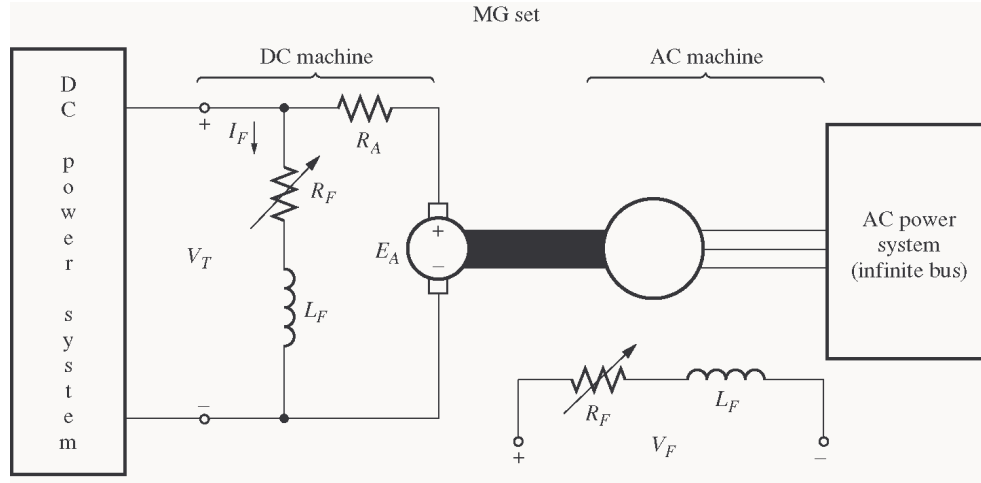

The dc machine has four poles and is rated at 50 kW and 240 V. It has a per-unit armature resistance of 0.04. The ac machine has four poles and is Y-connected. It is rated at 50 kVA, 480 V, and 0.8 PF, and its saturated synchronous reactance is 2.0Ω per phase.

All losses except the dc machine's armature resistance may be neglected in this problem. Assume that the magnetization curves of both machines are linear.

- (a) Initially, the ac machine is supplying 50 kVA at 0.8 PF lagging to the ac power system.
1. How much power is being supplied to the dc motor from the dc power system?
 2. How large is the internal generated voltage E_A of the dc machine?
 3. How large is the internal generated voltage E_A of the ac machine?
- (b) The field current in the ac machine is now increased by 5 percent. What effect does this change have on the real power supplied by the motor-generator set? On the reactive power supplied by the motor-generator set? Calculate the real and reactive power supplied or consumed by the ac machine under these conditions. Sketch the ac machine's phasor diagram before and after the change in field current.
- (c) Starting from the conditions in part (b), the field current in the dc machine is now decreased by 1 percent. What effect does this change have on the real power supplied by the motor-generator set? On the reactive power supplied by the motor-generator set? Calculate the real and reactive power supplied or consumed by the ac machine under these conditions. Sketch the ac machine's phasor diagram before and after the change in the dc machine's field current.
- (d) From the above results, answer the following questions:
1. How can the real power flow through an ac-dc motor-generator set be controlled?
 2. How can the reactive power supplied or consumed by the ac machine be controlled without affecting the real power flow?

SOLUTION

(a) The power supplied by the ac machine to the ac power system is

$$P_{AC} = S \cos \theta = (50 \text{ kVA})(0.8) = 40 \text{ kW}$$

and the reactive power supplied by the ac machine to the ac power system is

$$Q_{AC} = S \sin \theta = (50 \text{ kVA}) \sin \cos^{-1}(0.8) = 30 \text{ kvar}$$

The power out of the dc motor is thus 40 kW. This is also the power converted from electrical to mechanical form in the dc machine, since all other losses are neglected. Therefore,

$$P_{\text{conv}} = E_A I_A = (V_T - I_A R_A) I_A = 40 \text{ kW}$$

$$V_T I_A - I_A^2 R_A - 40 \text{ kW} = 0$$

The base resistance of the dc machine is

$$R_{\text{base,dc}} = \frac{V_{T,\text{base}}^2}{P_{\text{base}}} = \frac{(230 \text{ V})^2}{50 \text{ kW}} = 1.058 \Omega$$

Therefore, the actual armature resistance is

$$R_A = (0.04)(1.058 \Omega) = 0.0423 \Omega$$

Continuing to solve the equation for P_{conv} , we get

$$0.0423 I_A^2 - 230 I_A + 40,000 = 0$$

$$I_A^2 - 5434.8 I_A + 945180 = 0$$

$$I_A = 179.9 \text{ A}$$

and $E_A = 222.4 \text{ V}$.

Therefore, the power *into the dc machine* is $V_T I_A = 41.38 \text{ kW}$, while the power converted from electrical to mechanical form (which is equal to the output power) is $E_A I_A = (222.4 \text{ V})(179.9 \text{ A}) = 40 \text{ kW}$. The internal generated voltage E_A of the dc machine is 222.4 V.

The armature current in the ac machine is

$$I_A = \frac{S}{\sqrt{3} V_\phi} = \frac{50 \text{ kVA}}{\sqrt{3}(480 \text{ V})} = 60.1 \text{ A}$$

$$\mathbf{I}_A = 60.1 \angle -36.87^\circ \text{ A}$$

Therefore, the internal generated voltage \mathbf{E}_A of the ac machine is

$$\mathbf{E}_A = \mathbf{V}_\phi + jX_s \mathbf{I}_A$$

$$\mathbf{E}_A = 277 \angle 0^\circ \text{ V} + j(2.0 \Omega)(60.1 \angle -36.87^\circ \text{ A}) = 362 \angle 15.4^\circ \text{ V}$$

(b) When the field current of the ac machine is increased by 5%, it has *no effect* on the real power supplied by the motor-generator set. This fact is true because $P = \tau \omega$, and the speed is constant (since the MG set is tied to an infinite bus). With the speed unchanged, the dc machine's torque is unchanged, so the total power supplied to the ac machine's shaft is unchanged.

If the field current is increased by 5% and the OCC of the ac machine is linear, E_A increases to

$$E'_A = (1.05)(262 \text{ V}) = 380 \text{ V}$$

The new torque angle δ can be found from the fact that since the terminal voltage and power of the ac machine are constant, the quantity $E_A \sin \delta$ must be constant.

$$E_A \sin \delta = E'_A \sin \delta'$$

$$\delta' = \sin^{-1} \frac{E_A \sin \delta}{E'_A} = \sin^{-1} \frac{362 \text{ V}}{380 \text{ V}} \sin 15.4^\circ = 14.7^\circ$$

Therefore, the armature current will be

$$\mathbf{I}_A = \frac{\mathbf{E}_A - \mathbf{V}_\phi}{jX_S} = \frac{380 \angle 14.7^\circ \text{ V} - 277 \angle 0^\circ \text{ V}}{j2.0 \Omega} = 66.1 \angle -43.2^\circ \text{ A}$$

The resulting reactive power is

$$Q = \sqrt{3} V_T I_L \sin \theta = \sqrt{3} (480 \text{ V})(66.1 \text{ A}) \sin 43.2^\circ = 37.6 \text{ kvar}$$

The reactive power *supplied to the ac power system* will be 37.6 kvar, compared to 30 kvar before the ac machine field current was increased. The phasor diagram illustrating this change is shown below.

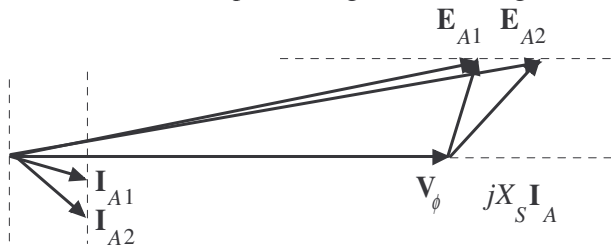

(c) If the dc field current is decreased by 1%, the dc machine's flux will decrease by 1%. The internal generated voltage in the dc machine is given by the equation $E_A = K \phi \omega$, and ω is held constant by the infinite bus attached to the ac machine. Therefore, E_A on the dc machine will *decrease* to $(0.99)(222.4 \text{ V}) = 220.2 \text{ V}$. The resulting armature current is

$$I_{A,\text{dc}} = \frac{V_T - E_A}{R_A} = \frac{230 \text{ V} - 220.2 \text{ V}}{0.0423 \Omega} = 231.7 \text{ A}$$

The power into the dc motor is now $(230 \text{ V})(231.7 \text{ A}) = 53.3 \text{ kW}$, and the power converted from electrical to mechanical form in the dc machine is $(220.2 \text{ V})(231.7 \text{ A}) = 51 \text{ kW}$. This is also the output power of the dc machine, the input power of the ac machine, and the output power of the ac machine, since losses are being neglected.

The torque angle of the ac machine now can be found from the equation

$$P_{\text{ac}} = \frac{3V_\phi E_A}{X_S} \sin \delta$$

$$\delta = \sin^{-1} \frac{P_{\text{ac}} X_S}{3V_\phi E_A} = \sin^{-1} \frac{(51 \text{ kW})(2.0 \Omega)}{3(277 \text{ V})(380 \text{ V})} = 18.9^\circ$$

The new \mathbf{E}_A of this machine is thus $380 \angle 18.9^\circ \text{ V}$, and the resulting armature current is

$$\mathbf{I}_A = \frac{\mathbf{E}_A - \mathbf{V}_\phi}{jX_S} = \frac{380 \angle 18.9^\circ \text{ V} - 277 \angle 0^\circ \text{ V}}{j2.0 \Omega} = 74.0 \angle -33.8^\circ \text{ A}$$

The real and reactive powers are now

$$P = \sqrt{3} V_T I_L \cos \theta = \sqrt{3} (480 \text{ V})(74.0 \text{ A}) \cos 33.8^\circ = 51 \text{ kW}$$

$$Q = \sqrt{3} V_T I_L \sin \theta = \sqrt{3} (480 \text{ V})(74.0 \text{ A}) \sin 33.8^\circ = 34.2 \text{ kvar}$$

The phasor diagram of the ac machine before and after the change in dc machine field current is shown below.

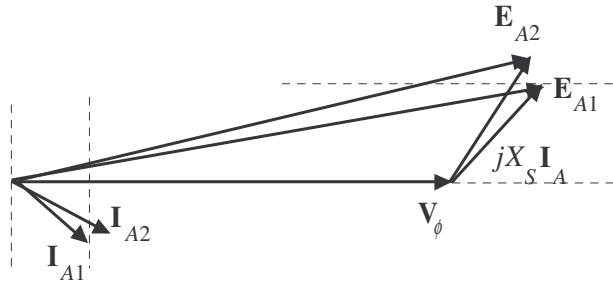

(d) The *real power* flow through an ac-dc motor-generator set can be controlled by adjusting the field current of the *dc machine*. (Note that changes in power flow also have some effect on the reactive power of the ac machine: in this problem, Q dropped from 35 kvar to 30 kvar when the real power flow was adjusted.)

The *reactive power* flow in the ac machine of the MG set can be adjusted by adjusting the ac machine's field current. This adjustment has basically *no effect* on the real power flow through the MG set.

Chapter 10: Single-Phase and Special-Purpose Motors

10-1. A 120-V, 1/3-hp 60-Hz, four-pole, split-phase induction motor has the following impedances:

$$\begin{aligned} R_1 &= 1.80 \, \Omega & X_1 &= 2.40 \, \Omega & X_M &= 60 \, \Omega \\ R_2 &= 2.50 \, \Omega & X_2 &= 2.40 \, \Omega & & \end{aligned}$$

At a slip of 0.05, the motor's rotational losses are 51 W. The rotational losses may be assumed constant over the normal operating range of the motor. If the slip is 0.05, find the following quantities for this motor:

- (a) Input power
- (b) Air-gap power
- (c) P_{conv}
- (d) P_{out}
- (e) τ_{ind}
- (f) τ_{load}
- (g) Overall motor efficiency
- (h) Stator power factor

SOLUTION The equivalent circuit of the motor is shown below

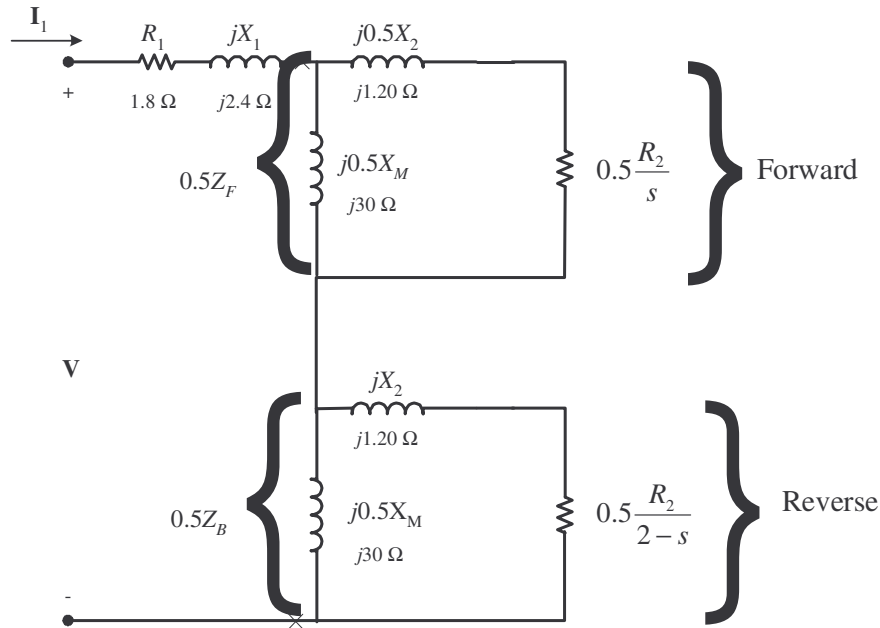

$$\begin{aligned} Z_F &= \frac{(R_2/s + jX_2)(jX_M)}{R_2/s + jX_2 + jX_M} \\ Z_F &= \frac{(50 + j2.40)(j60)}{50 + j2.40 + j60} = 28.15 + j24.87 \, \Omega \\ Z_B &= \frac{R_2/(2-s) + jX_2}{R_2/(2-s) + jX_2 + jX_M} \end{aligned}$$

$$Z_B = \frac{(1.282 + j2.40)(j60)}{1.282 + j2.40 + j60} = 1.185 + j2.332 \Omega$$

(a) The input current is

$$I_1 = \frac{\mathbf{V}}{R_1 + jX_1 + 0.5Z_F + 0.5Z_B}$$

$$I_1 = \frac{120\angle 0^\circ \text{ V}}{(1.80 + j2.40) + 0.5(28.15 + j24.87) + 0.5(1.185 + j2.332)} = 5.23\angle -44.2^\circ \text{ A}$$

$$P_{\text{IN}} = VI \cos \theta = (120 \text{ V})(5.23 \text{ A}) \cos 44.2^\circ = 450 \text{ W}$$

(b) The air-gap power is

$$P_{\text{AG},F} = I_1^2 (0.5R_F) = (5.23 \text{ A})^2 (14.1 \Omega) = 386 \text{ W}$$

$$P_{\text{AG},B} = I_1^2 (0.5R_B) = (5.23 \text{ A})^2 (0.592 \Omega) = 16.2 \text{ W}$$

$$P_{\text{AG}} = P_{\text{AG},F} - P_{\text{AG},B} = 386 \text{ W} - 14.8 \text{ W} = 371 \text{ W}$$

(c) The power converted from electrical to mechanical form is

$$P_{\text{conv},F} = (1-s)P_{\text{AG},F} = (1-0.05)(386 \text{ W}) = 367 \text{ W}$$

$$P_{\text{conv},B} = (1-s)P_{\text{AG},B} = (1-0.05)(16.2 \text{ W}) = 15.4 \text{ W}$$

$$P_{\text{conv}} = P_{\text{conv},F} - P_{\text{conv},B} = 367 \text{ W} - 15.4 \text{ W} = 352 \text{ W}$$

(d) The output power is

$$P_{\text{OUT}} = P_{\text{conv}} - P_{\text{rot}} = 352 \text{ W} - 51 \text{ W} = 301 \text{ W}$$

(e) The induced torque is

$$\tau_{\text{ind}} = \frac{P_{\text{AG}}}{\omega_{\text{sync}}} = \frac{371 \text{ W}}{(1800 \text{ r/min}) \frac{2\pi \text{ rad}}{1 \text{ r}} \frac{1 \text{ min}}{60 \text{ s}}} = 1.97 \text{ N} \cdot \text{m}$$

(f) The load torque is

$$\tau_{\text{load}} = \frac{P_{\text{OUT}}}{\omega_m} = \frac{301 \text{ W}}{(0.95)(1800 \text{ r/min}) \frac{2\pi \text{ rad}}{1 \text{ r}} \frac{1 \text{ min}}{60 \text{ s}}} = 1.68 \text{ N} \cdot \text{m}$$

(g) The overall efficiency is

$$\eta = \frac{P_{\text{OUT}}}{P_{\text{IN}}} \times 100\% = \frac{301 \text{ W}}{450 \text{ W}} \times 100\% = 66.9\%$$

(h) The stator power factor is

$$\text{PF} = \cos 44.2^\circ = 0.713 \text{ lagging}$$

10-2. Repeat Problem 10-1 for a rotor slip of 0.025.

$$Z_F = \frac{(R_2/s + jX_2)(jX_M)}{R_2/s + jX_2 + jX_M}$$

$$Z_F = \frac{(100 + j2.40)(j60)}{100 + j2.40 + j60} = 28.91 + j43.83 \Omega$$

$$Z_B = \frac{R_2 / (2 - s) + jX_2 + jX_M}{R_2 / (2 - s) + jX_2 + jX_M}$$

$$Z_B = \frac{(1.282 + j2.40)(j60)}{1.282 + j2.40 + j60} = 1.170 + j2.331 \Omega$$

(a) The input current is

$$I_1 = \frac{\mathbf{V}}{R_1 + jX_1 + 0.5Z_F + 0.5Z_B}$$

$$I_1 = \frac{120\angle 0^\circ \text{ V}}{(1.80 + j2.40) + 0.5(25.91 + j43.83) + 0.5(1.170 + j2.331)} = 4.03\angle -59.0^\circ \text{ A}$$

$$P_{IN} = VI \cos \theta = (120 \text{ V})(4.03 \text{ A}) \cos 59.0^\circ = 249 \text{ W}$$

(b) The air-gap power is

$$P_{AG,F} = I_1^2 (0.5R_F) = (4.03 \text{ A})^2 (12.96 \Omega) = 210.5 \text{ W}$$

$$P_{AG,B} = I_1^2 (0.5R_B) = (4.03 \text{ A})^2 (0.585 \Omega) = 9.5 \text{ W}$$

$$P_{AG} = P_{AG,F} - P_{AG,B} = 210.5 \text{ W} - 9.5 \text{ W} = 201 \text{ W}$$

(c) The power converted from electrical to mechanical form is

$$P_{\text{conv},F} = (1 - s)P_{AG,F} = (1 - 0.025)(210.5 \text{ W}) = 205 \text{ W}$$

$$P_{\text{conv},B} = (1 - s)P_{AG,B} = (1 - 0.025)(9.5 \text{ W}) = 9.3 \text{ W}$$

$$P_{\text{conv}} = P_{\text{conv},F} - P_{\text{conv},B} = 205 \text{ W} - 9.3 \text{ W} = 196 \text{ W}$$

(d) The output power is

$$P_{\text{OUT}} = P_{\text{conv}} - P_{\text{rot}} = 205 \text{ W} - 51 \text{ W} = 154 \text{ W}$$

(e) The induced torque is

$$\tau_{\text{ind}} = \frac{P_{AG}}{\omega_{\text{sync}}} = \frac{210.5 \text{ W}}{(1800 \text{ r/min}) \frac{2\pi \text{ rad}}{1 \text{ r}} \frac{1 \text{ min}}{60 \text{ s}}} = 1.12 \text{ N} \cdot \text{m}$$

(f) The load torque is

$$\tau_{\text{load}} = \frac{P_{\text{OUT}}}{\omega_m} = \frac{154 \text{ W}}{(0.975)(1800 \text{ r/min}) \frac{2\pi \text{ rad}}{1 \text{ r}} \frac{1 \text{ min}}{60 \text{ s}}} = 0.84 \text{ N} \cdot \text{m}$$

(g) The overall efficiency is

$$\eta = \frac{P_{\text{OUT}}}{P_{\text{IN}}} \times 100\% = \frac{154 \text{ W}}{249 \text{ W}} \times 100\% = 61.8\%$$

(h) The stator power factor is

$$\text{PF} = \cos 59.0^\circ = 0.515 \text{ lagging}$$

10-3. Suppose that the motor in Problem 10-1 is started and the auxiliary winding fails open while the rotor is accelerating through 400 r/min. How much induced torque will the motor be able to produce on its main

winding alone? Assuming that the rotational losses are still 51 W, will this motor continue accelerating or will it slow down again? Prove your answer.

SOLUTION At a speed of 400 r/min, the slip is

$$s = \frac{1800 \text{ r/min} - 400 \text{ r/min}}{1800 \text{ r/min}} = 0.778$$

$$Z_F = \frac{(R_2/s + jX_2)(jX_M)}{R_2/s + jX_2 + jX_M}$$

$$Z_F = \frac{(100 + j2.40)(j60)}{100 + j2.40 + j60} = 2.96 + j2.46 \Omega$$

$$Z_B = \frac{R_2/(2-s) + jX_2 + jX_M}{R_2/(2-s) + jX_2 + jX_M}$$

$$Z_B = \frac{(1.282 + j2.40)(j60)}{1.282 + j2.40 + j60} = 1.90 + j2.37 \Omega$$

The input current is

$$I_1 = \frac{\mathbf{V}}{R_1 + jX_1 + 0.5Z_F + 0.5Z_B}$$

$$I_1 = \frac{120 \angle 0^\circ \text{ V}}{(1.80 + j2.40) + 0.5(2.96 + j2.46) + 0.5(1.90 + j2.37)} = 18.73 \angle -48.7^\circ \text{ A}$$

The air-gap power is

$$P_{AG,F} = I_1^2 (0.5R_F) = (18.73 \text{ A})^2 (1.48 \Omega) = 519.2 \text{ W}$$

$$P_{AG,B} = I_1^2 (0.5R_B) = (18.73 \text{ A})^2 (0.945 \Omega) = 331.5 \text{ W}$$

$$P_{AG} = P_{AG,F} - P_{AG,B} = 519.2 \text{ W} - 331.5 \text{ W} = 188 \text{ W}$$

The power converted from electrical to mechanical form is

$$P_{\text{conv},F} = (1-s)P_{AG,F} = (1-0.778)(519.2 \text{ W}) = 115.2 \text{ W}$$

$$P_{\text{conv},B} = (1-s)P_{AG,B} = (1-0.778)(331.5 \text{ W}) = 73.6 \text{ W}$$

$$P_{\text{conv}} = P_{\text{conv},F} - P_{\text{conv},B} = 115.2 \text{ W} - 73.6 \text{ W} = 41.6 \text{ W}$$

The induced torque is

$$\tau_{\text{ind}} = \frac{P_{AG}}{\omega_{\text{sync}}} = \frac{188 \text{ W}}{(1800 \text{ r/min}) \frac{2\pi \text{ rad}}{1 \text{ r}} \frac{1 \text{ min}}{60 \text{ s}}} = 1.00 \text{ N} \cdot \text{m}$$

Assuming that the rotational losses are still 51 W, *this motor is not producing enough torque to keep accelerating*. P_{conv} is 41.6 W, while the rotational losses are 51 W, so there is not enough power to make up the rotational losses. The motor will slow down⁵.

- 10-4.** Use MATLAB to calculate and plot the torque-speed characteristic of the motor in Problem 10-1, ignoring the starting winding.

⁵ Note that in the real world, rotational losses decrease with decreased shaft speed. Therefore, the losses will really be less than 51 W, and this motor might just be able to keep on accelerating slowly—it is a close thing either way.

SOLUTION This problem is best solved with MATLAB, since it involves calculating the torque-speed values at many points. A MATLAB program to calculate and display both torque-speed characteristics is shown below. Note that this program shows the torque-speed curve for both positive and negative directions of rotation. Also, note that we had to avoid calculating the slip at exactly 0 or 2, since those numbers would produce divide-by-zero errors in Z_F and Z_B respectively.

```
% M-file: torque_speed_curve3.m
% M-file create a plot of the torque-speed curve of the
% single-phase induction motor of Problem 10-4.

% First, initialize the values needed in this program.
r1 = 1.80; % Stator resistance
x1 = 2.40; % Stator reactance
r2 = 2.50; % Rotor resistance
x2 = 2.40; % Rotor reactance
xm = 60; % Magnetization branch reactance
v = 120; % Single-Phase voltage
n_sync = 1800; % Synchronous speed (r/min)
w_sync = 188.5; % Synchronous speed (rad/s)

% Specify slip ranges to plot
s = 0:0.01:2.0;

% Offset slips at 0 and 2 slightly to avoid divide by zero errors
s(1) = 0.0001;
s(201) = 1.9999;

% Get the corresponding speeds in rpm
nm = (1 - s) * n_sync;

% Calculate Zf and Zb as a function of slip
zf = (r2 ./ s + j*x2) * (j*xm) ./ (r2 ./ s + j*x2 + j*xm);
zb = (r2 ./ (2-s) + j*x2) * (j*xm) ./ (r2 ./ (2-s) + j*x2 + j*xm);

% Calculate the current flowing at each slip
i1 = v ./ (r1 + j*x1 + zf + zb);

% Calculate the air-gap power
p_ag_f = abs(i1).^2 .* 0.5 .* real(zf);
p_ag_b = abs(i1).^2 .* 0.5 .* real(zb);
p_ag = p_ag_f - p_ag_b;

% Calculate torque in N-m.
t_ind = p_ag ./ w_sync;

% Plot the torque-speed curve
figure(1)
plot(nm,t_ind,'Color','b','LineWidth',2.0);
xlabel('\itn_{m} \rm(r/min)');
ylabel('\tau_{ind} \rm(N-m)');
title('Single Phase Induction motor torque-speed
characteristic','FontSize',12);
grid on;
hold off;
```

The resulting torque-speed characteristic is shown below:

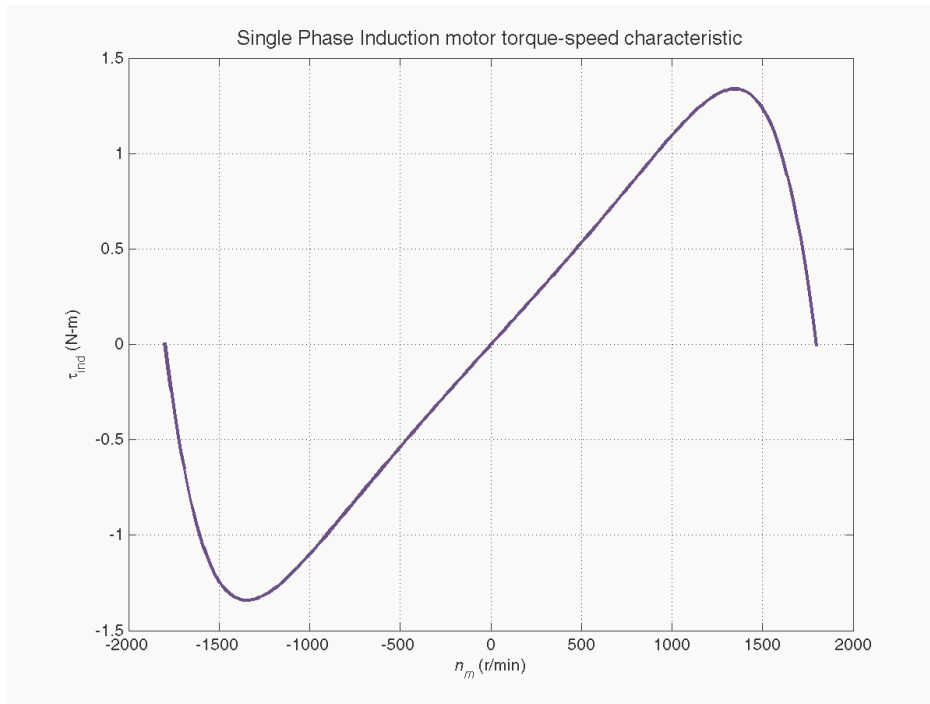

- 10-5. A 220-V, 1.5-hp 50-Hz, two-pole, capacitor-start induction motor has the following main-winding impedances:

$$\begin{array}{lll}
 R_1 = 1.40 \, \Omega & X_1 = 2.01 \, \Omega & X_M = 105 \, \Omega \\
 R_2 = 1.50 \, \Omega & X_2 = 2.01 \, \Omega &
 \end{array}$$

At a slip of 0.05, the motor's rotational losses are 291 W. The rotational losses may be assumed constant over the normal operating range of the motor. Find the following quantities for this motor at 5 percent slip:

- (a) Stator current
- (b) Stator power factor
- (c) Input power
- (d) P_{AG}
- (e) P_{conv}
- (f) P_{out}
- (g) τ_{ind}
- (h) τ_{load}
- (i) Efficiency

SOLUTION The equivalent circuit of the motor is shown below

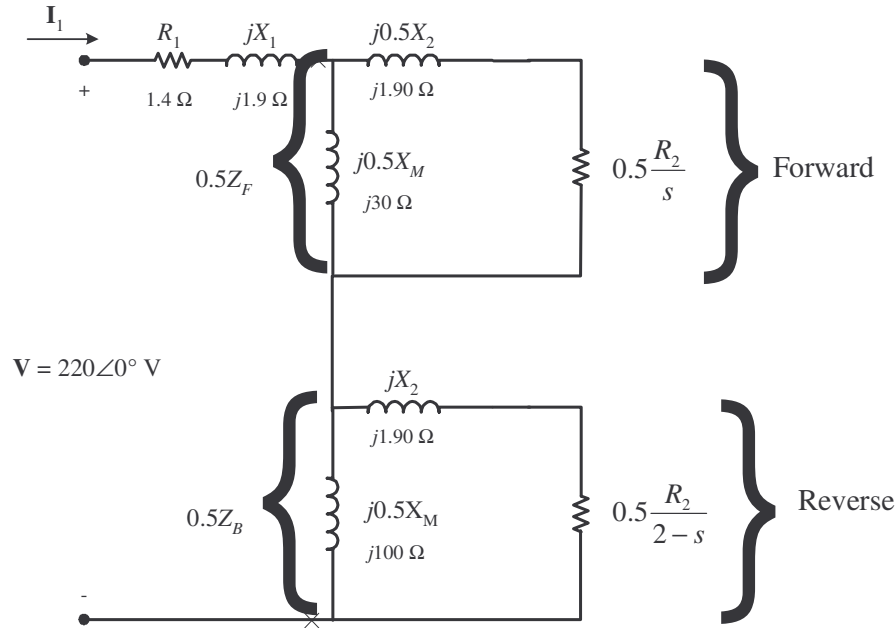

$$Z_F = \frac{(R_2 / s + jX_2)(jX_M)}{R_2 / s + jX_2 + jX_M}$$

$$Z_F = \frac{(30 + j1.90)(j100)}{30 + j1.90 + j100} = 26.59 + j9.69 \Omega$$

$$Z_B = \frac{R_2 / (2 - s) + jX_2 (jX_M)}{R_2 / (2 - s) + jX_2 + jX_M}$$

$$Z_B = \frac{(0.769 + j1.90)(j100)}{0.769 + j1.90 + j100} = 0.741 + j1.870 \Omega$$

(a) The input stator current is

$$I_1 = \frac{V}{R_1 + jX_1 + 0.5Z_F + 0.5Z_B}$$

$$I_1 = \frac{220 \angle 0^\circ \text{ V}}{(1.40 + j1.90) + 0.5(26.59 + j9.69) + 0.5(0.741 + j1.870)} = 13.0 \angle -27.0^\circ \text{ A}$$

(b) The stator power factor is

$$\text{PF} = \cos 27^\circ = 0.891 \text{ lagging}$$

(c) The input power is

$$P_{\text{IN}} = VI \cos \theta = (220 \text{ V})(13.0 \text{ A}) \cos 27^\circ = 2548 \text{ W}$$

(d) The air-gap power is

$$P_{\text{AG},F} = I_1^2 (0.5R_F) = (13.0 \text{ A})^2 (13.29 \Omega) = 2246 \text{ W}$$

$$P_{\text{AG},B} = I_1^2 (0.5R_B) = (13.0 \text{ A})^2 (0.370 \Omega) = 62.5 \text{ W}$$

$$P_{\text{AG}} = P_{\text{AG},F} - P_{\text{AG},B} = 2246 \text{ W} - 62.5 \text{ W} = 2184 \text{ W}$$

(e) The power converted from electrical to mechanical form is

$$P_{\text{conv},F} = (1-s)P_{\text{AG},F} = (1-0.05)(2246 \text{ W}) = 2134 \text{ W}$$

$$P_{\text{conv},B} = (1-s)P_{\text{AG},B} = (1-0.05)(62.5 \text{ W}) = 59 \text{ W}$$

$$P_{\text{conv}} = P_{\text{conv},F} - P_{\text{conv},B} = 2134 \text{ W} - 59 \text{ W} = 2075 \text{ W}$$

(f) The output power is

$$P_{\text{OUT}} = P_{\text{conv}} - P_{\text{rot}} = 2134 \text{ W} - 291 \text{ W} = 1843 \text{ W}$$

(g) The induced torque is

$$\tau_{\text{ind}} = \frac{P_{\text{AG}}}{\omega_{\text{sync}}} = \frac{2184 \text{ W}}{(3000 \text{ r/min}) \frac{2\pi \text{ rad}}{1 \text{ r}} \frac{1 \text{ min}}{60 \text{ s}}} = 6.95 \text{ N} \cdot \text{m}$$

(h) The load torque is

$$\tau_{\text{load}} = \frac{P_{\text{OUT}}}{\omega_m} = \frac{1843 \text{ W}}{(0.95)(3000 \text{ r/min}) \frac{2\pi \text{ rad}}{1 \text{ r}} \frac{1 \text{ min}}{60 \text{ s}}} = 6.18 \text{ N} \cdot \text{m}$$

(i) The overall efficiency is

$$\eta = \frac{P_{\text{OUT}}}{P_{\text{IN}}} \times 100\% = \frac{1843 \text{ W}}{2548 \text{ W}} \times 100\% = 72.3\%$$

10-6. Find the induced torque in the motor in Problem 10-5 if it is operating at 5 percent slip and its terminal voltage is (a) 190 V, (b) 208 V, (c) 230 V.

$$Z_F = \frac{(R_2/s + jX_2)(jX_M)}{R_2/s + jX_2 + jX_M}$$

$$Z_F = \frac{(30 + j1.90)(j100)}{30 + j1.90 + j100} = 26.59 + j9.69 \Omega$$

$$Z_B = \frac{R_2/(2-s) + jX_2 (jX_M)}{R_2/(2-s) + jX_2 + jX_M}$$

$$Z_B = \frac{(0.769 + j1.90)(j100)}{0.769 + j1.90 + j100} = 0.741 + j1.870 \Omega$$

(a) If $\mathbf{V}_T = 190\angle 0^\circ \text{ V}$,

$$\mathbf{I}_1 = \frac{\mathbf{V}}{R_1 + jX_1 + 0.5Z_F + 0.5Z_B}$$

$$\mathbf{I}_1 = \frac{190\angle 0^\circ \text{ V}}{(1.40 + j1.90) + 0.5(26.59 + j9.69) + 0.5(0.741 + j1.870)} = 11.2\angle -27.0^\circ \text{ A}$$

$$P_{\text{AG},F} = I_1^2 (0.5R_F) = (11.2 \text{ A})^2 (13.29 \Omega) = 1667 \text{ W}$$

$$P_{\text{AG},B} = I_1^2 (0.5R_B) = (11.2 \text{ A})^2 (0.370 \Omega) = 46.4 \text{ W}$$

$$P_{\text{AG}} = P_{\text{AG},F} - P_{\text{AG},B} = 1667 \text{ W} - 46.4 \text{ W} = 1621 \text{ W}$$

$$\tau_{\text{ind}} = \frac{P_{\text{AG}}}{\omega_{\text{sync}}} = \frac{1621 \text{ W}}{(3000 \text{ r/min}) \frac{2\pi \text{ rad}}{1 \text{ r}} \frac{1 \text{ min}}{60 \text{ s}}} = 5.16 \text{ N}\cdot\text{m}$$

(b) If $\mathbf{V}_T = 208\angle 0^\circ \text{ V}$,

$$\mathbf{I}_1 = \frac{\mathbf{V}}{R_1 + jX_1 + 0.5Z_F + 0.5Z_B}$$

$$\mathbf{I}_1 = \frac{208\angle 0^\circ \text{ V}}{(1.40 + j1.90) + 0.5(26.59 + j9.69) + 0.5(0.741 + j1.870)} = 12.3\angle -27.0^\circ \text{ A}$$

$$P_{\text{AG},F} = I_1^2 (0.5R_F) = (12.3 \text{ A})^2 (13.29 \Omega) = 2010 \text{ W}$$

$$P_{\text{AG},B} = I_1^2 (0.5R_B) = (12.3 \text{ A})^2 (0.370 \Omega) = 56 \text{ W}$$

$$P_{\text{AG}} = P_{\text{AG},F} - P_{\text{AG},B} = 2010 \text{ W} - 56 \text{ W} = 1954 \text{ W}$$

$$\tau_{\text{ind}} = \frac{P_{\text{AG}}}{\omega_{\text{sync}}} = \frac{1954 \text{ W}}{(3000 \text{ r/min}) \frac{2\pi \text{ rad}}{1 \text{ r}} \frac{1 \text{ min}}{60 \text{ s}}} = 6.22 \text{ N}\cdot\text{m}$$

(c) If $\mathbf{V}_T = 230\angle 0^\circ \text{ V}$,

$$\mathbf{I}_1 = \frac{\mathbf{V}}{R_1 + jX_1 + 0.5Z_F + 0.5Z_B}$$

$$\mathbf{I}_1 = \frac{230\angle 0^\circ \text{ V}}{(1.40 + j1.90) + 0.5(26.59 + j9.69) + 0.5(0.741 + j1.870)} = 13.6\angle -27.0^\circ \text{ A}$$

$$P_{\text{AG},F} = I_1^2 (0.5R_F) = (13.6 \text{ A})^2 (13.29 \Omega) = 2458 \text{ W}$$

$$P_{\text{AG},B} = I_1^2 (0.5R_B) = (13.6 \text{ A})^2 (0.370 \Omega) = 68 \text{ W}$$

$$P_{\text{AG}} = P_{\text{AG},F} - P_{\text{AG},B} = 2458 \text{ W} - 68 \text{ W} = 2390 \text{ W}$$

$$\tau_{\text{ind}} = \frac{P_{\text{AG}}}{\omega_{\text{sync}}} = \frac{2390 \text{ W}}{(3000 \text{ r/min}) \frac{2\pi \text{ rad}}{1 \text{ r}} \frac{1 \text{ min}}{60 \text{ s}}} = 7.61 \text{ N}\cdot\text{m}$$

Note that the induced torque is proportional to the square of the terminal voltage.

10-7. What type of motor would you select to perform each of the following jobs? Why?

- | | |
|-----------------------------------|-------------------------|
| (a) Vacuum cleaner | (b) Refrigerator |
| (c) Air conditioner compressor | (d) Air conditioner fan |
| (e) Variable-speed sewing machine | (f) Clock |
| (g) Electric drill | |

SOLUTION

(a) *Universal motor*—for its high torque

(b) *Capacitor start* or *Capacitor start and run*—For its high starting torque and relatively constant speed at a wide variety of loads

(c) Same as (b) above

- (d) *Split-phase*—Fans are low-starting-torque applications, and a split-phase motor is appropriate
- (e) *Universal Motor*—Direction and speed are easy to control with solid-state drives
- (f) *Hysteresis motor*—for its easy starting and operation at n_{sync} . A reluctance motor would also do nicely.
- (g) *Universal Motor*—for easy speed control with solid-state drives, plus high torque under loaded conditions.

10-8. For a particular application, a three-phase stepper motor must be capable of stepping in 10° increments. How many poles must it have?

SOLUTION From Equation (10-18), the relationship between mechanical angle and electrical angle in a three-phase stepper motor is

$$\theta_m = \frac{2}{P} \theta_e$$

so
$$P = 2 \frac{\theta_e}{\theta_m} = 2 \frac{60^\circ}{10^\circ} = 12 \text{ poles}$$

10-9. How many pulses per second must be supplied to the control unit of the motor in Problem 10-7 to achieve a rotational speed of 600 r/min?

SOLUTION From Equation (10-20),

$$n_m = \frac{1}{3P} n_{\text{pulses}}$$

so
$$n_{\text{pulses}} = 3 P n_m = 3(12 \text{ poles})(600 \text{ r/min}) = 21,600 \text{ pulses/min} = 360 \text{ pulses/s}$$

10-10. Construct a table showing step size versus number of poles for three-phase and four-phase stepper motors.

SOLUTION For 3-phase stepper motors, $\theta_e = 60^\circ$, and for 4-phase stepper motors, $\theta_e = 45^\circ$. Therefore,

Number of poles	Mechanical Step Size	
	3-phase ($\theta_e = 60^\circ$)	4-phase ($\theta_e = 45^\circ$)
2	60°	45°
4	30°	22.5°
6	20°	15°
8	15°	11.25°
10	12°	9°
12	10°	7.5°

Appendix A: Review of Three-Phase Circuits

A-1. Three impedances of $4 + j3 \Omega$ are Δ -connected and tied to a three-phase 208-V power line. Find I_ϕ , I_L , P , Q , S , and the power factor of this load.

SOLUTION

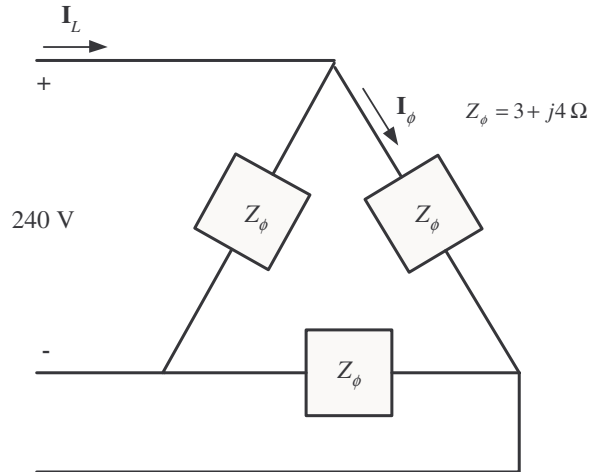

Here, $V_L = V_\phi = 208 \text{ V}$, and $Z_\phi = 4 + j3 \Omega = 5\angle 36.87^\circ \Omega$, so

$$I_\phi = \frac{V_\phi}{Z_\phi} = \frac{208 \text{ V}}{5 \Omega} = 41.6 \text{ A}$$

$$I_L = \sqrt{3}I_\phi = \sqrt{3}(41.6 \text{ A}) = 72.05 \text{ A}$$

$$P = 3 \frac{V_\phi^2}{Z} \cos \theta = 3 \frac{(208 \text{ V})^2}{5 \Omega} \cos 36.87^\circ = 20.77 \text{ kW}$$

$$Q = 3 \frac{V_\phi^2}{Z} \sin \theta = 3 \frac{(208 \text{ V})^2}{5 \Omega} \sin 36.87^\circ = 15.58 \text{ kvar}$$

$$S = \sqrt{P^2 + Q^2} = 25.96 \text{ kVA}$$

$$\text{PF} = \cos \theta = 0.8 \text{ lagging}$$

A-2. Figure PA-1 shows a three-phase power system with two loads. The Δ -connected generator is producing a line voltage of 480 V, and the line impedance is $0.09 + j0.16 \Omega$. Load 1 is Y-connected, with a phase impedance of $2.5\angle 36.87^\circ \Omega$ and load 2 is Δ -connected, with a phase impedance of $5\angle -20^\circ \Omega$.

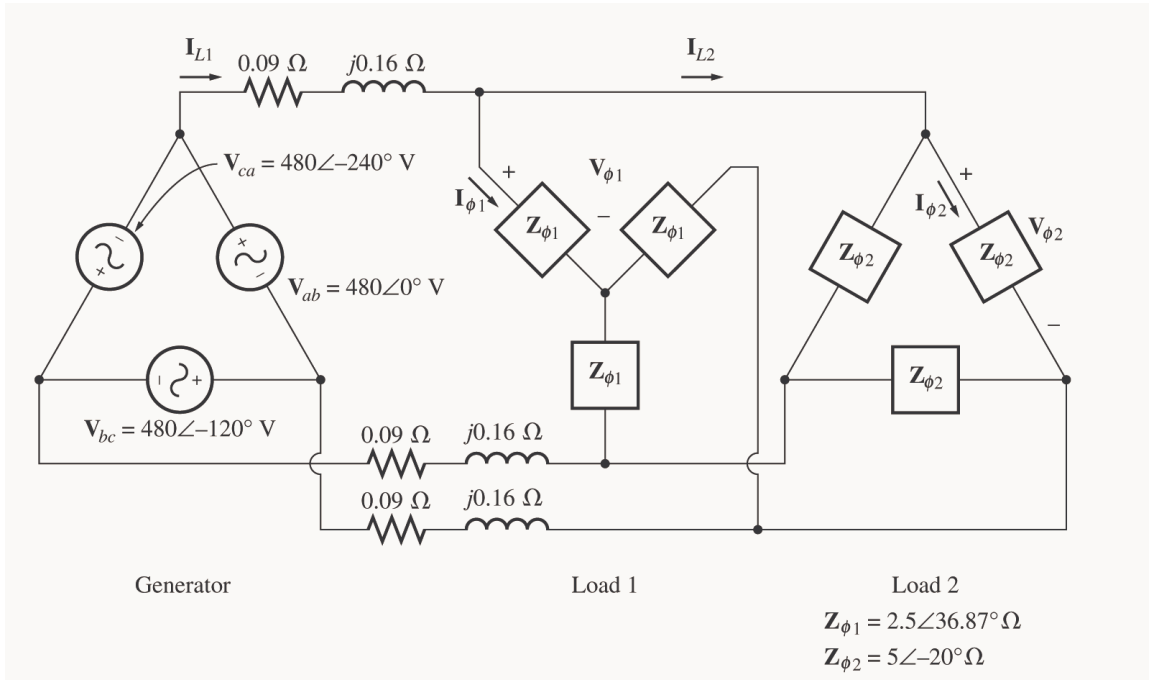

- (a) What is the line voltage of the two loads?
- (b) What is the voltage drop on the transmission lines?
- (c) Find the real and reactive powers supplied to each load.
- (d) Find the real and reactive power losses in the transmission line.
- (e) Find the real power, reactive power, and power factor supplied by the generator.

SOLUTION To solve this problem, first convert the two deltas to equivalent wyes, and get the per-phase equivalent circuit.

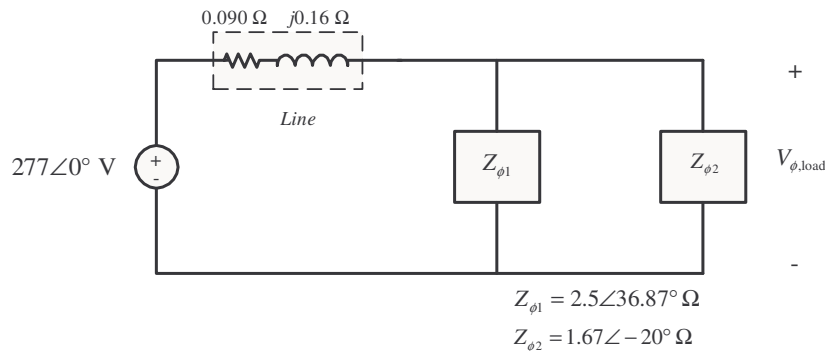

- (a) The phase voltage of the equivalent Y-loads can be found by nodal analysis.

$$\frac{V_{\phi,load} - 277\angle 0^\circ \text{ V}}{0.09 + j0.16 \Omega} + \frac{V_{\phi,load}}{2.5\angle 36.87^\circ \Omega} + \frac{V_{\phi,load}}{1.67\angle -20^\circ \Omega} = 0$$

$$(5.443\angle -60.6^\circ) (V_{\phi,load} - 277\angle 0^\circ \text{ V}) + (0.4\angle -36.87^\circ) V_{\phi,load} + (0.6\angle 20^\circ) V_{\phi,load} = 0$$

$$(5.955\angle -53.34^\circ) V_{\phi,load} = 1508\angle -60.6^\circ$$

$$V_{\phi,load} = 253.2\angle -7.3^\circ \text{ V}$$

Therefore, the line voltage at the loads is $V_L \sqrt{3} V_\phi = 439 \text{ V}$.

(b) The voltage drop in the transmission lines is

$$\Delta \mathbf{V}_{\text{line}} = \mathbf{V}_{\phi, \text{gen}} - \mathbf{V}_{\phi, \text{load}} = 277 \angle 0^\circ \text{ V} - 253.2 \angle -7.3^\circ = 41.3 \angle 52^\circ \text{ V}$$

(c) The real and reactive power of each load is

$$P_1 = 3 \frac{V_\phi^2}{Z} \cos \theta = 3 \frac{(253.2 \text{ V})^2}{2.5 \Omega} \cos 36.87^\circ = 61.6 \text{ kW}$$

$$Q_1 = 3 \frac{V_\phi^2}{Z} \sin \theta = 3 \frac{(253.2 \text{ V})^2}{2.5 \Omega} \sin 36.87^\circ = 46.2 \text{ kvar}$$

$$P_2 = 3 \frac{V_\phi^2}{Z} \cos \theta = 3 \frac{(253.2 \text{ V})^2}{1.67 \Omega} \cos (-20^\circ) = 108.4 \text{ kW}$$

$$Q_2 = 3 \frac{V_\phi^2}{Z} \sin \theta = 3 \frac{(253.2 \text{ V})^2}{1.67 \Omega} \sin (-20^\circ) = -39.5 \text{ kvar}$$

(d) The line current is

$$\mathbf{I}_{\text{line}} = \frac{\Delta \mathbf{V}_{\text{line}}}{Z_{\text{line}}} = \frac{41.3 \angle 52^\circ \text{ V}}{0.09 + j0.16 \Omega} = 225 \angle -8.6^\circ \text{ A}$$

Therefore, the losses in the transmission line are

$$P_{\text{line}} = 3 I_{\text{line}}^2 R_{\text{line}} = 3 (225 \text{ A})^2 (0.09 \Omega) = 13.7 \text{ kW}$$

$$Q_{\text{line}} = 3 I_{\text{line}}^2 X_{\text{line}} = 3 (225 \text{ A})^2 (0.16 \Omega) = 24.3 \text{ kvar}$$

(e) The real and reactive power supplied by the generator is

$$P_{\text{gen}} = P_{\text{line}} + P_1 + P_2 = 13.7 \text{ kW} + 61.6 \text{ kW} + 108.4 \text{ kW} = 183.7 \text{ kW}$$

$$Q_{\text{gen}} = Q_{\text{line}} + Q_1 + Q_2 = 24.3 \text{ kvar} + 46.2 \text{ kvar} - 39.5 \text{ kvar} = 31 \text{ kvar}$$

The power factor of the generator is

$$\text{PF} = \cos \tan^{-1} \frac{Q_{\text{gen}}}{P_{\text{gen}}} = \cos \tan^{-1} \frac{31 \text{ kvar}}{183.7 \text{ kW}} = 0.986 \text{ lagging}$$

A-3. Figure PA-2 shows a one-line diagram of a simple power system containing a single 480 V generator and three loads. Assume that the transmission lines in this power system are lossless, and answer the following questions.

(a) Assume that Load 1 is Y-connected. What are the phase voltage and currents in that load?

(b) Assume that Load 2 is Δ -connected. What are the phase voltage and currents in that load?

(c) What real, reactive, and apparent power does the generator supply when the switch is open?

(d) What is the total line current I_L when the switch is open?

(e) What real, reactive, and apparent power does the generator supply when the switch is closed?

(f) What is the total line current I_L when the switch is closed?

(g) How does the total line current I_L compare to the sum of the three individual currents $I_1 + I_2 + I_3$? If they are not equal, why not?

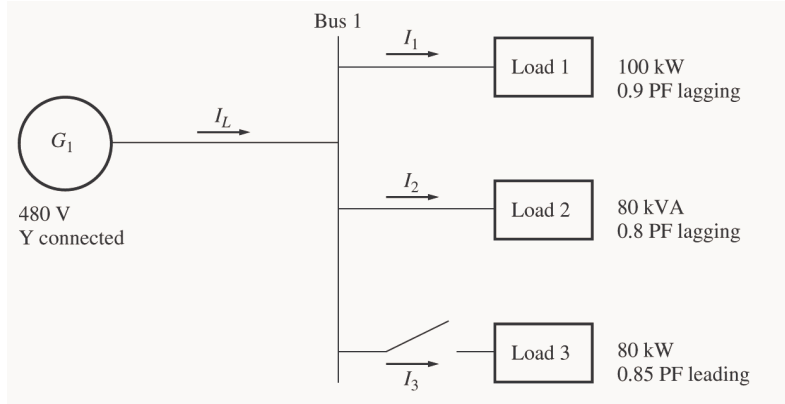

SOLUTION Since the transmission lines are lossless in this power system, the full voltage generated by G_1 will be present at each of the loads.

(a) Since this load is Y-connected, the phase voltage is

$$V_{\phi 1} = \frac{480 \text{ V}}{\sqrt{3}} = 277 \text{ V}$$

The phase current can be derived from the equation $P = 3V_{\phi}I_{\phi} \cos \theta$ as follows:

$$I_{\phi 1} = \frac{P}{3V_{\phi} \cos \theta} = \frac{100 \text{ kW}}{3(277 \text{ V})(0.9)} = 133.7 \text{ A}$$

(b) Since this load is Δ -connected, the phase voltage is

$$V_{\phi 2} = 480 \text{ V}$$

The phase current can be derived from the equation $S = 3V_{\phi}I_{\phi}$ as follows:

$$I_{\phi 2} = \frac{S}{3V_{\phi}} = \frac{80 \text{ kVA}}{3(480 \text{ V})} = 55.56 \text{ A}$$

(c) The real and reactive power supplied by the generator when the switch is open is just the sum of the real and reactive powers of Loads 1 and 2.

$$P_1 = 100 \text{ kW}$$

$$Q_1 = P \tan \theta = P \tan(\cos^{-1} \text{PF}) = (100 \text{ kW})(\tan 25.84^\circ) = 48.4 \text{ kvar}$$

$$P_2 = S \cos \theta = (80 \text{ kVA})(0.8) = 64 \text{ kW}$$

$$Q_2 = S \sin \theta = (80 \text{ kVA})(0.6) = 48 \text{ kvar}$$

$$P_G = P_1 + P_2 = 100 \text{ kW} + 64 \text{ kW} = 164 \text{ kW}$$

$$Q_G = Q_1 + Q_2 = 48.4 \text{ kvar} + 48 \text{ kvar} = 96.4 \text{ kvar}$$

(d) The line current when the switch is open is given by $I_L = \frac{P}{\sqrt{3} V_L \cos \theta}$, where $\theta = \tan^{-1} \frac{Q_G}{P_G}$.

$$\theta = \tan^{-1} \frac{Q_G}{P_G} = \tan^{-1} \frac{96.4 \text{ kvar}}{164 \text{ kW}} = 30.45^\circ$$

$$I_L = \frac{P}{\sqrt{3} V_L \cos \theta} = \frac{164 \text{ kW}}{\sqrt{3}(480 \text{ V}) \cos(30.45^\circ)} = 228.8 \text{ A}$$

(e) The real and reactive power supplied by the generator when the switch is closed is just the sum of the real and reactive powers of Loads 1, 2, and 3. The powers of Loads 1 and 2 have already been calculated. The real and reactive power of Load 3 are:

$$P_3 = 80 \text{ kW}$$

$$Q_3 = P \tan \theta = P \tan(\cos^{-1} \text{PF}) = (80 \text{ kW}) \tan(31.79^\circ) = 49.6 \text{ kvar}$$

$$P_G = P_1 + P_2 + P_3 = 100 \text{ kW} + 64 \text{ kW} + 80 \text{ kW} = 244 \text{ kW}$$

$$Q_G = Q_1 + Q_2 + Q_3 = 48.4 \text{ kvar} + 48 \text{ kvar} - 49.6 \text{ kvar} = 46.8 \text{ kvar}$$

(f) The line current when the switch is closed is given by $I_L = \frac{P}{\sqrt{3} V_L \cos \theta}$, where $\theta = \tan^{-1} \frac{Q_G}{P_G}$.

$$\theta = \tan^{-1} \frac{Q_G}{P_G} = \tan^{-1} \frac{46.8 \text{ kvar}}{244 \text{ kW}} = 10.86^\circ$$

$$I_L = \frac{P}{\sqrt{3} V_L \cos \theta} = \frac{244 \text{ kW}}{\sqrt{3} (480 \text{ V}) \cos(10.86^\circ)} = 298.8 \text{ A}$$

(g) The total line current from the generator is 298.8 A. The line currents to each individual load are:

$$I_{L1} = \frac{P_1}{\sqrt{3} V_L \cos \theta_1} = \frac{100 \text{ kW}}{\sqrt{3} (480 \text{ V}) (0.9)} = 133.6 \text{ A}$$

$$I_{L2} = \frac{S_2}{\sqrt{3} V_L} = \frac{80 \text{ kVA}}{\sqrt{3} (480 \text{ V})} = 96.2 \text{ A}$$

$$I_{L3} = \frac{P_3}{\sqrt{3} V_L \cos \theta_3} = \frac{80 \text{ kW}}{\sqrt{3} (480 \text{ V}) (0.85)} = 113.2 \text{ A}$$

The sum of the three individual line currents is 343 A, while the current supplied by the generator is 298.8 A. These values are *not* the same, because the three loads have different impedance angles. Essentially, Load 3 is supplying some of the reactive power being consumed by Loads 1 and 2, so that it does not have to come from the generator.

A-4. Prove that the line voltage of a Y-connected generator with an *acb* phase sequence lags the corresponding phase voltage by 30° . Draw a phasor diagram showing the phase and line voltages for this generator.

SOLUTION If the generator has an *acb* phase sequence, then the three phase voltages will be

$$\mathbf{V}_{an} = V_\phi \angle 0^\circ$$

$$\mathbf{V}_{bn} = V_\phi \angle -240^\circ$$

$$\mathbf{V}_{cn} = V_\phi \angle -120^\circ$$

The relationship between line voltage and phase voltage is derived below. By Kirchhoff's voltage law, the line-to-line voltage \mathbf{V}_{ab} is given by

$$\mathbf{V}_{ab} = \mathbf{V}_a - \mathbf{V}_b$$

$$\mathbf{V}_{ab} = V_\phi \angle 0^\circ - V_\phi \angle -240^\circ$$

$$\mathbf{V}_{ab} = V_\phi - \left[-\frac{1}{2} V_\phi + j \frac{\sqrt{3}}{2} V_\phi \right] = \frac{3}{2} V_\phi - j \frac{\sqrt{3}}{2} V_\phi$$

$$\mathbf{V}_{ab} = \sqrt{3} V_\phi \left[\frac{\sqrt{3}}{2} - j \frac{1}{2} \right]$$

$$\mathbf{V}_{ab} = \sqrt{3} V_\phi \angle -30^\circ$$

Thus the line voltage *lags* the corresponding phase voltage by 30° . The phasor diagram for this connection is shown below.

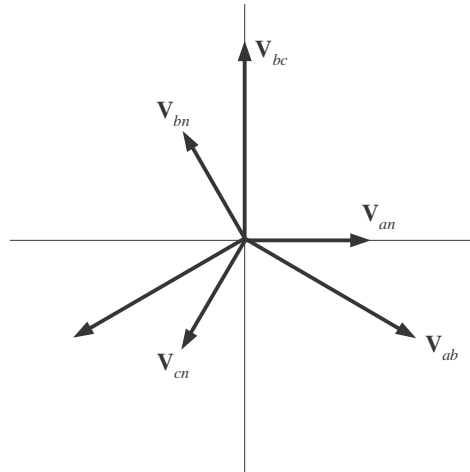

A-5. Find the magnitudes and angles of each line and phase voltage and current on the load shown in Figure P2-3.

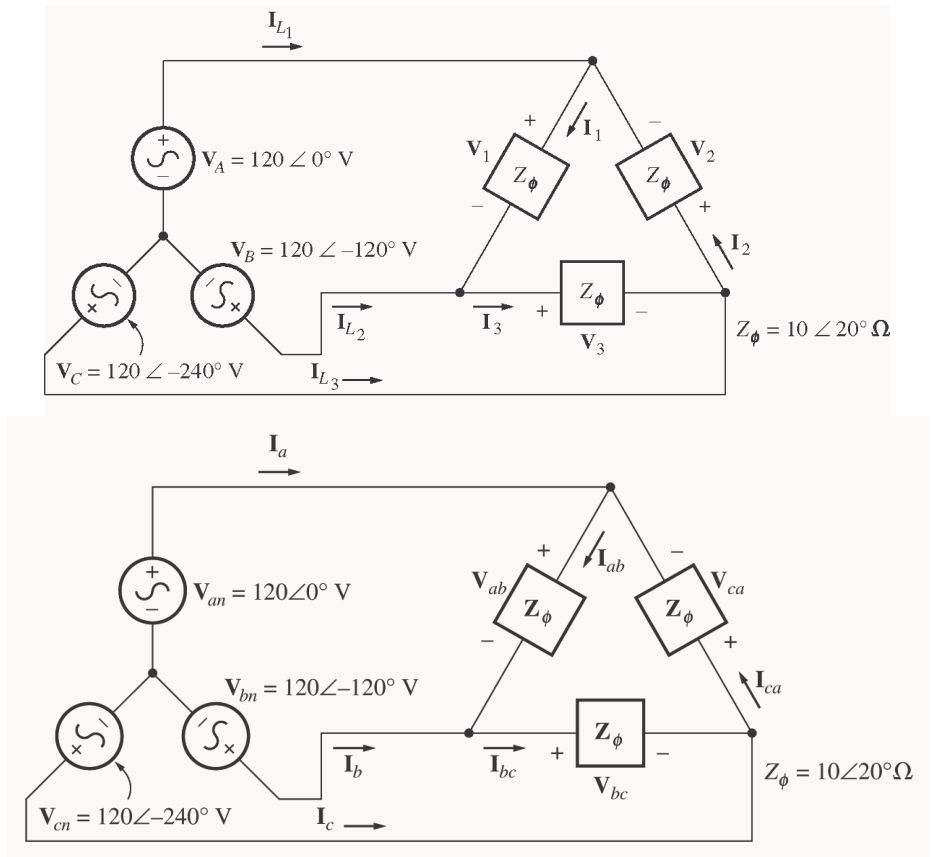

SOLUTION Note that because this load is Δ -connected, the line and phase voltages are identical.

$$\begin{aligned} \mathbf{V}_{ab} &= \mathbf{V}_{an} - \mathbf{V}_{bn} = 120\angle 0^\circ \text{ V} - 120\angle -120^\circ \text{ V} = 208\angle 30^\circ \text{ V} \\ \mathbf{V}_{bc} &= \mathbf{V}_{bn} - \mathbf{V}_{cn} = 120\angle -120^\circ \text{ V} - 120\angle -240^\circ \text{ V} = 208\angle -90^\circ \text{ V} \\ \mathbf{V}_{ca} &= \mathbf{V}_{cn} - \mathbf{V}_{an} = 120\angle -240^\circ \text{ V} - 120\angle 0^\circ \text{ V} = 208\angle 150^\circ \text{ V} \end{aligned}$$

$$\begin{aligned} \mathbf{I}_{ab} &= \frac{\mathbf{V}_{ab}}{\mathbf{Z}_{\phi}} = \frac{208\angle 30^{\circ} \text{ V}}{10\angle 20^{\circ} \Omega} = 20.8\angle 10^{\circ} \text{ A} \\ \mathbf{I}_{bc} &= \frac{\mathbf{V}_{bc}}{\mathbf{Z}_{\phi}} = \frac{208\angle -90^{\circ} \text{ V}}{10\angle 20^{\circ} \Omega} = 20.8\angle -110^{\circ} \text{ A} \\ \mathbf{I}_{ca} &= \frac{\mathbf{V}_{ca}}{\mathbf{Z}_{\phi}} = \frac{208\angle 150^{\circ} \text{ V}}{10\angle 20^{\circ} \Omega} = 20.8\angle 130^{\circ} \text{ A} \\ \mathbf{I}_a &= \mathbf{I}_{ab} - \mathbf{I}_{ca} = 20.8\angle 10^{\circ} \text{ A} - 20.8\angle 130^{\circ} \text{ A} = 36\angle -20^{\circ} \text{ A} \\ \mathbf{I}_b &= \mathbf{I}_{bc} - \mathbf{I}_{ab} = 20.8\angle -110^{\circ} \text{ A} - 20.8\angle 10^{\circ} \text{ A} = 36\angle -140^{\circ} \text{ A} \\ \mathbf{I}_c &= \mathbf{I}_{ca} - \mathbf{I}_{bc} = 20.8\angle 130^{\circ} \text{ A} - 20.8\angle -110^{\circ} \text{ A} = 36\angle 100^{\circ} \text{ A} \end{aligned}$$

A-6. Figure PA-4 shows a small 480-V distribution system. Assume that the lines in the system have zero impedance.

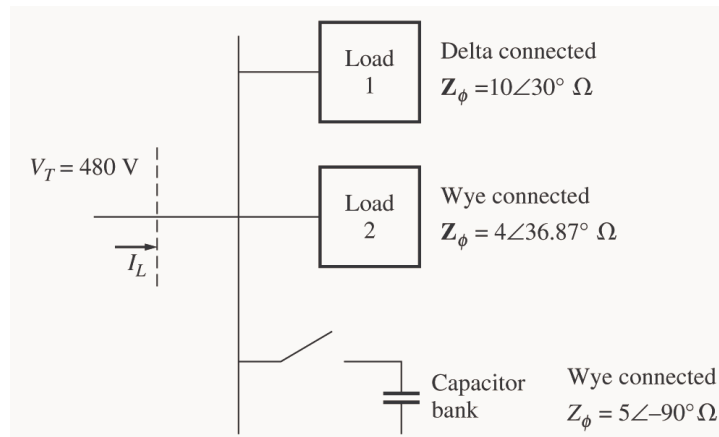

- (a) If the switch shown is open, find the real, reactive, and apparent powers in the system. Find the total current supplied to the distribution system by the utility.
- (b) Repeat part (a) with the switch closed. What happened to the total current supplied? Why?

SOLUTION

- (a) With the switch open, the power supplied to each load is

$$\begin{aligned} P_1 &= 3 \frac{V_{\phi}^2}{Z} \cos \theta = 3 \frac{(480 \text{ V})^2}{10 \Omega} \cos 30^{\circ} = 59.86 \text{ kW} \\ Q_1 &= 3 \frac{V_{\phi}^2}{Z} \sin \theta = 3 \frac{(480 \text{ V})^2}{10 \Omega} \sin 30^{\circ} = 34.56 \text{ kvar} \\ P_2 &= 3 \frac{V_{\phi}^2}{Z} \cos \theta = 3 \frac{(277 \text{ V})^2}{4 \Omega} \cos 36.87^{\circ} = 46.04 \text{ kW} \\ Q_2 &= 3 \frac{V_{\phi}^2}{Z} \sin \theta = 3 \frac{(277 \text{ V})^2}{4 \Omega} \sin 36.87^{\circ} = 34.53 \text{ kvar} \\ P_{\text{TOT}} &= P_1 + P_2 = 59.86 \text{ kW} + 46.04 \text{ kW} = 105.9 \text{ kW} \\ Q_{\text{TOT}} &= Q_1 + Q_2 = 34.56 \text{ kvar} + 34.53 \text{ kvar} = 69.09 \text{ kvar} \end{aligned}$$

The apparent power supplied by the utility is

$$S_{\text{TOT}} = \sqrt{P_{\text{TOT}}^2 + Q_{\text{TOT}}^2} = 126.4 \text{ kVA}$$

The power factor supplied by the utility is

$$\text{PF} = \cos \tan^{-1} \frac{Q_{\text{TOT}}}{P_{\text{TOT}}} = \cos \tan^{-1} \frac{69.09 \text{ kvar}}{105.9 \text{ kW}} = 0.838 \text{ lagging}$$

The current supplied by the utility is

$$I_L = \frac{P_{\text{TOT}}}{\sqrt{3} V_T \text{PF}} = \frac{105.9 \text{ kW}}{\sqrt{3} (480 \text{ V}) (0.838)} = 152 \text{ A}$$

(b) With the switch closed, P_3 is added to the circuit. The real and reactive power of P_3 is

$$P_3 = 3 \frac{V_\phi^2}{Z} \cos \theta = 3 \frac{(277 \text{ V})^2}{5 \Omega} \cos (-90^\circ) = 0 \text{ kW}$$

$$Q_3 = 3 \frac{V_\phi^2}{Z} \sin \theta = 3 \frac{(277 \text{ V})^2}{5 \Omega} \sin (-90^\circ) = -46.06 \text{ kvar}$$

$$P_{\text{TOT}} = P_1 + P_2 + P_3 = 59.86 \text{ kW} + 46.04 \text{ kW} + 0 \text{ kW} = 105.9 \text{ kW}$$

$$Q_{\text{TOT}} = Q_1 + Q_2 + Q_3 = 34.56 \text{ kvar} + 34.53 \text{ kvar} - 46.06 \text{ kvar} = 23.03 \text{ kvar}$$

The apparent power supplied by the utility is

$$S_{\text{TOT}} = \sqrt{P_{\text{TOT}}^2 + Q_{\text{TOT}}^2} = 108.4 \text{ kVA}$$

The power factor supplied by the utility is

$$\text{PF} = \cos \tan^{-1} \frac{Q_{\text{TOT}}}{P_{\text{TOT}}} = \cos \tan^{-1} \frac{23.03 \text{ kVAR}}{105.9 \text{ kW}} = 0.977 \text{ lagging}$$

The current supplied by the utility is

$$I_L = \frac{P_{\text{TOT}}}{\sqrt{3} V_T \text{PF}} = \frac{105.9 \text{ kW}}{\sqrt{3} (480 \text{ V}) (0.977)} = 130.4 \text{ A}$$

(c) The total current supplied by the power system drops when the switch is closed because the capacitor bank is supplying some of the reactive power being consumed by loads 1 and 2.

Appendix B: Coil Pitch and Distributed Windings

- B-1.** A 2-slot three-phase stator armature is wound for two-pole operation. If fractional-pitch windings are to be used, what is the best possible choice for winding pitch if it is desired to eliminate the fifth-harmonic component of voltage?

SOLUTION The pitch factor of a winding is given by Equation (B-19):

$$k_p = \sin \frac{v\rho}{2}$$

To eliminate the fifth harmonic, we want to select ρ so that $\sin \frac{5\rho}{2} = 0$. This implies that

$$\frac{5\rho}{2} = (180^\circ)n, \text{ where } n = 0, 1, 2, 3, \dots$$

or
$$\rho = \frac{2(180^\circ)n}{5} = 72^\circ, 144^\circ, \dots$$

These are acceptable pitches to eliminate the fifth harmonic. Expressed as fractions of full pitch, these pitches are $2/5$, $4/5$, $6/5$, etc. Since the desire is to have the maximum possible fundamental voltage, the best choice for coil pitch would be $4/5$ or $6/5$. *The closest that we can approach to a $4/5$ pitch in a 24-slot winding is $10/12$ pitch, so that is the pitch that we would use.*

At $10/12$ pitch,

$$k_p = \sin \frac{150^\circ}{2} = 0.966 \quad \text{for the fundamental frequency}$$

$$k_p = \sin \frac{(5)(150^\circ)}{2} = 0.259 \quad \text{for the fifth harmonic}$$

B-2. Derive the relationship for the winding distribution factor k_d in Equation B-22.

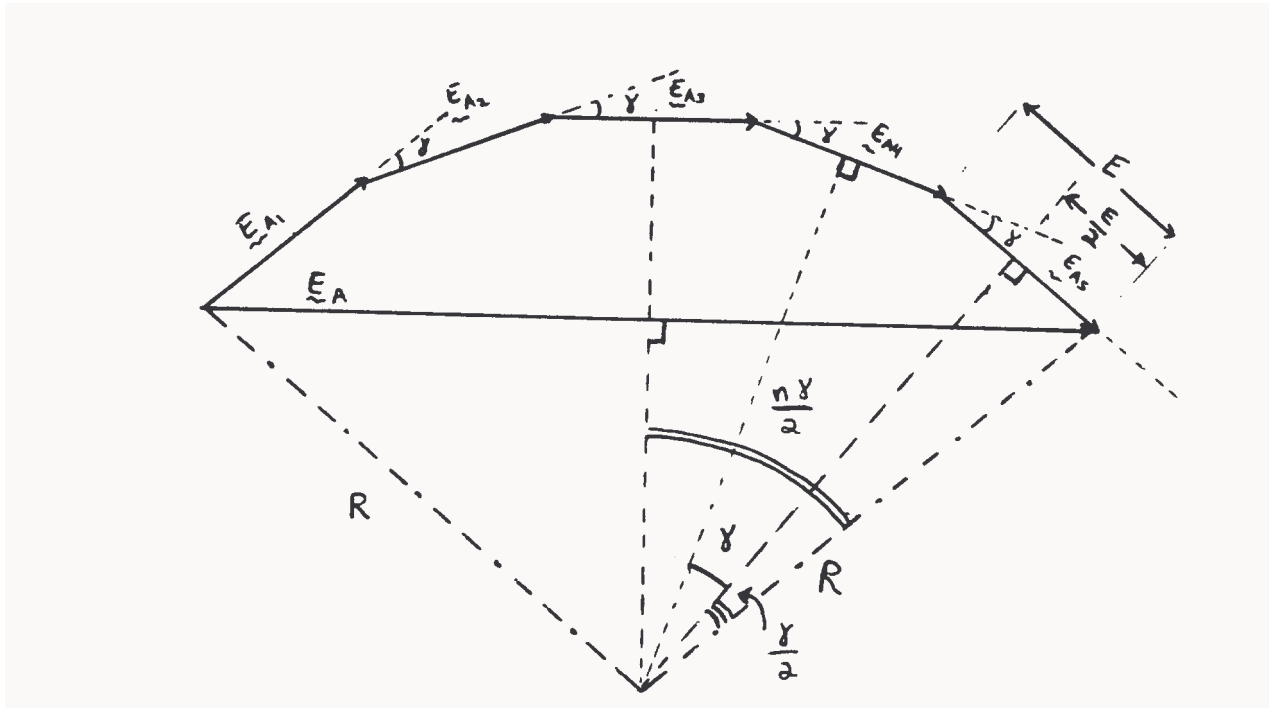

SOLUTION The above illustration shows the case of 5 slots per phase, but the results are general. If there are 5 slots per phase, each with voltage \mathbf{E}_{A_i} , where the phase angle of each voltage increases by γ° from slot to slot, then the total voltage in the phase will be

$$\mathbf{E}_A = \mathbf{E}_{A_1} + \mathbf{E}_{A_2} + \mathbf{E}_{A_3} + \mathbf{E}_{A_4} + \mathbf{E}_{A_5} + \dots + \mathbf{E}_{A_n}$$

The resulting voltage \mathbf{E}_A can be found from geometrical considerations. These “ n ” phases, when drawn end-to-end, form equally-spaced chords on a circle of radius R . If a line is drawn from the center of a chord to the origin of the circle, it forms a right triangle with the radius at the end of the chord (see voltage \mathbf{E}_{A_5} above). The *hypotenuse* of this right triangle is R , its *opposite side* is $E/2$, and its smaller angle is $\gamma/2$. Therefore,

$$\sin \frac{\gamma}{2} = \frac{E/2}{R} \Rightarrow R = \frac{\frac{1}{2}E}{\sin \frac{\gamma}{2}} \quad (1)$$

The total voltage \mathbf{E}_A also forms a chord on the circle, and dropping a line from the center of that chord to the origin forms a right triangle. For this triangle, the *hypotenuse* is R , the *opposite side* is $\mathbf{E}_A/2$, and the *angle* is $n\gamma/2$. Therefore,

$$\sin \frac{n\gamma}{2} = \frac{\mathbf{E}_A/2}{R} \Rightarrow R = \frac{\frac{1}{2}\mathbf{E}_A}{\sin \frac{n\gamma}{2}} \quad (2)$$

Combining (1) and (2) yields

$$\frac{\frac{1}{2}E}{\sin \frac{\gamma}{2}} = \frac{\frac{1}{2}E_A}{\sin \frac{n\gamma}{2}}$$

$$\frac{E_A}{E} = \frac{\sin \frac{n\gamma}{2}}{\sin \frac{\gamma}{2}}$$

Finally,

$$k_d = \frac{E_A}{nE} = \frac{\sin \frac{n\gamma}{2}}{n \sin \frac{\gamma}{2}}$$

since k_d is *defined* as the ratio of the total voltage produced to the sum of the magnitudes of each component voltage.

- B-3.** A three-phase four-pole synchronous machine has 96 stator slots. The slots contain a double-layer winding (two coils per slot) with four turns per coil. The coil pitch is 19/24.
- Find the slot and coil pitch in electrical degrees.
 - Find the pitch, distribution, and winding factors for this machine.
 - How well will this winding suppress third, fifth, seventh, ninth, and eleventh harmonics? Be sure to consider the effects of both coil pitch and winding distribution in your answer.

SOLUTION

(a) The coil pitch is 19/24 or 142.5°. Note that these are *electrical degrees*. Since this is a 4-pole machine, the coil pitch would be 71.25 mechanical degrees.

There are 96 slots on this stator, so the *slot pitch* is $360^\circ/96 = 3.75$ mechanical degrees or 7.5 electrical degrees.

(b) The pitch factor of this winding is

$$k_p = \sin \frac{\rho}{2} = \sin \frac{142.5^\circ}{2} = 0.947$$

The distribution factor is

$$k_d = \frac{\sin \frac{n\gamma}{2}}{n \sin \frac{\gamma}{2}}$$

The electrical angle γ between slots is 7.5°, and each phase group occupies 8 adjacent slots. Therefore, the distribution factor is

$$k_d = \frac{\sin \frac{n\gamma}{2}}{n \sin \frac{\gamma}{2}} = \frac{\sin \frac{(8)(15^\circ)}{2}}{8 \sin \frac{15^\circ}{2}} = 0.956$$

The winding factor is

$$k_w = k_p k_d = (0.947)(0.956) = 0.905$$

- B-4.** A three-phase four-pole winding of the double-layer type is to be installed on a 48-slot stator. The pitch of the stator windings is $5/6$, and there are 10 turns per coil in the windings. All coils in each phase are connected in series, and the three phases are connected in Δ . The flux per pole in the machine is 0.054 Wb, and the speed of rotation of the magnetic field is 1800 r/min.

- (a) What is the pitch factor of this winding?
 (b) What is the distribution factor of this winding?
 (c) What is the frequency of the voltage produced in this winding?
 (d) What are the resulting phase and terminal voltages of this stator?

SOLUTION

- (a) The pitch factor of this winding is

$$k_p = \sin \frac{\rho}{2} = \sin \frac{150^\circ}{2} = 0.966$$

- (b) The coils in each phase group of this machine cover 4 slots, and the slot pitch is $360/48 = 7.5$ mechanical degrees or 15 electrical degrees. Therefore, the distribution factor is

$$k_d = \frac{\sin \frac{n\gamma}{2}}{n \sin \frac{\gamma}{2}} = \frac{\sin \frac{(4)(15^\circ)}{2}}{4 \sin \frac{15^\circ}{2}} = 0.958$$

- (c) The frequency of the voltage produces by this winding is

$$f_e = \frac{n_m P}{120} = \frac{(1800 \text{ r/min})(4 \text{ poles})}{120} = 60 \text{ Hz}$$

- (d) There are 48 slots on this stator, with two coils sides in each slot. Therefore, there are 48 coils on the machine. They are divided into 12 phase groups, so there are 4 coils per phase. There are 10 turns per coil, so there are 40 turns per phase group. The voltage in one phase group is

$$E_G = \sqrt{2}\pi N_p k_p k_d \phi f_e = \sqrt{2}\pi(40 \text{ turns})(0.966)(0.958)(0.054 \text{ Wb})(60 \text{ Hz}) = 533 \text{ V}$$

There are two phase groups per phase, connected in series (this is a 4-pole machine), so the total phase voltage is $V_\phi = 2E_G = 1066 \text{ V}$. Since the machine is Δ -connected,

$$V_T = V_\phi = 1066 \text{ V}$$

- B-5.** A three-phase Y-connected six-pole synchronous generator has six slots per pole on its stator winding. The winding itself is a chorded (fractional-pitch) double-layer winding with eight turns per coil. The distribution factor $k_d = 0.956$, and the pitch factor $k_p = 0.981$. The flux in the generator is 0.02 Wb per

pole, and the speed of rotation is 1200 r/min. What is the line voltage produced by this generator at these conditions?

SOLUTION There are 6 slots per pole \times 6 poles = 36 slots on the stator of this machine. Therefore, there are 36 coils on the machine, or 12 coils per phase. The electrical frequency produced by this winding is

$$f_e = \frac{n_m P}{120} = \frac{(1200 \text{ r/min})(6 \text{ poles})}{120} = 60 \text{ Hz}$$

The phase voltage is

$$V_\phi = \sqrt{2}\pi N_p k_p k_d \phi f_e = \sqrt{2}\pi(96 \text{ turns})(0.981)(0.956)(0.02 \text{ Wb})(60 \text{ Hz}) = 480 \text{ V}$$

Therefore, the line voltage is

$$V_L = \sqrt{3}V_\phi = 831 \text{ V}$$

B-6. A three-phase Y-connected 50-Hz two-pole synchronous machine has a stator with 18 slots. Its coils form a double-layer chorded winding (two coils per slot), and each coil has 60 turns. The pitch of the stator coils is 8/9.

(a) What rotor flux would be required to produce a terminal (line-to-line) voltage of 6 kV?

(b) How effective are coils of this pitch at reducing the fifth-harmonic component of voltage? The seventh-harmonic component of voltage?

SOLUTION

(a) The pitch of this winding is $8/9 = 160^\circ$, so the pitch factor is

$$k_p = \sin \frac{160^\circ}{2} = 0.985$$

The phase groups in this machine cover three slots each, and the slot pitch is 20 mechanical or 20 electrical degrees. Thus the distribution factor is

$$k_d = \frac{\sin \frac{n\gamma}{2}}{n \sin \frac{\gamma}{2}} = \frac{\sin \frac{(3)(20^\circ)}{2}}{3 \sin \frac{20^\circ}{2}} = 0.960$$

The phase voltage of this machine will be

$$V_\phi = \sqrt{2}\pi N_p k_p k_d \phi f_e = \sqrt{2}\pi(6 \text{ coils})(60 \text{ turns/coil})(0.985)(0.960)\phi(50 \text{ Hz})$$

$$V_\phi = 75621\phi$$

The desired phase voltage is $6 \text{ kV} / \sqrt{3} = 3464 \text{ V}$, so

$$\phi = \frac{3464 \text{ V}}{75621} = 0.046 \text{ Wb}$$

(b) The **fifth harmonic**: $k_p = \sin \frac{(5)(160^\circ)}{2} = 0.643$

The **seventh harmonic**: $k_p = \sin \frac{(7)(160^\circ)}{2} = -0.342$

Since the fundamental voltage is reduced by 0.985, the fifth and seventh harmonics are suppressed relative to the fundamental by the fractions:

$$5^{\text{th}}: \quad \frac{0.643}{0.985} = 0.653$$

$$7^{\text{th}}: \quad \frac{0.342}{0.985} = 0.347$$

In other words, the 5th harmonic is suppressed by 34.7% relative to the fundamental, and the 7th harmonic is suppressed by 65.3% relative to the fundamental frequency.

- B-7.** What coil pitch could be used to completely eliminate the seventh-harmonic component of voltage in ac machine armature (stator)? What is the *minimum* number of slots needed on an eight-pole winding to exactly achieve this pitch? What would this pitch do to the fifth-harmonic component of voltage?

SOLUTION To totally eliminate the seventh harmonic of voltage in an ac machine armature, the pitch factor for that harmonic must be zero.

$$k_p = 0 = \sin \frac{7\rho}{2}$$

$$\Rightarrow \quad \frac{7\rho}{2} = (180^\circ)n, \quad n = 0, 1, 2, \dots$$

$$\rho = \frac{2(180^\circ)n}{7}$$

In order to maximize the fundamental voltage while canceling out the seventh harmonic, we pick the value of n that makes ρ as nearly 180° as possible. If $n = 3$, then $\rho = 154.3^\circ$, and the pitch factor for the *fundamental* frequency would be

$$k_p = \sin \frac{154.3^\circ}{2} = 0.975$$

This pitch corresponds to a ratio of 6/7. For a two-pole machine, a ratio of 6/7 could be implemented with a total of 14 slots. If that ratio is desired in an 8-pole machine, then 56 slots would be needed.

The *fifth harmonic* would be suppressed by this winding as follows:

$$k_p = \sin \frac{(5)(154.3^\circ)}{2} = 0.434$$

- B-8.** A 13.8-kV Y-connected 60-Hz 12-pole three-phase synchronous generator has 180 stator slots with a double-layer winding and eight turns per coil. The coil pitch on the stator is 12 slots. The conductors from all phase belts (or groups) in a given phase are connected in series.

- (a) What flux per pole would be required to give a no-load terminal (line) voltage of 13.8 kV?
 (b) What is this machine's winding factor k_w ?

SOLUTION

- (a) The stator pitch is $12/15 = 4/5$, so $\rho = 144^\circ$, and

$$k_p = \sin \frac{144^\circ}{2} = 0.951$$

Each phase belt consists of $(180 \text{ slots}) / (12 \text{ poles}) (6) = 2.5$ slots per phase group. The slot pitch is 2 mechanical degrees or 24 electrical degrees. The corresponding distribution factor is

$$k_d = \frac{\sin \frac{n\gamma}{2}}{n \sin \frac{\gamma}{2}} = \frac{\sin \frac{(2.5)(24^\circ)}{2}}{2.5 \sin \frac{24^\circ}{2}} = 0.962$$

Since there are 60 coils in each phase and 8 turns per coil, all connected in series, there are 480 turns per phase. The resulting voltage is

$$V_\phi = \sqrt{2} \pi N_p k_p k_d \phi f_e = \sqrt{2} \pi (480 \text{ turns}) (0.951) (0.962) \phi (60 \text{ Hz})$$

$$V_\phi = 117,061 \phi$$

The phase voltage of this generator must be $13.8 \text{ kV} / \sqrt{3} = 7967 \text{ V}$, so the flux must be

$$\phi = \frac{7967 \text{ V}}{117,061} = 0.068 \text{ Wb}$$

(b) The machine's winding factor is

$$k_w = k_p k_d = (0.951)(0.962) = 0.915$$

Appendix C: Salient Pole Theory of Synchronous Machines

C-1. A 480-V 200-kVA 0.8-PF-lagging 60-Hz four-pole Y-connected synchronous generator has a direct-axis reactance of 0.25Ω , a quadrature-axis reactance of 0.18Ω , and an armature resistance of 0.03Ω . Friction, windage, and stray losses may be assumed negligible. The generator's open-circuit characteristic is given by Figure P5-1.

- How much field current is required to make V_T equal to 480 V when the generator is running at no load?
- What is the internal generated voltage of this machine when it is operating at rated conditions? How does this value of \mathbf{E}_A compare to that of Problem 5-2b?
- What fraction of this generator's full-load power is due to the reluctance torque of the rotor?

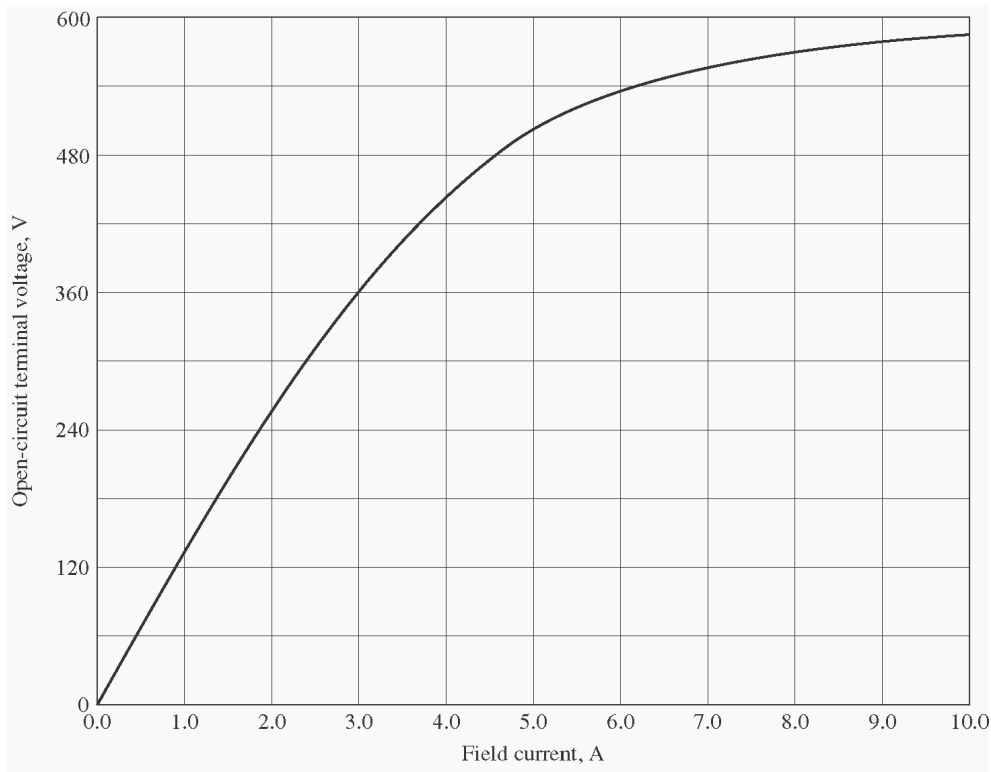

SOLUTION

(a) If the no-load terminal voltage is 480 V, the required field current can be read directly from the open-circuit characteristic. It is 4.55 A.

(b) At rated conditions, the line and phase current in this generator is

$$I_A = I_L = \frac{P}{\sqrt{3} V_L} = \frac{200 \text{ kVA}}{\sqrt{3}(480 \text{ V})} = 240.6 \text{ A at an angle of } -36.87^\circ$$

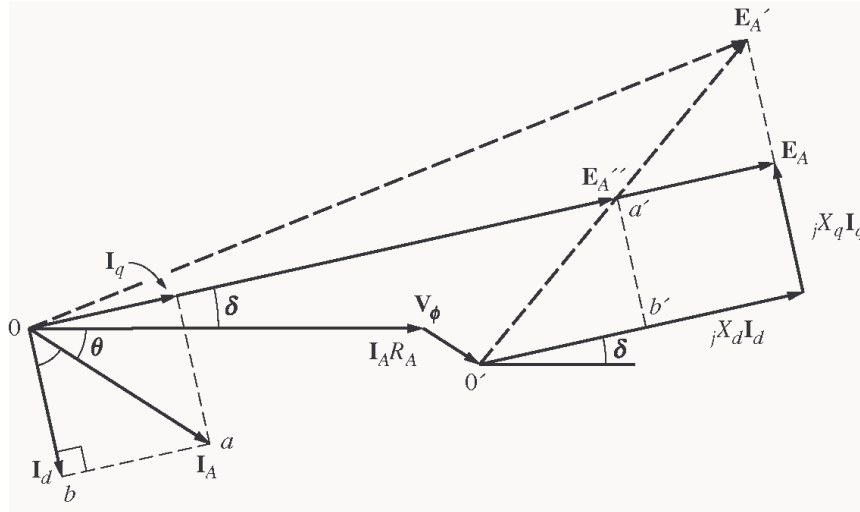

$$\mathbf{E}_A'' = \mathbf{V}_\phi + R_A \mathbf{I}_A + jX_q \mathbf{I}_A$$

$$\mathbf{E}_A'' = 277 \angle 0^\circ + (0.03 \Omega)(240.6 \angle -36.87^\circ \text{ A}) + j(0.18 \Omega)(240.6 \angle -36.87^\circ \text{ A})$$

$$\mathbf{E}_A'' = 310 \angle 5.61^\circ \text{ V}$$

Therefore, the torque angle δ is 5.61° . The direct-axis current is

$$\mathbf{I}_d = I_A \sin(\theta + \delta) \angle \delta - 90^\circ$$

$$\mathbf{I}_d = (240.6 \text{ A}) \sin(42.48^\circ) \angle -84.4^\circ$$

$$\mathbf{I}_d = 162.5 \angle -84.4^\circ \text{ A}$$

The quadrature-axis current is

$$\mathbf{I}_q = I_A \cos(\theta + \delta) \angle \delta$$

$$\mathbf{I}_q = (240.6 \text{ A}) \cos(42.48^\circ) \angle 5.61^\circ$$

$$\mathbf{I}_q = 177.4 \angle 5.61^\circ \text{ A}$$

Therefore, the internal generated voltage of the machine is

$$\mathbf{E}_A = \mathbf{V}_\phi + R_A \mathbf{I}_A + jX_d \mathbf{I}_d + jX_q \mathbf{I}_q$$

$$\mathbf{E}_A = 277 \angle 0^\circ + (0.03)(240.6 \angle -36.87^\circ) + j(0.25)(162.5 \angle -84.4^\circ) + j(0.18)(177.4 \angle 5.61^\circ)$$

$$\mathbf{E}_A = 322 \angle 5.61^\circ \text{ V}$$

$|\mathbf{E}_A|$ is approximately the same magnitude here as in Problem 5-2b, but the angle is about 2.2° different.

(c) The power supplied by this machine is given by the equation

$$P = \frac{3V_\phi E_A}{X_d} \sin \delta + \frac{3V_\phi^2}{2} \left(\frac{X_d - X_q}{X_d X_q} \right) \sin 2\delta$$

$$P = \frac{3(277)(322)}{0.25} \sin 5.61^\circ + \frac{3(277)^2}{2} \left(\frac{0.25 - 0.18}{(0.25)(0.18)} \right) \sin 11.22^\circ$$

$$P = 104.6 \text{ kW} + 34.8 \text{ kW} = 139.4 \text{ kW}$$

The cylindrical rotor term is 104.6 kW, and the reluctance term is 34.8 kW, so the reluctance torque accounts for about 25% of the power in this generator.

C-2. A 14-pole Y-connected three-phase water-turbine-driven generator is rated at 120 MVA, 13.2 kV, 0.8 PF lagging, and 60 Hz. Its direct-axis reactance is 0.62Ω and its quadrature-axis reactance is 0.40Ω . All rotational losses may be neglected.

- What internal generated voltage would be required for this generator to operate at the rated conditions?
- What is the voltage regulation of this generator at the rated conditions?
- Sketch the power-versus-torque-angle curve for this generator. At what angle δ is the power of the generator maximum?
- How does the maximum power out of this generator compare to the maximum power available if it were of cylindrical rotor construction?

SOLUTION

- At rated conditions, the line and phase current in this generator is

$$I_A = I_L = \frac{P}{\sqrt{3} V_L} = \frac{120 \text{ MVA}}{\sqrt{3}(13.2 \text{ kV})} = 5249 \text{ A at an angle of } -36.87^\circ$$

$$\mathbf{E}_A'' = \mathbf{V}_\phi + R_A \mathbf{I}_A + jX_q \mathbf{I}_A$$

$$\mathbf{E}_A'' = 7621 \angle 0^\circ + 0 + j(0.40 \Omega)(5249 \angle -36.87^\circ \text{ A})$$

$$\mathbf{E}_A'' = 9038 \angle 10.7^\circ \text{ V}$$

Therefore, the torque angle δ is 10.7° . The direct-axis current is

$$\mathbf{I}_d = I_A \sin(\theta + \delta) \angle \delta - 90^\circ$$

$$\mathbf{I}_d = (5249 \text{ A}) \sin(47.57^\circ) \angle -79.3^\circ$$

$$\mathbf{I}_d = 3874 \angle -79.3^\circ \text{ A}$$

The quadrature-axis current is

$$\mathbf{I}_q = I_A \cos(\theta + \delta) \angle \delta$$

$$\mathbf{I}_q = (5249 \text{ A}) \cos(47.57^\circ) \angle 10.7^\circ$$

$$\mathbf{I}_q = 3541 \angle 10.7^\circ \text{ A}$$

Therefore, the internal generated voltage of the machine is

$$\mathbf{E}_A = \mathbf{V}_\phi + R_A \mathbf{I}_A + jX_d \mathbf{I}_d + jX_q \mathbf{I}_q$$

$$\mathbf{E}_A = 7621 \angle 0^\circ + 0 + j(0.62)(3874 \angle -79.3^\circ) + j(0.40)(3541 \angle 10.7^\circ)$$

$$\mathbf{E}_A = 9890 \angle 10.7^\circ \text{ V}$$

- The voltage regulation of this generator is

$$\frac{V_{nl} - V_{fl}}{V_{fl}} \times 100\% = \frac{9890 - 7621}{7621} \times 100\% = 29.8\%$$

- The power supplied by this machine is given by the equation

$$P = \frac{3V_\phi E_A}{X_d} \sin \delta + \frac{3V_\phi^2}{2} \left(\frac{X_d - X_q}{X_d X_q} \right) \sin 2\delta$$

$$P = \frac{3(7621)(9890)}{0.62} \sin \delta + \frac{3(7621)^2}{2} \left(\frac{0.62 - 0.40}{(0.62)(0.40)} \right) \sin 2\delta$$

$$P = 364.7 \sin \delta + 77.3 \sin 2\delta \text{ MW}$$

A plot of power supplied as a function of torque angle is shown below:

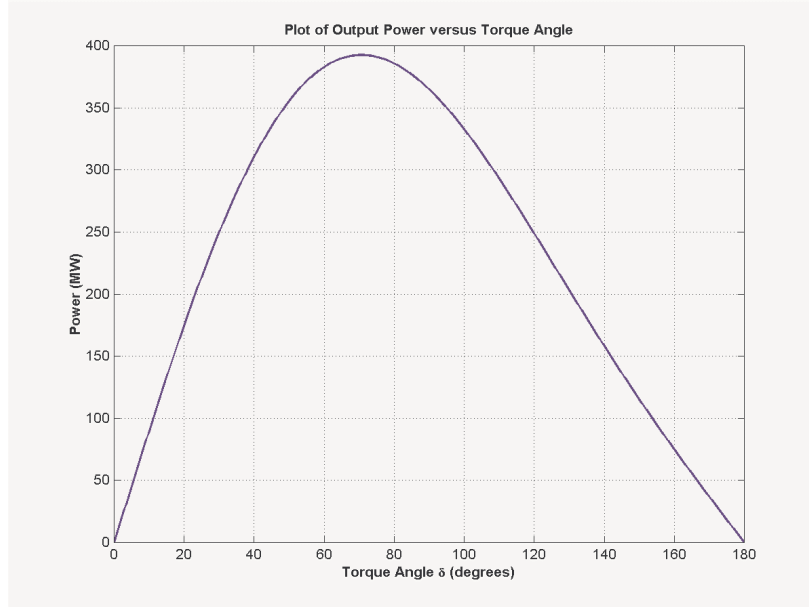

The peak power occurs at an angle of 70.6° , and the maximum power that the generator can supply is 392.4 MW.

(d) If this generator were non-salient, P_{MAX} would occur when $\delta = 90^\circ$, and P_{MAX} would be 364.7 MW. Therefore, the salient-pole generator has a *higher maximum power* than an equivalent non-salient pole generator.

C-3. Suppose that a salient-pole machine is to be used as a motor.

- Sketch the phasor diagram of a salient-pole synchronous machine used as a motor.
- Write the equations describing the voltages and currents in this motor.
- Prove that the torque angle δ between \mathbf{E}_A and \mathbf{V}_ϕ on this motor is given by

$$\delta = \tan^{-1} \frac{I_A X_q \cos \theta - I_A R_A \sin \theta}{V_\phi + I_A X_q \sin \theta + I_A R_A \cos \theta}$$

SOLUTION

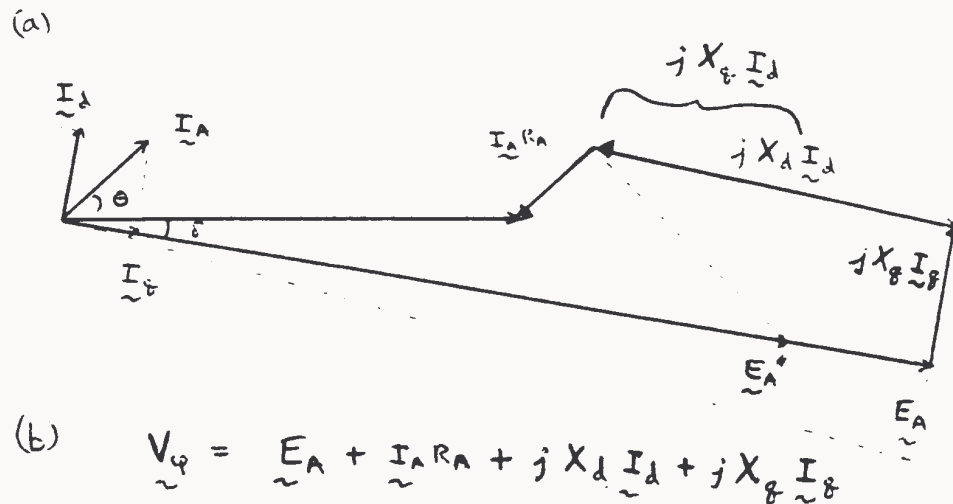

Also

$$\underline{V}_\phi = \underline{E}_A'' + \underline{I}_A R_A + jX_g \underline{I}_d + jX_f \underline{I}_f$$

$$\underline{V}_\phi = \underline{E}_A + \underline{I}_A R_A + jX_g \underline{I}_A$$

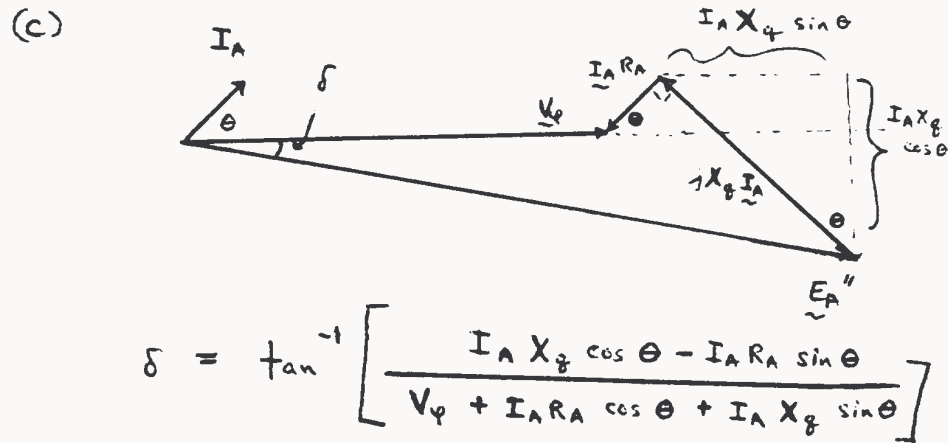

- C-4.** If the machine in Problem C-1 is running as a *motor* at the rated conditions, what is the maximum torque that can be drawn from its shaft without it slipping poles *when the field current is zero?*

SOLUTION When the field current is zero, $E_A = 0$, so

$$P = \frac{3V_\phi^2}{2} \left(\frac{X_d - X_q}{X_d X_q} \right) \sin 2\delta$$

$$P = \frac{3(277)^2}{2} \left(\frac{0.25 - 0.18}{(0.25)(0.18)} \right) \sin 2\delta = 179 \sin 2\delta \text{ kW}$$

At $\delta = 45^\circ$, 179 kW can be drawn from the motor.

Appendix D: *Errata for Electric Machinery Fundamentals 4/e*

(Current at 10 January 2004)

Please note that some or all of the following errata may be corrected in future reprints of the book, so they may not appear in your copy of the text. PDF pages with these corrections are attached to this appendix; please provide them to your students.

1. Page 56, Problem 1-6, there are 400 turns of wire on the coil, as shown on Figure P1-3. The body of the problem incorrectly states that there are 300 turns.
2. Page 56, Problem 1-7, there are 400 turns of wire on the left-hand coil, and 300 turns on the right-hand coil, as shown on Figure P1-4. The body of the problem is incorrect.
3. Page 62, Problem 1-19, should state: "Figure P1-14 shows a simple single-phase ac power system with three loads. The voltage source is $\mathbf{V} = 120\angle 0^\circ \text{ V}$, and the three loads are ..."
4. Page 64, Problem 1-22, should state: "If the bar runs off into a region where the flux density falls to 0.30 T...". Also, the load should be 10 N, not 20.
5. Page 147, Problem 2-10, should state that the transformer bank is $\mathbf{Y}\text{-}\Delta$, not $\Delta\text{-Y}$.
6. Page 226, Problem 3-10, the holding current I_H should be 8 mA.
7. Page 342, Figure p5-2, the generator for Problems 5-11 through 5-21, the OCC and SCC curves are in error. The correct curves are given below. Note that the voltage scale and current scales were both off by a factor of 2.

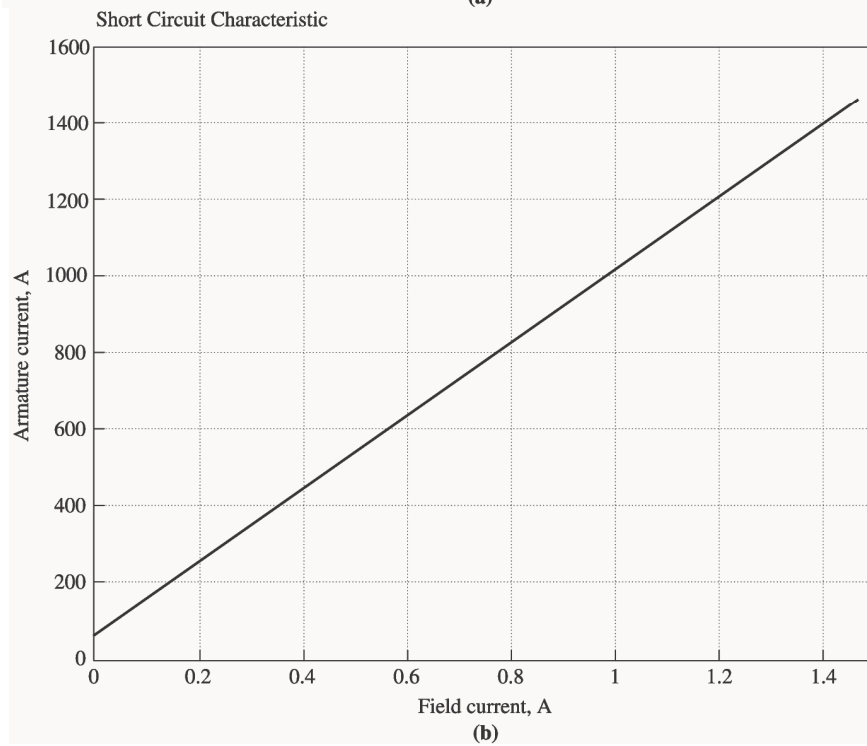
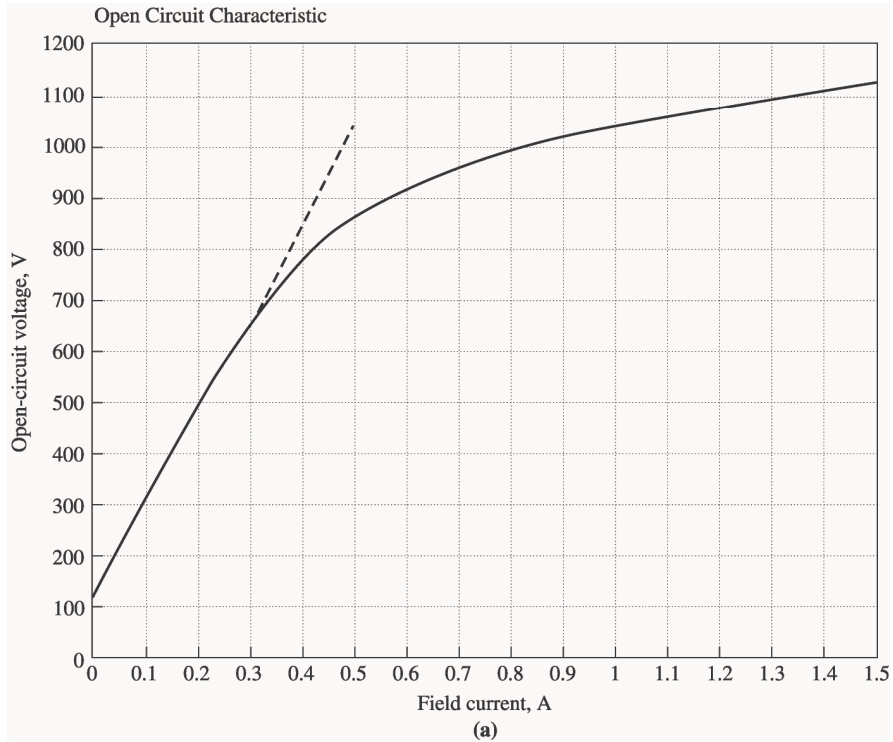

8. Page 344, Problem 5-28, the voltage of the infinite bus is 12.2 kV.
9. Page 377, Problem 6-11, the armature resistance is 0.08Ω , and the synchronous reactance is 1.0Ω .
10. Page 470, Problem 7-20 (a), the holding the infinite bus is 460-V.

11. Page 623, Figure P9-2 and Figure P9-3, $R_A = 0.40 \Omega$ and $R_F = 100 \Omega$. Values are stated correctly in the text but shown incorrectly on the figure.
12. Page 624, Figure P9-4, $R_A + R_S = 0.44 \Omega$ and $R_F = 100 \Omega$. Values are stated correctly in the text but shown incorrectly on the figure.
13. Page 627, Problem 9-21, R_{adj} is currently set to 90Ω . Also, the magnetization curve is taken at 1800 r/min.
14. Page 627, Problem 9-22, R_A is 0.18Ω .
15. Page 630, Figure P9-10, $R_A + R_S = 0.21 \Omega$ N_{SE} is 20 turns. Values are stated correctly in the text but shown incorrectly on the figure.
16. Page 680, Problem 10-6, refers to Problem 10-5 instead of Problem 10-4.

56 ELECTRIC MACHINERY FUNDAMENTALS

- 1-4. A motor is supplying $60 \text{ N} \cdot \text{m}$ of torque to its load. If the motor's shaft is turning at 1800 r/min, what is the mechanical power supplied to the load in watts? In horsepower?
- 1-5. A ferromagnetic core is shown in Figure P1-2. The depth of the core is 5 cm. The other dimensions of the core are as shown in the figure. Find the value of the current that will produce a flux of 0.005 Wb. With this current, what is the flux density at the top of the core? What is the flux density at the right side of the core? Assume that the relative permeability of the core is 1000.

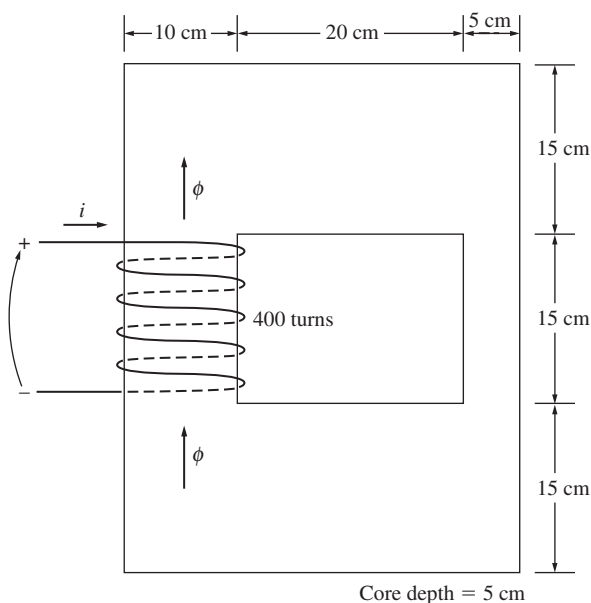

FIGURE P1-2

The core of Problems 1-5 and 1-16.

- 1-6. A ferromagnetic core with a relative permeability of 1500 is shown in Figure P1-3. The dimensions are as shown in the diagram, and the depth of the core is 7 cm. The air gaps on the left and right sides of the core are 0.070 and 0.050 cm, respectively. Because of fringing effects, the effective area of the air gaps is 5 percent larger than their physical size. If there are 400 turns in the coil wrapped around the center leg of the core and if the current in the coil is 1.0 A, what is the flux in each of the left, center, and right legs of the core? What is the flux density in each air gap?
- 1-7. A two-legged core is shown in Figure P1-4. The winding on the left leg of the core (N_1) has 400 turns, and the winding on the right (N_2) has 300 turns. The coils are wound in the directions shown in the figure. If the dimensions are as shown, then what flux would be produced by currents $i_1 = 0.5 \text{ A}$ and $i_2 = 0.75 \text{ A}$? Assume $\mu_r = 1000$ and constant.
- 1-8. A core with three legs is shown in Figure P1-5. Its depth is 5 cm, and there are 200 turns on the leftmost leg. The relative permeability of the core can be assumed to be 1500 and constant. What flux exists in each of the three legs of the core? What is the flux density in each of the legs? Assume a 4 percent increase in the effective area of the air gap due to fringing effects.

62 ELECTRIC MACHINERY FUNDAMENTALS

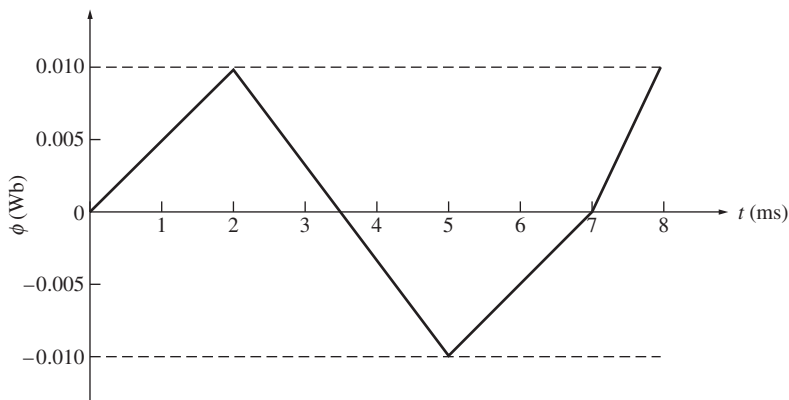

FIGURE P1-12
Plot of flux ϕ as a function of time for Problem 1-16.

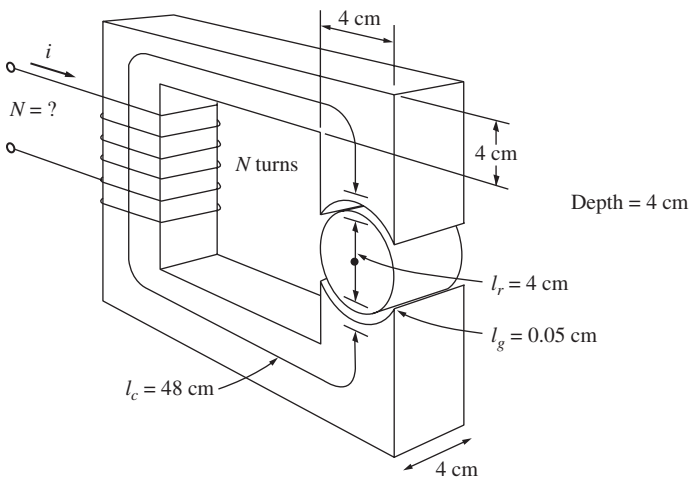

FIGURE P1-13
The core of Problem 1-17.

(d) Calculate the reactive power consumed or supplied by this load. Does the load consume reactive power from the source or supply it to the source?

1-19. Figure P1-14 shows a simple single-phase ac power system with three loads. The voltage source is $\mathbf{V} = 120\angle 0^\circ \text{ V}$, and the impedances of the three loads are

$$Z_1 = 5\angle 30^\circ \Omega \quad Z_2 = 5\angle 45^\circ \Omega \quad Z_3 = 5\angle -90^\circ \Omega$$

Answer the following questions about this power system.

(a) Assume that the switch shown in the figure is open, and calculate the current \mathbf{I} , the power factor, and the real, reactive, and apparent power being supplied by the load.

64 ELECTRIC MACHINERY FUNDAMENTALS

- (a) If this bar has a load of 10 N attached to it opposite to the direction of motion, what is the steady-state speed of the bar?
- (b) If the bar runs off into a region where the flux density falls to 0.30 T, what happens to the bar? What is its final steady-state speed?
- (c) Suppose V_B is now decreased to 80 V with everything else remaining as in part *b*. What is the new steady-state speed of the bar?
- (d) From the results for parts *b* and *c*, what are two methods of controlling the speed of a linear machine (or a real dc motor)?

REFERENCES

1. Alexander, Charles K., and Matthew N. O. Sadiku: *Fundamentals of Electric Circuits*, McGraw-Hill, 2000.
2. Beer, F., and E. Johnston, Jr.: *Vector Mechanics for Engineers: Dynamics*, 6th ed., McGraw-Hill, New York, 1997.
3. Hayt, William H.: *Engineering Electromagnetics*, 5th ed., McGraw-Hill, New York, 1989.
4. Mulligan, J. F.: *Introductory College Physics*, 2nd ed., McGraw-Hill, New York, 1991.
5. Sears, Francis W., Mark W. Zemansky, and Hugh D. Young: *University Physics*, Addison-Wesley, Reading, Mass., 1982.

- 2-8.** A 200-MVA, 15/200-kV single-phase power transformer has a per-unit resistance of 1.2 percent and a per-unit reactance of 5 percent (data taken from the transformer's nameplate). The magnetizing impedance is $j80$ per unit.
- Find the equivalent circuit referred to the low-voltage side of this transformer.
 - Calculate the voltage regulation of this transformer for a full-load current at power factor of 0.8 lagging.
 - Assume that the primary voltage of this transformer is a constant 15 kV, and plot the secondary voltage as a function of load current for currents from no load to full load. Repeat this process for power factors of 0.8 lagging, 1.0, and 0.8 leading.
- 2-9.** A three-phase transformer bank is to handle 600 kVA and have a 34.5/13.8-kV voltage ratio. Find the rating of each individual transformer in the bank (high voltage, low voltage, turns ratio, and apparent power) if the transformer bank is connected to
- Y–Y, (b) Y– Δ , (c) Δ –Y, (d) Δ – Δ , (e) open Δ , (f) open Y–open Δ .
- 2-10.** A 13,800/480-V three-phase Y- Δ -connected transformer bank consists of three identical 100-kVA 7967/480-V transformers. It is supplied with power directly from a large constant-voltage bus. In the short-circuit test, the recorded values on the high-voltage side for one of these transformers are

$$V_{SC} = 560 \text{ V} \quad I_{SC} = 12.6 \text{ A} \quad P_{SC} = 3300 \text{ W}$$

- If this bank delivers a rated load at 0.85 PF lagging and rated voltage, what is the line-to-line voltage on the high-voltage side of the transformer bank?
 - What is the voltage regulation under these conditions?
 - Assume that the primary voltage of this transformer is a constant 13.8 kV, and plot the secondary voltage as a function of load current for currents from no-load to full-load. Repeat this process for power factors of 0.85 lagging, 1.0, and 0.85 leading.
 - Plot the voltage regulation of this transformer as a function of load current for currents from no-load to full-load. Repeat this process for power factors of 0.85 lagging, 1.0, and 0.85 leading.
- 2-11.** A 100,000-kVA, 230/115-kV Δ – Δ three-phase power transformer has a resistance of 0.02 pu and a reactance of 0.055 pu. The excitation branch elements are $R_C = 110$ pu and $X_M = 20$ pu.
- If this transformer supplies a load of 80 MVA at 0.85 PF lagging, draw the phasor diagram of one phase of the transformer.
 - What is the voltage regulation of the transformer bank under these conditions?
 - Sketch the equivalent circuit referred to the low-voltage side of one phase of this transformer. Calculate all the transformer impedances referred to the low-voltage side.
- 2-12.** An autotransformer is used to connect a 13.2-kV distribution line to a 13.8-kV distribution line. It must be capable of handling 2000 kVA. There are three phases, connected Y–Y with their neutrals solidly grounded.
- What must the N_C/N_{SE} turns ratio be to accomplish this connection?
 - How much apparent power must the windings of each autotransformer handle?
 - If one of the autotransformers were reconnected as an ordinary transformer, what would its ratings be?
- 2-13.** Two phases of a 13.8-kV three-phase distribution line serve a remote rural road (the neutral is also available). A farmer along the road has a 480-V feeder supplying

226 ELECTRIC MACHINERY FUNDAMENTALS

- 3-10. A series-capacitor forced commutation chopper circuit supplying a purely resistive load is shown in Figure P3-5.

$$\begin{array}{ll} V_{DC} = 120 \text{ V} & R_1 = 20 \text{ k}\Omega \\ I_H = 8 \text{ mA} & R_{load} = 250 \Omega \\ V_{BO} = 200 \text{ V} & C = 150 \mu\text{F} \end{array}$$

- When SCR₁ is turned on, how long will it remain on? What causes it to turn off?
- When SCR₁ turns off, how long will it be until the SCR can be turned on again? (Assume that 3 time constants must pass before the capacitor is discharged.)
- What problem or problems do these calculations reveal about this simple series-capacitor forced-commutation chopper circuit?
- How can the problem(s) described in part *c* be eliminated?

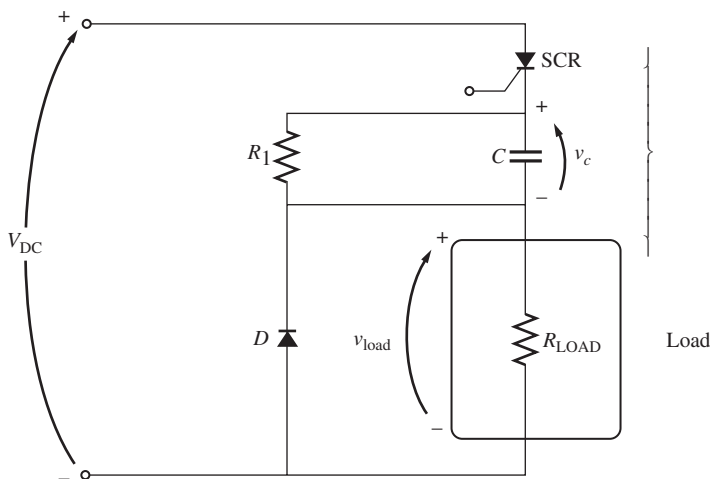

FIGURE P3-5

The simple series-capacitor forced-commutation circuit of Problem 3-10.

- 3-11. A parallel-capacitor forced-commutation chopper circuit supplying a purely resistive load is shown in Figure P3-6.

$$\begin{array}{ll} V_{DC} = 120 \text{ V} & R_1 = 20 \text{ k}\Omega \\ I_H = 5 \text{ mA} & R_{load} = 250 \Omega \\ V_{BO} = 250 \text{ V} & C = 15 \mu\text{F} \end{array}$$

- When SCR₁ is turned on, how long will it remain on? What causes it to turn off?
 - What is the earliest time that SCR₁ can be turned off after it is turned on? (Assume that 3 time constants must pass before the capacitor is charged.)
 - When SCR₁ turns off, how long will it be until the SCR can be turned on again?
 - What problem or problems do these calculations reveal about this simple parallel-capacitor forced-commutation chopper circuit?
 - How can the problem(s) described in part *d* be eliminated?
- 3-12. Figure P3-7 shows a single-phase rectifier-inverter circuit. Explain how this circuit functions. What are the purposes of C_1 and C_2 ? What controls the output frequency of the inverter?

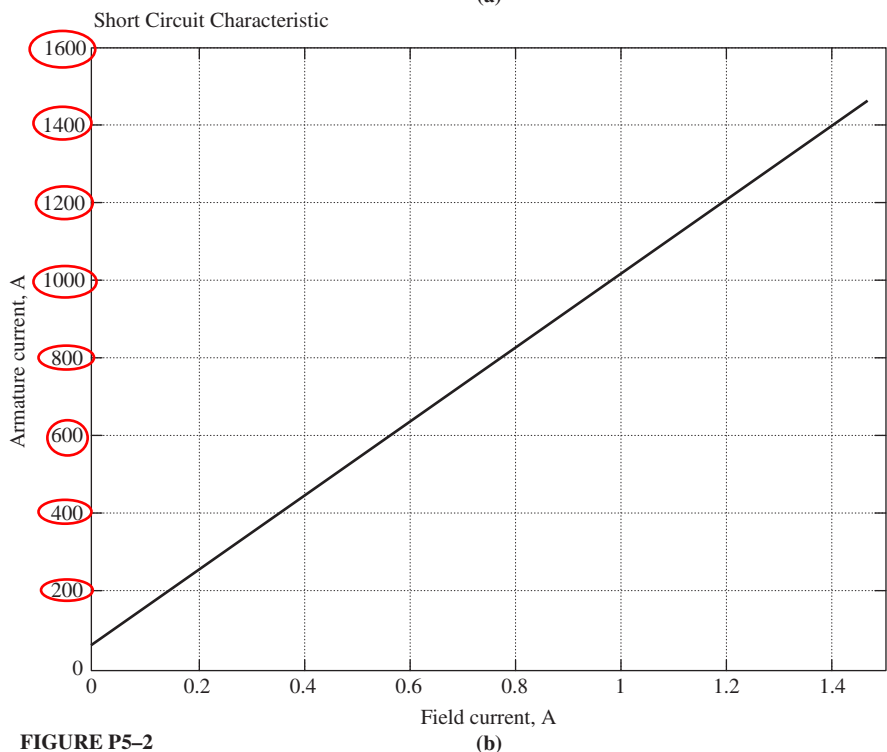
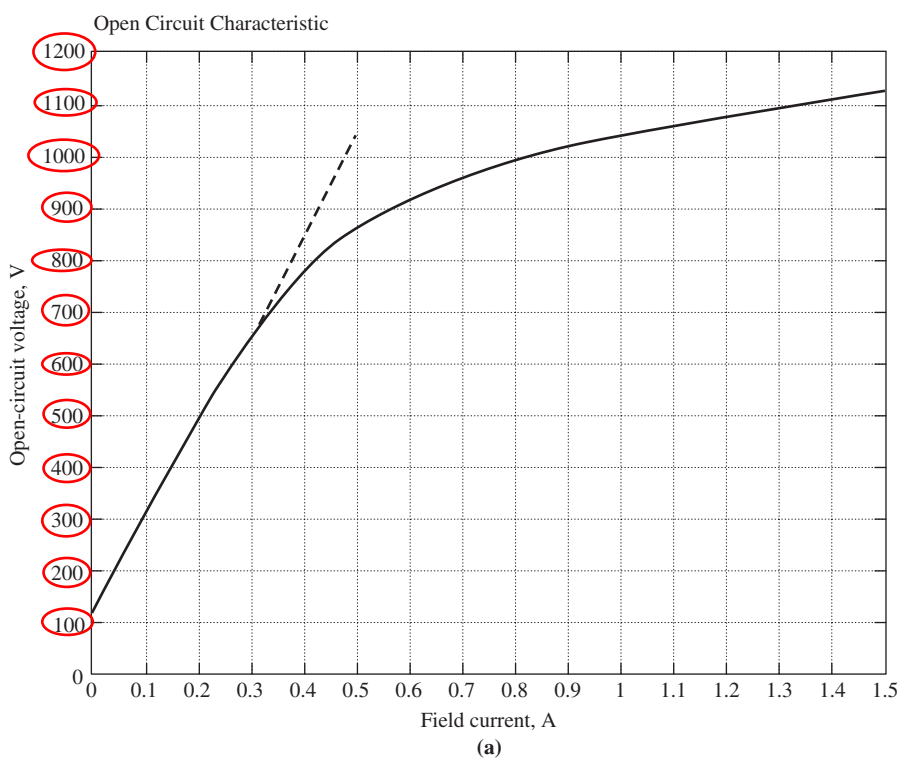

FIGURE P5-2 (a) Open-circuit characteristic curve for the generator in Problems 5–11 to 5–21. (b) Short-circuit characteristic curve for the generator in Problems 5–11 to 5–21.

344 ELECTRIC MACHINERY FUNDAMENTALS

- 5–27. A 25-MVA, three-phase, 13.8-kV, two-pole, 60-Hz Y-connected synchronous generator was tested by the open-circuit test, and its air-gap voltage was extrapolated with the following results:

Open-circuit test					
Field current, A	320	365	380	475	570
Line voltage, kV	13.0	13.8	14.1	15.2	16.0
Extrapolated air-gap voltage, kV	15.4	17.5	18.3	22.8	27.4

The short-circuit test was then performed with the following results:

Short-circuit test					
Field current, A	320	365	380	475	570
Armature current, A	1040	1190	1240	1550	1885

The armature resistance is 0.24Ω per phase.

- Find the unsaturated synchronous reactance of this generator in ohms per phase and per unit.
 - Find the approximate saturated synchronous reactance X_S at a field current of 380 A. Express the answer both in ohms per phase and per unit.
 - Find the approximate saturated synchronous reactance at a field current of 475 A. Express the answer both in ohms per phase and in per-unit.
 - Find the short-circuit ratio for this generator.
- 5–28. A 20-MVA, 12.2-kV, 0.8-PF-lagging, Y-connected synchronous generator has a negligible armature resistance and a synchronous reactance of 1.1 per unit. The generator is connected in parallel with a 60-Hz, 12.2-kV infinite bus that is capable of supplying or consuming any amount of real or reactive power with no change in frequency or terminal voltage.
- What is the synchronous reactance of the generator in ohms?
 - What is the internal generated voltage \mathbf{E}_A of this generator under rated conditions?
 - What is the armature current \mathbf{I}_A in this machine at rated conditions?
 - Suppose that the generator is initially operating at rated conditions. If the internal generated voltage \mathbf{E}_A is decreased by 5 percent, what will the new armature current \mathbf{I}_A be?
 - Repeat part *d* for 10, 15, 20, and 25 percent reductions in \mathbf{E}_A .
 - Plot the magnitude of the armature current I_A as a function of E_A . (You may wish to use MATLAB to create this plot.)

6-9. Figure P6-2 shows a synchronous motor phasor diagram for a motor operating at a leading power factor with no R_A . For this motor, the torque angle is given by

$$\tan \delta = \frac{X_S I_A \cos \theta}{V_\phi + X_S I_A \sin \theta}$$

$$\delta = \tan^{-1} \left(\frac{X_S I_A \cos \theta}{V_\phi + X_S I_A \sin \theta} \right)$$

Derive an equation for the torque angle of the synchronous motor if the armature resistance is included.

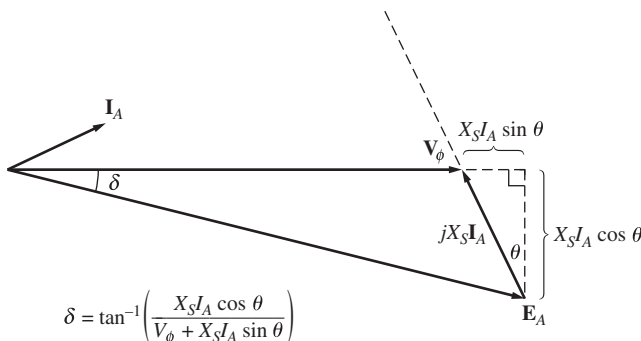

FIGURE P6-2 Phasor diagram of a motor at a leading power factor.

6-10. A 480-V, 375-kVA, 0.8-PF-lagging, Y-connected synchronous generator has a synchronous reactance of 0.4Ω and a negligible armature resistance. This generator is supplying power to a 480-V, 80-kW, 0.8-PF-leading, Y-connected synchronous motor with a synchronous reactance of 1.1Ω and a negligible armature resistance. The synchronous generator is adjusted to have a terminal voltage of 480 V when the motor is drawing the rated power at unity power factor.

- (a) Calculate the magnitudes and angles of E_A for both machines.
- (b) If the flux of the motor is increased by 10 percent, what happens to the terminal voltage of the power system? What is its new value?
- (c) What is the power factor of the motor after the increase in motor flux?

6-11. A 480-V, 100-kW, 50-Hz, four-pole, Y-connected synchronous motor has a rated power factor of 0.85 leading. At full load, the efficiency is 91 percent. The armature resistance is 0.08Ω , and the synchronous reactance is 1.0Ω . Find the following quantities for this machine when it is operating at full load:

- (a) Output torque
- (b) Input power
- (c) n_m
- (d) E_A
- (e) $|I_A|$
- (f) P_{conv}
- (g) $P_{\text{mech}} + P_{\text{core}} + P_{\text{stray}}$

470 ELECTRIC MACHINERY FUNDAMENTALS

- (a) The line current I_L
 (b) The stator power factor
 (c) The rotor power factor
 (d) The stator copper losses P_{SCL}
 (e) The air-gap power P_{AG}
 (f) The power converted from electrical to mechanical form P_{conv}
 (g) The induced torque τ_{ind}
 (h) The load torque τ_{load}
 (i) The overall machine efficiency η
 (j) The motor speed in revolutions per minute and radians per second
- 7-15. For the motor in Problem 7-14, what is the pullout torque? What is the slip at the pullout torque? What is the rotor speed at the pullout torque?
- 7-16. If the motor in Problem 7-14 is to be driven from a 440-V, 60-Hz power supply, what will the pullout torque be? What will the slip be at pullout?
- 7-17. Plot the following quantities for the motor in Problem 7-14 as slip varies from 0 to 10 percent: (a) τ_{ind} ; (b) P_{conv} ; (c) P_{out} ; (d) efficiency η . At what slip does P_{out} equal the rated power of the machine?
- 7-18. A 208-V, 60 Hz six-pole, Y-connected, 25-hp design class B induction motor is tested in the laboratory, with the following results:

No load:	208 V, 22.0 A, 1200 W, 60 Hz
Locked rotor:	24.6 V, 64.5 A, 2200 W, 15 Hz
DC test:	13.5 V, 64 A

Find the equivalent circuit of this motor, and plot its torque–speed characteristic curve.

- 7-19. A 460-V, four-pole, 50-hp, 60-Hz, Y-connected, three-phase induction motor develops its full-load induced torque at 3.8 percent slip when operating at 60 Hz and 460 V. The per-phase circuit model impedances of the motor are

$$\begin{aligned} R_1 &= 0.33 \, \Omega & X_M &= 30 \, \Omega \\ X_1 &= 0.42 \, \Omega & X_2 &= 0.42 \, \Omega \end{aligned}$$

Mechanical, core, and stray losses may be neglected in this problem.

- (a) Find the value of the rotor resistance R_2 .
 (b) Find τ_{max} , s_{max} , and the rotor speed at maximum torque for this motor.
 (c) Find the starting torque of this motor.
 (d) What code letter factor should be assigned to this motor?
- 7-20. Answer the following questions about the motor in Problem 7-19.
- (a) If this motor is started from a 460-V infinite bus, how much current will flow in the motor at starting?
 (b) If transmission line with an impedance of $0.35 + j0.25 \, \Omega$ per phase is used to connect the induction motor to the infinite bus, what will the starting current of the motor be? What will the motor's terminal voltage be on starting?
 (c) If an ideal 1.4:1 step-down autotransformer is connected between the transmission line and the motor, what will the current be in the transmission line during starting? What will the voltage be at the motor end of the transmission line during starting?

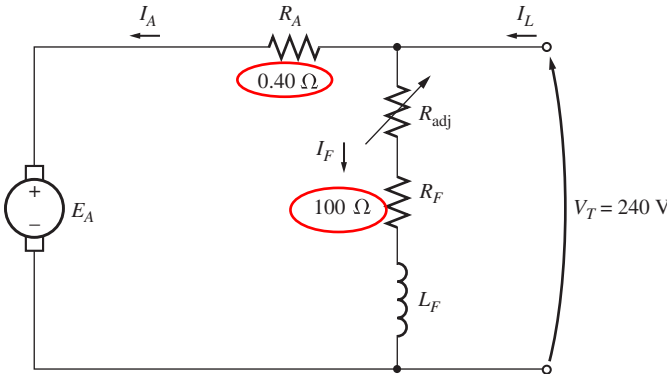

FIGURE P9-2
The equivalent circuit of the shunt motor in Problems 9-1 to 9-7.

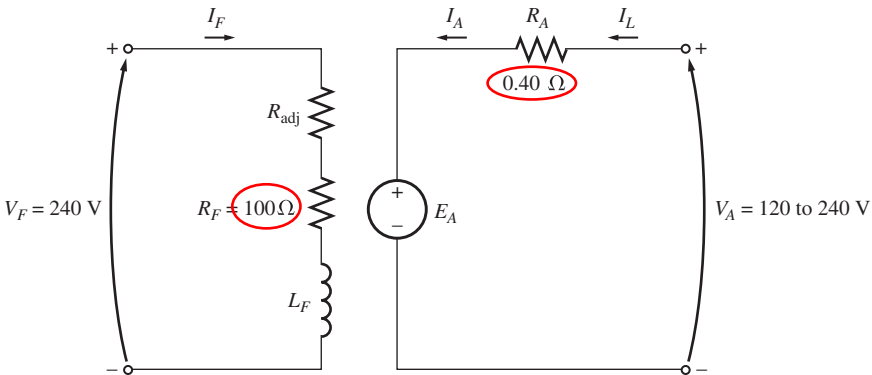

FIGURE P9-3
The equivalent circuit of the separately excited motor in Problems 9-8 and 9-9.

- 9-10.** If the motor is connected cumulatively compounded as shown in Figure P9-4 and if $R_{adj} = 175 \Omega$, what is its no-load speed? What is its full-load speed? What is its speed regulation? Calculate and plot the torque–speed characteristic for this motor. (Neglect armature effects in this problem.)
- 9-11.** The motor is connected cumulatively compounded and is operating at full load. What will the new speed of the motor be if R_{adj} is increased to 250Ω ? How does the new speed compare to the full-load speed calculated in Problem 9-10?
- 9-12.** The motor is now connected differentially compounded.
- If $R_{adj} = 175 \Omega$, what is the no-load speed of the motor?
 - What is the motor’s speed when the armature current reaches 20 A? 40 A? 60 A?
 - Calculate and plot the torque–speed characteristic curve of this motor.
- 9-13.** A 7.5-hp, 120-V series dc motor has an armature resistance of 0.2Ω and a series field resistance of 0.16Ω . At full load, the current input is 58 A, and the rated speed is

624 ELECTRIC MACHINERY FUNDAMENTALS

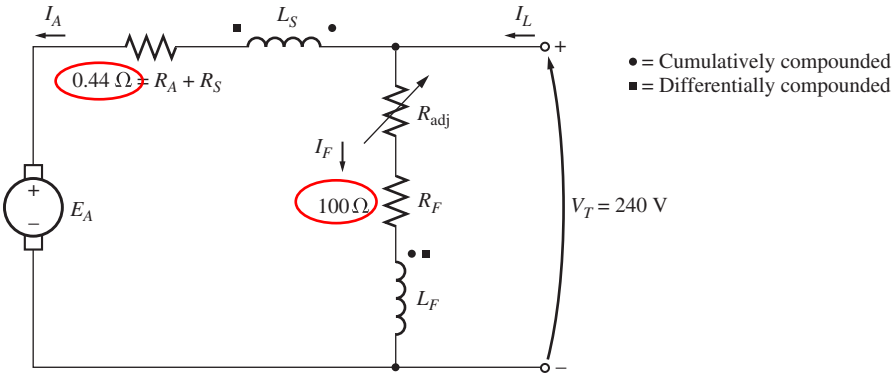

FIGURE P9-4
The equivalent circuit of the compounded motor in Problems 9-10 to 9-12.

1050 r/min. Its magnetization curve is shown in Figure P9-5. The core losses are 200 W, and the mechanical losses are 240 W at full load. Assume that the mechanical losses vary as the cube of the speed of the motor and that the core losses are constant.

- (a) What is the efficiency of the motor at full load?
 - (b) What are the speed and efficiency of the motor if it is operating at an armature current of 35 A?
 - (c) Plot the torque–speed characteristic for this motor.
- 9-14.** A 20-hp, 240-V, 76-A, 900 r/min series motor has a field winding of 33 turns per pole. Its armature resistance is 0.09 Ω, and its field resistance is 0.06 Ω. The magnetization curve expressed in terms of magnetomotive force versus E_A at 900 r/min is given by the following table:

E_A, V	95	150	188	212	229	243
$\mathcal{F}, A \cdot \text{turns}$	500	1000	1500	2000	2500	3000

Armature reaction is negligible in this machine.

- (a) Compute the motor’s torque, speed, and output power at 33, 67, 100, and 133 percent of full-load armature current. (Neglect rotational losses.)
 - (b) Plot the torque–speed characteristic of this machine.
- 9-15.** A 300-hp, 440-V, 560-A, 863 r/min shunt dc motor has been tested, and the following data were taken:

Blocked-rotor test:

$$\begin{aligned} V_A &= 16.3 \text{ V} && \text{exclusive of brushes} && V_F &= 440 \text{ V} \\ I_A &= 500 \text{ A} && && I_F &= 8.86 \text{ A} \end{aligned}$$

No-load operation:

$$\begin{aligned} V_A &= 16.3 \text{ V} && \text{including brushes} && I_F &= 8.76 \text{ A} \\ I_A &= 23.1 \text{ A} && && n &= 863 \text{ r/min} \end{aligned}$$

- 9–19.** A series motor is now constructed from this machine by leaving the shunt field out entirely. Derive the torque–speed characteristic of the resulting motor.
- 9–20.** An automatic starter circuit is to be designed for a shunt motor rated at 15 hp, 240 V, and 60 A. The armature resistance of the motor is 0.15Ω , and the shunt field resistance is 40Ω . The motor is to start with no more than 250 percent of its rated armature current, and as soon as the current falls to rated value, a starting resistor stage is to be cut out. How many stages of starting resistance are needed, and how big should each one be?
- 9–21.** A 15-hp, 230-V, 1800 r/min shunt dc motor has a full-load armature current of 60 A when operating at rated conditions. The armature resistance of the motor is $R_A = 0.15 \Omega$, and the field resistance R_F is 80Ω . The adjustable resistance in the field circuit R_{adj} may be varied over the range from 0 to 200Ω and is currently set to 90Ω . Armature reaction may be ignored in this machine. The magnetization curve for this motor, taken at a speed of 1800 r/min , is given in tabular form below:

$E_A, \text{ V}$	8.5	150	180	215	226	242
$I_F, \text{ A}$	0.00	0.80	1.00	1.28	1.44	2.88

- (a) What is the speed of this motor when it is running at the rated conditions specified above?
- (b) The output power from the motor is 7.5 hp at rated conditions. What is the output torque of the motor?
- (c) What are the copper losses and rotational losses in the motor at full load (ignore stray losses)?
- (d) What is the efficiency of the motor at full load?
- (e) If the motor is now unloaded with no changes in terminal voltage or R_{adj} , what is the no-load speed of the motor?
- (f) Suppose that the motor is running at the no-load conditions described in part e. What would happen to the motor if its field circuit were to open? Ignoring armature reaction, what would the final steady-state speed of the motor be under those conditions?
- (g) What range of no-load speeds is possible in this motor, given the range of field resistance adjustments available with R_{adj} ?
- 9–22.** The magnetization curve for a separately excited dc generator is shown in Figure P9–7. The generator is rated at 6 kW, 120 V, 50 A, and 1800 r/min and is shown in Figure P9–8. Its field circuit is rated at 5 A. The following data are known about the machine:

$$\begin{aligned}
 R_A &= 0.18 \Omega & V_F &= 120 \text{ V} \\
 R_{adj} &= 0 \text{ to } 30 \Omega & R_F &= 24 \Omega \\
 N_F &= 1000 \text{ turns per pole}
 \end{aligned}$$

Answer the following questions about this generator, assuming no armature reaction.

- (a) If this generator is operating at no load, what is the range of voltage adjustments that can be achieved by changing R_{adj} ?
- (b) If the field rheostat is allowed to vary from 0 to 30Ω and the generator's speed is allowed to vary from 1500 to 2000 r/min, what are the maximum and minimum no-load voltages in the generator?

630 ELECTRIC MACHINERY FUNDAMENTALS

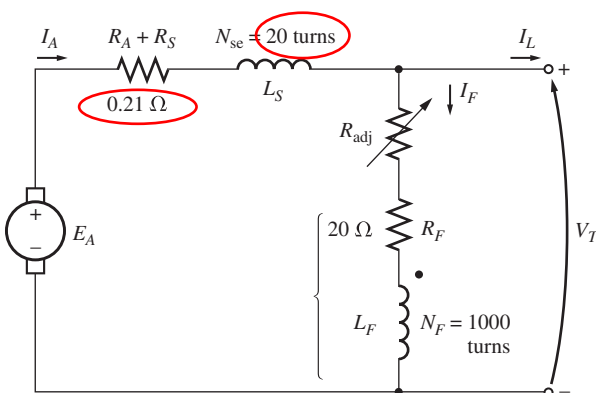

FIGURE P9-10
The compounded dc generator in Problems 9-27 and 9-28.

The machine has the magnetization curve shown in Figure P9-7. Its equivalent circuit is shown in Figure P9-10. Answer the following questions about this machine, assuming no armature reaction.

- (a) If the generator is operating at no load, what is its terminal voltage?
 - (b) If the generator has an armature current of 20 A, what is its terminal voltage?
 - (c) If the generator has an armature current of 40 A, what is its terminal voltage?
 - (d) Calculate and plot the terminal characteristic of this machine.
- 9-28.** If the machine described in Problem 9-27 is reconnected as a differentially compounded dc generator, what will its terminal characteristic look like? Derive it in the same fashion as in Problem 9-27.
- 9-29.** A cumulatively compounded dc generator is operating properly as a flat-compounded dc generator. The machine is then shut down, and its shunt field connections are reversed.
- (a) If this generator is turned in the same direction as before, will an output voltage be built up at its terminals? Why or why not?
 - (b) Will the voltage build up for rotation in the opposite direction? Why or why not?
 - (c) For the direction of rotation in which a voltage builds up, will the generator be cumulatively or differentially compounded?
- 9-30.** A three-phase synchronous machine is mechanically connected to a shunt dc machine, forming a motor-generator set, as shown in Figure P9-11. The dc machine is connected to a dc power system supplying a constant 240 V, and the ac machine is connected to a 480-V, 60-Hz infinite bus.

The dc machine has four poles and is rated at 50 kW and 240 V. It has a per-unit armature resistance of 0.04. The ac machine has four poles and is Y-connected. It is rated at 50 kVA, 480 V, and 0.8 PF, and its saturated synchronous reactance is 2.0 Ω per phase.

All losses except the dc machine's armature resistance may be neglected in this problem. Assume that the magnetization curves of both machines are linear.

- (a) Initially, the ac machine is supplying 50 kVA at 0.8 PF lagging to the ac power system.

680 ELECTRIC MACHINERY FUNDAMENTALS

- (f) P_{out}
 - (g) τ_{ind}
 - (h) τ_{load}
 - (i) Efficiency
- 10-6.** Find the induced torque in the motor in Problem 10-5 if it is operating at 5 percent slip and its terminal voltage is (a) 190 V, (b) 208 V, (c) 230 V.
- 10-7.** What type of motor would you select to perform each of the following jobs? Why?
- (a) Vacuum cleaner
 - (b) Refrigerator
 - (c) Air conditioner compressor
 - (d) Air conditioner fan
 - (e) Variable-speed sewing machine
 - (f) Clock
 - (g) Electric drill
- 10-8.** For a particular application, a three-phase stepper motor must be capable of stepping in 10° increments. How many poles must it have?
- 10-9.** How many pulses per second must be supplied to the control unit of the motor in Problem 10-8 to achieve a rotational speed of 600 r/min?
- 10-10.** Construct a table showing step size versus number of poles for three-phase and four-phase stepper motors.

REFERENCES

1. Fitzgerald, A. E., and C. Kingsley, Jr. *Electric Machinery*. New York: McGraw-Hill, 1952.
2. National Electrical Manufacturers Association. *Motors and Generators*, Publication No. MG1-1993. Washington, D.C.: NEMA, 1993.
3. Veinott, G. C. *Fractional and Subfractional Horsepower Electric Motors*. New York: McGraw-Hill, 1970.
4. Werninck, E. H. (ed.). *Electric Motor Handbook*. London: McGraw-Hill, 1978.