



MILLENNIUM[®]
AIR-COOLED SCREW LIQUID CHILLERS

INSTALLATION, OPERATION & MAINTENANCE

New Release

Form 201.18-NM3 (300)

MILLENNIUM[®]
YCAS AIR COOLED LIQUID CHILLER
YCAS 250, 270, 300, 330 (3 COMPRESSOR)
YCAS 360, 400, 440 (4 COMPRESSOR)
STYLE F
60 Hz

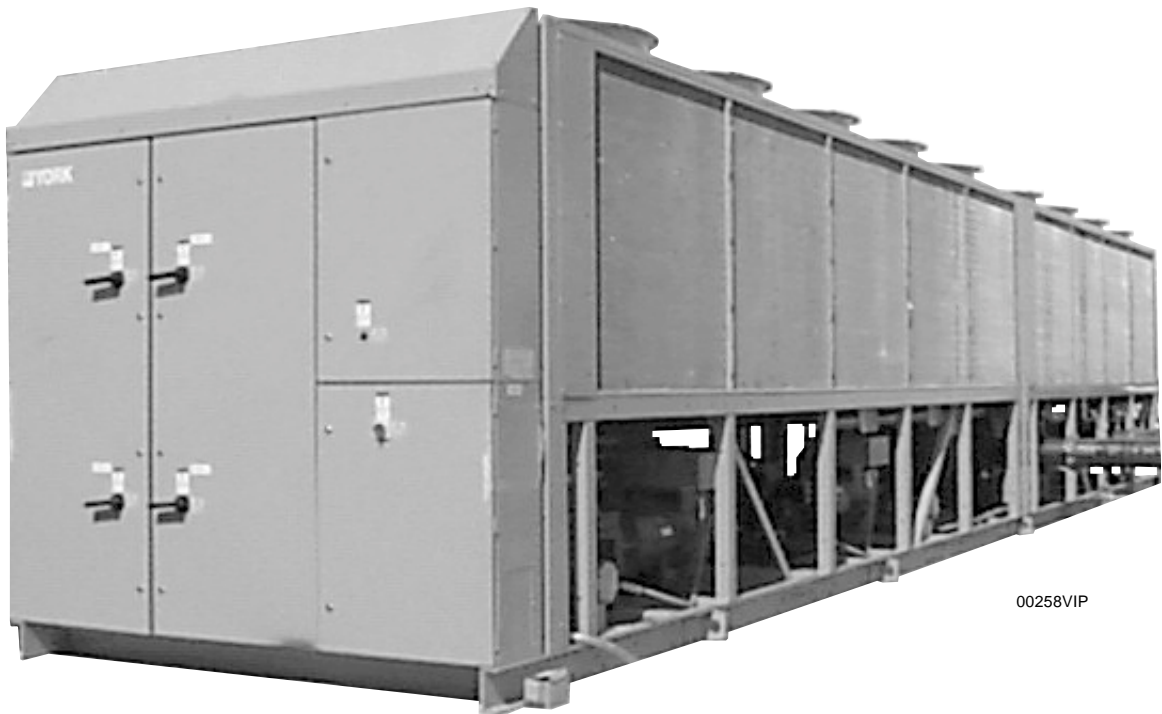

00258VIP

YCAS 3 SYSTEM EPROMs

Microprocessor Board

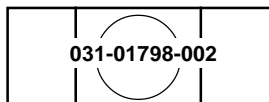

I/O Board #2 EPROM

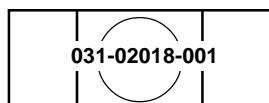

YCAS 4 SYSTEM EPROMs

Microprocessor Board

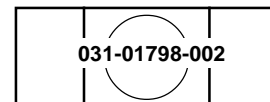

I/O Board #2 EPROM

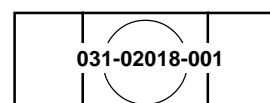

BASIC PART NUMBER

YCAS0300EC40YFA

1	2	3	4	5	6	7	8	9	10	11	12	13	14	15
BASE PRODUCT TYPE				NOMINAL CAPACITY				UNIT DESIGNATOR	REFRIGERANT	VOLTAGE/STARTER			DESIGN/DEVELOPMENT LEVEL	
Y	C	A	S	#	#	#	#	E	C	1	7		F	A
: YORK : Chiller : Air Cooled S : Screw				Tons 0250 0270 0300 0330 0360 0400 0440				High Efficiency	R-22	2 :200 / 3/ 60 4 :230 / 3/ 60 4 :380 / 3/ 60 4 :460 / 3/ 60 5 :575 / 3/ 60 Y :Wye (Star) Delta X :Across the Line	:Design Series F :Engineering Change or PIN Level			

OPTIONS SECTION OF PART NUMBER

16 17 18 19	20 21 22 23 24 25 26 27 28	29 30 31 32 33 34 35 36 37
POWER FIELD	CONTROLS FIELD	COMPRESSOR / PIPING FIELD
M D : MP NF Disconnect Switches M B : MP Supply w/ Ind. Sys. Brkr & L. Ext. Handles S B : SP Supply TB w/ Ind. Sys. Brkr. & L. Ext. Handles D B : SP NF Discnct. w/ Ind. Sys. Brkr & L. Ext. Handles S X : SP Supply TB S D : SP NF Disconnect Switch B X : SP Circuit Breaker w/ Lockable Handle C : Control Circuit Power Terminal Strip X : No Option	X Y C B M S F G X L C X P R S : Seq. Cntrl & Automatic Lead Trans. : No Option : BAS/EMS Temp Reset / Offset : BAS/EMS Current Reset / Offset : BAS/EMS Both Temp. & Current : Millennium Controls : Spanish LCD & Keypad Display : French LCD & Keypad Display : German LCD & Keypad Display : No Option : N Amer. Safety Code (cU.L./cETL) : European Safety Code (CE) : No Option : Pump Control : Remote Control Panel	# # : Low Temp Brine (LBrT) T S : Thermal Storage C : Chicago Relief Code G : Mechanical Gauge Kit

MP = Multiple Point
SP = Single Point
NF = Non-Fused
TB = Terminal Block
Ser. = Service
Ind. Sys. Brkr. & L. Ext. Handles = Individual System Breaker & Lockable External Handle

UNIT NOMENCLATURE
NAMEPLATE ENGINEERING DATA

**UNIT NOMENCLATURE
NAMEPLATE ENGINEERING DATA**

<p>38 EVAP. FIELD</p> <p>3 </p> <p>D </p> <p>W </p> <p>V </p> <p>S </p>	<p>42 </p> <p>M </p> <p>A </p> <p>S </p> <p>F </p> <p>T </p> <p>I </p> <p>P </p>	<p>43 </p> <p>R </p>	<p>44 </p> <p>X </p>	<p>: 300 PSIG DWP Waterside</p> <p>: Double Thick Insulation</p> <p>: Weld Flange Kit</p> <p>: Victaulic Flange Kit</p> <p>: Flow Switch</p> <p>: Multinat'l Vessel & Assoc.Safety Codes</p> <p>: ASME Pressure Vessel & Associated Codes (American)</p> <p>: AS 1210 Vessel & Associated Codes (Australian)</p> <p>: French Vessel & Associated Codes (DRIRE)</p> <p>: German TUV Vessel & Associated Codes (A.D. Merkblatter)</p> <p>: Italian Vessel & Associated Codes (ISPESL)</p> <p>: Polish Vessel & Associated Codes</p> <p>: Remote DX Cooler</p> <p>: No Option</p>	<p>45 CONDENSER FIELD</p> <p>X </p> <p>C </p> <p>B </p> <p>P </p>	<p>46 </p>	<p>47 </p> <p>X </p>	<p>: Aluminum</p> <p>: Copper</p> <p>: BlackFin</p> <p>: Phenolic</p> <p>: TEOA Fan</p>	<p>48 CABINET FIELD</p> <p>1 </p> <p>2 </p> <p>3 </p> <p>4 </p> <p>5 </p> <p>6 </p> <p>7 </p> <p>8 </p>	<p>E </p> <p>X </p> <p>B </p> <p>L </p> <p>H </p>	<p>: Wire (Full Unit) Enc. Panels (factory)</p> <p>: Wire (Full Unit) Enc. Panels (field)</p> <p>: Wire/Louvered Enc. Panels (factory)</p> <p>: Wire/Louvered Enc. Panels (field)</p> <p>: Louvered (Cond. Only) Enc. Panels (factory)</p> <p>: Louvered (Cond. Only) Enc. Panels (field)</p> <p>: Louvered (Full Unit) Enc. Panels (factory)</p> <p>: Louvered (Full Unit) Enc. Panels (field)</p> <p>: Compressor Sound Enclosure</p> <p>: No Option</p> <p>: Acoustic Sound Blanket</p> <p>: Low Sound Fans</p> <p>: High Static Fans</p> <p>S : Final Overspray Paint</p> <p>1 : 1" Deflection</p> <p>S : Seismic</p> <p>N : Neoprene Pads</p>
---	---	-------------------------------	-------------------------------	---	--	--------------------	-------------------------------	--	--	--	--

NOTES:

1. Q :DENOTES SPECIAL / S.Q.

2. # :DENOTES STANDARD

3. X :w/in OPTIONS FIELD, DENOTES NO OPTION SELECTED

PHYSICAL DATA

ENGLISH UNITS

	MODEL NUMBER YCAS						
	0250EC	0270EC	0300EC	0330EC	0360EC	0400EC	0440EC
General Unit Data							
Unit Capacity at ARI Conditions, Tons	242.4	264.0	286.7	313.2	351.0	385.0	417.9
Number of Independent Refrig. Circuits	3	3	4	4	4	4	
Refrig. Charge, R-22, Ckt.-1 / Ckt.-2, lbs.	154/154	154/154	187/187	203/203	187/187	212/212	229/229
Ckt-3 / Ckt-4, lbs.	154 / -	172 / -	176 / -	190 / -	187/187	198/198	216/216
Oil Charge, Ckt.-1 / Ckt.-2, gallons	5 / 5	5 / 5	5 / 5	5 / 5	5 / 5	5 / 5	5 / 5
Ckt-3, Ckt-4, gallons	5 / -	5 / -	5 / -	5 / -	5 / 5	5 / 5	5 / 5
Shipping Weight:							
Aluminum Fin Coils, lbs.	15,022	15,190	16,570	16,748	21,164	22,476	22,926
Copper Fin Coils, lbs.	16,922	17,090	18,785	18,964	23,695	25,322	25,772
Operating Weight:							
Aluminum Fin Coils, lbs.	18,334	17,531	18,896	19,251	24,191	25,564	26,049
Copper Fin Coils, lbs.	19,235	19,431	21,111	21,466	26,722	28,411	28,896
Compressors, DXS Semihermetic Twin Screw							
Quantity per Chiller	3	3	3	3	4	4	4
Nominal Ton Size, Ckt.-1 / Ckt.-2	78/78	78/78	95/95	105/105	95/95	95/95	105/105
Ckt-3 / Ckt-4	78 / -	105 / -	95 / -	105 / -	78/78	95/95	105/105
Condensers, High Efficiency Fin / Tube with Integral Subcooler							
Total Chiller Coil Face Area, ft ²	384	384	448	448	512	576	576
Number of Rows	3	3	3	3	3	3	3
Fins per Inch	13	13	13	13	13	13	13
Condenser Fans							
Number, Ckt.-1 / Ckt.-2	4 / 4	4 / 4	5 / 5	5 / 5	4 / 4	5 / 5	5 / 5
Number, Ckt-3 / Ckt-4	4 / -	4 / -	4 / -	4 / -	4 / 4	4 / 4	4 / 4
Standard Fans							
Fan Motor, HP / kW	2 / 1.8	2 / 1.8	2 / 1.8	2 / 1.8	2 / 1.8	2 / 1.8	2 / 1.8
Fan & Motor RPM	1140	1140	1140	1140	1140	1140	1140
Fan Diameter, inches	35.4	35.4	35.4	35.4	35.4	35.4	35.4
Fan Tip Speed, feet/min.	10,575	10,575	10,575	10,575	10,575	10,575	10,575
Total Chiller Airflow, CFM	171,600	171,600	200,200	200,200	228,800	257,400	257,400
Low Noise Fans							
Fan Motor, HP / kW	2 / 1.53	2 / 1.53	2 / 1.53	2 / 1.53	2 / 1.53	2 / 1.53	2 / 1.53
Fan & Motor RPM	840	840	840	840	840	840	840
Fan Diameter, inches	35.4	35.4	35.4	35.4	35.4	35.4	35.4
Fan Tip Speed, feet/min.	7,792	7,792	7,792	7,792	7,792	7,792	7,792
Total Chiller Airflow, CFM	168,600	168,600	196,700	196,700	224,800	252,900	252,900
High Static Fans							
Fan Motor, HP / kW	5 / 3.79	5 / 3.79	5 / 3.79	5 / 3.79	5 / 3.79	5 / 3.79	5 / 3.79
Fan & Motor RPM	1,140	1,140	1,140	1,140	1,140	1,140	1,140
Fan Diameter, inches	35.4	35.4	35.4	35.4	35.4	35.4	35.4
Fan Tip Speed, feet/min.	10,575	10,575	10,575	10,575	10,575	10,575	10,575
Total Chiller Airflow, CFM (@0.4" additional static)	171,600	171,600	200,200	200,200	200,200	228,800	228,800
Evaporator, Direct Expansion							
Water Volume, gallons	116	116	94	94	150	135	135
Maximum ¹ Water Side Pressure, PSIG	150	150	150	150	150	150	150
Maximum Refrigerant Side Pressure, PSIG	300	300	300	300	300	300	300
Minimum Chilled Water Flow Rate, GPM	225	225	255	255	300	330	330
Maximum Chilled Water Flow Rate, GPM	800	800	800	800	1060	1060	1060
Water Connections, inches	10	10	10	10	10	10	10

1 Optional 300PSIG Waterside available

DIMENSIONS - YCAS 300 - 330 (ENGLISH)

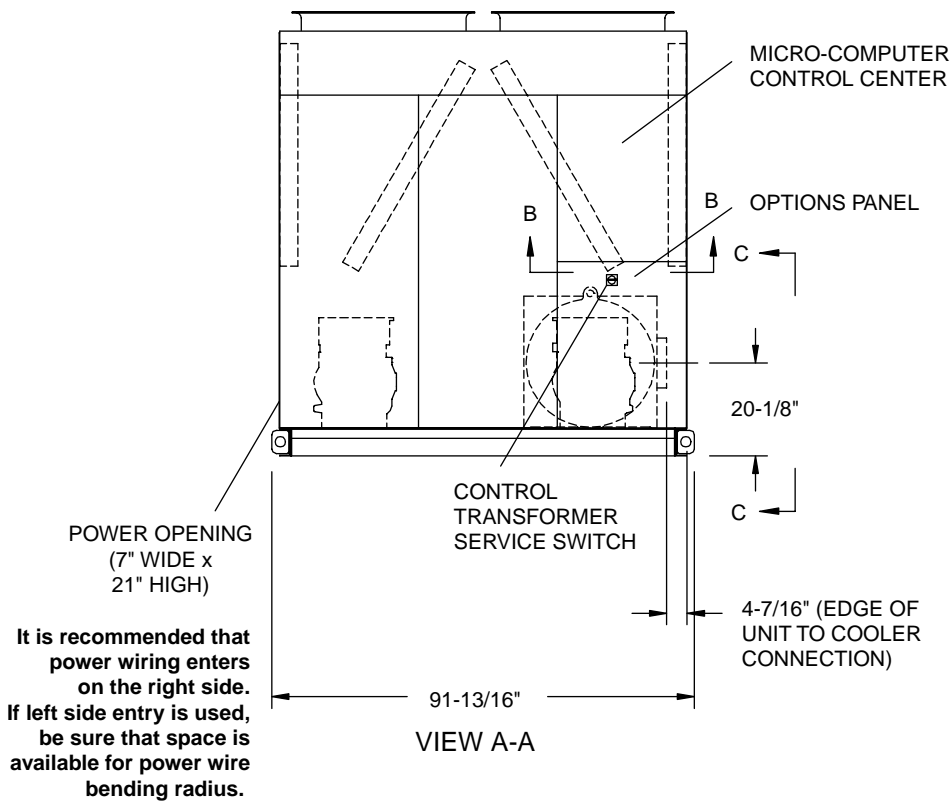
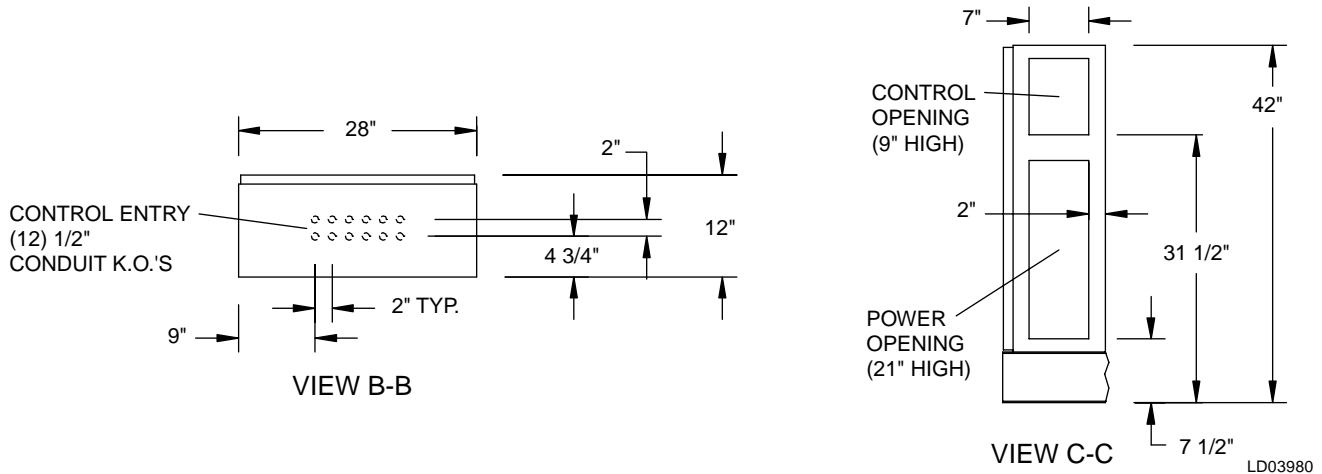

NOTES:

1. Placement on a level surface free of obstructions (including snow, for winter operation) or air recirculation ensures rated performance, reliable operation and ease of maintenance. Site restrictions may compromise minimum clearances indicated below, resulting in unpredictable air flow patterns and possible diminished performance. YORK's unit controls will optimize operation without nuisance high pressure safety cutout; however, the system designer must consider potential performance degradation. Access to the unit control center assumes the unit is no higher than on spring isolators. Recommended minimum clearances: Side to wall - 6'; rear to wall - 6'; control panel end to wall - 4'; top - no obstructions allowed; distance between adjacent units - 10'. No more than one adjacent wall may be higher than the unit.

FIG. 49 – MODEL 300 - 330 DIMENSIONS (ENGLISH DIMENSIONS)

DIMENSIONS - YCAS 300 - 330 (ENGLISH)

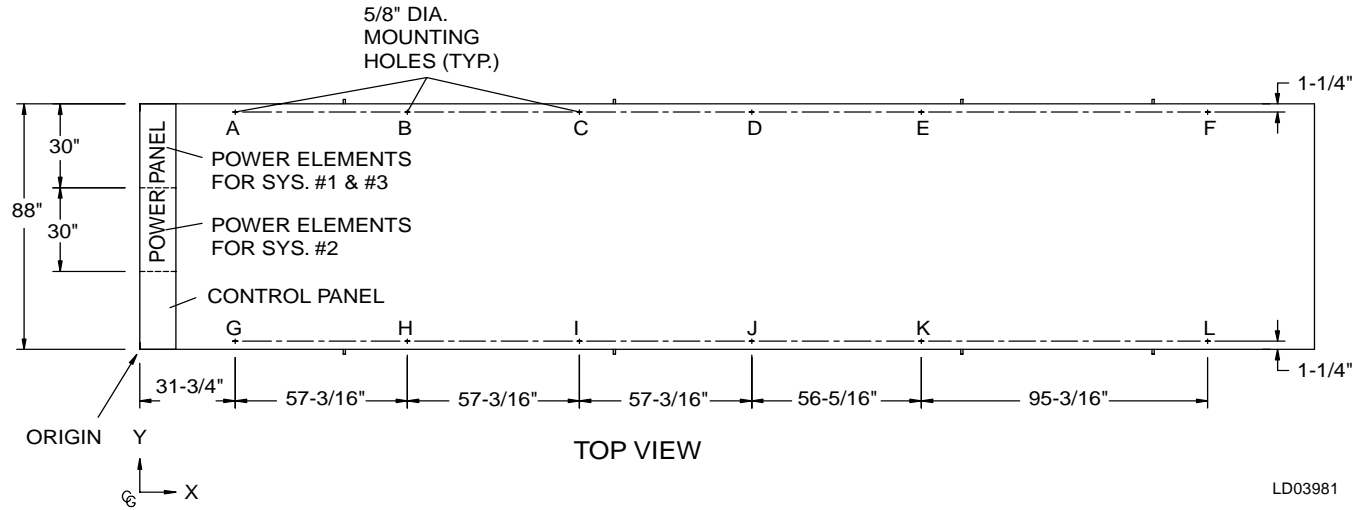

CENTER OF GRAVITY (Alum.)			
YCAS	X	Y	Z
0300	154.0"	41.6"	34.8"
0330	151.3"	41.7"	34.5"

CENTER OF GRAVITY (Copper)			
YCAS	X	Y	Z
0300	159.2"	41.9"	41.8"
0330	156.8"	41.9"	41.4"

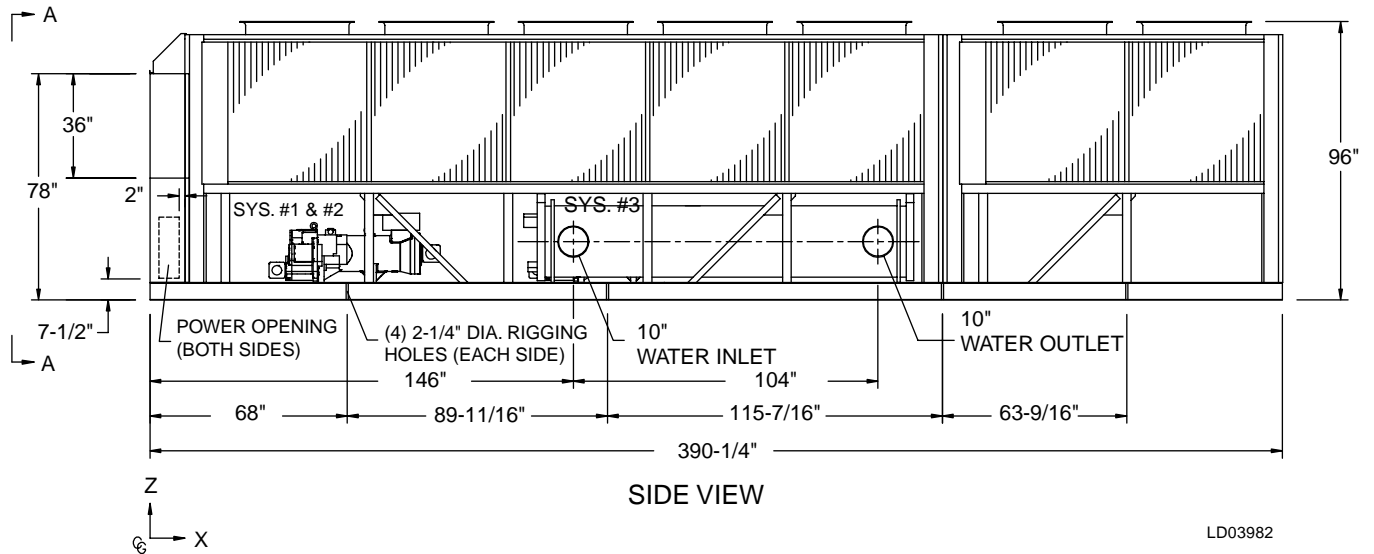

Operating Weights – Aluminum Fin Coils

ALUMINUM FIN COIL WEIGHT DISTRIBUTION BY MODEL (LBS)

YCAS	A	B	C	D	E	F	G	H	I	J	K	L	M	N	O	P	TOTAL
0090	1,405	1,191	977	1,565	1,326	1,088	—	—	—	—	—	—	—	—	—	—	7,552
0100	1,415	1,203	992	1,587	1,350	1,113	—	—	—	—	—	—	—	—	—	—	7,660
0110	1,508	1,399	1,290	1,566	1,452	1,339	—	—	—	—	—	—	—	—	—	—	8,554
0120	1,510	1,405	1,301	1,573	1,464	1,355	—	—	—	—	—	—	—	—	—	—	8,608
0130	1,550	1,339	1,657	678	1,573	1,111	1,707	700	—	—	—	—	—	—	—	—	10,315
0140	1,576	1,356	1,692	688	1,614	1,136	1,764	711	—	—	—	—	—	—	—	—	10,537
0150	1,634	1,227	1,517	1,095	1,794	1,194	1,472	1,330	—	—	—	—	—	—	—	—	11,263
0160	1,637	1,210	1,538	1,109	1,796	1,163	1,460	1,334	—	—	—	—	—	—	—	—	11,247
0170	1,639	1,231	1,554	1,114	1,798	1,198	1,485	1,339	—	—	—	—	—	—	—	—	11,358
0180	1,662	1,227	1,561	1,132	1,836	1,188	1,494	1,369	—	—	—	—	—	—	—	—	11,358
0200	1,856	1,358	2,077	869	1,983	1,207	2,261	902	—	—	—	—	—	—	—	—	12,513
0210	1,859	1,387	2,089	874	1,986	1,254	2,278	907	—	—	—	—	—	—	—	—	12,634
0230	1,862	1,415	2,098	878	1,989	1,303	2,289	911	—	—	—	—	—	—	—	—	12,745
0250	1,209	1,821	1,964	1,051	1,038	830	1,209	2,010	2,351	797	2,112	943	—	—	—	—	17,334
0270	1,225	1,837	2,015	1,082	1,039	832	1,225	2,027	2,374	817	2,113	945	—	—	—	—	17,531
0300	1,254	1,924	2,094	1,227	1,183	1,017	1,254	2,069	2,511	1,030	2,316	1,017	—	—	—	—	18,896
0330	1,295	1,966	2,137	1,269	1,186	1,022	1,295	2,112	2,554	1,072	2,320	1,022	—	—	—	—	19,251
0360	1,323	1,866	1,792	1,064	1,001	2,098	1,727	1,224	1,323	1,866	1,792	1,064	1,001	2,098	1,727	1,224	24,191
0400	1,380	1,882	1,851	1,285	1,048	2,185	1,813	1,338	1,380	1,882	1,851	1,285	1,048	2,185	1,813	1,338	25,564
0440	1,435	1,938	1,907	1,341	1,051	2,190	1,888	1,274	1,435	1,938	1,907	1,341	1,051	2,190	1,888	1,274	26,049



ALUMINUM FIN COIL WEIGHT DISTRIBUTION BY MODEL (KGS)

YCAS	A	B	C	D	E	F	G	H	I	J	K	L	M	N	O	P	TOTAL
0090	637	540	443	710	601	494	—	—	—	—	—	—	—	—	—	—	3,426
0100	642	546	450	720	612	505	—	—	—	—	—	—	—	—	—	—	3,475
0110	684	635	585	710	659	607	—	—	—	—	—	—	—	—	—	—	3,880
0120	685	637	590	714	664	615	—	—	—	—	—	—	—	—	—	—	3,905
0130	703	607	752	308	714	504	774	318	—	—	—	—	—	—	—	—	4,679
0140	715	615	767	312	732	515	800	323	—	—	—	—	—	—	—	—	4,780
0150	741	557	688	497	814	542	668	603	—	—	—	—	—	—	—	—	5,109
0160	743	549	698	503	815	528	662	605	—	—	—	—	—	—	—	—	5,102
0170	743	558	705	505	816	543	674	607	—	—	—	—	—	—	—	—	5,152
0180	754	557	708	513	833	539	678	621	—	—	—	—	—	—	—	—	5,202
0200	842	616	942	394	899	547	1026	409	—	—	—	—	—	—	—	—	5,676
0210	843	629	948	396	901	569	1033	411	—	—	—	—	—	—	—	—	5,731
0230	845	642	952	398	902	591	1038	413	—	—	—	—	—	—	—	—	5,781
0250	548	826	891	477	471	376	548	912	1066	362	958	428	—	—	—	—	7,863
0270	556	833	914	491	471	377	556	919	1077	370	958	429	—	—	—	—	7,952
0300	569	873	950	556	537	461	569	939	1139	467	1051	461	—	—	—	—	8,571
0330	587	892	969	576	538	464	587	958	1158	486	1052	464	—	—	—	—	8,732
0360	600	846	813	483	454	952	783	555	600	846	813	483	454	952	783	555	10,973
0400	626	854	840	583	476	991	822	607	626	854	840	583	476	991	822	607	11,596
0440	651	879	865	608	477	993	856	578	651	879	865	608	477	993	856	578	11,816

ISOLATOR TYPE & SIZE	MAX LOAD		DEFL.	
	lbs.	kg	in.	mm
AWMR-1-53	1000	453.6	2	51
AWMR-1-530	1150	521.6	2	51
AWMR-1-531	1276	578.8	2	51
AWMR-1-532	1500	680.4	2	51
AWMR-1-551	1676	760.2	2	51
AWMR-1-552	1900	861.8	2	51
AWMR-1-553	2200	997.9	2	51
AWMR-2-520	1300	589.7	2	51
AWMR-2-521	1552	704.0	2	51
AWMR-2-53	2000	907.2	2	51
AWMR-1-530	2300	1043.3	2	51
AWMR-2-531	2552	1157.6	2	51
AWMR-2-532	3000	1360.8	2	51

ISOLATOR TYPE & SIZE	MAX LOAD		DEFL.		SPRING COLOR
	lbs.	kg	in.	mm	
CP-2-25	900	408.2	1.22	30.9	Red
CP-2-26	1200	544.3	1.17	29.7	Purple
CP-2-27	1500	680.4	1.06	26.9	Orange
CP-2-28	1800	816.4	1.02	25.9	Green
CP-2-31	2200	997.9	0.83	21.0	Gray
CP-2-32	2600	1179.3	0.74	18.7	White
CP-2-35	3000	1360.8	0.70	17.7	Gold